

Product Selection Guide 2024

Marine Propulsion Systems

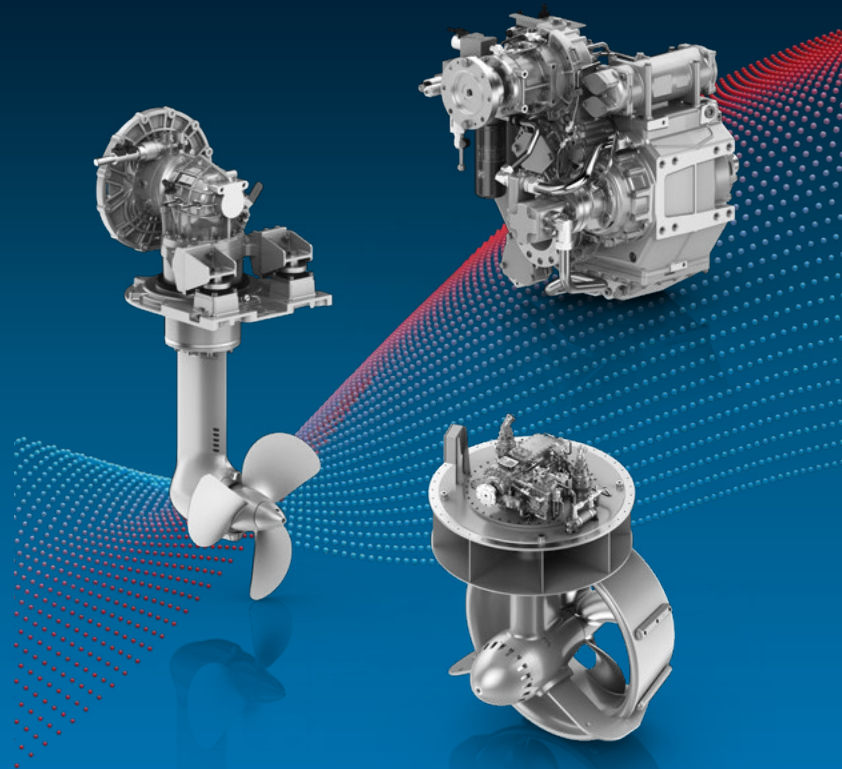

ZF Group

ZF Friedrichshafen AG
Marine & Special Driveline Technology
Ehlersstr. 50
88046 Friedrichshafen
GERMANY
Phone +49 7541 77-2207
info.zfmarine@zf.com

ZF Padova s.r.l.
Via Penghe, 48
35030 Caselle di Selvazzano (PD)
ITALY
Phone +39 049 8299 311
info.zfmarine@zf.com

ZF Marine Krimpen B.V.
Zaag 27, P.O. Box 2020
2930 AA Krimpen aan de Lek
THE NETHERLANDS
Phone +31 180 331000
info.zfmarine@zf.com

www.zf.com/marine



twitter.com/zf_group
facebook.com/zffriedrichshafen
youtube.com/zffriedrichshafenag





Contents

Introduction	Page 4
Sales, Aftersales Offices and Service Competence Centers	Page 6
ZF duty classification definitions	Page 14
Application engineering data	Page 15
Key to configurations and model designations	Page 18
Transmission configuration and type	Page 20
Pleasure Duty – Single Speed	Page 32
Pleasure Duty – Single Speed Gasoline	Page 70
Pleasure Duty – 2 Speed	Page 74
Light Duty – Single Speed	Page 82
Light Duty – 2 Speed	Page 128
Medium Duty – Single Speed	Page 136
Continuous Duty – Single Speed	Page 184
PTO options	Page 240
PTO / PTI / Shaft Brake Options	Page 242
Hybrid Systems	Page 246
Transmissions drawings and dimensions	Page 258
SAE Bell housing dimensions	Page 310
Thruster Systems	Page 312
Other products	Page 324
Control Systems	
ZF POD 4600	
Sail Drive	
Surface Drive System	
Fixed Pitch Propellers	
Approximate conversions	Page 339

There are many ways to reach ZF Marine Aftersales

1 Create a ticket

Go to www.zf.com/contact and select "technical inquiries". You will find a web-form to enter the data of your vessel and your request.

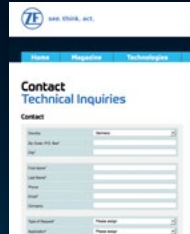
A screenshot of the ZF Marine website's 'Contact Technical Inquiries' page. The page features a header with the ZF logo and navigation tabs for 'Home', 'Propulsion', and 'Technology'. Below the header is a 'Contact' section with a form containing fields for Name, Surname, Email, Phone, and a large text area for the inquiry. There are also dropdown menus for 'Country' and 'Product'.

2 Look for the nearest service location

Go to www.zf.com/marine-service. Select "Find us" and then "Service Network for marine" to get a map with the nearest ZF Marine Service locations.



3 Call the technical support line

ZF Friedrichshafen AG +49 171 360 1282
ZF Padova S.r.l. – Location Arco +39 320 47 89 245
ZF Marine Krimpen B.V. +31 180 331 000 (during office hours)
+31 180 331 033 (after office hours)

service.marine@zf.com · www.zf.com/contact

ZF Marine Propulsion Systems is a leader in the marine market

ZF Marine supplies propulsion systems and components for all types of vessels – motor yachts, defense craft, high-speed ferries, workboats and commercial vessels, in a power range from 10 to 12,000 kW – to customers including major shipyards and engine manufacturers worldwide.

The product portfolio includes a comprehensive range of transmissions (reversing, non-reversing and hybrid), propellers, steering systems and CANbus-compatible, electronic control systems, azimuth thrusters, tunnel thrusters and sail drives.

This selection guide is intended to help the reader select an appropriate ZF Marine product. Contact ZF for assistance in determining an appropriate product in case of particular applications and requirements.

Please read the respective comments that apply to the selected product. Model numbers, ratings, text and data contained in this brochure are subject to change without notification.

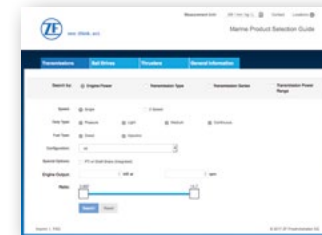

You can find online our Product Selection Guide in the following link: www.zf.com/marine/matran to easily find the right product for you, and its specifications. Here you can find more information like drawings, among others, always up to date. Should you find any difference, our online portal has the most updated information

For further information about the ZF Marine Group, please refer to www.zf.com/marine

Sales, Aftersales and Service Competence Centers

ZF utilizes a global network of factory owned locations and independent business partners to support our customers. Approximately 400 partners worldwide are dedicated to Sales, Aftersales and Service of ZF Marine products.

To find your nearest ZF product support, please contact your Regional Competence Center from the list below or visit: www.zf.com and follow: Products & Services/Service Network to find a ZF partner in your country.

service.marine@zf.com
www.zf.com/contact

Product Competence Centers

ZF Friedrichshafen AG*
Marine Propulsion Systems
Ehlersstr. 50
88046 Friedrichshafen
GERMANY
Phone +49 7541 77 2207
service.marine@zf.com

ZF Padova s.r.l.*
Via Penghe, 48
35030 Caselle di Selvazzano (PD)
ITALY
Phone +39 049 8299-311
info.zfpadova@zf.com

ZF Padova s.r.l. – Location Arco*
Via S. Andrea, 16
38062 Arco (Trento)
ITALY
Phone +39 0464 580-555
service.marine@zf.com

ZF Marine Krimpen B.V.*
Zaag 27, P.O. Box 2020
2930 AA Krimpen aan de Lek
THE NETHERLANDS
Phone +31 180 331-000
info.thruster@zf.com

ZF Faster Propulsion System Co., Ltd.*
17, Dayou 1st Street
Dafa Industrial District
Daliuo District
83163 Kaohsiung City
TAIWAN, R.O.C.
Phone +886 7 787 1831
info.kaohsiung@zf.com

* Manufacturing locations

Europe

Local Competence Centers

CYPRUS

Char. Pilakoutas (Industrial) Ltd.
7, Larnacos Str, 1035
P.O. Box 21168
1503 Nicosia
CYPRUS
Phone +357 225 8630 0
industrial@charpilakoutas.com.cy
www.pilakoutas-industrial.com

CROATIA

Duing, d.o.o.
Stupari 18b
51216 Viškovo
CROATIA
Phone +385 51 683 242
zf-marine@duing.hr
www.duing.hr

DENMARK

ZF Danmark ApS
Taastrupgaardsvæ 8-10
2630 Taastrup
DENMARK
Phone +45 70 2262 43
zf.dk@zf.com

WEST Marine

Fiskerihavnsgade 30
6700 Esbjerg
DENMARK
Phone +45 75 45 70 44
Sales@west-marine.dk
www.west-marine.dk

ESTONIA

Baltic Marine Group AS
Paljassaare tee 14
10313 Tallinn
ESTONIA
Phone +372 68333 00
bm@bm.ee

FINLAND

Atoy Oy
Ruukintie 7-9
02330 Espoo
FINLAND
Phone +358 9 682 71
zf@atoy.fi

FRANCE

ZF Services France SAS
1 Rue du Général Leclerc
92800 Puteaux
FRANCE
Phone +33 6 78 69 82 68
stephane.rouillard@zf.com

GERMANY

Beissbarth u. Müller GmbH & Co. KG
Zamdorfer Str. 90
81677 München
GERMANY
Phone +49 89 93 00 94-0
Fax +49 89 93 00 94-93
marine@beissbarth.de
www.beissbarth.de

Otto Piening GmbH

Am Altendeich 83
25348 Blomesche Wildnis
GERMANY
Phone +49 4124 9168 0
Fax +49 4124 3716
Luetjens@piening-propeller.de
www.piening-propeller.de

GREECE

K. & E. Malerdos Co.
20, Ymittou str
18 540 Piraeus
GREECE
Phone +30 210 417 9693
malerdos@malerdos.gr
www.malerdos.gr

ITALY

ZF Italia S.r.l.

Via Donizetti, 11
20090 Assago (MI)
ITALY
Phone + 39 02 488 831
Fax +39 02 48 844 829
zfitalia@zf.com
www.zf.com/it

MALTA

Oceans

17, Main Street
Zurrieq ZRQ 03
MALTA
Phone +356 7906 9229
publius1948@hotmail.com

NORWAY

KGK Norge AS

Strømsveien 177
0664 Oslo
NORWAY
Phone +47 22 8846 80
firmapost@kgk.no
henning.fjeldberg@kgk.no

POLAND

Marine Works

Ateney 10
80299 Gdansk
POLAND
Phone +48 58 324-4930
www.marineworks.eu

ROMANIA

SC Service Faur SRL

OP 72 Ghiseu 1
OP 40 Sectore 3
30352 Bucharest
ROMANIA
Tel: +40 21 2564645
Fax: +40 21 2564648
ana.sprincenatu@servicefaur.ro
www.servicefaur.ro

SPAIN

ZF Services España, S.A.U.

Avenida Fuentemara, 11
28823 Coslada (Madrid)
SPAIN
Phone +34 91 485 2698
jorge.torre@zf.com

SWEDEN

KG Knutsson AB

Hammarbacken 8
19149 Sollentuna (Stockholm)
SWEDEN
Phone +46 8 923 000
zf@kgk.se

THE NETHERLANDS

ZF Services Nederland B.V.

Distributieweg 7
2645 EG Delfgauw
PostBox 557, 2600 AN Delft
THE NETHERLANDS
Phone +31 15 2702350
nlinfo@zf.com
www.zf.nl

ADSvanSTIGT

Avelingen West 30
4202 MS Gorinchem
THE NETHERLANDS
Phone +31 183 650 000
info@vanstigt.com

TURKEY

ZF Services Türk San. Ve Tic. A.S.

ZF Marine Eurasia
Adil Mah. Demokrasi Cad.
No:17
34935 Sultanbeyli, Istanbul
TURKEY
Phone +90 216 592 1144
caglar.colak@zf.com

UNITED KINGDOM

ZF Services UK

Abbeyfield Road
Lenton
Nottingham NG7 2SX
ENGLAND
Phone +44 0333 240 1123
paul.dean@zf.com

North America, Mexico, Central America, Caribbean

Regional Competence Centers

ZF Marine Propulsion Systems

Miramar, LLC

15351 SW 29th Street, Suite 300
Miramar, Florida 33027
USA
Phone +1 954 441 4040
service.marine.na@zf.com

Local Competence Centers

USA

ZF Marine Propulsion Systems

Miramar, LLC

12125 Harbor Reach Drive
Ste. B
Mukilteo, WA 98275
USA
Phone +1 425 583 1900

South America

Regional Competence Centers

ZF Automotive Brasil Ltda.

Rod. Senador José Ermirio de Moraes,
S/N – km 11 – Bairro Varejão – ITU/SP
CEP: 13314-012
BRAZIL
Phone +55 15 4009 2158
eduardo.aguero@zf.com

Local Competence Centers

ARGENTINA

Transmisiones Marinas S.A.

Hernandarias 3656
B7603GNH Mar Del Plata
ARGENTINA
Phone +54 223 480 7174
tm@tmgroup.com.ar
www.tmgroup.com.ar

CHILE

INDUSMAR LTDA.

Repuestos y Servicios
Indusmar Limitada
Salvador Vergara 450-1
2571190 Viña del Mar
CHILE
Phone +56 9 9482 51 09
glarenas@indusmar.cl
www.indusmar.cl

COLOMBIA

LJPROPcenter

Km 3 Via Mamonal
Cra 56 # 1-340
Cartagena
COLOMBIA
Phone +57 320 549 1818
Mobile +1 954 246 9802
luis@ljpropcenter.com
www.ljpropcenter.com

ECUADOR

Comercial de Productos Industriales y Marinos S.A. "COPRIMARSA"

Km 12.5 Vía a Daule Urb.
Colina del Sol Mz. 2021 V.5
Guayaquil – Guayas
ECUADOR
Phone +593 4 2017489
Mobile +593 9 99613032 -
1235328
Fax +593 4 2017490
coprimarsa@gmail.com
www.coprimarsa.amawebs.com

PARAGUAY

Ingeniería Civil y Arquitectura S.A. (I.C.A.S.A) – ICATURBO

Ruta n° 9 Trasnchaco km 14.5 n°
2457 esquina Juan de Ayolas
Mariano Roque Alonso
PARAGUAY
Phone +595 21 753563
Mobile +595 981 404258
mfk@icaturbo.com.py

PERU

PGO INTERNATIONAL S.A.C.

Calle Toribio Pacheco
390 Miraflores
Lima 18
PERÚ
Phone +51 1421 6055
Mobile +51 999 654283
pgorbegoso@pgoperu.com

Asia Pacific

Regional Competence Centers

ZF Asia Pacific Pte. Ltd.

11 Tuas Drive 1,
638678 Singapore
SINGAPORE
Phone +65 6424 8787
Fax +65 6424 8788
info.zf-services.sg@zf.com
www.zf.com/ap

Local Competence Centers

AUSTRALIA

ZF Services Australia Pty Ltd.

Unit 1, 13 Bessemer Street
Blacktown NSW 2148
AUSTRALIA
Phone +61 2 9679-5555
customersolutions.au@zf.com
www.zf.com/au

ZF Services Australia Pty Ltd. (WA)

U2, 201 Beringarra Avenue,
Malaga WA 6090
AUSTRALIA
customersolutions.au@zf.com

KOREA (SOUTH)

ZF Services Korea Co. Ltd.

195 Pyeongcheon-ro
Bupyeong-gu
Incheon 21314
REP. OF KOREA
Phone +82 32 505-1532
info.zf-services.kr@zf.com

CHINA

ZF Services (China) Co., Ltd.

No 162 Luoxiu Road
Xuhui District, Shanghai, 200231
P.R. CHINA
Phone +86 21 2350-0600
info.zf-services.cn@zf.com
www.zf.com/cn

Holyfort Industrial (HK) Ltd. (China Office)

Unit 703, Block A of Li An
Commercial Bldg
Wanghai Rd., Nanshan Dist.
Shenzhen 518067
Guangdong Province
P.R. CHINA
Phone +86 755 2669 4351
sales@holyfort.com

HONG KONG

Foilborne Engineering Ltd.

Unit A7-10, 13/F, Veristrong
Industrial Centre,
34-36 Au Pui Wan Street,
Fotan, Shatin,
N.T. HONG KONG
Phone +852 26872988
foilborne@foilborne.com.hk

INDIA

ZF India Private Limited

ZF India Services – Mumbai Branch
Unit no. 207 & 208, A Wing,
Kailas Business Park
Godrej – Hiranandani Road, Park Site
Vikhroli West, Mumbai 400079
INDIA
Phone +91 22 67080660
Fax +91 22 67080661
Info.me@zf.com

ISRAEL

Diuk Hydraulica ACS Ltd.

Upper galilee 2
12315 Kibbutz Mahanayim,
Kibbutz Mahanayim, ISRAEL
Phone +97 2(4)6 93 3333
asafr@diuk-zf.com

JAPAN

ZF Asia Pacific Pte. Ltd.

11 Tuas Drive 1,
638678 Singapore
SINGAPORE
Phone +65 6424 8787
Fax +65 6424 8788
info.zf-services.sg@zf.com
www.zf.com/ap

Mizuno Marine Co, Ltd.

1-12-15 Meishinguchi,
Toyonaka-City
Osaka 561-0841 JAPAN
Phone +81 6 6863-5233
info@mizuno-marine.co.jp
www.mizuno-marine.co.jp

Shin Kurushima Sanoyas Shipbuilding Co., Ltd

13-37, Minami-Tsumori 5-Chome
Nishinari-Ku, Osaka 567-0063
JAPAN
Phone +81 6 6661-1026
kazuo_aoki@sanoyas.skyd.co.jp
www.sanoyas.skyd.co.jp

PHILIPPINES

ZF Philippines Inc.

Lot D 3A Sta. Rita Street,
Brgy BF Homes
Parañaque City 1720
PHILIPPINES
Phone +63 2 88382855
info.zf-services.ph@zf.com

TAIWAN

SYNERGON TECHNOLOGY CO., LTD.

No. 48, Changtai St.,
Xiaogang Dist.,
Kaohsiung City 81266,
Taiwan (R.O.C.)
Phone +88 678718682
service@synergom.com.tw

THAILAND

ZF (Thailand) Limited

(Company Reg. no :
0105541022257)
159/33 Moo 3,
Soi Vipavadee-Rangsit 64,
Vipavadee-Rangsit Rd.,
Talad Bangkhen,
Laksi, Bangkok 10210
THAILAND
Phone +66 25216520
Fax +66 25216523

Middle East

Regional Competence Center

ZF Services Middle East LLC

The Galleries 4
Floor 12, Office 1202
Jebal Ali Downtown
Dubai, UAE
Phone +971 (0) 4 333 1530
info.me@zf.com
www.zf.com/me

Africa

Regional Competence Centers

ZF Services South Africa (Pty)

Ltd. – Cape Town branch

29 Proton Crescent
Stikland Bellville 7530
SOUTH AFRICA
Phone +27 21 950-9300
info.zfsa@zf.com

Local Competence Centers

ALGERIA

ZF Algérie S.a.r.l.

143A Postfach B.P.
Route nationale no.5
16300 Rouiba
ALGERIA
Phone +213 21 817595

MOROCCO, MAURITANIA, SENEGAL

CAPCI s.a.r.l

78 Rue El Houd Houd
(Ex: Calais)
Casablanca, MOROCCO 20000
Phone +212 522 20 01 90 91
Fax +212 522 27 88 49
info@capci.ma

TANZANIA

Hansa Group –

Diamond Motors Limited

Plot No. 22B, Nyerere Road
Vingunguti Estate
Dar es Salaam no
TANZANIA
Phone +255 222928372
Fax +255 222928383
info@hansa-global.com

ZF duty classification definitions

P Pleasure Duty

Highly intermittent operation with very large variations in engine speed and power.

- Average engine operation hours limit: 500 hours/year (for mechanical (“M”) transmissions: 300 hours/years)
- Typical hull forms: Planing
- Applications: Private, non-commercial, non-charter, leisure activities, no racing

L Light Duty

Intermittent operation with large variations in engine speed and power.

- Average engine operation hours limit: 2500 hours/year (for hydraulic transmissions smaller than ZF 2000 series: 2000 hours/year)
- Typical hull forms: Planing and semi-displacement
- Typical applications: Private and charter, sport/leisure activities, government applications, no racing

M Medium Duty

Intermittent operation with some variations in engine speed and power.

- Average engine operation hours limit: 4000 hours/year (for transmissions smaller than ZF 2000 series and workboat ZF W2300 series: 3500 hours/year)
- Typical hull forms: Semi-displacement and displacement
- Typical applications: Charter and commercial craft (example: crew boats) sport/leisure activities, government applications

C Continuous Duty

Continuous operation with little or no variations in engine speed and power.

- Average engine operation hours limit: unlimited
- Typical hull forms: Displacement
- Typical applications: Heavy duty commercial vessels

Application engineering data

Torsional Vibration and Torsional Couplings

The responsibility for ensuring complete propulsion system torsional vibration and stress analysis compatibility rests with the overall propulsion system integrator. The analysis must include excitations induced by the engine governor.

ZF cannot accept any liability for gearbox noise or for damage to the gearbox, the flexible coupling or to other parts of the drive unit caused by torsional vibrations. Contact ZF for further information and assistance.

For single engine powered boats, where loss of propulsion can result in loss of control, ZF recommends and Survey Societies normally require the use of a torsional limit stop.

It is the buyer’s responsibility to specify this option. ZF cannot accept any liability for personal injury, loss of life or damage or loss of property due to the failure of the buyer to specify a torsional limit stop. ZF selects torsional couplings on the basis of nominal input torque at commonly rated engine speeds. Consult ZF for details concerning speed limits of standard offered torsional couplings, which can be below transmission limits. Special torsional couplings may be required for Survey Society requirements.

Special oil cooler

For gearbox orders without oil cooler or cooler supplied as loose part it is the integrator’s responsibility to respect cooler oil side interface data. Customer to ask ZF factory for information. ZF is not responsible for inadequate cooling, if integral original components are disconnected and replaced by others or assembly is modified.

Ratings

Ratings apply to marine diesel engines at the indicated speeds, unless mentioned differently (e.g. “gasoline”). At other engine speeds, the respective power capacity (kW) of the transmission can be obtained by multiplying the Power/Speed ratio by the speed.

NOTE: The maximum rated input power and maximum speed must not be exceeded. For some products max power is limited independent of speed (see columns “max. kW”, “max. hp”, “max. rpm”).

Approximate conversion factors:

1 kW	=	1.36 metric hp
1 kW	=	1.34 U.S. hp (SAE)
1 U.S. hp	=	1.014 metric hp
1 Nm	=	0.74 lb.ft

Ratings apply to right hand turning engines, i.e. engines having

counterclockwise rotating flywheels when viewing the flywheel end of the engine. These ratings allow full power through forward and reverse gear trains, unless otherwise stated. Contact your nearest ZF Sales and Service office for ratings applicable to gas turbines, as well as left hand turning engines, and marine transmissions for large horsepower capacity engines. Ratings apply to marine transmissions currently in production or in development and are subject to change without prior notice.

Surface Drive Propellers

For applications with surface-drive propellers limitations apply. Please contact ZF Marine for maximum allowed rating.

Safe Operation Notice

The safe operation of ZF products depends upon adherence to technical data presented in our brochures. Safe operation also depends upon proper installation, operation and routine maintenance and inspection under prevailing conditions and recommendations set forth by ZF. Damage to transmission caused by repeated or continuous emergency manoeuvres or abnormal operation is not covered under warranty. It is the responsibility of users and not ZF to provide and install guards and safety devices, which may be required by recognized safety standards of the respective country (e.g. for U.S.A. – the Occupational Safety Act of 1970 and its subsequent provisions).

Non-Standard Ratios (*)

Where non-standard ratios are indicated (*) these are available on request and may incur additional price/longer delivery compared to standard ratios. Consult ZF for details.

Monitoring Notice

The safe operation of ZF products depends upon adherence to ZF monitoring recommendations presented in our operating manuals, etc. It is the responsibility of users and not ZF to provide and install monitoring devices and safety interlock systems as may be deemed prudent by ZF. Consult ZF for details and recommendations.

Survey Society Classification

In most cases, the ratings permitted by ZF are accepted by major classification societies. If classification is required, contact ZF regarding proper procedures (also for yacht service and ice classification service).

Trolling Valves

Trolling valves are available as an option on most models of marine transmissions. In most cases, trolling valves are easily retrofitted. A thermostatic oil by-pass valve may be required to maintain proper operation and recommended oil temperature. Consult ZF for details and limits.

Standard / Non-Reversing / U-Drive Option

Standard configurations are reversing transmissions with three shafts and parallel vertical offsets (output shaft / input shaft). In principle, all transmissions are also available as non-reversing units (for instance, for controllable pitch propeller applications). Some parallel shaft transmissions can also be supplied with input and output on the same side (U-Drive). Consult ZF for details.

Power Take-Offs (PTO'S)

All PTO'S are retrofittable except where stated otherwise. Most transmissions can be offered with clutchable or permanently driven (live) PTO'S. Consult ZF for details and limits.

Power Take In (PTI)

Many gearbox types are available with PTI accessory. PTI can be used for different options, also in hybrid applications. Depending on operation modes (boost, generator operation, etc.) and torque rate of main engine versus auxiliary drive, limitations may apply. These limitations are documented in respective installation drawings and have to be verified by application engineering for each project.

Dimensions, Weight and Oil Filling

Dimensions and weights refer to transmissions with bell housing (where appropriate) but excluding options such as: trolling valves, power take-offs, propeller shaft companion flanges, torsional couplings etc. Selection Guide data relative to dimensioning, weight and (oil) filling values are "approximate" values. Values indicated in installation drawings are the binding values.

Key to configurations and model designations

Standard Configuration (without name extension)

- Reversing transmissions
- 3-Shaft configuration
- Vertical offset (input above output)
- Parallel offset

Other Configurations / Model Designations

NR:	Non-Reversing *
NR2:	Non-Reversing, two shafts (input above output)
NR2B:	Non-Reversing, two shafts (input below output)
NR2H:	Non-Reversing, two shafts (input horizontal output)
NC:	No clutch *
SG:	Spur Gear
SGDL:	Spur Gear Diagonal Left
SGDR:	Spur Gear Diagonal Right
U:	Remote U-Drive
TS:	2-Speed (power-shifting)
M:	Mechanical clutch actuation
A:	Down-Angle
IV:	Integral Vee-drive (flanged on to engine)
V:	Remote Vee-drive
D:	Diagonal
H:	Horizontal
C:	Coaxial
W:	Workboat
PTI:	Power take in
EW:	Engine wise
CEW:	Counter engine wise

Shaft Rotation

These designations are not part of the model name but the required shaft rotation must be specified when ordering the transmissions. This is particularly important for non-reversing (NR) transmissions.

- Engine-wise (EW): output-shaft rotates in same direction as input shaft, or
- Counter Engine-wise (CEW): output-shaft rotates in opposite direction to input shaft

For standard reversing transmissions full power can be transmitted through either the forward or the reverse gear trains, unless stated otherwise.

* In general NC and NR versions are available for most gearbox models in the range of ZF 2000 and above (technical data on request).

Transmission configuration and type

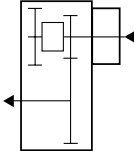
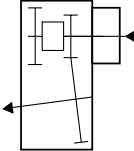
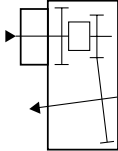
	Parallel offset	Offset down-angle	Integral V-drive
TRANSMISSION FAMILY (2 Speed)			
ZF 90	ZF 90 TS	ZF 90 ATS	ZF 90 IVTS
ZF 115		ZF 115 ATS	ZF 115 IVTS
ZF 325	ZF 325 TS	ZF 325 ATS	ZF 325 IVTS
ZF 550	ZF 550-1 TS	ZF 550-1 ATS	
ZF 665	ZF 665 TS	ZF 665 ATS	

Transmission configuration and type

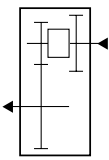
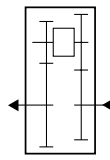
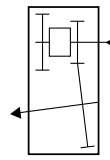
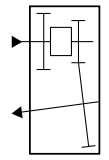
	Parallel offset	Coaxial	Down-angle	V-drive
TRANSMISSION FAMILY				
ZF M	ZF 12 M, ZF 15 M, ZF 25 M, ZF 30 M		ZF 15 MA ZF 25 MA	ZF 15 MIV
ZF 25	ZF 25		ZF 25 A	
ZF 45	ZF 45-1	ZF 45 C	ZF 45 A	
ZF 48				ZF 48 IV
ZF 63		ZF 63 C		
ZF 68	ZF 68		ZF 68 A	ZF 68 IV
ZF 85			ZF 85 A	ZF 85 IV

Transmission configuration and type

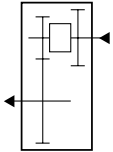
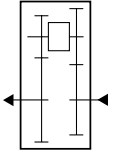
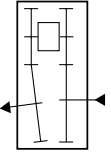
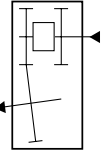
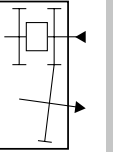
	Parallel offset	Coaxial or near coaxial parallel	Near coax. down-angle	Down-angle	V-drive
TRANSMISSION FAMILY					
ZF 220	ZF 220, ZF W220			ZF 220 A	
ZF 280 ZF 286	ZF 280-1 ZF 286			ZF 280-1 A ZF 286 A	ZF 280 IV ZF 286 IV
ZF 301 ZF 305	ZF 305-3	ZF 301-1 C	ZF 301-1 A	ZF 305-3 A	
ZF 325	ZF 325-1			ZF 325-1 A	ZF 325 IV
ZF 350	ZF W350-1				
ZF 400	ZF 400 ZF W340			ZF 400 A	ZF 400 IV ZF 400 V
ZF 500 ZF 510 ZF 550	ZF 500 ZF 550-1			ZF 500-1 A ZF 510-1 A ZF 550-1 A	ZF 500-1 IV ZF 510 V ZF 550-1 V
ZF 665 ZF W650	ZF 665 ZF W650			ZF 665 A	ZF 665 V

Transmission configuration and type

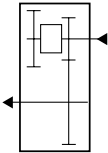
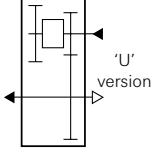
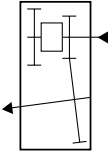
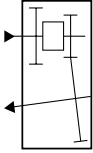
	Parallel offset	Extended parallel offset	Down-angle	V-drive
TRANSMISSION FAMILY				
ZF 2000	ZF 20xx ZF 21xx	ZF 22xx, ZF 23xx, ZF 24xx ZF W23xx, ZF W24xx	ZF 20xx A ZF 21xx A	ZF 20xx V ZF 21xx V
ZF 3000	ZF 30xx	ZF 33xx, ZF 37xx ZF W33xx, ZF W37xx	ZF 30xx A ZF 31xx A	ZF 30xx V ZF 31xx V
ZF 5000	ZF 50xx ZF 50xx NR2H	ZF 53xx ZF W53xx	ZF 50xx A ZF 52xx A	ZF 50xx V ZF 52xx V

Transmission configuration and type

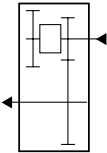
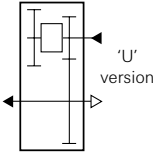
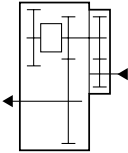
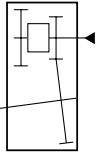
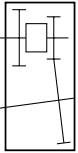
	Parallel offset	Extended parallel offset	Coaxial or near coax. parallel	Down-angle	V-drive
TRANSMISSION FAMILY					
ZF 8000	ZF 80xx	ZF 83xx		ZF 80xx A	ZF 80xx V
ZF 9000	ZF 90xx ZF 90xx NR2 ZF 90xx NR2B ZF 90xx NR2H	ZF 93xx		ZF 90xx A	ZF 90xx V
ZF 23500			ZF 23560 C, ZF 23860 C		
ZF 24000	ZF 24060 D ZF 24060 NR2 ZF 24060 NR2B ZF 24060 NR2H	ZF 24360 D	ZF 24060 SGC ZF 24360 SG ZF 24360 SGDL/DR		
ZF 30000	ZF 30050 NR2 ZF 30050 NR2B ZF 30050 NR2H		ZF 30050 SGC ZF 30350 SG ZF 30350 SGDL/DR		
ZF 40000	ZF 40060 NR2 ZF 40060 NR2B ZF 40060 NR2H		ZF 40060 SGC ZF 40360 SG ZF 40360 SGDL/DR		
ZF 53000	ZF 53000 NR2B, ZF 53000 NR2H ZF 53500 NR2B, ZF 53500 NR2H ZF 53800 NR2B, ZF 53800 NR2H				
ZF 60000	ZF 60000 NR2H				
ZF 83000	ZF 837xx NR2H				

Transmission configuration and type

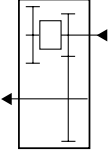
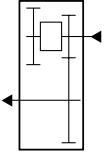
	Parallel offset	Extended parallel offset
TRANSMISSION FAMILY		
ZF W10000	ZF W100x0, ZF W100x0 NR/NC	ZF W101x0, ZF W101x0 NR/NC ZF W102x0, ZF W102x0 NR/NC ZF 108x0, ZF 108x0 NR/NC
ZF W11000	ZF W110x0, ZF W110x0 NR/NC	ZF W111x0, ZF W111x0 NR/NC ZF W112x0, ZF W112x0 NR/NC ZF 118x0, ZF 118x0 NR/NC
ZF W17000	ZF W170x0, ZF W170x0 NR/NC	ZF W171x0, ZF W171x0 NR/NC ZF W172x0, ZF W172x0 NR/NC
ZF W33000		ZF W33100 NR2/NC2
ZF W43000	ZF W43000 NR2/NC2 ZF 43600 NR2/NC2	ZF W43100 NR2/NC2 ZF 43700 NR2/NC2
ZF W63000	ZF W63000 NR2/NC2 ZF 53600 NR2/NR2H	
ZF W83000	ZF W83000 NR2/NC2	ZF W83100 NR2/NC2
ZF W93000		ZF W93300 NC2
ZF W103000		ZF W103100 NC2

P

**Transmissions
Pleasure Duty**

Pleasure Duty Single Speed

P

PRODUCT	Ratios		Power factor		Input power capacity						Max. kW	Max. hp	Max. rpm	Weight		Bell hgs. & notes
	'A' Pos	'B' Pos	kW/rpm	hp/rpm	2800 rpm		3000 rpm		3600 rpm					kg	lb	
ZF 12 M ¹²	2.136	1.955	0.0131	0.0176	37	49	39	53	47	63	55	73	5000	13	29	B/W, Yanmar JH
	2.632	1.955	0.0111	0.0149	31	42	33	45	40	54	55	73	5000			
ZF 15 M ¹²	1.556	1.955	0.0152	0.0204	46	61	55	73	55	73	55	73	5000	13	29	B/W, Yanmar JH Ratio 1.556 'B' Pos max torque 120 Nm. Ratio 1.875 'B' Pos max torque 120 Nm.
	1.875	1.955														
ZF 15 MA ¹² 8 degrees	1.875	1.955	0.0152	0.0204	46	61	55	73	55	73	55	73	5000	14	30	B/W, Yanmar JH Ratio 1.875 'B' Pos max torque 120 Nm. Ratio 2.136 'B' Pos max torque 120 Nm.
	2.136	1.955	0.0131	0.0176	39	53	47	63	50	67	55	73	5000			
	2.632	1.955	0.0111	0.0149	33	45	40	54	42	57	55	73	5000			
ZF 15 MIV ¹² 15 degrees	2.134	2.224	0.0152	0.0204	46	61	55	73	55	73	55	73	5000	20	44	B/W, Yanmar JH Ratio 2.134 'B' Pos max torque 120 Nm.
	2.718	2.224	0.0111	0.0149	33	45	40	54	42	57	55	73	5000			
	2.995	2.224														
ZF 25	1.969	1.969	0.0325	0.0436	98	131	117	157	124	166	179	240	5500	24	53	B/W, Yanmar JH
	2.800	2.800	0.0251	0.0337	75	101	90	121	95	128	138	185	5500			
ZF 25 A 8 degrees	1.548	1.548	0.0325	0.0436	98	131	117	157	124	166	179	240	5500	24	53	B/W, Yanmar JH
	1.926	1.926														
	2.480*	2.480*	0.0277	0.0371	83	111	100	134	105	141	152	204	5500			
	2.292	2.292	0.0262	0.0351	79	105	94	126	100	133	144	193	5500			
	2.714	2.714	0.0251	0.0337	75	101	90	121	95	128	138	185	5500			
ZF 25 M ¹²	1.880	2.095	0.0262	0.0351	79	105	80	107	80	107	80	107	5000	19	41	B/W, Yanmar JH Ratio 1.880 'B' Pos max torque 230 Nm.
	2.273	2.095	0.0215	0.0288	65	86	77	104	80	107	80	107	5000			
	2.737	2.722	0.0177	0.0237	53	71	64	85	67	90	80	107	5000			
ZF 25 MA ¹² 8 degrees	2.227	2.737	0.0215	0.0288	65	86	77	104	80	107	80	107	5000	21	46	B/W, Yanmar JH Ratio 2.227 'B' Pos max torque 169 Nm.
	2.737	2.737	0.0177	0.0237	53	71	64	85	67	90	80	107	5000			
ZF 30 M ¹²	2.148	2.636	0.0241	0.0323	72	97	87	116	92	123	95	128	5000	23	51	4 & 5 Yanmar JH Ratio 2.148 'B' Pos max torque 185 Nm. Ratio 2.696 'B' Pos max torque 185 Nm.
	2.696	2.636														

* Special Order Ratio.

¹² Reduced power capacity by the following shock factors: 1 cylinder engine ÷ 1.25, 2 cylinder engine ÷ 1.20, 3 cylinder engine ÷ 1.15

'A' POS = continuous running position (normally AHEAD).

'B' POS = reverse position.

B/W = Borg Warner adaptor.

Pleasure Duty Single Speed

P

PRODUCT	Ratios		Power factor		Input power capacity						Max. kW	Max. hp	Max. rpm	Weight		Bell hgs. & notes											
	'A' Pos	'B' Pos	kW/rpm	hp/rpm	2800 rpm		3300 rpm		3800 rpm					kg	lb												
					kW	hp	kW	hp	kW	hp																	
ZF 45 A 8 degrees	1.256	1.256	0.0471	0.0632	132	177	155	209	179	240	259	348	5500	28	62	B/W, Volvo D4-D6, Volvo 30-40, Yanmar 4LH-4JH											
	1.514	1.514																									
	2.034	2.034																									
	2.435	2.435															0.0440	0.0590	123	165	145	195	167	224	242	325	5500
ZF 45 C ¹	1.000	1.031	0.0555	0.0744	155	208	183	246	211	283	305	409	5500	31	68	B/W, Volvo D4-D6, Volvo 30-40, Yanmar 4LH-4JH											
ZF 45-1	2.200	2.200	0.0471	0.0632	132	177	155	209	179	240	259	348	5500	60	132	B/W, Volvo D4-D6, Volvo 30-40, Yanmar 4LH-4JH											
	2.512	2.512																									
	3.031	3.031																									
	3.741	3.741																									
ZF 48 IV ¹ 20 degrees	1.462	1.507	0.0712	0.0955	199	267	235	315	271	363	392	525	5500	47	104	B/W, Volvo D4-D6, Volvo 30-40, Yanmar 4LH											
	1.727	1.780																									
	1.950	2.010															0.0636	0.0853	178	239	210	281	242	324	350	469	5500
ZF 63 C ¹	1.000	1.031	0.0712	0.0955	199	267	235	315	271	363	392	525	5500	32	71	B/W, Volvo D4-D6, Volvo 30-40, Yanmar 4LH											
ZF 68	1.256	1.250	0.0712	0.0955	199	267	235	315	271	363	285	382	4000	46	101	B/W, Volvo D4-D6, Volvo 30-40, Yanmar 4LH											
	1.514	1.521																									
	1.750*	1.770																									
	1.933	1.973																									
	2.480	2.476															0.0591	0.0793	165	222	195	262	225	301	236	317	4000
	2.783	2.799																									
ZF 68 A 8 degrees	1.216	1.215	0.0712	0.0955	199	267	235	315	271	363	285	382	4000	44	97	B/W, Volvo D4-D6, Volvo 30-40, Yanmar 4LH											
	1.563	1.583																									
	2.037	2.017																									
	2.522*	2.536															0.0623	0.0835	174	234	206	276	237	317	249	334	4000
	2.682*	2.709																									
ZF 68 IV 12 degrees	1.294	1.288	0.0712	0.0955	199	267	235	315	271	363	285	382	4000	62	137	B/W, Volvo D4-D6, Volvo 30-40, Yanmar 4LH											
	1.560	1.567																									
	1.746	1.749																									
	1.992	2.033																									
	2.477	2.528															0.0659	0.0884	185	248	217	292	250	336	264	354	4000

* Special Order Ratio.

'A' POS = continuous running position (normally AHEAD).

'B' POS = reverse position.

B/W = Borg Warner adaptor.

¹ For ZF 45 C, ZF 45 IV, ZF 45-1 IV, ZF 48 IV and ZF 63 C
- full power in 'A' POS only, 'B' POS for docking and low speed.

Pleasure Duty Single Speed

P

PRODUCT	Ratios		Power factor		Input power capacity						Max. kW	Max. hp	Max. rpm	Weight		Bell hsgs. & notes
	'A' Pos	'B' Pos	kW/rpm	hp/rpm	2800 rpm		3000 rpm		3300 rpm					kg	lb	
ZF 85 A 8 degrees	1.567	1.567	0.1114	0.1494	312	418	334	448	368	493	501	672	4500	69	152	3 CAT, B/W, Volvo D4-D6
	1.750	1.750														
	1.962	1.962														
	2.500	2.500														
ZF 85 IV 12 degrees	1.644	1.638	0.1114	0.1494	312	418	334	448	368	493	390	523	3500	86	190	3 CAT, B/W, Volvo D4-D6
	2.008	1.996														
	2.493	2.468														

'A' POS = continuous running position (normally AHEAD).
 'B' POS = reverse position.
 B/W = Borg Warner adaptor.

Pleasure Duty Single Speed

P

PRODUCT	Ratios	Power factor		Input power capacity						Max. kW	Max. hp	Max. rpm	Weight		Bell hgs. & notes
		kW/rpm	hp/rpm	2300 rpm		2800 rpm		3200 rpm					kg	lb	
ZF 220	1.000, 1.128*, 1.237*, 1.400*, 1.500*, 1.963, 2.478	0.0985	0.1321	227	304	276	370	315	423	443	594	4500	63	139	3 CAT
	3.000	0.0855	0.1147	197	264	239	321	274	367	385	516	4500			
ZF 220 A 10 degrees	1.235*, 1.533, 1.750*, 2.040	0.0932	0.1250	214	288	261	350	298	400	419	563	4500	50	110	3 CAT, B/W
	2.455*	0.0855	0.1147	197	264	239	321	274	367	385	516	4500			
ZF 280 IV 14 degrees	1.252*, 1.561*, 1.772*, 2.063	0.1398	0.1875	350	469	391	525	461	619	503	675	3600	106	234	3 CAT
	2.276, 2.556*	0.1205	0.1616	301	404	337	452	398	533	434	582	3600			
	3.094*	0.1016	0.1362	254	340	284	381	335	449	366	490	3600			
ZF 280-1	0.814*, 1.000, 1.056*, 1.139*, 1.214*, 1.300, 1.514*, 2.000	0.1398	0.1875	350	469	391	525	461	619	503	675	3600	73	161	3 CAT
	2.478	0.1205	0.1616	301	404	337	452	398	533	434	582	3600			
	3.000*	0.1142	0.1531	286	383	320	429	377	505	411	551	3600			
ZF 280-1 A 7 degrees	1.118*, 1.483, 1.769, 2.000, 2.227*	0.1398	0.1875	350	469	391	525	461	619	503	675	3600	73	161	3 CAT
	2.476*	0.1205	0.1616	301	404	337	452	398	533	434	582	3600			
ZF 286	1.237*, 1.400*, 1.500, 1.966	0.1715	0.2300	429	575	480	644	566	759	617	828	3600	86	190	3 CAT
	0.923*, 1.000*, 2.269	0.1641	0.2201	410	550	459	616	542	726	591	792	3600			
	2.481*	0.1506	0.2020	377	505	422	566	497	667	542	727	3600			
	2.917	0.1297	0.1739	324	435	363	487	428	574	467	626	3600			
ZF 286 A 7 degrees	1.200*, 1.484*, 1.750, 1.962	0.1715	0.2300	429	575	480	644	566	759	617	828	3600	77	170	3 CAT
	2.208	0.1506	0.2020	377	505	422	566	497	667	542	727	3600			
	2.391	0.1471	0.1973	368	493	412	552	485	651	530	710	3600			
	2.500	0.1377	0.1847	344	462	386	517	454	610	496	665	3600			
ZF 286 IV 14 degrees	1.266*, 1.535, 2.011	0.1715	0.2300	429	575	480	644	566	759	617	828	3600	130	287	3 CAT
	2.322*	0.1620	0.2172	405	543	454	608	535	717	583	782	3600			
	2.539	0.1491	0.1999	373	500	417	560	492	660	537	720	3600			
ZF 301-1 A 10 degrees	1.190*, 1.516*, 2.005, 2.551, 2.901	0.1285	0.1723	296	396	321	431	360	482	386	517	3000	87	192	3 CAT
	1.236*, 1.408*, 1.862, 2.694	0.1446	0.1939	333	446	362	485	405	543	434	582	3000			
ZF 301-1 C	1.004*	0.1116	0.1497	257	344	279	374	312	419	335	449	3000	87	192	3 CAT

* Special Order Ratio.

Pleasure Duty Single Speed

P

PRODUCT	Ratios	Power factor		Input power capacity						Max. kW	Max. hp	Max. rpm	Weight		Bell hgs. & notes
		kW/rpm	hp/rpm	2100 rpm		2300 rpm		2500 rpm					kg	lb	
ZF 305-3	1.220, 1.486*, 1.968	0.2192	0.2940	460	617	504	676	548	735	658	882	3000	98	216	SAE 1, 2, 3
	0.884*, 1.000*	0.2143	0.2874	450	604	493	661	536	719	643	862	3000			
	2.250*	0.1946	0.2610	409	548	448	600	487	653	584	783	3000			
	2.500	0.1783	0.2391	374	502	410	550	446	598	535	717	3000			
	2.917	0.1556	0.2087	327	438	358	480	389	522	467	626	3000			
ZF 305-3 A 7 degrees	1.200*, 1.514, 1.733, 2.037	0.2192	0.2940	460	617	504	676	548	735	658	882	3000	97	214	SAE 1, 2, 3
	2.179	0.1864	0.2500	391	525	429	575	466	625	559	750	3000			
	2.423	0.1718	0.2304	361	484	395	530	430	576	515	691	3000			
ZF 325 IV 14 degrees	1.216, 1.485*, 1.733, 2.037	0.2595	0.3480	545	731	597	800	649	870	779	1044	3000	185	408	SAE 1, 2
	2.417	0.2334	0.3130	490	657	537	720	584	783	700	939	3000			
ZF 325-1	1.167*, 1.225*, 1.459*, 1.727, 2.033	0.2594	0.3479	545	731	597	800	649	870	778	1044	3000	130	287	SAE 1, 2
	1.000	0.2432	0.3261	511	685	559	750	608	815	730	978	3000			
	2.500	0.2334	0.3130	490	657	537	720	584	783	700	939	3000			
	2.957	0.2043	0.2740	429	575	470	630	511	685	613	822	3000			
ZF 325-1 A 7 degrees	1.216*, 1.485, 1.733, 2.037, 2.240*	0.2595	0.3480	545	731	597	800	649	870	779	1044	3000	130	287	SAE 1, 2
	2.417*	0.2334	0.3130	490	657	537	720	584	783	700	939	3000			
ZF 400 ¹⁵	0.854, 0.925, 1.000, 1.109, 1.233, 1.526, 1.781, 2.033, 2.214	0.3196	0.4286	671	900	735	986	799	1072	959	1286	3000	160	353	SAE 1, 2
	2.600	0.2917	0.3912	613	822	671	900	729	978	875	1174	3000			
	2.957	0.2557	0.3429	537	720	588	789	639	857	767	1029	3000			
ZF 400 A ¹⁵ 7 degrees	1.441, 1.594, 1.767, 1.964	0.3196	0.4286	671	900	735	986	799	1072	959	1286	3000	160	353	SAE 1, 2
	2.192	0.3064	0.4109	643	863	705	945	766	1027	919	1233	3000			
	2.458	0.2717	0.3644	571	765	625	838	679	911	815	1093	3000			
ZF 400 IV ¹⁵ 14 degrees	1.441, 1.594, 1.767, 1.964	0.3196	0.4286	671	900	735	986	799	1072	959	1286	3000	220	485	SAE 1, 2
	2.192	0.3064	0.4109	643	863	705	945	766	1027	919	1233	3000			
	2.458	0.2717	0.3644	571	765	625	838	679	911	815	1093	3000			
				2100 rpm		2300 rpm		2450 rpm							
ZF 400 V 10 degrees	1.125*, 1.774*, 2.000, 2.222*, 2.480	0.3196	0.4286	671	900	735	986	783	1050	959	1286	3000	200	441	

¹⁵ Free standing installation available.

* Special Order Ratio.

Pleasure Duty Single Speed

P

PRODUCT	Ratios	Power factor		Input power capacity						Max. kW	Max. hp	Max. rpm	Weight		Bell hgs. & notes
		kW/rpm	hp/rpm	2100 rpm		2300 rpm		2450 rpm					kg	lb	
				kW	hp	kW	hp	kW	hp						
ZF 500	1.000*, 1.125, 1.237*, 1.500, 1.774*, 1.966	0.3913	0.5247	822	1102	900	1207	959	1286	1174	1574	3000	185	408	SAE 0, 1
	0.925*, 2.185*	0.3654	0.4900	767	1029	840	1127	895	1201	1096	1470	3000			
	2.480*	0.3404	0.4565	715	959	783	1050	834	1118	1021	1370	3000			
	2.625*	0.3242	0.4348	681	913	746	1000	794	1065	973	1304	3000			
	2.917*	0.2675	0.3587	562	753	615	825	655	879	803	1076	3000			
ZF 500-1 A 7 degrees	1.216*, 1.485*, 1.767, 1.964	0.3913	0.5247	822	1102	900	1207	959	1286	1174	1574	3000	192	423	SAE 0, 1
	2.192	0.3683	0.4939	773	1037	847	1136	902	1210	1105	1482	3000			
	2.478*	0.3242	0.4348	681	913	746	1000	794	1065	973	1304	3000			
	2.609*	0.3080	0.4130	647	867	708	950	755	1012	924	1239	3000			
ZF 500-1 IV 14 degrees	1.216*, 1.767*, 1.964	0.3913	0.5247	822	1102	900	1207	959	1286	1174	1574	3000	230	507	SAE 1
	2.200	0.3837	0.5146	806	1081	883	1184	940	1261	1151	1544	3000			
	2.478*	0.3518	0.4718	739	991	809	1085	862	1156	1055	1415	3000			
	3.000*	0.2917	0.3912	613	822	671	900	715	958	875	1174	3000			
ZF 510 V 10 degrees	1.125*, 1.774*, 2.000, 2.222*	0.3913	0.5247	822	1102	900	1207	959	1286	1174	1574	3000	200	441	
ZF 510-1 A 10 degrees	1.125*, 1.774, 2.000, 2.222	0.3913	0.5247	822	1102	900	1207	959	1286	1174	1574	3000	193	425	SAE 0, 1
	2.480*	0.3654	0.4900	767	1029	840	1127	895	1201	1096	1470	3000			
ZF 550-1	1.111, 1.182*, 1.262*, 1.833*, 2.000	0.3913	0.5247	822	1102	900	1207	959	1286	1174	1574	3000	242	534	SAE 0, 1
	2.233*, 2.593	0.3729	0.5001	783	1050	858	1150	914	1225	1119	1500	3000			
	3.042*	0.3059	0.4102	642	861	704	943	749	1005	918	1231	3000			
ZF 550-1 A 10 degrees	1.525*, 1.757*, 1.971, 2.226, 2.448*	0.3913	0.5247	822	1102	900	1207	959	1286	1174	1574	3000	256	564	SAE 0, 1
	2.517	0.3729	0.5001	783	1050	858	1150	914	1225	1119	1500	3000			
	2.960*	0.3246	0.4353	682	914	747	1001	795	1066	974	1306	3000			
ZF 550-1 V 10 degrees	1.525*, 1.971, 2.226, 2.448*	0.3913	0.5247	822	1102	900	1207	959	1286	1174	1574	3000	260	573	
	2.960*	0.3246	0.4353	682	914	747	1001	795	1066	974	1306	3000			
ZF 665	1.111, 1.182*, 1.262, 1.400*, 1.500*, 1.743, 2.000, 2.233*	0.4476	0.6002	940	1260	1029	1380	1097	1470	1343	1801	3000	248	547	SAE 0, 1
	2.593	0.3997	0.5360	839	1126	919	1233	979	1313	1199	1608	3000			
	3.042*	0.3518	0.4718	739	991	809	1085	862	1156	1055	1415	3000			
ZF 665 A 10 degrees	1.525*, 1.971, 2.226	0.4476	0.6002	940	1260	1029	1380	1097	1470	1343	1801	3000	253	558	SAE 0, 1
	2.517	0.3890	0.5217	817	1096	895	1200	953	1278	1167	1565	3000			
	2.960*	0.3524	0.4726	740	992	811	1087	863	1158	1057	1418	3000			

* Special Order Ratio.

Pleasure Duty Single Speed

P

PRODUCT	Ratios	Power factor		Input power capacity						Max. kW	Max. hp	Max. rpm	Weight		Bell hgs. & notes
		kW/rpm	hp/rpm	2100 rpm		2300 rpm		2450 rpm					kg	lb	
				kW	hp	kW	hp	kW	hp						
ZF 665 V 10 degrees	1.525*, 1.757*, 1.971*, 2.226*	0.4476	0.6002	940	1260	1029	1380	1097	1470	1343	1801	3000	252	556	
	2.517*	0.3890	0.5217	817	1096	895	1200	953	1278	1167	1565	3000			
	2.960*	0.3524	0.4726	740	992	811	1087	863	1158	1057	1418	3000			
ZF 2000	1.086*, 1.111*, 1.191*, 1.250*, 1.350*, 1.436*, 1.500, 1.639*, 1.765*, 1.848*, 1.879*, 2.032, 2.276*, 2.519, 2.760*, 2.958	0.4580	0.6142	962	1290	1053	1413	1122	1504	1122	1504	2600	340	750	SAE 0, 1
ZF 2000 A 10 degrees	1.267*, 1.512*, 1.763, 2.029, 2.250*, 2.467, 2.714*, 2.920	0.4580	0.6142	962	1290	1053	1413	1122	1504	1122	1504	2600	348	767	SAE 0, 1
	3.250*	0.3243	0.4349	681	913	746	1000	794	1064	794	1064	2600			
ZF 2000 V 10 degrees	1.267*, 1.512*, 1.763, 2.029, 2.250*, 2.467, 2.714*, 2.920	0.4580	0.6142	962	1290	1053	1413	1122	1504	1122	1504	2600	352	776	
	3.250*	0.3243	0.4349	681	913	746	1000	794	1064	794	1064	2600			
ZF 2050	1.086*, 1.111*, 1.191*, 1.250*, 1.350*, 1.436*, 1.500, 1.639*, 1.765*, 1.848*, 1.879*, 2.032, 2.276*, 2.519	0.5028	0.6743	1056	1416	1156	1551	1231	1650	1231	1650	2600	342	754	SAE 0, 1
ZF 2050 A 10 degrees	1.267*, 1.512*, 1.763, 2.029, 2.250*, 2.467	0.5028	0.6743	1056	1416	1156	1551	1231	1650	1231	1650	2600	350	772	SAE 0, 1
ZF 2050 V 10 degrees	1.267*, 1.512*, 1.763, 2.029, 2.250*, 2.467	0.5028	0.6743	1056	1416	1156	1551	1231	1650	1231	1650	2600	354	780	
ZF 2060	1.086*, 1.111*, 1.191*, 1.250*, 1.350*, 1.436*, 1.500, 1.639*, 1.765*, 1.848*, 1.879*, 2.032, 2.276*, 2.519	0.5511	0.7390	1157	1552	1268	1700	1350	1811	1350	1811	2450	342	754	SAE 0, 1
ZF 2060 A 10 degrees	1.267*, 1.512*, 1.763, 2.029, 2.250*, 2.467	0.5511	0.7390	1157	1552	1268	1700	1350	1811	1350	1811	2450	350	772	SAE 0, 1
ZF 2060 V 10 degrees	1.267*, 1.512*, 1.763, 2.029, 2.250*, 2.467	0.5511	0.7390	1157	1552	1268	1700	1350	1811	1350	1811	2450	354	780	
				2000 rpm		2100 rpm		2300 rpm							
ZF 2070 ²	1.086*, 1.111*, 1.191*, 1.250*, 1.350*, 1.436*, 1.500, 1.639*, 1.765*, 1.848*, 1.879*, 2.032, 2.276*, 2.519	0.5844	0.7837	1169	1567	1227	1646	1344	1803	1344	1803	2300	342	754	SAE 0, 1
ZF 2070 A ² 10 degrees	1.267*, 1.512*, 1.763, 2.029, 2.250*, 2.467	0.5844	0.7837	1169	1567	1227	1646	1344	1803	1344	1803	2300	350	772	SAE 0, 1
ZF 2070 V ² 10 degrees	1.267*, 1.512*, 1.763, 2.029, 2.250*, 2.467	0.5844	0.7837	1169	1567	1227	1646	1344	1803	1344	1803	2300	354	780	

² The ZF 2070 and ZF 2075 are not suitable for Surface-Drive applications.

* Special Order Ratio.

Pleasure Duty Single Speed

P

PRODUCT	Ratios	Power factor		Input power capacity						Max. kW	Max. hp	Max. rpm	Weight		Bell hgs. & notes
		kW/rpm	hp/rpm	2100 rpm		2300 rpm		2450 rpm					kg	lb	
ZF 2075 ²	1.086*, 1.111*, 1.191*, 1.250*, 1.350*, 1.436*, 1.500, 1.639*, 1.765*, 1.848*, 1.879*, 2.032, 2.276*, 2.519	0.5850	0.7845	1229	1647	1346	1804	1433	1922	1433	1922	2450	342	754	SAE 0, 1
ZF 2075 A ² 10 degrees	1.267*, 1.512*, 1.763, 2.029, 2.250*, 2.467	0.5850	0.7845	1229	1647	1346	1804	1433	1922	1433	1922	2450	350	772	SAE 0, 1
ZF 2075 V ² 10 degrees	1.267*, 1.512*, 1.763, 2.029, 2.250*, 2.467	0.5850	0.7845	1229	1647	1346	1804	1433	1922	1433	1922	2450	354	780	
ZF 2150	2.760*	0.5028	0.6743	1056	1416	1156	1551	1231	1650	1231	1650	2600	344	758	SAE 0, 1
	2.958	0.4802	0.6440	1008	1352	1104	1481	1176	1577	1176	1577	2600			
ZF 2150 A 10 degrees	2.714*, 2.920	0.5028	0.6743	1056	1416	1156	1551	1231	1650	1231	1650	2600	352	776	SAE 0, 1
	3.250*	0.4057	0.5441	852	1143	933	1251	993	1331	993	1331	2600			
ZF 2150 V 10 degrees	2.714*, 2.920	0.5028	0.6743	1056	1416	1156	1551	1231	1650	1231	1650	2600	356	785	
	3.250*	0.4057	0.5441	852	1143	933	1251	993	1331	993	1331	2600			
ZF 2200 ¹³	3.000, 3.286*, 3.519*	0.4580	0.6142	962	1290	1053	1413	1122	1504	1122	1504	2600	404	891	SAE 0, 1
ZF 2250 ¹³	3.000, 3.286*, 3.519*	0.5029	0.6744	1056	1416	1157	1551	1232	1652	1232	1652	2600	406	895	SAE 0, 1
ZF 2260 ¹³	3.000, 3.286*, 3.519*	0.5511	0.7390	1157	1552	1268	1700	1350	1811	1350	1811	2450	406	895	SAE 0, 1
				2000 rpm		2100 rpm		2300 rpm							
ZF 2270 ¹³	3.000	0.5840	0.7832	1168	1566	1226	1645	1343	1801	1343	1801	2300	406	895	SAE 0, 1
				2100 rpm		2300 rpm		2450 rpm							
ZF 2275 ¹³	3.000	0.5850	0.7845	1229	1647	1346	1804	1433	1922	1433	1922	2450	406	895	SAE 0, 1
ZF 2300 ⁸	4.000, 4.444	0.4580	0.6142	962	1290	1053	1413	1122	1504	1122	1504	2600	434	957	SAE 0, 1
ZF 2350 ⁸	4.000, 4.444	0.5029	0.6744	1056	1416	1157	1551	1232	1652	1232	1652	2600	436	961	SAE 0, 1
	4.760*	0.4802	0.6440	1008	1352	1104	1481	1176	1577	1176	1577	2600			
ZF 2360 ⁸	4.000, 4.444	0.5511	0.7390	1157	1552	1268	1700	1350	1811	1350	1811	2450	436	961	SAE 0, 1
				2000 rpm		2100 rpm		2300 rpm							
ZF 2370 ⁸	4.000, 4.444	0.5840	0.7832	1168	1566	1226	1645	1343	1801	1343	1801	2300	436	961	SAE 0, 1
				2100 rpm		2300 rpm		2450 rpm							
ZF 2375 ⁸	4.000, 4.444	0.5850	0.7845	1229	1647	1346	1804	1433	1922	1433	1922	2450	436	961	SAE 0, 1
ZF 3050	1.093*, 1.195*, 1.250*, 1.306*, 1.343*, 1.412*, 1.441*, 1.500, 1.563*, 1.594*, 1.645*, 1.700*, 1.733*, 1.800*, 1.828*, 2.037, 2.154*, 2.240*, 2.375*, 2.417*, 2.500, 2.609*, 2.773*, 2.952*	0.6165	0.8267	1295	1736	1418	1901	1510	2024	1510	2024	2600	482	1063	SAE 00, 0, 1

² The ZF 2070 and ZF 2075 are not suitable for Surface-Drive applications.

⁸ U-drive version also available.

¹³ No classification available.

* Special Order Ratio.

Pleasure Duty Single Speed

P

PRODUCT	Ratios	Power factor		Input power capacity						Max. kW	Max. hp	Max. rpm	Weight		Bell hsgs. & notes
		kW/rpm	hp/rpm	2100 rpm		2300 rpm		2450 rpm					kg	lb	
				kW	hp	kW	hp	kW	hp						
ZF 3050 A 10 degrees	1.351*, 1.486*, 1.750*, 2.034, 2.259*, 2.520, 2.750*, 3.000*	0.6165	0.8267	1295	1736	1418	1901	1510	2024	1510	2024	2600	485	1069	SAE 0, 1
	3.280*	0.5354	0.7180	1124	1508	1231	1651	1311	1758	1311	1758	2600			
	3.444*	0.4867	0.6527	1022	1371	1119	1500	1119	1500	1119	1500	2600			
ZF 3050 D CEW ^{9, 17}	1.093*, 1.195*, 1.250*, 1.306*, 1.343*, 1.412*, 1.441*, 1.500, 1.563*, 1.594*, 1.645*, 1.700*, 1.733*, 1.800*, 1.828*, 2.037, 2.154*, 2.240*, 2.375*, 2.417*, 2.500, 2.609*, 2.773*, 2.952*	0.6165	0.8267	1295	1736	1418	1901	1510	2024	1510	2024	2600	482	1063	
ZF 3050 D EW ⁹	1.093*, 1.195*, 1.250*, 1.306*, 1.343*, 1.412*, 1.441*, 1.500, 1.563*, 1.594*, 1.645*, 1.700*, 1.733*, 1.800*, 1.828*, 2.037, 2.154*, 2.240*, 2.375*, 2.417*, 2.500, 2.609*, 2.773*, 2.952*	0.6165	0.8267	1295	1736	1418	1901	1510	2024	1510	2024	2600	482	1063	
ZF 3050 V 10 degrees	1.351*, 1.486*, 1.750*, 2.034, 2.259*, 2.520, 2.750*, 3.000*	0.6165	0.8267	1295	1736	1418	1901	1510	2024	1510	2024	2600	500	1102	
	3.280*	0.5354	0.7180	1124	1508	1231	1651	1311	1758	1311	1758	2600			
	3.444*	0.4867	0.6527	1022	1371	1119	1500	1119	1500	1119	1500	2600			
ZF 3055	1.093*, 1.195*, 1.250*	0.6489	0.8702	1363	1827	1492	2001	1589	2130	1589	2130	2600	487	1074	SAE 00, 0, 1
	1.306*	0.6489	0.8702	1363	1827	1492	2001	1510	2024	1510	2024	2600			
	1.343*, 1.412*, 1.441*, 1.500, 1.563*, 1.594*, 1.645*, 1.700*, 1.733*, 1.800*, 1.828*, 2.037, 2.154*, 2.240*, 2.375*, 2.417*, 2.500, 2.609*, 2.773*, 2.952*	0.6489	0.8702	1363	1827	1492	2001	1589	2130	1589	2130	2600			
ZF 3055 A 10 degrees	1.351*, 1.486*, 1.750*, 2.034, 2.259*, 2.520, 2.750*, 3.000*	0.6489	0.8702	1363	1827	1492	2001	1589	2130	1589	2130	2600	490	1080	SAE 0, 1
	3.280*	0.5841	0.7833	1227	1645	1343	1802	1431	1919	1431	1919	2600			
	3.444*	0.5451	0.7310	1145	1535	1254	1681	1254	1681	1254	1681	2600			
ZF 3055 D CEW ^{3, 9, 17}	1.093*, 1.195*, 1.250*, 1.306*, 1.343*, 1.412*, 1.441*, 1.500, 1.563*, 1.594*, 1.645*, 1.700*, 1.733*, 1.800*, 1.828*, 2.037, 2.154*, 2.240*, 2.375*, 2.417*, 2.500, 2.609*, 2.773*, 2.952*	0.6489	0.8702	1363	1827	1492	2001	1589	2130	1589	2130	2600	482	1063	
ZF 3055 V 10 degrees	1.351*, 1.486*, 1.750*, 2.034, 2.259*, 2.520, 2.750*, 3.000*	0.6489	0.8702	1363	1827	1492	2001	1589	2130	1589	2130	2600	505	1113	
	3.280*	0.5841	0.7833	1227	1645	1343	1802	1431	1919	1431	1919	2600			
	3.444	0.5451	0.7310	1145	1535	1254	1681	1254	1681	1254	1681	2600			

³ Engine wise (EW) operation only for waterjet flushing.

⁹ Left and Right version available.

¹⁷ PTI (Hybrid) also available.

* Special Order Ratio.

Pleasure Duty Single Speed

P

PRODUCT	Ratios	Power factor		Input power capacity						Max. kW	Max. hp	Max. rpm	Weight		Bell hgs. & notes
		kW/rpm	hp/rpm	2100 rpm		2300 rpm		2450 rpm					kg	lb	
				kW	hp	kW	hp	kW	hp						
ZF 3060	1.093*, 1.195*, 1.250*, 1.306*, 1.343*, 1.412*, 1.441*, 1.500, 1.563*, 1.594*, 1.645*, 1.700*, 1.733*, 1.800*, 1.828*, 2.037, 2.154*, 2.240*, 2.375*, 2.417*, 2.500, 2.609*, 2.773*, 2.952*	0.7313	0.9807	1536	2059	1682	2256	1792	2403	1792	2403	2450	487	1074	SAE 00, 0, 1
ZF 3060 A 10 degrees	1.351*, 1.486*, 1.750*, 2.034, 2.259*, 2.520, 2.750*, 3.000*	0.7313	0.9807	1536	2059	1682	2256	1792	2403	1792	2403	2450	490	1080	SAE 0, 1
	3.280*	0.6489	0.8702	1363	1827	1492	2001	1590	2132	1590	2132	2450			
	3.444*	0.6009	0.8058	1262	1692	1382	1853	1382	1853	1382	1853	2450			
ZF 3060 D CEW ^{3, 9, 17}	1.093*, 1.195*, 1.250*, 1.306*, 1.343*, 1.412*, 1.441*, 1.500, 1.563*, 1.594*, 1.645*, 1.700*, 1.733*, 1.800*, 1.828*, 2.037, 2.154*, 2.240*, 2.375*, 2.417*, 2.500, 2.609*, 2.773*, 2.952*	0.7313	0.9807	1536	2059	1682	2256	1792	2403	1792	2403	2450	482	1063	
ZF 3060 V 10 degrees	1.351*, 1.486*, 1.750*, 2.034, 2.259*, 2.520, 2.750*, 3.000*	0.7313	0.9807	1536	2059	1682	2256	1792	2403	1792	2403	2450	505	1113	
	3.280*	0.6489	0.8702	1363	1827	1492	2001	1590	2132	1590	2132	2450			
	3.444	0.6009	0.8058	1262	1692	1382	1853	1382	1853	1382	1853	2450			
ZF 3070	1.093*, 1.195*, 1.250*, 1.306*, 1.343*, 1.412*, 1.441*, 1.500, 1.563*, 1.594*, 1.645*, 1.700*, 1.733*, 1.800*, 1.828*, 2.037, 2.154*, 2.240*, 2.375*, 2.417*, 2.500, 2.609*, 2.773*	0.7920	1.0621	1663	2230	1822	2443	1940	2602	1940	2602	2450	487	1074	SAE 00, 0, 1
ZF 3070 A 10 degrees	1.351*, 1.486*, 1.750*, 2.034, 2.259*, 2.520, 2.750*	0.7920	1.0621	1663	2230	1822	2443	1940	2602	1940	2602	2450	490	1080	SAE 0, 1
ZF 3070 V 10 degrees	1.351*, 1.486*, 1.750*, 2.034, 2.259*, 2.520, 2.750*	0.7920	1.0621	1663	2230	1822	2443	1940	2602	1940	2602	2450	505	1113	
ZF 3150 A ¹³ 10 degrees	1.257*, 1.500*, 1.759*, 1.963, 2.240, 2.478*	0.6165	0.8267	1295	1736	1418	1901	1510	2024	1510	2024	2600	470	1036	SAE 0, 1
	2.880*	0.5354	0.7180	1124	1508	1231	1650	1231	1650	1231	1650	2600			
ZF 3155 A ¹³ 10 degrees	1.257*, 1.500*, 1.759*, 1.963, 2.240, 2.478*	0.6489	0.8702	1363	1827	1492	2001	1493	2002	1493	2002	2600	470	1036	SAE 0, 1
	2.880*	0.5840	0.7832	1226	1645	1343	1800	1343	1800	1343	1800	2600			
ZF 3160 A ¹³ 10 degrees	1.257*, 1.500*, 1.759*, 1.963, 2.240, 2.478*	0.7313	0.9807	1536	2059	1682	2255	1682	2255	1682	2255	2450	470	1036	SAE 0, 1
	2.880*	0.6489	0.8702	1363	1827	1492	2001	1493	2002	1493	2002	2450			
ZF 3170 A ¹³ 10 degrees	1.257*, 1.500*, 1.759*, 1.963, 2.240	0.7923	1.0625	1664	2231	1822	2444	1941	2603	1941	2603	2450	470	1036	SAE 0, 1

³ Engine wise (EW) operation only for waterjet flushing.

⁹ Left and Right version available.

¹³ No classification available.

¹⁷ PTI (Hybrid) also available.

* Special Order Ratio.

Pleasure Duty Single Speed

P

PRODUCT	Ratios	Power factor		Input power capacity						Max. kW	Max. hp	Max. rpm	Weight		Bell hgs. & notes
		kW/rpm	hp/rpm	2100 rpm		2300 rpm		2450 rpm					kg	lb	
ZF 3350 ⁸	2.647*, 2.844*, 3.000*, 3.519*, 3.769*, 4.000, 4.250*, 4.478, 4.727*, 5.000	0.6165	0.8267	1295	1736	1418	1901	1510	2024	1510	2024	2600	665	1466	SAE 00, 0, 1
ZF 3355 ⁸	2.647*, 2.844*, 3.000*, 3.519*, 3.769*, 4.000, 4.250*, 4.478, 4.727*, 5.000	0.6489	0.8702	1363	1827	1492	2001	1589	2130	1589	2130	2600	670	1477	SAE 00, 0, 1
ZF 3360 ⁸	2.647*, 2.844*, 3.000*, 3.519*, 3.769*, 4.000, 4.250*, 4.478, 4.727*, 5.000	0.7313	0.9807	1536	2059	1682	2256	1792	2403	1792	2403	2450	670	1477	SAE 00, 0, 1
ZF 3370 ⁸	2.647*, 2.844*, 3.000*, 3.519*, 3.769*, 4.000, 4.250*, 4.478	0.7920	1.0621	1663	2230	1822	2443	1940	2602	1940	2602	2450	670	1477	SAE 00, 0, 1
ZF 5000	1.256*, 1.526, 1.585*, 1.722*, 1.771*, 1.853*, 2.031, 2.233*, 2.310*, 2.429*, 2.500, 2.630*, 2.731*, 2.880*, 2.920*, 2.963	0.8440	1.1318	1772	2377	1941	2603	2067	2771	2067	2771	2600	740	1631	SAE 00, 0
ZF 5000 A 8 degrees	1.431*, 1.512*, 1.757*, 2.029, 2.250*, 2.467, 2.714*, 2.962	0.8440	1.1318	1772	2377	1941	2603	2067	2771	2067	2771	2600	750	1653	SAE 00, 0
ZF 5000 D ^{9, 17}	1.256*, 1.526, 1.585*, 1.722*, 1.771*, 1.853*, 2.031, 2.233*, 2.310*, 2.429*, 2.500, 2.630*, 2.731*, 2.880*, 2.920*, 2.963	0.8440	1.1318	1772	2377	1941	2603	2067	2771	2067	2771	2600	765	1687	
ZF 5000 NR2H ⁹	1.256*, 1.526, 1.585*, 1.722*, 1.771*, 1.853*, 2.031, 2.233*, 2.310*, 2.429*, 2.500, 2.630*, 2.731*, 2.880*, 2.920*, 2.963	0.8440	1.1318	1772	2377	1941	2603	2067	2771	2067	2771	2600	615	1356	
ZF 5000 V 8 degrees	1.431*, 1.512*, 1.757*, 2.029, 2.250*, 2.467, 2.714*, 2.962	0.8440	1.1318	1772	2377	1941	2603	2067	2771	2067	2771	2600	768	1693	
ZF 5050	1.256*, 1.526, 1.585*, 1.722*, 1.771*, 1.853*, 2.031, 2.233*, 2.310*, 2.429*, 2.500, 2.630*, 2.731*	0.9435	1.2653	1981	2657	2170	2910	2311	3099	2311	3099	2600	740	1631	SAE 00, 0
	2.880*	0.9176	1.2305	1927	2584	2110	2830	2248	3014	2248	3014	2600			
	2.920*	0.9107	1.2213	1912	2565	2095	2809	2231	2991	2231	2991	2600			
	2.963	0.9031	1.2111	1897	2543	2077	2786	2212	2966	2212	2966	2600			
ZF 5050 A 8 degrees	1.431*, 1.512*, 1.757*, 2.029, 2.250*, 2.467, 2.714*, 2.962	0.9435	1.2653	1981	2657	2170	2910	2311	3099	2311	3099	2600	750	1653	SAE 00, 0
	3.222*	0.8586	1.1514	1803	2418	1975	2648	2103	2820	2103	2820	2600			
	3.429*	0.7920	1.0621	1663	2230	1822	2443	1940	2601	1940	2601	2600			

⁸ U-drive version also available.

⁹ Left and Right version available.

¹⁷ PTI (Hybrid) also available.

* Special Order Ratio.

Pleasure Duty Single Speed

P

PRODUCT	Ratios	Power factor		Input power capacity						Max. kW	Max. hp	Max. rpm	Weight		Bell hgs. & notes
		kW/rpm	hp/rpm	2100 rpm		2300 rpm		2450 rpm					kg	lb	
				kW	hp	kW	hp	kW	hp						
ZF 5050 D ^{9,17}	1.256*, 1.526, 1.585*, 1.722*, 1.771*, 1.853*, 2.031, 2.233*, 2.310*, 2.429*, 2.500, 2.630*, 2.731*	0.9435	1.2653	1981	2657	2170	2910	2311	3099	2311	3099	2600	765	1687	
	2.880*	0.9176	1.2305	1927	2584	2110	2830	2248	3014	2248	3014	2600			
	2.920*	0.9107	1.2213	1912	2565	2095	2809	2231	2991	2231	2991	2600			
	2.963	0.9031	1.2111	1897	2543	2077	2786	2212	2966	2212	2966	2600			
ZF 5050 NR2H ⁹	1.256*, 1.526, 1.585*, 1.722*, 1.771*, 1.853*, 2.031, 2.233*, 2.310*, 2.429*, 2.500, 2.630*, 2.731*	0.9435	1.2653	1981	2657	2170	2910	2311	3099	2311	3099	2600	615	1356	
	2.880*	0.9176	1.2305	1927	2584	2110	2830	2248	3014	2248	3014	2600			
	2.920*	0.9107	1.2213	1912	2565	2095	2809	2231	2991	2231	2991	2600			
	2.963	0.9031	1.2111	1897	2543	2077	2786	2212	2966	2212	2966	2600			
ZF 5050 V 8 degrees	1.431*, 1.512*, 1.757*, 2.029, 2.250*, 2.467, 2.714*, 2.962	0.9435	1.2653	1981	2657	2170	2910	2311	3099	2311	3099	2600	768	1693	
	3.222*	0.8586	1.1514	1803	2418	1975	2648	2103	2820	2103	2820	2600			
	3.429*	0.7920	1.0621	1663	2230	1822	2443	1940	2601	1940	2601	2600			
ZF 5060	1.256*, 1.526, 1.585*, 1.722*, 1.771*, 1.853*, 2.031, 2.233*, 2.310*, 2.429*, 2.500, 2.630*, 2.731*	1.0052	1.3480	2111	2831	2312	3100	2462	3301	2462	3301	2600	740	1631	SAE 00, 0
	2.880*	0.9656	1.2949	2028	2719	2221	2978	2365	3171	2365	3171	2600			
	2.920*	0.9549	1.2805	2005	2689	2196	2945	2339	3136	2339	3136	2600			
	2.963	0.9435	1.2653	1981	2657	2170	2910	2311	3099	2311	3099	2600			
ZF 5060 A 8 degrees	1.431*, 1.512*, 1.757*, 2.029, 2.250*, 2.467, 2.714*, 2.962	1.0052	1.3480	2111	2831	2312	3100	2462	3301	2462	3301	2600	750	1653	SAE 00, 0
	3.222*	0.9435	1.2653	1981	2657	2170	2910	2311	3099	2311	3099	2600			
	3.429*	0.9143	1.2261	1920	2575	2103	2820	2240	3003	2240	3003	2600			
ZF 5060 D ^{9,17}	1.256*, 1.526, 1.585*, 1.722*, 1.771*, 1.853*, 2.031, 2.233*, 2.310*, 2.429*, 2.500, 2.630*, 2.731*	1.0052	1.3480	2111	2831	2312	3100	2462	3301	2462	3301	2600	765	1687	
	2.880*	0.9656	1.2949	2028	2719	2221	2978	2365	3171	2365	3171	2600			
	2.920*	0.9549	1.2805	2005	2689	2196	2945	2339	3136	2339	3136	2600			
	2.963	0.9435	1.2653	1981	2657	2170	2910	2311	3099	2311	3099	2600			

⁹ Left and Right version available.

¹⁷ PTI (Hybrid) also available.

* Special Order Ratio.

Pleasure Duty Single Speed

P

PRODUCT	Ratios	Power factor		Input power capacity						Max. kW	Max. hp	Max. rpm	Weight		Bell hgs. & notes
		kW/rpm	hp/rpm	2100 rpm		2300 rpm		2450 rpm					kg	lb	
ZF 5060 NR2H ⁹	1.256*, 1.526, 1.585*, 1.722*, 1.771*, 1.853*, 2.031, 2.233*, 2.310*, 2.429*, 2.500, 2.630*, 2.731*	1.0052	1.3480	2111	2831	2312	3100	2462	3301	2462	3301	2600	615	1356	
	2.880*	0.9656	1.2949	2028	2719	2221	2978	2365	3171	2365	3171	2600			
	2.920*	0.9549	1.2805	2005	2689	2196	2945	2339	3136	2339	3136	2600			
	2.963	0.9435	1.2653	1981	2657	2170	2910	2311	3099	2311	3099	2600			
ZF 5060 V 8 degrees	1.431*, 1.512*, 1.757*, 2.029, 2.250*, 2.467, 2.714*, 2.962	1.0052	1.3480	2111	2831	2312	3100	2462	3301	2462	3301	2600	768	1693	
	3.222*	0.9435	1.2653	1981	2657	2170	2910	2311	3099	2311	3099	2600			
	3.429*	0.9143	1.2261	1920	2575	2103	2820	2240	3003	2240	3003	2600			
ZF 5200 A ¹⁶ 8 degrees	2.588, 2.844*, 3.100, 3.393*, 3.692	0.8440	1.1318	1772	2377	1941	2603	2068	2773	2068	2773	2600	870	1918	SAE 00, 0
ZF 5200 V ¹⁶ 8 degrees	2.588, 2.844*, 3.100, 3.393*, 3.692	0.8440	1.1318	1772	2377	1941	2603	2068	2773	2068	2773	2600	880	1940	
ZF 5250 A ¹⁶ 8 degrees	2.588, 2.844*, 3.100, 3.393*, 3.692	0.9435	1.2653	1981	2657	2170	2910	2312	3100	2312	3100	2600	870	1918	SAE 00, 0
	4.000	0.8586	1.1514	1803	2418	1975	2648	2104	2821	2104	2821	2600			
	4.250*	0.7920	1.0621	1663	2230	1822	2443	1940	2601	1940	2601	2600			
ZF 5250 V ¹⁶ 8 degrees	2.588, 2.844*, 3.100, 3.393*, 3.692	0.9435	1.2653	1981	2657	2170	2910	2312	3100	2312	3100	2600	880	1940	
	4.000	0.8586	1.1514	1803	2418	1975	2648	2104	2821	2104	2821	2600			
	4.250*	0.7920	1.0621	1663	2230	1822	2443	1940	2601	1940	2601	2600			
ZF 5260 A ¹⁶ 8 degrees	2.588, 2.844*, 3.100, 3.393*, 3.692	1.0052	1.3480	2111	2831	2312	3100	2463	3302	2463	3302	2600	870	1918	SAE 00, 0
	4.000	0.9529	1.2779	2001	2684	2192	2939	2335	3131	2335	3131	2600			
	4.250*	0.9143	1.2261	1920	2575	2103	2820	2240	3003	2240	3003	2600			
ZF 5260 V ¹⁶ 8 degrees	2.588, 2.844*, 3.100, 3.393*, 3.692	1.0052	1.3480	2111	2831	2312	3100	2463	3302	2463	3302	2600	880	1940	
	4.000	0.9529	1.2779	2001	2684	2192	2939	2335	3131	2335	3131	2600			
	4.250*	0.9143	1.2261	1920	2575	2103	2820	2240	3003	2240	3003	2600			
ZF 5300 ^{8, 16}	2.587*, 2.750*, 2.947*, 3.108*, 3.314*, 3.471*, 4.033, 4.464, 5.040	0.8440	1.1318	1772	2377	1941	2603	2067	2771	2067	2771	2600	950	2094	SAE 00, 0
ZF 5350 ^{8, 16}	2.587*, 2.750*, 2.947*, 3.108*, 3.314*, 3.471*, 4.033, 4.464, 5.040	0.9435	1.2653	1981	2657	2170	2910	2311	3099	2311	3099	2600	950	2094	SAE 00, 0
ZF 5360 ^{8, 16}	2.587*, 2.750*, 2.947*, 3.108*, 3.314*, 3.471*, 4.033, 4.464, 5.040	1.0052	1.3480	2111	2831	2312	3100	2462	3301	2462	3301	2600	950	2094	SAE 00, 0
	5.500	0.9110	1.2217	1913	2566	2095	2810	2231	2991	2231	2991	2600			

⁸ U-drive version also available.

⁹ Left and Right version available.

¹⁶ PTI (Hybrid) or Integrated Shaft Brake also available.

* Special Order Ratio.

Pleasure Duty Single Speed

P

PRODUCT	Ratios	Power factor		Input power capacity						Max. kW	Max. hp	Max. rpm	Weight		Bell hgs. & notes
		kW/rpm	hp/rpm	1800 rpm		2000 rpm		2100 rpm					kg	lb	
				kW	hp	kW	hp	kW	hp						
ZF 8000	1.250*, 1.500, 1.781*, 1.967, 2.296*, 2.560, 2.708*, 2.958, 3.174*	1.1623	1.5587	2092	2806	2325	3117	2441	3273	2441	3273	2300	1015	2238	SAE 00
ZF 8000 A 8 degrees	1.462, 1.743*, 2.000, 2.233*, 2.556, 2.731*, 3.000, 3.292*, 3.440	1.1623	1.5587	2092	2806	2325	3117	2441	3273	2441	3273	2300	1050	2315	SAE 00
ZF 8000 D ^{9, 17}	1.250*, 1.500, 1.781*, 1.967, 2.296*, 2.560, 2.708*, 2.958, 3.174*	1.1623	1.5587	2092	2806	2325	3117	2441	3273	2441	3273	2300	1015	2238	
ZF 8000 NR2	1.250*, 1.500, 1.781*, 1.967, 2.296*, 2.560, 2.708*, 2.958, 3.174*	1.1623	1.5587	2092	2806	2325	3117	2441	3273	2441	3273	2300	810	1786	
ZF 8000 NR2B	1.250*, 1.500, 1.781*, 1.967, 2.296*, 2.560, 2.708*, 2.958, 3.174*	1.1623	1.5587	2092	2806	2325	3117	2441	3273	2441	3273	2300	810	1786	
ZF 8000 NR2H ⁹	1.250*, 1.500, 1.781*, 1.967, 2.296*, 2.560, 2.708*, 2.958, 3.174*	1.1623	1.5587	2092	2806	2325	3117	2441	3273	2441	3273	2300	800	1764	
ZF 8000 V 8 degrees	1.462, 1.743*, 2.000, 2.233*, 2.556, 2.731*, 3.000, 3.292*, 3.440	1.1623	1.5587	2092	2806	2325	3117	2441	3273	2441	3273	2300	1075	2370	
ZF 8050	1.250*, 1.500, 1.781*, 1.967, 2.296*, 2.560, 2.708*, 2.958, 3.174*	1.3058	1.7511	2350	3152	2612	3502	2742	3677	2742	3677	2300	1015	2238	SAE 00
ZF 8050 A 8 degrees	1.462, 1.743*, 2.000, 2.233*, 2.556, 2.731*, 3.000	1.3058	1.7511	2350	3152	2612	3502	2742	3677	2742	3677	2300	1050	2315	SAE 00
	3.292*	1.2565	1.6850	2262	3033	2513	3370	2639	3538	2639	3538	2300			
	3.440	1.2356	1.6570	2224	2983	2471	3314	2595	3479	2595	3479	2300			
ZF 8050 D ^{9, 17}	1.250*, 1.500, 1.781*, 1.967, 2.296*, 2.560, 2.708*, 2.958, 3.174*	1.3058	1.7511	2350	3152	2612	3502	2742	3677	2742	3677	2300	1015	2238	
ZF 8050 NR2	1.250*, 1.500, 1.781*, 1.967, 2.296*, 2.560, 2.708*, 2.958, 3.174*	1.3058	1.7511	2350	3152	2612	3502	2742	3677	2742	3677	2300	810	1786	
ZF 8050 NR2B	1.250*, 1.500, 1.781*, 1.967, 2.296*, 2.560, 2.708*, 2.958, 3.174*	1.3058	1.7511	2350	3152	2612	3502	2742	3677	2742	3677	2300	810	1786	
ZF 8050 NR2H ⁹	1.250*, 1.500, 1.781*, 1.967, 2.296*, 2.560, 2.708*, 2.958, 3.174*	1.3058	1.7511	2350	3152	2612	3502	2742	3677	2742	3677	2300	800	1764	
ZF 8050 V 8 degrees	1.462, 1.743*, 2.000, 2.233*, 2.556, 2.731*, 3.000	1.3058	1.7511	2350	3152	2612	3502	2742	3677	2742	3677	2300	1075	2370	
	3.292*	1.2565	1.6850	2262	3033	2513	3370	2639	3538	2639	3538	2300			
	3.440	1.2356	1.6570	2224	2983	2471	3314	2595	3479	2595	3479	2300			
ZF 8060	1.250*, 1.500, 1.781*, 1.967, 2.296*, 2.560, 2.708*, 2.958	1.4052	1.8844	2529	3392	2810	3769	2951	3957	2951	3957	2300	1015	2238	SAE 00
	3.174*	1.3403	1.7974	2413	3235	2681	3595	2815	3774	2815	3774	2300			

⁹ Left and Right version available.

¹⁷ PTI (Hybrid) also available.

* Special Order Ratio.

Pleasure Duty Single Speed

P

PRODUCT	Ratios	Power factor		Input power capacity						Max. kW	Max. hp	Max. rpm	Weight		Bell hgs. & notes
		kW/rpm	hp/rpm	1800 rpm		2000 rpm		2100 rpm					kg	lb	
				kW	hp	kW	hp	kW	hp						
ZF 8060 A 8 degrees	1.462, 1.743*, 2.000, 2.233*, 2.556, 2.731*, 3.000	1.4052	1.8844	2529	3392	2810	3769	2951	3957	2951	3957	2300	1050	2315	SAE 00
	3.292*	1.3403	1.7974	2413	3235	2681	3595	2815	3774	2815	3774	2300			
	3.440	1.3058	1.7511	2350	3152	2612	3502	2742	3677	2742	3677	2300			
ZF 8060 D CEW ^{3, 9, 17}	1.250, 1.500, 1.781, 1.967, 2.296, 2.560, 2.708, 2.958	1.4052	1.8844	2529	3392	2810	3769	2951	3957	2951	3957	2300	1015	2238	
	3.174	1.3403	1.7974	2413	3235	2681	3595	2815	3774	2815	3774	2300			
ZF 8060 NR2	1.250*, 1.500, 1.781*, 1.967, 2.296*, 2.560, 2.708*, 2.958	1.4052	1.8844	2529	3392	2810	3769	2951	3957	2951	3957	2300	810	1786	
	3.174*	1.3403	1.7974	2413	3235	2681	3595	2815	3774	2815	3774	2300			
ZF 8060 NR2B	1.250*, 1.500, 1.781*, 1.967, 2.296*, 2.560, 2.708*, 2.958	1.4052	1.8844	2529	3392	2810	3769	2951	3957	2951	3957	2300	810	1786	
	3.174*	1.3403	1.7974	2413	3235	2681	3595	2815	3774	2815	3774	2300			
ZF 8060 NR2H ⁹	1.250*, 1.500, 1.781*, 1.967, 2.296*, 2.560, 2.708*, 2.958	1.4052	1.8844	2529	3392	2810	3769	2951	3957	2951	3957	2300	800	1764	
	3.174*	1.3403	1.7974	2413	3235	2681	3595	2815	3774	2815	3774	2300			
ZF 8060 V 8 degrees	1.462, 1.743*, 2.000, 2.233*, 2.556, 2.731*, 3.000	1.4052	1.8844	2529	3392	2810	3769	2951	3957	2951	3957	2300	1075	2370	
	3.292*	1.3403	1.7974	2413	3235	2681	3595	2815	3774	2815	3774	2300			
	3.440	1.3058	1.7511	2350	3152	2612	3502	2742	3677	2742	3677	2300			
ZF 8300 ^{8, 16}	2.576, 2.967, 3.214*, 3.538, 3.760*, 3.958, 4.174*, 4.522, 4.708*	1.1623	1.5587	2092	2806	2325	3117	2441	3273	2441	3273	2300	1220	2690	SAE 00
ZF 8311 ^{8, 16}	2.576, 2.967, 3.214*, 3.538, 3.760*, 3.958, 4.174*, 4.522, 4.708*	1.1623	1.5587	2092	2806	2325	3117	2441	3273	2441	3273	2300	1625	3583	SAE 00
ZF 8350 ^{8, 16}	2.576, 2.967, 3.214*, 3.538, 3.760*, 3.958, 4.174*, 4.522	1.3058	1.7511	2350	3152	2612	3502	2742	3677	2742	3677	2300	1220	2690	SAE 00
	4.708*	1.2639	1.6949	2275	3051	2528	3390	2654	3559	2654	3559	2300			
ZF 8351 ^{8, 16}	2.576, 2.967, 3.214*, 3.538, 3.760, 3.958, 4.174*, 4.522	1.3058	1.7511	2350	3152	2612	3502	2742	3677	2742	3677	2300	1625	3583	SAE 00
	4.708*	1.2639	1.6949	2275	3051	2528	3390	2654	3559	2654	3559	2300			
ZF 8360 ^{8, 16}	2.576, 2.967, 3.214*, 3.538, 3.760*, 3.958, 4.174*, 4.522	1.4052	1.8844	2529	3392	2810	3769	2951	3957	2951	3957	2300	1220	2690	SAE 00
	4.708*	1.3403	1.7974	2413	3235	2681	3595	2815	3774	2815	3774	2300			
ZF 8361 ^{8, 16}	2.576, 2.967, 3.214*, 3.538, 3.760*, 3.958, 4.174*, 4.522	1.4052	1.8844	2529	3392	2810	3769	2951	3957	2951	3957	2300	1625	3583	SAE 00
	4.708*	1.3403	1.7974	2413	3235	2681	3595	2815	3774	2815	3774	2300			

³ Engine wise (EW) operation only for waterjet flushing.

⁸ U-drive version also available.

⁹ Left and Right version available.

¹⁶ PTI (Hybrid) or Integrated Shaft Brake also available.

¹⁷ PTI (Hybrid) also available.

* Special Order Ratio.

Pleasure Duty Single Speed

P

PRODUCT	Ratios	Power factor		Input power capacity						Max. kW	Max. hp	Max. rpm	Weight		Bell hgs. & notes
		kW/rpm	hp/rpm	1800 rpm		2000 rpm		2100 rpm					kg	lb	
ZF 9055	1.186*, 1.515*, 1.576*, 1.742*, 1.862*, 2.036, 2.269*, 2.400*, 2.500*, 2.542, 2.739*, 2.957	1.7595	2.3595	3167	4247	3519	4719	3694	4953	3694	4953	2300	1400	3086	SAE 00
	3.250*	1.6571	2.2222	2983	4000	3314	4444	3479	4665	3479	4665	2300			
	3.360*	1.6190	2.1711	2914	3908	3238	4342	3399	4558	3399	4558	2300			
	3.448*	1.5833	2.1232	2850	3822	3167	4246	3324	4457	3324	4457	2300			
ZF 9055 A 8 degrees	1.381*, 1.514*, 1.750*, 1.967, 2.259*, 2.462, 2.750*, 2.958	1.7595	2.3595	3167	4247	3519	4719	3694	4953	3694	4953	2300	1380	3042	SAE 00
	3.208*	1.6571	2.2222	2983	4000	3314	4444	3479	4665	3479	4665	2300			
	3.462*	1.5833	2.1232	2850	3822	3167	4246	3324	4457	3324	4457	2300			
ZF 9055 NR2	1.186*, 1.515*, 1.576*, 1.742*, 1.862*, 2.036, 2.269*, 2.400*, 2.500*, 2.542, 2.739*, 2.957	1.7595	2.3595	3167	4247	3519	4719	3694	4953	3694	4953	2300	1040	2293	
	3.250*	1.6571	2.2222	2983	4000	3314	4444	3479	4665	3479	4665	2300			
	3.360*	1.6190	2.1711	2914	3908	3238	4342	3399	4558	3399	4558	2300			
	3.448*	1.5833	2.1232	2850	3822	3167	4246	3324	4457	3324	4457	2300			
ZF 9055 NR2B	1.186*, 1.515*, 1.576*, 1.742*, 1.862*, 2.036, 2.269*, 2.400*, 2.500*, 2.542, 2.739*, 2.957	1.7595	2.3595	3167	4247	3519	4719	3694	4953	3694	4953	2300	1040	2293	
	3.250*	1.6571	2.2222	2983	4000	3314	4444	3479	4665	3479	4665	2300			
	3.360*	1.6190	2.1711	2914	3908	3238	4342	3399	4558	3399	4558	2300			
	3.448*	1.5833	2.1232	2850	3822	3167	4246	3324	4457	3324	4457	2300			
ZF 9055 NR2H ⁹	1.186*, 1.515*, 1.576*, 1.742*, 1.862*, 2.036, 2.269*, 2.400*, 2.500*, 2.542, 2.739*, 2.957	1.7595	2.3595	3167	4247	3519	4719	3694	4953	3694	4953	2300	1040	2293	
	3.250*	1.6571	2.2222	2983	4000	3314	4444	3479	4665	3479	4665	2300			
	3.360*	1.6190	2.1711	2914	3908	3238	4342	3399	4558	3399	4558	2300			
	3.448*	1.5833	2.1232	2850	3822	3167	4246	3324	4457	3324	4457	2300			
ZF 9055 V 8 degrees	1.381*, 1.514*, 1.750*, 1.967, 2.259*, 2.462, 2.750*, 2.958	1.7595	2.3595	3167	4247	3519	4719	3694	4953	3694	4953	2300	1400	3086	
	3.208*	1.6571	2.2222	2983	4000	3314	4444	3479	4665	3479	4665	2300			
	3.462*	1.5833	2.1232	2850	3822	3167	4246	3324	4457	3324	4457	2300			
ZF 9060	1.186*, 1.515*, 1.576*, 1.742*, 1.862*, 2.036, 2.269*, 2.400*, 2.500*, 2.542, 2.739*, 2.957	1.8590	2.4930	3346	4487	3718	4986	3903	5234	3903	5234	2300	1400	3086	SAE 00
	3.250*	1.7381	2.3308	3129	4195	3476	4662	3650	4894	3650	4894	2300			
	3.360*	1.6810	2.2543	3026	4058	3362	4509	3530	4733	3530	4733	2300			
	3.448*	1.6381	2.1967	2949	3954	3276	4393	3440	4613	3440	4613	2300			

⁹ Left and Right version available.

* Special Order Ratio.

Pleasure Duty Single Speed

P

PRODUCT	Ratios	Power factor		Input power capacity						Max. kW	Max. hp	Max. rpm	Weight		Bell hgs. & notes
		kW/rpm	hp/rpm	1800 rpm		2000 rpm		2100 rpm					kg	lb	
ZF 9060 A 8 degrees	1.381*, 1.514*, 1.750*, 1.967, 2.259*, 2.462, 2.750*, 2.958	1.8590	2.4930	3346	4487	3718	4986	3903	5234	3903	5234	2300	1380	3042	SAE 00
	3.208*	1.7381	2.3308	3129	4195	3476	4662	3650	4894	3650	4894	2300			
	3.462*	1.6381	2.1967	2949	3954	3276	4393	3440	4613	3440	4613	2300			
ZF 9060 NR2	1.186*, 1.515*, 1.576*, 1.742*, 1.862*, 2.036, 2.269*, 2.400*	1.8590	2.4930	3346	4487	3718	4986	3903	5234	3903	5234	2300	1040	2293	
	2.500*	1.8590	2.4930	3346	4487	3694	4953	3694	4953	3694	4953	2300			
	2.542, 2.739*, 2.957	1.8590	2.4930	3346	4487	3718	4986	3903	5234	3903	5234	2300			
	3.250*	1.7381	2.3308	3129	4195	3476	4662	3650	4894	3650	4894	2300			
	3.360*	1.6810	2.2543	3026	4058	3362	4509	3530	4733	3530	4733	2300			
	3.448*	1.6381	2.1967	2949	3954	3276	4393	3440	4613	3440	4613	2300			
ZF 9060 NR2B	1.186*, 1.515*, 1.576*, 1.742*, 1.862*, 2.036, 2.269*, 2.400*, 2.500*, 2.542, 2.739*, 2.957	1.8590	2.4930	3346	4487	3718	4986	3903	5234	3903	5234	2300	1040	2293	
	3.250*	1.7381	2.3308	3129	4195	3476	4662	3650	4894	3650	4894	2300			
	3.360*	1.6810	2.2543	3026	4058	3362	4509	3530	4733	3530	4733	2300			
	3.448*	1.6381	2.1967	2949	3954	3276	4393	3440	4613	3440	4613	2300			
ZF 9060 NR2H ⁹	1.186*, 1.515*, 1.576*, 1.742*, 1.862*, 2.036, 2.269*, 2.400*, 2.500*, 2.542, 2.739*, 2.957	1.8590	2.4930	3346	4487	3718	4986	3903	5234	3903	5234	2300	1040	2293	
	3.250*	1.7381	2.3308	3129	4195	3476	4662	3650	4894	3650	4894	2300			
	3.360*	1.6810	2.2543	3026	4058	3362	4509	3530	4733	3530	4733	2300			
	3.448*	1.6381	2.1967	2949	3954	3276	4393	3440	4613	3440	4613	2300			
ZF 9060 V 8 degrees	1.381*, 1.514*, 1.750*, 1.967, 2.259*, 2.462, 2.750*, 2.958	1.8590	2.4930	3346	4487	3718	4986	3903	5234	3903	5234	2300	1400	3086	
	3.208*	1.7381	2.3308	3129	4195	3476	4662	3650	4894	3650	4894	2300			
	3.462*	1.6381	2.1967	2949	3954	3276	4393	3440	4613	3440	4613	2300			
ZF 9355 ^{8, 16}	2.471*, 3.034*, 3.538, 3.760*, 3.958, 4.217*, 4.522	1.7595	2.3595	3167	4247	3519	4719	3694	4953	3694	4953	2300	1910	4211	SAE 00
	4.783*	1.6571	2.2222	2983	4000	3314	4444	3480	4666	3480	4666	2300			
	4.958*	1.5833	2.1232	2850	3822	3167	4246	3324	4457	3324	4457	2300			
	5.185*	1.5119	2.0275	2721	3649	3024	4055	3174	4256	3174	4256	2300			

⁸ U-drive version also available.

⁹ Left and Right version available.

¹⁶ PTI (Hybrid) or Integrated Shaft Brake also available.

* Special Order Ratio.

Pleasure Duty Single Speed

P

PRODUCT	Ratios	Power factor		Input power capacity						Max. kW	Max. hp	Max. rpm	Weight		Bell hgs. & notes
		kW/rpm	hp/rpm	1800 rpm		2000 rpm		2100 rpm					kg	lb	
ZF 9356 ⁸	2.471*, 3.034*, 3.538, 3.760*, 3.958, 4.217*, 4.522	1.7595	2.3595	3167	4247	3519	4719	3694	4953	3694	4953	2300	2430	5357	SAE 00
	4.783*	1.6571	2.2222	2983	4000	3314	4444	3480	4666	3480	4666	2300			
	4.958*	1.5833	2.1232	2850	3822	3167	4246	3324	4457	3324	4457	2300			
	5.185*	1.5119	2.0275	2721	3649	3024	4055	3174	4256	3174	4256	2300			
ZF 9360 ^{8, 16}	2.471*, 3.034*, 3.538, 3.760*, 3.958, 4.217*, 4.522	1.8590	2.4930	3346	4487	3718	4986	3903	5234	3903	5234	2300	1910	4211	SAE 00
	4.783*	1.7595	2.3595	3167	4247	3519	4719	3695	4955	3695	4955	2300			
	4.958*	1.7048	2.2862	3069	4115	3410	4572	3580	4800	3580	4800	2300			
	5.185*	1.6381	2.1967	2949	3954	3276	4393	3440	4613	3440	4613	2300			
ZF 9361 ⁸	2.471*, 3.034*, 3.538, 3.760*, 3.958, 4.217*, 4.522	1.8590	2.4930	3346	4487	3718	4986	3903	5234	3903	5234	2300	2430	5357	SAE 00
	4.783*	1.7595	2.3595	3167	4247	3519	4719	3695	4955	3695	4955	2300			
	4.958*	1.7048	2.2862	3069	4115	3410	4572	3580	4800	3580	4800	2300			
	5.185*	1.6381	2.1967	2949	3954	3276	4393	3440	4613	3440	4613	2300			

⁸ U-drive version also available.

¹⁶ PTI (Hybrid) or Integrated Shaft Brake also available.

* Special Order Ratio.

Pleasure Duty Single Speed Gasoline

P

PRODUCT	Ratios		Power factor		Input power capacity						Max. kW	Max. hp	Max. rpm	Weight		Bell hgs. & notes
	'A' Pos	'B' Pos	kW/rpm	hp/rpm	3000 rpm		3600 rpm		3800 rpm					kg	lb	
ZF 25	1.969	1.969	0.0325	0.0436	98	131	117	157	124	166	179	240	5500	24	53	B/W, Yanmar JH
	2.800	2.800	0.0251	0.0337	75	101	90	121	95	128	138	185	5500			
ZF 25 A 8 degrees	1.548	1.548	0.0325	0.0436	98	131	117	157	124	166	179	240	5500	24	53	B/W, Yanmar JH
	1.926	1.926														
	2.480*	2.480*	0.0277	0.0371	83	111	100	134	105	141	152	204	5500			
	2.292	2.292	0.0262	0.0351	79	105	94	126	100	133	144	193	5500			
	2.714	2.714	0.0251	0.0337	75	101	90	121	95	128	138	185	5500			
					2800 rpm		3300 rpm		3800 rpm							
ZF 45 A 8 degrees	1.256	1.256	0.0471	0.0632	132	177	155	209	179	240	259	348	5500	28	62	B/W, Volvo D4-D6, Volvo 30-40, Yanmar 4LH-4JH
	1.514	1.514														
	2.034	2.034														
	2.435	2.435	0.0440	0.0590	123	165	145	195	167	224	242	325	5500			
ZF 45 C¹	1.000	1.031	0.0555	0.0744	155	208	183	246	211	283	305	409	5500	31	68	B/W, Volvo D4-D6, Volvo 30-40, Yanmar 4LH-4JH
ZF 48 IV¹ 20 degrees	1.462	1.507	0.0712	0.0955	199	267	235	315	271	363	392	525	5500	47	104	B/W, Volvo D4-D6, Volvo 30-40, Yanmar 4LH
	1.727	1.780														
	1.950	2.010	0.0636	0.0853	178	239	210	281	242	324	350	469	5500			
ZF 63 C¹	1.000	1.031	0.0712	0.0955	199	267	235	315	271	363	392	525	5500	32	71	B/W, Volvo D4-D6, Volvo 30-40, Yanmar 4LH
ZF 68	1.256	1.250	0.0712	0.0955	199	267	235	315	271	363	427	573	6000	46	101	B/W, Volvo D4-D6, Volvo 30-40, Yanmar 4LH
	1.514	1.521														
	1.750*	1.770														
	1.933	1.973														
	2.480	2.476	0.0591	0.0793	165	222	195	262	225	301	355	476	6000			
	2.783	2.799														
ZF 68 A 8 degrees	1.216	1.215	0.0712	0.0955	199	267	235	315	271	363	427	573	6000	44	97	B/W, Volvo D4-D6, Volvo 30-40, Yanmar 4LH
	1.563	1.583														
	2.037	2.017														
	2.522*	2.536	0.0623	0.0835	174	234	206	276	237	317	374	501	6000			
	2.682*	2.709														

* Special Order Ratio.

'A' POS = continuous running position (normally AHEAD).

'B' POS = reverse position.

B/W = Borg Warner adaptor.

¹ For ZF 45 C, ZF 45 IV, ZF 45-1 IV, ZF 48 IV and ZF 63 C
- full power in 'A' POS only, 'B' POS for docking and low speed.

Pleasure Duty Single Speed Gasoline

P

PRODUCT	Ratios		Power factor		Input power capacity						Max. kW	Max. hp	Max. rpm	Weight		Bell hsgs. & notes
	'A' Pos	'B' Pos	kW/rpm	hp/rpm	2800 rpm		3300 rpm		3800 rpm					kg	lb	
ZF 68 IV 12 degrees	1.294	1.288	0.0712	0.0955	199	267	235	315	271	363	427	573	6000	62	137	B/W, Volvo D4-D6, Volvo 30-40, Yanmar 4LH
	1.560	1.567														
	1.746	1.749														
	1.992	2.033														
	2.477	2.528	0.0659	0.0884	185	248	217	292	250	336	395	530	6000			
					2800 rpm		3000 rpm		3300 rpm							
ZF 85 A 8 degrees	1.567	1.567	0.1114	0.1494	312	418	334	448	368	493	501	672	4500	69	152	3 CAT, B/W, Volvo D4-D6
	1.750	1.750														
	1.962	1.962														
	2.500	2.500														

'A' POS = continuous running position (normally AHEAD).

'B' POS = reverse position.

B/W = Borg Warner adaptor.

Pleasure Duty 2 Speed

P

PRODUCT	Ratios				Power factor		Input power capacity						Max. kW	Max. hp	Max. rpm	Weight		Bell hgs. & notes
	1st 'A'	1st 'B'	2nd 'A'	2nd 'B'	kW/rpm	hp/rpm	2800 rpm		3300 rpm		3800 rpm					kg	lb	
ZF 90 ATS 8 degrees	1.216	1.215	0.946	0.945	0.0848	0.1137	237	318	280	375	322	432	466	625	5500	64	141	3 CAT, B/W, Yanmar 4LH
	1.563	1.583	1.216	1.231														
	2.037	2.017	1.584	1.569														
ZF 90 IVTS 12 degrees	1.294	1.288	1.006	1.002	0.0848	0.1137	237	318	280	375	322	432	466	625	5500	82	181	3 CAT, B/W, Yanmar 4LH
	1.560	1.567	1.213	1.219														
	1.992	2.033	1.549	1.581														
	2.477	2.528	1.927	1.967	0.0747	0.1002	209	281	247	331	284	381	411	551	5500			
ZF 90 TS	1.256	1.250	0.977	0.972	0.0848	0.1137	237	318	280	375	322	432	466	625	5500	67	148	3 CAT, B/W, Yanmar 4LH
	1.514	1.521	1.178	1.183														
	1.933	1.973	1.503	1.535														
	2.480	2.476	1.929	1.926	0.0658	0.0882	184	247	217	291	250	335	362	485	5500			
	2.783	2.799	2.165	2.177														
							2600 rpm		2800 rpm		3300 rpm							
ZF 115 ATS 8 degrees	1.567	1.567	1.219	1.219	0.1114	0.1494	290	388	312	418	368	493	368	493	3300	82	181	3 CAT, B/W
	1.750	1.750	1.361	1.361														
	1.962	1.962	1.526	1.526														
	2.500	2.500	1.945	1.945														
ZF 115 IVTS 12 degrees	1.644	1.638	1.279	1.274	0.1114	0.1494	290	388	312	418	368	493	368	493	3300	107	236	3 CAT, B/W
	2.008	1.996	1.562	1.553														
	2.493	2.468	1.939	1.920														

'A' POS = continuous running position (normally AHEAD).
 'B' POS = reverse position.
 B/W = Borg Warner adaptor.

Pleasure Duty 2 Speed

P

PRODUCT	Ratios		Power factor		Input power capacity						Max. kW	Max. hp	Max. rpm	Weight		Bell hgs. & notes
	1st	2nd	kW/rpm	hp/rpm	1800 rpm		2100 rpm		2300 rpm					kg	lb	
ZF 325 IVTS 14 degrees	1.216	0.968, 1.011, 1.062, 1.087, 1.113	0.2594	0.3479	467	626	545	731	597	800	649	870	2500	235	518	SAE 1
	1.485	1.182, 1.235, 1.297, 1.327, 1.359														
	1.733	1.380, 1.441, 1.514, 1.549, 1.586														
	1.793*	1.427, 1.490, 1.565, 1.603, 1.641														
	2.037	1.622, 1.694, 1.779, 1.821, 1.864														
	2.417	1.924, 2.009, 2.111, 2.160, 2.212	0.2334	0.3130	420	563	490	657	537	720	584	783	2500			
ZF 325-1ATS 7 degrees	1.216	0.968, 1.011, 1.062, 1.087, 1.113	0.2594	0.3479	467	626	545	731	597	800	649	870	2500	180	397	SAE 1
	1.485	1.182, 1.235, 1.297, 1.327, 1.359														
	1.733	1.380, 1.441, 1.514, 1.549, 1.586														
	2.037	1.622, 1.694, 1.779, 1.821, 1.864														
	2.417	1.924, 2.009, 2.111, 2.160, 2.212			0.2334	0.3130	420	563	490	657	537	720	584			
ZF 325-1TS	1.000	0.796, 0.831, 0.873, 0.894, 0.915	0.2594	0.3479	467	626	545	731	597	800	649	870	2500	180	397	SAE 1
	1.167*	0.929, 0.970, 1.019, 1.043, 1.068														
	1.225*	0.975, 1.019, 1.070, 1.095, 1.121														
	1.459	1.162, 1.213, 1.275, 1.305, 1.336														
	1.727	1.375, 1.436, 1.509, 1.544, 1.581														
	2.033	1.619, 1.691, 1.776, 1.818, 1.861														
	2.250*	1.791, 1.871, 1.965, 2.011, 2.059														
	2.500	1.990, 2.079, 2.184, 2.235, 2.288			0.2334	0.3130	420	563	490	657	537	720	584			
	2.957	2.354, 2.458, 2.582, 2.643, 2.706	0.2043	0.2740	368	493	429	575	470	630	511	685	2500			

* Special Order Ratio.

Pleasure Duty 2 Speed

P

PRODUCT	Ratios		Power factor		Input power capacity						Max. kW	Max. hp	Max. rpm	Weight		Bell hsgs. & notes
	1st	2nd	kW/rpm	hp/rpm	2100 rpm		2300 rpm		2450 rpm					kg	lb	
ZF 550-1 ATS 10 degrees	1.525	1.225, 1.277, 1.325, 1.363, 1.401	0.3602	0.4830	756	1014	828	1111	882	1183	901	1208	2500	356	785	SAE 1
	1.757															
	1.971	1.583, 1.650, 1.712, 1.762, 1.810														
	2.517	2.022, 2.107, 2.187, 2.251, 2.312														
	2.960	2.377, 2.478, 2.572, 2.646, 2.718	0.3246	0.4353	682	914	747	1001	795	1066	812	1088	2500			
ZF 550-1 TS	1.111	0.892, 0.930, 0.965, 0.993, 1.020	0.3602	0.4830	756	1014	828	1111	882	1183	901	1208	2500	344	758	SAE 1
	1.182*	0.949, 0.989, 1.027, 1.057, 1.085														
	1.262*	1.013, 1.056, 1.096, 1.128, 1.159														
	1.400*	1.124, 1.172, 1.216, 1.252, 1.286														
	1.500	1.205, 1.256, 1.303, 1.341, 1.378														
	1.743	1.400, 1.459, 1.514, 1.558, 1.601														
	2.000	1.606, 1.674, 1.738, 1.788, 1.837														
	2.233	1.794, 1.870, 1.941, 1.997, 2.051														
	2.593	2.082, 2.171, 2.253, 2.318, 2.381														
	3.042	2.443, 2.547, 2.643, 2.719, 2.793	0.3058	0.4101	642	861	703	943	749	1005	765	1025	2500			

* Special Order Ratio.

Pleasure Duty 2 Speed

P

PRODUCT	Ratios		Power factor		Input power capacity						Max. kW	Max. hp	Max. rpm	Weight		Bell hgs. & notes											
	1st	2nd	kW/rpm	hp/rpm	2100 rpm		2300 rpm		2450 rpm					kg	lb												
ZF 665 ATS 10 degrees	1.525	1.225, 1.277, 1.325, 1.363, 1.401	0.4348	0.5831	913	1225	1000	1341	1065	1429	1087	1458	2500	353	778	SAE 1											
	1.757	1.411, 1.471, 1.526, 1.571, 1.613																									
	1.971	1.583, 1.650, 1.712, 1.762, 1.810																									
	2.226	1.788, 1.863, 1.934, 1.990, 2.044																									
	2.448	1.966, 2.050, 2.127, 2.189, 2.248															0.4156	0.5573	873	1170	956	1282	1018	1365	1039	1393	2500
	2.517	2.022, 2.107, 2.187, 2.251, 2.312															0.3890	0.5217	817	1096	895	1200	953	1278	973	1304	2500
ZF 665 TS	1.111	0.892, 0.930, 0.965, 0.993, 1.020	0.4348	0.5831	913	1225	1000	1341	1065	1429	1087	1458	2500	344	758	SAE 1											
	1.182	0.949, 0.989, 1.027, 1.057, 1.085																									
	1.262	1.013, 1.056, 1.096, 1.128, 1.159																									
	1.400	1.124, 1.172, 1.216, 1.252, 1.286																									
	1.500	1.205, 1.256, 1.303, 1.341, 1.378																									
	1.743	1.400, 1.459, 1.514, 1.558, 1.601																									
	2.000	1.606, 1.674, 1.738, 1.788, 1.837																									
	2.233	1.794, 1.870, 1.941, 1.997, 2.051																									
	2.593	0.3997															0.5360	839	1126	919	1233	979	1313	999	1340	2500	
	3.042	2.443, 2.547, 2.643, 2.719, 2.793															0.3518	0.4718	739	991	809	1085	862	1156	880	1180	2500

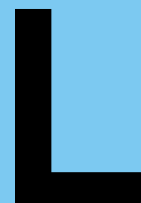

Transmissions Light Duty

Light Duty Single Speed



PRODUCT	Ratios		Power factor		Input power capacity						Max. kW	Max. hp	Max. rpm	Weight		Bell hgs. & notes
	'A' Pos	'B' Pos	kW/rpm	hp/rpm	2800 rpm		3000 rpm		3600 rpm					kg	lb	
ZF 12 M ¹²	2.136	1.955	0.0118	0.0158	33	44	35	47	42	57	50	67	5000	13	29	B/W, Yanmar JH
	2.632	1.955	0.0099	0.0133	28	37	30	40	36	48	50	67	5000			
ZF 15 M ¹²	1.556	1.955	0.0137	0.0184	38	52	41	55	49	66	50	67	5000	13	29	B/W, Yanmar JH Ratio 1.556 'B' Pos max torque 120 Nm. Ratio 1.875 'B' Pos max torque 120 Nm.
	1.875	1.955														
ZF 15 MA ¹² 8 degrees	1.875	1.955	0.0137	0.0184	38	52	41	55	49	66	50	67	5000	14	30	B/W, Yanmar JH Ratio 1.875 'B' Pos max torque 120 Nm.
	2.136	1.955	0.0118	0.0158	33	44	35	47	42	57	50	67	5000			
	2.632	1.955	0.0099	0.0133	28	37	30	40	36	48	50	67	5000			
ZF 15 MIV ¹² 15 degrees	2.134	2.224	0.0137	0.0184	38	52	41	55	49	66	50	67	5000	20	44	B/W, Yanmar JH Ratio 2.134 'B' Pos max torque 120 Nm.
	2.718	2.224	0.0099	0.0133	28	37	30	40	36	48	50	67	5000			
	2.995	2.224														
ZF 25	1.969	1.969	0.0249	0.0334	52	70	62	84	70	94	137	184	5500	24	53	B/W, Yanmar JH
	2.800	2.800	0.0239	0.0321	50	67	60	80	67	90	131	177	5500			
ZF 25 A 8 degrees	1.548	1.548	0.0249	0.0334	52	70	62	84	70	94	137	184	5500	24	53	B/W, Yanmar JH
	1.926	1.926														
	2.292	2.292														
	2.480*	2.480*														
	2.714	2.714	0.0239	0.0321	50	67	60	80	67	90	131	177	5500			
ZF 25 M ¹²	1.880	2.095	0.0236	0.0316	66	88	71	95	72	96	72	96	5000	19	41	B/W, Yanmar JH
	2.273	2.095	0.0194	0.0260	54	73	58	78	70	94	72	96	5000			
	2.737	2.722	0.0159	0.0213	45	60	48	64	57	77	72	96	5000			
ZF 25 MA ¹² 8 degrees	2.227	2.737	0.0194	0.0260	54	73	58	78	70	94	72	96	5000	21	46	B/W, Yanmar JH Ratio 2.227 'B' Pos max torque 169 Nm.
	2.737	2.737	0.0159	0.0213	45	60	48	64	57	77	72	96	5000			
ZF 30 M ¹²	2.148	2.636	0.0216	0.0290	60	81	65	87	78	104	86	115	5000	23	51	4 & 5 Yanmar JH Ratio 2.148 'B' Pos max torque 185 Nm. Ratio 2.696 'B' Pos max torque 185 Nm.
	2.696	2.636														

* Special Order Ratio.

'A' POS = continuous running position (normally AHEAD).

'B' POS = reverse position.

B/W = Borg Warner adaptor.

¹² Reduced power capacity by the following shock factors: 1 cylinder engine ÷ 1.25, 2 cylinder engine ÷ 1.20, 3 cylinder engine ÷ 1.15

Light Duty Single Speed



PRODUCT	Ratios		Power factor		Input power capacity						Max. kW	Max. hp	Max. rpm	Weight		Bell hgs. & notes
	'A' Pos	'B' Pos	kW/rpm	hp/rpm	2100 rpm		2500 rpm		2800 rpm					kg	lb	
ZF 45 A 8 degrees	1.256	1.256	0.0450	0.0603	95	127	113	151	126	169	248	332	5500	28	62	B/W, Volvo D4-D6, Volvo 30-40, Yanmar 4LH-4JH
	1.514	1.514														
	2.034	2.034														
	2.435	2.435														
ZF 45 C¹	1.000	1.031	0.0414	0.0555	87	117	104	139	116	155	228	305	5500	31	68	B/W, Volvo D4-D6, Volvo 30-40, Yanmar 4LH-4JH
ZF 45-1	2.200	2.200	0.0455	0.0610	96	128	114	153	127	171	250	336	5500	60	132	B/W, Volvo D4-D6, Volvo 30-40, Yanmar 4LH-4JH
	2.512	2.512														
	3.031	3.031														
	3.741	3.741														
ZF 48 IV¹ 20 degrees	1.462	1.507	0.0482	0.0646	135	181	159	213	183	245	265	355	5500	47	104	B/W, Volvo D4-D6, Volvo 30-40, Yanmar 4LH
	1.727	1.780														
	1.950	2.010														
ZF 63 C¹	1.000	1.031	0.0500	0.0671	105	141	125	168	140	188	275	369	5500	32	71	B/W, Volvo D4-D6, Volvo 30-40, Yanmar 4LH
ZF 68	1.256	1.250	0.0678	0.0909	142	191	170	227	190	255	271	364	4000	46	101	B/W, Volvo D4-D6, Volvo 30-40, Yanmar 4LH
	1.514	1.521														
	1.933	1.973														
	1.750*	1.770	0.0677	0.0908	142	191	169	227	190	254	271	363	4000			
	2.480	2.476	0.0563	0.0755	118	159	141	189	158	211	225	302	4000			
	2.783	2.799														
ZF 68 A 8 degrees	1.216	1.215	0.0679	0.0911	143	191	170	228	190	255	272	364	4000	44	97	B/W, Volvo D4-D6, Volvo 30-40, Yanmar 4LH
	1.563	1.583														
	2.037	2.017														
	2.522*	2.536	0.0557	0.0747	117	157	139	187	156	209	223	299	4000			
	2.682*	2.709														

* Special Order Ratio.

'A' POS = continuous running position (normally AHEAD).

'B' POS = reverse position.

B/W = Borg Warner adaptor.

¹ For ZF 45 C, ZF 45 IV, ZF 45-1 IV, ZF 48 IV and ZF 63 C
- full power in 'A' POS only, 'B' POS for docking and low speed.

Light Duty Single Speed



PRODUCT	Ratios		Power factor		Input power capacity						Max. kW	Max. hp	Max. rpm	Weight		Bell hgs. & notes
	'A' Pos	'B' Pos	kW/rpm	hp/rpm	2100 rpm		2500 rpm		2800 rpm					kg	lb	
ZF 68 IV 12 degrees	1.294	1.288	0.0678	0.0909	142	191	170	227	190	255	271	364	4000	62	137	B/W, Volvo D4-D6, Volvo 30-40, Yanmar 4LH
	1.560	1.567														
	1.746	1.749														
	1.992	2.033														
	2.477	2.528	0.0628	0.0842	132	177	157	211	176	236	251	337	4000			
ZF 85 A 8 degrees	1.567	1.567	0.1043	0.1399	219	294	261	350	292	392	469	630	4500	69	152	3 CAT, B/W, Volvo D4-D6
	1.750	1.750														
	1.962	1.962														
	2.500	2.500														
ZF 85 IV 12 degrees	1.644	1.638	0.1043	0.1399	219	294	261	350	292	392	365	490	3500	86	190	3 CAT, B/W, Volvo D4-D6
	2.008	1.996														
	2.493	2.468														

'A' POS = continuous running position (normally AHEAD).
 'B' POS = reverse position.
 B/W = Borg Warner adaptor.

Light Duty Single Speed



PRODUCT	Ratios	Power factor		Input power capacity						Max. kW	Max. hp	Max. rpm	Weight		Bell hgs. & notes
		kW/rpm	hp/rpm	2100 rpm		2500 rpm		2800 rpm					kg	lb	
ZF 220	1.000, 1.128*, 1.237*, 1.400*, 1.500*, 1.963, 2.478	0.0887	0.1189	186	250	222	297	248	333	399	535	4500	63	139	3 CAT
	3.000	0.0769	0.1031	161	217	192	258	215	289	346	464	4500			
ZF 220 A 10 degrees	1.235*, 1.533, 1.750*, 2.040	0.0877	0.1176	184	247	219	294	246	329	395	529	4500	50	110	3 CAT, B/W
	2.455*	0.0789	0.1058	166	222	197	265	221	296	355	476	4500			
ZF 280 IV 14 degrees	1.252*, 1.561*, 1.772*, 2.063	0.1162	0.1558	244	327	291	390	325	436	418	561	3600	106	234	3 CAT
	2.276, 2.556*	0.1085	0.1455	228	306	271	364	304	407	391	524	3600			
	3.094*	0.0914	0.1226	192	257	229	307	256	343	329	441	3600			
ZF 280-1	0.814*, 1.000, 1.056*, 1.139*, 1.214*, 1.300, 1.514*, 2.000	0.1162	0.1558	244	327	291	390	325	436	418	561	3600	73	161	3 CAT
	2.478	0.1085	0.1455	228	306	271	364	304	407	391	524	3600			
	3.000*	0.1026	0.1376	215	289	257	344	287	385	369	495	3600			
ZF 280-1 A 7 degrees	1.118*, 1.483, 1.769, 2.000	0.1162	0.1558	244	327	291	390	325	436	418	561	3600	73	161	3 CAT
	2.227, 2.476*	0.1085	0.1455	228	306	271	364	304	407	391	524	3600			
ZF 286	1.237*, 1.400*, 1.500, 1.966, 2.269	0.1545	0.2072	324	435	386	518	433	580	556	746	3600	86	190	3 CAT
	0.923*, 1.000*	0.1491	0.1999	313	420	373	500	417	560	537	720	3600			
	2.481*	0.1372	0.1840	288	386	343	460	384	515	494	662	3600			
	2.917	0.1193	0.1600	251	336	298	400	334	448	429	576	3600			
ZF 286 A 7 degrees	1.200*, 1.484*, 1.750, 1.962	0.1545	0.2072	324	435	386	518	433	580	556	746	3600	77	170	3 CAT
	2.208	0.1417	0.1900	298	399	354	475	397	532	510	684	3600			
	2.391	0.1343	0.1801	282	378	336	450	376	504	483	648	3600			
	2.500	0.1268	0.1700	266	357	317	425	355	476	456	612	3600			
ZF 286 IV 14 degrees	1.266*, 1.535, 2.011	0.1545	0.2072	324	435	386	518	433	580	556	746	3600	130	287	3 CAT
	2.322*	0.1417	0.1900	298	399	354	475	397	532	510	684	3600			
	2.539	0.1372	0.1840	288	386	343	460	384	515	494	662	3600			
ZF 301-1 A 10 degrees	1.190*, 1.516*, 2.005, 2.551*, 2.901*	0.1157	0.1552	243	326	289	388	324	435	347	466	3000	87	192	3 CAT
ZF 301-1 C	1.236*, 1.408*, 1.862, 2.694	0.1285	0.1723	270	362	321	431	360	482	386	517	3000	87	192	3 CAT
	1.004*	0.0997	0.1337	209	281	249	334	279	374	299	401	3000			
ZF 305-3	0.884*, 1.000*, 1.220, 1.486*, 1.968	0.1864	0.2500	391	525	429	575	466	625	559	750	3000	98	216	SAE 1, 2, 3
	2.250*	0.1755	0.2353	369	494	404	541	439	588	527	706	3000			
	2.500	0.1632	0.2189	343	460	375	503	408	547	490	657	3000			
	2.917	0.1461	0.1959	307	411	336	451	365	490	438	588	3000			

* Special Order Ratio.

B/W = Borg Warner adaptor.

Light Duty Single Speed



PRODUCT	Ratios	Power factor		Input power capacity						Max. kW	Max. hp	Max. rpm	Weight		Bell hgs. & notes
		kW/rpm	hp/rpm	2100 rpm		2300 rpm		2500 rpm					kg	lb	
ZF 305-3 A 7 degrees	1.200*, 1.514, 1.733, 2.037	0.1864	0.2500	391	525	429	575	466	625	559	750	3000	97	214	SAE 1, 2, 3
	2.179	0.1755	0.2353	369	494	404	541	439	588	527	706	3000			
	2.423	0.1632	0.2189	343	460	375	503	408	547	490	657	3000			
ZF 325 IV 14 degrees	1.216, 1.485*, 1.733, 2.037	0.2340	0.3138	491	659	538	722	585	785	702	941	3000	185	408	SAE 1, 2
	2.417	0.2108	0.2827	443	594	485	650	527	707	632	848	3000			
ZF 325-1	1.000, 1.167*, 1.225*, 1.459*, 1.727, 2.033	0.2340	0.3138	491	659	538	722	585	785	702	941	3000	130	287	SAE 1, 2
	2.500	0.2107	0.2826	442	593	485	650	527	707	632	848	3000			
	2.957	0.1881	0.2522	395	530	433	580	470	631	564	757	3000			
ZF 325-1 A 7 degrees	1.216*, 1.485, 1.733, 2.037, 2.240*	0.2340	0.3138	491	659	538	722	585	785	702	941	3000	130	287	SAE 1, 2
	2.417	0.2108	0.2827	443	594	485	650	527	707	632	848	3000			
ZF 400 ¹⁵	0.854, 0.925, 1.000, 1.109, 1.233, 1.526, 1.781, 2.033, 2.214	0.2917	0.3912	613	822	671	900	729	978	875	1174	3000	160	353	SAE 1, 2
	2.600	0.2660	0.3567	559	749	612	820	665	892	798	1070	3000			
	2.957	0.2351	0.3153	494	662	541	725	588	788	705	946	3000			
ZF 400 A ¹⁵ 7 degrees	1.441, 1.594, 1.767, 1.964	0.2917	0.3912	613	822	671	900	729	978	875	1174	3000	160	353	SAE 1, 2
	2.192	0.2878	0.3859	604	810	662	888	720	965	863	1158	3000			
	2.458	0.2432	0.3261	511	685	559	750	608	815	730	978	3000			
ZF 400 IV ¹⁵ 14 degrees	1.441, 1.594, 1.767, 1.964	0.2917	0.3912	613	822	671	900	729	978	875	1174	3000	220	485	SAE 1, 2
	2.192	0.2878	0.3859	604	810	662	888	720	965	863	1158	3000			
	2.458	0.2432	0.3261	511	685	559	750	608	815	730	978	3000			
ZF 400 V 10 degrees	1.125*, 1.774*, 2.000, 2.222*, 2.480	0.2917	0.3912	613	822	671	900	715	958	875	1174	3000	200	441	
ZF 500	1.000*, 1.125, 1.237*, 1.500, 1.774*, 1.966	0.3567	0.4783	749	1004	820	1100	874	1172	1070	1435	3000	185	408	SAE 0, 1
	0.925*, 2.185*	0.3242	0.4348	681	913	746	1000	794	1065	973	1304	3000			
	2.480*	0.3080	0.4130	647	867	708	950	755	1012	924	1239	3000			
	2.625*	0.2917	0.3912	613	822	671	900	715	958	875	1174	3000			
	2.917*	0.2594	0.3479	545	731	597	800	636	852	778	1044	3000			
ZF 500-1 A 7 degrees	1.216*, 1.485*, 1.767, 1.964	0.3567	0.4783	749	1004	820	1100	874	1172	1070	1435	3000	192	423	SAE 0, 1
	2.192	0.3242	0.4348	681	913	746	1000	794	1065	973	1304	3000			
	2.478*	0.3080	0.4130	647	867	708	950	755	1012	924	1239	3000			
	2.609*	0.2917	0.3912	613	822	671	900	715	958	875	1174	3000			

¹⁵ Free standing installation available.

* Special Order Ratio.

Light Duty Single Speed



PRODUCT	Ratios	Power factor		Input power capacity						Max. kW	Max. hp	Max. rpm	Weight		Bell hgs. & notes
		kW/rpm	hp/rpm	2100 rpm		2300 rpm		2450 rpm					kg	lb	
ZF 500-1 IV 14 degrees	1.216*, 1.767*, 1.964	0.3567	0.4783	749	1004	820	1100	874	1172	1070	1435	3000	230	507	SAE 1
	2.200	0.3242	0.4348	681	913	746	1000	794	1065	973	1304	3000			
	2.478*	0.3080	0.4130	647	867	708	950	755	1012	924	1239	3000			
	3.000*	0.2756	0.3696	579	776	634	850	675	906	827	1109	3000			
ZF 510 V 10 degrees	1.125*, 1.774*, 2.000	0.3567	0.4783	749	1004	820	1100	874	1172	1070	1435	3000	200	441	
	2.222*	0.3404	0.4565	715	959	783	1050	834	1118	1021	1370	3000			
ZF 510-1 A 10 degrees	1.125*, 1.774, 2.000	0.3567	0.4783	749	1004	820	1100	874	1172	1070	1435	3000	193	425	SAE 0, 1
	2.222	0.3404	0.4565	715	959	783	1050	834	1118	1021	1370	3000			
	2.480*	0.3242	0.4348	681	913	746	1000	794	1065	973	1304	3000			
ZF 550-1	1.111, 1.182*, 1.262*, 1.833*, 2.000, 2.233*, 2.593	0.3246	0.4353	682	914	747	1001	795	1066	974	1306	3000	242	534	SAE 0, 1
	3.042*	0.2759	0.3700	579	777	635	851	676	907	828	1110	3000			
ZF 550-1 A 10 degrees	1.525*, 1.757*, 1.971, 2.226, 2.448, 2.517	0.3246	0.4353	682	914	747	1001	795	1066	974	1306	3000	256	564	SAE 0, 1
	2.960*	0.2759	0.3700	579	777	635	851	676	907	828	1110	3000			
ZF 550-1 V 10 degrees	1.525*, 1.971, 2.226, 2.448*	0.3246	0.4353	682	914	747	1001	795	1066	974	1306	3000	260	573	
	2.960*	0.2759	0.3700	579	777	635	851	676	907	828	1110	3000			
ZF 665	1.111, 1.182*, 1.262, 1.400*, 1.500*, 1.743, 2.000	0.3729	0.5001	783	1050	858	1150	914	1225	1119	1500	3000	248	547	SAE 0, 1
	2.233*, 2.593	0.3654	0.4900	767	1029	840	1127	895	1201	1096	1470	3000			
	3.042*	0.2917	0.3912	613	822	671	900	715	958	875	1174	3000			
ZF 665 A 10 degrees	1.525*, 1.971	0.3729	0.5001	783	1050	858	1150	914	1225	1119	1500	3000	253	558	SAE 0, 1
	2.226	0.3654	0.4900	767	1029	840	1127	895	1201	1096	1470	3000			
	2.517	0.3567	0.4783	749	1004	820	1100	874	1172	1070	1435	3000			
	2.960*	0.2917	0.3912	613	822	671	900	715	958	875	1174	3000			
ZF 665 V 10 degrees	1.525*, 1.757*, 1.971*	0.3729	0.5001	783	1050	858	1150	914	1225	1119	1500	3000	252	556	
	2.226*	0.3654	0.4900	767	1029	840	1127	895	1201	1096	1470	3000			
	2.517*	0.3567	0.4783	749	1004	820	1100	874	1172	1070	1435	3000			
	2.960*	0.2917	0.3912	613	822	671	900	715	958	875	1174	3000			
ZF 2000	1.086*, 1.111*, 1.191*, 1.250*, 1.350*, 1.436*, 1.500, 1.639*, 1.765*, 1.848*, 1.879*, 2.032, 2.276*, 2.519, 2.760*	0.4061	0.5446	853	1144	934	1253	994	1332	994	1332	2600	340	750	SAE 0, 1
	2.958	0.3758	0.5040	789	1058	864	1159	920	1233	920	1233	2600			

* Special Order Ratio.

Light Duty Single Speed



PRODUCT	Ratios	Power factor		Input power capacity						Max. kW	Max. hp	Max. rpm	Weight		Bell hgs. & notes
		kW/rpm	hp/rpm	2100 rpm		2300 rpm		2450 rpm					kg	lb	
ZF 2000 A 10 degrees	1.267*, 1.512*, 1.763, 2.029, 2.250*, 2.467, 2.714*, 2.920	0.4061	0.5446	853	1144	934	1253	994	1332	994	1332	2600	348	767	SAE 0, 1
	3.250*	0.2926	0.3924	614	824	673	903	716	960	716	960	2600			
ZF 2000 V 10 degrees	1.267*, 1.512*, 1.763, 2.029, 2.250*, 2.467, 2.714*, 2.920	0.4061	0.5446	853	1144	934	1253	994	1332	994	1332	2600	352	776	
	3.250*	0.2926	0.3924	614	824	673	903	716	960	716	960	2600			
ZF 2050	1.086*, 1.111*, 1.191*, 1.250*, 1.350*, 1.436*, 1.500, 1.639*, 1.765*	0.4382	0.5876	920	1234	1008	1351	1073	1438	1073	1438	2600	342	754	SAE 0, 1
	1.848*	0.4382	0.5876	920	1234	1008	1351	1074	1440	1139	1528	2600			
	1.879*, 2.032, 2.276*, 2.519	0.4382	0.5876	920	1234	1008	1351	1073	1438	1073	1438	2600			
ZF 2050 A 10 degrees	1.267*, 1.512*, 1.763, 2.029, 2.250*, 2.467	0.4382	0.5876	920	1234	1008	1351	1073	1438	1073	1438	2600	350	772	SAE 0, 1
ZF 2050 V 10 degrees	1.267*, 1.512*, 1.763, 2.029, 2.250*, 2.467	0.4382	0.5876	920	1234	1008	1351	1073	1438	1073	1438	2600	354	780	
ZF 2150	2.760*	0.4382	0.5876	920	1234	1008	1351	1073	1438	1073	1438	2600	344	758	SAE 0, 1
	2.958	0.4057	0.5441	852	1143	933	1251	993	1331	993	1331	2600			
ZF 2150 A 10 degrees	2.714*, 2.920	0.4382	0.5876	920	1234	1008	1351	1073	1438	1073	1438	2600	352	776	SAE 0, 1
	3.250*	0.3717	0.4985	781	1047	855	1147	910	1220	910	1220	2600			
ZF 2150 V 10 degrees	2.714*, 2.920	0.4382	0.5876	920	1234	1008	1351	1073	1438	1073	1438	2600	356	785	
	3.250*	0.3717	0.4985	781	1047	855	1147	910	1220	910	1220	2600			
ZF 2200 ¹³	3.000	0.4062	0.5447	853	1144	934	1253	995	1334	995	1334	2600	404	891	SAE 0, 1
	3.286*, 3.519*	0.4062	0.5447	853	1144	934	1253	995	1335	1056	1416	2600			
ZF 2250 ¹³	3.000, 3.286*, 3.519*	0.4382	0.5876	920	1234	1008	1351	1073	1438	1073	1438	2600	406	895	SAE 0, 1
ZF 2300 ⁸	4.000, 4.444	0.4062	0.5447	853	1144	934	1253	995	1334	995	1334	2600	434	957	SAE 0, 1
ZF 2350 ⁸	4.000, 4.444, 4.760*	0.4382	0.5876	920	1234	1008	1351	1073	1438	1073	1438	2600	436	961	SAE 0, 1
ZF 3000	1.093*, 1.195*, 1.250*, 1.306*, 1.343*, 1.412*, 1.441*, 1.500, 1.563*, 1.594*, 1.645*, 1.700*, 1.733*, 1.800*, 1.828*, 2.037, 2.154*, 2.240*, 2.375*, 2.417*, 2.500, 2.609*, 2.773*, 2.952*	0.5062	0.6788	1063	1425	1164	1561	1240	1662	1240	1662	2600	482	1063	SAE 00, 0, 1
ZF 3000 A 10 degrees	1.351*, 1.486*, 1.750*, 2.034, 2.259*, 2.520, 2.750*, 3.000*	0.5062	0.6788	1063	1425	1164	1561	1240	1662	1240	1662	2600	485	1069	SAE 0, 1
	3.280*	0.4542	0.6091	954	1279	1045	1401	1112	1491	1112	1491	2600			
	3.444*	0.4218	0.5656	886	1188	970	1300	970	1300	970	1300	2600			

⁸ U-drive version also available.

¹³ No classification available.

* Special Order Ratio.

Light Duty Single Speed



PRODUCT	Ratios	Power factor		Input power capacity						Max. kW	Max. hp	Max. rpm	Weight		Bell hgs. & notes
		kW/rpm	hp/rpm	2100 rpm		2300 rpm		2450 rpm					kg	lb	
ZF 3000 D CEW ^{9, 17}	1.093*, 1.195*, 1.250*, 1.306*, 1.343*, 1.412*, 1.441*, 1.500, 1.563*, 1.594*, 1.645*, 1.700*, 1.733*, 1.800*, 1.828*, 2.037, 2.154*, 2.240*, 2.375*, 2.417*, 2.500, 2.609*, 2.773*, 2.952*	0.5026	0.6740	1055	1415	1156	1550	1231	1651	1240	1662	2600	482	1063	
ZF 3000 D EW ⁹	1.093*, 1.195*, 1.250*, 1.306*, 1.343*, 1.412*, 1.441*, 1.500, 1.563*, 1.594*, 1.645*, 1.700*, 1.733*, 1.800*, 1.828*, 2.037, 2.154*, 2.240*, 2.375*, 2.417*, 2.500, 2.609*, 2.773*, 2.952*	0.5026	0.6740	1055	1415	1156	1550	1231	1651	1240	1662	2600	482	1063	
ZF 3000 V 10 degrees	1.351*, 1.486*, 1.750*, 2.034, 2.259*, 2.520, 2.750*, 3.000*	0.5062	0.6788	1063	1425	1164	1561	1240	1662	1240	1662	2600	500	1102	
	3.280*	0.4542	0.6091	954	1279	1045	1401	1112	1491	1112	1491	2600			
	3.444*	0.4218	0.5656	886	1188	970	1300	970	1300	970	1300	2600			
ZF 3050	1.093*, 1.195*, 1.250*, 1.306*, 1.343*, 1.412*, 1.441*, 1.500, 1.563*, 1.594*, 1.645*, 1.700*, 1.733*, 1.800*, 1.828*, 2.037, 2.154*, 2.240*, 2.375*, 2.417*, 2.500, 2.609*, 2.773*, 2.952*	0.5614	0.7528	1179	1581	1291	1731	1375	1843	1375	1843	2600	482	1063	SAE 00, 0, 1
ZF 3050 A 10 degrees	1.351*, 1.486*, 1.750*, 2.034, 2.259*, 2.520, 2.750*, 3.000*	0.5614	0.7528	1179	1581	1291	1731	1375	1843	1375	1843	2600	485	1069	SAE 0, 1
	3.280*	0.5062	0.6788	1063	1425	1164	1561	1240	1662	1240	1662	2600			
	3.444*	0.4796	0.6432	1007	1351	1103	1479	1103	1479	1103	1479	2600			
ZF 3050 D CEW ^{3, 9, 17}	1.093*, 1.195*, 1.250*, 1.306*, 1.343*, 1.412*, 1.441*, 1.500, 1.563*, 1.594*, 1.645*, 1.700*, 1.733*, 1.800*, 1.828*, 2.037, 2.154*, 2.240*, 2.375*, 2.417*, 2.500, 2.609*, 2.773*, 2.952*	0.5614	0.7528	1179	1581	1291	1731	1375	1843	1375	1843	2600	482	1063	
ZF 3050 V 10 degrees	1.351*, 1.486*, 1.750*, 2.034, 2.259*, 2.520, 2.750*, 3.000*	0.5614	0.7528	1179	1581	1291	1731	1375	1843	1375	1843	2600	500	1102	
	3.280*	0.5062	0.6788	1063	1425	1164	1561	1240	1662	1240	1662	2600			
	3.444*	0.4796	0.6432	1007	1351	1103	1479	1103	1479	1103	1479	2600			
ZF 3055	1.093*, 1.195*, 1.250*, 1.306*, 1.343*, 1.412*, 1.441*, 1.500, 1.563*, 1.594*, 1.645*, 1.700*, 1.733*, 1.800*, 1.828*, 2.037, 2.154*, 2.240*, 2.375*, 2.417*, 2.500, 2.609*, 2.773*, 2.952*	0.5847	0.7841	1228	1647	1345	1803	1432	1920	1432	1920	2600	487	1074	SAE 00, 0, 1

³ Engine wise (EW) operation only for waterjet flushing.

⁹ Left and Right version available.

¹⁷ PTI (Hybrid) also available.

* Special Order Ratio.

Light Duty Single Speed



PRODUCT	Ratios	Power factor		Input power capacity						Max. kW	Max. hp	Max. rpm	Weight		Bell hgs. & notes
		kW/rpm	hp/rpm	2100 rpm		2300 rpm		2450 rpm					kg	lb	
ZF 3055 A 10 degrees	1.351*, 1.486*, 1.750*, 2.034, 2.259*, 2.520, 2.750*, 3.000*	0.5847	0.7841	1228	1647	1345	1803	1432	1920	1432	1920	2600	490	1080	SAE 0, 1
	3.280*	0.5354	0.7180	1124	1508	1231	1651	1311	1758	1311	1758	2600			
ZF 3055 D CEW ^{3, 9, 17}	1.093*, 1.195*, 1.250*, 1.306*, 1.343*, 1.412*, 1.441*, 1.500, 1.563*, 1.594*, 1.645*, 1.700*, 1.733*, 1.800*, 1.828*, 2.037, 2.154*, 2.240*, 2.375*, 2.417*, 2.500, 2.609*, 2.773*, 2.952*	0.5847	0.7841	1228	1647	1345	1803	1432	1920	1432	1920	2600	482	1063	
ZF 3055 V 10 degrees	1.351*, 1.486*, 1.750*, 2.034, 2.259*, 2.520, 2.750*, 3.000*	0.5847	0.7841	1228	1647	1345	1803	1432	1920	1432	1920	2600	505	1113	
	3.280*	0.5354	0.7180	1124	1508	1231	1651	1311	1758	1311	1758	2600			
ZF 3060	1.093*, 1.195*, 1.250*, 1.306*, 1.343*, 1.412*, 1.441*, 1.500, 1.563*, 1.594*, 1.645*, 1.700*, 1.733*, 1.800*, 1.828*, 2.037, 2.154*, 2.240*, 2.375*, 2.417*, 2.500, 2.609*, 2.773*, 2.952*	0.6674	0.8950	1402	1880	1535	2059	1635	2193	1635	2193	2450	487	1074	SAE 00, 0, 1
ZF 3060 A 10 degrees	1.351*, 1.486*, 1.750*, 2.034, 2.259*, 2.520, 2.750*, 3.000*	0.6674	0.8950	1402	1880	1535	2059	1635	2193	1635	2193	2450	490	1080	SAE 0, 1
	3.280*	0.6002	0.8049	1260	1690	1380	1851	1470	1972	1470	1972	2450			
ZF 3060 D CEW ^{3, 9, 17}	1.093*, 1.195*, 1.250*, 1.306*, 1.343*, 1.412*, 1.441*, 1.500, 1.563*, 1.594*, 1.645*, 1.700*, 1.733*, 1.800*, 1.828*, 2.037, 2.154*, 2.240*, 2.375*, 2.417*, 2.500, 2.609*, 2.773*, 2.952*	0.6674	0.8950	1402	1880	1535	2059	1635	2193	1635	2193	2450	482	1063	
ZF 3060 V 10 degrees	1.351*, 1.486*, 1.750*, 2.034, 2.259*, 2.520, 2.750*, 3.000*	0.6674	0.8950	1402	1880	1535	2059	1635	2193	1635	2193	2450	505	1113	
	3.280*	0.6002	0.8049	1260	1690	1380	1851	1470	1972	1470	1972	2450			
ZF 3100 A ¹³ 10 degrees	1.257*, 1.500*, 1.759*, 1.963, 2.240, 2.478*	0.5062	0.6788	1063	1425	1164	1560	1164	1560	1164	1560	2600	470	1036	SAE 0, 1
	2.880*	0.4543	0.6092	954	1279	1045	1401	1045	1401	1045	1401	2600			
ZF 3150 A ¹³ 10 degrees	1.257*, 1.500*, 1.759*, 1.963, 2.240, 2.478*	0.5614	0.7528	1179	1581	1291	1731	1375	1843	1375	1843	2600	470	1036	SAE 0, 1
	2.880*	0.5062	0.6788	1063	1425	1164	1560	1164	1560	1164	1560	2600			
ZF 3155 A ¹³ 10 degrees	1.257*, 1.500*, 1.759*, 1.963, 2.240, 2.478*	0.5840	0.7832	1226	1645	1343	1800	1343	1800	1343	1800	2600	470	1036	SAE 0, 1
	2.880*	0.5354	0.7180	1124	1508	1231	1650	1231	1650	1231	1650	2600			

³ Engine wise (EW) operation only for waterjet flushing.

⁹ Left and Right version available.

¹³ No classification available.

¹⁷ PTI (Hybrid) also available.

* Special Order Ratio.

Light Duty Single Speed



PRODUCT	Ratios	Power factor		Input power capacity						Max. kW	Max. hp	Max. rpm	Weight		Bell hgs. & notes
		kW/rpm	hp/rpm	2100 rpm		2300 rpm		2450 rpm					kg	lb	
				kW	hp	kW	hp	kW	hp						
ZF 3160 A ¹³ 10 degrees	1.257*, 1.500*, 1.759*, 1.963, 2.240, 2.478*	0.6674	0.8950	1402	1880	1535	2058	1535	2058	1535	2058	2450	470	1036	SAE 0, 1
	2.880*	0.6003	0.8050	1261	1691	1381	1851	1381	1851	1381	1851	2450			
ZF 3310 ⁸	2.647*, 2.844*, 3.000*, 3.519*, 3.769*, 4.000, 4.250*, 4.478, 4.727*, 5.000	0.5052	0.6775	1061	1423	1162	1558	1237	1658	1237	1658	2600	665	1466	SAE 00, 0, 1
ZF 3311 ^{8, 16}	2.647*, 2.844*, 3.000*, 3.519*, 3.769*, 4.000, 4.250*, 4.478, 4.727*, 5.000	0.5052	0.6775	1061	1423	1162	1558	1237	1658	1237	1658	2600	850	1874	SAE 00, 0, 1
ZF 3350 ⁸	2.647*, 2.844*, 3.000*, 3.519*, 3.769*, 4.000, 4.250*, 4.478, 4.727*, 5.000	0.5614	0.7528	1179	1581	1291	1731	1375	1843	1375	1843	2600	665	1466	SAE 00, 0, 1
ZF 3351 ^{8, 16}	2.647*, 2.844*, 3.000*, 3.519*, 3.769*, 4.000, 4.250*, 4.478, 4.727*, 5.000	0.5614	0.7528	1179	1581	1291	1731	1375	1843	1375	1843	2600	850	1874	SAE 00, 0, 1
ZF 3355 ⁸	2.647*, 2.844*, 3.000*, 3.519*, 3.769*, 4.000, 4.250*, 4.478, 4.727*, 5.000	0.5847	0.7841	1228	1647	1345	1803	1432	1920	1432	1920	2600	670	1477	SAE 00, 0, 1
ZF 3356 ^{8, 16}	2.647*, 2.844*, 3.000*, 3.519*, 3.769*, 4.000, 4.250*, 4.478, 4.727*, 5.000	0.5847	0.7841	1228	1647	1345	1803	1432	1920	1432	1920	2600	855	1885	SAE 00, 0, 1
ZF 3360 ⁸	2.647*, 2.844*, 3.000*, 3.519*, 3.769*, 4.000, 4.250*, 4.478, 4.727*, 5.000	0.6674	0.8950	1402	1880	1535	2059	1635	2193	1635	2193	2450	670	1477	SAE 00, 0, 1
ZF 3361 ^{8, 16}	2.647*, 2.844*, 3.000*, 3.519*, 3.769*, 4.000, 4.250*, 4.478, 4.727*, 5.000	0.6674	0.8950	1402	1880	1535	2059	1635	2193	1635	2193	2450	850	1874	SAE 00, 0, 1
ZF 3711 ⁸	3.767*, 4.259*, 5.545, 5.952	0.5052	0.6775	1061	1423	1162	1558	1237	1658	1237	1658	2600	920	2028	SAE 0, 1
ZF 3751 ⁸	3.767*, 4.259*, 5.545, 5.952	0.5614	0.7528	1179	1581	1291	1731	1375	1843	1375	1843	2600	920	2028	SAE 0, 1
ZF 3756 ⁸	3.767*, 4.259*, 5.545, 5.952	0.5847	0.7841	1228	1647	1345	1803	1432	1920	1432	1920	2600	920	2028	SAE 0, 1
ZF 3761 ⁸	3.767*, 4.259*, 5.545, 5.952	0.6674	0.8950	1402	1880	1535	2059	1635	2193	1635	2193	2450	920	2028	SAE 0, 1
ZF 5000	1.256*, 1.526, 1.585*, 1.722*, 1.771*, 1.853*, 2.031, 2.233*, 2.310*, 2.429*, 2.500, 2.630*, 2.731*, 2.880*, 2.920*, 2.963	0.7508	1.0068	1577	2114	1727	2316	1839	2467	1840	2467	2600	740	1631	SAE 00, 0
ZF 5000 A 8 degrees	1.431*, 1.512*, 1.757*, 2.029, 2.250*, 2.467, 2.714*, 2.962	0.7508	1.0068	1577	2114	1727	2316	1839	2467	1840	2467	2600	750	1653	SAE 00, 0
	3.222*	0.6675	0.8951	1402	1880	1535	2059	1635	2192	1635	2192	2600			

⁸ U-drive version also available.

¹³ No classification available.

¹⁶ PTI (Hybrid) or Integrated Shaft Brake also available.

* Special Order Ratio.

Light Duty Single Speed



PRODUCT	Ratios	Power factor		Input power capacity						Max. kW	Max. hp	Max. rpm	Weight		Bell hgs. & notes
		kW/rpm	hp/rpm	2100 rpm		2300 rpm		2450 rpm					kg	lb	
ZF 5000 D ^{9, 17}	1.256*, 1.526, 1.585*, 1.722*, 1.771*, 1.853*, 2.031, 2.233*, 2.310*, 2.429*, 2.500, 2.630*, 2.731*, 2.880*, 2.920*, 2.963	0.7508	1.0068	1577	2114	1727	2316	1839	2467	1840	2467	2600	765	1687	
ZF 5000 NR2H ⁹	1.256*, 1.526, 1.585*, 1.722*, 1.771*, 1.853*, 2.031, 2.233*, 2.310*, 2.429*, 2.500, 2.630*, 2.731*, 2.880*, 2.920*, 2.963	0.7508	1.0068	1577	2114	1727	2316	1839	2467	1840	2467	2600	615	1356	
ZF 5000 V 8 degrees	1.431*, 1.512*, 1.757*, 2.029, 2.250*, 2.467, 2.714*, 2.962	0.7508	1.0068	1577	2114	1727	2316	1839	2467	1840	2467	2600	768	1693	
	3.222*	0.6675	0.8951	1402	1880	1535	2059	1635	2192	1635	2192	2600			
ZF 5050	1.256*, 1.526, 1.585*, 1.722*, 1.771*, 1.853*, 2.031, 2.233*, 2.310*, 2.429*, 2.500, 2.630*, 2.731*	0.9157	1.2280	1923	2579	2106	2824	2243	3007	2243	3007	2600	740	1631	SAE 00, 0
	2.880*	0.8874	1.1900	1864	2499	2041	2737	2174	2915	2174	2915	2600			
	2.920*	0.8799	1.1800	1848	2478	2024	2714	2155	2889	2155	2889	2600			
	2.963	0.8717	1.1690	1831	2455	2005	2689	2136	2864	2136	2864	2600			
ZF 5050 A 8 degrees	1.431*, 1.512*, 1.757*, 2.029, 2.250*, 2.467, 2.714*, 2.962	0.9157	1.2280	1923	2579	2106	2824	2243	3007	2243	3007	2600	750	1653	SAE 00, 0
	3.222*	0.8272	1.1093	1737	2330	1903	2551	2027	2718	2027	2718	2600			
	3.429*	0.7508	1.0068	1577	2114	1727	2316	1839	2467	1840	2467	2600			
ZF 5050 D ^{9, 17}	1.256*, 1.526, 1.585*, 1.722*, 1.771*, 1.853*, 2.031, 2.233*, 2.310*, 2.429*, 2.500, 2.630*, 2.731*	0.9157	1.2280	1923	2579	2106	2824	2243	3007	2243	3007	2600	765	1687	
	2.880*	0.8874	1.1900	1864	2499	2041	2737	2174	2915	2174	2915	2600			
	2.920*	0.8799	1.1800	1848	2478	2024	2714	2155	2889	2155	2889	2600			
	2.963	0.8717	1.1690	1831	2455	2005	2689	2136	2864	2136	2864	2600			
ZF 5050 NR2H ⁹	1.256*, 1.526, 1.585*, 1.722*, 1.771*, 1.853*, 2.031, 2.233*, 2.310*, 2.429*, 2.500, 2.630*, 2.731*	0.9157	1.2280	1923	2579	2106	2824	2243	3007	2243	3007	2600	615	1356	
	2.880*	0.8874	1.1900	1864	2499	2041	2737	2174	2915	2174	2915	2600			
	2.920*	0.8799	1.1800	1848	2478	2024	2714	2155	2889	2155	2889	2600			
	2.963	0.8717	1.1690	1831	2455	2005	2689	2136	2864	2136	2864	2600			
ZF 5050 V 8 degrees	1.431*, 1.512*, 1.757*, 2.029, 2.250*, 2.467, 2.714*, 2.962	0.9157	1.2280	1923	2579	2106	2824	2243	3007	2243	3007	2600	768	1693	
	3.222*	0.8272	1.1093	1737	2330	1903	2551	2027	2718	2027	2718	2600			
	3.429*	0.7508	1.0068	1577	2114	1727	2316	1839	2467	1840	2467	2600			

⁹ Left and Right version available.

¹⁷ PTI (Hybrid) also available.

* Special Order Ratio.

Light Duty Single Speed



PRODUCT	Ratios	Power factor		Input power capacity						Max. kW	Max. hp	Max. rpm	Weight		Bell hgs. & notes
		kW/rpm	hp/rpm	2100 rpm		2300 rpm		2450 rpm					kg	lb	
ZF 5060	1.256*, 1.526, 1.585*, 1.722*, 1.771*, 1.853*, 2.031, 2.233*, 2.310*, 2.429*, 2.500, 2.630*, 2.731*	0.9739	1.3060	2045	2743	2240	3004	2386	3199	2386	3199	2600	740	1631	SAE 00, 0
	2.880*	0.9543	1.2797	2004	2687	2195	2943	2338	3135	2338	3135	2600			
	2.920*	0.9491	1.2728	1993	2673	2183	2927	2325	3117	2325	3117	2600			
	2.963	0.9435	1.2653	1981	2657	2170	2910	2311	3099	2311	3099	2600			
ZF 5060 A 8 degrees	1.431*, 1.512*, 1.757*, 2.029, 2.250*, 2.467, 2.714*, 2.962	0.9739	1.3060	2045	2743	2240	3004	2386	3199	2386	3199	2600	750	1653	SAE 00, 0
	3.222*	0.9157	1.2280	1923	2579	2106	2824	2243	3007	2243	3007	2600			
	3.429*	0.8483	1.1376	1781	2389	1951	2616	2078	2787	2079	2787	2600			
ZF 5060 NR2H ⁹	1.256*, 1.526, 1.585*, 1.722*, 1.771*, 1.853*, 2.031, 2.233*, 2.310*, 2.429*, 2.500, 2.630*, 2.731*	0.9739	1.3060	2045	2743	2240	3004	2386	3199	2386	3199	2600	615	1356	
	2.880*	0.9543	1.2797	2004	2687	2195	2943	2338	3135	2338	3135	2600			
	2.920*	0.9491	1.2728	1993	2673	2183	2927	2325	3117	2325	3117	2600			
	2.963	0.9435	1.2653	1981	2657	2170	2910	2312	3100	2312	3100	2600			
ZF 5060 V 8 degrees	1.431*, 1.512*, 1.757*, 2.029, 2.250*, 2.467, 2.714*, 2.962	0.9739	1.3060	2045	2743	2240	3004	2386	3199	2386	3199	2600	768	1693	
	3.222*	0.9157	1.2280	1923	2579	2106	2824	2243	3007	2243	3007	2600			
	3.429*	0.8483	1.1376	1781	2389	1951	2616	2078	2787	2079	2787	2600			
ZF 5200 A ¹⁶ 8 degrees	2.588, 2.844*, 3.100, 3.393*, 3.692	0.7508	1.0068	1577	2114	1727	2316	1839	2466	1839	2466	2600	870	1918	SAE 00, 0
	4.000	0.6675	0.8951	1402	1880	1535	2059	1635	2192	1635	2192	2600			
ZF 5200 V ¹⁶ 8 degrees	2.588, 2.844*, 3.100, 3.393*, 3.692	0.7508	1.0068	1577	2114	1727	2316	1839	2466	1839	2466	2600	880	1940	
	4.000	0.6675	0.8951	1402	1880	1535	2059	1635	2192	1635	2192	2600			
ZF 5250 A ¹⁶ 8 degrees	2.588, 2.844*, 3.100, 3.393*, 3.692	0.9157	1.2280	1923	2579	2106	2824	2243	3007	2243	3007	2600	870	1918	SAE 00, 0
	4.000	0.8272	1.1093	1737	2330	1903	2551	2027	2718	2027	2718	2600			
	4.250*	0.7508	1.0068	1577	2114	1727	2316	1839	2466	1839	2466	2600			
ZF 5250 V ¹⁶ 8 degrees	2.588, 2.844*, 3.100, 3.393*, 3.692	0.9157	1.2280	1923	2579	2106	2824	2243	3007	2243	3007	2600	880	1940	
	4.000	0.8272	1.1093	1737	2330	1903	2551	2027	2718	2027	2718	2600			
	4.250*	0.7508	1.0068	1577	2114	1727	2316	1839	2466	1839	2466	2600			
ZF 5260 A ¹⁶ 8 degrees	2.588, 2.844*, 3.100, 3.393*, 3.692	0.9739	1.3060	2045	2743	2240	3004	2386	3199	2386	3199	2600	870	1918	SAE 00, 0
	4.000	0.9157	1.2280	1923	2579	2106	2824	2243	3007	2243	3007	2600			
	4.250*	0.8483	1.1376	1781	2389	1951	2616	2078	2786	2078	2786	2600			

⁹ Left and Right version available.

¹⁶ PTI (Hybrid) or Integrated Shaft Brake also available.

* Special Order Ratio.

Light Duty Single Speed



PRODUCT	Ratios	Power factor		Input power capacity						Max. kW	Max. hp	Max. rpm	Weight		Bell hgs. & notes
		kW/rpm	hp/rpm	2100 rpm		2300 rpm		2450 rpm					kg	lb	
ZF 5260 V ¹⁶ 8 degrees	2.588, 2.844*, 3.100, 3.393*, 3.692	0.9739	1.3060	2045	2743	2240	3004	2386	3199	2386	3199	2600	880	1940	
	4.000	0.9157	1.2280	1923	2579	2106	2824	2243	3007	2243	3007	2600			
	4.250*	0.8483	1.1376	1781	2389	1951	2616	2078	2786	2078	2786	2600			
ZF 5300 ^{8, 16}	2.587*, 2.750*, 2.947*, 3.108*, 3.314*, 3.471*, 4.033, 4.464, 5.040	0.7508	1.0068	1577	2114	1727	2316	1839	2467	1840	2467	2600	950	2094	SAE 00, 0
ZF 5311 ^{8, 16}	2.587*, 2.750*, 2.947*, 3.108*, 3.314*, 3.471*, 4.033, 4.464, 5.040	0.7508	1.0068	1577	2114	1727	2316	1839	2467	1840	2467	2600	1290	2844	SAE 00, 0
ZF 5350 ^{8, 16}	2.587*, 2.750*, 2.947*, 3.108*, 3.314*, 3.471*, 4.033, 4.464, 5.040	0.9157	1.2280	1923	2579	2106	2824	2243	3007	2243	3007	2600	950	2094	SAE 00, 0
ZF 5351 ^{8, 16}	2.587*, 2.750*, 2.947*, 3.108*, 3.314*, 3.471*, 4.033, 4.464, 5.040	0.9157	1.2280	1923	2579	2106	2824	2243	3007	2243	3007	2600	1290	2844	SAE 00, 0
ZF 5360 ^{8, 16}	2.587*, 2.750*, 2.947*, 3.108*, 3.314*, 3.471*, 4.033, 4.464	0.9739	1.3060	2045	2743	2240	3004	2386	3199	2386	3199	2600	950	2094	SAE 00, 0
	5.040	0.9435	1.2653	1981	2657	2170	2910	2312	3100	2312	3100	2600			
	5.500	0.8717	1.1690	1831	2455	2005	2689	2136	2864	2136	2864	2600			
ZF 5361 ^{8, 16}	2.587*, 2.750*, 2.947*, 3.108*, 3.314*, 3.471*, 4.033, 4.464	0.9739	1.3060	2045	2743	2240	3004	2386	3199	2386	3199	2600	1290	2844	SAE 00, 0
	5.040	0.9435	1.2653	1981	2657	2170	2910	2312	3100	2312	3100	2600			
	5.500	0.8717	1.1690	1831	2455	2005	2689	2136	2864	2136	2864	2600			
				1800 rpm		2000 rpm		2100 rpm							
ZF 8000	1.250*, 1.500, 1.781*, 1.967, 2.296*, 2.560, 2.708*, 2.958, 3.174*	1.1623	1.5587	2092	2806	2325	3117	2441	3273	2441	3273	2300	1015	2238	SAE 00
ZF 8000 A 8 degrees	1.462, 1.743*, 2.000, 2.233*, 2.556, 2.731*, 3.000, 3.292*, 3.440	1.1623	1.5587	2092	2806	2325	3117	2441	3273	2441	3273	2300	1050	2315	SAE 00
ZF 8000 D ^{9, 17}	1.250*, 1.500, 1.781*, 1.967, 2.296*, 2.560, 2.708*, 2.958, 3.174*	1.1623	1.5587	2092	2806	2325	3117	2441	3273	2441	3273	2300	1015	2238	
ZF 8000 NR2	1.250*, 1.500, 1.781*, 1.967, 2.296*, 2.560, 2.708*, 2.958, 3.174*	1.1623	1.5587	2092	2806	2325	3117	2441	3273	2441	3273	2300	810	1786	
ZF 8000 NR2B	1.250*, 1.500, 1.781*, 1.967, 2.296*, 2.560, 2.708*, 2.958, 3.174*	1.1623	1.5587	2092	2806	2325	3117	2441	3273	2441	3273	2300	810	1786	
ZF 8000 NR2H ⁹	1.250*, 1.500, 1.781*, 1.967, 2.296*, 2.560, 2.708*, 2.958, 3.174*	1.1623	1.5587	2092	2806	2325	3117	2441	3273	2441	3273	2300	800	1764	
ZF 8000 V 8 degrees	1.462, 1.743*, 2.000, 2.233*, 2.556, 2.731*, 3.000, 3.292*, 3.440	1.1623	1.5587	2092	2806	2325	3117	2441	3273	2441	3273	2300	1075	2370	
ZF 8050	1.250*, 1.500, 1.781*, 1.967, 2.296*, 2.560, 2.708*, 2.958, 3.174*	1.3058	1.7511	2350	3152	2612	3502	2742	3677	2742	3677	2300	1015	2238	SAE 00

⁸ U-drive version also available.

⁹ Left and Right version available.

¹⁶ PTI (Hybrid) or Integrated Shaft Brake also available.

¹⁷ PTI (Hybrid) also available.

* Special Order Ratio.

Light Duty Single Speed



PRODUCT	Ratios	Power factor		Input power capacity						Max. kW	Max. hp	Max. rpm	Weight		Bell hgs. & notes
		kW/rpm	hp/rpm	1800 rpm		2000 rpm		2100 rpm					kg	lb	
				kW	hp	kW	hp	kW	hp						
ZF 8050 A 8 degrees	1.462, 1.743*, 2.000, 2.233*, 2.556, 2.731*, 3.000	1.3058	1.7511	2350	3152	2612	3502	2742	3677	2742	3677	2300	1050	2315	SAE 00
	3.292*	1.2565	1.6850	2262	3033	2513	3370	2639	3538	2639	3538	2300			
	3.440	1.2356	1.6570	2224	2983	2471	3314	2595	3479	2595	3479	2300			
ZF 8050 D ^{9, 17}	1.250*, 1.500, 1.781*, 1.967, 2.296*, 2.560, 2.708*, 2.958, 3.174*	1.3058	1.7511	2350	3152	2612	3502	2742	3677	2742	3677	2300	1015	2238	
ZF 8050 NR2	1.250*, 1.500, 1.781*, 1.967, 2.296*, 2.560, 2.708*, 2.958, 3.174*	1.3058	1.7511	2350	3152	2612	3502	2742	3677	2742	3677	2300	810	1786	
ZF 8050 NR2B	1.250*, 1.500, 1.781*, 1.967, 2.296*, 2.560, 2.708*, 2.958, 3.174*	1.3058	1.7511	2350	3152	2612	3502	2742	3677	2742	3677	2300	810	1786	
ZF 8050 NR2H ⁹	1.250*, 1.500, 1.781*, 1.967, 2.296*, 2.560, 2.708*, 2.958, 3.174*	1.3058	1.7511	2350	3152	2612	3502	2742	3677	2742	3677	2300	800	1764	
ZF 8050 V 8 degrees	1.462, 1.743*	1.3058	1.7511	2350	3152	2612	3502	2742	3677	2742	3677	2300	1075	2370	
	2.000	1.3058	1.7511	2350	3152	2441	3273	2441	3273	2441	3273	2300			
	2.233*, 2.556, 2.731*, 3.000	1.3058	1.7511	2350	3152	2612	3502	2742	3677	2742	3677	2300			
	3.292*	1.2565	1.6850	2262	3033	2513	3370	2639	3538	2639	3538	2300			
	3.440	1.2356	1.6570	2224	2983	2471	3314	2595	3480	2598	3483	2300			
ZF 8060	1.250*, 1.500, 1.781*, 1.967, 2.296*, 2.560, 2.708*, 2.958	1.4052	1.8844	2529	3392	2810	3769	2951	3957	2951	3957	2300	1015	2238	SAE 00
	3.174*	1.3403	1.7974	2413	3235	2681	3595	2815	3774	2815	3774	2300			
ZF 8060 A 8 degrees	1.462, 1.743*, 2.000, 2.233*, 2.556, 2.731*, 3.000	1.4052	1.8844	2529	3392	2810	3769	2951	3957	2951	3957	2300	1050	2315	SAE 00
	3.292*	1.3403	1.7974	2413	3235	2681	3595	2815	3774	2815	3774	2300			
	3.440	1.3058	1.7511	2350	3152	2612	3502	2742	3677	2742	3677	2300			
ZF 8060 D CEW ^{3, 9, 17}	1.250, 1.500, 1.781, 1.967, 2.296, 2.560, 2.708, 2.958	1.4052	1.8844	2529	3392	2810	3769	2951	3957	2951	3957	2300	1015	2238	
	3.174	1.3403	1.7974	2413	3235	2681	3595	2815	3774	2815	3774	2300			
ZF 8060 NR2	1.250*, 1.500, 1.781*, 1.967, 2.296*, 2.560, 2.708*, 2.958	1.4052	1.8844	2529	3392	2810	3769	2951	3957	2951	3957	2300	810	1786	
	3.174*	1.3403	1.7974	2413	3235	2681	3595	2815	3774	2815	3774	2300			
ZF 8060 NR2B	1.250*, 1.500, 1.781*, 1.967, 2.296*, 2.560, 2.708*, 2.958	1.4052	1.8844	2529	3392	2810	3769	2951	3957	2951	3957	2300	810	1786	
	3.174*	1.3403	1.7974	2413	3235	2681	3595	2815	3774	2815	3774	2300			
ZF 8060 NR2H ⁹	1.250*, 1.500, 1.781*, 1.967, 2.296*, 2.560, 2.708*, 2.958	1.4052	1.8844	2529	3392	2810	3769	2951	3957	2951	3957	2300	800	1764	
	3.174*	1.3403	1.7974	2413	3235	2681	3595	2815	3774	2815	3774	2300			

³ Engine wise (EW) operation only for waterjet flushing.

⁹ Left and Right version available.

¹⁷ PTI (Hybrid) also available.

* Special Order Ratio.

Light Duty Single Speed



PRODUCT	Ratios	Power factor		Input power capacity						Max. kW	Max. hp	Max. rpm	Weight		Bell hgs. & notes
		kW/rpm	hp/rpm	1800 rpm		2000 rpm		2100 rpm					kg	lb	
ZF 8060 V 8 degrees	1.462, 1.743*, 2.000, 2.233*, 2.556, 2.731*, 3.000	1.4052	1.8844	2529	3392	2810	3769	2951	3957	2951	3957	2300	1075	2370	
	3.292*	1.3403	1.7974	2413	3235	2681	3595	2815	3774	2815	3774	2300			
	3.440	1.3058	1.7511	2350	3152	2612	3502	2742	3677	2742	3677	2300			
ZF 8300 ^{8, 16}	2.576, 2.967, 3.214*, 3.538, 3.760*, 3.958, 4.174*, 4.522, 4.708*	1.1623	1.5587	2092	2806	2325	3117	2441	3273	2441	3273	2300	1220	2690	SAE 00
ZF 8311 ^{8, 16}	2.576, 2.967, 3.214*, 3.538, 3.760*, 3.958, 4.174*, 4.522, 4.708*	1.1623	1.5587	2092	2806	2325	3117	2441	3273	2441	3273	2300	1625	3583	SAE 00
ZF 8350 ^{8, 16}	2.576, 2.967, 3.214*, 3.538, 3.760*, 3.958, 4.174*, 4.522	1.3058	1.7511	2350	3152	2612	3502	2742	3677	2742	3677	2300	1220	2690	SAE 00
	4.708*	1.2639	1.6949	2275	3051	2528	3390	2654	3559	2654	3559	2300			
ZF 8351 ^{8, 16}	2.576, 2.967, 3.214*, 3.538, 3.760*, 3.958, 4.174*, 4.522	1.3058	1.7511	2350	3152	2612	3502	2742	3677	2742	3677	2300	1625	3583	SAE 00
	4.708*	1.2639	1.6949	2275	3051	2528	3390	2654	3559	2654	3559	2300			
ZF 8360 ^{8, 16}	2.576, 2.967, 3.214*, 3.538, 3.760*, 3.958, 4.174*, 4.522	1.4052	1.8844	2529	3392	2810	3769	2951	3957	2951	3957	2300	1220	2690	SAE 00
	4.708*	1.3403	1.7974	2413	3235	2681	3595	2815	3774	2815	3774	2300			
ZF 8361 ^{8, 16}	2.576, 2.967, 3.214*, 3.538, 3.760*, 3.958, 4.174*, 4.522	1.4052	1.8844	2529	3392	2810	3769	2951	3957	2951	3957	2300	1625	3583	SAE 00
	4.708*	1.3403	1.7974	2413	3235	2681	3595	2815	3774	2815	3774	2300			
ZF 9000	1.186*, 1.515*, 1.576*, 1.742*, 1.862*, 2.036, 2.269*, 2.400*, 2.500*, 2.542, 2.739*, 2.957	1.5000	2.0115	2700	3621	3000	4023	3150	4224	3150	4224	2300	1400	3086	SAE 00
	3.250*	1.4143	1.8966	2546	3414	2829	3793	2970	3982	2970	3982	2300			
	3.360*	1.3810	1.8520	2486	3334	2762	3704	2900	3888	2900	3888	2300			
	3.448*	1.3524	1.8136	2434	3264	2705	3627	2840	3808	2840	3808	2300			
ZF 9000 A 8 degrees	1.381*, 1.514*, 1.750*, 1.967, 2.259*, 2.462, 2.750*, 2.958	1.5000	2.0115	2700	3621	3000	4023	3150	4224	3150	4224	2300	1380	3042	SAE 00
	3.208*	1.4143	1.8966	2546	3414	2829	3793	2970	3982	2970	3982	2300			
	3.462*	1.3524	1.8136	2434	3264	2705	3627	2840	3808	2840	3808	2300			
ZF 9000 NR2	1.186*, 1.515*, 1.576*, 1.742*, 1.862*, 2.036, 2.269*, 2.400*, 2.500*, 2.542, 2.739*, 2.957	1.5000	2.0115	2700	3621	3000	4023	3150	4224	3150	4224	2300	1040	2293	
	3.250*	1.4143	1.8966	2546	3414	2829	3793	2970	3982	2970	3982	2300			
	3.360*	1.3810	1.8520	2486	3334	2762	3704	2900	3888	2900	3888	2300			
	3.448*	1.3524	1.8136	2434	3264	2705	3627	2840	3808	2840	3808	2300			

⁸ U-drive version also available.

¹⁶ PTI (Hybrid) or Integrated Shaft Brake also available.

* Special Order Ratio.

Light Duty Single Speed



PRODUCT	Ratios	Power factor		Input power capacity						Max. kW	Max. hp	Max. rpm	Weight		Bell hgs. & notes
		kW/rpm	hp/rpm	1800 rpm		2000 rpm		2100 rpm					kg	lb	
ZF 9000 NR2B	1.186*, 1.515*, 1.576*, 1.742*, 1.862*, 2.036, 2.269*, 2.400*, 2.500*, 2.542, 2.739*, 2.957	1.5000	2.0115	2700	3621	3000	4023	3150	4224	3150	4224	2300	1040	2293	
	3.250*	1.4143	1.8966	2546	3414	2829	3793	2970	3982	2970	3982	2300			
	3.360*	1.3810	1.8520	2486	3334	2762	3704	2900	3888	2900	3888	2300			
	3.448*	1.3524	1.8136	2434	3264	2705	3627	2840	3808	2840	3808	2300			
ZF 9000 NR2H ⁹	1.186*, 1.515*, 1.576*, 1.742*, 1.862*, 2.036, 2.269*, 2.400*, 2.500*, 2.542, 2.739*, 2.957	1.5000	2.0115	2700	3621	3000	4023	3150	4224	3150	4224	2300	1040	2293	
	3.250*	1.4143	1.8966	2546	3414	2829	3793	2970	3982	2970	3982	2300			
	3.360*	1.3810	1.8520	2486	3334	2762	3704	2900	3888	2900	3888	2300			
	3.448*	1.3524	1.8136	2434	3264	2705	3627	2840	3808	2840	3808	2300			
ZF 9000 V 8 degrees	1.381*, 1.514*, 1.750*, 1.967, 2.259*, 2.462, 2.750*, 2.958	1.5000	2.0115	2700	3621	3000	4023	3150	4224	3150	4224	2300	1400	3086	
	3.208*	1.4143	1.8966	2546	3414	2829	3793	2970	3982	2970	3982	2300			
	3.462*	1.3524	1.8136	2434	3264	2705	3627	2840	3808	2840	3808	2300			
ZF 9050	1.186*, 1.515*, 1.576*, 1.742*, 1.862*, 2.036, 2.269*, 2.400*, 2.500*, 2.542, 2.739*, 2.957	1.6381	2.1967	2949	3954	3276	4393	3440	4613	3440	4613	2300	1400	3086	SAE 00
	3.250*	1.5429	2.0691	2777	3724	3086	4138	3240	4344	3240	4344	2300			
	3.360*	1.5048	2.0180	2709	3632	3010	4036	3160	4237	3160	4237	2300			
	3.448*	1.4738	1.9764	2653	3558	2948	3953	3094	4149	3094	4149	2300			
ZF 9050 A 8 degrees	1.381*, 1.514*, 1.750*, 1.967, 2.259*, 2.462, 2.750*, 2.958	1.6381	2.1967	2949	3954	3276	4393	3440	4613	3440	4613	2300	1380	3042	SAE 00
	3.208*	1.5429	2.0691	2777	3724	3086	4138	3240	4344	3240	4344	2300			
	3.462*	1.4738	1.9764	2653	3558	2948	3953	3094	4149	3094	4149	2300			
ZF 9050 NR2	1.186*, 1.515*, 1.576*, 1.742*, 1.862*, 2.036, 2.269*, 2.400*, 2.500*, 2.542, 2.739*, 2.957	1.6381	2.1967	2949	3954	3276	4393	3440	4613	3440	4613	2300	1040	2293	
	3.250*	1.5429	2.0691	2777	3724	3086	4138	3240	4344	3240	4344	2300			
	3.360*	1.5048	2.0180	2709	3632	3010	4036	3160	4237	3160	4237	2300			
	3.448*	1.4738	1.9764	2653	3558	2948	3953	3094	4149	3094	4149	2300			
ZF 9050 NR2B	1.186*, 1.515*, 1.576*, 1.742*, 1.862*, 2.036, 2.269*, 2.400*, 2.500*, 2.542, 2.739*, 2.957	1.6381	2.1967	2949	3954	3276	4393	3440	4613	3440	4613	2300	1040	2293	
	3.250*	1.5429	2.0691	2777	3724	3086	4138	3240	4344	3240	4344	2300			
	3.360*	1.5048	2.0180	2709	3632	3010	4036	3160	4237	3160	4237	2300			
	3.448*	1.4738	1.9764	2653	3558	2948	3953	3094	4149	3094	4149	2300			

⁹ Left and Right version available.

* Special Order Ratio.

Light Duty Single Speed



PRODUCT	Ratios	Power factor		Input power capacity						Max. kW	Max. hp	Max. rpm	Weight		Bell hgs. & notes
		kW/rpm	hp/rpm	1800 rpm		2000 rpm		2100 rpm					kg	lb	
ZF 9050 NR2H ⁹	1.186*, 1.515*, 1.576*, 1.742*, 1.862*, 2.036, 2.269*, 2.400*, 2.500*, 2.542, 2.739*, 2.957	1.6381	2.1967	2949	3954	3276	4393	3440	4613	3440	4613	2300	1040	2293	
	3.250*	1.5429	2.0691	2777	3724	3086	4138	3240	4344	3240	4344	2300			
	3.360*	1.5048	2.0180	2709	3632	3010	4036	3160	4237	3160	4237	2300			
	3.448*	1.4738	1.9764	2653	3558	2948	3953	3094	4149	3094	4149	2300			
ZF 9050 V 8 degrees	1.381*, 1.514*, 1.750*, 1.967, 2.259*, 2.462, 2.750*, 2.958	1.6381	2.1967	2949	3954	3276	4393	3440	4613	3440	4613	2300	1400	3086	
	3.208*	1.5429	2.0691	2777	3724	3086	4138	3240	4344	3240	4344	2300			
	3.462*	1.4738	1.9764	2653	3558	2948	3953	3094	4149	3094	4149	2300			
ZF 9055	1.186*, 1.515*, 1.576*, 1.742*, 1.862*, 2.036, 2.269*, 2.400*, 2.500*, 2.542, 2.739*, 2.957	1.7381	2.3308	3129	4195	3476	4662	3650	4894	3650	4894	2300	1400	3086	SAE 00
	3.250*	1.6381	2.1967	2949	3954	3276	4393	3440	4613	3440	4613	2300			
	3.360*	1.5976	2.1424	2876	3856	3195	4285	3354	4497	3354	4497	2300			
	3.448*	1.5652	2.0990	2817	3778	3130	4198	3286	4406	3286	4406	2300			
ZF 9055 A 8 degrees	1.381*, 1.514*, 1.750*, 1.967, 2.259*, 2.462, 2.750*, 2.958	1.7381	2.3308	3129	4195	3476	4662	3650	4894	3650	4894	2300	1380	3042	SAE 00
	3.208*	1.6381	2.1967	2949	3954	3276	4393	3440	4613	3440	4613	2300			
	3.462*	1.5652	2.0990	2817	3778	3130	4198	3286	4406	3286	4406	2300			
ZF 9055 NR2	1.186*, 1.515*, 1.576*, 1.742*, 1.862*, 2.036, 2.269*, 2.400*, 2.500*, 2.542, 2.739*, 2.957	1.7381	2.3308	3129	4195	3476	4662	3650	4894	3650	4894	2300	1040	2293	
	3.250*	1.6381	2.1967	2949	3954	3276	4393	3440	4613	3440	4613	2300			
	3.360*	1.5976	2.1424	2876	3856	3195	4285	3354	4497	3354	4497	2300			
	3.448*	1.5652	2.0990	2817	3778	3130	4198	3286	4406	3286	4406	2300			
ZF 9055 NR2B	1.186*, 1.515*, 1.576*, 1.742*, 1.862*, 2.036, 2.269*, 2.400*, 2.500*, 2.542, 2.739*, 2.957	1.7381	2.3308	3129	4195	3476	4662	3650	4894	3650	4894	2300	1040	2293	
	3.250*	1.6381	2.1967	2949	3954	3276	4393	3440	4613	3440	4613	2300			
	3.360*	1.5976	2.1424	2876	3856	3195	4285	3354	4497	3354	4497	2300			
	3.448*	1.5652	2.0990	2817	3778	3130	4198	3286	4406	3286	4406	2300			
ZF 9055 NR2H ⁹	1.186*, 1.515*, 1.576*, 1.742*, 1.862*, 2.036, 2.269*, 2.400*, 2.500*, 2.542, 2.739*, 2.957	1.7381	2.3308	3129	4195	3476	4662	3650	4894	3650	4894	2300	1040	2293	
	3.250*	1.6381	2.1967	2949	3954	3276	4393	3440	4613	3440	4613	2300			
	3.360*	1.5976	2.1424	2876	3856	3195	4285	3354	4497	3354	4497	2300			
	3.448*	1.5652	2.0990	2817	3778	3130	4198	3286	4406	3286	4406	2300			

⁹ Left and Right version available.

* Special Order Ratio.

Light Duty Single Speed



PRODUCT	Ratios	Power factor		Input power capacity						Max. kW	Max. hp	Max. rpm	Weight		Bell hgs. & notes
		kW/rpm	hp/rpm	1800 rpm		2000 rpm		2100 rpm					kg	lb	
				kW	hp	kW	hp	kW	hp						
ZF 9055 V 8 degrees	1.381*, 1.514*, 1.750*, 1.967, 2.259*, 2.462, 2.750*, 2.958	1.7381	2.3308	3129	4195	3476	4662	3650	4894	3650	4894	2300	1400	3086	
	3.208*	1.6381	2.1967	2949	3954	3276	4393	3440	4613	3440	4613	2300			
	3.462*	1.5652	2.0990	2817	3778	3130	4198	3286	4406	3286	4406	2300			
ZF 9060	1.186*, 1.515*, 1.576*, 1.742*, 1.862*, 2.036, 2.269*, 2.400*, 2.500*, 2.542, 2.739*, 2.957	1.8590	2.4930	3346	4487	3718	4986	3903	5234	3903	5234	2300	1400	3086	SAE 00
	3.250*	1.7381	2.3308	3129	4195	3476	4662	3650	4894	3650	4894	2300			
	3.360*	1.6810	2.2543	3026	4058	3362	4509	3530	4733	3530	4733	2300			
	3.448*	1.6381	2.1967	2949	3954	3276	4393	3440	4613	3440	4613	2300			
ZF 9060 A 8 degrees	1.381*, 1.514*, 1.750*, 1.967, 2.259*, 2.462, 2.750*, 2.958	1.8590	2.4930	3346	4487	3718	4986	3903	5234	3903	5234	2300	1380	3042	SAE 00
	3.208*	1.7381	2.3308	3129	4195	3476	4662	3650	4894	3650	4894	2300			
	3.462*	1.6381	2.1967	2949	3954	3276	4393	3440	4613	3440	4613	2300			
ZF 9060 NR2	1.186*, 1.515*, 1.576*, 1.742*, 1.862*, 2.036, 2.269*, 2.400*, 2.500*, 2.542, 2.739*, 2.957	1.8590	2.4930	3346	4487	3718	4986	3903	5234	3903	5234	2300	1040	2293	
	3.250*	1.7381	2.3308	3129	4195	3476	4662	3650	4894	3650	4894	2300			
	3.360*	1.6810	2.2543	3026	4058	3362	4509	3530	4733	3530	4733	2300			
	3.448*	1.6381	2.1967	2949	3954	3276	4393	3440	4613	3440	4613	2300			
ZF 9060 NR2B	1.186*, 1.515*, 1.576*, 1.742*, 1.862*, 2.036, 2.269*, 2.400*, 2.500*, 2.542, 2.739*, 2.957	1.8590	2.4930	3346	4487	3718	4986	3903	5234	3903	5234	2300	1040	2293	
	3.250*	1.7381	2.3308	3129	4195	3476	4662	3650	4894	3650	4894	2300			
	3.360*	1.6810	2.2543	3026	4058	3362	4509	3530	4733	3530	4733	2300			
	3.448*	1.6381	2.1967	2949	3954	3276	4393	3440	4613	3440	4613	2300			
ZF 9060 NR2H ⁹	1.186*, 1.515*, 1.576*, 1.742*, 1.862*, 2.036, 2.269*, 2.400*, 2.500*, 2.542, 2.739*	1.8590	2.4930	3346	4487	3718	4986	3903	5234	3903	5234	2300	1040	2293	
	2.957	1.8252	2.4476	3285	4406	3650	4895	3832	5138	3832	5138	2300			
	3.250*	1.7381	2.3308	3129	4195	3476	4662	3650	4894	3650	4894	2300			
	3.360*	1.6810	2.2543	3026	4058	3362	4509	3530	4733	3530	4733	2300			
	3.448*	1.6381	2.1967	2949	3954	3276	4393	3440	4613	3440	4613	2300			

⁸ U-drive version also available.

⁹ Left and Right version available.

¹⁶ PTI (Hybrid) or Integrated Shaft Brake also available.

* Special Order Ratio.

Light Duty Single Speed



PRODUCT	Ratios	Power factor		Input power capacity						Max. kW	Max. hp	Max. rpm	Weight		Bell hgs. & notes
		kW/rpm	hp/rpm	1800 rpm		2000 rpm		2100 rpm					kg	lb	
				kW	hp	kW	hp	kW	hp						
ZF 9060 V 8 degrees	1.381*, 1.514*, 1.750*, 1.967, 2.259*, 2.462, 2.750*, 2.958	1.8590	2.4930	3346	4487	3718	4986	3903	5234	3903	5234	2300	1400	3086	
	3.208*	1.7381	2.3308	3129	4195	3476	4662	3650	4894	3650	4894	2300			
	3.462*	1.6381	2.1967	2949	3954	3276	4393	3440	4613	3440	4613	2300			
ZF 9300 ^{8, 16}	2.471*, 3.034*, 3.538, 3.760*, 3.958, 4.217*, 4.522	1.5000	2.0115	2700	3621	3000	4023	3150	4224	3150	4224	2300	1910	4211	SAE 00
	4.783*	1.4143	1.8966	2546	3414	2829	3793	2970	3982	2970	3982	2300			
	4.958*	1.3524	1.8136	2434	3264	2705	3627	2840	3808	2840	3808	2300			
	5.185*	1.2952	1.7369	2331	3126	2590	3474	2719	3646	2719	3646	2300			
ZF 9311 ⁸	2.471*, 3.034*, 3.538, 3.760*, 3.958, 4.217*, 4.522	1.5000	2.0115	2700	3621	3000	4023	3150	4224	3150	4224	2300	2430	5357	SAE 00
	4.783*	1.4143	1.8966	2546	3414	2829	3793	2970	3982	2970	3982	2300			
	4.958*	1.3524	1.8136	2434	3264	2705	3627	2840	3808	2840	3808	2300			
	5.185*	1.2952	1.7369	2331	3126	2590	3474	2719	3646	2719	3646	2300			
ZF 9350 ^{8, 16}	2.471*, 3.034*, 3.538, 3.760*, 3.958, 4.217*, 4.522	1.6381	2.1967	2949	3954	3276	4393	3440	4613	3440	4613	2300	1910	4211	SAE 00
	4.783*	1.5429	2.0691	2777	3724	3086	4138	3240	4344	3240	4344	2300			
	4.958*	1.4738	1.9764	2653	3558	2948	3953	3094	4149	3094	4149	2300			
	5.185*	1.4071	1.8870	2533	3397	2814	3774	2954	3961	2954	3961	2300			
ZF 9351 ⁸	2.471*, 3.034*, 3.538, 3.760*, 3.958, 4.217*, 4.522	1.6381	2.1967	2949	3954	3276	4393	3440	4613	3440	4613	2300	2430	5357	SAE 00
	4.783*	1.5429	2.0691	2777	3724	3086	4138	3240	4344	3240	4344	2300			
	4.958*	1.4738	1.9764	2653	3558	2948	3953	3094	4149	3094	4149	2300			
	5.185*	1.4071	1.8870	2533	3397	2814	3774	2954	3961	2954	3961	2300			
ZF 9355 ^{8, 16}	2.471*, 3.034*, 3.538, 3.760*, 3.958, 4.217*, 4.522	1.7381	2.3308	3129	4195	3476	4662	3650	4894	3650	4894	2300	1910	4211	SAE 00
	4.783*	1.6381	2.1967	2949	3954	3276	4393	3440	4613	3440	4613	2300			
	4.958*	1.5652	2.0990	2817	3778	3130	4198	3286	4406	3286	4406	2300			
	5.185*	1.4952	2.0051	2691	3609	2990	4010	3139	4209	3139	4209	2300			
ZF 9356 ⁸	2.471*, 3.034*, 3.538, 3.760*, 3.958, 4.217*, 4.522	1.7381	2.3308	3129	4195	3476	4662	3650	4894	3650	4894	2300	2430	5357	SAE 00
	4.783*	1.6381	2.1967	2949	3954	3276	4393	3440	4613	3440	4613	2300			
	4.958*	1.5652	2.0990	2817	3778	3130	4198	3286	4406	3286	4406	2300			
	5.185*	1.4952	2.0051	2691	3609	2990	4010	3139	4209	3139	4209	2300			

⁸ U-drive version also available.

¹⁶ PTI (Hybrid) or Integrated Shaft Brake also available.

* Special Order Ratio.

Light Duty Single Speed



PRODUCT	Ratios	Power factor		Input power capacity						Max. kW	Max. hp	Max. rpm	Weight		Bell hgs. & notes
		kW/rpm	hp/rpm	1800 rpm		2000 rpm		2100 rpm					kg	lb	
ZF 9360 ^{8, 16}	2.471*, 3.034*, 3.538, 3.760*, 3.958, 4.217*, 4.522	1.8590	2.4930	3346	4487	3718	4986	3903	5234	3903	5234	2300	1910	4211	SAE 00
	4.783*	1.7595	2.3595	3167	4247	3519	4719	3695	4955	3695	4955	2300			
	4.958*	1.7048	2.2862	3069	4115	3410	4572	3580	4800	3580	4800	2300			
	5.185*	1.6381	2.1967	2949	3954	3276	4393	3440	4613	3440	4613	2300			
ZF 9361 ⁸	2.471*, 3.034*, 3.538, 3.760*, 3.958, 4.217*, 4.522	1.8590	2.4930	3346	4487	3718	4986	3903	5234	3903	5234	2300	2430	5357	SAE 00
	4.783*	1.7595	2.3595	3167	4247	3519	4719	3695	4955	3695	4955	2300			
	4.958*	1.7048	2.2862	3069	4115	3410	4572	3580	4800	3580	4800	2300			
	5.185*	1.6381	2.1967	2949	3954	3276	4393	3440	4613	3440	4613	2300			
ZF 23560 C (iSG=1.000)	1.721, 2.278, 2.839, 3.577	2.6639	3.5723	4795	6430	5328	7145	5594	7502	5594	7502	2100	2600	5732	
ZF 23560 C (iSG=1.130)	4.042	2.3574	3.1613	4243	5690	4715	6323	4951	6639	4951	6639	2100	2600	5732	
ZF 23560 C (iSG=1.273)	4.552*	2.0926	2.8062	3767	5051	4185	5612	4394	5893	4394	5893	2100	2600	5732	
ZF 23560 C (iSG=1.432)	5.122*	1.8601	2.4944	3348	4490	3720	4989	3906	5238	3906	5238	2100	2600	5732	
				750 rpm		900 rpm		1000 rpm							
ZF 23860 C (iSG=0.574)	0.697, 0.847, 1.121, 1.397, 1.760	4.1880	5.6162	3141	4212	3769	5055	4188	5616	5026	6739	1200	2600	5732	
ZF 23860 C (iSG=0.493)	0.697*, 0.847*, 1.121*, 1.397*, 1.760*	4.1880	5.6162	3141	4212	3769	5055	4188	5616	4188	5616	1000	2600	5732	
				1800 rpm		2000 rpm		2100 rpm							
ZF 24060 D ^{9, 16}	1.514*, 1.583*, 2.032, 2.207*, 2.357*, 2.577, 2.760*, 3.043, 3.476	2.6597	3.5667	4787	6420	5319	7133	5585	7490	5585	7490	2100	2650	5842	
	3.947*	2.4063	3.2269	4331	5808	4813	6454	5053	6776	5053	6776	2100			
ZF 24060 NR2	1.514*, 1.583*, 2.032, 2.207*, 2.357*, 2.577, 2.760*, 3.043, 3.476	2.6597	3.5667	4787	6420	5319	7133	5585	7490	5585	7490	2100	1890	4167	
	3.947*	2.4063	3.2269	4331	5808	4813	6454	5053	6776	5053	6776	2100			
ZF 24060 NR2B	1.514*, 1.583*, 2.032, 2.207*, 2.357*, 2.577, 2.760*, 3.043, 3.476	2.6597	3.5667	4787	6420	5319	7133	5585	7490	5585	7490	2100	1890	4167	
	3.947*	2.4063	3.2269	4331	5808	4813	6454	5053	6776	5053	6776	2100			
ZF 24060 NR2H ⁹	1.514*, 1.583*, 2.032, 2.207*, 2.357*, 2.577, 2.760*, 3.043, 3.476	2.6597	3.5667	4787	6420	5319	7133	5585	7490	5585	7490	2100	1860	4101	
	3.947*	2.4063	3.2269	4331	5808	4813	6454	5053	6776	5053	6776	2100			

⁸ U-drive version also available.

⁹ Left and Right version available.

¹⁶ PTI (Hybrid) or Integrated Shaft Brake also available.

* Special Order Ratio.

Light Duty Single Speed



PRODUCT	Ratios	Power factor		Input power capacity						Max. kW	Max. hp	Max. rpm	Weight		Bell hgs. & notes
		kW/rpm	hp/rpm	1800 rpm		2000 rpm		2100 rpm					kg	lb	
ZF 24060 SGC ¹⁶ (iSG=1.000)	1.514*, 1.583*, 2.032, 2.207*, 2.357*, 2.577, 2.760*, 3.043, 3.476	2.6597	3.5667	4787	6420	5319	7133	5585	7490	5585	7490	2100	3250	7165	
	3.947*	2.4063	3.2269	4331	5808	4813	6454	5053	6776	5053	6776	2100			
ZF 24060 SGC ¹⁶ (iSG=1.173)	4.630	2.0513	2.7508	3692	4951	4103	5502	4308	5777	4308	5777	2100	3250	7165	
ZF 24060 SGC ¹⁶ (iSG=1.280)	5.052	1.8799	2.5210	3384	4538	3760	5042	3948	5294	3948	5294	2100	3250	7165	
ZF 24060 SGC ¹⁶ (iSG=1.354)	5.344	1.7772	2.3833	3199	4290	3554	4767	3732	5005	3732	5005	2100	3250	7165	
ZF 24360 D ^{8, 9, 16}	4.036, 5.087, 5.950	2.6597	3.5667	4787	6420	5319	7133	5585	7490	5585	7490	2100	3870	8532	
	6.421	2.4063	3.2269	4331	5808	4813	6454	5053	6776	5053	6776	2100			
ZF 24360 SG ^{8, 9, 16} (iSG=1.000)	4.036, 5.087, 5.950	2.6597	3.5667	4787	6420	5319	7133	5585	7490	5585	7490	2100	4500	9921	
	6.421	2.4063	3.2269	4331	5808	4813	6454	5053	6776	5053	6776	2100			
ZF 24360 SG ^{8, 9, 16} (iSG=1.173)	6.980	2.2673	3.0405	4081	5473	4535	6081	4761	6385	4761	6385	2100	4500	9921	
ZF 24360 SG ^{8, 9, 16} (iSG=1.280)	7.616	2.0779	2.7865	3740	5016	4156	5573	4364	5852	4364	5852	2100	4500	9921	
	8.056	1.9643	2.6342	3536	4742	3929	5268	4125	5532	4125	5532	2100	4500	9921	
ZF 24360 SG ^{8, 9, 16} (iSG=1.354)	8.694	1.7772	2.3833	3199	4290	3554	4767	3732	5005	3732	5005	2100			
				1100 rpm		1200 rpm		1300 rpm							
ZF 30050 NR2	1.514*, 1.583*, 1.735, 1.906, 2.032, 2.207*	3.4721	4.6562	3819	5122	4167	5587	4514	6053	4514	6053	1300	1900	4189	
ZF 30050 NR2B	1.514*, 1.583*, 1.735, 1.906, 2.032, 2.207*	3.4721	4.6562	3819	5122	4167	5587	4514	6053	4514	6053	1300	1900	4189	
ZF 30050 NR2H ⁹	1.514*, 1.583*, 1.735, 1.906, 2.032, 2.207*	3.4721	4.6562	3819	5122	4167	5587	4514	6053	4514	6053	1300	1870	4123	
				1200 rpm		1400 rpm		1600 rpm							
ZF 30050 SGC ¹⁶ (iSG=0.759)	1.542, 1.955, 2.483	3.5059	4.7015	4207	5642	4908	6582	5609	7522	5609	7522	1600	3250	7165	
	2.807	3.3389	4.4775	4007	5373	4674	6269	5342	7164	5342	7164	1600			
	2.994	3.1719	4.2536	3806	5104	4441	5955	5075	6806	5075	6806	1600			
ZF 30350 SG ^{8, 9, 16} (iSG=0.759)	3.062, 4.514	3.5059	4.7015	4207	5642	4908	6582	5609	7522	5609	7522	1600	4575	10086	
	4.871	3.1719	4.2536	3806	5104	4441	5955	5075	6806	5075	6806	1600			

⁸ U-drive version also available.

⁹ Left and Right version available.

¹⁶ PTI (Hybrid) or Integrated Shaft Brake also available.

* Special Order Ratio.

Light Duty Single Speed



PRODUCT	Ratios	Power factor		Input power capacity						Max. kW	Max. hp	Max. rpm	Weight		Bell hgs. & notes
		kW/rpm	hp/rpm	1100 rpm		1200 rpm		1300 rpm					kg	lb	
ZF 40060 NR2	1.514*, 1.583*, 1.735, 1.906	4.5550	6.1084	5011	6719	5466	7330	5922	7941	5922	7941	1300	2010	4431	
ZF 40060 NR2B	1.514*, 1.583*, 1.735, 1.906	4.5550	6.1084	5011	6719	5466	7330	5922	7941	5922	7941	1300	2010	4431	
ZF 40060 NR2H⁹	1.514*, 1.583*, 1.735, 1.906	4.5550	6.1084	5011	6719	5466	7330	5922	7941	5922	7941	1300	1880	4145	
ZF 40060 SGC¹⁶ (iSG=0.522)	1.588	5.0952	6.8328	4586	6150	5095	6833	5095	6833	5095	6833	1000	3260	7187	
ZF 40060 SGC¹⁶ (iSG=0.603)	1.554, 2.097	4.5538	6.1067	4554	6107	5465	7328	5920	7939	5920	7939	1300	3260	7187	
	2.381	3.9894	5.3499	3989	5350	4787	6420	5186	6955	5186	6955	1300			
ZF 40360 SG^{8, 9, 16} (iSG=0.522)	2.107, 2.655, 3.106	5.0952	6.8328	4586	6150	5095	6833	5605	7516	5605	7516	1100	4625	10196	
	3.352	4.6097	6.1817	4149	5564	4610	6182	5071	6800	5071	6800	1100			
ZF 40360 SG^{8, 9, 16} (iSG=0.603)	2.434, 3.068, 3.589	4.5538	6.1067	4098	5496	5009	6717	5920	7939	5920	7939	1300	4625	10196	
	3.873	3.9894	5.3499	3590	4815	4388	5885	5186	6955	5186	6955	1300			

⁸ U-drive version also available.

⁹ Left and Right version available.

¹⁶ PTI (Hybrid) or Integrated Shaft Brake also available.

* Special Order Ratio.

Light Duty 2 Speed



PRODUCT	Ratios				Power factor		Input power capacity						Max. kW	Max. hp	Max. rpm	Weight		Bell hgs. & notes
	1st 'A'	1st 'B'	2nd 'A'	2nd 'B'	kW/rpm	hp/rpm	2100 rpm		2500 rpm		2800 rpm					kg	lb	
ZF 90 ATS 8 degrees	1.216	1.215	0.946	0.945	0.0753	0.1010	158	212	188	253	211	283	414	556	5500	64	141	3 CAT, B/W, Yanmar 4LH
	1.563	1.583	1.216	1.231														
	2.037	2.017	1.584	1.569														
ZF 90 IVTS 12 degrees	1.294	1.288	1.006	1.002	0.0752	0.1008	158	212	188	252	211	282	414	554	5500	82	181	3 CAT, B/W, Yanmar 4LH
	1.560	1.567	1.213	1.219														
	1.992	2.033	1.549	1.581	0.0697	0.0935	146	196	174	234	195	262	383	514	5500			
	2.477	2.528	1.927	1.967														
ZF 90 TS	1.256	1.250	0.977	0.972	0.0752	0.1008	158	212	188	252	211	282	414	554	5500	67	148	3 CAT, B/W, Yanmar 4LH
	1.514	1.521	1.178	1.183														
	1.933	1.973	1.503	1.535														
	2.480	2.476	1.929	1.926	0.0624	0.0837	131	176	156	209	175	234	343	460	5500			
	2.783	2.799	2.165	2.177														
ZF 115 ATS 8 degrees	1.567	1.567	1.219	1.219	0.1043	0.1399	219	294	261	350	292	392	344	462	3300	82	181	3 CAT, B/W
	1.750	1.750	1.361	1.361														
	1.962	1.962	1.526	1.526														
	2.500	2.500	1.945	1.945														
ZF 115 IVTS 12 degrees	1.644	1.638	1.279	1.274	0.1043	0.1399	219	294	261	350	292	392	344	462	3300	107	236	3 CAT, B/W
	2.008	1.996	1.562	1.553														
	2.493	2.468	1.939	1.920														

'A' POS = continuous running position (normally AHEAD).
 'B' POS = reverse position.
 B/W = Borg Warner adaptor.

Light Duty 2 Speed



PRODUCT	Ratios		Power factor		Input power capacity						Max. kW	Max. hp	Max. rpm	Weight		Bell hgs. & notes											
	1st	2nd	kW/rpm	hp/rpm	1800 rpm		2100 rpm		2300 rpm					kg	lb												
ZF 325 IVTS 14 degrees	1.216	0.968, 1.011, 1.062, 1.087, 1.113	0.2340	0.3138	421	565	491	659	538	722	585	785	2500	235	518	SAE 1											
	1.485	1.182, 1.235, 1.297, 1.327, 1.359																									
	1.733	1.380, 1.441, 1.514, 1.549, 1.586																									
	1.793*	1.427, 1.490, 1.565, 1.603, 1.641																									
	2.037	1.622, 1.694, 1.779, 1.821, 1.864																									
	2.417	1.924, 2.009, 2.111, 2.160, 2.212															0.2107	0.2826	379	509	442	593	485	650	527	707	2500
ZF 325-1ATS 7 degrees	1.216	0.968, 1.011, 1.062, 1.087, 1.113	0.2340	0.3138	421	565	491	659	538	722	585	785	2500	180	397	SAE 1											
	1.485	1.182, 1.235, 1.297, 1.327, 1.359																									
	1.733	1.380, 1.441, 1.514, 1.549, 1.586																									
	2.037	1.622, 1.694, 1.779, 1.821, 1.864																									
	2.240*	1.783, 1.862, 1.956, 2.002, 2.050																									
	2.417	1.924, 2.009, 2.111, 2.160, 2.212															0.2107	0.2826	379	509	442	593	485	650	527	707	2500
ZF 325-1TS	1.000	0.796, 0.831, 0.873, 0.894, 0.915	0.2340	0.3138	421	565	491	659	538	722	585	785	2500	180	397	SAE 1											
	1.167*	0.929, 0.970, 1.019, 1.043, 1.068																									
	1.225*	0.975, 1.019, 1.070, 1.095, 1.121																									
	1.459	1.162, 1.213, 1.275, 1.305, 1.336																									
	1.727	1.375, 1.436, 1.509, 1.544, 1.581																									
	2.033	1.619, 1.691, 1.776, 1.818, 1.861																									
	2.250*	1.791, 1.871, 1.965, 2.011, 2.059																									
	2.500	1.990, 2.079, 2.184, 2.235, 2.288															0.2107	0.2826	379	509	442	593	485	650	527	707	2500
	2.957	2.354, 2.458, 2.582, 2.643, 2.706															0.1784	0.2392	321	431	375	502	410	550	446	598	2500

* Special Order Ratio.

Light Duty 2 Speed



PRODUCT	Ratios		Power factor		Input power capacity						Max. kW	Max. hp	Max. rpm	Weight		Bell hsgs. & notes
	1st	2nd	kW/rpm	hp/rpm	2100 rpm		2300 rpm		2450 rpm					kg	lb	
ZF 550-1 ATS 10 degrees	1.525	1.225, 1.277, 1.325, 1.363, 1.401	0.3246	0.4353	682	914	747	1001	795	1066	812	1088	2500	356	785	SAE 1
	1.757															
	1.971	1.583, 1.650, 1.712, 1.762, 1.810														
	2.517	2.022, 2.107, 2.187, 2.251, 2.312														
	2.960	2.377, 2.478, 2.572, 2.646, 2.718	0.2759	0.3700	579	777	635	851	676	907	690	925	2500			
ZF 550-1 TS	1.111	0.892, 0.930, 0.965, 0.993, 1.020	0.3246	0.4353	682	914	747	1001	795	1066	812	1088	2500	344	758	SAE 1
	1.182*	0.949, 0.989, 1.027, 1.057, 1.085														
	1.262*	1.013, 1.056, 1.096, 1.128, 1.159														
	1.400*	1.124, 1.172, 1.216, 1.252, 1.286														
	1.500	1.205, 1.256, 1.303, 1.341, 1.378														
	1.743	1.400, 1.459, 1.514, 1.558, 1.601														
	2.000	1.606, 1.674, 1.738, 1.788, 1.837														
	2.233	1.794, 1.870, 1.941, 1.997, 2.051														
	2.593	2.082, 2.171, 2.253, 2.318, 2.381														
	3.042	2.443, 2.547, 2.643, 2.719, 2.793	0.2759	0.3700	579	777	635	851	676	907	690	925	2500			

* Special Order Ratio.

Light Duty 2 Speed



PRODUCT	Ratios		Power factor		Input power capacity						Max. kW	Max. hp	Max. rpm	Weight		Bell hsgs. & notes	
	1st	2nd	kW/rpm	hp/rpm	2100 rpm		2300 rpm		2450 rpm					kg	lb		
ZF 665 ATS 10 degrees	1.525	1.225, 1.277, 1.325, 1.363, 1.401	0.3729	0.5001	783	1050	858	1150	914	1225	932	1250	2500	353	778	SAE 1	
	1.757	1.411, 1.471, 1.526, 1.571, 1.613															
	1.971	1.583, 1.650, 1.712, 1.762, 1.810															
	2.226	1.788, 1.863, 1.934, 1.990, 2.044	0.3654	0.4900	767	1029	840	1127	895	1201	914	1225	2500				
	2.448	1.966, 2.050, 2.127, 2.189, 2.248															
	2.517	2.022, 2.107, 2.187, 2.251, 2.312	0.3567	0.4783	749	1004	820	1100	874	1172	892	1196	2500				
	2.960	2.377, 2.478, 2.572, 2.646, 2.718	0.2917	0.3912	613	822	671	900	715	958	729	978	2500				
ZF 665 TS	1.111	0.892, 0.930, 0.965, 0.993, 1.020	0.3729	0.5001	783	1050	858	1150	914	1225	932	1250	2500	344	758	SAE 1	
	1.182	0.949, 0.989, 1.027, 1.057, 1.085															
	1.262	1.013, 1.056, 1.096, 1.128, 1.159															
	1.400	1.124, 1.172, 1.216, 1.252, 1.286															
	1.500	1.205, 1.256, 1.303, 1.341, 1.378															
	1.743	1.400, 1.459, 1.514, 1.558, 1.601															
	2.000	1.606, 1.674, 1.738, 1.788, 1.837															
	2.233	1.794, 1.870, 1.941, 1.997, 2.051	0.3654	0.4900	767	1029	840	1127	895	1201	914	1225	2500				
	2.593																
	3.042	2.443, 2.547, 2.643, 2.719, 2.793	0.2917	0.3912	613	822	671	900	715	958	729	978	2500				



Transmissions
Medium Duty

Medium Duty Single Speed



PRODUCT	Ratios		Power factor		Input power capacity						Max. kW	Max. hp	Max. rpm	Weight		Bell hgs. & notes
	'A' Pos	'B' Pos	kW/rpm	hp/rpm	2100 rpm		2500 rpm		2800 rpm					kg	lb	
ZF 12 M ¹²	2.136	1.955	0.0111	0.0149	23	31	28	37	31	42	46	61	5000	13	29	B/W, Yanmar JH
	2.632	1.955	0.0097	0.0130	20	27	24	33	27	36	46	61	5000			
ZF 15 M ¹²	1.556	1.955	0.0131	0.0176	28	37	33	44	37	49	46	61	5000	13	29	B/W, Yanmar JH
	1.875	1.955	0.0121	0.0162	25	34	30	41	34	45	46	61	5000			
ZF 15 MA ¹² 8 degrees	1.875	1.955	0.0121	0.0162	25	34	30	41	34	45	46	61	5000	14	30	B/W, Yanmar JH
	2.136	1.955	0.0111	0.0149	23	31	28	37	31	42	46	61	5000			
	2.632	1.955	0.0097	0.0130	20	27	24	33	27	36	46	61	5000			
ZF 15 MIV ¹² 15 degrees	2.134	2.224	0.0121	0.0162	25	34	30	41	34	45	46	61	5000	20	44	B/W, Yanmar JH
	2.718	2.224	0.0097	0.0130	20	27	24	33	27	36	46	61	5000			
	2.995	2.224														
ZF 25	1.969	1.969	0.0212	0.0284	45	60	53	71	59	80	117	156	5500	24	53	B/W, Yanmar JH
	2.800	2.800	0.0203	0.0272	43	57	51	68	57	76	112	150	5500			
ZF 25 A 8 degrees	1.548	1.548	0.0213	0.0286	45	60	53	72	60	80	117	157	5500	24	53	B/W, Yanmar JH
	1.926	1.926														
	2.292	2.292														
	2.480*	2.480*														
	2.714	2.714	0.0203	0.0272	43	57	51	68	57	76	112	150	5500			
ZF 25 M ¹²	1.880	2.095	0.0210	0.0282	44	59	53	71	59	79	64	85	5000	19	41	B/W, Yanmar JH
	2.273	2.095	0.0172	0.0231	36	49	43	58	48	65	64	85	5000			
	2.737	2.722	0.0142	0.0190	30	40	36	48	40	53	64	85	5000			
ZF 25 MA ¹² 8 degrees	2.227	2.737	0.0172	0.0231	36	49	43	58	48	65	64	85	5000	21	46	B/W, Yanmar JH
	2.737	2.737	0.0141	0.0189	30	40	35	47	39	53	64	85	5000			
ZF 30 M ¹²	2.148	2.636	0.0193	0.0259	41	54	48	65	54	73	76	102	5000	23	51	4 & 5 Yanmar JH
	2.696	2.636														
ZF 45 A 8 degrees	1.256	1.256	0.0382	0.0512	80	108	96	128	107	143	210	282	5500	28	62	B/W, Volvo D4-D6, Volvo 30-40, Yanmar 4LH-4JH
	1.514	1.514														
	2.034	2.034														
	2.435	2.435														
	2.435	2.435	0.0357	0.0479	75	101	89	120	100	134	196	263	5500			
ZF 45-1	2.200	2.200	0.0440	0.0590	92	124	110	148	123	165	242	325	5500	60	132	B/W, Volvo D4-D6, Volvo 30-40, Yanmar 4LH-4JH
	2.512	2.512														
	3.031	3.031														
	3.741	3.741														

* Special Order Ratio.

¹² Reduced power capacity by the following shock factors: 1 cylinder engine ÷ 1.25, 2 cylinder engine ÷ 1.20, 3 cylinder engine ÷ 1.15

'A' POS = continuous running position (normally AHEAD).

'B' POS = reverse position.

B/W = Borg Warner adaptor.

Medium Duty Single Speed



PRODUCT	Ratios		Power factor		Input power capacity						Max. kW	Max. hp	Max. rpm	Weight		Bell hgs. & notes
	'A' Pos	'B' Pos	kW/rpm	hp/rpm	2100 rpm		2500 rpm		2800 rpm					kg	lb	
ZF 68	1.256	1.250	0.0539	0.0723	113	152	135	181	151	202	189	253	3500	46	101	B/W, Volvo D4-D6, Volvo 30-40, Yanmar 4LH
	1.514	1.521														
	1.750*	1.770														
	1.933	1.973	0.0518	0.0695	109	146	130	174	145	195	181	243	3500			
	2.480	2.476														
	2.783	2.799														
ZF 68 A 8 degrees	1.216	1.215	0.0578	0.0775	121	163	145	194	162	217	202	271	3500	44	97	B/W, Volvo D4-D6, Volvo 30-40, Yanmar 4LH
	1.563	1.583	0.0539	0.0723	113	152	135	181	151	202	189	253	3500			
	2.037	2.017	0.0475	0.0637	100	134	119	159	133	178	166	223	3500			
	2.522*	2.536														
	2.682*	2.709														
ZF 68 IV 12 degrees	1.294	1.288	0.0578	0.0775	121	163	145	194	162	217	202	271	3500	62	137	B/W, Volvo D4-D6, Volvo 30-40, Yanmar 4LH
	1.560	1.567	0.0539	0.0723	113	152	135	181	151	202	189	253	3500			
	1.746	1.749	0.0518	0.0695	109	146	130	174	145	195	181	243	3500			
	1.992	2.033														
	2.477	2.528														
ZF 85 A 8 degrees	1.567	1.567	0.0838	0.1124	176	236	210	281	235	315	377	506	4500	69	152	3 CAT, B/W, Volvo D4-D6
	1.750	1.750														
	1.962	1.962														
	2.500	2.500														
ZF 85 IV 12 degrees	1.644	1.638	0.0889	0.1192	187	250	222	298	249	334	311	417	3500	86	190	3 CAT, B/W, Volvo D4-D6
	2.008	1.996														
	2.493	2.468	0.0838	0.1124	176	236	210	281	235	315	293	393				

* Special Order Ratio.

'A' POS = continuous running position (normally AHEAD).

'B' POS = reverse position.

B/W = Borg Warner adaptor.

Medium Duty Single Speed



PRODUCT	Ratios	Power factor		Input power capacity						Max. kW	Max. hp	Max. rpm	Weight		Bell hgs. & notes
		kW/rpm	hp/rpm	2100 rpm		2500 rpm		2800 rpm					kg	lb	
ZF 220	1.000, 1.128*, 1.237*, 1.400*	0.0745	0.0999	156	210	186	250	209	280	238	320	3200	63	139	3 CAT
	1.500*, 1.963, 2.478	0.0698	0.0936	147	197	175	234	195	262	223	300	3200			
	3.000	0.0598	0.0802	126	168	150	200	167	225	191	257	3200			
ZF W220	2.618	0.0792	0.1062	166	223	198	266	222	297	253	340	3200	105	231	3 CAT
	3.133	0.0768	0.1030	161	216	192	258	215	288	246	330	3200			
	3.556	0.0696	0.0933	146	196	174	233	195	261	223	299	3200			
	3.960	0.0644	0.0864	135	181	161	216	180	242	206	276	3200			
	4.636	0.0552	0.0740	116	155	138	185	155	207	177	237	3200			
ZF 220 A 10 degrees	1.235*, 1.750*	0.0745	0.0999	156	210	186	250	209	280	335	450	4500	50	110	3 CAT, B/W
	1.533, 2.040	0.0698	0.0936	147	197	175	234	195	262	314	421	4500			
	2.455*	0.0629	0.0844	132	177	157	211	176	236	283	380	4500			
ZF 280 IV 14 degrees	1.252*, 1.561*, 1.772*, 2.063	0.0904	0.1212	190	255	226	303	253	339	325	436	3600	106	234	3 CAT
	2.276, 2.556*	0.0844	0.1132	177	238	211	283	236	317	304	408	3600			
	3.094*	0.0711	0.0953	149	200	178	238	199	267	256	343	3600			
ZF 280-1	0.814*, 1.000, 1.056*, 1.139*, 1.214*, 1.300, 1.514*, 2.000	0.0904	0.1212	190	255	226	303	253	339	325	436	3600	73	161	3 CAT
	2.478	0.0844	0.1132	177	238	211	283	236	317	304	408	3600			
	3.000*	0.0806	0.1081	169	227	202	270	226	303	290	389	3600			
ZF 280-1 A 7 degrees	1.118*, 1.483, 1.769, 2.000	0.0904	0.1212	190	255	226	303	253	339	325	436	3600	73	161	3 CAT
	2.227, 2.476*	0.0844	0.1132	177	238	211	283	236	317	304	408	3600			
ZF 286	1.237*, 1.400*, 1.500, 1.966, 2.269	0.1152	0.1545	242	324	288	386	323	433	415	556	3600	86	190	3 CAT
	0.923*, 1.000*, 2.481*	0.1053	0.1412	221	297	263	353	295	395	379	508	3600			
	2.917	0.0959	0.1286	201	270	240	322	269	360	345	463	3600			
ZF 286 A 7 degrees	1.200*, 1.484*, 1.750, 1.962	0.1152	0.1545	242	324	288	386	323	433	415	556	3600	77	170	3 CAT
	2.208	0.1086	0.1456	228	306	272	364	304	408	391	524	3600			
	2.391, 2.500	0.1005	0.1348	211	283	251	337	281	377	362	485	3600			
ZF 286 IV 14 degrees	1.266*, 1.535, 2.011	0.1152	0.1545	242	324	288	386	323	433	415	556	3600	130	287	3 CAT
	2.322*	0.1086	0.1456	228	306	272	364	304	408	391	524	3600			
	2.539	0.1053	0.1412	221	297	263	353	295	395	379	508	3600			
ZF 301-1 A 10 degrees	1.190*, 1.516*, 2.005, 2.551*, 2.901*	0.0911	0.1222	191	257	228	306	255	342	273	367	3000	87	192	3 CAT
ZF 301-1 C	1.236*, 1.408*	0.1070	0.1435	225	301	268	359	300	402	321	430	3000	87	192	3 CAT
	1.862, 2.694	0.0963	0.1291	202	271	241	323	270	361	289	387	3000			

* Special Order Ratio.

B/W = Borg Warner adaptor.

Medium Duty Single Speed



PRODUCT	Ratios	Power factor		Input power capacity						Max. kW	Max. hp	Max. rpm	Weight		Bell hgs. & notes
		kW/rpm	hp/rpm	1800 rpm		2100 rpm		2300 rpm					kg	lb	
ZF 305-3	0.884*, 1.000*, 1.220, 1.486*, 1.968	0.1423	0.1908	256	343	299	401	327	439	427	572	3000	98	216	SAE 1, 2, 3
	2.250*	0.1305	0.1750	235	315	274	368	300	403	392	525	3000			
	2.500	0.1220	0.1636	220	294	256	344	281	376	366	491	3000			
	2.917	0.1084	0.1454	195	262	228	305	249	334	325	436	3000			
ZF 305-3 A 7 degrees	1.200*, 1.514, 1.733, 2.037	0.1423	0.1908	256	343	299	401	327	439	427	572	3000	97	214	SAE 1, 2, 3
	2.179	0.1305	0.1750	235	315	274	368	300	403	392	525	3000			
	2.423	0.1220	0.1636	220	294	256	344	281	376	366	491	3000			
ZF 325 IV 14 degrees	1.216, 1.485*, 1.733, 2.037	0.1776	0.2382	320	429	373	500	408	548	533	715	3000	185	408	SAE 1, 2
	2.417	0.1669	0.2238	300	403	350	470	384	515	501	671	3000			
ZF 325-1	1.000, 1.167*, 1.225*, 1.459*, 1.727, 2.033	0.1775	0.2380	320	428	373	500	408	547	533	714	3000	130	287	SAE 1, 2
	2.500	0.1669	0.2238	300	403	350	470	384	515	501	671	3000			
	2.957	0.1473	0.1975	265	356	309	415	339	454	442	593	3000			
ZF 325-1 A 7 degrees	1.216*, 1.485, 1.733, 2.037, 2.240*	0.1776	0.2382	320	429	373	500	408	548	533	715	3000	130	287	SAE 1, 2
	2.417*	0.1669	0.2238	300	403	350	470	384	515	501	671	3000			
ZF W340 ¹⁵	2.938, 3.233, 3.500, 4.080*, 4.522*	0.1953	0.2619	410	550	449	602	469	629	586	786	3000	330	728	SAE 1, 2, 3
	4.957*	0.1793	0.2404	377	505	412	553	430	577	538	721	3000			
	5.227*	0.1589	0.2131	334	448	365	490	381	511	477	639	3000			
ZF W350-1	3.026*, 3.500*, 3.968*, 4.536, 4.962, 5.955*	0.2379	0.3190	428	574	500	670	547	734	571	766	2400	500	1102	SAE 0, 1
	6.409*	0.2078	0.2787	374	502	436	585	478	641	499	669	2400			
ZF 400 ¹⁵	0.854, 0.925, 1.000, 1.109, 1.233, 1.526, 1.781, 2.033, 2.214	0.2130	0.2856	383	514	447	600	490	657	639	857	3000	160	353	SAE 1, 2
	2.600	0.2101	0.2817	378	507	441	592	483	648	630	845	3000			
	2.957	0.1882	0.2524	339	454	395	530	433	581	565	757	3000			
ZF 400 A ¹⁵ 7 degrees	1.441, 1.594, 1.767, 1.964	0.2130	0.2856	383	514	447	600	490	657	639	857	3000	160	353	SAE 1, 2
	2.192	0.2101	0.2817	378	507	441	592	483	648	630	845	3000			
	2.458	0.1802	0.2417	324	435	378	508	414	556	541	725	3000			
ZF 400 IV ¹⁵ 14 degrees	1.441, 1.594, 1.767, 1.964	0.2130	0.2856	383	514	447	600	490	657	639	857	3000	220	485	SAE 1, 2
	2.192	0.2101	0.2817	378	507	441	592	483	648	630	845	3000			
	2.458	0.1802	0.2417	324	435	378	508	414	556	541	725	3000			

¹⁵ Free standing installation available.

* Special Order Ratio.

Medium Duty Single Speed



PRODUCT	Ratios	Power factor		Input power capacity						Max. kW	Max. hp	Max. rpm	Weight		Bell hgs. & notes
		kW/rpm	hp/rpm	1800 rpm		2100 rpm		2250 rpm					kg	lb	
ZF 400 V 10 degrees	1.125*, 1.774*, 2.000, 2.222*, 2.480	0.2130	0.2856	383	514	447	600	479	643	639	857	3000	200	441	
ZF 500	1.000*, 1.125, 1.237*, 1.500, 1.774*, 1.966	0.2694	0.3613	485	650	566	759	606	813	808	1084	3000	185	408	SAE 0, 1
	2.185*	0.2486	0.3334	447	600	522	700	559	750	746	1000	3000			
	0.925*, 2.480*, 2.625*	0.2279	0.3056	410	550	479	642	513	688	684	917	3000			
	2.917*	0.1989	0.2667	358	480	418	560	448	600	597	800	3000			
ZF 500-1 A 7 degrees	1.216*, 1.485*, 1.767, 1.964	0.2694	0.3613	485	650	566	759	606	813	808	1084	3000	192	423	SAE 0, 1
	2.192	0.2486	0.3334	447	600	522	700	559	750	746	1000	3000			
	2.478*	0.2279	0.3056	410	550	479	642	513	688	684	917	3000			
	2.609*	0.2130	0.2856	383	514	447	600	479	643	639	857	3000			
ZF 500-1 IV 14 degrees	1.216*, 1.767*, 1.964	0.2574	0.3452	463	621	541	725	579	777	772	1036	3000	230	507	SAE 1
	2.200	0.2486	0.3334	447	600	522	700	559	750	746	1000	3000			
	2.478*	0.2279	0.3056	410	550	479	642	513	688	684	917	3000			
	3.000*	0.2071	0.2777	373	500	435	583	466	625	621	833	3000			
ZF 510 V 10 degrees	1.125*, 1.774*, 2.000	0.2694	0.3613	485	650	566	759	606	813	808	1084	3000	200	441	
	2.222*	0.2486	0.3334	447	600	522	700	559	750	746	1000	3000			
ZF 510-1 A 10 degrees	1.125*, 1.774, 2.000	0.2694	0.3613	485	650	566	759	606	813	808	1084	3000	193	425	SAE 0, 1
	2.222, 2.480*	0.2486	0.3334	447	600	522	700	559	750	746	1000	3000			
ZF 550-1	1.111, 1.182*, 1.262*, 1.833*, 2.000, 2.233*, 2.593	0.2577	0.3456	464	622	541	726	580	778	773	1037	3000	242	534	SAE 0, 1
	3.042*	0.2347	0.3147	422	566	493	661	528	708	704	944	3000			
ZF 550-1 A 10 degrees	1.525*, 1.757*, 1.971, 2.226, 2.448, 2.517	0.2576	0.3454	464	622	541	725	580	777	773	1036	3000	256	564	SAE 0, 1
	2.960*	0.2346	0.3146	422	566	493	661	528	708	704	944	3000			
ZF 550-1 V 10 degrees	1.525*, 1.971, 2.226, 2.448*	0.2576	0.3454	464	622	541	725	580	777	773	1036	3000	260	573	
	2.960*	0.2346	0.3146	422	566	493	661	528	708	704	944	3000			
ZF W650	3.605*, 4.057, 4.531*, 5.138, 5.593	0.2576	0.3454	464	622	541	725	592	794	670	898	2600	561	1237	SAE 0, 1
	6.417*	0.2346	0.3146	422	566	493	661	540	724	610	818	2600			
ZF 665	1.111, 1.182*, 1.262, 1.400*, 1.500*, 1.743, 2.000	0.3107	0.4167	559	750	652	875	699	938	932	1250	3000	248	547	SAE 0, 1
	2.233*, 2.593	0.2900	0.3889	522	700	609	817	653	875	870	1167	3000			
	3.042*	0.2382	0.3194	429	575	500	671	536	719	715	958	3000			

* Special Order Ratio.

Medium Duty Single Speed



PRODUCT	Ratios	Power factor		Input power capacity						Max. kW	Max. hp	Max. rpm	Weight		Bell hgs. & notes
		kW/rpm	hp/rpm	1800 rpm		2100 rpm		2250 rpm					kg	lb	
ZF 665 A 10 degrees	1.525*, 1.971	0.3107	0.4167	559	750	652	875	699	938	932	1250	3000	253	558	SAE 0, 1
	2.226	0.2900	0.3889	522	700	609	817	653	875	870	1167	3000			
	2.517	0.2817	0.3778	507	680	592	793	634	850	845	1133	3000			
	2.960*	0.2486	0.3334	447	600	522	700	559	750	746	1000	3000			
ZF 665 V 10 degrees	1.525*, 1.757*, 1.971*	0.3107	0.4167	559	750	652	875	699	938	932	1250	3000	252	556	
	2.226*	0.2900	0.3889	522	700	609	817	653	875	870	1167	3000			
	2.517*	0.2817	0.3778	507	680	592	793	634	850	845	1133	3000			
	2.960*	0.2486	0.3334	447	600	522	700	559	750	746	1000	3000			
ZF 2000	1.086*, 1.111*, 1.191*, 1.250*, 1.350*, 1.436*, 1.500, 1.639*, 1.765*, 1.848*, 1.879*, 2.032, 2.276*, 2.519	0.3210	0.4305	578	775	674	904	722	968	722	968	2600	340	750	SAE 0, 1
	2.760*	0.2953	0.3960	532	713	620	832	664	890	664	890	2600			
	2.958	0.2698	0.3618	486	651	567	760	607	814	607	814	2600			
ZF 2000 A 10 degrees	1.267*, 1.512*, 1.763, 2.029, 2.250*, 2.467, 2.714*	0.3210	0.4305	578	775	674	904	722	968	722	968	2600	348	767	SAE 0, 1
	2.920	0.3072	0.4120	553	742	645	865	691	926	691	926	2600			
	3.250*	0.2860	0.3835	515	690	601	805	643	862	643	862	2600			
ZF 2000 V 10 degrees	1.267*, 1.512*, 1.763, 2.029, 2.250*, 2.467, 2.714*	0.3210	0.4305	578	775	674	904	722	968	722	968	2600	352	776	
	2.920	0.3072	0.4120	553	742	645	865	691	926	691	926	2600			
	3.250*	0.2860	0.3835	515	690	601	805	643	862	643	862	2600			
ZF 2050	1.086*, 1.111*, 1.191*, 1.250*, 1.350*, 1.436*, 1.500, 1.639*, 1.765*, 1.848*, 1.879*, 2.032, 2.276*, 2.519	0.3771	0.5057	679	910	792	1062	848	1137	848	1137	2600	342	754	SAE 0, 1
ZF 2050 A 10 degrees	1.267*, 1.512*, 1.763, 2.029, 2.250*, 2.467	0.3771	0.5057	679	910	792	1062	848	1137	848	1137	2600	350	772	SAE 0, 1
ZF 2050 V 10 degrees	1.267*, 1.512*, 1.763, 2.029, 2.250*, 2.467	0.3771	0.5057	679	910	792	1062	848	1137	848	1137	2600	354	780	
ZF 2150	2.760*	0.3490	0.4680	628	842	733	983	785	1052	785	1052	2600	344	758	SAE 0, 1
	2.958	0.3210	0.4305	578	775	674	904	722	968	722	968	2600			
ZF 2150 A 10 degrees	2.714*	0.3771	0.5057	679	910	792	1062	848	1137	848	1137	2600	352	776	SAE 0, 1
	2.920	0.3581	0.4802	645	864	752	1008	805	1079	805	1079	2600			
	3.250*	0.3333	0.4470	600	805	700	939	749	1004	749	1004	2600			

* Special Order Ratio.

Medium Duty Single Speed



PRODUCT	Ratios	Power factor		Input power capacity						Max. kW	Max. hp	Max. rpm	Weight		Bell hgs. & notes
		kW/rpm	hp/rpm	1800 rpm		2100 rpm		2250 rpm					kg	lb	
ZF 2150 V 10 degrees	2.714*	0.3771	0.5057	679	910	792	1062	848	1137	848	1137	2600	356	785	
	2.920	0.3581	0.4802	645	864	752	1008	805	1079	805	1079	2600			
	3.250*	0.3333	0.4470	600	805	700	939	749	1004	749	1004	2600			
ZF 2200 ¹³	3.000, 3.286*, 3.519*	0.3210	0.4305	578	775	674	904	722	968	722	968	2600	404	891	SAE 0, 1
ZF 2250 ¹³	3.000, 3.286*, 3.519*	0.3771	0.5057	679	910	792	1062	848	1137	848	1137	2600	406	895	SAE 0, 1
ZF 2300 ⁸	4.000, 4.444	0.3210	0.4305	578	775	674	904	722	968	722	968	2600	434	957	SAE 0, 1
ZF W2300 ⁸	3.028*, 3.500*, 4.000, 4.444	0.3210	0.4305	578	775	674	904	722	968	722	968	2600	590	1301	SAE 0, 1
ZF 2350 ⁸	4.000, 4.444, 4.760*	0.3771	0.5057	679	910	792	1062	848	1137	848	1137	2600	436	961	SAE 0, 1
ZF W2350 ⁸	3.028*, 3.500*, 4.000, 4.444, 4.760*	0.3771	0.5057	679	910	792	1062	848	1137	848	1137	2600	590	1301	SAE 0, 1
ZF W2450 ⁸	5.036	0.3771	0.5057	679	910	792	1062	792	1062	792	1062	2600	760	1676	SAE 0, 1
	5.500	0.3560	0.4774	641	859	748	1003	748	1003	748	1003	2600			
	6.042	0.3210	0.4305	578	775	674	903	674	903	674	903	2600			
	6.160	0.3109	0.4169	560	750	653	875	653	875	653	875	2600			
	6.458	0.2585	0.3467	465	624	543	728	543	728	543	728	2600			
	6.923	0.2249	0.3016	405	543	472	632	472	632	472	632	2600			
ZF 3000	1.093*, 1.195*, 1.250*, 1.306*, 1.343*, 1.412*, 1.441*, 1.500, 1.563*, 1.594*, 1.645*, 1.700*, 1.733*, 1.800*, 1.828*, 2.037, 2.154*, 2.240*, 2.375*, 2.417*, 2.500, 2.609*, 2.773*, 2.952*	0.4194	0.5624	755	1012	881	1181	943	1264	943	1264	2600	482	1063	SAE 00, 0, 1
ZF 3000 A 10 degrees	1.351*, 1.486*, 1.750*, 2.034, 2.259*, 2.520, 2.750*, 3.000*	0.4194	0.5624	755	1012	881	1181	943	1264	943	1264	2600	485	1069	SAE 0, 1
	3.280*	0.3554	0.4766	640	858	746	1001	799	1071	799	1071	2600			
	3.444*	0.3181	0.4266	573	768	668	895	668	895	668	895	2600			
ZF 3000 D CEW ^{9, 17}	1.093*, 1.195*, 1.250*, 1.306*, 1.343*, 1.412*, 1.441*, 1.500, 1.563*, 1.594*, 1.645*, 1.700*, 1.733*, 1.800*, 1.828*, 2.037, 2.154*, 2.240*, 2.375*, 2.417*, 2.500, 2.609*, 2.773*, 2.952*	0.4194	0.5624	755	1012	881	1181	944	1265	944	1265	2600	482	1063	
ZF 3000 D EW ⁹	1.093*, 1.195*, 1.250*, 1.306*, 1.343*, 1.412*, 1.441*, 1.500, 1.563*, 1.594*, 1.645*, 1.700*, 1.733*, 1.800*, 1.828*, 2.037, 2.154*, 2.240*, 2.375*, 2.417*, 2.500, 2.609*, 2.773*, 2.952*	0.4194	0.5624	755	1012	881	1181	944	1265	944	1265	2600	482	1063	

⁸ U-drive version also available.

⁹ Left and Right version available.

¹³ No classification available.

¹⁷ PTI (Hybrid) also available.

* Special Order Ratio.

Medium Duty Single Speed



PRODUCT	Ratios	Power factor		Input power capacity						Max. kW	Max. hp	Max. rpm	Weight		Bell hgs. & notes
		kW/rpm	hp/rpm	1800 rpm		2100 rpm		2250 rpm					kg	lb	
ZF 3000 V 10 degrees	1.351*, 1.486*, 1.750*, 2.034, 2.259*, 2.520, 2.750*, 3.000*	0.4194	0.5624	755	1012	881	1181	943	1264	943	1264	2600	500	1102	
	3.280*	0.3554	0.4766	640	858	746	1001	799	1071	799	1071	2600			
	3.444*	0.3181	0.4266	573	768	668	895	668	895	668	895	2600			
ZF 3050	1.093*, 1.195*, 1.250*, 1.306*, 1.343*, 1.412*, 1.441*, 1.500, 1.563*, 1.594*, 1.645*, 1.700*, 1.733*, 1.800*, 1.828*, 2.037, 2.154*, 2.240*, 2.375*, 2.417*, 2.500, 2.609*, 2.773*, 2.952*	0.5153	0.6910	928	1244	1082	1451	1159	1554	1159	1554	2600	482	1063	SAE 00, 0, 1
ZF 3050 A 10 degrees	1.351*, 1.486*, 1.750*, 2.034, 2.259*, 2.520, 2.750*, 3.000*	0.5153	0.6910	928	1244	1082	1451	1159	1554	1159	1554	2600	485	1069	SAE 0, 1
	3.280*	0.4194	0.5624	755	1012	881	1181	943	1264	943	1264	2600			
	3.444*	0.3625	0.4861	653	875	761	1020	761	1020	761	1020	2600			
ZF 3050 D CEW ^{3, 9, 17}	1.093*, 1.195*, 1.250*, 1.306*, 1.343*, 1.412*, 1.441*, 1.500, 1.563*, 1.594*, 1.645*, 1.700*, 1.733*, 1.800*, 1.828*, 2.037, 2.154*, 2.240*, 2.375*, 2.417*, 2.500, 2.609*, 2.773*, 2.952*	0.5153	0.6910	928	1244	1082	1451	1159	1554	1159	1554	2600	482	1063	
ZF 3050 V 10 degrees	1.351*, 1.486*, 1.750*, 2.034, 2.259*, 2.520, 2.750*, 3.000*	0.5153	0.6910	928	1244	1082	1451	1159	1554	1159	1554	2600	500	1102	
	3.280*	0.4194	0.5624	755	1012	881	1181	943	1264	943	1264	2600			
	3.444*	0.3625	0.4861	653	875	761	1020	761	1020	761	1020	2600			
ZF 3055	1.093*	0.5508	0.7386	991	1329	1157	1551	1239	1661	1239	1661	2600	487	1074	SAE 00, 0, 1
	1.195*	0.5508	0.7386	991	1329	1157	1551	1159	1554	1159	1554	2600			
	1.250*, 1.306*, 1.343*, 1.412*, 1.441*, 1.500, 1.563*, 1.594*, 1.645*, 1.700*, 1.733*, 1.800*, 1.828*, 2.037, 2.154*, 2.240*, 2.375*, 2.417*, 2.500, 2.609*, 2.773*	0.5508	0.7386	991	1329	1157	1551	1239	1661	1239	1661	2600			
	2.952*	0.5331	0.7149	960	1287	1120	1501	1199	1607	1199	1607	2600			
ZF 3055 A 10 degrees	1.351*, 1.486*, 1.750*, 2.034, 2.259*, 2.520, 2.750*	0.5508	0.7386	991	1329	1157	1551	1239	1661	1239	1661	2600	490	1080	SAE 0, 1
	3.000*	0.5331	0.7149	960	1287	1120	1501	1199	1607	1199	1607	2600			
	3.280*	0.4552	0.6104	819	1099	956	1282	1024	1373	1024	1373	2600			
	3.444*	0.3998	0.5361	720	965	840	1126	840	1126	840	1126	2600			

³ Engine wise (EW) operation only for waterjet flushing.

⁹ Left and Right version available.

¹⁷ PTI (Hybrid) also available.

* Special Order Ratio.

Medium Duty Single Speed



PRODUCT	Ratios	Power factor		Input power capacity						Max. kW	Max. hp	Max. rpm	Weight		Bell hgs. & notes
		kW/rpm	hp/rpm	1800 rpm		2100 rpm		2250 rpm					kg	lb	
ZF 3055 D CEW ^{3, 9, 17}	1.093*, 1.195*, 1.250*, 1.306*, 1.343*, 1.412*, 1.441*, 1.500, 1.563*, 1.594*, 1.645*, 1.700*, 1.733*, 1.800*, 1.828*, 2.037, 2.154*, 2.240*, 2.375*, 2.417*, 2.500, 2.609*, 2.773*, 2.952*	0.5508	0.7386	991	1329	1157	1551	1239	1661	1239	1661	2600	482	1063	
ZF 3055 V 10 degrees	1.351*, 1.486*, 1.750*, 2.034, 2.259*, 2.520, 2.750*	0.5508	0.7386	991	1329	1157	1551	1239	1661	1239	1661	2600	505	1113	
	3.000*	0.5331	0.7149	960	1287	1120	1501	1199	1607	1199	1607	2600			
	3.280*	0.4552	0.6104	819	1099	956	1282	1024	1373	1024	1373	2600			
	3.444	0.3998	0.5361	720	965	840	1126	840	1126	840	1126	2600			
				1800 rpm		1800 rpm		1800 rpm							
ZF 3060	1.093*, 1.195*, 1.250*, 1.306*, 1.343*, 1.412*, 1.441*, 1.500, 1.563*, 1.594*, 1.645*, 1.700*, 1.733*, 1.800*, 1.828*, 2.037, 2.154*, 2.240*, 2.375*, 2.417*, 2.500, 2.609*, 2.773*	0.5800	0.7778	1044	1400	1044	1400	1044	1400	1102	1478	1900	487	1074	SAE 00, 0, 1
ZF 3060 D CEW ^{3, 9, 17}	1.093*, 1.195*, 1.250*, 1.306*, 1.343*, 1.412*, 1.441*, 1.500, 1.563*, 1.594*, 1.645*, 1.700*, 1.733*, 1.800*, 1.828*, 2.037, 2.154*, 2.240*, 2.375*, 2.417*, 2.500, 2.609*, 2.773*	0.5800	0.7778	1044	1400	1044	1400	1044	1400	1102	1477	1900	482	1063	
				1800 rpm		2100 rpm		2250 rpm							
ZF 3100 A ¹³ 10 degrees	1.257*, 1.500*, 1.759*, 1.963, 2.240, 2.478*	0.4193	0.5623	755	1012	881	1181	881	1181	881	1181	2600	470	1036	SAE 0, 1
	2.880*	0.3554	0.4766	640	858	746	1000	746	1000	746	1000	2600			
ZF 3150 A ¹³ 10 degrees	1.257*, 1.500*, 1.759*, 1.963, 2.240, 2.478*	0.5153	0.6910	928	1244	1082	1451	1159	1554	1159	1554	2600	470	1036	SAE 0, 1
	2.880*	0.4193	0.5623	755	1012	881	1181	881	1181	881	1181	2600			
ZF 3155 A ¹³ 10 degrees	1.257*, 1.500*, 1.759*, 1.963, 2.240, 2.478*	0.5508	0.7386	991	1329	1157	1551	1157	1551	1157	1551	2600	470	1036	SAE 0, 1
	2.880*	0.4552	0.6104	819	1099	956	1282	956	1282	956	1282	2600			
ZF 3310 ⁸	2.647*, 2.844*, 3.000*, 3.519*, 3.769*, 4.000, 4.250*, 4.478, 4.727*, 5.000	0.4194	0.5624	755	1012	881	1181	943	1264	943	1264	2600	665	1466	SAE 00, 0, 1

³ Engine wise (EW) operation only for waterjet flushing.

⁸ U-drive version also available.

⁹ Left and Right version available.

¹³ No classification available.

¹⁶ PTI (Hybrid) or Integrated Shaft Brake also available.

¹⁷ PTI (Hybrid) also available.

* Special Order Ratio.

Medium Duty Single Speed



PRODUCT	Ratios	Power factor		Input power capacity						Max. kW	Max. hp	Max. rpm	Weight		Bell hgs. & notes
		kW/rpm	hp/rpm	1800 rpm		2100 rpm		2250 rpm					kg	lb	
ZF 3311 ^{8, 16}	2.647*, 2.844*, 3.000*, 3.519*, 3.769*, 4.000, 4.250*, 4.478, 4.727*, 5.000	0.4194	0.5624	755	1012	881	1181	943	1264	943	1264	2600	850	1874	SAE 00, 0, 1
ZF 3350 ⁸	2.647*, 2.844*, 3.000*, 3.519*, 3.769*, 4.000, 4.250*, 4.478, 4.727*, 5.000	0.5153	0.6910	928	1244	1082	1451	1159	1554	1159	1554	2600	665	1466	SAE 00, 0, 1
ZF 3351 ^{8, 16}	2.647*, 2.844*, 3.000*, 3.519*, 3.769*, 4.000, 4.250*, 4.478, 4.727*, 5.000	0.5153	0.6910	928	1244	1082	1451	1159	1554	1159	1554	2600	850	1874	SAE 00, 0, 1
ZF 3355 ⁸	2.647*, 2.844*, 3.000*, 3.519*, 3.769*, 4.000, 4.250*, 4.478, 4.727*	0.5508	0.7386	991	1329	1157	1551	1239	1661	1239	1661	2600	670	1477	SAE 00, 0, 1
	5.000	0.5331	0.7149	960	1287	1120	1501	1199	1607	1199	1607	2600			
ZF 3356 ^{8, 16}	2.647*, 2.844*, 3.000*, 3.519*, 3.769*, 4.000, 4.250*, 4.478, 4.727*	0.5508	0.7386	991	1329	1157	1551	1239	1661	1239	1661	2600	855	1885	SAE 00, 0, 1
	5.000	0.5331	0.7149	960	1287	1120	1501	1199	1607	1199	1607	2600			
ZF 3361 ^{8, 16}	2.647*, 2.844*, 3.000*, 3.519*, 3.769*, 4.000, 4.250*, 4.478, 4.727*	0.5800	0.7778	1044	1400	1218	1633	1305	1750	1305	1750	2450	850	1874	SAE 00, 0, 1
	5.000	0.5570	0.7469	1003	1344	1170	1568	1253	1680	1253	1680	2450			
ZF 3711 ⁸	3.767*, 4.259*, 5.545, 5.952	0.4194	0.5624	755	1012	881	1181	943	1264	943	1264	2600	920	2028	SAE 0, 1
ZF 3751 ⁸	3.767*, 4.259*, 5.545, 5.952	0.5153	0.6910	928	1244	1082	1451	1159	1554	1159	1554	2600	920	2028	SAE 0, 1
ZF 3756 ⁸	3.767*, 4.259*, 5.545, 5.952	0.5331	0.7149	960	1287	1120	1501	1199	1607	1199	1607	2600	920	2028	SAE 0, 1
ZF 3761 ⁸	3.767*, 4.259*, 5.545	0.5800	0.7778	1044	1400	1218	1633	1305	1750	1305	1750	2450	920	2028	SAE 0, 1
	5.952	0.5570	0.7469	1003	1344	1170	1568	1253	1680	1253	1680	2450			
				1800 rpm		1900 rpm		2250 rpm							
ZF 5000	1.256*, 1.526, 1.585*, 1.722*, 1.771*, 1.853*, 2.031, 2.233*, 2.310*, 2.429*, 2.500, 2.630*, 2.731*, 2.880*, 2.920*, 2.963	0.6670	0.8945	1201	1610	1267	1700	1501	2012	1501	2012	2600	740	1631	SAE 00, 0
ZF 5000 A 8 degrees	1.431*, 1.512*, 1.757*, 2.029, 2.250*, 2.467, 2.714*, 2.962	0.6670	0.8945	1201	1610	1267	1700	1501	2012	1501	2012	2600	750	1653	SAE 00, 0
ZF 5000 D ^{9, 17}	1.256*, 1.526, 1.585*, 1.722*, 1.771*, 1.853*, 2.031, 2.233*, 2.310*, 2.429*, 2.500, 2.630*, 2.731*, 2.880*, 2.920*, 2.963	0.6670	0.8945	1201	1610	1267	1700	1501	2012	1501	2012	2600	765	1687	
ZF 5000 NR2H ⁹	1.256*, 1.526, 1.585*, 1.722*, 1.771*, 1.853*, 2.031, 2.233*, 2.310*, 2.429*, 2.500, 2.630*, 2.731*, 2.880*, 2.920*, 2.963	0.6670	0.8945	1201	1610	1267	1700	1501	2012	1501	2012	2600	615	1356	

⁸ U-drive version also available.

⁹ Left and Right version available.

¹⁶ PTI (Hybrid) or Integrated Shaft Brake also available.

¹⁷ PTI (Hybrid) also available.

* Special Order Ratio.

Medium Duty Single Speed



PRODUCT	Ratios	Power factor		Input power capacity						Max. kW	Max. hp	Max. rpm	Weight		Bell hgs. & notes
		kW/rpm	hp/rpm	1800 rpm		1900 rpm		2250 rpm					kg	lb	
ZF 5000 V 8 degrees	1.431*, 1.512*, 1.757*, 2.029, 2.250*, 2.467, 2.714*, 2.962	0.6670	0.8945	1201	1610	1267	1700	1501	2012	1501	2012	2600	768	1693	
ZF 5050	1.256*, 1.526	0.7466	1.0012	1344	1802	1419	1902	1680	2252	1680	2252	2600	740	1631	SAE 00, 0
	1.585*	0.7466	1.0012	1344	1802	1419	1902	1501	2012	1501	2012	2600			
	1.722*, 1.771*, 1.853*, 2.031, 2.233*, 2.310*, 2.429*, 2.500, 2.630*, 2.731*, 2.880*, 2.920*, 2.963	0.7466	1.0012	1344	1802	1419	1902	1680	2252	1680	2252	2600			
ZF 5050 A 8 degrees	1.431*, 1.512*, 1.757*, 2.029, 2.250*, 2.467, 2.714*, 2.962	0.7466	1.0012	1344	1802	1419	1902	1680	2252	1680	2252	2600	750	1653	SAE 00, 0
	3.222*	0.7120	0.9548	1282	1719	1353	1814	1602	2148	1602	2148	2600			
	3.429*	0.6670	0.8945	1201	1610	1267	1700	1501	2012	1501	2012	2600			
ZF 5050 D ^{9, 17}	1.256*, 1.526, 1.585*, 1.722*, 1.771*, 1.853*, 2.031, 2.233*, 2.310*, 2.429*, 2.500, 2.630*, 2.731*, 2.880*, 2.920*, 2.963	0.7466	1.0012	1344	1802	1419	1902	1680	2252	1680	2252	2600	765	1687	
ZF 5050 NR2H ⁹	1.256*, 1.526, 1.585*, 1.722*, 1.771*, 1.853*, 2.031, 2.233*, 2.310*, 2.429*, 2.500, 2.630*, 2.731*, 2.880*, 2.920*, 2.963	0.7466	1.0012	1344	1802	1419	1902	1680	2252	1680	2252	2600	615	1356	
ZF 5050 V 8 degrees	1.431*, 1.512*, 1.757*, 2.029, 2.250*, 2.467, 2.714*, 2.962	0.7466	1.0012	1344	1802	1419	1902	1680	2252	1680	2252	2600	768	1693	
	3.222*	0.7120	0.9548	1282	1719	1353	1814	1602	2148	1602	2148	2600			
	3.429*	0.6670	0.8945	1201	1610	1267	1700	1501	2012	1501	2012	2600			
ZF 5055	1.256*, 1.526, 1.585*, 1.722*, 1.771*, 1.853*, 2.031, 2.233*, 2.310*, 2.429*, 2.500, 2.630*, 2.731*	0.8906	1.1943	1603	2150	1692	2269	2004	2687	2004	2687	2600	740	1631	SAE 00, 0
	2.880*	0.8509	1.1411	1532	2054	1617	2168	1915	2567	1915	2568	2600			
	2.920*	0.8403	1.1269	1513	2028	1597	2141	1891	2535	1891	2535	2600			
	2.963	0.8288	1.1114	1492	2001	1575	2112	1865	2501	1865	2501	2600			
ZF 5055 A 8 degrees	1.431*, 1.512*, 1.757*, 2.029, 2.250*, 2.467, 2.714*, 2.962	0.8906	1.1943	1603	2150	1692	2269	2004	2687	2004	2687	2600	750	1653	SAE 00, 0
	3.222*	0.8063	1.0813	1451	1946	1532	2054	1814	2432	1814	2432	2600			
	3.429*	0.7225	0.9689	1301	1744	1373	1841	1626	2180	1626	2180	2600			

⁹ Left and Right version available.

¹⁷ PTI (Hybrid) also available.

* Special Order Ratio.

Medium Duty Single Speed



PRODUCT	Ratios	Power factor		Input power capacity						Max. kW	Max. hp	Max. rpm	Weight		Bell hgs. & notes
		kW/rpm	hp/rpm	1800 rpm		1900 rpm		2250 rpm					kg	lb	
ZF 5055 D ^{9, 17}	1.256*, 1.526, 1.585*, 1.722*, 1.771*, 1.853*, 2.031, 2.233*, 2.310*, 2.429*, 2.500, 2.630*, 2.731*	0.8272	1.1093	1489	1997	1572	2108	1861	2495	1861	2495	2600	765	1687	
	2.880*, 2.920*	0.8272	1.1093	1489	1997	1572	2108	1861	2496	1891	2535	2600			
	2.963	0.8272	1.1093	1489	1997	1572	2108	1861	2495	1861	2495	2600			
ZF 5055 NR2H ⁹	1.256*, 1.526, 1.585*, 1.722*, 1.771*, 1.853*, 2.031, 2.233*, 2.310*, 2.429*, 2.500, 2.630*, 2.731*	0.8906	1.1943	1603	2150	1692	2269	2004	2687	2004	2687	2600	615	1356	
	2.880*	0.8509	1.1411	1532	2054	1617	2168	1915	2567	1915	2568	2600			
	2.920*	0.8403	1.1269	1513	2028	1597	2141	1891	2535	1891	2535	2600			
	2.963	0.8288	1.1114	1492	2001	1575	2112	1865	2501	1865	2501	2600			
ZF 5055 V 8 degrees	1.431*, 1.512*, 1.757*, 2.029, 2.250*, 2.467, 2.714*, 2.962	0.8906	1.1943	1603	2150	1692	2269	2004	2687	2004	2687	2600	768	1693	
	3.222*	0.8063	1.0813	1451	1946	1532	2054	1814	2432	1814	2432	2600			
	3.429*	0.7225	0.9689	1301	1744	1373	1841	1626	2180	1626	2180	2600			
ZF 5200 A ¹⁶ 8 degrees	2.588, 2.844*, 3.100, 3.393*, 3.692	0.6670	0.8945	1201	1610	1267	1700	1501	2012	1501	2012	2600	870	1918	SAE 00, 0
ZF 5200 V ¹⁶ 8 degrees	2.588, 2.844*, 3.100, 3.393*, 3.692	0.6670	0.8945	1201	1610	1267	1700	1501	2012	1501	2012	2600	880	1940	
ZF 5250 A ¹⁶ 8 degrees	2.588, 2.844*, 3.100, 3.393*, 3.692	0.7466	1.0012	1344	1802	1419	1902	1680	2252	1680	2252	2600	870	1918	SAE 00, 0
	4.000	0.7120	0.9548	1282	1719	1353	1814	1602	2148	1602	2148	2600			
	4.250*	0.6670	0.8945	1201	1610	1267	1700	1501	2012	1501	2012	2600			
ZF 5250 V ¹⁶ 8 degrees	2.588, 2.844*, 3.100, 3.393*, 3.692	0.7466	1.0012	1344	1802	1419	1902	1680	2252	1680	2252	2600	880	1940	
	4.000	0.7120	0.9548	1282	1719	1353	1814	1602	2148	1602	2148	2600			
	4.250*	0.6670	0.8945	1201	1610	1267	1700	1501	2012	1501	2012	2600			
ZF 5255 A ¹⁶ 8 degrees	2.588, 2.844*, 3.100, 3.393*, 3.692	0.8906	1.1943	1603	2150	1692	2269	2004	2687	2004	2687	2600	870	1918	SAE 00, 0
	4.000	0.8063	1.0813	1451	1946	1532	2054	1814	2432	1814	2432	2600			
	4.250*	0.7225	0.9689	1301	1744	1373	1841	1626	2180	1626	2180	2600			
ZF 5255 V ¹⁶ 8 degrees	2.588, 2.844*, 3.100, 3.393*, 3.692	0.8906	1.1943	1603	2150	1692	2269	2004	2687	2004	2687	2600	880	1940	
	4.000	0.8063	1.0813	1451	1946	1532	2054	1814	2432	1814	2432	2600			
	4.250*	0.7225	0.9689	1301	1744	1373	1841	1626	2180	1626	2180	2600			
ZF 5300 ^{8, 16}	2.587*, 2.750*, 2.947*, 3.108*, 3.314*, 3.471*, 4.033, 4.464, 5.040	0.6670	0.8945	1201	1610	1267	1700	1500	2011	1500	2011	2600	950	2094	SAE 00, 0

⁸ U-drive version also available.

⁹ Left and Right version available.

¹⁶ PTI (Hybrid) or Integrated Shaft Brake also available.

¹⁷ PTI (Hybrid) also available.

* Special Order Ratio.

Medium Duty Single Speed



PRODUCT	Ratios	Power factor		Input power capacity						Max. kW	Max. hp	Max. rpm	Weight		Bell hgs. & notes
		kW/rpm	hp/rpm	1800 rpm		1900 rpm		2250 rpm					kg	lb	
ZF 5311 ^{8, 16}	2.587*, 2.750*, 2.947*, 3.108*, 3.314*, 3.471*, 4.033, 4.464, 5.040	0.6670	0.8945	1201	1610	1267	1700	1500	2011	1500	2011	2600	1290	2844	SAE 00, 0
ZF 5350 ^{8, 16}	2.587*, 2.750*, 2.947*, 3.108*, 3.314*, 3.471*, 4.033, 4.464, 5.040	0.7466	1.0012	1344	1802	1419	1902	1679	2251	1679	2251	2600	950	2094	SAE 00, 0
ZF 5351 ^{8, 16}	2.587*, 2.750*, 2.947*, 3.108*, 3.314*, 3.471*, 4.033, 4.464, 5.040	0.7466	1.0012	1344	1802	1419	1902	1679	2251	1679	2251	2600	1290	2844	SAE 00, 0
ZF 5355 ^{8, 16}	2.587*, 2.750*, 2.947*, 3.108*, 3.314*, 3.471*, 4.033, 4.464	0.8906	1.1943	1603	2150	1692	2269	2003	2686	2003	2686	2600	950	2094	SAE 00, 0
	5.040	0.8377	1.1234	1508	2022	1592	2134	1884	2526	1884	2526	2600			
	5.500	0.7447	0.9987	1340	1798	1415	1898	1675	2246	1675	2246	2600			
ZF 5356 ^{8, 16}	2.587*, 2.750*, 2.947*, 3.108*, 3.314*, 3.471*, 4.033, 4.464	0.8906	1.1943	1603	2150	1692	2269	2003	2686	2003	2686	2600	1290	2844	SAE 00, 0
	5.040	0.8377	1.1234	1508	2022	1592	2134	1884	2526	1884	2526	2600			
	5.500	0.7447	0.9987	1340	1798	1415	1898	1675	2246	1675	2246	2600			
				1600 rpm		1800 rpm		2000 rpm							
ZF 8000	1.250*, 1.500, 1.781*, 1.967, 2.296*, 2.560, 2.708*, 2.958, 3.174*	1.0667	1.4305	1707	2289	1920	2575	2133	2860	2133	2860	2300	1015	2238	SAE 00
ZF 8000 A 8 degrees	1.462, 1.743*, 2.000, 2.233*, 2.556, 2.731*, 3.000, 3.292*, 3.440	1.0667	1.4305	1707	2289	1920	2575	2133	2860	2133	2860	2300	1050	2315	SAE 00
ZF 8000 D ^{9, 17}	1.250*, 1.500, 1.781*, 1.967, 2.296*, 2.560, 2.708*, 2.958, 3.174*	1.0667	1.4305	1707	2289	1920	2575	2133	2860	2133	2860	2300	1015	2238	
ZF 8000 NR2	1.250*, 1.500, 1.781*, 1.967, 2.296*, 2.560, 2.708*, 2.958, 3.174*	1.0667	1.4305	1707	2289	1920	2575	2133	2860	2133	2860	2300	810	1786	
ZF 8000 NR2B	1.250*, 1.500, 1.781*, 1.967, 2.296*, 2.560, 2.708*, 2.958, 3.174*	1.0667	1.4305	1707	2289	1920	2575	2133	2860	2133	2860	2300	810	1786	
ZF 8000 NR2H ⁹	1.250*, 1.500, 1.781*, 1.967, 2.296*, 2.560, 2.708*, 2.958, 3.174*	1.0667	1.4305	1707	2289	1920	2575	2133	2860	2133	2860	2300	800	1764	
ZF 8000 V 8 degrees	1.462, 1.743*, 2.000, 2.233*, 2.556, 2.731*, 3.000, 3.292*, 3.440	1.0667	1.4305	1707	2289	1920	2575	2133	2860	2133	2860	2300	1075	2370	
ZF 8050	1.250*, 1.500, 1.781*, 1.967, 2.296*, 2.560, 2.708*, 2.958, 3.174*	1.2042	1.6149	1927	2584	2168	2907	2408	3229	2408	3229	2300	1015	2238	SAE 00
ZF 8050 A 8 degrees	1.462, 1.743*, 2.000, 2.233*, 2.556, 2.731*, 3.000	1.2042	1.6149	1927	2584	2168	2907	2408	3229	2408	3229	2300	1050	2315	SAE 00
	3.292*	1.1602	1.5559	1856	2489	2088	2801	2320	3111	2320	3111	2300			
	3.440	1.1361	1.5235	1818	2438	2045	2742	2272	3046	2272	3046	2300			
ZF 8050 D ^{9, 17}	1.250*, 1.500, 1.781*, 1.967, 2.296*, 2.560, 2.708*, 2.958, 3.174*	1.2042	1.6149	1927	2584	2168	2907	2408	3229	2408	3229	2300	1015	2238	

⁸ U-drive version also available.

⁹ Left and Right version available.

¹⁶ PTI (Hybrid) or Integrated Shaft Brake also available.

¹⁷ PTI (Hybrid) also available.

* Special Order Ratio.

Medium Duty Single Speed



PRODUCT	Ratios	Power factor		Input power capacity						Max. kW	Max. hp	Max. rpm	Weight		Bell hgs. & notes
		kW/rpm	hp/rpm	1600 rpm		1800 rpm		2000 rpm					kg	lb	
				kW	hp	kW	hp	kW	hp						
ZF 8050 NR2	1.250*, 1.500, 1.781*, 1.967, 2.296*, 2.560, 2.708*, 2.958, 3.174*	1.2042	1.6149	1927	2584	2168	2907	2408	3229	2408	3229	2300	810	1786	
ZF 8050 NR2B	1.250*, 1.500, 1.781*, 1.967, 2.296*, 2.560, 2.708*, 2.958, 3.174*	1.2042	1.6149	1927	2584	2168	2907	2408	3229	2408	3229	2300	810	1786	
ZF 8050 NR2H⁹	1.250*, 1.500, 1.781*, 1.967, 2.296*, 2.560, 2.708*, 2.958, 3.174*	1.2042	1.6149	1927	2584	2168	2907	2408	3229	2408	3229	2300	800	1764	
ZF 8050 V 8 degrees	1.462, 1.743*, 2.000, 2.233*, 2.556, 2.731*, 3.000	1.2042	1.6149	1927	2584	2168	2907	2408	3229	2408	3229	2300	1075	2370	
	3.292*	1.1602	1.5559	1856	2489	2088	2801	2320	3111	2320	3111	2300			
	3.440	1.1361	1.5235	1818	2438	2045	2742	2272	3046	2272	3046	2300			
ZF 8055	1.250*, 1.500, 1.781*, 1.967, 2.296*, 2.560, 2.708*, 2.958	1.3131	1.7609	2101	2817	2364	3170	2626	3521	2626	3521	2300	1015	2238	SAE 00
	3.174*	1.2565	1.6850	2010	2696	2262	3033	2513	3369	2513	3369	2300			
ZF 8055 A 8 degrees	1.462, 1.743*, 2.000, 2.233*, 2.556, 2.731*, 3.000	1.3131	1.7609	2101	2817	2364	3170	2626	3521	2626	3521	2300	1050	2315	SAE 00
	3.292*	1.2220	1.6387	1955	2622	2200	2950	2444	3277	2444	3277	2300			
	3.440	1.1780	1.5797	1885	2528	2120	2843	2356	3159	2356	3159	2300			
ZF 8055 D CEW^{3, 9, 17}	1.250, 1.500, 1.781, 1.967, 2.296, 2.560, 2.708, 2.958	1.3131	1.7609	2101	2817	2364	3170	2626	3521	2626	3521	2300	1015	2238	
	3.174	1.2565	1.6850	2010	2696	2262	3033	2513	3369	2513	3369	2300			
ZF 8055 NR2	1.250*, 1.500, 1.781*, 1.967, 2.296*, 2.560, 2.708*, 2.958	1.3131	1.7609	2101	2817	2364	3170	2626	3521	2626	3521	2300	810	1786	
	3.174*	1.2565	1.685	2010	2696	2262	3033	2513	3369	2513	3369	2300			
ZF 8055 NR2B	1.250*, 1.500, 1.781*, 1.967, 2.296*, 2.560, 2.708*, 2.958	1.3131	1.7609	2101	2817	2364	3170	2626	3521	2626	3521	2300	810	1786	
	3.174*	1.2565	1.685	2010	2696	2262	3033	2513	3369	2513	3369	2300			
ZF 8055 NR2H⁹	1.250*, 1.500, 1.781*, 1.967, 2.296*, 2.560, 2.708*, 2.958	1.3131	1.7609	2101	2817	2364	3170	2626	3521	2626	3521	2300	800	1764	
	3.174*	1.2565	1.685	2010	2696	2262	3033	2513	3369	2513	3369	2300			
ZF 8055 V 8 degrees	1.462, 1.743*, 2.000, 2.233*, 2.556, 2.731*, 3.000	1.3131	1.7609	2101	2817	2364	3170	2626	3521	2626	3521	2300	1075	2370	
	3.292*	1.2220	1.6387	1955	2622	2200	2950	2444	3277	2444	3277	2300			
	3.440	1.1780	1.5797	1885	2528	2120	2843	2356	3159	2356	3159	2300			
ZF 8300^{8, 16}	2.576, 2.967, 3.214*, 3.538, 3.760*, 3.958, 4.174*, 4.522, 4.708*	1.0667	1.4305	1707	2289	1920	2575	2133	2860	2133	2860	2300	1220	2690	SAE 00

³ Engine wise (EW) operation only for waterjet flushing.

⁸ U-drive version also available.

⁹ Left and Right version available.

¹⁶ PTI (Hybrid) or Integrated Shaft Brake also available.

¹⁷ PTI (Hybrid) also available.

* Special Order Ratio.

Medium Duty Single Speed



PRODUCT	Ratios	Power factor		Input power capacity						Max. kW	Max. hp	Max. rpm	Weight		Bell hgs. & notes
		kW/rpm	hp/rpm	1600 rpm		1800 rpm		2000 rpm					kg	lb	
				kW	hp	kW	hp	kW	hp						
ZF 8311 ^{8, 16}	2.576, 2.967, 3.214*, 3.538, 3.760*, 3.958, 4.174*, 4.522, 4.708*	1.0667	1.4305	1707	2289	1920	2575	2133	2860	2133	2860	2300	1625	3583	SAE 00
ZF 8350 ^{8, 16}	2.576, 2.967, 3.214*, 3.538, 3.760*, 3.958, 4.174*, 4.522	1.2042	1.6149	1927	2584	2168	2907	2408	3229	2408	3229	2300	1220	2690	SAE 00
	4.708*	1.1278	1.5124	1804	2420	2030	2722	2256	3025	2256	3025	2300			
ZF 8351 ^{8, 16}	2.576, 2.967, 3.214*, 3.538, 3.760*, 3.958, 4.174*, 4.522	1.2042	1.6149	1927	2584	2168	2907	2408	3229	2408	3229	2300	1625	3583	SAE 00
	4.708*	1.1278	1.5124	1804	2420	2030	2722	2256	3025	2256	3025	2300			
ZF 8355 ^{8, 16}	2.576, 2.967, 3.214*, 3.538, 3.760*, 3.958, 4.174*	1.3131	1.7609	2101	2817	2364	3170	2626	3521	2626	3521	2300	1220	2690	SAE 00
	4.522	1.2565	1.6850	2010	2696	2262	3033	2513	3369	2513	3369	2300			
ZF 8356 ^{8, 16}	2.576, 2.967, 3.214*, 3.538, 3.760*, 3.958, 4.174*	1.3131	1.7609	2101	2817	2364	3170	2626	3521	2626	3521	2300	1625	3583	SAE 00
	4.522	1.2565	1.6850	2010	2696	2262	3033	2513	3369	2513	3369	2300			
ZF 9000	1.186*, 1.515*, 1.576*, 1.742*, 1.862*, 2.036, 2.269*, 2.400*, 2.500*, 2.542, 2.739*, 2.957	1.3825	1.8540	2212	2966	2489	3337	2765	3707	2765	3707	2300	1400	3086	SAE 00
	3.250*	1.3060	1.7514	2090	2802	2351	3153	2612	3502	2612	3502	2300			
	3.360*	1.2700	1.7031	2032	2725	2286	3066	2540	3406	2540	3406	2300			
	3.448*	1.2425	1.6662	1988	2666	2237	2999	2485	3332	2485	3332	2300			
ZF 9000 A 8 degrees	1.381*, 1.514*, 1.750*, 1.967, 2.259*, 2.462, 2.750*, 2.958	1.3825	1.8540	2212	2966	2489	3337	2765	3707	2765	3707	2300	1380	3042	SAE 00
	3.208*	1.3060	1.7514	2090	2802	2351	3153	2612	3502	2612	3502	2300			
	3.462*	1.2425	1.6662	1988	2666	2237	2999	2485	3332	2485	3332	2300			
ZF 9000 NR2	1.186*, 1.515*, 1.576*, 1.742*, 1.862*, 2.036, 2.269*, 2.400*, 2.500*, 2.542, 2.739*, 2.957	1.3825	1.8540	2212	2966	2489	3337	2765	3707	2765	3707	2300	1040	2293	
	3.250*	1.3060	1.7514	2090	2802	2351	3153	2612	3502	2612	3502	2300			
	3.360*	1.2700	1.7031	2032	2725	2286	3066	2540	3406	2540	3406	2300			
	3.448*	1.2425	1.6662	1988	2666	2237	2999	2485	3332	2485	3332	2300			
ZF 9000 NR2B	1.186*, 1.515*, 1.576*, 1.742*, 1.862*, 2.036, 2.269*, 2.400*, 2.500*, 2.542, 2.739*, 2.957	1.3825	1.8540	2212	2966	2489	3337	2765	3707	2765	3707	2300	1040	2293	
	3.250*	1.3060	1.7514	2090	2802	2351	3153	2612	3502	2612	3502	2300			
	3.360*	1.2700	1.7031	2032	2725	2286	3066	2540	3406	2540	3406	2300			
	3.448*	1.2425	1.6662	1988	2666	2237	2999	2485	3332	2485	3332	2300			

⁸ U-drive version also available.

¹⁶ PTI (Hybrid) or Integrated Shaft Brake also available.

* Special Order Ratio.

Medium Duty Single Speed



PRODUCT	Ratios	Power factor		Input power capacity						Max. kW	Max. hp	Max. rpm	Weight		Bell hgs. & notes
		kW/rpm	hp/rpm	1600 rpm		1800 rpm		2000 rpm					kg	lb	
ZF 9000 NR2H ⁹	1.186*, 1.515*, 1.576*, 1.742*, 1.862*, 2.036, 2.269*, 2.400*, 2.500*, 2.542, 2.739*, 2.957	1.3825	1.8540	2212	2966	2489	3337	2765	3707	2765	3707	2300	1040	2293	
	3.250*	1.3060	1.7514	2090	2802	2351	3153	2612	3502	2612	3502	2300			
	3.360*	1.2700	1.7031	2032	2725	2286	3066	2540	3406	2540	3406	2300			
	3.448*	1.2425	1.6662	1988	2666	2237	2999	2485	3332	2485	3332	2300			
ZF 9000 V 8 degrees	1.381*, 1.514*, 1.750*, 1.967, 2.259*, 2.462, 2.750*, 2.958	1.3825	1.8540	2212	2966	2489	3337	2765	3707	2765	3707	2300	1400	3086	
	3.208*	1.3060	1.7514	2090	2802	2351	3153	2612	3502	2612	3502	2300			
	3.462*	1.2425	1.6662	1988	2666	2237	2999	2485	3332	2485	3332	2300			
ZF 9050	1.186*, 1.515*, 1.576*, 1.742*, 1.862*, 2.036, 2.269*, 2.400*, 2.500*, 2.542, 2.739*, 2.957	1.4660	1.9659	2346	3145	2639	3539	2932	3931	2932	3931	2300	1400	3086	SAE 00
	3.250*	1.3825	1.8540	2212	2966	2489	3337	2765	3707	2765	3707	2300			
	3.360*	1.3500	1.8104	2160	2897	2430	3259	2700	3620	2700	3620	2300			
	3.448*	1.3200	1.7701	2112	2832	2376	3186	2640	3540	2640	3540	2300			
ZF 9050 A 8 degrees	1.381*, 1.514*, 1.750*, 1.967, 2.259*, 2.462, 2.750*, 2.958	1.4660	1.9659	2346	3145	2639	3539	2932	3931	2932	3931	2300	1380	3042	SAE 00
	3.208*	1.3825	1.8540	2212	2966	2489	3337	2765	3707	2765	3707	2300			
	3.462*	1.3200	1.7701	2112	2832	2376	3186	2640	3540	2640	3540	2300			
ZF 9050 NR2	1.186*, 1.515*, 1.576*, 1.742*, 1.862*, 2.036, 2.269*, 2.400*, 2.500*, 2.542, 2.739*, 2.957	1.4660	1.9659	2346	3145	2639	3539	2932	3931	2932	3931	2300	1040	2293	
	3.250*	1.3825	1.8540	2212	2966	2489	3337	2765	3707	2765	3707	2300			
	3.360*	1.3500	1.8104	2160	2897	2430	3259	2700	3620	2700	3620	2300			
	3.448*	1.3200	1.7701	2112	2832	2376	3186	2640	3540	2640	3540	2300			
ZF 9050 NR2B	1.186*, 1.515*, 1.576*, 1.742*, 1.862*, 2.036, 2.269*, 2.400*, 2.500*, 2.542, 2.739*, 2.957	1.4660	1.9659	2346	3145	2639	3539	2932	3931	2932	3931	2300	1040	2293	
	3.250*	1.3825	1.8540	2212	2966	2489	3337	2765	3707	2765	3707	2300			
	3.360*	1.3500	1.8104	2160	2897	2430	3259	2700	3620	2700	3620	2300			
	3.448*	1.3200	1.7701	2112	2832	2376	3186	2640	3540	2640	3540	2300			
ZF 9050 NR2H ⁹	1.186*, 1.515*, 1.576*, 1.742*, 1.862*, 2.036, 2.269*, 2.400*, 2.500*, 2.542, 2.739*, 2.957	1.4660	1.9659	2346	3145	2639	3539	2932	3931	2932	3931	2300	1040	2293	
	3.250*	1.3825	1.8540	2212	2966	2489	3337	2765	3707	2765	3707	2300			
	3.360*	1.3500	1.8104	2160	2897	2430	3259	2700	3620	2700	3620	2300			
	3.448*	1.3200	1.7701	2112	2832	2376	3186	2640	3540	2640	3540	2300			

⁹ Left and Right version available.

* Special Order Ratio.

Medium Duty Single Speed



PRODUCT	Ratios	Power factor		Input power capacity						Max. kW	Max. hp	Max. rpm	Weight		Bell hgs. & notes
		kW/rpm	hp/rpm	1600 rpm		1800 rpm		2000 rpm					kg	lb	
				kW	hp	kW	hp	kW	hp						
ZF 9050 V 8 degrees	1.381*, 1.514*, 1.750*, 1.967, 2.259*, 2.462, 2.750*, 2.958	1.4660	1.9659	2346	3145	2639	3539	2932	3931	2932	3931	2300	1400	3086	
	3.208*	1.3825	1.8540	2212	2966	2489	3337	2765	3707	2765	3707	2300			
	3.462*	1.3200	1.7701	2112	2832	2376	3186	2640	3540	2640	3540	2300			
ZF 9055	1.186*, 1.515*, 1.576*, 1.742*, 1.862*, 2.036, 2.269*, 2.400*, 2.500*, 2.542, 2.739*, 2.957	1.6600	2.2261	2656	3562	2988	4007	3320	4452	3320	4452	2300	1400	3086	SAE 00
	3.250*	1.5050	2.0182	2408	3229	2709	3633	3010	4036	3010	4036	2300			
	3.360*	1.4550	1.9512	2328	3122	2619	3512	2910	3902	2910	3902	2300			
	3.448*	1.4170	1.9002	2267	3040	2551	3420	2834	3800	2834	3800	2300			
ZF 9055 A 8 degrees	1.381*, 1.514*, 1.750*, 1.967, 2.259*, 2.462, 2.750*, 2.958	1.6600	2.2261	2656	3562	2988	4007	3320	4452	3320	4452	2300	1380	3042	SAE 00
	3.208*	1.5050	2.0182	2408	3229	2709	3633	3010	4036	3010	4036	2300			
	3.462*	1.4170	1.9002	2267	3040	2551	3420	2834	3800	2834	3800	2300			
ZF 9055 NR2	1.186*, 1.515*, 1.576*, 1.742*, 1.862*, 2.036, 2.269*, 2.400*, 2.500*, 2.542, 2.739*, 2.957	1.6600	2.2261	2656	3562	2988	4007	3320	4452	3320	4452	2300	1040	2293	
	3.250*	1.5050	2.0182	2408	3229	2709	3633	3010	4036	3010	4036	2300			
	3.360*	1.4550	1.9512	2328	3122	2619	3512	2910	3902	2910	3902	2300			
	3.448*	1.4170	1.9002	2267	3040	2551	3420	2834	3800	2834	3800	2300			
ZF 9055 NR2B	1.186*, 1.515*, 1.576*, 1.742*, 1.862*, 2.036, 2.269*, 2.400*, 2.500*, 2.542, 2.739*, 2.957	1.6600	2.2261	2656	3562	2988	4007	3320	4452	3320	4452	2300	1040	2293	
	3.250*	1.5050	2.0182	2408	3229	2709	3633	3010	4036	3010	4036	2300			
	3.360*	1.4550	1.9512	2328	3122	2619	3512	2910	3902	2910	3902	2300			
	3.448*	1.4170	1.9002	2267	3040	2551	3420	2834	3800	2834	3800	2300			
ZF 9055 NR2H⁹	1.186*, 1.515*, 1.576*, 1.742*, 1.862*, 2.036, 2.269*, 2.400*, 2.500*, 2.542, 2.739*, 2.957	1.6600	2.2261	2656	3562	2988	4007	3320	4452	3320	4452	2300	1040	2293	
	3.250*	1.5050	2.0182	2408	3229	2709	3633	3010	4036	3010	4036	2300			
	3.360*	1.4550	1.9512	2328	3122	2619	3512	2910	3902	2910	3902	2300			
	3.448*	1.4170	1.9002	2267	3040	2551	3420	2834	3800	2834	3800	2300			
ZF 9055 V 8 degrees	1.381*, 1.514*, 1.750*, 1.967, 2.259*, 2.462, 2.750*, 2.958	1.6600	2.2261	2656	3562	2988	4007	3320	4452	3320	4452	2300	1400	3086	
	3.208*	1.5050	2.0182	2408	3229	2709	3633	3010	4036	3010	4036	2300			
	3.462*	1.4170	1.9002	2267	3040	2551	3420	2834	3800	2834	3800	2300			

⁹ Left and Right version available.

* Special Order Ratio.

Medium Duty Single Speed



PRODUCT	Ratios	Power factor		Input power capacity						Max. kW	Max. hp	Max. rpm	Weight		Bell hgs. & notes
		kW/rpm	hp/rpm	1600 rpm		1800 rpm		2000 rpm					kg	lb	
				kW	hp	kW	hp	kW	hp						
ZF 9300 ^{8, 16}	2.471*, 3.034*, 3.538, 3.760*, 3.958, 4.217*, 4.522	1.3825	1.8540	2212	2966	2489	3337	2765	3707	2765	3707	2300	1910	4211	SAE 00
	4.783*	1.3060	1.7514	2090	2802	2351	3153	2612	3502	2612	3502	2300			
	4.958*	1.2425	1.6662	1988	2666	2237	2999	2485	3332	2485	3332	2300			
	5.185*	1.1850	1.5891	1896	2543	2133	2860	2370	3178	2370	3178	2300			
ZF 9311 ⁸	2.471*, 3.034*, 3.538, 3.760*, 3.958, 4.217*, 4.522	1.3825	1.8540	2212	2966	2489	3337	2765	3707	2765	3707	2300	2430	5357	SAE 00
	4.783*	1.3060	1.7514	2090	2802	2351	3153	2612	3502	2612	3502	2300			
	4.958*	1.2425	1.6662	1988	2666	2237	2999	2485	3332	2485	3332	2300			
	5.185*	1.1850	1.5891	1896	2543	2133	2860	2370	3178	2370	3178	2300			
ZF 9350 ^{8, 16}	2.471*, 3.034*, 3.538, 3.760*, 3.958, 4.217*, 4.522	1.4660	1.9659	2346	3145	2639	3539	2932	3931	2932	3931	2300	1910	4211	SAE 00
	4.783*	1.3825	1.8540	2212	2966	2489	3337	2765	3707	2765	3707	2300			
	4.958*	1.3200	1.7701	2112	2832	2376	3186	2640	3540	2640	3540	2300			
	5.185*	1.2575	1.6863	2012	2698	2264	3035	2515	3372	2515	3372	2300			
ZF 9351 ⁸	2.471*, 3.034*, 3.538, 3.760*, 3.958, 4.217*, 4.522	1.4660	1.9659	2346	3145	2639	3539	2932	3931	2932	3931	2300	2430	5357	SAE 00
	4.783*	1.3825	1.8540	2212	2966	2489	3337	2765	3707	2765	3707	2300			
	4.958*	1.3200	1.7701	2112	2832	2376	3186	2640	3540	2640	3540	2300			
	5.185*	1.2575	1.6863	2012	2698	2264	3035	2515	3372	2515	3372	2300			
ZF 9355 ^{8, 16}	2.471*, 3.034*, 3.538, 3.760*, 3.958, 4.217*, 4.522	1.6600	2.2261	2656	3562	2988	4007	3320	4452	3320	4452	2300	1910	4211	SAE 00
	4.783*	1.5350	2.0585	2456	3294	2763	3705	3070	4116	3070	4116	2300			
	4.958*	1.4800	1.9847	2368	3176	2664	3572	2960	3969	2960	3969	2300			
	5.185*	1.4170	1.9002	2267	3040	2551	3420	2834	3800	2834	3800	2300			
ZF 9356 ⁸	2.471*, 3.034*, 3.538, 3.760*, 3.958, 4.217*, 4.522	1.6600	2.2261	2656	3562	2988	4007	3320	4452	3320	4452	2300	2430	5357	SAE 00
	4.783*	1.5350	2.0585	2456	3294	2763	3705	3070	4116	3070	4116	2300			
	4.958*	1.4800	1.9847	2368	3176	2664	3572	2960	3969	2960	3969	2300			
	5.185*	1.4170	1.9002	2267	3040	2551	3420	2834	3800	2834	3800	2300			
ZF 10830 ¹⁶	3.341, 4.742, 5.357, 5.846, 6.417, 7.091, 7.476, 7.524	1.3130	1.7608	2101	2817	2363	3169	2626	3522	2757	3697	2100	3500	7716	
	7.900	1.2500	1.6763	2000	2682	2250	3017	2500	3353	2625	3520	2100			
	8.368	1.0800	1.4483	1728	2317	1944	2607	2160	2897	2268	3041	2100			

⁸ U-drive version also available.

¹⁶ PTI (Hybrid) or Integrated Shaft Brake also available.

* Special Order Ratio.

Medium Duty Single Speed



PRODUCT	Ratios	Power factor		Input power capacity						Max. kW	Max. hp	Max. rpm	Weight		Bell hgs. & notes
		kW/rpm	hp/rpm	1600 rpm		1800 rpm		2000 rpm					kg	lb	
ZF 10830 NR ¹⁶	3.341, 4.742, 5.357, 5.846, 6.417, 7.091, 7.476, 7.524	1.3130	1.7608	2101	2817	2363	3169	2626	3522	2757	3697	2100	3185	7022	
	7.900	1.2500	1.6763	2000	2682	2250	3017	2500	3353	2625	3520	2100			
	8.368	1.0800	1.4483	1728	2317	1944	2607	2160	2897	2268	3041	2100			
ZF 10850 ¹⁶	3.341, 4.742, 5.357, 5.846, 6.417, 7.091, 7.476, 7.524	1.3830	1.8546	2213	2967	2489	3338	2766	3709	2800	3754	2100	3500	7716	
ZF 10850 NR ¹⁶	3.341, 4.742, 5.357, 5.846, 6.417, 7.091, 7.476, 7.524	1.3830	1.8546	2213	2967	2489	3338	2766	3709	2904	3894	2100	3185	7022	
ZF 11830 ¹⁶	3.244, 4.613, 5.000, 5.444, 5.960, 6.250, 6.565, 6.909, 7.286, 7.526	1.4660	1.9659	2346	3145	2639	3539	2932	3932	3079	4128	2100	3840	8466	
	7.700	1.4270	1.9136	2283	3062	2569	3444	2854	3827	2997	4019	2100			
	8.158	1.3250	1.7769	2120	2843	2385	3198	2650	3554	2783	3731	2100			
	8.700	1.0500	1.4081	1680	2253	1890	2535	2100	2816	2205	2956	2100			
ZF 11830 NR ¹⁶	3.244, 4.613, 5.000, 5.444, 5.960, 6.250, 6.565, 6.909, 7.286, 7.526	1.4660	1.9659	2346	3145	2639	3539	2932	3932	3079	4128	2100	3460	7628	
	7.700	1.4270	1.9136	2283	3062	2569	3444	2854	3827	2997	4019	2100			
	8.158	1.3250	1.7769	2120	2843	2385	3198	2650	3554	2783	3731	2100			
	8.700	1.0500	1.4081	1680	2253	1890	2535	2100	2816	2205	2956	2100			
ZF 11850 ¹⁶	3.244, 4.613, 5.000, 5.444, 5.960, 6.250, 6.565	1.6600	2.2261	2656	3562	2988	4007	3320	4452	3320	4452	2100	3840	8466	
	6.909	1.5880	2.1295	2541	3407	2858	3833	3176	4259	3320	4452	2100			
	7.286	1.5080	2.0223	2413	3236	2714	3640	3016	4045	3167	4247	2100			
ZF 11850 NR ¹⁶	3.244, 4.613, 5.000, 5.444, 5.960, 6.250, 6.565	1.6600	2.2261	2656	3562	2988	4007	3320	4452	3486	4674	2100	3460	7628	
	6.909	1.5880	2.1295	2541	3407	2858	3833	3176	4259	3335	4472	2100			
	7.286	1.5080	2.0223	2413	3236	2714	3640	3016	4045	3167	4247	2100			
				1600 rpm		1800 rpm		2050 rpm							
ZF 23560 C (iSG=1.000)	1.721, 2.278, 2.839, 3.577	2.2513	3.0190	3602	4830	4052	5434	4615	6188	4615	6188	2100	2600	5732	
ZF 23560 C (iSG=1.130)	4.042	1.9924	2.6719	3188	4275	3586	4809	4084	5476	4084	5476	2100	2600	5732	
ZF 23560 C (iSG=1.273)	4.552*	1.7686	2.3717	2830	3795	3183	4269	3625	4861	3625	4861	2100	2600	5732	
ZF 23560 C (iSG=1.432)	5.122*	1.5725	2.1088	2516	3374	2831	3796	3223	4322	3223	4322	2100	2600	5732	

¹⁶ PTI (Hybrid) or Integrated Shaft Brake also available.

* Special Order Ratio.

Medium Duty Single Speed



PRODUCT	Ratios	Power factor		Input power capacity						Max. kW	Max. hp	Max. rpm	Weight		Bell hgs. & notes
		kW/rpm	hp/rpm	700 rpm		800 rpm		900 rpm					kg	lb	
ZF 23860 C (iSG=0.574)	0.697, 0.847, 1.121, 1.397, 1.760	3.9220	5.2595	2745	3682	3138	4208	3922	5260	4706	6311	1200	2600	5732	
ZF 23860 C (iSG=0.493)	0.697*, 0.847*, 1.121*, 1.397*, 1.760*	4.1880	5.6162	2932	3931	3350	4493	4188	5616	4188	5616	1000	2600	5732	
				1600 rpm		1800 rpm		2050 rpm							
ZF 24060 D^{9, 16}	1.514*, 1.583*, 2.032, 2.207*, 2.357*, 2.577, 2.760*, 3.043, 3.476	2.2513	3.0190	3602	4830	4052	5434	4615	6189	4728	6340	2100	2650	5842	
	3.947*	2.0368	2.7314	3259	4370	3666	4917	4175	5599	4277	5736	2100			
ZF 24060 NR2	1.514*, 1.583*, 2.032, 2.207*, 2.357*, 2.577, 2.760*, 3.043, 3.476	2.2513	3.0190	3602	4830	4052	5434	4615	6189	4728	6340	2100	1890	4167	
	3.947*	2.0368	2.7314	3259	4370	3666	4917	4175	5599	4277	5736	2100			
ZF 24060 NR2B	1.514*, 1.583*, 2.032, 2.207*, 2.357*, 2.577, 2.760*, 3.043, 3.476	2.2513	3.0190	3602	4830	4052	5434	4615	6189	4728	6340	2100	1890	4167	
	3.947*	2.0368	2.7314	3259	4370	3666	4917	4175	5599	4277	5736	2100			
ZF 24060 NR2H⁹	1.514*, 1.583*, 2.032, 2.207*, 2.357*, 2.577, 2.760*, 3.043, 3.476	2.2513	3.0190	3602	4830	4052	5434	4615	6189	4728	6340	2100	1860	4101	
	3.947*	2.0368	2.7314	3259	4370	3666	4917	4175	5599	4277	5736	2100			
ZF 24060 SGC¹⁶ (iSG=1.000)	1.514*, 1.583*, 2.032, 2.207*, 2.357*, 2.577, 2.760*, 3.043, 3.476	2.2513	3.0190	3602	4830	4052	5434	4615	6189	4728	6340	2100	3250	7165	
	3.947*	2.0368	2.7314	3259	4370	3666	4917	4175	5599	4277	5736	2100			
ZF 24060 SGC¹⁶ (iSG=1.173)	4.630	1.7363	2.3284	2778	3725	3125	4191	3559	4773	3646	4890	2100	3250	7165	
ZF 24060 SGC¹⁶ (iSG=1.280)	5.052	1.5913	2.1340	2546	3414	2864	3841	3262	4375	3342	4481	2100	3250	7165	
ZF 24060 SGC¹⁶ (iSG=1.354)	5.344	1.5043	2.0173	2407	3228	2708	3631	3084	4135	3159	4236	2100	3250	7165	
ZF 24360 D^{8, 9, 16}	4.036, 5.087, 5.950	2.2513	3.0190	3602	4830	4052	5434	4615	6189	4728	6340	2100	3870	8532	
	6.421	2.0368	2.7314	3259	4370	3666	4917	4175	5599	4277	5736	2100			
ZF 24360 SG^{8, 9, 16} (iSG=1.000)	4.036, 5.087, 5.950	2.2513	3.0190	3602	4830	4052	5434	4615	6189	4728	6340	2100	4500	9921	
	6.421	2.0368	2.7314	3259	4370	3666	4917	4175	5599	4277	5736	2100			
ZF 24360 SG^{8, 9, 16} (iSG=1.173)	6.980	1.9191	2.5736	3071	4118	3454	4632	3934	5276	4030	5405	2100	4500	9921	
ZF 24360 SG^{8, 9, 16} (iSG=1.280)	7.616	1.7588	2.3586	2814	3774	3166	4245	3606	4835	3693	4953	2100	4500	9921	
ZF 24360 SG^{8, 9, 16} (iSG=1.354)	8.056	1.6627	2.2297	2660	3568	2993	4013	3409	4571	3492	4682	2100	4500	9921	
	8.694	1.5043	2.0173	2407	3228	2708	3631	3084	4135	3159	4236	2100			

⁸ U-drive version also available.

⁹ Left and Right version available.

¹⁶ PTI (Hybrid) or Integrated Shaft Brake also available.

* Special Order Ratio.

Medium Duty Single Speed



PRODUCT	Ratios	Power factor		Input power capacity						Max. kW	Max. hp	Max. rpm	Weight		Bell hgs. & notes
		kW/rpm	hp/rpm	1000 rpm		1150 rpm		1250 rpm					kg	lb	
ZF 30050 NR2	1.514*, 1.583*, 1.735, 1.906, 2.032, 2.207*	2.9391	3.9414	2939	3941	3380	4533	3674	4927	3674	4927	1250	1900	4189	
ZF 30050 NR2B	1.514*, 1.583*, 1.735, 1.906, 2.032, 2.207*	2.9391	3.9414	2939	3941	3380	4533	3674	4927	3674	4927	1250	1900	4189	
ZF 30050 NR2H⁹	1.514*, 1.583*, 1.735, 1.906, 2.032, 2.207*	2.9391	3.9414	2939	3941	3380	4533	3674	4927	3674	4927	1250	1870	4123	
				1200 rpm		1400 rpm		1520 rpm							
ZF 30050 SGC¹⁶ (iSG=0.759)	1.542, 1.955, 2.483	2.9676	3.9796	3561	4776	4155	5571	4511	6049	4511	6049	1520	3250	7165	
	2.807	2.8263	3.7901	3392	4548	3957	5306	4296	5761	4296	5761	1520			
	2.994	2.6849	3.6005	3222	4321	3759	5041	4081	5473	4081	5473	1520			
ZF 30350 SG^{8, 9, 16} (iSG=0.759)	3.062, 4.514	2.9676	3.9796	3561	4776	4155	5571	4511	6049	4511	6049	1520	4575	10086	
	4.871	2.6849	3.6005	3222	4321	3759	5041	4081	5473	4081	5473	1520			
				1000 rpm		1200 rpm		1300 rpm							
ZF 33700 NR2	2.485, 2.966, 3.423, 3.714	3.8000	5.0959	3800	5096	4560	6115	4940	6624	4940	6624	1300	6080	13404	
	4.273	3.5700	4.7874	3570	4787	4284	5745	4641	6223	4641	6223	1300			
	4.524	3.4670	4.6493	3467	4649	4160	5579	4506	6042	4506	6042	1300			
	4.708	3.3910	4.5474	3391	4547	4069	5457	4408	5911	4408	5911	1300			
	4.957	3.2880	4.4093	3288	4409	3946	5291	4274	5732	4274	5732	1300			
	5.318	3.1400	4.2108	3140	4211	3768	5053	4082	5474	4082	5474	1300			
	5.900	2.9000	3.8890	2900	3889	3480	4667	3770	5055	3770	5055	1300			
				1000 rpm		1150 rpm		1250 rpm							
ZF 40060 NR2	1.514*, 1.583*, 1.735, 1.906	4.2304	5.6731	4230	5673	4865	6524	5288	7091	5288	7091	1250	2010	4431	
ZF 40060 NR2B	1.514*, 1.583*, 1.735, 1.906	4.2304	5.6731	4230	5673	4865	6524	5288	7091	5288	7091	1250	2010	4431	
ZF 40060 NR2H⁹	1.514*, 1.583*, 1.735, 1.906	4.2304	5.6731	4230	5673	4865	6524	5288	7091	5288	7091	1250	1880	4145	
				900 rpm		1000 rpm		1050 rpm							
ZF 40060 SGC¹⁶ (iSG=0.522)	1.588	4.3129	5.7837	3882	5205	4313	5784	4529	6073	4529	6073	1050	3260	7187	
				1000 rpm		1100 rpm		1230 rpm							
ZF 40060 SGC¹⁶ (iSG=0.585)	1.507, 2.032	4.2276	5.6693	4228	5669	4650	6236	5200	6973	5200	6973	1230	3260	7187	
	2.307	3.4840	4.6721	3484	4672	3832	5139	4285	5747	4285	5747	1230			
				900 rpm		1000 rpm		1050 rpm							
ZF 40360 SG^{8, 9, 16} (iSG=0.522)	2.107, 2.655, 3.106	4.3129	5.7837	3882	5205	4313	5784	4529	6073	4529	6073	1050	4625	10196	
	3.352	3.9019	5.2325	3512	4709	3902	5233	4097	5494	4097	5494	1050			

⁸ U-drive version also available.

⁹ Left and Right version available.

¹⁶ PTI (Hybrid) or Integrated Shaft Brake also available.

* Special Order Ratio.

Medium Duty Single Speed



PRODUCT	Ratios	Power factor		Input power capacity						Max. kW	Max. hp	Max. rpm	Weight		Bell hgs. & notes
		kW/rpm	hp/rpm	1000 rpm		1100 rpm		1230 rpm					kg	lb	
ZF 40360 SG ^{8, 9, 16} (iSG=0.585)	2.360, 2.974, 3.478	4.2276	5.6693	4228	5669	4650	6236	5200	6973	5200	6973	1230	4625	10196	
	3.754	3.4840	4.6721	3484	4672	3832	5139	4285	5747	4285	5747	1230			
ZF 43600 NR2	2.536, 2.960, 3.667	5.2000	6.9733	5200	6973	6240	8368	6760	9065	6760	9065	1300	6400	14110	
	3.714	4.7060	6.3108	4706	6311	5647	7573	6118	8204	6118	8204	1300			
	3.950	4.3890	5.8857	4389	5886	5267	7063	5706	7651	5706	7651	1300			
	4.409	3.7710	5.0570	3771	5057	4525	6068	4902	6574	4902	6574	1300			
ZF 43700 NR2 ¹⁷	2.516, 3.037, 3.500, 3.739, 4.400, 4.478	5.2000	6.9733	5200	6973	6240	8368	6760	9065	6760	9065	1300	9300	20503	
	4.609	5.0690	6.7976	5069	6798	6083	8157	6590	8837	6590	8837	1300			
	4.684	4.9940	6.6971	4994	6697	5993	8037	6492	8705	6492	8705	1300			
	4.952	4.7270	6.3390	4727	6339	5672	7607	6145	8240	6145	8240	1300			
	6.238	3.4450	4.6198	3445	4620	4134	5544	4479	6006	4479	6006	1300			
ZF 53000 NR2B	1.302, 1.487, 1.694, 1.771, 1.853, 1.912, 2.129, 2.464	5.6000	7.5097	4200	5632	5600	7510	6720	9011	6720	9011	1350	3900	8598	
	ZF 53000 NR2H ⁹	1.302, 1.487, 1.694, 1.771, 1.853, 1.912, 2.129, 2.464	5.6000	7.5097	4200	5632	5600	7510	6720	9011	6720	9011	1350	3750	8267
ZF 53500 NR2B	1.302, 1.487, 1.694, 1.771, 1.853, 1.912, 2.129, 2.464	7.3298	9.8294	5497	7372	7330	9829	8795	11794	8795	11794	1350	3980	8774	
ZF 53500 NR2H ⁹	1.302, 1.487, 1.694, 1.771, 1.853, 1.912, 2.129, 2.464	7.3298	9.8294	5497	7372	7330	9829	8795	11794	8795	11794	1350	3825	8433	
ZF 53600 NR2	2.481, 2.917, 3.476, 3.700	7.2800	9.7626	7280	9763	8736	11715	9464	12691	9464	12691	1350	9200	20283	
	4.000	6.7209	9.0129	6721	9013	8065	10815	8737	11716	8737	11716	1350			
	4.154	6.4333	8.6272	6433	8627	7720	10353	8363	11214	8363	11214	1350			
	4.500	5.7889	7.7630	5789	7763	6947	9316	7525	10091	7525	10091	1350			
ZF 53600 NR2H ⁹	2.481, 2.917, 3.476, 3.700	7.2800	9.7626	7280	9763	8736	11715	9464	12691	9464	12691	1350	9900	21826	
	4.000	6.7209	9.0129	6721	9013	8065	10815	8737	11716	8737	11716	1350			
	4.154	6.4330	8.6268	6433	8627	7720	10352	8363	11214	8363	11214	1350			
	4.500	5.7889	7.7630	5789	7763	6947	9316	7525	10091	7525	10091	1350			

⁸ U-drive version also available.

⁹ Left and Right version available.

¹⁶ PTI (Hybrid) or Integrated Shaft Brake also available.

¹⁷ PTI (Hybrid) also available.

* Special Order Ratio.

Medium Duty Single Speed



PRODUCT	Ratios	Power factor		Input power capacity						Max. kW	Max. hp	Max. rpm	Weight		Bell hsgs. & notes
		kW/rpm	hp/rpm	750 rpm		1000 rpm		1200 rpm					kg	lb	
ZF 53800 NR2B	1.302, 1.487, 1.694, 1.771, 1.853, 1.912, 2.129	8.0000	10.7282	6000	8046	8000	10728	9600	12873	9600	12873	1350	4080	8995	
ZF 53800 NR2H⁹	1.302, 1.487, 1.694, 1.771, 1.853, 1.912, 2.129	8.0000	10.7282	6000	8046	8000	10728	9600	12873	9600	12873	1350	3925	8653	
ZF 60000 NR2H⁹	1.500, 2.125, 2.226, 2.741	9.1000	12.2033	6825	9152	9100	12203	10920	14643	10920	14643	1350	4650	10251	
ZF 60500 NR2H⁹	1.500, 2.125, 2.226, 2.367	10.0000	13.4102	7500	10058	10000	13410	12000	16092	12000	16092	1350	4650	10251	
				1000 rpm		1150 rpm		1300 rpm							
ZF 83700 NR2H⁹	2.867, 3.462, 4.227, 4.800	8.0000	10.7282	8000	10728	9200	12337	10400	13946	10400	13946	1350	15500	34172	
	5.042*	7.6160	10.2132	7616	10213	8758	11745	9900	13276	9900	13276	1350			
	5.591	6.7200	9.0117	6720	9012	7728	10363	8736	11715	8736	11715	1350			
				900 rpm		1000 rpm		1150 rpm							
ZF 83750 NR2H⁹	2.867, 3.462, 4.227	10.0000	13.4102	9000	12069	10000	13410	11500	15421	11500	15421	1350	15500	34172	
	4.800	9.0800	12.1765	8172	10959	9080	12177	10442	14002	10442	14002	1350			
	5.042*	8.6860	11.6481	7817	10483	8686	11648	9989	13395	9989	13395	1350			
	5.591	7.8000	10.4600	7020	9414	7800	10460	8970	12028	8970	12028	1350			

⁹ Left and Right version available.

* Special Order Ratio.



Transmissions Continuous Duty

Continuous Duty Single Speed



PRODUCT	Ratios		Power factor		Input power capacity						Max. kW	Max. hp	Max. rpm	Weight		Bell hgs. & notes
	'A' Pos	'B' Pos	kW/rpm	hp/rpm	1800 rpm		2300 rpm		2600 rpm					kg	lb	
ZF 12 M ¹²	2.136	1.955	0.0105	0.0141	19	25	24	32	27	37	40	53	5000	13	29	B/W, Yanmar JH
	2.632	1.955	0.0094	0.0126	17	23	22	29	24	33	40	53	5000			
ZF 15 M ¹²	1.556	1.955	0.0126	0.0169	23	30	29	39	33	44	40	53	5000	13	29	B/W, Yanmar JH
	1.875	1.955	0.0115	0.0154	21	28	26	35	30	40	40	53	5000			
ZF 15 MA ¹² 8 degrees	1.875	1.955	0.0115	0.0154	21	28	26	35	30	40	40	53	5000	14	30	B/W, Yanmar JH
	2.136	1.955	0.0103	0.0138	19	25	24	32	27	36	40	53	5000			
	2.632	1.955	0.0094	0.0126	17	23	22	29	24	33	40	53	5000			
ZF 15 MIV ¹² 15 degrees	2.134	2.224	0.0115	0.0154	21	28	26	35	30	40	40	53	5000	20	44	B/W, Yanmar JH
	2.718	2.224	0.0094	0.0126	17	23	22	29	24	33	40	53	5000			
	2.995	2.224														
ZF 25	1.969	1.969	0.0172	0.0231	31	42	36	49	41	55	55	74	3200	24	53	B/W, Yanmar JH
	2.800	2.800	0.0166	0.0223	30	40	35	47	40	54	53	71	3200			
ZF 25 A 8 degrees	1.548	1.548	0.0172	0.0231	31	42	36	49	41	55	55	74	3200	24	53	B/W, Yanmar JH
	1.926	1.926														
	2.292	2.292														
	2.480*	2.480*														
	2.714	2.714	0.0166	0.0223	30	40	35	47	40	54	53	71	3200			
ZF 25 M ¹²	1.880	2.095	0.0189	0.0253	34	46	43	58	49	66	57	76	5000	19	41	B/W, Yanmar JH
	2.273	2.095	0.0153	0.0205	28	37	35	47	40	53	57	76	5000			
	2.737	2.722	0.0127	0.0170	23	31	29	39	33	44	57	76	5000			
ZF 25 MA ¹² 8 degrees	2.227	2.737	0.0153	0.0205	28	37	35	47	40	53	57	76	5000	21	46	B/W, Yanmar JH
	2.737	2.737	0.0126	0.0169	23	30	29	39	33	44	57	76	5000			
ZF 30 M ¹²	2.148	2.636	0.0173	0.0232	31	42	40	53	45	60	68	92	5000	23	51	4 & 5 Yanmar JH
	2.696	2.636														

* Special Order Ratio.

'A' POS = continuous running position (normally AHEAD).

'B' POS = reverse position.

B/W = Borg Warner adaptor.

¹² Reduced power capacity by the following shock factors: 1 cylinder engine ÷ 1.25, 2 cylinder engine ÷ 1.20, 3 cylinder engine ÷ 1.15

Continuous Duty Single Speed



PRODUCT	Ratios		Power factor		Input power capacity						Max. kW	Max. hp	Max. rpm	Weight		Bell hgs. & notes
	'A' Pos	'B' Pos	kW/rpm	hp/rpm	1800 rpm		2100 rpm		2400 rpm					kg	lb	
ZF 45 A 8 degrees	1.256	1.256	0.0312	0.0418	56	75	66	88	75	100	100	134	3200	28	62	B/W, Volvo D4-D6, Volvo 30-40, Yanmar 4LH-4JH
	1.514	1.514														
	2.034	2.034														
	2.435	2.435														
ZF 45-1	2.200	2.200	0.0429	0.0575	77	104	90	121	103	138	137	184	3200	60	132	B/W, Volvo D4-D6, Volvo 30-40, Yanmar 4LH-4JH
	2.512	2.512														
	3.031	3.031														
	3.741	3.741														
ZF 68	1.256	1.250	0.0442	0.0593	80	107	93	125	106	142	141	190	3200	46	101	B/W, Volvo D4-D6, Volvo 30-40, Yanmar 4LH
	1.514	1.521														
	1.750*	1.770														
	1.933	1.973														
	2.480	2.476	0.0433	0.0581	78	105	91	122	104	139	139	186	3200			
	2.783	2.799														
ZF 68 A 8 degrees	1.216	1.215	0.0471	0.0632	85	114	99	133	113	152	151	202	3200	44	97	B/W, Volvo D4-D6, Volvo 30-40, Yanmar 4LH
	1.563	1.583	0.0443	0.0594	80	107	93	125	106	143	142	190	3200			
	2.037	2.017	0.0387	0.0519	70	93	81	109	93	125	124	166	3200			
	2.522*	2.536														
	2.682*	2.709														
ZF 68 IV 12 degrees	1.294	1.288	0.0471	0.0632	85	114	99	133	113	152	151	202	3200	62	137	B/W, Volvo D4-D6, Volvo 30-40, Yanmar 4LH
	1.560	1.567	0.0442	0.0593	80	107	93	125	106	142	141	190	3200			
	1.746	1.749	0.0433	0.0581	78	105	91	122	104	139	139	186	3200			
	1.992	2.033														
	2.477	2.528														
ZF 85 A 8 degrees	1.567	1.567	0.0696	0.0933	125	168	146	196	167	224	223	299	3200	69	152	3 CAT, B/W, Volvo D4-D6
	1.750	1.750														
	1.962	1.962														
	2.500	2.500														
ZF 85 IV 12 degrees	1.644	1.638	0.0726	0.0974	131	175	152	205	174	234	232	312	3200	86	190	3 CAT, B/W, Volvo D4-D6
	2.008	1.996	0.0696	0.0933	125	168	146	196	167	224	223	299	3200			
	2.493	2.468														

* Special Order Ratio.

'A' POS = continuous running position (normally AHEAD).

'B' POS = reverse position.

B/W = Borg Warner adaptor.

Continuous Duty Single Speed



PRODUCT	Ratios	Power factor		Input power capacity						Max. kW	Max. hp	Max. rpm	Weight		Bell hgs. & notes
		kW/rpm	hp/rpm	1800 rpm		2100 rpm		2300 rpm					kg	lb	
ZF 220	1.000, 1.128*, 1.237*, 1.400*	0.0603	0.0809	109	146	127	170	139	186	193	259	3200	63	139	3 CAT
	1.500*, 1.963, 2.478	0.0592	0.0794	107	143	124	167	136	183	189	254	3200			
	3.000	0.0513	0.0688	92	124	108	144	118	158	164	220	3200			
ZF W220	2.618	0.0666	0.0893	120	161	140	188	153	205	213	286	3200	105	231	3 CAT
	3.133	0.0615	0.0825	111	149	129	173	141	190	197	264	3200			
	3.556	0.0562	0.0754	101	136	118	158	129	173	180	241	3200			
	3.960	0.0510	0.0684	92	123	107	144	117	157	163	219	3200			
	4.636	0.0462	0.0620	83	112	97	130	106	143	148	198	3200			
ZF 220 A 10 degrees	1.235*, 1.750*	0.0603	0.0809	109	146	127	170	139	186	193	259	3200	50	110	3 CAT, B/W
	1.533, 2.040	0.0581	0.0779	105	140	122	164	134	179	186	249	3200			
	2.455*	0.0523	0.0701	94	126	110	147	120	161	167	224	3200			
ZF 280-1	0.814*, 1.000, 1.056*, 1.139*, 1.214*, 1.300, 1.514*, 2.000	0.0775	0.1039	140	187	163	218	178	239	279	374	3600	73	161	3 CAT
	2.478	0.0724	0.0971	130	175	152	204	167	223	261	350	3600			
	3.000*	0.0667	0.0894	120	161	140	188	153	206	240	322	3600			
ZF 280-1 A 7 degrees	1.118*, 1.483, 1.769, 2.000	0.0775	0.1039	140	187	163	218	178	239	279	374	3600	73	161	3 CAT
	2.227, 2.476*	0.0724	0.0971	130	175	152	204	167	223	261	350	3600			
ZF 286	1.237*, 1.400*, 1.500, 1.966, 2.269	0.1047	0.1404	188	253	220	295	241	323	377	505	3600	86	190	3 CAT
	0.923*, 1.000*, 2.481*	0.0959	0.1286	173	231	201	270	221	296	345	463	3600			
	2.917	0.0875	0.1173	158	211	184	246	201	270	315	422	3600			
ZF 286 A 7 degrees	1.200*, 1.484*, 1.750, 1.962	0.1047	0.1404	188	253	220	295	241	323	377	505	3600	77	170	3 CAT
	2.208, 2.391, 2.500	0.0906	0.1215	163	219	190	255	208	279	326	437	3600			
ZF 301-1 A 10 degrees	1.190*, 1.516*, 2.005, 2.551*, 2.901*	0.0681	0.0913	123	164	143	192	157	210	204	274	3000	87	192	3 CAT
ZF 301-1 C	1.236*, 1.408*, 1.862	0.0733	0.0983	132	177	154	206	169	226	220	295	3000	87	192	3 CAT
	2.694	0.0716	0.0960	129	173	150	202	165	221	215	288	3000			
ZF 305-3	0.884*, 1.000*, 1.220, 1.486*, 1.968	0.1296	0.1738	207	278	233	313	272	365	389	521	3000	98	216	SAE 1, 2, 3
	2.250*	0.1154	0.1548	185	248	208	279	242	325	346	464	3000			
	2.500	0.1136	0.1523	182	244	204	274	239	320	341	457	3000			
	2.917	0.1012	0.1357	162	217	182	244	213	285	304	407	3000			

* Special Order Ratio.

B/W = Borg Warner adaptor.

Continuous Duty Single Speed



PRODUCT	Ratios	Power factor		Input power capacity						Max. kW	Max. hp	Max. rpm	Weight		Bell hgs. & notes
		kW/rpm	hp/rpm	1600 rpm		1800 rpm		2100 rpm					kg	lb	
ZF 305-3 A 7 degrees	1.200*, 1.514, 1.733, 2.037	0.1296	0.1738	207	278	233	313	272	365	389	521	3000	97	214	SAE 1, 2, 3
	2.179	0.1154	0.1548	185	248	208	279	242	325	346	464	3000			
	2.423	0.1136	0.1523	182	244	204	274	239	320	341	457	3000			
ZF 325-1	1.000, 1.167*, 1.225*, 1.459*, 1.727, 2.033	0.1556	0.2087	249	334	280	376	327	438	467	626	3000	130	287	SAE 1, 2
	2.500	0.1450	0.1944	232	311	261	350	305	408	435	583	3000			
	2.957	0.1326	0.1778	212	284	239	320	278	373	398	533	3000			
ZF 325-1 A 7 degrees	1.216*, 1.485, 1.733, 2.037, 2.240*	0.1556	0.2087	249	334	280	376	327	438	467	626	3000	130	287	SAE 1, 2
	2.417*	0.1450	0.1944	232	311	261	350	305	408	435	583	3000			
ZF W340 ¹⁵	2.938, 3.233, 3.500, 4.080*	0.1802	0.2417	324	435	378	508	432	580	541	725	3000	330	728	SAE 1, 2, 3
	4.522*, 4.957*	0.1657	0.2222	298	400	348	467	398	533	497	667	3000			
	5.227*	0.1450	0.1944	261	350	305	408	348	467	435	583	3000			
ZF W350-1	3.026*, 3.500*, 3.968*, 4.536, 4.962, 5.955*	0.2071	0.2777	331	444	373	500	435	583	497	666	2400	500	1102	SAE 0, 1
	6.409*	0.1781	0.2388	285	382	321	430	374	501	427	573	2400			
ZF 400 ¹⁵	0.854, 0.925, 1.000, 1.109, 1.233, 1.526, 1.781, 2.033, 2.214, 2.600, 2.957	0.1802	0.2417	288	387	324	435	378	508	541	725	3000	160	353	SAE 1, 2
ZF 400 A ¹⁵ 7 degrees	1.441, 1.594, 1.767, 1.964, 2.192	0.1802	0.2417	288	387	324	435	378	508	541	725	3000	160	353	SAE 1, 2
	2.458	0.1699	0.2278	272	364	306	410	357	478	510	683	3000			
ZF 400 IV ¹⁵ 14 degrees	1.441, 1.594, 1.767, 1.964, 2.192	0.1802	0.2417	288	387	324	435	378	508	541	725	3000	220	485	SAE 1, 2
	2.458	0.1699	0.2278	272	364	306	410	357	478	510	683	3000			
ZF 400 V 10 degrees	1.125*, 1.774*, 2.000, 2.222*, 2.480	0.1802	0.2417	288	387	324	435	378	508	541	725	3000	200	441	
ZF 500	1.000*, 1.125, 1.237*, 1.500, 1.774*, 1.966	0.2486	0.3334	398	533	447	600	522	700	746	1000	3000	185	408	SAE 0, 1
	2.185*	0.2279	0.3056	365	489	410	550	479	642	684	917	3000			
	0.925*	0.2217	0.2973	355	476	399	535	466	624	665	892	3000			
	2.480*	0.2079	0.2788	333	446	374	502	437	585	624	836	3000			
	2.625*	0.1989	0.2667	318	427	358	480	418	560	597	800	3000			
	2.917*	0.1864	0.2500	298	400	336	450	391	525	559	750	3000			

¹⁵ Free standing installation available.

* Special Order Ratio.

Continuous Duty Single Speed



PRODUCT	Ratios	Power factor		Input power capacity						Max. kW	Max. hp	Max. rpm	Weight		Bell hgs. & notes
		kW/rpm	hp/rpm	1600 rpm		1800 rpm		2100 rpm					kg	lb	
ZF 500-1 A 7 degrees	1.216*, 1.485*, 1.767, 1.964	0.2486	0.3334	398	533	447	600	522	700	746	1000	3000	192	423	SAE 0, 1
	2.192	0.2279	0.3056	365	489	410	550	479	642	684	917	3000			
	2.478*	0.2079	0.2788	333	446	374	502	437	585	624	836	3000			
	2.609*	0.1989	0.2667	318	427	358	480	418	560	597	800	3000			
ZF 510 V 10 degrees	1.125*, 1.774*, 2.000	0.2486	0.3334	398	533	447	600	522	700	746	1000	3000	200	441	
	2.222*	0.2279	0.3056	365	489	410	550	479	642	684	917	3000			
ZF 510-1 A 10 degrees	1.125*, 1.774, 2.000	0.2486	0.3334	398	533	447	600	522	700	746	1000	3000	193	425	SAE 0, 1
	2.222, 2.480*	0.2279	0.3056	365	489	410	550	479	642	684	917	3000			
ZF 550-1	1.111, 1.182*, 1.262*, 1.833*, 2.000, 2.233*	0.2492	0.3342	399	535	449	602	523	702	748	1003	3000	242	534	SAE 0, 1
	2.593	0.2399	0.3217	384	515	432	579	504	676	720	965	3000			
	3.042*	0.1991	0.2670	319	427	358	481	418	561	597	801	3000			
ZF 550-1 A 10 degrees	1.525*, 1.757*, 1.971, 2.226, 2.448	0.2492	0.3342	399	535	449	602	523	702	748	1003	3000	256	564	SAE 0, 1
	2.517	0.2398	0.3216	384	515	432	579	504	675	719	965	3000			
	2.960*	0.1990	0.2669	318	427	358	480	418	560	597	801	3000			
ZF 550-1 V 10 degrees	1.525*, 1.971, 2.226, 2.448*	0.2492	0.3342	399	535	449	602	523	702	748	1003	3000	260	573	
	2.960*	0.1990	0.2669	318	427	358	480	418	560	597	801	3000			
ZF W650	3.605*, 4.057, 4.531*, 5.138, 5.593	0.2487	0.3335	398	534	448	600	522	700	647	867	2600	561	1237	SAE 0, 1
	6.417*	0.2105	0.2823	337	452	379	508	442	593	547	734	2600			
ZF 665	1.111, 1.182*, 1.262, 1.400*, 1.500*, 1.743, 2.000	0.2900	0.3889	464	622	522	700	609	817	870	1167	3000	248	547	SAE 0, 1
	2.233*, 2.593	0.2692	0.3610	431	578	485	650	565	758	808	1083	3000			
	3.042*	0.2237	0.3000	358	480	403	540	470	630	671	900	3000			
ZF 665 A 10 degrees	1.525*, 1.971	0.2900	0.3889	464	622	522	700	609	817	870	1167	3000	253	558	SAE 0, 1
	2.226	0.2692	0.3610	431	578	485	650	565	758	808	1083	3000			
	2.517	0.2652	0.3556	424	569	477	640	557	747	796	1067	3000			
	2.960*	0.2382	0.3194	381	511	429	575	500	671	715	958	3000			
ZF 665 V 10 degrees	1.525*, 1.757*, 1.971*	0.2900	0.3889	464	622	522	700	609	817	870	1167	3000	252	556	
	2.226*	0.2692	0.3610	431	578	485	650	565	758	808	1083	3000			
	2.517*	0.2652	0.3556	424	569	477	640	557	747	796	1067	3000			
	2.960*	0.2382	0.3194	381	511	429	575	500	671	715	958	3000			

* Special Order Ratio.

Continuous Duty Single Speed



PRODUCT	Ratios	Power factor		Input power capacity						Max. kW	Max. hp	Max. rpm	Weight		Bell hgs. & notes
		kW/rpm	hp/rpm	1600 rpm		1800 rpm		2100 rpm					kg	lb	
ZF 2000	1.086*, 1.111*, 1.191*, 1.250*, 1.350*, 1.436*, 1.500, 1.639*, 1.765*, 1.848*, 1.879*, 2.032, 2.276*, 2.519	0.2817	0.3778	451	604	507	680	592	793	592	793	2100	340	750	SAE 0, 1
	2.760*	0.2595	0.3480	415	557	467	626	545	731	545	731	2100			
	2.958	0.2454	0.3291	393	527	442	592	515	691	515	691	2100			
ZF 2000 A 10 degrees	1.267*, 1.512*, 1.763, 2.029, 2.250*, 2.467, 2.714*	0.2817	0.3778	451	604	507	680	592	793	592	793	2100	348	767	SAE 0, 1
	2.920	0.2550	0.3420	408	547	459	616	536	718	536	718	2100			
	3.250*	0.2162	0.2899	346	464	389	522	454	609	454	609	2100			
ZF 2000 V 10 degrees	1.267*, 1.512*, 1.763, 2.029, 2.250*, 2.467, 2.714*	0.2817	0.3778	451	604	507	680	592	793	592	793	2100	352	776	
	2.920	0.2550	0.3420	408	547	459	616	536	718	536	718	2100			
	3.250*	0.2162	0.2899	346	464	389	522	454	609	454	609	2100			
ZF 2050	1.086*, 1.111*, 1.191*, 1.250*, 1.350*, 1.436*, 1.500, 1.639*, 1.765*, 1.848*, 1.879*, 2.032, 2.276*, 2.519	0.3111	0.4172	498	668	560	751	653	876	653	876	2100	342	754	SAE 0, 1
ZF 2050 A 10 degrees	1.267*, 1.512*, 1.763, 2.029, 2.250*, 2.467	0.3111	0.4172	498	668	560	751	653	876	653	876	2100	350	772	SAE 0, 1
ZF 2050 V 10 degrees	1.267*, 1.512*, 1.763, 2.029, 2.250*, 2.467	0.3111	0.4172	498	668	560	751	653	876	653	876	2100	354	780	
ZF 2150	2.760*	0.2866	0.3843	459	615	516	692	602	807	602	807	2100	344	758	SAE 0, 1
	2.958	0.2711	0.3636	434	582	488	654	569	764	569	764	2100			
ZF 2150 A 10 degrees	2.714*	0.3111	0.4172	498	668	560	751	653	876	653	876	2100	352	776	SAE 0, 1
	2.920	0.2817	0.3778	451	604	507	680	592	793	592	793	2100			
	3.250*	0.2388	0.3202	382	512	430	576	501	672	501	672	2100			
ZF 2150 V 10 degrees	2.714*	0.3111	0.4172	498	668	560	751	653	876	653	876	2100	356	785	
	2.920	0.2817	0.3778	451	604	507	680	592	793	592	793	2100			
	3.250*	0.2388	0.3202	382	512	430	576	501	672	501	672	2100			
ZF 2200 ¹³	3.000, 3.286*, 3.519*	0.2819	0.3780	451	605	507	680	592	794	592	794	2100	404	891	SAE 0, 1
ZF 2250 ¹³	3.000, 3.286*, 3.519*	0.3111	0.4172	498	668	560	751	653	876	653	876	2100	406	895	SAE 0, 1
ZF 2300 ⁸	4.000, 4.444	0.2819	0.3780	451	605	507	680	592	794	592	794	2100	434	957	SAE 0, 1
ZF W2300 ⁸	3.028*, 3.500*, 4.000, 4.444, 4.760*	0.2819	0.3780	451	605	507	680	592	794	592	794	2100	590	1301	SAE 0, 1
ZF 2350 ⁸	4.000, 4.444	0.3109	0.4169	497	667	560	750	653	875	653	875	2100	436	961	SAE 0, 1
	4.760*	0.2985	0.4003	478	640	537	721	627	841	627	841	2100			

⁸ U-drive version also available.

¹³ No classification available.

* Special Order Ratio.

Continuous Duty Single Speed



PRODUCT	Ratios	Power factor		Input power capacity						Max. kW	Max. hp	Max. rpm	Weight		Bell hgs. & notes
		kW/rpm	hp/rpm	1600 rpm		1800 rpm		2100 rpm					kg	lb	
ZF W2350 ⁸	3.028*, 3.500*, 4.000, 4.444	0.3109	0.4169	497	667	560	750	653	875	653	875	2100	590	1301	SAE 0, 1
	4.760*	0.2985	0.4003	478	640	537	721	627	841	627	841	2100			
ZF W2450 ⁸	5.036, 5.500, 6.042, 6.160	0.3109	0.4169	497	667	560	750	653	875	653	875	2100	760	1676	SAE 0, 1
	6.458	0.2585	0.3467	414	555	465	624	543	728	543	728	2100			
	6.923	0.2249	0.3016	360	483	405	543	472	632	472	632	2100			
ZF 3000	1.093*, 1.195*, 1.250*, 1.306*, 1.343*, 1.412*, 1.441*, 1.500, 1.563*, 1.594*, 1.645*, 1.700*, 1.733*, 1.800*, 1.828*, 2.037, 2.154*, 2.240*, 2.375*, 2.417*, 2.500, 2.609*, 2.773*, 2.952*	0.3980	0.5337	637	854	716	961	836	1121	836	1121	2100	482	1063	SAE 00, 0, 1
ZF 3000 A 10 degrees	1.351*, 1.486*, 1.750*, 2.034, 2.259*, 2.520, 2.750*, 3.000*	0.3980	0.5337	637	854	716	961	836	1121	836	1121	2100	485	1069	SAE 0, 1
	3.280*	0.3400	0.4559	544	729	612	821	714	957	714	957	2100			
	3.444*	0.3068	0.4114	491	658	552	740	552	740	552	740	2100			
ZF 3000 D CEW ^{9, 17}	1.093*, 1.195*, 1.250*, 1.306*, 1.343*, 1.412*, 1.441*, 1.500, 1.563*, 1.594*, 1.645*, 1.700*, 1.733*, 1.800*, 1.828*, 2.037, 2.154*, 2.240*, 2.375*, 2.417*, 2.500, 2.609*, 2.773*, 2.952*	0.3980	0.5337	637	854	716	961	836	1121	836	1121	2100	482	1063	
ZF 3000 D EW ⁹	1.093*, 1.195*, 1.250*, 1.306*, 1.343*, 1.412*, 1.441*, 1.500, 1.563*, 1.594*, 1.645*, 1.700*, 1.733*, 1.800*, 1.828*, 2.037, 2.154*, 2.240*, 2.375*, 2.417*, 2.500, 2.609*, 2.773*, 2.952*	0.3980	0.5337	637	854	716	961	836	1121	836	1121	2100	482	1063	
ZF 3000 V 10 degrees	1.351*, 1.486*, 1.750*, 2.034, 2.259*, 2.520, 2.750*, 3.000*	0.3980	0.5337	637	854	716	961	836	1121	836	1121	2100	500	1102	
	3.280*	0.3400	0.4559	544	729	612	821	714	957	714	957	2100			
	3.444*	0.3068	0.4114	491	658	552	740	552	740	552	740	2100			
ZF 3050	1.093*, 1.195*, 1.250*, 1.306*, 1.343*, 1.412*, 1.441*, 1.500, 1.563*, 1.594*, 1.645*, 1.700*, 1.733*, 1.800*, 1.828*, 2.037, 2.154*, 2.240*, 2.375*, 2.417*, 2.500, 2.609*, 2.773*, 2.952*	0.4664	0.6255	746	1001	840	1126	979	1314	979	1314	2100	482	1063	SAE 00, 0, 1
ZF 3050 A 10 degrees	1.351*, 1.486*, 1.750*, 2.034, 2.259*, 2.520, 2.750*, 3.000*	0.4664	0.6255	746	1001	840	1126	979	1314	979	1314	2100	485	1069	SAE 0, 1
	3.280*	0.4105	0.5505	657	881	739	991	862	1156	862	1156	2100			
	3.444*	0.3607	0.4837	577	774	649	870	649	870	649	870	2100			

⁸ U-drive version also available.

⁹ Left and Right version available.

¹⁷ PTI (Hybrid) also available.

* Special Order Ratio.

Continuous Duty Single Speed



PRODUCT	Ratios	Power factor		Input power capacity						Max. kW	Max. hp	Max. rpm	Weight		Bell hgs. & notes
		kW/rpm	hp/rpm	1600 rpm		1800 rpm		2100 rpm					kg	lb	
ZF 3050 D CEW ^{3, 9, 17}	1.093*, 1.195*, 1.250*, 1.306*, 1.343*, 1.412*, 1.441*, 1.500, 1.563*, 1.594*, 1.645*, 1.700*, 1.733*, 1.800*, 1.828*, 2.037, 2.154*, 2.240*, 2.375*, 2.417*, 2.500, 2.609*, 2.773*, 2.952*	0.4664	0.6255	746	1001	840	1126	979	1312	979	1312	2100	482	1063	
ZF 3050 V 10 degrees	1.351*, 1.486*, 1.750*, 2.034, 2.259*, 2.520, 2.750*, 3.000*	0.4664	0.6255	746	1001	840	1126	979	1314	979	1314	2100	500	1102	
	3.280*	0.4105	0.5505	657	881	739	991	862	1156	862	1156	2100			
	3.444*	0.3607	0.4837	577	774	649	870	649	870	649	870	2100			
ZF 3100 A ¹³ 10 degrees	1.257*, 1.500*, 1.759*, 1.963, 2.240, 2.478*	0.3980	0.5337	637	854	716	960	716	960	716	960	2100	470	1036	SAE 0, 1
	2.880*	0.3400	0.4559	544	729	612	820	612	820	612	820	2100			
ZF 3150 A ¹³ 10 degrees	1.257*, 1.500*, 1.759*, 1.963, 2.240, 2.478*	0.4664	0.6255	746	1001	840	1126	840	1126	840	1126	2100	470	1036	SAE 0, 1
	2.880*	0.4104	0.5504	657	881	739	991	739	991	739	991	2100			
ZF 3310 ⁸	2.647*, 2.844*, 3.000*, 3.519*, 3.769*, 4.000, 4.250*, 4.478, 4.727*, 5.000	0.3980	0.5337	637	854	716	961	836	1121	836	1121	2100	665	1466	SAE 00, 0, 1
ZF W3310 ^{8, 16}	2.647*, 2.844*, 3.000*, 3.519*, 3.769*, 4.000, 4.250*, 4.478, 4.727*, 5.000	0.3980	0.5337	637	854	716	961	836	1121	836	1121	2100	850	1874	SAE 00, 0, 1
ZF 3350 ⁸	2.647*, 2.844*, 3.000*, 3.519*, 3.769*, 4.000, 4.250*, 4.478, 4.727*, 5.000	0.4750	0.6370	760	1019	855	1147	998	1338	998	1338	2100	665	1466	SAE 00, 0, 1
ZF W3350 ^{8, 16}	2.647*, 2.844*, 3.000*, 3.519*, 3.769*, 4.000, 4.250*, 4.478, 4.727*, 5.000	0.4750	0.6370	760	1019	855	1147	998	1338	998	1338	2100	850	1874	SAE 00, 0, 1
ZF W3355 ^{8, 16}	2.647*, 2.844*, 3.000*, 3.519*, 3.769*, 4.000, 4.250*	0.5556	0.7451	667	894	889	1192	1000	1341	1000	1341	2100	855	1885	SAE 00, 0, 1
	4.478	0.5298	0.7105	636	853	848	1137	954	1279	954	1279	2100			
	4.727*	0.5089	0.6824	611	819	814	1092	916	1228	916	1228	2100			
	5.000	0.4838	0.6488	581	779	774	1038	871	1168	871	1168	2100			
ZF W3710 ⁸	3.767*, 4.259*, 5.545, 5.952	0.3980	0.5337	1600 rpm		1800 rpm		2100 rpm		836	1121	2100	920	2028	SAE 0, 1
				637	854	716	961	836	1121						
ZF W3750 ⁸	3.767*, 4.259*, 5.545, 5.952	0.4750	0.6370	760	1019	855	1147	998	1338	998	1338	2100	920	2028	SAE 0, 1

³ Engine wise (EW) operation only for waterjet flushing.

⁸ U-drive version also available.

⁹ Left and Right version available.

¹³ No classification available.

¹⁶ PTI (Hybrid) or Integrated Shaft Brake also available.

¹⁷ PTI (Hybrid) also available.

* Special Order Ratio.

Continuous Duty Single Speed



PRODUCT	Ratios	Power factor		Input power capacity						Max. kW	Max. hp	Max. rpm	Weight		Bell hgs. & notes
		kW/rpm	hp/rpm	1600 rpm		1800 rpm		2100 rpm					kg	lb	
ZF W3755 ⁸	3.767*, 4.259*, 4.538*, 5.042*	0.5556	0.7451	889	1192	1000	1341	1167	1565	1167	1565	2100	920	2028	SAE 0, 1
	5.545	0.5131	0.6881	821	1101	924	1239	1078	1445	1078	1445	2100			
	5.952	0.4838	0.6488	774	1038	871	1168	1016	1362	1016	1362	2100			
ZF 5000	1.256*, 1.526, 1.585*, 1.722*, 1.771*, 1.853*, 2.031, 2.233*, 2.310*, 2.429*, 2.500, 2.630*, 2.731*, 2.880*, 2.920*, 2.963	0.5497	0.7372	1600 rpm		1800 rpm		1900 rpm		1044	1400	2000	740	1631	SAE 00, 0
				880	1180	989	1327	1044	1400						
				880	1180	989	1327	1044	1400						
ZF 5000 A 8 degrees	1.431*, 1.512*, 1.757*, 2.029, 2.250*, 2.467, 2.714*, 2.962	0.5497	0.7372	880	1180	989	1327	1044	1400	1044	1400	2000	750	1653	SAE 00, 0
ZF 5000 D ^{9, 17}	1.256*, 1.526, 1.585*, 1.722*, 1.771*, 1.853*, 2.031, 2.233*, 2.310*, 2.429*, 2.500, 2.630*, 2.731*, 2.880*, 2.920*, 2.963	0.5497	0.7372	880	1180	989	1327	1044	1400	1044	1400	2000	765	1687	
ZF 5000 NR2H ⁹	1.256*, 1.526, 1.585*, 1.722*, 1.771*, 1.853*, 2.031, 2.233*, 2.310*, 2.429*, 2.500, 2.630*, 2.731*, 2.880*, 2.920*, 2.963	0.5497	0.7372	880	1180	989	1327	1044	1400	1044	1400	2000	615	1356	
ZF 5000 V 8 degrees	1.431*, 1.512*, 1.757*, 2.029, 2.250*, 2.467, 2.714*, 2.962	0.5497	0.7372	880	1180	989	1327	1044	1400	1044	1400	2000	768	1693	
ZF 5050	1.256*, 1.526, 1.585*, 1.722*, 1.771*, 1.853*, 2.031, 2.233*, 2.310*, 2.429*, 2.500, 2.630*, 2.731*, 2.880*, 2.920*, 2.963	0.6319	0.8474	1011	1356	1137	1525	1200	1609	1200	1609	2000	740	1631	SAE 00, 0
ZF 5050 A 8 degrees	1.431*, 1.512*, 1.757*, 2.029, 2.250*, 2.467, 2.714*, 2.962	0.6319	0.8474	1011	1356	1137	1525	1200	1609	1200	1609	2000	750	1653	SAE 00, 0
	3.222*	0.5864	0.7864	938	1258	1056	1416	1114	1493	1114	1493	2000			
	3.429*	0.5497	0.7372	880	1180	989	1327	1044	1400	1044	1400	2000			
ZF 5050 D ^{9, 17}	1.256*, 1.526, 1.585*, 1.722*, 1.771*, 1.853*, 2.031, 2.233*, 2.310*, 2.429*, 2.500, 2.630*, 2.731*, 2.880*, 2.920*, 2.963	0.6319	0.8474	1011	1356	1137	1525	1200	1609	1200	1609	2000	765	1687	
ZF 5050 NR2H ⁹	1.256*, 1.526, 1.585*, 1.722*, 1.771*, 1.853*, 2.031, 2.233*, 2.310*, 2.429*, 2.500, 2.630*, 2.731*, 2.880*, 2.920*, 2.963	0.6319	0.8474	1011	1356	1137	1525	1200	1609	1200	1609	2000	615	1356	
ZF 5050 V 8 degrees	1.431*, 1.512*, 1.757*, 2.029, 2.250*, 2.467, 2.714*, 2.962	0.6319	0.8474	1011	1356	1137	1525	1200	1609	1200	1609	2000	768	1693	
	3.222*	0.5864	0.7864	938	1258	1056	1416	1114	1493	1114	1493	2000			
	3.429*	0.5497	0.7372	880	1180	989	1327	1044	1400	1044	1400	2000			

⁹ Left and Right version available.

¹⁷ PTI (Hybrid) also available.

* Special Order Ratio.

Continuous Duty Single Speed



PRODUCT	Ratios	Power factor		Input power capacity						Max. kW	Max. hp	Max. rpm	Weight		Bell hgs. & notes
		kW/rpm	hp/rpm	1600 rpm		1800 rpm		1900 rpm					kg	lb	
ZF 5055	1.256*, 1.526, 1.585*, 1.722*, 1.771*, 1.853*, 2.031, 2.233*, 2.310*, 2.429*, 2.500, 2.630*, 2.731*	0.7331	0.9831	1173	1573	1320	1770	1392	1866	1392	1866	2000	740	1631	SAE 00, 0
	2.880*	0.7041	0.9442	1127	1511	1267	1700	1337	1792	1337	1792	2000			
	2.920*	0.6964	0.9339	1114	1494	1254	1681	1322	1772	1322	1772	2000			
	2.963	0.6880	0.9226	1101	1476	1238	1661	1307	1752	1307	1752	2000			
ZF 5055 A 8 degrees	1.431*, 1.512*, 1.757*, 2.029, 2.250*, 2.467, 2.714*, 2.962	0.7331	0.9831	1173	1573	1320	1770	1392	1866	1392	1866	2000	750	1653	SAE 00, 0
	3.222*	0.6880	0.9226	1101	1476	1238	1661	1307	1752	1307	1752	2000			
	3.429*	0.6319	0.8474	1011	1356	1137	1525	1200	1609	1200	1609	2000			
ZF 5055 D ^{9, 17}	1.256*, 1.526, 1.585*, 1.722*, 1.771*, 1.853*, 2.031, 2.233*, 2.310*, 2.429*, 2.500, 2.630*, 2.731*	0.7331	0.9831	1173	1573	1320	1770	1392	1866	1392	1866	2000	765	1687	
	2.880*	0.7041	0.9442	1127	1511	1267	1700	1337	1792	1337	1792	2000			
	2.920*	0.6964	0.9339	1114	1494	1254	1681	1322	1772	1322	1772	2000			
	2.963	0.6880	0.9226	1101	1476	1238	1661	1307	1752	1307	1752	2000			
ZF 5055 NR2H ⁹	1.256*, 1.526, 1.585*, 1.722*, 1.771*, 1.853*, 2.031, 2.233*, 2.310*, 2.429*, 2.500, 2.630*, 2.731*	0.7331	0.9831	1173	1573	1320	1770	1392	1866	1392	1866	2000	615	1356	
	2.880*	0.7041	0.9442	1127	1511	1267	1700	1337	1792	1337	1792	2000			
	2.920*	0.6964	0.9339	1114	1494	1254	1681	1322	1772	1322	1772	2000			
	2.963	0.6880	0.9226	1101	1476	1238	1661	1307	1752	1307	1752	2000			
ZF 5055 V 8 degrees	1.431*, 1.512*, 1.757*, 2.029, 2.250*, 2.467, 2.714*, 2.962	0.7331	0.9831	1173	1573	1320	1770	1392	1866	1392	1866	2000	768	1693	
	3.222*	0.6880	0.9226	1101	1476	1238	1661	1307	1752	1307	1752	2000			
	3.429*	0.6319	0.8474	1011	1356	1137	1525	1200	1609	1200	1609	2000			
ZF 5200 A ¹⁶ 8 degrees	2.588, 2.844*, 3.100, 3.393*, 3.692	0.5497	0.7372	880	1180	989	1327	1044	1400	1044	1400	2000	870	1918	SAE 00, 0
ZF 5200 V ¹⁶ 8 degrees	2.588, 2.844*, 3.100, 3.393*, 3.692	0.5497	0.7372	880	1180	989	1327	1044	1400	1044	1400	2000	880	1940	
ZF 5250 A ¹⁶ 8 degrees	2.588, 2.844*, 3.100, 3.393*, 3.692	0.6319	0.8474	1011	1356	1137	1525	1201	1610	1201	1610	2000	870	1918	SAE 00, 0
	4.000	0.5864	0.7864	938	1258	1056	1416	1114	1493	1114	1493	2000			
	4.250*	0.5497	0.7372	880	1180	989	1327	1044	1400	1044	1400	2000			
ZF 5250 V ¹⁶ 8 degrees	2.588, 2.844*, 3.100, 3.393*, 3.692	0.6319	0.8474	1011	1356	1137	1525	1201	1610	1201	1610	2000	880	1940	
	4.000	0.5864	0.7864	938	1258	1056	1416	1114	1493	1114	1493	2000			
	4.250*	0.5497	0.7372	880	1180	989	1327	1044	1400	1044	1400	2000			

⁹ Left and Right version available.

¹⁶ PTI (Hybrid) or Integrated Shaft Brake also available.

¹⁷ PTI (Hybrid) also available.

* Special Order Ratio.

Continuous Duty Single Speed



PRODUCT	Ratios	Power factor		Input power capacity						Max. kW	Max. hp	Max. rpm	Weight		Bell hgs. & notes
		kW/rpm	hp/rpm	1600 rpm		1800 rpm		1900 rpm					kg	lb	
ZF 5255 A ¹⁶ 8 degrees	2.588, 2.844*, 3.100, 3.393*, 3.692	0.7331	0.9831	1173	1573	1320	1770	1393	1868	1393	1868	2000	870	1918	SAE 00, 0
	4.000	0.6880	0.9226	1101	1476	1238	1661	1307	1752	1307	1752	2000			
	4.250*	0.6319	0.8474	1011	1356	1137	1525	1201	1610	1201	1610	2000			
ZF 5255 V ¹⁶ 8 degrees	2.588, 2.844*, 3.100, 3.393*, 3.692	0.7331	0.9831	1173	1573	1320	1770	1393	1868	1393	1868	2000	880	1940	
	4.000	0.6880	0.9226	1101	1476	1238	1661	1307	1752	1307	1752	2000			
	4.250*	0.6319	0.8474	1011	1356	1137	1525	1201	1610	1201	1610	2000			
ZF 5300 ^{8, 16}	2.587*, 2.750*, 2.947*, 3.108*, 3.314*, 3.471*, 4.033, 4.464, 5.040	0.5497	0.7372	880	1180	989	1327	1044	1400	1044	1400	2000	950	2094	SAE 00, 0
ZF W5300 ^{8, 16}	2.587*, 2.750*, 2.947*, 3.108*, 3.314*, 3.471*, 4.033, 4.464, 5.040	0.5497	0.7372	880	1180	989	1327	1044	1400	1044	1400	2000	1290	2844	SAE 00, 0
ZF 5350 ^{8, 16}	2.587*, 2.750*, 2.947*, 3.108*, 3.314*, 3.471*, 4.033, 4.464, 5.040	0.6319	0.8474	1011	1356	1137	1525	1200	1609	1200	1609	2000	950	2094	SAE 00, 0
ZF W5350 ^{8, 16}	2.587*, 2.750*, 2.947*, 3.108*, 3.314*, 3.471*, 4.033, 4.464, 5.040, 5.500	0.6319	0.8474	1011	1356	1137	1525	1200	1609	1200	1609	2000	1290	2844	SAE 00, 0
ZF 5355 ^{8, 16}	2.587*, 2.750*, 2.947*, 3.108*, 3.314*, 3.471*, 4.033, 4.464, 5.040	0.7331	0.9831	1173	1573	1320	1770	1392	1866	1392	1866	2000	950	2094	SAE 00, 0
	5.500	0.6670	0.8945	1067	1431	1201	1610	1267	1699	1267	1699	2000			
ZF W5355 ^{8, 16}	2.587*, 2.750*, 2.947*, 3.108*, 3.314*, 3.471*, 4.033, 4.464, 5.040	0.7331	0.9831	1173	1573	1320	1770	1392	1866	1392	1866	2000	1290	2844	SAE 00, 0
	5.500	0.6670	0.8945	1067	1431	1201	1610	1267	1699	1267	1699	2000			
				1200 rpm		1600 rpm		1800 rpm							
ZF 8000	1.250*, 1.500, 1.781*, 1.967, 2.296*, 2.560, 2.708*, 2.958, 3.174*	0.8806	1.1809	1057	1417	1409	1889	1585	2125	1585	2125	1800	1015	2238	SAE 00
ZF 8000 A 8 degrees	1.462, 1.743*, 2.000, 2.233*, 2.556, 2.731*, 3.000, 3.292*, 3.440	0.8806	1.1809	1057	1417	1409	1889	1585	2125	1585	2125	1800	1050	2315	SAE 00
ZF 8000 D ^{9, 17}	1.250*, 1.500, 1.781*, 1.967, 2.296*, 2.560, 2.708*, 2.958, 3.174*	0.8806	1.1809	1057	1417	1409	1889	1585	2125	1585	2125	1800	1015	2238	
ZF 8000 NR2	1.250*, 1.500, 1.781*, 1.967, 2.296*, 2.560, 2.708*, 2.958, 3.174*	0.8806	1.1809	1057	1417	1409	1889	1585	2125	1585	2125	1800	810	1786	
ZF 8000 NR2B	1.250*, 1.500, 1.781*, 1.967, 2.296*, 2.560, 2.708*, 2.958, 3.174*	0.8806	1.1809	1057	1417	1409	1889	1585	2125	1585	2125	1800	810	1786	
ZF 8000 NR2H ⁹	1.250*, 1.500, 1.781*, 1.967, 2.296*, 2.560, 2.708*, 2.958, 3.174*	0.8806	1.1809	1057	1417	1409	1889	1585	2125	1585	2125	1800	800	1764	
ZF 8000 V 8 degrees	1.462, 1.743*, 2.000, 2.233*, 2.556, 2.731*, 3.000, 3.292*, 3.440	0.8806	1.1809	1057	1417	1409	1889	1585	2125	1585	2125	1800	1075	2370	

⁸ U-drive version also available.

⁹ Left and Right version available.

¹⁶ PTI (Hybrid) or Integrated Shaft Brake also available.

¹⁷ PTI (Hybrid) also available.

* Special Order Ratio.

Continuous Duty Single Speed



PRODUCT	Ratios	Power factor		Input power capacity						Max. kW	Max. hp	Max. rpm	Weight		Bell hsgs. & notes
		kW/rpm	hp/rpm	1200 rpm		1600 rpm		1800 rpm					kg	lb	
ZF 8050	1.250*, 1.500, 1.781*, 1.967, 2.296*, 2.560, 2.708*, 2.958, 3.174*	1.0262	1.3762	1231	1651	1642	2202	1847	2476	1847	2476	1800	1015	2238	SAE 00
ZF 8050 A 8 degrees	1.462, 1.743*, 2.000, 2.233*, 2.556, 2.731*, 3.000	1.0262	1.3762	1231	1651	1642	2202	1847	2476	1847	2476	1800	1050	2315	SAE 00
	3.292*	0.9686	1.2989	1162	1559	1550	2078	1743	2337	1743	2337	1800			
	3.440	0.9377	1.2575	1125	1509	1500	2012	1688	2263	1688	2263	1800			
ZF 8050 D ^{9, 17}	1.250*, 1.500, 1.781*, 1.967, 2.296*, 2.560, 2.708*	1.0262	1.3762	1231	1651	1642	2202	1847	2476	1847	2476	1800	1015	2238	
	2.958	0.9801	1.3143	1176	1577	1568	2103	1764	2365	1764	2365	1800			
	3.174*	0.9319	1.2497	1118	1500	1491	2000	1677	2248	1677	2248	1800			
ZF 8050 NR2	1.250*, 1.500, 1.781*, 1.967, 2.296*, 2.560, 2.708*, 2.958, 3.174*	1.0262	1.3762	1231	1651	1642	2202	1847	2476	1847	2476	1800	810	1786	
ZF 8050 NR2B	1.250*, 1.500, 1.781*, 1.967, 2.296*, 2.560, 2.708*, 2.958, 3.174*	1.0262	1.3762	1231	1651	1642	2202	1847	2476	1847	2476	1800	810	1786	
ZF 8050 NR2H ⁹	1.250*, 1.500, 1.781*, 1.967, 2.296*, 2.560, 2.708*, 2.958, 3.174*	1.0262	1.3762	1231	1651	1642	2202	1847	2476	1847	2476	1800	800	1764	
ZF 8050 V 8 degrees	1.462, 1.743*, 2.000, 2.233*, 2.556, 2.731*, 3.000	1.0262	1.3762	1231	1651	1642	2202	1847	2476	1847	2476	1800	1075	2370	
	3.292*	0.9686	1.2989	1162	1559	1550	2078	1743	2337	1743	2337	1800			
	3.440	0.9377	1.2575	1125	1509	1500	2012	1688	2263	1688	2263	1800			
ZF 8055	1.250*, 1.500, 1.781*, 1.967, 2.296*, 2.560, 2.708*	1.1518	1.5446	1382	1854	1843	2471	2073	2779	2073	2779	1800	1015	2238	SAE 00
	2.958	1.0785	1.4463	1294	1736	1726	2314	1941	2602	1941	2602	1800			
	3.174*	1.0262	1.3762	1231	1651	1642	2202	1847	2476	1847	2476	1800			
ZF 8055 A 8 degrees	1.462, 1.743*, 2.000, 2.233*, 2.556, 2.731*, 3.000	1.1518	1.5446	1382	1854	1843	2471	2073	2779	2073	2779	1800	1050	2315	SAE 00
	3.292*	1.0681	1.4323	1282	1719	1709	2292	1923	2578	1923	2578	1800			
	3.440	1.0262	1.3762	1231	1651	1642	2202	1847	2476	1847	2476	1800			
ZF 8055 D CEW ^{3, 9, 17}	1.250, 1.500, 1.781, 1.967, 2.296, 2.560, 2.708	1.1518	1.5446	1382	1854	1843	2471	2073	2779	2073	2779	1800	1015	2238	
	2.958	1.0785	1.4463	1294	1736	1726	2314	1941	2602	1941	2602	1800			
	3.174	1.0262	1.3762	1231	1651	1642	2202	1847	2476	1847	2476	1800			
ZF 8055 NR2	1.250*, 1.500, 1.781*, 1.967, 2.296*, 2.560, 2.708*	1.1518	1.5446	1382	1854	1843	2471	2073	2779	2073	2779	1800	810	1786	
	2.958	1.0785	1.4463	1294	1736	1726	2314	1941	2602	1941	2602	1800			
	3.174*	1.0262	1.3762	1231	1651	1642	2202	1847	2476	1847	2476	1800			

³ Engine wise (EW) operation only for waterjet flushing.

⁹ Left and Right version available.

¹⁷ PTI (Hybrid) also available.

* Special Order Ratio.

Continuous Duty Single Speed



PRODUCT	Ratios	Power factor		Input power capacity						Max. kW	Max. hp	Max. rpm	Weight		Bell hgs. & notes
		kW/rpm	hp/rpm	1200 rpm		1600 rpm		1800 rpm					kg	lb	
				kW	hp	kW	hp	kW	hp						
ZF 8055 NR2B	1.250*, 1.500, 1.781*, 1.967, 2.296*, 2.560, 2.708*	1.1518	1.5446	1382	1854	1843	2471	2073	2779	2073	2779	1800	810	1786	
	2.958	1.0785	1.4463	1294	1736	1726	2314	1941	2602	1941	2602	1800			
	3.174*	1.0262	1.3762	1231	1651	1642	2202	1847	2476	1847	2476	1800			
ZF 8055 NR2H ⁹	1.250*, 1.500, 1.781*, 1.967, 2.296*, 2.560, 2.708*	1.1518	1.5446	1382	1854	1843	2471	2073	2779	2073	2779	1800	800	1764	
	2.958	1.0785	1.4463	1294	1736	1726	2314	1941	2602	1941	2602	1800			
	3.174*	1.0262	1.3762	1231	1651	1642	2202	1847	2476	1847	2476	1800			
ZF 8055 V 8 degrees	1.462, 1.743*, 2.000, 2.233*, 2.556, 2.731*, 3.000	1.1518	1.5446	1382	1854	1843	2471	1847	2476	1847	2476	1800	1075	2370	
	3.292*	1.0681	1.4323	1282	1719	1709	2292	1923	2578	1923	2578	1800			
	3.440	1.0262	1.3762	1231	1651	1642	2202	1847	2476	1847	2476	1800			
ZF 8300 ^{8, 16}	2.576, 2.967, 3.214*, 3.538, 3.760*, 3.958, 4.174*, 4.522, 4.708*	0.8806	1.1809	1057	1417	1409	1889	1585	2125	1585	2125	1800	1220	2690	SAE 00
ZF 8311 ^{8, 16}	2.576, 2.967, 3.214*, 3.538, 3.760*, 3.958, 4.174*, 4.522, 4.708*	0.8806	1.1809	1057	1417	1409	1889	1585	2125	1585	2125	1800	1625	3583	SAE 00
ZF 8350 ^{8, 16}	2.576, 2.967, 3.214*, 3.538, 3.760*, 3.958, 4.174*	1.0262	1.3762	1231	1651	1642	2202	1847	2476	1847	2476	1800	1220	2690	SAE 00
	4.522	0.9670	1.2968	1160	1556	1547	2075	1741	2334	1741	2334	1800			
	4.708*	0.9319	1.2497	1118	1500	1491	2000	1677	2248	1677	2248	1800			
ZF 8351 ^{8, 16}	2.576, 2.967, 3.214*, 3.538, 3.760*, 3.958, 4.174*	1.0262	1.3762	1231	1651	1642	2202	1847	2476	1847	2476	1800	1625	3583	SAE 00
	4.522	0.9670	1.2968	1160	1556	1547	2075	1741	2334	1741	2334	1800			
	4.708*	0.9319	1.2497	1118	1500	1491	2000	1677	2248	1677	2248	1800			
ZF 8355 ^{8, 16}	2.576, 2.967, 3.214*, 3.538, 3.760*, 3.958, 4.174*	1.1518	1.5446	1382	1854	1843	2471	2073	2779	2073	2779	1800	1220	2690	SAE 00
	4.522	1.0785	1.4463	1294	1736	1726	2314	1941	2602	1941	2602	1800			
	4.708*	1.0262	1.3762	1231	1651	1642	2202	1847	2476	1847	2476	1800			
ZF 8356 ^{8, 16}	2.576, 2.967, 3.214*, 3.538, 3.760*, 3.958, 4.174*	1.1518	1.5446	1382	1854	1843	2471	2073	2779	2073	2779	1800	1625	3583	SAE 00
	4.522	1.0785	1.4463	1294	1736	1726	2314	1941	2602	1941	2602	1800			
	4.708*	1.0262	1.3762	1231	1651	1642	2202	1847	2476	1847	2476	1800			

⁸ U-drive version also available.

⁹ Left and Right version available.

¹⁶ PTI (Hybrid) or Integrated Shaft Brake also available.

* Special Order Ratio.

Continuous Duty Single Speed



PRODUCT	Ratios	Power factor		Input power capacity						Max. kW	Max. hp	Max. rpm	Weight		Bell hgs. & notes
		kW/rpm	hp/rpm	1200 rpm		1600 rpm		1800 rpm					kg	lb	
ZF 9000	1.186*, 1.515*, 1.576*, 1.742*, 1.862*, 2.036, 2.269*, 2.400*, 2.500*, 2.542, 2.739*, 2.957	1.2200	1.6360	1464	1963	1952	2618	2196	2945	2196	2945	1800	1400	3086	SAE 00
	3.250*	1.1500	1.5422	1380	1851	1840	2468	2070	2776	2070	2776	1800			
	3.360*	1.1222	1.5049	1347	1806	1796	2408	2020	2709	2020	2709	1800			
	3.448*	1.1000	1.4751	1320	1770	1760	2360	1980	2655	1980	2655	1800			
ZF 9000 A 8 degrees	1.381*, 1.514*, 1.750*, 1.967, 2.259*, 2.462, 2.750*, 2.958	1.2200	1.6360	1464	1963	1952	2618	2196	2945	2196	2945	1800	1380	3042	SAE 00
	3.208*	1.1500	1.5422	1380	1851	1840	2468	2070	2776	2070	2776	1800			
	3.462*	1.1000	1.4751	1320	1770	1760	2360	1980	2655	1980	2655	1800			
ZF 9000 NR2	1.186*, 1.515*, 1.576*, 1.742*, 1.862*, 2.036, 2.269*, 2.400*, 2.500*, 2.542, 2.739*, 2.957	1.2200	1.6360	1464	1963	1952	2618	2196	2945	2196	2945	1800	1040	2293	
	3.250*	1.1500	1.5422	1380	1851	1840	2468	2070	2776	2070	2776	1800			
	3.360*	1.1222	1.5049	1347	1806	1796	2408	2020	2709	2020	2709	1800			
	3.448*	1.1000	1.4751	1320	1770	1760	2360	1980	2655	1980	2655	1800			
ZF 9000 NR2B	1.186*, 1.515*, 1.576*, 1.742*, 1.862*, 2.036, 2.269*, 2.400*, 2.500*, 2.542, 2.739*, 2.957	1.2200	1.6360	1464	1963	1952	2618	2196	2945	2196	2945	1800	1040	2293	
	3.250*	1.1500	1.5422	1380	1851	1840	2468	2070	2776	2070	2776	1800			
	3.360*	1.1222	1.5049	1347	1806	1796	2408	2020	2709	2020	2709	1800			
	3.448*	1.1000	1.4751	1320	1770	1760	2360	1980	2655	1980	2655	1800			
ZF 9000 NR2H⁹	1.186*, 1.515*, 1.576*, 1.742*, 1.862*, 2.036, 2.269*, 2.400*, 2.500*, 2.542, 2.739*, 2.957	1.2200	1.6360	1464	1963	1952	2618	2196	2945	2196	2945	1800	1040	2293	
	3.250*	1.1500	1.5422	1380	1851	1840	2468	2070	2776	2070	2776	1800			
	3.360*	1.1222	1.5049	1347	1806	1796	2408	2020	2709	2020	2709	1800			
	3.448*	1.1000	1.4751	1320	1770	1760	2360	1980	2655	1980	2655	1800			
ZF 9000 V 8 degrees	1.381*, 1.514*, 1.750*, 1.967, 2.259*, 2.462, 2.750*, 2.958	1.2200	1.6360	1464	1963	1952	2618	2196	2945	2196	2945	1800	1400	3086	
	3.208*	1.1500	1.5422	1380	1851	1840	2468	2070	2776	2070	2776	1800			
	3.462*	1.1000	1.4751	1320	1770	1760	2360	1980	2655	1980	2655	1800			
ZF 9050	1.186*, 1.515*, 1.576*, 1.742*, 1.862*, 2.036, 2.269*, 2.400*, 2.500*, 2.542, 2.739*, 2.957	1.3560	1.8184	1627	2182	2170	2909	2441	3273	2441	3273	1800	1400	3086	SAE 00
	3.250*	1.2556	1.6838	1507	2021	2009	2694	2260	3031	2260	3031	1800			
	3.360*	1.2250	1.6428	1470	1971	1960	2628	2205	2957	2205	2957	1800			
	3.448*	1.2000	1.6092	1440	1931	1920	2575	2160	2897	2160	2897	1800			

⁹ Left and Right version available.

* Special Order Ratio.

Continuous Duty Single Speed



PRODUCT	Ratios	Power factor		Input power capacity						Max. kW	Max. hp	Max. rpm	Weight		Bell hgs. & notes
		kW/rpm	hp/rpm	1200 rpm		1600 rpm		1800 rpm					kg	lb	
ZF 9050 A 8 degrees	1.381*, 1.514*, 1.750*, 1.967, 2.259*, 2.462, 2.750*, 2.958	1.3560	1.8184	1627	2182	2170	2909	2441	3273	2441	3273	1800	1380	3042	SAE 00
	3.208*	1.2556	1.6838	1507	2021	2009	2694	2260	3031	2260	3031	1800			
	3.462*	1.2000	1.6092	1440	1931	1920	2575	2160	2897	2160	2897	1800			
ZF 9050 NR2	1.186*, 1.515*, 1.576*, 1.742*, 1.862*, 2.036, 2.269*, 2.400*, 2.500*, 2.542, 2.739*, 2.957	1.3560	1.8184	1627	2182	2170	2909	2441	3273	2441	3273	1800	1040	2293	
	3.250*	1.2556	1.6838	1507	2021	2009	2694	2260	3031	2260	3031	1800			
	3.360*	1.2250	1.6428	1470	1971	1960	2628	2205	2957	2205	2957	1800			
	3.448*	1.2000	1.6092	1440	1931	1920	2575	2160	2897	2160	2897	1800			
ZF 9050 NR2B	1.186*, 1.515*, 1.576*, 1.742*, 1.862*, 2.036, 2.269*, 2.400*, 2.500*, 2.542, 2.739*, 2.957	1.3560	1.8184	1627	2182	2170	2909	2441	3273	2441	3273	1800	1040	2293	
	3.250*	1.2556	1.6838	1507	2021	2009	2694	2260	3031	2260	3031	1800			
	3.360*	1.2250	1.6428	1470	1971	1960	2628	2205	2957	2205	2957	1800			
	3.448*	1.2000	1.6092	1440	1931	1920	2575	2160	2897	2160	2897	1800			
ZF 9050 NR2H ⁹	1.186*, 1.515*, 1.576*, 1.742*, 1.862*, 2.036, 2.269*, 2.400*, 2.500*, 2.542, 2.739*, 2.957	1.3560	1.8184	1627	2182	2170	2909	2441	3273	2441	3273	1800	1040	2293	
	3.250*	1.2556	1.6838	1507	2021	2009	2694	2260	3031	2260	3031	1800			
	3.360*	1.2250	1.6428	1470	1971	1960	2628	2205	2957	2205	2957	1800			
	3.448*	1.2000	1.6092	1440	1931	1920	2575	2160	2897	2160	2897	1800			
ZF 9050 V 8 degrees	1.381*, 1.514*, 1.750*, 1.967, 2.259*, 2.462, 2.750*, 2.958	1.3560	1.8184	1627	2182	2170	2909	2441	3273	2441	3273	1800	1400	3086	
	3.208*	1.2556	1.6838	1507	2021	2009	2694	2260	3031	2260	3031	1800			
	3.462*	1.2000	1.6092	1440	1931	1920	2575	2160	2897	2160	2897	1800			
ZF 9300 ^{8, 16}	2.471*, 3.034*, 3.538, 3.760*, 3.958, 4.217*, 4.522	1.2200	1.6360	1464	1963	1952	2618	2196	2944	2196	2944	1800	1910	4211	SAE 00
	4.783*	1.1500	1.5422	1380	1851	1840	2468	2070	2775	2070	2775	1800			
	4.958*	1.1000	1.4751	1320	1770	1760	2360	1980	2655	1980	2655	1800			
	5.185*	1.0500	1.4081	1260	1690	1680	2253	1890	2534	1890	2534	1800			
ZF 9311 ⁸	2.471*, 3.034*, 3.538, 3.760*, 3.958, 4.217*, 4.522	1.2200	1.6360	1464	1963	1952	2618	2196	2944	2196	2944	1800	2430	5357	SAE 00
	4.783*	1.1500	1.5422	1380	1851	1840	2468	2070	2775	2070	2775	1800			
	4.958*	1.1000	1.4751	1320	1770	1760	2360	1980	2655	1980	2655	1800			
	5.185*	1.0500	1.4081	1260	1690	1680	2253	1890	2534	1890	2534	1800			

⁸ U-drive version also available.

⁹ Left and Right version available.

¹⁶ PTI (Hybrid) or Integrated Shaft Brake also available.

* Special Order Ratio.

Continuous Duty Single Speed



PRODUCT	Ratios	Power factor		Input power capacity						Max. kW	Max. hp	Max. rpm	Weight		Bell hgs. & notes
		kW/rpm	hp/rpm	1200 rpm		1600 rpm		1800 rpm					kg	lb	
ZF 9350 ^{8, 16}	2.471*, 3.034*, 3.538, 3.760*, 3.958, 4.217*, 4.522	1.3560	1.8184	1627	2182	2170	2909	2441	3273	2441	3273	1800	1910	4211	SAE 00
	4.783*	1.2556	1.6838	1507	2021	2009	2694	2260	3030	2260	3030	1800			
	4.958*	1.2000	1.6092	1440	1931	1920	2575	2160	2896	2160	2896	1800			
	5.185*	1.1470	1.5382	1376	1846	1835	2461	2065	2769	2065	2769	1800			
ZF 9351 ⁸	2.471*, 3.034*, 3.538, 3.760*, 3.958, 4.217*, 4.522	1.3560	1.8184	1627	2182	2170	2909	2441	3273	2441	3273	1800	2430	5357	SAE 00
	4.783*	1.2556	1.6838	1507	2021	2009	2694	2260	3030	2260	3030	1800			
	4.958*	1.2000	1.6092	1440	1931	1920	2575	2160	2896	2160	2896	1800			
	5.185*	1.1470	1.5382	1376	1846	1835	2461	2065	2769	2065	2769	1800			
				1000 rpm		1200 rpm		1600 rpm							
ZF W10020 ¹⁶	1.683, 2.056, 2.548, 3.074, 3.583, 4.000	1.1520	1.5449	1152	1545	1382	1854	1843	2472	2189	2935	1900	2550	5622	
	4.500	1.1400	1.5288	1140	1529	1368	1835	1824	2446	2166	2904	1900			
ZF W10020 NR ¹⁶	1.683, 2.056, 2.548, 3.074, 3.583, 4.000	1.1520	1.5449	1152	1545	1382	1854	1843	2472	2189	2935	1900	2235	4927	
	4.500	1.1400	1.5288	1140	1529	1368	1835	1824	2446	2166	2904	1900			
ZF W10030 ¹⁶	1.683, 2.056, 2.548, 3.074, 3.583, 4.000	1.2200	1.6360	1220	1636	1464	1963	1952	2618	2318	3108	1900	2550	5622	
ZF W10030 NR ¹⁶	1.683, 2.056, 2.548, 3.074, 3.583, 4.000	1.2200	1.6360	1220	1636	1464	1963	1952	2618	2318	3108	1900	2235	4927	
ZF W10050 ¹⁶	1.683, 2.056, 2.548, 3.074, 3.583	1.3560	1.8184	1356	1818	1627	2182	2170	2909	2540	3406	1900	2550	5622	
	4.000	1.3350	1.7903	1335	1790	1602	2148	2136	2864	2500	3352	1900			
ZF W10050 NR ¹⁶	1.683, 2.056, 2.548, 3.074, 3.583	1.4000	1.8774	1400	1877	1680	2253	2240	3004	2600	3486	1900	2235	4927	
	4.000	1.3350	1.7903	1335	1790	1602	2148	2136	2864	2500	3352	1900			
ZF W10120 ¹⁶	2.439, 4.036, 4.423, 4.875, 5.130, 5.409, 5.714	1.1520	1.5449	1152	1545	1382	1854	1843	2472	2189	2935	1900	2950	6504	
	6.050	1.1400	1.5288	1140	1529	1368	1835	1824	2446	2166	2904	1900			
	6.421	0.9600	1.2874	960	1287	1152	1545	1536	2060	1824	2446	1900			
	6.810	0.6000	0.8046	600	805	720	966	960	1287	1140	1528	1900			
ZF W10120 NR ¹⁶	2.439, 4.036, 4.423, 4.875, 5.130, 5.409, 5.714	1.1520	1.5449	1152	1545	1382	1854	1843	2472	2189	2935	1900	2635	5809	
	6.050	1.1400	1.5288	1140	1529	1368	1835	1824	2446	2166	2904	1900			
	6.421	0.9600	1.2874	960	1287	1152	1545	1536	2060	1824	2446	1900			
	6.810	0.6000	0.8046	600	805	720	966	960	1287	1140	1528	1900			

⁸ U-drive version also available.

¹⁶ PTI (Hybrid) or Integrated Shaft Brake also available.

* Special Order Ratio.

Continuous Duty Single Speed



PRODUCT	Ratios	Power factor		Input power capacity						Max. kW	Max. hp	Max. rpm	Weight		Bell hgs. & notes
		kW/rpm	hp/rpm	1000 rpm		1200 rpm		1600 rpm					kg	lb	
ZF W10130 ¹⁶	2.439, 4.036, 4.423, 4.875, 5.130, 5.409, 5.714	1.2200	1.6360	1220	1636	1464	1963	1952	2618	2318	3108	1900	2950	6504	
ZF W10130 NR ¹⁶	2.439, 4.036, 4.423, 4.875, 5.130, 5.409, 5.714	1.2200	1.6360	1220	1636	1464	1963	1952	2618	2318	3108	1900	2635	5809	
ZF W10150 ¹⁶	2.439, 4.036, 4.423, 4.875, 5.130	1.3560	1.8184	1356	1818	1627	2182	2170	2909	2540	3406	1900	2950	6504	
	5.409	1.3350	1.7903	1335	1790	1602	2148	2136	2864	2500	3352	1900			
	5.714	1.2600	1.6897	1260	1690	1512	2028	2016	2704	2375	3184	1900			
ZF W10150 NR ¹⁶	2.439, 4.036, 4.423, 4.875, 5.130	1.4000	1.8774	1400	1877	1680	2253	2240	3004	2600	3486	1900	2635	5809	
	5.409	1.3350	1.7903	1335	1790	1602	2148	2136	2864	2500	3352	1900			
	5.714	1.2600	1.6897	1260	1690	1512	2028	2016	2704	2375	3184	1900			
ZF W10200 SG ¹⁶ (iSG=1.256)	8.909, 9.453, 9.926, 10.514	0.6000	0.8046	600	805	720	966	960	1287	1140	1528	1900	3826	8435	
ZF W10200 SG ¹⁶ (iSG=1.441)	11.385, 12.060	0.6000	0.8046	600	805	720	966	960	1287	1040	1394	1900	3798	8373	
ZF W10200 SG ¹⁶ (iSG=1.531)	12.814	0.6000	0.8046	600	805	720	966	960	1287	980	1314	1900	3798	8373	
ZF W10200 SG ¹⁶ (iSG=1.581)	13.228	0.6000	0.8046	600	805	720	966	960	1287	960	1287	1900	3783	8340	
ZF W10200 SG ¹⁶ (iSG=1.633)	13.668	0.5740	0.7697	574	770	689	924	918	1231	918	1231	1900	3783	8340	
ZF W10200 SG ¹⁶ (iSG=1.690)	14.140	0.5550	0.7443	555	744	666	893	888	1190	888	1190	1900	3783	8340	
ZF W10220 ¹⁶	3.341, 4.742, 5.357, 5.846, 6.417, 7.091, 7.476, 7.524	1.1520	1.5449	1152	1545	1382	1854	1843	2472	2189	2935	1900	3500	7716	
	7.900	1.1400	1.5288	1140	1529	1368	1835	1824	2446	2166	2904	1900			
	8.368	0.9600	1.2874	960	1287	1152	1545	1536	2060	1824	2446	1900			
ZF W10220 NR ¹⁶	3.341, 4.742, 5.357, 5.846, 6.417, 7.091, 7.476, 7.524	1.1520	1.5449	1152	1545	1382	1854	1843	2472	2189	2935	1900	3185	7022	
	7.900	1.1400	1.5288	1140	1529	1368	1835	1824	2446	2166	2904	1900			
	8.368	0.9600	1.2874	960	1287	1152	1545	1536	2060	1824	2446	1900			
ZF W10230 ¹⁶	3.341, 4.742, 5.357, 5.846, 6.417, 7.091, 7.476, 7.524	1.2200	1.6360	1220	1636	1464	1963	1952	2618	2318	3108	1900	3500	7716	
ZF W10230 NR ¹⁶	3.341, 5.357, 5.846, 6.417, 7.091, 7.476, 7.524	1.2200	1.6360	1220	1636	1464	1963	1952	2618	2318	3108	1900	3185	7022	
ZF W10250 ¹⁶	3.341, 4.742, 5.357, 5.846, 6.417	1.3560	1.8184	1356	1818	1627	2182	2170	2909	2540	3406	1900	3500	7716	
	7.091	1.3350	1.7903	1335	1790	1602	2148	2136	2864	2500	3352	1900			
	7.476	1.2600	1.6897	1260	1690	1512	2028	2016	2704	2375	3184	1900			
	7.524	1.2500	1.6763	1250	1676	1500	2012	2000	2682	2375	3184	1900			

¹⁶ PTI (Hybrid) or Integrated Shaft Brake also available.

Continuous Duty Single Speed



PRODUCT	Ratios	Power factor		Input power capacity						Max. kW	Max. hp	Max. rpm	Weight		Bell hgs. & notes
		kW/rpm	hp/rpm	1000 rpm		1200 rpm		1600 rpm					kg	lb	
ZF W10250 NR ¹⁶	3.341, 4.742, 5.357, 5.846, 6.417	1.4000	1.8774	1400	1877	1680	2253	2240	3004	2600	3486	1900	3185	7022	
	7.091	1.3350	1.7903	1335	1790	1602	2148	2136	2864	2500	3352	1900			
	7.476	1.2600	1.6897	1260	1690	1512	2028	2016	2704	2375	3184	1900			
	7.524	1.2500	1.6763	1250	1676	1500	2012	2000	2682	2375	3184	1900			
ZF W11010 NR ¹⁶	1.683, 2.056, 2.548, 3.074, 3.583, 4.000	1.4900	1.9981	1490	1998	1788	2398	2384	3197	2680	3593	1900	2480	5467	
	4.500	1.3500	1.8104	1350	1810	1620	2172	2160	2897	2440	3272	1900			
ZF W11020 ¹⁶	1.683, 2.056, 2.548, 3.074, 3.583, 4.000	1.4000	1.8774	1400	1877	1680	2253	2240	3004	2570	3446	1900	2860	6305	
	4.500	1.3500	1.8104	1350	1810	1620	2172	2160	2897	2440	3272	1900			
ZF W11020 NR ¹⁶	1.683, 2.056, 2.548, 3.074, 3.583	1.6000	2.1456	1600	2146	1920	2575	2560	3433	2900	3888	1900	2480	5467	
ZF W11030 ¹⁶	1.683, 2.056, 2.548, 3.074, 3.583, 4.000	1.4900	1.9981	1490	1998	1788	2398	2384	3197	2680	3593	1900	2860	6305	
ZF W11030 NR CEW _{7, 16}	1.683, 2.056, 2.548, 3.074	1.6700	2.2395	1670	2240	2004	2687	2672	3583	3040	4076	1900	2480	5467	
ZF W11050 ¹⁶	1.683, 2.056, 2.548, 3.074, 3.583	1.6000	2.1456	1600	2146	1920	2575	2560	3433	2900	3888	1900	2860	6305	
ZF W11050 NR CEW _{7, 16}	1.683, 2.056, 2.548, 3.074	1.7750	2.3803	1775	2380	2130	2856	2840	3808	3280	4398	1900	2480	5467	
ZF W11110 NR ¹⁶	2.415, 3.516, 4.000, 4.600, 5.087	1.4900	1.9981	1490	1998	1788	2398	2384	3197	2680	3593	1900	2960	6526	
	5.667	1.4250	1.9110	1425	1911	1710	2293	2280	3058	2570	3446	1900			
	6.000	1.3500	1.8104	1350	1810	1620	2172	2160	2897	2440	3272	1900			
ZF W11120 ¹⁶	2.415, 3.516, 4.000, 4.600, 5.087, 5.667	1.4000	1.8774	1400	1877	1680	2253	2240	3004	2570	3446	1900	3340	7363	
	6.000	1.3500	1.8104	1350	1810	1620	2172	2160	2897	2440	3272	1900			
ZF W11120 NR ¹⁶	2.415, 3.516, 4.000, 4.600	1.6000	2.1456	1600	2146	1920	2575	2560	3433	2900	3888	1900	2960	6526	
	5.087	1.5500	2.0786	1550	2079	1860	2494	2480	3326	2800	3754	1900			
ZF W11130 ¹⁶	2.415, 3.516, 4.000, 4.600, 5.087	1.4900	1.9981	1490	1998	1788	2398	2384	3197	2680	3593	1900	3340	7363	
	5.667	1.4250	1.9110	1425	1911	1710	2293	2280	3058	2570	3446	1900			
ZF W11130 NR CEW _{7, 16}	2.415, 3.516, 4.000, 4.600	1.6700	2.2395	1670	2240	2004	2687	2672	3583	3040	4076	1900	2960	6526	
ZF W11150 ¹⁶	2.415, 3.516, 4.000, 4.600	1.6000	2.1456	1600	2146	1920	2575	2560	3433	2900	3888	1900	3340	7363	
	5.087	1.5500	2.0786	1550	2079	1860	2494	2480	3326	2800	3754	1900			
ZF W11150 NR CEW _{7, 16}	2.415, 3.516, 4.000	1.7750	2.3803	1775	2380	2130	2856	2840	3808	3280	4398	1900	2960	6526	
ZF W11200 SG ¹⁶ (iSG=1.581)	13.752	0.6000	0.8046	600	805	720	966	960	1287	960	1287	1900	4233	9332	

⁷ EW version on request.

¹⁶ PTI (Hybrid) or Integrated Shaft Brake also available.

Continuous Duty Single Speed



PRODUCT	Ratios	Power factor		Input power capacity						Max. kW	Max. hp	Max. rpm	Weight		Bell hgs. & notes
		kW/rpm	hp/rpm	1000 rpm		1200 rpm		1600 rpm					kg	lb	
ZF W11200 SG ¹⁶ (iSG=1.633)	14.210	0.5740	0.7697	574	770	689	924	918	1231	918	1231	1900	4233	9332	
ZF W11200 SG ¹⁶ (iSG=1.690)	14.700	0.5550	0.7443	555	744	666	893	888	1190	888	1190	1900	4233	9332	
ZF W11200 SG ¹⁶ (iSG=1.750)	15.225	0.5250	0.7040	525	704	630	845	840	1126	840	1126	1900	4228	9321	
ZF W11210 NR ¹⁶	3.244, 4.613, 5.000, 5.444, 5.960, 6.250, 6.565, 6.909	1.4900	1.9981	1490	1998	1788	2398	2384	3197	2680	3593	1900	3460	7628	
	7.286	1.4250	1.9110	1425	1911	1710	2293	2280	3058	2570	3446	1900			
	7.526	1.3800	1.8506	1380	1851	1656	2221	2208	2961	2500	3352	1900			
	7.700	1.3500	1.8104	1350	1810	1620	2172	2160	2897	2440	3272	1900			
	8.158	1.2100	1.6226	1210	1623	1452	1947	1936	2596	2240	3003	1900			
	8.700	1.0500	1.4081	1050	1408	1260	1690	1680	2253	1995	2675	1900			
ZF W11220 ¹⁶	3.244, 4.613, 5.000, 5.444, 5.960, 6.250, 6.565, 6.909, 7.286	1.4000	1.8774	1400	1877	1680	2253	2240	3004	2570	3446	1900	3840	8466	
	7.526	1.3800	1.8506	1380	1851	1656	2221	2208	2961	2500	3352	1900			
	7.700	1.3500	1.8104	1350	1810	1620	2172	2160	2897	2440	3272	1900			
	8.158	1.2100	1.6226	1210	1623	1452	1947	1936	2596	2240	3003	1900			
	8.700	1.0500	1.4081	1050	1408	1260	1690	1680	2253	1995	2675	1900			
ZF W11220 NR ¹⁶	3.244, 4.613, 5.000, 5.444, 5.960, 6.250	1.6000	2.1456	1600	2146	1920	2575	2560	3433	2900	3888	1900	3460	7628	
	6.565	1.5500	2.0786	1550	2079	1860	2494	2480	3326	2800	3754	1900			
ZF W11230 ¹⁶	3.244, 4.613, 5.000, 5.444, 5.960, 6.250, 6.565, 6.909	1.4900	1.9981	1490	1998	1788	2398	2384	3197	2680	3593	1900	3840	8466	
	7.286	1.4250	1.9110	1425	1911	1710	2293	2280	3058	2570	3446	1900			
ZF W11230 NR CEW ^{7, 16}	3.244, 4.613, 5.000, 5.444, 5.960	1.6700	2.2395	1670	2240	2004	2687	2672	3583	3040	4076	1900	3460	7628	
ZF W11250 ¹⁶	3.244, 4.613, 5.000, 5.444, 5.960, 6.250	1.6000	2.1456	1600	2146	1920	2575	2560	3433	2900	3888	1900	3840	8466	
	6.565	1.5500	2.0786	1550	2079	1860	2494	2480	3326	2800	3754	1900			
ZF W11250 NR CEW ^{7, 16}	3.244, 4.613, 5.000, 5.444	1.7750	2.3803	1775	2380	2130	2856	2840	3808	3280	4398	1900	3460	7628	
				750 rpm		1000 rpm		1200 rpm							
ZF W17000	1.974, 2.548, 3.074, 3.231, 3.583, 4.000, 4.500	1.8500	2.4809	1388	1861	1850	2481	2220	2977	2220	2977	1600	4550	10031	

⁷ EW version on request.

¹⁶ PTI (Hybrid) or Integrated Shaft Brake also available.

Continuous Duty Single Speed



PRODUCT	Ratios	Power factor		Input power capacity						Max. kW	Max. hp	Max. rpm	Weight		Bell hgs. & notes
		kW/rpm	hp/rpm	750 rpm		1000 rpm		1200 rpm					kg	lb	
ZF W17000 NR	1.974, 2.548, 3.074, 3.231, 3.583, 4.000	2.1300	2.8564	1598	2142	2130	2856	2556	3427	2556	3427	1800	3900	8598	
	4.500	1.8800	2.5211	1410	1891	1880	2521	2256	3025	2256	3025	1800			
ZF W17010	1.974, 2.548, 3.074, 3.231, 3.583, 4.000	2.0000	2.6820	1500	2012	2000	2682	2400	3218	2400	3218	1600	4550	10031	
	4.500	1.8800	2.5211	1410	1891	1880	2521	2256	3025	2256	3025	1600			
ZF W17010 NR	1.974, 2.548, 3.074, 3.231, 3.583, 4.000	2.2500	3.0173	1688	2263	2250	3017	2700	3620	2700	3620	1800	3900	8598	
ZF W17030	1.974, 2.548, 3.074, 3.231, 3.583, 4.000	2.1300	2.8564	1598	2142	2130	2856	2556	3427	2556	3427	1600	4620	10185	
ZF W17030 NR CEW ⁷	1.974, 2.548, 3.074, 3.231, 3.583	2.4740	3.3177	1856	2488	2474	3318	2969	3981	2969	3981	1800	3940	8686	
ZF W17050	1.974, 2.548, 3.074, 3.231, 3.583, 4.000	2.2500	3.0173	1688	2263	2250	3017	2700	3620	2700	3620	1600	4620	10185	
ZF W17050 NR CEW ⁷	1.974, 2.548, 3.074, 3.231	2.6670	3.5765	2000	2682	2667	3577	3200	4291	3200	4291	1800	3940	8686	
	3.583	2.5400	3.4062	1905	2555	2540	3406	3048	4087	3048	4087	1800			
ZF W17100	2.821, 3.516, 4.185, 4.600, 5.087, 5.364, 5.667, 6.000	1.8500	2.4809	1388	1861	1850	2481	2220	2977	2220	2977	1600	5350	11795	
ZF W17100 NR	2.821, 3.516, 4.185, 4.600, 5.087, 5.364	2.1300	2.8564	1598	2142	2130	2856	2556	3427	2556	3427	1800	4750	10472	
	5.667	2.0740	2.7813	1555	2086	2074	2781	2489	3337	2489	3337	1800			
	6.000	1.8800	2.5211	1410	1891	1880	2521	2256	3025	2256	3025	1800			
ZF W17110	2.821, 3.516, 4.185, 4.600, 5.087, 5.364, 5.667	2.0000	2.6820	1500	2012	2000	2682	2400	3218	2400	3218	1600	5350	11795	
	6.000	1.8800	2.5211	1410	1891	1880	2521	2256	3025	2256	3025	1600			
ZF W17110 NR	2.821, 3.516, 4.185, 4.600, 5.087, 5.364	2.2500	3.0173	1688	2263	2250	3017	2700	3620	2700	3620	1800	4750	10472	
ZF W17130	2.821, 3.516, 4.185, 4.600, 5.087, 5.364	2.1300	2.8564	1598	2142	2130	2856	2556	3427	2556	3427	1600	5420	11949	
	5.667	2.0740	2.7813	1555	2086	2074	2781	2489	3337	2489	3337	1600			
ZF W17130 NR CEW ⁷	2.821, 3.516, 4.185, 4.600	2.4740	3.3177	1856	2488	2474	3318	2969	3981	2969	3981	1800	4790	10560	
	5.087	2.4010	3.2198	1801	2415	2401	3220	2881	3863	2881	3863	1800			
ZF W17150	2.821, 3.516, 4.185, 4.600, 5.087, 5.364	2.2500	3.0173	1688	2263	2250	3017	2700	3620	2700	3620	1600	5420	11949	
ZF W17150 NR CEW ⁷	2.821, 3.516, 4.185, 4.600	2.6670	3.5765	2000	2682	2667	3577	3200	4291	3200	4291	1800	4790	10560	
ZF W17200	3.436, 4.258, 5.037, 5.520, 6.087, 6.409, 6.762, 7.150	1.8500	2.4809	1388	1861	1850	2481	2220	2977	2220	2977	1600	5800	12787	

⁷ EW version on request.

Continuous Duty Single Speed



PRODUCT	Ratios	Power factor		Input power capacity						Max. kW	Max. hp	Max. rpm	Weight		Bell hgs. & notes
		kW/rpm	hp/rpm	750 rpm		1000 rpm		1200 rpm					kg	lb	
ZF W17200 NR	3.436, 4.258, 5.037, 5.520, 6.087, 6.409	2.1300	2.8564	1598	2142	2130	2856	2556	3427	2556	3427	1800	5250	11574	
	6.762	2.0740	2.7813	1555	2086	2074	2781	2489	3337	2489	3337	1800			
	7.150	1.8800	2.5211	1410	1891	1880	2521	2256	3025	2256	3025	1800			
ZF W17210	3.436, 4.258, 5.037, 5.520, 6.087, 6.409, 6.762	2.0000	2.6820	1500	2012	2000	2682	2400	3218	2400	3218	1600	5800	12787	
	7.150	1.8800	2.5211	1410	1891	1880	2521	2256	3025	2256	3025	1600			
ZF W17210 NR	3.436, 4.258, 5.037, 5.520, 6.087, 6.409	2.2500	3.0173	1688	2263	2250	3017	2700	3620	2700	3620	1800	5250	11574	
ZF W17230	3.436, 4.258, 5.037, 5.520, 6.087, 6.409	2.1300	2.8564	1598	2142	2130	2856	2556	3427	2556	3427	1600	5870	12941	
	6.762	2.0740	2.7813	1555	2086	2074	2781	2489	3337	2489	3337	1600			
ZF W17230 NR CEW ⁷	3.436, 4.258, 5.037, 5.520	2.4740	3.3177	1856	2488	2474	3318	2969	3981	2969	3981	1800	5290	11662	
	6.087	2.4010	3.2198	1801	2415	2401	3220	2881	3863	2881	3863	1800			
ZF W17250	3.436, 4.258, 5.037, 5.520, 6.087, 6.409	2.2500	3.0173	1688	2263	2250	3017	2700	3620	2700	3620	1600	5870	12941	
ZF W17250 NR CEW ⁷	3.436, 4.258, 5.037, 5.520	2.6670	3.5765	2000	2682	2667	3577	3200	4291	3200	4291	1800	5290	11662	
				1200 rpm		1600 rpm		1800 rpm							
ZF 23560 C (iSG=1.000)	1.721, 2.278, 2.839, 3.577	1.7801	2.3872	2136	2865	2848	3820	3204	4297	3204	4297	1800	2600	5732	
ZF 23560 C (iSG=1.130)	4.042	1.5754	2.1126	1890	2535	2521	3380	2836	3803	2836	3803	1800	2600	5732	
ZF 23560 C (iSG=1.273)	4.552*	1.3984	1.8753	1678	2250	2237	3000	2517	3376	2517	3376	1800	2600	5732	
ZF 23560 C (iSG=1.432)	5.122*	1.2429	1.6668	1491	2000	1989	2667	2237	3000	2237	3000	1800	2600	5732	
				500 rpm		600 rpm		700 rpm							
ZF 23860 C (iSG=0.574)	0.697, 0.847, 1.121, 1.397, 1.760	3.1010	4.1585	1551	2079	1861	2495	2171	2911	3101	4159	1000	2600	5732	
ZF 23860 C (iSG=0.493)	0.697*, 0.847*, 1.121*, 1.397*, 1.760*	3.6178	4.8515	1809	2426	2171	2911	2532	3396	3075	4124	850	2600	5732	
				1200 rpm		1600 rpm		1800 rpm							
ZF 24060 D ^{9, 16}	1.514*, 1.583*, 2.032, 2.207*, 2.357*, 2.577, 2.760*, 3.043, 3.476	1.7801	2.3872	2136	2865	2848	3820	3204	4297	3204	4297	1800	2650	5842	
	3.947*	1.6105	2.1597	1933	2592	2577	3456	2899	3887	2899	3887	1800			

⁷ EW version on request.

⁹ Left and Right version available.

¹⁶ PTI (Hybrid) or Integrated Shaft Brake also available.

* Special Order Ratio.

Continuous Duty Single Speed



PRODUCT	Ratios	Power factor		Input power capacity						Max. kW	Max. hp	Max. rpm	Weight		Bell hgs. & notes
		kW/rpm	hp/rpm	1200 rpm		1600 rpm		1800 rpm					kg	lb	
ZF 24060 NR2	1.514*, 1.583*, 2.032, 2.207*, 2.357*, 2.577, 2.760*, 3.043, 3.476	1.7801	2.3872	2136	2865	2848	3820	3204	4297	3204	4297	1800	1890	4167	
	3.947*	1.6105	2.1597	1933	2592	2577	3456	2899	3887	2899	3887	1800			
ZF 24060 NR2B	1.514*, 1.583*, 2.032, 2.207*, 2.357*, 2.577, 2.760*, 3.043, 3.476	1.7801	2.3872	2136	2865	2848	3820	3204	4297	3204	4297	1800	1890	4167	
	3.947*	1.6105	2.1597	1933	2592	2577	3456	2899	3887	2899	3887	1800			
ZF 24060 NR2H ⁹	1.514*, 1.583*, 2.032, 2.207*, 2.357*, 2.577, 2.760*, 3.043, 3.476	1.7801	2.3872	2136	2865	2848	3820	3204	4297	3204	4297	1800	1860	4101	
	3.947*	1.6105	2.1597	1933	2592	2577	3456	2899	3887	2899	3887	1800			
ZF 24060 SGC ¹⁶ (iSG=1.000)	1.514*, 1.583*, 2.032, 2.207*, 2.357*, 2.577, 2.760*, 3.043, 3.476	1.7801	2.3872	2136	2865	2848	3820	3204	4297	3204	4297	1800	3250	7165	
	3.947*	1.6105	2.1597	1933	2592	2577	3456	2899	3887	2899	3887	1800			
ZF 24060 SGC ¹⁶ (iSG=1.173)	4.630	1.3729	1.8411	1647	2209	2197	2946	2471	3314	2471	3314	1800	3250	7165	
ZF 24060 SGC ¹⁶ (iSG=1.280)	5.052	1.2582	1.6873	1510	2025	2013	2700	2265	3037	2265	3037	1800	3250	7165	
ZF 24060 SGC ¹⁶ (iSG=1.354)	5.344	1.1894	1.5950	1427	1914	1903	2552	2141	2871	2141	2871	1800	3250	7165	
ZF 24360 D ^{8, 9, 16}	4.036, 5.087, 5.950	1.7801	2.3872	2136	2865	2848	3820	3204	4297	3204	4297	1800	3870	8532	
	6.421	1.6105	2.1597	1933	2592	2577	3456	2899	3887	2899	3887	1800			
ZF 24360 SG ^{8, 9, 16} (iSG=1.000)	4.036, 5.087, 5.950	1.7801	2.3872	2136	2865	2848	3820	3204	4297	3204	4297	1800	4500	9921	
	6.421	1.6105	2.1597	1933	2592	2577	3456	2899	3887	2899	3887	1800			
ZF 24360 SG ^{8, 9, 16} (iSG=1.173)	6.980	1.5176	2.0351	1821	2442	2428	3256	2732	3663	2732	3663	1800	4500	9921	
ZF 24360 SG ^{8, 9, 16} (iSG=1.280)	7.616	1.3907	1.8650	1669	2238	2225	2984	2503	3357	2503	3357	1800	4500	9921	
ZF 24360 SG ^{8, 9, 16} (iSG=1.354)	8.056	1.3147	1.7630	1578	2116	2104	2821	2366	3173	2366	3173	1800	4500	9921	
	8.694	1.1894	1.5950	1427	1914	1903	2552	2141	2871	2141	2871	1800			
				900 rpm		1000 rpm		1100 rpm							
ZF 30050 NR2 ¹⁰	1.514*, 1.583*, 1.735, 1.906, 2.032, 2.207*	2.3239	3.1164	2092	2805	2324	3116	2556	3428	2556	3428	1100	1900	4189	
ZF 30050 NR2B ¹⁰	1.514*, 1.583*, 1.735, 1.906, 2.032, 2.207*	2.3239	3.1164	2092	2805	2324	3116	2556	3428	2556	3428	1100	1900	4189	
ZF 30050 NR2H ^{9, 10}	1.514*, 1.583*, 1.735, 1.906, 2.032, 2.207*	2.3239	3.1164	2092	2805	2324	3116	2556	3428	2556	3428	1100	1870	4123	

¹⁰ Intermittent operation with some variations in engine speed and power, 5000 hours/year.

¹⁶ PTI (Hybrid) or Integrated Shaft Brake also available.

* Special Order Ratio.

⁸ U-drive version also available.

⁹ Left and Right version available.

Continuous Duty Single Speed



PRODUCT	Ratios	Power factor		Input power capacity						Max. kW	Max. hp	Max. rpm	Weight		Bell hgs. & notes
		kW/rpm	hp/rpm	1000 rpm		1200 rpm		1380 rpm					kg	lb	
ZF 30050 SGC ¹⁶ (iSG=0.759)	1.542, 1.955, 2.483	2.3465	3.1467	2347	3147	2816	3776	3238	4342	3238	4342	1380	3250	7165	
	2.807	2.2347	2.9968	2235	2997	2682	3596	3084	4136	3084	4136	1380			
	2.994	2.1229	2.8469	2123	2847	2547	3416	2930	3929	2930	3929	1380			
ZF 30350 SG ^{8, 9, 16} (iSG=0.759)	3.062, 4.514	2.3465	3.1467	2347	3147	2816	3776	3238	4342	3238	4342	1380	4575	10086	
	4.871	2.1229	2.8469	2123	2847	2547	3416	2930	3929	2930	3929	1380			
				600 rpm		750 rpm		1000 rpm							
ZF W33100 NC2 ⁵	2.485	4.6820	6.2787	2809	3767	3512	4709	4682	6278	4682	6278	1300	4500	9921	
	2.966	4.2300	5.6725	2538	3404	3173	4254	4230	5672	4230	5672	1300			
	3.423	3.8000	5.0959	2280	3058	2850	3822	3800	5095	3800	5095	1300			
	3.714	3.5260	4.7284	2116	2837	2645	3546	3526	4728	3526	4728	1300			
	4.273	3.3470	4.4884	2008	2693	2510	3366	3347	4488	3347	4488	1300			
	4.524	3.2670	4.3811	1960	2629	2450	3286	3267	4381	3267	4381	1300			
	4.708	3.2080	4.3020	1925	2581	2406	3226	3208	4301	3208	4301	1300			
	4.957	3.1290	4.1961	1877	2518	2347	3147	3129	4196	3129	4196	1300			
	5.318	3.0130	4.0405	1808	2424	2260	3030	3013	4040	3013	4040	1300			
ZF W33100 NR2 ⁵	2.485, 2.966, 3.423	3.8000	5.0959	2280	3058	2850	3822	3800	5095	3800	5095	1300	6080	13404	
	3.714	3.5260	4.7284	2116	2837	2645	3546	3526	4728	3526	4728	1300			
	4.273	3.3470	4.4884	2008	2693	2510	3366	3347	4488	3347	4488	1300			
	4.524	3.2670	4.3811	1960	2629	2450	3286	3267	4381	3267	4381	1300			
	4.708	3.2080	4.3020	1925	2581	2406	3226	3208	4301	3208	4301	1300			
	4.957	3.1290	4.1961	1877	2518	2347	3147	3129	4196	3129	4196	1300			
	5.318	3.0130	4.0405	1808	2424	2260	3030	3013	4040	3013	4040	1300			
	5.900	2.8270	3.7911	1696	2275	2120	2843	2827	3791	2827	3791	1300			
				900 rpm		1000 rpm		1100 rpm							
ZF 40060 NR2 ¹⁰	1.514*, 1.583*, 1.735, 1.906	3.0487	4.0884	2744	3680	3049	4088	3354	4497	3354	4497	1100	2010	4431	
ZF 40060 NR2B ¹⁰	1.514*, 1.583*, 1.735, 1.906	3.0487	4.0884	2744	3680	3049	4088	3354	4497	3354	4497	1100	2010	4431	
ZF 40060 NR2H ^{9, 10}	1.514*, 1.583*, 1.735, 1.906	3.0487	4.0884	2744	3680	3049	4088	3354	4497	3354	4497	1100	1880	4145	

⁵ Classification: on request. In most cases standard ratings are accepted by major classification bureau. Ratings are valid for application without class notation.

⁸ U-drive version also available.

⁹ Left and Right version available.

¹⁰ Intermittent operation with some variations in engine speed and power, 5000 hours/year.

¹⁶ PTI (Hybrid) or Integrated Shaft Brake also available.

* Special Order Ratio.

Continuous Duty Single Speed



PRODUCT	Ratios	Power factor		Input power capacity						Max. kW	Max. hp	Max. rpm	Weight		Bell hgs. & notes
		kW/rpm	hp/rpm	700 rpm		800 rpm		940 rpm					kg	lb	
ZF 40060 SGC ¹⁶ (iSG=0.522)	1.588	3.4102	4.5732	2387	3201	2728	3659	3206	4299	3206	4299	940	3260	7187	
ZF 40360 SG ^{8, 9, 16} (iSG=0.522)	2.107, 2.655, 3.106	3.4102	4.5732	2387	3201	2728	3659	3206	4299	3206	4299	940	4625	10196	
	3.352	3.0852	4.1373	2160	2896	2468	3310	2900	3889	2900	3889	940			
ZF W43000 NC2 ⁵	2.536	5.8000	7.7779	3480	4667	4350	5833	5800	7778	6276	8416	1300	5400	11905	
	2.960	5.2000	6.9733	3120	4184	3900	5230	5200	6973	5817	7800	1300			
	3.667	4.3320	5.8093	2599	3486	3249	4357	4332	5809	5410	7254	1300			
	3.714	4.2740	5.7315	2564	3439	3206	4299	4274	5732	5200	6973	1300			
	3.950	3.9840	5.3426	2390	3206	2988	4007	3984	5343	4613	6186	1300			
	4.409	3.4200	4.5863	2052	2752	2565	3440	3420	4586	4446	5962	1300			
ZF W43000 NR2 ⁵	2.536, 2.960	5.2000	6.9733	3120	4184	3900	5230	5200	6973	5200	6973	1300	6400	14110	
	3.667	4.3320	5.8093	2599	3486	3249	4357	4332	5809	5200	6973	1300			
	3.714	4.2740	5.7315	2564	3439	3206	4299	4274	5732	5200	6973	1300			
	3.950	3.9840	5.3426	2390	3206	2988	4007	3984	5343	4613	6186	1300			
	4.409	3.4200	4.5863	2052	2752	2565	3440	3420	4586	4446	5962	1300			
ZF W43100 NC2 ⁵	2.516	6.2760	8.4163	3766	5050	4707	6312	6276	8416	6276	8416	1300	6800	14991	
	3.037	5.8170	7.8007	3490	4680	4363	5851	5817	7800	5817	7800	1300			
	3.500	5.4100	7.2549	3246	4353	4058	5441	5410	7254	5410	7254	1300			
	3.739	5.2000	6.9733	3120	4184	3900	5230	5200	6973	5200	6973	1300			
	4.400	4.6130	6.1861	2768	3712	3460	4640	4613	6186	4613	6186	1300			
	4.478	4.5490	6.1003	2729	3660	3412	4575	4549	6100	4549	6100	1300			
	4.609	4.4340	5.9461	2660	3568	3326	4460	4434	5946	4434	5946	1300			
	4.684	4.3680	5.8576	2621	3515	3276	4393	4368	5857	4368	5857	1300			
	4.952	4.1320	5.5411	2479	3325	3099	4156	4132	5541	4132	5541	1300			
	6.238	3.0000	4.0231	1800	2414	2250	3017	3000	4023	3000	4023	1300			

⁵ Classification: on request. In most cases standard ratings are accepted by major classification bureau. Ratings are valid for application without class notation.

⁸ U-drive version also available.

⁹ Left and Right version available.

¹⁶ PTI (Hybrid) or Integrated Shaft Brake also available.

Continuous Duty Single Speed



PRODUCT	Ratios	Power factor		Input power capacity						Max. kW	Max. hp	Max. rpm	Weight		Bell hgs. & notes
		kW/rpm	hp/rpm	600 rpm		750 rpm		1000 rpm					kg	lb	
ZF W43100 NR2 ⁵	2.516, 3.037, 3.500, 3.739	5.2000	6.9733	3120	4184	3900	5230	5200	6973	5200	6973	1300	9300	20503	
	4.400	4.6130	6.1861	2768	3712	3460	4640	4613	6186	4613	6186	1300			
	4.478	4.5490	6.1003	2729	3660	3412	4575	4549	6100	4549	6100	1300			
	4.609	4.4340	5.9461	2660	3568	3326	4460	4434	5946	4434	5946	1300			
	4.684	4.3680	5.8576	2621	3515	3276	4393	4368	5857	4368	5857	1300			
	4.952	4.1320	5.5411	2479	3325	3099	4156	4132	5541	4132	5541	1300			
	6.238	3.0000	4.0231	1800	2414	2250	3017	3000	4023	3000	4023	1300			
ZF 53000 NR2B ¹⁰	1.302, 1.487, 1.694, 1.771, 1.853, 1.912, 2.129, 2.464	5.6000	7.5097	750 rpm		900 rpm		1000 rpm		5600	7509	1350	3900	8598	
				4200	5632	5040	6759	5600	7509						
ZF 53000 NR2H ^{9,10}	1.302, 1.487, 1.694, 1.771, 1.853, 1.912, 2.129, 2.464	5.6000	7.5097	4200	5632	5040	6759	5600	7509	5600	7509	1350	3750	8267	
ZF 53500 NR2B ¹⁰	1.302, 1.487, 1.694, 1.771, 1.853, 1.912, 2.129, 2.464	7.3298	9.8294	5497	7372	6597	8846	7329	9828	7329	9828	1350	3980	8774	
ZF 53500 NR2H ^{9,10}	1.302, 1.487, 1.694, 1.771, 1.853, 1.912, 2.129, 2.464	7.3298	9.8294	5497	7372	6597	8846	7329	9828	7329	9828	1350	3825	8433	
ZF 53800 NR2B ¹⁰	1.302, 1.487, 1.694, 1.771, 1.853, 1.912, 2.129	8.0000	10.7282	6000	8046	7200	9655	8000	10728	8000	10728	1350	4080	8995	
ZF 53800 NR2H ^{9,10}	1.302, 1.487, 1.694, 1.771, 1.853, 1.912, 2.129	8.0000	10.7282	6000	8046	7200	9655	8000	10728	8000	10728	1350	3925	8653	
ZF 60000 NR2H ⁹	1.500, 2.125, 2.226, 2.741	9.1000	12.2033	6825	9152	8190	10983	9100	12203	9100	12203	1350	4650	10251	
ZF 60500 NR2H ⁹	1.500, 2.125, 2.226, 2.367	10.0000	13.4102	7500	10058	9000	12069	10000	13410	10000	13410	1350	4650	10251	
ZF W63000 NR2 ⁵	2.481, 2.917	7.2800	9.7626	4368	5858	5460	7322	7280	9763	7280	9763	1000	9200	20283	
	3.476	6.0247	8.0793	3615	4848	4519	6059	6025	8079	6025	8079	1000			
	3.700	5.4240	7.2737	3254	4364	4068	5455	5424	7274	5424	7274	1000			
	4.000	4.6123	6.1852	2767	3711	3459	4639	4612	6185	4612	6185	1000			
	4.154	4.3203	5.7936	2592	3476	3240	4345	4320	5794	4320	5794	1000			
	4.500	3.6644	4.9140	2199	2948	2748	3686	3664	4914	3664	4914	1000			

⁵ Classification: on request. In most cases standard ratings are accepted by major classification bureau. Ratings are valid for application without class notation.

⁹ Left and Right version available.

¹⁰ Intermittent operation with some variations in engine speed and power, 5000 hours/year.

Continuous Duty Single Speed



PRODUCT	Ratios	Power factor		Input power capacity						Max. kW	Max. hp	Max. rpm	Weight		Bell hgs. & notes
		kW/rpm	hp/rpm	600 rpm		750 rpm		1000 rpm					kg	lb	
ZF W63000 NR2H ^{5,9}	2.481, 2.917	7.2800	9.7626	4368	5858	5460	7322	7280	9763	7280	9763	1000	9900	21826	
	3.476	6.0247	8.0793	3615	4848	4519	6059	6025	8079	6025	8079	1000			
	3.700	5.4240	7.2737	3254	4364	4068	5455	5424	7274	5424	7274	1000			
	4.000	4.6123	6.1852	2767	3711	3459	4639	4612	6185	4612	6185	1000			
	4.154	4.3203	5.7936	2592	3476	3240	4345	4320	5794	4320	5794	1000			
	4.500	3.6644	4.9140	2199	2948	2748	3686	3664	4914	3664	4914	1000			
ZF W83000 NC2 ⁵				500 rpm		600 rpm		750 rpm					9270	20437	
	2.536	10.8500	14.5501	5425	7275	6510	8730	8138	10913	8138	10913	750			
	2.960	10.0000	13.4102	5000	6705	6000	8046	7500	10058	7500	10058	750			
	3.261	8.9829	12.0463	4491	6023	5390	7228	6737	9035	6737	9035	750			
	3.500	8.1766	10.9650	4088	5483	4906	6579	6132	8224	6132	8224	750			
	3.900	6.7728	9.0825	3386	4541	4064	5450	5080	6812	5080	6812	750			
	4.300	5.6203	7.5369	2810	3768	3372	4522	4215	5653	4215	5653	750			
4.591	4.8426	6.4940	2421	3247	2906	3896	3632	4871	3632	4871	750				
ZF W83100 NC2 ⁵	2.486	11.5100	15.4352	5755	7718	6906	9261	8633	11576	8633	11576	750	14800	32628	
	3.031	10.7600	14.4294	5380	7215	6456	8658	8070	10822	8070	10822	750			
	3.300	10.2000	13.6784	5100	6839	6120	8207	7650	10259	7650	10259	750			
	3.962	9.6001	12.8739	4800	6437	5760	7724	7200	9655	7200	9655	750			
	4.333	8.9651	12.0224	4483	6011	5379	7213	6724	9017	6724	9017	750			
	4.609	8.4927	11.3889	4246	5694	5096	6833	6370	8542	6370	8542	750			
	4.818	8.1922	10.9859	4096	5493	4915	6592	6144	8239	6144	8239	750			
	5.095	7.6629	10.2761	3831	5138	4598	6166	5747	7707	5747	7707	750			
	5.450	6.8613	9.2012	3431	4601	4117	5521	5146	6901	5146	6901	750			
	5.950	5.7110	7.6586	2856	3829	3427	4595	4283	5744	4283	5744	750			
	6.364	5.1711	6.9346	2586	3467	3103	4161	3878	5201	3878	5201	750			

⁵ Classification: on request. In most cases standard ratings are accepted by major classification bureau. Ratings are valid for applications without class notation.

⁹ Left and Right version available.

Continuous Duty Single Speed



PRODUCT	Ratios	Power factor		Input power capacity						Max. kW	Max. hp	Max. rpm	Weight		Bell hgs. & notes
		kW/rpm	hp/rpm	500 rpm		600 rpm		750 rpm					kg	lb	
ZF W83100 NR2 ⁵	2.486, 3.031, 3.300	10.2000	13.6784	5100	6839	6120	8207	7650	10259	7650	10259	750	16600	36597	
	3.962	9.6001	12.8739	4800	6437	5760	7724	7200	9655	7200	9655	750			
	4.333	8.9651	12.0224	4483	6011	5379	7213	6724	9017	6724	9017	750			
	4.609	8.4927	11.3889	4246	5694	5096	6833	6370	8542	6370	8542	750			
	4.818	8.1922	10.9859	4096	5493	4915	6592	6144	8239	6144	8239	750			
	5.095	7.6629	10.2761	3831	5138	4598	6166	5747	7707	5747	7707	750			
	5.450	6.8613	9.2012	3431	4601	4117	5521	5146	6901	5146	6901	750			
	5.950	5.7110	7.6586	2856	3829	3427	4595	4283	5744	4283	5744	750			
	6.364	5.1711	6.9346	2586	3467	3103	4161	3878	5201	3878	5201	750			
ZF 83700 NR2H ^{9, 10}	2.867, 3.462, 4.227, 4.800	8.0000	10.7282	8000	10728	9200	12337	10400	13946	10400	13946	1350	15500	34172	
	5.042*	7.6160	10.2132	7616	10213	8758	11745	9900	13276	9900	13276	1350			
	5.591	6.7200	9.0117	6720	9012	7728	10363	8736	11715	8736	11715	1350			
ZF 83750 NR2H ^{9, 10}	2.867, 3.462, 4.227	10.0000	13.4102	9000	12069	10000	13410	11500	15421	11500	15421	1350	15500	34172	
	4.800	9.0800	12.1765	8172	10959	9080	12177	10442	14002	10442	14002	1350			
	5.042*	8.6860	11.6481	7817	10483	8686	11648	9989	13395	9989	13395	1350			
	5.591	7.8000	10.4600	7020	9414	7800	10460	8970	12028	8970	12028	1350			
ZF W93300 NC2 ⁵	2.486	17.2778	23.1699	8639	11585	9503	12743	10367	13902	10367	13902	600	21000	46297	
	3.161	15.4000	20.6517	7700	10326	8470	11358	9240	12391	9240	12391	600			
	3.516	14.4200	19.3375	7210	9669	7931	10636	8652	11603	8652	11603	600			
	3.929	12.7700	17.1249	6385	8562	7024	9419	7662	10275	7662	10275	600			
	4.545	11.5820	15.5317	5791	7766	6370	8542	6949	9319	6949	9319	600			
	5.000	10.3230	13.8434	5162	6922	5678	7614	6194	8306	6194	8306	600			
	5.789	8.1035	10.8670	4052	5434	4457	5977	4862	6520	4862	6520	600			
ZF W103100 NC2 ⁵	2.438	24.0000	32.1845	9600	12874	10272	13775	12000	16092	12000	16092	500	27000	59525	
	3.231	22.7340	30.4868	9094	12195	9730	13048	11367	15243	11367	15243	500			
	3.583	20.8000	27.8933	8320	11157	8902	11938	10400	13947	10400	13947	500			
	4.000	19.4910	26.1379	7796	10455	8342	11187	9746	13069	9746	13069	500			
	4.238	18.2000	24.4066	7280	9763	7790	10446	9100	12203	9100	12203	500			

⁵ Classification: on request. In most cases standard ratings are accepted by major classification bureau. Ratings are valid for applications without class notation.

⁹ Left and Right version available.

¹⁰ Intermittent operation with some variations in engine speed and power, 5000 hours/year.

* Special Order Ratio.

PTO options

ZF W33100 – ZF W103100 family*

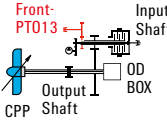
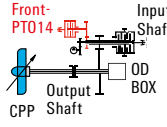
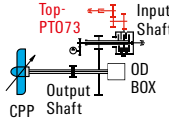
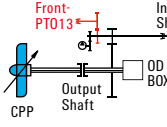
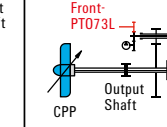
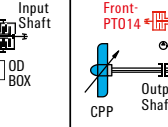
SERIES	INTEGRATED FRONT PTO		INTEGRATED TOP PTO	INTEGRATED FRONT PTO		
	Propeller driven	Propeller driven	Engine driven	Engine driven	Engine driven	Engine driven
	No Clutch	Clutch	No Clutch	No Clutch	No Clutch	Clutch
						
ZF W103100 NC2				x	x	x
ZF W93300 NC2				x	x	x
ZF W83100 NR2		x	x		x	
ZF W83100 NC2				x	x	x
ZF W83000 NC2				x	x	x
ZF W63000 NR2			x		x	
ZF W63000 NR2H			x		x	
ZF 53600 NR2H			x		x	
ZF 43700 NR2			x		x	
ZF 43600 NR2	x	x	x		x	
ZF W43100 NR2			x		x	
ZF W43100 NC2				x	x	x
ZF W43000 NR2	x	x	x		x	
ZF W43000 NC2				x	x	
ZF 33700 NR2			x		x	
ZF W33100 NR2			x		x	
ZF W33100 NC2				x	x	

* For maximum combinations please contact ZF Marine representative.

PTO / PTI / shaft brake options ZF W10000 – ZF W17000 family*

SERIES	FRONT PTI / PTO		FRONT PTO			
	Propeller driving / driven		Propeller driven			
	Clutch		Clutch			
	<p>Front-PTO24</p>	<p>Front-PTI24S</p>	<p>Front-PTO23</p>	<p>Front-PTO83</p>	<p>Front-PTO81</p>	<p>Front-PTO73L</p>
ZF W17000 ZF W17100 ZF W17200 all versions			X ratios: 0.310 0.389 0.415 0.490 0.500 0.511 0.604 0.667 0.810 0.900 1.000 1.054 1.200 1.333 1.621	X ratios: 0.310 0.389 0.415 0.490 0.500 0.511 0.604 0.667 0.810 0.900 1.000 1.054 1.200 1.333 1.621	X	X ratios: 0.299 0.378 0.449 0.500 0.548 0.662* 0.794* 0.883*
ZF W17000 NR CEW ZF W17100 NR CEW ZF W17200 NR CEW all versions		X ratios: 0.617 0.750 0.833 0.949 1.000 1.111 1.235 1.500 1.655 1.815 2.000 2.040 2.409 2.517 3.222	X ratios: 0.310 0.389 0.415 0.490 0.500 0.511 0.604 0.667 0.810 0.900 1.000 1.054 1.200 1.333 1.621	X ratios: 0.310 0.389 0.415 0.490 0.500 0.511 0.604 0.667 0.810 0.900 1.000 1.054 1.200 1.333 1.621	X	X ratios: 0.299 0.378 0.449 0.500 0.548 0.662* 0.794* 0.883*
ZF W11000 ZF W11100 ZF W11200 all versions	X a=170 ratios: 0.417 0.500 0.585 0.667 0.809 1.000 1.075 1.211 1.400 1.500 a=200 ratios: 0.419 0.500 0.673 0.813 1.000 1.071 1.200 1.389		X a=170 ratios: 0.417 0.500 0.585 0.667 0.809 1.000 1.075 1.211 1.400 1.500 a=200 ratios: 0.419 0.500 0.673 0.813 1.000 1.071 1.200 1.389	X a=170 ratios: 0.417 0.500 0.585 0.667 0.809 1.000 1.075 1.211 1.400 1.500	X 1	X ratios: 0.392 0.511 0.605 0.732 0.889 also valid for Front-PTO83L (same as Front-PTO73L, but located at intermediate shaft)
ZF W10000 ZF W10100 ZF W10200 all versions	X a=170 ratios: 0.417 0.500 0.585 0.667 0.809 1.000 1.075 1.211 1.400 1.500		X a=170 ratios: 0.417 0.500 0.585 0.667 0.809 1.000 1.075 1.211 1.400 1.500	X a=170 ratios: 0.417 0.500 0.585 0.667 0.809 1.000 1.075 1.211 1.400 1.500	X 1	X ratios: 0.392 0.511 0.605 0.732 0.889

* For maximum combinations please contact
ZF Marine representative.

PTO / PTI / shaft brake options ZF W10000 – ZF W17000 family*

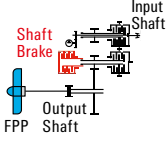
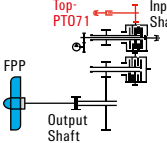
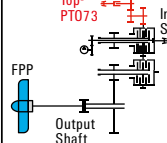
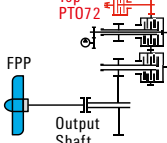
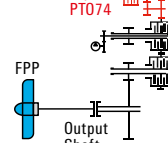
SERIES	INTEGRATED PROPELLER SHAFT BRAKE	TOP PTO		TOP PTO	
		Engine driven		Engine driven	
		No Clutch		Clutch	
					
ZF W17000 ZF W17100 ZF W17200 all versions	X		X ratios: 0.401 0.415 0.498 0.559 0.570 0.598 0.671 0.792 0.830 0.889 1.000 1.071 1.199 1.209		
ZF W17000 NR CEW ZF W17100 NR CEW ZF W17200 NR CEW all versions	X		X ratios: 0.401 0.415 0.498 0.559 0.570 0.598 0.671 0.792 0.830 0.889 1.000 1.071 1.199 1.209		
ZF W11000 ZF W11100 ZF W11200 all versions	X	X ratios: 0.571 0.592 0.612 0.653 0.673 0.694 0.755 0.796 0.816	X ratios: 0.450 0.551 0.653 0.717 0.813 0.992 1.058 1.177 1.256	X ratios: 0.571 0.592 0.612 0.653 0.673 0.694 0.755 0.796 0.816	X ratios: 0.450 0.551 0.653 0.717 0.813 0.992 1.058 1.177 1.256
ZF W10000 ZF W10100 ZF W10200 all versions	X	X ratios: 0.592 0.612 0.653 0.694 0.735 0.755 0.796	X ratios: 0.517 0.592 0.592 0.653 0.813 0.889 0.992 1.058 1.177 1.256	X ratios: 0.592 0.612 0.653 0.694 0.735 0.755 0.796	X ratios: 0.517 0.592 0.592 0.653 0.813 0.889 0.992 1.058 1.177 1.256

* For maximum combinations please contact
ZF Marine representative.

Hybrid Systems

Contents

Power Range of Electric Motors for PTI Transmissions	page	248
Electric Motors	page	250
Frequency Converters	page	253
ZF Scope of Supply	page	254
Hybrid Operation Modes	page	255

Power Range of Electric Motors for PTI Transmissions

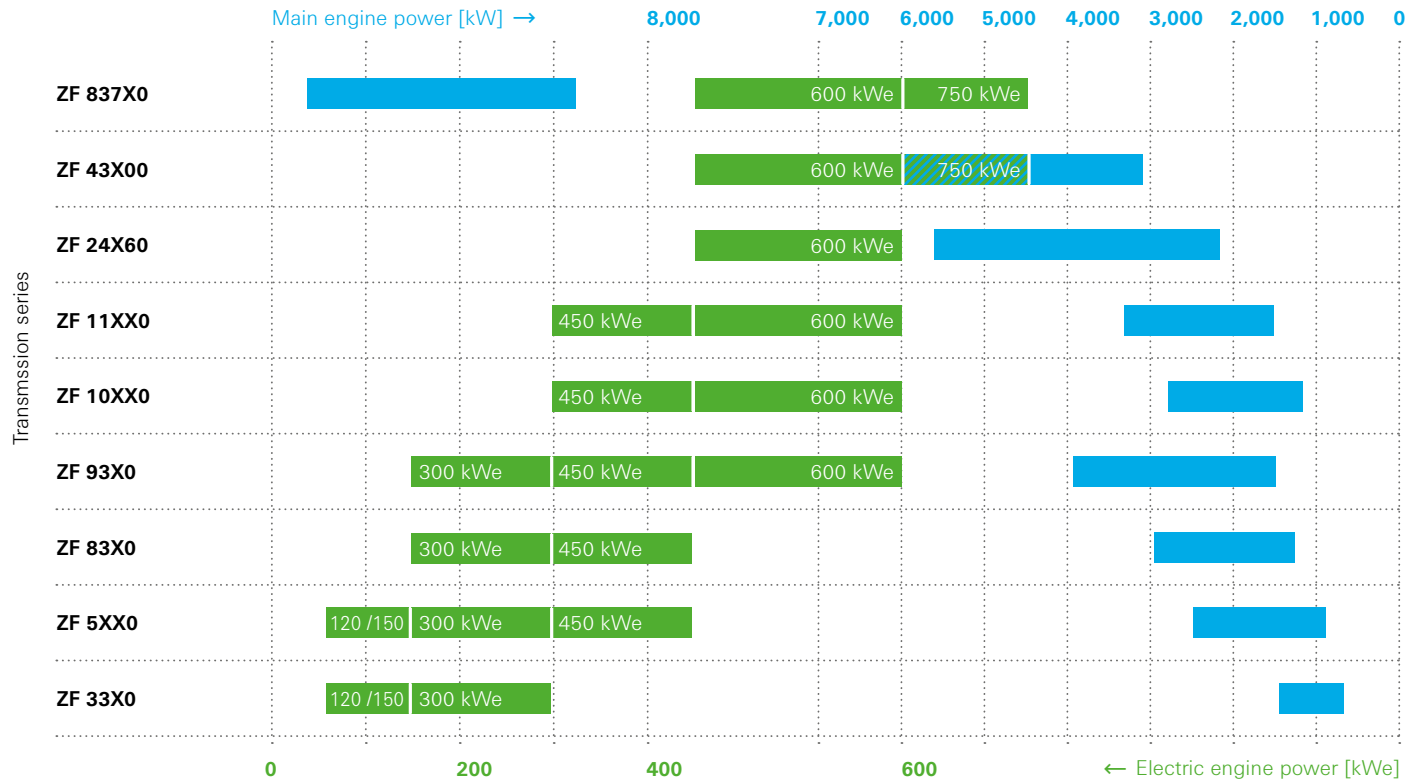

The matching of power take in (PTI), transmission with optional spur gear, frequency converter and e-motor is project-specific. Therefore consultancy by ZF is required for the final matching.

You can find details on our hybrid-ready transmissions in the respective section.

Electric Motors

(Permanent Magnet Machines)

PRODUCT	Operating speed rpm	Cooling method	Diameter		Length		Weight		Protection degree
			mm	in	mm	in	kg	lb	
150 kW	2700	Liquid cooled	450	17.7	368	14.5	172	379	IP65
300 kW	2900	Liquid cooled	450	17.7	548	21.6	295	650	IP65
450 kW	2100	Liquid cooled	648	25.5	598	23.5	490	1080	IP65
600 kW	1600	Liquid cooled	665	26.2	1040	40.9	950	2094	IP65
750 kW	1600	Liquid cooled	665	26.2	1040	40.9	950	2094	IP65



150 kW



450 kW



300 kW



600/750 kW

Electric Motors

(Asynchronous Machines)

Frequency Converters

(Liquid Cooled)

PRODUCT	120 kW*	
Operating speed	2500 rpm	
Cooling method	Liquid cooled	
Diameter	440 mm	17.3 in
Length	849 mm	33.4 in
Weight	270 kg	595 lb
Protection degree	IP6K9K	



PRODUCT	Dimensions		Weight	
	(WxDxH) mm	(WxDxH) in	kg	lb
120 kW	on request		on request	
150 kW	1560x640x2170	61.4x25.2x85.4	1100	2425
300 kW	1560x640x2170	61.4x25.2x85.4	1200	2646
450 kW	2060x840x2170	81.1x33.1x85.4	1400	3086
600 kW	2260x840x2170	89.0x33.1x85.4	1600	3527
750 kW	2260x840x2170	89.0x33.1x85.4	1600	3527

The dimensions and weights mentioned here are standard values for the electric drive mode, generator mode and boost mode. If required, adaptations can be arranged. The size and weight of the cabinet depends mainly on the requirements for filters and short circuit current protection .



*Only for non classified applications available.



Display



Maneuvering System



Control System

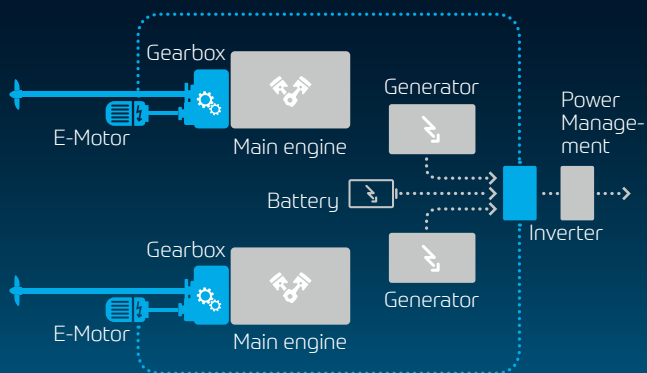

■ ZF Scope of Supply

■ Other Suppliers

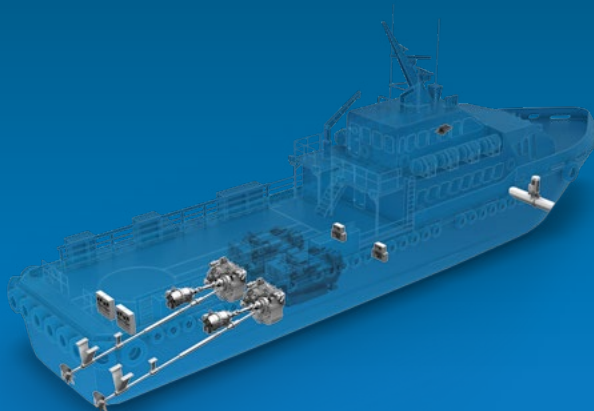

Engines can be operated in different modes depending on priorities

DIESEL DRIVE MODE

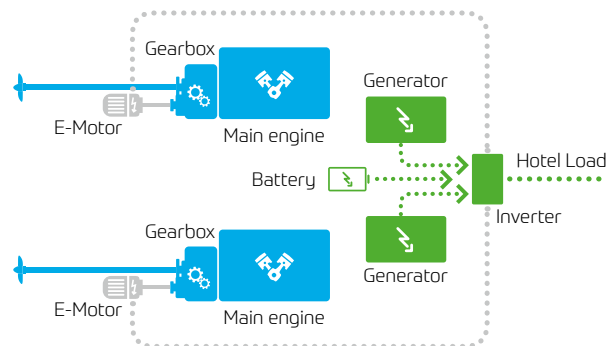

- E-Motor off, PTI disengaged
- Propulsion by main engine (diesel)
- Hotel load by main generator or battery*

BOOST MODE

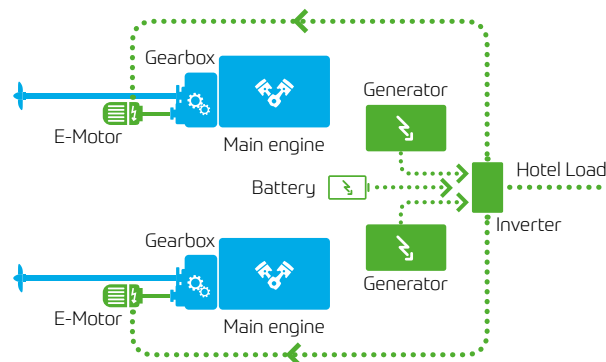

- Main engine (diesel) and main generator on
- Propulsion by E-motor and main engine (diesel)
- Powered by generator or battery*
- Hotel load by main generator or battery*

*if battery available

Hybrid Operation Modes

ELECTRIC DRIVE MODE

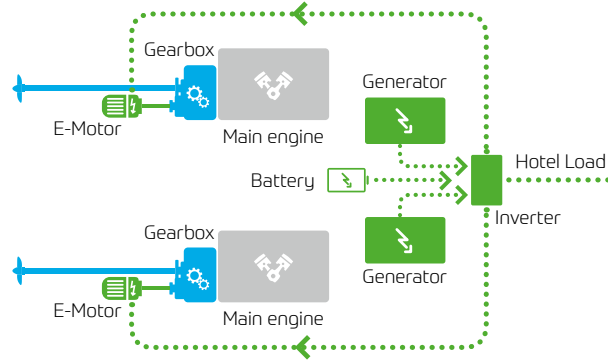

- Main engine (diesel) off
- Propulsion by E-motor
- Powered by main generator or battery*
- Hotel load by main generator or battery*

GENERATOR MODE

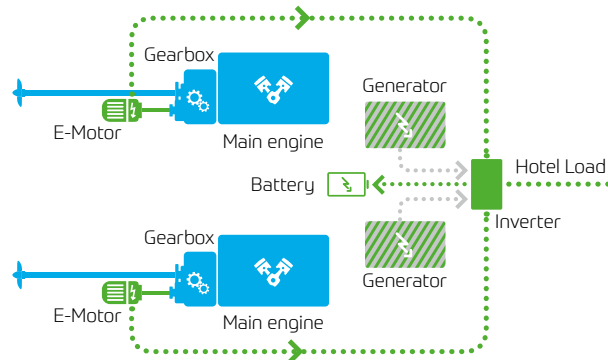

- Main engine (diesel) on
- Main generator supply only on demand
- Propulsion by main engine (diesel)
- E-motor as generator driven by main engine to load battery* or to supply hotel load

*if battery available

SPLIT MODE

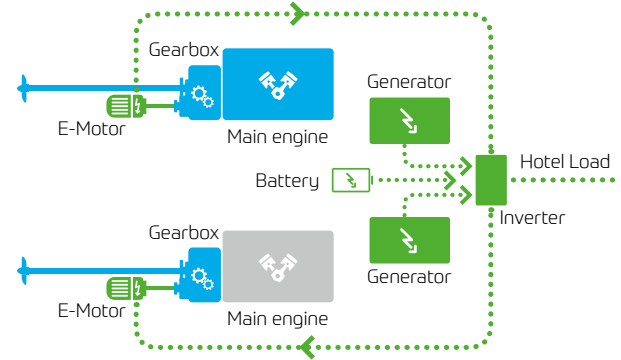

- One main engine (diesel) on
- One main engine (diesel) off
- Main generator on
- One E-motor as generator
- Propulsion by one main engine (diesel) and one E-motor
- Hotel load by main generator or battery*

RECUPERATION MODE

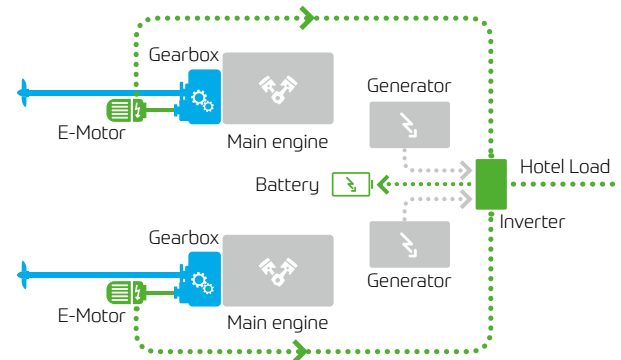

- Main engine (diesel) off
- Main generator off
- Vessel sailing
- E-Motor as generator driven by propeller to load battery* or to supply hotel load

Transmissions drawings and dimensions

PRODUCT	A		B1		B2		H1		H2		L		L2		L3		SAE BELL HSGS.	WEIGHT		OIL	
	mm	in	mm	in	mm	in	mm	in	mm	in	mm	in	mm	in	mm	in		kg	lb	L	US qt
ZF 12 M	72.0	2.83	80.0	3.15	134	5.28	122	4.80	89.0	3.50	192	7.56	60.0	2.36	33.0	1.30	4	13.0	29.0	0.600	0.640
ZF 15 M	72.0	2.83	80.0	3.15	134	5.28	122	4.80	89.0	3.50	193	7.60	60.0	2.36	33.0	1.30	4	13.0	29.0	0.600	0.640
ZF 25 M	85.0	3.35	96.0	3.78	149	5.87	139	5.47	93.0	3.66	218	8.58	65.0	2.56	33.0	1.30	4	18.5	41.0	0.750	0.800
ZF 30 M	90.0	3.54	103	4.07	149	5.87	144	5.67	94.0	3.70	254	10.0	62.5	2.46	-	-	-	23.0	51.0	1.00	1.06

Vertical Offset
Direct Mount

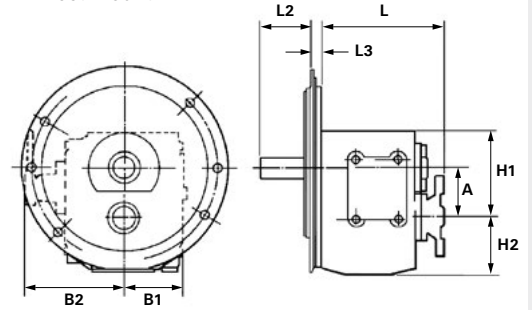

PRODUCT	ANGLE (°)	A		B1		B2		H1		H2		L		L2		L3		SAE BELL HSGS.	WEIGHT		OIL	
		mm	in	mm	in	mm	in	mm	in	mm	in	mm	in	mm	in	mm	in		kg	lb	L	US qt
ZF 15 MIV	15	147	5.79	80.0	3.15	133	5.24	106	4.17	197	7.76	265	10.4	60.0	2.36	33.0	1.30	4	20.0	44.0	1.00	1.06

V-Drive
Direct Mount

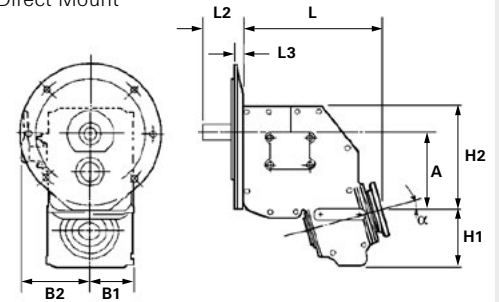

PRODUCT	ANGLE (°)	A		B1		B2		H1		H2		L		L2		L3		SAE BELL HSGS.	WEIGHT		OIL	
		mm	in	mm	in	mm	in	mm	in	mm	in	mm	in	mm	in	mm	in		kg	lb	L	US qt
ZF 15 MA	8	91.8	3.61	80.0	3.15	133	5.24	78.2	3.08	142	5.59	193	7.60	60.0	2.36	33.0	1.30	4	13.5	30.0	0.560	0.590
ZF 25 MA	8	110	4.33	96.0	3.78	149	5.87	84.3	3.32	164	6.46	223	8.78	65.0	2.56	33.0	1.30	4	21.0	46.0	0.750	0.800

Down Angle
Direct Mount

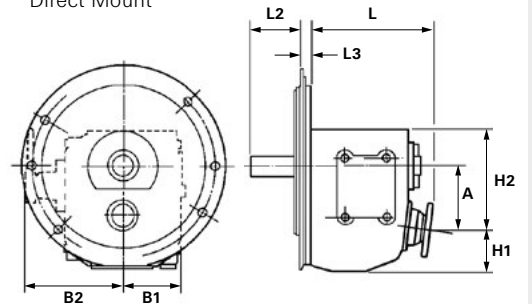

Transmissions drawings and dimensions

PRODUCT	ANGLE (°)	A		B1		B2		H1		H2		L		L1		L2		L3		SAE-BELL #HGS.	WEIGHT		OIL	
		mm	in	mm	in	mm	in	mm	in	mm	in	mm	in	mm	in	mm	in	mm	in		kg	lb	L	US qt
ZF 25 A	8	115	4.54	147	5.79	147	5.79	75.0	2.95	228	8.98	293	11.5	216	8.50	82.5	3.25	29.0	1.14	3	24.0	53.0	1.80	1.91
ZF 45 A	8	126	4.94	158	6.20	158	6.20	78.5	3.09	270	10.6	305	12.0	228	8.96	65.0	2.56	11.0	0.430	3	28.0	62.0	2.50	2.65
ZF 68 A	8	144	5.67	178	7.01	178	7.01	82.0	3.23	284	11.2	329	13.0	265	10.4	65.0	2.56	11.0	0.430	3	44.0	97.0	4.00	4.24
ZF 85 A	8	160	6.30	210	8.27	210	8.27	112	4.41	303	11.9	379	14.9	291	11.4	71.0	2.80	13.0	0.510	2	69.0	152	5.50	5.83
ZF 220 A	10	145	5.69	187	7.36	187	7.36	116	4.57	230	9.06	376	14.8	246	9.70	93.0	3.66	40.0	1.57	2	50.0	110	4.00	4.24
ZF 280-1 A	7	147	5.77	215	8.46	175	6.89	114	4.47	282	11.1	362	14.3	280	11.0	71.0	2.80	49.0	1.93	1	73.0	161	4.00	4.24
ZF 286 A	7	149	5.87	215	8.46	215	8.46	126	4.96	315	12.4	418	16.5	300	11.8	55.0	2.17	35.0	1.38	1	77.0	170	5.00	5.30
ZF 301-1 A	10	55.9	2.20	235	9.25	235	9.25	167	6.57	295	11.6	484	19.1	324	12.8	88.0	3.46	80.0	3.15	1	87.0	192	6.00	6.36
ZF 305-3 A	7	169	6.65	254	10.0	254	10.0	123	4.84	395	15.6	435	17.1	315	12.4	55.0	2.17	45.0	1.77	1	97.0	214	5.00	5.30
ZF 325-1 A	7	180	7.09	265	10.4	265	10.4	128	5.03	350	13.8	480	18.9	365	14.4	55.0	2.17	45.0	1.77	1	130	287	5.50	5.83
ZF 400 A	7	183	7.20	265	10.4	265	10.4	140	5.51	462	18.2	508	20.0	392	15.4	57.0	2.24	45.0	1.77	1	160	353	10.0	10.6
ZF 500-1 A	7	195	7.68	280	11.0	280	11.0	165	6.50	379	14.9	621	24.5	495	19.5	-	-	0.0	0.0	0	192	423	10.0	10.6
ZF 510-1 A	10	217	8.54	298	11.7	298	11.7	174	6.85	400	15.8	622	24.5	492	19.4	-	-	0.0	0.0	0	193	425	13.0	13.8
ZF 550-1 A	10	269	10.6	310	12.2	310	12.2	156	6.14	435	17.1	676	26.6	524	20.6	-	-	0.0	0.0	0	256	564	16.0	17.0
ZF 665 A	10	269	10.6	310	12.2	310	12.2	156	6.14	435	17.1	676	26.6	524	20.6	-	-	0.0	0.0	0	253	558	16.0	17.0
ZF 2000 A	10	280	11.0	320	12.6	320	12.6	167	6.57	575	22.6	595	23.4	394	15.5	115	4.53	115	4.53	0	348	767	21.0	22.3
ZF 2050 A	10	280	11.0	320	12.6	320	12.6	167	6.57	575	22.6	589	23.2	394	15.5	115	4.53	115	4.53	0	350	772	21.0	22.3
ZF 2060 A	10	280	11.0	320	12.6	320	12.6	167	6.57	575	22.6	589	23.2	394	15.5	115	4.53	115	4.53	0	350	772	21.0	22.3
ZF 2070 A	10	280	11.0	320	12.6	320	12.6	167	6.57	575	22.6	589	23.2	394	15.5	115	4.53	115	4.53	0	350	772	21.0	22.3
ZF 2075 A	10	280	11.0	320	12.6	320	12.6	167	6.57	575	22.6	589	23.2	394	15.5	115	4.53	115	4.53	0	350	772	21.0	22.3
ZF 2150 A	10	280	11.0	320	12.6	320	12.6	167	6.57	575	22.6	589	23.2	394	15.5	115	4.53	115	4.53	0	352	776	21.0	22.3
ZF 3000 A	10	327	12.9	365	14.4	365	14.4	218	8.59	665	26.2	668	26.3	452	17.8	132	5.20	150	5.91	0	485	1,069	31.0	32.9
ZF 3050 A	10	327	12.9	365	14.4	365	14.4	218	8.59	665	26.2	668	26.3	452	17.8	132	5.20	150	5.91	0	485	1,069	31.0	32.9
ZF 3055 A	10	327	12.9	365	14.4	365	14.4	218	8.59	665	26.2	668	26.3	452	17.8	132	5.20	150	5.91	0	490	1,080	31.0	32.9

Down Angle
Direct Mount

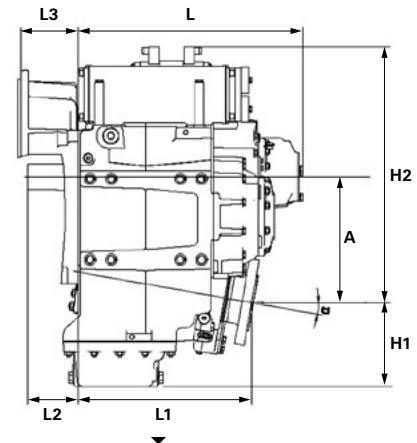
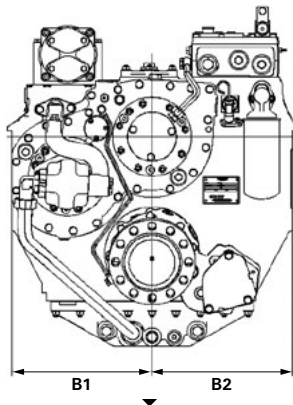

Transmissions drawings and dimensions

PRODUCT	ANGLE (°)	A		B1		B2		H1		H2		L		L1		L2		L3		SAE BELL HOSES	WEIGHT		OIL	
		mm	in	mm	in	mm	in	mm	in	mm	in	mm	in	mm	in	mm	in	mm	in		kg	lb	L	US qt
ZF 3060 A	10	327	12.9	365	14.4	365	14.4	218	8.59	665	26.2	668	26.3	452	17.8	132	5.20	150	5.91	0	490	1,080	31.0	32.9
ZF 3070 A	10	327	12.9	365	14.4	365	14.4	218	8.59	665	26.2	668	26.3	452	17.8	132	5.20	150	5.91	0	490	1,080	31.0	32.9
ZF 3100 A	10	302	11.9	365	14.4	365	14.4	178	7.02	640	25.2	668	26.3	452	17.8	132	5.20	150	5.91	0	470	1,036	31.0	32.9
ZF 3150 A	10	302	11.9	365	14.4	365	14.4	178	7.02	640	25.2	668	26.3	452	17.8	132	5.20	150	5.91	0	470	1,036	31.0	32.9
ZF 3155 A	10	302	11.9	365	14.4	365	14.4	178	7.02	640	25.2	668	26.3	452	17.8	132	5.20	-	-	0	470	1,036	31.0	32.9
ZF 3160 A	10	302	11.9	365	14.4	365	14.4	178	7.02	640	25.2	668	26.3	452	17.8	132	5.20	150	5.91	0	470	1,036	31.0	32.9
ZF 3170 A	10	302	11.9	365	14.4	365	14.4	178	7.02	640	25.2	668	26.3	452	17.8	132	5.20	150	5.91	0	470	1,036	31.0	32.9
ZF 5000 A	8	369	14.5	425	16.7	425	16.7	221	8.70	764	30.1	776	30.6	539	21.2	149	5.87	180	7.09	00	750	1,653	42.0	44.5
ZF 5050 A	8	369	14.5	425	16.7	425	16.7	221	8.70	764	30.1	776	30.6	539	21.2	149	5.87	180	7.09	00	750	1,653	42.0	44.5
ZF 5055 A	8	369	14.5	425	16.7	425	16.7	221	8.70	764	30.1	776	30.6	539	21.2	149	5.87	180	7.09	00	750	1,653	42.0	44.5
ZF 5060 A	8	369	14.5	425	16.7	425	16.7	221	8.70	764	30.1	776	30.6	539	21.2	149	5.87	180	7.09	00	750	1,653	42.0	44.5
ZF 5200 A	8	430	16.9	445	17.5	445	17.5	280	11.0	826	32.5	776	30.6	549	21.6	149	5.87	180	7.09	00	870	1,918	45.0	47.7
ZF 5250 A	8	430	16.9	445	17.5	445	17.5	280	11.0	826	32.5	776	30.6	549	21.6	149	5.87	180	7.09	00	870	1,918	45.0	47.7
ZF 5255 A	8	430	16.9	445	17.5	445	17.5	280	11.0	826	32.5	776	30.6	549	21.6	149	5.87	180	7.09	00	870	1,918	45.0	47.7
ZF 5260 A	8	430	16.9	445	17.5	445	17.5	280	11.0	826	32.5	776	30.6	549	21.6	149	5.87	180	7.09	00	870	1,918	45.0	47.7
ZF 8000 A	8	430	16.9	500	19.7	500	19.7	260	10.2	861	33.9	864	34.0	600	23.6	150	5.91	280	11.0	00	1,050	2,315	59.0	62.5
ZF 8050 A	8	430	16.9	500	19.7	500	19.7	260	10.2	861	33.9	864	34.0	600	23.6	150	5.91	280	11.0	00	1,050	2,315	59.0	62.5
ZF 8055 A	8	430	16.9	500	19.7	500	19.7	260	10.2	861	33.9	864	34.0	600	23.6	150	5.91	280	11.0	00	1,050	2,315	59.0	62.5
ZF 8060 A	8	430	16.9	500	19.7	500	19.7	260	10.2	861	33.9	864	34.0	600	23.6	150	5.91	280	11.0	00	1,050	2,315	59.0	62.5
ZF 9000 A	8	475	18.7	545	21.5	545	21.5	340	13.4	858	33.8	897	35.3	615	24.2	164	6.46	280	11.0	00	1,380	3,042	80.0	84.8
ZF 9050 A	8	475	18.7	545	21.5	545	21.5	340	13.4	858	33.8	897	35.3	615	24.2	164	6.46	280	11.0	00	1,380	3,042	80.0	84.8
ZF 9055 A	8	475	18.7	545	21.5	545	21.5	340	13.4	858	33.8	897	35.3	615	24.2	164	6.46	280	11.0	00	1,380	3,042	80.0	84.8
ZF 9060 A	8	475	18.7	545	21.5	545	21.5	340	13.4	858	33.8	897	35.3	615	24.2	164	6.46	280	11.0	00	1,380	3,042	80.0	84.8
ZF 9055 A	8	475	18.7	545	21.5	545	21.5	340	13.4	858	33.8	897	35.3	615	24.2	164	6.46	280	11.0	00	1,380	3,042	80.0	84.8
ZF 9060 A	8	475	18.7	545	21.5	545	21.5	340	13.4	858	33.8	897	35.3	615	24.2	164	6.46	280	11.0	00	1,380	3,042	80.0	84.8

Down Angle
Direct Mount

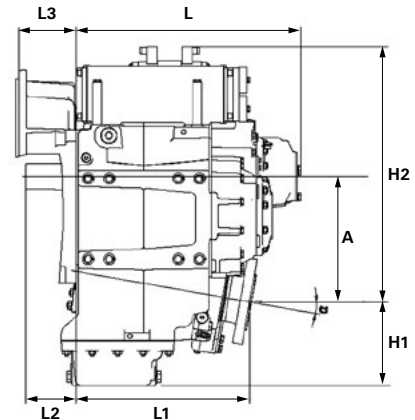
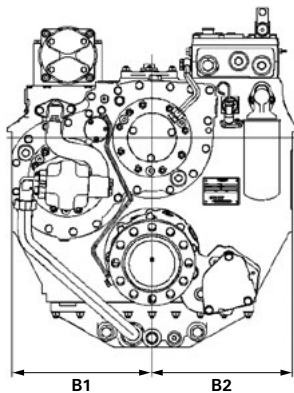

Transmissions drawings and dimensions

PRODUCT	A		B1		B2		H1		H2		L		L1		L2		L3		SAE BELL HOLES	WEIGHT		OIL	
	mm	in	mm	in	mm	in	mm	in	mm	in	mm	in	mm	in	mm	in	mm	in		kg	lb	L	US qt
ZF 25	99.0	3.90	147	5.79	147	5.79	101	3.98	212	8.35	296	11.7	270	10.6	82.5	3.25	29.0	1.14	3	24.0	53.0	2.00	2.12
ZF 45-1	151	5.94	170	6.69	170	6.69	139	5.47	271	10.7	303	11.9	221	8.70	74.0	2.91	40.0	1.57	2	60.0	132	3.00	3.18
ZF 68	127	4.98	178	7.01	178	7.01	118	4.65	266	10.5	329	13.0	273	10.8	65.0	2.56	11.0	0.430	3	46.0	101	3.80	4.03
ZF 220	135	5.31	215	8.46	175	6.89	125	4.92	281	11.1	386	15.2	287	11.3	94.5	3.72	35.5	1.40	2	63.0	139	3.50	3.71
ZF W220	210	8.27	218	8.58	218	8.58	210	8.27	425	16.7	397	15.6	309	12.2	87.0	3.43	13.0	0.510	2	105	231	7.00	7.42
ZF 280-1	146	5.75	230	9.06	175	6.89	131	5.16	301	11.9	394	15.5	299	11.8	71.0	2.80	49.0	1.93	1	73.0	161	4.00	4.24
ZF 286	146	5.75	230	9.06	230	9.06	150	5.91	315	12.4	457	18.0	316	12.4	55.0	2.17	35.0	1.38	1	86.0	190	5.30	5.62
ZF 305-3	155	6.10	254	10.0	254	10.0	147	5.79	372	14.7	444	17.5	330	13.0	55.0	2.17	45.0	1.77	1	98.0	216	5.50	5.83
ZF 325-1	165	6.50	265	10.4	265	10.4	156	6.14	355	14.0	489	19.3	382	15.0	55.0	2.17	45.0	1.77	1	130	287	7.20	7.63
ZF W340	245	9.65	295	11.6	295	11.6	248	9.76	612	24.1	519	20.4	439	17.3	57.3	2.25	-	-	1	330	728	16.0	17.0
ZF W350-1	335	13.2	335	13.2	335	13.2	315	12.4	585	23.0	636	25.0	500	19.7	92.0	3.62	0.0	0.0	0	500	1,102	24.0	25.4
ZF 400	175	6.89	290	11.4	290	11.4	177	6.97	405	15.9	521	20.5	420	16.5	57.0	2.24	45.0	1.77	1	160	353	10.0	10.6
ZF 500	180	7.09	290	11.4	290	11.4	167	6.57	358	14.1	633	24.9	544	21.4	-	-	0.0	0.0	0	185	408	9.00	9.54
ZF 550-1	200	7.87	310	12.2	310	12.2	200	7.87	400	15.8	676	26.6	537	21.1	-	-	0.0	0.0	0	242	534	16.0	17.0
ZF W650	365	14.4	355	14.0	355	14.0	340	13.4	652	25.7	517	20.4	390	15.4	99.0	3.90	100	3.94	0	561	1,237	26.0	27.6
ZF 665	200	7.87	310	12.2	310	12.2	200	7.87	400	15.8	676	26.6	537	21.1	-	-	0.0	0.0	0	248	547	16.0	17.0
ZF 2000	220	8.66	320	12.6	320	12.6	203	7.99	515	20.3	589	23.2	421	16.6	115	4.53	115	4.53	0	340	750	21.0	22.3
ZF 2050	220	8.66	320	12.6	320	12.6	203	7.99	515	20.3	589	23.2	421	16.6	115	4.53	115	4.53	0	342	754	21.0	22.3
ZF 2060	220	8.66	320	12.6	320	12.6	203	7.99	515	20.3	589	23.2	421	16.6	115	4.53	115	4.53	0	342	754	21.0	22.3
ZF 2070	220	8.66	320	12.6	320	12.6	203	7.99	515	20.3	589	23.2	421	16.6	115	4.53	115	4.53	0	342	754	21.0	22.3
ZF 2075	220	8.66	320	12.6	320	12.6	203	7.99	515	20.3	589	23.2	421	16.6	115	4.53	115	4.53	0	342	754	21.0	22.3
ZF 2150	220	8.66	320	12.6	320	12.6	203	7.99	515	20.3	589	23.2	421	16.6	115	4.53	115	4.53	0	344	758	21.0	22.3

Vertical Offset
Direct Mount

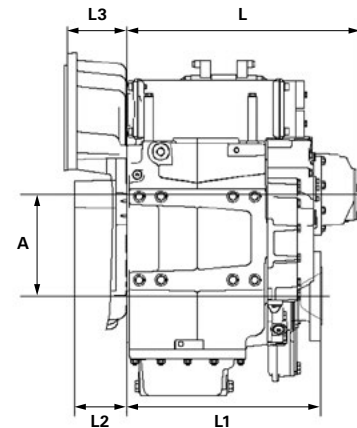
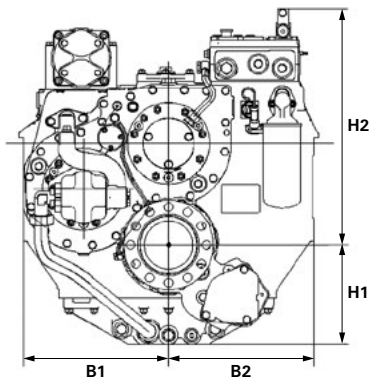

Transmissions drawings and dimensions

PRODUCT	A		B1		B2		H1		H2		L		L1		L2		L3		SAE BELL HOSES	WEIGHT		OIL	
	mm	in	mm	in	mm	in	mm	in	mm	in	mm	in	mm	in	mm	in	mm	in		kg	lb	L	US qt
ZF 2200	280	11.0	330	13.0	330	13.0	250	9.84	612	24.1	589	23.2	435	17.1	115	4.53	115	4.53	0	404	891	22.0	23.3
ZF 2250	280	11.0	330	13.0	330	13.0	250	9.84	612	24.1	589	23.2	435	17.1	115	4.53	115	4.53	0	406	895	22.0	23.3
ZF 2260	280	11.0	330	13.0	330	13.0	250	9.84	612	24.1	589	23.2	435	17.1	115	4.53	115	4.53	0	406	895	22.0	23.3
ZF 2270	280	11.0	330	13.0	330	13.0	250	9.84	612	24.1	589	23.2	435	17.1	115	4.53	115	4.53	0	406	895	22.0	23.3
ZF 2275	280	11.0	330	13.0	330	13.0	250	9.84	612	24.1	589	23.2	435	17.1	115	4.53	115	4.53	0	406	895	22.0	23.3
ZF 2300	335	13.2	340	13.4	340	13.4	300	11.8	667	26.3	589	23.2	435	17.1	115	4.53	115	4.53	0	434	957	27.0	28.6
ZF W2300	335	13.2	340	13.4	340	13.4	300	11.8	667	26.3	589	23.2	435	17.1	115	4.53	115	4.53	0	590	1,301	27.0	28.6
ZF 2350	335	13.2	340	13.4	340	13.4	300	11.8	667	26.3	589	23.2	435	17.1	115	4.53	115	4.53	0	436	961	27.0	28.6
ZF W2350	335	13.2	340	13.4	340	13.4	300	11.8	667	26.3	589	23.2	435	17.1	115	4.53	115	4.53	0	590	1,301	27.0	28.6
ZF 2360	335	13.2	340	13.4	340	13.4	300	11.8	667	26.3	589	23.2	435	17.1	115	4.53	115	4.53	0	436	961	27.0	28.6
ZF 2370	335	13.2	340	13.4	340	13.4	300	11.8	667	26.3	589	23.2	435	17.1	115	4.53	115	4.53	0	436	961	27.0	28.6
ZF 2375	335	13.2	340	13.4	340	13.4	300	11.8	667	26.3	589	23.2	435	17.1	115	4.53	115	4.53	0	436	961	27.0	28.6
ZF W2450	390	15.4	400	15.8	400	15.8	365	14.4	702	27.6	589	23.2	435	17.1	115	4.53	115	4.53	0	760	1,676	30.0	31.8
ZF 3000	255	10.0	365	14.4	365	14.4	250	9.84	593	23.4	668	26.3	485	19.1	132	5.20	-	-	00	482	1,063	31.0	32.9
ZF 3050	255	10.0	365	14.4	365	14.4	250	9.84	593	23.4	668	26.3	485	19.1	132	5.20	-	-	00	482	1,063	31.0	32.9
ZF 3055	255	10.0	365	14.4	365	14.4	250	9.84	593	23.4	668	26.3	485	19.1	132	5.20	-	-	00	487	1,074	31.0	32.9
ZF 3060	255	10.0	365	14.4	365	14.4	250	9.84	593	23.4	668	26.3	485	19.1	132	5.20	-	-	00	487	1,074	31.0	32.9
ZF 3070	255	10.0	365	14.4	365	14.4	250	9.84	593	23.4	668	26.3	485	19.1	132	5.20	-	-	00	487	1,074	31.0	32.9
ZF 3310	385	15.2	375	14.8	375	14.8	345	13.6	722	28.4	670	26.4	595	23.4	132	5.20	-	-	00	665	1,466	36.0	38.2
ZF W3310	385	15.2	375	14.8	375	14.8	345	13.6	722	28.4	670	26.4	595	23.4	132	5.20	-	-	00	850	1,874	36.0	38.2
ZF 3311	385	15.2	375	14.8	375	14.8	345	13.6	722	28.4	670	26.4	595	23.4	132	5.20	-	-	00	850	1,874	36.0	38.2
ZF 3350	385	15.2	375	14.8	375	14.8	345	13.6	722	28.4	670	26.4	595	23.4	132	5.20	-	-	00	665	1,466	36.0	38.2
ZF W3350	385	15.2	375	14.8	375	14.8	345	13.6	722	28.4	670	26.4	595	23.4	132	5.20	-	-	00	850	1,874	36.0	38.2

Vertical Offset
Direct Mount

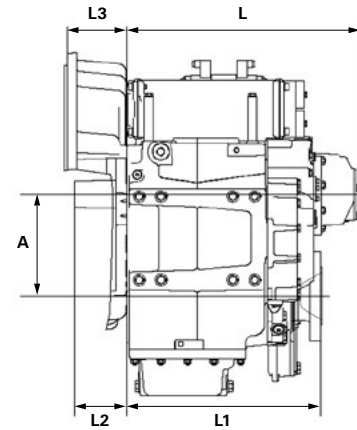
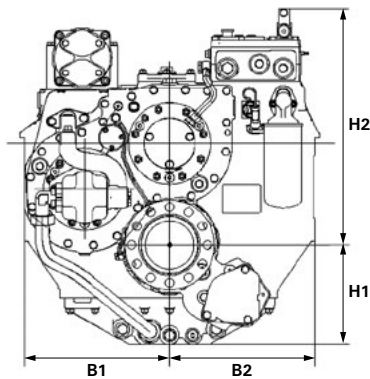

Transmissions drawings and dimensions

PRODUCT	A		B1		B2		H1		H2		L		L1		L2		L3		SAE BELL HOSES	WEIGHT		OIL	
	mm	in	mm	in	mm	in	mm	in	mm	in	mm	in	mm	in	mm	in	mm	in		kg	lb	L	US qt
ZF 3351	385	15.2	375	14.8	375	14.8	345	13.6	722	28.4	670	26.4	595	23.4	132	5.20	-	-	00	850	1,874	36.0	38.2
ZF 3355	385	15.2	375	14.8	375	14.8	345	13.6	722	28.4	670	26.4	595	23.4	132	5.20	-	-	00	670	1,477	36.0	38.2
ZF W3355	385	15.2	375	14.8	375	14.8	345	13.6	722	28.4	670	26.4	595	23.4	132	5.20	-	-	00	855	1,885	36.0	38.2
ZF 3356	385	15.2	375	14.8	375	14.8	345	13.6	722	28.4	670	26.4	595	23.4	132	5.20	-	-	00	855	1,885	36.0	38.2
ZF 3360	385	15.2	375	14.8	375	14.8	345	13.6	722	28.4	670	26.4	595	23.4	132	5.20	-	-	00	670	1,477	36.0	38.2
ZF 3361	385	15.2	375	14.8	375	14.8	345	13.6	722	28.4	670	26.4	595	23.4	132	5.20	-	-	00	850	1,874	36.0	38.2
ZF 3370	385	15.2	375	14.8	375	14.8	345	13.6	722	28.4	670	26.4	595	23.4	132	5.20	-	-	00	670	1,477	36.0	38.2
ZF W3710	445	17.5	425	16.7	425	16.7	410	16.1	782	30.8	670	26.4	595	23.4	132	5.20	150	5.91	0	920	2,028	38.0	40.3
ZF 3711	445	17.5	425	16.7	425	16.7	410	16.1	782	30.8	670	26.4	595	23.4	132	5.20	150	5.91	0	920	2,028	38.0	40.3
ZF W3750	445	17.5	425	16.7	425	16.7	410	16.1	782	30.8	670	26.4	595	23.4	132	5.20	150	5.91	0	920	2,028	38.0	40.3
ZF 3751	445	17.5	425	16.7	425	16.7	410	16.1	782	30.8	670	26.4	595	23.4	132	5.20	150	5.91	0	920	2,028	38.0	40.3
ZF W3755	445	17.5	425	16.7	425	16.7	410	16.1	782	30.8	670	26.4	595	23.4	132	5.20	150	5.91	0	920	2,028	38.0	40.3
ZF 3756	445	17.5	425	16.7	425	16.7	410	16.1	782	30.8	670	26.4	595	23.4	132	5.20	150	5.91	0	920	2,028	38.0	40.3
ZF 3761	445	17.5	425	16.7	425	16.7	410	16.1	782	30.8	670	26.4	595	23.4	132	5.20	150	5.91	0	920	2,028	38.0	40.3
ZF 5000	295	11.6	425	16.7	425	16.7	270	10.6	690	27.2	776	30.6	565	22.2	149	5.87	180	7.09	00	740	1,631	40.0	42.4
ZF 5050	295	11.6	425	16.7	425	16.7	270	10.6	690	27.2	776	30.6	565	22.2	149	5.87	180	7.09	00	740	1,631	40.0	42.4
ZF 5055	295	11.6	425	16.7	425	16.7	270	10.6	690	27.2	776	30.6	565	22.2	149	5.87	180	7.09	00	740	1,631	40.0	42.4
ZF 5060	295	11.6	425	16.7	425	16.7	270	10.6	690	27.2	776	30.6	565	22.2	149	5.87	180	7.09	00	740	1,631	40.0	42.4
ZF 5300	460	18.1	465	18.3	465	18.3	415	16.3	855	33.7	776	30.6	570	22.4	149	5.87	180	7.09	00	950	2,094	60.0	63.6
ZF W5300	460	18.1	465	18.3	465	18.3	415	16.3	855	33.7	776	30.6	570	22.4	149	5.87	180	7.09	00	1,290	2,844	60.0	63.6
ZF 5311	460	18.1	465	18.3	465	18.3	415	16.3	855	33.7	776	30.6	570	22.4	149	5.87	180	7.09	00	1,290	2,844	60.0	63.6
ZF 5350	460	18.1	465	18.3	465	18.3	415	16.3	855	33.7	776	30.6	570	22.4	149	5.87	180	7.09	00	950	2,094	60.0	63.6
ZF W5350	460	18.1	465	18.3	465	18.3	415	16.3	855	33.7	776	30.6	570	22.4	149	5.87	180	7.09	00	1,290	2,844	60.0	63.6

Vertical Offset
Direct Mount

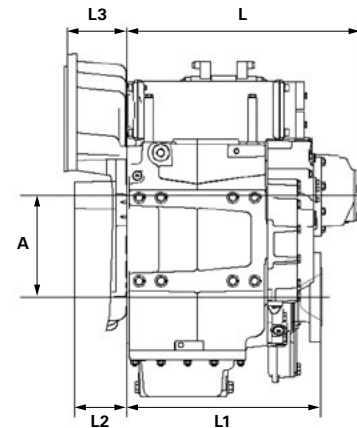
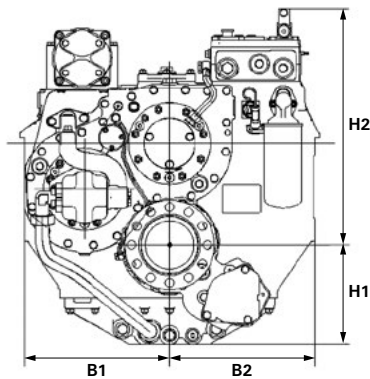

Transmissions drawings and dimensions

PRODUCT	A		B1		B2		H1		H2		L		L1		L2		L3		SAE BELL HOLES	WEIGHT		OIL	
	mm	in	mm	in	mm	in	mm	in	mm	in	mm	in	mm	in	mm	in	mm	in		kg	lb	L	US qt
ZF 5351	460	18.1	465	18.3	465	18.3	415	16.3	855	33.7	776	30.6	570	22.4	149	5.87	180	7.09	00	1,290	2,844	60.0	63.6
ZF 5355	460	18.1	465	18.3	465	18.3	415	16.3	855	33.7	776	30.6	570	22.4	149	5.87	180	7.09	00	950	2,094	60.0	63.6
ZF W5355	460	18.1	465	18.3	465	18.3	415	16.3	855	33.7	776	30.6	570	22.4	149	5.87	180	7.09	00	1,290	2,844	60.0	63.6
ZF 5356	460	18.1	465	18.3	465	18.3	415	16.3	855	33.7	776	30.6	570	22.4	149	5.87	180	7.09	00	1,290	2,844	60.0	63.6
ZF 5360	460	18.1	465	18.3	465	18.3	415	16.3	855	33.7	776	30.6	570	22.4	149	5.87	180	7.09	00	950	2,094	60.0	63.6
ZF 5361	460	18.1	465	18.3	465	18.3	415	16.3	855	33.7	776	30.6	570	22.4	149	5.87	180	7.09	00	1,290	2,844	60.0	63.6
ZF 8000	340	13.4	500	19.7	500	19.7	330	13.0	771	30.4	864	34.0	630	24.8	150	5.91	280	11.0	00	1,015	2,238	59.0	62.5
ZF 8050	340	13.4	500	19.7	500	19.7	330	13.0	771	30.4	864	34.0	630	24.8	150	5.91	280	11.0	00	1,015	2,238	55.0	58.3
ZF 8055	340	13.4	500	19.7	500	19.7	330	13.0	771	30.4	864	34.0	630	24.8	150	5.91	280	11.0	00	1,015	2,238	55.0	58.3
ZF 8060	340	13.4	500	19.7	500	19.7	330	13.0	771	30.4	864	34.0	630	24.8	150	5.91	280	11.0	00	1,015	2,238	55.0	58.3
ZF 8300	450	17.7	500	19.7	500	19.7	410	16.1	881	34.7	864	34.0	640	25.2	150	5.91	280	11.0	00	1,220	2,690	60.0	63.6
ZF 8311	450	17.7	500	19.7	500	19.7	410	16.1	881	34.7	864	34.0	640	25.2	150	5.91	280	11.0	00	1,625	3,583	60.0	63.6
ZF 8350	450	17.7	500	19.7	500	19.7	410	16.1	881	34.7	864	34.0	640	25.2	150	5.91	280	11.0	00	1,220	2,690	60.0	63.6
ZF 8351	450	17.7	500	19.7	500	19.7	410	16.1	881	34.7	864	34.0	640	25.2	150	5.91	280	11.0	00	1,625	3,583	60.0	63.6
ZF 8355	450	17.7	500	19.7	500	19.7	410	16.1	881	34.7	864	34.0	640	25.2	150	5.91	280	11.0	00	1,220	2,690	60.0	63.6
ZF 8356	450	17.7	500	19.7	500	19.7	410	16.1	881	34.7	864	34.0	640	25.2	150	5.91	280	11.0	00	1,625	3,583	60.0	63.6
ZF 8360	450	17.7	500	19.7	500	19.7	410	16.1	881	34.7	864	34.0	640	25.2	150	5.91	280	11.0	00	1,220	2,690	60.0	63.6
ZF 8361	450	17.7	500	19.7	500	19.7	410	16.1	881	34.7	864	34.0	640	25.2	150	5.91	280	11.0	00	1,625	3,583	60.0	63.6
ZF 9000	390	15.4	545	21.5	545	21.5	405	15.9	800	31.5	897	35.3	640	25.2	164	6.46	280	11.0	00	1,400	3,086	80.0	84.8
ZF 9050	390	15.4	545	21.5	545	21.5	405	15.9	800	31.5	897	35.3	640	25.2	164	6.46	280	11.0	00	1,400	3,086	80.0	84.8
ZF 9055	390	15.4	545	21.5	545	21.5	405	15.9	800	31.5	897	35.3	640	25.2	164	6.46	280	11.0	00	1,400	3,086	80.0	84.8
ZF 9060	390	15.4	545	21.5	545	21.5	405	15.9	800	31.5	897	35.3	640	25.2	164	6.46	280	11.0	00	1,400	3,086	80.0	84.8
ZF 9300	545	21.5	570	22.4	570	22.4	485	19.1	968	38.1	897	35.3	714	28.1	164	6.46	280	11.0	00	1,910	4,211	90.0	95.4

Vertical Offset
Direct Mount

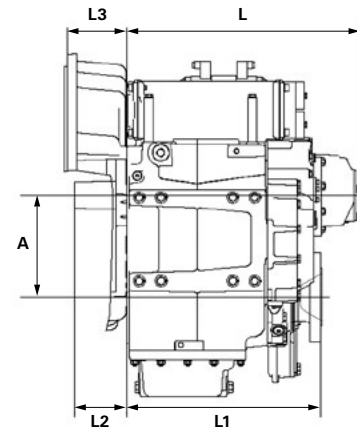
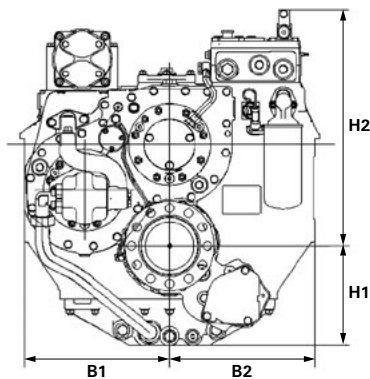

Transmissions drawings and dimensions

PRODUCT	A		B1		B2		H1		H2		L		L1		L2		L3		SAE BELL HOSES	WEIGHT		OIL	
	mm	in	mm	in	mm	in	mm	in	mm	in	mm	in	mm	in	mm	in	mm	in		kg	lb	L	US qt
ZF 9311	545	21.5	570	22.4	570	22.4	485	19.1	968	38.1	897	35.3	714	28.1	164	6.46	280	11.0	00	2,430	5,357	90.0	95.4
ZF 9350	545	21.5	570	22.4	570	22.4	485	19.1	968	38.1	897	35.3	714	28.1	164	6.46	280	11.0	00	1,910	4,211	90.0	95.4
ZF 9351	545	21.5	570	22.4	570	22.4	485	19.1	968	38.1	897	35.3	714	28.1	164	6.46	280	11.0	00	2,430	5,357	90.0	95.4
ZF 9355	545	21.5	570	22.4	570	22.4	485	19.1	968	38.1	897	35.3	714	28.1	164	6.46	280	11.0	00	1,910	4,211	90.0	95.4
ZF 9356	545	21.5	570	22.4	570	22.4	485	19.1	968	38.1	897	35.3	714	28.1	164	6.46	280	11.0	00	2,430	5,357	90.0	95.4
ZF 9360	545	21.5	570	22.4	570	22.4	485	19.1	968	38.1	897	35.3	714	28.1	164	6.46	280	11.0	00	1,910	4,211	90.0	95.4
ZF 9361	545	21.5	570	22.4	570	22.4	485	19.1	968	38.1	897	35.3	714	28.1	164	6.46	280	11.0	00	2,430	5,357	90.0	95.4
ZF 9360	545	21.5	570	22.4	570	22.4	485	19.1	968	38.1	897	35.3	714	28.1	164	6.46	280	11.0	00	1,910	4,211	90.0	95.4
ZF 9361	545	21.5	570	22.4	570	22.4	485	19.1	968	38.1	897	35.3	714	28.1	164	6.46	280	11.0	00	2,430	5,357	90.0	95.4
ZF 9000	390	15.4	545	21.5	545	21.5	405	15.9	800	31.5	897	35.3	640	25.2	164	6.46	280	11.0	00	1,400	3,086	80.0	84.8
ZF 9050	390	15.4	545	21.5	545	21.5	405	15.9	800	31.5	897	35.3	640	25.2	164	6.46	280	11.0	00	1,400	3,086	80.0	84.8
ZF 9055	390	15.4	545	21.5	545	21.5	405	15.9	800	31.5	897	35.3	640	25.2	164	6.46	280	11.0	00	1,400	3,086	80.0	84.8
ZF 9060	390	15.4	545	21.5	545	21.5	405	15.9	800	31.5	897	35.3	640	25.2	164	6.46	280	11.0	00	1,400	3,086	80.0	84.8
ZF 9300	545	21.5	570	22.4	570	22.4	485	19.1	968	38.1	897	35.3	714	28.1	164	6.46	280	11.0	00	1,910	4,211	90.0	95.4
ZF 9311	545	21.5	570	22.4	570	22.4	485	19.1	968	38.1	897	35.3	714	28.1	164	6.46	280	11.0	00	2,430	5,357	90.0	95.4
ZF 9350	545	21.5	570	22.4	570	22.4	485	19.1	968	38.1	897	35.3	714	28.1	164	6.46	280	11.0	00	1,910	4,211	90.0	95.4
ZF 9351	545	21.5	570	22.4	570	22.4	485	19.1	968	38.1	897	35.3	714	28.1	164	6.46	280	11.0	00	2,430	5,357	90.0	95.4
ZF 9355	545	21.5	570	22.4	570	22.4	485	19.1	968	38.1	897	35.3	714	28.1	164	6.46	280	11.0	00	1,910	4,211	90.0	95.4
ZF 9356	545	21.5	570	22.4	570	22.4	485	19.1	968	38.1	897	35.3	714	28.1	164	6.46	280	11.0	00	2,430	5,357	90.0	95.4
ZF 9360	545	21.5	570	22.4	570	22.4	485	19.1	968	38.1	897	35.3	714	28.1	164	6.46	280	11.0	00	1,910	4,211	90.0	95.4
ZF 9361	545	21.5	570	22.4	570	22.4	485	19.1	968	38.1	897	35.3	714	28.1	164	6.46	280	11.0	00	2,430	5,357	90.0	95.4

Vertical Offset
Direct Mount

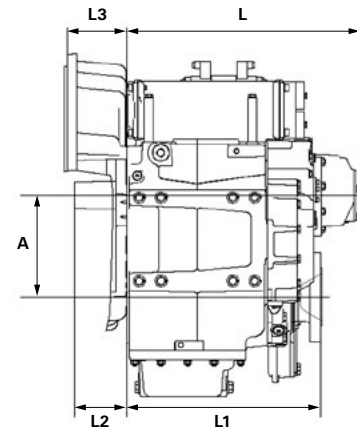
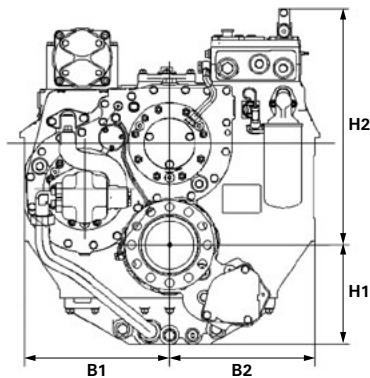

Transmissions drawings and dimensions

PRODUCT	ANGLE (°)	A		B1		B2		B3		H1		L		L1		L2		SAE BELL HSGS.	WEIGHT		OIL	
		mm	in	mm	in	mm	in	mm	in	mm	in	mm	in	mm	in	mm	in		kg	lb	L	US qt
ZF 48 IV	20	150	5.91	160	6.30	142	5.59	320	12.6	132	5.20	582	22.9	420	16.5	233	9.17	3	47.0	104	3.00	3.18

V-Drive
Direct Mount

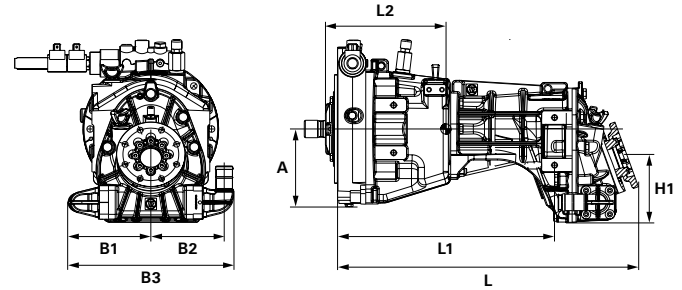

PRODUCT	B1		B2		H1		H2		L		L1		L2		L3		SAE BELL HSGS.	WEIGHT		OIL	
	mm	in	mm	in	mm	in	mm	in	mm	in	mm	in	mm	in	mm	in		kg	lb	L	US qt
ZF 45 C	136	5.33	131	5.16	145	5.71	198	7.80	-	-	267	10.5	64.5	2.54	11.0	0.430	3	31.0	68.0	2.00	2.12
ZF 63 C	136	5.33	131	5.16	145	5.71	198	7.80	-	-	267	10.5	64.5	2.54	11.0	0.430	3	32.0	71.0	2.00	2.12
ZF 301-1 C	235	9.25	235	9.25	200	7.87	270	10.6	480	18.9	344	13.5	89.3	3.52	80.0	3.15	1	87.0	192	6.00	6.36

Co-Axial or
Near Co-Axial
Direct Mount

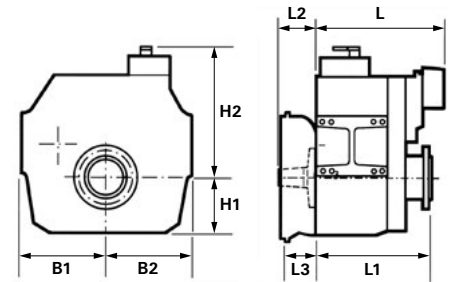

PRODUCT	ANGLE (°)	A		B1		B2		H1		H2		L		L1		L2		L3		SAE BELL HSGS.	WEIGHT		OIL	
		mm	in	mm	in	mm	in	mm	in	mm	in	mm	in	mm	in	mm	in	mm	in		kg	lb	L	US qt
ZF 68 IV	12	219	8.61	178	7.01	178	7.01	107	4.22	355	14.0	329	12.9	326	12.8	65.0	2.56	11.0	0.430	3	62.0	137	4.00	4.24
ZF 85 IV	12	246	9.69	190	7.48	190	7.48	132	5.20	389	15.3	370	14.6	375	14.8	76.0	2.99	13.0	0.510	2	86.0	190	7.00	7.42

V-Drive
Direct Mount

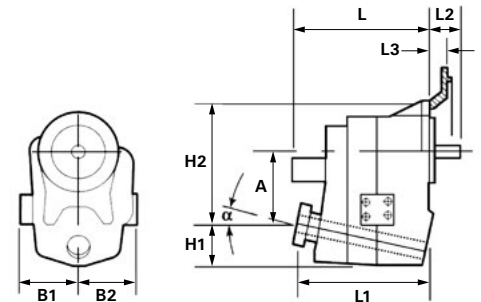

Transmissions drawings and dimensions

PRODUCT	A		B1		B2		H1		H2		L		L1		L2		L3		SAE BELL HSGS.	WEIGHT		OIL	
	mm	in	mm	in	mm	in	mm	in	mm	in	mm	in	mm	in	mm	in	mm	in		kg	lb	L	US qt
ZF 90 TS	127	4.98	178	6.99	178	6.99	119	4.67	319	12.6	484	19.1	414	16.3	76.0	2.99	11.0	0.430	3	67.0	148	3.50	3.71
ZF 325-1TS	165	6.50	265	10.4	265	10.4	156	6.14	424	16.7	714	28.1	607	23.9	-	-	0.0	0.0	1	180	397	6.50	6.89
ZF 550-1 TS	200	7.87	310	12.2	310	12.2	200	7.87	400	15.8	884	34.8	737	29.0	-	-	0.0	0.0	1	344	758	15.0	15.9
ZF 665 TS	200	7.87	310	12.2	310	12.2	200	7.87	400	15.8	884	34.8	737	29.0	-	-	0.0	0.0	1	344	758	15.0	15.9

2 Speed
Vertical Offset
Direct Mount

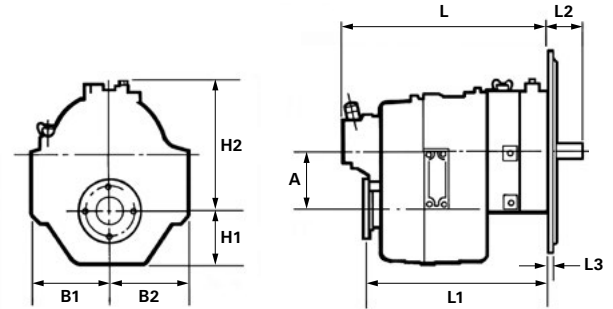

PRODUCT	ANGLE (°)	A		B1		B2		H1		H2		L		L1		L2		L3		SAE BELL HSGS.	WEIGHT		OIL	
		mm	in	mm	in	mm	in	mm	in	mm	in	mm	in	mm	in	mm	in	mm	in		kg	lb	L	US qt
ZF 90 IVTS	12	219	8.62	178	6.99	178	6.99	107	4.22	415	16.3	485	19.1	467	18.4	76.0	2.99	11.0	0.430	3	82.0	181	4.50	4.77
ZF 115 IVTS	12	246	9.69	190	7.48	190	7.48	132	5.20	445	17.5	532	20.9	516	20.3	76.0	2.99	0.0	0.0	2	107	236	7.50	7.95
ZF 325 IVTS	14	378	14.9	292	11.5	220	8.66	-	-	-	-	714	28.1	249	9.81	-	-	0.0	0.0	1	235	518	8.00	8.48

2 Speed V-Drive
Direct Mount

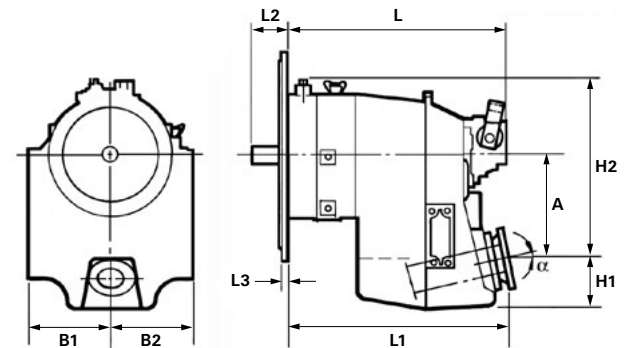

Transmissions drawings and dimensions

PRODUCT	ANGLE (°)	A		B1		B2		H1		H2		L		L1		L2		L3		SAE BELL HSGS.	WEIGHT		OIL	
		mm	in	mm	in	mm	in	mm	in	mm	in	mm	in	mm	in	mm	in	mm	in		kg	lb	L	US qt
ZF 90 ATS	8	144	5.67	178	6.99	178	6.99	82.0	3.23	336	13.2	484	19.1	406	16.0	76.0	2.99	11.0	0.430	3	64.0	141	3.50	3.71
ZF 115 ATS	8	160	6.30	210	8.27	210	8.27	112	4.41	356	14.0	537	21.1	432	17.0	76.0	2.99	0.0	0.0	2	82.0	181	6.00	6.36
ZF 325-1ATS	7	180	7.09	265	10.4	265	10.4	128	5.04	439	17.3	703	27.7	590	23.2	-	-	0.0	0.0	1	180	397	6.50	6.89
ZF 550-1 ATS	10	269	10.6	310	12.2	310	12.2	157	6.17	592	23.3	884	34.8	724	28.5	-	-	0.0	0.0	1	356	785	15.0	15.9
ZF 665 ATS	10	269	10.6	310	12.2	310	12.2	157	6.18	592	23.3	884	34.8	724	28.5	-	-	0.0	0.0	1	353	778	15.0	15.9

2 Speed Down Angle
Direct Mount

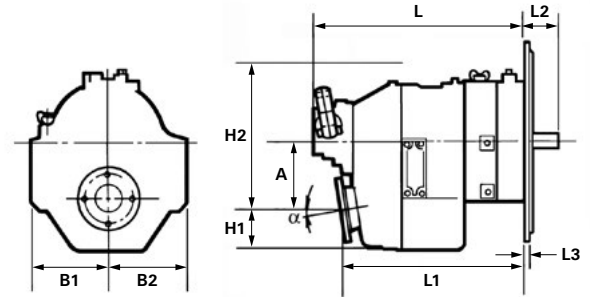

PRODUCT	ANGLE (°)	A		B1		B2		H1		H2		L		L1		L2		L3		SAE BELL HSGS.	WEIGHT		OIL	
		mm	in	mm	in	mm	in	mm	in	mm	in	mm	in	mm	in	mm	in	mm	in		kg	lb	L	US qt
ZF 280 IV	14	331	13.0	184	7.24	184	7.24	90.1	3.55	501	19.7	395	15.6	285	11.2	59.0	2.32	35.0	1.38	2	106	234	5.00	5.30
ZF 286 IV	14	358	14.1	185	7.28	225	8.86	100	3.94	-	-	212	8.35	322	12.7	165	6.50	35.0	1.38	1	130	287	5.00	5.30
ZF 325 IV	14	378	14.9	292	11.5	220	8.66	140	5.51	655	25.8	489	19.3	357	14.1	55.0	2.17	45.0	1.77	1	185	408	8.00	8.48
ZF 400 IV	14	383	15.1	220	8.66	242	9.53	145	5.71	627	24.7	409	16.1	-	-	519	20.4	-	-	1	220	485	10.0	10.6
ZF 500-1 IV	14	392	15.4	292	11.5	220	8.66	145	5.71	627	24.7	358	14.1	372	14.7	280	11.0	0.0	0.0	1	230	507	9.00	9.54

V-Drive
Direct Mount

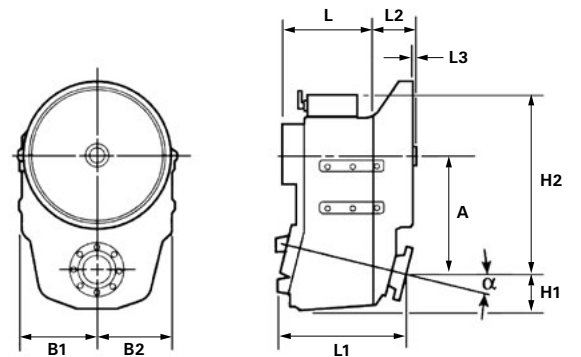

Transmissions drawings and dimensions

PRODUCT	ANGLE (°)	A		B1		B2		H1		H2		L		L1		L2		L3		L4		WEIGHT		OIL	
		mm	in	mm	in	mm	in	mm	in	mm	in	mm	in	mm	in	mm	in	mm	in	mm	in	kg	lb	L	US qt
ZF 400 V	10	217	8.52	298	11.7	298	11.7	167	6.56	357	14.0	127	4.98	439	17.3	123	4.84	127	4.98	127	4.98	200	441	12.0	12.7
ZF 510 V	10	217	8.52	298	11.7	298	11.7	167	6.56	357	14.0	439	17.3	439	17.3	123	4.84	-	-	125	4.92	200	441	12.0	12.7
ZF 550-1 V	10	269	10.6	310	12.2	310	12.2	156	6.13	550	21.7	452	17.8	452	17.8	134	5.28	-	-	95.0	3.74	260	573	16.0	17.0
ZF 665 V	10	269	10.6	310	12.2	310	12.2	156	6.13	550	21.7	452	17.8	452	17.8	134	5.28	-	-	95.0	3.74	252	556	16.0	17.0
ZF 2000 V	10	280	11.0	320	12.6	320	12.6	167	6.57	575	22.6	375	14.8	394	15.5	200	7.87	50.0	1.97	111	4.37	352	776	21.0	22.3
ZF 2050 V	10	280	11.0	320	12.6	320	12.6	167	6.57	575	22.6	375	14.8	394	15.5	200	7.87	50.0	1.97	111	4.37	354	780	21.0	22.3
ZF 2060 V	10	280	11.0	320	12.6	320	12.6	167	6.57	575	22.6	375	14.8	394	15.5	200	7.87	50.0	1.97	111	4.37	354	780	21.0	22.3
ZF 2070 V	10	280	11.0	320	12.6	320	12.6	167	6.57	575	22.6	375	14.8	394	15.5	200	7.87	50.0	1.97	111	4.37	354	780	21.0	22.3
ZF 2075 V	10	280	11.0	320	12.6	320	12.6	167	6.57	575	22.6	375	14.8	394	15.5	200	7.87	50.0	1.97	111	4.37	354	780	21.0	22.3
ZF 2150 V	10	280	11.0	320	12.6	320	12.6	167	6.57	575	22.6	375	14.8	394	15.5	200	7.87	50.0	1.97	111	4.37	356	785	21.0	22.3
ZF 3000 V	10	327	12.9	365	14.4	365	14.4	218	8.59	665	26.2	418	16.5	452	17.8	253	9.96	38.5	1.52	153	6.02	500	1,102	31.0	32.9
ZF 3050 V	10	327	12.9	365	14.4	365	14.4	218	8.59	665	26.2	418	16.5	452	17.8	253	9.96	38.5	1.52	153	6.02	500	1,102	31.0	32.9
ZF 3055 V	10	327	12.9	365	14.4	365	14.4	218	8.59	665	26.2	418	16.5	452	17.8	253	9.96	38.5	1.52	153	6.02	505	1,113	31.0	32.9
ZF 3060 V	10	327	12.9	365	14.4	365	14.4	218	8.59	665	26.2	418	16.5	452	17.8	253	9.96	38.5	1.52	153	6.02	505	1,113	31.0	32.9
ZF 3070 V	10	327	12.9	365	14.4	365	14.4	218	8.59	665	26.2	418	16.5	452	17.8	253	9.96	38.5	1.52	153	6.02	505	1,113	31.0	32.9
ZF 5000 V	8	369	14.5	425	16.7	425	16.7	221	8.70	764	30.1	425	16.7	539	21.2	285	11.2	49.0	1.93	136	5.35	768	1,693	42.0	44.5
ZF 5050 V	8	369	14.5	425	16.7	425	16.7	221	8.70	764	30.1	425	16.7	539	21.2	285	11.2	49.0	1.93	136	5.35	768	1,693	42.0	44.5
ZF 5055 V	8	369	14.5	425	16.7	425	16.7	221	8.70	764	30.1	425	16.7	539	21.2	285	11.2	49.0	1.93	136	5.35	768	1,693	42.0	44.5
ZF 5060 V	8	369	14.5	425	16.7	425	16.7	221	8.70	764	30.1	425	16.7	539	21.2	285	11.2	49.0	1.93	136	5.35	768	1,693	42.0	44.5
ZF 5200 V	8	430	16.9	445	17.5	445	17.5	280	11.0	826	32.5	425	16.7	549	21.6	285	11.2	62.0	2.44	126	4.96	880	1,940	45.0	47.7
ZF 5250 V	8	430	16.9	445	17.5	445	17.5	280	11.0	826	32.5	425	16.7	549	21.6	285	11.2	62.0	2.44	126	4.96	880	1,940	45.0	47.7
ZF 5255 V	8	430	16.9	445	17.5	445	17.5	280	11.0	826	32.5	425	16.7	549	21.6	285	11.2	62.0	2.44	126	4.96	880	1,940	45.0	47.7
ZF 5260 V	8	430	16.9	445	17.5	445	17.5	280	11.0	826	32.5	425	16.7	549	21.6	285	11.2	62.0	2.44	126	4.96	880	1,940	45.0	47.7
ZF 8000 V	8	430	16.9	500	19.7	500	19.7	260	10.2	861	33.9	460	18.1	600	23.6	315	12.4	50.0	1.97	130	5.12	1,075	2,370	59.0	62.5

V-Drive
Remote Mount

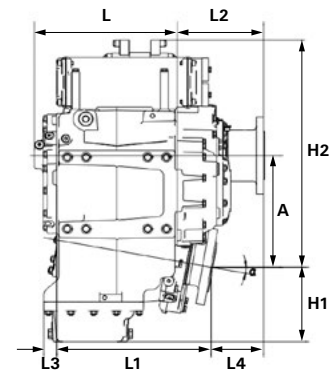
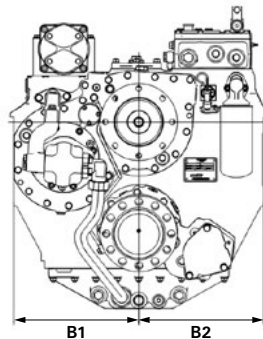

Transmissions drawings and dimensions

PRODUCT	ANGLE (°)	A		B1		B2		H1		H2		L		L1		L2		L3		L4		WEIGHT		OIL	
		mm	in	mm	in	mm	in	mm	in	mm	in	mm	in	mm	in	mm	in	mm	in	mm	in	kg	lb	L	US qt
ZF 8050 V	8	430	16.9	500	19.7	500	19.7	260	10.2	861	33.9	460	18.1	600	23.6	315	12.4	50.0	1.97	130	5.12	1,075	2,370	59.0	62.5
ZF 8055 V	8	430	16.9	500	19.7	500	19.7	260	10.2	861	33.9	460	18.1	600	23.6	315	12.4	50.0	1.97	130	5.12	1,075	2,370	59.0	62.5
ZF 8060 V	8	430	16.9	500	19.7	500	19.7	260	10.2	861	33.9	460	18.1	600	23.6	315	12.4	50.0	1.97	130	5.12	1,075	2,370	59.0	62.5
ZF 9000 V	8	475	18.7	545	21.5	545	21.5	340	13.4	858	33.8	533	21.0	615	24.2	332	13.1	76.0	2.99	157	6.18	1,400	3,086	80.0	84.8
ZF 9050 V	8	475	18.7	545	21.5	545	21.5	340	13.4	858	33.8	533	21.0	615	24.2	332	13.1	76.0	2.99	157	6.18	1,400	3,086	80.0	84.8
ZF 9055 V	8	475	18.7	545	21.5	545	21.5	340	13.4	858	33.8	533	21.0	615	24.2	332	13.1	76.0	2.99	157	6.18	1,400	3,086	80.0	84.8
ZF 9060 V	8	475	18.7	545	21.5	545	21.5	340	13.4	858	33.8	533	21.0	615	24.2	332	13.1	76.0	2.99	157	6.18	1,400	3,086	80.0	84.8
ZF 9055 V	8	475	18.7	545	21.5	545	21.5	340	13.4	858	33.8	533	21.0	615	24.2	332	13.1	76.0	2.99	157	6.18	1,400	3,086	80.0	84.8
ZF 9060 V	8	475	18.7	545	21.5	545	21.5	340	13.4	858	33.8	533	21.0	615	24.2	332	13.1	76.0	2.99	157	6.18	1,400	3,086	80.0	84.8

V-Drive
Remote Mount

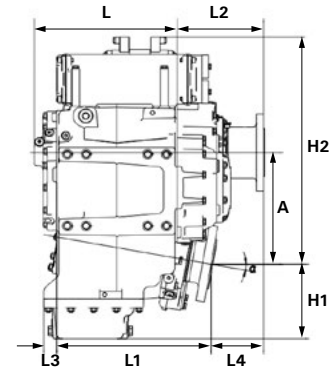
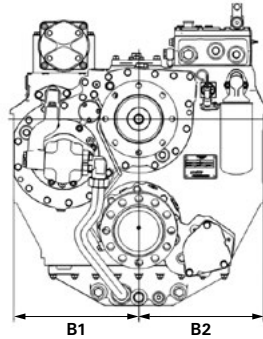

Transmissions drawings and dimensions

PRODUCT	A		B1		B2		B3		B4		H1		H2		L		L1		L2		WEIGHT		OIL	
	mm	in	mm	in	mm	in	mm	in	mm	in	mm	in	mm	in	mm	in	mm	in	mm	in	kg	lb	L	US qt
ZF 3000 D CEW	140	5.52	365	14.4	365	14.4	213	8.39	213	8.39	250	9.84	593	23.4	670	26.4	485	19.1	132	5.20	482	1,063	31.0	32.9
ZF 3000 D EW	140	5.52	365	14.4	365	14.4	213	8.39	213	8.39	250	9.84	593	23.4	670	26.4	485	19.1	132	5.20	482	1,063	31.0	32.9
ZF 3050 D CEW	140	5.52	365	14.4	365	14.4	213	8.39	213	8.39	250	9.84	593	23.4	670	26.4	485	19.1	132	5.20	482	1,063	31.0	32.9
ZF 3050 D EW	140	5.52	365	14.4	365	14.4	213	8.39	213	8.39	250	9.84	593	23.4	670	26.4	485	19.1	132	5.20	482	1,063	31.0	32.9
ZF 3055 D CEW	140	5.52	365	14.4	365	14.4	213	8.39	213	8.39	250	9.84	593	23.4	670	26.4	485	19.1	132	5.20	482	1,063	31.0	32.9
ZF 3060 D CEW	140	5.52	365	14.4	365	14.4	213	8.39	213	8.39	250	9.84	593	23.4	670	26.4	485	19.1	132	5.20	482	1,063	31.0	32.9
ZF 5000 D	164	6.46	425	16.7	425	16.7	245	9.65	245	9.65	270	10.6	745	29.3	776	30.6	565	22.2	149	5.87	765	1,687	40.0	42.4
ZF 5050 D	164	6.46	425	16.7	425	16.7	245	9.65	245	9.65	270	10.6	745	29.3	839	33.0	565	22.2	149	5.87	765	1,687	40.0	42.4
ZF 5055 D	295	11.6	425	16.7	425	16.7	245	9.65	245	9.65	270	10.6	745	29.3	776	30.6	565	22.2	149	5.87	765	1,687	40.0	42.4
ZF 5060 D	164	6.46	425	16.7	425	16.7	245	9.65	245	9.65	270	10.6	745	29.3	776	30.6	565	22.2	149	5.87	765	1,687	40.0	42.4
ZF 8000 D	189	7.44	500	19.7	500	19.7	282	11.1	282	11.1	330	13.0	771	30.4	864	34.0	630	24.8	150	5.91	1,015	2,238	55.0	58.3
ZF 8050 D	189	7.44	500	19.7	500	19.7	282	11.1	282	11.1	330	13.0	771	30.4	864	34.0	630	24.8	150	5.91	1,015	2,238	55.0	58.3
ZF 8055 D CEW	189	7.44	500	19.7	500	19.7	282	11.1	282	11.1	330	13.0	771	30.4	864	34.0	630	24.8	150	5.91	1,015	2,238	55.0	58.3
ZF 8060 D CEW	189	7.44	500	19.7	500	19.7	282	11.1	282	11.1	330	13.0	771	30.4	864	34.0	630	24.8	150	5.91	1,015	2,238	55.0	58.3

Diagonal Offset Remote Mount

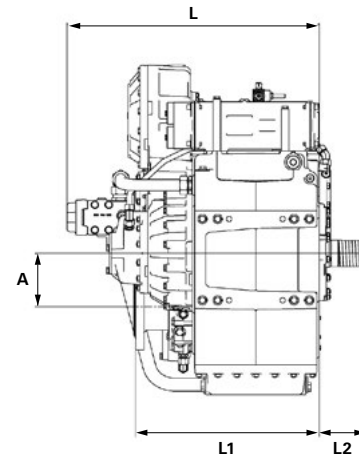
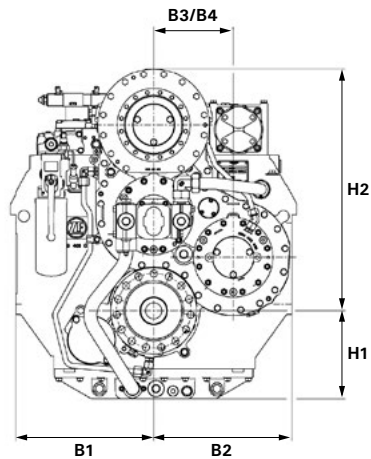

Transmissions drawings and dimensions

PRODUCT	A		B1		B2		B3		B4		H1		H2		L		L1		L2		WEIGHT		OIL	
	mm	in	mm	in	mm	in	mm	in	mm	in	mm	in	mm	in	mm	in	mm	in	mm	in	kg	lb	L	US qt
ZF 24060 D	421	16.6	640	25.2	640	25.2	220	8.66	220	8.66	513	20.2	1,022	40.2	1,041	41.0	750	29.5	479	18.9	2,650	5,842	150	159
ZF 24360 D	675	26.6	890	35.0	890	35.0	220	8.66	220	8.66	690	27.2	1,289	50.8	1,072	42.2	845	33.3	448	17.6	3,870	8,532	200	212

Diagonal Offset Remote Mount

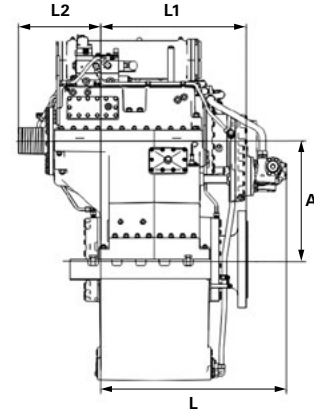
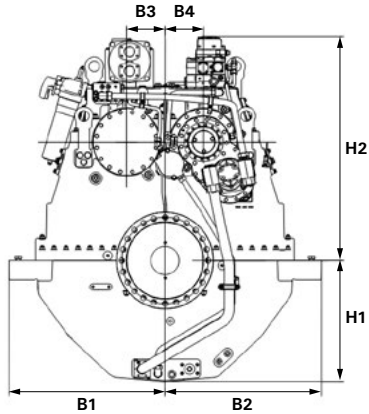

Transmissions drawings and dimensions

PRODUCT	A		B1		B2		H1		H2		L		L1		L2		WEIGHT		OIL	
	mm	in	mm	in	mm	in	mm	in	mm	in	mm	in	mm	in	mm	in	kg	lb	L	US qt
ZF 5000 NR2H	295	11.6	195	7.68	310	12.2	297	11.7	452	17.8	839	33.0	565	22.2	149	5.87	615	1,356	35.0	37.1
ZF 5050 NR2H	295	11.6	195	7.68	310	12.2	297	11.7	452	17.8	839	33.0	565	22.2	149	5.87	615	1,356	35.0	37.1
ZF 5055 NR2H	295	11.6	195	7.68	310	12.2	297	11.7	452	17.8	839	33.0	565	22.2	149	5.87	615	1,356	35.0	37.1
ZF 5060 NR2H	295	11.6	195	7.68	310	12.2	297	11.7	452	17.8	839	33.0	565	22.2	149	5.87	615	1,356	35.0	37.1
ZF 8000 NR2H	340	13.4	210	8.27	350	13.8	380	15	531	20.9	810	31.9	630	24.8	150	5.91	800	1,764	45	47.7
ZF 8050 NR2H	340	13.4	210	8.27	350	13.8	380	15	531	20.9	810	31.9	630	24.8	150	5.91	800	1,764	45	47.7
ZF 8055 NR2H	340	13.4	210	8.27	350	13.8	380	15	531	20.9	810	31.9	630	24.8	150	5.91	800	1,764	45	47.7
ZF 8060 NR2H	340	13.4	210	8.27	350	13.8	380	15	531	20.9	810	31.9	630	24.8	150	5.91	800	1,764	45	47.7
ZF 9000 NR2H	390	15.4	240	9.45	390	15.4	445	17.5	540	21.3	851	33.5	640	25.2	164	6.46	1,040	2,293	60.0	63.6
ZF 9050 NR2H	390	15.4	240	9.45	390	15.4	445	17.5	540	21.3	851	33.5	640	25.2	164	6.46	1,040	2,293	60.0	63.6
ZF 9055 NR2H	390	15.4	240	9.45	390	15.4	445	17.5	540	21.3	851	33.5	640	25.2	164	6.46	1,040	2,293	60.0	63.6
ZF 9060 NR2H	390	15.4	240	9.45	390	15.4	445	17.5	540	21.3	851	33.5	640	25.2	164	6.46	1,040	2,293	60.0	63.6
ZF 24060 NR2H	475	18.7	320	12.6	460	18.1	480	18.9	637	25.1	1,032	40.6	750	29.5	480	18.9	1,860	4,101	90.0	95.4
ZF 30050 NR2H	475	18.7	320	12.6	460	18.1	480	18.9	637	25.1	1,032	40.6	750	29.5	480	18.9	1,870	4,123	90.0	95.4
ZF 40060 NR2H	475	18.7	320	12.6	460	18.1	480	18.9	637	25.1	1,032	40.6	750	29.5	480	18.9	1,880	4,145	90.0	95.4
ZF 30050 NR2H	475	18.7	320	12.6	460	18.1	480	18.9	637	25.1	1,032	40.6	750	29.5	480	18.9	1,870	4,123	90.0	95.4
ZF 40060 NR2H	475	18.7	320	12.6	460	18.1	480	18.9	637	25.1	1,032	40.6	750	29.5	480	18.9	1,880	4,145	90.0	95.4

Horizontal Offset
Remote Mount

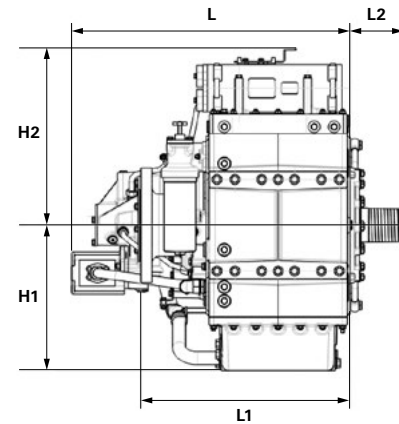
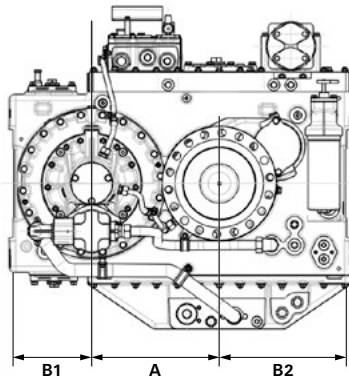

Transmissions drawings and dimensions

PRODUCT	A		B1		B2		H1		H2		L		L1		L2		WEIGHT		OIL	
	mm	in	mm	in	mm	in	mm	in	mm	in	mm	in	mm	in	mm	in	kg	lb	L	US qt
ZF 8000 NR2B	340	13.4	340	13.4	340	13.4	700	27.6	511	20.1	810	31.9	630	24.8	150	5.91	810	1,786	42	44.5
ZF 8050 NR2B	340	13.4	340	13.4	340	13.4	700	27.6	511	20.1	810	31.9	630	24.8	150	5.91	810	1,786	42	44.5
ZF 8055 NR2B	340	13.4	340	13.4	340	13.4	700	27.6	511	20.1	810	31.9	630	24.8	150	5.91	810	1,786	42	44.5
ZF 8060 NR2B	340	13.4	340	13.4	340	13.4	700	27.6	511	20.1	810	31.9	630	24.8	150	5.91	810	1,786	42	44.5
ZF 9000 NR2B	390	15.4	390	15.4	390	15.4	835	32.9	503	19.8	851	33.5	640	25.2	164	6.46	1,040	2,293	60.0	63.6
ZF 9050 NR2B	390	15.4	390	15.4	390	15.4	835	32.9	503	19.8	851	33.5	640	25.2	164	6.46	1,040	2,293	60.0	63.6
ZF 9055 NR2B	390	15.4	390	15.4	390	15.4	835	32.9	503	19.8	851	33.5	640	25.2	164	6.46	1,040	2,293	60.0	63.6
ZF 9060 NR2B	390	15.4	390	15.4	390	15.4	835	32.9	503	19.8	851	33.5	640	25.2	164	6.46	1,040	2,293	60.0	63.6
ZF 24060 NR2B	475	18.7	455	17.9	455	17.9	915	36.0	637	25.1	1,032	40.6	750	29.5	480	18.9	1,890	4,167	90.0	95.4
ZF 30050 NR2B	475	18.7	455	17.9	455	17.9	915	36.0	637	25.1	1,032	40.6	750	29.5	480	18.9	1,900	4,189	90.0	95.4
ZF 40060 NR2B	475	18.7	455	17.9	455	17.9	915	36.0	637	25.1	1,032	40.6	750	29.5	480	18.9	2,010	4,431	90.0	95.4
ZF 53000 NR2B	600	23.6	575	22.6	575	22.6	1,286	50.6	770	30.3	959	37.8	995	39.2	710	28.0	3,900	8,598	200	212
ZF 53500 NR2B	600	23.6	575	22.6	575	22.6	1,286	50.6	770	30.3	959	37.8	995	39.2	710	28.0	3,980	8,774	200	212
ZF 53800 NR2B	600	23.6	575	22.6	575	22.6	1,286	50.6	770	30.3	959	37.8	995	39.2	710	28.0	4,080	8,995	200	212

2-Shaft,
Non-Reversing
(Input BELOW Output)
Remote Mount

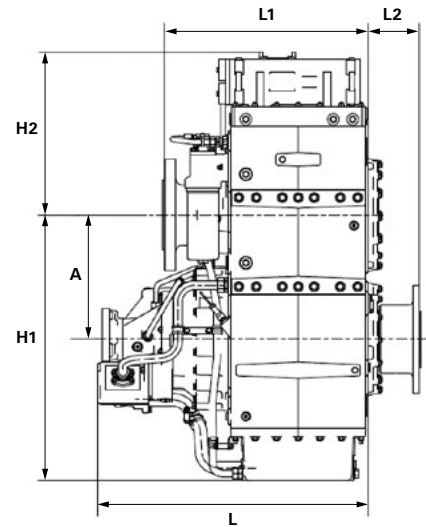
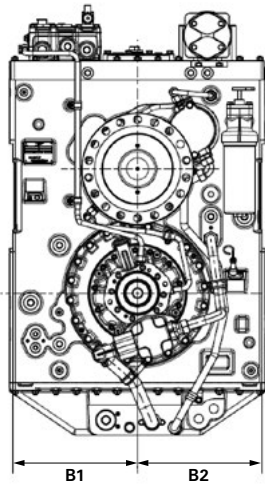

Transmissions drawings and dimensions

PRODUCT	A		B1		B2		H1		H2		L		L1		L2		WEIGHT		OIL	
	mm	in	mm	in	mm	in	mm	in	mm	in	mm	in	mm	in	mm	in	kg	lb	L	US qt
ZF 8000 NR2	340	13.4	340	13.4	340	13.4	360	14.2	851	33.5	810	31.9	630	24.8	150	5.91	810	1,786	42	44.5
ZF 8050 NR2	340	13.4	340	13.4	340	13.4	360	14.2	851	33.5	810	31.9	630	24.8	150	5.91	810	1,786	42	44.5
ZF 8055 NR2	340	13.4	340	13.4	340	13.4	360	14.2	851	33.5	810	31.9	630	24.8	150	5.91	810	1,786	42	44.5
ZF 8060 NR2	340	13.4	340	13.4	340	13.4	360	14.2	851	33.5	810	31.9	630	24.8	150	5.91	810	1,786	42	44.5
ZF 9000 NR2	390	15.4	390	15.4	390	15.4	445	17.5	893	35.2	851	33.5	640	25.2	164	6.46	1,040	2,293	60.0	63.6
ZF 9050 NR2	390	15.4	390	15.4	390	15.4	445	17.5	893	35.2	851	33.5	640	25.2	164	6.46	1,040	2,293	60.0	63.6
ZF 9055 NR2	390	15.4	390	15.4	390	15.4	445	17.5	893	35.2	851	33.5	640	25.2	164	6.46	1,040	2,293	60.0	63.6
ZF 9060 NR2	390	15.4	390	15.4	390	15.4	445	17.5	893	35.2	851	33.5	640	25.2	164	6.46	1,040	2,293	60.0	63.6
ZF 24060 NR2	475	18.7	455	17.9	455	17.9	480	18.9	1,072	42.2	1,032	40.6	750	29.5	480	18.9	1,890	4,167	90.0	95.4
ZF 30050 NR2	475	18.7	455	17.9	455	17.9	480	18.9	1,072	42.2	1,316	51.8	750	29.5	480	18.9	1,900	4,189	90.0	95.4
ZF 40060 NR2	475	18.7	455	17.9	455	17.9	480	18.9	1,072	42.2	1,032	40.6	750	29.5	480	18.9	2,010	4,431	90.0	95.4

2-Shaft,
Non-Reversing
(Input ABOVE Output)
Remote Mount

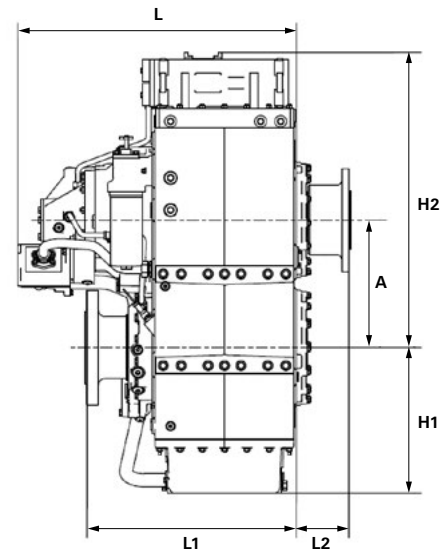
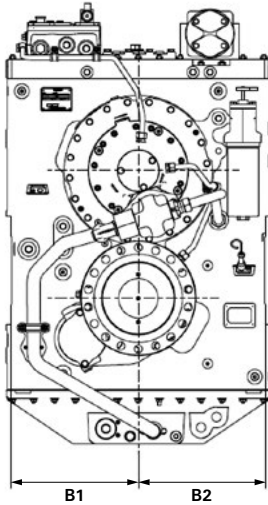

Transmissions drawings and dimensions

PRODUCT	A		B1		B2		H1		H2		L		L1		L2		L3		WEIGHT		OIL	
	mm	in	mm	in	mm	in	mm	in	mm	in	mm	in	mm	in	mm	in	mm	in	kg	lb	L	US qt
ZF W10020	390	15.4	600	23.6	600	23.6	500	19.7	720	28.4	1,540	60.6	1,192	46.9	369	14.5	714	28.1	2,550	5,622	80.0	84.8
ZF W10020 NR	390	15.4	600	23.6	600	23.6	500	19.7	720	28.4	1,540	60.6	1,192	46.9	369	14.5	714	28.1	2,235	4,927	80.0	84.8
ZF W10030	390	15.4	600	23.6	600	23.6	500	19.7	720	28.4	1,540	60.6	1,192	46.9	369	14.5	714	28.1	2,550	5,622	80.0	84.8
ZF W10030 NR	390	15.4	600	23.6	600	23.6	500	19.7	720	28.4	1,540	60.6	1,192	46.9	369	14.5	714	28.1	2,235	4,927	80.0	84.8
ZF W10050	390	15.4	600	23.6	600	23.6	500	19.7	720	28.4	1,540	60.6	1,192	46.9	369	14.5	714	28.1	2,550	5,622	80.0	84.8
ZF W10050 NR	390	15.4	600	23.6	600	23.6	500	19.7	720	28.4	1,540	60.6	1,192	46.9	369	14.5	714	28.1	2,235	4,927	80.0	84.8
ZF W10120	500	19.7	650	25.6	650	25.6	530	20.9	880	34.7	1,540	60.6	1,200	47.2	369	14.5	714	28.1	2,950	6,504	80.0	84.8
ZF W10120 NR	500	19.7	650	25.6	650	25.6	530	20.9	880	34.7	1,540	60.6	1,200	47.2	369	14.5	714	28.1	2,635	5,809	80.0	84.8
ZF W10130	500	19.7	650	25.6	650	25.6	530	20.9	880	34.7	1,540	60.6	1,200	47.2	369	14.5	714	28.1	2,950	6,504	80.0	84.8
ZF W10130 NR	500	19.7	650	25.6	650	25.6	530	20.9	880	34.7	1,540	60.6	1,200	47.2	369	14.5	714	28.1	2,635	5,809	80.0	84.8
ZF W10150	500	19.7	650	25.6	650	25.6	530	20.9	880	34.7	1,540	60.6	1,200	47.2	369	14.5	714	28.1	2,950	6,504	80.0	84.8
ZF W10150 NR	500	19.7	650	25.6	650	25.6	530	20.9	880	34.7	1,540	60.6	1,200	47.2	369	14.5	714	28.1	2,635	5,809	80.0	84.8
ZF W10220	625	24.6	795	31.3	795	31.3	660	26.0	1,035	40.8	1,540	60.6	1,212	47.7	369	14.5	714	28.1	3,500	7,716	120	127
ZF W10220 NR	625	24.6	795	31.3	795	31.3	660	26.0	1,035	40.8	1,540	60.6	1,212	47.7	369	14.5	714	28.1	3,185	7,022	120	127
ZF W10230	625	24.6	795	31.3	795	31.3	660	26.0	1,035	40.8	1,540	60.6	1,212	47.7	369	14.5	714	28.1	3,500	7,716	120	127
ZF W10230 NR	625	24.6	795	31.3	795	31.3	660	26.0	1,035	40.8	1,540	60.6	1,212	47.7	369	14.5	714	28.1	3,185	7,022	120	127
ZF W10250	625	24.6	795	31.3	795	31.3	660	26.0	1,035	40.8	1,540	60.6	1,212	47.7	369	14.5	714	28.1	3,500	7,716	120	127
ZF W10250 NR	625	24.6	795	31.3	795	31.3	660	26.0	1,035	40.8	1,540	60.6	1,212	47.7	369	14.5	714	28.1	3,185	7,022	120	127
ZF 10830	625	24.6	795	31.3	795	31.3	660	26.0	1,035	40.8	1,540	60.6	1,212	47.7	369	14.5	714	28.1	3,500	7,716	120	127
ZF 10830 NR	625	24.6	795	31.3	795	31.3	660	26.0	1,035	40.8	1,540	60.6	1,212	47.7	369	14.5	714	28.1	3,185	7,022	120	127
ZF 10850	625	24.6	795	31.3	795	31.3	660	26.0	1,035	40.8	1,540	60.6	1,212	47.7	369	14.5	714	28.1	3,500	7,716	120	127
ZF 10850 NR	625	24.6	795	31.3	795	31.3	660	26.0	1,035	40.8	1,540	60.6	1,212	47.7	369	14.5	714	28.1	3,185	7,022	120	127
ZF W11010 NR	415	16.3	650	25.6	650	25.6	530	20.9	748	29.5	1,562	61.5	1,210	47.6	379	14.9	714	28.1	2,480	5,467	80.0	84.8

Vertical Offset
Remote Mount

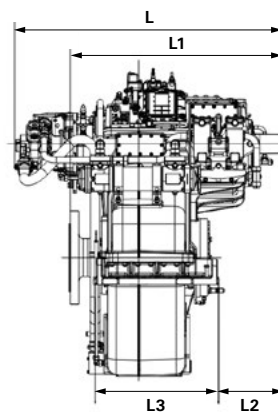
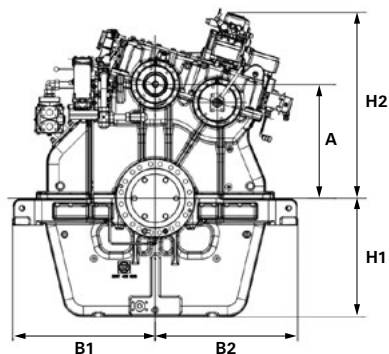

Transmissions drawings and dimensions

PRODUCT	A		B1		B2		H1		H2		L		L1		L2		L3		WEIGHT		OIL	
	mm	in	mm	in	mm	in	mm	in	mm	in	mm	in	mm	in	mm	in	mm	in	kg	lb	L	US qt
ZF W11020	415	16.3	650	25.6	650	25.6	530	20.9	748	29.5	1,562	61.5	1,210	47.6	379	14.9	714	28.1	2,860	6,305	80.0	84.8
ZF W11020 NR	415	16.3	650	25.6	650	25.6	530	20.9	748	29.5	1,562	61.5	1,210	47.6	379	14.9	714	28.1	2,480	5,467	80.0	84.8
ZF W11030	415	16.3	650	25.6	650	25.6	530	20.9	748	29.5	1,562	61.5	1,210	47.6	379	14.9	714	28.1	2,860	6,305	80.0	84.8
ZF W11030 NR CEW	415	16.3	650	25.6	650	25.6	530	20.9	748	29.5	1,562	61.5	1,210	47.6	379	14.9	714	28.1	2,480	5,467	80.0	84.8
ZF W11050	415	16.3	650	25.6	650	25.6	530	20.9	748	29.5	1,562	61.5	1,210	47.6	379	14.9	714	28.1	2,860	6,305	80.0	84.8
ZF W11050 NR CEW	415	16.3	650	25.6	650	25.6	530	20.9	748	29.5	1,562	61.5	1,210	47.6	379	14.9	714	28.1	2,480	5,467	80.0	84.8
ZF W11110 NR	530	20.9	700	27.6	700	27.6	570	22.4	915	36.0	1,562	61.5	1,246	49.1	379	14.9	714	28.1	2,960	6,526	90.0	95.4
ZF W11120	530	20.9	700	27.6	700	27.6	570	22.4	915	36.0	1,562	61.5	1,246	49.1	379	14.9	714	28.1	3,340	7,363	90.0	95.4
ZF W11120 NR	530	20.9	700	27.6	700	27.6	570	22.4	915	36.0	1,562	61.5	1,246	49.1	379	14.9	714	28.1	2,960	6,526	90.0	95.4
ZF W11130	530	20.9	700	27.6	700	27.6	570	22.4	915	36.0	1,562	61.5	1,246	49.1	379	14.9	714	28.1	3,340	7,363	90.0	95.4
ZF W11130 NR CEW	530	20.9	700	27.6	700	27.6	570	22.4	915	36.0	1,562	61.5	1,246	49.1	379	14.9	714	28.1	2,960	6,526	90.0	95.4
ZF W11150	530	20.9	700	27.6	700	27.6	570	22.4	915	36.0	1,562	61.5	1,246	49.1	379	14.9	714	28.1	3,340	7,363	90.0	95.4
ZF W11150 NR CEW	530	20.9	700	27.6	700	27.6	570	22.4	915	36.0	1,562	61.5	1,246	49.1	379	14.9	714	28.1	2,960	6,526	90.0	95.4
ZF W11210 NR	660	26.0	825	32.5	825	32.5	688	27.1	1,075	42.3	1,562	61.5	1,238	48.7	379	14.9	714	28.1	3,460	7,628	145	154
ZF W11220	660	26.0	825	32.5	825	32.5	688	27.1	1,075	42.3	1,562	61.5	1,238	48.7	379	14.9	714	28.1	3,840	8,466	145	154
ZF W11220 NR	660	26.0	825	32.5	825	32.5	688	27.1	1,075	42.3	1,562	61.5	1,238	48.7	379	14.9	714	28.1	3,460	7,628	145	154
ZF W11230	660	26.0	825	32.5	825	32.5	688	27.1	1,075	42.3	1,562	61.5	1,238	48.7	379	14.9	714	28.1	3,840	8,466	145	154
ZF W11230 NR CEW	660	26.0	825	32.5	825	32.5	688	27.1	1,075	42.3	1,562	61.5	1,238	48.7	379	14.9	714	28.1	3,460	7,628	145	154
ZF W11250	660	26.0	825	32.5	825	32.5	688	27.1	1,075	42.3	1,562	61.5	1,238	48.7	379	14.9	714	28.1	3,840	8,466	145	154
ZF W11250 NR CEW	660	26.0	825	32.5	825	32.5	688	27.1	1,075	42.3	1,562	61.5	1,238	48.7	379	14.9	714	28.1	3,460	7,628	145	154
ZF 11830	660	26.0	825	32.5	825	32.5	688	27.1	1,075	42.3	1,562	61.5	1,238	48.7	379	14.9	714	28.1	3,840	8,466	145	154
ZF 11830 NR	660	26.0	825	32.5	825	32.5	688	27.1	1,075	42.3	1,562	61.5	1,238	48.7	379	14.9	714	28.1	3,460	7,628	145	154
ZF 11850	660	26.0	825	32.5	825	32.5	688	27.1	1,075	42.3	1,562	61.5	1,238	48.7	379	14.9	714	28.1	3,840	8,466	145	154
ZF 11850 NR	660	26.0	825	32.5	825	32.5	688	27.1	1,075	42.3	1,562	61.5	1,238	48.7	379	14.9	714	28.1	3,460	7,628	145	154

Vertical Offset
Remote Mount

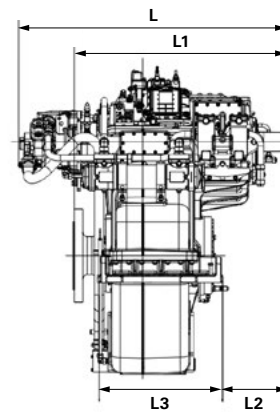
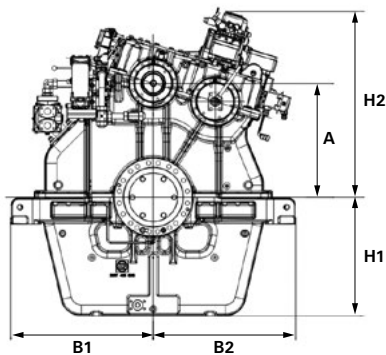

Transmissions drawings and dimensions

PRODUCT	A		B1		B2		H1		H2		L		L1		L2		L3		WEIGHT		OIL	
	mm	in	mm	in	mm	in	mm	in	mm	in	mm	in	mm	in	mm	in	mm	in	kg	lb	L	US qt
ZF W17000	475	18.7	785	30.9	785	30.9	610	24.0	940	37.0	1,866	73.5	1,504	59.2	488	19.2	890	35.0	4,550	10,031	170	180
ZF W17000 NR	475	18.7	785	30.9	785	30.9	610	24.0	940	37.0	1,866	73.5	1,504	59.2	488	19.2	890	35.0	3,900	8,598	170	180
ZF W17010	475	18.7	785	30.9	785	30.9	610	24.0	940	37.0	1,866	73.5	1,504	59.2	488	19.2	890	35.0	4,550	10,031	170	180
ZF W17010 NR	475	18.7	785	30.9	785	30.9	610	24.0	940	37.0	1,866	73.5	1,504	59.2	488	19.2	890	35.0	3,900	8,598	170	180
ZF W17030	475	18.7	785	30.9	785	30.9	610	24.0	940	37.0	1,866	73.5	1,504	59.2	488	19.2	890	35.0	4,620	10,185	170	180
ZF W17030 NR CEW	475	18.7	785	30.9	785	30.9	610	24.0	940	37.0	1,866	73.5	1,504	59.2	488	19.2	890	35.0	3,940	8,686	170	180
ZF W17050	475	18.7	785	30.9	785	30.9	610	24.0	940	37.0	1,866	73.5	1,504	59.2	488	19.2	890	35.0	4,620	10,185	170	180
ZF W17050 NR CEW	475	18.7	785	30.9	785	30.9	610	24.0	940	37.0	1,866	73.5	1,504	59.2	488	19.2	890	35.0	3,940	8,686	170	180
ZF W17100	600	23.6	850	33.5	850	33.5	725	28.5	1,030	40.6	1,866	73.5	1,504	59.2	488	19.2	925	36.4	5,350	11,795	220	233
ZF W17100 NR	600	23.6	850	33.5	850	33.5	725	28.5	1,030	40.6	1,866	73.5	1,504	59.2	488	19.2	925	36.4	4,750	10,472	220	233
ZF W17110	600	23.6	850	33.5	850	33.5	725	28.5	1,030	40.6	1,866	73.5	1,504	59.2	488	19.2	925	36.4	5,350	11,795	220	233
ZF W17110 NR	600	23.6	850	33.5	850	33.5	725	28.5	1,030	40.6	1,866	73.5	1,504	59.2	488	19.2	925	36.4	4,750	10,472	220	233
ZF W17130	600	23.6	850	33.5	850	33.5	725	28.5	1,030	40.6	1,866	73.5	1,504	59.2	488	19.2	925	36.4	5,420	11,949	220	233
ZF W17130 NR CEW	600	23.6	850	33.5	850	33.5	725	28.5	1,030	40.6	1,866	73.5	1,504	59.2	488	19.2	925	36.4	4,790	10,560	220	233
ZF W17150	600	23.6	850	33.5	850	33.5	725	28.5	1,030	40.6	1,866	73.5	1,504	59.2	488	19.2	925	36.4	5,420	11,949	220	233
ZF W17150 NR CEW	600	23.6	850	33.5	850	33.5	725	28.5	1,030	40.6	1,866	73.5	1,504	59.2	488	19.2	925	36.4	4,790	10,560	220	233
ZF W17200	700	27.6	885	34.8	885	34.8	825	32.5	1,180	46.5	1,866	73.5	1,504	59.2	488	19.2	925	36.4	5,800	12,787	250	265
ZF W17200 NR	700	27.6	885	34.8	885	34.8	825	32.5	1,180	46.5	1,866	73.5	1,504	59.2	488	19.2	925	36.4	5,250	11,574	250	265
ZF W17210	700	27.6	885	34.8	885	34.8	825	32.5	1,180	46.5	1,866	73.5	1,504	59.2	488	19.2	925	36.4	5,800	12,787	250	265
ZF W17210 NR	700	27.6	885	34.8	885	34.8	825	32.5	1,180	46.5	1,866	73.5	1,504	59.2	488	19.2	925	36.4	5,250	11,574	250	265
ZF W17230	700	27.6	885	34.8	885	34.8	825	32.5	1,180	46.5	1,866	73.5	1,504	59.2	488	19.2	925	36.4	5,870	12,941	250	265
ZF W17230 NR CEW	700	27.6	885	34.8	885	34.8	825	32.5	1,180	46.5	1,866	73.5	1,504	59.2	488	19.2	925	36.4	5,290	11,662	250	265
ZF W17250	700	27.6	885	34.8	885	34.8	825	32.5	1,180	46.5	1,866	73.5	1,504	59.2	488	19.2	925	36.4	5,870	12,941	250	265
ZF W17250 NR CEW	700	27.6	885	34.8	885	34.8	825	32.5	1,180	46.5	1,866	73.5	1,504	59.2	488	19.2	925	36.4	5,290	11,662	250	265

Vertical Offset
Remote Mount

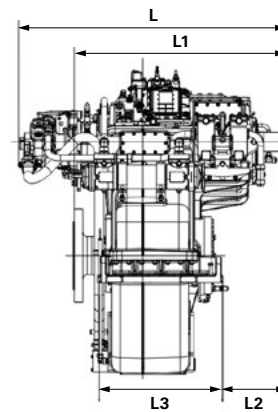
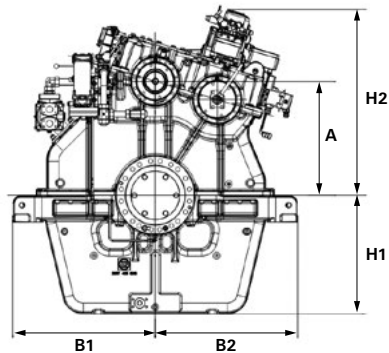

Transmissions drawings and dimensions

PRODUCT	A		B1		B2		B4		F		H1		H2		L		L1		L2		L3		WEIGHT		OIL	
	mm	in	mm	in	mm	in	mm	in	mm	in	mm	in	mm	in	mm	in	mm	in	mm	in	mm	in	kg	lb	L	US qt
ZF W10200 SG (iSG=1.256)	930	36.6	795	31.3	795	31.3	89.0	3.50	155	6.10	660	26.0	1,194	47.0	1,440	56.7	1,106	43.5	262	10.3	714	28.1	3,826	8,435	120	127
ZF W10200 SG (iSG=1.441)	907	35.7	795	31.3	795	31.3	82.3	3.24	155	6.10	660	26.0	1,175	46.3	1,440	56.7	1,106	43.5	262	10.3	714	28.1	3,798	8,373	120	127
ZF W10200 SG (iSG=1.531)	907	35.7	795	31.3	795	31.3	82.3	3.24	155	6.10	660	26.0	1,175	46.3	1,440	56.7	1,106	43.5	262	10.3	714	28.1	3,798	8,373	120	127
ZF W10200 SG (iSG=1.581)	903	35.6	795	31.3	795	31.3	81.2	3.20	155	6.10	660	26.0	1,175	46.3	1,440	56.7	1,106	43.5	262	10.3	714	28.1	3,783	8,340	120	127
ZF W10200 SG (iSG=1.633)	903	35.6	795	31.3	795	31.3	81.2	3.20	155	6.10	660	26.0	1,175	46.3	1,440	56.7	1,106	43.5	262	10.3	714	28.1	3,783	8,340	120	127
ZF W10200 SG (iSG=1.690)	903	35.6	795	31.3	795	31.3	81.2	3.20	155	6.10	660	26.0	1,175	46.3	1,440	56.7	1,106	43.5	262	10.3	714	28.1	3,783	8,340	120	127
ZF W11200 SG (iSG=1.581)	952	37.5	825	32.5	825	32.5	86.1	3.39	155	6.10	570	22.4	1,220	48.0	1,455	57.3	1,131	44.5	272	10.7	714	28.1	4,233	9,332	150	159
ZF W11200 SG (iSG=1.633)	952	37.5	825	32.5	825	32.5	86.1	3.39	155	6.10	688	27.1	1,220	48.0	1,455	57.3	1,131	44.5	272	10.7	714	28.1	4,233	9,332	150	159
ZF W11200 SG (iSG=1.690)	952	37.5	825	32.5	825	32.5	86.1	3.39	155	6.10	570	22.4	1,220	48.0	1,455	57.3	1,131	44.5	272	10.7	714	28.1	4,233	9,332	150	159
ZF W11200 SG (iSG=1.750)	952	37.5	825	32.5	825	32.5	86.1	3.39	155	6.10	570	22.4	1,220	48.0	1,455	57.3	1,131	44.5	272	10.7	714	28.1	4,228	9,321	150	159

Vertical Offset
Remote Mount

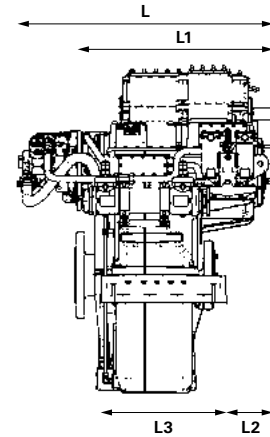
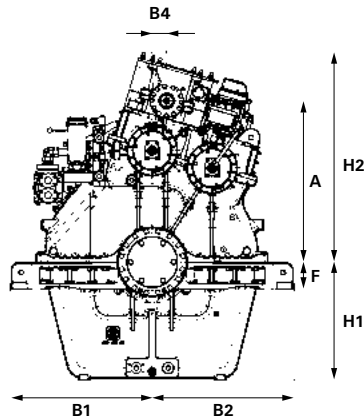

Transmissions drawings and dimensions

PRODUCT	A		B1		B2		H1		H2		L		L1		L2		WEIGHT		OIL	
	mm	in	mm	in	mm	in	mm	in	mm	in	mm	in	mm	in	mm	in	kg	lb	L	US qt
ZF 23560 C (iSG=1.000)	0.0	0.0	592	23.3	592	23.3	440	17.3	1,113	43.8	1,217	47.9	934	36.8	221	8.70	2,600	5,732	180	191
ZF 23560 C (iSG=1.130)	0.0	0.0	592	23.3	592	23.3	440	17.3	1,113	43.8	1,217	47.9	934	36.8	221	8.70	2,600	5,732	180	191
ZF 23560 C (iSG=1.273)	0.0	0.0	592	23.3	592	23.3	440	17.3	1,113	43.8	1,217	47.9	934	36.8	221	8.70	2,600	5,732	180	191
ZF 23560 C (iSG=1.432)	0.0	0.0	592	23.3	592	23.3	440	17.3	1,113	43.8	1,217	47.9	934	36.8	221	8.70	2,600	5,732	180	191
ZF 23860 C (iSG=0.574)	0.0	0.0	592	23.3	592	23.3	440	17.3	1,113	43.8	1,217	47.9	934	36.8	221	8.70	2,600	5,732	180	191
ZF 23860 C (iSG=0.493)	0.0	0.0	592	23.3	592	23.3	440	17.3	1,113	43.8	1,217	47.9	934	36.8	221	8.70	2,600	5,732	180	191
ZF 24060 SGC (iSG=1.000)	0.0	0.0	640	25.2	640	25.2	513	20.2	1,022	40.2	1,041	41.0	750	29.5	776	30.6	3,250	7,165	150	159
ZF 24060 SGC (iSG=1.173)	0.0	0.0	640	25.2	640	25.2	513	20.2	1,022	40.2	1,041	41.0	750	29.5	776	30.6	3,250	7,165	150	159
ZF 24060 SGC (iSG=1.280)	0.0	0.0	640	25.2	640	25.2	513	20.2	1,022	40.2	1,041	41.0	750	29.5	776	30.6	3,250	7,165	150	159
ZF 24060 SGC (iSG=1.354)	0.0	0.0	640	25.2	640	25.2	513	20.2	1,022	40.2	1,041	41.0	750	29.5	776	30.6	3,250	7,165	150	159
ZF 24360 SG (iSG=1.000)	254	10.0	890	35.0	890	35.0	690	27.2	1,289	50.8	1,072	42.2	845	33.3	745	29.3	4,500	9,921	200	212
ZF 24360 SG (iSG=1.173)	254	10.0	890	35.0	890	35.0	690	27.2	1,289	50.8	1,072	42.2	845	33.3	745	29.3	4,500	9,921	200	212
ZF 24360 SG (iSG=1.280)	254	10.0	890	35.0	890	35.0	690	27.2	1,289	50.8	1,072	42.2	845	33.3	745	29.3	4,500	9,921	200	212
ZF 24360 SG (iSG=1.354)	254	10.0	890	35.0	890	35.0	690	27.2	1,289	50.8	1,072	42.2	845	33.3	745	29.3	4,500	9,921	200	212
ZF 30050 SGC (iSG=0.759)	0.0	0.0	640	25.2	640	25.2	513	20.2	1,022	40.2	1,041	41.0	750	29.5	776	30.6	3,250	7,165	150	159
ZF 30350 SG (iSG=0.759)	254	10.0	890	35.0	890	35.0	690	27.2	1,289	50.8	1,072	42.2	845	33.3	745	29.3	4,575	10,086	200	212
ZF 40060 SGC (iSG=0.522)	0.0	0.0	640	25.2	640	25.2	513	20.2	1,022	40.2	1,041	41.0	750	29.5	776	30.6	3,260	7,187	150	159
ZF 40060 SGC (iSG=0.585)	0.0	0.0	640	25.2	640	25.2	513	20.2	1,022	40.2	1,041	41.0	750	29.5	776	30.6	3,260	7,187	150	159
ZF 40060 SGC (iSG=0.603)	0.0	0.0	640	25.2	640	25.2	513	20.2	1,022	40.2	1,041	41.0	750	29.5	776	30.6	3,260	7,187	150	159
ZF 40360 SG (iSG=0.522)	254	10.0	890	35.0	890	35.0	690	27.2	1,289	50.8	1,072	42.2	845	33.3	745	29.3	4,625	10,196	200	212
ZF 40360 SG (iSG=0.585)	254	10.0	890	35.0	890	35.0	690	27.2	1,289	50.8	1,072	42.2	845	33.3	745	29.3	4,625	10,196	200	212
ZF 40360 SG (iSG=0.603)	254	10.0	890	35.0	890	35.0	690	27.2	1,289	50.8	1,072	42.2	845	33.3	745	29.3	4,625	10,196	200	212

Near Co-Axial
Remote Mount

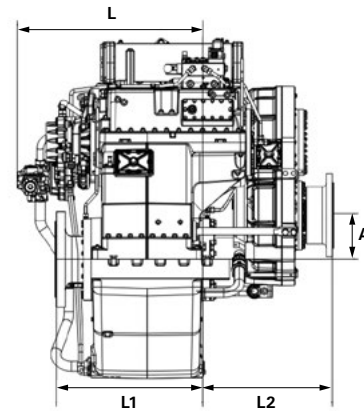
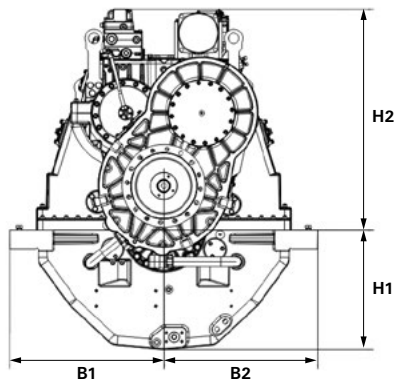

Transmissions drawings and dimensions

PRODUCT	A		B1		B2		H1		H2		L		L1		L2		WEIGHT		OIL	
	mm	in	mm	in	mm	in	mm	in	mm	in	mm	in	mm	in	mm	in	kg	lb	L	US qt
ZF W33100 NR2	700	27.6	860	33.9	860	33.9	800	31.5	1,260	49.6	1,596	62.8	1,493	58.8	301	11.9	6,080	13,404	280	297
ZF 33700 NR2	700	27.6	860	33.9	860	33.9	800	31.5	1,260	49.6	1,596	62.8	1,493	58.8	301	11.9	6,080	13,404	280	297
ZF W43000 NR2	600	23.6	860	33.9	860	33.9	800	31.5	1,210	47.6	1,768	69.6	1,598	62.9	336	13.2	6,400	14,110	280	297
ZF W43100 NR2	770	30.3	995	39.2	995	39.2	900	35.4	1,380	54.3	1,768	69.6	1,653	65.1	336	13.2	9,300	20,503	370	392
ZF 43600 NR2	600	23.6	860	33.9	860	33.9	800	31.5	1,210	47.6	1,768	69.6	1,598	62.9	336	13.2	6,400	14,110	280	297
ZF 43700 NR2	770	30.3	995	39.2	995	39.2	900	35.4	1,380	54.3	1,768	69.6	1,653	65.1	336	13.2	9,300	20,503	370	392
ZF 53600 NR2	670	26.4	995	39.2	995	39.2	900	35.4	1,937	76.3	1,836	72.3	1,785	70.3	346	13.6	9,200	20,283	370	392
ZF W63000 NR2	670	26.4	995	39.2	995	39.2	900	35.4	1,367	53.8	1,836	72.3	1,785	70.3	346	13.6	9,200	20,283	370	392
ZF W83100 NR2	980	38.6	1,230	48.4	1,230	48.4	1,120	44.1	1,760	69.3	1,989	78.3	2,059	81.1	376	14.8	16,600	36,597	720	763

Vertical Offset

Remote Mount

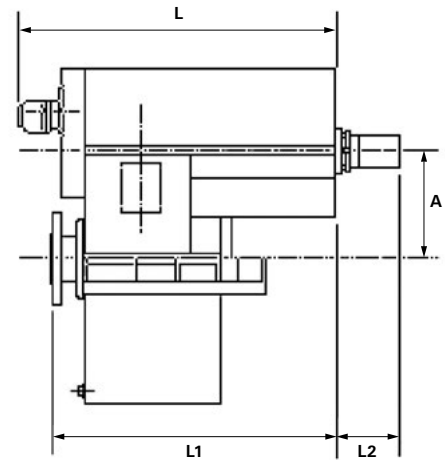
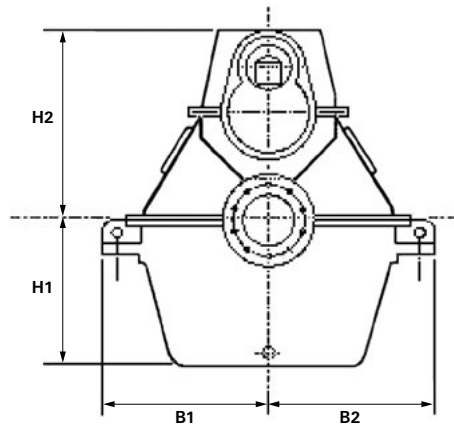

Transmissions drawings and dimensions

PRODUCT	A		B1		B2		H1		H2		L		L1		L2		WEIGHT		OIL	
	mm	in	mm	in	mm	in	mm	in	mm	in	mm	in	mm	in	mm	in	kg	lb	L	US qt
ZF W33100 NC2	700	27.6	860	33.9	860	33.9	800	31.5	1,350	53.2	1,040	40.9	880	34.7	290	11.4	4,500	9,921	280	297
ZF W43000 NC2	600	23.6	860	33.9	860	33.9	800	31.5	1,255	49.4	1,100	43.3	930	36.6	340	13.4	5,400	11,905	280	297
ZF W43100 NC2	770	30.3	995	39.2	995	39.2	900	35.4	1,432	56.4	1,100	43.3	985	38.8	340	13.4	6,800	14,991	370	392
ZF W83000 NC2	750	29.5	1,090	42.9	1,090	42.9	1,000	39.4	1,562	61.5	1,225	48.2	1,130	44.5	360	14.2	9,270	20,437	600	636
ZF W83100 NC2	980	38.6	1,230	48.4	1,230	48.4	1,120	44.1	1,792	70.6	1,225	48.2	1,210	47.6	360	14.2	14,800	32,628	720	763
ZF W93300 NC2	980	38.6	1,235	48.6	1,235	48.6	1,125	44.3	2,140	84.3	1,915	75.4	2,490	98.0	425	16.7	21,000	46,297	800	848
ZF W103100 NC2	1,120	44.1	1,375	54.1	1,375	54.1	1,340	52.8	1,810	71.3	1,840	72.4	2,190	86.2	425	16.7	27,000	59,525	1,050	1,113

Vertical Offset Remote Mount

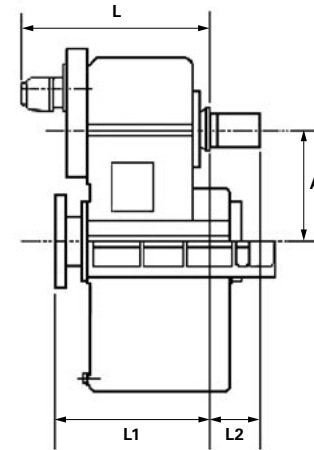
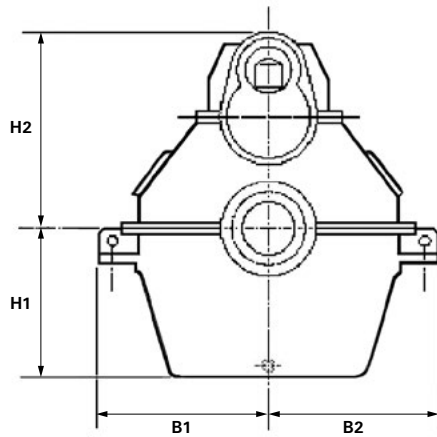

Transmissions drawings and dimensions

PRODUCT	A		B1		B2		H1		H2		L		L1		L2		WEIGHT		OIL	
	mm	in	mm	in	mm	in	mm	in	mm	in	mm	in	mm	in	mm	in	kg	lb	L	US qt
ZF 53000 NR2H	600	23.6	730	28.7	515	20.3	535	21.1	770	30.3	705	27.8	995	39.2	716	28.2	3,750	8,267	200	212
ZF 53500 NR2H	600	23.6	730	28.7	515	20.3	535	21.1	770	30.3	705	27.8	995	39.2	746	29.4	3,825	8,433	200	212
ZF 53600 NR2H	670	26.4	948	37.3	772	30.4	770	30.3	1,146	45.1	759	29.9	996	39.2	1,136	44.7	9,900	21,826	300	318
ZF 53800 NR2H	600	23.6	730	28.7	515	20.3	535	21.1	770	30.3	705	27.8	995	39.2	761	30.0	3,925	8,653	200	212
ZF 60000 NR2H	665	26.2	750	29.5	590	23.2	600	23.6	819	32.2	715	28.2	1,045	41.1	817	32.2	4,650	10,251	200	212
ZF 60500 NR2H	665	26.2	750	29.5	590	23.2	600	23.6	819	32.2	715	28.2	1,045	41.1	817	32.2	4,650	10,251	200	212
ZF W63000 NR2H	670	26.4	948	37.3	772	30.4	770	30.3	1,146	45.1	1,531	60.3	1,768	69.6	364	14.3	9,900	21,826	300	318
ZF 83700 NR2H	880	34.7	1,135	44.7	825	32.5	950	37.4	1,217	47.9	910	35.8	1,229	48.4	1,147	45.2	15,500	34,172	500	530
ZF 83750 NR2H	880	34.7	1,135	44.7	825	32.5	950	37.4	1,217	47.9	910	35.8	1,229	48.4	1,147	45.2	15,500	34,172	500	530

Horizontal Offset Remote Mount

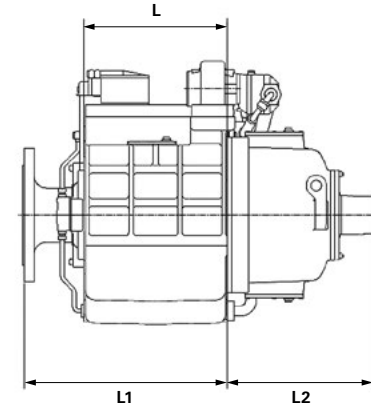
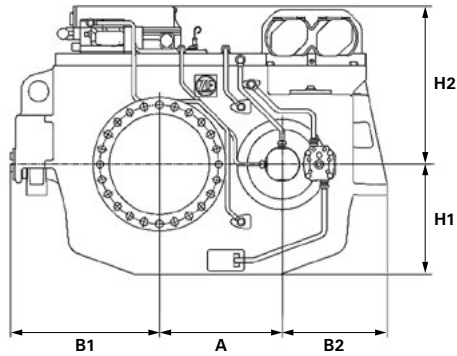

SAE Bell housing dimensions

SAE No.	A		B		C		Bolt holes		
	mm	inch	mm	inch	mm	inch	No.	Diameter	
								mm	inch
00	787.40	31	850.90	33 1/2	882.65	34 3/4	16	13.49	17/32
0	647.70	25 1/2	679.45	26 3/4	711.20	28	16	13.49	17/32
1/2	584.20	23	619.13	24 3/8	647.70	25 1/2	12	13.49	17/32
1	511.18	20 1/8	530.23	20 7/8	552.45	21 3/4	12	11.91	15/32
2	447.68	17 5/8	466.73	18 3/8	488.95	19 1/4	12	10.32	13/32
3	409.58	16 1/8	428.63	16 7/8	450.85	17 3/4	12	10.32	13/32
4	361.95	14 1/4	381.00	15	403.23	15 7/8	12	10.32	13/32
5	314.33	12 3/8	333.38	13 1/8	355.60	14	8	10.32	13/32
6	266.70	10 1/2	285.75	11 1/4	307.98	12 1/8	8	10.32	13/32

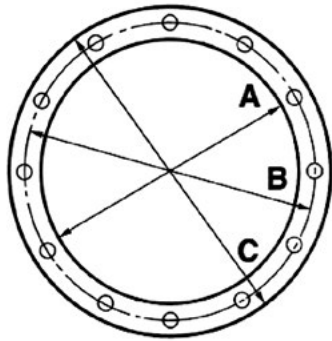

Thruster Systems

Contents





Well Mounted Azimuth Thrusters	page	314
Contra Rotation Azimuth Thrusters	page	315
Deck Mounted Azimuth Thrusters	page	316
Stern Mounted Azimuth Thrusters	page	317
Retractable Azimuth Thrusters	page	318
Shallow Draught Thrusters	page	319
Fixed Pitch Tunnel Thrusters	page	320
Controllable Pitch Tunnel Thrusters	page	321
Thruster Control Systems	page	322

Abbreviations

ATL	Azimuth Thruster L-Drive
ATZ	Azimuth Thruster Z-Drive
CP	Controllable Pitch Propeller
CR	Contra Rotation Propeller
DM	Deck Mounted
FP	Fixed Pitch Propeller
RT	Retractable Thruster
SDL	Shallow Draught L-Drive
SDZ	Shallow Draught Z-Drive
SM	Stern Mounted
TTL	Tunnel Thruster L-Drive
TTZ	Tunnel Thruster Z-Drive
WM	Well Mounted

Well Mounted Azimuth Thrusters

Contra Rotation Azimuth Thrusters



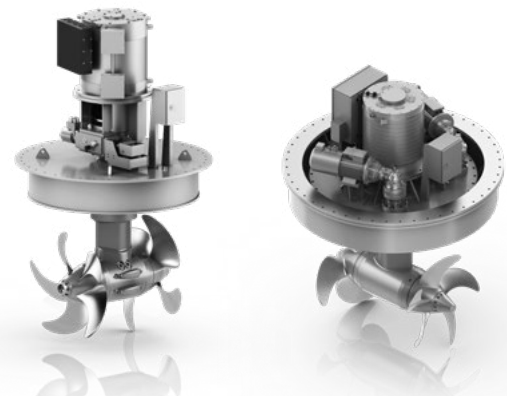
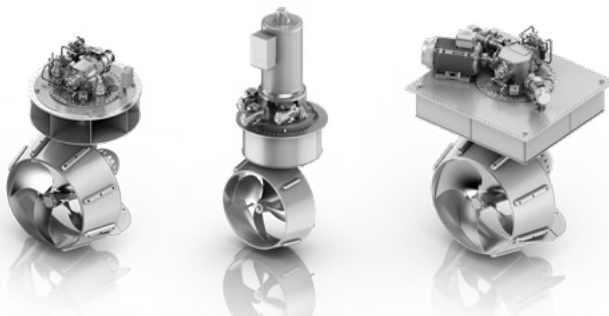

MODEL	Max. power*		Nominal input speed (min ⁻¹)	Typical propeller diameter		MODEL	Max. power*		Nominal input speed (min ⁻¹)	Typical diam. pulling propeller		Typical diam. pushing propeller	
	kW	hp		mm	in		kW	hp		mm	in	mm	in
L-Drive 						L-Drive 							
ZF ATL 1000 WM	95	127	1500	600	24	ZF ATL 10 CR	230	308	1500	850	33	720	28
ZF ATL 2000 WM	200	267	1500	700	28	ZF ATL 20 CR	345	462	1500	950	37	850	33
ZF ATL 3000 WM	332	445	1500	1000	39	ZF ATL 30 CR**	443	594	1500	1130	44	1020	40
ZF ATL 4000 WM**	595	798	1200/1500/1800	1300	51	ZF ATL 40 CR**	604	809	1200	1300	51	1170	46
ZF ATL 50 WM**	815	1093	1200/1500	1500	59	ZF ATL 50 CR**	815	1092	1200	1450	57	1310	52
ZF ATL 5000 WM**	941	1261	1200/1500	1650	65	ZF ATL 60 CR	1035	1387	1200	1600	63	1440	57
ZF ATL 6000 WM	1380	1849	1200	1900	75	ZF ATL 70 CR	1311	1757	1000	1730	68	1560	61
ZF ATL 80 WM	1587	2126	900/1200/1500	2200	87	ZF ATL 80 CR	1587	2127	900	1900	75	1710	67
ZF ATL 90 WM	1978	2651	850/1000	2400	94	ZF ATL 90 CR	1978	2651	850	2100	83	1890	74
ZF ATL 8000 WM	2500	3350	900	2400	94	Z-Drive 							
Z-Drive 						ZF ATZ 10 CR	230	308	1800	800	31	720	28
ZF ATZ 2000 WM	182	244	1800	700	28	ZF ATZ 20 CR	345	462	1800	950	37	850	33
ZF ATZ 3000 WM	305	409	1800	1000	39	ZF ATZ 30 CR**	443	594	1800	1130	44	1020	40
ZF ATZ 4000 WM**	584	783	1800	1300	51	ZF ATZ 40 CR**	604	809	1800	1300	51	1170	46
ZF ATZ 50 WM**/***	815	1093	1600/1800/ 2100/2300	1500	59	ZF ATZ 50 CR**	815	1092	1600/1800	1450	57	1310	52
ZF ATZ 5000 WM**	875	1173	720/900/1000/ 1600/1800	1650	65	ZF ATZ 60 CR	1035	1387	1600/1800	1600	63	1440	57
ZF ATZ 6000 WM	1330	1782	720/900/1000/ 1600/1800	1900	75	ZF ATZ 70 CR	1311	1757	1600/1800	1730	68	1560	61
ZF ATZ 80 WM***	1587	2126	1600/1800	2200	87	ZF ATZ 80 CR	1587	2127	1600/1800	1900	75	1710	67
ZF ATZ 7000 WM	1850	2479	720/900/1000	2200	87	ZF ATZ 90 CR	1978	2651	1600/1800	2100	83	1890	74
ZF ATZ 90 WM***	1978	2651	1600/1800	2400	94								
ZF ATZ 8000 WM	2500	3350	720/750/900/1000/ 1200/1500/1600/ 1800	2400	94								

- * Rating, subject to classification and application. Mentioned data for indication purpose only. Consult ZF Marine Krimpen's technical staff to determine applicable power for each specific use.
- ** Also available as WMC (compact type); a space saving design, making it the right choice when reduced installation height is required. It will fit most applications, especially in combination with a permanent magnet electric motor.
- *** Also available as hybrid thruster for a combination of diesel and electric driven upper gearbox (PTI).



Deck Mounted Azimuth Thrusters

Stern Mounted Azimuth Thrusters

MODEL***	Max. power*		Nominal input speed (min ⁻¹)	Typical propeller diameter		MODEL***	Max. power*		Nominal input speed (min ⁻¹)	Typical propeller diameter	
	kW	hp		mm	in		kW	hp		mm	in
Z-Drive** 						L-Drive 					
ZF ATZ 2000 DM	182	244	1800	700	28	ZF ATL 1000 SM	95	127	1500	600	24
ZF ATZ 3000 DM	305	409	1800	1000	39	ZF ATL 2000 SM	200	267	1500	700	28
ZF ATZ 4000 DM	584	783	1800	1300	51	ZF ATL 3000 SM	332	445	1500	1000	39
ZF ATZ 50 DM	815	1093	1600/1800/ 2100/2300	1500	59	ZF ATL 4000 SM	595	798	1200/1500/1800	1300	51
ZF ATZ 5000 DM	875	1173	720/900/1000/ 1600/1800	1650	65	ZF ATL 50 SM	815	1093	1200/1500	1500	59
ZF ATZ 6000 DM	1330	1782	720/900/1000/ 1600/1800	1900	75	ZF ATL 5000 SM	941	1261	1200/1500	1650	65
						ZF ATL 6000 SM	1380	1849	1200	1900	75
Z-Drive** 						Z-Drive** 					
						ZF ATZ 2000 SM	182	244	1800	700	28
						ZF ATZ 3000 SM	305	409	1800	1000	39
						ZF ATZ 4000 SM	584	783	1800	1300	51
						ZF ATZ 50 SM	815	1093	1600/1800/ 2100/2300	1500	59
						ZF ATZ 5000 SM	875	1173	720/900/1000/ 1600/1800	1650	65
						ZF ATZ 6000 SM	1330	1782	720/900/1000/ 1600/1800	1900	75

* Rating, subject to classification and application. Mentioned data for indication purpose only. Consult ZF Marine Krimpen's technical staff to determine applicable power for each specific use.



** Can be supplied with any type or make of diesel engine.

*** Larger sizes available on request



Retractable Azimuth Thrusters

Shallow Draught Thrusters



MODEL	Max. power*		Nominal input speed (min ⁻¹)	Typical propeller diameter		MODEL	Max. power*		Nom. input speed (min ⁻¹)	Propeller diameter		Diameter outer well approx.		Height of outer well approx.	
	kW	hp		mm	in		kW	hp		mm	in	mm	in	mm	in
L-Drive 						L-Drive 									
ZF ATL 1000 RT	95	127	1500	600	24	ZF SDTL 2000	100	134	1600	515	20	1365	54	650	26
ZF ATL 2000 RT	200	267	1500	700	28	ZF SDTL 3000	195	261	1500	750	30	1845	73	830	33
ZF ATL 3000 RT	332	445	1500	1000	39	ZF SDTL 4000	350	469	1200	990	39	2450	97	1130	44
ZF ATL 4000 RT	595	798	1200/1500/1800	1300	51	ZF SDTL 5000	575	770	1200	1250	49	3020	119	1530	60
ZF ATL 50 RT	815	1093	1200/1500	1500	59	ZF SDTL 6000	825	1105	1200	1530	60	3485	137	1800	71
ZF ATL 5000 RT	941	1261	1200/1500	1650	65	Z-Drive 									
ZF ATL 6000 RT	1380	1849	1200	1900	75	ZF SDTZ 2000	100	134	2000	515	20	1365	54	650	26
ZF ATL 80 RT	1587	2126	900/1200/1500	2200	87	ZF SDTZ 3000	195	261	1800	750	30	1845	73	830	33
ZF ATL 90 RT	1978	2651	850/1000	2400	94	ZF SDTZ 4000	350	469	1800	990	39	2450	97	1130	44
ZF ATL 8000 RT	2500	3350	900	2400	94	ZF SDTZ 5000	575	770	1800	1250	49	3020	119	1530	60
Z-Drive 						ZF SDTZ 6000	825	1105	1600/1800	1530	60	3485	137	1800	71
ZF ATZ 2000 RT	182	244	1800	700	28										
ZF ATZ 3000 RT	305	409	1800	1000	39										
ZF ATZ 4000 RT	584	783	1800	1300	51										
ZF ATZ 50 RT	815	1093	1600/1800/ 2100/2300	1500	59										
ZF ATZ 5000 RT	875	1173	720/900/1000/ 1600/1800	1650	65										
ZF ATZ 6000 RT	1330	1782	720/900/1000/ 1600/1800	1900	75										
ZF ATZ 80 RT	1587	2126	1600/1800	2200	87										
ZF ATZ 7000 RT	1850	2479	720/900/1000	2200	87										
ZF ATZ 90 RT	1978	2651	1600/1800	2400	94										
ZF ATZ 8000 RT	2500	3350	720/750/900/1000/ 1200/1500/1600/ 1800	2400	94										

* Rating, subject to classification and application.
Mentioned data for indication purpose only. Consult
ZF Marine Krimpen's technical staff to determine
applicable power for each specific use.



Fixed Pitch Tunnel Thrusters

Controllable Pitch Tunnel Thrusters

MODEL****	Max. power*		Nominal input speed (min ⁻¹)	Typical propeller diameter		Tunnel length standard***		MODEL	Max. power*		Nominal input speed (min ⁻¹)	Typical propeller diameter		Tunnel length standard***	
	kW	hp		mm	in	mm	in		kW	hp		mm	in	mm	in
L-Drive 								L-Drive 							
ZF TTL 1000**	99	133	1500/1800	600/550	24/22	1000	39	ZF TTL 4000 CP	500	670	1200/1500/1800	1350	53	1480	58
ZF TTL 2000**	200	267	1500/1800	700/670	28/26	1000	39	ZF TTL 5000 CP	880	1179	1200/1500	1700	67	2000	79
ZF TTL 3000**	350	469	1500/1800	1000	39	1200	47								
ZF TTL 4000	595	798	1200/1500/1800	1350	53	1480	58								
ZF TTL 50	865	1195	1200/1500	1500	59	2000	79								
ZF TTL 5000	945	1267	1200/1500	1650	65	2000	79								
ZF TTL 6000	1380	1849	1200	1900	75	2000	79								
ZF TTL 80	1786	2393	900/1200/1500	2200	87	2980	117								
ZF TTL 90	2187	2930	850/1000	2400	94	2980	117								
ZF TTL 8000	2500	3350	900	2500	99	2550	100								

* Rating, subject to classification and application. Mentioned data for indication purpose only. Consult ZF Marine Krimpen's technical staff to determine applicable power for each specific use.
 ** Also available in aluminum gearbox and tunnel.
 *** Tunnel length can be adjusted on request.
 **** TT also available as retractable TT.



Thruster Control Systems

	Thruster Command	Thruster Command	Thruster Command Light
	Azimuth Thrusters	Transverse Thrusters FP/CP	Transverse Thrusters FP
Thruster Control Unit			
Remote operating stations, maximum 3			●
Remote operating stations, maximum 5	●	●	
Build in data log	●	●	●
Tandem mode	●		
Redundant ethernet commun.	●	●	●
Steering control			
Electric	●		
Hydraulic	●		
Propeller pitch control			
Hydraulic		●	
Clutch control			
Hydraulic	●	●	
Propulsion drive control			
Diesel Engine	●	●	
Electric drive	●	●	●
Hydraulic drive	●	●	
Interface options			
External indicators	●	●	
Power management system (PMS)	●	●	●
Dynamic positioning system (DP)	●	●	
Joystick system (JS)	●	●	
Autopilot	●		
Speedlog	●		
Alarm monitoring system	●	●	●
Voyage Data Recorder (VDR)	●	●	●
Fire Fighting system	●		
Class approved (IACS)	●	●	
Other project specific interfaces	●	●	

● included / optionally available

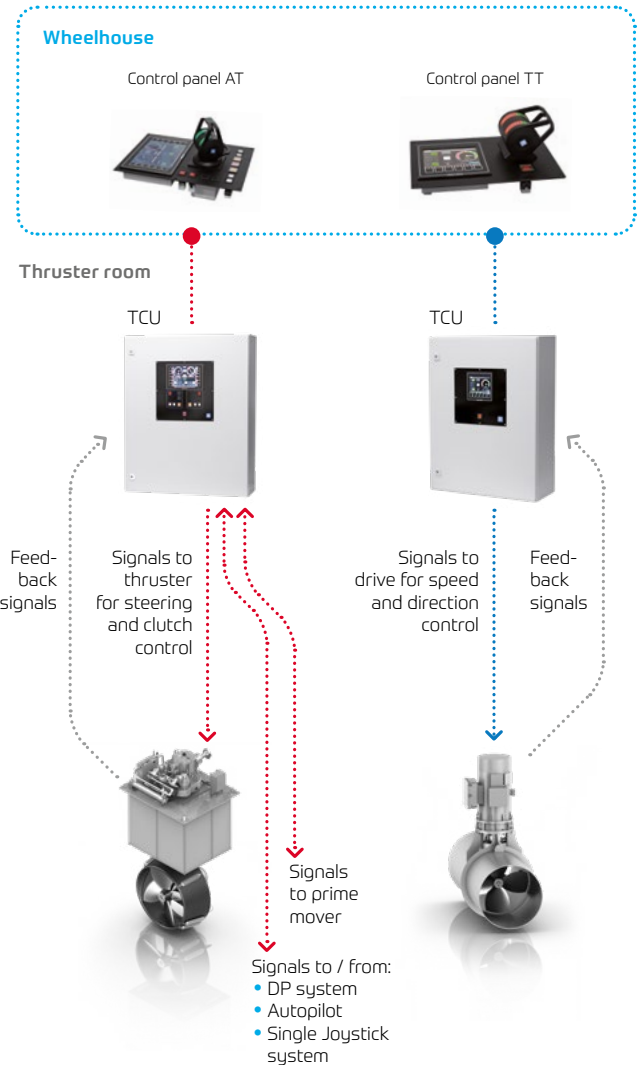

Other Products

Contents

Control Systems	page	326
POD 4600	page	328
Sail Drive	page	330
Surface Drive System	page	334
Fixed Pitch Propellers	page	336

Control Systems

	MicroCommander	TotalCommand	ClearCommand	CruiseCommand	SmartCommand	MiniCommand
Actuation	Mech. Engine	•	•	•		
	Elec. Engine		•	•	•	•
	Mech. Gear	•	•	•		
	Elec. Gear		•	•	•	•
Options	Mech. Troll	•	•			
	Elec. Troll		•	•	•	•
	POC (Proportional Oil Control)		•			
	Up to 2 stations					
	Up to 4 stations				•	
	Up to 5 stations	•		•		
	Up to 6 stations		•			•
	Back up	•		•	•	•
	Joystick Maneuvering System JMS		•			•
	SteerCommand					•
	Dynamic Positioning Interface			•		
	iAnchor/iDrift function		•			•



CruiseCommand



MiniCommand



TotalCommand



JMS



SteerCommand



SmartCommand 5200



MicroCommander



ClearCommand



TotalCommand Grey



MiniCommand 4200



MC 2000-2



460 Series

ZF POD 4600

MODEL	Ratio	Power/rpm		Input power capacity						Max. rpm	Weight	
		kW/rpm	hp/rpm	2100 rpm		2300 rpm		2450 rpm			kg	lb
Pleasure Duty												
ZF POD 4600	2.434	0.5275	0.7069	1108	1484	1213	1626	1292	1732	2500	1540	3395
Light Duty												
ZF POD 4600	2.434	0.4382	0.5872	920	1233	1008	1351	1074	1439	2500	1540	3395
Medium Duty												
ZF POD 4600	2.434	0.3771	0.5054	716	960	792	1061	848	1137	2500	1540	3395

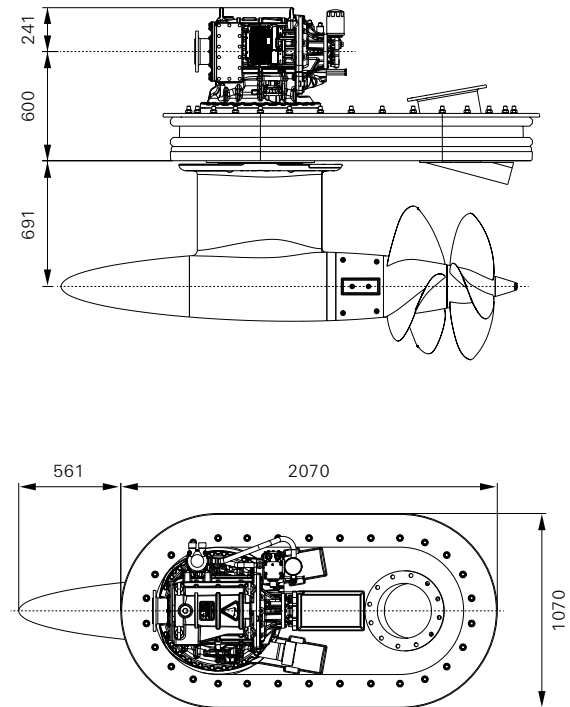

Sail Drive – Pleasure Duty

MODEL	Ratios		Power factor		Input power capacity				Max. kW	Max. hp	Max. rpm	Weight		A		B		H1		H2		H3		L	
	kW/rpm	hp/rpm	kW	hp	kW	hp	kg	lb				mm	in	mm	in	mm	in	mm	in	mm	in	mm	in	mm	in
					2800				3200																
ZF SD 10	2.231	0.0157	0.0211	44	59	50	68	60	80	3800	40	88	611	24.1	378	14.9	74	2.9	739	29.1	210	8.3	463	18.2	
	2.493	0.0157	0.0211	44	59	50	68																		
ZF SD 12	2.231	0.0188	0.0252	53	71	60	81	71	96	3800	40	88	611	24.1	378	14.9	74	2.9	739	29.1	210	8.3	463	18.2	
	2.493	0.0188	0.0252	53	71	60	81																		
					2800				3600																
ZF SD 12 SPP	2.231	0.0188	0.0252	53	71	68	91	71	96	3800	113	249	760	29.9	378	14.9	74	2.9	1,018	40.1	307	12.1	463	18.2	
	2.493	0.0188	0.0252	53	71	68	91																		

SPP: Steerable Propulsion Pod

Propeller downpropping is not accepted. In the need of special approval please contact ZF for official release whereas acceptable.

Above ratings are valid for pleasure duty only; please refer to ZF Offices for other uses

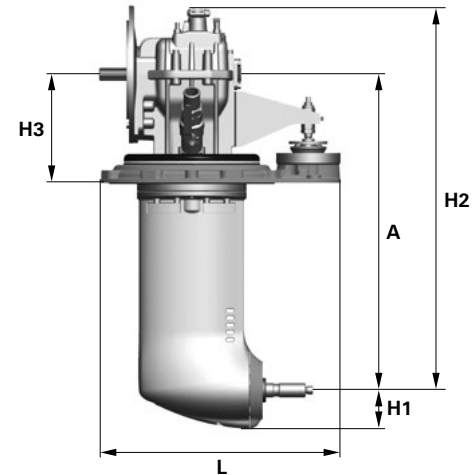

Sail Drive – Pleasure/Light Duty

MODEL	Ratios	Power factor		Input power capacity				Max. kW	Max. hp	Max. rpm	Weight		A		B		H1		H2		H3		L	
		kW/rpm	hp/rpm	kW	hp	kW	hp				kg	lb	mm	in	mm	in	mm	in	mm	in	mm	in	mm	in
Pleasure Duty		2800				3200																		
ZF SD 15	2.506	0.0377	0.0506	106	142	121	162	136	182	3600	105	231	797	31.4	441	17.4	104	4.11	951	37.4	305	12.0	508	20.0
ZF SD 15 EXT	2.506	0.0377	0.0506	106	142	121	162	136	182	3600	109	240	879	34.6	441	17.4	104	4.11	1033	40.7	305	12.0	508	20.0
Light Duty		2800				3200																		
ZF SD 15	2.506	0.0261	0.0350	73	98	84	112	86	116	3300	105	231	797	31.4	441	17.4	104	4.11	951	37.4	305	12.0	508	20.0
ZF SD 15 EXT	2.506	0.0261	0.0350	73	98	84	112	86	116	3300	109	240	879	34.6	441	17.4	104	4.11	1033	40.7	305	12.0	508	20.0

EXT: Extended

Propeller downpropping is not accepted. In the need of special approval please contact ZF for official release whereas acceptable.

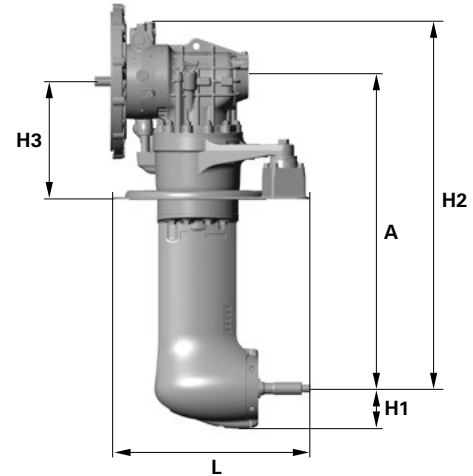

Surface Drive System

MODEL	Max. input torque		Max. input power hp at prop. rpm		Weight*		Diam. propeller shaft		Transom flange diam. – D		Mounting height – H		Overall length – L	
	Nm	ftlb	1500 rpm	1150 rpm	kg	lb	mm	inch	mm	inch	mm	inch	mm	inch
SeaRex 120 S	9090	6705	1915	–	370	815	90	3.5	350	13.78	813	32	1617	63.7
SeaRex 140 S	15070	11116	3175	–	708	1559	108	4.3	540	21.25	848	33.4	1958	77.1
SeaRex 160 S	24000	17702	–	3875	990	2181	121	4.7	584	23	988	38.9	2221	87.4

Above ratings are valid for pleasure duty only; please refer to ZF Offices for other uses.

* Weights refer to one tail assembly as per drawing below.

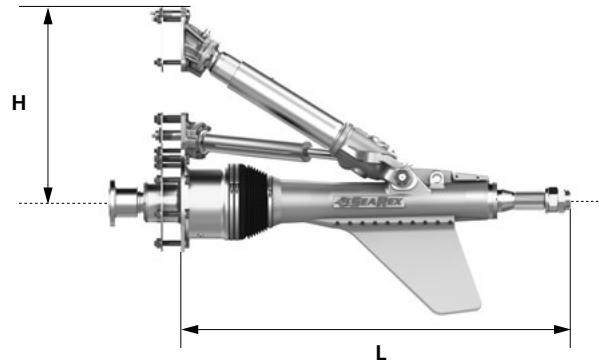

 **SEAREX®**

Fixed Pitch Propellers

MODEL	Blades	DAR range*	Category		Application	Remarks
			PC	CC		
SailMaster	3	0.5-0.55	x		Sailing Vessels	
CruiseMaster	4, 5	0.55-0.80	x		Cruisers/Trawlers	
FishMaster	4, 5	0.8-1.20	x		Sportfish Boats (> 30 knots)	
YachtMaster	4, 5	0.55-1.20	x		Displacement Yachts	
SpeedMaster	4, 5	0.8-1.20	x	x	Planing Hulls (> 25 knots)	Progressive Pitch
TorqueMaster	4	0.6-0.9	x	x	Planing Hulls (< 25 knots)	Constant Pitch
SurfMaster	4, 6	0.8-1.20	x	x	Surface Drives	
CrewMaster	4	0.8-0.85		x	Crew Boats	
TowMaster	3, 4, 5	0.55-0.75		x	Tugs/Push Boats	Kaplan
WorkMaster	4	0.7		x	General Workboat	



 SailMaster



 CruiseMaster



 FishMaster



 CrewMaster



 TowMaster



 WorkMaster



 YachtMaster



 SpeedMaster



 TorqueMaster



 SurfMaster

* Other DARs are available upon customer request.
 'PC' = Pleasure Craft / 'CC' = Commercial Craft

MULTIPLY	BY	TO GET OR MULTIPLY	BY	TO GET
SI UNIT	CONV. FACTOR	USA NON-SI UNIT	CONV. FACTOR	SI UNIT
LENGTH				
millimeter (mm)	× 0.03937	= inch	× 25.4	= mm
(1 inch=25.4 mm exactly)				
centimeter (cm) 10 mm	× 0.3937	= inch	× 2.54	= cm
meter (m) 1000 mm	× 3.28	= foot	× 0.305	= m
kilometer (km) 1000 m	× 0.539	= nautical mile	× 1.854	= km
kilometer (km) 1000 m	× 0.62	= statute mile	× 1.61	= km
AREA				
millimeter ² (mm ²)	× 0.00155	= inch ²	× 645	= mm ²
centimeter ² (cm ²)	× 0.155	= inch ²	× 6.45	= cm ²
meter ² (m ²)	× 10.8	= foot ²	× 0.0929	= m ²
meter ² (m ²)	× 1.2	= yard ²	× 0.836	= m ²
VOLUME				
centimeter ³ (cm ³)	× 0.061	= inch ³	× 16.4	= cm ³
liter (l) dm ³	× 61	= inch ³	× 0.016	= l
milliliter (ml) (1ml=1cm ³)	× 0.034	= oz-liqu	× 29.6	= ml
liter (l) 1000 ml	× 1.06	= quart	× 0.946	= l
liter (l) dm ³	× 0.26	= gallon	× 3.79	= l
meter ³ (m ³) 1000 l	× 1.3	= yard ³	× 0.76	= m ³
MASS				
gram (g)	× 0.035	= ounce	× 28.3	= g
kilogram (kg) 1000 g	× 2.2	= pound	× 0.454	= kg
metric ton (t) 1000 kg	× 1.1	= ton (short)	× 0.907	= t
FORCE (N = kg · m/s²)				
newton (N)	× 0.225	= pound	× 4.45	= N
kilonewton (kN)	× 225	= pound	× 0.00445	= kN
TORQUE				
newton meter (Nm)	× 8.9	= lb in.	× 0.113	= Nm
newton meter (Nm)	× 0.74	= lb ft.	× 1.36	= Nm
PRESSURE (Pa = N/m²)				
kilopascal (kPa)	× 4.0	= in H ₂ O	× 0.249	= kPa
kilopascal (kPa)	× 0.30	= in. Hg	× 3.38	= kPa
kilopascal (kPa)	× 0.145	= psi	× 6.89	= kPa
bar	× 14.5	= psi	× 0.069	= bar
newton/mm ²	× 145.04	= psi	× 0.0069	= bar
STRESS (Pa = N/m²)				
megapascal (MPa)	× 145	= psi	× 0.00689	= MPa
POWER (W = J/s)				
kilowatt (kW)	× 1.36	= PS (cv)	× 0.736	= kW
kilowatt (kW)	× 1.34	= HP	× 0.746	= kW
kilowatt (kW)	× 0.948	= Btu/s	× 1.055	= kW
watt (W)	× 0.74	= ft.lb/s	× 1.36	= W
ENERGY (J = N·m)				
kilojoule (kJ)	× 0.948	= Btu	× 1.055	= kJ
joule (J)	× 0.239	= calorie	× 4.19	= J
VELOCITY AND ACCELERATION				
meter per sec ² (m/s ²)	× 3.28	= ft/s ²	× 0.305	= m/s ²
meter per sec (m/s)	× 3.28	= ft/s	× 0.305	= m/s
kilometer per hour (km/h)	× 0.62	= mph	× 1.61	= km/h
HORSE POWER/TORQUE				
$\frac{\text{BHP} \times 5252}{\text{RPM}}$	=	Torque (lb ft)	$\frac{\text{kW} \times 9550}{\text{RPM}}$	= Torque (Nm)
Metric HP	× 0.9863	=		U.S. Horsepower
U.S. HP	× 1.014	=		Metric HP
TEMPERATURE				
$^{\circ}\text{C} = (^{\circ}\text{F} - 32) / 1.8$		$^{\circ}\text{F} = (^{\circ}\text{C} \times 1.8) + 32$		
FLOW RATE				
liter/min (l/min)	× 0.264	= US gal/min	× 3.785	= l/min
MILES				
Nautical Mile	× 1.15078	= Statute Mile	× 0.86897	= Naut. Mile