

Solenoid valves for gas VAS, Double solenoid valves VCS

Technical Information · GB
3.1.0.2 Edition 03.08

- Safety shut-off of gaseous fuels, a further development of the solenoid valves for gas VG and VS
- Suitable for a max. inlet pressure of 500 mbar (7 psig)
- Easy installation into a system
- Compact design saves space
- No extra valve required owing to integrated flow adjustment
- Check indication by blue LED
- Position indicator with integral visual indicator
- Suitable for high-duty cycling
- Higher flow rates with the same nominal size
- EC type-tested and certified
- VAS/VCS: FM and CSA approved
- AGA approved

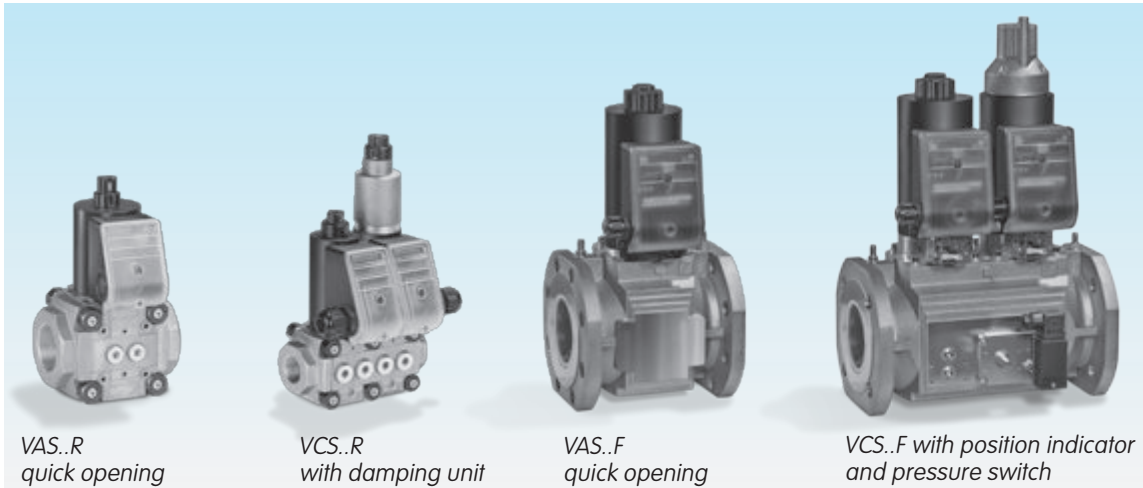

Table of contents

Solenoid valves for gas VAS, Double solenoid valves VCS . . .	1	5 Flow rate	22
Table of contents	2	5.1 VAS	22
1 Application	4	5.1.1 Calculate nominal size	22
1.1 Examples of application	5	5.2 VCS	23
1.1.1 Solenoid valve for gas VAS 1–3, Double solenoid valve VCS 1–3	6	5.2.1 Calculate nominal size	23
1.1.2 Gas solenoid valve with inlet and outlet pressure switch	7	5.3 k_v value	24
1.1.3 Double solenoid valve VCS with damping unit	7	6 Selection	25
1.1.4 Solenoid valve for gas VAS 6–9, Double solenoid valve VCS 6–9	8	6.1 Solenoid valve for gas VAS	25
1.1.5 Solenoid valve for gas VAS 6–9, Double solenoid valve VCS 6–9 with connection for adapter plates	9	6.2 Double solenoid valve VCS	28
1.1.6 Gas solenoid valve with pilot gas valve and pressure switch	10	7 Project planning information	32
1.1.7 Double solenoid valve with tightness control	10	7.1 Installation	32
2 Certification	11	8 Accessories	33
3 Function	12	8.1 Gas pressure switch	33
3.1 VAS..N, quick opening	13	8.1.1 DG..VC for VAS/VCS	33
3.2 Solenoid valve for gas VAS..L, slow-opening	14	8.1.2 DG..VCT for VAS..T/VCS..T	33
3.3 Solenoid valve for gas VAS..S, proof of closure switch	15	8.1.3 Installation on VAS 1–3	33
3.4 Animation	16	8.1.4 Installation on VAS 6–9	34
3.5 VAS connection diagram	17	8.1.5 Installation on VCS 6–9	34
3.5.1 VAS with M20 cable gland	17	8.2 Bypass/pilot gas valve VAS 1	35
3.5.2 VAS with plug	17	8.2.1 Scope of delivery, VAS 1 attached to VAS 1	35
3.5.3 VCS with M20 cable gland	17	8.2.2 Scope of delivery, VAS 1 attached to VAS 2, VAS 3	35
3.5.4 VCS with plug	17	8.2.3 Scope of delivery, VAS 1 attached to VAS/VCS 6–9	36
4 Replacement possibilities	18	8.2.4 Flow rate, VAS 1 attached to VAS 1, VAS 2, VAS 3	37
4.1 Solenoid valve for gas VG is to be replaced by VAS	18	8.2.5 Flow rate, VAS 1 attached to VAS/VCS 6–9	38
4.1.1 Search for an order number or type	19	8.3 Bypass/pilot gas valve VBY 8	39
4.2 MODULINE solenoid valves for gas VS is to be replaced by VAS	20	8.3.1 Scope of delivery, as bypass valve	39
		8.3.2 Scope of delivery, as pilot gas valve	39
		8.3.3 Selection	39
		8.3.4 Flow rate	40
		8.3.5 Technical data	40



8.4 Tightness control TC 116V	41
8.5 Pressure test points	41
8.6 Grommet	42
8.7 Attachment block	42
8.8 Flange set for Moduline	42
8.9 Adapter plates for VAS/VCS 6–9	43
8.9.1 Bypass adapter plate	43
8.9.2 Measuring adapter plate	43
8.9.3 Pipe adapter plate for VCS 6–9	43
8.10 Seal set VA 1–3	44
9 Technical data	45
9.1 Dimensions	47
9.1.1 VAS with Rp internal thread [mm]	47
9.1.2 VAS..T with NPT internal thread [inch]	48
9.1.3 VAS/VCS with ISO flange	49
9.1.4 VAS/VCS..T with ANSI flange [inch]	50
9.2 Conversion factors	51
10 Maintenance cycles	52
Feedback	53
Contact	53



VAS..R
quick opening

VCS..R
with damping unit

VAS..F
quick opening

VCS..F with position indicator
and pressure switch

The modular design principle allows the individual components of the VAS, VCS Series to be easily assembled: e.g. quick opening, slow opening, with position indicator and visual indicator, slow opening with attached pressure switch.

1 Application

Solenoid valves for gas VAS and double solenoid valves VCS for safeguarding and controlling the air and gas supply to gas burners and gas appliances. For use in gas control and safety systems in all sectors of the iron, steel, glass and ceramics industries, also in commercial heat generation, such as the packaging, paper and foodstuffs industries.

1.1 Examples of application

Ceramics industry



*Aluminium industry:
curing oven for
wheel rims*



*Foodstuffs industry:
baking oven*

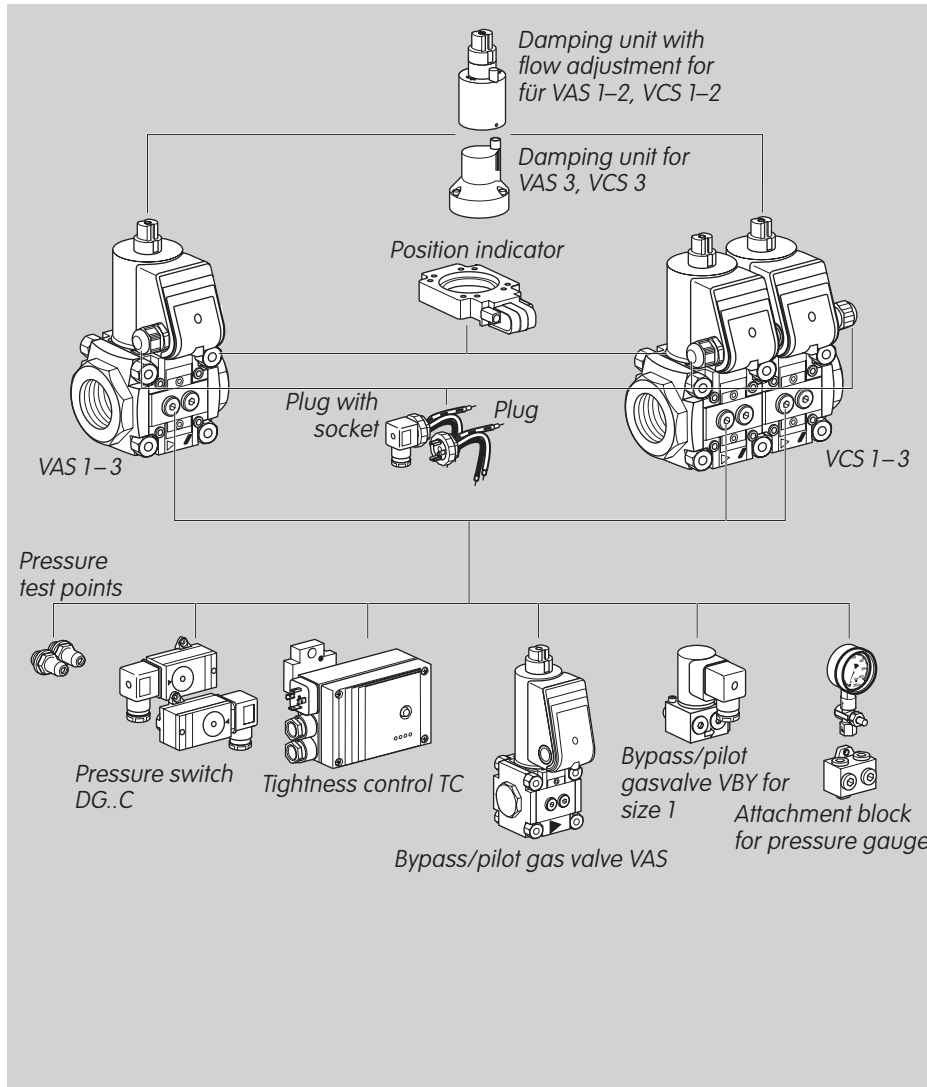

1.1.1 Solenoid valve for gas VAS 1-3, Double solenoid valve VCS 1-3

With threaded flange for pipe connections from DN 10 to 65.

Modularly expandable with:

- Damping unit
- Position indicator
- Plug (with or without socket)
- Pressure test points
- Pressure switch DG..C for inlet and/or outlet pressure
- Tightness control TC
- Bypass/pilot gas valve
- Attachment block for the connection of a pressure gauge, for example.

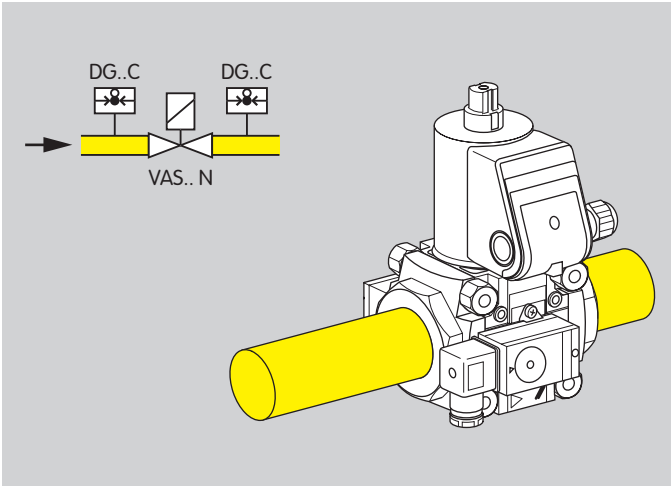

1.1.2 Gas solenoid valve with inlet and outlet pressure switch

VAS..N, quick opening,
pressure switch DG..C (DG..VT) for inlet pressure p_e and outlet pressure p_a

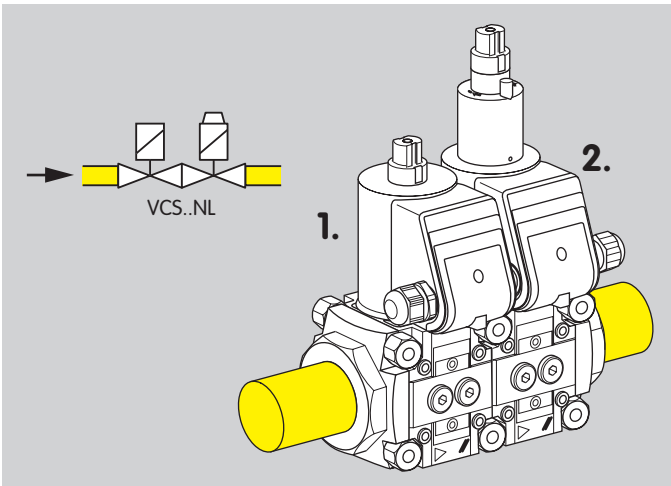

1.1.3 Double solenoid valve VCS with damping unit

VCS..NL,
1st valve: quick opening, quick closing, with flow adjustment,
2nd valve: slow opening, quick closing.

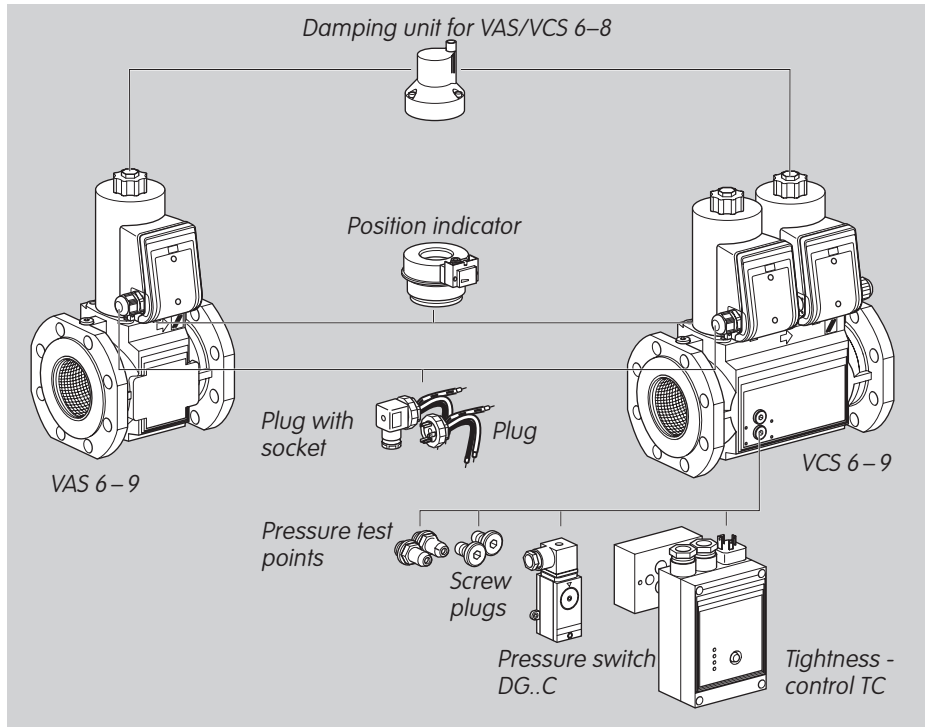

1.1.4 Solenoid valve for gas VAS 6-9, Double solenoid valve VCS 6-9

Gas solenoid valve and double solenoid valve with flanged connection (ISO or ANSI) for pipe connections from DN 65 to 125.

Modularly expandable with:

- Damping unit for VAS/VCS 6-8
- Position indicator
- Plug

- Plug with socket

VCS 6-9 with two threaded connections for:

- Screw plugs
- Pressure test points
- Pressure switch DG..C for inlet/inter-space pressure
- Tightness control TC

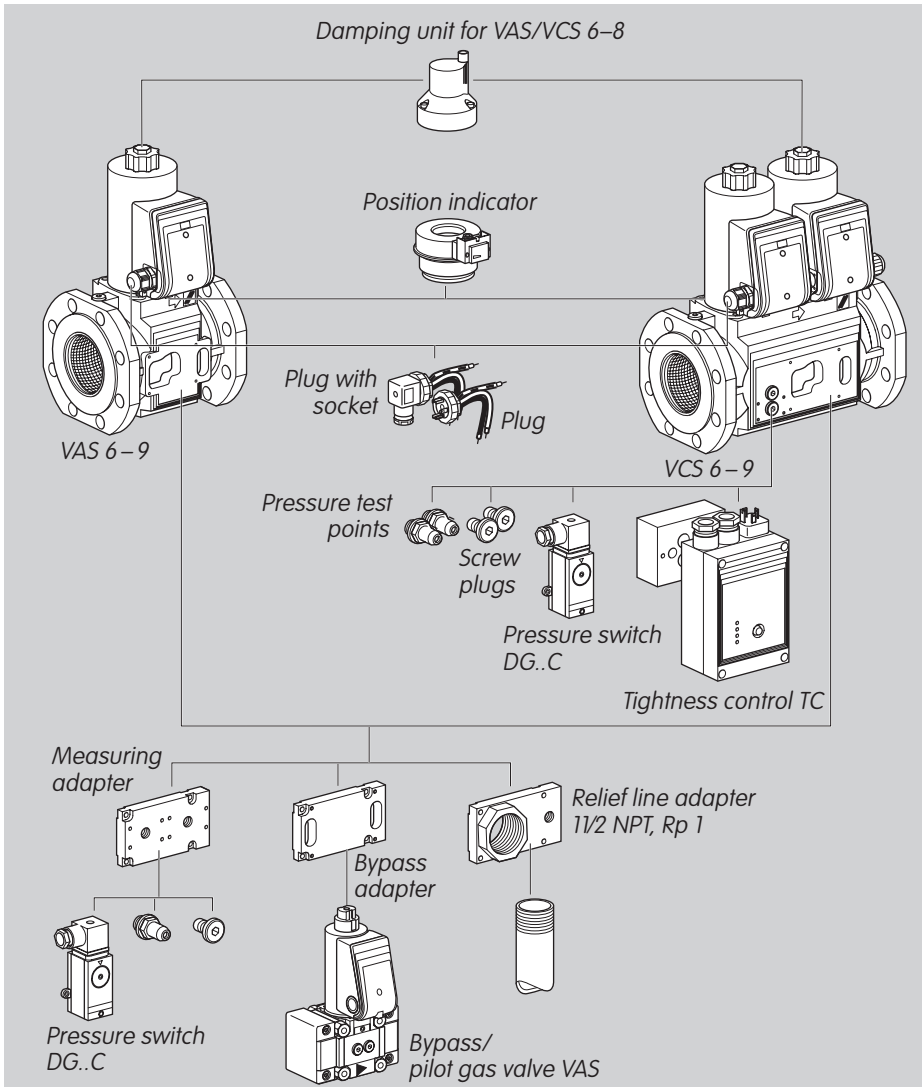

1.1.5 Solenoid valve for gas VAS 6-9, Double solenoid valve VCS 6-9 with connection for adapter plates

Gas solenoid valve and double solenoid valve with flanged connection (ISO or ANSI) for pipe connections from DN 65 to 125.

Modularly expandable with:

- Damping unit for VAS/VCS 6-8
- Position indicator
- Plug
- Plug with socket

With adapter plates, expandable with:

- Pressure switch DG..C
VAS 6-9: for inlet/outlet pressure
VCS 6-9: for interspace/outlet pressure
- Pressure test points
- Screw plug
- Bypass or pilot gas valve VAS

VCS 6-9

With two threaded connections for:

- Screw plugs
- Pressure test points
- Pressure switch DG..C for inlet/inter-space pressure
- Tightness control TC

Expandable with relief line adapter (1/2 NPT, Rp 1) for relief line.

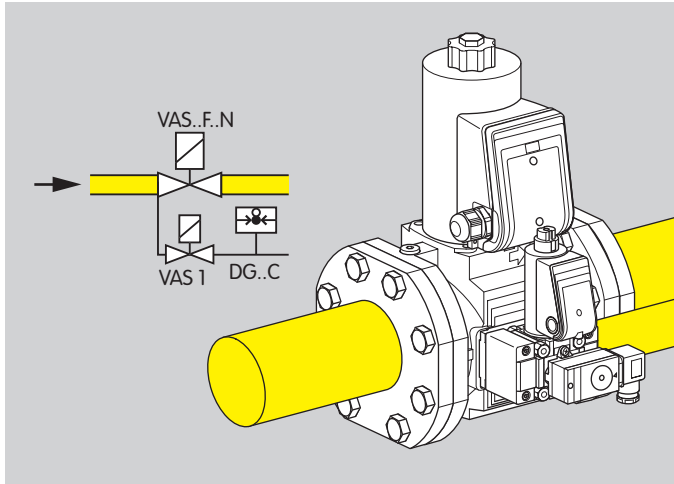

1.1.6 Gas solenoid valve with pilot gas valve and pressure switch

VAS..F..N: quick opening, quick closing,
VAS 1 as pilot gas valve with pressure switch DG..C.

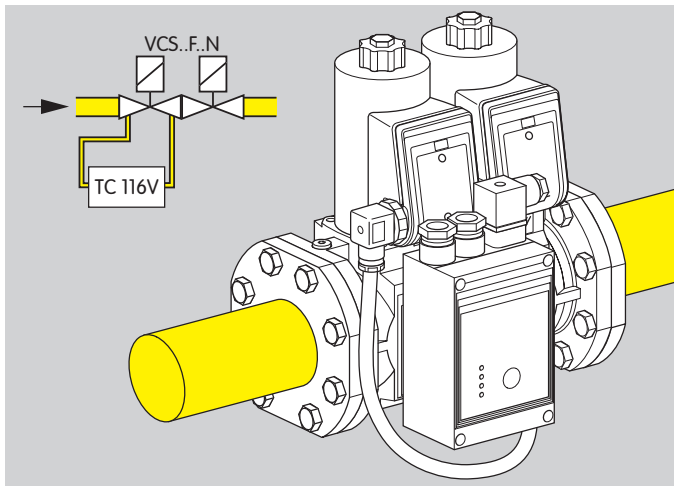

1.1.7 Double solenoid valve with tightness control

VCS..F..N: quick opening, quick closing valves,
tightness control TC 116V.



2 Certification

EC type-tested and certified

pursuant to

- Gas Appliances Directive (90/396/EEC) in conjunction with EN 161, EN 13611

Meets the requirements of the

- Low Voltage Directive (2006/95/EC) in conjunction with the relevant standards,
- EMC Directive (2004/108/EC) in conjunction with EN 55014-1.

FM approved

Factory Mutual Research Class: 7410 and 7411 Safety overpressure slam shut valves.

Designed for applications pursuant to NFPA 85 and NFPA 86.

CSA approved

Canadian Standard Association – ANSI Z21.21 and CSA 6.5

UL approval

In preparation.

AGA approved

Australian Gas Association

3 Function

The gas solenoid valve VAS is closed when it is disconnected from the power supply.

Opening: Connect the system to the electrical power supply (alternating voltage will be rectified). The blue LED lights up. The coil's magnetic field pulls the armature with the attached valve disc upwards. The gas solenoid valve VAS opens. The double valve seat means that the forces from the inlet pressure are divided almost equally between the two valve seats.

Closing: Disconnect the VAS from the electrical power supply. The blue LED goes out. The armature is pressed into its initial position by the closing spring. The gas solenoid valve closes within 1 s.

The strainer in the inlet of the gas solenoid valve prevents deposits of dirt particles on the valve seats. The pressure loss through the strainer is very low.

VAS 1–8..N, VAS 1–2..L:

The flow rate can be varied by a flow adjusting screw on the actuator within a range from 20 to 100%. On VAS 1–3, the setting can be monitored on an indicator.

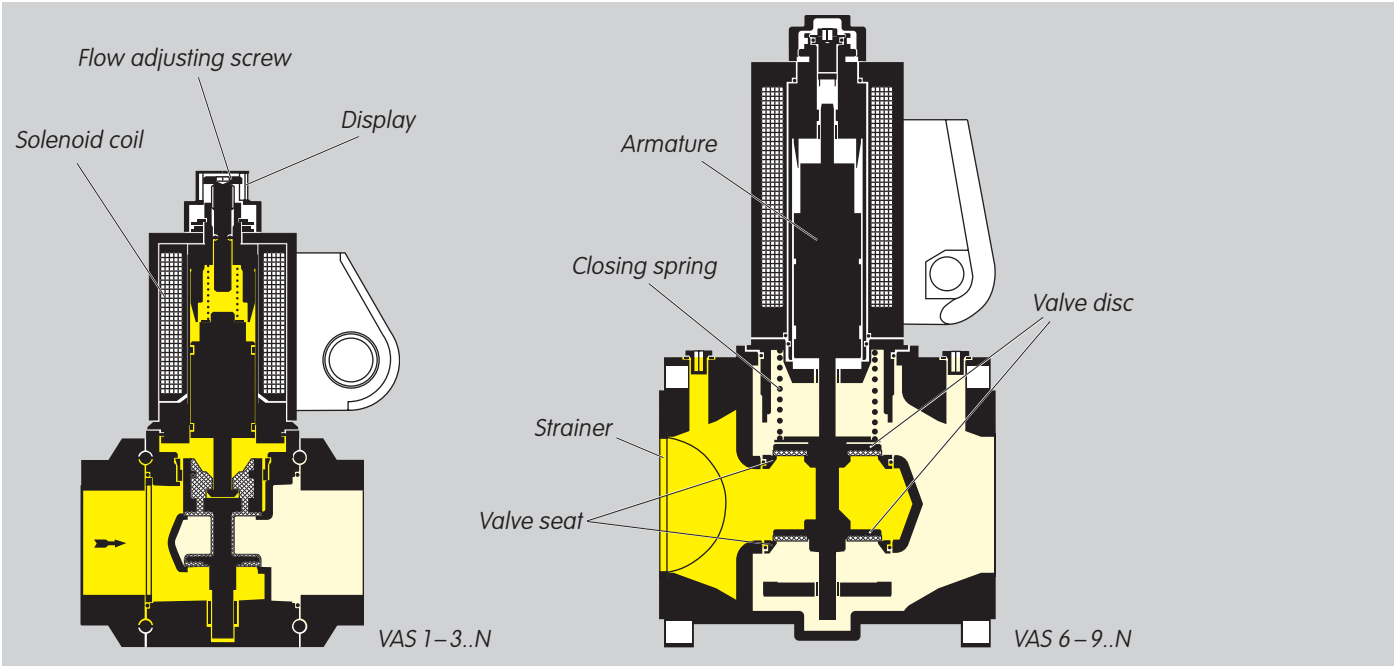

3.1 VAS..N, quick opening

The solenoid valve for gas VAS..N opens within 0.5 s.

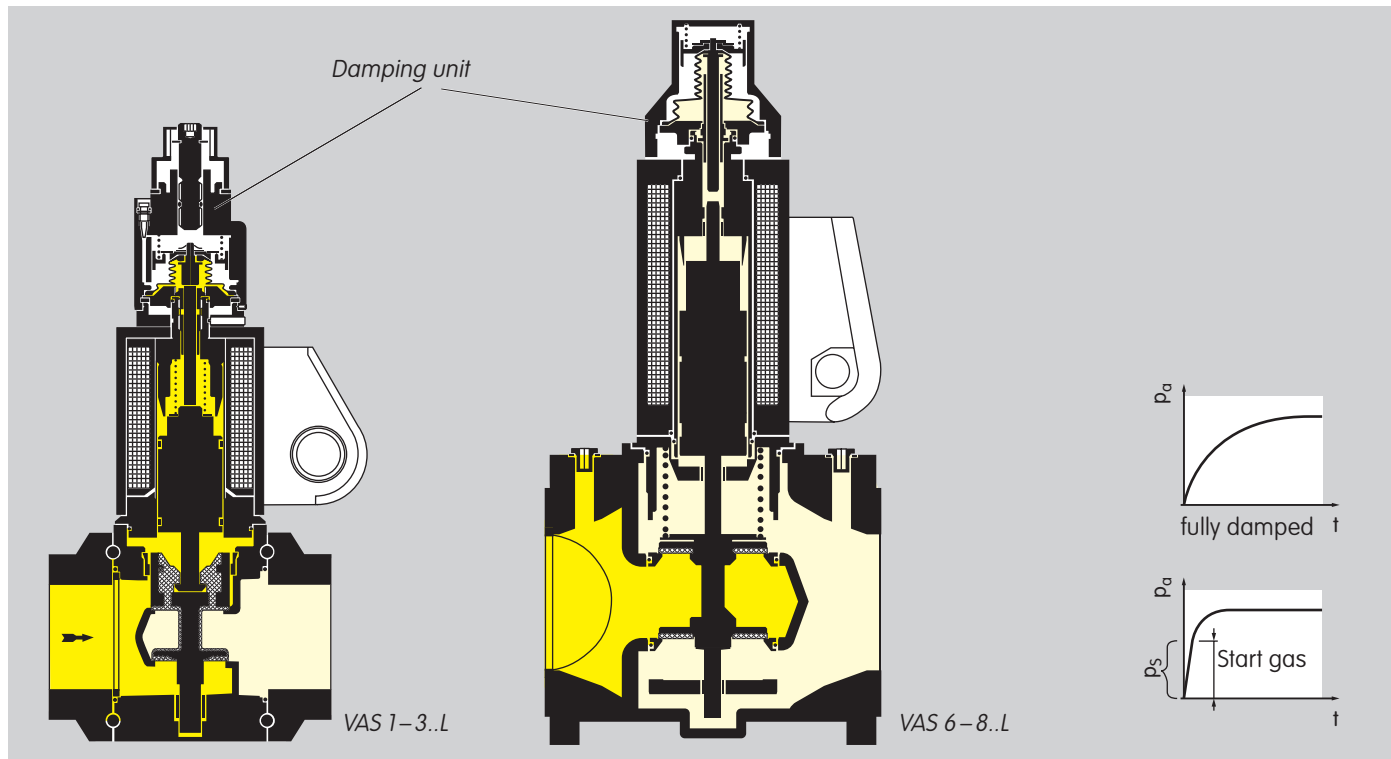

3.2 Solenoid valve for gas VAS..L, slow-opening

The solenoid valve for gas VAS..L opens within 10 s.

Start gas rate adjustment: The gas solenoid valve opens with a quick initial lift and then continues slowly until it is fully open. The start gas rate can be set. This setting is required, for example if a tightness control TC is to be used.

By turning the damping unit the start gas rate can be set between 0 and 70%:

turning it clockwise will reduce the start gas rate, turning it anti-clockwise will increase the gas start rate.

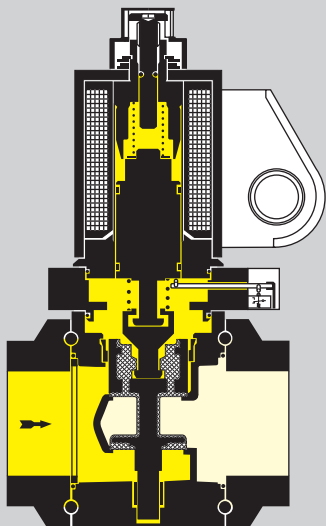

3.3 Solenoid valve for gas VAS..S, proof of closure switch

Opening: When the gas solenoid valve is opened, the proof of closure switch is operated first. The visual indicator is activated. The "open" signal is marked in red. Only then does the double valve seat open to release the volume of gas (overtravel principle).

Closing: The gas solenoid valve VAS is disconnected from the voltage supply and the closing spring presses the double valve disc on to the valve seat. Then the proof of closure switch is actuated. The visual indicator is white for "closed".

The actuator cannot be rotated on a gas solenoid valve with a proof of closure switch.

NOTE: NFPA 86 – the following must be taken into account as soon as the capacity of the pilot or main burner exceeds 117 kW (400,000 BTU/h): Safety shut-off valve VAS..S must be fitted with a visual indicator and proof of closure switch, and the burner-side pressure regulator with gas solenoid valve VAx..S must also be fitted with a visual indicator. One gas solenoid valve must be verifiably closed. The closed position can be verified using the position indicator of the gas solenoid valve VAS..S.

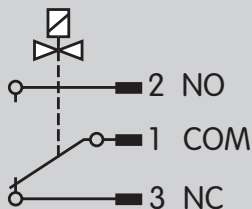

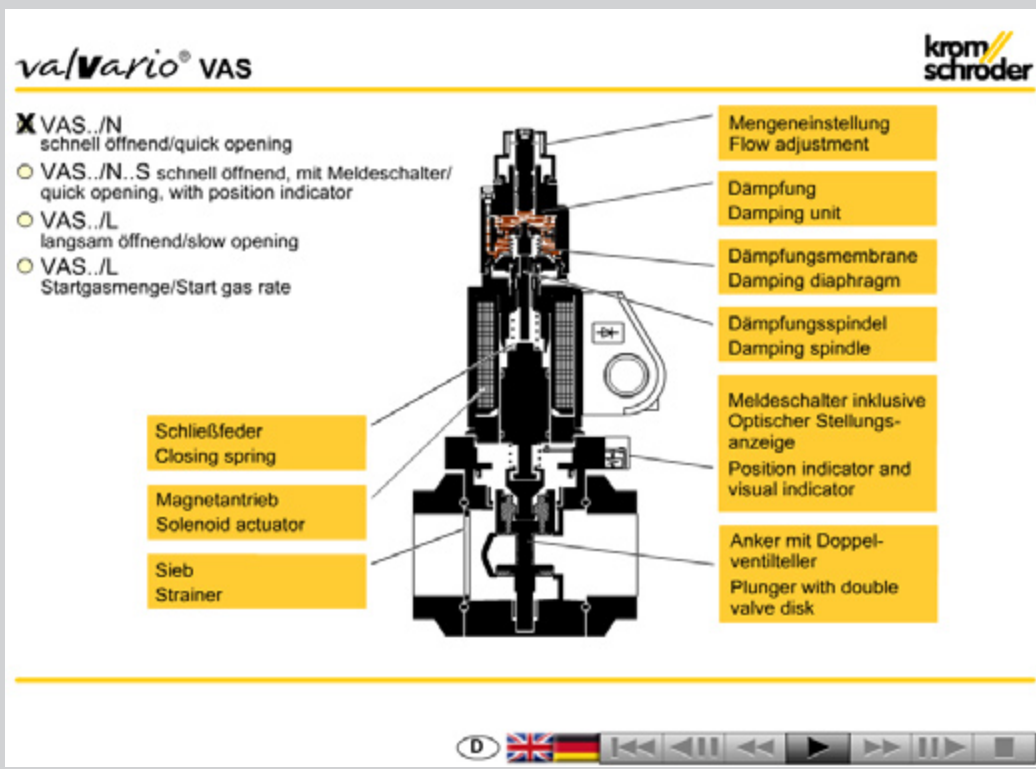

3.4 Animation

The interactive animation shows the function of the gas solenoid valve VAS.

Click on the picture. The animation can be controlled using the control bar at the bottom of the window (as on a DVD player).

To play the animation, you will need Adobe Reader 7 or a newer version. If you do not have Adobe Reader on your system, you

can download it from the Internet. Go to www.adobe.com, click on "Get Adobe Reader" and follow the instructions.

If the animation does not start to play, you can download it from the document library (Docuthek) as an independent application.

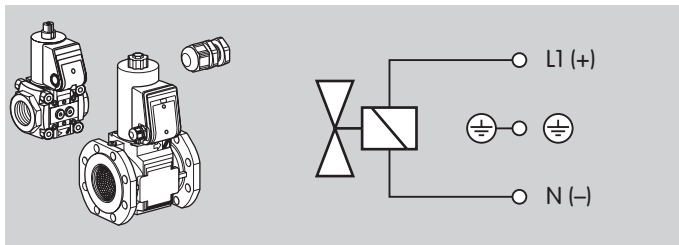

3.5 VAS connection diagram

Wiring to EN 60204-1.

Connection diagram for VAS..S with position indicator (see Function, VAS..S)

3.5.1 VAS with M20 cable gland

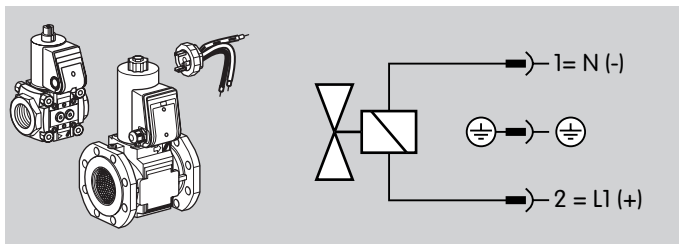

3.5.2 VAS with plug

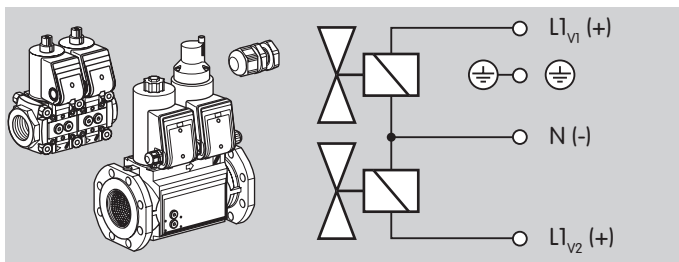

3.5.3 VCS with M20 cable gland

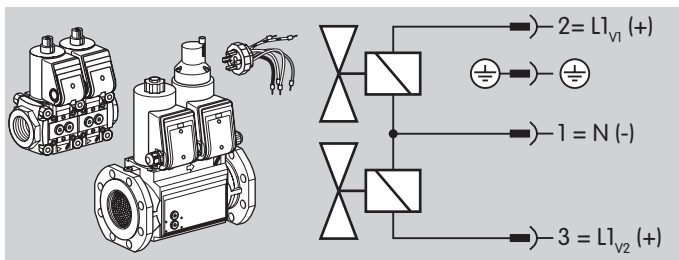

3.5.4 VCS with plug

4 Replacement possibilities

4.1 Solenoid valve for gas VG is to be replaced by VAS

Type				Type
VG		Solenoid valve for gas	Solenoid valve for gas	VAS
10/15	DN 10	internal 15 mm (0.59")	Size 1 DN 10	110
15	DN 15		Size 1 DN 15	115
15/12	DN 15	internal 12 mm (0.47")	–	–
20	DN 20		Size 1 DN 20	120
25	DN 25		Size 1 DN 25	125
25/15	DN 25	internal 15 mm (0.59")	–	–
40/32	DN 40	internal 32 mm (1.26")	Size 2 DN 40	240
40	DN 40		Size 2 DN 40	240
40/33	DN 40	internal 33 mm (1.30")	–	–
50	DN 50		Size 3 DN 50	350
50/39	DN 50	internal 39 mm (1.54")	–	–
50/65	DN 50	internal 65 mm (2.59")	Size 3 DN 50	350
65	DN 65		Size 3 DN 65	365
65			Size 6 DN 65	665
65/49	DN 65	internal 49 mm (1.93")	–	–
80	DN 80		Size 7 DN 80	780
100	DN 100		Size 8 DN 100	8100
T		T-product	T-product	T
R		Rp internal thread	Rp internal thread	R
N		NPT internal thread	NPT internal thread	N
F		ISO flange	ISO flange	
A		ANSI flange	ANSI flange	
02		$p_{e \text{ max.}}$: 200 mbar (2 psig)	$p_{e \text{ max.}}$: 500 mbar (7 psig)	●
03		360 mbar (5 psig)	500 mbar (7 psig)	●
10		1000 mbar (14.5 psig)	–	–
18		1800 mbar (26.1 psig)	–	–
N		Quick opening	Quick opening	/N
L		Slow opening	Slow opening	/L



Cont.			
K	Mains voltage: 24 V DC	Mains voltage: 24 V DC	K
Q	120 V AC	120 V AC	Q
T	220/240 V AC	230 V AC	W
3	Electrical connection via terminals	Electrical connection via terminals	3
6	Electrical connection via socket	Electrical connection via socket	○
9	Metal terminal connection box	Electrical connection via terminals	3
1	Screw plug at the inlet	Screw plug at the inlet and outlet	●
3	Screw plug at the inlet and outlet	Screw plug at the inlet and outlet	●
4	Pressure test point at the inlet	Pressure test point at the inlet and outlet*	○
6	Pressure test point at the inlet and outlet	Pressure test point at the inlet and outlet*	○
D	Flow adjustment	Flow adjustment***	●
S	Position indicator	Position indicator with visual indicator**	S
G	Position indicator for 24 V	Position indicator for 24 V with visual indicator**	G
OCS	Valve stem overtravel switch	Position indicator with visual indicator**	S
CPS	Position indicator	Position indicator with visual indicator**	S
VI	Visual indicator	Position indicator with visual indicator**	S
M	Suitable for biologically produced methane	Suitable for biologically produced methane	●
V	Viton valve disc seal	Viton valve disc seal	-
VG 25R02NT31DM	Example	Example	VAS 125R/NW

● = standard, ○ = available
 * Pressure test points may be attached at the left and/or right-hand side.
 ** Position indicator with visual indicator can be attached at the left- or right-hand side.
 *** Flow adjustment for VAS/VCL..N 1 -3, VAS/VCL 1 – 2..L.

4.1.1 Search for an order number or type

Order No. VG
Type designation VG

Hits: 0

VG is to be replaced by VAS

Order No. VAS

Type designation VAS

4.2 MODULENE solenoid valves for gas VS is to be replaced by VAS

Type	Flange		Solenoid valve for gas	Solenoid valve for gas	Flange	Type
VS						VAS
115	3/8"		Size 115	Size 1	DN 10	110
125			Size 125			
115	1/2"		Size 115	Size 1	DN 15	115
125			Size 125			
115	3/4"		Size 115	Size 1	DN 20	120
125			Size 125			
115	1"		Size 115	Size 1	DN 25	125
125			Size 125			
230	1"		Size 232	Size 2	DN 25	225
240			Size 240			
232	1 1/2"		Size 232	Size 2	DN 40	240
240			Size 240			
350	1 1/2"		Size 350	Size 3	DN 40	340
350	2"		Size 350	Size 3	DN 50	350
ML		MODULINE + connection flanges	Rp internal thread	Rp internal thread		R
TML		MODULINE + connection flanges	NPT internal thread	NPT internal thread		N
02		$p_{e \max.}$ 200 mbar (2 psig)	$p_{e \max.}$ 500 mbar (7 psig)	$p_{e \max.}$ 500 mbar (7 psig)		●
03		$p_{e \max.}$ 360 mbar (3 psig)	$p_{e \max.}$ 500 mbar (7 psig)	$p_{e \max.}$ 500 mbar (7 psig)		●
N		Quick opening	Quick opening	Quick opening		/N
L		Slow opening	Slow opening	Slow opening		/L
D		Flow adjustment	Flow adjustment*	Flow adjustment*		●

* Flow adjustment for VAS/VCL..N 1 -3, VAS/VCL 1 – 2..L.



Cont.			
K	Mains voltage: 24 V DC	Mains voltage: 24 V DC	K
Q	120 V AC	120 V AC	Q
T	220/240 V AC	230 V AC	W
3	Electrical connection via terminals	Electrical connection via terminals	3
6	Electrical connection via socket	Electrical connection via socket	○
9	Metal terminal connection box	Electrical connection via terminals	3
●	Pressure test point at the inlet	Pressure test point at the inlet and outlet	○
S	Position indicator	Position indicator	S
G	Position indicator for 24 V	Position indicator for 24 V	G
M	non-ferrous metals	non-ferrous metals	●
V	Viton valve disc seal	–	–

VS 240ML02LT3
with Rp 1½ connection flanges

Example

Example

VAS 240R/LW
with test points

● = standard, ○ = available

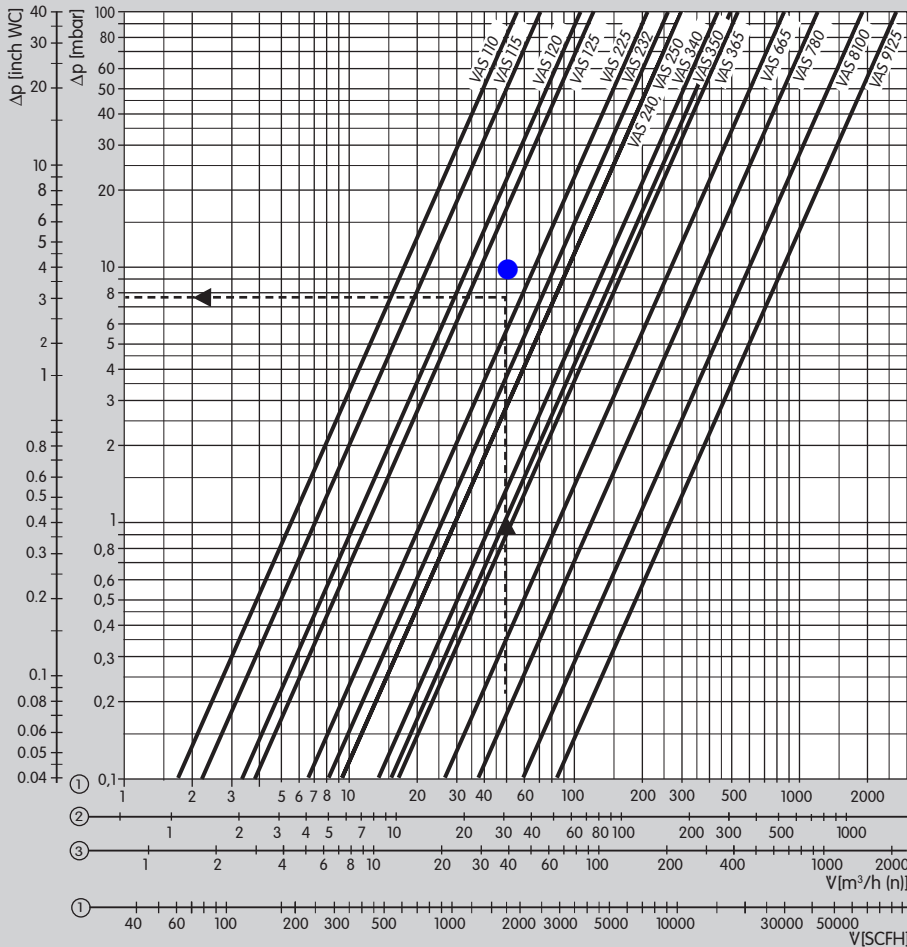

- ① = Natural gas ($\rho = 0.80 \text{ kg/m}^3$)
- ② = Propane ($\rho = 2.01 \text{ kg/m}^3$)
- ③ = Air ($\rho = 1.29 \text{ kg/m}^3$)

The characteristic flow rate curves have been measured with the specified flanges and a fitted strainer.

5 Flow rate

5.1 VAS

Reading instructions: Should operating cubic metres (m^3/h (b)) have been used in the flow rate diagram, instead of standard cubic metres m^3/h (n), then the pressure lost read must be multiplied by the absolute inlet pressure in bar ($1 +$ positive pressure in bar).

Example:

Inlet pressure p_e (positive pressure) = 0.3 bar,
 Gas type: Natural gas,
 Operating flow rate $V = 50 \text{ m}^3/h$ (b),
 Δp in the diagram = 5.6 mbar,
 $\Delta p = 5.6 \text{ mbar} \times (1 + 0.3) = 7.3 \text{ mbar}$ on the solenoid valve VAS 225.

5.1.1 Calculate nominal size

- Standard
- T-product

Erdgas	0.80	kg/m ³
Flow rate V (standard)	64.8	m ³ /h
Inlet pressure p_e	300	mbar
Δp_{max}	10.0	mbar
Medium temperature	0	°C
Flow rate V(operation)	50.0	m ³ /h

Product	Δp [mbar]	V_{min} [m ³ /h]	v [m/s]
VAS 225	7.3	13.8	22
VAS 232	4.6	11.0	13
VAS 240	3.7	9.9	10
VAS 250	3.7	9.9	6
VAS 340	1.8	10.9	10
VAS 350	1.4	9.6	6
VAS 365	1.2	9.0	4

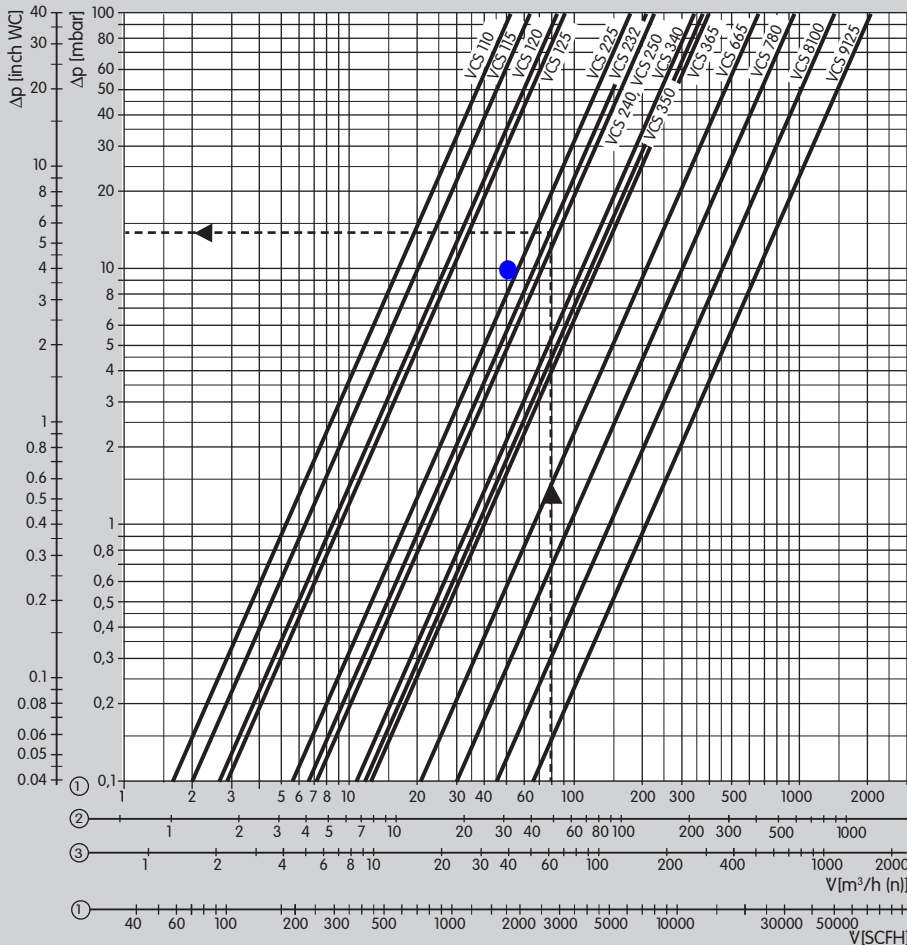

- ① = Natural gas ($\rho = 0.80 \text{ kg/m}^3$)
- ② = Propane ($\rho = 2.01 \text{ kg/m}^3$)
- ③ = Air ($\rho = 1.29 \text{ kg/m}^3$)

The characteristic flow rate curves have been measured with the specified flanges and a fitted strainer.

5.2 VCS

Reading instructions: Should operating cubic metres (m^3/h (b)) have been used in the flow rate diagram, instead of standard cubic metres m^3/h (n), then the pressure lost read must be multiplied by the absolute inlet pressure in bar ($1 + \text{positive pressure in bar}$).

Example:

Inlet pressure p_e (positive pressure) = 0.2 bar,
 Gas type: Natural gas,
 Operating flow rate $V = 80 \text{ m}^3/\text{h}$ (b),
 Δp in the diagram = 14.5 mbar,
 $\Delta p = 14.5 \text{ mbar} \times (1 + 0.2) = 17.4 \text{ mbar}$ on the solenoid valve VCS 232.

5.2.1 Calculate nominal size

Standard T-product

Erdgas	0.80	kg/m ³
Flow rate V (standard)	64.8	m ³ /h
Inlet pressure p_e	300	mbar
Δp_{max}	10.0	mbar
Medium temperature	0	°C
Flow rate V(operation)	50.0	m ³ /h

Product	Δp [mbar]	V_{min} [m ³ /h]	v [m/s]
VCS 232	7.3	13.9	13
VCS 240	6.4	13.0	10
VCS 250	6.3	12.8	6
VCS 340	2.8	13.6	10
VCS 350	2.3	12.5	6
VCS 365	2.1	11.8	4
VCS 665	0.7	10.0	4

5.3 k_v value

The size and nominal flange width is determined using the flow rate diagram or by calculation using the k_v value.

$\dot{V}_{(n)}$ = Flow rate (standard state) [m³/h]

k_v = Valve coefficient (see table)

Δp = Pressure loss [bar]

p_a = Outlet pressure (absolute) [bar]

ρ_n = Density [kg/m³] (air 1.29, natural gas 0.80, propane 2.01, butane 2.71)

T = Medium temperature (absolute) [K]

(see conversion factors)

$$k_v = \frac{\dot{V}_{(n)}}{514} \cdot \sqrt{\frac{\rho_n \cdot T}{\Delta p \cdot p_a}} \quad \dot{V}_{(n)} = 514 \cdot k_v \cdot \sqrt{\frac{\Delta p \cdot p_a}{\rho_n \cdot T}}$$

$$\Delta p = \left(\frac{\dot{V}_{(n)}}{514 \cdot k_v} \right)^2 \cdot \frac{\rho_n \cdot T}{p_a}$$

VAS	k_v max. m ³ /h	k_v min. m ³ /h	VCS	k_v max. m ³ /h	k_v min. m ³ /h
VAS 110	5.0	2	VCS 110	4.7	2
VAS 115	6.4	2	VCS 115	5.7	2
VAS 120	9.6	2	VCS 120	7.6	2
VAS 125	10.9	2	VCS 125	8.1	2
VAS 225	19.2	5.3	VCS 225	16.3	5.3
VAS 232	24.1	5.3	VCS 232	19.1	5.3
VAS 240	26.9	5.3	VCS 240	20.4	5.3
VAS 250	26.9	5.3	VCS 250	20.7	5.3
VAS 340	39.1	8.5	VCS 340	31.2	8.5
VAS 350	44.4	8.5	VCS 350	34.1	8.5
VAS 365	47.4	8.5	VCS 365	35.9	8.5
VAS 665	69.0	–	VCS 665	61.0	–
VAS 780	112.0	–	VCS 780	87.0	–
VAS 8100	171.0	–	VCS 8100	131.0	–
VAS 9125	251.0	–	VCS 9125	193.0	–

Example

We want to find the size and nominal flange width for a gas solenoid valve VAS.

We have the maximum flow rate $\dot{V}_{(n) \max}$, the inlet pressure p_e and the natural gas temperature T .

$\dot{V}_{(n) \max} = 60 \text{ m}^3/\text{h}$

$p_e = 70 \text{ mbar} = 0.07 \text{ bar} \Rightarrow$

$p_{e \text{ absolute}} = 0.07 \text{ bar} + 1 \text{ bar} = 1.07 \text{ bar}$

$\Delta p_{\max} = 0.01 \text{ bar (desired)}$

$p_a \text{ absolute} = p_{e \text{ absolute}} - \Delta p_{\max}$

$p_a \text{ absolute} = 1.07 \text{ bar} - 0.01 \text{ bar} = 1.06 \text{ bar}$

$T = 27 \text{ }^\circ\text{C} \Rightarrow$

$T_{\text{absolute}} = 27 + 273 \text{ K} = 300 \text{ K}$

$$k_v = \frac{60}{514} \cdot \sqrt{\frac{0.83 \cdot 300}{0.01 \cdot 1.06}} = 17.9$$

The gas solenoid valve is selected using the next higher k_v value (see table): VAS 225.

6 Selection

6.1 Solenoid valve for gas VAS

Type	T	-	-0	10	15	20	25	32	40	50	65	80	100	125	/-	/-0	/10	/15	/20	/25	/32	/40	/50	/65	/80	/100	/125		
VAS 1	<input type="radio"/>	●	●	●	●	●	●								●	●	●	●	●	●									
VAS 2	<input type="radio"/>	●					●	●	●	●					●					●	●	●	●						
VAS 3	<input type="radio"/>	●							●	●	●				●							●	●	●					
VAS 6	<input type="radio"/>										●												●						
VAS 7	<input type="radio"/>											●													●				
VAS 8	<input type="radio"/>												●													●			
VAS 9	<input type="radio"/>													●													●		
T-Product = T																													
Inlet flange nominal size																													
No inlet flange = -																													
Blind flange = -0																													
Outlet flange nominal size																													
No outlet flange = -																													
Blind flange = /0																													
Specification may be omitted if outlet = inlet																													



Cont.

Type	R	N	F	A	05 ⁴⁾	N	L	K	Q	W	A	S ¹⁾	G ¹⁾	R ¹⁾	L ¹⁾	3 ⁴⁾			P	M
VAS 1	●	○			●	●	●	●	●	●		○	○	○	○	●	○	○		
VAS 2	●	○	○ ²⁾		●	●	●	●	●	●		○	○	○	○	●	○	○		
VAS 3	●	○	○ ²⁾		●	●	●	●	●	●		○	○	○	○	●	○	○		
VAS 6			●	○	●	●	●	●	●	●		○	○	○	○	●	○	○	●	●
VAS 7			●	○	●	●	●	●	●	●		○	○	○	○	●	○	○	●	●
VAS 8			●	○	●	●	●	●	●	●		○	○	○	○	●	○	○	●	●
VAS 9			●	○	●	●					●	○	○	○	○	●	○	○	●	●

Rp internal thread = R
 NPT internal thread = N
 ISO flange = F²⁾
 ANSI flange = A

Max. inlet pressure p_e max. 500 mbar = 05⁴⁾

Quick opening, quick closing = N
 Slow opening, quick closing = L

Mains voltage: 24 V DC = K
 120 V AC; 50/60 Hz = Q
 230 V AC; 50/60 Hz = W
 120–230 V AC; 50/60 Hz = A

Position indicator with visual indicator = S¹⁾
 Position indicator for 24 V with visual indicator = G¹⁾

Viewed from the right (in the direction of flow) = R¹⁾
 Viewed from the left (in the direction of flow) = L¹⁾

Electrical connection:
 M20 cable gland = 3⁴⁾
 Plug with socket
 Plug without socket

Measuring connection at the top: 2 screw plugs at the inlet and outlet = P
 2 pressure test points at the inlet and outlet = M

¹⁾ VAS 1–3: Position indicator and bypass-/pilot gas valve cannot be fitted together on one side.
²⁾ For inlet and outlet flanges of the same nominal size: VAS 240 and VAS 350 can be supplied.
⁴⁾ The specifications are only included in the type designation for VAS 6–9.



Cont.

Type	/P ⁴⁾	/M ⁴⁾	/1 ⁴⁾	/2 ⁴⁾	/3 ⁴⁾	/4 ⁴⁾	5)	5)	1)	/B ⁴⁾ 5)	/Z ⁴⁾ 5)	V	E	/- ⁴⁾	P ⁴⁾	M ⁴⁾	1 ⁴⁾	2 ⁴⁾	3 ⁴⁾	4 ⁴⁾	- ⁴⁾	
VAS 1	○	○	○	○	○	○	○	○	○		○			○	○	○	○	○	○	○	○	○
VAS 2	○	○	○	○	○	○					○			○	○	○	○	○	○	○	○	○
VAS 3	○	○	○	○	○	○					○			○	○	○	○	○	○	○	○	○
VAS 6	○	○	○	○	○	○				○	○	○	○	○	○	○	○	○	○	○	○	○
VAS 7	○	○	○	○	○	○				○	○	○	○	○	○	○	○	○	○	○	○	○
VAS 8	○	○	○	○	○	○				○	○	○	○	○	○	○	○	○	○	○	○	○
VAS 9	○	○	○	○	○	○				○	○	○	○	○	○	○	○	○	○	○	○	○

Accessories, right, inlet:

Screw plugs = /P⁴⁾
 Pressure test point for inlet pressure p_e = /M⁴⁾
 Gas pressure switch (see accessories): DG..VC 17 = /1⁴⁾
 DG..VC 40 = /2⁴⁾
 DG..VC 110 = /3⁴⁾
 DG..VC 300 = /4⁴⁾

Bypass valve VBY, fitted = 5)
 Pilot gas valve VBY, fitted = 5)
 Main valve attachment side = 4)
 Bypass valve VAS 1, fitted = /B⁴⁾ 5)
 Pilot gas valve VAS 1, fitted = /Z⁴⁾ 5)
 Prepared for breather line 1½ NPT = V
 Prepared for breather line Rp 1 = E
 None accessories = /-⁴⁾

Accessories, right, outlet:

Screw plug = P⁴⁾
 Pressure test point for outlet pressure p_a = M⁴⁾
 Gas pressure switch (see accessories): DG..VC 17 = 1⁴⁾
 DG..VC 40 = 2⁴⁾
 DG..VC 110 = 3⁴⁾
 DG..VC 300 = 4⁴⁾
 None accessories = -⁴⁾

Accessories on left-hand side equivalent to those on right-hand side²⁾

³⁾ The "accessories on the left-hand side" have the same type code as the "accessories on the right-hand side" (see order example: 1 screw plug each at the inlet and outlet on the left-hand side = /PP).
⁴⁾ The specifications are only included in the type designation for VAS 6–9.
⁵⁾ VAS 1–3: Position indicator and bypass-/pilot gas valve cannot be fitted together on one side. The "accessories on the left-hand side" have the same type code as the "accessories on the right-hand side" (see order example: 1 screw plug each at the inlet and outlet on the left-hand side = /PP).

● = standard, ○ = available

Order example VAS 665F05NW3P/B-/PP

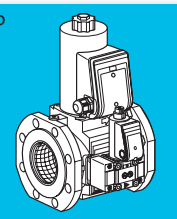

6.2 Double solenoid valve VCS

Type	T	-	-0	10	15	20	25	32	40	50	65	80	100	125	/-	/-0	/10	/15	/20	/25	/32	/40	/50	/65	/80	/100	/125		
VCS 1	<input type="radio"/>	●	●	●	●	●	●								●	●	●	●	●	●									
VCS 2	<input type="radio"/>	●					●	●	●	●					●					●	●	●	●						
VCS 3	<input type="radio"/>	●							●	●	●				●							●	●	●					
VCS 6	<input type="radio"/>										●													●					
VCS 7	<input type="radio"/>											●													●				
VCS 8	<input type="radio"/>												●													●			
VCS 9	<input type="radio"/>													●													●		
T-Product = T																													
Inlet flange nominal size																													
No inlet flange = -																													
Blind flange = -0																													
Outlet flange nominal size																													
No outlet flange = -																													
Blind flange = /0																													
Specification may be omitted if outlet = inlet																													



Cont.

Type	R	N	F	A	05 ³⁾	N	L	N	L	K	Q	W	A	S ¹⁾	G ¹⁾	R ¹⁾	L ¹⁾	3 ³⁾	P	M		
VCS 1	●	○			●	●	●	●	●	●	●	●		○	○	○	○	●	○	○		
VCS 2	●	○	○ ²⁾		●	●	●	●	●	●	●	●		○	○	○	○	●	○	○		
VCS 3	●	○	○ ²⁾		●	●	●	●	●	●	●	●		○	○	○	○	●	○	○		
VCS 6			●	○	●	●		●	●	●	●	●		○	○	○	○	●	○	○	●	●
VCS 7		●	○		●	●		●	●	●	●	●		○	○	○	○	●	○	○	●	●
VCS 8			●	○	●	●		●	●	●	●	●		○	○	○	○	●	○	○	●	●
VCS 9			●	○	●	●		●					●	○	○	○	○	●	○	○	●	●

Rp internal thread = R
 NPT internal thread = N
 ISO flange = F²⁾
 ANSI flange = A

Max. inlet pressure p_e max. 500 mbar = 05³⁾

1st valve quick opening, quick closing = N
 1st valve slow opening, quick closing = L

2nd valve quick opening, quick closing = N
 2nd valve slow opening, quick closing = L

Mains voltage: 24 V DC = K
 120 V AC; 50/60 Hz = Q
 230 V AC; 50/60 Hz = W
 120–230 V AC; 50/60 Hz = A

Position indicator with visual indicator = S¹⁾
 Position indicator for 24 V with visual indicator = G¹⁾

Viewed from the right (in the direction of flow) = R¹⁾
 Viewed from the left (in the direction of flow) = L¹⁾

Electrical connection:
 M20 cable gland = 3³⁾
 Plug with socket
 Plug without socket

Measuring connections at the top of the inlet/outlet flange: Screw plugs = P
 Pressure test points = M

¹⁾ VCS 1–3: Position indicator and bypass-/pilot gas valve cannot be fitted together on one side.
²⁾ For inlet and outlet flanges of the same nominal size: VAS 240 and VAS 350.
³⁾ The specifications are only included in the type designation for VAS 6–9.



Cont.

Type	/P ¹⁾	/M ¹⁾	/1 ¹⁾	/2 ¹⁾	/3 ¹⁾	/4 ¹⁾	5 ¹⁾	5 ¹⁾	1 ¹⁾	/B ¹⁾ 5 ¹⁾	/Z ¹⁾ 5 ¹⁾	/- ¹⁾	P ¹⁾	M ¹⁾	1 ¹⁾	2 ¹⁾	3 ¹⁾	4 ¹⁾	- ¹⁾	
VCS 1	<input type="radio"/>	<input type="radio"/>	<input type="radio"/>	<input type="radio"/>	<input type="radio"/>	<input type="radio"/>	<input type="radio"/>	<input type="radio"/>	<input type="radio"/>	<input type="radio"/>	<input type="radio"/>	<input type="radio"/>	<input type="radio"/>	<input type="radio"/>	<input type="radio"/>	<input type="radio"/>	<input type="radio"/>	<input type="radio"/>	<input type="radio"/>	<input type="radio"/>
VCS 2	<input type="radio"/>	<input type="radio"/>	<input type="radio"/>	<input type="radio"/>	<input type="radio"/>	<input type="radio"/>			<input type="radio"/>	<input type="radio"/>	<input type="radio"/>	<input type="radio"/>	<input type="radio"/>	<input type="radio"/>	<input type="radio"/>	<input type="radio"/>	<input type="radio"/>	<input type="radio"/>	<input type="radio"/>	<input type="radio"/>
VCS 3	<input type="radio"/>	<input type="radio"/>	<input type="radio"/>	<input type="radio"/>	<input type="radio"/>	<input type="radio"/>			<input type="radio"/>	<input type="radio"/>	<input type="radio"/>	<input type="radio"/>	<input type="radio"/>	<input type="radio"/>	<input type="radio"/>	<input type="radio"/>	<input type="radio"/>	<input type="radio"/>	<input type="radio"/>	<input type="radio"/>
VCS 6	<input type="radio"/>	<input type="radio"/>	<input checked="" type="radio"/>	<input type="radio"/>	<input type="radio"/>	<input type="radio"/>			<input type="radio"/>	<input type="radio"/>	<input type="radio"/>	<input type="radio"/>	<input checked="" type="radio"/>	<input type="radio"/>	<input type="radio"/>	<input type="radio"/>	<input type="radio"/>	<input type="radio"/>	<input type="radio"/>	<input type="radio"/>
VCS 7	<input type="radio"/>	<input type="radio"/>	<input type="radio"/>	<input type="radio"/>	<input type="radio"/>	<input type="radio"/>			<input type="radio"/>	<input type="radio"/>	<input type="radio"/>	<input type="radio"/>	<input type="radio"/>	<input type="radio"/>	<input type="radio"/>	<input type="radio"/>	<input type="radio"/>	<input type="radio"/>	<input type="radio"/>	<input type="radio"/>
VCS 8	<input type="radio"/>	<input type="radio"/>	<input type="radio"/>	<input type="radio"/>	<input type="radio"/>	<input type="radio"/>			<input type="radio"/>	<input type="radio"/>	<input type="radio"/>	<input type="radio"/>	<input type="radio"/>	<input type="radio"/>	<input type="radio"/>	<input type="radio"/>	<input type="radio"/>	<input type="radio"/>	<input type="radio"/>	<input type="radio"/>
VCS 9	<input type="radio"/>	<input type="radio"/>	<input type="radio"/>	<input type="radio"/>	<input type="radio"/>	<input type="radio"/>			<input type="radio"/>	<input type="radio"/>	<input type="radio"/>	<input type="radio"/>	<input type="radio"/>	<input type="radio"/>	<input type="radio"/>	<input type="radio"/>	<input type="radio"/>	<input type="radio"/>	<input type="radio"/>	<input type="radio"/>

Accessories, right, inlet:

Screw plugs = /P¹⁾

Pressure test point p_e = /M¹⁾

Gas pressure switch (see accessories):
 DG 17VC = /1¹⁾
 DG 40VC = /2¹⁾
 DG 110VC = /3¹⁾
 DG 300VC = /4¹⁾

Bypass valve VBY, fitted = 5¹⁾

Pilot gas valve VBY, fitted = 5¹⁾

Main valve attachment side = 1¹⁾

Bypass valve VAS 1, fitted = /B¹⁾ 5¹⁾

Pilot gas valve VAS 1, fitted = /Z¹⁾ 5¹⁾

None accessories = /-¹⁾

Accessories, right, interspace 1:

Screw plug = P¹⁾

Pressure test point p_a = M1

Gas pressure switch:
 DG 17VC = 1¹⁾
 DG 40VC = 2¹⁾
 DG 110VC = 3¹⁾
 DG 300VC = 4¹⁾

None accessories = -¹⁾

¹⁾ The specifications are only included in the type designation for VAS 6–9.

⁵⁾ VCS 1–3: Position indicator and bypass-/pilot gas valve cannot be fitted together on one side.



Cont.																							
Type	P ¹⁾	M ¹⁾	1 ¹⁾	2 ¹⁾	3 ¹⁾	4 ¹⁾	5 ¹⁾	5 ¹⁾	1 ¹⁾	B ¹⁾⁵⁾	Z ¹⁾⁵⁾	V	E	- ¹⁾	P ¹⁾	M ¹⁾	1 ¹⁾	2 ¹⁾	3 ¹⁾	4 ¹⁾	- ¹⁾		
VCS 1	○	○	○	○	○	○	○	○	○	○	○			○	○	○	○	○	○	○	○	○	
VCS 2	○	○	○	○	○	○			○	○	○			○	○	○	○	○	○	○	○	○	
VCS 3	○	○	○	○	○	○			○	○	○			○	○	○	○	○	○	○	○	○	
VCS 6	○	○	○	○	○	○				●	○	○	○	○	○	○	○	○	○	○	○	○	
VCS 7	○	○	○	○	○	○				○	○	○	○	○	○	○	○	○	○	○	○	○	
VCS 8	○	○	○	○	○	○				○	○	○	○	○	○	○	○	○	○	○	○	○	
VCS 9	○	○	○	○	○	○				○	○	○	○	○	○	○	○	○	○	○	○	○	
Accessories, right, interspace 2:																							
Screw plugs = P ¹⁾																							
Pressure test point for inlet pressure p _e = M ¹⁾																							
Gas pressure switch: DG 17VC = 1 ¹⁾																							
DG 40VC = 2 ¹⁾																							
DG 110VC = 3 ¹⁾																							
DG 300VC = 4 ¹⁾																							
Bypass valve VBY, fitted = 5 ¹⁾																							
Pilot gas valve VBY, fitted = 5 ¹⁾																							
Main valve attachment side = 1 ¹⁾																							
Bypass valve VAS 1, fitted = B ¹⁾⁵⁾																							
Pilot gas valve VAS 1, fitted = Z ¹⁾⁵⁾																							
Prepared for breather line 1½ NPT = V																							
Prepared for breather line Rp 1 = E																							
None accessories = - ¹⁾																							
Accessories, right, outlet:																							
Screw plug = P ¹⁾																							
Pressure test point p _a = M ¹⁾																							
Gas pressure switch: DG..VC 17 = 1 ¹⁾																							
DG..VC 40 = 2 ¹⁾																							
DG..VC 110 = 3 ¹⁾																							
DG..VC 300 = 4 ¹⁾																							
None accessories = - ¹⁾																							
Accessories on left-hand side equivalent to those on right-hand side ⁴⁾																							

Order example

VCS 665F05NLWSR3P/1PB-/PPPP

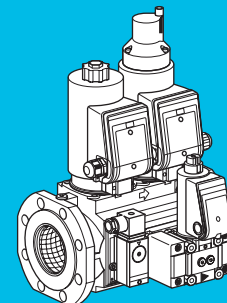

¹⁾ The specifications are only included in the type designation for VAS 6–9.

⁴⁾ The “accessories on the left-hand side” have the same type code as the “accessories on the right-hand side” (see order example: 1 screw plug each at the inlet, interspace 1, interspace 2 and outlet on the left-hand side = /PPPP).

⁵⁾ VCS 1–3: Position indicator and bypass-/pilot gas valve cannot be fitted together on one side.

● = standard, ○ = available

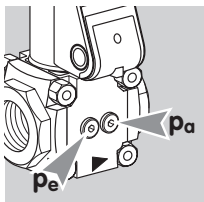

7 Project planning information

The inlet pressure p_e and the outlet pressure p_a can be measured at the pressure test points at both ends.

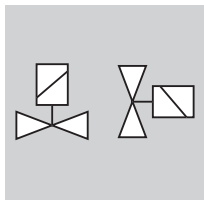

7.1 Installation

Installation position: black solenoid actuator in the vertical upright position or tilted up to the horizontal, not upside down.

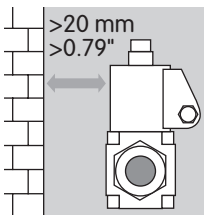

Gas solenoid valve VAS and double solenoid valve VCS must not be in contact with masonry.

Do not store or install the unit in the open air.

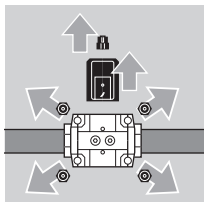

Ensure that there is sufficient space for installation and adjustment.

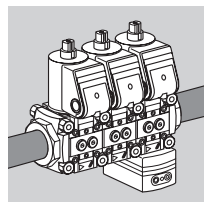

If more than three valVario controls are installed in line, the controls must be supported.

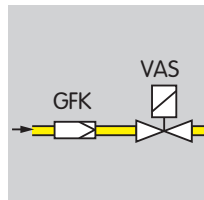

Sealing material and thread cuttings must not be allowed to get into the valve housing.

We recommend that a filter be installed upstream of every system.

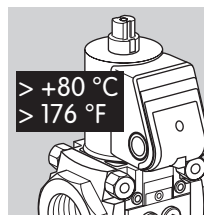

The solenoid body heats up during operation depending on ambient temperature and voltage.

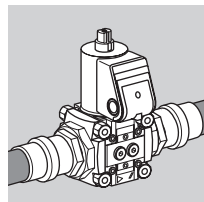

The seals in some gas compression fittings are approved for temperatures of up to 70°C. This temperature limit will not be exceeded if the flow through the pipe is at least 1 m³/h of gas and the maximum ambient temperature is 50°C.

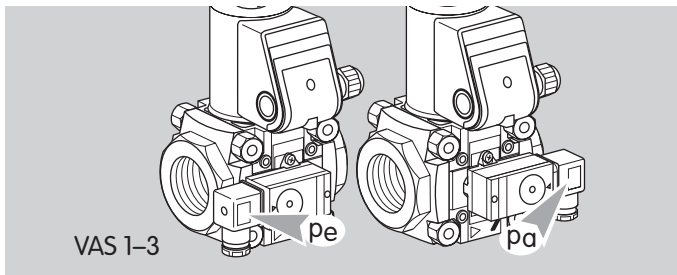
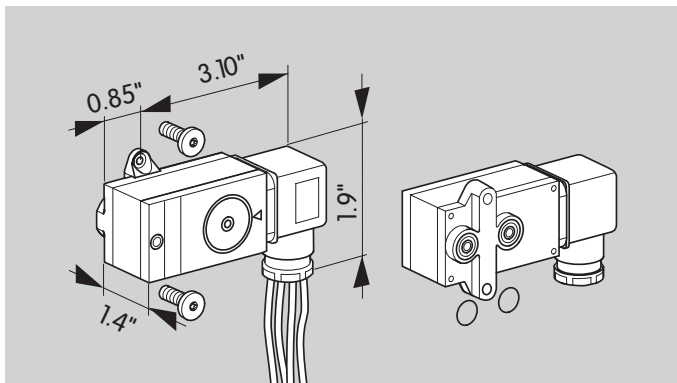
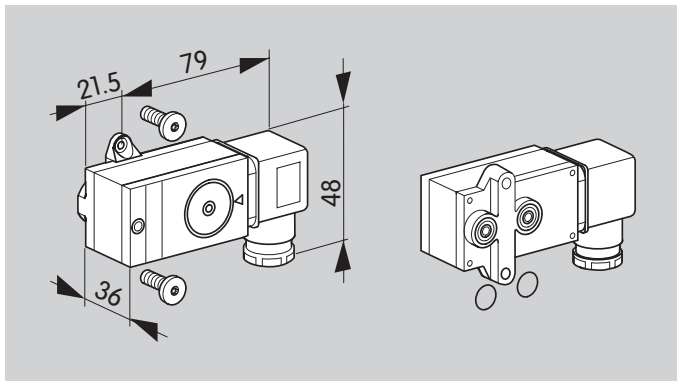

8 Accessories

8.1 Gas pressure switch

8.1.1 DG..VC for VAS/VCS

Type	Identification No. (see Selection table)	Adjusting range [mbar]
DG 17VC	1	2...17
DG 40VC	2	5...40
DG 110VC	3	30...110
DG 300VC	4	100...300

Scope of delivery:

- 1 x pressure switch for gas,
- 2 x retaining screws,
- 2 x sealing rings.

8.1.2 DG..VCT for VAS..T/VCS..T

Type	Identification No. (see Selection table)	Adjusting range [°WC]
DG 17VCT	1	0.8...6.8
DG 40VCT	2	2...16
DG 110VCT	3	12...44
DG 300VCT	4	40...120

Scope of delivery:

- 1 x gas pressure switch with 18" connection wires,
- 2 x retaining screws,
- 2 x sealing rings.

8.1.3 Installation on VAS 1–3

Monitor the inlet pressure p_e : The plug of the pressure switch for gas points towards the inlet flange.

Monitor the outlet pressure p_a : The plug of the pressure switch for gas points towards the outlet flange.

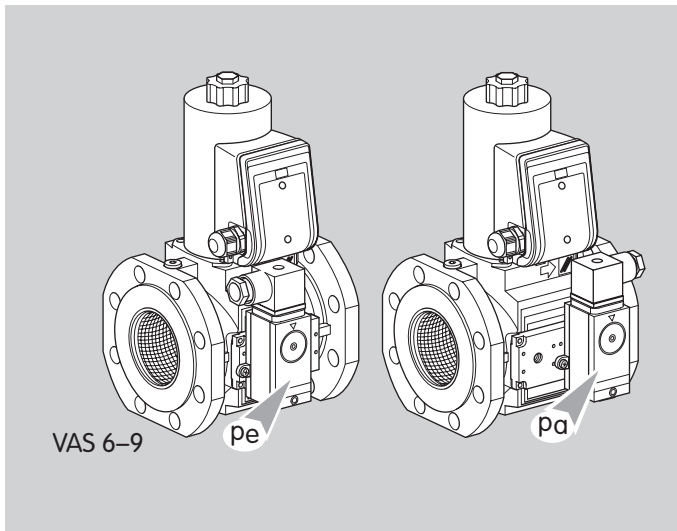

8.1.4 Installation on VAS 6-9

Monitor the inlet pressure p_e : The pressure switch for gas is mounted on the inlet side. Monitor the outlet pressure p_a : The pressure switch for gas is mounted on the outlet side.

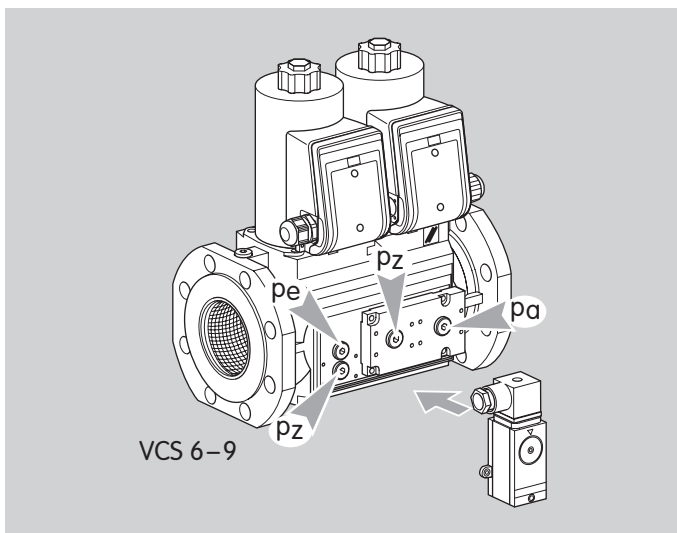

8.1.5 Installation on VCS 6-9

Monitor the inlet pressure p_e : The pressure switch for gas is mounted on the upper part of the flow body.

Monitor the interspace pressure p_z : The pressure switch for gas is mounted on the lower part of the flow body or on the adapter plate at the left-hand side.

Monitor the outlet pressure p_a : The pressure switch for gas is mounted on the adapter plate at the outlet side.

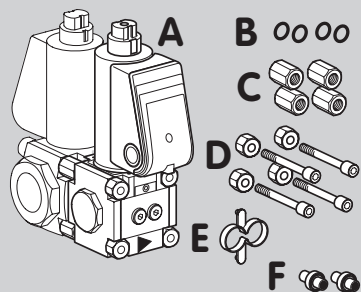

VAS 1 → VAS 1

8.2 Bypass/pilot gas valve VAS 1

8.2.1 Scope of delivery, VAS 1 attached to VAS 1

- A** 1× bypass valve VAS 1,
- B** 4× O-rings,
- C** 4× double nuts,
- D** 4× connection parts,
- E** 1× Mounting aid.

Bypass valve VAS 1

F 2× connection pipe, if the bypass valve has a blind flange at the outlet side.

Pilot gas valve VAS 1

F 1× connection pipe, 1× sealing plug, if the pilot gas valve has a threaded flange at the outlet side.

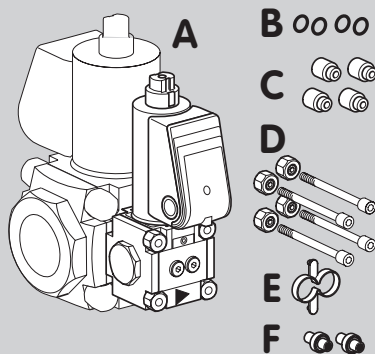

VAS 1 → VAS 2, VAS 3

8.2.2 Scope of delivery, VAS 1 attached to VAS 2, VAS 3

- A** 1× bypass valve VAS 1,
- B** 4× O-rings,
- C** 4× spacer sleeves,
- D** 4× connection parts,
- E** 1× Mounting aid.

Bypass valve VAS 1

F 2× connection pipe, if the bypass valve has a blind flange at the outlet side.

Pilot gas valve VAS 1

F 1× connection pipe, 1× sealing plug, if the pilot gas valve has a threaded flange at the outlet side.

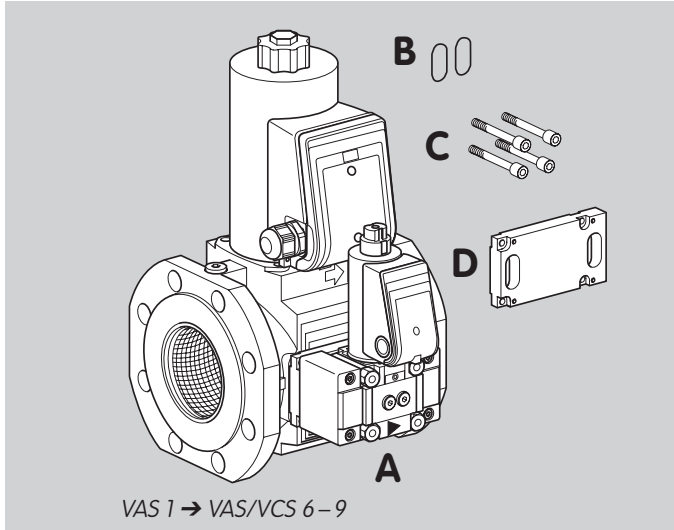

8.2.3 Scope of delivery, VAS 1 attached to VAS/VCS 6–9

A 1× bypass valve VAS 1,

B 2× O-rings,

C 4× connection parts,

D 1× bypass adapter plate

Bypass valve VAS 1:

2× adapter flanges

Pilot gas valve VAS 1:

1× adapter flange,

1× adapter flange with threaded hole

8.2.4 Flow rate, VAS 1 attached to VAS 1, VAS 2, VAS 3

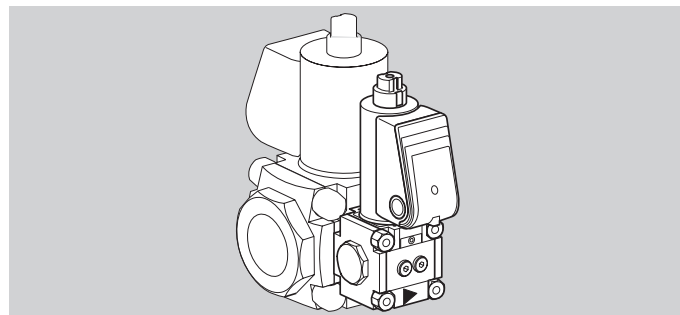
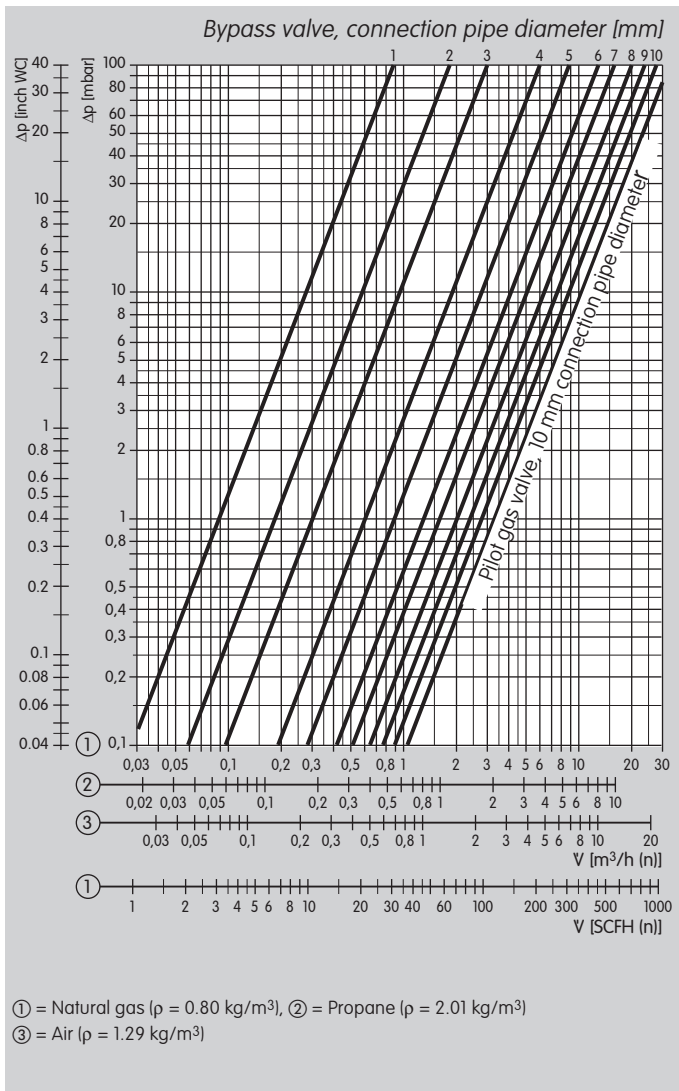

The characteristic flow rate curves have been measured for bypass valve VAS 1 with connection pipe diameter 1 to 10 mm and for the pilot gas valve with 10 mm connection pipe.

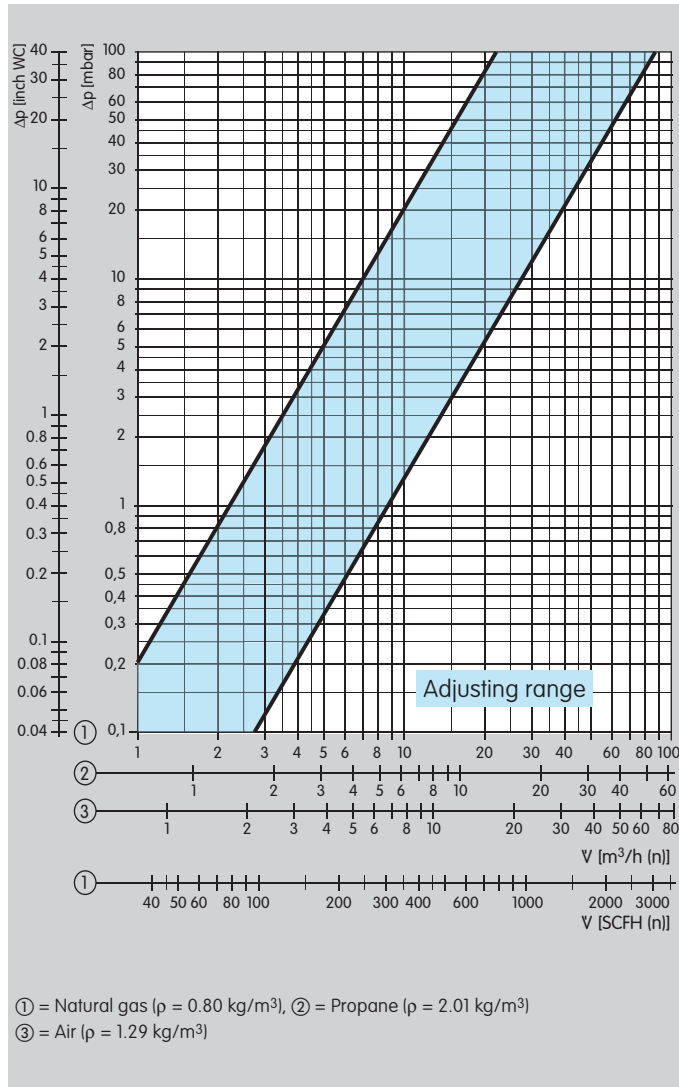

8.2.5 Flow rate, VAS 1 attached to VAS/VCS 6 – 9

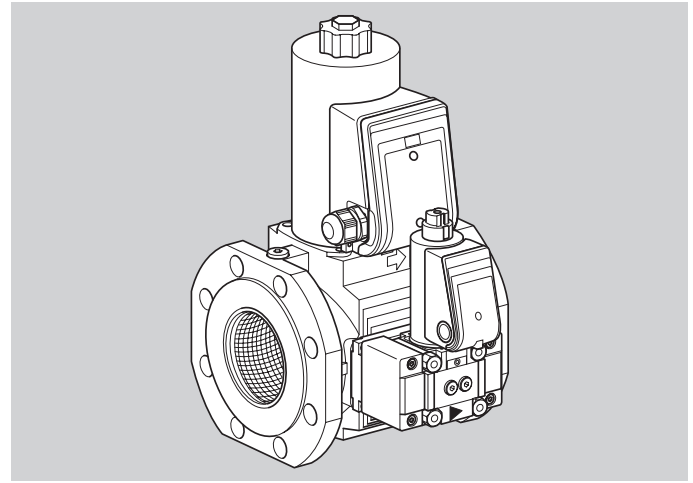

The adjusting range for the bypass valve, and pilot gas valve VAS 1, was determined using the values measured for open flow adjustment ($V_{max.}$) and fully reduced flow adjustment ($V_{min.}$)..

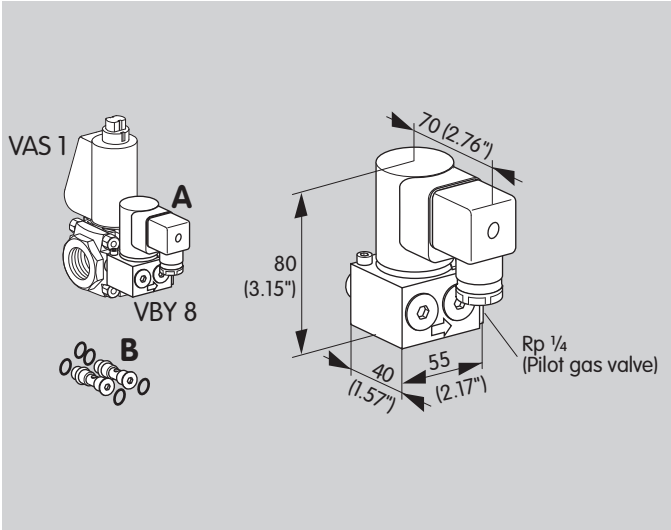

8.3 Bypass/pilot gas valve VBY 8

For mounting on gas solenoid valve VAS 1 and double solenoid valve VCS 1.

8.3.1 Scope of delivery, as bypass valve

- A** 1× bypass valve VBY 8
- B** 2× retaining screws with 4× O-rings: Both retaining screws have a bypass orifice.

8.3.2 Scope of delivery, as pilot gas valve

- A** 1× pilot gas valve VBY 8
- B** 2× retaining screws with 5× O-rings: Only one of the retaining screws has a bypass orifice.

8.3.3 Selection

Type	I	R	W	Q	K	6L	-R	-L	E	B	D	05
VBY 8	●	●	●	●	●	●	●	●	●	●	●	●
Bypass valve (internal bypass)	= I											
Pilot gas valve (Rp internal thread at the outlet) = R	= R											
Mains voltage: 24 V DC	= K											
120 V AC, 50/60 Hz	= Q											
230 V AC, 50/60 Hz	= W											
Electrical connection via plug and socket with LED	= 6L											
Attachment side of main valve: right-hand side	= -R											
Attachment side of main valve: left-hand side	= -L											
Attached to the VAS	= E											
Enclosed (separate packing unit)	= B											
Flow adjustment	= D											
Nozzle diameter	= 0.5 mm											

Example

VBY 8RW6L-LED

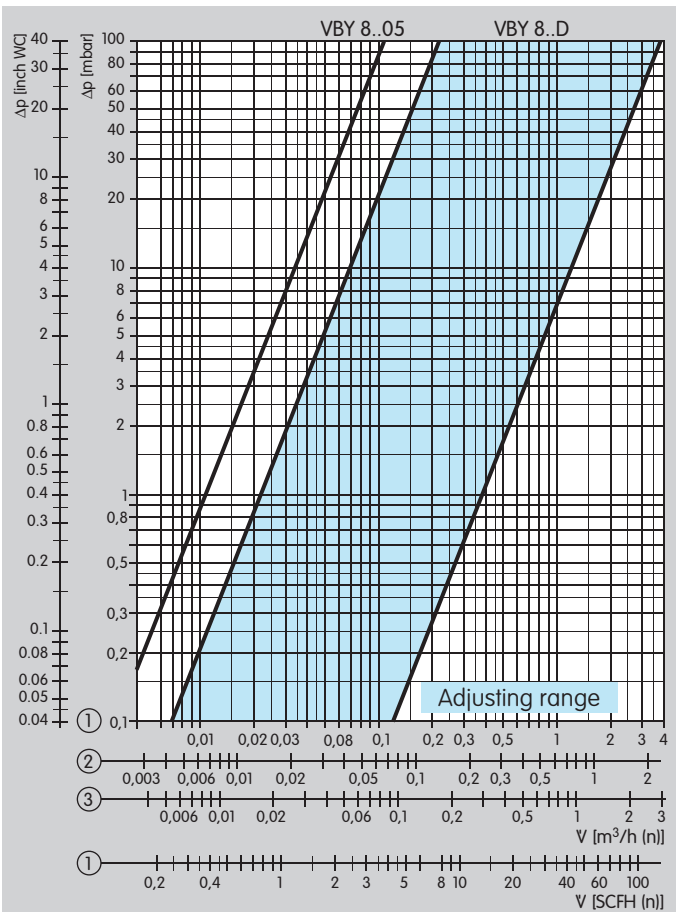

① = Natural gas ($\rho = 0.80 \text{ kg/m}^3$), ② = Propane ($\rho = 2.01 \text{ kg/m}^3$)
 ③ = Air ($\rho = 1.29 \text{ kg/m}^3$)

8.3.4 Flow rate

VBY 8..D

The flow rate can be set by turning the flow rate restrictor (4 mm allen screw) $\frac{1}{4}$ of a turn.

Max. flow rate: 10 to 100%.

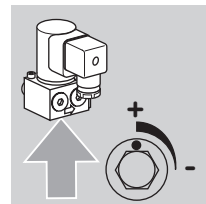

VBY 8..05

The flow is routed through a 0.5 mm nozzle (0.02 inches) and thus has a fixed characteristic flow rate curve.

Adjustment is not possible.

8.3.5 Technical data

Ambient temperature:

0 bis $+60^\circ\text{C}$ ($32 \dots 140^\circ\text{F}$), no condensation permitted.

Storage temperature:

0 bis $+40^\circ\text{C}$ ($32 \dots 104^\circ\text{F}$), no condensation permitted.

Power consumption:

24 V = 8 W,

120 V = 8 W,

230 V = 9,5 W

Enclosure: IP 54

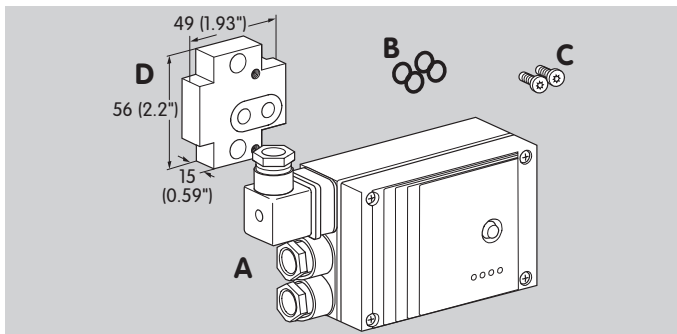

8.4 Tightness control TC 116V

for VAS 1–3

Scope of delivery

A 1× tightness control TC 116V

B 4× O-rings

C 2× retaining screws

An adapter plate is required to attach the tightness control to the right- or left-hand side of the gas solenoid valve:

D 1× adapter plate

For attachment to: left-hand side: Order No. 74922391

right-hand side: Order No. 74921995

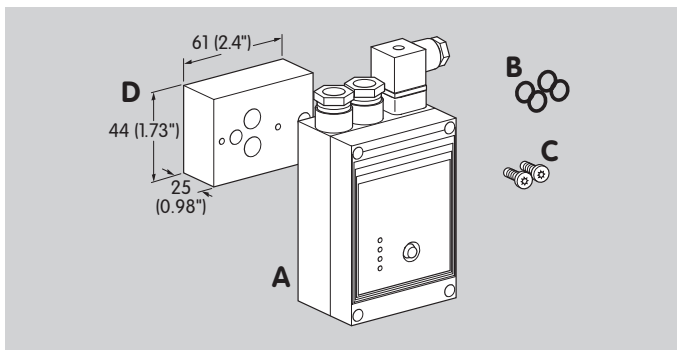

for VCS 6–9:

Scope of delivery

A 1× tightness control TC 116V

B 4× O-rings

C 2× retaining screws

An adapter plate is required to attach the tightness control to the double solenoid valve:

D 1× adapter plate, Order No. 74922822

8.5 Pressure test points

Test points to check the inlet pressure p_e and outlet pressure p_a .

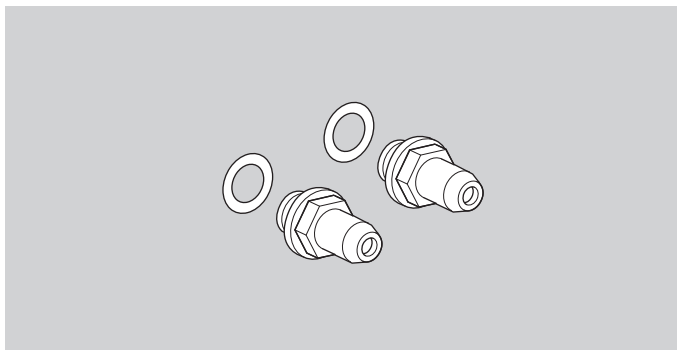

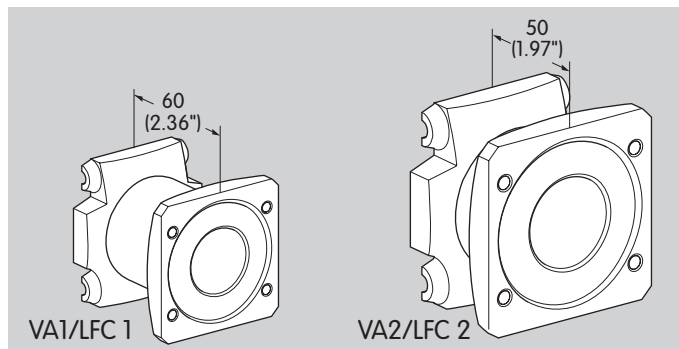
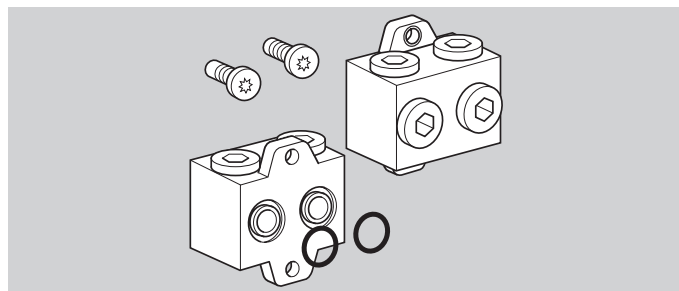
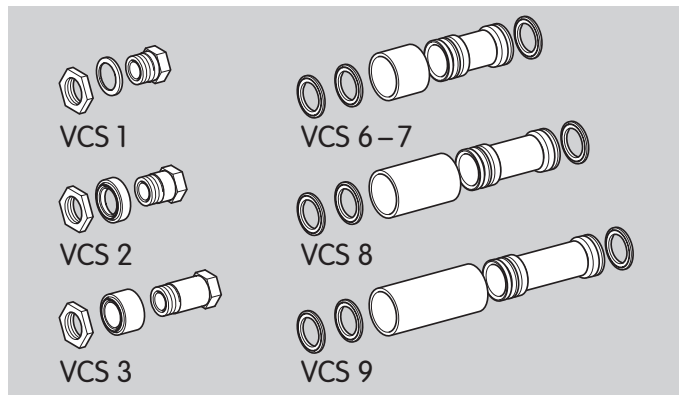

8.6 Grommet

When wiring double solenoid valve VCS 1–9, the connection boxes are to be connected using a grommet.

The grommet can only be used if the connection boxes are at the same height and on the same side and if both valves are equipped either with or without a position indicator.

8.7 Attachment block

For locked installation of pressure gauge or other accessories on the gas solenoid valve VAS 1–3.

Scope of delivery:

2× self-tapping screws for installation,
2× O-rings.

8.8 Flange set for Moduline

For attaching VAS/VCS 1, VAS/VCS 2 to Moduline controls, sizes 1 and 2:

Flange set VA 1/LFC 1, Order No. 74922171,
Flange set VA 2/LFC 2, Order No. 74922172.

Scope of delivery:

1 x flange,
1 x O-ring,
4 x cheese-head screws,
4 x square nuts.

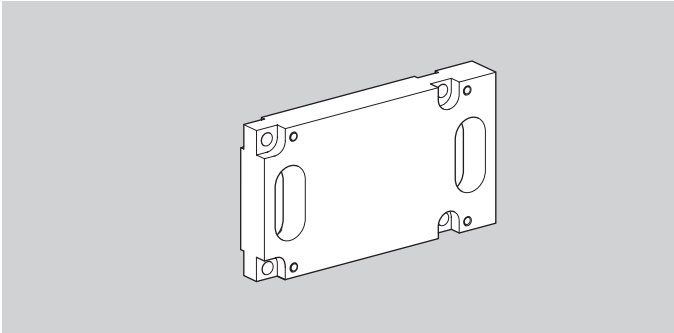

8.9 Adapter plates for VAS/VCS 6–9

8.9.1 Bypass adapter plate

For the connection of the bypass/pilot gas valve VAS 1.

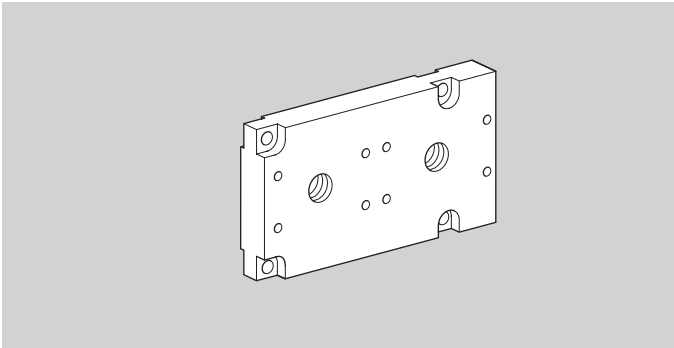

8.9.2 Measuring adapter plate

For the connection of the pressure switch DG..VC with screw plug or pressure test point.

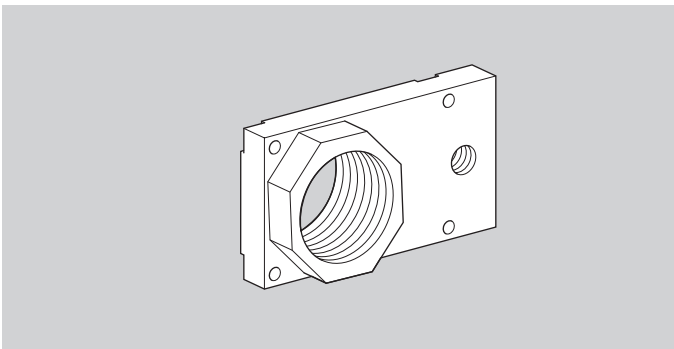

8.9.3 Pipe adapter plate for VCS 6–9

For the connection of a relief line (1½ NPT, Rp 1) with screw plug or pressure test point.

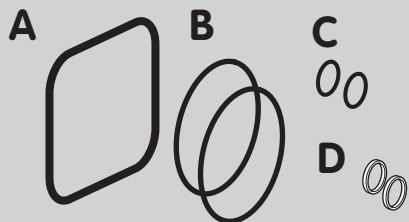

8.10 Seal set VA 1–3

Scope of delivery:

- A** 1 x double block seal,
- B** 2 x O-rings (flange),
- C** 2 x O-rings (pressure switch),
- D** 2 x sealing rings (test nipple).

9 Technical data

Types of gas: Natural gas, LPG (gaseous), biologically produced methane (max. 0.1 %-by-vol. H₂S) or air; other gases on request.

The gas must be dry in all temperature conditions and must not condense.

Max. inlet pressure p_e : 500 mbar (7 psig).

FM approved, non operational pressure: 700 mbar (10 psig).

CSA approved: 350 mbar (5 psig).

Flow adjustment limits the maximum flow volume between 20 and 100%. On VAS 1–3, the setting can be monitored on an indicator.

Adjustment of the start gas rate: 0 to 70%.

Opening times:

VAS../N quick opening: ≤ 1 s;

VAS../L slow opening: up to 30 s.

Closing time:

VAS../N, VAS../L quick closing: < 1 s.

Ambient temperature: $-20 - +60^\circ\text{C}$ ($-4 - +140^\circ\text{F}$), no condensation permitted.

Storage temperature: $-20 - +40^\circ\text{C}$ ($-4 - +104^\circ\text{F}$), no condensation permitted.

Safety valve:

Class A Group 2 pursuant to EN 13611 and EN 161,

Factory Mutual Research Class: 7410 and 7411,

ANSI Z21.21 and CSA 6.5.

Mains voltage:

230 V AC, $+10/-15\%$, 50/60 Hz;

120 V AC, $+10/-15\%$, 50/60 Hz;

24 V DC, $\pm 20\%$.

VAS/VCS 9:

120–230 V~, $+10/-15\%$, 50/60 Hz.

Cable gland: M20 x 1.5

Electrical connection: max. 2.5 mm² (AWG 12) or plug with socket to EN 175301-803.

Power consumption:

Type	24 V= [W]	120 V~ [W]	230 V~ [W]
VAS 1	29	30	30
VAS 2	46	54	53
VAS 3	58	63	63
VAS 6	70	63	63
VAS 7	75	90	83
VAS 8	99	117	113
VAS 9	–	200 (15*)	200 (15*)
VCS 1	58	60	60
VCS 2	92	108	106
VCS 3	116	126	126
VCS 6	140	126	126
VCS 7	150	180	166
VCS 8	198	234	226
VCS 9	–	400 (30*)	400 (30*)

* After opening.



Enclosure: IP 65.

Duty cycle: 100%.

Power factor of the solenoid coil: $\cos \varphi = 1$.

Switching frequency:

VAS..N: Arbitrary,

VAS..L: There must be a period of 20 seconds between switching off and on again so that the damping is fully effective.

Valve housing: Aluminium,

Valve seal: NBR.

Connection flanges:

VAS/VCS 1-3 with internal thread:

Rp pursuant to ISO 7-1, NPT pursuant to

ANSI/ASME

VAS/VCS 6-9 with ISO flange pursuant to ISO 7005, with

ANSI flange pursuant to ASA.

Position indicator contact rating:

Type	Voltage	min. current (resistive load)	max. current (resistive load)
VAS..S, VCS..S	12...250 V~, 50/60 Hz	100 mA	3 A
VAS..G, VCS..G	12...250 V~, 50/60 Hz	2 mA	0,1 A

Switching frequency: 5x per minute.

switching current [A]	switching cycles	
	$\cos \varphi = 1$	$\cos \varphi = 0,6$
0.1	500,000	500,000
0.5	300,000	250,000
1	200,000	100,000
3	100,000	–

VAS/VCS 9

Switching frequency: 1x per minute.

Max. temperature of solenoid coil:

+20°C (+68°F) above ambient temperature.

Current consumption at 20°C (68°F):

Pick-up current: 1.8 A

Holding current: 0.3 A.

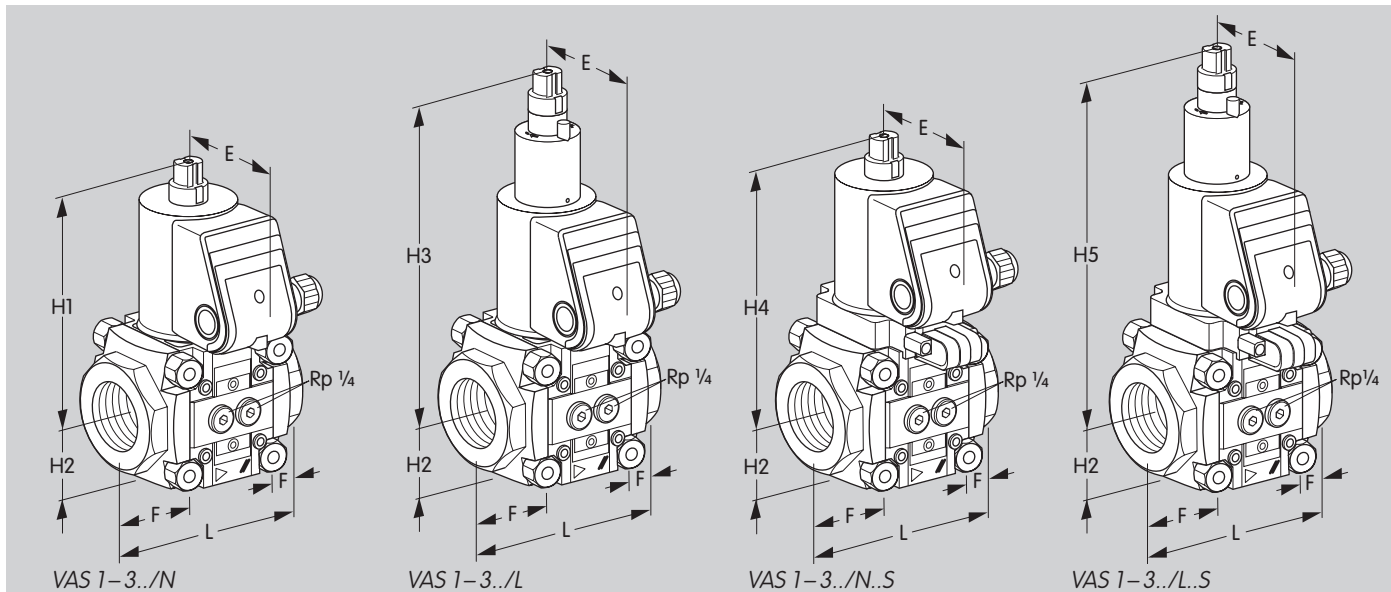

9.1 Dimensions

9.1.1 VAS with Rp internal thread [mm]

Type	Connection		Dimensions								V air for $\Delta p = 1 \text{ mbar}$ m ³ /h	k _v max. m ³ /h	k _v min. m ³ /h	Weight kg
	Rp	DN	L mm	E mm	F mm	H1 mm	H2 mm	H3 mm	H4 mm	H5 mm				
VAS 110	3/8	10	75	75	15	140	32	209	159	227	4.4	5.0	2	1.4
VAS 115	1/2	15	75	75	15	140	32	209	159	227	5.5	6.4	2	1.4
VAS 120	3/4	20	91	75	23	140	32	209	159	227	8.3	9.6	2	1.5
VAS 125	1	25	91	75	23	140	32	209	159	227	10.0	10.9	2	1.4
VAS 225	1	25	127	88	29	164	47	233	185	254	15.5	19.2	5.3	3.8
VAS 232	1 1/4	32	127	88	29	164	47	233	185	254	19.5	24.1	5.3	3.7
VAS 240	1 1/2	40	127	88	29	164	47	233	185	254	21.0	26.9	5.3	3.8
VAS 250	2	50	127	88	29	164	47	233	185	254	22.5	26.9	5.3	3.6
VAS 340	1 1/2	40	155	96	36	229	59	298	250	319	30.5	39.1	8.5	7.4
VAS 350	2	50	155	96	36	229	59	298	250	319	37.0	44.4	8.5	7.2
VAS 365	2 1/2	65	155	96	36	229	59	298	250	319	41.0	47.4	8.5	7.0

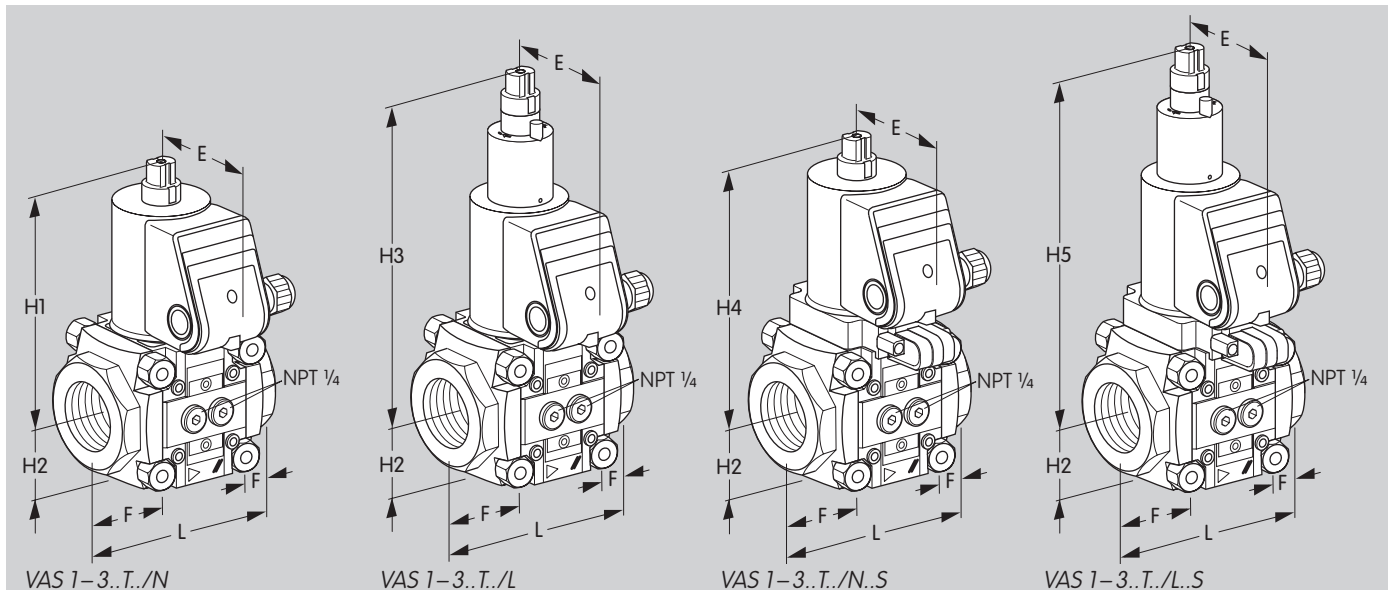

9.1.2 VAS..T with NPT internal thread [inch]

Type	Connection		Dimensions								Vair for $\Delta p = 0.4$ "WC	Weight lbs
	NPT	DN	L inch	E inch	F inch	H1 inch	H2 inch	H3 inch	H4 inch	H5 inch	SCFH	
VAS 110	3/8	10	2.95	2.95	0.59	5.51	1.26	8.23	6.26	8.94	155.36	3.08
VAS 115	1/2	15	2.95	2.95	0.59	5.51	1.26	8.23	6.26	8.94	194.23	3.08
VAS 120	3/4	20	3.58	2.95	0.91	5.51	1.26	8.23	6.26	8.94	300.17	3.3
VAS 125	1	25	3.58	2.95	0.91	5.51	1.26	8.23	6.26	8.94	374.34	3.08
VAS 225	1	25	5.00	3.47	1.14	6.46	1.85	9.17	7.28	10	618.01	8.36
VAS 232	1 1/4	32	5.00	3.47	1.14	6.46	1.85	9.17	7.28	10	759.27	8.14
VAS 240	1 1/2	40	5.00	3.47	1.14	6.46	1.85	9.17	7.28	10	829.89	8.36
VAS 250	2	50	5.00	3.47	1.14	6.46	1.85	9.17	7.28	10	868.74	7.92
VAS 340	1 1/2	40	6.10	3.78	1.42	9.02	6.85	11.73	9.84	12.56	1165.38	16.28
VAS 350	2	50	6.10	3.78	1.42	9.02	6.85	11.73	9.84	12.56	1447.90	15.84
VAS 365	2 1/2	65	6.10	3.78	1.42	9.02	6.85	11.73	9.84	12.56	1518.53	15.40

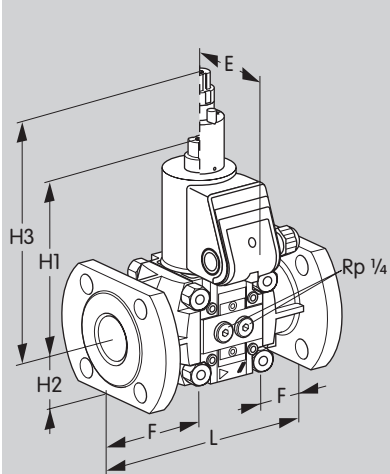

VAS 240..N, VAS 240..L
VAS 350..N, VAS 350..L

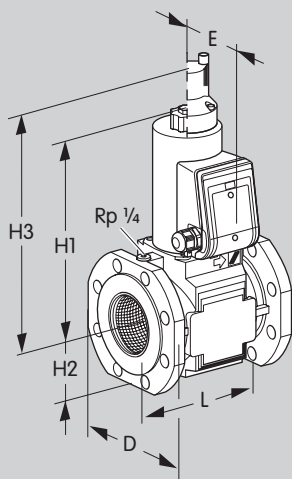

VAS 6-8..N,
VAS 6-8..L

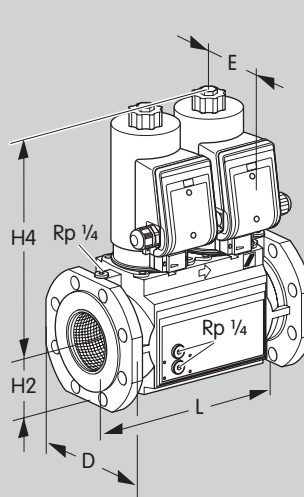

VCS 6-9..N..S

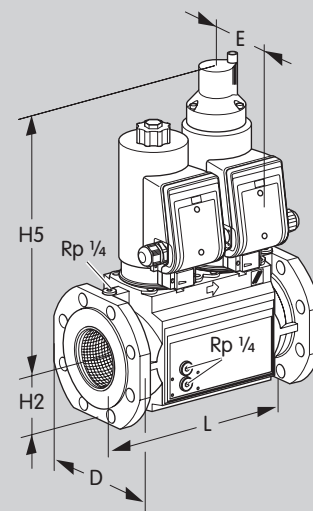

VCS 6-8..NL..S

9.1.3 VAS/VCS with ISO flange

Type	Con- nection DN	Dimensions								V _{air} for Δp = 1 mbar m ³ /h	k _v min. m ³ /h	k _v max. m ³ /h	Weight kg
		L mm	E mm	F mm	H1 mm	H2 mm	H3 mm	H4 mm	H5 mm				
VAS 240	40	200	88	66	164	47	233	–	–	21.0	26.9	5.3	5.0
VAS 350	50	230	96	74	229	59	298	–	–	37.0	44.4	8.5	8.7
VAS 665	65	190	106	175	287	77	342	310	365	68.4	69	–	11
VCS 665	65	290	106	175	287	77	342	310	365	53.3	61	–	18
VAS 780	80	203	106	190	295	86	350	318	373	97.9	112	–	12
VCS 780	80	310	106	190	295	86	350	318	373	75.8	87	–	21
VAS 8100	100	229	120	210	348	101	403	380	426	148.4	171	–	23
VCS 8100	100	350	120	210	348	101	403	380	426	114.3	131	–	40
VAS 9125	125	254	120	240	362	114	–	394	–	222	251	–	27
VCS 9125	125	400	120	240	362	114	–	394	–	170.5	193	–	45

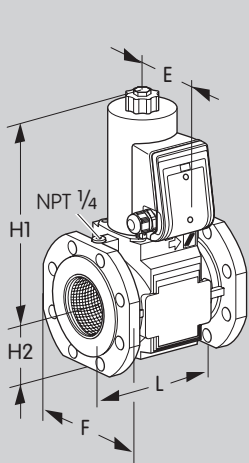

VAS 6-9../N

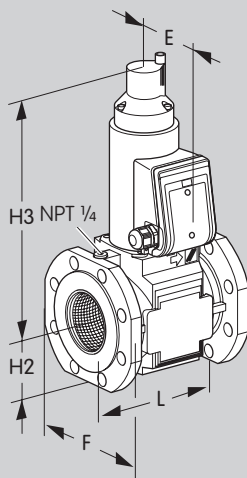

VAS 6-8../L

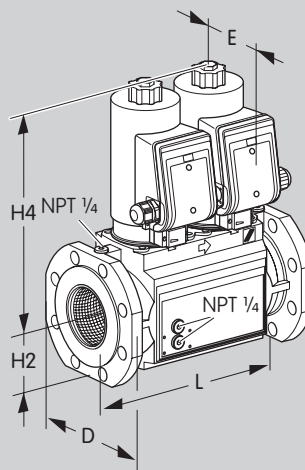

VCS 6-9../N..S

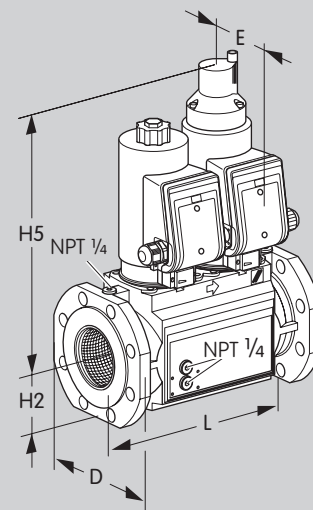

VCS 6-8../NL..S

9.1.4 VAS/VCS..T with ANSI flange [inch]

Type	Connec- tion DN	Dimensions								V _{air} for Δp = 0,4 "WC SCFH	Weight lbs
		L inch	E inch	F inch	H1 inch	H2 inch	H3 inch	H4 inch	H5 inch		
VAS 665	65	7.48	4.17	6.89	11.3	3	13.47	12.2	14.37	2415	24.25
VCS 665	65	11.41	4.17	6.89	11.3	3	13.47	12.2	14.37	1882	39.68
VAS 780	80	7.99	4.17	7.84	11.61	3.38	13.78	12.52	14.68	3456	26.45
VCS 780	80	12.2	4.17	7.84	11.61	3.38	13.78	12.52	14.68	2676	46.3
VAS 8100	100	9	4.72	8.27	13.7	3.97	13.86	14.96	16.77	5240	50.71
VCS 8100	100	13.78	4.72	8.27	13.7	3.97	13.86	14.96	16.77	4035	88.18
VAS 9125	125	10	4.72	9.45	14.25	4.48	-	15.51	-	7838	59.52
VCS 9125	125	15.75	4.72	9.45	14.25	4.48	-	15.51	-	6020	99.21

9.2 Conversion factors

SI unit ×	multiplier =	US unit
m ³ /h	35.31	SCFH
bar	0.0145	psi
mbar	14.52	psi
mbar	0.39	"WC
mm	0.039	inch
kg	2.2	lbs
litres	0.26	gal

US unit ×	multiplier =	SI unit
SCFH	0.0283	m ³ /h
psi	0.0689	bar
psi	68.89	mbar
"WC	2.54	mbar
inch	25.4	mm
lbs	0.45	kg
gal	3.79	litres

$$^{\circ}\text{C} = (^{\circ}\text{F} - 32) \times \frac{5}{9}$$

$$^{\circ}\text{F} = (^{\circ}\text{C} \times \frac{9}{5}) + 32$$

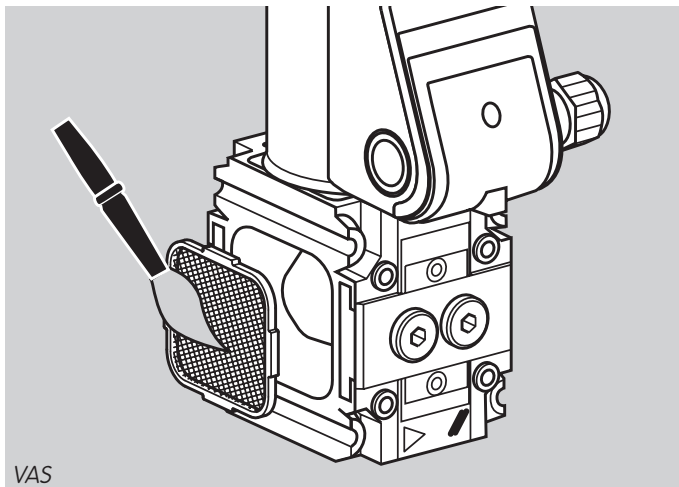

10 Maintenance cycles

At least once per annum, at least twice per annum for biologically produced methane.

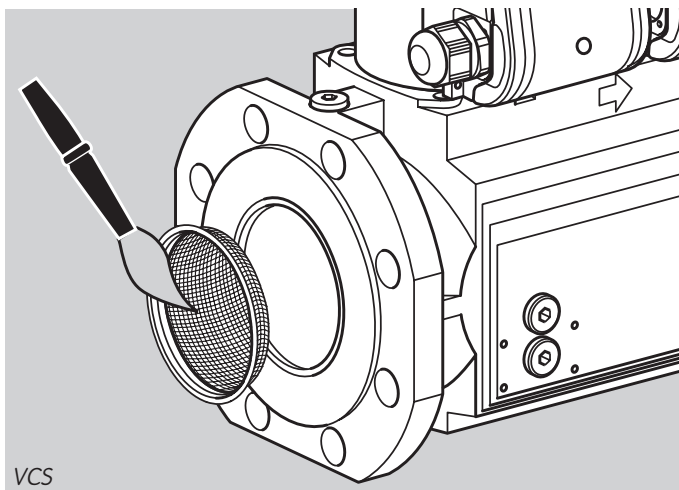

Feedback

Finally, we are offering you the opportunity to assess this "Technical Information (TI)" and to give us your opinion, so that we can improve our documents further and suit them to your needs.

Clarity

- Found information quickly
- Searched for a long time
- Didn't find information
- What is missing
- No answer

Comprehension

- Coherent
- Too complicated
- No answer

Scope

- Too little
- Sufficient
- Too wide
- No answer

Use

- To get to know the product
- To choose a product
- Planning
- To look for information

Navigation

- I can find my way around
- I got "lost"
- No answer

My scope of functions

- Technical department
- Sales
- No answer

Remarks



(Adobe Reader 7 or higher required)

Contact

Elster GmbH
 Postfach 2809 · 49018 Osnabrück
 Stroheweg 1 · 49504 Lotte (Büren)
 Germany
 T +49 541 1214-0
 F +49 541 1214-370
 info@kromschroeder.com
 www.kromschroeder.com
 www.elster.com

The current addresses of our international agents are available on the Internet:
www.kromschroeder.com → Sales

Kromschroöder, a product brand of the Elster Group

We reserve the right to make technical modifications in the interests of progress.
 Copyright © 2007 Elster Group
 All rights reserved.