

Solenoid valves for gas VAS, Double solenoid valves VCS

Technical Information · GB

3 Edition 07.15



- Safety shut-off valves for gas
- Suitable for a max. inlet pressure of 500 mbar (7 psig)
- Easy installation into a system
- Compact design saves space
- No extra valve required owing to integrated flow adjustment
- Check indication by blue LED
- Proof of closure switch with integrated visual position indicator
- Suitable for high-duty cycling
- EU certified
- FM, ANSI/CSA and AGA approved, UL listed
- Certified for systems up to SIL 3 and PL e



elster
Thermal Solutions

Contents

- Solenoid valves for gas VAS, Double solenoid valves VCS . . . 1
- Contents 2
- 1 Application 4
 - 1.1 Examples of application 6
 - 1.1.1 Solenoid valve for gas VAS 1–3, double solenoid valve VCS 1–3 6
 - 1.1.2 Gas solenoid valve with inlet and outlet pressure switch . . . 7
 - 1.1.3 Double solenoid valve VCS with damping unit 7
 - 1.1.4 Solenoid valve for gas VAS 6–9, double solenoid valve VCS 6–9 8
 - 1.1.5 Solenoid valve for gas VAS 6–9, double solenoid valve VCS 6–9 with connection for adapter plates 9
 - 1.1.6 Gas solenoid valve with pilot gas valve and pressure switch 10
 - 1.1.7 Double solenoid valve with tightness control 10
- 2 Certification 11
- 3 Function 12
 - 3.1 Solenoid valve for gas VAS..N, quick opening 13
 - 3.2 Solenoid valve for gas VAS..L, slow opening 14
 - 3.3 Solenoid valve for gas VAS..S/VAS..G, proof of closure switch with visual position indicator 15
 - 3.4 Animation 16
 - 3.5 Connection diagram 17
 - 3.5.1 VAS with M20 cable gland 17
 - 3.5.2 VAS with plug 17
 - 3.5.3 Solenoid valve for gas VAS..S/VAS..G, proof of closure switch with visual position indicator 17
 - 3.5.4 VCS with M20 cable gland 17
 - 3.5.5 VCS with plug 17
- 4 Replacement possibilities 18
 - 4.1 Solenoid valve for gas VG is to be replaced by VAS . . . 18
 - 4.1.1 Searching for an order number or type 19
 - 4.2 MODULINE solenoid valve for gas VS is to be replaced by VAS 20

- 5 Flow rate 22
 - 5.1 VAS 22
 - 5.1.1 Calculating the nominal size 22
 - 5.2 VCS 23
 - 5.2.1 Calculating the nominal size 23
 - 5.3 k_v value 24
- 6 Selection 25
 - 6.1 Selection table for VAS 1–3 25
 - 6.2 Type code for VAS 1–3 26
 - 6.3 Selection table for VAS 6–9 27
 - 6.4 Type code for VAS 6–9 28
 - 6.5 Selection table for VCS 1–3 29
 - 6.6 Type code for VCS 1–3 30
 - 6.7 Selection table for VCS 6–9 31
 - 6.8 Type code for VCS 6–9 32
- 7 Project planning information 33
 - 7.1 Installation 33
- 8 Accessories 35
 - 8.1 Gas pressure switch 35
 - 8.1.1 DG..VC for VAS/VCS 35
 - 8.1.2 DG..VCT for VAS..T/VCS..T 35
 - 8.1.3 Installation on VAS 1–3 35
 - 8.1.4 Installation on VCS 1–3 36
 - 8.1.5 Installation on VAS 6–9 36
 - 8.1.6 Installation on VCS 6–9 36
 - 8.2 Bypass/pilot gas valve VAS 1 37
 - 8.2.1 Scope of delivery, VAS 1 attached to VAS 1 37
 - 8.2.2 Scope of delivery, VAS 1 attached to VAS 2, VAS 3 37
 - 8.2.3 Scope of delivery, VAS 1 attached to VAS/VCS 6–9 38
 - 8.2.4 Flow rate, VAS 1 attached to VAS 1, VAS 2, VAS 3 39
 - 8.2.5 Flow rate, VAS 1 attached to VAS/VCS 6–9 40

8.3 Bypass/pilot gas valve VBY 8 41

8.3.1 Scope of delivery, VBY 8I as bypass valve 41

8.3.2 Scope of delivery, VBY 8R as pilot gas valve 41

8.3.3 Selection 41

8.3.4 Type code 41

8.3.5 Flow rate 42

8.3.6 Technical data 42

8.4 Tightness control TC 116V 43

8.5 Pressure test points 43

8.6 Cable gland set 44

8.7 Attachment block 44

8.8 Seal set VA 1–3 44

8.9 Adapter plates for VAS/VCS 6–9 45

8.9.1 Bypass adapter 45

8.9.2 Measuring adapter 45

8.9.3 Relief line adapter 45

8.10 Measuring orifice VMO 46

8.11 Filter module VMF 46

8.12 Fine-adjusting valve VMV 46

8.13 Retaining frame 47

8.14 Adapter for length compensation VAS 6–9 47

9 Technical data 48

9.1 Safety-specific characteristic values for VAS 50

9.1.1 Determining the PFH_D value, the λ_D value and the $MTTF_d$ value 51

9.1.2 Calculating the PFH_D and PFD_{avg} 51

9.2 Dimensions 52

9.2.1 VAS 1–3 with Rp internal thread [mm] 52

9.2.2 VAS 2–9 with ISO flange [mm] 53

9.2.3 VCS 1–3 with Rp internal thread [mm] 54

9.2.4 VCS 2–9 with ISO flange [mm] 55

9.2.5 VAS 1–3..T with NPT internal thread [inch] 56

9.2.6 VAS 6–9..T with ANSI flange [inch] 57

9.2.7 VCS 1–3..T with NPT internal thread [inch] 58

9.2.8 VCS 6–9..T with ANSI flange [inch] 59

10 Converting units 60

11 Maintenance cycles 60

12 Glossary 61

12.1 Diagnostic coverage DC 61

12.2 Mode of operation 61

12.3 Category 61

12.4 Common cause failure CCF 61

12.5 Fraction of undetected common cause failures β . . 61

12.6 B_{10d} value 61

12.7 T_{10d} value 61

12.8 Hardware fault tolerance HFT 61

12.9 Mean dangerous failure rate λ_D 61

12.10 Safe failure fraction SFF 62

12.11 Probability of dangerous failure PFH_D 62

12.12 Mean time to dangerous failure $MTTF_d$ 62

12.13 Demand rate n_{op} 62

12.14 Average probability of dangerous failure on demand PFD_{avg} 62

Feedback 63

Contact 63

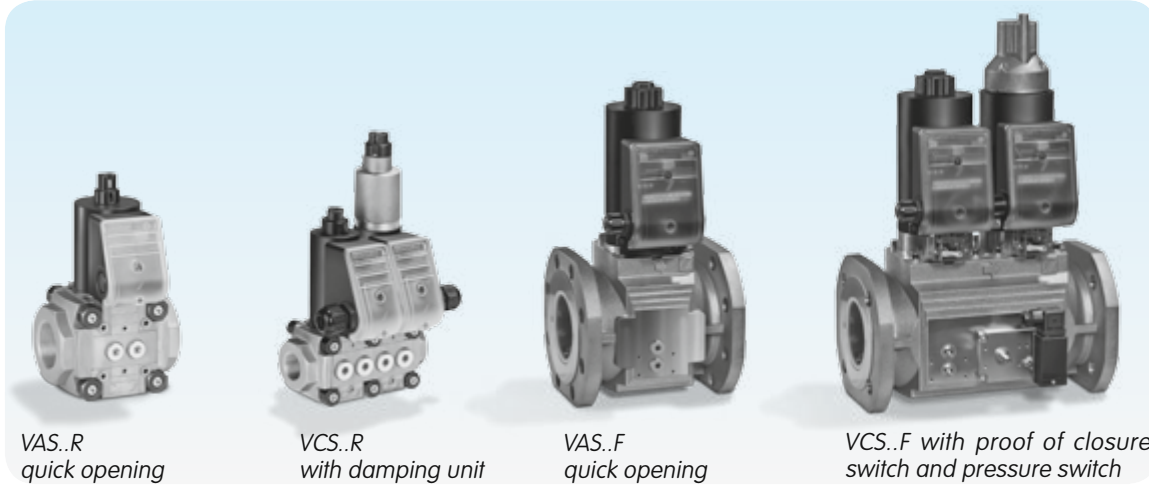

VAS..R
quick opening

VCS..R
with damping unit

VAS..F
quick opening

VCS..F with proof of closure
switch and pressure switch

The modular design principle allows the individual components of the VAS, VCS Series to be easily assembled: e.g. quick opening, slow opening, with proof of closure switch and visual position indicator, slow opening with attached pressure switch.

1 Application

Solenoid valves for gas VAS and double solenoid valves VCS for safeguarding and controlling the air and gas supply to gas burners and gas appliances. For use in gas control and safety systems in all sectors of the iron, steel, glass and ceramics industries, also in commercial heat generation, such as the packaging, paper and foodstuffs industries.



Ceramics industry



*Aluminium industry:
curing oven for
wheel rims*



*Foodstuffs industry:
baking oven*

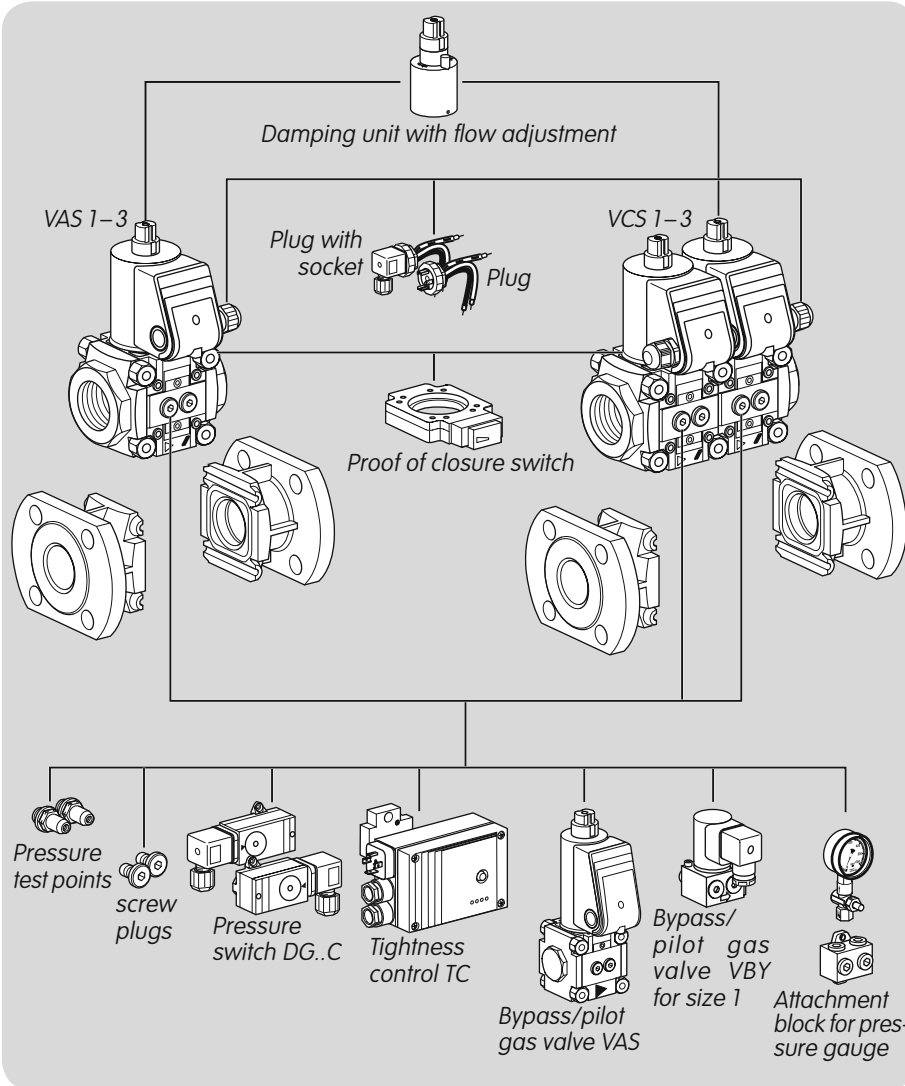

1.1 Examples of application

1.1.1 Solenoid valve for gas VAS 1–3, double solenoid valve VCS 1–3

Threaded flange for pipe connections (Rp or NPT) from DN 10 to 65, flanged connection for sizes 2 and 3 for pipe connections (ISO or ANSI) DN 40 and 50.

Modularly configurable with:

- Damping unit
- Proof of closure switch
- Plug (with or without socket)
- Pressure test points
- Screw plugs
- Pressure switch DG..C for inlet and/or outlet pressure
- Tightness control TC
- Bypass/pilot gas valve
- Attachment block for the connection of a pressure gauge, for example.

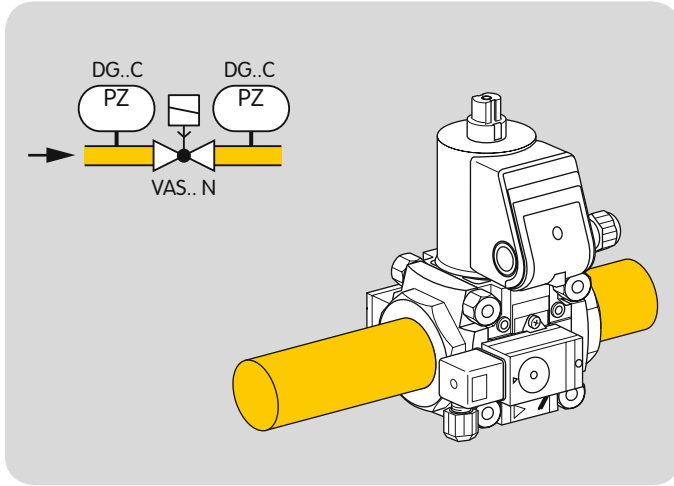

1.1.2 Gas solenoid valve with inlet and outlet pressure switch
VAS..N, quick opening, pressure switch DG..C for inlet pressure p_u and outlet pressure p_d

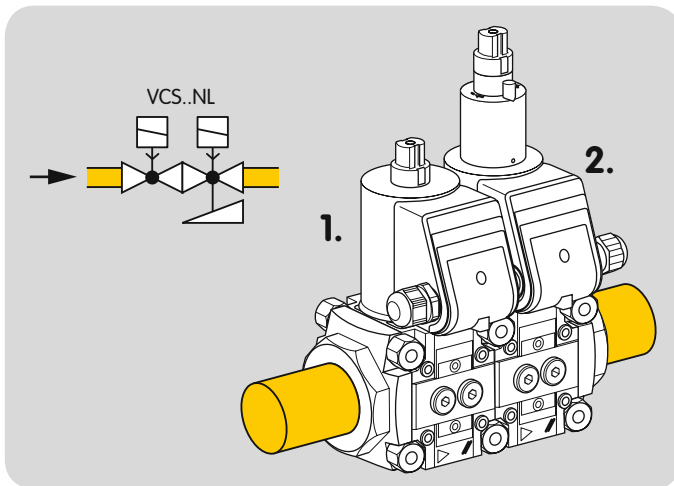

1.1.3 Double solenoid valve VCS with damping unit

VCS..NL,

1st valve: quick opening, quick closing, with flow adjustment

2nd valve: slow opening, quick closing

Damping unit for VAS/VCS 6–8

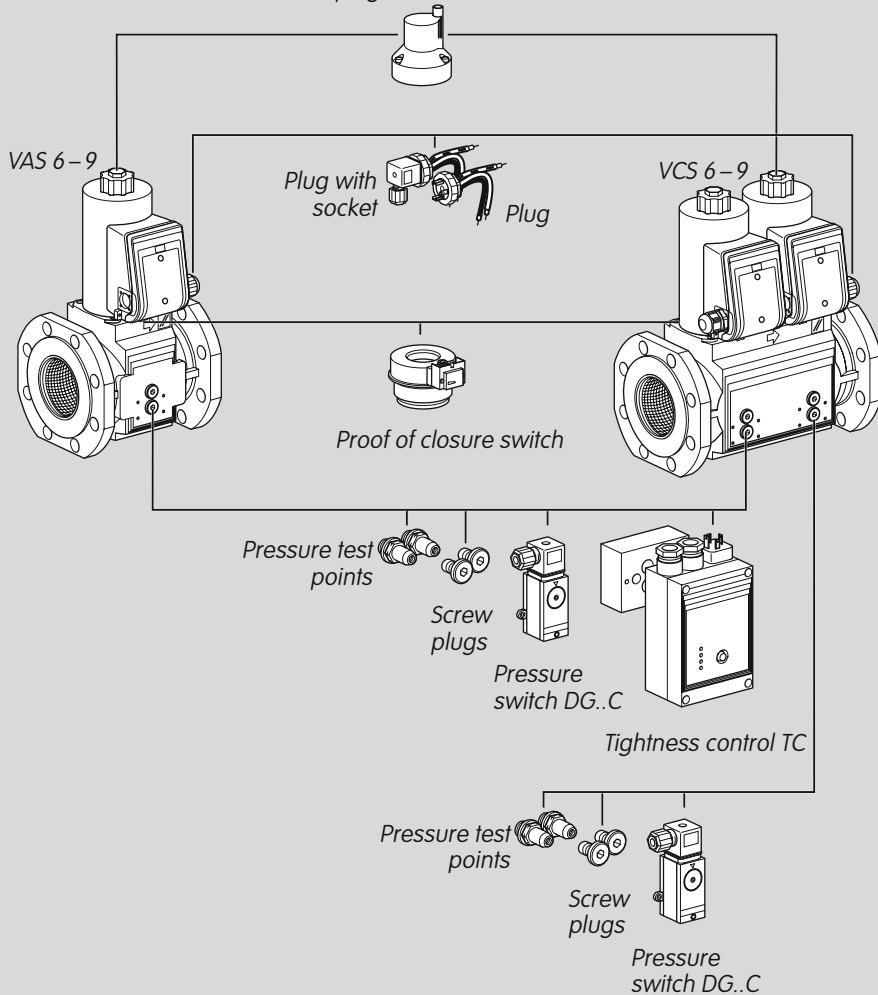

1.1.4 Solenoid valve for gas VAS 6–9, double solenoid valve VCS 6–9

Gas solenoid valve and double solenoid valve with flanged connection (ISO or ANSI) for pipe connections from DN 65 to 125.

Modularly configurable with:

- Damping unit for VAS/VCS 6–8
- Proof of closure switch
- Plug
- Plug with socket

VCS 6–9 with threaded connections for:

- Screw plugs
- Pressure test points
- Pressure switch DG..C for inlet/inter-space pressure
- Tightness control TC

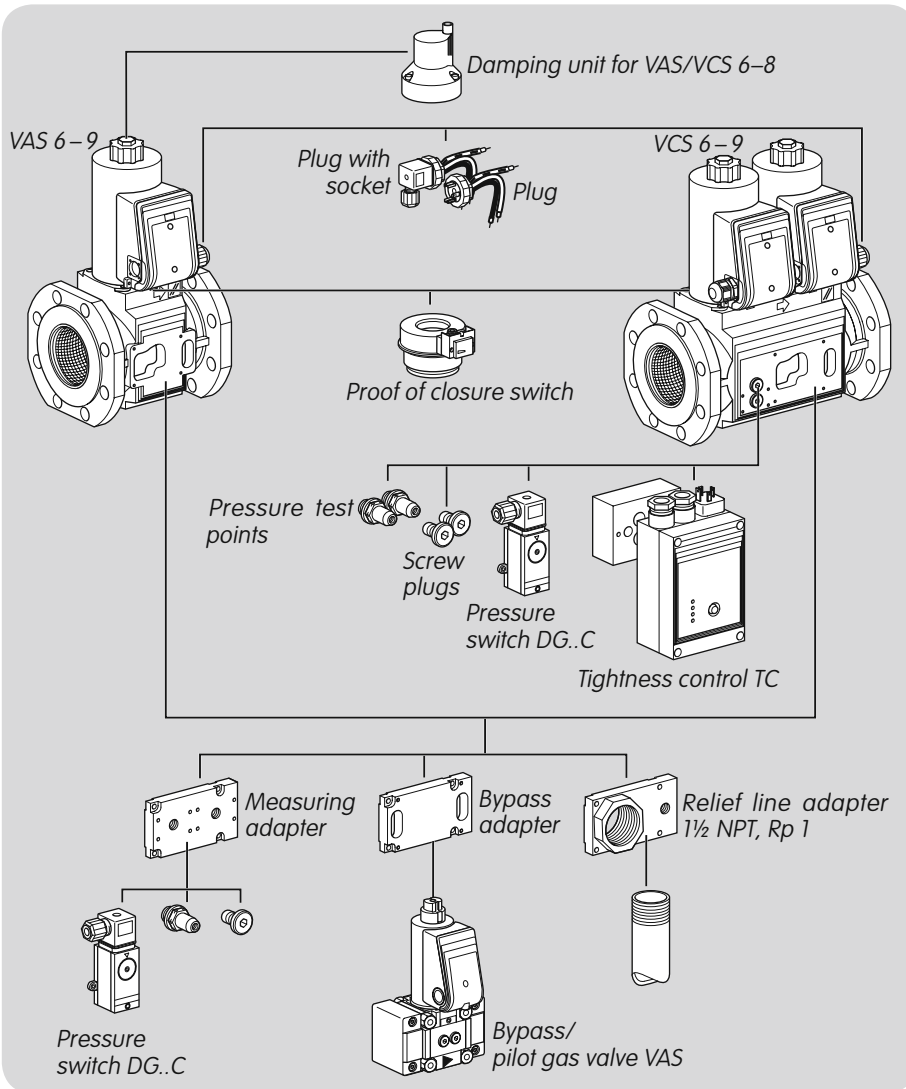

1.1.5 Solenoid valve for gas VAS 6-9, double solenoid valve VCS 6-9 with connection for adapter plates

Gas solenoid valve and double solenoid valve with flanged connection (ISO or ANSI) for pipe connections from DN 65 to 125.

Modularly configurable with:

- Damping unit for VAS/VCS 6-8
- Proof of closure switch
- Plug
- Plug with socket

With adapter plates, expandable with:

- Pressure switch DG..C
 VAS 6-9: for inlet/outlet pressure
 VCS 6-9: for interspace/outlet pressure
- Pressure test points
- Screw plug
- Bypass or pilot gas valve VAS

VCS 6-9

With two threaded connections for:

- Screw plugs
- Pressure test points
- Pressure switch DG..C for inlet/interspace pressure
- Tightness control TC

Expandable with relief line adapter (1½ NPT, Rp 1) for relief line.

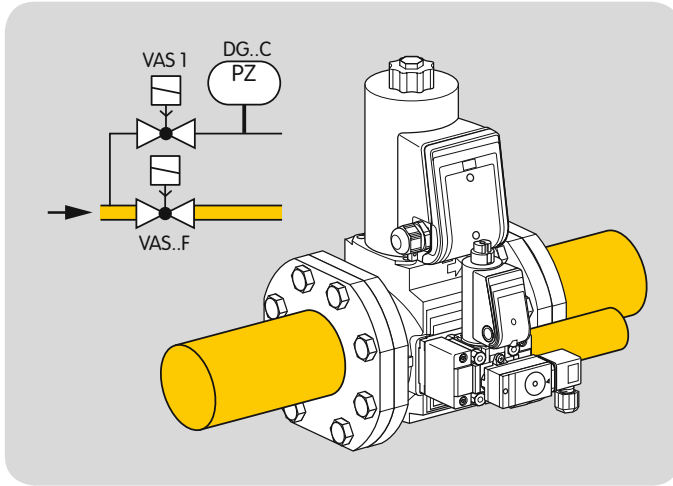

1.1.6 Gas solenoid valve with pilot gas valve and pressure switch

VAS..F..N: quick opening, quick closing, VAS 1 as pilot gas valve with pressure switch DG..C.

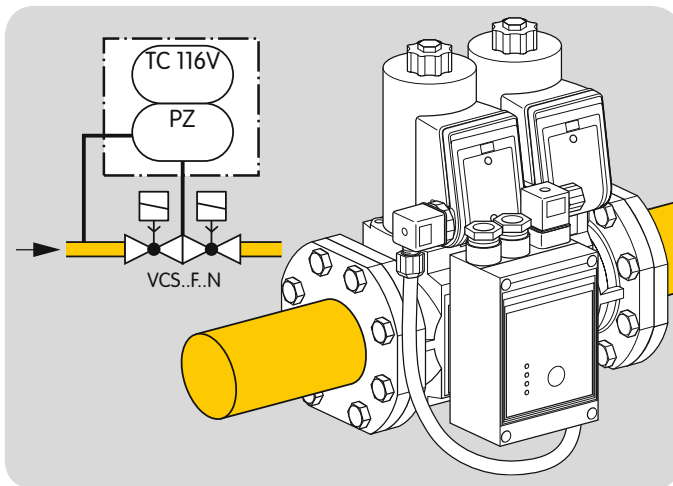

1.1.7 Double solenoid valve with tightness control

VCS..F..N: quick opening, quick closing valves, tightness control TC 116V.

2 Certification

Certificates – see Docuthek.

Certified to SIL and PL



For systems up to SIL 3 pursuant to EN 61508 and PL e pursuant to ISO 13849

EU certified pursuant to



- Gas Appliances Directive (2009/142/EC) in conjunction with EN 13611 and EN 161.

Meets the requirements of the

- Low Voltage Directive (2006/95/EC),
- EMC Directive (2004/108/EC).

FM approved*



Factory Mutual Research Class: 7400 and 7411 Safety overpressure slam shut valves. Designed for applications pursuant to NFPA 85 and NFPA 86. www.approvalguide.com

ANSI/CSA approved*



American National Standards Institute/Canadian Standards Association – ANSI Z21.21/CSA 6.5. www.csagroup.org –

Class number: 3371-83 (natural gas, LPG), 3371-03 (natural gas, propane)

VAS 1–3 (120 V AC), VAS 6–8: UL listed*



Underwriters Laboratories – UL 429 “Electrically operated valves”. www.ul.com → Tools (at the bottom of the page) → Online Certifications Directory

AGA approved*



Australian Gas Association, Approval No.: 3968
http://www.agasn.au/product_directory

Eurasian Customs Union



The product VAS, VCS meets the technical specifications of the Eurasian Customs Union (the Russian Federation, Belarus, Kazakhstan).

** Approval does not apply for 100 V AC and 200 V AC.*

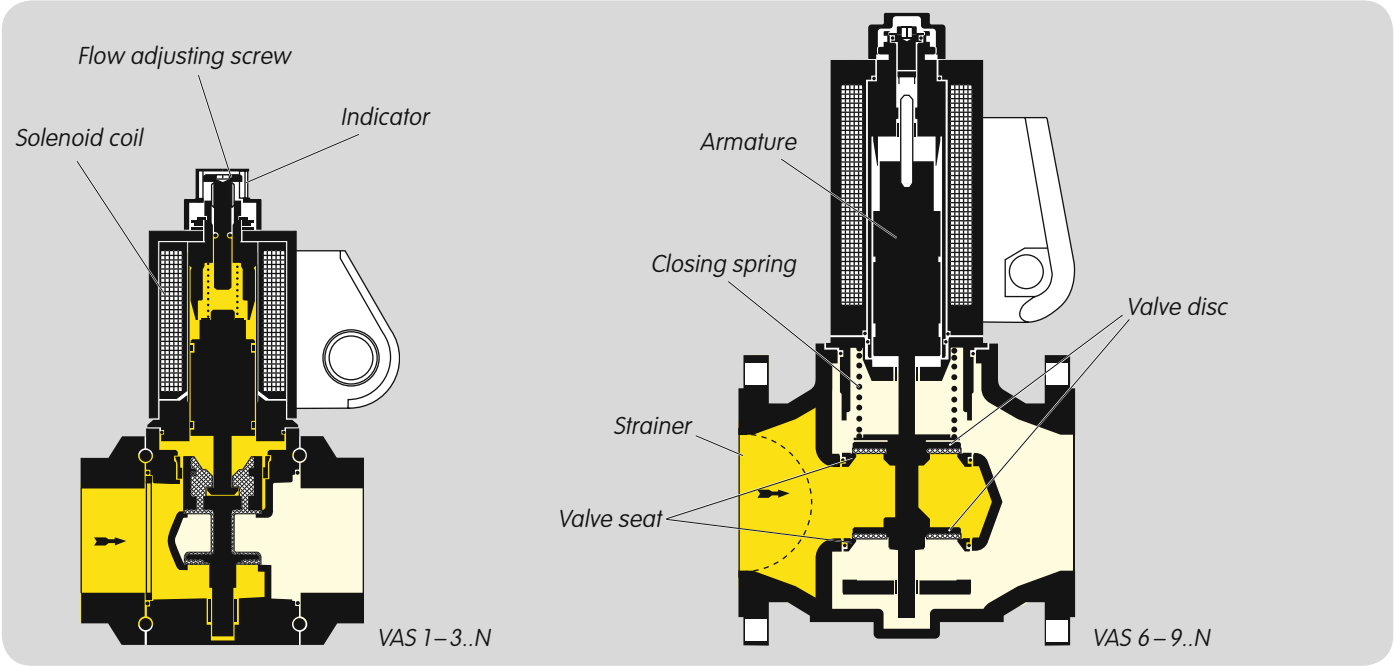

3 Function

The gas solenoid valve VAS is closed when it is disconnected from the power supply.

Opening: connect the system to the electrical power supply (alternating voltage will be rectified). The blue LED lights up. The coil's magnetic field pulls the armature with the attached valve discs upwards. The gas solenoid valve VAS opens. The double valve seat means that the forces from the inlet pressure are divided almost equally between the two valve seats.

Closing: disconnect the VAS from the electrical power supply. The blue LED goes out. The armature is pressed into its initial

position by the closing spring. The gas solenoid valve closes within 1 s.

The strainer in the inlet of the gas solenoid valve prevents deposits of dirt particles on the valve seats. The pressure loss through the strainer is very low.

VAS 1-8..N, VAS 1-3..L

The flow rate can be varied by a flow adjusting screw on the actuator within a range from 20 to 100%. On VAS 1-3, the setting can be monitored on an indicator.

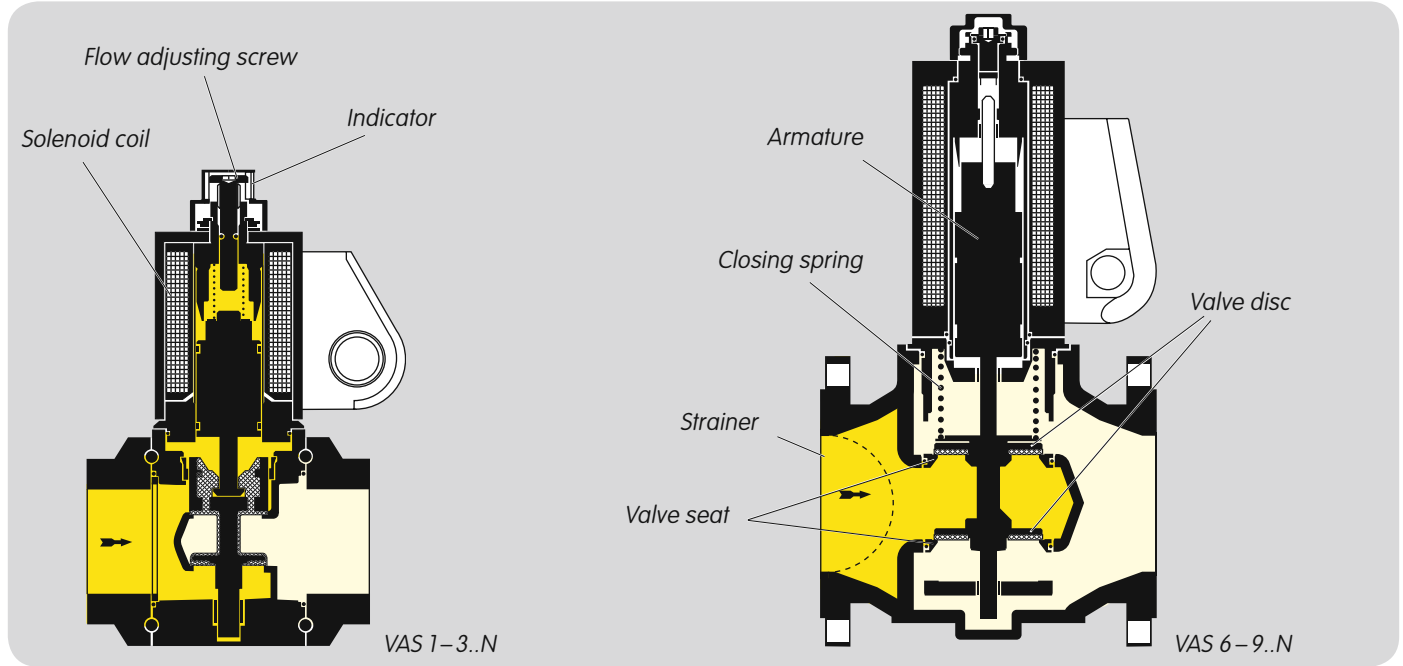

3.1 Solenoid valve for gas VAS..N, quick opening

The solenoid valve for gas VAS..N opens within 0.5 s.

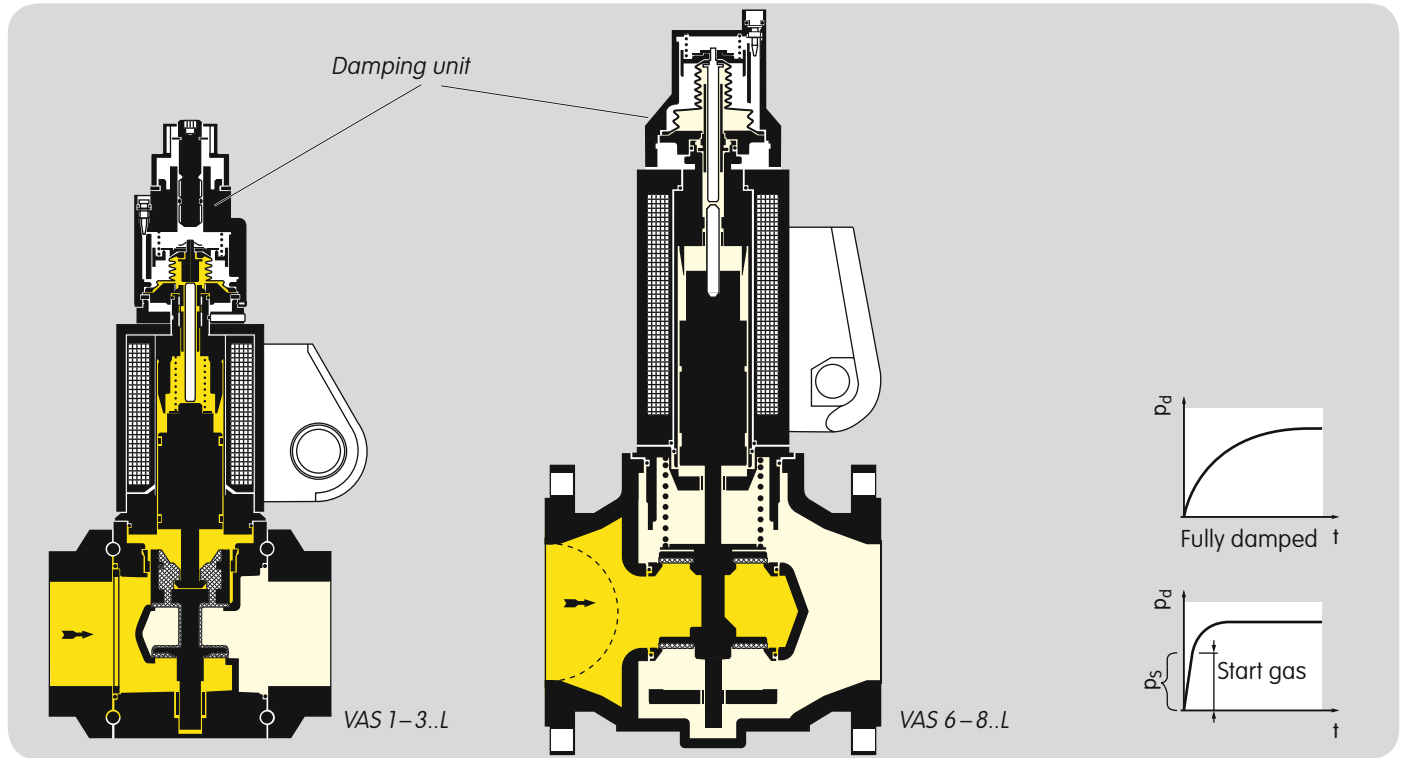

3.2 Solenoid valve for gas VAS..L, slow opening

The solenoid valve for gas VAS..L opens within 10 s.

Start gas rate adjustment: the gas solenoid valve opens with a quick initial lift and then continues slowly until it is fully open. The start gas rate can be set. This setting is required, for example if a tightness control TC is to be used.

By turning the damping unit, the start gas rate can be set between 0 and 70%: turning it clockwise will reduce the start gas rate, turning it anti-clockwise will increase the start gas rate.

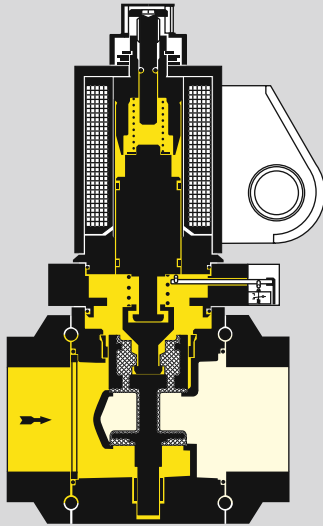

3.3 Solenoid valve for gas VAS..S/VAS..G, proof of closure switch with visual position indicator

Opening: when the gas solenoid valve is opened, the proof of closure switch is operated first. The visual position indicator is activated. The "open" signal is marked in red. Only then does the double valve seat open to release the volume of gas (overtravel principle).

Closing: the gas solenoid valve VAS is disconnected from the voltage supply and the closing spring presses the double valve disc on to the valve seat. Then the proof of closure switch is actuated. The visual position indicator is white for "closed".

The actuator cannot be rotated on a gas solenoid valve with a proof of closure switch and visual position indicator.

NOTE: NFPA 86 – the following must be taken into account as soon as the capacity of the pilot or main burner exceeds 117 kW (400,000 BTU/h): safety shut-off valve VAS..S must be fitted with a proof of closure overtravel switch with a visual position indicator, and the burner-side pressure regulator with gas solenoid valve VAX..S must also be fitted with a proof of closure switch with visual position indicator. One gas solenoid valve must be verifiably closed. The closed position can be verified using the proof of closure switch of the gas solenoid valve VAS..S/VAS..G.

valVario® VAS

krom
schroder

- VAS../N
schnell öffnend/quick opening
- VAS../N..S schnell öffnend, mit Meldeschalter/
quick opening, with position indicator
- VAS../L
langsam öffnend/slow opening
- VAS../L
Startgasmenge/Start gas rate

Schließfeder
Closing spring

Magnetantrieb
Solenoid actuator

Sieb
Strainer

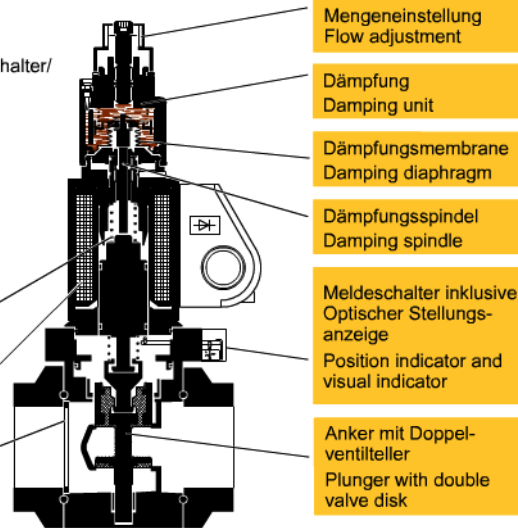

Mengeneinstellung
Flow adjustment

Dämpfung
Damping unit

Dämpfungsmembrane
Damping diaphragm

Dämpfungsspindel
Damping spindle

Meldeschalter inklusive
Optischer Stellungs-
anzeige

Position indicator and
visual indicator

Anker mit Doppel-
ventilteller
Plunger with double
valve disk



3.4 Animation

The interactive animation shows the function of the gas solenoid valve VAS.

Click on the picture. The animation can be controlled using the control bar at the bottom of the window (as on a DVD player).

To play the animation, you will need Adobe Reader 7 or a newer version. If you do not have Adobe Reader on your system, you can download it from the Internet.

Go to www.adobe.com, click on "Adobe Reader" in the "Downloads" section and follow the instructions.

If the animation does not start to play, you can download it from the document library (Docuthek) as an independent application.

3.5 Connection diagram

Wiring to EN 60204-1.

3.5.1 VAS with M20 cable gland

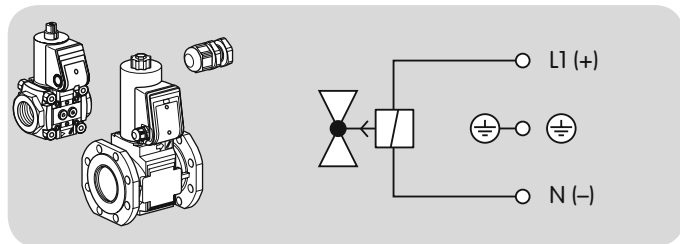

3.5.2 VAS with plug

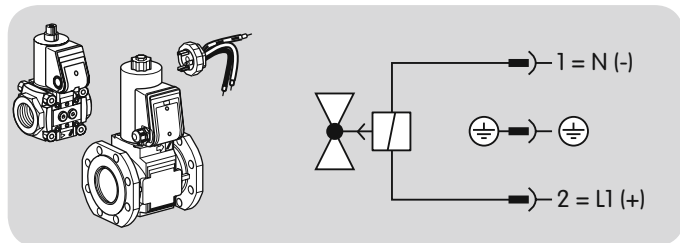

3.5.3 Solenoid valve for gas VAS..S/VAS..G, proof of closure switch with visual position indicator

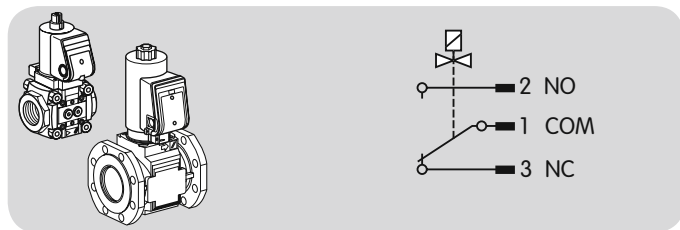

The designed lifetime of the proof of closure switch cannot be reached with frequent cycling operation, see page 48 (Technical data).

3.5.4 VCS with M20 cable gland

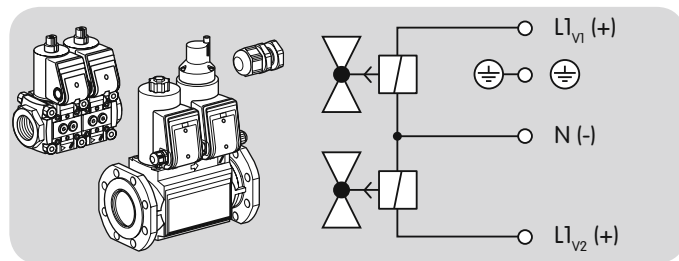

3.5.5 VCS with plug

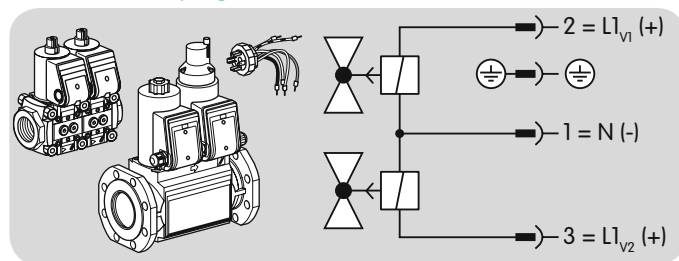

VAS, VCS

Further connection options, see Docuthek → Operating instructions VAS 1–3, VCS 1–3 or Operating instructions VAS 6–9, VCS 6–9.

4 Replacement possibilities

4.1 Solenoid valve for gas VG is to be replaced by VAS

Type				Type
VG		Solenoid valve for gas	Solenoid valve for gas	VAS
10/15	DN 10	internal 15 mm (0.59")	Size 1 DN 10	110
15	DN 15		Size 1 DN 15	115
15/12	DN 15	internal 12 mm (0.47")	–	–
20	DN 20		Size 1 DN 20	120
25	DN 25		Size 1 DN 25	125
25/15	DN 25	internal 15 mm (0.59")	–	–
40/32	DN 40	internal 32 mm (1.26")	Size 2 DN 40	240
40	DN 40		Size 2 DN 40	240
40/33	DN 40	internal 33 mm (1.30")	–	–
50	DN 50		Size 3 DN 50	350
50/39	DN 50	internal 39 mm (1.54")	–	–
50/65	DN 50	internal 65 mm (2.59")	Size 3 DN 50	350
65	DN 65		Size 3 DN 65	365
65	DN 65		Size 6 DN 65	665
65/49	DN 65	internal 49 mm (1.93")	–	–
80	DN 80		Size 7 DN 80	780
100	DN 100		Size 8 DN 100	8100
T		T-product	T-product	T
R		Rp internal thread	Rp internal thread	R
N		NPT internal thread	NPT internal thread	N
F		ISO flange	ISO flange	F
A		ANSI flange	ANSI flange	A
02		P _{u max.} : 200 mbar (2 psig)	P _{u max.} : 500 mbar (7 psig)	●
03		360 mbar (5 psig)	500 mbar (7 psig)	●
10		1000 mbar (14.5 psig)	–	–
18		1800 mbar (26.1 psig)	–	–
N		Quick opening	Quick opening	/N
L		Slow opening	Slow opening	/L
K		Mains voltage: 24 V DC	Mains voltage: 24 V DC	K
–		–	100 V AC	P
Q		120 V AC	120 V AC	Q
–		–	200 V AC	Y
T		220/240 V AC	230 V AC	W



Continuation

Type			Type
3	Electrical connection via terminals	Electrical connection via terminals	3
6	Electrical connection via socket	Electrical connection via socket	○
9	Metal terminal connection box	Electrical connection via terminals	3
1	Screw plug at the inlet	Screw plug at the inlet and outlet	●
3	Screw plug at the inlet and outlet	Screw plug at the inlet and outlet	●
4	Pressure test point at the inlet	Pressure test point at the inlet and outlet*	○
6	Pressure test point at the inlet and outlet	Pressure test point at the inlet and outlet*	○
D	Flow adjustment	Flow adjustment***	●
S	Proof of closure switch	Proof of closure switch with visual position indicator**	S
G	Proof of closure switch for 24 V	Proof of closure switch for 24 V with visual position indicator**	G
OCS	Valve stem overtravel switch	Proof of closure switch with visual position indicator**	S
CPS	Proof of closure switch	Proof of closure switch with visual position indicator**	S
VI	Visual position indicator	Proof of closure switch with visual position indicator**	S
M	Suitable for biologically produced methane	Suitable for biologically produced methane	●
V	Viton valve disc seal	–	–

Example

VG 25R02NT31DM

● = standard, ○ available

For length compensation when replacing VG by VAS 6 – 9, install an adapter for length compensation – see Accessories, Adapter for length compensation.

* Pressure test points may be attached at the left- and/or right-hand side.

** Proof of closure switch with visual position indicator can be attached at the left- or right-hand side.

*** Flow adjustment for VAS/VCS..N 1 – 8, VAS/VCS 1 – 3..L.

Example

VAS 125R/NW

4.1.1 Searching for an order number or type

VG Order No.	VG type designation	
		Hits: 0

VG is to be replaced by VAS

VAS Order No.	
VAS type designation	

4.2 MODULINE solenoid valve for gas VS is to be replaced by VAS

Type	Flange			Type
VS		Solenoid valve for gas	Solenoid valve for gas	VAS
115 125	3/8"	Size 115 Size 125	Size 1, DN 10	110
115 125	1/2"	Size 115 Size 125	Size 1, DN 15	115
115 125	3/4"	Size 115 Size 125	Size 1, DN 20	120
115 125	1"	Size 115 Size 125	Size 1, DN 25	125
230 240	1"	Size 232 Size 240	Size 2, DN 25	225
232 240	1 1/2"	Size 232 Size 240	Size 2, DN 40	240
350	1 1/2"	Size 350	Size 3, DN 40	340
350	2"	Size 350	Size 3, DN 50	350
ML		MODULINE + connection flanges Rp internal thread	Rp internal thread	R
TML		MODULINE + connection flanges NPT internal thread	NPT internal thread	N
02		p _{U max.} 200 mbar (2 psig)	p _{U max.} 500 mbar (7 psig)	●
03		p _{U max.} 360 mbar (3 psig)	p _{U max.} 500 mbar (7 psig)	●
N		Quick opening	Quick opening	/N
L		Slow opening	Slow opening	/L
D		Flow adjustment	Flow adjustment*	●
K		Mains voltage: 24 V DC	Mains voltage: 24 V DC	K
-		-	100 V AC	P
M		120 V AC	120 V AC	Q
-		-	200 V AC	Y
T		220/240 V AC	230 V AC	W



Replacement possibilities > MODULINE solenoid valve for gas VS is to be replaced by VAS

Continuation

Type	Flange			Type
3		Electrical connection via terminals	Electrical connection via terminals	3
6		Electrical connection via socket	Electrical connection via socket	○
9		Metal terminal connection box	Electrical connection via terminals	3
●		Pressure test point at the inlet	Pressure test point at the inlet and outlet	○
S		Proof of closure switch	Proof of closure switch	S
G		Proof of closure switch for 24 V	Proof of closure switch for 24 V	G
M		Contains no non-ferrous metals	Contains no non-ferrous metals	●
V		Viton valve disc seal	–	–

Example

VS 350ML02LT3
with Rp 1½ connection flanges

Example

VAS 340R/LW
with test points

* Flow adjustment for VAS/VCS..N 1 – 3, VAS/VCS 1 – 2..L.

● = standard, ○ available

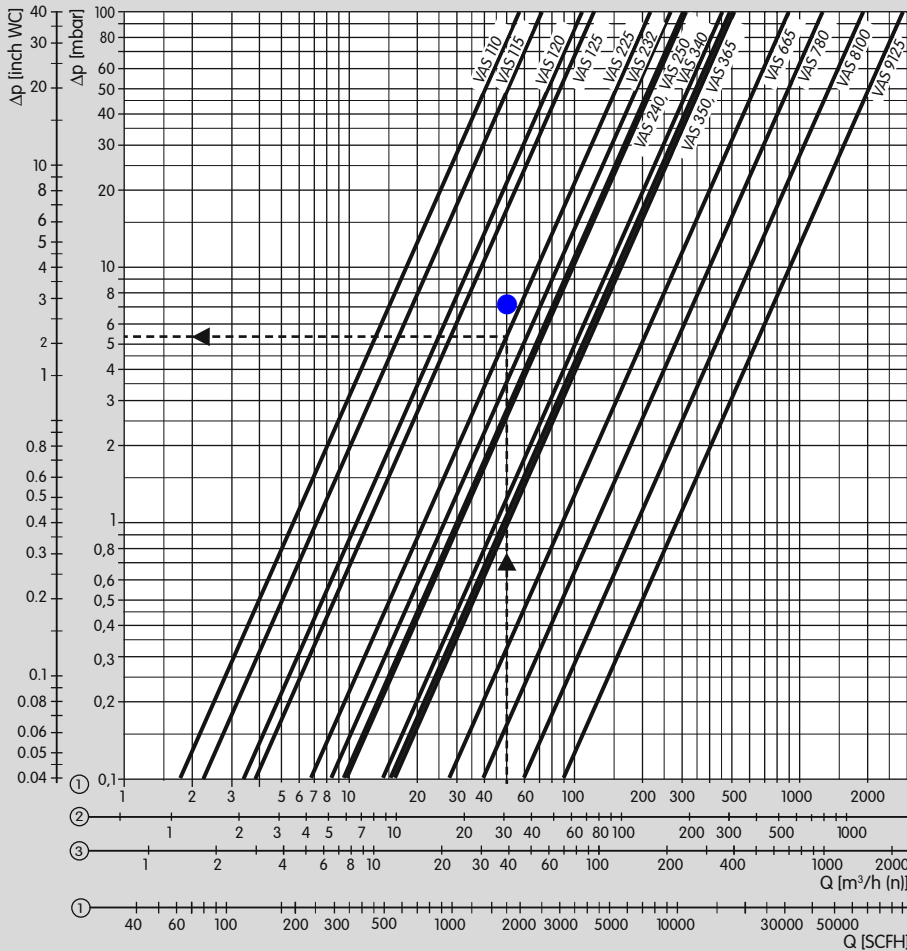

- ① = natural gas ($\rho = 0.80 \text{ kg/m}^3$)
- ② = propane ($\rho = 2.01 \text{ kg/m}^3$)
- ③ = air ($\rho = 1.29 \text{ kg/m}^3$)

The characteristic flow rate curves have been measured with the specified flanges and a fitted strainer.
 * $Q_{\min.}$ = rough specification for fully restricted flow adjustment and $\Delta p_{\max.}$

5 Flow rate

5.1 VAS

When determining the pressure loss, operating cubic metres must be entered. Then the pressure loss Δp read must be multiplied by the absolute pressure in bar (positive pressure + 1) to account for the change in the medium's density.

Example:

inlet pressure p_U (positive pressure) = 0.3 bar,
 gas type: natural gas,
 operating flow rate $Q = 50 \text{ m}^3/\text{h}$ (b),
 Δp in the diagram = 5.5 mbar,
 $\Delta p = 5.5 \text{ mbar} \times (1 + 0.3) = 7.2 \text{ mbar}$ on the solenoid valve VAS 225

5.1.1 Calculating the nominal size

- metric
- imperial

Natural gas	0,80	kg/m ³
Flow rate Q (standard)	64,8	m ³ /h
Inlet pressure p_U	300	mbar
$\Delta p_{\max.}$	10,0	mbar
Medium temperature	0	°C
Flow rate Q (operation)	50,0	m ³ /h

Product	Δp [mbar]	$Q_{\min.}^*$ [m ³ /h]	v [m/s]
VAS 225	7,2	21,0	22
VAS 232	4,6	21,0	13
VAS 240	3,7	21,0	10
VAS 250	3,6	21,0	6
VAS 340	1,8	33,7	10
VAS 350	1,5	33,7	6
VAS 365	1,4	33,7	4

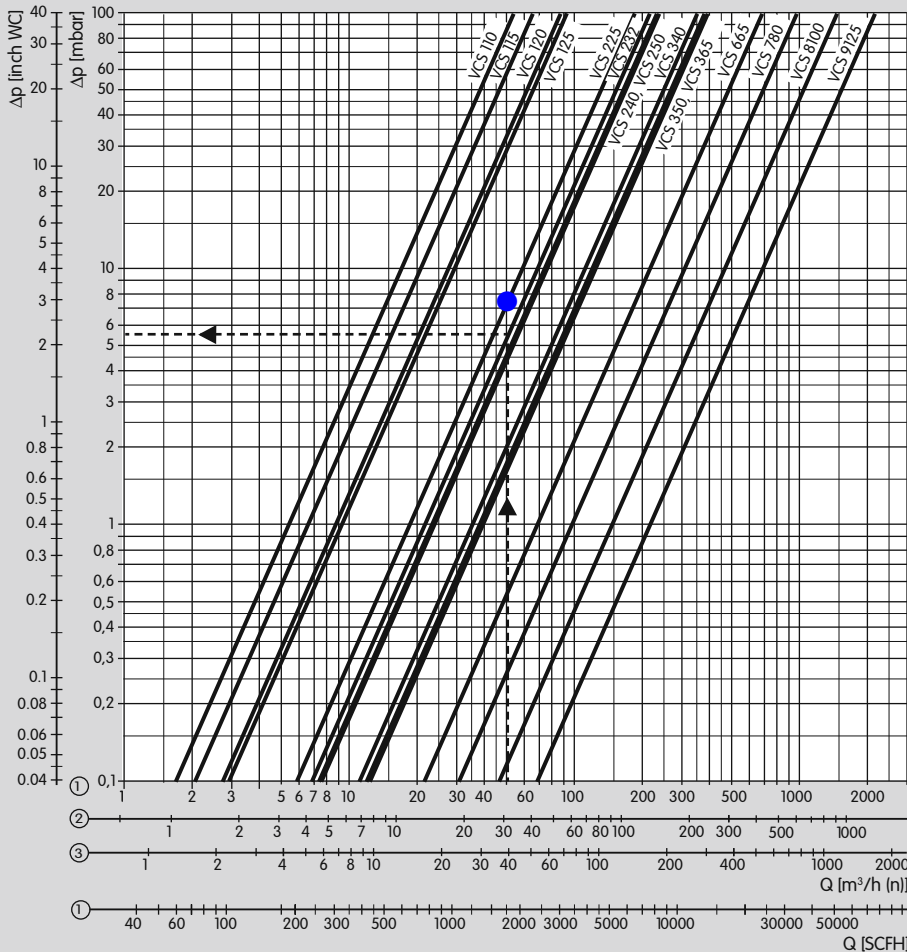

The characteristic flow rate curves have been measured with the specified flanges and a fitted strainer.

* $Q_{\min.}$ = rough specification for fully restricted flow adjustment and $\Delta p_{\max.}$

5.2 VCS

When determining the pressure loss, operating cubic metres must be entered. Then the pressure loss Δp read must be multiplied by the absolute pressure in bar (positive pressure + 1) to account for the change in the medium's density.

Example:

inlet pressure p_U (positive pressure) = 0.3 bar,
 gas type: natural gas,
 operating flow rate $Q = 64.8 \text{ m}^3/\text{h}$ (b),
 Δp in the diagram = 5.7 mbar,
 $\Delta p = 5.7 \text{ mbar} \times (1 + 0.3) = 7.4 \text{ mbar}$ on
 the solenoid valve VCS 232

5.2.1 Calculating the nominal size

metric imperial

Natural gas	0,80	kg/m ³
Flow rate Q (standard)	64,8	m ³ /h
Inlet pressure p_U	300	mbar
$\Delta p_{\max.}$	10,0	mbar
Medium temperature	0	°C
Flow rate Q (operation)	50,0	m ³ /h

Product	Δp [mbar]	$Q_{\min.}^*$ [m ³ /h]	v [m/s]
---------	----------------------	--------------------------------------	------------

VCS 232	7,4	21,0	13
VCS 240	6,4	21,0	10
VCS 250	6,3	21,0	6
VCS 340	2,8	33,7	10
VCS 350	2,5	33,7	6
VCS 365	2,3	33,7	4
VCS 665	0,7	47,2	4

5.3 k_v value

The size and nominal flange width is determined using the flow rate diagram or by calculation using the k_v value.

$Q_{(n)}$ = Flow rate (standard state) [m³/h]

k_v = Valve coefficient ($k_{v \text{ min.}}$ = rough specification for fully restricted flow adjustment)

Δp = Pressure loss [bar]

p_d = Outlet pressure (absolute) [bar]

ρ_n = Density [kg/m³] (air 1.29, natural gas 0.80, propane 2.01, butane 2.71)

T = Medium temperature (absolute) [K]

see page 60 (Converting units)

$$k_v = \frac{Q_{(n)}}{514} \cdot \sqrt{\frac{\rho_n \cdot T}{\Delta p \cdot p_d}} \quad Q_{(n)} = 514 \cdot k_v \cdot \sqrt{\frac{\Delta p \cdot p_d}{\rho_n \cdot T}}$$

$$\Delta p = \left(\frac{Q_{(n)}}{514 \cdot k_v} \right)^2 \cdot \frac{\rho_n \cdot T}{p_d}$$

VAS	$k_{v \text{ max.}}$ m ³ /h	$k_{v \text{ min.}}$ m ³ /h	VCS	$k_{v \text{ max.}}$ m ³ /h	$k_{v \text{ min.}}$ m ³ /h
VAS 110	5.0	2	VCS 110	4.7	2
VAS 115	6.4	2	VCS 115	5.7	2
VAS 120	9.6	2	VCS 120	7.6	2
VAS 125	10.9	2	VCS 125	8.1	2
VAS 225	19.2	5.3	VCS 225	16.2	5.3
VAS 232	24.1	5.3	VCS 232	19.0	5.3
VAS 240	26.7	5.3	VCS 240	20.3	5.3
VAS 250	27.2	5.3	VCS 250	20.6	5.3
VAS 340	38.6	8.5	VCS 340	30.8	8.5
VAS 350	41.8	8.5	VCS 350	32.7	8.5
VAS 365	43.5	8.5	VCS 365	33.9	8.5
VAS 665	76.4	15.3	VCS 665	59.5	11.9
VAS 780	109.3	21.9	VCS 780	84.6	16.9
VAS 8100	165.7	33.1	VCS 8100	127.7	25.5
VAS 9125	247.9	–	VCS 9125	190.5	–

Example

We want to find the size and nominal flange width for a gas solenoid valve VAS.

We have the maximum flow rate $Q_{(n) \text{ max.}}$, the inlet pressure p_U and the natural gas temperature T .

$Q_{(n) \text{ max.}} = 60 \text{ m}^3/\text{h}$

$p_U = 70 \text{ mbar} = 0.07 \text{ bar} \rightarrow$

$p_U \text{ absolute} = 0.07 \text{ bar} + 1 \text{ bar} = 1.07 \text{ bar}$

$\Delta p_{\text{max}} = 0.01 \text{ bar}$ (desired)

$p_d \text{ absolute} = p_U \text{ absolute} - \Delta p_{\text{max}}$

$p_d \text{ absolute} = 1.07 \text{ bar} - 0.01 \text{ bar} = 1.06 \text{ bar}$

$T = 27 \text{ }^\circ\text{C} \rightarrow$

$T_{\text{absolute}} = 27 + 273 \text{ K} = 300 \text{ K}$

$$k_v = \frac{60}{514} \cdot \sqrt{\frac{0.83 \cdot 300}{0.01 \cdot 1.06}} = 17.9$$

The gas solenoid valve is selected using the next higher k_v value (see table): VAS 225.

6 Selection

6.1 Selection table for VAS 1–3

Type	T	Nominal size DN													Accessories, right						Accessories, left																
			R	N	F	/N	/L	K	P	Q	Y	W	S1)	G1)	R1)	L1)	M20 cable gland	Plug with socket	Plug without socket	Screw plug	Pressure test point	DG 17VC ²⁾	DG 40VC ²⁾	DG 110VC ²⁾	DG 300VC ²⁾	Bypass valve VBY	Bypass valve VAS 1	Screw plug	Pressure test point	DG 17VC ²⁾	DG 40VC ²⁾	DG 110VC ²⁾	DG 300VC ²⁾	Bypass valve VBY	Bypass valve VAS 1		
VAS 1	○					●	●		○	○	○	○	○	●	○	○	○	○	○	○	○	○	○	○	○	○	○	○	○	○	○	○	○	○	○	○	○
VAS 1	○	-0				●				○	○	○	○	○	○	○	○	○	○	○	○	○	○	○	○	○	○	○	○	○	○	○	○	○	○	○	○
VAS 1	○	10–25	●	○		●	●			○	○	○	○	○	○	○	○	○	○	○	○	○	○	○	○	○	○	○	○	○	○	○	○	○	○	○	○
VAS 2	○					●	●			○	○	○	○	○	○	○	○	○	○	○	○	○	○	○	○	○	○	○	○	○	○	○	○	○	○	○	○
VAS 2	○	25	●	○		●	●			○	○	○	○	○	○	○	○	○	○	○	○	○	○	○	○	○	○	○	○	○	○	○	○	○	○	○	○
VAS 2	○	32	●	○		●	●			○	○	○	○	○	○	○	○	○	○	○	○	○	○	○	○	○	○	○	○	○	○	○	○	○	○	○	○
VAS 2	○	40	●	○	○	●	●			○	○	○	○	○	○	○	○	○	○	○	○	○	○	○	○	○	○	○	○	○	○	○	○	○	○	○	○
VAS 2	○	50	●	○		●	●			○	○	○	○	○	○	○	○	○	○	○	○	○	○	○	○	○	○	○	○	○	○	○	○	○	○	○	○
VAS 3	○					●	●			○	○	○	○	○	○	○	○	○	○	○	○	○	○	○	○	○	○	○	○	○	○	○	○	○	○	○	○
VAS 3	○	40	●	○		●	●			○	○	○	○	○	○	○	○	○	○	○	○	○	○	○	○	○	○	○	○	○	○	○	○	○	○	○	○
VAS 3	○	50	●	○	○	●	●			○	○	○	○	○	○	○	○	○	○	○	○	○	○	○	○	○	○	○	○	○	○	○	○	○	○	○	○
VAS 3	○	65	●	○		●	●			○	○	○	○	○	○	○	○	○	○	○	○	○	○	○	○	○	○	○	○	○	○	○	○	○	○	○	○

● = standard, ○ = available

¹⁾ Proof of closure switch and bypass/pilot gas valve cannot be fitted together on the same side.

²⁾ Specify the test point for inlet pressure p_u or outlet pressure p_d .

Help for selecting the gas solenoid valve VAS can be found on the ProFi DVD → www.kromschroeder.com → Products → DVD → Product finder “ProFi”.

Order example

VAS 225R/NW

Fitted pressure
switch for test
point p_u

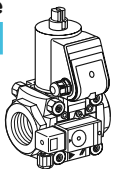

6.2 Type code for VAS 1–3

Code	Description
VAS	Gas solenoid valve
1–3	Size
T	T-product
–	No inlet and outlet flange
–0	Blind flange
10, 15, 20, 25, 32, 40, 50, 65	Nominal inlet and outlet diameter
R	Rp internal thread
N	NPT internal thread
F	ISO flange
/N	Quick opening, quick closing
/L	Slow opening, quick closing
K	Mains voltage 24 V DC
P	Mains voltage: 100 V AC; 50/60 Hz
Q	Mains voltage: 120 V AC; 50/60 Hz
Y	Mains voltage: 200 V AC; 50/60 Hz
W	Mains voltage: 230 V AC; 50/60 Hz
S	Proof of closure switch with visual position indicator
G	Proof of closure switch for 24 V with visual position indicator
R	Viewed from the right (in the direction of flow)
L	Viewed from the left (in the direction of flow)

6.4 Type code for VAS 6–9

Code	Description
VAS	Gas solenoid valve
6–9	Size
T	T-product
65, 80, 100, 125	Inlet flange nominal size
F	ISO flange
A	ANSI flange
05	Max. inlet pressure $p_{U \max}$: 500 mbar (7 psig)
N	Quick opening, quick closing
L	Slow opening, quick closing
K	Mains voltage: 24 V DC
Q	Mains voltage: 120 V AC; 50/60 Hz
W	Mains voltage: 230 V AC; 50/60 Hz
A	Mains voltage: 120–230 V AC; 50/60 Hz
S	Proof of closure switch with visual position indicator
G	Proof of closure switch for 24 V with visual position indicator
R	Viewed from the right (in the direction of flow)
L	Viewed from the left (in the direction of flow)
3	Electrical connection: M20 cable gland
B	Basic
E	Prepared for adapter plates

Code	Description
	Accessories, right, inlet
/P	Screw plug
/M	Pressure test point for inlet pressure p_U
/1	Gas pressure switch DG 17VC
/2	Gas pressure switch DG 40VC
/3	Gas pressure switch DG 110VC
/4	Gas pressure switch DG 300VC
/B	Bypass valve VAS 1, fitted
/Z	Pilot gas valve VAS 1, fitted
/V	Prepared 1½ NPT for breather line
/E	Prepared for Rp 1 breather line
	Accessories, right, outlet
P	Screw plug
M	Pressure test point for outlet pressure p_d
1	Gas pressure switch DG 17VC
2	Gas pressure switch DG 40VC
3	Gas pressure switch DG 110VC
4	Gas pressure switch DG 300VC
-	No accessories
	Accessories, left, inlet
/P	Screw plug
/M	Pressure test point for inlet pressure p_U
/1	Gas pressure switch DG 17VC
/2	Gas pressure switch DG 40VC
/3	Gas pressure switch DG 110VC
/4	Gas pressure switch DG 300VC
/B	Bypass valve VAS 1, fitted
/Z	Pilot gas valve VAS 1, fitted
/V	Prepared for 1½ NPT breather line
/E	Prepared for Rp 1 breather line
	Accessories, left, outlet
P	Screw plug
M	Pressure test point for outlet pressure p_d
1	Gas pressure switch DG 17VC
2	Gas pressure switch DG 40VC
3	Gas pressure switch DG 110VC
4	Gas pressure switch DG 300VC
-	No accessories

6.5 Selection table for VCS 1–3

Type	T	Nominal size DN												Accessories right, 1st valve ²⁾						Accessories left, 2nd valve ²⁾																						
			R	N	F	N	L	N	L	K	P	Q	Y	W	S ¹⁾	G ¹⁾	R ¹⁾	L ¹⁾	M20 cable gland	Plug with socket	Plug without socket	Screw plug	Pressure test point	DG 17VC ³⁾	DG 40VC ³⁾	DG 110VC ³⁾	DG 300VC ³⁾	Bypass valve VBY	Bypass valve VAS 1	Screw plug	Pressure test point	DG 17VC ³⁾	DG 40VC ³⁾	DG 110VC ³⁾	DG 300VC ³⁾	Bypass valve VBY	Bypass valve VAS 1					
VCS 1	○					●	●	●	○	○	○	○	●	○	○	○	○	●	○	○	●	○	○	○	○	○	○	○	○	○	●	○	○	○	○	○	○	○	○	○	○	○
VCS 1	○	10–25	●	○		●	●	●	○	○	○	○	●	○	○	○	○	●	○	○	●	○	○	○	○	○	○	○	○	○	●	○	○	○	○	○	○	○	○	○	○	○
VCS 2	○					●	●	●	○	○	○	○	●	○	○	○	○	●	○	○	●	○	○	○	○	○	○	○	○	○	●	○	○	○	○	○	○	○	○	○	○	○
VCS 2	○	25	●	○		●	●	●	○	○	○	○	●	○	○	○	○	●	○	○	●	○	○	○	○	○	○	○	○	○	●	○	○	○	○	○	○	○	○	○	○	○
VCS 2	○	32	●	○		●	●	●	○	○	○	○	●	○	○	○	○	●	○	○	●	○	○	○	○	○	○	○	○	○	●	○	○	○	○	○	○	○	○	○	○	○
VCS 2	○	40	●	○	○	●	●	●	○	○	○	○	●	○	○	○	○	●	○	○	●	○	○	○	○	○	○	○	○	○	●	○	○	○	○	○	○	○	○	○	○	○
VCS 2	○	50	●	○		●	●	●	○	○	○	○	●	○	○	○	○	●	○	○	●	○	○	○	○	○	○	○	○	○	●	○	○	○	○	○	○	○	○	○	○	○
VCS 3	○					●	●	●	○	○	○	○	●	○	○	○	○	●	○	○	●	○	○	○	○	○	○	○	○	○	●	○	○	○	○	○	○	○	○	○	○	○
VCS 3	○	40	●	○		●	●	●	○	○	○	○	●	○	○	○	○	●	○	○	●	○	○	○	○	○	○	○	○	○	●	○	○	○	○	○	○	○	○	○	○	○
VCS 3	○	50	●	○	○	●	●	●	○	○	○	○	●	○	○	○	○	●	○	○	●	○	○	○	○	○	○	○	○	○	●	○	○	○	○	○	○	○	○	○	○	○
VCS 3	○	65	●	○		●	●	●	○	○	○	○	●	○	○	○	○	●	○	○	●	○	○	○	○	○	○	○	○	○	●	○	○	○	○	○	○	○	○	○	○	○

● = standard, ○ = available

- ¹⁾ Proof of closure switch and bypass/pilot gas valve cannot be fitted together on the same side.
- ²⁾ The same accessories can be selected for the left- or right-hand side.
- ³⁾ Specify the test point for inlet pressure p_u , interspace pressure p_z or outlet pressure p_d . When attaching DG..VC for p_z , the installation space left at the other valve is only sufficient for screw plugs.

Order example

VCS 225RNNW
Fitted pressure switch for test point p_u

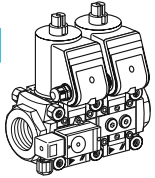

6.6 Type code for VCS 1–3

Code	Description
VCS	Gas solenoid valve
1–3	Size
T	T-product
–	No inlet and outlet flange
10, 15, 20, 25, 32, 40, 50, 65	Nominal inlet and outlet diameter
R	Rp internal thread
N	NPT internal thread
F	ISO flange
N	1 st valve quick opening, quick closing
L	1 st valve slow opening, quick closing
N	2 nd valve quick opening, quick closing
L	2 nd valve slow opening, quick closing
K	Mains voltage: 24 V DC
P	Mains voltage: 100 V AC; 50/60 Hz
Q	Mains voltage: 120 V AC; 50/60 Hz
Y	Mains voltage: 200 V AC; 50/60 Hz
W	Mains voltage: 230 V AC; 50/60 Hz
S	Proof of closure switch with visual position indicator
G	Proof of closure switch for 24 V with visual position indicator
R	Viewed from the right (in the direction of flow)
L	Viewed from the left (in the direction of flow)

6.7 Selection table for VCS 6–9

Type	T	Nominal size DN	Accessories, right ¹⁾																																				
			F	A	05	N	L	N	L	K	Q	W	A	S	G	R	L	3	Plug with socket				Plug without socket				Inlet				Interspace 1				Interspace 2				Outlet
VCS 6	○	65	●	○	○	●	●	●	●	○	○	●	○	○	○	○	●				○				○				○				○						
VCS 7	○	80	●	○	○	●	●	●	●	○	○	●	○	○	○	○	●				○				○				○				○						
VCS 8	○	100	●	○	○	●	●	●	●	○	○	●	○	○	○	○	●				○				○				○				○						
VCS 9	○	125	●	○	○	●	○	○	○	○	○	○	○	○	○	○	●				○				○				○				○						

● = standard, ○ = available

¹⁾ The same accessories can be selected for the left- or right-hand side.

Order example
VCS 665F05NLW3E/2B-/PPPP

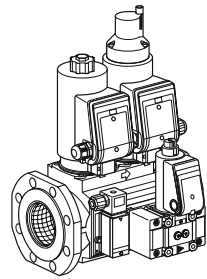

6.8 Type code for VCS 6–9

Code	Description
VCS	Gas solenoid valve
6–9	Size
T	T-product
65, 80, 100, 125	Inlet flange nominal size
F	ISO flange
A	ANSI flange
05	Max. inlet pressure $p_{U \max}$. 500 mbar (7 psig)
N	1 st valve quick opening, quick closing
L	1 st valve slow opening, quick closing
N	2 nd valve quick opening, quick closing
L	2 nd valve slow opening, quick closing
K	Mains voltage: 24 V DC
Q	Mains voltage: 120 V AC; 50/60 Hz
W	Mains voltage: 230 V AC; 50/60 Hz
A	Mains voltage: 120–230 V AC; 50/60 Hz
S	Proof of closure switch with visual position indicator
G	Proof of closure switch for 24 V with visual position indicator
R	Viewed from the right (in the direction of flow)
L	Viewed from the left (in the direction of flow)
3	Electrical connection: M20 cable gland
B	Basic
E	Prepared for adapter plates

Code	Description
Accessories, right, inlet	
/P	Screw plug
/M	Pressure test point for inlet pressure p_U
/1	Gas pressure switch DG 17VC
/2	Gas pressure switch DG 40VC
/3	Gas pressure switch DG 110VC
/4	Gas pressure switch DG 300VC
Accessories, right, interspace 1	
P	Screw plug
M	Test point for interspace pressure p_z
1	Gas pressure switch DG 17VC
2	Gas pressure switch DG 40VC
3	Gas pressure switch DG 110VC
4	Gas pressure switch DG 300VC
Accessories, right, interspace 2	
P	Screw plug
M	Test point for interspace pressure p_z
1	Gas pressure switch DG 17VC
2	Gas pressure switch DG 40VC
3	Gas pressure switch DG 110VC
4	Gas pressure switch DG 300VC
B	Bypass valve VAS 1, fitted
Z	Pilot gas valve VAS 1, fitted
V	Prepared for 1½ NPT breather line
E	Prepared for Rp 1 breather line
-	No accessories
Accessories, right, outlet	
P	Screw plug
M	Pressure test point for outlet pressure p_d
1	Gas pressure switch DG 17VC
2	Gas pressure switch DG 40VC
3	Gas pressure switch DG 110VC
4	Gas pressure switch DG 300VC
-	No accessories

The same accessories can be selected for the left- or right-hand side.

7 Project planning information

Do not store or install the unit in the open air.

The inlet pressure p_u , the interspace pressure p_z and the outlet pressure p_d can be measured at the pressure test points on both sides.

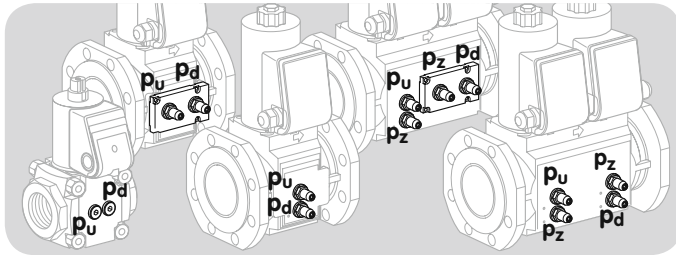

7.1 Installation

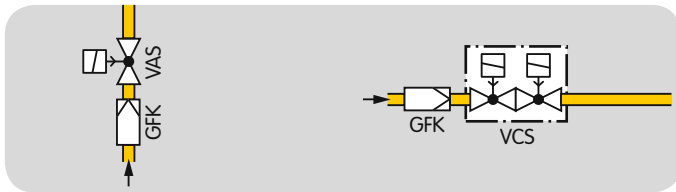

Installation position: black solenoid actuator in the vertical upright position or tilted up to the horizontal, not upside down.

Sealing material and thread cuttings must not be allowed to get into the valve housing.

Install a filter upstream of every system.



The unit must not be in contact with masonry. Minimum clearance 20 mm (0.79 inches).

Ensure that there is sufficient space for installation and adjustment.

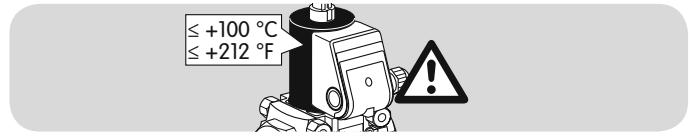

The solenoid body heats up during operation – depending on ambient temperature (max. 60°C/140°F) and intrinsic heating (approx. 40°C/104°F).

In the case of double solenoid valves, the position of the connection box can only be changed by removing the actuator and reinstalling it offset by 90° or 180°.

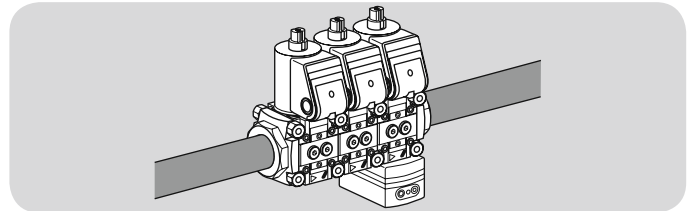

If more than three valVario controls are installed in line, the controls must be supported.

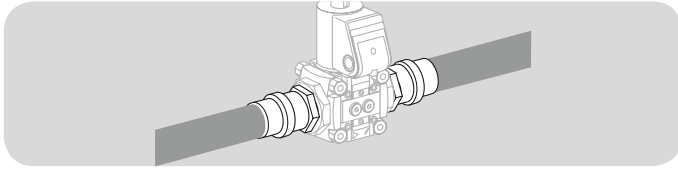

The seals in some gas compression fittings are approved for temperatures of up to 70°C (158°F). This temperature limit will not be exceeded if the flow through the pipe is at least 1 m³/h (35.31 SCFH) of gas and the maximum ambient temperature is 50°C (122°F).

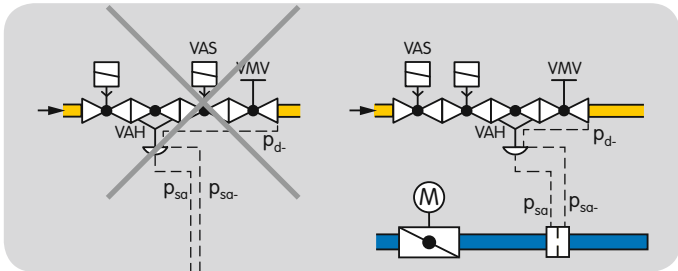

It is not permitted to install a gas solenoid valve VAS downstream of flow rate regulator VAH and upstream of fine-adjusting valve VMV. The VAS would no longer be able to perform its function as a second safety valve if installed in the above-mentioned position.

The measuring orifice in the air line for impulse lines p_{sa} and p_{sa-} must always be installed downstream of the air control valve.

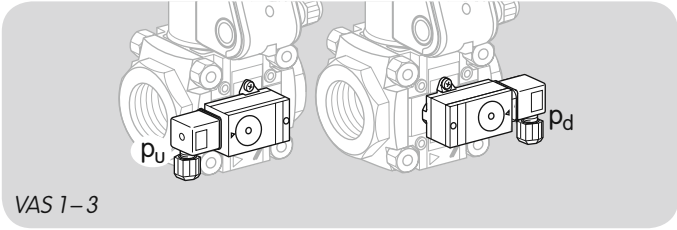
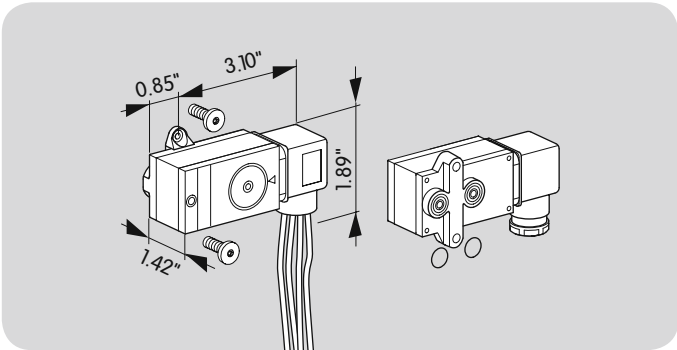
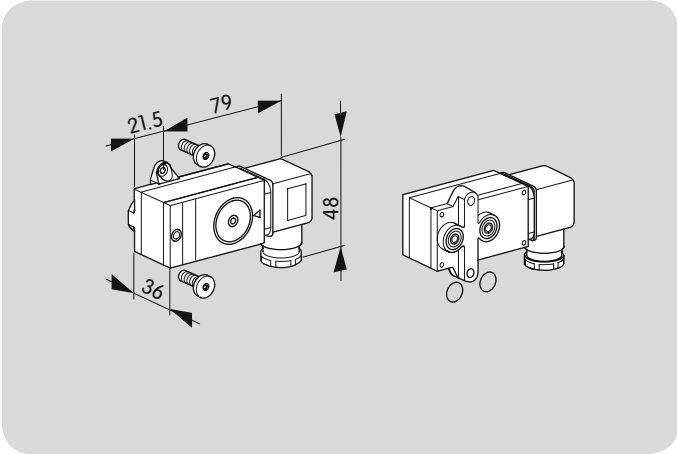

VAS 1–3

8 Accessories

8.1 Gas pressure switch

8.1.1 DG..VC for VAS/VCS

Type	Adjusting range [mbar]
DG 17VC	2 to 17
DG 40VC	5 to 40
DG 110VC	30 to 110
DG 300VC	100 to 300

Scope of delivery:

- 1 x pressure switch for gas,
- 2 x retaining screws,
- 2 x sealing rings.

8.1.2 DG..VCT for VAS..T/VCS..T

Type	Adjusting range [“WC]
DG 17VCT	0.8 to 6.8
DG 40VCT	2 to 16
DG 110VCT	12 to 44
DG 300VCT	40 to 120

Scope of delivery:

- 1 x gas pressure switch with AWG 18 connection wires,
- 2 x retaining screws,
- 2 x sealing rings.

8.1.3 Installation on VAS 1–3

Monitoring the inlet pressure p_u : the plug of the pressure switch for gas points towards the inlet flange.

Monitoring the outlet pressure p_d : the plug of the pressure switch for gas points towards the outlet flange.

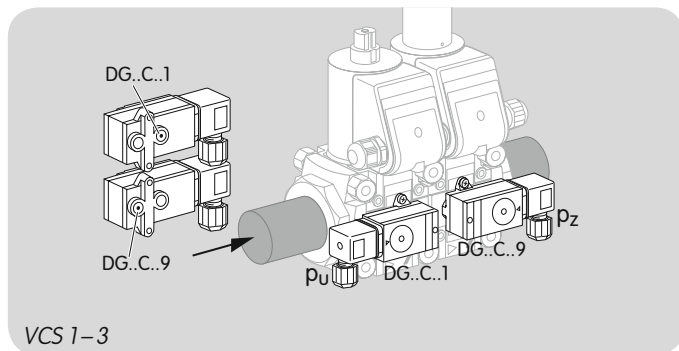

8.1.4 Installation on VCS 1-3

If, when monitoring the inlet or outlet pressure and the interspace pressure, both pressure switches should be fitted on the same side of the valve, only the combination DG..C..1 and DG..C..9 may be used for design reasons. The socket for the gas pressure switch DG..C..1 points towards the test point p_u (towards the inlet flange). The DG..C..9 is also optionally available for monitoring the interspace pressure p_z . The socket points towards the outlet flange.

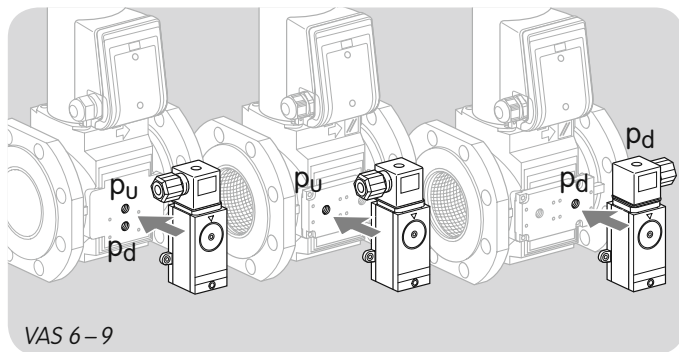

8.1.5 Installation on VAS 6-9

Monitoring the inlet pressure p_u : the pressure switch for gas is mounted on the inlet side.

Monitoring the outlet pressure p_d : the pressure switch for gas is mounted on the outlet side.

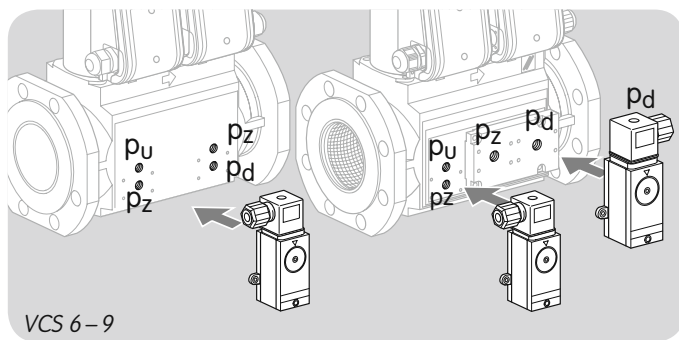

8.1.6 Installation on VCS 6-9

Monitoring the inlet pressure p_u , interspace pressure p_z , outlet pressure p_d : for this, attach the pressure switch for gas at the relevant position in each case.

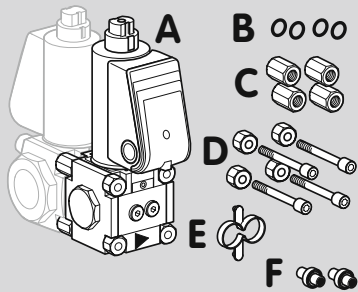

VAS 1 → VAS 1

8.2 Bypass/pilot gas valve VAS 1

8.2.1 Scope of delivery, VAS 1 attached to VAS 1

- A** 1 x bypass/pilot gas valve VAS 1,
- B** 4 x O-rings,
- C** 4 x double nuts,
- D** 4 x connection parts,
- E** 1 x mounting aid.

Bypass valve VAS 1:

- F** 2 x connection pipes, if the bypass valve has a blind flange at the outlet side.

Pilot gas valve VAS 1:

- F** 1 x connection pipe, 1 x sealing plug, if the pilot gas valve has a threaded flange at the outlet side.

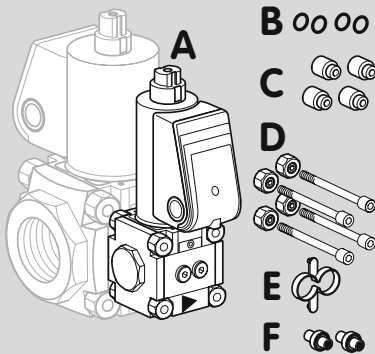

VAS 1 → VAS 2, VAS 3

8.2.2 Scope of delivery, VAS 1 attached to VAS 2, VAS 3

- A** 1 x bypass/pilot gas valve VAS 1,
- B** 4 x O-rings,
- C** 4 x spacer sleeves,
- D** 4 x connection parts,
- E** 1 x mounting aid.

Bypass valve VAS 1:

- F** 2 x connection pipes, if the bypass valve has a blind flange at the outlet side.

Pilot gas valve VAS 1:

- F** 1 x connection pipe, 1 x sealing plug, if the pilot gas valve has a threaded flange at the outlet side.

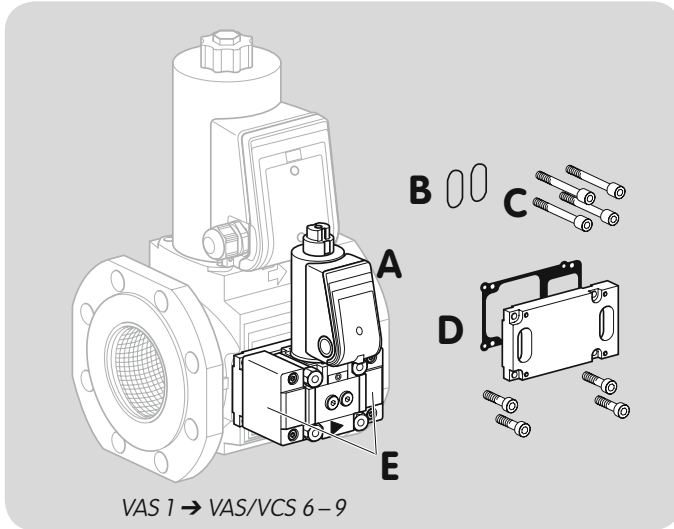

8.2.3 Scope of delivery, VAS 1 attached to VAS/VCS 6-9

- A** 1 x bypass or pilot gas valve VAS 1,
- B** 2 x flange O-rings,
- C** 4 x connecting screws,
- D** 1 x bypass adapter plate,
1 x seal,
4 x connecting screws.

Bypass valve VAS 1:

- E** 2 x adapter flanges.

Pilot gas valve VAS 1:

- E** 1 x adapter flange,
1 x adapter flange with threaded hole.

8.2.4 Flow rate, VAS 1 attached to VAS 1, VAS 2, VAS 3

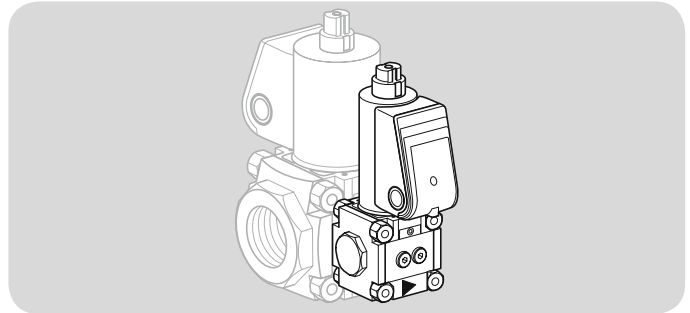

The characteristic flow rate curves have been measured for bypass valve VAS 1 with connection pipe diameter 1 to 10 mm (0.04 to 0.4") and for the pilot gas valve with 10 mm (0.4") connection pipe.

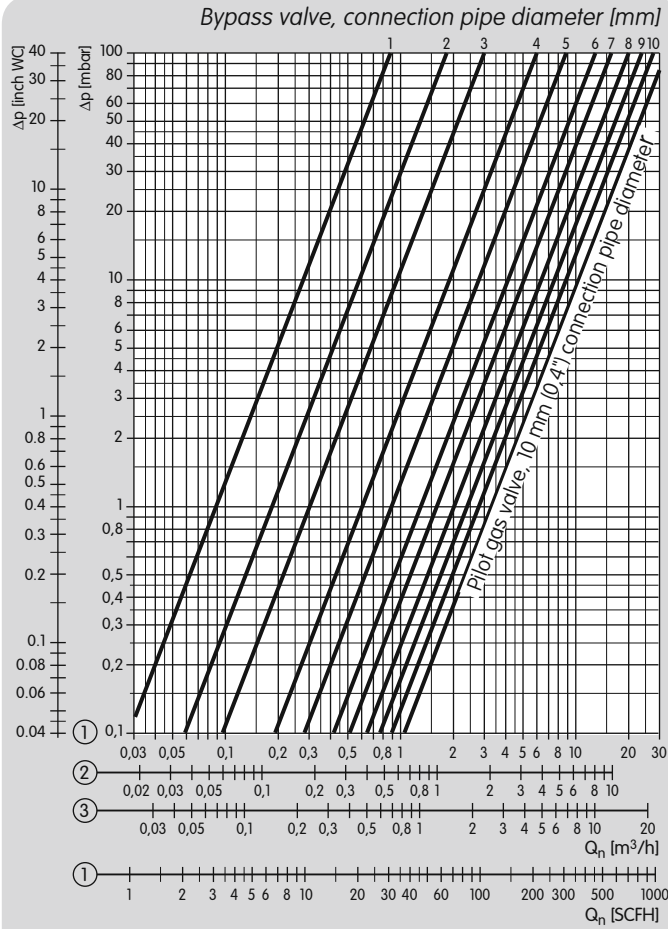

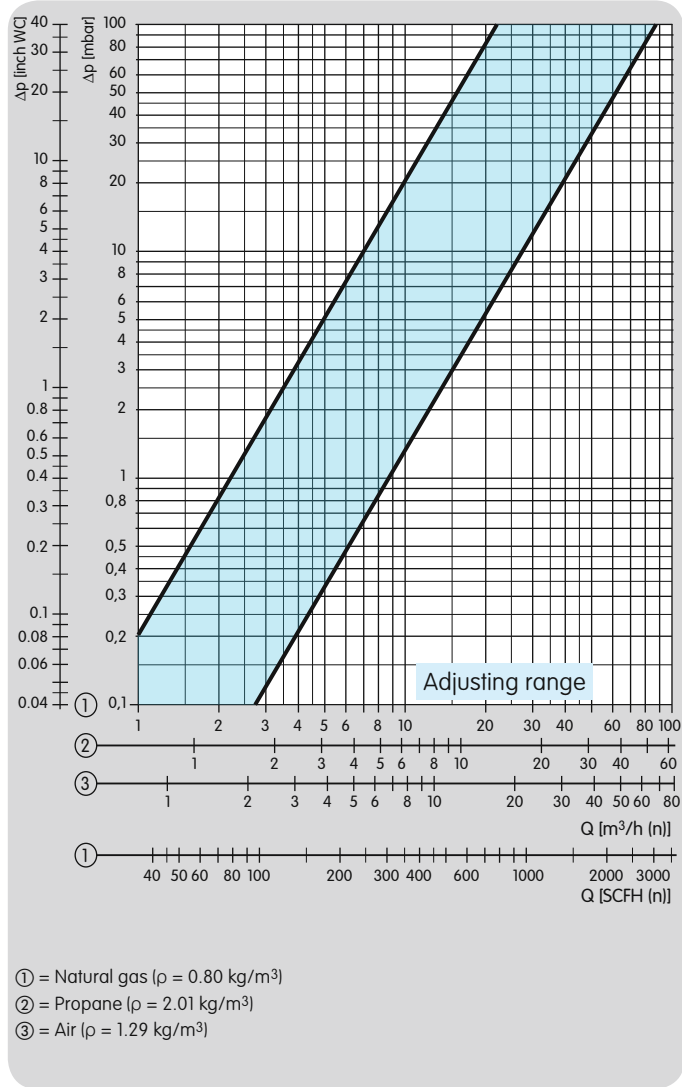

8.2.5 Flow rate, VAS 1 attached to VAS/VCS 6–9

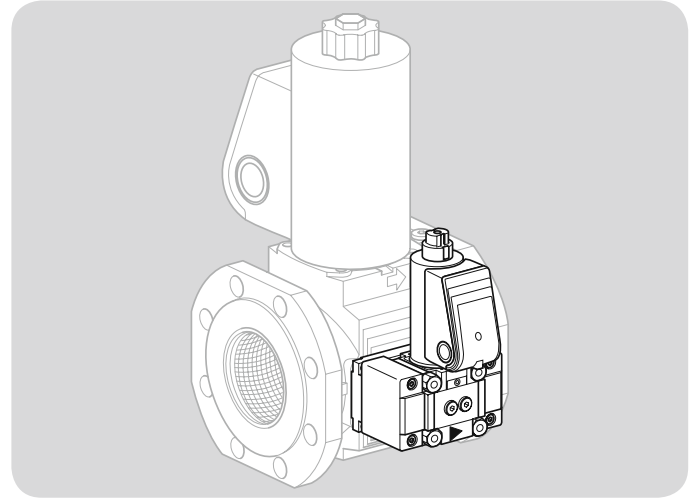

The adjusting range for the bypass valve, and pilot gas valve VAS 1, was determined using the values measured for open flow adjustment ($Q_{\max.}$) and fully reduced flow adjustment ($Q_{\min.}$).

8.3 Bypass/pilot gas valve VBY 8

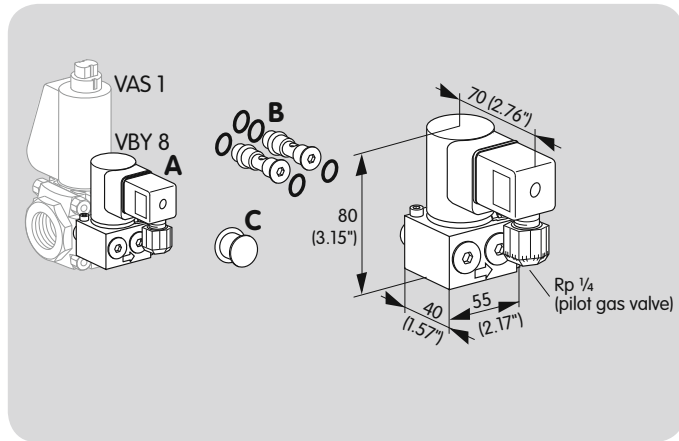

For mounting on gas solenoid valve VAS 1 and double solenoid valve VCS 1.

8.3.1 Scope of delivery, VBY 8I as bypass valve

- A** 1 × bypass valve VBY 8I,
- B** 2 × retaining screws with 4 × O-rings: both retaining screws have a bypass orifice,
- C** 1 × grease for O-rings.

8.3.2 Scope of delivery, VBY 8R as pilot gas valve

- A** 1 × pilot gas valve VBY 8R,
- B** 2 × retaining screws with 5 × O-rings: one retaining screw has a bypass orifice (2 × O-rings), the other does not (3 × O-rings),
- C** 1 × grease for O-rings.

8.3.3 Selection

Type	I	R	W	Q	K	6L	-R	-L	E	B	D	05
VBY 8	●	●	●	●	●	●	●	●	●	●	●	●

Order example

VBY 8RW6L-LED

8.3.4 Type code

Code	Description
VBY	Gas solenoid valve
8	Nominal size
I	For internal gas pick-up as bypass valve
R	For external gas pick-up as pilot gas valve
K	Mains voltage: 24 V DC
Q	Mains voltage: 120 V AC; 50/60 Hz
W	Mains voltage: 230 V AC; 50/60 Hz
6L	Electrical connection via plug and socket with LED
-R	Attachment side of main valve: right-hand side
-L	Attachment side of main valve: left-hand side
E	Attached on the VAS
B	Enclosed (separate packing unit)
D	Flow adjustment
05	Nozzle diameter = 0.5 mm (0.02")

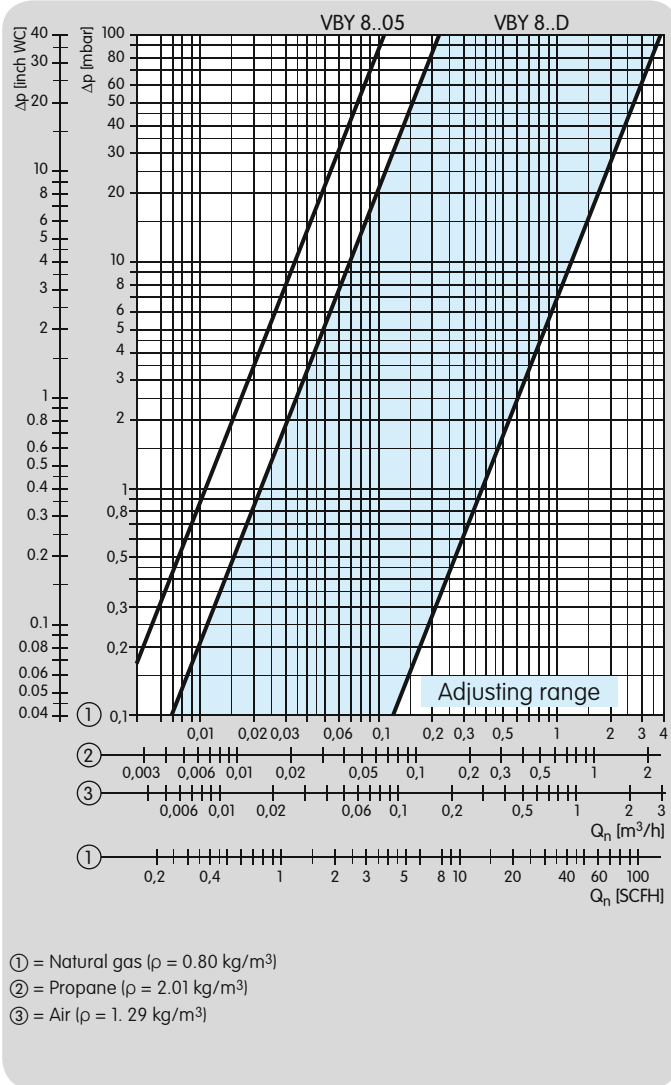

8.3.5 Flow rate VBY 8..D

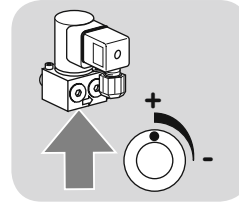

The flow rate can be set by turning the flow rate restrictor (4 mm/0.16" Allen screw) ¼ of a turn. Flow rate: 10 to 100%.

VBY 8..05

The flow is routed through a 0.5 mm (0.02") nozzle and thus has a fixed characteristic flow rate curve. Adjustment is not possible.

8.3.6 Technical data

Inlet pressure $p_{U \text{ max}}$:
500 mbar (7 psig).

Ambient temperature:
0 to +60°C (32 to 140°F),
no condensation permitted.

Storage temperature:
0 to +40°C (32 to 104°F).

Power consumption:
24 V DC = 8 W,
120 V AC = 8 W,
230 V AC = 9.5 W.

Enclosure: IP 54.

8.4 Tightness control TC 116V

For VAS 1–3

An adapter plate is required to attach the tightness control to the right- or left-hand side of the gas solenoid valve VAS 1–3:

Scope of delivery: **A** 1 × adapter plate,
B 2 × O-rings,
C 2 × retaining screws.

For attachment to: left-hand side: Order No. 74922391
 right-hand side: Order No. 74921995

For VCS 6–9

An adapter plate is required to attach the tightness control to the double solenoid valve VCS 6–9:

Scope of delivery: **A** 1 × adapter plate,
B 2 × O-rings,
C 2 × retaining screws.

Order No. 74922822

8.5 Pressure test points

Test points to check the inlet pressure p_U and outlet pressure p_D .

Scope of delivery: 1 x test points with 1 x profiled sealing rings,
 Order No. 74923390

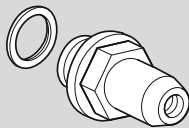
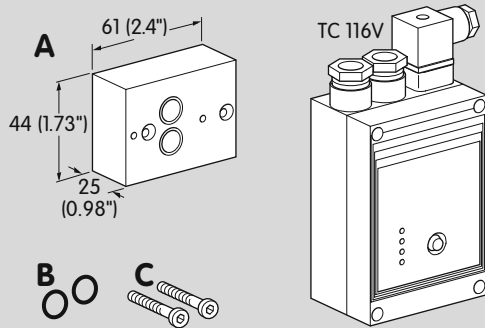
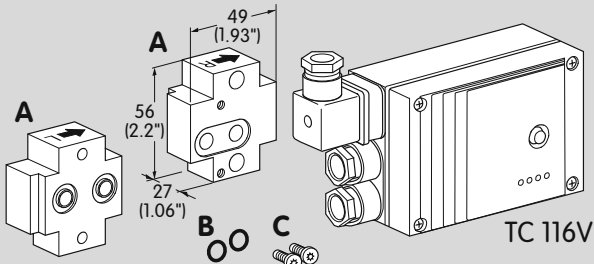

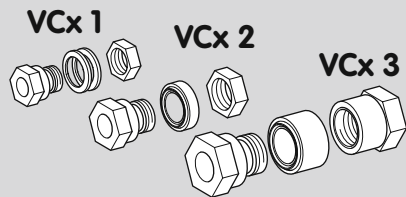

8.6 Cable gland set

When wiring double solenoid valve VCS 1–3, the connection boxes are to be connected using a cable gland set.

The cable gland set can only be used if the connection boxes are at the same height and on the same side and if both valves are equipped either with or without a proof of closure switch.

VA 1, Order No. 74921985,

VA 2, Order No. 74921986,

VA 3, Order No. 74921987.

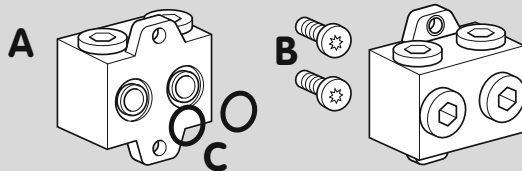

8.7 Attachment block

For locked installation of pressure gauge or other accessories on the gas solenoid valve VAS 1–3.

Order No. 74922228

Scope of delivery:

A 1 x attachment block,

B 2 x self-tapping screws for installation,

C 2 x O-rings.

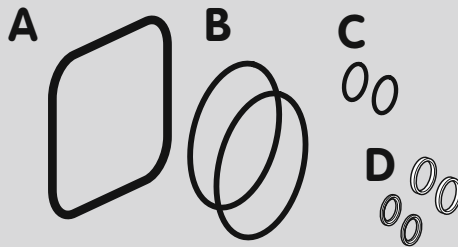

8.8 Seal set VA 1–3

VA 1, Order No. 74921988,

VA 2, Order No. 74921989,

VA 3, Order No. 74921990.

Scope of delivery:

A 1 x double block seal,

B 2 x O-rings (flange),

C 2 x O-rings (pressure switch),

for pressure test point/screw plug:

D 2 x sealing rings (flat sealing) and 2 x profiled sealing rings.

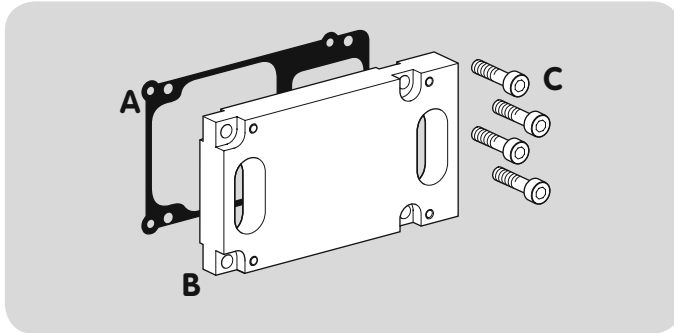

8.9 Adapter plates for VAS/VCS 6–9

8.9.1 Bypass adapter

For the connection of the bypass/pilot gas valve VAS 1.

Order No. 74923023

Scope of delivery:

- A** 1 x seal
- B** 1 x bypass plate,
- C** 4 x set screws M5.

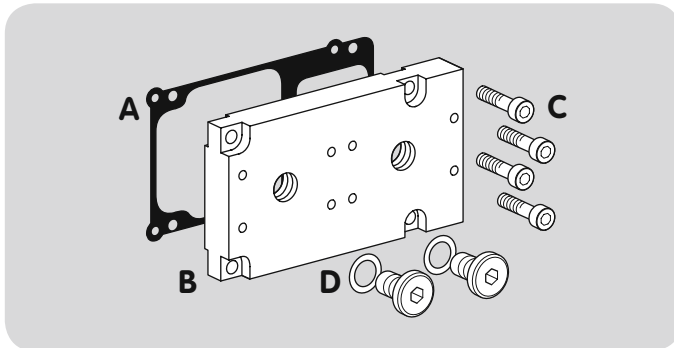

8.9.2 Measuring adapter

For the connection of the pressure switch DG..C, with a screw plug or pressure test point.

VAS/VCS 6–9, Order No. 74923021,

VAS..T/VCS..T 6–9, Order No. 74923022.

Scope of delivery:

- A** 1 x seal,
- B** 1 x measuring plate,
- C** 4 x set screws M5,
- D** 2 x screw plugs with sealing rings.

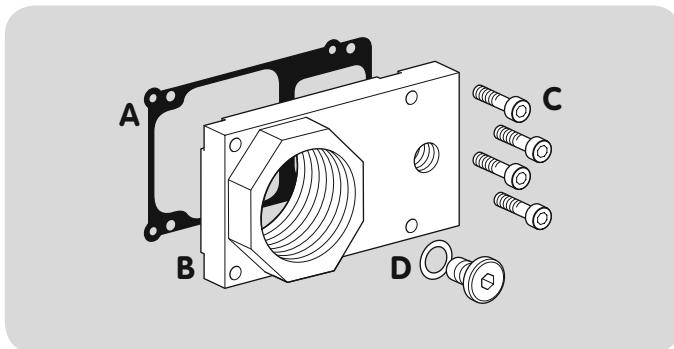

8.9.3 Relief line adapter

For the connection of a relief line (1½ NPT, Rp 1), with a screw plug or pressure test point.

Rp 1, VAS/VCS 6–9, Order No. 74923025,

1½ NPT, VAS..T/VCS..T 6–9, Order No. 74923024.

Scope of delivery:

- A** 1 x seal,
- B** 1 x Z flange,
- C** 4 x set screws M5,
- D** 1 x screw plug with sealing ring.

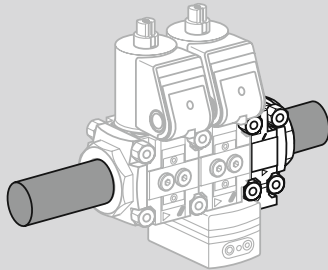

8.10 Measuring orifice VMO

The measuring orifice VMO is designed to reduce the gas and air flow rates and is installed downstream of the valVario control. The measuring orifice is available with Rp internal thread (NPT internal thread) or flange to ISO 7005.

See www.docuthek.com → Elster Kromschroder → Kromschroder, LBE → Products → 03 Valves and butterfly valves → valVario accessories → Type of document: Technical Information → VMO

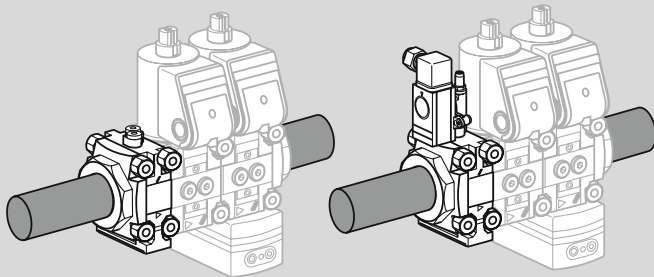

8.11 Filter module VMF

Using the filter module VMF, the gas flow upstream of the gas solenoid valve VAS and the air/gas ratio control is cleaned. The filter module is available with Rp internal thread (NPT internal thread) or flange to ISO 7005 and can also be supplied with fitted pressure switch as an option.

See www.docuthek.com → Elster Kromschroder → Kromschroder, LBE → Products → 03 Valves and butterfly valves → valVario accessories → Type of document: Technical Information → VMF

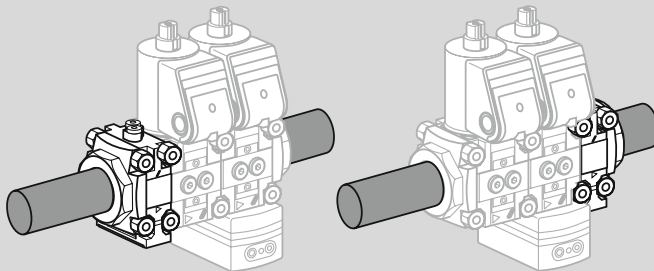

8.12 Fine-adjusting valve VMV

The flow rate is set using the fine-adjusting valve VMV. The fine-adjusting valve is available with Rp internal thread (NPT internal thread) or flange to ISO 7005.

See www.docuthek.com → Elster Kromschroder → Kromschroder, LBE → Products → 03 Valves and butterfly valves → valVario accessories → Type of document: Technical Information → VMV

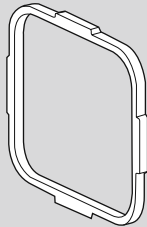

8.13 Retaining frame

In the event that a pressure regulator VAX is installed at a later point upstream of a gas solenoid valve VAS, a measuring orifice VMO or a fine-adjusting valve VMV: the retaining frame must be fitted at the inlet of the second device in order to fasten the differential pressure orifice at the regulator outlet. Order the retaining frame separately.

Retaining frame for

VAS 1: Order No. 74923029,

VAS 2: Order No. 74923030,

VAS 3: Order No. 74923031.

8.14 Adapter for length compensation VAS 6–9

For length compensation when replacing VG by VAS 6–9.

Adapter for length compensation:

VAS 6, Order No. 74923271,

VAS 7, Order No. 74923272,

VAS 8, Order No. 74923273

VAS 9, Order No. 74923274.

Scope of delivery VAS/VCS 6:

A 1 x adapter for length compensation,

B 4 x threaded bolts,

C 8 x nuts,

D 6 x washers,

E 2 x serrated lock washers.

Scope of delivery VAS/VCS 7 to 9:

A 1 x adapter for length compensation,

B 8 x threaded bolts,

C 16 x nuts,

D 14 x washers,

E 2 x serrated lock washers.

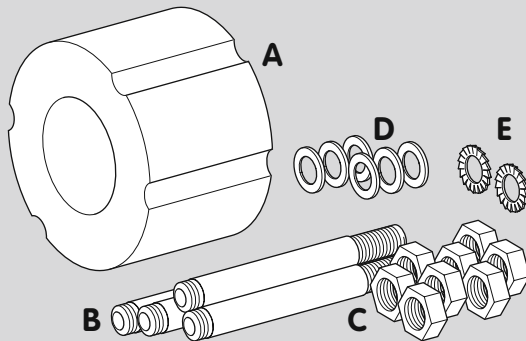

9 Technical data

Gas types: natural gas, LPG (gaseous), biologically produced methane (max. 0.1 %-by-vol. H₂S) or clean air; other gases on request. The gas must be clean and dry in all temperature conditions and must not contain condensate.

CE and FM approved, UL listed, max. inlet pressure p_U : 500 mbar (7 psig).

FM approved, non operational pressure: 700 mbar (10 psig).

ANSI/CSA approved: 350 mbar (5 psig).

Flow adjustment limits the maximum flow volume between approx. 20 and 100%. On VAS 1–3, the setting can be monitored on an indicator.

Adjustment of the start gas rate: 0 to approx. 70%.

Opening times:

VAS../N quick opening: ≤ 1 s;

VAS../L slow opening: up to 10 s.

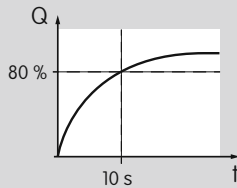

Closing time:

VAS../N, VAS../L quick closing: < 1 s.

Medium and ambient temperatures:

-20 to +60°C (-4 to +140°F),

no condensation permitted.

Storage temperature: -20 to +40°C (-4 to +104°F).

Safety valve:

Class A Group 2 pursuant to EN 13611 and EN 161,

Factory Mutual (FM) Research Class: 7400 and 7411, ANSI Z21.21 and CSA 6.5.

Mains voltage:

230 V AC, +10/-15%, 50/60 Hz,

200 V AC, +10/-15%, 50/60 Hz,

120 V AC, +10/-15%, 50/60 Hz,

100 V AC, +10/-15%, 50/60 Hz,

24 V DC, $\pm 20\%$.

Cable gland: M20 x 1.5.

Electrical connection: cable with max. 2.5 mm² (AWG 12) or plug with socket to EN 175301-803.

Power consumption:

Type	24 DC [W]	100 AC [W]	120 AC [W]	200 AC [W]	230 AC [W]
VAS 1	25	25 (26 VA)	25 (26 VA)	25 (26 VA)	25 (26 VA)
VAS 2	36	36 (40 VA)	40 (44 VA)	40 (44 VA)	40 (44 VA)
VAS 3	36	36 (40 VA)	40 (44 VA)	40 (44 VA)	40 (44 VA)
VAS 6	70	–	63	–	63
VAS 7	75	–	90	–	83
VAS 8	99	–	117	–	113
VAS 9	–	–	200 (15*)	–	200 (15*)
VCS 1	58	66	60	66	60
VCS 2	92	106	108	108	106
VCS 3	92	106	108	108	106
VCS 6	140	–	126	–	126
VCS 7	150	–	180	–	166
VCS 8	198	–	234	–	226
VCS 9	–	–	400 (30*)	–	400 (30*)

* After opening.



Technical data

Enclosure: IP 65.

Duty cycle: 100%.

Power factor of the solenoid coil: $\cos \varphi = 0,9$.

Switching frequency:

VAS../N 1 – 8, VCS..N 1 – 8: max. 30 x per minute.

VAS../L, VCS..L: there must be a period of 20 seconds between switching off and on again so that the damping is fully effective.

Valve housing: aluminium,

Valve seal: NBR.

Connection flanges:

VAS/VCS 1–3 with internal thread:

Rp pursuant to ISO 7-1, NPT pursuant to ANSI/ASME;

VAS/VCS 2–9 with ISO flange (pursuant to ISO 7005) PN 16, with ANSI flange pursuant to ANSI 150.

Proof of closure switch contact rating:

Type	Voltage	Min. current (resistive load)	Max. current (resistive load)
VAS..S, VCS..S	12–250 V AC, 50/60 Hz	100 mA	3 A
VAS..G, VCS..G	12–30 V DC	2 mA	0.1 A

Proof of closure switching frequency: max. 5 x per minute.

Switching current [A]	Switching cycles*	
	$\cos \varphi = 1$	$\cos \varphi = 0.6$
0.1	500,000	500,000
0.5	300,000	250,000
1	200,000	100,000
3	100,000	–

* Limited to max. 200,000 cycles for heating systems.

VAS 6–8/VCS 6–8

Mains voltage:

120 V AC, +10/-15 %, 50/60 Hz,

230 V AC, +10/-15 %, 50/60 Hz,

24 V DC, ± 20 %.

VAS 9/VCS 9

Mains voltage: 120–230 V AC, +10/-15%, 50/60 Hz.

Switching frequency: max. 1 x per minute.

Max. temperature of solenoid coil:

+20°C (+68°F) above ambient temperature.

Current consumption at 20°C (68°F):

pick-up current: 1.8 A,

holding current: 0.3 A.

9.1 Safety-specific characteristic values for VAS

For SIL	
Suitable for Safety Integrity Level	SIL 1, 2, 3
Diagnostic coverage DC	0
Type of subsystem	Type A to EN 61508-2, 7.4.4.1.3
Mode of operation	High demand mode pursuant to EN 61508-4, 3.5.16
For PL	
Suitable for Performance Level	PL a, b, c, d, e
Category	B, 1, 2, 3, 4
Common cause failure CCF	> 65
Application of essential safety requirements	Satisfied
Application of tried-and-tested safety requirements	Satisfied
For SIL and PL	
B_{10d} value	Operating cycles: VAS 1: 15,845,898 VAS 2–3: 15,766,605 VAS 6–9: 6,700,000
Hardware fault tolerance (1 valve) HFT	0
Hardware fault tolerance (2 valves) HFT	1
Safe failure fraction SFF	> 90%
Fraction of undetected common cause failures β	2%

Max. service life under operating conditions: 10 years after date of production, plus max. 1/2 year in storage prior to first use, or once the given number of operating cycles has been reached, depending on which is achieved first.

The solenoid valves are suitable for single-channel systems (HFT = 0) up to SIL 2/PL d, and up to SIL 3/PL e when two redundant valves are installed in a double-channel architecture (HFT = 1), provided that the complete system complies with the requirements of EN 61508/ISO 13849.

For a glossary of terms, see page 61 (Glossary).

9.1.1 Determining the PFH_D value, the λ_D value and the MTTF_d value

$$PFH_D = \lambda_D = \frac{1}{MTTF_d} = \frac{0.1}{B_{10d}} \times n_{op}$$

9.1.2 Calculating the PFH_D and PFD_{avg}

Type.	VAS 1	
n _{op}	1,00	1/h
n _{op}	8.760	1/a
Cycle time	3.600	s
B _{10d}	9.725.220	
T _{10d}	10,0	a
PFH _D (1 VAS)	6,31 e-9	1/h
PFD _{avg} (1 VAS)	0,00 e-0	
suitable for	PL d, SIL 2	
PFH _D (2 VAS)	1,30 e-10	1/h
PFD _{avg} (2 VAS)	0,00 e-0	
suitable for	PL e, SIL 3	

PFH_D = Probability of dangerous failure (HDM = high demand mode) [1/hour]

PFD_{avg} = Average probability of dangerous failure on demand (LDM = low demand mode)

λ_D = Mean dangerous failure rate [1/hour]

MTTF_d = Mean time to dangerous failure [hours]

n_{op} = Demand rate (mean number of annual operations) [1/hour]

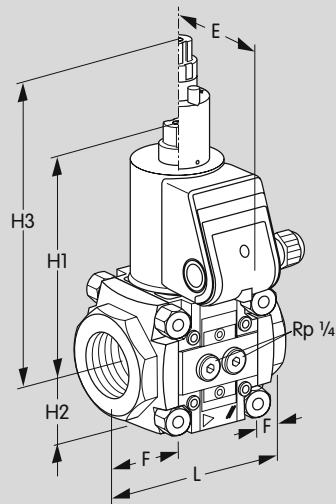

VAS 1-3../N, VAS 1-3../L

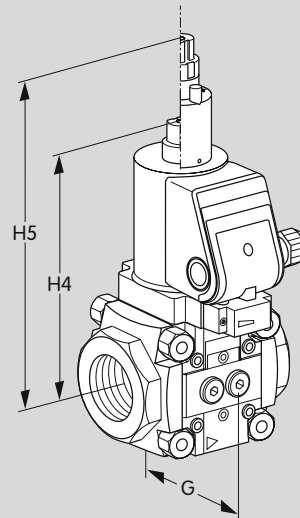

VAS 1-3../N..S, VAS 1-3../L..S,
VAS 1-3../N..G, VAS 1-3../L..G

9.2 Dimensions

9.2.1 VAS 1-3 with Rp internal thread [mm]

Type	Connection		L mm	E mm	F mm	G mm	Dimensions					Weight kg
	Rp	DN					H1 mm	H2 mm	H3 mm	H4 mm	H5 mm	
VAS 110	3/8	10	75	75	15	67.3	143	32	208	161	226	1.4
VAS 115	1/2	15	75	75	15	67.3	143	32	208	161	226	1.4
VAS 120	3/4	20	91	75	23	67.3	143	32	208	161	226	1.5
VAS 125	1	25	91	75	23	67.3	143	32	208	161	226	1.4
VAS 225	1	25	128	85	29	98.2	170	47	235	191	256	3.8
VAS 232	1 1/4	32	128	85	29	98.2	170	47	235	191	256	3.8
VAS 240	1 1/2	40	128	85	29	98.2	170	47	235	191	256	3.8
VAS 250	2	50	128	85	29	98.2	170	47	235	191	256	3.6
VAS 340	1 1/2	40	155	85	36	113.3	180	59	245	201	266	5.2
VAS 350	2	50	155	85	36	113.3	180	59	245	201	266	5.0
VAS 365	2 1/2	65	155	85	36	113.3	180	59	245	201	266	4.8

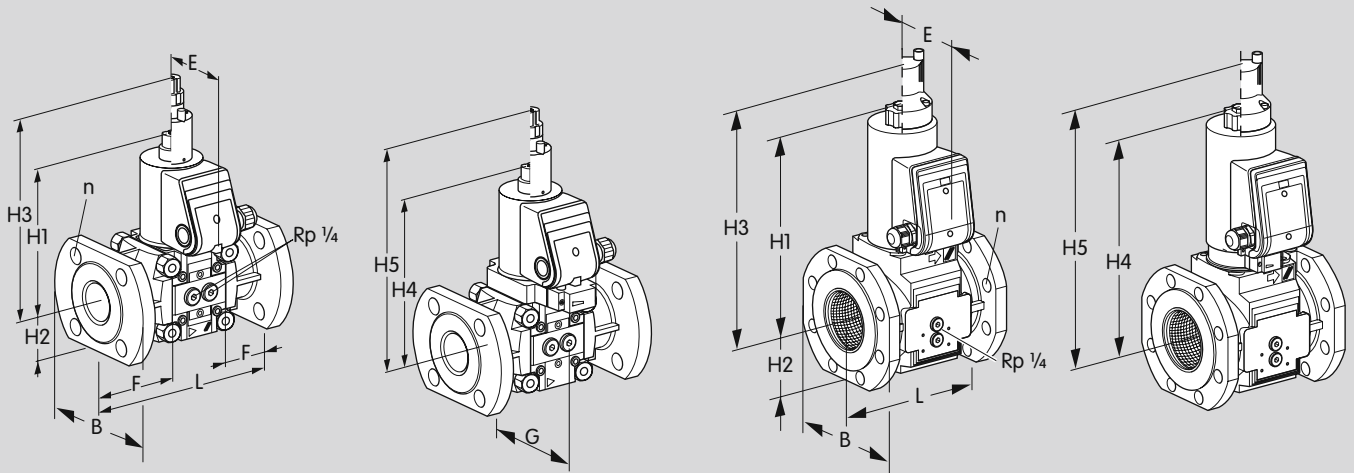

VAS 240../N, VAS 240../L VAS 240-VAS 350../N.S, VAS 240-VAS 350../L.S,
 VAS 350../N, VAS 350../L VAS 240-VAS 350../N.G, VAS 240-VAS 350../L.G

VAS 6-9../N.S*, VAS 6-8../L.S
 VAS 6-8../L VAS 6-9../N.G*, VAS 6-8../L.G

9.2.2 VAS 2-9 with ISO flange [mm]

Type	Connection DN	Dimensions											Weight kg
		L mm	E mm	F mm	G mm	B mm	n	H1 mm	H2 mm	H3 mm	H4 mm	H5 mm	
VAS 240	40	200	85	66	98.2	150	4	175	56	240	196	258	5
VAS 350	50	230	85	74	113.3	165	4	180	65	245	200	265	6.5
VAS 665	65	190	106	-	-	175	4	285	77	340	310	365	11
VAS 780	80	203	106	-	-	190	8	295	88	350	320	380	12
VAS 8100	100	229	120	-	-	210	8	350	103	405	380	430	23
VAS 9125*	125	254	120	-	-	240	8	365	114	-	395	-	27

* VAS 9 only available without damping unit

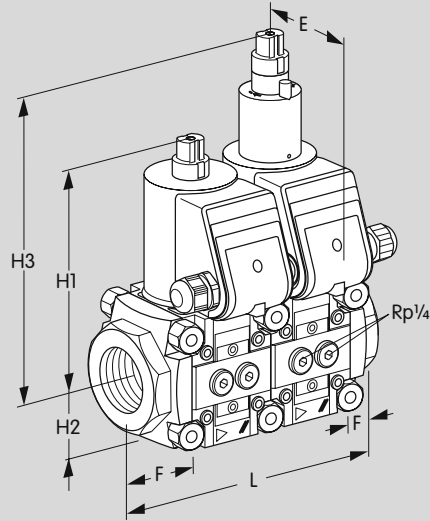

VCS 1-3..NL

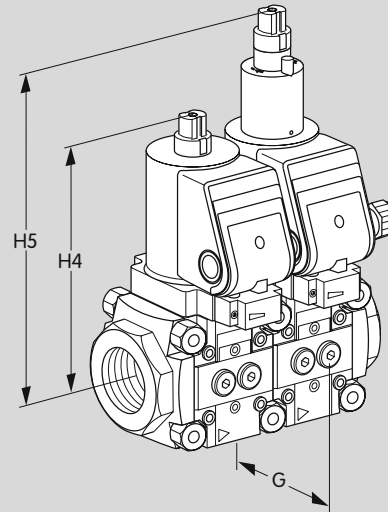

VCS 1-3..NL..S, VCS 1-3..NL..G

9.2.3 VCS 1-3 with Rp internal thread [mm]

Type	Connection		Dimensions										Weight kg
	Rp	DN	L mm	E mm	F mm	G mm	H1 mm	H2 mm	H3 mm	H4 mm	H5 mm		
VCS 110	3/8	10	120	75	15	67.3	143	32	208	161	226	2.6	
VCS 115	1/2	15	120	75	15	67.3	143	32	208	161	226	2.6	
VCS 120	3/4	20	136	75	23	67.3	143	32	208	161	226	2.7	
VCS 125	1	25	136	75	23	67.3	143	32	208	161	226	2.5	
VCS 225	1	25	198	85	29	98.2	170	47	235	191	256	6.8	
VCS 232	1 1/4	32	198	85	29	98.2	170	47	235	191	256	6.9	
VCS 240	1 1/2	40	198	85	29	98.2	170	47	235	191	256	6.8	
VCS 250	2	50	198	85	29	98.2	170	47	235	191	256	6.6	
VCS 340	1 1/2	40	238	85	36	113.3	180	59	245	201	266	8.8	
VCS 350	2	50	238	85	36	113.3	180	59	245	201	266	8.6	
VCS 365	2 1/2	65	238	85	36	113.3	180	59	245	201	266	8.5	

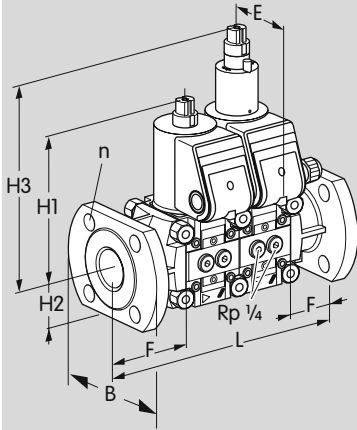

VCS 2-3..NL

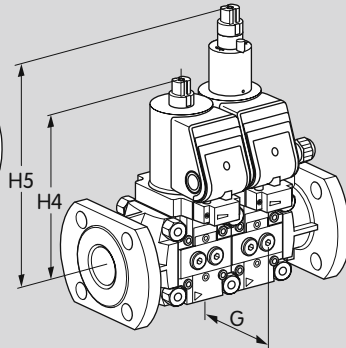

VCS 2-3..NL..S,
VCS 2-3..NL..G

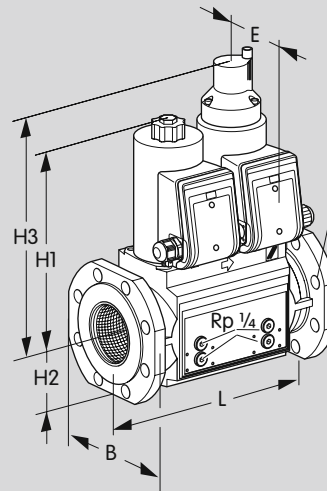

VCS 6-9..NL*

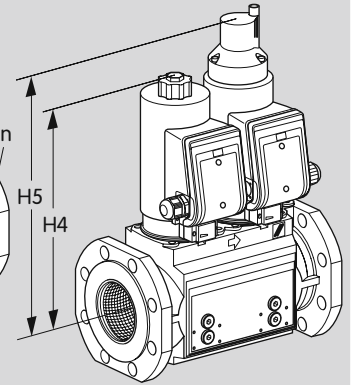

VCS 6-9..NL..S*,
VCS 6-9..NL..G*

9.2.4 VCS 2-9 with ISO flange [mm]

Type	Connection	Dimensions											Weight
		L	E	F	G	B	n	H1	H2	H3	H4	H5	
VCS 240	40	270	85	66	98.2	150	4	175	56	240	196	258	8.3
VCS 350	50	314	85	74	113.3	165	4	180	65	245	200	265	10.8
VCS 665	65	295	106	-	-	175	4	285	77	340	310	365	18
VCS 780	80	310	106	-	-	190	8	295	88	350	320	380	21
VCS 8100	100	350	120	-	-	210	8	350	103	405	380	430	40
VCS 9125*	125	400	120	-	-	240	8	365	114	-	395	-	45

* VCS 9 only available without damping unit

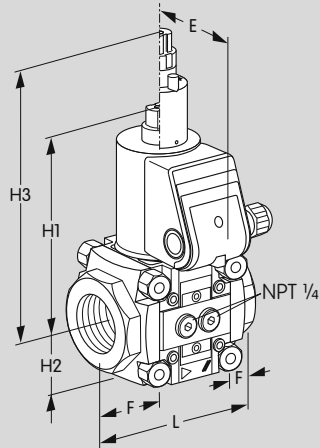

VAS 1-3..T../N, VAS 1-3..T../L

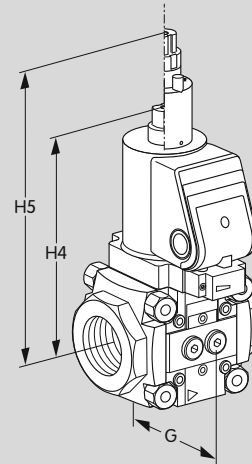

VAS 1-3..T../N..S, VAS 1-3..T../L..S,
VAS 1-3..T../N..G, VAS 1-3..T../L..G

9.2.5 VAS 1-3..T with NPT internal thread [inch]

Type	Connection		Dimensions									Weight lbs
	NPT	DN	L inch	E inch	F inch	G inch	H1 inch	H2 inch	H3 inch	H4 inch	H5 inch	
VAS 110	3/8	10	2.95	2.95	0.59	2.56	5.63	1.26	8.19	6.34	8.9	3.08
VAS 115	1/2	15	2.95	2.95	0.59	2.56	5.63	1.26	8.19	6.34	8.9	3.08
VAS 120	3/4	20	3.58	2.95	0.91	2.56	5.63	1.26	8.19	6.34	8.9	3.30
VAS 125	1	25	3.58	2.95	0.91	2.56	5.63	1.26	8.19	6.34	8.9	3.08
VAS 225	1	25	5.04	3.32	1.14	3.87	6.69	1.85	9.25	7.52	10.1	8.36
VAS 232	1 1/4	32	5.04	3.32	1.14	3.87	6.69	1.85	9.25	7.52	10.1	8.36
VAS 240	1 1/2	40	5.04	3.32	1.14	3.87	6.69	1.85	9.25	7.52	10.1	8.36
VAS 250	2	50	5.04	3.32	1.14	3.87	6.69	1.85	9.25	7.52	10.1	7.92
VAS 340	1 1/2	40	6.10	3.32	1.42	4.46	7.09	2.3	9.65	7.91	10.5	11.40
VAS 350	2	50	6.10	3.32	1.42	4.46	7.09	2.3	9.65	7.91	10.5	11.00
VAS 365	2 1/2	65	6.10	3.32	1.42	4.46	7.09	2.3	9.65	7.91	10.5	10.56

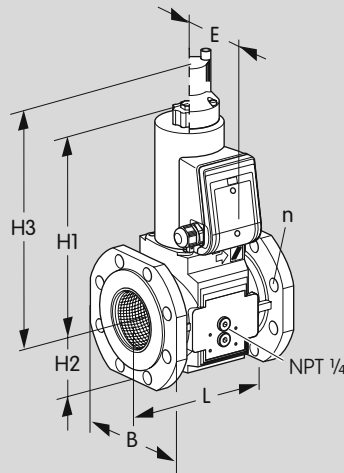

VAS 6-9..T./N*

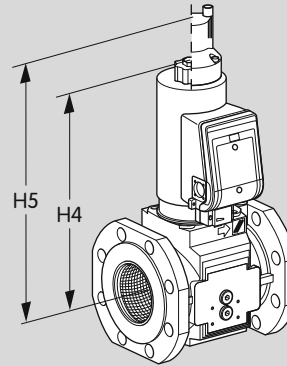

VAS 6-8..T./L

9.2.6 VAS 6-9..T with ANSI flange [inch]

Type	Connection DN	Dimensions									Weight lbs
		L inch	E inch	B inch	n	H1 inch	H2 inch	H3 inch	H4 inch	H5 inch	
VAS 665	65	7.48	4.17	6.89	4	11.2	3.03	13.4	12.2	14.4	24.25
VAS 780	80	7.99	4.17	7.48	4	11.6	3.46	13.8	12.6	15.0	26.45
VAS 8100	100	9	4.72	8.27	8	13.8	4.06	15.9	15.0	16.9	50.71
VAS 9125*	125	10	4.72	9.45	8	14.4	4.49	-	15.6	-	59.52

* VAS 9 only available without damping unit

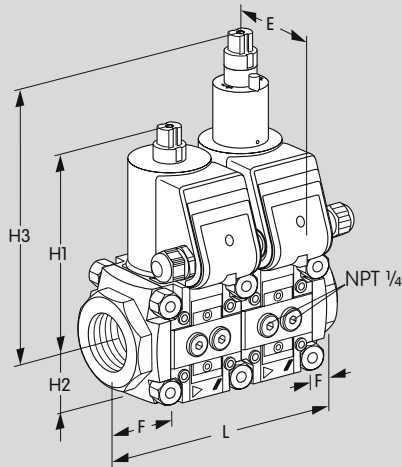

VCS 1-3..T.NL

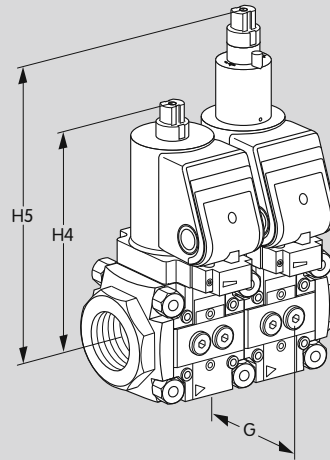

VCS 1-3..T.NL..S, VCS 1-3..T.NL..G

9.2.7 VCS 1-3..T with NPT internal thread [inch]

Type	Connection		Dimensions										Weight lbs
	NPT	DN	L inch	E inch	F inch	G inch	H1 inch	H2 inch	H3 inch	H4 inch	H5 inch		
VCS 110	3/8	10	4.72	2.95	0.59	2.65	5.63	1.26	8.19	6.34	8.9	5.72	
VCS 115	1/2	15	4.72	2.95	0.59	2.65	5.63	1.26	8.19	6.34	8.9	5.72	
VCS 120	3/4	20	5.35	2.95	0.91	2.65	5.63	1.26	8.19	6.34	8.9	5.94	
VCS 125	1	25	5.35	2.95	0.91	2.65	5.63	1.26	8.19	6.34	8.9	5.72	
VCS 225	1	25	7.80	3.32	1.14	3.87	6.69	1.85	9.25	7.52	10.1	14.96	
VCS 232	1 1/4	32	7.80	3.32	1.14	3.87	6.69	1.85	9.25	7.52	10.1	15.18	
VCS 240	1 1/2	40	7.80	3.32	1.14	3.87	6.69	1.85	9.25	7.52	10.1	14.96	
VCS 250	2	50	7.80	3.32	1.14	3.87	6.69	1.85	9.25	7.52	10.1	14.52	
VCS 340	1 1/2	40	9.37	3.32	1.42	4.46	7.09	2.3	9.65	7.91	10.5	19.36	
VCS 350	2	50	9.37	3.32	1.42	4.46	7.09	2.3	9.65	7.91	10.5	18.92	
VCS 365	2 1/2	65	9.37	3.32	1.42	4.46	7.09	2.3	9.65	7.91	10.5	18.70	

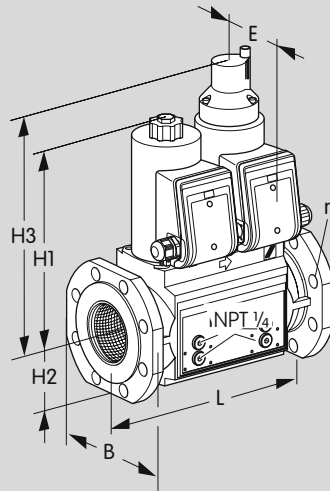

VCS 6-9..T.NL*

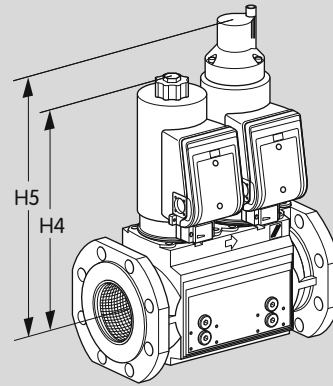

VCS 6-9..T.NL..G*,
VCS 6-9..T.NL..G*

9.2.8 VCS 6-9..T with ANSI flange [inch]

Type	Connection DN	Dimensions									Weight lbs
		L inch	E inch	B inch	n	H1 inch	H2 inch	H3 inch	H4 inch	H5 inch	
VCS 665	65	11.41	4.17	6.89	4	11.2	3.03	13.4	12.2	14.4	39.68
VCS 780	80	12.20	4.17	7.48	4	11.6	3.46	13.8	12.6	15.0	46.30
VCS 8100	100	13.78	4.72	8.27	8	13.8	4.06	15.9	15.0	16.9	88.18
VCS 9125*	125	15.75	4.72	9.45	8	14.4	4.49	-	15.6	-	99.21

* VCS 9 only available without damping unit

10 Converting units

see www.adlatus.org

11 Maintenance cycles

At least once per annum, at least twice per annum for biologically produced methane.

If the flow rate drops, clean the strainer!

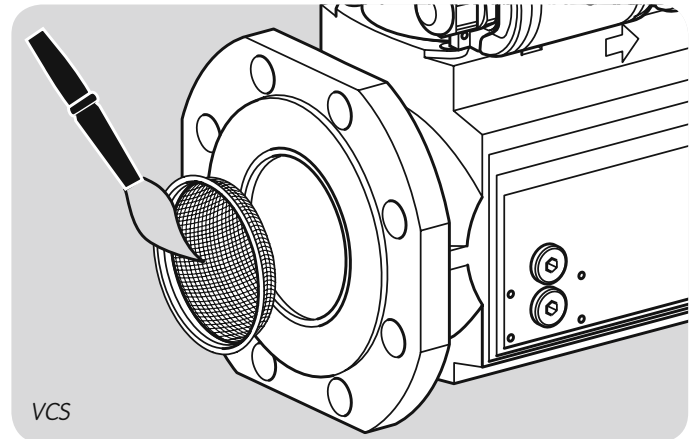
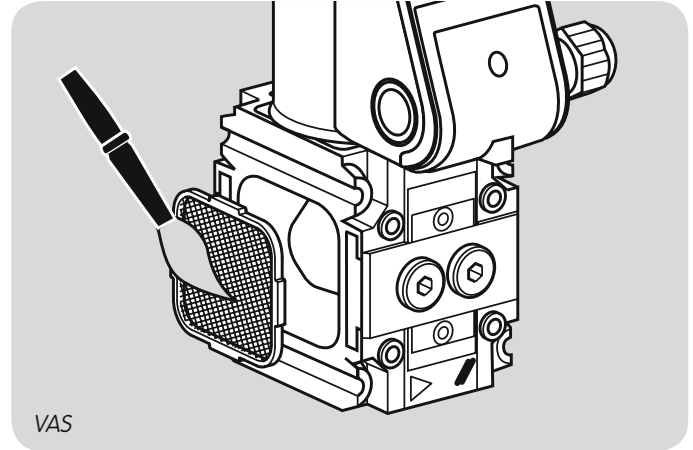

12 Glossary

12.1 Diagnostic coverage DC

Measure of the effectiveness of diagnostics, which may be determined as the ratio between the failure rate of detected dangerous failures and the failure rate of total dangerous failures

NOTE: Diagnostic coverage can exist for the whole or parts of a safety-related system. For example, diagnostic coverage could exist for sensors and/or logic system and/or final elements. Unit: %

from EN ISO 13849-1:2008

12.2 Mode of operation

High demand mode or continuous mode

Operating mode, where the frequency of demands for operation made on a safety-related system is greater than one per year or greater than twice the proof-test frequency

from EN 61508-4:2008

12.3 Category

Classification of the safety-related parts of a control system in respect of their resistance to faults and their subsequent behaviour in the fault condition, and which is achieved by the structural arrangement of the parts, fault detection and/or by their reliability

from EN ISO 13849-1:2008

12.4 Common cause failure CCF

Failures of different items, resulting from a single event, where these failures are not consequences of each other

from EN ISO 13849-1:2008

12.5 Fraction of undetected common cause failures β

Fraction of undetected failures of redundant components due to a single event, whereby these failures are not based on mutual causes

NOTE: β is expressed as a fraction in the equations and as a percentage elsewhere

from EN 61508-6:2010

12.6 B_{10d} value

Mean number of cycles until 10% of the components fail dangerously

from EN ISO 13849-1:2008

12.7 T_{10d} value

Mean time until 10% of the components fail dangerously

from EN ISO 13849-1:2008

12.8 Hardware fault tolerance HFT

A hardware fault tolerance of N means that N + 1 is the minimum number of faults that could cause a loss of the safety function

from IEC 61508-2:2010

12.9 Mean dangerous failure rate λ_D

Mean rate of dangerous failures during operation time (T_{10d}). Unit: 1/h

from EN ISO 13849-1:2008

12.10 Safe failure fraction SFF

Fraction of safe failures related to all failures, which are assumed to appear

from EN 13611/A2:2011

12.11 Probability of dangerous failure PFH_D

Value describing the likelihood of dangerous failure per hour of a component for high demand mode or continuous mode.

Unit: 1/h.

from EN 13611/A2:2011

12.12 Mean time to dangerous failure $MTTF_D$

Expectation of the mean time to dangerous failure

from EN ISO 13849-1:2008

12.13 Demand rate n_{op}

Mean number of annual operations

from EN ISO 13849-1:2008

12.14 Average probability of dangerous failure on demand

PFD_{avg}

(LDM = 1 – 10 switching cycles/year)

Average probability of a dangerous failure of the safety function on demand (LDM = low demand mode)

see EN 61508-6

Feedback

Finally, we are offering you the opportunity to assess this "Technical Information (TI)" and to give us your opinion, so that we can improve our documents further and suit them to your needs.



Clarity

- Found information quickly
- Searched for a long time
- Didn't find information
- What is missing?
- No answer

Comprehension

- Coherent
- Too complicated
- No answer

Scope

- Too little
- Sufficient
- Too wide
- No answer

Use

- To get to know the product
- To choose a product
- Planning
- To look for information

Navigation

- I can find my way around
- I got "lost"
- No answer

My scope of functions

- Technical department
- Sales
- No answer

Remarks



Contact

Elster GmbH
Postfach 2809 · 49018 Osnabrück
Strothweg 1 · 49504 Lotte (Büren)
Germany

T +49 541 1214-0
F +49 541 1214-370
info@kromschroeder.com
www.kromschroeder.com

The current addresses of our international agents are available on the Internet:
www.kromschroeder.de/index.php?id=718&L=1

We reserve the right to make technical modifications in the interests of progress.

Copyright © 2007 – 2015 Elster GmbH
All rights reserved.