

THE VICTOR'S WEEKLY!

# Technical Wireless

3<sup>D</sup>!

Published every Wednesday by  
**GEORGE NEWNES LTD.**

No. 2. — No. 50.  
SEPTEMBER 2nd, 1933.

The G.P.O. as a Newspaper

FURTHER NOTES ON THE

## "Superset"



**THE SET OF THE SEASON**

**RECEPTRU**  
FOR TRUE RECEPTION

—the wonderful new low loss lead in cable definitely eliminates crackle, background noises, mush and all man-made static. It improves selectivity and increases sensitivity. Get one to-day. You can fix it in less than five minutes.

**OF ALL DEALERS in lengths of 15 feet 10/-**

Longer sizes at proportionate prices.

BRITISH RADIOPHONE LTD., ALDWYCH HOUSE, LONDON, W.C.2



# NEW COSSOR MELODY

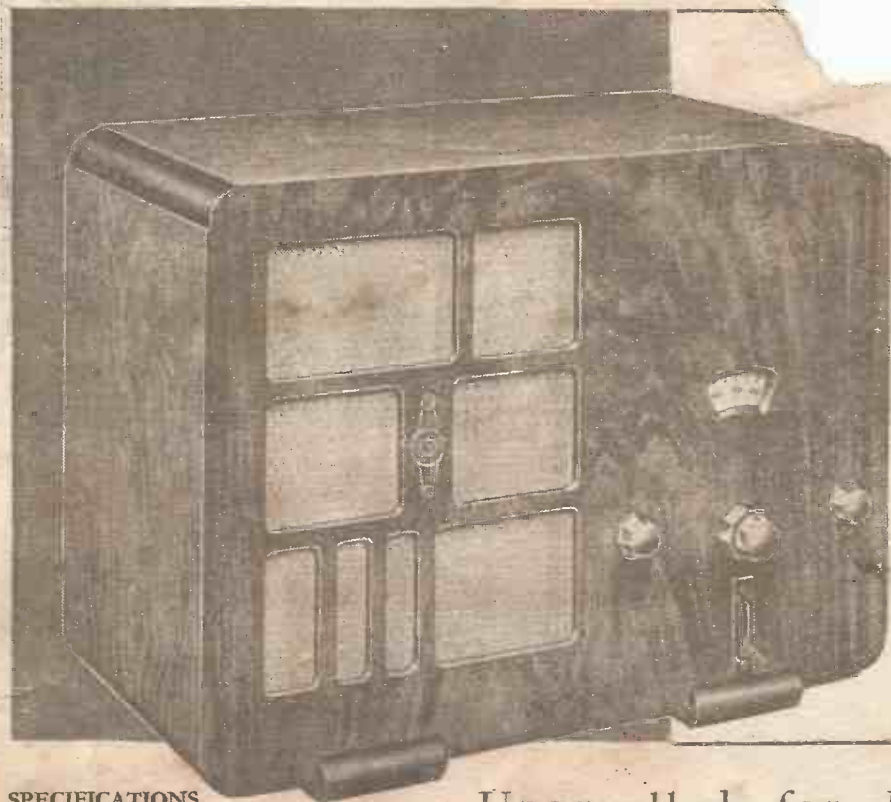

VARIABLE-MU  
SCREENED GRID  
CIRCUIT

PENTODE, CLASS "B"  
MAINS POWER OUTPUT

BALANCED ARMATURE  
OR  
MOVING COIL  
LOUD SPEAKER

BATTERY  
OR ALL-ELECTRIC

**SPECIFICATIONS**

**BATTERY MODEL 341**  
**PENTODE OUTPUT**

Balanced Armature Loud Speaker

Complete Kit of Parts for assembling Cossor Melody Maker, Model 341, similar to illustration, including Cossor Variable-Mu Screened Grid, Cossor Detector, and Cossor Pentode Valves. Fully screened coils, Double-Gang Condenser, Combined Volume Control and On-Off Switch, all-metal chassis, and all the parts for simple home assembly. Handsome cabinet 18 1/2" x 13 1/2" x 10", space for batteries and accumulator. Balanced Armature Speaker; provision for Gramophone Pick-up Plug and Jack.  
Wave-length range 200/530 and 200/2,000 metres. Price **£6.7.6**

*Hire Purchase Terms 16/- deposit and 10 monthly payments of 12/6 or alternatively 20/- deposit and 6 monthly payments of 20/-.*

**BATTERY MODEL 342**  
**MOVING COIL LOUD SPEAKER**

Complete Kit of Parts similar to Model 341 described above, except that it is supplied with a Permanent Magnet Moving Coil Loud Speaker. Price **£7.2.6**

*Hire Purchase Terms 17/6 deposit and 9 monthly payments of 15/6.*

**BATTERY MODEL 344**  
**CLASS "B" OUTPUT**

Complete Kit of Parts as Model 341 described above, but with four Cossor Valves, Class "B" Output Stage and Permanent Magnet Moving Coil Speaker. Price **£8.2.6**

*Hire Purchase Terms 20/- deposit and 10 monthly payments of 16/-.*

**ALL-ELECTRIC MODEL 347**

Complete Kit of Parts, similar to Model 341 described above, but with four Cossor A.C. Mains Valves. Factory-built and tested Power Unit and Mains Energised Moving Coil Loud Speaker. For A.C. Mains only 200/250 volts (adjustable) 40/100 cycles. Price **£8.19.0**

*Hire Purchase Terms 20/- deposit and 9 monthly payments of 20/-.*

Unequaled for Range, Selectivity  
and True-to-Life Tone . . . .

"All-Europe" range—amazing selectivity—rich, true-to-life tone—generous volume—all that you'd expect from a highly-priced Receiver for £6.7.6.6!—the price of the Cossor Melody Maker (Model 341). Never before has such efficiency been obtainable at so low a price. Send at once for a free Constructional Chart which tells you how you can save pounds by assembling this remarkable Set at home—even if you know nothing about Wireless. Please use the coupon.

## COSSOR MELODY MAKER

COUPON BRINGS  
YOU FULL-SIZE  
CONSTRUCTIONAL CHART.

*Prices do not apply in I.F.S.*

To A. C. Cossor Ltd., Melody Dept., Highbury Grove, London, N.5.

Please send me free of charge a Constructional Chart which tells me how to build a Cossor Melody Maker.

- \*Battery Model 341
- \*Battery Model 342
- \*Battery Model 344 (Class "B")
- \*All-Electric Model 347

*\*Strike out those not required.*

Name .....

Address .....

PRAC. 2/5/-



# THE LEADING HOME CONSTRUCTORS' WEEKLY!



**EDITOR:**  
Vol. II. No. 50 || F. J. CAMM || Sept. 2nd, 1933.

**Technical Staff:**  
H. J. Barton Chapple, Wh. Sch., B.Sc. (Hons.), A.M.I.E.E.  
W. J. Delaney, Frank Preston, F.R.A., W. B. Richardson

## ROUND *the* WORLD of WIRELESS

### At the Exhibition

**U**NDoubtedly the most outstanding feature of the Press section of the recent Radio Exhibition at Olympia was the stand of Messrs. Geo. Newnes, No. 8 on the Ground Floor—one of the most packed stands in the whole of Olympia. It was the centre of discussion for every intelligent home constructor. It was really amazing to see the number of different books relating to wireless and published by Geo. Newnes Ltd., which were shown on our stand. Until this stand was visited one could hardly appreciate that so many books had been produced on the subject, yet alone that so many had been published by one firm. Judging by the number of people who stopped, and did not depart without purchasing one or more of these publications, many will have commenced to take an even greater interest in wireless than before.

### Our Query Service at Olympia

**A**NOTHER feature of the Exhibition was the large number of visitors who availed themselves of our free advice service. The technical staff were kept very busy, at times dozens of visitors were seated or standing awaiting their turn to lay their difficulty before one of our technical staff. Some of the problems were very interesting, and all the various points which were touched upon during the course of these discussions are being carefully abulated and filed away for careful consideration.

### The Fury Four

**I**T is well known now that a receiver built from identical parts, and exactly to a wiring diagram, must give uniform results. During the Exhibition some readers came to inspect the model of the Fury Four which was exhibited, and after looking at the wiring remarked that they had built the set, and expressed their intense satisfaction at the service they were obtaining from the receiver. Two cases are particularly interesting. In one case a gentleman stated that he had made the receiver and it worked so well that all his friends and neighbours had heard it, and he had been busy for months building up these receivers. His total number to date

was seventy. *And they all worked uniformly well!* Another reader was full of regrets because he had sold his Fury Four in order to purchase a 7-valve superheterodyne by one of the biggest makers in the country. It did not give results anywhere near so good as his old Fury, and he said that the biggest regret of his life was when he disposed of the set. This just shows that by adhering to the instructions and constructing a receiver carefully, you definitely can reproduce the original results.

what his neighbours would have said if we had given him the instructions to build such a unit!

### One-Armed Constructors

**H**OW many readers, afflicted by the loss of a hand or arm, are keen wireless constructors? It would appear at first thought that the loss of such a limb would prevent one from indulging in this hobby, but two readers of PRACTICAL WIRELESS called at our Stand and asked for details for a receiver employing only one control for all purposes. The reason in each case was that they had lost the right arm. They had each built many of our receivers despite their handicap, and were full of praise for the results they had obtained.

### Talks by Well-known Journalists

**A**N original series of talks will be included in the autumn syllabus of the B.B.C. In "Anywhere for a News Story" a dozen of Fleet Street's "star" newspapermen will describe some of their outstanding exploits. One of these will tell of a classic photographic scoop, a picture taken by him of a sinking ship—the vessel in which he was wrecked. The water was up to his neck when he got the picture, but he preserved the plate intact. Another will relate his adventures when he was sent during the 1906 election to interview the "topmost voter" in the British Isles on his

### " PRACTICAL WIRELESS "

#### at Forthcoming Exhibitions!

**MODEL ENGINEER EXHIBITION,**  
Royal Horticultural Hall, Westminster,  
August 31st to September 9th.

*Our Stand No. 35.*

**THE SCOTTISH RADIO EXHIBITION,**  
KELVIN HALL, GLASGOW  
September 1st to 9th.

*Our Stand No. 17*

**NATIONAL RADIO EXHIBITION,**  
CITY HALL, MANCHESTER  
September 27th to October 7th.

*Our Stand No. 11 (New Hall)*

Provincial readers will find these stands the home of Real, Reliable and Unrivalled Reader Service!

**A Cordial Invitation is Extended to Every Reader to Visit Us.**

### What Power to Use

**T**HERE has always been a question regarding the power which is necessary for good reproduction. We have stated, not once, but many times, that although 2 watts will deliver sufficient volume for all normal domestic purposes, it is worth while building a 5 or 6 watt amplifier in order to ensure that at maximum volume the full musical range will be reproduced without distortion. At the Exhibition one visitor came to our stand and asked if we had a blue-print of a 50-watt amplifier. He referred to 50 watts undistorted (not anode dissipation), and when he was asked if it was for outdoor or concert hall use he looked surprised and said, "No, just for gramophone records at home." We do not know

political views. A third broadcaster in this series had been three times round the world and travelled half a million miles in search of news. A well-known war correspondent will describe the relief of Ladysmith where he was one of the beleaguered garrison; while another journalist, whose name is a household word, will talk about many amazing things that he has done in his search for copy. A bicycle ride round the world was one of his adventures. The talks start in September and the final broadcast will be given by one of the best known personalities in Fleet Street during the past quarter-century, Mr. R. D. Blumenfeld, whose subject will be "Journalism in my Time."



# ROUND the WORLD of WIRELESS (Continued)

## Revival of Bach Cantatas

ACCORDING to a B.B.C. announcement the broadcasting of Bach Cantatas will be resumed on Sunday, September 17th, and thereafter they will be heard on alternate Sundays, at 4.50 to 5.30 p.m. The Cantatas are to be given from the Concert Hall, Broadcasting House, and the B.B.C. organ will be employed for the continuo part.

## Broadcast Character Studies

IN the interludes between items in the Birmingham Military Band programme, on September 7th, Irene Malin, of Leicester, gives character studies and impressions. Miss Malin's career as an entertainer began at the age of six, when she was entertaining wounded soldiers in Leicester hospitals. She has organized many charity concerts and given a number of recitals, her last being at the Little Theatre, Leicester, in the spring. She is especially successful in character-studies in broken English, founded upon observations made during her residence in France and Germany.

## Sunday Programmes

THE British Broadcasting Corporation announces that on and after September 17th next there will be continuous broadcasting on Sundays from 12.30 p.m. to 10.30 p.m. The hitherto silent period between 6 and 8 p.m. will be appropriately filled.

## Wireless and the Italian Transatlantic Flight

GENERAL BALBO, in his first report to Signor Mussolini, emphasized the valuable assistance that wireless has given the Italian Flying Squadron on its flight from Italy to Chicago, especially during the most difficult section of the flight over the Atlantic. On this section of the flight six deep-sea trawlers were fitted with wireless by the Marconi organizations in Italy and in England, to act as contact vessels with the Squadron throughout the Atlantic crossing and to provide wireless direction-finding services as required. Most of the apparatus was specially manufactured at the Marconi Works in Genoa, Italy, while the direction-finding equipment was supplied from the Company's works in England.

## New Broadcasting Station for Norway

AS a first step in the reorganization of the Norwegian broadcasting system, which comes under Government control from July 1st, a new high-power broadcasting station is to be erected by Marconi's Wireless Telegraph Co., at Trondhjem, to replace the existing low-powered station. The power of the transmitter is 20 kilowatts unmodulated aerial energy and modulation up to 100 per cent. is arranged. The transmitter, which will be adjustable to any wavelength between 200 and 545 metres, is built in the form of a switch-board, on which are mounted all the controls. Behind the board are the transmitting valves with their attendant circuits. The masts of the existing station will be used, but the aerial, instead of leading

## INTERESTING and TOPICAL PARAGRAPHS.

straight into the transmitting house, will be connected to the output stage of the transmitter by means of a two-wire high-frequency feeder to convey the energy from the transmitter to the aerial. The transfer

## HOW IT IS DONE.



Girls assembling Lissen wireless sets at the recent Radio Show at Olympia.

of the modulated high-frequency energy will take place by means of suitable coupling circuits, located in a small feeder house situated underneath the aerial.

## Broadcasting in British India

ALTHOUGH the total population of British India is roughly 35,000,000 souls the broadcasting system has received comparatively little support in view of the diversity of languages. The number of licences has only increased from 3,000 in 1928 to a figure in the neighbourhood of 10,000 to-day.

## SOLVE THIS!

### Problem No. 50.

Coates built a two-valve short-wave receiver to a published design, and although this worked perfectly well on a short indoor aerial, a certain amount of difficulty was experienced when a normal outdoor aerial was employed. The trouble was that the set was quite "dead" at certain settings of the tuning condenser. It was known that the aerial was not in any way faulty, since it afforded excellent reception with a normal broadcast receiver.

What was the reason for the peculiar effect observed on short waves? Three books will be awarded for the first three correct solutions opened. Mark your envelopes Problem No. 50, and address them to The Editor, PRACTICAL WIRELESS, Geo. Newnes, Ltd., 8-11, Southampton Street, Strand, London, W.C.2. No entries will be accepted after September 4th.

### SOLUTION TO PROBLEM No. 49

The aerial coil in Lawrence's short-wave receiver was open-circuited, and the reception of the telephone messages was due to earth induction.

The following three readers received books in connection with Problem No. 48:—

Mr. J. Harriman, 17, Osborne Road, Nether Edge, Sheffield.

Mr. D. Martin, 20, Lynchford Road, S. Farnborough, Hants.

Mr. C. Fyfe, The Square, Tarlands, Aberdeenshire.

## 37,000 Musicians in a Strange Concert

ONE of the queerest concerts ever heard was recently given in London when music of more than twenty nations, played by over 37,000 musicians was played at the Science Museum, South Kensington. The opening reception of the World Petroleum Congress took place in this building when oil experts from every quarter of the globe were present. In place of an orchestra a high power H.M.V. electric gramophone, which is one of the museum exhibits, was used to provide authentic music representative of the nations of all the delegates present.

Among the records heard were some which have been made in the jungle of Africa under great difficulties. Queer music of African tribes in which a whole village of thousands of inhabitants have all played at once was heard, besides a record in which the unique instrument called the Zalka provided the rhythm. This resembles a harp and is played with the toes of native musicians. Another similar instrument is the Vena, which has an octave of 64 notes compared with ours of 8.

There was also an Indian record of flutes which are played with the noses of the instrumentalists, and it was difficult to detect any difference between this music and our more conventional mode of performance. Another record made near the source of the Amazon had as its principal "instrument" the teeth of wild animals which are mounted in hard clay and struck with a flint.

## "Sultanah"

MIDLAND Regional's principal light feature, in the week beginning September 3rd, is a Charles Brewer production, *Sultanah*, described as "a 'currant' tale of the East with plums from the musical comedies." The author, Dorothy Eaves, has had several sketches broadcast. Evelyn Over and Dorothy Summers, William Hughes, Peter Howard, Alfred Butler and Ernest Shannon are in the cast, and Frank Cantell conducts the Midland Revue Chorus and Orchestra.

## A Dickens' Recital

WORTLEY ALLEN gives one of his Dickens recitals on September 8th, the characters he impersonates being Sidney Carton, Mr. Micawber and Mark Tapley. He will be heard by Midland Regional listeners. On the same evening a concert by the Cheltenham Municipal Orchestra, conducted by Arthur Cole, will be relayed. The vocalist is Samuel Saul (baritone), one of whose groups consists of songs from the Hungarian by Torbay.

## France's 90 Kilowatt Transmitter

WORK on the super-power station to be erected at Tramoyes near Lyons has already begun, and every effort is to be made to complete its construction by the spring of 1934. The aerial system will be of the latest type, namely a single pylon 730 ft. high.



ANOTHER OUTSTANDING  
"PRACTICAL  
WIRELESS"  
RECEIVER!



# The Superset

*The Set that Supersedes*

Further Notes on Adjusting and Operating this New  
Five Valve Receiver. By F. J. CAMM.

### The Tuned Circuits

In this receiver there are three such coils, each of which is tuned by a separate section of a three-gang condenser. Now it is obvious that each section must be adjusted so that when the tuning control is rotated an equivalent frequency adjustment will be made in each circuit. With the normal type of three-gang condenser and ordinary air-core tuning coil this adjustment of each circuit—known as "trimming"—is not very difficult to carry out. When, however, high-efficiency iron-core coils are employed the sharpness of tuning is of such an order that the trimming must be carried out with very great care, otherwise many stations will be lost entirely.

When you remember

trimming adjustment must be your first attention. Connect up batteries and speaker as instructed last week, and rotate the main control until you hear your local station. It may be necessary to turn the volume control full on for this purpose. When the station is heard the small screws at the top of the tuning condenser must be adjusted, and as it is possible to be misled by slight hand-capacity effects I would recommend that you make for the purpose a special trimming adjuster. You require a piece of wood about 10 to 12 ins. long and about a 1/4 in. or so in diameter. A piece of dowelling answers admirably. Sharpen one end of this to a flat blade similar to the end of a screw-driver. Make this blade just thick enough to fit in the cuts in the adjusting screws. The first trimmer to be adjusted is that nearest the panel, and you should unscrew this, at the

It is now two weeks since I first gave details regarding this new type of receiver, and although I was unable to give you very explicit details last week, owing to the pressure on our space, I have no doubt that the many hundreds who have built the receiver have by now mastered the operation of the receiver, and need no further remarks from me regarding it. It is always best, however, to explain the little points which have been found by experiment to introduce difficulty, in order that those who have before had no experience with the handling of a receiver employing so many valves may obtain a working knowledge of the use of the various controls, and so proceed from one stage to another without meeting obstacles which might cause them to form a poor opinion of home-constructed receiving apparatus. It has already become obvious that this receiver employs iron-cored tuning coils, and from articles which have appeared from time to time in this journal you are all aware that one of the great points of this type of coil is its extreme selectivity.

### LIST OF COMPONENTS FOR THE 1934 SUPERSSET.

One Three-gang Condenser with full-vision scale (Type 604) (British Radiophone).  
Three Iron Core Coils—one Aerial and two H.F. (Lissen).  
One Class B. Driver Transformer (Wearite).  
Two Superhet H.F. Chokes (Belgin).  
One Midget H.F. Choke (Belgin).  
One Type 34.0001 mfd. Fixed Condensers (T.C.C.).  
One Type 34.002 mfd. Fixed Condensers (T.C.C.).  
Two Type 50 2 mfd. Fixed Condensers (T.C.C.).  
Five Type 50 1 mfd. Fixed Condensers (T.C.C.).  
Two Type 34.0002 mfd. Fixed Condensers (T.C.C.).  
One Type 23 Component Bracket (British Radiogram).  
Two Type 21 Component Brackets (British Radiogram).  
One "Nictel" L.F. Transformer (Wardley).  
One 25,000 ohm Potentiometer (Wearite).  
One Type B "Controlatone" (Belgin).  
Four 4-pin Chassis type Valve-holders (Clx).  
One 7-pin Chassis type Valve-holder (Clx).  
Ten "Ohmites"—500, 500, 500, 500, 8,000, 40,000, 85,000, 60,000, 30,000 ohms and 2 megohms (Graham Farish).  
Eight Junior Type Terminals, A1, A2, E, P.U., P.U., L.S.—, H.T., and L.S.— (Belling-Lee).  
One Type 50 S.P.D.T. Switch (British Radiogram).  
One Type 50 3-point Switch (British Radiogram).  
One eight-way Battery Cord (Belling-Lee).  
One "Metaplex" Chassis (Peto-Scott).  
One W/B Microloide Loud-speaker (Type P.M. 4A).  
Two Type 220 V.S. Valves (Cossor).  
One Type 210 H.F. Valve (Cossor).  
One Type 213 P. Valve (Cossor).  
One Type 220 B. Valve (Cossor).  
One 120-volt H.T. Battery (Ediswan).  
One 9-volt G.B. Battery (Ediswan).  
One 2-volt 40-ampere L.T. Accumulator (Ediswan).  
One "Superset" Cabinet (Osborn).  
One Length Receptor Screened Down Lead (British Radiophone).  
One Filtr Earthing Device (Graham Farish).

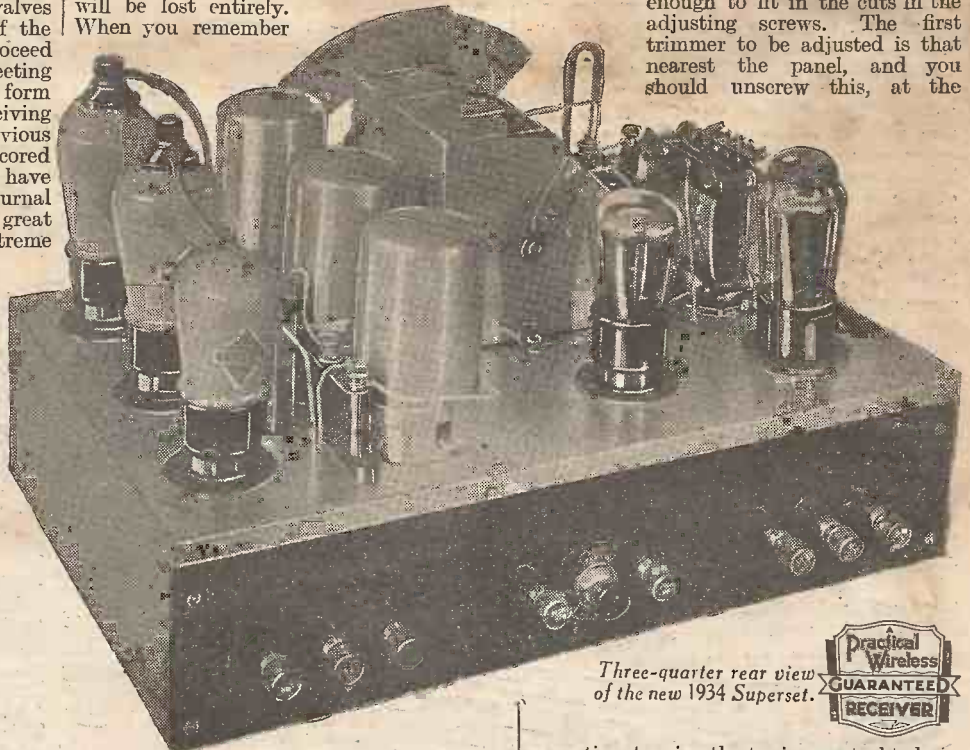

Three-quarter rear view  
of the new 1934 Superset.



that a station may be tuned in and out in one degree on a single iron-core coil, you will realize that it requires only a small deviation in each of three circuits to result in a complete absence of signal. Therefore, this

same time turning the tuning control to keep the station on the speaker. As this trimmer adjusts the aerial coil it is possible that the moment you turn it one way or the other the station will disappear, but by rotating

(Continued on page 875)



# AN EXPERIMENTER'S BASEBOARD

A Practical Article Explaining its Construction and Uses.

By A. V. D. HORT

THE experimenter with wireless circuits has one or more of many possible objectives in view. He may experiment with different arrangements of connections, with methods of coupling valves, with the valves themselves or with other individual components. Whether you are trying to find the best layout of the components for an accepted circuit, or endeavouring to discover the circuit which will give the best possible signal strength from a given number of valves, there will be certain parts of the circuit which will always remain constant.

For example, you must have valve-holders, and their attendant wiring for the filament circuits. At least one variable condenser will come into your layout, and a few well-placed terminals will assist in connecting batteries, aerial and earth, with the assurance of satisfactory contacts. For this reason, it will be well worth your while as an experimenter to mount permanently on a board such components as you will need for every experiment. In this way you will save yourself a great deal of routine assembling every time you try something new.

A glance at Fig. 1, which illustrates a suggested design for such an experimenter's baseboard, will show you that your expenditure on the necessary parts will not be considerable. If you are only going to try out one particular circuit preparatory to building it into a finished receiver, you will, of course, be able to use these parts when you have completed your tests. This, however, is not the real object of the baseboard, which is to provide a permanent nucleus for the trial of circuits of all kinds.

An important consideration in the layout of the baseboard is that of space. You will see from Fig. 1 that 6in. is allowed between the valve-holders, and a further 6in. at each end of the board. This gives ample room for the insertion of the other components. Overcrowding might well give false results, owing to the increased possibility of unsuspected interaction between different parts of the circuit. The board allows for three valves. If you want to use more than this, you should extend the board proportionately, and not try to crowd the components into the smaller space.

### Constructional Details

The board itself may consist of two pieces,

ANGLE BRASS NEGATIVE BUSBAR SUPPORTED ON HARDWOOD BLOCKS

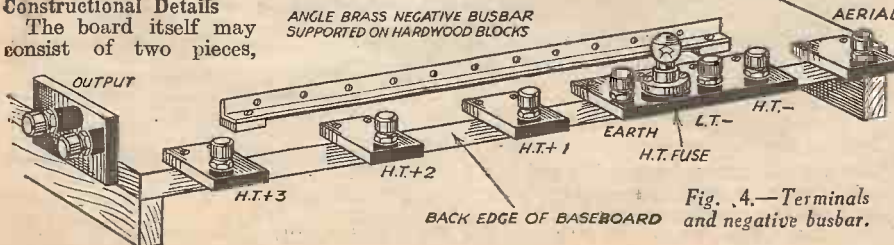

Fig. 4.—Terminals and negative busbar.

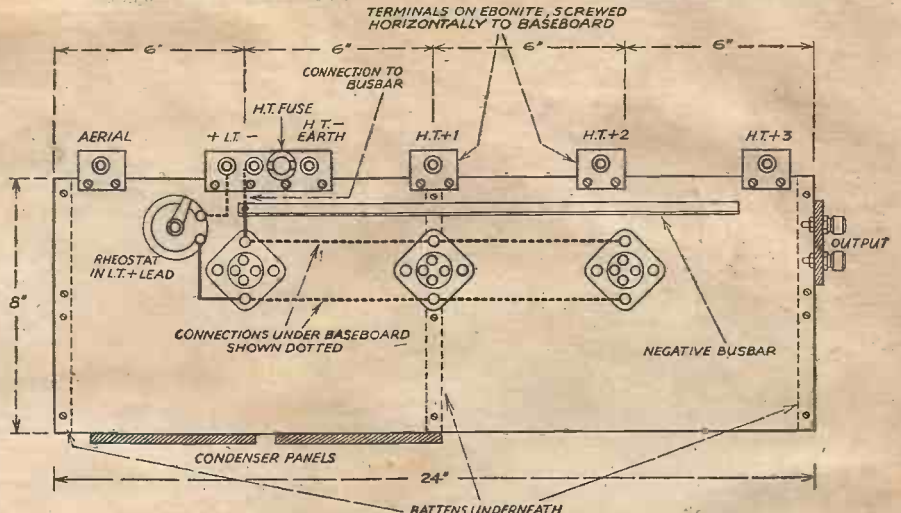

Fig. 1.—The layout of the baseboard.

each 4in. wide, of deal "matching" or "flooring." Avoid hard woods; screws for fixing the components can be put into and removed from a soft wood with much less trouble. Across each end of the boards fix underneath a batten about 1/2in. thick

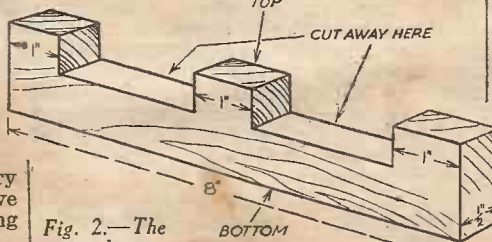
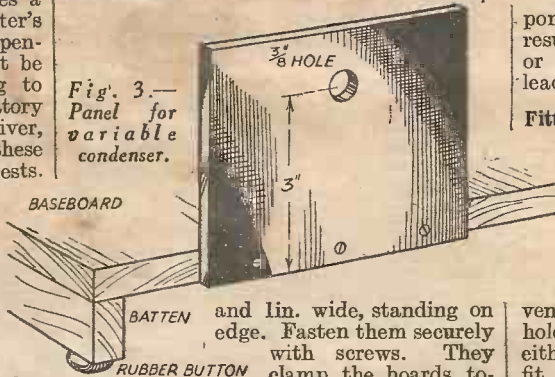

Fig. 2.—The centre batten.

Fig. 3.—Panel for variable condenser.



and 1in. wide, standing on edge. Fasten them securely with screws. They clamp the boards together, as well as support them clear of the table. Across the centres of the boards fix a piece of the same batten, with part cut away, as in Fig. 2. This centre batten will then support the boards from sagging, and will, at the same time, leave a space for wiring underneath. You can finish off underneath by fitting small rubber feet on the battens, so as to

be able to do your work wherever you like, without damaging polished furniture. Pieces of ebonite are screwed to the edge of the board in an upright position in front, to carry the variable condensers. Scrap ebonite will do quite well here, as appearance is not a serious consideration. Note that the ebonite strips carrying the terminals are fixed flat on the board along the back edge, so that the terminals themselves overhang the edge. The wires from their shanks to the components in the circuit can then be brought underneath the board and up through holes in suitable positions. The terminals may be an odd set, and not necessarily all alike. You would be unwise to omit the terminals altogether, and to make the battery connections direct to the components. This practice almost invariably results in a disastrous "short" sooner or later. The fuse in the H.T. negative lead should be included for the same reason.

### Fitting the Busbar

The negative busbar, which runs right along the back of the board about 1in. from the edge, is a most useful fitting. It may consist of a stout copper wire (12 s.w.g. at least), held by terminals at each end. The connections are then soldered to this wire. Better still, and more convenient, is a length of angle brass. Drill holes in it at intervals of about 3in., and either tap these out for small bolts, or fit small terminals. Mount the bar on a piece of hard wood at each end. There are leads from the components between each valve stage which have to be connected to H.T. negative; the provision of the busbar makes these connections as short as possible. You must, of course, be careful with your H.T. positive leads, as the busbar is bare metal, but with reasonable care there is little risk of damage from this cause.

When you have screwed the valve-holders to the board, drill a hole at each side of each holder, and run the positive and negative filament leads down underneath the board. Between the end valve-holder and the L.T. plus terminal insert a rheostat. This should be of the double-winding type, with an "off" position. This component permits you to use any type of battery valves, and also acts as a switch for the circuit. If you are going to mix 2-volt

(Continued on page 880)



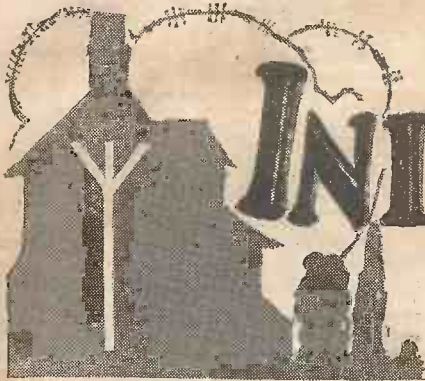

# INDOOR AERIALS

An Efficient Indoor Aerial is Better than an Inefficient Outdoor Aerial. This Article Gives Some Practical Hints on Their Installation. By DEREK ARCHER.

THE majority of us live in or around big cities or towns, and although we, in imagination, build wonderful erections of steel and wire to support the hindmost end of the aerial, in practice we usually produce a temporary affair, which lasts until the wind blows it down, when we apply a few more nails and "stick it up again," and leave the tall mast to a later date.

The area of many of our gardens does not allow of the erection of a first-class aerial, and in many cases, especially should we dwell in a modern flat, an outside aerial is often a total impossibility. There is, however, usually far more area of unimpeded space let us call it, in the roof, or if it is impossible to get into the roof, round the walls, or even between the floors, if they are of wood. In many cases an indoor aerial can be erected which can be just as efficient as a make-shift arrangement put up outside. Brick-work and plaster does not stop wireless waves sufficiently to interfere in the slightest with a modern receiver. There are some cases where difficulty does arise, and that is where the portion of the roof under which one wants to put up

the aerial is lead covered. An aerial put up under such a roof would not be very efficient, but the cure is a very simple one, although rather unorthodox. That is—use the lead roof as the aerial. I have found in many cases that, providing the area is not too large, such an arrangement is very good.

But most important is the advance in receiver design. Practically every receiver,

drilled in two places, one hole in the front to take the screw *C*, which holds the piece of  $\frac{1}{2}$  in. dowelling and another to take the screw *D*, which is used on corners, and at the end of the aerial to keep the hanger in position. The dowelling should be about 1  $\frac{1}{2}$  in. long, drilled through at *E* to take the wire, and painted to match the colour of the picture rail. Pictures can, of course, be suspended from the hook at the bottom of the hanger in the legitimate way.

The actual arrangement of the aerial round the room depends to a large extent on the shape of the room, and the position of the set. The general direction of the aerial is not important, and the arrangement shown in Fig. 2 will be found suitable in most cases. Four of the hangers shown in Fig. 1 are used for this layout, but only one need be used in the corner, making a total of three. Fig. 3 shows another layout of two wires running round both sides of the same room, but it should be noted that many more hangers are required to get the aerial round the corners, and the chimney piece, than in the simple arrangement of Fig. 2, and the results, although better, do not warrant the extra trouble.

(Continued on page 842)

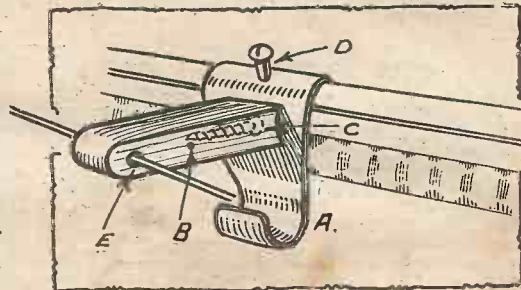

Fig. 1.—A simple hanger for an indoor aerial.

even if of the two-valve type, the simple detector, and a power valve, using about 10ft. of wire for an aerial, is capable of giving loud-speaker results within thirty miles of a main broadcasting station. If the receiver has a stage of screened-grid amplification, then many foreign stations can also be received. Further, if such a receiver is used on a large outdoor aerial, difficulty will be experienced in separating stations, unless special circuits are used. In cases of selectivity troubles, the usual advice given is that the size of the aerial be reduced, and it can usually be cut down to an insignificant size before real relief is obtained. It seems, therefore, that for ordinary listening either a very small outside, or an indoor aerial is all that is required.

### Hangers For Indoor Aerial

However, even if the aerial is short it should not be treated as insignificant. The normal losses in an indoor aerial are usually a little greater than that of a carefully-erected outdoor aerial, due generally to being close to walls which always retain a little dampness. Keeping the wire away from the wall even an inch or two will be found better than dropping the wire behind the picture rail, which is usually done. Special hangers for wire can be bought fairly cheaply, but if you prefer to make your own, Fig. 1 shows how this can be done. *A* is an ordinary picture hook,

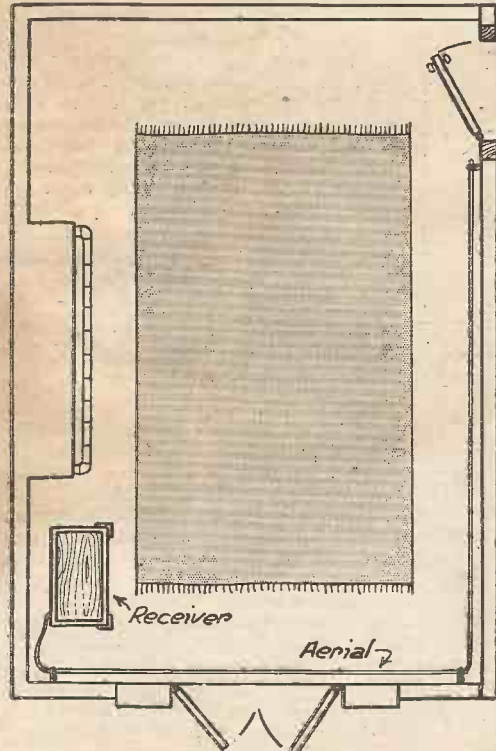

Fig. 2.—How the aerial can be arranged round a room.

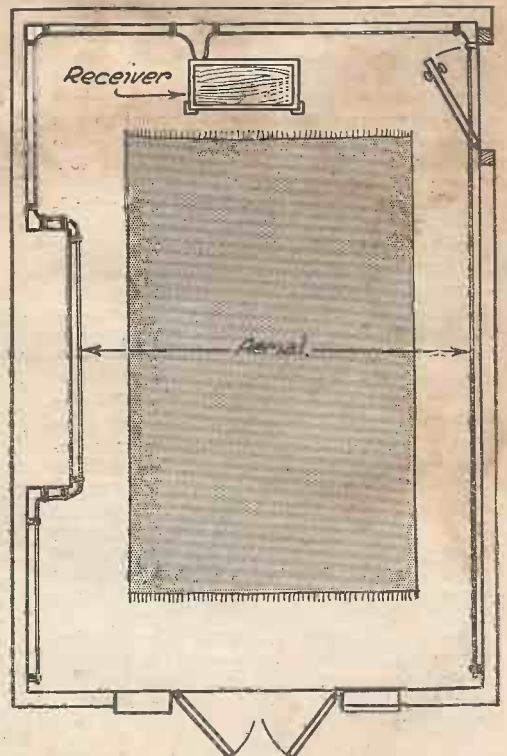

Fig. 3.—An alternative arrangement for an indoor aerial.



(Continued from page 841)

If the picture rail is rather high, the loose wire hanging from the rail looks very untidy, and the appearance of

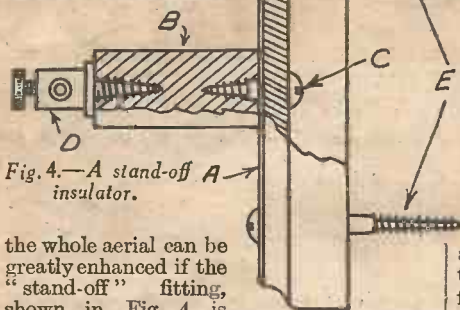

Fig. 4.—A stand-off A insulator.

the whole aerial can be greatly enhanced if the "stand-off" fitting, shown in Fig. 4, is made up and used. A is a round wood switch block, which can be purchased at any electrical shop for a few pence, already polished or painted to suit the decorations of the room. B is a piece of dowelling attached to the block from the underside by the screw C. An ordinary wood screw type terminal is screwed into the top end of the dowelling, and the block secured to the wall by the two long screws D. This type of stand-off insulator can be used in place of the hangers should there be no picture rail in the room in which it is desired to erect the aerial.

**Loft Aerials**

One hears of some remarkable arrangements, and occasionally sees them, of aerials fixed up in the loft. No arrangement which passes round and round the loft or up and over, down and round again is any more efficient than a straight wire; in fact, it is less efficient, due, of course, to the greater capacity and the unnecessary additional inductance and resistance. The best and the least difficult of all arrangements of an aerial in the roof is that shown in Fig. 5. Here the wire is brought straight up into the roof and passed round an insulated screw eye, turned into one of the roof trusses, and carried to the far end of the loft, where it is attached to an insulator, which, in turn, is attached to a hook in the end wall.

There are two ways of getting the lead-in into the roof. Fig. 6 shows a simple view of the edge of a roof. Just behind the gutter there is a small space, allowed by the builder for ventilation in order to keep the roof dry, and if the lead in is brought up out of the window and into the loft

covered with thick rubber, no difficulties are usually met with in the way of efficiency. A piece of rubber hose pipe can be used to cover the lead-in. A much better way, is, however, shown in Fig. 7, which represents a section of an ordinary ceiling. The rafters, of which the ends are shown, support laths, which in turn hold the plaster up by reason of the plaster forming a key on the top of the laths. This arrangement is not very strong, and should be treated with reasonable care. First of all, gently tap the ceiling to find the position of the rafters which give forth a "duller" sound than the space between them. Do not try to force a way through from the top of the ceiling, as this will be almost certain to result in pushing a lot more ceiling down than is necessary. Pierce through the plaster with a sharp

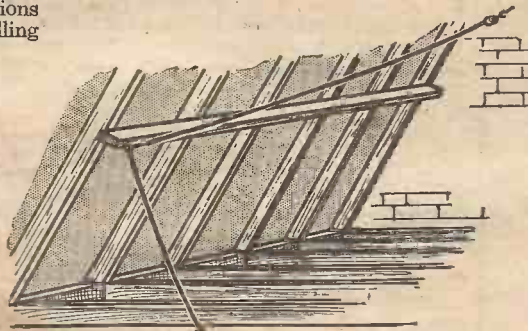

Fig. 5.—The simplest form of roof aerial.

pointed screwdriver or a long bradawl. If you meet with an obstruction try a

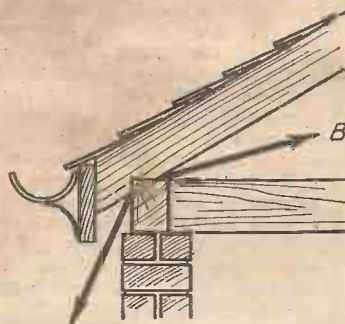

Fig. 6.—Bringing the down lead under the eaves of the roof.

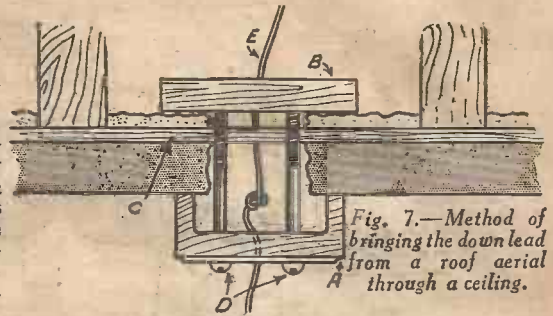

Fig. 7.—Method of bringing the down lead from a roof aerial through a ceiling.

spot half-an-inch away from the first. Enlarge the aperture through the plaster until a clear space with a slot between two laths has been made. Next cut a piece of wood about an inch thick, six inches long and two inches wide. Drill a half inch hole right through the centre of the piece of wood, through which to pass the lead-in. Drill a small hole through the centre of a circular wood block, the same as that used for the stand-off insulator shown in Fig. 4, and also two holes for screws. Place the block over the piece of wood previously cut, and mark off the positions of the two fixing holes. Enlarge these two holes in the wood, and insert the screws which are going to be used, so that they will enter easily when the whole job is being assembled on the ceiling. Fig. 7 shows how the pieces are put together, and how the aerial is brought through. A knot is tied on the lead-in wire to prevent pulling it through.

Very often, it is required to bring an aerial down through two or three floors, and this can be done in the corner of the room, especially if a cupboard occupies this space. The ceiling can be fitted with a wood block as shown in Fig. 7, and the hole in the floor provided with a guard of thick rubber hose to prevent damage. The aerial should not be attached to the wall or run down alongside water pipes.

Aerials can also be fixed under wood floors, but this is not advised if some other form can be installed, partly due to the trouble entailed in getting the floor boards up and running across the joists, and partly because of the inconvenience due to the upsetting of the tuning when some one walks across the aerial.

**SCOTTISH RADIO EXHIBITION**  
September 1st—September 9th.  
OUR STAND NO. - - - - 17

**Brussels and the Congo**

FOR some weeks past the Belgian authorities have been considering an interchange of broadcast programmes between the Belgian capital and Leopoldville (Congo). For the purpose of testing possibilities of the scheme transmissions have been carried out through the short-wave station ORK, at Ruysselede (East Flanders) and with OPM, Leopoldville, working respectively on 29.04 m. (10,330 kc/s) and 29.58 m. (10,140 kc/s). As these experiments have been of a satisfactory nature steps will be taken to erect a medium broadcasting station in the Congo capital for the re-transmission of the Brussels programmes.

**Italy behind her Neighbours**

NOTWITHSTANDING an active publicity campaign for her broadcasting

**ROUND THE WORLD OF WIRELESS**

(Continued from page 838)

system, and an equally intense hunt for radio pirates by her police, the number of wireless licences in Italy has remained relatively low. Over the period 1929-1932 Rome did not succeed in securing more than 20,000 subscribers.

The *Radio Corriere*, official organ of the E.I.A.R., in commenting on the matter, states that the total number of licence holders in the country in proportion to population is much below that of other countries. Italy, the home of Galvani, Volta, Marconi and other great inventors, cannot possibly remain at the bottom of

the list of nations possessing well equipped broadcasting stations.

**German Propaganda**

AS the authorities have noticed that the political character of the broadcast programmes has seriously checked the growth of wireless licences, the studios have been instructed to organise brighter entertainments. Most of the propaganda transmissions are being diverted to the short-wave stations, and an intensive campaign in this direction is contemplated. Programmes of this nature are being made on 19.72 m. daily from B.S.T. 13.55-22.30; from 16.00-24.00 on 25.51 m. specially destined to the United States; from 23.00-03.15 on 31.28 m.; and from 01.00-03.15 on 49.83 m. On this last wavelength an official news bulletin is broadcast nightly in German, Spanish and English.



STILL LEADING AND SHOWING THE WAY!

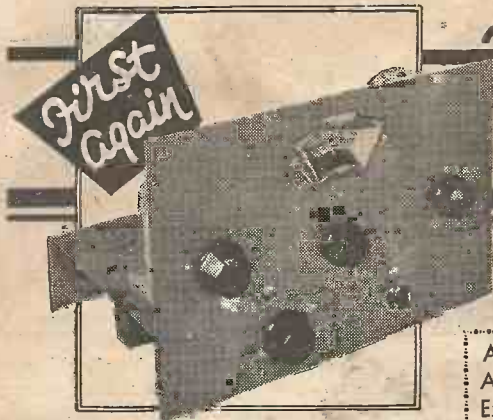

# The Auto-B Three

Every Home Constructor Should Build This Class B Receiver, which is the First Class B Set to Use Automatic Grid Bias. By W. J. DELANEY

Although There Are No Difficult Adjustments to be Made, this Article Explains How to Get the Best from this Receiver.

IN the previous article it was stated that the loud-speaker which is recommended for this receiver (the Amplion Sonette) is fitted with three terminals. Actually, this particular model is now provided with five terminals, and these are fitted with coloured indicating discs. Accompanying the loud-speaker is a pamphlet which indicates the correct terminals to use for any type of output valve, and it is necessary to adhere to the makers' instructions regarding the correct matching of this speaker to the Class B valve. Although this may seem a small point, it is, in fact, one of relatively great importance, as not only is the output reduced if matching is not correct, but the quality will suffer and the loud-speaker may be blamed for not producing the quality which is expected. The output from the Class B valve which is employed, the Cossor 240.B, is approximately 2 watts, but this will not be obtained, for instance, when tuned to Fécamp in a locality such as the North of England. Do not be disappointed, therefore, if this station can only be heard at moderate loud-speaker strength. The actual circuit of the Auto-"B" is a simple detector and two L.F. stages, and the range of a detector valve is not very great. It may be relied upon, however, to bring in a fair number of stations at really good loud-speaker strength, and if a B.B.C. station is situated within a few miles from your locality you may rely upon obtaining the full output of the Class B valve, with its attendant high quality of reproduction.

### Tuning

It was mentioned in the previous article that a tuning coil employing the new dust-iron core was employed. This coil, a Colvern product, is wound on a slightly different principle from the customary aerial coil, as may be seen from the theoretical circuit published on page 712 of the issue dated August 19th. This particular winding enables a very high degree of selectivity to be obtained, and the tuning dial must therefore be rotated quite slowly when searching for stations situated at

some distance. The best way of handling the receiver is to take the tuning control in the left hand and the reaction control in the right. Advance the reaction control

will be found that in this way many stations will be obtained which would otherwise be passed. If the station is too loud, of course the reaction control should be turned back slightly.

### Gramophone Reproduction

To use the receiver for the reproduction of gramophone records, the pick-up should be joined to the two terminals at the rear of the chassis marked "Pick-up." It does not matter which way round the pick-up is

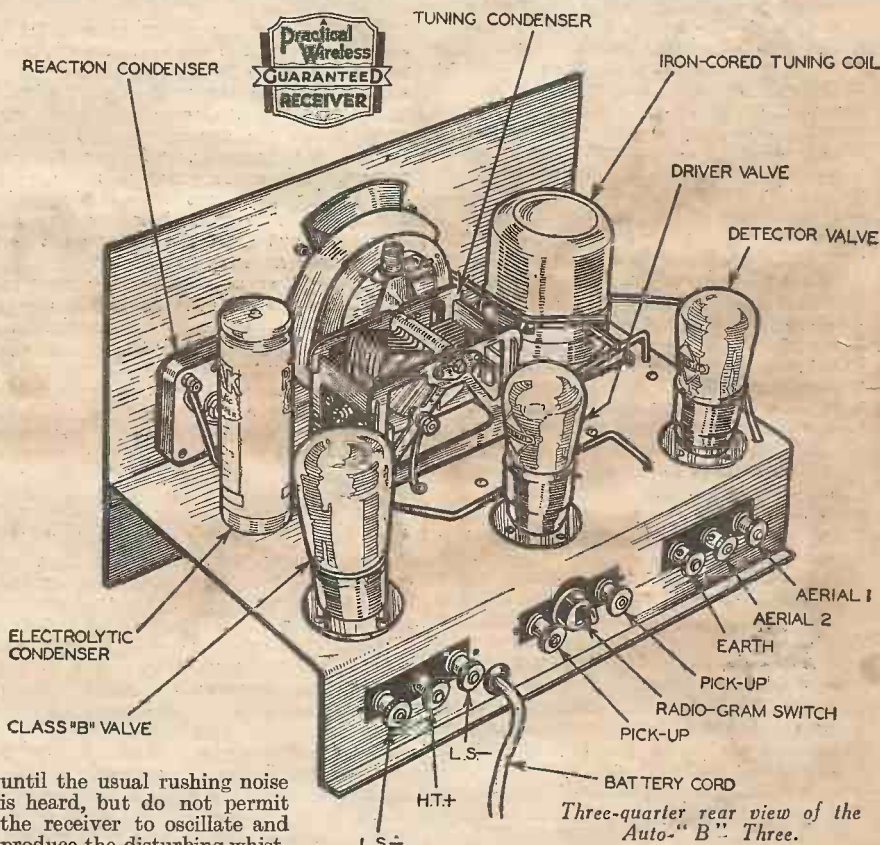

until the usual rushing noise is heard, but do not permit the receiver to oscillate and produce the disturbing whistling noise. Now, keeping the receiver in this condition, slowly turn the tuning control. When the receiver commences to oscillate, slacken off the reaction slightly, and so proceed through the complete tuning range. It

connected, nor whether or not the pick-up is fitted with a volume control. If your pick-up is fitted with three leads you will find that one of these is simply for earthing

(Continued on page 848)

### LIST OF COMPONENTS FOR THE AUTO-"B" THREE

- One "Magnum" Auto-"B" Metal Chassis (Burne Jones).
- One .0005 mfd. Variable Condenser with Vernier Dial (Telsen).
- One .0003 mfd. Reaction Condenser (Telsen).
- One Type "F.5" "Ferrocort" Coil (Colvern).
- Two 4-pin sub-baseboard Valve-holders (Clix).
- One 7-pin sub-baseboard Valve-holder (Clix).
- One On-off Switch (Busby).
- One "Toco" 4-1 L.F. Transformer (Multitone).
- One Graded Potentiometer (Multitone).
- One Class B 1-1.5 ratio Driver Transformer (Multitone).
- One 8 mfd. Electrolytic Condenser (Peak).

- Two 1 mfd. Condensers (Peak).
- Three .0001 mfd. Type "M" Condensers (T.C.C.).
- Two .01 mfd. Condensers (Peak).
- One Type "L.M.S." H.F. Choke (Graham Farish).
- One 2 megohm Grid Leak (Dubilier).
- One 250,000 ohm Resistance (Eric).
- One 25,000 ohm Resistance (Erie).
- One 500 ohm Resistance (Erie).
- Eight Treble Duty Terminals Marked "Aerial," "Aerial 2," "Earth," "Loud-speaker," "Loud-speaker —," "H.T.+", "Two "Pick-up" (Ealex).
- One Four-Way Battery Cord (Belling Lee).
- One 210 Det. Valve (Cossor).

- One 215 P. Valve (Cossor).
- One 240 B. Valve (Cossor).
- One Auto-B Cabinet (Camco).
- One "Sonette" Loud-speaker (Amplion).
- One 120-volt Annodex Class "B" H.T. Battery (Smiths).
- One 2-volt 40-Ampere Hour L.T. Accumulator (Smiths).
- One Coil Glazite.
- One Length Receptu Screened Down Lead (British Radiophone).
- One Filt Earthing Device (Graham Farish).
- One Toggle Switch (Type 460) (Becker).



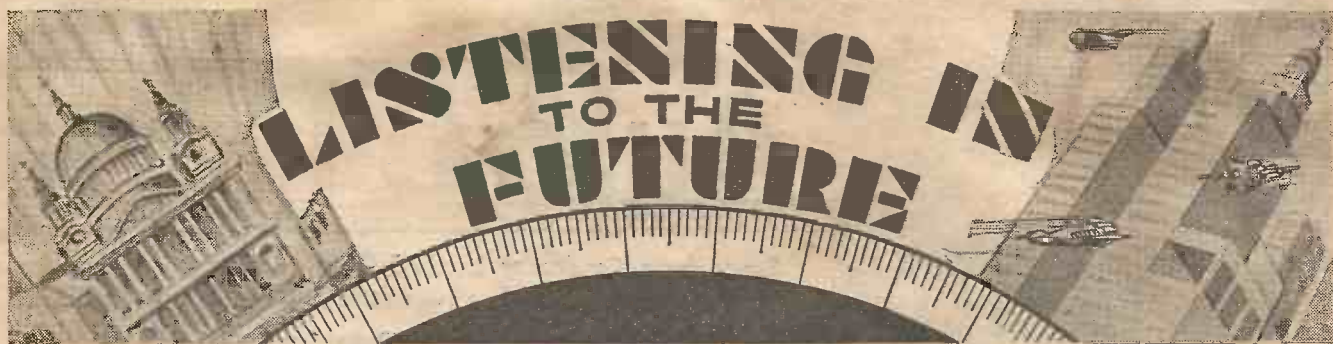

"COMING events cast their shadows before"; "History repeats itself."

These two sayings are familiar to everyone, and it is certainly true that events which take place often can be traced to have had a counterpart some time back in our history. Furthermore, certain scientists hold that events which appear to take place in our daily lives are simply etheric vibrations, and that objects which to us appear solid and substantial do not exist in fact. It is, of course, beyond my powers to argue that this book which you are now reading does not exist as an actual object, but that you are instead receiving waves of certain frequencies and your mind is being influenced to the extent that it conveys to the brain the thoughts which I now think I am typing on what appears to my mind to be a sheet of paper. But there are many things which happen every day which to some appear quite commonplace, but which to thousands are beyond comprehension. Before entering into this little talk on what may, after all, be mere fiction, I should like to explain a point which I know is inexplicable to many and which will give you some idea of the point which I raised above. Scientists tell us, and it can, of course, be proved, that many stars which we see at night ceased to exist thousands of years ago. In fact it is possible to gaze into the sky one night and "discover" a new star. That is, a star which has hitherto never been seen. By means of astronomical computation, it is perhaps possible to state that this star existed so many thousands of years ago, that it is now extinct—and yet the light from it has only just reached our earth. It has come into being, has existed for perhaps hundreds of years, and has passed out, yet the light has not reached here until years after it had ceased to exist. I know that many people cannot comprehend this fact, and when they try to visualize the distance away which that star must have been situated they become so lost that they give it up. It is the same with the problem which I now propose to deal with. To many it will appear feasible, but to others it will appear utterly ridiculous. But so long as I can give you food for thought I shall be satisfied, for I am almost convinced that I am not describing an impossibility, although it may be a long time yet before such a thing becomes possible.

#### Ether Waves

In reading your descriptions of the elementary principles of wireless, you will have read how the electrical impulses are "radiated" from an aerial and travel outwards in the form of ether vibrations. That is to say, the oscillations produced at the transmitter, together with the speech or music mixed with them, are fed into the

Will it ever be possible to tune in to the events of next year? The possibilities of such a development are discussed by  
W. J. DELANEY.

aerial wire, and the disturbance so set up travels through the medium of a substance which we call ether. I have often seen writers describe the radiation of wireless waves as being similar to the ripples on a pond which are caused when a stone is thrown into the water. This is not strictly correct. When the stone hits the water the ripples flow out in ever-increasing circles on the surface. Wireless waves do not travel out from the aerial on a level in the same manner. It is quite true that they consist of undulations (or rises and falls) in a similar manner to the ripples, but they travel away from the aerial in all directions, the aerial being the centre point. Therefore they travel outwards towards the sky and downwards towards the earth, as well as along a plane parallel with the earth. When a wireless signal is transmitted from the aerial, one part of the resultant "wave" would travel outwards and so round the earth. Would it come back to the point from which it started? The answer is "Yes." This is not guesswork, but on more than one occasion the returning oscillation has been seen in a television receiver. Obviously, it will arrive at the transmitting aerial, or any receiving aerial on the way round, at a slightly later period than when it first passes. As, however, the wireless waves travel at the speed of light—namely 186,000 miles per second—the actual difference in time is very slight indeed. From the sound point of view, therefore, it is highly improbable that the second set of signals would be heard above the first set; but in a television receiver the picture which results from the second set of signals has been seen just behind the primary image, and takes the form of a shadow. It might be argued that this is not the result of receiving a signal which has already passed round the earth, but one which is deflected from the Heaviside Layer. This is believed to be a sort of ionized layer which has the property of preventing the passage of wireless waves. It is not a perfectly smooth-surfaced belt, but has irregularities in the surface nearest the earth, and therefore varies in its height above the earth's surface. When the wireless waves strike this layer they are deflected back towards the earth, and naturally the relation between the angles of incidence and the angles of reflection are the same,

with the result that the signal will reach the earth slightly after the direct, or earth oscillation. When, however, we remember the distance round the earth, and compare this with the probable height of the Heaviside Layer, we can see that the second signal above referred to cannot have come from above, but must be the one which has already passed round the earth.

#### Duration of an Oscillation

When a signal leaves a wireless aerial it has a definite strength, and quite naturally this gets weaker as we get further away from the station. What is the degree of decrease in strength? Or in other words, does the signal ever die out? If you throw a stone into a pond a large ripple immediately starts to travel shorewards, but this gets smaller and smaller, until it hits against the side of the pond. It has not died out, but has been stopped by the bank at the waterside. Have you ever watched the passing of a ship at the seaside? Although many miles from land you can see the ship pass along with the water spreading out behind in what we call the "wake" of the ship. This seems to us from the shore or cliff to disappear, but if we watch the waves breaking on the shore, what do we see? After quite an appreciable time several successive waves break with greater force, or come higher up the beach, and it is quite easy to see that these are the increased impulses due to the original disturbance right out at sea. So it is with the wireless waves; they appear to fade out to the present apparatus. But they have not entirely died out. They are still travelling round and round, and if a sufficiently sensitive apparatus can be designed, it should be possible easily to tune in to a programme which has already passed by, and as each signal has its own frequency (or wavelength), and the individual signals are naturally travelling in their original order, a selective piece of apparatus should not be difficult to design which would pick out, for instance, last Wednesday's programme from the North National. At first, this may sound absurd, but let me remind you again of the star episode. In case you are unable to appreciate also, the fact that the waves never really die away I would give you a small problem, one which is quite well-known. A frog has to cross a road 20ft. wide. The frog covers 10ft. with his first hop, 5ft. at the second, and so on, each successive hop being half the distance of the preceding one. How long would it take for him to cross the road. When you eventually give it up you will find that it takes many, many years, because you get down to such infinitesimal amounts towards the end that practically no progress is made. So it must be with the wireless waves,

(Continued on page 860)



# IGRANIPAK

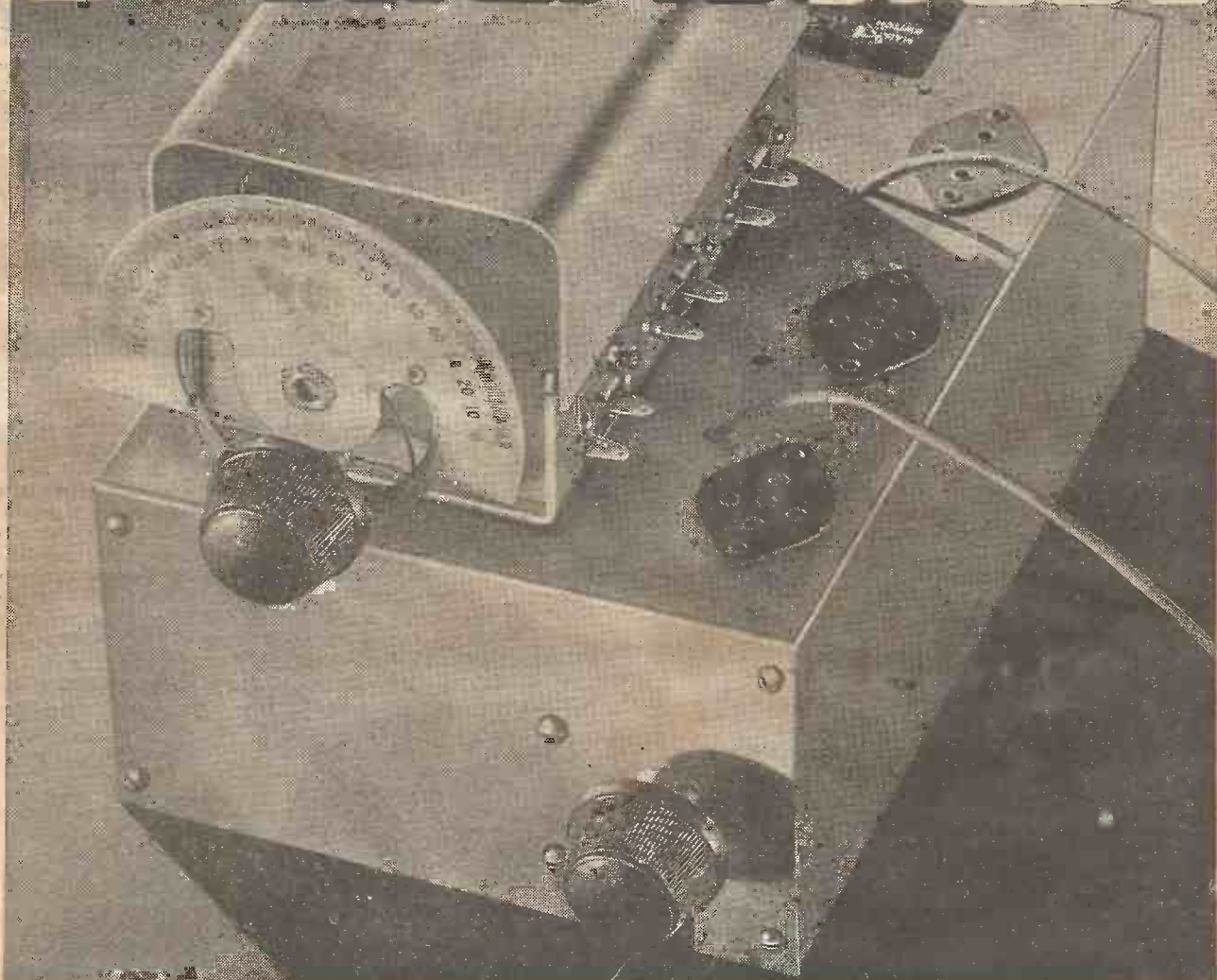

However expert or amateur you may be, this new 'Igranipak' cannot fail to save you time, trouble and expense. 'Igranipak' is a complete and compact tuning unit. Upon its rigid metal chassis are mounted:—screened coils with built-in wave-change switch, Igranic 3-gang condenser with cover, escutcheon and disc drive assembly with pilot lamp attachment, mains switch, three 5-pin valve-holders, grid leak and condenser, engraved terminal board. Wavelengths covered : 210-520m. and 900-2,000m. Complete with instructions and simple circuit diagram

**57'6**  
 If your local dealer cannot supply you please write to us direct



Write for fully illustrated Catalogue No. J126d

Igranic Electric Co., Ltd.,  
 149, Queen Victoria St., E.C.4



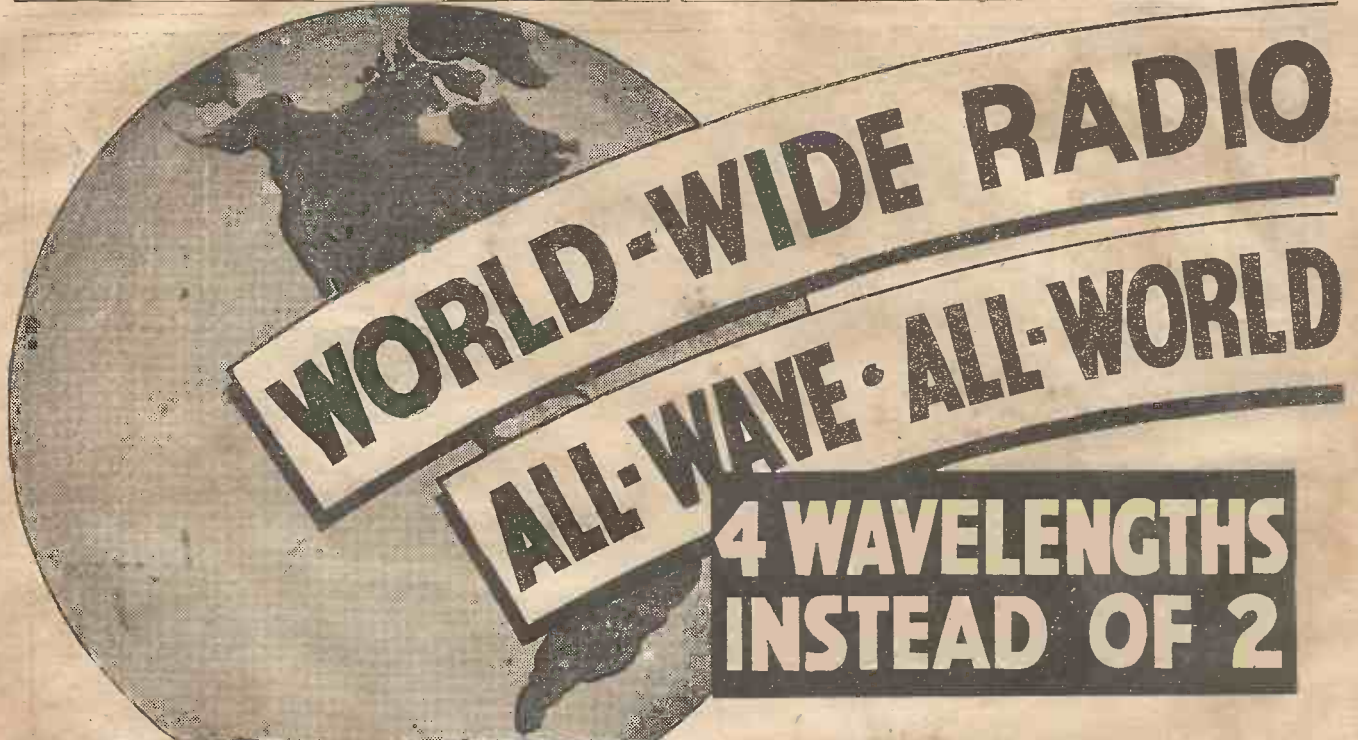

**ENGLAND and EUROPE** were always easy to get

At last the day of All-World Radio has arrived, and all the thrill of conquest has returned to radio reception with the introduction of a new Home Constructor's Kit Set by Lissen, which incorporates for the first time four wavelength ranges instead of two—which tunes from 12 to 2,000 metres—which brings America and Australia direct within the range of British listeners who hitherto have only known the home stations and the chief Continental programmes.

The Lissen All-Wave All-World "Skyscraper" 4 marks a milestone in radio progress—a milestone so important that it can only be compared to the change from crystal sets to valves. As the first valve sets made practical a range of hundreds of miles, so the new principles involved in this Lissen All-Wave, All-World "Skyscraper" make practical the thousands-of-miles ranges of Australia and America. It brings two whole new wavelength bands within reach of the ordinary listener—stations and programmes which before he was unable to receive—and leaves open for future development a field which may well be used to solve all the problems of ether-congestion at present perplexing the authorities.

**GREAT CHART FREE!**

**CHASSIS KIT COMPLETE WITH 4 VALVES £5.12.6**

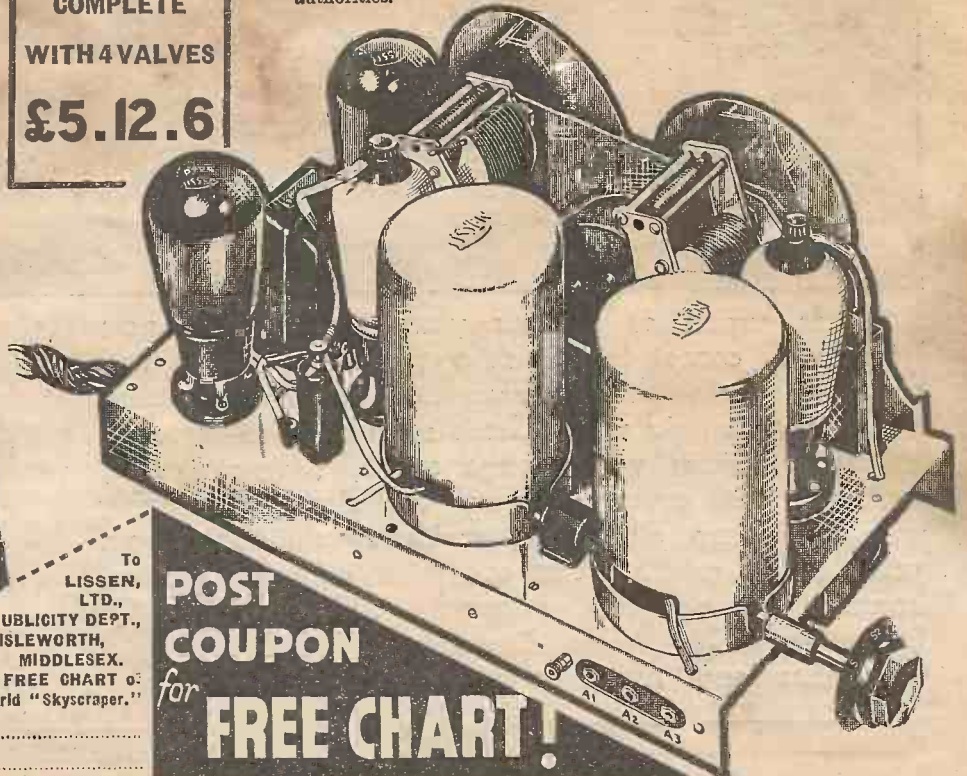
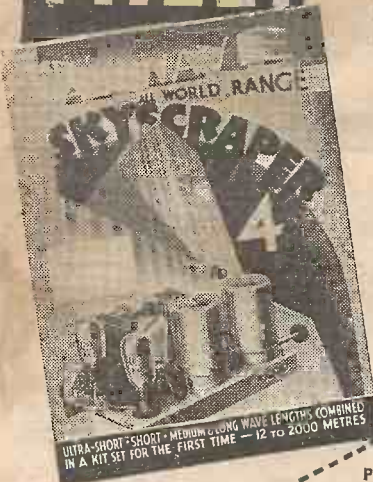

**POST COUPON for FREE CHART!**

To LISSEN, LTD., PUBLICITY DEPT., ISLEWORTH, MIDDLESEX.

Please send me FREE CHART of the All-Wave All-World "Skyscraper."

NAME.....

P.R.334 ADDRESS.....



**RECEPTION FOR YOU AT LAST!**  
**"SKYSCRAPER"**

**ULTRA-SHORT-SHORT  
 MEDIUM *and* LONG**



but you've never heard **AMERICA & AUSTRALIA!**  
**DIRECT!**

And you can build the Lissen All-Wave All-World "Skyscraper" 4 for yourself. Lissen have made it a Home Constructor's Kit Set because they feel there are thousands who, when told how, can use their own hands. Building it yourself saves you pounds in first cost, it makes you an enthusiast to feel and to hear what a wonderful thing you have created!

And when you see the Great Free Chart of the All-Wave All-World "Skyscraper" which tells you how to build it and how to work it and why it gives such marvellous results, you will agree at once that it would be wise of you to build for yourself rather than buy a factory assembled receiver when Lissen have so simplified home construction. **YOU CAN'T GO WRONG!** There are pictures of every part, with every wire numbered, every hole lettered, every terminal identified. Even the exact length of every connection is given to you!

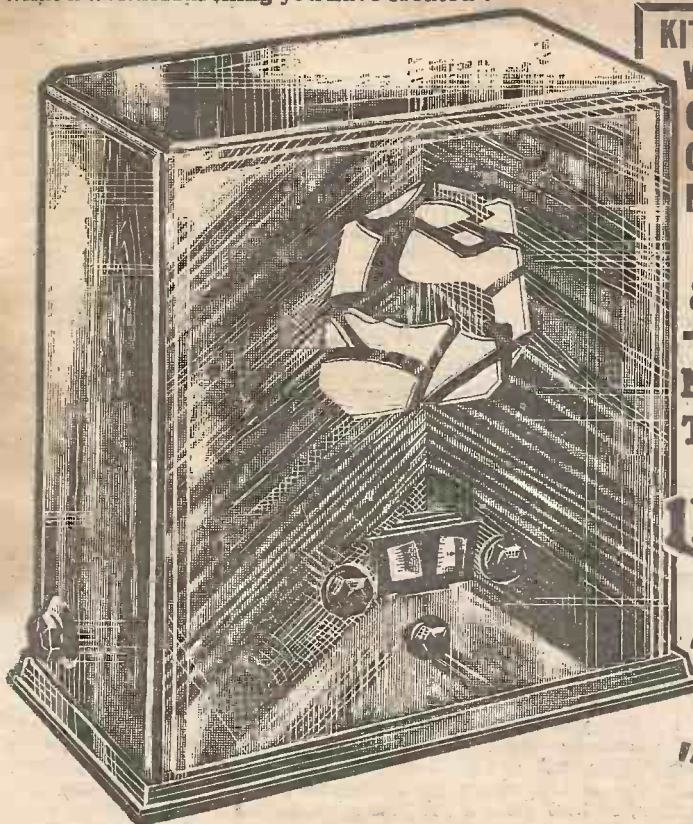

**KIT COMPLETE  
 WITH WALNUT  
 CONSOLETTA  
 CABINET AND  
 MOVING COIL  
 SPEAKER  
 £8:2:6**

But get the Chart and see for yourself—then build the Lissen All-Wave All-World "Skyscraper" 4 and become a pioneer of the World Range Radio of 1934—hear the ultra-short and short wavelength stations for the first time.

Lissen have published a splendid Chart of the All-Wave All-World "Skyscraper." It tells you exactly what to do with every single nut and screw, so that success is certain. Post coupon on left for your FREE copy.

**NOW BUILD THE SET  
 THAT SPANS THE WORLD!**

**LISSEN**  
**ALL-WAVE ALL-WORLD**  
**"SKYSCRAPER" 4**



# The Superhet

## Its Evolution & Possibilities

A Practical Article Dealing With Its Development and Modern Improvements.

By H. J. BARTON CHAPPLE, Wh.Sch., B.Sc., A.M.I.E.E.

(Continued from page 790, August 26th issue)



An early American superhet of large proportions and complete with frame aerial.

THE primary reason for the renewed interest in the superhet is the vital need for greater selectivity occasioned by the ever-increasing congestion of the broadcast wave-band. It is very unlikely that this circuit would ever have come back into favour, however, if advances in other directions had not made possible efficient solutions to the problems which, so many years before, had doomed the superhet to almost complete oblivion.

In the first place, the vastly superior efficiency of modern valves makes it possible to design a highly

employing no more than four valves, or five at the most. This, of course, economizes in both first cost and in running expenses.

Such a set might consist of one screen-grid valve operating as normal high-frequency amplifier, another screen-grid valve or high-frequency pentode which functions as detector oscillator, one, and certainly not more than two, intermediate frequency amplifying stages, also screen-grid valves, a normal detector, and pentode output stage. Alternatively, instead of the combined detector oscillator, a triode may be used as separate oscillator, with a screen-grid valve as mixer or frequency changer.

#### No Re-radiation

Modern practice has had other profound effects on the design of superheterodyne receivers. In the first place, the new circuits are quite free from risk of re-radiation, and it is therefore not necessary to employ a frame aerial. Indeed, most present-day superhets are definitely intended for use with an outside aerial.

The band-pass circuit gives ample selectivity in conjunction with the additional tuned circuits represented by the anode coupling of the high-frequency pre-amplifier and the intermediate frequency transformers, all of which are far

more efficient and more carefully adjusted than their early prototypes. Indeed, the inclusion of the high-frequency or pre-amplifier stage and the use of an outside aerial bears testimony to this, for both are required primarily to provide some reserve of amplification to make good the losses of signal strength associated with highly selective circuits.

Other remarkable improvements are the result of modern precision manufacture, whereby coils and transformers can be matched very accurately, and condensers ganged and trimmed to a nicety. In the superhet set of to-day, all the tuned circuits, including the local oscillating circuit, are controlled by one knob—at any rate, in the shop-made receivers. The extent to which accurate ganging of tuning and local oscillator can be achieved by the home constructor is open to debate—it certainly cannot be done properly without a considerable amount of careful adjustment and quantitative measurements, although a certain degree of success may be possible by trial and error.

Finally, the design of the present-day superhet is not open to very serious criticism on the score of quality of reproduction. The use of output valves giving reasonably large maximum outputs, high-class components in the audio frequency stages, and, what is much more important, the judicious use of tone control circuits places the 1933 superhet in association with real "quality" receivers.

On the other hand, it must be admitted, more recent developments in "straight" high-frequency amplification are again challenging the superhet, and as straight sets are still simpler to build and adjust, at any rate for the non-technical amateur, it is not safe to prophesy.

efficient superhet receiver, giving results very much in advance of those obtained with an old seven or eight valve outfit, yet

represented by the anode coupling of the high-frequency pre-amplifier and the intermediate frequency transformers, all of which are far

purposes, and this should be joined to the adjacent earth terminal. Push the switch down and the gramophone pick-up is in circuit. It may be found, however, that the radio may still be heard if the receiver is tuned to the local station. All that is necessary to remove this signal is to rotate the tuning condenser to its zero position, or to some point on the tuning scale where no interference is experienced. In the case of the majority of pick-ups no volume control will be necessary, but if it is found that the output from the particular pick-up in use is so great that overloading takes place, or the resultant loud-speaker signals are too great, a volume control should be fitted across the pick-up. It is not possible to give any value for this as the different

makes of pick-up require different values for the control, and therefore the makers' instructions should be rigidly adhered to in this respect. As, however, the majority of modern pick-ups are fitted with a volume control this point will not be troublesome. The automatic biasing arrangement for the driver valve will still operate when the receiver is used for gramophone reproduction, so that there is

no necessity to make any changes in the circuit. The receiver may, therefore, be installed in a radio-gramophone cabinet and used for either broadcast reproduction or gramophone record reproduction at will, although it must be remembered that the pick-up leads must on no account be permitted to wander about the cabinet, but must be kept short, and preferably screened. I think you will agree, when you put the receiver into commission, that it is capable of a really high-class performance, both from the point of view of volume and purity of signals. As a final reminder—if you experience any difficulty, either in construction or operation, do not hesitate to avail yourself of the service of our Free Advice department.

### FURTHER NOTES ON THE AUTO-"B" THREE

(Continued from page 843)



Still Leading and Showing the Way!

# The ALL-WAVE TWO

Further Notes on Operating and Testing this Remarkable Receiver, which Covers not Only the Short Waves, but Also the Usual Broadcasting Band on Medium and Long Waves.

By FRANK PRESTON, F.R.A.



THE "All-Wave Two" is a delightfully simple receiver to operate, and the average constructor will find no difficulty in obtaining excellent results within a few minutes of connecting up. But for the benefit of new readers with little experience, and for those who are unaccustomed to short-wave work, a few notes additional to the brief instructions given last week will probably be of assistance in getting the very best out of this truly remarkable little instrument.

#### Correct Grid Bias

First of all, it will be assumed that the set has been connected to the batteries in the manner outlined in the previous article, and that everything is ready for giving the set its first trial. The actual voltage of the high-tension battery is not critical, but should be not less than 100 volts—if it is, there will be some trouble in obtaining steady oscillation over the complete range of wavelengths. On the other hand, it is very important that the grid-bias voltage should be adjusted with some care, not only with a view to obtaining "quality" reproduction, but also to minimize the consumption of H.T. current. To find the optimum G.B. voltage it is best to tune in the most powerful station and then to try various voltages from 3 to 6. The highest voltage which enables the set to function correctly without producing a "choking" effect on loud passages of music should be employed; in all probability this will be either  $4\frac{1}{2}$  or 3, but it will depend to a great extent upon the particular sample of pentode valve and upon the condition of the 120-volt H.T. battery. Perhaps I may be excused for repeating the old, yet very important, warning that the set must be switched off every time a grid-bias adjustment is to be made; failure to follow this rule might result in the pentode being damaged. After the most suitable G.B. voltage has been decided upon it should not require to be altered again for several weeks, or until the H.T. battery begins to run down.

#### Selectivity Adjustments

To avoid any unnecessary complications the set should first be tried on the broadcast bands, which are brought into use by pushing in the knob of the upper (3-point) wave-range switch. The crocodile clip attached to the pre-set aerial condenser can first of all be connected to the least selective, and, incidentally, the most sensitive tap-

ping—terminal number 3 on the short-wave coil (nearest the panel). This clip is merely opened with the finger and thumb and allowed to grip the head of the terminal. Next, set the reaction condenser to its "all out" position by rotating the knob counter-clockwise, and find the local station by slowly rotating the tuning dial. When the station has been found its strength can be increased by advancing the reaction control, taking care not to turn it so far that the set is allowed to oscillate. The next operation is to adjust the value of the pre-set aerial condenser; this is done by screwing the knob up or down until maximum volume is obtained. In almost every case it will be found that the latter condition is fulfilled when the knob is screwed as far down as possible. It should be noted in passing that the tuning will be altered to a slight extent by changing the capacity of the pre-set and should, therefore, be readjusted accordingly. After this setting has been found, selectivity will most likely be insufficient, so the crocodile clip should be transferred first of all to terminal 4 on the

short-wave coil and then to terminal 2 on the broadcast one, until tuning is as sharp as is required. Provided that the aerial is suitable, and that other conditions are right, the most powerful station on the medium-wave band should not "spread" over more than three or four degrees on the tuning dial. If the "spread" is greater than this, due to the use of a particularly long or directional aerial, it would be best to reduce the length of the aerial, but tuning can also be sharpened by slightly unscrewing the knob of the aerial pre-set. This latter method is not to be recommended, because it is bound to result in the loss of signal strength, especially on more distant stations. On long waves (wave-change switch turned clockwise), tuning will be a little broader, but even then no station should cover more than seven degrees or so, whilst it should not be difficult to separate stations like Daventry and Radio-Paris; if it is, there is obviously something wrong with the aerial system.

#### Increasing Volume on Long Waves

In some localities it might be found that long-wave stations do not come in so loudly as may be desired. This will be due to the situation and to shielding effects, but quite often an appreciable improvement can be obtained by connecting the aerial lead-in direct to the crocodile clip.

(Continued overleaf)



A three-quarter rear view of the "All-Wave Two."





(Continued from previous page)

### Short-Wave Tuning

Short-wave tuning is perfectly easy if the operator will remember to rotate the condenser knob *as slowly as possible*. Selectivity is extremely good, and stations will be missed entirely if the condenser is turned quickly. It will generally be best to commence short-wave "searching" by turning to the lowest waveband (15 to 30 metres), since there are more signals to be heard here. The knob of the 3-point switch must be pulled out and the wavechange switch turned to the left; also put the crocodile clip on terminal number 3 on the short-wave coil. Before trying for stations it is best to make sure that the set is oscillating properly, and this can be done by turning the reaction condenser first one way and then the other. After it gets to a certain point a "rushing" or "breathing" sound should be heard in the speaker (or 'phones, which are to be preferred for S.W. reception). Moreover, it should be possible to keep the set oscillating over the whole of the condenser dial between 0 and 60 degrees. At first it will probably be found that the set either does not oscillate at all, or only oscillates over a small portion of the dial. In that case the pre-set aerial condenser should be slacked off until the desired state is obtainable. Where an extremely long or inefficient aerial is employed it might be found that proper oscillation cannot be obtained no matter how the pre-set is adjusted—the cure is obvious.

After the receiver has been made to oscillate properly, set the tuning dial to zero and turn the reaction control to the point at which the "breathing" sound can just be heard. Next turn the tuning knob slowly and, if necessary, alter the reaction setting at the same time, so as to keep the set in its most sensitive condition. Reaction control is critical on short waves and makes all the difference between good and moderate reception; either too much or too little reaction reduces sensitivity tremendously. By slowly turning the condenser dial various "chirps" and "squeaks" will be heard; some of these will be telephony stations and some the less interesting morse ones. The latter can be identified by the fact that they sound like a series of sharp "chirps." Telephony stations are heard as a continuous "whistle," and can be made to give clear reception by slightly reducing the capacity of the reaction condenser and at the same time carefully re-tuning. A very little practice will soon enable the beginner to become quite proficient in the art of short-wave tuning.

### Good Loud-Speaker Reception

Before presenting the "All-Wave Two" to readers of PRACTICAL WIRELESS, I subjected it to a series of rigid tests to make perfectly sure that it could be relied on to give satisfactory results in the hands of any and every constructor, and to ensure that it was worthy of the guarantee which goes with every receiver described in these pages. The set was tested on a 20ft. indoor aerial situated some twelve miles south-west of Brookmans Park. During the summer afternoon the London Regional and National, Midland Regional, Hilversum, and Langenberg were all heard at good speaker strength at approximately 70, 32, 76, 47, 93 degrees respectively on the medium-wave band. On the long waves, Luxemburg, Warsaw, Daventry, and Radio-Paris were received at 20, 60, 74, and 83 degrees. All the stations just

mentioned were entirely free from interference of any kind, and were sufficiently loud to enable comfortable listening. Naturally, the two London stations were received most loudly, and these were, in fact, at sufficient strength to make it necessary to cut down the volume by slacking off the reaction condenser. The quality of reproduction was very fine indeed, and superior to that of any two-valve receiver I had ever heard before. Entire absence of "background" noises was a feature that was very welcome after being accustomed to listening on a more powerful set, and this alone provides a very strong argument in favour of the two-valver. The fact that there was at no time any sign of break-

in the tests. Nevertheless, the tuning positions mentioned above will serve as a guide, and will enable the constructor to judge with fair accuracy the positions on the dial of other stations.

### Short-Wave Stations Received

Listening at 9 p.m., a number of stations could be well received on the short waves, the most powerful of these being Zeesen (5 degrees), Rome (31 degrees), and Khabarovsk (48 degrees), on the 28 to 80 metre waveband, and Buenos Aires (42 degrees), Chapultepec (36 degrees), Schenectady (17 degrees), and Bound Brook (8 degrees) on the lowest waveband. Actually, all these stations were picked up on the loud-speaker, but only about four of them were at comfortable "programme" strength. All of them, and dozens more, could be heard with perfect ease on the 'phones. The condenser readings given will be of assistance in helping you to locate some of the more easily received short-wavers, although the figures will not apply exactly to sets used on different aerial systems. As a further guide, it might be pointed out that the stations working on the 19-metre band are to be found between 5 and 10 degrees of the dial, on the lowest waveband, those working on about 30 metres come in between about 36 and 50 degrees on the same band, whilst hosts of amateur stations in all parts of the world working on 40 metres or thereabouts, are to be found between 21 and 26 degrees of the condenser on the higher short-wave band.

As a conclusion to the tests, measurements were made of the current consumption of the "All-Wave Two," when it was found that the H.T. current was slightly over 6 milliamps. In consequence, the low-capacity, high-tension battery specified should have a useful life of from four to six months. The low-tension current was found to be just .3 amp (as was to be expected), so that the accumulator will operate the set for at least sixty hours on each charge. Should you experience the slightest difficulty, either in construction or operation, remember that our Query Department is available, free of charge, to answer any of your problems.

### Just Published

## The WIRELESS CONSTRUCTOR'S ENCYCLOPÆDIA

(2nd Edition)

By F. J. CAMM

(Editor of "Practical Wireless")

THIS invaluable encyclopædia is written in plain language by one of the most accomplished designers and writers on wireless construction. The whole subject is fully covered, and the volume is remarkable for the number of practical illustrations it contains.

No matter in what branch of radio you are interested, you will find everything adequately dealt with here.

Obtainable at all Booksellers, or by post 5/4 from George Newnes, Ltd., 8-11, Southampton Street, Strand, London, W.C.2.

5/-

through on the long waves is striking testimony to the new iron-core coils, whilst the knife edge tuning was a feature that I have never experienced before with a single-tuned-circuit receiver.

After dark, the number of stations brought in on the loud-speaker was very great, and a selection of half a dozen good

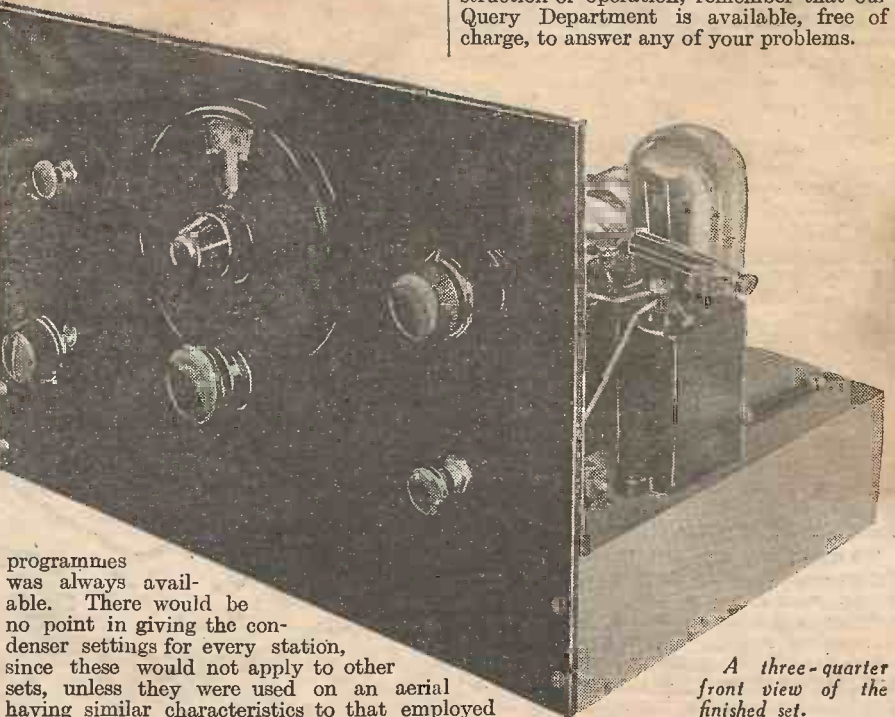

A three-quarter front view of the finished set.

programmes was always available. There would be no point in giving the condenser settings for every station, since these would not apply to other sets, unless they were used on an aerial having similar characteristics to that employed



# TELSEN

## cover every **COIL** requirement

At the new reduced prices, the wonderful Telsen range of components represents more than ever radio's finest value. Whatever your coil requirements, be sure and insist on Telsen for lasting efficiency at the lowest cost consistent with quality.

### TELSEN IRON-CORED SCREENED COILS

The result of extensive research, these Coils employ an iron-dust core, achieving greatly reduced size, with considerably higher efficiency than that of the majority of air-cored coils. Magnification and selectivity are correspondingly improved, the metal screening also preventing inter-action. For use either as aerial tuning coils or H.F. transformers, a reaction winding being included.

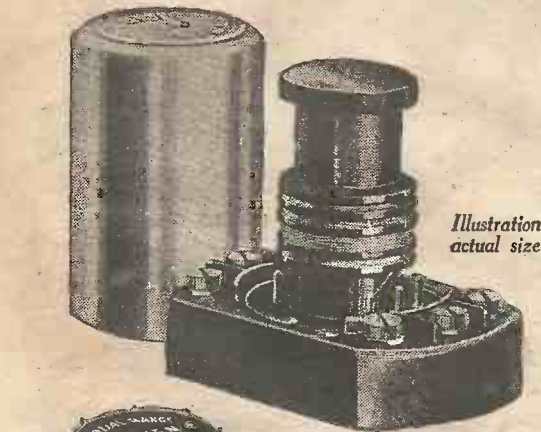
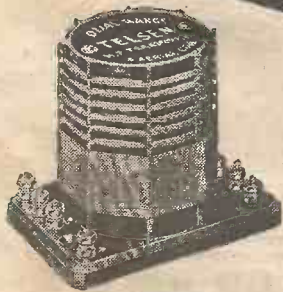

Illustration actual size

|           |                      |         |       |      |
|-----------|----------------------|---------|-------|------|
| No. W.349 | Single Coil          | .. .. . | Price | 8/6  |
| No. W.422 | Twin Matched Coils   | .. .. . |       | 17/- |
| No. W.423 | Triple Matched Coils | .. .. . |       | 25/6 |



### TELSEN DUAL-RANGE AERIAL COIL

Incorporates a variable selectivity device, making the coil suitable for widely varying reception conditions. This adjustment also acts as an excellent volume control, and is equally effective on long and short waves. The wave-band change is effected by means of a three-point switch and a reaction winding is included.

Price .. .. . 5/6

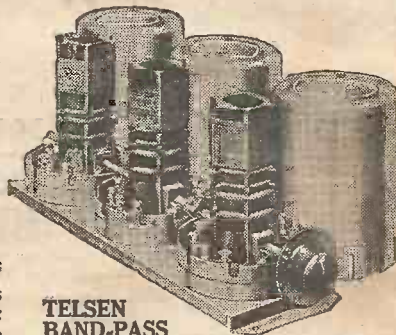

### TELSEN BAND-PASS AND OSCILLATOR COIL UNIT

Comprises the Band-Pass Coils and Oscillator Coil combined into a single compact unit. All wave change switches are ganged, with single knob control. Ideal for any Superheterodyne circuit.

Price .. .. . 21/6

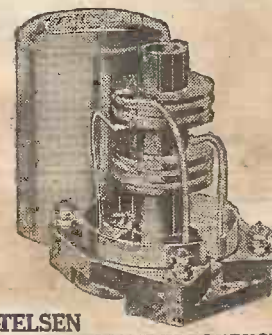

### TELSEN INTERMEDIATE FREQUENCY TRANSFORMER COIL

Consists of two tuned circuits comprising a Band-Pass intermediate frequency filter tuned to 110 kc. by two pre-set balancing condensers. Adjustable for different values of stray capacities, with variable filter coupling. Price 7/6

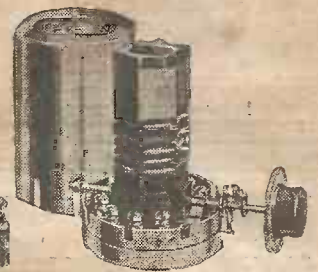

### TELSEN SCREENED TUNING COILS

With separate coupling coils for medium and long waves. Highly suitable for use as aerial coils or as anode coils following a screened grid valve, giving selectivity equal to that of a well-designed band-pass filter. Price .. .. . 7/-  
Twin Matched .. .. . 14/6  
Triple Matched .. .. . 21/6

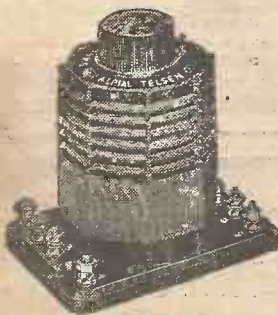

### TELSEN H.F. TRANSFORMER COIL

May be used for H.F. amplification with Screened Grid Valve, either as an H.F. Transformer, or, alternatively as a tuned grid or tuned anode coil. It also makes a highly efficient Aerial Coil where the adjustable selectivity feature is not required. Price 4/6

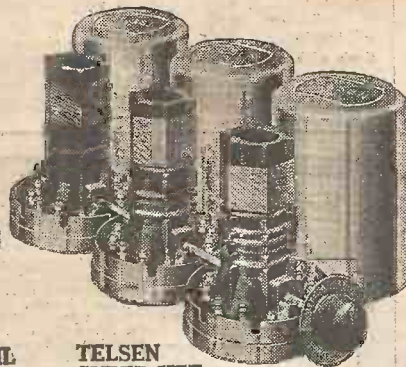

### TELSEN SUPER-HET. COILS (TYPE No. S 330)

For Superhets which do not employ band-pass tuning in their pre-detector H.F. stages. Mechanical construction and wave-change switch assembly almost identical with standard Telsen Screened Coils .. .. . Price 21/6

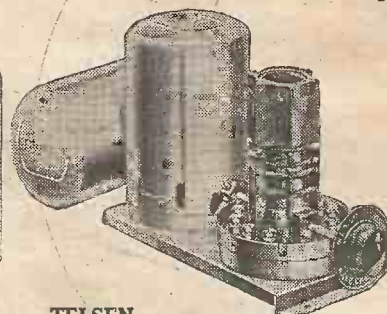

### TELSEN BAND-PASS COIL UNIT

Comprises two accurately matched Screened Band-Pass Coils, on a single rigid plinth base. The coils are independent of each other and can be wired for any of the three types of Band-Pass Filter to give exceptional quality with selectivity. Price .. 14/6

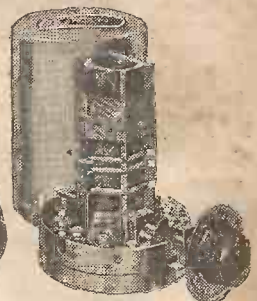

### TELSEN OSCILLATOR COIL

Particularly suited to Superheterodyne circuits in conjunction with the Telsen Band-Pass Coils. Operates at a frequency separation of 110 kilocycles from the Band-Pass tuning range. Price .. 7/6

**TELSEN FOR EVERYTHING IN RADIO**  
ANNOUNCEMENT OF THE TELSEN ELECTRIC CO., LTD., ASTON, BIRMINGHAM



# COLVERN FERROCART COILS

Made under licence from the patentee, Hans Vogt.



**SPECIAL G Type GANGED COILS**  
Complete with gramophone and wave change switch

- Two Gang .. .. 25/-
- Three Gang .. .. 37/6
- Four Gang .. .. 50/-

On and off Switch if required 1/6 extra. State if required for battery or mains receivers.

**COLPAK Type H**  
Comprising Ferrocart G type Coils, Tuning Condenser, Gramophone and on and off Switch (state if required for battery or mains receivers).

Coils can be supplied for 1 SGHF stage receivers with Band Pass filter or Band Pass filter and Oscillator Coil for Super-heterodyne receivers.

Price 57/6

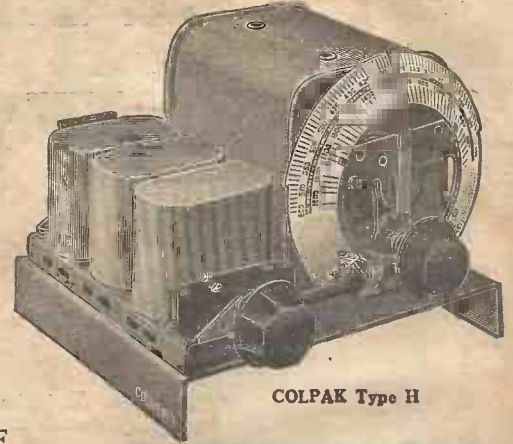

COLPAK Type H

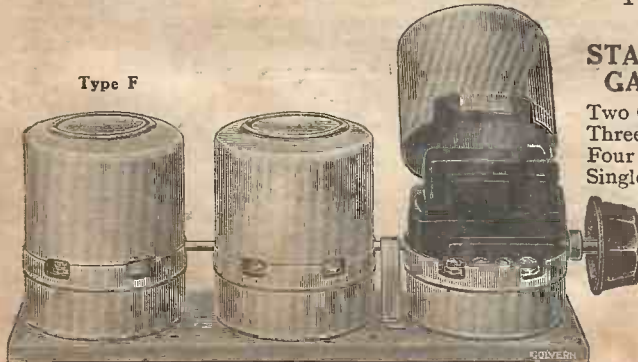

Type F

**STANDARD Type F GANGED COILS**

- Two Gang .. .. 25/-
- Three Gang .. .. 37/6
- Four Gang .. .. 50/-
- Single Coils .. .. 12/6

Send for the Colvern Ferrocart Booklet.

**COLVERDYNE FERROCART INTERMEDIATES**

- Type F C 110 } 12/6 each
- Type F C 150 }

With universal mounting bracket, limited capacity adjustment and band pass coupling controlled externally.



**COLVERN LIMITED, MAWNEYS ROAD, ROMFORD, ESSEX**  
London Wholesale Depot: 150, King's Cross Road, London, W.C.1

## BE UP TO DATE

CONVERT THAT OLD SPEAKER BY FITTING CONTRA RESONANT CONES, & OBTAIN MOVING-COIL REPRODUCTION WITH YOUR PRESENT UNIT



If your local dealer cannot supply—please send us his name

**R. O. BRIDGER & CO.,**  
No. 4 FACTORY, SHELFORD PLACE, CHURCH ST., LONDON, N.16

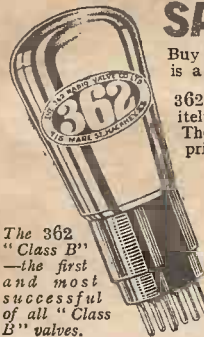

The 362 "Class B" —the first and most successful of all "Class B" valves.

## SAVE 50% ON VALVES

Buy British 362 by post direct from the makers. There is a FULLY GUARANTEED type for every purpose.

362 are Non-Microphonic and are definitely as good as any and better than most. They bring you better radio at lower prices. **BRITISH ALL THROUGH.**

Post Free from

**3/6**

- R.O., H.F., L.F., or Det., 3/6. Power, 4/- Super-Power, 4/6. S.G. or Var-Mu., 7/6. Pentode type, 10/-
- All in 2v., 4v., or 6v. Metallised 3d. extra.
- "CLASS B" 2v. filament, 7-pin base, 9/-
- A.O. MAINS VALVES, 4-volt, 1 amp. (Indirectly Heated). Prices 7/6 to 12/6. Full List post free.
- 362 UNBREAKABLE METAL VALVES (BATTERY type) will shortly be released.

Cash with order. Cheques and P.O.'s must be crossed and made payable to: THE 362 RADIO VALVE Co., Ltd. (Dept. W. 16), Stoneham Road, London, E.5.

"NEW RADIOS FOR OLD"

## RADIALADDIN'S RECORD BUSINESS AT RADIOLYMPIA

Radialaddin obtained a record number of enquiries and sales at Radiolympia this year, demonstrating that Radialaddin's popularity and reputation for genuine "exchanges" is steadily growing. Read this typical letter from a Radialaddin customer.

"I consider your allowance on my old set most generous, particularly as I was unable to find anyone in this district prepared to make any allowance at all, and I shall have much pleasure in recommending you."

—A. J. A. Ringwood, March 3rd, 1933.

★ IT WILL PAY YOU TO CHANGE YOUR OLD SET BECAUSE WE CAN GIVE MORE AND CHARGE LESS FOR YOUR UP-TO-DATE MODEL. BALANCE BY CASH OR H.P. EVERY MAKE OF SET, KIT OR RADIOGRAM SUPPLIED. ★

COMPLETE TRANSACTIONS EXECUTED BY MAIL. Write for particulars of our amazing exchange offer enclosing 1½d. stamp, naming your old set and the new model you fancy.

A FREE QUOTATION WILL FOLLOW

Visit our Showrooms for wonderful bargains.

**RADIALADDIN LTD.** (Dept. P.R.), 46, Brewer St., London, W.1.  
The largest Radio Exchange in the United Kingdom. Phone: Gerrard 4055.











# NOW YOU CAN BUILD A SET FOR BOTH A.C. & D.C. MAINS

## TUNGSRAM PRODUCE AN A.C.-D.C. UNIVERSAL VALVE

Tungsrans have achieved it—a Universal Valve which works on both A.C. and D.C. mains. With these Tungsrans Universal Valves any circuit can be built. All valves, including rectifier, are indirectly heated—there is practically no hum—and they are really economical, for the mains consumption is only 35 watts. Your dealer stocks them—go to him to-day! Or post the coupon for full particulars and circuit diagrams.

### THERE IS A TUNGSRAM VALVE FOR EVERY RADIO NEED

| Type     | Amp. Fac.                 | Slope mA/V | Use                        | Price |
|----------|---------------------------|------------|----------------------------|-------|
| HP 2018  | 5,000                     | 3.5        | H.F. Pen/Det freq. changer | 14/6  |
| HPE 2118 | 2,000                     | 3.5        | V/mu H.F. Pen A.V.C. Mixer | 14/6  |
| SS 2018  | 900                       | 3.0        | S.G.H.F.—Det               | 14/6  |
| SE 2118  | 700                       | 3.0        | V.Mu steep Slope S.G.      | 14/6  |
| S 2018   | 400                       | 3.0        | S.G.H.F. Det               | 10/6  |
| SE 2018  | 400                       | 1.2        | V/mu S.G.H.F.              | 10/6  |
| R 2018   | 40                        | 1.4        | Steep Slope Det.           | 13/-  |
| G 2018   | 25                        | 3.0        | Det L.F.                   | 17/-  |
| P 2018   | 7                         | 4.0        | Power Driver               | 17/-  |
| PP 2018  | 80                        | 2.5        | Multigr. Output ditto      | 17/-  |
| PP 4018  | 60                        | 3.0        | Wave Rect.                 | 10/6  |
| V 2018   | 70 M.A. D.C. Resist. 250  |            | Fullwave Rect.             |       |
| PV 4018  | 120 M.A. D.C. Resist. 250 |            |                            |       |

All Valves '18 Ampere indirectly heated for series heating.



# TUNGSRAM UNIVERSAL VALVES

### COUPON

To TECHNICAL DEPT., TUNGSRAM, LTD., 72, OXFORD STREET, LONDON, W.1.  
Please send me full details of Tungsrans Universal A.C.-D.C. VALVES, AND OF THE COMPLETE TUNGSRAM RANGE.

NAME .....

ADDRESS .....

PR.W. ....



# "MATCHED PERFECTION"

## -a necessity for every modern set

THE high standard of selectivity demanded to-day makes it essential to have ganged condensers matched to the nth degree. For this reason British Radiophone Condensers are invariably chosen by professional designers and by private constructors. There are no more perfect or accurately matched components on the market. Radiophone condensers are guaranteed to be within  $\frac{1}{2}$  of 1%, and each product has to pass sixteen different tests before despatch. The all-steel frame and girder construction ensure freedom from mechanical distortion and give you permanent matched perfection.

You can use any Radiophone product with confidence. But to be SURE of satisfaction INSIST on British Radiophone.

# RADIOPHONE

## MATCHED PERFECTION

BRITISH RADIOPHONE LTD., ALDWYCH HOUSE, ALDWYCH, W.C.2

INSIST ON "MATCHED PERFECTION"



# SOLUS SPECIFICATION

for the

# "SUPERSET"

No more haphazard matching! Seventeen transformer ratios for really accurate matching to any power valve or pentode and four ratios for Class B or QPP all available on one speaker by a simple switch adjustment! Added sensitivity due to the "Mansfield" magnetic system and better balance through accurate matching give a performance you must hear to believe!

'MICROLODE' type  
P.M.4A 42/-  
P.M.6 - 32/6



# 'MICROLODE' feature

(Regd. Trade Mark)

Write NOW for the W.B. MICROLODE folder  
Whiteley Electrical Radio Co., Ltd., Dept. D., Radio Works, Mansfield, Notts.



# LIGHT MODULATION for TELEVISION

A Brief Description of the Various Methods Employed. By H. J. BARTON CHAPPLE,

Wh.Sch., B.Sc., A.M.I.E.E.



Fig. 5.—The complete Baird grid cell unit, showing the lamp mounted in the holder.

A SHORT time ago in PRACTICAL WIRELESS I drew the attention of readers to the importance of the source of light which has to be modulated by the incoming radio signals in any form of television receiver. Upon the successful functioning of this part of the complete apparatus will depend the brightness and colour of the resultant images. In the simple disc model machine a neon lamp is utilized, but the prime objection here is the relatively low intensity of light available

**Glow Modulation**  
In addition, of course, we have the hot cathode or crater point type of neon lamp, which furnishes a relatively intense spot of light that can be employed in conjunction with a mirror drum to produce an image field on a front screen, as in the experimental model illustrated in Fig. 1. Both the flat plate neon lamp, for use with a perforated disc, and the crater point neon lamp, for projection work with mirror drums, are shown in Fig. 2, left and right respectively, and it should be remembered that these lamps are worked direct. That is to say, they are first of all "struck" or made to glow with a definite applied voltage and current, which acts as a polarizing source, and then their resultant illumination is made to vary (glow darker or brighter) according to the strength of the received television signal passed on from the radio set, and in this way build up the image in association with the scanning device.

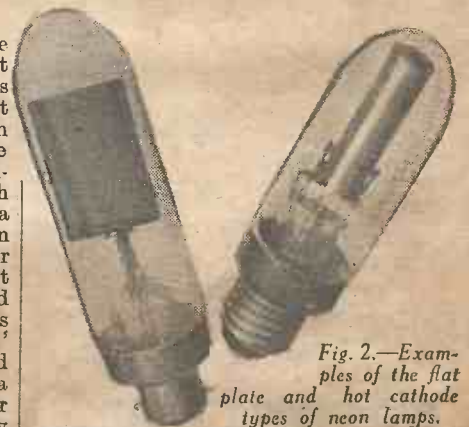

Fig. 2.—Examples of the flat plate and hot cathode types of neon lamps.



Fig. 3.—Representative samples of Iceland Spar.

for building up the images. With the ordinary type of neon lamp, therefore, it is not possible to project the light through the small holes in the disc so that the image can be viewed on any form of translucent screen placed in front of the revolving disc. On the other hand, I pointed out recently in another "Tele-Talkie" article how developments are taking place rapidly in these gas-filled light sources, and should these materialize in a simple practical form one of the prime objections to employing disc television receiving apparatus may be removed.

As I indicated earlier, however, the images as a rule lack intrinsic brilliancy, and for mirror drum working at least a light modulation device of greater efficiency is called for. As a result of this many experiments and television workers have turned their attention to what is termed the Kerr cell.

**The Kerr Effect**

A complete explanation of the Kerr effect and the manner in which it is utilized is too involved to deal with here, so I shall content myself with a brief analysis. A Kerr cell consists principally of a combination of plates arranged alternately somewhat as in a fixed condenser, and interposed with separators at the edges, all of which is immersed in a liquid called nitro-benzine, or a medium of similar electro optical properties. Now anyone who has had anything to do with the study of light knows that a beam

of light consists of transverse vibrations in all directions at right angles to the direction of propagation.

**Nicol Prism Action**

If we take a Nicol prism and insert it in the light beam its action is to select the component of all these vibrations lying in the direction of a given line, fixed with respect to the prism. For the benefit of those readers who are unfamiliar with a Nicol prism, let me enlighten them by stating that it is a suitable length of Iceland spar (samples of which are shown in Fig. 3) cut along the long diagonal, ground and joined together again by a thin layer of Canada balsam. The refractive index of Canada balsam for any light

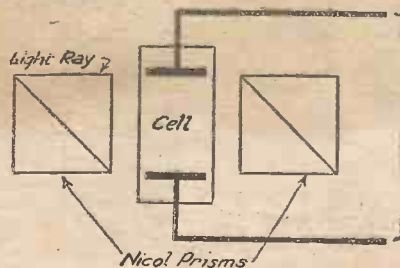

Fig. 4.—A schematic representation of a Kerr cell combination.



Fig. 1.—An experimental model television projector receiver using a hot cathode neon lamp.

is intermediate to the refractive indices of the Iceland spar for the ordinary and extraordinary rays into which the light  
(Continued overleaf)



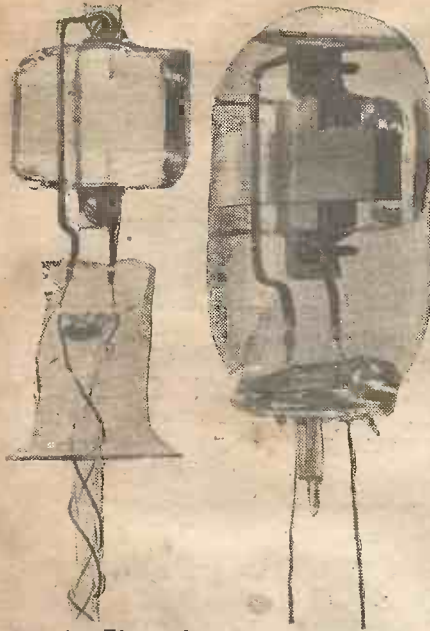

Fig. 6.—The grid cell resembles somewhat this form before it is immersed in the fluid.

Fig. 7.—The cell hermetically sealed in its glass container.

(Continued from previous page)

ray is split. It is therefore possible to get rid of what is known as the ordinary ray by total reflection, while the extraordinary ray passes on practically unaffected.

The ray which passes through the Nicol prism is polarized in a certain plane, and to prove that the light is in this peculiar condition we have only to take a second Nicol prism and view the light through it. When the two Nicol prisms are placed so as to have the similar crystalline faces parallel to one another, the second Nicol will transmit the light which has passed through the first Nicol. On the other hand, if the second Nicol prism is rotated through a right angle and thus set so as to pass only components in

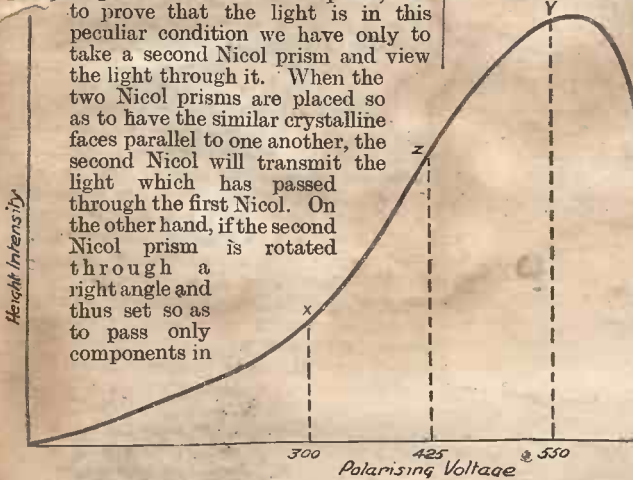

Fig. 8.—The light intensity polarizing volts curve for the grid cell combination.

a direction at right angles to that of the components passed by the first, the net result would be that no light would get through the combination.

The two Nicols are then said to be "crossed" and if either is rotated, light will again appear. The first Nicol prism is called the polarizer, and the second the analyser, because by it the polarized condition of the ray, after it has passed through the polarizer, is recognised.

**Cell Action**

The foregoing may at first sight appear irrelevant to the subject we are discussing, that is, a certain aspect of television, but in reality it is of the greatest importance.

for Nicol prisms and their peculiar "reactions" to light play a most important part in a Kerr cell combination. If we place one of these cells between the two Nicol prisms, whose action we have just been discussing, and apply a varying voltage to it as roughly indicated in Fig. 4, then it has the effect of distorting the line of vibration passing through the first prism into an ellipse, of eccentricity progressively changing as the applied electrical voltage between alternate layers is increased, passing through a circle and eventually becoming a line of vibration at right angles to the initial direction.

Accordingly, a progressively increasing component is available for passage through the second or analysing Nicol prism. With a good cell the variations of light passing through the combination are practically proportional over a definite range to the corresponding voltage variations due to an applied signal. If we make the voltage variations those due to received television signals passed on from a radio receiver, the reader will at once see that with this device we have a method of modulating a light beam so that the light variation is almost proportional to the light scanning analysis which produced the signal originally at the transmitting end with the aid of photo-electric cells.

Now this scheme has been known and tried by television investigators for some time, but apart from results obtained in a laboratory under skilled attention, little success seems to have been achieved. Originally, the cells, for good action, needed a few thousand volts and, according to the degree of craftsmanship used in building up the cell, gave images which were not consistent. Naturally amateurs have made up cells themselves when building television receivers of the projector type, but although images of a kind have been obtained, they were disappointing and crude, and obviously this course is one which is not recommended to readers of PRACTICAL WIRELESS any more than it would be suggested that they should make

up valves for themselves and expect to achieve good results. The production is a specialist's job, backed by considerable experience.

**A New Product**

Attention should therefore be turned to the proper commercial product, and I am glad to be able to pass on the first news concerning such a device. It is known as the Baird Grid Cell Unit, being marketed by Baird Television, Ltd. The complete arrangement is seen in Fig. 5, the cell alone

being featured in Figs. 6 and 7, and these illustrations call for an explanation.

Briefly, the cell is made up from a set of very thin interleaved electrodes as indicated in Fig. 6. These are then immersed in a fluid in a glass container and hermetically sealed, giving a clear aperture for the passage of light which is one tenth of an inch square. The sealed cell is shown in Fig. 7, and this is mounted finally in a holder or insulating base having two terminal pins,

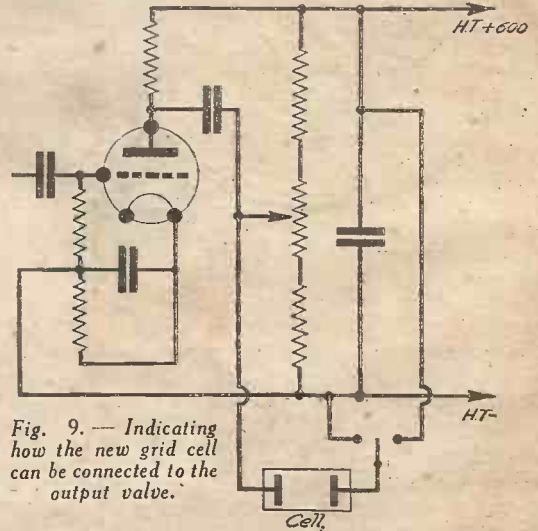

Fig. 9.— Indicating how the new grid cell can be connected to the output valve.

as seen on the right of Fig. 5. The cell is then mounted in a shaped holder so that it is positioned between two light polarizing or Nicol prisms. These prisms, whose action I described earlier, have been made to a very efficient formula, and in this way effect a considerable increase in light, a factor which was one of the objections to the original Kerr cell Nicol prism combinations. In the commercial unit the prisms are orientated one to the other so that a minimum of light is passed through the assembly when zero voltage is applied across the cell pins, this corresponding to the "crossed" condition to which I referred in my explanation of the Nicol prism action.

**Cell Range.**

What happens now when a difference of potential which can be varied is given to the cell electrodes through the medium of the pair of pins? This is shown quite clearly in Fig. 8 where we have light passed through (that is, light intensity) plotted vertically against polarizing volts horizontally. First of all, the curve indicates a somewhat gradual rise up to a value of 300 volts, and

(Continued on page 869)



Fig. 10.—The unit with lamp removed, and showing the condenser lens.



# TESTS WITH A NEON LAMP

How It Can Be Used for the Checking of High Resistances by the "Flash" Method. By W. B. RICHARDSON

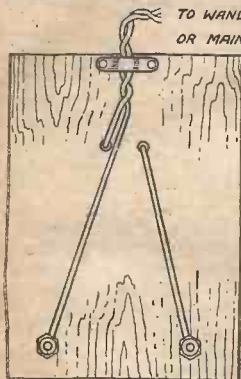

Fig. 2.—The wiring underneath the test board.

**T**HE ordinary neon lamp as sold for domestic lighting has other applications than that of an "electric night light." Perhaps its greatest sphere of usefulness is as a testing device for the radio constructor. Continuity and insulation tests, condenser tests,

and the determination of the values of resistances are all possible with the aid of one of these useful gadgets.

Before carrying out any work with the lamp it is just as well to mount it in a holder on a small wooden base. A small "charging" board as used for accumulator charging from D.C. mains will answer the purpose very well. Such a board is illustrated in Fig. 1 and the wiring underneath is given in Fig. 2.

### A "Flashing Sign"

The usual application of the lamp by the radio constructor is as a circuit tester, and indeed, in this direction it is very useful. However, the purpose of this article is to give not only these tests but to describe a further use of the lamp, namely, a means of finding out the values of grid leaks and high resistances. By a suitably arranged circuit the lamp will give a series of intermittent flashes, the speed of the flashes determining the value of the resistances under test. Besides being a very interesting experiment in itself—it provides quite a novel "flashing sign" without any mechanical mechanism—it is an easy method of checking just those resistances which are usually most difficult to measure, namely, very high ones. With ordinary meters accurate results are very difficult to secure owing to the small readings obtainable.

The neon lamp does not, of course, re-

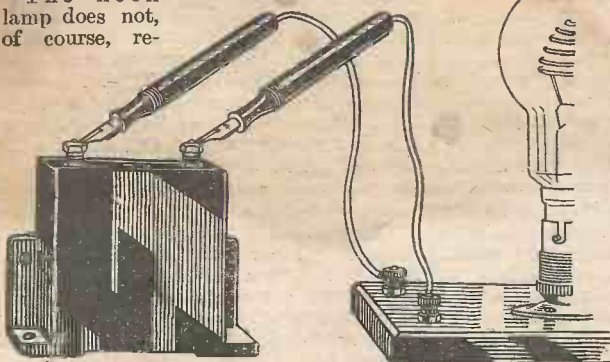

Fig. 4.—Testing the insulation of a fixed condenser with the lamp.

place meters, but may be looked upon as supplementary to the ordinary moving-iron instruments. It must be admitted that the method I shall describe is one of substitution, but by drawing a simple graph many different values can be determined from two or three "known" resistances.

### Useful Tests

Before going into details of the "flashing sign" tests I will describe some of the more common applications of the lamp.

By fitting two insulated test prods to the ends of a length of twin flex taken from the terminals on the lamp board the lamp may be quickly connected to any part of the circuit or component under test without fear of the conductivity of the constructor's

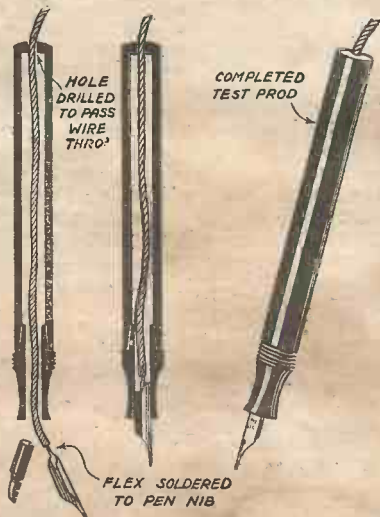

Fig. 3.—How a testing prod can be easily made from an old fountain pen.

hands upsetting the results. The prods can be bought or are easily made from pieces of vulcanite rod with the flex passing through the centre and connecting with metal contacts sticking from the end of the prod. A couple of old fountain pens will make excellent prods. A hole should be drilled in the top of each pen for the flex to pass through while the original nib or a cheap brass one will do as the contact. The wire is soldered to the nib before it is inserted in the feed as in Fig. 3.

To make the lamp glow it will have to be either connected to an H.T. battery, or plugged into D.C. mains. When buying the lamp the voltage required should be stated. On touching the two prods together the circuit will be completed and the lamp will glow.

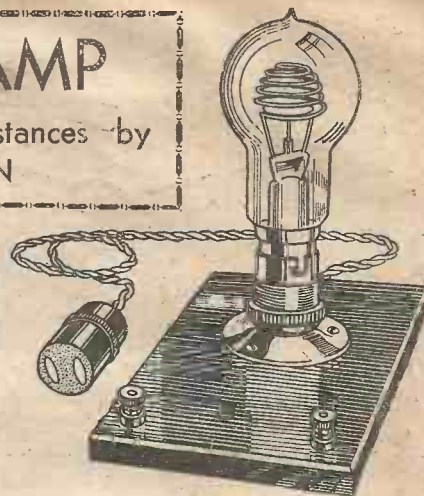

Fig. 1.—The completed neon lamp tester.

### Testing Condensers

Owing to the comparatively high voltages used the lamp will provide a very stringent test of insulation, and is therefore particularly useful in testing condensers. The test prods are held in contact with the terminals of the condenser for a minute or two as in Fig. 4. If the condenser is leaky a series of flashes will occur in the lamp, that is to say, that after a short time it will glow momentarily and then go out again immediately, and then after a similar period of time it will suddenly flash again. If this only occurs at long and regular intervals, say once every minute, the condenser may be considered as O.K. although, of course, a perfect condenser would give no flashes at all. However, in a test of this sort allowance has to be made for any slight leakage in the lamp holder, wiring, and test prods, which would give the same effect as leakage in the condenser, so that an occasional flash does not mean the condenser is a "dud." In fact, this test is so searching that a flash every minute or half minute represents a leakage resistance of not less than several million ohms. It is when the flashes occur several times per minute or when they gradually increase in frequency that the insulation may be taken as very poor or broken down. This test may be applied equally well to fixed or variable condensers but cannot, of course, be used for the electrolytic type.

A multitude of other insulation tests may be carried out by placing the prods across the suspected part. For instance, the insulation between the sockets of a valve-holder can be tried by placing the prods in the sockets themselves, or again, the insulation between the windings of a

(Continued overleaf)

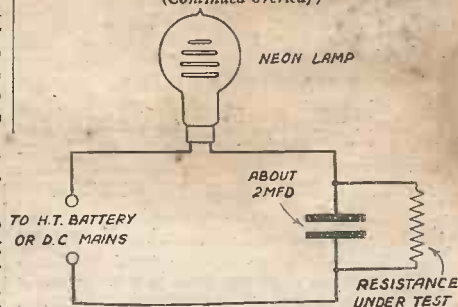

Fig. 5.—The circuit used when testing resistances by the method described in the text.



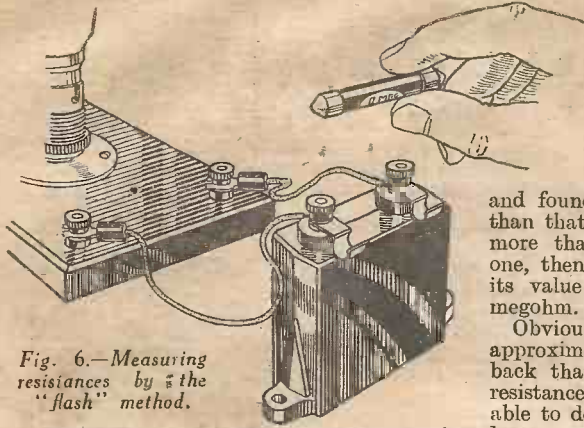

Fig. 6.—Measuring resistances by the "flash" method.

transformer may be checked by connecting one prod to one of the primary terminals and the other to one of the secondary terminals.

**Continuity Tests**

To test for breaks in the wiring of coils, transformers, etc., the prods should be connected across the terminals of the component in the same way as with a condenser. A continuous glow indicates that there is no break in the wire, but erratic glowing or no light at all means there is respectively only a partial connection or else a complete break.

Another use for the neon tester is in determining whether a variable resistance or potentiometer is working properly. If the two terminals of the variable resistance, or, in the case of a potentiometer, the terminal joined to the slider and one of the other two, are connected to the lamp and the slider is moved slowly round then any place where there is a faulty contact will be indicated by the lamp going out at that point. If the instrument has a fairly high resistance, such as 5,000 ohms or more, then the glow of the lamp should steadily increase or decrease as the knob is turned first one way and then the other. If it flickers it means the slider is not making proper contact at the point where the flickering occurs.

In testing a variable resistance or potentiometer in this way we get a very good idea of how the lamp will behave when resistances of various values are connected in series with it, for in moving the slider we vary the resistance from zero to the full value of the instrument. Now if we look at the lamp we shall see that the glow does not gradually get paler as the resistance is increased, but rather does it diminish in area. First of all the whole of the beehive shaped electrode or the disc glows (according to the direction of the current), and then the glow becomes smaller until only a small point is illuminated. Instead of the variable resistance several fixed resistances may be tried. It will be noticed that each one will give a different amount of glow according to its value. This in itself will provide a rough means of finding out the value of an unknown resistance.

**LISTENING IN TO THE FUTURE**

(Continued from page 844)

they get weaker and weaker, but they must take an enormous time to really die right away, and all that we need is a sufficiently sensitive apparatus in order to pick them up.

From the above remarks, and from the fact that events are probably present in the atmosphere as electrical impulses, or electric waves, can we not, given the

As an example we may find that a grid leak of two megohms makes the lamp just glow, whereas a half megohm leak makes about a quarter of the total area of the electrodes light up. If a leak of unknown value is then submitted to the test and found to give a glow area smaller than that of the half megohm leak but more than that of the two megohm one, then we may fairly safely assume its value to be in the region of one megohm.

Obviously this method gives only approximate results, and has the drawback that a large number of known resistances is needed in order to be able to determine the value of any unknown one. A far more accurate and reliable method is that mentioned earlier, namely, the "flash" method.

**Measuring Resistances**

The circuit necessary is shown in Fig. 5. It consists simply of a large fixed condenser in series with the lamp, and an H.T. battery or other direct current source, while the resistance under test is placed across the condenser. A good idea is to discard the prods and connect the condenser with two wires to the lamp as in Fig. 6. Grid-leak clips or stiff wires can be fitted to the condenser terminals to facilitate the quick attachment and removal of the resistances. A good quality condenser of about 2 mfd. capacity should be used, and when the current is switched on there should be no glow or flashes from the lamp until the resistance is connected up. On placing a resistance in position the lamp will start flashing at regular intervals. There may be five, ten, twenty, or more flashes per minute until the lower values are reached, when the flashes become too fast to count, or else merge into one continuous glow.

Now in order to test a range of different resistances it is best to make a simple graph as in Fig. 7. By placing three or four different resistances of known value across the fixed condenser in turn a table such as the following may be compiled.

| Resistance | Flashes per minute. |
|------------|---------------------|
| 3 megohms. | 14                  |
| 2 "        | 20                  |
| 1 "        | 26                  |
| ½ "        | 33                  |

From this it is a very simple matter to make the graph. For the benefit of those readers who may not be familiar with plotting graphs, I will describe how this one is made. The results tabulated above were those actually obtained with an "Osglim" neon lamp and several good quality resistances. You will see that the resistances chosen vary from ½ megohm to 3 megohms, therefore we divide the graph vertically into equal increments of resistance to cover this range. Along the base we mark the number of flashes

per minute from 0 upwards. Now taking the first figures in the table we see that a resistance of 3 megohms gave 14 flashes. We run a pencil along the horizontal line marked 3 megs. and one along the vertical line marked 14. Where they intersect at A we put a small cross. We carry out the same procedure for the other points, thus 2 megs. meets 20 at point B, and so on. The points A, B, C and D, are then joined up with a line as shown.

Once the graph is complete we can read off the value of any unknown resistance within the limits of the graph. Suppose, for instance, that we placed an unmarked resistance across the terminals of the condenser and the lamp flashed 30 times per minute. Following up from the 30 line on the graph we see that it meets the curve at the same point as the horizontal line marked ½ meg. The value of the resistance is therefore ½ meg. In the same way a resistance giving 17 flashes would be approximately 2½ megohms.

The accuracy of these results depends to a large extent on getting the lamp to flash at regular and easily countable intervals. To ensure this, a little care in the adjustment of the voltage and the capacity may be required. If the flashes occur too quickly to count then a larger

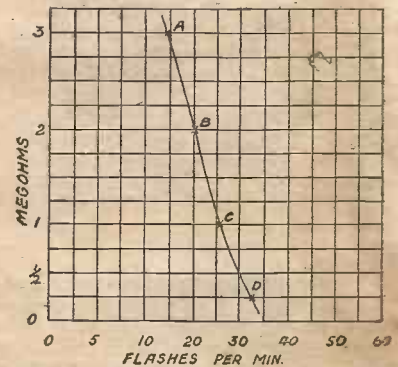

Fig. 7.—The curve used for finding the values of resistances.

condenser, say, 4 mfd., should be used. This will slow up the flashes considerably. Keeping the voltage of the supply as low as possible will also help, although naturally it must not be reduced so much that the lamp will not glow at all.

There is one peculiarity in connection with neon lamps which must be mentioned here, as it is possible for it to cause slightly erratic results, and that is there is sometimes a time lag between the flash and the voltage producing it. This means that although the upper critical voltage necessary for producing a discharge is reached, yet the discharge does not immediately take place. This is due to insufficient ionization within the lamp itself. However, it may be overcome by having a bright light, or another neon lamp glowing in the near vicinity of the test lamp, when the work is in progress.

apparatus, "tune-in" as it were, to the past. If it can be eventually proved that an event does not actually take place, but is simply a form of etheric vibration, it should be possible to design apparatus to receive those vibrations and convert them into sound or vision. Thus, the past could be re-created, and by the same reasoning so could the future.

Bearing in mind that "there is nothing

new under the sun," and that "coming events cast their shadows before," events which may occur next year should already exist in the form of these vibrations, and there may come a time when suitable apparatus will be available which could select a vibration of a definite period and convert it into sound or vision, and which would enable us, in effect, to see into the future.











# PETO-SCOTT

**EVERYTHING RADIO—CASH C.O.D. or EASY TERMS**

FIRST WITH RADIO ON EASY TERMS, we can supply you with all the leading manufacturers' products. Largest stocks in the Country. Send us a list of your requirements for quotation by return. Parcel of parts or accessories over £2 for small first payment. Strict Privacy Guaranteed.

NEW R. & A. "ALPHA" P.M. MOVING-COIL SPEAKER DE-LUXE, with tapped input transformer. Cash or C.O.D. Carriage paid. £2/12/6. Balance in 8 monthly payments of 6/6. **Send 6/6 only**

**NEW W.B. P.M.4.A. MICROLODE PERMANENT MAGNET SPEAKER** complete with switch controlled multi-ratio input Transformer. Cash or C.O.D. Carriage paid. £2/2/0. Balance in 7 monthly payments of 5/9. **Send 5/9 only**

**NEW ROLA CLASS-B PERMANENT MAGNET MOVING-COIL SPEAKER AND AMPLIFIER.** Complete with Valve and Input Transformer. Two models: A for PM2B, PD220, and 220B; B for 240B and HF2 (state which when ordering). Cash or C.O.D. Carriage paid. £3/11/0. Balance in 11 monthly payments of 6/6. **Send 6/6 only**

**LISSEN KITS**  
**7-VALVE SUPER-HET** Complete with Lissen Valves in Sealed Carton. Cash or C.O.D. Carriage Paid. £2/17/6. Balance in 11 monthly payments of 16/6. **YOURS FOR 15/-**  
**NEW LISSEN SKYSCRAPER FOUR ALL-WAVE CHASSIS MODEL**, complete kit comprising all components, including set of Lissen Valves. Cash or C.O.D. Carriage paid. £5/12/6. Balance in 11 monthly payments of 10/3. **Send 10/3 only**  
**NEW LISSEN SKYSCRAPER FOUR ALL-WAVE CONSOLETTA CABINET MODEL**, complete kit, comprising all components, including set of Lissen Valves, Cabinet and Moving-coil Speaker. Cash or C.O.D. Carriage paid, £8/2/6. Balance in 11 monthly payments of 15/-. **Send 15/- only**

**NEW BLUE SPOT 99P.M. PERMANENT MAGNET MOVING-COIL SPEAKER.** Complete with tapped input Transformer. Cash or C.O.D. Carriage paid, £2/19/6. Balance in 11 monthly payments of 5/6. **Send 5/6 only**  
**NEW GARRARD MODEL 202A.** 12-in. Turntable. Electric Motor for A.C. mains. Cash or C.O.D. Carriage paid, £2/10/0. Balance in 8 monthly payments of 6/-. **Send 6/- only**  
**NEW ATLAS ELIMINATOR G.A. 25** for A.C. Mains, Class "B" and Q.P.P. Four Tappings, 60/80; 50/90, 120; 150, 25 m.a. Cash or C.O.D. Carriage Paid, £2/19/6. Balance in 11 monthly payments of 5/6. **Send 5/6 only**

**TELSEN RADIO**  
**TELSEN CLASS "B" 4 CHASSIS KIT** in Sealed Carton, less Valves, Cabinet and Speaker. Cash or C.O.D. Carriage Paid, £3/17/6. Balance in 11 monthly payments of 7/-. **Send 7/- only**  
**TELSEN CLASS "B" 4 CONSOLETTA KIT**, including Telsen Class "B" Moving-coil Speaker and Consolette Cabinet, less Valves. Cash or C.O.D. Carriage paid, £5/17/6. Balance in 11 monthly payments of 10/9. **Send 10/9 only**  
**TELSEN SUPER-SELECTIVE SIX CHASSIS KIT**, excluding Valves, Cabinet and Speaker. Cash or C.O.D. Carriage Paid, £5/18/6. Balance in 11 monthly payments of 10/9. **Send 10/9 only**  
**TELSEN 325 STAR KIT**, less Valves and Cabinet. Cash or C.O.D. Carriage Paid, £1/19/6. Balance in 7 monthly payments of 5/3. **Send 5/3 only**  
**TELSEN H.T. AND L.T. A.C. MAINS UNIT W.348.** H.T. Portion: Max. Det. and 8.G. tappings each adjustable for High, Med. or Low voltages. Maximum 28 m/a at 130 v. L.T. trickle charger, 2, 4 or 6 volts at 1 amp. Cash or C.O.D. Carriage paid, £4/17/6. Balance in 11 monthly payments of 9/-. **Send 9/- only**  
**TELSEN D.C. MAINS H.T. UNIT W.348**, with 3 tappings, each adjustable for High, Med., and Low voltages. Output, 28 m/a at 130 volts. Cash or C.O.D. Carriage paid, £1/15/0. Balance in 6 monthly payments of 5/8. **Send 5/6 only**

## 1934 SUPER-SET PILOT AUTHOR KITS

**KIT "A"** Author's Kit of First Specified parts, including Peto-Scott "Metaplex" chassis (less valves and cabinet). **YOURS FOR 14/9** Balance in 11 payments of 14/9. **CASH or C.O.D. Carriage paid, £8 : 2 : 0**

**KIT "B"** As Kit "A," including valves but less cabinet. **CASH or C.O.D. Carriage Paid, £11 : 2 : 9** or 12 monthly payments of 20/6.

**KIT "C"** As Kit "A," including valves and cabinet. **CASH or C.O.D. Carriage Paid, £12 : 7 : 9** or 12 monthly payments of 22/6.

## AUTO-"B" 3

**KIT "A"** Author's Kit of First Specified Parts, including metal chassis, but less Valves, Cabinet, Speaker. **YOURS FOR 8/6** Balance in 11 monthly payments of 8/6. **CASH or C.O.D. Carriage Paid, £4 : 11 : 0**

**KIT "B"** As Kit "A," but with Valves only. **CASH or C.O.D. Carriage Paid, £6 : 0 : 9** or 12 monthly payments of 11/3.

**KIT "C"** As Kit "A," but complete with Valves and Cabinet less Speaker. **CASH or C.O.D. Carriage Paid, £7 : 18 : 9** or 12 monthly payments of 14/6.

Set of Specified Valves - £1 : 9 : 9  
Camco "Argyll" Cabinet - £1 : 18 : 0  
Amplion Sonette Class "B" Speaker £1 : 7 : 6

## Exact to Specification

**NEW FERRANTI "CLASS B" SUPER POWER CONVERTOR.** Instantly converts your present set to "Class B." Complete with valve. Ready assembled. Cash or C.O.D., Carriage Paid, £3/3/0. Balance in 11 monthly payments of 5/9. **Send 5/9 only**  
**NEW BLUE SPOT PERMANENT MAGNET MOVING-COIL SPEAKER 29 P.M.** With input transformer. Cash or C.O.D. Carriage Paid, £1/12/6. Balance in 6 monthly payments of 5/-. **Send 5/- only**

## AMAZING OFFER PETO-SCOTT PERMANENT MAGNET MOVING-COIL SPEAKER



**15/-**  
Cash or C.O.D. Carriage Paid.  
R exquisite tone: sensitive to every sound inflection. Moulded diaphragm. Cobalt magnet. Tapped in put transformer for Power or Pentode. Also Mains Models for A.C. (2,500 ohms) or D.C. Mains (5,000 ohms) .. 15/-  
All models in Walnut polished Cabinet. Cash or C.O.D., 25/-  
**IMMEDIATE DELIVERY**

## BUILD YOUR NEW SET INTO THE INLAID WALNUT ADAPTAGRAM



**DIRECT FROM FACTORY.** No MIDDLE-MAN'S PROFITS. Built by master craftsmen of the piano trade. Real inlaid walnut, mortised, tenoned, french-polished. With screened motor-board by the new METAPLEX PROCESS. Front ready drilled to take your set. Ample room for Speaker and batteries. Size 38" high, 22" wide, 15 1/2" deep. Baseboard depth, 14". Speaker compartment, 17" x 10" x 14". Plain front or vignnetted for panels up to 18" x 8". Baffle-board 3/6 extra. **YOURS FOR 8/3** Balance in 11 monthly payments of 5/9, Carriage Paid. **CASH or C.O.D. 63/- CARRIAGE 2/6 EXTRA**

## Pilot Class "B" Conversion Kit

Converts your present Battery Set to "Class B" Send Amplification. Complete with all necessary components, including driver transformer, "Class B" output choke, W.B. 7-pin valve holder, B.V.A. 240B valve, wire and screws, etc. Full-size Blueprint, assembly instructions and diagrams. Cash or C.O.D., 37/6. Balance in 7 monthly payments of 5/6. ALL "CLASS B" Components and other Parts obtainable from your local dealer SENT C.O.D. We have the largest stocks in the country. Orders over 10/- sent Post Paid. (Easy Terms available on orders over 35/-) Quotations by return. No obligation. **5/-**

**IMPORTANT.** Miscellaneous Components, Parts, Kits, Finished Receivers or Accessories for Cash, C.O.D. or H.P. on our own system of Easy Payments. Send us a list of your wants. We will quote you by return. C.O.D. orders value over 10/- sent carriage and post charges paid.

**PETO-SCOTT CO. LTD., 77, City Rd., London, E.C.1.**  
Telephone: Clerkenwell 0406/7  
West End Showrooms: 62, High Holborn, London, W.C.1.  
Telephone: Holborn 3248.

Dear Sirs,  
Please send me CASH/C.O.D./H.P. \_\_\_\_\_  
for which I enclose £ \_\_\_\_\_  
CASH/H.P./DEPOSIT \_\_\_\_\_

NAME \_\_\_\_\_  
ADDRESS \_\_\_\_\_  
Pr. W. 2/9/33.

**STRICT PRIVACY GUARANTEED—WE DEAL WITH YOU DIRECT**



# WALK IN and hear CLASS B demonstrated

at one of the Multitone Dealers, with the components that first made Class "B" available to the public, or with the new

## MULTITONE CLASS "B" CONVERTER

You have only to plug this converter into any battery set to convert it immediately to Class "B." There is no interference whatever with the existing circuit. Universally adapted to any driver or Class "B" valve, and any loud-speaker. No terminals or switches. All you do is plug-in!

PRICE ONLY **37/6**  
(Without Valve)

**Other Multitone Products:**

|   |      |
|---|------|
| BEPU Driver Transformers (ratios : 1/1, 1.5/1 and 2/1) .. .. .                            | 9/6  |
| PUCHOKE for matching your existing speaker to Class "B" output                            | 9/6  |
| TOCO Tone-control transformers, in the 1st L.F. stage, give 30% extra H.T. saving .. .. . | 17/6 |
| Graded Potentiometer .. .. .  | 3/6  |

If you do not know who is your nearest Multitone dealer, please write to us (Dept. H).

**"MULTITONE BRINGS SOUND TO LIFE"**

The Multitone Wireless Set for the Deaf was the sensation of the Radio Exhibition, Olympia. Write for particulars of this amazing new invention.

(71) **MULTITONE**  
ELECTRIC COMPANY LIMITED  
95-98, White Lion Street, London, N.1. Terminus 5063

# VARIAL ELECTRON'S VARIABLE AERIAL

## THE LATEST & BEST STATION SELECTOR



Will give aeriels every desired degree of selectivity, cutting out interference from other stations. It is also a most efficient volume control. Can be used with any set on any aerial. Fixed in a few moments, and requires no alterations. A marvellous invention.

**1/6**

Also supplied as the  
**ONLY SELF-CONTAINED VARIABLE AERIAL**

Already part of SUPERIAL, Electron's Super Aerial. In this form it is positively the world's finest and most selective aerial. There is £100 Free Lightning Insurance with SUPERIAL.

|            |            |            |
|------------|------------|------------|
| 100 FEET   | 75 FEET    | 50 FEET    |
| <b>4/6</b> | <b>3/6</b> | <b>2/9</b> |

Ask your dealer, or in case of difficulty send remittance direct to:—

**The NEW LONDON ELECTRON WORKS Ltd.**  
6, EAST HAM LONDON, E.6

Telephone: Grannewood 1408-9-1368.

Telegrams: "Stanum," London.

# The SERADEX BATTERY CHARGER

(For A.C. Mains 200 to 250 v 50 cycles upwards).

All units entirely enclosed in metal cases, with only meter and controls visible. Illustrated catalogue free on mentioning Pr.W.

|           |   |                |
|-----------|---|----------------|
| Type      | Output  | Price complete |
| V.R.328a  | 1-10 cells at up to 1.3 amps.   | £3 - 5 - 0     |
| V.R.1326a | 1-20 cells at up to 1.3 amps.   | £4 - 4 - 0     |
| V.R.367c  | 1-18 cells on each line,<br>Total output 6 amps (3 split<br>outputs and economy switch<br>fitted) | £9 - 10 - 0    |

Full particulars from your dealer or

**TREVOR PEPPER,** WAKE GREEN ROAD,  
BIRMINGHAM, 13.

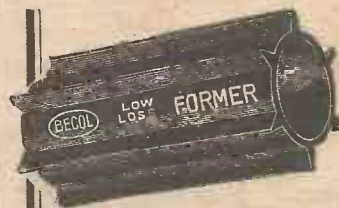

## Read this QUALITY Produces EFFICIENCY

**TESTED BEFORE DESPATCH**

The original BECOL ebonite low loss formers are thoroughly reliable. They are used in all parts of the world. Look for the BECOL trade mark. Ask your dealer. If unable to supply, write direct. SEND NOW, enclosing 6d. (post free) for third edition up-to-date handbook of tuning coils for DUAL RANGE, BAND-PASS, and SUPER-HET. circuits. Fully illustrated with data. A very interesting handbook.

**RODS, SHEET, TUBES, PANELS**  
**The BRITISH EBONITE Co., Ltd.,**  
Hanwell, London, W.7.

# THE ELEMENTS OF WIRELESS

By RALPH STRANGER

Indispensable to everybody who wants to understand the working of wireless receivers. The Author starts with elementary principles, covers the whole field of wireless reception, both from the theoretical and practical points of view, and finishes with a complete survey of a four-valve wireless receiver, explaining its working from the aerial terminal to the loud-speaker.

On sale at all Booksellers, or by post 3/9 from George 3/6  
Nevnes, Ltd., 8-11, Southampton St., Strand, London, W.C.2

# UNIVERSE

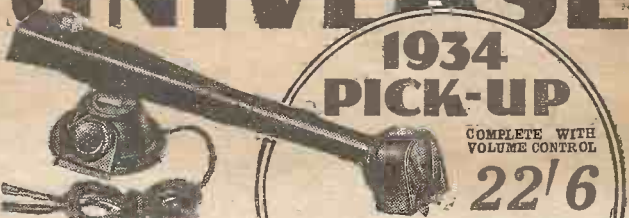

## 1934 PICK-UP

COMPLETE WITH  
VOLUME CONTROL

**22/6**

Ask your dealer for  
demonstration or  
write us direct for  
Catalogue.

Phone: Enfield 3846.

The finest pick-up of its type yet produced. Fully guaranteed. Output is extraordinarily high. Special swivel head for easy needle changing. Impossible for pick-up head to get out of adjustment. Weight on record adjustable by compensator on end of arm. Smart brown bakelite.

COSMOCORD LTD. DEPT. P. CAMBRIDGE ARTERIAL RD. ENFIELD MIDDXX











# TELSEN TUNING CONDENSERS cover every requirement

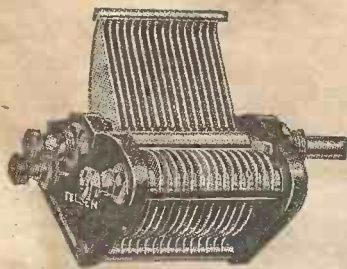

**TELSEN  
AIR-DIELECTRIC  
TUNING CONDENSERS**

The precision and sturdy construction of this component ensure years of faithful service. Its frame is braced by three solid pillars, and the vanes clamped at three points, making distortion impossible. The rotor is also built into a rigid unit, generous bearings preventing backlash or end-play.

| Capacity       | Price |
|----------------|-------|
| *00025 mfd. .. | 2/6   |
| *00035 " ..    | 3/6   |
| *0005 " ..     | 3/6   |

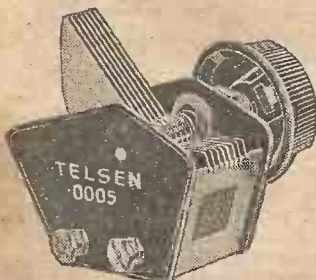

**TELSEN BAKELITE  
DIELECTRIC TUNING  
CONDENSERS**

Represent really remarkable value at the new reduced prices.

Very rigid construction, with high grade dielectric, ensuring permanently accurate spacing with minimum losses. Exceptionally compact. Complete with knob.

| Capacity      | Price |
|---------------|-------|
| *0003 mfd. .. | 2/-   |
| *0005 " ..    | 2/-   |

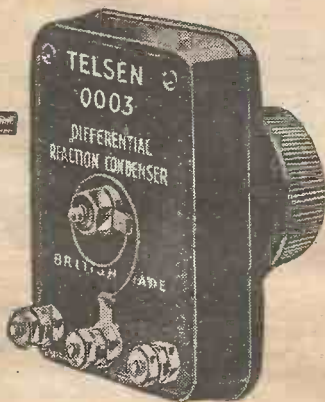

**TELSEN  
DIFFERENTIAL  
CONDENSERS**

Similar in design and construction to the reaction condensers. Supplied complete with knob.

| Capacity            | Price |
|---------------------|-------|
| *0003 mfd. W.351 .. | 2/-   |
| *00015 " W.352 ..   | 2/-   |
| *0001 " W.353 ..    | 2/-   |

**TELSEN  
GANGED CONDENSERS**

The finest ganged condensers ever produced, and, at their new reduced prices, the finest value ever offered in their class.

For use where accurate and simultaneous tuning of two or three circuits is obtained by the rotation of one dial. A pressed steel frame of great rigidity eliminates distortion, the rotor and stator vanes being let into one-piece high pressure die castings to ensure accurate spacing. All sections are very carefully matched by means of split end vanes, and trimmers are provided. Complete with knob, pilot light escutcheon and two alternative tuning scales.

|                           | Price |
|---------------------------|-------|
| Single Unit .. ..         | 7/6   |
| Twin Ganged .. ..         | 12/6  |
| With dust cover 2/- extra |       |
| Triple Ganged .. ..       | 17/6  |
| With dust cover 2/6 extra |       |

**TELSEN REACTION  
CONDENSERS**

Entirely re-designed. Now incorporate several valuable improvements with no increase in price, the whole unit being also now enclosed in a strong dust-proof bakelite case. Supplied complete with knob.

| Capacity            | Price |
|---------------------|-------|
| *0003 mfd. W.354 .. | 1/9   |
| *00015 " W.355 ..   | 1/9   |
| *0001 " W.356 ..    | 1/9   |
| *00075 " W.357 ..   | 2/-   |
| *0005 " W.358 ..    | 2/-   |



**TELSEN AERIAL  
SERIES CONDENSER  
With Switch**

Built on similar lines to the new reaction condensers, providing an ideal selectivity and volume control. Supplied complete with knob.

| Max. Cap.            | Price |
|----------------------|-------|
| *0003 mfd. No. W.350 | 2/-   |

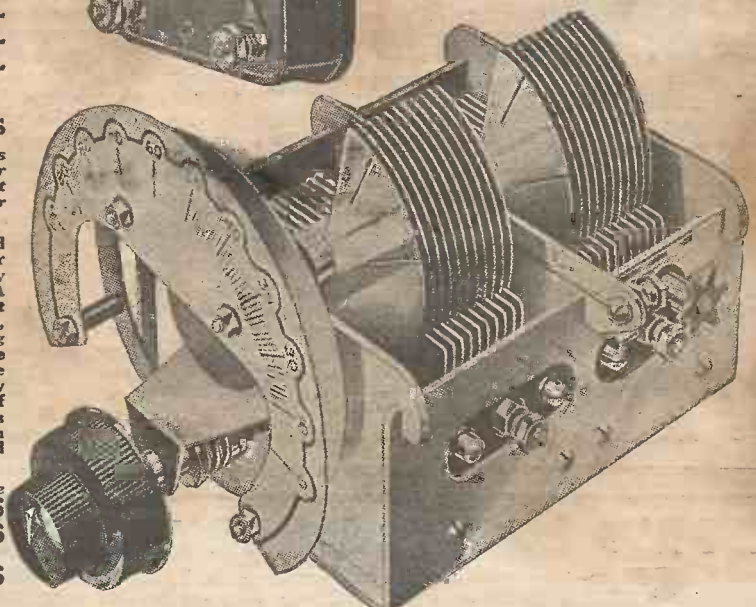

**TELSEN FOR EVERYTHING IN RADIO**

ANNOUNCEMENT OF THE TELSEN ELECTRIC CO., LTD., ASTON, BIRMINGHAM



# RADIO RAMBLINGS

By JACE

*Gettings from my Notebook*

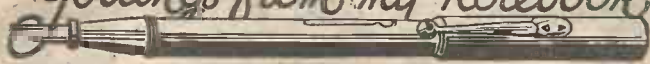

## On the Ultra Short Waves

**S**HORT-WAVE activities seem to be on the increase again, assisted no doubt by the possibility of television on a few metres. By the way, there was a lot of hush-hush work going on at half a metre: possibly something really interesting may be announced shortly in this direction.

## Iron-cored Tuning Coils

**I**RON-CORED tuning coils are becoming popular, and many constructors have been surprised to find that they have rendered their sets unstable by fitting these new coils. This is, of course, a compliment to the coil and the reverse to the receiver, which is either badly laid out or lacking in screening.

## Dust Bags and Moving-coil Speakers

**M**ANY moving-coil loud-speakers are equipped with a little muslin bag in which they are totally shrouded, with the intention of preventing dust from jamming between the coil and the pole piece. This is a very sensible precaution, but, unfortunately, few constructors can reconcile the bag as part of the equipment, and make the fatal mistake of removing it.

## Cinemas and Acoustics

**M**ANY of our large new cinemas have been designed with a view to good loud-speaker reproduction, but the critical listener cannot fail to notice that many fall short of the standard reached by others. Does this mean that nobody knows much about acoustics, or that correct designing, from the sound point of view, is hopelessly limited by the necessity for a pleasing appearance? It is said that a certain cinema noted for its excellent acoustic properties has the ceiling made of a material so mechanically weak that light can be seen through it in the day-time.

## Mains Valve with Three Grids

**O**NE of the latest American mains valves is equipped with three grids, and by suitable connection it may be used as a pentode or a power valve, or may be adjusted for a maximum undistorted output ranging from about 300 milliwatts to 6 watts; thus the valve can be adjusted to give the best performance on whatever H.T. current is available.

## Emergency Chokes

**O**CCASIONS doubtless arise when a smoothing choke breaks down, and

it is seldom that anybody attempts to patch up the trouble before the choke is replaced. One way out of the difficulty is to use the secondary winding of a spare mains transformer, or under certain circumstances the field coil of a mains energized moving-coil loud-speaker.

## Multi-mu Valves

**T**HERE is a growing number of radio enthusiasts who employ maximum high-tension voltages of 400 volts or over in order to use large output valves, realizing that with valves of this type large outputs and excellent quality can be obtained from moving-coil speakers. Needless to say, these high voltages are obtained from some sort of mains unit as a rule, and many amateurs use resistances to cut down the high voltage output to a more handy voltage for feeding the anodes of the other valves in the receiver. This is, of course, wasteful in running cost, but at a few pence per unit the cost does not become excessive, although in many ways it would be preferable to utilize a second rectifier to give a lower voltage output for feeding the other valves. The first cost is then much higher, it is true, but in some cases it is practically essential that a separate rectifier be used to supply a lower voltage. With one make of A.C. mains variable-mu valves it is desirable that such an arrangement be used. While it is a simple matter to calculate the correct voltage dropping resistances for ordinary screened grid or detector valves when operated from a 400-volt high-tension supply, this calculation does not hold good in the case of multi-mu valves, because the correct value of resistance depends upon the current flowing in the circuit and the anode current to the multi-mu valves varies between wide limits when the grid bias is adjusted for volume control purposes. As a result, when the anode current is decreased by increasing the grid bias, the drop in voltage in the voltage-dropping resistance is correspondingly decreased and the actual voltage on the anode rises. Owners or builders of receivers employing multi-mu valves in addition to high voltage valves for the output stages should therefore use a second rectifier unit if really satisfactory results are desired, the second rectifier giving a reduced voltage of about 250 volts. It is practically impossible to design a perfect self-compensating system whereby a voltage dropping

network for use on a 400-volt supply maintains the anode voltage to multi-mu valves constant for all values of grid bias.

## Novel Use for Radiogram Wrappings

**D**ID you know that "His Master's Voice" radiograms are now delivered wrapped up in quite good flannelette? It seems that waxed paper was used for covering radio receivers, gramophones and radio-gramophones originating from "His Master's Voice" factories, but sometimes the cabinets arrived slightly scratched. The Gramophone Company then decided to use a softer material and ultimately chose flannelette. This step caused a minor sensation with girl assistants in radio stores, for they all claimed the material for the making of pyjamas, overalls, and other garments. Others have made hiking shorts of the material, dyeing them to the desired shade by the use of cold coffee, and a proprietor of a large radio shop had to make the rule that the assistant who sold the set was entitled to the flannelette. Well, well! This is yet another industry that has benefited by radio.

## Snake Charming by Wireless

**A** PARIS radio paper states that at the Algiers studio, before an invited audience, a native Arab snake-charmer, instead of using for her performance the conventional reed pipes, was able to make her serpents dance to "canned music." Later, as a further experiment, in order to show that any music would charm these reptiles, they were made to sway rhythmically to the strains of a foreign syncopated dance band, the performance of which was being relayed to North African listeners. It may be true—and also, it may not!

## The Diode Valve as Detector

**T**HERE are quite a number of people living so close to the powerful regional stations that they do not know how to control the volume owing to the enormous field strength even when the aerial is removed altogether. One useful suggestion is to use a diode as the detector, which has the advantage in this case of being extraordinarily insensitive, and permits the volume to be reduced to reasonable proportions even when used under the transmitting aerial.

## Preventing Break-through on the Long Waves

**A**NOTHER trouble experienced by listeners so unfortunately situated is the breaking in of the short-wavelengths when trying to receive a long-wave station, but a No. 60 or 75-coil of really good design will invariably stop the trouble if placed in series with the aerial when listening to the long-wavelengths. A shorting switch can, of course, be used for cutting out this coil when it is desired to listen to the short-waveband.

## DON'T LEAVE MONEY IN THE DUSTBIN

LET us take your old Set or components in PART EXCHANGE for New Season's Radio—NEW KITS, NEW ACCESSORIES, or PART KITS—in fact, any RADIO APPARATUS. Best quotations and fullest allowance given. Balance payable by Cash or H.P. Send us your enquiry for quotation by return, stating apparatus you wish to dispose of and NEW KIT, SET or Miscellaneous Components required. WE GIVE YOU MORE.



**LIGHT MODULATION**

(Continued from page 858)

the rise is then much more rapid and almost straight up to 550 volts.

After this, we have an effect known as chromatic dispersion taking place, that is to say, there is a different treatment for different colours of the spectrum, and in consequence no greater quantity of light is passed through, but the colour of the light changes red, brown, and deep purple.

An examination of this characteristic curve of the Grid Cell unit makes it clear that the maximum range of voltage over which the cell should be worked is 300 to 550 volts (X to Y of Fig. 8). As in the case of ordinary L.F. amplifying triodes, where it is necessary to apply a bias to the valve in order to bring the datum point of working to the centre of the straight part of the valve's characteristic, so the same must be done with this unit. There is this difference, however. First of all, the magnitude of the polarizing voltage is much greater than for valve working, namely about 425 volts, and secondly it is positive instead of negative, being shown by Z in Fig. 8. Under this polarized condition full cell modulation is achieved by a signal voltage of 125 volts.

In order to achieve the greatest efficiency from this new unit it is natural that care should be taken in the method by which it is connected to the output valve of the radio set used for receiving the television signals. One of the best methods is shown in Fig. 9, the valve employed being a PX25 which is a large output triode.

The valve is resistance capacity coupled to the previous stage, appropriate automatic bias being allowed, while the cell itself is resistance capacity fed, the applied potential being furnished by the fixed resistance potentiometer combination arranged direct across the 600-volt high tension feed. The object of including a single pole change-over switch is to enable a negative picture to be converted into a positive one.

When using the cell, apart from the question of mounting, it is necessary to observe one or two points if a premature demise is to be guarded against. First of all it is necessary to see that too great a voltage is not applied, whether this voltage is polarizing or introduced by the signal. Above a voltage of 800 a spark discharge occurs and this has the effect of reducing the life of the cell. Like valves, the cell has a "life" which can be expressed in hours, and when "worn out" may be renewed. As a guide to this worn out or low efficiency condition it may be noted here that the colour of the spot of light given by the combination under these circumstances is orange, whereas a good or new cell has a yellow light spot.

When fitted into the holder the cell has incorporated a mask which limits the square aperture to a size of 0.09 inch square. In addition to the Nicol prisms there is included in the whole outfit a condenser lens, this being seen in Fig. 10, a photograph which shows the unit with the lamp removed. It will be noticed at the end of the nickel plated tube. Naturally the projection lamp seen in Fig. 5 forms an integral part of the component, it being held in the specially shaped clips to enable an accurate lining up of the filament to be undertaken. The lamp has a bunched filament, being rated at 12 volts 100 watts, and this can be fed quite conveniently from an additional secondary winding on the mains equipment transformer.

**-ACCEPT NO SUBSTITUTE-**

**INSIST UPON**



**COMPONENTS**

**SPECIFIED BY MR. F. J. CAMM IN THE**

**1934 SUPER-SET ALL-WAVE TWO.**



**B.R.G. SHORT-WAVE H.F. CHOKE**

Solely specified for **ALL-WAVE TWO**  
Single layer wound for lowest possible loss. Terminal Connections. **1/9**

**B.R.G. REACTION CONDENSER**

Solely specified for **ALL-WAVE TWO**  
with solid di-electric positive contacts. **2/6**  
.0002 mfd.



**ALSO SPECIFIED—**  
**B.R.G. 2 POINT SWITCH No. 49**  
Push-pull type. Solely specified for **F. J. CAMM SUPER-SET AND ALL-WAVE TWO**  
Specially strong phosphor-bronze self-cleaning contacts. **1/3**

**B.R.G. 3 POINT SWITCH No. 50**  
Solely specified for **F. J. CAMM 1934 SUPER-SET**  
Push-pull type, with special contacts. **2/0**

**B.R.G. 3 POINT SWITCH No. 50**  
Solely specified for **F. J. CAMM 1934 SUPER-SET**  
Push-pull type, with special contacts. **2/0**

**B.R.G. COMPONENT MOUNTING BRACKETS**  
Solely specified for **F. J. CAMM 1934 SUPER-SET**  
Set of 3, Drilled and Plate-finished. **1/6**

**B.R.G. Components are obtainable from all dealers. In cases of difficulty send for name and address of nearest stockist.**

**SOLE DISTRIBUTORS OF METAPLEX BASEBOARDS**



Specified in the **F. J. CAMM 1934 SUPER-SET AND THE ALL-WAVE TWO**, and by all the leading technical designers.

**BRITISH RADIO GRAMOPHONE CO. LTD.**

PILOT HOUSE, CHURCH STREET, STOKE NEWINGTON, LONDON, N.16.

Telephone: Clissold 6287/8.

**APPOINTED TELSEN WHOLESALE DISTRIBUTORS**

Trade enquiries invited.

**Indispensable to Every Wireless Enthusiast**

**MR. RALPH STRANGER**, who is a master of lucidity, has produced in this book a valuable and fully explained synopsis of technical terms that everybody can understand. It will prove indispensable to everybody who reads technical books and journals. Fully illustrated throughout.

**DICTIONARY OF WIRELESS TERMS**

By **RALPH STRANGER**

Obtainable at all Booksellers, or by post 2/9 from George Newnes, Ltd., 8-11, Southampton Street, Strand, London, W.C.2.

**2/6**

**PEARL & PEARL RADIO BARGAINS**

The Famous British General Band Pass 10 K.C. tuning unit aerial of 'Anode' type. Now sold and listed at 14/6. Special offer **4/11**

The well-known Slektun Screened H.F. Coil. Usual price 6/6. **2/11**

Slektun Dual Range Screened Aerial Coil as recommended and used by famous designers for use with above H.F. Coil. Usual price 6/6. **2/11**

Slektun 4-pole balanced armature loud speaker units. Ultra sensitive. List price 8/6. **3/11**

Famous Lincoln Stewart Permanent Magnet Moving Coil Speakers. Special purchase. List price 47/6. **16/11**

Limited number of Telsen Major Speaker chassis. This is a super bargain and is available while stock lasts. Usually 10/6. **3/3**

**All Goods sent Carriage Paid.**

**PEARL & PEARL**  
190, Bishopsgate, E.C.2.



# OUR SHORT-WAVE SECTION

—IMPORTANT FACTORS WHICH INFLUENCE THEIR EFFICIENCY.

## HIGH FREQUENCY CHOKES FOR SHORT-WAVE RECEIVERS—

IN order to know what points to look for in a high-frequency choke, whatever wavelength it is to be used on, it is necessary to have some idea of the way in which a choke does its job and of the factors that can influence its efficiency. Before going on to practical details, therefore, I will say a little about the theory of the subject.

Fig. 1 shows the circuit of the detector portion of a standard short-wave receiver, or for that matter a long-wave receiver without a high-frequency valve, because the only difference between the two is in the size of the coils and condensers. What is the purpose of the high-frequency choke in the plate circuit of the valve? Without going into details we can say that when a signal from a broadcasting station arrives at the detector grid the action of the valve is to separate the incoming wave into its constituents, which are a low-frequency part representing the speech and music and a high-frequency carrier wave, and both of which appear in the plate circuit. We really only need the low-frequency part, however, and that is wanted in the primary of the L.F. transformer, but we can make use of the high-frequency part by passing it through a coil coupled to the grid coil and making it boost the energy in the grid circuit; this is known as applying reaction, and the coil  $L_2$  is the reaction coil. It is clear from the figure that there are two paths available to both the high- and the low-frequency currents, namely, either through the L.F. transformer primary or through the reaction coil and condenser. Both of these paths offer some opposition to the passage of an alternating current, the amount of which depends on the frequency. The opposition offered by a coil, which is chiefly an inductance, is called an inductive reactance, and it increases as the frequency and inductance increase; a condenser offers a capacitive reactance which decreases as the frequency and capacity increase. Note that reactance has nothing whatever to do with reaction, but merely means "resistance to an alternating current."

### The Reaction Coil

Now the reaction coil is small and would not do much to impede the flow of the low-frequency current, but the condenser in series with it is quite small and would therefore offer a very large reactance to this current, consequently it is unlikely

By K. E. BRIAN JAY

that the low-frequency current would follow that path: the high-frequency current on the other hand would not find much opposition this way because of its much greater frequency, and would therefore tend to flow down it. In the alternative path the primary of the low-frequency transformer has a moderately high inductance and while still offering a fairly easy path to the low-frequency currents it should present a great barrier to the high-

high-frequency currents into their proper path through the reaction circuit and at the same time offer as little opposition as possible to the low-frequency currents.

### A Simple Method

A small inductance will do the trick, because it can be made to offer great resistance to the high-frequency currents without being big enough to impede the passage of the low-frequency currents. For example, a coil having a pure inductance of 150 millihenries will have a reactance of 940,000 ohms to a current of frequency of 1,000 kilocycles, i.e., a wavelength of 300 metres, but to the highest speech frequency of 10,000 cycles (10 kilocycles) it will only be 9,400 ohms and to the frequency of 5,000 cycles, which is the usual upper limit for a receiver, it will only be 4,700 ohms, whereas the reaction circuit will offer a reactance of more than 300,000 ohms to the same frequency. Such a choke would therefore be quite effective in keeping the two currents of different frequencies in the parts of the circuit where they are wanted. Note however, that I referred to a "pure" inductance, that is to say, a coil which has only inductance and nothing else; unfortunately, it is impossible to make such a coil

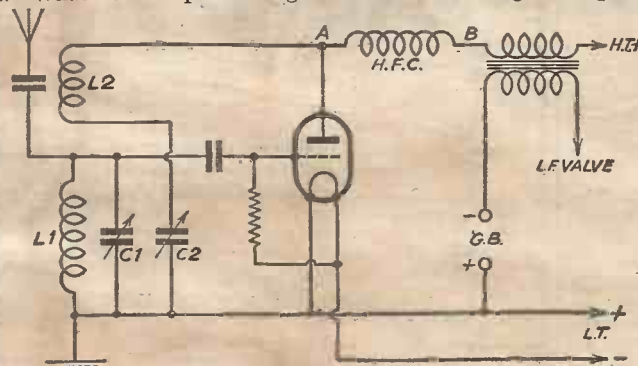

Fig. 1.—Detector circuit of a short-wave receiver with H.F. choke in the plate circuit.

frequency currents, so turning them in the direction of the reaction circuit; unfortunately this transformer winding has another property, arising from the fact that the adjacent turns of wire in its winding form little condensers which taken all together are equivalent to quite a large capacity across the primary, not large enough to have any effect on the low-frequency currents, but quite enough to present an easy path to the high-frequency currents, which would be by-passed by this so-called self-capacity in spite of the choking effect of the inductance of the winding, with the result that very little high-frequency would flow through the reaction circuit. The reactance of this self-capacity would be much less at very high frequencies, i.e. short wavelengths, than at the ordinary broadcast wavelengths and therefore the effect would be particularly bad in a short-wave set; it would be hard to get a proper reaction effect and there would be high-frequency currents in the L.F. stage with almost certain instability and general upset. We require therefore some device inserted between the points A and B in Fig. 1 that will turn the

and every practical choke will have, in addition, resistance, due to the resistance of the wire used to make it, and self-capacity due to the small condensers formed by the adjacent turns of the wire. The presence of these two other properties will seriously modify the reactance of the choke, which will never be as high as the calculated values given above, but the greatest menace to efficient performance is the self-capacity. The presence of this intruder will have two effects; it behaves as a small condenser across the coil and therefore the two form a tuned circuit in the same way as the grid coil and tuning condenser form a tuned circuit, and the condenser also acts as a leak for high-frequency currents, to which it may offer less reactance than the inductance, in a bad case. The action of a parallel tuned circuit is to absorb current at its resonant frequency, so that in this case, the choke, when acting as a tuned circuit, will absorb the high-frequency current that we want to flow through the reaction circuit and we shall not be able to make our receiver oscillate. Furthermore the absorption will

(Continued on facing page.)



(Continued from previous page)

not be on only one wavelength, because a tuned circuit can also absorb energy at its harmonics, i.e., at wavelengths which are an exact multiple of the fundamental resonant wavelength, so that the reaction effect will be upset at several wavelengths in the tuning range.

**Short-Wave Chokes**

Everything I have said so far applies to chokes at all wavelengths. Let us now consider those meant specifically for use on short waves. There is, of course, no difference in principle between a short-wave

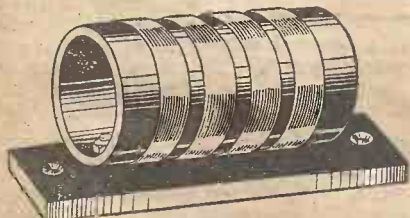

Fig. 2.—A choke wound in sections.

choke and one designed for long waves, the chief difference being in size. On short waves we do not need so much inductance; for example, the 150 millihenry choke referred to above will have a reactance of 9,400,000 ohms at 30 metres, which is unnecessarily large, since if 940,000 ohms was enough at 300 metres it will be enough at 30, so that we can do with a choke of one-tenth the inductance. Furthermore, in a short-wave choke the self-capacity is of first importance, and must be kept down to an absolute minimum, partly because the smaller the capacity the less marked will be the tuned-circuit-absorption effect, and partly because the reactance of a condenser decreases with wavelength. An example will emphasize this latter point; a self-capacity of 2 micro-microfarads, quite a probable value for our 150 millihenry choke will have a reactance of 60,000 ohms at 300 metres, but this will drop to 6,000 at 30 metres, which is equivalent to a partial short circuit for 30-metre waves. Of course, reducing the inductance of the choke makes the use of fewer turns of wire necessary and, consequently, the self-capacity is automatically reduced, but it is not enough to rely on this reduction only, and the method of winding must be such as to make for low self-capacity; of this more anon. Another point arises in connection with short-wave chokes, and that is that the tuned-circuit effect will be much more of a nuisance if the choke is large, because the absorption will be greater and because a greater number of harmonics of the fundamental resonant frequency will lie in the range of wavelengths over which the receiver is used, so that more dead spots, where the receiver refuses to oscillate, will be found. It must not be assumed that a long-wave choke will not work at all in a short-wave receiver: it probably will, but its efficiency will not usually be high and there will be a great many dead spots. The same applies to a badly-designed short-wave choke; at some wavelengths it will work well, but at others it most certainly will not.

**Designing a S.W. Choke**

In designing our short-wave choke, then, we must first look for a method that avoids self-capacity as far as possible, and as is not uncommonly the case, the simplest is the best. The simplest coil is, of course, the

single-layer type, and this is admirable for choke construction. In order to prevent interaction with other coils, it is important to keep the diameter small in any choke, but doubly so on short waves, and it should certainly not exceed one inch, half an inch being a more satisfactory size. Various materials may be used as formers; very satisfactory are small glass test tubes, obtainable from most chemists for a penny; small diameter ribbed-ebonite formers can be obtained, and half-inch ebonite tube or rod is very good. Any kind of ebonite or bakaite tube permits the use of small terminals to fasten off the end of the wire, but this is not possible when glass is used, and in that case the simplest thing to do is to fix the end of the wire in place on the glass with a small spot of sealing wax. As a matter of fact, I always prefer to omit terminals and connect the choke straight into the circuit by the ends of the winding so as to avoid the little additional self-capacity introduced by the large bulk of the terminals. If terminals are used they should always be placed as far apart as possible on the former; after all, the only advantage in using them is that they permit ready removal from the circuit, and although this is useful in an experimental layout, in the ordinary way it is unnecessary.

**Putting the Wire on the Former**

The size of wire to be used is quite uncritical, although it should be fairly thin; 36 s.w.g. d.s.c. is a useful compromise between strength and thickness, but anything between 30 and 40 s.w.g. is satisfactory. The actual method of putting the wire on to the former will make a considerable difference to the self-capacity of the finished choke; one way of minimizing this self-capacity is to space the turns apart by about the thickness of the wire, which is wound on simultaneously with a piece of thread or silk, the silk being removed when the winding is finished. This method is a little tiresome and is really a refinement on wavelengths above 20 metres; although it might well be worth while in a receiver intended for use on the ultra-short waves. Another good method of reducing self-capacity and one which is much less tedious to put into practice is to wind the choke in sections, as illustrated in Fig. 2, each section of the winding containing about 20 to 30 turns and spaced from its neighbour by, say, a quarter of an inch. On a three-quarter to one inch former a total of 100 turns will be enough, and these may be increased up to 150 on a half-inch tube.

Fig. 3.—Simple method of mounting a choke wound on a test-tube.

These are quite easily fixed to the receiver baseboard by screws through holes in the tube or by providing the choke with a base made of a rectangular piece of ebonite attached by screws tapped into holes in the tube, as in Fig. 2. This method will not serve when test tubes are used; the simplest way of mounting these is to obtain a cork that is a good fit in the tube and glue it head down on to the base; the choke is then pushed on to the cork and kept in a vertical position, as shown in Fig. 3.

single-layer type, and this is admirable for choke construction. In order to prevent interaction with other coils, it is important to keep the diameter small in any choke, but doubly so on short waves, and it should certainly not exceed one inch, half an inch being a more satisfactory size. Various materials may be used as formers; very satisfactory are small glass test tubes, obtainable from most chemists for a penny; small diameter ribbed-ebonite formers can be obtained, and half-inch ebonite tube or rod is very good. Any kind of ebonite or bakaite tube permits the use of small terminals to fasten off the end of the wire, but this is not possible when glass is used, and in that case the simplest thing to do is to fix the end of the wire in place on the glass with a small spot of sealing wax. As a matter of fact, I always prefer to omit terminals and connect the choke straight into the circuit by the ends of the winding so as to avoid the little additional self-capacity introduced by the large bulk of the terminals. If terminals are used they should always be placed as far apart as possible on the former; after all, the only advantage in using them is that they permit ready removal from the circuit, and although this is useful in an experimental layout, in the ordinary way it is unnecessary.

The size of wire to be used is quite uncritical, although it should be fairly thin; 36 s.w.g. d.s.c. is a useful compromise between strength and thickness, but anything between 30 and 40 s.w.g. is satisfactory. The actual method of putting the wire on to the former will make a considerable difference to the self-capacity of the finished choke; one way of minimizing this self-capacity is to space the turns apart by about the thickness of the wire, which is wound on simultaneously with a piece of thread or silk, the silk being removed when the winding is finished. This method is a little tiresome and is really a refinement on wavelengths above 20 metres; although it might well be worth while in a receiver intended for use on the ultra-short waves. Another good method of reducing self-capacity and one which is much less tedious to put into practice is to wind the choke in sections, as illustrated in Fig. 2, each section of the winding containing about 20 to 30 turns and spaced from its neighbour by, say, a quarter of an inch. On a three-quarter to one inch former a total of 100 turns will be enough, and these may be increased up to 150 on a half-inch tube.

Fig. 3.—Simple method of mounting a choke wound on a test-tube.

These are quite easily fixed to the receiver baseboard by screws through holes in the tube or by providing the choke with a base made of a rectangular piece of ebonite attached by screws tapped into holes in the tube, as in Fig. 2. This method will not serve when test tubes are used; the simplest way of mounting these is to obtain a cork that is a good fit in the tube and glue it head down on to the base; the choke is then pushed on to the cork and kept in a vertical position, as shown in Fig. 3.

**New Times Sales Co.**  
**1934 RADIO**  
on the easiest of  
**Easy Terms**

Choose your **NEW RADIO** and send us your requirements. We will quote you the **Easiest of Terms** per return. **WE DEAL WITH YOU DIRECT.** No Third Party Finance Company, thereby ensuring the strictest privacy. Immediate delivery from stock.

- 1934 TELSEN KITS**
- TELSEN CLASS "B" 4 KIT** (Chassis), less Valves, Cabinet and Speaker. Cash or C.O.D. Carriage paid, £3/17/6. Balance in 11 monthly payments of 7/- order **With 7/-**
  - TELSEN SUPER - SELECTIVE SIX** (Chassis), less Valves, Cabinet, and Speaker. Cash or C.O.D. Carriage paid, £5/17/6. Balance in 11 monthly payments of 10/9 order **With 10/9**
  - TELSEN 325 STAR KIT**, less Valves and Cabinet. Cash or C.O.D. Carriage paid, £1/19/6. Balance in 7 monthly payments of 5/3 order **Send 5/3 only**

- TELSEN H.T. and L.T. A.C. MAINS UNIT** W.34C H.T. Portion, Max.; Det. and S.G. tappings, each adjustable for High, Medium, or Low Voltages. Maximum output, 28 m/a at 150 v. Trickle Charges, 2, 4 or 6 v. at 1 amp. Cash or C.O.D. Carriage paid, £1/17/6. Balance in 11 monthly payments of 9/- order **With 9/-**
- TELSEN D.C. MAINS H.T. UNIT**. Three tappings, each adjustable to High, Medium or Low Voltage. Maximum output, 28 m/a at 150 v. Cash or C.O.D. Carriage paid, £1/15/0. Balance in 6 monthly payments of 5/6 order **With 5/6**

- NEW W.B. TYPE P.M.4A. MICROLODE PERMANENT MAGNET MOVING-COIL SPEAKER**, Switch-controlled Multi-ratio Input Transformer. Cash or C.O.D. Carriage paid, £2/2/0. Balance in 7 monthly payments of 5/9 order **With 5/9**

- ATLAS C.A.25**, for Mains, Class B and Q.P.P. four tappings; 60/80, 50/90, 120, 150, 25 m.a. Cash or C.O.D. Carriage paid, £2/19/6. Balance in 11 monthly payments of 6/6 order **With 5/6**

- NEW ROLA CLASS-B PERMANENT MAGNET MOVING-COIL SPEAKER AND AMPLIFIER**, with Valve and Input Transformer. Two models: A for PM2B, PD220 and 220B; B for 240B, H.P.2 (state which when ordering). Cash or C.O.D. Carriage paid, £3/11/0. Balance in 11 monthly payments of 6/6 order **With 6/6**

- NEW R. & A. "ALPHA" P.M. MOVING-COIL SPEAKER DE-LUXE**, with tapped Input Transformer. Cash or C.O.D. Carriage paid, £2/12/6. Balance in 8 monthly payments of 6/6 order **With 6/6**

- NEW BLUE SPOT 99P.M. PERMANENT MAGNET MOVING-COIL SPEAKER**. Complete with tapped Input Transformer. Cash or C.O.D. Carriage paid, £2/19/6. Balance in 11 monthly payments of 5/6 order **With 5/6**

- NEW LISSÉN KITS**
- Free constructional chart with each Kit.
- NEW SKYSCRAPER 7-VALVE SUPER-HET CHASSIS MODEL** with Lissen Valves. Cash or C.O.D. Carriage paid, £3/17/6. Balance in 11 monthly payments of 16/6 order **With 15/-**
  - NEW SKYSCRAPER FOUR ALL-WAVE CHASSIS MODEL**, complete kit comprising all components including set of Lissen Valves. Cash or C.O.D. Carriage paid, £5/12/6. Balance in 11 monthly payments of 10/3 order **With 10/3**

To **EST. 1924**  
**NEW TIMES SALES CO.** 56, Ludgate Hill, London, E.C.4.

Please send me ..... s. d. Cash Deposit for which I enclose 2 .....  
Name .....  
Address .....  
Pr. W. 2/9/33.





## Mains Units by Specialists!

When choosing Mains apparatus it is advisable to buy from Specialists. Only thus can you be sure that your purchase is safe, sound and reliable. Heayberd Mains Units and Components are not skimped or "cut down" to a price. Skilled technicians, using the finest British materials produce Heayberd Mains Apparatus. A searching test is carried out at each stage of manufacture—that is why all Heayberd Units and components carry the well-known Guarantee. For nearly eleven years Heayberd have specialised in Mains apparatus, and the result of their research and experience is at your service. A complete display of the latest Mains Units, Kits, Transformers, Home Chargers and Amplifiers will be shown at Manchester. You will be welcomed at the Heayberd Stand.

STAND  
**39**  
MANCHESTER  
RADIO SHOW

### POST COUPON NOW

I enclose 3d. stamps for NEW and complete Revised 1934 Handbook—packed with blueprints and hints.

Mr. ....

Address .....

Prac.

10, FINSBURY STREET, LONDON, E.C.2.



## FIFTY TESTED WIRELESS CIRCUITS

By F. J. CAMM  
(Editor of "Practical Wireless")

This handbook contains every modern circuit, complete with instructions for assembling, component values, and notes on operation.

2/6

On sale at Booksellers, or by post 2/9 from  
George Newnes, Ltd., 8-11 Southampton Street,  
Strand, London, W.C.2.

# IMPRESSIONS ON THE WAY

## A REVIEW OF THE LATEST DISCS

### Classical, But Popular

HERE is abundant choice of fine orchestral

pieces this month, which, although they may sound formidable from their titles, have really popular entertainment value, so tuneful and straightforward are they. We will begin, enthusiastically, with Bach, who has two gems for us. First, *The Brandenburg Concerto No. 5, H.M.V. DB1783-4*. Here is gorgeous music, delicate and uplifting. There is something about it which brings a fresh delightful picture every time one hears it. The orchestra is the Ecole Normale of Paris and the soloists Cortot (piano), Thibaud (violin), and Cortet (flute). The best of everything in music and performers. Then two more well-known Bach compositions—*Air on the G String* and *Gavotte in E for Strings (Columbia DX475)*. Here the British Symphony Orchestra under Sir Henry Wood are the players. There is simple, placid beauty in these two, melody in its loveliest form. Hear them without fail.

Now for Haydn. First performed in London, the *Military Symphony (No. 100)* is a tremendously attractive piece. It is not really bellicose; in fact, the Minuetto movement makes one completely forget that it is anything other than a happy, simple piece. It might be well to hear this third movement first to get the atmosphere. The orchestra is the Berlin Grand Symphony Orchestra and the record *Parlophone R1537-40*. Now this same orchestra have done (on *Parlophone R1561-2*) *Six German Dances* by Mozart. Quite inelaborate music, played with perhaps more opulence than was necessary, but these dances are tuneful throughout and very interesting as comparisons with those of even Edwardian days.

Wagner looks in with the *Rienzi Overture*, played by the Grenadier Guards' Band on *Columbia DX476*. The purists will doubtless object, but the reply is that (i) Military Bands cannot for ever record Sousa, (ii) Rienzi is a happy choice, (iii) the Grenadiers make a very fine job of it. And that—is that!

### In Lighter Tone

It will be a pity when the supply of worth-while waltzes gives out for Marek Weber's *Pot-pourri* Series. He has reached No. 3 on *H.M.V. B4454*, and how very excellent the selection and the playing seem. Quite a treat. Then a wonderful *Russian Night at the Hungaria* by Colombo's Tzigane Orchestra (*Columbia DB1146*). The Russian vogue has been done to death, but here is a performance of amazing versatility which must not be missed. The real thing all through. A Strauss waltz which is not so well known is *Acceleration*. You will find a very well-played version of Edith Lorand's Orchestra on *Parlophone R1571*. Some of Albert Sandler's best heart-throb music is played by his orchestra on *Columbia 1148*. The titles are *Gipsy,*

By E. REID-WARR

*Sing for Me, and Heartless.* Quite his customary Sunday evening touch! There

is a pleasant pair of tunes very brightly played by Reginald King's Light Orchestra. They are *Persian March* and *The Coon Among the Chickens (Sterno 1216)*.

### The Best of the Songs

We have heard much of the Italian lyric tenor, Gigli, and not without reason. Here is a truly great artist whose voice is superb and who makes his songs throb with realism. His latest record is *H.M.V. DA1292*. On it he sings *Lucia, Lucia* and *'A Canzone e Napule*. These Neapolitan songs are perfect entertainment from every angle. Equally fascinating is his singing of the famous *Santa Lucia* and the farewell of Turiddu at the end of *Cavalleria Rusticana (Mamma, quel vine e generoso)* on *H.M.V. DB1902*. Here is illustrated his genius. The first is Gigli—lyrical; the second Gigli—operatic. Each is as impressive as it can be.

On an entirely different plane but endowed with much simple charm are Walter Glynn's pair on *H.M.V. B4426*. Here are *Bird Songs at Eventide* and *Just Because the Violets*. This record is sure to be popular—the appeal of these two songs is very wide. Then Richard Crooks, the American singer. He sings *Neapolitan Love Song* and *In My Garden* on *H.M.V. DB1876*. Into these trifles he puts very considerable artistry, and the result is a performance which reaches a high level. Still amongst the tenors, we reach Tauber, who gives us his best for a long time—Strauss's *Ständchen* and *Dream In The Twilight*. The first is an old favourite and it suits Tauber's style admirably. As each of these songs is well worth while, I recommend cordially *Parlophone RO20222*.

### Keys and Strings

Another record on that electrical marvel—the Neo-Bechstein, has come along from John Hunt (*H.M.V. B4438*). He plays Schumann's *Romance in F Sharp* and Bach's *Partita in B flat*. This invention somehow brings to mind the paradoxical saying about things changing and yet remaining the same. Here and there in this performance is a distinct likeness to the clavichord and the harpsichord with its lingering tone. And that is how to hear Bach, really. Altogether a very fascinating record.

These are the days of juvenile musical genius and Wolfi (Schneiderhan) is a violinist of extraordinary dexterity. He plays two pieces of average merit on *Columbia DX477*. The first (and best tune, although not so showy) is *d'Ambrosio's Serenade* and the other *Perpetuum Mobile (Ries)*, which please do not confuse with Strauss's masterpiece. There is a fascinating inlistening to this record, for the very clever execution makes one wonder how so young a person does it.

(Continued on page 880)



# FROM THE FLASHLAMP

By Photon

## The Measurement of "B."

THE measurement of "B" in the field gap of a moving-coil speaker may be effected in different ways; far the simplest—the method adopted by the author—is to weigh a search coil of known diameter and number of turns, situated symmetrically in the field when carrying a measured current. Alternatively, the load

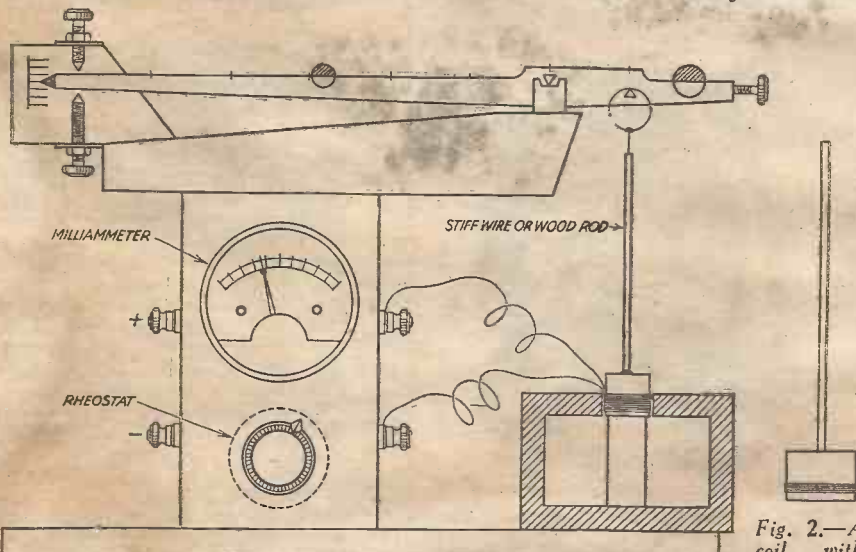

Fig. 1.—A "steel-yard" balance for measuring the value of "B" in the field gap of a moving-coil speaker.

carried is fixed, and the balance is effected by varying the current. Some four or five years ago the writer constructed a "steel-yard" balance for this purpose, as illustrated in the accompanying illustration, Fig. 1. This instrument, which was regarded at the time as little more than a make-shift, has since been used for the measurement of many hundreds of speaker magnet fields and has given perfect satisfaction. It is an instrument that any amateur could make for himself in an afternoon.

The appropriate coil to use depends upon the immediate object in view. If it be desired to explore the gap and ascertain the value of "B" at different points, both within and external to the gap, the winding is made as compact as possible, and of few turns, as shown in Fig. 2. If, on the other hand, the mean value for the gap is to be determined, then the length of the winding should be approximately the same as the axial length of the gap, or, if preferred, it can be made the same length as the speech coil which it is intended to use. The support for the winding is a paper sleeve of cylindrical form with a wire or thin wooden rod, as illustrated.

The circuit is clearly indicated in Fig. 1.

The equation, giving the value of "B" from the load in grams and current in amperes is:—

$$B = \frac{F \times 9800}{l \times i} = \text{lines per cm.}^2$$

Where

- F=force in grams.
- l=length of wire in search coil.
- i=current in amps.

To illustrate the use of the instrument more fully, the following example may be given:—

- Force=10 grams.
- Length of wire in search coil=120 cm.
- Current=119 milliamps.

$$B = \frac{10 \times 9800}{120 \times .119} = 6860 \text{ lines per cm.}^2$$

Other methods have been proposed and used for exploring the field, but none is so simple and easy as that above described.

In the case of permanent Cobalt steel field magnets, such as ordinarily marketed, the value of "B" is usually found to lie

between 6,000 and 7,500; for an ordinary speaker of the open cone type this may be regarded as adequate. Claims are often made for far higher figures, but the writer has tested many of these and has never found these claims justified. In one case where, with a great flourish of trumpets, a new construction of field magnet was said by its makers to give a 50 per cent. higher field than its competitors, the magnet assembly, when tested, gave B=6,050. By employing massive magnets of 35 per cent. Cobalt steel the writer has succeeded in getting up to 8,000 or 9,000, which is about equal to an average magnet with electrically excited field, but any such figure obtained with a permanent magnet is extravagant and the high cost makes its use prohibitive.

### THE MOTOR-CYCLISTS' REFERENCE YEAR BOOK

Edited by F. J. CAMM.

1932-1933 Edition.

THIS is the only Reference Year Book covering every phase of Motor Cycling. Contains complete and comprehensive information with practical illustrations relating to all makes of machines and accessories, facts and figures regarding competitions, records, clubs, legal matters, overhauling and repairing, tuning, classified buyers' guide, etc. Obtainable at all Newsagents and Bookstalls, or post free 1/2 from George Neumes, Ltd., 8-11, Southampton Street, Strand, London, W.C.2. **1/-**

## acknowledged THE WORLD'S BEST



The most popular and efficient type of fixed resistance for all general purposes. "Better than wire wound." All values 50 ohms to 5 megohms.

100 deg. F. Temperature rise.

| Ohms   | Milliamps | Ohms                  | Milliamps |
|--------|-----------|-----------------------|-----------|
| 1,000  | 40        | 30,000                | 6.75      |
| 2,000  | 35        | 40,000                | 6         |
| 3,000  | 29        | 100,000               | 3.5       |
| 20,000 | 8         | Other values pro rata |           |

Heavy Duty type, approximately double the above ratings.

## OHMITE RESISTANCES

# 1/6 EACH

### HEAVY DUTY TYPE 2/3

Ensure a safe and efficient Aerial and Earth. The new AEROFICIENT KIT provides all you need. 6/6 complete.

Send for copy of New Catalogue ready shortly.

# GRAHAM FARISH PRODUCTS

Advertisement of GRAHAM FARISH, LTD., Bromley, Kent. Export Office: 11/12, Fenchurch St., E.C.3.



You want  
**SHARP, CLEAR,  
BETTER RECEPTION?**

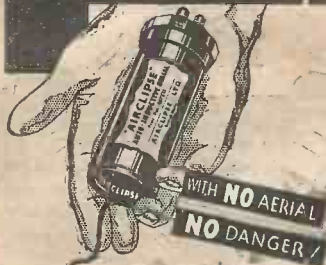

Discard your present aerial and connect up to the AIRCLIPSE. You will be delighted with the immediate improvement in selectivity and clarity. The AIRCLIPSE is not another gadget—not a condenser—but an auto-inductive aerial that filters incoming signals. It eliminates lightning danger. Can be placed inside or outside the set. Enables the set to be moved from room to room.

The Secretary of an important Radio Society writes: "The efficiency of this is so amazing that I shall have no hesitation in recommending it on all occasions."

# AIRCLIPSE

Auto-Inductive AERIAL

For A.C. Mains and Battery Sets.

Of all dealers, or in case of difficulty order from:—

AIRCLIPSE Ltd., 132, NAUXHALL BRIDGE RD., LONDON, S.W.1  
Telephone: Victoria 5022.

**HIGH  
IN  
QUALITY**



**LOW  
PRICE**

## EXHIBITION SETS . . . .

The following HIVAC Valves are recommended:

For "Practical Wireless" 1934 SUPERSET

|        |      |
|--------|------|
| VS 210 | 10/6 |
| H 210  | 4/6  |
| P 220  | 5/6  |
| B 220  | 10/6 |

For "Practical Wireless" ALL-WAVE TWO

|       |      |
|-------|------|
| L 210 | 4/6  |
| Z 220 | 12/6 |

THE HIVAC VALVE GUIDE "N"

gives our complete range of 2-volt valves for battery receivers, together with a comparative table of equivalent high efficiency valves at low cost.

WRITE NOW FOR A FREE COPY.

British Made in our own Factory.

From all dealers. If any difficulty, send us P.O. and address of nearest dealer.

**HIVAC**  
THE SCIENTIFIC VALVE

HIGH VACUUM VALVE CO., LTD., 112-117, Farringdon Rd., E.C.1

# Facts and Figures

Components Tested in our Laboratory

BY THE PRACTICAL WIRELESS TECHNICAL STAFF

### AMPLION "SONETTE" LOUD-SPEAKER

ALTHOUGH not a Midget in the strict sense, this new speaker is a remarkably small model, and is particularly noticeable for its ingenious magnet system. As may be seen from the illustration, this does not take the usual form, but is provided with a rather large central piece which gives a much larger magnet system than some larger types of speaker. The chassis has an overall diameter of 6 1/2 in., whilst the cone itself is 5 1/2 in. in diameter. The magnet is actually 1 1/2 in. wide and nearly 4 in. long, so that it is really rather out of proportion for the size of the remainder of the chassis. This is all to the good, however, as it greatly increases the sensitivity, and makes the

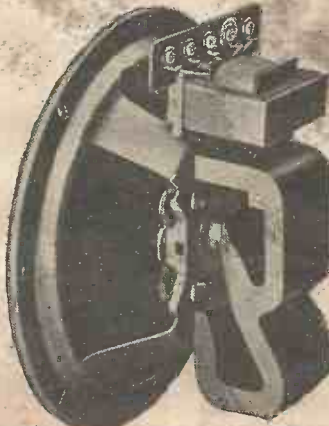

The Amplion "Sonette" Loud-speaker.

speaker much more powerful than one would expect from an inspection of the instrument from the front. A very efficient multi-ratio transformer is fitted to the chassis and this is provided with five terminals, and enables the speaker to be matched to practically any triode, pentode, or push-pull type of valve. The response is very even, and the bass is particularly noticeable for a speaker of such small size. The top, as was to be expected, is nice and brilliant, and the speaker is a remarkably good model, with an additional attraction of a really low price, namely 27s. 6d. It was used, as no doubt many readers are aware, in the Auto-B Three, and this alone should be sufficient guarantee of our satisfaction with the results which are obtainable from it.

### NEW EARTH TUBE

WE have repeatedly stressed the importance of a low-resistance earth, and although this may be effectively obtained by means of a good earth tube or other metallic body buried in moist earth, the problem is, very often, how to maintain the earth in a moist condition. Several various materials have been produced from time to time by manufacturers for the purpose, and so far all have been very effective. A newcomer to this market is the Ronnie Material, and unlike the majority of earthing materials this does not consist entirely of a chemical of a deliquescent nature. A process has been developed, after much patient research, which results in a new alkaline solution of copper in granule form which attracts moisture from the air. The usual type of crystal is added to this material, and the whole mixed together resulting in a really highly efficient product. It is sold by the Ronnie Engineering Company packed in airtight cartons ready for burying round an existing earth connection, and in addition a very neat earth tube has been produced and is sold by the same company, packed with the material. The tube may be obtained in plain copper, or cadmium plated. The price of the carton of mineral is 1s. 3d., and the earth tube costs 5s. in copper and 6s. in cadmium.

### BRITISH RADIOPHONE TWIN DRIVE

SEVERAL new types of disc drive have been produced this season, and that illustrated is a departure from the conventional type which has hitherto been obtainable. In place of the usual single escutcheon window two are provided on this drive,

and they are situated at opposite sides of the complete unit. The dial itself is graduated in degrees, but ample space is left for the insertion, in pencil, of station names. By using one window for the medium-wave stations, and the other window for long-wave stations, the dial will become, after a few night's use, a very

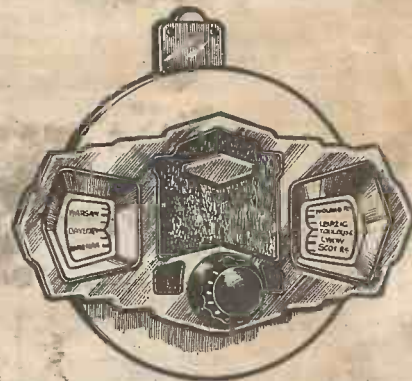

A British Radiophone twin drive dial with double windowed escutcheon.

useful calibrated chart, enabling any station to be tuned-in rapidly on either wave-band. A separate pilot light is provided for each window, and the new type of lamp-holder is fitted. This may be pulled off in a moment for bulb replacement, and clips into place. The reduction gear is 10 to 1, and the fixing bush will accommodate a quarter-inch spindle. The price is 7s. 6d.

### GRAHAM FARISH AERIAL KIT

WHEN installing a wireless receiver for the first time, an aerial has to be erected and an earth connection fitted. In the ordinary way, this means that insulators, wire, lead-in tube, and other sundries have to be bought, and this results in the efficiency of the system being impaired owing to the fact that the purchasing is usually carried out rather hurriedly, and is skipped in order to get the set working. Messrs. Graham Farish have now introduced a very neat



A new Bulgin signal device.

kit boxed in an attractive manner, and including every necessity for the efficient aerial and earth system. By purchasing this kit you get at one purchase an aerial, insulators, lead-in tube, a tin of Fil (the well-known chemical earth), and in addition a logging chart and an insurance policy. By this means there is no difficulty in getting any part of the system and a slight saving is effected in cost. The various parts are arranged in the box in a neat manner and not just thrown together, and it is certain that by the introduction of this kit many new listeners will be ensured of



good reception owing to the fact that all the essentials for a good aerial and earth are so readily obtainable. The cost is 6s. 6d., and the makers are to be congratulated upon their foresight in introducing a kit of this nature. It will do a lot towards improving reception generally.

**BULGIN SIGNAL FITTINGS**

ALTHOUGH the majority of mains receivers are equipped with an illuminated dial, there are many receivers, especially in the battery-operated class, which have no indication (other than a signal from a broadcasting station), whether the valves are switched on or off. Many listeners have experienced the disappointment of finding, when attempting to switch their receiver on for the evening's programme, that the receiver has been left "On" since the previous day, and the accumulator has run out.

In the case of mains apparatus, this is not only a waste of current, but it also reduces the length of service which the valves will give. Messrs. Bulgin have introduced many different types of signal lamp to avoid this difficulty, and some of these are well known. There is, for instance, the small red-glass window with a metal escutcheon fitting round it, which may be attached to the panel, and a small bulb screwed into the holder at the rear. By wiring this bulb in parallel with one of the valve-holders, the red window is illuminated when the valves are switched on, and this forms a very valuable safeguard, as the illumination afforded is sufficiently bright to attract the attention. The latest introduction by this firm, however, is of a much more attractive nature, and the illustration on page 874 gives only a slight idea of the actual component. A lamp-holder is fitted to a base, and in front of this holder is a curved opal screen, cut with attractive lines. Mounted in front of this small screen is a neat figure, at present obtainable in four different forms. That illustrated is known as "Knowledge" and is in the shape of an owl. "Meditation" is the figure of a young girl, and was illustrated on page 816 of last week's issue. Another figure is of a dog—known as "Doggy"—and we understand that one or two other designs will be introduced. As many people prefer (during the winter evenings) to listen in the dark or in subdued lighting, this ornament offers a very attractive illumination of the right character for concentrated listening. The price is 15s.



The Ronnie earth tube.

**OPERATING THE SUPERSET**

(Continued from page 839)

the tuning dial it may be kept on the dial. Make quite certain that this trimmer is at its minimum (all out) position. If this point is not attended to first you will find it impossible to tune in the low wave stations such as Fécamp. Now, keeping one hand on the tuning control, transfer the adjusting device to the next screw and carefully turn this first one way and then the other, at the same time rocking the tuning control slowly over two or three degrees. You will find that a position is obtainable where rotation of the trimming screw in either direction results in loss of signal strength. The same process should then be carried out with the remaining screw, although it will be found useful here to readjust the central screw slightly at the same time. It should be your aim to get an adjustment on each trimmer where it is possible to find on the tuning dial a weak station, and where no further adjustment of any trimmer will increase its strength. It may, in some cases, be found that a station can be made louder at one end of the dial by readjusting a trimmer, but when a return is made to the other end of the dial, a further readjustment, upsetting the former adjustment, is necessary. In this case the first trimmer should be given a slight turn, and trimming carried out again. Where the wiring is such that it is found impossible to obtain a setting which holds over the entire range, the wires between coils and valves should be carefully spaced until the inter-stage capacities are evened up.

Your complete guide to the construction of Radio Power Units. A 32-page publication which deals fully and clearly with the theory and practice of the subject, giving full working instructions and diagrams for the building of eight different units—AC and DC—from modest to super-power output.

Published by Ferranti, it may be looked upon with confidence as a responsible and authoritative treatise. As such, it is only natural that the components recommended are of unsurpassed quality and unquestioned reliability. The fact that many of these components bear the Ferranti name will be taken as a guarantee that the completed Power Units are entirely safe and exceptionally efficient.

This Booklet W522, as well as a 16-page list of all Ferranti Mains Components, will be sent, post free 4½d. Address enquiries to Dept. "P.W."

The full range of Ferranti Mains and General Radio Components may be inspected at Stand No. 38, Scottish National Radio Exhibition, Glasgow; also at Stand No. 20, Main Hall, Northern National Radio Exhibition, Manchester.

**FRONT OF PANEL** **MILLED NUT**

**ENDS FOR SETTING HANDS** **U-SHAPED BAR** **BATTERY**

**FIT THIS ELECTRIC CLOCK TO YOUR SET!**  
**NO MAINS NEEDED!**  
**KEEPS CORRECT TIME!**  
**NO WINDING!**

Works off small battery lasting 12 months, or can be plugged into G.B. battery without affecting reception. Uses practically no current. Fits into hole 3½ in. dia. in any panel up to ½ in. thick. Easy to fix—no screws required. Only ½ in. from front of panel to back of case. Swiss movement. Hands set from front. Nickel-plated bezel. Useful addition to any set.

**RIVERSIDE MFG. Co., Ltd.,**  
 Dept. 21, Crisp Road,  
 Hammersmith, W.G.  
 Telephone: Riverside 6392.

**12/6**  
 COMPLETE WITH BATTERY  
**POSTAGE 6D**

Write for Illustrated Catalogue of

**Radio-Gramophone Cabinets** of exclusive modern design, made by craftsmen in highly figured Oak, Walnut or Mahogany, roset free. Cabinets made to order a speciality. *Maker under licence of the*

**HOWE BOX**  
**BAFFLE.**  
 Recommended by the B.B.C. Full details on request.

**GILBERT**  
 Cabinet Maker,  
**SWINDON**, Estimates free. Est. 1866.

**CHARGING WITHOUT MAINS**  
 Thousands are charging their own accumulators, why don't you? "TONIC" trickle-charger kits keep two-volt accumulators fully charged. Ideal for remote districts. From 7/-, postage 9d. Full particulars, stamp.

**WILLIAMS, Netherend, Cradley, Nr. Birmingham.**



# BENJAMIN RADIO PRODUCTS

Constructors realise that the ultimate success of their circuits depends almost entirely on the quality of component used in assembly. Good components made by skilled craftsmen are necessary; components made by engineers who have a thorough grasp of modern Radio requirements.

A noteworthy addition to the Benjamin programme this year is a range of Magnavox Permanent Magnet Speakers. The most striking quality about these speakers is their sensitivity and lively attack. Illustrated is the "Senior" Model Type 252. Price **£3.3.0** "Standard" Model type 254 - - **£1.17.6**



"B" Input Driver Transformer—For use with all types of Class "B" circuits and valves. Tapped to give choice of overall ratios  $1\frac{1}{2}$  to 1 and 1 to 1.

Price **10/6**

The 7-pin holder specially designed for Class "B" and all other 7-pin valves. Equipped with easy wiring reversible terminals. The terminal holes in valve platform are countersunk for flush under-chassis mounting. Price **2/-**



Data sheets are available giving full particulars of the complete Benjamin range of valveholders, transformers, chokes and Magnavox Mains-energised Speakers. Quote P.R.13.

THE BENJAMIN ELECTRIC LTD., TARRIFF ROAD, TOTTENHAM, N.17.

## SOUND AND THE EAR

By E. G. ROWE, B.Sc., A.C.C.I.



RADIO has developed with tremendous rapidity during the last ten years, but it must be remembered that its advent has caused much research to be made in other branches of physics. One of the most prominent of these is acoustics, and it is very helpful, in fact we might say essential, that every wireless enthusiast worthy of the name should have a working knowledge of sound. It is the beginning and the end of radio—we start off with sound when the speaker addresses the microphone, and we finish with sound as it comes from our reproducers—and the whole problem of broadcasting consists of the conveyance and reproduction with the utmost fidelity of what the microphone hears. The above sketch illustrates diagrammatically the chain of operations.

First, what is sound? Well, sound is a form of energy just like heat and light, and while being similar in many respects, it differs greatly in another, in that the actual quantities we have to deal in when studying it are very small. Sound energy is usually dissipated in the form of friction and heat, but if we had two million people talking continuously for two whole hours they would only generate heat sufficient to boil enough water to make a cup of tea. That statement obviously knocks on the head the ideas of many inventors who seek to get the noise of our cities to do work for us. Thus you can see that the power required to affect the ear is extremely small. Loud voice tones do not alter the normal pressure of the air by more than a few millionths of an atmosphere, and as the talking voice varies its power over a range of about 100 to 1 in normal conversation we can realize the wonderful adaptability of the ear.

To look at the statement electrically, an ordinary good pair of headphones gives a loud signal if 5 microamperes flow through them at 1,000 cycles/sec. frequency. This amount of current represents an input power of about one ten-millionth part of a watt. Now the efficiency of a receiver held close to the ear is somewhere between 1 and 10 per cent., so that the actual amount of sound coming from the diaphragm is something like one thousand millionth part of a watt! This is rather small, when you consider it needs a 60-watt lamp to illuminate a small room!

### Frequency of Various Notes

Now sound may also be defined as that set of vibrations in the frequency spectrum

that affect the air. Suppose we had something which could apply pulses of pressure to the ear at any frequency we desired. Up to sixteen pulses a second we should hear nothing, although we might feel the successful applications of pressure if they were hard enough. At sixteen pulses a second we should just begin to hear, because this frequency represents the lowest note of a large organ. As the frequency is increased so the tone gets higher; at 256 pulses a second we have the middle C of the piano; at 6,000-7,000 pulses a second we have a very shrill whistle; while at 15,000 to 20,000 cycles/second, depending on the individual, the sound completely disappears. Before leaving this it might be well to look at sound from the wavelength point of view in the same way that we do radio. The low notes of an organ have a wavelength of 60 to 70ft.; a man with a deep bass voice might reach a length of 20ft., while the highest soprano might touch notes having a wavelength of 1ft.; and, finally, the uppermost limit of the audible range has wavelengths of about  $\frac{1}{2}$ in.

### How Vibrations are Set Up

Let us consider how these vibrations are set up by looking at a tuning fork. With each vibration of the prong it strikes sharply against the air in contact with it, compressing it, and with the recoil of the prong the air again expands. The impact, however, is passed on to the layer of air beyond the first, and so on. Sound travels like this at a constant speed through any particular medium, and we can imagine that if air at any point is shaken, due to, say, vibrating a drum, then rhythmic variations of air pressure travel outwards in all directions at constant speed. Various sounds are distinguished by their frequency in much the same way as wireless stations are. Thus:

$$\text{wavelength} = \frac{\text{speed}}{\text{frequency}}$$

The speed of sound, for air, is 1,080ft. per sec.

It must, however, be clearly understood that it is the variations of air pressure which travel outwards, and not the air itself. The air particles only move a very short distance backwards and forwards along the line of propagation of the sound. Thus to carry the average speech power of 10 microwatts the air particles near the mouth only vibrate through a distance of 1-100th of a millimetre.

### THE NEW RUSSIAN WAVELENGTHS

WITH the bringing into operation of the Lucerne Plan Moscow's 500 kilowatt station will work on 1,714 m. (175 kc/s) and her second high power transmitter on 1,107 m. (271 kc/s). Lenin-

grad, Minsk and Kharkov will continue to use the long channels, but will adopt respectively 1,224 m. (245 kc/s), 1,442 m. (208 kc/s) and 1,345 m. (223 kc/s), the latter being a wavelength which must be shared with Huizen (Holland). According to a Norwegian report the U.S.S.R. intends to build a number of stations in Siberia and in Asiatic Russia, one of which may be actually planned to radiate some twelve-hundred kilowatts.





# Practical Letters from Readers.

The Editor does not necessarily agree with opinions expressed by his correspondents.

### Super-selective Superhet Wanted

I SHOULD be glad to see a really super-selective superhet with a minimum of valves—Class B output—using the new iron dust coils, particularly suitable for battery users. I am one of those readers without mains.—P. GREGORY (Maida Vale).

### All That's Colour-coded is Not Erie

SIR,—When we introduced colour-coded resistors to the public we fully appreciated the possibility of the colour code being used by others, and therefore resistors of other origin being mistaken for our product.

To obviate this difficulty every Erie resistor distributed to the trade is individually labelled, and it is apparent that trouble cannot occur if this fact is widely known. We have several times circularized the trade to this effect, and have consistently conveyed this information to the public and the service man in our advertisements. Notwithstanding this fact, we frequently have faulty resistors returned to this address which invariably turn out to be someone else's product. Just as consistently we find that the goods have been purchased as Erie products.

We are not so perturbed about the effect of this on our sales, but we are deeply concerned regarding the effect this may have upon the reputation of our product. May we ask your assistance in further emphasizing this information. We feel it is a matter of great importance to the trade generally.—P. NEWMAN (Radio Resistor Company).

### Featherweight Portable Four

SIR,—I take this opportunity of offering my thanks for such a compact portable as the Featherweight Four which you sponsored. I have named my set "Julia," and I enclose a few verses concerning it, which may interest you.

In operation, the middle wave is the better of the two, but a graph is of little use as dial readings keep changing with L.T. and H.T. voltage changes. I set the right dial 20 degrees back to match left dial on our North Regional at 140 degrees. Here are some of the other readings:—

|                      | Left dial. | Right dial. |
|----------------------|------------|-------------|
| Munich ..            | 153        | 160         |
| Brussels No. 1 ..    | 150        | 152         |
| North Regional ..    | 140        | 140         |
| Rome ..              | 122        | 120         |
| Rabat ..             | 119        | 109         |
| Athlone ..           | 108        | 115         |
| Midland Regional ..  | 98         | 110         |
| Scottish Regional .. | 89         | 99          |
| Muhlacker ..         | 84         | 94          |
| London Regional ..   | 82         | 92          |
| Poste-Parisien ..    | 80         | 72          |
| West Regional ..     | 70         | 60          |
| North National ..    | 67         | 54          |
| London National ..   | 54         | 28          |
| Trieste ..           | 48         | 22          |

I had Rabat (Morocco) (416 metres) at 12.30 a.m. after Athlone (213 metres) had closed. Also Ecole Superieure just above Rome tuning. These results prove there is not much wrong with searching qualities and sensitivity. Midget Ormond S.M. Dials are fitted, 1—180 readings. These are earthed, as well as the reaction knob spindle, with a copper foil behind oak, and a layer of card between foil and condenser; this foil is earthed. We are on a bank of the Mersey estuary, six miles north of Liverpool, on the way to Southport. I can only get Daventry 5XX (1554.4) by reducing H.T. volts to 100. Readings are as follows:—

|                | L.  | R.    |
|----------------|-----|-------|
| Hilversum ..   | 118 | 100   |
| Radio-Paris .. | 100 | 66    |
| Daventry ..    | 82  | 22-24 |

Again thanking you for your "Featherweight," which I very much like.—JAMES THOMSON (Liverpool).

(Thanks for the poem.—ED.)

### Our Show Issue

SIR,—This morning when I went to the front door to get my PRACTICAL WIRELESS, imagine my anger to see what I thought to be a magazine. I was turning over in my mind what I would say to that newsagent, but, to my surprise, when I picked the book up, it was my PRACTICAL WIRELESS, only greatly enlarged. Thanking you for your wonderful book.—ALEC BROWNE (Grimsby).

CUT THIS OUT EACH WEEK.

## DO YOU KNOW?

- THAT the new Variable-mu H.F. Pentodes have an amplification factor of 5,000 or so.
- THAT an output transformer is unnecessary with a Class B valve, if a special Class B loud-speaker is employed.
- THAT mains transformers designed for use on 25 cycle mains may be employed satisfactorily on 50 cycle mains.
- THAT mains transformers designed for 50 cycle mains should on no account be used on 25 cycle mains.
- THAT a poor earth connection often gives rise to serious hum troubles with D.C. mains units.
- THAT a home-cinema may give rise to noises in a wireless receiver as far away as 100 yards.
- THAT large metal parts should be kept away from a frame aerial.

### NOTICE.

The Editor will be pleased to consider articles of a practical nature, suitable for publication in PRACTICAL WIRELESS. Such articles should be written on one side of the paper only, and should contain the name and address of the sender. Whilst the Editor does not hold himself responsible for manuscripts, every effort will be made to return them if a stamped addressed envelope is enclosed. All correspondence intended for the Editor should be addressed: The Editor, PRACTICAL WIRELESS, Geo. Neaves, Ltd., 8-11, Southampton Street, Strand, W.C.2.

Owing to the rapid progress in the design of wireless apparatus and to our efforts to keep our readers in touch with the latest developments, we give no warranty that apparatus described in our columns is not the subject of letters patent.

# ANNOUNCEMENT

★ to men who want careers in RADIO



In the sign language of the Broadcasting Room this symbol means "Announcement."

The I.C.S. Radio Courses cover every phase of radio work, from the requirements of the youth who wishes to make wireless engineering his career to the man who wants to construct and maintain a broadcasting set for his home.

The Radio industry is progressing with amazing rapidity. Only by knowing thoroughly the basic principles can pace be kept with it. Our instruction includes American broadcasting as well as British wireless practice. It is a modern education, covering every department of the industry.

### OUR COURSES

Included in the I.C.S. range are Courses dealing with the installing of radio sets and, in particular, with their servicing, which to-day intimately concerns every wireless dealer and his employees. The Operating Course is vital to mastery of operating and transmitting.

There is also a Course for the Wireless Salesman. This, in addition to inculcating the art of salesmanship, provides that knowledge which enables the salesman to hold his own with the most technical of his customers.

We will be pleased to send you details of any or all of these subjects. Just fill in, and post the coupon, or write in any other way, stating which branch of Wireless interests you—the information you require will be forwarded at once.

International Correspondence Schools, Ltd.,  
Dept. 94, International Buildings,  
Kingsway, London, W.C.2.

Without cost, or obligation, please send me full information about the Courses I have marked X

- COMPLETE RADIO
- RADIO SERVICE
- RADIO EQUIPMENT
- RADIO SERVICING AND SALESMANSHIP
- WIRELESS ENGINEERING
- WIRELESS OPERATORS

Name .....

Address .....



# PIONEERS OF RADIO

## A VISIT TO THE WORKS OF Messrs. A. C. COSSOR, LTD.

ON the morning of Thursday, August 10th, a few of the members of the PRACTICAL WIRELESS Technical Staff, in company with other members of the Press, were privileged to inspect the two large and up-to-date works of Messrs. A. C. Cossor, Ltd. The first works to be visited were those in Highbury Grove, from whence a considerable proportion of the world's valves emanate. We were entertainingly shown over the factory by one of the Cossor engineers and had the pleasure of seeing what can be done under perfectly-organized mass production methods. The first impression on entering the commodious factory was that the whole was operating so smoothly that, despite the tremendous output, there were no signs whatever of rushed or haphazard work. The majority of the operatives were girls, who had obviously received a thorough training in the particular task assigned to them, and they were so arranged on their benches that immediately any one had done her share of the work, her (still incomplete) valves were automatically passed on to the next.

We first of all saw how the sheet metal anodes were constructed, then how the grids were made in lathe-like machines by winding a length of thin nickel wire on two long stiffer supports. The grids were made in lengths of some ten inches and were next cut off into appropriate lengths by another operative. After this, each one was carefully fitted on to a standard steel former to ensure that all were perfectly identical.

Once the two larger electrodes had been made they were passed on to another department where the special Cossor 7-point filament suspension was attended to. This consisted in spot welding seven extremely small insulators to the grid, the complete operation taking but a few seconds despite the thoroughness with which it was carried out. In another part of the factory girls were engaged in spot welding the "inverted V" filament to its supports—again a most delicate task, but which, due to the high degree of efficiency maintained, occupied a surprisingly short space of time. Later, we saw the glass bulbs being moulded and cut off to size in a large machine. Bulbs a good deal longer than those finally required

were mounted on rotating pegs projecting from a huge disc, which was itself rotating. A number of fine flame jets played on the bulbs as they rotated, so that by the time the disc had completed one revolution the bulbs were just sufficiently hot to allow them to be quickly cut by a small circular steel cutter. This process was continued indefinitely by girls "feeding" the machine with new bulbs, whilst those which had been finished were automatically removed and passed on to a tray in readiness for further use.

After all the electrodes had been mounted in the glass bulbs, these were placed on the evacuating pump. What could be seen of this was a large hollow ring with a number of rubber tubes projecting upwards and other connecting pipes leading off below. The unfinished valves, without bases, were placed on this

automatically) directed against the leading out tube, which was thus sealed and cut off in a single operation.

The final process was to fire the magnesium "getter" in every valve by lowering a coil carrying H.F. currents at still higher voltage over the bulb. This, of course, caught all traces of residual gases and trapped them against the inside of the bulb. Before packing, every valve was individually tested on carefully calibrated machines to ensure perfect accuracy, and any which did not show precisely the correct characteristics were rejected. There is no wonder, therefore, that one very seldom hears of a Cossor valve that does not come up to expectations.

After going through the valve factory (our only regret was that we could not stay longer) we went along to the Kelvin Works, where the famous Cossor receivers and

"Melody Maker" kits are produced in tremendous numbers. We saw fine blued-steel chassis pressed out of sheet material in a single operation by means of huge hydraulic presses, whilst condenser vanes and transformer stampings were being produced by similar means. Transformers of both L.F. and mains types were wound with absolute accuracy on specially-made lathes fitted with counters by which the operator was able to make every winding exactly the same. Resistances were being produced in large quantities for use in Cossor sets and it was amazing to find how rapidly they were made, adjusted to the exact value required, doubly tested and given a coat of moisture-resisting cellulose paint.

One came away from the Cossor works with a feeling that the products could be relied on implicitly for accuracy and permanence, so carefully and yet so speedily were they made.



Loading up and sealing off Cossor 220B (Class B) valves from one of the super rotary pumps. Some idea of the enormous size can be gleaned from this picture.—Cossor Works.

so that their glass leading-out tubes fitted tightly into the rubber ones of the machine. As the valves were being processed in the machine, a coil of copper tubing carrying H.F. currents at a very high voltage was automatically lowered over each in turn. This had the effect of making the electrodes red hot, so that any residual gases which they might contain were liberated and could be drawn off. After each valve had been made a complete revolution in this machine a flame was (again auto-



One of the battery of multiple head-winding machines used for winding Cossor transformers.—Kelvin Works.











9965  
 38400 AM 39600 AM 820150 AM 168754 AM 374566 AM 82799 AM 384491 AM 64090 AM 5873  
 67133 AP 56299

**£1**

will be paid to holders of

|           |           |           |           |           |
|-----------|-----------|-----------|-----------|-----------|
| AI 523797 | AL 855924 | AN 669623 | AN 951703 | AO 32751  |
| AI 496146 | AM 699870 | AN 538440 | AO 810316 | AO 715889 |
| AI 006812 | AL 479487 | AM 053498 | AN 496138 | AO 086793 |
| AI 346952 | AL 670733 | AM 934625 | AN 821664 | AO 845144 |
| AI 731789 | AL 784000 | AM 886315 | AN 501501 | AO 907428 |
| AI 821391 | AL 846681 | AM 712742 | AN 964715 | AP 246240 |
| AI 970773 | AL 946681 | AM 639625 | AN 639625 | AP 337772 |
| Ad 523900 | AL 946681 | AM 955782 | AN 955782 | AP 655209 |

This offer applies to securities which are actually included on Saturday, September 2, 1939. Before the awards are made, claimants will be asked to undertake a responsibility in their own names to the Post Office Wireless List. If they are unable to do so, they will be asked to undertake a responsibility in their own names to the Post Office Wireless List. Claims cannot be considered in connection with the date of issue of this list.

For full particulars for claimants and a complete list of numbers see

**TIT-BITS**

ON SALE EVERYWHERE SATURDAY SEPT. 2.

the very  
 charging  
 also  
 how to erect a charging station

**FOR CAR UPKEEP AND OVERHAUL**

information covering the engine, decarburizing, valve grinding, the lighting system, the distributor, cooling system, lubrication, springs and shock absorbers, steering gear, brakes, wheels, axles, tracing noises, etc. etc.

**TOY-MAKING FOR AMATEURS**

How to make clockwork toys, model aeroplanes, model locomotives, model boats, ingenious toys operated by sand, wooden models and toys, electrical toys, steam toys, guns, kaleidoscopes, acrobats, etc.

**SIMPLE ELECTRICAL APPARATUS**

An excellent little book for those who wish to make simple and useful electrical appliances, such as galvanometers, electric motors, dynamos and Leyden jars.

**NEWNES' HOME MECHANIC BOOKS**

Obtainable at all Newsagents and Bookstalls, or by post 1/2 each from George Newnes, Ltd., 8-11, Southampton St., Strand, W.C.2

**1/-** each



Specified by  
the leading  
designers

**MAZDA**



**The  
FOREMOST  
BRITISH  
VALVES**

The Edison Swan Electric Co. Ltd.  155 Charing Cross Rd., London, W.C.2

Mazda Radio Valves are manufactured in Great Britain for The British Thomson-Houston Co. Ltd., London and Rugby.

**RECOMMENDED BY ALL GOOD RADIO DEALERS**

V.212

**P. W. Gift Stamp No. 49**

Printed by NEWNES & PEARSON PRINTING CO., LTD., Exmoor Street, Ladbroke Grove, W.10, and published by GEORGE NEWNES, LTD., 8-11, Southampton Street, Strand, W.C.2. Sole Agents for Australia and New Zealand: GORDON & GOTCH, LTD. South Africa: CENTRAL NEWS AGENCY, LTD. *Practical Wireless* can be sent to any part of the world post free, for 17/4 per annum; six months, 9/8. Registered at the General Post Office for Transmission by Canadian Magazine Post.



THE MOST PROGRESSIVE WIRELESS WEEKLY!

# Practical Wireless

3<sup>D</sup>

Published every Wednesday by

**GEORGE  
NEWNES  
LTD.**

Vol. 2. — No. 51.

SEPTEMBER 9th, 1933.

Registered at the G.P.O. as a Newspaper.

## The Editor looks at the Show!



Building the  
**A.C.  
THREE**



### ESSENTIAL TO GOOD RECEPTION

The **AEROFICIENT KIT**

Contains every component needed to make an efficient and permanently safe Aerial and Earth, complete with full instructions, Tuning Chart, etc. Sold by all dealers.

A GRAHAM FARISH PRODUCT

ADVERTISEMENT OF GRAHAM FARISH LIMITED, BROMLEY, KENT

# 66

ADVT.



The most informative & sought after book at Olympia!

**Choosing your CONDENSERS AND RESISTANCES**

An up-to-date guide for the Constructor and Set User

**DUBILIER**  
1933-4

- MICA CONDENSERS
- NEW PAPER CONDENSERS
- NEW ELECTROLYTIC HIGH, MEDJUM, AND LOW VOLTAGE CONDENSERS
- NEW COLOUR CODED RESISTANCES
- LATEST TYPE RESISTANCES
- MOTOR RADIO SUPPRESSORS
- ANTI-INTERFERENCE FILTERS

**Supplied FREE**

**To DUBILIER CONDENSER CO. (1925), LTD.,**  
VICTORIA ROAD, NORTH ACTON, LONDON, W.3.

Please send me a copy of the new Dubilier Booklet.

Name .....

Address .....

USE BLOCK LETTERS. Pr.W.

Gives full details of the latest developments in Condenser and Resistance design.



# TRIUMPH OF NEW IGRANIC SPEAKER

EFFICIENT REPRODUCTION FROM  
THE SMALL OUTPUT RECEIVER AS WELL  
AS HEAVY VOLUME  
WITHOUT  
DISTORTION

29/6

IGRANIC DUAL TRANSFORMER

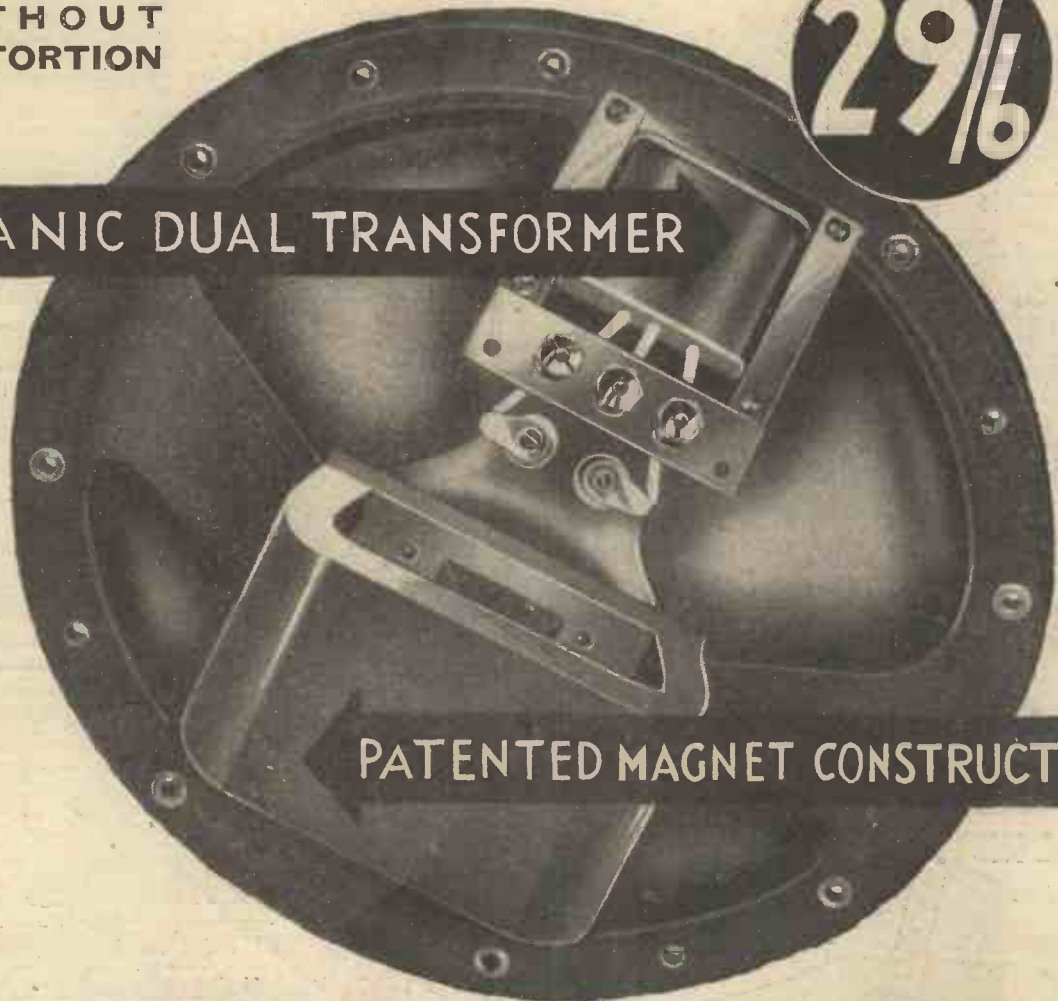

PATENTED MAGNET CONSTRUCTION

- The patented magnet construction overcomes all amplitude distortion.
- Every frequency in its true proportion, perfect maintenance of tonal balance.
- The Igranitic D.9, thanks chiefly to the patented magnet construction, has earned the preference of the experts. In quality of reproduction and price it fears no rival.

*Write for fully illustrated Catalogue  
No. J. 1268 to Igranitic Electric Co.  
Ltd., 149, Queen Victoria Street,  
London, E.C.4.*



PERMANENT MAGNET  
MOVING-COIL LOUDSPEAKER

If unable to obtain Igranitic Components from your local dealer, we will supply you post free direct on receipt of remittance and the name of your dealer.

HEAR IT AT YOUR DEALERS NOW



# Interested In Better Radio



—call at Stand No. 6  
Glasgow Radio Exhibition  
or send 3d. for a  
copy of the 1934  
edition of the  
"ALL METAL WAY"  
which gives full  
details of the  
complete  
range of

## WESTINGHOUSE METAL RECTIFIERS & WESTECTORS



### Post COUPON to-day!

Please send me "The All Metal Way, 1934," containing full particulars of Westinghouse Metal Rectifiers and Westectors. I enclose 3d. in stamps.

NAME.....

ADDRESS.....

P.R.A. 9.9.33

The Westinghouse Brake & Saxby Signal Co., Ltd.,  
82 York Road, King's Cross, London, N.1.

## The Only Book Of Its Kind

COMPILED by an acknowledged expert, this volume forms a complete guide, in alphabetical order, to the construction, operation, repair, and principles of every type of wireless receiver, with a special section on television, and complete instructions on the making of various wireless components.

A unique volume with every technical term, formula and fact explained in language which even the beginner will understand. A feature of the work is the illustrations, which include a complete series of circuits for every type of modern receiver. The contents include every modern development up to the 1933 Wireless Exhibition. An invaluable volume which is a treasury of knowledge to the beginner, the expert, and the ordinary listener.

392 pages :

490 illustrations.

# THE WIRELESS CONSTRUCTOR'S ENCYCLOPÆDIA

By F. J. CAMM  
(Editor of "Practical Wireless")

Obtainable at all Booksellers, or by post 5/4  
from George Newnes, Ltd., 8-11, Southampton  
Street, Strand, London, W.C.2

**5/-**

Geo. Newnes, Ltd.

**THE HEART  
OF THE  
SET-**

The 362  
UNBREAKABLE  
METAL VALVES  
(BATTERY Types) fully protected will shortly be released

**362 VALVES**

**DIRECT BY POST FROM THE  
MAKERS AT 50% SAVING.**

362 are Non-Microphonic and are definitely as good as any and better than most. They bring you better radio at lower prices. **BRITISH ALL THROUGH.** There is a **FULLY GUARANTEED** type for every purpose.

Post Free from

**3/6**

R.C., H.F., L.F., or Det., 3/6. Power, 4/- Super-Power, 4/6. S.G. or Var-Mu, 7/6. Pentode type, 10/-.  
All in 2v., 4v., or 6v. Metallised 3d. extra.

**"CLASS B"** 2-v. filament 9/-  
A.C. MAINS VALVES, 4-volt, 1 amp. (Indirectly Heated). Prices 7/6 to 12/6. Full List post free.

Cash with order. Cheques and P.O.'s must be crossed and made payable to—  
**THE 362 RADIO VALVE Co., Ltd. (Dept. W. 17), Stoneham Road, London, E.5**

## CUT THIS OUT

and post it to-day for your FREE copy of the Camco Cabinet Catalogue which illustrates and describes the complete range of cabinets, and shows all the latest additions. Don't hesitate—post it off to-day; a half-penny stamp will do if you leave the flap unsealed.

### FREE CAMCO CABINET CATALOGUE



Post in 1d. envelope.

NAME.....

ADDRESS.....

13 PR.W.....



**CARRINGTON MFG. CO., LTD.**  
Showrooms:  
24, Hatton Garden, London, E.C.1.  
Holborn 8202. Works: S. Croydon.





# EDISWAN

*The name that means 'EXCELLENCE'*

**Why**  
**EDISWAN H.T.**  
**will give you**  
**EXTRA service**

Here is the answer. These special features clearly demonstrate Ediswan superiority. You can get Ediswan Batteries in all standard sizes, including portable types—Standard or Super Capacity—at the usual prices.

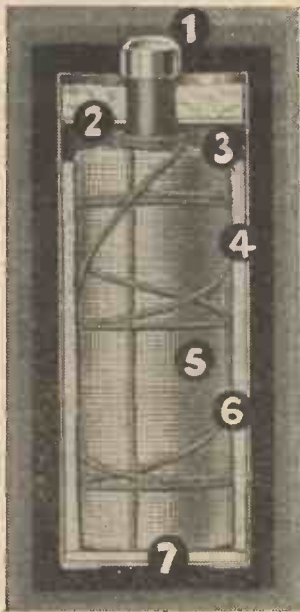

- 1 A brass cap tightly affixed to the carbon rod forms the positive connection.
- 2 The cell is sealed by means of a waxed washer over which paraffin wax is poured. This washer assists in centralising the sac in the cell.
- 3 An air space is left between the top of the sac and the washer to allow for the expansion of the electrolyte during discharge.
- 4 A substantial zinc container which forms the negative pole of the cell.
- 5 The sac consists of a highly efficient depolariser, tightly compressed round the carbon rod, the whole being securely wrapped and tied.
- 6 Electrolytic paste of a special chemical composition which fills the space between sac and zinc container and activates the cell.
- 7 A waxed paper disc which insulates the sac from the bottom of the zinc container.

# EDISWAN

## H.T. BATTERIES



THE EDISON SWAN ELECTRIC CO. LTD.  
 PONDERS END, MIDDLESEX

EDISWAN - the Better Service Batteries

# What is your Output Stage?

Power or Super Power Valve, Pentode, Q.P.-P. or Class "B"—  
*there is an R. & A. Reproducer specially designed for it*

**"TYPE 60"**  
**DIFFERENTIAL**  
**ARMATURE**  
**REPRODUCER**  
 for small output valves.

For receivers in which the output is not sufficient to drive even the super-sensitive R. & A. Moving-Coil Reproducers, the Type 60 offers the most satisfactory alternative. It has been specially designed to give maximum volume, purity of reproduction and true balance between bass, middle and upper register when used in conjunction with even the 21/- smallest output valve

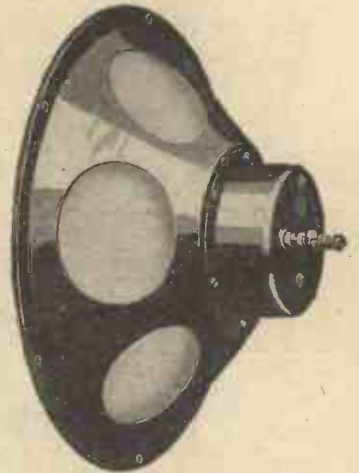

For Super Power, Pentode, Q.P.-P. or Class "B" outputs choose the appropriate

**"CHALLENGER"**  
**P.M. MOVING COIL**  
**REPRODUCER**

Standard Model for use with Super Power and Pentode Outputs. Includes 3-ratio Transformer.

OTHER "CHALLENGER" MODELS—

- TYPE "B" for Class B Amplification. (B8 for Cossor, and B15 for Mullard and Mazda Class B Valves.)
- "P" An extension Instrument for Commercial Receivers.
- "Q" for Quiescent Push-Pull (15,000 ohms Plate-to-Plate Load.)



EACH MODEL 35/-  
 Your dealer can supply.

# R & A

## REPRODUCERS

REPRODUCERS AND AMPLIFIERS LTD., WOLVERHAMPTON.





# Improve the volume of those "whispering" stations



Those stations that you can only just hear—the ones that are mere whispers in the distance—they too can give you entertainment. Fit a Cossor Screened Grid Valve. You'll be surprised at

the difference it will make—longer range, and a general all-round improvement. Your dealer will gladly advise you on the most suitable type for your receiver. Ask him to-day.

Cossor 2-volt Screened Grid Valves

| Type        | Fila-ment Amps. | Anode Volts | Imped.  | Amp. Factor | Mutual Conduc-tance m.a./v. | Price |
|-------------|-----------------|-------------|---------|-------------|-----------------------------|-------|
| *215 S.G.   | -15             | 120-150     | 300,000 | 330         | 1-10                        | 15/6  |
| *220 S.G.   | -2              | 120-150     | 200,000 | 320         | 1-60                        | 15/6  |
| *220 V.S.G. | -2              | 120-150     | 110,000 | —           | 1-60                        | 15/6  |
| *220 V.S.   | -2              | 120-150     | 400,000 | —           | 1-60                        | 15/6  |

Cossor A.C. Mains Screened Grid Valves

| Type       | Purpose                  | Imped.  | Amp. Factor | Mutual Conduc-tance m.a./v. | Price |
|------------|--------------------------|---------|-------------|-----------------------------|-------|
| **MSG-HA   | Super H.F. Amp'n.        | 500,000 | 1,000       | 2.0                         | 17/6  |
| *41 MSG    | Super H.F. Amp'n.        | 400,000 | 1,000       | 2.5                         | 17/6  |
| **MSG-LA   | Super H.F. Amp'n.        | 200,000 | 750         | 3.75                        | 17/6  |
| **MVS      | Variable-Mu              | 200,000 | —           | 2.5                         | 17/6  |
| **MS/PEN-A | H.F. Pentode             | —       | —           | 4.0                         | 17/6  |
| **MS/PEN   | H.F. Pentode             | —       | —           | 2.8                         | 17/6  |
| **MVS/PEN  | Variable-Mu H.F. Pentode | —       | —           | 2.2                         | 17/6  |

The above Valves have Indirectly Heated Cathode, 4 Volts, 1 Amp.

Cossor D.C. Mains Screened Grid Valve

|       |             |   |   |     |      |
|-------|-------------|---|---|-----|------|
| *DVSG | Variable-Mu | — | — | 2.5 | 17/6 |
|-------|-------------|---|---|-----|------|

The above Valve has Indirectly Heated Cathode, 16 Volts, 0.25 Amp.

\*These Valves available with or without Metallised Bulbs.

† Characteristics measured at 1.5 grid volts.

\*\* Stocked with Metallised Bulb only.

# COSSOR SCREENED GRID VALVES

To A. C. COSSOR LTD., Melody Dept., Highbury Grove, London, N.5.

Please send me, free of charge, a copy of the 40-page Cossor Valve and Wireless Book B.17.

Name.....

Address.....

PRAC. 9/8/33



# THE LEADING HOME CONSTRUCTORS' WEEKLY



EDITOR :  
Vol. II. No. 51 || F. J. CAMM || Sept. 9th, 1933.

Technical Staff :  
H. J. Barton Chapple, Wh.Sch., B.Sc. (Hons.), A.M.I.E.E.  
W. J. Delaney, Frank Preston, F.R.A., W. B. Richardson

## ROUND *the* WORLD of WIRELESS

**New Long-Wave Station at Droitwich**  
STEADY progress is being maintained in the construction of the new long-wave station near Droitwich, both with the building and technical equipment, and it is anticipated that the long-wave National transmitter will begin public transmissions in about a year's time, that is, in the summer of 1934. The transmitter will work on the slightly altered wave allotted to this country under the Lucerne plan, namely 1,500 metres (200 kc/s). The new Midland Regional transmitter, which, as stated previously, will be on the same site at Droitwich, will not begin radiating transmissions for some months after the long-wave National transmitter goes into regular service.

**Better Signals from Cincinnati**  
BROADCASTS from WLW, Cincinnati (Ohio) on 428.3 m. (700 kc/s) have been recently heard at better volume on this side of the Atlantic Ocean in the early hours of the morning. This is due to the fact that this 50-kilowatt transmitter is now using its new 830-foot aerial tower. The broadcasts from the Cincinnati and other studios of the Red and Blue networks of the National Broadcasting Company of America, are also available nightly through W8XAL on 49.5 m.

### New Television Receiver

KURT SCHLESINGER, a Berlin engineer, recently demonstrated in that city a new receiver for television transmissions; it has aroused considerable interest in German wireless circles. The instrument has been specially constructed for the reception of ultra short waves, and it is stated that the image projected on a small screen is in many ways equal in quality and clearness to that given by a 16 millimetre home cinematograph projector.

### More Ascents to the Stratosphere

ALMOST every week news reaches us regarding new attempts to beat Professor Piccard's altitude record. The latest ascent to be tried out is one from Leningrad by the Russian engineer Tcherkovski who, for this purpose, has built a

gondola of a specially light alloy, and which has been coated with a new preparation capable of resisting both excessive heat and intense cold. Some items of the technical description would appear to suggest that the inventor has based the construction of his gondola on the lines of a Thermos flask!

### The Housewife's Hour

A FEATURE which has proved a great favourite in the A.V.R.O. (Hilversum-Huizen) broadcasts is the Housewife's

radio clubs in France, and in every instance support has been promised. Such an organization would bring both experimental amateurs and listeners in closer touch with their respective governments, and would no doubt permit their representation at international radio conferences.

### Forty-four Stations—One City

SHANGHAI, as the chief port of China, in view of its numerous international settlements, possesses forty-four different broadcasting stations; in all, seven Asiatic and European languages are used in the course of a day. In a lesser degree there are also transmitters in other centres, the most powerful being that of the recently completed station XGOA, at Nanking, working on 440.6 m. (681 kc/s). It is rated at 75 kilowatts and is mostly used for commercial purposes, although some of the broadcasts are devoted to musical entertainments. Chinese compositions and American jazz gramophone records are equally appreciated by the native population.

### League of Nations Short-Waver

THE political and news bulletin hitherto broadcast by the League of Nations through the Prangins (Switzerland) transmitter on Sunday nights are now given on Saturdays on 31.3 and 38.47 metres. The English version is timed to start at 11.30 p.m. and is followed by the French and Spanish translations at, respectively, 11.45 p.m. and midnight B.S.T.

### PTT Grenoble Now 15 Kilowatts

FOLLOWING a complete overhaul of its plant, the PTT Grenoble station of the French broadcasting network has increased its power from roughly four to fifteen kilowatts, and tests of the new installation are now being carried out daily. Although 309.9 m. (968 kc/s) is the channel on which the station may be requested to broadcast in January, 1934, in view of the mountainous character of the area for which the service is required, efforts are to be made to retain a wavelength in the 500 metre band. Grenoble PTT, at present, may be heard on 569 metres.

## "PRACTICAL WIRELESS" at Three Exhibitions!

**MODEL ENGINEER EXHIBITION,  
Royal Horticultural Hall, Westminster**  
*Our Stand No. 35*

**THE SCOTTISH RADIO EXHIBITION,  
KELVIN HALL, GLASGOW**  
*Our Stand No. 17*

**NATIONAL RADIO EXHIBITION,  
CITY HALL, MANCHESTER**  
September 27th to October 7th.  
*Our Stand No. 11 (New Hall)*

Provincial readers will find these stands the home of Real, Reliable and Unrivalled Reader Service!  
**A Cordial Invitation is Extended to Every Reader to Visit Us.**

Hour, in which, alternately, lessons are given in cooking, dressmaking, and other accomplishments required by the perfect Dutch "vrouw." Lectures are given in designing clothes for the bairns, and pamphlets with patterns published by the studio have been sold in thousands.

### Protect the Listener

IN the opinion of French fans, in view of the fact that European broadcasting stations possess their own union, and that there also exist conventions of State authorities in regard to radio transmissions, a scheme to form an International union to protect the interest of the listener would meet with general approval. The proposal has been put forward to a number of



# ROUND the WORLD of WIRELESS (Continued)

## Radio Nantes

WORK on the construction of the high-power transmitter at Thouries, near Nantes, destined to provide an adequate broadcast service to France's north-western provinces, is progressing so favourably that it is hoped to begin tests towards the end of the year. Broadcasts from this station would be well heard in the British Isles, and might prove an agreeable alternative to programmes from Paris.

## Back to the Jungle

THE French newspaper, *Dépêche Coloniale*, states that the authorities of the Upper Katanga province of the Congo have been asked by native chiefs to erect a broadcasting transmitter at Brazzaville. It is suggested that for the benefit of dwellers in distant villages the studio might brighten the programmes with concerts on tom-toms and other primitive instruments played by native musicians. The Government had already considered the advisability of building a station at Brazzaville for the relay of news bulletins from Paris via the *Paris Coloniale* short-wave transmitter. If the scheme matures listeners in the French capital, in exchange, may be given the opportunity of hearing broadcasts from equatorial Africa.

## Monte Ceneri

**RADIO SVIZZERA ITALIANO** (Lugano), on 1,145 m., which has been closed down for a week or so for adjustments to the transmitter, still broadcasts its time signals by verbal announcements. Listeners are warned to stand-by, and the exact time is indicated by a stroke on a gong. For this purpose the ordinary studio clock is not consulted, but the "announcers" utilise a ship's chronometer set to signals received from the Neuchâtel Observatory.

## For the Unemployed

IN Germany, where free licences are granted to the unemployed, some of the stations broadcast at the end of the mid-day programmes a few details regarding the evening transmission with special reference to particular items which should prove of interest to these listeners. The step has been taken to assist people who cannot afford to buy the individual official programme papers published by the studios.

## Ceylon to Relay Empire Broadcasts

IN order to facilitate the reception by English residents in Ceylon of the "home" wireless entertainments, a short-wave station is to be erected on a suitable site, with a view to relaying the programmes of the Daventry Empire broadcasters.

## Radio Agen

NOW and again, when conditions are favourable, you may pick up a broadcast from one of France's smallest transmitters, namely, Radio Agen, situated at

### INTERESTING and TOPICAL PARAGRAPHS.

some eighty-four miles south-east of Bordeaux. Usually working on 453 m., it broadcasts a programme daily between 7.30 and 8.30 p.m. B.S.T. For such a small station, it puts out relatively a long call: *Ici poste départementale de Radio Agen en Lot-et-Garonne*. It is one of the many private transmitters which may be frozen

out of the waveband when the Lucerne Plan comes into force.

## Hourly Weather Reports

TO secure weather bulletins at times other than those at which such broadcasts are made by the B.B.C. stations, tune in to Heston Airport on 833 m. for forecasts transmitted by the Automobile Association. Information secured from the Air Ministry is broadcast almost hourly throughout the day from 9.30 a.m. until 6.30 p.m. B.S.T.

## Ee-En-Air

ON many occasions when listening to Brussels (No. 1) on 509 m., you may have heard the announcer call: *Ici Bruxelles ee-en-air*. The last words stand for the letters I.N.R., an abbreviation of *Institut National de Radiodiffusion* (National Broadcasting Institute). When the concerts are provided by a private organization the individual initials follow the call: thus, R.C.B. (phonetic: *air-say-bay*) would indicate that the entertainment was offered by the Radio Catholique Belge.

## The Lucerne Broadcasting Conference

IT is learnt from the B.B.C. that after five weeks' deliberations a wavelength plan for European broadcasting stations has been accepted by a large majority of countries, represented at the Conference recently held at Lucerne. The new "Plan de Lucerne" is embodied in a Convention which has been signed by twenty-seven countries. The delegates of seven countries—Finland, Greece, Holland, Hungary, Lithuania, Poland and Sweden—have not signed the Convention, but it is anticipated that they will in fact adopt the wavelengths allocated to them. As far as Great Britain is concerned, the number of waves available will be the same, but in general the wavelengths are slightly lower than formerly, several of them also being shared with distant countries. The actual wavelengths allocated to Great Britain are as follows:—

| Kilocycles per second. | Metres. |
|------------------------|---------|
| 200                    | 1,500   |
| 668                    | 449.1   |
| 767                    | 391.1   |
| 804                    | 373.1   |
| 877                    | 342.1   |
| 977                    | 307.1   |
| 1,013                  | 296.2   |
| 1,050                  | 285.7   |
| 1,122                  | 267.4   |
| 1,149                  | 261.1   |
| 1,474                  | 203.5   |

The plan will come into force on January 15th, 1934, and in due course a further statement will be issued as to the exact use to which the wavelengths allotted to Great Britain will be put.

## A SET OF THE FUTURE?



A television and sound set which obeys the human voice and gives any station asked for. It is described as Marconi's vision of 1960.

## SOLVE THIS!

### Problem No. 51

Blacksmith had a commercial receiver fitted with a moving-coil loud-speaker. As the most-convenient mains plug was in one room and he desired to listen in another, he removed the loud-speaker, and fitted the speaker transformer into the cabinet with extension leads to the next room for the speaker. When put into use, results were definitely poor, and he was unable to trace the reason. He measured the extension leads, but found these were only 7 ohms total resistance, so concluded that this was not the cause. What do you think was wrong? Three books will be awarded for the first three correct solutions opened. Address your envelopes to The Editor, PRACTICAL WIRELESS, Geo. Newnes, Ltd., 8-11, Southampton Street, Strand, London, W.C.2, and mark the envelope Problem No. 51. No entries will be received after September 11th.

### SOLUTION TO PROBLEM No. 50.

The length of Coates' aerial-earth system was such that a harmonic of its natural wavelength came within the wave-range covered by the receiver. This resulted in the "dead spots."

Only two readers succeeded in correctly solving Problem No. 49, and books have therefore been awarded to:—

T. Warrington, 8, Coronation Road, Hartshill, S.O.T.; A. H. Thorpe, Millfield Road, Plateley Bridge, Nr. Harrogate.

SCOTTISH RADIO EXHIBITION  
Kelvin Hall, Glasgow.  
OUR STAND No. 17.  
MODEL ENGINEER EXHIBITION  
Royal Horticultural Hall, Westminster.  
OUR STAND No. 35.



# THE EDITOR LOOKS AT THE SHOW

PRACTICAL WIRELESS (Copyright)  
Illustrations from sketches made by our  
artist at Olympia.

Mr. F. J. CAMM Makes a Critical Survey of the Radio Show at Olympia, and Gives Here His Impressions of His Stand-to-Stand Inspection.

IT is not possible to survey the present position of the radio industry so attractively encompassed this year at Olympia unless one has the perspective

scruples about the accuracy of the matter which appears beneath it. It is for them, too, an occasion to gaze upon and quaff the vintage. I feel that editors of daily papers ought in their own interests to avoid this sort of tosh which does immeasurable harm.

As one of the earliest radio journalists in this country (and also one of the first manufacturers of radio sets and components), I have watched the growth of the radio industry; the rise and fall of catch-penny manufacturers; the introduction of every improvement; the booms and the sloughs, and naturally I have visited every Radio Exhibition.

With the publication of No. 1 of PRACTICAL WIRELESS last September it was felt that a fillip could be given to the radio industry in general, and the home constructor market in particular, by pursuing a policy of catering in a practical way for the practical reader. The events of the past year have proved that we were right, for a greatly increased interest, as evinced by the increased sales of those who cater for the home constructor,

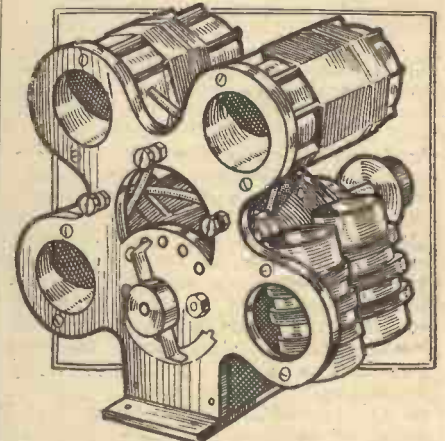

An ingenious multi-coil unit manufactured by the makers of the well-known Eddystone components. Five different wave-ranges are covered by these coils which represents a complete departure from conventional practice.

This year, however, most of the sets are battery-operated, and even battery-operated radiograms are marketed by some of our largest radio manufacturers.

This year I made a very careful study of every stand, for which purpose I visited Olympia every day during the nine days it was open, and in the course of my discussions with various manufacturers I learned that my belief that 1933-34 would be a home-constructors' year was shared by all of them. In making personal contact also with many hundreds of my readers (may I now apologize to those many hundreds whom I was unable to see?) I have also obtained valuable knowledge as to their requirements for the coming season.

The fact that this year's attendances broke all previous records is further evidence of the re-awakened interest in home-constructed radio, and we take extreme pride in the fact that we have played no mean part in bringing (Continued overleaf)

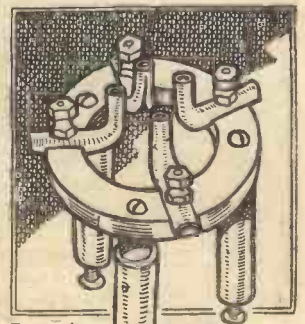

For short-wave work great care has to be taken to reduce losses. This valve-holder by the Eddystone people shows how losses have been removed in the mounting of the valve, and in the leads to it.

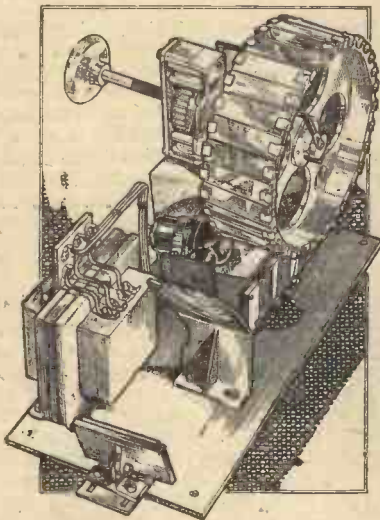

The new Baird Telesistor. The arrangement of the mirror-drum, the new light valve, the legs and the synchronising coils can be seen clearly from this illustration.

and the outlook acquired by association with that industry from the earliest inception. It is the absence of such outlook and such experience which leads some "experts" who write for the daily press to besmirch their respective papers with such unmitigated balderdash about radio. You know the sort of stuff: "Firm books million pounds worth of orders"; "Unruly crowd storms Olympia"; "New valve revolutionizes radio," etc., etc.

Most of these hack scribes merely go to Olympia to find a catch headline with no



Something new in switches. Although the control knob rotates, the movement is converted into a push-pull action with improved results. This is a Utility product designed especially for coil switching.

has been evident everywhere. Another point which makes this self-evident is the tendency of the manufacturers to cater more this year for the home constructor; last year mains sets represented by far the greater proportion of each manufacturer's programme.

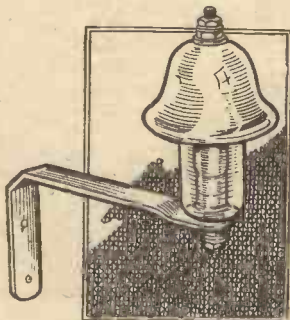

A safety device for the aerial system. This is the Phillips Aerial Discharger and it removes the necessity for an aerial-earth switch, and renders the aerial perfectly safe.

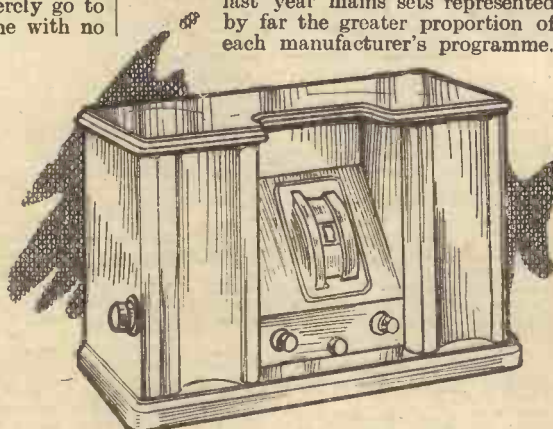

Something new in battery receivers. This is the Burton Two-valve Midget, and costs only 40/- complete with valves.



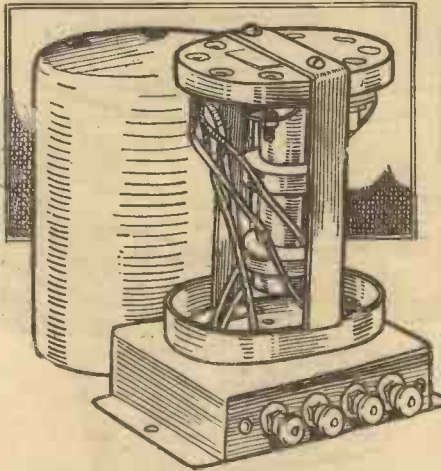

An Intermediate Frequency Transformer made by British Radiophone. This is of the Band-Pass type and is provided with screened adjustable trimmers to enable the self capacity to be counter-balanced.

(Continued from previous page)

about this state of affairs, and this year, more than any other, the home constructor found at Olympia plenty to interest him. The succession of important developments which took place during the past few months—iron-core tuning coils—quiescent push-pull—Class B amplification—all-metal valves—cold valves—delayed automatic volume-control—all were responsible for the greatly increased attendance this year. Readers freely

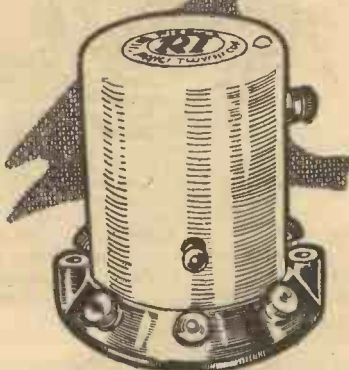

This is one of the most interesting new types of tuning coil. It has a powdered iron core, and is provided with an adjustment so that circuits may be matched up. It is an R.I. product.

expressed the hope that future developments should not occur with such bewildering and almost interecine frequency, for, as quite a number of visitors to our stand said, "we hesitate to build a set because we do not know what is coming next." I pass along the hint to the manufacturers.

The arrangement of the Show this year was commendable; the wider gangways permitted even at crowded periods a ready inspection of any exhibit. The theatrical



For obtaining various voltages from a mains unit, a potential divider is very useful. The illustration shows an Igranite Potential Divider, which may also be obtained without the metal containing case,

entertainment was a sheer inspiration on the part of the organisers. There might have been, perhaps, better arrangements in the body of the hall and in the gallery for the seating of those visitors who were fatigued. I have no doubt that this will be attended to next year.

Perhaps the most outstanding feature of the Show was the tendency of all manufacturers to increase the sensitivity and the selectivity of the completed receivers. From this aspect alone 1934 receivers by comparison with 1930 receivers are ten years ahead. Another feature of outstanding interest which early impressed even the casual observer was the tendency to reduce

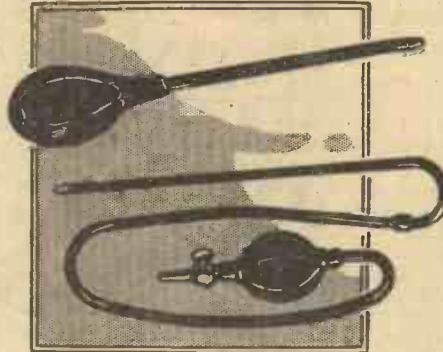

The Milnes H.T. Supply Unit is a most efficient battery, but the filling must be carried out carefully to avoid spilling. The fillers illustrated have been produced especially for this purpose.



To remove interference from the sparking plugs on a car fitted with radio, special suppressors are required. The illustration shows a suppressor sold by Page Car Radio at a cost of 3s. 6d. each.

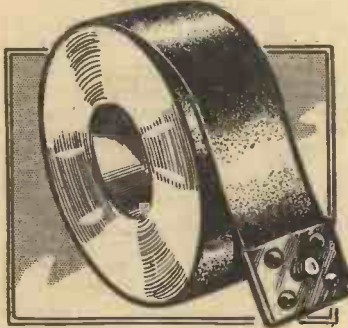

A novel indoor aerial. A film of metal is deposited on paper provided with an adhesive back, and is obtainable in silver or gilt at 1s. 6d. This is the Het aerial made by Univolt Electric, Ltd.

the size of the set. I am not quite certain, from the point of view of the public which often takes an obtuse point

of view, that this is a move in the right direction, for I overheard a remark to the effect that as the prices of sets were reduced the size seemed

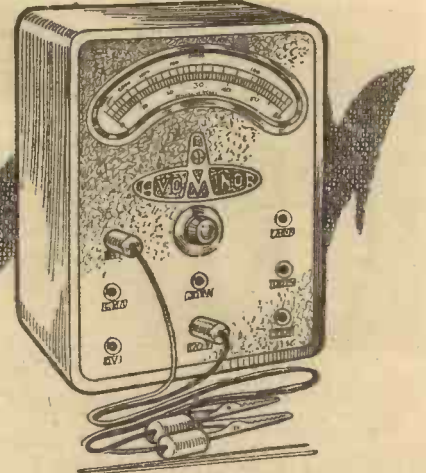

This is the Avomator, a small brother to the Avometer. It provides for the reading of volts, amps and ohms and may be used in conjunction with the well-known Avodapter.

to have been reduced also. Apparently this visitor thought that the size of a set was commensurate with its price! In point of fact, it actually is more expensive to make a satisfactory set of reasonable proportions, and it is certainly a move in the right direction to house, say, a six-valve set in a cabinet of such proportions that it looks in place even in the smallest flat.



Messrs. Belling-Lee have produced this mains disturbance suppressor which is simply connected to the mains and removes troubles from electric cleaners, fans, etc.

That is where design is leading—smaller radio sets. The fact, too, that they can be made in such small sizes yet vastly more efficient than their larger brethren of a year or so ago is an indicative straw which shows the vast improvement which has been made in detail design, efficient screening, avoidance of interaction, and so on. A point not so apparent to the visitor was the preponderance of battery-operated sets. I have no doubt that the introduction of Q.P.P. and Class B has been responsible for this, for one can now

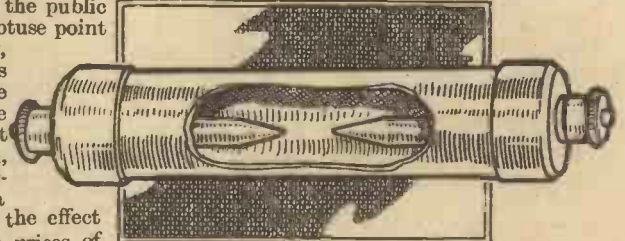

The "Instant" Pole Finder suitable for voltages from 1 to 250. The negative pole turns purple on D.C., and both points purple on A.C. It costs 4s.



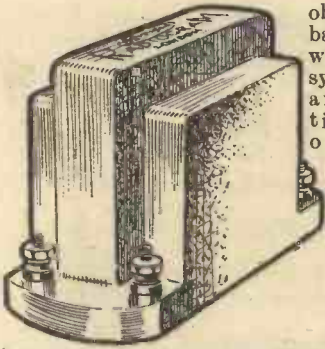

A very neat L.F. transformer produced by the British Radiogram Company. This is less than two inches tall and can be fitted into the most compact receiver with admirable results.

The heterodyne was well represented. Here again the battery version was in the majority. Several firms are marketing a battery-operated radiogram with Q.P.P. or Class B.

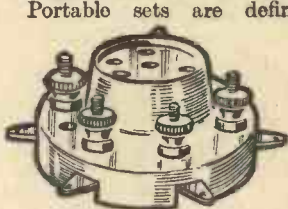

Low-loss; soldering tags or terminals; reversible connections and other interesting features are included in this Benjamin valveholder. It may be obtained with 4 or 5 pins.

those included in the complete receivers, revealed the important fact that the large diameter cone ("to bring out the bass") is obsolete. Cones are getting smaller and smaller; one, in fact, was only 3 1/2 ins. in diameter, which seems to indicate that eventually the cone will vanish altogether, the coil itself operating direct on to a correctly designed combined diaphragm and baffle.

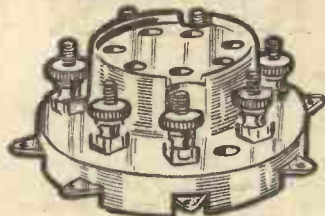

For the new 7-pin valves, this Benjamin valveholder also possesses the attractive features of the standard valveholder illustrated above. The contacts are of nickel-silver and provide a very firm contact with the valve legs.

to contend with almost insurmountable difficulties set them by the designers of the receivers. Too often the set has been designed and batteries made to fit the available space. If the portable (do not confuse this with the transportable) is under a cloud, I fear it is the set manufacturers themselves who are to blame, for midget accumulators and midget H.T. batteries cannot give satisfactory service. We have demonstrated with our Featherweight

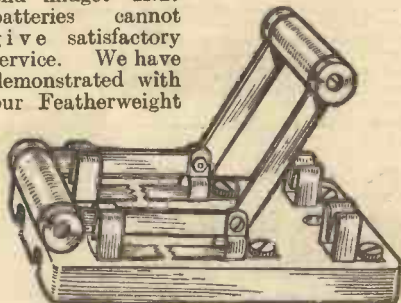

Produced by the Whiteley Electrical, this knife switch is provided with a spark gap, and is very useful for inclusion in the aerial-earth system.

obtain from battery sets with these systems of amplification and output which is quite equal in every way to that obtainable from the mains.

refer, of course, to battery-operated portable sets. An examination of the speakers, both those sold separately and those included in the complete receivers, revealed the important fact that the large diameter cone ("to bring out the bass") is obsolete. Cones are getting smaller and smaller; one, in fact, was only 3 1/2 ins. in diameter, which seems to indicate that eventually the cone will vanish altogether, the coil itself operating direct on to a correctly designed combined diaphragm and baffle.

In this direction battery manufacturers have had to contend with almost insurmountable difficulties set them by the designers of the receivers. Too often the set has been designed and batteries made to fit the available space. If the portable (do not confuse this with the transportable) is under a cloud, I fear it is the set manufacturers themselves who are to blame, for midget accumulators and midget H.T. batteries cannot give satisfactory service. We have demonstrated with our Featherweight

Portable Four that a satisfactory portable receiver, small in size, and light in weight, yet accommodating batteries of ample capacity can be made. There is still a market for a satisfactory portable set, and I would here pay tribute to those few firms (the survival of the fittest!) who continue to make a satisfactory portable.

Cabinet work is vastly improved this season. In the past that time-honoured

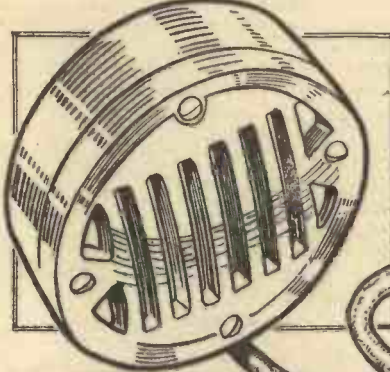

This neat little microphone, manufactured by Igonic, and operating on the transverse current principle, will find many uses.

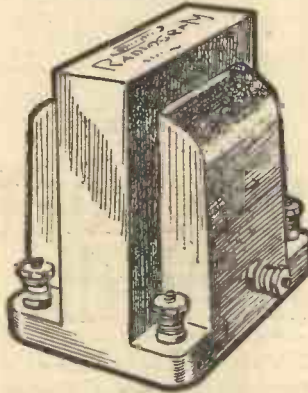

This is the British Radiogram Class B Driver transformer. It is suitable for most modern Class B valves.

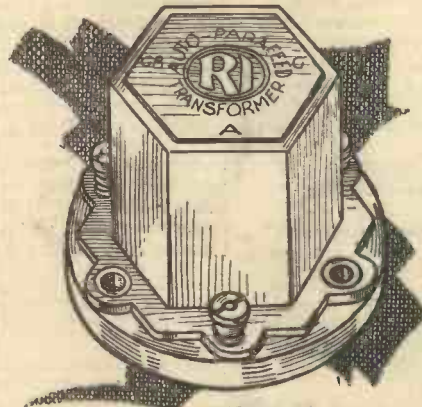

Apart from its novel electrical characteristics this Parafeed Transformer by Radio Instruments is also fitted with a case of new design. It costs 6s. 9d.

A synchronous turntable for the gramophone which is fitted by means of a one-hole fixing device. If you already possess a clock-work machine, the present motor may be removed and this turntable fitted to the present clearance hole for the spindle. It may, of course, only be used on A.C. mains.

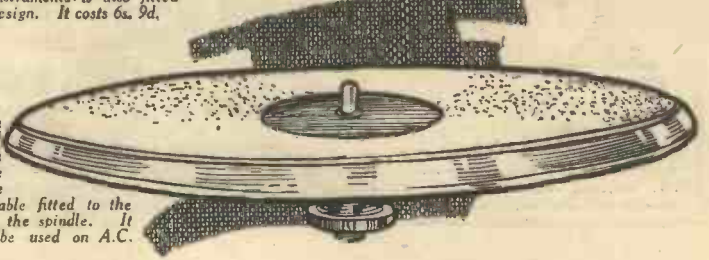

Good meters will be found invaluable, and this neat tester, incorporating two of the high-class Ferranti meters, is designed for measuring A.C. and D.C. potentials.

craft has been invoked to supply veneered imitations with inferior joints and inferior finish. In passing round from stand to stand it occurred to me that the speaker grille, with its

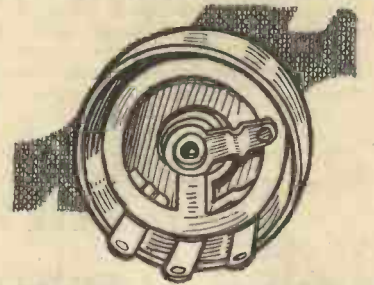

This Ormond volume control is extremely small, occupying a back of panel space only half-an-inch deep. It is of the one-hole fixing type.

frets and gauze backing, is something of an anachronism. No one to-day would dream of purchasing a piano with a fretted front backed by old-fashioned (Continued on page 891.)

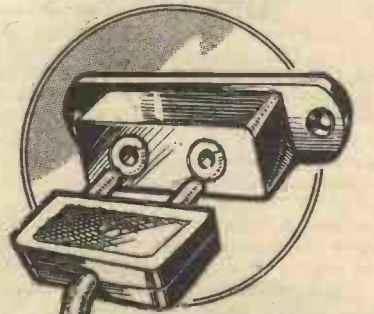

Extending the loud-speaker leads is not always a simple problem, but this ingenious extension kit, produced by Messrs. Lamplugh makes it a simple task. A kit for one extension consists of two switches and plugs and 50 feet of flat twin wire, and it costs 10s. 6d.



**BETTER TO BUILD THAN TO BUY!**

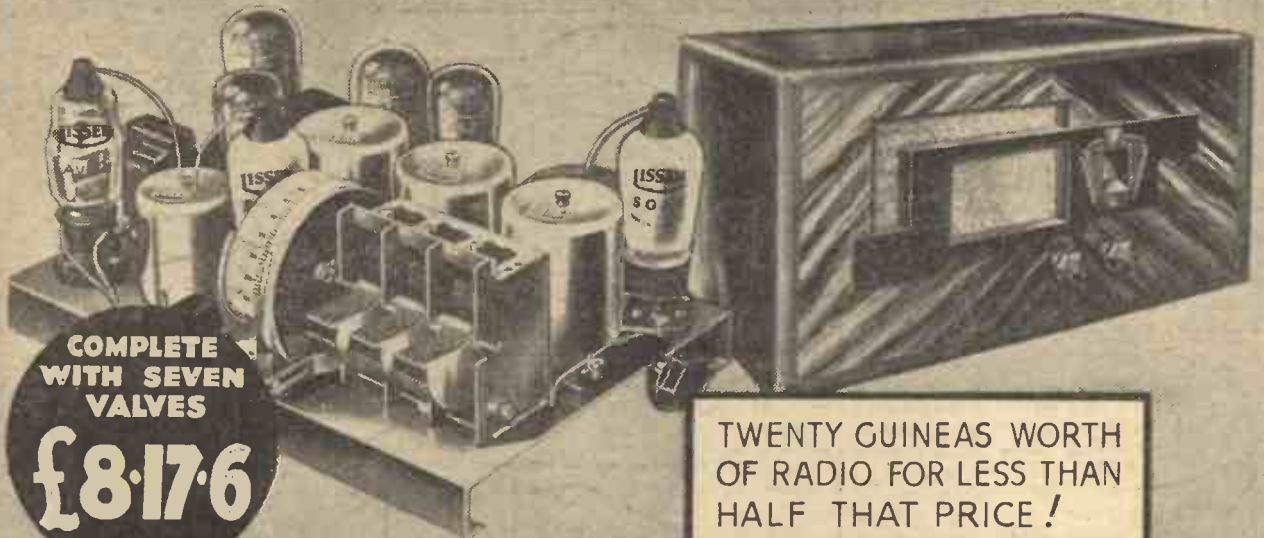

**COMPLETE WITH SEVEN VALVES**  
**£8.17.6**

TWENTY GUINEAS WORTH OF RADIO FOR LESS THAN HALF THAT PRICE!

# Seven Valve Superheterodyne for Home Constructors - All the Luxury Features!

- 6 STAGE BAND PASS
- EXACT 9 K/C CHANNELS
- AMPLIFIED AUTOMATIC VOLUME CONTROL
- CLASS "B" OUTPUT

MOVING COIL LOUDSPEAKER

Never before has there been any receiver for Home Constructors on such an ambitious scale as this new Lissen "Skyscraper" Seven-valve Superhet. It embodies every up-to-the-minute advance and refinement of the most luxurious factory-built superhets—it gives the constructor the opportunity to build a £20 receiver for less than half that price. The circuit of the Lissen "Skyscraper" Seven-valve Superhet incorporates a 6-stage bandpass filter, giving exact 9-kilocycle channels and therefore providing a standard of selectivity never before achieved by a home-constructor's kit set and very rarely found except in laboratory apparatus. Amplified Automatic Volume Control is provided, a special valve for this purpose having been produced by Lissen for use in this receiver. The use of this Amplified Automatic Volume Control constitutes an entirely new experience in listening; no "fading," no "blasting"—you will find yourself enjoying every word of every programme, however near or however distant, without the slightest temptation to interfere with the receiver once you have tuned it. This is radio listening as it should be enjoyed!

Lissen Class-B Output through a new full-power Lissen Moving-coil Loud-speaker—glorious rich tone and majestic volume, actually more faultless in its reproduction than anything you ever heard from even the most powerful mains receiver, yet working economically in this Lissen "Skyscraper" from H.T. batteries.

Lissen have published for this great new "Skyscraper" Seven-valve Superhet a most luxurious Chart which gives more detailed instructions and more lavish illustrations than have ever before been put into a constructional chart. It makes success certain for everybody who decides to build this set; it shows everybody, even without previous constructional experience, how they can have a luxury receiver and save pounds by building it themselves. A copy of this Chart will be sent FREE in return for coupon on the left, or your radio dealer can supply you. Get your FREE CHART now!



**GREAT CHART FREE**

**LISSEN**

**"SKYSCRAPER 7" SEVEN VALVE SUPERHET**

To LISSEN, LTD.,  
Publicity Dept., Isleworth.  
Please send me FREE CHART of the  
"Skyscraper" Seven-valve Superhet.

Name .....

Address .....

.....P.R.534

**POST COUPON**



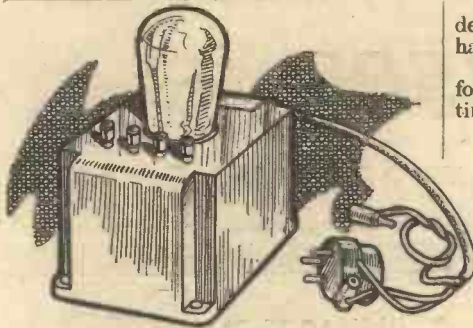

To obtain the full advantages of Class B working, this neat Adaptor, made by Sound Sales, Ltd., may be plugged into the last valueholder of your present set, replacing the present valve in the top of the adaptor plug. The necessary connections and voltages are then automatically obtained and the conversion is complete.

(Continued from page 889)

plush or silk. I forecast that the grille will eventually go.

The knob twiddler must have been sadly disappointed with this year's Radio Exhibition for the introduction of unified control with its attendant simplicity of operation was a feature of the range of most manufacturers. The improved tuning system, with their full vision scales and shadow-line tuning are steps—many steps—in the right direction. The band-pass tuning unit complete with ganged iron-core coils, ganged condenser, and combined controls (on-off, reaction, volume control, radiogram, etc.), represents the very last word in simplified control, and at once gets rid of a number of bugbears.



The new skeleton W.B. valueholder.

Components vied with sets in point of size, for most of the components used by the home constructor, speakers, con-

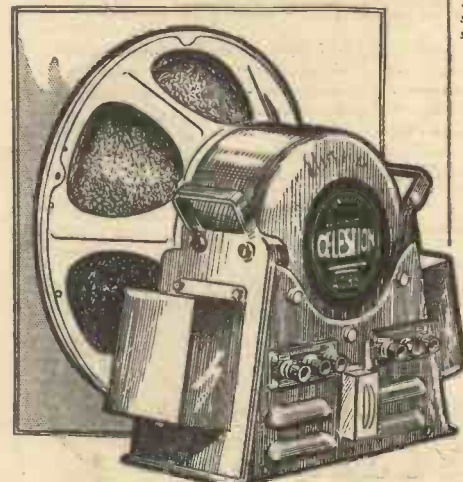

This loud-speaker is designed to handle a really hefty power input and is known as an Auditorium model. Manufactured by Celestion, it weighs round about 70 pounds and costs 15 guineas.

densers, transformers, etc., are only about half the size they were formerly.

For the first time, a set specially designed for car radio was shown. Also, for the first time, was exhibited a combined receiver

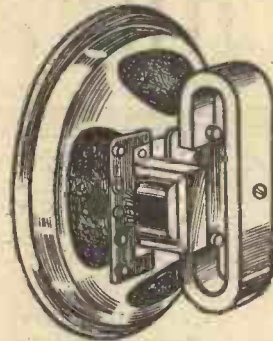

The name of Magnavox is well-known in association with loud-speakers, and the above model is the Senior permanent-magnet. It costs 3 guineas, and is a new addition to the comprehensive Magnavox range

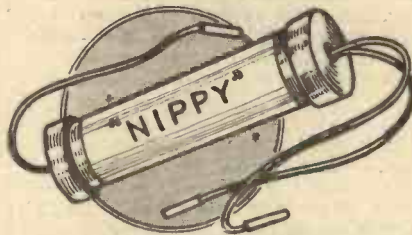

This little device is known as an "Aerial Exempter," and is claimed to prolong the life of the H.T. battery, remove noises, modulation hum and interference, and give vastly clearer reception. It costs 2s. 6d.

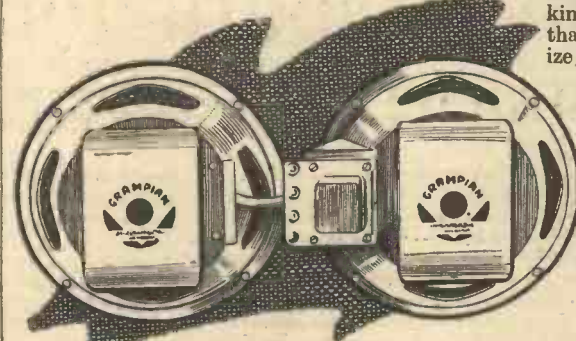

A pair of Midget loud-speakers made by Grampian Reproducers. These two speakers are balanced and give a much better reproduction curve than one single speaker, and cost very little more. They may be obtained with permanent magnets or with energized field windings.

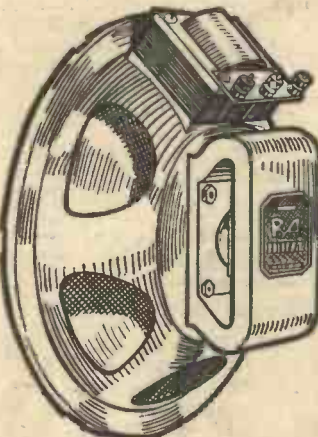

This is the Challenger speaker made by R. & A. We have previously drawn attention to the many good points possessed by this speaker which is in a class by itself.

and television viewer. Automatic volume control has evidently come to stay for many manufacturers were fitting this as standard. Only one firm showed a permeability tuning unit, and this was suitable only for a single tuned circuit.

The luxury market was catered for by sets which combined mental refreshment with that of a more tangible nature, namely, receivers which house also a cocktail bar, a bookcase, etc. The comfort of the listener was borne in mind by one manufacturer who exhibited an adjustable footrest so that the listener could recline in luxurious comfort and operate his receiver by means of remote control attached to the arm of his favourite chair. No novel circuits were featured. That is to say, if we exclude as novel Class B, Q.P.-P., etc. The tendency both in sets and components is towards cheaper radio. It is impossible in a survey of this kind to do more than summarize, as I have done, the tendencies and my reaction to them. The reactions of our draughtsmen which pictorially illustrate this review will throw into relief most of the points mentioned.

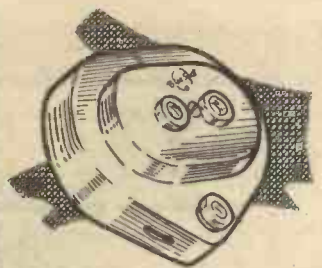

Another device for removing disturbances introduced in a receiver via the electric mains. This is a Blue Spot product. It is plugged into the mains socket, and the receiver plug inserted into the device.

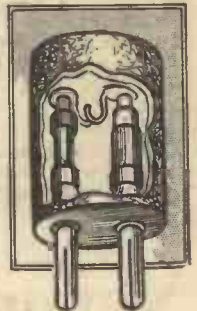

Safety First! This plug has two fuses included in the moulded body and they are instantly replaceable by unscrewing the end. This is a new Lissen product and costs 3s.

SCOTTISH RADIO EXHIBITION  
Our Stand, No. 17

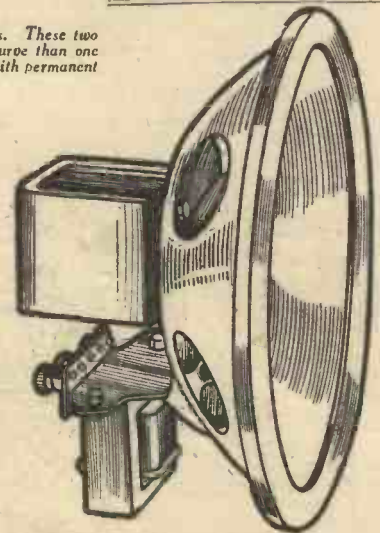

Costing only 27s. 6d, this speaker by Goodmans has an energized field-winding, and the input transformer will carry 50 mA.





# Practical uses for Old Components

By W. B. RICHARDSON.

How They Can Be Adapted for a Number of Useful Purposes.

SOME time ago I was severely criticized by a number of readers for suggesting in one of my articles that the hoarding of old "junk" was a silly practice. I fear I went even farther. It was my remark that such hoarding was merely a sign of meanness which brought forth the greatest wrath and indignation. Of course, I admit that such a statement was rather sweeping. Naturally, we all keep a junk box, but I was thinking at the time more of the person who stores up every little piece of rubbish with the idea that one day it may come in useful, than of the average constructor who naturally collects a few "spare" components in the course of his hobby. Obviously, there is a happy medium in all things, and I should be the last person to suggest discarding good com-

"burnt out." You may have discarded it when it got to the crackling stage—when it produced a good imitation of atmospherics all the time the set was in use; or it may have ceased to function altogether. Anyway, the point is that it has no further use as a transformer. However, the secondary winding is most unlikely to be damaged, and for that reason it may still be used as a choke.

Choke coupling in the L.F. stages is preferred by many designers to transformer coupling. It is particularly suitable where there is already one transformer stage and where further high stage gain would be neither necessary nor desirable. The connections for a choke-coupled stage using the secondary winding of an old transformer as a choke is shown in Figs. 1-3 (the secondary terminals of a transformer are usually marked "G" and "G.B.—"). It will be noticed that the only extra parts required are a fixed condenser of from about

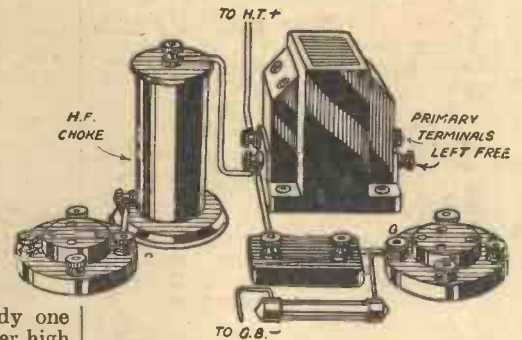

Fig. 3.—How a "burnt out" transformer can be used for coupling two valves. See also Figs. 1 and 2.

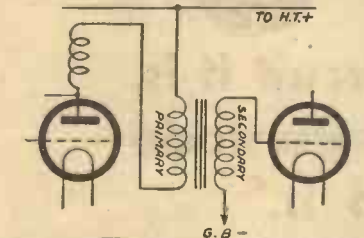

Fig. 1.—Circuit showing ordinary transformer coupling in which a burnt-out transformer would be useless.

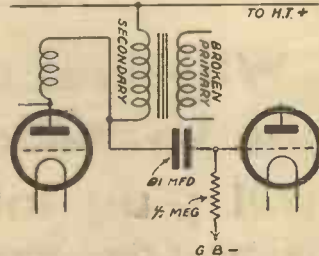

Fig. 2.—How the circuit can be altered using the faulty transformer as a choke.

ponents because there is no immediate use for them. It is, therefore, to placate my critics and detractors that I put forward the following suggestions for the use of some of the contents of the inevitable junk box.

You may happen to have an old transformer the primary winding of which has

.01 mfd. to .1 mfd. capacity, and a grid-leak round about  $\frac{1}{2}$  or 1 megohm.

Although choke coupling is usually used where there are two L.F. stages, it does not mean to say that it is not suitable in a single stage. I have several times proved this when a transformer has suddenly ceased to function during a performance, owing to the primary winding burning out. By quickly changing over the connections, and using the offending instrument as a choke, the receiver has been going again within a few minutes, while the loss in volume was hardly perceptible.

### Plug-in Coils

It always seems a great pity that no use can be found for disused tuning coils. Many of these are perfectly sound and quite efficient components, but, owing to the changing trend in design, have become ousted by others of a more

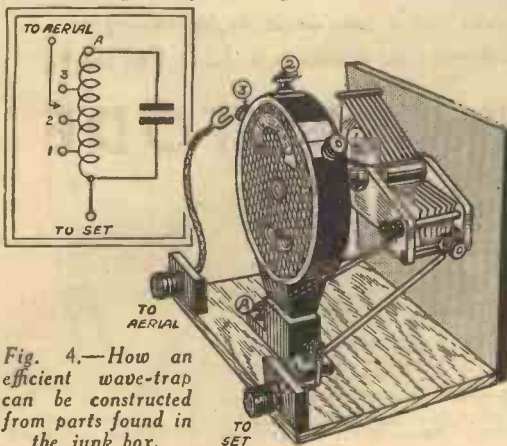

Fig. 4.—How an efficient wave-trap can be constructed from parts found in the junk box.

advanced type. I am afraid that to try to use them as anything else than coils is not usually very successful. I have certainly used a long-wave plug-in coil before now as a temporary H.F. choke, but I cannot recommend the use of any long-wave coil in this capacity. If you happen to have a coil of large inductance and very small self-capacity, it may work. Of course, two large coils connected in series would be better, but here the question of space arises, besides the risk of interaction with other components.

### A Wave Trap

If you happen to suffer from interference from one source only, such as a powerful local station, then a wave trap is quite a useful accessory to have. It is connected between the aerial and the aerial terminal of the set, and will enable you to cut out the local station and so receive others. It cannot, however, cut out more than one station, so that if there

(Continued on page 894)

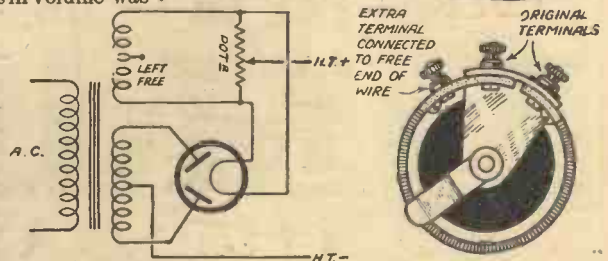

Fig. 6.—Circuit illustrating how the potentiometer may be used to stop mains hum.

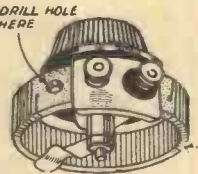
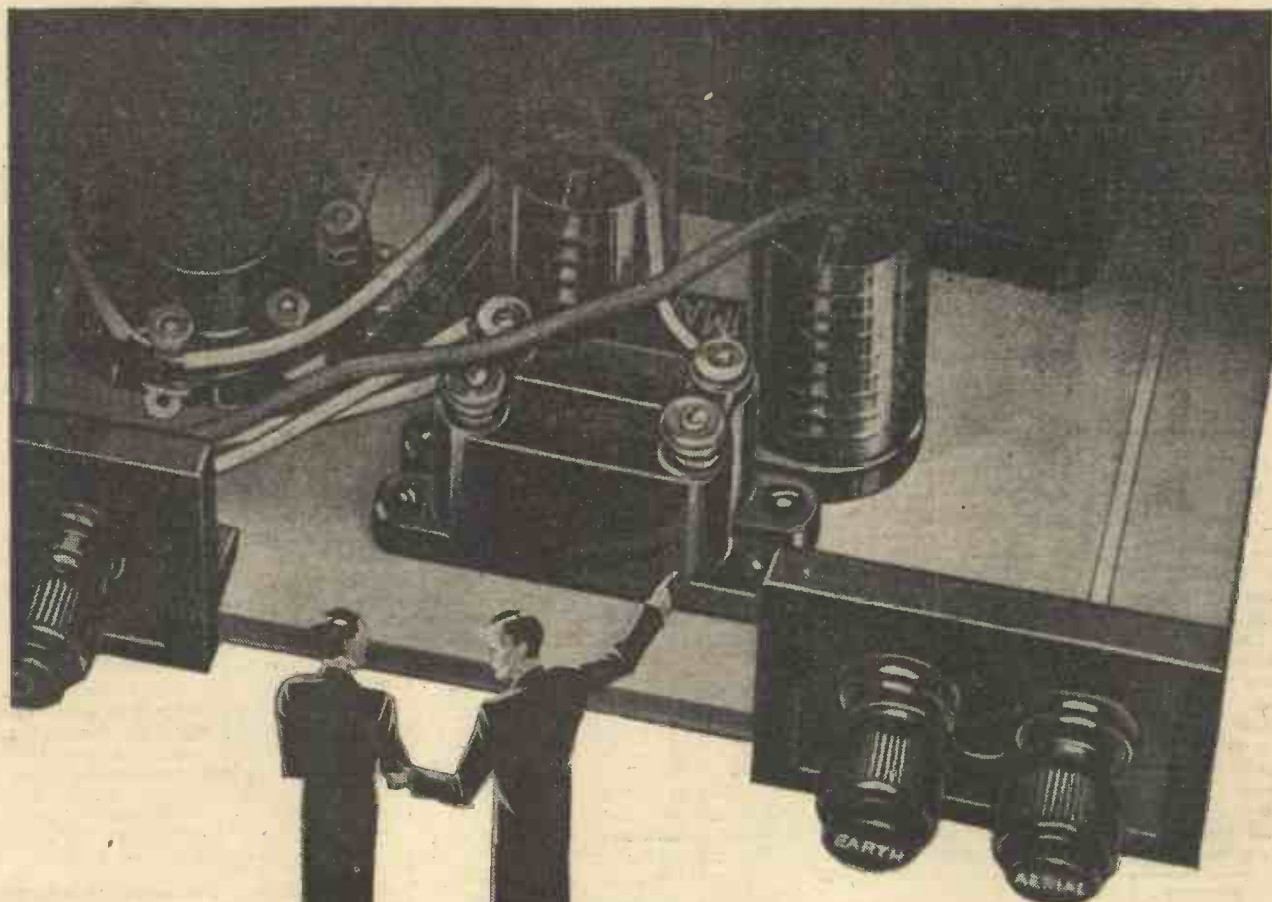

Fig. 5.—How to convert an old filament rheostat into a potentiometer.





**"Whatever circuit it is,  
the Screened Pentode  
will plug into it."**

That is the wonderful fact about this remarkable new Mullard Valve. Whatever the A.C. circuit, however old, however new, however many valves, this new H.F. Pentode will plug into it, will modernise it, will Pentodise it. Because that's the new ideal in circuit design — complete Pentodisation. Pentode-Detector-Pentode means Pentode power in the first stage as well as in the final stage. Mullard Research first introduced the Pentode type of valve and gave Pentode Power to the L.F. stage. Now it comes along with Pentode for the H.F. stage. Ask your dealer about it. It's going to do a great deal for your receiver.

ASK T.S.D. Whenever you want advice about your set or about your valves—ask T.S.D.—Mullard Technical Service Department—always at your service. You're under no obligation whatsoever. We help ourselves by helping you. When writing, whether your problem is big or small, give every detail, and address your envelope to T.S.D., Ref. D.K.P.

# THE NEW SCREENED PENTODE

# Mullard

## THE · MASTER · VALVE



(Continued from page 892)

is another station causing trouble besides the local it will not be able to deal with both of them. This is because of the principle on which it works. It is tuned to the station it is desired to eliminate, and cannot, of course, be tuned to two stations at once. Now a wave trap can be quite easily constructed from parts found in the junk box. The chief components needed are a tuning coil and variable condenser. The circuit is

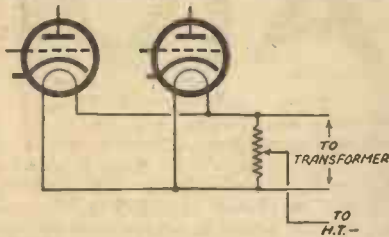

Fig. 7.—Another hum-reducing circuit using a potentiometer made from an old rheostat

shown in Fig. 4. This is what is known as a "rejector" type of trap. As you see, it consists essentially of a tuned circuit. If this is connected in series with the aerial and tuned to the wavelength of the unwanted station, then signals from that station will be unable to reach your set.

The construction of such a wave trap, using plug-in coils, is illustrated in Fig. 4. It is best to use tapped coils, then a greater range of control is possible. For instance, with the aerial connected to the end A of the coil (Fig. 4) the trap is most effective, although it alters the tuning positions of the set somewhat. When joined to the other end, that is, to No. 1 tapping, the cutting-out station is least powerful, but there is very little disturbance of the usual tuning positions.

**A Stand-by Receiver**

Another use which may be found for old coils, etc., is in the construction of a small stand-by receiver. Such a receiver will be very little trouble to make, and should be kept handy for use in an emergency. How three plug-in coils may be arranged to provide medium and long-wave reception without coil-changing is shown in Fig. 9. A medium-wave and a long-wave coil are mounted on the baseboard and another coil placed between them for reaction purposes. As there is only one reaction coil it will naturally be a compromise as regards size. It should be rather larger than is normally needed for the medium waves, but placed nearer to the long-wave coil than to the medium-wave one. In this way it will be effective on both wavebands. A simple on-off switch is all that is needed for wave-changing.

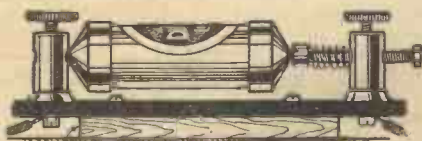

Fig. 11.—A resistance holder made from parts found in the junk box.

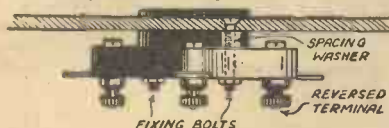

Fig. 12.—How to convert an ordinary valve holder into the chassis mounting type.

Valves which are no longer used because they have lost some of their original emission, and those which have been replaced by later types, provide yet another example of those many parts which it seems sacrilege to place on the scrap heap. I have seen many suggestions for using the bases of old valves as plugs for plugging in amplifiers, short-wave adaptors, etc., but I doubt if the conversion is worth the trouble, since such parts can be bought so cheaply. No, I think the best use for old valves is for testing purposes. Whenever I construct a new receiver I always plug-in old valves when I first switch on. Should there then be any fault which has escaped my checking, I do not run the risk of damaging my new valves.

Of course, one or two spare valves, even if they are past their prime, should always be kept handy in case of emergencies, for although modern valves do not usually cease to function without warning it is best to be prepared. An old valve is better than no valve!

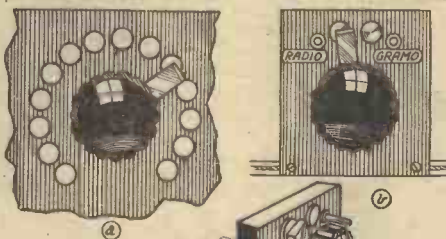

Fig. 8.—Simple conversion of an old multi-stud switch into a radio-to-gram switch.

**Old Type Filament Rheostats**

One of the chief features of sets of a few years ago was the array of variable filament resistances on the front panel. There was usually one rheostat for each valve. Many of these have since found a resting place in the bottom of the junk box. However, some of the higher resistance ones, say about 30 ohms, need not necessarily continue to lie there. It is usually a simple matter to provide a third connection, and so convert them into potentiometers. How this was done with one well-known type is shown in Fig. 5. A hole was drilled through the fibre support and a terminal fitted and joined to the free end of the resistance wire. Now, a 30-ohm potentiometer has quite a number of uses, especially if you have a mains set and are troubled with mains hum.

Sometimes mains hum is due to the centre tapping on the mains transformer winding, which supplies the rectifier valve filament with current, being electrically slightly out of balance. In this case a 30-ohm potentiometer should be placed across the ends of the winding, and instead of taking the H.T.—lead from the centre tap it is taken from the slider of a potentiometer as in Fig. 6. The slider is moved until the exact electrical centre is obtained as denoted by the disappearance of the hum. If the arm of the potentiometer is bent so that it works rather stiffly it will

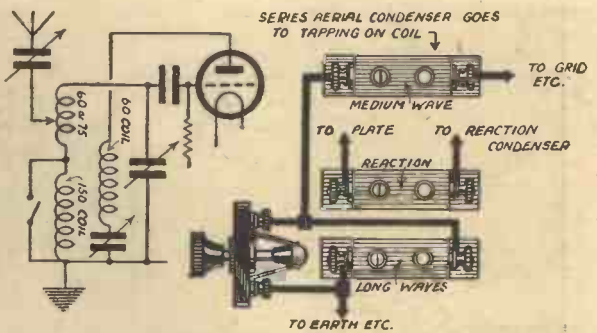

Fig. 9.—Circuit layout showing method of wave-changing with old plug-in coils without coil changing.

then "stay put" once the correct position is found. In a similar manner a potentiometer may often with advantage be connected across the heater winding to the other valves in the set. It is best to place it across the leads nearest the valves as in Fig. 7, and not across the transformer terminals themselves. (The same remark applies in the case of the rectifier valve just referred to.) The centre tap of the heater winding is left free and the wire joined as in the other case to the slider of the potentiometer. The value of both these potentiometers is not critical. The only thing is that their resistance must not be so low as to cause an appreciable drop in the voltage to the heaters or filament. As already stated those made from 30-ohm rheostats are quite suitable. A 5-ohm rheostat would be too low.

**Converting Old Switches**

The type of switch which is used probably less than any other nowadays is the multi-contact type which figured so largely in the days of elaborately tapped tuning coils. The arm of the switch was mounted direct on the panel of the set and was surrounded by an array of studs as in Fig. 8. Such an arrangement on the front of a set would be considered very unsightly nowadays. However it is quite possible to use one of the smaller types as a radio-gram switch. Two studs only are used, so that the appearance is nothing like so fearsome as with a dozen or more. The arm is moved one way for radio reception and the other way for the gramophone. Such a switch may easily be mounted on a small strip of ebonite at the back of the set and will save the cost of a modern rotary switch. The studs should be mounted fairly close together as in Fig. 8 so that the arm does not drop between them as it moves from one to the other. The action will then be quite smooth. Stops to prevent the arms swinging beyond the studs should not be forgotten. The pins sold for making home-made six-pin coils are suitable for this purpose.

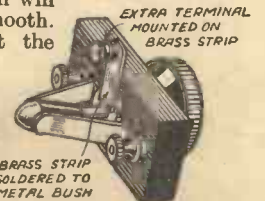

Fig. 10.—How a discarded filament switch may be converted into a 3-point wave-change switch.

Ordinary push-pull filament switches which may have been discarded through the conversion of a battery set to all-mains can be used as three-point wave-change switches by a very simple modification. A small strip of brass with a terminal

(Continued on page 919)





A Useful Unit Intended to Help the Amateur to Adjust His Set. By "TEST ENGINEER."

# A SIMPLE OSCILLATOR

MANY readers who have constructed receivers described from time to time in this journal, must have wondered whether they are getting the best results possible, after adjusting them while listening to broadcast stations. There are many difficulties attendant on the

panel and baseboard, and the writer would emphasize that almost any make of variable condenser which has no vanes touching will serve to tune the coil, though if a metal panel is used, or the unit is enclosed complete in a screening box (which is strongly advocated), the spindle which is connected to the moving vanes must be insulated from the panel as it is at H.T. potential. The L.F. choke should possess a low inductive value and must not be enclosed in a case of any sort, but mounted in clamps. Should the constructor possess an old L.F. transformer with the primary intact, this may be used as the choke, the secondary winding being left disconnected.

### Adjusting and Testing

When the components have been mounted and wired as shown in Figs. 2 and 3, it only remains to connect H.T. and L.T. batteries to their appropriate terminals, and we are ready to begin adjusting our oscillator. First plug a 35-turn coil into the coil-holder, and place the plug attached to H.T.+1 into the 60-volt pocket of your H.T. battery. The plug attached to H.T.+2 should be placed in the socket giving the highest H.T. available (120 volts being convenient). The oscillator should then be stood near the aerial connection of the receiver to be tested and, with the set switch on and tuned to roughly 250 metres, the tuning dial of your oscillator should be slowly rotated from zero to maximum. Now if our S.G. valve is oscillating, a rushing noise will be heard

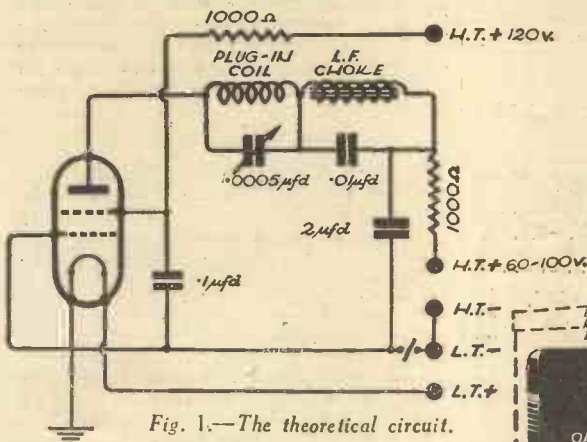

Fig. 1.—The theoretical circuit.

procedure often advocated, of tuning in a weak foreign station on the medium wave-band, and then adjusting trimming condensers, H.T. voltages, and grid-bias until loudest signals are obtained, then repeating the process on long waves; not the least being the tendency for the transmission to fade at the critical moment and upset all one's calculations.

Having had some experience of these annoying phenomena, the writer is of the opinion that the simple oscillator described will prove of exceptional value to the reader who wishes to get the best results from his set. Far from being expensive, the whole apparatus can be rigged up from parts which are usually to be found in every junk-box, and no difficulty should be encountered in procuring satisfactory results if the instructions are followed carefully.

### Principle of Operation

For its operation, the oscillator depends upon the so called dynatron principle, which is merely that a screen-grid valve, suitably fed with anode and screen voltages, will oscillate without the need for coupled circuits, and moreover can be made to provide its own modulating note.

Fig. 1, shows the theoretical circuit, and it will at once be noticed that, contrary to usual practice, the H.T. voltage on the screen of the S.G. valve is higher than that applied to the plate, and because it is this fact which is responsible for the whole functioning of the oscillator, it is the one adjustment which must be made carefully when the apparatus has been assembled.

The first steps in the assembly consist in mounting the components shown on the

the loud-speaker at one point in our oscillator condenser travel. Should this not be heard, increase H.T.+1 to 66 volts (or the next tapping), and rotate the oscillator condenser again. This process must be repeated until the rushing noise is heard, when the oscillator condenser should be left tuned to the point where the noise is heard.

It is possible that the rushing noise will be accompanied by a musical note like the B.B.C. tuning note, but it is unlikely that we shall be lucky enough to make an oscillator function at both high and low frequencies at the first attempt.

If, however, such should be the case, do not interfere further with the adjustments, but use the oscillator as described later.

### Obtaining the Tuning Note

To obtain the musical note it is necessary to adjust the inductance of the L.F. choke

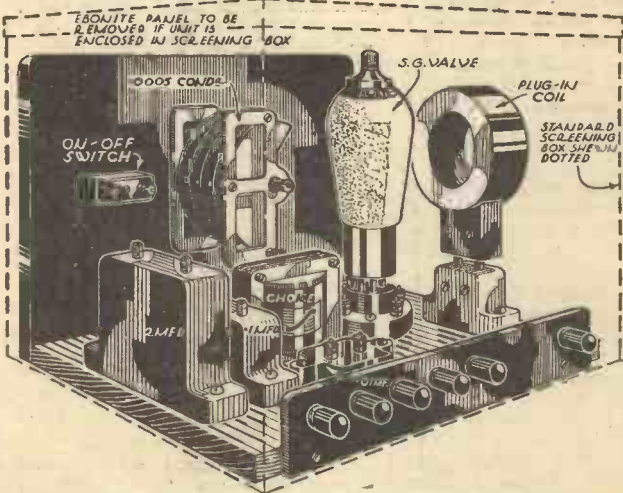

Fig. 2.—The unit ready for wiring, showing the position of the main components. Any type or make of the latter may be used, and the spacing of same is not at all critical. If screening box is used the .0005 variable condenser must be fitted with an insulating bush.

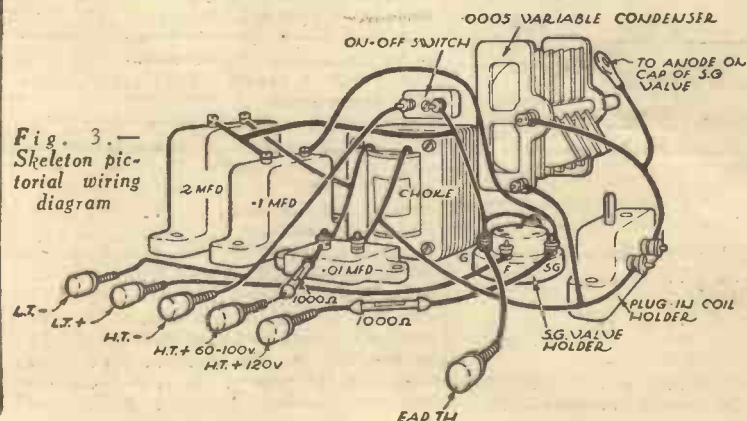

Fig. 3.—Skeleton pictorial wiring diagram



and the easiest method is to remove some of the laminations from its core. For this purpose, and without altering the tuning of the oscillator in any way, disconnect the H.T. from the unit, take out the choke, unclamp the core and remove, say, ten pairs of laminations. Then reclamp the remaining laminations, reconnect in the circuit and try again. It may be necessary to remove nearly all the laminations in this way before a musical note is heard in the receiver, but trial and error is the only method which will ensure success in this instance. It is interesting to note that the pitch of the note heard may be raised or lowered by removing or adding one or more laminations at a time (Fig. 4) until a note pleasing to the ear is obtained.

Having now made our oscillator function at 250 metres, remove it some distance from the receiver under test, i.e., until the note in the loud-speaker is barely audible, and then readjust the trimmers of the gang condensers in the receiver until the note is heard at its loudest. We can now be reasonably certain that our receiver is correctly adjusted. Then tune the receiver to roughly 500 metres, rotate the oscillator condenser until the musical note is again heard in the loud-speaker and make sure,

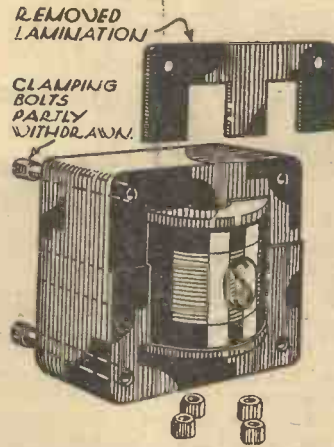

Fig. 4.—The easiest method of adjusting the inductance of the choke is by removing some of the core laminations.

by carefully moving the gang condenser trimmers, that the receiver is still correctly aligned.

**Further Adjustments**

Now by removing the 35-turn coil from

the oscillator and inserting a 120-turn coil in the holder, we can check up the performance of our receiver on long waves, the procedure being exactly similar except that we must switch our receiver to long waves and check at, say, 1,200 and 1,900 metres. It will be found comparatively easy to adjust any receiver with the aid of the steady note given by the modulated oscillator, and the ear is quite sensitive to the changes of intensity of a single note while adjustments to the receiver are being made.

More accurate adjustments can be made to the receiver when there is a visual indication of relative signal strengths. In addition to its use as indicated above, the oscillator can easily be calibrated quite accurately as a wave-meter, it being only necessary to tune in powerful broadcasting stations of known wavelength on the receiver, and then to rotate the oscillator condenser until the note is heard superimposed upon the broadcast transmission, and a record made of the oscillator dial reading. Many other uses will be found for this handy instrument, and the constructor will find it well worth while to make up such a versatile and interesting piece of apparatus.

|  |           |    |
|--|-----------|----|
| Balcombe, Ltd., A. J. . . . .              | STAND NO. | 29 |
| Ballantine, Robert . . . . .               | ..        | 65 |
| Belling & Lee, Ltd. . . . .                | ..        | 56 |
| Biggar, Ltd., Alexander . . . . .          | ..        | 18 |
| Black, Ltd., Michael . . . . .             | ..        | 28 |
| Blackadder, William . . . . .              | ..        | 60 |
| Block Batteries, Ltd. . . . .              | ..        | 67 |
| Britannia Batteries, Ltd. . . . .          | ..        | 69 |
| British Blue Spot Co., Ltd. . . . .        | ..        | 4  |
| British Broadcasting Corporation . . . . . | ..        | 74 |
| British Rola Co., Ltd. . . . .             | ..        | 19 |
| Brown & Co. (Simplex), Ltd. . . . .        | ..        | 24 |
| Bulgin & Co., Ltd., A. F. . . . .          | ..        | 72 |
| Clark & Co. (M/c), Ltd., H. . . . .        | ..        | 44 |

**INDEX TO EXHIBITORS AT THE SCOTTISH RADIO EXHIBITION, Kelvin Hall, Glasgow, Sept. 1st-9th. OUR STAND No. 17.**

|   |           |    |
|---|-----------|----|
| Epoch Radio Manufacturing Co., Ltd. . . . .             | STAND NO. | 61 |
| Ever Ready Co. (G.B.), Ltd. . . . .                     | ..        | 30 |
| Ewing & McIntosh . . . . .                              | ..        | 1  |
| Ferranti, Ltd. . . . .                                  | ..        | 38 |
| Forbes Bros., Ltd. . . . .                              | ..        | 71 |
| General Electric Co., Ltd. . . . .                      | ..        | 34 |
| Harper & Co., William . . . . .                         | ..        | 40 |
| Hellesens, Ltd. . . . .                                 | ..        | 45 |
| His Master's Voice (The Gramophone Co., Ltd.) . . . . . | ..        | 33 |
| Houghtons the Wholesalers (Ensign, Ltd.) . . . . .      | ..        | 47 |
| Hunter, James R. . . . .                                | ..        | 10 |
| Hustler, Simpson & Webb, Ltd. . . . .                   | ..        | 12 |
| Hutchison, E. W. . . . .                                | ..        | 58 |
| Igranic Electric Co., Ltd. . . . .                      | ..        | 23 |
| Itonia, Ltd. . . . .                                    | ..        | 39 |
| Johnson Talking Machine Co., Ltd. . . . .               | ..        | 54 |
| McMichael Radio, Ltd. . . . .                           | ..        | 27 |
| Machell & Sons, Thomas . . . . .                        | ..        | 48 |

**PRACTICAL WIRELESS, for Real and**

|   |           |    |
|---|-----------|----|
| <b>Reliable Reader Service</b> . . . . .            | STAND NO. | 17 |
| Pye Radio, Ltd. . . . .                             | ..        | 41 |
| Radio Gramophone Development Co., Ltd. . . . .      | ..        | 13 |
| Radio Instruments, Ltd. . . . .                     | ..        | 63 |
| Robertson, James . . . . .                          | ..        | 22 |
| Ross & Adam . . . . .                               | ..        | 73 |
| Scottish Radio Retailers' Association . . . . .     | ..        | 59 |
| Siemens Electric Lamps & Supplies, Ltd. . . . .     | ..        | 11 |
| Thompson, Diamond & Butcher . . . . .               | ..        | 55 |
| Thomson & Brown Bros., Ltd. . . . .                 | ..        | 53 |
| Turner, James . . . . .                             | ..        | 20 |
| Ultra Electric Ltd. . . . .                         | ..        | 42 |
| Varley (Oliver Pell Control, Ltd.) . . . . .        | ..        | 25 |
| Westinghouse Brake & Saxby Signal Co., Ltd. . . . . | ..        | 6  |
| Whiteford & Co., James . . . . .                    | ..        | 9  |

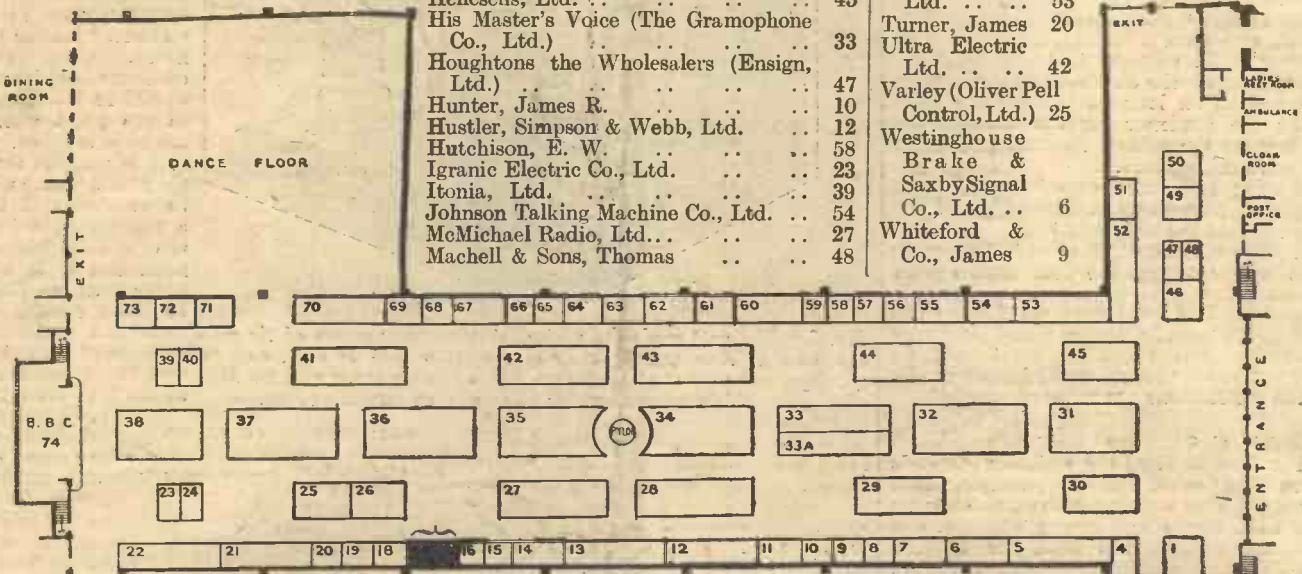

**"Practical Wireless" Stand No. 17.**

|  |    |     |  |    |    |   |    |    |
|--|----|-----|--|----|----|---|----|----|
| Cohen, S. W. . . . .                   | .. | 15  | Marconiphone Co., Ltd. . . . .             | .. | 35 | Whiteley Electrical Radio Co., Ltd. . . . . | .. | 70 |
| Cole, Ltd., E. K. . . . .              | .. | 32  | Muir & Bryden . . . . .                    | .. | 57 | Woolfson, Ltd., Philip . . . . .            | .. | 50 |
| Columbia Graphophone Co., Ltd. . . . . | .. | 33A | Mullard Wireless Service Co., Ltd. . . . . | .. | 36 | Wylie, Hill & Co., Ltd., R. . . . .         | .. | 5  |
| Cossor, Ltd., A. C. . . . .            | .. | 31  | Murdoch, McKillop & Co., Ltd. . . . .      | .. | 21 | Young's (Glasgow), Ltd. . . . .             | .. | 68 |
| Cuthbertson & Co., Ltd. . . . .        | .. | 66  | Newnes, Ltd., George . . . . .             | .. | 17 |   |    |    |
| Denholm, J. Stuart . . . . .           | .. | 49  | North British Machine Co., Ltd. . . . .    | .. | 16 |   |    |    |
| Dulcetto-Polyphon, Ltd. . . . .        | .. | 7   | Partridge, Wilson & Co. . . . .            | .. | 14 |   |    |    |
| "Econasign" Co., Ltd. . . . .          | .. | 2   | Paterson, Sons & Co., Ltd. . . . .         | .. | 46 |   |    |    |
| Edinburgh Rubber Co. . . . .           | .. | 8   | Philips Lamps, Ltd. . . . .                | .. | 43 |   |    |    |
| Edison Swan Electric Co., Ltd. . . . . | .. | 37  | Portadyne Radio . . . . .                  | .. | 64 |   |    |    |



# of GREAT strength

## BUT LITTLE SIZE

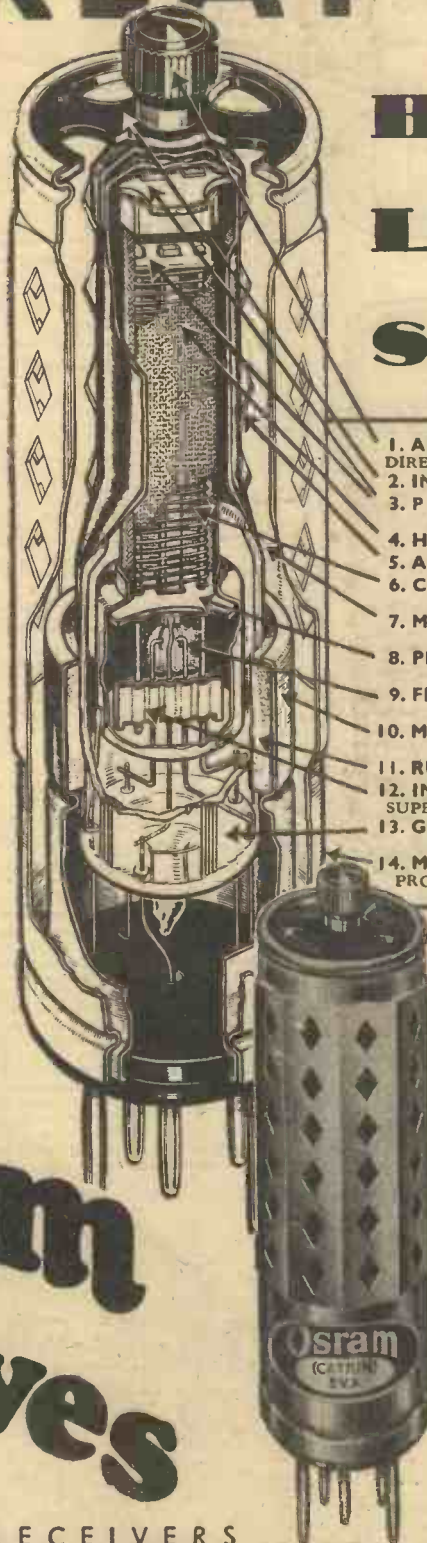

1. ANODE TERMINAL DIRECTLY CONNECTED—LOOSE CAP IMPOSSIBLE
2. INSULATION BETWEEN ANODE & SHIELD
3. PRECISION INSULATORS LOCKING ELECTRODES
4. HEXAGONAL SCREEN GRID
5. AIR COOLED ANODE
6. CONTROL GRID  
STRAIGHT WIRE CONSTRUCTION
7. METAL ANODE TO GLASS VACUUM TIGHT JOINT
8. PRECISION INSULATOR LOCKING ELECTRODES
9. FILAMENT CONNECTIONS THE ONLY WELDS IN THE ELECTRODE SUPPORT SYSTEM
10. METAL CAPPING SHELL GIVING MINIMUM GRID—ANODE CAPACITY
11. RUBBER MOUNTING ANTI-MICROPHONIC.
12. INSULATED STEEL CLAMP SUPERSIDING DELICATE PINCH OF GLASS VALVE
13. GLASS CIRCULAR SEAL GIVING MAXIMUM INSULATION SPACING BETWEEN WIRES
14. METAL SHIELD GIVING MECHANICAL PROTECTION AND ELECTRO STATIC SHIELDING

OSRAM "CATKIN" VALVES are essential for modern receiver practice. Immensely strong yet compact in design they are constructed to microscopically precise limits and therefore allow for greatly improved set performance. A set equipped with OSRAM "CATKIN" VALVES gives the highest quality reception.

The all-metal construction of OSRAM "CATKIN" VALVES is a radical departure and results prove beyond dispute that they definitely give more uniform results, complete freedom from microphonicity and more effective screening. A change to OSRAM "CATKIN" VALVES is a change to faultless radio reception.

# Osram (CATKIN) Valves

Made in England.  
Covered by World  
Patents.

FOR A.C. MAINS RECEIVERS

METAL INSTEAD OF GLASS

Advt. of The General Electric Co. Ltd., Magnet House, Kingsway, London, W.C.2.

### TYPES AND PRICES

- M54B High Efficiency Screen-Grid A.C. Mains Valve - 17/6
- VMS4 Improved Variable Mu Screen-Grid A.C. Mains Valve - 17/6
- MH4 High Magnification Detector A.C. Mains Valve - 13/6
- MPT4 Power Pentode A.C. Mains Valve - 18/6

(Other types to follow)

Sold by all Wireless Dealers

WRITE for the OSRAM VALVE GUIDE (1933 Edition) sent post free.

"CATKIN" is the Trade Mark of the M.O. Valve Co. Ltd., manufacturers and patentees.



# TELSEN

## ELECTROLYTIC PAPER AND MICA

# CONDENSERS



### TELSEN MICA CONDENSERS

Adaptable to flat and vertical mounting. H.F. losses, even in the larger sizes, have been virtually eliminated. Grid leak clips supplied free with the smaller capacities. In capacities of from '0001 mfd. to '001 mfd. '002 - 1/3 6.



### TELSEN TAG CONDENSERS

At reduced prices

Of compact and sturdy construction. May be mounted on either insulated or metal panels. Tags enable the condensers to be connected to any other components, either directly or by soldering. H.F. losses are negligible. In capacities of '0001 mfd. to '001 mfd. '002 mfd. 6d. 4 1/2



### TELSEN PRE-SET CONDENSERS

At reduced prices

Give widest variation between maximum and minimum capacities, and exceptional range of selectivity adjustment when used in the aerial circuit. High insulation with low loss. In mfd. capacities of from '0001 to '002 1/3



### TELSEN HIGH VOLTAGE ELECTROLYTIC CONDENSERS

An outstanding achievement in condenser design.

Excellent for use in smoothing circuits and other positions in which high voltage high capacity condensers are required. The special bracket and terminal supplied with the condenser enables it to be mounted on any type of baseboard or chassis.

| Cap.   | 275 working peak voltage | 500 working peak voltage |
|--------|--------------------------|--------------------------|
| 4 mfd. | - - - - 3/6              | - - - - 4/6              |
| 6 "    | - - - - 3/9              | - - - - 5/-              |
| 8 "    | - - - - 4/-              | - - - - 5/6              |



### TELSEN LOW VOLTAGE ELECTROLYTIC CONDENSERS

Ideal where a very high capacity with a fairly low voltage is required, as in automatic bias circuits for L.F. valves. Very compact, with wired ends for easy suspension in the wiring.

|                     |       |
|---------------------|-------|
| 25 mfd. at 25 volts | - 2/6 |
| 50 " at 25 "        | - 3/- |
| 25 " at 50 "        | - 3/- |



### TELSEN SMALL TUBULAR CONDENSERS

Very small yet highly efficient, with wired ends for easy suspension in the wiring.

| Cap.       | Price | Cap.      | Price |
|------------|-------|-----------|-------|
| '0001 mfd. | 1/-   | '002 mfd. | 1/-   |
| '0002 "    | 1/-   | '005 "    | 1/-   |
| '0003 "    | 1/-   | '006 "    | 1/3   |
| '0005 "    | 1/-   | '01 "     | 1/6   |
| '001 "     | 1/-   | '1 "      | 1/6   |

### TELSEN PAPER CONDENSERS

At reduced prices

Represent a very definite advance in current condenser practice. Only the highest quality foil paper and the finest linen tissue are employed, each individual plate being self-sealing and the case itself being finally triple-sealed with a newly discovered bitumastic compound, for permanent efficiency. Every condenser is subjected to rigorous tests up to Post Office and Admiralty standards, the exclusive method of construction making them genuinely non-inductive. They give the highest insulation with complete freedom from breakdown—built for lasting efficiency under all conditions.



### TELSEN PAPER CONDENSERS

Specially designed for 2-way fixing.

| Cap. mfd. | 500 Volt Test | 1,000 Volt Test |
|-----------|---------------|-----------------|
| '01       | 1/3           | 1/9             |
| '04       | 1/3           | 1/9             |
| '1        | 1/6           | 2/-             |
| '25       | 1/6           | 2/-             |
| '5        | 1/6           | 2/-             |
| '1        | 1/9           | 2/6             |
| '2        | 2/6           | 3/6             |

### TELSEN PAPER BLOCK CONDENSERS

In metal cases with soldering tags.

| Cap. mfd. | 500 Volt Test | 1,000 Volt Test |
|-----------|---------------|-----------------|
| 4         | 4/9           | 6/6             |
| 6         | 7/-           | 9/6             |
| 8         | 9/6           |                 |

### TELSEN RESISTORS WITH WIRED ENDS

Very small and light, and easily suspended in the wiring of a receiver. Supplied in the following values:—Power rating of 1/2 and 1 watt: 250, 500, 1,000, 1,250, 5,000, 10,000, 20,000, 25,000, 50,000, 100,000, 250,000, 500,000 ohms resistance. Price 1/-

Power rating of 2 watts: 250, 500, 1,000, 1,250, 5,000, 10,000, 20,000, 25,000, 50,000, 100,000 ohms resistance. Price 2/-

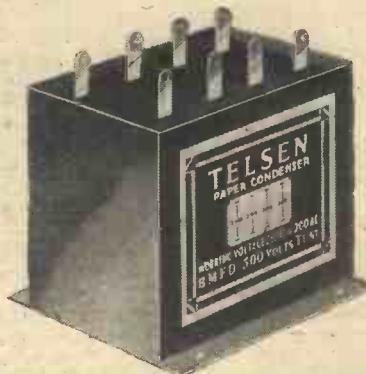

**TELSEN FOR EVERYTHING IN RADIO**

ANNOUNCEMENT OF THE TELSEN ELECTRIC CO., LTD., ASTON, BIRMINGHAM



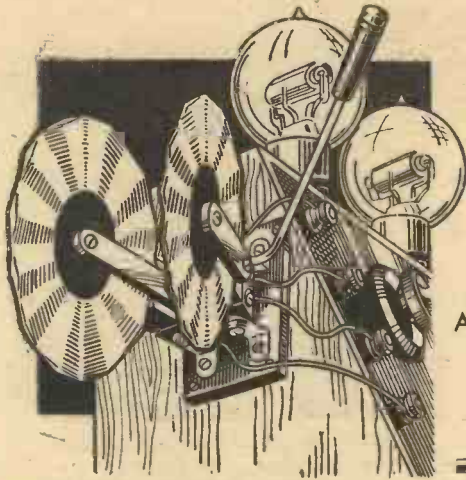

# The History of Reaction

And How it is Employed in Several Well-known Circuits

By LAMBDA

It was about twenty years ago that the principle of reaction was first disclosed, but it was not, however, until the advent of broadcasting after the war that this principle was put to any very extensive use. The demand then arose for cheap and efficient receiving sets, and at the prices then ruling the application of reaction to two and three-valve receivers was a tremendous advantage. In the early days receivers were expensive, small battery receivers costing as much as twenty pounds, and by incorporating reaction a saving of practically one valve was effected. Without reaction the cost of a receiver would have been prohibitive, so that few of us could have afforded to indulge in what would have been a very expensive luxury. Reaction properly handled can be of great benefit, and with care quality does not suffer to any appreciable extent.

To the constructor it has been of considerable utility. Although the cost of receivers and components has been enormously reduced, even now we cannot all afford the more pretentious sets incorporating two or more high-frequency stages, or superhets. Even in the two H.F. set, reaction is often incorporated. It is particularly useful in boosting up signals, especially for constructors who live in parts of the country which are rather remote from the local station, or who wish to receive that rather distant foreigner. A three-valve circuit embodying reaction, in the hands of a skilled constructor, has been known to perform prodigious feats, and the number of stations logged by constructors of even some of the more simple receivers described in this journal have been amazing.

During recent years reaction has been somewhat neglected, possibly due to the reduction in the price of components. Many of the early constructors have indulged in more ambitious receivers. Most of us are like the car owner: we start with the modest baby car, but are not satisfied; we want to launch out; want more power; so that eventually the car enthusiast graduates into the six-cylinder type. Likewise the constructor: he wants greater

power, greater command over the ether; and why shouldn't he?

However, there now seems to be a tendency for research engineers to direct their attention to regenerative receivers, and it is possible that we may hear of great improvements in this type of circuit in the near future.

In spite of the great benefits derived from the application of reaction in receiving circuits, there has been from time to time an outcry against its use. Unfortunately, over enthusiastic persons have misapplied this instrument, and in forcing their reaction control to the point of oscillation have caused considerable annoyance to their neighbours. The majority of constructors, however, know better, and this interference has been minimized to a very considerable extent.

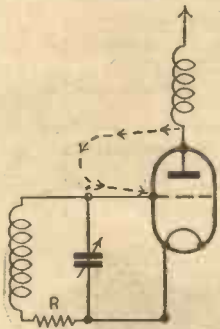

Fig. 1.—Showing principle of reaction.

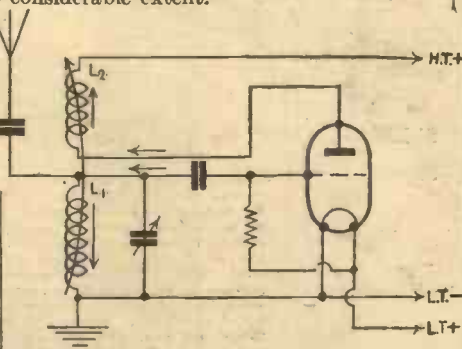

Fig. 2.—Circuit with swinging coil reaction.

What does reaction do to produce such wonderful amplification as is obtained in some receivers? Is it affected by circuit conditions? What are the limits of regenerative amplification? We all know that reaction is only possible in a power amplifier. A crystal detector cannot be made to produce reaction effects, as it is not a power amplifier: the wireless valve is essentially a power amplifier. Regeneration consists in taking a small portion of the output power from a valve and sending it back to the input side of the amplifier. The amplified H.F. currents flowing in the anode circuit are fed back to the grid circuit to be further amplified.

Now the potential available for application to the grid-filament of the valve is inversely proportional to the resistance of the tuned circuit. When the aerial is coupled to the tuned circuit it is rather difficult to keep this resistance very low. By employing

reaction, however, it is possible to compensate for the resistance of the tuned circuit. The principle can be shown in Fig. 1. Some of the energy flowing in the anode circuit is fed back into the grid circuit, so compensating for some of the energy lost in the resistance R of the circuit. Actually, this is tantamount to reducing the resistance R, and therefore increasing the potential which is applied to the grid of the valve. Let us proceed and examine this principle a step further.

In Fig. 2 is shown a simple tuned circuit, with swinging-coil reaction (which will be discussed later). Assume a current is oscillating in the aerial circuit at the frequency of the transmitting station, and a corresponding voltage is impressed on the grid of the valve. A rectified H.F. current is therefore produced in the plate circuit of the valve which flows through the reaction coil L2. As far as we are concerned in this discussion, we are not interested in the modulated H.F. currents which cause speech and music to be heard in the loud-speaker. By coupling the coil L2 to the grid coil L1, an E.M.F. is induced across the latter coil, adding to the current in this coil. We are assuming, of course, that coil L2 is connected in the correct manner. If connections were reversed, the result would be a decrease in signal strength.

In Fig. 2 the direction of the arrows indicate the conditions which are essential for producing regeneration. The currents flow outward from the grid and plate respectively, and pass through the coils in opposite directions. Therefore, the reaction coil should be wound in an opposite direction. The same effect can, however, be produced by reversing the connections to the reaction winding if it is wound in the same direction as the grid coil. By increasing the feed back of energy there should be a definite increase of signal strength. If we go on increasing the coupling of the reaction coil, the decrease in resistance of the grid coil is further reduced until it theoretically reaches zero. Eventually, the valve will oscillate, and these oscillations will manifest themselves by a howl in the loud-speaker.

(To be concluded next week.)

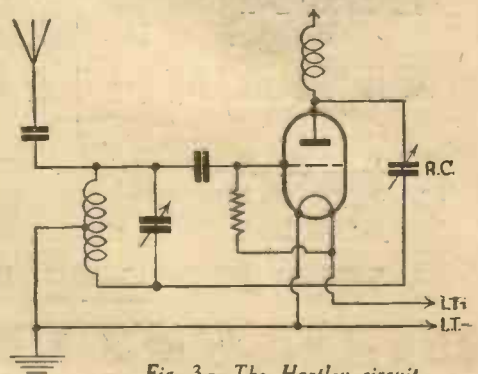

Fig. 3.—The Hartley circuit.





# SUPREME

## AMONG TABLE RADIO SETS

### BECAUSE

- IT IS A SUPERHET SEVEN
- IT HAS CONCERT TONE & VOLUME
- IT HAS DELAYED AUTOMATIC VOLUME CONTROL
- IT HAS A SPECIAL STATIC SUPPRESSOR
- IT HAS ADJACENT CHANNEL SELECTIVITY

and

### BECAUSE

- IT IS BUILT BY

☞ The Superhet Concert Seven combines the very latest improvements in radio science, such as delayed automatic volume control (which eliminates fading of long-distance programmes), static suppressor (which prevents the amplification of any signal in the "mush"), and real adjacent channel selectivity. It provides not only a range of stations to satisfy the inveterate station hunter, but also a tone to please the most sensitive musical ear.

☞ To prove its supremacy needs but a fractional turn of the tuning knob—to prove its supremacy as a musical instrument, *just listen!* Here is the realism of the Concert Hall itself—a tone that is true to life! The technically minded will find further details to interest them in the brief specification below.

☞ But besides being good to hear, the set is also remarkably good to look at. Altogether, an instrument you will be pleased to listen to, pleased to look at, and, since it is made by "His Masters' Voice," proud to own. Price 22 Gns. (or by Hire Purchase).

**BRIEF SPECIFICATION:**  
Superhet Concert Seven

**Model 467**

Seven - valve (inc. rectifier) superheterodyne circuit Marconi valves. Automatic Volume Control. Illuminated Scale with wavelengths and station names. Duplex tone control. Moving coil, mains-excited loud-speaker. Sockets for gramophone pick-up. Power to operate three additional loud-speakers.  
Height - 1 ft. 7½ ins.  
Width - 1 ft. 5¾ ins.  
Depth - 11½ ins



# "HIS MASTER'S VOICE"

## TRUE - TO - LIFE RADIO & RADIO - GRAMOPHONES



# READERS' HALF-GUINEA WRINKLES

The Page

### An Earthing Clamp

A VERY effective earthing device may be constructed from a piece of copper sheet  $\frac{1}{8}$  in. thick and 1 in. square, two 4BA nuts, bolts and washers. The copper sheet is bent around the water-pipe to which

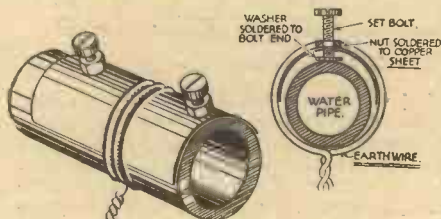

An efficient earthing clamp.

the earth-wire is to be attached, and  $\frac{1}{4}$  in. from the extreme curved edges and along the centre line are drilled two 4BA clearance holes. The two 4BA nuts are firmly soldered to the outside surface of the sheet, above the holes, the bolts being threaded down through the nuts, and, to prevent penetration of the pipe when the device is in position, the washers are soldered to the ends of the bolts. The device is placed on the pipe and the earth wire wound around the extreme outside and between the two bolts. By screwing the bolts on to the pipe a varying degree of tension on the earth wire may be made thus ensuring good electrical contact.—G. MCGAHAN (Sunderland).

### Switching Arrangement for All-mains Working

THE conversion of a battery set to all-mains operation can be done by a method of simple switching, which I have

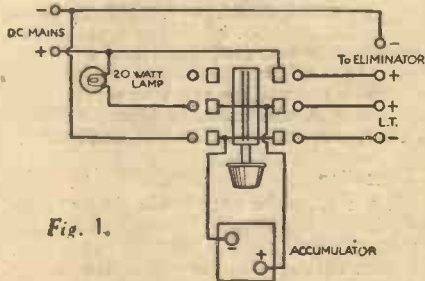

Fig. 1.

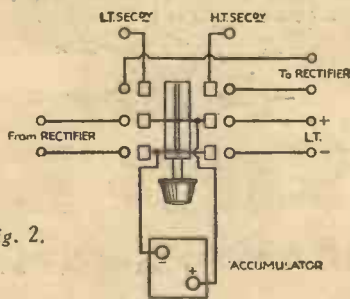

Fig. 2.

A switching arrangement for all-mains working.

### THAT DODGE OF YOURS!

Every reader of "PRACTICAL WIRELESS" must have originated some little dodge which would interest other readers. Why not pass it on to us? We pay £1-10-0 for the best wrinkle submitted, and for every other item published on this page we will pay half-a-guinea. Turn that idea of yours to account by sending it in to us addressed to the Editor, "PRACTICAL WIRELESS," George Newnes, Ltd., 8-11, Southampton Street, Strand, W.C.2. Put your name and address on every item. Please note that every notion sent in must be original. Mark envelopes "Radio Wrinkles." Do NOT enclose queries with your wrinkle.

evolved to meet the circumstances of my own case. I have a D.C. eliminator, but found that my accumulators were not being properly charged by the so-called charging stations. Having a six-point switch, I decided to use it to help solve my problem.

I now have no trouble and may say that my set is now "all-mains," using 2-volt battery valves. The switch is of the six point type, though any similar switch will do. The lighting point, or load lamp, can be extended to a table lamp, for use on any small table near the set. When the switch is in top position set is on; central, all off; and when in the bottom position, the accumulator is on trickle charge.

This arrangement, as shown in Fig. 1, completely isolates the accumulator from set so that the H.T. fuse in the set is unaffected, and is still serving the purpose of protecting the valves. The circuit can be adapted to A.C. working, as shown in Fig. 2.

### Increasing Volume and Sensitivity

THE following description of a gadget may interest readers who use portable or transportable receivers and find that reception grows worse during the summer months, and also when their H.T. voltage begins to drop. It consists of a home-made coil of 40 to 50 turns, tuned by an old .0005 tuning condenser, connected in parallel and joined to any form of aerial and earth, as indicated diagrammatically in Fig. 3. The coil and condenser are in my case mounted in a small box which carries terminals for aerial and earth leads. The box is placed close to the frame aerial of the receiver, as in Fig. 4, which is tuned in to a station normally. The gadget is then roughly brought into tune by rotating the knob of the .0005 condenser. A great increase in

volume and sensitivity is obtained, whilst the receiver loses a little of its directional property; this, however, is easily overcome by varying the distance between the device and the receiver, or turning the whole device so that the frame aerial of the receiver and the coil in the device are varied from parallel to right angles to each other. Operation is simplicity itself and the sketch is self-explanatory. By tuning it to the unwanted station the gadget can be made to act as an absorption wave trap. Of course, the medium waves only are covered.—R. STROUD (Wendover).

### A Useful Microphone Unit

AN old telephone, or W.D. microphone, can be built up into a useful portable unit, in the manner indicated in the accompanying sketches. The case in this instance

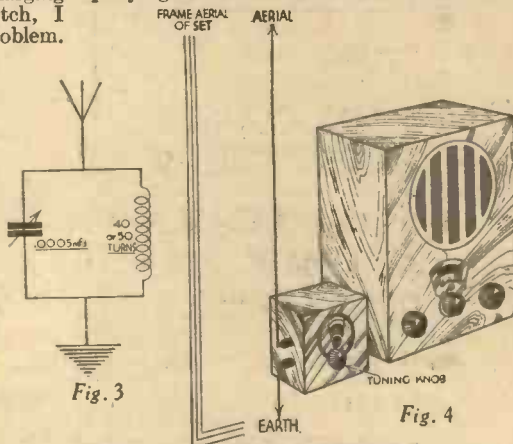

Fig. 3

Fig. 4

A device for increasing volume and sensitivity.

is made from an old fuseboard cover with the glass removed, but anything light and strong will serve. The "mike" is surrounded with a wide rubber band, thick enough to "insulate" it (mechanically) from the large spiral spring. This spring is cut to such a length that, when wound round the microphone, it holds it tightly

(Continued overleaf)

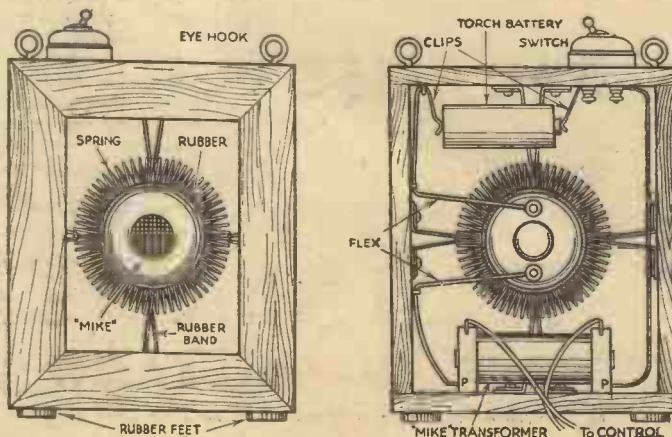

Front and rear views of a simple microphone unit.



**RADIO WRINKLES**

(Continued from previous page)

enough to prevent a normal jar from displacing it. Next, four stiff rubber bands are passed through the spring at appropriate points, and secured to the case sides by means of small tacks or screws. Place large washers over these screws if the rubber shows signs of tearing away.

The microphone transformer is now screwed into the base of the case at the back, taking care that it does not touch any part of the suspension. An old resistance or crystal detector-clip is now fastened at the top left-hand corner of the case, and another in such a position that an ordinary small torch battery will clip tightly between them.

If the switch is of the type with long-fixing bolts, it can be mounted directly over this clip, and one of its bolts used as both connection and fixing for the clip, as shown; otherwise it will have to be wired separately. The wiring and connections will be seen from the diagrams. Small rubber feet and eye hooks complete the job and make the "mike" readily adaptable. The control-panel (potentiometer, etc.), could, if desired, be mounted as a back for the unit, but usually it is more convenient to have it separate.—L. SHEPHERD (Bradford).

**Work Board for Dining-Table**

**M**OST radio-enthusiasts are, like myself, compelled to do all their set constructing, soldering, etc., on the dining-table, owing to lack of space for the accommodation of a proper work bench. An ordinary dining-table is quite satisfactory to work on, but great care has to be taken to avoid burning the table top with the soldering iron, and the flux tin has a nasty trick of falling face downwards on to the table! Even the most careful constructor cannot help scratching the surface, owing to the fact that the set is always being turned round when wiring up.

In order to prevent this, I used a thick deal board as long as the width of the table (in my case 3ft. and about 2ft. wide, which I planed and sandpapered. I also obtained a piece of felt the same size, which I fastened with strong glue to one side of the board. A piece of thin sheet metal, about 6ins. wide, is screwed to one end of the other side of the board, upon which a hot soldering iron can be rested without fear of burning.

The idea is that when you have any constructing or soldering to do the board is fastened felt side downwards on one end of the dining-table by means of small

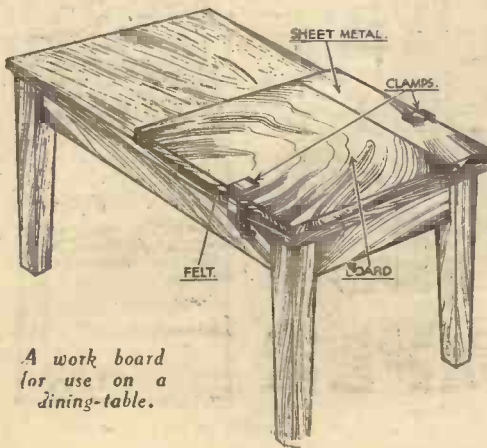

A work board for use on a dining-table.

clamps, as used for fretwork, and there is then no fear of spoiling the polished table-top when doing soldering, drilling, or other work.

The board can, of course, be of different dimensions to those mentioned. If thought necessary, it could be made large enough to cover the whole of the table, but a smaller board usually provides sufficient space for working on, and is quite easily stored in a cupboard when not in use.—C. C. ALGAR (Forest Gate).

**A Pick-up Adaptor**

**A**N old valve base makes an excellent plug for connecting a pick-up to a set and at the same time breaking the filament connection to the H.F. valve or valves. Fig. 5 gives a circuit diagram of the switching arrangement and connections of a Clix 4-pin chassis mounting valve-holder which is fitted at the back of the set over the terminal strip.

About 1/4 in. of one of the filament legs of this valve-holder is cut off as in Fig. 6, and a small brass strip, bent as shown, is fitted to the uncut leg, so that it bears firmly against the cut leg and makes a good

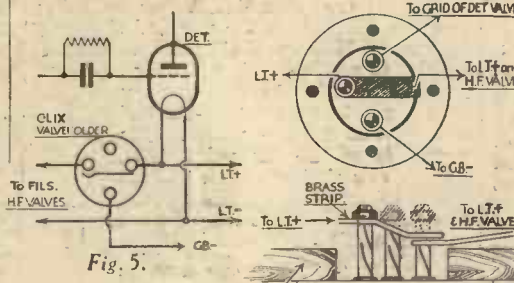

Fig. 5.

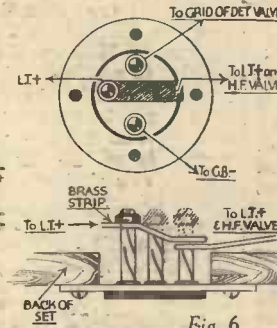

Fig. 6.

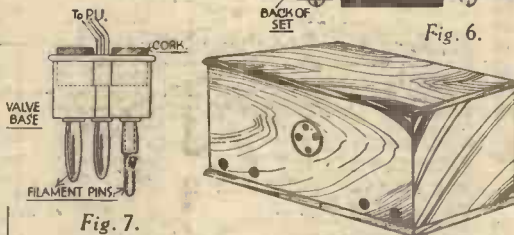

Fig. 7.

A pick-up adaptor made from an old valve base.

electrical contact. The grid of the valve-holder is connected to the grid of the detector valve in the set, and the anode to G.B.—1 1/2 volts. A connection is made with the cut leg of the valve-holder and L.T.+ on H.F. valves, and the uncut leg is joined to L.T.+ on the detector valve. On the valve base a portion of the identical banana pin is also cut off and a piece of thin ebonite or other insulating material fitted firmly, as in Fig. 7, so that when the plug is inserted in the valve-holder the insulating material will push up the brass strip and break the L.T.+ connection to the H.F. valve. The grid and anode terminals on the valve-base are connected permanently to the pick-up. From the foregoing it will be obvious that to play records it is only necessary to insert the plug in the valve-holder. On withdrawing it the set functions in the ordinary way.—J. GALLAGHER (Belfast).

**A Useful Shorting Switch**

**W**ITH a large number of sets employing a triple range coil, tuning with a .0005 mfd. variable condenser on the short-wave section

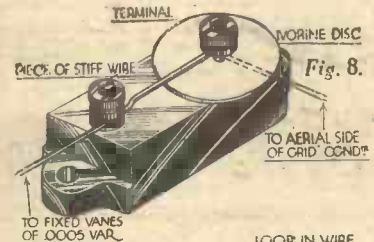

Fig. 8.

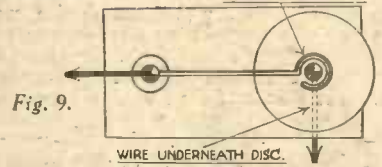

Fig. 9.

A simple condenser shorting device.

of the coil is often a very delicate and troublesome business. This can be remedied to a great extent by the inclusion of a .0005 mfd. fixed condenser in series with the variable condenser, thus halving the capacity to .00025 mfd. Of course, this condenser must be shorted when reverting to the medium and long waves or the tuning ranges would be restricted. The following arrangement will be found very convenient for this purpose, and as can be seen from Fig. 8, is quite simple. The parts required are: an ivorine disc (an old terminal indicator), about 2ins. of bare No. 18 gauge wire, and of course a .0005 mfd. fixed condenser. First, make a small loop at one end of the wire just sufficient to clear the terminal shank of the fixed condenser, and at the other end make a larger loop so that the terminal shank does not touch the loop. (See Fig. 9.) Then disconnect the wire that goes from the grid condenser to the variable condenser and take it to one side of the .0005 mfd. fixed condenser. On the same terminal place the ivorine disc. From the other terminal of the fixed condenser take a wire to the fixed vanes of the variable condenser and place the smaller loop on, and tighten. Put the large loop over the other terminal shank so that it rests on the disc but does not touch the shank. On replacing the terminal head and screwing down, the condenser is shorted and is then suitable for the medium and long waves. On unscrewing it, the capacity becomes .00025 for short-wave use.—J. IRWIN (Blackburn).

**A Correction**

**O**N our Wrinkles page in the August 19th issue, under the heading A Handy Tester, we published a wrinkle by J. G. Simpson, of Durham, for which the wrong illustration was inadvertently used. The correct illustration is given below.

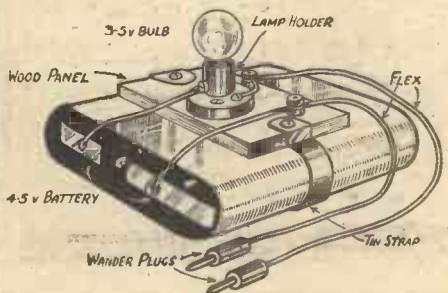

A handy tester.



# Home-built radio that gets EUROPE-AMERICA-AUSTRALIA - all on the same set!

**ULTRA SHORT**

**SHORT**

**MEDIUM**

**LONG WAVES**

At last the day of All-World Radio has arrived, and you can build with your own hands the first receiver to give you not only England and Europe, but America and Australia direct. The Lissen All-Wave All-World "Skyscraper" 4 tunes from 12 to 2100 metres. It brings two complete new wavelength ranges within reach of the ordinary listener—stations and programmes which before he was never able to receive—Ultra Short and Short-Wave transmissions from the ends of the earth. And remember you get these stations through Double-Balanced Pentode Output giving brilliant reproduction on a Moving-Coil Speaker—as much power as a Mains Set from ordinary high-tension batteries.

**FOUR WAVELENGTH RANGES INSTEAD OF TWO!**



**COMPLETE WITH FOUR VALVES £5.12.6**

**DOUBLED BALANCED PENTODE OUTPUT AND MOVING COIL LOUDSPEAKER**

The output stage of the All-Wave All-World "Skyscraper" 4 is Quiescent Push-Pull output at its best, incorporating TWO BALANCED LISSEN POWER PENTODE VALVES and giving you brilliant reproduction on a Moving-Coil Speaker. You get mains volume from this set, yet it works from ordinary high-tension batteries and is an economical set to run.

WITH WALNUT CABINET and MOVING COIL LOUDSPEAKER

**£8.2.6**



**POST COUPON for FREE CHART**



To LISSEN LTD., Publicity Dept., ISLEWORTH.

Please send me FREE copy of All-Wave All-World "Skyscraper" Chart.

Name .....

Address .....



OUR SHORT-WAVE SECTION

# THE PENTODE SHORT-WAVE DETECTOR

By K. E. BRIAN JAY.

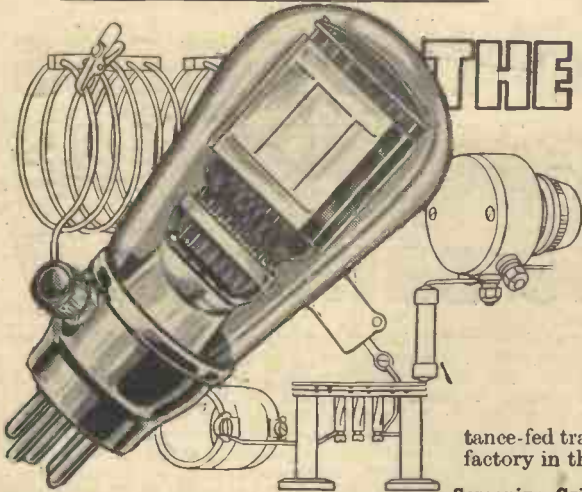

THE introduction of the new high-frequency pentodes has done much to remove the idea that the pentode is solely an L.F. output valve, and it is almost certain that in a very short time H.F. pentodes will have ousted screen-grid valves from receivers altogether, as they have done already in the U.S.A., for there is practically nothing that a screen-grid valve can do that a properly designed pentode cannot do as well or better. This applies as much to detectors in short-wave receivers as to anything else, and these notes are intended to help experimentally-inclined readers to try out the pentode in the detector socket of their short-wave sets. At present there are no battery-operated, high-frequency pentodes available, although no doubt they will appear soon, but excellent results were obtained with the ordinary low-frequency power type. The chief advantage of the pentode over the screen-grid valve is that owing to its lower internal resistance it does not need such a high impedance load for maximum voltage output; also, the removal of the negative resistance kink in the characteristic curve, by the introduction of the third grid, makes larger voltage swings possible, and the potential of the screening grid of the pentode is not as critical as in the tetrode. The circuit arrangement found most satisfactory is shown in the accompanying illustration, and is practically identical with that used with a tetrode detector; throttle control of reaction is indicated, although the more usual modified Reinartz arrangement can be used; in either case the capacity of C2 can be about .0002 mfd. Screening-grid voltage is supplied by a potentiometer of 50,000 ohms resistance, in series with another 50,000 ohm fixed resistance, the variable contact on the potentiometer being by-passed by a fixed condenser C3, whose capacity may be between .01 and 1 mfd.; C3 should be a mica component for preference, although a non-inductive paper condenser would probably be satisfactory. The detector plate circuit is decoupled by the resistance R6 and condenser C5, whose respective values are 10,000 ohms and 2 mfd. Coupling to the L.F. valve is by an auto-transformer, resistance fed by the 50,000 ohm resistance R5. Choke feed can be tried and may be successful with some valves, but the writer found that it is very conducive to threshold howl. With either feed system, or, if simple resistance or choke coupling is used, the coupling condenser C4 can be about .01 mfd. or more. One of the complete coupling units containing a resis-

tance-fed transformer would be very satisfactory in this position.

### Screening Grid Voltage

Although the pentode does not seem to be quite as fussy about its screening-grid voltage as the tetrode, none the less it is desirable to have a means of close adjustment of this potential, hence the provision of R3; it will be found that the voltage should be quite small, about 30 to 40 volts with 135 volts H.T., as otherwise reaction will be very harsh indeed and the tendency to threshold howl accentuated; also, keeping the screen volts low will reduce the plate current taken by the valve and hence prolong the life of the H.T. battery. Too low a screen voltage is undesirable, however, both with screen-grid valves and pentodes, because the amplification may be considerably reduced and it is worth while varying the size of the reaction coil until a combination is obtained, which gives the smoothest control with maximum screen volts. If, in making the initial adjustment, the screen voltage is too high the set will sound dead, as though it was not oscillating, whereas, actually, it is oscillating much too strongly, as can be verified by putting a moistened finger on the aerial terminal and noting the sharp double click on touching it and again on letting it go.

### Reaction Control

Two methods of reaction control are available with the circuit given, viz., by variation of the capacity of the reaction condenser in the usual way, and by variation of the screen-grid potential. This latter method is particularly popular in America, but while offering very smooth control it suffers from the disadvantage that one cannot be sure of working at the

optimum screen-grid potential, since the setting of R3 to give maximum signal strength will not necessarily coincide with that for no oscillation. A third control of reaction is possible by making the decoupling resistance R6 a 50,000 ohm variable component; from the point of smoothness and absence of detuning effect this is probably the best method, but it was found difficult to obtain controllable reaction over a wide range of wavelengths with a single reaction coil. It could be used with advantage as an auxiliary source of control to C2 over fairly small bands of wavelengths.

Any ordinary short-wave coil unit can be used, the value of C1 depending on the recommendation of the manufacturers. In the interests of easy tuning it should be as small as possible, of course, and, as usual, the writer prefers the band-spread system, using a small .00005 mfd. condenser C1a in parallel with C1, in the manner previously described in these pages.

The pentode oscillates very easily, but the low-frequency type has a high grid filament input capacity, consequently, the minimum wavelength of a given tuning coil will be somewhat increased and the valve might be a little unsatisfactory on very short waves, around 10 metres. Doubtless a special high-frequency pentode would be free from this fault. No marked increase in signal strength over the screen-grid detector has been noticed when using a pentode, but it does seem to be less critical in its adjustments and to that extent worth while.

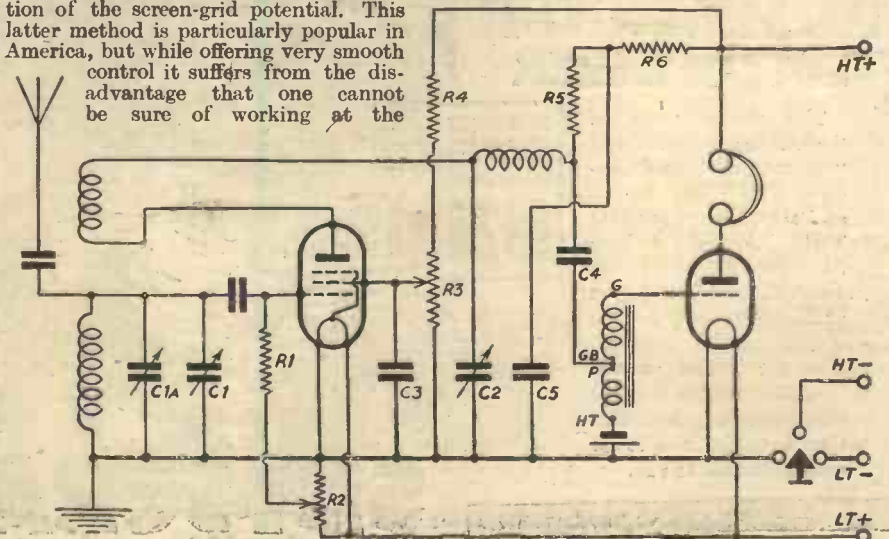

A two-valve circuit using an H.F. pentode as detector.



# Telsen

## MAINS UNITS

### cover every requirement



#### TELSEN H.T. UNIT AND L.T. CHARGER FOR A.C. MAINS.

For input voltages between 200 and 250 at 40 to 100 cycles. H.T. output is 28 m.a. at 150 volts, with separate Max., Det. and S.G.appings, at each of which a choice of high, medium or low voltages is available. Very generous smoothing equipment eliminates hum. Charges 2, 4 or 6 volt accumulators at 0.5 ampere, the use of these facilities leading to such a saving of charging costs that the unit soon pays for itself. Very solidly built, and completely screened by an artistically finished metal case.

**97/6**

#### TELSEN H.T. AND L.T. UNIT FOR A.C. MAINS.

Similar to the "H.T. unit and L.T. charger" but, as it is intended to provide complete power for receivers employing A.C. valves, the L.T. charger is replaced by a centre tapped transformer winding capable of supplying 2.5 amps. at 4 volts. Very well made in every respect and completely screened by its artistically finished metal case.

**67/6**

THE new Telsen Mains Units are the outcome of long research and experiment by some of the finest radio engineers in the country. No effort has been spared to achieve their perfection, every conceivable refinement being embodied in their up-to-the-minute design. Switch over to Telsen now—and rid yourself for good of the distortion and L.F. oscillation which accompany run-down batteries, and the constant expense incurred in their replacement.



#### TELSEN H.T. UNIT FOR D.C. MAINS.

For D.C. inputs of from 200 to 250 volts. Adequate smoothing is provided to remove ripple. Output is approximately 28 m.a. at 150 volts. Max., S.G. and Det.appings are provided, at each of which a choice of high, medium or low voltages is available. Enclosed in a well-finished metal case which provides complete screening.

**35/-**

**TELSEN FOR EVERYTHING IN RADIO**

ANNOUNCEMENT OF THE TELSEN ELECTRIC CO., LTD., ASTON, BIRMINGHAM



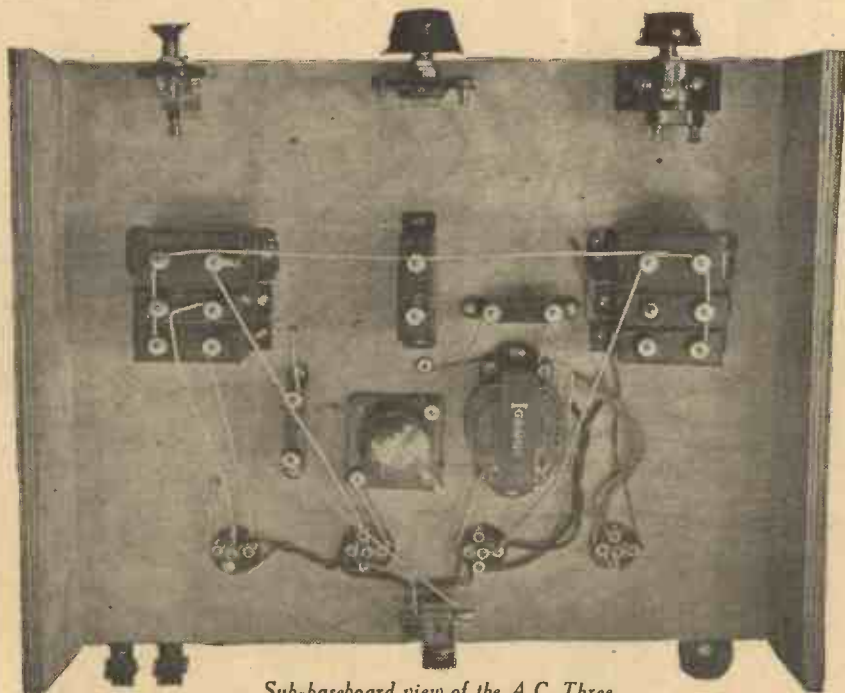

*Sub-baseboard view of the A.C. Three.*

IT might seem somewhat contrary to the policy of PRACTICAL WIRELESS to introduce yet another new receiver so soon after the three sets described in the "Show" numbers, but there is a very good reason for our describing the "Modern A.C. Three." Whilst we were at Olympia we had the pleasant opportunity of meeting a very large number of our readers, and by so doing to learn just what their views were, and what kind of receivers they would like to build. And despite the enormous amount of interest and enthusiasm shown in our latest battery receivers we discovered that many readers were desirous of changing over to all-electric instruments. We therefore made detailed inquiries in order to learn exactly what type of set in the A.C. class would prove of interest to the majority. It was at once clear that careful consideration must be given to the price question, whilst at the same time all the most important and reliable modern improvements must be incorporated. Immediately after the Exhibition, then, we set to work to design a set which would fulfil the requirements mentioned above, in order that we might maintain the high reputation for which PRACTICAL WIRELESS is now noted of giving Real Reader Service. After carefully surveying the problem and carrying out a number of experiments another PRACTICAL WIRELESS *guaranteed* receiver was evolved.

#### High Selectivity and Power Output

It will be of interest briefly to describe the system which was followed in combining the requirements and ideas of our readers to produce a thoroughly efficient and likeable receiver which will give really good reproduction from a number of stations. The set had to be eminently up to date, which means that it must be ultra-selective and capable of providing an undistorted output of not less than two watts. Tuning must be easy and of the "single-knob" variety; a real pre-detector volume control must be incorporated to prevent any possi-

bility of overloading when receiving local stations; there must be provision for connecting a gramophone pick-up and, above all the set must be perfectly safe electrically. Furthermore, the construction must be on easy and straightforward lines.

It was evident that a three-valve circuit, consisting of variable- $\mu$  S.G., detector and pentode stages would be most suitable, so this was decided upon. To ensure ample selectivity for all purposes meant that either a band-pass input circuit or iron core coils must be used. Since the latter are both more efficient and cheaper there was no hesitation in adopting them, and it only remained to find two of a type that would most suit the requirements of a provisional circuit which had been drawn up. Telsen type W. 349 were decided upon because they are of the double-wound pattern and can be used as high-frequency transformers to give an extraordinarily high degree of selectivity. By using transformer coupling between the variable- $\mu$  and detector valves the usual coupling choke is not required and thus expense is saved, despite the fact that a slightly greater degree of efficiency is at the same time secured. To facilitate the connection of a gramophone pick-up a plug and jack connector was employed, so that when gramophone reproduction is required it is only necessary to insert the plug (to which the pick-up leads have been connected) into the jack. This simple process automatically breaks the lead between the grid and grid condenser of the detector valve and connects the pick-up in place of the tuning circuit. Due to the method of wiring up the grid leak and a voltage dropping resistance a suitable bias voltage is also applied to the detector to make it function as a most efficient amplifier.

#### Good Bass Response

So as to improve bass response the detector valve is coupled to the AC/Pen. output valve through a resistance-fed transformer.



# THE A.C. THREE

A Really Efficient and Economical All-Mains Receiver for the Home Constructor. It Has Iron Core Tuning Coils, a Variable-Mu H.F. Valve and Numerous Other Modern Refinements. By THE TECHNICAL STAFF.

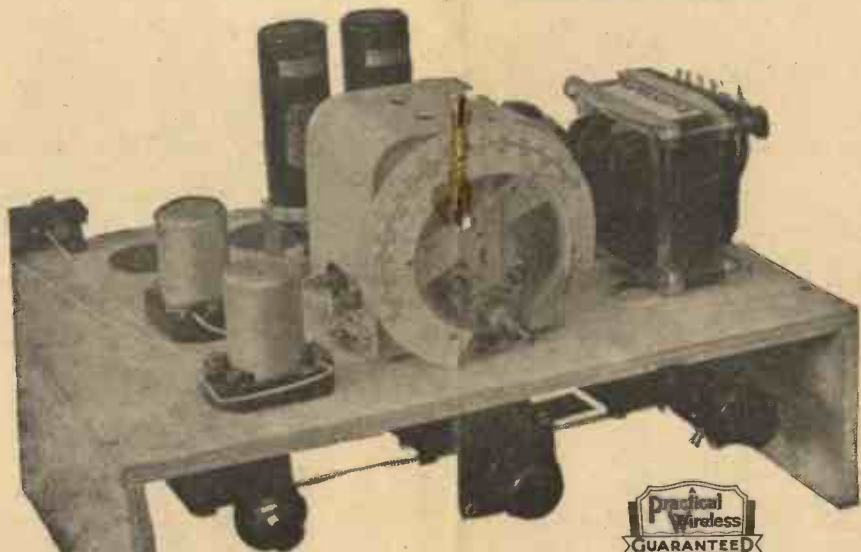

Front view of the A.C. Three. Note the compact lay-out and the simplicity of wiring.

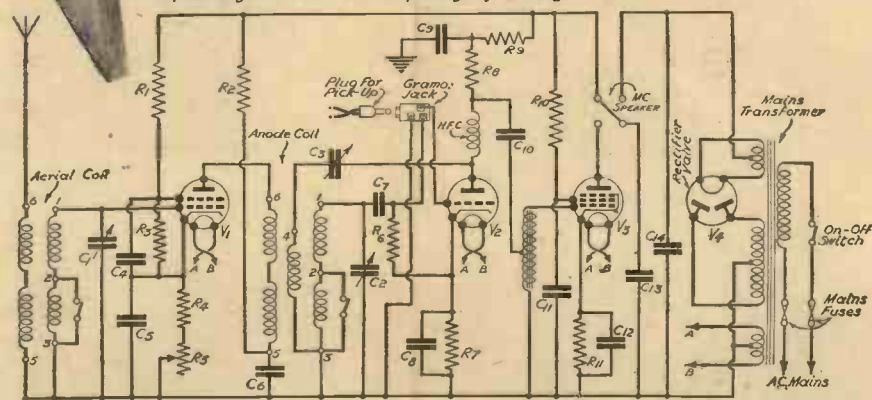

Theoretical Circuit of the A.C. Three.

C1, C2—.0005 mfd. ganged. C3—.00015 mfd. C4, C5, C6, C9, C11—1 mfd. C7—.0002 mfd. C8, C12—2 mfd. C10—.05 mfd. R1, R8—30,000 ohms. R3, R9—20,000 ohms. R2, R10—5,000 ohms. R4—150 ohms. R6—2 megohms. R7—400 ohms. R11—300 ohms. R5—15,000 ohms graded potentiometer.

## LIST OF COMPONENTS FOR THE A.C. THREE.

Two Telsen Iron-core Tuning Coils, type W.349.  
 One Polar Uni-knob .0005 mfd. Twin Gang Condenser.  
 One Graham Farish "Litlos" .00015 mfd. Reaction Condenser.  
 One Bulgin 15,000 ohm Volume Control with Switch, type G.S.15.  
 One British Radiogram Mains Transformer, type 55.  
 One Igranic Jack, type No. 72.  
 One Igranic Plug, type No. 40.  
 One Bulgin Mains Connector with Fuses, type F.15.  
 One Igranic L.F. Transformer, type T.24.B.  
 Four Clix 5-pin Chassis Mounting Valve Holders, Standad type.  
 One British Radiogram 2-point Switch, type No. 48.  
 Four British Radiogram Component Brackets, type 21.  
 One Graham Farish H.F. Choke, type H.M.S.

Two Telsen 4 mfd. Electrolytic Condensers with Brackets.  
 Five T.C.C. 1 mfd. Condensers, type 80.  
 Two T.C.C. 2 mfd. Condensers, type 80.  
 One T.C.C. .0002 mfd. Condenser, type 34.  
 One T.C.C. .05 mfd. Condenser, type 40.  
 One Graham Farish 2 megohm Grid Leak.  
 Nine Graham Farish "Ohmite" Resistances; two each 5,000, 20,000 and 30,000 ohms; one each 150, 300 and 400 ohms.  
 One Belling Lee Terminal Mount.  
 Two Belling Lee Terminals, marked "A" and "B," type B.  
 One Peto Scott "A.C. Three" Cabinet, and Metaplex Chassis.  
 One Celestion Energized Speaker with 1,500 ohm field, type B.8.  
 Two Coils Glazite, length screening braid, flex, screws, etc.  
 One Mazda AC-SG VM Valve.  
 One Mazda AC-2HL Valve.  
 One Mazda AC-PEN Valve.  
 One Mazda UU.2 Rectifying Valve.

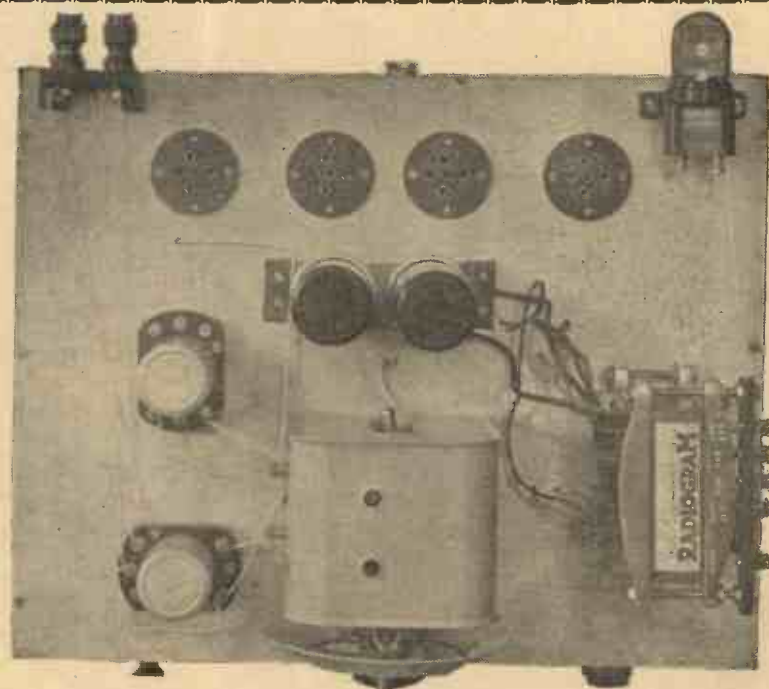

Plan view of the A.C. Three. The wiring is part completed.

This transformer is of a type rated at 3:1 ratio, but by connecting it on the auto-transformer principle (both windings being in series) an actual voltage step-up of 4:1 is obtained, and this ratio has been found to be just sufficient to enable the pentode to be fully loaded on signals of average strength. Thus, the output valve is able to operate under conditions of maximum efficiency and so to give an undistorted signal output of approximately two watts.

### Novel System of Smoothing

It need scarcely be mentioned that every stage is thoroughly decoupled to ensure that the set shall be perfectly stable and free from all kinds of motor-boating and similar noises which are often very objectionable in a mains receiver.

Once the main features of the receiver proper had been decided upon the question of the power supply unit came up for consideration. With a view to economy it was decided to employ a valve rectifier, and that chosen is rated to give 220 volts at 60 milliamps when fed from a centre tapped transformer supplying 250 volts on each side of the tapping. As the current consumption of the three valves chosen, plus that of the potentiometer used to supply the screening grid voltage, is rather less than 35 milliamps, the rectifying valve is not fully loaded and the unsmoothed output therefore attains a voltage of about 260. Allowing 200 volts high tension there is a "surplus" of some 60 volts to be "dropped" in the smoothing system and across the automatic bias resistance of the pentode. In order to save the expense of a smoothing choke a loud speaker of the energized type was chosen, and the field winding of this was employed for smoothing purposes. Incidentally, it might be pointed out that this type of speaker is actually cheaper than a permanent magnet one of similar sensitivity, and thus the saving is two-fold. The Celestion speaker employed has a field resistance of 1,500 ohms and the inductance of the winding is slightly over 60 henries when passing a current of 35 milliamps. Thus the speaker gives better smoothing than the average type of choke and only produces a voltage drop of about 50. It is also interesting to observe that the field strength of the magnet under the

conditions of use does not fall far short of 6,000 lines, and this compares very favourably with the corresponding figure for good speakers of the permanent magnet kind.

In order that the smoothing should be as complete as possible a dry electrolytic condenser was connected from each side of the field coil (serving as smoothing choke) to H.T. negative.

### High Quality—Low Cost

After working out the design in the manner outlined, and after the set had been tested and every point checked, the total cost was calculated. For the complete receiver, including mains unit and speaker, the price was found to be approximately £8 15s.; to this must be added the price of the cabinet and valves, so that the inclusive figure comes out at rather less than thirteen pounds. It can be seen from these prices that the cost of the set is distinctly reasonable, especially when the many up-to-date features and the high quality of the parts employed are taken into consideration. It might have been possible to cut down the cost still further, but only at the expense of quality, and we feel sure that such a procedure would not have been welcomed by our readers.

### Metallized Chassis for Easy Construction

Although it is not possible to give all constructional details in this issue, because of space limitations, it will be of interest to mention the form of construction employed. The complete instrument, comprising both receiver and power supply unit, is built on a Peto-Scott "Metaplex" (metallized wood) chassis which can be obtained completely assembled and drilled. To facilitate the construction and to enable the set to be easily fitted into the cabinet there is no panel, the controls being mounted on small angle brackets which are screwed to the front edge of the baseboard. At the rear of the chassis there is a two-point mains

(Continued overleaf)



THE A.C. THREE

(Continued from previous page)

plug fitted with twin fuses and this is of moulded bakelite so that it would be impossible to receive a shock whilst making the mains connections, and any wrong wiring in the set could do no more than cause one of the fuses to "blow."

The controls are four in number and comprise a knob for the two gang tuning condenser, a wavechange switch, reaction condenser and combined variable- $\mu$  volume control and on-off switch.

Look out for full constructional details next week; in the meantime you can order the necessary components of which a complete list is given on the preceding page.

Instability with Class "B."

A DIFFICULTY which is occasionally experienced with a class "B" output stage is that there is a certain amount of parasitic oscillation due to slight variations in the class "B" valve, or to other causes.

A satisfactory cure can nearly always be effected by connecting a condenser of about .005 mfd. across each half of the primary winding of the output transformer. The condensers also have a tendency to reduce the high-note emphasis which is always produced by class "B" valves, but they are not usually quite sufficient in themselves for this purpose.

Another point to watch in a class "B" set is that there should be no leakage of H.F. current from the detector anode circuit into the amplifier, because this is liable to be magnified and to cause serious low-frequency instability and distortion.

He Never Switched Off!

A GOOD French story was recently published in one of the Paris "dailies." It concerns a forty-year-old citizen who, wishing to secure an annuity policy from an Insurance Company, consulted his doctor as to the means to be adopted to live to the ripe old age of four-score-and-ten.

TOP AND SUB-BASEBOARD WIRING OF THE A.C. THREE

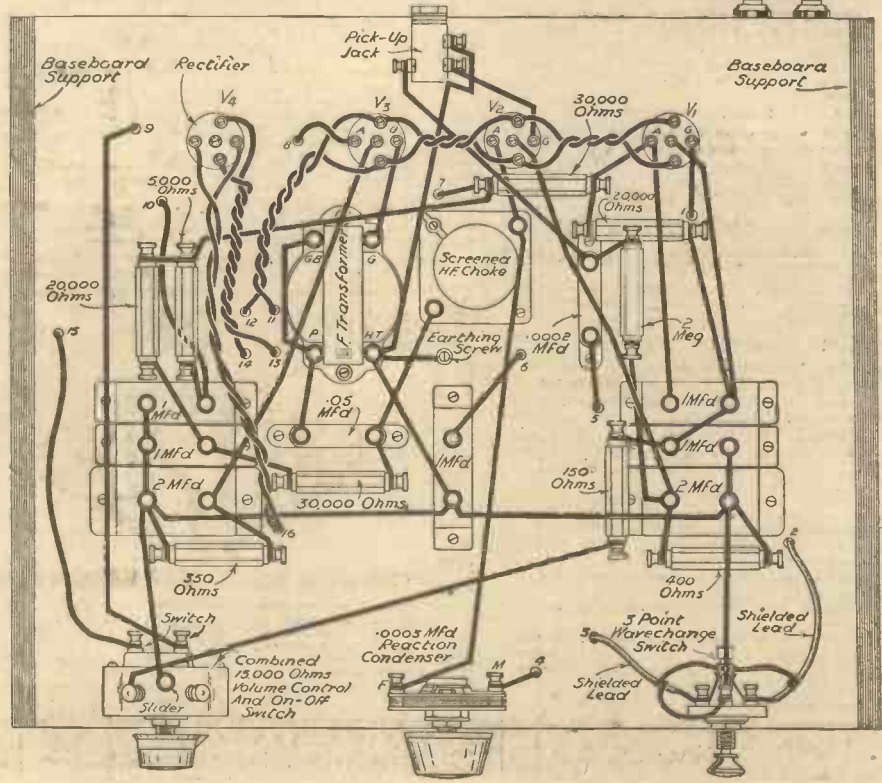
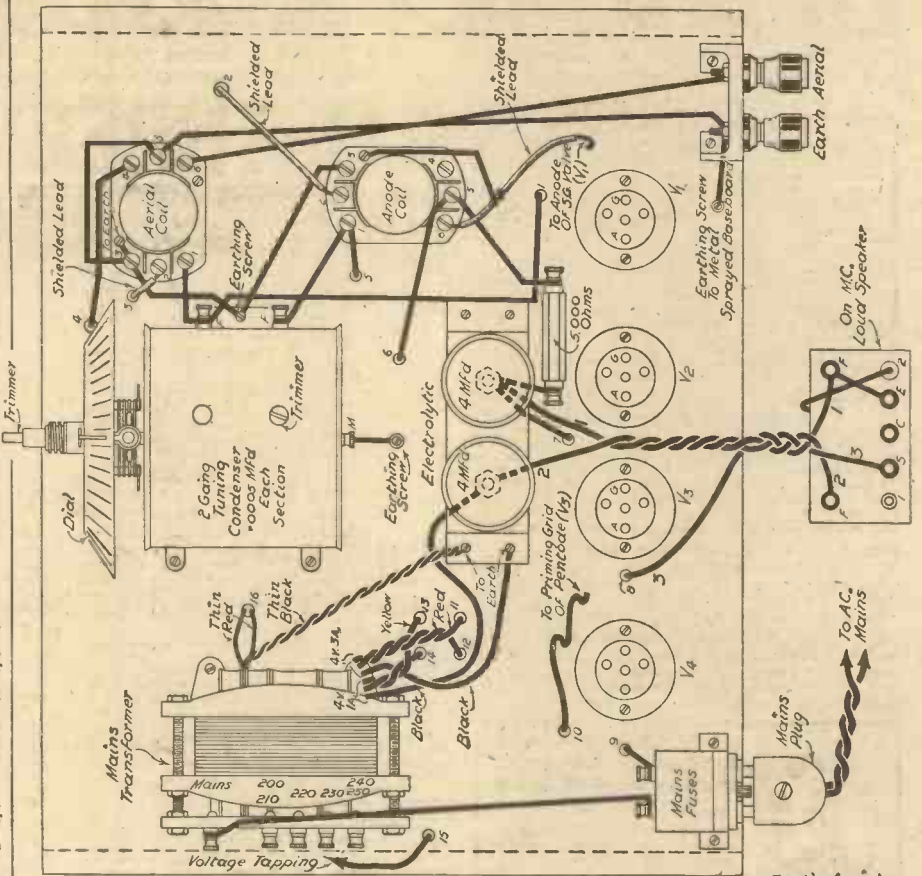



# PETO-SCOTT

## EVERYTHING RADIO - CASH C.O.D. or EASY TERMS

FIRST WITH RADIO ON EASY TERMS, we can supply you with all the leading manufacturers' products. Largest stocks in the Country. Send us a list of your requirements for quotation by return. Parcel of parts or accessories over £2 for small first payment. Strict Privacy Guaranteed.

### TELSEN RADIO

**TELSEN CLASS "B" 4 CHASSIS KIT** in Sealed Carton, less Valves, Cabinet and Speaker. Cash or C.O.D. Carriage Paid, £21/7/6. Balance in 11 monthly payments of 7/-.

**TELSEN CLASS "B" 4 CONSOLE KIT**, including Telsen Class "B" Moving-coil Speaker and Console Cabinet, less Valves. Cash or C.O.D. Carriage Paid, £25/17/6.

Balance in 11 monthly payments of 10/9.

**TELSEN SUPER-SELECTIVE SIX CHASSIS KIT**, excluding Valves, Cabinet and Speaker. Cash or C.O.D. Carriage Paid, £5/18/6.

Balance in 11 monthly payments of 10/9.

**TELSEN 325 STAR KIT**, less Valves and Cabinet. Cash or C.O.D. Carriage Paid, £1/19/6.

Balance in 7 monthly payments of 5/3.

**TELSEN H.T. AND L.T. A.C. MAINS UNIT W.346 H.T. Portion**: Max. Det. and S.G. tapping each adjustable for High, Med. or Low voltages. Maximum 28 m/a at 130 v. L.T. trickle charger, 2, 4 or 6 volts at 1 amp. Cash or C.O.D. Carriage Paid, £21/7/6.

Balance in 11 monthly payments of 9/-.

**TELSEN D.C. MAINS H.T. UNIT W.348**, with 3 tappings, each adjustable for High, Med., and Low voltages. Output, 28 m/a at 150 volts. Cash or C.O.D. Carriage Paid, £1/19/6.

Balance in 6 monthly payments of 5/6.

Send 7/- only  
Send 10/9 only  
Send 10/9 only  
Send 5/3 only  
Send 9/- only  
Send 5/6 only

**NEW R. & A. "ALPHA" P.M. MOVING-COIL SPEAKER DE-LUXE**, with tapped input transformer. Cash or C.O.D. Carriage Paid, £2/12/6.

Balance in 8 monthly payments of 6/6.

Send 6/6 only

**NEW BLUE SPOT 99P.M. PERMANENT MAGNET MOVING-COIL SPEAKER**. Complete with tapped input transformer. Cash or C.O.D. Carriage Paid, £2/19/6.

Balance in 11 monthly payments of 5/6.

Send 5/6 only



### NEW W.B. P.M. 4.A. MICROLODE PERMANENT MAGNET SPEAKER

complete with switch controlled multi-ratio input transformer. Cash or C.O.D. Carriage Paid, £2/12/0.

Balance in 7 monthly payments of 5/9.

Send 5/9 only

**EPOCH MODEL 20C, 20CB and 20CC PERMANENT MAGNET MOVING-COIL SPEAKER** for ordinary power. Class B and Q.P.P. respectively, complete with input transformers. Cash or C.O.D. Carriage Paid, £1/15/0.

Balance in 6 monthly payments of 5/6.

With 5/6 order

**NEW BLUE SPOT PERMANENT MAGNET MOVING-COIL SPEAKER 29 P.M.** With input transformer. Cash or C.O.D. Carriage Paid, £1/12/6.

Balance in 6 monthly payments of 5/-.

Send 5/- only

### ROLA P.M. MOVING-COIL SPEAKERS

**F.R.6. P.M.** Complete with input transformer. Cash or C.O.D. Carriage Paid, £1/19/6.

Balance in 7 monthly payments of 5/3.

Send 5/3 only

**F.6. P.M.** Complete with input transformer. Cash or C.O.D. Carriage Paid, £2/9/6.

Balance in 8 monthly payments of 6/-.

Send 6/- only

**IGRANIC D.9 PERMANENT MAGNET MOVING-COIL SPEAKER**. Complete with Dual Transformer. Cash or C.O.D. Carriage Paid, £1/9/6.

Balance in 5 monthly payments of 5/3.

Send 5/3 only

**HEAYBERD D120 ELIMINATOR for A.C. Mains**. 120 volt 18 m/a and 2 volt .25 amp trickle charger, tappings 40/110 var. S.G. 100 volt and 120 volt fixed. Cash or C.O.D. Carriage Paid, £4/5/0.

Balance in 11 monthly payments of 7/9.

Send 7/9 only

**NEW ATLAS ELIMINATOR G.A. 25 for A.C. Mains, Class "B" and Q.P.P.** Four Tappings, 80/80; 50/90, 120; 150, 25 m.a. Cash or C.O.D. Carriage Paid, £2/19/6.

Balance in 11 monthly payments of 5/6.

Send 5/6 only

## A.C. THREE PILOT AUTHOR KITS

**KIT "A"** Author's Kit of First Specified parts, including Peto-Scott "Metaplex" chassis (less valves, speaker and cabinet). **YOURS FOR 13/-**

CASH or C.O.D. Carriage Paid. Balance in 11 payments of 13/-

£7 : 0 : 0

**KIT "B"** As Kit "A," including valves but less speaker and cabinet. CASH or C.O.D. Carriage Paid. £10 : 2 : 0

or 12 monthly payments of 19/3.

**KIT "C"** As Kit "A," including Ready Assembled Metaplex Chassis and Baffle Board, valves and cabinet, less speaker. CASH or C.O.D. Carriage Paid. £11 : 10 : 6

or 12 monthly payments of 21/-.

**CELESTION E.8** Moving-Coil Speaker. Field Energised. Cash or C.O.D. Carriage Paid 35/-, or 7 monthly payments of 5/6.

### THESE ARE THE PARTS THE AUTHOR USED

- 2 Telsen Iron Core Tuning Coils . . . . . 17 0
  - 1 Polar Uniknob Condenser .0005 mfd. 2 gang with Rotating Scale . . . . . 18 6
  - 1 Graham Farish Little .00015 mfd. Condenser . . . . . 2 0
  - 1 Bulgin 15,000 ohm Volume Control and Switch. G.8.15. . . . . 5 3
  - 1 British Radiogram Mains Transformer, Type 35 . . . . . 1 0
  - 1 Igranic Jack, Type 72 . . . . . 1 6
  - 1 Igranic Plug, Type 49 . . . . . 1 3
  - 1 Bulgin Mains Connector and Fuse, Type F.15 . . . . . 3 0
  - 1 Igranic, Type T.24, L.F. Transformer, ratio 1:1 . . . . . 5 6
  - 4 Clix 5-pin sub-baseboard valve holders . . . . . 3 0
  - 1 British Radiogram 3-point Switch, Type 48 . . . . . 1 3
  - 1 Graham Farish H.F. Choke, Type H.M.S. . . . . 2 6
  - 2 Telsen 4 mfd. 500 volt working Electrolytic . . . . . 9 0
  - 5 T.C.C. 1 mfd. Fixed Condensers, Type 80 . . . . . 15 0
  - 2 T.C.C. 3 mfd. Condensers, Type 80 . . . . . 8 0
  - 1 T.C.C. .002 mfd. Condenser, Type 34 . . . . . 1 3
  - 1 T.C.C. .05 mfd. Condenser, Type 40 . . . . . 1 9
  - 1 Graham Farish 4 meg. grid leak . . . . . 1 6
  - 3 Graham Farish "Obmittes" (150, 300, 400, and 2 each, 5,000, 20,000 and 30,000 ohms) . . . . . 13 6
  - 1 Belling-Lee Terminal Mount . . . . . 6
  - 2 Belling-Lee B. Terminals (A. & E.) . . . . . 1 0
  - 1 Peto-Scott Metaplex Chassis to Specification, 16 x 12 x 4 1/2 . . . . . 3 9
  - Wire, Screws, Flex, etc. . . . . 3 0
- Kit "A" Cash or C.O.D. £7 0 0

**A.C. THREE H.P. PARCEL** Consists of B.R.G. Mains Transformer, 2 Telsen Iron Core Coils and 1 Polar .0005 mfd Two Gang Condenser, B.R.G. Switch, Type 48, and Metaplex Chassis. Cash or C.O.D. Carriage Paid, £3/17/6.

Balance in 12 monthly payments of 5/9.

Send 5/9 only

**EXCLUSIVELY SPECIFIED PETO-SCOTT A.C.3 WALNUT CABINET 25/-** Cash or C.O.D. Carr. Paid. Internal Dimensions: 15" x 12" x 17" high. Baffleboard and Baseboard Assembly, 3/6 extra.

SEND FOR 1934 CABINET CATALOGUE

## BUILD ON



### THE NEW METALISED BASEBOARD

Specified by all the leading experts. Automatic screening, prevents pick-up, cuts out interference, easily soldered, non-tarnishing, easily drilled with simple woodworking tools.

14" x 10" 16" x 10" 18" x 10"

1/9 2/- 2/3

In Sealed Envelope.

### LISSEN KITS

**7-VALVE SUPER-HET** Complete with Lissen Valves in Sealed Carton. Cash or C.O.D. Carriage Paid, £8/17/6. Balance in 11 monthly payments of 16/6.

**LISSEN 7 VALVE SUPER-HET TABLE CABINET MODEL**, complete with valves. Cash or C.O.D. Carriage Paid, £9/15/0. Balance in 11 monthly payments of 17/6.

**LISSEN 7 VALVE SUPER-HET CONSOLE LETTE MODEL**, complete with valves, console cabinet, and Permanent Magnet Moving-Coil Speaker. Cash or C.O.D. Carriage Paid, £11/10/0.

Balance in 11 monthly payments of 21/-.

**NEW LISSEN SKYSCRAPER FOUR ALL-WAVE CHASSIS MODEL**, complete kit comprising all components, including set of Lissen Valves. Cash or C.O.D. Carriage Paid, £5/12/6.

Balance in 11 monthly payments of 10/3.

**NEW LISSEN SKYSCRAPER FOUR ALL-WAVE CONSOLE TABLE MODEL**, complete kit, comprising all components, including set of Lissen Valves, Cabinet and Moving-coil Speaker. Cash or C.O.D. Carriage Paid, £8/2/6.

Balance in 11 monthly payments of 15/-.

**LISSEN ALL-ELECTRIC SKYSCRAPER 3**. Complete with 4 valves and constructional chart in sealed Lissen carton. Cash or C.O.D. Carriage Paid, £2/19/6.

Balance in 11 monthly payments of 14/8.

**LISSEN SKYSCRAPER 3, BATTERY MODEL**. Complete with valves and constructional chart in sealed Lissen carton. Cash or C.O.D. Carriage Paid, £4/9/6.

Balance in 11 monthly payments of 8/3.

YOURS FOR 15/-  
Send 17/6 only  
Send 21/- only  
Send 10/3 only  
Send 15/- only  
Send 14/8 only  
Send 8/3 only

**NEW FERRANTI "CLASS B" SUPER POWER CONVERTOR**. Instantly converts your present set to "Class B." Complete with valve. Ready assembled. Cash or C.O.D. Carriage Paid, £3/3/0.

Balance in 11 monthly payments of 5/9.

Send 5/9 only

**NEW B.T.H. SENIOR DE LUXE PICK-UP AND TONE-ARM**. Cash or C.O.D. Carriage Paid, £2/2/0.

Balance in 7 monthly payments of 5/9.

Send 5/9 only

**NEW GARRARD MODEL 202A**. 12-in. Turntable. Electric Motor for A.C. mains. Cash or C.O.D. Carriage Paid, £2/10/0.

Balance in 8 monthly payments of 6/-.

Send 6/- only

**NEW EXIDE H.T. ACCUMULATOR, 120 VOLTS, W.H.**, in crates, 5,000 m.a. Cash or C.O.D. Carriage Paid, £4/13/-.

Balance in 11 monthly payments of 8/6.

Send 8/6 only

### Pilot Class "B" Conversion Kit

Converts your present Battery Set to "Class B" Amplification. Complete with all necessary components, including driver transformer, "Class B" output choke, W.B. 7-pin valve holder, B.V.A. 240B valve, wire and screws, etc. Full-size Blueprint, assembly instructions and diagrams. Cash or C.O.D., 37/6. Balance in 7 monthly payments of 5/6. ALL "CLASS B" Components and other Parts obtainable from your local dealer SENT C.O.D. We have the largest stocks in the country. Orders over 10/- sent Post Paid. (Easy Terms available on orders over £2.) Quotations by return. No obligation.

Send 5/-

**IMPORTANT. Miscellaneous Components, Parts, Kits, Finished Receivers, or Accessories for Cash, C.O.D. or H.P. on our own system of Easy Payments.** Send us a list of your wants. We will quote you by return. C.O.D. orders value over 10/- sent carriage and post charges paid.

**PETO-SCOTT CO. LTD.** 77, City Rd., London, E.C.1. Telephone: Clerkenwell 9406-7. West End Showrooms: 62 High Holborn, London, W.C.1. Telephone: Holborn 3248.

Dear Sirs,  
Please send me CASH C.O.D. H.P. ....  
for which I enclose £.....  
CASH/H.P./DEPOSIT .....  
NAME .....  
ADDRESS .....  
Fr. W. 9/9/33.

# STRICT PRIVACY GUARANTEED - WE DEAL WITH YOU DIRECT





# Short Cuts in Wiring

The Best Methods of Making the Connection in a Set to Ensure Efficient Working.

By H. J. BARTON CHAPPLE, Wh.Sch., B.Sc., A.M.I.E.E.

AS I sit at my desk writing, I can see on the bench at the other side of the room my latest receiver—a useful hook up with two of the new screened pentodes in the high-frequency stages, pentode output, and power pack complete. I am rather proud of that set; proud of its wonderful performance, that is, and a little bit proud of the layout. But I am most decidedly *not* proud of the wiring.

There is this to be said in extenuation; the set was built in a great hurry because I simply had to try out right away a new idea which had come to me overnight. Then, again, in adjusting the layout for best results much of the internal wiring had to be altered more than once—and that, of course, plays havoc with the stiffest and most carefully bent wires.

Some time in the near future, when I have more leisure, I am going to rewire my new receiver, and I am going to do the job carefully and well, using for every connection just the right kind of wire, running each lead along just the best route, and employing the best and most suitable materials for every section of the wiring. Perhaps you will be interested to know what I shall use, and how I shall go about the job?

## The First Task

Well, in the first place I shall make a clear sketch of the top and underneath portion of the baseboard, marked with the positions of all the components—coils, condensers, valve holders, chokes, transformers and the rest of them, and then I shall sketch in the runs of every wire and connection. This, of course, I shall take from the present "lash up" which, as I have remarked, has been altered several times, and now is about as satisfactory as it is ever likely to be. My drawing will naturally correspond to the blue print or point to point wiring diagram which most home constructors follow when building up a set.

The next step will be to complete the wiring of the filament circuit. As this set is for A.C. mains a good heavy twin metal-braided flex will be used, with the braiding properly connected to earth. Remember, in this connection, that the heater leads have to carry one ampere per valve, and that thin wires not only overheat but cause a voltage drop which may be serious. The earthed metallic braiding is, of course, to avoid risk of inducing hum in other neighbouring leads. It is, I admit, a counsel of perfection, and I have built many a successful and hum-less mains set using thick twin twisted flex without metal screening, but in those cases the routes of the heater wires were carefully selected.

One merit of metal-covered heater leads is that they may be run almost anywhere without much risk of hum.

## Filament Wiring

If the set had been a battery operated one there would not have been the necessity for these precautions—usually the shortest and most convenient route is also the best. For filament wiring in battery sets I prefer No. 16 gauge tinned copper wire—either bought as a roll of bare wire, and with sleeving cut to length for every lead, or one of the many good wires obtainable in convenient coils, and ready insulated. Good insulation of battery wires is a wise precaution, for many a set of valves has been ruined by an accidental contact between H.T. and L.T. due to bare wires sagging and touching each other, or by a loose wire carrying H.T. flicking against the bare filament wiring.

Some constructors like to use different coloured wires for different circuits—red for L.T., blue for high-frequency wiring, yellow for audio-frequency wiring, and so forth. I do not myself, for I think nothing looks nicer than a set neatly wired up with yellow Glazite, but you can suit your own taste in this connection. By the way, if an illuminated dial is incorporated in the set the dial light wiring should be completed with the filament wiring. It is frequently not an easy task to wire up a dial lamp after the whole of the set has been connected up.

Having finished the heater circuit I shall proceed to make every connection which has to be joined to earth. This set is a chassis one, and the chassis itself forms the common earth return. I am not relying

on this entirely, however, because I have found from experience that a multitude of earth connections taken to a metal chassis at times causes all sorts of small currents to flow in the chassis, slight differences of potential existing across different connections, and the magnetic effects of these stray currents are not unlikely to affect the general stability of the set. So although the chassis, screening cans, transformer and condenser cases and the like, are earthed *via* the chassis, I shall run a good stout earth lead from point to point in the set.

## Power Pack and L.F. Side

The next stage will be the wiring of the power pack. Good high insulation rubber-covered and metal-braided flex will be used for the incoming mains, and the connection to the power transformer primary. The rectifier filament connections will be carried out in the same wire as the heater circuit of the receiving portion and the same No. 16 gauge for the H.T. leads. A really good quality insulating sleeving is essential here—avoid cheap or inferior makes. The remainder of the audio-frequency circuit may now be finished off, still using No. 16 wire and always running by the shortest route provided neat right angled bends are made wherever possible, as the finished set looks so much smarter.

At this stage of the proceedings I usually make a preliminary test of the low-frequency portion of the set, and the power pack, with a gramophone record or two. Anything wrong with this section can then be put right without the risk of upsetting

(Continued on page 913)

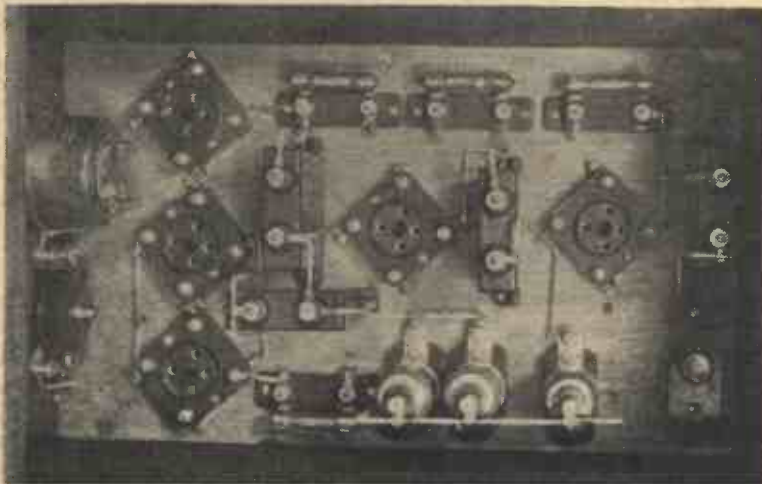

Indicating how careful component positioning shortens the wiring runs.





"Did you notice that Practical Wireless says the 'Microlode' was probably the high spot at Olympia?"

"It certainly is a very far-reaching development in speaker technique!"

**ACCURATE MATCHING AT LAST!**



• 17 transformer ratios for really accurate matching to ANY power valve or pentode and 4 ratios for Class B or QPP **all available on one speaker** by a simple switch adjustment!  
 • Added sensitivity due to the "Mansfield" magnetic system! Better balance through really accurate matching! The difference in performance must be heard to be believed.

**MICROLODE**

(Regd. Trade Mark)

Type PM4a - 42" Type PM6 - 32 1/2"  
**MOVING COIL SPEAKERS**

With the new Microlode feature and the famous "Mansfield" magnetic system.

Write for the MICROLODE Folder

*We are exhibiting at Stand No. 70, Scottish National Radio Exhibition, Glasgow*

Whiteley Electrical Radio Co., Ltd., Dept. D, Radio Works, Mansfield, Notts.

**"PARALLEL FED"**

**TRANSFORMER COUPLING UNIT**

Incorporating a high efficiency 6-1 nickel core transformer, tapped resistance and a fixed non-inductive condenser. This compact unit gives a response hitherto unknown and should be used in all modern designed circuits.

*Technical data and diagrams supplied Free with each.*



**PRICE 10/-**

*From all dealers or direct from the manufacturers:*

**BRITISH GENERAL**

BRITISH GENERAL MANUFACTURING CO., LTD., Brockley Works London, S.E.4.



Mr. L. S. Hargreaves, Managing Director of Aerialite Ltd.

....I have produced **THE FINEST AERIAL**



THE success of Aerialite Aerial Wire last season so convinced me that wireless enthusiasts definitely appreciate every step made in the progress of radio reproduction, that I have now produced a super aerial, LEVENSTRAND, which BETTERS THE BEST. This super aerial has a larger copper surface than any other on the market, which ensures better results than have ever been possible before. Double thickness of the now famous Aerialite covering ensures perfect insulation, and our stupendous offer of £200 FREE LIGHTNING INSURANCE with every coil is your guarantee and safeguard from lightning. LEVENSTRAND is absolutely guaranteed to give better results, more stations and greater volume.

**£200 FREE LIGHTNING INSURANCE**

THERE IS NO STEEL WIRE IN LEVENSTRAND.  
 50 ft. 1/9, 75 ft. 2/6, 100 ft. 3/6.

**PERCOLITE ALL-COPPER EARTH TUBE**

PERCOLITE proves how all important is a good earth. This improved chemical earth gives remarkable results compared with any other. Percolite will definitely improve reception and is the world's best earth by test. Simple to fix, Percolite is the earth that gets right down to it. PRICE 2/6  
**AERIALITE 7-STRAND PURE COPPER AERIAL.** You can still obtain AERIALITE 7-strand Pure Copper Aerial Wire in boxes. Prices: 50 ft. 1/3, 75 ft. 1/10, 100 ft. 2/5. From your dealer or direct from:

**AERIALITE LTD. AERIALITE HOUSE  
 AMBER ST., MANCHESTER**



# Amazing new Radio invention

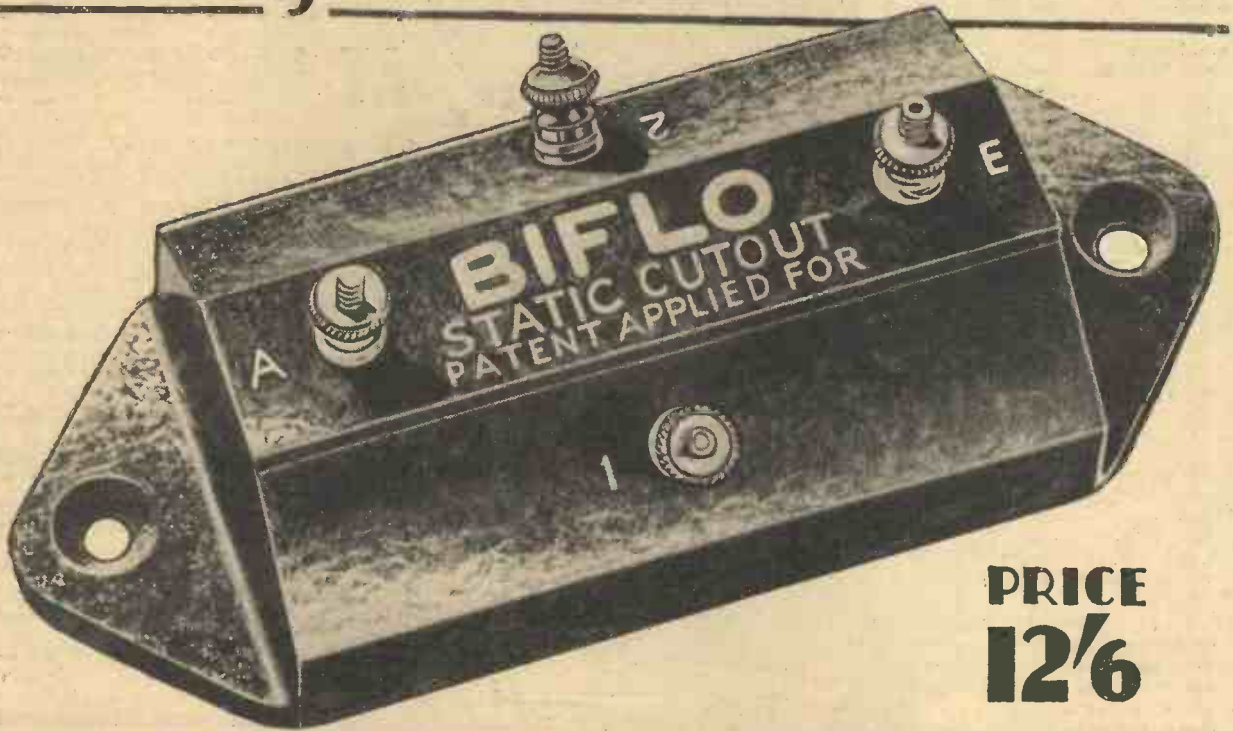

PRICE  
**12/6**

**definitely cuts out electrical inter-  
ference, atmospheric & all unwanted  
noises — money back guarantee**

No more atmospherics!!—electrical interferences!! No more of those hisses and crackles that have interrupted radio programmes in the past.

The "Biflo" Static Cut-out definitely cuts out electrical interference—including ATMOSPHERICS, and the improvement in clarity is amazing.

Every "Biflo" carries a MONEY-BACK GUARANTEE—there can be no greater proof of the genuineness of this instrument. The "Biflo" fits any set and can be quickly and easily fixed without technical knowledge.

The principle on which the "Biflo" is based is admitted by experts to be entirely new. The only article of its kind in the world and BRITISH MADE. Fit a "Biflo" and see for yourself. Price 12/6 from your radio dealer—remember the money-back guarantee! If you would like to know more about "Biflo" SEND THE COUPON in 1/2d. stamped unsealed envelope.

# BIFLO

## STATIC CUT-OUT

OSDUR MANUFACTURING COMPANY,  
26, ADAM ST., LONDON, W.1. Phone: Welbeck 9327.

To the OSDUR MANUFACTURING CO.,  
26, ADAM STREET, LONDON, W.1.

Please send me details of the "Biflo" for which I enclose 1/2d. stamp for postage.

NAME .....

ADDRESS .....

.....DEPT. P



(Continued from page 910)

Carefully spaced radio frequency wiring. Having passed this test, the high-frequency end may be tackled. It is here that the trickiest part of the work occurs. Carefully screened coils and condensers, metallized valves, and precision coils and ganged condensers, avail little or nothing if stray couplings exist between high-frequency circuit.

Widely spaced wires, but always running by the most direct routes possible, are the rule here. Danger points are those at which wires enter screening cans. Be certain that the insulation is intact right up to the terminal head in every case. Also bend each wire so that it is centred accurately in the opening to the can, thus minimizing and equalizing the small capacities to earth.

Grid and anode leads of the high-frequency valve or valves should be kept well apart, and as the wire from the top anode cap of these valves has usually to be a fairly long one, often passing down through the chassis, it is best to screen it.

**Joints**

So much for the wiring itself. Now for a word on the subject of joints. There are two main types of junctions in set wiring—the connection between a wire and a component, and a joint between two wires, and each demands special treatment.

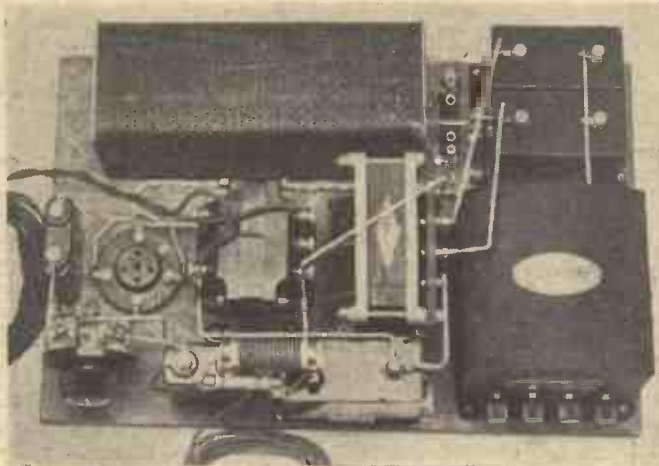

An eliminator and amplifier with the wiring all neatly arranged and completed.

Most components are fitted with screw down terminals, and a connection made in this way is usually quite satisfactory if properly carried out. Make the loop just big enough to slip over the thread of the terminal—too loose a fit will cause it to open out or escape from the securing nut.

If the terminal nut is very small (and unfortunately there are still some manufacturers who will fit 'mean little terminals') slip a washer above and below the wire loop. Similarly, use washers when more than one wire is connected to a terminal and always on those rare occasions when you find it necessary to fix flexible wire under a terminal. I strongly advise you not to fix flexibles under terminal nuts—single strands will ride up between the thread and the nut, and prevent it from being screwed home. Where flexible wires must be used it is best to solder the flex to a spade end or tag of some sort. To my mind this is the only instance where a soldering tag is necessary or essential in the main permanent wiring of a set. If a terminal is of any use at all, use it, by all means; but if it is necessary to solder the wire to a tag, why not incorporate the tag in the component and solder direct on to it, thus saving one junction! There are frequently instances in receivers where it is desirable to join one wire to another. A T-joint can be easily made with solder, using a well-tinned iron.

It is fashionable, I know, to make the "outside" wires and leads—battery cords and so forth—permanent connections, but I admit that I have a great partiality for the older system where a terminal strip is provided at the back of the set for all these leads. It makes it so easy to disconnect the set for adjustment. A favourite choice is a set of sockets on the terminal strip, all clearly labelled, and a set of connecting cords bearing corresponding labels. Alternatives are good, large, non-rotating terminals with engraved heads, the leads being fitted with spade ends.

# POLAR

## for Sound Design

POLAR Condensers have set a high standard of reliability and performance. The new models are in every way worthy additions to this range.

**FAMOUS SINCE 1922**

The Designer of the

**'A.C. THREE'**

Specifies the

# POLAR

**'UNIKNOB' TWO-GANG CONDENSER**

Steel Frame, Air dielectric trimmer controlled by Knob fitted concentrically with tuning knob. Slow-motion drive. Scale in wavelengths and degrees.

2 x .0005

**PRICE 18'6**

Can be supplied with either of the three Polar "Full Vision" drives 1/8 extra.

**WINGROVE & ROGERS, LTD.,**

188-189, STRAND, LONDON, W.C.2

**POLAR WORKS, OLD SWAN, LIVERPOOL**

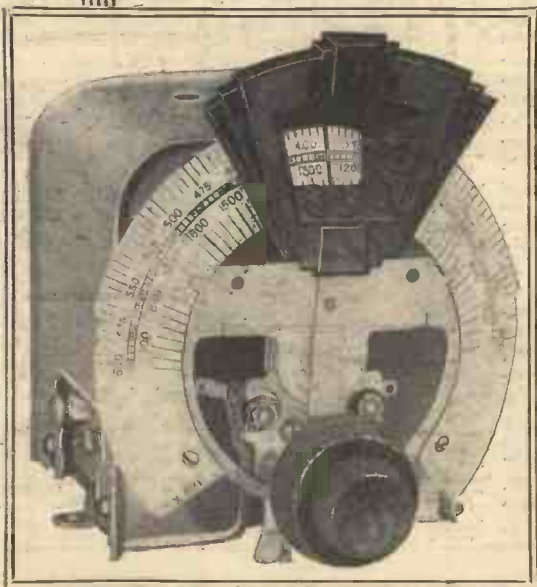

Send for the latest POLAR Catalogue



# HOW YOUR RECEIVER WORKS—1

The first of a series of articles in which the author shows how a wireless signal passes through a receiver and explains in simple terms the function of each component.

*This week the Aerial Tuning Circuit is dealt with.*

By FRANK PRESTON, F.R.A.

[T was recently suggested to me by the Editor that readers of PRACTICAL WIRELESS would appreciate a straightforward and semi-technical article explain-

we should have a clear idea of the material upon which it works, or in other words, of the signal energy which is collected by the aerial-earth system. We speak very loosely about wireless "waves," carrier "waves," and the like whilst, in point of fact, they are probably not waves at all. The analogy of dropping a stone into a pool of water and so creating waves which will cause a cork floating on the surface to "bob" up and down, is frequently exploited to explain the function of a transmitter (the stone), the receiver (cork), and intervening ether (the water). But is this analogy a correct one? It is certainly difficult to imagine a surface on the ether, which we understand as being all-pervading, and if there is no surface there can be no waves.

ment of a piece of paper placed in the water.

### Electro - Magnetic Vibrations

Please bear in mind that the above is only an analogy intended to convey the idea of oscillation, and once the principle has been grasped, the analogy can be set aside. Let us now see more exactly what happens in the

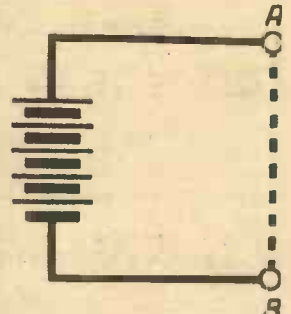

Fig. 2.—There would normally be a voltage or pressure between A and B, but this would vanish if the two terminals were short-circuited as shown by the broken line.

(Continued on page 917.)

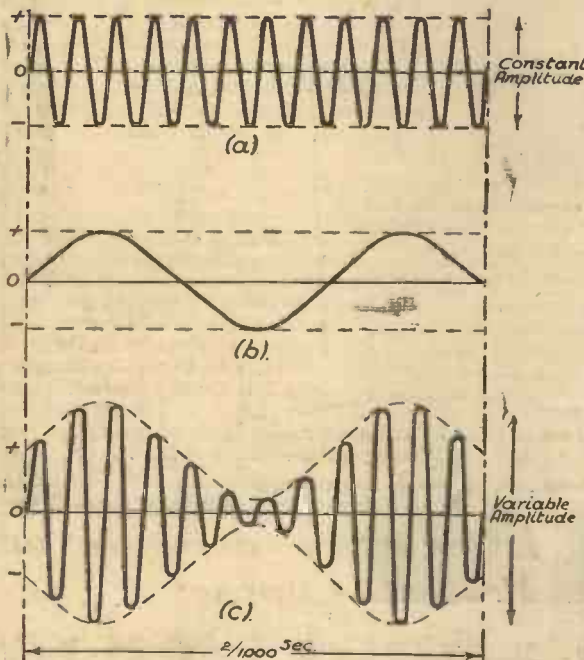

Fig. 1.—(a) Graphical representation of a carrier wave having a frequency of 10,000 cycles per second. (b) This graph represents a musical note of 14,000 cycles frequency. (c) A graphical representation of the oscillating signal voltage applied to the receiver; it represents the "modulated" carrier wave.

ing the functioning of a wireless receiver. I must confess that at first I was under the impression that the subject had already been dealt with so frequently in various handbooks that further articles on it would appear superfluous. But on collecting and perusing a number of the books I had in mind, it seemed that very many of them were lacking in some way or other. Some were too highly technical to be of interest, to the average wireless amateur, others had been written so long ago that they had become more or less obsolete, whilst in other cases the authors had made their books so "readable" that they had found it necessary to omit many things of importance, or to use simple analogies, which were far from accurate. In attempting to write an article which will be free from the above-mentioned defects, I realize to the full that I have set myself a difficult task, but if I succeed in making clear the function of the various components in a typical wireless set I shall feel more than repaid for my efforts.

### An Analogy

Before we can appreciate just what a wireless receiver does, it is essential that

bulb containing compressed air be exploded under water, the explosion would momentarily force a certain amount of water away from the bulb, but due to the pressure of water outside the spot where the explosion occurred there would be some opposition to the water's movement, and, therefore, it would be compressed. Immediately the explosion ceased, however, pressure would be reduced and the water would rush back to the place it had previously occupied. By this simple process, the water would have been set into a state of oscillation, that is, it would have been caused to move backward and forward. But the disturbance would not be confined to the spot where the explosion occurred, and would have been transmitted to the whole volume of water. In consequence there would be an oscillatory movement throughout the mass, so that the pressure at any point would be changing at the same rate as the original oscillations, and this could be detected by the move-

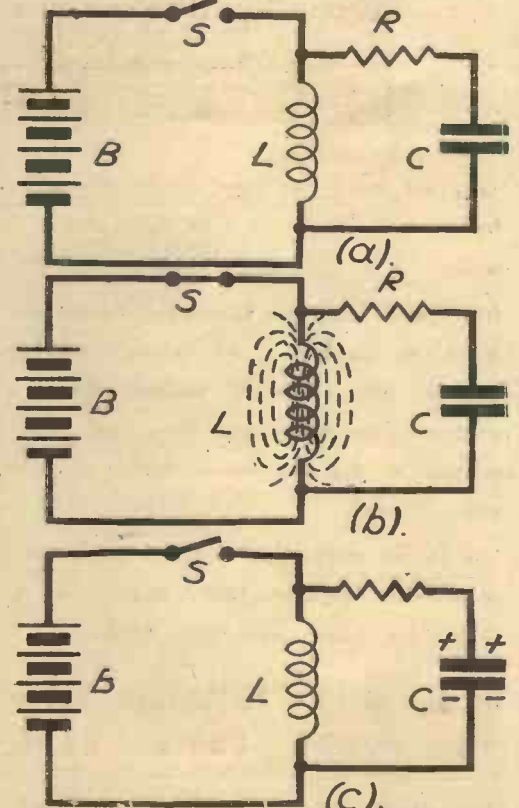
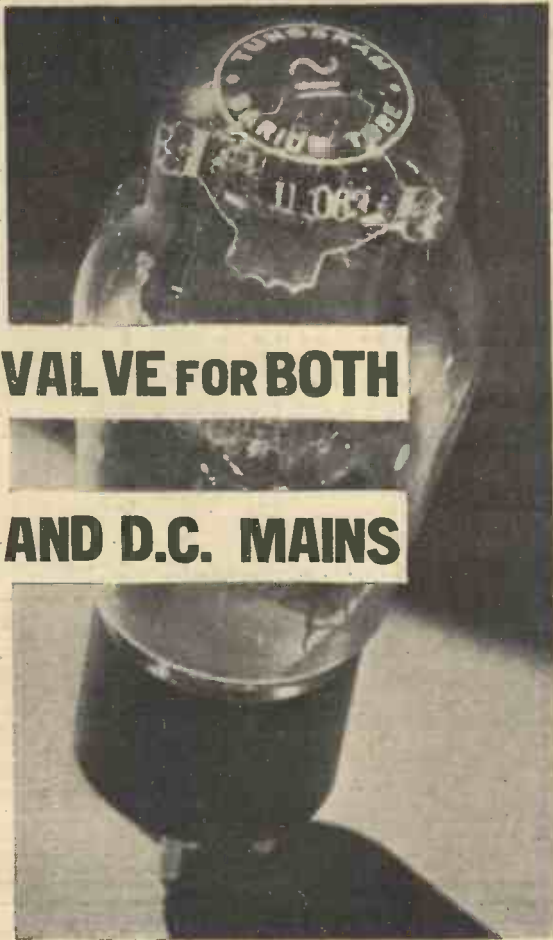

Fig. 3.—Showing the action of an oscillating circuit comprising a coil, condenser, and resistance. (a) A simple oscillating circuit connected through a switch to a battery. (b) When the switch is "closed" current flows through L and causes it to become an electromagnet. (c) When the battery circuit is again broken current flows through the coil L and "charges" condenser C.





**ONE VALVE FOR BOTH**

**A.C. AND D.C. MAINS**

Tungram have achieved it—a Universal Valve which works on both A.C. and D.C. mains.

With these Tungram Universal Valves any circuit can be built. All valves, including rectifier, are indirectly heated—there is practically no hum—and they are really economical, for the mains consumption is only 35 watts.

Your dealer stocks them—go to him to-day! Or write to Tungram Technical Dept. Pr. W. for full particulars and circuit diagrams.

**THERE IS A TUNGSRAM VALVE FOR EVERY RADIO NEED.**

**TUNGSRAM**

TUNGSRAM LTD., 72, OXFORD ST., LONDON, W.1

**MAN-MADE STATIC**

LET "GOLSTONE"  
ELIMINATE IT  
FOR YOU.

Baffling Interference  
Problems Solved By

**"GOLSTONE"**

AIR-SPACED  
METAL-SCREENED  
DOWN-LEAD  
and other devices

Obtainable from all First-Class  
Radio Stores—Refuse Substitutes—  
if any difficulty write direct.

GOLSTONE can help you to  
cure electrical interference  
at source, or by screening  
the aerial down-lead.

Send postcard for Interference  
Elimination Form, and descriptive  
folders.

Whatever the fault, there is  
a GOLSTONE device for  
your assistance.

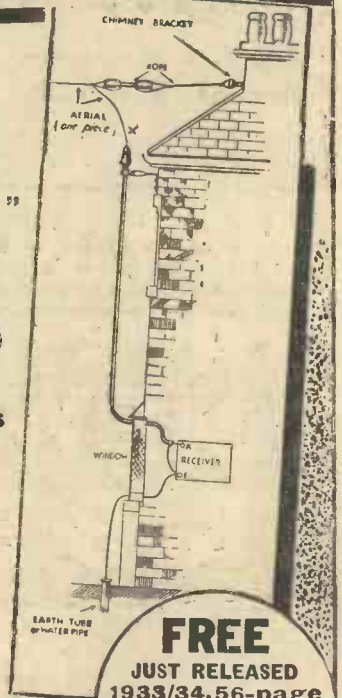

**FREE**  
JUST RELEASED  
1933/34, 56-page  
Radio Catalogue  
— R130 —  
FREE ON  
REQUEST

**Ward & Goldstone**  
PENDLETON MANCHESTER LTD.

*Efficiency depends on  
Perfect Contact . . .*

. . . therefore Clix is *Specified* for the

**A.C. THREE**

To ensure perfect, reliable  
contact and the highest  
possible efficiency from any  
receiver, follow experienced  
designers—always use Clix.

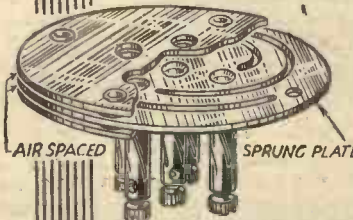

**"AIRSPRUNG" VALVEHOLDER**  
(ANTI-MICROPHONIC, NON-METAL)  
4-pin . . . . . 1/2  
5-pin . . . . . 1/3  
STANDARD TYPE  
4-pin . . . . . 8d.  
5-pin . . . . . 9d.

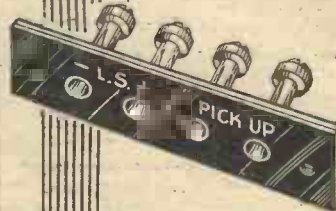

**CHASSIS MOUNTING STRIPS**  
TYPE A: —LS + Pick-up . . . 8d.  
TYPE B: A1, A2, E. . . . . 7d.  
TYPE C: Mains Aerial, In-out. . 6d.  
Shorting Plug . . . . . 3d.

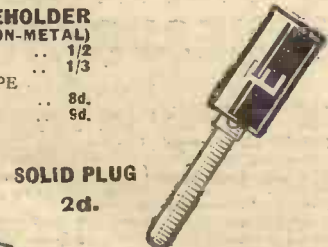

**"A MATTER OF CONNECTION."**

Clix New Folder "N" gives  
details of over 30 Perfect  
Contact Components.

**CLIX**

FOR PERFECT CONTACT.

LECTRO LINX LTD., 79a, Rochester Row, London, S.W.1.





**Blue Spot**  
REGISTERED TRADE MARK

**MOVING COILS  
give you the  
NEWEST  
& BEST**



**29PM**

Model from **27/-**

**OLYMPIA AGAIN PROVED BLUE SPOT SUPERIORITY**

*Some Special Features:*

**NO WARPING OR FOULING IN GAP**

Special moisture proof new process Cone and Speech Coil ensure positive protection against warping and fouling in the gap.

**EASY MATCHING** Special transformers fitted with terminals or plugs and sockets for easy valve matching to all outputs. No troublesome switch contacts. (Q.P.P. Pentode models 2/6 extra).

**EXTENSION SPEAKERS** Fit extra Blue Spot speakers to your set and have Radio throughout the house.

Special Extension models without transformers are supplied for sets already incorporating suitable transformers.

**OTHER FEATURES** Magnets forged from highest grade materials; balanced response over all frequencies, clear pure tone—true top, true middle, true bass, and brilliancy in attack.

Send for catalogue P.R. 19.S., giving full range of Blue Spot Moving Coil and Moving Iron Speakers. Prices 5/6 to 87/6

**THE BRITISH BLUE SPOT COMPANY LTD**

BLUE SPOT HOUSE · 94/96 ROSOMAN ST. · ROSEBERY AV. · LONDON · EC1  
Telephone: Clerkenwell 3570 Telegrams: "Bluspot, Isling, London."

Distributors for Northern England, Scotland and Wales: H. C. RAWSON (Sheffield and London), Ltd., 100 London Road, Sheffield; 22 St. Mary's Parsonage, Manchester; 177 Westgate Road Newcastle-upon-Tyne; 37, 38, 39 Clyde Place, Glasgow.

*"I must get my Blue Spot!"*

**ONLY 5/- DEPOSIT To Try The EPOCH For 7 days**

**THE LEADING CLASS B COMBINATION SPEAKER**  
(Adaptor & Unit Combined)



**GET MAINS VOLUME from YOUR BATTERY SET**

Enjoy the same perfect performance, colossal volume and increased sensitivity as you would get in a good-quality all-mains set, by connecting this superb EPOCH "Class B" Combination Speaker to your battery set. The EPOCH, which combines a complete "Class B" adaptor and high-class Cobalt P.M. Unit, can be easily fitted without any alteration being made to your present set and at very little extra H.T. cost.

**SEND ONLY 5/-** deposit for 7 days' trial, if satisfied, pay further 5/- at once, then 8 monthly payments of 7/6. Cash 62/-. (Supplied complete with "Class B" Valve and full instructions.)



**THE FAMOUS EPOCH 'CLASS B' ADAPTOR**

If you already have a moving-coil speaker and wish to incorporate Class B amplification, the EPOCH "Class B" Adaptor is ideal for this purpose. It converts your set to "Class B" without any alteration whatever. (Supplied complete with "Class B" valve.)

**ONLY 5/- DOWN**

for 7 days' trial, if satisfied, pay further 5/- at once, then 8 monthly payments of 5/-. (Cash 45/-.)

E. J. HERAUD, Ltd., Dept. P.22, NUMBER ONE, EDMONTON, LONDON, N.18.  
Branches: 78/82, Fore St., Edmonton; 77, West Green Rd., Tottenham; 34, St. James St. Walthamstow; and 130, Hertford Rd., Enfield Wash.

**CRAMMED WITH EXTRA CHEMICALS!**

-and MERCURY Means Enormously Increased LIFE!

THE life of a battery is the life of its cells. That is where the Grosvenor MERCURY process works such wonders. It guards the cells against corrosion—makes them last so long that they are crammed by hydraulic pressure with extra chemicals to use them up.

Grosvenor Mercury Batteries are made in three grades for every Radio Need :-  
Grosvenor Red Line 5/6 to 11/-  
Grosvenor Brown Line 6/- to 15/6  
Grosvenor Blue Line 7/- to 20/-

Next time you buy a battery, remember the amazingly long life, the extra reserves of power that are packed into Grosvenor. Insist on Grosvenor—and get the most for your money!



GROSVENOR ELECTRIC BATTERIES Ltd., 2-3, White Street, London, E.C.2. Phone: Metropolitan 6866 (3 lines). Works: Watford, Herts.



(Continued from page 914)

case of wireless oscillations or signals. They are electromagnetic vibrations and, although they have a pressure of several volts, or even hundreds of volts on leaving the transmitter, the pressure falls off rapidly until, by the time signals reach the aerial-earth system of the receiver, it is measurable only in millionths of one volt. The voltage of the oscillations is not the same as that given out by a battery, where one pole is always positive and the other negative, but is constantly changing between positive and negative. It is this fact which gives rise to the use of the name "wave" as applied to the oscillations, because they can be represented graphically as a wave, in the manner shown in Fig. 1 (a). The graph is really a mathematical expression used to show how the voltage varies between maximum positive and maximum negative values with the passage of time, and the number of changes from positive to negative which occur over a given period is dependent, of course, upon the frequency of oscillation. Actually the graph given covers a period of only two thousandths of a second assuming the frequency of the signal voltages to be 10,000 per second (corresponding to a wavelength of 30,000 metres). I have purposely chosen a low-frequency (high wavelength) to simplify the illustration, because to represent a high frequency so many "waves" would be required that it would be impossible to show them clearly on a page of this size.

The oscillations we have considered so far, are those of the "carrier wave" (I refer to it by its popular name, although we know that it is not really a wave at all), but in addition to these we have other

oscillations corresponding to sound frequencies. At Fig. 1 (b), a graph is drawn to represent a musical note having a frequency of vibration equal to about 1,400 per second, and which, incidentally, approximately corresponds to the highest note of a cornet. The frequencies applied to the receiver consist of a mixture of those of the carrier-wave and those due to the musical sounds impressed upon it, and can be represented in graphical form in the manner shown at Fig. 1 (c). It is seen from the latter figure, that the "amplitude" (maximum positive and negative voltage) of the signal currents is constantly varying in sympathy with the musical note, but that the frequency is precisely the same as that of the carrier-wave.

We must now see how the signal affects the receiver. The aerial and earth act like two plates of a condenser, each of which is constantly receiving a fluctuating or oscillatory voltage, and so a potential difference occurs between them; whenever one is positive the other is negative, and vice versa. In consequence, if the two were connected together there would be a flow of current similar to that obtained if points A and B in Fig. 2 were joined together, the difference being that in one case the current would be oscillating, or constantly changing in value, whilst in the other it would be of uniform intensity. But we know from our experience of electricity, that if the battery of Fig. 2 was short-circuited by connecting A and B together, there would be no indication of voltage between the latter points. In the same way, there would be no voltage, or potential, difference between the aerial and earth if they were joined together. And since it is the voltage that is required

to operate our receiver, we must avoid making a direct connection between the aerial and earth.

**Tuning**

This brings us to the reason for "tuning" the aerial circuit, generally by means of a coil and condenser. We wish so to arrange things that at any one frequency (corresponding to that of the transmission it is desired to receive) there shall be an infinitely high resistance between the aerial and earth, so that a maximum voltage will be developed between them. On the other hand, however, the signal currents of all other frequencies must not be allowed to develop a voltage, and the aerial and earth must therefore be short-circuited so far as they are concerned. It is thus essential that those components connected in the aerial-earth circuit shall be able to discriminate between various frequencies. When the oscillatory (or tuning) circuit is adjusted to have a frequency of vibration equal to that of the desired signal it prevents the signal current from passing through it, but at the same time provides a very easy leakage path to currents of every other frequency. "But," you say, "how can a coil and condenser be made to have a particular frequency of vibration?" This can best be explained by making a reference to the diagram of Fig. 3 (a), which shows a battery (B) connected through a switch (S) to an "oscillatory circuit" consisting of a coil (L), a condenser (C), and a resistance (R). Now suppose the switch be momentarily closed; what will happen? Nothing, so far as the eye can see, but there will be many changes which could be detected by suitable instruments.

# GANGED CONDENSERS

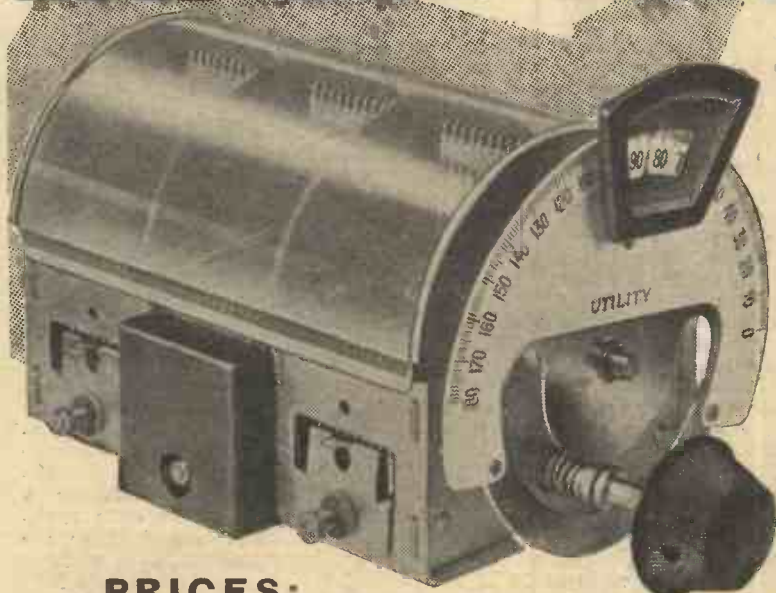

You can fit for yourself two or three condensers on one spindle and you will have a ganged condenser cheaper than we can sell to you. But it will not be as efficient as a Utility Ganged Condenser because it will not be accurately matched.

Utility Condensers are sold with a guarantee of a maximum matching error of 1/2% between sections, and only the most elaborate apparatus and skilled specialists enable that figure to be attained. But that is not all. The least stress in the chassis of the condenser would upset the delicate matching, so all Utility Ganged Condensers are built into a specially reinforced steel chassis which cannot distort or develop a stress. That also is guaranteed. So buy a Utility Ganged Condenser now and avoid trouble later.

**FROM YOUR DEALER OR POST FREE FROM THE MAKERS.**

Write for a copy of our new catalogue, it contains full details of our complete range of condensers, dials and switches.

**PRICES:**

|                              |           |                               |              |
|------------------------------|-----------|-------------------------------|--------------|
| Ref. No.                     | Less Dial | Ref. No.                      | Less Dial    |
| W. 314/2. Screened, Two Gang | .. 15/-   | W. 314/4. Screened, Four Gang | .. 30/-      |
| W. 314/3 (as illustrated)    | .. 22/-   | With Dial (Flat Type)         | .. 2/6 extra |
|                              |           | " " (Bevel " )                | .. 3/- extra |

**WILKINS & WRIGHT LTD.**

UTILITY WORKS, HOLYHEAD ROAD, BIRMINGHAM.

London Agents: E. R. MORTON, Ltd., 22, Bartlett's Buildings, Holborn Circus, E.C.4





# RADIO RAMBLINGS

By JACE

*Gettings from my Notebook*



## A Precaution Concerning Accumulators

I HOPE you all know that it is dangerous to hold naked lights over accumulators whilst they are being charged, but you may or may not have read of the accident that befell a Continental family the other day. It appears that paterfamilias was a "junk-merchant" who had bought up a lot of old accumulators. He salvaged the lead plates and not knowing of a use for the old celluloid cases, thought they would make good fire-lighters. They did, but the fumes given off poisoned the family, and the economy nearly cost several of them their lives. It appears that on most accumulators a deposit of lead in the form of lead sulphate becomes coated on the cases and, this, when heated, gives off noxious fumes that cause lead poisoning to anyone inhaling them. Don't, therefore, burn up your old accumulators, though I don't suppose you will relish the thought of having anything to do with burning celluloid any more than I do. A risky business, at the best!

## Using a Pentode Output Valve

BATTERY set users whose sets employ small power valves in the output stage often ask if it is possible for them to use a pentode valve output and thus obtain "that little extra" which perhaps enables loud-speaker reception to be possible on an increased number of stations. It is usually possible to do so to advantage, but only when one stage of low-frequency amplification is used as attempts to use a pentode in conjunction with another L.F. valve are generally not successful. If a moving-coil speaker is being used, it is necessary to see that an output transformer with a pentode tapping is included in the circuit somewhere, either as a part of the speaker or else as an adjunct to the output side of the receiver. This also applies where an inductor type of speaker is used and often speakers of the balanced armature type give improved results if an output transformer is used to ensure that the impedance of the loud-speaker does not under-load the valve. Especially is this important when pentodes of the low-consumption types are chosen.

## Tone Control

IN connection with the use of pentodes it often happens that the change over to this type of output valve reduces the apparent selectivity of the receiver owing to the fact that signals that were previously inaudible now become a nuisance because of the increased low-frequency amplification, which gives greater prominence to all signals, both weak and strong. This can be often overcome by fitting a series aerial condenser of the compression type which has a small variable capacity, or by the use of a variable- $\mu$  valve in the screen grid stage, although the latter cure is perhaps too elaborate for listeners other than ardent

enthusiasts. Mention must be made, too, of the fact that the tonal qualities given by a pentode valve may not be to the taste of the listener who has become used to the low, rather woolly, quality given by some power valves. The output from a pentode is often quite brilliant and has a decided "attack" which some people consider lacking in bass response. This can be overcome by the fitting of one of the various methods of tone control or compensation described at length in previous issues of PRACTICAL WIRELESS.

## Improvised Resistances

A FAULT particularly common with older sets of the det. 2 L.F. type is the breakdown of the anode resistance, and if a spare is not immediately available it is necessary to look around for a substitute. A piece of wet string can be used, although when it dries its resistance becomes so high that it ceases to be a conductor at all, and a piece of lead pencil or a small piece of paper soaked in Indian ink will often work satisfactorily if placed between the two resistance holding clips. Better still, however, is the use of a high-resistance voltmeter for a temporary resistance and as the usual value is 1,000 ohms per volt, a 150-volt scale would give a resistance of some 150,000 ohms. This is quite a suitable value, but care must be taken to ensure that the deflection of the needle over the scale is not less than the value of the H.T. voltage through the resistance, otherwise damage might be done to the meter. By this I mean that it is no good using a voltmeter reading up to 150 volts if the H.T. feeding the anode in question has a value of, say, 200 volts.

## Sensitivity and Power

DO you know the difference between a sensitive set and a powerful one—and when is a set both sensitive and powerful? No prizes are offered for solutions of these conundrums, but I hope you will agree that sensitivity is not necessarily power. If you had an efficient detector followed by a multi-stage amplifier you might get a dozen stations at tremendous volume, but a man with a detector stage preceded by one or more stages of efficient H.F. amplification would get a nightly bag of stations at medium strength running well into three figures. The first set would be powerful, but the other one would be the most sensitive, so that the ideal set is one with an efficient H.F. stage to get in the stations and feed their weak signals, sufficiently amplified so as to be capable of being handled by the detector, to the rectifying stage, and followed by a good low-frequency amplification side to make all the signals audible at good strength on the loud-speaker.

## Cold-emitter Valves

THERE is another problem, the solution of which would do much to further the

progress of Empire Broadcasting—or, at least, Empire listening. I refer to the development of cold-emitter valves. You might think it impossible to invent a valve which will give off an electron stream from a perfectly cold cathode, but remember, that it was at one time considered necessary to heat a filament to incandescence to persuade it to emit electrons; since then the dull-emitter has been universally adopted. Various methods have been tried in attempts to produce a cold-emitter valve, but as yet none have proved satisfactory. One way was to coat the cathode with light-sensitive substance such as is used in photoelectric cells, but, although this did give some emission, it was not sufficient to enable the valve to operate successfully. I understand that an alternative method is being experimented with in Germany at the present time. In this case two electrodes, an anode and a cathode, are mounted very close together in a glass bulb containing a small amount of some inert gas. The high-tension voltage is applied between the two electrodes and this produces a kind of glow discharge such as occurs in a neon lamp, and like we used to get when using the old Dutch valves. Under conditions of discharge the gas becomes a conductor, and a free flow of electrons takes place between the cathode and anode. I have not been given any definite facts in regard to the "glow-discharge" valve, and I cannot quite see where the grid is going to fit, since it is apparently essential that the other two electrodes must be separated by only a minute space. Nevertheless the idea offers some interesting possibilities.

## The Transmitting Licence

IT might prevent a good deal of misunderstanding if I point out that a transmitting licence is not an easy thing to acquire, unless the applicant has in mind some useful experimental or research work. I have no desire to damp the ardour of anyone, and it would please me tremendously to know that PRACTICAL WIRELESS numbered among its readers a good proportion of amateur transmitters, but I do think that the position should be made clear.

Any reader who contemplates serious transmitting experiments should, first of all, write to: The Secretary, General Post Office, London, E.C.1, for a Licence Application Form, which will be accompanied by a list of "Conditions of Issue." After studying the latter he will be in a better position to understand what is required of him before a licence can be granted. Space does not permit of my reproducing all the conditions here, but I will give the most important one. Condition Number 4 reads as follows: "Applicants must satisfy the Postmaster-General that they are qualified to conduct experiments of scientific value or public utility. If scientific research is intended they should be certified as competent investigators by a Government Department or some recognized scientific body. Authority to use wireless sending apparatus, even with an 'artificial' aerial (i.e., a practically non-radiating aerial), can be granted only if the nature of the proposed experiments and other circumstances warrant that course." It will be seen from this that a licence is not just issued to anyone who cares to make application, and that the applicant must first have in mind the carrying out of some definite and useful experimental work.





In order to meet the requirements of readers who prefer to work from a full-size blueprint when building up any of the "Practical Wireless" Receivers, we can now supply full-size Blueprint Wiring Diagrams of all the "Practical Wireless" receivers for 1s. each, post free. When ordering, quote the number. Copies of the paper containing descriptions of the particular receiver cost 4d. each. Address orders to: The Publisher, George Newnes, Ltd., 8-11, Southampton Street, Strand, W.C.2.

Blueprint. Receiver.

- No.
1. Dolphin Straight Three.
  2. Long Range Express Three.
  3. Mains Express Three.
  4. Sonotone Four.
  5. Bijou Three.
  6. Argus Three.
  7. Empire Short-Wave Three.
  8. Solo Knob Three.
  9. Midget Two (6d. only).
  10. Selectone Battery Three.
  11. Fury Four.
  12. Featherweight Class B Four-valver.
  13. Q.P.-P. Three-Four.
  14. Alpha Q.P.-P. Three.
  15. Ferrocart Q.P.-P. Hi-Mag Three.
  16. Supersonic Six.
  17. Beta Universal Four.
  18. A.C. Twin.
  19. Selectone A.C. Radio-Gram Two.
  20. A.C. Fury Four.
  21. Radiopax Class B Four.
  22. Three-Valve Push-Pull Detector. (6d. only.)
  23. Double Diode Triode Three.
  24. Three-Star Nicore.
  25. The D.C. Ace.
  26. The Superset.
  27. The Auto-B Three.
  28. The All-Wave Two.
  29. The A.C. Three.

**OLD COMPONENTS**

(Continued from page 894.)

mounted on it is soldered on to the centre bush of the switch as in Fig. 10, or else a flexible wire is connected to the same point. The switch thus becomes a 3-point instead of a 2-point instrument.

**A Resistance Holder from Odds and Ends**

A use for old telephone terminals which may appeal to some readers is shown in Fig. 11. Two terminals are mounted on a strip of ebonite to form an anode resistance or grid-leak holder. One point of the resistance fits in the hole in one terminal, while the other point fits in a hole drilled in the head of a screw held by the other terminal. The screw has a spring behind it to keep it pressed in contact with the resistance and is fitted with a nut at the other end to keep it from jumping out of the terminal when the resistance is removed.

Ordinary type valve-holders of most makes can usually be converted to the chassis-mounting type for under-baseboard wiring by the method shown in Fig. 12. The terminals are reversed and a hole is drilled in the baseboard or wooden chassis to allow the body of the holder to pass up through as shown. The fixing screws are fitted with small spacing washers to keep the holder well away from the underside of the baseboard so that the heads of the terminal screws do not touch the wood. With a metal chassis instead of a wooden one the fixing is just the same except that small bolts will be required instead of wood screws for securing the holder in position. In this case the spacing washers must on no account be omitted, otherwise the terminal screws will short-circuit against the chassis.

The *plate-less*  
**ACCUMULATOR**  
*revolution*



**DOUBLE CAPACITY**

LOW TENSION

*halves your re-charging*

No bigger than your present 40 a.h. accumulator, costing little more, a Block plate-less accumulator lasts you twice as long per charge—gives 80 a.h. Far more durable, too—and handsome, in its richly coloured bakelite. (Detachable hand-lamp fitting, 10/6.)

**"CONDENSED" HIGH TENSION**  
*no need for dry battery expense*

Because a Block cell gives twice the capacity for its size, a Block H.T. accumulator of usual capacity can be condensed to half the usual bulk! So give up expensive dry batteries—the new accumulator in its beautiful bakelite casket is little bigger and is remarkably inexpensive. Relieves you at once of radio's biggest nuisance.



**PRICES**

L.T. 20 a.h. 20. - - 11/6  
H.T. 60v. 5000a.h. 14 1/2" x 4 1/2"  
x 5 1/2" 37/6. 30v. 8 3/16" x 4 1/2"  
x 5 1/2" 21/-

Block Batteries Ltd., Abbey Road, Barking, Essex. Tel: Grangewood 3346/7

TAS. Bb. 51.



# MOVING-COIL INSTRUMENTS

How to Adjust and Test Them for Accuracy By "MICRON"

**A**N article was published in PRACTICAL WIRELESS recently on fitting up a workshop, and no workshop can be complete until one of the most indispensable pieces of apparatus is included, namely, a moving-coil instrument. There are many such instruments that can be bought to-day quite cheaply. Its uses are numerous, and while many of them have been ably described, there are still some little-known facts about these instruments—which I will try to make clear—that are an advantage to anyone who buys either a second-hand or new instrument and wants to make it suitable for universal use.

For general utility, I would recommend one to buy a milliammeter that gives a full scale deflection with one milliamp, and, having bought the instrument, the following points should be noted:—

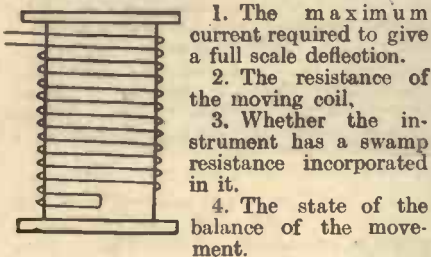

1. The maximum current required to give a full scale deflection.
2. The resistance of the moving coil.
3. Whether the instrument has a swamp resistance incorporated in it.
4. The state of the balance of the movement.

Figs. 1 and 2.—Methods of winding a swamp resistance.

Now let us take these points one by one and sift them out. Number one can easily be found by noting the maximum reading on the scale, and as regards number two, an easy method of finding this was given a week or so ago. At this stage, perhaps it would be better to explain a few of the basic principles which govern the operation of these instruments.

## Ohm's Law

All moving-coil instruments take a definite current to give a full-scale deflection, and, as the moving coil has resistance, it always obeys Ohm's Law, namely, the voltage necessary to drive the current through this resistance is always equal to the value of the current multiplied by the resistance, and, knowing any two factors, we can always find the third. Perhaps an example will make this clear. Supposing our milliammeter will give a full-scale deflection when one milliamp flows through it, and that we have found that the moving coil has a resistance of 20 ohms. When we put this in a circuit that is passing one milliamp, we find that across the moving coil we have a difference of pressure equal to .02 volt—or 20 millivolts—and you can now appreciate the fact that our milliammeter is also a calibrated millivoltmeter, giving a full-scale deflection with 20 millivolts, the scale reading being multiplied by 20.

Most milliammeters are designed to

give a full scale deflection with 60, 75, or 100 millivolts, and as such, providing the current in the circuit is much greater than that taken by the instrument, it will measure millivolt drop accurately. We have already found that our instrument will give a full-scale deflection with 20 millivolts, and the question that comes to one's mind is, how can we make our instrument give a full-scale reading with any of these pressures? This is where item number three—the swamp resistance—comes in.

If we were to examine the inside of a moving-coil instrument that has been designed as a multi-range ammeter, we should find a resistance permanently connected in series with the moving coil.

## Swamp Resistance

This is the swamp, or, swamping resistance. It is wound with either Eureka, Manganin, or Constantan wire, or any wire that has a low temperature coefficient, and is silk covered, the value of this resistance being from three to four times the value of the moving coil. It is wound non-inductively on either an ebonite or porcelain bobbin. There are two methods by which this can be done, as shown in Figs. 1 and 2.

In the first case the wire is doubled in two, and the loop fixed to the bobbin with a spot of shellac varnish, and the two wires are then wound on side by side, finishing with a piece of fine flex soldered on to each end of the wires. The winding is now covered with shellac varnish, and over this is placed a layer of insulating tape. If it is found that more than one layer of wire is required a different method must be adopted. One layer must be wound on, say, in a clock-wise direction, insulate this with shellac varnish and tape, then wind the next layer back over the first layer, but in an anti-clockwise direction, insulate as in the previous layer, then the next layer should be wound in a clockwise direction and so on, until the whole amount is on, taking care to thoroughly insulate each layer. This case is extended in the case of series resistances for voltmeters. Here we have a slab of insulating material cut as shown in Fig. 3.

The wire is first wound in the end slot for a pre-determined number of turns, then the next slot is filled by winding the wire in a reverse direction until the whole amount of wire is on. You must now be wondering what the swamp resistance is used for. Taking our moving-coil instrument, we know that it gives a full scale deflection with one milliamp, and its resistance is 20 ohms. We further found from Ohm's Law that the difference of pressure across the coil is .02 volt. If we were to use this instrument to read a

greater current than one milliamp we would employ a shunt connected as in Fig. 4.

The value of the shunt depends on the resistance of the instrument, and the maximum value of the current which we want to measure. If the milliammeter did not have a swamp resistance in its coil circuit the value of the shunt resistance

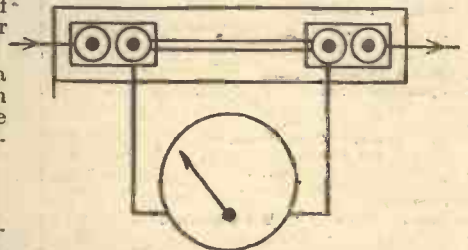

Fig. 4.—Using a milliammeter in shunt for measuring small currents.

would have to be very low and contact resistance would be a serious factor; furthermore, after the instrument had been in circuit for some time—assuming no swamp—we would find that its readings would become inaccurate owing to temperature errors. Most shunts are designed to give a pressure drop of 60 millivolts (.06 v.), 75 millivolts (.075 v.) or, in the case of some commercial instruments, 100 millivolts (.10 v.), when carrying a certain current. Having found that our instrument requires 20 millivolts for a full-scale deflection, and we want to use it with a shunt that has a drop of pressure of 60 millivolts when carrying a certain current we must design the swamp resistance to absorb 40 millivolts, and therefore it should have a resistance of twice the value of the moving coil, namely, 40 ohms. Working this out by Ohm's Law we have  $R = E/C$  .06/.001=60 w., but the moving coil has a resistance of 20 w., so we shall require a swamp of  $60-20=40$  ohms.

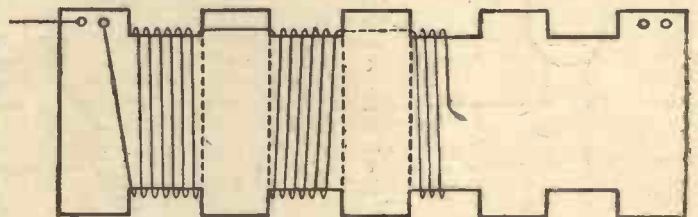

Fig. 3.—Winding a series resistance for a voltmeter.

## Checking the Balance

We now come to the final operation, that of checking the balance of the movement, and it is as well to check this very thoroughly, as an instrument that is fairly accurate, and the movement of which is slightly out of balance, can be made most accurate, while if the balance is correct, the instrument can be used in any position, and from this it follows that if the balance is not correct, the instrument can only be used in the position it was calibrated in. Spend plenty of time on this operation.



even if it takes three or four hours, and your trouble will be well repaid, at the same time not forgetting that it is a delicate operation. If you look at the movement of the instrument you will find an extension to the pointer at the other end of it, and on this will be found a balance weight which is usually some very small nuts on a thin screwed wire. The nuts are prevented from moving by a spot of shellac varnish. Fig. 5 shows the movement with balance weight.

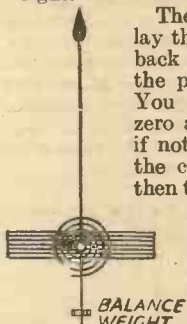
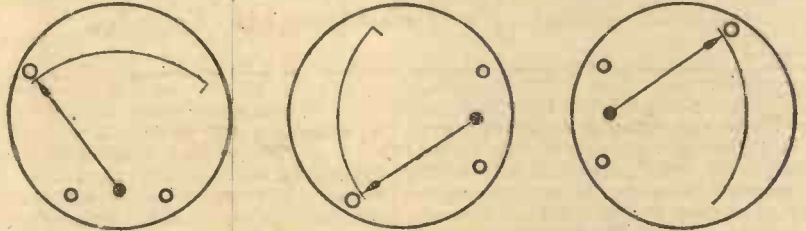

Fig. 5.—The movement for a moving-coil instrument.

The first thing to do is to lay the instrument flat on its back on the table, and bring the pointer to the 0 position. You will undoubtedly find a zero adjuster for this purpose, if not, you will have to take the cover off the instrument, then this operation can be carried out by altering the arm to which the control spring is soldered. Under these conditions the balance weight does not come into operation, and it has no control over the movement, the position of the pointer being determined by the control springs. Now mount the instrument vertically, as in Fig. 6. The pointer should now remain at the 0 position. In this position the balance weight comes into operation, and if the pointer deviates from 0 it can be brought back by altering the position of the balance weight, by running it up or down the screwed thread. However, before you can do this, you will have to free the little nut or nuts, and the

best way of doing this is to heat a large steel knitting needle until it is red hot, then hold this on the balance weight when it will be found that the shellac melts, allowing the weight to be moved with a



Figs. 6, 7 and 8.—Three positions for checking the balance of the instrument.

pair of tweezers. Of course this operation will have to be done every time the balance weight requires to be moved. Our next operation is to place the instrument on its side, as in Fig. 7, and if the balance is correct the pointer will stop at 0. If it is out, this must be corrected by moving the balance weight. We have still the final operation to carry out, and that is to turn the instrument until the zero lies in the other direction, as indicated in Fig. 8, and if you have made your adjustments accurately the pointer should still stop on the 0. If you find that the balance has been accurate up to this stage, but out on this test, it is best to correct it, and to go through the three previous operations again, and when you find that the instrument obeys all these operations: it should read accurately throughout its range, and in any position. By the way, you may find that you want to lower your weight more than the screwed thread will allow it, in this case a spot of solder on it will

allow a further range of adjustments to be carried out, and the converse case is also true. If you find that you have to screw the weight right up to the moving coil, and still cannot get a true balance,

taking off one of the nuts will enable you to do it. Should you find that through frequent manipulation the weight has become unstuck, a little spot of shellac varnish will put it right, but it must be just a speck or else you will undo all the good work you have done, by upsetting the balance.

By paying attention to these small points and carrying out these tests with great care, you will find that not only are you improving the reliability of your instrument, but you are also acquiring skill and knowledge, and do not forget that the finest way to learn and acquire knowledge is to experiment. Perhaps a useful tip—one which the author has found to serve him well for many years as a test engineer—is to assume that everything is wrong, until you have proved it correct by experiment. This is by far a better method than to assume that everything is correct until you find something that is wrong.

It is surprising how many times one comes across A.C. mains operated wireless receivers, especially home-constructed ones, in which the quality of reproduction is marred somewhat by the presence of residual mains hum. One of the most effective methods for overcoming this is to incorporate a special resistance with a

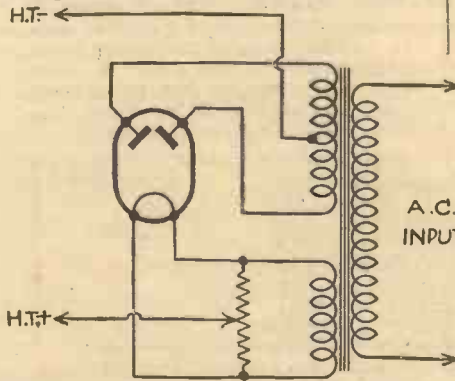

Fig. 1.—A potentiometer used to obtain a centre-tap.

movable centre contact which moves over the centre portion of the winding in order to determine the true electrical centre.

Many eliminators have a low voltage winding for the direct application of raw alternating current to the filament of a power valve. The resistance mentioned provides a method for obtaining the necessary electrical centre of this filament supply winding, and in this way cancels out the last traces of A.C. hum which may be present in the amplifier output stage. It is best to place the resistance as near to the

### CURING MAINS HUM

valve terminals as is conveniently possible and not actually across the transformer terminals. To a lesser degree the same course can be adopted when indirectly heated cathode valves are being used, and, furthermore, such a scheme is by no means limited to application in the final stage of the receiver.

The resistance should be adjusted for the elimination of the hum when no signals are being received, but with the receiver or eliminator in operation. The tuning circuits are brought into resonance, but at a wavelength on which no station is transmitting at that moment. This permits the degree of A.C. hum to be noted and the resistance control is turned slowly to left or to right until the hum is "tuned" out. It is necessary to select the value of this resistance so that there is no undue

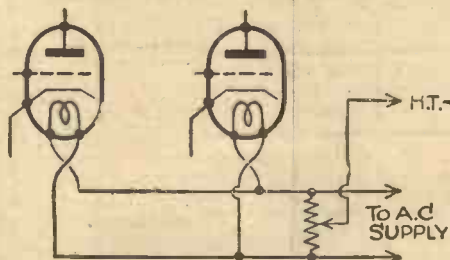
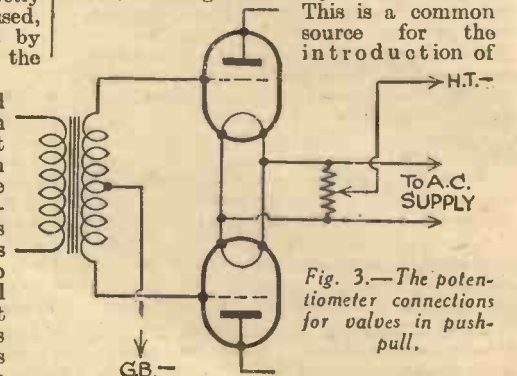

Fig. 2.—How to use the potentiometer when two indirectly heated valves are used.

extra "load" imparted to the circuit, and a resistance of 30 or 50 ohms generally will be found suitable. Three diagrams are given to show exactly how the resistance can be included in certain circuits.

#### Examples.

In double wave rectifying valve circuits the mains transformer sometimes has its centre winding electrically out of balance.



This is a common source for the introduction of

Fig. 3.—The potentiometer connections for valves in push-pull.

objectionable A.C. hum into the filter circuit. If a suitable resistance be connected across the filament winding as shown in Fig. 1 this hum can invariably be balanced out with ease. The centre tap terminal of the transformer winding is of course left blank.

Where indirectly heated cathode valves are employed the filament leads should be bridged as near as possible to the valves by the resistance, the centre tap of which is taken to H.T.—as indicated in Fig. 2. The variable position of the movable contact should then be adjusted.



# A BATTERY ELIMINATOR FOR A.C. MAINS

Constructional Details of this Unit Are Here Given, Together with Some Notes on Voltage Dropping and Decoupling.  
By G. H. WRAY, F.C.S.

THE construction of an eliminator for use on A.C. mains is a matter which neither calls for specialized technical knowledge nor unusual engineering skill. Many readers who have alternating current in their homes are deterred from building up their own eliminators through having the impression that it is a complex business, involving a multiplicity of calculations and technicalities which are beyond their scope.

On the other hand they would, however, have no hesitation in embarking upon the construction of a complicated receiver, which would require considerably more skill and care to carry to successful completion than does an eliminator. The advantages to be derived from a supply from a battery eliminator are manifest, and readers may commence operations without any qualms as to their ability to successfully construct one suitable to their requirements, and without doubt as to the successful working of the finished assembly. The constructional details of the H.T. eliminator described here will enable them to build one which will provide an ample supply of current for the average three-valve set, free from any trace of distortion, motor boating, or hum, on good speakers.

The advantages of a mains supply over that obtained from H.T. batteries are, briefly, current at approximately one sixtieth of the cost, unvarying voltage (neglecting the small variation existing in the mains voltage itself), and a liberal anode current supply for the output valve, enabling the use of a super-power valve in this stage which would otherwise be impossible owing to the heavy drain on the H.T. battery. In addition, the installation of an eliminator ensures an inexhaustible trouble free supply, and the inconvenience usually associated with battery charging becomes a thing of the past.

An eliminator consists essentially of two circuits, the rectifying, and the smoothing circuit. The components contained in the rectifying circuit are the mains transformer, the rectifier, and the reservoir condensers. The smoothing circuit contains the smoothing choke and the filter condensers. The eliminator described here was designed to supply H.T. for a three-valve set—screened grid, detector, and power valve—and the results under working conditions leave nothing to be desired, particularly with regard to absence of background noise.

## Constructional Details

The first step in building the eliminator is to consider the necessary components. The mains transformer has already been described in a previous issue of PRACTICAL WIRELESS, and by referring to this article readers can obtain full constructional details. These details also apply very closely to the construction of the smoothing choke, the essential difference being that the choke coil consists of only a single winding wound on a smaller spool, which in turn surrounds an iron core of smaller cross sectional area than that of the transformer.

The coil is wound with  $4\frac{1}{2}$  ounces of No. 38 S.W.G. enamelled wire on a  $\frac{3}{4}$  in. spool, and the winding should be carried out as firmly and evenly as possible, the

inductance should be approximately 30 henries when the choke is carrying the full anode current taken by the set. This latter proviso is a necessary one, as the inductance of a choke varies inversely with the current which it is carrying. That is to say, the inductance becomes less if the current is increased, and if the current is reduced the inductance becomes greater.

The actual constructional work is now completed, and the next step is to assemble the components. The rectifier used is the Westinghouse style H.T.8, giving a smoothed output of 250 volts, 60 milliamps, in the voltage doubler circuit. This is a larger output than is required for present needs, but the H.T.8 was chosen in preference to a smaller rectifier, with a view to possible future requirements.

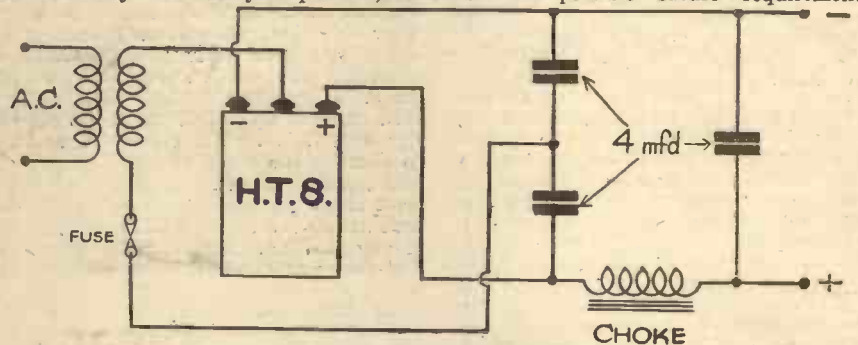

Fig. 1.—The circuit of a mains battery eliminator.

starting and finishing leads being brought out through holes drilled in one of the end cheeks of the spool. The coil, when completed, may be covered with one layer of thin leatheroid, which protects the winding and improves the finished appearance of the coil.

The laminated core is next built up, for which 6 doz. pairs of No. 30a pattern stalloy stampings are required, and the whole assembly is tightly clamped together in accordance with the instructions already given for assembling the transformer, and the leads enclosed in insulated sleeving are connected to the terminals.

The chief requirements in the design of an efficient choke will be provided for if the choke is built to the constructional details given. These requirements are, generous dimensions of the iron core, as low a D.C. resistance as possible, and the

The reservoir and filter condensers are Ferranti 2 mfd. type. Six of these are required, four of them are for reservoir condensers and should have a working voltage of 200 volts, and the other two are filter condensers and must be of the 400 working voltage type. The Ferranti condensers are made only in 2 mfd. capacity, and 4 mfd. is obtained by connecting two such condensers in parallel.

The circuit arrangement for rectifying and smoothing is shown in the diagram, Fig. 1. A "Bulgin" fuse, blowing at 1 amp. should be incorporated in the primary circuit of the transformer, and one blowing at  $\frac{1}{2}$  amp. in the secondary circuit. The capacity values given for the condensers apply only if the frequency of the mains supply is at 50 cycles. If the supply is at 25 cycles, the capacity values must be doubled. The H.T. rectifier must be mounted in a horizontal position and not placed on end, but otherwise the positioning or layout of the components is not of great importance.

## Voltage Dropping and Decoupling

We now have a smoothed output available, capable of delivering 250 volts, 60 milliamps, but before it can be used it is necessary to provide the means of obtaining the different voltages required by the valves in the receiver. Separate feeds are provided for each valve, and this is done by means of resistances and condensers. The problems arising from this are really quite simple ones, and are easily solved by the application of Ohm's law, which for our purpose may be expressed in a simplified form, as:—

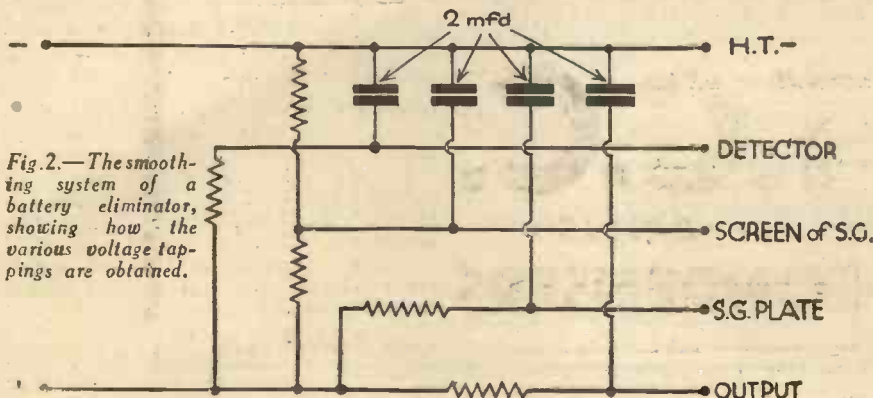

Fig. 2.—The smoothing system of a battery eliminator, showing how the various voltage tapings are obtained.



Resistance required = volts to be absorbed, divided by current taken in milliamps, multiplied by 1,000.

We will assume that from the valve-maker's curve we ascertain that the approximate anode current consumed by the power valve is 30 mA. at 200 volts, the detector valve 3 mA. at 150 volts, and that the screened grid valve requires .5 mA. at 100 v. on the screen, and 2 mA. at 180 v. on the plate. The total current consumed by the set is therefore,  $30 + 3 + .5 + 2 = 35.5$  milliamps.

Examining next the maker's voltage regulation curve of the H.T.8 rectifier, we find the 35 mA. position on the "smoothed current" line and we see that at 35 mA. the smoothed output of the rectifier is approximately 360 volts. This voltage is in excess of that required by any of the valves, so it must be lowered to suitable values. The maximum anode voltage required is 200 v. for the power valve therefore the output voltage from the rectifier must be dropped from 360 v. to 200 v. by absorbing the surplus voltage by means of a series resistance.

Applying the simplified formula already given, we find that the value in ohms of the resistance required is  $\frac{160}{30} \times 1,000 = 5,333$  ohms, and the nearest standard resistance obtainable would be used. Exactly the same procedure is adopted in calculating the values of the resistance required for the supplies to the other valves in the set.

#### Decoupling

We now come to decoupling. Each resistance, together with a fixed condenser, forms a decoupling unit in the circuit which forms the H.T. feed to the valve being supplied. The capacity of the decoupling condensers is 2 mfd. This value is adequate, and no advantage is to be gained by increasing the capacities. The condensers should be of the 200 working voltage type.

The object of decoupling is to prevent stray coupling between the different anode feeds to the valves, which would result in low frequency instability with the consequent possibility of "motor boating" and distortion. The circuit arrangement for decoupling and voltage dropping is shown in the diagram Fig. 2.

Two resistances are connected in series across the H.T. supply and by-passed to earth in the case of the feed to the screen of the S.G. valve. One of these resistances may, with advantage, be made variable, to provide for adjustment of the voltage to obtain the best results, but the actual potential applied is not really critical.

Wiring connections throughout are made with Glazite, or with copper wire, about 18 gauge, insulated with Systoflex sleeving. Neatness in laying out and wiring up the components will reflect itself in the finished eliminator. No connection to the lighting mains should be made until the apparatus is completely wired up. Provision for ventilation is essential, and the enclosure of the complete eliminator in an earthed metal case, while not absolutely necessary, is an added refinement.

In the construction of mains transformers or chokes to requirements other than those specified in this article, material assistance will be obtained by reference to PRACTICAL WIRELESS Data Sheets, Nos. 4 and 6.

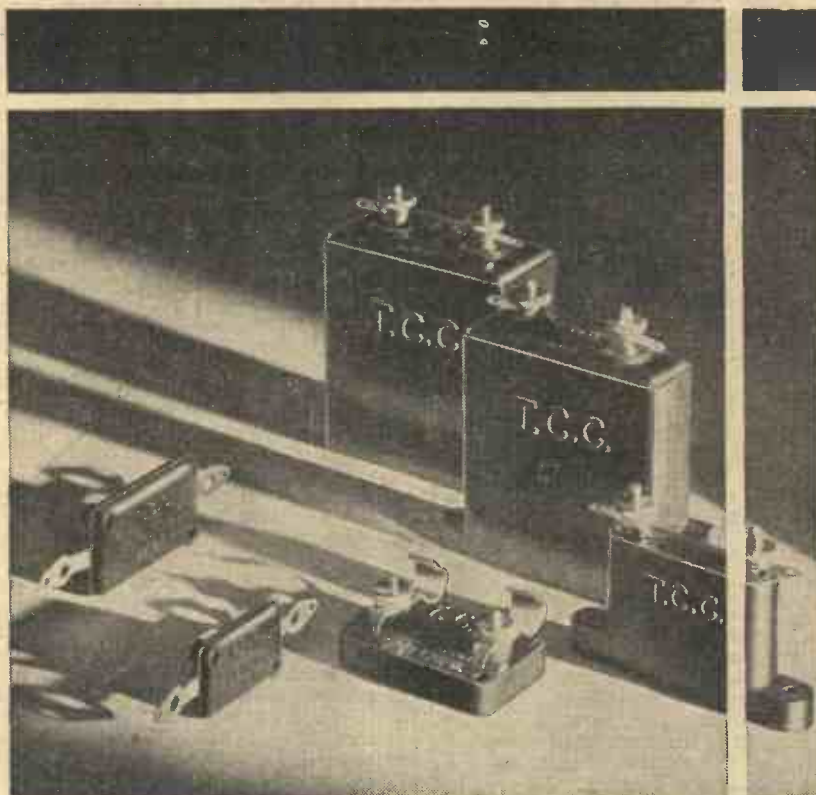

T.C.C. means  
SAFETY.....  
ALWAYS



Research — intensive  
concentrated research — Creating the means to solve the ever present problems of Radio — Rejecting all but what experience has found 100% right. That is the job of the vast T.C.C. organisation—that is why none but the perfect product finds its way to the storeroom. But even more, that is why T.C.C. spells SAFETY at all times. Throughout the world the "condenser in the green case" is synonymous with condenser efficiency—whatever the need there is a T.C.C. to fulfil it—adequately—the reason for the choice of T.C.C. by all the leading set designers.

**T.C.C.**  
ALL-BRITISH  
**CONDENSERS**

The Telegraph Condenser Co., Ltd., Wales Farm Road, N. Acton, W.3.



# HOW WE HEAR DX

In This Article the Author Explains How Wireless Waves are Returned to the Earth by Reflection at the Heaviside Layer.

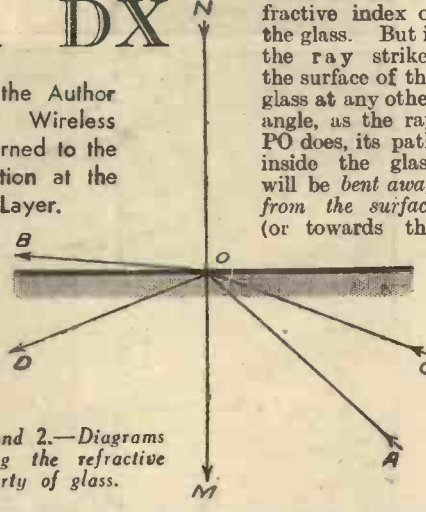
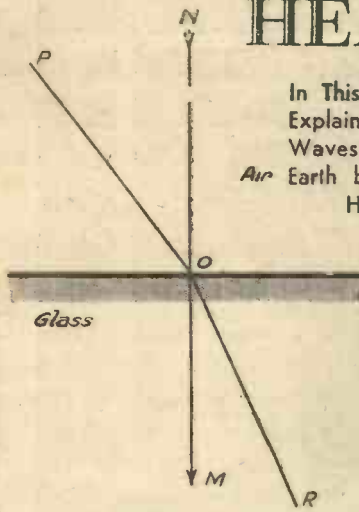

Figs. 1 and 2.—Diagrams illustrating the refractive property of glass.

straight through without changing its direction whatever the refractive index of the glass. But if the ray strikes the surface of the glass at any other angle, as the ray PO does, its path inside the glass will be bent away from the surface (or towards the

rate depends on the gas pressure, is most important, as we shall see later. We cannot regard the ionised layer merely as a solid layer of ionised gas clearly defined at top and bottom, and whose ionisation is equally strong throughout. Quite to the contrary; the boundaries are very ill-defined and constantly moving and the density of ionisation is very much more intense somewhere near the middle than either at the top or bottom. For convenience in describing the mechanism of returning a wireless wave to earth the layer is generally regarded as a number of strata of different intensities of ionisation piled one on top of another, as indicated in Fig. 3.

The case of a radio wave entering a highly ionised medium from one of lesser ionisation is parallel to the case of a light wave entering a less dense medium from a more dense one; the electrical quantity corresponding to the refractive index (which increases with density) is the dielectric constant and the dielectric constant of a gas is decreased by ionisation by an amount proportional to the number of free electrons. Consequently a radio wave starting from a point T on the earth's surface and striking the bottom of the layer at O will, on passing into the more highly ionised region, be bent towards the surface of the layer; this refracted wave will then strike the next stratum of higher ionisation at P and will be bent still more nearly parallel to the surface so that it will enter the next more highly ionised stratum at such an angle that it strikes the upper surface of the stratum at an angle greater than the critical angle and hence undergoes total internal reflection, with the result that the wave is started downwards in the direction of the earth's surface. On its downward journey it is refracted at the boundary of each stratum in the opposite direction to that in which it was refracted on going up, being bent farther and farther from the surface. If the strata of the layer were absolutely parallel to one another and to the earth the angle of emergence RAB of the ray would be equal to the angle of incidence, TON, but this of course is unlikely to occur in practice. By continuing the paths TO and RA of the ray along the dotted lines until they intersect at X we have what is called the "equivalent path" of the ray, the path it would have traversed if it had gone straight up to X and been completely reflected there. The vertical distance of X from the earth is called the equivalent height of the layer and it is

WHEN Marconi first demonstrated telegraphy-without-wires so many years ago the pundits of the time announced that although it was undoubtedly an interesting experiment, as a signalling system it could be of no practical use because the radiations would shoot off at a tangent to the earth and consequently nothing would be heard of them outside a comparatively small radius. Marconi had faith in his method, however, so he transported his receiver across the Atlantic, and showed that signals from England could be heard 3,000 miles away, wherefore the pundits had to think again. An explanation of this distinctly puzzling result was finally offered independently by the English and American physicists, Heaviside and Kenelly. Their suggestion was that the earth was surrounded, like a yolk by its shell, by a blanket in the upper atmosphere that reflected the signals back on to the earth. The kind of blanket that would do this would be a layer of ionised gas molecules, whose height above the earth they calculated as about sixty miles. This layer was our now familiar friend, the Kenelly-Heaviside layer. Many years elapsed before a method was devised to determine its height, but when measurements were made the results were in close agreement with the value predicted. Later on, in the course of some height measurements carried out on the then newly-introduced short waves it was found that the layer sometimes appeared to go up to more than twice its usual height; this phenomenon led Professor Appleton to suggest the existence of a second layer above the first, about 160 miles up, and the new layer, which was christened after its discoverer, is generally regarded as being mainly responsible for long distance transmission of short waves. I will try to explain how these layers actually reflect the wireless waves, but before doing so it is necessary to refresh my reader's memories of an important optical phenomenon.

perpendicular NOM, called the normal by an amount that depends only on the refractive index, so that the ray will follow the path OR. This bending process is called refraction, and the refractive index is a measure of the bending ability of a medium. Now consider the opposite case of a ray starting inside the dense medium, glass in this case, and passing out into a less dense medium such as air; such a ray would be one starting at R and traversing the path ROP, and we see that on emerging into the air it is bent towards the surface of the glass, i.e., the direction of bending is reversed. Let us take this a step farther. There will be one ray starting inside the glass which will be bent so much on emergence that it will come out only just skimming the surface of the glass. Such a ray is AOB in Fig. 1B and the angle between AO and the normal MON (the angle of incidence) is called the critical angle. From this it is quite easy to see that any ray striking the surface at an angle to the normal greater than the critical angle will not emerge at all, but will be completely reflected inside the glass as COD as in Fig. 2. This phenomenon is called total internal reflection.

### Ionised Region of the Atmosphere

Now let us turn to the Heaviside layer. I have referred to it previously as an ionised region and now I must explain this term. A gas molecule is said to be ionised when some external agency supplies enough energy to detach an electron from it so leaving a free electron and a positively charged gas ion. An ionised region of the atmosphere, then, is one which contains a great many atmospheric-gas ions and free electrons; this is the state of the two upper layers. Of course, both ions and electrons will combine with other electrons or ions if they collide and consequently there is a continual recombination of molecules, but since at the same time there is a continual disintegration the aggregate effect is to maintain a constantly ionised layer. The recombination effect, whose

What happens when a ray of light, travelling in the air, passes into a more dense medium such as glass? This depends on the angle at which it strikes the glass and a certain property of the glass called its refractive index. Suppose a ray of light starts in air at the point N in Fig. 1 and follows the path NOM, striking the glass at right angles; in this case it goes

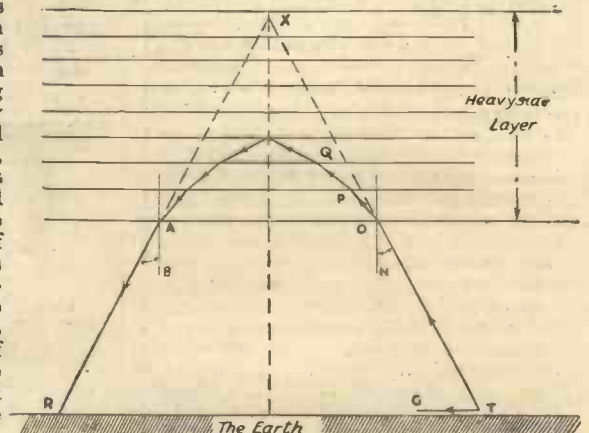

Fig. 3.—Illustrating how a wireless wave returns to earth after passing through the Heaviside layer.



clear from the figure that other things being equal the range of transmission represented by TR will be greater the more the equivalent height increases.

**Refraction of Wireless Waves**

We see then that the process of returning a wireless wave to earth is not truly one of reflection, but of refraction. In the case of long waves, however, the depth the wave penetrates the layer is so small compared with the wavelength that the process may be regarded as true reflection.

The bending power decreases with wavelength and short waves require a higher density of ionisation than long waves. Hence it is easy to see that some waves will be so short that they will not be completely bent round before they reach the upper strata of less highly ionised gas, which will tend to straighten them out again so that they will go right through the layer and not be reflected at all. It is also clear that small angles of incidence TON at the layer will make it necessary for the wave to go farther into the layer before it is bent round and this again may permit some waves to go right through. These short waves will then continue to go upwards until they reach the second, or Appleton, layer, which is much more highly ionised than the first. Here they stand a good chance of being returned, but even this is not enough for very short waves and there are good reasons for believing that waves below about eight metres go clean through the Appleton layer as well so that they are not reflected back to the earth at all.

**Skip Distance Effect**

We must now discuss a phenomenon known as the skip distance effect. A transmitter at T (Fig. 3) can radiate waves in all directions, the ray TO being one particular case, and so in addition to the so-called "air waves" or "indirect waves" to which TO is an example, there is a wave that clings close to the surface of the earth and is called the "ground" or "direct" wave. Because it is so close to the ground it encounters many sources of loss so that it is rapidly reduced in strength, the attenuation increasing very quickly as the wavelength is decreased, a twenty-metre ground wave seldom covering more than twenty miles. Suppose TG in Fig. 3 represents the distance covered by a ground wave and R is the nearest point to T at which the indirect wave is heard; then between G and R there will be a region where no signals at all will be heard; this is called the skipped distance. Skip effects are especially prominent on short waves.

Returning to the indirect wave we have to consider another important effect. Since the atmosphere is not a perfect dielectric waves passing through it will be attenuated, although this attenuation is very small indeed for all except very long waves. When the wave passes into the ionised part of the atmosphere the attenuation becomes very much greater, because it is proportional to the density of free electrons and this is, of course, much higher in the ionised layer than outside, where it is nearly zero. Short waves are also attenuated less than long waves in the ionised regions, which is one of the reasons for their utility for long distance work. In connection with the effect of the sun on radio however, the chief points of importance about the attenuation of waves in the ionised region are that it depends on the intensity of ionisation and the atmospheric pressure in the layer.

# SEND FOR OUR NEW SEASON'S CATALOGUE



**BIGGER & BETTER THAN EVER**

**269 ILLUSTRATIONS**

More Radio Components than ever are included in this New Season's Catalogue. The Guide to Home Constructors.

**ASK FOR CATALOGUE No. 153 "N"**

Enclose 2d. Postage.

*Enclose 2<sup>d</sup> Postage.*

**A. F. BULGIN & CO., ABBEY ROAD, BARKING, ESSEX.**

London Showrooms: 9, 10, 11, Cursitor Street, Chancery Lane, E.C.4. Phone: Grange Wood 3266 & 7. Telephone: Holborn 2072.

## IF YOUR RECEPTION IS GOOD



## WILL MAKE IT PERFECT



The most selective and powerful aerial ever devised. Extra heavy rubber insulation abolishes masts, poles, insulators and separate leads-in. The first and only efficient indoor or invisible aerial. Don't be misled into buying inferior imitations. SUPERIAL is strong, cheap, efficient and lightning proof. £100 Free Lightning Insurance - send in your Form to-day. From all Dealers.

100 ft 3/6 : 75 ft 2/6 : 50 ft 1/9 : 25 ft 1/4  
THE NEW LONDON ELECTRON WORKS LTD 6 EAST HAM LONDON E.6

## Fully Illustrated Throughout

MR. RALPH STRANGER, who is a master of lucidity, has produced in this book a valuable and fully explained synopsis of technical terms that everybody can understand.

## DICTIONARY OF WIRELESS TERMS

By RALPH STRANGER

Obtainable at all Booksellers, or by post 2/9 from George Newnes, Ltd., 8-11, Southampton Street, Strand, London, W.C.2.

2/6

## EASY TERMS

The very latest Radio sets, loudspeakers and kits supplied on the lowest monthly terms. Strict Privacy. Prompt delivery. All carriage paid. Price list free.

- |   |                        |
|---|------------------------|
| New LISSEN SKYSCRAPER ALL-WAVE 4 KIT, with valves, cash £5 12s. 6d. or and 11 monthly payments of 10/3                                  | <b>WITH ORDER 10/-</b> |
| As above, but with cabinet, cash £8 8s. or and 11 monthly payments of 11/9  | <b>11/6</b>            |
| New BLUE SPOT 99 PM UNIT, with transformer (the finest perm. magnet unit available). Cash £2 19s. 6d. or and 11 monthly payments of 5/6 | <b>5/-</b>             |
| New EPOCH, 20c, 20cb, or 20cq UNIT, with trans. Cash £1 15s., or and 6 monthly payments of 5/7  | <b>5/-</b>             |
| New W. B. MICROLODE, PM4A unit with trans. and special matching switch. Cash £2 2s. or and 8 monthly payments of 5/1                    | <b>5/1</b>             |
| MULTITONE CLASS "B" CONVERTER with valve, ready for plugging in to any set. Cash £2 11s. 6d. or and 10 monthly payments of 5/2          | <b>5/-</b>             |
| New ATLAS MODEL CA25 HT ELIMINATOR output 25 MA. Cash £2 19s. 6d. or and 11 monthly payments of 5/6                                     | <b>5/-</b>             |
| New GARRARD AC4 ELECT. GRAMOMOTOR. Cash £2 2s. 6d. or and 8 monthly payments of 5/1   | <b>5/-</b>             |

Interesting descriptive leaflets of any of the above free. To avoid delay will customers kindly send first payment with order.

ESTD. 1925. THE LONDON RADIO SUPPLY COMPANY. PHONE: NATIONAL 1977

## LONDON RADIO SUPPLY COMPANY

11, OAT LANE, NOBLE STREET, LONDON, E.C.2



# THE MAINS SUPPLY CHANGE OVER

An Explanation of the Reasons Governing the Change from D.C. to A.C., and the Advantages Which Will Accrue from the Change. By L. A. HODGES, Grad.I.E.E.

WITH the increased popularity of running wireless sets from the electric supply mains, the change-over system from direct current to alternating current, at present taking place in this country, is having a marked effect on many users of mains-operated sets. To the mains set owner a direct current supply seems to be just what he requires to adapt easily for his high-tension current and battery charging, since no rectifying apparatus is required as with alternating current. However, the current consumed in mains-driven sets is so small that the supply companies cannot let wireless preferences govern the type of electricity that they are to generate and distribute—there are far more important power users to consider.

It will be interesting to see just why a change-over to A.C. is taking place.

## Demand for Standardization

As most readers know, there are at present A.C. and D.C. supplies at varying frequencies and voltages throughout the country. Electricity consumers (including mains set users) cannot with confidence buy a considerable amount of electrical apparatus, because if they move to different parts of the country, or sometimes a different part of the same town, the type of supply may be different and their apparatus rendered useless. Manufacturers cannot quote or supply for electrical apparatus without lengthy inquiries as to the type of electric supply available.

These inconveniences, coupled with the recent rapid growth in the demand for electricity, calls, in a definite manner, for standardization in the voltage and type of current to be supplied. This would give advantages to manufacturers and consumers

alike; further, a standard system should reduce the cost of electrical apparatus and thereby probably increase the demand for electricity still more, and cheapen it. Consequently the big point arises: is it to be universally direct current or universally alternating current.

## Advantages of A.C.

The Central Electricity Board is at present engaged, at a heavy expenditure, in securing the maximum efficiency in the generation and transmission of electrical energy. It seems to be generally accepted that alternating current systems are the better, from the supply company's point of view, as well as from the manufacturer's and the consumer's.

Concerning the electrification of a new area, the advantages of an A.C. system over a D.C. system are summed up as follows: 1. Reduction in capital outlay. 2. Reduction in maintenance and development charges. 3. Reduction in valuation for rating purposes. 4. Increased efficiency, with longer life of plant and network.

## Where D.C. Systems Exist

In areas where a direct current supply exists the increased demand for electricity has caused these systems to be overloaded, and to make proper provision for the future it would, in some cases, be necessary to double or even quadruple the capacity of the system. However, the Electricity Commissioners have decided that in many cases like this it is less expensive to install an A.C. system (concurrent with the advantages of standardization and increased efficiency) to give the total capacity required, than to lay down more D.C. plant

and network to give the extra required capacity. Hence the decision for an A.C. system for distribution throughout the country.

## Concerning the Consumer

The maintenance charges of A.C. motors and control gear are less than those of the corresponding D.C. plant. A.C. is more adaptable to all classes of electric furnaces and heaters. Certain types of high-temperature furnaces, electrode water-heaters, and a large variety of electro-medical apparatus cannot be made for use on D.C. Engineering firms find A.C. a necessity for the many resistance welding methods. For city areas the use of Neon signs as advertisement has brought the advantages of A.C. to the front. Where D.C. systems are already installed the supply companies carry out, at their own expense, any alteration to consumers existing apparatus to make it suitable for the A.C. change-over supply.

These claims for A.C. distribution, in addition to the generating advantages, form an overwhelming case in favour of installing A.C. systems, or where D.C. systems exist, a change-over to a standard supply of alternating current throughout the country.

## Mains Wireless Sets

Concerning mains-operated wireless sets, there seems no doubt that, taking all things into consideration, a set can be operated more efficiently, more safely, and much more economically on A.C. than on D.C.

So that on the whole, the standardization of A.C. supply is all to the good from every one's point of view.

## Making Short-wave Coils

A REALLY neat job may be made of a home-constructed coil, of the type illustrated, if a special but inexpensive former is used for shaping the turns.

This former consists of a round piece of wood, about 2 1/2 in. diameter and 6 in. long—a short length of stout curtain pole will do—with channels cut along it. In these channels are slipped the ebonite spacers, ready drilled with holes to take the wire, which should be 16 or 18 gauge, enamelled. The depth of the channels must be such that the spacing holes come just level with the surface of the former.

The wire is then threaded through the

holes, and bent to the circular shape of the former as it is eased on turn by turn. When the required number of turns is reached,

the whole coil can be slipped off, down the channels, with each turn equally and neatly circular.—W. H. CAZALY (London, W.C.).

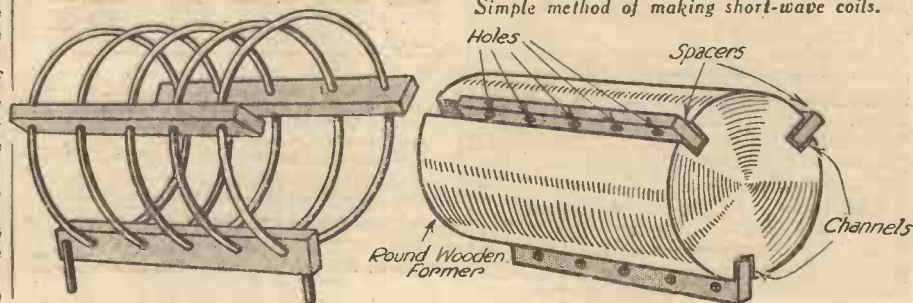



# RADIO CLUBS & SOCIETIES

Club Reports should not exceed 200 words in length and should be received First Post each Monday morning for publication in the following week's issue.

## SLADE RADIO

It was a members' night at the meeting of the above society held last week, and suggestions for lectures were invited, and a very large number of these were forthcoming. After this members were asked to raise questions on any point which had not been clear to them in the lectures during the past quarter. A number of members availed themselves of the opportunity and in each case a satisfactory answer was given. The innovation proved very popular, and will be repeated at a later date. Anyone interested in wireless is invited to attend the meetings, full details of which can be obtained on application.—Hon. Sec., 110, Hillaries Road, Gravelly Hill, Birmingham.

## THE NEW ZEALAND D.X. CLUB

This club welcomes reports from members on stations of interest. Certificates for the best reports of the month will shortly be issued. The "Club Notes" will shortly be here, containing items of interest to every member. New members are welcomed and the fee is only 2s. 6d., which includes membership badge and card. Lists of stations are supplied, and bulletins issued, to make your hobby much more interesting. Those interested should write to Mr. S. Cullen, 33, Dilston Grove, London, S.E.16, the London representative.

## THE KETTERING RADIO AND PHYSICAL SOCIETY

The first annual Radio Exhibition to be held in Kettering will take place on September 14th, 15th and 16th at the Co-operative Central Hall, Kettering. This Exhibition, which is being sponsored by the above Society, will take the form of exhibits by local dealers, and in addition Television, short-wave transmitters and receivers—including those used on 56 m.—and several other experimental sets will be shown.—R. Pankhurst, secretary, 9, Shakespeare Road, Kettering.

## RADIO SOCIETY OF GREAT BRITAIN

The following letter from the British Empire Radio Union (British Section International Amateur Radio Union) has just been received by the High-Vacuum Valve Co., Ltd., 113-117, Farringdon Road, London, E.C.1:—

Sir,  
Attention of Mr. S. de Laszlo.  
On behalf of the Council of the Radio Society of Great Britain, I wish to thank you for the kindness extended to a number of our members on Saturday last, when they were conducted around your works in Farringdon Road, London.

I have had an opportunity of obtaining impressions from several of the persons who were included in the party, and all expressed extreme interest in the methods used for assembly and pumping. As a point of additional interest "Hi-Vac" valves have been recommended by the designers of short-wave receivers and frequency meters described in "A Guide to Amateur Radio," recently published by my Society. "Hi Vac" valves have also been employed successfully in 56 mc/s (5 metre) transmitters and receivers operated by certain of our members. (Signed) JOHN CLARRICOATS, Secretary.

## EXPERIMENTAL TRANSMISSION TESTS

We have received the following letter from Dr. Ceell G. Lemon, Electrical Research Laboratory, 72a, North End Road, West Kensington:—

Sir,  
I am carrying out a series of tests on Radio Transmission utilizing various kinds of transmitting antennae on wavelengths of 42.2 m. (7,007 k/c.) and 5 m. (59,000 k/c.). The times of the transmissions are as follows:—

From Monday to Friday.—5 m.: 10.45 p.m. to 11 p.m., telephony. 42.2 m.: 11 p.m. to 11.15 p.m., telephony.

Sunday.—42.2 m.: 10.30 a.m. to 11 a.m., telephony. 5 m.: 11 a.m. to 11.30 a.m., telephony. 42.2 m.: 11.30 a.m. to 12 noon, telephony.

The tests commenced on Monday, the 28th ult., and will continue till Sunday, the 10th inst. My call sign is G2GL, and the address of the station is given above.

I shall appreciate any reports upon my transmission, and all reports will be duly acknowledged.

C. G. LEMON.

THE SCOTTISH RADIO EXHIBITION  
KELVIN HALL, GLASGOW,  
OUR STAND, No. 17.

MODEL ENGINEER EXHIBITION  
ROYAL HORTICULTURAL HALL,  
WESTMINSTER,  
OUR STAND, No. 35.

# MR. F. J. CAMM CHOOSES THE BEST

hence the Exclusive Specification for

## B. R. G. (TYPE 55) MAINS TRANSFORMER for his latest triumph, the A.C. THREE

INPUT: 200, 210, 220, 230, 240 and 250 volts.

OUTPUT: H.T. Secondary  
250 + 250 volts at 60 m/a.  
Rectifier Filament 2 + 2  
volts at 1 amp. L.T. 2 + 2  
volts at 2.3 amps.

21/-

WITH COLOURED OUTPUT LEADS FOR QUICK ASSEMBLY.  
TYPE 55 WITH OUTPUT TERMINALS IN PLACE 25/-  
OF COLOURED LEADS



## B.R.G. 3-POINT SWITCH No. 48

Solely specified for  
F. J. Camm's  
A.C. THREE.

With specially strong  
phosphor-bronze  
self-cleaning  
contacts. 1/3

# BRITISH RADIOGRAM

Appointed TELSEN WHOLESALERS

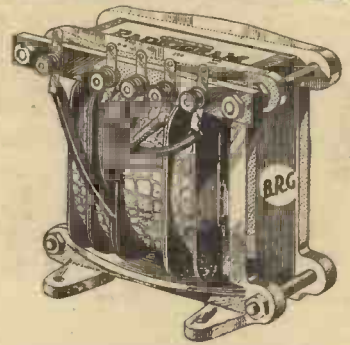

# METAPLEX

WE ARE SOLE WHOLESALE DISTRIBUTORS OF THE NEW METAPLEX CHASSIS, SPECIFIED IN THE NEW A.C. THREE. Price 3/9

B.R.G. components are obtainable from all Dealers. In cases of difficulty send for name and address of nearest stockist. Dealers are invited to send for latest lists of B.R.G. components and Metaplex Baseboards.

BRITISH RADIOGRAMPHONE CO. LTD., Pilot House, Church Street, Stoke Newington, London, N.16

Telephone: GLISSOLD 6287/6288

# "SIR MIKE"

## The Story of a Studio Tyrant

MIKE is a tyrant and a bully. He is only a little chap, too—but I have seen large men and hard-boiled ladies quail before him. I have seen actors with big West-end names, used to playing to crowded houses, gulp convulsively, start to speak their lines, then falter and finally dry up...

AN interesting article explaining difficulties which have to be overcome when using the microphone appears in the September issue.

# HOME MOVIES

## AND HOME TALKIES

URNS BEGINNERS INTO EXPERTS

Obtainable at all Newsagents, Bookstalls and Dealers, or post free 7/6. (Subscription rates: Inland and Abroad 7/6 per annum. Canada, 7/- per annum) from Geo. Newnes, Ltd., 8-11, Southampton Street, Strand, London, W.C.2.



Geo. Newnes, Ltd.





# AMATEURS!

here is  
your 1934  
Guide to  
Mains Power

Why not learn all about running your radio from the electric power supply? The Heyberd Handbook will show you how to build Mains Units, Battery Chargers and Units for energising low voltage M.C. speakers. It tells you how to run your present battery set from A.C. or D.C. mains; how to charge L.T. accumulators in your own kitchen; how to ascertain the working cost of any eliminator or power pack; and how to find the correct resistance for any purpose. Fifteen blueprints are given with a complete list of components required to construct units of varying types. And—in addition—full details of the wide range of Mains Units, Kits, Transformers, Battery Chargers, Amplifiers and Chokes manufactured by Heyberd—the Mains Specialists.

**POST THIS TODAY**

I enclose 3d. stamps for 1934 Handbook "Mains Power for your Radio," completely revised and containing the latest information on mains working.

Mr. ....  
Address .....



MONARCH OF THE MAINS.

10, FINSBURY STREET, LONDON, E.C.2.  
(One minute from Moorgate Und. Sta.)

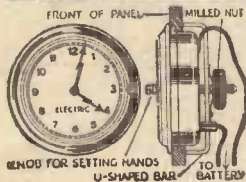

**FIT THIS  
ELECTRIC  
CLOCK  
TO YOUR SET!**  
NO MAINS NEEDED!  
KEEPS CORRECT TIME!  
NO WINDING!

Works off small battery lasting 12 months, or can be plugged into G.B. battery without affecting reception. Uses practically no current. Fits into hole 3 1/2 in. dia. in any panel up to 1/2 in. thick. Easy to fix—no screws required. Only 1/2 in. from front of panel to back of case. Swiss movement. Hands set from front. Nickel-plated bezel. Useful addition to any set.  
**RIVERSIDE MFG. Co., Ltd.**  
Dept. 21, Crisp Road,  
Hammersmith, W.6.  
Telephone: Riverside 6592

**12/6**  
COMPLETE WITH BATTERY  
POSTAGE 6D



**£5 Radio-gram CABINET for 65/- SEVEN DAYS' FREE TRIAL (OR 10/- MONTHLY)**  
Polished Oak and Piano built! The acoustic Tone brings a fine thrill. Makers to Radio-Press, B.B.C., 3,000 clients.  
MODELS FROM 35/- to £15.  
Photographs and List FREE.  
**PICKETTS** Cabinets, Gramophones, Radios, etc.  
(R.P.A. Albion Road, Heston, Middlesex)

**CHARGING WITHOUT MAINS**  
Thousands are charging their own accumulators, why don't you? "TONIC" trickle-charger Kits keep two-volt accumulators fully charged. Ideal for remote districts. From 7/6, postage 9d. Full particulars, stamp.  
**WILLIAMS, Netherend, Cradley, Nr. Birmingham.**

# SOME D.C. DODGES

Useful Hints on the Construction of Simple Eliminators.  
By G. HOWES.

NOWADAYS, owing to the increase of the extent of the grid scheme, listeners on A.C. are generally more often catered for than D.C. listeners. In this article a few hints and circuits

voltage, assuming for this example that the latter is 200 v.

$$\frac{1}{2} = \frac{200}{X}$$

where X is the unknown resistance.

From the above, it is evident that the only value of X which fits is 400 ohms. Therefore the resistance must have a value of 400 ohms: but the power used by the circuit is equal to the current squared times the resistance, i.e.,  $C^2R = \text{power}$  (in watts).

$$\therefore \left(\frac{1}{2}\right)^2 \times 400 = \text{power.}$$

$$= \frac{1 \times 1}{2 \times 2} \times 400 = \frac{1}{4} \times 400 = 100 \text{ watts.}$$

Thus the power used is 100 watts (approximately) and, consequently, a 100-watt lamp can satisfactorily be used. The reason that the power is only approximately 100 watts is that, owing to the fact that the accumulator's 2 volts oppose the mains voltage, only 198 volts are used to pass the current of 1/2 amp. A double pole single throw switch is necessary and should be connected as shown.

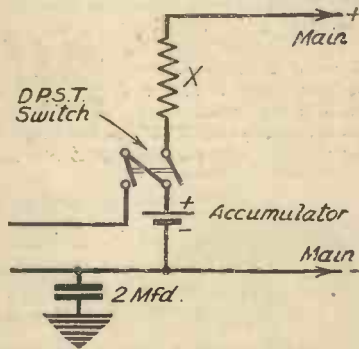

Fig. 1.—How the accumulator may be charged from D.C. mains.

are given which can be applied to any D.C. circuit with success.

**Charging Accumulators**

The first problem is that of obtaining L.T. This either means a periodic journey with an accumulator to a charging station or the use of special D.C. valves and associated resistances. Fig. 1 shows how to charge the accumulator.

To take an example: Suppose a 3-valve receiver takes a total L.T. current of .45 amps. Then some suitable resistance will have to be found to insert at X to pass about 1/2 an amp. To calculate this, use Ohm's Law, i.e., that the current flowing is equal to the voltage divided by the resistance.

Fig. 2.—A cheap eliminator arrangement.

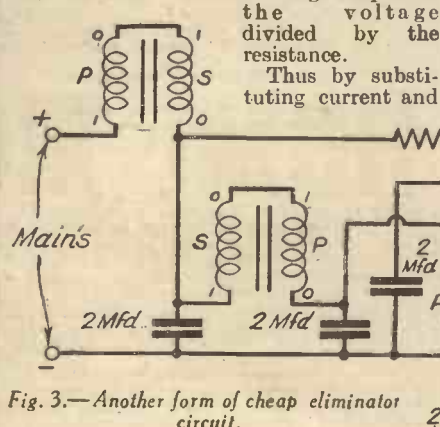

Fig. 3.—Another form of cheap eliminator circuit.

**Eliminator Construction**

After L.T. comes the question of providing H.T., which with D.C. is a fairly easy problem. In Figs. 2 and 3 are shown two circuits, illustrating how ordinary L.F. transformers, new or old, may be used to make eliminators. The additional resistances shown are made by coating strips of marble, stone or asbestos with grate polish. For the potentiometer P (Fig. 3), a strip 2 ins. long and 1/4 in. wide, coated fairly heavily and tapped in the centre, is all that is necessary. The resistances in Figs. 2 and 3 are all about 1 in. long and 1/4 in. to 1/2 in. wide, coated one side only.

With an eliminator made as in Fig. 2, the tappings on the maximum voltage give 40 mA. at approximately 100 volts and 15 mA. at approximately 160 volts.

In view of the fact that these eliminators can be built for a few shillings, they are well worth trying. One word of warning is necessary, however: before manipulating a home-made eliminator, make a stout metal cover to fit over the base-board and apparatus.

This will prevent any danger of receiving shocks, whilst if an earth connection is joined to it, the cover will act as a good screen.





# Practical Letters from Readers.

The Editor does not necessarily agree with opinions expressed by his correspondents

### "Real Reader Service"

SIR,—It is difficult to express in writing my appreciation of your journal. I visited the Radio Exhibition, and had several queries to put to your technical staff. I might say that I received better attention at their hands than at any other stand in the Exhibition. This I consider to be real reader service.

In conclusion, I would like to add that I consider PRACTICAL WIRELESS to be the best paper ever published for the wireless amateur. It has set a very high standard, and kept it up. The show numbers were particularly interesting, and lived up to their title by providing a really practical and efficient guide to the Show.—H. E. QUINN (Highbury).

### Gramovision

SIR,—Besides being interested in wireless I am also interested in television, although, as yet, I don't know much about it. I have a suggestion to make. Why not make a gramophone record of a televised scene. It would facilitate experimenting and making adjustments during the day when none of the available transmitters are working. Of course, the reproduction would not be so good, but I should think it would make a good substitute, like the radio-gram. I am a comparatively new reader, but I must congratulate you on producing such a fine practical paper.—J. G. ECCLES (Beds.).

### A.C. Fury Four Radio-Gram.

SIR,—A few particulars of my "A.C. Fury Four Radio-gram," which I have recently completed, may be of interest. It is absolutely the best set I have handled, and it gave me great pleasure to build. I have built or rebuilt over twenty sets for friends and acquaintances. I completed the whole of the work in a small top back room equipped as a workshop. The set was built last April and actually tested on April 16th (Sunday) at 6.15 p.m. Paris on the long wave at this time came through at almost unbelievable strength and quality. The set and mains pack were simply laid out on a table and the W.B. Speaker propped against the wall. But what a test. Everyone concerned was delighted and, except to reduce the volume, not a thing was altered. I have taken PRACTICAL WIRELESS from the start and look forward to my weekly treat. Many congratulations for such a fine and trouble free A.C. set.—F. C. H. COLE (Harlesden).

### A Bouquet from Rochdale

SIR,—Considering the number of periodicals that have been published on wireless, it is nothing less than wonderful that in these days of perfection, and more or less standardization of reproducing apparatus, you should have evolved a paper which is absolutely practical, remarkably constructional, and at the same time entirely different from any other. To be different

does not always mean better, but in your case, no one could seriously suggest that you were not leading the field. However, I have said enough to show you how much I appreciate your work, and I wish you every success.—HORACE CHADWICK (Rochdale).

### From a Reader in the Far East

SIR,—As a wireless constructor beginner, may I congratulate you on your admirable practical weekly, to which I have been a subscriber since its inception. Also, I can certainly recommend to others the "Short-Wave Two," in "Tested Circuits," by F. J. Camm.

May I point out that you promised, in issue of November 5th, 1932, page 353, to give us the "Experimenter's Short-Wave Three," which is so anxiously awaited by we exiles from home.

I again thank you for such excellent, interesting, and practical articles for the beginner, and trust that we may have more on the Short Waves, which is the band of interest to the wireless enthusiast in this country.—JAS. R. DAY (Rangoon, Burma).

[The article on The Experimenter's Short-Wave Three was published in our other journal, *Hobbies*, for January 21st and 28th, 1933. These issues can be obtained from our publishing department for 8d. post free.—Ed.]

### CUT THIS OUT EACH WEEK

## DO YOU KNOW?

- THAT the product of amperes squared and ohms gives the power in watts.
- THAT the square root of the power in watts divided by ohms gives the current in amps.
- THAT iron has a resistance approximately six times greater than that of copper.
- THAT mercury is nearly ten times greater than this, or approximately sixty times greater than copper.
- THAT a mains transformer should not get hot under normal working conditions.
- THAT practically every form of man-made interference may now be removed.
- THAT special units will shortly be obtainable for incorporating automatic volume control in a receiver.
- THAT the battery superheterodyne will come into its own next season.
- THAT the popular mains multi-stage valves will shortly be obtainable for battery users.

### NOTICE

The Editor will be pleased to consider articles of a practical nature suitable for publication in PRACTICAL WIRELESS. Such articles should be written on one side of the paper only, and should contain the name and address of the sender. Whilst the Editor does not hold himself responsible for manuscripts, every effort will be made to return them if a stamped addressed envelope is enclosed. All correspondence intended for the Editor should be addressed: The Editor, PRACTICAL WIRELESS, Geo. Newnes, Ltd., 8-11, Southampton Street, Strand, W.C.2.

Owing to the rapid progress in the design of wireless apparatus and to our efforts to keep our readers in touch with the latest developments, we give no warranty that apparatus described in our columns is not the subject of letters patent.

## New Times Sales Co

# 1934 RADIO

on the easiest of

## Easy Terms

Choose your NEW RADIO and send us your requirements. We will quote you the Easiest of Terms per return. WE DEAL WITH YOU DIRECT. No Third Party Finance Company, thereby ensuring the strictest privacy. Immediate delivery from stock.

### NEW LISSEN KITS

Free constructional chart with each Kit.

- NEW SKYSCRAPER 7-VALVE SUPER-HET CHASSIS MODEL with Lissen Valves. Cash or C.O.D. Carriage paid, £8/17/6. With 15/- order
- Balance in 11 monthly payments of 16/6.
- NEW SKYSCRAPER FOUR ALL-WAVE CHASSIS MODEL, complete kit comprising all components including set of Lissen Valves. Cash or C.O.D. Carriage paid, £5/12/6. With 10/3 order
- Balance in 11 monthly payments of 10 3.
- NEW LISSEN SKYSCRAPER FOUR ALL-WAVE CONSOLETTA CABINET MODEL, complete kit, comprising all components, including set of Lissen Valves, Cabinet and Moving-coil Speaker. Cash or C.O.D. Carriage paid £8/2/6. With 15/- order
- Balance in 11 monthly payments of 15/-.
- NEW LISSEN SKYSCRAPER 7-VALVE SUPER-HET CONSOLETTA MODEL, complete kit, comprising all components, including set of Lissen Valves, Consolette Cabinet and Permanent Magnet Moving-Coil Speaker. Cash or C.O.D. Carriage paid, £11/10/0. With 21/- order
- Balance in 11 monthly payments of 21/-.

- NEW W.B. TYPE P.M.4A. MICROLODE PERMANENT MAGNET MOVING-COIL SPEAKER, switch-controlled multi-ratio input transformer. Cash or C.O.D. Carriage paid, £2/2/0. With 5/9 order
- Balance in 7 monthly payments of 5/9
- NEW ROLA CLASS-B PERMANENT MAGNET MOVING-COIL SPEAKER AND AMPLIFIER, with Valve and Input Transformer. Two models: A for PM2B, PD220 and 220B; B for 240B, H.P.2 (state which when ordering). Cash or C.O.D. Carriage paid, £3/11/0. With 6/6 order
- Balance in 11 monthly payments of 5/6.
- NEW BLUE SPOT 99P.M. PERMANENT MAGNET MOVING-COIL SPEAKER. Complete with tapped Input Transformer. Cash or C.O.D. Carriage paid, £2/19/6. With 5/6 order
- Balance in 11 monthly payments of 5/6.

### 1934 TELSEN KITS

- TELSEN CLASS "B" 4 KIT (Chassis), less Valves, Cabinet and Speaker. Cash or C.O.D. Carriage paid, £3/17/6. With 7/- order
- Balance in 11 monthly payments of 7/-.
- TELSEN SUPER - SELECTIVE SIX (Chassis), less Valves, Cabinet, and Speaker. Cash or C.O.D. Carriage paid, £5/18/6. With 10/9 order
- Balance in 11 monthly payments of 10/9.
- TELSEN 325 STAR KIT, less Valves and Cabinet. Cash or C.O.D. Carriage paid, £1/19/6. Send 5/3 only
- Balance in 7 monthly payments of 5/3.

- NEW FERRANTI "CLASS B" SUPER POWER CONVERTOR. Instantly converts your present set to "Class B." Complete with valve. Ready assembled. Cash or C.O.D. Carriage paid, £3/3/0. With 5/9 order
- Balance in 11 monthly payments of 5/9
- ATLAS C.A.25, for Mains, Class B and Q.P.P. four tappings; 60/80, 50/90, 120, 150, 25 m.a. With 5/6 order
- Cash or C.O.D. Carriage paid, £2/19/6.
- Balance in 11 monthly payments of 5/6.

Miscellaneous Components, Accessories, Kits, and Parts, Kits supplied CASH, C.O.D., or R.P. in our own private system of Easy Payments. Any item advertised in this journal sent C.O.D. is value over 10/-, sent all C.O.D. charges paid.

To EST. 1924  
NEW TIMES SALES CO. 56, Ludgate Hill, London, E.C.4.

Please send me ..... for which I enclose £ ..... s. d. Cash Deposit

Name .....

Address .....

Pr. W. 9/9/33.



# Facts and Figures

Components Tested in our Laboratory

BY THE PRACTICAL WIRELESS TECHNICAL STAFF

### WARD AND GOLDSTONE COIL SWITCH

SOME very efficient coils are manufactured by Messrs. Ward & Goldstone, but these are not of the type which include a switch in the base. Consequently, when two or more of these coils are included in a receiver it is necessary to arrange a multi-contact switch on the panel and to run wires from each coil to the switch. In some cases this may result in instability unless the wires are efficiently screened. Furthermore, the layout of a receiver with coils arranged in this manner is not always very neat. To overcome these defects Messrs. Ward & Goldstone have introduced a special switch unit chassis, and a two-unit chassis is illustrated below. It will be seen that a solid aluminium baseplate is provided with mounts and a combined switching rod. Cams are provided on this rod, and terminals and contact fingers are fitted to the coil mount. In addition to the wave-change contacts for each coil a S.P.D.T. switch is fitted for

account of its neatness of design and general efficiency. In appearance it is not unlike a large T.C.C. condenser with the double fixing lugs moulded into the case. At the top is a twin-fuse holder, and a substantial earthing terminal. The unit consists of two high-voltage test T.C.C. condensers designed for working on 250 volts raw A.C. or 450 volts D.C. These are joined in series with an earth connection from the centre point, and the input from the mains is connected, *via* a fuse, to each side of the two condensers. This is, of course, the standard method of removing mains interference, and it must be remembered that this will not effect a cure in every case. There are many forms of interference which call for special attention, but where the mains are badly smoothed, or interference from a motor or some similar apparatus is fed to a receiver *via* the mains the unit will be found most useful in removing at least the greater part of the interference. The price is 9s. 6d. complete.

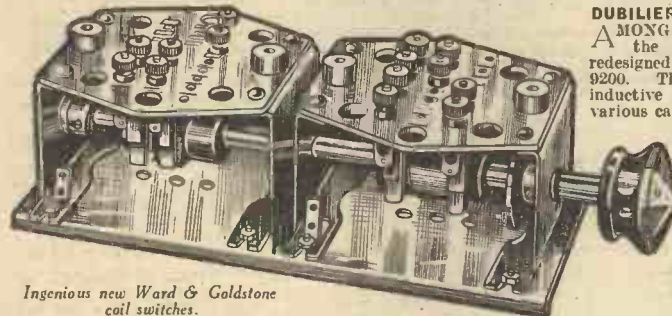

Ingenious new Ward & Goldstone coil switches.

pick-up switching, and a pair of contacts for switching the L.T. supply on and off. A special fitting is also provided at the end of each chassis to accommodate a Q.M.B. switch for use with mains receivers, the chassis in this case costing slightly more than the battery model. The control knob is engraved with indications for "Off," "Medium," "Long" and "Gramo," and the cost of the model illustrated is 8s. 3d. for the battery model, and 9s. 6d. for the mains model. A 4-coil unit costs 15s. and 17s. 6d. respectively.

### J. B. LINAGORE BAND PASS TUNER

MESSRS. JACKSON BROS. have introduced a very neat complete Band Pass Tuner which obviates the difficulties of accurate trimming and ganging. It consists of one of the well-known J.B. three-gang condensers with the addition of three screened iron-core coils, a combined reaction and volume control, and an on/off and radio-gram switch. The complete unit makes the erection of a highly-efficient receiver a really simple matter, and the wiring is reduced to a minimum. The new straight-line dial is fitted to the condenser drive, and the control for this is fitted on the right of the complete assembly. On the left is a combined control for switching, etc., and the straight-line dial is mounted centrally above these two controls. This results in a very neat layout and also enables the complete unit to be built in a very compact manner. The Unit is intended, of course, for a circuit comprising an H.F. valve followed by a detector, and band-pass tuning is provided for the input circuit, and H.F. transformer coupling, with reaction, for the detector grid circuit. The complete unit costs 69s. 6d.

### T.C.C. CONDENSER ANTI-INTERFERENCE UNIT

AMONG the many new interference eliminators which have been introduced this season the new T.C.C. component is one which calls for attention on

### DUBILIER CONDENSERS

AMONG the new developments in the Dubilier components is a redesigned version of the popular type 9200. This is a cylindrical non-inductive condenser, obtainable in various capacities from .1 to 10 mfd.

A difficulty which was previously encountered in this particular model was that the metal case was too near the terminals and short-circuiting sometimes occurred due to the connecting wires coming into contact with the case. In the new design the top is domed and the terminals are so disposed that the risk of shorting is almost removed. In addition the bottom of the metal container is provided with a coarse thread and a small cap is screwed on to the lower end and is fitted with screw holes. The great advantage of this idea is that the small cap may be screwed to the base and any value condenser screwed into it and is then held firmly in position. Changes in values may thus be carried out and the condenser is at the same time held firmly in position. The prices remain unchanged, namely 2s. for the lower value and 16s. for the 10 mfd., with proportional rates for intermediate values.

Some neat dry electrolytic condensers are also announced, and these are obtainable in aluminium cases and also in impregnated cardboard containers with connecting wires fitted to the ends.

These are especially suitable for grid bias smoothing purposes.

### NEW BRITISH RADIOGRAM COMPONENTS

WE have received three interesting new components from the British Radiogram Company, and these include an L.F. Transformer, a Class B Driver transformer and a Class B choke. The Transformer is rated at a ratio of 3 to 1, and has a primary resistance of approximately 1,000 ohms. It is admirably suited for inclusion in the anode circuit of a small L.F. valve, but better results are obviously obtained by means of the parallel-fed arrangement. It is a very small component, measuring less than two inches tall, and being just over one inch wide. The overall response is very good for such a small component, the price of which is not at the moment fixed, but which will probably be about 6s. The Class B Driver has a primary resistance of approximately 300 ohms and the secondary is of similar rating. The ratio is thus 1 to 1, and this renders it suitable for the ordinary

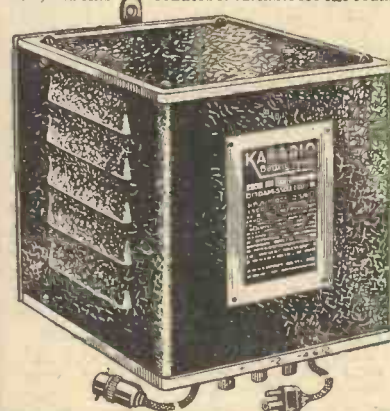

On page 755 of our issue dated August 19th, we included a photograph of two Crypto Chargers, and owing to a misunderstanding described one of these chargers as the Karadio apparatus manufactured by the same firm. The Karadio apparatus, which is manufactured by the Lancashire Dynamo & Crypto Ltd., is illustrated above, and the two pieces of apparatus illustrated on the page above-mentioned are both Valve Rectifier Battery Chargers.

type of Class B valve. A test showed that the component was perfectly satisfactory in all the normal Class B circuits, the inclusion of tone compensating devices acting in a perfectly normal manner. The Output Choke is designed to provide three ratios, namely 1 to 1, 1.5 to 1, and 3 to 1. The total D.C. resistance is only 450 ohms, although, of course, this is of no importance in the Class B circuit. The load offered is suitable for the normal type of Class B valve and results are fully up to standard. The prices of these two Class B components are not yet decided upon, but they will be no doubt in the neighbourhood of seven or eight shillings.

### NEW TELSEN IRON-CORE COIL

AMONG the many new Iron-core coils which we have received, the new Telsen coil possesses many novelties. It is used, as readers will no doubt have noticed, in the new A.C. Three receivers described in this issue, but its various characteristics are not described in that article. The actual dimensions of the coil are smaller than any which we have so far received, and the method of winding also differs in several ways. The former is of bakelite, and the core is inserted from the base. The medium-wave winding is of enamelled wire wound in strict solenoid fashion (in contrast with the majority of Litz section-wound coils now available). The long-wave winding is wound in slots at the lower end of the former, and a reaction winding is situated in these slots and is designed to cover both wavebands without switching complications. To enable the coil to be kept compact no switching is incorporated, and to avoid losses due to inefficient wiring to the coil the reaction winding has been internally connected to one end of one of the windings so that only six terminals are now fitted to the base. The method of winding enables the coil to be used in the aerial circuit (with a periodic aerial coil) or as an H.F. transformer, and the actual windings are so arranged that selectivity and sensitivity are of a much greater order than with the ordinary air-core coil. The coils cost 8s. 6d. each.



The two receivers illustrated above were included on page XV of the Show Supplement in our issue dated August 26th, but the wrong descriptions were applied to them. The receiver on the left is the Varley model A.P.48, a self-contained 5-valve Superhet. The model on the right is Model A.P.52, a Superhet Radiogramophone which includes automatic volume control and other modern refinements.



LET OUR TECHNICAL STAFF SOLVE YOUR PROBLEMS

REPLIES TO



QUERIES and ENQUIRIES by Our Technical Staff

The coupon on this page must be attached to every query.

If a postal reply is desired, a stamped addressed envelope must be enclosed. Every query and drawing which is sent must bear the name and address of the sender. Send your queries to the Editor, PRACTICAL WIRELESS, Geo. Newnes, Ltd., 8-11, Southampton St., Strand, London, W.C.2.

SPECIAL NOTE

We wish to draw the reader's attention to the fact that the Queries Service is intended only for the solution of problems or difficulties arising from the construction of receivers described in our pages, from articles appearing in our pages, or on general wireless matters. We regret that we cannot, for obvious reasons—

- (1) Supply circuit diagrams of complete multi-valve receivers.
- (2) Suggest alterations or modifications of receivers described in our contemporaries.
- (3) Suggest alterations or modifications to commercial receivers.
- (4) Answer queries over the telephone.

Please note also, that all sketches and drawings which are sent to us should bear the name and address of the sender.

SCREENING LEADS

"I am building a mains receiver, and think it advisable to screen some of the leads. I know that special screening sleeving is obtainable, but being an electrician I have quite a lot of lead-covered lighting cable on hand. Is there any objection to my using this for wiring, and connecting the lead covering to earth? I believe that lead is as good as the ordinary thin copper screening that is used, but should like your confirmation."—W. T. (Bromley.)

We do not recommend the use of the wire you specify. From your remarks we believe that you intend to use the wire for all leads, which would certainly not do. Certainly one or two leads may be screened with advantage, but the indiscriminate use of covered wire (especially with the large surface which is exposed in such wire) will inevitably lead to instability. Where you do employ this wire, make quite certain that the earth connection is of low resistance, by scraping the surface of the lead cable before wrapping the connecting wire round it.

on the panel, this would result in a grid lead being brought from the coil up to the panel and then back to the grid wire, resulting inevitably in hum or instability. If you must use your cabinet you will have to install your own remote control for the switch, but we must remind you that the receiver has been designed as a whole to be fitted into the Osborn cabinet, wherein the switch is easily controllable.

BUILDING RECEIVERS FROM OLD COMPONENTS

We have had many requests from readers who wish to build modern receivers described in our pages, and who also wish to utilize the components from an existing set. In many cases these sets are two or three years old and we do not, therefore, recommend the use of the old parts in the construction of modern receivers. Whilst in many cases the components may be of high-class design and quite expensive in their time, they may be quite unsuited for inclusion in a modern receiver, due to their physical characteristics as well as their electrical characteristics. If, therefore, you wish to build one of our Guaranteed Designs, and have a receiver already in use, our advice is to try and sell the present receiver complete, and purchase the new parts for the new receiver. This will not only save disappointment, but will result in the acquisition of modern apparatus which will give the utmost satisfaction.

DATA SHEET No. 51.

Cut this out each week and paste it in a notebook

OUTPUT TRANSFORMER RATIOS

| Valve impedance. ohms. | Speech coil impedance. ohms. | Transformer Ratio. |
|------------------------|------------------------------|--------------------|
| 1,000                  | 4                            | 22 to 1            |
|                        | 10                           | 15 to 1            |
|                        | 14                           | 12 to 1            |
| 2,000                  | 4                            | 33 to 1            |
|                        | 10                           | 20 to 1            |
|                        | 14                           | 15 to 1            |
| 4,000                  | 4                            | 45 to 1            |
|                        | 10                           | 25 to 1            |
|                        | 14                           | 22 to 1            |
| 8,000                  | 4                            | 65 to 1            |
|                        | 10                           | 40 to 1            |
|                        | 14                           | 33 to 1            |

NOTE.—The ratios given are the nearest commercial ranges which are obtainable. The Impedance of a speech coil is approximately double the D.C. resistance.

PICK-UP SWITCH AND SUPERSSET

"I have examined your new set, the Superset, and should very much like to make this up. Unfortunately, however, I notice that the pick-up switch is on the back of the baseboard, and this will be impossible to operate from the front of the receiver. As I wish to put the gramophone in a radio-gramophone cabinet I am unable to make the set, as I cannot use the switch. Can you give your reasons for putting the switch in such an awkward position, and let me know whether I can put it in a sane position on the front of the panel."—G. J. (Nottingham).

We are afraid you have overlooked the theoretical considerations which govern the design of a receiver in an endeavour to make the receiver suit your own requirements. First of all it should be unnecessary to point out that the grid lead is broken to insert the gramophone switch, and if the switch were mounted

ADDING AN L.F. VALVE TO THE FEATHERWEIGHT

"I live in the remote districts of Cornwall, and have built the Featherweight Portable. This gives splendid results on several stations, but I find that Daventry 5XX, and several long-wave foreigners are not sufficiently loud to be really comfortable. The volume on the West Regional is more than sufficient for home use, and several other short-wave stations come in at similar strength, but I cannot build quite a lot up to what I call full room strength. Would you advise me to add a stage of L.F. coupling between the detector and the driver valves? If so, what will be the connections?"—G. H. (St. Ives).

We certainly do not recommend any alteration to the published circuits which appear in PRACTICAL WIRELESS, but you may, of course, build a receiver to incorporate the arrangements which we show. Thus, you may build a five-valve portable, in which the arrangement of the Featherweight is utilized, plus an intermediate L.F. stage, but we must remind you that we do not guarantee such a circuit, nor can we undertake to help you in redesigning the circuit. A great deal of time and thought is expended in arranging a receiver to function satisfactorily, and the whole lay-out may have to be changed in order to insert your intermediate L.F. stage, with the result that you may spend many days before you get the set in a stable and efficient condition.

FREE ADVICE BUREAU COUPON

This coupon is available until Sept. 16th, 1933, and must be attached to all letters containing queries.

PRACTICAL WIRELESS, 9/9/33.

H.F. INSTABILITY

"My receiver has been built up from ideas which I have obtained through reading your interesting book. I have adapted various components which I have had by me, and the result is shown on the attached sheet. Unfortunately, I have apparently not yet fully understood wireless, as the set won't work. Can you offer any suggestions as to the reason. When I switch on all I can hear is a high-pitched whistle, and I have yet to hear a broadcasting station. Any suggestions will be thankfully accepted."—T. G. B. (Preston, Lanes.).

You do not give any details regarding the actual results which are obtained, and it is therefore rather difficult to offer a really helpful suggestion. However, after carefully examining the layout and the various parts which you have bought or used, and bearing in mind your remarks regarding a whistle, we are definitely of the opinion that the H.F. side is unstable. You should at least screen the coils from one another, as well as arrange the parts in a more regular manner. The whole arrangement is rather haphazard, and as you are using a rather efficient valve we think you will find that it will be very difficult to stabilize the circuit without adequate screening between the two H.F. and detector stages. We shall be glad to help you again if this does not result in stabilizing the circuit.

UNDISTORTED OUTPUT

"I am very anxious to work out the various technical details of my receiver, and your data sheets and other interesting data has been of great use to me. Unfortunately, I have not yet found a formula for working out the undistorted output from a power valve, and I should like to find this out for myself without accepting the valve-maker's figures. Can you give me the formula for working this out?"—A. L. (Kensington).

There are several different ways of working out the undistorted output of a valve, but the following formula will probably be found the most accurate:—

$$\text{Output} = \frac{kI}{2} (V - kIR_1) \text{ watts.}$$

- where
- kI = 6 I.
- I = Normal anode current (in amps).
- V = NgV.
- n = Amplification factor.
- G = Normal Grid Bias.
- R<sub>1</sub> = Valve impedance.



1934 KITS ELIMINATORS COMPONENTS ...

Please send ALL your HIRE PURCHASE ORDERS to Peto-Scott Co. Ltd.

77, City Rd. London, E.C.1

Telephone: Clerkenwell 9406/7 Adv. of Peto-Scott Co., Ltd.



# CATALOGUES RECEIVED

To save readers trouble, we undertake to send on catalogues of any of our advertisers. Merely state, on a postcard, the names of the firms from whom you require catalogues, and address it to "Catalogue," PRACTICAL WIRELESS, Gro. Newnes, Ltd., 8/11, Southampton St., Strand, London, W.C.2. Where advertisers make a charge, or require postage, this should be enclosed with applications for catalogues. No other correspondence whatsoever should be enclosed.

## UTILITY COMPONENTS

SEVERAL new lines are shown in the new season's catalogue just issued by Wilkins and Wright, Ltd., including Mite Gang Condensers. These are small but efficient instruments and are obtainable either with diecast or steel frames. Bakelite ganged and single condensers with disc dials; full vision dials; micro-dials; a straight line dial complete with a .0005 condenser; a combined volume control and reaction condenser; and anti-capacity switches with silver contacts are amongst other new components listed. Constructors desirous of using high quality components of modern design in their sets would do well to obtain a copy of this catalogue. The address is Utility Works, Holyhead Road, Birmingham, 21.

## COLUMBIA RECEIVERS AND RADIOGRAMS

WE have received two folders from the Columbia Graphophone Co., Ltd., one dealing with the C.Q.A. Battery Four, a high-class receiver giving tone and volume comparable to an all-electric equivalent model. Embodying three-stage band-pass tuning, Q.P.-P. pentode amplification, and a P.M. moving-coil speaker. This model is priced at eleven guineas. The other folder deals with the C.Q.A. Battery Radiogram, a high-class instrument embodying all the latest improvements, the selling price of which is twenty guineas. Interested readers can obtain copies of these folders by applying to the firm at 98-108, Clerkenwell Road, London, E.C.1.

## G.E.C. RADIO

AN attractive folder issued by the General Electric Co., Ltd., displays a new range of superhet. all-mains receivers. Two 5-valve models, one for table use, priced at fourteen guineas, and the other of the console type priced at seventeen guineas, are shown, and also two 8-valve models. The table model in this series is listed at twenty-one guineas, and the console model at twenty-four guineas. There is also the G.E.C. Superhet 5 Radiogram, priced at twenty-five guineas. All the 5-valve models are fitted with an illuminated index dial, a moving pointer indicating the name and wavelength of the station received on a full vision illuminated tuning scale. The 8-valve models have a vertical tuning indicator, a moving oblong of distinctive colour indicating the wave band. Keen selectivity, ample volume, and flexibility of control are appealing features of these fine sets. A copy of the folder can be obtained from Magnet House, Kingsway, London, W.C.2. Ask for G.E.C. Radio, 1933-4 Folder.

## FULLER BATTERIES

FOR upwards of sixty years the name of Fuller has been associated with battery construction, coupled with the highest possible quality of materials. This reputation is fully maintained in the range of accumulators and dry batteries shown in this firm's latest price list. Accumulators suitable for multi-valve receivers, or for lighting and ignition purposes are obtainable in glass, celluloid or ebonite cases. There is also a range of Fuller 2-volt "Non-Spill" accumulators, and dry batteries for all purposes. Copies of this list can be obtained from Fuller Accumulator Co., Ltd., Woodland Works, Chadwell Heath, Essex.

## VARLEY COMPONENTS

A FINE range of Varley components is given in this firm's new season's list. Particulars and prices of "Nicore" tuning coils, together with their associated equipment, are given; also the "Nicore" A.V.C. Unit, a compact and efficient little component which enables automatic volume control to be fitted to almost any type of receiver. Other components include a compensating R.C. coupling unit, power potentiometers, wire-wound resistances, L.F. transformers, various Q.P.-P. and Class "B" components, and a useful range of L.F. chokes. Messrs. Varley have also sent us a batch of instruction folders with diagrams showing the connections for their components in various circuits. These folders should prove very useful to home constructors, who can obtain copies of the catalogue and folders from Kingsway House, 108, Kingsway, London, W.C.2.

## THE COSOR 3456 MODEL

In our issue dated August 5th, 1933, we gave a test report of the new Cosor 3456 Model receiver. In this article the price was erroneously given as £19 19s. It should, of course, have been £9 19s.

## THE THREE-STAR NICORE

We described, in our issue dated June 24th last, a receiver with the name "The Three-Star Nicore." In this receiver a unique component known as the Duovol was employed for controlling reaction and the bias on the H.F. valve on a single control. The makers of this component, The British Radiophone, Ltd., now inform us that they have decided to withdraw this component owing to the fact that it is difficult to set this control to give smooth working on the various types of valve which might be obtained by the constructor. Consequently, it will be necessary to employ two separate components in future models of this receiver, and a new circuit will appear in our pages in due course.

## CHANGE OF ADDRESS

SIR,—We beg to advise you that we have removed our offices and stores from 129, Park Lane, to:—54, WELLINGTON STREET, LEEDS, 1, where new premises have been prepared for us containing larger office and stores accommodation, which will enable us to hold more comprehensive stocks of goods manufactured and dealt in by us. We

shall also have extensive showrooms displaying modern lighting fittings, domestic electrical apparatus, telephone equipment and industrial electrical materials. Our telephone number—Leeds 27395 (Private Branch Exchange)—and telegraphic address—"SIEMENS, LEEDS"—remain unchanged. SIEMENS ELECTRIC LAMPS AND SUPPLIES, LIMITED, A. M. Hicks, Secretary.

## "THE ALL-WAVE TWO"—PETO-SCOTT PRICE CORRECTION

In the advertisement of Peto-Scott Ltd., which appeared in our August 26th issue the details and price of the Kit A were omitted, owing to an error in proof reading. The wording of the advertisement should read "Kit A Authors kit of first specified parts including Peto-Scott Metaplex chassis, ready drilled panel, but less valves, cabinet, and speaker. Cash or C.O.D. Carriage Paid £4 2s. 0d."

## ● by RIDGWELL CULLUM

THIS absorbing story of life in a gold-rush camp, tells of "Bull Moose," a mysterious renegade white and leader of a murderous tribe of Indians who pillage the prospectors of their hard-won gold. Undoubtedly Ridgwell Cullum at his best.

# The BULL MOOSE

It's a Newnes' Novel

On sale at all Newsagents and Bookstalls, or by post, 2/6, from George Newnes, Ltd., 8-11, Southampton Street, Strand, London, W.C.2.

2/6



The novel Mullard Stand at Radiolympia.

# ADVERTISEMENT INDEX

|   |                    |
|---|--------------------|
| Aerialite Ltd. ....                       | 911                |
| British General Mfg. Co., Ltd. ....       | 911                |
| Block Batteries, Ltd. ....                | 919                |
| British Blue Spot Co. ....                | 916                |
| British Radio-gramophone Co., Ltd. ....   | 927                |
| Bulgin, A. F. & Co., Ltd. ....            | 925                |
| Carrington Mfg. Co., Ltd. ....            | 882                |
| Cosor A.C. Ltd. ....                      | 884                |
| Dubilier Condenser Co. (1925), Ltd. ....  | Inside Front Cover |
| Edison Swan Electric Co., Ltd. ....       | 883 and Back Cover |
| General Electric Co., Ltd. ....           | 897                |
| Graham-Farish, Ltd. ....                  | 916                |
| Grosvenor Electric Batteries, Ltd. ....   | 916                |
| Hayber, F. C. & Co. ....                  | 928                |
| Heraud, E. J., Ltd. ....                  | 918                |
| Igranic Electric Co., Ltd. ....           | 881                |
| Lectro Linc, Ltd. ....                    | 915                |
| Lissen, Ltd. ....                         | 890 and 903        |
| London Radio Supply Co. ....              | 925                |
| Mullard Wireless Service Co., Ltd. ....   | 893                |
| Newnes' Dictionary of Wireless Terms .... | 925                |
| Newnes' "Home Mechanic" ....              | Inside Back Cover  |

|  |             |
|--|-------------|
| Newnes' "Home Movies" ....                             | 927         |
| Newnes' "Tit-Bits" ....                                | 882         |
| Newnes' Wireless Constructor's Encyclopaedia ....      | 929         |
| New Times Sales Co. ....                               | 925         |
| New London Electron Works ....                         | 909 and 931 |
| Peto-Scott, Ltd. ....                                  | 912         |
| Osdur Mfg. Co. ....                                    | 928         |
| Picketts ....  | 883         |
| Reproducers & Amplifiers, Ltd. ....                    | 928         |
| Riverside Mfg. Co., Ltd. ....                          | 898 and 905 |
| Telsen Electric Co., Ltd. ....                         | 923         |
| Telegraph Condenser Co. ....                           | 900         |
| The Gramophone Co., Ltd. ....                          | 912         |
| The 362 Radio Valve Co., Ltd. ....                     | 882         |
| Tungstram Electric Lamp Works (Gt. Britain), Ltd. .... | 915         |
| Ward & Goldstone, Ltd. ....                            | 882         |
| Westinghouse Brake & Saxby Signal Co., Ltd. ....       | 911         |
| Whiteley Electrical Radio Co. ....                     | 917         |
| Wilkins & Wright ....                                  | 913         |
| Wingrove & Rogers ....                                 | 928         |
| Williams ....  | 928         |

## REPLIES TO BROADCAST QUERIES

MOSS (Exeter): Many thanks for your information. RAC WIRE (Poplar): Athlone (IFS); sponsored concert. The announcements are in English and Gaelic. MEACHEM (Bletchley): PAOLM, Dutch experimental amateur (M. B. Gorter, 30, Pieter de Hooghstraat, Amsterdam); (2) Cannot trace GB6AD, as call appears to be incorrect. The call-letters of the s.s. Bremen are DDAS; (3) Details required by transmitters are: Call heard, locality of receiver, time of reception, signal strength; receiver used, quality of transmission and any other information you may care to give. PRALESS (Glasgow): PAOOPA, J. W. Wehkamp, Radio Centrale, Markt, 21, Coevorden (Holland); cannot trace PAOQPA and PAOLOP in latest lists. Advise you to write to *Nederlandsche Vereeniging voor Internationale Radio Amateursime, Post Box 400, Rotterdam (Holland)*. We do not know the address of GGZT; would advise you to send your advice of reception to Radio Society of Great Britain, 53, Victoria Street, London, S.W.1.



# PRACTICAL HANDBOOKS

Clearly written and fully illustrated.

This series covers a wide field and will prove of the greatest value to everyone interested in models and how to make them; woodwork and other crafts.

## ACCUMULATORS

An up-to-date handbook dealing with every type of accumulator, methods of charging them at home, care and maintenance, also explains how to erect a charging station.

## MOTOR CAR UPKEEP AND OVERHAUL

Information covering the engine, decarbonising, valve grinding, the lighting system, the carburettor, cooling system, lubrication, springs and shock absorbers, steering gear, brakes, wheels, axles, tracing noises, etc. etc.

## TOY MAKING FOR AMATEURS

How to make clockwork toys, model aeroplanes, model locomotives, model boats, ingenious toys operated by sand, wooden models and toys, electrical toys, steam toys, guns, kaleidoscopes, acrobats, etc.

## SIMPLE ELECTRICAL APPARATUS

An excellent little book for those who wish to make simple and useful electrical appliances, such as galvanometers, electric motors, dynamos and Leyden jars.

## MODEL BOAT BUILDING

Contains designs for battleship, speed boat, paddle steamer and yachts. Excellent models can be built with the simple directions and diagrams given.

## THE HOME WOODWORKER

Clear instructions on how to make a large variety of articles in wood, together with many useful hints on wood-working.

## MODEL AEROPLANES AND AIRSHIPS

Contains full descriptions of easy-to-make models of every description that will fly.

## THE HANDYMAN'S ENQUIRE WITHIN

Hundreds of practical ideas and hints of value to the man who is clever with his hands.

## 25 SIMPLE WORKING MODELS

Ingenious and practical designs for electric, steam and clock-work models.

# NEWNES' HOME MECHANIC BOOKS

Obtainable at all Newsagents and Bookstalls, or by post 1/2 each from George Newnes, Ltd., 8-11, Southampton St., Strand, W.C.2.

**1/-**  
each

Geo. Newnes, Ltd.

# 'LISTENERS IN'!

## LOOK UP YOUR WIRELESS LICENCE IT MAY BE WORTH £50

 Compare your number and claim your reward

**£50** will be paid to holder of Licence No. AN 771316

**£25** will be paid to holders of Licences: Nos. AP 367735 AM 178037

**£10** will be paid to holders of Licences: Nos. AO 944188 AQ 580611

**£5** will be paid to holders of Licences: AP 148320 AO 848605 AQ 177056 AM 867999 AN 244733

**£2** will be paid to holders of Licences:

|           |           |           |           |           |           |           |
|-----------|-----------|-----------|-----------|-----------|-----------|-----------|
| AH 843302 | AK 326700 | AM 168938 | AN 238060 | AO 212645 | AP 22259  | AP 882522 |
| AI 117794 | AK 810259 | AM 544619 | AN 712884 | AO 637742 | AP 042607 | AP 330639 |
| AJ 199628 | AM 456831 | AM 053656 | AN 821810 | AO 834937 | AP 219530 | AP 762903 |
| AJ 50234  | AM 887209 | AM 734467 | AN 067155 | AO 059402 | AP 110405 | AP 082644 |
| AJ 396322 | AM 661824 | AN 952603 | AN 171204 | AO 181020 | AP 588864 | AQ 203620 |
| AK 008793 | AM 973914 | AN 496084 | AN 528333 | AO 488893 | AP 912278 | AQ 797436 |

**£1** will be paid to holders of Licences:

|           |           |           |           |           |           |           |
|-----------|-----------|-----------|-----------|-----------|-----------|-----------|
| AH 923642 | AJ 006385 | AL 100894 | AN 146931 | AN 538921 | AO 511816 | AP 118246 |
| AH 71631  | AJ 39042  | AM 801655 | AN 473913 | AO 802780 | AO 368432 | AP 822769 |
| AH 557643 | AJ 593922 | AM 482592 | AN 006894 | AO 183087 | AO 992389 | AP 692435 |
| AI 605801 | AL 500703 | AM 228879 | AN 951448 | AO 181555 | AO 867230 | AP 738950 |
| AI 248879 | AL 826945 | AM 374818 | AN 248752 | AO 795368 | AP 638005 | AP 330025 |
| AI 932016 | AL 54029  | AM 748744 | AN 384100 | AO 886931 | AP 027468 | AP 820589 |
| AI 368777 | AL 432116 | AM 709999 | AN 872808 | AO 415589 | AP 218332 | AP 655498 |
| AJ 211794 | AL 789943 | AN 869730 | AN 434659 | AO 350700 | AP 054009 | AP 286133 |

 This offer applies to licences which are actually in force on Saturday, September 9, 1933.

Before the awards are paid, claimants will be asked to undertake a simple publicity service in distributing leaflets to encourage the sale of licences amongst those who at present do not fulfil their obligations by taking out a Post Office Wireless Licence before receiving broadcast programmes. Claims cannot be considered in connection with any Licence the date of issue of which is after September 7, 1933.

For full particulars for claiming awards and a complete list of numbers see

# TIT-BITS

ON SALE EVERYWHERE SATURDAY SEPT. 9.



PURVEYORS OF  
ELECTRIC LAMPS  
BY APPOINTMENT



# EDISWAN



MANUFACTURERS  
& PURVEYORS OF  
ELECTRIC LAMPS  
BY APPOINTMENT



# some take chances ...

# others buy



Research goes on all the while in every radio valve laboratory, and every once in a while (but not nearly as often as you might suppose!), there is a real step forward in valve design or construction. But the real all-day and every-day problem of the valve maker is to achieve reliability! It is reliability that has brought Mazda right up to the top in the last three or four years. And it is because of reliability that Mazda will remain there.

# MAZDA

THE  
**SAFETY  
VALVE**



*Mazda Radio Valves are manufactured in Gt. Britain for The British Thomson-Houston Co. Ltd., London & Rugby*

THE EDISON SWAN ELECTRIC CO. LTD., 155, CHARING CROSS ROAD, W.C.2.

P. W. Gift Stamp No. 50

Printed by NEWNES & PEARSON PRINTING CO., LTD., Exmoor Street, Ladbroke Grove, W.10, and published by GEORGE NEWNES, LTD., 8-11, Southampton Street, Strand, W.C.2. Sole Agents for Australia and New Zealand: GORDON & GOTCH, LTD. South Africa: CENTRAL NEWS AGENCY, LTD. *Practical Wireless* can be sent to any part of the world, post free, for 17/4 per annum; six months, 8/8. Registered at the General Post Office for Transmission by Canadian Magazine Post.



STUPENDOUS FREE GIFT NEXT WEEK!

# Practical Wireless

3<sup>D</sup>

Published every Wednesday by

**GEORGE  
NEWNES  
LTD.**

Vol. 2. — No. 52.

SEPTEMBER 16th, 1933.

Registered at the G.P.O. as a Newspaper.

EDITED BY F. J. CAMM.

## BUILDING THE



**MAINS SHORT-WAVE-  
RECEIVERS**

**ALL ABOUT  
BAND-PASS FILTERS**

**LESSONS OF  
RADIOLYMPIA**

**WHY THAT FADING?**

**HOW MANY KNOBS?  
Etc., etc.**



## RECEPTRU

FOR TRUE RECEPTION

—the wonderful new low loss lead in cable definitely eliminates crackle, background noises, mush and all man-made static. It improves selectivity and increases sensitivity. Get one to-day. You can fix it in less than five minutes.

**OF ALL DEALERS** in lengths of 15 feet 10/-  
Longer sizes at proportionate prices.

BRITISH RADIOPHONE LTD., ALDWYCH HOUSE, LONDON, W.C.2



# IGRANIC

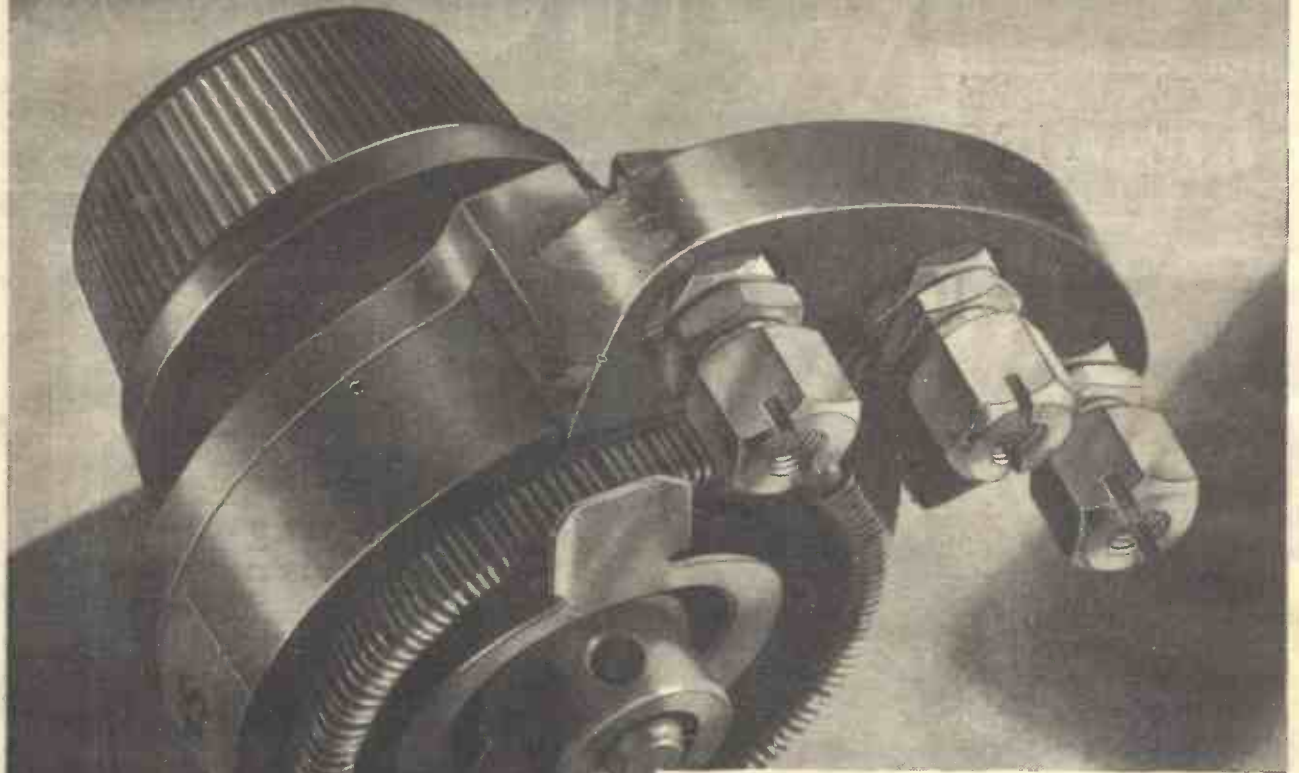

The Igran Variable "Megostat" High Resistance. Designed and constructed to the highest standards of radio engineering—finish in keeping with the reputation of Igran—special contact preventing wear and ensuring constant resistance value—can be used as a volume or tone control, as a variable grid leak or as stabilising resistance, etc., in single-hole fixing—at the reduced price of 3/6 in four sizes—another example of that efficiency of performance and reasonableness in price which are typical of every item in the Igran range. Let Igran Components be the making of your set.



Send for fully illustrated Catalogue No. J.1271

If you cannot obtain Igran Components, write to us direct and include the name of your local dealer.

Igran Electric Co., Ltd.,  
149, Queen Victoria Street, E.C.4.

OTS-91



# YOU BE THE JUDGE



# "I present to you INCONTESTABLE EVIDENCE

... I place before you the actual EVIDENCE of where your set is right or wrong. I am giving you conclusive and all-inclusive evidence of radio faults and efficiency. I give you—not just the circumstantial evidence of amperes, volts and ohms, no mere hypothesis, but proved and tested ACCURACY. I present the precision of the AvoMinor, a younger brother of the famous Avometer, the instrument that is so accurate and efficient that it is preferred and insisted upon by the world's foremost technical experts and service engineers. This in itself is evidence enough that nothing less than the AvoMinor is dependable enough for you.

# The AVOMINOR

TRADE MARK

# TELLS THE WHOLE TRUTH

Now YOU can test YOUR set—examine it, locate the faults, get first-class results from it—with the ease and precision of the technical expert. You can test ACCURATELY with the AvoMinor—test circuits, valves, components, batteries and power units. There is no test you need that you cannot make with the AvoMinor. It gives TEN different ranges of readings in milliamps, volts and ohms. It is a moving-coil combination testing instrument with a total resistance of 100,000 ohms. Full scale deflection is obtained with only 3 milliamps. No other instrument in the world gives you, at such a convenient price, so many tests with such dependable accuracy.

*Ask your radio dealer to show you the AvoMinor. Be satisfied with nothing less. Remember, it's accuracy that is all important. In case of difficulty, write for fully descriptive folder.*

THE AUTOMATIC COIL WINDER & ELECTRICAL EQUIPMENT CO., LTD.,  
Winder House, Douglas Street, London, S.W.1. Telephone: Victoria 3405-7.



DEFERRED TERMS if desired. Write for particulars.

Complete in handsome case with pair of leads and interchangeable crocodile clips and testing prods.



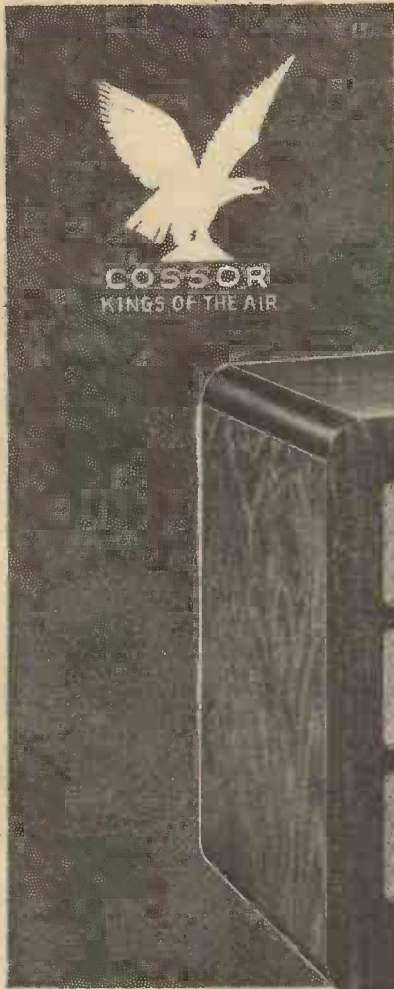

NEVER BEFORE SUCH RANGE . . .

SUCH SELECTIVITY . . . SUCH

TRUE-TO-LIFE TONE AT SUCH

MODEST PRICES



# The COSSOR MELODY MAKER

VARIABLE-MU  
SCREENED GRID  
CIRCUIT

PENTODE, CLASS "B" or  
MAINS POWER OUTPUT

BALANCED ARMATURE  
or  
MOVING COIL  
LOUD SPEAKER

BATTERY  
or ALL-ELECTRIC

Up-to-the minute in design, incorporating Variable-Mu S.G. stage, fully shielded high-efficiency coils, single dial tuning etc., this remarkable new Cossor Melody Maker is exceptional value. Capable of bringing in a wide choice of programmes this powerful Receiver is, in every way, equal to much more costly Sets. Yet, in spite of its efficiency, it is so simple that you can build it at home. No wireless knowledge necessary. Send at once for Constructional Chart—use the coupon.

To A. C. Cossor Ltd., Melody Dept., Highbury Grove, London N.5

Please send me a Constructional Chart which tells me how to build a Cossor Melody Maker Model No. ....

NAME .....

ADDRESS .....

PRAC. 14/9/33

## SPECIFICATIONS

### BATTERY MODEL 344 PENTODE OUTPUT

#### Balanced Armature Loud Speaker

Complete Kit of Parts for assembling Cossor Melody Maker, Model 344, similar to illustration, including Cossor Variable-Mu Screened Grid, Cossor Detector, and Cossor Pentode Valves. Fully screened coils, Double-Gang Condenser, Combined Volume Control and On-Off Switch, all-metal chassis, and all the parts for simple home assembly. Hand-some cabinet 18 1/2" x 13 1/2" x 10", space for batteries and accumulator. Balanced Armature Speaker; provision for Gramophone Pick-up Plug and Jack. Wave-length range 200/530 and 900/2,000 metres. Price **£6.7.6**

Hire Purchase Terms 16/- deposit and 10 monthly payments of 12/6 or alternatively 20/- deposit and 6 monthly payments of 20/-

### BATTERY MODEL 342 MOVING COIL LOUD SPEAKER

Complete Kit of Parts similar to Model 344 described above, except that it is supplied with a Permanent Magnet Moving Coil Loud Speaker. Price **£7.2.6**

Hire Purchase Terms 17/6 deposit and 9 monthly payments of 15/6

### BATTERY MODEL 344 CLASS "B" OUTPUT

Complete Kit of Parts as Model 344 described above, but with four Cossor Valves, Class "B" Output Stage and Permanent Magnet Moving Coil Loud Speaker. Price **£8.2.6**

Hire Purchase Terms 20/- deposit and 10 monthly payments of 16/-

### ALL-ELECTRIC MODEL 347

Complete Kit of Parts, similar to Model 344 described above, but with four Cossor A.C. Mains Valves. Factory-built and tested Power Unit and Mains Energised Moving Coil Loud Speaker. For A.C. Mains only 200/250 volts (adjustable) 40/100 cycles. Price **£8.19.0**

Hire Purchase Terms 20/- deposit and 9 monthly payments of 20/-

Prices do not apply in I.F.S.



THE STANDARD BY WHICH ALL OTHERS ARE JUDGED!



# Practical Wireless



**EDITOR :**  
 Vol. II. No. 52 || F. J. CAMM || Sept. 16th, 1933.  
**Technical Staff :**  
 H. J. Barton Chapple, Wh.Sch., B.Sc. (Hons.), A.M.I.E.E.  
 W. J. Delaney, Frank Preston, F.R.A., W. B. Richardson

## ROUND *the* WORLD of WIRELESS

"Practical Wireless"—the Most-copied Radio Paper  
**P**RACTICAL WIRELESS was the first paper to inaugurate (*in the interests of the home constructor*), the solus specification, which enables us to guarantee every receiver described in our pages. PRACTICAL WIRELESS is the first popular radio weekly to adopt a 100% practical policy, and it is the most-copied radio paper in the world. Most of our features have since found their counterpart in many other radio weeklies. Even in radio periodicals published in foreign countries and in English Settlements and Colonies you will find articles and illustrations lifted *en bloc* from the pages of PRACTICAL WIRELESS. The worst offenders in this respect appear to be certain Australian papers. Perhaps the editors of these particular journals will take this hint!

**Next Week's Birthday Number—Great Free Gift for Every Reader**  
**T**HIS week's issue of PRACTICAL WIRELESS—Number 52—completes the first year of publication of PRACTICAL WIRELESS (and also of Volume II). Next week's issue will be a great Birthday Number, and to commemorate the phenomenal success which has rewarded our efforts we are presenting every Reader with a splendid set of Steel Spanners. They are illustrated actual size in the centre of this page. Two spanners will be given next week (the upper two), and the largest spanner will be given the following week. These spanners are made to the proportions recommended by the Engineering Standards Committee, and fit the normal range of B.A.-size nuts used in a wireless receiver—0 B.A., 2 B.A., 4 B.A., 6 B.A., 8 B.A. and 10 B.A. They are specially made for readers of PRACTICAL WIRELESS, and cannot be obtained in any other way. By a unique manufacturing process, they have a smooth finish and all rough edges are removed. They are made from a heavy gauge of high-class steel, and will last for ever!

PRACTICAL WIRELESS always gives Real, Reliable Reader Service—this also extends to its free gifts as well as its editorial contents.

**The Most Stupendous Offer Ever, Next Week**  
**A**DDITIONALLY, next week's issue will contain details of the most amazing offer ever made to the readers of a wireless paper. Full details will be given with next week's issue. Owing to the phenomenal demand, it is very necessary for you to order next week's and the following week's issue NOW.

**Our Birthday Superhet**  
**N**EXT week's issue will also contain details of a special Superhet designed at the special request of the many hundreds

**His American Tour**  
**F**OUR days after his return from his "busman's holiday" to the United States, Henry Hall will broadcast a feature programme with the B.B.C. Dance Orchestra; it will be entitled *My American 'our*. In it, following a brief description of places seen and people met, he will present a selection of the latest American numbers, played according to the interpretation of well-known dance-band conductors on the other side.

**Vienna's Tick-Tock**  
**A**S so many European studios have adopted melodious interval signals, Austrian listeners are loudly complaining of the monotony of their ticking metronome. It had been hoped that the broadcasting officials would replace it by a few bars of *The Blue Danube*, but it was not to be, as it was deemed that the almost incessant reiteration of even a few notes of this classical waltz would discredit it in the ears of the world. It is now suggested that something less widely known but still reminiscent of Vienna may be chosen for the purpose. In the meantime, the high-power Bisamberg station will suspend its transmissions pending the erection of the reflector aerial tower. Possibly, when the transmitter again comes on the air, the question of a new interval signal may have been solved. The metronome is a thing of the past.

**FREE WITH NEXT WEEK'S GREAT BIRTHDAY NUMBER!**  
**TWO STEEL WIRELESS SPANNERS**

The third Spanner will be given in the following week's issue.  
 See next week's issue also for the most stupendous offer ever made to wireless constructors.

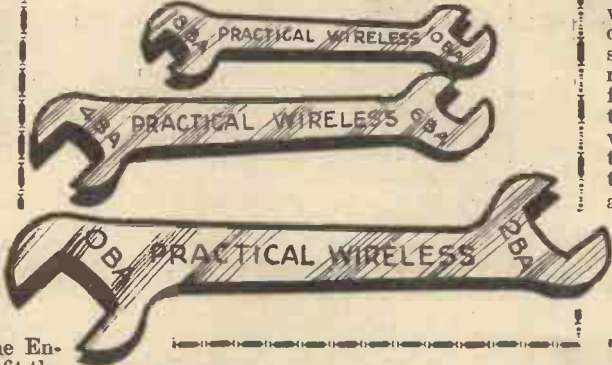

of readers who called at our stands at Radiolympia and Kelvin Hall, Glasgow.  
**Belgian Kursaal Concerts**  
**T**HE Brussels broadcasting stations have decided to extend the period of relays of concerts from the Ostend Kursaal and Knocke Casino until September 30th. Musical entertainments from these seaside resorts will continue to be broadcast alternately by Brussels No. 1 and No. 2 two or three times weekly. In view of their high power, the transmissions from these stations are well received in the British Isles.

**More Native Broadcasts from Morocco**  
**T**HE number of registered licences issued in Morocco in the first six months of the present year has already reached twelve thousand, or twice the figure declared for the whole of 1932. Although the broadcasts so far have been destined in the main to a European population of some one hundred thousand souls, it is now hoped to develop them with a view to making them appeal to the six millions of Arabs dwelling within the range of the transmitter. In order to secure the favour of the native population, the authorities have decided to increase the times devoted to oriental concerts in response to appeals



# ROUND *the* WORLD of WIRELESS (Continued)

made in favour of transmissions at more suitable hours. It is expected that during the winter months native broadcasts will be given in the early afternoon, and again between 19.30 and 20.30 nightly. So far they have been limited to four transmissions weekly.

## What Chile Listens to

THE Republic of Chile possesses some twenty-five transmitters, most of which, however, only range in power from 100 watts to one kilowatt. Of these sixteen are located in the capital of Santiago. The most important station is CE94 of 4 kilowatts working on 317 m. (945 kc/s.). As the studios mainly subsist on sponsored programmes considerable use is made of gramophone records. In order to introduce more novelty in the entertainments the Santiago stations have been relaying the British Empire broadcasts, much to the delight of English-speaking residents.

## Hier Hanover

THE old Cologne relay station, which was dismantled shortly after the opening of the high power Langenberg transmitter, has been re-erected at Hanover to take the Hamburg programmes. The plant has been entirely overhauled and converted to secure a power of 1.5 kilowatts (aerial). Although not yet officially opened, it is already working on 566 m. (530 kc/s.). From January, 1934, the station will operate on a common wavelength with Magdeburg, Bremen, Flensburg, and Kiel.

## Monte Generi Temporarily Closed

AS considerable alterations have to be made to the aerial system of the Lugano (Switzerland) transmitter, the station, except for occasional tests, will suspend its regular broadcasts until about September 20th next. Steps are to be taken to adapt the aerial to the wavelength allocated by Lucerne to this Tessin transmitter, namely, 257.1 m. (1,167 kc/s.) which, in the opinion of the Swiss authorities, may prove a very unfavourable channel.

## Ambrose and His Orchestra

THE B.B.C. announces that from September 30th, Ambrose and his orchestra will provide dance music on Saturday nights from 10.30 p.m. until midnight from a studio at Broadcasting House.

## Radio Balears Testling

A SMALL broadcasting station with the call-letters EAJ13 has been erected at Palma (Majorca) with a view to providing daily radio programmes to

## INTERESTING and TOPICAL PARAGRAPHS.

the inhabitants of the Balearic Islands. These include, amongst others, Majorca, Minorca and Cabrera, forming an archipelago in the Mediterranean off the eastern coast of Spain.

## Radio Warnings to Smugglers

ALTHOUGH the Austrian frontier posts on the Swiss border are equipped with powerful searchlights to assist excise officers in stopping the illicit importation over the Rhine bridges of such commodities as coffee, sugar, tea, and so on, it is reported from Bregenz that the smugglers, to further their operations, have installed small wireless stations on both sides of the frontier, and give a regular service of warnings in regard to the presence of government officials. Smuggling on the Voralberg-Swiss border has lately grown to large proportions owing to increased unemployment in the neighbouring Austrian districts.

## The French State and Radio Normandie

ACCORDING to a Paris wireless journal, Radio Normandie (Fécamp) had advised its French listeners, and supporting amateur associations, that in view of a refusal by the authorities to place telephone lines at the disposal of its studio, the station will no longer be able to relay outside broadcasts. More-

over, it is also stated that Fécamp may be compelled to reduce its power to 700 watts, its original energy in 1928. The late transmissions, in particular on Sundays, have proved great favourites with British listeners, and such a drastic reduction in the power of the broadcasts would be keenly felt by them.

## High-Power Station for Argentine Republic

IN the Argentine the broadcasting systems, as in the United States of America, have remained in private hands. One of the most important concerns is that of Radio Nacional, which controls a chain of six transmitters. An order has now been placed with a Berlin firm for the erection of a 50-kilowatt station in the neighbourhood of Buenos Aires. When installed this will prove to be the most powerful broadcaster on the South American continent.

## Greece May Soon Broadcast

APPARENTLY Greece will make a further attempt to establish a broadcasting system in 1934, as its Government has decided to raise a loan from the Post Office Savings Bank for a sum of five million drachmas. At to-day's rate of exchange there are approximately 580 drachmas to the pound sterling. It is stated that two years ago radio plant and accessories to the value of three times this amount were purchased and have since been stored in Government warehouses.

## "PRACTICAL WIRELESS" AT RADIOLYMPIA.



A general view of our stand at Radiolympia.

## SOLVE THIS!

### Problem No. 52

Arnolds had a commercial three-valve A.C. mains receiver which had given good service for a long time. He switched on one day and immediately noticed that no hum was audible from the speaker. He waited to see if any signals came through, and after a few minutes switched off. He removed the back of the cabinet and examined all wiring, but found nothing loose. He therefore switched on again to see if the set would work, but noticed that the rectifying valve seemed to heat up much quicker than when first installed, and in addition, it became filled with an intense blue glow. There was still no sound from the speaker, and as the glow was assuming rather alarming strength, he switched off. What had happened to his set? Three books will be awarded for the first three correct solutions opened. Address your entries to The Editor, PRACTICAL WIRELESS, Geo. Newnes, Ltd., 8-11, Southampton Street, Strand, London, W.C.2. Mark the envelope Problem No. 52, and post to reach here not later than September 18.

### SOLUTION TO PROBLEM No. 51

Blacksmith's speech coil had a much lower impedance than the extension leads, hence the loss in signal strength. He should, of course, have extended the Primary, or used an output filter arrangement to avoid the loss.

The following three readers succeeded in correctly solving Problem No. 50, and books have been forwarded to them:—

H. Solomon, 27, Lamb Lane, Hackney, E.8.  
L. T. Smith, 59, Pendragon Road, Downham, Bromley, Kent.  
J. V. Foster, 29, Wherstead Road, Ipswich.



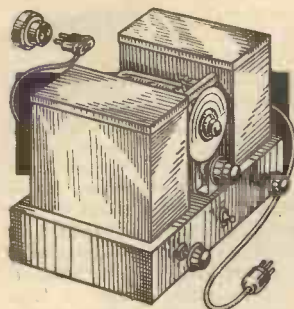

# MAINS SHORT-WAVE RECEIVERS & ADAPTORS

## Points to be Considered to Ensure Their Efficient Working.

THE short-wave amateur has in the past been rather inclined to fight shy of using the mains for supplying any part of the power necessary for the operation of a short-wave receiver. More recently, however, the practice of using the mains for this purpose has grown to some extent, and it has been shown that by careful design of the necessary apparatus it is quite possible in the majority of cases to obtain comparatively successful working. Certain precautions have to be noted, of course, but if attention is paid to one or two definite points, successful working) which in this case

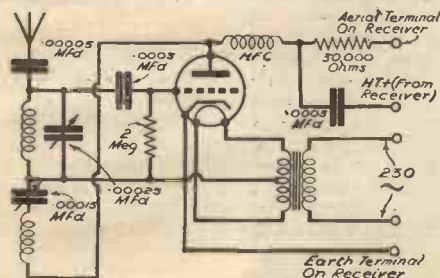

Fig. 1.—Diagram showing the necessary alterations for converting a short-wave adaptor to A.C. mains working.

means, in addition to the usual features, freedom from background hum and modulation hum) is practically assured.

### Short-Wave Adaptors

First of all let us deal with short-wave adaptors. A normal battery type of adaptor needs only the addition of a filament transformer and a five-pin valve-holder for complete electrification (plus an A.C. valve, of course!). The circuit of a complete A.C. short-wave superheterodyne adaptor is shown in Fig. 1. The transformer requires to supply only four volts at one ampere, and no rectifier is necessary as the high tension supply can be taken from the receiver with which the adaptor is used, the total current required only being in the neighbourhood of two or three milliamps, according to the actual type of valve used. The transformer should preferably be shielded from the remainder of the circuit, particularly the grid tuning circuit. If an unshielded transformer has to be used, this may be accomplished by building the adaptor on a metal chassis with the tuning coils and condensers on the upper side and the transformer mounted in the far corner underneath the chassis. If the adaptor is used with a commercial A.C. receiver, there may at first sight be a little problem as to exactly where the necessary high tension is to come from, but on modern A.C. receivers there are at least two points on the upper side of the chassis which may be tapped for this purpose without disturbing any wiring. The first is the screening grid of the H.F.

valve and the second is the high tension side of the speaker transformer. The latter will generally be the most satisfactory, as the former method sometimes fails owing to the fact that the extra drain caused by the adaptor valve reduces the voltage to such a low figure as to cause unsatisfactory working. The reason for this will be seen at once, because the reduced voltage necessary for the screening grid is generally obtained through a high resistance and even a small extra load here is sufficient to drop the voltage still very much farther. However, either method should be tried in individual cases.

Here it cannot be too strongly stressed that the A.C. short-wave adaptor or receiver should be very well shielded and in the case of a receiver where the apparatus is being built solely for short-wave reception, the receiver and the power supply apparatus can very well be built in two separate and completely shielded units.

It is sometimes an advantage to provide a separate smoothing system for the detector circuit, and this can be done as shown in Fig. 2. A high frequency filter is also included in the detector supply lead. When building up an A.C. short-wave receiver on the lines indicated, it is a good plan to complete the receiver first and then make one or two experiments with the power supply in order to ascertain which arrangement provides the quietest background and freedom from modulation hum plus a quiet reaction control. The reader can then decide for himself whether or not the extra smoothing indicated in the diagram is actually necessary in each individual case.

### Reducing Hum

One type of hum which is liable to be rather pronounced in an A.C. short-wave receiver is a hum which comes in at certain definite positions on the dial when the receiver is oscillating. As the approach to the edge of oscillation is made, the

hum becomes louder and, of course, this is a rather hopeless state of affairs, because a quiet background is essential here for the weaker signals. One way of very materially reducing this trouble is to use a superheterodyne arrangement, and the possibilities of this method should be well considered before actually building an all-mains short-wave receiver. In the superheterodyne receiver the reaction control is, of course, far less critical of adjustment than in a straight circuit, and it is thus much easier to obtain an accurate and delicate variation over the range of wavelengths covered. This is a particularly useful feature in a short-wave set. If, however, insufficient smoothing is provided, hum (although it will not be audible when there is no station tuned in) will increase to such an extent in the detector-oscillator valve that every signal tuned in will be modulated by the hum, and every carrier wave heard will carry a definite ripple. So that, although the superheterodyne method reduces the possibility of hum, the same amount of attention must still be paid to other points. The skeleton diagram of such a receiver is shown in Fig. 3.

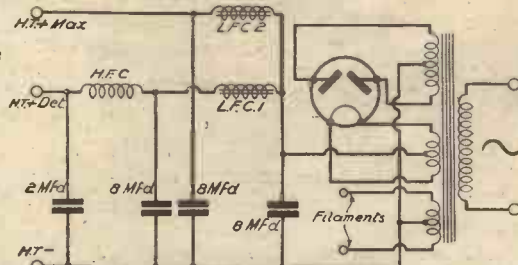

Fig. 2.—The suggested separate detector smoothing circuit.

Finally, in the case of a short-wave adaptor which hums badly, the first step towards correction should be to ascertain whether the humming is caused by the high tension or the filament supply. This can easily be done by substituting temporarily a high tension battery for the power supply, disconnecting the normal H.T. leads to the power section. If the hum still persists, then the trouble is to be found somewhere in the filament circuit. Perhaps the filament centre tap is badly out of centre—then an artificial tap must be made by means of a potentiometer. Beware of the grid circuit and keep all power wires, high or low tension, as far away as possible from any part of the grid circuit.

If attention is paid to some of these points, there is no reason why successful short-wave reception should not be possible with mains apparatus.

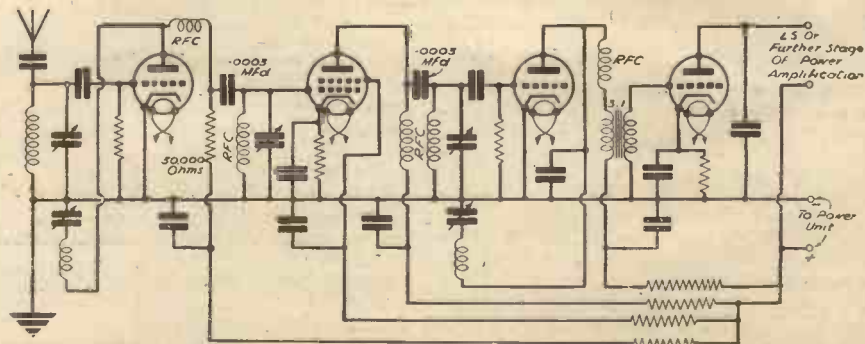

Fig. 3.—Showing the A.C. short-wave receiver referred to in the text. When no further L.F. stages are to be used, the output valve may be replaced by a directly heated type of triode or pentode.



# LEARNING THE MORSE CODE

By "SHORT-WAVER"

THE owner of a short-wave set soon realizes that there are vastly more morse transmissions to be heard on his receiver than telephony or broadcasting, and it is inevitable that he should feel that it would be extremely interesting to know what some of it was all about. This is very

phonetically, as "A—dit dah" (clipping the t in "dit" very short). The English letters of the alphabet and the numerals are as follows:—

|        |        |          |
|--------|--------|----------|
| A .-   | N -.   | 1 .----  |
| B -... | O ---  | 2 .-.-.- |
| C -.-. | P .--- | 3 .-.-.- |
| D -..  | Q ---. | 4 .-.-.- |
| E .--- | R -.-  | 5 .-.-.- |
| F ..-  | S ...  | 6 -....  |

tend to put down the opposite of the letter which they have just heard. You should get your fellow-learner to send the letters on a buzzer slowly and clearly and you should write them down as letters and not as dots and dashes, as some beginners do, in the hope of transcribing them afterwards. Practice with a buzzer is necessary to accustom the learner to the sound of the code and should be used even if you are learning alone and have to send to yourself.

For buzzer practice a morse key, dry battery and buzzer are necessary and a pair of telephones and a small fixed condenser of about .002 mfd. desirable; the connections are made as in Fig. 1. If the telephones are not used the buzzer is listened to with the unaided ear, but using 'phones gives a much closer approximation to actual operating conditions and is, therefore, to be preferred. It is important to have a good key, although this need not be expensive; it should, however, have an easy, smooth action, with adjustable tension and gap width between contacts, and it must have back contacts, i.e., it should not be the type often described as "tapping keys," which consists merely of a strip of brass providing contacts at one end and screwed to the base at the other. The key arm should be pivoted near the middle, with the far end carrying an adjustable screw permitting variation of the gap between the contacts in the front; for a beginner, the gap between the contacts should be fairly large and the spring fairly tight; these adjustments cannot be made on "tapping keys," which is why they are unsatisfactory. At first, sending must be very slow, but, at the same time, even, that is to say, the dashes must not be long, and then the dots hurried, but the proper proportion of timing observed, and each letter must be sent as a whole, without big gaps between its component dots and dashes; for example, do not send C (-.-.) as NN (-.-.), a very common fault, or Q (-.-.) as MA (-.-.), etc. This fault is sometimes due to stiffness of unaccustomed muscles, and should, therefore, wear off, but the learner must keep his eye on it to make sure that he does get rid of it.

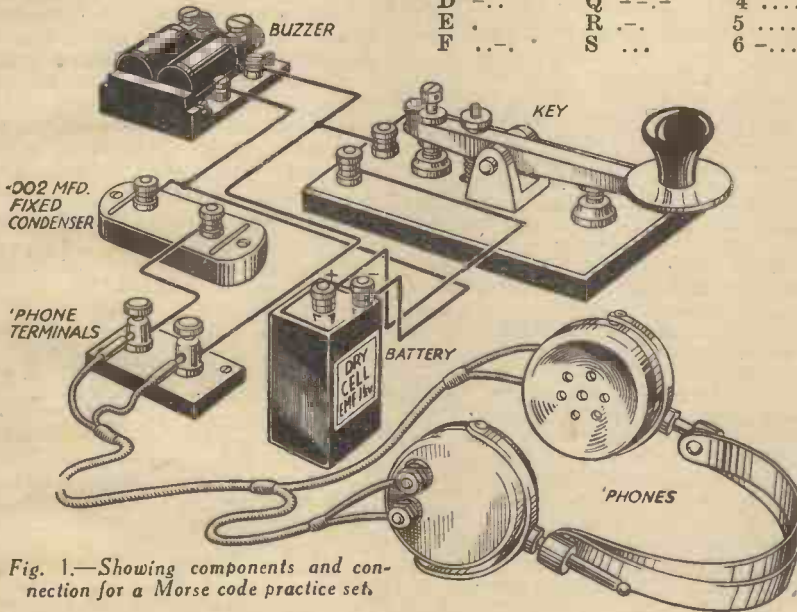

Fig. 1.—Showing components and connection for a Morse code practice set.

true, and it is perhaps not too much to say that he who does not know the morse code is losing ninety per cent. of the possible enjoyment of short-wave reception, not so much in listening to the big commercial transmitters, although when their wavelength is known these are very useful for locating one's position on an unfamiliar or new receiver, but in listening to amateur transmissions, most of which are continuous wave morse, and which afford the possibility of very impressive and exciting DX reception.

It is by no means difficult to learn the morse code, the process calling mainly for a certain amount of patience and a very great deal of practice. First of all, the code must be memorized. As is generally known, each letter of the alphabet is represented by certain combinations of long and short sounds, usually called dashes and dots. In radio transmission these are produced by stopping and starting the oscillation of the transmitter by means of a telegraph key, and they are heard in the receiver as a series of long and short whistles, when continuous wave transmission is employed; in the case of the now obsolete spark transmission and of what are known as interrupted continuous waves, the sound heard is a series of buzzes, whose pitch depends on the spark or interruption frequency. With either system the receiving operator hears the signals as long and short sounds and not as dashes and dots, and it is therefore very necessary that in learning the code it should not be memorized as it is usually written or printed, i.e., "A—dot dash," etc., but as two sounds, which may either be whistled or written down

|        |        |         |
|--------|--------|---------|
| G --.  | T -    | 7 ----. |
| H .... | U ..-  | 8 ----. |
| I ..   | V ...- | 9 ----. |
| J .--- | W -.-- | 0 ----. |
| K --.  | X --.  |         |
| L ...  | Y -.-. |         |
| M ---  | Z ---. |         |

A dash is three times as long as a dot; the space between the elements of a letter is equal to one dot, that between two letters three dots and between two words, five dots.

### Memorizing the Letters

These letters must all be memorized, but it is best to do it slowly, learning only three or four at a time and when a new group of three or four is tackled make sure that you have not forgotten the last four. The learning will be much simplified if a friend works with you so that you can test one another, dodging about among the letters in order to prevent any tendency to remember them in alphabetical order or by association. Incidentally, I cannot recommend the method sometimes advocated of learning by opposites, i.e., learning "A .- is the opposite of N -." or "B -... is the opposite of J .-.-." I have noticed that operators who learn in this way

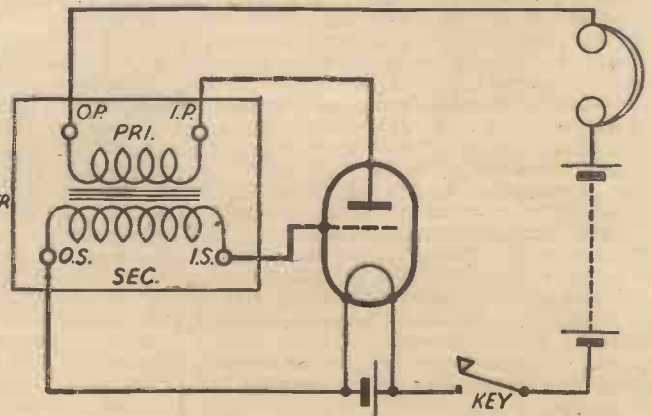
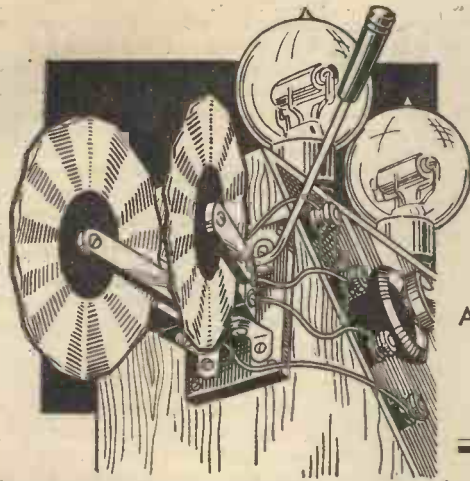

Fig. 2.—A valve oscillator in circuit with an L.F. transformer.





(Concluded from page 899, Sept. 9th issue.)

ACTUALLY, the set has become a miniature transmitter, and this howl may be heard in other receivers in the vicinity which may be tuned to the same wavelength.

What are the essential requirements of a satisfactory reaction system? First of all it must be critical and capable of being adjusted up to the point where the receiver is nearly in a state of oscillation. It is essential that we have simplicity of operation: some of the circuits to be discussed did not possess this feature and, consequently, fell into disuse. Freedom from hand-capacity effects is also necessary. If other remedies fail, this trouble can generally be cured by employing a differential reaction condenser. This method will be discussed later. It was not, however, available to early experimenters. There must be no back-lash. This is occasionally found in receivers, and suggestions for cure will be given later.

There are a considerable number of reaction circuits, but they all embody the principle just described—"a feed back of energy from the plate to the grid circuit."

**Swinging-Coil Reaction**

One of the first methods to be employed in broadcast receivers was what was commonly known as "swinging-coil reaction." In this method the reaction-coil was magnetically coupled to the grid circuit, as shown in Fig. 2. This system was rather difficult to handle, even if some form of vernier control was employed, and it was not easy to get a really fine degree of coupling which was desirable if best results were to be obtained. Also, the close proximity of the reaction coil upset tuning so much that it became necessary, after every reaction adjustment, to retune the receiver. This made the tuning-in of distant stations a very difficult process.

**Hartley Circuit**

The Hartley circuit, shown in Fig. 3 was, at one time, fairly extensively used in straight sets. The aerial and reaction coil comprise one continuous winding which is centre tapped. It is a circuit particularly suitable for frame-aerial receivers, as a centre-tapped frame can be used in place of coil. The great disadvantage of this circuit is that both rotor and stator of the variable condensers were above earth potential.

**Reinartz Circuit**

Among the many adherents to receivers

# The History of Reaction

And How it is Employed in Several Well-known Circuits

By LAMBDA

of the detector, low-frequency type, it is safe to say the majority favoured the Reinartz circuit. Particularly efficient on the ultra short-wave band, for which it

setting of the reaction condenser to vary over different parts of the tuning dial, but this does not make tuning unduly difficult.

With this type of circuit, it is preferable to have a reaction condenser of fairly large capacity, say 0.0003 mfd., and a fairly small reaction coil, as this appears to make receivers easier to handle. It is often found that the amount of capacity required to produce reaction effects is not sufficient to by-pass the H.F. energy completely. To provide the extra by-pass capacity fit a 0.0002 mfd. condenser between anode and negative filament of detector valve.

**Neutralized H.F. Receivers**

With the employment of the screen-grid valve for high-frequency amplification, the neutralized H.F. receiver fell into disuse. Its interest to us is merely to illustrate one method employed in obtaining reaction effects in earlier type receivers. This type of circuit was rather difficult to operate, and some of them were notorious for the howls they emitted.

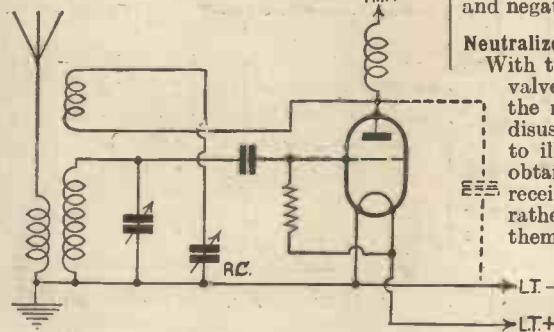

Fig. 4.—A form of reaction circuit which avoids hand-capacity effects.

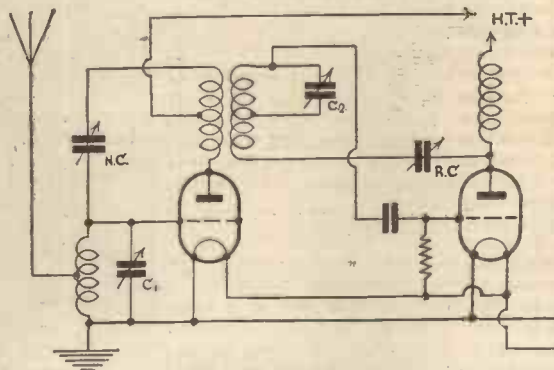

Fig. 5.—This shows what is known as the "Hartley" reaction circuit.

was originally employed, it has been adapted for reception on the other wave bands. This circuit is an improvement on those of other types, but with the original circuit the reaction coil was a continuation of the tuning coil. As in the Hartley circuit, both sets of vanes of the reaction condenser were at high potential in respect to earth, so hand capacity effects were troublesome. The employment of a metal panel did not overcome this trouble. In its present form, shown in Fig. 4, the moving vanes of the reaction condenser are at earth potential. This circuit is quite satisfactory, and the reaction control is almost independent of the tuning of the receiver, therefore adjustment is fairly easy. It is not unusual, however, for the

**Capacity Controlled Reaction**

Practically every receiver which incorporates reaction now employs capacity control. Capacity control is shown in the Reinartz circuit in Fig. 4. The radio frequency current in the anode circuit of the detector valve is provided with an alternative path back to the filament via the variable condenser, and the tuned circuit connected between grid and filament. Upon the reactance of this variable condenser depends the proportion of current which takes this alternative path, and is, therefore, capable of being controlled by varying the value of the capacity.

Ordinary capacity controlled reaction suffered from the same inherent weakness as the swinging coil reaction arrangement, namely,

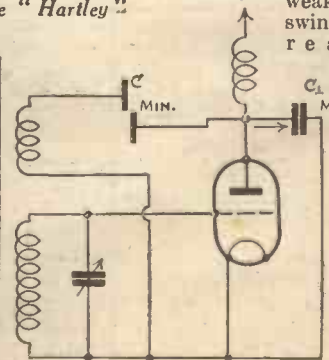

Fig. 6.—Showing how reaction is reduced with the setting of the condenser.

hand capacity effects. With ordinary plug-in coils this can easily be obviated by connecting the moving vanes of the con-



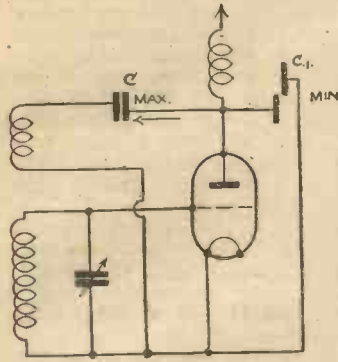

Fig. 7.—Reaction is at maximum in this position.

denser to earth, the fixed vanes being connected to one end of the reaction winding, the other end of the winding being connected to the anode of the detector valve. Upon the introduction of dual range coils, however, it was not always possible to achieve this, as in many cases the low potential end of the winding was taken direct to the same terminal as the low potential end of the grid winding. By employing an ordinary condenser, hand capacity effects would become apparent. A system of reaction control was eventually evolved which overcame this trouble. It must not be thought, however, that this system will not function when the reaction winding is isolated from the grid winding; it can be used with either type of coil.

**Differential Reaction**

We noticed earlier that for maximum efficiency a detector valve needs a capacity between the anode and filament. In the early days of broadcasting detector efficiency was rather poor, and it was only by careful manipulation of the reaction control and bringing the set to the point of oscillation that foreign station reception could be obtained. In such circumstances quality was bound to suffer. Let us return to our Reinartz circuit (Fig. 4). When the reaction condenser is set at zero there is practically no capacity existing between plate and filament except stray capacities. To remedy this it was quite a simple matter to connect a fixed condenser of about 0.0002 mfd. as shown. If this capacity be too high it may pass an excessive amount of H.F. energy and difficulties may be experienced in obtaining satisfactory reaction over the whole of the tuning scale; it is advisable in this case to use a smaller

capacity. With differential reaction a fairly large capacity is provided for between plate and filament. When the condenser is at its maximum setting, reaction effects are nearly zero as in Fig. 6. If the capacity of C increased, the H.F. current flows through the reaction coil (Fig. 7) and at the same time there is a corresponding decrease in the capacity between anode and filament, but a certain proportion of the capacity always remains between anode and filament. This is because the reaction coil is generally so arranged that it is not necessary to employ to the full extent the whole capacity of the reaction condenser; therefore, the moving vanes are never fully enmeshed between the fixed vanes connected to the reaction coil. A certain amount of capacity consequently remains connected between

filter in conjunction with his straight set. He possibly has wondered why so few sets have been described employing this arrangement. Here, however, is one of the few instances where reaction is not a great success. An illustration of the principle is shown in Fig. 9. Rather unusual effects are experienced with this type of circuit: signal strength does not increase to any appreciable extent, and there is a marked tendency towards double-humped tuning. For ordinary straight sets, the writer prefers a loosely-coupled single-tuned circuit, and with this arrangement reception is relatively quite satisfactory, except when situated very near to a transmitting station.

**Reaction Difficulties**

Are there any snags encountered in reaction circuits? Like the motor-car, they sometimes prove troublesome. A few suggestions are, therefore, offered which will solve most of the common difficulties arising with reaction circuits. If a receiver refuses to oscillate, fault is generally in the detector circuit, such as a faulty valve, reaction coil or condenser, or open circuit. If failure occurs after a period of use, it may be due to a faulty grid leak, valves losing their emission, high-tension voltage dropping due to the H.T. battery failing. Another trouble in reaction circuits is overlap. A common cause of this is the H.T. or L.T. battery running down, insufficient bypassing, high resistance H.T. supply, incorrect anode voltage or unsuitable grid leak. Instead of taking grid return lead to positive filament, connect to slider of 400 ohms potentiometer connected between positive and negative of L.T. battery.

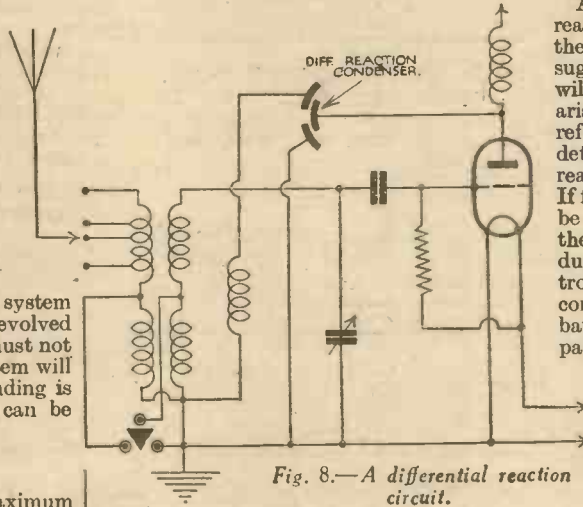

Fig. 8.—A differential reaction circuit.

anode and filament of valve. As the hand capacity of the operator is nearly always less than this capacity, it will have little effect.

An excellent example of this system of reaction control was that employed in the Selectone 3 described in this journal some time ago. The essential portion of the circuit is reproduced in Fig. 8.

**Band Pass Filter and Reception**

The reader will undoubtedly be interested to know if it is possible to employ a band-pass

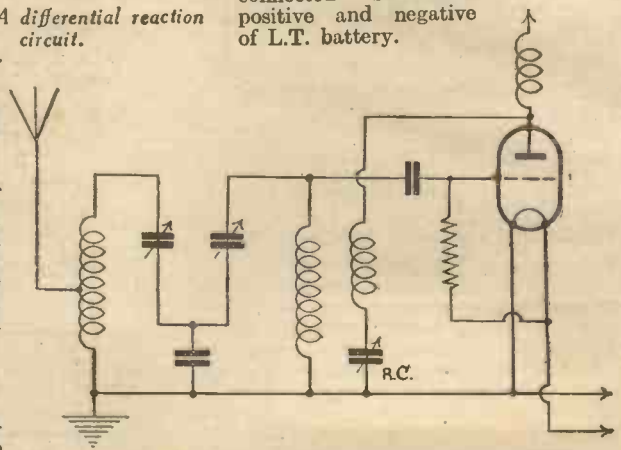

Fig. 9.—Reaction with a band-pass circuit, showing how the reaction winding is coupled to one coil only.

**Instability When Using an Eliminator**

SOMETIMES, when a rather old-fashioned battery set is connected to an eliminator, mains hum is very troublesome and motor-boating makes good reception impossible. This has often led the user to believe that the eliminator was faulty, though actually the defect was in the set itself. The instability was due to the fact that insufficient decoupling was used and although this passed unnoticed when using a battery of comparatively low voltage it increased very considerably when a greater high tension voltage was employed and the valves began to operate more efficiently.

In a case of this kind it is generally sufficient to decouple the detector by means of a 50,000 ohm resistance and 2 mfd. condenser. Sometimes, however,

this is not enough and so the first L.F. valve should also be decoupled by inserting a 20,000 ohm resistance in its anode lead and connecting the customary 2 mfd. by-pass condenser between the resistance and H.T. negative. A still further improvement can be effected by feeding the loud-speaker through an output transformer or choke-capacity filter circuit.

**Automatic Volume Controls**

SEVERAL of the larger American receivers are fitted with automatic volume controls, but there are very few British sets with this refinement. Because of this please do not draw the conclusion that British designers are backward. The point is that the advantages of the system are rather doubtful, and in the

minds of many they are more than offset by the disadvantages. The idea is that the sensitivity of the set is increased when the signal is weak, and reduced when tuned to a powerful signal. But as the signal fades, the atmospherics, "mush," and other forms of interference remain at constant strength, and are therefore amplified to an undesirable extent. In consequence it is not infrequent to find that the required programme is almost drowned out, or at least so swamped as to be not worth listening to. I have recently made a set with automatic volume-control, just to amuse myself, and I must say I have not been disappointed. Two V.-M. S.G. valves were used, followed by an anode bend detector and a pentode output valve.



# ALL-ELECTRIC WORKING



Useful Hints and "Danger Don'ts" Associated with the Choice and Operation of All-Electric Eliminators

By an ELECTRIC SUPPLY ENGINEER

**A**LTHOUGH the average wireless enthusiast may possess considerable practical knowledge on the operation of his wireless receiver, he often experiences difficulty when the problem of all electric sets is under consideration, chiefly on account of the purely electrical technical knowledge required. Furthermore, due to the very complicated methods of charging for the electrical energy consumed, and the non-standard voltages, frequencies, and nature of the electric supply, restrictions, etc., the problem is still further amplified to an almost incomprehensible degree.

Before starting to build an eliminator or installing an all-electric set, the nature, voltage and frequency of the electricity supply should be determined; and undoubtedly this information is best obtained direct from the offices or showrooms of the supply authority concerned, or from the name plate of the electricity meter installed in the house, but often the figures become obscured and are unreliable. Circumstances have been found in practice where two houses, maybe only one hundred yards apart, are supplied at different voltages, one with A.C. current and the other D.C., therefore the importance of obtaining really authentic information on this question is not to be neglected.

If the supply is found to be D.C., further precautions should be taken, and for these, a visit or communication addressed to your supply authority is to be strongly advised, owing to the fact that D.C. is now becoming very rare; what remains is being rapidly converted to A.C., and wireless apparatus installed after a certain date may not be replaced at the supply authority's expense when the conversion takes place, thus, if an understanding is definitely arrived at, future trouble and expense may be avoided. Much the same advice is applicable for A.C. current when the frequency differs from 50 cycles, as this frequency is to be standardized throughout the country, and again replacements in some apparatus will be necessary. The effect of a change in frequency is very pronounced on the speed of the motors usually installed in A.C. radiograms, the motor speed generally being in proportion to the frequency of supply, and the number of poles of the motor, therefore a reduction in frequency means a serious reduction in turntable speed, and a converse effect for an increase in frequency. Electric clocks are similarly affected.

Although the frequency is to be standardized, the supply voltages are not, and may be found in general practice to vary for both A.C. and D.C. from 200 to 250 volts. Change-overs from D.C. to A.C. are at the supply authority's own instigation, and are chiefly governed by financial considerations; therefore information concerning future change-overs is rarely obtainable.

### Methods of Charging for Electrical Energy

The Board of Trade unit of electrical energy is termed the Kilowatt-hour, and its derivation is very easy to understand. The word Kilo of course means one thousand of anything, in this case one thousand watts. Now volts multiplied by amps. (irrespective of their magnitude) gives the value in watts, and this is merely still further multiplied by the time in hours the current has been flowing or switched on. Thus, kilowatt hours, or in short,

$$\text{kWhs.} = \frac{\text{Volts} \times \text{amps} \times \text{time in hours.}}{1,000}$$

Therefore, an electric lamp supplied at a pressure of 200 volts, taking 1 amp current

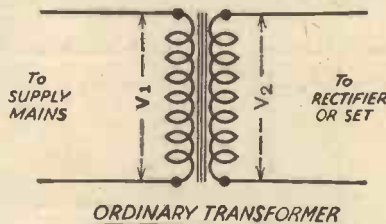

Fig. 1.—The voltages developed across a standard transformer.

consumption, will consume in five hours 1 kWh. of electrical energy, or one unit. A wireless set having a normal consumption of 50 watts will consume 1 kWh. in 20 hours.

The cost of the kWh. made on the flat rate basis at present varies from approximately ¼d. to 1s. per unit, which explains the great difference in running costs of various receivers in different localities. The average charge is about 4½d. per kWh. for lighting, and it is important to remember that in houses where there are two distinct charges, i.e., for lighting and heating, etc., it is often not permissible to utilize the wireless set on the heating circuit, or cheaper rate. In houses where there is only one running charge as when all-in or assessment tariffs are used, this problem does not arise. One word to hired wiring consumers. Where the running charge and installation wiring charge is made in one payment it may often work out at the equivalent of 8d. to 11d. per unit. In these circumstances it is advisable to consider very carefully the consumption of the proposed all-electric receiver or eliminator, as the running cost, if the set is utilized considerably, may be greater than the equivalent battery model.

### Connecting to A.C. Mains

With all A.C. commercially-manufactured sets, the problem may safely be left in the hands of the maker, providing it is utilized on the conditions for which it is designed regarding voltage, frequency, etc. For home-constructed models too much caution cannot be taken. First of all the eliminator, wireless set or battery charger,

must definitely be isolated from the supply mains, in such a manner that any internal faults occurring in the apparatus cannot interfere with the supply mains or blow the service fuses. This rule is strictly adhered to by the majority of supply authorities, and means that a transformer having a distinct primary and secondary winding, must be used, therefore the use of auto transformers is not permitted. This type of transformer is similar to a tapped inductance or choke coil, the essential difference from the ordinary type is easily seen from Figs. 1 and 2, where V1 and V2 represent the primary and secondary voltages, respectively, and I1 and I2 the relative current intensities.

It will be noticed that the connection marked Z in the case of the auto transformer, which comes from one side of the supply mains passes straight on to the rectifier or receiver, and thus if either happens to be faulty when this method of connection is used, a considerable shock may be sustained, and the apparatus seriously damaged, therefore the use of this type of transformer is generally not allowed for mains work.

### Connecting to D.C. Mains

As the apparatus in this case cannot be isolated from the supply mains, suitable fuses must be placed in each lead, and

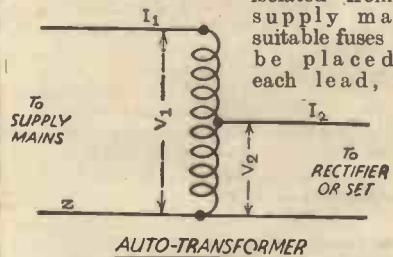

Fig. 2.—The voltages developed across an auto-transformer.

supply authorities generally insist that whatever earthing is undertaken in the set or other apparatus, it must be effected through a condenser not less than 2 mfd, which should be capable of withstanding at least three or four times the normal working pressure. A condenser of proved reliability should be used for this purpose as failure of its insulation may lead to a serious short circuit of the supply mains and subsequent damage to apparatus. The reason for this happening is that one of the supply mains is usually earthed by the supply authority already.

The reason for this has been fully and clearly dealt with in a recent issue of PRACTICAL WIRELESS, in an article entitled "D.C. Mains Problems," Vol. 2, No. 35; an interested reader cannot do better than refer back to this article.

### Fixing Aerials, etc.

For rural and suburban distribution, overhead supply mains for ordinary dwelling houses are coming into considerable use owing to their cheapness. Strict precaution should be exercised in keeping aerials, etc., well clear of these wires, in such a way that if either breaks, contact cannot be made with each other. For some houses the electric supply by this method enters the house in the region of the attic or roof. Before starting to erect an aerial, whether externally or in the rafters, the entire position of such wires should be determined, as they are often bare conductors. People have been known to accidentally come in contact with these wires with very serious results.



# THE TESTING AND ADJUSTMENT OF BAND-PASS FILTERS

By P. E. BARNES

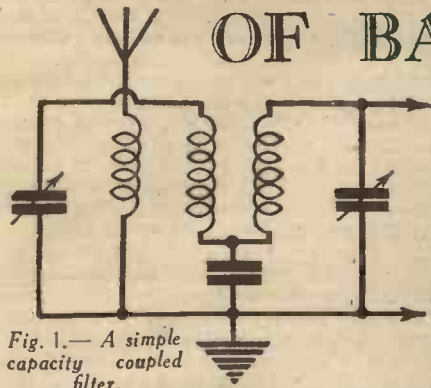

Fig. 1.—A simple capacity coupled filter.

THE increasing use of band-pass filters in both commercial and home-made sets is a tribute to their effectiveness, and also to the high standard of accuracy attained in the matching and testing of the manufactured article. But to the practical man (and quite rightly) no advertisement, and no amount of faith in the skill of designers and testers, can give him the same feeling of certainty as a practical demonstration, and it is fortunate that simple and conclusive tests can be made of the performance of such filters.

The majority of band-pass filters consist of two similar circuits of the normal type, tuned by two sections of a condenser gang, with the addition of one or more components (inductances, condensers and/or resistances) which are common to both circuits and provide the coupling between them. Figs. 1, 2, 3, 4 and 8 show typical examples of the more common types of filter. Fig. 5 shows the effect of such a filter and explains its considerable popularity. Curve "A" shows the response to different frequencies of one tuned circuit, curve "B" shows the improvement in selectivity due to the use of two such circuits as aerial and tuned anode (or tuned grid) coils.

It will be seen that the filter (curve "C") gives us a good response to all the frequencies in a band of 9 kilocycles, while sensitivity outside this band decreases as fast as that of the curve "B." Usually the filter is used as an aerial coil, with an ordinary circuit to couple the detector valve to the H. F. valve, and this combination, which gives us three tuned circuits where the normal arrangement only allows for two, has the effect shown by curve "D." A second band-pass unit can, of course be used in the interval coupling, but it is not usually necessary. In some sets, too, the band-pass unit is arranged here in order that the set may be used on a frame aerial with the minimum of switching on the high-frequency side.

### Working Principles

The theory of band-pass filters is somewhat advanced, but a few of the essentials can be stripped of unnecessary formulae and will enable the working of the filter to be grasped fairly easily. The width of the approximately flat top of the filter curve is dependent on the separation of the "peaks." If they are far apart then the coupling between the coils is said to be "tight," and the degree of tightness depends on the voltage developed across the coupling component. If, to take a simple example, we are using a simple capacity filter as in Fig. 1, the voltage will

vary as the frequency (or wavelength) is changed. This might be expected, for we know that high-frequency currents will pass a condenser easily, but the lower frequencies require a larger voltage—this is the property of the condenser of which we make use in by-passing high notes in an amplifier, or high-frequency currents from the plate of a detector valve.

The result, which is what matters, is that as we tune to the higher wavelengths (lower frequencies) the voltage drop increases, the coupling gets "tighter," and our peaks separate, with the result that the set gets less selective. If the coupling were of the type shown in Fig. 2, we know that as an inductance offers more resistance to the higher frequencies, the opposite effect will occur, and the peaks will draw together at higher wavelengths, and we will not get a band-pass action.

As might be imagined the practical solution is a combination, and this generally takes

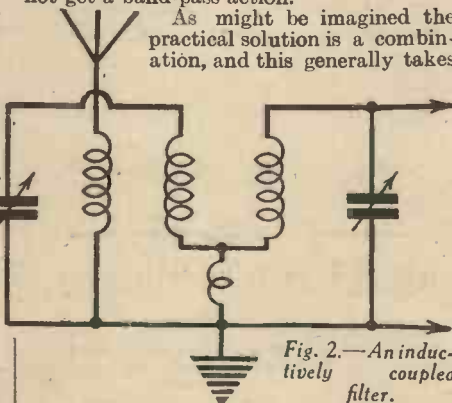

Fig. 2.—An inductively coupled filter.

the form of two small coils, one wound on each tuning coil former (Fig. 3) and a condenser.

### Matching: Trimmers and Screening

The practical conditions for satisfactory operation are:—

1. The tuned circuits must be exactly the same, i.e., must have the same inductance, capacity and resistance.
2. The sections of the ganged condenser must be matched to give the same capacity for all dial readings.
3. All couplings other than the one we provide in the filter must be avoided as far as possible.

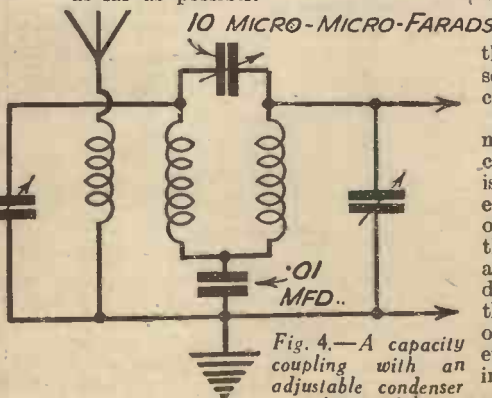

Fig. 4.—A capacity coupling with an adjustable condenser for coupling.

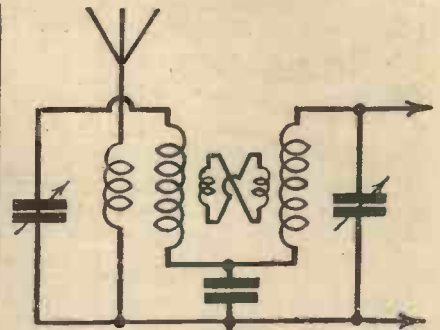

Fig. 3.—A combination of inductance and capacity.

(1) The condition of equal inductance will be satisfied as a rule if matched coils of reputable make are used. Later on will be found the method for detecting and remedying faults in matching. The capacity includes all the stray capacities of wiring and screening cans, but we can make it the same in each circuit by the use of the trimming condensers built into the ganged condenser. The resistance should be low for efficiency, but two similar coils will not differ by any amount worth considering.

(2) As far as the matching of the condenser sections is concerned, we must trust the manufacturer. The moral here is too well-known to need repetition. It must be remembered that the trimmers can only be used to equalize the stray capacities in the circuits—they cannot be moved afterwards without upsetting the ganging and necessitating re-adjustment.

For the same reason, the use of an external trimmer is "taboo"; we must have nothing but our one tuning control variable from the panel once the set has been adjusted.

Some makes of condensers have the end vanes divided so that the capacity at any point of the scale can be increased to effect matching, but this is a factory process, and outside the scope of an ordinary amateur's equipment. If a condenser should turn out really badly matched, the best proceeding is to take it back and make yourself a nuisance. When the circuit is adjusted, do not forget to have one last look at the trimmers. One of these should be at zero, and if it is not, then all trimmers can be reduced in succession until one of them is at its minimum. This will reduce the minimum wavelength to which the set will tune, by reducing the capacity in circuit when the dial reading is 0.

(3) To avoid stray couplings, the usual method is to enclose the coils in aluminium cans and use screened condensers, and this is undoubtedly the best method, as it eliminates all couplings due to external objects, prevents "shock excitation" of the coils due to very near transmitters, and ensures that no alterations in conditions can occur. Make certain, however, that the screens or cans are rigidly fixed, or they may move with most unexpected effects on the tuning, due to the changes in the capacity of the circuit.

(Continued on page 944)



If you want to build the most ambitious kit set ever offered to Home Constructors—HERE IT IS!



**COMPLETE WITH SEVEN VALVES**  
**£8-17-6**

TWENTY GUINEAS WORTH OF RADIO FOR LESS THAN HALF THAT PRICE!

A Seven Valve Superhet-8 Stages in all and a 6 stage Band Pass filter - exact 9 Kc tuning channels with Amplified Automatic Control-Class B' output driving full power Moving Coil Speaker

Never before has there been any receiver for Home Constructors on such an ambitious scale as this new Lissen "Skyscraper" Seven-valve Superhet. It embodies every up-to-the-minute advance and refinement of the most luxurious factory-built superhets—it gives the constructor the opportunity to build a £20 receiver for less than half that price. The circuit of the Lissen "Skyscraper" Seven-valve Superhet incorporates a 6-stage bandpass filter, giving exact 9-kilocycle channels and therefore providing a standard of selectivity never before achieved by a home-constructor's kit set and very rarely found except in laboratory apparatus. Amplified Automatic Volume Control is provided, a special valve for this purpose having

been produced by Lissen for use in this receiver. The use of this Amplified Automatic Volume Control constitutes an entirely new experience in listening; no "fading," no "blasting"—you will find yourself enjoying every word of every programme, however near or however distant, without the slightest temptation to interfere with the receiver once you have tuned it. This is radio listening as it should be enjoyed! Lissen Class-B Output through a new full-power Lissen Moving-coil Loud-speaker—glorious rich tone and majestic volume, actually more faultless in its reproduction than anything you ever heard from even the most powerful mains receiver, yet working economically in this Lissen "Skyscraper" from H.T. batteries.

# LISSEN "SKYSCRAPER" 7

SEVEN - VALVE - SUPERHET

Lissen have published for this great new "Skyscraper" Seven-valve Superhet a most luxurious chart which gives more detailed instructions and more lavish illustrations than have ever before been put into a constructional chart. It makes success certain for everybody who decides to build this set; it shows everybody, even without previous constructional experience, how they can have a luxury receiver and save pounds by building it themselves. A copy of this Chart will be sent FREE in return for coupon on the left, or your radio dealer can supply you. Get your FREE CHART now!



**FREE CHART POST COUPON**

COMPLETE WITH SEVEN VALVES  
**£8-17-6**

To LISSEN, LTD.,  
Publicity Dept., Isleworth.

Please send me FREE CHART of the "Skyscraper" Seven-valve Superhet.

Name.....

Address.....

PR 635

THE CONSTRUCTOR'S LUXURY SET



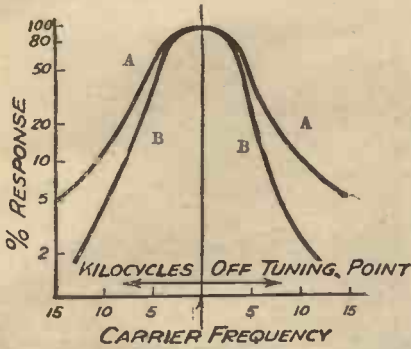

Fig. 5.—Normal response curve of a sharply tuned circuit.  
(Continued from page 942)

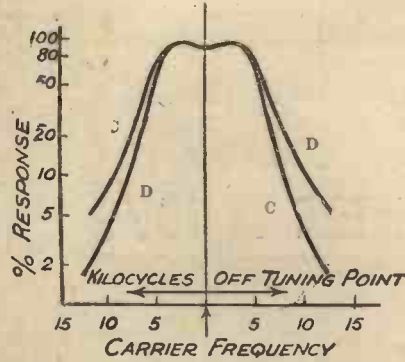

Fig. 6.—The response curve of a band-pass circuit.

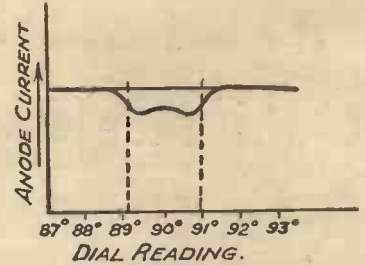

Fig. 7.—How the meter will show the actual tuning point.

**Testing**

Now we have dealt with the main points of constructing or assembling a filter, and we must test it to see to what extent it really does its job. The apparatus consists of the ubiquitous milliammeter, and one can usually be begged, borrowed, or otherwise procured if you have not one. This should be connected in the anode circuit of the detector-valve, either by using a split anode connector (this can be bought cheaply, and is useful for other tests), or by breaking the circuit at any accessible point, and inserting the milliammeter there.

With the set switched on, rotate the tuning dial slowly until a loud transmission is tuned in, when there will be a drop in the reading which should occur suddenly, remain for a degree or two, and slight further rotation will bring the needle back to its old position. (Some sets use an anode bend detector, in which case the terms "rise" and "fall" should be exchanged.)

If the rise and fall are sudden, and there is a "still-point" between them, we are securing a band-pass action, but we have yet to check the band width. This we do by tuning in another station on a nearby wavelength. Suppose we receive the London and Midland Regionals on 90 degrees and 110 degrees, respectively. Their frequencies are 843 and 752 kilocycles, so we now know that the 20 degrees difference of dial reading corresponds to 91 kilocycles. The usual band width is 9 kilocycles, or one-tenth of this, i.e., 2 degrees on our dial. That is, the needle must remain still at its lowest point while the dial is turned through 2 degrees. If this is much less, then we are not getting a

band-pass effect at all, while if it is much more we are in danger of the station on the next wavelength channel breaking through, perhaps louder than if we were not using a band-pass tuner at all! If the filter is one which has a very small condenser at the high-potential ends of the coils, then matters can usually be put right by adjusting this, until the needle drop remains nearly the same over the desired 2 degrees rotation of the tuning control.

This applies to filters shown in Figs. 4 and 8. The commercial mixed filters

**Adjustments to Coil Windings**

If, instead of our square top curve, we have a lop-sided one, then this points to the coils not being matched. This sometimes occurs from careless handling having shifted some of the turns. Try the effect of very gently spacing out the end few turns of one coil, so lessening its inductance. If this improves matters, then space a bit more, or space those at the other end of the coil. If matters are worse, then press the turns back carefully, and try the spacing out of the turns on the other coil.

If the filter is home made, then we can match the coils roughly by using each in turn as the tuning coil of a simple set, adding or removing turns until the local station comes in at the same dial reading with both. Care must be taken not to alter the shape of any of the wiring when changing the coils. Quite satisfactory filter coils can be made by this process, but usually the expense of a good ganged condenser is such that the saving represents only an insignificant part of the total cost.

Finally, a word on conversions. Many sets have been modernized by the addition of a filter which uses one coil already in the set, and coupling is commonly effected by the use

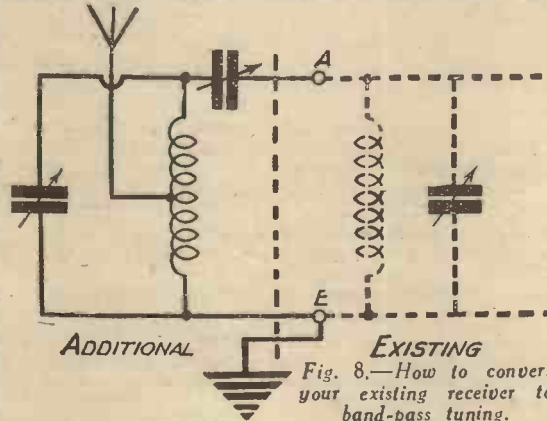

Fig. 8.—How to convert your existing receiver to band-pass tuning.

of a very small condenser at the high potential ends of the coils, which are tuned by independent condensers. See Fig. 8. The coupling condenser should be variable, and will want adjustment as the tuning dials are rotated. It is very convenient, with sets so modernized, to draw up a chart of corresponding dial readings if these differ very much, to make it easier to tune at once to any wavelength when the station is not transmitting

of a very small condenser at the high potential ends of the coils, which are tuned by independent condensers. See Fig. 8.

The coupling condenser should be variable, and will want adjustment as the tuning dials are rotated. It is very convenient, with sets so modernized, to draw up a chart of corresponding dial readings if these differ very much, to make it easier to tune at once to any wavelength when the station is not transmitting

IT is only when one looks back over the past ten years or so that it is realized how very few changes have taken place in the methods of tuning a receiver. We still use a number of coils of wire in conjunction with a similar number of variable condensers, and although it is true that the design of both coils and condensers has changed in matters of detail, the principles have remained unaltered. The coils are so designed that their natural wavelengths are approximately equal to the lowest part of the waveband to be covered, and then necessary adjustments are made by means of variable condensers.

The system has certainly worked very well and has been considered good, because we knew of nothing better. But I think that we shall shortly see great changes in

**"PERMEABILITY" TUNING**

the tuning arrangements of our receivers; the introduction of "Ferrocort" coils (recently put on the market) has opened up a vast field for experiment. As you will remember, "Ferrocort" coils are wound on a core consisting of very small particles of iron contained in a solid insulating substance. As a result, a much higher inductance can be obtained by the use of fewer turns of wire. The complete coils are thus more efficient than those of the usual "air cored" type, since there is appreciably less resistance loss. To my mind, however, the new coils should give us a further, and possibly greater, advan-

tage than increased efficiency. It would appear that if they were so constructed that the core could be withdrawn, an accurate adjustment of wavelength could be made without the necessity for variable condensers. In addition to the great simplicity of the arrangement, it would seem that a much wider wavelength range could be covered by a coil of any particular size. I should not be at all surprised to find "permeability" tuning, as this system could be called, becoming very popular during the next few years. P.

**TWO STEEL SPANNERS GIVEN FREE NEXT WEEK!**



# BUILDING AND OPERATING THE A.C. THREE

Full Constructional Details are Given Below for this Most Efficient and Economical All-electric Receiver  
By THE TECHNICAL STAFF

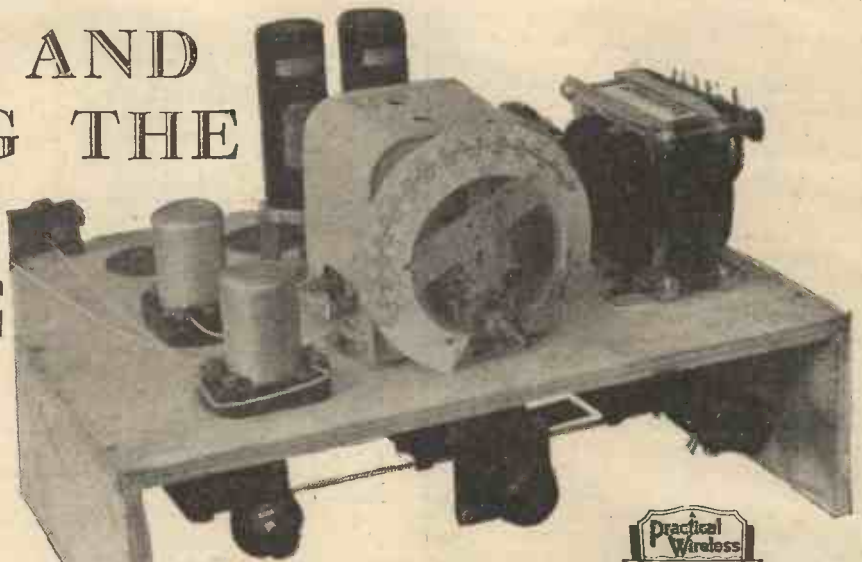

Front view of the A.C. Three. Note the compact lay-out and the simplicity of wiring.



A COMPLETE list of parts required for this new receiver was given last week, but it is reproduced on this page for easy reference. The first step is obviously to obtain all the necessary components, and it cannot be emphasized too strongly that it is absolutely essential that no deviation whatever should be made from the specification. This statement applies not only to the parts for the receiver itself, but is of even greater significance in respect to the loud-speaker. It was explained last week that the speaker specified had been chosen with considerable care, and the design of the whole outfit was worked out round it. For that reason the set cannot be expected to function properly (if at all) should any other type of instrument be employed.

All the parts are of standard patterns and can be obtained from any reliable dealer. It has frequently come to our notice that certain dealers have informed readers that some of the parts specified for other PRACTICAL WIRELESS receivers could not be obtained; this has never been the case, and we therefore ask readers, in their own interests, to insist upon being supplied with the exact types and makes of parts stated. In case a local tradesman refuses to obtain particular items which he does not keep in stock, any constructor can obtain them from reliable firms who advertise in these pages, whilst complete kits can be purchased in this way if desired.

### Assembling the Components

The first step in commencing the constructional work is to mount the parts on the special "Metaplex" chassis, which may be obtained already drilled and ready for immediate use. It will be found most convenient to start on the underside of

the chassis, arranging the parts in the positions indicated on the wiring plan. Attach the fixed condensers, L.F. transformer, and H.F. choke by means of 1/4 in. or 3/8 in. screws and then attach the four angle brackets with 1/4 in. screws. Next, turn the chassis over and mount the valve-holders, taking care that they are placed in the exact centres of the 1 in. diameter holes provided. The gang condenser is fixed in place with the screws supplied, and it should be observed that it must be so placed that the end of the spring retaining bush is exactly in line with the front edge of the baseboard. The two coils can next receive attention, and must be arranged with their terminals in the positions shown in the wiring diagram. Finally, the mains plug, mains transformer, electrolytic condensers, and terminal block can be mounted.

### Systematic Wiring

Wiring should present no difficulties, even to the beginner, provided that some sequence is followed. We ourselves found it best to start by attaching most of the output leads from the mains transformer. These leads are not marked to show which is which, but they are of different colours and thicknesses; the two thin red leads are the outsides of the high-tension second-

ary winding, and thus go to the grid and anode terminals of the rectifier valve-holder; the thin (double) black lead is the centre tapping from the H.T. secondary, and is the H.T. negative lead; the thick yellow leads are from the 4 volt 3 amp. heater winding, and go to the filament terminals of the pentode valve-holder, whilst the corresponding black lead is the centre tapping and goes to H.T. negative; the thinner yellow leads are for the rectifier heater, and the corresponding black lead is high-tension positive. Most of the transformer leads are slightly longer than they are actually required to be, so it is best to lay them in position and then cut

(Continued overleaf)

### LIST OF COMPONENTS FOR THE A.C. THREE.

- Two Telsen Iron-core Tuning Coils, type W.349.
- One Polar Uni-knob .0005 mfd. Twin Gang Condenser.
- One Graham Farish "Litlos" .00015 mfd. Reaction Condenser.
- One Bulgin 15,000 ohm Volume Control with Switch, type G.S.15.
- One British Radiogram Mains Transformer, type 55.
- One Igranic Jack, type No. 72.
- One Igranic Plug, type No. 40.
- One Bulgin Mains Connector with Fuses, type F.15.
- One Igranic L.F. Transformer, type T.24.B.
- Four Clix 5-pin Chassis Mounting Valve-holders, Standard type.
- One British Radiogram 2-point Switch, type No. 48.
- Four British Radiogram Component Brackets, type 21.
- One Graham Farish H.F. Choke, type H.M.S.
- Two Telsen 4 mfd. Electrolytic Condensers with Brackets.
- Five T.C.C. 1 mfd. Condensers, type 80.
- Two T.C.C. 2 mfd. Condensers, type 80.
- One T.C.C. .0002 mfd. Condenser, type 34.
- One T.C.C. .05 mfd. Condenser, type 40.
- One Graham Farish 2 megohm Grid Leak.
- Nine Graham Farish "Ohmite" Resistances; two each 5,000, 20,000 and 30,000 ohms; one each 150, 300 and 400 ohms.
- One Belling Lee Terminal Mount.
- Two Telsen E Terminals, marked "A" and "E" type B.
- One Peto Scott "A.C. Three" Cabinet, and Metaplex Chassis.
- One Celestion Energized Speaker with 1,500 ohm field, type E.8.
- Two Coils Glazite, length screening braid, flex, screws, etc.
- One Mazda AC-SG.VM Valve.
- One Mazda AC-2HL Valve.
- One Mazda AC-PEN Valve.
- One Mazda UU.2 Rectifying Valve.

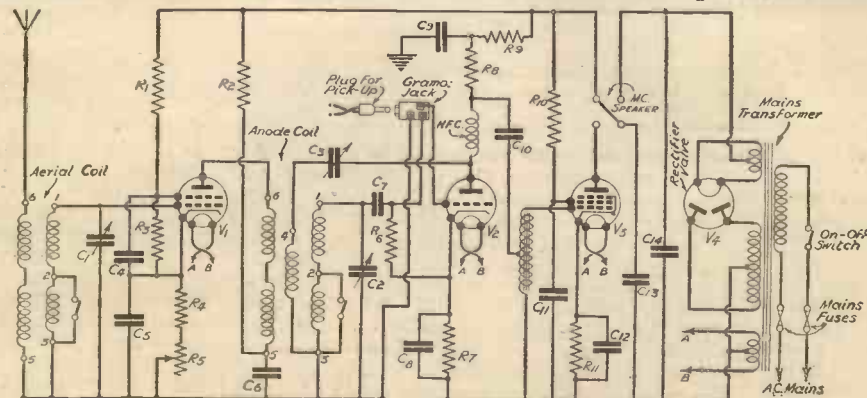

Theoretical Circuit of the A.C. Three.

C1, C2—.0005 mfd. ganged. C3—.00015 mfd. C4, C5, C6, C9, C11—1 mfd. C7—.0002 mfd. C8, C12—2 mfd. C10—.05 mfd. R1, R8,—30,000 ohms. R3, R9—20,000 ohms. R2, R10—5,000 ohms. R4—150 ohms. R6—2 megohms. R7—400 ohms. R11—300 ohms. R5—15,000 ohms graded potentiometer.



(Continued from previous page)  
 them off to such lengths that they will just reach the appropriate terminals. The valve heaters can next be joined together by using a short length of twin flex. It will be found most convenient to connect up the large capacity condensers next, and to put the various "Ohmite" resistances in place. A number of "earth return" connections are made to the metallized chassis, and it should also be noticed that earth connections are made from one holding down screw of each coil to terminal 3, which is adjacent to it. The leads from terminal 2 on both coils to the wavechange switch are screened to prevent capacity couplings, and the screening braid is earthed by binding a short length of thin bare wire round it and connecting this to the most convenient earthing point. In using the screening braid care must be taken that it does not touch the bared end of the connecting wire, and to ensure this it is best to bind the ends with a length of thread or thin wire. A screened lead is also used between terminal 6 on the second coil (nearer aerial terminal), and the same precautions must also be taken here.

Three flexible leads are taken to the loud-speaker, whilst there are four terminals on the latter component; two of these, however, are joined together, as shown in the wiring plan.

In connecting the leads to the primary of the mains transformer the two terminals appropriate to the supply voltage should, of course, be used. Where the supply voltage is not exactly the same as that marked on any terminal, it is quite correct to use the terminal which most nearly corresponds.

**Preparing the Cabinet**

After all the wiring has been completed the set can be fitted into its cabinet by drilling four holes in the latter to receive the controls; the positions and diameters of these are clearly indicated in the diagram. The chassis fits exactly into the cabinet, and the aerial and earth terminals, mains socket, and pick-up jack thus project from the back and are easily accessible. The speaker is screwed to the cabinet immediately behind the fretted opening, and it is well to see that the leads to it are as direct as possible, so as to avoid the possibility of hum due to their coming too close to the valves and wiring.

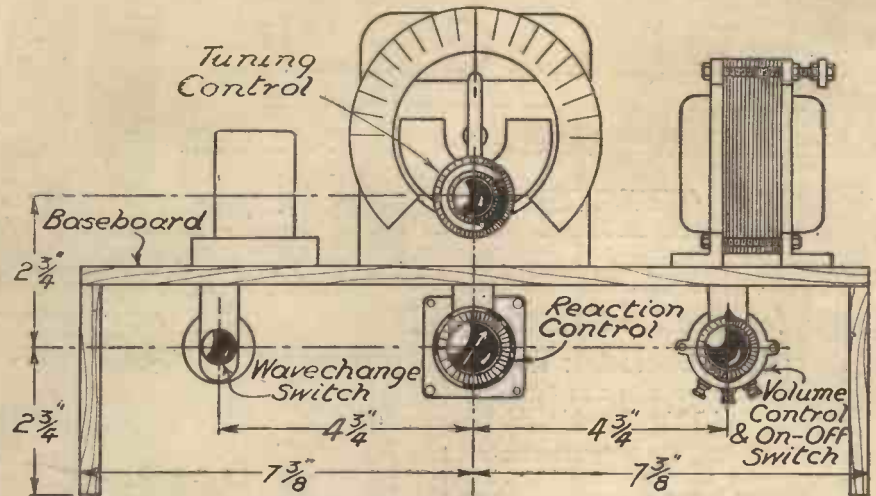

Use this diagram to mark off the control spindle positions on the front of the cabinet.

**Simplicity of Operation**

The "Modern A.C. Three" is delightfully easy to operate, but one or two suggestions on how to get the best out of it will perhaps not be amiss. Almost any kind of aerial can be used with every success, but where extreme selectivity is required it is well to limit the length to some 60 or 70ft. When the set is to be used in very close proximity to a Regional station, it might even be advisable to reduce the length of aerial to 40ft. or so, or to include a small pre-set condenser in series with the lead-in. Actually, however, it will seldom be found that either of these expedients is necessary, since the set is extremely selective. It need not be stressed that a really good earth lead is of particular importance, not only as an aid to long distance reception, but in eliminating the last traces of mains hum.

After connecting the mains leads, switch on by turning the volume control knob clockwise; a click will be heard as the contacts close and the knob can then be turned as far as it will go in order to bring the variable-mu valve into its most sensitive condition. Turn reaction "off" by rotating the control knob anti-clockwise, and set the wavechange switch to the wavelength required—for long waves, push in; for medium, pull out. You can then find

the local station by rotating the larger condenser knob. When this has been tuned in it can be brought up to full strength by adjusting the smaller (trimmer) condenser knob and increasing reaction. It will no doubt be found that the volume is a good deal greater than is required, but it can be reduced by means of the potentiometer control. Other stations can be tuned in similarly, but for the more distant ones a certain amount of reaction will in most cases be required. In all cases the degree of selectivity can be increased by turning the volume control "down" and the reaction condenser "up."

**In Case of Difficulty**

Should it be found after switching on that no signals can be heard, the first thing to do is to look at the valves and make sure that their heaters are glowing properly. If no light can be seen it is probable that one of the fuses will have been "blown," due to a fault in the wiring. The fuses can easily be removed and replaced if necessary by unscrewing the two thumb screws on the mains socket. When a fuse is found to be faulty, it should not be replaced until the cause of its "blowing" has been traced—this will almost certainly be found to be a short circuit or wrong connection in the wiring.

THE advantages of the automatic method of supplying grid bias to valves are well known and need not be amplified. If your receiver is not already fitted with it, the change can very easily be made.

The neat little unit about to be described entirely replaces the grid-bias battery, and can be fixed in the clips which normally held the battery. There are no alterations to be made to the receiver wiring. The

**AN AUTOMATIC BIAS UNIT**

By T. A. WILSON.

extra components needed for the change over are one resistance, and one condenser for each grid-bias voltage required. The condenser should have a capacity of one microfarad. The value of the resistance will be dealt with later.

Let us assume that two tapplings are to be used. First of all, obtain a piece of wood about 1/2 in. thick, and the width of a bias battery. The length of the wood should be such that two condensers can be mounted end to end. The method of connecting the resistances and the condensers is made clear in the sketch. The connections to

the receiver are also shown. Note that the high tension negative lead must be removed from its usual position to the new point.

So much for the construction of the unit. It now remains for us to find the value of the resistances. To do this it is necessary to know the total H.T. consumption of the set. Now, by dividing the maximum grid voltage required by the consumption in milliamps, and multiplying the answer by 1,000 we get the total resistance needed in the circuit; in other words, the combined value of R<sup>1</sup> and R<sup>2</sup>. The resistance of R<sup>1</sup> is found by dividing the voltage required for G.B.1 by the total consumption, and multiplying, as before, by 1,000. R<sup>2</sup> is then found by simple subtraction.

To exemplify this, suppose voltages of 3 and 12 are needed, and the total consumption of the receiver is 10 milliamps. The combined resistance of R<sup>1</sup> and R<sup>2</sup> would then be 12/10 × 1,000, which equals 1,200-ohms. R<sup>1</sup> would equal 3/10 × 1,000, or 300 ohms. Resistances of 300 and 900 ohms would therefore be required.

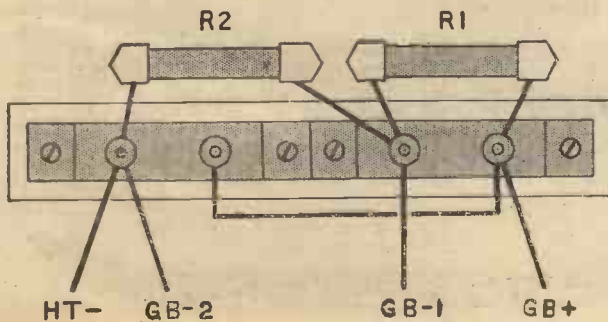



# "CLASS B" SIMPLIFIED!

## THE NEW ROLA P.M. MC. & UNIT SPEAKER IN ONE

MAINS VOLUME FROM ANY BATTERY SET AT VERY LOW USE OF H.T.

JUST CONNECT TO YOUR SET WITHOUT ANY ALTERATION!

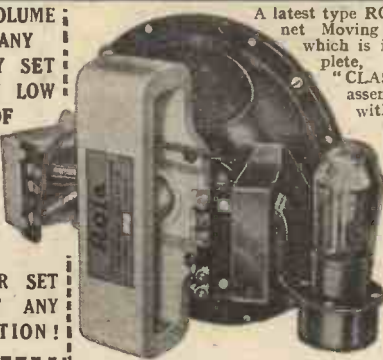

A latest type ROLA Permanent Magnet Moving Coil Speaker with which is incorporated a complete, properly matched "CLASS B" amplifier. This assembly when connected with any Battery Set converts it to "Class B" output, increasing the overall sensitivity of the set several times, and increasing the Power Output or Volume up to 5 Times!



**SEND FOR IT ON 7 DAYS' TRIAL**

Send only 5s. for 7 days' trial, if satisfied, pay balance in 10 monthly payments of 7s. 6d. (Cash, in 7 days, £3 11s.).



The British Made WATES UNIVERSAL METER is the only popular priced instrument testing resistance as well as batteries, valves, circuit, and all components; 4 readings on one dial.

**SEND ONLY 1/6**

for 7 days' trial, if satisfied complete purchase by 8 monthly payments of 2/6 (Cash 12/6)

This Rola "CLASS B" SPEAKER AMPLIFIER UNIT can quickly and simply be connected to any battery set, and is complete with Cosmor, Mullard, or B.T.H. "Class B" valve, with full instructions.

The result of adding this unit to your battery, set will be equivalent in performance, as regards richness of tone and volume, to a high grade all mains set, whilst at the same time retaining economy in battery consumption. Send deposit to-day!

E. J. HERAUD, Ltd., Dept. P.23, Number One, EDMONTON, LONDON, N.18  
Branches: 78/82, Fore St., Edmonton; 77, West Green Rd., Tottenham; 34, St. James St., Walthamstow; and 139, Hertford Road, Enfield Wash.



**Read this**  
**QUALITY**  
Produces  
**EFFICIENCY**

**TESTED BEFORE DESPATCH**

The original BECOL ebonite low loss formers are thoroughly reliable. They are used in all parts of the world. Look for the BECOL trade mark. Ask your dealer. If unable to supply write direct. SEND NOW, enclosing 6d. (post free) for third edition up-to-date handbook of tuning coils for DUAL RANGE, BAND-PASS, and SUPER-HET. circuits. Fully illustrated with data. A very interesting handbook.

RODS. SHEET. TUBES. PANELS

The BRITISH EBONITE Co., Ltd.,  
Hanwell, London, W.7.

# EQUAL TO THE BEST — BUT 50% LESS



The 362 "Class B" — the first and most successful of all "Class B" valves.

If your dealer does not stock, send for 362 post free direct from the makers. 362 are NON-MICROPHONIC and are definitely as good as any, and better than most. FULLY GUARANTEED and BRITISH ALL THROUGH.

Post Free from **3/6**

"362" BATTERY TYPE VALVES:— H., HL & L., 3/6. Power 4/-. Super-Power, 4/6. S.G., 7/6. Var-Mu 7/6. "Class B" 9/-. Pentode type 10/-. (Metallised 3d. extra.)

"362" UNBREAKABLE METAL VALVES (BATTERY TYPES):— HL., 4/6. Power 5/6. Super-Power 6/-. S.G. 10/-. Var-Mu 10/-. (Metallised 3d. extra.)

"362" MAINS TYPE VALVES:— Small Rect. and General Purpose 7/6. Super-Power 8/6. S.G. and Var-Mu 12/6. Pentode type 15/-. (Metallised 3d. extra.)

Cash with order. Cheques and P.O.'s must be crossed and made payable to — THE 362 RADIO VALVE Co., Ltd. (Dept. W 18), Stoneham Road, London, E.5.



# EDISWAN

The name that means 'EXCELLENCE'

This Ediswan H.T. Battery cell reveals the secrets of extra H.T. service

A brass cap tightly affixed to the carbon rod forms the positive connection.

The cell is sealed by means of a waxed washer over which paraffin wax is poured. This washer assists in centralising the sac in the cell.

An air space is left between the top of the sac and the washer to allow for the expansion of the electrolyte during discharge.

A substantial zinc container which forms the negative pole of the cell.

The sac consists of a highly efficient depolariser, tightly compressed round the carbon rod, the whole being securely wrapped and tied.

Electrolytic paste of a special chemical composition which fills the space between sac and zinc container and activates the cell.

A waxed paper disc which insulates the sac from the bottom of the zinc container.

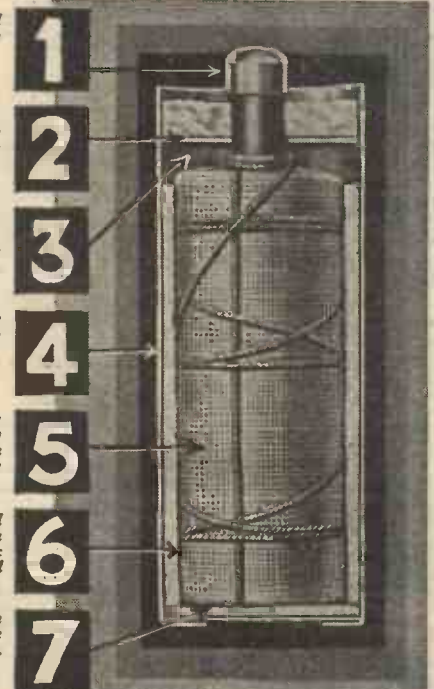

Don't risk wasting your money on inferior batteries. Insist on Ediswan. You can get them in all standard sizes including portable types—Standard or Super Capacity—at the usual prices.

# EDISWAN H.T. BATTERIES



THE EDISON SWAN ELECTRIC CO. LTD.  
PONDERS END, MIDDLESEX

EDISWAN—the Better Service Batteries



# THE NATIONAL RADIO EXHIBITION, MANCHESTER

## Sept. 27th—Oct. 7 LIST OF EXHIBITORS

6a Tonman Hall—Hellesens, Ltd., Hellesent Works, Morden Road, London, S.W.  
(Continued on page 954)

### OUR STAND No. 11 GROUND FLOOR

- 85 Gallery—Aerialite, Ltd., Aerialite House, Amber Street, Manchester.
- 34 Tonman Hall—Amplion (1932), Ltd., 82/4, Rosoman Street, London, E.C.1.
- 11b New Hall—Automatic Coil Winder and Electric Equipment Co., Ltd., Winder House, Douglas Street, London.
- 79 Gallery—Berry and Wilson, Ltd., Mansion Works, Great Horton, Bradford.
- 73 Main Hall—Balcombe, A. J., Ltd., 52/8, Tabernaacle Street, London, E.C.2.
- 27 Main Hall—Belling and Lee, Ltd., Cambridge Arterial Road, Enfield.
- 54 Main Hall—Block Batteries, Ltd., Abbey Road, Barking, Essex.
- 2 Main Hall—Britannia Batteries, Ltd., 233, Shaftesbury Avenue, London, W.C.2.
- 50 Main Hall—British Blue Spot Co., Ltd., 94/6, Rosoman Street, E.C.1.
- 86 Gallery—British Pix Co., Ltd., 118, Southwark Street, London, S.E.1.
- 14 Tonman Hall—British Radiophone, Ltd., Aldwych House, W.C.2.
- 75 Main Hall—British Rola Co., Ltd., Minerva Road, Park Royal, N.W.10.
- 69 Main Hall—Bulgin, A. F., and Co., Ltd., Abbey Road, Barking, Essex.
- 94/7 Gallery—British Broadcasting Corporation, Portland Place, London.
- 44 B—Beardsall, W. E., and Co., Victoria Bridge, Manchester.
- 44 New Hall—Carrington Mfg. Co., Ltd., Camco Works, Sanderstead Road, South Croydon.
- 1 Main Hall—Celestion, Ltd., London Road, Kingston-on-Thames.
- 114 Gallery—Cifel Products, Ltd., 134, Pentonville Road, London, N.1.
- 29 Main Hall—Clarke, H., and Co. (M/C), Ltd., Atlas Works, Patricroft.
- 16 Main Hall—Climax Radio Electric, Ltd., 59, Parkhill Road, Hampstead.
- 18 Main Hall—Cole, E. K., Ltd., Ekco Works, Southend-on-Sea.
- 32 Main Hall—Colvern, Ltd., Mawneys Road, Romford, Essex.
- 61 Main Hall—Cossor, A. C., Ltd., Cossor House, Highbury Grove, London, N.5.
- 104 Gallery Bridge—Cosmocord, Ltd., Cambridge Arterial Road, Enfield.
- 30 Main Hall—Cromwell (Southampton), Ltd., 32, Brinton's Terrace, Southampton.
- 79 Gallery—City Accumulator Co., Ltd., 7, Angel Court, Strand, London, W.C.2.
- 9b New Hall—Clifford Pressland (Sales), Ltd., 84, Eden Street, Kingston.
- 107 Gallery Bridge—Dawes, F., London Road, Manchester.
- 84a Gallery—Diggle, A., and Co., Jane Street, Rochdale, Lancs.
- 36 Tonman Hall—Dyson, J., and Co., Ltd., Godwin Street, Bradford.
- 9a New Hall—Dent, R. H., 309, Oxford Street, London, W.1.
- 81 Gallery—Econasign Co., Ltd., 92, Victoria Street, London, S.W.1.
- 12 Tonman Hall—Edge, W., and Sons, Ltd., Bolton, Lancs.
- 28 Main Hall—Edison Swan Electric Co., Ltd., 155, Charing Cross Road, London, W.C.2.
- 109 Gallery Bridge—Electric Dynamic Construction Co., Ltd., Devonshire Grove, London, S.E.
- 53 Main Hall—Ever Ready Co. (Gt. Britain), Ltd., Hercules Place, Holloway, London, N.7.

- 6 Tonman Hall—Express Radio Factors, Ltd., 25, Great Eastern Street, London, E.C.2.
- 83 Gallery—Epoch Radio Mfg. Co., Ltd., Exmouth House, Exmouth Street, London, E.C.
- 20 Main Hall—Ferranti, Ltd., Hollinwood, Lancs.
- 19 Main Hall—General Electric Co., Ltd., Magnet House, Victoria Bridge, Manchester.
- 52 Main Hall—Gramophone Co.,

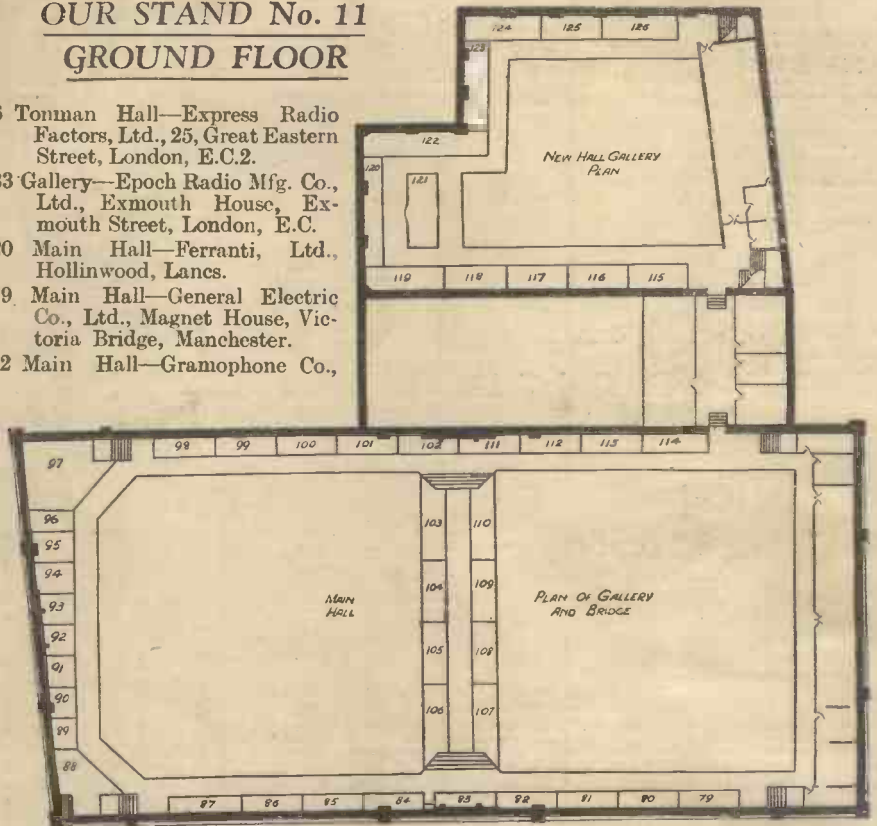

- Ltd., 98/108, Clerkenwell Road, E.C.1.
- 23/6 Main Hall—Graham Farish, Ltd., Bromley, Kent.
- 33 Main Hall—Grampian Reproducers, Ltd., Station Avenue, Kew Gardens, Surrey.
- 106 Gallery Bridge—Garnetts Gresley Radio, Ordsall Lane, Salford.
- 103 Gallery Bridge—Goodmans, Ltd., 69, St. John Street, Clerkenwell, London, E.C.
- 92/3 Gallery—Hacker, H., and Sons, Ray Lea Road, Maidenhead, Berks.
- 39 New Hall—Hayberd, F. C., and Co., 10, Finsbury Street, London, E.C.2.

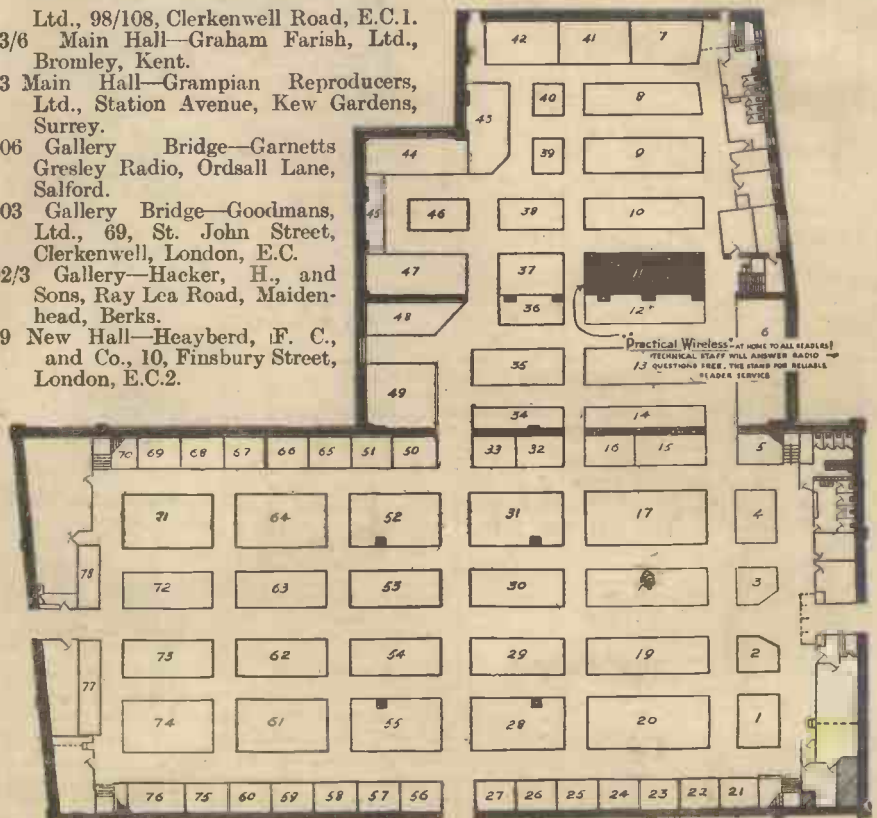



# READERS' *The* HALF-GUINEA *Page* WRINKLES

## Ebonite Anchor Plates for Battery Leads

A USEFUL battery lead holder can be made from odd pieces of ebonite found in the scrap box. Slots are filed across each piece of ebonite and screw holes

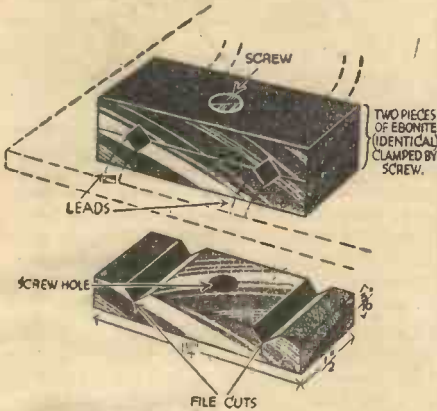

Ebonite anchor plates for battery leads.

are made between to take the clamping screw, as shown in the accompanying sketches. If desired, the ebonite strips can be of sufficient length to take a number of slots for accommodating various leads, with screw holes between.—C. P. CHILTON (Thornton Heath).

## Tantalum Charger

THE wrinkle recently published with reference to fixing the tantalum strip reminds me of the method I used to overcome the difficulty. In my case the strip was not wide enough to permit a hole to be drilled through it, so I obtained a one-hole-fixing bush, drilled and threaded a 4BA hole in the side, near the flange. The tantalum strip was then inserted in the flanged end of the bush just far enough for the fixing screw in the hole in the side to grip it. This screw was then filed down flush with the bush, and the whole was mounted on the piece of ebonite carrying the lead. I covered the whole of the flange, etc., on the underside of the ebonite with sealing wax. The result has been a perfectly satisfactory joint.—G. A. PORTER (Fulham).

## A Home-made Loud-speaker Unit

THE accompanying sketches illustrate how I constructed an excellent cone loud-speaker unit. The coil was taken

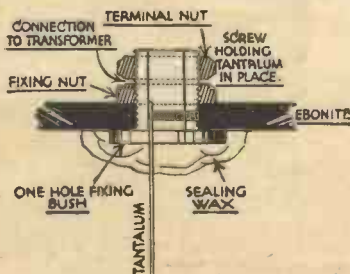

Fixing the tantalum strip in a charging cell.

## THAT DODGE OF YOURS!

Every Reader of "PRACTICAL WIRELESS" must have originated some little dodge which would interest other readers. Why not pass it on to us? We pay £1-10-0 for the best wrinkle submitted, and for every other item published on this page we will pay half-a-guinea. Turn that idea of yours to account by sending it in to us addressed to the Editor, "PRACTICAL WIRELESS," George Newnes, Ltd., 8-11, Southampton Street, Strand, W.C.2. Put your name and address on every item. Please note that every notion sent in must be original. Mark envelopes "Radio Wrinkles." Do NOT enclose Queries with your Wrinkle.

from an old horn loud-speaker. The armature is made from a piece of sheet iron about  $\frac{1}{8}$  in. thick, and to this is fixed the reed, to the underside of which is fixed a V-shaped spring. As to the magnet, this can be purchased for a few pence. The

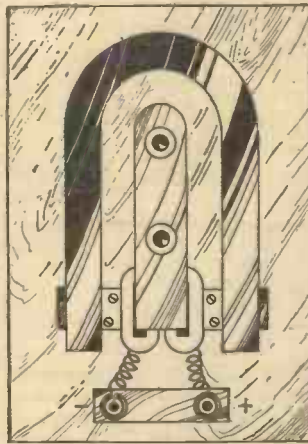

The complete loud-speaker unit.

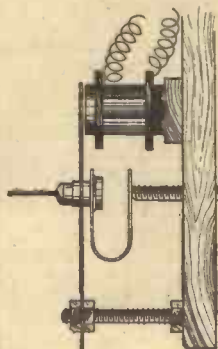

Showing the coil and spring.

fixed condenser is shorted. When tuning on the long-waves the switch is opened, and the fixed series capacity reduces the effective aerial series capacity. The values are not critical and may be varied a little. The unit may be made up in a small box measuring not more than 3in. by 4in. by 2in. deep, as indicated in Fig. 1. The unit may be made up in the cabinet of a receiver if the necessary space is available.

The circuit is shown in Fig. 2.—C. F. SHARP (Henley-on-Thames).

## Modernizing Variable Condensers

HERE is a dodge for modernizing an old variable condenser with an ebonite dial. The condenser is mounted, as shown

in the sketch, on a piece of plywood behind the panel. A hole is cut in the panel, level with the scale, to receive the condenser window which can be made with a fretsaw from some scraps of plywood. A small knob is fitted below, and turns a metal rod, fixed on each side of the plywood supporting the condenser, by two washers with screws. One washer is placed so that in rotating it causes the ebonite dial to rotate by friction. An excellent slow motion arrangement is thus obtained. A dial light can be fixed if desired above the scale, as shown.—L. J. STEVENS (Bristol).

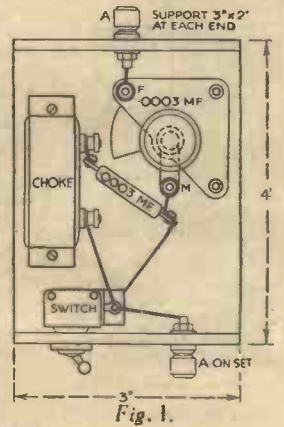

Fig. 1.

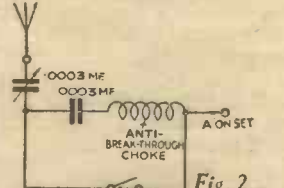

Fig. 2.

A simple unit for improving long-wave selectivity.

A dial light can be fixed if desired above the scale, as shown.—L. J. STEVENS (Bristol).

(Continued overleaf)

## Improving Selectivity

HERE is a useful gadget for eliminating two of the common faults in long-wave tuning, viz., non-selectivity and the breaking through of the

medium-waves. All the parts may be found in the junk box, except the break-through choke. When tuning medium-waves the

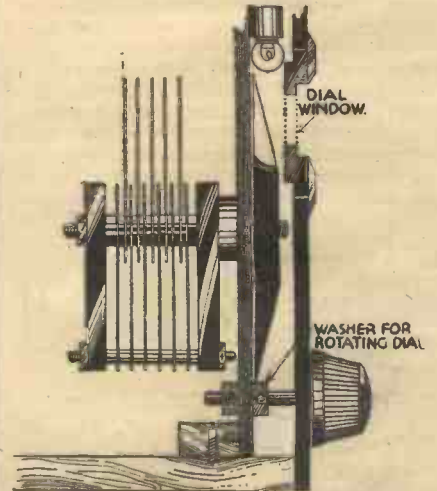

Slow motion device for a variable condenser.

## NEXT WEEK'S FREE GIFT!

TWO HANDY STEEL SPANNERS! will be given with every copy of next week's Birthday Number. A third Spanner, to complete the set, will be given the following week.



**RADIO WRINKLES**

(Continued from previous page)

**Plug-in Connections for Receiver in Different Rooms**

TO save the expense of an extra loud-speaker, I fixed up the arrangement shown in the accompanying sketch for receiving programmes in another room in the house. An outdoor aerial is led into one room and an indoor aerial into the other. The indoor aerial I have brought down the wall underneath the wall-paper in a corner of the room, thus hiding an otherwise unsightly wire. The lead-in is then fixed to one side of an ordinary wall socket, the earth being taken from the other. This is fastened to the skirting board. Both aeri- als are treated in the same way. The aerial and earth terminals on the set are then joined to a plug which is inserted in the socket. When there happens to be a thunderstorm in the neighbourhood, the receiving set plug is taken out and another, the points of which are shorted, inserted. Sometimes long-distance reception is improved by reversing aerial and earth. This is done quite easily by removing the plug and inserting it round the other way.—R. TAYLOR (Sunderland).

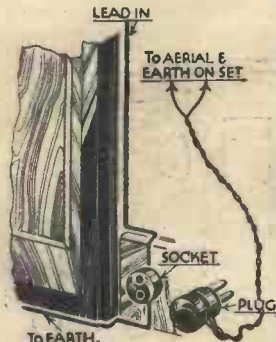

Details of the plug-in connections for receivers in different rooms.

to be a thunderstorm in the neighbourhood, the receiving set plug is taken out and another, the points of which are shorted, inserted. Sometimes long-distance reception is improved by reversing aerial and earth. This is done quite easily by removing the plug and inserting it round the other way.—R. TAYLOR (Sunderland).

**A Double Circuit Speaker Connector**

AN old type panel-mounting valve-holder, mounted on an ebonite strip, connected as shown in the accompanying sketch, and used in conjunction with a specially wired valve-base, forms an efficient combined battery switch and speaker connector. The valve-holder is connected in the following manner: Plate socket to plate terminal on output valve-holder; grid socket to H.T.— cable; lower filament to earthed filament terminal; higher filament to L.T. and H.T.— cable. On the valve-base plug, flexible speaker wires pass through nearby holes to grid and plate. A well-insulated wire short circuits filament legs, and all wires are soldered. The inserting plug connects the speaker in the usual manner; joined filament legs bridge broken battery circuit at filament sockets. Removing the plug disconnects both batteries.—F. J. GOUGH (Salop).

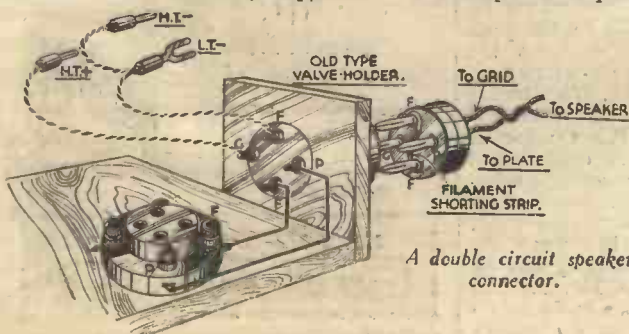

A double circuit speaker connector.

**A Simple Time Switch**

THE accompanying sketch shows a cheap, simple, and reliable time switch which has been used with great success during the last three years for the control of a battery receiver. Any type of cheap alarm clock is suitable, providing it has an alarm winding wing nut, as shown in the sketch. If the wing nut is made to swivel on the winding spindle, it should be secured rigidly to the spindle by a touch of solder. Two springy pieces of brass of "U" shape are mounted on blocks of ebonite, wood, or other insulating material. The strips are secured by means of a long screw and a back nut, a second nut and washers being fitted to form connections for the battery lead. The blocks may be mounted on the back of the clock in any suitable manner. A simple way is as shown in the sketch, and consists of a metal lug secured by a screw to the block, and then soldered to the side of the clock. One of the leads from the L.T. battery is broken, and connection is made to the time switch. It will be seen that when the wing nut is in an approximately vertical position, connection is made between the two brass strips, and consequently the switch is "on." When the wing nut moves through a few degrees, so as to clear one or both contacts, the circuit is broken. If the receiver is to be switched off at a certain time, the alarm of the clock is set to operate at the desired time in the usual manner. The alarm action is then partially wound so that the wing nut is left approximately vertical in the "on" position. When the alarm operates, the nut turns just enough to clear both contacts. A few moments experiment will be enough to decide exactly how much winding is required. It will be understood that by a slight variation in the initial angle of the winding wing nut, the time switch may be set to switch on the receiver at any desired time instead of switching it off.—C. MUSTILL (Leeds).

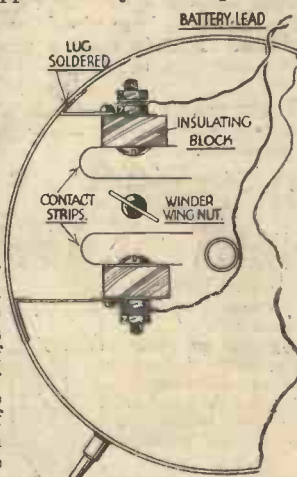

A simple time switch.

**A Simple Continuity Tester**

THE accompanying sketch shows a simple method of making a sensitive continuity tester. An ordinary pocket compass is required, and a coil of wire is placed flat underneath it, as shown. To make the coil, wind about 150 or 200 turns of 38 or 40 gauge D.S.C. wire round two fingers, and give the coil thus formed a half twist like a figure 8. Fix two lengths of flex to the two ends of the coil by a touch of solder. Place the compass on top of the coil, and mount them on a small wooden base

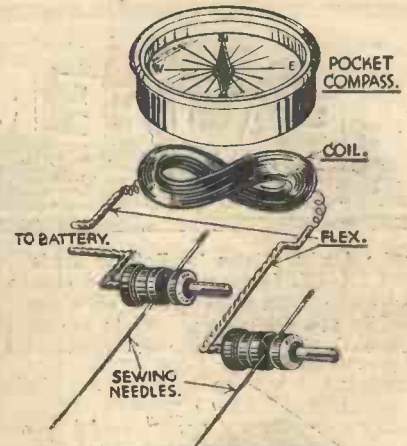

A simple continuity tester.

with sealing wax. An extra length of flex is needed, and two wander-plugs are fixed as shown, with two ordinary needles pushed through the holes and clamped. The needles are used for piercing the insulations of covered wire, to make contact with the wire underneath. A flash-lamp battery connected in circuit completes the tester.—W. AINSWORTH (Blackburn).

**A Divided Five-Valve Set**

A SHORT time ago I decided to build a five-valve set, 2 S.G., det., and 2 L.F., but not wishing to do away with the comparatively small cabinet I then had in use, I adopted the following idea: The 2 S.G. and det. stages were built into the existing cabinet, and the 2 L.F. stages into the loud-speaker cabinet, thus forming two entirely independent units. I use two separate H.T. batteries, which I find is a more economical method, besides saving extra wiring between the units. As for the 2 S.G. and det. stage, this can be disconnected from the speaker portion, and phones used only, thus making alterations an easier job. I may add that the L.S. portion is very good on gramophone reproduction (using a pick-up), and may be carried from room to room without the inconvenience of carrying the whole set, provided a spare L.T. battery is available for heating the filaments of the L.F. valves! Of course, a separate on-off switch should be provided if the speaker portion is used in this manner.—J. S. BROSTER (Liverpool).

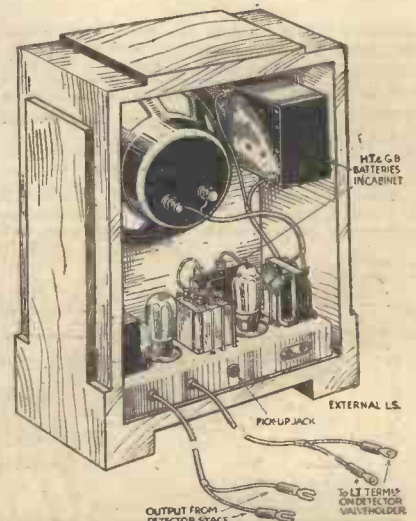

Part of a five-valve set fitted into a loud-speaker cabinet.



# All-World Listening for Home-Constructors ONLY!

## ULTRA SHORT

## AND SHORT WAVES

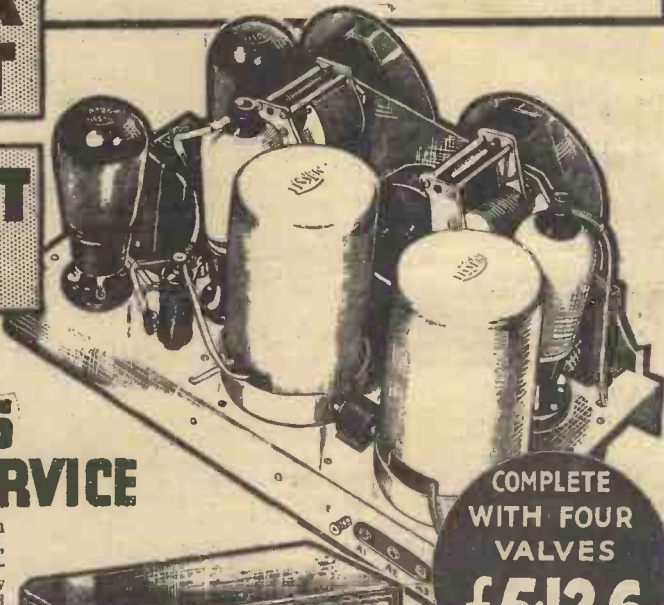

### PROVIDE UNIQUE INTERNATIONAL NEWS AND ENTERTAINMENT SERVICE

At last the day of All-World Radio has arrived, and you can build with your own hands the first receiver to give you not only England and Europe, but America and Australia direct. The Lissen All-Wave All-World "Skyscraper" 4 tunes from 12 to 2,100 metres. It brings two complete new wavelength ranges within reach of the ordinary listener—stations and programmes which before he was never able to receive—Ultra Short and Short-Wave transmissions from the ends of the earth. And remember you get these stations through Double-Balanced Pentode Output giving brilliant reproduction on a Moving-Coil Speaker—as much power as a Mains Set from ordinary high-tension batteries.

COMPLETE  
WITH FOUR  
VALVES

£5.12.6

### Hear the news & views of AMERICA & AUSTRALIA DIRECT and AT FIRST HAND



WITH WALNUT  
CABINET AND  
MOVING COIL  
SPEAKER

£8.2.6

Lissen have made this All-Wave All-World Radio available to Home Constructors first, because it brings back the thrill of conquest to hear America and Australia direct on a set you have built yourself, it makes you an enthusiast to realise what a wonderful thing you have created!

When you see the Great Free Chart of the All-Wave All-World "Skyscraper" 4, which tells you how to build it and how to work it and why it gives such marvellous results, you will agree at once that it will be wise of you to build for yourself rather than buy a factory assembled receiver which cannot give you these new and intriguing short-wave stations. The FREE CHART simplifies everything; there are pictures of every part, with every wire numbered, every hole lettered, every terminal identified. YOU CAN'T GO WRONG! But get the Chart and see for yourself—then build the Lissen All-Wave All-World "Skyscraper" 4, the SET THAT SPANS THE WORLD!

DOUBLE  
BALANCED  
PENTODE  
OUTPUT  
AND  
MOVING COIL  
SPEAKER

LISSEN



# 4

# "SKYSCRAPER"

To LISSEN LTD.,  
Publicity Dept., ISLEWORTH.  
Please send me FREE copy of  
All-Wave All-World "Skyscraper"  
Chart.  
Name .....  
Address .....

POST  
COUPON  
FOR  
**FREE CHART**

PR634



# LESSONS FROM

## An Analysis of the Exhibits at the Recent Radio Exhibition By W. J. DELANEY.

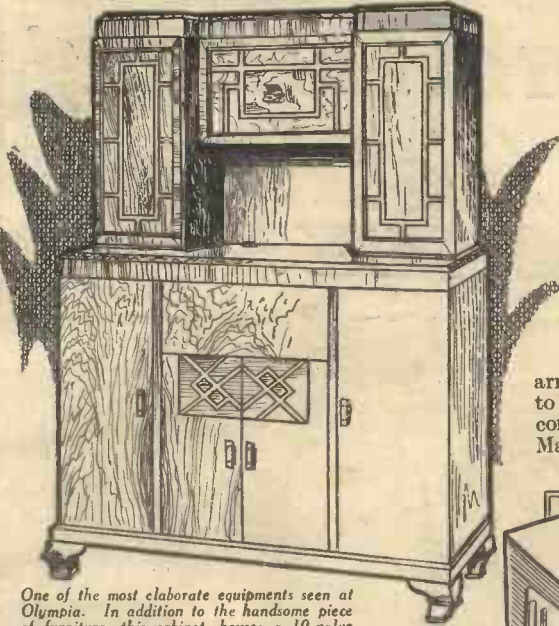

One of the most elaborate equipments seen at Olympia. In addition to the handsome piece of furniture, this cabinet houses a 10-valve superhet with an automatic gramophone and no less than four dual speakers. A device is incorporated to eliminate man-made static.

WE have already dealt at some length with the Radio Exhibition, and have covered all the exhibits from the point of view of a simple review. Now that there is time to settle down and examine all the various new features which were introduced, and the new styles and fashions which were set, we can, as it were, analyse the position. What can we learn from the exhibits? Are there any features of principles involved which are worth stressing? Has the design of radio apparatus improved? These and many other questions occur when we begin to look into the exhibition from a distance, as it were, and the purpose of this article is to try and show how the modern wireless receiver reveals new ideas, and in some cases reveals fallacies which exist regarding the design of radio apparatus.

The illustration above shows what was probably the most elaborate wireless receiver in the whole of the Exhibition. Taking the cabinet work first of all, we can see typified in this particular receiver the aim of the manufacturer to disguise the technical side of the apparatus, and to bring

the actual wireless set into the home as part of the furnishing. If we cast our minds back only a few years we can remember the wireless set of that time with its exposed valves standing up like small lamps, and a formidable array of knobs and switches, all tending to give the set the appearance of some complicated laboratory apparatus. Many people, in fact, were afraid to

maximum. These may be divided into the main tuning control; wave-change control; volume control and tone control. Switches to bring the receiver into operation and to switch it off are in most cases combined with a volume control or other control. The Baird television receiver, illustrated at the foot of this page, reveals a further attempt at making the apparatus less conspicuous, and this particular receiver houses both a wireless receiver with loud-speaker, and television receiver with viewing screen. It can be classified under the above description of "fool-proof," and is certainly capable of taking its place in any room without giving an air of workshop or laboratory intrusion. The first lesson, then, is that the modern wireless set must not obtrude, but must be obscured so far as possible, whilst permitting ease of control and unobstructed reproduction.

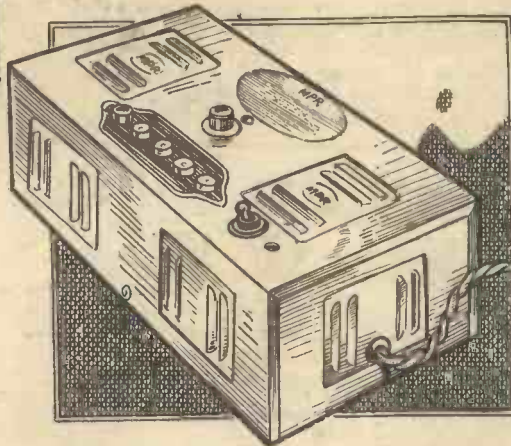

For the user who has just gone over to mains, a unit of this type will prove a great benefit over ordinary dry batteries. The model illustrated is the Mains Power Radio model which also enables the accumulator to be kept charged by means of a trickle charger.

### Circuit Design

WHEN we come to analyse circuit design we find that we have a rather formidable task. In these pages alone we have the two extremes of thought. The elaborate receiver first mentioned employs no less than

touch it in case of shocks, etc. As, however, the wireless programme to-day is regarded as a part of the normal home-life of the citizen, it is only natural that the means for receiving these programmes should be an integral part of the home, and this can only be brought about by making the apparatus both fool-proof and "domesticated" for want of a better word. This particular piece of apparatus has certainly succeeded in disguising the wireless receiver, and it has also succeeded in combining a really high-class wireless set with an electric gramophone, with the result that perfect music may be obtained at any time of the day from any source. Leaving for a moment the electrical side of this receiver, all the other receivers which were on show at Olympia revealed the same point of view—namely, disguise. With this end in view the number of controls has obviously got to be reduced, and we find that

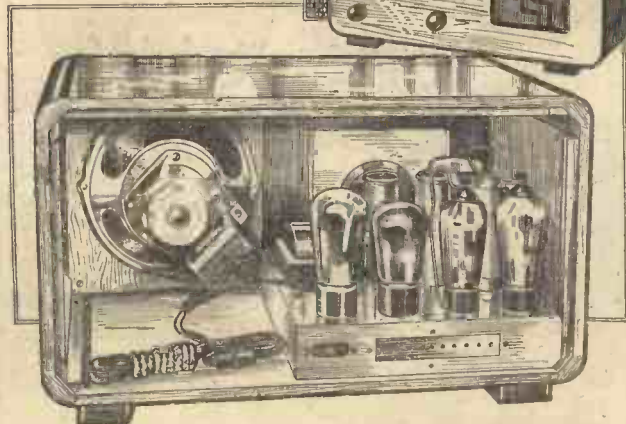

This illustration gives some idea of the workmanship which is put into the inside of most commercial sets. Note the all-metal chassis and the neat disposition of the valves and other components. This particular model is the Atlas 4 for A.C. mains operation.

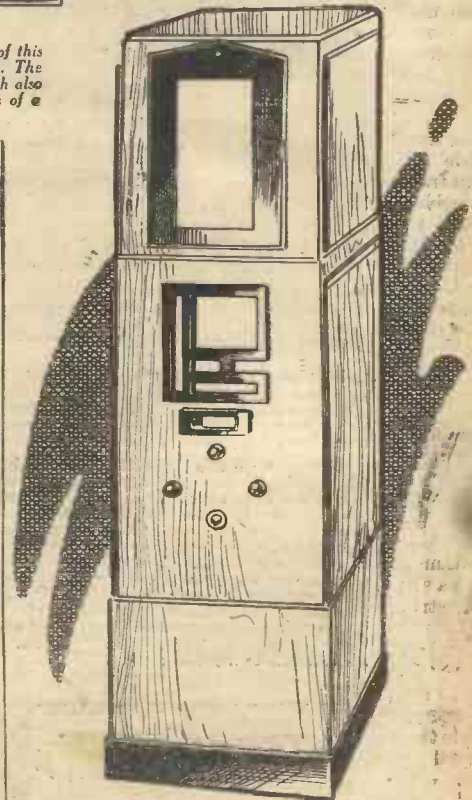

A complete Television receiver. At the upper end is the viewing screen, below this the loud-speaker, and below this the controls for the complete apparatus. This is made by Bush-Radio.



# MELBOURNE RADIO LYMPIA

...tion, with an Explanation of the Points which are Revealed.  
With Illustrations Drawn at The Show by Our Artists.

ten valves and four balanced loud-speakers. In addition to the normal super-heterodyne circuit which is employed there are included means for automatic volume control, automatic record changing, auto-fidelity control, automatic static eliminator, and every other known refinement. At the other end of the scale is the Cossor Melody Maker receiver illustrated at the end of this article. Here is a three-valve receiver (obtainable in kit form) which costs a mere six or seven pounds, complete with cabinet and loud-speaker, etc. They both enable the modern broadcast programme to be received at good strength and with good quality. There are thousands who would be pleased to own a Melody Maker in place of their existing equipment, and it will undoubtedly give very good reproduction and a choice of many programmes. Yet it cannot be compared with the first receiver. Between these extremes, however, there are a number of receivers which all play their part in revealing not only the tendency of [the set designer but the tastes of the general public. For instance, the mains four-valve receiver, made by Messrs. Clarke & Co. and shown at the foot of page 952 is built into a cabinet which has the loud-speaker at the side of the receiver, in contrast to the majority of receivers of last year which had the speaker on top. This former arrangement is certainly much more useful, as it gives a cleaner appearance to the finished apparatus and provides for easier wiring. But look at the manner in which the chassis-construction is employed in this receiver. All-metal, barely any wiring exposed, and perfectly safe. A great deal of selectivity trouble is due to direct pick-up on the wiring of a set, but when this particular all-metal chassis construction is employed all the wiring is screened inside the chassis and much trouble is avoided. Furthermore, the layout may be simplified

so as to enable the valves to be arranged direct in line and so provide easy replacement or examination. The second lesson, therefore, may be said to be compactness of layout, which, of course, is a tribute to modern component manufacture. Two years ago we could not have attempted to get a two-valver into the space this particular four-valve occupies.

### Combination Apparatus

ONE trend of thought which impressed me most in the new apparatus was the combining of the wireless set with some other article of domestic utility.

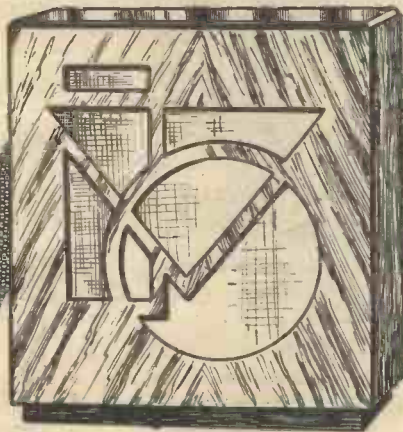

The cabinet for a loud-speaker may be designed to provide a neat ornament as well as keep dust from the speaker. This neat cabinet houses the Goodman speaker and has a speaker fret of novel design.

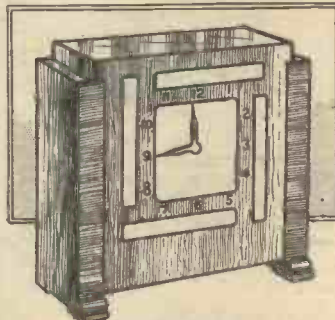

Although this has the appearance of a clock, it is actually a highly efficient loud-speaker plus a synchronous electric clock. It is an Earl product.

Messrs. Ferranti, for instance, realising

that there are occasions when the programme introduces some item which is not desired by the listener, have combined a wireless receiver with a small bookcase. The whole arrangement is

very compact, as may be seen from the illustration above. It may be stood at the side of an easy-chair and the programme enjoyed until an unsuitable item is introduced, when it is extremely simple to reach over and switch it off and take a suitable book from the space at the bottom without the necessity of getting out of the chair. Another type of combination apparatus is shown below the illustration just referred to, and in this case a clock has been combined on the speaker front. This will permit of the speaker being stood upon a sideboard or other article of furniture and the speaker operated by means of extension leads. The clock is of the synchronized type,

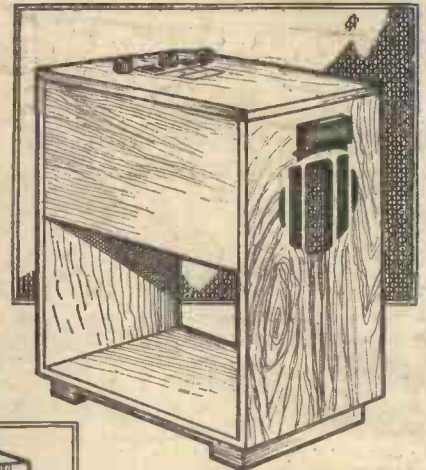

A bookshelf plus a receiver. The upper portion of this Ferranti product houses the complete receiver, whilst the lower portion is designed to accommodate books. It proves a valuable accessory to stand beside the chair for an evening's recreation.

operated direct from the light mains. There was also a combined cocktail bar and receiver to be seen at Olympia, but this would only interest a few, although it serves to emphasise the fact that the designer is out to cater for everyone.

### Car Radio

FINALLY we have the equipment which has been introduced to enable the owner of a car to enjoy a particular item of music or news whilst driving through the country. I cannot say that I agree with the idea of a driver

(Continued overleaf)

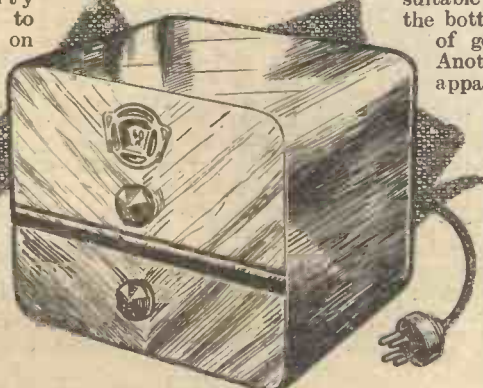

To enable the normal broadcast receiver to be used for short-wave reception, this converter, a K.B. product, proves highly valuable.

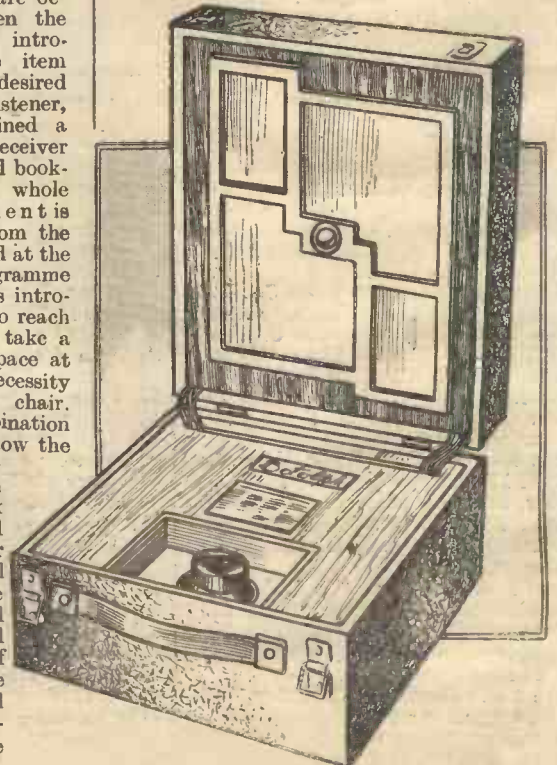

Known as the "Underarm" portable, this small receiver, by Boloph Radio, uses five valves. The chassis is all-metal and one-dial control is employed.



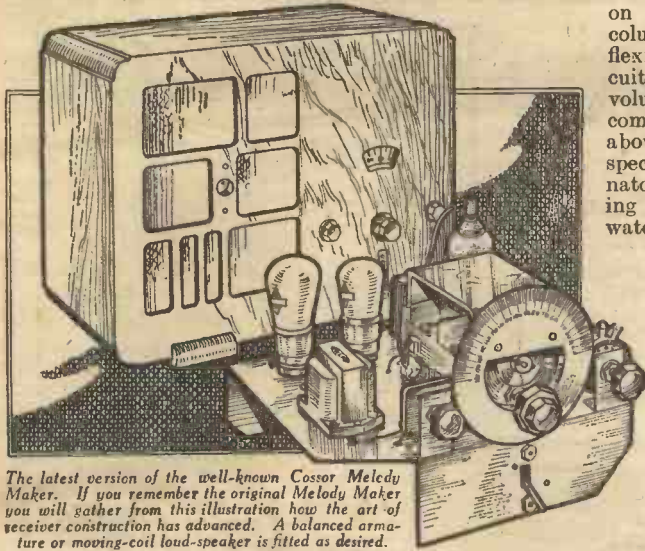

The latest version of the well-known Cosor Melody Maker. If you remember the original Melody Maker you will gather from this illustration how the art of receiver construction has advanced. A balanced armature or moving-coil loud-speaker is fitted as desired.

(Continued from previous page)

(alone) listening to a broadcast programme whilst endeavouring to control a car travelling at speed along a busy road, but no doubt there are many drivers who can give their attention to the task of avoiding foolhardy pedestrians whilst listening to Julian Rose or enjoying a Bach Cantata, but then, perhaps the manufacturers intend the car radio to be for the enjoyment of the passengers and not for the driver. However, leaving aside all other points, the designer of this type of apparatus has had many obstacles to overcome. Interference from the engine, screening effects due to bridges, buildings, etc., ease of control, even the actual disposition of the receiver have claimed careful attention, and the result is well illustrated by the Page Car Radio illustrated on this page. The size may be gathered from the valves, and the control is shown in the inset. This clamps

accommodate the set, and this is sunk into the floorboards, and to ensure that it is correctly operated the manufacturers supply a generator with it, together with a loud-speaker, and the inclusive cost is only 27 guineas. I think I have said sufficient to enable you to see how the trend of design in wireless apparatus is advancing, and to draw your own conclusions regarding the rectitude of some of the ideas.

However, another twelve months will have passed by the time the next exhibition is due, and this will, perhaps, introduce apparatus that is as much unlike present-day equipment as is the 1920 receiver.

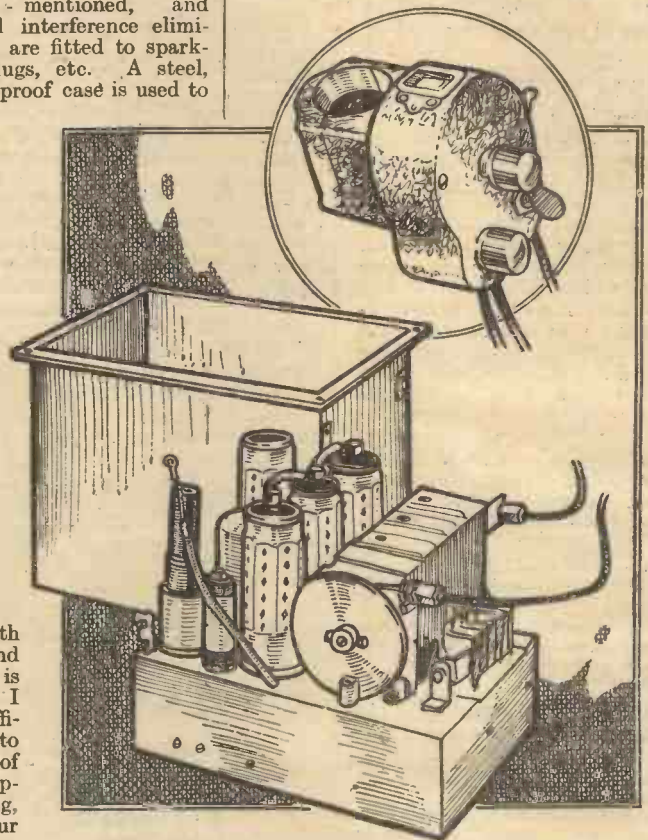

Of extremely small dimensions, this receiver is interced for operation in a car. The inset shows the small control which is fitted to the steering column. Page Car Radio are the makers of this item.

(Continued from page 948.)

STAND No.

- 91 Gallery—Hollingdrake, H., and Sons, Ltd., Princes Street, Stockport.
- 56/9 Main Hall—Hobday Bros., Ltd., 14/20, Turner Street, Manchester.
- 10 New Hall—Hustler, Simpson and Webb, Ltd., Aerodyne Works, Hoe Street, Walthamstow, E.17.
- 80 Gallery—High Vacuum Valve Co., Ltd., 113/117, Farringdon Road, E.C.1.
- 72 Main Hall—Igranic Electric Co., Ltd., 147, Queen Victoria Street, E.C.4.
- 64 Main Hall—Lissen, Ltd., Lissenium Works, Worple Road, Isleworth.
- 71 Main Hall—McMichael Radio, Ltd., Slough, Bucks.
- 17 Main Hall—Mullard Radio Valve Co., Ltd., 111, Charing Cross Road, W.C.2.
- 43a New Hall—Marlborough Radio Co., Ltd., Ashton Road, Oldham.
- 108 Gallery Bridge—Milnes Radio Co., Bingley, Yorks.
- 11 New Hall—Newnes, G., Ltd., 8/11, Southampton Street, Strand, W.C.2.
- 3 Main Hall—New London Electron Works, Ltd., East Ham, London, E.6.
- 70 Main Hall—Newtons of Taunton, Ltd., 319, Regent Street, London, W.1.
- 11a New Hall—Osdur Mfg. Co., 26, Adam Street, London, W.1.
- 78 Main Hall—Osborn, C. E., Regent Works, Arlington Street, London, N.1.
- 67/8 Main Hall—Ormond Eng. Co., Ltd.,

- Ormond House, Rosebery Avenue, London, E.C.1.
- 46 New Hall—Orr Radio, Ltd. (United Radio, Ltd.), 63, Lincoln's Inn Fields, London, W.
- 4 Main Hall—Partridge, Wilson and Co., Davenet Works, Evington Valley Road, Leicester.
- 98 Gallery—Priestley and Ford, 3/11, Carrs Lane, Birmingham.
- 45 New Hall—Provincial Incandescent Fittings Co., Ltd., High St., Manchester.
- 55 Main Hall—Pye Radio, Ltd., Africa House, Kingsway, London, W.C.2.
- 66 Main Hall—Portadyne Radio, Ltd., Gorst Road, North Acton, N.W.10.
- 112 Gallery—Quicksign, Ltd., 106, Queen Victoria Street, London, E.C.4.
- 44a, New Hall—Rawlplug Co., Ltd., Rawlplug House, Cromwell Road, S.W.7.
- 111 Gallery—362 Radio Valve Co., Ltd., Stoneham Works, Stoneham Road, London, E.5.
- 49 Tonman Hall—Richardsons (R. M. L.), Ltd., 24, St. John Street, Manchester.
- 5 Main Hall—Reproducers and Amplifiers, Ltd., Frederick Street, Wolverhampton.
- 13 Tonman Hall—Ridings Reliance, Ltd., 334, Stockport Road, Manchester, 13.
- 112a Gallery—Roberts, J., Bridgewater Viaduct, Knott Mill, Manchester.
- 65 Main Hall—Radio Instruments, Ltd., Purley Way, Croydon, Surrey.
- 113 Gallery—Radiomes, Ltd., 129/131, Bridge Street, Warrington.

- 47 New Hall—Radialaddin, Ltd., 46, Brewer Street, London, W.1.
- 38 New Hall—Standard Telephones and Cables, Ltd., 364, Grays Inn Road, London, W.C.
- 99 Gallery—Small Power Dynamo and Motor Co., Ltd., Old Lane, Nr. Openshaw, Manchester.
- 15 Main Hall—Siemens Electric Lamps and Supplies, Ltd., 38, Upper Thames Street, London, E.C.
- 100 Gallery—Sovereign Products, Ltd., 52/4, Rosebery Avenue, London, E.
- 102 Gallery—Star Radio Products, Ltd., 11, Sugar Lane, Manchester.
- 90 Gallery—Thomas and Bishop, Ltd., 37, Tabernacle Street, London, E.C.2.
- 87 Gallery—Tannoy Products, Ltd., Dalton Street, West Norwood, S.E.27.
- 31 Main Hall—Ultra Electric, Ltd., Erskine Road, Chalk Farm, London, N.W.3.
- 110 Gallery Bridge—Universal Electric Supply Co., Ltd., 4, Brown Street, Manchester.
- 77 Main Hall—Varley (O. Pell Control), Ltd., 103, Kingsway, London, W.C.2.
- 74 Main Hall—Vince's Dry Batteries, Ltd., Garford Works, Garford Street, E.14.
- 84 Gallery—Wellworth Wireless Co., 8, Wither Grove, Manchester.
- 63 Main Hall—Westinghouse Brake and Saxby Signal Co., Ltd., 82, York Road, King's Cross, N.1.

(Continued on page 970.)



# PETO-SCOTT

## EVERYTHING RADIO—CASH C.O.D. or EASY TERMS

FIRST WITH RADIO ON EASY TERMS, we can supply you with all the leading manufacturers' products. Largest stocks in the Country. Send us a list of your requirements for quotation by return. Parcel of parts or accessories over £2 for small first payment. Strict Privacy Guaranteed.



### MANUFACTURERS' KITS IN SEALED CARTONS

## PILOT AUTHOR KITS

### A.C. THREE

**KIT "A"** Author's Kit of First Specified parts, including Peto-Scott "Metaplex" chassis (less valves, speaker and cabinet). **YOURS FOR 13/-** CASH or C.O.D. Carriage Paid. Balance in 11 payments of 13/-

**KIT-BITS** You pay the Postman. We pay post charges on orders over 10/-

|   |        |
|---|--------|
| 1 PETO-SCOTT Metaplex Chassis to Specification, 15 x 12 x 4 1/2 | 3 9    |
| 2 TELSEN Iron Core Tuning Coils                                 | 17 0   |
| 1 POLAR Uniknob Condenser .0005 mfd. 2 gang with Rotating Scale | 18 6   |
| 1 BRITISH RADIOGRAM Mains Transformer, Type 55                  | 1 1 0  |
| CELESTION E. 8, Moving Coil Speaker                             | 1 15 0 |
| 1 set of Specified Valves                                       | 3 2 0  |
| PETO-SCOTT Walnut Cabinet, less Baffle and Baseboard Assembly   | 1 5 0  |

**A.C. THREE H.P. PARCEL** Consists of B.R.G. Mains Transformer, 2 Telsen Iron Core Coils and 1 Polar .0005 mfd. Two Gang Condenser, B.R.G. Switch, Type 48, and Metaplex Chassis. **Send 5/9** CASH or C.O.D. Carriage Paid, £3/1/6. Balance in 12 monthly payments of 5/9.

## F. J. CAMM'S SUPER-SET

**KIT "A"** Author's Kit of First Specified parts, including Peto-Scott "Metaplex" chassis (less valves and cabinet). **YOURS FOR 14/9** CASH or C.O.D. Carriage paid, Balance in 11 payments of 14/9

**KIT-BITS** You pay the postman. We pay post charges on all orders over 10/-

|   |         |
|---|---------|
| 1 Set of Valves   | £3 0 9  |
| 1 BRITISH RADIOPHONE 3-gang Cond., with full vision scale, Type 604 | £1 8 6  |
| 1 (LISSEN) Set of 3 Iron Core Coils                                 | £1 17 6 |
| 1 VARLEY "Nictel" L.F. Transformer                                  | 7 6     |
| 1 BULGIN Type "B" "Controlatone"                                    | 5 0     |
| 1 PETO-SCOTT "Metaplex" Chassis                                     | 3 6     |
| 1 PETO-SCOTT "Luxor" Cab.   | £1 5 0  |

**ALL-WAVE TWO** **KIT "A"** Author's finest specified parts, including Peto-Scott "Metaplex" Chassis, Ready-Drilled Panel, but less Valves, Cabinet and Speaker. **YOURS FOR 7/9** CASH or C.O.D. Carriage Paid, 11 payments of 7/9. £4 : 4 : 6

**KIT-BITS** You pay the postman. We pay post charges on all orders over 10/-

|  |        |
|--|--------|
| 1 Set of Specified Valves                                | £1 3 6 |
| 1 Pair of IGRANICON Coils, type A, and S.W. with Coupler | £1 5 0 |
| 1 BULGIN "Senator" L.F. Transformer                      | 6 0    |
| 1 Loudspeaker, R. & A. Bantam                            | £1 7 6 |
| 1 PETO-SCOTT "Metaplex" Chassis (12 x 7 1/2 x 2 1/2)     | £0 3 6 |

## Exact to Specification

### IMPORTANT

Parts, Kits, Miscellaneous Components. Finished Receivers or Accessories for Cash, C.O.D. or H.P. on our own System of Easy Payments. Send us a list of your wants. We will quote you by return. C.O.D. orders value over 10/- sent carriage and post charges paid.

PETO-SCOTT CO. LTD. 77 CITY RD. LONDON, E.C.1. West End Showrooms : 62, High Holborn, London, W.C.2.

Tel. : Clerkenwell 9406/7 Tel. : Holborn 3248

Dear Sirs, Please send me CASH/C.O.D./H.P. for which I enclose £..... d. CASH/H.P./Deposit.

NAME ADDRESS Pr. W. 16/9/33.



## MOVING-COIL SPEAKERS

**NEW BLUE SPOT PERMANENT MAGNET MOVING-COIL SPEAKER 29 P.M.** With input transformer. Cash or C.O.D. Carriage Paid, £1/12/6. Balance in 6 monthly payments of 5/-

**NEW BLUE SPOT 99P.M. PERMANENT MAGNET MOVING-COIL SPEAKER.** Complete with tapped input transformer. Cash or C.O.D. Carriage Paid, £2/19/6. Balance in 10 monthly payments of 6/-



## NEW W.B. P.M.4.A. MICROLEODE PERMANENT MAGNET SPEAKER

complete with switch controlled multi-ratio input transformer. Cash or C.O.D. Carriage Paid, £2/2/0. Balance in 7 monthly payments of 5/9

**EPOCH MODEL 20C, 20CB and 20CC PERMANENT MAGNET MOVING-COIL SPEAKER** for ordinary power. Class B and Q.P.P. respectively, complete with input transformers. Cash or C.O.D. Carriage Paid, £1/15/0. Balance in 6 monthly payments of 5/6

**AMPLION SONETTE PERMANENT MAGNET MOVING-COIL SPEAKER**, with input transformer. Cash or C.O.D. Carriage Paid, £1/7/6. Balance in 5 monthly payments of 5/-



## PETO-SCOTT PERMANENT MAGNET MOVING-COIL SPEAKER

with tapped input transformer for power or pentode. Cash or C.O.D. Carriage Paid, 15/- only. Balance in 2 monthly payments of 5/6. Class "B" Type 22/6 Cash or C.O.D. or 4 monthly payments of 6/3.



## GRAMO MOTORS AND PICK-UPS

**NEW AMPLION COMBINED TONE-ARM AND PICK-UP**, with Volume Control. Cash or C.O.D. Carriage Paid, £1/5/0. Balance in 5 monthly payments of 4/6

**NEW B.T.H. SENIOR DE LUXE PICK-UP AND TONE-ARM.** Cash or C.O.D. Carriage Paid, £1/17/6. Balance in 7 monthly payments of 5/-

**NEW GARRARD MODEL 202A.** 12-in. Turntable. Electric Motor for A.C. mains. Cash or C.O.D. Carriage paid, £2/10/0. Balance in 8 monthly payments of 6/-

## Pilot Class "B" Conversion Kit

Converts your present Battery Set to "Class B" Send Amplification. Complete with all necessary components, including driver transformer, "Class B" output choke, W.B. 7-pin valve holder, B.V.A. 240B valve, wire and screws, etc. Full-size Blueprint, assembly instructions and diagrams. Cash or C.O.D., 37/6. Balance in 7 monthly payments of 5/6. ALL "CLASS B" Components and other Parts obtainable from your local dealer SENT C.O.D. We have the largest stocks in the country. Orders over 10/- sent Post Paid. (Easy Terms available on orders over £2-0-0.) Quotations by return. No obligation. **5/-**



## ELIMINATORS

**ATLAS C.A.25** for A.C. Mains, Class "B" and Q.P.P. Four Tappings, 60/80, 50/90, 120, 150, 25 m.a. Cash or C.O.D. Carriage Paid, £2/19/6. Balance in 10 monthly payments of 6/-

**ATLAS D.C. 15/25 D.G. MAINS ELIMINATOR.** Class "B" and Q.P.P. 3 tappings 60/80, 50/90, 120/150, 15 or 25 m.a. Cash or C.O.D. Carriage Paid, £1/19/6. Balance in 7 payments of 5/3.

**HEYBERD D120 ELIMINATOR** for A.C. Mains. 120 volt 18 m/a and 2 volt .25 amp trickle charger, tappings 40/110 var. S.G. 100 volt and 120 volt fixed. Cash or C.O.D. Carriage Paid, £4/5/0. Balance in 11 monthly payments of 7/9.

**TELSEN H.T. AND L.T. A.C. MAINS UNIT W.348** H.T. Portion: Max. Det. and S.G. tappings each adjustable for High, Med. or Low voltages. Maximum 28 m/a at 150 v. L.T. trickle charger, 2, 4 or 8 volts at 1 amp. Cash or C.O.D. Carriage Paid, £1/17/6. Balance in 11 monthly payments of 9/-

**TELSEN D.C. MAINS H.T. UNIT W.348**, with 3 tappings, each adjustable for High, Med., and Low voltages. Output, 28 m/a at 150 volts. Cash or C.O.D. Carriage Paid, £1/15/0. Balance in 6 monthly payments of 5/0.

ANY ITEM SUPPLIED SEPARATELY—ORDERS OVER 10/- SENT C.O.D. CARRIAGE AND POST CHARGES PAID



**Longer life**  
**unwavering power**  
**greater selectivity**  
**from the**

**EVER READY**  
**TRADE MARK**  
**WIRELESS BATTERIES**

**MADE TO POWER YOUR SET PRECISELY!**

**IF YOURS IS A BEETHOVEN PORT. S.G.4**  
 you need Ever Ready Batteries — H.T./108 Pop; G.B./9 v. Winner; L.T./2178B.—all made specially for it. If not, simply ask your dealer for the Ever Ready List, showing all popular makes with their special Ever Ready batteries. Your set will be powered perfectly by its appropriate Ever Ready batteries.

THE EVER READY CO. (GREAT BRITAIN) LTD.,  
 HERCULES PLACE, HOLLOWAY, LONDON, N.7

**CONVERT YOUR SET INTO AN ALL WAVE SET**

for **9/6** only **9/6**



All wave lengths from 14.5 to 2,000 metres covered by this British General All-Wave Tuner.

Free wiring diagrams showing how you can build or convert your set supplied Free. State circuit when ordering.

From all dealers or direct from the manufacturers:

**BRITISH GENERAL**

BRITISH GENERAL MANUFACTURING CO., LTD.,  
 Brockley Works London, S.E.4

**YOUR SET CAN SPAN THE WORLD**



Patt. App. No. 5339/32

This adaptor enables you to tune in world-wide SHORT WAVE programmes from Chelmsford, America, Canada, Africa, etc. No extra valves or other components required—no alteration to your set at all. Wave length range 14—66 metres.

**FULLY TESTED CARRIAGE PAID U.K. WEIGHT PACKED 8LB. FULL INSTRUCTIONS. PRICE 29/6**

**FOR BATTERY SETS ONLY**

**SCIENTIFIC SUPPLY STORES (WIRELESS) LTD. (Dept. P.), 126, NEWINGTON CAUSEWAY, SOUTHWARK, LONDON, S.E.1. Phone: Hop 4177**

**UNIVERSE**

**1934 PICK-UP**



Complete with volume control and connecting leads.

**20/-**

Output nearly 4 volts. Average output 2 volts. Base can be used in any position. Impossible for pick-up reel to go out of adjustment (patt. applied for). Special ball-catch swivel head for easy needle changing. In attractive brown bakelite-moulded case. Ask your dealer for demonstration or write us for catalogue.

**NORTHERN NATIONAL RADIO EXHIBITION.**  
 Manchester, Sept. 27—Oct. 7. STAND NO. 104. GALLERY.

COSMOCORD L<sup>1</sup> D<sup>2</sup> P CAMBRIDGE ARTERIAL RD. ENFIELD MIDD<sup>X</sup>



# RADIO RAMBLINGS

By JACE

*Gottings from my Notebook*



## Changing Over to Mains Operation

WE are constantly receiving queries from readers who have a battery set and who wish to convert it for mains working; our advice is asked for in regard to the best method of procedure. On the face of things the question appears perfectly simple, but when the time comes to draft out a reply numerous difficulties crop up, especially if the querist has omitted to supply complete details of his set. In the first place, if it is desired to make the receiver suitable for "all-mains" operation, that is, to take high tension, low tension and grid bias from the mains supply, a complete re-design is almost invariably essential. The reasons for this are too numerous to state in full, but the principal one is that A.C. valves of the indirectly-heated cathode type have different characteristics from those designed for battery operation. The former are considerably more efficient and give a much greater degree of amplification, and in consequence the circuit must be designed to deal effectively with the amplification afforded. This means that decoupling must be carried out with especial thoroughness if various forms of instability are to be avoided. Again, the mains valves consume more H.T. current and therefore the anode circuit components must be chosen to carry the heavier load. In addition, several precautions have to be taken to prevent mains hum, which can result from all kinds of unsuspected causes.

In writing this I do not wish to imply that all-mains working is not worth while or that it is difficult to manage—if the set is properly designed for the purpose. It would obviously be quite impossible to supply a complete receiver design in the form of a reply to a query because, even though there are a number of more or less "standardized" arrangements, each one requires a certain amount of experiment before it can successfully be embodied in a broadcast set. If you wish to be independent of the charging station and are using a battery set the best thing is to obtain an eliminator fitted with a trickle charger. This will give a very satisfactory form of H.T. supply and will enable you to charge the L.T. accumulator overnight. Generally speaking, no alteration will be required to the set and the system is extremely economical, costing, in fact, only a few coppers per week.

## D.C. Mains

WHERE the electric lighting mains are D.C. a trickle charger is unnecessary since the accumulator can be charged by connecting it in series with a lamp used for lighting purposes. I need not give details of the method here, because it has been explained once or twice in previous issues of PRACTICAL WIRELESS. It is possible to obtain low tension from D.C. mains merely by connecting a suitable

resistance in series with one mains lead, but this is neither a good nor economical method. As the valve filaments are all connected in parallel, should one burn out an excessive voltage will be applied to the others and this will probably impair their efficiency or entirely ruin them. And since the voltage actually required by the valves is only from 2 to 6 (according to the type of valves in use) there is a dead loss of something like 200 volts. To translate this in terms of expense, and assuming the L.T. consumption is .5 ampere, the consumption of power will be .5 multiplied by the mains voltage. If the latter is 200 the number of watts used will be 100, or one-tenth of a unit, per hour. From this you can soon estimate the cost per week and you will find it to be well in excess of that for accumulator charging.

## "Helping Out" the H.T. Battery

A SEMI-TECHNICAL wireless friend was shocked when I recently suggested that he should connect a new 60-volt battery in series with his 120-volt one which was running down. "But surely," he remonstrated, "the old battery would soon ruin the new one." "Nothing of the kind!" I replied. "If the batteries were connected in parallel the old one would certainly discharge the new one, but when they are in series, how could it?" He didn't quite know, but he thought I was wrong. In trying to prove to him that his ideas were entirely fallacious, I eventually succeeded in wringing out of him the confession that he had once tried the scheme I was now suggesting. When the old battery began to run down the set was subject to "motor-boating" and other signs of L.F. instability. So he connected another battery in series, but this had no effect on the motor-boating, and in consequence results were no better than with the old battery alone. I had to explain to my friend that the previous set had no decoupling in the anode circuits and therefore the high resistance of the old battery was the cause of instability. When a new battery was joined up, the high resistance remained, and thus the effect of the additional voltage was nullified. "But the set you are now using, like all other reasonably up-to-date sets, is properly decoupled and therefore the internal resistance of the battery can have no ill effect. In short, you can make your results just as good as when the battery was new by putting another small battery in series. When the old 120-volt battery is completely exhausted you can use the new 60-volt battery in conjunction with another similar one to maintain the high-tension voltage at 120"—Economy!

**MAKE SURE OF YOUR GIFT SPANNERS**

By Ordering NEXT WEEK'S ISSUE NOW!

## EASY TERMS

The very latest Radio Sets, Loud-speakers, and Kits supplied on the lowest monthly terms. Strict privacy. Prompt delivery. All carriage paid. Price List FREE.

New LISSEN SKYSCRAPER ALL-WAVE 4 KIT, with valves. Cash price £5/12/6, or 10/- with order and 11 monthly payments of 10/3. As above, but with Cabinet. Cash price £6/8/0, or 11/6 with order and 11 monthly payments of 11/9.

MULTITONE CLASS B CONVERTER, with valve, ready for plugging in to any set. Cash price £2/11/6 or 5/- with order and 10 monthly payments of 5/2.

|   | Cash Price | With Order | Monthly Payments |
|---|------------|------------|------------------|
| New BLUE SPOT 99 PM UNIT, with transformer. (The finest permanent-magnet unit available.) | 50/6       | 5/-        | 11 of 5/6        |
| New ROLA CLASS B SPEAKER AMPLIFIER, including valve                                       | 71/-       | 5/-        | 11 of 6/7        |
| New BLUE SPOT 29 PM, with transformer   | 38/6       | 5/-        | 6 of 5/-         |
| New BLUE SPOT PICK-UP, including built-in volume control                                  | 35/-       | 6/-        | 6 of 5/8         |
| New EPOCH 20c, 20cb, or 20cc. Unit, with trans.   | 35/-       | 5/-        | 6 of 5/7         |
| New W.B. MICROLODE PM4A UNIT, with transformer and special matching switch                | 42/-       | 5/1        | 8 of 5/1         |
| FERRANTI CLASS B SPEAKER AMPLIFIER, moving-coil unit with valve                           | 84/-       | 10/-       | 4 of 7/6         |
| New ATLAS MODEL CA25 H.T. ELIMINATOR, output 25 milliamps                                 | 59/8       | 5/-        | 11 of 5/6        |

Interesting descriptive leaflets of any of the above free. To avoid delay, will customers kindly send first payment with order.

EST. 1925. THE LONDON RADIO SUPPLY COMPANY. Phone: National 1977

**THE LONDON RADIO SUPPLY COMPANY**

11, OAT LANE, NOBLE STREET, LONDON, E.C.2

# Specified or not specified . . .

Use Clix Contact Components to ensure highest efficiency from any receiver.



PANEL TERMINALS  
Type B, with special hexagonal shoulder for easy mounting - 4d.  
Type A - - - - 2½d.

Non-Corrosive SPADE TERMINALS  
Small 1½d.  
Large 2d.

"MASTER" PLUGS 1½d.

"A MATTER OF CONNECTION." Clix New Folder "N" gives details of over 30 components for Perfect Contact. Write for a copy now.



Lectro Linx Ltd., 79a, Rochester Row, S.W.1.



# COLVERN FERROCART COILS

Made under licence from the patentee, Hans Vogt.

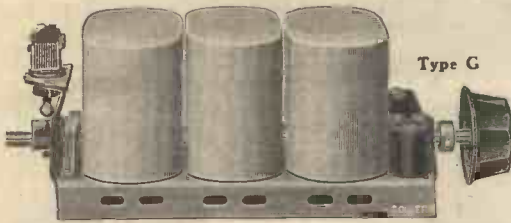

Type G

**SPECIAL G Type GANGED COILS**  
Complete with gramophone and wave change switch

- Two Gang .. .. 25/-
- Three Gang .. .. 37/6
- Four Gang .. .. 50/-

On and off Switch if required 1/6 extra. State if required for battery or mains receivers.

**COLPAK Type H**  
Comprising Ferrocart G type Coils, Tuning Condenser, Gramophone and on and off Switch (state if required for battery or mains receivers).  
Coils can be supplied for 1 SGHF stage receivers with Band Pass filter or Band Pass filter and Oscillator Coil for Super-heterodyne receivers.

Price 57/6

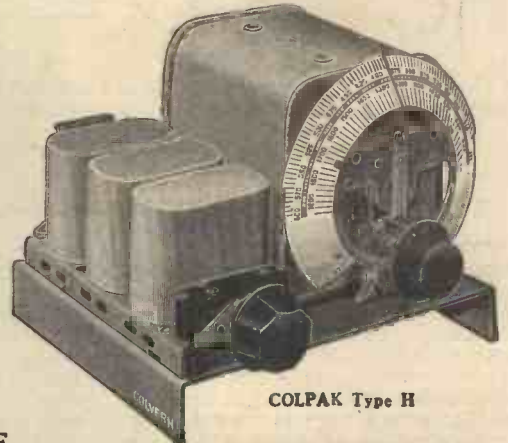

COLPAK Type H

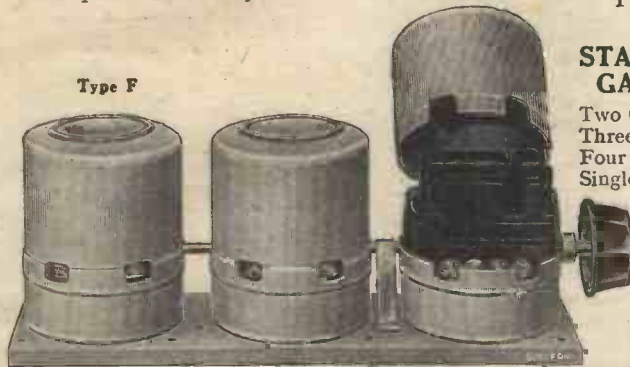

Type F

**STANDARD Type F GANGED COILS**

- Two Gang .. .. 25/-
- Three Gang .. .. 37/6
- Four Gang .. .. 50/-
- Single Coils .. .. 12/6

Send for the Colvern Ferrocart Booklet.

**COLVERDYNE FERROCART INTERMEDIATES**

Type FC 110 } 12/6 each  
Type FC 150 }  
With universal mounting bracket, limited capacity adjustment and band pass coupling controlled externally.



**COLVERN LIMITED, MAWNEYS ROAD, ROMFORD, ESSEX**

London Wholesale Depot: 150, King's Cross Road, London, W.C.1

## "Universal" High Voltage Valves

- S 100. S.G. valve for H.F. stages, L.F. couplings. Very high slope. Great amplification. Impedance over 1 million ohms .. .. 18/9
- B 25. S.G. valve for Det.—Audio and H.F. stages. High slope. Impedance 250,000 ohms .. .. 18/9
- MS 18. S.G. Vari-mu. with variable slope .. .. 18/9
- MS. 70. S.G. Vari-mu. Excellent for A.V. control .. .. 18/9
- D 130. Outstanding characteristics: High-mu. Triode valve. Impedance 40,000. Amp. factor 100 .. .. 17/6
- PT 3. Multi-grid valve. Very remarkable slope and high internal resistance .. .. 19/9
- K 3560. Output stage amplifying valve. Dissipation 15 watts. Amplification factor 3. Impedance 500 ohms. Remarkable scale of 6 mA/V. .. .. 25/6

Other types and rectifiers as previously listed all in stock. Details on request. Proc. Blueprint with first order.

THE ONLY ones which operate direct from  
**FULL MAINS VOLTAGE, either A.C. or D.C.**  
without the use of transformers or resistances, and greatly reduce the cost of running your set.  
Do not confuse these with valves which can only be wired in series.

**OSTAR-GANZ.**

'UNIVERSAL' HIGH-VOLTAGE MAINS VALVES

### "UNIVERSAL" KITS

- Work from either A.C. or D.C. supply without alteration.
- 2-valve Set .. .. £5 15s.
  - 3-valve Set .. .. £8 15s.
  - 2-valve Amplifier .. .. £4 4s.
  - 3-valve Amplifier .. .. £5 5s.
  - All-electric Radiogram Complete £12 18s.
- All prices include Valves, Rectifier and full size Blueprint.

Ostar-Ganz Valves and Kits are obtainable through Dealers or from Sole Agent for Great Britain:

**EUGEN FORBAT**

28-29, Southampton Street, Strand, W.C.2.

## Full Details of a HOME-MADE ENLARGER

AN ordinary folding camera, a few oddments purchased here and there—a little home-made woodwork—these are the components of the highly efficient but inexpensive enlarger described in the September issue. With it you can make enlargements of professional quality from your holiday negatives.

OTHER valuable articles in this issue deal with the Why and Wherefore of Filters, Photographing Windmills, How to make Prints on Self-toning paper, Readers' Results and new apparatus.

VALUABLE cash prizes are given each month for readers' pictures and free cameras for the Young Folks.

The **HOME PHOTOGRAPHER**  
and **SNAPSHOTS**

Obtainable at all Newsagents, Bookstalls and Dealers, or post free 7½d. (Subscription rates: Inland and Abroad 7/6 per annum; Canada 7/- per annum) from Geo. Newnes, Ltd., 8-11, Southampton Street, Strand, London, W.C.2.





BEGINNER'S SUPPLEMENT

# HOW YOUR RECEIVER WORKS—II

The second of a series of articles in which the author shows how a wireless signal passes through a receiver and explains in simple terms the function of each component.

*This week the Action of the H.F. Amplifier is dealt with.*

By FRANK PRESTON, F.R.A.

(Continued from page 917, Sept. 9 issue.)

IN the first place, it is obvious that a current will flow through the low-resistance windings of coil L, and this will cause the coil to become an electro-magnet having "lines of force" like those represented by broken lines in Fig. 3 (b). When the switch contacts are opened again the magnetic field created (and represented by the lines of force) will again transform itself into an electric current and the latter will flow through the coil in the same direction as the original current supplied by the battery. But where does the current flow to? It must go somewhere. It passes through the resistance to the condenser which it charges as shown at Fig. 3 (c). For a brief period the condenser stores the current and then feeds it back again to the coil through the resistance. Another magnetic field is built up round the coil, and this again causes a current to flow to the condenser. And thus the transference of current from coil to condenser and from condenser to coil could go on indefinitely were it not for the resistance which absorbs a certain amount of current at each transference.

**Band-pass Tuning**

It would obviously be very convenient if we could combine the advantages of the two circuits considered and, as a

matter of fact, we can by employing what is known as a "band-pass" circuit. We cannot go very fully into the theory of the band-pass arrangement here, but it will be interesting to study it briefly in the light of our

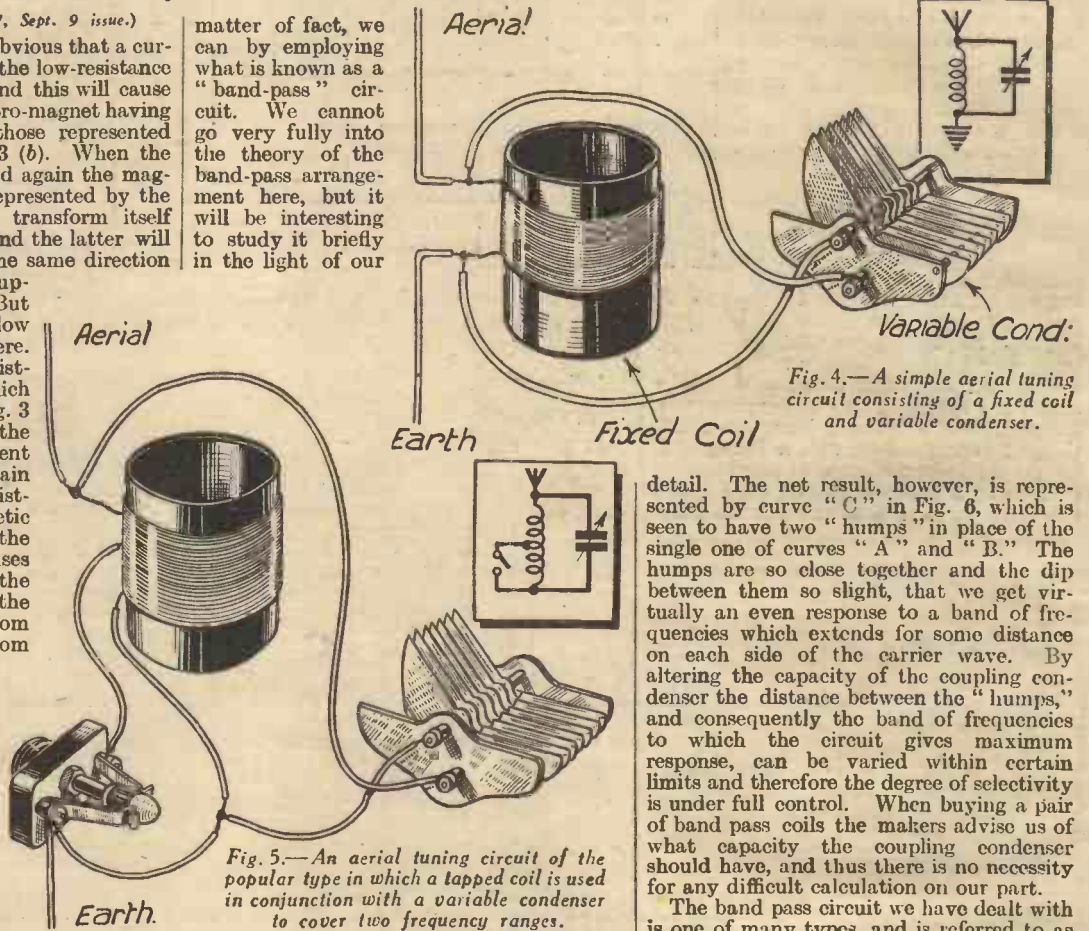

Fig. 4.—A simple aerial tuning circuit consisting of a fixed coil and variable condenser.

Fig. 5.—An aerial tuning circuit of the popular type in which a tapped coil is used in conjunction with a variable condenser to cover two frequency ranges.

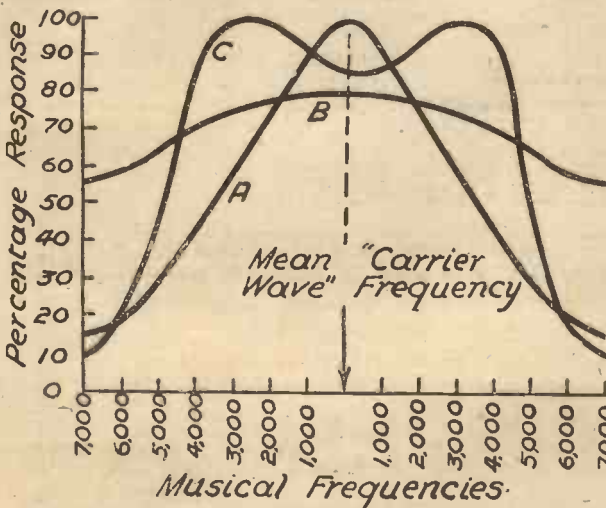

Fig. 6.—"Response curves" for different types of tuning circuits; A represents a low-resistance (selective) circuit, B a higher resistance circuit and C a band-pass circuit.

previously acquired knowledge. Essentially, a band-pass circuit consists of the arrangement of components shown in the diagram of Fig. 7. Instead of a single tuning coil and condenser we have two of each, and these are connected together through a coupling condenser marked C. The current flowing round the first tuned circuit (marked A) causes a voltage to be set up across C, and this, in turn, drives a current round the circuit marked B. The current in B develops its own voltage across C, and this reacts on the original voltage and so changes the current in circuit A. The whole theory regarding the action and reaction of the two circuits is somewhat involved, and we will not consider it in

detail. The net result, however, is represented by curve "C" in Fig. 6, which is seen to have two "humps" in place of the single one of curves "A" and "B." The humps are so close together and the dip between them so slight, that we get virtually an even response to a band of frequencies which extends for some distance on each side of the carrier wave. By altering the capacity of the coupling condenser the distance between the "humps," and consequently the band of frequencies to which the circuit gives maximum response, can be varied within certain limits and therefore the degree of selectivity is under full control. When buying a pair of band pass coils the makers advise us of what capacity the coupling condenser should have, and thus there is no necessity for any difficult calculation on our part.

The band pass circuit we have dealt with is one of many types, and is referred to as a "capacity" filter since the two circuits are coupled together through the medium of a condenser. This system, although frequently used, suffers a serious disadvantage, because the voltage across the coupling condenser is not constant, but varies with the frequency of the signal being received. Actually, the voltage becomes greater as the frequency is reduced (wave-length increased), and therefore the transference of current from circuit "A" to "B" is increased. For this reason the "band-width" varies with the wave-length of the received signal. But by introducing another form of coupling between the two circuits which varies in the opposite manner it is possible to obtain a constant band-width irrespective of wavelength. This other kind of coupling takes the form of two small windings, one of which is placed near to each of the tuning coils. The windings are cross-connected as shown in the sketch of Fig. 8, so that current can flow between them. Each coupling winding "picks up" a small amount of current from its associated coil, and

(Continued overleaf)



**HOW YOUR RECEIVER WORKS**

(Continued from previous page)

passes it on to the other. The transference of current is greater at high than at low frequencies and so counter-balances the opposite effect of the coupling condenser and produces the result of constant band-width. A circuit of the kind shown in Fig. 8 is known as an "inductance-capacity" or "link circuit" band-pass filter.

We have now obtained a fairly clear idea of what happens in the aerial-earth circuit of the average receiver, and are ready to study the effect of the oscillating voltage obtained across the tuner on the amplifying or rectifying valve which follows.

We have seen how the aerial circuit is tuned in order to obtain a maximum voltage of signal current between the "ends" of the tuner, and we must now consider how that voltage can most profitably be employed to operate the rest of the receiver. If it is already fairly large it might be "rectified" immediately to separate the high and low frequencies, so that the latter may be converted into sound again. On the other hand, it might be considered necessary to "amplify," or increase, the voltage prior to rectification. In almost every case it is desirable to use at least one stage of amplification comprising a screened grid or variable- $\mu$  valve, so we will first examine the function of this.

**The Action of an H.F. Amplifying Valve**

Any type of valve consists essentially of a filament (or cathode), a grid and a plate (or anode), and although S.G. and V.-M. valves have a second grid in addition, we can overlook this for the moment. The three essential electrodes of the amplifying valve are connected as shown in the circuit of Fig. 9. It is seen that the filament is heated by an accumulator; a source of high tension is connected between one side of the filament and the anode, the latter electrode being joined to the positive H.T. terminal; the tuning circuit, across which the oscillating voltage develops, is connected between the grid and filament; a resistance (R) is shown as being joined between the anode and high-tension positive, but as this does not affect the functioning of the valve it can be ignored until we reach a later stage.

Let us first consider what happens before a signal is tuned in. Essentially a current flows from the high-tension supply by way of the filament to the anode, just as if the valve were an ordinary resistance; the positive potential on the anode attracts the negative potential on the filament. This action is often explained by saying that the filament emits "electrons," which are, according to existing theories, what might be called (most unscientifically, I agree) particles of negative electricity. I think that we shall obtain a

better impression of what actually happens, however, if we merely say that current flows through the valve from the filament to the anode. The density of the current depends entirely upon the voltage of the high-tension supply.

affect the amount of current flowing from the filament to a much greater extent than will the anode potential; when the grid is positive it will attract current from the filament and when negative it will tend to repel the current. Current will not actually flow to the grid, but since it is of open mesh will pass straight through to the anode, which is of much higher potential. The action of the grid will be more easily understood by considering the three circuits of Fig. 10. At (a) the grid is at zero potential, and the current passing from the filament to the anode is represented by small arrows; (b) shows the increase in current as the grid becomes positive, whilst (c) shows how the current is reduced when the grid is made negative. From this brief explanation it will be understood that the varying grid potential causes the filament-anode current to fluctuate. This current fluctuation results in the formation of a fluctuating voltage which appears across the ends of resistance R. The latter voltage is appreciably greater than that applied to the grid and so we have reproduced

the original signal voltage in amplified form. It will be seen later that the resistance R represents the coupling components which are used between the first and second valves.

At this point it will be helpful to give a little attention to the property of an amplifying valve known as "mutual conductance," or, less scientifically, as "slope." Mutual conductance is the ratio of the change in anode current to the change in grid potential causing it. Thus a valve having a high value of M.C. will give a high degree of amplification, and *vice versa*. It is for this reason that a valve of high slope must always be chosen for the H.F. stage when maximum "stage gain" is required.

**The S.G. Valve**

The action we have considered is that of a three-electrode (often referred to as an "ordinary") high-frequency valve, so we must next see what is the function of the fourth electrode used in a valve of the more popular screened grid type. It was mentioned before that the additional electrode is another grid and it is situated between the first (or control) grid and the anode. This "screening grid," as it is called, is connected to a positive terminal on the H.T. supply and also through a fixed condenser to H.T. negative, as shown in Fig. 11.

In the case of a three-electrode valve there is a certain amount of capacity between the grid and anode due to their close proximity, and as the two electrodes are at different potentials some current is liable to pass back from the anode to the grid across that capacity. If current did pass back the valve would oscillate.

(To be continued.)

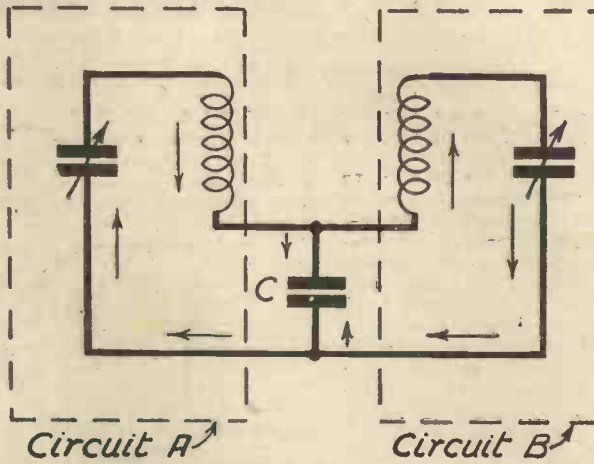

Fig. 7.—This diagram shows the functioning of a "capacity coupled" band-pass circuit.

And now suppose a signal is tuned in—an oscillating voltage will at once be applied between the grid and filament so that the grid will receive a potential constantly varying between positive and negative with the frequency of the carrier wave, and changing in amplitude at the

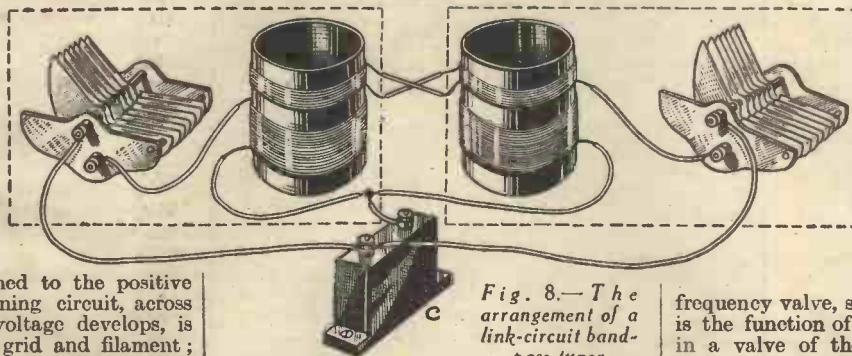
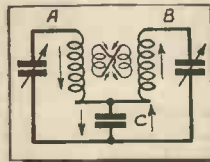

Fig. 8.—The arrangement of a link-circuit band-pass tuner.

frequency of the impressed modulation. As the grid is situated between the filament and anode in the valve its potential will



A pair of commercial band-pass tuners.



# SHORT-WAVE DIODE DETECTION

Its Advantages in Ultra Short-Wave Circuits.

By ERIC JOHNSON

THE most popular of all short-wave circuits is still undoubtedly the straight detector, plus one or more stages of amplification. It is true that a screen-grid stage is becoming increasingly common, but the inherent simplicity of the "det. and note-mag." commends itself to newcomer and experienced alike. The efficiency of such a receiver depends almost entirely on the detector—more particularly the control of reaction. Before proceeding farther, let us examine the essential adjustments of a short-wave set to achieve this end.

The circuit shown in Fig. 1 is quite conventional. Easy and silky control of

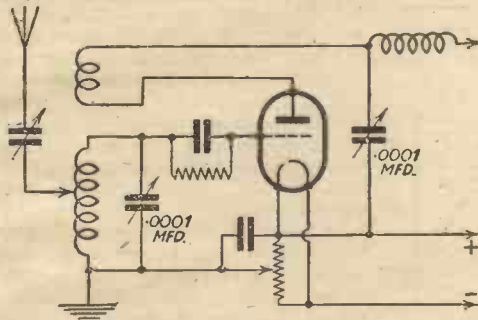

Fig. 1.—The conventional circuit for a single valve short-wave receiver.

reaction depends largely on a correct choice of component values; there must be no signs of "plop" or "backlash," as the full amplification of the detector can only be obtained when the valve is capable of being adjusted to the very verge of oscillation without actually slipping over. Firstly, it will be obvious that the reaction condenser must not be unduly large, otherwise a small adjustment will mean a big change in feed-back, making it extremely difficult to work the receiver in the hyper-sensitive state so necessary for success; for this reason a value of .0001 mfd. should not be exceeded. More important than this is the correct adjustment of grid-potential. It is customary to return the grid lead to L.T. positive, and although this invariably gives the best sensitivity, it is seldom that reaction is smooth. On the other hand, the valve usually goes into oscillation with ideal silkiness when the grid return lead goes to L.T. negative.

Obviously there will be a useful compromise between the two positions; thus it is that a potentiometer is usually employed to adjust the grid-potential at a small positive bias only. In the same way it will be found that a detector oscillates far more smoothly with a much lower value of H.T. than is really the optimum for sensitivity. Modern detector valves often acquit themselves far better with a fairly high anode voltage, perhaps as much as 100 volts or more.

Contrasted with this we find that best reaction control may be obtained with as low as 20-30 volts, although, of course, sensitivity will be very much decreased. Any arrangement which would separate the dual functions of the detector valve and allow of the optimum adjustment of each would, therefore, seem a solution. Happily, such a solution is offered by the diode detector shown in Fig. 2.

### More Lively Reaction

We are not now concerned with amplification, as the diode does not amplify at all, except, of course, by virtue of reaction.

This being so, we can reduce the anode voltage as much as we like without affecting the sensitivity of the circuit. If the valve is of high mutual conductance we may even be able to work it at 20 volts or less, a condition ideal for smooth oscillation. The first L.F. stage, which deputizes for the usual amplifying properties of the triode detector, may be adjusted for maximum amplification, i.e., high anode voltage, without affecting reaction control, as would happen in the normal leaky-grid detector. There are also several other advantages of the diode, perhaps not so noticeable in short-wave reception, but nevertheless worthy of mention. In the first place, it is virtually impossible to overload it; this virtue will hardly be obvious on a short-wave set, but bearing in mind that many listeners use the same set for broadcast also, it is quite a useful adjunct. Secondly, owing to the entire absence of grid-current, there is little or no loading on the preceding tuned circuit. This is borne out in practice by the very real increase in selectivity, although, once again, this is an advantage not appreciated on the short waves. A natural corollary of the very light damping, however, is the tendency to make reaction more lively. It would appear, therefore, that diode detection offers an attraction on ultra short waves. An objection often levelled against the diode is naturally the necessity for another valve. The condition under which it operates, however, means a very low anode current, so objection can hardly be raised on this score.

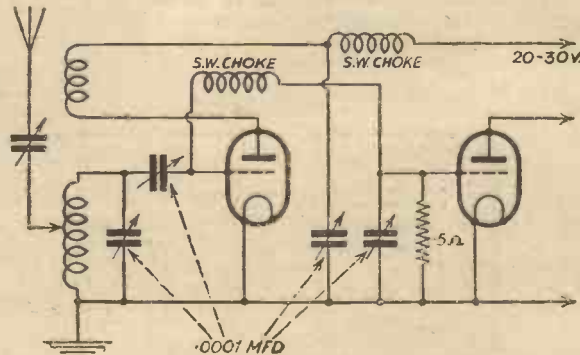

Fig. 2.—The circuit of a diode valve with reaction control; this is recommended for short-wave reception.

# SUPERIOR at every point



## H.F. CHOKE

The very latest in high frequency practice, embodying the advantages of the binocular with the screened type. Its efficiency on long and medium wave-lengths is of a very high order while it may satisfactorily be employed for wave-lengths as low as 12 metres.

Impedance at 500 metres, 400,000 ohms. Inductance 200,000 microhenries.

# 4/6

Ensure a safe and efficient Aerial and Earth. The AEROFICIENT KIT provides all you need. 6/6 complete.

Send for copy of New Catalogue which describes all our products.

# GRAHAM FARISH PRODUCTS

Advertisement of Graham Farish Ltd., Bromley, Kent. Export Office: 11/12, Fenchurch Street, E.C.3.



# Constructor! KNOW your set—and save money!

Every constructor should be able to service the sets he builds. An "EMICOL" Test Meter makes set-testing the simplest of jobs. Every component, every wire in your set can be tested in a twinkling. You can KNOW the efficiency of every part of your set.

EMICOL Test Meters can be relied upon for unflinching accuracy and first-class workmanship, and there is one for every purpose.

Write for free descriptive literature, giving details of the whole range of EMICOL Test Meters.

- "EMICOL" Double reading Voltmeter, Range 0-6v., 0-150v., Price 6/.
- "EMICOL" 3-in-1 Test Meter (Wates Patent), Range 0-6v., 0-150v., 0-30mA. Price 8/6.
- "EMICOL" 4-in-1 Test Meter (Wates Patent), Range 0-6v., 0-150v., 0-30mA. Price 9/8.
- "EMICOL" Universal Meter (Wates Patent), Range 0-6v., 0-15v., 0-150v., 0-30mA., 0-2000 ohms. Price 12/6.



## EMICOL BRITISH MADE

Manufactured solely by:—  
Electrical Measuring Instruments Co., Ltd.,  
55, Caddington Street, LONDON, N.1.

You want  
**SHARP, CLEAR,  
BETTER RECEPTION?**



"I congratulate you on your Airclipse Auto-Inductive Aerial. The sensitivity was far above what I expected from it; in fact, I have received several U.S.A. stations with it. My friends are also much impressed by its wonderful merits; two of them have asked me to get them one straight away."

This is an extract from a letter received from Cowes, Isle of Wight, August 29th, 1933. YOU will be equally delighted with the Airclipse. It is not a gadget—not a condenser, but an auto-inductive aerial that filters incoming signals. Improves selectivity; eliminates lightning risk. Non-directional; can be placed anywhere inside or outside the set. Makes any set portable.

# AIRCLIPSE Auto-Inductive AERIAL

For A.C. Mains and Battery Sets.

Of all dealers, or in case of difficulty order from:—

AIRCLIPSE Ltd., 182, VAUXHALL BRIDGE RD., LONDON, S.W.1  
Telephone: Victoria 5022.

# ABOUT "L"-TYPE AERIALS

By "GRID LEAK"

THE directional property of an aerial is an important matter in radio reception. Any antennae having a horizontal component must be

set, trying this and that without material advantage. They are perfectly satisfied with the aerial and earth system. In their estimation it could not be better and it is the last place they would look to help them out of their difficulty. Yet, if they would only try a new aerial, placed at right angles to the interfering station they would find a marked difference in the set's selective properties. For this purpose, the inverted "L" type of aerial is the best all-round for broadcast reception. It requires the least wire and supports. About 70 feet of wire serves excellently, this length including the lead-in. The earth lead should be as short as possible. The lead-in is important.

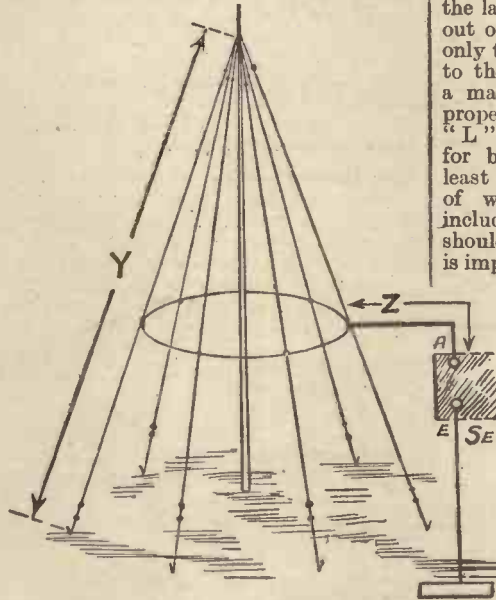

Y+Z LEAD 70 FEET  
UNIFORM IN ALL DIRECTIONS  
(Y = 4 TO 10 WIRES IN PARALLEL.)

Run it as direct and straight as is feasible, being insulated from lead-in tube to the set. The diagrams give a good idea of the three best aerials for broadcast reception.

It is obvious, however, that in many gardens it is not possible to erect an aerial of the most suitable type for the particular situation, and therefore some scheme must be devised where the aerial which is erected acts in the most efficient manner. Thus, the Inverted L type may require to be erected across a garden in order to avoid troubles due to the signals from the local station being overpowering strong. In any case it is well worth while trying various arrangements before definitely settling upon the final arrangement and where the utmost efficiency is desired it may prove worth while to erect an aerial which is perhaps unsightly from some points of view.

directional. Transmitting stations which are in line with it will be heard at much stronger signal strength than those at right angles to the horizontal stretch.

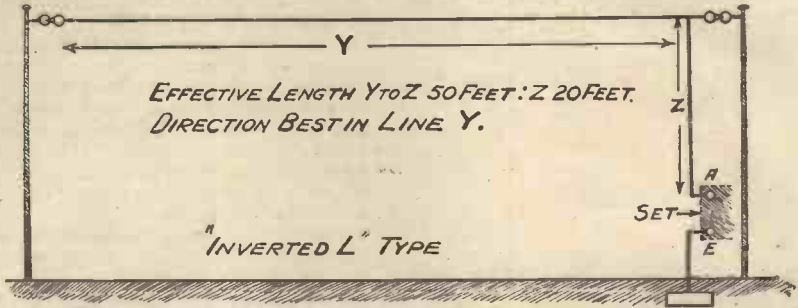

EFFECTIVE LENGTH Y TO Z 50 FEET: Z 20 FEET.  
DIRECTION BEST IN LINE Y.

"INVERTED L" TYPE

This brings a very interesting point to view. Thousands of my readers are up against the trespassing of stations over a great portion of the tuning dial to the detriment of reception from other stations. Time, money, and patience have been spent on the

**OUR FREE GIFT SET OF  
STEEL WIRELESS SPANNERS!**  
Two GIVEN FREE with next week's issue—and  
ONE GIVEN FREE with the following week's issue

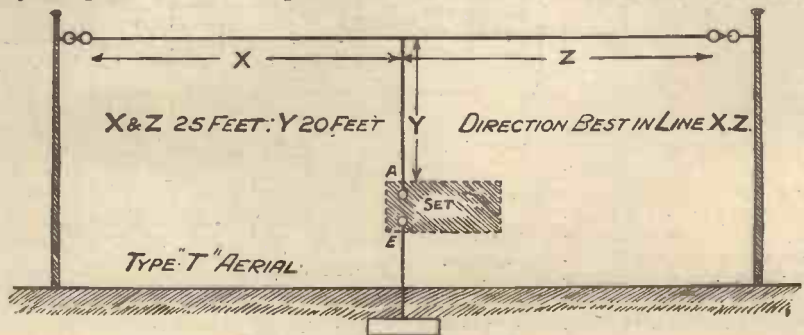

X & Z 25 FEET: Y 20 FEET  
DIRECTION BEST IN LINE X, Z

TYPE "T" AERIAL





A Simple Explanation of its Chief Causes.

THE question has recently been raised as to why fading affects to a serious extent certain comparatively near stations whilst it may not be appreciably affecting stations at very considerable distances.

Throw a small pebble into a pond of still water; waves will spread out at regular intervals from the spot where the pebble entered. Next, throw a large stone into the pond: again waves will be formed on the surface of the water, but these waves will be bigger ones, and with a greater distance from crest to crest. Roughly speaking, the waves produced by the small pebble and by the large stone correspond respectively to short waves and to long waves. (It should always be remembered that the water wave analogy is only a diagrammatic one, representative of extremely rapid alternations of electric and magnetic forces moving through the ether at a speed of 186,000 miles a second.)

Now for another experiment. When the surface of the pond is ruffled by wind, throw a small pebble into the water with all the force you can muster. If you try to follow the waves now you will find that before travelling far they are so buffeted as to almost or completely disappear. Now throw a large stone into the water: the waves so produced will seem to ride over the ruffled surface, and will certainly travel much farther than the waves made by the small pebble. "How does this correspond in the case of wireless waves?" one may ask. Well, as I pointed out, the waves correspond in a measure to wireless waves, and if this be so we should expect (in view of the probability of disturbance being ever present) that long waves would travel farther than short waves. This is substantially true so long as the waves travel near to the surface of the earth; and the waves we receive in bright daylight have done so. (I am referring particularly to waves between 200 and 2,000 metres in length.) However, wireless waves possess a characteristic which we could hardly suspect from the analogy of water waves. The shorter the wavelength, the greater is the tendency for the waves to "shoot" outwards at an angle off the earth, as well as attempting to follow its curvature. Now, it has been established that surrounding the earth there are a number of layers, and therefore their surfaces, which are continually in movement, and which under favourable conditions can reflect wireless waves. The layer with which we are particularly concerned in this article is known as the Kennelly-Heaviside layer, and is situated about sixty miles from the earth's surface.

**Absence of Sufficient Reflection**

Think, for a moment, of standing on a large domed surface of so irregular a nature as to prevent a ball rolling over it, and with a domed roof above your head. You have been ordered to throw a rubber ball to a part of the domed surface about fifty yards away, and out of sight. The most satisfactory way would be to throw the ball at

the domed roof, so that it would be reflected to the place you wanted it to go. This reflection to get round a curve is similar to what has happened when we receive a far-distant station. We should have been unable to receive anything if we had only the ground waves. Absence of sufficient reflection is the reason why it is almost impossible in America to receive Daventry on the long wave.

When we say conditions are favourable we mean (apart from absence of atmospheric) that the reflection on which we rely is occurring satisfactorily, and that the wireless waves are not encountering serious disturbance similar in effect to the ruffled water. On ordinary medium waves (between 200 and 600 metres) this reflection will only occur when darkness is falling, or has fallen. Hence the reasons for conditions being far more favourable at night than in the daytime.

"Yes," you may say, "but you set out to explain why fading affects some stations more than others, and apart from showing that high waves will give less fading than short waves, you have not shown why Rome may not fade when, say, the Scottish stations, when received in the Midlands, for instance, will." I am coming to that point. Think of the case of any station receivable by both the waves travelling near the ground, and by the waves travelling through space to be reflected to the receiver, both waves being, at the place of arrival, about equal in strength.

**Ground and Indirect Waves**

Now try to get a picture of two waves trying to combine; with the aid of a memory of the pond experiments it should be fairly easy. Imagine one wave travelling along the surface, and another wave of similar size and shape trying to combine itself with the original wave. If both the waves were humped in the same direction at the same time, a wave of double the depth of one wave would obviously be produced. But if one wave were inverted (i.e. 180 degrees out of phase) in respect to the other, each would be cancelled out. So it is with the ground wave and the indirect wave. Obviously any degree of partial cancellation or addition can occur in practice from the above cause, and also due to the relative strengths of the two waves. This last factor is largely controlled by the distance from a station, and the wavelength of the transmitter: consequently for a given wavelength the fading will be most marked at one particular distance.

Summing up: if a station is at such a distance as to be receivable by the ground wave and the indirect wave at approximately equal strength, very pronounced fading is likely to occur. If so far away that the ground wave is practically unreceivable, fading of a very severe kind is much less likely, for big disturbances are needed to completely absorb the waves. But to receive with absolute surety we must be situated at such a distance from a station that the ground waves are always strong, and the indirect waves always weak.

**New Times Sales Co.**

**1934 RADIO**  
on the easiest of

*Easy Terms*

Choose your NEW RADIO and send us your requirements. We will quote you the Easiest of Terms per return. WE DEAL WITH YOU DIRECT. No Third Party Finance Company, thereby ensuring the strictest privacy. Immediate delivery from stock.

**NEW LISSEN KITS**

- Free constructional chart with each Kit.
- NEW SKYSCRAPER 7-VALVE SUPER-HET CHASSIS MODEL, complete kit in sealed carton. Cash or C.O.D. Carriage Paid, £8/17/6. With order 15/-
- Balance in 11 monthly payments of 16/6.
- NEW SKYSCRAPER FOUR ALL-WAVE CHASSIS MODEL, complete kit in sealed carton. Cash or C.O.D. Carriage Paid, £5/12/6. With order 10/3
- Balance in 11 monthly payments of 10/3.
- NEW LISSEN SKYSCRAPER FOUR ALL-WAVE CONSOLETTA CABINET MODEL, complete kit in sealed carton. Cash or C.O.D. Carriage Paid, £8/2/6. With order 15/-
- Balance in 11 monthly payments of 15/-.
- NEW LISSEN SKYSCRAPER 7-VALVE SUPER-HET CONSOLETTA MODEL, complete kit in sealed carton. Cash or C.O.D. Carriage Paid, £11/10/0. With order 21/-
- Balance in 11 monthly payments of 21/-.

PETO-SCOTT (P.M.) MOVING-COIL SPEAKER with multi-ratio input transformer for power or pentode. Cash or C.O.D. Carriage Paid, 15/-. With order 5/6  
Balance in 2 monthly payments of 5/6.

NEW BLUE SPOT 99P.M. PERMANENT MAGNET MOVING-COIL SPEAKER. Complete with tapped input transformer. Cash or C.O.D. Carriage Paid, £2/19/6. With order 6/-  
Balance in 10 monthly payments of 6/-.

NEW W.B. TYPE P.M.4A. MICRO-LODE PERMANENT MAGNET MOVING-COIL SPEAKER, switch-controlled with multi-ratio input transformer. Cash or C.O.D. Carriage Paid, £2/2/0. With order 5/9  
Balance in 7 monthly payments of order 5/9.

NEW ROLA CLASS-B PERMANENT MAGNET MOVING-COIL SPEAKER AND AMPLIFIER, with Valve and Input Transformer. Two models: A for PM2B, PD220 and 220 B; B for 240B, H.P.2 (state which when ordering). Cash or C.O.D. Carriage Paid, £3/11/0. With order 6/6  
Balance in 11 monthly payments of 6/6.

**1934 TELSEN KITS**

- TELSER CLASS "B" 4 KIT (Chassis), less Valves, Cabinet, and Speaker. Cash or C.O.D. Carriage Paid, £3/17/6. With order 7/-
- Balance in 11 monthly payments of 7/-.
- TELSER SUPER-SELECTIVE SIX (Chassis), less Valves, Cabinet, and Speaker. Cash or C.O.D. Carriage Paid, £5/17/6. With order 10/9
- Balance in 11 monthly payments of 10/9.
- TELSER 325 STAR KIT, less Valves and Cabinet. Cash or C.O.D. Carriage Paid, £1/19/6. With order 5/3
- Balance in 7 monthly payments of 5/3 order

AMPLION PICK-UP & TONE-ARM complete with combined Volume Control. Cash or C.O.D. Carriage Paid, £1/5/0. With order 4/6  
Balance in 5 monthly payments of 4/6.

NEW ATLAS C.A.25 for Mains, Class B and Q.P.P. Four tappings: 60/80, 50/90, 120/150, 25 m.a. Cash or C.O.D. Carriage Paid, £2/19/6. With order 6/-  
Balance in 10 monthly payments of 6/-.

Miscellaneous Components, Accessories, Kits and Part Kits supplied CASH, C.O.D., or H.P. on our own Private System of Easy Payments. Any Item advertised in this journal sent C.O.D. If value over 10/- sent all C.O.D. charges paid.

EST. 1924  
**NEW TIMES SALES CO.** 56, Ludgate Hill, London, E.C.4.

Please send me .....  
for which I enclose £ : s. d. Cash Deposit  
Name .....  
Address .....  
.....Pr. W.16/9/33







# SOUND AND THE EAR-2

An Interesting Article Explaining How the Human Ear Functions, and on what it Depends for its Response to Various Sounds

By E. G. ROWE

IN my earlier article I described sound generally. In this one I want to tell you something about our ears and their peculiarities. In some ways they are most accommodating but in others they are disconcerting in their sensitivity. It would be well to first describe briefly how they work. Fig. 1 is a rough section of the ear. Air waves impinge on the stretched tympanum or eardrum T, whose motion is transmitted by a chain of bones, which reduces their amplitude to two-thirds, to the membrane covering an oval window

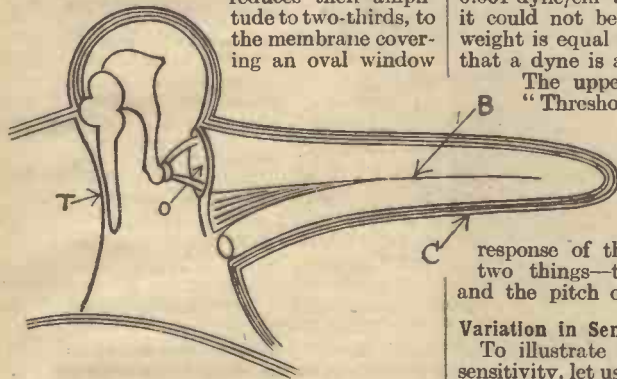

Fig. 1.—Section of the human ear.

O. Here the force is intensified by about seventy times and this force is able to disturb the liquid filling the "cochlea," a snail-shell-like cavity C. (It is shown unrolled in the sketch.) B is the basilar membrane which takes up the vibrations of the liquid and transmits them to the brain. So sensitive is this arrangement that it is estimated that the weight of a single transverse slice of human hair 1/1,000in. thick (that is, the thickness of a cigarette paper), if applied to the eardrum a thousand times a second

will produce the sensation of sound. That in itself is fine, but we come up against a difficulty now in that the ear has not the same sensitivity over the whole band of audio-frequencies. Fig. 2 will help you to understand my meaning. These curves relate to the hearing of a normal person. The lower one is called the "Threshold of Audibility," and any frequencies and pressure variations coming below it would be inaudible. Thus if we had a pressure of 0.001 dyne/cm<sup>2</sup> at a frequency of 100 cycles it could not be heard. (A force of 1 lb. weight is equal to about 450,000 dynes, so that a dyne is a very small unit of force.)

The upper limit is known as the "Threshold of Feeling." Thus, if we have sounds of such intensity and frequency that they lie above the curve, then those sounds are actually felt as pain. So we see that the response of the human ear depends on two things—the acoustic air pressure and the pitch or frequency.

### Variation in Sensitivity

To illustrate the very big variation in sensitivity, let us further consider the graph. You will see that a tone of 1,000 cycles/sec. frequency can be quite comfortably heard with a pressure of only 0.001 dynes per square centimetre, but to get the same loudness at 100 cycles per second we require a pressure of 0.1 dynes per square centimetre—a pressure 100 times as great. And again, if the power imparted to the surrounding air by the vibrating diaphragm of a loud-speaker is doubled, then the increase of volume as perceived by the ear is only just appreciable and not doubled as one might expect. Hence it is apparent that another

(Continued on page 970)

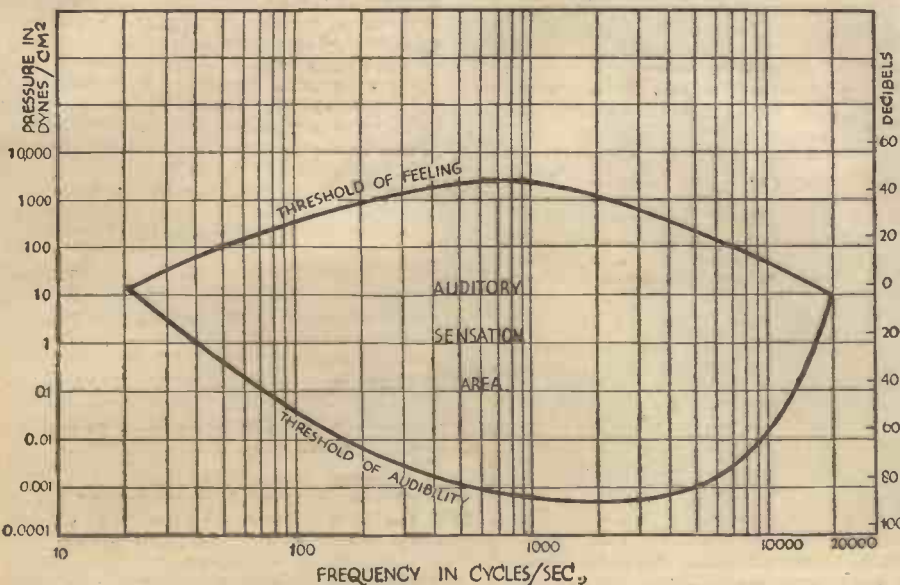
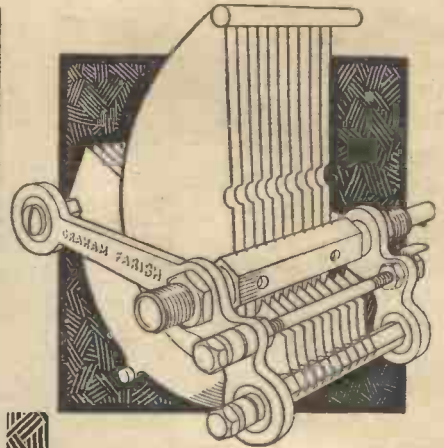

Fig. 2.—Graph showing relation between "feeling" and audibility.



## The New ZELOS the Condenser built for Modern Needs

A superb component, possessing extreme rigidity of construction, mechanical perfection of moving parts and high electrical efficiency. Negligible H.F. loss, large accessible terminals, shaft provides easy ganging. Capacity .0005.

**5!**  
EACH

Ensure a safe and efficient Aerial and Earth. The AEROFICIENT KIT provides all you need. 6/6 complete.

Send for copy of New Catalogue which describes all our products.

# GRAHAM FARISH PRODUCTS

Advertisement of Graham Farish Ltd., Bromley, Kent.

Export Office: 11/12, Fenchurch Street, E.C.3.





By H. J. BARTON CHAPPLE, Wh.Sch., B.Sc.(Hons.), A.C.G.I., D.I.C., A.M.I.E.E.

I CAN very well remember a certain four-valve wireless receiver which I constructed in the very early 'twenties. It was a desk-shaped affair, and the four bright emitter valves projected at an angle near the top of the panel, while the flat top of the cabinet supported a weird array of swinging coil holders. Serried ranks of knobs were arranged with military precision beneath the valves, and altogether there were no fewer than eighteen controls, distributed as follows:—

Three main tuning condensers—one in series and one in parallel with the aerial coil, and one for the high-frequency coupling.

Three "vernier" condensers, one associated with each of the above for fine adjustment.

Two coil adjustments—one for varying the aerial coupling and one for reaction.

Four filament rheostats.

A filament switch.

A switch for cutting out one of the two low-frequency stages.

Four variable grid leaks or resistances in the resistance capacity couplings.

With all this paraphernalia it was possible to receive some half dozen or so stations at good headphone strength, and to operate a diminutive loud-speaker on about two programmes, and this was regarded as a good achievement.

#### Gradual Development

A year or so later I constructed a still more ambitious set, having five valves—two neutralized high-frequency valve stages, a detector valve and two low-frequency valves. In spite of the fact that by this time slow-motion drives and improved design had rendered the use of vernier condensers unnecessary, and that increased knowledge of circuit conditions had led to the disuse of variable anode resistances and grid leaks, the new set had quite as many controls. There were three tuning condensers—aerial and two high-frequency couplings—a reaction condenser, two neutralizing condensers, five filament rheostats, three separate wave change switches, filament switch and a switch for changing over from headphones to loud-speaker.

The performance of the set was considered extremely fine. At least two dozen stations were receivable on 'phones, and about six at good loud-speaker strength on favourable evenings. But how different to the modern four- or five-valve set, such as the "Fury Four," which, under infinitely more trying conditions, will give a much larger selection of programmes with considerably better volume and quality, yet has no more knobs than can be counted on the fingers of one hand.

To give the reader a fair idea of what is meant by multi-knob sets he is referred to Figs. 1 and 2. Although of an experimental character and of more recent date than the designs referred to, they indicate the multiplicity of controls, which modern technique has abolished except for very special purposes.



Fig. 1.—A really good example of a multi-knob set for experimental purposes.

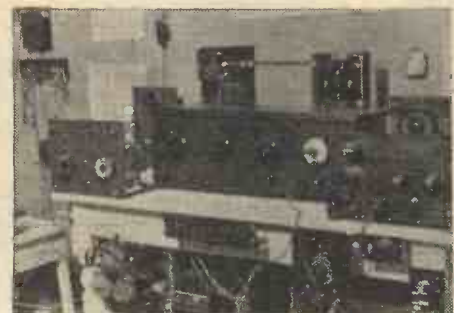

Fig. 2.—Another case of a multi-knob affair used by a radio enthusiast.



Fig. 3.—Several condenser adjustments are necessary in this intermediate control panel.

It is interesting to note the gradual developments which have made possible the reduction of the number of essential knobs on the set of to-day. First, I think, must rank the improved uniformity in the construction of valves so that a two-volt valve, for example, can be operated from a two-volt accumulator without the use of a filament regulating resistance. The old bright emitter valves, and even the early dull emitters, required somewhat critical adjustment of the filament current for best results, particularly in the detector stage.

#### Variable Condensers

Next in order comes the vast improvements in the design and manufacture of variable condensers. The earliest types, with semi-circular vanes, had no particular frequency characteristics, were often hand assembled, frequently by the constructor himself, the spacing of the vanes was seldom uniform, and the ordinary direct-connected dial gave no opportunity for fine adjustment. A small two-vaned "vernier" condenser was therefore necessary, in parallel with each main condenser to give accurate tuning, and, of course, with condensers varying so much between themselves, "ganging" was quite impossible. In Fig. 3 we have shown an example of several controls in the case of tuning condensers, but this unit is an intermediary link at the transmitting end, and in consequence need not worry the listener.

Further reductions in the number of variable condensers required in a receiver came with the introduction of the screened-grid valve, for the inter-electrode capacity of valves of this type is so small that there is no longer any need to balance it out by means of a neutralizing circuit containing a small variable condenser.

Better knowledge of the requirements of detector and resistance capacity circuits has brought about also a decrease in the number of adjustable components. It is now possible, thanks to valves of uniform characteristics, and to a fuller technical appreciation of their capabilities, to design circuits with fixed values of anode resistances, grid leaks and so forth, thus eliminating from one to four knobs in the average set. Modern receivers also use sets of coils or coil kits, so designed that wave-changing can be performed by a single knob—either by using a single switch or by ganging several switches on one spindle.

#### Simplicity

It is true that the more general use of the gramophone pick-up and volume control, and also the need for variable grid-bias to valves of the variable- $\mu$  type, have necessitated one or two extra

(Continued on opposite page)



ANNOUNCEMENT

★ to men who want careers in RADIO

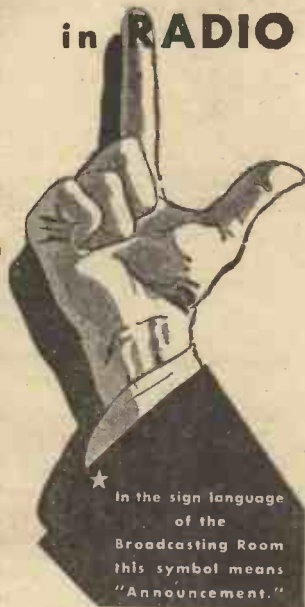

The I.C.S. Radio Courses cover every phase of radio work, from the requirements of the youth who wishes to make wireless engineering his career to the man who wants to construct and maintain a broadcasting set for his home.

The Radio industry is progressing with amazing rapidity. Only by knowing thoroughly the basic principles can pace be kept with it. Our instruction includes American broadcasting as well as British wireless practice. It is a modern education, covering every department of the industry.

OUR COURSES

Included in the I.C.S. range are Courses dealing with the installing of radio sets and, in particular, with their Servicing, which to-day intimately concerns every wireless dealer and his employees. The Operating Course is vital to mastery of operating and transmitting.

There is also a Course for the Wireless Salesman. This, in addition to inculcating the art of salesmanship, provides that knowledge which enables the salesman to hold his own with the most technical of his customers.

We will be pleased to send you details of any or all of these subjects. Just fill in, and post the coupon, or write in any other way, stating which branch of Wireless interests you—the information you require will be forwarded at once.

International Correspondence Schools, Ltd.,  
Dept. 94, International Buildings,  
Kingsway, London, W.C.2.

Without cost, or obligation, please send me full information about the Courses I have marked X

- COMPLETE RADIO
- RADIO SERVICING
- RADIO EQUIPMENT
- RADIO SERVICING AND SALESMANSHIP
- WIRELESS ENGINEERING
- WIRELESS OPERATORS

Name..... Age.....

Address .....

(Continued from previous page)

knobs which were not wanted on the older receivers, but on balance the number of operating controls on a modern receiver are at least only one quarter as numerous as on sets of five years ago.

Probably the most important factor in the "fewer knobs" movement, however, is the growing desire of the average listener for greater simplicity in his receiver. In the early days when programmes were much less satisfactory than to-day, and radio was a great novelty, experiment and knob twiddling was rampant.

To-day, however, although amateurs are just as keen as ever, the programme is essentially the thing, and the average listener wants to secure a reasonable choice of programme with good quality and the minimum of technical complication, and then to sit down and listen.

How Many?

What, then, can we consider as the desirable number of "knobs" on a modern receiver? The answer depends upon several factors. In the first place, the number of essential knobs depends upon the type of set—how many valves it contains and the performance it is required to give.

Let us consider, first of all, battery receivers. The simplest is the two- or three-valve detector and low-frequency set. Here the number of essential controls is three only—tuning condenser, reaction condenser, and battery switch. A fourth, a wave-change switch, must be added if both long and medium wave stations are to be received. Other non-essential but useful controls are: a selectivity device, consisting of either a variable aerial coupling or a semi-variable series condenser in the aerial lead and a gramophone pick-up switch with volume control.

For a three-valve battery set employing one high-frequency stage no addition to the above number of controls is necessary. The two tuned circuits (or three if band pass filter is used) can be tuned by ganged condensers; there is the usual reaction condenser, a filament switch, and a wave-change switch, the latter being well worth while, because modern coils all incorporate dual wave range and the long-wave stations have very high programme value.

If you are situated fairly close to the local station it is worth while to use a variable-mu valve in the high-frequency stage, and then a potentiometer for varying the bias to this valve will have to be fitted. Then, if you are using a pentode valve in the output stage, it is wise to fit a combined protective and tone-control circuit across the output. This consists of a small fixed condenser and variable resistance, and is for the purpose of avoiding the destructive voltage rises if the loud-speaker should accidentally be disconnected. In addition, by varying the resistance some of the higher tones can be reduced in order to give a more sonorous reproduction.

In a four- or five-valver, with two high-frequency stages, an actual reduction in the number of knobs can be made, for, if the set is well designed, reaction will be quite unnecessary. On the other hand, with a set of this type variable-mu valves are practically essential, so that the necessary grid bias potentiometers must be included.

Mains sets are even simpler than battery receivers in the matter of knobs, for no filament switch is actually necessary. The mains switch for a set of this type need not be fitted on the set itself, for it is usually included on the wall plug.

acknowledged THE WORLD'S BEST



The most popular and efficient type of fixed resistance for all general purposes. "Better than wire wound."

All values 50 ohms to 5 megohms.

100 deg. F. Temperature rise

| Ohms   | Milliamps | Ohms                  | Milliamps |
|--------|-----------|-----------------------|-----------|
| 1,000  | 40        | 30,000                | 6.75      |
| 2,000  | 35        | 40,000                | 6         |
| 3,000  | 29        | 100,000               | 3.5       |
| 20,000 | 8         | Other values pro rata |           |

Heavy Duty type, approximately double the above ratings.

OHMITE RESISTANCES

1/6 EACH

HEAVY DUTY TYPE 2/3

Ensure a safe and efficient Aerial and Earth. The new AEROFICIENT KIT provides all you need. 6/6 complete.

Send for copy of New Catalogue which describes all our products.

GRAHAM FARISH PRODUCTS

Advertisement of GRAHAM FARISH, LTD., Bromley, Kent. Export Office: 11/12, Fenchurch St., E.C.3.



# BELLING-LEE

FOR EVERY RADIO CONNECTION



Write for Booklet, "Radio Connections."

**BELLING & LEE LTD**  
CAMBRIDGE ARTERIAL ROAD, ENFIELD, MIDD'X

# Facts and Figures

Components Tested in our Laboratory

BY THE PRACTICAL WIRELESS TECHNICAL STAFF

**BRITISH GENERAL ALL-WAVE TUNING UNIT**  
THE original British General Tuner is, of course, very familiar to most home-constructors. It covers the normal broadcast wavebands. The latest type of tuner, however, is designed to cover two short-wave bands of 14.5 to 40 metres, and 32 to 90 metres, in addition to the bands of 200 to 550 and 900 to 2,000 metres. The new unit is much smaller than the original model, in spite of the fact that the extra wavebands have been included, and many of the original features have been retained. Two controls only are fitted to the unit, one controlling the Aperiodic

majority of these valves is 20, although two special valves have a 40-volt heater. Amongst this range is included a special H.F. Pen/Det. frequency changer and a Variable-Mu H.F. Pen A.V.C. mixer. These cost 14s. 6d. each. A special pentode is also obtainable at 17s., which delivers an undistorted output of nearly one and a half watts.

**ELECTRON VARIAL**  
MANY devices have been introduced from time to time to aid in the search for selectivity, and some of these possess, apart from their electrical novelties, peculiarities in design or construction which render them very popular with the listener. The latest device is the Electron Varial which consists of two lengths of the well-known electron wire, joined together in an ingenious manner. One wire is coloured black and is continuous from end to end. The second wire (red) is held in contact with the former wire by means of an erinoid or similar cap. No electrical contact exists. The two wires are twisted in the manner of ordinary flex, and an ingenious bakelite moulding is clamped around them. This may be slid along the twisted wires and in doing so untwists them. When it is at one end of the assembly the two wires are twisted for their whole length, and when moved to the opposite end the two wires are single and separated. To use the device the single black

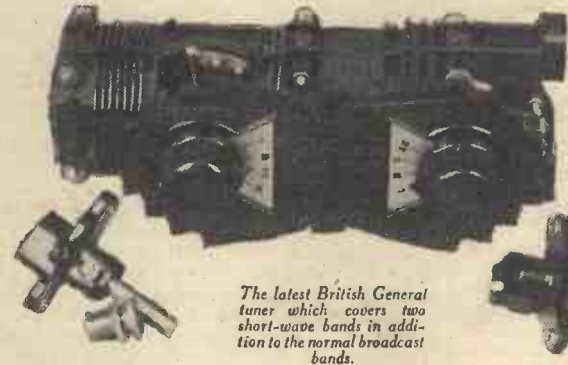

The latest British General tuner which covers two short-wave bands in addition to the normal broadcast bands.

tapping and the other the wave-change switch. Rotary selector switches are employed in both cases, and the circuit arrangement shows that separate aerial coils are employed for each wave-band. The result of this arrangement is that perfect control is effected for each range, and signal strength is at a maximum commensurate with adequate selectivity. The reaction control works very smoothly on each band showing that the reaction windings have been finely proportioned and arranged. Six terminals only are provided for connections, and in addition to the unit special insulated switch couplings and extension rods are supplied at the inclusive price of only 9s. 6d. This unit should find great favour among home-constructors.

end is joined to the aerial lead-in, and the other end of this black wire is connected to the aerial terminal on the set. The device is then simply an extension of the aerial and has no effect whatever on the performance. When, however, the red wire is joined to the aerial terminal instead of the black one, the connection from aerial to receiver is through the capacity which exists between the two twisted wires and this may be varied by sliding the moulded portion along and so untwisting the aerial. Any degree of selectivity may thus be obtained instantly and the adjustment made according to the conditions prevailing at any moment. The cost is 1s. 6d.

**TUNGSRAM UNIVERSAL VALVES**

THE construction of a Universal receiver—that is, one which may be used indiscriminately on either D.C. or A.C. mains—has hitherto been difficult owing to the fact that one had to use ordinary D.C. valves and rely upon the use of an ordinary type of rectifier connected to provide half-wave rectification on A.C. mains and to act simply as a resistance on D.C. mains. Whilst this arrangement certainly works quite well, it is not so good as when using special "universal" valves, and there were very few of these available. The Tung-ram factory has now produced a complete range of these valves, all of which are provided with .18 amp. heaters of the indirectly fed type which makes it a simple matter to wire the valves in series. The voltage of the

**NEW CLASS B VALVE**  
A NEW type of Class B valve is announced by the Osram factory, and this is outstanding in two ways: first, it works on a combination of Q.P.-P. and positive grid drive, that is to say, it combines the advantages of both systems without many of the disadvantages hitherto associated with each of them. Most listeners have noticed that when using Class B a peculiar form of distortion is sometimes apparent which has been described as Class B "rattle." This seems to occur on certain passages of music giving a "twang" effect often exceedingly unpleasant.

The new Osram B.21 Class B valve differs from the ordinary Class B type in the fact that it works with a small negative grid bias. This is because it has been found that by making the valve in such a way the impedance of the associated circuits can be reduced and the tendency to introduce spurious oscillation (which is the cause of distortion) avoided.

A second point of outstanding interest in the B.21 is the fact that each of the triode sections is in itself designed with a double grid. These two grids are internally connected so that there is no added complication to the user, but it has been established that by using the double grid system a better ratio of power output to input is obtained; in other words, such a valve will give a better volume output without the necessity for a very large power driver stage. In addition to these two points, the total filament current for the two sections of the B.21 is only 0.2 amp., and an entirely new form of bulb has been employed, giving an extremely small and neat appearance, together with a rigid electrode construction. The electrodes are actually held rigidly within the glass bulb by means of specially shaped mica supports. In common with other Class B valves, the B.21 is fitted with the new 7-pin base.



One of the new Tung-ram valves.

**A GREAT SURPRISE BIRTHDAY OFFER NEXT WEEK!**



"We're Fluxite and Solder—the reliable pair—Famous for Soldering—known everywhere!"  
See that Fluxite and Solder are always by you—in the house—garage—workshop—anywhere where simple, speedy soldering is needed.

**ALL MECHANICS WILL HAVE FLUXITE**  
IT SIMPLIFIES ALL SOLDERING

All Ironmongers sell Fluxite in tins: 4d., 8d., 1s. 4d., and 1s. 8d. Ask to see the FLUXITE POCKET SOLDERING SET—complete with full instructions—7s. 6d. Ask also for our leaflet on HARDENING STEEL with Fluxite.

**FLUXITE, LTD.**  
(Dept. W.P.), ROTHERHITHE, S.E.16.

**FOR ALL REPAIRS!**







# Practical Letters from Readers.

The Editor does not necessarily agree with opinions expressed by his correspondents

### "Helping Him Out"

SIR,—I must ask you to forgive me for not writing before, but I feel it my duty to thank you for the "Wireless Encyclopaedia." I have received from you. I must say it is very invaluable to new beginners. It explains things so simple, especially with the "Shorthand of Wireless" in the beginning of the book. It is a book to be proud of.

Also your weekly paper, PRACTICAL WIRELESS. There are many useful hints to be obtained from it. It makes a novice feel that he has someone behind him, when he knows that if he experiences any difficulty he can easily have it explained by your "Technical Staff," through the pages of Queries and Enquiries.

Trusting that PRACTICAL WIRELESS will carry on helping its readers in all wireless matters.—W. A. FRY (Rhondda).

### "An Annual?"

SIR,—I do not know if you intend to bring out the Encyclopaedia each year, but I suggest you do something on similar lines. Why not an Annual which would deal with the events of the preceding year, giving details and the pros and cons of the different developments that have been introduced? Standing matter, such as Ohm's Law, etc., could, of course, be omitted, as we have this already. The advice and information by your experts in such a publication would be invaluable to the home constructor. Also, what about a PRACTICAL WIRELESS Diary?—G. WREN (S.E.14).

[What do readers think of these suggestions?—ED.]

### "A Critic with a Jaundiced Eye"

SIR,—Tell me! Did you attend "The Parade of Artists' Models" at the Royal Academy Exhibition? You didn't! Too bad. Perhaps you saw "The Dirt Track Racing" at the Motor Show? There wasn't any! Too bad, and quite right, too, neither should the B.B.C. be allowed to trespass with their Variety Show at the Radio Exhibition and you, with many of my fellow readers, will, I am sure, agree with me.

My opinion of Radiolympia is that it is just a large hall with plenty of gadgets everywhere to look at (attended by the usual 80 per cent. of nice-looking fellows who haven't the faintest idea of the reactance of a 2 mfd. condenser at 50 cycles, etc.), plenty of music which might be coming from the speaker in front of you or the one behind; and judging the performance of a wireless set by its beautifully polished cabinet or nickel-plated chassis, etc. I tell you, Mr. Editor, that there must be many of my fellow readers who agree with me when I say that, to an amateur with a little knowledge, an experimenter, or professional man, the Show is a wash-out, excepting the latest coil-winding

machinery, the battery-making machine, and the Oscillograph demonstrations.

Tell me, Mr. Editor, have we lost the audition rooms for ever, where we could retire to cut out the noise of the hall, and listen to the needle-scratch of a pick-up, or compare Speaker Model 4 with Speaker Model 5? The good old shows when we could hear for ourselves that the extra ten shillings for Model 5 was really worth while, and that although a pick-up looked beautiful, had a V.C. incorporated, with plated tone arm and V.C. knob, plus feather-weighting, etc., etc., the needle-scratch was awful! Tell me, Mr. Editor, when shall we have men on the "Stands" who know all about the things they are selling—even if they have a bit of dirt on their hands, or broken finger nails (and how those workmen would work, study and fight, for the chance to go to the Show to tell the world about the article they had made with their own hands, instead of what we have now—comfy chairs, cigarettes, and the latest jokes).

Let's have the audition rooms back; and to Broadcasting House with the B.B.C. and their Shows.—E. CROOK (Beckenham).

(Continued on next page)

### CUT THIS OUT EACH WEEK

## DO YOU KNOW?

- THAT there are a large number of various valve types on the American market which are, unfortunately, not obtainable in this country.
- THAT many of these valves render the construction of highly efficient receivers extremely simple.
- THAT a convertible triode-pentode for battery receivers is only one of the valves above referred to.
- THAT higher efficiency is now being obtained in practically every component for the home constructor.
- THAT the self-capacity of an H.F. choke plays a great part in its functioning.
- THAT some new developments in aerial-earth systems may be expected this season.
- THAT a mechanical wave-change colour signal may now be obtained for fitting to existing tuning dials.
- THAT this device shows a different coloured pilot light for each wave-band.
- THAT troublesome hum in a mains operated gramophone may often be traced to interaction between a pick-up and a synchronous motor.
- THAT the pick-up should be moved about with the apparatus switched on, to ascertain whether the above cause is responsible for hum.

### NOTICE.

The Editor will be pleased to consider articles of a practical nature suitable for publication in PRACTICAL WIRELESS. Such articles should be written on one side of the paper only, and should contain the name and address of the sender. Whilst the Editor does not hold himself responsible for manuscripts, every effort will be made to return them if a stamped and addressed envelope is enclosed. All correspondence intended for the Editor should be addressed: The Editor, PRACTICAL WIRELESS, Geo. Newnes, Ltd., 8-11, Southampton Street, Strand, W.C.2.

Owing to the rapid progress in the design of wireless apparatus and to our efforts to keep our readers in touch with the latest developments, we give no warranty that apparatus described in our columns is not the subject of letters patent.

## Mr. F. J. CAMM Chooses THE BEST hence the Exclusive Specification of

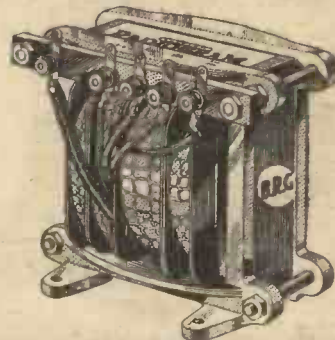

### B. R. G. TYPE 55 MAINS TRANSFORMER

INPUT: 200, 210, 220, 230, 240 and 250 volts.  
OUTPUT: H.T. Secondary 250 + 250 volts at 60 m/a. Rectifier Filament 2 + 2 volts at 1 amp. L.T. 2 + 2 volts at 2-3 amps.  
With Coloured Output Leads for Quick Assembly.

TYPE 55 WITH OUTPUT TERMINALS IN PLACE OF COLOURED LEADS 25/-

B.R.G. 3-POINT SWITCH No. 48. Specially Specified for F. J. Camm's A.C. THREE. With specially strong phosphor-bronze self-cleaning contacts 1/3  
B.R.G. components are obtainable from all Dealers. In cases of difficulty send for name and address of nearest stockist.

SOLE DISTRIBUTORS OF "METAPLEX"  
The New Metallised Baseboard.

## BRITISH RADIOGRAM

BRITISH RADIOGRAMPHONE CO. LTD. Pilot House, Church Street, Stoke Newington, London, N.16  
Telephone: C18:014 6287/6288.

Appointed TELSEN WHOLESALERS

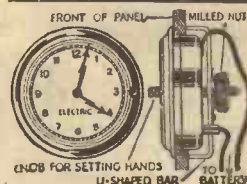

### FIT THIS ELECTRIC CLOCK

TO YOUR SET!  
NO MAINS NEEDED!  
KEEPS CORRECT TIME!  
NO WINDING!

Works off small battery lasting 12 months, or can be plugged into G.B. battery without affecting reception. Uses practically no current. Fits into hole 3 1/2 in. dia. in any panel up to 1/2 in. thick. Easy to fix—no screws required. Only 1/2 in. from front of panel to back of case. Swiss movement. Hands set from front. Nickel-plated bezel. Useful addition to any set.

RIVERSIDE MFG. Co., Ltd., Dept. 21, Crisp Road, Hammersmith, W.6.  
Telephone: Riverside 6392.

12/6  
COMPLETE WITH BATTERY  
POSTAGE 6D

Write for Illustrated Catalogue of

Radio-Gramophone Cabinets of exclusive modern design, made by craftsmen in highly figured Oak, Walnut, or Mahogany, most free. Cabinets made to order or a speciality. Maker under license of the  
**HOWE BOX BAFLE.**  
Recommended by the B.B.C. Full details on request.  
**GILBERT**  
Cabinet Maker.  
SWINDON. Estimates free. Est. 1866.

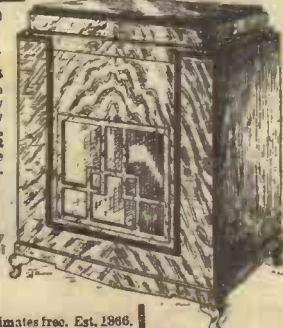

## FIFTY TESTED WIRELESS CIRCUITS

By F. J. CAMM (Editor of "Practical Wireless.")

Obtainable at all Booksellers, or by post 2/9 from George Newnes, Ltd., 8-11 Southampton Street, Strand, London, W.C.2.

2/6



SECRETS OF

CELESTION

SUPREMACY

No. 1.

Acoustically  
Perfect  
Cabinets!

The cabinets in which Celestion Moving-Coil Loudspeakers are housed are acoustically designed as *part of the speaker* and not only as an attractive article of furniture. As a result, reproduction over the whole range of frequencies is of the highest Celestion quality.

It is such *attention to detail* that puts Celestion in the forefront of modern loudspeaker design. The name Celestion stands for high-quality reproduction combined with unflinching efficiency. Celestion speakers can be supplied to match any set or type of output.

Ask your dealer for a demonstration, or write for full details.

PPM 39 Cabinet Model £3 10 0

PPM 9 Chassis Model £1 15 0

Celestion Ltd., London Road, Kingston-on-Thames.

Celestion energised Model E. 8 is specified for the A.C. 3

MODEL P.P.M. 39

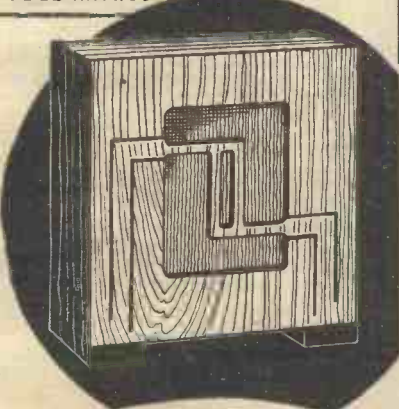

CELESTION

The Very Soul of Music

THE FOREMOST NAME  
IN SOUND REPRODUCTION

## PRACTICAL LETTERS

(Continued from page 969)

## Our Weekly Problem

SIR,—I want to thank you very much for the book that I have received from you as my prize in connection with Problem 46. It is a very nice gift, and I am quite pleased with it. I think that the problem is an interesting competition, and look forward to it every week.—C. MCKENNA (Liverpool).

## Our Exhibition Numbers

SIR,—May I congratulate you on the excellent Exhibition Numbers you have just published? Though unable to visit Olympia this year your two issues have made me feel as though I had been there. I always look forward to PRACTICAL WIRELESS, it always being packed with such useful information. All best wishes for the future.—G. WILBOURNE (Deptford).

## Our Technical Staff at the Show

SIR,—May I ask you to accept, on behalf of yourself and your staff, my many thanks and sincere appreciation of the unstinted and valuable advice tendered me at the Radio Show? That you and your very excellent paper may enjoy a long and brilliant career, as it richly deserves, is the very sincere and earnest wish of ROBERT A. KEMP (Muswell Hill, N.).

## A Typographical Treat—Not Tripe!

SIR,—In the hope that my opinion interests you, I am sending it to you. The proportion of the different items is about right.

I would urge that you keep that "freshness" that all the practical articles have. It is a treat to read articles by your staff. Their stuff is *not* journalism turned out by the yard.—H. PHILLIPS (Birmingham).

## SOUND AND THE EAR

(Continued from page 965)

unit of comparison is necessary in addition to the pressure one of "dynes per square centimetre," and we have this in the well-known "decibel."

The "decibel" scale shows to the eye what the ear will appreciate. The increase in intensity necessary to double the loudness of a note represents an addition of three decibels, while a gain of one decibel represents the minimum increase in loudness capable of being recognised by the trained ear.

Let us study Fig. 2 again.

## Auditory Sensation Area

We see that normal hearing is between 20 and 20,000 cycles (although many people cannot hear higher than 15,000 cycles), and that the pressure varies between 0.0005 dynes per square centimetre and 5,000 dynes per square centimetre, that is ten million to one. These limits enclose what is known as the Auditory Sensation Area.

Now following along the threshold of audibility we see that the minimum pressure required for a sound to be audible is at about 1,000 to 2,000 cycles per second and it is therefore in this range that the ear is most sensitive. The ear is relatively much more insensitive at both high and low frequencies, particularly the low frequencies. This accounts for the fact that musical instruments are designed so that tones of different pitch have approximately the same loudness as interpreted by the ear.

If you turn the volume control of your set well down so that it is reproducing at

a low loudness level, the result will appear thin and lacking. The shape of the lower curve in Fig. 2 explains this because at a low loudness level the low-pitched instruments are all inaudible. Then as the intensity is increased so we reach a point when the loudness of the low frequencies increases more rapidly than that of the higher frequencies and once again we get an unbalanced effect, this time with the low frequency predominating.

RADIO CLUBS  
& SOCIETIES

Club Reports should not exceed 200 words in length and should be received First Post each Monday morning for publication in the following week's issue.

## SLADE RADIO

There was a talk on "Olympia, 1933" by Mr. A. S. Freeman at the meeting held last week. The first part of this talk was carried out with a microphone, and his voice was heard from the speaker of an Ekco set, which was made to introduce itself to the members. The set was the new 7-stage superhet, with band-pass tuning and light beam station selector, which was then demonstrated. Mr. Freeman then went on to give general details of the Show and the developments which have taken place. Samples of early types of valves were shown together with the latest, which included the Catkin, also the new Osram Class B (B21) and the driver (L21). Samples were also exhibited of the early type of variable condenser, together with the latest type. The new Ferranti "Gloria" was demonstrated and proved exceptionally interesting, and the new McMichael with dual speakers and the new R.I. were also exhibited. The talk proved very interesting, especially to those members who had not been able to attend the Show. The society still has room for more members, and the Hon. Sec. will welcome enquiries from anyone interested. Address: 110, Hillaries Road, Gravelly Hill, Birmingham.

## INTERNATIONAL SHORT-WAVE CLUB, LONDON

A big audience attended the reopening of the London Chapter of the International Short Wave Club at the R.A.C.S. Hall, Wandsworth Road, S.W.8, on Friday, September 1st. Among the attractions were demonstrations of a 5-metre receiver, a Halford 4/5 M.S. and 2 S.W. receivers, which gave quite good results. A lecture on Radiation and Frequencies by a well-known radio authority followed. Great interest was shown in an exhibition of photographs of the world's short-wave stations, among which were many photographs of the Empire Broadcasting Station at Daventry.

## HACKNEY RADIO AND PHYSICAL SOCIETY

During the holiday period our meetings have been informal and generally consisted of discussions on the future programme. From these talks an interesting programme for the next few weeks has been evolved and a copy is appended. In addition, talks by representatives of various firms and visits to places of interest are being arranged.

Sept. 18th—Sound.

" 25th—Lecture-Demonstration—The Modern Superhet.

Oct. 2nd—Class B Amplification.

" 9th—Operating a Low Power Transmitter.

" 16th—General Revision of Frequencies.

" 23rd—Low-frequency Coupling.

" 30th—Oscillatory Circuits.

Nov. 6th—Application of the Cathode Ray Oscilloscope.

" 13th—A.C. and D.C. Eliminators.

" 20th—Adding a S.G. Valve to a Det. and 1 L.F.

" 27th—Remote Control.

The Secretary will be pleased to send details of membership to any local reader of PRACTICAL WIRELESS interested.

## LIST OF EXHIBITORS

(Continued from page 954)

- Stand No.
- 62 Main Hall—Whiteley Electrical Radio Co., Ltd., Victoria Street, Mansfield.
- 51 Main Hall—Wingrove and Rogers, Ltd., Polar Works, Old Swan, Liverpool.
- 101 Gallery—Wharfedale Wireless Works, Ltd., 62, Leeds Road, Bradford.
- 80a Gallery—Wright and Weaire, Ltd., 740, High Road, London, N.17.



REPLIES TO

LET OUR TECHNICAL STAFF SOLVE YOUR PROBLEMS



If a postal reply is desired, a stamped addressed envelope must be enclosed. Every query and drawing which is sent must bear the name and address of the sender. Send your queries to the Editor, PRACTICAL WIRELESS, Geo. Neunes, Ltd., 8-11, Southampton St., Strand, London, W.C.2.

QUERIES and ENQUIRIES by Our Technical Staff

The coupon on this page must be attached to every query.

SPECIAL NOTE

We wish to draw the reader's attention to the fact that the Queries Service is intended only for the solution of problems or difficulties arising from the construction of receivers described in our pages, from articles appearing in our pages, or on general wireless matters. We regret that we cannot, for obvious reasons—

- (1) Supply circuit diagrams of complete multi-valve receivers.
- (2) Suggest alterations or modifications of receivers described in our contemporaries.
- (3) Suggest alterations or modifications to commercial receivers.
- (4) Answer queries over the telephone.

Please note also, that all sketches and drawings which are sent to us should bear the name and address of the sender.

GRAMOPHONE PICK-UP

"I have just purchased a gramophone pick-up and am studying, more or less, the theories of sound reproduction. During the course of the little experimenting I have done I have noticed that the angle which the needle forms with the surface of the sound groove affects the reproduction. I should be glad to know whether there is any optimum position, or whether considerable latitude is permissible in this direction."—Y. A. N. M. (Exeter).

The majority of pick-ups are designed to give the correct needle angle and it is not possible on these to alter the position. However, as you are apparently experimenting with various types of tone arm, etc., we would advise you to endeavour to have the needle at an angle of 50 to 60 degrees from the surface of the record. It must, of course, be perfectly vertical when viewed from the front.

LONG-WAVE WINDING

"Why is it that the long-wave section of a coil is invariably wound in sections instead of in a single hank? I appreciate the fact that it could not be wound in solenoid fashion, but is there any reason why one good pile winding would not do?"—(F. T. P., Balham).

The reason is that a coil has to possess inductance and capacity in certain proportions if it is to be efficient. The inductance is decided by the amount of wire, and the capacity results from the effect between adjacent turns of wire. By splitting the coil up into a number of small sections we reduce the over-all capacity, and therefore preserve the efficiency.

SIZE OF FILAMENT FUSE

"I wish to fit a fuse in my battery-driven receiver to safeguard the valves from being burnt-out in the event of a short from the H.T. What size must this fuse be?"—(H. K. B. G., Bristol).

In the majority of receivers the filaments are wired in parallel, and you must therefore add together the filament current of each valve. You should then choose a fuse with a rating just lower than this figure—remembering that 100 mA. is the same as .1 amp.

DETECTOR-VALVE BROKEN

"I fancy that my detector valve has become damaged, and I wonder if you could tell me any easy way of testing whether it is broken?"—(S. P. F., Bromley).

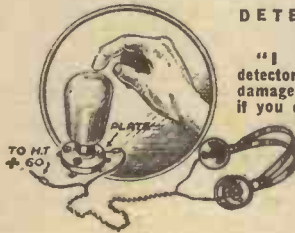

To test the detector valve, disconnect the wire from the valveholder terminal lettered A or P, and connect one lead from a pair of headphones to the terminal, and the other lead to H.T. positive GO. Tap the valve with your finger and you should hear a ringing noise in the phones.

The simplest test is illustrated. Join a pair of 'phones in the Plate circuit, and tap the glass bulb gently with your fingertip. A ringing noise will be indicative of the fact that the valve filament is unbroken.

DATA SHEET No. 52

Cut this out each week and paste it in a notebook.

OUTPUT TRANSFORMER RATIOS.

| Valve Impedance Ohms. | Loud Speaker Impedance Ohms. | Transformer Ratio |
|-----------------------|------------------------------|-------------------|
| 1,000                 | 2,000                        | 1 to 1.5          |
|                       | 4,000                        | 1 to 2            |
|                       | 6,000                        | 1 to 2.5          |
|                       | 8,000                        | 1 to 3            |
| 2,000                 | 2,000                        | 1 to 1            |
|                       | 4,000                        | 1 to 1.5          |
|                       | 6,000                        | 1 to 2            |
|                       | 8,000                        | 1 to 2            |
| 4,000                 | 2,000                        | 2 to 1            |
|                       | 4,000                        | 1 to 1            |
|                       | 6,000                        | 1 to 1.5          |
|                       | 8,000                        | 1 to 2            |
| 8,000                 | 2,000                        | 3 to 1            |
|                       | 4,000                        | 2 to 1            |
|                       | 6,000                        | 1.5 to 1          |
|                       | 8,000                        | 1 to 1            |

NOTE.—The ratios given are the nearest commercial ranges which are obtainable. The impedance of a loud-speaker is approximately double the D.C. resistance.

SOLDERING FLUXES

"I am busy trying out various ways of soldering, a task which I have always dodged in the past."

notice, however, that all commercial sets are soldered and I believe that many of the crackles given by my set are due to loose contacts under screws. I am finding it very difficult to get the joints to hold together, and should like your advice as to the best way to solder say two wires together, or one or more wires to a terminal head. Do you recommend ordinary spirits of salts as a flux."—(T. G., East Twickenham).

Soldering is a very simple job, when once the principles are understood. Firstly, the work must be cleaned from grease and other impurities, so that it is really essential to scrape it or use some other form of surface remover. Next, the soldering iron must be sufficiently hot to melt the solder which is used and cause it to run round the part to be joined. The heat in the iron invariably causes the metal to oxidize, and therefore a flux must be put on the work to prevent this and allow the solder to come into direct contact with the metal. Therefore, the rules are—thoroughly clean the wire or other work; apply a small quantity of flux; and use a really hot iron. For wireless purposes do not use spirits of salts or other corrosive material, but resin or some similar substance. If you hold the soldering iron about two inches from your cheek you will be able in time to judge the correct heat of the iron. The most suitable solder for wireless purposes is that known as Timmans solder, consisting generally of equal parts of tin and lead.

L.F. TRANSFORMER CONNECTIONS

"I have been told that it is possible to alter the ratio of an ordinary L.F. transformer, but I do not understand how this can be done without interfering with the wiring. Would it be possible to explain the method (if it is possible) in a simple manner, as I am only a beginner in radio, but am fast picking up hints from your valuable pages."—(T. Y. S., Grangemouth, Stirling).

The transformer consists of two windings, one of which is larger than the other. There is thus a step-up in ratio between primary and secondary windings, the actual ratio being proportional to the turns on each winding. If the primary is connected direct in the anode circuit of a valve the secondary (which is connected to the grid of the following valve) will deliver a signal which is louder by the ratio of the transformer. If the two windings are joined in series, with the turns correctly arranged, the entire winding may be included in the grid circuit of the second valve, and the first valve connected (via a condenser) to the junction of primary and secondary windings. If the windings are connected to provide inductive coupling between each other, then the ratio of the transformation will be one more than the original rating (in other words primary plus secondary). If the windings are connected to provide opposition, the ratio will be one less than the original rating. Thus a 4 to 1 transformer may be used direct in the anode circuit to provide a ratio of 4 to 1. It may be connected as first described above to provide a ratio of 5 to 1, or in the second method above mentioned to provide 3 to 1. An article will shortly be published in these pages explaining the arrangement more fully. The A.C. Three, described in this issue employs the arrangement to obtain a gain of 1.1.

FREE ADVICE BUREAU COUPON

This coupon is available until Sept. 23rd, 1933, and must be attached to all letters containing queries.

PRACTICAL WIRELESS, 16/9/33.

ISSSEN SKYSCRAPER KITS

Please send ALL your HIRE PURCHASE ORDERS to Peto-Scott Co., Ltd., 77, City Road, London, E.C.1

Agents of Peto-Scott Co., Ltd.



# CATALOGUES RECEIVED

To save readers trouble, we undertake to send on catalogues of any of our advertisers. Merely state, on a postcard, the names of the firms from whom you require catalogues, and address it to "Catalogue," PRACTICAL WIRELESS, Geo. Newnes, Ltd., 8/11, Southampton St., Strand, London, W.C.2. Where advertisers make a charge, or require postage, this should be enclosed with applications for catalogues. No other correspondence whatsoever should be enclosed.

## MULLARD VALVE GUIDE

WE have just received a copy of the new Mullard Master Valve Guide for the ensuing season, a very useful book of pocket size, giving the operating data and characteristics of the complete range of Mullard valves. The application of each valve is simply explained and useful hints concerning such matters as grid bias voltage, operating notes, and so forth are included for each type. The Technical Appendix, which occupies thirty-four pages, includes a useful article with many diagrams on Automatic Grid Bias, an authoritative article on the operation of rectifier valves, a handy method of calculating the correct ratios for output transformers, a guide to the standard connections to the new seven-pin base, and many other informative articles. Copies of the handy book can be obtained from the Publicity Dept., Mullard Wireless Service Company, 111, Charing Cross Road, London, W.C.2.

## SERADEX BATTERY CHARGERS

PARTICULARS of a range of high-class battery chargers and eliminators are given in a new season's list issued by Trevor Pepper, 48, Wake Green Road, Moseley, Birmingham. The Seradex V.R. 328a Charger will charge from one to ten cells in series at a maximum charging rate of 1.3 amps. It is listed at £3 5s. There are also H.T. Chargers, combined Chargers, D.C. Charging Boards, and Westinghouse Service Chargers. All models are fitted with ammeters and continuously variable resistances for controlling output. The eliminators include D.C. and A.C. models, the latter incorporating Westinghouse rectifiers. A range of Seradex Rectifiers, incorporating Westinghouse rectification, is also included in the list, copies of which can be obtained from above address.

## MARCONIPHONE PRODUCTS

FULL particulars of Marconiphone radiograms and receivers are given in an attractive new season's catalogue just issued by the Marconiphone Company, Ltd. In the radiogram section there are 7-valve and 5-valve superhet models for A.C. working, at prices ranging from 50 guineas to 28 guineas. A 4-valve A.C. model is priced at 23 guineas, and for the same price there is a 3-valve D.C. model. The receiver section includes an all-mains 7-valve superhet; a 5-valvesuperhet; an all-mains transportable (4-valve A.C. or 3-valves D.C.); a 6-valve M.C. superhet Portable; a 4-valve M.C. Battery Receiver; and 3-valve and 2-valve battery receivers, the latter model being priced at only 4 guineas, complete with a well-finished cabinet of modern design. P.M. Moving-coil Speakers in cabinets; P.M. Moving-coil Units; and Marconi Valves are also listed. The address is Radio House, 210-212, Tottenham Court Road, London, W.1.

## BULGIN RADIO PRODUCTS

WE have just had the pleasure of perusing a copy of the latest edition of the Bulgin Radio catalogue for the season 1933-4. It is, undoubtedly, one of the most comprehensive catalogues we have yet seen, and covers everything the constructor is likely to require. Included in the list are a fine array of

switches for various purposes; screened H.F. chokes for chassis or baseboard mounting; tuning coils; valve-holders and adaptors; cartridge fuses; signal lamps and panel lights; and numerous other small components. In the back part of the catalogue there is a 24-page technical manual giving instructive information and showing how various Bulgin components are connected in different circuits. Copies of this useful list can be obtained on application to A. F. Bulgin and Company, Ltd., Abbey Road, Barking, Essex, enclosing 2d. for postage.

## OSRAM VALVES

TO keep pace with modern circuit conditions several new types of Osram valves of considerable interest to set designers and constructors have just been released by the General Electric Company, Ltd., and we have received a number of leaflets giving full particulars and characteristic curves of these valves. Included in the range are two-volt battery valves; A.C. mains valves; power output triodes and pentodes; rectifiers and D.C. mains valves. We have also received three useful booklets (1) "The Osram Valve Guide," giving full particulars of the complete range, including the new catkin valves; (2) a handbook of suggested circuits in which the latest types of valves can be successfully employed; and (3) "Osram Valves for Wireless Receivers," a tabulation of Osram valves suitable for a wide range of modern receivers made by various manufacturers, and for circuits devised by the Wireless Press. Copies of any of the leaflets or handbooks can be obtained from the General Electric Co., Ltd., Magnet House, Kingsway, London, W.C.2.

## "NEW RADIO FOR OLD"

Particulars of a Novel and Economical Method of Disposing of Unwanted Wireless Apparatus.

THE fact that wireless sets are liable to become obsolete so very quickly is one of the greatest deterrents to the amateur keeping abreast of all the latest developments. To keep entirely up-to-date entails the building or purchasing of at least one new set per year, whilst the enthusiastic amateur would undoubtedly prefer to change his receiver even more frequently than this. The trouble is that to do so more often than 28 entails the scrapping of a considerable amount of gear which is probably in perfectly good condition, and this represents a waste of money which few can afford. The difficulty of disposing of unwanted receivers or apparatus in an economical way was, however, solved some time ago by Messrs. Radialaddin, Ltd. (Dept. P.R.), 46, Brewer Street, London, W.1, and the methods of this firm have been keenly appreciated, by a tremendous number of wireless users.

The slogan of Messrs. Radialaddin, Ltd. is "New Radios for Old," and the idea is that they will make a generous allowance on old receivers and components in exchange for new ones. Any type of new wireless



In order to meet the requirements of readers who prefer to work from a full-size blueprint when building up any of the "Practical Wireless" Receivers, we can now supply full-size Blueprint Wiring Diagrams of all the "Practical Wireless" receivers for 1s. each, post free. When ordering, quote the number. Copies of the paper containing descriptions of the particular receiver cost 4d. each. Address orders to: The Publisher, George Newnes, Ltd., 8-11, Southampton Street, Strand, W.C.2.

## Blueprint. Receiver.

- No. 1. Dolphin Straight Three.
2. Long Range Express Three.
3. Mains Express Three.
4. Sonotone Four.
5. Bijou Three.
6. Argus Three.
7. Empire Short-Wave Three.
8. Solo Knob Three.
9. Midget Two (6d. only).
10. Selectone Battery Three.
11. Fury Four.
12. Featherweight Class B Four-valver.
13. Q.P.P. Three-Four.
14. Alpha Q.P.P. Three.
15. Ferrocart Q.P.P. Hi-Mag Three.
16. Supersonic Six.
17. Beta Universal Four.
18. A.C. Twin.
19. Selectone A.C. Radio-Gram Two.
20. A.C. Fury Four.
21. Radiopax Class B Four.
22. Three Valve Push-Pull Detector. (6d. only.)
23. Double Diode Triode Three.
24. Three-Star Nicore.
25. The D.C. Ace.
26. The Superset.
27. The Auto-B Three.
28. The All-Wave Two.
29. The A.C. Three.

apparatus can be obtained in this way, and it is only necessary to write to the above address, stating what kind of new material or set is required and giving details of the parts it is wished to dispose of, when a free quotation will be given at once. The offer is open to anyone in any part of the country, and the whole transaction can satisfactorily and speedily be effected through the post.

We know of several readers who have availed themselves of the efficient Radialaddin service, and in every case they have been entirely satisfied with the generous treatment received.

# ADVERTISEMENT INDEX

|  | Page          |
|--|---------------|
| Airlipse, Ltd.   | 962           |
| Automatic Coil Winder & Electrical Equipment Co., Ltd. | 933           |
| Belling & Lee, Ltd.                                    | 968           |
| British Ebonite Co., Ltd.                              | 947           |
| British General Manufacturing Co., Ltd.                | 956           |
| British Institute of Engineering Technology            | 964           |
| British Radiophone, Ltd.                               | Front Cover   |
| British Radio-Gramophone Co., Ltd.                     | 969           |
| Celestion, Ltd.  | 970           |
| Colvern, Ltd.  | 958           |
| Cosmocord, Ltd.  | 956           |
| Cossor, A. C., Ltd.                                    | 934           |
| Edison Swan Electric Co., Ltd.                         | 947           |
| Electrical Measuring Instruments Co., Ltd.             | 962           |
| Eugen Forbat (Ostar-Ganz)                              | 958           |
| Ever Ready Co. (Gt. Britain), Ltd.                     | 956           |
| Fluxite, Ltd.  | 968           |
| Gilbert, J. C.   | 969           |
| Graham Farish, Ltd.                                    | 961, 965, 967 |

|   | Page               |
|---|--------------------|
| Heyberd, F. C., & Co.                     | 964                |
| Heraud, E. J., Ltd.                       | 947                |
| High Vacuum Valve Co., Ltd.               | 964                |
| Igranite Electric Co., Ltd.               | Inside Front Cover |
| International Correspondence Schools      | 967                |
| King's Patent Agency, Ltd.                | 964                |
| Lectro Linx, Ltd.                         | 957                |
| Lissen, Ltd.                              | 943, 951           |
| London Radio Supply Co.                   | 957                |
| New Times Sales Co.                       | 963                |
| Newnes' "Home Mechanic"                   | Inside Back Cover  |
| Newnes' "Home Photographer"               | 958                |
| Newnes' "Tit-Bits"                        | Inside Back Cover  |
| Peto Scott, Ltd.                          | 955, 971           |
| Riverside Mfg. Co., Ltd.                  | 969                |
| Scientific Supply Stores (Wireless), Ltd. | 956                |
| The Columbia Graphophone Co., Ltd.        | Back Cover         |
| The 362 Radio Valve Co., Ltd.             | 947                |
| Trevor Pepper                             | 972                |
| Wilburn & Co.                             | 964                |
| Williams                                  | 964                |

## NEXT WEEK!

THE MOST STUPENDOUS OFFER EVER  
—AND Our Free Gift STEEL SPANNERS

The full range of catalogues describing  
**SERADEX PRODUCTS**  
will be sent on receipt of completed form:—

To TREVOR PEPPER, 575d Moseley Rd., Birmingham, 12.

Please place the following on your regular mailing list.

Name.....  
Address.....  
.....  
.....



Clearly written and fully illustrated.

## NEWNES' HOME MECHANIC BOOKS

This series covers a wide field and will prove of the greatest value to everyone interested in models and how to make them; woodwork and other crafts.

### ACCUMULATORS

An up-to-date handbook dealing with every type of accumulator, methods of charging them at home, care and maintenance, also explains how to erect a charging station.

### MOTOR CAR UPKEEP AND OVERHAUL

Information covering the engine, decarbonising, valve grinding, the lighting system, the carburettor, cooling system, lubrication, springs and shock absorbers, steering gear, brakes, wheels, axles, tracing noises, etc. etc.

### TOY MAKING FOR AMATEURS

How to make clockwork toys, model aeroplanes, model locomotives, model boats, ingenious toys operated by sand, wooden models and toys, electrical toys, steam toys, guns, kaleidoscopes, acrobats, etc.

### SIMPLE ELECTRICAL APPARATUS

An excellent little book for those who wish to make simple and useful electrical appliances, such as galvanometers, electric motors, dynamos and Leyden jars.

### MODEL BOAT BUILDING

Contains designs for battleship, speed boat, paddle steamer and yachts. Excellent models can be built with the simple directions and diagrams given.

### THE HOME WOODWORKER

Clear instructions on how to make a large variety of articles in wood, together with many useful hints on wood-working.

### MODEL AEROPLANES AND AIRSHIPS

Contains full descriptions of easy-to-make models of every description that will fly.

### THE HANDYMAN'S ENQUIRE WITHIN

Hundreds of practical ideas and hints of value to the man who is clever with his hands.

### 25 SIMPLE WORKING MODELS

Ingenious and practical designs for electric, steam and clock-work models.

**1/- each**

Obtainable at all Newsagents and Bookstalls, or by post 1/2 each from George Newnes, Ltd., 8-II, Southampton St., Strand, W.C.2.

Geo. Newnes, Ltd.

# 'LISTENERS IN'!

## LOOK UP YOUR WIRELESS LICENCE

### IT MAY BE WORTH £50

Compare your number and claim your reward

**£50** will be paid to holder of Licence No. AP 820624

**£25** will be paid to holders of Licences : Nos. AO 836174 AM 095040

**£10** will be paid to holders of Licences : Nos. AO 796222 AN 952893

**£5** Will be paid to holders of Licences : AK-189973 AO 059386 AL 262797 AQ 589937 AJ 421109

**£2** will be paid to holders of Licences :

|           |           |           |           |           |           |           |
|-----------|-----------|-----------|-----------|-----------|-----------|-----------|
| AH 247668 | AK 008847 | AM 604195 | AN 383298 | AO 058260 | AP 991022 | AP 638999 |
| AI 995333 | AK 395619 | AM 370846 | AN 162482 | AO 641866 | AP 736201 | AP 027812 |
| AJ 274860 | AM 95773  | AM 168758 | AN 434310 | AO 846725 | AP 054138 | AP 210255 |
| AJ 282942 | AM 544892 | AM 200002 | AN 061578 | AO 613999 | AP 947250 | AP 383936 |
| AJ 004515 | AM 950444 | AN 859755 | AN 239428 | AO 734900 | AP 120120 | AQ 697570 |
| AK 782140 | AM 801561 | AN 249600 | AN 933894 | AO 902843 | AP 692499 | AQ 308109 |

**£1** will be paid to holders of Licences :

|           |           |           |           |           |           |           |
|-----------|-----------|-----------|-----------|-----------|-----------|-----------|
| AH 963118 | AJ 973208 | AL 194283 | AN 712854 | AN 299500 | AO 073271 | AP 99604  |
| AH 646567 | AJ 331471 | AM 947637 | AN 021379 | AO 183100 | AO 371086 | AP 149080 |
| AH 726416 | AJ 858958 | AM 66661  | AN 108412 | AO 085113 | AO 458662 | AP 524966 |
| AI 421109 | AL 908318 | AM 063294 | AN 863448 | AO 944218 | AO 753762 | AP 246002 |
| AI 353862 | AL 839921 | AM 163007 | AN 525922 | AO 004622 | AP 943274 | AP 445709 |
| AI 778516 | AL 465100 | AM 699883 | AN 72389  | AO 849700 | AP 732219 | AP 367689 |
| AI 830002 | AL 35410  | AN 637111 | AN 238741 | AO 086592 | AP 415682 | AP 882524 |
| AJ 212866 | AL 685400 | AN 588925 | AN 496152 | AO 280694 | AP 221735 | AP 436600 |

This offer applies to licences which are actually in force on Saturday, September 16, 1933.

Before the awards are paid, claimants will be asked to undertake a simple publicity service in distributing leaflets to encourage the sale of licences amongst those who at present do not fulfil their obligations by taking out a Post Office Licence before receiving broadcast programmes. Claims cannot be considered in connection with any Licence the date of issue of which is after September 14, 1933.

For full particulars for claiming awards and a complete list of numbers see

# TIT-BITS

ON SALE EVERYWHERE SATURDAY SEPT. 16.



# 9,000 "HANDS" — MORE THAN EIGHTY ACRES OF FLOOR-SPACE... THE GREAT HIVE OF INDUSTRY WHERE COLUMBIA SETS ARE BORN!

● Huge, towering buildings of concrete, glass, and steel . . . as eloquent in their clean severity of line, as in their materials, keen, relentless modern efficiency . . .

What you see illustrated here is only a part of the great factory where Columbia sets are made—only a part of the largest and most up-to-date radio factory in the world. It is capable of

turning out with ease a thousand sets a day — six thousand a week. And yet with this tremendous production there is coupled the *most exact microscopic accuracy* in a thousand tiny details of each set, to give you the performance and finish the world expects from Columbia, at Columbia prices. Ask to hear any of the four Columbia models listed below at the nearest Columbia dealer.

*Columbia Battery Sets can be bought at prices as low as £4-4-0. Send coupon below for full particulars.*



Columbia

## Columbia RADIO AND RADIO-GRAPHOPHONES

**THE C.Q.A. BATTERY RADIOGRAPH FOUR, Model 1003**—the battery Radiogram with an all-mains performance: three-stage band-pass receiver. Columbia Constant Quality Amplification. 65 amp. hour L.T. battery. 175 v. H.T. battery including 9 v. G.B. Automatic flood-lighting of scales from switch M.W.-L.V.-Gram. Permanent magnet moving coil speaker. Marconi valves. Walnut cabinet of fine workmanship. **20 Gns.** (Prices not valid in I.F.S.)

**THE C.Q.A. BATTERY FOUR, Model 1001**—an entirely new standard of performance and economy from a battery set. Columbia Constant Quality Amplification. Triple action volume control. 60 amp. hour accumulator. 175 v. coded H.T. battery, including 9 v. G.B. battery. Marconi valves. Alternative Aerial tappings and pick-up connection. **11 Gns.**

**3-VALVE BATTERY SET, Model 1005.** A highly selective set with band-pass tuning, at an unusually low price. Inductively coupled band-pass aerial circuit. Screen grid, high-frequency amplifier. Permanent-magnet moving coil speaker. Single tuning knob for three gang condenser. Marconi valves. **£8. 15. 0**

**ALL-ELECTRIC RADIOGRAPH FOUR, Model 620**—a low-priced all-mains radiogram, embodying every modern development. Band-pass aerial circuit. Screen-grid high frequency amplifier. Energised moving-coil speaker Wave range, 200-550 med. and 1000-2,000 metres. Single knob tuning for three gang condenser. Volume control operating on radio and gramophone. Marconi valves. Fine walnut cabinet. **23 Gns.**

**COUPON :**

To The Columbia Graphophone Co. Ltd., 98 Clerkenwell Road, London, E.C.1.

Please send me particulars of the new Columbia models without obligation.

NAME .....

ADDRESS .....

PR. W.

P. W. Gift Stamp No. 51







# RADIOPHONE

## MATCHED PERFECTION

**YOU CAN'T GET BETTER than the Best!**

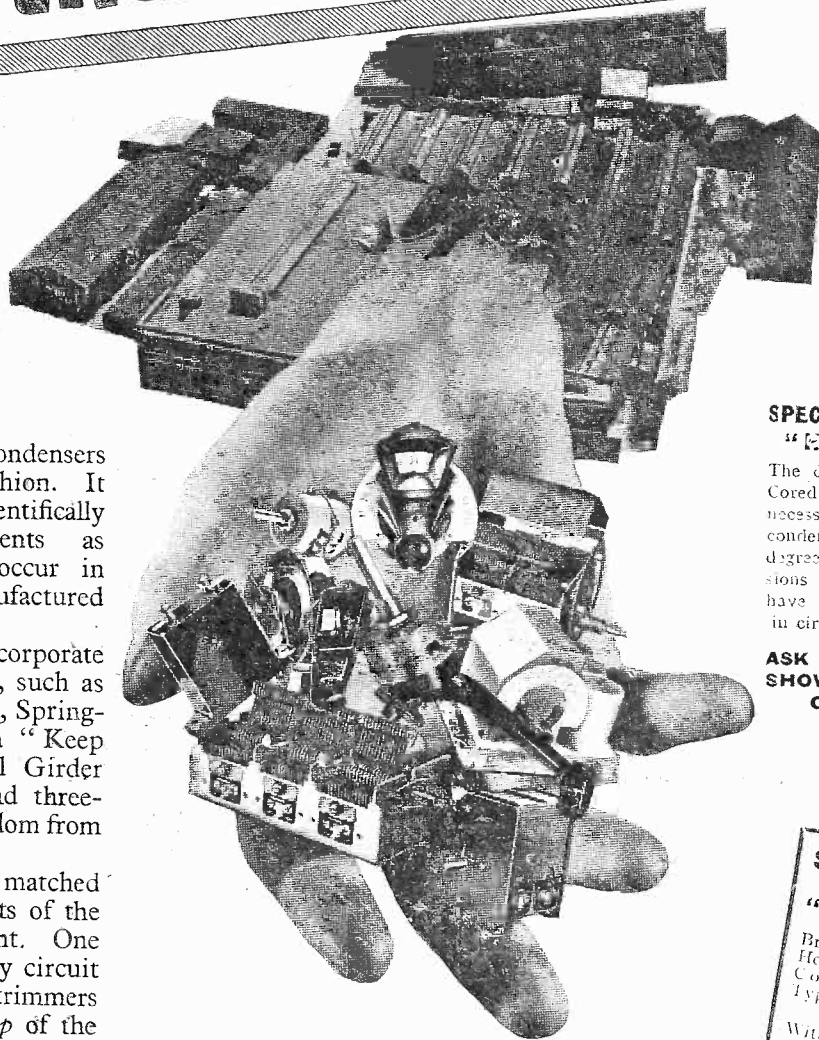

British Radiophone Ganged Condensers have consistently set the fashion. It is imperative to employ scientifically designed precision instruments as surprisingly big losses can occur in badly designed or poorly manufactured Condensers.

Radiophone Condensers incorporate many patented unique features, such as Radial Wedge assembly of vanes, Spring-loaded Tapered Bearings with "Keep Plate" Anchorage. The Steel Girder Frame method of assembly and three-point Suspension guarantee freedom from mechanical distortion.

Every Radiophone Condenser is matched section by section at SIX points of the tuning scale to within  $\frac{1}{2}$  per cent. One has only to balance out the stray circuit capacities with the aid of the trimmers conveniently provided at the top of the unit to ensure permanent MATCHED PERFECTION.

**SPECIALLY SUITABLE FOR "IRON CORED" COILS**

The delicate matching of "Iron Cored" Coils makes it more necessary than ever to employ condensers matched to the *nth* degree, hence the numerous occasions on which these condensers have been exclusively specified in circuits using these new coils.

**ASK YOUR DEALER TO SHOW YOU ONE—INSIST ON RADIOPHONE**

**SPECIFIED**  
for the  
**"PREMIER SUPER"**  
British Radiophone Super  
Hot Three Gang Midget  
Condenser  
Type 693. Price **22/6**  
With Full vision  
tuning dial **31/-**  
complete.

Write for list of components to :

**BRITISH RADIOPHONE LTD**  
ALDWYCH HOUSE, LONDON, W. C. 2 TELEPHONE: HOLBORN 6744



# BENJAMIN COMPONENTS

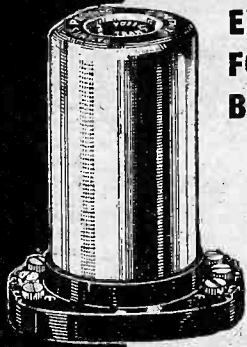

**EXCLUSIVELY SPECIFIED FOR SHORT-WAVE WORK BY CHIEF DESIGNERS.**

The Transfeeda has been officially specified by the designers of the "Experimenter Shortwave 3" on account of the pure distortionless amplification it affords in the L.F. Stage. The Transfeeda can be used to advantage in all your circuits as an efficient substitute to expensive transformers. Ratio 3 to 1. Price 11/6.

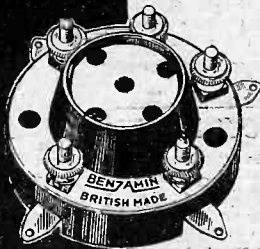

The Five Pin—Solid bakelite valveholder fitted with air-spaced nickel-silver self-cleaning contacts and easy wiring reversible terminals. Ideal for Short-wave sets. Price 10d.

## THE BENJAMIN ELECTRIC LTD

TARIFF ROAD, TOTTENHAM, N.17.

**MODEL No. 253:** A very modern Table Model radio cabinet with speaker combined. Inside measurements 24 in. long, 11 in. high, and 11 in. deep. Ample accommodation for H.T., L.T., and G.B. Batteries.

**PRICES:** Machined Kit of Parts, Oak 12/6, Mahogany or Walnut 15/-. Assembled Ready to Polish, Oak 17/6, Mahogany or Walnut £1. 0. 0. Assembled and Polished, Oak £1. 2. 6., Mahogany or Walnut £1. 5. 0. CARRIAGE PAID U.K.

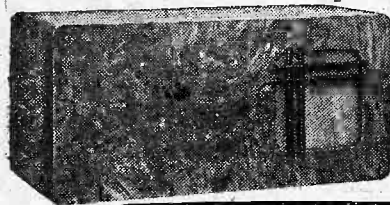

## a new modern Osborn cabinet

**NORTHERN NATIONAL RADIO EXHIBITION,** Manchester, September 27—October 7, Stand No. 75, Main Hall.

Sole manufacturers of the **OSBORN BAFFLE BOX**, 18in. by 18in. £1. 0. 0., 24in. by 24in. £2. 0. 0.

**WRITE FOR CATALOGUE**  
**CHAS. A. OSBORN** (Dept. P.), Regent Works, Arlington St., New North Road, London, N.1. Tel.: Clerkenwell 5095. Showrooms: 21, Essex Rd., Islington, N.1. Tel.: Clerkenwell 5634.

*An Invaluable Handbook*

# ACCUMULATORS

An up-to-date practical handbook dealing with every type of accumulator, methods of charging them at home, care and maintenance. This little handbook also explains how to erect a charging station.

This is one of

**Newnes' HOME MECHANIC Books**

Ask your Newsagent to show you other Titles in This

*Helpful Series*

Obtainable at all Booksellers, or by post 1/2 each from George Newnes, Ltd., 8-11, Southampton Street, Strand, London, W.C.2

1/- EACH



# EDISWAN

*The name that means 'EXCELLENCE'*

## Why EDISWAN H.T. will give you EXTRA service

Here is the answer. These special features clearly demonstrate Ediswan superiority. You can get Ediswan Batteries in all standard sizes, including portable types—Standard or Super Capacity—at the usual prices.

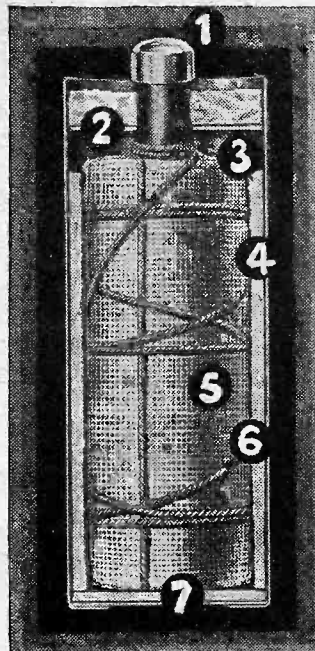

- 1 A brass cap tightly affixed to the carbon rod forms the positive connection.
- 2 The cell is sealed by means of a waxed washer over which paraffin wax is poured. This washer assists in centralising the sac in the cell.
- 3 An air space is left between the top of the sac and the washer to allow for the expansion of the electrolyte during discharge.
- 4 A substantial zinc container which forms the negative pole of the cell.
- 5 The sac consists of a highly efficient depolariser, tightly compressed round the carbon rod, the whole being securely wrapped and tied.
- 6 Electrolytic paste of a special chemical composition which fills the space between sac and zinc container and activates the cell.
- 7 A waxed paper disc which insulates the sac from the bottom of the zinc container.

# EDISWAN H.T. BATTERIES



THE EDISON SWAN ELECTRIC CO. LTD.  
PONDERS END, MIDDLESEX

**EDISWAN - the Better Service Batteries**



# A WONDERFUL RECEPTION



## for the NEW AMPLION SONETTE

It is not surprising that a speaker having so many virtues should arouse such enthusiasm amongst constructors.

The Amplion Sonette is the sturdiest and most compact little speaker ever offered. It gives a remarkable performance and the price is really something to write home about. Fitted with a universal transformer, it can be used for Power, Super Power, Pentode, Class "B," Q.P.P., and Push-pull.

SEE THE COMPLETE AMPLION RANGE AT STAND 34, TONMAN HALL, MANCHESTER.

The "M.C.22" Universal P.M. Speaker fitted with climate-proof cone. Will handle 5-6 watts undistorted A.C. Price 39/6

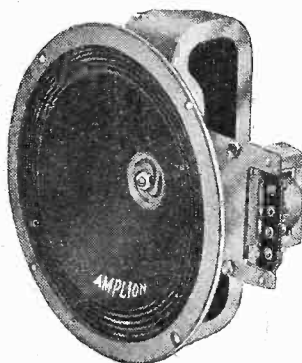

# AMPLION

AMPLION (1932), LTD., 82/84, ROSOMAN STREET, E.C.1.

## SUPERB "CLASS B" UNIT BUILT TO PRACTICAL WIRELESS DESIGN AND MATCHED TO ALL SPEAKERS

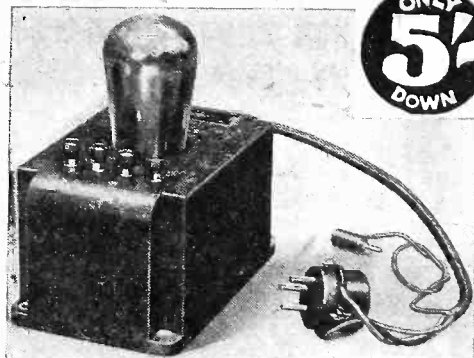

ONLY 5/- DOWN

The "SOUND UNIT" made by Sound Sales, Ltd. is offered by the famous Mail Order House of E. J. Heraud, Ltd., on straightforward easy terms. This "Class B" Unit is MADE EXACTLY TO THE DESIGN AND OF THE SPECIFIED COMPONENTS GIVEN BY MR. F. J. CANN, Editor of "Practical Wireless," in that journal, Apl. 8th. A most important point is that the Output Choke is "universal" and therefore this Unit is PROPERLY MATCHED to practically any Speaker. Fitting is simplicity itself; in 2 minutes your Set is accurately converted to "Class B."

SEND FOR IT ON 7 DAYS' TRIAL

### KIT OF COMPONENTS FOR BUILDING YOUR OWN UNIT

ONLY 5/- DEPOSIT

The Kit comprises all the exact components specified by Mr. Cann in "Practical Wireless," together with "Class B" Valve and FULL SIZE BLUE PRINT. The positions of everything are clearly marked, mistakes are absolutely impossible, and you have not to provide even a single screw. Built in an interesting half-hour!

Send only 5/- deposit, if satisfied, pay balance by 7 monthly payments of 5/- (Cash in 7 days, 35/-).

Send only 5/- for 7 days trial; if satisfied, balance by 9 monthly payments of 5/- (Cash in 7 days, 45/-). It comes to you carefully packed and carriage paid, complete with "Class B" Valve and full simple instructions. Note its small, neat size, 6 x 5 x 4", yet it will drive a full-sized moving-coil speaker to perfection, giving amazing volume from any battery set at extremely small use of H.T.

Send deposit to-day. PROMPT DELIVERY guaranteed, orders accepted in strict rotation.

E. J. HERAUD, Ltd., Dept. P.24, NUMBER ONE, EDMONTON, LONDON, N.18.  
Branches: 78/82, Fore St., Edmonton; 77, West Green Rd., Tottenham; 34, St. James St., Walthamstow; and 139, Hertford Rd., Enfield, Wash.

## Write for this new guide to Class 'B'

WRITE to-day for a free copy of this new Complete Guide to Class "B," which has just been published. It describes fully the theoretical and practical sides of Class "B" amplification and tells you all about the Multitone True Tone-Control Transformers, which save an extra 30% H.T. besides ensuring the best quality under all conditions.

TOCO TONE CONTROL TRANSFORMER Ratio 1/4 (saves an extra 30% H.T.) Price 17/6

Graded Potentiometer Price 3/6

BEPU DRIVER TRANSFORMER Ratios 1/1, 1.5/1, 2/1 High Power Efficiency over 85%. Very low overall secondary resistance 100 ohms. Price 9/6

PUCHOKE CENTRE-TAPPED CHOKE For matching any speaker to Class "B" output. Price 9/6

CLASS "B" CONVERTER UNIT Those who do not wish to interfere with the wiring of their present set can buy this simple unit. Just plug in adaptor to last valve stage and enjoy Class "B" advantages. Price 37/6 (less valve)

OR IN KIT FORM .. .. . 27/6

Write to Dept. H.

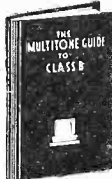

(72)

**MULTITONE**  
ELECTRIC COMPANY LIMITED  
95-98, White Lion Street, London, N.1. Terminus 5063

MULTITONE BRINGS SOUND TO LIFE!





**SUCCESSFUL CAREERS IN**

**180 page Guide to Careers FREE**

*J. D. C. Mackay  
Principal.*

**Commerce, Industry, Accountancy, Secretaryship, Shipping,  
Public Services, Banking, Insurance and Civil Service.**

## BRITAIN'S GREAT HIGHWAY TO SUCCESSFUL CAREERS

Not just a few, but literally thousands of School of Accountancy students have risen from the ranks to important, well-paid positions in Commerce, Industry, Banking, Insurance and Public Services at salaries ranging from £350 to £2,000 a year. They have achieved their successes as a definite and direct result of School of Accountancy Postal Training. Not only have these men and women, most of them of average intelligence and education, multiplied their salaries; they have also made their futures secure.

Many great Business Leaders strongly advise School of Accountancy training as the surest and quickest method by which ambitious men and women can achieve successful careers. Eminent University Lecturers who have examined our lessons and literature have publicly vouched for their efficiency and thoroughness.

If you will make an effort, by training at home in your spare time to qualify for a responsible position, The School of Accountancy will stand by you until you succeed.

*J. D. C. Mackay.*

## THE PROSPECTS FOR TRAINED MEN WERE NEVER BETTER

The need for a higher standard of ability and administration in Commerce and Industry is creating greater opportunities than ever for *trained* men and women who can apply more efficient methods of working and organising. Whilst the prospects of the untrained tend definitely to deteriorate, the prospects were never better for those who have the courage and enterprise to fall into step with the new conditions of business and to qualify, in their spare time, for higher-paid positions.

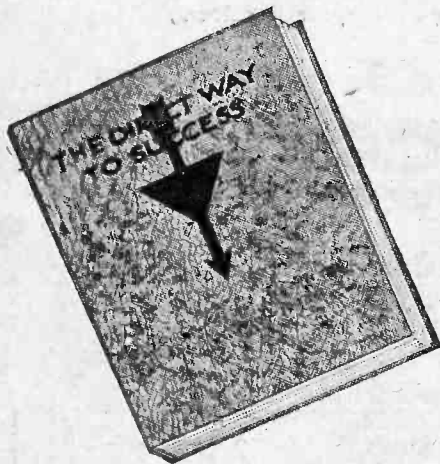

Write to-day for this free 180 page Guide to Careers.

### SPECIAL AUTUMN OFFER

For full particulars of a special Autumn offer, whereby students enrolling soon can obtain tuition at considerably reduced fees—see special note in the prospectus. Write for your copy to-day.

### CIVIL SERVICE CAREERS

Inspector of Taxes, Customs and Excise, Executive Class, Clerical Class, Post Office, Writing Assistants, Typists, etc. Age limits 15 to 24.

### This valuable 180 page Guide to Careers.

Some Chapters in the Guide: Advice from Business Leaders. How Office men and women can rise to appointments such as Accountants, Company Secretaries, Cost Accountants, Office Managers, Auditors, Cashiers, etc. How technical men can qualify as Commercial and Works Managers. How salesmen can climb to management positions. Courses for Youths and Young Ladies. Students' Success Reports certified by a Chartered Accountant. Opinions of eminent University Lecturers on The School's service. Tutorial Staff and Methods of training. The School's incomparable record of successes in the Accountancy, Secretarial, Banking, Insurance, Matriculation and Commercial Examinations. How the Principal's advice on the problem of your career can be obtained free.

● Civil Service Careers—Ask for Special Civil Service Guide.

# THE SCHOOL OF ACCOUNTANCY

55 Bush House, London, W.C.2



15 Regent House, Glasgow C.2  
Shell House, Johannesburg



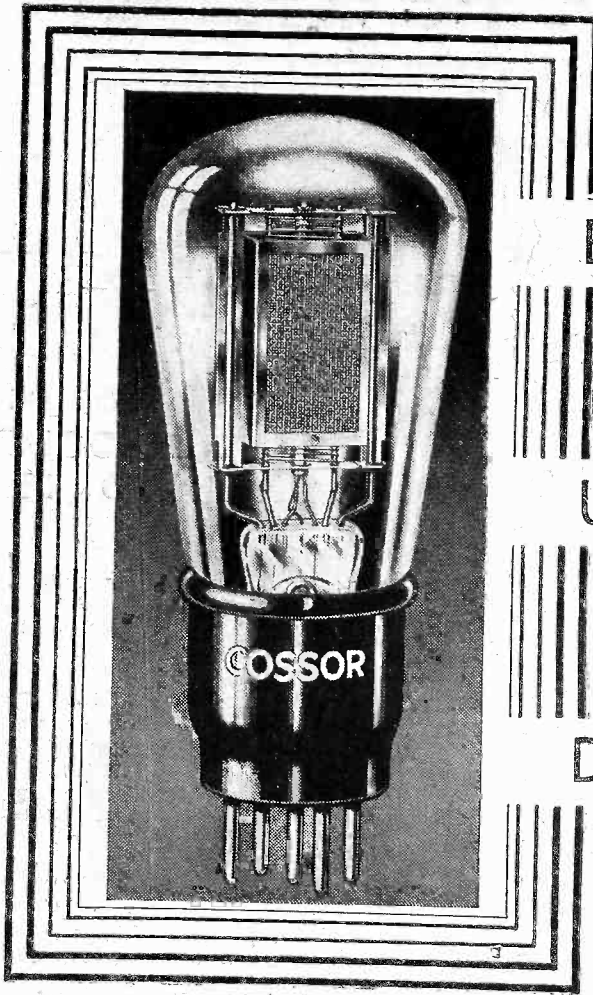

EFFICIENCY  
UNIFORMITY  
DEPENDABILITY

Variation of characteristics or of efficiency is definitely prevented in Cossor Mains Valves by the use of the famous Mica Bridge. This well-tried method of construction permits a degree of accuracy in assembly that ensures strict adherence

to characteristics, uniform efficiency and, due to the great mechanical strength it imparts to the electrode assembly, long and dependable service. Your dealer will be glad to help you choose the correct types for your Receiver.

COSSOR A.C. MAINS VALVES (4 Volt Indirectly Heated Cathodes)

| Type          | Purpose                         | Impedance | Amp. Factor | Mut. Cqn. m.a.v. | Price |
|---------------|---------------------------------|-----------|-------------|------------------|-------|
| *†M.S.G.-H.A. | Super H.F. Amp'n                | 500,000   | 1,000       | 2.0              | 17/6  |
| *41 M.S.G.    | Super H.F. Amp'n                | 400,000   | 1,000       | 2.5              | 17/6  |
| *†M.S.G.-L.A. | Super H.F. Amp'n                | 200,000   | 750         | 3.75             | 17/6  |
| †*M.V.S.G.    | Variable Mu                     | 200,000   | —           | 2.5              | 17/6  |
| *†M.S./PEN.-A | H.F. Pentode                    | —         | —           | 4.0              | 17/6  |
| *†M.S./PEN.   | H.F. Pentode                    | —         | —           | 2.8              | 17/6  |
| †*M.V.S./PEN. | Variable Mu                     | —         | —           | —                | —     |
|               | H.F. Pentode                    | —         | —           | 2.2              | 17/6  |
| *41 M.D.G.    | Bigrid                          | 40,000    | 10          | .25              | 19/-  |
| D.D./PEN.     | A.V.C. (Detector and L.F. Amp.) | —         | —           | 2.7              | 20/-  |
| *†D.D.T.      | A.V.C.                          | 17,000    | 41          | 2.4              | 15/6  |
| 41 M.R.C.     | R.C.C. or Det.                  | 19,500    | 50          | 2.6              | 14/-  |
| *41 M.H.      | Detector                        | 18,000    | 72          | 4.0              | 13/6  |
| 41 M.H.F.     | H.F. or Det.                    | 14,500    | 41          | 2.8              | 14/-  |
| *41 M.H.L.    | Det. or H.F.                    | 11,500    | 52          | 4.5              | 13/6  |
| 41 M.L.F.     | Low Frequency                   | 7,900     | 15          | 1.9              | 14/-  |
| 41 M.P.       | Normal Power                    | 2,500     | 18.7        | 7.5              | 14/-  |
| 41 M.X.P.     | Extra Power                     | 1,500     | 11.2        | 7.5              | 16/6  |
| M.P./PEN.     | Pen. Power Output               | —         | —           | 3.3              | 18/6  |
| †P.T. 41B     | Pen. Power Output               | —         | —           | 2.25             | 22/6  |
| †P.T. 41      | Pen. Power Output               | —         | —           | 3.0              | 18/6  |

\* Supplied with Plain or Metallised Bulbs. \*\* Stocked with Metallised Bulb only.  
† Characteristics measured at -1.5 Grid Volts. ‡ Directly heated filaments.

COSSOR D.C. MAINS VALVES (16 Volt 0.25 amp. Indirectly Heated Cathodes)

| Type       | Purpose         | Impedance | Amp. Factor | Mut. Con. m.a.v. | Price |
|------------|-----------------|-----------|-------------|------------------|-------|
| †*D.V.S.G. | Super H.F. Amp. | —         | —           | 2.5              | 17/6  |
| *D.H.L.    | Detector        | 13,000    | 58          | 4.5              | 13/6  |
| D.P./PEN.  | Power Pentode   | —         | —           | 3.5              | 18/6  |

\* Supplied with plain or metallised bulbs. † Characteristics measured at -1.5 grid volts.  
Prices in this List do not apply in I.F.S. All prices subject to alteration without notice.

**COSSOR**  
A.C. and D.C.  
MAINS VALVES

To A. C. COSSOR LTD., Melody Department, Highbury Grove, London, N.5.

Please send me, free of charge, a copy of the 64-page Cossor Valve Catalogue B.14.

Name .....

Address .....

PRAC. 23/9/33.



# THE "PREMIER SUPER"—THE BEST "HET" YET See Page 7



EDITOR :  
Vol. III. No. 53 || F. J. CAMM || Sept. 23rd, 1933.  
Technical Staff :  
W. J. Delaney,  
H. J. Barton Chapple, Wh.Sch., B.Sc. (Hons.), A.M.I.E.E.,  
Frank Preston, F.R.A., W. B. Richardson.

## ROUND *the* WORLD of WIRELESS

### Birthday Greetings

SINCERE thanks to all those readers who have taken the trouble to wish us Many Happy Returns on the occasion of our Birthday! We are quite sure that these good wishes are echoed by our contemporaries with perhaps a slight accent on the "returns."

It is a source of great pleasure to us to learn that we have supplied what the home constructor has needed for the past twelve years. We shall do our best in the second year of our history even to surpass our past year's record. Again, many thanks.

### Our Great Birthday Commemoration Scheme

TO commemorate our first year we have had specially designed and made the ingenious and handy Pocket Tool Kit which you see illustrated on the cover and on pages 31 to 33 of this week's issue, as well as in the centre of this page. You cannot obtain these tools in any other way, and they are all soundly made, accurate, and smoothly finished. They could not be purchased in the ordinary way for less than 12s. 6d. Those readers who care to avail themselves of this special Birthday offer should comply with the simple conditions given on pages 31 to 33 *without delay*, for, owing to the time taken to manufacture the tools, this offer cannot remain open for long. Notice that we have provided a recess beneath the Set Square for our Free Gift Spanners.

### Our Free Gift Spanners

THE two spanners given this week form the first two of a set of three. The largest spanner completing the set will be given next week. These spanners are made of steel, and are correctly proportioned according to the Engineering Standard Committee's recommendation. Additionally, they are accurate. Real reliable and unrivalled reader service again, you see!

### The World's Broadcasters

STATISTICS recently published by the U.I.R. (*Union Internationale de Radiodiffusion*), Geneva, show that whereas

there were 1,323 broadcasting transmitters operating in the world in 1931, the number had increased to 1,444 by the following year. In the first half of 1933 roughly 50 transmitters were added to the list, thus bringing up the number to a grand total approaching 1,500 stations.

## OUR GREAT BIRTHDAY OFFER! RESERVE YOURS TO-DAY!

See pages 31—33



### THE HANDIEST POCKET KIT OF TOOLS

This illustration shows the handy size and form of our Birthday Offer Tool Kit. It contains one four-inch Chesterman rule; one steel pocket scriber with chuck; one accurate 60-degree steel set square; a pair of ebonite test prods; one reflecting mirror for viewing obscure parts of the set; one set of trammels, with heads, for scribing, cutting holes in ebonite, etc.; one steel centre punch, and one handled screwdriver. The case is of metal finished in blue, and is specially reinforced with a metal-recessed bed into which the tools snugly fit. Owing to the extreme care used in manufacture and the length of time taken to produce these Kits, it is necessary for every reader to reserve without delay, as the offer is only available for a short time. Turn to pages 31 to 33 and comply with the conditions now!

### Farthest North?

THE Norwegian wireless telegraphy station LGV, at Vardö, has been equipped with broadcasting apparatus and is now testing on relays of the Oslo programmes on 800 metres (375 kilocycles). Vardö lies to the north of Varanger fjord, 137 miles east-south-east of North Cape; it is well within the arctic circle and in consequence the station may claim to be the "farthest north" transmitter in Europe.

### Overhauling the Short-Wavers

WITH a view to an improvement in the quality of transmissions from the Poznań (Poland) short-wave station on 31.6 m., broadcasts have been suspended until September 30th. In the same way UOR 2 Vienna, which for many months has been working on 49.4 m., has temporarily closed down. It is to be completely re-equipped with new plant to obtain increased power. No date for its re-opening has so far been fixed.

### Mexico's Fifty-ninth Station

WITH the re-opening of XEB, Mexico City—now a 10 kilowatt— the number of transmitters in the State of Mexico has almost reached the "60" mark. The new station, now operating on 291.3 m. (1,030 kc/s), is owned by a cigarette manufacturer and will devote the greater part of its daily programmes to publicity.

### Relays of Casino Concerts

LISTENERS to the Belgian and French studios may now hear programmes from kursaals and casinos in popular foreign seaside and watering places. By tuning to one or other of the Brussels transmitters on most evenings it is possible to pick up entertainments given at Ostend or at the Knocke-le-Zoute Casino. Radio Tou-

louse has also made arrangements to relay concerts from Biarritz on several dates in September at 9.0 p.m. B.S.T. Poste Parisien (Paris) in its turn takes you regularly over to Deauville, one of the most fashionable of French coastal resorts, and the French P.T.T. stations, including Eiffel Tower and Radio Strasbourg, frequently broadcast operatic works performed at Vichy-les-Bains.



# ROUND *the* WORLD of WIRELESS (Continued)

## Broadcasting on Ultra-Short Waves

**E**XPERIMENTS carried out at Amsterdam over a period of several months have clearly demonstrated the utility of short waves of the nature of seven to eight metres for the establishment of local broadcasting services. Tests proved that only a power of 300 watts was required for a good reception over small areas. Moreover, on these channels, it was found that static interference was almost non-existent. As the working range of these transmitters is strictly limited, neighbouring cities could use the same wavelength without any risk of mutual interference. In a band of frequencies from 40,000 (7.50 m.) to 38,460 kilocycles (7.80 m.) there is a difference of 1,540 kc/s, which is greater than the separation existing between 200 m. and 2,000 m. (actually only 1,350 kilocycles) or somewhat more than the entire broadcasting band. In effect, this would mean that the band would be sufficient to house with ease all the European transmitters provided for by the new Lucerne plan. The utilization of these short waves may result in the solution of many knotty problems in the development of wireless communications. In Holland, a scheme is being considered to link up Java with the neighbouring island of Bali in the Dutch East Indies by 7-metre transmissions. The depth of the sea in those districts is such that the laying of a special submarine cable for the purpose would be a much more expensive item than the installation of the necessary wireless transmitting and receiving plant.

## Lugano via Sottens

**D**URING the temporary suspension of the Monte Ceneri transmission concerts from the Lugano (Switzerland) studio will be broadcast through the Sottens station on 403.8 metres.

## America Calling

**T**HE success of the burlesque American programme recently presented by the B.B.C. has induced the organizers to offer another edition in November. In this instance it will take off a number of radio stars like the Mills Brothers and Ted Lewis, for which room could not be found in the original programme. The first broadcast was relayed to America through the Columbia system, and so amused were listeners on the other side that in their turn they are planning retaliation with a special entertainment which will include their impersonations of well-known British microphone artists. It is hoped that we shall be given an opportunity of hearing this version when it is presented.

## New Interval Signals

**B**OTH Brussels stations have adopted new and distinctive musical signals between items to identify themselves to their listeners. From Brussels No. 1 you now hear a short phrase (three bars only) of a melody by Grétry, a famous Walloon composer; Brussels No. 2, on the other hand, utilizes chimes giving an excerpt of an old song by Peter Benoit, the founder of the Flemish school of music. Whereas the 509-metre transmitter usually closes down with the playing of *La Brabançonne* (the Belgian National anthem), the

## INTERESTING and TOPICAL PARAGRAPHS

### A RADIO RECORD.

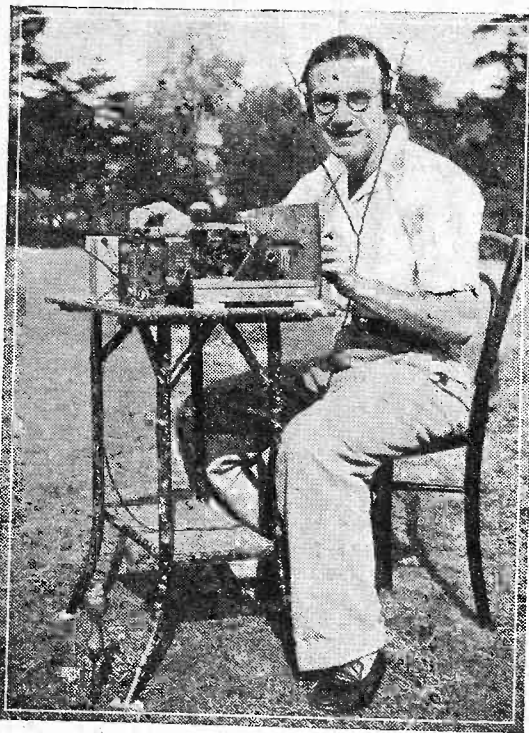

Two ultra-short-wave experimenters, Mr. Hilton O'Hefferman and Mr. T. E. Myatt, have broken the world's record for ultra-short-wave transmission. Mr. Myatt, at Hoddesdon, Herts, picked up the five-metre transmissions of Mr. O'Hefferman from Mount Snowdon, 200 miles away. The record distance for such transmission has previously been 160 miles. The photograph shows Mr. T. E. Myatt with his five-metre set.

337.8-metre station plays an old Flemish patriotic song: *De Vlaamsche Leeuw*.

## German Television Development

**O**NE of the most remarkable exhibits at the Berlin Radio Show was a new television projector exhibited by the *Fernseh A.G.* with which Baird Television (London) is associated. The picture produced by the instrument may be compared in quality to that of the average home cinematograph projector. The instrument uses a sensitive coated film on which the televised object has been photographed, and projects the picture on to a large screen. In this system the exposed film can be cleaned off and the celluloid used again for a different subject.

## Ici Bordeaux Lafayette

**T**HE French station you hear almost nightly on 304.9 metres immediately above North National is the PTT transmitter at Bordeaux. Although it frequently broadcasts its own studio programmes the bulk of its radio entertainment is relayed from *École Supérieure*, Paris. There is no interval signal, but at times a gong is struck at the end of an item. The full opening call is: *Ici la station du réseau français de radiodiffusion des Postes et Télégraphes de Bordeaux-Lafayette*. Fortunately for listeners who do not understand the French language the last two words are pronounced almost as written.

## Another Television System

**A**CCORDING to a report from New York, a San Francisco scientist, Philo Farnsworth, is said to have invented a new television system. The test transmissions would appear to have been perfectly successful, and in statements made by the inventor it is claimed that the means adopted make of the system a commercial proposition of high value.

## Notice to Short-Wave Fans

**F**ROM January 1st, 1934, as its call sign, Austria will take the International prefix OE instead of UO as hitherto. As an example, an amateur in that country now calling UOIDA would from that date take the call-letters OEIDA and UOR 2, Vienna, will be known as OER 2.

## Alteration in German Wavelength

**T**HE new 1½ kilowatt Hanover relay station was formally opened on August 13th last; it now works on a common wavelength with Flensburg, namely, 227.4 m. (1,319 kc/s). With the closing down of the old station operating on 566 metres it is now possible to pick up broadcasts from Wilno (Poland) on 563 m. without any interference.

## Berlin's New High-Power Station

**T**HE 100 kilowatt transmitter now in course of construction at Berlin and which is destined to replace the weaker Witzleben station may possibly be ready by the Christmas holidays. According to the new wavelength plan it will work on 356.7 metres (841 kilocycles) thus displacing from this position London Regional, which will drop to 342.1 metres (877 kc/s). With a separation of 36 kilocycles between them there should be no mutual interference.

## SOLVE THIS!

### Problem No. 53.

Blenkinsop wished to make up an output transformer to suit his particular valve and speaker, and, using the Data Sheets presented in various issues of PRACTICAL WIRELESS, he found the gauge of wire, transformer stampings, etc. He ascertained the ratio of the transformer required by taking the square root of the valve impedance divided by the speaker impedance, and built up quite a good transformer. When tested, results were not up to his expectations. The windings were found intact, correct according to all his figures, and no shorts or other faults appeared to exist. What was wrong? Three books will be awarded for the first three correct solutions opened. Address your attempt to The Editor, PRACTICAL WIRELESS, Geo. Newnes, Ltd., 8-11, Southampton Street, Strand, London, W.C.2. All entries must be received not later than September 25th, and envelopes must be marked Problem No. 53.

### SOLUTION TO PROBLEM No. 52.

The trouble with Arnolds' set was due to the smoothing condenser in the mains equipment breaking down. A short circuit was accordingly introduced across the secondary windings of the mains transformer, resulting in overloading of the rectifier valve and the consequent lack of H.T. voltage to the receiver proper.

The following three readers gave correct solutions to this Problem, and books have accordingly been forwarded to them:—

A. L. Beedle, 15a, Fontenoy Road, Balham, S.W.12; C. L. Philips, Runnymede, Hawkwell Chase, Hockley, Essex; G. Day, 24, Collindale Avenue, Brith, Kent.



# Building the PREMIER SUPER

A ★ SET AND THE BEST SUPERHETERODYNE EVER PLACED BEFORE HOME CONSTRUCTORS.

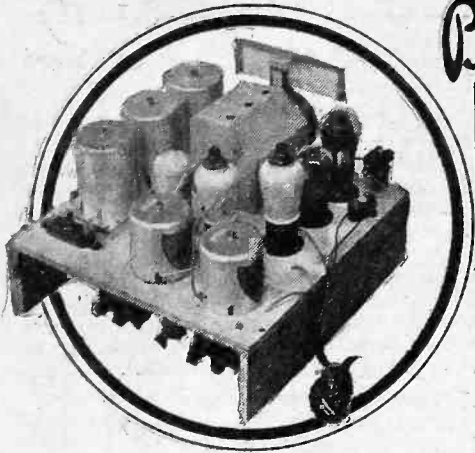

An Entirely New Five-valve Superheterodyne of High Efficiency and Low Cost. Specially Designed for Our Birthday Number. By The Technical Staff.

THE Wireless Exhibitions at Olympia and Glasgow have given us a unique opportunity of meeting a very large number of our readers and learning what kinds of receiver appeal to them most strongly. At both Exhibitions we have been asked many times if we would publish details of a really efficient battery-operated superheterodyne of a type suited for use with an outside aerial. To these inquirers we have said that we had such a receiver on our test bench, and that as soon as we were satisfied that it was better than any other similar instrument which had previously been described we should publish full details. Our tests are now completed, and we offer the results to our readers in the form of a five-valve superheterodyne, which we feel is worthy of the seal of perfection which the PRACTICAL WIRELESS guarantee automatically bestows upon it.

been carefully considered, for it was realized that the set would appeal not only to the experimenter, but also to hundreds of new readers who have never before built a receiver of their own. Nevertheless,



“Premier Super” demonstrates in a practical manner that it is neither. Some have always regarded the superheterodyne as an expensive piece of apparatus; the fact that this new PRACTICAL WIRELESS receiver can be built for just over £14 0 0, including cabinet, batteries, valves, and moving-coil loud-speaker, or for £6 12 6 for the bare receiver, proves the fallacy of that idea.

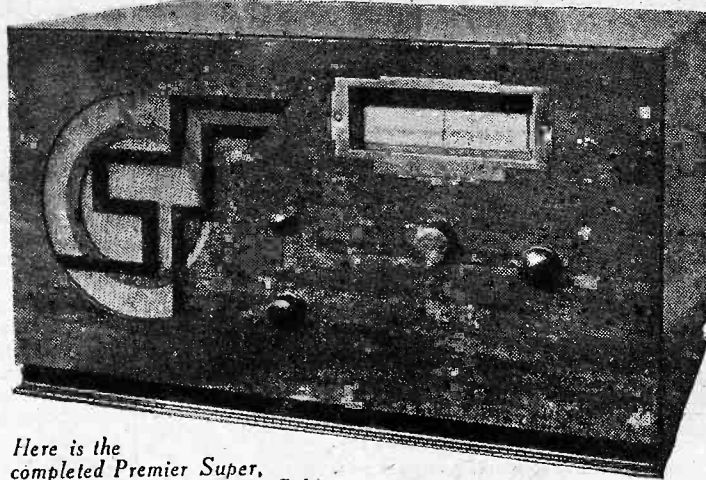

Here is the completed Premier Super, in its modern Peto-Scott Cabinet.

**Special Features**

Before proceeding with the practical constructional details it will be well briefly to mention some of the practical features that have been incorporated in the set. Perhaps the most important of these concerns the use of a metallized chassis. All PRACTICAL WIRELESS sets, right from Number I, have been built on the chassis principle, since this has proved to show innumerable advantages over the use of a flat baseboard. The set can be made more compact, a much “cleaner” appearance is secured and

The “Premier Super” is entirely free from those defects which have been responsible for our not describing a superheterodyne of this type previously. It is tuned by means of a single knob; requires no difficult preliminary “trimming” and “balancing” adjustments; is free from heterodyne whistles; gives real “quality” reproduction; is delightfully easy to build; is economical in the way of battery current, and can be built very cheaply. It need scarcely be mentioned that the degree of selectivity is as good as it is possible to obtain with any type of receiver when good quality reproduction is insisted upon. Combined with these advantages are those of excellent appearance and compactness.

this simplicity has not been secured at the expense of efficiency, but, instead, the two qualities have been combined.

We know that many readers have in the past avoided the superheterodyne receiver because they were under the impression that it was tricky and involved; the

utmost efficiency can be obtained because the wiring is reduced in length whilst the components can be better disposed. Just as PRACTICAL WIRELESS set the fashion a year ago by adopting chassis construction as standard, so have we more recently made our receivers still better by

being the first to use the “Metaplex” chassis. This latter has but recently been available, and although it is made of wood and thus has all the advantages of easy working, it is specially sprayed with metal, under high pressure, so that it also has the advantages of metal, being a perfect conductor. Not only does the metallized chassis act as a screen, therefore, but it can also be used for “earth return” leads, thus considerably simplifying the task of wiring.

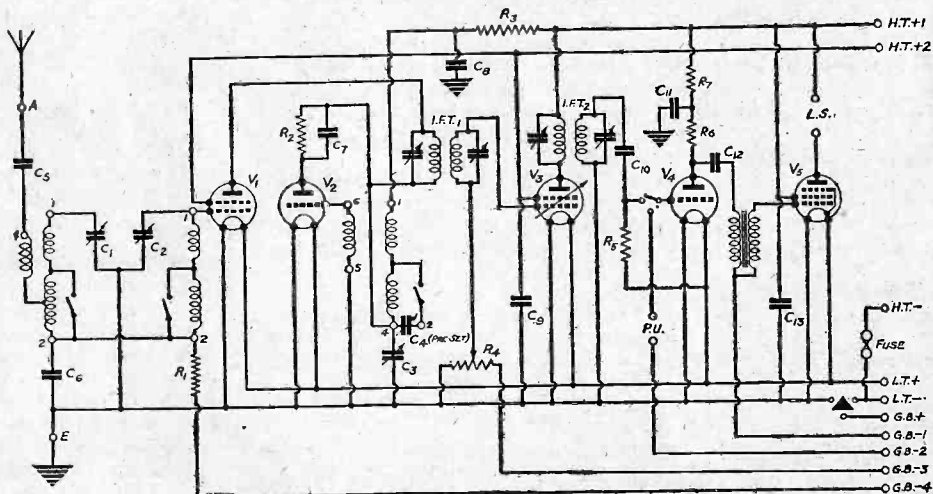

Theoretical circuit of the Premier Super.

**Extreme Simplicity**  
It will be evident from the photographs on this page that simplicity and ease of construction have

(Continued overleaf)



# HIGHLY SELECTIVE—LOW PRICED—SINGLE-KNOB TUNING

Some readers will perhaps question the use of air-core coils, now that iron-core ones are available in nearly every make. The point is that iron-core coils are not necessary in a superheterodyne, because an ample degree of selectivity can be obtained without

anode bend principle, the second is the oscillator, whilst the single variable-mu intermediate frequency amplifier comes next. This is followed by a three-electrode second detector acting as leaky-grid rectifier, and this feeds into the pentode output valve. Band-pass tuning is employed in the aerial circuit to prevent the possibility of second channel or other form of interference, and this is tuned by two sections of a three-gang condenser of which the third

(which has specially-shaped vanes to ensure proper "tracking"), tunes the oscillator coil. Two band-pass intermediate frequency transformers are used to couple together the first detector and I.F. valve, and the I.F. and second detector respectively. These transformers have a pre-set condenser connected across each winding, but as this is accurately adjusted by the makers before leaving the factory it does not need to be touched by the constructor.

Perfect volume control is obtained by

**NO TRICKY ADJUSTMENTS OF  
ANY KIND AND—  
IT'S GUARANTEED!**

adjusting the grid-bias to the variable-mu intermediate frequency amplifier by means of a 50,000 ohm potentiometer. A radiogram change-over switch is included in the grid circuit of the second detector so that a pick-up can easily be brought into circuit

when required. To ensure an ample bass response and to obtain the maximum amount of amplification between the second detector and the pentode the L.F. transformer is resistance coupled.

## Battery or Eliminator Operation

Ample decoupling is provided throughout the receiver and only two H.T. positive leads are required. Thus the set can be operated from batteries in the ordinary way, or from practically any type of eliminator giving an output of about 15 milliamps at 120 volts. Actually, the anode current consumption varies between about 11 and 15 milliamps, according to the setting of the volume control.

## Assembling the Components

A complete list of components is given below, and the first step is to obtain all the parts listed. Please do not think that any other similar components will serve; in rare instances they might, but it is unlikely that they will be so good as those around which the circuit was designed, and in any case our guarantee would not apply. The metallized chassis is supplied all ready drilled to receive the valve-holders and other parts, so all you have to do is to mount them in the positions indicated in the wiring plans. It will be found best to carry out the work in a systematic manner by first screwing down the valve-holders, then mounting the components on the under side of the chassis and leaving until last the coil assembly, intermediate frequency transformers, and three-gang tuning condenser. No special instructions are necessary in regard to the method of mounting, since every component is attached in a straightforward manner by means of suitable screws. These latter are supplied with the kits of parts advertised on other pages of this issue, but for those who prefer to buy separate parts locally it might be mentioned that about one and a half dozen  $\frac{1}{16}$  in. screws are needed and approximately two dozen  $\frac{1}{8}$  in. ones. It will be noticed that the two grid-bias battery clips are attached to one of the chassis side members; they can be dealt with without dismantling the chassis, but it will be found somewhat easier to remove the side member by taking out the three screws by means of which it is attached to the baseboard.

## The Wiring

The wiring need present no difficulty at all so long as some sequence is followed.

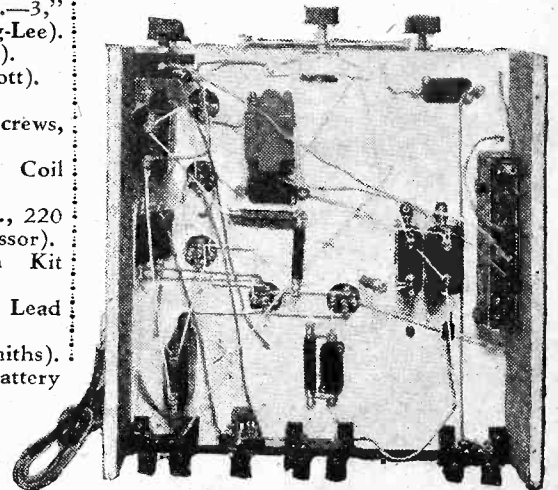

The simplicity of wiring is evident from this illustration.

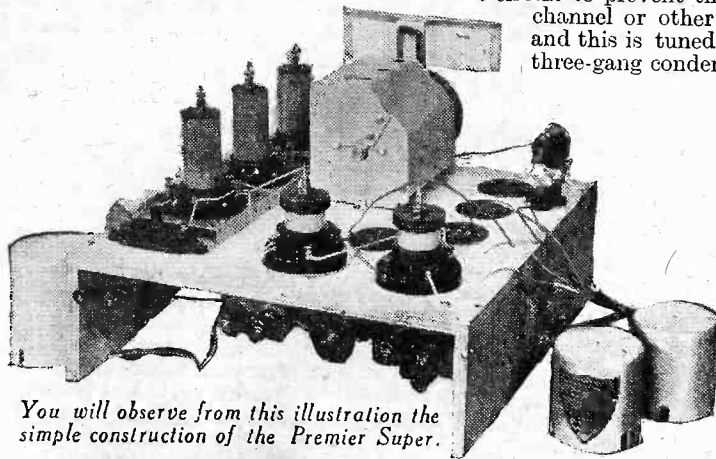

You will observe from this illustration the simple construction of the Premier Super.

them, and we have found that they do not confer any advantages whatever. In fact, our experiments have shown that air-core coils are slightly better in a band-pass circuit, due to the fact that they can be "matched" more easily, and with a better degree of accuracy. There is also another point which is too important to overlook; that is that air-core coils are appreciably cheaper.

## A Tested and Reliable Circuit

It will be obvious from a cursory examination of the circuit diagram that there are no "stunt" arrangements, or, in fact, any items which have not been fully proved in practice. Of the five valves, the first is a screened-grid first detector working on the

## LIST OF PARTS FOR THE PREMIER SUPER.

Don't depart from these specially selected components.

- One Superhet 3-gang Midget Variable Condenser, Type 693, with Straight Line Dial (British Radiophone).
- One Set Matched Superheterodyne Coils (2 Bandpass and Oscillator) (Lissen).
- Two Intermediate Frequency Transformers (Lissen).
- One 50,000 ohm Volume Control Potentiometer, Type V.C.36 (Bulgin).
- One 3-point Switch, Type 48 (British Radiogram).
- One Push-Pull Radio Gram. Switch, Type 50 (British Radiogram).
- Three Chassis Brackets, Type 21 (British Radiogram).
- One "Pip"  $\frac{3}{1}$  L.F. Transformer (Graham Farish).
- Six "Ohmite" Resistances—2,000 ohms, 10,000 ohms, 20,000 ohms, 30,000 ohms, 100,000 ohms, and 2 megohms (Graham Farish).
- Two .1 mfd. Condensers, Type B.B. (Dubilier).
- Two 2 mfd. Condensers, Type B.B. (Dubilier).
- One .0001 mfd. Condenser, Type 670 (Dubilier).
- One .0002 mfd. Condenser, Type 670 (Dubilier).
- Two .01 mfd. Condensers, Type 670 (Dubilier).
- One .002 mfd. Pre-Set Condenser (Polar).
- Four 4-pin Chassis Mounting Valveholders (Clix).
- One 5-pin Chassis Mounting Valveholder (Clix).
- Three Terminal Mounts (Belling-Lee).
- Six Terminals, Type "R," marked "A," "E," "L.S.," "L.S.+" and two marked "Pick Up" (Belling-Lee).
- Six Wander Plugs, (marked "G.B.+," "G.B.-1," "G.B.-2," "G.B.-3," "G.B.-4," and "G.B.-5" (Belling-Lee).
- One "Metaplex" Chassis (Peto-Scott).
- One Premier Super Cabinet (Peto-Scott).
- One Fuse Holder and Fuse (Bulgin).
- Two Coils Quickwire, length of Flex, Screws, etc. (Bulgin).
- One P.M.6 "Microlode" Moving Coil Speaker (W.B.).
- Five Valves Types 215 S.G., 210 H.L., 220 V.S., 210 Det., and 220 H.P.T. (Cossor).
- One "Aeroficient" Aerial Earth Kit (Graham Farish).
- One Length Metal Screened Down Lead (Goltone).
- One 2-volt 40 amp. Accumulator (Smiths).
- One 9-volt G.B. "Anodex" Battery (Smiths).
- One 120 volt Triple "Anodex" H.T. Battery (Smiths).
- One Baffle Baseboard Assembly (Peto-Scott).



# SUPERB QUALITY—LONG RANGE—ONLY 5 VALVES

Thus you should commence by joining together the filament pins of all the valve-holders. After that, start at the aerial "end" and work right through the set to the loud-speaker terminals. If you are new to set construction you will probably find it a good plan to cross off, or mark in some way, every wire on the wiring plan as you put it into the set. Practically all the connections are made by looping the bare end of the wire to fit over the terminal, but in one case a soldered contact is used to prevent the use of an unduly long lead. If you cannot lay hands on a soldering

and then attached to the base of the cabinet by means of four 1/4 in. screws, making sure that the baffle fits closely against the fret in the front of the cabinet.

You can now get along with the construction of the "Premier Super."

first detector (through plug "G.B.—4"), but the optimum voltage is best found by trial.

Should it be decided that 1 1/2 volts gives best results, the two flexible leads to plugs 2 and 4 can be joined to the same wander plug.



## TOP AND SUB-BASEBOARD WIRING DIAGRAM OF THE PREMIER SUPER.

### Connecting and Adjusting.

Next week we shall give you full particulars in regard to the method of making the few simple preliminary adjustments which are required and will describe in detail just how the best results can be obtained. For the benefit of those readers who are more experienced, however, and who finish the constructional work before next week's issue is available, the following notes respecting the most suitable voltages will perhaps prove useful. The grid bias battery should first of all be fitted into the clips which are mounted on the underside of the chassis, when the "G.B.—1" plug should be inserted in the corresponding socket. Put plug "G.B.—1" (which is that supplying the pentode) into the 4 1/2 volt socket; put the "G.B.—2" plug (that for the pick-up) into the 1 1/2 volt socket; insert plug "G.B.—3," which is that for the variable-mu intermediate frequency amplifier, into the maximum (9 volt) socket and try the fourth "G.B.—" plug first of all in the 3-volt socket. After trying out the receiver it might be found that better results can be obtained by applying 1 1/2 volts negative to the grid of the

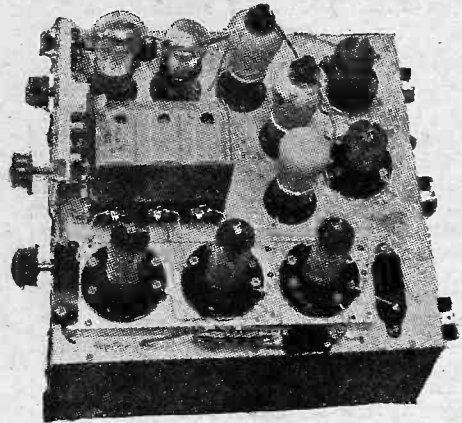
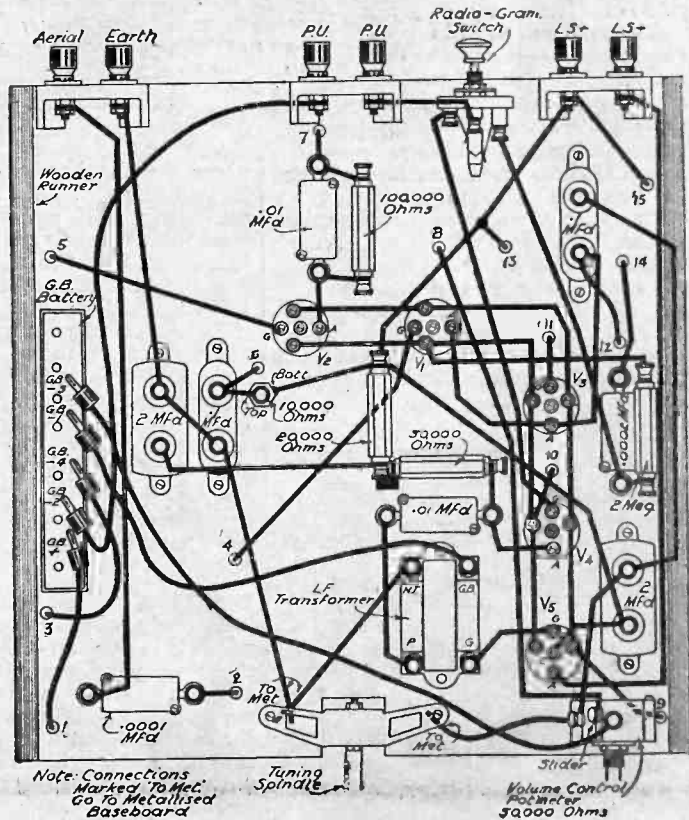
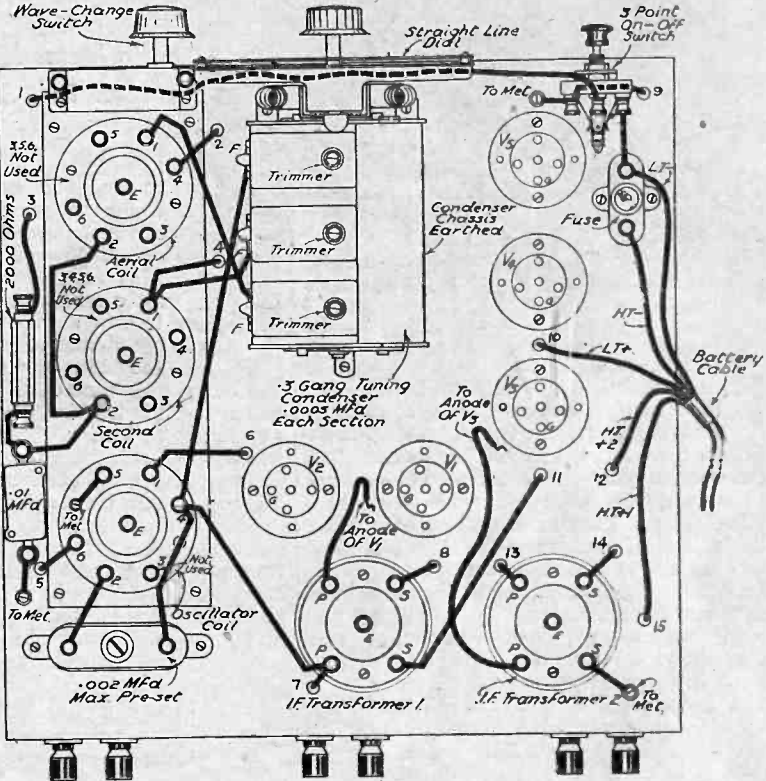

Note the clean layout of the Premier Super.

iron, this connection can be made by looping the wire and nipping the joint up tightly with a pair of pliers. You will notice that several wires are secured under the heads of screws attached to the chassis; these are "earth return" leads and by connecting them in this way a good deal of extra wiring is avoided. A few other similar connections are made to the foot of the tuning dial underneath the chassis. The ends of wire are simply bared for a short distance and slipped under the metal strip forming the foot before the securing screws are finally tightened down. Notice carefully the connections to the push-pull radio-gram switch attached to a component bracket at the rear of the chassis. There are three terminals on this component, and they are in contact with three flat springs of different lengths. The terminal on the shortest spring is joined to the pick-up terminal; the next one connects up with the grid terminal on the second detector valve-holder, whilst the terminal on the longest spring is connected to the grid condenser. Short lengths of flex are used for the grid-bias battery tapplings and also for the anode terminal connections to the screened-grid and variable-mu valves; all these should be just long enough to connect up to the appropriate points and should not be allowed to stray about among the other wiring.

The special cabinet specified is supplied ready drilled to receive all the controls and also the tuning condenser escutcheon, so that there will be no difficulty whatever in fitting the set provided that care has been taken in following the dimensions given in the wiring plans. The loud-speaker is first screwed to the baffle board

**CAREFULLY DESIGNED FOR YOUR BENEFIT AND BACKED BY OUR GUARANTEE.**

Note: Connections Marked "To Met." Go To Metallised Baseboard

Volume Control Resistor 50000 Ohms



# RADIO-GRAM MOTORS

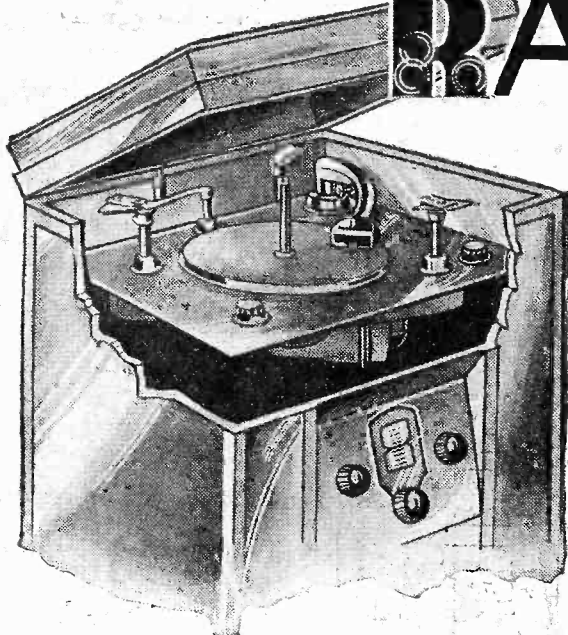

The Purpose of This Article is to Help Readers in Their Choice of a Motor for Radiogram Work and, After They Have Obtained the Motor Best Suited to Their Requirements, to Give Some Hints on Its Proper Maintenance.

By ALFRED J. POTTS

It is greatly to be regretted that far too many owners of gramophone motors, particularly of the spring-driven type, have the fixed impression that once put in place the motor needs no attention whatever. Not only this, but they blissfully continue to use the motor after it is out of condition until the spring breaks, when, of course, something has to be done. Would you, on having bought a new car, keep on using it until it would not work satisfactorily and would not run smoothly? Why, then, do this with your gramophone motor?

A further point that is of great importance but which is frequently overlooked is that if the motor does not carry out its required work smoothly and efficiently, then the best pick-up and amplifier ever designed cannot give good, clear and undistorted reproduction. This point will become obvious when the explanations given later in this article have been considered.

First to choose the type of motor to be used. Those with electric light are in the fortunate position of having an enormous choice of really good motors, but great care has to be used if a satisfactory choice is to be made.

As it would take a great deal of space to explain all the advantages and disadvantages of the various types of motors, I will give just a short description of each which will aid the reader in his choice of type.

### The Synchronous Motor

The simplest and, incidentally, cheapest form of electric gramophone motor is, of

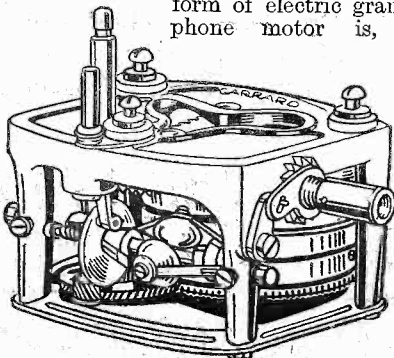

A clockwork driven apparatus.

course, the synchronous type which makes use of the frequency of the A.C. mains to keep it at a constant speed of seventy-eight. This is, of course, very useful, since many people seem unable to run a record at its proper speed and always run it either too slow or too fast, generally the latter, owing, no doubt, to the fact that when the pitch rises the output volume appears to be louder. It should be remembered, however, that this type of motor has only the flywheel effect of the turntable to keep it at a constant speed and that it depends very much upon its design to be efficient for satisfactory results. In addition to this, it must be remembered that most of these motors have to be started with the finger, "to put them " in

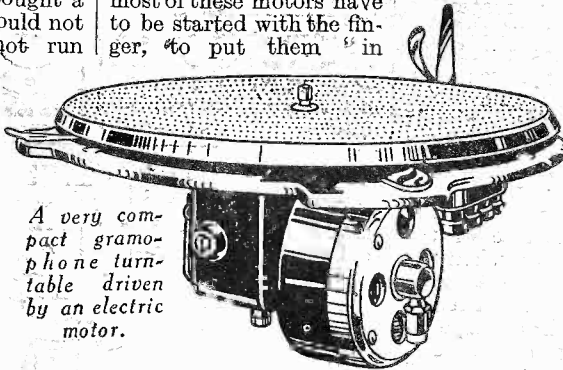

A very compact gramophone turntable driven by an electric motor.

phase" with the electricity supply before they will go at all. This motor is only suitable for A.C. mains.

There is then the universal motor, which can be used on either A.C. or D.C. mains, and which, if of good design, can be very efficient. These motors have a speed regulation of similar nature to a spring-driven motor. Some hints on regulating the speed of all these types of motors being described will be given later in this article. The great trouble in this type of motor which has to be looked out for is sparking, but most motors made by good reliable firms are free from this trouble.

### The Induction Motor

The only other type of motor which is in demand is the induction type, which again often has a speed regulation and was mainly designed to overcome the commutator sparking which is sometimes troublesome in the universal type. This type of motor can, of course, only be used on A.C. mains.

Various other types of electric motors have been brought out, but the three types described above are among the best available and are the most popular types.

Many of us are not fortunate enough to have electric light and many, whose pockets are not very deep, cannot afford the extra expense of the mains-driven motor. It should always be kept in mind, too, that even if you are in the happy position of having the mains, a good spring-driven motor is far better than a cheap electrical one.

The choice of a spring motor is just as important as an electric one, and since there is rather more liability in the spring motor for mechanical faults, cheap motors should be definitely put aside. When possible, a double spring motor, or even a triple spring one, should always be used for the following reasons. Many people are under the impression that the governor keeps the speed of the motor *absolutely* constant. This is not quite true, for this reason.

The governor's duty in the motor is to take the main load of the driving spring. Therefore it is quite easy to see that even if no record is being played, when the motor is fully wound up the pressure on the governor is considerably greater than when it is nearly run down. Thus when a record is being played this fault is emphasized considerably owing to the extra pull on loud passages. Since this fault is more noticeable when the motor is nearly run down, it will be seen that it is better for this reason to purchase a double or triple spring motor as, of course, the period in which it is "nearly run down" is lessened to a half and third respectively. A further important reason for the use of the more powerful types of motor is that the tendency

(Continued on page 16)

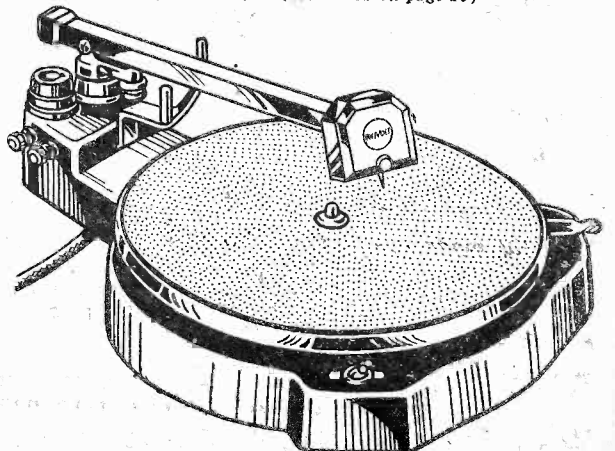

A synchronous turntable showing how compact this apparatus becomes.



# ACCURATE MATCHING AT LAST!



● 17 transformer ratios for really accurate matching to ANY power valve or pentode and 4 ratios for Class B or Q.P.P. all available on one speaker by a simple switch adjustment!

● Added sensitivity due to the "Mansfield" magnetic system! Better balance through really accurate matching! The difference in performance must be heard to be believed.



We are exhibiting at the Manchester Radio Exhibition Sept. 27 - Oct. 7.

"Did you notice 'Practical Wireless' says the 'Microlode' was probably the high spot of Radiolympia?"

"I can quite believe it. Perfect matching has certainly made a difference to my set."

|          |     |     |          |      |
|----------|-----|-----|----------|------|
| W.B.PM4A | ... | ... | Complete | 42/- |
| W.B.PM6  | ... | ... | Complete | 32/6 |

With the new "Microlode" feature and the "Mansfield" magnetic system. There are other models. Have you a copy of the new "Microlode" folder? If not write now.

## AND ONE TYPE SUITS ANY OUTPUT

All the important new constructor sets specify a W.B. "Microlode" either solely or as a first choice

Whiteley Electrical Radio Co., Ltd., Dept. D, Radio Works, Mansfield, Notts.  
 Sole Agents in Scotland: Radiovision Ltd., 233, St. Vincent St., Glasgow, C.2  
 Sole Agents in I.F.S.: Kelly & Shiel, Ltd., 47, Fleet Street, Dublin.



# FIRST DETAILS OF A NEW OUTPUT VALVE

## VALVE

By LAMBDA

THE subject under discussion was valves and valve progress—opinions were divided—finality had definitely been reached and no further developments were possible was the opinion of the majority. There could not be any revolutionary designs for some time to come, they said. The Radio Exhibition at Olympia had not produced any surprises. Class B and H.F. Pentodes were in evidence and the Pentagrid or Hexode would shortly be available for the constructor.

Apart from these valves with which we are fairly familiar, there did not seem to be any further developments forthcoming. However, history tells us that the opinions of the majority are not always correct, and now still further valve improvements have once again proved them to be mistaken.

It is a rather interesting fact that the recent valve developments seem to alternate between this country and America. The Q.P.P. system and the Catkin valve were

extent, perform the same service for the owner of small mains sets, but with the added advantage that it will not be necessary to

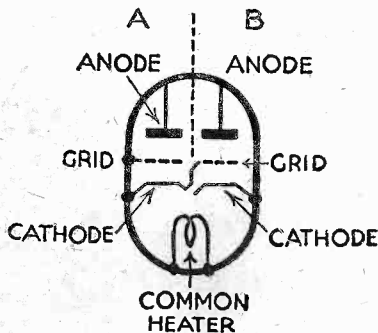

Fig. 1.—The electrode connections of the new valve.

employ a driver valve or special input transformer.

### Two in One

The theoretical circuit of the new valve is shown in Fig. 1, notice the two sets of triode elements mounted side by side using a common heater, but electrically separate cathodes. An unusual feature of this valve is the tying of the cathode of the first portion to the grid of the second portion. In order to understand its functions the diagram has been divided by means of the dotted line and the sections have been marked A and B respectively. The elements marked A are the input and those marked B the output, and the circuit arrangements are shown in Fig. 2.

### Biasing Arrangements

The bias for the first portion is provided by the resistance  $R_1$ , which is also part of the load for the triode A. We have already mentioned that the cathode was tied to the grid of the output triode B, therefore the voltage drop across this resistance puts the output section at a rather high positive bias, in fact much too high. This high bias is necessary for the triode A but not for triode B. To remedy this state of affairs the output portion is also biased by a resistance in the cathode lead. In calculating the value of this resistance, however, it is necessary to take into consideration the bias on the input section. The

output bias is therefore arranged so that there is a difference between the voltage drop across  $R_1$  and  $R_2$  actually  $2\frac{1}{2}$  volts. Let us re-state this as it is rather unusual.

### Positive and Negative Bias

Triode A is biased 24 volts negative but tied to grid of triode B, therefore the latter will be 24 volts positive as it is 24 volts above H.T. negative. The biasing arrangements of triode A are quite orthodox; that is if the cathode is made 24 volts positive with respect to earth, the grid will be 24 volts negative.

Now the next step. Triode B is 24 volts positive, quite obviously considerably too much. To make it negative we adopt the usual procedure—a resistance in the cathode lead. But we do not want it negative, but  $2\frac{1}{2}$  volts positive. So subtract  $2\frac{1}{2}$  volts from 24, leaving us 22 $\frac{1}{2}$ , and calculate our biasing resistance for 22 $\frac{1}{2}$  volts, which when placed in the cathode lead will make the grid less positive, thus leaving us the  $2\frac{1}{2}$  volts we require. It is quite simple if each triode of the complete valve is taken separately.

It is really worth while understanding the principle involved in the calculation of the biasing arrangements, because when this valve becomes available in this country it will be essential for you to be able to make the necessary calculations if you wish to fit one of them in the output stage of your receiver. With this valve the first triode A is biased negatively and the second triode B is biased positively, rather a unique arrangement.

### Output Power

Output power is delivered by triode B, which operates at the middle point of its  $E_g I_p$  characteristic. The input section performs a function somewhat analogous to that of the driver valve in Class B circuits, but a step-down transformer is unnecessary.

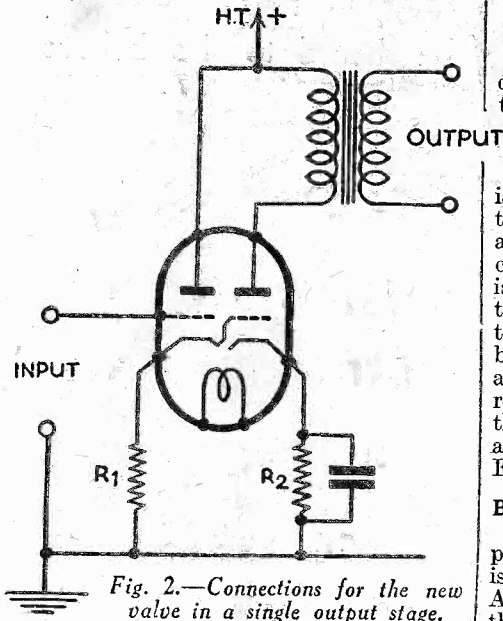

Fig. 2.—Connections for the new valve in a single output stage.

developed in the laboratories of this country, whilst Class B and the Pentagrid valve were originally American inventions.

### Mains Receivers

Now a new output valve for mains sets has been designed which appears to be quite revolutionary. With it excellent quality is obtainable without excessively high anode voltages, and with an output of about 4 watts. It is claimed that this new valve can be substituted for many of the existing output valves at present employed in mains receivers, where only relatively low anode voltages of about 250 to 300 are available.

### Triodes and Class B

It is generally conceded that the triode output valve provides the best quality, so long as high anode voltages can be obtained. In order to provide an undistorted output of, say, 5 watts, an anode voltage of at least 400 is usually necessary. The introduction of Class B valves for battery sets enabled  $1\frac{1}{2}$  to 2 watts output to be obtained with a minimum of H.T. current and voltage. This new valve will, to some

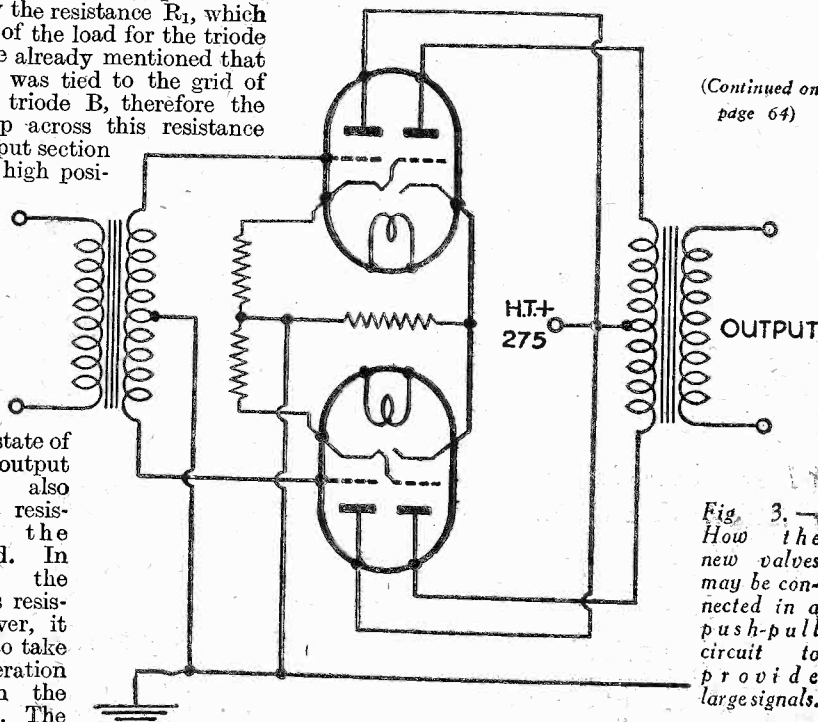

(Continued on page 64)

Fig. 3.—How the new valves may be connected in a push-pull circuit to provide large signals.



**Now hear  
DIRECT what  
AMERICA thinks  
CHICAGO · NEW YORK  
· PHILADELPHIA · all  
within your reach  
on the ULTRA SHORT  
& SHORT WAVES!**

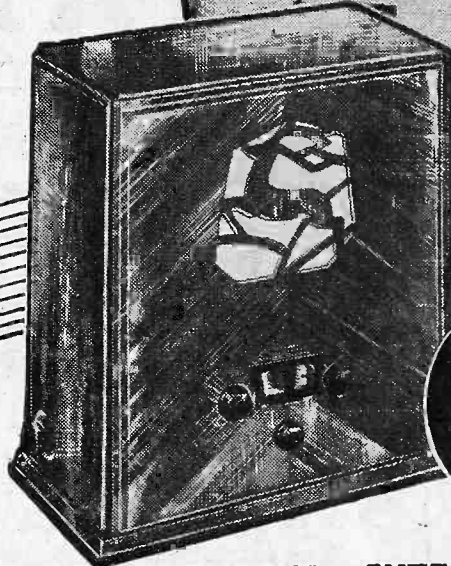

**IN CONSOLE  
CABINET WITH  
MOVING COIL  
SPEAKER  
£8.2.6**

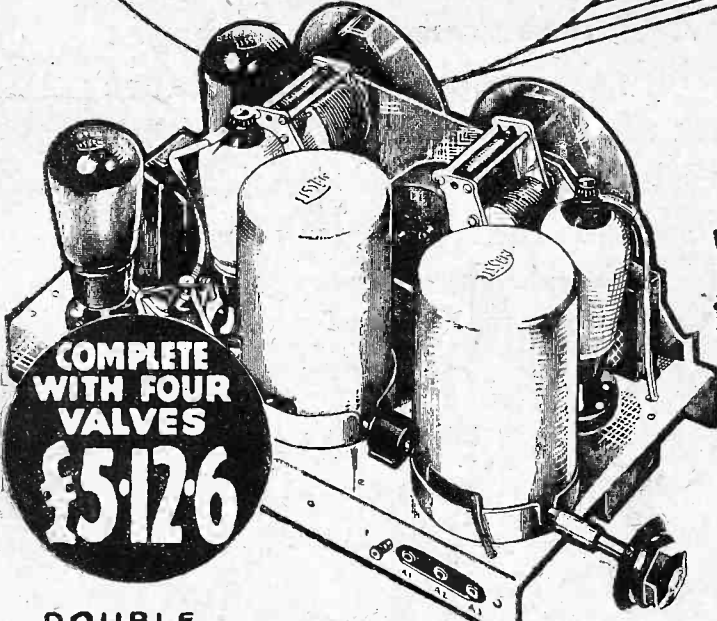

**COMPLETE  
WITH FOUR  
VALVES  
£5.12.6**

**WORLD WIDE NEWS & ENTERTAINMENT  
for Home Constructors ONLY!**

**4 WAVELENGTH RANGES INSTEAD  
OF 2 IN NEW LISSEN ALL-WAVE  
ALL-WORLD SKYSCRAPER KIT SET!**

At last the day of the All-World Radio has arrived, and you can build with your own hands the first receiver to give you not only England and Europe, but America and Australia direct. The Lissen All-Wave All-World "Skyscraper" 4 tunes from 12 to 2,100 metres. It brings two complete new wavelength ranges within reach of the ordinary listener—stations and programmes which before he was never able to receive—Ultra Short and Short-Wave transmissions from the ends of the earth. And remember you get these stations through Double-Balanced Pentode Output giving brilliant reproduction on a Moving-Coil Speaker—as much power as a Mains Set from ordinary high-tension batteries.

Lissen have made this All-Wave All-World Radio available to Home Constructors first, because it brings back the thrill of conquest to hear America and Australia direct on a set you have built yourself; it makes you an enthusiast to realise what a wonderful thing you have created!

When you see the Great Free Chart of the All-Wave All-World "Skyscraper" 4, which tells you how to build it and how to work it and why it gives such marvellous results, you will agree at once that it will be wise of you to build for yourself rather than buy a factory assembled receiver which cannot give you these new and intriguing short-wave stations. The FREE CHART simplifies everything; there are pictures of every part, with every wire numbered, every hole lettered, every terminal identified. YOU CAN'T GO WRONG! But get the Chart and see for yourself—then build the Lissen All-Wave All-World "Skyscraper" 4, the SET THAT SPANS THE WORLD!

**DOUBLE  
BALANCED  
PENTODE  
OUTPUT &  
MOVING COIL  
SPEAKER**

**BUILD WITH YOUR OWN HANDS  
SAVE POUNDS-SUCCESS CERTAIN**



To LISSEN LTD.,  
Publicity Dept., ISLEWORTH.  
Please send me FREE copy of  
All-Wave All-World "Skyscraper"  
Chart.  
Name .....  
Address .....  
..... P.R.734

**CHART  
FREE  
POST  
COUPON**





# A Publishing Sensation

FOR THE FIRST TIME IN PART FORM

# THE GREAT WAR

BY THE RT. HON.

# WINSTON CHURCHILL

Mr. Churchill has all the gifts of a great writer, with an unsurpassed style. He can make the past live—The great dramatic moments of the War, the anxious days of hopes and fears, of disasters and triumphs, come vividly before the mind's eye as chapter succeeds chapter. Mr. Churchill's brilliant Work gives the most vivid pictures of battles lost and won. But it is far more than that. It is the most instructive and informative History of the Great War. It tells plainly and clearly the Causes and Events that led up to the War, the whole story of the War itself, the history of the peace and the tragic happenings of the years that have followed the Peace treaties. Clearly, and with great dramatic skill, Mr. Churchill relates What happened—all through the Years—and Why.

This brilliant work will be completed in 24  
fortnightly parts—order your copies to-day.

PART ONE ON SALE THURSDAY, SEPT. 21st.

**ONE SHILLING**

AT ALL NEWSAGENTS, BOOKSTALLS & BOOKSELLERS  
or Post Free 1/3 each part from

**GEORGE NEWNES LTD.**

8-11, SOUTHAMPTON ST., STRAND, W.C.2



# How Electrical Units are Derived

AN ARTICLE GIVING SOME INTERESTING FACTS ABOUT—

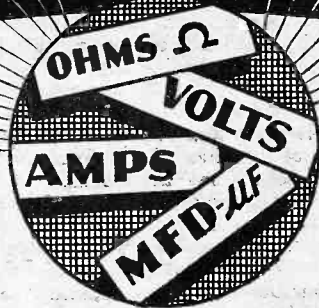

—VOLTS, AMPS, AND WATTS.  
By W. B. RICHARDSON.

**M**OST of us are, of course, quite at home with volts, amps, and watts. We talk quite glibly of kilowatts and amp-hours and show a condescending familiarity with Ohm's law; but I wonder how many radio enthusiasts when tackled could give a satisfactory answer to such a simple question as "What is a volt?" or "What is meant by power?" I am afraid quite a number would find such blunt inquiries rather embarrassing. "Oh, hang it all," they would say, "a volt is a volt, just the same as a pound is a pound, or an inch an inch"; or they might answer brightly that a volt was the product of amps and ohms, at the same time fervently hoping they would not be asked for a definition of either an amp or an ohm. Of course, to define a unit in terms of other units without really knowing what the others are derived from is only begging the question.

Now units may not appear to be particularly interesting things in themselves, but to those who like to know the "whys and wherefores" of things a study of their derivations is most illuminating.

### Mechanical Units

To get an idea of how the familiar units used by electricians are arrived at, we must have some knowledge of the simple mechanical units which were in use long before electricity was thought of.

The unchanging fundamentals from which other units are derived are:—Time, Length, and Mass. These hardly need any explanation, except perhaps the last one, which means the amount of matter or substance

in a body. It must not be confused with *weight*, which is measured by units of the same name, but which is the force exerted by gravity, although for practical purposes they may often be considered synonymous. Thus a body weighing a pound may be taken as containing a mass of one pound, and a gramme weight as the same as one gramme mass. The slight discrepancies which sometimes exists between the two measurements is due to the fact that weight varies on different parts of the earth's

technical, but a study of Fig. 1, will no doubt help to make it clear. Here the mass of one gramme is shown as a cube composed of just one gramme of matter. This is being pushed from left to right by the force. In one second it moves from A to B, that is one centimetre. However, it is gradually increasing in speed due to the force and in the next second travels two centimetres—from B to C. During the third second it is going so fast as to cover three centimetres, and so on. Actually, a force of one dyne is very small, and for practical purposes units of a gramme weight or a

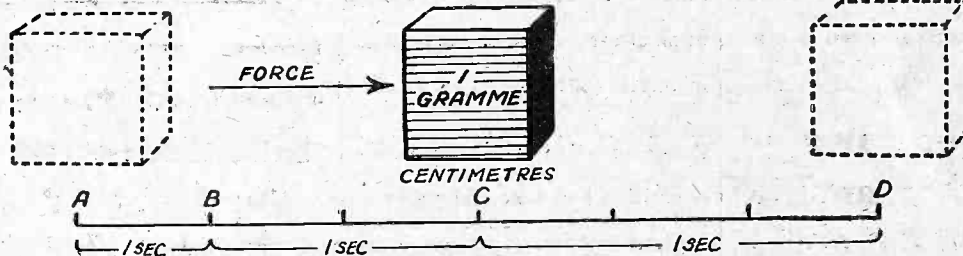

Fig. 1.—Diagram illustrating the derivation of the dyne, a mechanical unit of force.

pound are used. The gramme is the metric unit and the pound the English unit. The former is equal to 981 dynes and the latter to 445,000 dynes.

### Electro-Motive Force

Well, so much for the mechanical units of force. Now what of the electrical

surface. A pound mass, for instance, may weigh just over a pound in one place and just under in another. It is due to this that mass is used instead of weight as the fundamental measure.

### Force

One of the most important units apart from time, length, and mass is *force*. A force is defined as that which tends to produce movement in a body. For instance, a man pushing a truck along uses force. "Yes, very obvious," you may say, "but how do we measure a force?" Well, there are several different units in use. There is what is called the *absolute unit*, that is a unit which is independent of any varying factor—a sort of rock bottom unit, and there are several *practical units*.

The absolute unit of force under the metric system is the *dyne*, and is that force which, acting for one second on a mass of one gramme, produces an acceleration of one centimetre per second, per second. This may sound rather

equivalents? Electrical force or pressure is known as the *electro-motive force*, abbreviated to E.M.F., and is the "push" that moves or tends to move electrons from one place to another, in other words causes electricity to flow.

Just in the same way that pressure in pounds or grammes is required to force water through a pipe, so an electro-motive force or "voltage" is necessary to make electricity move in a wire. The unit

(Continued overleaf)

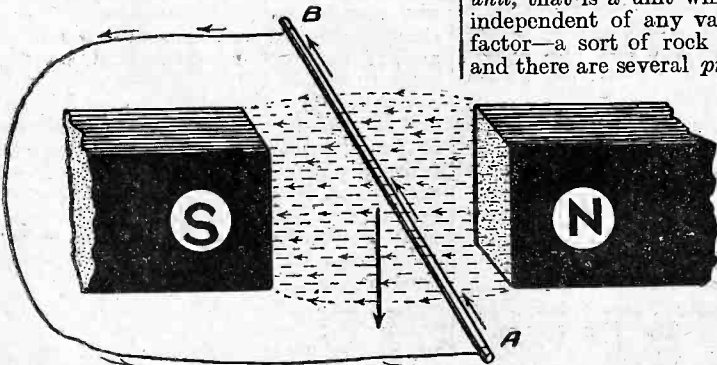

Fig. 2.—Showing how the volt may be expressed in the pressure created in a conductor cutting a certain number of magnetic lines of force.

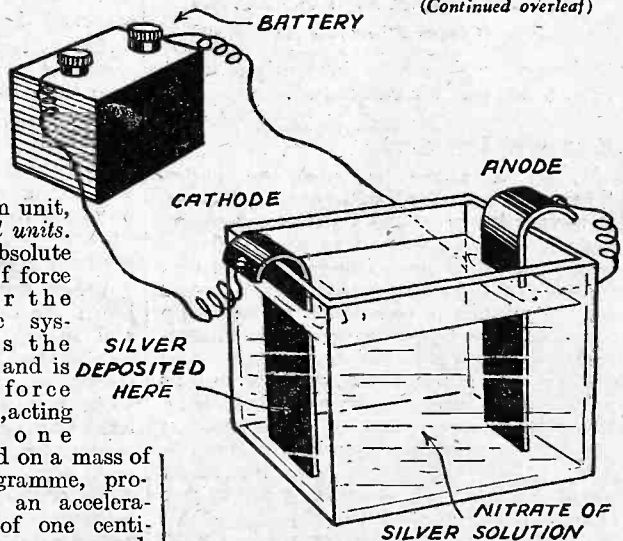

Fig. 3.—Diagram explaining the definition of the ampere.



(Continued from previous page)

used is the *volt*. The volt is not so easy to define as a mechanical unit since we cannot give it directly in terms of time, length, and mass. One definition states that it is

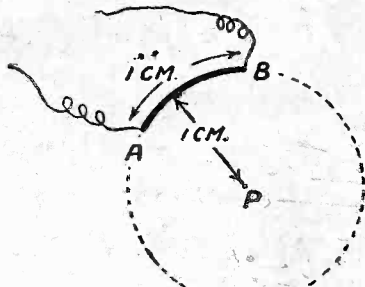

Fig. 4.—How the absolute unit of current is measured.

the electro-motive force or electrical pressure produced when a conductor is cut by magnetic lines of force at the rate of 100,000,000 per second. It is well known that when a wire or other conductor is moved about near the poles of a magnet that electricity is generated in it. Look at Fig. 2, for example. Suppose the conductor A B to be moved up and down through the magnetic field between the poles N and S, of a permanent magnet. Whenever it is moved it will cut through lines of force, and an electro-motive force will be set up in it so that current will flow. If as many as 100,000,000 lines of force are cut per second, then the pressure created will be one volt.

#### Definition of an Ampere

Let us now consider how current is measured. Current is the rate of flow of electricity. The practical unit is, of course, the *ampere*. It is the constant electrical current which, when passed through a neutral solution of silver nitrate, deposits on the negative pole or cathode .001118 grammes of silver in one second. The process employed for this measurement is the same kind as is used in electro-plating, namely electrolysis. An electric current is passed through a cell, shown diagrammatically in Fig. 3, consisting of two electrodes dipping in an electrolyte consisting of a solution of silver nitrate. The passage of the current causes silver to be deposited on the cathode, and it is the weight of silver deposited per

second by which the amount of current flowing is measured.

As with mechanical units there is often more than one unit for the measurement of the same force or property, so it is with electrical units. For instance, there is the absolute unit of electric current and also the practical, the latter being the ampere which I have just defined. The absolute unit is equal to one tenth of an amp, and is that current which, flowing in a circuit, part of which is formed into a circular arc one centimetre long, and one centimetre radius, will act upon a unit magnetic pole at the centre of that arc with a force of 1 dyne. Fig. 4 shows what this means. A B is the conductor of the current. It is 1 centimetre long, and curved to form the arc of a circle 1 centimetre in radius. The centre of the circle P is the point where the magnetic field surrounding the wire, and due to the current through it, will act on a magnet of unit strength with a force of 1 dyne. Naturally this definition will not convey much unless we know what a "unit magnetic pole" is. This again is another absolute unit, and means a magnetic pole of such strength that if placed one centimetre from a similar pole, as in Fig. 5, would exert a force of repulsion of one dyne.

#### Resistance and the Ohm

Of equal importance with the volt and amp is the *ohm*—the practical unit of resistance. Resistance is the opposition a body offers to the passage of an electric current. It may also be described as the property of converting the energy of the swiftly moving electrons (which constitute an electric current) into heat. In this connection it is analogous to mechanical friction, which is the opposition encountered by all moving bodies, and which also manifests itself as heat.

The ohm is described as the resistance of a column of mercury 106.3 cms. long and 1 sq. mm. in cross section, and of a mass of 14.4521 grammes at a temperature of 0 degrees Centigrade. Again there is also an absolute or electro-magnetic unit based on unvarying factors. There is scarcely need to go into details as to how this unit was evolved, but I mention it, as I have done the other absolute units, to show that it is possible to define such an apparently

evanescent thing as electricity in terms of such tangible factors as time, length and mass. In fact, electro-motive force (E.M.F.) current, resistance, and inductance, etc., can all be expressed in terms of T, L, and M, and from this the absolute units have been derived. As we have seen, they are not always of a convenient size for ordinary use, and this has led to the introduction of the practical units. In the case of resistance the practical unit, namely the ohm, is equal to 1,000,000,000 (one thousand million or  $10^9$ ) absolute units.

#### Power

Volts multiplied by amps gives *watts*. A watt is the electrical unit of power. Power is the rate of doing work. Perhaps this needs a little explanation. "Work" is here used in the restricted sense, not in the general. When a force overcomes a resistance and so moves something, work is said to be done; for instance, when a man lifts a pound weight one foot from the ground he does work. In such a case the work done would equal one *foot-pound*. If he raised it two feet he would do two *foot-pounds* of work. Of course time does not enter into the matter. However, if he does the work quickly, he uses more *power* than if he does it slowly. The English unit of a horse-power is equal to 550 *foot-pounds* of work performed in one second.

The electrical unit of power—the watt, is

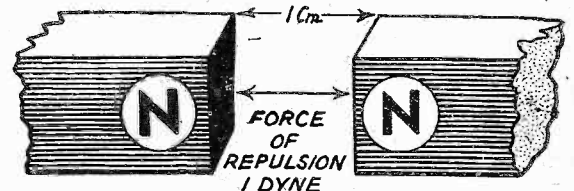

Fig. 5.—A unit magnetic pole is one which will repel a similar pole 1 centimetre away with a force of 1 dyne.

equal to  $\frac{1}{746}$  horse-power and is the power developed when one volt produces a current flow of one coulomb per second (one ampere).

If an electric lamp takes a current of, say,  $\frac{1}{4}$  amp at 240 volts, then the power used is 60 watts ( $\frac{1}{4} \times 240$ ). Similarly a lamp taking  $\frac{1}{2}$  amp at 120 volts also consumes 60 watts. From these two examples you will see that voltage or amperage alone is no indication of the power expended in a circuit. Power is dependent on both current and voltage.

## RADIO-GRAM MOTORS

(Continued from page 10)

to drag on loud passages is greatly reduced, even if not entirely eliminated.

#### Keep Well Lubricated

When a motor is new the spring "barrels" are filled with a thick grease. It is very important to see that this grease does not get exhausted in any way and cause "sticking" or undue friction between the coils of the springs, as the force applied by the springs is sometimes momentarily arrested, thereby giving very erratic movement to the turntable and causing bad quality and reproduction. An important point should, perhaps, be mentioned here. If for the above reason, or any other, you are taking out the barrels holding the springs, be very careful indeed not to let the spring come out in any way unless you have experience with these springs. To those who have not had experience with motor springs, let me remind them that these springs are very powerful, and if they

spring out suddenly are liable to do considerable damage.

In addition to this, of course, it would be extremely difficult to get them back again into the case.

The gears of the motor should be kept well oiled but not over-oiled. The friction pad of the governor should not be oiled if it is running smoothly, otherwise it will be anything but a friction pad and consequently will not carry out its proper operations in the motor.

When buying a spring motor, always listen for sounds such as gear humming and rattles very carefully indeed, as it should be remembered that when this motor is mounted on the motor-board these sounds are frequently very much louder owing to the motor-board becoming a kind of diaphragm and baffleboard. A good rough and ready test is to lay the motor on the shop counter when examining before purchasing. The motor should, of course, be going when this is done, and the counter will act in a similar way to the motor-board.

#### Hints on All Types of Motor

To conclude this article some general hints of use for all types of motors may be appreciated. The regulator indicating table should not be relied on too blindly; but should be tested in one of the following ways.

Chalk a mark on the edge of a record and play it, counting the times the chalk-mark passes a given spot over a minute, and, if incorrect, regulate until seventy-eight turns per minute is obtained. Make a note of where this comes on the indicator and set there in future. Another method of similar nature is to slip a small piece of white paper under the record so that it just shows and count the times this revolves in a similar way. There are many other methods of obtaining the speed, but two should be quite sufficient, and these two are very simple.

As a final note, may I remind you that you are far less likely to damage or break your springs if you keep the motor running when winding, as the motor does not have to take the sudden jerk when fully wound as it often does when the turntable is stopped.



# VOLTAGE STEADY AS A ROCK

*while Current Drain varies from zero to 30 milliamps*

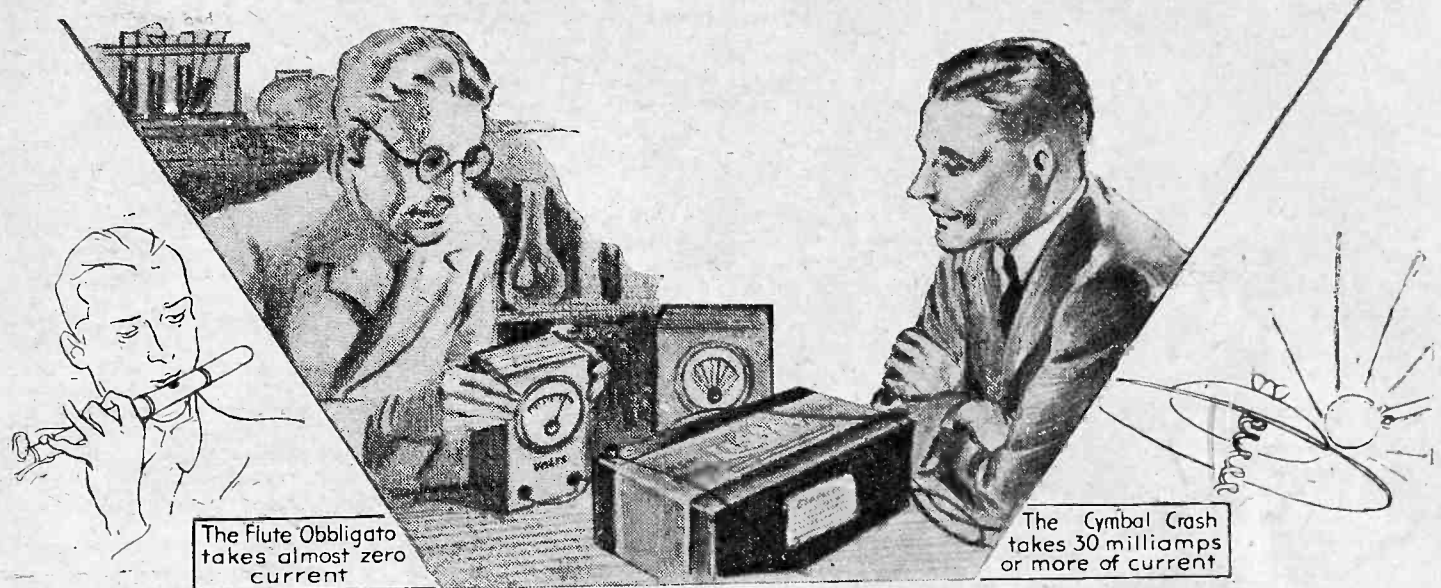

The Flute Obligato takes almost zero current

The Cymbal Crash takes 30 milliamps or more of current

## THE NEW DEMANDS OF MODERN TRANSIENT LOAD CIRCUITS CAN ONLY BE MET BY A BATTERY OF BIG OXYGEN CONTENT & LOW INTERNAL RESISTANCE

In a modern Transient Load—Q.P.P., Push Pull or Class "B"—Receiver, the amount of high-tension current called for by the receiver depends upon the "noise value" of the programme. That saves a lot of high-tension current because the average programme is relatively quiet. But it reveals also a danger of severe distortion, because **VERY FEW BATTERIES** can stand up to the load imposed upon them by these new output stages when, for example, a heavy orchestral item is being played or when the drums predominate. A Queen's Hall Concert, for instance, might well call for 30 milliamps current output from your battery on certain passages. An ordinary high-tension battery simply cannot do it—the voltage immediately drops off alarmingly and the quality of reproduction is ruined.

**HOW MANY BATTERIES CAN STAND UP TO 30 MILLIAMP DRAIN WITHOUT VOLT DROP?**  
 The Lissen Secret Process Battery contains a catalytic agent of great potency which liberates oxygen in abundance in the cells and keeps the internal resistance of the battery very low. The new circuits reveal the great advantage of this low internal resistance very strikingly, because a Lissen Battery when called upon can deliver 30 milliamps or more of current instantaneously without volt drop. You have paid a big price and waited a long time for a battery set capable of giving you all the volume you want on an economical basis; it is penny wise and pound foolish to sacrifice this new beauty and power of radio by using inferior batteries. Ask very firmly for a Lissen High-Tension Battery this year—you will **HEAR A DECIDED IMPROVEMENT IN LOUD-SPEAKER TONE** and enjoy **LONGER BATTERY LIFE** for **LESS MONEY**.

**"IT STUBBORNLY  
 RESISTS  
 VOLT  
 DROP"**

# LISSEN

SECRET

PROCESS

## HIGH TENSION BATTERY

*Mention of "Practical Wireless" to Advertisers will Ensure Prompt Attention*





# LION

## ... the MASTER H.T. BATTERY

*British throughout*

**LOW Prices!**

60 Volt H.T. 4/6

100 Volt H.T. 7/-

120 Volt H.T. 9/-

9 v. G.B. 10d.

4½ v. Pocket Lamp Battery 4½d

**P**AY what you like for your H.T. you cannot get a finer Battery than the LION. For the LION is the MASTER Battery, full of the power that enables your set to give its best performance. Long-lasting and low-priced, the LION H.T. Battery is the finest on the market to-day. Don't think that because you pay more you get a better Battery. Stop paying fancy prices for your H.T. . . . and follow the lead of the expert Set Designers who specify the LION H.T. Battery in their circuits.

**See the name LION on  
the next Battery you buy**

# FULL OF LASTING ENERGY



# CLASS B—AND YOUR SET

**C**LASS B amplification has formed the subject of several articles previously given in PRACTICAL WIRELESS, whilst a complete Class B amplifier and a number of receivers incorporating this wonderful system of amplification have been described in these pages. But despite these facts the numerous inquiries relating to Class B which we received at Olympia and which continue to pour in by post make it perfectly clear that there are many readers who would welcome some additional practical information on the subject. It is therefore proposed to deal in general terms with the methods of adding Class B, as well as with the choice of components for building an amplifier. Some information on how to obtain the best results from Class B will also be given. In short, an attempt will be made to cover, as briefly as possible, all the queries that are most frequently addressed to us.

Although Class B is now well established, there are not a few readers who find it hard to believe that it can give the tremendous volume of output which is claimed with such a modest consumption of H.T. current. As a matter of fact, the claims made—that the undistorted output of a battery set with "B" output is equal to that given by a mains set consuming considerably more power—are entirely borne out in practice and I have no hesitation in saying that the new system of amplification has come to stay and is well worth adopting by every battery set user.

### Adding a Class B Amplifier

Having decided to fit Class B, the constructor next wants to know the best way of doing it. This, of course, depends upon the design of the existing set and upon personal inclinations. If the set has a single low-frequency stage a Class B amplifier can be added without altering the set in any way, by simply connecting it to the loud-speaker terminals. The normal L.F. valve (generally of the small power type) then performs the duties of the "driver" which is necessary to feed the new output valve. When there are two L.F. stages, one of them should be removed because it will no longer be required; as a matter of fact, it could be kept, but it would serve no good purpose and would naturally add to the battery consumption. A pentode can be used as "driver," but an ordinary triode is better. The reason is that both pentodes and Class B valves tend to give emphasis to the higher musical notes, and thus when the two are combined there is some danger of making reproduction "screechy."

Some Useful Notes explaining How a Class B Stage can be Added to any Battery Receiver, and also How Optimum Results can be Obtained from it.

By FRANK PRESTON, F.R.A.

### Choosing the Loud-Speaker

Complete Class B amplifiers, which may be connected direct to the set with a minimum of trouble, can be obtained, but most readers will prefer to make their own. Particulars relating to the construction of an amplifier will be given later. A loud-speaker of the balanced armature or moving

coil type is suitable for connection to any single L.F. receiver, whilst the practical wiring connections are given in Fig. 2. It will be seen from these drawings that the only essential components are: one "driver" transformer, one seven-pin valve-holder and an output choke (unless a Class B speaker is used, in which case the choke is not required). A Class B valve is, of course, needed in addition, and it is mainly upon this that the choice of "driver" transformer ratio depends. In any case the ratio will be either 1:1 or 1.5:1, and as several transformers are available with tapings to provide either ratio, it is suggested that one of these should be used, and the better ratio found by trial. At the same time it will be helpful to know the correct ratio for different Class B valves used after a small power "driver"; they are as follows: For the Cossor 240B valve the ratio should be 1:1; for the Cossor 220B, Marconi or Osram B21 the ratio may be either 1:1 or 1.5:1; for the Mazda PD 220 and Mullard PM2B the optimum ratio is 1.5:1.

It is not anticipated that any reader would find any difficulty in constructing a Class B eliminator by following the connections shown in Fig. 2, but a few words of explanation might be of use. The two leads from the primary of the "driver" transformer marked "L.S." go to the speaker terminals on the existing set; the lead with wander plug marked "H.T.+" is taken to the socket on the H.T. battery giving maximum voltage; the two "L.T." leads can be joined directly to the accumulator, but in that case it would be necessary to disconnect one of them when the set was switched off, so it is much more convenient to join them to the filament terminals on one of the valve-holders so that the ordinary on-off switch attached to the set operates on the Class B valve

also. An output choke (of special Class B type, having a low D.C. resistance) is shown, and is required when using an ordinary loud-speaker, but when a special Class B speaker is employed the three leads marked "P.," "H.T." and "P." will go direct to the corresponding speaker terminals. Most Class B output chokes are tapped to provide three ratios of from 1:1 to 3:1, and although very accurate matching is seldom essential for good results it is generally best to try the alternative ratios and judge the most suitable by ear.

### Curing Distortion

Actually, Class B amplification gives particularly good "quality," but for various reasons many users find the reproduction far from good. Distortion is generally traceable to a lack of sufficient decoupling

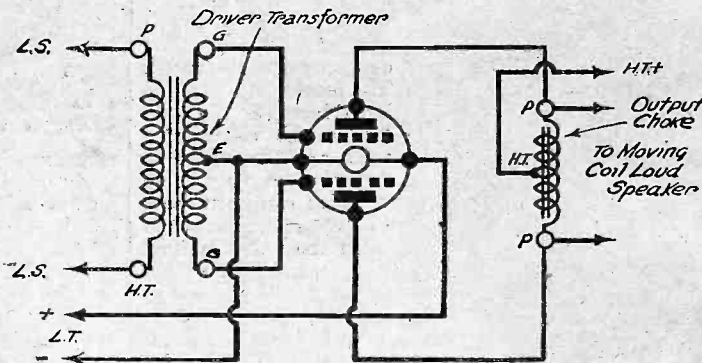

Fig. 1.—The circuit of a Class B amplifier suitable for use with any type of battery receiver having a single L.F. stage.

iron type is useless with Class B since it is incapable of handling the full output, which is anything from ten to twenty times as great as that given by an ordinary power valve. For this reason those who contemplate changing over to Class B are recommended to buy a new moving-coil speaker already fitted with a special Class B transformer, or even to buy one of the amplifier-speaker assemblies which are now made by several firms. Those who already have a

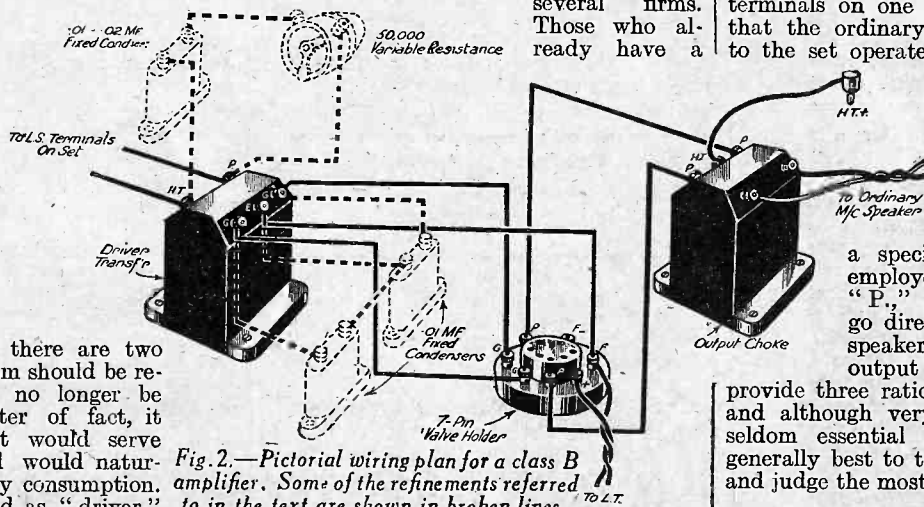

Fig. 2.—Pictorial wiring plan for a class B amplifier. Some of the refinements referred to in the text are shown in broken lines.

moving-coil speaker of normal type can use this on Class B by feeding it through a centre-tapped choke.

### The Essential Components

Fig. 1 shows the circuit of a Class B



of the detector valve or to the leakage of H.F. currents into the amplifying stages. The cure in the first instance is obvious, and a larger decoupling resistance will generally do the trick. When the second cause of trouble is suspected it can be checked by seeing if hand-capacity in the region of the Class B valve has any effect; if it has, a "stopper" resistance of about 100,000 ohms should be connected between the first L.F. transformer and the grid of the "driver" valve. Alternatively—or in really severe cases, additionally—a .01 mfd. condenser should be connected between each "Grid" terminal of the "driver" transformer and the centre tap, as shown in broken lines in Fig. 2. Very often the same result can be obtained by connecting a .005 mfd. condenser across each half of the output choke or transformer.

#### Tone Correction

It is by now well known that all Class B valves, like pentodes, tend to give too great a degree of amplification to the higher notes, with a result that reproduction

economical working, which is, of course, one of the main features of Class B. The anode current consumption of a Class B valve is proportional to the signal voltages applied to its grids. It is therefore wasteful to allow the valve to amplify the high notes and then to "cut" them, but by suppressing these high frequencies prior to the output stage they do not pass to the grids of the Class B valve and thus do not "cost" anything in the way of high-tension current.

If a tone control transformer is used in the anode circuit of the detector valve this can be employed to reduce the high note response, but if not, the best position for the tone control components is between the primary terminals of the "driver" transformer, as shown in broken lines in Fig. 2. The variable resistance should have a maximum value of 50,000 ohms, whilst the condenser may have a value of between .01 and .02 mfd.

#### The H.T. Supply

Even though Class B amplification is inherently economical there are two or three ways in which a still greater degree of economy can be secured. The most useful of these is to increase the grid bias on the valve being used as "driver"; in nearly every case the bias can be at least  $1\frac{1}{2}$  volts higher than when the valve is used as a normal L.F. amplifier. Another way, which is applicable when the maximum output of the Class B stage is not required, is to use a type L. or HL. valve as "driver."

It need scarcely be mentioned that there are two general types of Class B valves, one of which gives an output of 2 watts, takes an average H.T. current of 9 milliamps and a filament current of .4 amp, whilst the other gives  $1\frac{1}{2}$  watts output and requires H.T. and L.T. currents of approximately 6 milliamps and .2 amp respectively. The smaller valve is adequate for most purposes and the larger one is only actually required when the speaker is to be used out of doors or in a very large room.

one of which gives an output of 2 watts, takes an average H.T. current of 9 milliamps and a filament current of .4 amp, whilst the other gives  $1\frac{1}{2}$  watts output and requires H.T. and L.T. currents of approximately 6 milliamps and .2 amp respectively. The smaller valve is adequate for most purposes and the larger one is only actually required when the speaker is to be used out of doors or in a very large room.

Several readers who have H.T. eliminators ask if these can be used with a Class B set. If the eliminator is operated from D.C. mains it is almost invariably suitable, provided that it is a good quality instrument rated to give not less than 30 milliamps maximum. The reason for the latter proviso is that the "peak" anode current of a Class B valve often attains a figure of from 25 to 35 milliamps, even though the average consumption is less than 10 milliamps. With a cheap eliminator the

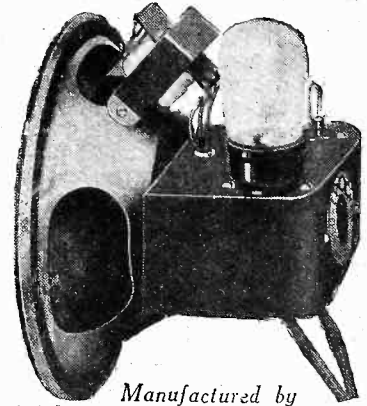

Manufactured by Epoch, this complete loud-speaker and Class B Amplifying stage forms a valuable unit for adding to an existing low-powered receiver.

resistance of the smoothing chokes is often fairly considerable, and in consequence the output voltage drops as the current drain is increased. When this happens distortion is immediately produced by the voltage fluctuation on the anodes of the detector and "driver" valves.

The same kind of ruling applies when an A.C. mains unit is employed, although there are now a number of units on the market specially designed for Class B work. An ordinary eliminator of the A.C. type, giving an output of not less than 25 milliamps at 180 volts, can nearly always be used with every satisfaction on a Class B outfit, by connecting a neon stabiliser of the kind specially produced by Messrs. Cossor between the positive and negative output terminals.

I would conclude these notes by emphasising that Class B is not only worth while but is indispensable to the battery user who requires a good volume of undistorted output in the most economical way. There are no "snags" or "catches" in the system and it is just as easy to deal with as is any ordinary low-frequency stage.

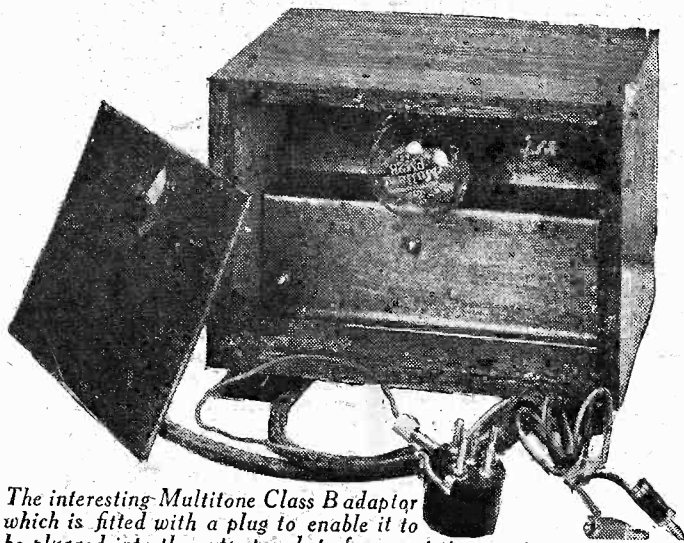

The interesting Multitone Class B adaptor which is fitted with a plug to enable it to be plugged into the output socket of any existing receiver.

is liable to sound rather "shrill." Because of this it is usual to fit some kind of tone control or tone compensating device. This consists of a variable resistance and fixed condenser connected in series, and may be inserted in the anode circuit of the "driver" valve or between the two anodes of the Class B valve. Although often used in practice, the latter position is not good from the point of view of

**W**ILL you join me for a minute or two in the realms of "Might Be," or, if you would rather have it so, "Phantasy"? I have just been listening to an argument on the fourth dimension in which several promising students in the medical world were taking part. One gentleman, who had been paying careful attention to the opinions expressed, got up from his chair with a look of disgust on his face, and before leaving bent down and whispered in my ear: "Crackers." Now I expect many of you will know that theories have been advanced as to the fourth dimension, and the most interesting and easily understood theory is that it is a plane superimposed upon the one on which we live, so that countries, towns, and their peoples may be intermingled with ours without our being able to detect them, we not being able to perceive this fourth dimension, as it has neither length, breadth, nor thickness. Suppose I give you a slight illustration. Take

### THE FOURTH DIMENSION

By GRID LEAK

a sheet of very thin paper and hold it edgewise between you and the light; when you get it in the correct position it will almost disappear from your sight, as it has almost the minimum of length, breadth, and thickness. If you could take away from it these three dimensions it would disappear, becoming a fourth-dimensional object, and if you could add these three dimensions to a fourth-dimensional object it would become visible to you and be on the material plane. We know we live in a three-dimensional world and that every material thing must have length, breadth, and thickness; in other words, that all matter must have solidity. Our scientific friends tell us that there is another dimen-

sion, and they have sought through the ages for real proof of its existence. Theoretical proof is provided to the students of mathematics, and accepted as proof by the scientist, through algebraic formulae. Now, if this theory is correct, and such a dimension does really exist, the argument suggested a new line of thought to me as to whether radio might prove the key to this fourth dimension, and may offer us at last the means of finding and proving its existence, together with the possibility of communicating with its inhabitants. What a new field it would make for the radio experimenter! What type of coils, condensers, and power valves would be required to bolster up the undiscovered signals which may be flashing through the ambient ether? It may be that much of the strange phenomena heard by experimenters have an equally strange source of excitation which even a most discriminating ear may pass over as a crash of static, when it is really an authentic signal of another kind.



# NOW YOU CAN BUILD A SET FOR BOTH A.C. & D.C. MAINS

## TUNGSRAM PRODUCE AN A.C.-D.C. UNIVERSAL VALVE

Tungram have achieved it—a Universal Valve which works on both A.C. and D.C. mains.

With these Tungram Universal Valves any circuit can be built. All valves, including rectifier, are indirectly heated—there is practically no hum—and they are really economical, for the mains consumption is only 35 watts.

Your dealer stocks them—go to him to-day! Or post the coupon for full particulars and circuit diagrams.

### THERE IS A TUNGSRAM VALVE FOR EVERY RADIO NEED

| Type     | Amp. Fac. | Slope mA/V       | Use                        | Price |
|----------|-----------|------------------|----------------------------|-------|
| HP 2018  | 5,000     | 3.5              | H.F. Pen/Det freq. changer | 14/6  |
| HPE 2118 | 2,000     | 3.5              | V/mu H.F. Pen A.V.C. Mixer | 14/6  |
| SS 2018  | 900       | 3.0              | S.G.H.F.—Det               | 14/6  |
| SE 2118  | 700       | 3.0              | V.Mu steep Slope S.G.      | 14/6  |
| S 2018   | 400       | 1.2              | S.G.H.R. Det               | 10/6  |
| SE 2018  | 400       | 1.4              | V/mu S.G.H.F.              | 10/6  |
| R 2018   | 40        | 3.0              | Steep Slope Det.           | 13/-  |
| G 2018   | 25        | 4.0              | Det. L.F.                  | 17/-  |
| P 2018   | 7         | 2.5              | Power Driver               | 17/-  |
| PP 2018  | 80        | 3.0              | Multigr. Output            | 10/6  |
| PP 4018  | 60        |                  | ditto                      |       |
| V 2018   | 70 M.A.   | D.C. Resist. 250 | Wave Rect.                 |       |
| PV 4018  | 120 M.A.  | D.C. Resist. 250 | Fullwave Rect.             |       |

All Valves '18 Ampere indirectly heated for series heating.

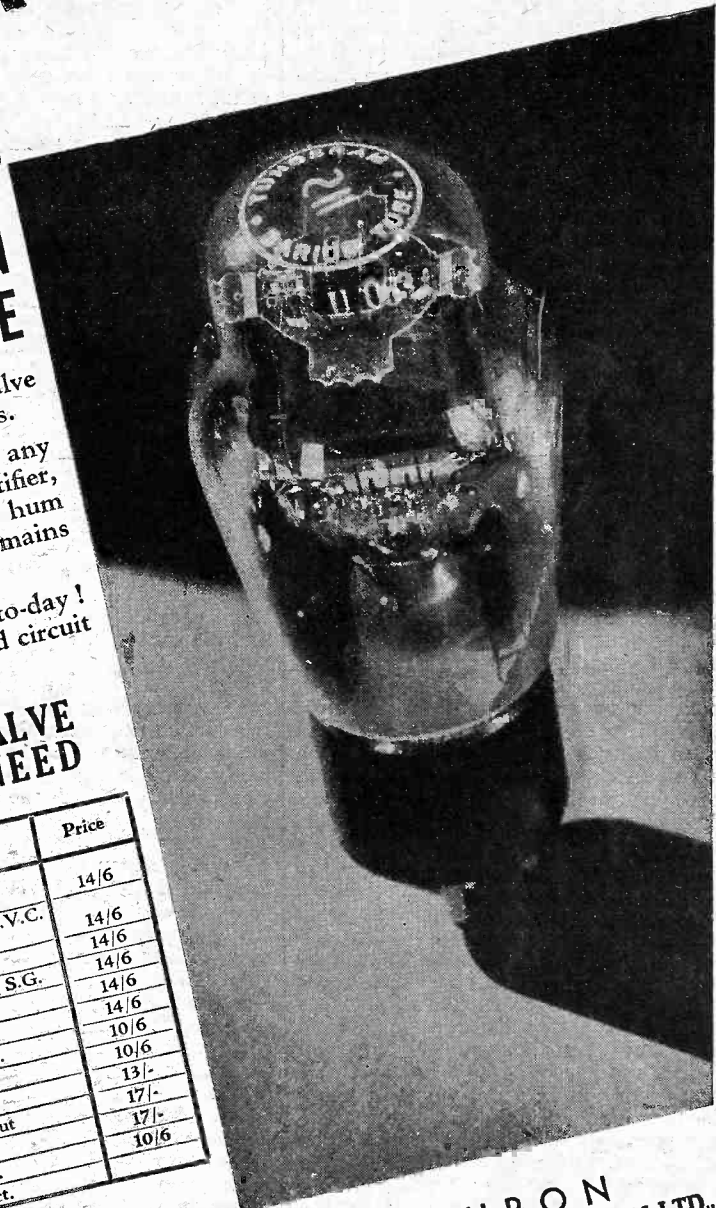

# TUNGSRAM UNIVERSAL VALVES

### COUPON

To TECHNICAL DEPT., TUNGSRAM, LTD.,  
72, OXFORD STREET, LONDON, W.1.  
Please send me full details of Tungram  
Universal A.C.-D.C. VALVES, AND  
OF THE COMPLETE TUNGSRAM  
RANGE.

NAME .....

ADDRESS .....

Pr.W. ....



# LEARNING THE MORSE CODE—II

By "SHORT-WAVER"

(Concluded from page 938, September 16th issue.)

## Sending and Receiving

**B**ECAUSE it seems easier, many people try to learn to send before they can receive, but this is very undesirable, and the two should go hand in hand, with the receiving getting the most attention; the ordinary listener will do more receiving in any case, and if he graduates to a transmitter it is of no use to be able to send at high speeds and not be equally expert at reading the code, in addition to which a bad receiving operator is certain to be a bad sending operator. Once the code is completely memorized and words of two or three letters can be read, however slow the speed, it is best to drop the buzzer practice and concentrate on listening only. Search round on the receiver for someone sending quite slowly; the most likely place to find such transmissions is in one of the amateur bands of wavelengths, particularly that from 41.1 to 42.9 metres, but some of the commercial stations are slow enough for this work. Having found a suitable transmission try to copy as many letters as possible; as soon as a letter is recognised write it down and *forget it*, passing on to the next at once. When learning morse code one of the hardest things to avoid is trying to think what the letter was that you just missed, instead of forgetting it and going straight on to the next; while you are searching your mind for the missed letter you are losing the next five as well! It must be frankly confessed that this listening and trying to copy letters is the most disheartening part of the whole process because so little is received and so much seems to be sent, but it is very well worth persevering because it is undoubtedly far and away the best way of learning. As soon as it is found that most of the transmitted matter can be copied, a search should be made for a station sending faster, always aiming to copy a few words a minute more than your maximum. When the stage is reached of being able to read at about eight words a minute the commercials should be used in preference to amateur transmissions, partly because they send faster and for longer uninterrupted stretches, and partly because most of their transmissions are in code, which is much better practice than plain language because it is impossible to guess the end of a word after the first few letters are copied! This is a point to be remembered when getting someone to give you buzzer practice; the best plan is for the sending operator to take as material for his transmissions a passage from a book or magazine and send it backwards, *i.e.*, from the end of the sentence to the beginning, so that the receiving operator cannot guess what is coming next.

## Logging Call Signs

Once a speed of about eight words a minute has been attained a great deal of fun can be had on the amateur bands in logging call signs, while at the same time the operating ability will be improved. It will perhaps be as well, therefore, to give some idea of the type of transmissions that are likely to be heard. One of the first things to be noticed will be the great number of times the group CQ is heard, usually repeated three or four times in

succession and sometimes more often. CQ is sent out by a station wishing to get into touch with any other station; it may be translated as meaning "will anyone who hears this please call me," and is sent three times followed once by DE (meaning from), and then by the call sign of the transmitting station repeated three or four times. At least, that is the correct procedure; unfortunately a regrettably large number of stations abuse the signal by sending CQ far too many times and signing their call far too little. The use of CQ, though permitted to all other countries, is forbidden to amateurs in this country and so they use the group TEST implying a desire to conduct some tests with the other station. After either of these groups comes the DE, and then the call sign of the sending station, which consists of one, two or three letters (which give the nationality) followed as a rule by a single figure and one, two or three more letters. Examples are:—

X9A—Mexican  
G5EE—British  
OZ7MI—Danish  
HAF5H—Hungarian  
W6GAT—American

When answering a CQ call the calling station sends the call sign of the CQ'ing station several times, followed by DE and his own call, repeated. Owing to the repetitions these transmissions are most likely to be picked up by the novice and quite a large bag of stations can soon be recorded, many of which may be a very great distance off, although DX is more likely to come when the listener is sufficiently familiar with the code to be able to read the call signs of very weak stations. The text of amateur transmissions, when contact has been established, is very largely interlarded with abbreviations, some merely compressions of ordinary words and some the Q signals, groups of three letters beginning with Q which were laid down in the International Radiotelegraph Convention, for the speeding up of ordinary ship to shore traffic, and which have been adopted, with occasional modifications of the literal translation, by amateurs for their own use. There is no room to give them here, but they are obtainable in several publications, notably the "Handbook for Wireless Telegraph Operators" published by His Majesty's Stationery Office at ninepence.

## An Audio Frequency Oscillator

Another, somewhat aristocratic, method of providing morse signals for practice is the use of an audio frequency oscillator. This is simply a valve oscillator working at an audible frequency, and an excellent one can be rigged up with a low-frequency transformer in the circuit given last week, which it will be seen is simply an ordinary reaction circuit with the windings of an L.F. transformer in place of the usual coils and with the grid condenser and leak omitted. Such an oscillator will give a pure whistle whose pitch depends on the inductance of the transformer winding and the capacity across it, the addition of more capacity lowering the pitch. The strength of the oscillations depends chiefly on the H.T. voltage, sixty volts or so providing enough volume to work a loud-speaker, while reducing H.T. to the minimum required to maintain oscillations will permit headphones to be used and practice to be carried out without interfering with other people in the same room. If the short-wave receiver is provided with plug-in coils it can easily be converted for use as an audio oscillator without any permanent change by fitting an L.F. transformer with leads going to a plug mounting similar to that used for the ordinary coils, except that if the usual Reinartz control of reaction is used a separate lead will have to be brought out for the headphones and H.T. positive connection, the usual detector H.T. plus wander plug being removed; it is also necessary to short the grid condenser by means of a short piece of wire and two crocodile clips. Fig. 3 shows the arrangement; if no oscillations are obtained the leads to one of the transformer windings must be reversed. The advantage of using an audio oscillator is that it gives a note similar to the beat note of a C.W. station.

The code given in last week's issue is that usually referred to as the morse code, but it is more correctly the Continental morse code, morse code proper being used only in America on line telegraph circuits. In addition to the English alphabet there are

(Continued on page 56)

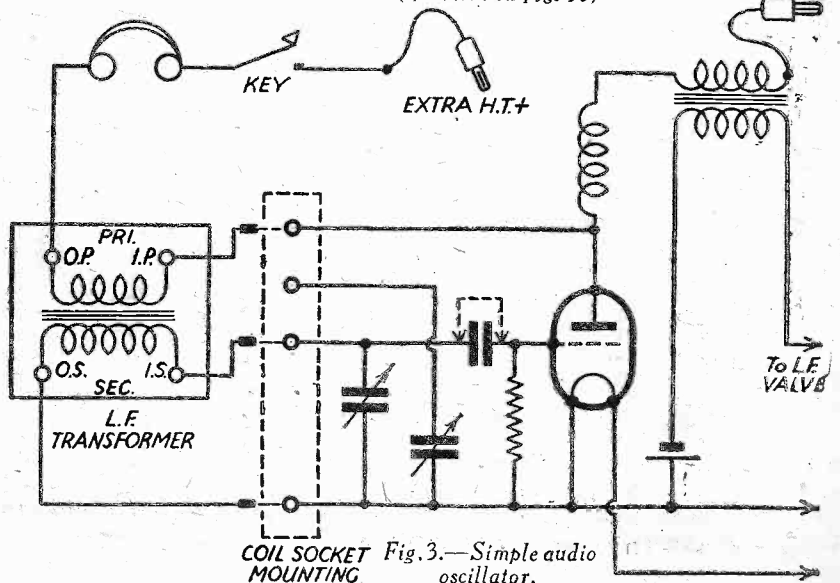

Fig. 3.—Simple audio oscillator.



# OVERLOADING THE DETECTOR

A PRACTICAL ARTICLE DEALING WITH VARIOUS METHODS OF AVOIDING THE TROUBLE. By ERIC JOHNSON



UNTIL the advent of the regional scheme the question of overloading of the detector valve rarely arose. Unless the listener actually lived under the aerial of the broadcasting station, so to speak, he was unlikely to experience this trouble. Nowadays, however, with super-power stations springing up all around us, this fault is becoming increasingly common. The popularity of one or more screened grid stages has also contributed in no small degree to this annoyance by reason of the very high stage gain.

Detector overloading manifests itself as

sacrifice our distant stations we must look around for other cures. If our receiver is a battery model, most probably rectification will be on the "leaky-grid" system which will only deal with a limited input. It is quite a simple matter, however, to convert to the "power grid" principle, which actually shows at its best with a large input such as one is accustomed to get nowadays from the local station.

this may have a very small value, and should certainly not exceed .0001 mfd., provision being made for shorting the condenser when necessary. The great disadvantage of this system is the upsetting

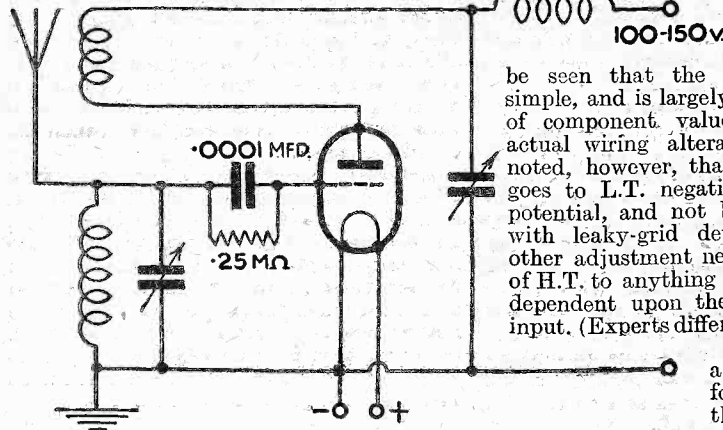

Fig. 1.—The circuit of a power grid detector.

a rather peculiar form of distortion which is somewhat dissimilar to overloading of the L.F. stages. To the inexperienced ear there is little difference—in both cases harshness and blasting are prominent; over-accentuation of sibilants, however, which are produced with a curious rasping sound, may be taken as a likely indication of detector overloading. A cure may be effected in a number of ways. Let us examine these in detail.

**Converting to Power Grid Detection**  
The most obvious method of curing the trouble is, of course, to reduce the pick up of the aerial by shortening it; whilst being most effective, it must be remembered that with a simple set the reaching out capabilities depend almost solely on a good aerial system, so unless we are prepared to

From an examination of Fig. 1 it will be seen that the conversion is very simple, and is largely a matter of change of component values rather than any actual wiring alterations. It should be noted, however, that the grid return lead goes to L.T. negative, i.e., it is at zero potential, and not biased positively as with leaky-grid detection. The only other adjustment necessary is an increase of H.T. to anything from 100-150 volts, dependent upon the valve used and the input. (Experts differ on this point.—Ed.)

Even with this alteration, if we are so unfortunate as to live in the shadow of the station, or our detector is preceded by one or more efficient H.F. stages, overloading may still occur. As mentioned above, we do not want to restrict the range of our set by reducing aerial size; the only alternative, therefore, is to fit some form of pre-detector volume control of which there are several methods. Of course, the fitting of variable- $\mu$  S.G. stages goes a long way to solving our problem, but does not in any way assist the man with the still popular detector plus L.F. set. The cheapest remedy of all is doubtlessly obtained by connecting a small condenser in the lead-in as shown in Fig. 2; for the best results

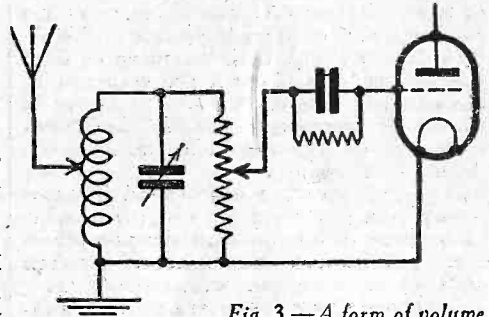

Fig. 3.—A form of volume control which does not affect tuning.

of calibration should our tuned circuit be a simple one as depicted, which is still quite common even in these days of ether congestion.

An arrangement which does not suffer from this drawback is given in Fig. 3. Here a high resistance potentiometer is pressed into service, and the input may thus be reduced at will from zero to the maximum. A rather serious snag is the unavoidable damping introduced and the resistance of the potentiometer must in consequence be high—certainly not less than 10,000 ohms. A variation of this scheme is depicted in Fig. 4, but as this involves a constant changing of aerial capacity across the coil, calibration will be seriously affected. A method very much akin to the foregoing, and one which is superior in many respects, is offered us by the capacity potentiometer system shown in Fig. 5. The only additional component needed is a differential condenser. One set of fixed plates is connected to the "top" end of the grid coil, and the other set goes to earth, the aerial being con-

(Continued on page 36)

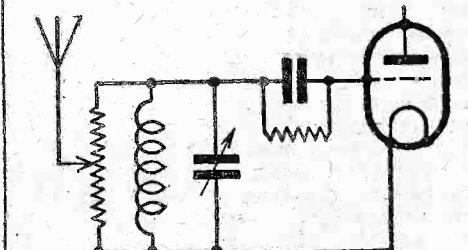

Fig. 4.—A volume control in the form of a potentiometer, which may prove noisy if a good component is not used.

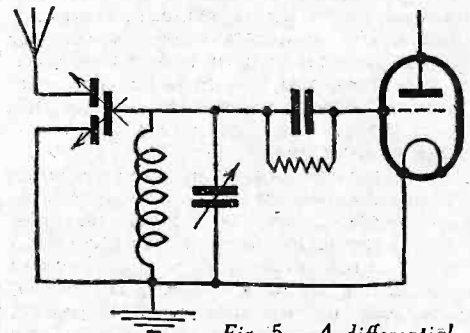
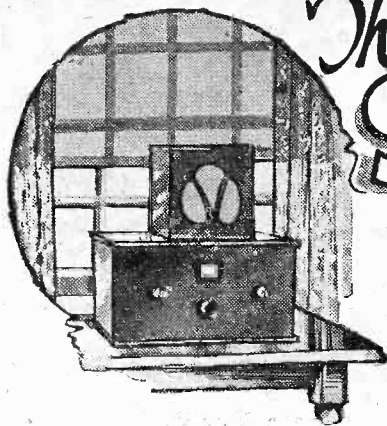

Fig. 5.—A differential reaction condenser used to reduce the input.





# The SUN & WIRELESS SIGNALS

How the Changes in the Ionization of the Heaviside and Appleton Layers Affect Radio Waves

By K. E. BRIAN JAY

**I**N my last article, "How we hear DX," I outlined the way in which the Kennelly-Heaviside and Appleton ionized layers do their job so that my readers should be clear as to the importance of the ionization of these layers. Let me summarize the chief points in that article:—

(a) Radio waves radiated upwards from the surface of the earth are returned to the earth by one of two ionized layers in the upper atmosphere, called the Heaviside layer (60 miles up) and the Appleton layer (160 miles up).

(b) The waves are bent round in these layers by a refractive process, the amount of bending increasing with the number of free electrons per cubic centimetre (electron density) and decreasing with wavelength.

(c) The waves affected are called the indirect waves, and in conjunction with the direct or ground wave give rise to skip distance effects.

(d) The range of indirect waves depends on the height of the layer.

(e) The indirect wave is attenuated in the layer, the attenuation increasing with electron density and decreasing with wavelength.

The important fact that emerges from this summary is that all the processes undergone by the indirect waves depend on the degree of ionization of the layers. It is the ionization that matters, and therefore it is the changes in the ionization that cause most of the queer effects to which radio signals are prone. Clearly, then, we must look to the ionizing agent for an explanation of these effects.

## The Causes of Ionization

In defining ionization I said that a gas molecule becomes ionized when some external agency supplies enough energy to detach an electron from it. In the case of the ionized layers of the atmosphere the source of this energy is the sun, the energy being actually supplied by radiation from the sun. The most obvious of the sun's radiations are, of course, light and heat, but in addition there are the invaluable ultra-violet radiations whose therapeutic properties have been so widely recognised of late years, and it is to these very short wavelength rays that the bulk of the ionization of the reflecting layers is attributed. The invisible ultra-violet rays possess immense energy which easily splits up the gas molecules into ions and electrons. In the case of the lower Heaviside layer there is reason to believe that some of the ionization may arise from another ionizing agent in the form of a stream of corpuscles, actual concrete bodies, shot out by the sun. These corpuscles travel at the relatively slow rate of about 1,000 miles per second

and possess enough energy when they impinge on the atmosphere to split up the gas molecules and ionize them; definite proof of the existence of this corpuscular stream, however, has not yet been obtained. In any case there is no doubt that the sun's radiations are responsible for the existence of our exceedingly useful layers and therefore we should be able to find some connexion between variations in the sun's behaviour and radio conditions.

## Day and Night Effects

The most obvious solar variation is between daytime and night and the corresponding, almost equally obvious, radio variation is in the considerable improvement in signal strength and long and medium waves and the equally marked falling away in signals on waves below about 20 metres, when night time comes on. This may be explained as follows. In full daylight the amount of ultra-violet radiation from the sun is a maximum and therefore the ionization of the layers is very high. The height of the lower surface of the Heaviside layer from the ground depends on the pressure of the atmospheric gas in that region, because the greater the gas pressure the more quickly free ions and electrons will combine with other electrons and ions, so leaving an un-ionized region: below about sixty miles the pressure is so great that ions recombine almost as quickly as the ionizing agent disintegrates the molecules and so there is practically no ionization. It is fairly clear, however, that with a continual stream of ultra-violet radiation there will be a continual supply of ions and electrons and so in spite of the recombination ionization can exist at a fairly low level. As soon as the ultra-violet stream is interrupted no more ions will be supplied and, recombination taking place, the level of the layer will rise. That is what happens at night time; the stream of electron-producing energy is turned off and ions and electrons recombine to form un-ionized gas molecules, the rate of recombination being greatest nearest the surface of the earth and fairly small in the low-pressure regions of the top of the layer and the upper layer. This results in the bottom of the layer rising so that its effective height increases and thus the range of medium waves increases. Also since the electron density is reduced when the sun disappears the attenuation of the waves is decreased, another reason

for medium wave signals being louder. The case of short waves is rather different. Medium-short waves give increased signal strength because the reduced electron density in the Heaviside layer results in less attenuation as the waves pass through it on their way to the Appleton layer. Short waves below 25 to 30 metres, however, find the number of free electrons in the upper layer (Appleton layer) insufficient to bend them round so that they are not returned to earth and therefore not heard at all. In the daytime they are stronger than medium-short waves because although both are returned to earth the short waves are much less attenuated than the medium-short waves.

The height of the Heaviside layer rises about twelve miles during the night, but drops very quickly to its lower value when the sun appears again. Actually the layer is affected by the sun before the latter is visible on the earth (*i.e.*, before sunrise) because the layer is nearer the sun than the earth's surface is.

The above explanation of day and night effects serves also for the difference between summer and winter reception conditions. In summer, of course, the ionization is always much greater and the nights much shorter than in winter, so that medium and medium-short wave conditions are not so good. Below 25 metres, however, many stations may be heard and daylight conditions may last up to 1 a.m. as far as 20-metre signals are concerned.

## Varying Radio Conditions

The next major variation is by no means so obvious, but is noticeable to listeners who have used their sets regularly for a long time and have found that some years produce a better bag of DX stations than others. It has, in fact, been found that general conditions for radio reception vary from year to year, but that the variation is repeated every eleven years. That is to say, that if general conditions were

(To be concluded next week.—Ed.)

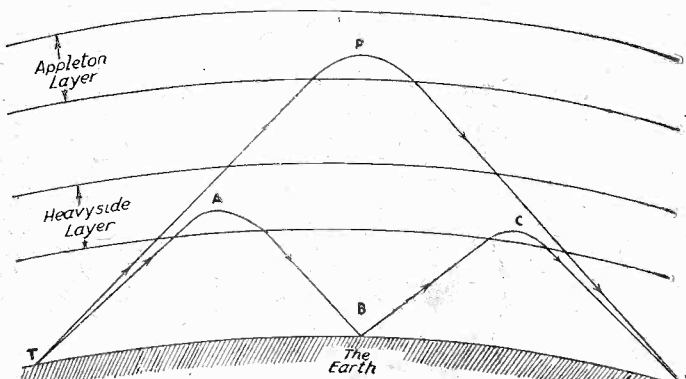

Fig. 1.—Diagram showing the path of reflected signals from the Appleton and Heaviside layers.



Wherever  
wireless  
terms are  
understood  
"Ohmite"  
means  
"The  
Best  
Resistance"



"Better than wire wound."

# OHMITE RESISTANCES

The most popular and efficient type of fixed resistance for all general purposes. "Better than wire wound." All values, 50 ohms to 5 megohms.

HEAVY DUTY TYPE 2/3

# 1/6

# GRAHAM FARISH PRODUCTS



Safe maximum current carrying capacity of "Ohmites."

| 100° F Temperature Rise |            |         |            |
|-------------------------|------------|---------|------------|
| Ohms.                   | Milliamps. | Ohms.   | Milliamps. |
| 1,000                   | 40         | 20,000  | 8          |
| 2,000                   | 35         | 30,000  | 6.75       |
| 3,000                   | 29         | 40,000  | 6          |
| 4,000                   | 24         | 50,000  | 5.5        |
| 5,000                   | 20.25      | 60,000  | 5          |
| 10,000                  | 12         | 80,000  | 4.24       |
| Other values pro rata   |            | 100,000 | 3.5        |

Safe maximum current carrying capacity of "Ohmites" Heavy Duty Type.

| 100° F Temperature Rise |            |         |            |
|-------------------------|------------|---------|------------|
| Ohms.                   | Milliamps. | Ohms.   | Milliamps. |
| 1,000                   | 80         | 20,000  | 16         |
| 2,000                   | 70         | 30,000  | 13.5       |
| 3,000                   | 58         | 40,000  | 12         |
| 4,000                   | 48         | 50,000  | 11         |
| 5,000                   | 40.5       | 60,000  | 10         |
| 10,000                  | 24         | 80,000  | 8.48       |
| Other values pro rata.  |            | 100,000 | 7          |

Ensure a safe and efficient Aerial and Earth. The new AEROFICIENT KIT provides all you need. Complete 6/6  
Send a postcard for our new Catalogue, which describes all our products.

Advertisement of GRAHAM FARISH LTD. } Masons Hill, BROMLEY, Kent.

Export Office : 11/12, Fenchurch Street, E.C.3.





All-important new features *plus*  
*unrivalled quality*



Note how condenser screws so conveniently into base for easy fixing.

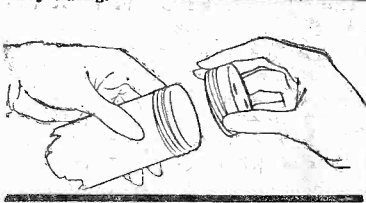

# DUBILIER

## PAPER CONDENSERS

1. True non-inductive type of construction.
2. Available for working voltages from 300-900 D.C. peak.
3. Adequate factor of safety.
4. New method of fixing to chassis.
5. Aluminium containers with moulded bakelite top of distinctive appearance to match other components.
6. Takes up minimum amount of space on chassis.

Prices from 1/9.

Write for your copy of the new Dubilier Catalogue now!

**DUBILIER CONDENSER CO. (1925) LTD.,**  
DUCON WORKS, VICTORIA ROAD, NORTH ACTON, W.3.

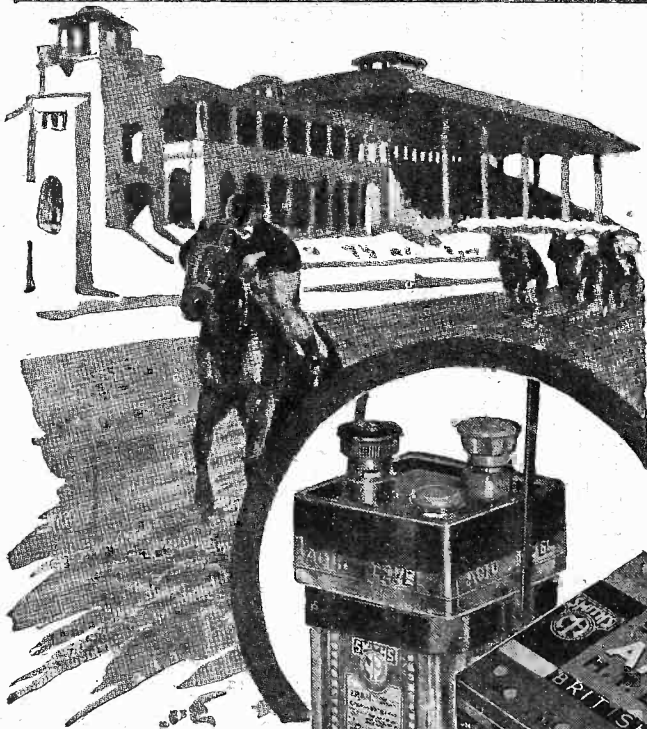

Ask for Smith's 2-volt 40-amp. Accumulator, Anodex 120-volt Triple Power H.T. Battery and 9-volt Grid Bias.

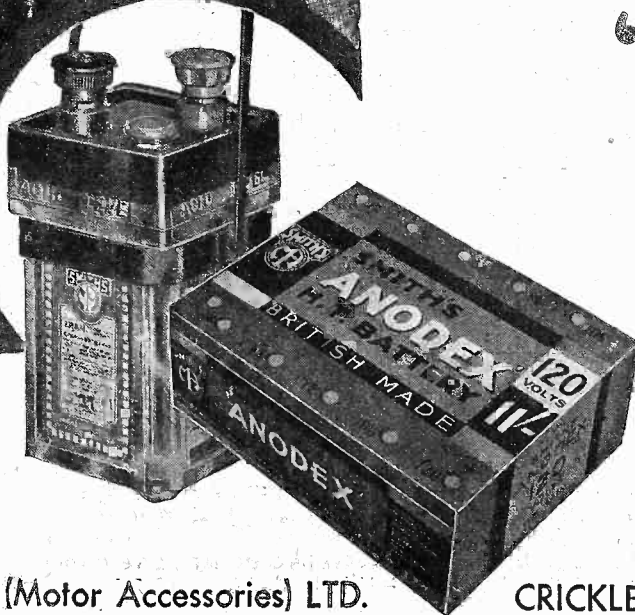

Another Brilliant  
win—

for **SMITH'S**  
ACCUMULATORS

**'ANODEX'**  
DRY BATTERIES

exclusively  
specified  
for the

**"PREMIER  
SUPER"**

S. SMITH & SONS (Motor Accessories) LTD.

CRICKLEWOOD, LONDON, N.W.2.





# READERS' WRINKLES

THE HALF-GUINEA PAGE

**Slow-Motion Device and Full-Vision Scale**  
**T**HOSE constructors who have found the "wrinkle" in June 3rd issue, on "A slow-motion device for reaction condensers" useful, may be interested in this added refinement, so that it may be adapted to a tuning-condenser with a full-vision scale. It requires instead of a narrow piece of ebonite a slightly larger piece. It must be made long enough to be able to glue a scale on underneath the end of the pointer. This is made by cutting a piece of aluminium (an old condenser plate will answer) to the shape shown. A hole is drilled in the end opposite the pointer and a slot cut at the other end. Just clear of the slow-motion gear drill a hole in the ebonite and fasten a bolt in, allowing it to protrude through the slot. The other end of the pointer is

**THAT DODGE OF YOURS!**  
 Every reader of "PRACTICAL WIRELESS" must have originated some little dodge which would interest other readers. Why not pass it on to us? We pay £1-10-0 for the best wrinkle submitted, and for every other item published on this page we will pay half-a-guinea. Turn that idea of yours to account by sending it in to us addressed to the Editor, "PRACTICAL WIRELESS," George Newnes, Ltd., 8-11, Southampton Street, Strand, W.C.2. Put your name and address on every item. Please note that every notion sent in must be original. Mark envelopes "Radio Wrinkles." Do NOT enclose Queries with your Wrinkle.

have another mount short-circuited, as in Fig. 2. I have also extended this idea for plugging in a loud-speaker to the set, as in Fig. 3.—F. RICHARDSON (Poole, Dorset).

**Keeping Battery Leads Tidy**  
**U**SUALLY, when working on a new set, the constructor finds a great deal of trouble in keeping his battery leads from getting entangled. This can be remedied as follows: Take a piece of corrugated

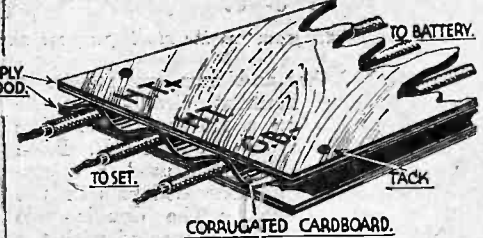

A simple dodge for keeping battery leads tidy. cardboard and run your wires through the corrugations, as shown in the accompanying sketch. Now glue a piece of three-ply wood on the top of this, and mark the connections for the leads, as shown. This simple device keeps the bench tidy and prevents any accidents, such as putting H.T. on the filaments, as very often happens when wires are mixed up. The device can be kept steady on the baseboard by means of tacks.—G. BURNS (Glasgow).

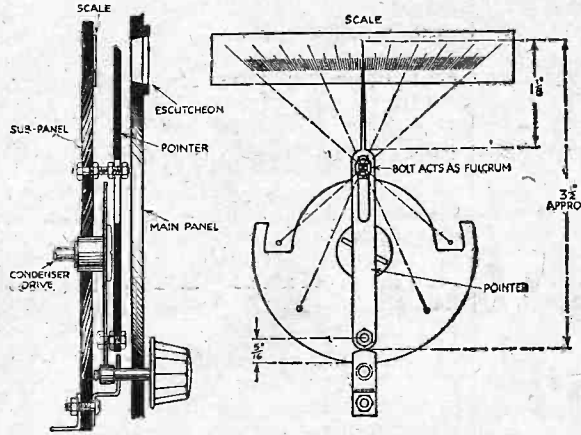

A side and front view of the slow-motion device and full vision scale.

slipped on a bolt on the slow-motion gear. It must be allowed to move freely, but not too much so. Now turn your mechanism to its limit, and make a pencil mark on a slip of paper. Holding it firm, turn the gear through 180 degrees and mark the other end. Between these two marks divide a line into as many divisions as you require (90, 100 or 180) and when finished glue it down in the position it was in when you marked it. A window, slightly larger than the scale, should then be cut in the panel. The sketches clearly show the arrangement.—R. TAYLOR (Sunderland).

**Inexpensive Test Prods**  
**T**HE materials required for making the useful set of prods, shown in the accompanying sketches, is as follows: One 6in. length of tough rubber-stranded wire; one 8in. length of rubber tubing; 1yd. of thin flex, and two clips, wander plugs or spades, as required. The tough rubber-covered stranded wire is used by electricians for power circuits.

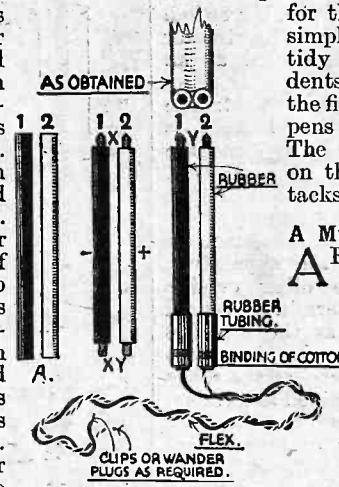

First cut away the outer tough rubber, leaving two separate rubber covered wires, as shown at A. Next remove 1/4in. of rubber from each end of both wires, as shown at X. Coat one end

**A Multi-Purpose Unit**  
**A**FTER a good deal of experimenting I have made a unit which I use for trickle charging, a microphone or pick-up amplifier, half-wave rectifier, and other purposes.

All the components are assembled in an old crystal set cabinet measuring 6ins. by 7ins. by 5ins. The microphone

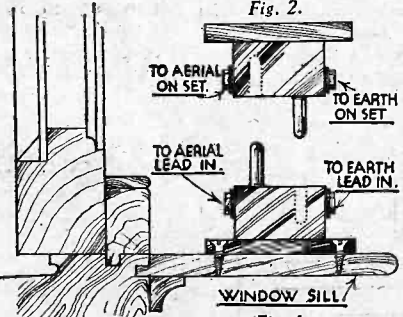

Showing how a use may be found for old plug-in coil mounts.

**Use for Old Plug-in Coil Mounts**  
**I**HAVE utilized two of these mounts as a connection from the set to aerial and earth leads-in, one mount being fixed to the window-sill as shown in Fig. 1. For short-circuiting these when the set is not in use, or during a thunderstorm, I

find it an advantage to bend them whenever an awkward position confronted me. The colours of the rubber are black and white, therefore, an advantage, inasmuch that the meter will always be correctly connected.—W. A. HOOK (Birmingham).

is enclosed in the lid, while the valve and transformer are inside the cabinet with the terminals arranged on a piece of bakelite running across the top of the box. I also have a nine-volt grid bias battery in the circuit of the pick-up terminals and trans-

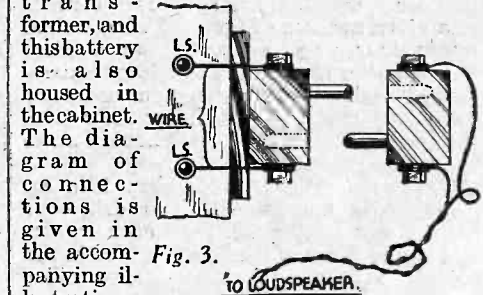

A further use for plug-in coil mounts. (Continued on page 28)



**RADIO WRINKLES**

(Continued from previous page)

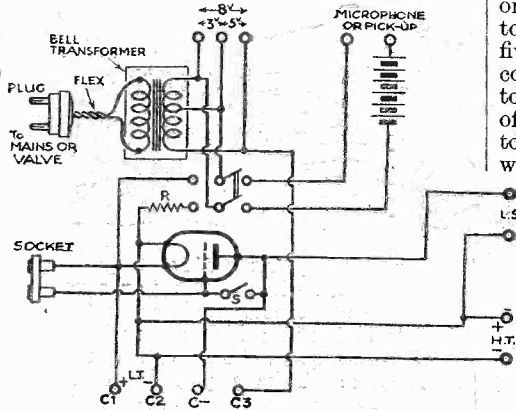

The circuit diagram for the multi-purpose unit.

ponents together as shown, my resistance in the valve filament circuit from the transformer being a 1.5 fuse bulb. The valve used was an old I.L.F. P.M., bought for a shilling. I used a microphone button, and concealed this in the lid of my cabinet. The double-pole double-throw switch is connected with the poles to the three-volt output of the transformer, two spring contacts to the valve filament, and two spring contacts to the microphone or pick-up circuit. The break and contact switch is between the grid and anode of the valve, the switch being closed when using the apparatus for charging, and opened when used as an amplifier.

When the apparatus is used as a trickle charger the negative of the battery is joined to terminal marked C.1— and the positive to L.T.+ terminal on apparatus. In the case of charging three accumulators, they are joined in series, and the positive end of one outside accumulator joined to terminal marked C.3 on the apparatus; the negative end of the other outside accumulator is joined to terminal marked C.— which is always used as the negative pole in charging. For charging two accumulators the positive end of the series connected accumulators is joined to terminal marked L.T.—. For charging, the plug on flex joined to primary of transformer is plugged into the mains supply. When used as an amplifier, the plug is plugged into socket on apparatus.—C. SUTTIE (South Shields).

**An Efficient Indoor Aerial**

TO those readers who are looking for an indoor aerial of an unusual type, the one described below may be of interest. It is quite easy to construct, the cost is negligible, but it will give results far superior to the average indoor aerial, and compares favourably with a well erected outdoor aerial. Briefly, it consists of a given number of turns of wire, wound round four pegs, supported on a piece of wood after the manner of a large square-shaped coil. The construction offers no difficulties and the sketch, together with the following description, should make the method quite clear.

Cut two pieces of plywood about 12in. sq. (the size is not critical), and drill four holes 1/2in. diameter 1/2in. from each corner, and in one piece a fifth hole is drilled in the centre to take an ordinary type pillar terminal; this is for the connection to the lead-in. From a length of 1/2in. diameter wood or ebonite rod, cut four pegs 1/2in. long plus double the thickness of the wooden

sides. Glue the wooden pegs in the piece of wood having five holes, leaving the centre one out. Allow a short time for the glue to set, and then proceed to wind on twenty-five turns of 20 or 22 gauge d.s.c. or d.c.c. copper wire. Commence winding at the top left-hand peg (anchoring the start of winding securely to same), and proceed to put remainder of turns on in a clockwise direction, taking care to keep the wire tight and free from kinks. At the twenty-fifth turn, stop at the bottom right-hand peg, and finish off by looping end of wire round the centre pillar terminal. The insulation will have to be removed before making connection to this point, this being the connection for the lead-in to the set. The second side can now be glued in position, and if strips of wood, cut to size, are glued to sides of frame, the winding will be dust-proof. A small eye screwed to the back of the frame will enable it to be hung in any part of the room.

When hung on the wall in an upper room with a good shielded lead-in of the seven strand type, this arrangement will give remarkable results, both as regards selectivity and volume; it will also eliminate the interference from the house wiring installa-

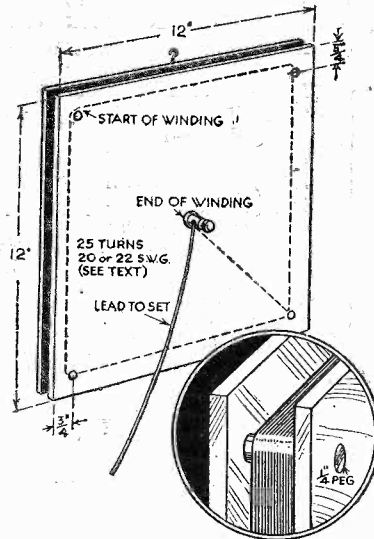

An efficient indoor frame aerial.

tion. If you use a series condenser in your aerial lead, you can dispense with it, as there is no need for it with an aerial of this type. If the wood is stained or papered to match the colour scheme of the room, the lead-in taken along the picture moulding, down the wall, through the floor board, and then to the set, it will not be seen, but the aerial will still function efficiently. If tuning should be too sharp, add one or

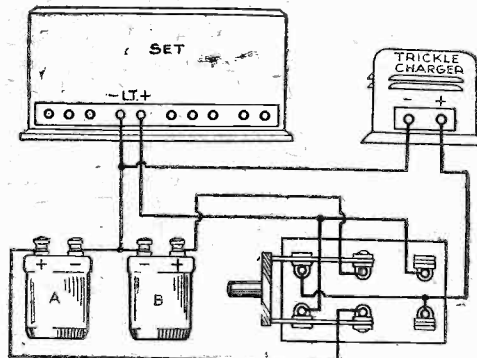
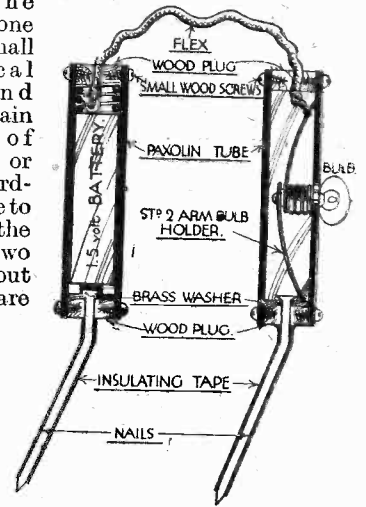

Fig 2.—A switching arrangement for accumulator charging.

two more turns to winding.—W. ASPINALL (Manchester).

**A Pair of Testing Prods.**

AS can be seen from the accompanying sketch, these testing prods are very easy to construct, and they are very useful for testing in difficult corners. First choose the battery, one of the small cylindrical type, and then obtain a piece of paxolin, or tough card-board tube to fit over the battery. Two nails about 3in. long are next required, and four pieces of hard-wood, 1/2in. thick, and the same diameter as



Useful self-contained test prods.

the inside of the tube. Hammer a nail through the centre of each piece of wood, taking care not to split them. Put a washer under the head of each nail to ensure good contact, and proceed to bind insulating tape round the nails, leaving a 1/4in. bare at the ends. Then fit another wooden disc in end of tube, either by two wood screws or glue. Thread flex through holes in the discs, which should be about 1/2in. diameter, and solder to the spring, which can be obtained from an old torch. After putting the battery in the tube, fix the plugs, holding the prods with two wood screws.—E. BARNES (West Ealing).

**Two Useful Dodges**

A SIMPLE method of "slowing down" the tuning on the short-wave band is to reverse the end fixed plate of the tuning condenser (the inside one is to be preferred to avoid fouling any other components), so that, as you tune up the scale, the moving plates are travelling "in" to the reversed plate, as they are travelling "out" to the normal fixed plates. It broadens the tuning to a remarkable degree, due, I suppose, to the starting with a higher minimum, moving to a lower maximum. (See Fig. 1.)

The second illustration, Fig. 2, shows the connections for switching an accumulator (A) from a trickle-charger to the set, at the same time switching another accumulator (B) from the set to the trickle-charger with one movement of an ordinary double-

pole, double-throw switch (or a D.P. D.T. jack-switch), and without any troublesome changing over of leads. The first-named type of switch is to be preferred on account of the greater isolation of the

Fig. 1.—Method of slowing down tuning on the short-wave band. —A. BINGHAM (Liverpool).

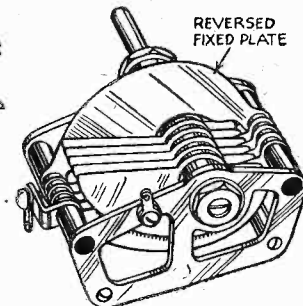



**NEW—  
and better  
than many  
at double  
its price**

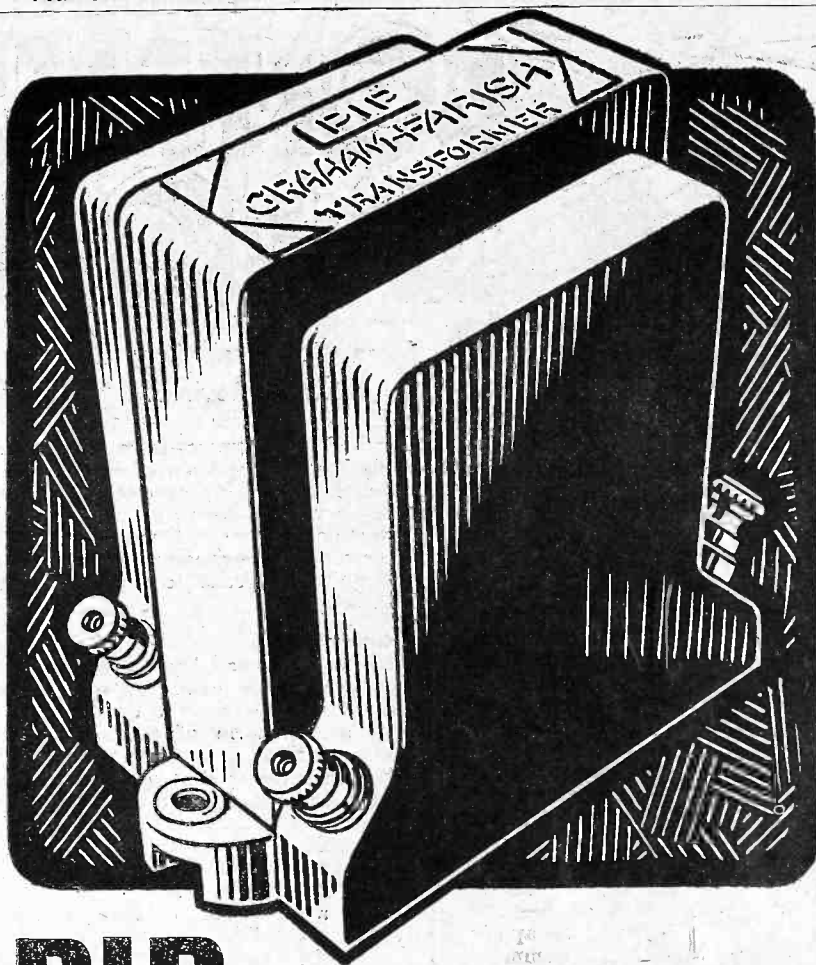

## PIP TRANSFORMER

The PIP transformer is thoroughly sound in construction and design and gives a result equalling and often better than others at a much higher price.

In distinctive red case with nickel terminals.

Made in 3:1 and 5:1 ratios.

PRICE

**6'6**

# GRAHAM FARISH PRODUCTS



Ensure a safe and efficient Aerial and Earth. The new **6'6** AEROFICIENT KIT provides all you need. Complete

Send a postcard for our new Catalogue, which describes all our products.

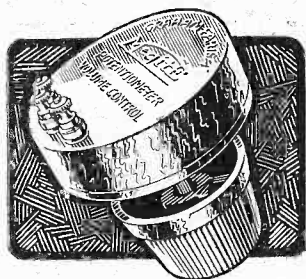

### MEGITE POTENTIOMETER VOLUME CONTROL

The element is of the fine nickel-chrome wire embedded in bakelite. The action is through a slipper plate, giving a smooth, positive contact, absolutely silent operation and making broken contacts impossible. Three terminal type. Single hole fixing. Complete with operating knob.

PRICE 3/6

25,000 ohms. and over 4/6.

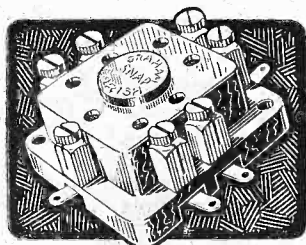

### VALVE HOLDERS

These Valve Holders have exceptionally low loss moulded bases, the insulating material between sockets being reduced to a minimum. Contacts are of phosphor bronze, sturdy in design.

Four Pin Type, 6d.      Five Pin Type, 8d.      Seven Pin Type, 1/3.





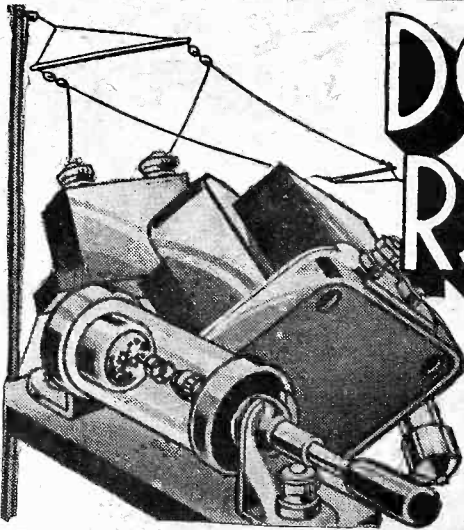

# DON'T PERPETUATE RADIO FALLACIES

Some Notes and Suggestions on a few Common Ideas that need to be Forgotten or Revised.

By H. BEAT HEAVYCHURCH

**E**VEN such a comparatively new scientific development as radio is not free from the danger of being hedged in by false ideas very akin to superstitions. For this reason, every technically-minded listener ought to endeavour to keep abreast with the advances in both the theory and the practice of radio and be ready to jettison old beliefs in favour of the latest ideas.

Looking back to the early days of broadcasting, in the light of modern knowledge, it is easy to see how a number of misconceptions and fallacies arose—fallacies of which listeners ought to disabuse their minds at once.

## First of All, Aerials

For example, just because the original broadcast licence limited the total length of wire in a receiving aerial to one hundred feet, the public came to the conclusion that the longer the aerial the more efficient it was. Actually, of course, it is the effective height and not the length of aerial which counts, the longitudinal portion having very little to do with its efficiency. Another fallacy in connection with aerials is that it is desirable always to use the full hundred feet of wire. With present-day high-power transmissions and congested wavebands, and with modern highly-sensitive radio frequency amplification, a too-efficient aerial is something of a disadvantage; stations come in too powerfully to be tuned out, i.e., selectivity is at a premium. It often pays, if selectivity is poor, to reduce the height and length of the aerial and to make fuller use of your H.F. stages.

Before we leave the aerial, let us scotch another superstition, namely, that the best reception is obtained when the aerial is pointing directly in line and away from the station it is required to receive. There is little, if any, foundation in fact for this theory, and if there was, the effect of a directional aerial would be almost entirely masked by other local conditions, such as the contour of the surrounding country, shielding, and so forth. Besides, with our modern receivers, we desire to receive stations from every point of the compass, so that little purpose would be served in designing an aerial which would be particularly effective in one direction.

## L.F. Coupling

The next fallacy which I should like to lay low is that L.F. transformer coupling is vastly inferior to R.C.C. I admit to a particular liking, personally, for resistance capacity coupling—but for quite other reasons. I will readily admit, however, that the average, let alone the best present-

day L.F. transformer, is so very superior to the best production of early broadcasting days, that this form of coupling, properly used, is very unlikely to introduce serious distortion. Indeed, I would go farther, and say that a reasonably good transformer is definitely superior to a poorly-designed R.C. coupling.

## Detectors

Many fallacies have arisen around detectors. For example, many people imagine that a crystal detector is the most perfect form of rectifier from the quality point of view. As a matter of fact, the curve of the average specimen of crystal is very far from linear, and the device can distort quite badly. This may not be very noticeable when using headphones, but many of us recollect the bitter disappointment we experienced when first we coupled a crystal set to a two-valve low-frequency amplifier.

Then there is a fallacy that an anode bend detector is necessarily freer from distortion than a leaky grid detector. It is nothing of the sort. On weak signals it distorts far more than a rectifier of the leaky grid type, while if the applied signals are too strong, double rectification will also occur, with the consequent distortion. All statements concerning detectors need to be governed by other conditions, one of the most important being strength of signal.

Do not run away with the idea, also, that all you have to do to convert an ordinary leaky grid rectifier into a power grid detector is to increase the high-tension voltage. Increase them you must, for that is one of the essential features of power grid, but you must also make certain alterations to the values of the grid condenser and grid leak—usually both must be very considerably reduced.

Again, the unfortunate choice of the term "power grid" has given rise to the wholly fallacious idea that a detector of this type necessarily increases the output power, and hence the volume of the receiver. The only reason for power grid detection is to enable the detector stage to rectify bigger signals without an undue amount of distortion—in other words, to increase the effective grid base of the detector valve. In a receiver employing one or more efficient stages of high frequency amplification, comparatively large voltages are available at the grid of the detector and an ordinary leaky grid detector operated at a low anode voltage is apt to distort them. By increasing the working anode voltage, however, the acceptance of the valve is greatly increased.

## Distortion

While on the subject of distortion, it will be as well to point out that the belief

that distortion occurs mainly in the low frequency and detector stages is quite erroneous. From personal observation I am convinced that in the average set the low-frequency side is usually remarkably free from distortion—components have improved so greatly in design and the valve makers instructions anent correct grid-bias have very generally been taken to heart. What distortion does occur on the low-frequency side generally is the result of overloading the output valve, of which, however, more later.

A considerable amount of distortion certainly occurs in the detector stage, generally due to incorrect operating conditions, or to the misuse of reaction, but the stage which is the most prolific source of distortion is the high-frequency stage. Overloading, by which, of course, is meant applying too great a signal voltage to the grid of the valve, is of very frequent occurrence in the high-frequency side, and especially in the second of two radio frequency stages. As a result, partial rectification of the signal occurs in the high-frequency stages, the H.F. valves being able to amplify without distortion only a limited input signal. It is for this reason that the variable- $\mu$  screened-grid valve was introduced. The effect of increasing the negative grid-bias applied to a variable- $\mu$  valve is very similar to the effect of increasing the anode voltage to a "power-grid" detector, namely, to increase the acceptance of the valve, that is to say, to increase the valve's signal handling capacity. In the case of the variable- $\mu$  valve, however, an increase of grid-bias also has the effect of decreasing the sensitivity of the valve. A variable- $\mu$  valve, therefore, not only permits of adjustment in order to avoid overloading and distortion on strong signals, but also forms a very convenient method of controlling volume.

## On the Output Side

The output stage of a receiver is a most fruitful source of radio fallacies. A very common one is that by reducing the volume of sound it is possible to reduce the anode consumption and thus save high-tension current. Except in the case of a Class "B" valve, this is absolutely untrue. A receiving set fitted with an ordinary triode or pentode output valve will always take the same amount of high-tension current, whether the signal volume is loud or soft and even when no signal is being received at all. The high-tension current is fixed by the value of grid-bias and high-tension voltage. What actually happens is that as the volume control is turned up, a larger proportion of the power drawn from the high-tension source is converted into sound energy. Things are rather different in the case of a

(Continued on page 56)



# GREAT BIRTHDAY OFFER



*The*  
**"Practical Wireless"**  
**POCKET TOOL KIT**

*For Every Reader*

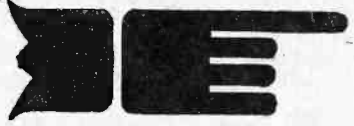

**SEE OVER**



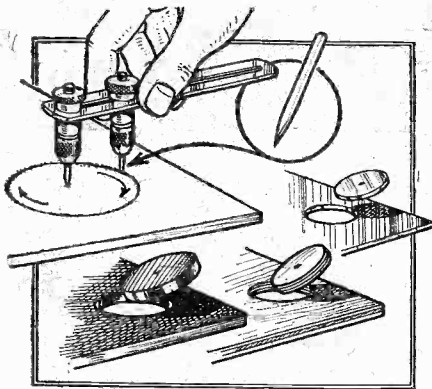

# Exclusive Offer

## the "Practical Wireless"

**T**HIS is unquestionably the most amazing offer ever made by a wireless paper to its readers.

With the object of serving the needs of home constructors and regular readers of PRACTICAL WIRELESS (and thereby still further strengthening their regard for this paper) the Editor has designed for the purpose of this great offer the special case of wireless instruments illustrated on the previous page. These tools could not be purchased in the ordinary way for less than 12s. 6d. The case is of handy size, coloured in Emerald Green and measuring 6½ in. x 4 in.

Every item in the Kit is made from the best quality steel, and each tool fits snugly in its place in the handy metal case with its specially recessed bed.

The battery of tools provides the home constructor with a ready means of carrying out the various operations required in the construction of the most complex circuit. Every tool has been

### HERE ARE THE SIMPLE CONDITIONS

All you have to do to obtain your Pocket Tool Kit is:—

- (a) Complete the Forms below in ink.
- (b) Post Form No. 1 and stamped address label.
- (c) If not already a regular reader hand Form No. 2 to your Newsagent.

On receipt of Form No. 1 and the address label, we will send you a special Subscription Voucher, on which to qualify for your Pocket Tool Kit. Your Kit will be reserved for you, and will be despatched immediately we receive the completed Subscription Voucher.

Affix to the Subscription Voucher which we post to you 11 Gift Stamps cut from the bottom left-hand corner of the back page of PRACTICAL WIRELESS for 11 consecutive weeks commencing this week. (Gift Stamp No. 52).

When your Subscription Voucher is complete, send it, together with a Postal Order for 3s. 6d., to include registration, postage, packing, insurance, etc., to PRACTICAL WIRELESS Presentation Department, and your Pocket Tool Kit will be despatched to you immediately.

No reader may qualify for more than one Pocket Tool Kit.

This offer applies to persons residing in Great Britain and Ireland. Readers in the Irish Free State must pay any duty imposed.

IT FITS THE POCKET!



*Made to fit the pocket*

The Test Prods.

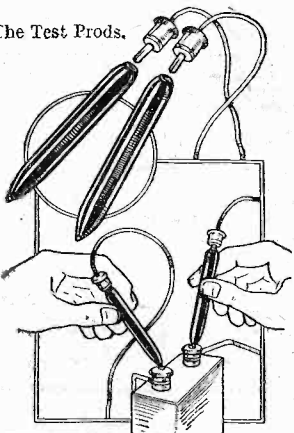

The Viewing Mirror.

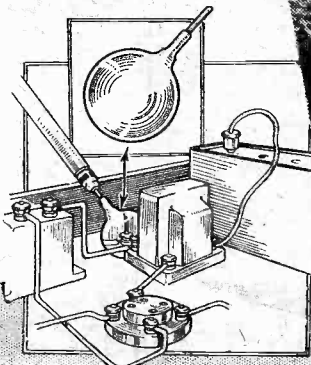

If undelivered to Geo. Newn

Name .....

Street .....

Town & County .....



# To Every Reader! POCKET TOOL KIT

The Free Gift Spanners.

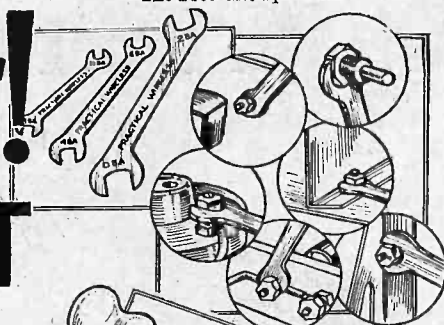

Designed for the purpose and can only be bought in the shops.

Designed to the accommodating recesses for the tools mentioned in the accompanying list, recesses are provided in the metal bed to receive the tools presented with this week's and next issues of PRACTICAL WIRELESS.

This is a sound engineering job. All of them, for all the many uses to which they may be put, are illustrated here.

It is necessary to stress the extreme value of the kit for the practical man, but for the sake of the ordinary reader we may point out the virtue of the kit by saying "a place for everything and everything in its place!"

To the care and expense necessary in the design of the Kit it will not be possible to offer. Do not therefore delay—but get your Pocket Tool Kit at once!

Note the slots specially provided in the box for the three Gift Spanners given free with this week's and next week's issues of PRACTICAL WIRELESS. When these are added the battery of tools is complete.

## LIST OF TOOLS IN THE "PRACTICAL WIRELESS" KIT

One 4in. spring steel Chesterman rule No. 300D-2.

One special steel scriber with adjustable chuck for scribing point renewal.

One pair of special ebonite test prods with wander plug socket ends and brass test points.

One special 4in. trammel with one fixed and one sliding head enabling circles to be scribed from 0 up to 3 3/8 in. in radius. This tool may also be used for cutting holes in ebonite and baseboards too large to be drilled in the ordinary way.

One 60 degree 16-gauge steel set square with finger fret, for easy use.

One special viewing mirror for inspecting obscure parts of the set. This viewing mirror fits into the scriber chuck.

One steel screwdriver with brass ferruled handle, extremely useful for locking screws, securing components to baseboard, etc.

And the three steel spanners O-B.A., 2-B.A., 4-B.A., 6-B.A., 8-B.A., 10-B.A., given Free to every reader of PRACTICAL WIRELESS fit in a special recess beneath the set-square.

The Special Screwdriver and Centro Punch.

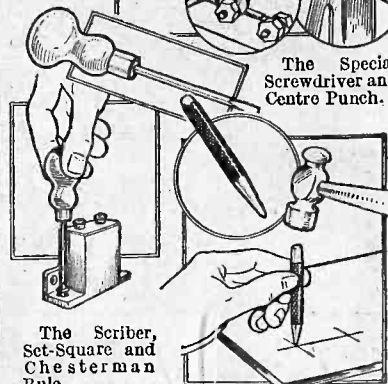

The Scriber, Set-Square and Chesterman Rule.

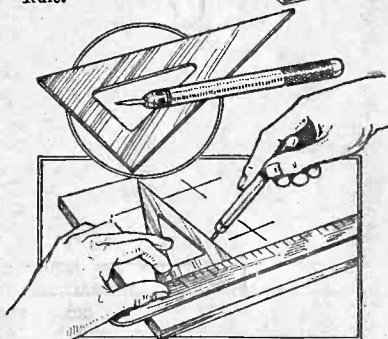

The Scribing and Cutting Trammel.

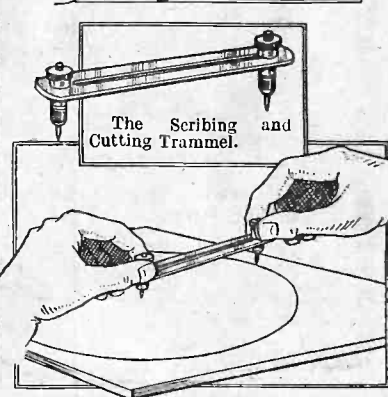

### DON'T DELAY — ACT TO-DAY AND THUS MAKE SURE OF YOUR KIT!

return to W.C.2

1d. Stamp must be affixed here.

**1 POST THIS FORM IMMEDIATELY TO PRACTICAL WIRELESS**  
Presentation Department, T.K.  
39, King Street, Covent Garden, London, W.C.2.

In accordance with the conditions of your special offer please send me a SUBSCRIPTION VOUCHER on which to qualify for my Pocket Tool Kit. I have asked my Newsagent to deliver PRACTICAL WIRELESS regularly every week until further notice.

Reader's Name .....

Full Address .....

Newsagent .....

Address .....

Reader's Signature .....

Fill in this form and the label on left in Block Letters. Stamp the label as directed and post both of them in an unsealed envelope (1d. stamp only required)

**2** If you have NOT placed a standing order with your Newsagent for the regular delivery of PRACTICAL WIRELESS, hand him the order form below without delay.

**PRACTICAL WIRELESS ORDER FORM for NEWSAGENT**

To .....  
Newsagent)

Address .....

Please deliver (or reserve) PRACTICAL WIRELESS for me weekly until further notice.

Name .....

Address .....

Date .....

**PLEASE WRITE IN CAPITAL LETTERS.**



# Britain's Foremost Reproducers

"TYPE 60" DIFFERENTIAL ARMATURE. Dia., 12in. **21/-**

"BANTAM" P.M. MOVING COIL. 2 models. Dia., 7½ in. **27/6**

"CHALLENGER" P.M. MOVING COIL. 5 models. Dia., 8½ in. **35/-**

"ALPHA" P.M. MOVING COIL. 2 models. Dia., 10½ in. **52/6**

"VICTOR" P.M. MOVING COIL. Dia., 10½ in. **70/-**

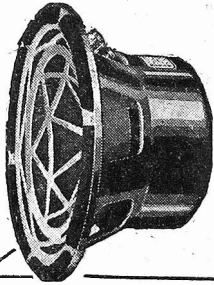
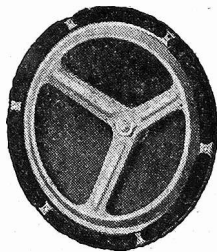
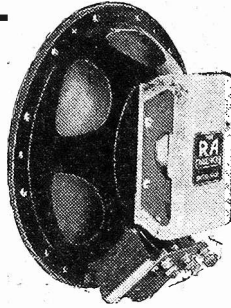
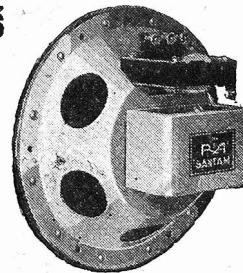
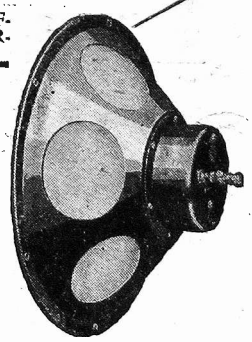

Write us for 1934 leaflet and ask your dealer to demonstrate.

REPRODUCERS AND AMPLIFIERS, LTD., WOLVERHAMPTON.



## POLAR for SOUND DESIGN

### FAMOUS SINCE 1922!

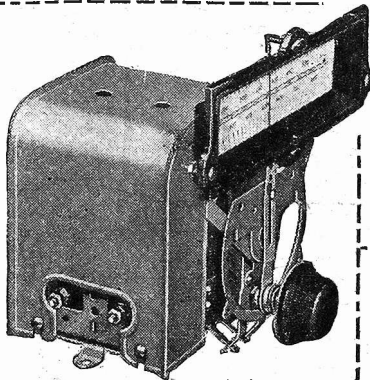

#### POLAR STAR MINOR TWO-GANG CONDENSER

Cadmium plated steel frame. Trimmers operated from top. Matched within 1% or 1 mfd. (whichever is the greater.)

2 x '0005 With full vision "horizontal" drive as illustrated, **18/3.**

**12/6**

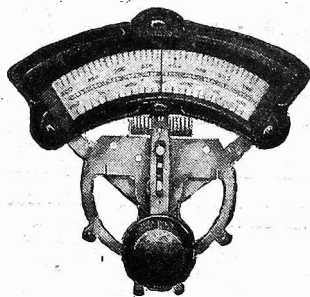

#### POLAR "ARCUATE" DRIVE

Slow-motion drive. Bevelled scale in wavelengths and 0-100 degrees. Moulded escutcheon, Lampholder.

**5/9**

Fitted with air-dielectric trimmer as "Uniknob" design, **7/9.**

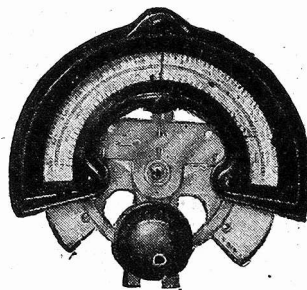

#### POLAR "SEMI-CIRCULAR" DRIVE

Slow-motion drive. Bevelled scale in wavelengths and 0-180 degrees. Moulded escutcheon. Lampholder.

**5/9**

Fitted with air-dielectric trimmer as "Uniknob" design, **7/9.**

#### POLAR 'MOVING SCALE' DISC DRIVE

Slow-motion drive. Bevelled scale in wavelengths, and degrees 0-180. Moulded escutcheon. Lampholder.

**4/6**

Fitted with air-dielectric trimmer as "Uniknob" design, **6/6.**

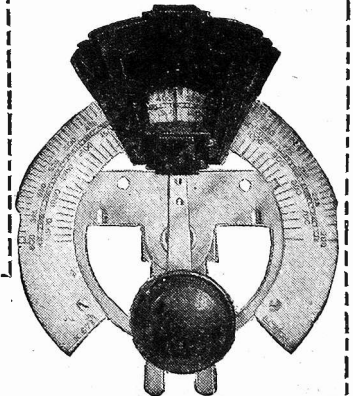

SEND FOR NEW POLAR CATALOGUE

### WINGROVE & ROGERS, LTD.,

188/9, STRAND, LONDON, W.C.2.

Polar Works: Old Swan, Liverpool.

Phone: Temple Bar 2244/5/6.



# TELE-TALKIE TOPICS

By H. J. BARTON CHAPPLE, Wh.Sch., B.Sc. (Hons.), A.C.G.I., D.I.C., A.M.I.E.E.

**R**ADIOLYMPIA provided an excellent opportunity for learning exactly what readers wanted, and it was most gratifying to find that such a number are

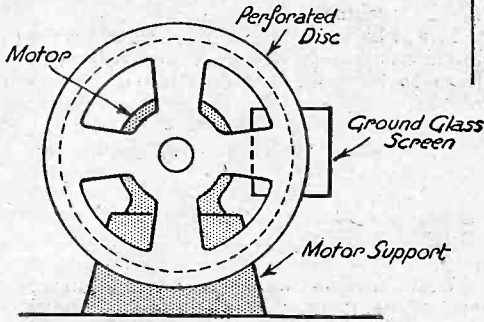

Fig. 1.—Testing the disc for faults arising from incorrect spacing.

keenly interested in the practical side of television. In response to many requests, therefore, I am continuing my Tele-Talkie series, and in this article I propose to continue the subject where it was left in the July 15th issue.

Let us assume that the directions have been followed carefully and that the thirty-hole disc has been punched and the brass boss added. Obviously the thing to do now is to carry out one or two simple tests in order to ascertain whether the marking out and punching operations have produced a disc free from mechanical errors. There are several ways of doing this, but I shall content myself with describing one.

### Common Disc Faults

The commonest disc faults arise from two causes—namely, lines (black or white) due to incorrect spacing of the holes along the radii, and “steps,” or a jagged line effect brought about by mistakes in marking-out the angles between individual radii. To check the former, mount the disc on its motor shaft and revolve it before a diffused light source, such as a ground-glass screen in front of a metal filament lamp, or even butter-paper will do if you cannot lay your hands on a

Overlap (White Line)    Underlap (Black Line)    Angulation (Error)

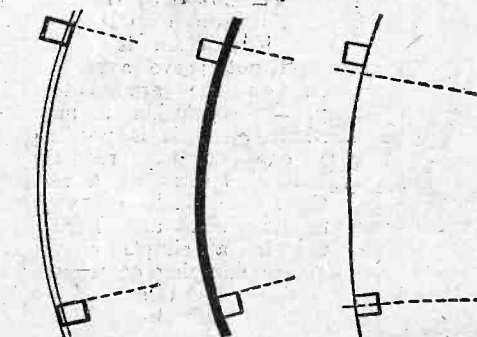

Fig. 2.—Indicating the three possible mechanical errors in the disc.

piece of suitable glass. The idea is shown in Fig. 1, the screen with the lamp behind it being mounted conveniently on a block of wood.

If any black vertical lines are noticed as the screen is observed through the disc holes, then this may be due to dust clogging the punched apertures, and the offending particles are best removed with a stiff brush. Or again, the punching operations may have produced burrs, and these should be rubbed down with very fine blue-back emery paper. Should any black lines still persist, it shows that two adjacent holes have their respective inner and outer edges underlapping instead of being on the same circumferential arc. The defect is remedied with

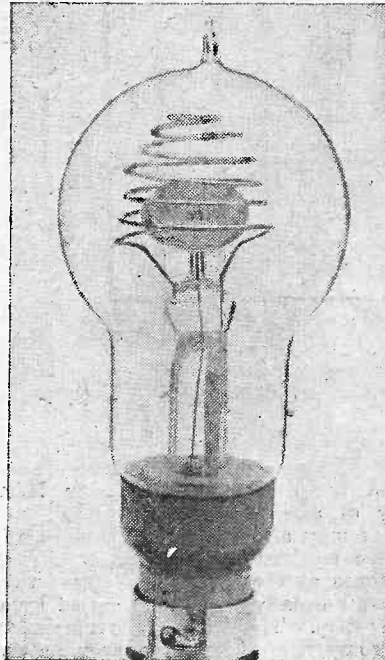

Fig. 3.—A simple-beehive Neon which can be used in a disc model television receiver.

a fine three-cornered jeweller's needle file. Be sure to check the disc repeatedly while carrying out these filing operations, so as to ensure that too much metal is not removed from the offending hole sides.

Sometimes the hole edges overlap, and this causes white lines to appear. This effect can be quite readily tolerated, but for those amateurs who desire to remove them it will be found a good plan to “spread” the metal at the hole edges by using a flat punch and light hammer taps. The jeweller's file will then be brought into commission once more to trim the hole sides.

Where angular errors exist their presence will not be detected until the disc is actually being used for receiving the television images. Then a straight line will have an irregular stepped effect, and metal spreading and filing will soon put

matters right again. The three effects just described are shown in simple form in Fig. 2, and are self explanatory. Of course, if the disc should be mounted eccentrically on the motor shaft then naturally the scanning operation will be very irregular and matters can only be put right by remounting the boss.

### The Neon Lamp

Assuming that we now have our disc mechanically perfect, attention must be turned to the source of illumination which has to be modulated by the incoming television signals. A Neon lamp is used here and can be of the flat plate variety such as was illustrated on page 857 of the September 2nd issue or of the beehive

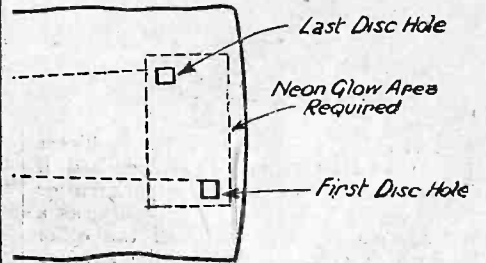

Fig. 4.—The dotted rectangle shows the neon glow area necessary.

pattern as shown in Fig. 3. The former is the better type as the neon glow is diffused evenly over the rectangular plate surface. It is necessary to furnish a polarizing current of about 25 milliamperes, however, while a voltage in the neighbourhood of 180 is essential for “striking” the lamp and maintaining the required brilliancy.

These two facts, coupled with the high cost of this special type of lamp, make it necessary in many cases to adopt the beehive or lettered neon pattern as a substitute. They work quite satisfactorily, but naturally, since they are rated at a much smaller milliamp consumption, the resultant television image is not so bright. Again, the neon glow is not diffused evenly over a flat area, and it is a great advantage therefore to “doctor” the lamp before using it.

This is done by attaching very carefully over the glass bulb a layer of tinfoil such as one obtains from chocolate or cigarette packets, leaving a “window” slightly larger than the area formed by the rectangle as indicated in Fig. 4, which shows the first and last holes on the punched disc. The foil may be stuck on with glue and where possible the “window” should be “frosted.” The neon glow will then be diffused, while the tinfoil covering will serve to reflect the light inside the bulb and give a better illumination. In my next article I shall deal with suitable lenses.

## Just Published THE WIRELESS CONSTRUCTOR'S ENCYCLOPEDIA

(2nd Edition) By F. J. GAMM (Editor of "Practical Wireless")

THIS invaluable encyclopedia is written in plain language by one of the most accomplished designers and writers on wireless construction. The whole subject is fully covered, and the volume is remarkable for the number of practical illustrations it contains.

No matter in what branch of radio you are interested, you will find everything adequately dealt with here.

Obtainable at all Booksellers, or by post 5/4 from Geo. Neumes, Ltd., 8-11, Southampton Street, Strand, London, W.C.2.

5/-



# Short Wave Section

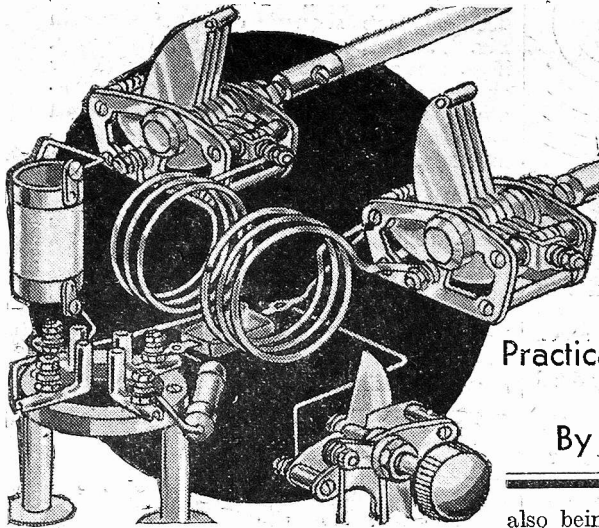

Practical Points on the Technical Side  
By MANDER BARNETT

THE value of a short-wave test oscillator would be more, quickly realized if more short-wave experimenters would regard this piece of apparatus as a very necessary addition to all the other parts which go to make up the average short-wave amateur's test bench—or, to be rather less polite, the "junk box"! A test oscillator has many practical uses, and it can easily be built up from old parts lying on hand. The circuit of such an oscillator is given on this page. It can be regarded more or less as the foundation circuit for a single-valve oscillator, as there are very many variations of this circuit in use to-day. This one is, however, probably the most useful for general work. The coils in the oscillator circuit, comprising L1 and L2, may take the form of any convenient type of plug-in coils, preferably also with coils available for the medium and long waves. The choke L3 will either have to be of the special type of choke which will operate efficiently from about 14 to 2,000 metres or, alternatively, two chokes may be used to cover these wavebands, a short-wave choke being connected immediately after the valve anode, followed by a normal choke, the two being connected in series. The whole oscillator can be built into a small wooden case (don't make the mistake of shielding it as we are relying on the coils in the oscillator to do an amount of radiating, although there is no objection to using a metal front panel), the batteries themselves

also being included in the case. For any degree of accurate calibration it is very important to see that the value of high

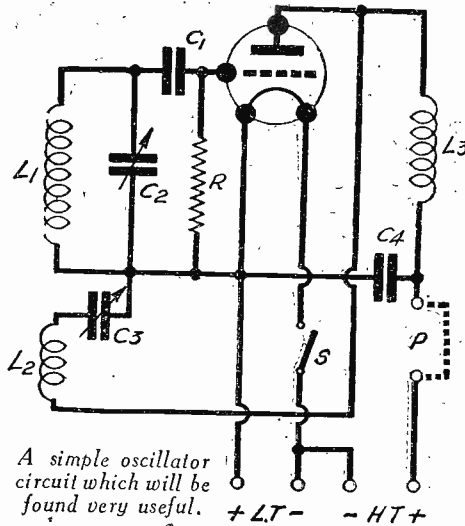

A simple oscillator circuit which will be found very useful.

tension used is kept constant—thus a lower or higher value will produce slight alterations in the dial readings. If an H.T. battery of about 60 volts is used, the oscillator may also be used as a complete one-valve receiver by inserting a pair of headphones at the point "P," these two terminals normally being kept closed by a shorting strip. The values of the remainder of the components used are approximately

as follows: C1—.003 mfd., C2—.00025 mfd., C3—.00025 mfd., C4—.0003 mfd., R—2 megohms.

It will be seen that in order to cover the broadcast bands a number of coils will have to be used, owing to the small size of the condenser C2. A larger condenser could be used, but this would very materially reduce the usefulness of the unit on the short waves. Almost any type of 2-volt battery valve can be used to produce oscillations, but with a general purpose type of valve the H.T. consumption will not be more than about 1.5 milliamps.

Using the oscillator is a very simple matter as it only requires to be placed near the short-wave receiver, and it can then be calibrated by tuning in one or two of the more prominent short-wave stations on the receiver and turning the oscillator dial until a "chirp" is heard, plotting the oscillator dial readings on some squared paper. For anything approaching accurate calibration it is necessary to receive at least three stations of definitely known wavelength. It is also very important to note the setting of the reaction condenser C3. If the position of this condenser is changed, the corresponding dial setting on the tuning condenser C2 will also be changed. It is, however, necessary to use a variable condenser here owing to the fact that reaction effects are very much stronger at one end of the tuning dial than at the other, and that if they become too strong the oscillator will not produce a pure note and will become more or less uncontrollable. It is therefore advisable to fit a small dial on the reaction condenser in order that a definite note of the required setting in relation to that of the tuning dial may be made.

In the next article some further notes will be given concerning the various uses of this oscillator.

## OVERLOADING THE DETECTOR

(Continued from page 23)

ected to the moving vanes. The great point in favour of this scheme is that tuning is not altered to such a serious degree; as the aerial capacity across the coil is reduced when we are decreasing the input, so a compensating increase in capacity results by the moving vanes engaging with the other set of fixed plates. By a happy choice of condenser size, which should be selected by trial and error, it will be found that the capacity increase on one side can be very nearly balanced by the corresponding decrease on the other. Little change of tuning should then be noticed.

### Using a Diode

Although any of the above suggestions can be very effective for the prevention of detector overloading, by far the best

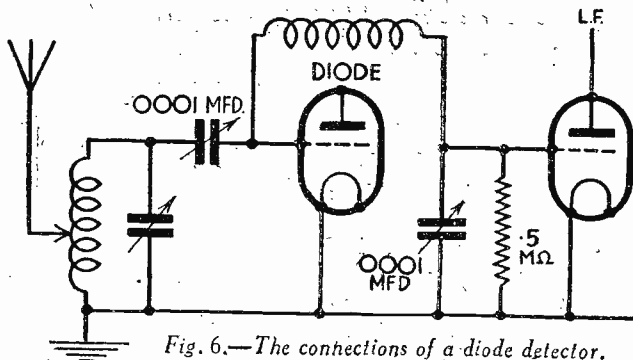

Fig. 6.—The connections of a diode detector.

solution to the problem is to choose some system of rectification which will not overload however high the input, and should the output be in excess of our requirements, fit post-detector volume control which, in general, is more easily achieved without any accompanying disadvantages.

Diode detection is undoubtedly the only sound method; it is virtually impossible to overload a diode, but absolutely no amplification is obtained therefrom, and an extra L.F. stage will be necessary as shown by Fig. 6. As a diode consumes no H.T. (or very little if reaction is fitted) this should not prove a serious drawback on the grounds of economy. In conclusion, it may be mentioned that it is possible to use one of the recently introduced Westectors as a rectifier; these will deal with very large inputs, but are hardly suitable for use in a simple circuit owing to the severe damping occasioned by their low resistance. Where a receiver is intended solely for local station reception, however, and selectivity is unimportant, one of these should certainly be tried.



# PETO-SCOTT

**EVERYTHING RADIO—CASH C.O.D. or EASY TERMS**

FIRST WITH EVERYTHING RADIO ON EASY TERMS: We carry huge stocks of all the leading Manufacturers' Products advertised in this Journal. If not advertised on this page, send us a list of your requirements for quotation by return without obligation. Any parcel of parts or accessories over £2 supplied on EASY TERMS. STRICT PRIVACY GUARANTEED.

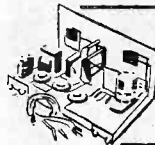

## MANUFACTURERS' KITS IN SEALED CARTONS

**NEW LISSEN SKYSCRAPER FOUR ALL-YOURS WAVE CHASSIS MODEL**, in Sealed Carton. Cash or C.O.D. Carriage Paid, **£5/12/6**. Balance in 11 monthly payments of 10/3. Send **15/-** only

**NEW LISSEN SKYSCRAPER FOUR ALL-WAVE CONSOLETTA CABINET MODEL**, in Sealed Carton. Cash or C.O.D. Carriage Paid, **£8/2/6**. Balance in 11 monthly payments of 15/-. Send **15/-** only

**NEW LISSEN 7-VALVE SUPER-HET**, in Sealed Carton. Cash or C.O.D. Carriage Paid, **£8/17/6**. Balance in 11 monthly payments of 16/6. Send **21/-** only

**NEW LISSEN 7-VALVE SUPER-HET CONSOLETTA MODEL**, in Sealed Carton. Cash or C.O.D. Carriage Paid, **£11/10/0**. Balance in 11 monthly payments of 21/-. Send **13/-** only

**NEW STATION MASTER MODEL 34 M.C.** Completé Kit, with Valves, Cabinet and Permanent Magnet Moving-Coil Speaker. Cash or C.O.D. Carriage Paid, **£7/2/6**. Balance in 11 monthly payments of 13/-. Send **8/-** only

**NEW STATION MASTER 34. S.G.**, Detector and Pentode, complete Kit with Valves, but less Speaker and Cabinet. Cash or C.O.D. Carriage Paid, **£4/6/6**. Balance in 11 monthly payments of 8/-. Send **11/9** only

**NEW GOSSOR, MODEL 341. S.G.**, Detector and Pentode, and Balanced Armature Speaker, complete with Cabinet. Cash or C.O.D. Carriage Paid, **£6/7/6**. Balance in 11 monthly payments of 11/9. Send **7/-** only

**TELSEN CLASS B 4 CHASSIS KIT** in Sealed Carton, less Valves, Cabinet and Speaker. Cash or C.O.D. Carriage Paid, **£3/17/6**. Balance in 11 monthly payments of 7/-. Send **9/-** only



## ELIMINATORS

**TELSN H.T. AND L.T. A.C. MAINS UNIT W.346.** H.T. Portion: Max. Det. and S.G. Tappings each adjustable for High, Med. or Low voltages. Maximum 28 m.A. at 150-v. L.T. trickle charges 2, 4, or 6 volts at 1 amp. Cash or C.O.D. Carriage Paid, **£4/17/6**. Balance in 11 monthly payments of 9/-. Send **6/-** only

**NEW REGENTONE A.C. ELIMINATOR**, Type W.I.F. 7 voltage Tappings. 120/150 volts at 12 m.A. Cash or C.O.D. Carriage Paid, **£2/15/0**. Balance in 9 monthly payments of 6/-. Send **6/-** only

**ATLAS C.A.25**, for Mains, "Class B" and Q.P.P., four tappings: 60/80, 50/90, 120, 150, 25 m.A. Cash or C.O.D. Carriage Paid, **£2/19/6**. Balance in 10 monthly payments of 6/-. Send **6/-** only



## GRAMO MOTORS AND PICK-UPS

**NEW GARRARD MODEL 202A.** 12-in. Turntable. Electric Motor for A.C. mains. Cash or C.O.D. Carriage Paid, **£2/10/0**. Balance in 8 monthly payments of 6/-. Send **5/-** only

**B.T.H. SENIOR PICK-UP AND TONE-ARM.** Cash or C.O.D. Carriage Paid, **£1/17/6**. Balance in 7 monthly payments of 5/-. Send **5/-** only

**NEW MARCONIPHONE MODEL 19 PICK-UP.** Cash or C.O.D. Carriage Paid, **£1/12/6**. Balance in 6 monthly payments of 5/-. Send **5/9** only

**NEW FERRANTI "CLASS B" SUPER POWER CONVERTOR.** Instantly converts your present set to "Class B." Complete with valve. Ready assembled. Cash or C.O.D. Carriage Paid, **£3/3/0**. Balance in 11 monthly payments of 5/9. Send **5/9** only

# PREMIER SUPER

## PILOT AUTHOR KITS

**KIT 'A'** Author's Kit of FIRST SPECIFIED Parts, including Peto-Scott METAPLEX Chassis, but less valves, speaker and cabinet. Cash or C.O.D., Carriage Paid, **£6/12/6**. Yours for **12/3** Balance in 11 monthly payments of 12/3.

**KIT "B."** As Kit "A" but with valves only. Cash or C.O.D., Carriage Paid, **£9/14/0**. Send **17/9** only

**KIT "C."** As Kit "A" but including valves and PETO-SCOTT cabinet with baseboard and baffle assembly but less speaker. Cash or C.O.D., Carriage Paid, **£11/2/6**. Send **20/6** only

**W.B. P.M.4.A MICROLODE SPEAKER**, as specified. Cash or C.O.D. Carriage Paid, **£2/2/0**.

These are the parts the Author used:

|   |    |    |
|---|----|----|
| 1 PETO-SCOTT "Metaplex" Chassis, 12in. by 12in., with holes for valve holders ready drilled | 3  | 9  |
| 1 BRITISH RADIOPHONE No. 711 Dial   | 8  | 0  |
| 1 BRITISH RADIOPHONE Superhet, 3-gang, Midget var. condenser, No. type 693                  | 1  | 2  |
| 1 set of LISSEN Matched Superheterodyne Coils (2 Band-pass and Oscillator)                  | 1  | 10 |
| 2 LISSEN Intermediate Frequency Transformers  | 15 | 0  |
| 1 IGRANIC 50,000 ohm Volume Control Potentiometer   | 3  | 6  |
| 1 BRITISH RADIOGRAM 3 pt. switch, type 48   | 1  | 3  |
| 1 BRITISH RADIOGRAM Push-Pull Radio Gram. switch, type 80                                   | 2  | 0  |
| 3 BRITISH RADIOGRAM Chassis Brackets  | 1  | 6  |
| 1 GRAHAM FARISH, "Pip" 3/1 L.F. Transformer   | 6  | 6  |
| 6 GRAHAM FARISH "Ohmite" Resistances  | 9  | 0  |
| 1 DUBILIER, 1 mfd. non-inductive condensers, type B.B.                                      | 3  | 8  |
| 2 DUBILIER 2 mfd. condensers, type B.B.   | 7  | 0  |
| 1 DUBILIER, type 670, .0001 mfd. condenser  | 1  | 0  |
| 1 DUBILIER, type 670, .01 mfd. condenser  | 1  | 0  |
| 1 POLAR, .002 mfd. pre-set condenser  | 4  | 0  |
| 1 CLIX 4-pin chassis mounting valveholders  | 2  | 0  |
| 4 CLIX 5-pin chassis mounting valveholder   | 2  | 8  |
| 3 BELLING LEE Terminal Mounts   | 1  | 6  |
| 6 BELLING LEE Terminals, type "R" marked  | 1  | 3  |
| 1 BELLING LEE Wander Plugs, marked  | 1  | 6  |
| 1 BULGIN Fuseholder and Fuse  | 1  | 0  |
| 2 Coils connecting wire, length of flex, screws, etc.                                       | 2  | 6  |

Kit "A" Cash or C.O.D. Carriage Paid **£6 12 6**

**EXCLUSIVELY SPECIFIED**  
**PETO-SCOTT PREMIER SUPER WALNUT CABINET** Cash or C.O.D. Carriage Paid **25/-**  
 Peto-Scott "Premier Super" Baffle and Baseboard Assembly, 3/6 extra.  
 —SEND FOR 1934 CABINET CATALOGUE—

## Exact to Specification THE NEW METALLISED BASEBOARD

**EXCLUSIVELY SPECIFIED FOR THE PREMIER SUPER**  
 Metaplex Chassis, 12in. by 12in., with holes ready drilled for valveholders. Cash or C.O.D. Carriage Paid **3/9** extra.



## SPEAKERS

RECOMMENDED FOR THE PREMIER SUPER—  
**PETO-SCOTT PERMANENT MAGNET MOVING-COIL SPEAKER**  
 Cash or C.O.D. Carriage Paid, 15/- "CLASS B" Type. Cash or C.O.D. Carriage Paid, **£2/6/6**, or 4 monthly payments of 6/3. Send **5/6** only

**NEW BLUE SPOT PERMANENT MAGNET MOVING-COIL SPEAKER 29 P.M.** With input transformer. Cash or C.O.D. Carriage Paid, **£1/12/6**. Balance in 6 monthly payments of 5/-. Send **5/-** only

**NEW BLUE SPOT 99 P.M. PERMANENT MAGNET MOVING-COIL SPEAKER.** Complete with tapped input transformer. Cash or C.O.D. Carriage Paid, **£2/19/6**. Balance on 10 monthly payments of 6/-. Send **6/-** only

**AMPLION AUDIOLA PERMANENT MAGNET MOVING-COIL SPEAKER**, with input transformer. Cash or C.O.D. Carriage Paid, **£2/9/6**. Balance in 8 monthly payments of 6/-. Send **6/-** only

**NEW ROLA SPEAKER**  
**£6P.M. PERMANENT MAGNET MOVING-COIL SPEAKER**, with input transformer. Cash or C.O.D. Carriage Paid, **£2/9/6**. Balance in 8 monthly payments of 6/-. Send **6/-** only

**NEW W.B. P.M.4.A. MICROLODE PERMANENT MAGNET SPEAKER**  
 complete with switch controlled multi-ratio input transformer. Cash or C.O.D. Carriage Paid, **£2/2/0**. Balance in 7 monthly payments of 5/9. Send **5/9** only

**EPOCH MODEL 20C, 20CB and 20CQ PERMANENT MAGNET MOVING-COIL SPEAKER** for ordinary power. "Class B" and Q.P.P. respectively, complete with input transformers. Cash or C.O.D. Carriage Paid, **£1/15/0**. Balance in 6 monthly payments of 5/6. Send **5/6** only

**NEW LISSEN P.M. MOVING-COIL SPEAKER** with input transformer. Cash or C.O.D. Carriage Paid, **£1/5/0**. Balance in 4 monthly payments of 5/6. Send **5/6** only

**BAKER "PERMAG" MINOR MOVING-COIL SPEAKER** with transformer for "Class B" or ordinary inputs. Cash or C.O.D. Carriage Paid, **£1/15/0**. Balance in 6 monthly payments of 5/6. Send **5/6** only

**NEW OLDHAM H.T. ACCUMULATOR** (Block type), 120-v., 2,750 m/A., complete with crates only. Guaranteed 3 years. Cash or C.O.D. Carriage Paid, **£3/15/0**. Balance in 11 monthly payments of 7/-. Send **7/-** only

**IMPORTANT.—Parts, Kits, Miscellaneous Components, Finished Receivers or Accessories for Cash, C.O.D. or H.P. on our own System of Easy Payments.** Send us a list of your wants. We will quote you by return. C.O.D. orders value over 10/- sent carriage and post charges paid.

PETO-SCOTT CO., Ltd., 77, City Road, London, E.C.1. Telephone: Clerkenwell 9406-7. West End Showrooms: 62, High Holborn, London, W.C.2. Telephone: Holborn 3248.

Dear Sirs,—Please send me CASH/C.O.D./H.P. \_\_\_\_\_ for which I enclose £.....s.....d.

CASH/H.P. \_\_\_\_\_

NAME \_\_\_\_\_

ADDRESS \_\_\_\_\_ Pr.W. 23/9/3.

ANY ITEM SUPPLIED SEPARATELY—ORDERS OVER 10/- SENT C.O.D. CARRIAGE AND POST CHARGES PAID



# "Intricate deduction, Watson, BUT THE 'ALL-IN-ONE' CONFIRMED IT."

"A broken-down grid-bias resistance is a fault that, normally, would need some locating, Doctor, but with the aid of an 'All-in-One' Radiometer it took me very little time to test the whole set and eventually narrow down the field until the real culprit was revealed."



If YOU possess a radio set you should also possess an "All-in-One" Radiometer. With this wonderful instrument you can always keep your set in 100% condition.

It tests everything quickly and surely, enabling you to keep the set up to par at all times. Ask to see it demonstrated at your radio dealers, or write direct to PIFCO LTD., High Street, MANCHESTER, or 150, Charing Cross Road, London, W.C.2.



## PIFCO ALL IN ONE RADIOMETER

Standard Model "All-in-One" Radiometer, for Battery Sets only, as shown here

Price - - - 12/6

De Luxe Model, for Battery Sets, Electric Receivers, and Mains Units

Price - - £2:2

## FREE

### Disturbance Suppressor

ELECTRICAL disturbance, or as it is frequently called, "man made static," consists of high frequency electrical currents or radiations produced by various types of electrical apparatus. It is recognizable as clicks, crackling, buzzing, roaring, rumbling or sizzling noises in your loud speaker. It may be caused by electric motors, lifts, vacuum cleaners, electric sewing machines, hair-drying machines, fans, electric apparatus, refrigerators, television sets, electric railways, battery chargers, mercury trolley buses, traffic control lights, battery chargers, mercury rectifiers, switches or electric bells. These disturbances are conveyed to your receiver by any system of wires which happens to be running between the source of the disturbance and the proximity of your receiver. In most cases it is the electric wiring of your house, but in some cases it may be other causes, such as the overhead wires of a tram or trolley bus system. It is possible for certain powerful disturbances to be carried for considerable distances underground, along the electric supply mains, into your house. Once the disturbance has entered your house, it will be conveyed all over the house by the electric wiring which will in effect become a transmitting aerial, and will radiate the high frequency electrical disturbances into the space around the house wiring, so that the aerial and earth

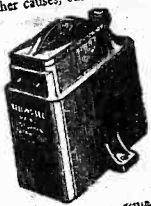

Pat. No. 190813. Regd. Design 707316. No. E116. Price each 9/6. 1000-10000 ohm set.

system of the receiver will pick up these unwanted radiations and greatly amplify them until they become very annoying sounds in the loud speaker. In a few cases with all-electric sets the disturbance also enters the receiver via the mains lead, but in the vast majority of cases it enters via the aerial or earth lead or both. The ideal method of curing electrical disturbances is to stop them at the source, and in 90 per cent. of cases the Belling-Lee Disturbance Suppressor connected to the electric mains and to earth at the source of the interference will do it for you. There are a few cases of interference where the ideal method is to connect special choke coils as well as the Belling-Lee suppressor to the source of interference, such as in the case of Neon signs and trams and trolley buses. Where there are many sources of interference, some may need suppression at the source, while the disturbance from others may be effectively silenced by the suppressor on your own switch board. If you are using electrical apparatus in your own home which causes interference, you will find that a suppressor on the main switch board will make a great deal of difference, and will probably make sufficient reduction, but if it does not it will be necessary to fit a suppressor to the source of interference. As electrical disturbance is one of the commonest causes of electrical disturbance a sketch is given on Page 6 showing how the disturbance suppressor is connected across the brushes or slip rings of the motor, while the centre point is connected to the frame. It is quite impossible for any expert to predict with certainty the best cure in each individual case, but we repeat that in 90 per cent. of cases the Belling-Lee disturbance suppressor is all that is necessary, that it should if possible be connected to the source of interference, although it will usually give the desired results if connected to your own mains switch board.

## Write for this Booklet

Make sure of your copy of this valuable booklet. Free on request. Two typical pages are illustrated showing the Disturbance Suppressor, describing it in detail. Other pages give clear and interesting explanations with useful data on Pick-ups, Mains Input Connectors, Fuses, Fuseholders, Terminals, Wander-plugs, Plugs and Sockets, and Battery Cords.

SEND THE COUPON NOW

**BELLING & LEE LTD**  
CAMBRIDGE ARTERIAL ROAD, ENFIELD, MIDDX

Please forward Booklet

Name .....

Address .....



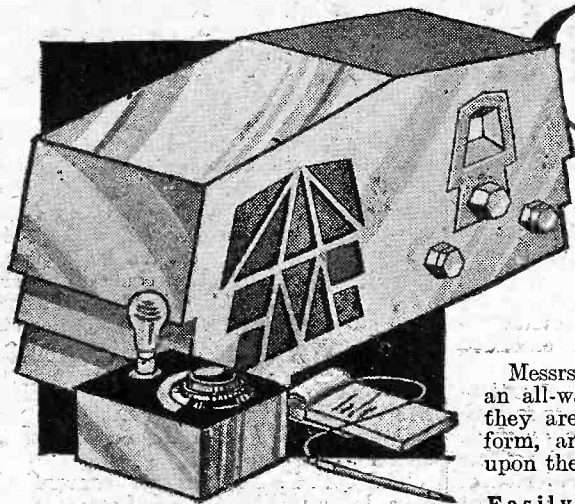

# OUR VIEWS ON RECEIVERS

## The Lissen "All-Wave Skyscraper 4" Kit Set.

Messrs. Lissen are not the first to produce an all-wave receiver, but we believe that they are the first to produce one in kit form, and they are to be congratulated upon their enterprise.

ponent holding down screws, and the task of mounting the parts is one that can be completed in less than an hour by following the full-size drawings supplied. The wiring has been simplified to a considerable

**M**ESSRS. LISSEN, of Isleworth, Middlesex, need no introduction to our readers as makers of all wireless components and kits of parts for complete receivers. The 3-valve "Skyscraper," which Lissens have produced in kit form during the last two seasons, has proved to be an amazingly popular set for home-constructors, but we feel sure that the latest "Skyscraper," the "All-Wave 4," will be made in even greater numbers. It has for some little time past been obvious that our previous conceptions of a broadcast receiver (one which could be tuned to wavelengths between about 200 and 2,000 metres) must be modified since there are now hundreds of broadcasting stations in all parts of the world which are sending out excellent and interesting programmes on the short and ultra-short waves. With a short-wave receiver of good design there is no difficulty in obtaining entertaining programmes not only from European, but also from American and Australian stations at most hours of the day, but as there are few amateurs who care to go to the expense of buying two separate sets for normal and short-wave reception it is perfectly clear that sooner or later receiver manufacturers must turn their attention to the production of receivers which will cover every waveband.

### Easily followed Constructional Chart

It gave us great pleasure to receive the "All-Wave Skyscraper 4" for test, and we were more than pleased with the performance which it gave. Perhaps it would be best to describe the set by beginning with the kit of parts which are supplied to the constructor in a strong and partitioned carton. Every component is clearly marked so that the veriest beginner can recognise it by making reference to the constructional broad sheet, whilst it is soon found that there is a supply of screws and wire so that the complete set can be assembled by means of nothing more than a screwdriver and a pair of pliers. A stout aluminium baseplate is accurately drilled to receive all the com-

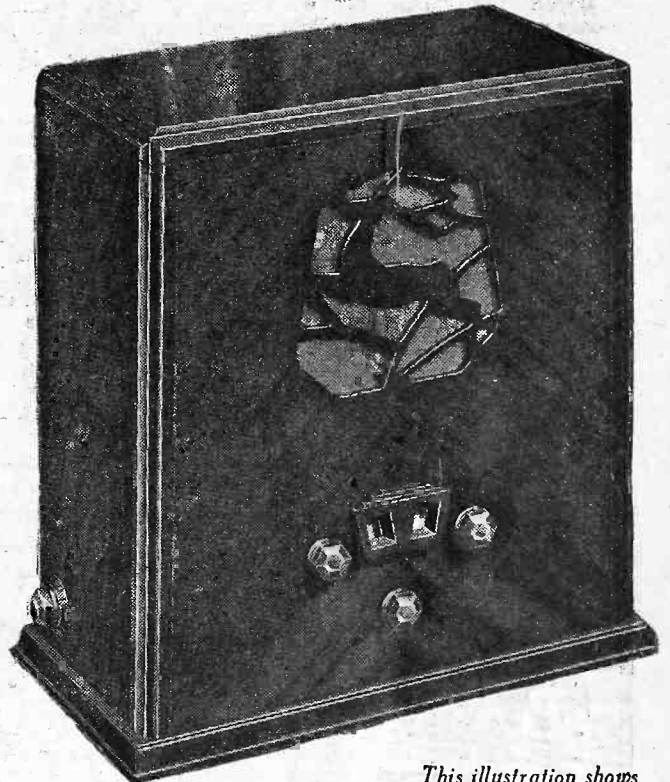

*This illustration shows the pleasing lines of the Lissen All-Wave Skyscraper 4.*

extent by extremely careful design, and every connection required is numbered on the plans. Still further to simplify the work, however, the connections are fully described; for example, "Connection 13.—Wire 4½ in.—secure under T 31—Sleeving 3½ in.—pass up through hole "G" and secure under terminal "P" of the Q.P.P. transformer." Incidentally, there are only 30 connections in all, so it will be realized from this that the construction has been reduced to the simplest possible form.

### Alternative Kits

The kit can be obtained in three different forms, the first of which is suitable when the constructor already has a cabinet and speaker which he wishes to use; the second includes a table cabinet (which can be assembled in next to no time without the use of glue) and the third includes a console type of cabinet fitted with the excellent Lissen permanent magnet moving-coil speaker. The prices of the three models, including Lissen valves in each case, are £5 12s. 6d., £6 8s., and £8 2s. 6d. respectively—extremely good value.

*(Continued overleaf)*

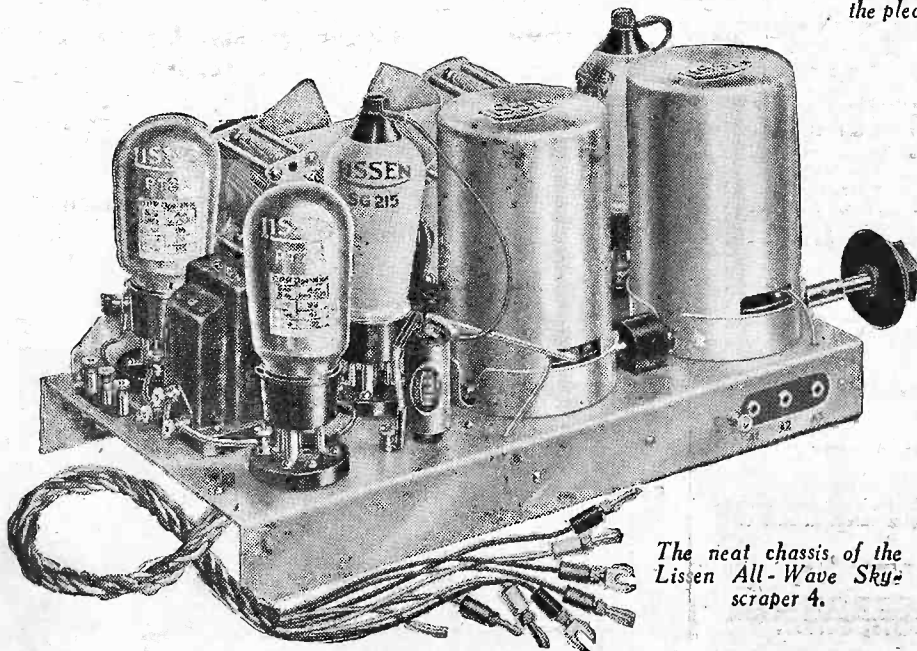

*The neat chassis of the Lissen All-Wave Skyscraper 4.*



The completed set was fitted into its cabinet, which was of the console type with self-contained M.C. speaker in our case, and the batteries connected up exactly as stated in the instructions, when Rome was immediately tuned in. After this, no less than thirty other medium-wave stations were brought in at good programme strength, despite the fact that the aerial in use consisted of only a 40-ft. length of wire erected at a height of 25 feet. To keep the volume down to reasonable proportions in the averaged size drawing-room the volume control had to be made use of on about half the total number of stations received. By connecting the aerial to the least selective of the three tappings provided, the "spread" of the local stations less than ten miles away was no more than six degrees on the dials, whilst when the most selective tapping was employed the "spread" was reduced to only two degrees, with a slight reduction in maximum volume. Without doubt the set is amply selective for modern requirements, and should give every satisfaction in this respect when used in any part of the country. On the long waves we were able to bring in eight stations at good strength, and no difficulty was experienced in receiving Radio Paris, Warsaw, or Eiffel Tower entirely free from the National. There was no trace of medium-wave breakthrough at any long-wave condenser setting. Although two tuning dials are used they worked so well "in step" that the operation was almost as easy as with any single knob set we have used.

Tuning on the short waves was found to be just as easy as on the higher bands,

once the knack of rotating the condensers slowly had been acquired, and within half an hour we were able to bring in eleven stations on the short-wave range (that is, between 28 and 80 metres) and eight on the ultra-short waveband (12 to 35 metres). Of these, three were the American stations, Pittsburgh, Springfield, and Bound Brook, one was Sydney, four were European broadcast transmitters, and the others were amateurs in various parts of the world. Of particular interest among the latter was a Canadian station calling up G2SO in London. No doubt a considerably greater number of short-wavers could have been received had the tests been extended over a longer period.

We feel that the makers are to be particularly commended upon the perfectly smooth reaction control which is to be obtained on the short waves, for this is one of the greatest difficulties with the majority of short-wave sets. Due to this excellent control, the "Skyscraper" was just as docile and reliable on the short as upon the normal broadcast wavebands.

As the same coils are used to cover the four wavelength ranges we rather expected to find some little interference or "breakthrough" of the local transmitters, but there was absolutely nothing of this kind.

After trying out the set we measured the high-tension current consumption and found this to be almost exactly 9 milliamps, which is an extremely low figure when the tremendous volume of signal output is taken into consideration.

In regard to the technical details of the "Skyscraper All-Wave 4," the interested amateur can find many points of

particular interest. The circuit comprises four valves, of course, of which the first is a variable-mu high-frequency amplifier, the second is a screened-grid detector (which is no doubt due in no small measure for the excellent short-wave performance of the set), whilst two Lissen type PT2A pentodes are used in quiescent push-pull for the output stage. An extremely interesting and ingenious device is the volume-control, which consists of a grid-bias potentiometer acting on the V.-M. valve, ganged with the reaction condenser. This is so arranged that over the first half revolution of the knob the potentiometer is varied from "minimum" to "maximum" volume. Once the V.-M. valve has been brought to its most sensitive condition the reaction condenser comes into play and enables a further degree of amplification to be obtained.

The Q.P.-P. stage is on conventional lines, but a practical point of great importance is that the two pentodes supplied with the kit are carefully tested before despatch and labelled to show their optimum anode and priming grid voltages. Thus, by applying these voltages the constructor knows that the valves will be perfectly matched.

To anyone who intends to buy a kit set for battery operation and who desires to obtain an up-to-date receiver at a most reasonable price, we recommend the Lissen "Skyscraper All-Wave 4."

A well-illustrated constructional broadsheet can be obtained free from the Publicity Dept., Messrs. Lissen, Ltd., Isleworth, Middlesex, if mention is made of PRACTICAL WIRELESS.

## AN INTERESTING GIFT



### RESISTORS

To prove the superiority of our "B.A.T." (Best-After-Test) **BRITISH-MADE FIXED RESISTANCES** (1/2, 1, 2, 3, and 5-WATTS) we will send Free and Post-Free to applicants mentioning this Journal, our 2-Colour Art Booklet, 2nd ENLARGED EDITION, 16pp., entitled:

### "OHMS LAW WITHOUT TEARS"

A Complete Treatise, with Circuits, Simple Formulae, Voltage-Dropping and Current-Carrying Charts, "ABAC," worked examples, etc. It tells you all you ought to know about the "mysteries" of Volts, Amps, Resistance Values and Watts-Dissipation as applied to the use of Resistors for Radio purposes. The edition is limited.

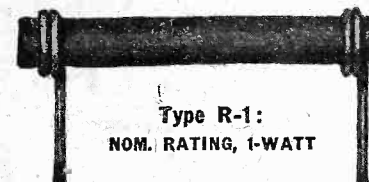

Type R-1:  
NOM. RATING, 1-WATT

ALSO—  
**DOES YOUR SET SUFFER FROM "HUM-M-M"**

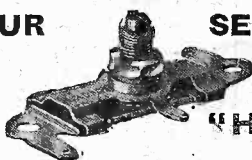

Do not let your reception be spoiled by objectionable Mains HUM-M-M. This can be either reduced to an extremely low level or entirely eliminated, by the use of our Type HD-30 "HUMDINGER" (Regd. No. 508,868). The cost is insignificant—only Half-a-crown. Full instructions, with circuits, with each. Obtainable from all good dealers, or direct in case of difficulty. Explanatory leaflet free on request.

**CLAUDE LYONS, LIMITED,**  
76, OLDHALL STREET, LIVERPOOL.  
40, BUCKINGHAM GATE, LONDON, S.W.1.

## The SCIENTIFIC MICROPHONE BUTTON HAS A HUNDRED USES

It is a simple and inexpensive gadget, which can be used by any novice in hundreds of ways to demonstrate the wonders of sound. It provides an

endless source of amusing and instructive experiments in home broadcasting, relaying music, detecting and overhearding; baby alarms, 'phones, etc.



The book, "The Wonders of the Microphone"

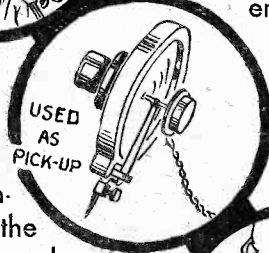

explains in simple language the science of sound.

Over 25 diagrams and illustrations of numerous useful and interesting experiments.

6d.



### A FREE GIFT

of this book will be made to all purchasers of the Scientific Microphone Button until Oct. 31

**Scientific Supply Stores**  
(WIRELESS) LTD. (DEPT. P.), 126, NEWINGTON CAUSEWAY, SOUTHWARK, LONDON, S.E.1. PHONE: HOP. 417Z.

This is the little device that does the trick,  
**3/6**  
THE SCIENTIFIC MICROPHONE BUTTON post free or C.O.D. Guaranteed.

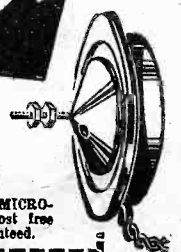





*Twenty Guineas worth of Radio for less than half that Price!*

## BETTER TO BUILD THAN TO BUY!

Never before has there been any receiver for Home Constructors on such an ambitious scale as this new Lissen "Skyscraper" Seven Valve Superhet. It embodies every up-to-the-minute advance and refinement of the most luxurious factory-built superhet—it gives the constructor the opportunity to build a £20 receiver for less than half that price. The circuit of the Lissen "Skyscraper" Seven Valve Superhet incorporates a 6-stage bandpass filter giving exact 9-kilocycle channels and therefore providing a standard of selectivity never before achieved by a home constructor's kit set and very rarely found except in

laboratory apparatus. Amplified Automatic Volume Control is provided, a special valve for this purpose having been produced by Lissen for use in this receiver. The use of this Amplified Automatic Volume Control constitutes an entirely new experience in listening; no "fading" no "blasting"—you will find yourself enjoying every word of every programme, however near or however distant, without the slightest temptation to interfere with the receiver once you have tuned it. This is radio listening as it should be enjoyed!

Lissen Class "B" Output through a new full-power Lissen Moving-coil Loudspeaker—glorious rich tone and majestic volume, actually more faultless in its reproduction than anything you ever heard from even the most powerful mains receiver, yet working economically in this Lissen "Skyscraper" from H.T. batteries. Lissen have published for this great new "Skyscraper" Seven Valve Superhet a most luxurious Chart which gives more detailed instructions and more lavish illustrations than have ever before

been put into a constructional chart. It makes success certain for everybody who decides to build this set, for it shows everybody, even without previous constructional experience, how they can have a luxury receiver and save pounds by building it themselves. A copy of this Chart will be sent FREE in return for coupon on the left, or your radio dealer can supply you. Get your FREE CHART now!



**CHART FREE POST COUPON**

To LISSEN, LTD.,  
Publicity Dept., Isleworth.  
Please send me FREE CHART of the  
"Skyscraper" Seven Valve Superhet

Name .....

Address .....

..... P.R.734

# LISSEN

# "SKYSCRAPER" 7

## SEVEN VALVE SUPERHET



*“This battery has given me wonderful service”*

(Sgd.) P. G., Monkseaton



Most of the leading set-makers fit Exide Batteries for L.T. or Drydex Batteries for H.T. • Obtainable from Exide Service Stations and all reputable dealers.

# Drydex

by Exide

**DRY BATTERIES  
FOR WIRELESS**

Exide Batteries, Exide Works, Clifton Junction, nr: Manchester. Branches: London, Manchester, Birmingham, Bristol, Glasgow, Dublin, Belfast



# THE EXPERIMENTERS' SHORT-WAVE THREE

A Very Sensitive S.G. Receiver Which is Designed Principally for Use on Short Waves, but Which Can Also Be Used Satisfactorily on the Broadcast Bands.

By FRANK PRESTON, F.R.A.



SOME time ago I described in these columns two or three circuits suitable for efficient short-wave reception. I explained that although good short-wave reception could be obtained with an adaptor used in conjunction with the normal broadcast receiver, it was a much better plan to employ a separate and complete short-wave set. After briefly discussing different circuit arrangements, I drew the conclusion that, for all-round efficiency and reliability, making use of a screened-grid valve was most satisfactory.

The little set now to be described, and of which you see a photograph on this page, has been designed to embody all those features which experience has taught to be desirable, whilst at the same time cutting out all unnecessary gadgets and "frills." It is a sound job, which has

### Circuit and Components

The circuit given on this page makes clear the sequence of the valve stages and requires only little explanation. The aerial circuit is untuned, a  $\frac{1}{2}$  megohm resistance providing aperiodic coupling. This obviates the necessity for a second tuning control, which would make tuning tricky. A metallized screened-grid valve is used for the first stage, the metal coating acting as a screen between grid and anode circuits. Its screening-grid receives high-tension from a separate tapping, and is by-passed to earth through a .1 mfd. non-inductive condenser. Coupling between the S.G. and detector stages is by means of a high-frequency transformer with tuned secondary. A reaction winding is also included on the transformer, and the degree of feed-back is controlled by a .0002 mfd. reaction condenser. The transformer is of the plug-in type, different units being used for different wavelength

alternative valves are specified. It was found quite unnecessary to use a potentiometer in conjunction with the grid-leak, because perfect reaction control proved possible by taking the leak to low-tension positive. A special "Universal" H.F. choke is used in the detector anode circuit because it is required to cover both long and short waves. The L.F. valve receives its input through a "Transfeeda" (one of the now popular resistance-fed transformers), and a  $\frac{1}{2}$  megohm stopping-resistance is included in its grid circuit. A portion of the resistance in the "Transfeeda" is used in conjunction with a 2 mfd. condenser to decouple the detector anode circuit. The last valve is of the high amplification power-valve type, capable of giving good speaker signals even on small inputs. A .002 mfd. fixed condenser is joined between its anode and earth to keep high-frequency currents out of the loud-speaker leads.

### Assembling the Components

A list of components is given elsewhere, from which it will be seen that three mounting-brackets are specified. These are for holding the tuning-condenser, reaction condenser, and switch respectively, and replace the more usual panel. Should any constructor prefer to make the set as a finished receiver rather than as an experimental model the brackets should be replaced by a 14in. by 7in. panel. The positions of all components on the baseboard can be followed and duplicated by making reference to the wiring plan and photographs.

It will be found best to commence by attaching the brackets and then fixing the condensers and switch to them. Before mounting the tuning condenser a dial pointer must be made and secured under the mounting nut. The pointer is made from a piece of thin brass, or copper-strip to the dimensions given in the accompanying sketch. If copper or soft brass is chosen it can easily be cut with a pair of strong scissors. Next mount the valve holders and terminal blocks, but before screwing down the other components lay them all on the baseboard, insert valves and a coil, and carefully arrange them so that there is ample clearance.

### Easy Wiring

The wiring is extremely straightforward, and you should try to duplicate that of my original set by carefully studying the photographs in conjunction with the wiring plan. Glazite is used throughout, a single

(Continued overleaf)

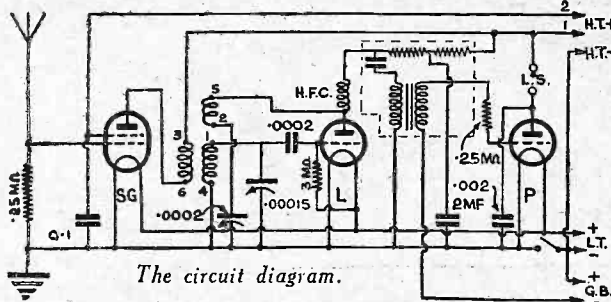

been evolved after a good deal of experimenting, and it has been thoroughly tested under varying conditions. I do not claim that the set is "perfect"—I have never made a perfect one—but I do say that it is extremely good, and forms an ideal arrangement for the experimenter. The set is built in skeleton form, no panel or cabinet being used, so that every component is readily accessible and alterations can be made without disfiguring it, at all.

### Universal Wavelength Range

Although every component is specially chosen to be "just right" for the function it has to perform, the set can be built for no more than sixty shillings. Again, despite the fact that the set was designed as an ideal short-waver, it can be used with almost equal efficiency on the broadcast wavebands. Unlike most short-wave sets, it will cover a range of from 260 to 550 metres, or from 900 to 1,800 metres, with a single coil. Needless to say, its range of reception on short waves is literally world-wide, and on the higher wavebands it is capable of bringing in some thirty-odd European stations. In all cases, loud-speaker reproduction, to say the least, is very good. Tuning is almost as easy as with a one-knob family receiver, and even the beginner need have no fears in this respect.

ranges. This system is considerably more efficient than that of employing tapped coils and shorting switches, and has the decided advantage of being adaptable to absolutely any range, rather than to two or three only. Moreover, it is only very slightly more costly.

The tuning condenser has a maximum capacity of only .00015 mfd., but, thanks to its very low minimum, will cover a very wide range of frequencies. This is very evident by the fact, previously mentioned, that it will cover either broadcast range with a single coil. Both grid-leak and condenser have more or less usual values, but these components were chosen to match the detector valve (a Cossor 210 Det. metallized). It was found afterwards, however, that they were almost equally well suited to the Cossor 210 L.F., and that is why

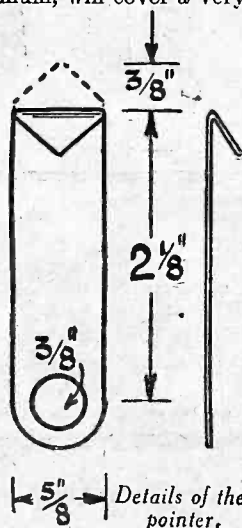







# TRIUMPH FOR LISSEN COILS IN THE "PREMIER SUPER"



**"Practical Wireless" build a star superhet around Lissen Coils**

"Practical Wireless" have designed the Premier Super in response to an insistent public demand at Olympia for a simple and economical Superhet. The designers have based the set upon the perfectly matched Lissen Triple Ganged and Shielded Coil Unit—a sure foundation for any set requiring selectivity of a really high order with simplicity of control and construction.

In addition, "Practical Wireless" have specified two Lissen Intermediate Frequency Transformers, so that the whole coil-assembly of the set is matched and balanced in the one factory and made to the most exacting standards. LISSEN KNOW THE NEEDS OF HOME CONSTRUCTORS BETTER THAN ANYBODY—which is why you find Lissen components predominating in this year's star sets of the constructional papers.



LISSEN Triple - Gang Super-Heterodyne Dual Range Shielded Coils **26/-** The Set      LISSEN Intermediate Frequency Trans-formers **7/6** Each

**LISSEN**  
INTERMEDIATE  
FREQUENCY  
TRANSFORMERS  
SPECIFIED

# LISSEN

# SHIELDED COILS



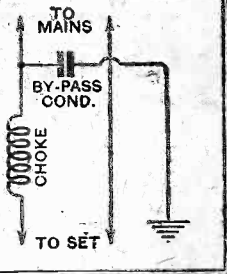
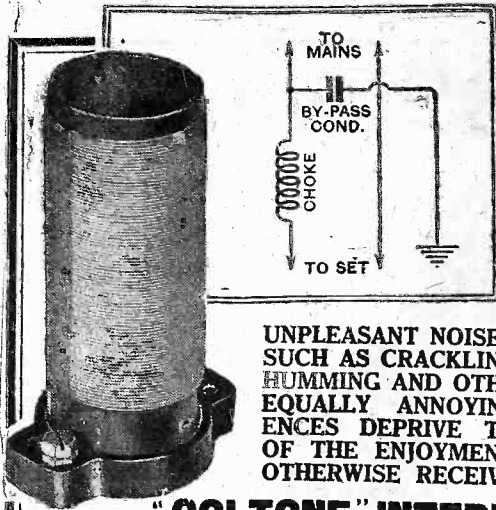

**STOP THOSE NOISES!**

UNPLEASANT NOISES, SUCH AS CRACKLING, HUMMING AND OTHER EQUALLY ANNOYING INTERFERENCES DEPRIVE THE LISTENER OF THE ENJOYMENT HE WOULD OTHERWISE RECEIVE.

**"GOLSTONE" INTERFERENCE SUPPRESSING DEVICES**

"GOLSTONE" MAINS H.F. CHOKES

(For A.C. and D.C. Supplies) as illustrated W.H.F. 3/6. INTERFERENCE COMPENSATORS. HIGH-VOLTAGE CONDENSERS. SCREENED AERIAL DOWN LEADS. IMPEDANCE MATCHING DEVICES. SCREENED TRANSMISSION LINES. SCREENED TUBINGS are some of the wide range manufactured. Obtainable from all First-Class Radio Stores. See the name "GOLSTONE" on each component before purchasing and refuse substitutes. If any difficulty write direct. Let "GOLSTONE" Technical Department solve your Interference Problems. Send Postcard for "Interference Elimination" Form and descriptive folders.

**FREE**  
Large 56 page  
1933/34 RADIO  
CATALOGUE sent  
FREE on request.



**IMPROVE SPEAKER TONE WITH THE CAMCO "MELODEE" CABINET**



To obtain first-class results from a speaker, it is essential to house it in a cabinet with sufficient depth—such a cabinet as the Camco "Melodee" No. 2, which measures 12in. from back to front and gives effect of a large baffleboard but without booming. Suitable for housing most speakers. In oak, 30/- Mahogany and Walnut, 33/- with baffleboard, having hole ready cut.

**FREE** See it at our Showrooms or send coupon for Camco Cabinet Catalogue. Carrington Manufacturing Co., Ltd., Showrooms: 24, Hatton Garden, London, E.C.1. Phone: Holborn 8202. Works: S. Croydon.

Name .....

Address .....

POST IN 1d. ENVELOPE P.P.14



**EDISWAN**

Hear **Gracie Fields** records as they were meant to be heard

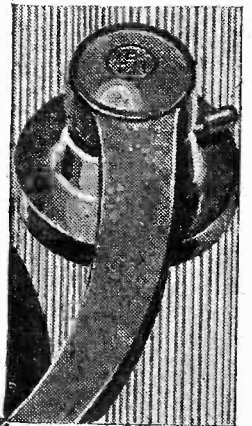

Minor Pick-up and Tone Arm with 10,000 ohm. volume control, flexible lead, pick-up rest and template for fixing 2/1-

Senior De-Luxe Pick-up and Tone Arm complete with pick-up rest, flexible lead, template for fixing and 20,000 ohm. volume control as illustrated 37/6

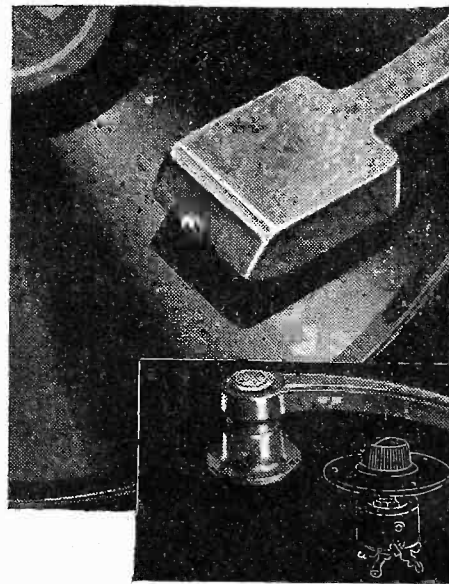

Comedy, sentiment, a beautiful voice—versatile Gracie Fields! To hear her records at their best you should play them with a B.T.H. Pick-up. Then you don't miss anything—it's just as if you were seeing as well as hearing. It is because B.T.H. Pick-ups are highly sensitive, correctly damped and properly balanced—and it is those qualities that make experienced radio men use and recommend them and radiogram manufacturers fit them as standard. Ask your dealer to demonstrate

with a



**PICK-UP**



The Edison Swan Electric Co. Ltd. 155 Charing Cross Rd., London, W.C.2

GOOD RADIO DEALERS RECOMMEND EDISWAN

W.217



# SIMPLE TESTS WITHOUT INSTRUMENTS

By W. B. R.

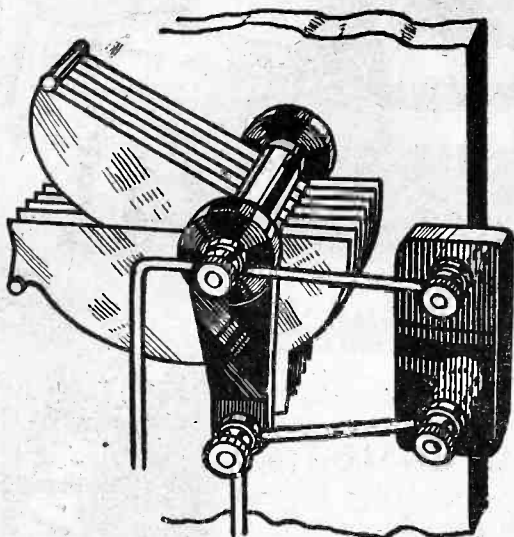

Fig. 1.—Fixed condensers under test are connected across the aerial tuning condenser.

### Checking Capacity of Small Condensers

THE value of small condensers up to about .0004 or .0005 mfd. can readily be checked if you have on hand one or two condensers of known value. The method is one of substitution, the idea being to compare the effect on the tuning of your set of first the condenser of known value and then those of unknown value. This method is also very useful if you are making your own fixed condensers and wish to have the capacities correct. It is easier and at the same time more accurate than trying to make them up to certain values by formula alone. Making a condenser by formula means cutting the foil to exactly the right size, using mica or paper of exactly the right thickness (usually entailing the use of a micrometer) and finally making perfect contact between the layers. Unless this is done the resulting value is likely to be very uncertain and can easily be two or three times too large or too small. However, by the method to be described, such very great care need not be used in construction, since the values can be checked before the condenser is finally sealed up or mounted. Any adjustments necessary can then be carried out by adding or removing plates.

### The Modus Operandi

Say you have a grid condenser marked ".0003 mfd." which you wish to check. What you do is to connect a good quality .0003 mfd. fixed condenser (one

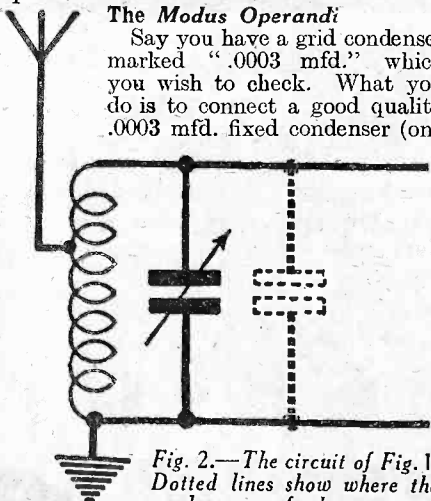

Fig. 2.—The circuit of Fig. 1. Dotted lines show where the condensers of known and unknown value are connected.

which is guaranteed accurate by the makers), across the aerial tuning condenser of your set, as in Figs. 1 and 2. Then tune in a fairly loud station, if possible somewhere near the centre of the dial. Note the dial reading and remove the condenser. In its place connect the condenser to be tested. If this has exactly the same value as the guaranteed one, the tuning will be unaltered, but if not the dial will have to be readjusted to bring in the same station as before. If the reading has to be increased the second condenser is of smaller value than the first, if decreased, then it is larger.

When making a home-made condenser it is best to build it up layer by layer, checking it each time a layer is added until the station is tuned-in in the right

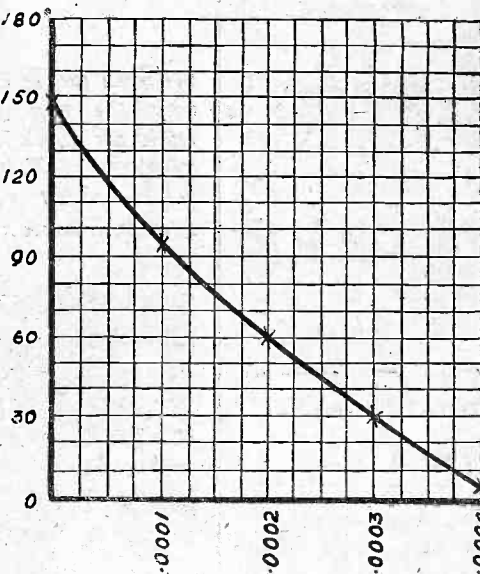

Fig. 3.—Graph for determining condenser values.

place. When nearing the correct value it may be found that the addition of another layer will carry its capacity above the required value, although it is too small without it. To make it exact you can either cut the last piece of foil so that there is less overlap or put a slightly thicker piece of mica between two of the sheets of foil.

It may happen that you want to know more than just whether a condenser is larger or smaller than one of known value. You may want to know by how much. In this case it is best to plot a graph. Get several condensers of known value, say, a .0001, a .0002, a .0003 and a .0004 mfd. and connect each one in turn across the tuning condenser. Tune-in to the same station each time and make a note of the various settings. The station chosen will have to be one which normally tunes near the top of the tuning scale (tuning condenser nearly all in), otherwise when the larger fixed condensers are

connected up it will be impossible to tune down far enough to get it. When the dial setting for each condenser has been obtained, they are plotted on squared paper, as in Fig. 3. The plotted points are joined by a line as shown. This is usually a curve. Once the graph is made, the value of any condenser up to .0004 mfd. can be read off in a moment. Suppose, for example, a condenser of unknown value was connected up and the chosen station tuned-in at 50 degrees. If you follow across from 50 on the graph till you strike the curve and then follow down to the microfarads scale you will strike it at about .000225 mfd.

### Larger Sizes

It is obvious that this method is limited to condensers up to about .0005 mfd. as the placing of larger condensers across the aerial coil would considerably reduce signal strength besides taking the tuning range into a region above the ordinary broadcast limits where it is often difficult to find a suitable station to which to tune.

### Testing Polarity with Neon Lamp

A quick and convenient way of testing the polarity of D.C. mains is to plug in one of the neon lamps or electric night lights shown in Fig. 4. It will be noticed that it has two electrodes. One is a wire spiral shaped like a beehive and the other is a flat metal disc inside the spiral. When connected to a D.C. supply either the spiral or the disc glows, but not both. The one which glows is the one connected to the negative pole. A glance at the wires passing from the electrodes through the "pinch" show to which of the contacts each one is connected. The contact leading to the glowing electrode is the one which connects with the negative plunger in the lamp holder.

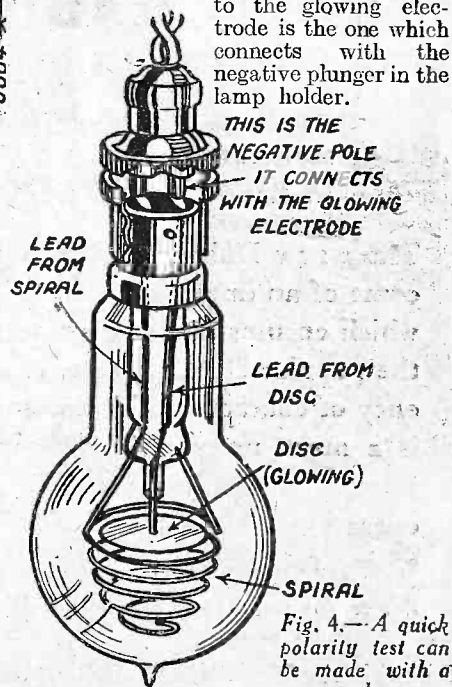

Fig. 4.—A quick polarity test can be made with a neon lamp.



# Silent in operation



|             |  |         |
|-------------|--|---------|
| 1 WATT TYPE |  |         |
| 1¢ EACH     |  |         |
| 2 WATT      |  | 3 WATT  |
| 2¢ EACH     |  | 3¢ EACH |

Individually tested and packed. Plus unrivalled quality

# DUBILIER RESISTANCES

These new Dubilier Resistances are the outcome of an improved process of manufacture which ensures an even better resistance than the popular Dubilier Type of 1932. Consistency of characteristics under prolonged load is a most noteworthy feature, and you are always assured of long life and silence in operation. Undoubtedly the finest resistances selling to-day.

Write for your copy of the new Dubilier Catalogue!

**DUBILIER CONDENSER CO. (1925) LTD., DUCON WORKS, VICTORIA ROAD, NORTH ACTON, W.3**

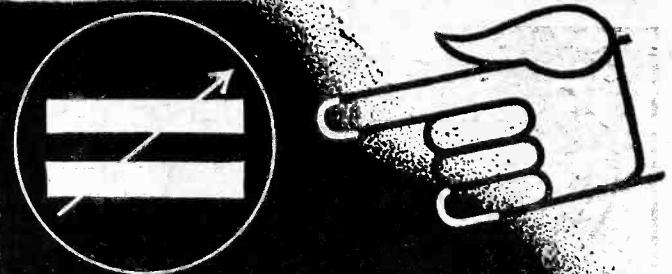

**JUST ANOTHER WAY OF SAYING -**

Whatever the circuit, the experienced constructor will always choose "J.B." For tuning iron-cored coils, in particular, the accurate matching found in J.B. Gangs becomes imperative; and the mechanical rigidity of "J.B." ensures the permanence of this matching.

Illustrated is the new J.B. LINATUNE with one trimmer panel—operated by a knob concentric with the main tuning control. It is fitted with the new J.B. Straight-Line Dial, the whole scale being always on view and illuminated by a lamp-holder which travels with the cursor. Prices (with cover) 2-Gang .. 22/6 3-Gang .. 27/6

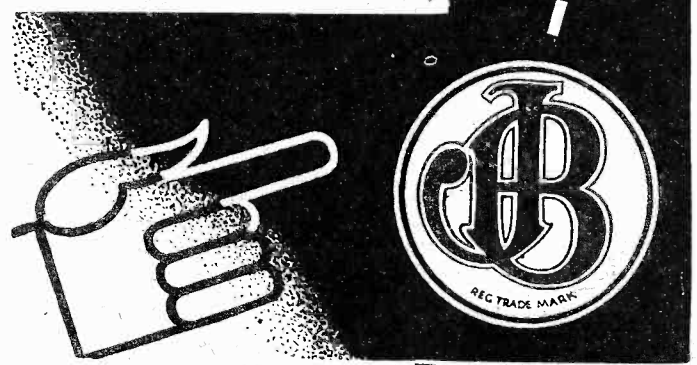

THE NEW "J.B." LINATUNE GANG

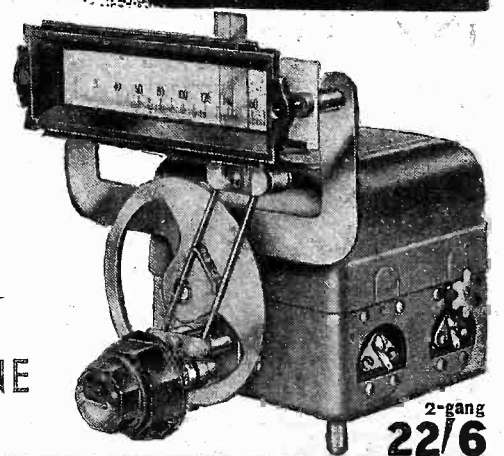

**PRECISION INSTRUMENTS**

Advertisement of Jackson Bros. (London) Ltd., 72, St. Thomas St., London, S.E.1. Telephone: Hop. 1837.





# THE BEGINNER'S SUPPLEMENT

## HOW YOUR RECEIVER WORKS—III By FRANK PRESTON, F.R.A.

(Continued from page 960, Sept. 16 issue.)

### Variable-Mu

The functioning of a variable-mu is not greatly different from that of an S.G. valve, but its control grid is supplied with a steady negative potential in addition to the oscillating potential representing the incoming signal. The steady potential is derived from a grid-bias battery through the medium of a potentiometer connected as shown in Figure 12, so that the actual amount of grid bias may be varied between the maximum of the battery and zero. As the negative grid-bias voltage is increased the current flowing to the anode is, of course, reduced, and in addition the valve becomes less "sensitive." Why does it become less sensitive? To appreciate the reason we must think in comparative terms; if the grid is already receiving a voltage of, say, two or three volts it is fairly clear that the effect of the few millionths of a volt of signal currents will be less significant than if the initial grid potential were zero. It will be seen in the same way that the higher the bias voltage, the smaller will be the effect of the signal voltage, and therefore the less will be the response of the valve to it. By varying the amount of steady grid potential we can regulate the sensitiveness of the valve, and the potentiometer therefore serves as a volume control.

In the circuit of Fig. 12 a fixed condenser is joined between the "lower" end of the tuning coil and high-tension negative, its object being to allow the free circulation of oscillating, or high-frequency, currents, and at the same time to prevent a short-circuit of the grid-bias supply.

### The H.F. Coupling

As we have already seen, the output from the amplifying valve (whatever its type) is in the form of an oscillating voltage which appears between the ends of resist-

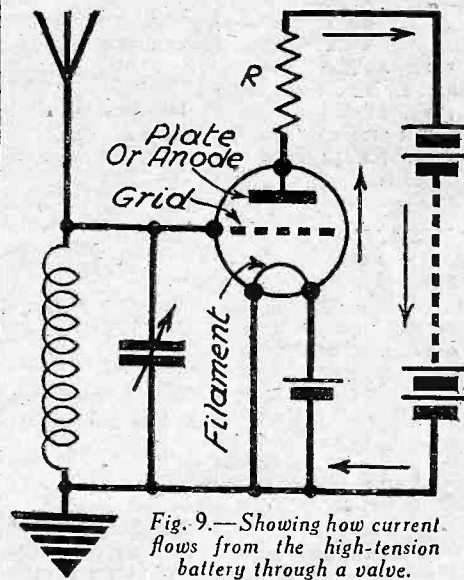

Fig. 9.—Showing how current flows from the high-tension battery through a valve.

ance R connected in its anode circuit. This voltage is an exact copy of that across the aerial tuning circuit, but is of much greater magnitude. We can either amplify it still further by the use of another high-frequency valve or we can rectify it. Since the function of a second H.F. valve

would be precisely the same as that already considered, we will assume that the second valve is to be a rectifier, or detector.

There are various ways of feeding the amplified voltages to the detector, so perhaps we had better examine each in turn. One way, which is never used at the present time, is to connect one end of the resistance we have called R to the grid of the detector as shown in Fig. 13 (a). At first sight it is a little difficult to see how the voltage developed across R can be applied to the second valve by taking a connection from one end only, but on reflection it will be understood that the other end of the resistance is connected to the filament of the second valve, through the H.T. supply, as shown by a heavy line. The object of the condenser marked C is to pass on oscillating or high-frequency currents whilst preventing the high-tension voltage from being applied to the detector as excessive positive grid-bias. This form of coupling, known as resistance-capacity, is not by any means efficient, since if the resistance is of sufficiently high value to develop a maximum oscillating voltage across it, it will at the same time cause a large drop in the high-tension voltage reaching the anode of the first valve. It is clear that what is required in place of the resistance is some component that will have a high resistance (or impedance) to oscillating current and a low one to direct current. A high-frequency choke fulfils these conditions, and is connected as shown in Fig. 13 (b). Choke-capacity coupling is used in practice, but not to any great extent due to its comparative inefficiency. One reason is that the impedance of a choke differs according to the frequency of the current passing through it, and therefore its efficiency varies tremendously as the frequency changes.

But there is another very important reason why neither of the above systems of H.F. coupling are efficient, and this is because the capacity between the anode of the first valve and earth (by "earth" we mean in this case any point which is at low potential in respect to H.F. currents, such as H.T. positive or H.T. negative) is always sufficiently high to permit of an appreciable leakage of signal current unless some method of counteracting it can be

(Continued overleaf)

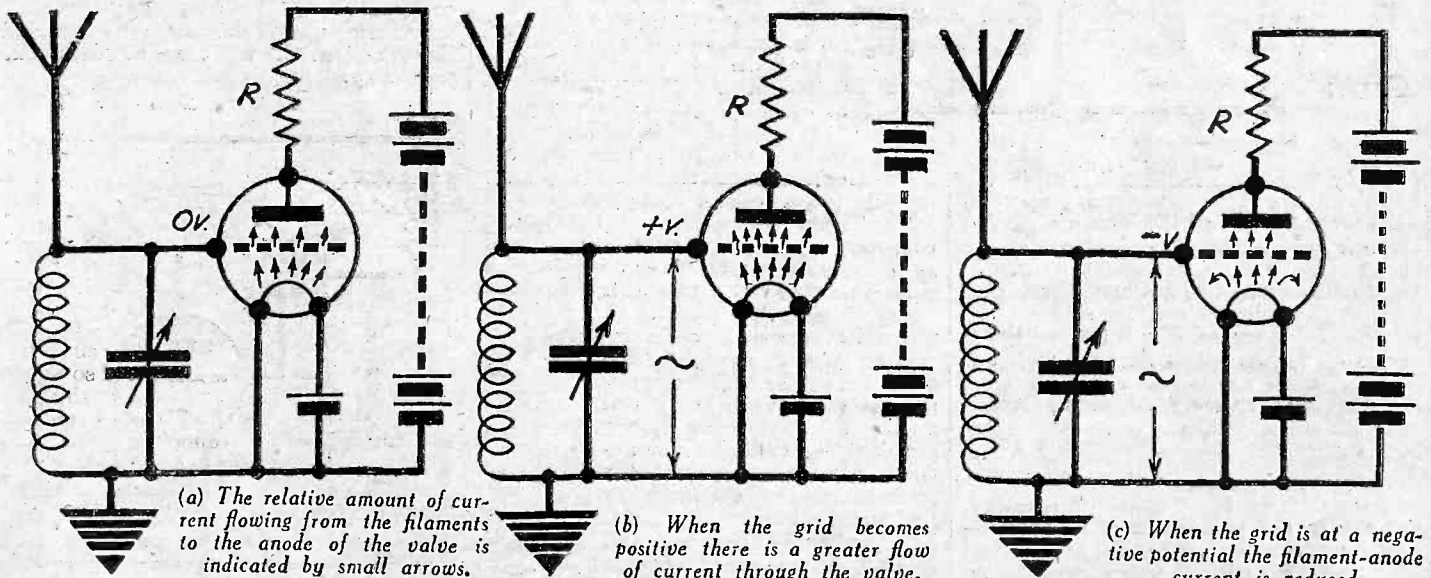

Fig. 10.—Showing the relative amounts of current flowing through a valve when the grid is at (a) zero potential, (b) positive potential, and (c) negative potential.



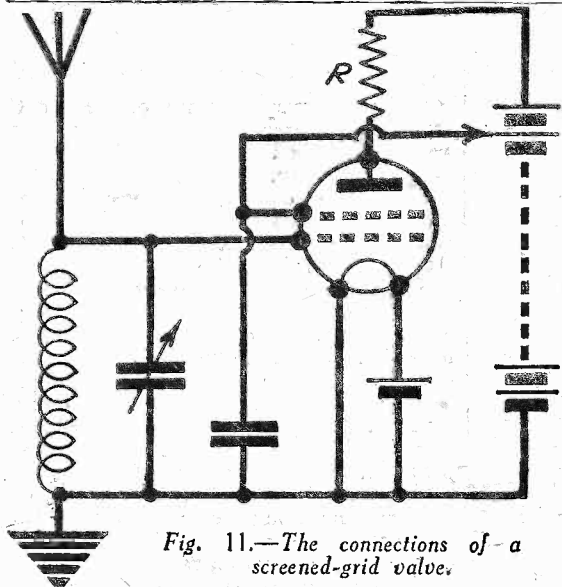

Fig. 11.—The connections of a screened-grid valve.

**THE BEGINNER'S SUPPLEMENT**  
(Continued from previous page)

found. It is not only the actual capacity of the valve which causes the trouble, but the inevitable capacity between connecting wires and between the terminals of the coupling components themselves. This capacity is certainly small in amount, but is sufficient to cause a large and measurable loss in efficiency. Expressed in terms of impedance the capacity is often equivalent to only 5,000 ohms or so, and being in parallel with the coupling component we have called R, the impedance, and in consequence the efficacy, of the latter is reduced very considerably. The

valves. The tuned circuit of V.C. and L. is actually almost identical with that connected between aerial and earth but, as we have seen, its purpose is somewhat different.

**Tuned Grid Coupling**

The tuned anode circuit, although perfect in theory and in performance, has some mechanical disadvantages, the chief of which is that it cannot be tuned by the normal type of gang condenser of which the moving vanes are connected to H.T. negative.

It is principally because of this that tuned anode coupling is not extensively employed. But by making what is really a very slight alteration it can be converted to the tuned-grid circuit (to be shown next week). In this case the tuning circuit is connected, through condensers C, from the anode of the S.G. valve to H.T. negative instead of to H.T. positive. The function of the tuned circuit is precisely the same as before, since both sides of the H.T. supply are at the same high frequency potential. An H.F. choke is used to carry the anode current supply to the first valve and it also serves to divert the high-frequency currents from the high tension to the tuned circuit comprising L and V.C. The moving vanes of the tuning condenser are now connected to earth and so the condenser may be one section of a ganged unit, of which the other tunes the aerial circuit.

We have seen how the incoming signal voltages are amplified by the high-frequency (S.G. or V.-M.) valve and passed on to the inter-valve tuning circuit. The voltages now appear across the ends of the second tuning coil and are ready for further use. They still consist of a mixture of high and low-frequency oscillations and are not therefore suitable for operating a sound-producing system. Before they can do

this the low-frequency, or audio-frequency, portion must be separated from the high-frequency fluctuations which comprise the carrier wave. In other words we must reverse the process which takes place at the transmitting station where the current fluctuations representing sound frequencies are impressed upon the carrier.

**Rectification**

This process is known as rectification or detection and is usually carried out by a

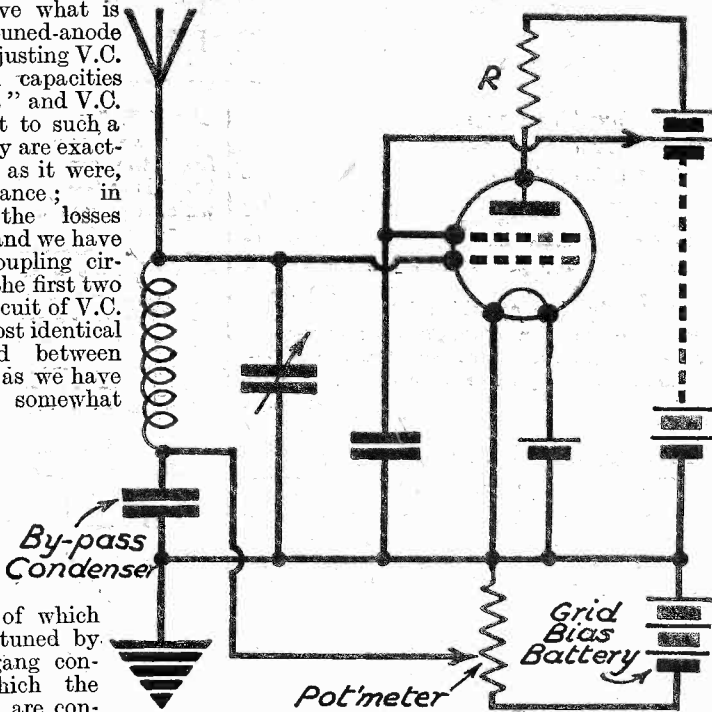

Fig. 12.—How a variable-mu valve is connected.

three-electrode valve. There are four general methods of rectification, which are known respectively as "grid leak," "power grid," "anode bend" and "diode," but only the first two are now in general use. Both are very similar in principle so we will consider them jointly.

The process of rectification, as performed by a valve connected on the leaky-grid principle is somewhat involved, since there are several different actions taking place at once. However, I do not think we shall experience much difficulty in following these actions if we examine each one separately.

(To be continued.)

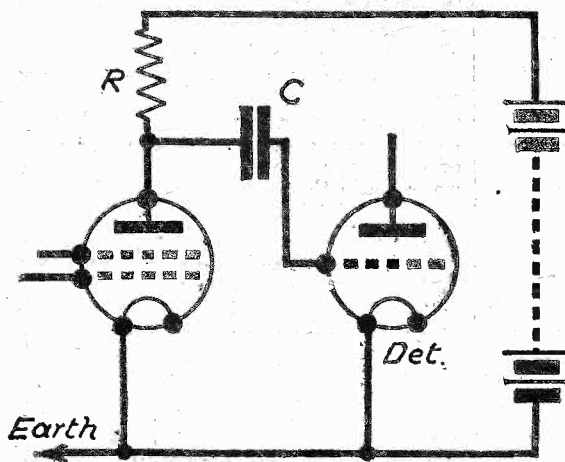

Fig. 13 (a)—Connections for resistance-capacity H.F. coupling.

impedance of a capacity varies in proportion to the wavelength of the currents passing through it, and thus the capacity is of less consequence at higher wavelengths. In point of fact, the two systems of coupling we have considered can be made to be fairly satisfactory on long wavelengths (in excess of 2,000 metres, for example), but as such waves are not now employed for broadcasting purposes, resistance and choke-coupling are of little use to us.

**Tuned Anode**

We previously mentioned the possibility of counteracting the "leakage" capacity, and this is not so difficult of accomplishment as might first appear. The electrical opposite of capacity is inductance, and so if we connect a coil of suitable inductance in parallel with the capacity we can nullify the effects of the latter. In other words

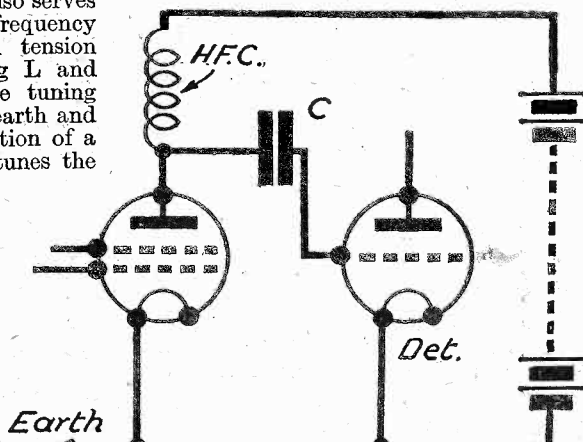

Fig. 13 (b)—Choke capacity H.F. coupling. Heavy lines show how one end of the coupling component is connected to the filament of the detector valve.



**Any Intelligent Man or Woman CAN Make These and Make Money!**



**Many People LIKE YOU Have Doubled Their Incomes!**

Let us introduce you to genuine, honest, spare-time work in the comfort of your home at which men and women to-day are making handsome profits regularly—week in and week out.

By simply posting the Coupon below you can learn at once how you can BUILD UP PRESENT AND FUTURE PROSPERITY. You can commence on your Kitchen Table, in a spare room or outhouse. The work is clean, safe, pleasant and quite simple. It is the making of our Patented Wireless Batteries. The demand for Wireless Batteries is so enormous that it runs into MILLIONS.

Help us to supply this demand and help yourself to the profits. You can make anything up to £300 a year this self-same way! Think what you could do with all those extra £'s! Why, it means freedom, independence, and a definite "knock-out blow" to Financial Worry and Trade Depression.

The wonderful part of it is that you need not have the slightest previous experience or technical knowledge. There is no expensive "plant" to buy. Only a few small hand tools and presses, most of

which you can make yourself at trifling cost. And you are not "tied" in any way whatever. Your profits are only limited by the amount of time you choose to devote to the work.

**One Man Earned £960 in Spare Time**

We GUARANTEE you profit, and, if necessary, we will take sufficient of your output off your hands to ensure it, provided only that your work comes up to the easily attained standard of efficiency—we undertake to continue your training FREE as long as required.

Start now. The Market is unlimited and cannot possibly become overcrowded. It is A GOOD, CLEAN, HONEST, STRAIGHT FORWARD BUSINESS which will help you to become your own "Master."

Send this Form for FREE Instructions How to Start

**COUPON**

To Mr. V. ENGLAND-RICHARDS, THE ENGLAND-RICHARDS CO., LTD., 247, King's Lynn, Norfolk.

Sir,—Please send me at once, and FREE, full details as to how I can Make Wireless Batteries and Make Money at Home in my spare time; also Big Broadsheet of fully-illustrated original Testimony of those already making Big Money. I enclose 2d. stamps for postage.

Print your name and address boldly in capital letters on a plain sheet of paper and pin this coupon to it.

"Practical Wireless" 23/9/33.

**£6**  
A WEEK in a Business of Your Own Opportunity Knocks NOW

STUDY AT HOME **U** IN YOUR SPARE TIME

CAN HAVE A COLLEGE TRAINING IN ALMOST ANY CAREER FOR A FEW SHILLINGS MONTHLY

**MATRICULATION**  
There are many ways of commencing a career, but Matriculation is the jumping-off board for all the best ones.

**CIVIL SERVICE**  
Suitable to both sexes. Ages 15½ to 24.

**G.P.O.** ENG. DEPT. CUSTOMS AND EXCISE; INSP. OF TAXES, Etc. NO EXPERIENCE REQUIRED. OPEN EXAMS.  
We prepare candidates for all

**INSTITUTE EXAMS.**  
TECHNICAL, INSURANCE, COMMERCIAL, GENERAL, POLICE, Etc., Etc.

**ENGINEERS ALL BRANCHES**  
There are examinations which are open and suitable to you, others which are not. Get our advice before deciding.

Let me give you that fatherly advice which is FREE to you, but which may mean so much to you in the future.



DO NOT DELAY—There may be chances for you to-day for which you may be too late to-morrow. Every day counts in a man's career.

*J. Bennett*

**LET ME BE YOUR FATHER**

|   |  |
|---|--|
| <ul style="list-style-type: none"> <li>Accountancy Examinations</li> <li>Advertising and Sales Management</li> <li>A.M.E. Fire E. Examination</li> <li>Applied Mechanics</li> <li>Army Certificates</li> <li>Auctioneers and Estate Agents</li> <li>Aviation Engineering</li> <li>Banking</li> <li>Boilers</li> <li>Bookkeeping, Accountancy and Modern Business Methods</li> <li>B.Sc. (Eng.)</li> <li>B.Sc. (Estate Management)</li> <li>Building, Architecture and Clerk of Works</li> <li>Chemistry</li> <li>Civil Engineering</li> <li>Civil Service</li> <li>All Commercial Subjects</li> <li>Commercial Art</li> <li>Concrete and Structural Engineering</li> <li>Draughtsmanship, all branches</li> <li>Engineering, all branches, subjects and examinations</li> <li>General Education</li> <li>G.P.O. Eng. Dept.</li> <li>Heating and Ventilating</li> <li>Insurance</li> </ul> | <ul style="list-style-type: none"> <li>Mathematics</li> <li>Matriculation</li> <li>Metallurgy</li> <li>Mining, all subjects</li> <li>Mining Electrical Engineering</li> <li>Motor Engineering</li> <li>Municipal and County Engineers</li> <li>Naval Architecture</li> <li>Pattern Making</li> <li>Police. Special course</li> <li>Preceptors, College of Pumps and Pumping Machinery</li> <li>Radio Reception</li> <li>Road Making and Maintenance</li> <li>Salesmanship</li> <li>Sanitation</li> <li>Secretarial Exams.</li> <li>Ship-building</li> <li>Shorthand (Pltman's)</li> <li>Structural Engineering</li> <li>Surveying</li> <li>Teachers of Handicrafts</li> <li>Telephony and Telegraphy</li> <li>Transport Inst. Exams.</li> <li>Weights and Measures "Insp."</li> <li>Wireless Telegraphy and Telephony</li> <li>Works Managers</li> </ul> |
|---|--|

If you do not see your own requirements above, write to us on any subject—IT COSTS NOTHING TO ENQUIRE WE TEACH BY POST IN ALL PARTS OF THE WORLD Also ask for Our New Book (FREE OF CHARGE)

**THE HUMAN MACHINE**  
SECRETS OF SUCCESS.

Note Address carefully:  
**THE BENNETT COLLEGE, Ltd.**  
(Dept. 192), SHEFFIELD.



ESTAB. 1900 SHEFFIELD Dept. 192



# NICORE

TUNING COILS

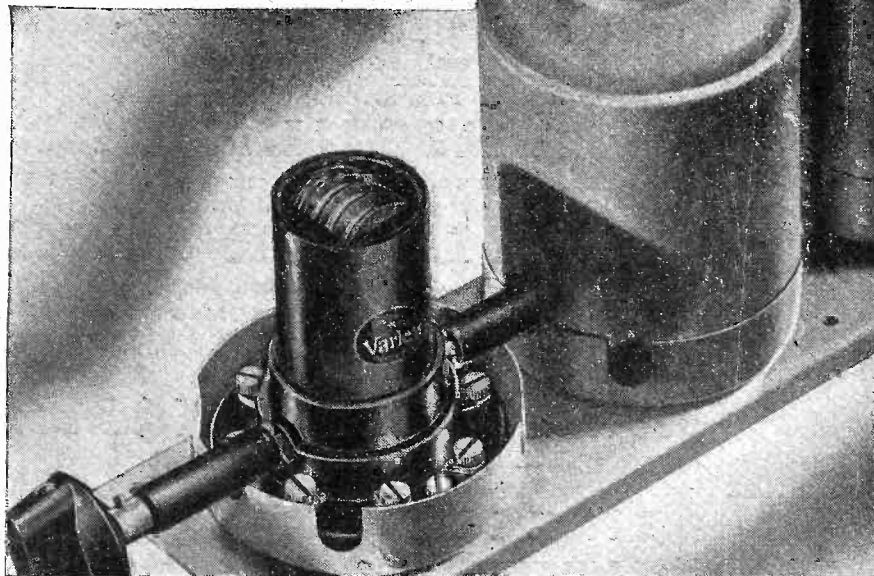

... an outstanding result of years of research by Varley into powdered-metal cores. These new coils combine maximum efficiency with maximum selectivity and are suitable for all circuits. Incidentally, the remarkable consistency of the NICORE core material and its high efficiency have been largely instrumental in enabling Varley to produce the first ganged and working Permeability Tuner—Varley first again.

B.P.30—Aerial or Tuned Grid with Reaction, 10/6. B.P.31—H.F. Intervalve Transformer with Reaction, 10/6. Set of 3 coils ganged on base, 33/-. Also complete range for Superhet Circuits.

Write for free illustrated literature.



FOREMOST AS PIONEERS

Advt. of Oliver Pell Control Ltd., Kingsway House, 103, Kingsway, London, W.C.2. Telephone: Hol. 5303

The Best Low-Priced  
L.F. Transformer on  
the market

BRITISH GENERAL

"VICTORY"

Beautifully made.  
Superb performance.  
Ratio 3½—1, suitable  
for single or double  
stage.

4/6

From all dealers or  
direct from the manu-  
facturers :

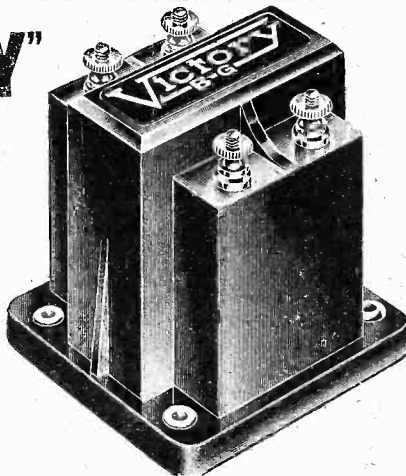

BRITISH GENERAL MANUFACTURING CO., LTD.,  
Brockley Works - - - London, S.E.4

## BRITISH 362 VALVES

DIRECT BY POST FROM THE  
ACTUAL MAKERS AT 50% SAVING

362 Valves are FULLY GUARANTEED, have  
as high characteristics as any valve (British  
or Foreign) and are NON-MICROPHONIC.  
They are ENTIRELY BRITISH.

Post Free from

3/6

"362" BATTERY TYPE VALVES:—H., HL &  
L. 3/6. Power 4/-. Super-Power 4/6. S.G. 7/6.  
Var-Mu 7/6. "Class B" 9/-. Pentode type 10/-.  
(Metalised 3d. extra.)

"362" UNBREAKABLE METAL VALVES (BAT-  
TERY TYPES):—HL. 4/6. Power 5/6. Super-  
Power 6/-. S.G. 10/-. Var-Mu 10/-.  
"362" MAINS TYPE VALVES:—Small Rect-  
and General Purpose 7/6. Super-Power 8/6. S.G.  
and Var-Mu 12/6. Pentode type 15/-.  
Obtain  
Mains  
Valves  
from a Bat-  
tery Set at  
Negligible Cur-  
rent Drain by  
using the 362  
"Class B" Valve.



Cash with order. Cheques and P.O.'s must be crossed and made payable to:—  
THE 362 RADIO VALVE Co., Ltd. (Dept. W. 19), Stoneham Road, London, E.5.

### "NEW RADIOS FOR OLD." WILL RADIALADDIN BEAT RADIOLYMPIA RECORDS?

At Radiolympia all records for Radialaddin sales and enquiries were  
easily broken. The country-wide reputation of Radialaddin for genuine  
exchanges is growing so rapidly that even this record may be broken at

RADIALADDIN STAND No. 47  
MANCHESTER RADIO EXHIBITION

★ IT WILL PAY YOU TO CHANGE YOUR OLD SET BECAUSE WE  
CAN GIVE MORE WHEN YOU BUY YOUR UP-TO-DATE MODEL.  
BALANCE BY CASH OR H.P. EVERY MAKE OF SET, KIT OR  
RADIOGRAM SUPPLIED. ★

COMPLETE TRANSACTIONS EXECUTED BY MAIL  
HUNDREDS OF TESTIMONIALS FROM SATISFIED CLIENTS

Write for particulars of our amazing exchange offer, enclosing 1/d. stamp,  
naming your old set and the new model you fancy.

A FREE QUOTATION WILL FOLLOW

Visit our Showrooms for wonderful bargains.

RADIALADDIN LTD. (Dept. P.R.), 46, Brewer Street, London, W.1.

The largest Radio Exchange in the United Kingdom. Phone: Gerrard 4055.



# FROM THE FLASHLAMP

By Photon

## A High Resistance Potentiometer.

A USEFUL adjunct to an experimental outfit is a high resistance potentiometer, such as may be used as a variable grid leak or as a means of volume control or a similar purpose. One important attribute of a potentiometer or variable resistance for any high-frequency circuit is low electrostatic capacity, and many of the potentiometers on the market are not too good in this respect.

An old method of improvising a grid leak, at one time very popular with the amateur, was to draw a line with an ordinary black lead (plumbago) pencil on any suitable insulator such as ebonite, porcelain, or ground glass, or even on a strip of paper; sometimes the resistance so formed was protected by a coat of varnish or lacquer, sprayed on or carefully applied by means of a soft brush. A resistance constructed in this manner is quite able to serve its purpose, but it is not permanent and is only fit for use in an experimental set or "lash up." One advantage of such a grid leak is that its electrostatic capacity may be made very small, and by choosing a suitable "support," and being as sparing as possible in the quantity of insulating material used, the parasitic dielectric losses may be kept down; this is important in an H.F. stage.

It is difficult to say why a resistance or grid leak of this kind is not permanent, and it is difficult to believe that any slow burning away or oxidation of the graphite takes place; the temperature cannot be high enough for normal combustion, and there can scarcely be anything in the nature of electrolytic action. Nevertheless the

separation of the graphitic particles. So far as the writer knows, the matter has never been thoroughly investigated; it might be well worth while experimenting with various dielectrics and methods of "fixing" the graphite streak. The convenience of being able to prepare grid leaks or resistances as and when required would probably justify the labour. The current such a resistance can safely carry is, generally speaking, small, but obviously several lines can be drawn in parallel and so this objection can be easily met.

In solving a problem involving differential reception it became necessary to devise a potentiometer of minimum capacity and high resistance, and the use of a graphite streak suggested itself as a possible solution. The obvious difficulty is that any rubbing contact would tend to destroy the continuity of the streak (pencil line) and so vary or increase the resistance to an unknown extent. The method adopted to overcome this objection was simplicity itself, the tap or contact was itself made of graphite, in fact it was constituted by a piece of "refill lead" of a pocket pencil, and this laid its own track and maintained it. After several movements of the arm

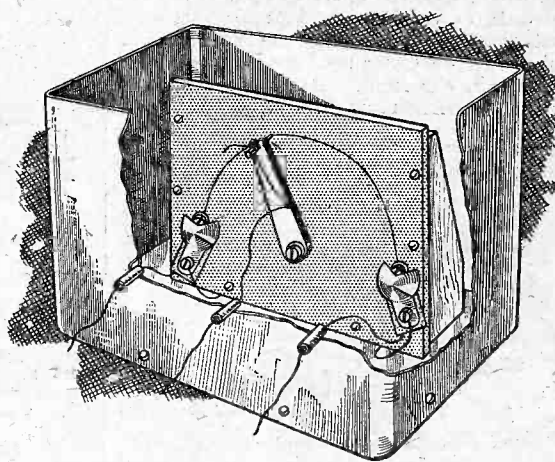
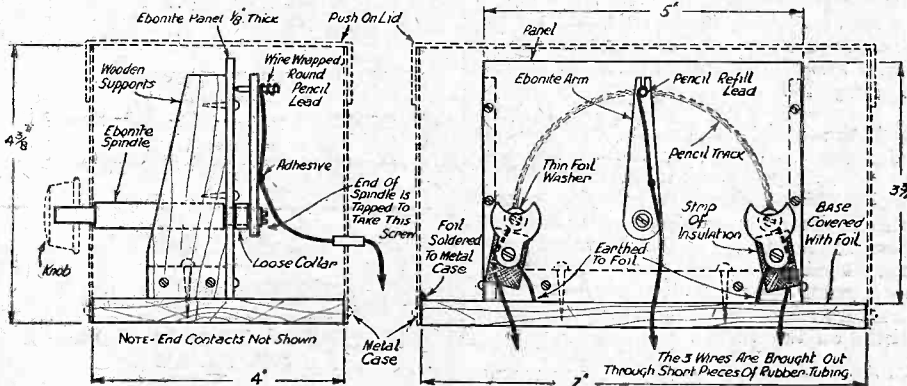

Fig. 1.—Sectional view of the complete instrument.

carrying the pencil contact, the graphite streak (a semicircle) became "formed" and tended towards a stable condition, when the resistance became reasonably constant.

The complete potentiometer is illustrated in Fig. 1, which shows the interior, while Figs. 2 and 3 show the general arrangement



Figs. 2 and 3.—General arrangement of parts and connections.

resistance is not permanent, and its constancy is ever suspect; perhaps a change in the surface condition of the dielectric may result in some kind of

interferences the potentiometer was mounted in a screen box (earthed) as shown in Fig. 1.

# MARCUS, OVERTON

## RADIO, LTD.

62, Borough High Street, London Bridge, S.E.1.

GUARANTEED EFFICIENCY



SERVICE

## THE "PREMIER SUPER" DE LUXE KIT

|   | £ s. d.        |
|---|----------------|
| 1 British Radiophone Superhet 3 gang Midget variable condenser, complete with full vision disc drive. Type 582a ... | 1 11 0         |
| 1 Set Lissen matched Superhet coils ...   | 1 10 0         |
| 2 Lissen Intermediate Frequency Transformers ...  | 15 0 0         |
| 1 Belling Lee v.w. 50,000 ohm Potentiometer ...   | 1 10 0         |
| 1 Bulgin 3-point switch ...   | 1 10 0         |
| 1 Bulgin Push-Pull Radio-Gram switch ...  | 1 9 9          |
| 3 Chassis Brackets ...  | 15 6           |
| 1 R.T. "New Hypermu" L.F. Transformer ...   | 6 0            |
| 6 Erie 1 watt resistances, 20,000, 10,000, 20,000, 30,000, 100,000 ohms and 2 megohms ...                           | 3 8            |
| 2 Dubilier .1 mfd condensers type BB ...  | 7 0            |
| 2 Dubilier 2 mfd condensers type BB ...   | 1 0            |
| 1 Dubilier .0001 mfd condenser type 670 ...   | 1 0            |
| 1 Dubilier .0002 mfd condenser type 670 ...   | 1 0            |
| 1 Dubilier .0003 mfd condenser type 670 ...   | 1 0            |
| 2 Dubilier .01 mfd condensers type 670 ...  | 4 0            |
| 1 Polar Preset condenser .002 mfd ...   | 2 0            |
| 4 Clix 4 pin chassis valve holders ...  | 4 8            |
| 1 Clix 5 pin chassis valve holder ...   | 1 3            |
| 3 Belling Lee Terminal mounts ...   | 1 6            |
| 6 Belling Lee "R" type terminals ...  | 1 3            |
| 6 Belling Lee "Bowspring" wander plugs ...  | 7 9            |
| 1 "Ace" drilled and foil covered chassis ...  | 3 0            |
| 1 Belling Lee fuse and holder ...   | 1 0            |
| 5 Cossor valves to specification ...  | 3 1 6          |
| Connecting wire, flex, screws, etc. ...   | 1 5            |
| <b>Kit B, including valves</b> ...  | <b>£10 1 0</b> |

Any component supplied separately.

|   |         |
|---|---------|
| Kit A, as above Specification, but without valves ...   | £6 19 6 |
| or 12 monthly payments of ...   | 12 6    |
| Kit B, as above Specification ...   | 10 1 0  |
| or 12 monthly payments of ...   | 18 6    |
| Kit C, as above Specification, with valves and "ACE" Brand Super Cabinet in Walnut ...  | 10 16 6 |
| or 12 monthly payments of ...   | 1 0 0   |
| Kit D, as above Specification, with valves and "ACE" Brand Super Console Cabinet in Walnut, fitted with W.B.P.M.6 speaker ... | 12 18 6 |
| or 12 monthly payments of ...   | 1 4 0   |

## "PREMIER SUPER" ACCESSORIES.

|  |         |
|--|---------|
| Ever Ready 9 Volt G.B. Battery ...   | 1 0     |
| Ever Ready 120 Volt H.T. Battery, Winner type ...                          | 11 0    |
| or Popular type ...  | 15 6    |
| Block New Plateless L.T. Accumulator 80 amp/hrs. ...                       | 11 6    |
| Block 120 Volt Plateless H.T. Accumulator 5,000 ma./hrs. ...               | £3 15 0 |
| M.P.R. Eliminator with trickle charger for 5-valve receiver type AC210 ... | 3 12 6  |
| W.B. Type P.M.6 Microloide Moving Coil Loud Speaker ...                    | 1 12 6  |
| Belling Lee Unit Gramophone Pick-up ...                                    | 1 2 6   |
| Belling Lee Volume Control for above ...                                   | 4 0     |
| Garrard No. 30 Double Spring Turntable ...                                 | 1 5 0   |

|   |        |
|---|--------|
| Lissen All Wave Four complete kit with valves   | 5 12 6 |
| Lissen 7 Valve Superhet complete kit with valves  | 8 17 6 |
| Telsen Super Six complete kit with valves ...   | 9 15 6 |
| Sound Sales Class B Unit complete with Class B valve ...                                      | 2 9 0  |
| (Ready for use with any receiver using 2 Volt battery operated valves.)                       |        |
| Westinghouse A.O. Mains Superhet. Blue-print, constructional details and prices Post Free ... | 1 3    |
| Scott-Taggart S.T.400 Kit A ...   | 4 15 0 |
| or 12 monthly payments of ...   | 8 9    |

## HERE'S A WAY TO SAVE MONEY . . .

Old sets rewired and modernised. Send full details of your present set and state approximate amount you are prepared to spend and we will give you free advice and quotations. We stock everything connected with Radio. Component parts—Speakers—Manufactured Receivers—Mains Units, etc. Cash, C.O.D. and Easy Terms.

**COUPON**  
**MARCUS OVERTON RADIO LTD.**  
 62, Borough High St., London Bridge, S.E.1.  
 Phone: Hop 4431.

Please supply Cash/C.O.D./Terms.....  
 for which I enclose £.....s.....d.  
 Cash/Deposit.

NAME .....

ADDRESS .....

..... Pr.V. 23/9/33.

**TRADE SUPPLIED.**

# RADIO RAMBLINGS

By JACE

*Notings from my Notebook*

## American M.W. Reception!

FOR the last two weeks I have been receiving some of the medium-wave U.S.A. stations and suggest that you should sit up one evening and have a "go" for them. Recently I have been too busy to attempt such reception myself, but I am pleased to say that up to the time of writing these notes I have been able to spare an hour between 12.30 and 1.30 a.m. This was on the night of September 10th (or more correctly, the morning of the 11th), and although using a Det.-2 L.F. receiver I was able to obtain fairly good speaker reception from Pittsburgh KDKA on 306 metres and Schenectady, WGY, on 379.5 metres. As I have just said, I commenced to listen at 12.30 a.m., and by taking the tuning position of North Regional as a guide

I was very soon able to tune in KDKA. The announcements which were being made did not come in too well and the transmission suffered from high speed fading. So at about 12.45 a.m. I tried for WGY, the station operated by the General Electric Company of America, taking the tuning position of the Scottish Regional (376.4 metres) as a guide. After a little juggling with the reaction and tuning condensers I was able to hear two comedians in a kind of "back-chat" item, but reception was very weak and subject to a good deal of fading. Having located

these two stations, however, I made a mental note of the dial settings and kept changing from one to the other. Neither was received really well before 1 a.m., but after that conditions gradually improved until I finally switched off. Atmospheric conditions were far from good and at times signals were entirely drowned by static, but I was satisfied that the reception of these stations was possible. Had I stayed up a little longer I have no doubt that reception would gradually have improved, but I knew that I must be up in good time for work and so, against my will, went to bed at 1.30.

## M.C. Speakers with Battery Sets

WHILST I was in a wireless shop the other day a customer came in and asked for a demonstration of a few loud-

speakers. He was allowed to hear six or seven and decided that he liked the fifth one best of all. Before purchasing it he asked the assistant for a full specification (he already knew the price and thought it most reasonable). On being told that it was a permanent magnet moving coil, the customer looked horrified and declared that it would be no use to him because his set was battery-operated and he could not afford to be constantly buying new H.T. batteries. I was rather puzzled by this statement, but the assistant had evidently run up against the same complaint before. He tried in vain to convince his would-be customer that the moving-coil speaker would not affect the consumption of high-tension current in the least. After the customer had left, without making a purchase, I



## SHORT-WAVE WIRELESS TESTS ON SHOOTERS HILL.

Photo shows: Two members of the International Short-Wave Wireless Club who camped on Shooters Hill (London), the highest point in the Metropolis, during the week-end, in an effort to secure a record five-metre reception of 200 miles from Snowdon, the previous record on this wavelength being 130 miles.

asked the assistant for an explanation. Apparently there are numerous listeners who think that a moving-coil speaker, especially if it happens to look big, causes a heavier drain on the high-tension battery. Of course, the idea is entirely wrong, and I cannot think how it can have originated. The current consumption has nothing whatever to do with the speaker but depends entirely on the valves.

### NEXT WEEK!

ANOTHER FREE GIFT SPANNER

Have YOU Reserved Your Tool Kit Yet?

See pages 31-33 of this week's issue.

# RADIALADDIN BARGAINS

(RECONDITIONED)

## EASY TERMS

**FOLLOWING GUARANTEED SETS OFFERED SUBJECT TO BEING UNSOLD. SEND 10/- DEPOSIT TO SECURE YOUR CHOICE**

### MAINS RECEIVERS

| Ref. No. | Receiver.                         | List Price, £ s. d. | Our Price, £ s. d. |
|----------|-----------------------------------|---------------------|--------------------|
| 3        | Philco 4-v. A.C. 1933             | 14 14 0             | 7 7 0              |
| 95       | Lumophone 3-v. S.G. A.C. 1933     | 15 15 0             | 8 9 0              |
| 17       | Pye M.M. 3-v. A.C. 1933           | 17 17 0             | 10 10 0            |
| 4        | Ferranti 4-v. S.G. A.C. 1932      | 12 12 0             | 5 5 0              |
| 113      | Philips 3-v. S.G. D.C. 1932       | 12 12 0             | 7 7 0              |
| 5        | Selector 4-v. S.G. A.C. 1930      | 57 15 0             | 10 10 0            |
| 11       | Ultra Lynx 3-v. S.G. A.C. 1933    | 10 10 0             | 6 10 0             |
| 12       | Ultra Panther 4-v. S.G. A.C. 1933 | 18 18 0             | 12 0 0             |
| 119      | Lincoln 4-v. A.C. 1931            | 10 0 0              | 4 10 0             |
| 117      | Marconi 3-v. D.C. 1932            | 16 16 0             | 9 9 0              |
| 70       | Home Lovers 3-v. A.C. 1932        | 12 12 0             | 5 5 0              |

### RADIOGRAMS

|     |   |         |         |
|-----|---|---------|---------|
| 133 | H.M.V. 12-v. S/Het E/Gram Auto Changer 1932   | 73 10 0 | 35 0 0  |
| 113 | Faraday All-Wave 5-v. A.C. 1933               | 57 15 0 | 31 10 0 |
| 13  | Alba 4-v. S.G. A.C. 1933                      | 19 19 0 | 13 13 0 |
| 114 | E.R.P. 3-v. A.C. Oak finished Cabinet 1933    | 18 18 0 | 12 12 0 |
| 115 | E.R.P. 3-v. A.C. Walnut finished Cabinet 1933 | 18 18 0 | 12 12 0 |

### BATTERY RECEIVERS

|     |                               |         |        |
|-----|-------------------------------|---------|--------|
| 57  | Pye G/B. Q.P.P. 1933          | 12 12 0 | 8 8 0  |
| 38  | S.T. 400 in Cabinet 1932      | 7 0 0   | 4 4 0  |
| 61  | Carlton S.G. 4. 1932          | 11 11 0 | 3 0 0  |
| 90  | Carlton S.G. 4                | 11 11 0 | 3 0 0  |
| 93  | Zoophone S.G. 3. 1932         | 8 6 0   | 2 15 0 |
| 49  | Ferranti S.G. 3               | 12 12 0 | 4 4 0  |
| 36  | Miracle 4-v. and Speaker 1931 | 12 12 0 | 4 4 0  |
| 78  | Red Star 3-v. 1932            | 4 4 0   | 1 10 0 |
| 120 | Lotus 3-v. 1933               | 8 8 0   | 4 10 0 |
| 74  | K.B. 8-v. 1930                | 8 10 0  | 4 0 0  |
| 118 | Marconi 5-v. Transp. 1930     | 15 15 0 | 6 6 0  |
| 123 | Pye G/B. (Q.P.P.) 1933        | 12 12 0 | 8 8 0  |

### SUITCASE PORTABLES

|     |                           |         |        |
|-----|---------------------------|---------|--------|
| 108 | Faggin 5-v. 1933          | 5 5 0   | 2 10 0 |
| 123 | McMichael Super Four 1931 | 17 17 0 | 6 6 0  |
| 31  | Burgeyne 5-v. 1931        | 6 0 0   | 2 10 0 |

### SUNDRIES

|    |                                  |       |        |
|----|----------------------------------|-------|--------|
| 80 | Regentone Eliminator             | —     | 1 10 0 |
| 22 | Tunewell Eliminator              | —     | 1 10 0 |
| 41 | Ekco "Ekcone" Speaker in cab.    | 5 5 0 | 1 10 0 |
| 35 | Blue Spot Cone Speaker in cab.   | 2 2 0 | 0 12 6 |
| 33 | V.D.F.I. Speaker in Mhgnay. cab. | —     | 0 12 6 |

## "NEW SETS FOR OLD"

ALL MAKES OF 1934 MODELS SUPPLIED EASY TERMS ANY SET TAKEN IN PART EXCHANGE

**RADIALADDIN LTD.**  
46, BREWER ST., W.1  
Telephone: Gerrard 4053/6



## CONDENSER SPINDLE EXTENSIONS

By V. W. GREENHALGH

SOONER or later most experimenters feel the need for some kind of insulated extension for variable condenser spindles. Such an extension is very useful in short-wave work where hand-capacity effects are often a nuisance.

There are many good extension spindles with insulated couplings on the market, but none of them are cheap; so perhaps a description of an insulated extension spindle which is at once cheap and efficient may be of interest.

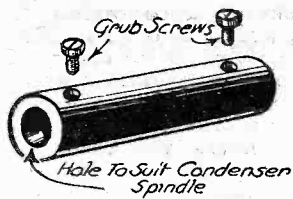

Fig. 1.—The insulating piece made from ebonite rod.

The insulating piece, Fig. 1, is made from  $\frac{1}{2}$ in. diameter ebonite rod. A 2in. length of this is used, and a hole drilled through the length of it with a  $\frac{1}{8}$ in.

drill. This hole must be true and great care must be taken in drilling it. It does not matter if the hole is not quite parallel with the sides of the tube, but the hole itself must not waver or change direction at all.

Perhaps the best way of doing this is to clamp the hand-drill to the bench so that it lies parallel to the bench top and far enough above it to allow of easy working. Cut a straight, shallow, V-shaped groove in a piece of timber, and lay it on the bench so that it is exactly in line with the drill, then fix it in this position either by clamping or nailing to the bench. Now place the ebonite rod in the groove and feed it up to the drill with one hand whilst working the drill with the other.

Two small holes will have to be drilled at right-angles to the longitudinal hole to take the fixing screws. These holes should be rather less in diameter than the screws they are to take, in order to allow for the thread.

If no taps are available, the screws themselves can be used as taps, since the ebonite is soft enough to be tapped in this way. Slightly countersink the holes to

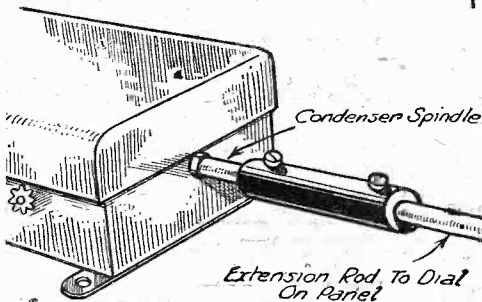

Fig. 2.—Showing the insulating sleeve connecting the condenser spindle and extension rod.

start the screws, and then force them in slowly but firmly with a screw-driver, taking care that they are kept vertical. Ordinary brass screws may be used if desired, but steel grub-screws are better, and can be bought for about a penny a pair at any ironmonger's.

The condenser spindle goes into one end of the tube, and is secured by the grub-screw, and a piece of  $\frac{1}{2}$ in. brass rod, cut to suitable length to connect with the dial, fits in the other end, as depicted in Fig. 2.

# The VALUE of T.C.C. RESEARCH to YOU....



EVERY T.C.C. announcement has been a plain statement of fact—of achievement. No extravagant claims have been needed. Year by year T.C.C. research has been going on, large sums of money have been expended on pioneer work, the best brains employed. The T.C.C. efforts have been rewarded. Every development of note in condenser practice has emanated from the T.C.C. laboratories.

The following facts provide the reason for the wonderful confidence held by set designers, serious experimenters and amateurs in T.C.C. Condensers.

### MILESTONES IN RADIO HISTORY

- 1906 T.C.C. founded with factory operating solely on Condensers and artificial line for submarine cable work.
- 1914 T.C.C. introduce Mansbridge Condensers, and manufacture under original licenses.
- 1915 T.C.C. working on Condensers for War Office, to Admiralty—Air Service—etc.
- 1918
- 1920 T.C.C. manufacture heavy duty Transmitting Condensers.
- 1922 T.C.C. manufacture Power Condensers.
- 1926 T.C.C. contract with B.B.C. to supply Condensers for 2LO.
- 1927 T.C.C. discard Mansbridge type, and introduce Rolled Condensers using Aluminium Foil of higher conductivity—and greater reliability.
- 1928 T.C.C. introduce Dry Electrolytic Condensers of very high capacity for low tension smoothing.
- 1929 T.C.C. introduce Dry Electrolytics for 100 volt working.
- 1930 T.C.C. introduce Moulded-in Mica Condensers—the now famous "M" Type.
- T.C.C. introduce Non-inductive condensers.
- 1931 T.C.C. introduce Wet Electrolytic Condensers.
- 1932 T.C.C. manufacture Dry Electrolytic High Voltage Condensers—(550v. peak).
- T.C.C. first to publish Surge Voltage ratings of paper condensers.
- 1933 T.C.C. research still building up data, still adding to its specialised knowledge so that Radio Technicians may have available not only a "pedigree" range of condensers, but a range ahead of time.

# T.C.C.

ALL-BRITISH

## CONDENSERS

The Telegraph Condenser Co., Ltd., Wales Farm Rd., N. Acton, W. 3

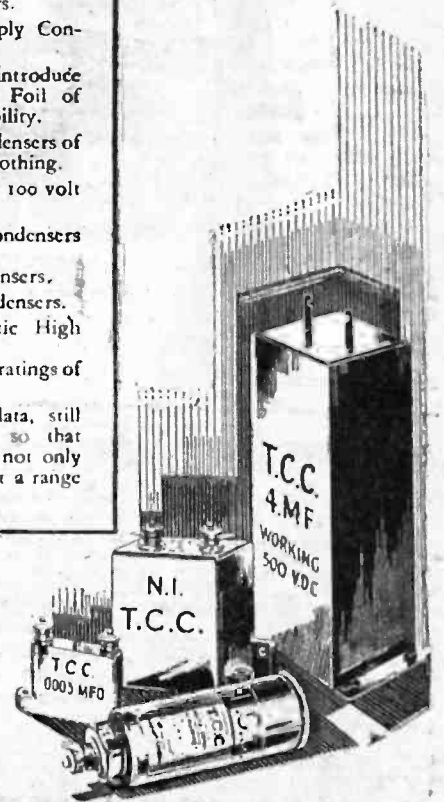

# EVERY FOTOS VALVE NOW HAS THE

# NEW FOTOS FILAMENT

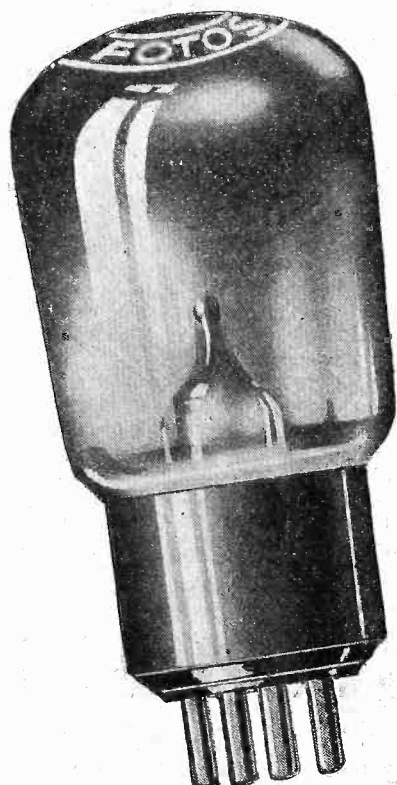

—to give it greater power, range, and tonal clarity with less current consumption. These improved Fotos Valves in your set mean louder, clearer radio, keener tuning of stations all round the dial. Prices remain as low as before, general-purpose types costing from 5/-; screened grid, 12/6. Test one of the new Fotos Valves now!

## EVEN CLASS B . . .

is catered for with the Fotos Class-B Valve for output stages adapted to this new method of double-valve amplification.

Write for Descriptive Folder

**CONCERTON RADIO AND ELECTRICAL CO., LTD.**

256, Bank Chambers, 329, High Holborn, London, W.C.1  
Telephone: Holborn 8667.

**FIT**

# fotos

**NON-MICROPHONIC**

---

**NEW FILAMENT VALVES**

**100%  
BRITISH  
MADE**



## ● IMPROVE YOUR SHORT WAVE RESULTS

SHORT-WAVE ENTHUSIASTS will welcome this "EDDYSTONE" high efficiency lead-in device. It makes sure that weak short-wave signals from thousands of miles away are carried safely to the set without loss at the point of lead-in—usually the weakest link of any aerial system

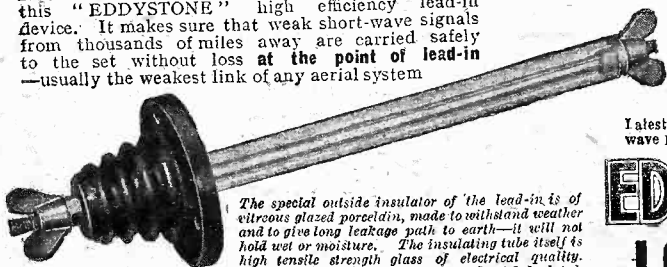

"EDDYSTONE" LOW  
LOSS LEAD IN  
CAT. No. 946,  
Price 2/6.

Latest list of "EDDYSTONE" short wave parts now ready, free on request.

# EDDYSTONE

## LOW LOSS LEAD IN

The special outside insulator of the lead-in is of vitreous glazed porcelain, made to withstand weather and to give long leakage path to earth—it will not hold wet or moisture. The insulating tube itself is high tensile strength glass of electrical quality. All metal parts are polished and nickel plated. Also available for use with transmitters.

STRATTON & CO., LTD., BROMSGROVE ST., BIRMINGHAM.  
LONDON SERVICE DEPOT—WEBB'S RADIO STORES, 164, Charing Cross Rd., W.C.2

## DON'T PERPETUATE RADIO FALLACIES

(Continued from page 30)

Class "B" valve, for here the anode current, when no signals are being received, is very small, and it rises as the signal voltage applied to its grids is increased.

Another wrong idea about the output stage is that if a super-power valve is fitted the volume of sound will automatically become greater than when a power type valve is used. Nothing could be more erroneous. Actually, for a given signal input a power valve will give a greater volume of sound than a super-power valve because of its higher amplification factor. A power valve, however, can only handle without distortion comparatively weak signals, and if, in order to increase volume, big grid swings are applied, bad distortion is sure to result. The main advantage of a super-power valve is that it has a longer working grid base, that is to say, it will handle without distortion much bigger incoming signals than a power valve, and is therefore not so readily overloaded.

As the maximum signals corresponding to the loudest passages in a programme are some four to five times greater than the average signal from a given station, a small-power valve is very apt to blast and distort when a loud passage occurs. This risk is not so great with a super-power valve, so this type should be used when really good quality is required.

On the other hand, because a super-power valve has a greater acceptance than a small-power valve, it can give for a given percentage distortion a larger volume than a power valve, providing you have a sufficiently strong signal voltage to apply to it. The increased volume, however, will not be in the same proportion as the increase in grid signal voltage, because usually the super-power valve has a considerably lower amplification factor than a power valve, which is designed primarily to give the largest output possible from a fairly small input compatible with reasonably good quality.

## LEARNING THE MORSE CODE

(Continued from page 22)

several accented letters, but I have not given these, since they are very seldom heard and there is quite enough for the beginner to do in mastering the English letters. Also there are various punctuation signs which are used; it will perhaps be as well to mention the more common of these:—

Preamble — . — . — (sent once at the beginning of a transmission)

Break sign — . . . — (used by amateurs very much as a full stop)

Query (?) . . . — . . .

Exclamation mark (!) — — . . . — —

Other groups of this kind consist of one or two letters run together, without a break between them, and are usually referred to by the constituent letters, as for example, . . . — — — . . . the distress call, popularly known as S O S. Others commonly heard are the end of message sign . — . — . (AR) and the end of work signal . . . — . — (SK).

Lastly I must warn readers to remember the clause in their licence which forbids anyone to reveal the contents of any message intercepted by them to anybody other than a duly authorized official of His Majesty's Post Office.



# QUALITY Class B...

Whatever make of Class B Valve you are using there is a Rola Class B Speaker exactly suited to its characteristics. For amazing performance and enduring quality there is no speaker made that is comparable with these Rola units. Here is the Rola Class B range.

For MULLARD P.M. 2B, B.T.H. PD220, COSSOR 220B, STANDARD 13B1, H1VAC B220, MARCONIPHONE B21, G.E.C. B21, CLARION B22.

- ROLA FR5-PM-33-Class B ..... 29/6
- ROLA FR6-PM-23-Class B ..... 39/6
- ROLA F6-PM-22-Class B ..... 49/6
- ROLA F7-PM-23-Class B ..... 60/-

For COSSOR 240, FERRANTI HP2, CLARION B24.

- ROLA FR5-PM-32-Class B ..... 29/6
- ROLA FR6-PM-22-Class B ..... 39/6
- ROLA F6-PM-22-Class B ..... 49/6
- ROLA F7-PM-22-Class B ..... 60/-

All prices include Transformer.

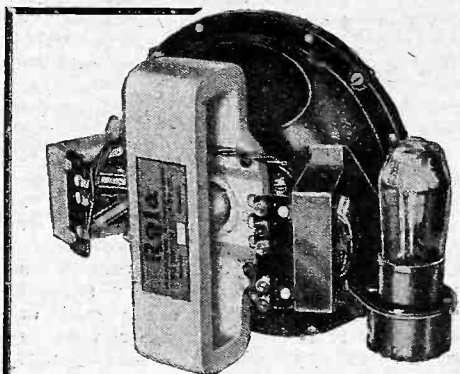

## ROLA Class B Speaker Amplifier Unit

If you are a battery set owner you can convert your receiver to Class B output in five seconds and secure five times the original volume by connecting a Rola Class B Speaker Amplifier Unit. No alteration to the set is necessary.

Model A—For MULLARD P.M.2B, B.T.H. PD220, COSSOR 220B, STANDARD 13B1, H1VAC B220, MARCONIPHONE B21, G.E.C. B21, CLARION B22.

Model B—For COSSOR 240, FERRANTI HP2, CLARION B24.

PRICE (Both Models less Valve) **57/-**

# ROLA

*the World's Finest Reproducers*

THE BRITISH ROLA CO., LTD.,

Minerva Rd., Park Royal, N.W.10.  
Phone: Willesden 4322-3-4-5.

ROLA  
SPEAKERS  
for better  
Radio Reception

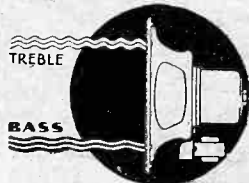

## CUTTING LARGE HOLES IN EBONITE By J.M.D.

FACED with the necessity for cutting a large circular hole in an ebonite panel, many amateurs will drill holes all round and use the file to smooth up the inside edge. Using the same equipment—a small hand brace and drills—a quicker and neater job can be produced by adopting the following method.

Make a jig from a small strip of wood by drilling two holes as shown in the accompanying illustrations, one to take a centre-pin (a drill shank will do) round which the jig rotates, and the other to take a guide bush, which may be simply a screwed socket. Drill the hole for the guide bush first, push the latter home, then mark off the radius of the hole to be cut from the outer edge of the hole in the bush—see dimension X in Fig. 1. This ensures that the centre-pin hole will be accurately spaced. To avoid marking the panel, the underside of the strip should have clearance filed at both ends.

To use the jig, drill

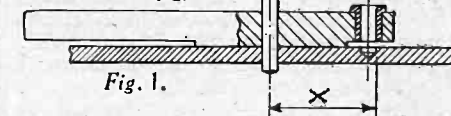

Fig. 1.

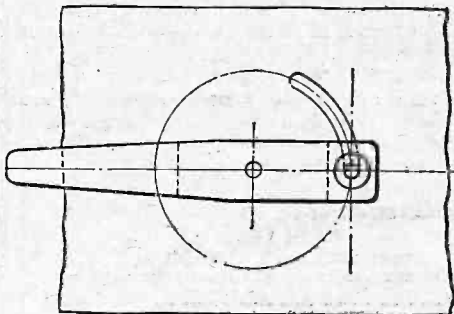

Fig. 2.

Diagrams illustrating the method of drilling large holes in ebonite.

a hole in the panel for the centre-pin, and place the jig on the panel with the pin through the hole. Fix a collar to the drill in the hand brace at such a height from the point that, when lowered through the bush, it allows the drill to be fed down into the ebonite a short distance (see Fig. 1).

To operate the device, get someone to slowly turn the jig round the centre-pin whilst the drill, with the collar resting on the top of the guide bush, is revolved fairly rapidly. Fig. 2 shows the groove made after travelling a short distance. After once round, sink the drill a further amount and repeat. Then turn the panel over and cut from the other side. After two or three times round the centre piece will fall out, and the slight fin left can be removed with a pocket knife.

ANOTHER STEEL SPANNER,  
TO COMPLETE THE SET,  
FREE NEXT WEEK!

## B.R.G. SPECIFIED AGAIN FOR THE PREMIER SUPER

B. R. G. 3-POINT SWITCH No. 48. With specially strong phosphor bronze self-cleaning contacts 1/3

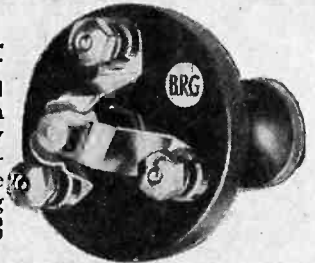

B.R.G. 3-POINT SWITCH No. 50, 2/- with special contacts

3 B.R.G. Component Mounting Brackets, drilled, slotted and plate finished. 1/6

SOLE WHOLESALE DISTRIBUTORS FOR

METAPLEX CHAS. P. ETO-SCOTT  
SIS as specified for PREMIER SUPER  
Premier Super, size CABINET—Hand  
12in. by 12in., with polished Walnut.  
ready drilled holes With front  
ready drilled 25/-  
for valve- 3/9 Baffle and Baseboard  
holders Assembly 3/6.

In cases of difficulty send direct

## BRITISH RADIOGRAM

BRITISH RADIOGRAMPHONE CO. LTD. Pilot House,  
Church Street, Stoke Newington, London, N.18  
Telephone: Glasohd 6287/8288.

Appointed TELSEN WHOLESALERS

FRONT OF PANEL MILLED HUT  
  
FIT THIS  
ELECTRIC  
CLOCK  
TO YOUR SET!  
NO MAINS NEEDED!  
KEEPS CORRECT TIME!  
NO WINDING!

Works off small battery lasting 12 months, or can be plugged into G.B. battery without affecting reception. Uses practically no current. Fits into hole 3 1/2 in. dia. In any panel up to 1/2 in. thick. Easy to fix—no screws required. Only 1/2 in. from front of panel to back of case. Swiss movement. Hands set from front. Nickel-plated bezel. Useful addition to any set.

RIVERSIDE MFG. Co., Ltd.,  
Dept. 21, Crisp Road,  
Hammersmith, W.6.  
Telephone: Riverside 6392. **12/6**  
COMPLETE WITH BATTERY  
POSTAGE 6D

What is **ENGINEERING OPPORTUNITIES**?  
250 pages

"ENGINEERING OPPORTUNITIES" is a 250-Page Hand-Book showing the possibilities of various Engineering Careers. It shows clearly and definitely the way in which you may carve out a successful career in your chosen branch of Engineering, irrespective of your age, education or experience. It outlines Home-Study Courses in all branches of Civil, Mech., Elec., Motor, Aero., Wireless and "Talkie" Engineering, and shows the easiest way to pass A.M.I.C.E., A.M.I.Mech.E., I.F.P., A.M.I.A.E., M.I.M.T., G.P.O., Matriculation, Civil Service, and other Examinations. "ENGINEERING OPPORTUNITIES" is a unique Hand-Book that you should most certainly read. Send for your copy to-day—FREE of any cost. BRITISH INSTITUTE OF ENGINEERING TECHNOLOGY, 300, SHAKESPEARE HOUSE, 23/32, OXFORD STREET, LONDON.

CHARGING WITHOUT MAINS  
Thousands are charging their own accumulators, why don't you? "TONIO" trickle-charger Kits keep two-volt accumulators fully charged. Ideal for remote districts. From 7/-, postage 9d. Full particulars, stamp. WILLIAMS, Netherend, Cradley, Nr. Birmingham

**Right from the beginning—**  
**"PRACTICAL WIRELESS"**  
 designers have specified Heayberd Mains Components

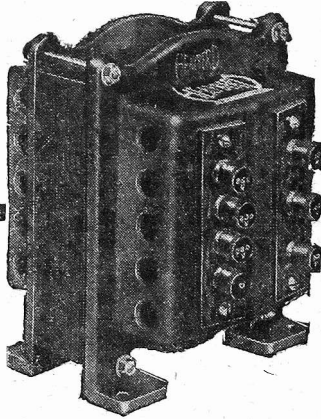

Ever since the early days of "Practical Wireless," their technicians have exclusively specified Heayberd Mains Apparatus for the majority of their mains circuits. Surely a fine tribute to the reliability and efficiency of Heayberd products. The sets detailed below incorporated Heayberd transformers and chokes:

ALPHA A.C.—D.C. UNIT,

A.C. CHARGER,

A.C. FURY FOUR,

A.C. TWIN,

SELECTONE A.C. RADIOGRAM.

It is not too late to build one or more of those units now, you can get all the mains components from Heayberd. Whenever it's a question of "mains power for your radio," Heayberd are ready to help you—especially with high-power models. Complete Mains Units, Mains Unit Kits, L.T. Battery Chargers, Amplifiers and Mains Components—all are fully described, together with helpful hints, tips and circuit diagrams, in the 36-page Handbook. Write TO-DAY for your copy. VISIT STAND 39—MANCHESTER RADIO SHOW.

**F. C. HEAYBERD & CO.,**  
 10, FINSBURY STREET, LONDON, E.C.2  
 (One minute from Moorgate Und. Sta.)

POST COUPON NOW

I enclose 3d. stamps for the Heayberd Handbook, "Mains Power for your Radio"—please send it by return.

Mr. ....

Address .....

Prac.

**HEAYBERD**  
 MONARCH OF THE MAINS.

## NEW MULLARD HIGH-VOLTAGE OUTPUT VALVE

WHERE it is desired to get the very best out of the broadcast programme, it is essential that the output valve should be capable of delivering a really high undistorted output. This term is constantly occurring in reference to output valves, and there would appear to be some misconception among amateurs as to the precise meaning of the term. Another point which seems to cause confusion is the actual value of this output, as it is often stated that for real quality an output of 5 watts is desirable, whilst the average two-volt power valve only delivers a power in the neighbourhood of .3 or .4 watts. The following explanation may help to solve the difficulty, and will tend to show why these large super-power valves are necessary in delivering really high quality programmes.

The B.B.C. transmissions are radiated at a certain strength, and while over a very large proportion of programme time a certain average value is maintained, this strength is greatly increased (perhaps to five or six times the average) when specially loud passages occur in the items being broadcast. In other words, while the radio-frequency power transmitted from a station is constant, the audio-frequency modulation varies in accordance with the programme. It is important, therefore, that the output valve in a radio set should be able to handle these extra loud passages without introducing distortion. For all normal purposes the usual triode or pentode output valves provide ample "overload capacity" for domestic reception, but those listeners who require super-excellent quality, combined, perhaps, with rather more volume than that given by the average sets, can use in the output stage of an A.C. mains receiver or radio-gram one of the larger valves giving maximum undistorted outputs of 5 watts

and upwards. These valves, it should be noted, require anode voltages ranging from 400 to 500 volts.

There are many such valves obtainable, and one of the most popular domestic valves which has been available for some time now was the Mullard D.O.25. This valve had the remarkably low impedance of 800 ohms, and required 400 volts H.T. with a filament rating of 1.1 amps at 6 volts. This latter requirement prevented many listeners from taking advantage of the volume obtainable from this type of valve, as it necessitated a special transformer winding to deliver the 6 volts, or a separate accumulator had to be used. In accordance with the Mullard policy of producing a Master Valve for every purpose, experiments were carried out in order to improve this particular valve, and bring it into line with the more general type of mains-operated valve. The results of these experiments are embodied in the new D.O.26, and the valve is certainly superior to its predecessor. The H.T. voltage remains at 400, but the filament has been converted into one of the 4 volt 2 amp. type, with the additional improvement that the internal resistance of the valve has been reduced to 600 ohms. This results in an improvement of the conductance which now stands at 6.3 mA-volt. The grid bias required at maximum working voltages is 92 volts when the anode current is of the order of 60 milliamps, enormous signals may be handled by this valve, the total input capacity being 65 volts R.M.S. This valve will undoubtedly do much towards bringing better radio to many of the keener amateurs who do not mind the high rating of the H.T. supply, and to those who do not think such voltages and valves are justified, we would heartily suggest that they take an early opportunity of hearing a receiver or amplifier working under these conditions. We are confident that they will have a pleasant surprise.

The latest Valve Guide issued by the same firm contains most interesting details of many other valves, both of this high-powered type and for the ordinary small battery receiver.

## NEW PETO-SCOTT SPEAKER

AN interesting speaker is illustrated herewith, and is supplied by Messrs. Peto-Scott. As shown, it is ready for mounting into any type of cabinet, and many of the difficulties of correctly fitting one of these heavier types of moving-coil speakers are overcome by this simple baffle mount. The actual speaker is obtainable in permanent magnet or field-wound types, and the transformer fitted may be obtained for any type of output valve. The cone is of the corrugated type, with a neat, accurate centring device, and the magnet system is mounted rigidly on the metal chassis. We have tested two types, one of the permanent type and one with a mains-excited field, and the results in both cases were certainly very good. Speech was bright and forward, whilst musical items had all the characteristic timbre of the original instruments. Even when grossly overloaded, the distortion was not of the type which makes listening really unpleasant, and this appeared to be due to the particular spider and

surround which was fitted. The sensitivity is not quite so great as our standard, but is sufficiently good to enable really good results to be obtained with a two-valver using a suitable output valve. The speaker is obtainable in the chassis form or in a neat cabinet.

The chassis model Peto-Scott speaker, which costs only 15/-.

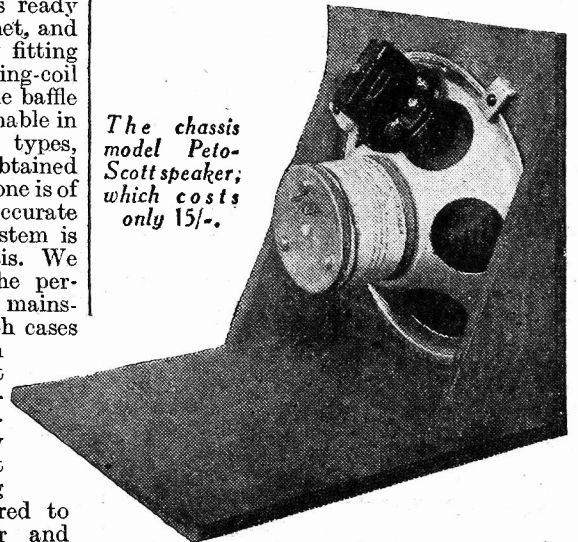





**A Dramatic Episode in Music**

**A**MONG the bigger orchestral pieces under review

there are perhaps only two which are conceived and done on the grand scale. First of all I want to mention Liszt's *Mazeppa Symphony* on three half-a-crown Parlophone records (R1579-1581). The subject has been a favourite one of painter and poet, and here we have the musical presentation of the story. Mazeppa, tied to the back of an untamed horse, is borne across the plains, until rescue comes only at the point of death. The music portrays it all with a realism that makes the present technique of cinema music seem somewhat crude. View it as you will—as noble music or as a musical drama played on a vast background—it remains still great. The *Mazeppa* thematic air, here and there, persisting against the noise of the horse's hoofs is impressive to a degree. Finally, the rescue, and then Liszt lets himself go. Yes; you should hear this piece, nobly played by the Berlin Grand Symphony Orchestra, and, if you please, read Byron's poem first. Then you will enjoy it.

**Lighter Fare from Mozart**

Next, the *Concertante Sinfonie for Violin and Viola* (K364) on Columbia DX478-481. First, do not imagine that the two soloists (Sammons and Tertis) are awarded the lion's share of the performance. The orchestral part (played by the London Philharmonic Orchestra), occupies the stage a great deal. This composition is Mozart on the grand scale and yet in the Rondo movement we get the delicate, intimate touch of which he was so great a master. But the whole work is one of his finest, for his own prowess with the violin has enabled us to hear a work in which this instrument plays some beautiful passages. The recording is a superb bit of craftsmanship, and the placing of the microphones uncannily accurate. Altogether a treasure to keep for your delight.

**Lighter Still**

A very welcome addition to the "afternoon tea" music, albeit real music, is Beethoven's famous *Menuett in G*, and the *Entr'acte Gavotte from Mignon* on H.M.V. B4466. These make a perfect coupling, the more so as they are played by Marek Weber's Orchestra. Altogether delightful, this. Then another—the *Overture to the Secret Marriage*, by Cimarosa. Here is very sprightly music with, it seems, an abundance of quips. The Berlin Philharmonic go merrily through it on H.M.V. DA4404. Entirely on a different plane, but suitable for the same occasions, is a pot-pourri played by Edith Lorands' Orchestra on Parlophone R1586. This is *Vienna Memories*, and it is by no means a collection

By E. REID-WARR

of the hackneyed pieces one might expect. There are two bits of very good marches, for instance. Another

to be commended—also by Parlophone (R1586) is *Love's Joy and Sorrow and Fairy Tale of Love*. Here the Orchestra Mascotte (in which everybody seems able to play at least three instruments), give a very cheery little performance. Then one from Columbia. I know this mention will cause a smile from our young moderns, but there is something very attractive about J. H. Squire's Celeste Octet's playing of *Silver Threads Among the Gold* and *My Sweetheart When a Boy*. The Aunts and Uncles will love it. The number is DB1155. Lastly, a real up-to-the-minute attraction—*Here's the Circus and A Song Goes Round the World*, on Parlophone R1587. One of the best recording dance bands on the continent—the Bravour—are responsible.

**... Where They sing**

Not many vocal hits to write of in this list, but there are one or two which are very tempting. The one I liked far and away the best is by a Children's Choir—that of St. Mary's School, Bridgnorth. I believe they average about twelve years, but their training must have been the work of an artist. Hear *The Lass With The Delicate Air* and Handel's *Oh! Had I Jubal's Lyre* on Columbia DB1166. From every standpoint—vocal, enunciate, artistic—the performance is a real gem. In the Handel piece, their "runs" are taken with the confidence of highly trained adults. This kind of record is scarce—hear it. I like Essie Ackland's *Song of Sleep on H.M.V. B4465*. It is a beautiful song, musically and poetically. The other side, *Danny Boy*, is hardly new (!) but many people collect it, I believe. It's very well done. Here is a queer choice—Tauber singing *My Curly Headed Baby* (Parlophone RO20223). In German, the song sounds equally attractive, and he does sing it as a lullaby. The other side, *The Ratcatcher's Song*, is not attractive, unfortunately. Norman Allin is very good in W. S. Henley's *Invictus* and *The Blind Ploughman* on Columbia DB1157.

**A New Pianoforte Star**

When a comparatively unknown pianist arrives at the studio to make a record at her own expense, the recording manager is not unduly thrilled. But in a certain case the "play-back" of the record left him a very excited man. This happened when Eileen Joyce recorded the Liszt *Etude de Concert in F Minor* and *Etude de Concert in A flat Major*, by Paul de Schloger. Each piece is of the "brilliant" type. The performance is flawlessly certain, every note a clear, identifiable unit. For those who want something really thrilling in piano playing I commend Parlophone E11237.

**New Times Sales Co**

**1934 RADIO**  
on the easiest of

**Easy Terms**

Choose your NEW RADIO and send us your requirements. We will quote you the Easiest of Terms per return. WE DEAL WITH YOU DIRECT. No Third Party Finance Company, thereby ensuring the strictest privacy. Immediate delivery from stock.

**NEW LISSEN KITS**

- Free constructional chart with each Kit.
- NEW SKYSCRAPER 7-VALVE SUPER- With**  
**HET CHASSIS MODEL**, complete kit in sealed carton. Cash or C.O.D. Carriage Paid, £8/17/6. **15/-**  
order
- Balance in 11 monthly payments of 16/6.
- NEW SKYSCRAPER FOUR ALL-WAVE With**  
**CHASSIS MODEL**, complete kit in sealed carton. Cash or C.O.D. Carriage Paid, £5/12/6. **10/3**  
order
- Balance in 11 monthly payments of 10/3.
- NEW LISSEN SKYSCRAPER FOUR With**  
**ALL-WAVE CONSOLETTTE CABINET MODEL**, complete kit in sealed carton. Cash or C.O.D. Carriage Paid, £8/2/6. **15/-**  
order
- Balance in 11 monthly payments of 15/-.
- NEW LISSEN SKYSCRAPER 7-VALVE With**  
**SUPER-HET CONSOLETTTE MODEL**, complete kit in sealed carton. Cash or C.O.D. Carriage Paid, £11/10/0. **21/-**  
order
- Balance in 11 monthly payments of 21/-.

**TELSEN CLASS "B" 4 KIT** (Chassis), less Valves, Cabinet, and Speaker. Cash or C.O.D. Carriage Paid, £3/17/6. **7/-**  
order

Balance in 11 monthly payments of 7/-.

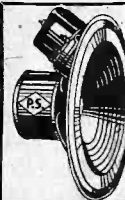

**PETO-SCOTT PERMANENT MAGNET MOVING-COIL SPEAKER** with tapped input transformer for power or pentode. Cash or C.O.D. Carriage Paid, 15/- only **5/6**  
order

Balance in 2 monthly payments of 5/6.

Class "B" Type 22, 6 Cash or C.O.D. or 4 monthly payments of 6/3.

**NEW BLUE SPOT 99P.M. PERMANENT MAGNET MOVING-COIL SPEAKER** With Complete with tapped input transformer. Cash or C.O.D. Carriage Paid, £2/19/6. **6/-**  
order

Balance in 10 monthly payments of 6/-.

**NEW LISSEN P.M. MOVING-COIL SPEAKER** with input transformer. Cash or C.O.D. Carriage Paid £1/5/0. **5/6**  
order

Balance in 4 monthly payments of 5/6.

**NEW W.B. TYPE P.M.4A. MICRO-LODE PERMANENT MAGNET MOVING-COIL SPEAKER**, switch-controlled multi-ratio Input Transformer. Cash or C.O.D. Carriage Paid, £2/2/0. **5/9**  
order

Balance in 7 monthly payments of 5/9.

**NEW ROLA CLASS-B PERMANENT MAGNET MOVING-COIL SPEAKER AND AMPLIFIER**, with Valve and Input Transformer. Two models: A for PM2B, PD220 and 220 B; B for 240B, H.P.2 (state which when ordering). Cash or C.O.D. Carriage Paid, £3/11/0. **6/6**  
order

Balance in 11 monthly payments of 6/6.

**NEW GARRARD MODEL 202A**. 12-in. Turntable. Electric Motor for A.C. mains. Cash or C.O.D. Carriage Paid, £2/10/0. **6/-**  
order

Balance in 8 monthly payments of 6/-.

**NEW ATLAS C.A.25** for Mains, Class B and Q.P.P. Four tappings: 60/80, 50/90, 120/150, 25 m.a. Cash or C.O.D. Carriage Paid, £2/19/6. **6/-**  
order

Balance in 10 monthly payments of 6/-.

*Miscellaneous Components, Accessories, Kits and Part Kits supplied CASH, C.O.D., or H.P. on our own Private System of Easy Payments. Any Item advertised in this journal sent C.O.D. If value over 10/- sent all C.O.D. charges paid.*

To **EST. 1924**  
**NEW TIMES SALES CO.** 69, Ludgate Hill, London, E.C.4.

Please send me.....  
for which I enclose £ : s. d. Cash Deposit  
Name : .....  
Address : .....  
.....Pr. W.23/0/33

# Facts and Figures

Components tested in our Laboratory

BY THE PRACTICAL WIRELESS TECHNICAL STAFF

### NICORE A.V.C. UNIT

THE method of overcoming fading by including what is known as Automatic Volume Control is fast growing in popularity, and there are no doubt many receivers in existence into which A.V.C. could be incorporated. The difficulty, however, of knowing just what extra components to add, and the method of connection, keeps many from employing the scheme. Messrs. Varley have now introduced a very neat unit which contains all the essential parts for A.V.C., and which may easily be wired into an appropriate circuit to provide perfect volume control—the actual degree of control depending, of course, upon the H.F. amplification which is available in the circuit. Although the instrument is very small, it contains, in addition to an H.F. choke, two fixed condensers, a resistance and a "cold valve." This is of the half-wave type, and the connections are arranged in such a way that all that is necessary to include the unit in circuit is to remove the present H.F. choke and replace it with the unit. Two connections are available for this purpose, and the two remaining connections on the unit are joined to earth and the H.F. stage. The ordinary manual volume control is then adjusted

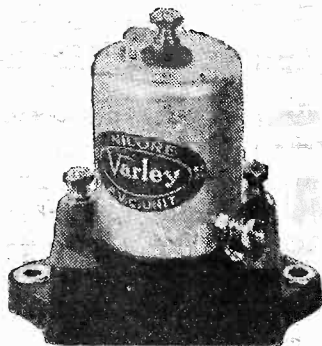

The Varley Nicore A.V.C. unit.

to give the volume normally required from the receiver, when the A.V.C. unit reduces powerful stations to that level and enables the receiver to employ its maximum sensitivity when tuning-in weak or distant stations. The price is 15s. 6d.

### OUR SHOW REPORTS

IN the course of the Show Numbers we mentioned the fact that Stand No. 12 at Radiolympia was in respect of Higgs Motors (Birmingham). The name of the owners of this Stand should have been given as Higgs (Great Britain), Ltd., and we shall be glad, therefore, if readers will kindly note this difference.

### BORST "BETTBUFF"

MESSRS. BORST BROS., the well-known timber merchants, have produced an interesting baffle, bearing the above trade name. This consists of a square of plywood, 24in. by 24in., with a neat fret cut in the centre. In the particular model submitted this was 9in. in diameter, but presumably any size fret can be obtained. The finish of the front veneer may be

obtained in birch, oak and mahogany, the prices being 6s., 7s. and 7s. 6d., respectively. The novelty lies in the use in the centre of the board of a layer of some compressed material about 5/16in. thick, four layers of thin ply being arranged on each side of this layer to form a total thickness of 3/4in. Resonances are effectively avoided by this construction, and the reproduction with this baffle certainly sounds less "boomy" than with a similar board of ordinary plywood. In addition, a slight added crispness could just be detected on speech. In view of the little increase in cost over the ordinary baffle, it is certainly worth while obtaining one of these "Bettbaffs" for the construction of a radio cabinet.

### SERADIX LOUD-SPEAKER

A NEAT loud-speaker has been submitted for test by Trevor Pepper. The illustration will show that a novel type of spider is employed, which is extremely light and has very little restoring effect on the cone, whilst at the same time permitting perfect freedom from side play. The magnet is particularly large for such a small type of speaker and lends great strength to the gap, namely, 7,500 gauss. A rubber gasket is fitted at the rear of this to avoid troubles due to metallic dust, etc., finding its way into the gap and thus giving rise to noises or preventing smooth movement of the speech coil, which has an impedance of 15 ohms. A pressed metal frame is employed to hold the periphery of the cone and this is fitted with a corrugated edge to enable the movement to be quite free and "piston-like." On actual test the sensitivity was quite up to standard, and reproduction was forward and brilliant, without any noticeable resonances or

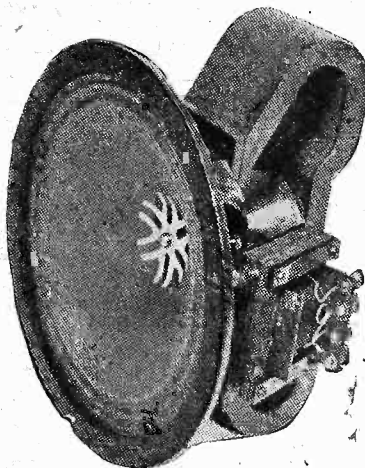

The Seradix Loud Speaker.

dips in the curve. The falling off at either end of the scale was at a suitable point to avoid bad effects, and the speaker may be said to represent very good value for money. The price is 31s. 6d., and the transformer offers ratios of suitable value.

### AMPLION SCREENED H.F. CHOKE

ONE of the new chokes introduced by Amplion (1932), Ltd., has been submitted to us for test, and is of rather larger dimensions than the usual type of low-priced choke. The aluminium screen, for

instance, is 1 1/2in. in diameter and nearly 3in. long. The choke is wound on a slotted eboniteformer of a diameter sufficiently small to prevent losses due to the screen, yet large enough to enable a high inductance value to be obtained with a suitable gauge of wire. Eight slots are provided, and the wire is wound in these slots in the usual manner. The base is of moulded bakelite fitted with two terminals and two fixing holes, one of

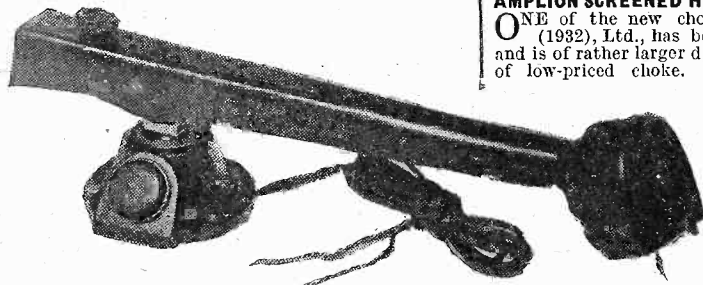

The Cosmochord "Universe" Pick-up, which was reported upon in our issue dated August 12th. The compensating adjustment on the rear of the carrier arm may be seen in this illustration. This enables the weight on the record to be controlled. The price is 22/6d.

## EASY TERMS

The very latest Radio sets, loudspeakers and kits supplied on the lowest monthly terms. Strict privacy. Prompt delivery. All carriage paid. Price list free.

New BLUE SPOT 89 PM UNIT with transformer. (The finest perm. magnet unit available.) Cash price 59/6, or 5/- with order and 11 monthly payments of 5/6.

MULTITONE CLASS "B" CONVERTER with valve ready for plugging-in to any set. Cash price 51/6, or 5/- with order and 10-monthly payments of 5/8.

New LISSEN SKYSCRAPER ALL-WAVE-4 KIT with valves... As above, but with Cabinet...

New BLUE SPOT 89 PM with transformer...

New W.B. MICROLODE PMAA UNIT with transformer and special matching switch...

FERRANTI CLASS "B" SPEAKER AMPLIFIER moving-coil unit with valve...

New ATLAS MODEL CA25 H.T. ELIMINATOR, output 25MA...

Interesting descriptive leaflet of any of the above free! To avoid delay will customers kindly send first payment with order!

Estd. 1925 THE LONDON RADIO SUPPLY COMPANY 'Phone: National 1977.

## LONDON RADIO SUPPLY COMPANY

11, OAT LANE, NOBLE STREET, LONDON, E.C.2

## MAKE YOUR SET SUPER SELECTIVE

Separate those stations that overlap each other.



JUST FIX A

PIX IN YOUR AERIAL

2!

with Clip 2/6

Cut out the local or any other powerful station and tune in foreign programmes previously swamped.

From all Wireless Shops or from BRITISH PIX CO., LTD. (Dept. 603) 118, Southwark St., London, S.E.1.

## Famous Maker's Offer! £5 Radio-Gram 65/- CABINET for SEVEN DAYS' FREE TRIAL (OR 10/- MONTHLY)

Polished Oak! and Piano built! The acoustic Tone brings a fine thrill. Makers to Radio-Press, B.B.C., 3,000 clientele. MODELS FROM 35/- to £15. Photographs and List FREE. PICKETTS Piano-Tone Cabinets, (R.P.), Albion Road, Bexleyheath

## MAKE A RADIOGRAM OR GRAMOPHONE

Our 64-page Illustrated List for 3d. will tell you how, and show you a great variety of Spring and Electric Motors, Turntables, Tone Arms, Soundboxes, Horns, Loudspeakers, Pickups, Cabinets, hinges, lidstays, door-locks, knobs, handles and catches. Also Receivers, Kits, complete Gramophones, accessories, springs, needles, and repair parts at lowest prices, wholesale or retail. The Regent Fittings Co., D. 285, (Est. 30 years), 120 Old Street, London, E.C.1.



## SEND TO FOYLES FOR BOOKS!

New and second-hand books on Wireless and all other subjects. Over two million volumes in stock. Catalogues free on mentioning your interests. 119-125, CHARING CROSS RD., LONDON, W.C.2 Telephone: Gerrard 5660 (7 lines).



(Continued from previous page)

the latter being furnished with the usual eyelet and providing an earthing connection to the screen. The latter makes contact with a disc of aluminium in the base of the choke, so that the screening is absolutely complete. The actual characteristics of the choke are very good indeed, the inductance being sufficiently high to permit of maximum amplification being obtained with a screen-grid valve when using the choke for H.F. coupling. The self-capacity is reasonably low and the D.C. resistance is only of the order of 700 ohms, in spite of the large amount of wire which is utilized. At 3s. 6d., we can thoroughly recommend this choke.

**HIVAC CLASS B VALVE**

THE latest valve to be released from the High Vacuum Valve Co.'s works is the B.220. This is one of the new economy Class B valves designed with a filament of the 2 volt .2 amp type, and requiring a maximum high tension voltage of 150. The anode current under these conditions, with no signal, is only just over 1 milliamp, and on peaks it rises to the usual value of 25 to 30 milliamps. The normal current works out, during an evening programme, to approximately 15 milliamps, on actual test. The output load required is about 15,000 ohms, and the valve was tested in various circuits where this load was already in circuit. The results were fully up to standard, and the output approximated 1.25 to 1.5 watts when fully loaded. The quality was very bright and clear, with no necessity in our particular case for any tone compensation, although perhaps to some the higher notes would require slightly reducing. Various drivers and driver transformers were tried, all with a high degree of success, and we have no hesitation in recommending this valve, which costs 10s. 6d. The normal seven-pin base is, of course, fitted to the valve.

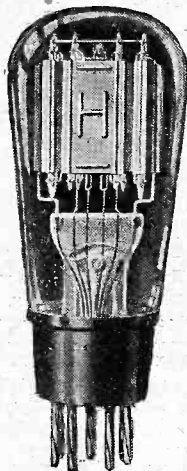

One of the HiVac Valves, from which the method of electrode assembly may be seen to be extremely robust and rigid.

**"BIFLO" STATIC CUT-OUT**

ONE of the recently introduced interference eliminators which we have just examined is known as the "Biflo," presumably on account of the fact that the instrument provides two separate circuits for the aerial currents. The device is housed in a fairly substantial bakelite case, and is provided with four terminals, marked A, B, 1 and 2. According to the instruction sheet supplied with the device the aerial is joined to one terminal, the earth to another, and the aerial and earth terminals of the receiver joined to the remaining two terminals. The device consists of a resistance network arranged around the various terminals, and according to the degree of interference the connections introduce varying resistances between aerial and earth, or across the receiver, or both. As soon as a suitable "noisy" transmission is experienced, we shall be able to test the device more fully. The price is 12s. 6d., and is available in three types according to the nature of the interference and the type of receiver, whether battery-operated, A.C. or D.C.



SEND FOR 80 PAGE CATALOGUE-MANUAL ENCLOSE 2" POSTAGE



**BRILLIANT RESPONSE FROM BASS TO TREBLE NOTES**

**GET THE BEST FROM YOUR SET !**

The circuit diagram shown below illustrates one method of improving your reproduction by introducing a "Bulgin Senator" Nickel Alloy Core Transformer as an intercoupling between valves.

It replaces all old type transformers and will give even amplification from lowest bass to treble notes.

The ohmic value of the wire-wound "Spaghetti" resistance should be three times the impedance (in ohms) of the valve whose anode it feeds.

**BULGIN "SENATOR" TRANSFORMER**

Nickel Alloy Core. Primary Inductance between 75 H and 95 H. Uniform amplification from below 50 to 8,000 cycles. Ratio 1-4. LIST No. L.F. 12

PRICE 6/- EACH

Send for Catalogue No. 153 N. Enclose 2d. Postage.

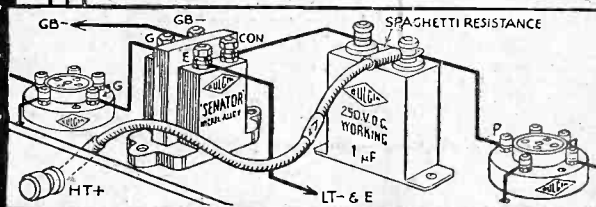

A. F. BULGIN & CO., ABBEY ROAD, BARKING, ESSEX. Phone: Grange Road 3266 & 7. London Showrooms: 9, 10, 11, Cursitor St., Chancery Lane, E.C.4. Telephone: Holborn 2072.

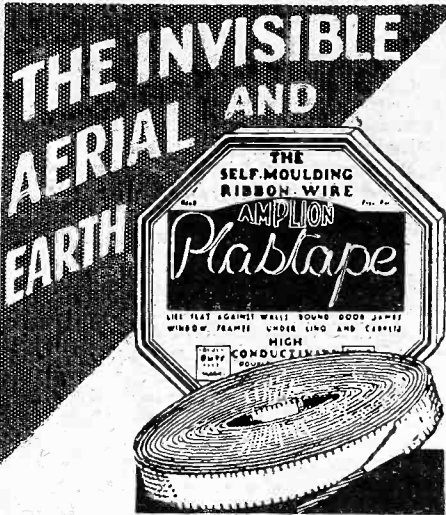

By moulding the "PLASTAPE" aerial along your picture rail, you have virtually what is an "invisible aerial."

"PLASTAPE" Earth, in the same way, makes an equally neat and professional job of earthing your set.

PRICES: AERIAL complete with fixing staples, 30ft. 3/6d. EARTH complete with fixing staples, 30ft. 2/6d. IN THREE COLOURS TO MATCH YOUR DECORATION.

**AMPLION**

Amplion (1932) Ltd., 82/84, Rosoman St., E.C.1.

**PEARL & PEARL RADIO BARGAINS**

!! 100 ONLY !! LOWEST PRICE TO CLEAR

Famous Lamplugh P.M. Moving Coil Speakers. Will handle any volume, originally made and sold at 42/-—selling at cost price to clear stock. . . . . 23/8

The well-known Lincoln Stewart dual range shielded coils 200-550 meters, 800, 2,100 meters. List price, 6/6 . . . . . 2/11

K.B., H.C., or D.C. Pup. Self-contained, simple, safe, trouble-free. The K.B. 2-valve all-electric "Pup" for excellent and reliable mains-operated receiver for A.C. or D.C. mains. List price, £7.10.0 . . . . . £3.12.6

Famous Amplion A.B.4. Balanced Armature Speaker in beautiful Oak Cabinet, suitable for power or Pentode outputs. This model was made and originally sold for 50/-—special price to clear . . . . . 17/6

Limited number of Telsen Major Speaker chassis. This is a super bargain and is available while stock lasts. Usually 10/6 . . . . . 3/3

All goods sent cash or C.O.D. Carriage paid PEARL & PEARL, 190, Bishopsgate, E.C.2

**50 TESTED WIRELESS CIRCUITS**

By F. J. CAMM

(Editor of "Practical Wireless")

This handbook contains every modern circuit, complete with instructions for assembling, component values, and notes on operation. Whatever the circuit you require, it is in this book.

Obtainable at all Booksellers, or by post 2/9 from George Newnes, Ltd., 8-11, Southampton Street, Strand, London, W.C.2. **2/6**

**EASY PAYMENTS****"There's no place like HOLMES."**

The first firm to supply Wireless parts on easy payments. Nine years advertiser in Wireless Press. Thousands of satisfied customers.

After visiting the Show you will undoubtedly choose the finest speaker.

**EPOCH 11in. SUPER 4/11**  
**45/- CASH** Deposit 9 Payments of 4/11

|                          | De-       | Monthly   |
|--------------------------|-----------|-----------|
|                          | posit     | Payments  |
| LISSEN SKYSCRAPER Kit    | 89/6 8/3  | 11 of 8/3 |
| EISEN 325 Star Kit       | 39/6 5/5  | 7 of 5/5  |
| EXIDE H.T. Accum., 120v. | £3 6/-    | 9 of 6/8  |
| EKCO Eliminator A.C.18   | 67/6 7/5  | 9 of 7/5  |
| CELESTION M.C. P.-M.     | 35/- 4/10 | 7 of 4/10 |
| B.T.H. Pick-up           | 25/- 4/8  | 5 of 4/8  |

Parts for any Kit Set. Any make of Speaker.

**New Goods Obtained for Every Order.**

Send us a list of the parts you require and the payments that will suit your convenience, and we will send you a definite quotation. Anything Wireless.

**H. W. HOLMES, 29, POLEY STREET,**  
Great Portland Street, London, W.1.

Phone: Museum 1414.

**SOUTHERN RADIO'S Wireless Bargains.—Set manufacturer's guaranteed surplus:—****VARIABLE** Condensers.—British Radiophone 4-gang superhet type, fully screened and trimmers, 0.0005, 8/9 (list 45/-). Same type, complete with dial knob and escutcheon, 12/9 (list 50/-). Polar 3-gang condensers, 0.0005, fully screened with trimmers escutcheon, knob and dial, 11/- (list 45/-). Hydra block condensers brand new, 16 mid., 2+2+8+2+1+1, 1,000 volt test (made for Canadian Marconiphone Co.), 8/9; 4 mid., 2/9; 2 mid., 1/9; 1 mid., 1/-; all 750 volt.**SPEAKERS**—Celestion Soundex permanent magnet, 16/- (list 27/6); Rola F6 permanent magnet, 28/- (list 49/6); D.C. mains energised, 2,500 to 6,500 ohms, complete with bumping coils and transformers, 16/6 (list 39/6); Peter Grassman dynamic speakers and chassis, 10/6 each (list 35/-); G.E.C. Stork speakers, complete in mahogany cabinet, 19/6 (list 43/15); Ormond speakers, complete in cabinets, 10/- (list 25/-); Utah D.C. mains energised pentode or power, 9in. cone, 21/-, 9in. cone, 13/6; ultra-permanent magnet speakers, 95 P.M., 35/- each. A really hefty job (list 44/15/0).**CONSTRUCTORS' Kits**—Ready Radio "303" battery 3-valve kits, less valves, 18/- each; complete with 3 Mullard valves (P.M.1L.P., P.M.2, 2D.X.), 39/- each (list 70/-); Ready Radio Meteor screen grid 3-valve kit, less valves, 20/-; with 3 Mullard valves (P.M.12a, P.M.2D.X., P.M.2a), 49/- (list 75/6); Universal Radio 3-valve kits, ready assembled on chassis, 12/6 (list 42/-).**READY RADIO S.T.100 Kits**, as specified by Scott Taggart, £2/19/6 each (list 44/17/6); Mullard Radio for Million, 3-valve A.C. kit, complete with 3 Mullard A.C. valves (Pen. 4V, 354 V, 84V), £3/10 (list 46/10); Mullard Radio for Million 3-valve battery kits, complete with 3 Mullard valves, £3/30 (list 46/2/6); all kit brand new, in original sealed cartons.**P.F.I.C.O.**—All-in-One latest type bakelite case, 8/9 (list 12/6), 6 only; B.T.H. Junior Pick-ups, 17/6 (list 25/-); British General Band Pass tuning units, 10-K.C. aerial or anode, 6/- each (list 14/6).**ALL Goods Guaranteed Brand New and Perfect and Sent Carriage Paid.****PLEASE Note**—We have opened Branches at 271-275, High Rd., Willesden Green, N.W.10, and at 46, Lisle Street, W.C.2, where callers are cordially invited to inspect our large stocks of wireless bargains. Please send all post orders to 323, Euston Rd., N.W.1.**SOUTHERN RADIO, 323, Euston Rd., London, N.W.1** (near Warren St. Tube). Phone: Museum 6324.

Ryall's Radio, 33, Chancery Lane, London, offer guaranteed new goods. Mains transformers, 250v 60ma, 4V 1 amp, 4V 3 amp, 10/6. 350v ditto, 12/9, for HT7/12/13, with 4V 4amp, 10/6, 4V 3amp only, 6/9. Condensers, 4mf 250v working, 2/6. 500v working, 4/6. 750v working, 6/6. TCC 2mf 350v working, 1/6. 1mf ditto, 1/3. TCC or mica, 1/-, TCC 15mf 100v working, 1/3. Chokes 25H at 60ma, 6/9. 20H at 100ma, 8/9. Meters. 0-6v AC, 0-3amp AC, 0-12v AC, N. 0-50ma or 0-20ma DC, 10/- each. 0-250v DC 1000 ohm per volt, 32/6, all flush, Bakelite case, 2 1/2 in. face, single range Polar Star 3-gang condensers, new, 15/-, with drive, 17/6. HAV condenser blocks 4x4mf 250v working, 4/9. Radiophone 4-gangs, 12/9, with cover and drive complete, 17/6. Radiophone 4-gang super het type, 9/-, post gd. Output transformers, ratios 18/23/32 to one, similar to R&amp;A, 6/- each. Mains valves, slightly used, guaranteed perfect, tested here for callers, MS4B, AC/SG, S1VA, MSG/HA, MSG/LA, VMS4, AC/Pl, 41MXP, 9/- each. MS4, S4VB, AC/HL, 354V, 904V, DC/HL, AC/P, 41MP, 7/6 each. MPT4, 10/-, Mazda VMS/GAC, 10/-, Telsen .05 mica condensers, 2/3. One inch paxolin tubes, slotted, with guides, 1/- each. Close 1 o'clock Thursdays, open all day Saturdays.



All letters must be accompanied by the name and address of the sender (not necessarily for publication).

The Editor does not necessarily agree with opinions expressed by his correspondents.

**The Featherweight Portable**

SIR,—I enclose a photograph of my Featherweight Portable, which, I trust, will interest you. I am getting on with the tuning. On the middle wave the dial now reads more uniformly. The North Regional and North National are at



142 and 62 respectively. All I can account for bringing about this change is the new grid bias flex. I tuned in Rabat, Katowice, Belfast, and Barcelona last night. I also logged Daventry at 81 and 24 on the dials, using 110 volts.—J. THOMSON (Liverpool).

**An Appreciation from S. Africa**

SIR,—I wish to inform you that I received the Wireless Constructors' Encyclopaedia, for which I thank you. I have, so far, been highly satisfied with the information that adorns its many pages.

After about ten years' experience in the construction of wireless sets (as an amateur) I find the Encyclopaedia a most up-to-date library for any constructor, whether a beginner or an old-stager.—L. LANE (Transvaal, S. Africa).

**A Three-valver With Permeability Tuning**

SIR,—I am very interested in any articles on Permeability Tuning. It may be of interest to you and to some readers to know that I have a "Straight Three" of my own design working on that principle; there is no tuning condenser, the aerial and reaction coils are on two cylinder formers, one inside the other fairly close coupled. A metal cylinder passes into this between the two coils, and as the cylinder passes into the coils the stations come in without any reaction condenser in the circuit, but with a reaction condenser it makes a great improvement. The tuning is much sharper than it is when using a condenser for tuning the aerial coil. The set has a

straight reading-scale. If any readers are interested I shall be pleased to give full details. I have taken PRACTICAL WIRELESS since No. 1, and every issue seems to get better. Wishing your paper a very long run and every success.—JOHN BLACK (Kirkcubbin).

**A Woman Constructor**

SIR,—I should like to take this opportunity of thanking you for the very valuable help that your book, PRACTICAL WIRELESS, has been to me. I have taken it from the first number and I still have them from No. 1. They are the best books of reference I have on wireless. I have constructed three sets from your specifications and have never had any trouble with them. My wife has also take a great interest in your journal, and she has constructed a three-valve set to one of your designs.—R. FLETCHER (Rochester).

CUT THIS OUT EACH WEEK

**DO YOU KNOW?**

—THAT short wave coils are often constructed of copper tube instead of ordinary copper wire.

—THAT the reason for this is that high-frequency currents travel along the surface of a conductor.

—THAT when the reactance of a coil and condenser are equal the total reactance is nil.

—That a circuit in the above condition is said to be tuned.

—THAT the sign  $\Omega$  should not be used for the word "megohm," but reserved for "ohm."—THAT the correct expression for "megohm" is M $\Omega$ .

—THAT a condenser should always be included in the earth lead of a D.C. mains receiver.

—THAT an artificial centre-tap for a push-pull input transformer may be introduced by means of two high resistances joined in series across the secondary.

—THAT a pentode valve may be used as a grid-leak detector with a high degree of efficiency.

**NOTICE**

The Editor will be pleased to consider articles of a practical nature suitable for publication in PRACTICAL WIRELESS. Such articles should be written on one side of the paper only, and should contain the name and address of the sender. Whilst the Editor does not hold himself responsible for manuscripts, every effort will be made to return them if a stamped and addressed envelope is enclosed. All correspondence intended for the Editor should be addressed: The Editor, PRACTICAL WIRELESS, Geo. Newnes, Ltd., 8-11, Southampton Street, Strand, W.C.2.

Owing to the rapid progress in the design of wireless apparatus and to our efforts to keep our readers in touch with the latest developments, we give no warranty that apparatus described in our columns is not the subject of letters patent.

**ANOTHER FREE GIFT  
SPANNER NEXT WEEK!**



LET OUR TECHNICAL STAFF SOLVE YOUR PROBLEMS

REPLIES TO



QUERIES and ENQUIRIES by Our Technical Staff

The coupon on this page must be attached to every query.

If a postal reply is desired, a stamped addressed envelope must be enclosed. Every query and drawing which is sent must bear the name and address of the sender. Send your queries to the Editor, PRACTICAL WIRELESS, Geo. Newnes, Ltd., 8-11, Southampton St., Strand, London, W.C.2.

SPECIAL NOTE

We wish to draw the reader's attention to the fact that the Queries Service is intended only for the solution of problems or difficulties arising from the construction of receivers described in our pages, from articles appearing in our pages, or on general wireless matters. We regret that we cannot, for obvious reasons—

- (1) Supply circuit diagrams of complete multi-valve receivers.
- (2) Suggest alterations or modifications of receivers described in our contemporaries.
- (3) Suggest alterations or modifications to commercial receivers.
- (4) Answer queries over the telephone.

Please note also, that all sketches and drawings which are sent to us should bear the name and address of the sender.

THE DIODE AND REACTION

"I have been using a diode detector for a long time now and in my opinion it is impossible to find a better form of rectification. The only drawback is that it is, so far as I am at present aware, impossible to employ reaction, and my H.F. stage is arranged on the low gain principle. Do you think it is possible to add any form of regeneration to the H.F. valve, without upsetting stability, so as to give me a little extra boost in weak stations?"—(C. P., Nottingham).

We presume that you are using an ordinary valve as a diode, with the anode left free. If, however, you have linked anode and grid, you may disconnect the anode and use this for the purpose of applying reaction. We would not recommend the use of feedback in the H.F. stage, but an ordinary H.F. coil with a reaction winding could be used in the diode stage, and the anode of the diode connected in the usual way to the reaction winding and a reaction condenser. An H.F. choke should, of course, be included in the anode circuit between a positive tapping on the H.T. battery and anode. It should be possible to find a voltage which will enable smooth reaction to be obtained and which will in no way affect the quality of the diode detector.

GANGING AND INSTABILITY

"I have finished building a three-valver (S.G., detector and pentode), but do not like the arrangement of the circuit. I find that the small screws on the side of the ganged condenser are rather flat, and I have to turn the middle one right in to get the set to oscillate. Can I alter this so that I can control it from the panel as it is awkward to get at it inside the cabinet?"—(M. H., Lancaster).

We are afraid that your set is unstable, and you have not quite understood its adjustment. The receiver should be perfectly stable with the trimmer controls adjusted correctly. As the centre one controls oscillation it is obvious that the H.F. stage is unstable, and when you adjust the trimmer for resonance the receiver goes into oscillation. You must therefore find the cause of the instability, and when correctly adjusted you will find that the trimmers may be adjusted to give a maximum setting without any trace of oscillation, and then the panel controls will function normally.

MAINS INTERFERENCE

"I am troubled by a peculiar form of interference in my house. Some nights, when I am listening to the wireless programmes I hear a rather noisy scraping from the loud-speaker. It does not occur every night,

but two or three times a week. It starts with a faint click and seems to be very regular, with a form of up-and-down singing hum. I do not know whether you can recognize any fault from this description, but any suggestions you can make will be very thankfully received."—S. A. (Margate).

The noise is probably due to some form of electrical apparatus being used in a nearby house. It may be some medical instrument, or even an electric fan. As, however, the sound appears to rise and fall, it would seem to be due to a motor of some sort which runs under varying loads, and you can prevent the interference by fitting a double-centre-tapped condenser across your mains input leads. If you do not wish to make up the condenser (which should, of course, be totally enclosed in the interests of safety), you should purchase one of the many devices which are now available and advertisements regarding which appear in our pages.

DATA SHEET No. 52

Cut this out each week and paste it in a notebook.

OHMS LAW SIMPLIFIED

$$\text{OHMS} = \frac{\text{Volts}}{\text{Amperes}}$$

$$\text{or } \frac{\text{Volts} \times 1,000}{\text{Milliamperes}}$$

$$\text{VOLTS} = \frac{\text{Amperes} \times \text{Ohms}}{1,000}$$

$$\text{or } \frac{\text{Milliamperes} \times \text{Ohms}}{1,000}$$

$$\text{AMPERES} = \frac{\text{Volts}}{\text{Ohms}}$$

$$\text{MILLIAMPERES} = \frac{\text{Volts} \times 1,000}{\text{Ohms}}$$

COLOURED SWITCHING LIGHTS

"I have seen remarks regarding a form of dial-light which changes colour as you switch from one wave-band to another, and I should like to rig up an arrangement for my set on these lines. Could you please give me any details regarding how to wire the scheme, so that I could fit it to my set?"—R. M. S. (Rotherham).

There is nothing in the arrangement which can be called difficult, and the simplest method is to use two separate pilot lamps, one coloured, say, red and the other blue. One side of each lamp should be connected together and to one L.T. lead, and the remaining side of each lamp to a change-over switch. The arm of the switch should be joined to the remaining L.T. lead. The switch should be ganged or otherwise controlled by your normal wave-change switch, and the method of doing this will depend upon the special switch which your set employs. A much neater arrangement would, of course, be to purchase the new Bulgin Colour Signal, which is suitable for any type of coil switch.

EXTENSION SPEAKERS

"I have added a moving-coil loud-speaker to my receiver, which is at present fitted with an ordinary speaker. I find, however, that the speaker in the other room takes all the power from my old speaker, and this is too weak. Is it due to the leads to the next room, or does the moving-coil speaker take more power

and thus starve the old one?"—R. Y. (Westbourne Park).

Whilst a moving-coil speaker may require a little more volume to operate it efficiently, it does not take this power at the expense of the old speaker which you have. You have overlooked the fact that the impedances of the two speakers are different. (There is, too, the possibility that the extension leads are having an adverse effect.) If it is not possible to obtain a transformer which will enable you to match up both speakers with your valve, it will be preferable to join them both in series and so obtain more or less equal signal strength from both. An alternative method would be to obtain an output transformer of correct rating to enable the moving-coil loud-speaker to be included in the anode circuit, and use the primary of the transformer as a choke for feeding the ordinary speaker by means of an output filter arrangement.

BINOCULAR H.F. CHOKES

"I notice that there are several firms who now make H.F. chokes with the winding split into two sections, each on a separate bobbin. This I understand is called a 'binocular' choke, and the reason is to reduce the stray field. However, some manufacturers also screen their H.F. chokes, the purpose being the same, namely, to reduce the field. Where, then, is the sense in making a binocular screened choke, as some firms do? Surely it is unnecessary, and a waste of good time and money."—H. S. F. (Romford).

On the face of it your final remark would appear to be quite right, but there are some points you have overlooked. First, the binocular choke construction does reduce the size of the field, but if this choke is fitted to a baseboard close to another inductive component, coupling between the two could exist, and perhaps instability would result. Again, we think you will find that the majority of chokes which are made up in the form you criticize consist of two ordinary chokes such as are supplied by the same firms, and therefore, instead of a waste of money, the firms in question are enabled to use a standard component, and in the binocular form you have two such components in series, which will undoubtedly give better results than one alone. Thus you get two components for your money, and in general this is not double the cost of the two single chokes. Finally, the screening serves to prevent interaction with other components and enables a more compact layout to be built.

SUPERHET CONNECTIONS

"I am trying to build up a superhet receiver, but am somewhat mystified when looking through the catalogues. I admit I do not know a lot about the subject, but the point which confuses me most is the tuning condenser. I see in some catalogues that special superheterodyne tuning condensers are used, and I do not know how these differ from an ordinary condenser. What sort should I get?"—Y. C. A. (Guiseley).

The tuning condenser must be chosen according to the coils which you use. Some types of coil require that the section of the ganged condenser which tunes the oscillator coil must be cut to conform to a different law from the remaining sections so that it will keep in step with the other coils. Other coils are designed so that an ordinary ganged condenser may be used, but special padding condensers are necessary. You must, therefore, follow the coil maker's instructions.

FREE ADVICE BUREAU COUPON

This coupon is available until Sept. 30th, 1933, and must be attached to all letters containing queries. PRACTICAL WIRELESS, 23/9/33.



MICROLOODE SPEAKERS

Please send all your HIRE PURCHASE ORDERS to PETO-SCOTT CO. LTD. 77, CITY ROAD, LONDON

E.C.1. Advt. of Peto-Scott Co. Ltd.

# CATALOGUES RECEIVED

To save readers trouble, we undertake to send on catalogues of any of our advertisers. Merely state, on a postcard, the names of the firms from whom you require catalogues, and address it to "Catalogue," PRACTICAL WIRELESS, Gco. Newses, Ltd., 3/11, Southampton St., Strand, London, W.C.2. Where advertisers make a charge, or require postage, this should be enclosed with applications for catalogues. No other correspondence whatsoever should be enclosed.

**DUBILIER CONDENSERS AND RESISTANCES**  
 IN a neat booklet we have received from Dubilier Condenser Co. (1925) Ltd., full particulars are given of their well-known condensers and resistances. Included in the range are mica, paper, and block condensers of various capacities, a new type of non-inductive condenser, and high voltage dry electrolytic condensers. Metallized resistances of an improved type, covering a wide range of standard values in 1, 2 or 3 watt ratings, are also listed. The data given concerning these resistances should be particularly useful to home constructors. These resistances are now obtainable with their ohmic value indicated by means of distinctive colour markings. Also included in the list are motor radio suppressors and "Spirohm" ten-watt wire-wound resistances. The address is Ducon Works, Victoria Road, North Acton, W.3.

**EDISWAN H.T. BATTERIES**  
 FROM the Edison Swan Electric Co., Ltd., comes a neat booklet giving some useful information concerning the Ediswan H.T. and grid-bias batteries. Users of these batteries who wish to know how to obtain the maximum length of life from them, together with the highest quality of reproduction from their sets, will find the information in this booklet, which also contains a handy two-page chart for logging stations.

# RADIO CLUBS & SOCIETIES

**SLADE RADIO**  
 A LECTURE on "5 metre work" was given by Mr. H. K. Bourne, B.Sc. (G2KB), at the meeting held last week. After stating that he was dealing with what are known as ultra-short waves, and explaining that the first experiments by Hertz were probably on a wavelength of about one metre, he went on to the year 1921, when the outlook was changed, and instead of using long waves, much lower wavelengths were adopted even by commercial stations. He then proceeded to deal with propagation, skip distances, advantages, interference, and applications, both existing and possible. The receiver and transmitter were then described and the circuits given, after which aerials, including various beam types, were dealt with. During the interval members took the opportunity of examining the apparatus, and on resuming he described the commercial equipment which is used for transmission and reception across the Bristol Channel. A number of questions were raised and answered, after which some details of his experiences were given. The lecture proved exceptionally interesting and was enjoyed by those present. A hearty invitation to

attend a meeting of the Society is extended to anyone interested. For details apply Hon. Sec., 110, Hillaries Road, Gravelly Hill, Birmingham.

**B.R.I.—NEW SESSION**  
 THE new session of the B.R.I. opened on Friday, September 22nd, at 7.30 p.m., with a lecture by Dr. L. E. O. Hughes, who chose for his subject "The Reproduction of Sound via Radio." The meeting was held at King's College, Strand, W.C.2, the chair being taken by Prof. C. L. Fortescue, O.B.E., M.A.

**Replies to Broadcast Queries**  
 COPPERNOB (East Ham): PAOAZ, H. E. Jacobs, 44, Graaf Florislaan, Hilversum (Holland). We do not know wavelength used but many Dutch experimenters work on the 75 m. (4,000 kc/s)—85.7 m. (3,500 kc/s) band. HAYWARD (Stoke-on-Trent): Without doubt an amateur experimental transmitter in your immediate vicinity. Although transmission was made on a lower wavelength, this would account for a break-through on a higher portion of the wave-band. Cannot trace identity unless call-letters are given. LENIN (Southport): Telephony between ships (trawlers, etc.) on 177.5 m. (1,690 kc/s.) e.g. GLNK, River Clyde.

## FIRST DETAILS OF A NEW OUTPUT VALVE (Continued from page 12)

An output of 4 watts is obtainable and it appears to be quite suitable for operation in conjunction with existing H.T. power arrangements, in the great majority of mains receivers. Fig. 3 shows the circuit arrangements when this valve is employed in push-pull. With this circuit excellent quality can be obtained with about 10 watts output. Harmonic distortion is generally reduced with push-pull arrangements and particularly so with this valve, especially the odd harmonics, which are considerably reduced.

The output stage of battery sets have recently received considerable attention. Is the pendulum swinging once more in the direction of mains receivers?

## 7 DAYS' FREE APPROVAL!

### H.T. ELIMINATORS AND TRICKLE CHARGERS.

BRITISH THROUGHOUT. 2 YEARS' GUARANTEE. A.C. models incorporate Westinghouse metal rectifier and a special power supply for illuminating tuning dials. Trickle charger 15s. Od. extra.

Catalogue free from actual manufacturers:  

|      |                              |      |
|------|------------------------------|------|
| D.C. | <b>V.M.C. RADIO COMPANY,</b> | A.C. |
| 15/- | 154, Holmleigh Road,         | 30/- |
|      | LONDON, N.16.                |      |
|      | No Trade Discounts.          |      |

**A PRACTICAL HOME-STUDY COURSE IN RADIO**  
 leads to a recognised Certificate of Proficiency and "A.M.R.T.I." We guarantee success and give recommendations. Send P.C. for particulars and Free Specimen lesson.—Radio Training Institute of Gr. Brit., 85, New Oxford Street, London, W.C.1.

## ADVERTISEMENT INDEX

|  |                        |
|--|------------------------|
| Amplion (1932), Ltd. ... ..                        | Page 2, 61             |
| Belling and Lee, Ltd. ... ..                       | 38                     |
| Benjamin Electric, Ltd. ... ..                     | 1                      |
| Bennett College, Ltd. ... ..                       | 51                     |
| British General Mfg. Co., Ltd. ... ..              | 52                     |
| British Institute of Engineering Technology ... .. | 57                     |
| British Pix Co., Ltd. ... ..                       | 60                     |
| British Radio-Gramophone Co., Ltd. ... ..          | 57                     |
| British Radiophone, Ltd. ... ..                    | Inside Front Cover     |
| British Rola Co., Ltd. ... ..                      | 57                     |
| Bulgin, A. E., and Co. ... ..                      | 61                     |
| Carrington Mfg. Co., Ltd. ... ..                   | 46                     |
| Claude Lyons, Ltd. ... ..                          | 40                     |
| Concerton Radio and Electrical Co., Ltd. ... ..    | 56                     |
| Cossor, A. C., Ltd. ... ..                         | 4                      |
| Dubilier Condenser Co. (1925), Ltd. ... ..         | 26, 48                 |
| Edison Swan Electric Co., Ltd. ... ..              | 1, 46                  |
| England-Richards Co., Ltd. ... ..                  | 51                     |
| Exide Batteries ... ..                             | 42                     |
| Foyles ... ..                                      | 60                     |
| Graham Farish, Ltd. ... ..                         | Front Cover Strip, 25, |
| Hayberd, F. C., and Co. ... ..                     | 58                     |
| Heraud, E. J., Ltd. ... ..                         | 2                      |
| High Vacuum Valve Co., Ltd. ... ..                 | 64                     |
| Holmes, H. W. ... ..                               | 62                     |
| Igranic Electric Co., Ltd. ... ..                  | Back Cover             |
| Jackson Bros. (London), Ltd. ... ..                | 48                     |
| Lectro Linx, Ltd. ... ..                           | 64                     |
| Lissen, Ltd. ... ..                                | 13, 17, 41, 45         |
| London Radio Supply Co. ... ..                     | 60                     |
| Marcus Overton Radio, Ltd. ... ..                  | 53                     |

|   |                   |
|---|-------------------|
| Multitone Electric Co., Ltd. ... ..                     | Page 2            |
| New London Electron Works, Ltd. ... ..                  | Inside Back Cover |
| Newnes' "Home Mechanic" ... ..                          | 1                 |
| Newnes' "The Great War" ... ..                          | 14                |
| New Times Sales Co. ... ..                              | 59                |
| Osborn, C. A. ... ..                                    | 1                 |
| Pearl and Pearl ... ..                                  | 61                |
| Peto Scott, Ltd. ... ..                                 | 37, 63            |
| Picketts ... ..   | 60                |
| Pifco, Ltd. ... ..                                      | 38                |
| Radialaddin, Ltd. ... ..                                | 52, 54            |
| Radio Training Institute of Gr. Britain ... ..          | 64                |
| Regent Fittings Co. ... ..                              | 60                |
| Reproducers and Amplifiers, Ltd. ... ..                 | 34                |
| Riverside Mfg. Co., Ltd. ... ..                         | 57                |
| Ryall's Radio ... ..                                    | 62                |
| School of Accountancy ... ..                            | 3                 |
| Scientific Supply Stores (Wireless), Ltd. ... ..        | 40                |
| Smith, S., and Sons (Motor Accessories), Ltd. ... ..    | 26                |
| Southern Radio ... ..                                   | 62                |
| Stratton and Co., Ltd. ... ..                           | 56                |
| Telegraph Condenser Co., Ltd. ... ..                    | 55                |
| The 362 Radio Valve Co., Ltd. ... ..                    | 52                |
| Tungstram Electric Lamp Works (Gr. Britain) Ltd. ... .. | 21                |
| Varley, Ltd. ... ..                                     | 52                |
| V.C.M. Radio Co. ... ..                                 | 64                |
| Vinces Dry Batteries, Ltd. ... ..                       | 18                |
| Ward and Goldstone, Ltd. ... ..                         | 46                |
| Whiteley Electrical Radio Co., Ltd. ... ..              | 11                |
| Williams ... ..   | 57                |
| Wingrove and Rogers, Ltd. ... ..                        | 34                |

**HIGH IN QUALITY**

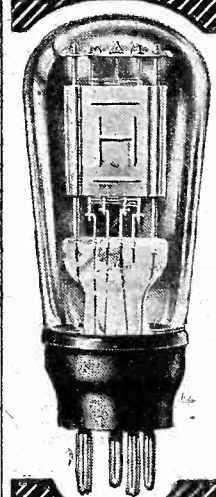

**LOW IN PRICE**

## THE PREMIER VALVES

Recommended for the "PREMIER SUPER"

described in this issue

### "HIVAC"

|        |      |
|--------|------|
| SG 210 | 10/6 |
| H 210  | 4/6  |
| VS 210 | 10/6 |
| D 210  | 5/6  |
| Y 220  | 12/6 |

For "Practical Wireless" ALL-WAVE TWO

|       |      |
|-------|------|
| L 210 | 4/6  |
| Z 220 | 12/6 |

For details of full range, write for

HIVAC VALVE GUIDE "C"

It puts you right when choosing the valves to suit your set.

Hivac Valves are British Made in our own factory.

Obtainable from all dealers. If any difficulty, send us P.O. and address of nearest dealer.

**HIVAC THE SCIENTIFIC VALVE**

HIGH VACUUM VALVE CO., LTD., 113-117, Farringdon R.I., E.C.1

## CLIX Specified for the PREMIER SUPER

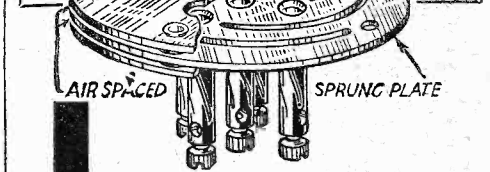

**"AIRSPRUNG"**  
 Anti-microphonic, non-metal VALVE HOLDER  
 5 Pin 1/3 4 Pin 1/2  
 STANDARD TYPE  
 4 Pin 8d. 5 Pin 9d.

**PANEL TERMINALS**  
 Type B: with special hexagonal shoulder for easy mounting 4d.  
 Type A: ... .. 2 1/2d.

**"A MATTER OF CONNECTION"**  
 Clix New Folder "N" gives details of over 30 Components for Perfect Contact. Write for a copy now.



LECTRO LINX Ltd., 79a, Rochester Row, S.W.1



# PUBLIC WARNING

Magnified portion of SUPERIAL showing the only correct method of Insulation.



Some "covered" wires are being boxed and made to look like SUPERIAL. Imitators know that the way to sell you another wire is to make it seem like SUPERIAL.

They imitate the box and the name, but they cannot imitate its vulcanized rubber insulation or the scientific combination of ferrous and non-ferrous metals (including copper). They offer you a stranded wire of one metal only which has a cheap and ineffective cotton "covering." This is not insulation and will not protect the aerial after a little exposure to weather. Some dealers try to deceive you. Avoid deception. **DON'T BUY ANOTHER WIRE** made to look like SUPERIAL. **That cheats you of something you prize.**

### LOOK AT THE NAME AND THE BOX.

SUPERIAL is more than just an aerial—it is a very particular kind of aerial. It is the **ONLY** properly insulated aerial. It brings envied results, and does for your reception what every enthusiast wants—**BETTER SELECTIVITY, BIGGER VOLUME, BEAUTIFUL TONE.** Imitations do not bring what you seek. They are **NOT SUPERIAL.**

**TRY IT** at our Expense and then you will know why it is so efficient. Ask your dealer for SUPERIAL — But you must agree to return it if it does not "prove up" to every claim made for it. We guarantee to refund your money unconditionally if SUPERIAL disappoints you. If your dealer does not stock SUPERIAL he can get it for you, or we will send it direct to you upon receipt of your remittance.

Good reception is worth any price you pay. Ask your dealer for SUPERIAL. You will get perfect reception and a £100 Free Lightning Insurance for two years from a Company which is in a position to meet all its obligations.

**SUPERIAL**  
THE AERIAL WHICH MADE BROADCASTING POPULAR  
ELECTRON'S SUPER-AERIAL

100 FT. 3/6 75 FT. 2/6 50 FT. 1/9 25 FT. 1/1

From dealers everywhere or write to:—

**The NEW LONDON ELECTRON WORKS Ltd.**  
6, EAST HAM LONDON. E.6

Telephones:—  
Grangewood 1048-9—1363

Telegrams:—  
"Stannum, London."

**Beware of Imitations**

Try it at  
**OUR EXPENSE**



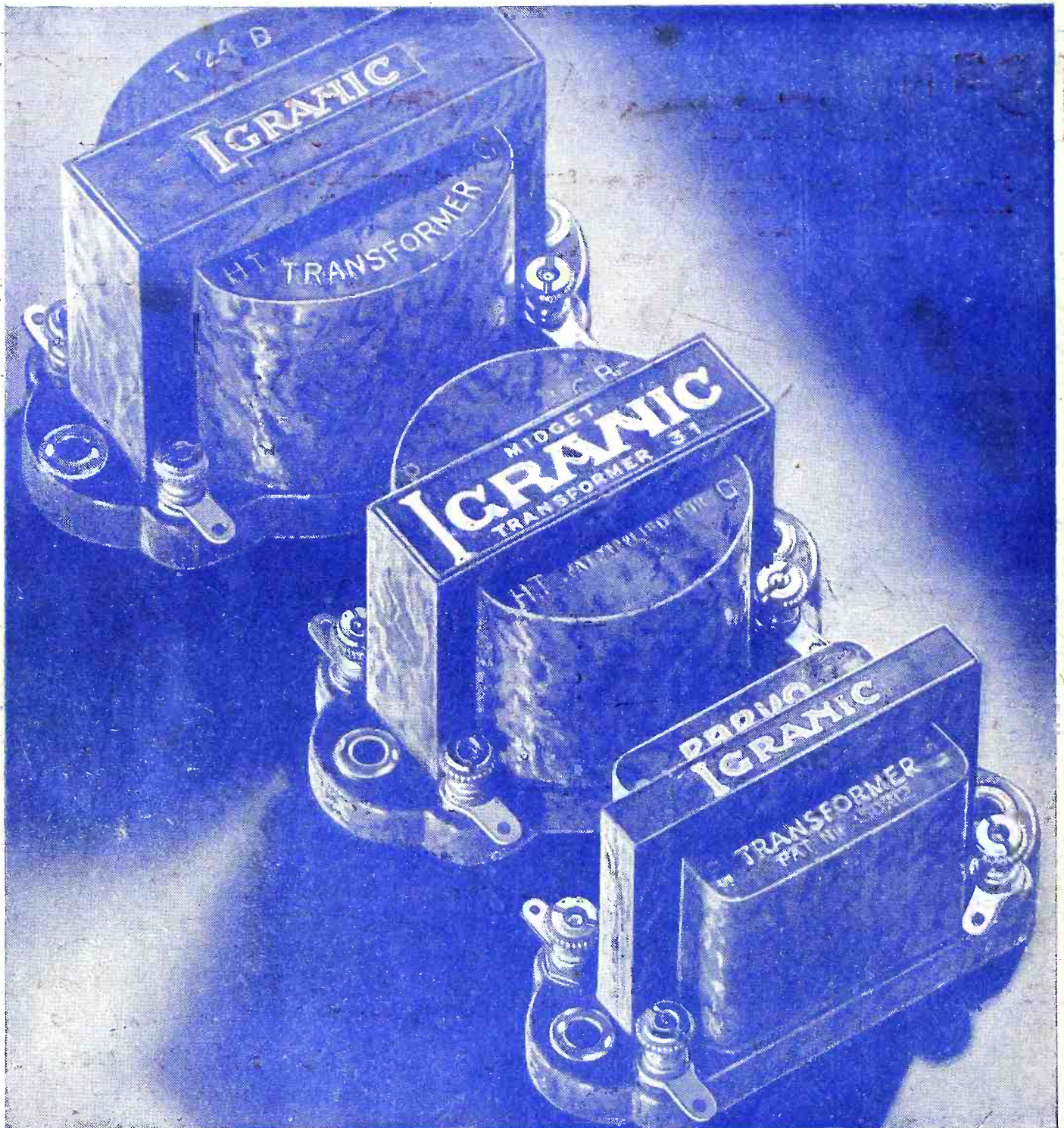

The time has come—not to talk of many things, nor even to sing the praises of any specific "Igranitic" component—but simply announce that Igranitic are first, as always, with those ultimate refinements in radio design which you very properly demand. We do not hope to convey to you any idea of the Igranitic range within the sixty-five square inches of this advertisement. We are content to recommend the new fifty-page Igranitic catalogue, which meets the needs of every radio constructor with understanding and due economy. A copy will be sent you free, and by return of post. The prices of the Igranitic Transformers illustrated above are:

**T.24B 5/6**

**Parvo 6/9**

**Midget 8/6**

Write for fully illustrated Catalogue No. J.1275 of Igranitic Quality Components.  
**IGRANIC ELECTRIC CO., LTD., 149, Queen Victoria Street, E.C.4**



If you cannot obtain Igranitic components, write to us direct and include the name of your local dealer.

CVS-01

**P. W. Gift Stamp No. 52**

Printed by NEWNES & PEARSON PRINTING CO., LTD., Exmoor Street, Ladbroke Grove, W.10, and published by GEORGE NEWNES, LTD., 8-11, Southampton Street, Strand, W.C.2. Sole Agents for Australia and New Zealand: GORDON & GOTOH, LTD., South Africa: CENTRAL NEWS AGENCY, LTD. *Practical Wireless* can be sent to any part of the world, post free, for 17/4 per annum; six months, 8/8. Registered at the General Post Office for Transmission by Canadian Magazine Post.



ANOTHER FREE GIFT STEEL WIRELESS SPANNER WITH THIS ISSUE!

# Practical Wireless

3<sup>p</sup>

Published every Wednesday by  
**GEORGE  
NEWNES  
LTD.**

EDITED BY F. CA

Vol. 3. — No. 54.  
SEPTEMBER 30th, 1933.

Registered at the G.P.O. as a Newspaper

**OUR FREE GIFT  
SET OF  
SPANNERS**



*They fit  
every nut  
on your Set.*

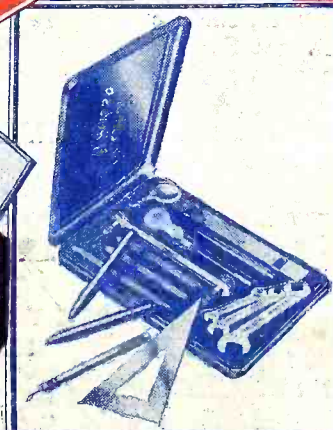
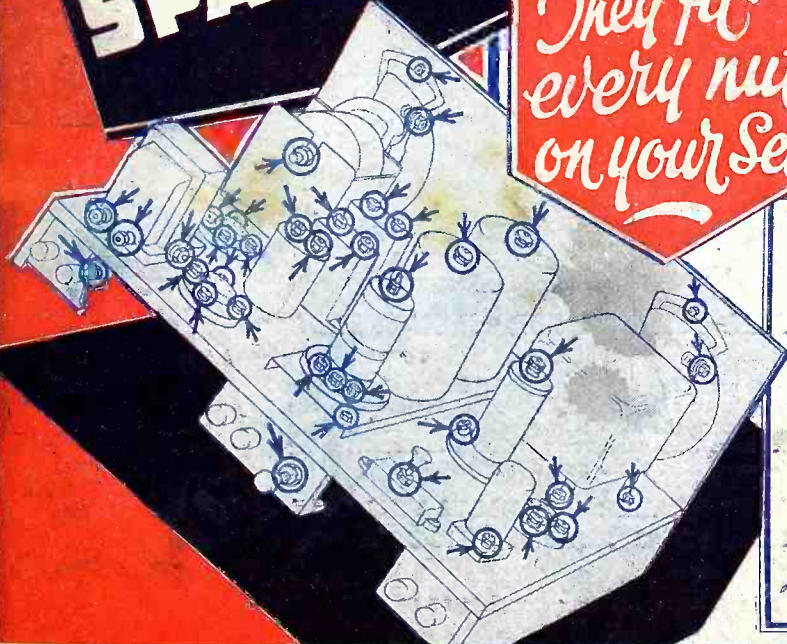

Have you  
reserved  
*your*  
**Pocket  
Tool  
Kit ?**

**RECEPTRU**  
FOR TRUE RECEPTION

—the wonderful new low loss lead in cable definitely eliminates crackle, background noises, mush and all man-made static. It improves selectivity and increases sensitivity. Get one to-day. You can fix it in less than five minutes.

**OF ALL DEALERS** in lengths of 15 feet 10/-

Longer sizes at proportionate prices.

BRITISH RADIOPHONE LTD., ALDWYCH HOUSE, LONDON, W.C.2



# RADIOPHONE

## MATCHED PERFECTION

**YOU CAN'T GET BETTER  
than the Best!**



British Radiophone Ganged Condensers have consistently set the fashion. It is imperative to employ scientifically designed precision instruments: as surprisingly big losses can occur in badly designed or poorly manufactured Condensers.

Radiophone Condensers incorporate many patented unique features, such as Radial Wedge assembly of vanes, Spring-loaded Tapered Bearings with "Keep Plate" Anchorage. The Steel Girder Frame method of assembly and three-point Suspension guarantee freedom from mechanical distortion.

Every Radiophone Condenser is matched section by section at SIX points of the tuning scale to within  $\frac{1}{2}$  per cent. One has only to balance out the stray circuit capacities with the aid of the trimmers conveniently provided at the top of the unit to ensure permanent MATCHED PERFECTION.

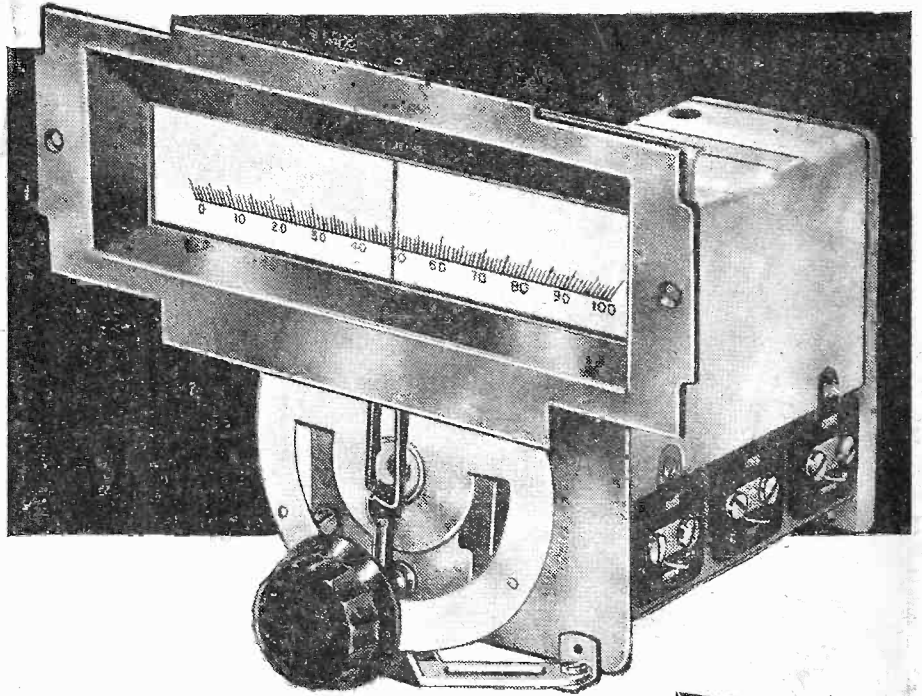

**SPECIALLY SUITABLE FOR "IRON-CORED" COILS.**

The delicate matching of "Iron Cored" Coils makes it more necessary than ever to employ condensers matched to the *n*th degree, hence the numerous occasions on which these condensers have been exclusively specified in circuits using these new coils.

**ASK YOUR DEALER TO SHOW YOU ONE  
INSIST ON RADIOPHONE**

*Write for list of components to:*

**SPECIFIED**  
*for the*  
**"PREMIER SUPER"**  
British Radiophone Super  
Het Three Gang Midget  
Condenser  
Type 693.  
Price **22/6**  
With full vision  
tuning dial **31/-**  
complete.

# BRITISH RADIOPHONE LTD.

ALDWYCH HOUSE, LONDON, W. C. 2

TELEPHONE:  
HOLBORN 6744



# BLUE SPOT MOVING COILS

## for complete reliability

MANCHESTER EXHIBITION STAND 50

### A NOTE TO CONSTRUCTORS

Hundreds of constructors have purchased moving-coil speakers and suffered grievous disappointment with both the performance and the service they have received. The only wise and safe thing to do is to purchase a modern Blue Spot Speaker—Moving Coil or Moving Iron—and be **absolutely sure** of satisfaction. Only the topmost grade of materials and the most skilled workmanship are employed in the manufacture of Blue Spot Speakers. When you buy Blue Spot you **know** you are buying the best at the lowest possible price for the highest possible quality. Don't risk disappointment. Don't risk wasting your money. Insist on Blue Spot and be sure.

BLUE SPOT MOVING COIL SPEAKERS ARE ON SALE AT YOUR DEALERS, PRICES 27/- to 87/6.

### MOVING IRON SPEAKERS, 12/6 to 30/-

For those listeners whose receivers, by reason of their output, cannot provide really good moving-coil performance, one of the famous Blue Spot moving iron speakers is a sound investment.

The famous 66R unit, illustrated here, is now 27/6 (Class B model, 30/-), and is everywhere acknowledged the best speaker of its kind. A cabinet model in oak, 44R, costs 39/6 (Class B model, 42/-). 66R units when mounted on a Blue Spot Major Chassis, ensure complete satisfaction. Price of chassis, 10/6.

**NEW BLUE SPOT PICK-UP MODEL 33.** Complete with wire wound volume control and rotating head. Price 35/-

Send to-day for illustrated catalogue No. P.R. 20S, showing the full range of Blue Spot Loudspeakers, Units and new Pick-Up 33.

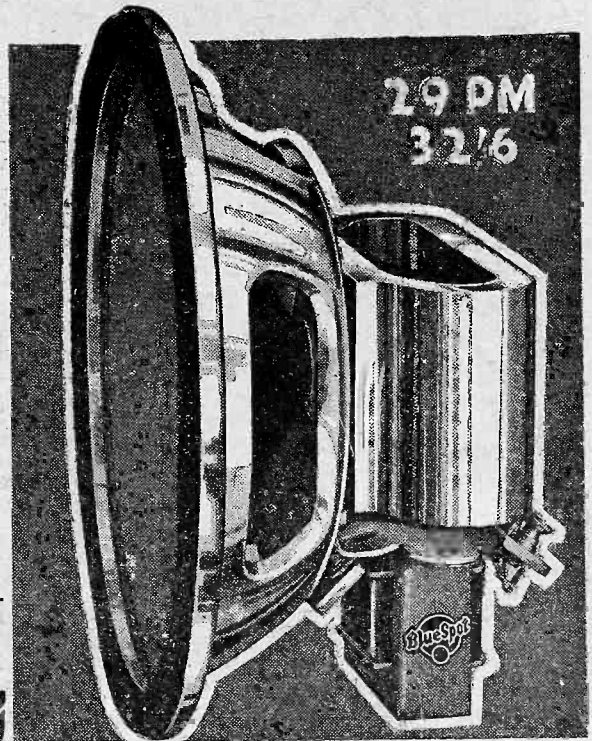
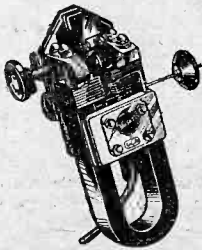

THE BRITISH BLUE SPOT COMPANY LTD., Blue Spot House 94-96 Rosoman Street, Rosebery Avenue, LONDON, E.C.1.  
Phone: Clerkenwell 3570. Telegrams: "Bluspot, Isling, London"  
Distributors for Northern England, Scotland and Wales: H. C. RAWSON (Sheffield and London), Ltd., 100, London Road, Sheffield; 29, St. Mary's Parsonage, Manchester; 177, Westgate Road, Newcastle-upon-Tyne; 37, 38, 39, Clyde Place, Glasgow.

*I must get my Blue Spot!*

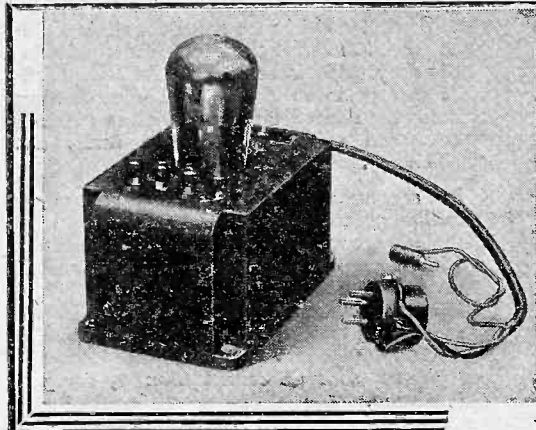

## The FIRST and STILL the FINEST CLASS B CONVERSION UNIT

All the essential points of superiority are provisionally Patented.

- Dance Hall Volume.
- Less H.T. Consumption.
- Suits all Speakers.
- No alterations to your set.
- Simply Plugs in.

There is no substitute for the famous **SOUND UNIT.**

Suits Cossor, Mullard and Mazda Class-B valves.

No need to scrap the valves in your set—The **SOUND UNIT** will work from Pentode or Triode Valves.

Price still only **35/-** (less valve)

**SOUND SALES LTD., Tremlett Grove, Highgate, N.19**

You can obtain the famous Sound Unit, or a Complete Kit of Messrs. E. J. HERAUD, Ltd., No. 1, Edmonton, London, N.18. Phone: Tottenham 2256.

## 362 GUARANTEED VALVES SAVE YOU 50%!



If your dealer does not stock, send for 362 post free direct from the makers. 362 are NON-MICROPHONIC and are definitely as good as any, and better than most. **FULLY GUARANTEED and BRITISH ALL THROUGH.**

Post Free from **3/6**

"362" BATTERY TYPE VALVES:—H., HL. & L. 3/6. Power 4/-. Super-Power 4/6. S.G. 7/6. Var-Mu 7/6. "Class B" 9/-. Pentode type 10/-. Metallised 3d. extra.)  
**COMPLETE 362 "CLASS B" KIT,** including "Class B" Valve, 7-pin valveholder, Input Transformer and Output Choke, with full instructions, 28/6. Ditto, wired complete with Moving Coil Loud-speaker, 50/-.

Cash with order. Cheques and P.O.'s must be crossed and made payable to:—**THE 362 RADIO VALVE Co., Ltd.** (Dept. W. 20), Stoneham Road, London, E.5.

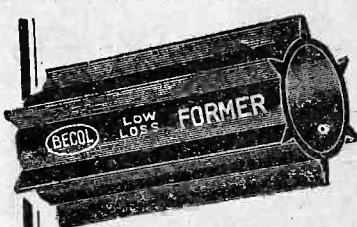

## Read this QUALITY Produces EFFICIENCY

**TESTED BEFORE DESPATCH**  
The original BECOL ebonite low loss formers are thoroughly reliable. They are used in all parts of the world. Look for the BECOL trade mark. Ask your dealer. If unable to supply write direct. SEND NOW, enclosing 6d. (post free) for third edition up-to-date handbook of tuning coils for DUAL RANGE, BAND-PASS, and SUPER-HET. circuits. Fully illustrated with data. A very interesting handbook.

**RODS, SHEET, TUBES, PANELS**  
**The BRITISH EBONITE Co., Ltd.,** Hanwell, London, W.7.

# COLVERN FERROCART COILS

Made under licence from the patentee, Hans Vogt.

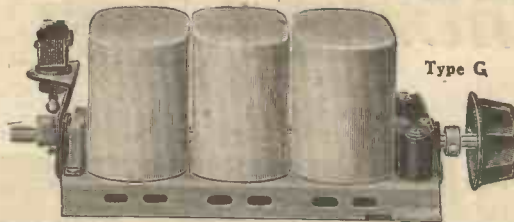

Type G

## SPECIAL G Type GANGED COILS

Complete with gramophone and wave change switch

- Two Gang .. .. 25/-
- Three Gang .. .. 37/6
- Four Gang .. .. 50/-

On and off Switch if required 1/6 extra. State if required for battery or mains receivers.

## COLPAK Type H

Comprising Ferrocart G type Coils, Tuning Condenser, Gramophone and on and off Switch (state if required for battery or mains receivers).

Coils can be supplied for 1 SGHF stage receivers with Band Pass filter or Band Pass filter and Oscillator Coil for Super-heterodyne receivers.

Price 57/6

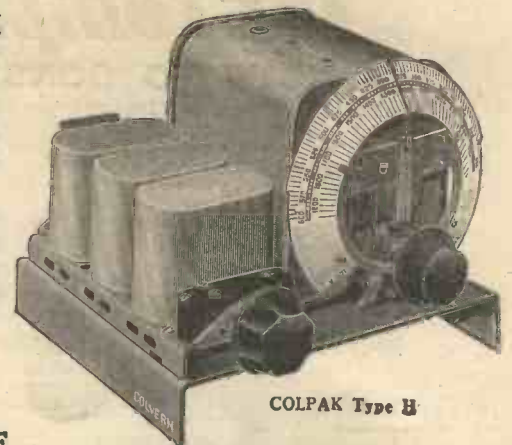

COLPAK Type H

## STANDARD Type F GANGED COILS

- Two Gang .. .. 25/-
- Three Gang .. .. 37/6
- Four Gang .. .. 50/-
- Single Coils .. .. 12/6

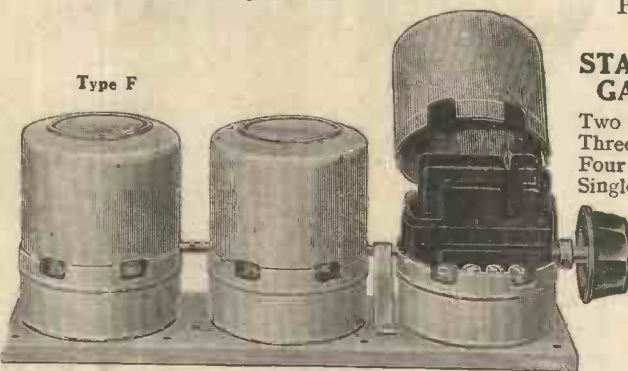

Type F

## COLVERDYNE FERROCART INTERMEDIATES

Type F C 110 } 12/6 each  
 Type F C 150 }  
 With universal mounting bracket, limited capacity adjustment and band pass coupling controlled externally.



Send for the Colvern Ferrocart Booklet.

COLVERN LIMITED, MAWNEYS ROAD, ROMFORD, ESSEX.  
 London Wholesale Depot: 150, King's Cross Road, London, W.C.1

# FINE 40/



### MILLIAMPS

- 0-6 milliamps.
- 0-30 "
- 0-120 "

### VOLTS

- 0-6 volts.
- 0-120 "
- 0-300 "

### OHMS

- 0-10,000 ohms.
- 0-60,000 "
- 0-1,200,000 "
- 0-3 megohms.



NOTHING LESS WILL DO

DEFERRED TERMS if desired. Write for particulars

THERE could be no surer conviction than that!... that the AvoMinor, priced at only 40/-, is supremely ACCURATE! It means more than mere fault-finding, more than mere testing. It gives precisely measured evidence of radio faults and efficiency.

It measures TEN different ranges of milliamps, volts and ohms—affording testing facilities combined with positive accuracy which no other instrument at anywhere near its price can give. The AvoMinor is a self-contained moving-coil combination measuring instrument with a total resistance of 100,000 ohms. Full scale deflection is obtained with a consumption of only 3 milliamps.

Make any comparison you like. This little brother of the world-famous Avometer does more, and does it more accurately, than any other combination testing instrument priced so modestly. Ask your radio dealer—he knows!

Be satisfied with nothing less. You will prefer the precision of the AvoMinor. Fully descriptive pamphlet post free.

TEN TESTING INSTRUMENTS IN ONE

BRITISH MADE

The AVOMINOR TELLS THE WHOLE TRUTH!

Dimensions, 4" x 3" x 1 1/2". Complete in handsome case, with pair of leads and interchangeable crocodile clips and testing prods.  
 The Automatic Coil Winder & Electrical Equipment Co., Ltd., Winder House, Douglas Street, London, S.W.1.  
 Phone: VIC 3405-7.



# "CLASS B" SIMPLIFIED!

## THE NEW ROLA P.M. M.C. UNIT SPEAKER & IN ONE

MAINS VOLUME FROM ANY BATTERY SET AT VERY LOW USE OF H.T.

JUST CONNECT TO YOUR SET WITHOUT ANY ALTERATION!

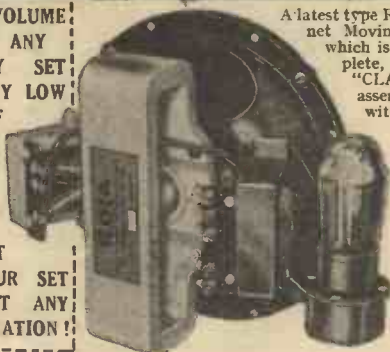

A latest type ROLA Permanent Magnet Moving Coil Speaker with which is incorporated a complete, properly matched "CLASS B" amplifier. This assembly when connected with any Battery Set converts it to "Class B" output, increasing the overall sensitivity of the set several times, and increasing the Power Output or Volume up to 5 Times!



### SEND FOR IT ON 7 DAYS' TRIAL

Send only 5s. for 7 days' trial, if satisfied, pay balance in 10 monthly payments of 7s. 6d. (Cash in 7 days, £3 11s.)



The British Made WATES UNIVERSAL METER is the only popular priced instrument testing resistances as well as batteries, valves, circuit, and all components; 4 readings on one dial.

SEND ONLY 1/6

for 7 days' trial, if satisfied complete purchase by 8 monthly payments of 2/6 (Cash 12/6)

This Rola "CLASS B" SPEAKER AMPLIFIER UNIT can quickly and simply be connected to any battery set, and is complete with Coscor, Mullard, or B.T.H. "Class B" valve, with full instructions.

The result of adding this unit to your battery set will be equivalent in performance, as regards richness of tone and volume, to a high grade all mains set, whilst at the same time retaining economy in battery consumption. Send deposit to-day!

E. J. HERAUD, Ltd., Dept. P.25, Number One, EDMONTON, LONDON, N.18  
Branches: 78/82, Fore St., Edmonston; 77, West Green Rd., Tottenham; 34, St. James St., Walthamstow; and 139, Hertford Rd., Enfield Wash.

## The Sensation of the OLYMPIA AND GLASGOW RADIO EXHIBITIONS . . .



# SONOCHORDE

Midget Moving Coil Speakers  
Cone Dia. 4 1/2". Overall Dia. 5". Depth 2 3/8"

MIDGET P.M. complete with either p-wer or pentode transformer

21/-



MIDGET D.C. 2,500 or 6,500 ohm field with either power or pentode transformer.

17/6

P.M. model complete in handsome walnut cabinet

35/-

As an extension unit, for your midget or portable set and for use in your automobile, these new Sonochorde units are ideal. Although small in size the Sonochorde midgets are capable of giving a marvellous and wonderfully realistic performance equivalent to that of many moving-coil speakers selling at double the price. Rated to carry 1 1/2 watts undistorted output, the Sonochorde midget is in a class of its own, and for that reason created a great sensation at the recent Olympia and Glasgow Radio Exhibitions. Sonochorde manufactures the most complete range of moving-coil speakers available from midget to auditorium types in both P.M. and energised models.

Write to-day for full list and technical data sheet to dept. P.W.

SONOCHORDE REPRODUCERS LTD.

1 Willesden Lane, N.W.6.

Phone: Maida Vale 6066 (5 lines)

# HELLESENS NEW HI-LIFE BATTERIES

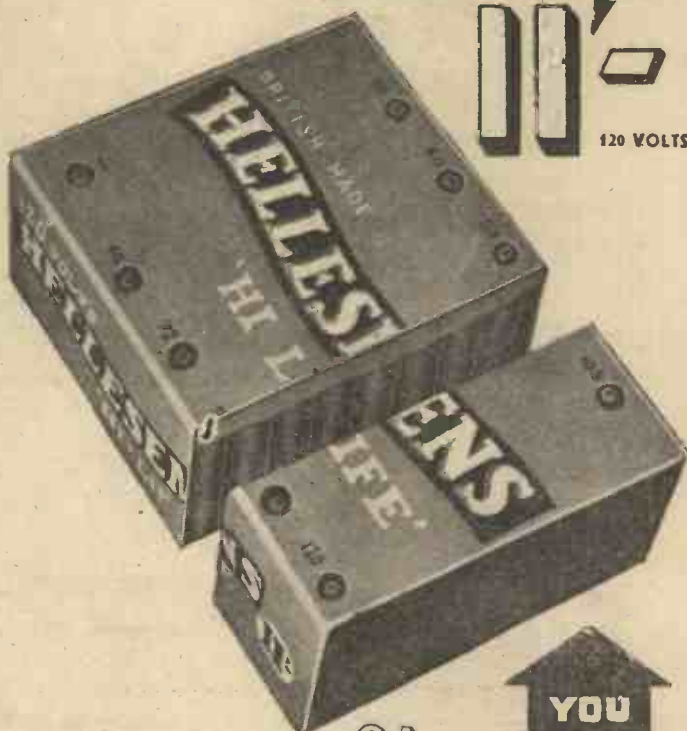

YOU GET THIS FREE

# 50.2%

## LONGER LIFE PROVED BY TEST

50.2% free in every battery — proved by a famous British set-maker. The reputation of his sets hung on every part he used in them. The batteries must be the best, therefore he chose Hellesens. But first he put them on test, and was convinced by the amazing result his test produced. Only Hellesens have over forty years' experience in battery manufacture. Only Hellesens could produce a battery with this high standard of performance — longer life, greater power, higher capacity, and offer it to you at so low a price. BRITISH MADE BY BRITISH LABOUR Stand No. 6A Manchester Radio Exhibition. Sept. 27—Oct. 7

# HELLESENS

HI-LIFE BATTERY  
Hellesens Limited, Morden Road, South Wimbledon, S.W.19.

# COSSOR Console Receivers



KINGS  
OF THE  
AIR

## COSSOR CLASS "B" BATTERY CONSOLE Model 3456

Complete Receiver, as illustrated, with Cossor 220 VS Variable-Mu Screened Grid, Cossor 210 HL Detector, Cossor 215 P Driver and Cossor 220 Class "B" Output Valves. Single-dial tuning, selectivity control and combined volume control and "on-off" switch. Wavechange switch for 200-530 and 900-2000 metres. Handsome walnut finished Console Cabinet, 2 ft. 11 in. high, 1 ft. 2 in. wide, 11 in deep, giving ample accommodation for batteries. Permanent Magnet Moving Coil Loud Speaker of the latest type. Gramophone Pick-Up Plug and Socket.

PRICE **£9.19.0**

Price does not include Batteries or Accumulator.

Hire Purchase Terms: 20/- deposit and 10 monthly payments of 20/-.

## COSSOR ALL-ELECTRIC CONSOLE (for A.C. Mains) Model 3468

Specification similar to Battery Model 3456, but for operating from Electric Light Supply. Complete with four Cossor A.C. Mains Valves viz: M.V.S.G. (Met.) Variable-Mu S.G., 41 M.H. (Met.) Detector, 41 M.P. Output and 442 B.U. Rectifier. Mains Energised Moving Coil Speaker. Illuminated tuning-dial (Model 3468 only). For A.C. Mains only, 200/250 volts adjustable, 40/100 cycles.

PRICE **£10.15.0**

Hire Purchase Terms: 25/- deposit and 10 monthly payments of 21/-.

## COSSOR ALL-ELECTRIC CONSOLE (for D.C. Mains) Model 3469

As Model 3468, but for operation on D.C. Mains. Supplied complete with three Cossor D.C. Mains Valves viz: D.V.S.G. (Met.) Variable-Mu S.G., D.H.L. (Met.) Detector and D.P. Power Output. For D.C. Mains only, 200/250 volts (adjustable).

PRICE **£10.15.0**

Hire Purchase Terms: 25/- deposit and 10 monthly payments of 21/-.

Legs are detachable on all Console Models and the receivers can be used as table models with legs detached.

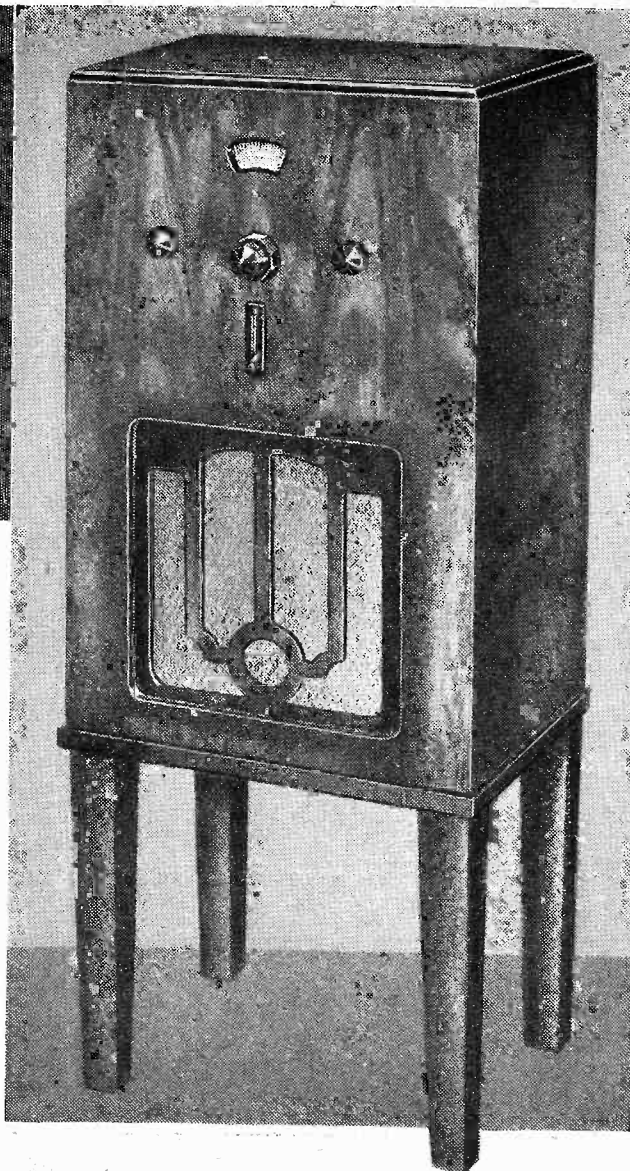

**SCREENED GRID CIRCUIT**

**MOVING COIL SPEAKER**

**SINGLE-DIAL TUNING**

Handsome in appearance, simple to operate and economical to use, these Cossor Console Models—due to their moving coil loud speakers—give unusually true-to-life reproduction. Their performance is considerably above that which would be expected from such moderately priced Receivers—they provide a wide choice of programmes with adequate selectivity. Your dealer will be glad to demonstrate the capabilities of these fine Sets.

# COSSOR

## BATTERY & ALL-ELECTRIC RADIO

Prices do not apply in I.F.S.

A. C. COSSOR LTD., Highbury Grove, London, N.5. Depots at Birmingham, Bristol, Glasgow, Leeds, Liverpool, Manchester, Newcastle, Sheffield, Belfast, Cardiff and Dublin.

3701

To A. C. COSSOR LTD., Melody Dept., Highbury Grove, London, N.5.

Please send me free of charge, Folder No. L99 which gives full particulars of Cossor Console Receivers.

NAME .....

ADDRESS .....

PBAC. 30/9/33.



# THE LEADING HOME CONSTRUCTORS' WEEKLY!



EDITOR:  
Vol. III. No. 54 || F. J. CAMM || Sept. 30th, 1933.  
Technical Staff:  
W. J. Delaney,  
H. J. Barton Chapple, Wh.Sch., B.Sc. (Hons.), A.M.I.E.E.,  
Frank Preston, F.R.A., W. B. Richardson.

## ROUND *the* WORLD of WIRELESS

### Swiss Radiodiffusion Services

THE relay services by which subscribers in many Swiss cities are given the broadcasting programmes *via* the telephone system have been so arranged that the intervals in the Swiss studio programmes are filled by taking entertainments from neighbouring countries. Such cities as Berne, Basle, St. Gall, and Lausanne at odd times relay concerts and other radio programmes from Bremen, Leipzig, Frankfurt, Stuttgart, Lugano, and Milan. In this manner the subscriber has music on "tap" throughout the day and evening hours.

### Would You Recognize Your Voice?

IT has been the experience of many broadcasting artists and speakers to be told by acquaintances who have listened to them that their voices were not recognizable on the air. But how many people would recognize their own talking voice as reproduced on a gramophone record? In experiments recently made at the Physiological Institute at Berlin, "phonograms" of a number of students were made, and it was found although production was as nearly perfect as possible, the original speaker was seldom able to pick out his own record. Similar tests were made with dogs, by playing a record of their master's voice; in each case the animal showed recognition, but a reproduction of his own bark merely raised the idea that a strange dog was in the room!

### New High-Power Romanian Station

BOD (Brenndorf), some seven miles distant from Brasov, is the site chosen for the new high-power Romanian

station destined to take over the Bucarest transmissions. According to the new Lucerne Plan the exclusive wavelength of 1,875 metres (160 kc/s) was allotted to Rumania with freedom to use in that channel up to 150 kilowatts. It is hardly likely that plant of such energy will be installed, but as the wavelength is one which Holland is not likely to relinquish, it is expected that another position in the waveband will be sought. The sharing of

in spiral form. It was the forerunner of the low-tension accumulator as used to-day.

### The Amateur Transmitter's Paradise

APPARENTLY Brazil fulfils these conditions, for according to a recent report radio fans wishing to install transmitting stations may do so "without let or hindrance." The annual subscription is a small one and the limit of power allowed 1 kilowatt!

## HAVE YOU RESERVED YOUR POCKET TOOL KIT?

Turn to pages 90 and 91 and DO IT NOW!

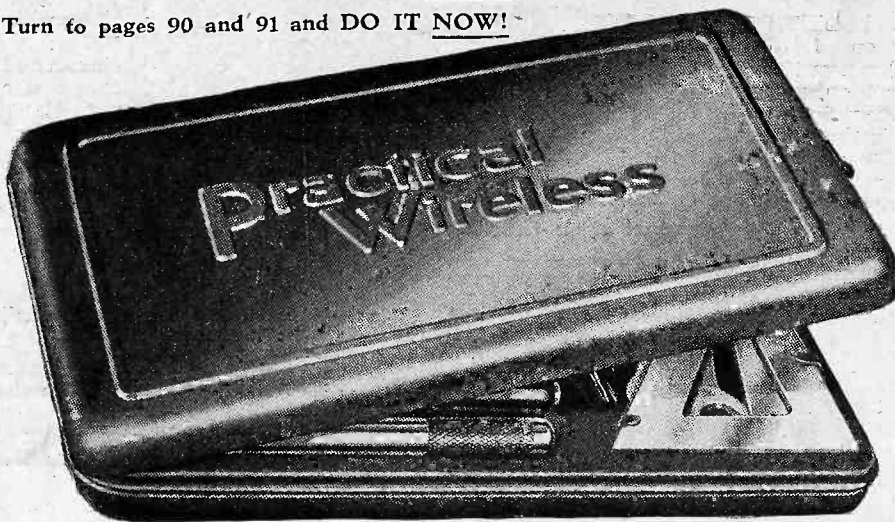

### THE HANDIEST POCKET KIT OF TOOLS

This illustration shows the handy size and form of our Birthday Offer Tool Kit. It contains one four-inch Chesterman rule; one steel pocket scriber with chuck; one accurate 50-degree steel set square; a pair of ebonite test prods; one reflecting mirror for viewing obscure parts of the set; one set of trammels, with heads, for scribing, cutting holes in ebonite, etc.; one steel centre punch, and one handled screwdriver. The case is of metal finished in blue, and is especially reinforced with a metal-recessed bed into which the tools snugly fit. Owing to the extreme care used in manufacture and the length of time taken to produce these Kits, it is necessary for every reader to reserve without delay, as the offer is only available for a short time. Turn to pages 90 and 91 and comply with the conditions now!

such a channel with the Kootwijk (Holland) station would be out of the question.

### Jubilee of the Accumulator

AN International Committee has been formed in France to arrange for centenary celebrations, in 1934, of the birthday of the French scientist, Gaston Planté, the inventor of the electrical accumulator. Devised by him in 1859, it was originally made up of two sheets of lead separated by rubber strips and rolled

### An Expensive Toy!

ACCORDING to the French newspaper *L'Antenne*, the price paid by the French Ministry of Posts and Telegraphs for the new Radio-Paris transmitter, which is being taken over by the State in November, is some twelve million francs. At to-day's rate of exchange this works out at roughly £150,000. Yet if rumour is to be believed, the Paris P.T.T. contemplates erecting another high-power station in the neighbourhood of the French capital.

### Listen to the News Reel

EVERY Saturday evening between October 14th and December 30th, the B.B.C. will broadcast a news reel consisting of a summary of the outstanding events of the day, followed by a reproduction of the details of the events. These will include such items as eye-witness accounts.

### Muhlacker Temporarily Closing Down

IN order to permit the erection of new aerial masts, the Muhlacker 60 kilowatt station will temporarily suspend its broadcasts; the programmes will be put out by the older 1½ kilowatt plant. Later, Muhlacker, of which the power is to be increased to 100 kilowatts, will exchange wavelengths with Munich.

# ROUND the WORLD of WIRELESS (Continued)

## Radio-Paris P.T.T.

FROM November 1st, the high-power transmitter erected for Radio-Paris at Remy St. Honoré near the French capital will be taken over by the State authorities, and from that date will act as a unit of the P.T.T. network. It has not yet been decided whether and when the entertainment broadcasts from the Eiffel Tower are to be suspended, but if and when this takes place the station will solely carry out its official telegraphy and telephony transmissions.

## The Freedom of the Ether!

WITH the launching on the German market of the *Volksempfänger* (People's Receiver), which the wireless industry in that country has been required to produce at a low price, steps are to be taken by the authorities to prohibit owners of other types of multivalve sets from listening to foreign broadcasts. The VE 301 (People's Receiver) is a two-valve battery or mains set designed to permit its owner to listen only to the *Deutschlandsender*, and to his local transmitter. Every effort is to be made to bring this set into general use in Germany. Persons convicted of listening to foreign anti-Nazi broadcasts are liable to a heavy fine, imprisonment, and to immediate confiscation of their wireless receivers!

## Interference

THE transmitter from which occasional broadcasts are to be heard in the background of the Hilversum programmes on 1,875 metres, is Moscow (RCZ), a new 100 kilowatt station used for telephonic communication with other Soviet cities. Another station in the Russian capital, RAX, on 1,760 metres, with a power of 30 kilowatts, may sometimes be tuned in when Radio-Paris is silent. During the past few months the Soviet authorities have added many new stations, working on both medium and short waves, to their ever-increasing radio system.

## Late Night Special

FOR the benefit of British listeners to the night concerts of Radio Normandie, the Fécamp studio now broadcasts a special news bulletin in the English language between midnight and 12.15 a.m., B.S.T.; it is followed an hour later by a French transmission of news from Paris.

## A Weekly Ether Tour

IF, on occasion, you should pick up an English or foreign programme on a wavelength immediately below that of Scottish Regional make a note that it may emanate from Radio Lyons (France) which as a weekly "treat" takes its local listeners for a tour through the European ether. The foreign broadcasts are captured by the Radio Club of Lyons, and passed over by land-line to its more powerful colleague. In this call the announcer will refer to the city as *Lee-yon*, and not *Lyons* as we know it on this side.

## Anti-Propaganda Measures

FOLLOWING steps taken by the governments of Czechoslovakia and Lithuania against the public broadcasts of

propaganda talks adverse to their respective countries, Austria has also passed a similar law prohibiting its nationals from listening to foreign transmissions of that nature. In the last country, where conviction is obtained, the culprit may be condemned to three months' imprisonment.

## A Popular Relay

ON September 30th, the B.B.C. will place its microphones at the Sadler's Wells

Theatre (Islington) for the relay of Act I of Gounod's opera *Faust*, for the benefit of listeners to the National programme.

## Japan's Broadcasters

THE number of registered listeners in Japan has already reached 1,470,000, the majority of licensees using crystal or small two-valve receivers. Eight of the bigger stations in daily operation are: JOAK, Tokio (345 m.); JOHK, Sendai (394.7 m.); JOIK, Sapporo (361 m.); JOBQ, Osaka (400 m.); JOCK, Nagoya (370.3 m.); JOGK, Kumamoto (380 m.); JOFK, Hiroshima (353 m.); and JODK, Keiyo (435 m.); with the exception of the last transmitter all are rated at 10 kilowatts. In view of the great success achieved by the broadcasting system, the authorities are considering the installation of a 150 kilowatt station in the neighbourhood of the capital. Without doubt, on favourable nights broadcasts at such power would be heard in Europe.

## Entertaining the Troops

IN Italy, a special radio-cinema motor lorry has been attached to the Army during the summer manoeuvres. It is fully equipped with electrical turntable, pick-up, and amplifiers, as well as with a talkie projector and wireless receiving apparatus. The entire installation is worked by a picked staff of engineers. The lorry follows the troops on the march, providing them with martial music en route, and in the evenings furnishes both cinema and radio entertainments. By means of a public address system of multiple loud-speakers entertainments, including broadcasts of news bulletins, are given to a very large military audience.

## Vaudeville and Revue

FOR the autumn and winter months the B.B.C. announces great plans for the development of the lighter kind of entertainment. From the end of September under the title of *First Time Here*, a vaudeville matinee will be broadcast every Saturday afternoon to which will contribute a number of artists appearing for the first time before the microphone. Billy Merson will appear in and present his own revue, and Elsie and Doris Waters will take the principal parts in a new show written by Ashley Sterne. *The Follies of the Air*, in future a regular feature, is a new concert party working on the lines of performances devised by the producers of *Songs from the Shows* and *The White Coons*. Musical plays, such as the great Drury Lane success *The Desert Song*, will also be adapted for ether transmission, and Kalmann's operetta, *The Circus Princess*, will be heard for the first time in English during the same month. The main item of the Christmas entertainment will be a grand pantomime, of which the subject is still being kept a secret.

## Austria's Fifth Relay

CONTRARY to the original plan, the Ravag will build in the neighbourhood of Bregenz, on Lake Constance, a 2 kilowatt relay station, as the Vorarlberg district appears to be beyond the range of the Innsbrueck broadcasts.

## THE LATEST RADIOGRAM



A piano-shaped radio-gramophone, priced at £110.10.0, shown at the recent Radio Show at Olympia.

## SOLVE THIS!

### Problem No. 54.

Whitaker decided that he would build up a three-valve mains receiver, and accordingly wound a mains transformer and choke, using data obtained from our data sheets. He decided to use a Mullard V.P.4 for the H.F. stage, an Osram M.H.4 for the detector and a Mazda A.C. Pen. for the output stage. All these valves are rated at 200 volts maximum H.T., and he accordingly wound his transformer to suit the Westinghouse H.T. 7. All his figures and workings were correct; and when the receiver was finished and checked it was found to be perfectly O.K. Results were, however, very disappointing, volume being sadly lacking and quality very poor. All good components were employed and all were tested and found in order. What was wrong? Three books will be awarded for the first three correct solutions opened. Address your envelopes to The Editor, PRACTICAL WIRELESS, Geo. Newnes, Ltd., 8-11, Southampton Street, Strand, London, W.C.2, and post to reach here not later than October 2nd. Mark your envelopes "Problem No. 54."

### SOLUTION TO PROBLEM No. 53.

Blenkinsop made a mistake in the formula, which requires that the nominator of the equation should be the optimum valve load, and not its impedance. The following three readers received books in connection with Problem No. 52.  
F. Rooke, "Clydene," Bramstan Gardens, Bramley, Leeds; H. A. White, 39, Royston Avenue, Wallington, Surrey; A. E. Boozer, 125, Butt Rd., Colchester, Essex.



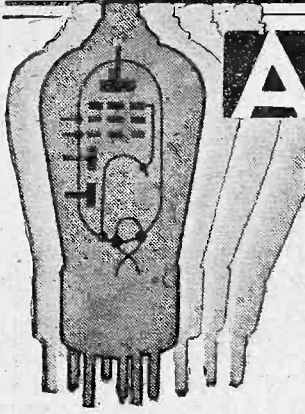

# ARE MULTI-ELECTRODE DETECTORS WORTH WHILE?

A Practical Article Dealing with the Possibilities of the Different Types

By PERCY RAY

THE last twelve months have seen an increasing tendency towards the use of multi-electrode detectors, and a review of the receivers employing this form of rectification suggests that 50 per cent. of them would work far better with an ordinary 3-electrode valve, while a large percentage of the remainder fail to justify the extra expense involved. There are a few commercial receivers employing such an arrangement, but in all the cases that have come to the writer's notice there is reasonable justification for such a procedure.

Before going into the matter farther, the advantages and alleged disadvantages of multi-electrode detectors will require considerable investigation.

There are only three possible advantages:

- (1) Greater gain.
- (2) Superior quality of reproduction, and
- (3) Less damping on the tuned circuit immediately preceding the detector valve.

Take first of all the question of gain, where the greatest justification for this form of detection has been found. A valve such as the Cossor MS/Pen-A has considerable possibilities. Readers will probably be aware that this valve is classed as a high-frequency pentode, although a far better idea of the valve can be conveyed by describing it as a screened-grid valve with an extra grid interposed between outer grid and anode to straighten out the kink in the characteristic, which is inevitable with the ordinary screened-grid valve. This valve will give 29 volts output when .55 volts are applied between grid and cathode. This represents a stage gain of just over fifty-four times, or, assuming a 3 to 1 transformer, a total gain of over 160.

It is difficult to see how such a gain could be obtained by the use of any 3-electrode valve, and where the number of valves is of paramount importance this valve might appear to be a candidate for the detector position. On the other hand, these valves, having practically no Miller effect, the damping on the preceding tuning circuit will be small.

### The Miller Effect

At this juncture it will be as well to explain exactly what is meant by the Miller effect. Fig. 2 shows a triode valve with its preceding tuning circuit and succeeding coupling in the form of a 50,000 ohm resistance. The condenser shown in dotted lines is representative of the capacity existing between anode and grid, and it will be seen that a path can be traced

through the condenser, through the resistance, through the H.T. battery or power pack to the other end of the tuned circuit. Consequently, the capacity and resistance in question are in parallel with the coil,

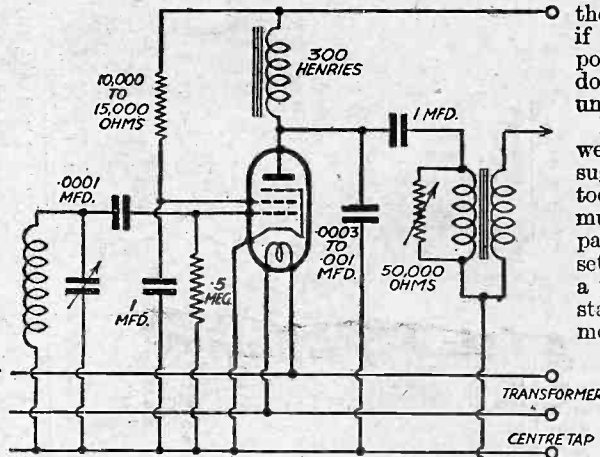

Fig. 1.—Circuit diagram showing a Cossor MS/Pen-A used as a power grid detector. This arrangement was employed in the A.C. Twin.

and will reduce the efficiency and selectivity considerably.

With a screened-grid valve the capacity between grid and anode is very small; consequently this effect is proportionately immaterial.

This explanation of the Miller effect would seem to indicate that the high-frequency pentode had the advantages of gain and extra efficiency, but unfortunately this extra efficiency is often a serious disadvantage, because modern components force the constructor to use everything screened except the short wires between one terminal and another. When the pre-detector coil is heavily damped by the detector valve, everything is all right, but when this damping is removed the average set becomes hopelessly unstable.

To achieve stability with such a valve extravagant screening is necessary, and infinite care must be bestowed on the actual layout of the chassis. Furthermore, if the set is to be used with reaction, the Miller effect is of no consequence, as the reaction will more than overcome the damping arising from this source.

This valve either requires an external anode voltage of 400 or else the

inter-valve transformer must be choke-fed, and the total cost of the stage will be about equal to the cost of an ordinary detector, plus an L.F. stage with R.C. coupling between them, which would give greater gain than the high-frequency pentode by itself.

Summing up the high-frequency pentode within the meaning of the word at the time of writing, it would appear that although it probably represents one of if not the most advanced form of power-grid detector technique, it is doubtful if its presence is desirable under normal circumstances.

Following the lines of thought that we have just explored, the possibility suggests itself of using an ordinary pentode valve as a power grid detector, but much the same arguments can be applied, particularly in the case of a battery set where the relatively high cost of a pentode valve makes the use of two stages a definite economy; and furthermore, the difficulties of straightening out the peak in the middle of the speech band of frequencies practically throws away anything that may have been gained.

### Screened-Grid Valves

The next multi-electrode detector that presents itself is an ordinary screened-grid valve, which automatically branches into two classes, the use of a high impedance or low-impedance type.

The high-impedance type offers remarkable gain and has great possibilities in receivers not employing any high-frequency stages; but when one or more such stages are used a high-impedance S.G. detector valve will overload far too easily.

(Continued on page 116)

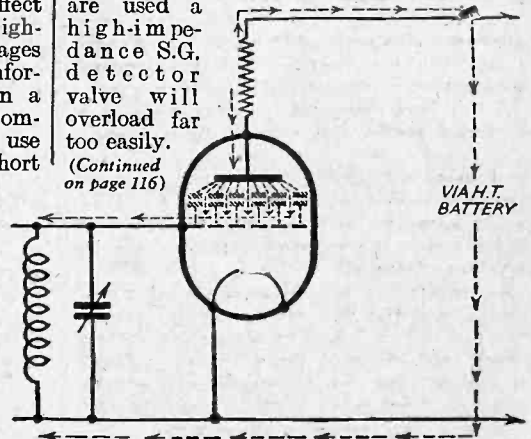
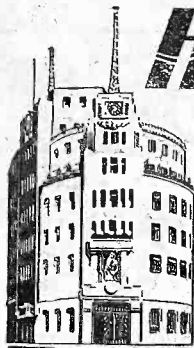

Fig. 2.—Showing how the component in the anode circuit is in parallel with the preceding tuned circuit via the grid to anode capacity of the valve. (Represented by ghost condensers). This condition is known as the "Miller Effect."



# How the B.B.C. Does It

An Informative Article by our B.B.C. Correspondent on the Way in which the B.B.C. Experts Design and Operate their Receivers and Amplifiers. This Article will help you in Designing your own Apparatus



**Y**OU can learn much from B.B.C. receivers and amplifiers, and many of the circuit arrangements used and component values chosen are a help when you come to designing apparatus for yourself. Examine the circuit diagram of the check receivers used at Broadcasting House and you will see what I mean.

These receivers are, of course, a little more elaborate than you would use for ordinary B.B.C. reception, as they are real quality jobs, and no expense is spared nor economy in valves studied. But they are planned for a rather special job, namely, the reception of local transmission with knife-edge selectivity and the best possible quality.

After all, this is what is wanted in any receiver.

In the case of the B.B.C. receivers at Broadcasting House, there are three. Each is tuned definitely to one station. Thus there is one for Daventry, one for London Regional, and one for London National. The tuning circuits are pre-set, and the adjustments checked over every morning. The sets themselves consist of a screen-grid H.F. stage and push-pull detectors. The output is coupled to an ordinary low-frequency amplifier to bring the volume up to loud-speaker level. However, each of the B.B.C. loud-speakers is fitted with a two-stage mains driven L.F. amplifier in addition.

## H.F. and Detector Stages

We will first concern ourselves with the H.F. and detector stages of the check receivers. The tuning circuit is normal. There is a tuning condenser of .0005 microfarads and a series condenser of .0002 microfarads. The tuning condenser is not directly in parallel with the coil, but there is a fixed resistance in series with the coil as part of the tuning circuit. The value of this resistance depends on the wavelength to which the set is tuned and is not the same in both the Daventry National and London National receivers.

A hundred thousand ohm potentiometer is placed across the whole tuning circuit as a pre-detector volume control. This is used to adjust the rectified current output from the detector and is always adjusted to the same value for all the receivers, so that there is the same output to the L.F. amplifiers from all of them.

An indirectly heated screen grid valve is used, and the bias on its normal grid is obtained by a 1.5 ohm resistance in the heater lead shunted by a .01 microfarad condenser. In the anode circuit of the screen grid valve is an H.F. choke and a by-pass condenser of 1 microfarad.

There is a common high-tension supply of 300 volts to all stages of the check receiver. There is a 20,000 ohm resistance in series with the screen grid valves to cut down the voltage for the anode.

A split primary H.F. transformer coupled between the screen grid valve and the push-pull detector stage. The coupling between the two primary sections and the secondary section of this H.F. transformer is variable, and both the primary and secondary are tuned. There is a .0003 microfarad condenser across the primary and a .0005 across the secondary. Incidentally the screening grid voltage for the screen grid valve is obtained by dropping

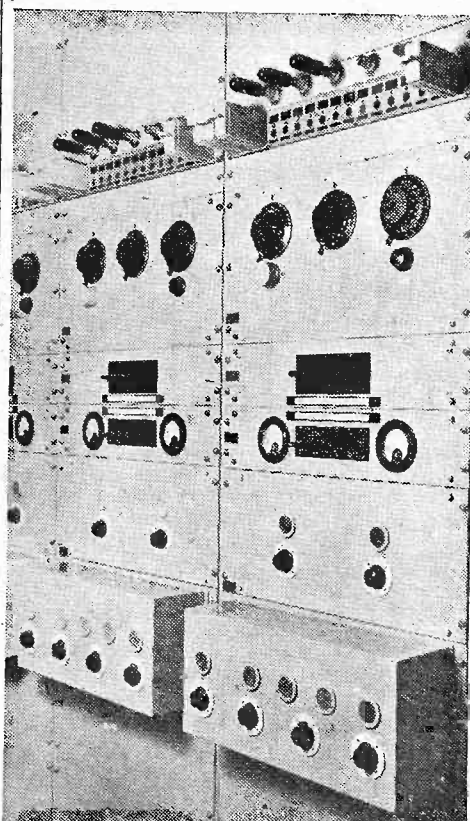

Two of the check receivers at Broadcasting House.

resistances. There is a 35,000 ohm resistance between the main high-tension terminal and the screening grid itself.

Ordinary triode valves are used as push-pull detectors, and as there is a common 6-volt low-tension supply to the valves in the check receivers, 35 ohm resistances are placed in the filament leads to cut down the voltage. Half megohm grid leaks are used in both grid circuits of the push-pull detectors. A by-pass condenser of .0001 microfarads is used and there is resistance and condenser output to the L.F. amplifier line.

The mounting and arrangement of these check receivers is on conventional lines. The controls are carried on metal panels at the front and the main components are

on brackets at right angles, but actually these panels are mounted in the control room racks at Broadcasting House. There are three tuning controls and a volume control on one panel, and the loud-speaker output arrangement and switches are on a separate panel beneath.

The output of each of these check receivers is taken to two separate L.F. amplifiers, one feeds the local headphones used for quality checking, and the other goes to the mains operated amplifiers installed in the engineers' listening rooms and in other points of the building. The purpose of the check 'phone amplifier is to prevent any feed back between the 'phones and the H.F. side of the circuit. As there is an intermediary L.F. amplifier the 'phones can be cut in or out of circuit as required without causing clicks to be heard on the loud-speaker line.

However, I do not want to take up too much space with a description of the way in which the B.B.C. uses its apparatus, but rather I want to show you how this apparatus is constructed.

## L.F. Amplifiers

Now let us consider one of the ordinary low-frequency amplifiers which the B.B.C. engineers use for microphone and gramophone pick-up amplification. These are what is known as the "A" type amplifiers and are for the first stages of amplification. Power amplifiers, known as "B" amplifiers, are used for the later stages.

There are three stages in each "A" amplifier, but four valves. This is in order to suit the rather special B.B.C. needs of two separate outputs from each amplifier, and so there are two separate output valves, each with its own output transformer. Although the coupling between the valves and the amplifiers is by means of resistances, the coupling to the amplifiers in the first place is by means of an iron-cored transformer shunted with resistances.

The iron-cored input transformer to the "A" amplifiers is shunted on the primary side by a 374 ohm resistance and on the secondary side by a .25 megohm resistance. There is a 10,000 ohm resistance in series with the slider of the potentiometer connected across the secondary side of the transformer. This potentiometer, of course, acts as a volume control.

All the four valves in the "A" amplifier are of the indirectly heated type and are triodes. Each valve is separately decoupled, and, of course, there are in addition the ordinary resistances of the resistance coupling. The anode resistance of the first stage has a value of 25,000 ohms and the decoupling resistance is 20,000 ohms. The decoupling condensers in both cases have a value of 2 microfarads and the coupling condenser between the first and second valves has a value of .5 microfarads. There is a .5 megohm grid leak and, of course, the usual automatic bias resistances. There are separate grid bias supplies of 2, 12 and 24 volts. The anode resistance in the second stage has a value again of 25,000 ohms, but this time the decoupling resistance has a value of only 10,000 ohms. The coupling condenser to both the output valves again has a value of .5 microfarads, and in the anode of each of the output valves there is a 6-microfarad condenser coupling an iron-cored choke to the output transformer for each stage; in series with the iron-cored choke in each anode circuit there is a 1,200 ohm resistance.

A 4-volt supply is given to the heaters

(Continued on page 116)



Some Interesting Points Concerning A.C. Mains Rectifying Valves

# The RECTIFIER — and its Peculiarities

By H. J. BARTON CHAPPLE,  
Wh.Sch., B.Sc., A.M.I.E.E.

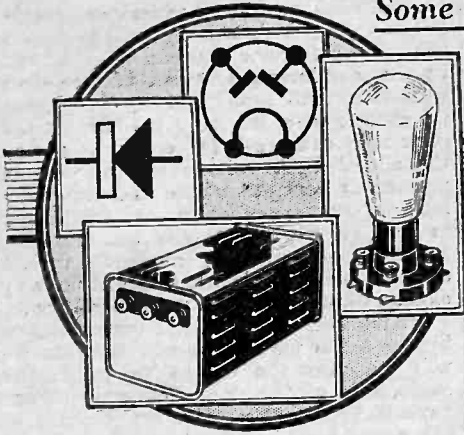

EVERY owner of an A.C. mains set realizes that one of the most important elements in his equipment is the rectifier, the duty of which is to convert a portion of the alternating current supply to a uni-directional current so that, after it has been smoothed, it will serve as high-tension current for the various receiving valves.

Two types of rectifier unit are available, the electrolytic or metal rectifier and the

due to vastly different reasons. The metal rectifier consists essentially of metal plates, usually copper, one side of each being covered by a very thin film of copper oxide, arranged alternately with plates of lead.

I do not know if any satisfactory scientific explanation of the process has yet been found, but, at any rate, the fact remains that such an arrangement has the property of permitting current to pass in one direction but not in the other.

The valve rectifier, however, operates on the well-known principle that a heated filament emits electrons, these electrons being attracted across the vacuum in the valve by a positive charge on a metal plate or anode. In the half-wave rectifier valve, the filament or cathode is heated by a four-volt A.C. supply taken from a separate low tension

usual circuit for metal rectifiers is that known as the voltage doubling arrangement (Fig. 6). Here, during positive half-cycles, the circuit is from the top of the transformer winding, through rectifier A to the H.T. positive terminal, through the receiving valves, etc., and back to the H.T. negative terminal and thence through the condenser C<sub>2</sub> to the bottom end of the transformer winding. During the negative half-cycles the circuit is from the bottom end of the transformer winding, through condenser C<sub>1</sub> to the H.T. positive terminal, through the load (valves, etc.); and back to the H.T. negative, then *via* rectifier B to the top end of the transformer winding.

In the case of the full-wave valve rectifier, it is usual to employ a valve having a single filament but two anodes, connected as shown in Fig. 7. The H.T. winding of the

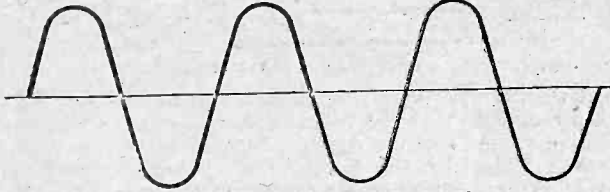

Fig. 1.—An alternating voltage with equal positive and negative pulsations.



Fig. 2.—The resultant current through the rectifier as a result of applying the voltage of Fig. 1.

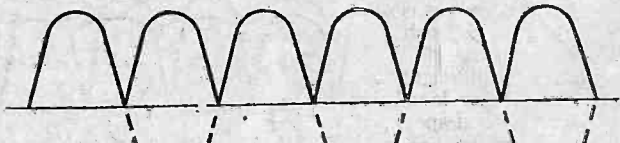

Fig. 3.—Resultant current in a full-wave rectifier arrangement.

two electrode valve rectifier. Both operate on the same principle, namely, that both pieces of apparatus will permit a current to pass in one direction but not in the reverse direction. Thus, if an alternating (that is, rapidly reversing) voltage as Fig. 1 is applied to a single rectifier, the actual current passing through the rectifier will consist of a number of impulses all in one direction, separated by quiescent periods corresponding to the negative halves of the A.C. cycles (Fig. 2). By a modified arrangement, using two or more rectifying units, the gaps between the half-wave impulses can be filled up as in Fig. 3. This method is known as full-wave rectification and is almost universally employed in modern A.C. receivers.

winding on the power transformer, while the A.C. high-tension voltage is applied between the filament and the anode. During positive half-cycles, when the anode has a positive potential, electrons will pass

transformer is centre tapped, and the transformer is so designed that the voltage developed across the whole of the high-tension secondary is twice the voltage it is intended to apply to each anode. It will be seen from the connections in Fig. 7, that while one anode, say A, is being fed with a positive half-cycle, a negative half-cycle is applied to anode B, and *vice versa*. It follows, therefore, that a load, such as the anode circuits of the various receiving valves, is connected between the filament of the rectifier and the centre tap of the high-tension winding, and high-tension current will flow from the filament connection (H.T. positive), through the load, and back to the centre tap (H.T. negative) through each rectifier anode in turn.

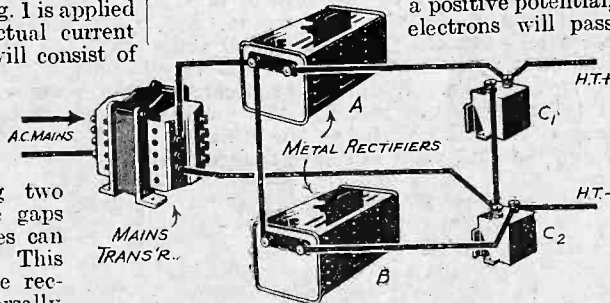

Fig. 6.—Using a voltage doubler circuit for full-wave rectification with metal rectifiers.

**Rectifier Operation**

Although both metal and valve rectifiers operate on the same principle, namely, that of unilateral conductivity, or, in simple English—one-way traffic, this property is

through the valve from filament to anode; thus, as far as the output is concerned, the filament will be the positive side of the high-tension supply and the anode the negative side. During negative half-cycles, of course, no current will pass through the valve because the anode, being negative, will not attract the electrons emitted by the filament.

**Circuit Connections**

Figs. 4 and 5 give the circuits of simple half-wave metal and valve rectifiers, respectively. For full-wave rectification the

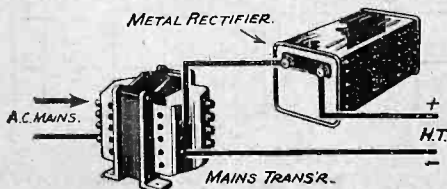

Fig. 4.—A half-wave metal rectifier scheme.

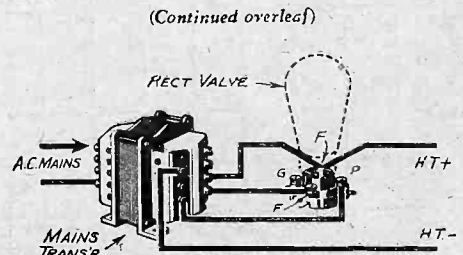

Fig. 5.—The arrangement for a half-wave valve rectifier.

(Continued overleaf)

(Continued from previous page)

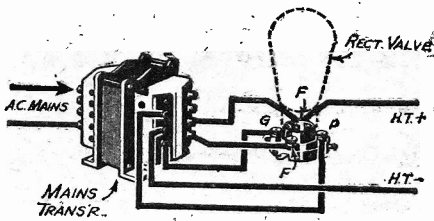

Fig. 7.—The connections for a full-wave rectifier.

**Some Interesting Points**

Now there are several interesting points about this full-wave rectifier system which, although well known, are not generally realized to the full. In the first place, it must be clearly understood that the rectifier does not supply a direct current. Unidirectional current, yes, but a steady direct current, certainly not. The output from such a rectifier is of the general form shown in Fig. 3—a series of impulses, all in the same direction, but dying down to zero every one hundredth of a second (for a standard 50 cycle supply). In this form, the rectifier output is quite unsuitable for high-tension supply in a broadcasting set, and its use would only result in an intolerable hum.

Fortunately, however, there are simple means available for improving matters, namely, the use of a smoothing circuit. This is, in essence, an arrangement of condensers and chokes, and its action may best be studied by examining the result of connecting a fairly large condenser of at least 4 microfarads across the rectifier out-

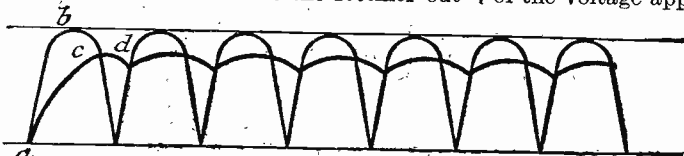

Fig. 9.—The effect of the reservoir condenser on the rectifier voltage is illustrated here.

put, as  $C_1$  in Fig. 8. What happens is this: As the rectified voltage grows (a-b in Fig. 9) the condenser begins to charge up, resulting in a slowing up of the rise in voltage (a-c). Then, when the rectified voltage begins to fall off, i.e., as soon as it becomes less than the maximum, the condenser commences to discharge and supplies energy to the circuit, thus partially making up for the reduction in rectifier output (c-d). During the next impulse from the rectifier the charge on the condenser is replenished, and the cycle of operation commences again. It will be seen from Fig. 9 that the voltage from a combina-

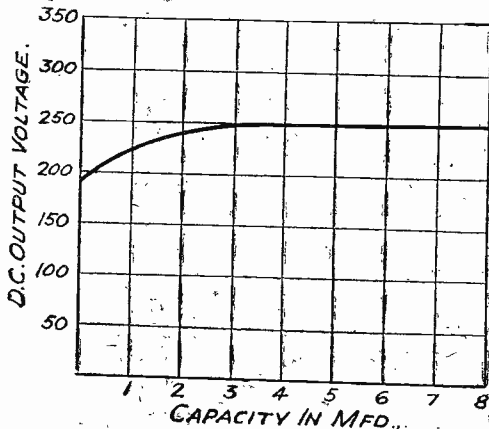

Fig. 10.—The variation in output voltage with reservoir condenser capacity.

tion of full-wave rectifier and "reservoir condenser," as it is called, is definitely more uniform than that from a rectifier by itself. Moreover, the average value of the voltage is definitely higher than the effective mean in the case of the rectifier alone. The relation between the effective voltage of a full-wave rectifier and the voltage from a rectifier plus condenser is given in the curve reproduced in Fig. 10—which shows, incidentally, that little improvement is obtained by increasing the value of the reservoir condenser above 4 microfarads.

**Further Smoothing**

But the smoothing provided by a single condenser is not sufficient to give a satisfactory high-tension supply, so the smoothing circuit is completed by the inclusion of the iron-cored choke in series with the load, and a further condenser as indicated in Fig. 8. The effect of the choke is to oppose changes in current—it may be considered as forcing back the peaks still existing in the output, and causing them to be dealt with more fully by the reservoir condenser; the second smoothing condenser plays a similar part to that of the first, but of course it has to deal with very much smaller variations, which may be described as mere ripples.

It has already been explained that the voltage obtained from a smoothed rectified supply is greater than the effective value of the voltage applied to each anode of the rectifier. It must not be thought, however, that a rectifier gives an absolutely constant H.T. voltage whatever the load applied. On open circuit, a rectifier will give a direct current voltage substantially greater than the R.M.S.

value of the alternating voltage applied to each anode. By the way, in case any reader has forgotten, R.M.S. stands for "root mean square," and is the effective value of an A.C. voltage.

Thus, the open circuit voltage of the usual type of 250 volt milliamper rectifier, when an alternating voltage of 250 volts R.M.S. is applied to each anode, is very nearly 350 volts. When, however, current is taken from the rectifier, the voltage begins to fall. With a 15 milliamper drain, the D.C. volts will have dropped to about 300; at 35 milliamper to about 275 volts, while when the valve is giving its rated output of 60 milliamper, the voltage will have fallen to the rated value of 250 volts.

**Performance**

The performance of a typical full-wave rectifier valve is given in the graph reproduced in Fig. 11 which gives the output voltage corresponding to various output currents for different values of anode voltage. This falling off of voltage as the drain on the rectifier increases is, of course, due to the fact that the rectifier

valve itself has a definite resistance, and the fall in voltage is in fact the voltage drop in the valve resistance and can be calculated by the well-known formula, voltage drop equals current multiplied by resistance. Of course, in a receiving set the output current is substantially constant, so that the actual H.T. voltage will also be of practically constant value, and the valve makers' curves, similar to that reproduced in Fig. 11, will enable any listener, once he has measured the amount of H.T. current taken by his set, to ascertain very closely what H.T. voltage he is getting.

I have said that the H.T. current taken by the set is practically constant, but we will see now the extent to which the modulation of the anode currents in the various valves affect the performance of the rectifier and, through the rectifier, of the whole set.

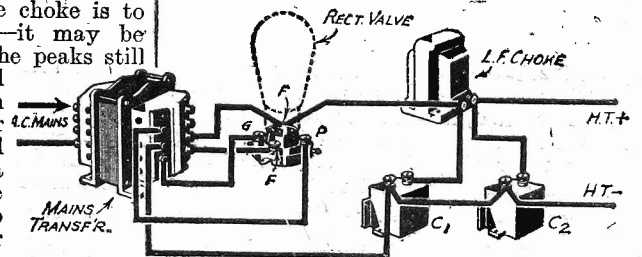

Fig. 8.—Add a smoothing circuit to a full-wave rectifier.

At the beginning of this article I explained that the output voltage available from the rectifier depended upon the current taken by the receiving set. As, however, the mean anode current of the valves remains substantially constant all the time the receiver is in operation, the actual high-tension voltage is also to all intents and purposes constant, as, of course, it should be, if the set is to give satisfactory operation. I qualified this statement, however, by saying that there were certain cases in which the high-tension voltage was caused to vary, and I want now to deal with these special cases. The first instance to be discussed is that in which a variable- $\mu$  high-frequency stage is incorporated in the receiver. It will be clear that when the grid bias of this valve is increased for volume control purposes, the anode current of the valve will be decreased, and as the anode current of the variable valve forms a part of the output taken from the rectifier, the actual output will increase, and this will mean a rise in the high-tension voltage.

(To be continued)

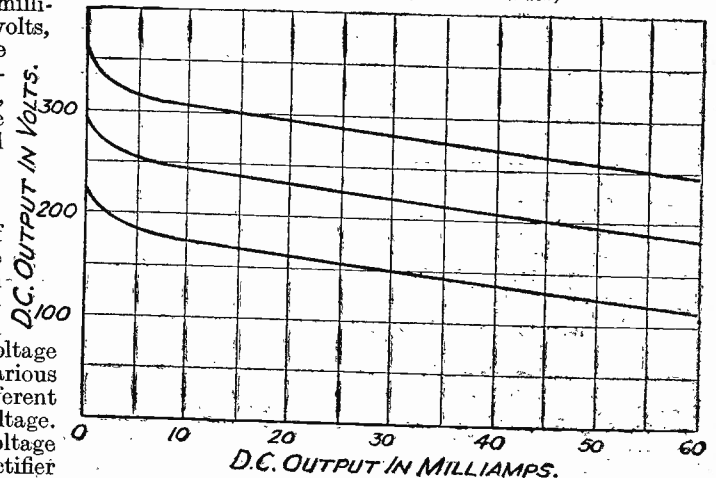

Fig. 11.—The variation in D.C. output voltage of a typical rectifier at various loads and for various anode voltages.



# SOME JUGGLES WITH JUNK

An Article describing how Several Useful Components can be Made with Scrap Materials

By ALFRED J. POTTS

A TYPE of indoor aerial popular at the moment is that which has some sort of foil as a conductor. A very good aerial of this type can be made from something that is usually found in every constructor's junk-box. A fairly large Mansbridge condenser, of 1 mfd. or even

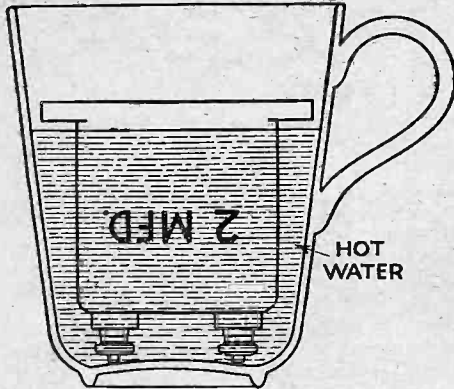

Fig. 1.—Softening the pitch in an old condenser.

.5 mfd. capacity, would do fairly well. As readers are no doubt aware, the Mansbridge type of fixed condenser consists of two long strips of metal foil insulated from each other by a thin greasy-looking kind of paper. If, therefore, we get these long strips out of the case without unduly damaging them we have the very thing required. It does not matter even if the condenser is burnt out or shorted in any other way; unless the damage is exceptionally bad, it will work just as well.

### Uses for an Old Condenser

The easiest way to get the condenser out of its case is to stand it upside down in a cup of boiling water for a few minutes, when it should be possible to get it out without trouble. It is sometimes easier to chip the pitch out first and then use the hot water to melt the wax inside. If this is done, do not let the water get into the condenser if it can be helped, but have the water only as high as indicated in Fig. 1.

Having got the condenser out we find the foil is in the form of a closely packed roll. Find the end and unroll carefully, taking care not to tear it. If it should be badly burnt out in any part, so that it is in two pieces, or nearly broken, cut the bad part out and join the ends together,

making sure, of course, that metal touches metal. If this strip is attached by drawing-pins or, if preferred, glued to a picture rail, it will result in quite an efficient aerial, owing to the fact that the surface of pickup area is large and that H.F. currents travel on the surface of a conductor. So much for the internals of that old condenser. Now what's to be done with the case?

Many listeners have a tone control, for compensating a pentode valve, already in their sets and consisting of a resistance and condenser wired as shown in Fig. 2. Surely it would be more convenient if this were one self-contained unit? Very well then. Disconnect them from the set and then connect them together inside the condenser case, as in Fig. 3. Practically any size of condenser case will be large enough to take these two small components. Seal up the bottom with a little pitch and you have a neat, self-contained tone-compensating control-unit ready to be reconnected in the set. Another use for the

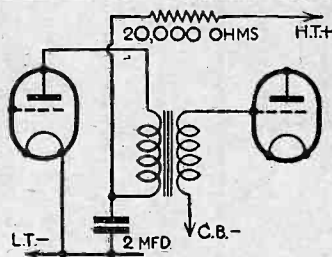

Fig. 4.—Circuit diagram showing connections for decoupling components.

condenser case is to mount two fairly large terminals in the top, or more if desired, to act as a terminal mount. There are several other uses for these old condenser cases, many of which depend on special individual circumstances.

Old coil holders are useful in many ways as plugs and sockets for extensions to loud-speakers, etc., and have one very important advantage over other forms of extension plugs and sockets. This advantage is that they are all standardized and, therefore, no difficulty is experienced in changing over from one connection to another.

Many amateurs, no doubt, have by them an old type transformer, and no self-respecting radio amateur needs to be told what the wire can be used for. The bobbins and laminations are not particularly useful things but they can, in certain circumstances, be found to be of use to the experimenter.

For instance, the case has many uses. The components of an R.C.C. stage can easily be accommodated inside and the con-

nections can be brought out to the terminals which were previously used for the connections to the transformer. Or a complete decoupling device can be equally well accommodated in most ordinary transformer cases, and can conveniently consist of a 2 mfd. condenser and a 20,000 ohms resistance with the connections brought out to the H.T. and plate and earth terminals. A diagram of the connections is given in Fig. 4 for those who are not sure of them. This by no means completes the possibilities of using the old transformer case, but it is not difficult to adapt these suggestions to suit your own requirements.

### Coil Formers from Old Ebonite

Old ebonite panels are probably the most persistent hangers on in the junk line. Uses for them are often rather lacking. If not in too bad a condition the holes can be filled up with Chatterton's compound, cobblers' wax or in some cases even pitch. Or they can be cut into useful terminal strips and insulating strips by carefully missing the holes. A rather good use, however, is to cut two pieces shaped as shown in Fig. 5, remembering that the central slots must be the same thickness of the ebonite used. The slot A must be in the position shown by the dotted lines marked B in the second piece. In all other respects both pieces are alike. The two parts are pressed into each other, as depicted, and attached by four small screws to a base of the same ebonite measuring about 4in. by 3in. If this former is wound with the requisite amount of wire a low-loss coil will result owing to the liberal quantity of air spacing and very little insulating material being close to the wires. The deeper slots can contain the long-wave winding and the shallow one the short and reaction windings. The design can be altered to suit any particular type of coil required.

### Useful Fitments made from Metal Panels

Old or damaged metal panels and screens, if unsuitable for their proper purpose, will provide the material for a strong pair

(Continued at foot of page 76.)

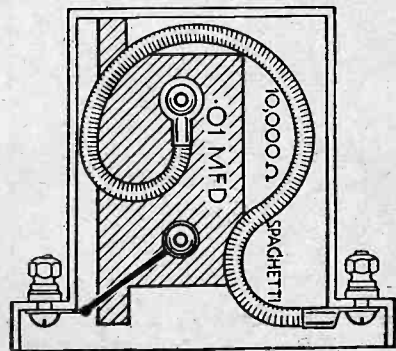

Fig. 3.—A simple tone control unit.

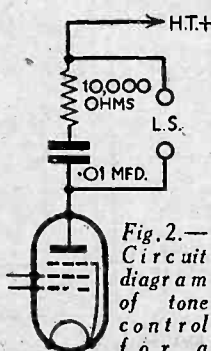

Fig. 2.—Circuit diagram of tone control for a pentode valve.

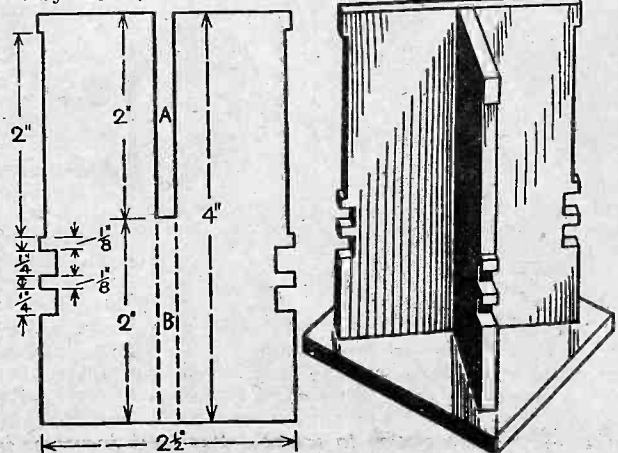
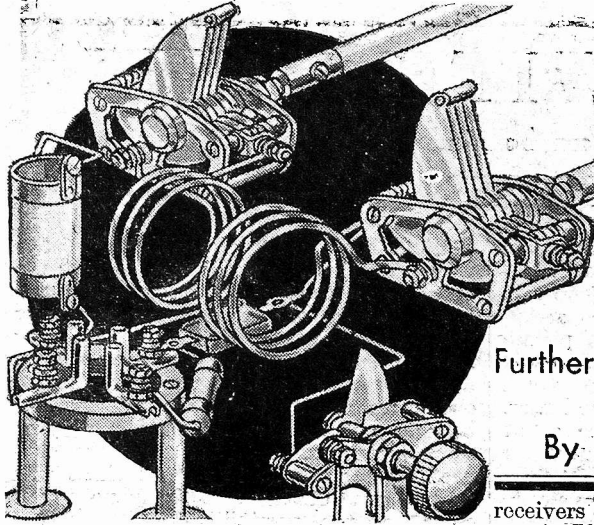

Fig. 5—Details of coil formers.

# Short Wave Section



## Further Practical Points on the Technical Side By MANDER BARNETT

THE short-wave oscillator described in these notes recently can very easily and efficiently be put to a number of uses other than that of a mere test oscillator. With very little alteration we can bring it into service either as a one-valve short-wave receiver, a one-valve "straight" adaptor, or a one-valve superheterodyne converter. The diagram on this page shows how the unit can be used in the latter manner, the only extra component necessary being a spaghetti or flexible resistance ( $R_2$ ) of about 30,000 ohms. Alternatively, a high-frequency choke (not a short-wave type) can be used here, but the resistance is very effective in this instance. The condenser  $C_4$ , instead of being earthed on one side, as in the original diagram, is brought out to an extra terminal (A). From this point a wire is taken to the aerial terminal on the receiver and the result is now a complete short-wave superheterodyne outfit. Enough has already been said concerning this type of adaptor, so that it is unnecessary for me to go into the details of operation here. Suffice it to say that the receiver must be tuned to as high a wavelength as possible for satisfactory reception on the converter. This unit is easily used as an adaptor of the "straight" type, merely by omitting the high-tension battery, and taking a wire from the H.T. plus terminal to the plate socket of the detector socket in the receiver. Two stages of L.F. are required to operate a speaker with the arrangement so that this method of wiring will prove the most satisfactory with

receivers of the detector and L.F. amplifier type. If the receiver itself has a screened-grid stage, however, we can make full use of the amplifying properties by wiring up the unit as in the circuit herewith.

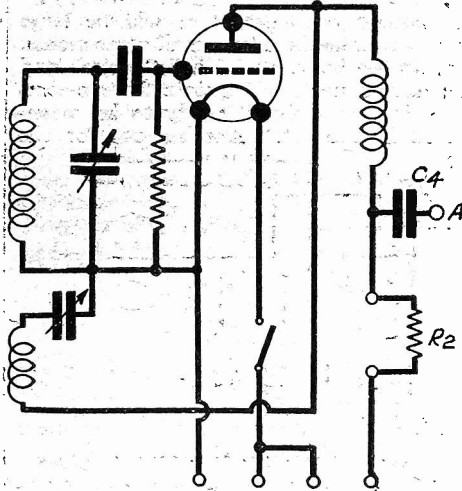

This circuit shows how the oscillator described can be used as a short-wave converter

### Short Waves and Interference

The fact that the short waves, at any rate, those below about fifty metres, are scarcely subject to atmospheric disturbance is very little consolation for the fact that these waves are very much more subject to interference by "man-made" sources—a fact which the newcomer to short waves will very soon discover for himself. It is

certainly rather puzzling, and not a little exasperating, to find that reception is liable to be spoilt at intervals by a series of noises mildly resembling machine-gun fire, until one realizes that such interference happens just when a motor-car passes the house! The difference between operating a short-wave receiver in the middle of a busy town and then out in the open country is really amazing, reception in the country making one realize that short waves can provide a really very quiet background! There is, unfortunately, really very little that the amateur can do to reduce the noise level in a location where such noise is produced mainly by local interference. Here, of course, I am referring strictly to short-wave reception—on the medium bands, by careful attention to certain aerial and other details, the noise level can be very materially reduced. With a short-wave receiver it is sometimes possible to use a very short aerial, and this can sometimes be shortened to such a point where the amount of signal strength picked up is still quite reasonable, but the local interference is very much reduced. When using a super-heterodyne type of short-wave adaptor with a powerful receiver, it is very advisable to use only a very short length of wire connecting the adaptor to the receiver, otherwise, if this wire is too long, the receiver itself will start picking up outside noises on the long waves—the intermediate frequency amplifier in this case—and thus the background level would be unnecessarily increased. Probably the worst type of interference on the short waves comes from various types of motor-cars, and where one is unfortunate enough to live very close to a main road the problem becomes rather acute. Probably the best procedure is to install the whole of the apparatus, including the aerial itself, as far away from the road as possible and then hope for the best!

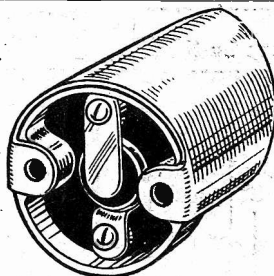
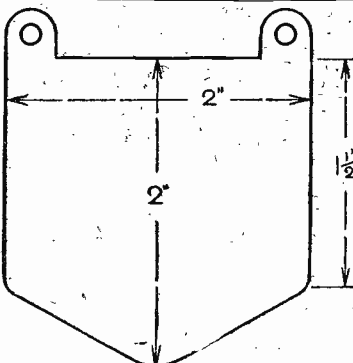

Fig. 8.—A reflector for a fuse bulb.

a very neat escutcheon plate for switches, volume controls, etc. A pair of good examples of simple yet neat designs, which can be used for these escutcheon plates, are shown in Fig. 7. A very simple yet neat shield and reflector can be made for use with a bakelite or porcelain fuse bulb-holder, so that when mounted it will throw a very useful light over the set so that adjustments can be made with ease. The shape for cutting the metal and diagram showing how the finished reflector is fixed are given in Fig. 8. It should be noted that the two wood screws which fix the bulb-holder in place also hold the reflector.

### SOME JUGGLES WITH JUNK

(Continued from previous page)

of panel brackets by cutting them to the shape shown in Fig. 6 and bending over the flanges at right angles on the dotted lines. A circular plate cut from an old screen, and having a hole in the centre, will make

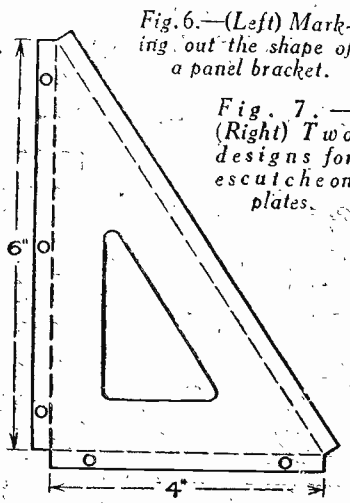
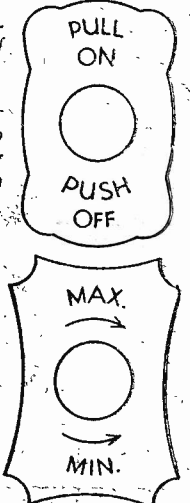

Fig. 6.—(Left) Marking out the shape of a panel bracket.

Fig. 7.—(Right) Two designs for escutcheon plates.







**Preferred  
and  
praised  
by  
every  
Expert**

**LIT-LOS CONDENSER**

A very carefully constructed instrument, compact in size and efficient in design, with accurately gauged bakelite dielectrics and solid brass pig-tail connection to moving vanes. Made in all sizes up to .0005 mfd. (500 cms.) in log mid line and straight line capacities. Used by many leading manufacturers and specified in sets by famous designers. One hole fixing; supplied complete with terminals. Particularly low loss. **PRICE**

**2/-**

**GRAHAM FARISH PRODUCTS**



**LIT-LOS DIFFERENTIAL CONDENSER**

A highly efficient condenser, similar in general construction to the Lit-Los Variable type, but having two sets of fixed vanes, enabling the rotor plates to engage differentially between them. The terminals are somewhat differently disposed, but otherwise the instrument is identical in construction with the Log line and Reaction types. All capacities up to .0005 mfd. (500 cms.) **PRICE 2/-**

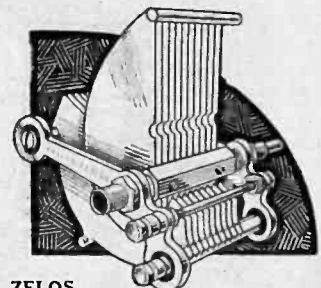

**ZELOS AIR VARIABLE CONDENSER**

A superb component possessing extreme rigidity of construction, mechanical perfection of moving parts, and high electrical efficiency. Negligible H.F. loss, large accessible terminals, floating shaft for easy ganging and adjustment of spindle length. **PRICE .0005 mfd. 5/-**

Ensure a safe and efficient Aerial and Earth. The new AEROFICIENT KIT provides all you need. Complete, 6/6.

Send a postcard for our new catalogue, which describes all our products.



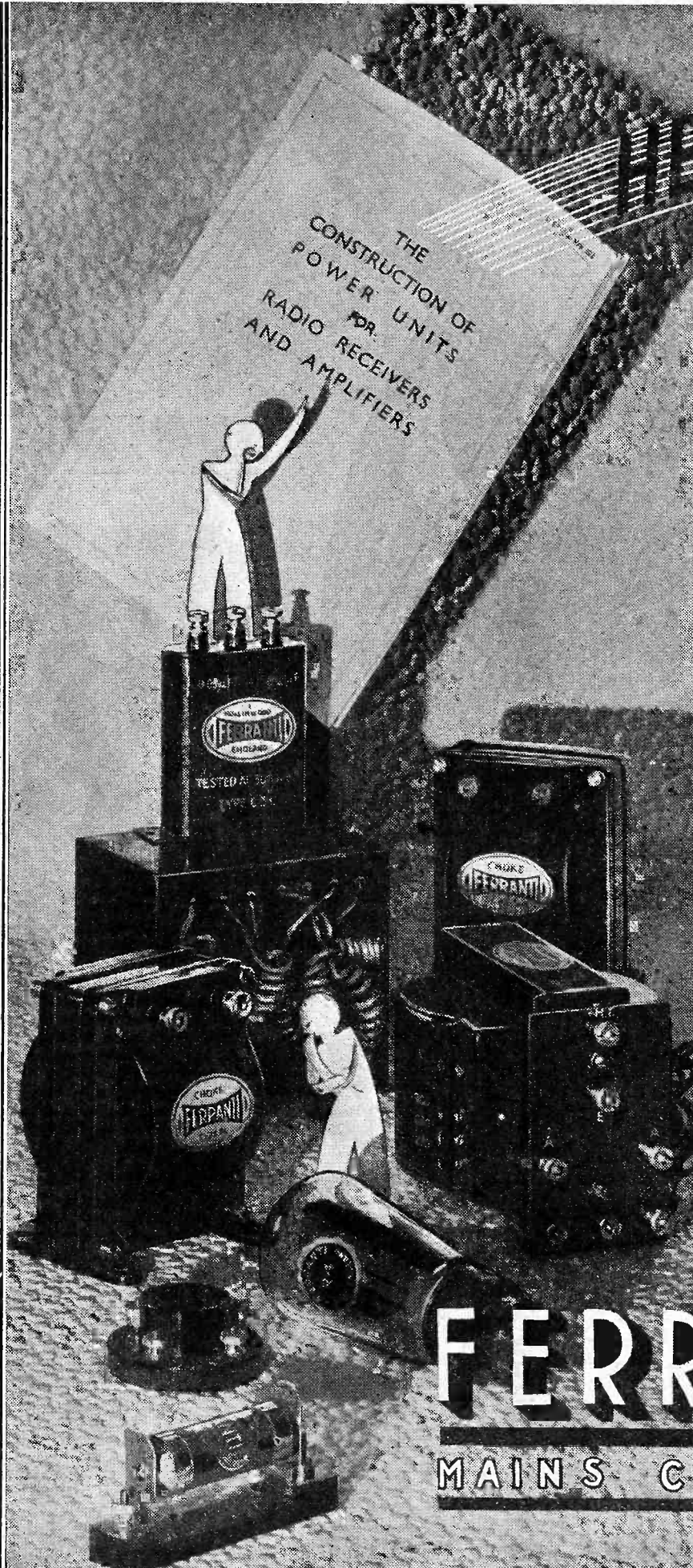

# HERE IT IS!

Your complete guide to the construction of Radio Power Units. A 32-page publication which deals fully and clearly with the theory and practice of the subject, giving full working instructions and diagrams for the building of eight different units—AC and DC—from modest to super-power output.

Published by Ferranti, it may be looked upon with confidence as a responsible and authoritative treatise. As such, it is only natural that the components recommended are of unsurpassed quality and unquestioned reliability. The fact that many of these components bear the Ferranti name will be taken as a guarantee that the completed Power Units are entirely safe and exceptionally efficient.

This Booklet W522 will be sent post free on receipt of 3d. in stamps.

List We522/1 (16 pages) gives details of all Ferranti Mains Components and will be sent on receipt of 1½d. stamp.

See the range at Stand No. 20, Main Hall, at the Northern National Radio Exhibition, City Hall, Manchester.

# FERRANTI

## MAINS COMPONENTS

FERRANTI Ltd., HOLLINWOOD, LANCASHIRE.  
London: Bush House, Aldwych, W.C.2.



Building the

A ★ SET AND THE BEST SUPER-  
HET EVER PLACED BEFORE  
HOME CONSTRUCTORS.

# PREMIER SUPER

## CONVERTING THE "PREMIER SUPER" TO A BATTERY RADIO-GRAM.

and Full Particulars Regarding the Adjustment and Operation of this Efficient Receiver. By The Technical Staff.

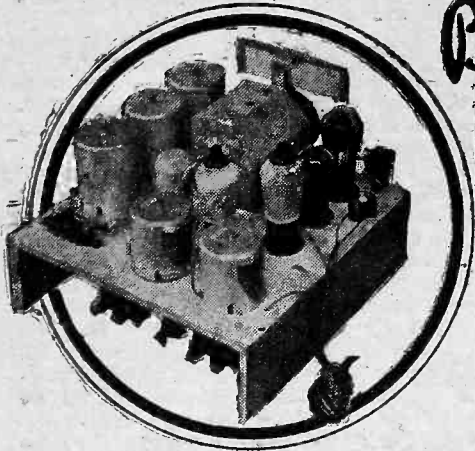

ASSUMING that you have connected up the batteries as explained last week, the next thing is to attach the loud-speaker. This is fitted with a multi-ratio output transformer with tappings brought out to a rotary switch, so that the correct ratio can be obtained immediately by rotating two switch contact arms. When the two outside (black) terminals are joined to the receiver the proper ratio will be secured by putting the two arms on contacts marked "B" and "F" respectively. Should you desire, however, it is not a bad plan to try various ratios by moving the two arms, finally using the one which produces what appear to be the best results.

The aerial and earth must, of course, be connected to their respective terminals, and it has been found in experimenting with this receiver that the earth connection is very important and has a great influence on the results to be obtained. The aerial is not so important, and may consist of any arrangement from a thirty-foot length of wire round the picture moulding of the room to an efficient outside aerial such as will be produced by using the "Aeroficient" kits specified.

### "Trimming" the Three-gang Condenser

When all the necessary connections have been made, set the wavechange switch (on right of set) to the long (anti-clockwise) or medium-wave (clockwise) position, turn the volume control knob to its maximum (clockwise) setting and slowly rotate the tuning knob. We would emphasize that word "slowly," since tuning is extremely sharp, and it is thus quite easy to miss even the local station completely if the knob is turned too quickly. It will probably be found that a number of different stations can be received without difficulty, although, on the other hand, it is not very unlikely that the first attempt at tuning will seem rather unsuccessful. It is all a matter of having

the three-gang condenser accurately "trimmed." In any case, a station on about 300 metres should be carefully tuned in and its volume reduced to bare audibility by means of the variable-mu potentiometer. Then, with a long screw-

driver, try adjusting the trimmer on that section of the condenser remote from the panel—this is the aerial tuning section—until signal strength attains a maximum. Slightly alter the main tuning control, if necessary, the trimmer dle condenser Lastly, do with the the oscillator

### Long-wave "Tracking"

After these adjustments have been made, the set will most likely operate perfectly well on the medium-wave band, but a further setting must be made before it can function at maximum efficiency on the long waves. We refer to the .002 mfd. pre-set "tracking" condenser, which must be set to its correct capacity after tuning in a long-wave station. Use a long screwdriver again to vary the capacity, and slowly screw down the adjusting screw. You will find that a very pronounced "peak" occurs at one particular setting; this is when the screw is turned almost to the end of its travel.

When this optimum position has been found the locking nut should be tightened so that the capacity will remain constant.

That completes all the preliminary adjustments and the set should now be ready to tune in almost any station required. All that the operator has to do is to turn the wave-change switch to the wave-band required, set the volume control to maximum and slowly rotate the tuning knob.

There are no "snags" or difficulties in either building or using the "Premier Super," but there is one little point which might have been mentioned last week. One reader found that the coils which he had bought were arranged in a different order to that indicated in the wiring plan, and thought that perhaps he had been given a wrong component. As a matter of fact, the coils, when obtained, are not in the correct positions for this set; it is, however, only necessary to reverse the positions of the two end ones (aerial and oscillator), and this can be done in a few seconds by removing the two screws which hold the coils to the aluminium baseplate. The method is also

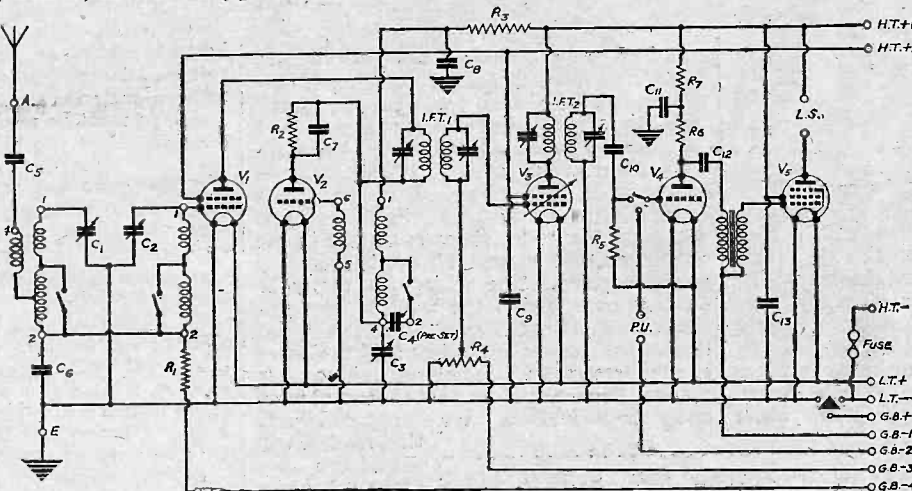

Theoretical circuit of the Premier Super.

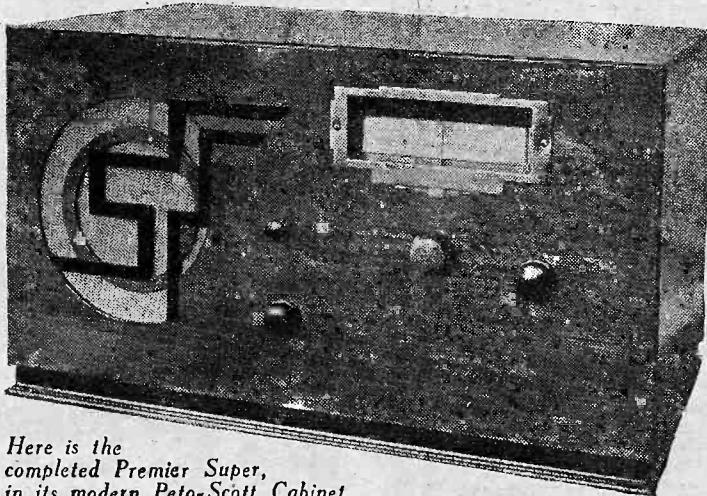

Here is the completed Premier Super, in its modern Peto-Scott Cabinet.

(Continued overleaf)

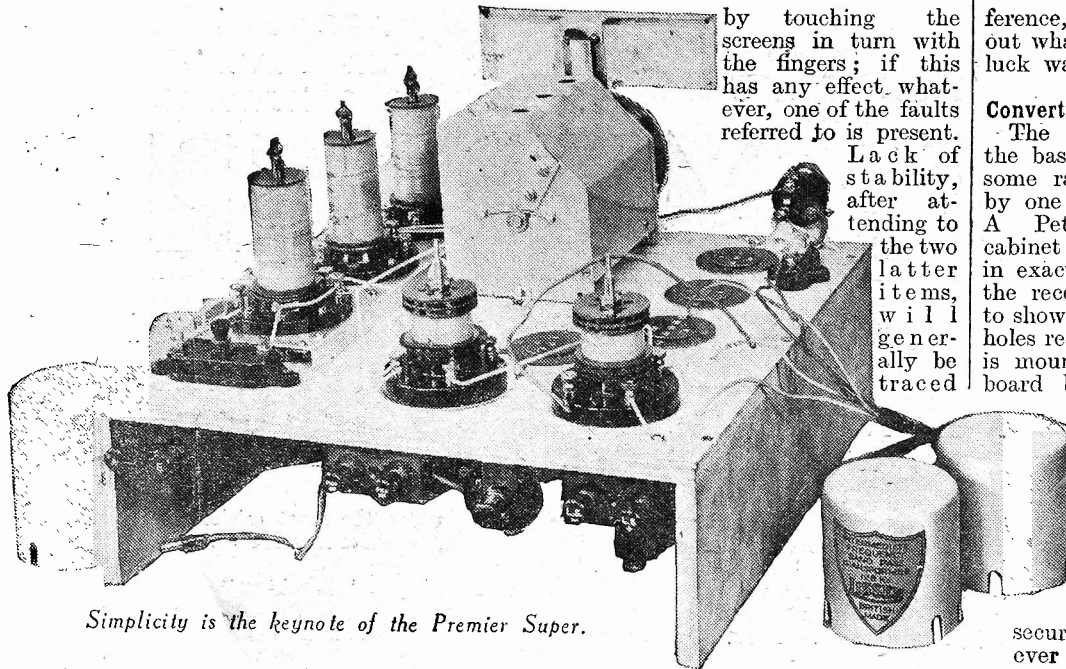

*Simplicity is the keynote of the Premier Super.*

*(Continued from previous page)*

explained on the instruction sheet supplied with the coils by Messrs. Lissen, so no difficulty can occur here.

#### In Case of Trouble—!

So that you may be "forewarned"—if that is necessary—we might just mention one or two minor troubles which may possibly be encountered. For instance, if it is found that the set seems to be prone to oscillation it is a sure sign that either one of the coil screens is not properly screwed down to make contact with the base, or that one of the connecting wires is short-circuiting to the screen cover. You can easily check both these points

by touching the screens in turn with the fingers; if this has any effect whatever, one of the faults referred to is present.

Lack of stability, after attending to the two latter items, will generally be traced

to a bad contact between some component and the metallized chassis. Remember that the chassis carries all the "earth return" leads and, therefore, connections to it must be sound. This also means that the components must be screwed down firmly to ensure that good electrical connection is secured. Should the fuse bulb "blow" you will know that either there is a make in the wiring, or that a short circuit is occurring at some point. The wiring can easily be checked over, whilst the most likely location of a short is between the coil cans and one of the connecting wires; if the wires are not arranged with some care it is possible for the screen to rub against them and wear away the insulation. We do not anticipate

that readers will experience any of the difficulties to which we have made re-

ference, but we thought it wise to point out what *might* happen, especially if one's luck was out.

#### Converting the Set to a Radio-Gram.

The "Premier Super" can be made the basis of a really excellent and handsome radio-gramophone, as you can see by one of the accompanying illustrations. A Peto-Scott "Premier-Adaptogram" cabinet is used and the front of this is drilled in exactly the same way as the front of the receiver cabinet—a drawing is given to show the exact location and sizes of the holes required. The Garrard spring motor is mounted in the centre of the motor-board by making use of the template supplied with it. The B.T.H. "Minor" pick-up, which is complete with track arm and volume control, is also attached to the motor-board by means of the three screws which are included. Its exact position is very important, since correct "tracking" is essential if good reproduction and minimum record wear are to be

secured. This offers no difficulty whatever because the thick cardboard base to which the pick-up is attached when

bought serves as an accurate template so that the exact position for the pick-up may be located in a few seconds.

A hole must be made in the motor-board directly below the pick-up flange, and the screened leads are passed through this. It will be found that there are three leads, although only two pick-up terminals are provided on the receiver; the third lead is merely connected to the screening braid and to the metal parts of the pick-up, and should be joined to the earth terminal. Take care that the leads are kept fairly clear of the receiver components and that the metal braiding cannot possibly make contact with the anode terminal on the screen grid or variable- $\mu$  valve, since if it were to touch either of these the H.T. battery would be short circuited.

Of the three terminals on the radio-gram switch mounted on the back of the chassis, that in contact with the longest

*(Continued on page 114)*

#### LIST OF PARTS FOR THE PREMIER SUPER.

Don't depart from these specially selected components.

- |  |   |
|--|---|
| One Superhet 3-gang Midget Variable Condenser, Type 693, with Straight Line Dial (British Radiophone).                   | One 5-pin Chassis Mounting Valve-holder (Clix).   |
| One Set Matched Superheterodyne Coils (2 Bandpass and Oscillator) (Lissen).  | Three Terminal Mounts (Belling-Lee).  |
| Two Intermediate Frequency Transformers (Lissen).  | Six Terminals, Type "R," marked "A," "E," "L.S.," "L.S.+" and two marked "Pick Up" (Belling-Lee).     |
| One 50,000 ohm Volume Control Potentiometer, Type V.C.36 (Bulgin).   | Six Wander Plugs (marked "G.B.+", "G.B.-1," "G.B.-2," "G.B.-3," "G.B.-4," and "G.B.-5" (Belling-Lee). |
| One 3-point Switch, Type 48 (British Radiogram).   | One "Metaplex" Chassis (Peto-Scott).  |
| One Push-Pull Radio-Gram. Switch, Type 50 (British Radiogram).   | One Premier Super Cabinet (Peto-Scott).   |
| Three Chassis Brackets, Type 21 (British Radiogram).   | One Fuse Holder and Fuse (Bulgin).  |
| One "Pip" 3/1 L.F. Transformer (Graham Farish).  | Two Coils Quickwire, length of Flex, Screws, etc. (Bulgin).   |
| Six "Ohmite" Resistances—2,000 ohms, 10,000 ohms, 20,000 ohms, 30,000 ohms, 100,000 ohms, and 2 megohms (Graham Farish). | One P.M.6 "Microloide" Moving Coil Speaker (W.B.).  |
| Two .1 mfd. Condensers, Type B.B. (Dubilier).  | Five Valves Types 215 S.G., 210 H.L., 220 V.S., 210 Det., and 220 H.P.T. (Cossor).                    |
| Two 2 mfd. Condensers, Type B.B. (Dubilier).   | One "Aeroficient" Aerial Earth Kit (Graham Farish).   |
| One .0001 mfd. Condenser, Type 670 (Dubilier).   | One Length Metal Screened Down Lead (Goltone).  |
| One .0002 mfd. Condenser, Type 670 (Dubilier).   | One 2-volt 40 amp. Accumulator (Smiths).  |
| Two .01 mfd. Condensers, Type 670 (Dubilier).  | One 9-volt G.B. "Anodex" Battery (Smiths).  |
| One .002 mfd. Pre-Set Condenser (Polar).   | One 120-volt Triple "Anodex" H.T. Battery (Smiths).   |
| Four 4-pin Chassis Mounting Valve-holders (Clix).  | One Baffle Baseboard Assembly (Peto-Scott).   |

#### LIST OF ADDITIONAL PARTS REQUIRED FOR THE RADIO-GRAM. CONVERSION.

- |   |   |
|---|---|
| One Peto-Scott "Premier-Adaptogram" Cabinet | One Garrard Spring Motor, Type 20.  |
| One B.T.H. "Minor" Pick-up with Track Arm.  | One length "Goltone" Screening Braid (if R.-G. switch is to be mounted on motor board). |

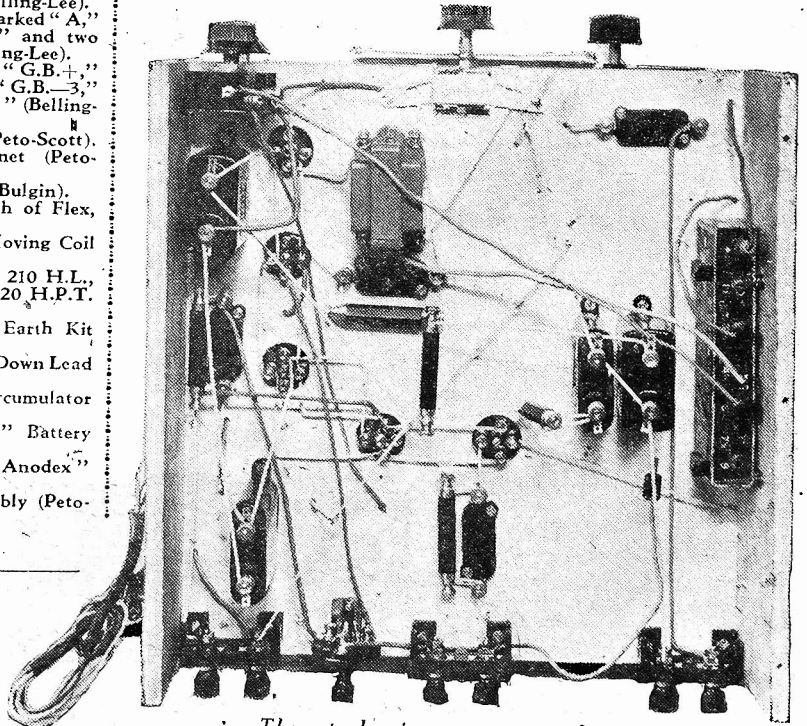

*The sub-chassis components and wiring.*



Wherever  
wireless  
terms are  
understood  
"Ohmite"  
means  
"The  
Best  
Resistance"



"Better than wire wound."

# OHMITE RESISTANCES

The most popular and efficient type of fixed resistance for all general purposes. "Better than wire wound." All values, 50 ohms to 5 megohms.

HEAVY DUTY TYPE 2/3

1/6

**GRAHAM FARISH PRODUCTS**



Safe maximum current carrying capacity of "Ohmites."

| 100° F Temperature Rise |            |         |            |
|-------------------------|------------|---------|------------|
| Ohms.                   | Milliamps. | Ohms.   | Milliamps. |
| 1,000                   | 40         | 20,000  | 8          |
| 2,000                   | 35         | 30,000  | 6.75       |
| 3,000                   | 29         | 40,000  | 6          |
| 4,000                   | 24         | 50,000  | 5.5        |
| 5,000                   | 20.25      | 60,000  | 5          |
| 10,000                  | 12         | 80,000  | 4.24       |
| Other values pro rata   |            | 100,000 | 3.5        |

Safe maximum current carrying capacity of "Ohmites" Heavy Duty Type.

| 100° F Temperature Rise |            |         |            |
|-------------------------|------------|---------|------------|
| Ohms.                   | Milliamps. | Ohms.   | Milliamps. |
| 1,000                   | 80         | 20,000  | 16         |
| 2,000                   | 70         | 30,000  | 13.5       |
| 3,000                   | 58         | 40,000  | 12         |
| 4,000                   | 48         | 50,000  | 11         |
| 5,000                   | 40.5       | 60,000  | 10         |
| 10,000                  | 24         | 80,000  | 8.48       |
| Other values pro rata.  |            | 100,000 | 7          |

Ensure a safe and efficient Aerial and Earth. The new AEROFICIENT KIT provides all you need. Complete 6/6  
Send a postcard for our new Catalogue, which describes all our products.



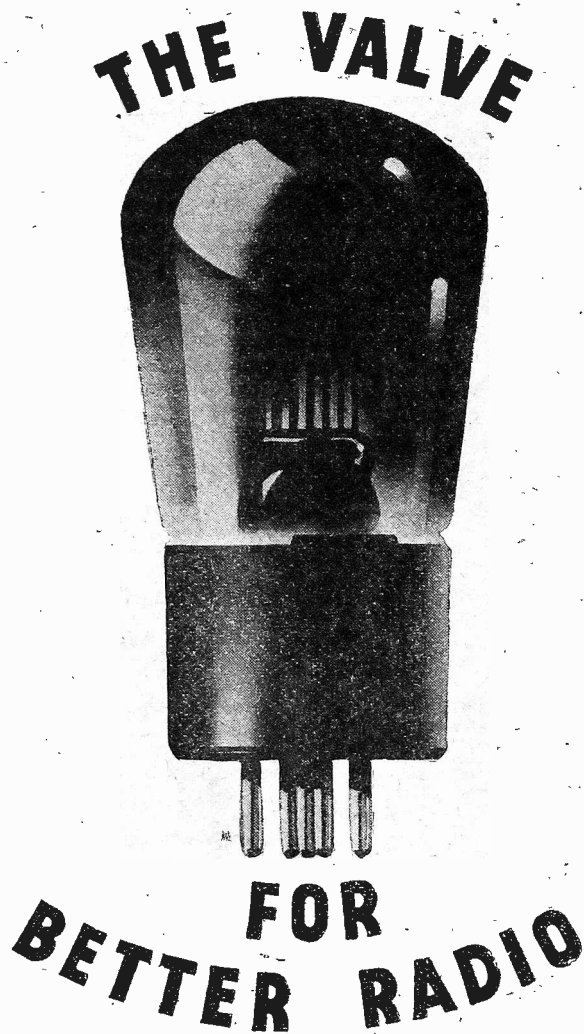

## *More than just making valves . .*

During the past ten years of radio, more Mullard Valves have been sold than any other make. This definitely proves two things: that Mullard Master Valves must be the finest radio valves obtainable, and that ten years' preference by the radio public has been maintained by continued research and experimenting.

Consequently, ever since Mullards first realised that public appreciation of their product had placed the responsibility of leadership on their shoulders, they have worked continuously in the interest of the public. Scientists are ceaselessly at work in the Mullard Research laboratories. Tests, vigorous and comprehensive, are carried out on every valve before it leaves the Mullard factory. There is a standard to be kept, a responsibility to be realised. And it is this realisation which results in three million aerials leading down to Mullard Master Valves, the finest radio valves in the world; the valves of the past, the present and the future.

*ASK T.S.D. Whenever you want advice about your set or about your valves—ask T.S.D.—Mullard Technical Service Department—always at your service. You're under no obligation whatsoever. We help ourselves by helping you. When writing, whether your problem is big or small, give every detail, and address your envelope to T.S.D., Ref. D.D.P.*

# **Mullard**

## **THE · MASTER · VALVE**

*The Mullard Wireless Service Co., Ltd., Mullard House, Charing Cross Road, London, W.C.2*



# The HALF-GUINEA Page

## READERS' WRINKLES

### Making Transformer Bobbins

A DIFFICULTY often experienced when wishing to wind a transformer or choke is that of obtaining a suitable bobbin. I have on several occasions used a bobbin made up in the following manner. A wooden former is planed up, about double the length and the same

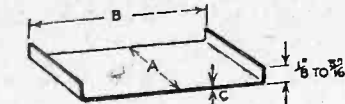
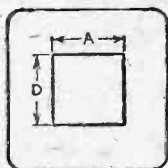

Fig. 1.



- A - SLIGHTLY WIDER THAN STAMPING.
- B - LENGTH OF LEG OF STAMPING.
- C - 18 TO 20 S.W.G.
- D - THICKNESS OF CORE + 2C.

Fig. 2.

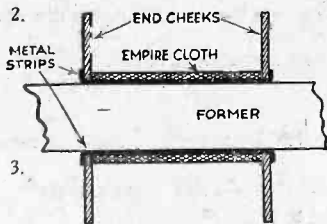

Fig. 3.

Details of cheeks for making transformer bobbins.

size as the core. Two pieces of brass or soft iron are made as in Fig. 1, and two cheeks are cut from stiff card, or bakelite sheet, and core holes fretted as in Fig. 2. The two metal strips (Fig. 1) are warmed and a little Chatterton's compound rubbed on the flanges. They are then inserted in the cheeks, drawn apart, and slid on to the former. The cheeks are then drawn well apart, metal strips dabbed with Chatterton's compound, and space wound with empire cloth or insulating tape to a thickness of about 3/32in. as in Fig. 3. Winding then proceeds, and on completion the bobbin is gently withdrawn and the core built in. —L. W. BOXES (Crayford).

### A Multiple Switch

THE switch illustrated was designed for a family set to save time and patience when returning to the local stations. With the only addition of two pre-set condensers a turn of the switch brings in either of the two locals, and also acts as wave-change and on-off switch. The bed of the switch is a piece of 2in. by 1 1/2in. ebonite or fibre, and to this the U-shaped frame of 4 1/2in. by 1/2in. brass is bolted. The contacts are of springy brass, 3/16in. wide, fixed to the ebonite at 5/16in. centres by means of bolts and nuts which serve as terminals. These contacts are closed by cam-shaped pieces of ebonite or wood 3/16in. thick, spaced 1/4in. apart by washers, glued, and tightly clamped with nuts and washers on a 3/16in. screwed rod. Care should be taken that these are shaped and placed as in drawing. After these have been mounted on the frame, as shown,

### THAT DODGE OF YOURS!

Every reader of "PRACTICAL WIRELESS" must have originated some little dodge which would interest other readers. Why not pass it on to us? We pay £1-10-0 for the best wrinkle submitted, and for every other item published on this page we will pay half-a-guinea. Turn that idea of yours to account by sending it in to us addressed to the Editor, "PRACTICAL WIRELESS," George Newnes, Ltd., 8-11, Southampton Street, Strand, W.C.2. Put your name and address on every item. Please note that every notion sent in must be original. Mark envelopes "Radio Wrinkles." Do NOT enclose queries with your wrinkle.

the switch is fixed to the panel and a lettered plate and knob fitted.

The only other components required are two .0003 pre-set condensers of reputable make, and wiring to these and the switch will be easily followed from the circuit diagram. An extension rod might, in many cases, shorten the wiring, and if so, this could easily be arranged. Checking up of the positions of the cams and adjusting should be carried out as follows. With switch knob in position 1 (off) all contacts should be open. In position 2 (Nat.) contacts 1 and 2, 3 and 4, and 5 and 7 should be closed and pre-set condenser C screwed up until the shorter wave local is tuned. In position 3 (Reg.) contacts 1 and 2, 3 and 4, 5 and 7, and 8 and 9 should be closed and condenser C<sub>1</sub> screwed up until the longer wave local is tuned in. Medium-wave stations can be tuned in on the dial in the normal manner with switch in position 4 (Short), when contacts 1 and 2, 3 and 4, and 5 and 6 should be closed, and in the same manner long-wave stations can be tuned with the switch in position 5 when contacts 1 and 2, and 5 and 6 are closed. If the set employs two tuned circuits a larger switch, with all contacts except 1 and 2 doubled or two switches as described ganged together, should be used. —WILLIAM MUIRHEAD (Falkirk).

### Concealing a Speaker

POSSESSING a speaker unit on a baffle board 2ft. square, and being desirous of keeping it out of sight, I housed it as

shown in the accompanying sketch: most kitchen tables have an underneath depth of 4 to 6ins., which is sufficient space for a speaker cone and unit. The baffle board faces the floor, and is fixed to the side framework of the table.

This arrangement gives excellent results, especially when the table is against the wall so that the table acts as a kind of sound box. This method is definitely superior to using the table-top as a baffle board with the cone facing upwards. No trouble was experienced with the drawer, which clears the unit. —ARTHUR GRIFFITHS (Blackwood, Mon.).

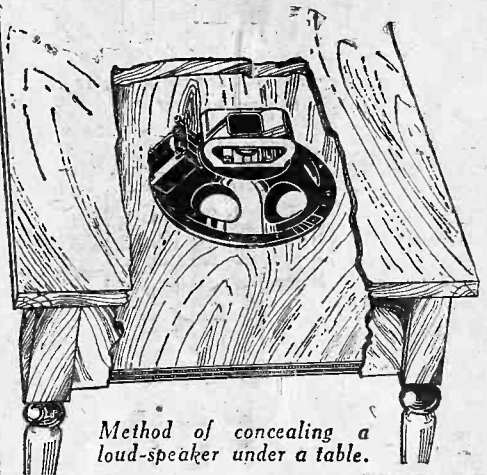

Method of concealing a loud-speaker under a table.

### A Combined L.T. and H.T. Trickle Charger for Use on D.C. Mains

THE following details apply to a charger that was operated on supply mains of 220 volts D.C.

The components required are two double-pole change-over switches (suitable for high voltage), two lampholders (batten type), eight insulated terminals, and a wood block, approx. 12in. by 9in. The parts are placed on the wood block and the holes marked and drilled for receiving the insulated wire. In my case I used two D.P.C.O. switches mounted on porcelain and coupled them together by means of a strip of ebonite, one knob being fixed midway between the two switches as

(Continued overleaf)

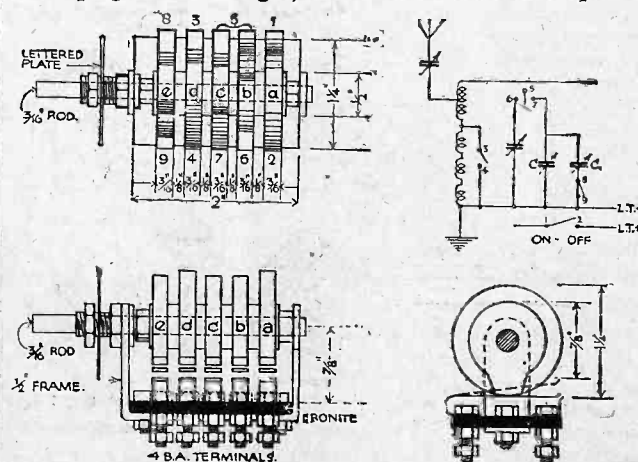

Two views of a multiple switch and details of operating cams.

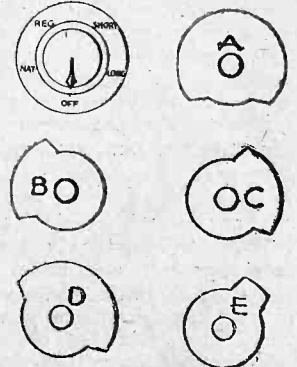

RADIO WRINKLES

(Continued from previous page)

in Fig. 2, and the other discarded. If this type of switch is used a cover should be made for each one, as shown in Fig. 1. The switches and lampholders are fixed to the block and wired as in Fig. 4. The lamp used for the resistance for the H.T. side is an ordinary 220 volt, 15 watt lamp, and for the L.T. a 60 watt, 220 volt. These give charging rates of approx. 60 milliamps for H.T., and .27 amps. for L.T. These rates

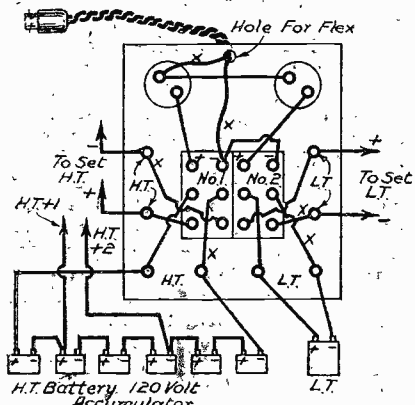

Fig. 4.—Diagram of connections for a D.C. trickle charger.

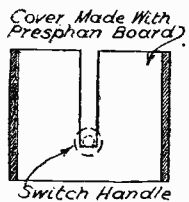

Fig. 1.

Details of switch and cover for a D.C. trickle charger.

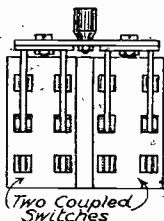

Fig. 2.

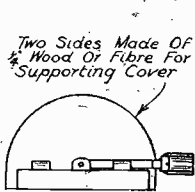

Fig. 3.

can be increased by putting in larger lamps or, of course, reduced by fitting smaller ones.

It would be best if the finding of the polarity of the main fuses is left until the board is fixed in position, and the adaptor or plug put in the socket and the supply switched on. Now, with the lamps in place, first dip into a jar of diluted acid the two wires connected to the left-hand terminals, or H.T. charging terminals, and mark the terminals with the plus and minus signs as they are ascertained. Next do the same with the low-tension leads and mark the terminals. The accumulators are then connected to their respective terminals and wires are run to the set from the terminals on the charging board. The charger is now ready for use. When the switch is down the batteries are connected to the set, and when in the uppermost position they are given a small trickle charge. Of course, if the switch knob is left in midway position the batteries are disconnected both from the set and also the charger. Both the H.T. and L.T. accumulators should be properly charged up before they are connected to this trickle charging system. It is only necessary to top up the batteries with distilled water at very long intervals, and it is best to keep the charging rate very low and make a practice of always changing over to charge position after set is finished with. I might add that if the charging board is fitted near the set the change-over switch can be used to switch the set on and off. It

should be noted that if you are connected on the positive live side of the main, this arrangement can be carried out with only one D.P.C.O. switch, provided that H.T.— is connected to L.T.— on the set in use. In this case all wires marked x would be joined together and the three wires on the positive side of Switch No. 2 are transferred to the right-hand contacts of switch No. 1. It is important also to note that when lampholder adaptor or two-pin plugs are used to obtain the supply, they must be left in position, or care taken to see that they are not put in the reverse way round after tests for polarity have been carried out.—C. T. COOPER (Barwell).

A Range-increasing Device

ON installing my set (a commercial one) I found I was unable to tune as low as Fecamp or as high as Radio-Paris, and evolved the attached gadget which might be of use to other readers. The box, which stands on the window ledge inside the room, is made of ordinary thin wood, the top being a piece of ebonite strip in which are fixed four sockets. A banana plug is attached to the aerial lead-in, and when plugged into socket A1, the preset is brought into use enabling me to tune lower. A2 gives the usual tuning, and A3; with the two-point switch closed, enables me to reach above Radio-Paris. When plugged into E the aerial is earthed. The gadget has been in use for some time now and answers the purpose very satisfactorily.—EDWARD JEFFERSON (St. Boswells).

A Simple Tester

ALTHOUGH this neat little device will prove invaluable to the service engineer, the amateur constructor will also find it extremely useful when carrying out various circuit tests. As may be seen from the illustration, an ordinary telephone headpiece is adapted to accommodate a small 1.5 volt cell. An extra hole is drilled in the metal 'phone case, and a small terminal or nut and bolt fitted into this hole. One lead from the 'phone bobbins is left in position, but the other is removed and wired to one of the battery terminals; the return being made by means of the zinc container of the battery and its contact with the metal frame of the 'phones. The battery is thus in series for continuity

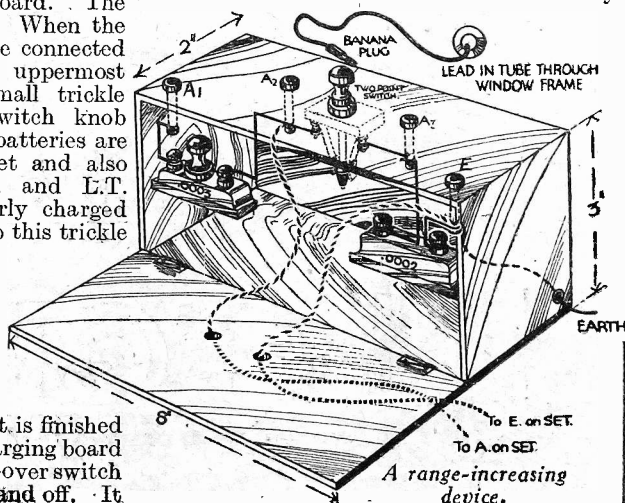

A range-increasing device.

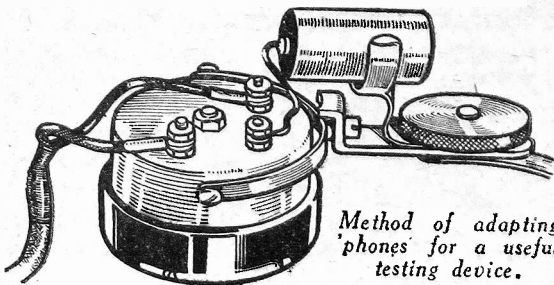

Method of adapting 'phones for a useful testing device.

tests, and the lead may be removed and replaced in its original position to enable the 'phones to be used in the ordinary way. The illustration should make the arrangement quite clear.—R. CRICHTON (Glasgow).

Earthing a Short-wave Set

ADVANCED short-wave practice condemns the use of long, straggling earth leads. Annoying hand-capacity and general instability, even in elaborate and well-designed receivers, may be directly traced to this source. Removing the earth lead entirely may sometimes render the exasperating "signal-shifting" a little less acute, but a short, direct earth connection is usually a complete cure. In instances where it is impossible to provide an ideal earth, an ordinary household bucket, partially filled with water and placed directly under the receiver, will answer the purpose admirably. When used on the ground floor, results are equal, if not superior, to those obtained with short-connection earths employing buried

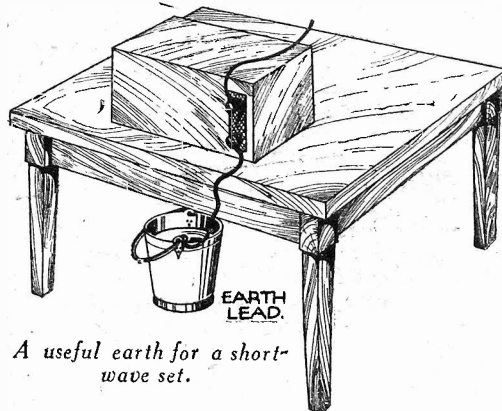

A useful earth for a short-wave set.

tubes; this applies to short-wave reception only. Connecting lead is taken to the bucket handle-hole, previously scraped bright.—F. J. GOUGH (Ellesmere).

A Pick-up Hint

WHEN connecting a pick-up to a set having two L.F. stages, many amateurs simply mount two extra terminals on the terminal strip, connecting one to the grid of the first L.F. valve and the second to the 1 1/2 volt tapping on the G.B. battery. In most cases it will be found that about 4 1/2 volts G.B. are already applied to this valve through the transformer secondary. In this way, when the pick-up is connected, the 1 1/2 volt tapping is connected to the 4 1/2 volt tapping through the pick-up and transformer secondary, even although the set is switched off. The two cells thus shorted become exhausted, the total voltage of the G.B. battery falls and distortion is caused through the valves being insufficiently biased. As long as the pick-up is, connected, therefore, the G.B. plug connected to the transformer secondary should be pulled out from the battery. Of course, if a proper radio-gram. switch is used this point does not arise.—J. J. SCULLION (Glasgow).



The  
 'Rolls Royce'  
 of  
 Condensers

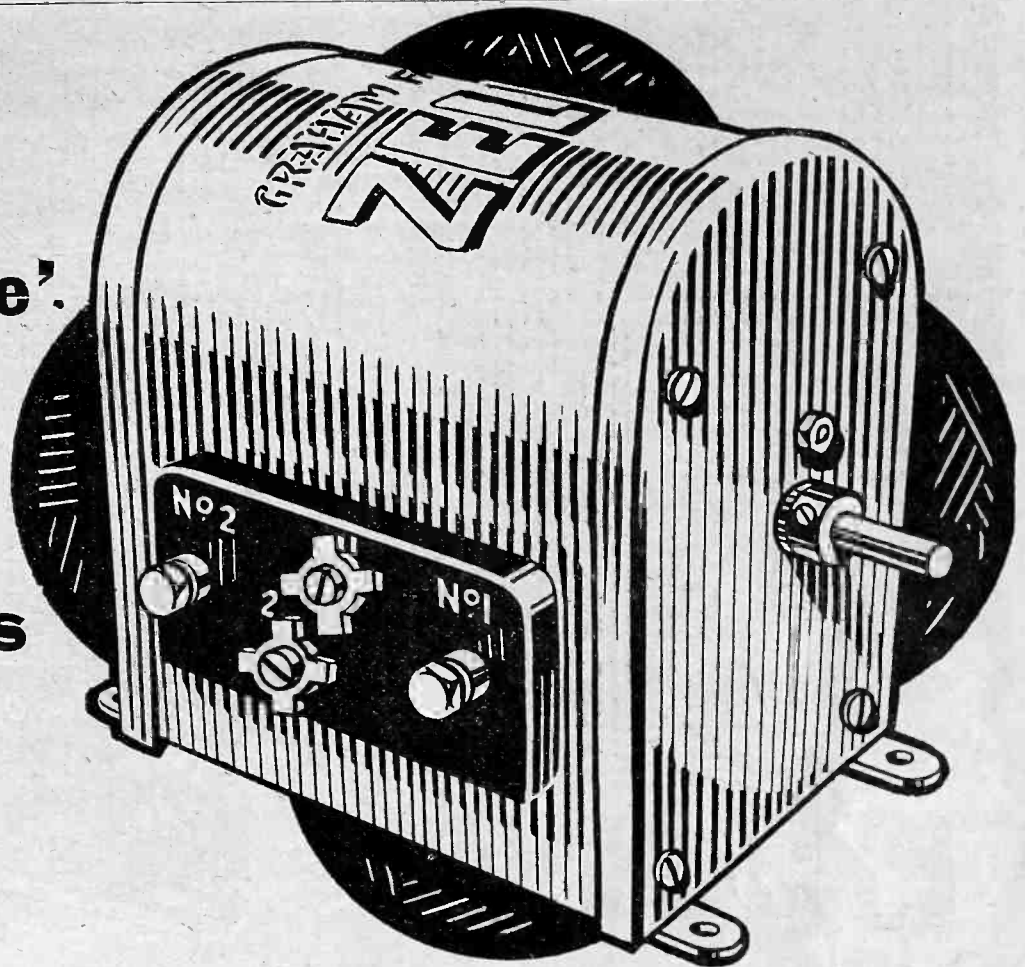

**ZELOS TWO-GANGED CONDENSERS**

The Condenser supreme for the modern Receiver, giving precise and simultaneous tuning for two circuits. Accurately spaced, carefully matched and efficiently screened. Fitted with low-loss trimming Condenser and star-wheel adjustment. Each set of fixed vanes attached to its own terminal, moving vanes connected to terminal on case. Rigid frame. Beautifully finished in frosted aluminium.

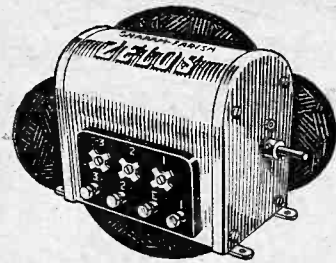

**ZELOS THREE-GANGED CONDENSER - - 19/6**

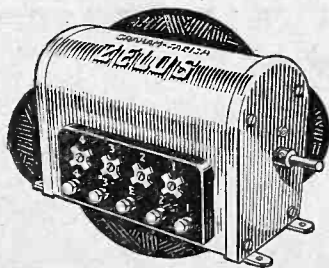

**ZELOS FOUR-GANGED CONDENSER - - 27/6**

Ensure a safe and efficient Aerial and Earth. The new **AEROFICIENT KIT** provides all you need.

**6/6** Complete.

Send a postcard for our new Catalogue which describes all our products.

**14/6**  
 2-GANGED

**GRAHAM FARISH PRODUCTS**



Advertisement of **GRAHAM FARISH LTD.**, Masons Hill, BROMLEY, Kent.

Export Office: 11/12 Fenchurch St., E.C.3.



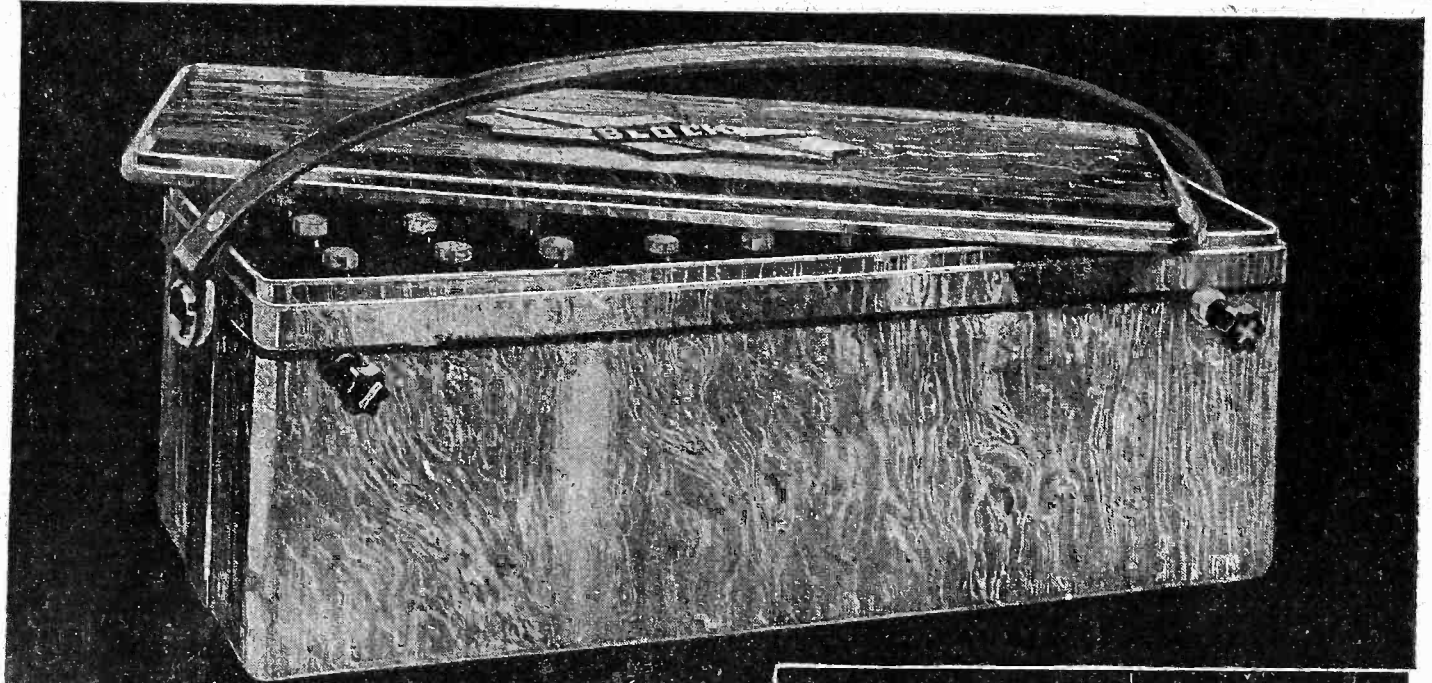

**Now H.T.**

*Imagine it!*

|           |   |         |             |
|-----------|---|---------|-------------|
| <b>60</b> | v. 5000 m.a.h. $14\frac{3}{4} \times 4\frac{5}{8} \times 5\frac{1}{2}$ high | 16 lbs. | <b>37/6</b> |
| <b>30</b> | v. 5000 m.a.h. $8\frac{3}{8} \times 4\frac{5}{8} \times 5\frac{1}{2}$ high  | 8 lbs.  | <b>21/-</b> |

*accumulators*

*half the size!*

**NO NEED NOW FOR DRY BATTERY EXPENSE**

● A new era opens. Gone are the costly dry batteries. Gone are the bulky H.T. accumulators. To-day comes a new kind of H.T. source—a plate-less accumulator hardly bigger than the old dry battery itself. ● Startlingly low in first cost, it costs you nothing after except for occasional re-charging. The secret is the Block plate-less cell, that does away with the old weight, space and weakness of accumulator plates. ● Non-fragile. Elegant (the case is coloured bakelite). More durable than the plate type; inexpensive. Demand is overwhelming—order at once for early delivery.

**DOUBLE CAPACITY L.T.**

**MANCHESTER STAND 54**

**BLOCK**

**PLATE-LESS ACCUMULATORS**

*What a boon!*

Cut away view of Block cell. — First the coloured bakelite that covers the L.T. type; next a lead cylinder (both the 'negative' and the cell's container.) Inside it, active paste. Last is the central 'positive' column and separator.

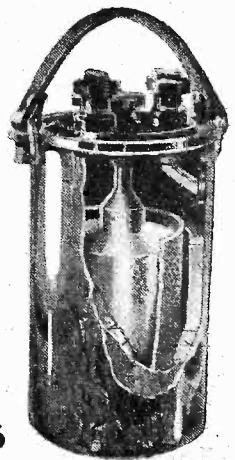

Price of L.T. **80<sup>a.h.</sup> 11/6<sub>2.v.</sub>**

**Block Batteries Ltd, Abbey Road, Barking, Essex.**

**Tel: Grangewood 3346/7**

Pa.S./BB. 43a



# TELE-TALKIE TOPICS

By H. J. BARTON CHAPPLE, Wh. Sch., B.Sc. (Hons.), A.C.G.I., D.I.C., A.M.I.E.E.

WHILE I appreciate that the prime interest of PRACTICAL WIRELESS readers is in the constructional or practical side of television, from time to time it will be necessary to place on record certain developments which may have a far reaching effect on the science itself. An occasion of that character has just transpired at the British Association Meeting, held at Leicester, where demonstrations were given daily of 120-line cathode ray tube television. In PRACTICAL WIRELESS dated 19th August, I dealt at length with the problems associated with cathode ray television, and interested

this is shown in simple schematic form in Fig. 1, and it may be stated briefly that a standard film projector was employed with the Maltese Cross removed. An image of the pictures on the film was thrown on to a disc revolving at the high speed of 3,000 revolutions per minute, and as one picture on the film is scanned by two revolutions of the disc, it will be seen that the combination gives twenty-five pictures per second. Instead of the disc having the more usual spiral of holes, the scanning apertures, which total sixty in number, are set round the periphery of a circle, and in this way it was possible to obtain a 120-line picture with horizontal scanning.

Located behind the disc was a single photo electric cell, the light variations passing through the disc holes being changed to equivalent voltage variations according to the normal functioning of this device. After amplification through the "A" and "B" amplifiers, the signal was fed to the cathode ray tube.

These demonstrations created an enormous amount of interest at the British Association meeting, a variety of well-known cinema films forming the subjects for transmission purposes. Referring to Fig. 2, we see the special large-ended cathode ray tube which has been developed, having a fluorescent screen size of one foot diameter and giving a nine inch image without lens magnification, and having an image area ratio of approximately six horizontal to five vertical. One important feature of this tube is the pleasing sepia colour of the image. Hitherto, cathode ray television images have been blue or green in colour, and somewhat unpleasant to the eyes, but with this new tube the cream high lights and the soft sepia half-tones are a delight to watch.

### The Ultra-Short Waves

It is very important to note that the television images demonstrated revealed a whole wealth of detail and were almost flickerless. To the uninitiated it may seem strange, therefore, that a television service embodying all these improvements is not yet available to the public. The problem is

to find a medium whereby the signals can be transmitted. The employment of ultra-short waves appears to be the most natural solution, but at the moment the difficulties associated with any form of service through this radio channel are considerable. First of all, we have the restrictions connected with the area of reception due to the fact that these waves, at least as far as can be ascertained with present knowledge, travel in straight lines, and are somewhat like a searchlight beam, inasmuch that obstacles in the wave path screen the radio receiver.

On top of this we have the deleterious effects of outside interference, which badly impair the received image. Then again, the amplifiers have to be designed to cover a frequency range of at least a hundred kilocycles, while phase changes are another item which has to be guarded against.

Naturally, intensive research technique is being applied towards a solution of these problems, which it should be noted are radio and not television difficulties, but it is likely to be some time before the full fruits of this work are made known. The Baird Company, fully cognisant of this, are pursuing a bold policy, and have rented one of the high towers at the Crystal Palace for a period of four years, so that they can conduct independent ultra-short-wave experiments. A special experimental licence has been granted by the Postmaster-General for this purpose, and every advantage will be taken of the valuable height given by this unique situation for an experimental transmitting station, and in due course it is hoped to supply readers with fuller details. In the meantime, there is the established thirty-line B.B.C. television service, and the fullest advantage should be taken by readers of these transmissions to gain an insight into television reception, as it is unlikely to be superseded by ultra-short waves for an indefinite time. It is more than probable that eventually the two services will be supplementary to one another, owing primarily to the limited range of the transmissions in the case of the ultra-short waves.



Fig. 2.

A special large ended cathode ray tube, developed in the Baird laboratories and giving a 9-inch image without lens magnification.

readers should refer to that article for further details.

### Previous Demonstrations

Television demonstrations have been staged at four previous British Association meetings, namely, Leeds—1927, Glasgow—1928, South Africa—1929, London—1931. At each of these a very definite stage in the progress of Mr. J. L. Baird's work was seen. Simple disc equipment formed the basis in 1927, while in 1928 both colour and stereoscopic images were shown. Images on a large screen, showing for the first time a modulated arc, were featured in 1931, and now, in 1933, a big step forward is portrayed, namely, a 120-line image scanned mechanically at the transmitting end by means of a rapidly rotating disc, but shown at the receiving end on a cathode ray tube.

It may not be known generally, but on April 6th, 1933, the first demonstration of true television on the cathode ray tube was given to the Press in the Baird laboratories. Hitherto, the demonstrations of cathode ray television had been confined to the transmission and reception of cinema films, but on the day referred to, not only were cinema films shown on the cathode ray tube's fluorescent screen, but also actual living persons.

### Apparatus Details

Regarding the actual apparatus used for the Leicester television demonstration,

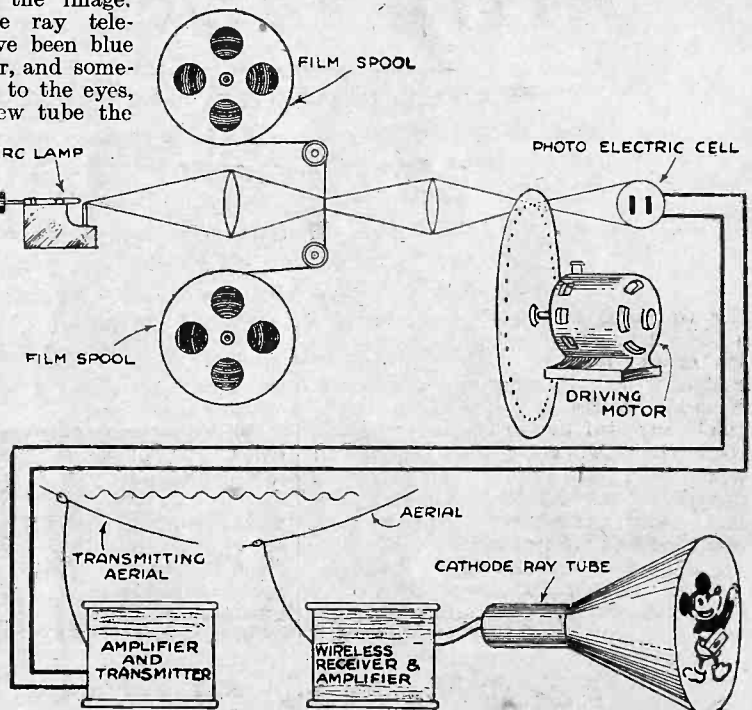

Fig. 1.—A simple schematic diagram showing how a 120-line mechanical tele-cine transmitter works, and employing cathode ray tube reception.

# THE FILAMENT CIRCUIT IN D.C. MAINS SETS

By H. T. GODLEY, A.Rad.A.

It may be thought that the much-spoken-of "grid-system" of A.C. distribution, which was to supply alternating current to everyone all over the country within a few months, has rendered the design of D.C. receivers of little importance, and, in fact, I think it may be said that the design of this type of set has, in consequence, been allowed to stagnate to some extent. Unfortunately, perhaps, the "grid-system" has not proceeded quite so rapidly as was

reduced owing to the fact that the choke is being partially short-circuited by the smoothing-condenser and the earth condenser, which are in series! Therefore, when designing a set or mains-unit for use on D.C. mains it is essential first to ascertain which side of the main is earthed, and then take care to see that the smoothing choke is in the other lead. If you omit to take this precaution, the chances are that you will hear practically nothing but hum!

In commercially-designed D.C. receivers, it is, of course, necessary to provide for adequate smoothing regardless of which side of the main is earthed, and consequently, it is the usual practice to insert a choke in each side, with a 4 mfd. condenser shunted across before the chokes. In this way, smoothing efficiency is assured, as, of course, one of the chokes must be doing its job properly even if the other is partially short-circuited.

### Types of D.C. Valves.

Now there are three

types of valves which can be used in an "all-mains D.C. set," as the manufacturers put it! Firstly, the ordinary battery valves, secondly, the indirectly-heated D.C. valve, and thirdly, the recently-introduced Ostar-Ganz universal valve, which can be used on either D.C. or A.C.

I will deal firstly with a three-valve set designed for D.C. mains using ordinary battery valves, S.G. Det. and Power. Assuming that the first two valves are two-volters, and the last one a six-volter, we must first decide by what means we can obtain filament current at the correct voltages.

As we cannot step-down the voltage by means of a mains-transformer, as we would in an A.C. set, all we can do is to dissipate the unwanted two hundred volts or so in the form of heat through a suitable resistance. Reference to Fig. 3 will show that the

filaments are wired in series and not in parallel as in a battery-driven set. The valve-filaments possess, of course, ohmic resistance, and being in series with the smoothing chokes and the mains-resistance, form part of what is virtually a "potential-divider" across the mains. This is clearly shown in Fig. 4, this circuit merely being that in Fig. 3 drawn in another way.

### Mains Resistance

The mains-resistance must, of course, be of such a value that it will allow only the required filament current to pass, no more and no less. (Incidentally, as the filaments are wired in series, the voltage ratings are of no importance except for calculating resistance values, but in order to avoid excessive use of shunt resistances, they should all require the same filament current.) Assuming, for our set, the valves are rated at .1 amp, then in order to pass this current from 250-volt mains, we should have to use a resistance having a value of 2,500 ohms ( $R = \frac{\text{Voltage}}{\text{Amps}}$ ), but as the filaments and chokes have ohmic resistance, we must decide what actual total resistance they

have and deduct it from our required total resistance of 2,500. The manufacturers of the choke will, of course, advise you of the choke resistance, or it can be determined by a suitable measuring instrument, such as the "Avometer"—they may very probably have a resistance of 200 ohms each, which we will assume is the case. Now for the resistance of the filaments. We use for this purpose the Ohms Law formula already given, i.e.,

$\text{Res.} = \frac{\text{Voltage}}{\text{Current}}$  which, in the case of a 2 volts .1 amp valve, becomes  $\text{Res} = \frac{2}{.1} = 20$  ohms. Equally, the six-volt filament resistance will be 60 ohms. Therefore, the total filament resistance is 100 ohms, plus the total choke resistance of 400 ohms, being 500 ohms, which we must deduct from the total resistance of 2,500 ohms.

(To be continued)

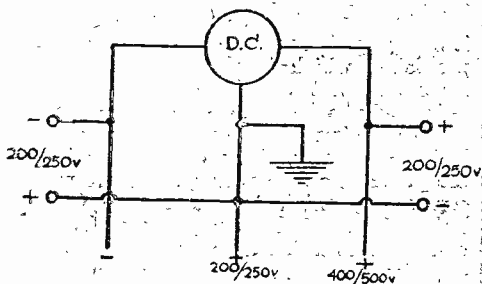

Fig. 1.—Showing the arrangement of the three-wire supply system.

at first anticipated, with the result that a very considerable number of amateur constructors now on D.C. mains are likely to remain restricted to a couple of hundred volts or so for some time yet. Actually, this restriction in available voltage is the only real grouse of the D.C. user, as generally speaking the construction of a D.C. set is less expensive and, to some extent, less complicated than its A.C. counterpart, as, in any event, a simple mains resistance takes the place of the expensive mains transformer and rectifiers essential in an A.C. set. Furthermore, if a large, undistorted output is required, the lack of available high-plate voltages can be overcome by using two pentodes in parallel, by which means an output of some two watts can be obtained with high-tension voltages of only 180 volts or so.

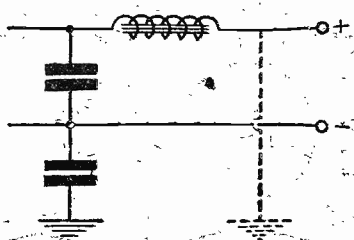

Fig. 2.—If the smoothing choke is in the earthed mains lead its efficiency is reduced.

### D.C. Distribution

The title of this article should restrict me entirely to filament and heater circuits, but in order to make the later text clear, I am obliged to enter into a short explanation of the method in general use of distributing D.C. Current is generated by the power station at twice the potential actually supplied to the consumer (i.e., if your input is 230 volts, then the current is generated at 460 volts). This generated output is separated into two branches by what is known as the "three-wire" system, the method being shown clearly in Fig. 1.

It will be seen that one side of the mains is always earthed, but not necessarily the negative side. Usually, on one side of the street, the negative leg is earthed, and on the other side, the positive. It will be clear from Fig. 2, that if the smoothing choke happens to be in the earthed mains lead, (whichever side it may be), then the smoothing efficiency is being seriously

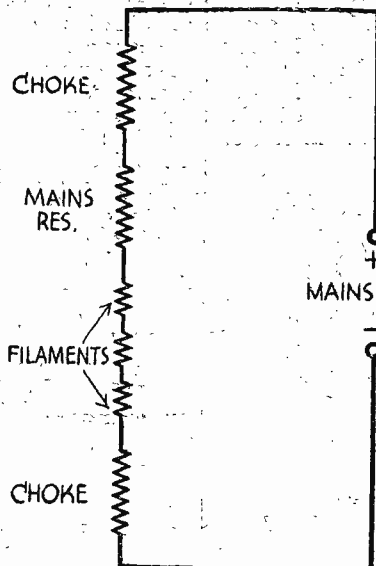

Fig. 4.—The circuit given in Fig. 3 is here shown in simplified form.

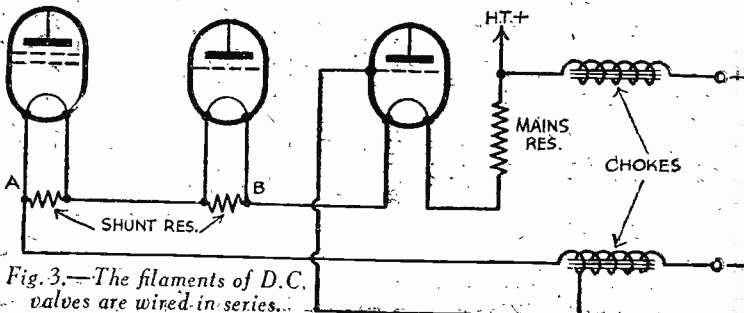
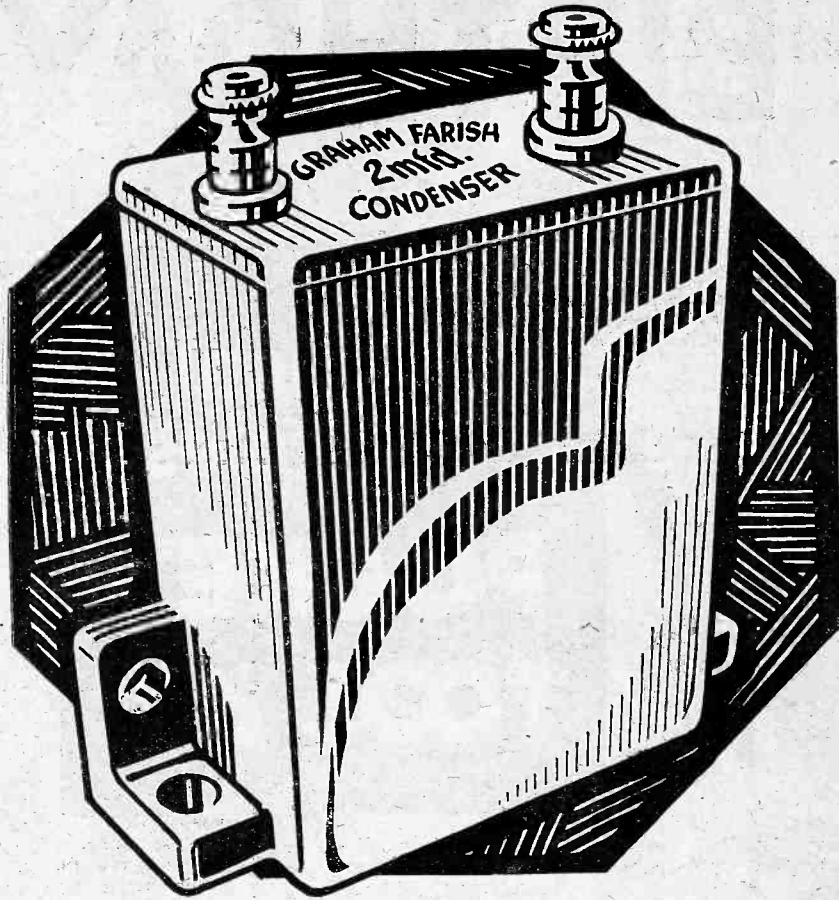

Fig. 3.—The filaments of D.C. valves are wired in series.





**The  
Condensers  
with an  
inner  
difference**

**NON-INDUCTIVE CONDENSERS**

Designed for years of good service. 500-volt test, 250-volt D.C. working. Insulation resistance, 5,000 megohms per mfd. Handsome Bakelite moulded case, providing both upright or flat mounting (Reg. design 723271), with large terminals. A handsome and extremely efficient component at a modest price.

**1/6**

·25 mfd.

·5 mfd. 1/9    1 mfd. 2/-    2 mfd. 3/-

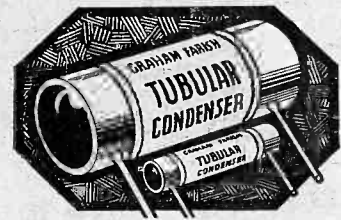

**TUBULAR CONDENSERS**

Wire ends anchored by means of eyelets in tube, avoiding any strain on the insert. 250-volts working, 500-volts D.C. test. Very high insulation resistance, hermetically sealed, high quality bakelite tubes made in various sizes.

·0001 mfd. to ·006 **1/-**  
·01 mfd. **1/3** ·02 to ·25 mfd. **1/6**

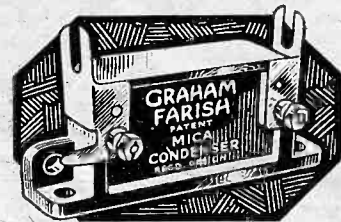

**FIXED CONDENSER**

In a complete range of capacities, upright or flat mounting. Every condenser is tested on 750 volts D.C. Capacities accurate within fine limits.

·00005 mfd. to ·004 mfd. **1/-**  
·005 mfd. to ·01 mfd. **1/6**

Ensure a safe and efficient Aerial and Earth. The new **AEROFICIENT KIT** provides all you need,

**6/6** Complete.

**GRAHAM FARISH PRODUCTS**



Send a postcard for our new Catalogue which describes all our products.

Advertisement of GRAHAM FARISH LTD., Masons Hill, BROMLEY, Kent.

Export Office: 11/12 Fenchurch St., E.C.3.



# GREAT BIRTHDAY OFFER



*The*  
**Practical  
 Wireless**  
**POCKET  
 TOOL KIT**

*For  
 Every  
 Reader*

● This amazing offer is made for a limited time only and owing to the care and expense necessary in the manufacture of the Kit it will not be possible to repeat it. Delay, therefore, is dangerous  
 ....

**DON'T MISS IT!**



# HAVE YOU RESERVED YOUR KIT?

**IF NOT, TIME IS FLYING—ACT NOW!**

**I**F you have not yet reserved your PRACTICAL WIRELESS Pocket Tool Kit to which, as a reader (new or old) of this paper you are entitled, you should lose no time in doing so.

Never before has a technical paper made such a generous offer and many thousands of readers have already availed themselves of it.

Every home constructor will appreciate the value of this Kit—which if sold in the ordinary way would cost at least 12s. 6d. Each tool is specially designed, made from best quality steel and fits snugly in its place in the neat metal case—which slips easily into the pocket.

In addition to accommodation for the tools mentioned in the accompanying list, recesses are provided for the three Gift Spanners presented with last week's and this week's issues of PRACTICAL WIRELESS.

A glance down the list of Tools and at the illustration opposite will show you that it is just the thing you, as a practical man, have long needed. A Kit will be reserved for you directly your Application Form is received. Don't delay.

## LIST OF TOOLS IN THE "PRACTICAL WIRELESS" KIT

One 4in. spring steel Chesterman rule No. 300D-2.

One special steel scribe with adjustable chuck for scribing point renewal.

One pair of special ebonite test prods with wander plug socket ends and brass test points.

One special 4in. trammel with one fixed and one sliding head enabling circles to be scribed from 0 up to 3 7/8 in. in radius. This tool may also be used for cutting holes in ebonite and baseboards too large to be drilled in the ordinary way.

One 60 degree 16-gauge steel set square with finger fret, for easy use.

One special viewing mirror for inspecting obscure parts of the set. This viewing mirror fits into the scribe chuck.

One steel screwdriver with brass ferruled handle, extremely useful for locking screws, securing components to baseboard, etc.

And the three steel spanners O-B.A., 2-B.A., 4-B.A., 6-B.A., 8-B.A., 10-B.A., given free to every reader of PRACTICAL WIRELESS fit in a special recess beneath the set-square.

## READ THESE SIMPLE CONDITIONS

All you have to do to obtain your Pocket Tool Kit is:—

(a) Read the simple conditions. (b) Complete the Forms on right in ink. (c) Post Form No. 1 and stamped address label. (d) If not already a regular reader hand Form No. 2 to your Newsagent.

On receipt of Form No. 1 and the address label, we will send you a special Subscription Voucher on which to qualify for your Pocket Tool Kit. Your Kit will be reserved for you, and will be despatched immediately we receive the completed Subscription Voucher.

Affix to the Subscription Voucher which we post to you 13 Gift Stamps cut from the bottom left-hand corner of the back page of PRACTICAL WIRELESS for 13 consecutive weeks commencing this or last week.

When your Subscription Voucher is complete, send it, together with a Postal Order for 3s. 6d., to include registration, postage, packing, insurance, etc., to PRACTICAL WIRELESS Presentation Department, and your Pocket Tool Kit will be despatched to you immediately.

No reader may qualify for more than one Pocket Tool Kit.

This offer applies to persons residing in Great Britain and Ireland. Readers in the Irish Free State must pay any duty imposed.

**● USE THESE APPLICATION FORMS TO-DAY!**

**2** If you have NOT placed a standing order with your Newsagent for the regular delivery of PRACTICAL WIRELESS, hand him the order form below without delay.

**PRACTICAL WIRELESS**  
**(ORDER FORM FOR NEWSAGENT)**

To ..... (Newsagent)

Address .....

Please deliver (or reserve) PRACTICAL WIRELESS for me weekly until further notice.

Name .....

Address .....

Date ..... PLEASE WRITE IN CAPITAL LETTERS.

**1** POST THIS FORM IMMEDIATELY TO PRACTICAL WIRELESS Presentation Department, T.K. 39, King Street, Covent Garden, London, W.C.2.

In accordance with the conditions of your special offer please send me a SUBSCRIPTION VOUCHER on which to qualify for my Pocket Tool Kit. I have asked my Newsagent to deliver PRACTICAL WIRELESS regularly every week until further notice.

Reader's Name .....

Full Address .....

Newsagent .....

Address .....

Reader's Signature ..... Leave blank.

Fill in this form and the label on left in Block Letters. Stamp the label as directed and post both of them in an unsealed envelope (\*d. stamp only required)

1d. Stamp must be affixed here.

If undelivered please return to Geo. Newnes, Ltd., W.C.2

Name .....

Street .....

Town & County .....

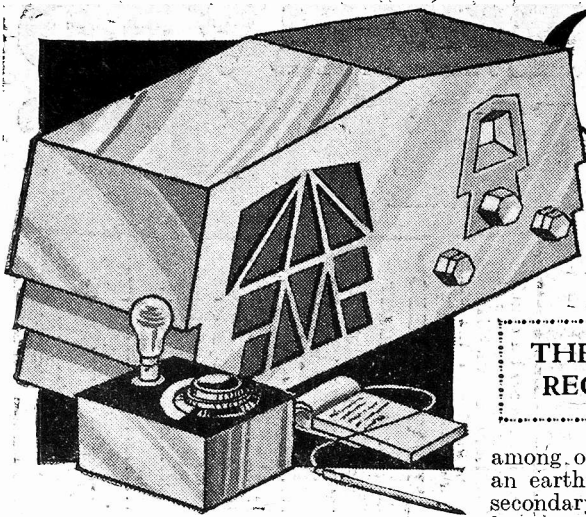

### THE COSSOR ALL-MAINS RECEIVER-MODEL 3468.

among other advantages it enjoys that of an earth shield between the primary and secondary windings to prevent modulation hum.

**R**ECEIVERS naturally drop into various classes, but this compact set stands more or less alone, as it provides a Console receiver using a modest number of valves, and priced at an equally modest figure.

Generally speaking, the man who wants a Console must have five or more valves whether he wants them or not; which is not always desirable to those who want a set of normal proportions, but prefer it to stand on its own legs as a complete unit.

The Coszor Model 3468 exactly fulfils these requirements, and the excellence of the general design will be more readily understood if the internal arrangements are touched upon.

It comprises a three-valve receiver built on an all-metal one-piece gun-finished chassis, and represents the latest manufacturing principles.

The first valve is a metallized Coszor MVSG variable-mu screened-grid valve, equipped with the usual bias volume-control upon which this type of valve depends if its advantages over the ordinary screened grid are to be realized. Coupling between this valve and the detector takes the form of a tapped auto-transformer, the coupling condenser being abnormally low—0.00025, which is presumably used to avoid risk of stray-hum reaching the detector grid from the S.G. anode. The fact that volume at the top of the long-wave dial is fully up to standard, notwithstanding this very low coupling condenser, is a great tribute to the efficiency of the coil.

The detector valve is the Coszor 41 MH, working with a grid-leak that would normally be associated with a leaky grid detector, but the anode voltage is higher than normal, resulting in rectification somewhere midway between leaky grid and power grid, which is probably the very best compromise between quality and sensitivity when preceded by only one screened-grid stage.

The output is taken care of by the Coszor 41 MP which, though classed as an ordinary power valve, is capable of an output of over 1 watt, and with the abnormal slope of 7.5 mA/V it possesses sensitivity equal to, if not greater than, that of an indirectly heated pentode.

The power pack is built round the Coszor 442 BU, a rectifying valve of exceptionally robust construction that will give abnormally long service. The smoothing associated with it is heavy, incorporating the field coil of the loud-speaker as the smoothing choke with generous smoothing condensers. The mains transformer is a particularly massive construction, and

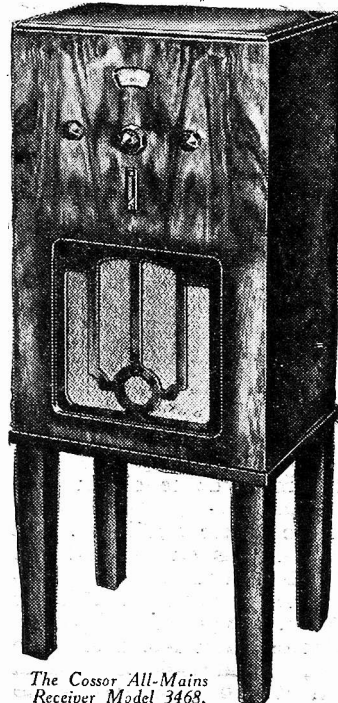

The Coszor All-Mains  
Receiver Model 3468.

The exterior of the set is both pleasing and simple, of walnut clear finish with a very slight matt, the main part of the cabinet being supported on four short legs. The total height is 2ft. 11in. The general

proportions and appearance of the cabinet may be readily seen in the accompanying illustration.

The controls are those normally associated with a three-valve variable-mu set, and include one-knob tuning, combined L.T. switch and volume and reaction controls.

The wave-change switch is delightfully light in action, and the wave bands, when checked with a heterodyne wave-meter, extended from 200 metres to rather more than 230 metres on the medium waves, and from rather less than 900 metres to 2,000 metres on the long-wave band.

Refinements include combined on-off switch and volume control, one-knob tuning with dial light, and provision for gramophone pick-up. An outstanding feature is the mains energized moving-coil loud-speaker, which is naturally more sensitive than a permanent magnet type could be, in addition to superior tonal qualities.

On test the receiver was found to be simple to use and came fully up to expectations, providing a wide choice of European stations. No difficulty was experienced in getting below Fécamp. An imposing list of stations received could be easily given, but owing to the variation between one locality and another it would mean very little; but it may be mentioned that at twenty-two miles from Brookmans Park all the usual worth-while European stations were received at excellent strength, and with more than pleasing quality and entirely without any trace of objectionable mains hum. On the long waves Radio-Paris was easily cleared from 5XX, and with careful adjustment Königswusterhausen could be almost entirely cleared from the former stations.

The selectivity is of a high order, and the variable-mu gives the perfect control of volume with which it is identified.

Mains consumption was measured and found to be 45 watts, which means that the set may be run for twenty-two hours for one unit of electricity, which is a little more than seven hours for 1d., assuming the electric current to cost 3d. per unit. The transformer is tapped to accommodate mains voltages from 200 to 250 alternating current only (40 to 100 cycles), and the receiver represents unique value at the modest price of £10 15s.

Using the gramophone, the receiver was found to give good quality with a somewhat brilliant top register, which is also true when working on radio. Owing to the sensitivity of the 41 MH it is essential that the pick-up be fitted with a volume control, the volume control on the receiver being out of use when reproducing gramophone records.

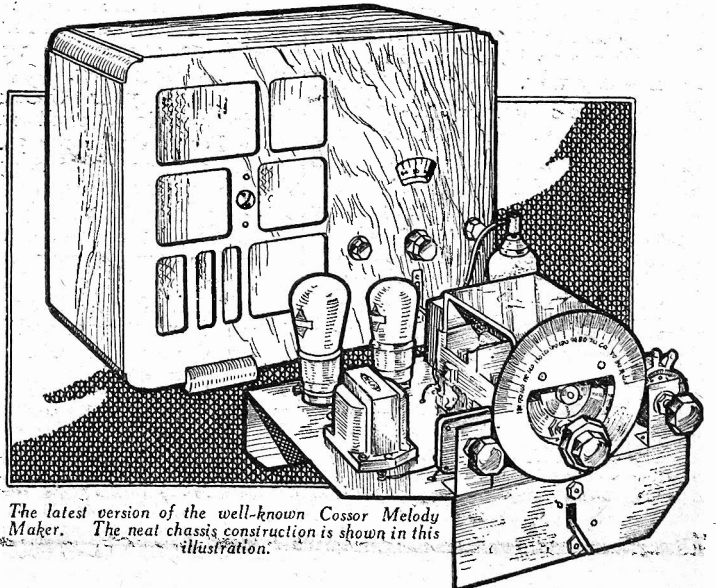

The latest version of the well-known Coszor Melody Maker. The neat chassis construction is shown in this illustration.



# PETO-SCOTT

**EVERYTHING RADIO—CASH C.O.D. or EASY TERMS**

Peto-Scott are pioneers in Radio and Television. Our service to the British public was introduced in 1919, and during fourteen years of Solid Service and Satisfaction we have established a reputation for fair dealing that defies competition. Customers in all parts of the globe come to us regularly for all their radio requirements—Sets, Kits of all descriptions, Part Kits, Miscellaneous Components, Speakers, Eliminators, and Accessories. Purchases can be made for cash, C.O.D., or on Easy Payments. **WE DEAL WITH YOU DIRECT.** Peto-Scott's Easy Way System, with its strict privacy and no third-party collections, will bring radio to your home by convenient monthly payments. Send list for quotation; no obligation.

Eliminators, and Accessories. Purchases can be made for cash, C.O.D., or on Easy Payments. **WE DEAL WITH YOU DIRECT.** Peto-Scott's Easy Way System, with its strict privacy and no third-party collections, will bring radio to your home by convenient monthly payments. Send list for quotation; no obligation.

## MANUFACTURERS' KITS IN SEALED CARTONS

**NEW LISSEN SKYSCRAPER FOUR ALL-YOURS WAVE CHASSIS MODEL**, in Sealed Carton. Cash or C.O.D. Carriage Paid, **£5/12/6**. Balance in 11 monthly payments of 10/3. Send **10/3**

**NEW LISSEN SKYSCRAPER FOUR ALL-WAVE CONSOLETTA CABINET MODEL** in Sealed Carton. Cash or C.O.D. Carriage Paid, **£8/2/6**. Balance in 11 monthly payments of 15/-. Send **15/-**

**NEW LISSEN 7-VALVE SUPER-HET.** in Sealed Carton. Cash or C.O.D. Carriage Paid, **£8/17/6**. Balance in 11 monthly payments of 16/6. Send **15/-**

**NEW LISSEN 7-VALVE SUPER-HET CONSOLETTA MODEL**, in Sealed Carton. Cash or C.O.D. Carriage Paid, **£11/10/0**. Balance in 11 monthly payments of 21/-. Send **21/-**

**NEW COSSOR, MODEL 341.** S.G., Detector and Pentode, and Balanced Armature Speaker, complete with Cabinet. Cash or C.O.D. Carriage Paid, **£6/7/6**. Balance in 11 monthly payments of 11/9. Send **11/9**

**TELSEN CLASS B 4 CHASSIS KIT** in Sealed Carton, less Valves, Cabinet and Speaker. Cash or C.O.D. Carriage Paid, **£3/17/6**. Balance in 11 monthly payments of 7/-. Send **7/-**

**BARGAIN KIT**

**GUARDIAN Q.P.P. 4-VALVE RECEIVER**, formerly **£3/19/6**. **KIT "A"**—Complete in Kit of Parts in sealed carton with full instructions, less valves and cabinet. Cash or C.O.D. Carriage Paid, **5/6**. Balance in 11 monthly payments of 5/6. Send **5/6**

**SHORT-WAVE KIT**

**DISCOVER S.G. THREE** **8/3** Send **8/3**

The finest S.G. 3 valve receiver ever designed exclusively for short-wave reception.

**KIT "A"** Author's Kit of Specified Parts in sealed carton, less valves and Cabinet. Cash or C.O.D. Carriage Paid, **£4/10/0**. Balance in 11 monthly payments of 8/3. Send **8/3**

## GRAMO MOTORS AND PICK-UPS

**GARRARD CLOCKWORK MOTOR, No. 30**, with automatic stop. Cash or C.O.D. Carriage Paid, **£1/5/0**. Balance in 5 monthly payments of 4/6. Send **4/6**

**NEW GARRARD MODEL 202A.** 12-in. Turntable. Electric Motor for A.C. mains. Cash or C.O.D. Carriage Paid, **£2/10/0**. Balance in 8 monthly payments of 6/-. Send **6/-**

**GARRARD ELECTRIC MOTOR A.C.4**, with 12-in. Turntable. Cash or C.O.D. Carriage Paid, **£2/2/6**. Balance in 7 monthly payments of 5/9. Send **5/9**

**B.T.H. SENIOR PICK-UP AND TONE-ARM.** Cash or C.O.D. Carriage Paid, **£1/17/6**. Balance in 7 monthly payments of 5/-. Send **5/-**

**B.T.H. MINOR PICK-UP AND TONE ARM.** Cash or C.O.D. Carriage Paid, **£1/1/0**. Balance in 4 monthly payments of 4/6. Send **4/6**

## ELIMINATORS

**NEW REGENTONE A.C. ELIMINATOR, Type W.I.F.** 7-voltage Tappings. 120/150 volts at 12 m/A. Cash or C.O.D. Carriage Paid, **£2/15/0**. Balance in 9 monthly payments of 6/-. Send **6/-**

**ATLAS C.A.25**, for Mains, "Class B" and Q.P.P., four tappings: 60/80, 50/90, 120, 150, 25 m/A. Cash or C.O.D. Carriage Paid, **£2/19/6**. Balance in 10 monthly payments of 6/-. Send **6/-**

**NEW OLDHAM H.T. ACCUMULATOR** (Block type), 120-v., 2,750 m/A., complete with crates only. Guaranteed 3 years. Cash or C.O.D. Carriage Paid, **£3/15/0**. Balance in 11 monthly payments of 7/-. Send **7/-**

## PREMIER SUPER PILOT AUTHOR KITS

**KIT "A"** Author's Kit of **FIRST SPECIFIED** Parts, including Peto-Scott **METAPLEX** Chassis, but less valves, speaker and cabinet. Cash or C.O.D., Carriage Paid, **£6/12/6**. Yours for **12/3** Balance in 11 monthly payments of 12/3.

**KIT "B."** As Kit "A" but with valves only. Cash or C.O.D., Carriage Paid, **£9/14/0**. Send **17/9** Balance in 11 monthly payments of 17/9

**KIT "C."** As Kit "A" but including valves and PETO-SCOTT cabinet with baseboard and baffle assembly but less speaker. Cash or C.O.D., Carriage Paid, **£11/2/6**. Send **20/6** Balance in 11 monthly payments of 20/6

**W.B. P.M.4.A. MICROLODE SPEAKER**, as specified. Cash or C.O.D. Carriage Paid, **£2/2/0**. Or 8 payments of 5/9.

### These are the parts the Author used:

|   |    |    |
|---|----|----|
| 1 PETO-SCOTT "Metaplex" Chassis, 12in. by 12in., with holes for valve holders ready drilled | 3  | 9  |
| 1 BRITISH RADIOPHONE No. 711 Dial   | 8  | 0  |
| 1 BRITISH RADIOPHONE Superhet, 3-gang Midget var. condenser, No. type 693                   | 1  | 2  |
| 1 set of LISSEN Matched Superheterodyne Coils (2 Band-pass and Oscillator)                  | 1  | 10 |
| 2 LISSEN Intermediate Frequency Transformers  | 15 | 0  |
| 1 IGRANIC 50,000 ohm Volume Control Potentiometer   | 3  | 8  |
| 1 BRITISH RADIOGRAM 3 pt. switch, type 48   | 1  | 3  |
| 1 BRITISH RADIOGRAM Push-Pull Radio Gram. switch, type 50                                   | 2  | 0  |
| 3 BRITISH RADIOGRAM Chassis Brackets  | 1  | 6  |
| 6 GRABAM FARISH "Pip" 3/1 L.F. Transformer  | 6  | 6  |
| 6 GRABAM FARISH "Ohmrite" Resistances   | 9  | 0  |
| 2 DUBILIER 2 mfd. non-inductive condensers, type B.B.                                       | 2  | 8  |
| 2 DUBILIER 2 mfd. condensers, type B.B.   | 7  | 0  |
| 1 DUBILIER, type 670, .0001 mid. condenser  | 1  | 0  |
| 1 DUBILIER, type 670, .0003 mid. condenser  | 1  | 0  |
| 2 DUBILIER, type 670, .01 mid. condensers   | 4  | 0  |
| 1 POLAR .002 mid. pre-set condenser   | 2  | 0  |
| 4 CLIX 4-pin chassis mounting valveholders  | 2  | 8  |
| 1 CLIX 5-pin chassis mounting valveholder   | 1  | 9  |
| 3 BELLING LEE Terminal Mounts   | 1  | 3  |
| 6 BELLING LEE Terminals, type "R" marked  | 1  | 6  |
| 1 BULGIN Fuseholder and Fuse  | 1  | 0  |
| 2 Coils connecting wire, length of flex, screws, etc.                                       | 2  | 2  |

Kit "A" Cash or C.O.D. Carriage Paid **£6 12 6**

**EXCLUSIVELY SPECIFIED**

**PETO-SCOTT PREMIER SUPER WALNUT CABINET** **25/-** Cash or C.O.D. Carriage Paid

Peto-Scott "Premier Super" Baffle and Baseboard Assembly, 3/6 extra.

SEND FOR 1934 CABINET CATALOGUE

**PETO-SCOTT 1934 WALNUT ADAPTAGRAM** RECOMMENDED FOR THE PREMIER SUPER

See Page 115, this issue.

## Exact to Specification

**AVOMINOR TEST METER.** Cash or C.O.D. Carriage Paid, **£2/0/0**. Balance in 7 monthly payments of 5/6. Send **5/6**

## Pilot Class "B" Conversion Kit

Converts your present Battery Set to "Class B" Amplification. Complete with all necessary components, including driver transformer, "Class B" output choke, W.B. 7-pin valve holder, B.V.A. 240B valve, wire and screws, etc. Full-size Blueprint, assembly instructions and diagrams. Cash or C.O.D. **37/6**. Balance in 7 monthly payments of 5/6. ALL "CLASS B" Components and other Parts unobtainable from your local dealer. SENT O.D. We have the largest stocks in the country. Orders over 10/- sent Post Paid. (Easy Terms available on orders over £2.) Quotations by return. No obligation. Send **5/-**

## SPEAKERS

RECOMMENDED FOR THE PREMIER SUPER—

**PETO-SCOTT PERMANENT MAGNET MOVING-COIL SPEAKER**

Cash or C.O.D. "CLASS B" Type. Cash or C.O.D. Carriage Paid, **22/6**, or 4 monthly payments of 6/3. Carriage Paid, **15/-** SEND ONLY **5/6** Balance in 2 monthly payments of 5/6.

**NEW BLUE SPOT PERMANENT MAGNET MOVING-COIL SPEAKER 2.9 P.M.** With input transformer. Cash or C.O.D. Carriage Paid, **£1/12/6**. Balance in 6 monthly payments of 5/-. Send **5/-**

**NEW BLUE SPOT 99 P.M. PERMANENT MAGNET MOVING-COIL SPEAKER.** Complete with tapped input transformer. Cash or C.O.D. Carriage Paid, **£2/19/6**. Balance in 10 monthly payments of 6/-. Send **6/-**

**NEW LISSEN P.M. MOVING-COIL SPEAKER** with input transformer. Cash or C.O.D. Carriage Paid, **£1/5/0**. Balance in 4 monthly payments of 5/6. Send **5/6**

**NEW LISSEN WALNUT CABINET MOVING-COIL SPEAKER**, with input transformer. Cash or C.O.D. Carriage Paid, **£2/10/0**. Balance in 9 monthly payments of 5/6. Send **5/6**

**NEW W.B. P.M.4.A. MICROLODE PERMANENT MAGNET SPEAKER** complete with switch controlled multi-ratio input transformer. Cash or C.O.D. Carriage Paid, **£2/2/0**. Balance in 7 monthly payments of 5/9. Send **5/9**

**EPOCH MODEL 20C, 20CB and 20CQ PERMANENT MAGNET MOVING-COIL SPEAKER** for ordinary power, "Class B" and Q.P.P. respectively, complete with input transformers. Cash or C.O.D. Carriage Paid, **£1/15/0**. Balance in 6 monthly payments of 5/6. Send **5/6**

**EPOCH MOVING-COIL SPEAKER AND CLASS "B" UNIT**, with Valve. Cash or C.O.D. Carriage Paid, **£3/3/0**. Balance in 11 monthly payments of 5/9. Send **5/9**

**NEW AMPLION SONNETTE PERMANENT MAGNET MOVING-COIL SPEAKER**, with Universal Transformer. Cash or C.O.D. Carriage Paid, **£1/17/6**. Balance in 7 monthly payments of 5/-. Send **5/-**

**NEW FERRANTI MOVING-COIL SPEAKER** (type M.5.T.) with input transformer suitable for Power, Pentode or "Class B" output. Cash or C.O.D. Carriage Paid, **£1/17/6**. Or 7 monthly payments of 5/-. Send **5/-**

**NEW FERRANTI "CLASS B" SUPER-POWER CONVERTOR.** Instantly converts your set to "Class B." Complete with Valves. Ready assembled. Cash or C.O.D. Carriage Paid, **£3/3/0**. Balance in 11 monthly payments of 5/9. Send **5/9**

**IMPORTANT.—Parts, Kits, Miscellaneous Components, Finished Receivers or Accessories for Cash, C.O.D. or H.P. on our own System of Easy Payments. Send us a list of your wants. We will quote you by return. C.O.D. orders value over 10/- sent carriage and post charges paid.**

**PETO-SCOTT CO., Ltd., 77, City Road, London, E.C.1.** Telephone: Clerkenwell 9406-7. West End Showrooms: 62, High Holborn, London, W.C.2. Telephone: Holborn 3248.

Dear Sirs,—Please send me CASH/C.O.D./H.P. \_\_\_\_\_ for which I enclose £.....s.....d.

CASH/H.P. \_\_\_\_\_

NAME \_\_\_\_\_

ADDRESS \_\_\_\_\_

Pr. IV. 30/9/3

ANY ITEM SUPPLIED SEPARATELY—ORDERS OVER 10/- SENT C.O.D. CARRIAGE AND POST CHARGES PAID

**Does your radio crackle!**

cure it with a  
**KB**  
**"REJECTOSTAT"**

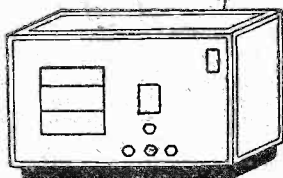

The KB "Rejectostat" helps you to suppress those interfering noises caused by trams, signs, sweepers and other electrical machinery, *without any alteration to your set.* Ask your local KB Authorised Dealer how a KB "Rejectostat" can be fixed to your aerial.

KB "REJECTOSTAT" UNITS—£1. 5s. 0d.  
Special shielded lead-in cable—4½d. a yard

For radio at its best—you must hear KB—THE NEW RADIO

**CUT OUT AND POST THIS COUPON**  
to Kolster-Brandes Ltd., Cray Works, Sidcup, Kent.  
*Please send me full particulars of KB "Rejectostat"*

Name .....

Address .....

K3

*Post in an unsealed envelope using 4d. stamp*

**A simple ★  
class "B"  
mains unit**

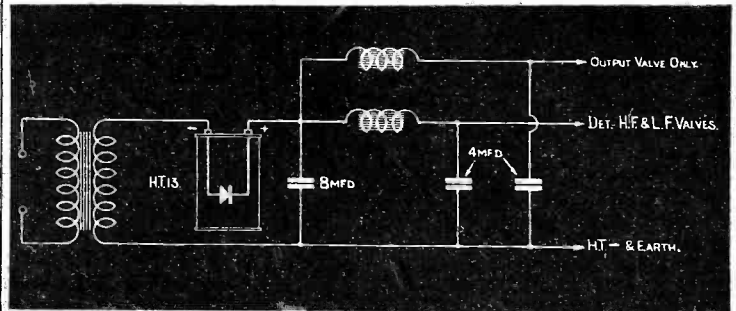

★ **Excellent voltage regulation**  
*without using stabilisers or ballast resistances*

Mains-driven Class "B" provides super volume with excellent quality. And here is an inexpensive A.C. Mains unit which has been specially designed to cope with the wide variations of current of a Class "B" valve and yet provide a nearly constant voltage output.

It is built round the new H.T.13 Westinghouse Metal Rectifier in a half-wave circuit, and no stabiliser or ballast resistance is necessary. The regulation obtained results in a variation of only 10 volts between the minimum and maximum values of anode current required by the Class "B" valve. Get a copy of "The All Metal Way, 1934," which tells you how to build it.

**Westinghouse  
metal rectifiers**

THE WESTINGHOUSE BRAKE & SAXBY SIGNAL CO. LTD.,  
82, YORK ROAD, KING'S CROSS, LONDON, N.1

..... Coupon .....

Please send me "The All Metal Way, 1934," for which I enclose 3d. in stamps.

Name .....

Address .....

..... Prac. 30933.





# THE BEGINNER'S SUPPLEMENT

## HOW YOUR RECEIVER WORKS.—IV

In this Instalment the Author Explains the Function of a Detector Valve and Deals with the Principles of Reaction Control.

(Continued from page 50, Sept. 23 issue)

OUR detector valve is connected to the tuned grid circuit as shown in Fig. 15, and the fluctuating signal voltages supplied to it can be represented graphically in the manner shown in Fig. 16. These voltages are of precisely the same nature as those which we previously saw were applied to the aerial circuit, but are of greater amplitude. Now as they are applied to the grid of the detector valve, they will cause more or less current to pass from the filament to the anode; at any moment when the grid receives a positive voltage more anode current will flow, and when the voltage is negative, the current will be reduced. So far, then, the detector performs in exactly the same manner as our H.F. valve. But—when the grid becomes positive it will attract a certain amount of the anode current (some of the electrons emitted by the filament) to itself. When

the grid-leak causes one end to become negative in respect to the other. This negative potential is applied to the grid in the form of grid-bias, the actual value of the latter being dependent upon the current flowing and thus, in turn, upon the "strength" of the signal voltages causing it. This grid-bias voltage quickly attains a steady value, and although it is always very small (since the grid current never exceeds a few millionths of an ampere), it is sufficient to serve a very useful purpose.

The steady grid-bias voltage is "added" to the fluctuating signal voltages, with a result that the positive half-cycles are reduced in amplitude, and the negative half-cycles are increased.

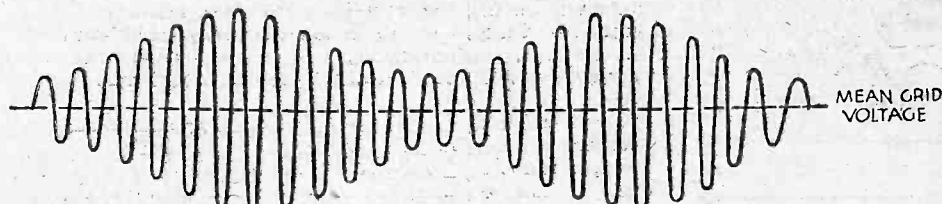

Fig. 16.—This diagram represents the signal voltages as applied to the grid circuit of the detector.

this occurs that current, being of a negative character, will flow through the grid-leak back to the filament from whence it came. And whenever current is passed through a resistance a "voltage drop" occurs between the ends of the latter component. This fact is made use of in obtaining automatic grid-bias and might be more readily appreciated by making reference to that excellent stand-by, Ohm's law, which states that the voltage drop across a resistance is equal to the product of the current and the ohmic value of the resistance. It can thus be seen that if the latter remains constant the V.D. is proportional to the current flowing.

We can now understand that the flow of current through

The net effect of this is that the mean or average value of the signal voltages is caused to fluctuate in sympathy with the variations in amplitude, as shown in Fig. 17. The latter fluctuation is, therefore, applied to the grid and produces corresponding variations in anode current. In other words, the anode circuit of the detector valve will contain not only the current fluctuations caused by the carrier wave (called high frequencies), but also others corresponding to the modulation and known as low or audio frequencies. It is the latter which we require to operate our loud-speaker after they have been amplified sufficiently for that purpose.

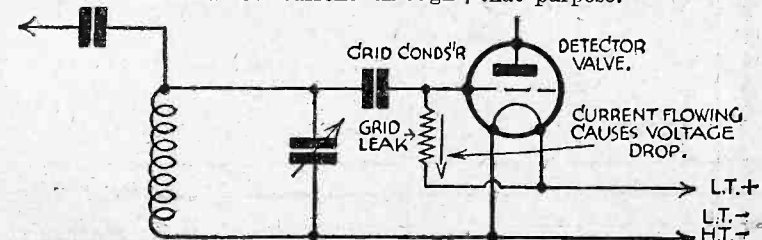

Fig. 15.—The principal connections of a leaky-grid detector.

### Throwing Away the H.F. Component

The high-frequency "component" is no longer required, so our first object must be to "throw it away" and prevent it from reaching the L.F. amplifier, where it could do no useful work and would be a nuisance. But how? There are two ways; one is to feed it back to the filament circuit by means of a condenser (C) connected as shown in Fig. 18. Here it should be noted that a condenser has the interesting property of passing high-frequency currents much more easily than those of low frequency, and if a suitable capacity is chosen for C, it will allow easy passage of all H.F. without having any effect whatever on the audio frequencies. By calculation we can find that the most suitable capacity lies between about .0001 mfd. and .001 mfd. Incidentally, if the capacity

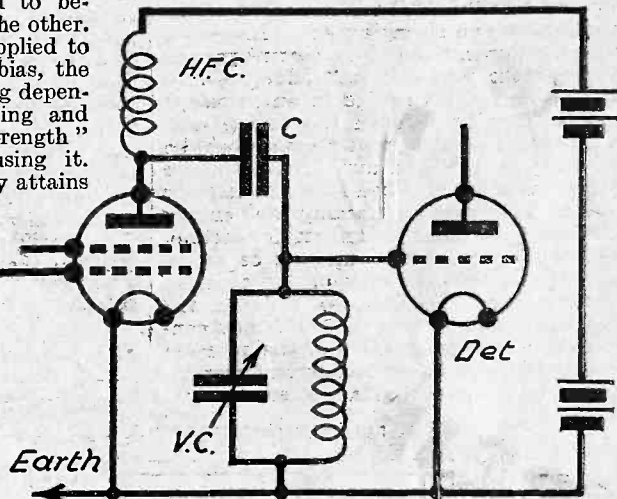

Fig. 14 (b).—The tuned grid circuit, which is really a modification of the circuit shown in Fig. 14 (a).

were greater than this it would allow some of the higher audio frequencies to leak away and would consequently reduce the strength of the higher musical notes and thus spoil the "quality" of loud-speaker reproduction.

### Reaction

In the method of "throwing away" the high frequencies which we have discussed, those currents are literally wasted, but we can put them to valuable use by feeding them back to the filament by the path

(Continued overleaf)

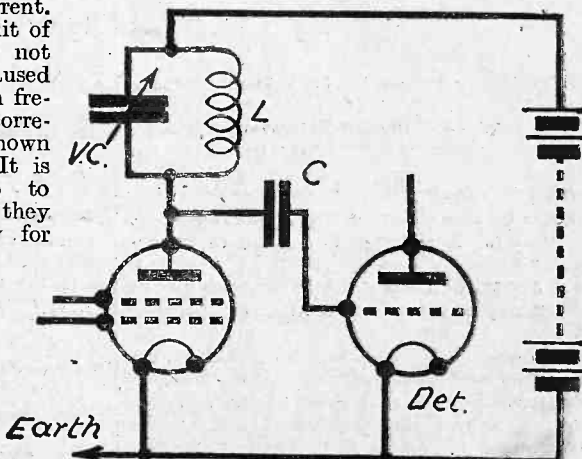

Fig. 14 (a).—Tuned anode coupling; this is similar to choke-capacity, except that the choke is replaced by a tuned circuit.

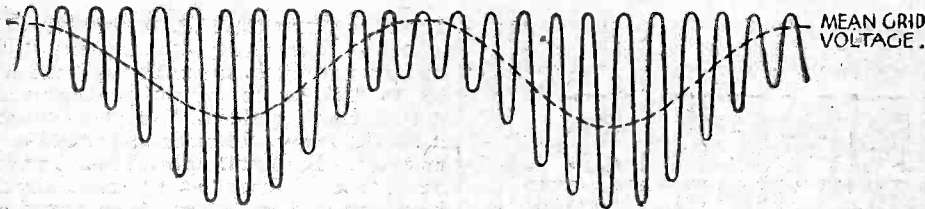

Fig. 17.—A diagrammatical representation of the combined signal voltages and steady bias voltage supplied by the grid leak.

**THE BEGINNER'S SUPPLEMENT**

(Continued from previous page)

illustrated in Fig. 19. They are now sent through a variable condenser and a coil which is situated close to the tuned-grid coil. The currents are still returned to the filament circuit, but in passing through the coil they cause a magnetic field to be set up and this "links" with the field of the tuning coil and strengthens it. Expressed in other words, some of the current passing through the first coil is "induced" into the second. This results in an increased current flowing through the tuning coil, which means that a greater voltage will be applied to the grid and hence a larger signal output is obtained from the detector valve. The process of feeding back energy into the grid circuit is known as reaction, and the degree of feed-back can be varied by altering the capacity of the reaction condenser or the distance between the reaction and tuned-grid coils. It is most convenient to fix the position of the reaction coil and vary the amount of current passed into it by means of the reaction condenser,

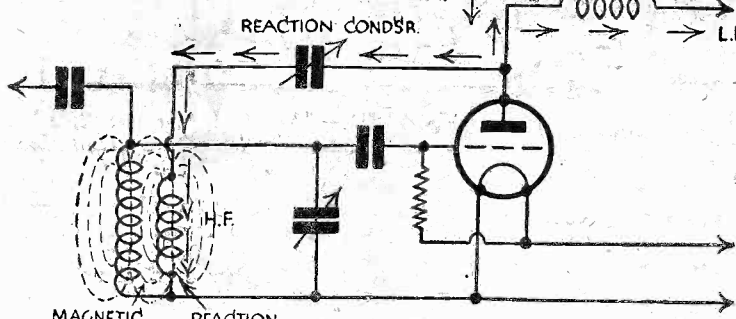

Fig. 19.—This circuit shows how the H.F. currents are made to do useful work by passing them through a reaction coil. Also notice the effect of the H.F. choke.

and although there are several variants of this method they all depend upon the same principle.

**The High-frequency Choke**

Although we have provided an easy leakage path for the H.F. currents, there is still nothing to prevent their passage into the L.F. amplifier, so we must fix some kind of "barrier" past which they cannot escape. Our barrier consists of a high-frequency choke connected in the position shown in Fig. 19, between the anode of the detector valve and the L.F. amplifier. The choke is a form of inductance which behaves in precisely the opposite manner to a condenser. In other words it does not restrict the passage of low so much as it does the high frequencies. By choosing a suitable value of inductance we can almost entirely prevent the passage of H.F. currents without offering any appreciable restriction to the audio impulses. By calculation it is not difficult to find that the best value of inductance for the choke is in the region of 200,000 microhenries.

**L.F. Amplification**

We can now revert to the audio-frequency component again and see what is to happen to that. In all probability it will require to be amplified (or increased in amplitude) before it is capable of operating the loud-speaker, so another valve will be required for this purpose. Our first problem is to devise a means of feeding the low-frequency currents into the next valve. As a matter of fact, there are three available methods which are not unlike those we considered for passing the amplified signal voltages from the H.F. to the detector valve.

**Inter-valve Coupling**

Let us make a start by using a resistance R as shown in Fig. 20 and passing the H.F. voltages developed across it to the grid of the amplifying valve through condenser C. As we saw in respect to the H.F. valve, a higher voltage will be developed across R as its resistance is increased, and it would therefore appear that best results would be obtained by making R of, say, 1 megohm. This would not work out in practice, though, because the resistance has to carry the steady high-tension current to the detector valve as well as the audio frequencies; thus, if its value were so high as the figure mentioned a high-tension battery of unduly high voltage would be required to supply a working voltage to the anode of the detector valve. Moreover, it is found that the improvement effected by increasing the resistance beyond a certain value

is so slight as to be of no consequence. That value is from two to three times the impedance of the detector valve. Thus, if we were using a detector valve having an impedance of 10,000 ohms, R should have a resistance of between 20,000 and 30,000 ohms. It is not difficult to prove by calculation that an efficiency of some ninety per cent. is obtained by employing a resistance whose value lies between the two limits quoted.

**Choke Coupling**

But whatever value of resistance is employed it will of necessity cause some

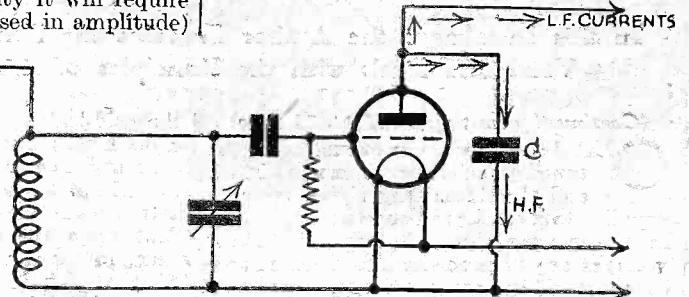

Fig. 18.—H.F. currents in the anode circuit of the detector are fed back to the filament through a condenser.

drop in high-tension voltage, and so unless there is a fair amount of "reserve" in the H.T. supply, the detector valve will be prevented from functioning efficiently. We can, however, replace the resistance by a low-frequency iron-cored choke which will offer the necessary resistance (or more correctly, impedance) to low-frequency currents whilst at the same time having only a small resistance to steady direct current.

We have not yet said very much about the coupling condenser marked C. This has to pass low-frequency currents without hindrance, and so must have a capacity of from about .005 mfd. upwards.

**The L.F. Grid-leak**

Both of the methods of coupling referred to—resistance capacity and choke capacity—are used in practice, and in each case a grid-leak must be connected between the grid of the L.F. valve and a grid-bias battery. The purpose of the grid-leak is to apply a steady negative voltage to the grid of the valve. We will leave an explanation of the reason for applying grid-bias until next article, when we study the action of the L.F. valve, and dismiss the matter for the present by saying that the leak should have an ohmic value of about four times that of the resistance R, or of the impedance of the L.F. choke.

(To be continued)

**RESERVE YOUR  
POCKET TOOL KIT NOW!**  
SEE PAGES 90 and 91

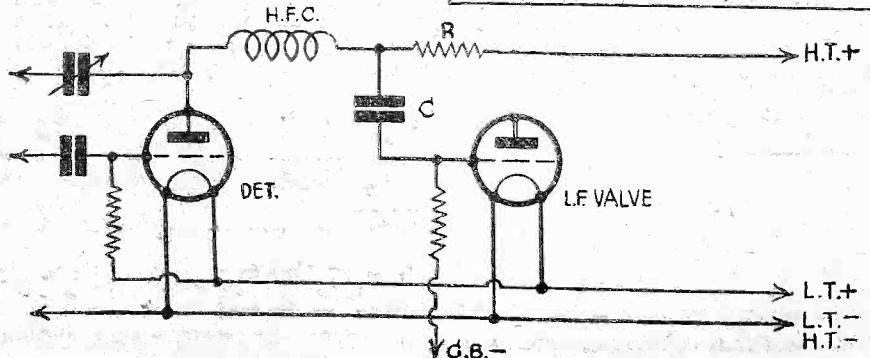
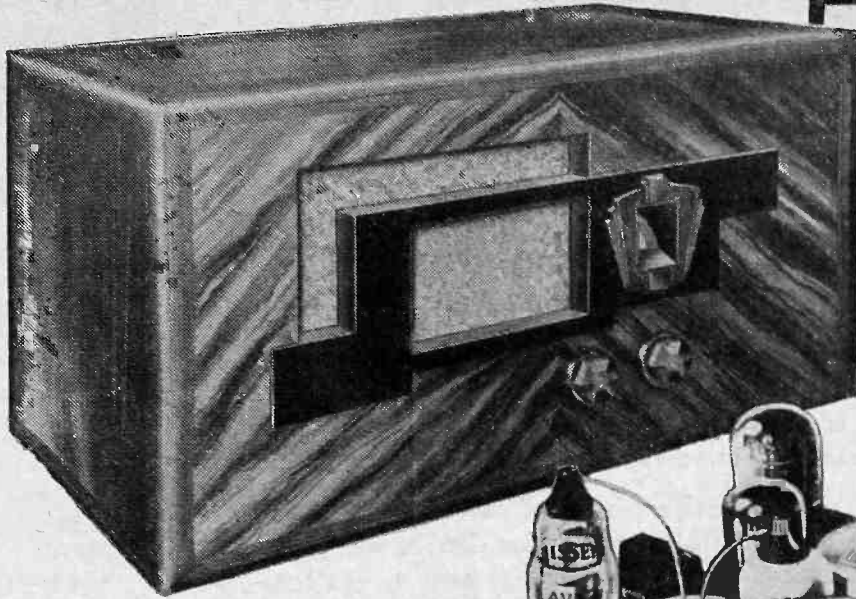

Fig. 20.—The circuit of a resistance-capacity coupled L.F. valve.





**HOME  
CONSTRUCTORS  
MOST AMBITIOUS  
DREAM  
REALISED  
AT LAST!**

Never before has there been any receiver for Home Constructors on such an ambitious scale as this new Lissen "Skyscraper" Seven-valve Superhet. It embodies every up-to-the-minute advance and refinement of the most luxurious factory-built superhets—it gives the constructor the opportunity to build a £20 receiver for less than half that price. The circuit of the Lissen "Skyscraper" Seven-valve Superhet incorporates a 6-stage bandpass filter, giving exact 9-kilocycle channels and therefore providing a standard of selectivity never before achieved by a home-constructor's kit set and very rarely found except in laboratory apparatus. Amplified Automatic Volume Control is provided, a special valve for this purpose having been produced by Lissen for use in this receiver.



**COMPLETE  
WITH SEVEN  
VALVES  
£8.17.6**

The use of this Amplified Automatic Volume Control constitutes an entirely new experience in listening; no "fading," no "blasting"—you will find yourself enjoying every word of every programme, however near or however distant, without the slightest temptation to interfere with the receiver once you have tuned it. This is radio listening as it should be enjoyed! Lissen Class-B Output through a new full-power Lissen Moving-coil Loudspeaker—glorious rich tone and majestic volume, actually more faultless in its reproduction than anything you ever heard from even the most powerful mains receiver, yet working economically in this Lissen "Skyscraper" from H.T. batteries.

Lissen have published for this great new "Skyscraper" Seven-valve Superhet a most luxurious Chart which gives more detailed instructions and more lavish illustrations than have ever before been put into a constructional chart. It makes success certain for everybody who decides to build this set; it shows everybody, even without previous constructional experience, how they can have a luxury receiver and save pounds by building it themselves. A copy of this Chart will be sent FREE in return for coupon on the left, or your radio dealer can supply you. Get your FREE CHART now!



A SEVEN VALVE SUPERHET  
8 STAGES IN ALL AND A 6 STAGE  
BANDPASS FILTER EXACT 9K/c  
TUNING CHANNELS WITH  
AMPLIFIED AUTOMATIC VOLUME  
CONTROL CLASS 'B' OUTPUT FULL  
POWER MOVING COIL SPEAKER

**CHART FREE  
POST COUPON**

**LISSEN**

To LISSEN, LTD.,  
Publicity Dept., Isleworth.  
Please send me FREE CHART  
of the "Skyscraper" Seven-valve Superhet.

Name .....

Address .....

.....

..... P.R. 834.

**"SKYSCRAPER" 7  
SEVEN VALVE SUPERHET**

# N I C O R E

## T U N I N G C O I L S

Varley again! Leaders in the new tuning technique as in the old...  
Varley NICORE Coils mark the biggest advance in radio tuning since the  
introduction of "Square Peak."

Consistency has been the great aim, and the characteristics of NICORE Coils  
will not alter in use. These New Coils combine maximum efficiency with  
maximum selectivity and are suitable for all circuits.

The use of powdered metal cores is not new to Varley. As far back as 1926  
Varley produced some Constant Inductance Chokes with powdered iron cores.  
Varley NICORE Coils are an outstanding result of years of research. Write  
to-day for FREE illustrated literature. B.P.30—Aerial or Tuned Grid with  
Reaction **10'6** B.P.31—H.F. Intervalve Transformer with Reaction **10'6**  
Set of 3 coils ganged on base **33'6**

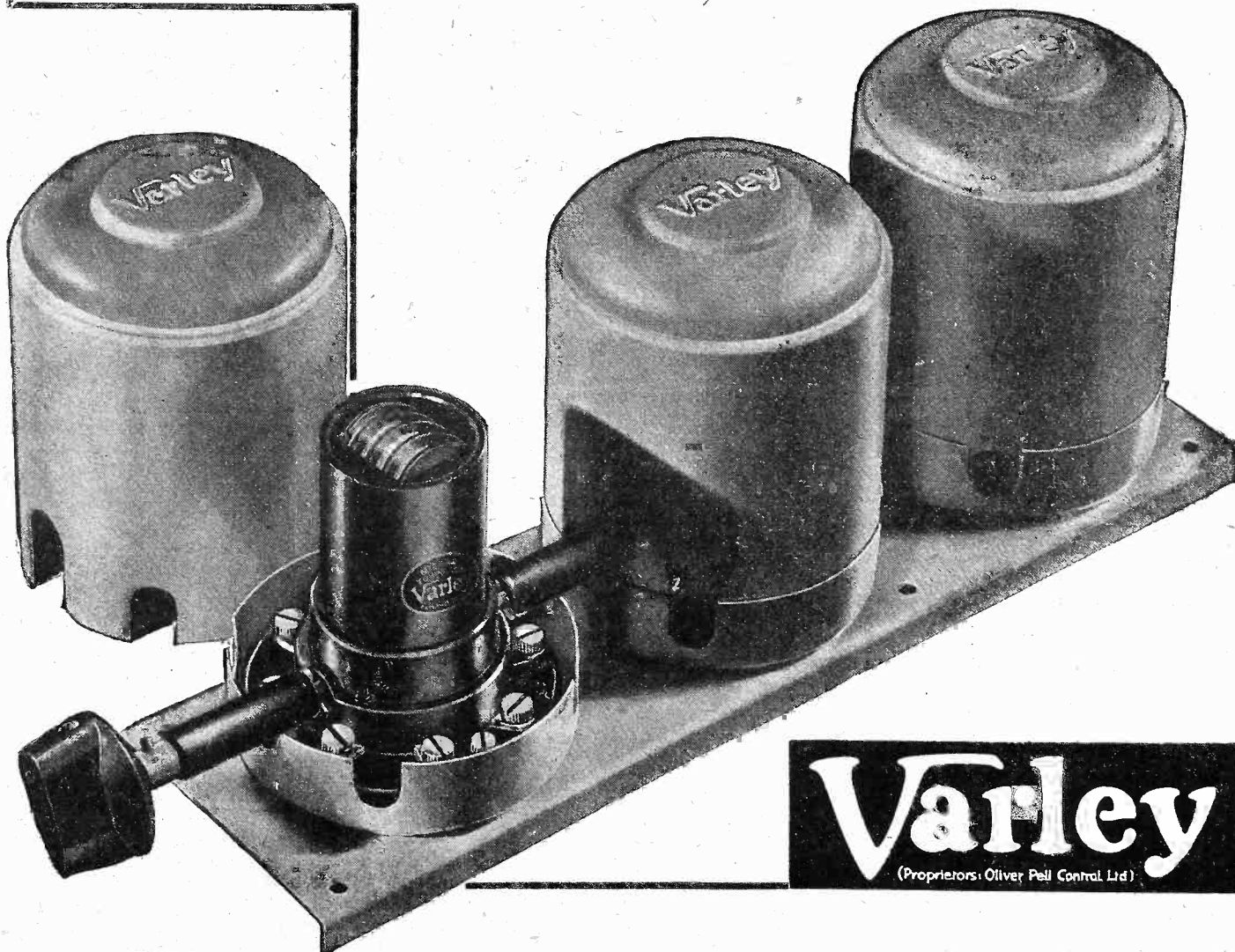

**Varley**  
(Proprietors: Oliver Pell Control Ltd.)

**VARLEY— FOREMOST AS PIONEERS**

Advertisement of Oliver Pell Control Ltd., Kingsway House, 103, Kingsway, London, W.C.2. Telephone: Holborn 5303



THE title which I have chosen for this article may at first sight seem rather peculiar, but I want if possible to try and show how we can arrive at an approximate cost (L.S.D.) for running our wireless sets (L.C.R.) from the mains. Almost daily I am confronted by some worried listener who feels that his electricity bill is going to soar in leaps and bounds because he has built or bought a radio receiver which is to derive its power from the mains. Although after a time it is possible to convince each individual that this is entirely a wrong impression I feel that the subject is of sufficient interest to readers of PRACTICAL WIRELESS to warrant an explanation of the items which are involved.

Unfortunately, a actual cost figures cannot be given as the various electricity supply companies upon whom we are dependent for our lighting and power requirements are singularly lacking in uniformity in their tariff charges. In some districts the cost per "unit" of electricity rules high, while in others the reverse is the case, but no doubt when the "Grid" scheme comes into full operation we shall all be able to obtain electricity at quite moderate charges.

**The B.T.U.**

Irrespective of whether the supply is direct or alternating in character, the charge is so much per "unit," that is, per kilowatt hour. Here is the first difficulty, what is meant by a kilowatt hour? It is the legal unit of electrical energy fixed by the Board of Trade (hence we sometimes speak of the kilowatt hour as the B.T.U.) for public supply services, and is the quantity of energy supplied in one hour by a current of electricity at such a pressure that the product of volts, amperes and hours equals one thousand. Thus, supposing we worked a piece of domestic apparatus which consumed a current of 2 amperes at a pressure of 250 volts for 6 hours, we should have a total consumption of:—  
 $2 \times 250 \times 6 = 3$  kilowatt hours or three 1,000 units in that time. This statement is strictly true when we are dealing with direct current, but, as will be shown later, needs to be qualified when we come to alternating current.

**D.C. Sets**

When the individual is using D.C. mains, and has instruments at his disposal he can very accurately measure the consumption of his radio set, and then calculate his running costs. This is shown in Fig. 1, and consists in connecting a voltmeter of the high resistance type, and an ammeter between the mains supply and the input to the set, and noting their readings. By multiplying these two figures together we obtain the power in watts and can then calculate how long the set may be run in order to consume one unit. For example, the voltmeter V may read 240, and the ammeter A say, 0.3 amp. The wattage is, therefore,  $240 \times 0.3 = 72$  watts, which

# L.C.R. and L.S.D.

Notes on Power Requirements for All-Mains Working

By H. BEAT HEAVYCHURCH

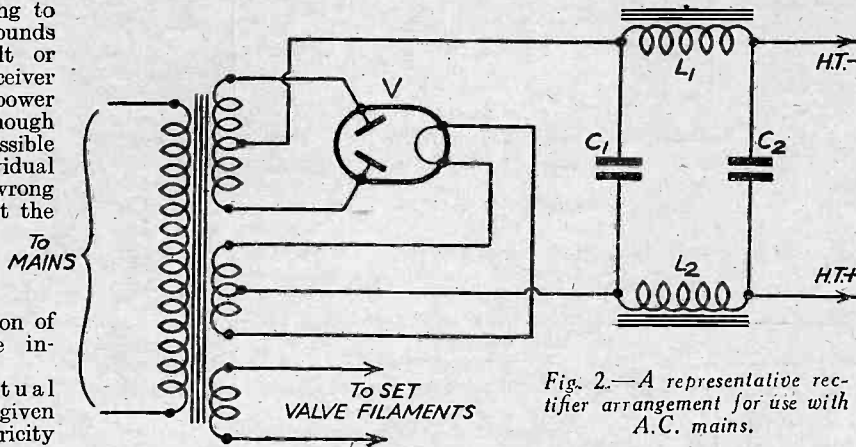

Fig. 2.—A representative rectifier arrangement for use with A.C. mains.

gives us nearly 14 hours radio for one unit consumed, and knowing the cost per unit in your own district the running costs per hour is only a matter of simple division.

In the absence of any meters, then a knowledge of the characteristics of the valves employed is called for, so that the figure for the current consumption may be computed, the mains voltage itself being stated on the supply meter. Generally, the bulk of the current drawn from the mains is used to supply the valve filaments which are wired in series. These may be of the 0.1 amp., 0.18 amp., 0.25 amp., etc., class, but a reference to the data sheet found in the valve cartons will soon settle this point. To this filament current must be added the total anode current drawn from the mains by the valves.

For example, we may have a three-valver with a high-frequency pentode or screened-grid valve taking 5 milliamps, a detector valve adding another 4 milliamps with a pentode taking a further 25 milliamps, thus giving a total of 34 milliamps. Adding this to the filament current of say 0.18 amp., we have a total current of 0.214 amp. If, for the sake of illustration we take a mains voltage of 200 volts the watts consumed are 42.8, giving just over twenty-three hours use before one unit is registered on the supply meter.

Readers will learn from this, therefore, that as far as D.C. mains working is con-

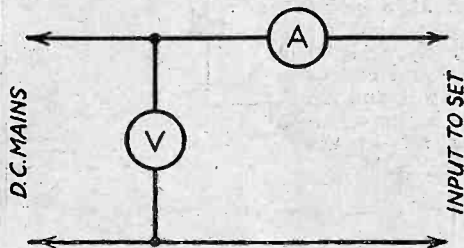

Fig. 1.—Making simple measurements for finding power consumption.

cerned, the relation between L.S.D. and L.C.R. is a very simple one, but when we come to alternating current mains matters are a trifle more involved.

**The Problems of A.C.**

First of all, owing to the very nature of the electricity supply, that is alternating, the current pulsates first in a positive direction and then in a negative direction, maintaining this double positive and negative effect (called a complete cycle) indefinitely. As it stands, this is useless for feeding our mains receiver so recourse is made to some means for rectifying the current or making it unidirectional, and we then proceed to smooth it by means of inductances and condensers before passing it to the valve anodes. Added to this we have to supply the valve filaments, generally of the indirectly-heated cathode type, and included in the combined power unit or power pack which is required for A.C. mains sets we have a transformer acting as the intermediary link between the unit and mains.

Looked at as a whole this seems somewhat complicated, and before we can begin to talk of running costs we shall have to analyse the scheme, and then the method of computation will follow automatically. First of all, then, can we multiply amperes, volts and hours together to obtain our kilowatt hours as we did in the case of D.C.? The answer is No! To attempt to give a full explanation of this interesting phenomena would take too much space here so I must try and deal with it briefly.

**The Importance of "Phase"**

If we take an alternating current supply and place across it separately a pure resistance load, a pure inductive load and, finally, a pure capacitive load, three different effects will take place. This arises from the fact that with alternating current we have to take account of the difference in phase between the voltage and current, both of which are pulsating. In the case of a pure resistance load both current and voltage are in phase, and the numerical value of both the current and the voltage can be multiplied together to give the power. With a pure inductive load, however, the current lags behind the voltage by 90 degrees, and for a pure capacitive load the current leads the voltage by 90 degrees. Here, then, we have our phase difference creeping in and when a complicated load is made up from a combination of resistance, inductance and capacity the phase difference between current and voltage will vary according to the values of each item.

Now when we speak of the power in an alternating current circuit, without in any way qualifying the expression, we understand by this term the mean value of the power over a complete period. Mathematically, it can be shown that the power is not simply equal to the product of voltage and current, but that it is equal to the product multiplied by a factor which is dependent on the phase difference which has just been mentioned. Actually, the multiplier which converts volt-amperes or apparent power into watts or true power is termed the power factor of the circuit.

(To be concluded next week.—Editor.)

# Artificial Aerial Transmitting

—By D. P. TAYLOR—

IN a recent article published in PRACTICAL WIRELESS it was stated that a beginner applying for a transmitting licence is usually allotted a licence to transmit with "Artificial Aerial" only for a probationary period, and the purpose of this article is to describe some experiments which can be done with an artificial aerial transmitter.

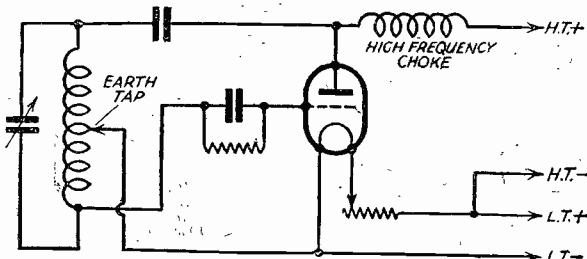

Fig. 1.—The Hartley circuit.

First, let us consider the term artificial aerial. It is defined by the Postmaster-General as "A closed, non-earthed oscillatory circuit, possessing inductance, capacity, and resistance, and functioning in the place of the usual aerial-earth system." It must be as nearly non-radiating as possible.

The inductance must be of one piece, and of small dimensions—as distinct from an inductance of large dimensions such as a frame aerial—the maximum area formed by the turns of the inductance not exceeding three square feet.

The artificial aerial should have the same values of inductance, capacity, and resistance as the aerial for which the transmitter is intended for use on, when the transmitter will function in exactly the same way as if it were coupled to the aerial.

In practice it is difficult for the amateur to measure these constants, but if experiments are to be performed on the short waves (below 100 metres) suitable values are—inductance 10 microhenries, capacity .0003 mfd. variable, and resistance 15 ohms.

By the choice of these values the aerial circuit can be brought into resonance, although, if it is desired to work mostly on waves lower than 50 metres the values of inductance and capacity could be reduced somewhat.

## Instruments Required

In series with the closed oscillatory circuit is connected a hot-wire ammeter to measure the current passing through the artificial aerial. The other pieces which are essential for experiments are—wavemeter, milliammeter, voltmeter, and listening device or monitor.

The wavemeter can conveniently be one of the absorption type consisting of a coil shunted with a variable condenser, and this is calibrated on the receiver from known stations and a graph plotted of wavelength, or frequency against condenser dial readings.

A lamp of the flash-lamp variety is included in the wavemeter circuit for the purpose of detecting resonance with the transmitter, or alternatively, resonance can be detected by the flick of the milliammeter needle in the

anode circuit of the transmitter valve when the condenser dial is rotated with the wavemeter coil held in coupling with the coil in the transmitter.

A milliammeter is an essential piece of apparatus, and a good value for use with low power transmitters is 0.25 mA and is used for reading the anode current of the oscillator valve.

A voltmeter is also a useful piece of apparatus for use with the milliammeter in measuring the power input to the transmitter.

A monitor is required for the purpose of listening to the transmissions, and this can consist of a small single valve receiver, using a pair of grid-bias batteries as high tension, alternatively a screened receiver could be used with the aerial disconnected, and if the received

signals are too powerful such as to overload the detector valve the harmonics of the transmitter should be tuned in.

## Hartley and Armstrong Circuits

Two of the most useful circuits of the self-oscillator variety are shown in Figs. 1 and 2. They are the Hartley and Armstrong or tuned-plate, tuned-grid respectively.

In the Hartley circuit the chief merits lie in the fact that there is only one tuned circuit, but it suffers from the disadvantage that both sides of the tuning condenser are at high-frequency potential above earth. In this circuit the amount of coupling between the anode and grid circuits is varied by altering the position of the earth clip on the coil.

The two fixed condensers have values of .001 mfd. and should be of the mica dielectric type in the interests of safety, whilst the grid leak can be a 50,000 ohm volume control type variable resistance.

The high-frequency choke in the anode circuit of the valve is a component of some considerable importance, and experiments should be made to determine the best value for this component starting with a single layer winding of 200 turns on a one-inch former of 30 S.W.G.

The adjustment of the Hartley transmitter is as follows:—

The earth clip on the inductance should be set at a point approximately one-third from the grid end of the coil, and the tuning condenser set to the

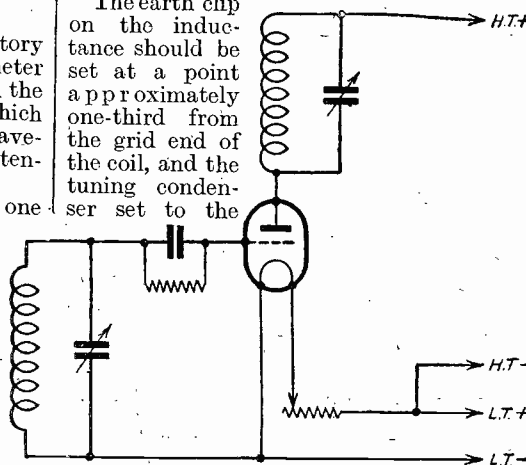

Fig. 2.—The Armstrong circuit.

required wavelength, this being measured by means of the wavemeter.

The exact position of the earth clip can now be located, and circuit adjustments such as the value of the grid resistance made, the object being to obtain the greatest efficiency.

## The Armstrong Circuit

The circuit shown in Fig. 2 is the Armstrong or tuned-plate tuned-grid, this circuit depends upon the inter-electrode capacity of the valve for the coupling between the grid and anode circuits. Similar values of components can be used in this circuit as described for use in the Hartley circuit.

The adjustment of the Armstrong circuit is as follows:—

The grid tuning condenser is set at approximately the required value and the anode condenser rotated, noting at the same time the anode current as shown by the milliammeter.

As the two circuits come into resonance it will be found that the anode current "dips" sharply and falls to a small value at exact resonance, the correct operating point being where the anode current is about 10 per cent. higher than the minimum value.

The wavelength is now measured, and, if necessary, readjustments of the condensers made to tune the circuit to the exact wavelength required. The artificial aerial circuit can now be coupled and the current in this circuit noted and adjustments made to obtain the greatest possible efficiency without impairing the stability or purity of tone of the transmitter.

It is essential that in the two transmitters described that the tuned circuits should be of a rigid and low-loss construction, as large circulating currents will flow around this circuit, even in low-power transmitters this current may be as large as an ampere.

The use of low-loss well-built condensers together with coils rigidly built and using heavy-gauge wire is necessary.

## Suitable Valves

Suitable for use with the previously described circuits are small power receiving valves and particular mention might be made of the LS5 type of valve for powers up to 10 watts. The anode supply can in the case of low power transmitters conveniently be either dry batteries, or high-tension accumulators, but those having the facilities to do so are advised to use the electric supply mains. A further useful addition which can be produced cheaply is a small flash-lamp bulb having its terminals bridged with a loop of say 6in. diameter, this is used for detecting oscillations and is brought into proximity with the transmitter coils, when the power induced into the loop causes the lamp to glow.

## Keeping a Log

It is required by the Postmaster-General that a log shall be kept of all transmissions which take place, and in this log should be entered a record of the power used, wavelength, circuit details, etc. The experimenter is advised to enter the fullest possible details of all experiments in the log, which will be found of great use when the radiating licence is granted. This is by no means the limit of the experiments which can be performed with an artificial aerial transmitter; many more could be described using transmitters of the crystal control type, of the master-oscillator type, or the use of telephony, but this is beyond the scope of this article.



# ALL-WORLD RADIO RECEPTION ON ULTRA-SHORT-SHORT-MEDIUM & LONG WAVES

|                               |                           |
|-------------------------------|---------------------------|
| Metres.                       | 31.3. DAVENTRY, G.S.C.    |
| 38. BANDOENG, Java            | 31.28. SYDNEY, Australia. |
| 50. VATICAN CITY, Rome.       | ON ULTRA SHORT WAVES.     |
| 50. MOSCOW.                   | Metres.                   |
| 49.83. ZEESEN, Berlin, D.J.C. | 30. MADRID Spain.         |

## STATIONS YOU HAVE NEVER HEARD BEFORE



|                                    |                                  |
|------------------------------------|----------------------------------|
| 49.67. Miami Beach, Florida.       | 25.63. PARIS, Radio Colonial.    |
| 49.65. CINCINNATI, U.S.A.          | 25.6. WINNIPEG, Canada.          |
| 49.5. NAIROBI, Kenya.              | 25.4. ROME, 2R.O.                |
| 49.18. BOUND-BROOK, New Jersey.    | 25.28. DAVENTRY G.S.E.           |
| 49.18. CHICAGO, U.S.A.             | 25.27. PITTSBURG W8XK.           |
| 49. JOHANNESBURG, South Africa.    | 23.39. RABAT, Morocco.           |
| 48.86 PITTSBURG U.S.A. W8XK.       | 19.48. VATICAN CITY, Rome.       |
| 48. CASABLANCA, Morocco.           | 19.82. DAVENTRY G.S.F.           |
| 32.26. RABAT, Morocco.             | 19.73. ZEESEN, D.J.E.            |
| 31.55 DAVENTRY G.S.B.              | 19.72. PITTSBURG, W8XK.          |
| 31.65 MELBOURNE, Australia.        | 19.56. SCHE-NICZADY, W8XAD.      |
| 31.48. SCHENECTADY, New York.      | 16.89. ZEESEN, D.J.E.            |
| 31.38. ZEESEN, Berlin, D.J.A.      | 16.88 DAVENTRY G.S.G.            |
| 31.35. SPRINGFIELD, Massachusetts. | 16.87. BOUND-BROOK, N.J., W8XAL. |
|                                    | 18.93. PITTSBURG U.S.A. W8XK.    |

**CHASSIS KIT COMPLETE WITH FOUR VALVES**  
**£5.12.6**

**4 WAVELENGTH RANGE INSTEAD OF TWO!**

**WITH DOUBLE BALANCED PENTODE OUTPUT AND MOVING COIL SPEAKER**

**WITH WALNUT CABINET & MOVING COIL LOUDSPEAKER**  
**£8.2.6**

**CHART FREE POST COUPON**

At last the day of All-World Radio has arrived, and you can build with your own hands the first receiver to give you not only England and Europe, but America and Australia direct. The Lissen All-Wave All-World "Skyscraper" 4 tunes from 12 to 2100 metres. It brings two complete new wavelength ranges within reach of the ordinary listener—stations and programmes which before he was never able to receive—Ultra-Short and Short-Wave transmissions from the ends of the earth. And, remember, you get these stations through Double-Balanced Output giving brilliant reproduction on a Moving-Coil Speaker—as much power as a Mains Set from ordinary high-tension batteries. Lissen have made this All-Wave All-World Radio available to Home Constructors first, because it brings back the thrill of conquest to hear America and Australia direct on a set you have built yourself, it makes you an enthusiast to realise what a wonderful thing you have created!

And when you see the Great Free Chart of the All-Wave All-World "Skyscraper" 4, which tells you how to build it and how to work it and why it gives such marvellous results, you will agree at once that it will be wise of you to build for yourself rather than buy a factory-assembled receiver which cannot give you these new and intriguing short-wave stations. The FREE CHART simplifies everything; there are pictures of every part, with every wire numbered, every hole lettered, every terminal identified. YOU CAN'T GO WRONG! But get the Chart and see for yourself—then build the Lissen All-Wave All-World "Skyscraper" 4, the SET THAT SPANS THE WORLD!

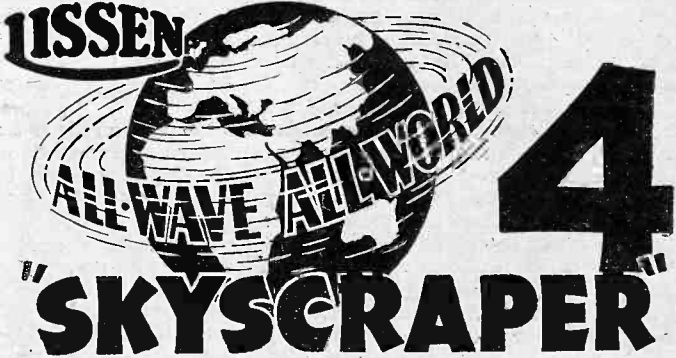

WITH WALNUT CABINET & MOVING COIL LOUDSPEAKER

**£8.2.6**

To LISSEN, LTD., Publicity Dept., ISLEWORTH, MIDDLESEX.  
Please send me FREE CHART of the All-Wave All-World "Skyscraper."

NAME .....

ADDRESS .....

P.R.834

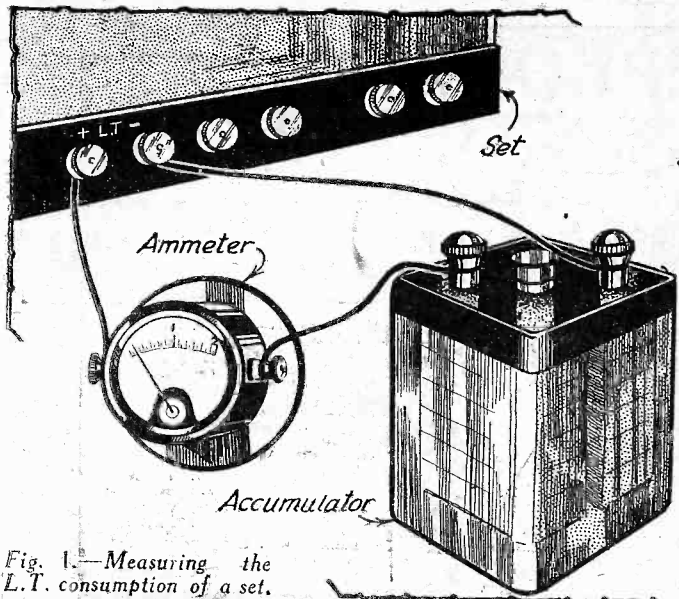

Fig. 1.—Measuring the L.T. consumption of a set.

THE correct choice and maintenance of a set's power supply—by which I refer to the low tension, high-tension, and grid bias—is of far more importance than most amateurs believe, and the exercise of a little thought on this matter can easily be the means not only of improving the performance of the set, but also of effecting an appreciable saving of hard cash in the way of running expenses. By way of amplifying and proving the latter statement let us consider the matter in detail by examining the three main voltage sources.

#### Low Tension

The object of the low-tension supply is, of course, to heat the valve filaments, and for this purpose we generally use a 2 volt accumulator of some particular "capacity." We can take it that by capacity we mean the amount of electricity which the accumulator will "hold." This is not scientifically correct, because an accumulator does not really hold electricity, but by applying a voltage to its terminals (charging) a certain chemical action takes place within; afterwards, when the accumulator is connected in an electrical circuit (such as to the L.T. terminals of a wireless set), the chemical action is reversed and the accumulator generates electricity. But to return to the subject of capacity; the accumulator is said to be of so many ampere-hours, for example, 30 a.-h. Broadly speaking a 30 a.-h. accumulator will deliver a current of 1 ampere for 30 hours or of 3 amperes for 10 hours. Theoretically it should also be capable of giving 30 amperes for 1 hour, but in practice it is known to be harmful to discharge or charge an accumulator at any current in excess of one tenth its ampere-hour rating. Thus, the maximum current which should be taken from a 30 a.-h. accumulator is 3 amperes. With any receiver having up to six or seven modern valves there is very little likelihood of our putting too heavy a current load on our accumulator unless it is also being used to supply high tension through one of those excellent Battery Superseders now on the market, or to charge a high-tension accumulator of the well-known type made by Milnes Radio Co. But the ampere-hour capacity also determines the number of hours of service that can be obtained per charge, so we must take full account of it even if our set is of the smallest type, con-

suming only a fraction of an ampere of low-tension current. Let us see how we can determine the number of hours that an accumulator will "last" on any particular set. First we must find out how much low-tension current our valves consume; this can be done by connecting an ammeter as shown in Fig. 1, or by adding together the current ratings of every valve in use. In the former case the ammeter should have a full scale reading of no more than 2 amperes or else an accurate result will be well nigh impossible. The latter method is just as good when the valves are of reliable British make, but should not be relied upon when foreign valves are employed, for they frequently consume far more than their rated current. (I hope no readers of PRACTICAL WIRELESS use foreign valves, because they are dear at any price.) The L.T. current consumption is given on the makers' instruction sheets and is also used as a "code figure" in the valve's designation. For example, an S.G. 215 valve requires a filament voltage of two and a current of .15 ampere, an H.L.210 requires the same voltage at a current of .1 ampere, whilst a 230 pen. takes .3 of an ampere. If the latter valves were used in a three valve S.G.—Det.—Pen. receiver their total consumption of low-tension current would be .55 (or rather more than half) ampere. When a 30 a.-h. accumulator was used, the number of hours it would last per charge is found by dividing .55 into 30; thus it works out at about 54 hours. In the same way it can be deduced that a 40 a.-h. accumulator would operate the set for approximately 73 hours.

#### The "Economic" Accumulator Capacity

Following the same line of reasoning it would appear that a 100 a.-h. accumulator could be used to drive the set for over 180 hours, but this is where we meet our first "snag." An accumulator should regularly be recharged at periods of no more than six weeks if it is to be kept in good condition, and it is actually rather better to reduce the time between charging to four or five weeks. It can be seen that if the latter accumulator were to be exhausted in six weeks the set would have to be in use for 30 hours a week or over four hours per day, whereas I daresay the average daily use of most receivers is not much more than two hours. Of course, it does not harm an accumulator to be recharged before it is completely run down, but there are very few of us who like to pay for anything we do not get. Consequently it is the most satisfactory policy to choose an accumulator of such a capacity that it will just drive the set for upwards of a month on one charge. One should not be "penny wise" in this respect, because an accumulator is damaged more by running it for three days in an

# YOUR SET'S POWER

Some Useful Advice for the Beginner on L.T., H.T., and G.B.

almost completely exhausted state than by three years of normal use.

Whilst it is uneconomical to use a battery of too large a capacity, it is still more wasteful to buy one which is too small and which will only last for a fortnight or so, because the cost of recharging is only slightly more for the larger one and there is not a great difference in initial cost.

#### Care of the Accumulator

Having decided on the most suitable capacity for the accumulator, let us form a few rules regarding its correct use. At this point it should be emphasised that a good accumulator properly cared for should have a life of at least five years, although I could recite innumerable cases where batteries have been ruined in less than half that time. The most important rule of all has already been dealt with, namely, recharge at regular intervals of not more than six weeks *whether the battery is running down or not*. Another rule is that the accumulator should be disconnected from the set immediately its voltage begins to fall, as indicated by a drop in volume or the necessity for the application of more reaction. After switching off the set the accumulator tends to recuperate to a cer-

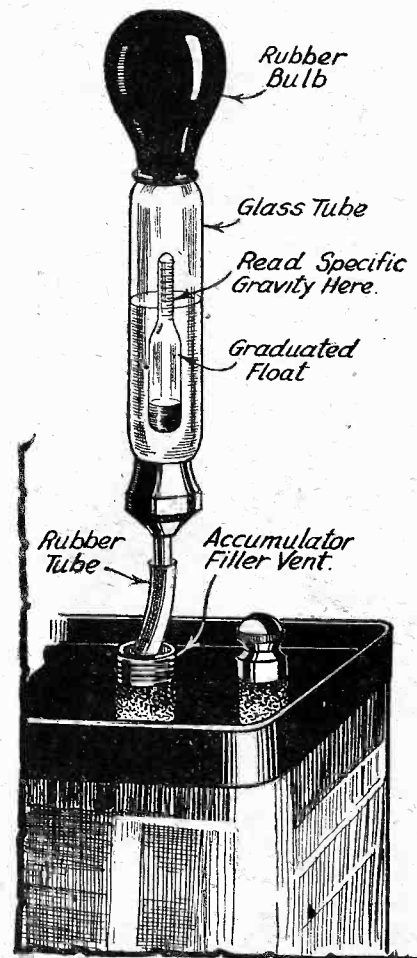

Fig. 2.—A Hydrometer used for measuring accumulator acid density.



# SUPPLY

By  
**FRANK PRESTON,**  
F.R.A.

the Choice and Maintenance of the Supplies

tain extent and there is a most foolish practice on the part of some people to use it again after such recuperation. This is distinctly wrong and might result in irreparable damage.

It is not always appreciated that an accumulator can seriously be damaged by allowing it to stand in an uncharged state. If it is not required for some months, it is much better to lend it to a friend who can use it, or otherwise to have it fully charged and then to pour out all the acid. After the acid had been emptied, the plates and inside of the case should be washed out with a small quantity of distilled water; the water must not be left in the case, but should be taken out after washing. When an accumulator runs down more quickly than it should, a fairly serious fault is indicated. The cause might be incorrect charging or careless discharging, but prompt attention is necessary. If the battery is fairly new a cure might be effected by having it charged slowly by a competent electrician, but with an old battery it is probable that the plates are being short-circuited by sediment which has collected in the bottom of the case. It is possible to remove the plates and wash out the sediment, but with modern accumulators this will be of little avail, because they are so designed that when the space below the plates becomes filled with sediment, which drops from the plates, the latter are of no further use.

The above rules apply to the user of the accumulator but there are others which concern the person who charges it. Many amateurs now charge their own from the mains, so a few pointers for them will not be out of place. It is vital to the accumulator that the plates should always be covered with acid and it is usual to maintain the acid level at least  $\frac{1}{8}$  in. above that of the top of the plates. The fall in level whilst the battery is in use is due to the evaporation of water in the acid and not of the acid itself. Consequently any drop should be made up with distilled water, which may be obtained cheaply from a chemist. On the other hand, if any acid is spilt, the level should be made up with more acid

of correct specific gravity or density. The correct density (often indicated by the letters S.G.) is always stated on the accumulator and should accurately

be maintained. It varies from about 1,300 to 1,200, and is measured by means of a hydrometer like that shown in Fig. 2. New acid should be added only when the battery is fully charged, because the S.G. specified by the makers does not apply under any other circumstances. It is usual to buy pure sulphuric acid of full strength (about 1,800 S.G.) and to let it down with distilled water, although it is possible to obtain battery acid of correct density from most accumulator service stations. If you mix your own, remember that the acid should slowly be added to the water, and not *vice versa*, because chemical action between the acid and water results in the generation of great heat which might be sufficient to crack the container if the proportion of acid to water were too great. This does not apply when adding water to the accumulator, because the acid inside the latter is already diluted.

A voltmeter is practically useless as a means of discovering whether or not the accumulator is fully charged; the only satisfactory test is to measure the acid-density by means of a hydrometer. Provided the acid was originally of correct density the hydrometer test will give a true indication of the accumulator's condition.

### How Long Shall I Charge ?

The length of time for which an accumulator must be charged is found in exactly the same way as the hours of discharge, that is by dividing the charging current into the ampere-hour capacity. For example, if the charger gives a current of .5 ampere it must be kept

in circuit with a 30 a.-h. accumulator for 60 hours. This assumes an efficiency of 100 per cent., so it is best to add about 10 per cent. to the calculated figure to ensure a full charge.

The latter calculation takes it for

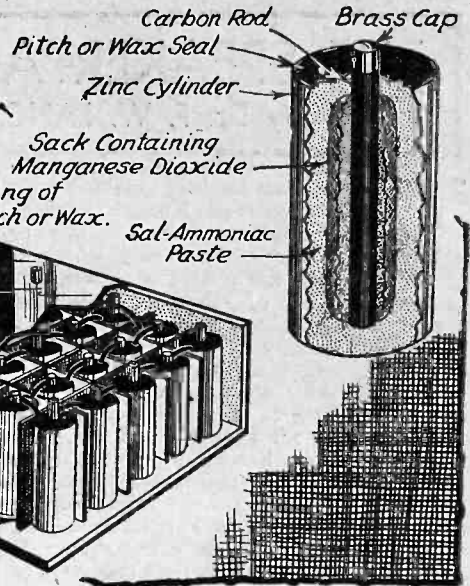

Fig. 3.—Showing the construction of a high-tension battery.

granted that the battery has been completely run down, but actually this should never be the case when a trickle charger is employed. It is better in every way to charge the accumulator overnight once or twice a week, putting just as much current into it as has been used by the set. As an example let us suppose that we have in use a receiver employing the valves referred to above, and that we keep it going for an average of  $2\frac{1}{2}$  hours per day or  $17\frac{1}{2}$  hours per week. Since the current consumption is .55 ampere we shall use  $17\frac{1}{2}$  multiplied by .55, or nearly 10 ampere-hours, and to replace this we must charge at, say, .5 ampere for 20 hours or at .25 ampere for 40 hours. As explained, the charging may be done at a stretch once weekly or for half the length of time twice a week, whichever is more convenient.

### Safety First

Just three safety-first rules about charging: (1) Stand the accumulator on a sheet of zinc, rubber, glass or porcelain when on charge, and keep it well away from fabrics, etc., which might be damaged by the fine spray given off when the battery approaches "full charge"; (2) Keep naked lights away from the accumulator, which gives off inflammable (not explosive or harmful) gas; (3) Carefully wipe the accumulator after charging to avoid acid stains in the receiver cabinet.

### High Tension—Dry Batteries

Probably 70 per cent. of set users derive their H.T. supply from dry batteries, so we will consider these first. That we may better understand later remarks in respect to dry batteries let us first get some idea as to how they are made and how they work. The sketch of Fig. 3 will simplify the explanation. The battery consists of a number of cylindrical cells, each giving 1.5 volts, connected in series and thus providing a total voltage equal to one-and-a-half times the number of cells in use. Each cell is made up of a central rod of carbon (fitted with a brass connecting cap) surrounded by a quantity of manganese dioxide contained in a small linen sack or bag. This fits in the middle of a cylindrical zinc container holding a paste made up of sal-ammoniac. The carbon rod forms the positive pole and the zinc cylinder the negative pole when the cell is in use.

(To be continued)

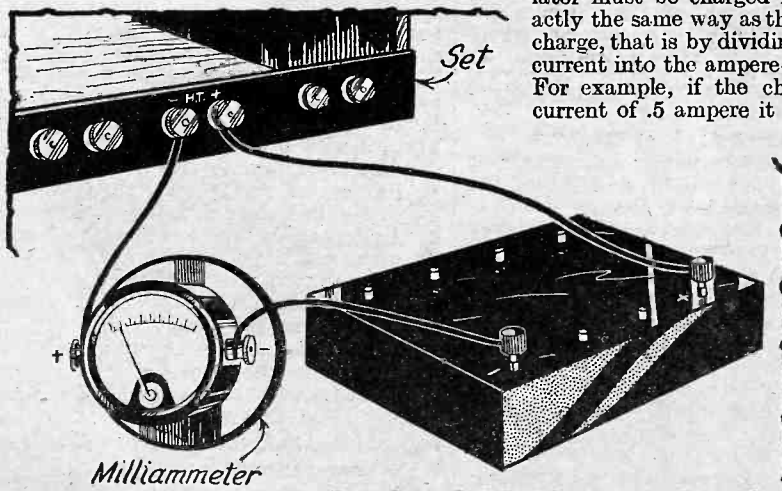

Fig. 4.—Finding how much high-tension current your set consumes.

# THE SPEAKER AND OVERLOAD

By Dr. F. W. LANCHESTER, LL.D., F.R.S.

THERE are two kinds of overload with which listeners are familiar, namely, the overloading of the amplifier or the speaker by the set. The latter, the true overloading of the speaker, is very rare indeed, the reason being that any decent moving-coil speaker, even a miniature, will take, under normal conditions, anything up to a  $\frac{1}{2}$  watt or 1 watt undistorted output at middle frequencies, whereas there are a vast number of sets, including all dry battery sets, which will not give more than 200 milliwatts undistorted output. The overloading of the set or amplifier is a subject which I propose to discuss in a later article; it will suffice to state here that this class of overload usually arises in the power stage, though it may come through from the detector. Such overload may cause the most distressing symptoms in the speaker; one of these is the well-known "rattle" that sounds as if it *must* be of mechanical origin, but which, actually, is not. In this, in my early acquaintance with radio, I have been deceived myself, and the general public can only be made to realize the truth by the most rigid demonstration; it is not unnatural: the ugly noise comes from the speaker, and the speaker is blamed. It is the same with a man who swears and blasphemes: people say he is "foul-tongued," when it is his mind (or brain) that is at fault!

In the present article I shall confine myself to the real overloading of the speaker such as is liable to occur when the amplifier output amounts to several watts; such amplifiers are being marketed to-day up to 5 and 10 A.C. output, and there are few speakers competent to handle so great a load. Furthermore, as I shall demonstrate, to ask, or to state, the power that a speaker will receive without some added qualification is to put a question (or make an assertion) in a form that cannot be regarded as having any exact meaning.

### Factors Relating to Overloading

There are, in any type of speaker and in any individual example, two limitations or two factors that limit the capacity and determine the condition of overload. These are the *maximum amplitude* and the *maximum mechanical force* the diaphragm or cone will stand without ultimate disruption. And both these are related to the acoustical emission. Another factor is the  $C^2R$  loss in the speech coil, which might come into the picture as related to the input; this is the part of the accepted input which is *not* represented by work done. If this were to come in as a limiting factor it would mean that the speech coil would be distorted by heat or burnt out; I have never heard of such an incident being reported.

The watts energy accepted by the speaker is disposed of in overcoming the impedance of same, which comprises the ohmic resistance of the speech coil (to which reference has just been made) and the motional impedance of the diaphragm or cone. The latter, in turn, may be considered as divided into the impedance due to acoustical emission and that due to a dissipation of energy in the cone and its mounting; much of this latter is absorbed in the fabric

or leather peripheral surround. The mass of the diaphragm introduces an impedance of a different character; inertia forces due to its motion are controlled by currents in the speech coil, but these are wattless currents; there are also other wattless components introduced from another cause. For our present discussion these wattless currents may be disregarded.

The motional impedance due to acoustical emission (with which we may lump that due to damping losses without serious objection) is of the same character as ohmic loss; that is to say, the maximum volts and the maximum current are in phase; this is counterpart to the fact that in the generation (or propagation) of an acoustical wave the phase of maximum pressure is also that of maximum forward velocity. Consequently we may treat the impedance as made up of two parts, the pure resistances whose algebraic sum gives the total resistance:—

$$R = R_1 + R_2$$

where  $R_1$  is the ohmic resistance and  $R_2$  the motional impedance. Furthermore, if  $W$  = total watts input, and  $W_1$  = watts dissipated in  $C^2R$  losses, and  $W_2$  = watts output:

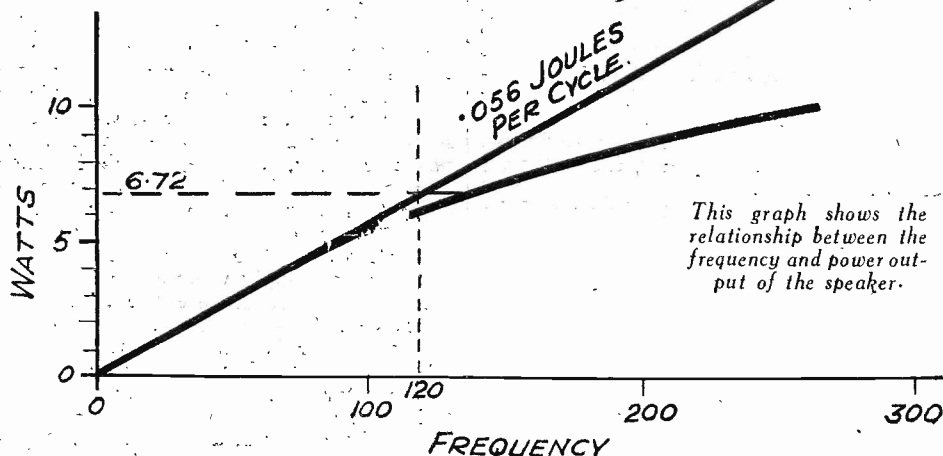

This graph shows the relationship between the frequency and power output of the speaker.

$W = W_1 + W_2$ , and the efficiency (we might say the mechanical efficiency) is given by the expression:—

$$\frac{W_2}{W} = \frac{R_2}{R}$$

In view of the fact that the word *sensitivity* is used in this connection where efficiency would be more appropriate, we might term  $\frac{R_2}{R}$  the "sensitivity factor."

### Wattage "Acceptance" of Speaker

The above is a necessary preliminary to what follows, for the overloading of the speaker is governed by considerations of watts acoustical emission or output, namely  $W_2$ , whereas the usual form of expression is "how much power (watts or milliwatts) will the speaker accept or handle without overload," which is  $W$  and includes  $W_1$ , the watts lost in the ohmic resistance of the speech coil. Obviously, a speaker with a low efficiency or sensitivity factor would, other things being equal, "accept" more watts than one whose efficiency was high, so that really it is not the acceptance, but the acoustical output which should be specified. The acceptance of watts to be converted into heat in the speech coil is

no good whatever, and a speaker that has a good acceptance in this sense only has nothing to commend it.

So we are led to concentrate our attention on the *acoustical output*, and here we have to take into account the effect of frequency. In this connection it is best to consider the diaphragm as an incident in the transmission of an acoustical wave; we could regard the wave as traversing a tube and postulate a weightless diaphragm or piston moving with the air disturbance as the wave progresses and exercising no restraint on same. The diaphragm will transmit movements and forces from the air column (in the tube) on the one side to that on the other; then if the frequency vary, but the energy transmitted remain constant, it is easy to demonstrate that the *amplitude*  $\times$  *frequency* is a constant. Also the *force* (across the diaphragm) for given power transmitted is constant (we are not here dealing with inertia forces due to the mass of the diaphragm, only the forces due to the acoustical output). Thus there is no power limit imposed by high acoustic frequencies; the force transmitted to the air, or force reaction on the diaphragm for a given power output, is independent of the frequency—it is only the amplitude we have to consider.

### Maximum Amplitude

Now in every actual speaker there is a maximum amplitude, whatever the fre-

quency that must not be exceeded; a point is reached when the diaphragm (or cone) reaches its limit of movement, whether this limit is imposed by the surround or centring device does not matter—there must be a limit. Sometimes the limit is signalled by the speech coil being blown out of the gap, or conversely it may be sucked in. And since *amplitude*  $\times$  *frequency* is constant for any given power output, a maximum value of amplitude means (for that output) a minimum value of frequency. Thus, if with 1 watt acoustical output the diaphragm amplitude reach its maximum at 100 cycles per second, then for any frequency less than 100 the speaker will not be capable of giving as much as 1 watt. So we appreciate that when the wattage output or input is stated, the lowest frequency at which this applies should be given in the same breath.

But we can go further; we can express the acceptance or output of the speaker (as the case may be) in terms of the frequency since the amplitude is definitely limited; in brief, the maximum amplitude is the constant of the speaker. Or,  $\frac{\text{watts}}{\text{frequency}} = \text{constant}$ . If we take the inverse of the

(Continued on opposite page)



**THE SPEAKER AND OVERLOAD**

*(Continued from previous page)*

frequency, namely, the *time* required to execute one complete cycle, and call this *t*, then ( $W_2 = \text{watts}$ ) we have:  $W_2 \times t = k$  where *k* is the constant, and *k* gives the speaker power output. Thus, if the limiting output of a speaker be two watts at 100 frequency,  $t = .01$  and  $W_2 = 2$   $W_2 t = .02$  or  $W_2 = k/t = .02/.01$ . And for any other value of frequency, say 50; and  $W_2 = .02/.02 = 1$  watt, and so for any other low frequency; the constant *k* defines the output or the acceptance as the case may be, and takes cognisance of the relation of power (watts) to frequency. The question naturally arises: "What is *k*; is it merely a numeral, constant, or is it a physical reality?" Now a *watt* is a measure of power just as a *joule* is a measure of energy; in fact, a watt is one *joule* (work done) per second,  $W = J/t$ , and since  $k = W \times t$  we have  $k = J$  or *k* is actually the *joules per cycle*.

**Acoustic Output**

We have seen that it is more scientific to specify acoustical output rather than acceptance, which latter relates to the electrical A.C. output of the amplifier, because a low efficiency or sensitivity factor would be a help to the acceptance, and tend to make a poor speaker look like a good one; but it is not always practicable to specify acoustic output. Authorities are not in very close agreement as to the proportion of energy supplied actually delivered as sound. Hence the assumption is made that the sensitivity in different speakers is up to a certain level, which, owing to commercial competition, is more nearly true than might be expected. This being so, the acceptance in *joules per cycle* may be allowed as a measure of the *acceptance* power capacity of the speaker. We then have *W*, the watts supplied in place of  $W_2$ , the watts output; the expression is the same form as before, but the value of *k* will be greater for *W* than for  $W_2$ .

In order to make sure that the meaning is understood, we will take a further example. A speaker accepting 2.8 watts is found to be just within its permissible amplitude at 50 cycles, the test being made at mains frequency. Then

$$k = W \times t = 2.8 \times .02 = .056.$$

That is to say, the speaker will accept .056 joules per cycle. We require to know how many watts it will accept at, say, 120 frequency,  $W = k/t = .056 \times 120 = 6.72$  watts.

It must not be thought that if an amplifier has an output of 6.72 watts, the speaker will be limited to 120 as its lowest frequency; all that is implied is that for frequencies below 120 in the example given the amplifier must have a falling characteristic, such that the A.C. output does not exceed .056 joule per cycle. Referring to Fig. 1, the acceptance graph of the speaker, is a straight inclined line which at 6.72 watts cuts the 120 frequency ordinate. Theory requires that the output characteristic of the set does not at any point rise above the acceptance curve.

**Frequency and Impedance**

The common or popular method of giving the acceptance of a speaker in watts without specifying the frequency, we have seen cannot be justified. But if we were dealing with some particular kind of music in which the lowest frequency can be inferred without

*(Continued on page 109)*

**NO MORE HAPHAZARD MATCHING**

**'MICROLODE' type**  
**PM4a - 42/-**  
**PM6 - 32/6**

With the new "Micro-lode" feature and the famous "Mansfield" magnetic system.

*Seventeen transformer ratios for really accurate matching to any power valve or pentode and four ratios for Class B or Q.P.P. all available on one speaker by a simple switch adjustment!*

*Added sensitivity due to the 'Mansfield' magnetic system! Better balance through really accurate matching! The difference in performance must be heard to be believed.*

*Write for the new folder and ask your dealer for a demonstration.*

*We are exhibiting at the Manchester Radio Exhibition, Sept. 27 to Oct. 7.*

**'MICROLODE' MOVING-COIL SPEAKERS**

(Regd. Trade Mark)

Whiteley Electrical Radio Company, Ltd., Dept. D., Radio Works, Mansfield, Notts.

# MARCUS, OVERTON RADIO, LTD.

62, Borough High Street,  
London Bridge, S.E.1.

GUARANTEED  
EFFICIENCY



EXPRESS  
SERVICES

## "PREMIER SUPER" DE LUXE KIT

| SPECIFICATION:-         |   | £ s. d. |
|-------------------------|---|---------|
| 1                       | British Radiophone Superhet 3 gang Midget variable condenser, complete with full vision disc drive, Type 582a | 1 11 0  |
| 1                       | Set Lissen matched Superhet coils   | 1 10 0  |
| 2                       | Lissen Intermediate Frequency Transformers  | 15 0 0  |
| 1                       | Belling Lee w.w. 50,000 ohm Potentiometer   | 4 0 0   |
| 1                       | Bulgin 5-point switch   | 1 0 0   |
| 1                       | Bulgin Push-Pull Radio-Gram switch  | 1 9 0   |
| 3                       | Glassia Brackets  | 15 6    |
| 1                       | R.I. "New Hypermu" L.F. Transformer   | 4 0 0   |
| 6                       | Erie 1 watt resistances, 20,000, 10,000, 20,000, 30,000, 100,000 ohms and 2 megohms                           | 6 0 0   |
| 2                       | Dubilier .1 mfd condensers type BB  | 3 8 0   |
| 2                       | Dubilier 2 mfd condensers type BB   | 7 0 0   |
| 1                       | Dubilier .0001 mfd condenser type 670   | 1 0 0   |
| 1                       | Dubilier .0002 mfd condenser type 670   | 1 0 0   |
| 1                       | Dubilier .0003 mfd condenser type 670   | 1 0 0   |
| 2                       | Dubilier .01 mfd condensers type 670  | 4 0 0   |
| 1                       | Polar Preset condenser .002 mfd   | 2 0 0   |
| 4                       | Clix 4 pin chassis valve holders (airspaced)  | 4 8 0   |
| 1                       | Clix 5 pin chassis valve holder (airspaced)   | 1 3 0   |
| 3                       | Belling Lee Terminal mounts   | 1 6 0   |
| 6                       | Belling Lee "R" type terminals  | 1 3 0   |
| 6                       | Belling Lee "Bowspring" warbler plugs   | 9 0 0   |
| 1                       | "Ace" drilled and foil covered chassis  | 3 0 0   |
| 1                       | Belling Lee fuse and holder   | 1 0 0   |
| 5                       | Cosson valves to specification  | 3 1 6   |
| 5                       | Connecting wire, flex, screws, etc.   | 1 5 0   |
| Kit B, including valves |   | £10 1 0 |

Any component supplied separately.  
**Kit A**, as above Specification, but without valves ... £6 19 6  
 or 12 monthly payments of ... 12 6  
**Kit B**, as above Specification ... 10 1 0  
 or 12 monthly payments of ... 18 6  
**Kit C**, as above Specification, with valves and "ACE" Brand Super Cabinet in Walnut ... 10 16 6  
 or 12 monthly payments of ... 1 0 0  
**Kit D**, as above Specification, with valves and "ACE" Brand Super Console Cabinet in Walnut, fitted with W.B.P.M.6 speaker ... 12 18 6  
 or 12 monthly payments of ... 1 4 0

### "PREMIER SUPER" ACCESSORIES.

|  |        |
|--|--------|
| Ever Ready 9 Volt G.B. Battery   | 1 0    |
| Ever Ready 120 Volt H.T. Battery, Winner type  | 11 0   |
| or Popular type  | 15 6   |
| Block New Plateless L.T. Accumulator 80 amp/hrs.   | 11 6   |
| Block 120 Volt Plateless H.T. Accumulator 5,000 ma/hrs.                                  | 3 15 0 |
| M.P.R. Eliminator with trickle charger for 5-valve receiver type AC20.                   | 3 12 6 |
| W.B. Type P.M.6 Microloide Moving Coil Loud Speaker                                      | 1 12 6 |
| Belling Lee Unit Gramophone Pick-up  | 1 2 6  |
| Belling Lee Volume Control for above   | 4 0 0  |
| Garrard No. 30 Double Spring Turntable   | 1 5 0  |
| Lissen All Wave Four complete kit with valves  | 5 12 6 |
| Lissen 7 Valve Superhet complete kit with valves   | 8 17 6 |
| Telsen Super Six complete kit with valves  | 9 15 6 |
| Sound Sales Class B Unit complete with Class B valve                                     | 2 9 0  |
| (Ready for use with any receiver using 2 Volt battery operated valves.)                  |        |
| Westinghouse A.C. Mains Superhet. Blueprint, constructional details and prices Post Free | 1 3    |
| Scott-Taggart S.T.400 Kit A  | 4 15 0 |
| or 12 monthly payments of  | 8 0    |

**HERE'S A WAY TO SAVE MONEY . . .**  
 Old sets rewired and modernised.  
 Send full details of your present set and state approximate amount you are prepared to spend and we will give you free advice and quotations.  
 We stock everything connected with Radio.  
 Component parts—Speakers—Manufactured Receivers—Mains Units, etc. Cash, C.O.D. and Easy Terms.

**COUPON**

MARCUS, OVERTON RADIO LTD.,  
 62, Borough High St., London Bridge, S.E.1.  
 Phone: Hop 4431.

Please supply Cash/C.O.D./Terms.....  
 for which I enclose £.....s.....d.  
 Cash/Deposit.

NAME .....

ADDRESS .....

Pr. W. 30/9/33.

TRADE SUPPLIED.

# FROM THE FLASH LAMP

"TUNING COILS." By "Photon"

PRIOR to the introduction of the iron-powder core the practice with regard to tuning coils had become standardized on the basis of a single layer solenoid winding for the medium waveband, and, generally speaking, bunch winding subdivided and accommodated in two or three slots for the long-wave band.

Confining our attention to the medium waveband solenoid winding, many formulas have been given at different times for the calculation of inductance, but such formulas only apply strictly when the winding is well clear of screening or other conductor capable of reacting on the winding by induction. The theoretical basis is that the coil is in the open far removed from any conducting body. In the case of potted coils this condition is violated to such an extent that the ordinary equation or formula is no longer applicable.

The writer always prefers to apply fundamental principles rather than employ a cut and dried formula, and in the first section of this article the subject dealt with is the solenoid winding under ideal conditions, that is, in the open.

The essential, which it is

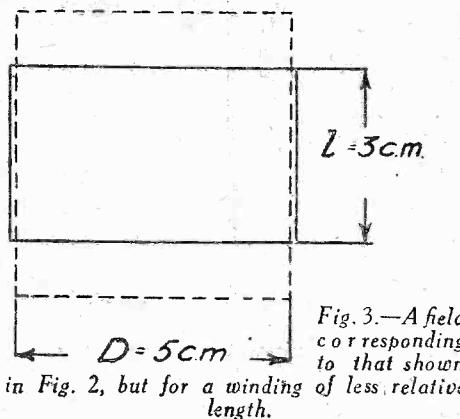

necessary to calculate, is the inductance; in the first place we go over old ground. The inductance of any given coil is the product of the number of turns, and the number of lines of force threading or interlacing same for one ampere current flowing in the winding. To give the inductance in henries, this must be divided by  $10^9$ , or in microhenries, by  $10^6$ . The problem centres itself round the calculation of the number of lines of force in question, that is to say, the flux.

If  $N$  = the number of turns, then with one ampere flowing  $N$  = the ampere turns

and the measure of this in gilberts is  $0.4\pi N$ . If the whole of the reluctance of the magnetic circuit were in the core of the solenoid all we should have to do to obtain the lines of force per  $\text{cm}^2$  would be to divide  $0.4\pi N$  by the length of the winding in centimetres. But part of the reluctance of the magnetic circuit is in the external field, and we must measure this or assess it on some basis. It is here that the complications of the usual formula come in. We find some constant has to be applied which is tabulated and has a different value for every diameter/length ratio. The writer's method avoids this, if a length equal to 0.45 of the coil diameter be added to  $l$ , the actual length of the winding, it exactly (within 1 per cent.) accounts for the reluctance of the external field. So we proceed as follows:—

We define  $l_2$  as equal to  $l + 0.45 D$ ,  $l$  and  $D$  being in centimetres. Then the lines of force per square centimetre within the winding will be  $0.4\pi N / l_2$  and total flux =  $\frac{0.4\pi N^2}{l_2}$  multiplied by the area  $\frac{\pi D^2}{4}$  =  $0.1 \times \pi^2 N^2 D^2 / l_2$  so that the inductance =

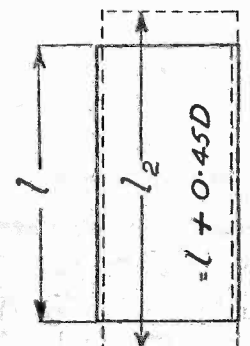
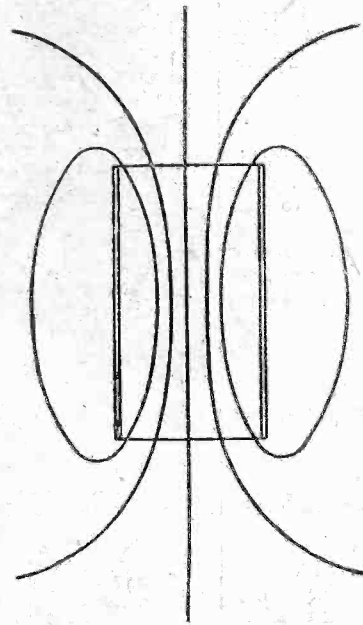

Fig. 1.—Diagram illustrating the magnetic field set up by a solenoid winding.

Fig. 2.—Showing the equivalent field according to the "Photon" rule.

$$0.1\pi^2 N^2 D^2 / l_2 \times 10^8 \text{ henries, or approximately } \frac{N^2 D^2}{l_2 \times 10^9}$$

In microhenries =  $\frac{N^2 D^2}{l_2 \times 10^6}$

The writer does not consider any formula is properly presented to the practical man unless accompanied by one or more examples. In Fig. 1 we have a graphic representation of the magnetic field set up by a solenoid winding. Fig. 2 represents the equivalent field according to the "Photon" rule, namely,  $l_2 = l + 0.45 D$ . Fig. 3 is a figure corresponding to Fig. 2 for a winding of less relative length, and Fig. 4

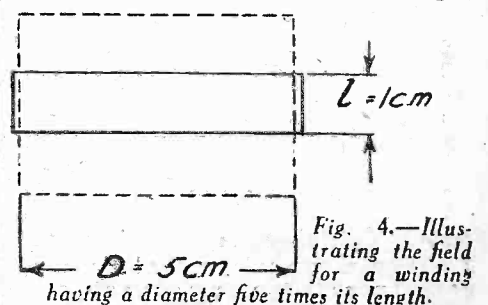

shows a similar diagram for a short winding whose diameter is five times its length. About this point the "Photon" rule begins

(Continued on page 109)



**The Best Low-Priced  
L.F. Transformer on  
the market**

**BRITISH GENERAL**

**"VICTORY"**

Beautifully made.  
Superb performance.  
Ratio 3½-1, suitable  
for single or double  
stage.

**4/6**

From all dealers or  
direct from the manu-  
facturers :

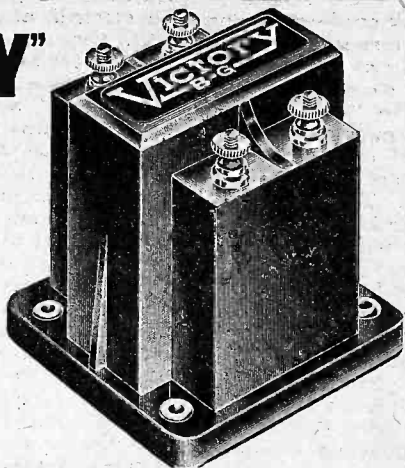

**BRITISH GENERAL MANUFACTURING CO., LTD.,**  
Brockley Works - - - London, S.E.4

**FROM EVERY  
POINT OF VIEW**



*The*  
**AMPLION M.C.22**

If quality is your aim then you will appreciate the pure natural tone of the M.C.22.

Equally is it sensitive to distant signals, thereby increasing the usefulness of your receiver.

The provision of a universal transformer means that you can fit the M.C.22 to any type of set, Power, Super-Power, Pentode, Class "B," Q.P.P. and Push-Pull.

As an extension speaker to powerful sets it is eminently suitable, having a power handling capacity of 5-6 watts, undistorted output.

Finally, such a perfect all-round moving-coil speaker at a price of 39/6 represents the finest value for money ever offered to constructors ; and so from every point of view your choice will undoubtedly be the Amplion M.C.22.

**AMPLION**

AMPLION (1932) LTD., 82-84 ROSOMAN STREET, LONDON, E.C.1.  
CLERKENWELL 5440-1.

**UNIVERSE**

**1934  
PICK-UP**



Complete with  
volume control  
and connecting  
leads.

**20/-**

Output nearly 4 volts. Average output 2 volts. Base can be used in any position. Impossible for pick-up reel to go out of adjustment (part. applied for). Special ball-catch swivel head for easy needle changing. In attractive brown bakelite moulded case. Ask your dealer for demonstration or write us for catalogue.

**NORTHERN  
RADIO EXHIBITION.**  
Manchester, Sept. 27-Oct. 7.  
STAND NO. 104. GALLERY.

**COSMOCORD LTD. 12, D'ARCY ST., CAMBRIDGE ARTERIAL RD., ENFIELD MIDDXX**

**MODEL No. 253.** A very modern Table Model radio cabinet with speaker combined. Inside measurements 24 in. long, 11 in. high, and 11 in. deep. Ample accommodation for H.T., L.T., and G.B. Batteries.

**PRICES:** Machined Kit of Parts, Oak 12/6, Mahogany or Walnut 15/-. Assembled Ready to Polish, Oak 17/6, Mahogany or Walnut £1.0.0. Assembled and Polished, Oak £1.2.6., Mahogany or Walnut £1.5.0. CARRIAGE PAID U.K.

**a new  
modern  
OSBORN  
cabinet**

**NORTHERN NATIONAL RADIO EXHIBITION,** Manchester, September 27—October 7. Stand No. 78, Main Hall.

Sole manufacturers of the  
**OSBORN BAFFLE BOX,** 18in. by 18in. £1.0.0. 24in. by 24in. £2.0.0.

**WRITE FOR CATALOGUE**

**CHAS. A. OSBORN** (Dept. P.);  
Recent Works, Arlington St., New  
North Road, London, N.1. Tel.:  
Clerkenwell 5095. Showrooms:  
21, Essex Rd., Islington, N.1.  
Tel.: Clerkenwell 5034.

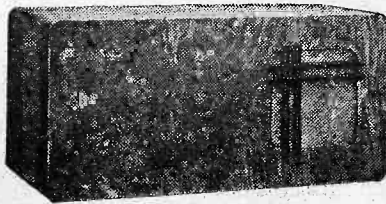

ANNOUNCEMENT

★ to men who want careers in RADIO



The I.C.S. Radio Courses cover every phase of radio work, from the requirements of the youth who wishes to make wireless engineering his career to the man who wants to construct and maintain a broadcasting set for his home.

The Radio industry is progressing with amazing rapidity. Only by knowing thoroughly the basic principles can pace be kept with it. Our instruction includes American broadcasting as well as British wireless practice. It is a modern education, covering every department of the industry.

OUR COURSES

Included in the I.C.S. range are Courses dealing with the Installing of radio sets and, in particular, with their Servicing, which to-day intimately concerns every wireless dealer and his employees. The Operating Course is vital to mastery of operating and transmitting.

There is also a Course for the Wireless Salesman. This, in addition to inculcating the art of salesmanship, provides that knowledge which enables the salesman to hold his own with the most technical of his customers.

We will be pleased to send you details of any or all of these subjects. Just fill in, and post the coupon, or write in any other way, stating which branch of Wireless interests you—the information you require will be forwarded at once.

International Correspondence Schools, Ltd.,  
Dept. 94, International Buildings,  
Kingsway, London, W.C.2.

Without cost, or obligation, please send me full information about the Courses I have marked X

- COMPLETE RADIO
- RADIO SERVICING
- RADIO EQUIPMENT
- RADIO SERVICING AND SALESMANSHIP
- WIRELESS ENGINEERING
- WIRELESS OPERATORS

Name..... Age.....

Address .....

# RADIO RAMBLINGS

By JACE



Condenser Drives

EVEN the best variable condenser cannot give satisfactory service if it is not fitted with suitable means of operation. Tuning is so extremely sharp and critical on short waves that the "spread" of a station on 30 metres is only about a third of a degree on the dial of a .0001 mfd. condenser, so some form of reduction drive is a practical essential. There is a good deal of disparity, both inside the trade and elsewhere, regarding the most suitable form of reduction drive and the mechanical principle upon which it should operate. Some manufacturers prefer a 100 to 1 reduction, and others favour a ratio of only 10 to 1; some say a positive gear drive is essential, and others swear by the frictional method.

I am of the personal opinion that a ratio somewhere between the two is most pleasing from the point of view of ease of operation. A high ratio allows of accurate tuning, but I find it very irksome to have to rotate the tuning knob through fifty whole revolutions to get from zero to 180 degrees on the tuning dial. On the other hand, a ratio of 10 to 1 is not quite sufficient to permit of really accurate tuning, although it does allow "searching" to be carried out more rapidly. A well-made drive, giving a reduction ratio of about 25 to 1 and having a good-sized operating knob, seems to be just about right. I don't think it matters whether the operating mechanism employs gears or friction discs, so long as it is really well made and is entirely free from backlash.

The Reaction Condenser

AS to the reaction condenser, the capacity must depend entirely upon the size of the reaction winding. Here again opinions differ, for some designers prefer a small condenser and a large reaction winding, and vice versa. I always prefer to use the smallest winding possible, and this entails the use of a larger condenser. As a general rule, I employ about two-thirds as many turns for reaction as for tuning purposes, and this involves the use of a reaction condenser having a capacity of from .0002 mfd. to .0001 mfd. When the reaction winding has more turns than the tuned winding it is liable to be tuned (by the series-connected condenser) to the same wavelength as the tuned circuit, and this can cause all kinds of queer effects. Not least of these is a complete "dead spot" on the tuning dial, over which it is quite impossible to obtain reaction.

Aerial-Earth Systems

ALTHOUGH surprisingly good short-wave reception is often obtained on what appears to be the worst possible aerial, it is worth while to give close attention to this item if maximum

efficiency is to result. When it can be erected, a short vertical wire about 20ft. long is best, but it should be kept as far away from earthed objects as the situation permits. If the normal "broadcast" aerial must be used, a small series condenser is essential, and the longer the aerial the smaller should the capacity of this be. It is often found that a short indoor aerial gives better results than a long outside one: such an aerial is certainly worth a trial when the outside one is long or has a high capacity.

The earth lead should either be a first-rate one, or should be discarded entirely. Most short-wave sets will give better results without an earth than with a poor one, but the absence of an earth almost invariably makes hand capacity more troublesome. The ideal is one consisting of a similar wire to the aerial and erected below and parallel to the latter. This is called a counterpoise earth, and although it is not commonly used by amateurs for receiving, it is very popular with transmitters. The wire should be insulated in the same way as the aerial and erected from 6 to 8ft. above the ground. A counterpoise earth has a very low resistance, and therefore does not add to the damping of the tuned circuit.

New Polish Stations

POLAND, one of the countries which did not agree to the findings of the Lucerne Conference, is adding two more transmitters to her wireless net. The Poznan 2 kilowatt transmitter will be dismantled and re-erected at Torun (Thorn) at no great distance from Danzig. It will work on a common wavelength with Cracow, in 1934, on 219.6 metres. Poznan, in compensation, will be endowed with a 20 kilowatt station. Work is being hurried forward, and tests may be made before the end of this year.

Cutting Down Broadcasts

IN consequence of a "cut" in its revenue, the I.N.R. responsible for radio transmissions from the two Brussels stations has been compelled to curtail its programmes. In future there will be only two broadcasts daily, namely, from midday to 2 p.m. (week-days), or 10 a.m. to 2 p.m. (Sundays) and from 5 to 10 p.m. daily.

Alternative Channels

IT is often very difficult to pick up transmissions from such stations as Belgrade and Ljubljana, and so far for these programmes no alternative channel has been available to the foreign listener. In future, Czechoslovakia and Yugoslavia will exchange a series of evening entertainments and in this manner the latter's best programmes will frequently be heard through Prague. This station is one of the most powerful in Europe as its 120 kilowatt broadcasts are easily receivable on almost any evening.



**THE SPEAKER AND OVERLOAD**

(Continued from page 105)

being stated—for example, a string quartet in which the lowest tone is approximately sixty-six, the open C string of the 'cello; or if concerned only with the spoken voice, as in public address, in which case the lowest tone is in the region of 100 or 120—then in either case it would be legitimate to talk in watts acceptance, but only so on account of the fact that the lowest tone is understood without being expressed. If, however, forgetting this limitation, the speaker be called upon to receive its declared watts from organ music at a frequency of, say, 30 cycles, it will immediately be found to be overloaded and the diaphragm will be overswinging with the emission of anything from a few unauthorized harmonics to a regular concatenation. Moreover, a speaker treated in this way will sooner or later show signs of disintegration.

The relation of the total watts supplied,  $W$  to the watts dissipated in the winding  $W_1$ , and the watts emitted acoustically,  $W_2$ , depends upon the value of  $B$ , the number of turns in the field, and the ohmic resistance of the winding; these relations will be discussed in a later article. It may be stated here that the theoretical value of  $W_2$  in terms of  $W$ , which is the same as the motional impedance in terms of the total impedance, is commonly in the region of 33 per cent. to 50 per cent., and this (if the theory were complete) would represent the mechanical efficiency of the speaker, or otherwise express its sensitivity factor. But authorities, generally speaking, give a very much lower figure as based on acoustical measurements. This is in part due to the damping losses and in part due to the "back-wash," i.e., the energy given out from the back of the diaphragm; this latter may easily represent nearly half of the motional impedance of the speech coil and watts sound emission of the diaphragm. It is not actually lost, or not wholly lost, in a speaker as used, but it is not recorded in the measurements made by the microphone in a padded room. There is also the question of the wattless component or components of the working current; it is difficult to say how much this may invalidate the conclusions drawn from the elementary theory.

**FROM THE FLASHLAMP**

(Continued from page 106)

to break down; with a coil whose diameter is eight to ten times its length, the addendum to be added to the length  $l$  is about 10 per cent. lower, namely, .040 D.

*Numerical Example:*

Let  $N=65$  turns;  $N^2=4,200$ .

Let  $D=5$  cm.;  $D^2=25$ .

Let  $l=3$  cm.;

Then  $l_2=3+(0.45 \times 5)$ .

$=3+2.25=5.25$ .

Let  $L$ =inductance in  $\mu$ h.

Then:

$L_1 = \frac{4,200 \times 25}{5.25 \times 10^3} = 200$  microhenries.

The reader is invited to work out examples and compare results with those obtained from other published formulas.

Some formulas give the inductance in centimetres. To those not accustomed to absolute units, or c.g.s. units, this is mystifying. All that is necessary is to remember that 1,000 cm. go to the microhenry, or one microhenry=ten metres.

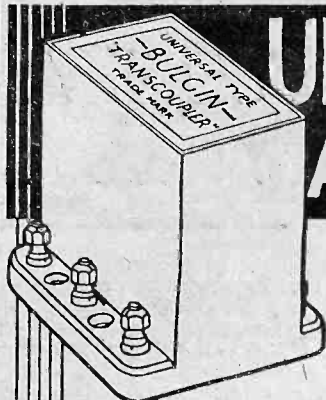

**UNIFORM RESPONSE AT EVERY FREQUENCY**

**SCRAP YOUR OLD TRANSFORMER**

Bring your set up-to-date by changing over to a modern "Parallel-Fed" inter-coupling unit. This change will give you improved quality of tone and conspicuously uniform amplification from bass to treble. The "Transcoupler" is a universal type for use after any valve and incorporates the necessary wire wound resistances and condenser in a handsome bakelite case.

Easy to fit. Connect as shown below in place of old transformer and simply add an earth connection.

Send for New 80-page Catalogue No. 153 N. Enclose 2d. postage.

A. F. BULGIN & CO., LTD., Abbey Road, BARKING, ESSEX.

Telephone - - - - - Grangewood 3266-3267.

London Showrooms: 9-10-11, Cursitor Street, Chancery Lane, E.C.4.

**TRANSCOUPLER TRADE MARK**

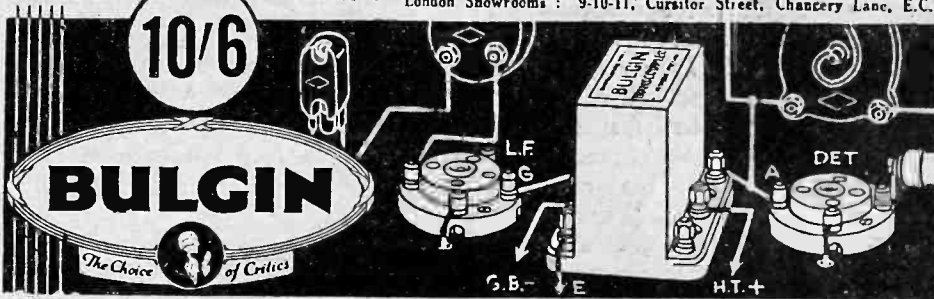

Instantly you get astonishing new clarity of reception by connecting up the AIRCLIPSE in place of your present aerial. Selectivity is amazingly improved. The Airclipse is not another gadget—not a condenser. It is an auto-inductive aerial that filters incoming signals. It eliminates lightning danger; disposes of untidy wires; fits inside or outside the set.

A delighted user writes:—"Sensitivity was far above what I expected from it. My friends are also much impressed."

**AIRCLIPSE AUTO-INDUCTIVE AERIAL**

FOR A.C. MAINS AND BATTERY SETS

Of all dealers or direct from.

AIRCLIPSE LTD., 182, VAUXHALL BRIDGE RD., LONDON, E.W.1. Phone: Victoria 5022



"We're Fluxite and Solder—the reliable pair; when making that Set: Famous for Soldering—known everywhere! The job will be 'super'—PERFECTION you'll get!"

See that Fluxite and Solder are always by you—in the house—garage—workshop—anywhere where simple, speedy soldering is needed.

ALL MECHANICS WILL HAVE

**FLUXITE**

IT SIMPLIFIES ALL SOLDERING

All Ironmongers sell Fluxite in tins: 4d., 8d., 1s. 4d., and 1s. 8d. Ask to see the FLUXITE POCKET SOLDERING SET—complete with full instructions—7s. 6d. Ask also for our leaflet on HARDENING STEEL with Fluxite.

FLUXITE, LTD.

(Dept. W.P.), ROTHERHITHE, S.E.16.

FOR ALL REPAIRS!



# SECRETS OF CELESTION SUPREMACY

No. 2.

## ACCURATELY PROPORTIONED MAGNETS!

The cobalt steel magnets fitted to Celestion Speakers are *accurately* proportioned. The proportions are such that wasteful magnetic leakage is reduced to a minimum and the whole of the cobalt steel used to its fullest advantage. As a result, Celestion Speakers are much more efficient—are much more sensitive—than other speakers fitted with far larger magnets less accurately designed. It is such *attention to detail* that puts Celestion in the forefront of modern loudspeaker design. The name Celestion stands for high-quality reproduction combined with unflinching efficiency. Celestion speakers can be supplied to match any set or type of output. Ask your dealer to demonstrate, or write for illustrated details.

PPM9 Chassis Model £1-15-0  
PPM19 Chassis Model £2-7-6  
PPM29 Chassis Model £3-17-6  
Celestion Ltd., London Road, Kingston-on-Thames.

MODEL P.P.M.9

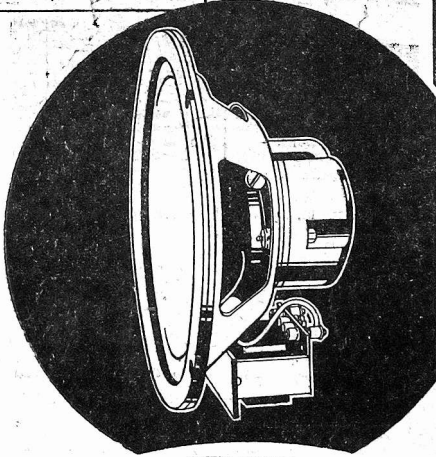

# CELESTION

*The Very Soul of Music*

THE FOREMOST NAME  
IN SOUND REPRODUCTION

# THE SUN AND WIRELESS SIGNALS

(Concluded from page 24,  
September 23rd issue)

FOR example, if reception conditions were good in 1917 and 1928 they will again be good in 1939, and during no year between those dates will the general level of conditions rise as high as it does in 1917, 1928 and 1939. Conversely, there will be years when the general level of conditions is bad; 1923 was the last of such, so that we may expect bad conditions again in 1934. It must be realized that since regular observations were only begun in 1915 the existence of this cycle cannot be regarded as proved beyond all doubt, but it has appeared quite regularly since 1915, and the interesting thing about it is that this cycle of variations follows very closely the sunspot cycle of the sun. Sunspots are believed to be cyclonic whirlwinds on the sun that show up black against its disc, and these have the interesting property that the number appearing in a year follows a definite cycle of eleven years; if a maximum number of spots is observed in 1917, the next maximum will appear in 1928, and a minimum in 1923 will be repeated in 1934. It has been found that over the period of time investigated the sunspot cycle is accompanied by a parallel variation in radio conditions on the earth, being at their best at sunspot maxima and worst at sunspot minima. It is believed that sunspots cause a great increase in the corpuscular radiation from the sun and hence increase the ionization of the Heaviside and Appleton layers. There is experimental evidence to show that the ionization at sunspot maximum is about 60 per cent. greater than that at sunspot minimum. The effect of such an increase in ionization on wireless signals depends on the wavelength. Short-wave signals will generally be stronger because, owing to the increased ionization, a greater part of the radiation from a station will be returned to the earth by the Appleton layer than is the case at times of low ionization. At the other end of the wireless spectrum Dr. L. W. Austin showed that very long wave signals also increased in strength at sunspot maximum. Both long and short waves therefore give louder signals at sunspot maximum and their eleven year period is parallel to the sunspot period. The medium-wave band between 150 and 400 metres, however, behaves in an opposite fashion, giving loudest signals at times of lowest ionization, i.e., at sunspot minima. This is because these wavelengths, known as "critical wavelengths," are much more strongly absorbed in the Heaviside layer than waves either above or below them, and this absorption increases with increased electron density and therefore ionization. Consequently at times of sunspot maximum medium-wave signals will be weak.

### Reflection from the Appleton Layer

In years of sunspot minimum ionization falls off with the result that short waves are not completely refracted, a higher percentage escaping from the Appleton layer and consequently the range and signal strength will be reduced. Medium waves, on the other hand, may give stronger

signals partly because attenuation is reduced and partly because they may pass through the lower layer, since it is much less ionized, and be reflected at the upper layer, with the result that the range is greater since the height of the reflecting layer is greater. Also it must be remembered that the earth acts as a not-very-efficient reflector, so that a signal on a wavelength, coming from the reflecting layer, may strike the earth and be returned once more to the layer whence the wave is again reflected to the earth, and a signal may make several hops of this kind, following a path such as TABCR in Figure 1. Clearly the longer the hop the less the attenuation, and reflection at the Appleton layer necessarily results in a greater hop than from the Heaviside layer; the path TPR in Figure 1 illustrates this point. This then is a possible reason for improved conditions on medium waves at times of sunspot minima and would explain the unusually good reception from North America during the past winter, which is near a sunspot minimum.

Another periodic change in conditions has been shown to exist by Dr. G. W. Pickard in some observations on medium-wave broadcast stations. In this case a cyclic change from good to poor conditions every fifteen months was noticed, and it was found that this cycle corresponded very closely with what is called the subsidiary sunspot cycle, a period of fifteen months during which sunspot numbers fluctuate from a minimum to a maximum, about the average value for the year in the eleven-year cycle. It is important to notice that during this fifteen-month cycle the best conditions for reception were found to coincide with sunspot minima. From the discussion of the behaviour of medium waves during the eleven-year cycle, this inverse relationship for the fifteen-month cycle is to be expected, since observations were made on medium-wave stations only; it is probable that the reverse effect would be observed on short and very long waves.

There is another important terrestrial phenomenon whose variations follow a cycle parallel to that of the sun's spottedness, and that is what is called the earth's magnetic activity. This refers to changes that occur in the normally steady magnetic field, changes which are called magnetic storms and are detected as violent perturbations of sensitive magnetic needles on the earth's surface. They are believed to arise from a great increase of ionization in the upper atmosphere, causing large electric currents to flow which disturb the magnetic field, but what causes the increased ionization is not clear. The cycle of magnetic activity is very closely parallel to that of the sun's spots and, consequently, a magnetic storm generally accompanies the appearance of a sunspot, but they do not necessarily appear together, and so it is becoming customary now to describe magnetic storms as arising from what are vaguely called M-regions of the sun.



# Facts and Figures

Components Tested in our Laboratory

BY THE PRACTICAL WIRELESS TECHNICAL STAFF

### WEARITE A.V.C. UNIT

THIS is a very neat component designed for inclusion in a powerful receiver employing H.F. stages for the purpose of removing the troubles caused by fading. It is, of course, an additional requirement to the normal manual or hand-operated volume control, but enables the output of the receiver to be kept at a more or less constant level. It measures approximately 3in. long by 1½in. wide and is just over 1in. deep. Six terminals are provided, together with two small shorting straps. The usual circuit arrangement employing a resistance, condensers and metal rectifier (or cold valve) is used, and the unit is connected

distance piece. The ends of the windings are brought out to four terminals mounted on a paxolin strip and they are numbered from 1 to 4. The resistance of each choke is approximately 500 ohms, and the inductance of each choke is sufficiently large to provide adequate smoothing at quite high currents. The price is 12s. 6d.

### B.R.G. MINOR BINOCULAR CHOKE

A VERY neat and compact H.F. choke of the binocular type is manufactured by the British Radiogram Company, and costs 3s. 6d. Two small ebonite pillars are grooved to accommodate the windings which are carried out in enamel covered wire, and terminals are fitted to the tops of the pillars for connection. A small base of rectangular shape is provided and the component is mounted on the base-board with two wood-screws. The D.C. resistance of the choke is only 150 ohms, so that it may be safely included in the anode circuit of a detector valve which is used alternatively as an L.F. valve with a gramophone pick-up, without undue voltage drop taking place. A larger type of choke is also obtainable and bears the name Major, at a cost of 4s. 6d. It is built up on similar lines but has a much larger winding and slightly greater D.C. resistance.

### EELEX MODULATED OSCILLATOR

ALTHOUGH primarily designed for testing purposes, this ingenious oscillator, an illustration of which appears below, will be found a most useful piece of apparatus for the amateur. It consists, as may be seen, of a neat case very much resembling a portable gramophone. A good clockwork motor and a pick-up of sound design is fitted, and beneath the motor-board is arranged the necessary electrical equipment. This consists of a single valve unit, coils, etc., arranged to provide a modulated circuit. The normal method of using the outfit is to connect a 60-volt H.T. battery and a 2-volt accumulator to the requisite leads and place a gramophone record on the turntable. When switched on the unit radiates the music with quite a good strength over a fair distance. If, therefore, the tuning scale on the oscillator is adjusted, say, to 250 metres, when the tuning dial of a receiver situated near to it is also adjusted to 250 metres, the music from the oscillator will be picked up by the receiver and reproduced from the loud-speaker. It thus offers a novel method of utilizing the radio-gramophone feature, without the necessity of building a large radiogram cabinet, and has the added advantage that needle scratch, etc., is removed in the oscillator. Furthermore, for test purposes, the oscillator may be adjusted to any frequency over the normal broadcast band, and the receiver under test then tuned to the same frequency in order to pick up the radiated oscillations. It is not necessary, therefore, to wait for a transmission in order to test some particular receiver.

It is altogether a most valuable piece of apparatus. With valve complete the cost is £2 15s., and a De Luxe model is available in oak cabinet for £3 15s. The makers are J. J. Eastick and Sons.

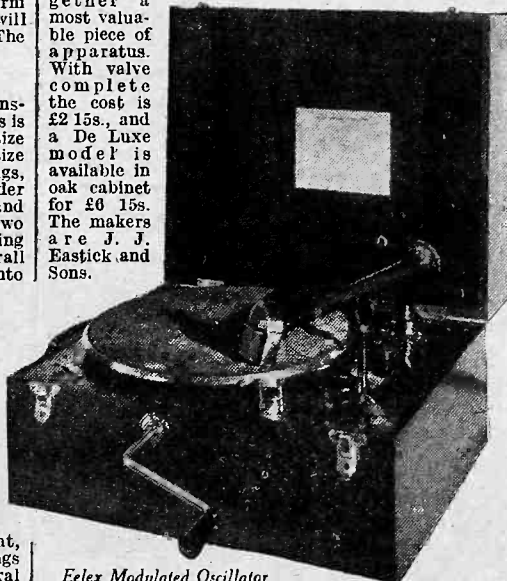

Eelex Modulated Oscillator

### MILLGATE H.T. BATTERY

THE principal feature of the Millgate battery is the inclusion of a fuse in the actual battery. The normal negative socket is connected, therefore, to the first cell of the battery via a screwed socket into which fits a neat fuse, rated in the model supplied for test at 150 m.A. There is no necessity, therefore, to use special battery cords, or to include a fuse in the receiver, as the entire circuit is safeguarded at the source. The battery supplied for test was rated at 60 volts, and when received the measured voltage was slightly in excess of this value. A shelf-life test was arranged, and the battery was stood by, without any precautions for protection, etc., for three months. At the end of this period the voltage was again measured and found to be just over 59 volts. In view of the fact that the position chosen for storage received quite a large proportion of direct sunlight during the period this is very good indeed. A discharge test was then arranged and the battery was short-circuited for a few minutes. The results of all our tests confirm that this is a splendid battery for normal use, and will be found to give adequate service and protection. The fuse is, of course, replaceable.

### GRAHAM-FARISH "PIP" TRANSFORMER

THIS is probably one of the smallest L.F. transformers we have received for test, although as is usual with modern wireless components, the size gives no indication of performance. In spite of its size this transformer employs quite substantial windings, the D.C. resistance of the primary being of the order of 500 ohms. Two ratios are obtainable, 3 to 1 and 5 to 1, and the instrument was tested in a simple two valver in order to obtain some idea of its quality-giving properties. We were agreeably surprised at the overall response, which seemed to extend much farther into the lower region than one would expect from such a component. In a three-valver, two of these transformers were used without ill-effects, and for all normal requirements, where expense is a consideration we have no hesitation in recommending the use of this component. The price is 6s. 6d., and the makers Graham Farish, Ltd.

### FORBAT DOUBLE CHOKE

THERE are a number of circuits where it is desirable to employ a smoothing choke having two separate windings wound over one core. Some types of Universal circuit, for instance, work better with one choke in each mains lead, a common iron core being included in both chokes. A neat component of this type has been received from Eugen Forbat, and employs a core ¼in. thick, with the two windings arranged on a former which is provided with a central

## EASY TERMS

The very latest Radio sets, loudspeakers and kits supplied on the lowest monthly terms. Strict privacy. Prompt delivery. All carriage paid. Price list free.

New BLUE SPOT 60 PM UNIT with transformer. (The finest perm. magnet unit available.) Cash price 59/6, or 5/- with order and 11 monthly payments of 5/6.

MULTITONE CLASS "B" CONVERTER with valve ready for plugging-in to any set. Cash price 51/6, or 5/- with order and 10 monthly payments of 5/2.

FERRANTI CLASS "B" SPEAKER AMPLIFIER moving-coil unit with valve. Cash price 24-4-0, or 3/- with order and 11 monthly payments of 7/8.

New LISSEN SKYSCRAPER ALL-WAVE-4 KIT with valves. Cash price 112/6 10/- or 11 of 10/3. As above, but with Cabinet. 128/- 11/6 11 of 11/9

New BLUE SPOT 60 PM with transformer. 32/6 5/- 6 of 5/-

New W.B. MICROLODE PM4A UNIT with transformer and special matching switch. 42/- 5/1 8 of 5/1

New ATLAS MODEL CA25 H.T. ELIMINATOR, output 25MA. 59/6 5/- 11 of 5/6

RADIOPHONE RADIOPAK 1-E.F. Band-pass stage. 60/- 5/6 11 of 5/6

Interesting descriptive leaflet of any of the above free. To avoid delay will customers kindly send first payment with order?

Estd. 1925 THE LONDON RADIO SUPPLY COMPANY. Phone: National 1977.

11, OAT LANE, NOBLE STREET, LONDON, E.C.2



## HOME BATTERY CHARGING

Why incur all the trouble, expense and waste of time incurred by taking your accumulator to a service station to be recharged? Simply connect a Heayberd Home Charger to the mains and to your accumulator which, in a very short time, is working at full efficiency again. It's cheaper and better this way and your L.T. battery lasts much longer.

MODEL AO.2 Battery Charger. Charges 2, 4 or 6v. at ½ amp. 35/-

MODEL AO.3 Battery Charger. Charges 2, 6 or 12v. at 1 amp. 42/6

Cut out this advert. and send with 3d. stamps for 36pp. Handbook, packed with hints and diagrams.

(Stand 39—Manchester Radio Show)

F. C. HEAYBERD & CO. 10, FINSBURY STREET, LONDON, E.C.2. One minute from Moorgate Station.

It was with profound interest that we recently took the opportunity of examining what must surely be the widest range of moving-coil speakers made by any British manufacturer. These speakers are made by the well-known firm of Messrs. Epoch Manufacturing Co., Ltd., Exmouth

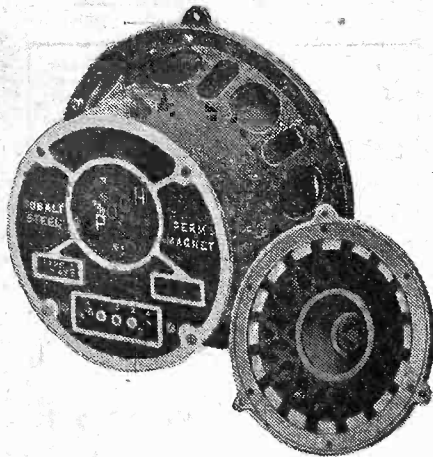

One of the larger Epoch P.M. moving-coil speakers, the type "A2 1/2 P.M."

Street, London, and vary in type from a "Super-Dwarf" permanent magnet model with 5-ratio transformer and selling at the attractive price of 23s. 6d. to the large "Super Cinema" model of the mains energized pattern listed at £14 10s. for D.C., or £17 10s. for A.C. The smallest speaker is of particular interest at the present time, due to the immense amount of interest which is being shown in miniature receivers for both car and domestic use. It has a diaphragm of only 5in. diameter and yet is well able to handle as much as two watts of signal output. Additionally, it is extremely sensitive for this type of instrument and will work perfectly on an input so low as one-quarter of a watt. An extremely interesting modification of the "Super-Dwarf" is a dual pair of accurately matched speakers mounted together on a small baffle board. This pair gives almost perfect response to the complete range of musical frequencies, and at the price of £2 7s. represents almost unprecedented value.

#### Excellent Magnet System

Other popular speakers in the Epoch range include the "Twentieth Century" permanent magnet model at £1 15s., the "Eleven-Inch Super" at £2 5s., the "Type A2 1/2 P.M." at £3 3s., the "Super

## A MOST INTERESTING RANGE OF LOUD-SPEAKERS

Junior" at £1 10s., the "B.5 P.M." at £4 4s., and the "Type D.2.S.P.M." at £4 11s. 6d. All the latter are of the permanent magnet type and are fitted with excellent 9 per cent. cobalt steel magnets which make them equal to the very best value in the trade. All can be obtained with a special multi-ratio output transformer by means of which they can be correctly matched to any power or pentode valve, or with a well-designed Class B transformer; the price is just the same in either case.

#### Energized Types

Messrs. Epoch, although they were the pioneers of permanent magnet moving-coil speakers and produced the first efficient instrument of this kind in Great Britain (some eight or nine years ago, by the way), also produce an extensive range of energized moving coils in patterns which can do

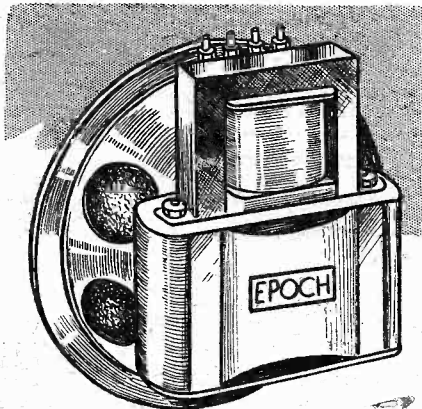

A new speaker of the "midget" type, the "Super-Dwarf."

justice to signal outputs up to 25 watts. The energized models are, of course, of chief value for public address and auditorium work, but they are also of particular interest to the amateur who requires a large output of really perfect quality. All of them can be obtained for either D.C. or A.C. operation or for use with an accumulator as field energizer.

#### A Combination Class "B" Speaker

A really ingenious and beautifully turned out instrument which Messrs. Epoch

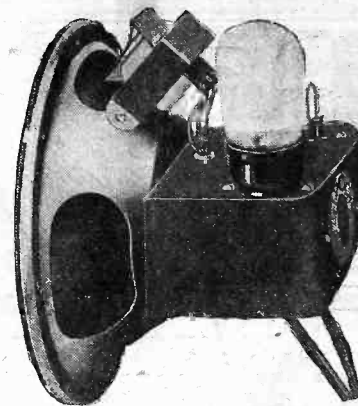

A very neat combination P.M. speaker and Class B amplifier made by Messrs. Epoch.

have introduced quite recently is the "Class B Combination Speaker." As the name implies, this is a combined permanent magnet speaker and most efficient Class B amplifier. The complete unit is extremely compact and of excellent appearance.

It would, of course, be quite impossible to give anything like full details of each type of Epoch speaker which is available, but the above notes will show very clearly that there is without question a type for every conceivable purpose and at a price which bears no comparison with the obviously high quality and well-made instruments.

The names and prices mentioned above refer to the actual units which can be fitted into any cabinet which might be to hand, but it is also interesting to note that any one can be supplied in a cabinet designed on the best acoustic principles and made from selected timber, beautifully polished.

#### Matched Pairs for Perfect Reproduction

A further advantage in these days when perfect reproduction is more nearly possible than ever before is that nearly all the smaller speakers can be purchased in matched and balanced pairs. The two units are so chosen that between them they give a practically-uniform response to notes of all frequencies from the lowest to the highest. In view of their low prices these dual speakers should find a very wide application in conjunction with modern efficient receivers.

We can only conclude by saying that any reader who is considering the purchase of a new speaker should at least examine the Epoch range before making a final choice.

SOME weeks ago I referred to the better earthing properties some soils had over others as regards wireless communication, and I mentioned the work that was being done by the National Physical Laboratory in this connection. You will probably remember that the conclusion was reached that soils consisting of the most part of clay made better "earths" than those whose chief constituent was sand, or similar material. On January 19th a paper was read before the Royal Society by Dr. R. L. Smith-Rose of the N.P.L., in which he described some investigations on the electrical properties of soil which have been carried out at the Laboratory on behalf of the Radio Research Board of the Department of Scientific and Industrial Research. The experiments consisted of the measuring of the electrical resistance of samples of soil from different localities under conditions met with in

## THE IMPORTANCE OF A GOOD EARTH

radio communication. The results of the experiments showed that while dry soil is a poor conductor, the conducting power is increased by more than one thousand times when water is added to bring its moisture content up to the value commonly met with in garden soil. The soil that was taken from different sites was studied and it was shown that its properties varied to a considerable extent, and it is obvious that a knowledge of these properties is important in connection with the location of a wireless transmitting station. At the same time most broadcast listeners are familiar with the function which the earth connection plays in reception. Unless the receiver is of the portable type, it is essential that

the earth connection should have a low electrical resistance. The earth plays another and more important part, however, in wireless communication, particularly in the distribution of broadcasting programmes, for at moderate distances of up to 50 or 100 miles the waves from the transmitting station travel along the earth's surface, and some of their energy is lost in setting up electrical currents which have to overcome the resistance of the earth. If the earth is a good conductor this energy loss is reduced to a minimum and thus the field strength of the waves is maintained to a considerable distance, and good reception results. If the ground is a poor conductor the waves lose their energy rapidly and poor or indifferent reception is obtained. It is because the sea is a good conductor that signals received over an all-sea path are much stronger than those received under similar conditions over land.





# PRACTICAL LETTERS FROM READERS

The Editor does not necessarily agree with opinions expressed by his correspondents.

## The "Selectone Three"

SIR,—I have built the "Selectone" from the particulars published in PRACTICAL WIRELESS and have had it in operation for some months. It is a first-class job and I am very satisfied with the set; a few of my friends who have heard it were greatly impressed with its performance. Many thanks to Mr. Preston and the rest of your technical staff.—A. J. ONIONS (Oldbury).

## A Barnsley Reader's Thanks

SIR,—I thank you very much for the Wireless Encyclopaedia just received. I consider the book one of the most interesting and helpful that I have ever read, and it compares with books far more expensive. I had your paper recommended to me about three months ago, and have enjoyed reading each number ever since, many of your articles being a great help to amateurs like myself wishing to improve their knowledge of wireless. Wishing your paper every success.—G. F. EASTWOOD (Barnsley).

## Birthday Congratulations

SIR,—May I take this opportunity to congratulate you and your staff on the completion of your first year's work with PRACTICAL WIRELESS.

The production is worthy of all praise and a credit to the House of Newnes.—H. H. THOMSON (Glasgow).

## From a Barmouth Reader

SIR,—I received "The Wireless Constructor's Encyclopaedia" safely, for which please accept my sincerest thanks. Mr. F. J. Camm is certainly to be congratulated for compiling this excellent work, which has already cleared the air that surrounded many obscure problems. He has also afforded the beginner a good chance of getting a sound working knowledge of wireless by providing him with ample scope for experimenting, and also with plenty of diagrams and illustrations to assist him in making his own components.—R. W. HUGHES (Barmouth).

## "Readers' Service"

SIR,—I duly received your answer to my inquiry, and have carefully noted all your remarks. Since sending my inquiry re modifications to the original "Selectone 3" I have noted the resemblance of the "Auto-B Three" to my suggested conversion to Ferrocort tuning, so your recommendation to that circuit has already been considered. I would like here to state my appreciation of the detailed study of my diagram which has obviously been taken, to say nothing of your very helpful notes on the circuit values, etc. You can be assured that the trouble you have taken over what must

All letters must be accompanied by the name and address of the sender (not necessarily for publication).

be, after all, a hackneyed and unsatisfying type of query is much appreciated, and cannot help being a real recommendation in any discussion on wireless matters with wireless "fans." I shall make it my business to mention it at our works.—C. J. CROSS (Bristol).

## A Really Wonderful Volume

SIR,—I have just received my copy of the "Wireless Constructors' Encyclopaedia" and wish to express my thanks. It is a really wonderful volume. With best wishes for the future of PRACTICAL WIRELESS.—R. V. LISTER (Heworth).

## A Storehouse of Information

SIR,—I have received my copy of the "Wireless Encyclopaedia" all right, for which many thanks. It is indeed a storehouse of information. I might add that Wednesday has become quite an important day for me, as I eagerly await my copy of PRACTICAL WIRELESS. Again thanking you.—J. LAWSON (Walton).

CUT THIS OUT EACH WEEK

## DO YOU KNOW?

—THAT valves are obtainable which operate with the full mains voltage (200 to 250 volts) on the heaters.

—THAT special short-wave systems are being experimented with in which no present-day practices are carried out.

—THAT as a result of research (on the above lines, some novel medical uses have been found for the short-wave radiations.

—THAT great care should be exercised when using headphones on a mains-operated receiver.

—THAT the reactance of a condenser varies with the frequency.

—THAT an H.F. decoupling condenser should be chosen with the above fact in mind.

—THAT tone control devices only operate on frequencies which are present—in other words you cannot put anything back which has already been lost.

—THAT peak values must always be considered when deciding upon the rating of a condenser.

—THAT a separate additional tapping may be fitted to an eliminator by means of a pair of resistances and a condenser joined across an existing tapping point.

## NOTICE.

The Editor will be pleased to consider articles of a practical nature suitable for publication in PRACTICAL WIRELESS. Such articles should be written on one side of the paper only, and should contain the name and address of the sender. Whilst the Editor does not hold himself responsible for manuscripts, every effort will be made to return them if a stamped addressed envelope is enclosed. All correspondence intended for the Editor should be addressed: The Editor, PRACTICAL WIRELESS, Geo. Newnes, Ltd., 8-11, Southampton Street, Strand, W.C.2.

Owing to the rapid progress in the design of wireless apparatus and to our efforts to keep our readers in touch with the latest developments, we give no warranty that apparatus described in our columns is not the subject of letters patent.

## PEARL & PEARL RADIO BARGAINS

The famous Synchro Blue Gramo. Motor suitable for all A.C. 50 cycle mains, low current consumption, no interference with radio sets. Special purchase. List price 39/6. Hire-purchase terms for "Practical Wireless" readers 12/- down, 6 monthly payments of 2/6. **Cash 25/-**. No references required.

!! 4 ONLY !!

1933 14 guinea model D.C. Tecalemit 3-valve all-electric receiver. 2 S.G. Valves and Pentode outputs, moving-coil speaker, beautiful walnut cabinet, tuning dial marked with **£6.19.6** stations. Special price to clear

K.B. Battery "Pup" includes speaker, valves, and batteries. Attractive cabinet, automatic grid bias and sockets for extra **£2.3.6** speaker. List price £4/10/0

The well-known Lincoln Stewart dual range shielded coils 200-550 metres, 800, 2,100 metres. List price, **2/11**

Limited number Daptacon pick-ups and tone-arms, specially designed to prevent wear and eliminate scratch, reduced price **6/11**

Famous Lincoln Stewart Permanent Magnet Moving Coil Speakers. Special **16/11** purchase. List price 47/6.

Limited number of Telsen Major Speaker chassis. This is a super bargain and is available while stock lasts. Usually **10/6** **3/3**

All goods sent cash or C.O.D. Carriage paid

**PEARL & PEARL**  
190, Bishopsgate, E.C.2

## ELECTRADIX MICROPHONES

1/- Units as illus.



35mm, 4d. Panel brackets, pivoted, 5/-. Reel Receiver Unit for Amplifier making, 3/-. High-ratio 100-1 Amplifying Transformers for all makes, 3/6, 5/6, and 7/6.

TRU-VIEW CAMERASCOPES, BROWNS. Double lens, folding, 2/- Telescopes, Cooke monocular prism R.F., with 3-mile distance scale 7 1/2 in. long, weight 3 1/2 lbs. 17/6. Naval Gun-Sighting Telescopes, internal focus ring, 9 1/2 in. long, 3 in. dia., weight 6 lbs., magnification 8, for short and long range. Cost 125.

Sale, 17/6. Navy Spotting Telescopes, 17 1/2 in. x 1 1/2 in., 25/- Pressure Gauges, 150 lb., 2/6. Meter Movements, 6/-. R.A.F. Watch Movement, 1/8.

The BATTERY SUPERSEDER makes H.T. from your L.T. 2-volt battery rectified and smoothed. Gives 3 tappings and lasts indefinitely. A boon to those who are not on the mains. Reduced from £3 15s. New and **37/6 LT.** Guaranteed

LESDEX CHARGERS We have 25 models to offer and build special types to special requirements. Three popular sizes are the AC100A for 36 cells at £10 9s.; the AC100 for 108 cells at £12 10s.; and the Lesdex Super Six for 200 cells at £22 7s. 6d. Ask for Charger Leaflet.

**ELECTRADIX RADIOS**  
218, UPPER THAMES STREET, LONDON

**PATENTS & TRADE**  
KING'S PATENT AGENCY, LTD.,  
Street, E.O.4, offer "Advice"  
Consultations free. 47 years' re-  
'phone (Central 0682). D.  
C.I.M.E., Reg. Patent Agent, G.

**Scrap your H.T. Batteries!**  
**THE WATBRO ELIMINATOR**  
 COSTS NO MORE THAN ONE H.T. BATTERY.  
 Banishes the continual expense of buying H.T. batteries, abolishes hum and background disturbances. Creates crystal clarity of Tone and Amazing magnitude of Volume. **FULLY GUARANTEED.**  
 D.C. Model for 2-3 valve sets 25 m/a output 150v., 17/6, post free.  
 ILLUSTR'D Folder of D.C. & A.C. Models FREE. Trade supplied.  
**WATKINS, BROS. & CO.,**  
 542, Kingsland Road, London, E.8.



**FRONT OF PANEL** **MILLED HUT**  
**FIT THIS ELECTRIC CLOCK TO YOUR SET!**  
 NO MAINS NEEDED! KEEPS CORRECT TIME! NO WINDING!  
 Works off small battery lasting 12 months, or can be plugged into G.B. battery without affecting reception. Uses practically no current. Fits into hole 3/4 in. dia. in any panel up to 1 in. thick. Easy to fit—no screws required. Only 1/4 in. from front of panel to back of case. Swiss movement. Hands set from front. Nickel-plated bezel. Useful addition to any set.  
**RIVERSIDE MFG. Co., Ltd.,**  
 Dept. 21, Crisp Road, Hammersmith, W.6  
 Telephone: Riverside 6392.



**12/6**  
 COMPLETE WITH BATTERY  
 POSTAGE 6D

Catalogues describing  
**SERADEX RESISTANCES**  
 will be sent on receipt of completed form:—

To **TREVOR PEPPER, 575d Moseley Rd., Birmingham, 12.**

Please place the following on your regular mailing list.

Name.....  
 Address.....  
 Pr. W. 30933

Write for Illustrated Catalogue of  
**Radio-Gramophone Cabinets**  
 of exclusive modern design made by craftsmen in highly figured Oak, Walnut, or Mahogany, post free. Cabinets made to order a speciality. *Maker under licence of the*  
**HOWE BOX BAZEL.**  
 Recommended by the B.B.C. Full details on request.  
**GILBERT**  
 Cabinet Maker.  
**SWINDON.** Estimates free. Est. 1866.



**HOW TO HALVE YOUR H.T. BILL**

Many thousands of listeners in all parts of the country have banished the bugbear of costly H.T. by installing the wonderful Sac Leclanche Wet H.T., the permanent battery that lasts for years. The Sac Leclanche Battery consists of a number of high-capacity cells in neat glass containers. The cells are self-regenerative and any slight current drop is made up when not in use. Popular Battery, 120 volts, No. 3 cell, 12,500 milliamps. Price, complete with chemical, etc., £2, carriage paid. Send for full particulars: All spares for Standard Batteries supplied.  
**THE WET H.T. BATTERY CO., 26 Lisle St., London, W.C.2.**  
 Phone: Gerrard 6121



**CONVERTING THE PREMIER SUPER**  
 (Continued from page 80)

spring goes to the grid condenser, that in contact with the shortest spring is joined to the pick-up terminal, and the third goes to the grid terminal on the detector valve-holder. It will thus be seen that the switch must be pushed in for "gram." and pulled out for "radio."

**A More Convenient Position for the R.-G. Switch**

For those who wish to use the gramophone side of the equipment fairly often, it will seem a little inconvenient to have to operate the switch through the back of the cabinet, but the particular position was chosen from the point of view of efficiency. At the same time, the switch can be mounted

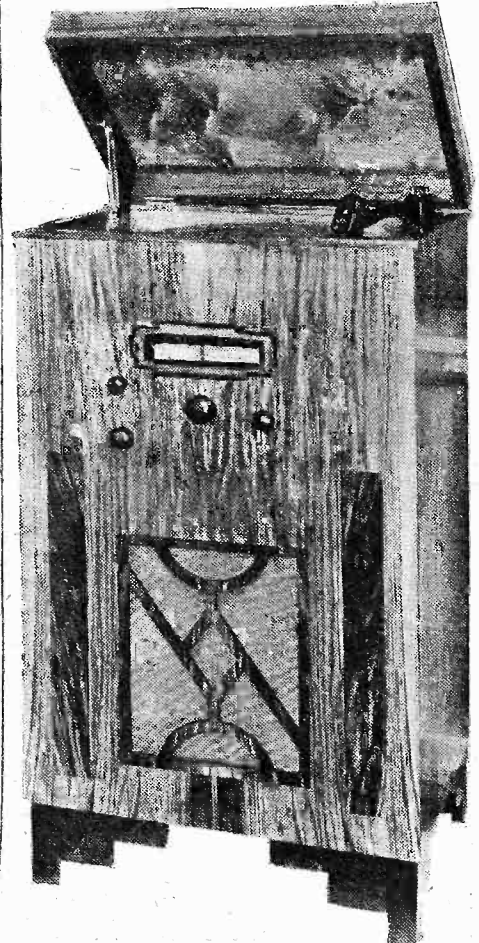

The Premier Super fitted into the handsome and reasonably priced Peto-Scott Adaptogram Cabinet.

in a more accessible position on the motor board if care is taken to keep the connections to it as short and direct as possible. The leads should also be screened by fitting lengths of "Goltone" screening braid over them. The braid should, of course, be earth connected by means of lengths of thin wire bound round them tightly and joined to the most convenient earthing point—the terminal on top of one of the coil screens.

Gramophone reproduction is particularly good and ample volume is obtainable. A wide control of volume is possible by means of the knob fitted to the pick-up, however, and this enables the sound intensity to be reduced to a mere whisper if desired.

You will find the "Premier Super," in either "radio" or "radio-gram" form, a particularly economical and likeable instrument.

**RADIO CLUBS AND SOCIETIES**

Club Reports should not exceed 200 words in length and should be received First Post each Monday morning for publication in the following week's issue.

**THE CROYDON RADIO SOCIETY**

The Society has not been idle during the summer, as informal meetings have taken place whereat plans for the ensuing season have been discussed. Indeed, the Society's tireless chairman, Mr. F. Nightingale, gave his committee no rest until his forceful views were ventilated. As a result, programmes are nearly complete. The Session starts on Tuesday, October 3rd, 1933, with a lecture-demonstration by the President, Mr. H. R. Rivers-Moore, B.Sc., on his unique amplifier. Mystery is attached to it, as three hefty members will be needed to carry it to the Society's transport vehicle en route to headquarters. Also, it will guide the destinies of four giant loud-speakers! Other events will be a monthly night organized by the short-wave section, and, of course, the Society's loud-speaker and gramophone pick-up nights appear in the syllabus with members' demonstrations meetings.

Better accommodation is obtained in the new headquarters at St. Peter's Hall, Ledbury Road, South Croydon. Meetings will be held weekly on Tuesdays, and PRACTICAL WIRELESS readers are welcome, to whom a fixture card will gladly be sent by the Hon. Secretary, E. L. Cumbers, Maycourt, Campden Road, South Croydon.

**INTERNATIONAL SHORT WAVE CLUB, LONDON**

One of the biggest attractions ever arranged by the London Chapter was given before a great gathering of short-wave listeners at the R.A.C.S. Hall, Wandsworth Road, S.W.8, on Friday, September 15th, when Mr. P. H. Spagnoletti, B.A., gave a lecture on the British Empire Broadcasting Station transmitters at Daventry. Mr. Spagnoletti was the engineer in charge of the installation of these transmitters and his lecture was illustrated by slides. His lecture dealt with every aspect of the transmitters, the lay-out of the station, and the aerials, etc. He preceded this lecture with a short talk on the propagation of short waves, a subject which always arouses keen interest at these meetings. The evening closed with an exhibition of over fifty photographs of the Empire Station at Daventry.—A. E. Bear, Secretary, 10, St. Mary's Place, Rotherhithe, London, S.E.16.

**BURTON-UPON-TRENT AMATEUR RADIO SOCIETY**

The above Society opened its winter season on Tuesday, August 5th, at the Wheatsheaf Hotel, Station Street, when Mr. F. Youle, B.Sc., gave a lecture on catkin valves, illustrated by lantern slides. In view of the fact that this was the first meeting of the season, the Society was honoured by the presence in the chair of its President, Councillor W. Hutson, J.P., Mayor of Burton. Mr. Youle outlined the various advantages of the catkin valve over the more familiar glass valve; these included mechanical strength, freedom from microphony due to double-ended suspension of electrodes, cooler running owing to circulation of air round the anode, and finally, uniformity of characteristics due to rigid construction. At the conclusion of the lecture various points were raised by members, and they were answered in a very lucid manner by Mr. Youle. The Society holds its meetings on the first and third Tuesdays of the month at the above address, and a cordial welcome is extended to anyone who cares to come along. Particulars of membership, and fixture lists for the season can be obtained on application to the Hon. Sec., W. A. Mead (G5YY), 139, Burton Road, Burton-on-Trent.

**SLADE RADIO**

A lecture on "Catkins, etc.," was given by Mr. F. Youle, B.Sc., at the meeting held last week. After giving details of the various steps in the assembly of the catkin he went on to describe the virtues and the many points of interest. This portion of the lecture was illustrated by a series of slides, which included an X-ray photo of a catkin and also the transmitting valve from which the former was developed. Details were then given of the new B21 and L21 valves, also the general working of Class B valves was explained in detail. The lecture proved to be one of considerable interest and was thoroughly enjoyed by those present. Details of the Society and its activities may be obtained on request from the Hon. Sec., 110, Hillaries Road, Gravely Hill, Birmingham.



REPLIES TO

LET OUR TECHNICAL STAFF SOLVE YOUR PROBLEMS

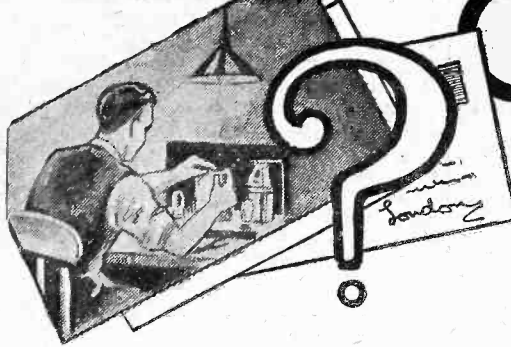

If a postal reply is desired, a stamped addressed envelope must be enclosed. Every query and drawing which is sent must bear the name and address of the sender. Send your queries to the Editor, PRACTICAL WIRELESS, Geo. Neumes, Ltd., 8-11, Southampton St., Strand, London, W.C.2.

QUERIES and ENQUIRIES by Our Technical Staff

The coupon on this page must be attached to every query.

SPECIAL NOTE

We wish to draw the reader's attention to the fact that the Queries Service is intended only for the solution of problems or difficulties arising from the construction of receivers described in our pages, from articles appearing in our pages, or on general wireless matters. We regret that we cannot, for obvious reasons—

- (1) Supply circuit diagrams of complete multi-valve receivers.
- (2) Suggest alterations or modifications of receivers described in our contemporaries.
- (3) Suggest alterations or modifications to commercial receivers.
- (4) Answer queries over the telephone.

Please note also, that all sketches and drawings which are sent to us should bear the name and address of the sender.

REPLACING OLD VALVES

"As a result of my visit to the recent Exhibition I have decided to replace all my old four-year-old valves with the latest ones, and I was told on one of the valve stands that this could be done with practically any set without any trouble and with a big increase in efficiency. Before I risk the outlay I should like you to confirm that I may do this without any risks, and to let me know whether you advise the change."—Y. S. (Glasgow).

It is certainly true that the majority of receivers may be vastly improved by replacing the old valves with those of more recent design, but in some cases instability will undoubtedly result, due to the inefficient wiring or layout of the receiver. If, for instance, your set employs an H.F. stage, it would be advisable to examine this carefully and make certain that no screening or alteration of the wiring is necessary. The detector and L.F. valves are, in most cases, free from trouble, except in so far as decoupling is concerned. You must remember that the modern valve is much more efficient than the older pattern and this may lead to instability. Each case must, therefore, be judged on its merit, but it should not be difficult to stabilise a receiver if it is found that the new valves introduce any troubles.

CALCULATING RESISTANCE VALUES

"Although I know that you will tell me that Ohm's law will help me, I should like you to show me how to use it in the calculation of the decoupling resistances for my set. I wish to fit the resistances in the anode leads, and I see that they are obtainable in 1 watt, 2 watt, and so on. I am not sure, either, how to find the exact value, and should be glad if you could explain it simply to me."—W. D. (Willesden, N.W.).

We will assume that the detector valve in a mains receiver needs decoupling. The H.T. line will no doubt be of the order of 250 volts, and the detector will pass a normal current of, say, 1 milliamp. The normal H.T. is given as 150 volts. We, therefore, have 100 volts excess voltage, which must be dropped through the decoupling resistance, and accordingly the value of

this resistance is found from the formula  $R = \frac{E}{I}$ , which is 100 divided by .001. This gives us 10,000 ohms. The wattage is obtained from the formula  $W = I^2 \times R$ , which gives us .001 x .001 x 10,000, or in other words .1 watts. From these figures we have therefore found

that we require a 10,000 ohms resistance which may be of the 1 watt type. The same method of calculation applies, of course, to biasing resistances, etc.

HOME-MADE TUNING COIL

"As I am making a neat dual-range tuning coil I should like to have your opinions regarding the various methods of aerial coupling which I can include in the circuit. I do not know which to choose between an ordinary tapping on the coil, or a loose coupled aerial coil. Which is most suitable for modern conditions?"—L. F. (Holloway).

If you intend to tap the aerial into the coil you must remember that this tapping will be at the top end of the coil when you switch over to long waves, and this will result in decreased selectivity. On the other hand, a separate aerial coil will enable you to wind a value of inductance which will give best results from the selectivity point of view on both bands. In the first case, a separate tapping will have to be made in the long-wave winding, and this will mean that the switching device will have to be arranged to transfer the aerial lead from the medium to the long-wave coil, and in the second case you will have to use a double switch so that the long-wave aerial coil may be short-circuited, as well as the grid coil, when listening on the medium waves. As regards the actual merits of the two systems, the tapped coil may prove as good as the separate coil if the tapping is made at the correct position, and a little experiment should enable you to decide this point to suit your own local conditions.

DATA SHEET No. 53

Cut this out each week and paste it in a notebook.

STANDARD ABBREVIATIONS.

|                |                    |
|----------------|--------------------|
| AMPERE .. ..   | A                  |
| FARAD .. ..    | F                  |
| HENRY .. ..    | H                  |
| IMPEDANCE ..   | Z                  |
| KILO .. ..     | k (One thousand)   |
| MEG(A) .. ..   | M (One million)    |
| MICRO .. ..    | μ (One millionth)  |
| MICRO-MICRO .. | μμ (One billionth) |
| MILLI .. ..    | m (One thousandth) |
| π .. ..        | 3.1416             |
| OHM .. ..      | Ω                  |
| VOLT .. ..     | V                  |
| WATT .. ..     | W                  |
| WAVELENGTH ..  | λ                  |
| ω .. ..        | 2πf                |

CORRESPONDENCE COURSE WANTED

"I have sent you my six months subscription and hope you will continue on the good lines already started. Will you please let me know whether there are any institutions which deal in correspondence courses for wireless. I wish to get a diploma or a certificate, as I am in the electrical line and have got a good elementary knowledge, and would like to proceed for advancement."—V. P. K. (Aurangabad, Dn., India).

We would advise you to communicate with either of the following: International Correspondence Schools, Ltd., Dept. 94, International Buildings, Kingsway, London, W.C.2, or British Institute of Engineering Technology, 396, Shakespeare House, 20/31, Oxford Street, London, W.

DEAF AID

"I am in the unfortunate position of being fairly deaf, and I find it a trifle difficult at meal times to hear the conversations which go on around me. I can hear the wireless quite well, as we have a fairly good set, but I should like to know whether I can make up a suitable apparatus to help me to join in the table conversations and other normal domestic discussions. I am handy with tools, and have made one or two sets quite successfully. What can you advise?"—V. B. N. E. (narrow).

One of the simplest devices would be to purchase one of the new home microphones, and connect this to the pick-up terminals of your wireless set. The microphone could be stood on the table and the volume adjusted to produce good signals from the loud-speaker, or, alternatively, a pair of headphones could be fitted in a suitable part of the circuit and worn by you to avoid inconveniencing others by the magnified conversations.

TONE-CONTROL AND CLASS B

"I have purchased a Class B unit and have added this to my set, but am not pleased with the reproduction. My set is S.G. Detector and Pentode, and I had no troubles before installing the new unit. How would you advise me to alter the pitch to sound more natural? I had no control before, and do not wish to interfere with the unit, as at present it is only on approx."—G. S. (Norwich).

It would be quite simple to fit a tone control in the input side of the Class B unit, and this should give perfect control over the tone of reproduction. We would recommend a Bulgin Controlatone, as this necessitates only two connections and contains both the condenser and the necessary resistance. These should be joined to the loud-speaker terminals on your original receiver, and you will then find that rotation of the control will vary the tone through quite an appreciable range.

MEASURING ANODE CURRENT

"I have repeatedly tried to measure the anode current of my mains variable-mu valve, but without success. The meter is one of the best, and I have tried it with a condenser across it and without. In every case, as soon as the valve begins to heat up, the set goes into oscillation. I have tried using long leads, and moving these about, and also short leads, but I cannot stop the trouble, and, consequently, cannot obtain an accurate measurement. Can you suggest some way of doing this, please?"—D. N. E. (Edgware).

The trouble is very often experienced in making measurements of the kind you refer to, and, generally speaking, the only way of overcoming the oscillation is to short-circuit either the grid or the anode coils. You will find that this will cure the oscillation, but there may be some inaccuracies in your reading due to the variation of bias or other alteration in the circuit, so that you must first of all examine the circuit wiring and make certain what will happen when the short-circuit is introduced. It should only be necessary to short one inductance, and generally this should be the one included in the grid circuit.

FREE ADVICE BUREAU COUPON

This coupon is available until October 7th, 1933, and must be attached to all letters containing queries.

PRACTICAL WIRELESS, 30/9/33.

BRITAIN'S FINEST WALNUT RADIOGRAM CABINET

1934 ADAPTAGRAM

Direct from Factory to you. NO MIDDLEMAN'S PROFITS. Built by master craftsmen of London's Piano Trade. Real inlaid walnut, mortised, tenoned, hand French polished. With motorboard, ready for Set. Room for Speaker and Batteries. Plain front or vignette for panels—14" x 7", 16" x 7", 18" x 8". Baffle Board 3/6 extra.

As illustrated. Cash or C.O.D. Carriage 2s. 6d.

Or 8/3 Deposit and 11 monthly payments

OAK OR MAHOGANY

Obtainable only direct from the M

PETO-SCOTT 77, City Road,

RADIO CABINET

38" high, 22" wide, 15 1/2" deep. Speaker Compartment 17" x 19" x 14"

YOURS FOR 8/3

DOWN

SEND FOR 1934 CABINET CATALOGUE

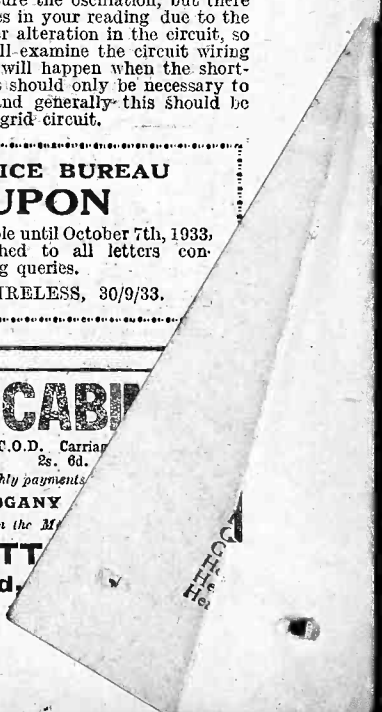

# CATALOGUES RECEIVED

To save readers trouble, we undertake to send on catalogues of any of our advertisers. Merely state, on a postcard, the names of the firms from whom you require catalogues, and address it to "Catalogue," PRACTICAL WIRELESS, Geo. Newnes, Ltd., 8/11, Southampton St., Strand, London, W.C.2. Where advertisers make a charge, or require postage, this should be enclosed with applications for catalogues. No other correspondence whatsoever should be enclosed.

## WAVEMETER COMPONENTS

IN a neat folder issued by Webb Condenser Co., Ltd., a range of well-finished condensers and knobs is given. Included in the list are midge log condensers, universal log slow- and fast-motion condensers, and solid di-electric two and three-gang condensers. There are also air-spaced and solid di-electric slow-motion condensers with ivory scales, moulded escutcheon plates and lampholders. Another neat component, listed at 3s., is a slow-motion disc drive, having an escutcheon plate with indicating hair-line, lampholder and bracket, and suitable for panel or baseboard mounting. The address is 42, Hutton Garden, London, E.C.1.

## THE BOOK OF IGRANIC

IN the making of a high-class receiver constructors must accept many of its components on the reputation of their makers—and Igranico radio components need no recommendation to those who know. Those who do not know would be well advised to obtain a copy of this handy book, which contains full descriptions and prices of every component likely to be required for the building of a modern receiver. Particulars of the new "Igranico" coils are, of course, included, together with screened dual-wave super-het. coils and the "Igranipak" tuning unit. H.F. chokes, fixed and variable condensers, slow-motion dials, transformers for all purposes, wire-wound volume controls and potentiometers, switches and terminals are amongst the other components listed. There is also the Igranico short-wave adaptor which has a wavelength range of 14.8 to 78 metres, and is available in two models—for battery and A.C. mains operation. Copies of this useful handbook can be obtained from Igranico Electric Co., Ltd., 149, Queen Victoria Street, London, E.C.

## HELLESEN'S BATTERIES

WITH a reputation of over forty years behind them Hellesen's Batteries are too well known to need introducing to our readers. In the Hi-Life range of H.T. batteries prices have been reduced to the lowest possible level, consistent with a high standard of performance and long life. In the "Super" Range, a new patented cell gives greatly increased capacity while in no way increasing the size or weight of the batteries. Also listed are a range of Hellesen's dry cells for flash lamps, bells, cycle lamps and other purposes. Copies of a folder, containing full particulars of these batteries can be obtained from Hellesens Ltd., Hellesen Works, Morden Road, South Wimbledon, London, S.W.19.

## SOVEREIGN COMPONENTS

CONSTRUCTORS desirous of being up to date with their receivers will find much to interest them in a new booklet just issued by the Sovereign people. Amongst the outstanding items in the new range of Sovereign components is a Permeability tuner, which gives great selectivity and volume and tunes over both medium and long waves perfectly. This compact unit, which is arranged for one-hole panel fixing, is priced at 15s., complete with slow-motion tuning-dial; escutcheon and blue print. Another noteworthy component is an iron-cored coil which sells at 7s. 6d. In addition, there are condensers of various types, dual-range coils, chokes, transformers, resist-

ances, volume controls, and a three-point miniature toggle-switch, a sturdy little component which will safely carry 3 amps. At the end of the booklet an electrical section is given in which are listed such handy parts as 5-amp. two-pin plugs, bayonet adaptors, bell pushes, ceiling roses and tumbler switches. These parts, although made of best moulded brown bakelite, with first quality metal fittings, are particularly low in price. The Sovereign electric iron, for ordinary domestic use, suitable for A.C. or D.C. mains, is also shown in the booklet, copies of which may be obtained from Sovereign Products, Ltd., 57, James Street, Camden Town, N.W.1.

## Replies to Broadcast Queries

R. X. (Port Glasgow): G5AP portable call of G5NW; E. J. Allen, 8, Westfield Place, Dundee, Angus, Scotland. G6JZ; C. Fenton, 18, Hill Top Road, Kells, Whitehaven, Cumberland. G5US: J. Croysdale, "Reamsley," Carlton Drive, Gatley, Cheshire. G2IM: E. B. Radford, 33, Whitehall Park, Upper Holloway, N.19. G2NY: H. Littley, "Radiohm," Bridgnorth Road, Stourton, Stourbridge, Worcestershire. G5CY: J. E. Cory, "Dallington," High Street, Sutton-on-Sea, Lincolnshire. G6PL: F. J. Popplewell, "Hollin' Bank," White Lee, Heckmondwike, Yorkshire. G6JG: C. W. Jennings, 150, Longmead Avenue, Bishopcleeve, Bristol, Glos. G2LU: Alderman's Green, Coventry. G6BT: E. A. Jamblin, 121, Queen's Road, Bury St. Edmunds, Suffolk. BARBER (Blackpool): The calls we can trace are the following: G6IE, M. E. Tapson, 115, Hadleigh Road, Leigh, Essex; G6JZ, C. J. H. Joyce, 9, Campbell Street, London, W.2; G6KA, Keith F. Hardie, 66, Ulverston Road, Walthamstow, E.17; G5GR, L. W. Gardner, 40, Medina Road, Coventry; G5ID, P. D. Coates, 55, Ennismore Street, Burnley, Lancs.; G5NR, E. G. Nurse, 1, Cambridge Road, London, W.6; G5RX, S. Newell, 9, Moor View, Rakehead, Stacksteads, Bacup, Lancs.; G5XF, J. Butterworth, 1088, Manchester Road, Castleton, Rochdale, Lancs.; G5YV, H. Beaumont, 14, Halliley Street, Dewsbury, Yorks.; G2AP, F. Adams, "Newhouses," Girningoe Street, Wick, Caithness, N.B.; G2CJ, S. Townsend, 115, Erlham Road, Norwich; G2GA, T. C. Platt, 70, Fieldhead Avenue, Elton, Bury, Lancs.; F8DS, J. Lory, 38, Rue Michel-Ange, Paris (16), France; F8LA, G. Barba, 140, Avenue du Roule, Neuilly-Sur-Seine, France; F8PR, Pierre Roy, 48, Rue Ph-Delassalle, Lyons, France; F8PV, Georges Vuillemot, 45, Rue de la Recette, Creteil, Seine, France.

## ARE MULTI-ELECTRODE VALVES WORTH WHILE?

(Continued from page 71)

The low-impedance screened-grid valve as a detector presents problems of stability on similar lines to those already touched upon, and difficulties regarding its coupling to the following valves.

If resistance coupling is to be used, the H.T. voltage will have to be somewhat high, to allow for the voltage drop in the anode resistance, and the gain of the stage will be disappointing, as the customary transformer step-up will be missing.

If a resistance-fed transformer is used, some difficulty will be experienced in getting a sufficiently high load for satisfactory working. In the first place, the impedance of the transformer must be very high; so high, in fact, that there are only about two suitable transformers on the market, and as the primary an-

resistance will be in parallel with each other (via the coupling condenser), the latter will have to be somewhat higher than if the resistance were used alone, which means that extra anode voltage will be required.

Broadly speaking, a screened-grid valve is better than a triode, provided that the obstacles can be overcome, but when fixing attention on battery receivers only, a triode detector and L.F. valve would be more efficient and less costly.

Many readers may be slightly acquainted with some of the very new multi-electrode detectors, such as the double-diode-triode and the double-diode-tetrode, but these constitute three valves in one bulb and are intended for automatic volume control.

## HOW THE B.B.C. DOES IT

(Continued from page 72)

of the valves, of course, and the cathodes are connected to the frame of the amplifier and to the metal panel front.

From the circuit arrangement and component values of an amplifier like this we can learn much in the design of a power amplifier for ordinary amateur radiogram use. I have not complicated the description by giving details of the special switching arrangement which the engineers have for listening on the amplifier circuits, and for the output arrangements. It is interesting to note that in Broadcasting House, London, alone there are 31 of these "A" amplifiers. They are arranged in racks with the four valves on metal brackets on the front of the panel and with the volume control potentiometer projecting. The components at the back are mainly the wire-wound resistances and the heavier components such as the iron-cored transformers and chokes.

In addition to these amplifiers there are the mains operated loud-speaker amplifiers which are installed in each of the moving-coil speaker cabinets in the studios, control rooms, listening rooms, press-listening room, and so on. These are complete units, and in fact are portable, being fitted with carrying handles. They are two stage amplifiers with the valves mounted on a little platform inside the box, and the couplings, components, iron-cored transformers, and so on, underneath. There is an on-off switch on the panel, a wire-wound volume control, and separate jack sockets for external speakers or listening head-phones.

Although the B.B.C. engineers use a large amount of apparatus which is quite different from that which ordinary listeners could use, the check receivers, "A" amplifiers, and loud-speaker amplifiers are typical of amateur practice. Yes, you can learn much from the way the B.B.C. does it!

# ADVERTISEMENT INDEX

|  | Page           |
|--|----------------|
| Airclipse Ltd. . . . .   | 109            |
| Amplion (1932) Ltd. . . . .                                      | 107            |
| Automatic Coil Winder and Electrical Equipment Co., Ltd. . . . . | 66             |
| Block Batteries Ltd. . . . .                                     | 86             |
| British Blue Spot Co. . . . .                                    | 65             |
| British Ebonite Co., Ltd. . . . .                                | 65             |
| British Institute of Engineering Technology . . . . .            | 116            |
| British General Mfg. Co., Ltd. . . . .                           | 107            |
| British Radiophone Ltd. . . . .                                  | 107            |
| <i>Front Cover Strip, Inside Front Cover</i>                     |                |
| Bulgin, A. F., & Co. . . . .                                     | 109            |
| Celestion, Ltd. . . . .  | 110            |
| Colvern, Ltd. . . . .  | 66             |
| Cosmochor Ltd. . . . .   | 107            |
| Cosser, A. C., Ltd. . . . .                                      | 68             |
| Electradix Radios . . . . .                                      | 113            |
| Ferranti, Ltd. . . . .   | 78             |
| Fluxite, Ltd. . . . .  | 109            |
| Gilbert, J. C. . . . .   | 114            |
| Ibrahim Farish, Ltd. . . . .                                     | 77, 81, 85, 89 |
| Jayberd, F. C., & Co. . . . .                                    | 111            |
| Hellesens, Ltd. . . . .  | 67             |
| Hood, E. J., Ltd. . . . .  | 67             |

|   | Page              |
|---|-------------------|
| Igranico Electric Co., Ltd. . . . .                   | Back Cover        |
| International Correspondence Schools . . . . .        | 108               |
| King's Patent Agency, Ltd. . . . .                    | 113               |
| Kolster Brandes, Ltd. . . . .                         | 94                |
| Lissen, Ltd. . . . .                                  | 97, 101           |
| London Radio Supply Co. . . . .                       | 111               |
| Marcus, Overton Radio, Ltd. . . . .                   | 106               |
| Mullard Wireless Service Co., Ltd. . . . .            | 82                |
| Newnes' "Home Mechanic" . . . . .                     | Inside Back Cover |
| Newnes' "Tit-Bits" . . . . .                          | Inside Back Cover |
| Osborn, C. A. . . . .                                 | 107               |
| Pearl and Pearl, Ltd. . . . .                         | 113               |
| Peto-Scott, Ltd. . . . .                              | 93, 115           |
| Riverside Mfg. Co., Ltd. . . . .                      | 114               |
| Sonochorde Reproducers, Ltd. . . . .                  | 67                |
| Sound Sales . . . . .                                 | 65                |
| The 362 Radio Valve Co., Ltd. . . . .                 | 65                |
| Trevor Pepper . . . . .                               | 114               |
| Varley, Ltd. . . . .                                  | 98                |
| Watkins Bros. and Co. . . . .                         | 114               |
| Westinghouse Brake and Saxby Signal Co., Ltd. . . . . | 94                |
| Wet H.T. Battery Co. . . . .                          | 114               |
| Whiteley Electrical Radio Co. . . . .                 | 105               |

## OPENINGS for ENGINEERS!

Never before has engineering offered such magnificent chances. With the rise of the depression, the industry is literally teeming with first-class opportunities. Our 250-page Hand-book, "ENGINEERING OPPORTUNITIES," shows where the opportunities lie, and the easiest way to prepare for them. The Hand-book gives details of A.M.I.Mech.E., A.M.I.E.E., A.M.I.C.E., G.P.O., etc. Exams., outlines Home-Study Courses in all branches of Civil, Mech., Elec., Motor, Radio, and "Talkie" Engineering, Building, etc., and explains our unique Employment Dept. Send for this valuable Hand-book to-day—FREE!

**FREE!**  
**250**  
**PAGES**

BRITISH INSTITUTE  
OF ENGINEERING TECHNOLOGY,  
293, Shaftesbury House,  
29, OXFORD ST., LONDON W.1.



Clearly written and fully illustrated.

## NEWNES' HOME MECHANIC BOOKS

This series covers a wide field and will prove of the greatest value to everyone interested in models and how to make them; woodwork and other crafts.

### ACCUMULATORS

An up-to-date handbook dealing with every type of accumulator, methods of charging them at home, care and maintenance, also explains how to erect a charging station.

### MOTOR CAR UPKEEP AND OVERHAUL

Information covering the engine, decarbonising, valve grinding, the lighting system, the carburettor, cooling system, lubrication, springs and shock absorbers, steering gear, brakes, wheels, axles, tracing noises, etc., etc.

### TOY MAKING FOR AMATEURS

How to make clockwork toys, model aeroplanes, model locomotives, model boats, ingenious toys operated by sand, wooden models and toys, electrical toys, steam toys, guns, kaleidoscopes, acrobats, etc.

### TWENTY-FIVE TESTED WIRELESS CIRCUITS

All the sets described have been designed to meet modern needs. They range from simple crystal receivers to a seven-valve super-heterodyne, and all the sets have been made and tested before inclusion.

### SIMPLE ELECTRICAL APPARATUS

An excellent little book for those who wish to make simple and useful electrical appliances, such as galvanometers, electric motors, dynamos and Leyden jars.

### MODEL BOAT BUILDING

Contains designs for battleship, speed boat, paddle steamer and yachts. Excellent models can be built with the simple directions and diagrams given.

### THE HOME WOODWORKER

Clear instructions on how to make a large variety of articles in wood, together with many useful hints on wood-working.

### MODEL AEROPLANES AND AIRSHIPS

Contains full descriptions of easy-to-make models of every description that will fly.

### THE HANDYMAN'S ENQUIRE WITHIN

Hundreds of practical ideas and hints of value to the man who is clever with his hands.

### 25 SIMPLE WORKING MODELS

Ingenious and practical designs for electric, steam and clock-work models.

**1/-**  
each

Obtainable at all Newsagents and Bookstalls, or by post 1/2 each from George Newnes, Ltd., 8-11, Southampton St., Strand, W.C.2.

Geo. Newnes, Ltd.

# 'LISTENERS IN'!

IS YOUR WIRELESS LICENCE NUMBER IN THIS LIST?

IT MAY BE WORTH  
**£50**

Compare your number and claim your reward

**£50** will be paid to holder of Licence No. AP 246106

**£25** will be paid to holders of Licences: Nos. AQ 308105 AO 511937

**£10** will be paid to holders of Licences: Nos. AP 330777 AN 463896

**£5** will be paid to holders of Licences: AM 606348 AP 027513 AO 832377 AP 219430 AO 734684

**£2** will be paid to holders of Licences:

|           |           |           |           |           |           |           |
|-----------|-----------|-----------|-----------|-----------|-----------|-----------|
| AH 735555 | AL 001844 | AM 571137 | AN 859763 | AO 886232 | AO 917445 | AP 950403 |
| AI 695032 | AL 561733 | AM 029400 | AN 492447 | AO 796099 | AP 140567 | AP 947206 |
| AJ 594889 | AL 478903 | AM 487486 | AN 384216 | AO 521380 | AP 331296 | AP 864031 |
| AJ 894021 | AM 867960 | AM 934750 | AN 112293 | AO 350825 | AP 505063 | AP 008704 |
| AK 829998 | AM 707763 | AN 093556 | AN 434770 | AO 802790 | AP 692337 | AP 326704 |
| AK 36871  | AM 168772 | AN 238040 | AN 538258 | AO 416007 | AP 721845 | AP 125954 |

**£1** will be paid to holders of Licences:

|           |           |           |           |           |           |           |
|-----------|-----------|-----------|-----------|-----------|-----------|-----------|
| AJ 897165 | AL 238044 | AM 099947 | AN 821956 | AO 964767 | AP 961050 | AQ 421175 |
| AJ 220437 | AL 093124 | AM 888534 | AN 923316 | AO 004879 | AP 367904 | AQ 570666 |
| AJ 169054 | AL 36712  | AM 606444 | AN 529333 | AO 370200 | AP 008361 | AQ 855501 |
| AK 538367 | AM 127703 | AM 947777 | AN 656781 | AO 153916 | AP 415738 | AQ 747359 |
| AK 293046 | AM 400206 | AN 023473 | AN 171528 | AO 577736 | AP 221475 | AQ 129895 |
| AK 985163 | AM 697871 | AN 263894 | AO 33019  | AO 458370 | AP 672422 | AQ 021173 |
| AK 008915 | AM 805768 | AN 895628 | AO 487500 | AO 792136 | AP 820508 | AQ 989779 |
| AK 404006 | AM 721221 | AN 588732 | AO 232532 | AP 318221 | AP 042666 | AQ 625312 |

This offer applies to licences which are actually in force on Saturday, September 30, 1933. Before the awards are paid, claimants will be asked to undertake a simple publicity service in distributing leaflets to encourage the sale of licences amongst those who at present do not fulfil their obligations by taking out a Post Office Licence before receiving broadcast programmes. Claims cannot be considered in connection with any Licence the date of issue of which is after September 28, 1933.

For full particulars for claiming awards and a complete list of numbers see

# TIT-BITS

ON SALE EVERYWHERE SATURDAY SEPT. 30.



# IGRANIPAK

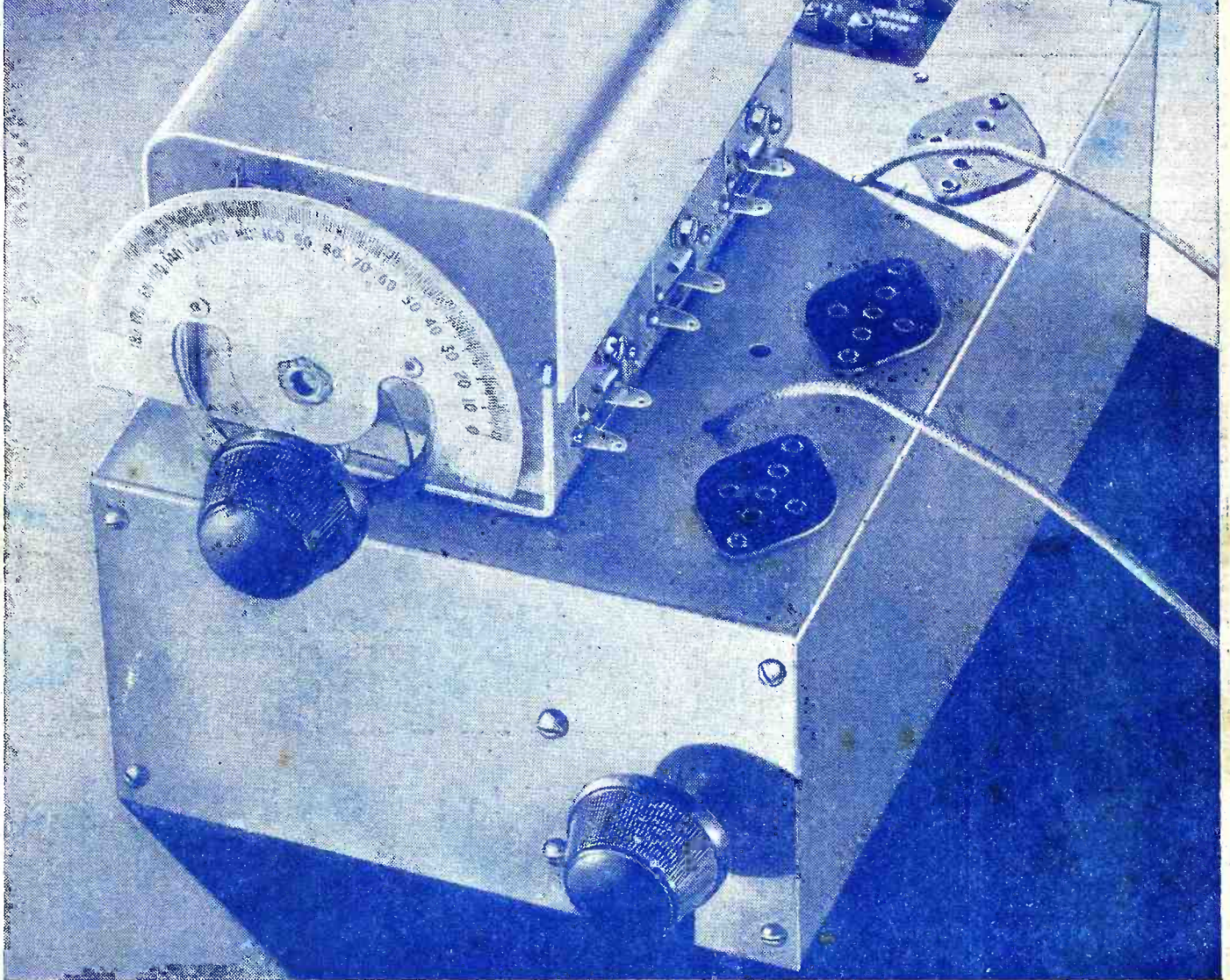

However expert or amateur you may be, this new 'Igranipak' cannot fail to save you time, trouble and expense. 'Igranipak' is a complete and compact tuning unit. Upon its rigid metal chassis are mounted:—screened coils with built-in wave-change switch, Igranic 3-gang condenser with cover, escutcheon and disc drive assembly with pilot lamp attachment, mains switch, three 5-pin valve-holders, grid leak and condenser, engraved terminal board. Wavelengths covered: 210-520 m. and 900-2,000 m. Complete with instructions and simple circuit diagram

## 57/6

*if your local dealer cannot supply you, please write to us direct.*



*Write for fully illustrated Catalogue No. J. 1277.*

Igranic Electric Co., Ltd.,  
149, Queen Victoria St., E.G.4.

**P. W. Gift Stamp No. 53**

Printed by NEWNES & PEARSON PRINTING CO., LTD., Exmoor Street, Ladbroke Grove, W.10, and published by GEORGE NEWNES, LTD., 8-11, Southampton Street, Strand, W.C.2. Sole Agents for Australia and New Zealand: GORDON & GOROU, LTD., South Africa: CENTRAL NEWS AGENCY, LTD. *Practical Wireless* can be sent to any part of the world, post free, for 17/4 per annum; six months, 8/8. Registered at the General Post Office for Transmission by Canadian Magazine Post.