

P Jones

Hi-Fi

WORLD

JUNE 1996 £2.30

For the love of music

**CLASSIFIED ADVERTS:
6 PAGES OF HI-FI
BARGAINS**

**ARE NAD STILL THE
ONES TO BEAT? WE
TEST THEIR 412 TUNER**

PIONEER CT-S740S

TOP QUALITY DOLBY S CASSETTE DECK

SUPPLEMENT NO. 22
(overseas: inside)
Free with this issue.



**AFFORDABLE AND
UPGRADABLE:
AMC'S CDM7 CD PLAYER**

**SPENDOR'S NEW 2030
FLOORSTANDERS**

**COMPETITION: WIN 5 PAIRS OF TECHNICS'
SBM LOUDSPEAKERS WORTH £1,800 IN TOTAL**



For more than 30 years
KEF's engineers have been
making audiophile
loudspeakers costing
thousands.

Now they've made a
range that costs a lot, lot
less. Outside, they're small,
they're beautiful and they
will fit easily into your home.

Inside, Codas have the
quality components and
engineering that
audiophiles expect.

The new Coda series
from KEF Brings a new
dimension to small speakers
- serious sound
at an affordable price.

For
those who
take their
sound
SERIOUSLY.



UK/WHAT HI-FI
Magazine
Best Buy Award



UK/HI-FI CHOICE
Magazine
Best Buy Award



France/DIAPARSON
D'OR HI-FI
Best Entry Level Speaker

Coda



MODELS SHOWN FROM LEFT TO RIGHT ARE THE CODA 9, CODA 8 AND CODA 7. KEF AND CODA ARE REGISTERED TRADEMARKS. FOR DETAILS ON THE KEF CODA SERIES PLEASE CONTACT KEF AUDIO (UK) LIMITED, DEPT HFW2, FREEPOST MA 1332, ECCLESTON ROAD, TOVIL, MAIDSTONE, KENT ME15 6BR. TELEPHONE (01622) 672261.

World Radio History

THIS MONTH'S WORLD

- First of a new breed from Marantz is the CD-63mkII KI-Signature CD player, bearing the initials of senior designer Ken Ishiwata. This £500 player looks set to turn heads - find out why on page 16.
- Arguably the King of budget tuners, NAD's 402 has now been replaced with a newly up-dated model, the 412. Will it continue to lead the field - answers on page 26.
- Spondor have recently launched a range of more affordable loudspeakers. Using a custom designed elliptical bass driver the 2030s have a few neat tricks up their sleeve - page 20.

Has British hi-fi been overtaken? I visited the Paris Salon HIFI show recently and was surprised to see such a strong and dedicated audiophile following. The range of equipment was spectacular, from high end valve amplifiers and High Definition Aerogel coned loudspeakers, to kits and affordable test equipment, aimed at the hobbyist as well as the audiophile.

There was a real buzz here, the kind you used to find years ago at the UK's leading shows. Perhaps we need to adopt a clearer path in the UK, one that everyone can relate to. Consumers must be confused by AV, DVD, MD, DCC, HDCD and what have you. The French show had a simple angle - music and fun. Perhaps there is a message here for the UK marketplace?

Dominic Baker, Editor

TEST EQUIPMENT



- Hi-Fi World has its own advanced test laboratory and acoustically treated listening room. No other hi-fi magazine has the benefit of such facilities.
- Hi-Fi World has a dedicated in-house team of experienced listeners, and uses selected freelance professionals. We review thoroughly by extensive auditioning, rather than by quick-fire group listening tests.
- Hi-Fi World's engineering team designs a wide range of products in-house. No other hi-fi magazine is so expert and dedicated.

LISTENING ROOM

(TREATED BY RFG ACOUSTIC TOOLS)



IN THE JULY ISSUE

ROTEL RDD/RDP980 CD TRANSPORT & CONVERTOR

Rotel have just added a new CD transport and convertor to their established and well liked range of CD players. The RDD/RDP980 look good value too at £450 apiece.

WILSON BENESCH TURNTABLE

Supplied with their new Hybrid carbon fibre bodied MC cartridge and ACT 2 carbon fibre tonearm, this Wilson Benesch turntable system offers a real taste of high-end sound.

JBL S2600 LOUDSPEAKERS

A winner of Japan's Golden Awards prize for "Excellent Audio Products", the JBL S2600 is a large floorstanding loudspeaker using a 12" bass driver along with a horn loaded compression driver. JBL claim 92dB sensitivity and ask £3,500 for the pleasure of owning a pair.

TECHNICS RS-AZ7 CASSETTE DECK

Technics' new 3-head RS-AZ7 cassette deck uses an Amorphous-Z head developed from thin film technology used in their DCC machines. It is said to bring new life to old recordings, with lower noise and wider frequency response.

AMC 3025 AMPLIFIER

Making a strong return to the UK's market, AMC have recently launched a wide range of equipment. We've covered their new CD player and valve CD convertor, now it's time for their entry level amplifier.

WHARFEDALE VALDUS 300

At a smidgen under £150, Wharfedale's 2-way Valdus 300 loudspeakers promise a big and powerful sound for their size. Can they worry the competition though?

AUDIO PUBLISHING LTD
64 CASTELLAIN ROAD,
MAIDA VALE,
LONDON W9 1EX.

CONTACT NUMBERS

Tel: 0171-269 3333
Fax: 0171-269 5000
Individual queries please
are answered by telephone.

MAIL ORDER

Tel: 0171-269 0461
(24 hour answering phone)

SUBSCRIPTIONS

See page 61 for details

EDITING

Noel Keywood

EDITORIAL

Dominic Baker

EDITORIAL ASSISTANTS

Jon Marks
Haider Bahrani

PRODUCTION

Shannon Deutrom

ADVERTISING

Caroline Knott
Tel: 01245 443555

ADVERTISING SALES EXECUTIVE

Amanda Sweeney
Tel: 0181 424 9783

ADVERTISING EXECUTIVE

Rosalind Day

MARKETING

Jon Dolan

TECHNICAL ASSISTANT

Nick Lucas

CONTRIBUTORS

Douglas Floyd-Douglass
David Price
Dominic Todd
Eric Braithwaite

MUSIC REVIEWERS

Peter Herring
Simon Hopkins
Giovanni Dadomo
Jon Clarke
Simon Cooke

EDITING

Simon Marsh

Distributed by

1111 Tottenham Court Road,
London W1P 0AU
Tel: 0 21 262 5333

Origination by

ABC Colour Services Ltd
111 Tottenham Court Road, London
W1P 0AU
Tel: 021 262 5333

Printed by

ABC Colour Services Ltd
111 Tottenham Court Road, London
W1P 0AU
Tel: 021 262 5333

All rights reserved. No part of this publication may be reproduced, stored in a retrieval system, or transmitted in any form or by any means, electronic, mechanical, photocopying, recording, or otherwise, without the prior written permission of the publisher.

Printed and published by ABC Colour Services Ltd, 111 Tottenham Court Road, London W1P 0AU. Tel: 021 262 5333.

THIS MONTH'S REVIEWS

AMPLIFIERS

CROFT EPOCH AND SERIES V 41

Haider Bahrani switches on to see if this new Croft pre/power combination can set his heart a-glow.

TEAC A-BX7R 65

Eric Braithwaite finds that size isn't everything with the A-BX7R from TEAC.

COMPACT DISC

MARANTZ CD-63mkII 16

Ken Ishiwata, Marantz's senior designer, has delved inside a CD-63 to bring us another super-tuned, audiophile aimed CD player.

AMC CDM7 23

Dominic Baker checks out AMC's CDM7, and hits the bottle with the optional plug-in valve output stage.



THORENS TCD/TDA2000 30

Eric Braithwaite pins back his ears for a session with the digital combo from the turntable company.

TUNER

NAD 412 26

Jon Marks listens in to find out if NAD's new 412 tuner is a worthy successor to the 402.

CASSETTE DECK

PIONEER CT-S740S 50

Noel Keywood records his verdict on Pioneer's CT-S740S deck. Read on to discover what it is.



LOUDSPEAKERS

SPENDOR 2030 20

Built around an oval mid-bass driver, the 2030 stands tall and slim. Dominic Baker lends an ear.



QLN QUBIC 122 28

Haider Bahrani tries out the QUBIC 122, budget sibling of QLN's Signature Series.

UKD CALLAS GOLD 33

With its hardwood cabinet and 24k gold-plated terminals, the UKD Callas Gold promises much. Eric Braithwaite is there to see if it delivers.

HARBETH HL COMPACT 7 57

Our very own in-house private eye Dominic Baker investigates Harbeth's HL Compact 7.



WORLD VERDICT

OUTSTANDING - Superb sound, something we'd use ourselves.

GOOD - Has strong merit. Well worth an audition.

ADEQUATE - Mediocre in vital areas. May be worth auditioning.

POOR - Seriously flawed. Not worth considering.

REGULARS

NEXT ISSUE

Find out about all of the wonderful things we'll be bringing you in the July issue.

NEWS

A tape deck, a subwoofer, some tiles and a web on the net amongst other things. Just say you read it here first.

READERS' LETTERS AND Q&A

Our letters pages are filled with intrigue and prizes too.

COLUMNS

Opinionated, they might be. In the know is a definitely maybe. Fun to read, absolutely.

SUBSCRIPTIONS

To be sure of a copy, because they go quickly, subscribe now.

WORLD FAVOURITES GUIDE

Over the years we've come across some top class hi-fi. Here's a list of the ones we might buy.

DIAL A DEALER

You want it, they could have it. Find a dealer now and get those index fingers punching.

SPECIALIST HI-FI DEALERS

Hi-Fi ills? See a specialist.

MEET YOUR MAKER

Pay your respects to the ones that brought heaven to your living room.

WORLD AUDIO DESIGN

Get kitted out here.

HI-FI WORLD LIBRARY

It'll probably be raining this summer, so you'll need a book or two to read.

3 MEASURED PERFORMANCE 103

Everything we listen to gets a thorough probing.

READERS' CLASSIFIEDS 118

7 A world of hi-fi bargains waiting to be snapped up.

ADVERTISERS INDEX 130

FEATURES

SALON HI-FI

The latest from Paris. Sham, or real hi-fi? Dominic Baker was our man with the phrase book finding out.

CASSETTE MYSTERIES EXPLAINED

Noel Keywood delves into the world of cassette deck technology.

DIY SUPPLEMENT NO.22

It's that time for us to give you another FREE DIY Hi-Fi Supplement. This month we build Hart's Chiara single-ended headphone amplifier, check out Electronics Workbench - a circuit simulator for the PC and of course all of the usual book reviews and DIY letters.

COMPETITION

Page 66

A chance to win Technics loudspeakers this month. First prize is a pair of SB-M500 loudspeakers and there are four pairs of SB-M300s for runners up too.



MUSIC

The best of this month's albums

ROCK AND POP 82

RECORD OF THE MONTH:
Sine: Mercury Falling

JAZZ 85

CLASSICAL 93

RECORD OF THE MONTH:
Biber, Schmeizer:
Sonatas, Freiburger
Barockorchester Consort

WHO SAYS THE

BRITISH DON'T

PLAY BRILLIANTLY

IN EUROPE?

EUROPEAN LOUDSPEAKER OF THE YEAR



At B&W we've just scored another major success. Our CDM1 has now won European Speaker of the Year, which was judged by the Editors-in-Chief of leading photo, video and audio magazines from thirteen countries. High praise indeed. But with a winning team of engineers coming up with a hat trick of technological innovations: outside tweeter mounting, kevlar drive unit and contoured edges for reduced sound diffraction, it's not an entirely unexpected result. For more information call B&W UK on 01903 750750. And see that the best European players don't have to start at £8.5m.



B&W

TRICHORD GENESIS

Take one Pioneer PDS 504 CD player and add a little spice, namely the Pulsar 1 DAC and the 'Clock 2' modification, and, hey presto, the Genesis CD player.

Retailing at £549

Trichord Research claim that their player offers a real taste of high end performance at a less than high end price. Watch out for the review

Trichord Research
73 Church St.,
Malvern,
Worcestershire
WR14 2AE
☎ 01684 573524



trade winds

AND THEY KEEP ON COMING

Hot on the tail of recent product launches NAD set another integrated amplifier onto the market. The new 314 builds on its highly acclaimed predecessor, the 304, delivering 35 watts per channel into 8 ohms.

The 314 has 6 line inputs and one MM phono stage, using precision metal film resistors and polypropylene capacitors. In fact the whole amplifier is built with discrete components for a high level of performance. The 314 also uses NAD's Extended Dynamic Power (EDP) circuit topology. This allows it to sustain high levels of dynamic power on transients; NAD claim 200watts into 2Ω is possible from this '35watt' amplifier. It's available now and retails for £259.95.

Audio Club
401-405 Nether St.,
London N3 1QG
☎ 0181 343 3240



G T AUDIO

THE VALVE AND VINYL SPECIALISTS



The new CROFT Epoch pre-amp and Series 5 power amp like all Croft amplifiers represent unparalleled performance at very realistic prices. As Ken Kessler once said "Croft has products which can take on the world" "they've proven to be reliable beyond my wildest dreams and embarrassingly underpriced" If you have had trouble finding a Croft dealer then look no further as we have these items on permanent demonstration

The new GRAAF 5050 power amplifier 50 watts of glorious power using the latest Russian KT88/6550. This Italian beauty which is built at Modena, the home of Ferrari, also equals their standard in performance and finish. The matching WFB TWO pre-amp with MM/MC input is also a little stunner. If you are considering valve pre/power combination for around £3000 then the GRAAF should be at the top of your list.



If you are considering purchasing a new piece of audio equipment and are totally confused by the volume of equipment available then have no fear. The equipment I recommend has to pass strict criteria before I undertake to sell it. These criteria are build quality, reliability, performance and appearance in that order. I also recommend equipment whose performance is above and beyond that of the established references, creating new references like the Nottingham Analogue Turntables and Posselt loudspeakers. Two new products that come firmly recommended are the new Glass Audio Tube Engineering (G.A.T.E.) KT88 & 300B amplifiers and the Yamamura Churchill Millennium 5000 cables. These cables are the most remarkable I have ever heard. The improvement they make to a system is greater than upgrading a major component for example a new amplifier or loudspeaker. If like me you appreciate the beauty of real music and want to re-create its illusion at home then consult Graham Tricker to arrange a demonstration or for information on the following products.

Agents for:- APOLLO, CROFT, G.A.T.E., GRAAF, G T AUDIO CABLES, LEAK TROUGHLINE TUNERS, MONRIO, NOTTINGHAM ANALOGUE, POSSELT, UNISON RESEARCH, UKD OPERA AND YAMAMURA CHURCHILL ACCESSORIES AND CABLES.

Ex-demonstration equipment for sale

BEARD CA35 pre-amp, BEARD M70 MkII monoblocks + matching stands (list over £4000) used once at Ramada, all boxed & still under warrant, a give-away at £1500. UKD Opera Loudspeakers:- Callas Mk1's £300, Operetta's inc. stands £400, Prima's (oak) £350, Divinas (walnut) inc stands £999, SME V £750, Unison research Smart 845's £2500.

Service and Repair Department

Vintage Equipment Restored

Tel/Fax: 01895 833099

DEMONSTRATION BY APPOINTMENT ONLY

We are situated on the outskirts of NW London 4 minutes from junction 16 of the M25 (M25/M40) or 20 minutes by train from Marylebone Railway Station

DIFFUSED WALLS

Confused sound? Is your living room too live? For these and any sound room niggles Barry Larcombe Associates might be able to help. As used in performance halls, recording studios and sound processing venues (not to mention HFV's in-house listening room), B.L. Associates supply the full range of RPG acoustic products from B.A.S.S. traps to wall diffusers.

Barry Larcombe Associates
52 Fryerning Lane,
Ingatstone,
Essex CM4 0DE
☎ 01277 352066



DENON'S 'S' QUE

The two head DRM-650S is Denon's first domestic outing into the field of Dolby S cassette decks. At £229.99 it battles head on with standard Dolby B and C models available.

This new machine from Denon boasts many other features alongside Dolby B, C, S and HX Pro, including Auto Tape Tuning which sets bias and sensitivity when recording. There's also a manual bias control for playback and the transport has two motors, 'Non-Slip Reel Drive' and a 'Silent Logic' mechanism. To minimise interference, completely separate power supplies are employed for the audio and transport circuitry.

Hayden Laboratories
Hayden House,
Chiltern Hill,
Chalfont St. Peter,
Buckinghamshire
SL9 9UG
☎ 01753 888447



THE ART OF COMPROMISE

Sennheiser, the headphone specialists, claim that they have mastered the art of compromise. Their new headphones, the HD 445s, are a cross breed using the drive units from their Expression line packaged in the more cost effective physical design of the HD 435 series of 'phones.

The aforementioned drivers use Neodymium-Iron magnets for a claimed high sensitivity, clean bass and extended treble. As with their other models construction is modular and all parts are user replaceable. The cables used are Oxygen Free Copper strengthened by strands of woven Kevlar. All this will set you back just £39.95.



Sennheiser
13 Century Point,
Halifax Road,
High Wycombe,
Bucks. HP12 3SL
☎ 01494 551551

NOW HEAR THIS SUBWOOFER

Updating their SW-2p powered subwoofer system, NHT have recently unleashed the SW-2pi. The new version uses a 10inch polypropylene, high excursion woofer in a vented enclosure. It is driven by a 120watt amplifier and produces bass, NHT claim, that extends down to 27Hz.

Amongst its features are high (fed from your amplifier's speaker outputs) and line level inputs, outputs for use with satellite speakers, adjustable low pass filtering and a phase switch. Retail price is £689.

Sound Dept.
19 Blacklands Way,
Abingdon Business
Park,
Abingdon,
Oxfordshire
OX14 1DY
☎ 01235 555622



We are too busy building the World's best hi-fi to design adverts.

But not too busy to talk to you if you want information.

dpa digital ltd., Units 7 & 8, Willowbrook Lab Units, Crickhowell Rd., St Mellons, Cardiff CF3 0EF
Tel: 01222 795621 fax: 01222 794267.

REFERENCE NEUTRONS

As the fad for miniature loudspeakers builds up to a frenzy, AVI have hopped on the bandwagon. Their offering is the Neutron, a natural Cherry veneered ported box housing a 4.5" bass/mid driver and a 19mm soft dome tweeter. The drive unit comes in a high pressure die cast chassis with a doped paper cone. The crossover unit uses large air cored inductors and polypropylene capacitors. Low frequency cut off is 70Hz at -6dB. Nominal impedance is 8Ω.

AVI claim a tonally accurate sound and a life-like image is produced from these tiny specimens. Retail price is £499.

AVI
Unit F3C3,
Bath Road
Trading Estate,
Stroud,
Gloucestershire
GL5 3QF
☎ 01453 765682



HIGH END RESEARCH

Harman Audio have formed a small company for the purpose of designing "loudspeakers of exceptional quality and performance". The current and supposedly temporary name for the new company, which is to be located in Los Angeles, is Newspeak.

The engineering team will be headed by Kevin Voecks of Mirage and Snell fame. Organisation and management will be directed by Sanford Berlin, the former chairman of Madrigal.

INTO THE QUADRASPIRE

New on the hi-fi furniture scene are a company called Quadraspire. Their first product, the Q4 table, comes with a choice of either Cherry or Walnut shelves with 12 aluminium spacers and 4 adjustable feet. The spacers are available in 4 different lengths from 100mm to 216mm.

The whole rack retails at £200.

Additional shelves including spacers are available at £50 each.

Quadraspire
62 Riverside,
Sir Thomas
Longley Rd,
Rochester,
Kent ME2 4BH
☎ 01634 296615



ITALIAN INVASION

GRAAF have handed over UK distribution to, um, U.K. Distribution. Their current range consists of two pre-amplifiers; the WFB One & Two, each with an in-built MM/MC phono stage, the GM 13.5B balanced line pre-amp and three power amplifiers; 5050, GM100 and GM200. Prices start at £1100 with the WFB Two and go up to £8000 for the GM200 power amplifier.

The amplifier shown is the £2100 5050 power amplifier. This model uses KT88A power valves in push-pull configuration driven by 6922 double triodes.

U.K. Distribution
23 Richings Way,
Iver,
Bucks. SL0 9DA
☎ 01753 652669



DESPERATELY SEEKING SIEMEL

Siemel, based at Vatan in France was originally founded in 1986 and now with a range of hi-fi components is making efforts to set up an international distribution network.

Their current range of products includes two line pre-amplifiers, one tube and one transistor and separate MM and MC phono pre-amps. Further new products are sitting on the test bench.

SN Siemel Industrie
ZI Les Noyers,
36150 Vatan, France
☎ (+33) 5449 9406



SUPER IMAGES

Musical Images have recently refurbished their Covent Garden store. They claim to be the only location in the UK to have the Systemline multi-room Super Controller on permanent demonstration. This system can be used to control up to four separate music/video systems in four separate zones.

Musical Images
18 Monmouth Street,
Covent Garden,
London WC2H 9HB
☎ 0171 497 1346

Audio Illusion

23 Langley Broom
Langley
Berkshire SL3 8NB
TEL: (01753) 542761; FAX: (01753 772 532)
10am-8pm Monday-Saturday

*When Reality
becomes a
Dream.....*

10W Pure Triode,
Single Ended & Balanced Inputs —
.....*Pure Magic*

FOR YOUR NEAREST
STOCKIST CONTACT _____

AUDIO ILLUSION

INFORMATION ALSO AVAILABLE
ON THE FOLLOWING:-
Class Audio
Enlightened Audio Design
Mirage Bipolar Loudspeakers

Koss

TRIODE 100 SB

MONO BLOCK / BLOC DE PUISSANCE

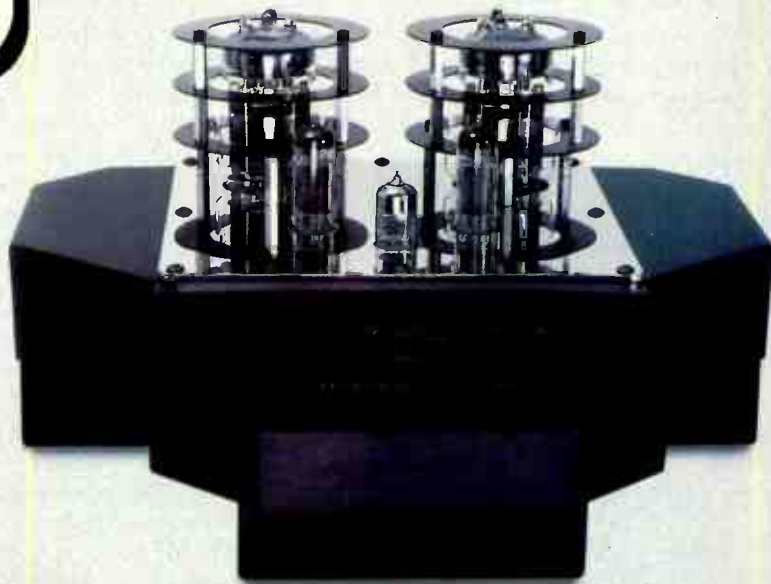

DON'T THINK TWICE IT'S ALRIGHT

Sometimes we ask too many questions. But always asking for explanations can be a waste of time. Trusting to your instincts, believing your own eyes and ears, that is the way to reach the truth. If you doubt that, just ask yourself why it is that a well-designed single-ended valve amplifier can beat its solid-state cousin hands down for sheer musical enjoyment, when the specifications on paper might have you believe just the opposite.

At Unison Research, we make amplifiers to give musical pleasure. And we believe that in the best designs, those which go on to achieve classic status, form should follow function. That is why our amplifiers are different from those of other manufacturers. We don't make 'black boxes with knobs on, and we never will. Take a close look at our Mystery One preamplifier. It certainly doesn't look like any other preamp you've ever seen. But like all our products, from the delightful Simply Two to the awesome 845 Absolute (considered by many to be the finest valve amplifier ever made, *irrespective* of price) it is intelligently-engineered, beautifully styled, and above all, made to give you a lifetime of musical pleasure.

The moral of the story, quite simply, is this: sit back, relax, and listen to your music. If it *sounds* right, and *looks* right then don't think twice, it *is* right



MYSTERY ONE by Unison Research.

Unison Research Mystery One valve preamplifier. £1750. For details on the full range and a dealer list call:

UKD
23 RICHINGS WAY,
IVER, SLO 9DA, BUCKS, ENGLAND
TEL: 01753-652669 FAX: 01753-654531

SALON HIFI 96

HAUTE FIDÉLITÉ & HOME CINEMA

LE MEILLEUR DE LA HIFI & DE L'AUDIO-VIDÉO

Dominic Baker visits Paris for the weekend, but gets caught by a hi-fi show on his way to the Eiffel tower.

Held over the weekend of 22-25th March, this year's Salon Hi-Fi 96, held at the Palais des Congrès in Paris, saw a strong enthusiast following. Standing outside in the sun I was amazed at the number of people who had flocked to this event, but once inside I could see why. Here was a show for dedicated audiophiles, with valve amplifiers and kits alongside numerous weird and wonderful loudspeaker designs.



Not available in the UK at present, but **Euraudio's** portable 1/3 octave analyser looked very sleek.

It comes with a built-in microphone and has a range of 80dB, ideal for home constructors or in-car response measurements.

Cairn seem to be addicted to High Definition Aerogel drivers - every loudspeaker in their range used them. Their top models, Eiger and Meane, also use the HD-3P oval piezo-electric dome tweeter - the first time we've seen it in a production loudspeaker. ▶



Marantz were showing the first samples of the soon to be re-launched Model 8B and Model 9 valve amplifiers.

Cabasse occupied a large part of the 6th floor with their huge range of loudspeakers. Pictured is a selection playing in front of an audience of a few hundred in a small concert hall. ▶



Leedh were also demonstrating loudspeakers using HDA drivers and the HD-3P oval piezo-electric dome tweeter - not surprisingly really, they're based just around the corner from the Audax factory in Chateau du Loir. ▶



Davis Acoustics, a name I've not come across, had a remarkable range of loudspeakers and drive units, both in built-up form and as kits. The drivers use a range of materials including kevlar and carbon fibre and included several boasting 90dB or higher sensitivity. ▼



ROUND UP - JM Lab (Focal) had a wide range of loudspeakers and drive units on display, including their new 'W' cone drivers. 'W' is a glass sandwich material comprising two fine veils of woven glass with a layer of rigid syntactic foam in-between. **Rogers** took the retro approach to a sweet sound and drove a pair of LS3/5as with an original Cadet III valve amplifier. In their other room the latest E-40a valve amplifier was driving the LS33/AB33 combination. **JBL** had a pair of S3600 loudspeakers on

demonstration. Again a product not available in the UK, they're bigger brothers to the award winning S2600 horn/bass reflex hybrid loudspeakers we hope to be reviewing next month. Both **Triangle** and **SEAS** were showing their latest kit designs. **Luxman** were showing their CL-38 valve preamplifier and MA-88 KT88 monoblock valve power amplifiers alongside their normal range of electronics. Sadly these valve amplifiers are not available in the UK at present ●

MUSICAL IMAGES



The Power House of Choice

Technology continues to march forward at an alarming rate – since the advent of Compact Disc in the early eighties there seems to have been an almost endless stream of new ideas, some successful, some not. Keeping abreast of all this new technology is difficult for both newcomer and enthusiast alike. So where do you go to receive expert, unbiased advice? Which equipment will suit your budget and, just as importantly, your listening or viewing environment?

An Isle of Sanity in a Sea of Madness

As an authorised dealer for over 100 of the world's premier manufacturers, Musical Images are able to offer superb choice for their customers and, having attended numerous Supplier Training Courses, their staff are fully qualified to offer expert advice on all aspects of Hi-Fi and Home Cinema.

The three branches in Hounslow, Edgware and Covent Garden offer a total of six demonstration rooms, with 'single speaker dems' a speciality. So whether you're looking to invest in a dream system or simply shopping for

accessories, you'll find nothing is too much trouble for the people at Musical Images.

An Audiophile's Delight

Award winning and well-reviewed Hi-Fi separates from all the top manufacturers form a major part of Musical Images' product line-up... However, as the old saying goes, "one man's meat is another man's poison", so you owe it to yourself to take advantage of the superb demonstration facilities and let Musical Images' staff guide you through the various options that are available.

Or, if you feel so inclined, why not enquire about Home Trial Facilities?

Lovers of vinyl have certainly not been neglected, because Musical Images realise that many of those treasured recordings will never be committed to CD. Therefore, you will find a comprehensive range of integrated turntables together with separate arms and cartridges at all branches.

And, if you're upgrading and are not sure what to do with your old equipment, don't 'Boot Sale' it! Talk to Musical Images about their Trade In scheme – you could be in for a nice surprise!

Home Cinema – The Future Beckons

Dolby AC-3, Dolby Pro Logic and THX – you've read about them in the magazines and have probably heard one or more formats, but if you're really interested in Home Cinema there can be no substitute for a well conducted demonstration carried out by professionals.

Musical Images' Covent Garden branch, for example, has installed a full Dolby AC-3 facility featuring the top brands.

This stunning, six-channel digital system replicates the sound heard in a Dolby SR-D cinema and shows just what can be achieved by 'state-of-the-art' equipment.



Full THX facilities are available at Hounslow and Edgware whilst many forms of Dolby Pro Logic products – including TVs, system packages and separates – can be auditioned at all 3 branches. Whatever your budget



Musical Images' staff will guide you carefully through your options.

Prices range from around £1000 for a good basic system right up to £30,000 for the ultimate cinematic experience. And, if an extra-large picture appeals to you, a CRT or LCD Projector may be the answer – the possibilities are endless.

Multi-room Hi-Fi

There's nothing new about running a pair of extension speakers in the kitchen (or indeed in any other room of the house), but what happens when you want to try a new CD and another member of the family insists on listening to a radio play?

This is where Multi-room Hi-Fi comes in. Any source connected to your system can now be routed to the room of your choice, and it's all controlled by a simple handset. Expert installation is handled by Musical Images with minimal disruption and you won't even have to redecorate. The control unit stacks neatly with your existing Hi-Fi and can feed four rooms – simply add another unit for further expansion.

Multi-room Hi-Fi is becoming incredibly popular, it can cost a lot less than you'd think and it's on permanent demonstration at Musical Images' Covent Garden store.

The Musical Images Club

By joining Musical Images' Privilege Club you'll receive benefits such as exclusive and priority offers on both new and ex-demo equipment, invitations to select demonstration evenings plus regular newsletters and up-dates.

Club members can also take advantage of Musical Images' unique Value Added Purchasing offers.

Details on how to join are available from all branches.

The Musical Images Pledge and Service Commitment

Established in 1984, Musical Images have gained an enviable reputation in the world of Hi-Fi retailing by getting the formula exactly right – a superb choice of products, qualified advice, a professional home installation service and total commitment to customer care and satisfaction.

Together with a worldwide mail order service, interest-free credit facilities, design consultancy, full service and repair back-up and three stores open seven days a week, Musical Images are the one stop shops for every audio visual need. We look forward to welcoming you.



**45 High Street,
Hounslow,
Middlesex TW3 1RH
0181 569 5802**

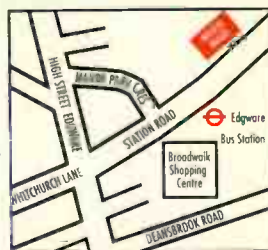

**173 Station Road,
Edgware,
Middlesex HA8 7JX
0181 952 5535**



**18 Monmouth St,
Covent Gdn,
London WC2H 9HB
0171 497 1346**

Signed, sealed

Marantz's senior designer, Ken Ishiwata, has lent his name to the latest version of the CD-63, the CD-63mkII KI-Signature. Jon Marks finds out whether it delivers.

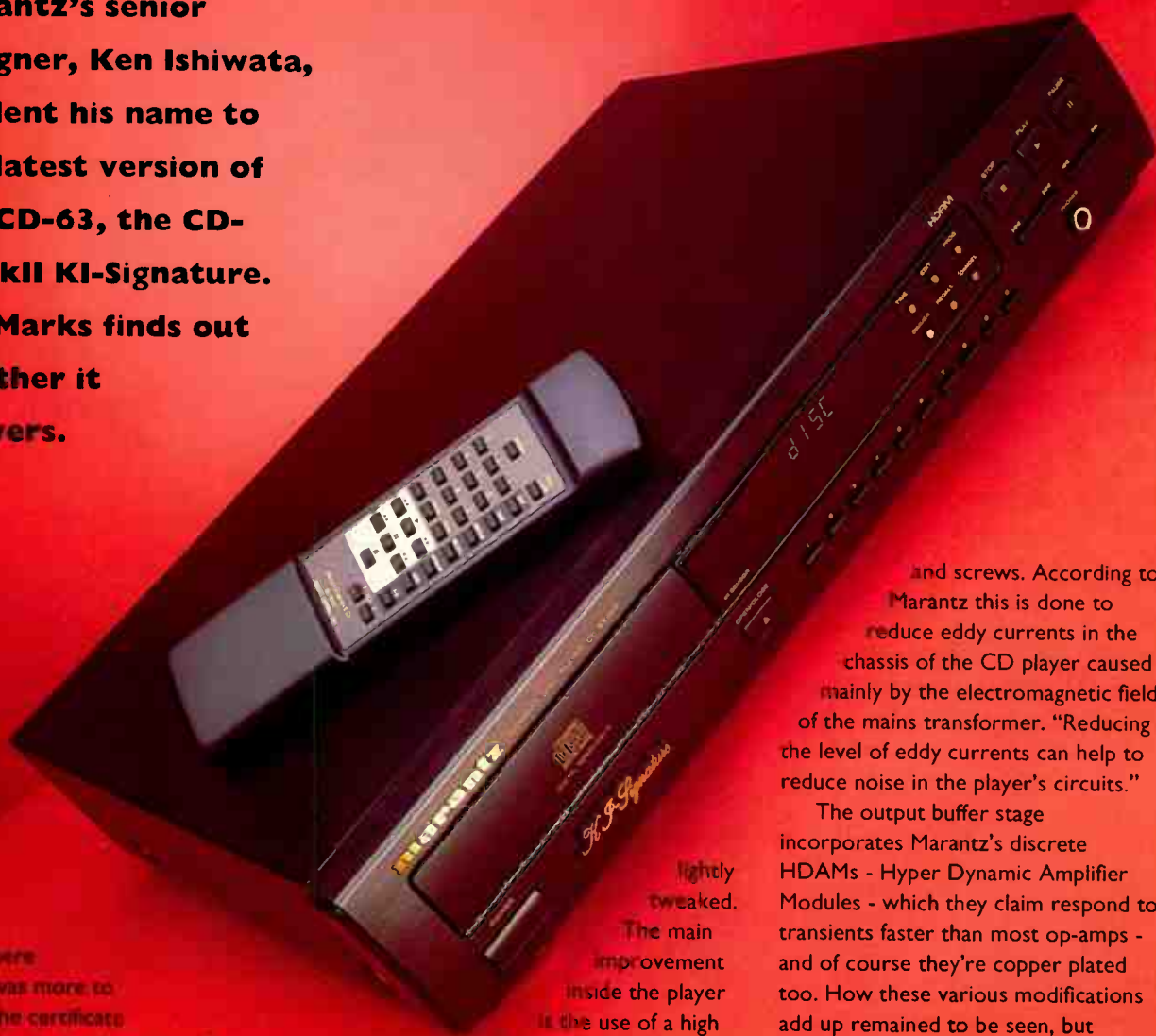

There was more to the certificate supplied with this latest tuned version of Marantz's CD-63mkII than the usual "Thank you for buying this..." and a spot on my wall. This particular piece of paper bore the seal of Ken Ishiwata, Marantz's senior designer, a man widely respected for his in-depth knowledge of all things high fidelity. This certificate and the gold-printed "KI-Signature" badge signifies more than Marantz's normal SE tag too - the KI-Signature is more super-tuned than

lightly tweaked. The main improvement inside the player is the use of a high quality toroidal mains transformer, which features composite materials and high grade copper windings. Marantz say this improves bass, both in terms of extension and punch, but it obviously also has a knock-on affect on sound quality as a whole.

Copper-plating has always been widely used by Marantz on their higher end products and the KI-Signature is no exception with copper finished chassis

and screws. According to Marantz this is done to reduce eddy currents in the chassis of the CD player caused mainly by the electromagnetic field of the mains transformer. "Reducing the level of eddy currents can help to reduce noise in the player's circuits."

The output buffer stage incorporates Marantz's discrete HDAMs - Hyper Dynamic Amplifier Modules - which they claim respond to transients faster than most op-amps - and of course they're copper plated too. How these various modifications add up remained to be seen, but carrying the kudos of Ken Ishiwata's signature and the weight of a £500 price tag, there was a certain air of expectancy as I inserted Tori Amos into the CD drawer and took my seat.

First impressions were good - it was nice to hear a vocal rendition so free from grain and spit, especially with breathy vocals like Ms. Amos'. Detailing was also fine, showing up a strange electrical whirring in the recording I'd never really noticed before on 'Beauty

& delivered

Queen' and 'Horses' from her Boys for Pele album.

It was with the fourth track, 'Professional Widow,' that this player really started to show some of its mettle. This song has a heavy drum machine beat with kick drum and electric bass in a dense mix which can get confused in the lower registers. With the Marantz I could make out the three bass-line components without having to strain. The leading edges of bass guitar notes were impressively detailed, dynamic and easily distinguished from the hard, artificial punch of the drum machine. Kick drum had the same organic quality as the bass guitar and for once the drum kit sounded like a vital part of the music, as opposed to merely providing the rhythm for other musicians to hang their performances on.

One particular quality which emerged as my listening progressed was the manner in which the Marantz presented music. There was an even-handedness which allowed me to look in on individual instruments as they appeared, rather than forcing me to follow the player's preference. I found myself noticing guitar notes and cymbals that had seemed merely incidental before.

Switching CDs to Archiv Produktion's Vivaldi's Four Seasons

produced a soundstage that, while little wider than usual at this price level, was impressively deep, allowing the players of the English Concert sufficient room to really let rip. With the separation and clarity of imaging on offer, it was easy to make out the different layers in the mix and the positions of the various sections.

Two aspects of the player's performance which really allowed the music to breath in a convincing, organic fashion were evident in this recording.

The first was its rendition of tonal colour. Period violins possessed the kind of woody, varnished resonance and acidic string tone that's simply delicious to listen to.

The second was the ability to play each note separately. I've often heard this piece produced in a rather off-hand way, the notes having a habit of

blurring together. With the KI-Signature though, each note was enunciated separately, with its attack and decay natural and complete - a subtle difference to listen consciously for, but one which has a large impact on its ability to portray a performance convincingly.

It was difficult not to simply press the repeat button at the end of the Four Seasons, but John Lee Hooker's

Chill Out CD was next in line and I was looking forward to a dose of the blues.

As I had hoped, here again was that natural tonal colour and easy articulation that allowed the essence of the music through. 'Serves Me Right To Suffer/Syndicator' has a wonderfully slow, grinding rhythm which caused the Marantz no problems whatsoever. The music slipped on its shades, buttoned up its jacket and stepped out looking so sharp it was a threat to public safety.

Regardless of the genre of the CD in its drawer, this player always turns in an impressively musical and involving performance. On that attractive owner's certificate is a quote from Ken Ishiwata, stating that "For me, hi-fi is about conveying the essence of a recording in its purest, most enjoyable form." I think that in the CD-63mkII KI-Signature he has succeeded better than anyone for £500 ●

Marantz CD-63mkII KI-Signature £500

Marantz
Kingsbridge House,
Padbury Oaks,
575-583 Bath Road,
Longfield,
Middx. UB7 0EH
☎ 01753 680868

"The music slipped on its shades, buttoned up its jacket and stepped out looking so sharp it was a threat to public safety"

WORLD VERDICT

Similar sweetness and smoothness of tone to the CD-63SE, but better still. Bass has greater power and authority too; top audiophile value.

Measured Performance
see P103



**PUT SOME SPACE BETWEEN
YOU AND THE NEIGHBOURS**



VALDUS



With over 63 years experience in producing loudspeakers for recording, for rock concerts, for discos, for instruments ranging from the wickedest rock guitar to thunderous church organs; only Wharfedale has the ability to give your music the power, the realism, the drama that you really deserve. VALDUS speakers are efficient so you get more sound out into the room for each watt of power delivered by the amplifier. VALDUS takes loudspeaker design into a new era; a new age; a new dimension. Connect-up; Power-up; Volume-up; and say goodbye to your neighbours.

Wharfedale

BRITAIN'S MOST FAMOUS LOUDSPEAKERS

Wharfedale International Limited, Sandeas Way, Leeds LS15 8AL England.
Telephone: 0113 260 1222 Fax: 0113 260 0267



100

£89.95



200

£109.95



300

£149.95



400

£199.95



500

£299.95

World Radio History

THE RUMOUR COMPANY

The Facts about the Rumour
 The Look: Black and White, twisted pair, slim and neat.
 The Content: Stranded, High purity, silver plated oxygen free copper, Teflon dielectric.
 The Design: Flexible, easy to terminate, single wire, bi-wire no problem.
 The Sound: Rhythmic, detailed, dynamic, neutral, conveys timing, compatible with any amp.
 The Chord Co., 30a Sarum Business Park, Portway, Salisbury, SP4 6EA. Tel: 01722 331674 Fax: 01722 411388

A New Speaker Cable RUMOUR

Rogers® GREAT BRITISH HI-FI WORLDWIDE

- AUSTRALIA Insignia Project Group PTY Ltd.
- CANADA Plurison
- CROATIA Audio Centar
- DENMARK Audio Consult
- FRANCE Professional Product Line
- GERMANY Pirol Audio Systeme GMBH
- GREECE Temet S.A.
- HONG KONG Conwall Ltd.
- ISRAEL Audition Stereo Ltd.
- ITALY British Sound
- JAPAN Rogers Japan Inc.
- KOREA Bando Pro Audio
- MALAYSIA Wo Kee Hong Electronics SDN BHD
- NEW ZEALAND Denco Audio Ltd.
- POLAND Hi Fi Sound
- RUSSIA Esoterica Ltd.
- SINGAPORE Wo Kee Hong (M) PTE Ltd.
- SOUTH AFRICA Tek Corp.
- SWEDEN Hi Fi Art
- TAIWAN Pai-Yuing Co. Ltd.
- THAILAND Kang Yong Co.
- UNITED KINGDOM Rogers International (UK) Ltd.
- VIETNAM Wo Kee Hong (M) PTE Ltd.

**DISTRIBUTORS SOUGHT IN
NEW EUROPEAN
TERRITORIES, INDIA, AFRICA
AND THE MIDDLE EAST.**

For distribution enquiries & dealer information:
+44 181 640 2172
 Rogers International Ltd.,
 310 Commonside East,
 Mitcham, Surrey
 CR4 1HXa
 FAX: +44 181 685 9496
 Int. **AUDIO CLUB**
 E-MAIL:
 gloots@rogerinter.win-uk.net



VIBRATION ISOLATION PLATFORMS AND THE MODULAR AUDIO SUPPORT SYSTEM

MUCH MORE THAN JUST A STAND!

The Reviewer Choice
 As a piece of functional furniture the BASE Racks and Platform together are a work of art - Dave Wiley, Audiophile Magazine.

The Customer Choice
 It's refreshing to find a complete isolation system that values aesthetics as highly as it does sonic benefits - Mr P M Rodwell, Cornwall.

Thanks!! The improvement is astonishing and after hearing and trying other audio stands, the performance of BASE is second to none - Mr M Slattery, Sussex.



"The Audiophile support brings the sound I hear at home one step closer to the sounds we create in the concert hall. Bravo".....Dr. K Murphy (Classical Musician)

WORLD VERDICT 
 Great Build and finish, and it sounds great too

Audiophile  For more details and a product portfolio please telephone

Tel: 01342 826262
 Audiophile Furniture Limited
 The Square, Forest Row,
 East Sussex RH18 5SE.

GOING ELLIPTICAL

Dominic Baker squares up to Spondor's elliptical drive unit in the new 2030 loudspeaker. Did it drive him 'round the bend?



Was I ever reluctant to return flagship SP9/I loudspeakers to Spondor. As traditional as they come, with heavy cabinets and real wood veneer, they were impressive. In their place, Spondor sent me something very different. "What a departure" I thought as their new high tech, grey satin textured 2030 speakers sat before me.

These floorstanders look as if they could have come from a different company. Perhaps one of the reasons for such a change was the input of designer Robin Marshall, who worked alongside Spondor's in-house designer Derek Hughes on the 2000 series. He's the man responsible for the Epos ES11.

One key feature of all loudspeakers in the 2000 series is an elliptical bass driver. The reason is down to a phenomenon known as cone 'break up', which describes where a driver's behaviour starts to become erratic, causing

response to become rough or uneven. Normally, a loudspeaker's electrical crossover circuits roll-off a driver's output before 'break up', to suppress the audibility of this effect, normally heard as a roughness or coarseness.

Cone 'break up' is really an acceleration limit beyond which a driver's cone fails to work in a controlled manner due to erratic flexure. It's a problem of bass/midrange drivers, because of the frequency range they must cover. Good bass demands a big cone, but this breaks up earlier than a medium size one. Most manufacturers cross over from the bass/mid driver to the tweeter at around 3kHz to avoid breakup. But this is where the human ear is sensitive to phase and amplitude distortion, so often the transition is, subjectively, not a smooth one.

Spondor's elliptical driver spreads and reduces the problems of break-up, due to its mechanical asymmetry. The short sides of the cone are stiffer and have a different flare to the longer sides. Also, surface wave reflections are staggered because of the different distances to the edges of the cone. These effects in combination smooth out high frequency response, allowing Spondor to raise the crossover point to around 5kHz. Aside from this, the 2030s are a simple enough two way design using a 1" soft dome tweeter and bass reflex loading.

From the opening few bars of Counting Crows' 'Omaha' that familiar Spondor sound was apparent. This was a bit of a surprise to me at first, for I'd expected something quite different. Not that Spondor's family sound is a bad thing - quite the opposite in fact. Bass had much of the taut and tuneful nature of their more up-market designs. It's not as expressive as, say, their SP2/3s, but it

certainly seemed to drive deeper. That tight, controlled and rhythmic thwack behind every note, without boom, waffle and all the other evils many fall prey to was a delight.

With 'Perfect Buildings' the image was as tightly defined as their smartly tailored appearance would suggest. Strings were snappy and cut crisply through the wash of sound. But the 2030s certainly couldn't be described as having holographic qualities. They're strongly focused in their delivery, precise, but on acoustic pieces they could sound a touch restricted.

Low level detail, the kind that paints a picture of the studio and creates the atmosphere of a song, wasn't captured by the 2030s as well as, say, Castle's Chesters or Mission's 752s.

Changing from my current fave integrated, the Audiolab 8000S, to a long trusted Sugden A21a brought a smidgen more out of the Spondors, but its 20watts weren't enough to grip them properly. Four feet from the back wall and three feet in from the sides, they had plenty of space and were able to describe stage width and depth well, but were not up with the best.

Dubstar's 'The Day I See You Again'

With 'It Could Be Sweet' the deliciously smooth and beautifully projected vocals, delicately performed treble and rich and fruity bass were a real treat.

shed more light on this. The tweeter in the 2030s is surprisingly sweet and open, with fantastic detail. It gave great insight, but as the frequency dropped the scale of the performance reduced with it. Lower midrange, although punchy and clear, didn't express the scale or acoustic well. This said, just sitting back and listening to several tracks on this album was satisfying. The 2030s have a smoothness and a charm

to their presentation that makes them easy to sit enjoy. They're very well balanced in this respect, being neither too bright nor hard but still clear enough to relay music coherently.

Although perhaps not the best loudspeaker for fastidious classical listeners, jazz and acoustic rock thrived. They have a BBC LS3/5a kind of sound, a touch thick through the midrange but full of texture - and with a nicely timed punch.

Portishead brought out the bass depth of the 2030s. With 'It Could Be Sweet' the deliciously smooth and beautifully projected vocals, delicately wrought treble and rich and fruity bass were a real

treat. Bass is heavy on this track, but even at quite high levels the 2030s held onto the notes tightly and cleanly.

At this point I reached for Bjork's 'Big Time Sensuality'. This is a neatly structured track with brightly metallic cymbals alongside full and vibrant bass. Simple keyboard chords between vocals were as cold and dryly etched as I expected. But there was also a hint of plasticity colouration, although it added texture and depth without affecting clarity.

With PJ Harvey's 'Working for the Man' a warming of tone could be heard, but again it didn't detract from my enjoyment. Bass was more than plentiful without becoming overbearing.

Rounding off with Inspiral Carpets' 'Uniform' I was reminded of quite how precise and well mannered the 2030s are. With this normally quite messy recording, they untangled instruments well, each allowed at least enough space to play its part unhindered. And 'Saturn 5' just rocked as well as it always does, drums beating out their tribal chant.

I suspect many listeners who aspire to Sendor's up-market designs will welcome the more affordable 2000 series. The 2030s are a fine loudspeaker, retaining enough of the Sendor sound and quality of engineering to give them strong appeal. It's a competitive market at this price level nowadays, but I believe the 2030s will carve out a niche in it.

Sendor 2030 £599.00

**Sendor Audio Systems
Station Road Ind. Est.,
Hailsham,
E. Sussex BN27 2ER
☎ 01323 843474**

CIRCULAR CONE

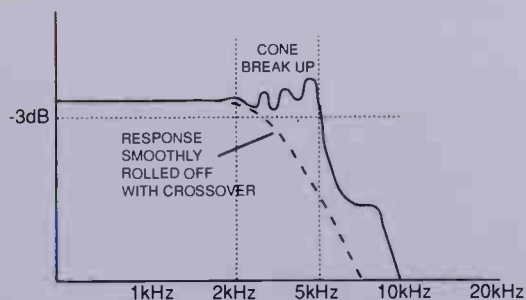

ELLIPTICAL CONE

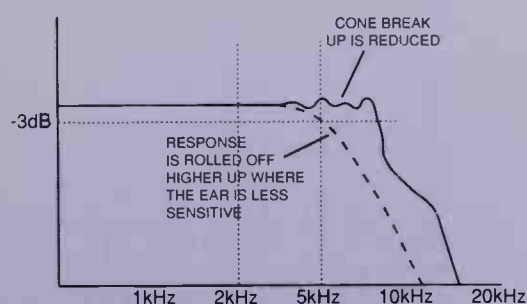

WORLD VERDICT

Smooth, focused and coherent in their delivery with deep and taut bass extension. Not the most spacious sound though.

**Measured Performance
see P103**



stereoplay
BEST OF HI-FI '96

**THE ONLY BRITISH PRODUCT TO WIN
THIS YEARS HIGHEST ACCOLADE FROM**

stereoplay
MAGAZINE GERMANY

EIN TFAUM VON EINEM LAUFWERK

Doug Brady Hi-Fi

WARRINGTON.
TEL: 01925 828009.

Wilson Benesch.
Craftsmanship,
Innovation,
Leading Edge Technology.



Turntable, Tonearms, Cartridges, Head Amplifier, Loudspeakers, Turntable Table, Equipment Platforms.

campaign audio design



Getting a better more involving sound often means spending a lot of hard earned money. It's such a waste, because every system can benefit from our cables and accessories, at a fraction of the cost of some new "black box". Here are some of the ways we can help.

We have Oxygen Free Copper interconnects (£12.48) up to High Purity Silver cables (£89.00) and high definition loudspeaker cables in Silver plated Copper or Pure Silver. Our mains cables add weight, power and scale, and with non inductive RF filtering (£10.00) and over voltage protection (£3.00) enhance performance still further. Gold plated AV cables, both RF (£19.95) and Scart (£23.52), help bring picture quality in line with NICAM sound resolution.

Valves, capacitors and transistors are all microphonic, they cannot perform optimally if vibrated. Our set of three Brass Isolation cones (£5.00) are worth their weight in gold - revealing low level resolution and dynamics hither to hidden beneath electronic noise. We also have a cure for your noisy fridge or central heating motor (£3.50), enabling you to throw away your big mains noise suppressor, which has been giving you that "sat upon sound" for years.

There's lots we can do to bring you closer to the emotion and energy of the performance. So confident are we, that we offer a 14 day money back guarantee.

Ring or write for details:-

CAMPAIGN AUDIO DESIGN
Llandudno Road (HW)
Cardiff CF3 8PG
Tel:- 01222 779401

Trade and International Enquiries Welcome.

ELEMENTAL OR ELEMENTARY?



Back in the good old days, when life was simple and so were those that lived it, there was a group of men that called themselves Alchemists. They heralded the beginnings of what we might call the scientific age. By questioning the world around

them, they devoted their lives to finding ways of changing the unchangeable: to transform. Transformation is the process of turning something that is plentiful but ordinary into something special. Water into wine, lead into gold, and in our case, hi-fi into art. That's why we called our company Alchemist. Anyone with a little technical know-how can build an amplifier. The components are freely available and a rectangular box is easy enough to make. At Alchemist we endeavour to transform the ordinary into something special, something unique - something you can be proud of owning.

Alchemist amplifiers are available for between £250 and £15,000.

Call us now on 0181-883 3008 for details. We just might transform your life.

Now that digital reproduction technology is so advanced, you can throw away all of your records.

"LOB LOCKS", as they say on the planet Anagramia



ortofon 01753-889949

Changing FACES

At a first glance, the AMC CDM7 appears to be just another CD transport. But Dominic Baker finds its appearances pleurably deceptive.



AMC's CDM7 is a CD transport. But it's also two CD players, depending on which module you choose to fit. They're simple to change, making upgrading simple. A nifty little idea that.

At present there are three. MD5401 is the standard bitstream convertor module, MD5402 is an optical digital output module for those who want to use the CDM7 as a transport only, and MD5403, the most interesting one, a bitstream convertor using a valve output stage. We had the standard bitstream convertor and the valve one supplied with the CDM7. Both use the same Philips SAA 7323 D/A convertor chip.

Swapping from one to another is a simple enough task. Four retaining screws hold the module in place, which slides in and out making its connection to the transport via a 15pin D-type socket. The standard bitstream module takes its power from the CDM7; the valve version has its own mains lead,

presumably because of the higher HT voltage and heater supply required by the ECC82 valves.

The MD5401 is pretty standard, with just a couple of phono sockets for audio output on the rear. The MD5403 not only has a valve output stage, but is also transformer-coupled to give a differential output for balanced operation. We didn't have a preamplifier with balanced inputs handy, and the leads supplied converted from XLR balanced to conventional phono plugs anyway, but this is how most are likely to use the CDM7.

CDM7 + MD5401 Standard

From the opening few bars of Pink Floyd's 'Marooned' it was obvious that the CDM7 had a strong presentation of its own. Hi-hats were sharply spot-lit and accentuated to give a real sense of attack and power to them. Bass too shared similarly captivating properties,

lending fantastic slam to bass guitar notes.

As the following track kicked in, the CDM7 demonstrated its impressive openness and clarity with David Gilmour's vocal. As he spoke the words in characteristic Floyd style "now life devalues day by day/as friends and neighbours turn away" there was a real sense of drama conveyed, firmly holding my attention. As the high pitched and powerful electric guitar played out though, I got my first hint of sharpness from the AMC, along with an almost nasal quality to the upper midrange.

On smoother, richer recordings like Sheryl Crow's 'Solidify' or Lou Reed's 'Perfect Day', the MD5401 convertor gave a thoroughly musical performance. With strong, clear treble, a well-focused

e



...a warm glow
from

Rogers

The E-Series. Pure class 'A', fully integrated, all-valve, hand-made British amplifiers. Uninhibited musical power that extends beyond conventional electronic and acoustical boundaries.

Guaranteed to send more than a tingle down your spine.



ROGERS INTERNATIONAL (UK) LTD. - Tel: 0181 640 2172. Fax: 0181 685 9496. E-mail: gloota2@rogerinter.wir-uk.net

*“The AMC’s
more one for
raw musicality
than a fine
polishing job”*

midrange and great power to the bass, performances really leapt into life.

'Mutant Jazz' by T-Power v. M.K. Ultra was supported by a deep, melodic bass line, percussion exploding into a wide soundstage to create a super sense of space and acoustic. The MD5401 was always involving, but could become a touch ragged at times.

CDM7 + MD5403 Valve

Moving eagerly on to the MD5403 valve output convertor, things softened noticeably. The slight nasal quality became warmer and smoother, giving a more angelic balance. Sadly, image definition and transients softened with it, but the sound stage was now spread even wider than before. The change in balance was a pleasant one though, being immediately more relaxing to sit in front of.

Back with Pink Floyd, cymbals were still as strong and clear, but sweeter in tone. They had all the presence of the solid state convertor, but with a more silky texture.

Bjork's 'Hyper-ballad' emphasised again the AMC's terrific bass power. The Mission 752s I was using don't have particularly deep bass, but fed by the AMC an Audiolab 8000S drove their cones to within millimetres of their end stops when describing the rolling subsonics on this track. Vocals were impressively smooth and free from the grittiness that plagues a number of players at this price level.

In many ways, in this guise the AMC reminded me of Marantz's CD-63SE. Its super-smooth, focused midrange and treble lacked a little of the Marantz's detail, but it more than made up for this in the bass. The AMC's more one for raw musicality than a fine polishing job.

On Nightmares on Wax's track 'Night Introlude' percussion was crisp and cutting enough to break cleanly through the sound stage. Keyboard notes had a juicy punch to them, behind which vocals soared effortlessly. It was a fantastic mix, combining tightly defined melodies with a sweeping backwash of ambient sound.

This ability to describe a wide-open soundscape punctuated with detail gave The The's Mind Bomb the immediacy and excitement it thrives on. I'd only intended to play the first track, but it wasn't until the rather droll and lethargic 'Beyond Love...', the final track, that I reached for another album. Gripping stuff.

Matched carefully in a well balanced system the AMC's a tough one to beat in this area, encouraging involvement at all times. Whatever you do, don't miss it ●

AMC CDM7 £339.95
AMC MD5403 £149.95

AMC
Home Entertainment Club,
St Giles House,
Narcot Lane,
Chalfont St Giles,
Bucks. HP8 4EU
☎ 01494 874366

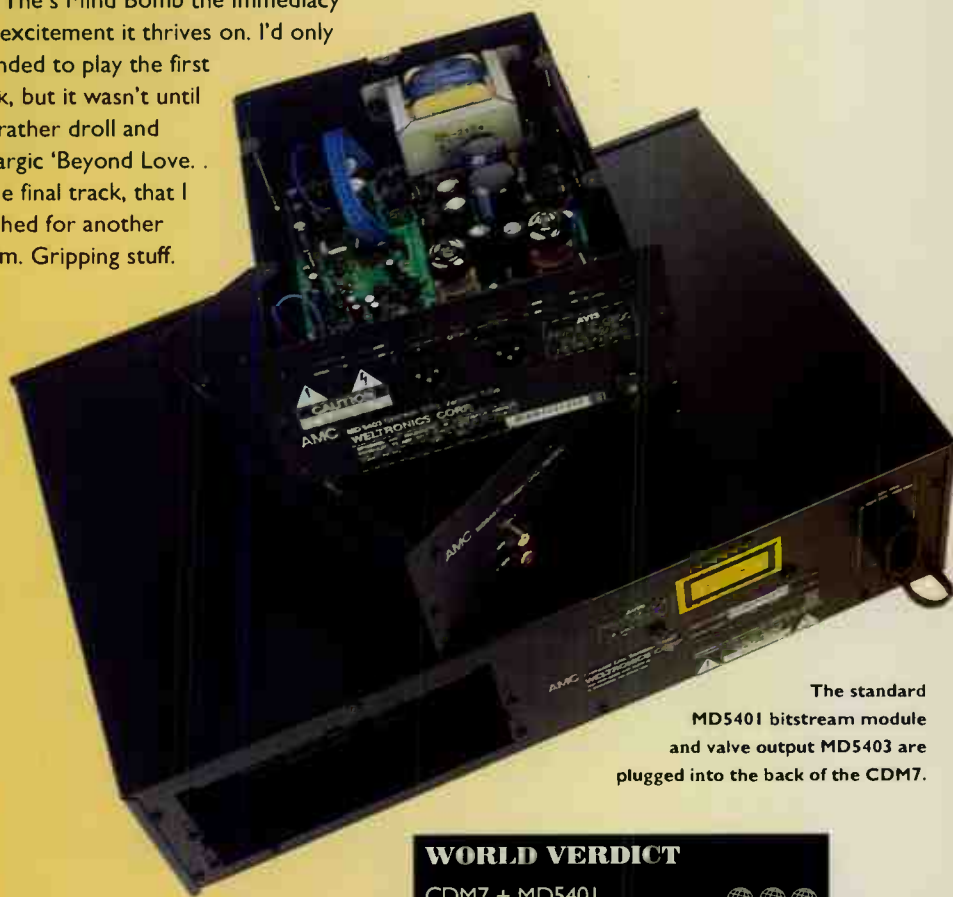



The standard MD5401 bitstream module and valve output MD5403 are plugged into the back of the CDM7.

CONCLUSION

I have my reservations about the AMC. The standard convertor's sharpness will be too much for many listeners, especially in already bright systems. Some of this bite also remains with the valve convertor, enough for it to be intrusive on classical music. But both have an underlying raw musicality that had me captivated for many hours.

WORLD VERDICT

CDM7 + MD5401 
A little sharp for some tastes, but its heart is firmly with the music.

CDM7 + MD5403 
Similar in character to the standard MD5401, but sweeter and more open with it. Musically involving.

Measured Performance
see p103



KING OF THE AIRWAVES

Jon Marks surfs the ether on NAD's new 412 tuner.

Cosmetically, there's little to tell the new NAD 412 tuner apart from its predecessor, the 402, which made such an impression on us back in January 1994. The colour of the casework is still an un-inspiring shade of industrial grey. The grey Tune and red Store buttons have been rationalised to a standard black to match the other

function buttons, although power on/off remains staunchly green. The LEDs used to be yellow and dark green - they're now orange and light green. Subtle changes to point out I know, but with NAD's styling that's all there is.

Round the back are the various aerial connections; 75ohm coax, with 300ohm balun adaptor and an AM

“The massed male voices were all easily distinguished, rising together in what amounted to a captivating performance”

terminal for a simple length of cable. There's one pair of phono sockets for audio out and another labelled NAD Link In and Out. This allows similarly equipped NAD components to be connected together and controlled from an overall system remote, leaving only one remote to be lost down the back of the sofa instead of the usual three or four.

Operating the tuner should be easy for anyone who's used a digital tuner before. The Tune buttons have three different uses, depending on which mode is selected. In Search, you can scan the airwaves, the tuner stopping automatically at a strong signal. Switching to Tune gives manual tuning, which crawls slowly between stations. Preset allows any one of twelve stations to be stored in memory, and then selected using the Tune buttons. It took just a minute or two to fill the memory with Radio 1 to 3 and several independent broadcasters.

The first frequency sampled was R3's Composer Of The Week, featuring the poems of Machaut. Immediately noticeable was a lack of noise - volume had to be uncomfortably high before any hiss became audible. The upshot of this was that retrieval of low level detail was especially good, making it easy to work out where a particular piece of music had been recorded, complete

with all of its ambience.

The solo voices of 'Puis qu'en oubli' for example hung crystal-clear in the reverberant acoustic. Both male and female vocals were treated even-handedly, the former sounding nicely weighty without any boominess in the lower registers and the latter smooth and coherent, avoiding compression even at high levels. The massed male voices of 'Dix et sept cinq' were all easily distinguished, rising together in what amounted to a captivating performance.

Changing stations to R2 found me listening in on Anne Robinson in the studio. A slightly nasal tone caught my ear here, but skipping around the various presets revealed that this was simply part of her delivery, and not a tonal error on the part of the NAD. Announcers in general came across with all their breathing and lip-smacking satisfyingly intact. Again, the 412 put together a convincingly musical performance. Electric bass was very well defined, individual notes tripping along with verve, never becoming muddled with the resonant thud of the kick-drum.

In fact, on Jools Holland's show on Jazz FM, featuring Sammy Rimmington, tonal colour was so good it was actually possible to tell where a close-miked cymbal was being struck. The track was obviously recorded in a large hall with high ceilings, saxophone and trombone soaring out above the audience. On a particularly energetic solo the power and inflection of the drumming was real enough to place me in the audience.

Imaging was above standard for any tuner under £500, let alone one of less than half that price, with the various instruments hanging together coherently within the soundstage. One very small quibble emerged at this point though. The spread of sound across the front of the 'speakers didn't stretch as wide as I'd have liked. Front-to-back depth was especially good, but this did highlight the narrowness of stage width further. The effect was more noticeable on orchestral than smaller-scale recordings, but it never got in the way of the music.

Dropping in on Lisa l'Anson on R1

showed that the NAD was equally skilful in its portrayal of Rock and Indie tracks. Although the quality of the signal isn't in quite the same league as R3's, it was still eminently listenable. The treble on World Party's 'Put the message in the box' was nicely detailed, but the mid and bass had lost some of their separation and dynamism, tending to sound a little slower in terms of rhythm than music on R3.

AM reception on Capital Gold was as impressively noise free as the FM stations had been, but the sound quality here was as poor as expected. Announcers' voices sounded clear enough though and 'Keep on Running' by the Spencer Davis Group was again treated very even-handedly, but I found myself constantly wanting to change back to FM.

I hate to state the obvious, but I was impressed by the 412. It didn't stand in the way of the music, or try to give it a euphonic boost; it simply allowed it to do its own thing, letting through whatever emotion the engineers managed to capture in the studio. There was a sense of life and colour to its performance that the average synthesiser tuner doesn't even hint at, with well-proportioned images hanging together in a three-dimensional soundstage. The 402 is dead. Long live the 412 ●

NAD 412

£189.95

NAD Marketing Ltd.
NAD Building,
401-405 Nether Street,
London N3 1QG
 ☎ 0181 343 3240

WORLD VERDICT ●●●●●

Like its predecessor, the 412 is a remarkably musical and natural sounding tuner. Unbeatable at the price, or even at twice the price for that matter.

Measured Performance
 see P103

SQUARING UP TO

The new Qubic 122 floorstanders claim to follow in the footsteps of QLN's more up-market designs. Haider Bahrani squares up to them.

QUBIC



At £269.95 QLN's new Qubic 122 loudspeakers come in at a price that you'd expect a good pair of shelf or stand mounters to cost. This came as a bit of a surprise: QLN's loudspeakers have traditionally been higher-end products, like the Signatures we reviewed recently.

As part of the new 100 Series from QLN, the 122s are a two way floorstander with a 6.5" paper coned bass unit and a Vifa 19mm dome tweeter, ferrofluid cooled. The drive unit chassis is made from fibreglass reinforced polycarbonate to improve stability and damping. The speaker

cabinets are braced and made from vinyl-wrapped dual density particle board.

The Qubics aspire to the greatness of their more up-market siblings and some aspects of these aspirations have certainly been met. To get the best out of the Qubics I partnered them with an Aura VA 80. Keeping the grilles on I let Poritshead's 'Wondering Star' out of the bag. The bass was well enough controlled without sounding dry and the treble was smooth and detailed.

Their delivery at the lower end is in keeping with floorstanders of greater stature in both price and size. Extension was impressively deep, easily hitting low notes with power and authority. They were kept reasonably well spaced with around 8ft between them and 2ft off the back wall. Bjork's 'Hyper-ballad' which is a little less than conservative in the bass, rumbled around the room, shaking the furniture. Buying a subwoofer to complement these speakers would be a complete waste of money.

“ Bjork's 'Hyper-ballad' rumbled around the room, shaking the furniture.”

Bjork's vocal on 'It's So Quiet', off her Post CD, suffered slightly, seeming to be 'gasping for air' at times, the richness lower down thickening the sound. The mid-band had a nice warmth about it, despite some muffling in the upper ranges which detracted from the solidity of image and projection.

I took the grilles off, as 'strongly' recommended in the User Instructions, to see if I could get rid of some of the muffling. This experiment seemed to be a success - there was certainly a new

openness to the treble. Bowie's 'Rock 'n' Roll Suicide' gave a similar impression, with some of the confusion experienced earlier disappearing into a wider and more dynamic sounding image.

But in this form there is definitely a brightness to the sound. On the one hand this gave them good detail, but on the other it could add some sharpness to the music. This property was evident on 'Lady Stardust' from David Bowie's Ziggy Stardust collection of ditties. The piano was duplicated well and Bowie's voice came across as being truthful, but tinkling the ivories at the top end of the scale gave rise to a slightly jangly tone.

Slipping in a disc of Mozart's 21st piano concerto, with the leading instrument played more than amiably by Vladimir Ashkenazy, I found some good control in nether regions, allowing the instruments to have their say. The violins though were thin sounding and the lower notes on the piano tended to bloom with the rest of it. Not all was lost, however, as a lot of the musicality was retained. What these speakers get right is done quite elegantly, but with a clear effort to impress.

I then changed over to the highly dynamic, fast responding Audiolab 8000S integrated amplifier. Playing something more acoustic like Lisa Loeb's 'Snow Day' and Tori Amos' harpsichord-riddled 'Talula' exposed more clearly some of the strengths and frailties of the Qubic 122s. On both of these tracks vocals were well positioned centrally in the image, with the instruments giving a good, clean impression. The bass response was there when called upon, although it could overshadow some of the instrumental goings on in the registers above it.

The result of this was that the image became cluttered at the centre with general confusion looming over the reproduction. Bruce Springsteen's title track of his Born To Run CD behaved in much the same manner. The difference was that Bruce's vocals, normally prominent, were lost among the instruments. On high notes

though, the sharp-edged saxophone, which was otherwise quite rich and full in its behaviour, did lend some sense of stability to the image.



Standing just under a metre tall, veneer finished, bi-wireable and sitting on spikes they do look a lot more expensive than their price tag would suggest. Bass hungry 'keepum tumpin' rave masters might just fall for these for their lower end characteristic alone. But they are certainly not loudspeakers for small rooms, where I suspect their power in the bass could become overwhelming.

In many ways the Qubic 122s very nearly succeed, hinting that with a little help they might just deliver. Be choosy with whom you let them play and you may be pleased ●

QLN Qubic 122

£269.95

QLN
Unit 7,
Aber Park Ind. Est.,
Aber Road,
Flint,
Clwyd CH6 5EX
☎ 01352 730251

WORLD VERDICT



Solid bottom end will drive a large room well, but they're a bit bright too.

Measured Performance
see P103

the levelling is done from above.

It feels, and looks, simply luxurious. As the lid rises on this top-loader, two small lights shine onto a CDM12 Pro mechanism and a gold-plated platter. Pretty and practical. Less practical, maybe, are two other gold-plated entities. One is the puck which has to be placed over the CD before play. As is common with the breed, haste results in a wobble and a nasty whine.

Practice makes perfect, however, as it does with the two control knobs. One 'knob' is pushed in to stop the player or raise the lid; the second pushed to start or again to pause, twisted a little to one side for track search or skip.

The TDA 2000 shares the slinky gold and black looks, has a single on/off knob to match the CD player and a central 'Thorens' name which lights up. A row of orange lights indicate sampling frequency, lock, which of the three co-axial and one optical inputs is selected, and another called 'Error'. This caused a bit of a fright; every time a CD started spinning it lit and I thought all my CDs had less digital data intact than I believed. It's supposed to do that at first, however, then indicate error correction later.

THORENS TCD 2000

At first hearing, the player is a typically smooth bitstream affair, reminiscent of a number around two or three years ago. Most marked is a smooth and gentle midrange, especially where instrumentals and vocals were involved. P J Harvey's vocals were clear, if a little subdued; the electric guitars fluid. Strings in Ravel were equally pleasantly sweet and flowing. Absolutely perfect for late night listening.

The best thing about it was no rocket-fuelled spectaculars designed to grab, and then strain, a listener's attention. The Thorens kept a very equable temperament throughout. Against, say, the Quad 77, orchestral tuttis however, were a little cramped for space, the players seemingly shoulder-to-shoulder, with the top end a little soft. Teac's similarly priced player, though on the bright side for some, produces a crisper bite. It was

almost as though the Thorens was striving - and in a sense doing it very successfully - for a turntable sound.

This was all very beguiling and a number of people will stop there and decide the Thorens is for them. Against the available competition at the price, however, the overall sound is at the lower end of the quality scale rather than at the totally expressive and innovative top.

“ *Combining convertor and CD player, the Thorens pair dance together like Torville and Dean.* ”

Against it is a shallower depth perspective than some players produce, with a mild compression (heard as a softening) of orchestral climaxes. The chorus in Bach's B Minor Mass by The Sixteen was also a trifle cramped in space against, say, the Quad 77. The orchestra on the Ravel disc also lacked some of the 77's spaciousness.

After a while, too, more critically listening to Gerry Mulligan on Telarc, I began to develop a desire to hear a sharper beat in the bass. Double-bass players in jazz recordings had a lovely rich, warm, buzzing tone, but somehow the timing sounded a touch lackadaisical. Like vocals and rhythm guitars on rock recordings, saxophones were forward, not overly projected, but attractively judged.

THORENS TDA 2000

The convertor was a real surprise. It is a different kettle of fish altogether. Suddenly, the CD player's transport sounded as though it was something rather special and deserving of the attention obviously paid to its build

quality. Now, the orchestral picture in Ravel snapped much more sharply into place. Top violin notes soared while cellos and double basses spun an almost visible spider's web of interlocking notes. The bass was tighter and drier and markedly better defined. Now, there was space around players' shoulder blades and plenty of space for their elbows.

A softening of sibilants that had been evident through the CD player on female vocals was sharpened up. Rhythm guitars snapped more cleanly into place, altogether brighter and with markedly cleaner individual notes. Equally suddenly, Gerry Mulligan's quartet gained more air, space and 'togetherness', now underpinned by a beat that was precisely timed. Rock music generally was tighter and faster, with better dynamics and almost 3-D projection.

Combining convertor and CD player, the Thorens pair dance together like Torville and Dean (well, like they used to, anyway.) The convertor is one well worth inspecting along with the Audiolabs and Sugdens of this world. It opens up the CDM-12 Pro mechanism of the player in a way that reveals what an excellent device it is ●

Thorens TCD 2000 £899.99
Thorens TDA 2000 £699.99

Portfolio Marketing
PO Box 442,
Great Missenden,
Bucks. HP16 0JB
☎ 01494 890277

WORLD VERDICT

TCD 2000: A soft and warm sound will please vinyl lovers, but it's not the last word in detail.

WORLD VERDICT

TDA 2000: Using the TCD 2000 as a transport, the TDA 2000 produces a sound that is focused, detailed and spacious.

Measured Performance
see P103



The ensemble Music System



PRIMADONNA GOLD

"Simply Stupendous"
"good real bass"
"so much dynamics"
"- amounts to quite frankly a
miracle"



LANDMARK STAND



EVOCCO AMP

"Beautiful, airy precise
sweet velvety - its magic"
"the Rolex of high fidelity"



DICHRONO DRIVE

COMPONENTS THAT MAKE THE MUSIC COME ALIVE



TUBE SOX



REFERENCE SILVER



VOICE FLUX



TOP CONE



HONEYPLATE

P M COMPONENTS LTD

Please ring for details on: 01474 560521

Major discounts available NOW on demonstration products

Dates of demonstrations in your area.

* Extracts from recent major reviews - Dealer enquiries welcome.



Divva!

New from UKD is an up-rated Opera Callas loudspeaker, the Callas Gold. Eric Braithwaite sings an aria over it.

When it's perfume, fancy packaging is to be expected. When it's a loudspeaker like the UKD Opera Callas Gold, it's a surprise. Not that the cardboard box that contains the pair is shaped like Maria Callas, either in her puppy-fat days or the later slim-line version. It's ordinary, brown and might well be recycled.

Inside, though, each loudspeaker is tucked away inside a colourful stripy cloth draw-bag. These are apparently made by a seamstress in the UK, and every one is different. They're just the thing for the laundry or carrying the swimming togs to a Club Med beach party. On second thoughts, it'd be empty then, wouldn't it, but it'd still make a natty accessory for carrying a six-pack of... something or other.

Not that I'm one for Club Med holidays, but the Opera Callas was lively enough to be the soul of a party there. It

KALYPSO

The tube amplifier that set new quality, price and performance standards. A true 18+15 Watts RMS output power that will take musical appreciation to new heights. Designed and built by engineers and music lovers.

Telephone or Fax for an information pack.



Supplied complete with cover

KALYPSO RRP £549.00

TEL: (44) 01702 469055

FAX: (44) 01702 601883

CR DEVELOPMENTS LTD. Unit 8, Craftsman Square, Temple Farm Ind. Est., Southend-on-Sea, Essex. SS2 5RH

One thing the Lalis did that few other speakers do was make listening to music fun.
Chris Beeching, Hi-Fi News '95

Lali

Impulse
Loudspeakers

Unit 14 - 16
62 Tritton Road
Dulwich
London SE21

Telephone
081 766 0474
Fax
081 766 0468

has a T-shirt and ripped jeans sound to it in just the right places. Starched-collared like Covent Garden, it isn't. Whatever they play in the Club Med discos I don't know, but to prove the Callases could bop, on went Madonna's 'Material Girl' on the illusory grounds the ladies would have their minds on material things at least some of the time.

They achieve an
extraordinarily
good balance of
virtues that offers
a real sense of
orchestral scale
and perspective

This was sharp, fast and very upbeat, enough to raise anybody's interest as Ms M puts it. Even more interesting was the near studio-monitor quality of the track as it powered out of these loudspeakers. There was Madonna's voice, trapped in a sound booth; here were a couple of tinkles on the triangle lifted right out forward two feet over the carpet; then the male backing vocalists in front and stretching beyond the side of the left-hand Callas. Wonderful, and more exciting and vibrant than any disco in Ibiza.

It is not very fashionable in hi-fi circles these days to talk about how loudspeakers are 'voiced', but the Callas Golds have what can only be described as a thoroughly lovable and musical balance. They are not true 'warts and all' monitors like the Harbeth HL Compact 7s which are my

favourites, and benchmarks, among box loudspeakers.

Listening to the Allegretto from Shostakovich's Tenth Symphony, for example, the cellos of the Bournemouth Symphony Orchestra had a burnished richness which was good for the ears but a little too good to be true. But that does mean they produced a thoroughly exciting sense of dynamic scale in something like Janacek's Sinfonietta or Copland's Rodeo, when you need a strong rasping muscularity and elbow grease in the brass sections.

In Rodeo, the Callas Golds were rhythmically right on their points, as they were with Vivaldi's concerto for two mandolins. This recording also showed where the Golds strayed just off the straight and narrow of the true monitors that exist at this price. The two mandolins have a different tonal quality, just a little more accentuated through the Golds than through the Harbeth HL-P3ES speakers that were briefly slotted in as a control.

The harpsichord which tinkles away amidst the strings was a touch brighter and more forward. That judicious added brightness led back to a rather rough early digital Sibelius Fifth, and lo and behold, the violins at the upper end of the treble clef had an almost searing quality. A cross-check with the Harbeths demonstrated that the recording was fairly piercing in any case, but the Callas Golds, richer and warmer lower down than the Harbeths, tended to make it more obtrusive.

It is this warmth towards the bottom end, and the remarkable bass strength for their size, that makes the Callas Golds a significantly good loudspeaker for their price. They achieve an extraordinarily good balance of virtues that offers a real sense of orchestral scale and perspective that few others at the price can offer. The change of tweeter, from Focal kevlar inverted dome to Scanspeak silk dome, and differences in the crossover and internal wiring over the 'ordinary' Callas, have resulted in a loudspeaker that gives a real sense of being present at the music-making, whatever genre it happens to be.



Whether the subjectively surprisingly extended bass is due to the solid wood cabinet or is a combination of other factors is not something I want to get into. The Italians have a 500-year tradition of cabinet-making and wood carving behind them which is still active, when the British have long ago dropped the methods of Chippendale (not the Chippendales!) and Hepplewhite for MFI.

What that draw-bag that took my fancy as I opened up the box really protects, much more imaginatively than a placky bag, is the gorgeous solid mahogany they are made of. It is beautifully carved into shape, too, tempting anybody to stroke it like the Venus de Milo's bottom. Or, let's not be sexist, Donatello's David, which I've seen tempt more than one girl in Florence. That's the effect of true Italian style. The Opera Callas has plenty of it.

Opera Callas Gold

£995

**UK Distribution,
23 Richings Way,
Iver,
Bucks. SL0 9DA
☎ 01753 652669**

WORLD VERDICT 

A rich and open sound, extremely musical if not strictly accurate. Great bass extension for their size.

**Measured Performance
see P103**

THE TRICKS OF TAPE

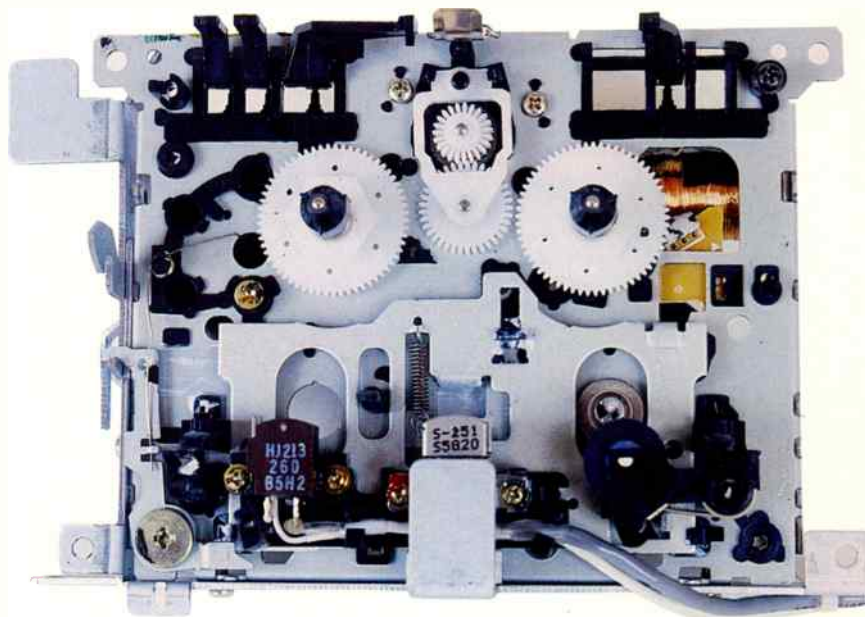

A Denon DRM-550 transport mechanism showing gear drive to left or right hub from a central hub motor (top). At bottom lies the head (centre) and capstan (right).

Pioneer and Technics are both showing new high technology cassette decks.

Noel Keywood explains the mysteries of cassette and what's so special about them.

Surprise, surprise! Just when the cassette seemed done with, about to be discarded for, er, not a lot, two major manufacturers have suddenly relented. Pioneer have released the unusually complex CT-S740S tested in this issue and Technics sent engineers all the way from Japan to tell us about a novel design they will be launching soon, the RS-AZ7 which we test next month.

These two put cassette jargon back on the agenda! The CT-S740S in particular possesses so many complex systems it is impossible to explain them in the body of a review. Instead, here's a look at cassette technology with brief and, I hope, understandable explanations of its mysteries, with special reference to these two machines.

HISTORY

Germany pioneered magnetic recording with ferric oxide coated paper during the Second World War, whilst Britain and the USA grappled with wire recorders. The Americans carted off German recorders after the war and started their own development of ferric oxide recording technology. Paper was replaced by acetate, then stronger and more stable polyester backing, producing tape much as we know it today.

Philips launched the Compact Cassette in 1963, for dictation purposes. It was too hissy for music until Ray Dolby, an American working

in London, introduced the Dolby B (domestic) noise reduction system in 1968. It offered a useful 10dB reduction in tape hiss.

Japanese audio companies like Sony proved skilful at the sort of precision engineering needed to develop the cassette transport mechanism. In conjunction with Dolby B and German BASF chrome dioxide tape, made quiet by use of stronger high frequency equalisation (70µS, instead of 120µS used by early ferrics), the cassette became acceptable for music recording.

Cassette outsold all other music media through much of the 1980s, Philips pointing out that it's the world's second most popular electrical item, after the electric light bulb.

By the end of the 1980s however, cassette sales - blank and prerecorded - had gone into decline in developed countries around the world. DAT, then MD and DCC have all been launched as digital replacements, but so far none have proven popular.

THE TECHNOLOGY

The basic circuit topology of a cassette deck is shown in Fig 1. The machine has two distinct functions: 1) Replaying 2) Recording

1) Replay

Replay must meet standards originally laid down by Philips and subsequently updated by the International Electrotechnical Commission (IEC), if compatibility is to exist between machines.

The replay head must sit perfectly upright, at right angles to the direction of tape travel, if it is to read high frequencies. Minute azimuth errors introduce high frequency loss, an intractable problem with cassette. The loss is amplified by Dolby action, producing dullness and muffling.

Replay equalisation must also be correct, so that the entire replay system exhibits flat frequency response from an IEC test tape. The replay EQ circuits switch from 120µS for ferric tape to 70µS for chrome and metal tape.

To combat azimuth error, Nakamichi introduced automatic head azimuth adjustment in the fabulous Dragon, and manual head adjustment in the CR-7E and DR-3.

Inspired by Dolby/B&O research, NAD offer a simpler alternative, Play Trim (See Fig 1). It adjusts treble level to compensate for losses caused by head azimuth error (and other errors), before Dolby processing. Only Yamaha followed them. This system has the benefit that it is simple and cheap, and it also compensates for innately dull or bright recordings.

In the CT-S740S Pioneer have taken the idea further by automating it. The deck measures the treble energy in music over a short period of time and adjusts high frequency gain to make it fall at a steady rate with increasing frequency (or 1/f as Pioneer put it). With 12dB of adjustment at 10kHz available, it brings even the most dull sounding prerecorded cassettes to life.

Technics tackle the azimuth

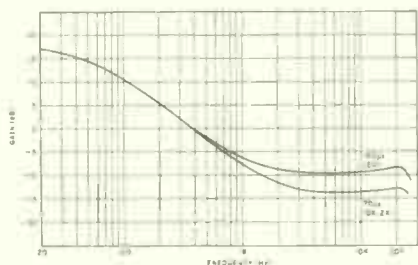

Playback equalisation (E.Q.) of a Nakamichi ZX-9 shows the greater treble cut of the 75µS characteristic, which lessens hiss.

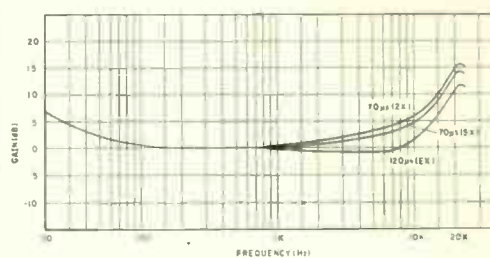

Record equalisation (E.Q.) of a Nakamichi ZX-9 shows the treble boost needed to minimise hiss and compensate for losses.

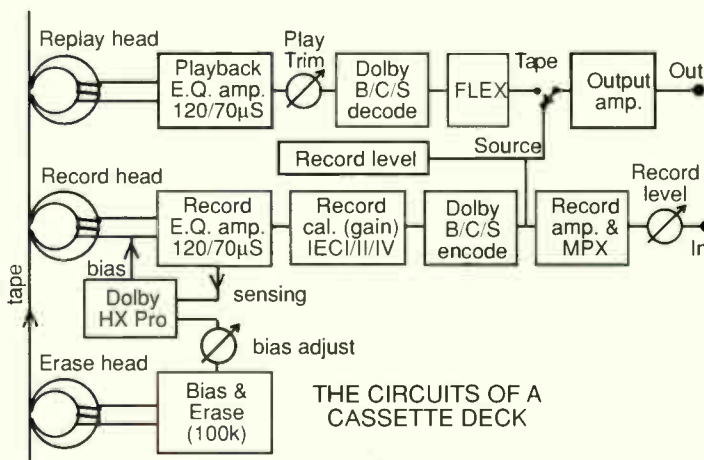

Fig 1: The circuit arrangement of a three-head deck most clearly shows how a tape recorder works. An incoming signal is amplified, Dolby encoded, treble-boosted by record EQ, then carried onto tape by a 100kHz bias signal. The bias oscillator also provides the erase signal.

Replay is basically a mirror image process, but with differences in replay EQ and no bias requirement. Two-head designs use one amplifier chain that switches function from record to replay.

problem by giving the playback head of their new RS-AZ7 a smaller span than usual, 489µm instead of 600µm (0.6mm). According to Technic's figures this makes the head less sensitive to azimuth error, by 10dB at 12.5kHz no less.

Dolby replay processors expand dynamic range in a process exactly complementary to the compression used during recording. Dolby S not only pushes down low level signals, it pushes up high level signals too, in a peak-comparing (companding = compressing/expanding) process that reduces overload distortion.

2) Recording

The signal goes direct into the record level control, then through an input amplifier with MPX filter (usually switchable) to remove 19kHz pilot tone from FM stereo transmissions. After this it is fed to the record level meters

and the recording compression circuits of the Dolby B/C/S noise reduction system. At this stage Dolby makes weak signals louder, raising them up above the noise floor. Dolby S also makes strong peaks weaker, so they don't cause the head to overload, at low frequencies as well as high frequencies. This makes recording more foolproof, but unfortunately manufacturers have recently reduced head quality to make savings, compromising potential benefits.

After Dolby compression the signal passes to the record equalisation circuits where treble lift is applied, to keep the signal well above tape hiss. The amount of lift is switched to suit ferric tapes (120µS), or chromes and metals which can accept more lift (70µS). This makes the latter types quieter by around 4dB.

The precise amount of record equalisation applied is adjusted to give

a net flat response from a tape when replayed through the replay system as calibrated by the IEC test tape. This process takes into account (as it must) frequency characteristics of the record head.

Ideally, to adjust to flatness the frequency response of recordings, it is record equalisation that should be altered; in other words, the amount of treble lift. Nobody bothers, including Nakamichi - except Pioneer in their CT-S740S. Their auto-tune system adjusts both bias and record equalisation, as well as sensitivity. I suspect they do this because it offers better adjustment control; the Pioneer tuned flat more consistently than is usual.

The audio signal is then mixed with

the high frequency (100kHz) bias current needed to carry the audio onto tape with least distortion. The composite signal is then fed to the recording head. The same bias signal also feeds the erase head.

Bias affects tape performance considerably, altering relative sensitivity (i.e. frequency response) and overload margins. Ideally, bias strength should be set to achieve balanced middle and high frequency overload figures, then record equalisation set to get flat frequency response. Trouble is, no one can agree what ideal overload figures should be (Nakamichi say treble overload should be 6dB lower than midrange overload; others say they should be equal; Nakamichi say they say that because

their heads aren't good enough, etc, etc).

The treble content of music acts like bias, the effect being amplified by record equalisation. Dolby HX Pro automatically cuts back bias with music possessing strong treble, in order to apply "constant bias energy" (a nebulous concept) to the head. This reduces treble overload, giving cleaner treble, Dolby say.

Nakamichi disagree, saying manufacturers wouldn't suffer such problems if they fitted better heads in the first place. Measurement confirms that Nakamichi decks without HX Pro (which they refuse to use) outperform rivals, if only by a small amount.

THE MECHANICS

The transport mechanism of a conventional cassette deck has just one rotating capstan that pulls tape from left supply reel to right take-up reel. The take-up reel must be powered, but the supply reel is unpowered. However, both must be driveable, in order to fast wind/rewind.

Budget transports use one motor for all functions, usually driving through belts.

Higher quality designs isolate the capstan motor from the loading fluctuations imposed by the reels, in

order to improve speed stability (wow & flutter) and constancy from start to end of a tape. The Denon transport shown at the start of this article works like this. A rear-mounted capstan motor drives the capstan flywheel via a belt.

Dual capstan transports are complex and expensive to make, and difficult to adjust. Their back tension capstan runs about 5% slow, keeping the tape in constant tension over the heads, whilst eliminating scrape flutter from cassette shell's guide pins, etc. Tape elasticity allows this to occur without damage. Potentially, the dual-

capstan system offers superb speed stability and low flutter, although mediocre ones suffer capstan wow. Below is a rear shot of Pioneer's CT-S740S dual-capstan transport, showing D.C. servo-motor for capstan drive, the drive belt and the closely spaced capstan flywheels.

Centrally positioned reel motor.

The heavy flywheel of the back-tension capstan. It is driven by belt from the main capstan flywheel.

Main capstan flywheel driven by belt from the capstan motor.

The drive pulley of the capstan motor. Note the belt which runs to the capstan flywheel.

Capstan motor. To maintain speed stability a D.C. servo motor is used.



BASIC CASSETTE TRANSPORT

TWO HEAD/ SINGLE CAPSTAN

Tape passes from the left **supply reel** to the right **take-up reel**, pulled across the heads at a steady 4.75cms/sec by the rotating **capstan**.

Drive is engaged by pushing the **pinch roller** against the **capstan**, sandwiching the tape inbetween.

The supply reel sometimes has a brake to maintain back-tension. The take-up reel winds on tape leaving the capstan.

The **erase head**, pinch roller and record/replay head sit on a platform that swings against the cassette when the transport is started. In order to maintain close contact, the record/replay head sandwiches the tape against a felt pressure pad mounted on a non-magnetic

phosphor bronze spring within the cassette shell. The erase head moves into the second capstan roller aperture.

During recording, the tape

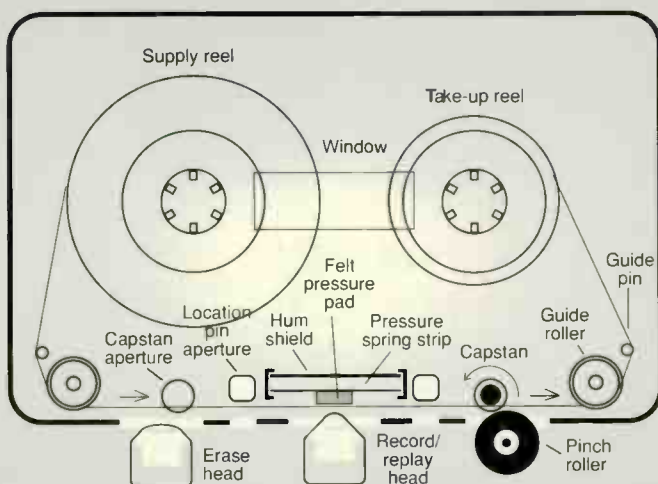

passes first across the erase head, where it is wiped clean, and is then recorded by the single head that serves to both record and then replay.

Two tracks, left and right, are recorded onto the bottom 1.5mm of the 3.8 mm wide tape. Each track is just 0.6mm wide, with a 0.3mm guard band between them, making tape guidance critical. Guide pins hold the cassette shell in position. When the tape is turned over, the remaining 1.5mm is recorded (with a 0.8mm guard band between sides A and B).

The cassette has left/right mirror image symmetry that allows it to be turned around (side A or B).

To replay, current to the erase head is switched off. The tape induces a signal into the

Record/replay head as it passes over it.

This basic arrangement uses a single capstan, a single motor that drives both the capstan and the reels, and two heads: one for erasure, one for recording and replaying.

QUALITY CASSETTE TRANSPORT

THREE-HEAD DECK/ DUAL CAPSTAN

This arrangement uses individual record and replay heads, "siamesed" together. With the erase head, this makes three heads in all. It allows a recording to be listened to (monitored) whilst it is being made, since the tape passes over the record head before the replay head.

Also shown is dual-capstan drive. Complex and expensive, it is always accompanied by three heads. The erase head must squeeze through a small aperture below the location pin. The back tension capstan runs 5% slower than the main capstan, eliminating scrape flutter and supply reel loading.

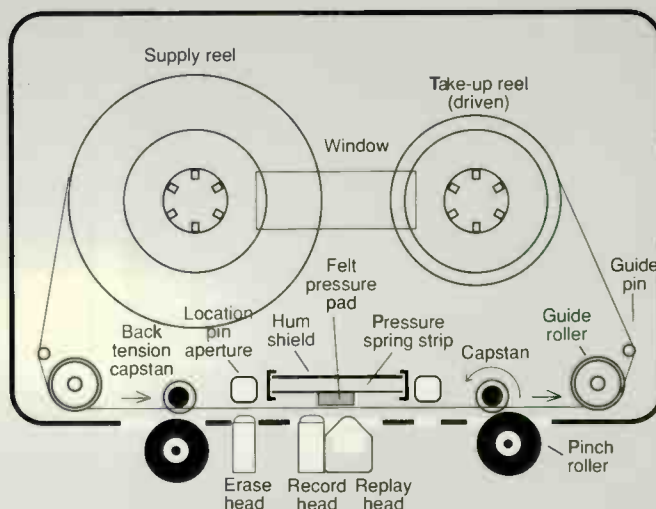

Next month we review Technics' RS-AZ7, which uses a high tech head developed from their DCC machines. There's a feature on head technology too.

THE NEW HARBETH HL-P3ES

Perfectly formed!

Remember the time traveller's box that was far bigger on the inside than out? It's the same with the new Harbeth HL-P3ES: the big-box sound from a conveniently small cabinet!

Jazz, classics, pop, speech whatever; the HL-P3ES brings the sweet, detailed and dynamic full-scale sound of reality to even the smallest room or studio!

Whatever your musical (or home theatre) tastes, the HL-P3ES transports you right into the recording – you're simply never aware of these unobtrusive mini-marvels. Just as *real hi-fi* should be.



Uncover hidden depths – sounds you'd never noticed before – in modern sessions and your most treasured recordings. That's what we mean by low-colouration.

A pair of these mini-Harbeths upgrade any hifi system and the screened magnet technology and super-size sound make them ideal for front and dialogue channels in AV systems.

In nine beautiful real-wood veneers the HL-P3ES blends into any room, acoustically and cosmetically.

The new Harbeth HL-P3ES: *dynamically!*

HL-P3ES
HARBETH
ACOUSTICS
MONITOR SPEAKERS MADE FOR MUSIC

NEW GENERATION
for
96

For information please contact Heather Lewis,
Harbeth Acoustics Ltd. Unit 1, Bridge Road, Haywards Heath, W. Sussex, RH16 1UA, UK.
Tel: 01444 440955 Fax: 440688 E-Mail CompuServe 100624,455

the AUDIO CONSULTANTS

dealers with a difference

At last we have received the Unison Research Mystery One Pre-amplifier. Exquisitely sculptured in solid cherry and offering superb sound quality. Combined with their Smart 845 amplifiers, it produces a sound so musical and very transparent.

Cary Audio have impressed us with their range of 300B amplifiers. Really good sound with a tighter bass than most. Their CD-300 player incorporates 3 tubes in the output stage and produces a sound tonally quite different to that normally associated with CD.

The new Mentor turntable from Nottingham Analogue is well ahead of the high level established by their first version. Hard to believe but true. Probably the last turntable that serious vinyl lovers need to consider, especially when combined with their Paragon linear tracking arm.

Because of the success we have had with the CDs and DACs designed by John Curl, we are pleased to be able to demonstrate pre- and power amplifiers from Parasound. This amplification not only provides incredible value for money but has a sound closer to valves than solid state.

A genuine consultancy offering totally independent advice providing audio systems for those that appreciate music rather than hi-fi

Alon Speakers
Analysis Ribbon Speakers
Analogue Tracer Cartridges
Arion Audio
Art Audio
Audio Note
Blue Oasis Cartridge
Cary Audio Design
Impulse Speakers
Klipsch
Nottingham Analogue Turntables
Paragon Linear Tracking Arms
Parasound
The Vamp
Trilogy
Unison Research
V-Damp Isolation System

Demonstrations by appointment only
0171 380 0866

PERFECTION IS A PASSION



"...PASSION took over the reference position... substantially ahead of the best active line pre-amps. PASSION's switched, discrete attenuator is clearly more accurate, more dynamic and transparent than the pot alternative. When audio products are as good as this, there is little more to say, save to endorse them with a firm recommendation... Now better still in all Vishay mode with a record score of 37".

*Review of PASSION - Martin Colloms
HiFi News April '93 and November '94*

For further details, brochures and prices please contact:
Audio Synthesis P.O. Box 100, Ilkley, West Yorkshire. LS29 9XW.
Tel: +44 (0) 1943 600404 Fax: +44 (0) 1943 600383

Croft's Epoch preamplifier and Series V power amplifier achieve a fine balance of qualities, finds Haider Bahrani.

VALVE

EQUILIBRIUM

Croft's Epoch is a valve preamplifier with four inputs; three line and one MM phono stage. There are separate volume controls for left and right channels, echoing the dual-mono construction inside. Component quality is high throughout, with the pair of ECC83s, ECC82 and ECL85 valves surrounded by custom made polypropylene capacitors, silver-plated switches and supplied by a 85A2 valve regulated power supply.

The Series V is a 30watt per channel power amplifier using four EL84s per channel in parallel push-pull operation. Again component quality is high. Small signal valves comprise three ECC83s and an ECC82. Both have front panels finished in chrome with gold plated fixings matching the control knobs on the preamp.

Attached to the Crofts I had a pair of Mission 752s and an Audiolab 8000CDM transport feeding a Pink Triangle Da Capo CD convertor. Playing through some of my standard run of test CDs, Prince's (I have it on good authority that we can call him that again now) explosively dynamic 'Max' off the Symbol album expressed width and depth with an open and easy quality.

Lisa Loeb's slower 'It's Over' off her Tails CD was very sweet sounding across the whole range with a cleanly plucked guitar sound that sent tingles down my spine. With the faster track

'Taffy' the Croft managed to deliver clean and snappy bass when called for. It definitely showed itself off as being able to handle pace well without getting too excited. Playing David Bowie's Ziggy Stardust CD, the first track 'Five Years' again had a breadth that far exceeded the boundaries of the loudspeakers. And Bowie's voice dominated the forefront of the stage.

'Starman' off the same album revealed a dryness in this amplifier's sound that made it almost transistor like in its grip and control. Joni Mitchell's Blue CD had some good acoustic tests waiting for the Crofts, particularly with the third track 'Little Green'. Joni sang intimately to me and the sparse instrumental was smooth at the top end and laid back and open in the mid to lower registers.

Mozart's piano concerto No.17 in G major was next. Strings, the piano on the Andante, in fact the whole thing was absolutely engaging. The staging allowed me to pick out the position of each instrument in the orchestra with ease. It's reproduction wasn't wholly truthful, but musically the slight richness of the Croft's midrange was wonderful.

The phono stage was a slightly different matter. First on the platter was Fleetwood Mac's Rumours LP. Stevie Nicks' voice was sumptuous on 'Dreams' though leaving the instrumental with some brightness at

the top end. Bass was well controlled, but economical. On the Texas' LP Ricks Road problems at the top and bottom were more obvious, but so were the wonderful happenings in between.

Together the Epoch and Series V don't do a bad job at all. Against similarly priced competition, valve or solid state, the Crofts will take some beating. I am sure that lovers of both idioms, who are often poles apart, will come together on this one ●

Croft Epoch £600
Croft Series V £800

Croft
15 Harrison Road,
Edrington,
Birmingham B24 9AB
☎ 01902 656840

WORLD VERDICT

Epoch ●●●●●
A fine sounding preamp, but phono stage weak in the bass.

Series V ●●●●●
Fast, clear and detailed sound will win friends in both the transistor and valve camps.

Measured Performance
see p103

World Mail

WRITE & WIN
WITH
HI-FI WORLD!

Every letter we print
wins a superb prize!

Audiophile
International
LPs & CDs,
Newnes Audio &
Hi-Fi handbooks,
or a FREE
subscription to
Hi-Fi World
for the best letter
of the month!

Please write to
Hi-Fi World Mail
(with prizes)
64 Castellain Rd
Maida Vale,
London W9 1EX



The writer of the
'Letter of the Month'
wins a free subscription
to Hi-Fi World

LETTER OF THE MONTH

WANTING JAM ON IT?

When I started work in 1979 I began to collect music on LPs- classical, jazz and dance- buying between five and twenty a month.

However, the poor quality of records was pretty alarming. Much of what was on offer was pressed on vinyl so thin it could not support its own weight when held by the edges, with appalling surface noise- caused either by the use of inferior or reconstituted vinyl, contamination in the manufacturing process, or both. Many LPs I bought were pressed off-centre too.

Most of these I returned as faulty, to be checked in the music shop on a music centre with an autochanger and ceramic cartridge complete with blunt needle by an assistant who would invariably pronounce the record "OK". Then digital recording was introduced on LPs. These put me off completely. After three years of attempting to collect music on record, I gave up.

Then CD arrived, publicised as the only reproducing medium you could spread jam on and still have 'perfect' sound. A Tomorrow's World demonstration proved this. I bought a CD player. Oh dear- not as good as I thought. Perhaps a different jam would help. I didn't buy many CDs.

I discovered Hi-Fi World in 1994 and was surprised that anyone was still supporting LP this far into the CD era. So I had my amp rebuilt by the manufacturers, bought a better turntable for the records I still had and started adding to my collection from charity shops and car boot sales. LPs from the mid-1950s to the mid-1970s are generally better than the stuff I was able to buy later on. I am glad that I bothered!

With this Hi-Fi World-generated enthusiasm, I've also been buying CDs again, with an alarmingly high rejection rate for the following reasons.

Recordings of classical works that I enjoy often suffer seriously from distant traffic or aeroplane noise. The latest reject is an EMI recording of Hampstead High Street and Ravel's String Quartet in F Major with heavy breathing.

(EMI UK: CDCFP 4652, for car engine and respiration fans.)

There are some really nasty edits audible on many classical CDs. Examples are changes in recorded reverberation pre- and post-edit, a wrong note changing into a right one after the wrong one has started, or if the aforementioned traffic noise is interrupted mid-flow (where did that bus go?).

The appalling quality of LPs by the time CDs became available meant that many people like me were prepared to spend on the new hardware and software merely to achieve results inferior to those obtained by earlier LP users who knew what the medium was capable of!

**Jonathan Gray
Feltham
Middx.**

The recording quality of fifties and sixties LPs was often superior. Mind you, there were some utterly dreadful labels then, too, though mercifully most seem to have been weeded out even from the car boot sales.

Where we might differ is on current CD quality (we are talking classical and jazz, here, be it noted; I find all too many current pop recordings downright dire).

Many pre-digital recordings did have obvious edits and changes in background noise; while some, when re-mastered, are digitally tidied up, some companies adopt a conservative approach and stay with the original.

Changes in reverberation and intrusive traffic noise are always awkward; I too, dislike the 'disappearing bus' syndrome. The trouble is, if a player fluffed a note in the middle of the Number 7's route, what does the engineer do? Fake another few seconds of bus noise behind a re-take? Leave the wrong note in? EB

MAKE A RIGHT!

Living in Tasmania, which as you know is a rather isolated place where we have limited access to products and information on anything high-end, brings out the importance of a magazine such as Hi-Fi World. It feeds interest accurately while introducing the new to help in the selection of hi-fi equipment.

we love it is exact.

So thank you for that particular review and for all the articles we have read and will read.

Nicole Duncan and Robert Shanahan Tasmania, Australia.

As you have gleaned from the review we were very taken with DPA's Renaissance CD player. It



DPA's Renaissance CD player brings its own uniquely musical style to the silver disc.

So it was with your recent review of DPA's Renaissance CD player. The fact that it was reviewed by three people was a most fair and fruitful approach for us, as it happened. After reading the triple critique, previous possibilities faded and we ordered a Renaissance player into our lives.

To say the Renaissance has met our audiophilic expectations is not enough (we listen to music all day and every day and have a weekly radio programme). It has exceeded them and has taken our whole system into a new aural world. All our CDs, of all musical styles, simply sound phenomenal. Their true depth is revealed, more detail, more natural-sounding, more musical. More of everything, really. A gift to music - to say

has a very musical and involving presentation, one that many music lovers appreciate. We printed several opinions because it was so different from the normal run of players, having qualities that few seem able to approach.

We like to print several views on equipment to give a balanced opinion. But you must remember that even when only one writer is named, the equipment reviewed will have been auditioned carefully by at least two listeners and with a wide variety of partnering equipment. We have an in-house listening room specifically for this purpose, allowing any member of the editorial staff to drop in on a listening session to express their views. So more

often than not the review you see is the collective thoughts of several listeners penned by one writer.

This becomes even more important when using freelance experts. Before a piece of equipment is sent out to Dominic Todd or Eric Braithwaite for example, it has first been measured on our test bench to ensure it performs as the manufacturer intended and will have been auditioned by an in-house member of staff. All this makes our reviews extremely consistent and reliable. DB



Let the music flow from your DPA with this Siren interconnect.

EXPERIMENT!

Your articles in the past on room acoustics and positioning of 'speakers have provided much impetus for experimenting. My current set up includes a Lingo'd LPI2 with Ekos and Denon DL304 as front end with Quad solid state amplification and bi-wired Ruark Sabre 'speakers.

My point in writing relates to tweaking hi-fi equipment. I first moved my 'speakers about 18 inches away from the back wall, initial impression was of a clearer midrange though bass was definitely lighter. Moving the 'speakers back to the wall confirmed that the bass was stronger, but less defined and thicker sounding.

My next step was to fill my open frame speaker stands with Sound Bytes. My

conclusion is that whilst firming and tightening the bass, the midrange and treble can sound lack lustre, robbed of sparkle.

Therefore Sound Bytes can only be recommended for systems that are very bright sounding.

Next, I experimented with stands and supports. I was initially sceptical but surprised at the results that I achieved. I purchased some Mana stands and found that the music improved significantly in terms of clarity, dynamics and timing.

However, I was still not happy with the tonal quality, particularly relating to vocals, so I bought a pair of Slate Audio stands. This improved stage depth and imaging considerably but slowed the overall pace slightly, but I was amazed at the naturalness of the sound.



The £579 Sonneteer Champion can bring a rare sense of involvement to systems.

Although the Slate and Mana stands were not cheap, they improved the sound quality beyond recognition. The difference was bigger than when I upgraded from an Ittok/Valhalla to an Ekos/Lingo so in real terms they were a sonic bargain.

... 44 ►

I find that too many people upgrade without first ensuring that their existing system is properly set-up.

Will changing my speaker cable and interconnects to silver ones improve my sound quality further in terms of transparency and imaging? At present I use Chord Cobra and Linn LK400. I was also very enamoured by the sonic quality of the Sonneteer Champion One, are there similar sounding amps around? Also, will the Ringmat work on a LPI2?
M. Ling
Hounslow,
Middx.

The effect that filling your speaker stands with Sound Bytes will be particular to your stands, 'speakers and system. We recently filled a pair of Tannoy's Profile stands with Sound Bytes when auditioning the Tannoy 631SE loudspeakers and performance improved considerably. Not only was the bass tighter and better defined, but the midrange became better focused and treble more precise. Like many 'tweaks' effects vary depending on the equipment you are using.

For the same reasons as above there is no definite answer to your queries regarding cables and the Ringmat. Silver cables do tend to have a sweeter balance, but rather than use silver for both interconnect and 'speaker I'd tend to use a combination to get the balance you want. Too much silver cable can swing things the wrong way, giving plummy bass.

Try Chord's Siren interconnect which is a silver plated copper cable with a fine balance. I'm a great fan of silver plated copper cables, they seem to

combine the sweetness of silver with the solidity and power of copper. For 'speaker cable I'd recommend Ortofon's SPK200, a high purity copper bi-wire cable. This I find has a very neutral, open and detailed sound; it's reasonably priced too.
DB



Try Chord's Siren Interconnect for the sweet, powerful sound you want.

FORWARD TO AN UPGRADE

My present system is: Yamaha CR600 receiver, Yamaha TC800GL cassette deck, Technics SLI500 direct-drive turntable and Chartwell LS3/5a 'speakers. All this equipment is approximately 20 years old and I feel I need to upgrade the entire system.

I have decided, for a variety of reasons, to abandon vinyl in favour of a CD-based system. To this end about a year ago I purchased an Arcam Alpha 5

(not 5+) CD player, which seems to have served well enough, although perhaps sounding a touch conservative?

With regard to 'speakers, I am considering very strongly the new Apogee Ribbon Monitor, the KEF Reference Model I or the Rogers ABI sub-woofers to partner my existing LS3/5as as alternatives for consideration. I intend to upgrade my system over the next 12 months or so and need help specifically with two questions regarding the CD player and prospective amplifier.

Regarding the choice of amplifier, it would be an obvious advantage to use the one remote handset for both the CD player and amplifier controls. With this in mind, I am considering both the Arcam Alpha 6+ and Delta 290. Is there anything to choose between them in terms of sound quality. I am seeking a very natural, transparent, airy and detailed sound, but with considerable presence, if anything on the forward side of neutral? I do not want anything that smacks of a warm, smooth, laid-back, rich, plummy or varnished quality.

Alternatively, would I do better to forgo the

convenience of one handset and choose something like the Mission Cyrus III, Audiolab 8000A or even perhaps the AVI S2000M1. If so, which one please?

Would it be worth spending extra money to upgrade my Arcam Alpha 5 CD player to a 5+ or even 6+? If so, which one, please?

Christopher J Pett
Croydon,
Surrey.

First, the LS3/5as. The Chartwell variety may be 20 years old, but to adapt Gertrude Stein's "a rose is a rose is a rose", an LS3/5a is an LS3/5a, and they are wasted on the Yamaha. Chartwell was taken over by Rogers, by the way, so check the drive unit surrounds for any signs of wear and tear, and if they look a bit dodgy, talk to Rogers International about having them serviced. Then buy the AB-1.

The criteria you propose for an amplifier are more problematic. The Mission Cyrus III arguably scores best against your criteria. I'd suggest you audition it against one of the Arcam's, probably the Delta 290 and see which you prefer. EB

As you seem keen to get a forward, detailed and transparent sound, I'd strongly recommend you take a look at Naim amplification. The £550 Nait 3 is their most affordable amplifier, producing a highly musical 20watts or so. This should go plenty loud enough for you in a modest size room, but if you feel you need a little more oomph, try their NAC92/NAP90 pre/power combination. These work out at around £850 the pair. Any good hi-



Typifying the Naim sound is the Nait III integrated.

fi dealer should be able to arrange a home demonstration of these products for you. DB

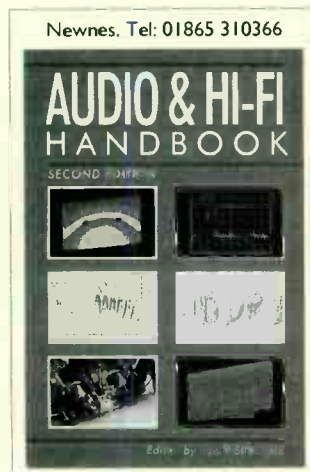

Keep up to date on Audio and Hi-Fi with the Newnes Handbook.

BASIC INSTINCTS!

I am looking to upgrade my Quad system, which comprises ESL-63s, 306 power amplifier and 34 pre-amplifier. I particularly want to extend the frequency response, top and bottom.

I have been variously advised to consider the 606 power amplifier, 77 integrated amplifier and/or REL Strata or Gradient sub-woofers. The latter are probably too big and too expensive (for me.)

Graham Peters, Maidstone, Kent.

I have never been particularly enthusiastic about adding subwoofers to the Quads, with the exception of the pricier REL subs. It's always seemed to me that the better the amplification, the more bass the Quads deliver. My favourite is the Mitchell Stereo Alecto or Alecto monoblocks, with Mitchell Argo pre-amplifier.

Actually, the 306 ain't that bad; it produces rather more with a Mitchell Argo driving it than you might expect. How about starting there, and experimenting

with the position of the ESLs. I find replacing the front feet with spikes and tilting them back works wonders; they are also very susceptible to their position vis-a-vis reflective and/or absorbent walls. Ideally, place at right angles to and against a side wall. This effectively extends the baffle area and deepens bass.

In the pipeline from Quad themselves are the 77SA stereo power amplifier, with monoblocs to come. Watch this space! EB

The Quad 306 has relatively light sounding bass, whilst the 606 is a

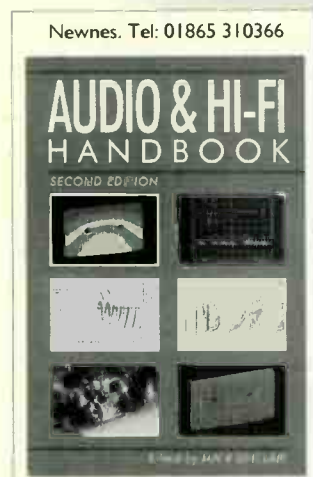

Find out more about acoustics with the Newnes handbook.

heavy slogger with lots of welly, so it may well help. I'm assured the latest ones sound a lot better than earlier models due, I believe, the use of higher component quality.

Extending baffle area is another simple option for improving bass, although for most people the ESL-63 is big enough in any case. Placing the speakers up on closed-front stands will both brighten them up and improve bass.

Another option is placing them close to, or against a side wall, but you need a narrow and

long room for this. NK

MARITAL DISPUTE

Our system has taken a good few years to acquire. It consists of a Rotel RCD 855 CD player, a Linn Basik turntable, a Rotel RA 820 BX4 amplifier and Mission 761i loudspeakers. We want to upgrade the CD player, amplifier and the 'speakers but are at odds on how to go about it.

While I am keen on a simpler system based around either the Naim CD3/Nait 3, the Musical Fidelity Elektra E600/E100 or the Cyrus DAD7/Cyrus III with Mission 752 'speakers, my husband is keen on adding the new Rotel RDP 980 DAC to our existing player and then at a later stage adding the RDD 980 transport and going the pre/power route with the Rotel



TDL's RTL3 is capable of filling large rooms without needing vast amounts of power.



Eric Braithwaite's favourite amp for driving Quad's ESLs - the Mitchell Alecto.

RC980BX/RB980BX and the 752s or 753s if we could afford them.

I really like minimalist systems, although I must admit the Rotel system my husband is keen on is not without appeal. As a matter of interest, would the above Rotel system upgraded to two RB980BX amplifiers in bridged mode outperform the other systems mentioned?

If you had around £2,000

to spend on a CD player, amplifier (not necessarily from the same manufacturer) and floorstanding 'speakers. what would you buy?

We also want to replace our ageing K5 cartridge and as the amplifier we choose will determine between an MC or MM we will go with either the Goldring 1042 or Ortofon MC15 Super II. We have a large LP collection, so a lot of our listening is on vinyl; but as we are buying mainly

... 47 ▶

**Give your outboard
converter the digital source
it deserves.**

Our no nonsense modifications will transform an average integrated C.D. Player into a top-notch C.D. Transport.

We operate a professional, well-organised factory service and guarantee all our work.

For a copy of our Company profile together with prices and details on our unique, affordable upgrades send an S.A.E. to:

**AUDIO SYNERGY LTD., VALLEY WORKS,
STATION LANE, HECKMONDWIKE,
WEST YORKSHIRE, WF16 ONF**

SERIOUS KIT

NORTH

**SORRY ABOUT THE COCK UP IN
LAST MONTHS AD.**

**THE ADVERTISEMENT SHOULD
READ:**

**FOR MAY ONLY 15-50% OF ALL EX.
DEM PRODUCTS INCLUDING
EQUIPMENT BY ABSOLUTE
SOUNDS, PROAC ETC., ETC.
RING FOR DETAILS**

**BY APPOINTMENT ONLY
0161 793 6742 / 0402 367843**



AUDIO LIMITED



New range includes:	4240 Integrated Amp	£279
	P42 Pre-Amplifier	£279
	A42 50W Power Amp	£279
	CD 42 CD Player	£500
	OBH-8 Phono Pre-Amplifier	£99
	OBH-10 Remote Volume Control	£129
	OBH-11 Headphone Amplifiers	£129

Over the last 14 years Creek Audio has designed and constructed Hi-Fi equipment for thousands of enthusiasts. Now that it is once again an independent company the story is set to continue, with a new range of equipment designed for the nineties.

For further information and a list of stockists

Phone 0181 - 361 4133 or send coupon to:

CREEK AUDIO LTD, 2 BELLEVUE ROAD, FRIERN BARNET, LONDON N11 3ER.

Name ----- Address -----

SPALDINGS

The South East's Leading Hi-Fi Specialists
352-354 Lower Addiscombe Road, Croydon, Surrey. CR0 7AF

0181 654 1231/2040

Arcam, Audiolab, Cable Talk, Chord, Copland, Denon, Ixos, Linn, Loewe T.V.'s,
Meridian, Mission, Marantz, NAD, Naim, Nordost Flatline, Panasonic, Quad,
Revolver, Ruark, Tannoy, Target Audio, Technics Yamaha.

INSTALLATION SERVICE, 0% FINANCE AND BADA. APPROVED

CDs now, this will become our main source in future.

We listen to all kinds of music, often at high levels, in a room measuring 13ft x 16ft and enjoy a full, rich and powerful sound with a deep, extended bass and a broad, open soundstage.

**Anita Plant
Cape Town,
South Africa.**

Although they have not been reviewed in this magazine, one of the best and most affordable pre/power combinations around is the Creek P42 pre-amplifier and a pair of A42 monoblocks used in bridged mode. With an MC board, that takes up a little under half the budget.

Since the system is an upgradable one, it doesn't have to be purchased all at once; you can start with the pre-amplifier and a single A42 as a stereo power amplifier, which would cost around £600.

There isn't so much agreement on what we would buy, given your budget. Mission 752 loudspeakers rate highly in this office as very balanced all-rounders, but so do the new Technics SB-M500s. Your budget may stretch to KEF Reference Series 1s, according to South African prices.

We all like Mission Cyrus amps too, which are clear, precise yet sweet. Otherwise, Sugden get a stronger vote amongst us than most. And for CD, try Teac, Marantz and DPA. NK

I'd tend to start at the loudspeaker end first, as you express a preference for high level listening in a large room. You also want a rich and full sound, and a good

sound stage. This suggests TDL's RTL 3s to me. These are a quite large floorstander using twin 6.5" bass drivers in a reflex transmission line design. They have a very powerful, large scale sound that I think would suit you down to the ground.

Even better news is that the RTL3s don't take that much to drive them. With their high sensitivity you wouldn't need to go to the expense of a pre/power. A higher quality, lower powered integrated will give fine results. I'd go for the Cyrus III and DAD7 combination. They're beautifully made and engineered and minimalist in approach which you like. If your husband is intent on more boxes, add a PSX power supply to each which will improve performance still further. The matching FM7 tuner is superb too. DB

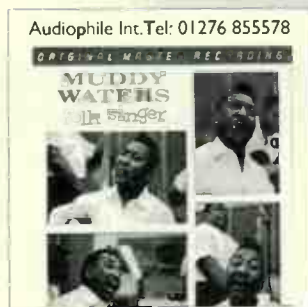

Check out your new cartridge with this Mobile Fidelity Sound Lab LP.

FINDING SOMETHING FOR THE FLOOR

For some time I have been considering purchasing a hi-fi system. I have now bought a Nakamichi amplifier (IA3) and a Nakamichi Compact Disc player (CD4). As I am new to hi-fi, I would be grateful if I would recommend a pair of floor-standing loudspeakers to

With their life and vigour, the 733s are a good match for a soft system.

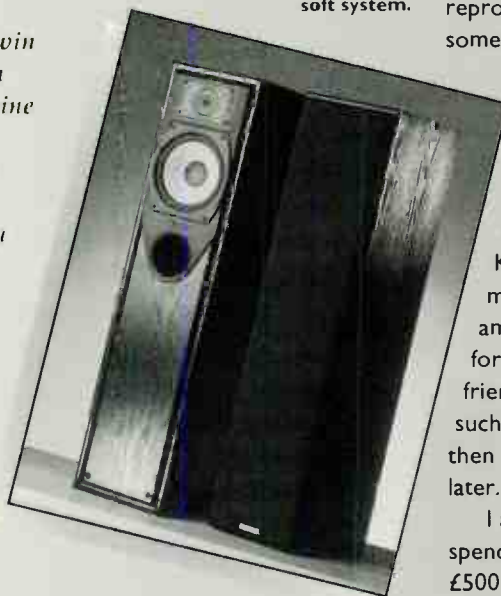

suit these units and advise on upgrading the interconnects and suitable 'speaker cable.

**T Anderson
Sutton Coldfield,
W. Midlands.**

Nakamichi only ever excelled with cassette decks. Their amplifiers and CD players were prosaic, so you are best off not spending too much. I'd suggest you try something good and effective, but not overly expensive, notably Mission 733s. NK



You can hook up your Nakamichi components with the Chord Siren Interconnect.

SYSTEM RENEWAL

My present system is a mixture of old and new and consists of an Arcam Alpha 5 CD player, Rega Planar 3 turntable, Sugden A48 amplifier (ca 1976/8) and Linn Kan 'speakers.

While I am pleased with many aspects of the sound produced and consider the

'speakers to be accurate in both vocal and instrumental reproduction, there is something missing which I find difficult to describe or diagnose.

Local dealers have suggested that I should either stick with the Kans and purchase a modern, better-quality amplifier, or swap them for a pair of more 'user-friendly' floor-standers such as Mission 752s and then upgrade the amplifier later.

I am restricted to spending no more than about £500 on any single item.

**Mark Wilson
Leeds.**



For real speed coupled with impressive bass weight, the new 631ses are very hard to beat.

If you have a pair of original Kans, then your senses have not been fooled. They had a large midband peak, I recall from measurement. Later Kans were flatter, so you may well find them more natural sounding.

Quite what you should do is difficult to be concise about. You'll find most floostanders a lot less tight and lively than the

... 49 >

Make the sound decision with May Audio...

...the Distributors of note!



Totem Loudspeakers

"Wonderfully communicative miniature; loads of fun"

SOUND QUALITY
★★★★★
Hi-Fi Choice



"Whatever sort of music you enjoy, if you're in the market for small speakers, you'll find the refined but invigorating Totems are poles apart from masses of more mundane miniatures"

MITE £495.00 MODEL 1 £1195.00
TABU £1795.00 MANI 2 £2495.00

Sequence Loudspeakers

"The SW12 subwoofer produced more extension of the listening experience than I expected. The sound was warmer, more solid and involving."

"...this subwoofer is remarkably self-effacing in appearance and easily accommodated in any room situation."

Gramophone

"...a natural sounding system that impressed from first listening and continued to provide musical enjoyment over an extended listening."

"...the Sequence 400s thus gain an enthusiastic recommendation."

Hi-Fi NEWS & RECORD REVIEW



MODEL 200 £200.00 MODEL 400 £330.00
MODEL 300 £250.00 SUBWOOFER £250.00
TRI-MOUNT RIGID SPEAKER STAND £50.00

LFD Amplifiers

"It's a diamond necklace in a world of plastic - but without the Tiffany price tag."

Eric Braithwaite, HiFi World

"Clearly then, these LFD components are of an outstanding quality."

Jimmy Hughes, Audiophile

"The result was music making without the Hi-Fi intruding."

Peter J Comeaux, HiFi News

"Spirolink I, Spirolink II and Digilink Copper"

HiFi Choice Recommended

"Airoflex, ★★★★★ rating" What HiFi

Integrated Zero £500.00 Phonostage MMO £400.00
Integrated Zero LE £800.00 LSB Linstage £2000.00
Linstage LSO £500.00 Power PA2M £2000.00
Powerstage PAO £500.00 DAC D to A £2800.00



Jecklin Float Headphones

"Speaker-like sound...
...it's in the cans!!!"

"To call these transducers 'headphones' is to do them an injustice 'headspeakers' would be a more accurate appellation."

Audiophile

"...the sound quality is more akin to a pair of speakers than most other headphones we know." What Hi-Fi



JECKLIN FLOAT TWO £99.00

JECKLIN FLOAT
ELECTROSTAT £399.00

Classical • Jazz • Blues • Big Band... the very best on Compact Disc

Our current C.D. catalogues feature some of the finest recordings of their genre and also offer unique repertoires to delight lovers of music and audiophiles alike.

- ORGAN ■ SOLO VOCAL ■ CHOIR ■ ORCHESTRA & OPERA
- CHAMBER MUSIC/ENSEMBLES ■ SOLO INSTRUMENTS
- JAZZ/FOLK MUSIC ■ TEST DISCS ■ LASER DISCS

proprius

≡ PROPHONE ≡



For literature please indicate your interests by ticking the relevant boxes-

HI-FI/W/195

- TOTEM LOUDSPEAKERS L.F.D. AMPLIFIERS SEQUENCE LOUDSPEAKERS
 JECKLIN FLOAT HEADPHONES ERGO HEADPHONES SONNETEER CAMPION
 CLASSICAL C.D. JAZZ C.D. BLUES C.D. BIG BAND C.D.

NAME _____

ADDRESS _____

NEW FOR 1996 SONNETEER CAMPION AMPLIFIER



"Campion is one of those very rare amplifiers that puts everything together and a tingle in all the vertebrae, especially the ones that keep a listener fully upright on the edge of the seat" HI-FI WORLD January 1996

ERGO HEADPHONES...
"Swiss precision made in sound"
ERGO 1...£POA ERGO 2...£POA
ERGO AMT...£POA

MAY AUDIO MARKETING, AIRESIDE MILLS, CONONLEY, KEIGHLEY, WEST YORKSHIRE, BD20 8LW • TELEPHONE 01 535 632700 • FAX 01 535 632887

Kans. You'd suffer less of a culture shock by going up to Toucans or the latest super-mini I've heard which is a real goer - the new Tannoy 631SE (on weighted stands). NK

I'd agree with Noel; once you're used to the Kans' speed and punch some floorstanders will sound slow. As well as the super 631SEs also audition Systemdek's 931s. These are a miniature similar in size to your Kans, but with a much more balanced presentation. As you're still using your Planar 3, audition them with a Linn Majik-I or an Audiolab 8000A, both of which have superb phono stages. DB

Sequence Model 30 (July '93, p45) which only rates 85dB is being driven at little more than half a watt because of its 14 ohm overall impedance. This 'speaker should be connected to the 16 ohm output and when driven by a full



The popular 300B power triode.

watt (4V!) would give an extra 3dB. It should therefore be rated as 'sensitive' rather than 'average' for valve amplifier use.

I agree with NK's reply to Chris Moorhouse (Jan. '96, p45) but I would have thought that pentode, ultra linear and triode output stages would react differently to impedance mismatches because of their different slope resistance and overall characteristics.

I would also expect some differences between single-ended and push-pull. M G Scroggie (Foundations of Wireless, 7th Edition, p312) gives the example of a single-ended pentode output stage where a small increase in load impedance from the optimum increases the output power slightly and also increases third harmonic distortion, although second harmonic distortion is reduced.

**Adrian Tollett
Addlestone,
Surrey.**

You are assuming that 'speakers not an exact 8Ω might be an exact 16Ω or 4Ω and also that suitable taps will be available. Most UK speakers lie in the

8-12Ω region and these are best connected to the 8Ω tap. Maximum power transfer will not occur, so the amplifier's output will not be fully utilised (but unless

the amp is run at full volume, it doesn't need to be) and we can say that sensitivity will decrease, but all this becomes unduly academic in the face of realities such as wildly varying impedances, absence of alternative output taps, etc.

Using a true watt for loudspeaker sensitivity specifications has problems with solid-state. Worst is that a high impedance loudspeaker looks more sensitive than it will seem in practice. This only causes confusion. A user would expect such a 'speaker to go loud with, say a low power amplifier, but in practice it will not. This rather defeats the object of making the measurement in the first place.

Our method of measuring sensitivity accurately reflects what a user will perceive. If we say one 'speaker produces 88dB and another 90dB then the 90dB one will be louder at any particular

volume control position, with a typical solid-state amplifier that is.

Of course, this means that using a low nominal impedance (e.g. 6Ω) gives higher apparent sensitivity, but since this is how it appears in practice to a user, fair enough. We always warn of this situation when we find it.

With valve amps the situation becomes more complex. As you say, any impedance other than correct nominal decreases sensitivity, but in my view the main issue to be addressed here is flatness of the impedance characteristic, rather than sensitivity differences.

Triodes are more load tolerant than pentodes and, in the past, there's been much debate about which is best. Pentodes have more gain and thus are a better choice for those wishing to use loop-feedback, which is why, in the past, they came to dominate. I've always found Scroggie's thoughts on such matters very illuminating; Second Thoughts on Radio Theory is a favourite of mine, where you'll find more on such fundamental matters. NK

Audiophile Int. Tel: 01276 855578



This Mobile Fidelity Sound Lab LP should keep you listening while you choose your new speakers.

SENSITIVE SOULS

Having spent some time studying your loudspeaker reviews, I note that you quote sensitivity in terms of dB for 2.8V input (Mar. '94, p27). I agree that this is the most suitable specification for use with solid-state amplifiers, but it can be misleading for valve amplifier use.

Since loudspeaker and valve amplifier impedances need to be matched anyway, it is more appropriate to quote the sensitivity of a loudspeaker for one watt of actual input power. This means that relative to your quoted sensitivity figures, low impedance 'speakers will be less sensitive and high impedance 'speakers more sensitive.

As an example, the

Newnes. Tel: 01865 310366

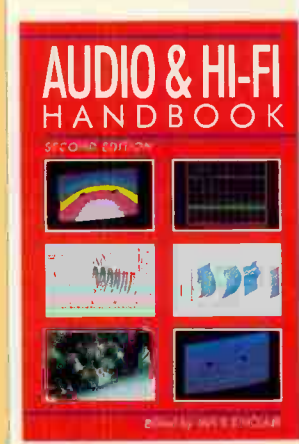

Any dedicated follower of audio should have one of these in their library.



That's not just another hollow acronym. In this case it's a relatively complex replay equalisation system that Pioneer offer as an automated version of NAD's Play Trim. It joins Super Auto BLE, with XD of course, that in turn complements Dolby B, C, and S, with HX Pro. In music search you get P+XX or P-XX, depending on whether you are going forwards or backwards. It's all so obvious!

Pioneer's CT-S740S came as something of a surprise to me. Here's an unusually well engineered cassette deck in a standard black box. Appearances are deceptive. The prosaic front hides a complex interior - one that is perhaps over engineered.

That's the sort of statement that may make Pioneer cry, but after reading about FLEX in the owner's manual I nearly did too. Flex isn't something you hang yourself with in frustration, but Frequency Level Expander System.

Any old cynic like myself may well assume Pioneer are not serious with all this. But in fact they are. Wherever I looked, the CT-S740S proved to be a very dedicated piece of cassette deck engineering. Tests confirmed its abilities, but how users will ever cope with Flex or Super Auto BLE, with XD, I wonder.

With cassette decks it is of primary importance to get the replay chain to reproduce right up to 20kHz. The head must be upright within minutes of arc, the tape guidance immaculate, the

DEVILISH DETAILS

With cassette, the devil's in the detail. Pioneer tackle them well in their CT-S740S recorder, says Noel Keywood.

replay amps perfectly equalised (with strong high frequency boost) and the head must be super smooth, or free of asperities. Curiously, it mustn't be too smooth, 'cos then the tape simply sticks to it. Peek inside the cassette compartment and the use of a cast head block gives some indication of the effort Pioneer have put into attaining such a result. Most heads sit on a cheap stamped metal bracket, but not Nakamichi's, nor this one.

The CT-S740S doesn't have, in its replay amps, the upper treble lift of a Nakamichi. Nor does it have Play Trim. Instead, it has FLEX which worked very well. Put simply, this senses when a pre-recorded tape sounds dull by measuring the roll-off rate of high frequency energy and, if excessive, adds treble boost to brighten up the sound.

That makes Flex an automatic equivalent of NAD's Play Trim. However, Flex offers 12dB of variation at 10kHz, against Play Trim's 3dB, and it was audible. I heard it hunting a bit at first, but was very impressed by the final outcome. Tapes so dull the vocalists seemed to be mumbling were transformed. Roy Orbison's *Mystery Girl* was one example; it was good to hear clearly at last Elvis Costello's bitter observations on *The Comedians*. If anything, Flex seemed to over compensate, but it was effective and offered a dramatic improvement in sound quality from pre-recordeds.

With Flex switched out replay response runs flat from 20Hz to 20kHz - quite an achievement. The deck will produce perfectly standard recordings that transfer properly to other machines, like a Walkman or car player. I tested this by transferring recordings to my Nakamichi ZX-9 and they came over as well balanced.

Over a wide range of pre-recorded tapes the CT-S740S showed great consistency, offering a silky smooth sound from an impressively stable soundstage. It didn't quite have the dynamics of my ZX-9, but Flex gave it better clarity and image definition. I suspect most people would be pretty surprised at what the CT-S740S can wring from pre-recorded tapes.

Having got replay performance right I

wasn't surprised to find record performance was superb. This deck does a fine job recording onto ferrics, chromes and metals. Its head may not offer Nakamichi magnetic overload levels, but they were good enough. Pioneer fit an effective automatic tuning system that adjusts bias, sensitivity, then record equalisation too. This is an impressively correct way of doing things, if rare because of its complexity.

“Pioneer weren't fooling around when they designed the CT-S740S. . . It's something of a bargain and one of the few decks available today I can award top marks to”

With all Dolby systems present, including the most recent Dolby S, the CT-S740S lacks nothing. Throw in superb speed stability from a well-honed dual-capstan transport and both hiss and wow are just about banished from recordings.

Ferrics like TDK AD and AR consistently sounded a little warm in balance, but hash-free in the treble and silky smooth generally. Metal tape (TDK MA) gave transients more bite - even Dolby S couldn't disguise this. The tune system coped with Sony Metal ES, which was a surprise, probably explained by the use of adjustable record EQ, even if there was a little residual brightness.

Most people, I suspect, would be more than happy with results from a good ferric, however, like Maxell XL-IS, or TDK AR/AD, providing Dolby S is

used to keep hiss down and help prevent saturation (treble overload). TDK AR is a great test here since it readily saturates and goes soft in the treble. Tuned in and with Dolby S engaged it captured the transients from Steve Earle's steel strung guitar well. The rub here is that AR has a low frequency performance superior to metal tape, at half the cost. With Dolby S to suppress its hiss and minimise treble saturation, it offers impressive recording quality.

Finally, the display panel legends of the CT-S740S are so small I had to stoop and peer to see them, especially B, C or S Dolby status. Although fully automated, I suspect many people will find the Pioneer confusing to use, it has so many obscure facilities.

This deck is a curious proposition. It offers superb performance at a bargain price of £429.95. Few people except tape professionals will ever really understand Super Auto BLE and Flex and they, I suspect, won't go for the automation. The deck needs simplifying and a better instruction book, preferably not written in bland Japlish. But in spite of these gripes, I have to say that in many areas this is one of the best cassette decks I have tested for a long, long time. Pioneer weren't fooling around when they designed the CT-S740S. It's something of a bargain and one of the few decks available today I can award top marks to ●

Pioneer CT-S740S

£429.95

Pioneer High Fidelity (UK)

**Pioneer House,
Hollybush Hill,
Stoke Poges,
Slough,
Berks. SL2 4PQ**

☎ 01753 789789

WORLD VERDICT 🌐🌐🌐🌐

Complex, but superb in every important area. Great engineering and a fine sound.

Measured Performance
see P103

MAGIC IN WEST ONE!



UNISON RESEARCH SMART 845

different in concept and in looks, both GRAAF and Unison have one thing in common. *A little touch of magic.* In design and construction, and in the quality of sound they provide, these amplifiers are quite simply in a class of their own. From the delightful Unison Research Simply Two to the awesome 845 Absolute, from the versatile GRAAF WFB Two to the stunning 5050, these are products which will put real enjoyment back into your music. Come and listen to the magic. Ring now to arrange a demonstration!

At KJ West One we pride ourselves on seeking out the very best audio equipment from around the world to offer our discerning customers. We try to put the magic back into your music.

With Unison Research and GRAAF we now have on demonstration two of the worlds finest brands of valve amplification. Although very



GRAAF 5050

The logo for KJ West One, featuring the letters 'kj' in a bold, stylized, lowercase font.

KJ WEST ONE
26 New Cavendish Street,
London. W1M 7LH
Tel: 0171-486-8262/3
Fax: 0171-487-3452

products shown: Unison Research Smart 845,
single ended pure triode monoblock
power amplifiers, £2995 the pair.
GRAAF 5050 Stereo Power amplifier, £2100

OPEN 5 DAYS, CLOSED
WEDNESDAY
AND SUNDAY

INTEREST FREE CREDIT
AVAILABLE

kaleidoscope

Mysteries from Noel Keywood



Many of the things we've been quick to abandon in the past had greater worth than most of us realised at the time. Hi-fi has been victim to the notion that tomorrow's technology must be better than today's.

Other industries are ahead of the hi-fi business in realising the drawbacks to this. I'm reminded often of the motor industry. Is the perfect car one that is ultimately fast, ultimately quiet and ultimately smooth? Surely not. Technically, it would be a great achievement, but who cares? Only motor industry boffos: it demonstrates their skills. Crossing Ditchling Beacon on a bright, sunny day, gimme a TR3A with the top down please!

The motor industry has realised that a big market sector will always exist for the safe, economical and, invariably, bland. I call this the negative attribute market; value is seen mainly in what the product does NOT do. That is, it must not intrude into people's lives in terms of cost, unreliability, visual ugliness, or what have you. In this market blandness is, in effect, a prime attribute.

But equally, there's a market for something that offers a specific and more intense experience than anything whose raison d'être is to be invisible. This is the market that looks for positive attributes, ones that DO intrude upon the senses; is it fast, fun, rorty, etc?

A similar situation afflicts the hi-fi business. A large number of buyers will always want something that is cheap and reliable, but effective too. For them the compact "black box" is ideal, because of the way it does its job unobtrusively, day in, day out. It may well not be the best going, but it hasn't been bought specifically for that property.

I see black boxes as part of the Consumer Electronics Industry. This embraces radios, TVs, Home Cinema and what have you. As much as

anything, the C.E. business has the wrong outlook to manufacture hi-fi. C.E. is all about mass manufacture at the lowest possible price. It produces what is known as a commodity; a faceless item sold by weight of advertising.

I realised just how far C.E. had gone recently when Ken Ishiwata of Marantz, a hi-fi man who

because it's a low cost/high volume item with a perfect CE profile. They'll tell you it's hi-fi; I insist it's CE. Let's look at this and why we differ.

The heart of every CD player contains parts designed solely, utterly and completely to be cheap to make. Forget quality; it isn't a prime consideration. It doesn't need to be,

Unfortunately, whilst the motor industry seemed to realise it had made a big mistake in telling its customers what it wanted to hear, namely that there was no demand for sports cars, soft tops and anything with character, the hi-fi industry hasn't yet made this distinction within itself, except I suspect at Philips/Marantz, where marketing and market research are used heavily.

Philips/Marantz have a few other "structural" advantages, as I'd call them. Marantz is a very powerful player within the group and that company is essentially Japanese (albeit with an American name). It brings to the group the Far East outlook, which Europeans and Americans have yet to really comprehend. For example, few Britons know that most Garrard 301 and 401 turntables left our shores ages ago, shipped out in containers to Japan. Marantz know this. They also know that these goods feed a voracious Far Eastern hi-fi market, that's why Philips relocated their Audio Division Headquarters to Singapore. This market values good hi-fi, irrespective of all other factors, much like a car enthusiast might value a TR3A. As I said earlier, many of the things we've been quick to abandon in the past had greater worth than most of us realised at the time. In hi-fi we've yet to discover where value really lies and why ●

" Few Britons know that most Garrard 301 and 401 turntables left our shores ages ago, shipped out in containers to Japan. "

works in the upper echelons of Philips/Marantz's global C.E. business (unusual that) explained to me that their Japanese factories are so carefully but thoroughly planned in terms of production efficiency that visitors aren't allowed in. These are the factories we do not see. What they are guarding are not fantastic circuits or components that yield unheard of sound quality so much as the latest in production techniques. So let us ask ourselves a rhetorical question: what are their priorities? It isn't difficult to see, no matter how the industry views itself.

Not unsurprisingly, CD turns the CE industry on

conventional engineers will insist, because at this stage the system is digital. Now do you understand why the CE industry loves digital and why it wouldn't or perhaps couldn't accept analogue ever again? Yep, it's cheap, cheap, cheap - and in cold engineering terms it delivers the goods.

Remember our perfect car? Digital delivers perfect hi-fi equipment. Perfect for whom is another matter of course. And this is the bit the industry itself is just beginning to sort out in its own head, under intense consumer buying resistance.

It isn't enough to turn out bland product after bland product in the blind belief it will sell.

Simple,



In art, the simplest disciplines can also be the most demanding. To write a haiku, a traditional Japanese poem, a poet is allowed just 17 syllables to capture a complete thought. So each word has to be weighed against every possible alternative to ensure there is no better alternative. The engineers and designers at Aura would immediately recognise the rigour of this approach. Like the poet, their goal is deceptively simple – to reproduce music perfectly. So each component must be carefully evaluated against alternatives. Every design route is checked against other possibilities. And when a decision is made, the key components are specially manufactured to

isn't it?

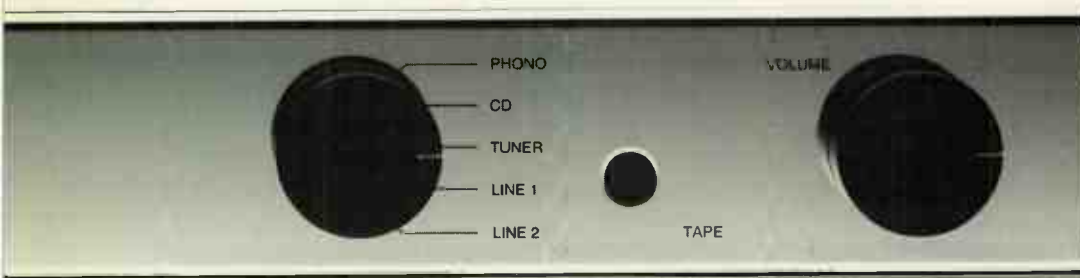

our own stringent specifications. Meticulous attention to detail has led to fewer and fewer details. The fascia of our amplifiers are uncluttered by unnecessary controls. Freedom from electronic gadgetry allows us to minimise the single paths to the electronic circuits inside the amplifier, reducing 'crosstalk' and distortion. Even Aura's distinctive chrome finish has taken us years to perfect. Stainless steel is repeatedly polished until it shines like a mirror. The result is simplicity and pure beauty. If you would like to know more about Aura amplifiers, tuners and CD players contact B&W Loudspeakers (UK Sales) 01903 750 750

Aura
PERFORMANCE : ART



Dominic Baker

dB on the level

What is happening to our masters? How long do you think a master tape lasts? Like me you'd probably never even thought about it, but after speaking with a representative of a major record label I made a few interesting discoveries that prompted me to investigate further. Before I tell the story of what I discovered though, lets describe what a master tape is and represents.

Analogue masters are multi-track tapes, with 8, 16, 24 or 32 tracks. Individual performers record their own parts separately, and once 'perfect' these are then mixed down and blended on to a master, along with any electronic sound effects the engineer chooses. The stereo mix down master represents the closest, most accurate representation of what the band and recording engineer wanted their track to sound like, and it's extremely valuable.

Imagine my horror then, when the representative told me that many of the original analogue master tapes they had were going sticky, causing them to jam in machines and become unplayable. There is a cure, called "incubation" in the trade, where they are baked to dry them out so that they can be re-played. But once they have been baked, they only have a limited life span, after which they are useless and are binned. During this

time a copy is made. Many are only copied to DAT (Digital Audio Tape) though, so the original analogue information is lost for ever. The copy quality is now limited to the 16-bit resolution of a digital system - inadequate in our opinion.

But why do the tapes become sticky in the first place? It all started when BASF, AGFA and AMPEX started producing tape with a matt back surface to

and they had never experienced it.

Obviously though, with BASF, AGFA and AMPEX tapes all suffering, there was a lot of very valuable material involved, so something had to be done. AMPEX took the lead here, developing a technique which involved incubating the tape at 55°C for four days. This would set the lubricant back into the tape, but only temporarily, before the tape would

Recording), which enables analogue copies to be made of the original masters without affecting their dynamic range. Tony also uses the original machines - he has one of every machine AMPEX have made since 1952, all serviced and in full working order. So if the original was recorded on a 1954 Ampex 8-track, he will use a 1954 Ampex 8-track to play back the incubated master copy.

This isn't just sentimentality though. If the tape was mastered on a machine that was only capable of recording up to 15kHz, but then played back on a newer machine that can resolve what's on the tape up to 20kHz, the chances are it will reveal all sorts of noise and distortion between 15-20kHz. Bob Marley's original master tapes were actually flown to Tony at AMPEX for this very reason.

As an interesting aside, AMPEX was formed in 1952. Les Paul invented the multi-track recorder, and Bing Crosby put up the

"Imagine my horror then, when the representative told me that many of the original analogue master tapes they had were going sticky, causing them to jam in machines and become unplayable"

improve the way they ran. These tapes had a special lubricant within the oxide, also to help running and lessen oxide shedding. Over time, this would rise and stick to the matt back surface. In some cases it would actually bring the big reel-to-reel machines to a halt, making them unplayable.

Scotch and EMI tapes don't seem to suffer from stickiness. They probably used a different chemical lubricant to that used by BASF, AGFA and AMPEX. I spoke to DECCA too, who said that the problem was confined to early tapes,

become sticky again. Depending on the type of tape and how bad it had become, this gave between 30-90 days of extra life, when duplicates could be made.

AMPEX carry out this service on their tapes. Examples of recent tapes which have been 'incubated' are King Crimson, Peter Green, Peter Sinfield (who wrote songs for ABBA) and Arthur Brown, but no doubt there are many more.

At AMPEX in Dorset, engineer Tony Arnold uses Dolby SR (Spectral

money to start AMPEX and put his ideas into use.

No one would confirm that they only make DAT copies of incubated master tapes, losing the analogue originals forever. But in today's market, where speed and profit seem to come before quality, I suspect that it is a regular occurrence.

Finally, I'll leave with one parting thought. Tony told me that some of the digital masters made on DAT machines are also starting to go sticky, but that's a whole new story ●

LIGHT WEIGHT

BOXER

Harbeth's HL Compact 7 loudspeakers rely on high quality drivers finely tuned to a light and rigid cabinet structure. Dominic Baker finds they've got a clean punch.



It's unfair on reviewers. But that's their lot. Eric was raving about Harbeth's new HL Compact 7 monitors - so I pinched them for review. Freelancers in particular have to live with the threat of their prize possessions being appropriated by an unsympathetic editorial department. There are situations in a hi-fi reviewer's life when silence is golden.

In the HL Compact 7s there's a 200mm bass driver, reflex loaded by a front firing port. This driver uses Harbeth's RADIAL™ injection moulded polymer cone. This material has been developed for low colouration. The cone sits in a cast chassis fitted with a central phase plug. The tweeter is a 25mm aluminium dome, ferrofluid cooled.



THORENS CD PLAYER TCD 2000

★★★★★ WHAT HI-FI? NOVEMBER 1995

VERDICT: Arise Sir Thorens, with high digital status...

FOR: Open fast sound with great depth

AGAINST: Don't listen if you can't afford it,

MAJOR THUMBS-UP

PORTFOLIO MARKETING

PO BOX 442, GREAT MISSENDEN, BUCKS. HP16 OJB

TEL: 01494 890277 FAX: 01494 890432

These drivers and every component in the crossover are measured to ensure consistency; a pair of HL Compact 7s are matched to within 0.75dB across their full audio bandwidth, a tight tolerance to adhere to in production.

A lot of the Harbeth sound is attributable to designer Alan Shaw's SuperTunedStructure (STS) cabinet. Where many manufacturers go for thick, heavy enclosures, trying to make them as solid as possible, Harbeth choose to laminate selected grades of MDF together, producing a thin 'lossy' structure. It is light, but very rigid, and Harbeth claim that when properly tuned, resonances are kept well away from the critical midband.

“ They seem in perfect harmony with the music, reproducing everything in seemingly correct proportion. ”

Another interesting feature is the grille. . . yes really. Grilles are troublesome objects. You spend months carefully engineering a loudspeaker to get an accurate response, then plonk the grilles on and ruin it all. The reflections caused by the grille frame can strongly affect the performance of a loudspeaker (see the QLN's measured performance section this month), causing phase suck-outs that affect the response and imaging. Harbeth loudspeakers are designed to be used with the grilles on, so they have developed a special frame that sits into the baffle leaving no hard edges that could cause these reflections.

Harbeth certainly pay a lot of attention to detail, and so did the Compact 7s when it came to the music.

I found the timbre of strings was described quite differently to usual, having a lighter, brighter tone and more of the woody resonance expected of cellos and violins.

From Nirvana's Unplugged in New York album, 'Come As You Are' had an open and breathy quality, free and easy in its expression. Acoustic bass was spot on, with just the right balance between the full and warm resonance of the body and the crisp leading edge of the steel strings. The HL 7s have quite a dry, analytical quality and a fiendish eye for detail when it comes to reproducing the complex harmonics of acoustic instruments like this.

Listening further into this album, 'Oh Me' had a perfectly weighted delivery and stereo images seemed tight in the certainty of their placement.

Acoustic bass was splendidly captured; soft, delicate and with a natural, uninhibited decay. But more captivating still was the way this live performance was delivered. You could feel the concentration of the performers, balancing lead guitar against percussion, whilst being careful not to overwhelm the gentle bass line. They left enough of a contrast for Kurt's vocal to push to the forefront. It was possible to hear the instrumental contribution soften slightly a fraction before each of Kurt's renditions, so as to clearly differentiate the vocal. It was an enchanting balancing act, an impressive live performance.

This demonstrated one of the Compact 7s greatest strengths: they seem in perfect harmony with the music, reproducing everything in seemingly correct proportion.

Harbeth's HL Compact 7s can almost sound over-dry at first, sterile maybe to the untrained and unaccustomed ear. But after hours, days, even weeks of listening you begin to realise that a lot of the time they're just very revealing of recording quality. Shifting back in time, The Doors' 'The End' on vinyl (I'd forgotten how thick and un-plastic like vinyl pressings were in those days) was captured in all its 70s splendour. Technicalities aside, it was surprising just how much the Goldring 1042's stylus dug out from the grooves. There was a realistic sense of acoustic space within the dry,

reverberant studio, which had a signature reminiscent of a small warehouse.

Although dry, the HL 7s are capable of producing surprisingly deep bass, I found. But they don't tell you about it often. There's little sense of drama as a powerful performance swells, but then you can't have everything, unless you have a subwoofer that is. That kind of stuff is all a little crude for the Compact 7s though; they're a Ming vase in a world of plant pots and deserve to be treated so.

With great insight and clear vocal projection, Bjork's 'Crying' from her Debut album was fast and incisive. Keyboards sounded solid and punchy across the upper bass spectrum; here the Harbeths appeared to dance along with the melody. The cymbals on 'Come To Me' were some of the best produced I've heard, sharply metallic and extended. Tuneful too, changes in pitch vividly discernible.

All this said, I can see that the Compact 7s won't be to everyone's taste. They could be accused of being dryly sterile next to a KEF Reference 1, but the KEF's equally could be labelled a little tubby perhaps. Here, taste and expectation affect judgement. The Harbeths are a thoroughly convincing and accurate monitor of recorded sound. They possess great resolution and clarity. Some might want more warmth or euphony, but I'm not sure they could wish for greater accuracy ●

Harbeth HL Compact 7 £1,329

Harbeth
Unit 1,
Bridge Road,
Haywards Heath,
W. Sussex RH16 1UA
☎ 01444 440955

WORLD VERDICT

Dry and analytical, but truthful with it. A first class monitor ideally suited to acoustic or classical music where its finer qualities shine.

Measured Performance
see p103

MS

Mordaunt-Short

Reach for the stars

The only thing better than a five star review - is *two* five star reviews!

In March 1996 WHAT HI-FI? reviewed the new Mordaunt-Short MS10i loudspeaker against five of its closest rivals.



"For small boxes they generate striking bass."

"We know there are those who find the KEFs' delivery a little relentless - those listeners will love the MS10is."

"But the stars here are the £140 Mordaunt-Short MS10is. They rock out with clarity, and deliver high standards of detail and focus at a price which makes them quite superb value for money."

We think they liked them!

Maybe it was our new, anodised aluminium gold dome tweeter which raises the first break-up mode of the tweeter dome beyond audibility, resulting in a sweeter, more detailed, more open treble. Or it could have been the new MCS Technology cone and surround, precision profiled to improve transient attack and termination characteristics, resulting in better midband performance. Possibly they liked the new, braced cabinet construction which improves the bass.

Whatever it was you'll find similar attention to detail in all loudspeakers from Mordaunt-Short, where engineering with a purpose and a love of music still mean something.

For your FREE copy of this review and a FREE Mordaunt-Short literature pack, including details of the new Music Series *i*, the new Performance loudspeakers and our new range of Home Entertainment loudspeakers, CALL FREE NOW on 0321 506550 (24 hours).

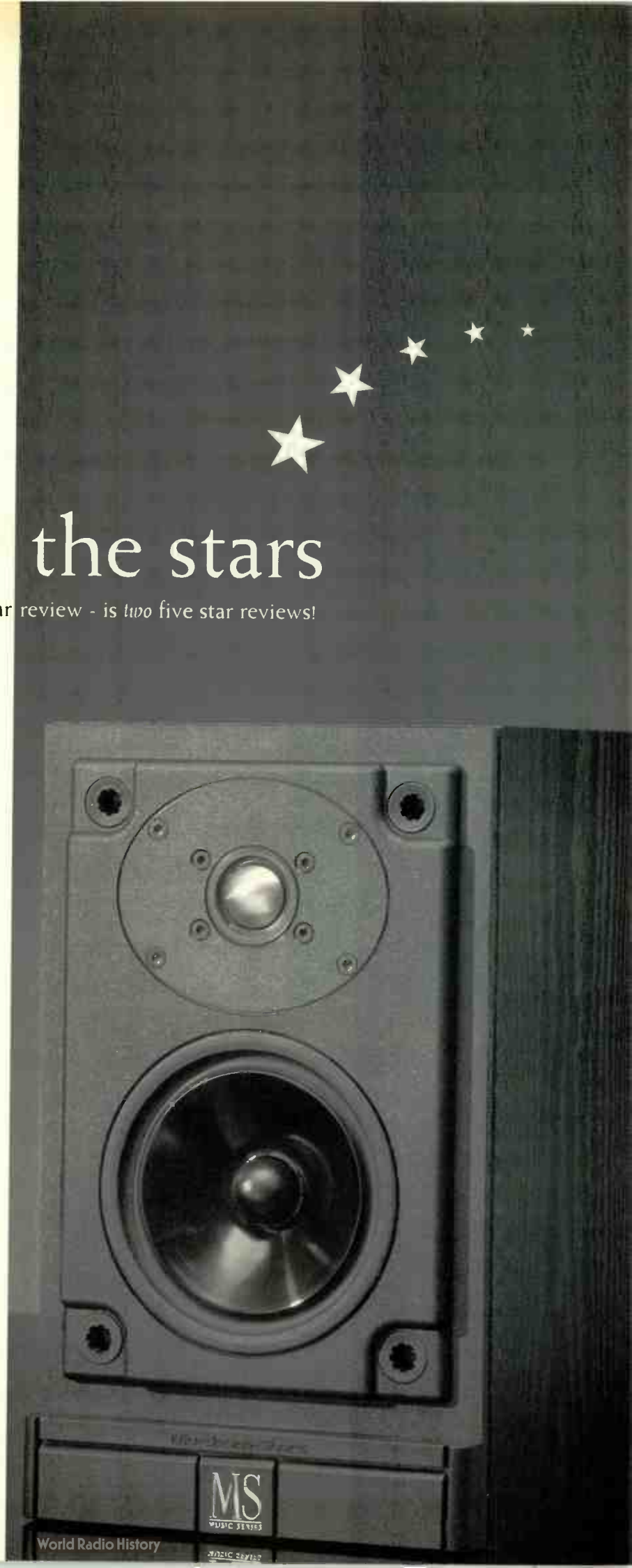

V' audio

Hi-Fi Consultants

Ian C. Vaudin
36 Druid Hill, Stoke Bishop,
Bristol BS9 1EJ
Tel/Fax: Bristol
(0117) 9686005

NEW BUDS FOR THE SPRING

THERE CAN BE NO DOUBT THAT ONE OF THE GREAT NEW FLOWERING IN THE 95/96 SEASON WAS THE AVI INTEGRATED 100W/CH AMPLIFIER, WHICH WAS A NATURAL FOR AN 'AUDIO CHOICE 1996' AWARD BY THE GRAMOPHONE MAGAZINE. THIS LITTLE WONDER TROUNCES MANY HIGHLY RESPECTED AMPLIFIERS COSTING UPWARDS OF £6000, WHICH CONSIDERING THE AVI ONLY COSTS £800 (INC. REMOTE) IS PRETTY GOOD FOR SALES. EVEN SOME OF THE BETTER KNOWN MASS PRODUCED SPEAKERS, SUDDENLY SOUND HALF DECENT WHEN CONFRONTED BY THIS LITTLE AMP. IT IS SO GOOD THAT ON SOME SPEAKERS SUCH AS THE RUARK CRUSADERS AND EQUINOX, THE INTEGRATED SOUNDED BETTER THAN THE MORE EXPENSIVE S200MP+MA PRE-POWER COMBINATION!

BUT ALL THAT IS ABOUT TO CHANGE WITH THE ARRIVAL OF THE NEW SPRING RANGE, NAMELY THE AVI S2000MP+P PRE-AMP AND MONOBLOCKS, EMPLOYING SIMILAR TECHNOLOGY TO THAT USED IN THE INTEGRATED, BUT WITH MORE POWER (150W/CH). PRICES HAVE GONE UP SLIGHTLY BUT STILL REPRESENT A BARGAIN AT £849 FOR THE LINE STAGE VERSION OF

THE PRE, AND £1049 FOR THE LINE + PHONO VERSION, AND A SUPERB MM/MC PHONO STAGE IT IS! THE MONOBLOCKS WILL SET YOU BACK £1250. THIS NEW COMBINATION, ESPECIALLY IF USED WITH THE NEW £1249 AVI REFERENCE CD PLAYER, ALSO DOES A SUPERB JOB DRIVING THE ATC 10, 20 AND 50'S, WHILE CUSTOMERS PRESENTLY USING THE ATC 50 ACTIVES WITH THE OLDER AVI PRE AND CD PLAYER ARE NOW SAVING TO UPGRADE TO THE LATEST COMBO. NOT TO BE FORGOTTEN IS THE NEW AVI NEUTRON SPEAKER; GREAT IN A SMALL STUDY.

BUT WE MUST NOT FORGET ALL THE OTHER NEW BUDS WHICH HAVE APPEARED RECENTLY, INCLUDING IN PARTICULAR THE ELECTROCOMPANET ECI-2 AMP AND QUBE SPEAKER, THE ALON PETITE, MODEL 1 AND 2 SPEAKERS, AND THE SHEARNE PHASE 1 TO 6 RANGE OF PRE, POWER AND INTEGRATED AMPS.

SO IF YOU FEEL THAT YOUR SYSTEM COULD DO WITH A SPRING CLEAN, DON'T FORGET THAT WE SPECIALISE IN PERSONAL VISITS TO ADVISE YOU WHAT TO DO NEXT TO PUT A BIT OF A SPRING BACK! DON'T MAKE THE SAME MISTAKE AGAIN, WE'RE ONLY A PHONE CALL AWAY.



THE PHASE LINKED LOUDSPEAKER
23 Hz - 24 KHz, 117 dB SPL peak, 300W

- BEAUTY - RARITY - POWER -

ORCHID

PRECISION AUDIO

In a world where many loudspeakers appear to be poured from a mould, we would like to show you something different, a loudspeaker which may turn out to be one of the most convincing in the world, a loudspeaker to give you and your music freedom and fidelity. Hidden beneath the classically styled cabinet is a radical 6 way design which might just change your pre-conceptions about "less being more".

To produce an experience as intense as live music takes not only a flat frequency response, it also takes high acoustic output and low distortion too, and achieving all these requires that each individual driver be operated only over a narrow, optimum frequency range. To do otherwise results in aberrant cone behaviour, high distortion, and gross coloration. Sorry.

If we had just stopped there; made a 4 way system from premium quality drivers, it would be a good 'speaker, but it would not have been a great one. Because there is the other criterion, the one nobody mentions, the **PHASE RESPONSE**. Without a good phase response, you will always be conscious that you are listening to electronic equipment, and you can do better, as we hope to show you.

The square wave test is one of the most revealing indicators of a 'speakers frequency and phase response. It is rarely published since many 'speakers, like the one in the top photo, have poor phase linearity.

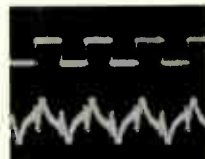

We use a 38 element crossover with unique trinary crossover points to achieve the fidelity shown here.

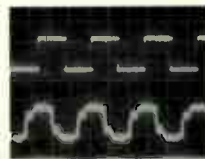

300 Hz TEST PLOTS

Hi-Fi nonsense? You are entitled to be sceptical, but we have only our commitment to excellence to rely on, and we believe that the Orchid Precision Audio PLL1 is the most convincing, powerful, and passionate loudspeaker you will find. If you're serious about high end audio you must audition this loudspeaker. To book a demo contact our dealer:

Westwood & Mason
46 George Street
Oxford
01865 24 77 83

ORCHID PRECISION
AUDIO,
Compton Court
Long Compton,
Warwickshire
CV36 5JW

With summer on its way, the hi-fi industry is set to follow the usual practice of going into hibernation. Thoughts move away from cosy nights indoors listening to music, to burning yourself half to death in some exotic location.

Yet, whilst all may be quiet on the retail front, this is the time when many manufacturers quietly launch new ranges of equipment. The manner and timing of this tells you much about the hi-fi company itself. There are those who are quite content to let the years go by without altering their products in any way, or if they do, it's simply a case of evolution rather than revolution, and often there is good reason for this.

Why should Quad want to replace their long standing ESL 63 electrostatic loudspeakers, or Nakamichi their Dragon cassette deck, when they'd risk losing the status that these individual models bring to the brand as a whole?

For other manufacturers, normally mass manufacturers, a constantly changing product range is an important part of their operation. These companies tend to fall into two categories: those that constantly introduce new model lines every year (or even every six months), and those who leave things a little longer, allowing products to become absorbed more by both dealers and public alike over several years.

Companies that fit into the first category tend to be the highly competitive multi-nationals. To them, a brand new product range every year is not so much a luxury but an absolute necessity in order to keep one step ahead of the competition. If your competitor has something new, normally with some new feature, then your year old model pales next to it. Yet there are potential problems.

Many of these larger companies have been

Fair Views

from
Dominic Todd,
our man in
retailing



opinion

stealing the limelight from smaller, usually home-grown companies, in areas they traditionally haven't done so well in. Notable recent successes have been the Pioneer A-400 and Kenwood KX3020SE amplifiers, Technics' SB-M300 loudspeakers and numerous other products that have surprised sometimes even the manufacturer concerned with the sheer demand for the product.

“Notable recent successes have been the Pioneer A-400 and Kenwood KX3020SE amplifiers, Technics' SB-M300 loudspeakers”

Then there are all the additional electronics that the multi-nationals often do well with. If an amplifier or CD player does exceptionally well in the hi-fi press, demand for the matching tuner and cassette deck in the same range soars alongside. You don't have to look too far to see examples of this, either. The previous season's favourites were the Denon TU260 tuner, Sony STS265 tuner and Aiwa ADF450 cassette deck amongst others.

The crunch comes, however, when attempts are made to follow up on a roaring success. So concerned that the new range won't take off, existing products are often

run in tandem. This year, it's the turn of Technics who, after having great success with their SLP570 CD player, are understandably reluctant to drop it totally in favour of the new 580. Hence, the two will be running alongside one another for the duration of the year.

The other alternative is the numbers game. Quite often a manufacturer will simply re-badge an existing unit with minimal changes.

Finally, if all these methods fail then there's always the good old stand-by of a marketing gimmick. I understand that this year we've got hi-fi containing bamboo (I kid you not) bursting on to the market. No doubt it'll be Super Linear, Super Clean Drive bamboo, too.

Not all hi-fi companies fall foul of their own success. The NADs, Arcams and Rotels of this world tend to take things at a steadier pace and, if something does well, will not be in a hurry to replace it. But a long product life can also be something of a double-edged sword, however. On the one hand, it may soon be overtaken by competition and end up

towards the end of its life-span almost totally forgotten. On the other hand, a long life can be beneficial in terms of the increased public awareness of a particular model that comes from steady exposure and word of mouth.

NAD for example have only just recently replaced their electronics range after four years of it remaining relatively unaltered. Yet the irony here is that the new 312 amplifier has been designed to sound more like the model its predecessor replaced (the 3020) than the predecessor itself (the 302). When a new model is less successful it's perhaps not such a bad idea to quickly change the model range again in the hope of rectifying things next time round.

What we must all learn from this is not to be wooed into buying a particular model simply because it's the latest thing. There are many excellent new products out there, but equally there will be some that are no better, or even worse than their predecessors. So the best advice, as always, is to keep an open mind and listen carefully to several options, both from the latest ranges and the not so recent. If you don't believe me, just take a look at some of the products in 'World Favourites'. A change, then, is not always for the better ●

Audiolab 8000S Stereo Amplifier



Imagine an amplifier which offers the simplicity of an Integrated Amplifier and the flexibility of a separate Pre-Power Amplifier. It is the new Audiolab 8000S Stereo Amplifier.

At the turn of a switch you can use it as an Integrated Amplifier, as a Pre-Power Amplifier together with the Audiolab 8000P Stereo Power Amplifier in a bi-amplified system, as a high performance stand alone Pre-amplifier, with an external surround sound processor, or with a sub-woofer. It has remote control and outstanding sound quality. We couldn't think of anything else an Amplifier needs to do!

Ask your Audiolab dealer for a demonstration.



- 8000A Integrated Amplifier
- 8000C Pre-amplifier
- 8000P Stereo Power Amplifier
- 8000M Monobloc Power Amplifier
- 8000T Tuner
- 8000Q Pre-amplifier
- 8000PPA Phono Pre-amplifier
- 8000CDM Compact Disc Transport
- 8000DAC Digital-Analogue Converter
- 8000S Stereo Amplifier



Audiolab 8000A

Audiolab 8000C/P

Audiolab 8000CDM/DAC

Audiolab 8000T

For more information about Audiolab products and details of your Audiolab dealer, call or write.



Hear the difference.

AUDIOLAB

Cambridge Systems Technology Ltd
Spitfire Close, Ermine Business Park
Huntingdon, Cambs PE18 6XY

Telephone 01480 52521
Fax 01480 52159

Simple

Are Teac hoping for a regular return from the interest their new A-BX7R amplifier generates? Eric Braithwaite counts the plus points.

INTEREST

Teach's new A-BX7R, like the A-BX10 before it, looks as though it's aimed squarely at the British hi-fi solar plexus. It is minimalist, with nothing more than a volume control, a selector for five inputs and a tape monitor button underneath for a second tape deck. There is an option for true balanced input using three-core cable and XLR plugs, as provided by some higher-end CD players and convertors (Audiolab and Meridian spring to mind). An optional phono board for MM and MC cartridges with a fully balanced signal path is available for unrepentant black disc addicts who haven't seen the digital light.

"That amplifier you were reviewing sounded impressive," said our layout artist after the session. And she heard it through the floorboards under her seat. . . It certainly sounds big with a lot of guts. Rhythm guitar on a Radiohead track was spectacular, with loads of full-frontal attack and a size that might have made Meatloaf look a bit on the small side, even before he went to Weightwatchers. So much so the vocals were all but left in the shade. On Sinéad O'Connor's 'Fire in Babylon', the Teac lent a good heavy, weighty, threatening feel to the bass, exactly what the song is meant to have.

Some flamenco-like acoustic guitar mixed in with a half-acoustic, half-electric band, had an equally sparky attack. Continual excitement like this is all very well, but like Ecstasy it can do with being watered down. The Teac's bass goes, subjectively, loud, but it isn't particularly accurate and it leaves a blurred impression. The cellos and double basses in Rebel's 'Les Elemens' had a kind of cross-fade timbre so they weren't clearly distinguishable. This piece relies on their melody for its rhythm and it

couldn't fly at all.

A spell with an Audiolab 8000S, in the same price range, showed there was detail missing in the bass. The Teac concentrated more on shoving the music and the musicians vividly out onto the carpet, while the Audiolab

stablemate, the A-BX10, this cheaper sibling sounds more like an adopted orphan. And it's up against very tough occidental island competition - Audiolab, Sugden, Sonneteer and others. Against them, just sounding big isn't enough. I mean, even Meatloaf tired of being big, didn't he?



demonstrated there was a good deal more space behind the 'speakers and around the players.

As so often, classical music gave the game away with a touch of hollowness in the midrange, a bass that was strong but not clear and, on piano as Arrau went up the scale in Chopin, a jarring jangly sound at times. In Beethoven's 7th, it was a pity that the lilting dance movement sounded off-hand and casual instead of tight and rhythmical. It was also tricky to 'see' the orchestra very clearly. As the 80-odd Chicago Symphony Orchestra's players started melting elbow grease, the Teac's sound became congested.

Definitely one for rockers, this, as little as I like making that kind of judgement. It's one to impress your friends with. It has a big, pushy sound, but it doesn't always pay enough attention to what's enveloped inside it. Given what has been reported of the almost-£1000

TEAC
A-BX7R £699.95

TEAC UK
5 Marlin House,
The Croxley Centre,
Watford,
Herts. WD1 8YA
☎ 01923 819630

WORLD VERDICT

Big and powerful sound, but a little unsubtle with it.

Measured Performance
see p103

WIN TECHNICS 'SPEAKERS WORTH £1800

We've five pairs of Technics loudspeakers to give away this month; one pair of SB-M500 floorstanders for 1st prize, and pairs of standmounting SB-M300s for four runners up.

Getting good bass from a compact loudspeaker has always presented difficulties to manufacturers. Technics' SB-M300 and 500 loudspeakers use a novel system to get around this problem, providing deep, powerful, and clean bass from relatively compact enclosures.

Technics' SB-M300 is a three way, four driver system housed in a cabinet little bigger than your average bookshelf design. Mounted on the front baffle are the tweeter and midrange drivers, both of which make use of mica diaphragms. Retaining the same material for both drivers means there is less chance of an audible change in sonic character as the two drivers cross over.

But it's in the bass that the SB-M300s get interesting. Inside there are two bass drivers, two passive radiators and three separate chambers, and that's not including the sealed case of the midrange and treble section. This design, which Technics call Dynamic Dual Drive (DDD), is essentially similar to KEF's coupled-cavity system. The two bass drivers share one common volume, but each drives into a separate chamber individually loaded by a passive radiator. In the SB-M300s one passive radiator can be found on the rear baffle, the other vents through three slots in the front baffle.



The SB-M500s are essentially the same loudspeaker, but arranged in a larger floorstander to give even deeper, more powerful bass. With the SB-M500s though, instead of venting around the front baffle, the second passive radiator is mounted behind a grille below the midrange driver on the front baffle.



When we auditioned the SB-M300s in November '95 and the '500s last month, we were very impressed. Both have a clear and detailed presentation and fine imaging. They are open and dynamic sounding loudspeakers but smooth at the same time. And of course both have taut and powerful bass thanks to the use of Technics' DDD system

Send your completed entry form, fixed to the back of an envelope, to:

**Technics competition,
Hi-Fi World Magazine,
64 Castellain Road, Maida Vale,
London W9 1EX**

Closing date: 4th June 1996.

APRIL ISSUE COMPETITION

In the April issue we gave three of you the chance to win an Aura VA 80SE-x amplifier along with matching B&W DM 601 loudspeakers.

**The lucky winners were:
Martin Harris of Horsham
Bill Bryce of Edinburgh
Mr M. Wegg of Felixstowe**

CONGRATULATIONS!

COMPETITION ENTRY QUESTIONS

Cut out and affix to the back of a sealed envelope

- 1) What does Technics' acronym 'DDD' stand for?
- A. Double Drive Design C. Dynamic Dual Drive
B. Dynamic Driver Design D. Dynamic Definition Drivers
- 2) Below are four systems used for good bass performance. Which is most similar to Technics' DDD bass system?
- A. Isobaric C. Transmission line
B. 1/4 Wave horn D. Coupled-cavity
- 3) How many drivers (including passive radiators) can be found in a pair of Technics' SB-M500s?
- A. 5 C. 7
B. 6 D. 8
- 4) What cone material do Technics use in the drivers for the SB-M300 and SB-M500 loudspeakers?
- A. Mica C. Kevlar
B. Paper D. Carbon Fibre

TIE BREAKER (obligatory)

Complete the following in less than 30 words

Dynamic Dual Drive loudspeakers,
With mica cones and tweeters,
Gives Technics a sound,
Good enough to astound,

.....
.....
.....
.....

Name:

Address:

.....

Post Code: Tel No.

Please do not add my name to your mailing list.

COMPETITION RULES AND CONDITIONS OF ENTRY

- [1] Only one entry per household. Multiple entries will be automatically disqualified.
- [2] In the event of more than one entrant submitting all-correct answers, the winner will be picked from the tie-breaker by the Editor. We will endeavour to publish the results in the second issue following the closing date.
- [3] Purchase of the magazine is not a precondition of entry.
- [4] No correspondence will be entered into; the Editor's decision is final.
- [5] No employees of Audio Publishing Ltd. or of any companies associated with the production or distribution of the prizes may enter.

If you would prefer *not* to receive details of new products or special offers please tick the box.

Hi-Fi World magazine is published by Audio Publishing Ltd.

For those of you that think
that modern life has been
immeasurably improved by
the advent of nuclear power,
soap operas and the ending
of all wars, you should replace
all your records with CD's.



ortofon

01753-889949

**The
Sound
Foundation**

SCOTLAND'S PREMIER SPECIALIST HI-FI DEALER

UNBIASED certainly not - that's why people come to us.

The Sound Foundation is a specialist audio retailer offering a traditional service, superb demonstration facilities and expert advice.

We only stock products from the best British companies including Sugden, ProAc, Castle, Michell Engineering and Audio Note UK.....WHY? Because these products are quite simply the best in their respective price categories.

For example, J.E. Sugden & co have been manufacturing Pure class A amplifiers for over Thirty years, and they just get better and better. The new Symetra monoblocks are 40 watts per channel class A, and combining them with ProAc loudspeakers you will find yourself in Hi-Fi heaven.

Regardless of your budget, please telephone for a chat and see how we can help you enjoy the long winter evenings with some great sounding cerebral Hi-Fi. (If you don't know what cerebral means, don't bother calling!)

AND NOW STOCKING ALL HARBETH PRODUCTS

01563 574185

22 Nelson St., Kilmarnock, Ayrshire, KA1 1BA

Specialist Hi-Fi Dealers

SOUTH

PRO
Musica

ROKSAN J NAIM J REGA J MICROMEGA J ARCAM J CREEK
J ROTEL J MARANTZ J DENON J RUARK J EPOS J
SYSTEMDEK J AUDIOLAB J NEAT J SHAHINIEN J SOUND
ORGANISATION J SOUND FACTORY J CHORD COMPANY J
AUDIO TECHNICA J MANA ACOUSTICS J

Records also available
PRO MUSICA
6 Vineyard St., Colchester, Essex
☎ 01206 577519

For the great sound of sound :

The Comflake Shop
37 Windmill Street London W1P 1HH
071 631 0472 Fax. 071 436 7165

We stock ATC, Arcam, Meridian, Naim,
Rega, Royde, Roksan, AVI, Monitor Audio,
DNM: as well as offering a marvellous mail-
order worldwide service • Crunch •

CHICHESTER
HIGH FIDELITY

7 ST. PANCRAS,
CHICHESTER,
WEST SUSSEX
CLOSED ALL DAY
MONDAY
Tel: (0243) 776402

Appointed stockists of: A+R Cambridge,
Castle Acoustic, Creek, Dual, Goldring, Linn
Products, Monitor Audio, Naim, Nakamichi,
Quad, Rega, Rogers, Royd Audio, Spondor

Stockists of: ARCAM • CREEK • EPOS
HEYBROOK • MICROMEGA • NAIM AUDIO
NEAT • REGA • ROKSAN • ROTEL • ROYD
TEAC • YAMAHA

Infidelity
indecently good hi-fi

9 High Street, Hampton Wick, Kingston upon
Thames, Surrey KT1 4DA. Tel: 081-943 3530
Open Tues - Sat 10.30am - 7.00pm.

QUAD 33 CONVERSION
A re-designed rear panel incorporating gold
phono sockets and up-dated selector boards
installed into your Quad 33. Free Ixos leads
supplied with conversion. Other Quad
modifications available. Also repairs to:
QUAD, LEAK, LOWTHER, BOSE, etc
ACADEMY SOUND (CORNWALL).
BANK HOUSE, ST AGNES, CORNWALL, TR5 0QW.
TEL: 01872 553317

AUDIO CONCEPT

27 BOND STREET, EALING
LONDON W5 5AS
TEL. 081 - 567 8703

AMC, Acoustic Energy, Aura, Audiolab, Audio
Innovations, B&O, B&W, Cannon, Castle, Cyrus, Denon,
Dual, Evolution, JPW, KEF, Marantz, Micromega,
Mission, Monitor audio, Musical Fidelity, NAD,
Nakamichi, Onix, Onkyo, Quad, REL, Rogers, Rotel,
Systemdek, Target, Teac, Thorens, Van den Hul.

10 - 6 pm Mon., Tues., Friday, & Sat.
Late night Thur., closed Wed.

Two demonstration rooms.
Free local delivery and installation.
Repairs and Services

SOUTH

WORTHING AUDIO
30 Trevill Gate, W Sussex. BN11 1UA
(0903) 212113

The friendly shop with the best sound system in the
South. Friendly advice
• 3yr guarantees • easy parking
Open Mon-Sat 10am-6pm Late night Wed. 7.30pm
Agencies include: Arcam, Exposure, Kinshaw, Naim
Audio, Marantz, Ruark, Audio Technica, Target, Tripod,
JPW, TDL, Orelle, and many more.....

R. J. F.

AUDIO VISUAL

CORNWALLS PREMIER DEALER

Analysis, Atacama, Audio note,
Audiomeca, beyer, Cable Talk, Chord,
Denon, Harman Kardon, Impulse, JBL,
JPW, Klipsch, McIntosh, Micromega,
Monitor audio, NAD, Ortofon, Project, REL,
Rotel, SD Acoustics, SME, Target, TDL,
Teac, Triangle, Trichord, Parasound,
Musical Technology, QLN,

Demo rooms & free installation (subject to
certain conditions). Interest Free Credit
available

LONDON & SOUTH EAST

the powerplant

BRIGHTON'S LEADING HI-FI SHOP
Cyrus, Roksan, Micromega, Audionote, Audiolab, Rega,
Arcam, Exposure, Aura, Epos, Thiel, Ryark, Rotel,
Marantz and other fine equipment.

66 Upper North Street, Brighton
Telephone 0273 775978

studio
99

79/81 Fairfax Road
Swiss Cottage
London NW6 4DY
071 624 8855/6
Mon-Fri 10.7-Sat 10.6

Front End Problem?
contact -
The Cartridge Man

It doesn't have to cost an arm and a
leg to get the best - listen to my
koetsu - and Decca - eater.

Also agents for croft, sugden,
Thorens, Pentachord Speakers &
Nottingham Analogue.

plus cartridge re-tipping service
081 - 688 6565

LONDON & SOUTH EAST

 THE INNOVATIVE
AUDIO AND VISUAL
HI-FI RETAILER

SERVING LONDON
FROM BATTERSEA

**ORANGES
& LEMONS**
0171- 924 2040
61/63 WEBBS ROAD, SW11

NOW IN OUR SECOND
FRUITFUL YEAR.

The Hi-Fi Shop
GUILDFORD'S SPECIALIST SINCE 1950

We are at:
3 BRIDGE STREET, GUILDFORD
(By the traffic lights - next door to Alfred Marks)
0483 504801 • 0483 304756
Access • Visa • Switch
Open Monday-Saturday 9am-6pm (later by appointment)

**"One of the 5
best hi-fi shops
in the world"**

GRAHAM'S HI-FI

Canonbury Yard, 190a New North Road
London N1 7BS, ☎ 071-226 5500
Ring for a chat, an appointment and a map!

 *Best place in town
for Hi-Fi and
Home Cinema*

UNILET
SOUND & VISION

- ★ Six superb demonstration rooms
- ★ Interest Free Credit
- ★ all Leading Brands
- ★ OPEN SUNDAYS

UNILET SOUND & VISION
35 High Street, New Malden, Surrey KT3 4BN
Tel 0181 942 9567 Fax: 0181 336 0820

SPALDINGS
THE SOUTH EAST'S LEADING HI-FI COMPANY

3 DEM ROOMS A.V.
HOME DEMS., 0% CREDIT
FREE INSTALLATION

**LINN . NAIM . QUAD . AUDIO LAB
DENON . MARANTZ . RUARK**
MON TO SAT 9.00 to 6.00, TUE 9.00 to 8.00

SEVICE DEPT
325-354 Lower Addiscombe Road, Croydon, Surrey CRO 7AF
Telephone: 0181 654 1231/2040 Facsimile: 0181 655 3922

*Hi-Fi in the
THE CITY*

Auditorium

119 Middlesex Street, Bishopsgate, London E1 7JF
Telephone 0171 247 5000
Facsimile 0717 247 0990

ARCAM CYRUS
BANG & OLUFSEN
DENON EPOS KEF
DYNAFECTOR
REL MICROMEGA
NAIM MISSION
NEAT WTT XLO
SHAHINIEN
SYSTEM AUDIO

TWO MINS WALK FROM LIVERPOOL STREET STATION

Specialist Hi-Fi Dealers

MIDLANDS

MIDLANDS

MIDLANDS

AUDIO EQUIPMENT FROM LEADING AND SPECIALIST BRANDS ON TWO FLOORS FOR YOU TO LISTEN AND CHOOSE FROM

- 3 Demonstration Rooms
- Home Trials
- Home Cinema - Instore Demonstration Theatre
- Audio Visual Equipment
- Evening Demonstrations by appointment
- Inhouse Service Department
- Mail Order Available
- Interest Free Credit on Selected Items (Apr. 0% - Written details on request)

SOUND ACADEMY



"Quality, Clarity, Expertise... and that's just the service!"

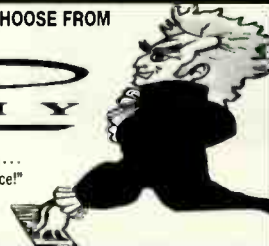

Sharing the ASDA Carpark with ample free parking, Off High Street, Bloxwich, Nr. Walsall, West Midlands Near M6 Jnc. 10 & 11
Open 6 Days, 9am - 6pm
Late night Friday



Hi-Fi for the Beginner, the Enthusiast and the Audiophile Telephone (0922) 493499/473499

ACOUSTIC ENERGY • ARCAM • ALEMA • AUDIO LAB • APOLLO • A.T. • AUDIO ALCHEMY • AUDIO QUEST • B&W • BDSE • BEYER • CABLE TALK • CHORD COMPANY • CHORD • CYRUS • CELESTION • DPA • EPOS • EXPOSURE • INFINITY • JPM • KEF REFERENCE • KENWOOD • MARANTZ • MICHELL • MONITOR AUDIO • MONSTER • MORDAUNT SHORT • MERIDIAN • MICROMEGA • MISSION • MOTH • MUSICAL FIDELITY • NAKAMICHI • ORTOFON • PROJECT • QUAD • ROKSAN • ROGERS • ROTEL • SENNHEISER • SONY • SPENDOR • SUMIKO • SYSTEMDEK • TARGET • TDL • THORENS • TRIANGLE • TUBE TECHNOLOGY • VAN DEN HUL • VANDERSTEEN • YAMAHA • YBA

MUSIC MATTERS



LATEST ARRIVALS

CHORD SPA3200 & SPMI200B PRE-POWER, MERIDIAN DSP6000 SPEAKER SYSTEM, S6SAC-3 SURROUND PROCESSOR, 557 POWER AMP, 518 DIGITAL PROCESSOR AND 566 20-BIT DAC,

ALCHEMIST MAXIM, NEMESIS AND FORSETI AMPLIFIERS, DYNAUDIO RANGE OF SPEAKERS, EPOS ES22, SPENDOR AND PRO-AC SPEAKERS, ROYD SQUIRE & DOUBLET SPEAKERS, QUAD 77 RANGE.....

CLEARANCE & SECOND HAND SALE

OUR VERY SUCCESSFUL SALE NOW MEANS WE HAVE A NEW LIST. PLEASE SEND A N.S.A.E. FOR AN UPDATE OF THE NEW BARGAINS AVAILABLE.

PLEASE NOTE OUR NEW OPENING TIMES

TUESDAY TO SATURDAY 10am TILL 5.30pm,
LATE NIGHT THURSDAY TILL 7pm.

Branches at:

- Birmingham : 363 Hagley Road, Edgbaston, Tel: 0121 429 2811
- Solihull : 93-95 Hobs Moat Road, Tel: 0121 742 0254
- Stourbridge : 156/157 Lower High Street, Tel 01384 444184
~Demonstrations By Appointment~

FRANK HARVEY Hi-Fi EXCELLENCE

163 Spa Street, Coventry, CV1 3BB Tel : (0203) 525200.
Mon to Sat 9.30 till 5.30. Closed Thursday



MUCH MORE THAN HI-FI
WE ARE A BADA DEALER

Audiolab • Audio Alchemy • Arcam • Alphason • Bose • Bang & Olufsen • Celestion • Cyrus • Denon • Dual • Foundation • Kef • Marantz • Monitor Audio • Mission • Musical Fidelity • Nakamichi • Nad • Quad • Rega • Rogers • Rotel • Target • Tripod • Tannoy • Thorens • Van Den Hul • Yamaha

MAILORDER • EXPORT • HOME TRIALS

3 Floors, 3 Dem rooms, 3000 sq feet in the pursuit of Hi-Fi Excellence

CREATIVE AUDIO

9 DOGPOLE, SHREWSBURY, SHROPSHIRE

Tel: (01743) 241924

Closed Mondays

- Comfortable listening rooms
- Home demonstrations available
- Part exchange welcome
- Free home installation
- Interest free credit

Authorised retailer for:

A&R ARCAM, AUDIOLAB, CELESTION, CYRUS, DENON, DUAL, MERIDIAN, MISSION, MONITOR AUDIO, QUAD, REVOLVER, ROKSAN, ROTEL, YAMAHA, EPOS, NAIM, KEF, NAD

SUFFOLK

Peter Ellis Audio

A wide range audio products always in stock including : Denon, Marantz, Arcam, Sugden, Tannoy, Castle, Nakamichi, Yamaha, TDL, Jamo, Musical Fidelity, JVC, Kenwood, Pioneer.

* Dolby ProLogic & Cinema in stock *

* Demonstration Room *

* Free delivery & installation *



29, KIRKGATE, NEWARK, NOTTINGHAMSHIRE NG24 1AD
01636 704 571



NORTH

HI-FI YOU CAN'T AFFORD not to listen to

EQUIPMENT BY ABSOLUTE SOUNDS

AUDIO INNOVATIONS, SUGDEN, IMPULSE, MICHELL, ROKSAN, PINK TRIANGLE, ACCUPHASE, THIEL, COUNTERPOINT, SONIC FRONTIERS, TRICHORD RESEARCH ETC.
By appointment only

SERIOUS KiT

061-707 4823

STEVE HANNAH AUDIO of WALSALL

neal
sugden
ukd-opera
unison research
slate audio
stemloort
j m lab

01922 640300

ation
audio innovations
audion
audiovector
audio synthesis
chord company
densen
ear
harbeth
kar
lyra
michell
morel
ortolon
project
quad
royal
spendor
steyr
heyrick
pierre lumie
sugden
teac
triangle
trichord
void

signals

hi-fi for grown-ups

ipswich 01473 622866

SOUNDS AROUND

NEW & USED HIFI
Professional Service Repairs and Accessories

146A Clarendon Park Road, Leicester
Telephone : 0533 702442

Specialist Hi-Fi Dealers

NORTH WEST

audio excellence THE ULTIMATE SOUND ADVICE

CHESTER 86-90 Boughton, Chester CH3 5AQ (01244) 345576 **CHESTER**

TUESDAY - SATURDAY 9.00 - 5.30 CLOSED MONDAY

SCOTLAND

ANCURUM ELECTRONICS

YOUR LOCAL HI-FI SHOP

PIONEER, TECHNICS, PROLOGIC AMPS + LASER
DISC FOR HOME ENTERTAINMENT

TEL: (01382) 480030
39 GRAY ST., BROUGHTY FERRY DUNDEE

REPAIRS/DIY

Russ Andrews Ltd.
Edge Bank House, Skelsmergh, Kendal, Westmorland, LA8 9AS, ENGLAND
Tel: 01539 823247 Fax: 01539 823317

If you like the Hi-Fi equipment you have, but want a better performance, don't change it -

UPGRADE IT!

You can build better than you can buy and we offer kits, parts and instructions for anything from simple component upgrades to complete rebuilds, plus kits to build high end equipment from scratch.

Upgrading Service.

If you are daunted at the prospect of taking the lid off your prized possession, send it to us and we can do the upgrade for you. We will advise on feasibility and cost before starting work and upgrade to the level of performance you require and can afford. We have a secure, low cost collection and delivery service within the UK.

Upgrades to: Audio Research, Celestion, KEF, Krell, Linn, Morantz, Meridian, Naim Nytech, Pioneer, Quad, Leak, Radford, Rotel etc....

To receive your copy of our 1995/96 catalogue, just Mail, Phone or Fax the address above.

EIRE

• REL • Audiolab • Arcam • B&W •

A Passion for Excellence

CLONEY
Audio
for those who demand the best

55 Main St Blackrock
Tel: 2889449 • 288477
Open: Tue-Sat 10AM-6PM. Thur/Fri 'till 9PM

• Naim • Castle • Epos • Technics •
• Audioquest • Pink Triangle • Rega •
• EAR • Classé • Meridian • TDL •

REPAIRS/DIY

TECHNICAL & GENERAL

THE ORIGINAL TURNTABLE SPECIALIST

for the Great Classical Turntable, Arms, Cartridges, Styli

CONNOISSEUR • GARRARD • GOLDRING •
LENCO • ORTOFON • SHURE • S.M.E •
THORENS • WATTS

All available Genuine spares and cur own re-manufacture of obsolete parts

NO ILLUSORY 'IMPROVEMENT' NO DUBIOUS OR HARMFUL 'MODIFICATIONS'

Cartridges and styli, correct radius diamonds, for early recordings - 78s & Lps

TECHNICAL & GENERAL

P.O.Box 53 Crowborough, East Sussex TN6 2BY
Tel: 01892 65 45 34

THE Service Specialists

From classic VALVES [we'll happily re-align your HRO] to the latest DIGITAL LASERDISC

You supply the problem... We supply the solution! REVOX • LEAK • QUAD • RADFORD • ALTOBASS • GRANT • RCA • PIONEER • YAMAHA • LUMLEY etc. Our services are already widely used by Professionals and Enthusiasts: ring now for more details

VALVE AMPLIFIER KIT ASSEMBLY

HAVE your amp kit professionally built.

We'll assemble it, wire it, de-bug it & provide you with an individual test report

PLEASE RING FOR DETAILS

AUDIO LABORATORIES (LEEDS)

0113 2440378

VALVES/TUBES

CVC Chelmer Valve Company for Audio Valves

Buy CVC PREMIUM Hi-Fi valves direct from us. All valves processed for improved performance. We also have Stock of MAJOR BRAND types including: MULLARD, GEC, BRIMAR, RCA, GE, etc

130, New London Road, Chelmsford, Essex, CM2 0RG
Tel: 01245 265865 Fax: 01245 490064

Lockwood Audio

THE
Authorised **TANNOY** Specialist

SPARES AND REPAIRS

DEALERS IN VINTAGE AND USED EQUIPMENT AND RECORDS



Callers welcome by appointment

Imperial Studios Maxwell Road Borehamwood Herts. WD6 1WE

Phone: +44(0)181 - 207 4472

Fax: +44(0)181 - 207 5283

Sowter Transformers
EA Sowters Ltd
PO Box 36
Ipswich IP1 2EL
0473 219390/252794

Output and mains transformers for GEC KT88 circuits. Can also make any other transformer to order. Send SA for lists and data.

MUSIC

G T AUDIO

Fully guaranteed top quality repairs, servicing & upgrading carried out to all types of audio equipment (including valve). Also agents for: Unison Research, UKD Opera, Croft, Nottingham Analogue, and Posselt. Contact Graham Tricker for details on

01895 833099

CD SELECTIONS

The UK's leading suppliers of bargain CDs and music for your free catalogue contact

CD SELECTIONS

PO BOX 1011

DORCHESTER DORSET D12 7YG

Tel. 0305 848 725

Specialist Hi-Fi Dealers

WEST & WALES

V'AUDIO
Tel: 0117 9686005

36 Druid Hill
Stoke Bishop
Bristol BS9 1EU

ATC, AVI, Acoustic Energy, Aanalysis, Alon, Audiomeca, Audio Technica, AMC, Analogue Electronics, Cadence Valve, Chord Amps, Electrocompaniet, Exposure, Goldring, Harman Kardon, Heybrook, Jamo, LFD, Lyra, Ortofon, Perception, Pink Triangle, Ruark, Michell, REL, Sansui, SME (inc. 20A), Sonic Link, Stax, Sugden, Sumiko, Townshend, Triangle, Wadia.

Demos by appointment only. Home trial facilities.
Free installations. Servicing facilities.
We are not a shop



WEST & WALES

Technics
AUTHORISED HI-FI SPECIALIST

BUDD WISER HI-FI

Probably the best Hi Fi shop in the World!
104 ALBANY ROAD CARDIFF TEL 01222 493535

SERVICES & CONSULTANTS

REVOX SERVICE

Fully Guaranteed Service and Repair
Insured Carriage arranged
Free Estimation

Also: Tape Supplies
Second User Reconditioned Machines
Spare Parts orders welcome
Free Advice

Ram Tek

Tel: (0181) 207 6159

Fax: (0181) 953 1118

Kinetic Centre, Theobald Street,
Borehamwood, Herts. WD6 4SE

audio excellence **BADA**
THE ULTIMATE IN SOUND SERVICE

WHERE THE MUSIC MATTERS

Bristol

65 Park Street
Bristol BS1 5PB
(01179) 264975

Cardiff

134/6 Crwys Road
Cardiff CF2 4NR
(01222) 228565

Gloucester

58 Bristol Road
Gloucester GL1 5SD
(01452) 300046

Swansea

9 High Street
Swansea SA1 1LE
(01792) 474608

TUESDAY - SATURDAY 9.00 - 5.30
CLOSED MONDAY

Retailers of Fine Audio Equipment
Congleton

▶ LINN
 ▶ ARCAM
 ▶ B&W
 ▶ DENON
 ▶ EPOS
 ▶ KEF
 ▶ MISSION
 ▶ NAKAMICHI
 ▶ PIONEER
 ▶ TARGET
 ▶ TRIPOD
 ▶ YAMAHA
 ▶ LOUSY COFFEE
 ▶ DEFINITIVE
 ▶ MILLER KRIESEL

▶ SUPERB DEMO FACILITIES

▶ FULL INSTALLATION & HOME DEMO SERVICE

OPEN 6 DAYS A WEEK
OTHER TIMES BY APPOINTMENT

01260 297544

LORICRAFT AUDIO

Required Garrard 301/401, Thorens TD124, Goldring GL75 any condition or any parts from new to completely used

Tel/Fax/Answer phone -
01488 72267

OVERSEAS

Information overload.

For just a catalog - a valuable source of information. The Parts Connection Catalog & Resource Guide, Volume 2 includes: tube and vacuum tube data for the most commonly used audio tubes as well as some classic tube lineaments theory from the PFA Recovering Tube Manual - and that's not all. There are schematics for many classic tube amplifiers and preamps from Danby, Minkitz, Quad, Whistler and more! Also included are wire-wraps on the technical benefits of premium wire cages and metal ball resistors.

If that's not enough for you, we'll add a wide range of books on vacuum tube electronics theory, tube data, practical projects, loudspeaker design and building, and audio history. We also have new additions in a wide range of power and output transformers and drivers from Hammond, the exciting new range of Veen loudspeaker and power transformers from Pilton, and an extensive range of the superb Mighel/Ortofon output transformers for push-pull and single-ended applications. We have a broad range of film capacitors, including the new MIT PPFK S and PPFK R series, and the new Hi-Fi Caps from Wavitec.

An expansion of the theme, here about expanded selections of Tripart and Hi-Fi Caps, Kimber Caps, RFI Cap Tapers, Solin Fast Caps. With our greatest Hi-Fi caps selection has also expanded to include new types of Amber Caps, Audio Caps, Cordis Audio, Van den Hul, Gdtrix and more. Along with a wide selection of components to meet your needs.

Expanding your opportunities. Order The Parts Connection Catalog & Resource Guide, Volume 2 today and see for yourself. Come see that you'll find all that you need for your next audio project. The 7.00 £* charge for the catalog includes a coupon good for \$10.00* off your first order of \$100.00* or more - or \$25.00* off your first order of \$250.00* or more. Offer today.

* or \$10.00 US

* catalogue delivered only in US dollars.

THE PARTS CONNECTION
A DIVISION OF SONIC FRONTIERS INC.

2790 Brighton Road, Oakville, Ontario, Canada L6H 5T4

Toll Free Order Line **1-800-769-0747**
(U.S. & Canada only)

Tel (905) 829-5858 Fax (905) 829-5388

e-mail: TPC@sonicfrontiers.com

WWW: http://www.sonicfrontiers.com/TPC



GT AUDIO

GUARANTEED TOP QUALITY REPAIRS AND SERVICING ON ALL TYPES OF VALVE AUDIO EQUIPMENT. SYMPATHETIC UPGRADING CARRIED OUT USING THE FINEST COMPONENTS AVAILABLE.

Also agents For:- CROFT, G.A.T.E., GRAAF, LEAK TROUGHLINE TUNERS, MONRIO, NOTTINGHAM ANALOGUE, POSSELT, UKD OPERA, UNISON RESEARCH, YAMAMURA CHURCHILL ACCESSORIES

TEL: 01895 833099

atv

- Service & Repairs
- Valve & transistor amplifiers
- Vintage valve Radios
- Hi-Fi VCR's
- Valves Tested

ATV SERVICES
LEATHERHEAD
01372 456921

**TO ADVERTISE
IN THIS SECTION
PLEASE CALL
0171-289-3533**

KITS HAVE NEVER BEEN SO GOOD!

300B VALVE AMPLIFIER



300B VALVE AMPLIFIER KIT

£850

This is a specialised 28watt amplifier based on the highly linear 300B triode valve. Our 300B runs in Class A, giving one of the most sweet, open and neutral sounds possible today. Matched with good loudspeakers, it is unsurpassed. All parts are included in the kit, except valves since different 300B makes are available.

KLP1/KLPP1 PREAMPLIFIERS



KLP1 VALVE LINE PREAMPLIFIER

£345

The KLP1 line level preamplifier uses one of the simplest and most elegant circuits to give a sound with remarkable clarity and detail. The components are all high quality and include Military Spec. Russian valves, Alps potentiometer, polypropylene signal capacitors, silver plated copper wire etc.

KLPP1 VALVE PHONO PREAMPLIFIER

£495

KLPP1 has five line inputs, a tape input with monitor, and a unique low noise valve MM/MC phono stage. There is a switchable subsonic filter to prevent output transformers of valve amplifiers saturating. The line stage has gain, so it will drive any power amplifier. Audio grade components are used and many parts are custom made for highest quality.

KLPP1 has a super clear sound, sweet and detailed through line and phono inputs.

NEW - K6L6 35W INTEGRATED £295

K6L6 - A high performance 35watt integrated valve amplifier using 6L6 beam tetrode valves. It has four line inputs and a tape output. It is a compact design that will fit into any system, bringing valve transparency, warmth and detail.



OVERSEAS DISTRIBUTORS

Selected World Audio Design Products are on demonstration at:

Octave Electronics

No. 81, Jalan 1/12,
46000 Petaling Jaya,
Selangor Darul Ehsan,
West Malaysia.
Tel: (603) 793 7939

New Best Co. Ltd.

No.199, Sec. 3,
Cheng-Teh Road,
Taipei,
Taiwan. R.O.C.
Tel: (886) 2 599 2598

SB International Inc.

Zenkyoren Bldg.,
2-7-9 Hirakawacyo,
Chiyodaku,
Tokyo 102, Japan.
Tel: (81) 3 3264 5321



World Audio
design

Tel: 0171 289 3533

WARNING

THESE ARE EXPERT KITS, NOT FOR THE INEXPERIENCED.

World Radio History

KLS3 THREE WAY CARBON-FIBRE DRIVER LOUDSPEAKER

KLS3 uses extremely light and stiff carbon fibre cone drive units for a fast and accurate sound. A dedicated 4inch carbon fibre midrange drive unit provides the cleanest, smoothest and most detailed midrange characterised by superb projection. Its high 90dB sensitivity and near flat 8Ω impedance make it one of the easiest loudspeakers to drive.

Drive Unit & Crossover kit etc £350
 Drive Unit Pack £230

KLS4 TWO WAY CARBON-FIBRE DRIVER LOUDSPEAKER

A two way standmounter using stagger-tuned reflex loading for good bass, plus light and fast carbon fibre drivers.

Drive Unit & Crossover kit etc £230
 Drive Unit Pack £120

KLS6 ADVANCED TECHNOLOGY THREE WAY LOUDSPEAKER

KLS6 is our most advanced loudspeaker to date. It uses a combination of Audax's HD-3P gold piezo-electric dome tweeter and High Definition Aerogel (HDA) midrange and bass drivers. To provide super bass depth and dynamics, an 8" HDA bass driver is used in a large, efficient reflex enclosure. With 89dB sensitivity, and a smooth impedance curve, KLS6 can be easily driven with amplifiers capable of producing 20watts or more.

Drive Unit Pack £640
 Drive Units & Crossover kit etc. £825

KLS7 TWO WAY CARBON FIBRE DRIVER FLOORSTANDER

A compact and affordable two way reflex loudspeaker. KLS7's slim dimensions make it easy to accomodate, but it uses light and fast carbon fibre drivers. so performance isn't compromised. An audiophile bargain.

Drive Unit Pack £110
 Drive Units & Crossover kit etc. £195

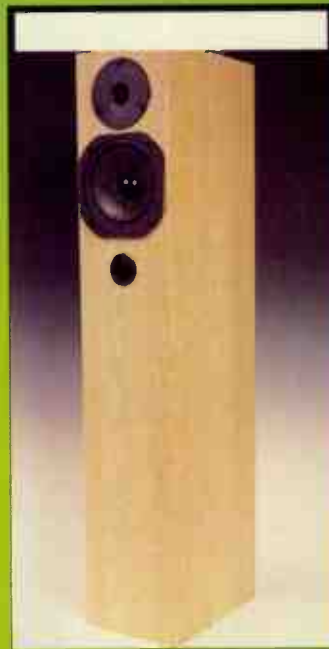

K588I KIT £395

A superb, Class A, 20watt stereo power amplifier that uses Russian 588I output valves, a military version of the American 6L6, designed for low distortion audio work.

Designed for long life, low running costs and excellent sound quality, K588I can be used with a simple passive pre-amp. or our own line-drive pre-amp, and it matches modern loudspeakers well.

K588IPSE KIT £650

An audiophile parallel-single-ended valve amplifier at an affordable price. K588IPSE uses the reliable Russian 588I output valve in parallel-single-ended mode for outstanding detail and atmosphere. It produces 17watts, enough to drive most loudspeakers, making high-end sound quality and design available to everyone. Can be easily monoblocked to give 32watts.



HIGH TECH AUDAX DRIVE UNITS

This range of Audax drive units sees many modern high tech materials and technologies that would normally be unavailable to the home constructor. We offer a small range of the highest quality drivers, including High Definition Aerogel (HDA) units, carbon fibre and three superb soft dome tweeters.

CAST CHASSIS UNITS

	3inch mid	4 inch mid	6.5inch bass/mid	8inch bass
HDA	HM100Z0	HM130Z0	HM170Z0	HM210Z0
=CARBON FIBRE	HM100C0	HM130C0	HM170C0	HM210C0

FABRIC DOME TWEETERS

TW025M0 (25mm 92dB suitable for 2-way systems)

TW025M1 (25mm 92dB suitable for 3-way systems)

TW034X0 (34mm 93dB a large dome with powerful sound)

OVAL GOLD DOME TWEETER HD-3P (complete with crossover. Works extremely well with HM100Z0 - ultra flat response from 400Hz to 20kHz.)



World Audio
design

Tel: 0171 289 3533

WARNING

THESE ARE EXPERT KITS, NOT FOR THE INEXPERIENCED.

DEMONSTRATIONS!!

Selected World Audio Design Products are on demonstration at:

2nd Audio

17 Maritime Court,
 Harboro Rd,
 Sale.
 Tel: Andy on
 0161-969-0460

Horsham Hi-Fi

28 Queensway,
 Horsham,
 W. Sussex.
 Tel: Jeff on
 01403-251587

World Radio History

See following page for order form...

"All I need is the right lead... "

- Sam Spade-Connector during his undercover investigations into the Mystery of the Lost Chord. He subsequently solved the case by utilizing a pair of ORTOFON SPK100 speaker cables.

SPK100

ortofon 01753-889949

Sound Investment

If you have invested expertise and money in building up a sound system to your own unique specifications, then why compromise with indifferent housing units?

Fi-Rax offers a new dimension in audio visual racking - from a range of standard designs to the flexibility to custom create a unit to suit your particular sound system and lifestyle.

- *High quality aluminium construction.
- *Finishes available to your choice.
- *Fully adjustable 6mm glass shelving.
- *Sound isolation on shelving/feet.
- *Custom created to suit your system.
- *Free delivery throughout the UK.

Fi-Rax - a sound investment for those who want the best from their equipment.



Audio Visual Furniture

For further information or a free brochure contact: JEM Distribution, Springfield Mills, Spa Street, Ossett Wakefield WF5 0HW. Tel: 01924 277626 Fax: 01924 270759

Better off DEAD
no vibrations dead sounds perfect

FoculPods are precisely replicated energy absorbing pads. They improve the detail / stereo imaging of sensitive audio and video equipment. They work by absorbing vibrations in the component chassis, or from the shelf or rack.

fit **FOCULPODS**

£14.95

4 pack



Loosely grouped molecules within the material rub together and transfer the vibration into heat. The tacky surface eagerly bonds to metal chassis and wooden shelves, further improving vibration absorption.

NOT ONLY DO FOCULPODS ISOLATE YOUR EQUIPMENT FROM VIBRATION, BUT THEY ALSO INCREASE THE AIR SPACE BETWEEN TO PROVIDE BETTER VENTILATION - 50mm DIA x 20mm THICK

DISTRIBUTORS WORLDWIDE (G - P) Germany Tel 30851 8074 - Fax 30851 8062 Greece Tel 01 246 6578 - Fax 01 246 6713 Holland Tel 765 715010 Fax 765 714773 Hong Kong Tel (852) 2898 8111 - Fax (852) 2558 0073 Indonesia Tel/Fax 31 311 598 Israel Tel 3 924 7524 - Fax 3 924 5117 Israel Tel 3 540 7279 - Fax 3 540 7438 Italy Tel 2 29 40 4437 - Fax 2 41 86 61 New Zealand Tel/Fax 0 9 849 8108 Norway Tel 9469 1937 - Fax 755 25335 Portugal Tel (01) 274 7758 - Fax (01) 274 1423

THIS MONTHS PRODUCT FEATURE 2

DEFLEX

Isolation Feet

FOCULPODS
WHAT THE PRESS HAVE TO SAY

"...I thought they worked very well on some low-cost CD players I had knocking about..."

Hi-Fi Choice July 1995



High performance vibration absorbing supports designed to be placed under Compact Disc Players, Turntables, Amplifiers, Loudspeakers and all other Audio, Video and computer equipment

Now available from most good Hi-Fi shops

Please add £2.00 P&P on all orders less than £20.00 - £1.00 on all orders over £20.00

For a FREE comprehensive information pack and details of other products from Spectra Dynamics

Tel. (01745) 571600
Fax. (01745) 570194

Spectra Dynamics Limited Talargoch Trading Estate Meliden Road Dyserth Chyrd L18 6DQ

WARNING

THESE ARE EXPERT KITS, NOT FOR THE INEXPERIENCED. YOU MUST BE ABLE TO SOLDER AND READ A CIRCUIT DIAGRAM. THE VALVE KITS CONTAIN LETHAL VOLTAGES. WE CANNOT BE HELD RESPONSIBLE FOR ANY ERRORS ARISING FROM THE CONSTRUCTION OF THE KITS.

ORDER FORM

Please send your completed order form to: WORLD AUDIO DESIGN, 64 Castellain Road, Maida Vale, London W9 1EX
Tel: 0171 289 3533 Fax: 0171 289 5620

240/120 option - delete the voltage NOT required. Valves included except where stated.

IF YOU WOULD LIKE A DATA SHEET ON ANY OF THE KITS, PLEASE WRITE A 'D' IN THE QTY BOX CONCERNED

'BUILT' - we can supply the amplifiers built up and tested by an approved service, for safety and guaranteed performance to specification.

WARNING - World Audio Design Ltd will accept no responsibility for kits, parts or modifications made or supplied by third parties and based on our designs.

DESCRIPTION	ORDER No.	QTY	UK (inc VAT& carriage)	OVERSEAS. (net)
NEW 35W integrated valve amplifier KIT	K6L6-K240/120	<input type="text"/>	£295	£255
4W single-ended integrated amplifier KIT	4WSE-K240/120	<input type="text"/>	£385	£330
BUILT	4WSE-B240/120	<input type="text"/>	£585	£495
K588I 20W push-pull valve power amplifier KIT	K588I-K240/120	<input type="text"/>	£395	£350
BUILT	K588I-B240/120	<input type="text"/>	£595	£550
K588IPSE 17W single-ended valve power amplifier KIT	K588IPSE-K240/120	<input type="text"/>	£650	£555
BUILT	K588IPSE-B240/120	<input type="text"/>	£850	£725
300B 28W valve power amplifier (prices do not include valves) KIT	300B-K240/120	<input type="text"/>	£850	£725
BUILT	300B-B240/120	<input type="text"/>	£1150	£950
KLPI line level preamplifier KIT	KLPI-K240/120	<input type="text"/>	£345	£295
BUILT	KLPI-B240/120	<input type="text"/>	£545	£465
KLPP1 full valve phono preamplifier KIT	KLPP1-K240/120	<input type="text"/>	£495	£425
BUILT	KLPP1-B240/120	<input type="text"/>	£695	£595
KLS3 3-way carbon fibre driver floorstanding loudspeaker Drive Units + Crossover kit etc	KLS3-C	<input type="text"/>	£350	£300
Drive Units	KLS3-D	<input type="text"/>	£230	£200
KLS4 2-way carbon fibre driver standmounting loudspeaker Drive units + Crossover kit etc	KLS4-C	<input type="text"/>	£230	£200
KLS6 3-way HDA driver floorstanding loudspeaker Drive Units + Crossover kit etc	KLS6-C	<input type="text"/>	£825	£700
Drive Units	KLS6-D	<input type="text"/>	£640	£545
KLS7 2-way carbon fibre driver floorstanding loudspeaker Drive Units + Crossover kit etc	KLS7-C	<input type="text"/>	£195	£170
Drive Units	KLS7-D	<input type="text"/>	£110	£95
AUDAX DRIVE UNITS (P&P Extra, please add £5.75 for individual units or tweeters, otherwise add £10)				
High Definition Aerogel				
3inch midrange	HMI00Z0	<input type="text"/>	£35	£30
4inch midrange	HMI30Z0	<input type="text"/>	£45	£40
6.5inch bass/mid	HMI70Z0	<input type="text"/>	£50	£45
8inch bass	HM210Z0	<input type="text"/>	£60	£55
Carbon Fibre				
4inch midrange	HMI30C0	<input type="text"/>	£40	£35
6.5inch bass/mid	HMI70C0	<input type="text"/>	£45	£40
8inch bass	HM210C0	<input type="text"/>	£55	£50
Fabric Dome Tweeters				
25mm 92dB for 2-way systems	TW025M0	<input type="text"/>	£15	£13
25mm 92dB for 3-way systems	TW025M1	<input type="text"/>	£16	£14
34mm 93dB - powerful sound	TW034X0	<input type="text"/>	£25	£22
Oval Gold Piezo electric dome tweeter	HD-3P	<input type="text"/>	£225	£195

NAME: _____
ADDRESS: _____

I enclose cheque/postal order for £ _____
made payable to World Audio design Ltd.
I wish to pay by Access/Visa. Debit my account no:

<input type="text"/>	<input type="text"/>	<input type="text"/>	<input type="text"/>	<input type="text"/>	<input type="text"/>	<input type="text"/>	<input type="text"/>	<input type="text"/>	<input type="text"/>	<input type="text"/>	<input type="text"/>	<input type="text"/>	<input type="text"/>	<input type="text"/>	<input type="text"/>	<input type="text"/>	<input type="text"/>	<input type="text"/>	<input type="text"/>
----------------------	----------------------	----------------------	----------------------	----------------------	----------------------	----------------------	----------------------	----------------------	----------------------	----------------------	----------------------	----------------------	----------------------	----------------------	----------------------	----------------------	----------------------	----------------------	----------------------

Expiry date:

POST CODE: _____ TEL: _____
CREDIT CARD ORDERS TELEPHONE 0171 266 0461 (24 HOURS)

Signature



world audio design mail order

OVERSEAS PRICES AND DETAILS
All our kits can be supplied overseas. Allow for your own local import taxes (customs duties) and for carnage charges, which must be added to our net price.

METHODS OF PAYMENT
International money order in Sterling. Visa. Mastercard/Access.
PHONE (9.30am-6pm) 0171-289-3533
ANSWERPHONE (24hrs) 0171-266-0461
FAX (24hrs) 0171-289-5620

OVERSEAS DISTRIBUTORS
Octave Electronics
No. 81, Jalan 1/12,
46000 Petaling Jaya,
Selangor Darul Ehsan,
West Malaysia.
Tel: (603) 793 7939
New Best Co. Ltd.
No.199, Sec. 3,
Cheng-Teh Road,
Taipei,
Taiwan. R.O.C.
Tel: (886) 2 599 2598

SB International Inc.
Zenkoyren Bldg.,
2-7-9 Hirakawacyo,
Chiyodaku,
Tokyo 102, Japan.
Tel: (81) 3 3264 5321

The Sound Gallery

The Facts about those really nice people at The Sound Gallery

- ▶ Formed in 1985
- ▶ Easy to approach 
- ▶ Best products in each field
- ▶ Comparative testing
- ▶ Depth of knowledge
- ▶ Multi-room experts
- ▶ AV system demonstrators
- ▶ Home Installations (we leave when you're happy)
- ▶ Finally, after all these years we still love music

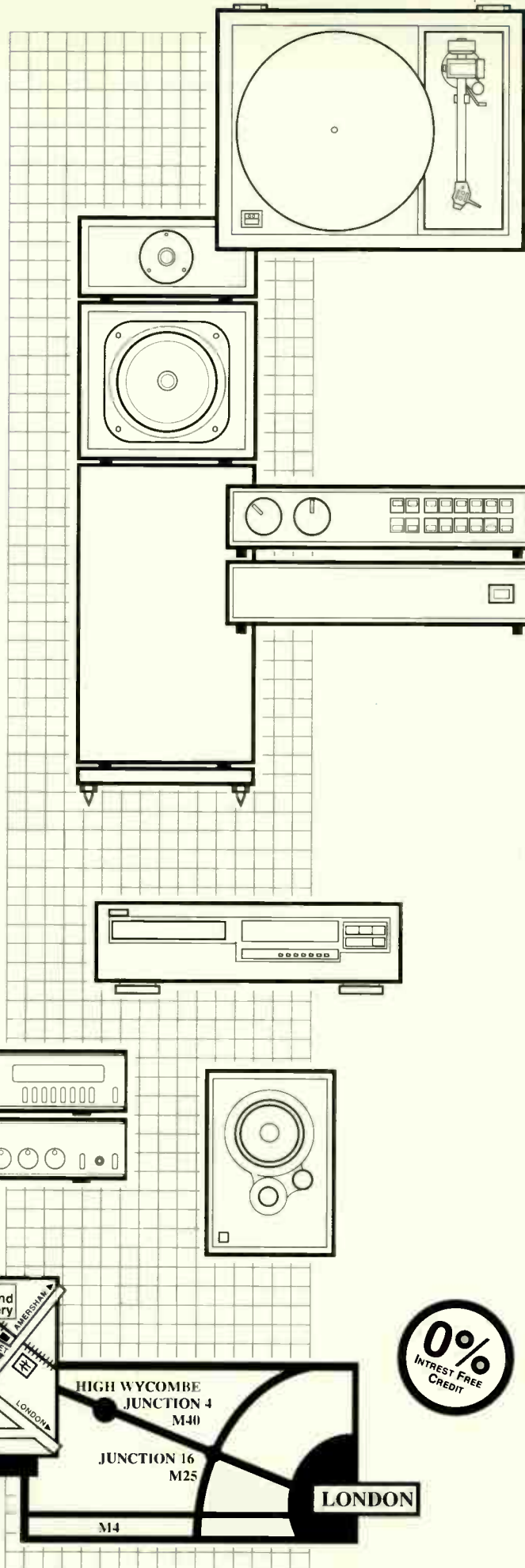

- Arcam ■
- Aura ■
- B&W ■
- Chord co ■
- Definitve Tec ■
- Denon ■
- Epos ■
- Kef ■
- Linn Hifi ■
- Linn Knekt ■
- Miller & Kreisel ■
- Mission ■
- Mordant Short ■
- Naim audio ■
- Nakamichi ■
- Rega ■
- Royd ■
- Stax ■
- TDL ■

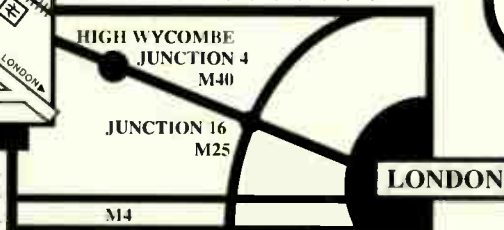
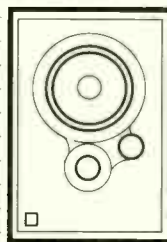
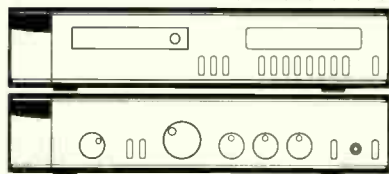

The Sound Gallery
 65 Castle Street
HIGH WYCOMBE
 Bucks HP13 6RN Tel,(01494) 531682
 Fax, (01494) 464770

Hi-Fi World WORLD LIBRARY

VALVE BOOKS

PRINCIPLES OF ELECTRON TUBES,
by **Herbert J. Reich** £29.95

Principles of Electron Tubes first appeared in 1941 as a textbook for beginners studying valves for the first time. The book starts with the basics of how a vacuum tube actually works and goes on to show how a simple circuit is designed as well as amplifiers, transformers and power supplies. A must for budding valve enthusiasts and an invaluable reference for hobbyists.

HERBERT J. REICH
PRINCIPLES OF ELECTRON TUBES
Understanding and Designing Simple Circuits

MULLARD TUBE CIRCUITS FOR AUDIO AMPLIFIERS. £13.95

First published in 1959 by Mullard, this book includes full designs for eleven power and control amplifiers, including the 5-20, using valves. This book begins with a four-chapter tutorial on getting the best sound from valve amplifiers.

THE WILLIAMSON AMPLIFIER,
by **D. T. N. Williamson.** £9.95

In April 1947, Williamson's valve power amplifier became an overnight success. The author takes you deep into his design decisions and offers practical advice on how to build the amplifier and set it up for best performance.

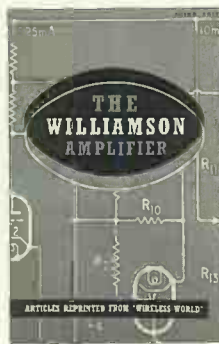

ELECTRONIC UNIVERSAL VADE-MECUM, by **Piotr Mikolajczyk & Bohdan Paszkowski** £49.95

This sizeable data book contains no fewer than 5693 valves divided into 442 groups. It contains connection details, operating parameters, load lines, example circuits and more making it one of the most comprehensive reference books we've seen, although there are some omissions, such as 300B and 211 valves.

LOUDSPEAKER BOOKS

LOUDSPEAKERS: THE WHY AND HOW OF GOOD REPRODUCTION,
by **G. A. Briggs.** £10.95

A popular and easy to understand book on building loudspeakers, using empirical techniques that pre-date computer analysis. A fine grounding, written by a manufacturer with first hand experience - recommended for beginners.

AN APPROACH TO AUDIO FREQUENCY AMPLIFIER DESIGN,
seventeen circuits from 5 to 1100watts.
General Electric Co. £19.95

High quality amplifier designs from the Research Labs of the General Electric Company (UK). Designs range from 5 to 100watts, using KT66s, KT88s, DA100s, etc. Also includes two valve pre-amplifiers complete with valve phono stages.

70 YEARS OF RADIO TUBES AND VALVES, by **John W. Stokes** £19.95

With over fifty years experience, John Stokes outlines the evolution of radio receiving tubes and the part they played in the domestic radio receiver in this beautifully illustrated (B&W) book. An ideal reference for those interested in the history and development of valves and for collectors alike.

ELECTROSTATIC LOUDSPEAKER DESIGN AND CONSTRUCTION,
by **Ronald Wagner.** £19.95

This book takes you step by step through the design and construction of a full range electrostatic loudspeaker, including the basic operating principles behind electrostatics. Whether you intend to build your own electrostatic, repair and restore a vintage electrostatic or are just interested in the principles behind electrostatics, this book is a must.

WORLD LIBRARY ORDER FORM

	PRICE	P&P U.K.
<input type="checkbox"/> An Approach to Audio Frequency Amplifiers.....	£19.95	£2.00
<input type="checkbox"/> Mullard Circuits for Audio Amplifiers.....	£13.95	£2.00
<input type="checkbox"/> The Williamson Amplifier.....	£9.95	£1.00
<input type="checkbox"/> Principles of Electron Tubes.....	£29.95	£2.00
<input type="checkbox"/> 70 Years of Radio Tubes & Valves.....	£19.95	£2.00
<input type="checkbox"/> Electronic Universal Vade Mecum.....	£49.95	£6.00
<input type="checkbox"/> Loudspeakers: The Why & How.....	£10.95	£1.00
<input type="checkbox"/> Electrostatic 'Speaker Design & Construction.....	£19.95	£2.00
<input type="checkbox"/> The Loudspeaker Design Cookbook.....	£23.75	£2.00
<input type="checkbox"/> Transmission Line Speaker Design.....	£10.95	£2.00
<input type="checkbox"/> Theory and Design of Loudspeaker Enclosures.....	£23.95	£4.00
<input type="checkbox"/> Bullock on Boxes.....	£12.95	£2.00
<input type="checkbox"/> Acoustics.....	£39.95	£4.00
<input type="checkbox"/> The Art of Electronics.....	£35.00	£5.50
<input type="checkbox"/> The Art of Linear Electronics.....	£16.95	£2.00
<input type="checkbox"/> Volume One.....	£14.95	£2.00
<input type="checkbox"/> Volume Two.....	£14.95	£2.00
<input type="checkbox"/> Volume Three.....	£14.95	£2.00
<input type="checkbox"/> Volume Four.....	£14.95	£2.00
<input type="checkbox"/> Volume Five.....	£14.95	£2.00
<input type="checkbox"/> Volume Six.....	£14.95	£2.00
<input type="checkbox"/> Audio Anthologies - complete set.....	£83.95	inc

For 10 or more books p&p in the UK is free. Overseas contact us for p&p prices
I enclose cheque/PO for £.....made payable to

Your name and address may be added to our mailing list only. If you would prefer not to receive details of new products or special offers please tick box.
Hi-Fi World magazine is published by Audio Publishing Ltd.

Please allow 28 days for delivery

Audio Publishing Ltd.

I wish to pay by Visa/Access, please debit my card no:

--	--	--	--	--	--	--	--	--	--	--	--

Expiry date:

Signature:

Name.....

Delivery Address.....

.....Tel:.....
N.B. If delivery address is different to the credit card holder's address please supply both.

Please send completed order form together with your cheque/PO to:

HI-FI WORLD, 64 Castellain Road, Maida Vale, London W9 1EX.



Credit Card Orders
Telephone 0171 - 266 0461 - 24 hour Mail Order Answerphone



FOR OFFICE USE ONLY

CC CH IMO O

AUTH CO DATE

DATE SENT

Audio Masters

Mail Order Accessory Specialist

Target Audio Racks by Mail!!

We stock the entire range of target products, here are just a few!

AER

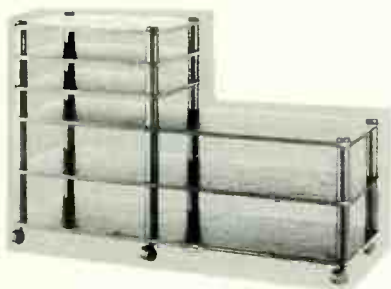

Beta



Modular



AER 3 (3 shelf) £154.00

AER 4 (4 shelf) £190.00

AER 5 (5 shelf) £205.00

B3 (3 shelf) £135.00

B4 (4 shelf) £159.00

B5 (5 shelf) £185.00

MB3/165 (3 shelf) £128.00

MB3/165+1 shelf £179.00

MB3/165+2shelves £220.00

All of the above are available in Matt Black, Piano White, red, Antique Gold and Antique silver

At no extra cost

All Target Racks are sent free of charge to mainland U.K.!!

Audio Alchemy

HPA v1.0 Headphone Amplifier

Since 1991, the name AudioAlchemy has been synonymous with outstanding performance and value in advanced digital and analog products such as the original Digital decoding Engine v1.0, DTI and Dac in the Box have established Audio alchemy as the leader in affordable high end audio.

The HPA v1.0 is set to follow on from the likes of the Dac-in-the-Box in it's success as one of those "Must not be without one" products! In the USA there is a product that you might be familiar with called the HEADROOM AMPLIFIER®. This headphone amp gives you the impression, like no other headphone amp, that the image of the music is outside your head and not just between your ears. Audio alchemy have used the same image processing circuit that is used in the headroom® amp, this is coupled with Audio Alchemy's knack of producing high-end products at realistic prices is a real winner!

Features Include

- >A precision, ganged, matched conductive plastic, Dale volume potentiometer for excellent tracking and long term reliability.
- >Sonically excellent, close tolerance parts in all critical stages. Such as 1% metal film resistors and polystyrene filter capacitors in both the amplifier and headroom® sections.
- >A "feed through" circuit that provides an identical copy of the input signal to the output jacks.

This is an amazing product at an amazing price! ONLY £249.99

Postage free anywhere in the UK!!

Other Agencies Include....

XLO, Target, Soundstyle, Beyer, Goldring, QED, Bib, Audioquest, Discwasher, Grado, Maxell, Ortofon, Shure, Sound Organisation, Stanton, Puresonic, Platform, Chord Co., Van Den Hul, Lyra, WBT, Audio Alchemy, Sennheiser, Kudos, Michell, AKG, Flatline, Ixos, Stax, Sumiko, MIT

And Many More!!

ALSO SEE OUR ADVERT ON PAGE 115

If you would like any of these products or would just like our latest price list, please feel free to drop us a line or give us a call!!!

1 Dunthorp Farm Cottages,
Heythrop, Chipping Norton,
Oxon.OX7 5TJ

How To Pay

By Post:- Please make cheques or Postal orders payable to:
AUDIO MASTERS.

By Phone:- We accept VISA, MASTERCARD and SWITCH
Phone or Fax:-

01608 644954

WORLD LIBRARY

THE LOUSPEAKER DESIGN COOKBOOK, 5th Edition,
by Vance Dickason.

£23.75

This best selling book in the field of loudspeakers offers good, up-to-date practical design information for the home constructor. Like today's manufacturers it uses modern Thiele Small theory and parameters.

BULLOCK ON BOXES,
by Robert M. Bullock

£12.95

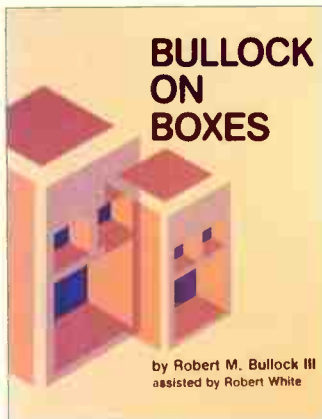

This book relies on manipulation of Thiele-Small parameters (supplied with all drive units) to optimise reflex box design, but with a calculator and at high school level. With lots of helpful tables and graphs, this straightforward book is every beginners best bet for getting to grips with sizing the box and port of a reflex loudspeaker.

ACOUSTICS,
by Leo L. Beranek

£39.95

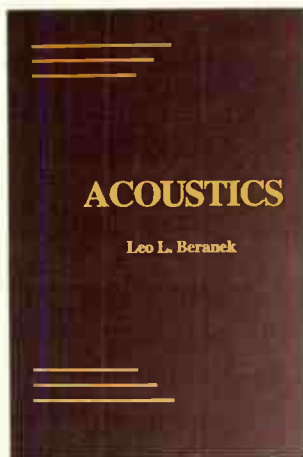

From analogous electrical circuits important for modelling, the author moves through to microphones then loudspeakers. He covers design factors, showing how theory influences practice in drive units. Loudspeaker enclosure types covered include sealed, ported and horn. The behaviour of sound in rooms, very important for hi-fi, is also covered extremely well here

QUICK & EASY TRANSMISSION LINE SPEAKER DESIGN,
by Larry D. Sharp.

£10.95

A practical approach to designing and building your own transmission line loudspeaker. Covers the background theory, but is very practical in approach. Design examples and equations, even a computer package to run under Lotus 123 which takes care of the maths.

THEORY AND DESIGN OF LOUSPEAKER ENCLOSURES,
by J. E. Benson.

£23.95

This book covers loudspeaker enclosure design; infinite baffle, reflex, passive radiator etc in great detail, with a highly mathematical approach, making it unsuitable for beginners, but highly authoritative to experienced designers with a good foundation in acoustics.

AUDIO ANTHOLOGIES

Audio Anthologies - When Audio Was Young

There are six volumes of the Audio Anthologies. Covering one of the most exciting and important eras of hi-fi, they contain many ground breaking circuits and theory covering all aspects of hi-fi design. A must for valve enthusiasts.

Volume One - May 1947 to December 1949

Summary of Contents: 9.5watt, 5watt and 6.5 watt 6AS7G amplifiers, 30watt 300B amplifier, valve FM tuning indicator, 30watt 211 power amplifier, cathode follower amplifier using 6V6, an adaptation of the Williamson amplifier, valve phono preamplifier, several horn and reflex loudspeaker designs and much more.

Volume Two - January 1950 to July 1952

Summary of Contents: Ultra linear 6L6 design and operation of the Williamson, a direct coupled amplifier, Williamson type amplifier using 6A5s, 40watt 845 push-pull amplifier, valve phono and line preamps, valves and loudspeaker damping, design and construction of reflex and horn loudspeakers.

Volume Three - August 1952 to June 1955

Summary of Contents: Simple valve phono stage, transformerless amplifier using 6082, 20watt 5881 amplifier, 10watt 6V6 amplifier, stereo valve preamp, high quality valve phono stage, a preamp for the Williamson, low distortion tone control preamp, binaural or stereophonic?, transistor phono amp, corner horn loudspeaker, concrete horn loudspeaker.

Volume Four - July 1955 to December 1957

Summary of Contents: 18watt 5881 amplifier, 4watt single-ended tweeter amplifier, budget 11 watt amplifier, versatile bass/treble control, transistor theory, transistor preamp, transistor techniques, battery powered transistor phono preamp, loudspeakers explained.

Volume Five - January 1958 to December 1959

Summary of Contents: Stereo valve multiplex decoder, 7watt EL84 amplifier, valve active crossover and 20watt treble amp/50watt bass amp., monaural, binaural, monophonic and stereophonic explained, heterodyne FM multiplex adapter, transistor preamp, 60watt EL34 amplifier, high power audio amplifiers, hi-fi loudspeaker enclosure.

Volume Six - January 1960 to December 1961

Summary of Contents: Transistor preamplifiers, feedback techniques, the coming of FM stereo, FM multiplex adapters, Tape recorders: distortion, frequency response and noise, 120watt 6550 amplifier, loudspeaker efficiency.

Price

£14.95 each

SOLID STATE ELECTRONICS

THE ART OF ELECTRONICS,
by P. Horowitz and W. Hill.

£35

The definitive electronics book. The Art of Electronics is an ideal book for the beginner through to the engineer. Written in easy to understand English, each chapter takes you from basic first principles through to full design exercises and practical circuits.

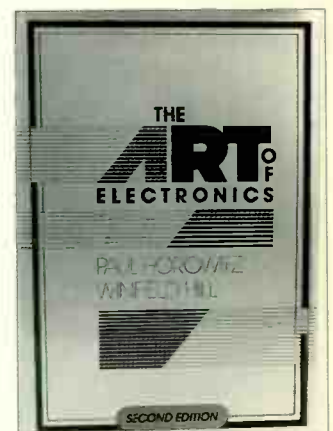

THE ART OF LINEAR ELECTRONICS,
by J. Linsley-Hood.

£16.95

Concentrates specifically on analogue electronics for audio and goes into detail on obscure topics like the drawbacks of feedback, as well as its advantages. Covers mainly solid state but also includes valves. A must for serious enthusiasts and budding designers.

RECORD REVIEWS i n d e x

rock & pop.....	82
Giovanni Dadomo	
Viv Craske	
jazz	85
Simon Hopkins	
Simon Cooke	
classical	93
Peter Herring	

Giovanni Dadomo



HOLY BARBARIANS HOLY BARBARIANS BEGGARS BANQUET

With the ashes of The Cult now consigned to the bargain bins of nostalgia and history, front-man Ian Astbury's gone right back to his roots to get his latest agglomeration off the ground. Born a Scouser of Yorkshire parentage, then spending his youth as far apart as Glasgow and Vancouver, Astbury has gone back to his Liverpool origins to record with his new band (the name doesn't need repeating yet, surely).

Perverse as That Name, the rest of the group are actually American in origin, starring a truly remarkable young guitar wizard from Los Angeles going by the name of Patrick Sugg. He may sound like a character from 'VIZ' comic (cue "Patrick Sugg - He Knows

Where To Put His Plug" jokes) but his fingers really do the biz on items like 'Cream', 'She' or 'You Are There'. Astbury's vocals are strong and clean, high in a mix that manages to let you hear the words whilst still allowing room for the aforementioned mad axeman, as well as the unsurprisingly solid rhythm work of brothers Scott and Matt Garret on drums and bass respectively.

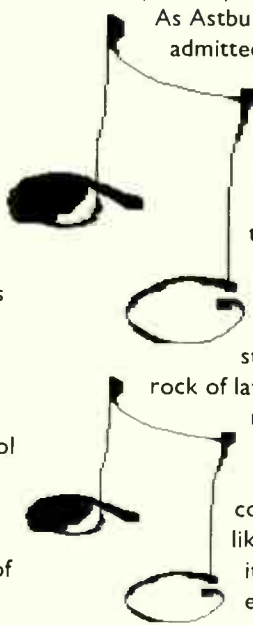

As Astbury himself has admitted, The Cult had got into something of a musical cul-de-sac, so it's a pleasant surprise to be able to report that Holy Barbarians (there, I've said it) are miles away from the more stadium-sized pomp rock of latter-day Cult. This may not be anywhere near as blatantly commercial as the likes of 'Electric', but it's a hell of a lot easier on the ear, as well as giving room to

a gentler, more melodic even romantic side of Ian Astbury, a man clearly still possessed of imagination and notable creative powers. Gold star stuff.

ROSA MOTA BIONIC 13 - CD3

Singer/guitarist Ian Bishop is one of the Smoke's most imaginative and surprising musicians, as this new album from his band Rosa Mota demonstrates again and again. Rock'n'roll may be the basic format, but the addition of strings on three songs (try 'Frostbitten' at your nearest Listening Post for a thrill) are remarkable, as is the welcome re-appearance of Clare Grogan, who duets with Ian on 'This Grudge'.

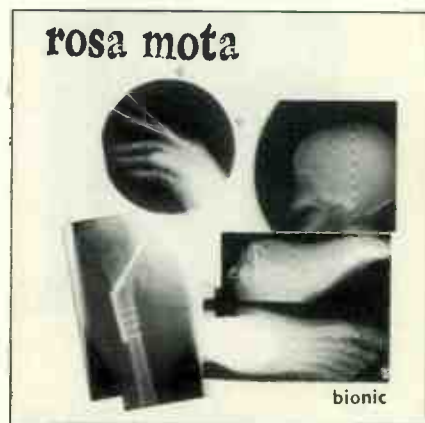

Titles such as 'From Her To Maternity' and the charming 'Sometimes Narcoleptic' are clues to a lyrical wit that matches the group's

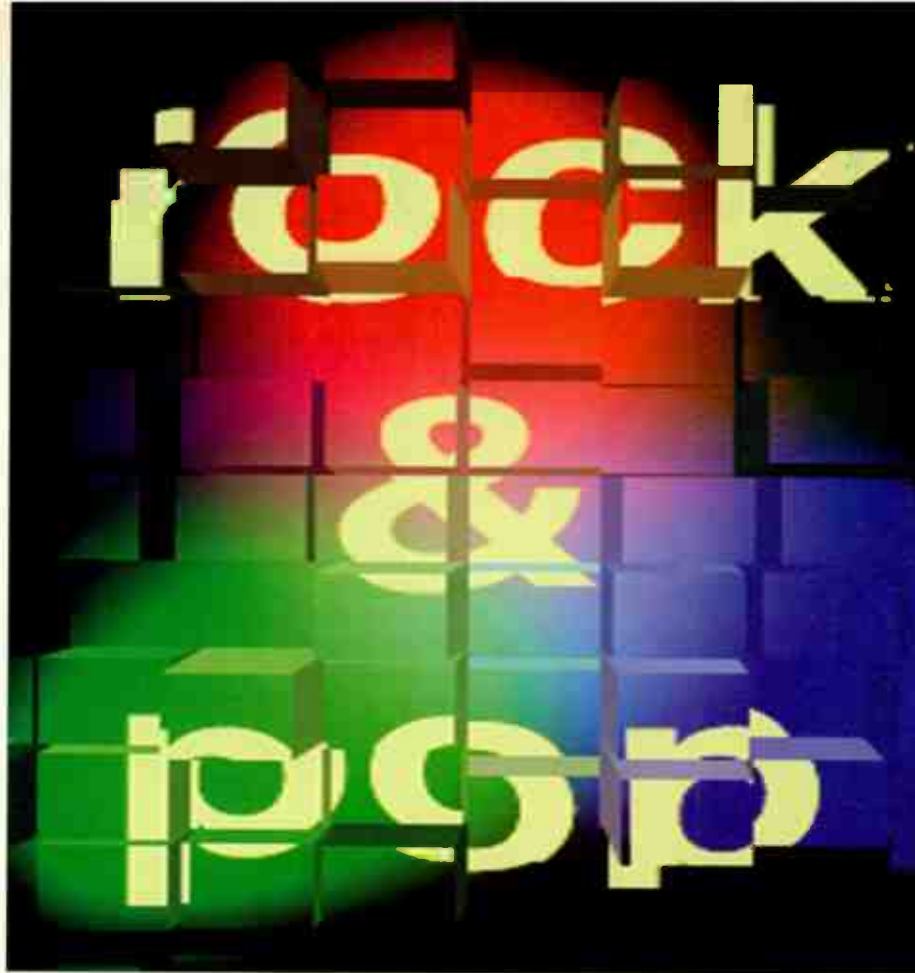

musical imaginativeness. And the mix and production, c/o the band and the truly legendary Steve Albini - a man who doesn't work with just anybody - are luminous and reflect much of the music's jagged harmonics with oodles of flair. True wizard stars, as Marc Bolan sort of said long time ago. (Somebody put something in my drink or what?).

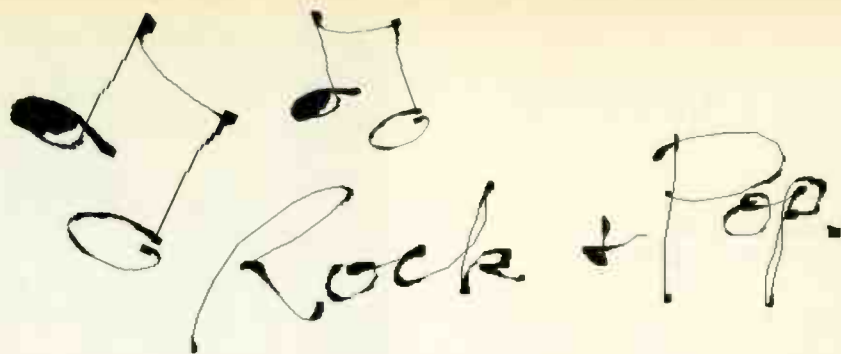

RECORD OF THE MONTH

STING

MERCURY FALLING

A&M 540 486-2

A funny thing happened the other day - I heard a Sting record and really liked it. "I really like that", I thought to myself, suddenly realising it was Sting's 'I Hung My Head'. This is not so odd as it seems. Like a lot of my chums I sort of lost interest in Sting after The Police split and he put on his 'serious jazzman' beret, much the same as we all got a tad bored after Paul Weller quit pretending to be Pete Townsend when he cut loose from The Jam and tried being Curtis Mayfield instead via his Style Council days.

Weller's return to form since his "... Wildwood" solo foray is generally agreed on, and if Sting's career may not have taken such extreme ups and downs ('Englishman In New York' for example, was and remains impeccable) as Weller's, he certainly hasn't stopped me in my tracks as he did in the good old days.

Happy to say therefore, that "Mercury Falling" finds the man back on his creative uppers. It's a disc full of colourful contrasts, exquisitely played and thought out, and positively bursting with a sensitive, ripe maturity - lyrically, musically and vocally. Sting's voice and bass are back in classic band format, joined by Dominic Miller on guitars, Kenny Kirkland's glowing and informed keyboard work, the whole lot underpinned by the sure but never pedantic drum-work of Vinnie Colaiuta (try saying that after a couple of Tequila Shlammers, hic! etcetera. . .)

So, and in the final analysis, we find that the former Gordon Sumner - late school teacher, even more-lately-turned-closet-academic-wot-reads-Arthur Koestler within the four small walls of his pop band's obligatory cramped Transit - is now one World Class exponent of Music For The

Masses - and so on and so on. . .

Anyway - and as already stated - the prime mover here is the Sting boy's unimpeachable intelligence, amplitude of wit and wisdom, which illuminate this latest recording. In short - how can one solitary mensch take such a mandatory Country theme as that of 'I Hung My Head' and create a Cracker of a Song whilst skipping all the inevitable, not to say blatantly corny, clichés of same? Yet Massa Sumner manages just that, not only here but many a time enough on



this 11-cut opus to make him sound fresh from the egg of creation, let alone an old war-horse who's been in the saddle for getting on twenty years. Perhaps most daring is 'La Belle Dame Sans Regrets' - a title most A-Level scholars would recognise as a word-play on a poem by none other than venerable British dope-fiend-cum-poete maudit St. Coleridge (see, Sting babes, deux can play at that game!). Whatever, Sting takes this jokelet, dresses it up with more than capably winsome French lyrics and pins the entire thing to an easily credible Bossa Nova/Samba back-up. If there's a question left to ask, it's how a person of genuinely Gaelic

extraction will react to an accent born Geordie and strained through primarily US musical mentors? Probably sounds quite sexy to the mademoiselles, I'd guess, speaking as one often charmed by the transcontinental manglings of the likes of Francoise Hardy, Jane Birkin or even the legendary Edith Piaf. . .

Kenny Kirkland's keyboards are a regular joy. Witness only his pepper-hot infusions alongside the justifiably legendary Memphis Horns, whose crisp but invariably note and taste-perfect fills liven up the better part of half the disc, from the blatantly Stax-Volt tribute of something like the funksome - and so aptly-titled - 'Let Your Soul Be Your Pilot', across to 'I Was Brought To My Senses', where a clean, all but skeletal intro leads to fulsome and rich arrangements that echo both Steely Dan at their best as well as Sting's more successful forays into jazz. And here, as elsewhere and almost needless to say, its horn-man extraordinaire adds oomph and subtle fills where and as required.

All just acclaim rendered to the diamonds and pearls contained herein - and as already, there is the inevitable odd clinker. 'Twenty Five To Midnight' is the sort of run-of-the-mill item Sting could do standing on his proverbial bonce, and so on. . . But that's still not to say any Joe Soap off the nearest bus-stop could do the same. This, it must be said, remains a special and particular talent, and therefore is inevitably bound to suffer more stringent, demanding responses than a green, straight off the farm, Stingy-come-lately. It's a tribute to the man's continuing energy and effervescence that, even by his own self-set high standards, 'Mercury Falling' shows no alarming loss of heat or power, more a frequently remarkable return to form.

Viv Craske

VARIOUS

Future Funk

A&M Records 540495-2

Hype. This is the word that first came to mind. A CD combining trip hop and drum'n'bass - the biggest dance buzz words of the last couple of years. Fluid was the second word, due to the likes of Bjork, Massive Attack, Chemical Brothers and Goldie adding chart success to a compilation of slow-tempo electronic funk.

The woodwind beginning of Bork's 'Isobel' quickly adapts to a lilting ballad encompassing heartbreak and hope, wistful lyrics and yearning violins.



While Massive Attack's 'Karmacoma' contains a drum rhythm that smacks of urban wastelands, and some of the most emotive and succinct words that have been put to music. These acts who have had mainstream success give an audience to the underground gems on Future Funk. D*Note's 'The Garden Of Earthly Delights' explains itself in the title, and Rob D's 'Clubbed To Death' alternates a moving string arrangement with chunky bass, to a crescendo.

Creativity in music is one thing that the British have always showcased and a large slice has been harnessed for the 26 tracks on Future Funk. An album of dance-based tracks to wind down to, with soul, jazz and funk to casually waft over the listener. It's hard to find one sub-standard track on this two CD set. Believe the hype - if you buy one compilation this month, make it this one.



MOLOKO

Do you like my tight sweater?

ECHCD7

Imagine - an upbeat, off beat Portishead bass line and on top, every conceivable musical influence of the last two decades. Moloko consists of alternating layers of funk, jungle, soul, dub and even a helping of eighties synthesiser pop all scrambling for attention at once. And holding it all together - the compressed melodic whine of Moloko vocals for which the best description could perhaps be found in their own kooky lyrics; "I always try to impress, I put my tongue in the trouser press".

This is a refreshing CD. It washes over your ears with a stream of rhythms and sounds, rarely waiting between songs before suddenly shifting from one style to another. The tracks themselves range from the thumping dark chants of 'Killa Bunnies' to the wheezy electronic 'Party Weirdo' which sounds like a bizarre cross between Kraftwerk and Michael Jackson in his disco phase. The variety extends to the more accessible 'Dominoid', the single of the album (if there is one) where deep and funky foundations hide beneath a powerful soulfulness always peppered with acidic sci-fi sounds which bounce from speaker to speaker, before fading back into the melting pot.

It may take a while, but this quite surreal musical style will grow to be very popular - don't fight the confusion.

TINA TURNER

Wildest Dreams

CDEST 2279

She's a legend. She's highly respected in the industry. She sings from the heart with every performance. Wildest dreams proves all of this by the name checks on the sleeve alone. There's U2's James Bond smash single 'Goldeneye' and 'On Silent Winds' has cameo vocals

by Sting. There's also a low-tempo number 'Confidential' written by the Pet Shop Boys and a cover of Massive Attack's 'Unfinished Symphony'. However, these songs are still noticeably the writers' own, Tina lending little of her own style to them.

Despite this, Tina shines through elsewhere on the album. 'Missing you' is Tina at her best, adding raunchiness to a ballad that came to public attention in the late '80s in an aftershave commercial. Other tracks, such as 'All kinds of People' offer simple chord changes and strong guitar hooks to draw the listener into the deeply emotional vocals, while 'Thief Of Hearts' is a classic disco anthem.



Now in the fifth decade of her recording career, Tina's passion for music comes through strong on this CD. The last proper studio album was released seven years ago and the passage of time is evident in the musical style of her latest release. This time around the music has mellowed and almost over-exudes an air of confidence. However, this also means that the vocal ferocity has lessened. The songs are not as instant as on her last album, Foreign Affair, but this a musical trade-off as Wildest Dreams is much more soulful. Whatever the changes in her personal life and on record, Tina's intuitive vocal style delivers the feel good factor as strong as ever.



Jazz

Simon Hopkins

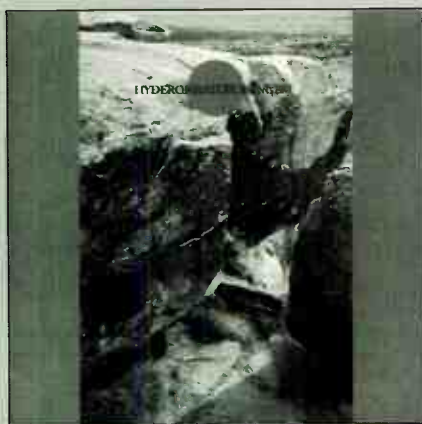

RUINS

Hyderomastgroningem TZADIK TZ7202

Released as part of Tzadik's New Japan series this album adds to the already substantial body of work by the rather incredible Japanese duo of bassist/singer Masuda Ryuichi and drummer/singer Yoshida Tatsuya, AKA Ruins. This series is home to recent releases from, among others, the extraordinary percussionist Ikuo Mori, outrockers Ground Zero and guitarist Keiji Haino (of whom more later).

Ruins were responsible for one of last year's most outstanding jazz records, *Saisoro*. Their collaboration, as Derek and the Ruins, with British improv. guitarist Derek Bailey, is just one of a bunch of recent releases which have seen the godfather of the British improv. scene on blazing form.

Hyderomastroningem, recorded at the end of '93, actually predates *Saisoro*

and is a very different record indeed. Like those European Goth-prog masters Magma, Ruins use their own made-up language to create a unique world. Into this they bring the most insane, virtuosic and breathtakingly audacious music.

Like other Japanese musicians, Ruins seem to have avoided the prog. vs punk wars which still plague - and help to neuter - so much British and American rock music. Instead, Ruins are happy to marry spellbinding musicianship, a love of complexity and an improvisatory openness to a certain punkish aggression and disregard for musical conformity.

The results, recalling at times King Crimson or - that name again - Magma, at others more contemporary genre-benders Naked City, or (another astonishing Japanese group) Boredoms - see the group jump-cut effortlessly from pounding, lop-sided odd-metre rhythms to wiggled-out psychedelic solos to bizarre ambient atmospheres to bouts of general vocal self-abuse.

Gripping stuff; certainly essential for all you unreconstituted prog-rock fans.

KEIJI HAINO

Saying I love you, I continue to curse myself BLAST FIRST BFFP109

While one might readily judge him to be part of the same scene - er, the extreme Jap New Music Scene (anybody?) - guitarist, singer, composer and sometime hurdy gurdy player Keiji Haino couldn't be more



different to the Ruins. Where their music delights in the rapid-fire and the quick change, and exhibits itself as a series of brief glimpses, Haino's prolific output, both as a solo artist and as leader of the truly magnificent rock-improv. quartet Fushitsusha and darkly ambient sound manipulators Nijiumu, generally reveals itself as long (indeed, giant) pieces, which are at once personal and blazingly declaratory.

Saying I Love You - a solo album - is Keiji at his most expansive, and at his most extreme. Just two tracks make up this album, with the opener really

setting the tone: a forty-five minute guitar solo, magnificent to the dying notes. Even as a self-confessed guitar junkie, I can think of few guitarists to whom I'd ever listen perform at that kind of self-indulgent length; Haino is a rare exception, but then his performance is beyond comparisons and categories.

This track is forty-five minutes of full-on feedback and distortion-drenched aural assault. Free of all clichés of jazz or rock guitar, this is the guitar solo as an act of public self-destruction, an endless exploration of the limits of sound.

The album's closing piece is altogether less expansive - though still fifteen or more minutes long - and entirely quieter, featuring an un-named, gorgeous string instrument and Haino's unearthly falsetto voice. Still stern and contemplative, this music is essential after the apocalypse that precedes it. A superb album.



We've a great deal in store...

AE, Atacama, Audio Innovations, Audiolab, B&W, Cable Talk, Cyrus, Harman-Kardon, JBL, KEF, Kenwood, Marantz, Michell, Mission, Monitor Audio, Mordaunt-Short, Musical-Fidelity, Pickering, Pink Triangle, Pioneer, Quad, REL, Rogers, Ruark, SME, Systemdek, Tannoy, TDL, Thorens, Tube Technology, Yamaha & lots more...



- Widest choice in the area
- Independent advice
- Qualified staff
- Comfortable dem rooms
- Superb showrooms
- Main road location
- Major car parks nearby
- Insurance estimates
- Over 30yrs experience.
- Service Dept
- Delivery & installation
- Part Exchange
- Interest Free Credit
- Up to 2yrs ask for details
- Visa/Access/Switch etc.
- Open 10.30 - 5.30 6 days

Best place in town for Hi-Fi and Home Cinema...



**24 Gillygate, York
Tel. 01904 629659**

High Fidelity Specialists est. 1967

X Dem. Sale...

Audiolab 8000A	£395
8000T	£650
8000CDM	£995
8000DAC	£650
8000M	£1195
Micromega Stage 1	£465
Ruark Crusader bk.	£1195
Templar r/wood	£425
Michell Alecto M.blox	£1550
Argo pre.+Hera	£685
KEF Q30	£295
Spendor SP3/1 L/cherry	£645
TDL RTL3 bk.	£335
Tube Technology...	
Genesis +Prophet	£2650
AE Aegis One	£350
Aegis Two	£650
Musical Fidelity E100	£495
Quad 66 inc remote	£695
34 pre amp	£325
77 Amp	£525
Pink Triangle PTA ash	£1350
Dacapo	£1250
Harman HD7725 CD	£650
REL Stadium r/w	£875
Systemdek...	
2X-900 inc. arm & PU	£295
Yamaha DSP-A2070	£895
DSP-E580	£385
Mission 753 r/wood	£650
752 bk.	£395
751 r/w	£265
776777 pre-power s/h	£950
Audio Innovations L1	£275
Series 1000 monoblox	£1250
2nd Audio s/h	£1250
Series 200 amp	£395
Monitor Audio 700 r/w s/h	£350
Studio 20SE r/wood	£1950
Naim Nait 2 s/h	£250
Pioneer VSA701 pro-logic	£425
CLD1950 laserdisc	£495
KEF Centre 90	£200
Marantz CD63SE	£295

HIGH END Export discount
50% or more

SALE

Only few units left!
Some prices negotiable

AUDIO RESEARCH

DAC1 D/A converter - LS1, SP15 preamplifiers - D250 MKIIS, M300 MKII, Classic150 power amplifiers

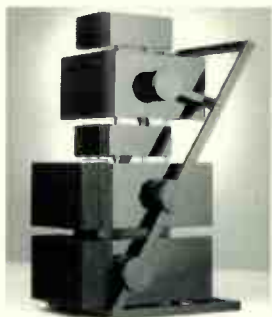

WELL TEMPERED

Record Player, Classic, Signature

export price from
£590



GOLDMUND

Studietto turntable - T5 tonearm - Mimesis 8 power amplifier - Apologue speakers

Also: Berning TF-10 preamplifier, Breuer tonearm, Cotter ultra-/subsonic filter, Eureka 1 and 2 step-up devices, MarkLevinson MLC-1 cartridge, Moersch tonearms

Call for catalogue!

Glotta AB, phone +46 8345251, fax +46 8346533

DO YOU USE AN OUTBOARD DAC?

If so, this could be the most cost-effective upgrade you'll ever make...

D·A·R·T

Digital Audio Real Time interconnect -

£49.95 direct from SDAV.

(See review by Jimmy Hughes, Hi-Fi Choice, September '95)

- Improved focus
- Improved inner detail
- Sweeter, more extended treble
- Cleaner midrange and bass
- Greater transparency
- Improved transient response

And that's guaranteed! If you are not satisfied with the results after 14 days home trial, we'll give you your money back - simple.

*Phone SDAV on 0181-399 6308 to place your order.

HiFi Cabinets?

Jan's SUPERB hand made units are the bees knees -

OAK ASH MAHOGANY
TEAK WALNUT ROSEWOOD

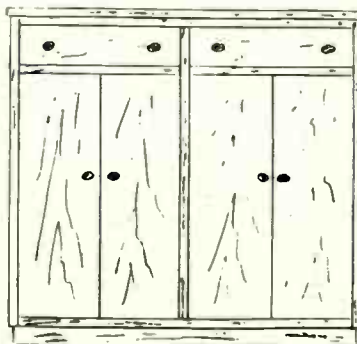

Also CD Storage

IAN EDWARDS
THE OLD CHAPEL
282 SKIPTON ROAD
HARROGATE HG1 3HB
PHONE: (01423) 500442



Simon Cooke

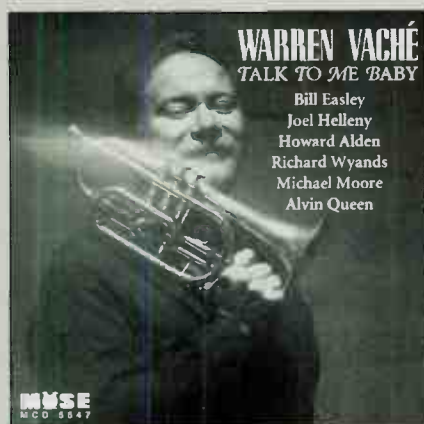

WARREN VACHE
Talk to me baby
MCD 5547

Well, it says in the notes that this is probably Vache's best recording to date; I'm not going to argue, not having enough experience of his oeuvre, but it's certainly impressive.

Trumpet-man Vache fronts an expert line-up; Bill Easley on sax, Joel Halleny's trombone, Howard Alden (a name which will certainly be familiar to Ruby Braff fans) on guitar, Richard Wyands on piano with Michael Moore on bass and Alvin Queen on drums completing - and complementing the support.

Vache's style obviously encompasses influences from a huge range of past trumpeters and cornet players. So many, in fact, that I found myself listening to this CD with a growing sense of uneasy *deja vu* ("now where have I heard that riff before. . .?")

accompanied by a sense of that mild ennui which I often find with - for instance - well-played trad jazz a la Humphrey Littleton or Kenny Ball. It's nothing to do with the technique, which is excellent, but more to do with the fact that such a level of expertise is being applied to tunes which the players have all heard and played too often before and so are no longer stretched by them.

Maybe Vache feels this too, as he sings rather than plays on two tracks, and at the very least that shows a willingness to expand his (and our) horizons musically.

There are eleven tracks on this CD, kicking off with Vache's own 'On Y Va' and running through ten standards like Gordon/Warren's 'You'll never know', Burke/Van Heusen's 'Polka dots and moonbeams' Kern/Fields' 'Pick yourself up' and Flip Phillips' 'The Claw'. All good mainstream stuff, well played and superbly recorded, if just failing to pin the players on the sound stage quite as precisely as I'd like. A good one, though.

ANNIE ROSS
Music is forever
DRG 91446

Here's one for the movie buffs out there; Annie Ross cropped up on screen in Robert Altman's 'The Player' and 'Short Cuts'. She's better known as a jazz singer; you can find out why with this album, although the theatrical aspect is clearly recognisable in her



delivery of some of these thirteen songs.

There's some real old chestnuts in here; Jones/Kahn's 'It had to be you' and Singer/Zaret's 'One Meat Ball', but all the tracks are handled brilliantly by Ross and her cohorts, from the Cleo Laine scat opening of Warren/Freeds' 'Coffee Time' to the seductively druggy atmosphere of Johnston/Coslow's 'Marajuana': It's good enough to be banned by those who think *Trainspotting* is a pro-drugs movie.

The band is excellent; Mike Renzi and Tommy Flanagan tickle the ivories while Peter Washington and Jay Leonhart provide bass. Frank Wess plays sax and flute, Al Grey trombone, Louis Hayes drums, and Joe Beck completes the line-up with just the right, light, touch on guitar.

It's an excellent recording, but can make Ross sound slightly under-powered and unsure occasionally. Maybe she was just having an off-day at the recording session or it could be the mix: I can't say. What I can say is that this release knocks the spots off most younger female vocalists. What else do you need to know?



SYSTEM LOUDSPEAKERS

MUSICMAKING BY
SYSTEMDEK

SYSTEMDEK LTD 34 KYLE ROAD IRVINE SCOTLAND KA12 8LD TEL:(01294) 271251 FAX:(01294) 277095

Klipsch[®]

HORN LOUDSPEAKERS

IMMORTAL SOUND FORESIGHT

Hear KLIPSCH for yourself in: Avon 01934 520248/01272 686005. Bucks 01296 28790. Cheshire 01925 828900. Cornwall 01209 612260. Hants 01730 895194. Herts 01923 856497. Kent 01303 256860. London (W1) 0171 486 8262. (NW3) 0171 431 7423. (NW6) 0171 794 7848. Middx 0181 892 7613. N. Ireland 01232 403634. Northants 01604 37871. Notts/Lincs 01777 870372. Oxon 01865 247783. Scotland 01381 620655. Suffolk 01284 724337. Sussex 01903 872288. Wales 01978 364500/01745 343060. W. Mids 0121 429 2811/455 01667/742 01254/354 2311, 01203 525200. Worcs 01384 444184. Yorks 01302 781387. UK Distributor 0121 430 7817

RINGMAT

FOR RECORD LOVERS

First record support to be properly designed

RINGMAT is the leading support for a record on a turntable platter and has been acclaimed around the world for its outstanding performance and cost-effectiveness.

NEW XLR VERSION OF 330 MkII AVAILABLE FROM APRIL 1996

Tracking even more secure. Sound is fuller and more natural. Greater power and expressiveness. Bass line goes much deeper.

PRICE:
RINGMAT 330 MkII XLR £47.50

RINGMATS can be obtained through good hi-fi retailers. There is an exchange scheme for earlier RINGMATS. For more information on this or on RINGMAT generally, or for mail order (including VISA/MasterCard), contact:

RINGMAT DEVELOPMENTS
PO BOX 200 BRENTWOOD ESSEX CM15 8QG
UNITED KINGDOM

Tel: 01277 200 210 Fax: 01277 201 225
(Mail order p&p: additional £2.50 UK; £5.50 outside UK)

Loricraft Audio

Specialists in Garrard, Thorens and SME.

PSU II Power Supply

Now in its second year of production PSU II mkII is a power supply that mimics a perfect mains supply, allowing Garrard 301/401 TD124 to be used anywhere in the world, and was developed as a result of our more technically minded customers requiring a more advanced PSU over our successful active PSU I. Whilst PSU I cleans and reshapes the incoming wave from PSU II generates a low distortion wave from which is both voltage and frequency stable. PSU II can also be used with CD players pre amps and tuners. PSU I £149.00 PSU II £400.00

Supply and service of Garrard, Thorens, and other high quality turntables using genuine and newly manufactured part to original specifications.

Also manufacturers of the world finest Plinth for Garrard 301/401 Thorens TD124 now with 5mm covers and finest hinges if required.

Loricraft PRC I Record Cleaning machine as used by the professionals. Please send for details.

Loricraft Garrard 401s with SME arms and record cleaning machines are in use with recording studios and record dealers.

T.M. O'Sullivan

4 Big Lane, Goose Green Lambourn,
Berks RG16 7XQ

• New 1996 catalogue available •

Fax /
Ansaphone: **01488 72267**

Suppliers of Art Audio Amplifiers, Goldring, Ortofon, & SME

AVON

AUDIO EXCELLENCE, 45 Park Street, Bristol BS1 5PB. Tel: 0117 264975 Fax: 01179 251327. All that's best in Hi-Fi carefully selected and demonstrated by friendly knowledgeable staff, at prices to suit all budgets. Delivery and installation, home dems, part exchange, in-house workshops, full credit facilities with interest free on selected items. Tuesday - Saturday 9.00 - 5.30. Closed monthly.

THE RIGHT NOTE, Tel: 01225 874728. Major new brands join our select group of products from reliable, high quality suppliers with international reputations who are dedicated to sound and build quality. We have many customers thrilled that they've covered these superb products rather than the 'magazines' favourites. Bring your own ears in your home where you can best judge the benefits. We aim for long-term satisfaction, not just a quick sale. Ask about our ex-dem and mint used items. Brands: Lumley (valve amps and pre-amps), HESTEK, Copland, Audio Synthesis (D&Z, Micell, Orle), Enlightened Audio Design, Sona, Tube Technology, CAT, Chameleon, Magnum Dynalab, Graham, Stratoplayer, March, Transfiguration, Spindler, Kewick, Mirage, Harbeth, NEAT, Sequence, Air Fods, Cable Silver Sounds, Sagan Hall, DNM, Similia.

BEDFORDSHIRE

RICHARD'S AUDIO VISUAL, 4 Greyfriars Bedford. Tel: 01234 365145. Stockists of: Arcam, Audio Innovations, Audioquest, Aura, Beyer, B&W, Bose, Celestion, Cyrus Denon, Haystack, Marantz, Mission, Moph, Musical Fidelity, Nakamichi, Ortofon, Pioneer, Pro-Ject, Rotel, Royd, Ruark, Sennheiser, Systemdek, Target, Thorens, Van den Hul & more. Experts friendly service: Listening room, Pioneer Reference Point, Visa / Access.

SEVENOAKS HI-FI, 29-31 St Peters Street, Bedford. (01234) 272779. The UK's leading independent Hi-Fi and home cinema retailer, specialising in quality products for discerning customers. Open six days, with dedicated single speaker and audio visual demonstration rooms. Major credit cards accepted, 0% finance available (details upon request), home trial and installation by arrangement. Major brands stocked include Arcam, Audiolab, Castle, Denon, KEF, Marantz, Meridian, Micromega, Mission, Monitor Audio, Quad, Rotel, Ruark and Yamaha.

BERKSHIRE

AUDIO ILLUSION, 33 Langley Broom, Langley, SL3 8NR. Tel: 0783 542761. FAX: 01753 72533. Distributors and Consultants for the World's Finest Audio Equipment:-

Clarke Audio - Solid State excellence in amplification design and now their new breakthrough digital component.
Enlightened Audio Design - Hi-End Digital featuring HDLDTM, Digital Filters and Dolby AC3TM. Core - Triode Valve Amplification - Integrated Amps from £1795. Mirage - The Original Bipolar LoudspeakersTM - Full range of Loudspeakers and Subwoofers from £185.

BUCKS

NORTHWOOD AUDIO II, 98 Cambridge St, Aylesbury, Bucks HP8 4BA. Tel: 01295 28790 (FAX) 01295 28791. Specialised sounds from Alchemists, Arcam, Audio Media, Aurs, Boston, B & W, Caberalk, Castle, Celestion, Denon, DPA, Epcor, Epsom, Gyratex, Harmon Kardon, Heybrook, Kef, Marantz, Micromega, Monitor Audio, Moph, Musical Technology, NAD, Nakamichi, Pioneer, Pro-Ject, Rotel, Royd, Ruark, Systemdek, Tannoy, Thorens, TDL, Tube Technology and a range of quality pre-used equipment. Expert advisers welcome. 2 Dem rooms. Credit facilities available.

CAMBRIDGESHIRE

THE HI-FI COMPANY, SOUND & VISION STUDIO, 11 CLOUATE, Peterborough, PE1 1NA. Tel: 01733 341735. Fax: 01733 311587. The

region's largest range of new and used hi-fi and audio equipment. Dedicated hi-fi and AV demonstration rooms including laserdisc and projection TV. Audio: Arcam, Denon, JVC, KEF, Kenwood, Marantz, Meridian, Mission, Mitsubishi, NAD, Pioneer, Quad, REL, Rotel, Rotel, NAD, Yamaha - and more. Part exchange especially welcome. Interest free. Open Tues-Sat 10am-5.50pm

UNIVERSITY AUDIO, 1-2 Pels Hill, Cambridge. 01223 354237. Mission-Cyrus, Arcam, Rotel, Denon, Meridian, Ruark, ATC, AVI, Quad, Linn, 2 dems, 1 single speaker. Home trial, free install, Service Dept. VISA, ACCESS, AMEX, Credit Terms. Open 9-5.30

CHESHIRE

SWIFT HI-FI, St. Annes Parade, Almsford. 01625 526213. Aura, B&W, Denon, Kenwood, Marantz, NAD, Pioneer, Rotel, Systemdek, Tannoy, Revolver, J.P.M., M. Short, Mission, Celestion, Technics, Audiolab, Castle. Open 9.30-6. Dem room. No pressure. BADA member.

ASTON AUDIO, 4 West Street, Alderley Edge, Cheshire. Tel: 01625 582704. Products include: Bang & Olufsen, Arcam, Audiolab, B&W, Cyrus, Denon, Epos, Meridian, Micromega, MF Mission, Nakamichi, Quad, Rotel, TDL & other leading brands. Demonstration Rooms, Installation Service, Interest Free Credit, Access, Visa. Open Mon-Sat

CHRIS BROOKS AUDIO, 29 Gaskell Street, Stratford Heath, Warrington, Cheshire, WA4 2UN. Tel: (01925) 261212. Tues-Sat 10.00-6.00. 2 dem-rooms, credit facilities. All credit cards. Established 1978. Total absence of bull****. Linn Specialist.

THE AUDIO COUNSEL, 14 Stockport Road, Cheshire, Cheshire. Tel: (0161) 428 7887 and 12 Shaw Road, Uxham, Manchester O11 3LQ Tel: (0161) 633 2602. Linn, Arcam, Naim, Audio Research, Martin Logan, Yamaha, Creek, Nakamichi, Denon, JFW, Marantz, Royd, Linncon. 3 dem rooms, free install, VISA/ACCESS full multi-room and AV. Installation 10.00 - 5.30pm Mon-Sat, till 8.00 Thursdays.

PRACTICAL HI-FI, 45 Bridge Street, Warrington, WA1 2EF. Tel: 0925 832779. See our main entry under Preston, Lancs.

AUDIO EXCELLENCE, 26, 30 Boughton, Chester, CH3 8AD. Tel: 01244 345576. All that's best in hi-fi carefully selected and demonstrated by friendly knowledgeable staff, at prices to suit all budgets. Delivery and installation, home dems, part exchange, in house workshops, full credit facilities with interest free on selected items. Tuesday - Saturday 9.00 - 5.30. Closed Monthly.

ACOUSTICA, 17 Hockley, Chester CH2 3JH. Tel: 01244 344227. All that's best in Hi-Fi from Linn, Rega, Naim, Arcam, Audiolab, Ruark, Rotel and many more. Multi room systems from Linn Knekt. Superb demonstration facilities, home demonstrations and installation a pleasure. We offer the best products, the best service and the best sounds. Open Tuesday to Saturday, evenings by appointment.

CLEVELAND

ACTION ACOUSTICS, 55-57 High St, Redcar, Cleveland TS11 3AN. 01642 480723. Audio Innovations, Audio Note, Denon, Harman Kardon, JBL, Michel, Musical Fidelity, Pini Tripp, Rogers, Sugden, Sennheiser, Tannoy, TDL, Thorens etc. Dem room appointment nec. Home Trial, Free installation, service dept. 0% free credit facility. Access, Visa & HP. Open 9.15-5.30

CORNWALL

RJF AUDIO VISUAL, 54 Penarves Street, Tucking Mill, Camborne, Cornwall, TR14 8NJ. 01209 707711/01282 Alchemists, Analogue, Atollama, Audiovision, Audioquest, Beyer, Cable Tail, Chord, Denon, Harmon, Harrold, Impulse, JBL, JFW, Klipsch, McIntosh, Micromega, Naim, Ortofon, Ortofon, Parsolini, Pro-Ject, REL, Rotel,

S.D. Acoustics, SME, Sugden, Target, TDL, Teac, Triangle, Trichord, XLO, Musical Technology. Integral dem/showroom and special home dems. Appts nec, home trial, free install, service dept. All cards Switch and Transax. Open Mon-Sat 9.30-5.30.

CUMBRIA

MISON6 SOUND & VISION, Viaduct House, Victoria Viaduct, Carlisle, CA3 8AN. Tel: (01228) 22620. Aura, Bang & Olufson, B & W, Castle, NAD, Quad, Rotel, Sony, Sugden, Yamaha, Demo Suite. No appts nec. Home trial facilities. Free installation. Service Department Mon - Sat. 9 - 5.30

PETER TYSON, 6 Abbey Street, Carlisle, Cumbria, CA3 8TX. Cumbria's premiere Hi-Fi centre. Part exchange welcome. (01228) 46756. Linn, Musical Fidelity, Cyrus, Marantz, Denon, Philips, Nakamichi, Technics, Pioneer, Creek and more. Dem Rooms. Demos without obligation. Home trial. Free installation. In-house service dept. Access, Visa, HP. 9-5.30pm

PRACTICAL HI-FI, 106 English Street, Carlisle, CA3 8ND Tel: 01228 44792. See our main entry under Lancaster.

DEVON

THE HI-FI ATTIC, 58 New George St., Plymouth, Devon. PL1 1RR. 01752 669511. We stock most leading brands including Linn, Arcam, Denon, Pioneer, Musical Fidelity amongst others, and have an expert enthusiastic staff. Premises include attractive hi-fi and home cinema demonstration rooms. We offer free installation and credit facilities (written details on request) also a fully equipped service department. We can also provide a mail order service for all your LaserDisc requirements. We accept Visa, Access, Amex.

UPTON ELECTRONICS, 31 Torquay Road, Paignton, Devon TQ3 3DT Tel: 01803 551229. Pioneer Reference Point Dealer. Sony, Technics, Harmon-Kardon, Ortofon, Kinsnow, Creek, Quad, NAD, Target, Alphason, Tannoy, Merduant-Short, Castle, TDL, JFW, Royd, Sequence, Linn, Monitor-Audio, Micromega, Project, Chord, Van Den Hul, Jumo. Full range of accessories etc. Demonstration room, home dems, Free delivery and installation. PX available. Own in-house service dept, Compact Discs, Access, Visa, Amex. Credit facilities. 9.00-5.30 9.10-1.00 Wed.

ESSEX

Audio T, 442-444 Cranbrook Road, Grants Hill, Harlow. (0181) 584-0395. Great Value on Aiva, Arcam, Audiolab, Cyrus, Denon, Kenwood, Linn, Marantz, Mission, Micromega, NAD, Ortofon, Rotel, Sony, Technics, Yamaha & more. Tues/Thurs/Fri 10-7 Wed/Sat 9.30-5.30. 3 year Hi-Fi guarantee. 30 day free upgrades. PX. Selected Interest Free Credit. Listening room. BADA Bonded.

SEVENOAKS HI-FI The Grove Centre, Witham, Essex, Tel: 01376 501733. The UK's leading independent Hi-Fi and home cinema retailer, specialising in quality products for discerning customers. Open six days, with dedicated single speaker and audio visual demonstration rooms. Major credit cards accepted, 0% finance available (details upon request), home trial and installation by arrangement. Major brands stocked include Arcam, Audiolab, Castle, Denon, KEF, Marantz, Michel, Micromega, Mission, Monitor Audio, Quad, Rotel, Ruark and Yamaha.

GLOUCESTERSHIRE

AUDIO T, 45-42 Albor Street, Cheltenham. (01242) 583060. Great Hi-Fi on Aiva, Arcam, Audiolab, Denon, Linn, Marantz, Meridian, Micromega, Mission, NAD, Nakamichi, Pioneer, Quad, Rotel, Sony, Technics, Yamaha & many more. Tues-Fri 9.30-6. Sat 9.30-5.30. 3 year Hi-Fi guarantee. 30 day free upgrades. Home demonstrations. Part exchange. Selected interest Free Credit. Listening room. BADA Bonded.

AUDIO EXCELLENCE, 58 Bristol Road, Gloucester, GL1 5SD. Tel: 01452 300046 Fax: 0452 310680. All that's best in hi-fi carefully selected and demonstrated by friendly knowledgeable staff, at prices to suit all budgets. Delivery and installation, home dems, part exchange, in house workshops, full credit facilities with interest free on selected items. Tuesday - Saturday 9.00 - 5.30. Closed Monday.

SEVENOAKS HI-FI 24 Pittville Street, Cheltenham, Gloucs. Tel: (01242) 241171. The UK's leading independent Hi-Fi and home cinema retailer, specialising in quality products for discerning customers. Open six days, with dedicated single speaker and audio visual demonstration rooms. Major credit cards accepted, 0% finance available (details upon request), home trial and installation by arrangement. Major brands stocked include Arcam, Audiolab, Castle, Cyrus, Denon, Epos, KEF, Marantz, Meridian, Micromega, Mission, Monitor Audio, Quad, Rotel, Ruark and Yamaha.

THE RIGHT NOTE - Bath for specialist advice and home demonstrations. See Avon.

HAMPSHIRE

AUDIO T, 4 Feathers Lane, Basingstoke. (01256) 24311. Great Value on Aiva, Arcam, Audiolab, Cyrus, Denon, Linn, Marantz, Micromega, Mission, Naim, Nakamichi, Sony, Technics, Yamaha & many more. Tues-Sat 9-5.30. 3 year Hi-Fi guarantee. Free delivery & installation. 30 day free upgrades. Home demonstrations. PX. Selected Interest Free Credit. Listening room. BADA Bonded.

HAMPSHIRE AUDIO LIMITED, 2-12 Hursley Road, Chancelors Ford, Hants, G053 2FU. Tel: Southampton (01703) 252827/265232. 3 Hi-Fi and 2 Home Cinema/Dolby Surround Sound Demonstration Rooms, one with Projection TV and an 8' wide screen. Brands stocked include ARCAM (incl Xeta), Audiolab, Audioquest, Celestion, Cyrus, Denon, Gradient, Infinity, KEF, Marantz, Meridian, Mission, Poik, Quad, Rotel, Selec, Sennheiser, Soundstyle, Tannoy, Target Audio, Thorens, & Yamaha. Established 1969, we offer a 2-year Guarantee covered by our own well-equipped Service Dept. We have a large FREE car parking facility and we are located within 3 miles from Junction 14 (M3/M27 Interchange) and Junctions 13 (M3) and 5 (M27), closed Mondays, except in December. Late Night: Thurs to 8pm. BADA Founder Member. All deposits fully covered by BADA Bonding.

HERTFORDSHIRE

DYNAMICS, Welwyn, Herts - Europe's largest stockist of ex-dem and second hand equipment. High End Audio - Bought, Sold or Exchanged. Many items in stock. (see our main ad pg. 128). Efficient servicing Dept. All items guaranteed. All major credit cards accepted. Please telephone 01438 - 714038 for appointment.

STUDIO 82, 82 High Street, Harpenden, Herts AL5 2SP. Tel: 0462 704246. Fax: 0462 467022. ATC, AVI, Arcam, Aurs, Audiolab, B&W, Denon, Epos, Marantz, Mission, Naim Audio, Nakamichi, Quad, NAD etc. Quiet single speaker dem room. Appts nec. Home trial, free installation. Service dept. Visa, Access and finance terms. 9-5.30 Mon-Sat.

RADLET AUDIO, 9 Holywell Hill, St. Albans, Herts, AL1 1EU. Tel: 01727 855577. Mark Levinson, Proceed, Proac, Tube Technology, Teac, Audiolab, Stax, ATC, Audio Alchemy, EAR, Sumiko, Quad, JBL, Denon, Creek, Michell, Micromega, XLO, Alchemist, B&W, Ruark, LFD and many others. Home trial facilities, free installation, Service Dept., Visa/Access, Open 9.30 - 5.30 Mon - Sat.

SEVENOAKS HI-FI, 478 St Albans Road, Watford, Herts. (01923) 213533. The UK's leading independent Hi-Fi and home cinema retailer, specialising in quality products for discerning customers. Open six days, with dedicated single speaker and audio visual demonstration rooms. Major credit cards

accepted, 0% finance available (details upon request), home trial and installation by arrangement. Major brands stocked include Arcam, Audiolab, Castle, Cyrus, Denon, KEF, Marantz, Meridian, Micromega, Mission, Monitor Audio, Quad, Rotel, Ruark and Yamaha.

HUMBERSIDE

Zen Audio George Street Hull Tel: 01482 587397. "Comfortable listening rooms. Home dems. Free installations. Agencies include: Audiolab, Audio Innovations, Aura, Audion, Denon, DNM, D.P.A., Cable Talk, Heybrook, J.P.W., Kar, Neat Petite, Micromega, Michell, Harmon Kardon, Impulse, Ruark, Rotel, Royd, Sugden and many more."

KENT

ELECTRICAL DISCOUNT CENTRE, EDC, 138 Pelham Road Gravesend, Kent DA11 0JH. Tel: 01474 569601. Pioneer, Marantz, Technics, Akai, JVC, Jamo.

ELECTRICAL DISCOUNT CENTRE, EDC, 109 The Broadway Bexley Heath Kent DA6 7JH. Tel: 0181 295 7890. Pioneer, Marantz, Technics, Akai, JVC, Jamo.

THE LINN STUDIO, 50ndek LP2' Kink' Kank' Kairn' Klout' Kremin' Keltik' Kaber' Kelehd' Numerik' Tukan' Walonda' Majk' Klmk' LK100' Ekos' Kudos' Arkiv' Brilliant' Lingo' Valhalla' Sekrit' Ariv'... Dream systems for everyone from £2,000 to £30,000+. A new dealership from a specialist family business, established in 1948. Outstanding service and facilities. Multi-room specialist. 123 Snargate Street, Dover, Kent. CT17 9AP. Tel: 01304 201925, Fax: 01304 240135.

DOVER HI-FI, 43 High Street, Dover. Tel: 01304 207562. Suppliers of quality hi-fi equipment including: Arcam, Akai, Aura, B&W, Denon, Jamo, J.P.W., Mordaunt Short, NAD, Panasonic, ProAc, Quad, Rotel, Ruark, TDL, Technics, Tannoy. Part exchange. Listening room. Service and repairs. Credit facilities. Accessible. Open 6 days 9-5.30.

V.J. HI-FI, 29 Guldhall St. Folkstone Kent Tel: 01303-256860. Stockists of: Mission, Tannoy, J.B.L., Pioneer, Philips, Aiwa, Marantz, Musical Fidelity, Quad, Yamaha, Denon and much more besides. Full audio and home cinema demonstration facilities. Fully bonded BADA members. Interest free credit available (subject to status). Open Mon-Sat 9:00-6:00.

SEVENOAKS HI-FI 28 St. Johns Road, Tunbridge Wells, Kent. Tel: 01892 531543. The UK's leading independent Hi-Fi and home cinema retailer, specialising in quality products for discerning customers. Open six days, with dedicated single speaker and audio visual demonstration room. Major credit cards accepted, 0% finance available (details upon request), home trial and installation by arrangement. Major brands stocked include Arcam, Audiolab, Castle, Cyrus, Denon, KEF, Marantz, Meridian, Micromega, Mission, Quad, Rotel, Ruark and Yamaha.

SEVENOAKS HI-FI 4 Railway Street, Chatham, Kent. Tel: 01634 846859. The UK's leading independent Hi-Fi and home cinema retailer, specialising in quality products for discerning customers. Open six days, with dedicated single speaker and audio visual demonstration rooms. Major credit cards accepted, 0% finance available (details upon request), home trial and installation by arrangement. Major brands include Arcam, Audiolab, Castle, Cyrus, Denon, KEF, Marantz, Meridian, Michell, Mission, Monitor Audio, Quad, Rotel, Ruark, and Yamaha.

SEVENOAKS HI-FI 20a Lower Bridge Street, Canterbury, Kent. Tel: 012276 462787. The UK's leading independent Hi-Fi and home cinema retailer, specialising in quality products for discerning customers. Open six days, with dedicated single speaker and audio visual demonstration rooms. Major credit cards accepted, 0% finance available (details upon request), home trial and installation by

arrangement. Major brands stocked include Arcam, Audiolab, Castle, Cyrus, Denon, KEF, Marantz, Meridian, Micromega, Mission, Monitor Audio, NAD, Pioneer, Quad, Rotel, Ruark, and Yamaha.

SEVENOAKS HI-FI, 109-113 London Road, Sevenoaks, Kent. 01732 459555. The UK's leading independent Hi-Fi and home cinema retailer, specialising in quality products for discerning customers. Open six days, with dedicated single speaker and audio visual demonstration rooms. Major credit cards accepted, 0% finance available (details upon request), home trial and installation by arrangement. Major brands stocked include Arcam, Audiolab, Castle, Cyrus, Denon, KEF, Marantz, Meridian, Michell, Micromega, Mission, Monitor Audio, Quad, Rotel, Ruark and Yamaha.

LANCASHIRE

ORPHEUS AUDIO Standish, Lancs Tel: 01257 473175 See our main entry under Greater Manchester.

PRACTICAL HI-FI, 43 Friargate, Preston. Tel: 01772 883958. The audio visual specialist, expert advice, instant demonstrations, best prices, instant free credit, part exchange welcome. Extended warranty. Stockists of Yamaha, Kenwood, Denon, Sony, Technics, Onkyo, Marantz, Pioneer, Mission, Kef, Jamo, Celestion, B&W. Also stockists of LaserDiscs.

PRACTICAL HI-FI, 84 Penny Street, Lancaster, LA1 1XN Tel: 01524 396557 - See our main entry under Lancaster.

PRACTICAL HI-FI, 33-35 Knowsley Street, Bolton, Lancs Tel: 01204 395789 - See our main entry under Lancaster.

PRACTICAL HI-FI, 10 Preston New Road, Blackburn, BB2 1AW Tel: 01254 691104. See our main entry under Lancaster.

PRACTICAL HI-FI, 81 Whitegates Drive, Blackpool, FY3 8DA Tel: 01253 300599. See our main entry under Lancaster.

NORMAN AUDIO, 31 Friargate, Preston, Lancashire, PR1 2EE. Tel: 01772 253057. Fax: 01772 562731. Marantz, Pioneer, Yamaha, Audiolab, Arcam, Mission, Cyrus, B & W, Kef. Send for your catalogue. Home cinema dem room plus three sales areas. No appt necessary, free install. service dept. instant credit subject to status. Open 9.30-5.30, late night Wed- thpm.

LEICESTERSHIRE

ENCORE! Mr. Melton Mowbray. Tel: 01664 823282. Sugden, Densen, Unison, Tube Technology, Quark, UKD Opera, Keswick Audio Research and P-Rax. As you can see from our agencies, we are open-minded and able to present diverse entries for your appraisal. Unbiased and unhurried demonstrations by appointment incl. evenings and weekends.

SEVENOAKS HI-FI 94 Granby Street, Leicester. Tel: 0153 255 7514. The UK's leading independent Hi-Fi and home cinema retailer, specialising in quality products for discerning customers. Open six days, with a dedicated single speaker and audio visual demonstration room. Major credit cards accepted, 0% finance available (details upon request), home trial and installation by arrangement. Major brands stocked include Arcam, Audiolab, Castle, Denon, KEF, Marantz, Meridian, Micromega, Mission, NAD, Pioneer, Quad, Rotel, Ruark and Yamaha.

CLASSIQUE SOUNDS, "Vintage Hi-Fi Specialist". Stockists of: Garrard 301/401, Thorens, Quad, Leak, Rega, Shirley Labs, Spondor, Wharfedale, Rogers, Arcam, SME, Decca, Pioneer, UKD, Sugden, Musical Fidelity, + much more. Tel: Fax Paul Greenfield on UK + 0166 245 5821 or 0812 213 740 (mobile) any - time Classique Sounds, Classique House, 61 Ayestone Drive, Leicester, LE2 8QE.

LINCOLNSHIRE

COTTAGE AUDIO, 17 Bridge Street, Saxby, Nr Lincoln. LN1 2PZ. Tel: (01522) 702834. Evenings: (01522) 696709. A.T.C., A.V.I., Chord

amplifiers, Harbeth, LFD, Michell, Origin Live, Kinshaw, QED, Royd, Sansui, Sequence, Something Solid, Sonic Link, etc. Demonstration rooms. Home trial facilities. Free installations and above all a personal, friendly service.

LONDON

AUDIO T, 190 West End Lane, West Hampstead. (0171) 794-7848. Great Value on Aiwa, Arcam, Audiolab, B&W, Denon, Linn, Marantz, Meridian, Micromega, Mission, Nakamichi, Rotel, Sony, Technics, Yamaha & many more. Tues-Sat 10-6 Late Thurs until 8.00. 3 year Hi-Fi guarantee. 30 day free upgrades. Home demonstrations. PX Selected Interest Free Credit. 2 listening rooms. BADA Bonded.

TIME & TUNE, For T.V., Video, Hi-Fi, and in-Car Hi-Fi we are dealers of: Aiwa, Bose, Hitachi, Jamo, Kenwood, Marantz, Mitsubishi, NAD, Panasonic, Pioneer, Sony, Technics. For these and more come and see us at Time & Tune, 218-220 Whitechapel Rd, London, E1 1BJ. Or call 0171 377 2000

AUDIO CONCEPT, 27 Bond Street, Ealing, W5 5AS. Tel: (0181) 567 8703. Acoustic Energy, Audiolab, Aura, B&O, B&M, Bowser Acoustics, Canon, Castle, Denon, Dual, Evolution, Infinity, J.P.W., KEF, Marantz, Mission, Monitor Audio, Musical Fidelity, NAD, Nakamichi, Onix, Quad, Relox, Rogers, Rotel, Systemdek, Target, Teac, Thorens, Van den Hul. Two dem rooms. Interest free credit, free local delivery & installation, service department. "Hi-Fi Specialists without the attitude"

AUDITORIUM, 119 Middlesex Street, Bishopsgate, London E1 7JF. Tel: 0171 247 5000. Full range of equipment from Arcam, Bang & Olufsen, Cyrus, Denon, Dynavector (amplifiers & cartridges), Epos, Kef, Micromega (including 3.1, 2.1, transports, B52, Pro2 DACs and Stage) Mission, Naim, Neat, REL, Shahinian, Well Tempered Turntables, and Xlo. Open Monday to Friday 10.30am to 7.00pm and Saturday 11.00am to 4.00pm. Two minutes walk from Liverpool Street Station

HIFI EXPERIENCE, 227 Tottenham Court Road, London W1. 0171 580 3535. Arcam, Audiolab, Mission, Cyrus, Quad, Celestion, Kef, Meridian, Rogers, Tannoy, Yamaha, TDL, Thorens, Marantz, Nakamichi, Musical Fidelity and many more. Open 10.00-7.00 Mon-Fri. 9-6 on Sat. Service dept. Credit facilities, delivery and free installation.

K J WEST ONE, 26 New Cavendish St., London W1M 7LH. 0171 486 8262/63. Fax 0171 487 3452. Two Hi-Fi & two home cinema dem studios. Appts pref. Home trial. Installation by arrangement. Service dept. Major credit cards. Interest free credit on selected items. Major brands stocked: Arcam, Audio Alchemy, Audio Innovations, Audion, Audiolab, Audio Research, B&W Castle, Chord, DPA, Harbeth, Harman Kardon, KEF, Klipsch, Krell, Marantz, Martin Logan, Meridian, Michell, Micromega, Mission, Musical Fidelity, Nitty Gritty, Pink, ProAc, Quad, Rel, Rotel, Sonus Faber, Stax, Tannoy, Theta. Open 6 days.

THE LISTENING ROOMS, 161 Old Brompton Road, London SW5 8LJ. (0171) 244 7753/59. Fax (0171) 370 0192. Linn, Quad, Meridian, Nakamichi, Arcam, Audiolab, Acoustic Energy, SME, Audio Research, Krell, Wadia, Theta, Apogee, Martin Logan, Pioneer, Tannoy, Systemdek, Stax, Pink Triangle, Michell, Monitor Audio, Yamaha, Marantz, Kef, Bose, Celestion, Epos, Mission, Denon, Neat Petite. Mon-Sat 10-6pm.

ORANGES AND LEMONS, 61-63 Webbs Road, Battersea, SW11. Tel: 0171 924 2040. Juicy fruit from London's freshest Hi-Fi / Home Cinema retailer, now in our second year. Telephone demonstrations, or just pop in. All the usual, i.e. friendly and efficient service, free home installation, credit cards, 0% credit finance available, plus...all the very best from Cable Talk, The Chord Co., Denon, Epos, Kef, Marantz, Micromega, NAD, Neat, Quad, Rega, Roksan, Rotel, Royd, Quark, Soundstyle, Stands Unique and more

ZEBRA, 18-24 Brighton Road, South Croydon. Tel: 0181 - 688 2093. The UK's First and

Finest Home Cinema Store. 3 Demonstration Rooms. Laser Disc CRT and Projection TV Centre. Many brands stocked including Arcam, Audiolab, Meridian, Linn, Onkyo, Kef, Pioneer, Rotel, Yamaha, REL and Panasonic. Mon-Sat 9.30-6.00pm. All major credit cards accepted. Finance available. Evening demonstrations by appointment.

SEVENOAKS HI-FI 403 New Kings Road, Chelsea, London Tel: 0171 352 9466 The UK's leading independent Hi-Fi and home cinema retailer, specialising in quality products for discerning customers. Open six days, with a dedicated single speaker and audio visual demonstration room. Major credit cards accepted, 0% finance available (details upon request), home trial and installation by arrangement. Major brands stocked include Arcam, Audiolab, Castle, Cyrus, Denon, KEF, Marantz, Meridian, Michell, Micromega, Mission, Monitor Audio, Quad, Rotel, Ruark and Yamaha.

SEVENOAKS HI-FI 162 Powis Street, Woolwich, London Tel: 0181 855 8016. The UK's leading independent Hi-Fi and home cinema retailer, specialising in quality products for discerning customers. Open six days, with a dedicated single speaker and audio visual demonstration room. Major credit cards accepted, 0% finance available (details upon request), home trial and installation by arrangement. Major brands stocked include Arcam, Audiolab, Castle, Cyrus, Denon, KEF, Marantz, Micromega, Mission, Monitor Audio, NAD, Pioneer, Quad, Rotel, Ruark and Yamaha.

ALPHABET LTD, 392 Finchley Road, London, NW2 2HR. Stockists of Bose, Boston, Clifford, Denon, Jamo, JVC, Grundig, KEF, NAD, Onkyo, Panasonic, Sony, Vivanco and Yamaha. Specialists in Multi-Room Installations. Full service facilities. Credit terms available. Open Mon-Sat 10am-6pm. Thurs 10am-1pm. Tel: 0171 431 9133.

GREATER MANCHESTER

ORPHEUS AUDIO, Less between you and the music... Anion Acoustics' Audiomeca (Pierre Lounie)' Audio Alchemy' Audio Note' Audio Synthesis' Burmester' E.A.R.' Cabasse' Campaign Audio Design' Chord Electronics' Gamma Acoustics' Grado' Klipsch' Koss' Trichord Research' Lieder' Origin Live' Ortofon' Project' QED' Teac' Triangle' YBA' Boulder' Arcam Systems' Sonic Link' Beyer' Sennheiser' Audio Quest. Demonstrations by arrangement in Standish, Lancs. or in your own home without obligation. Tel: 01257 473175 (evening calls welcome)

PRACTICAL HI-FI 65 Bridge Street, Manchester M3 3BQ. Tel: 0161 839 8869 See our main entry under Lancaster

MERSEYSIDE

WIRRAL HI-FI (Audio Consultants) 17 Shore Bank, Wirral, L62 1DB Tel/Fax: 0151 645 4621. We believe in value for money. That's why we only stock audio equipment that has been carefully selected for its price, build, & most important excellent sound quality. The following manufacturers offer all this DPA, Gamma, Klyne, Magnum, Monarchy, Mosh, Orele, Rose, Teac, Tube Technology, XLO, Audio Synthesis, Audio Alchemy, Audio Value, Anion, Bose, CR, Castle, Dynaudio, ElectroAcoustics, Heybrook, SD Acoustics, Triangle. For friendly advice, free local delivery & installation, demonstration facilities by appointment.

MIDDLESEX

AUDIO T, 159a Chase Side, Enfield. (0181) 367-3132. Great Value on Aiwa, Arcam, Audiolab, Celestion, Cyrus, Denon, Linn, Marantz, Meridian, Micromega, Mission, NAD, Nakamichi, Rotel, Sony, Yamaha & many more. Tues-Fri 9.30-6. Sat 9.30-5.30. 3 year Hi-Fi guarantee. 30 day free upgrades. PX Selected Interest Free. 2 listening rooms. Home Cinema specialists. BADA Bonded.

MUSICAL IMAGES, 45 High Street, Hounslow, Middlesex. Tel: 0181 569 5802. Fax: 0181 569 6353.

MUSICAL IMAGES, 173 Station Road, Edeyware, Middlesex. Tel: 0181 352 8535. Fax: 0181 942 8535. Most brands available - see full page advert. Interest free credit, ask for details. Demo rooms. Repairs & Service. Sunday opening - Open all week. A Home Cinema Specialist. Mail order. Part exchange.

ASTLEY AUDIO LTD, 3 Marketplace, Wallingford (3 miles from Berkshire border). 01491 839305. Aura, B&W, Technics, Panasonic, Pioneer, Kenwood, Sony, Yamaha, Denon, Dual, Marantz, Mission, Tannoy. 1 listening room. Home trial, free installation. Service department. Access, Visa, Amex, Diners. Instant credit. Tues-Fri 9-5.30, Sat 9-5. Records & CDs stocked.

SEVENOAKS HIFI 41 St Clements, Oxford. Tel: 01865 241773. The UK's leading independent Hi-Fi and home cinema retailer, specialising in quality products for discerning customers. Open six days, with dedicated single speaker and audio visual demonstration rooms. Major credit cards accepted, 0% finance available (details upon request), home trial and installation by arrangement. Major brands stocked include Arcam, Audiolab, Castle, Denon, KEF, Marantz, Michell, Micromega, Mission, Monitor Audio, Quad, Rotel, Ruark and Yamaha.

SEVENOAKS HIFI 7 Genesis Road, Enfield, Middlesex. Tel: 0181 342 1793. The UK's leading independent Hi-Fi and home cinema retailer, specialising in quality products for discerning customers. Open six days, with dedicated single speaker and audio visual demonstration rooms. Major credit cards accepted, 0% finance available (details upon request), home trial and installation by arrangement. Major brands stocked include Arcam, Audiolab, Castle, Denon, KEF, Marantz, Michell, Micromega, Mission, Monitor Audio, Quad, Rotel, Ruark and Yamaha.

NORFOLK

BASICALLY SOUND, The Old School, School Road, Bracon Ash (Nr Norwich), Norfolk, NR14 8HG. Tel: 01508 570 829. Stockists of the following leading Hi-Fi: Arcam, Audiolab, Audio Achemy, Denon, Naim, Epos, Micromega, Haybrook, Nakamichi, Rotel, Royd, TDL, Beyer, Grado, Sennheiser, Dynalocator, and more. Bada members, 2 comprehensive demo rooms.

NORTHAMPTON

CLASSIC HI-FI, At Classic Hi-Fi we cover the best in quality sounds. Be it a question of taste, a question of balance or a question of price, we're the ones to help. We stock: Marantz, Naa, Pioneer, Aura, Yamaha, Heybrook, LFD, Suggen, Rotel, Kenwood, B & W, Kef, Rogers, Monitor Audio, JMW, Shorane Audio, Royd, Audio Achemy, Teac and many more. For more details call: 01536 310855

THE AUDIO SHOP, 6 Hill Street, Raunds, Northants, NN9 6NN. Tel: 01933 622325. Rotel, Denon, Marantz, Philips, Kinsman, Moth, Project, Royd, TDL, JMW, Bose, Wharfedale, Goldring, Orstefon, Chord Co., Van Den Hul, Audioquest, QED, Sound Org., Beyer, Sennheiser, etc. Service dept, Home Demos, Free Installation, Easy Parking, Open 9.30am to 5.30pm (closed Wednesdays).

LISTEN INN, 32 Gold Street, Northampton, NN1 1ES. Tel: 01604 37871 Fax: 01604 601 430. Linn, Rega, Audiolab, Naim, Denon, Arcam, KEF, Marantz, Royd, Micromega, Mission, Cyrus, Rotel, Myriad, Heybrook, Epos, Nakamichi, and more. Open 10am-5.30pm (closed Thursday).

THE AUDIO SHOP, Hi-Fi Specialists. Appointed stockists of: Ariston, Creek, Denon, Dual, Goldmans, JPM, Mordaunt-Short, Rotel, Royd, Tannoy. 6 Hill Street, Raunds, Northamptonshire. Tel: 01933 622325

NOTTINGHAMSHIRE

CHANTRY AUDIO, 18-18a Eldon Street, Tuxford, Nr Newark, Notts, NG22 0LH. Tel: 01777 870372. Pink Triangle, Absolute Sounds, Micromega, DPA, Alchemist, CD developments, SME, Meridian, Ruark, Rotel, Mich, Audion, Monitor Audio + much more. Three demo rooms inc. Home Cinema, home trial, free installation, service dept, Access, Visa, credit facilities, Mail order. Mon-Sat 9.30-6.00, Sun and evenings by appointment.

NOTTINGHAM HI-FI CENTRE, 120-122 Alfreton Road, Nottingham. Tel: 01602 786899. Over 25 years experience, superb demo rooms, extensive range, free parking. Mon-Sat 9-5.30

OXFORDSHIRE

AUDIO T, 19 Old High Street, Headington, Oxford. 01865 05997. Great value on Awa, Arcam, Audiolab, Cyrus, Denon, Linn, Marantz, Meridian, Micromega, Mission, NAD, Pioneer, Rotel, Sony, Technics, Yamaha & more. Tues-Fri 10-6, Sat 9.30-5.30. Thurs until 8.00. 3 year Hi-Fi guarantee. 30 day free upgrades. PX. Selected interest free. 2 listening rooms. Home Cinema BADA Bonded.

W. Owen Est 1901 58 Market Street Oakengates Telford Shropshire. Tel: 01952 613818. "Audio/Video specialists. Pioneer, Reference Point, Kenwood, Sony, Akai, B & W, Bose, Dolby Pro-Logic Specialist- 16:9 screens in stock. Free installations and home deliveries."

STAFFORDSHIRE

ACTIVE AUDIO, 95, Stafford Street, Hanley, Stoke-on-Trent, Staffs. Tel: 01782 214994. Fax: 0782 283346. We have four studios including a dedicated Audio Visual studio for the demonstration of quality equipment from the largest range in the Midlands. Open six days per week. Own senior department. Free local delivery, home trial facility. Current special offers and buyers fact pack and quotation service on request.

ACTIVE AUDIO, 29, Market Street, Tamworth, Staffs. Tel: 01827 53355. Fax: 0827 59513. We have two studios including a dedicated Audio Visual studio for the demonstration of quality equipment from the largest range in the Midlands. Open six days per week. Own senior department. Free local delivery, home trial facility. Current special offers and buyers fact pack and quotation service on request.

SUFFOLK

AUDIO IMAGES, 7 All Saints Road, Patefield, South Linstead, Suffolk, NR33 6JL. Tel: 01502 582663. Quad, Triangle, Arcam, Castle, Rotel, Moth, JPM, Suggen, Mission, Project, Denon, Yamaha surround sound. Audio Innovations, plus the amazing ROTHWELL range. Separate dem room, no appts nec. 10-6.30 Tues-Thurs, 7pm Fri, 6pm Sat.

EASTERN AUDIO, 41 Brimford Road, Ipswich, Tel: 01473 217 217. Fax: 0473 215705. Quad, Arcam, Audiolab, Meridian, Mission, Denon, Rotel, Marantz, NAD, Sony, Rogers, Nakamichi, Systemdek, Technics, Celestion, B&W, Tannoy, Morel Thorens and Top Tape. Also stock a wide range of accessories, usual credit facilities. A BADA dealer.

SEVENOAKS HI-FI, 47 Churchgate Street, Bury St Edmunds, Suffolk. 01284 753776. The UK's leading independent Hi-Fi and home cinema retailer, specialising in quality products for discerning customers. Open six days, with dedicated single speaker and audio visual demonstration rooms. Major credit cards accepted, 0% finance available (details upon request), home trial and installation by arrangement. Major brands stocked include Arcam, Audiolab, Castle, Cyrus, Denon, KEF, Marantz, Meridian, Michell, Micromega, Mission, Monitor Audio, Quad, Rotel, Ruark and Yamaha.

SURREY

SURREY HIFI, 4th High Street, Godstone, Surrey, RH9 8LS. 01883 744755. Specialist Hi-Fi outlet, demonstration room and parking available. Quad, Audiolab, TDL, Tube Technology, Rel Acoustics, Nakamichi, Kef, Thorens, Musical Fidelity, Van Den Hul cables, Bose, Sennheiser, Beyer headphones, Marantz, Denon, Michell, Van den Hul, Musical Fidelity, Tannoy, Target, JPM. Single speaker dem rooms. Free installation service dept. Access/Visa/Mastercard. Open 9-6pm. Closed all day Wednesday

SPALDINGS HI-FI, 352-4 Lower Addiscombe Rd., Croydon, Surrey. 0181 654 1231 2040. 3 dem rooms and home dem. Free installation/credit. Linn, Naim, Quad, Arcam, Audiolab, Mission, Denon, Tannoy, Marantz, Ruark. Mon-Sat 9-6, Tues 9-6. Service dept. (3 Dem rooms incl. AV. 0% credit)

ROGERS HIFI, 13 Bridge Street, Guildford, Surrey, 01483 61049. Awa, Creek, Denon, Dual, JPM, Marantz, Onix, Pioneer, Systemdek, Ruark, Tannoy, Teac. Dem facilities available, no appts necessary, free installation, service dept. Access/Visa. Instant credit up to £1,000. Subject to status. Monday-Saturday, 9.30-6pm, later by appt.

SURREY HIFI, 4th High Street, Godstone, Surrey, RH9 8LS. 01883 744755. Specialist Hi-Fi outlet, demonstration room and parking available. Quad, Audiolab, TDL, Tube Technology, Rel Acoustics, Nakamichi, Kef, Thorens, Musical Fidelity, Van Den Hul cables, Bose, Sennheiser, Beyer headphones, Marantz, Denon, Michell, Van den Hul, Musical Fidelity, Tannoy, Target, JPM. Single speaker dem rooms. Free installation service dept. Access/Visa/Mastercard. Open 9-6pm. Closed all day Wednesday.

SEVENOAKS HI-FI 369-373 London Road, Croydon, Surrey. Tel: 0181 665 1213. The UK's leading independent Hi-Fi and home cinema retailer, specialising in quality products for discerning customers. Open six days, with dedicated single speaker and audio visual demonstration rooms. Major credit cards accepted, 0% finance available (details upon request), home trial and installation by arrangement. Major brands stocked include Arcam, Audiolab, Castle, Cyrus, Denon, KEF, Marantz, Meridian, Michell, Micromega, Mission, Monitor Audio, Quad, Rotel, Ruark and Yamaha.

SEVENOAKS HIFI 73th North Street, Guildford, Surrey. Tel: 01483 366066. The UK's leading independent Hi-Fi and home cinema retailer, specialising in quality products for discerning customers. Open six days, with dedicated single speaker and audio visual demonstration rooms. Major credit cards accepted, 0% finance available (details upon request), home trial and installation by arrangement. Major brands stocked include Arcam, Audiolab, Castle, Denon, KEF, Marantz, Meridian, Michell, Micromega, Mission, Monitor Audio, Quad, Rotel, Ruark and Yamaha.

SEVENOAKS HIFI, 43 Fife Road, Kingston, Surrey. 0181 547 0717. The UK's leading independent Hi-Fi and home cinema retailer, specialising in quality products for discerning customers. Open six days, with dedicated single speaker and audio visual demonstration rooms. Major credit cards accepted, 0% finance available (details upon request), home trial and installation by arrangement. Major brands stocked include Arcam, Audiolab, Castle, Denon, KEF, Marantz, Meridian, Micromega, Mission, Monitor Audio, NAD, Pioneer, Quad, Rotel, Ruark and Yamaha.

SUSSEX (EAST)

THE POWERPLANT "Brighton's Leading Hi-Fi Shop". 66 North Street, Brighton, Tel: 01273 775978. Comfortable listening rooms. Knowledgeable and approachable staff. Roksan, Micromega, Exposure, Audiolab, Epos, Rotel, Marantz, Cyrus, Regal, Arcam, Mission and more.

ADAMS & JARRETT, Hi-Fi and Home Cinema Specialist. Phone or visit us at 6-8, Norman

Road, St Leonards-on-Sea, E. Sussex. 01424 437165/432398. Stockist of quality equipment including: Audio Innovations, Meridian, KEF, Ruark, Marantz, NAD, JBL, Royd, Dali, Jamo, Onkyo, Rei, Traget, Cable Talk, Technics, TDC, Yamaha, Kenwood. Air conditioned listening rooms, on site service and repair facilities.

SEVENOAKS HI-FI 55 Preston Street, Brighton, Sussex. Tel: 01273 733338. The UK's leading independent hi-fi and home cinema retailer, specialising in quality products for discerning customers. Open six days, with dedicated single speaker and audio visual demonstration rooms. Major credit cards accepted, 0% finance available (details upon request), home trial and installation by arrangement. Major brands stocked include Arcam, Audiolab, Castle, Denon, KEF, Marantz, Meridian, Michell, Micromega, Mission, Monitor Audio, Quad, Rotel, Ruark and Yamaha.

SUSSEX (WEST)

HEATHERDALE AUDIO LTD, 202 Finaon Road, Worthing, Sussex. Tel: 01903 872288 or 0800 660001 eves. Three comfortable demonstration lounges where you can audition: Audionets, Kren, Audio Research, Klipsch, Martin Logan, Apogee, Sonus Faber, Theta, S.M.E. Copland, Vcyd, Magneplanar, E.M.F., Lumley Reference, Creek, Rotel, Heybrook, Clearaudio. Phone for used stock list. *We are the South Coast's Premier Hi-Fi Specialist

TYNE & WEAR

FERROGRAPH SPARES & SERVICES, Reel to reel tape recorder servicing facilities, spare part and refurbished equipment suppliers. Main brands supported: Ferrograph and Revox. In total, around 90% of the entire range of Ferrograph spare parts are still available from stock. Our service department also covers all Ferrograph recorders from the range. Call today for further information. Suite 7, Lookson House, River Drive, South Shields, Tyne and Wear, NE33 1JX. Tel: 0191 427 7774 Fax: 0191 427 5566 E-mail: lee@ferrograph.wn-uk.net.

WARWICKSHIRE

SOUNDS EXPENSIVE 12 Regent St., Rugby, Warwick CV21 2QF. Tel: 01788 540772. Agents for: Arcam, Audiolab, Awa, Castle, Celestion, Cyrus, Denon, Dual, Kef, Heybrook, Mission, Marantz, Meridian, Mordaunt-Short, NAD, Quad, Rotel, Tannoy, TDL, Yamaha & many more. 2 year warranty on all hi-fi separates. 2 Demonstration rooms, Home Trials, All Major Credit Cards Accepted, Mail Order Welcome. Ring Now For Keenest Prices. Open Monday Saturday 9-5.30. If We Haven't Got It It's Probably Not Worth Having.

WEST MIDLANDS

AMADEUS SOUND & VISION, 10 Boldmere Road, Sutton Coldfield, West Midlands. Tel: 0121 354 2311. Audio Innovations, B&O, Castle, QED, Wharfedale. Single speaker demo, appts preferred, service available, installations, B&O lim. install, home trials, Access/Visa, interest free credit available subject to status. 9.30-6.00pm 6 days.

GRIFFIN AUDIO, 94 Bristol St., Birmingham. Tel: 0121 622 2230/0121 692 1359. Tues-Sat 10 am-8 pm. Enjoy music at home with a system from Griffin Audio. We demonstrate and install the very best hi-fi, with systems from £500 to £25,000. Ask for Bob, Tim or Alex. Linn, Naim, Sihaniman, Quad, Arcam, Rega, Denon, Marantz, Rotel.

ELECTRO CENTRE, 244 Soho Rd, Handsworth, Birmingham. Tel: 0121 554 1878. Full range of Hi-Fi: Pioneer, Technics, Kenwood, JVC, Sony, Awa, Akai. "Guaranteed the lowest prices in the UK". 24hr Mail Order facility available.

FRANK HARVEY HI FI EXCELLENCE, 163 Spion Street, Coventry. Tel: 01203 525200. Fax: 01203 631403. Audiolab - Audio Achemy - Atacama Aura - Arcam - Audio Quest - Aprisnon - Apollo - Bang & Olufsen - Bose - Castle - Canon - Cable Talk - Celestion - Chord -

Dial-A-Dealer

Cyrus - Denon - Dual Foundation - Heybrook - IXOS - Kef Reference - JBL - JPW - Jamo - Kenwood - Laser Disc Marantz - Meridian - Monitor Audio - Micromega - Mission - Michell Gyrodec - Monster - Mordant Short - Musical Fidelity - Nakamichi - NAD - Ortofon - Onkyo - Panasonic - Pioneer - Polk Audio - Quad - QED - REL - Rega - Revolver - Rogers - Rotel - Royd - Sennheiser - Systemdek - Target - Teac - Technics - Tannoy - Thorens - TDL - Van Den Hul - Wessex - Yamaha Much Much More In Store on 3 Floors 4000 Sq Feet with 3 Dedicated Hi-Fi Demo Rooms of the very Best Hi-Fi Plus 2 AV Demo Rooms. Nice staff Nice coffee. Appts Nec. Service Dept. Free install & Home Trial. All Credit Facilities. Plus interest Free Credit. Open 9.30am to 5.30pm Monday to Saturday.

WILTSHIRE

AUDIO T, 60 Fleet Street, Swindon. (01793) 539222. Great Value from Auna, Arcam, Audiolab, Denon, Linn, Marantz, Meridian, Micromega, Mission, NAD, Naim, Nakamichi, Rotel, Sony, Technics, Yamaha & many more. Tues-Sat 9.30-6. 3 year Hi-Fi guarantee. Free delivery & installation. 30 day free upgrades. Home demonstrations. PK Selected Interest Free Credit. 2 listening rooms. Home Cinema specialists. BADA Banded.

WORCESTERSHIRE

ENGLISH AUDIO, 37 Whitecross Road, Hereford, HR4 0DG. (01432) 365081. Arcam, A.T.C., Audiolab, Audion, B&W, Castle, Celestion, Cyrus Centre, Denon, Exposure, KEF, Marantz, Michi, Micromega, Mission, Musical Technology, NAD, Nakamichi, Pink Triangle, Pioneer, REL, Rotel, Ruark, John Shearne, SME, Stax, Systemdeck TDL, Yamaha. Single speaker dem room, home trial facilities, free installation, service dept. Access/Visa. Credit arranged. Open Mon-Sat, 9.30-5.30pm. BADA members.

SPAINS HI-FI 2 & Za New Rd, Bromsgate Worcs Tel: 01527 872460. Aura, Apolic, Audioquest, B&W, Denon, Harmon Kardon, JBL, JVC, Kef, Kenwood, Marantz, Mission, NAD, Nakamichi, Onkyo, Pioneer, QED, REL, Revolver, Rotel, Sennheiser, Sony, Tannoy, Thorens, etc. 2 Demonstration Rooms, Home Cinema Specialists, 0% Finance available on selected products. Part Exchange welcome, on site service dept, wide range of television, video, mini systems etc. in stock.

COLORAMA H-FI, 27 Kingfisher Walk, Kingfisher Centre, Redditch, Worcs B97 4EY (01527) 597260. Aura, NAD, Onkyo, Kenwood, Denon, TDL, Polk Audio, B&W, Tannoy. Full Prologic products. In-store integrated dem facilities. No appts required, service dept. Access, Visa. Open 9-5.30, closed Thursdays.

SEVENOAKS HI-FI 2 Penelope Court, Worcester. Tel (01906) 612929. The UK's leading independent Hi-Fi and home cinema retailer, specialising in quality products for discerning customers. Open six days, with dedicated single speaker and audio visual demonstration rooms. Major credit cards accepted, 0% finance available (details upon request), home trial and installation by arrangement. Major brands stocked include Arcam, Audiolab, Castle, Denon, Epos, KEF, Marantz, Meridian, Micromega, Mission, Monitor Audio, Quad, Rotel, Royd, Ruark and Yamaha.

Midland Audio Exchange 181, Franche Road, Kidderminster, Worcs, DY11 5AD. Tel. 01562 822236. Mobile 0421 605966. Open seven days a week, 9.30am to 6.30pm. By appointment. Evening demos arranged. 2 demo rooms, home demos. Part exchange always welcome, service facility, free delivery. Analogue Hi-End specialist. Agencies include Roxan, Rega, NAD, KEF, Aura, Nakamichi, B+W + many more. Access and Visa finance on request.

WEST MIDLANDS AUDIO, 15B Ombersley Road, Worcester WR3 7HA. Tel 01905 458046. Fax. 0905 457585. Naim, Rega, Rotel, Marantz, Nakamichi, NAD, Audiolab, Roksan, Meridian, B&W, Audio Research, Krell, Martin Logan, Arcam. 9-5.30 Mon-Sat, eve's by appt only.

YORKSHIRE (SOUTH)

MOORGATE ACOUSTICS - 8 Westgate Chambers, Rotherham Tel: 01709 370666, 184 Fitzwilliam Street, Sheffield Tel: 01142 756048 - Audio Alchemy, Atacama, Arcam, Audio Lab, Audio Quest, Beyer, Bose, Canon, Castle, Cyrus, Celestion, Denon, Jamo, John Shearn (Amplifiers), Linn, Marantz, Mission, REL (Sub Woofers), Rogers (Speakers & Amplifiers), Royd, Sennheiser, Sendor, Tannoy "D", T.D.L., Technics, Yamaha. Demo rooms (6), Home Cinema, Access, Visa, Switch, interest free credit (details available upon request), up to 5 years guarantee.

HIFI STUDIOS DONCASTER The best range of quality Hi-Fi in the north of England - Unison valve amps and phono stages, Morel Gyrodec and Orbe - Alchemist amplifiers, Electrocompaniet, Sugden, John Shearne amplifiers, TDL, Audio Alchemy, Proac, Ruark, Castle, Teac, Impulse Horns, Densen Amplifiers, Apogee, Stemfoort, Kinshaw, Pink Triangle, Morel Speakers, Heybrook, Monitor Audio, Harbeth, Keswick Audio Research Speakers, AMC, CR Developments (valves), Art Audio (Valves), REL Subwoofers, Eposure, Target, Sonic Link, Chord, Audio Quest + Yamaha & Klipsch Home Cinema Demonstrations. BADA members. Phone Jeff or Neil on 01302 78387

YORKSHIRE (WEST)

AUDIO REFLECTIONS: For friendly advice from one of the UK's longest established, truly independent audio consultants. Audition some of the world's finest equipment. Chord pre-processor amps, Spondor, SP9/1, SP7/1, SP1/2, SP2/3, A.T.C., A.V.I., Sumo, Castle, Harbeth, Grammeleon, Bryston, TEAC, van den hul etc. Demonstrations by arrangement in Leeds, or in your own home without obligation. For further details contact John Bleakley. Phone/Fax Leeds (0113) 252 8850 (evening calls welcome). Generous part exchange and second hand equipment available.

PREMIER AUDIO, Barnsley (01226) 382530. A brand new company offering a range of exciting Audiophile products carefully selected and professionally demonstrated. Equipment includes Audio Synthesis, Chord Company, Classe, Cable Talk, DPA, EAD, Exposure, Harbeth, Kora, Mirage, Myriad, Orele, Trichord and many others. Demonstration facilities, home demonstrations & Free installation. Part Exchange & Used Equipment Available. Telephone for details and Opening Offers.

HUDDERSFIELD HI-FI CENTRE, 4 Cross Church St, Huddersfield. (01484) 544668. B&W, Cyrus, Kenwood, Denon, Rotel, Arcam, Musical Fidelity, Quad, Audio Lab, Marantz, Mission, est. Dem facilities - appointment reqd. Mon-Sat 9-5.30, Thurs 9-8. Closed Wed. Free installation, credit facilities. Access, Visa.

AUDIO PROJECTS, 45 Headingly Lane, Leeds 6. Tel: (0113) 2304565. Linn, Arcam, Quad, Audiolab, Musical Technology, Teac etc. Installation. Home Trials. Home Cinema. Multi-room. Tues-Fri 9.30-5.00, Sat 10.00-5.00.

ASTON AUDIO, 19 Crossgate, Otley, Leeds. LS21 1AA 01943 487689. Products: Naim, Arcam, Audiolab, Cyrus, Denon, Epos, Meridian, Micromega, MF, Mission, Nakamichi, Quad, Rotel, TDL & other leading brands. Demonstration Rooms, Installation Service, Interest Free Credit. Access, Visa, Open Tues-Sat.

SCOTLAND

LOTHIAN

MUSIC MILL - 72 Newhaven Road, Edinburgh EH6 5UG. Tel: 0131 555 3963. Stockists of Micromega, Proac, Audio Innovations, Lumley Reference, Tube Technology, DNM, B&W, Systemdek, Nottingham Analogue, Nakamichi, Rehdeko, Dali, Crimson, Harmon Kardon, Godingo, DPA, Royd, Alchemist, Beyer Dynamic. Mon-Sat 10-6.00 pm by appt. Closed Wednesdays. All Major Credit Cards Accepted. Contact Fraser or Mark

GRAMPIAN

HOLBURN HI-FI, 441 Holburn Street, Aberdeen. Tel: 02224 855713. Arcam, Audiolab, B&W, Celestion, Denon, Dual, Epos, Heybrook, ION, Kenwood, Creek, Marantz, Meridian, Mission, Cyrus, M.S., NAD, Nakamichi, Pioneer, QED, Quad, Revox, Rotel, Kuark, Tannoy, Technics, Wharfedale, Yamaha. 10.30-5.30 Mon-Sat.

SEVENOAKS HI-FI, 491 Union Street, Aberdeen, Grampian (0224) 587070. The UK's leading independent hi-fi and home cinema retailer, specialising in quality products for discerning customers. Open six days, with dedicated single speaker and audio visual demonstration rooms. Major credit cards accepted, 0% finance available (details upon request), home trial and installation by arrangement. Major brands stocked include Arcam, Audiolab, Castle, Denon, KEF, Marantz, Meridian, Micromega, Mission, Monitor Audio, Quad, Rotel, Kuark and Yamaha.

AYRSHIRE

THE SOUND FOUNDATION, The Sound Foundation, 22 Nelson Street, Kilmarnock, Ayrshire. KA1 1BA. (01563) 574185. Equipment by Sugden, Audio Note, Proac, Harbeth, Michell, Castle, Voyd, Trichord Research, Firax and Sounds Unique. Full credit facilities available, all major credit cards accepted.

STRAITHCLYDE

STEREO STEREO 272 St Vincent Street, Glasgow, Tel: 0141 248 4079 E mail Stereo@compulink.co.uk We will supply the most musical sound for your budget and if you take the time to visit us we will take the time to return the compliment with free installation of your chosen equipment. Open 10-6.00pm closed Sunday, Tuesday installation National Interest free credit available

COLIN MACKENZIE'S HI-FI CORNER 52 Gordon Street Glasgow G1 2AB 2HA. Rose St Edinburgh 0131 220 1535, 1 Haddington Place, Edinburgh 0131 556 7331 and 44 Cow Wynd, Falkirk 01324 629011.

Audiolab, Cyrus, Sound-Bytes, Meridian, etc. Most major Brands stocked. Free five year guarantee on all loudspeakers, keen prices. JAMES LERR & Co., 145 Bath St, Glasgow G1 22B 5TH. Glasgow's oldest established hi-fi specialist, now at new larger premises.

HIGHLANDS

THE MUSIC STATION, 49 Church Street, Inverness, N. IOR. Tel: 01463 225523. Beyer Dynamic, Celestion, Denon, Jamo, Kef, Kenwood, Mission, Marantz, Musical Fidelity, Pioneer, Rotel, Sony. Listening room, service department, free local delivery, part exchange, full range of credit facilities.

IRELAND

COUNTY DOWN

CLONEY AUDIO, 58 Main Street, Blackrock, Dublin. Tel. 2889449/2888477 Fax. 2834387. Products include: Arcam, Classe, Philips, Rogers, Epos, B&W, Naim Audio, Meridian and others. Open Tues/Sat 10am-6pm. Thurs Fri till 3pm Closed Mondays.

ASTON AUDIO, Unit 8, Kings Road Shopping Centre, Kings Road, Belfast. 01232 402220. Akai, Technics, JVC, Samsung, Toshiba, Panasonic and many more. Demos. Open Mon-Fri 10-8pm Sat 10-5pm.

LONDONDERRY

ZEUS AUDIO, 23a Lincolne Street, Colrairie, BT52 4LB. Tel. (01262) 56634. Marantz, Mission, Cyrus, Auna, Auna, Alphason, Sony, Pink Triangle, Celestion, Rotel Mon-Sat 10-5.30pm. Closed Thurs.

WALES

NORTH WALES

ACTON GATE AUDIO, 4 Ruabon Road, Wrexham, North Wales, Tel. 01978 364500. Audio Visual Specialists: Auna, Arcam, Aura, Bose, B&W, Biana, Canon, Celestion, Classe, Denon, Jamo, Marantz, Michell, Mission, Mordant Short, Pro-Ject, Musical Fidelity, NAD, Nakamichi, Micromega, QUAD, Radford, Rotel, Rega, Kuark, Tannoy, Thorens, UKD, Yamaha, DSE Club Member, Demo Room, installation service. Easy Parking and Motorway access. All major credit cards accepted. 9.30 - 5.30 daily. Closed Wed pm.

ELECTRO TRADER, 19 Colwyn Crescent, Rhyl on Sea, Colwyn Bay, Gwyn, Wales, LL28 4PN. (01492) 548932. NOW APPOINTED SUGDEN DEALER FOR THE NORTH WEST. Rotel, Yamaha, NAD, Harman, Gander, Teac, Alphason, Heco, Infinity, KEF, JBL, Sugden, Tannoy, Rotel, Michi, Haybrook, Acoustic Research, Plurac and Soundstyle tripod racks etc. Dem room appts. preferred. Home trial. Free install. Access, Visa. Open 9.30 - 1.00, 2.00 - 5.30 Mon-Sat.

GLAMORGAN (SOUTH)

AUDIO EXCELLENCE, 134-6 Crwys Road Cardiff CF2 4NR. Tel. 01222 228065 Fax. 0222398201. All that's best in hi-fi carefully selected and demonstrated by friendly knowledgeable staff, at prices to suit all budgets. Delivery and installation, home dems, part exchange, in house workshops, full credit facilities with interest free on selected items. Tuesday - saturday 9.00 - 5.30. Closed monday.

GLAMORGAN (WEST)

AUDIO EXCELLENCE, 9 High Street, Swansea, SA1 1LE. Tel. 01792 474608 Fax. 0192 645087. All that's best in hi-fi carefully selected and demonstrated by friendly knowledgeable staff, at prices to suit all budgets. Delivery and installation, home dems, part exchange, in house workshops, full credit facilities with interest free on selected items. Tuesday - saturday 9.00 - 5.30. Closed monday.

MAIL ORDER

TOP TAPE, 1 Crystal Way, Elm Grove Road, Harrow, Middlesex, HA1 2RJ. Tel: 0181 427 1404. The UK's largest and largest Tape Mail Order Service. TDK, Maxell, Sony, Ampex audio cassettes plus Fuji, JVC, Konica, Memorex, Snoton & TDK video tapes. Send for complete list of latest prices and offers including Video 8, VHS-C, 5-1/4, DAT, MiniDisc and Open Reel and tape accessories including Alltop. Local Dealer Listing available. Telephone orders on 0181 427 1404 Mastercard, Visa & Switch accepted.

TO ADVERTISE IN
THIS SECTION FOR
JUST £10.00 PER
MONTH
CALL HI-FI WORLD
ADVERTISING SALES
ON 0171 289 3533

Classical

Peter Herring

JOHANN SEBASTIAN BACH

Brandenburg Concertos Nos 1-6 BWV1046-1051/Oboe Concertos in F Major BWV1053; in A Major BWV1055; in D Minor BWV1059.

The Chamber Orchestra of Europe; conductor and soloist, Douglas Boyd



Deutsche Grammophon Masters 445 578-2 (2 CD set) (DDD/141.14) Although Bach was enchanted with the sound of the oboe, he appears to have composed not a single concerto for the instrument; or, more accurately, none have survived. Oboists must have been delighted, therefore, when music scholars opined that the Harpsichord Concerto BWV1055 had most probably begun life as a work for oboe and, moreover, set about assembling - again with considerable justification - two further oboe concertos from movements extracted from four of the church cantatas (the process is lucidly described in Malcolm Boyd's accompanying booklet notes).

From the above, you may deduce the end result must be something of a hotch-potch; quite the reverse. These three works have a genuine unity and balance and, in the hands of as fine a soloist as Douglas Boyd, are completely convincing.

Two symphonies, one conceived in wartime, one played in wartime, bring together two of the world's great orchestras in this batch of new issues. Another link is to be found between the music of seventeenth century Austria and that of the nineteenth: startling originality, striking sonorities and an inner spirituality that can only be illuminated by a special kind of musicianship.



Boyd produces a most appealing sound, with a clear, well-rounded tone and not a hint of stridency. He is fluent in the lively outer movements, surmounting the technical difficulties with ease and always alert to the dynamic nuances. Meanwhile the slow movements - the sublime larghetto of BWV1055, for example - bring playing full of sensitivity, but are free from sentimentality. I do not know of any more expressive or persuasive performances of these concertos, and the accompaniment from the Chamber Orchestra of Europe is a match for the solo playing.

The COE, with Douglas Boyd now directing the performances, also offer enjoyable and exhilarating interpretations of the Brandenburgs, combining great rhythmic vitality with keen attention to detail. These may not be 'period' performances, but they share the litheness and freshness which characterises the period instrument ensembles. Anyone looking for these virtues in a modern recording of the Brandenburgs will not be disappointed with this set. There is much superb solo playing from members of the orchestra in each of the six concertos, with perhaps Ian Watson's dazzling harpsichord obbligatos in No5 being the high spot.

The recordings, made in 1990 and 1991, are uniformly fine, despite employing three different venues: the Kammermusiksaal of the Philharmonie in Berlin for the Oboe Concertos; Snape Maltings for Brandenburgs Nos2, 4 and 5; and the Teatro Comunale in Ferrara, Italy, for Nos1, 3 and 6. Each delivers a clean, bright, naturally detailed sound, with pleasing breadth and perspectives. All-in-all, this generously filled two-disc package, reissued at a special price, is well worth considering as a 'library choice' in these most popular of Bach's orchestral works.

ANTON BRUCKNER

Symphony No5 in B flat Major, Berlin Philharmonic Orchestra; conductor, Wilhelm Furtwängler.

Music & Arts CD538 (AAD/68.18)



How attitudes have changed. It would be unthinkable among most modern conductors (the late Leonard Bernstein excepted) to take quite so many liberties with a score as Furtwängler does here, even given the disparities between the different editions of the Bruckner symphonies.

But, then, the conductor is unlikely to have had one eye on posterity when this recording was made. It is taken from a concert given in Berlin during October 1942. We can only guess at the effect this epic symphony, with its granite-like grandeur and deeply spiritual heart, had on the hearers, especially in this incandescent performance.

Furtwängler has to be taken on his own terms, accepting that if he is not always faithful to the score, he is never less-than-faithful to the spirit of Bruckner's vision. Eschew comparisons with modern interpretations, and this performance, for all its technical flaws, becomes both compelling and enlightening. It has something to do

The Sound Organisation London

The new SME Model 20.2 Turntable



On demonstration exclusively the Sound Organisation during May '96

Developed from the superb model 20 of 1992, the 20.2 benefits from an all new power supply and a new motor. The improvements made by these modifications are substantial and lift the performance of an already excellent player to new heights.

It is our view that this level of performance and ease of use, coupled with SME's legendary build quality, qualifies this player as truly 'state of the art', yet it is available at a price within reach of any serious vinyl enthusiast.

0% finance available subject to status

Saturdays at the Sound Organisation

Demonstrations by appointment. As we are away from the horrors of the West End, not only can you park right outside, but you can book an undisturbed demonstration for up to 90 minutes.

Real Hi-Fi in the City
4 Pickfords Wharf
Clink Street
London S.E.1
01403 2255

Aria. A new way to look at hi-fi support.

Introducing the Aria Modular Hi-Fi Support System. It can change the way you look at your components. Build up separate vertical shelves. Or link units side by side. Either way, Aria lets you vary shelf heights to suit your components.

Start with a Base Pack and go from there. There's no limit to the number of ways you can build it up.

Not only does Aria give you more flexibility than any other hi-fi support system, it also provides positive sound deadening and decoupling benefits. With black tubular steel legs. Grey tinted glass or black MDF shelves. And adjustable carpet-piercing spikes.

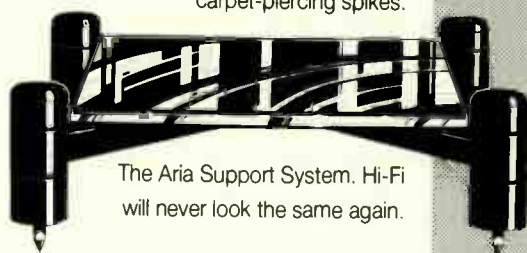

The Aria Support System. Hi-Fi will never look the same again.

I want a good look at the Aria system. Please send me a brochure

Name _____

Address _____

Post code _____

APOLLO
HI-FI FURNITURE

Our components improve yours

Zenith Crown Ltd., Tipton road, Dudley,
West Midlands, DY1 4SQ Tel: 0121 520 5070/1432

with the circumstances in which it was made, but is more concerned with Furtwangler's unerring grasp of this gigantic musical structure, the way that everything builds to the extraordinary final movement, with its colossal double fugue, weaving together the threads of the previous movements in a manner reminiscent of Beethoven's Ninth.

Bruckner's Fifth is a similar affirmation of the power of the human spirit to win through, and even at five decades-and-more removed, you sense that Furtwangler both shares that conviction and desperately wants to convey it to his audience.

Although this Berlin Philharmonic is not the Rolls-Royce ensemble we became accustomed to hearing under Furtwangler's successor, Herbert von Karajan, the playing leaves little to be desired. The woodwind and brass are especially fine, the latter intoning Bruckner's lofty chorale melodies with power and precision. Moreover, once the ear has adjusted to the audience noise, the sound - given the conditions - is surprisingly good, with an adequate dynamic range and a genuine ambience; there is none of the hollowness or boxiness which characterises many recordings from this period.

Clearly, this version (unquestionably the finer of Furtwangler's two extant recordings of the symphony) only qualifies as an 'addendum' - albeit a valuable one - alongside a modern stereo recording of the work (Karajan, Chailly, Haitink, Wand would be my first choices), but it is most assuredly not just a curio worthy only of the attention of Bruckner specialists. This is great music-making: you may not always agree with the course that Furtwangler plots, but its integrity is undeniable, as is the fact that it attains its goal. Some fifty years after his death, the Furtwangler legend shows no sign of diminishing; this wartime recording will give you a good idea why.

DMITRI SHOSTAKOVICH
Symphony No7 in C Major
Op.60 'Leningrad', St
Petersburg Philharmonic
Orchestra; conductor, Yuri
Temirkanov.

RCA Victor Red Seal 09026 62548 2 (DDD/76.38)

How does any conductor - let alone a Russian one - formulate an interpretation of this symphony, given the historical, and apocryphal 'baggage' attached to it? Surprisingly, perhaps, Yuri Temirkanov offers an admirably straightforward reading of a work whose musical qualities have so often been overlooked in the quest to discover Shostakovich's 'true' intentions.

In his book 'Testimony: The Memoirs of Shostakovich', Solomon Volkov quotes the composer as saying: "The Seventh Symphony became my most popular work. It saddens me, however, that people don't always understand what it's about; yet everything is clear in the music. . . the Seventh and Eighth Symphonies are my requiem."

the Soviet Union, Operation Barbarossa. It was to last almost 900 days and cost an untold number of lives from bombing, shelling and starvation. Yet there were those in the city who initially welcomed the prospect of German conquest as preferable to the oppression they were suffering under Stalin. And, according to Volkov, Shostakovich was only too aware of that: "I had to write about it; I felt that it was my responsibility, my duty. I had to write a requiem for all those who died, who



had suffered. I had to describe the horrible extermination machine and express protest against it."

If this is true, then the 'Leningrad Symphony' is one of the greatest ironies in all art, for the monstrous regime which Shostakovich set out to portray elevated him to the status of national hero on the strength of this music. It came to symbolise the defiance of the Russian people not just in the Soviet Union but around the world, and the much-parodied march theme of the first movement depicts both the tyranny within, as well as outside the city of Leningrad.

However, long acquaintance with this symphony (I acquired my first LP version - the USSR State Symphony Orchestra conducted by Yevgeni Svetlanov - in a shop on Leningrad's Nevsky Prospekt in 1971) has convinced me that too much importance is vested in the descriptive first

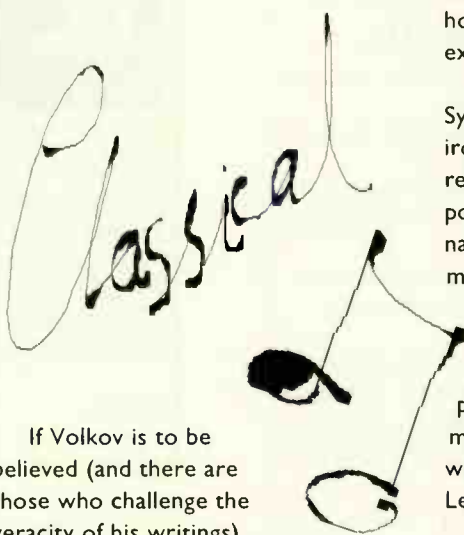

If Volkov is to be believed (and there are those who challenge the veracity of his writings), then Shostakovich intended this work to convey much more than the 'programme' he outlined in the newspaper 'Soviet Art' on October 9, 1941: "But if I succeed in writing this symphony, I shall dedicate it to Leningrad. Because all that I have expressed in it is bound up with my native city, with the historic days of the defence of Leningrad against fascist oppressors."

The siege of Leningrad began soon after Hitler had launched his attack on

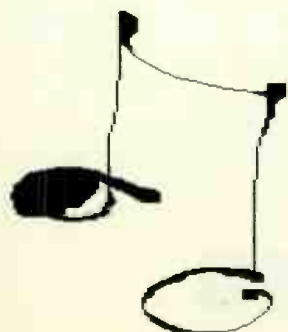

Wirral Hifi

GENUINE SALE OF:
VALVE, SOLID STATE, SPEAKERS,
DACs & TRANSPORTS

For a limited period only. Please ring for details.

VALVE: Gamma Acoustics, Audio Valve, Arion, CR, Tube Technology.

SOLID STATE: DPA, Klyne, Magnum, Orelle, Rose, Teac, Triangle.

SPEAKERS: SD Acoustics, Electrofluidics, Castle, Heybrook, Triangle

DACs & TRANSPORTS: DPA, Monarchy, Orelle, Audio Synthesis, Teac.

WE ARE PLEASED TO ANNOUNCE THE NEW ROSE SCION AMPLIFIER

The two box 70 watt integrated amplifier contains the power amp, power supply with volume control in box 1.

box 2 has the pre-amp source select excepting 5 input with 2 phonos MM/MC Price £545. Orders are now being taken.

TEL: 0151-645-4621

KEF CONSTRUCTOR SERIES

Wilmslow Audio

KEF Uni-Q Technology, the unique KEF driver design that delivers a sharply focused sound stage throughout a room, is now available to the home constructor.

KEF's Constructor Series of loudspeaker drive units and dividing networks, may be used in systems of your own design, or by following the KEF kit plans below:

KEF Kit 60 - A two-way bookshelf/stand-mounted loudspeaker using a single 8" Uni-Q drive unit in a compact 18 litre reflex loaded enclosure. The DN60 dividing network allows bi-wiring/bi-amping.

KEF Kit 80 - An 8" Auxiliary Bass Radiator augments the output of the main 8" Uni-Q driver used with a DN80 bi-wireable dividing network. This is a floorstanding loudspeaker with exceptional bass response.

KEF Kit 90 - An 8" dedicated bass unit, 8" Uni-Q and DN90 bi-wireable dividing network give this three way floorstander extended bass output down to 35 Hz (-6dB).

KEF have designed a range of drive units and dividing networks which, with simple D.I.Y. skills, can be transformed into State-of-the-Art loudspeakers capable of giving years of truly high-fidelity performance.

Kit	60	70	80
Boxed	£215	280	370
Total	£290	370	460



KEF Kit 60
2-way bookshelf/
stand-mounted



KEF Kit 80
2-way floorstanding



KEF Kit 90
3-way floorstanding

Free DIY speaker catalogue
export £3.50

Dept. HFW
Wellington Close, Parkgate Industrial
Estate,
Knutsford, Cheshire WA16 8XL
Tel: 01565 650605
Fax: 01565 650080

Open Tuesdays to Saturdays
4 demonstration rooms

ACCESS VISA
AMEX

Records at Cost

Now you can buy your CDs at dealer's cost price

As a member of the WSL Records at Cost Service you can buy **any brand CD** (subject to availability) at cost price plus a small handling charge of only 50p.

Now you have no need to shop around for the best discounts. Here at last clearly stated are CDs at the ultimate saving - **The Dealer's cost price.**

Only WSL - offering a mail order service for more than 30 years - can offer you such low cost listening.

So why not see what savings you really can make by checking our prices?

Return the coupon or write to us now and we'll send you full details of the Records at Cost Service, together with a special promotional membership offer.

Please send me full details of the new Records at Cost Service. Without obligation (I enclose two first class stamps for speedy reply).

Name: _____

Address: _____

Postcode: _____

To: Bill Wilson Stereo Library
PO Box 32 St. Leonards-on-Sea East Sussex TN38 0UZ
Telephone: (01424) 718254 Fax: (01424) 718262

HFW

Est. **WSL** 1961

movement; the 'pure' music of the other three movements surely tells us as much, if not more. It is here that this new reading from Temirkanov comes into its own. He uncovers the mixed emotions which characterise the lyrical moderato second movement. The glacial desolation of the brooding adagio is allowed to unfold naturally, and the transition to the triumphant finale is magically accomplished.

This is a performance of the 'Leningrad Symphony' for the post-glasnost era, an era when the city - and its orchestra, for that matter - has elected to revert to its pre-Stalin name of St Petersburg, with all that symbolises. Temirkanov rightly emphasises musical values above all else, and - given a score full of demanding solos, not least the 346-bar ostinato for side drum - the orchestral playing is outstanding. Moreover, it is

given a recording to match: rarely can the sound of this great orchestra have been so well captured on its 'home patch' - the Large Philharmonic Hall in St Petersburg, the concert hall dedicated to Dmitri Shostakovich.



RECORD OF THE MONTH

HEINRICH IGNAZ FRANZ BIBER
Sonatas No 1, 4, 6, 7, 8, 10, 12.

JOHANN HEINRICH SCHMELZER
**Sonata (Lamento) a tre;
Sonata a due; Lamento
"Sopra la morte Ferdinandi
a tre"; Sonata a due;
Lamento a tre; Harmonia a
cinque.**

Freiburger Barockorchester Consort
Deutsche Harmonia Mundi 0542 77348
2 (DDD/74.29)

The more I discover of the music of Heinrich Biber, the more I relish its highly idiomatic sonorities and colours, and the more I come to appreciate the achievement of this comparatively unknown seventeenth century Bohemian-born composer.

Born in Wartenberg in 1644, Biber's career took the course followed by most gifted musicians of the period in finding employment among the many ducal courts of central Europe. However, his dazzling violin playing singled him out for special treatment and, in the service of the Prince Archbishop of Salzburg (a role destined to be filled a century later by Wolfgang Amadeus Mozart), Biber rose to the position of principal conductor.

It was in Salzburg, in 1676, that Biber published his 'Sonatae, Tam Aris, quam Aulis servientes' (Sonatas both for the altar as well as the table), the title reflecting both the secular and the spiritual roles of his employer. The orchestration of these splendid pieces is diverse: some are for strings alone,

others for glittering combinations of strings and trumpets, all with basso continuo; all are rich in colour, melody and rhythmic variety, an endlessly rewarding feast of artistry and virtuosity.

Biber, and his contemporary, Johann Schmelzer, were the leading exponents of this distinctive Austrian style of ensemble music. It had its origins around 1640 and was clearly influenced by Italian music, chiefly the Venetian canzonas of Giovanni Gabrieli and the sonata concertata of Davio Castello. Schmelzer, born around 1620, rose through the ranks of the imperial court orchestra in the course of a

have taught Biber) and secured his reputation through the publication of a large number of sonatas and other instrumental works. While adhering to the established structure of the form, Schmelzer - like Biber - manages to explore all manner of techniques and sonorities, to stimulating and often thrilling effect.

Included among this selection of his works are two moving laments: one - from 1657 - in memory of Emperor Ferdinand III, and the Lamento a tre for which we have no date of composition but which was almost certainly to mark the death of another member of the imperial family. It is truly captivating music, archaic in some respects, but always accessible.

Naturally, much of the success of this recording in communicating this musical treasure-trove is down to the instrumentalists, with the string players especially tackling the demanding virtuoso writing with relish. All the performances by this consort drawn from the superb Freiburg Barockorchester are filled with enthusiasm, warmth and an evident affection for the music. Both Biber and Schmelzer could wish for no better modern-day advocates, and the former clearly merits wider recognition than that thus far accorded largely to his undisputed masterpiece the Mystery (or Rosenkranz) Sonatas.

The sound, I should add (a recording made in the Church of Maria Minor in Utrecht) is ideal for the music in its clarity, atmosphere, detail, timbre and balance: like the music-making, it is of demonstration standard.



thirty-year career, becoming its conductor in 1679. His tenure, however, was sadly short-lived: he died of the plague whilst in Prague the following year.

Like Biber, Schmelzer was an accomplished violinist (indeed, he may

Groove

You can follow the digital revolution or you can follow the



"The sounds from the Pro-ject 1 had the famous engaging bloom and warmth so characteristic of LP, which is either caused by analogue's inherent superiority over digital or a mixture of distortion, crosstalk and microphony according to your viewpoint. Anyway, I liked it ..."

John Borwick, Gramophone

Project 1 Turntable

PRO-JECT
AUDIO SYSTEMS

Pro-ject record playing systems are available for between £150 and £2,000. For more details and stockists, phone ORTOFON UK on 01753-889949

Studio One

We are flexible with our opening times
Free parking available by appointment.

117-119 HAMMERSMITH ROAD
LONDON, W14 0QH.

Tel: 0171 371 3037

Fax: 0171 371 1790

We are open Mon-Sat 10.00 - 6.00



Mail Order



SONNETEER CAMPION

Presents:
THORENS
CD PLAYER, PRE-
AMP & TUNER.



*We offer home
demos on Hi-Fi
equipment and
cables.
So you can make
your choice.*

AVAILABLE NOW

Agents for:- Alchemist, Audio Innovations, Audiolab, Aura, Alphason, Atacama, ATC, Audio Technica, Boston, B&W, Chord Company, Castle, Denon, Dynavector, Harman-Kardon, Heybrook, JBL, Jecklin, Jamo Ornel, Orelle, KEF, LFD, Marantz, Michell, Moth, Musical Fidelity, NAD, Nakamichi, Ortofon, Pro-ject, Rogers, S.M.E., Sequence, Spondor, Stemsfort, Sugden, Systm, Teac, Thorens, Totem, Tannoy, Townsend, Tube Technology, Van - Den - Hul, TDL Electronics. Studio series and many more.

- * Home Installations*
- * Free Local Deliveries*

*"Introducing a new brand of
amplifiers exclusive to Studio
One The Sonneteer Campion
Integrated amplifier."*

*"Call Joseph or Ossie now for Free advice"
Audition The ECA Servo A Point 2 True Ribbon
Loudspeakers "Be Amazed"!*

*"Records cleaned and sleeved on Nagaoka antistatic
for £1.50 per album"
Pay us a visit, we are near Olympia*

MICHELL GYRODEC AND QC POWER SUPPLY



A SYMBOL OF PRECISION



"THE MOST DESIRABLE DECK BELOW £1500"
Ken Kessler - Hi-Fi News & Record Review August '94

Michell Engineering, 2 Theobald Street, Borehamwood, Herts WD6 4SE
Tel:- 081 953 0771

COMPACT DISC PLAYERS

DENON DCD-315 £150

Real hi-fi and real music for a mere £150. Achieves a good semblance of orchestral dynamics and acoustic space.

NAD 510 £200

A competent all rounder with lifelike soundstaging and impressive treble clarity.

NAD 512 £250

Its smooth sound and fine treble extension make the 512 something of a rarity at the price. For the money rivals are few.

ARCAM ALPHA ONE £300

An excellent entry-level player from Arcam that's far better than equivalently priced Japanese machinery.

MARANTZ CD-63 Special Edition £350

A superb budget buy. Addressing the problems of the CD-52II SE, its detailed and musical sound embarrasses many expensive players.

NAD 514 £350

The 514 conveys deep bass notes with conviction and weight. A supremely relaxing player to listen to with fine build quality.

ARCAM ALPHA FIVE PLUS £480

A well built mid-price player that's a great all-rounder. Although highly musical and engaging, it has lost some of the warmth that made its antecedents so pleasant to listen to.

LINN MIMIK £839

The Mimik does what it's designed to do very well, with super-tight rhythmic presentation and plenty of detail. It can sound rather grey and clinical though.

QUAD 67 second-hand

One of Quad's best products for a long time, the 67 is warmer and smoother than most, yet is highly musical and revealing. Good enough to frighten many rivals.

DPA RENAISSANCE £895

Words cannot describe its infinite variety, but suffice to say you'll love it or hate it. Highly emotional, involving presentation with not a hint of self-doubt.

MARANTZ CD-16 £1399

An extremely neutral CD player, smooth and reserved in its performance. Beautifully built too.

LINN KARIK 3 £1600

Superb one-box player. Its supremely rhythmic, musical sound with delicacy and finesse puts it up with the best of the rest.

NAIM CD1 £1600

This single box 16-bit player sounds very engaging compared to your average bitstreamer. Has that vital tingle factor of the larger, two-box CDS.

MCINTOSH CDM7009 £2635

A thoroughly inspiring machine. One of the most musical CD players around; sweet, open and detailed.

COMPACT DISC TRANSPORTS

TEAC VDRS-T1 £550

Not as substantially built as its chunky looks suggest, the T1 is nevertheless a good entry-level transport with a warm, expansive sound.

ARCAM DELTA 250 £800

A well-built transport with serious sound quality. It partners the BB50 well, especially when sync-locked.

AUDIOLAB 8000CDM £1300

Beautifully built and finished, the CDM is packed with sensible features and performs superbly, day-in day-out.

CD CONVERTORS

DPA LITTLE BIT III £300

A lot more weight at frequency extremes than the II and far better control. For £300 there's nothing to beat it.

THORENS TDA2000 £700

Used with the TCD2000 as a transport, the TDA2000 produces a sound that is focused, detailed and spacious. Good value.

DPA ENLIGHTENMENT £795

Some believe this to be the best convertor around. A truly charismatic performer, it dives into rock music with rare passion.

PINK TRIANGLE ORDINAL £837

Pure, smooth sound free from hardness. One of the best at any price, losing little to the big guns.

PINK TRIANGLE DA CAPO £1450+

Offers a choice of filter modules, all up there with the best. The Da Capo is superb in many respects, but can sound a touch polite on rock.

DPA 1024 £6000

Proof positive that today's CDs needn't sound CD-like! Uses an in-house discrete convertor, and DPA haven't skimped on the build either!

TURNTABLES

GARRARD 401 second-hand

In a decent plinth with an arm of SME309 calibre, the 401 has a highly authoritative overall sound with the most solid, expressive bass in the business. Very musical, but treble isn't up to modern standards.

THORENS TD124 second-hand

One of Thorens' best-ever turntables. Needs a modern plinth to give its best. Duly installed, it's good enough to face off the Garrard 401, swapping some of its bass power for a more delicate, incisive treble.

SYSTEMDEK IIX900/RB250 £330

A fine all rounder and easy to upgrade. Brings more depth and breadth than a Rega 3.

RESON rs1 £600

A lean, yet vibrant sound quality that really draws the listener in. With good detail and rhythmic integrity this is an impressive turntable package.

MICHELL GYRODEC £800

Stunning looks, build and engineering, and don't underestimate the sound. Standard PSU and Rega arm gives a detailed, architectural, if undynamic sound. With QC PSU and SME V, its scale and insight kills the competition at the price.

PRO-JECT 6.1SA £999

The Pro-ject places the listener in the best seat in the control room. Outrageous dynamics and a punchy, seriously deep bass. Comes with Sumiko arm and Ortofon MC30 Supreme.

LINN SONDEK LP12 £840 - £1530

Cirkus bearing puts it back up with the best. Superbly beguiling, rhythmic sound that plays jazz like few others, but lacks the Gyrodec's detail or imaging. With a Lingo PSU and EKOS tonearm, you'll forget CDs were ever invented.

PINK TRIANGLE ANNIVERSARY £1200

One of the finest-sounding turntables around, the Anniversary takes the listener nearer the recording studio than almost any other deck. Works with Rega, Linn and SME arms alike.

MICHELL ORBE £1950

The Darth Vader of analogue, the Orbe builds on the strengths of the Gyrodec. An ultra-tuneful, expansive sound.

SME MODEL 20 £2495

Including the excellent SME V tonearm, the Model 20 is possibly the last great turntable, unless you've got £11,000 for the Model 30, that is.

TO NEARMS

REGA RB300 £130

Supremely capable at the price, but not quite humankind's salvation as has been suggested. Detailed, tight, rhythmic sound but tonally rather grey and cold-sounding.

LINN AKITO £300

A well made entry-level tonearm which works especially well with the LP12, but struggles to match the RB300 on other decks.

SME 3009SII £375

This Paleolithic device doesn't bother with frequency extremes or detail, but its legendary serviceability makes it a cult in Japan. Oh death, where is thy sting?

SME309 £570

A down-market version of the IV and V with aluminium armtube and detachable headshell. Tight, neutral sound with good tonality, but lacks the IV's pace and precision.

SME IV £850

A Series V with lower toleranced bearings, cheaper cables and no damper. Still vastly over-engineered and almost capable of its bigger brother's sonic fireworks. SME's best value product.

SME V £1235

A masterpiece of precision engineering with a cohesive, ultra-transparent sound. A dream to set up and use.

LINN EKOS £1400

A thunderous battleship of an arm, with a very impressive sound, masses of detail and dynamics, but lacks the SMEV's cohesion and musicality.

World favourites guide

CARTRIDGES

ORTOFON VMS-2E £110

Warm, full-bodied, punchy and fast. Not to be sniffed at for a tenner. Can be upgraded with a better stylus at a later date.

GOLDRING 1012GX £60

An accomplished MM with a solid bass, slightly forward midband and clean transients. £20 buys the faster, more dynamic 1022GX.

GOLDRING 1042 £100

The best moving magnet available. Has an extremely cohesive sound that's warm but highly involving. Deliciously delicate treble and strong, powerful bass.

ORTOFON MC15 SUPER II £109.95

An excellent budget moving coil with a smooth, polished, detailed sound. Tracks superbly but verges on the analytical at times. A bargain.

ORTOFON SUPREMES £225-£450

The MC10, MC20 and MC30 Supremes all offer superb sound and value for money, with a distinctively rich, smooth and detailed musical performance. The valve brigade love them.

LINN KLYDE £450

The Klyde's soft treble and prodigious bass mean it's tonally unbalanced, but it's still a real music-maker that many will love in the right system.

ORTOFON MC1000 £450

We came across this one in an SME IV on a Garrard 401; it duly gave one of the best results we've ever heard.

ORTOFON ROHMANN £1000

In a way it's MC2000 meets MC7500 with all the tonal strengths and dynamo sound Ortofon has been putting into its best moving-coil cartridges of late.

LYRA LYDIAN £649

A truly musical, sophisticated device that makes most other MCs sound frigid.

VAN DEN HUL MC-10 £840

Fluid bass, finely etched treble and highly tuneful in between. The MC10 is honey, pure and simple.

ORTOFON MC7500 £2000

Conclusive proof that there's hope for humankind. Makes music of enormous scale and vibrancy. CD lovers would die if they heard it.

INTEGRATED AMPLIFIERS

NAD 3020 second-hand

Classic sweet sounding, punchy budget super-amp with strong phono stage. Able to embarrass many modern budget amps.

NAD 310 £130

A real hi-fi amplifier at a bargain price. Forms the heart of a separates system that will murder any midi system at twenty paces. No phono stage, but you can't have everything at this price.

NAD 312 £200

Smooth, clear and dry. Fine detailing with little to complain about at the price. Good facilities.

ARCAM ALPHA 5 £230

A well-engineered budget amplifier with a bold, exciting presentation. Plenty of power and facilities, but lacks subtlety.

DENON PMA 450II SE £270

A solid, refined sound with plenty of power make this a good all rounder, but hard and steely with the wrong ancillaries. Mediocre phono stage.

AURA VA-80 £280

The VA-80 is superb for the price with a confident, powerful sound. One of the smoothest around, it is capable of embarrassing more upmarket competition.

PIONEER A400X £300

A good budget amplifier but not as competitive as it once was. Phono input lets the side down somewhat.

AUDIOLAB 8000A £500

A jack-of-all-trades whose facilities, build, power and top-rate phono input make it a steal. Sound is good, but less involving than the Naim Nait 3.

NAIM NAIT 3 £500

A taste of high-end audio. The most involving, musical design at the price, but low power. Superb phono stage is £100 extra.

MISSION CYRUS 3 £500

Superb engineering, a solid cast chassis and a clear, spacious sound. Phono stage could be better.

SONNETEER CHAMPION £579

An amplifier that delivers near studio definition along with exemplary timing. Utterly gripping.

DPA RENAISSANCE £595

Rich and smooth, the Renaissance is one of the sweetest amps around, if lightweight.

AUDION STERLING ETSE £600

Economically but well built single-ended valve amplifier. Wonderful clarity with vocals. £600 with 1 line input, £800 with 5.

SUGDEN A21a £640

Class A transistor amp. Rich, crisp, deep, tight sound and it images well too. Wonderful.

AUDIOLAB 8000S £650

Fast, clear, crisp sound with a wide-open sound stage. One of the best at the price.

MERIDIAN 551 £795

Beautifully-built integrated with a sweeter, clearer sound than mid-price alternatives. Plenty of facilities and remote controllable.

UNISON SIMPLY 2 £995

This single-ended valve amplifier is smooth, sweet and open. An extremely musical amplifier.

UNISON SIMPLY 4 £1495

Sonically similar to the Simply 2, but with more power and control.

AUDIONOTE QTO SE £1500

Ten watts of the sweetest sound around. Use sensitive speakers though, because it's unlikely to crack windows or trigger earthquakes.

McINTOSH MA6800 £1735

The MA6800 not so much plays music as takes control of it, with effortless bass drive and a three-dimensional sound stage. Versatile with a broad range of abilities.

PRE-AMPLIFIERS

NAIM NAC12.5 second-hand

Naim's one-time top preamp is still a force to be reckoned with thanks to its precise, fast sound and excellent phono stage.

ROTEL RQ-970BX £130

Superb value entry-level phono stage with audiophile quality components and clear sound.

DPA DSP1005 £495

Not quite the 50S, but there's little to match it at this price if outright sound quality is your priority.

ROSE RV23-S £495

This interesting valve/transistor hybrid has a smooth, rich, spacious sound.

AUDIOLAB 8000C £520

Versatile with superb phono input. Can sound sterile, but latest version is much improved.

MICHELL ISO/HERA £530

This phono stage has fine midband and treble detail, with taut bass. The £850 ISO/HR brings more of everything, and for many people is the last word on the subject.

AUDIO INNOVATIONS P2 £749

Fantastic bass and super insight make this one of the best phono stages around. One for vinyl lovers.

AUDIOLAB 8000Q £995

Excellent line-level only preamp, greatly improves on 8000C with a more fluid, musical sound and greater grip. Remote control.

NAIM NAC2 £1945

This remote control preamp thrusts detail forth in true Naim fashion.

POWER AMPLIFIERS

QUAD II second-hand

Classic valve monoblock with many thousands still in use around the world. Archetypal warm, smooth valve sound, although not the last word in detail or dynamics.

LEAK STEREO 20 second-hand

The Stereo 20 can sound impressively up-to-date, although power and detail are ultimately limited.

QUAD 405II second-hand

Solidly built, but lifeless sounding, power amp which can be substantially improved by a Quad factory service.

MISSION CYRUS POWER £450

This power amplifier is a honey. Rich and smooth, but with a firm grip; a fine blend of properties.

ROSE RP190 £495

Used with the partnering preamp it gives 70watts of smooth, relaxing sound.

SUGDEN AU41P £530

Extremely competitive at the price with 100W of unusually smooth, full-bodied sound.

SHEARNE PHASE 3 £619

A neutral, highly dynamic and thoroughly exciting amplifier. A sonic bargain.

World favourites guide

QUAD 606II £675

Quad's latest 140W powerhouse is smooth and civilised, but engagingly musical. Legendary back-up service.

DPA DPA2005 £750

Better than anything else at the price. Not as dry as the 505.

NAIM NAP1B3 £900

Partnered with a NAC82, this has classic Naim control, making for a superbly rhythmic presentation. A touch lean for some tastes.

MICHELL ALECTO STEREO £1300

A refined transistor amplifier with valve-like transparency and a full, warm, easy-going sound. The £1800 Alecto monoblocks have rare lucidity and three dimensional realism.

AUDIOLAB 8000M £1500

Beautifully built, powerful amps that will drive anything you care to throw at them. Detailed, analytical sound, but a touch grey compared to valve rivals.

CHORD SPH 1200 £2595

This is one of the best solid-state power amps around, with a massively powerful, dynamic and detailed sound.

TUNERS

LEAK TROUGHLINE second-hand

Our favourite way of listening to the wireless. A deliciously smooth, mellifluous sound that will have you junking your transistor radio in seconds. Ergonomics are crude, and you'll need a decent aerial and stereo decoder.

NAD 412 £190

The 412 is remarkably musical and natural sounding. Rich sound and full bass are a rarity. Unbeatable at the price

KENWOOD KT-6050L £300

Very, very tuneful and as clear and detailed as CD. Tuners like this have you sitting in your seat wondering at the sheer wealth of music out there.

MISSION CYRUS FM7 £300

Clear and lucid sound that puts it up with the best regardless of price. Superb build and superior ergonomics to the NAD.

ROTEL RT9906X £500

High quality Michl-based tuner with a sophisticated, forward sound with great imaging and soundstage. Sensible facilities and remote control.

NAIM NAT03 £380

The NAT03 is further proof of Naim's proficiency with tuners, with a warm, easy sound and a good sense of atmosphere.

FANFARE FT-1 £1350

In its native US the FT1 is no mere tuner but a 'broadcast monitor' no less, a task at which it acquires itself well, with a clear and powerful sound.

NAIM NAT01 £380

The best solid-state tuner available. For better radio, live in the studio.

CASSETTE DECKS

AIWA AD-S750 £150

Sonically a very decent machine. For the price there's nothing better. With Dolby B, C and S

AIWA AD-FH50 £210

A real bargain with fine recording quality and good playback.

PHILIPS DCC 730 £250

Digital playback gives a good 'analogue' presentation and analogue playback is reasonable too. A DCC bargain.

AIWA AD-S950 £300

A stable transport, superb head and Dolby S make this an excellent recorder.

PIONEER CT-S740S £410

A great piece of engineering from Pioneer, a bit complex, but a first rate sound on playback and recording. Dolby S included.

NAKAMICHI DR2 £600

Where serious cassette decks start. The DR2 pushes recordings to the limit, remaining unflustered at all times.

NAKAMICHI DR1 £850

Better still than the DR2, with manual head azimuth adjustment to boot.

NAKAMICHI CR7 £1500

Kills every other cassette deck and stamps on their graves. And the CR7 doesn't need baubles like Dolby S, either!

LOUDSPEAKERS

MISSION 7305E second-hand

Big clear sound and tuneful bass with plenty of punch. An audiophile bargain at a budget price.

KEF CODA 7 £129

Arguably the new king of budget standmounters, the 7 has a highly musical presentation.

MISSION 731 LE £149

An extensive reworking of Mission's entry level 'speaker, much tighter on transients and more refined treble. Neutral and revealing.

TANNOY 631 SE £170

Great bass extension, super open and focused midrange and fine detail up-top. Work best on filled dedicated stands; unmatched at the price.

BAW DM401 £200

Tight, solid and tuneful bass with a clean and pure tonal quality. Midrange is a little laid back, but sound stage is wide and open.

ROGERS LS33 £249

Big sound and a wonderful impressionist. Combine with matching AB33 subwoofers for extra bass depth.

TDL RTL 2 £300

Bass on a budget from one of TDL's best floorstanders. Solid, vibrant and spacious sound.

SYSTEMDEK SYSTEM 911 £300

One of the best mini-monitors around, with a coherent, involving sound that really sings.

REL Q-BASS £350

Few subwoofers match the Q-Bass at the price. The tuning controls can be a bit of a fiddle, but once set up the rest is pleasure.

EPOS ES11 £445

Extremely refined, well engineered standmounters that need distinguished partnering equipment if they are not to sound over-polite.

REL STRATA £500

The Strata is not a toy. Offers superb, true hi-fi bass depth and power.

MISSION 752 £500

More capable than many twice the price. Using advanced High Definition Aerogel drivers, the 752s are clear, crisp and focused. Good sensitivity makes them easy to drive.

TANNOY D100 £650

This small dual-concentric loudspeaker produces believable three dimensional imaging.

CASTLE CHESTER £700

Good sound allied to Castle's exquisite cabinetry and finish. Quarter-wave bass loading.

PROAC STUDIO 100 £700

Excellent monitors with detailed, natural sound and plenty of atmosphere.

HARBETH HL-PJES £799

A fine example of good loudspeaker engineering. The top of the mini-monitor league.

UKD CALLAS £850

High quality sound with a high quality bass from this solid walnut miniature.

KEF REFERENCE SERIES ONE £995

The KEF's combine pin-point imagery and detail with a smooth and polite balance. Good, agile bass too.

HEYBROOK SEXTET 11 £1129

Heybrook have retained the strengths of the original Sextet, whilst improving on bass extension and smoothness. Treble and imaging still up with the very best.

HARBETH HL COMPACT 7 £1329

Dry and analytical, but truthful and uncoloured with it. A cohesive sound from this top class monitor.

KEF REFERENCE SERIES TWO £1500

A truly endearing 'speaker, with clarity, cohesion, detail and precise imaging. Bass has superb extension.

EPOS ES25 £1505

Epos' best. Combines near-uncoloured tonality with characteristic fireworks in the rhythm department. Superb by any other name.

SPENDOR SP7 I £1970

This big Spendor is very appealing thanks to its lucid sound and valve-friendly load.

QUAD ESL-63 £2840

A reference against all other loudspeakers, with superb imaging qualities and genuine transparency. Earlier ESL model is an excellent second-hand buy, and both enjoy that legendary Quad service back-up.

SPENDOR SP9 I £3400-£3600

One of the clearest and most expressive loudspeakers you'll find for a large room. Beautifully finished.

TANNOY WESTMINSTER ROYAL £10,000

An incredibly dynamic, detailed full-range horn design with a rich sound. Its high sensitivity predisposes it to valve amplification.

Try me & see

U.K.'s No.1 Specialist
Mail Order Company

For the very best deal on any Hi-Fi, Home Cinema, A/V unit

- including all Award Winners!

- Try me & see is Britain's first dedicated Hi-Fi mail order company
- 1000s of satisfied customers nationwide

"...
I'm so delighted, that
words fail me. Thank goodness
I contacted you."



"...
What choice, what advice,
what knowledge.
Wow! What next?"



- Over half of our business is recommended or repeat
- You phoned the rest, now try the best!

AMAZING PRICES GUARANTEED!

... you'll get first-class
**service
savings
and support**

You can always buy from us with the complete confidence that we will never let you down.
We always put our customers first and constantly upgrade and update our systems in order to improve our service.

OUR COMMITMENT TO YOU

- ✓ To supply budget, regular and esoteric equipment.
- ✓ To deliver, insured, anywhere in the world within one week* - or your money back!
- ✓ To accept cheque, cash or major credit/debit cards.
- ✓ To offer a comprehensive warranty on all goods.
- ✓ FREE collection (within 24 hours) and delivery of repairs.
- ✓ To offer extended warranties up to 5 years.

* Subject to stock availability

If you are SERIOUS about
buying hi-fi, phone
(0181) 563 0003
NOW!

Fax (0181) 563 0300

"... no
hesitation in recommending
you to my friends"



... We will be opening a new showroom soon...

Try Me & See Ltd, 5 Rocks Lane, Barnes, London SW13 0DB

MEASURED PERFORMANCE

It's important to measure products to assess performance, find explanations of sound quality and warn of peculiarities or faults. Only Hi-Fi World has an advanced in-house laboratory with digital signal analysis for this purpose. In conjunction with this facility we assess sound quality in our own acoustically treated listening room. We measure most products reviewed. Here's a simple guide on our test results.

LOUDSPEAKERS

Smooth, flat frequency response is important to ensure a balanced sound. Look carefully at overall trends; rising treble will give a bright sound, falling treble a dull sound. A rise through the midrange normally corresponds with good projection.

High sensitivity (better than 86dB) means less power is needed for a certain volume, meaning a low power amp. can be used.

The impedance curve tells us how easy loudspeakers are to drive. Low or wildly varying impedance is bad; a flat impedance around 8Ω is good.

CD PLAYERS

Even small trends in frequency response of CD players can affect their subjective balance. Generally, those with a gently rolled off treble and, more

rarely, a rising bass will sound best. Rising treble can produce a sharp sound.

The distortion plot we show is taken at -30dB, to represent a typical music signal. High distortion at this level, combined with rising treble, can result in a harsh sound. Yet other effects have to be considered, especially low level linearity, which we also test for, including -90dB signals with dither applied.

AMPLIFIERS

Distortion from solid state amplifiers should be no more than around 0.2%. Even order (2nd, 4th, 6th etc) distortion is aurally innocuous, but odd order (3rd, 5th, 7th etc) distortion makes for a glassy, hard sound, or grittiness.

Frequency response can be band limited, with bass and treble rolled off just out of the ear's range, or wideband. Each has its own characteristics. Small wideband response variations colour tonal balance.

Power output is easy to understand: the higher the figure, the louder it will go. Just make sure there's enough power output to drive any loudspeakers you intend to use.

TUNERS

Frequency response, as always, says much about tonal balance and character traits, like peaky treble (due to a mis-matched MPX filter). Distortion and

channel separation need to be less than 0.3% (according to harmonic structure) and better than 25dB.

Hiss level must be lower than -70dB for Radio 3 silences to be just that - silent. And full quieting, the strength of aerial signal needed for optimum results, should be around 1mV or less.

Selectivity, the ability to separate stations under the most difficult conditions should be better than 60dB and sensitivity better than 30μV on stereo.

CASSETTE DECKS

Replay performance is measured to IEC 94 Standards using IEC test tapes. This ensures that recordings made on a machine transfer to a car player, personal stereo or another domestic recorder properly, as well as ensuring optimum results with commercially prerecorded tapes. Look for a quoted replay response of 40Hz-10kHz, no more than 1% speed error and hiss in the replay amps lower than -58dB.

Recording quality considers frequency response, bias variation, head performance and alignment. Frequency response should stretch from 40Hz-15kHz or so. Head overload (MOL315) must be above 0dB, reaching around +4dB for good results.

From the transport mechanism look for less than 0.15% wow or flutter. Overall (DIN weighted) wow and flutter should be no more than 0.1% or so.

AMPLIFIERS

CROFT EPOCH/SERIES V

Testing the Croft pre/power on an 8Ω load and with its 8Ω output tap, it delivered the specified 30watts. Frequency response was quite respectable, spanning 14Hz to 32kHz within 1dB limits. Noise was low.

Line stage sensitivity at 800mV was too low for most cassette decks and tuners, if not CD players. More gain is needed.

Distortion at normal listening levels was low at mid frequencies (0.035% at 1kHz, 1W) rising gradually with frequency, dominated by second order harmonic, although third was clearly evident. There was some deterioration at higher power levels.

The Moving Magnet phono stage didn't match exactly on both channels, bass rolled off earlier on the right channel, but stretched

between 40Hz and 30kHz at 1dB roll off points. This indicates some sort of warp filtering has been used. Otherwise phono

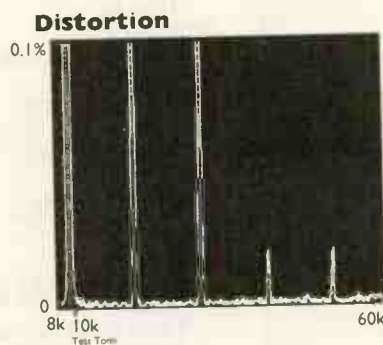

input figures were more than respectable, with 2mV sensitivity which should cope with most cartridges and an input impedance of 47kΩ paralleled with 100pF capacitance. HB

Power	30watts
CD/tuner/aux.	
Frequency response	14Hz-32kHz
Separation	58dB
Noise	-90.9dB
Distortion	0.4%
Sensitivity	800mV
Disc MM	
Frequency response	40Hz-30kHz
Separation	58dB
Noise	-72.9dB
Sensitivity	2mV
Overload	110mV

TEAC A-BX7R

Producing 60watts into 8Ω and 105watts into 4Ω, this amplifier gives a kindly punch. It will have little trouble driving most loudspeakers.

Frequency response at 1dB limits was flat between 12Hz and 100kHz which gives quite a wide bandwidth. The noise figure obtained was respectably low.

The one minor surprise was that the input sensitivity for line level signals was 400mV, lower than quoted (300mV). Except when using very low output sources, this shouldn't be too much of a hindrance.

Otherwise, dc offsets were low and

distortion average at normal listening levels, but it does rise somewhat at full power.

The workmanship inside the A-BX7R is immaculate, using surface mount technology throughout with a minimal amount of hard wiring. Very neat indeed. HB

Power	60.5watts
CD/tuner/aux.	
Frequency response	12Hz-100kHz
Separation	82.7dB
Noise	-114dB
Distortion	0.03%
Sensitivity	400mV

Distortion

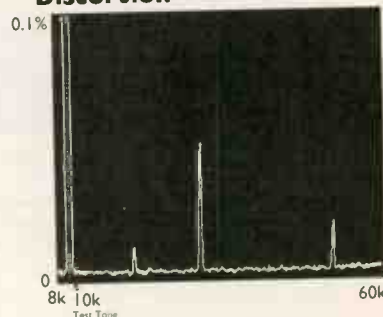

SUGDEN A21a - (class) A LIVING LEGEND

Telephone:
Melton
Mowbray

Encore!

(01664)
823282

Superb sound and style from:

SUGDEN DENSEN UNISON PROAC OPERA RUARK
TUBE TECHNOLOGY KESWICK AUDIO

East Midlands
M1 J23/J24 -
20 mins
Leics/Notts -
15 mins

Accessories by: Partington • Target • Tripos • Fi-Rax • Keswick Audio

Evening/
Weekend
calls welcome.
Demonstrations
by appointment.

Are you making the right connections?

Send for Britain's biggest catalogue of specialist cable and connections.

All available by mail order.

Phone 081-9429124 or clip the coupon for your Free copy.

CUSTOM CABLE SERVICE

PO Box 4007, London SW17 8XG

Please send me your FREE Custom Cable Catalogue

Name _____

Address _____

Postcode _____

NO FURTHER INFORMATION REQUIRED

Send to: Custom Cable Service
PO Box 4007
London SW17 8XG



Campion

by

SONNETEER

Our Amplifier Your Music



"It's almost too good to be true...utterly gripping" Eric Braithwaite Hi-Fi World Jan '96
"...exceptional value for money." Hi-Fi News & R.R. Dec '95

Hand Crafted In the U.K. by F.T.M. Marketing Limited.
PO box 163c, Esher, Surrey. KT10 0YH
Tel/Fax: 0181 450 5433 or Fax: 01372 470653

ADDITIONAL COMPONENTS AV SYSTEMS ACCESSORIES

VAIC VALVE NEW DESIGN 300B £352.50 PER PAIR

Doncaster Hi-Fi Studios
Sunnyfields 01302 781387

MAF
Burton-upon-Trent
01283 530550

Audible Difference
Diss + Norfolk 01379 740227

Paul Green Hi-Fi
Bath Avon 01225 316197

Hazelmere Audio
High Wycombe - Bucks
01494 4378892

The Hi-Fi Consultants
London - 0171 380 0866

What do the critics say:

QUINTET

The Art Audio gives you music with a sense of rightness that you don't really question but just get on and enjoy. Sweet open and lucid, the music is produced with an easy sense of naturalness which makes long term listening fatigue free and especially rewarding.

Roy Gregory Hi-Fi Choice

TEMPO

I feel that the Art Tempo amplifiers are among the finest valve power amplifiers currently available. The imagery that the Tempos create is vivid, lifelike and full of space and air.

Alan Sircom, Hi-Fi World

MAESTRO

...they are just so stunningly gorgeous and open to listen to, I can barely imagine anything more alluring.

Noel Keywood, Hi-Fi World

...the Maestro is part of that rare breed of Hi-Fi that makes you forget about the equipment and think about the music. In all, unlike the car, the Maestro lives up to its name

Alan Sircom, Hi-Fi World

AUDIO CABLES DIRECT FROM MANUFACTURER

MAINS CABLES FOR POWER/PRE AMPLIFIERS P.T.F.E. SILVER PLATED MAINS CABLE WITH IEC SOCKET £38/M. + £7/M ADDITIONAL LENGTHS.

SPEAKER CABLES 9 X 0.45MM P.T.F.E. INS.

2 CORE SHEATHED SILVER PLATED, FITTED WITH 4MM BANANA PLUG SPEAKER END AND 4MM STACKABLE BANANA PLUG/ SCOKET AMPLIFIER END FOR BI-WIRING.

CD TRANSWIRE REDUCE THE HARSHNESS IN YOUR CD SYSTEM WITH THIS CABLE THROUGHOUT. FITTED WITH GOLD PLATED PHONO'S £38/METRE - PAIR + £10/ METRE FOR ADDITIONAL LENGTHS.

TRANSWIRE SILVER SILVER PLATED COPPER SOLID CORE SCREENED RECOMMENDED FOR LONG INTERCONNECT £45/METRE - PAIR WITH GOLD PHONO'S + £12/METRE A PAIR FOR ADDITIONAL LENGTH.

TRANSWIRE GOLD SOLID CORE SILVER 99.9% OXYGEN FREE TEFLON COATED. £169/METRE - PAIR WITH HIGH QUALITY GOLD PHONOS + OR - £26 FOR 1/2 METRE ADJUSTMENTS.

ALL PRICES INCLUSIVE OF VAT + £3 POST & PACKING.

Art Audio

ART AUDIO 130 MAIN STREET, CALVERTON. NOTTINGHAM NG14 6LU tel: 01159 853604

LOUDSPEAKERS

SPENDOR 2030

The 2030s are part of a new line of products from Spendor. The bass driver is a completely new development, using an elliptical cone. Their frequency response is respectably smooth, but has some trends that prevent it being flat. Upper midrange level drops into a shallow trough above 1kHz or so, which will lessen projection but ensure a smooth sound. Above this, treble rises to a peak at 8kHz which will provide good apparent insight and detail. Bass extension was good, and the gentle lift here will give them a solid footing.

High current isn't going to be a necessity with the 2030s, since they exhibit a high overall impedance of 11.4Ω and a very smooth impedance curve. It's a bit of a pity

then that they are also insensitive, nearly as low as a Quad electrostatic at 83dB at 1m (2.83V pink noise signal). I'd recommend at least 50watts, to get enough voltage swing, for best results. DB

Impedance

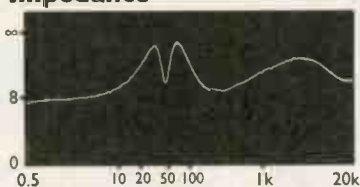

Frequency Response



QLN QUBIC 122

Testing with pink noise, straight away I heard the brightness of the QLNs; the Qubic 122s have rising treble above 5kHz or so. This, I suspect, will reveal itself more as extra detail and incision, rather than fierceness, which is normally caused by peaks lower down (1-3kHz). This was without the grilles on.

With the grilles, high treble level is attenuated significantly, losing around 3dB of level. But because the grille frame itself is made of 15mm thick MDF and surrounds the drivers quite closely, it causes strong reflections, producing a suck-out in the upper midrange. The same thick grille cloth on a thinner frame would seem ideal here, balancing high treble without disturbing

integration between midrange and treble.

With a very smooth impedance curve, overall impedance a high 12.4Ω and sensitivity around average at 86dB, the QLNs will be easy enough to drive properly. I'd recommend 30watts or more depending on the size of room. DB

Impedance

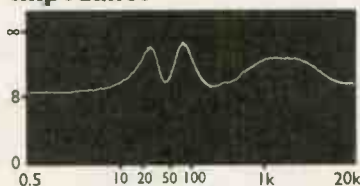

Frequency Response

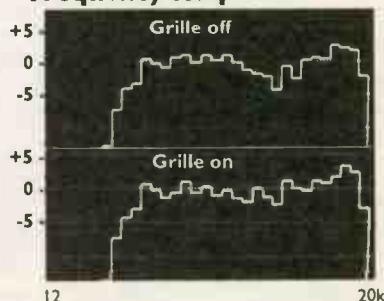

UKD CALLAS GOLD

The 'Gold' version of the Callas loudspeakers uses a version of the ScanSpeak D2905 tweeter, rather than the inverted Kevlar dome of the standard version. The Golds have a very well balanced response, with no strong dips or peaks to colour the sound. There is a shallow dip just before the tweeter comes in, but this should give the a smooth balance. Bass was surprisingly well extended for their size.

Looking at the impedance curve it can be seen that the Golds drop to around 4Ω in the bass. A sharp rise above 200Hz indicates they are reactive, but above 1kHz things level

out at a high 12Ω or so. Overall they averaged out at 8Ω and sensitivity was a mediocre 85dB. I'd recommend amplifiers capable of producing 40watts or more for best results. DB

Impedance

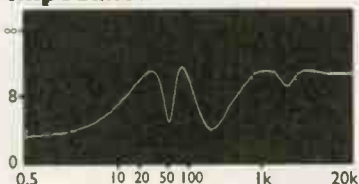

Frequency Response

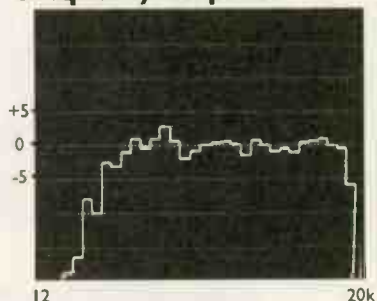

HARBETH HL COMPACT 7

The Compact 7s have an interestingly tailored response. It is very smooth, showing good engineering, but a peak in the treble will add detail and insight, balanced by an upper bass lift for punch and dynamics. I'd expect the HL Compact 7s to have a lively and engaging presentation as a result.

Their impedance curve is a relatively smooth one, staying above 6Ω across the whole of the audio band to give an overall figure of 10.5Ω. Sensitivity was quite high too; I measured 87dB at 1m using a nominal watt pink noise signal. This makes the HL Compact 7s suitable for a wide range of

amplifiers, including low-power valve designs. I'd recommend 20-50watts for best results. Oh yes, and keep the grilles on; that's how they work best. DB

Impedance

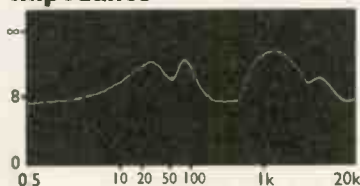

Frequency Response



SOUND-BYTES

High Density Filler Material for Speakers and Stands

For maximum benefit from your loud-speaker / speaker stand combination, you should fill your stands with a suitable material. **SOUND-BYTES** are uniquely shaped steel chips, **far more superior and four times more dense than sand**, that once poured into the speaker stand, effectively provide a solid steel core within. This makes the stand an extremely dense heavy platform, ideal for improving bass and imagery.

Available in 4 litre tubs of approximately 20Kgs in weight, each tub will provide enough **SOUND-BYTES** to adequately fill most commonly available speaker stands and floorstanding speakers.

"It'll transform your unfilled stands, budget or dear."

Ken Kessler
Hi Fi News & Record Review July 95

**RECOMMENDED BY THE UK'S
LEADING STAND AND
LOUDSPEAKER
MANUFACTURERS..**

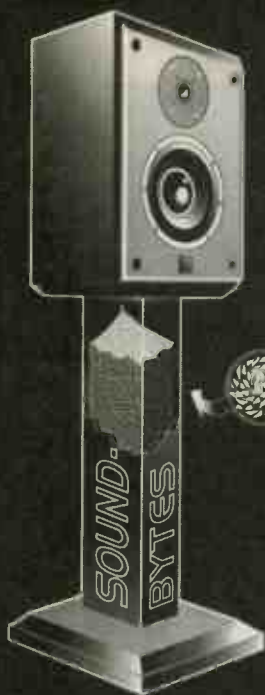

Partington

Atacama Audio



*RUIRK
A Stroke of Genius*

AVAILABLE MAIL ORDER FROM

Quality Suppliers of:

- Technics • Denon
- Mission • Arcam
- Wharfedale • Nad
- Micromega • Onkyo

Colin Mackenzie's
HI-FI-CORNER

Scotland's No.1
HI-FI Company



- Harman/kardon
- Kenwood • Tannoy
- Audiolab • Target
- Aiwa • Cyrus • TDL
- and other leading makes

52 Gordon Street,
Glasgow
01324 248 2840

INSTANT CREDIT
AVAILABLE (Subject to terms)
5 Years Guarantee on all Loudspeakers

HOME CINEMA
SPECIALISTS
2 Years Guarantee

121 Rose Street,
Edinburgh
0131 220 1535

42-44 Cow Wynd
Falkirk
01324 629011

0131 556 7901

1 Haddington Pl,
Edinburgh
0131 556 7901

Carriage £5.00 Allow 14 Days Delivery.

**SPECIAL OFFER PRICE £19.95
(INCLUSIVE OF VAT AND DELIVERY)**

ALSO AVAILABLE FROM
HI FI CORNER IS

**DENSEN
CD MAGIC**

£ 9.95

The Densen disc will demagnetize your system through the C.D. player. We don't know how it works, but if it doesn't improve your sound we'll give you your money back!

CD PLAYERS

AMC CDM7

With the standard MD5401 bitstream module fitted, the CDM7's response plot showed quite strong treble lift, up +0.3dB at 20kHz. AMC say that the response varies according to the input impedance of the amplifier used. The input impedance of our FFT analyser is 1MΩ, but an amplifier's input impedance is typically 10-50kΩ. We simulated this, but it didn't affect results. There is a lift in the bass too, so I would expect the AMC to have powerful bass.

The plot taken at -30dB shows a mainly odd-order structure with just a little 2nd and 4th visible. Higher than average distortion at -60dB yields a lower than average dynamic range of 98dB, but elsewhere the AMC performed well, with good separation, low noise, and output (2.3V) just above standard.

TEST RESULTS - MD5401

Frequency response	4Hz-20.8kHz	
Distortion (%)		
-6dB	0.005	0.006
-30dB	0.028	0.029
-60dB	1.44	1.00
-90dB	28.5	32.3
-90dB dithered	11.2	13.8
Separation (dB)	left	right
1kHz	96	107
20kHz	96	99
Noise		-95dB
with emphasis		-97dB
Dynamic range		98dB
Output		2.3V

Frequency Response

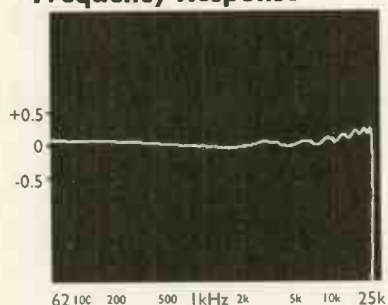

Distortion

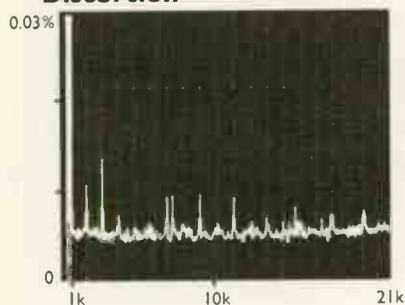

converter of 103dB (EIAJ test). Again, noise was low and separation wide, but output was a little lower than the standard at 1.85V. DB

TEST RESULTS - MD5403

Frequency response	4Hz-20.8kHz	
Distortion (%)		
-6dB	0.004	0.005
-30dB	0.021	0.025
-60dB	0.66	0.75
-90dB	34.9	40.4
-90dB dithered	14.8	15.1
Separation (dB)	left	right
1kHz	102	92
20kHz	98	87
Noise		-101dB
with emphasis		-102dB
Dynamic range		103dB
Output		1.85V

Frequency Response

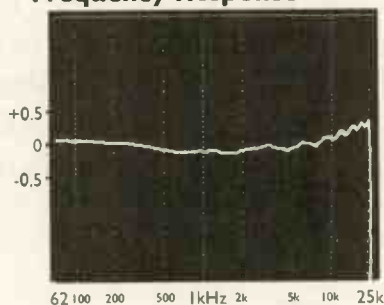

Distortion

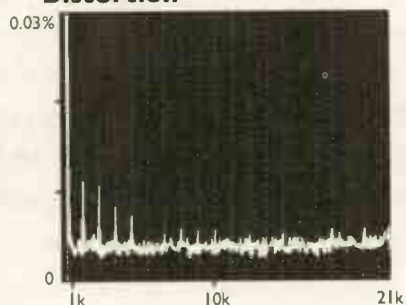

Noise	-110dB
with emphasis	-110dB
Dynamic range	104dB
Output	1.47V

Frequency Response

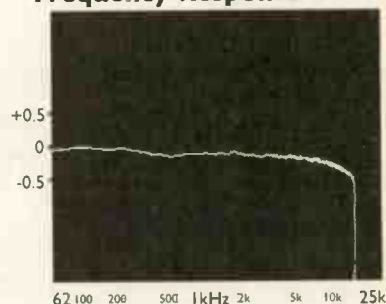

Distortion

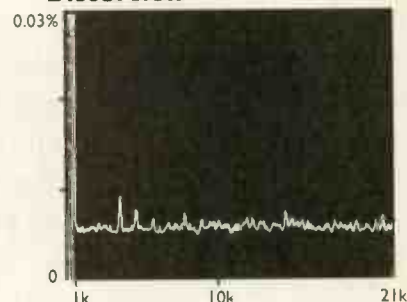

TDA2000 DAC

Frequency response 4Hz-21kHz

Distortion (%)		
-6dB	0.009	0.009
-30dB	0.03	0.025
-60dB	0.7	0.7
-90dB	18	17.1
-90dB dithered	6.3	5.9
Separation (dB)	left	right
1kHz	124	124
20kHz	106	107
Noise		-117dB
with emphasis		-124dB
Dynamic range		107.2dB
Output		2.3V

Frequency Response

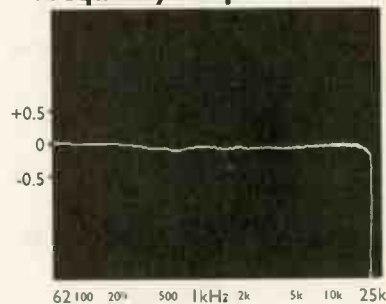

Distortion

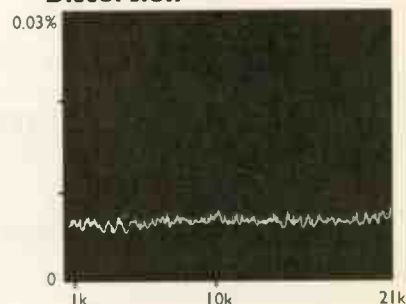

THORENS TCD2000 AND TDA2000

The frequency response of the TCD2000 CD player was a standard 4Hz to 21kHz at 1dB limits and distortion measurements were average, but quite acceptable. There was a lift at lower frequencies which may add a little weight to the sound, whilst the gentle roll off at the top will smooth treble. Output was lower than usual at 1.47V.

The response curve of the TDA2000 DAC starts to roll off at a higher frequency, resulting in a flatter trace than that of the CD player. Output was higher at 2.3V, there was better separation, a wider dynamic range and lower noise figures. HB

TCD2000 player

Frequency response	4Hz-21kHz	
Distortion (%)		
-6dB	0.012	0.012
-30dB	0.04	0.038
-60dB	0.69	0.69
-90dB	33	33
-90dB dithered	9.2	11.6
Separation (dB)	left	right
1kHz	92	92
20kHz	87	85

Next was the MD5403 'valve' converter. Interestingly, the treble and bass lift were notably stronger with the valve stage, treble now +0.5dB up. This alone will give the valve converter a different subjective performance.

More interesting still, the distortion figures were lower at all but the lowest signal level. At -30dB the distortion plot shows the harmonics falling towards higher frequencies, with an underlying even order structure.

Lower distortion at -60dB corresponds to a wider dynamic range for the valve

Electric Eel.

THE READING ROOM, THE STREET, STOWLANGTOFT, SUFFOLK. IP31 3JX
TEL: [01359] 231 023 FAX: [01359] 232 323

8 January 1995

Hello Peter,

Recently you supplied me with Slate Audio speaker stands for my Harbeth Compact 7 monitors and a plinth, arm and cartridge for my Garrard 301 turntable. I can honestly say that this was money well spent !

I am a studio engineer and as I use my Harbeths for mixing sessions, it is absolutely critical that they reproduce what has been recorded without colouration, warts and all ! Other stands, despite manufacturers' claims, are not always neutral, not so Slate Audio. They give me definition from the loudspeaker I have not heard before. They also give me positive imaging....I can place an instrument or effect wherever I want in the stereo sound stage with confidence. Recently I worked with a group that used a 26 inch kick drum...notoriously difficult to record. But I was able to record and mix knowing that what I was hearing was true. The proof of the pudding was when the test pressing arrived at my home and all the 30 and 40 Hz were still present and not "rolled off" in the cut. Thank you Abbey Road cutting room.

The marble plinth for my 301 is a work of art. I am happy to say that it sounds as good as it looks. I had been listening solely to compact discs at home for the last five or six years, and when I first put up the Slate Audio 301 I must admit to having quite a shock. It took me a short while to get used to the sonics of vinyl. However, once adjusted, forever converted! Now that my cartridge is run in I am more than happy to ditch the CD player in favour of my old records. They have new life, dynamics and energy.
Thank you Peter Soper.

Kind regards,

KEVIN VAN GREEN

STUDIO SALES - DESIGN - INSTALLATION

SLATE AUDIO

47 Gemini Close, Leighton Buzzard, England.

☎ 01525 384174

THE BEST SPEAKER STANDS & RECORD PLAYERS IN THE WORLD

CD PLAYERS

MARANTZ CD-63mkII KI-Signature

On the test bench this Marantz machine measured well. Its frequency response was a typical 4Hz to 21kHz, but with a very gentle plateau lift around 5kHz which, although subtle, may well help push detail forwards.

The distortion figures were around average at all levels. There was just the smallest amount of 2nd order poking through the noise floor, but even order distortion tends to be innocuous anyway.

Separation was very wide, being above 125dB at 1kHz and 20kHz. Dynamic range was good exceeding the 100dB barrier and noise was also very low indeed.

Compared to the 63SE reviewed in the May '95 issue most of these results are virtually identical with the exception of the distortion which appeared to be slightly worse. HB

Frequency response	4Hz-21kHz	
Distortion (%)		
-6dB	0.006	0.006
-30dB	0.027	0.028
-60dB	0.8	0.7
-90dB	47.6	41.9
-90dB dithered	15	13

Separation (dB)	left	right
1kHz	132	137
20kHz	126	127
Noise		-123dB
with emphasis		-123dB
Dynamic range		103dB
Output		2.3V

Frequency Response

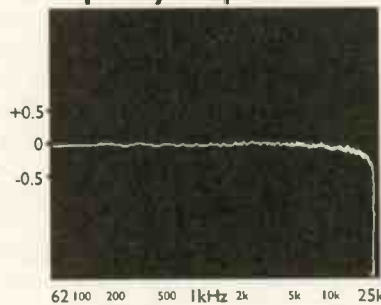

Distortion

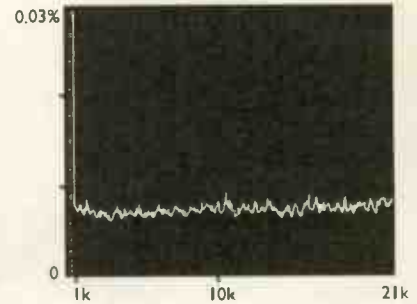

TUNER

NAD 412

The NAD has a flat audio frequency response that extends to 15.8kHz (see analysis), about normal these days. In spite of good flatness, the MPX filter worked well, getting rid of unwanted products like 19kHz pilot and 38kHz sub-carrier.

Channel separation on stereo was a healthy 41dB, again normal enough. Audio distortion (stereo) was satisfactorily low all round, measuring just 0.13% and hiss low enough to be inaudible at -73dB. For this performance to be met, however, a minimum of 0.8mV (800µV) of aerial signal is needed, which is quite a low value, indicating good sensitivity. This was borne out, stereo sensitivity measuring just 25µV. Selectivity was high also, at 74dB (alternate channel). At 380mV audio output was low.

The 412 measured well in all areas. I'd expect a clean, balanced sound. NK

Frequency response	10Hz-15.8kHz
Stereo separation	41 dB
Distortion (50% mod.)	0.13%
Hiss (CCIR)	-73dB
Signal for minimum hiss	0.8mV

Selectivity (at 0.4MHz)	74dB
Sensitivity	
mono	3µV
stereo	25µV
signal strength meter	none

Frequency Response

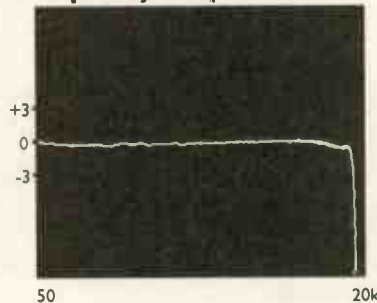

Distortion

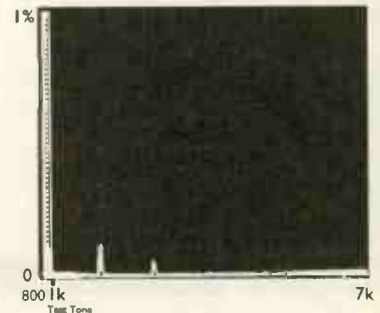

CASSETTE

PIONEER CT-S740S

The Pioneer is a great all rounder. The dual-capstan transport was incredibly speed stable, producing a meagre 0.025% wow - as low as you can get. There was minimal modulation noise and drift too.

The head might not provide spectacular overload levels, but it was very respectable all the same, giving +3.5dB at 300Hz and -3dB at 10kHz with metals, for example. Music peaks can be taken to around +5 or so on the record level meter, which puts 0VU high, at IEC 0dB flux level.

After auto-tuning, frequency response with blank tapes - ferrics, chromes and metals - was very flat from 20Hz to 20kHz.

Even better, at least in pure engineering terms, replay only response hit 20kHz flat.

Super-stable high-treble output told me head finish, azimuth alignment and replay equalisation all reach the highest standard. With low intrinsic noise figures and Dolby S too, the CT-S740S is quite a machine. Very impressive in all respects. NK

REPLAY (pre-recorded tapes)	
Frequency response (-2dB)	20Hz-20kHz
Speed accuracy	+0.8fast
Hiss (70uS, Dolby out)	-60dB

RECORDING (blank tapes)	
Frequency response (IEC Primary Refs.)	
ferric (IECI)	20Hz-20kHz
chrome (IECII)	20Hz-20kHz
metal (IECIV)	20Hz-20kHz

Separation (1kHz)	47dB
Distortion (315Hz)	1%
Hiss (70uS, Dolby out)	-56dB
Speed variations (DIN total)	0.025%
Flutter energy (3-3.13kHz)	-39dB
MOL/SAT (IEC Refs)	315/10k
IEC I (ferric)	+3dB/-9dB
IECII (chrome)	+2dB/-9dB
IECIV (metal)	+3.5dB/-3dB

Frequency Response

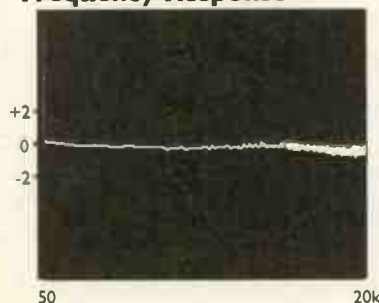

Speed Stability

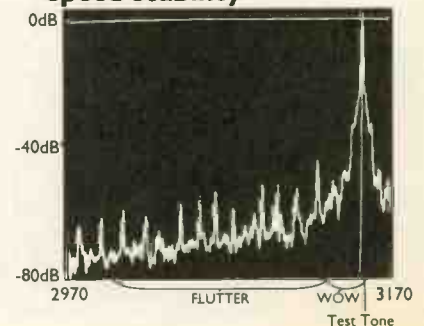

AUDIOPHILE

International Ltd.

The UK's Largest Selection Of Superior Pressings

To Order Call: 01276 855578

Fax 24 Hours: 01276 855580

For Any Information: 01267 855530



Feature;

Classic Records credo for creating the best possible products cannot be emphasised strongly enough. In order to be as faithful to the original RCA Living Stereo releases and the Master Tapes 'Classic' assembled the best possible team to make their dream a reality. Left we see Jack Pfeiffer, who in his youth was a pioneer for stereo sound and Bernie Grundman transferring the music from the original master tape to lacquer with extreme care after hours of direct comparison against numerous copies of different pressing's of original LPs. (In an attempt to preserve the intentions of the original producer(s), in terms of the equalisation that was often applied to the original LPs). The freshly grooved lacquer is taken to the plating plant as quickly as possible. It will be silvered and electroplated in 'the bathes' to produce a master, which is re-plated to produce 'Mothers', which are further re-plated to produce stampers, which are used to press records. Sample test pressing's are produced to assess strengths and weaknesses. If there are no problems the production run begins. If defects are found, Classic start the whole process again. It is this attention to detail that has helped Classic Records to become one of the most incredible reissue series of this century.

Audiophile International Present - a small selection



BLUES HOOT

Classic Records HQ LPs

Buy two or more of any £28 title for £25 each.

LSC 1806	STRAUSS - Also Sprach Zarathustra	£28
LSC 1817	OFFENBACH - Gaité Parisienne	£28
LSC 1831	BRAHMS - Piano Concerto No.1	£28
LSC 1893	RAVEL - Daphnis Et Chloe	£28
LSC 1900	BERLIOZ - Symphony Fantastique	£28
LSC 1901	TCHAIKOVSKY - Symphony No.6	£28
LSC 1934	BARTOK - Concerto For Orchestra	£28
LSC 2077	STRAUSS - Till Eulenspiegel	£28
LSC 2134	OVERTURE! OVERTURE!	£28
LSC 2135	PROKOFIEFF - Cinderella	£28
LSC 2150	STRAVINSKY - Lt. Kije (Reiner, CSO)	£28
LSC 2183	THE REINER SOUND	£28
LSC 2185	RACHMANINOFF - Symphony No.3	£28
LSC 2201	MUSSORGSKY - Pictures At An...	£28
LSC 2222	DEBUSSY - Iberia (Reiner)	£28
LSC 2225	WITCHES BREW (Gibson)	£28
LSC 2234	SAINT-SAENS - Piano Concerto No.2	£28
LSC 2257	ELGAR - Pomp & Circumstance	£28
LSC 2271	RAVEL/D'INDY - Pianon Concerto	£28
LSC 2285	WALTON - Facade	£28
LSC 2288	PROKOFIEFF - Symphony No.7	£28
LSC 2298	BORODIN - 2nd Symphony	£28
LSC 2313	SOLTI - Venice (Royal Opera House)	£37
LSC 2322	SHOSTAKOVICH - Sym. No.1	£28
LSC 2323	TCHAKOVSKY - Capricco Italien	£28
LSC 2418	ELGAR - Enigma Variations	£28
LSC 2419	DVORAK - Slavonic Dances	£28
LSC 2423	REINER - Festival (Chicago S.O)	£28
LSC 2430	RACHMANINOFF - Theme' Paganini	£28
LSC 2436	RESPIGHI - Pines Of Rome (Reiner)	£28

DCC Compact Classics

180gm Virgin Vinyl LPs & 24kt Gold CDs

RAY CHARLES AND BETTY CARTER	£25
THE BEACH BOYS - Pet Sounds	£25
LIGHTNIN HOPKINS - Blues Hoot	£25
SONNY ROLLINS - Saxophone Colossus	£25
RAIDERS OF THE LOST ARK (2LP Deluxe g.fold)	£35
ROD STEWART - Never A Dull Moment	£25
STAN GETZ & CHARLIE BYRD - Jazz Samba	£25
RAY CHARLES - Greatest Country & Western Hits	£25
ELTON JOHN - Greatest Hits Vol. 1	£25
ELTON JOHN - Greatest Hits Vol. 2 (LP Only)	£25
WES MONTGOMERY - Goin' Out Of My Head	£25
CREAM - Fresh Cream	£25
CREAM - Wheels Of Fire (2LP/CD Set)	£35

CD Only Titles

BOB DYLAN - Highway 61 Revisited	£25
THE EAGLES - Hotel California	£25
THE EAGLES - Greatest Hits	£25
THE DOORS - The Doors	£25
THE DOORS - Strange Days	£25
THE DOORS - L.A. Woman	£25
THE DOORS - Waiting For The Sun	£25
MILES DAVIS - Cookin'	£25
MILES DAVIS - Relaxin'	£25
MILES DAVIS - Steamin'	£25
MILES DAVIS - Workin'	£25
GETZ MEETS MULLIGAN IN HI-FI	£25
CREEDENCE CLEARWATER - Willy & The Poor.	£25
CREEDENCE CLEARWATER - Cosmo's Factory	£25
CREEDENCE CLEARWATER - Bayou Country	£25
CREEDENCE CLEARWATER - Green River	£25
THE BAND - Stage Fright	£25
BILL EVANS - Portrait In Jazz	£25
THE BEACH BOYS - Endless Summer	£25
LEON RUSSELL - Leon Russell	£25
HEART - Dreamboat Annie	£25
STEVE MILLER BAND - Book Of Dreams	£25
STEVE MILLER BAND - Fly Like An Eagle	£25
LINDA RONSTADT - Greatest Hits	£25
ELECTRIC LIGHT ORCHESTRA - Eldorado	£25
JIM CROCE - Gold In A Bottle	£25
WES MONTGOMERY - So Much Guitar!	£25
ELLA FITZGERALD - Sings Cole Porter Songbook	£35
JOHN COLTRANE & PAUL QUINICHETTE	£25
SONNY ROLLINS - Tenor Madness	£25
BAD FINGER - Straight Up	£25
CANNONBALL ADDERLEY - Know What I Mean? £25	

Classic Records HQ LPs

More RCA - LSC 180gm HQ LPs

LSC 2449	GOUND - Faust/BIZET - Carmen	£28
LSC 2456	LALO - Symphonie Espagnole	£28
LSC 2500	STRAUSS - Waltzes (Reiner, C.S.O)	£28
LSC 2541	LISZT - TODTENTANZ	£28
LSC 2625	MIHAUD - Creation (deluxe cover)	£35
LDS 6065	THE ROYAL BALLET GALA (2LP)	£50

Verve Jazz 180gm HQ LPs

ELLA FITZGERALD - Clap Hands Here Comes...	£25
ELLINGTON & HODGES - Back To Back	£25
COLEMAN HAWKINS ENCOUNTERS	£25
COLEMAN HAWKINS - Alive At The Village Gate	£25
BILLY HOLIDAY - Songs For Distingue Lovers	£25
ELLA FITZGERALD - Let No Man Write My...	£25
BILL EVANS - Live At Montreux	£25
ELLINGTON & HODGES - Side By Side	£25
SONNY STITT - Blowing The Blues	£25
JOHNNY HODGES - Blues A Plenty	£25

RCA 180gm HQ LPs

HARRY BELAFONTE - At Carnegie Hall 2LP	£37
BOB & RAY - Throw A Stereo Spectacular	£25
DICK SCHORY - Bang Baa-room & Harp	£25
SONNY ROLLINS - The Bridge	£25

CBS Jazz 180gm HQ LPs

DAVE BRUBECK - Time Out	£25
DUKE ELLINGTON - Blues In Orbit	£25

Jazz Planet 180gm LPs & HQ CDs

ART DAVIS - A Time Remembered (180gm LP)	£25
HQ CD	£15

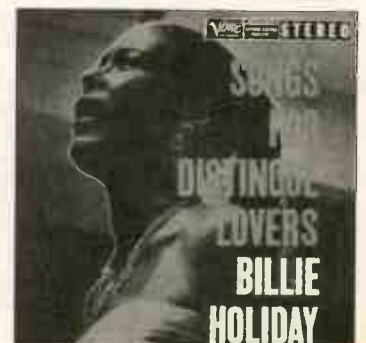

Look Whats New At : AUDIOPHILE INTERNATIONAL!

Classic Go Gold !

24kt Gold CDs

Classic Records famous for their excellent LP reissues have now launched whole heartedly into 24kt gold CD production. Again mastered from the original master tapes by Bernie Gruncman and Tony Hawkins.

Their first two titles boast excellent production and sound quality.



CSCD 6306 ESPAÑA!

One of the most highly treasured and sought after albums £25

LSCD 2225 WITCHES BREW

Probably the best of the British RCA's no collection should be without. £25

Recommended CDs & LPs

The following are recommended by Audiophile International Ltd For Sonics or content.

TORI AMOS - Boys For Pele (US import)	
Stunning new album. Two LP Clear Virgin Vinyl set	£15
TAB BENOIT - What I live For (Import CD only)	£13
RAY BROWN/J ROWLES - As Good As.(CD)	£13
MILES DAVIS - Live At The Plugged Nickel	
US imported 7CD box set	£125
BJORK - Post (European Black Vinyl)	£9
British Pink Vinyl	£12
k.d.LANG - All You Can Eat (US import LP)	£12
BRIAN ENO - Passengers (US import LP)	£12
TERRY EVANS - Putting It Down (HQ 180gm LP)	£17
HQ CD	£15
BEATLES - Anthology Volume 2 (3LP set)	£25
RED HOT CHILI PEPPERS - Out In LA (US import)	
An album that captures the best of this groups talents.	
19 unreleased cuts, rare versions and club mixes.	£10
STING - Mercurary Falling (LP)	£12
PULP - Different Class (LP)	£10
DIRE STRAIGHTS - Live At The BBC (LP)	£9

New - Books & Magazines

We now have in stock the following U.S. Imported Magazines.

the abso!ute sound

Although many believe that TAS is no longer with us we have in stock the following exciting new issues.

TAS 100 For Information call	£8
TAS 101..For Information call	£8
TAS 102 Analogue Issue	£8
TAS 103 Special Recordings	£8
TAS 104 Quo Vadis High-End	£8

the tracking angle

The tracking angle is an exciting new magazine written by Micheal Fremer. Following the success of his column in TAS Micheal has launched his own music review magazine.

TA 001 The First Issue	£5
TA 002 What Makes A Classic Record	£5
TA 003 Zen And The Art Of Record Cleaning	£5
TA 004 The Rolling Stones LPs & CDs Survey	£5
TA 005 Double Issue which includes; Hendrix LP & CD survey, Interviews with engineers Eddie Kramer & Shawn Murphy. Still only	£5



Another new magazine distributed exclusively by Audiophile International. FI is a stunning new U.S. publication written by such talents as Wayne Garcia, Ken Kessler, Jonathan Valin, Dick Olsner, Skip Rudolph and many others. Issues 2 & 3 now in stock @ £5.75 including P&P

Fi 02 Interviews Brian Wilson + Music + Audio Plinius, Audio Research, Altis, Sound Lab, VAC.
Fi 03 Sinatra Generation Man + Music + Audio: Well Tempered, Gallo Nucleus, Thiel CS 1.5...

Mapleshade HQ CDs

KENDRA SHANK - Afterglow.
Produced by the incomparable Shirley Horn to introduce a gifted new ballad singer - fresh, sensual. A new reference for female voice transparency and intimacy. £13

NORRIS TURNEY QUARTET - Big, Sweet 'N' Blue
Ellington's last alto star, Norris Turney with an historic rhythm section: Jimmy Cobb, Miles' drummer; Walter Booker, Thelonious' last bassist and Larry Wills on piano. Mapleshade's biggest, mellowest sax sound yet. £13

WALTER DAVIS JR. - In Walked Thelonious.
Breathtaking interpretations of Monk by the late renowned pianist who toured with Bird at 17 and became Monk's protege at 18. Creates an intense, mystical dialogue between Walter and Thelonious himself. Captures the powerfully percussive piano sound of the bebop master like no other recording. £13

THE FRANK KIMBROUGH TRIO - Lonely Woman
One of the most listenable, harmonically rich new piano trios since Bill Evans. Deep lyricism on slow ballads, haunting originals performed with great sensitivity. Transparently clear piano, warm and lucid bass, startlingly delicate cymbals. £13

EDDIE GALE QUINTET - A Minute With Miles.
A great trumpeter's odyssey: Eddie Gale takes you from Africa to New Orleans to modern jazz and beyond. Instruments sound stunningly present, 3-dimensional and focused. £13

Pope Music Dynamic Fidelity

Super high quality 24kt Gold CDs, PopeMusic have created the 'DYNAMIC FIDELITY' process to be the best canvas and brushes any artist could ask for, to provide the ultimate in expression; to evoke both the subtlety and strength of the entire range of human emotions.

LORI LIEBERMAN - A Thousand Dreams An original acoustic recording, that weaves you in a multitude of moods.	£25
THE UNLIKELY SILHOUETTES (Russian Sym) Unique interpretation of Bizet's "Camen Suite" and Shostakovitch "Bolt".	£25
ENTANGLED DEVOTIONS (Russian Sym) 18 Months in the making, Beethoven's Piano Concerto No.5 "Moonlight" Sonata arguably the most romantic performance of our generation.	£25
LORI LIEBERMAN - Home Of Whispers A classic follow up album, with Lori at her most personal, you will not be left unmoved!	£25
FAREWELL (Russian Symphony Orchestra) Mark Gorenstein's evocative interpretation of Tchaikovsky's Sixth Symphony.	£25



Analogue Productions

High quality 180gm HQ Vinyl LPs and 24kt Gold CDs

AP 027 JANIS IAN - Breaking Silence This all analogue album finds Janis' voice in its purest most vital form ever. The album has been praised not only for Ian's talents but also the staggering dynamics. Her very personal songs are delivered in a voice that creates confidence. Breaking Silence is one of the few recordings of recent years to attain audiophile status. Highly recommended. 180gm LP + 24kt Gold CD	£25
NANCY BRYAN - Lay Me Down. Analogue Productions proudly brings you Lay Me Down. Alternative rock/folk/pop diva Nancy Bryan's stunning debut of original songs. Likened to Joni Mitchell and Sarah McLachlan - but with an edge.	£25
Aluminium CD	£15

Mobile Fidelity Sound Labs

Super high quality 200gm LPs and 24kt Gold CDs.
Buy 2 single LPs @ £22 each, Buy 5+ @ £21 each!

MUDDY WATERS - Folk Singer	£25
PINK FLOYD - Atom Heart Mother	£25
EMERSON LAKE & PALMER - Tarkus	£25
THE MODERN JAZZ QUARTET - MJQ	£25
THE MODERN JAZZ QUARTET - At Carnegie Hall	£25
U2 - The Unforgettable Fire	£25
STAN GETZ & JOAO GILBERTO - Getz / Gilberto	£25
TRAFFIC - The Low Spark Of High Heeled Boys	£25
JOHN HIATT - Bring The Family	£25
QUEEN - The Game	£25
JEAN MICHEL JARRE - Oxygene	£25
ALLMAN BROTHERS BAND - Brothers & Sisters	£25
DUKE ELLINGTON - Anatomy Of A Murder (LP)	£25
MOODY BLUES - On The Threshold Of A Dream	£25
DAVE BRUBECK - We're All Together Again For ...	£25
COLLINS, CRAY & COPELAND - Showdown!	£25
EMERSON, LAKE & PALMER - Trilogy	£25
ERIC CLAPTON - Eric Clapton	£25
BOB MARLEY & THE WAILERS - Exodus	£25
JOHN MELLENCAMP - The Lonesome Jubilee	£25
JOE COCKER - Sheffield Steel	£25
HANK CRAWFORD - Soul Of The Ballad (LP only)	£25
TODD RUNDGREN - Something / Anything? (2LP)	£35
ALBERT COLLINS - Cold Snap	£25
JEAN MICHEL JARRE - Equinoxe	£25
THE MODERN JAZZ QUARTET - At Music Inn	£25
RICK WAKEMAN - Journey To The Centre Of ...	£25
REM - Murmur	£25
MOODY BLUES - Every Good Boy Deserves ...	£25
SONNY TERRY & BROWNIE MCGHEE	£25
GERRY MULLIGAN & BEN WEBSTER	£25
B.B.KING - Lucille	£25
BOB MARLEY & THE WAILERS - Catch A Fire	£25
COUNT BASIE - April In Paris	£25
JOAN BAEZ - Diamonds & Rust	£25
DEREK & THE DOMINOS - In Concert (2LP)	£35
BERNARD HERRMANN - The Fantasy Film World	£25
MULLIGAN & DESMOND - Blues In Time	£25
OSCAR PETERSON, MILT JACKSON - Very Tall	£25
STEVENS - Teaser And The FireCat	£25
AVERAGE WHITE BAND - AWB	£25
JOHN MAYALL - The Blues Alone	£25
BILLIE HOLIDAY - Body And Soul	£25
ELLA FITZGERALD & LOUIS ARMSTRONG (2LP)	£35
NEIL YOUNG - Old Ways	£25
DEREK & THE DOMINOS - Live (2LP Set)	£35
BOSTON - Boston.	£25
TOTO - IV	£25
MOODY BLUES - To Our Childrens Children	£25

Audiophile International Ltd. P.O. Box 303, Chobham, Surrey, GU24 8YP.

If you really like music and want a better selection of the latest releases on standard vinyl, gold CD and audiophile vinyl as well as the reassurance that your order will reach you safely you ought to join our world wide data base. Send £3 in postage stamps for our huge gloss catalogue (includes £3 refundable coupon) which contains the UK's largest selection of audiophile recordings. Then every month receive free of charge 'update' catalogues containing new releases and used mint condition LPs. To order call one of our numbers, your order will be handled that same day. First LP £3 additional 75p. First CD £2 additional 25p. Orders sent First Class Recorded. For large orders we offer Parcel Force Next Day fixed Price (any weight) £6.75.



Oxford Audio Consultants

HI-FI SPECIALISTS



Our superb service is the same, regardless of price.

KRELL INTEGRATED AMP
- yes, we've finally got it !!
- product of the year 1996

NOW DEMONSTRATING

COPLAND CD288 CD PLAYER - incredible sound quality for £1800
SONUS FABER CONCERTINO - £600 a knockout !
KRELL KPS30i CD PLAYER - a 'budget' version of the KPS20
WILSON WITT & SYSTEM 5 - the ultimate !
MUSICAL FIDELITY F23 / F16 - new and much improved !
UNISON RESEARCH SIMPLY FOUR
CASTLE HOWARD MK2, HARLECH & SEVERN - quality wood finish
TUBE TECHNOLOGY SYNERGY
SHUN MOOK ACCESSORIES - fascinating !
MARANTZ CD17 AND 63 SIGNATURE CD PLAYERS
MARTIN LOGAN AERIUS & SL3 - electrostatics at their best
ROGERS LS33 SPEAKERS
TEAC VRDS 10SE CD PLAYER - the follow up to the very successful 10
THORENS AMPS AND CD PLAYER
B & W CDM 1 & CDM 2 - superb newcomers from B & W
QUAD 77 CD PLAYER AND NEW 77 PRE AND POWER
QUAD ESL 63 LOUDSPEAKERS
MICHELL ORBE TURNTABLE - superb value for money
REL STORM/STRATA/STADIUM II/STENTOR - redefines our ideas about subwoofers
RUARK PALADIN - A worthy big brother to the Talismans
TDL NUCLEUS SUBWOOFER - astonishing value for money

EX DEM & P/EX BARGAINS

ARCAM XETA ONE	£750 SH
ARCAM DELTA 290P POWER AMPS	EACH £295
DELTA BLACKBOX 500	£475 SH
NAKAMICHI DR 2 CASSETTE DECK MINT	£495
ATC 20 LOUDSPEAKERS	£795 SH
SNELL J 2 SPEAKERS INC PIRATE STANDS	£495 SH
BURMESTER 785 PREAMP	£495 SH
REL STYGIAN SUBWOOFER	£195 SH
ARCAM 250 CD TRANSPORT	£495 SH
KRELL 200S POWER AMP	£5995 SH
AVI 2200 MONOBLOCK POWER AMPLIFIERS	£795 SH
MERIDIAN 602 TRANSPORT	£795 SH
DPA LITTLE BIT DAC	£100 SH
LINN STRATOS PREAMP	£100 SH
MISSION 781 LOUDSPEAKERS	£175 SH
LINN INDEX WITH STANDS	£250 SH
ORELLE CD480 CD PLAYER	£295 SH
TEAC 3500 CD PLAYER	£100 SH
LINN KABERS WALNUT	£695 SH
AUDIO RESEARCH D200 POWER AMP EX DEM	£2250 XD
ROTEL RT950 TUNER	£150 XD
AUDIO RESEARCH LS2 MK 1 PREAMP	£1295 SH
CLASSE DR15 POWER AMP	£1795 SH
MUSICAL FIDELITY F15 POWER AMP EX DEM	£1195 XD
ORELLE CD10T/DA180	£795 SH
AUDIO RESEARCH LS5 PREAMPLIFIER	£1995 XD
KINSHAW PERCEPTION DAC	£295 XD
RUARK BROADSWORD B STOCK	£595 XD
APOGEE CENTAUR	£995 SH



Oxford Audio Consultants

Oxford Audio Consultants, Cantay House, Park End Street OX1 1JE
Telephone: Oxford (01865) 790879 Facsimile: Oxford (01865) 791665



Don't let your
LISTENING ROOM
spoil his performance.

With the help of

Room Acoustics Services
you can achieve near concert hall realism,
in harmony with your home decor.

Full details, reviews etc, of our computerised postal
Hi-Fi room acoustics consultancy available from:-

ROOM ACOUSTICS SERVICES

3, Queen Elizabeth Way, BARTON-upon-HUMBER,
South Humberside, DN18 6AJ. Tel: (0652) 635523

MERIDIAN LUMLEY REFERE
AUDIO RESEARCH MARTIN
CASTLE ORELLE MICHELL
TANNOY ONKYO ROTEL MA
SILVER SOUNDS COGAN HA
TEAC AUDIO TECHNICA NA
VALVES MAXELL OKTUFON
DYNAUDIO APOLLO
MAF AUDIO ALCHEMY
GOLDRING MILTY SOU
THETA SILTECH
CABASSE DKOX ROTEL
STRATOSPHERE TUR
CONVERGENT AUDIO
FIGURATION GRAH
TRICHORD THX-HOM
MERIDIAN LUMLEY
AMPS MUSICAL FIDE
LOGAN CASTLE XTC
ONKYO ROTEL NAD P
SOUNDS COGAN HAL
RESEARCH CUPS OF
TEAC AUDIO TECHNIC
BILLINGTONVALVES
STANTONCELESTION
CABASSE-CONVERGE
MONSTER-MERIDIAN
AUDIO RESEARCH MU
MARTIN LOGAN SON
MICHELL RUARK STAX
TANNOY NAD CELESTION ON
LEXICON PROJECT SILVER SO
DNM HOME DEMONSTRATIONS
DEMONSTRATION ROOM SERV
TWO YEAR GUARANTEE ALL MA

Harrogate



hi-fi

NCE MUSICAL FIDELITY
LOGAN SONUS FABER
RUARK STAX COPLAND
RANTZ LEXICON PROJECT
LL DNM AUDIO RESEARCH
D BEYER BILLINGTON
STANTON CELESTION
TDL SOUNDSTYLE
ALPHASON QED
ND ORGANISATION
B&W CABLE TALK
J A M O
NTABLE AIRPOD
T R A N S
AM TONEARM
E CINEMA
REFERENCEVALVE
LITY MARTIN
ORELLE TANNOY
ROJEC T- SILVER
LDNMA U D I O
C O F F E E
A BEYER
MAXELL OKTUFON
D Y N A U D I O
NT AUDIO
GENESIS CABLES
SICAL FIDELITY
US FABER CASTLE
COPLAND
KYOTEL MARANTZ
UNDS CHORD LUMLEY
TRY BEFORE YOU BUY
ICE DEPARTMENT FREE
JOR CREDIT CARDS ACC

15 COMMERCIAL STREET, HG1 1UB (01423) 504274

BACK TO THE TONE AGE.

In these days of so-called advanced technology, isn't it great to find a place that understands and deals in classic valve equipment. Groove Tubes, the brand leader in valves have created our very own 'Temple of Tone' that offers a completely unique and friendly service.

We have:

- Groove Tubes—the world's finest tube.
- Great Tube amplifiers, new and secondhand.
- GT Pro Audio Mics and studio equipment.
- The Tube Amp Book—latest edition 840 pages.
- Lots of accessories and parts.
- The GT 'Lets tone up your amp service'.
- General service and repair work on any valve amplifier.
- 24 hour tour/preproduction/studio support.
- Mail order on tubes etc.

Phone us on the GT hotline for free advice or to book an appointment. Tel: 01902-620156, Fax: 01902-620207 or Mobile: 0831-794142

GROOVE TUBES UK LTD

8 Barn Green, Bradmore, Wolverhampton, West Midlands WV3 7AY



PROGRESSIVE AUDIO



DIGITAL:- AUDIOMECA:- MEPHISTO, KREATURA AND DAMNATION TEAC:- VRDS 7, 10SE, 2S, T1, D700+P700. SUGDEN:- OPTIMA, SDT-1, SDD-1, SDD-1 AND SDA-1, AUS1 PRO AND AUS1 DAC. AUDIO ALCHEMY DRIVES AND DACS. AUDIONOTE DAC 1, 2 AND 3. TRICHORD RESEARCH, PULSAR 1 DAC + TRANSPORT. HARMON KARDON.

AMPS:- SUGDEN:- WHOLERANGE, CHORD 3200PRE, 800, 1000 + 1200B POWER. MICHELL ISOS, ARGOS AND ALECTOS. AUDIONOTE OTO, MEISHU, QUESTS + CONQUESTS AND M2 PRE. TUBE TECHNOLOGY. UNISON RESEARCH 845s, SIMPLY TWO AND FOUR, DENSEN BEAT AND DM10. PARASOUND PRE+POWERS. CONRAD JOHNSON PV10+MVSS. AUDION STEREO + MONOLOCKS. LFD PRE+POWER. HARMON KARDON. AUDIO INNOVATIONS. MOTH.

LOUDSPEAKERS:- PROAC R1S, R2S, R2.S AND R3.S TABLETTESSO, STUDIO 100, 1S0 + 200. IMPULSE LALI + TA'US. SD ACOUSTICS SD3, S AND 1. UKD OPERA + CALLAS. AUDIONOTE K, J + E. SPENDOR. ORIGIN LIVE. JPW. TDL. QUANTUM AUDIO. HARLEQUIN. ALON PETIT, O.S AND 1. AUDIOSTATIC ELECTROSTATICS. ANALYSIS RIBBONS. REL SUB WOOFERS. MOREL. ORTOFON.

ANALOGUE:- MICHELL MYCRO GYRO + ORBE. VOYD. VPI. SYSTEMDEK. PROJECT. SME. ORTOFON. LYRA. DENON. GOLDRING. GRADO. REGA ARMS.

STANDS + RACKS:- TARGET. SOUNDSTYLE. SOUND ORGANISATION. ALPHASON. RATA + TRIPOD.

CABLES:- AUDIONOTE. VDH. KIMBER. SILVERSOUNDS. AUDIOQUEST. CARDAS. LFD. QED. CABLE TALK.

SECOND HAND:- ATC 10 LOUDSPEAKER (YEW) + STANDS (MINT) £795
MICHELL ARGO AND HERA (MINT) £425
MUSIC FIDELITY MX PREAMP (MINT) £525
AUDIO INNOVATIONS S.S00 AMP (EX COND) £395
QUESTAR QA2 ACTIVE LOUDSPEAKERS WITH STANDS AND 3M
KIMBER I/C CABLE (EX COND) £395

CALL ANYTIME FOR A DEM OF ANY OF THE ABOVE EITHER HERE OR IN THE COMFORT OF YOUR OWN HOME. ASK FOR DAVE ON RAINHAM, KENT (01634) 389 004

For Audio Visual equipment please call Brian Ridell on Medway (01634) 681 233

Sound Connections

Mail Order Suppliers Of Quality Hi-fi Accessories
Tel/Fax 0151 348 1988

AUDIO CABLES:

van den Hul • Soniklink • Dnm Reson • The Chord company • XLO
Audio Quest • Kimber • Nordost • QED • Ixos • Kontak • Ortofon

CARTRIDGES AND TONE ARMS:

Lyra • Sumiko • Dnm • Ortofon • Goldring • Moth • SME

HEADPHONES:

Stax • Sennheiser • Beyer • Jecklin • Grado

EQUIPMENT AND ISOLATION SUPPORT:

Black Diamond Racing • Target • Soundstyle • Townshend

AND MANY MORE INC:

Audio Alchemy • Cardas • Shun Mook • Kontak • Ixos • WBT
Mobile Fidelity • Bedini • Trichord • QED • Michell

**WE OFFER A HOME TRIAL SERVICE ON A
SELECTED RANGE OF
CABLES AND ACCESSORIES**

Major credit cards accepted

Please telephone or fax for our full product and price list

Mon-Fri 9.30am to 8.00pm (Sat to 1.00pm)

52 Green Lane, Great Sutton, South Wirral, Cheshire, L66 4LE

e-mail: sounconnec@aol.com

Cable Talk

Interconnects & Speaker Cables



**The full range of our
Award Winning Cables are
available from your
local dealer.**



PLEASE TELEPHONE **01252-373434**

FAX **01252-371818** FOR FURTHER INFORMATION

RESTORATION OF CLASSIC EQUIPMENT

ELECTRONICS ENGINEER (DEGREE/MAES) WITH OVER 40 YEARS EXPERIENCE AND SPECIALIST KNOWLEDGE OF QUAD, RADFORD, LEAK, ROGERS AND ARMSTRONG, ETC. EXTENSIVE FACILITIES ENABLE ORIGINAL STANDARDS WITH DETAILED REPORTS OF WORK CARRIED OUT. APPARATUS IS DEMONSTRATED PRIOR TO CLIENTS DEPARTURE. AVAILABLE 7 DAYS A WEEK. VALVE TESTING A SPECIALITY.

CIRCUIT DATA AND AUDIO EQUIP. ON OFFER...

PLEASE ENQUIRE

TEL 0181 504 5467 WOODFORD, ESSEX

DEFINITIVE AUDIO

Listening to music on most Hi-Fi systems is a pale imitation of the experience of live performed music. Finding a hi-fi system that can replicate the live experience is not easy, most systems present music in a small sanitised and ultimately unengaging manner.

Definitive Audio carries a strict selection of systems that reproduce music in the way that it was performed - with effortless energy, scale and subtlety. We achieve this with a range of highly acclaimed products some of which are exclusive to Definitive Audio.

SECOND HAND ITEMS FOR SALE

	SALE	RRP
WADIA 21 - Boxed - (30 HRS)	£3900	£4950
AUDIO NOTE I.O. MC CARTRIDGE - (<100HRS)	£700	£1500
HORNING AGATHON 3 WAY HORN	£3200	£3600
APOGEE CENTAUR MINOR	£680	£1350
QUAD 66 PRE AND CONTROL PANEL / 606 POWER AMP	£900	£1510
MICROMEGA DUO CD.2 TRANSPORT	£1380	£2500
MICROMEGA STAGE 2 - EX-DEM	£650	£750
MICROMEGA STAGE 3 - EX-DEM	£800	£900
ROGERS LS2a2	£150	£250
AUDIO INNOVATIONS 1000 MONO - EX-DEM	£1000	£1500
SNELL J11 LOUDSPEAKER SYSTEM	£450	£800
MONITOR AUDIO MA 800 ROSEWOOD	£375	£800
AUDIO INNOVATIONS CLASSIC 25 KIT - NEW	£600	£700
AUDIO INNOVATIONS S.200 POWER	£400	£500
VARIOUS EQ. SUPPORTS AND USED HIGH END I/C CABLES AND SPEAKER CABLES		

Audio for the first time buyer and seasoned enthusiast.

Quality advice, guidance and service

A wide range of interesting products, some mainstream, some unusual, all serious

Low and mid power valve amplifiers, horn and high sensitivity loudspeakers.

UK AGENT - Horning and Lowther. WORLDWIDE AGENT - Vitavox and Living Voice.

Please phone / fax for further details

Import/Export. Visa Amex Mastercard Tel/Fax 0044(0) 115 9813 562

TECHNICAL & GENERAL

Some Necessities - From the Original Classic Turntable Specialists

		P&P
Connoisseur	BD1/2 Drive Belt	10.25 1.85
	BD1/2 Motor Suspension kit	13.95 2.45
	SAU.2 Headshell	16.75 2.55
	SAU.2 Connecting lead	15.95 3.55
Garrard	Standard Models	
	Wired arm tubes	from 12.75 2.55
	Cartridge carriers (sliders)	10.25 1.85
	Idler Wheels	9.85 2.25
	301/401 Transcription Models	
	Original Thrust pad assembly	10.25 2.25
	Original Idler tension spring	2.95 1.85
	Original Speed control disc - 401	13.75 2.20
	Xeroxcopy Owners Manual 301 incl. full size mounting template	7.85 1.85
	Xeroxcopy Owners Manual 401 incl. full size mounting template	5.70 1.85
	Replacement Intermediate drive wheel	19.95 2.85
	Replacement 301 control knobs	
	On-Off/Speed select	pair 20.25 2.55
	Replacement 301 suppressor unit	5.65 2.25
	Replacement 301 motor pulley (-2%), (-1%), (Std), (+1%)	each 12.65 2.25
	Replacement 301 Chrome plated mounting bolts	set 4.70 2.25
	Recommended Lubrication set - early 301/standard 301/401 - please specify	5.60 1.85
Goldring/Lenco	Idler wheel (lock-nut or clip fixing)	19.95 2.85
	Arm Pivot bearings with instructions	8.25 1.85
	Spindle/Main bearing assembly complete	24.85 3.85
	Headshells	from 21.95 2.55
	Instruction books	from 4.20 1.85
Thorens	TD.124 series	
	Idler wheel - original	27.50 2.85
	Idler wheel - our redesigned replacement	15.35 2.55
	Drive belt	15.25 1.85
	Chassis spring suspension (replaces 'mushrooms')	13.85 2.55
	150/160 series	
	Drive belt	10.25 1.85
	Suspension springs (-1%), (Std), (+1%)	set 11.85 2.55
	Suspension bushes	set 12.50 2.25
	Armboards for most models	from 16.90 2.55
Cecil Watts Dustbugs/Parastats/ (spares incl. Preener wicks)		
Cartridges and styl for 78s & Mono LPs in addition to current Stereo LP		

TECHNICAL & GENERAL PO Box 53. Crowborough, E.Sussex. TN6 2BY Tel:- 01892 654534

Pure Sound

We want your used quality kit!

A selection from this month's used ex-dem bargains

- Call us for a list with your wants and disposals!

AMPS

California Audio Technology CAT SL1 phono preamp (as new)	£2,550
Marantz MA22 monoblocs and matching SC22 preamp, gold	£1,650
Copland CSA 14 (as new condition)	£875
Lumley Reference passive preamp (chrome)	£250
Alchemist Kraken preamp and pair power amps, anniversary edition	£845
Arion Tycho 50W chrome	£1650
YBA power 3	£899
Audio Note Meishu	£2250
Arion Elektra export	£999
Adyton Opera integrated amp	£1995

DIGITAL

Marantz CDA94 (Balanced and unbalanced outputs - excellent sound)	£650
Audiomeca Damnation CD Transport	£775
YBA CD2 player	£1650
Meridian 208 Transport + DAC, remote control preamp, (inc. volume control)	£650

TUNERS

Technics ST-9600 (one of the superb analogues, AM/FM)	£625
---	------

TURNTABLES

Michell Gyrodec / Well tempered arm / Supex cartridge	£825
---	------

SPEAKERS

Audio Physic Virgo (ex demonstration)	£2,950
Audio Physic Step (slightly marked)	£799
Sonus Faber Amator IIs (just fabulous)	£1699
Triangle Altiris (beautiful speaker, sensitive for low power valve amps)	£1499
Triangle Alcante speakers (sensitive, good match to valve amplifiers)	£550
Triangle Scalene speakers (smaller, but also good with valves)	£350
Lumley Reference 4s - bookshelf speaker - amazing value	£215

01784 458176 0831 178740

Audio Masters

Mail Order Accessory Specialist!!

Chord company Siren Interconnect Cable

The Chord Co. always seem to deliver very high quality sound without high quality prices, and their latest offering "The Siren" is no let down. Clad in an extremely fetching purple jacket it looks as good as it sounds. It is full bodied yet smooth cable with plenty of detail. Compatibility with most Hi-Fi separates is also one of its strong points.

All This For Just.....£65 + £1.50 P+P!!!

Kontak® Cleaning solution

Originally developed for military use, Kontak is the only cleaning solution capable of removing completely all traces of any contaminates on any connecting surface. The subjective benefits gained from cleaning a system with Kontak are improved bass response, an enchantment of low level detail and transparency and a greater sense of dynamic range.

Never Be Without a Bottle!.....£14.95 + £1.15P+P

XLO Reference AC Mains Cable

Not just another mains cable but probably one of the best mains cables in the world in our opinion! After connecting this mains lead to your power amp you too can experience a cleaner bass, less muddled midrange and better overall dynamics!! It also works wonders for pre-amps, CD's and most other Hi-Fi components.

3ft £125...4ft £150...5ft £175...6ft £200 P+P FREE!

WBT 4mm Banana Gun!!

The banana gun is the very latest in banana plug technology. Made to comply with all of the new CE regulations these banana plugs are anything but a compromise! Although they are fully insulated you can still stack them if your amp has just one output. The usual gold plated finish that you expect from WBT is no let down and also the locking mechanism is simple but effective. One innovation is that the speaker cable enters the plug at an angle to assist cable management, a must for all spaghetti fiends!!!

Only.....£39.95 + £1.50 P+P

Ortofon Rohmann MC Phono Cartridge

based on the flagship MC 7500 cartridge the "Rohmann" is named after Erik Rohmann who started Ortofon in 1970. It's not just a marketing gimmick it is just a superb cartridge. It is based on 7500, in fact the only big difference is that the body is milled out of a solid block of aluminium and not titanium. The sound you get from the Rohmann is warm yet incredibly dynamic. It epitomises the results you would expect from a cartridge of it's quality. In our opinion it's seriously underpriced.

Full Price £1000.....Ortofon Exchange Price £750

Sennheiser HD 565 Ovation Headphones

The name says it all "standing" ovation for the precise, natural and spacious sound. Even in difficult musical passages this top headphone of the 5-series is able to keep instruments separated and to reproduce voices with the correct volume and impulse. Fully adjustable for hours of comfortable listening, this headphone like all Sennheiser's top-quality headphones, comes complete with a detachable OFC copper cable.

A Must at Only.....£139.99 P+P FREE

Other Agencies Include....

XLO, Target, Soundstyle, Beyer, Goldring, QED, Bib, Audioquest, Discwasher, Grado, Maxell, Ortofon, Shure, Sound Organisation, Stanton, Puresonic, Platform, Chord Co., Van Den Hul, Lyra, WBT, Audio Alchemy, Sennheiser, Kudos, Michell, AKG, Flatline, Ixos, Stax, Sumiko

And Many More!!

AUDIO MASTERS makes buying accessories easy!!

1 Duntrop Farm Cottages
Heythrop, Chipping Norton
Oxon, OX7 5TJ
EXPORT ENQUIRIES WELCOME

Phone or fax...
01608 644954
Mobile....
0468 477288

EQUIPMENT SUPPORT

Mana Equipment Tables

- ↖ Superb upgrade for any hi-fi system; like changing every component and buying a new music collection into the bargain.
- ↖ Dust-trap par excellence; more addictive than crack cocaine.

"Now, I can only say that until I had the Mana equipment table fitted, my hi-fi system was at best half-cocked."

Alan Sircorn
Hi-Fi Choice March 1995

Photo: Paul Hartley Studios



"Mana Tables are not cheap. But they are essential if you want to unlock your system's true potential." BEST BUY
Malcolm Steward, Hi-Fi Choice February 1996

For information on MANA products please contact:

Mana Acoustics

59 Jubilee Close, Pinner, Middlesex HA5 3TB
Tel/fax: 0181 429 0118 Tel: 0181 868 2788

UNREPEATABLE OFFER MICROMEGA CLASSIC LINE CD PLAYERS

We have purchased the last stock of the fabulous sounding and stunning looking Micromega Classic Line Compact Disc Players and are able to offer them for quite unbelievable prices.

	WAS	NOW
Micromega CD3.1 Duo Pro. 2	£3000.00	£2400.00
Micromega CD2.1 Duo. Pro. 2	£4250.00	£3150.00
Micromega Trio .3	£6450.00	£3995.00

STOCKS OF ALL THE ABOVE ARE VERY LIMITED
All equipment is new, boxed and fully guaranteed

powerplant



66/67 Upper North Street Brighton BN1 3FL
Telephone: 01273 775978 Fax: 01273 748419

ATC, AVI, Audiolab, Arcam, B&O, Cyrus, Exposure, Micromega, Marantz, McIntosh, Procead, Rega, Roksan, Stax and other quality equipment.

Mail order and Worldwide Export service available

Information overload.



Not just a catalog - a valuable source of information. **The Parts Connection Catalog & Resource Guide, Volume 2** includes specs and curves for the most commonly used audio tubes as well as some basic tube electronics theory from the RCA Receiving Tube Manual - and that's not all. There are schematics for many classic tube amplifiers and pre-amps from Dynaco, Marantz, Quad, McIntosh and more! Also included are white papers on the technical benefits of premium film caps and metal foil resistors.

If that's not enough for you, we've added a wide range of books on vacuum tube electronics theory, tube data, practical projects, loudspeaker design and building, and audio history. You want more, you say. Alright, The Parts Connection has an even wider selection of premium parts. We are now stocking a wide range of power and output transformers and chokes from Hammond, the exciting new van der Veen toroidal output and power transformers from Plitron, and an expanded range of the superb MagneQuest output transformers for push-pull and single-ended applications. We have a broader range of film capacitors, including the new MIT PPFX-S and PPFMX-2 series, and the new InfiniCap from Wonder.

As expansion seems to be the theme, how about expanded selections of Howland Musi-Caps, Kimber Kaps, Rel-Cap Teflons, Solen Fast Caps, Wima and others! Our cable selection has also expanded to include new types of Kimber Kable, AudioQuest, Cardas Audio, van den Hul, Goertz and more. Along with a wide selection of connectors to hook it all up.

Expand your opportunities! Order **The Parts Connection Catalog & Resource Guide, Volume 2** today and see for yourself! We're sure that you'll find all that you need for your next audio project. The 7.00 £* charge for the catalog includes a coupon good for \$10.00* off your first order of \$100.00* or more, or \$25.00* off your first order of \$250.00* or more. Call today.

*or \$10.00 US. *Catalogue discounts are in US dollars.

2790 Brighton Road, Oakville
Ontario, Canada L6H 5T4

Toll Free Order Line 1-800-769-0747
(U.S. & Canada only)

Tel (905) 829-5858 Fax (905) 829-5388

e-mail: TPC@sonicfrontiers.com

WWW: <http://www.sonicfrontiers.com/TPC>



**THE PARTS
CONNECTION®**

A DIVISION OF SONIC FRONTIERS INC

GAMMA RHYTHM



NEW

RHYTHM 211/VT4C LINE INTEGRATED AMPLIFIER

Gamma Acoustics are proud to bring you another first, with the launch of our baby 211 line integrated valve amplifier designed for the 90's, offering 18 pure class A linear Single Ended watts per channel in a zero feedback, DC 211 Triode design.

With 1140 volts to the HT and a very substantial power supply it delivers and caters for every conceivable demand. The 'Rhythm' presents the bass authority of the best transistors with the sonic refinement and finesse of a Single Ended design.

It offers sonic levels of excellence until now completely unobtainable, except in a very few esoteric elite designs with extortionate price tags attached.

Presenting a flawless performance, awesome dynamic resolution and tonal accuracy, it promises to thrill and enrapture its listener passionately. A very simple sonic comparison allows the listener to discover for him/herself the obvious superiority over conventional and alternative amplifier designs, a statement not to be left unchallenged.

ONLY £2499

Tel. 01753 526939 Fax. 01753 532262

DISTRIBUTOR/DEALER ENQUIRIES WELCOME
GAMMA ACOUSTICS, IVY LODGE, 81 SUSSEX PLACE,
SLOUGH, ROYAL BERKSHIRE, SL1 INN. ENGLAND.

ANGLIA AUDIO

HI-FI AND SPEAKER CENTRE.

DEDICATED TO QUALITY

HI-FI SINCE 1971

EVENING AND SUNDAY
DEMONSTRATIONS BY
APPOINTMENT.

OPEN 10-6. CLOSED WEDNESDAY
AND SUNDAY

THE STREET
HESSETT
BURY ST EDMUNDS
SUFFOLK
IP30 9AZ

(5 MILES EAST OF BURY ST
EDMUNDS)

TEL / FAX: 01359 270212

FOR PEOPLE WITH EARS !

Valve amplifier sonic upgrades, cost effective critical components only or total rebuilds utilising your component preferences. Alternatively, I can select components to meet your particular sonic requirements. Most amplifiers are suitable subjects, both vintage and contemporary. I have musically enhanced amplifiers from the 1940's to Audio Research Inc. latest designs.

With regard to component choices I have them from Hovland music, I.A.R., Kimber, M.I.T., Wima, Sprague, Audio Note, Vishay, Allen Bradley, Sfernice, Noble, Solen and MANY MORE.
All work is carried out using I.A.R. Wonder Solder.

POWER SUPPLIES

State of the art power supplies are available for most solid state and valve equipment, also turntables; including Naim pre-amps, Audio Alchemy products i.e. DAC in the Box, QED Digit, Oracle Delphi, Rivelin Eclipse, Linn Sodek. PLEASE NOTE:- I can supply "one off" designs without a cost penalty and also modify equipment with built in power supplies, so please ASK! A good power supply is a fundamental requirement. You will be amazed at the improvement it brings.

CABLES

Interconnects, speaker cables, mains cables, digital connections, high purity silver or copper, Teflon or other dielectrics. All hand made e.g. 1 metre pair all silver, Teflon wonder soldered, £75. Tonearms rewired with silver or cardas wire. Valve pre-amps and power amps custom built. Passive pre-amps from budget to state-of-the-art (for less than the price of second best).

SPEAKER FEAT: SUPPORT PLINTHS THAT WORK!
CUSTOM MANUFACTURED FOR YOUR SPEAKERS £49.95 PAIR

THE AUDIO ÉCLAT

DISPOSAL SALE OF SOME OF MY OWN EQUIPMENT

AUDIO RESEARCH SP9	£750:
DAVID BERNING TRIODE POWER AMP	£450
QUAD 22 2XII VALVE AMPS	£295
FISHER FM200B "THE" VALVE TUNER	£695
NAIM NAC12 PREAMP	£150
NAIM ARO ARM	£495
LINN LINGO P.S.U.	£395
ROKSAN XERXES XPS3 ZETA V.D.H.	£595
EMT 930 STUDIO TURNTABLE	£1600
KOETSU URUSHI ONLY 2HRS USE SINCE V.D.H. RE-TIP RE-BUILD	£1200
GRADO SIGNATURE XTZ 100 HOURS USE	£595
FIDELITY RESEARCH FR7 UNUSED	£395
FIDELITY RESEARCH FR64S SILVER WIRED VERSION	£595
KOSHIN GST 801 ARM	£295
SHAHINIAN ARC SPEAKERS	£700
LOWTHER PM7A NEW UNUSED BUT WITH REMAGNETISED ORIGINAL TYPE ALNICO MAGNETS (THE BEST) PAIR	£595
VITAVOX AK124 12" BASS DRIVE UNITS PAIR	£350
VITAVOX GP1 COMPRESSION DRIVE UNITS PAIR WITH ALLOY HORNS	£350
DECCA LONDON RIBBONS PAIR	£175
ARCAM ALPHA 5 CD PLAYER WITH BLACKGATE OUTPUT CAPACITORS	£245

PHONE 01642 559543
FAX 01642 535655

SERIOUS KIT

26 CLARENDON ROAD, SWINTON, GTR.
MANCHESTER M27 4BP.

0161-793-6742 / 0402-367843

NEWS LETTER NO.1A

Welcome to the new Serious Kit. As some of you may be aware, our beloved founder, David W. Spiers has been headhunted by AUDIO NOTE UK, to co ordinate their Worldwide Sales/installation. I am sure all costumers and friends in the Audio industry wish him well in his new venture. As most of you who have followed David's newslwtters be aware, his philosophy of the merits of class A Amplification has gained many followers in the U.K. and abroad.

I too am in full agreement, having been experimenting with Sugdens wondrous Azla, Symmetra mono blocks and Audio

Note UK's OTO SE and Quest mono blocks, mainly fronted by Pro acs amazing Studio and Response range. The results I have heard either with Sugdens Digital range or Michells Gyrodek have been a revelation. To experience a truly amazing musical experience, arrange a demonstration either here or at home! I look forward to hearing from you

Till next time

May the music be with you.

Yours

PHILIP DONALDSON
(PROPRIETOR)



SOUND MANUFACTURERS NEED SOLIDLY RELIABLE VALVES

For continuity of supply, quality components that breathe life into your equipment and tailor made pricing, **talk to us.**

No fancy names, no pretty pictures, just true dedication to service and our customers.

Benefit from our 38 years of trading directly with Valve producing factories and Audio manufacturers

Edicron

Park Road, Faringdon, Oxfordshire, SN7
7BP

Tel: 01367 243030 Fax: 01367 243131

Liberty Audiosuite

a new standard in PC Audio Measurement and
Analysis Systems

advanced....powerful....practical....**£545**

- * *MLS and Gated Sinewave testing, with real phase angle*
- * *Amplitude, Impedance and Phase Angle vs frequency*
- * *Thiele/Small parameters*
- * *Waterfall plots and Energy vs Time displays*
- * *Distortion Analyser, Dual Channel Oscilloscope*
- * *Spectrum Analyser,.....Cepstral Analysis,.....and more..*

You provide the PC (a 486DX is best) and amplifier

I supply the LAUD software + manual, the assembled mic/probe preamp and probes, the ECHO soundcard, a calibrated microphone, and all the cables ready for easy "plug and go", plus fax/telephone support and advice for best use of this very sophisticated but easy to use system.

To order, or for more details, call Tony Seaford at
MARTON MUSIC 01282-773198

Classified Ads

For details on how to place a Classified Advertisement, please see page | 29

PRIVATE

NAIM/LINN BUY/SELL. 52, CDS, 250, 135, 140, HICAP, ARO, 72, 82, ETC
TEL BOB 01382 819732

TDL RTL-4 Speakers. 5 star What Hi-Fi review. Fantastic detail & sound staging, with great bass response. As new, 6 months old. Normally £650 only £450.
Tel: 0181 906 2119/906 0181

WADIA WT3200 Transport. Little used and in excellent condition. Offers-
Tel: 01932 345241 (evenings)

QUAD 306/34/FM4 in Castle stack box-£450, Philips CD 360-£120, Decca Kelly ribbon speakers, rosewood finish-£100, Rel Strata subwoofer, one year old - £450. All in excellent condition.
Tel: 0181 397 2273

KEF CHORALE Speakers in Teak, Goodmans Mod 80 stereo-tuner amplifier and Pioneer CT-4141A cassette tape deck. All with original documentation including tuner circuit/service sheet. £120.
Tel: 01295 750526

THREE LINN SPARK 280s, Active Isobariks, Kairn pre-amp, full spec. LP12, AVI pre-amp and DAC, KEF 104/2, clocked Sony 555 ESD CD player. Quantum 150 w/c monoblocks.
Tel: Doncaster 01302 857983

LINN SONDEK LP12, S.M.E. arm 3009, Aiwa cassette deck AD-6800, Luxman tuner-500, amp-5078, rosewood cases., A.D.C. equaliser, Sound Sharper two MkII, Shure-V15 type 3 unused, Pickering-XV15, Nagaoka-N-30MP unused. Reasonable offers.
Tel: 01772 452034 (daytime)
01204 591177 (evening)

DAC-IN-THE-BOX + Theta TLC + Digital Cable Kentak/Audioquest £230; 5x Monster M-1000 phono £300.
Tel: Michael 0171 937 7935

LINN KANS Walnut £110; Ariston Audio RD80 turntable with Systemdek arm and Linn K18 cartridge £160; Nytek Obelisk amp. £65; Sony CD P101 £120; All VGC.
Tel: 01505 874180 Scotland

FOR SALE Last design Isobariks. Black - excellent, receipt, boxed, £1400. LP12 Ittok LV11, Asaka, little use £600 ono.
Tel: Jonathan 01444 414141 (day)
01444 456772 (after 6pm)

QUAD 66 PRE/ 606.2 power/ 67CD/ 66FM £1825; Quad 606.2 power £430; Deltec T1/ PDM2 £1795; Deltec DSP505 pre/ DPA505 power £1355; Deltec DPA505 power £705; various Deltec cables.
Tel: Pontefract 01977 790310

QUAD STEREO valve amplifier, 22 pre-amp, pair II amps, with Quad mono FM tuner £300. Garrard 301 turntable £125.
Tel: 0116 287 2397 (Leicester).

KRELL DSP CD Player, £2500 RRP £5000+. Magneplaner 2a Tynpnis Electrostatics £1500 RRP £6000. Metaxus Ikarius amp, chrome knobs £600 RRP £1200. Audio Research CDI £1950. Mc Comack Transport £1500, all mint and boxed.
Tel: 0171 591 0395 Knightsbridge.

QUAD ELS63s, Gradient SW63s, Deltec DSP505 preamp, 2x DPA505 power amps, dedicated speaker cable, boxed, manuals. £3800. Alternatively will consider exchange for mint condition Isobariks with Naim amplification.
Tel: 01703 262276 (evenings)

A.R. RECORD DECK with Mission 774 arm and A.T. cartridge, only £100.
Tel: 01483 728916

LINN MIMIK CD PLAYER, latest version, £500 ono. Deltec 505 pre/power combination complete with outboard power supply and phono preamplifier, £1100. Garrard 401 in mint condition and serviced by Loricraft. Just needs plinth, £150. Kinshaw Perception 2-box phono stage, £250. Denon DF-10 mini hi-fi system, light use, mint condition, £500.
Tel: 01747 870280

QUAD 44/405 pre/power £300. Quad 306 power amp brand new, boxed, genuine reason for sale £275. Quad 33 preamp £50. Mission 720 loudspeakers with stands £150. Inkel cassette deck needs attention £15. Inkel tuner £20.
Tel: 01536 763102 (evenings)

SONY DAT DTC 690, RCT serv'd Feb. £400 ono. DPA 200/s pre/power as new boxed, manuals etc. £690 ono. Naim NAC 62 mint, 90's style facia. £340.
Tel: Jules 01792 280061

QUAD ESL Electrostatics, bronze grills working but require attention, £190. Tandberg 3000x reel to reel, faulty Decca arm needing leads Linear PTA15 mono amp. Any offers?
Tel: 0121 308 6129

MISSION 752s Black ash, 5 months old - boxed + receipt. Immaculate, as new £375. Also 2x7m lengths of Chord bi-wire Flatline terminated with gold Chord 4mm plugs 5 months old + boxed £130.
Tel: 01384 271571 (W.Mids)

ATC SCM50A Active Speakers, rosewood. Only five months old, as new. Genuine reason forces sale. Cost £5500, bargain at £4500. AVI S2000MC CD player, mint £850.
Tel: 0181 870 3630

WANTED NVA pre & power amps. P50/ Phono 2/ Sound Chords & A60/A70/A80 or w.h.y? For sale Naim 250 old style vgc £625.
Tel: 0171 701 4580(day) 0181 871 0424 (eve & w/end) SW London.

LOWTHER ACADEMY HORN Loudspeaker. Lacquered piano black. 2xPM7c p/side. 14th Months. £1500. or p/exchange Lowther BICOR 200. Price difference negotiable. Audion Silver Night 300B mono block. £1250.
Tel: 0171 482 4779 after 7pm.

LINN LP12/Rega RB300/ Decca Microscanner £250; REL Stentor £610; Sony STS100ES £140; Sony STS730ES £180; HFN&RR 1956 to 1990 £200; Marantz CD65 SEII £140; Philips CD104 £80.
Tel: Pontefract 01977 790310

AUDIO ALCHEMY DDSIII Transport. Four weeks old. Boxed, receipts. Mint. See the rave review in What Hi-Fi. Genuine reason for sale. £480.
Tel: 0191 281 5482 (Newcastle upon Tyne)

LINN LP12. Ekos, Troika, £850. Linn Isobariks £1200 (Afrosomia). Arcam Alpha 5 £225. Epos ES14s, bi-wire, grills, Epos stands, immaculate £425. Soniclink DM20 Mk1 Amplifier £75. Linn LK1/280 £450.
Tel: 01952 502097 Telford.

CHORD SPM 1200B monoblock power amps. Piano black laquer finish. Perfect condition - stunning £2900.
Tel: 01829 741270

LINN LK280 Power amp-£300; various magazines, 70s-80s-offers.
Tel: 01604 403947 Northampton (after 7pm)

DYNACO USA, Stereo valve tuner £150. Dynaco PAS valve preamp £165. PAT transistor preamp £85. Armstrong 521 amp. £30. Leak Stereo 30 plus amp. £30. All excellent.
Tel: 01372 467264 Esher.

SUGDEN A28 II series amp. Mint boxed. £150. SME 2009 Series II Improved. Non detachable shell. Brand new. Boxed. £120. Troughline 3 stereo tuner. Excellent. £150. Leak Stereo 70 amp. £75.
Tel: 01372 467264 Esher.

NAKAMICHI OMS 7E II CD Player RC excellent condition, £325 ono. Audio Innovations series 1000 pre-amp & first audio mono blocks (rare) excellent condition can demo £995.
Tel: 01252 614055

AUDIOQUEST LAPIS 1 metre interconnect £195 (£400) DPA Black Slink 1 metre interconnects £95 (£210). Both less than 6 months old.
Tel: 01623 798210 (Nottingham).

AUDIO SYNTHESIS DAX 20 bit Ultra Analogue (blk) as new £850 ono. Magnum Pre + Four mono blocks (blk), a staggering 340 wpc! Cost £4585, sell £1650 ono. NAD 302 amp as new £95. Acoustic Energy AE2s (blk) + AE2 stands £700 ovo. Audiophile upgrading, all must go.
Tel: 0181 332 6140

MUSICAL FIDELITY A1000, 50W pure Class A, rave reviews, tremendous build quality, combines valve like smoothness with transistor power. Cost £1400, sell £900 ovo.
Tel: David 01908 678628 (Home), 01908 342552 (Work)

QUAD 606 MKII, 66 control + remote, 66FM, 66CD, excellent condition & in Quad 66, 4 unit rack (£240 new!). Would all cost £3284 new. Only £1500.
Tel: 01733 702801 Peterborough

AVI S2000MC CD Player, hardly used and in absolutely mint condition, still under makers warranty. £850 no offers.
Tel: 0181 870 3630 day or Evenings.

NAIM S.B.L. SPEAKERS with crossovers. Latest spec mint condition £1150.
Tel: 01703 345188

AUDIONOTE P1 Valve power amp. Sadly unwanted prize-unused-£350 (worth £700).
Tel: Simon 0171 603 3755

MICROMEGA STAGE 3 CD boxed & in original condition. Cost new £900 offers over £500. Marantz CD-52IISE with Clock 2 modification. Mint with manuals £225 ono.
Tel: 01282 619809

PAIR OF TANNOY G.R.F. Memory loudspeakers (not horn loaded) made June 1984. excellent condition. £1495.
Tel: Paul 0181 660 3170

LINN NUMERIK D to A con-verter-SMPS as new-£750. Linn Ekos tone arm-MkII-£750. Linn Klout power amp.-as new-£1250.
Tel: Peter 01753 866042 after 6.

EPOS 11s, black, latest x/over, Target stands, £325, (£530). Campaign Audio Design Silver I/CS both 0.6m, each £40, (£76); I CAD D/C, 1.5m £40, (£75). All £420. Upgraded.
Tel: 0181 429 1788

APOGEE SCINTILLA Panel speakers, grey, 4 ohms integral stands, biwireable superb sound, giveaway £1595 (£5000 new). Sumo Athena preamp, Nine Plus 60 wpc class A power amp. £795 (£2200 new).
Tel: 01449 676335

AUDIOJUMBLE

“96”

SALE OF VINTAGE AND
MODERN
AUDIO EQUIPMENT AT
THE ROYAL VICTORIA HALL
SOUTHBOROUGH,
TUNBRIDGE WELLS, KENT.
SUNDAY 14TH JULY
10.30 AM - 4.30pm
ADMISSION £2.00
STALLHOLDERS £15.00

ALL ENQUIRIES:
01892 - 540022

REFRESHMENTS AVAILABLE

IAN HARRISON HI-FI

TEL: 01283 702875

CARTRIDGES

ORTOFON
MC7500
MC5000
MC3000
Rehmann
MC30 Supreme

DENON

DL-51
DL304

AUDIO TECHNICA

AT-OC9

GOLDRING

Elite
1042

SHURE

New Range

TRANS FIGURATION

Temper
Spirit

ROKSAN

Shiraz
Chorus Black
Tabriz 2
Tabriz

LONDON (DECCA)

Jubilee
Super Gold
Meridian

AUDIOQUEST

AQ7000

GRADO

Signature TLZ
Signature MCZ
Signature BMZ

VAN-DEN HUL

TONERMS

GRAHAM
MOTH
ROKSAN

TEST CASSETTES & CDs

Phone Or Write For
Details

HEADPHONES

SENNHEISER

HD580J
HD580P
HD5650
IS850
IS550

BEYER

HD265L
HE60V
HEV70
Orpheus
DT911
DT901
HS990
RS790
DT531
SR325
SR225
SR125
SR80
SR60

GRADO

ATH-F911
ATH-F910P
ATH-M7A
K1000
K340
K500
K400
240M

AUDIO TECHNICA

ATH-F911
ATH-F910P
ATH-M7A
K1000
K340
K500
K400
240M

AKG

280P
270S
270
240M

SONY

MDRCD1000
MDR610K
MDRCD750

AMPLIFIERS

Quad
Sonic Link
Lumley
Reference
Marantz
Sony
Technics
Convergent
AudioTechnology

TURNTABLES

Stratosphere

SPEAKERS

•Quad, Spondor,
•ATC, Sony,

MINI DISC

SONY

MDSJA3E5
MDS3E3
MDS302
MDS51
MDS30

CD

SONY

XA2E5
CDP761E
CDP561E
VRS20
VRS105E
VRS57
VRS5-T1
DT11
P700
D700
PS2
CD5
CD3
CD15
CD16
CD17
CD63SE
CD63

TEAC

MARANTZ

QUAD

77

CASSETTE DECKS

NAKAMICHI

DRAGON
DR1
DR2
V8030S
V6030S
V2030S
V1030
V610
W6000R
SONY

TEAC

SONY

TCK661S
TCK561S
TCK461S

DAT

SONY DT60E5
TEAC R9
PIONEER D9601
DC88

Panasonic SV3800
TASCAM DA30
DA20

TRANSFORMERS

Ortofon
Denon
Sowter

MARANTZ

ST83
ST72
ST65
ST55

SONY

STSA3E5
ST361
ST3261

CABLES

AUDIOQUEST
COGAN HALL
SONIC LINK
SILVERSOUNDS
QED
GOLDRING

MICROPHONES

SENNHEISER
AUDIO TECHNICA
NEUMANN
AKG

HI-FI FURNITURE

Apollo
Project
Soundstyle
Sound Organisation
Sound Factory-
Tripod

BLANK TAPES

TDK Maxell, Sony,
BASF, 353, Ampex,
FUJI, Scotch, JVC,
Conica

ACCESSORIES

Antiference, Labgear,
QED, Discwasher,
Goldring, Audioquest

MANY OTHER PRODUCTS CAN BE SUPPLIED PLEASE PHONE TO CONFIRM PRICE & AVAILABILITY
PRIOR TO ORDERING ALL GOODS ARE BRAND NEW AND BOXED WITH FULL U.K.
GUARANTEES
NO EX DEM EQUIPMENT NO GREY IMPORTS. GOODS NOT SUPPLIED ON APPROVAL POSTAGE
& PACKING, CARTRIDGES.
TEST CASSETTES & CD'S, FREE ALL OTHER PRODUCTS, £5.00
MAIL ORDER only FROM IAN HARRISON HI-FI, 7 MILL HILL, REPTON, DERBY, DE65 6GQ
TEL: 01283 702875



Sussex Surplus

13 STATION ROAD, HORSHAM, WEST SUSSEX RH13 5EZ

Telephone: (01403) 251302 Fax: (01403) 270339

Test Equipment • Components • Accessories
Electromechanical • Mechanical • Engineering

GZ37 Mullard	£7 each	EZ81 Mullard	£6 each
GZ33 Mullard	£13 each	EZ80 Mullard	£6 each
GZ33 Bulbous	£25 each	ECC82 Telefunken	£15 each
GZ32 Mullard	£15 each	ECC31 Mullard	£10 each
GZ34 Mullard	£15 each	ECC32 Mullard	£15 each
6SN7GT Brimar	£8 each	ECC33 Mullard	£15 each
5R4GY Brimar	£6 each	Ecc35 Mullard	£10 each
5U4GB USA	£6 each	3A/141A STC	£20 each
5U4G USA	£6 each	3A/108A STC	£20 each
6L6G USA	£25 each	3A/110A STC	£20 each
6L6WGB USA	£12 each	3A/110B STC	£25 each
6B4G USA	£35 each	LS7 STC	£30 each
L63 GEC	£12 each	3A/109B STC	£25 each
H63 GEC	£12 each	5B/255M STC	£12 each
KT61 GEC	£25 each	4212E STC	£P.O.A.
A2900 GEC	£20 each	4212H STC	£P.O.A.
12AX7 Brimar	£10 each	4242A STC	£P.O.A.
CV4004 Brimar	£12 each		
M8137 Mullard	£15 each		
ECC82 Mullard	£8 each		
CV4003 Brimar	£10 each	18H 60MA	£15 each
EL84 Mullard	£9 each	10H 180MA	£20 each
E88CC.01 Mullard	£17 each	10H 250MA	£30 each
E88CC Mullard	£10 each	10H 350MA	£35 each
ECC88 Mullard	£10 each	10H 100MA	£20 each
EF86 Mullard	£10 each	1H 300MA	£15 each
EL86 Mullard	£6 each	16H 120MA	£20 each
EF37A Mullard	£8 each	5H 200MA	£15 each
6SL7 Brimar	£8 each	5H 400MA	£25 each
5Z4G Brimar	£6 each	2.5H 220MA	£15 each
JAN 5751 USA	£6 each	3.5H 300MA	£15 each
ECC83 USA	£6 each	15H 150MA	£25 each

OIL FILLED CHOKES

25H 70MA	£20 each
5H 500MA	£30 each
1H 500MA	£20 each
OIL/PAPER CAPACITORS	
.1UF 1500V	£8 each
.5UF 1000V	£8 each
.5UF 5000V	£15 each
1UF 600V	£6 each
2UF 600V	£6 each
4UF 600V	£6 each
8UF 600V	£8 each
8UF 800V	£10 each
8UF 1000V	£12 each
8UF 1500V	£30 each
4UF 800V	£12 each
4UF 1000V	£12 each
2UF 1000V	£10 each
1UF 2500V	£15 each
.02 1000V	£4 each
.1UF 2500V	£10 each
2.2UF 630V	£6 each

MOSFET POWER TRANSFORMER

PRIMARY 10-0-200-220-240-SCR
SECONDARY 0-18.5-26-29V .35A
26V .5A £40 each

P&P £5 PER ORDER
17.5% VAT TO BE ADDED TO TOTAL ORDER

PRIVATE

EAR 834 Valve amp. Gold transformer tops. 2 sets of valves (one Mullard's) £850. UKD Callas speakers £400. (or both £1100). All boxed.
Tel: Richard 0171 229 7960

LINN SONDEK LP12, lingo, LVX+, K5, Walnut. Serviced by Grahams. Very good condition. £625 ono.
Tel: 0181 923 8375 (evenings).

TANNOY BERKLEYS 15" dual concentrics, Rosewood, excellent £550. Lowther fidelio horns, new PM2C's £425. new PM6A's £220 pair. Tresham two-box m/coil pre-amp £90 Connoisseur Craftsman III, Mayware unipivot, Mahogany plinth £75.
Tel: 01709 555 403 (Rotherham).

ROGERS LS3/5A with ABI subwoofers, almost new, £650. PS Audio 4.5 preamp, £225. Leak Troughline II, £70. Ariston Image II speakers, £50. Decca Blue cartridge, four months use, £40.
Tel: 0141 639 3702

MERIDIAN SYSTEM: Absolutely mint: 206 Delta Sigma CD player, 201 pre-amp, 2x205 monoblocks, 209 controller 2.5 years old. Sell for £1500.
Tel: Mike 0181 874 3278

CROFT MICRO Pre amplifier, phono input, mint £230. Stax Lambda headphones, SRM-Xh energiser, 6 months old, as new, boxed £150.
Tel: 0121 427 8810 (Birmingham).

SONY DTC-690 DAT £290, CDP-715E CD £160, ST-S505ES Tuner £150. AEI Rosewood speakers with STAE1 stands £650. All items as new.
Tel: 01452 611 917

LINN LP12. Walnut, Valhala, Tramp Cirkus, EKOS Mk2, new Linn K18. £1400 ono.
Tel: 01933 626 170

MUSICAL FIDELITY "F" Compact disk player. Mint condition, boxed, remote, £800 ono.
Tel: 01752 775887 (Evenings - after 6pm).

CHORD SPMI 200 Amplifier. Mint. Only £1500 (new £3000). Meridian Argent One bookshelf speakers. Vgc. £500 (new £995).
Tel: 01925 232 706(day) 01925 268 852(Eve)

AUDIOLAB 8000T Tuner, Pioneer CTS 830S Cassette, Pioneer A400X amplifier, Rotel RCD 945 BX CD, Audio Alchemy Dac-In-The Box + Kontak 50S digital interconnect, Mission 780SE speakers/stands. Serious offers.
Tel: 01482 666 339

LINN LP12 black, Cirkus, Lingo £650. Helius aureum £75. Marantz CD10 £625. AEI speaker stands £130.
Tel: 01603 633 451

LINN LP12/Ittok/Asaka - £450. Naim 32.5 pre amp + 160 power - £450. Linn Sara's + stands/cable - £300. Complete for £1100.
Tel: Alan 01379 687 648 (Diss, Norfolk).

AUDIOLAB 8000M's £450 each. 8000PLC £350. 8000DAC £450. Linn Mimik CD, Trichord Clock2 adapted £450. Pioneer D-07 DAT £600 (Unused). Arcam Delta 250 transport £350. Nakamichi DR-2 £400.
Tel: 0181 655 2733

CONRAD JOHNSON CV4 valve pre amp, 4 line inputs £225. Croft Micro (early) 2 valve pre-pre amp, £95. Toshiba ST230 AM/FM tuner £35.
Tel: 01582 25166 (Luton).

SNELL E11 Walnut Pirate stands £625; Audio Innovations 800 series Mk1 pre&power (tri-coupled) £425. WANTED: Quality integrated valve amp with phono stage. Arion Elektra/Talos or similar. Also Triange Zephyr speakers.
Tel: 01843 596 908 (East Kent)

ROKSAN XERXES Turntable with Kuzma Stogi Arm and Audio Technica OCSA MC Cartridge. XPS3 PSU. Black and boxed. Excellent condition. £650.
Tel: 01202 884 148 (Dorset).

BRYSTON 4B-NRB, Power amp., 300W per channel, 18 months old, mint, £1250. Meridian 506 CD player, remote control, mint, £620. Classical/Pop Lps with anti-static sleeves, £2 each, vgc.
Tel: 0171 268 6270 (D) 01689 855 063(E)

MAGNEPLANAR 1.5SE, 2 years old. Light oak and white cloth. £575. Meridian 508 20 bit CD player. December 1995. Sparkling, natural sound £1075. Linn LP12, Lingo Ekos, Arkiv. Perfect £1250.
Tel: 01379 641 584

WANTED. SONY E.L.D.8 portable Elcaset recorder.
Tel: 01491 835 090

MONITOR AUDIO, Monitor 14 floorstanding speakers, black ash finish, excellent condition, £175.
Tel: 01656 783 716 (S.Wales).

ROTEL 965BX Ltd edition, discrete CD player, excellent condition, boxed £150.
Tel: 01277 655 621

TARGET Speaker stands HJ15/3 £80 the pair- new price £130. Buyer collects.
Tel: 01203 310 343.

WANTED MAGNEPLANAR MG-10SE or MG-1.5SE in exchange for Spendor SPI/2 + M.A.F. stands or £900. Art Audio Quin-tet MkII valve amp (triode) or exchange for sold state amp £800.
Tel: 0181 531 5979

MASSIVE LUXM6000 Amp up to 400Wrms, rare, superb £425. LUXC1000 pre £190. Sub bass 3ft x 1ft 10in x 1ft 2in, home built, four 12in loudspeakers, (push pull configuration) 300W amp, active 70Hz xover, matches main loudspeakers upto 84dB (signals below 70Hz removed) suitable for ESL63? (£1000) £350. J.R. Low pass amp for sub bass £40.
Tel: 01474 708 631 (Dartford).

MUSICAL FIDELITY MXL pre amp./p180 power amp., excellent condition and boxed, £650 (cost £1350) ono.
Tel: 0181 874 8539 (evening London).

TRANSCRIPTORS HYDRAULIC reference turntable, complete, £490. Lowther PM6 Hi-ferric horn drive units, pair £125. Thorens TD124II + SME 3009, £350. (preferred to Garrard 401 - Hi-Fi World).
Tel: 0181 991 0762, or day 0181 810 7018.

LOWTHER ACOUSTA'S (4) £300; Revox B750 amplifier (needs service) £100; Revox F36/2T £80; Pye Mozart Pre/Power/Tuner £300; Quad FM1 - £20; FM2 - £50; AM2 - £50; Radford TT100 amplifier £600; Leak Tuners, Thorens turntables, Quad/Leak spares, valves
Tel: 01428 651 554

QUAD 606 Mk2 power amp, 5 weeks old, 21 months guarantee, boxed and manuals £500
Tel: 01772 315 723

QUAD 50E MONOBLOCK power amps. Balanced or unbalanced line level inputs. Solid 50 watts output. Complete with plugs and leads. £150 o.n.o. the pair.
Tel: 01473 311 259 after 6pm

PROAC RESPONSE 2 with stands £1300; Proac Studio 100 with stands £550; Shearpe Phase 2 £350 Minstrel Tube integrated £500 Sony CDP 761E £170. cables.
Tel: 0116 256 3639 (eves, Leicester)

QUAD ESL63 Electrostatic speakers £1100 o.n.o., Wadia 12 DAC Hi-end £1000 o.n.o., B+V DM4, £100. Recordable Mini Disc portable £260. All good condition
Tel: Andy 0956 129 286

MERIDIAN 563 DAC, mint £450 (£750); Marantz SX-72 vinyl scratch suppressor £60 (£100). Dynavector 17D2 moving coil cartridge, little used, superb sound £200 (£450). Musical Fidelity F22 valve preamp, remote, mint £650 (£1100)
Tel: Jerry 01372 468 266

VAN DEN HUL Thunderline interconnects, 19 1/2 feet £420. The Desert Cable USA speaker cable. Two sets 5ft. £300
Tel: Bert 01942 811 880

ARUN VALVE pre-amp, phono, CD, Tuner, Aux 1, Aux 2. Two sets outputs, ex cond, little used. £195 o.n.o., Audio Technica OC9 vgc, few hours use. £100 o.n.o.
Tel: 01273 592 958

AUDIOLAB 8000A amplifier. Boxed, in mint condition. £250
Tel: 0181 668 2409 (Coulsdon).

TOWNSEND ELITE Rock RB300 Decca Gold plinth, lid, vdH wiring, Decca recently recalibrated, all excellent any dem. £500.
Tel: 01366 384 241 (after 7pm, Norfolk)

ROKSAN XERXES (Black), Artemis tonearm. Shiraz cartridge (used for around 500 hours), XPS II power supply. Perfect condition, boxed £745 o.n.o.
Tel: 0161 429 0963 (Stockport, evenings)

CYRUS TUNER £80, PSX £80, also Cyrus 2 phono not working £40. All old style with power button. All boxed.
Tel: 01582 769 334

HECO ALLEGRO loudspeakers, superb quality, Walnut finish, bi-wirable, new and still boxed. Half-price bargain at £195. Also pair of standesign stands, brand new at £35
Tel: 01703 224 460 (Southampton)

AUDIO ALCHEMY DDS III. Boxed £500. Also Data Stream transceiver with PSU £120. van den Hul The First .8m £100. Also Digital interconnect 6m £55
Tel: 0181 449 8639 (Barnet)

NAIM NAC 32 Pre-amp / NAP 160 Power Amp / SNAPS Power Supply £475 o.n.o. Epos E511 Loudspeakers and dedicated stands £300 o.n.o. Sound Organisation Tables £25 each. All in excellent condition. Some boxed.
Tel: 01403 217 304 (Horsham).

MERIDIAN 263 Delta Sigma DAC, mint £285.
Tel: Pete 01375 390 893 (after 6pm)

LEAK 2075 SPEAKERS excellent condition, real monsters of the 70's, £290. Garrard 401 + SME arm 3009 Series 2, excellent condition, £200. All original with manuals.
Tel: 01295 711 275

PART EXCHANGE EAR 834 + 834P + cash against Naim 82 pre or 250 power. (New style).
Tel: 01849 479 385

NAIM NAP 140 power amp (new style 1993) Boxed £400. Spendor SP2/2 speakers, Walnut (£100 Worth Deflex Treatment) inc. Heybrook stands. Boxed £400. Will demonstrate.
Tel: 01565 733 525 (Cheshire)

FRIENDS TO THE ★ STARS LTD. ★

Bespoke support systems for loudspeakers
and audio equipment



Custom built
loud speaker stands
and equipment
supports designed and
built by international
sound engineer Andrew
Corrigan and weld
artist Micky Bolton.
Personal designs to
suit your listening
environment both
aurally and visually.

For further details or to discuss your individual
requirements please call.

TEL: 0181 961 0354
or
FAX: 0181 963 1527

diverse vinyl

A vinyl service aiming to cover the whole music spectrum est 1988
12 Upper Dock Street Newport Gwent NP9 1DF. 9am - 5.30pm Mon - Sat
phone/fax 01633 256261 / 259661

Mastercard Visa Catalogues available Amex Switch JCB

New and Forthcoming Releases

60ft Dalls	Big Three	£7 90
Alanis Morissette	Jagged Little Pill	£9 90
Angelique Kidja	Fifa	TBC
Cocoteau Twins	Milk And Kisses	£9 50
Cranberries	To The Faithful	7 May TBC
Eric Matthews	Its Heavy (Re-release)	£7 90
Everything But The Girl	Walking Wounded	7 May £9 90
George Michael	Older	13 May TBC
Herbie Hancock	Headhunters	£7 90
Herbie Hancock	Sextant	£7 90
Huskie And The Blowfish	Fair Weather	TBC
Jon McNabb	Marseybeat	7 May TBC
Manic Street Preachers	Everything Must Go	TBC
Ocean Colour Scene	Maseley Shoals	£9 90
Ronny Jordan	Light To Dark	TBC
Ruby	Saltpeper-2 LP set (remixes)	£9 90
Shed Seven	A Maximum High	£8 90
Small Faces	Decca Anthology 65-67	£11 90
Smashing Pumpkins	Melon Collie - 3 LP set	£15 90
Tina Turner	Wildest dreams	£9 50
	Current	
Almighty	Just Add Life	£9 90
Beafles	Anthology 2	£21 90
Blue Nile	walk across The Rooftops	£7 90
Cibo Matto	Viva La Woman	£11 90
David Bowie	Changesbowie	£9 90
Everclear	Sparkle And Fade	£8 90
Fairport Convention	Unhalfbricking	£9 90
Fourth World	feat. Airto Moreira	£9 90
Free	All Right Now - Best Of	£7 90
Girls Against Boys	House Of GVB	£7 50
Ivey Brothers	3+3	£7 90
Jeff Beck	Beck Olo	£7 90
John Lennon	Plastic Ono Band	£9 90
Kiss	MTV Unplugged	£11 90
Leo Katke	6 and 12 String Guitar	£6 50
Miles Davis	Bitches brew	£12 50
Miles Davis	Big Fun	£12 50
Neil Young	"Dead Man" soundtrack	£10 90
Pulp	Countdown 92-83	£7 90
Rolling Stones	Sticky fingers (Czech press)	£6 50
Ronettes	Greatest hits	£14 90
Skin	Lucky	£10 90
Sly And The Family Stone	Fresh	£7 90
Stoney Ray Vaughan	In Step	£7 90
Sting	Mercury Falling	£8 90
Underworld	Second Toughest	£8 90

Large Selection of Current 12" and 7" singles available.
New Dedicated telephone/fax number 01633 - 256261

THE EMPORIUM

OPEN MON TO
SAT 11AM-5.30PM

28 St Nicholas Street, Dkss, Norfolk.

TEL (01379) 650744 FAX (01379) 650744

FOR SALE

amplifier		£300
QUAD 44/4052	NAV INTEGRATED AMP	£400 £140
QUAD 66 pre amp	ARCAM ALPHA CD PLAYER (£400 new)	£500 £199
QUAD 66/606 Mk1		£850
MONITOR AUDIO Studio 6 Rosewood	ARCAM 70.2 CD PLAYER (£550 new)	£500 £250
AUDIOPLAN KONZEPT small floorstander 89dB	MERIDIAN 206 cd player boxed, upgraded	£450
(sweet as a nut)	MERIDIAN 207 CD/PRE	£500
LECSON HLI Horn Loaded Purple	MERIDIAN 201 PREAMP	£399
QUAD ELS 63 pair (6 mnth gtee)	MERIDIAN D600 B DIGITAL ACTIVE SPEAKERS	£1500
QUAD 33/303	serviced last year, had great reviews cost	£3000
QUAD 34	new, mint, boxed	£1299
QUAD 405.2	LEAK STEREO 20 Excellent condition	£200
QUAD 30d pair of rare fifty watt monoblocks	delivered anywhere in Europe for	£350
transistor with output transformer!		£300
QUAD electrostatics bronze grills	ALWAYS IN STOCK AMPS BY QUAD, LEAK,	
QUAD 33/FM3/303 with wooden sleeve	RADFORD, PYE, ROGERS, AVANIC, RCA, etc	
RADFORD SC22/STA25/fm1	Lowther PM6A, PM7A, PM3A IN STOCK	
NAIM 32/SNAPS/250	GOODMANS AXIOM 300,301 etc	
MUSICAL FIDELITY PRE 3A		£205
MUSICAL FIDELITY MXL line level pre	LINN SARAS & STANDS	£300
MUSICAL FIDELITY TUBALOG DAC	TDL STUDIO 2 transmission line	£300
PIONEER A400	MERIDIAN 203 dac	£200
INCA tech 50 watt integrated	MERIDIAN 263 dac	£250
SUGDEN A23b Integrated 5 years old	PINK TRIANGLE LPT PIANO BLACK TOP	
ION OBELISK 2	PLATE/RB300	£350
CROFT SUPERMICRO old style	PINK TRIANGLE EXPORT/abriz zi £625	
CROFT micro A with no transformers fitted	VOYD VALDI external psu 25mm platter	£395
CROFT MICRO A mm	GARRARD 401	£100
AUDIO INNOVATIONS " 200 pre	TECHNICS SL1210 Mk2 ortofon nightclub stylus	£295
AUDIO INNOVATIONS L1 line only pre	REVOX B77 MkII 4 track	£600
PS AUD-O passive pre and model two power	BRAND NEW HEADS	

MANTRA AUDIO

• Hi-Fi VIDEO ACCESSORIES
• MAIL ORDER DIRECT 1-10 DAYS
• COMPETITIVE PRICES (Inc P&P)

MAKE	MODEL	CARTRIDGE	STYLUS	SWISS QUALITY DIAMOND STYLI	PRICE	
Arcam	C77, C77 Mg	N/A	£18.00	AOC	OLM 30, RD 3/4	£8.00
	E77, E77 Mg	N/A	£36.00		R20 XE, OLM, 34/36, XLM III	£12.50
	P77, P77 Mg	N/A	£47.50	Atwa	AN 5/11/30/60/8745	£8.00
Audio Technica	AT 95E	£21.00	£12.50	AKAI	AN 2/50/70/77/4932/8743	
	AT 110 E	£26.50	£16.00	B & O	RS 33/35/38/46/85/90	£8.00
	AT DC9	£220.00	£160.00*	B & O	SP 8/9/12A	£25.00
Deanon	DL 110	£70.00	£55.00	BSR	ST 14/15/16/17/19/21	£3.00
	DL 160	£90.00	£72.00*	Dual	DN 145/155/165/165E DN 149 S	£12.50
	DL 304	£190.00	£160.00*	Goldring	G800/820/850 (D110/D120/D130)	£10.00
Dynavector	DV 50X MK2	£135.00	£108.00*		G800 Sup E	£12.50
	DV 10X4 MK2	£160.00	£128.00*	Hilachi	DS-ST 7/12/14/15/26/30/35/102	£8.00
	DV 23RS MK2	£319.00	£255.00*	JVC	DS-ST 5/16/23/24/25/55/103/114	£10.00
	DV 1702 MK2	£359.00	£288.00*	Kenwood	DT 33/35/36/45/55/60/65, DT Z1 S	£8.00
Goldring	ELECTRA	£24.00	£16.00	(Trio)	N 47/48/51/53/60/61/63/66/72	£8.00
	1006	£44.00	£29.00	National	N 36/37/43/45/56/59/62/67/69	£10.00
	1012 GX	£60.00	£40.00	(Technics)	EPS 23/24/25/30/33/51 CS/270 D	£8.00
	1022 GX	£76.00	£49.00		EPS 43/52/75/76/ STSD, P30/33 D	£8.00
	1042	£94.00	£61.00	P30 (E upgrade), EPS 205/207 E		£12.50
	ERONCA (LX/M)	£90.00	£60.00	Ortofon	FF 15A/M5 10/20 EII, OM/EP 20	£12.50
Ortofon	DMSA, DMP SE	£18.00	£16.00	Philips	GP 371/400/780/400 II/III	£8.00
	OM 78 (Stylus)	N/A	£26.00		GP 330/370/401/401 II/412 II	£10.00
	DM10, DMP10	£27.00	£20.00	Pioneer	PN 210/220/240/M65/2507/295T	£8.00
	DM20	£66.00	£36.00	Sansui	SN 27/28/29/33/34/37/41/50/80/101	£8.00
	DM30	£81.00	£67.00		ST 80/100/150/G6/G13	£6.00
	DM N CLUB S	£34.00	£21.00	Sanyo	ST G 8/9/10, ST 28/29/35/37/40 D	£8.00
	510	£34.00	£22.00	Sharp	STY 104/111/116/117/118/123/124	£8.00
	520	£59.00	£45.00	Shure	N 75-6/C/C, N 91 G, SS 35 C	£8.00
	530	£90.00	£67.00		N 44 E, N 70 EJ, N 75 ED/EJ T2	£10.00
	540	£117.00	£90.00		N 55 E, N 95 ED/EJ, N 97/105 ED	£12.50
	MC1 Turbo	£63.00	£49.00	Sony	VN 15E, VN 35E (V 15 IIIE)	£15.00
	MC3 Turbo	£117.00	£90.00		N 95/97 HE, VN 35 HE	£8.00
	MC 10 Super	£90.00	£67.00		ND 133/134/142/150/155/200 G	£20.00
	MC 15 Super	£85.00*	£85.00*		ND 115/143/148/153/220/250 G	£10.00
	MC 25 E	£160.00	£121.00*	Toshiba	N 53/55/60 DY N 62/282 N 71/250	£8.00
	MC 25 FL	£220.00	£165.00*			
	MC 10 Supreme	£260.00	£202.00*			
	MC 20 Supreme	£375.00	£280.00*			
	MC 30 Supreme	£465.00	£350.00*			
Shure	VN 45 MR	(V15 IV)	£90.00			
	V15 V MR	N/A	£130.00			
Slantone	500 AL Disco		£30.00			
	680 ALX Disco		£46.00			
	680 ELX Disco		£57.00			
	Trackmaster		£99.00			

A WORN STYLUS CAN DAMAGE PRECIOUS VINYL!
RECOMMENDED REPLACEMENT AFTER 500 HRS USAGE

PROFESSIONAL/DJ ITES/IS	DJ PACK	STYLUS	
Ortofon	OM Pro S	£40.00	£15.00
	Concorde Pro S	£54.00	£15.00
	OM Nightclub S	£54.00	£18.00
	OM Nightclub E	£58.50	£21.00
	Conc Nightclub S	£75.00	£18.00
	Conc Nightclub E	£78.00	£21.00

DJ Packs comprise 1 cartridge complete + 2 styli in a Presentation Box

Record/Disc Cleaner	Kit	Refill	
Milly	Permethation record cleaner	£12.00	£8.00
	permanent Anti-static spray	£12.00	£8.00
Discwasher CD cleaner		£14.00	£5.50

* Exchange any MC *** Over 500 styli types stocked *** Tel (01757) 288652
All records terms UK supplied, DJI, quaternions - No quality partners

MANTRA AUDIO (HFW), 22 GARTH AVENUE, NORTH DUFFIELD, SELBY, NORTH YORKS YO8 7RP

PRIVATE

FOR SALE: 1 pair of ATC SCM 50 passive speakers and stands £1100 o.n.o. One pair of Meridian MZ active speakers and stands, 101B pre-amp. Speakers need attention hence £225. Both for £1100
Tel: 01203 348 894

KITS BUILT AND RESCUED. Intimidated? Frustrated? Valve amp problems solved to get you up and running. Performance report of completed kit will be provided. Gravesend area.
Tel: 01322 386 560

AUDIO RESEARCH D115 MkII 100 watt valve amplifier. Perfect £1000 o.n.o. Revox B760 classic FM tuner serviced and guaranteed. £375
Tel: Morgan 01654 703 268

LEAK TROUGHLINE III (Stereo) tuner, perfect working order £100.
Tel: 01270 665 721 (after 6pm)

NOTTINGHAM ANALOGUE Mentor Reference turntable £1600, plus No.1 Parallel tracking arm £800. Both as new, genuine reason for sale.
Tel: Home - 01203 327 948 or Work - 01773 762 947

ELITE ROCK Turntable with Mission 774 arm, Linn K9 cartridge £350. Jecklin Floax 2 headphones £75. Marantz CD40 CD player £70. Quad valve FM mono tuner £60.
Tel: 01423 507 266 (Harrogate).

UNITY AUDIO SIGNATURE 3 speakers. A unique blend of beautiful looks and sound. Rave stereophile reviews. Mint condition and boxed. List £2000, Will accept £1150 o.n.o.
Tel: 01206 844 855

CONRAD JOHNSON MVI25 valve power amp boxed mint £1850. Chord SMP 1000B power amp, piano black finish £1450. Townshend Excaliber Mk2 £700 Concordant modified Quad 2 power amps £475 Pink Anniversary turntable £900. Roland Consumate Mk2 pre-amplifier with phono stage, cost £9500, £4200. VPI HW19JR £450, VPI TNT JR ET2 Tonearm Wisa pump high pressure manifold Phone. Koetsu Red cartridge, Garrard 301 SME 3009 Loricraft plinth Phone. Wanted: Nakamichi 1000 ZXL, Dragon, CR7.
Tel: 0181 450 7384 or 0956 639883

SPENDOR SPI speakers with stands £300. System Audio 1050 speakers (Danish) New, boxed £400.
Tel: 0181 393 4265

VINTAGE VALVE amplifiers for sale Leak, Quad etc. Phone for details. Rogers LS3-5a bi-wireable Walnut, boxed, as new £375. Wanted: Leak TL10, TL12.
Tel: 01548 821 360

KEF 104/2, Rosewood, boxed, £500. Musical Fidelity MA100 Class A monoblocs, immaculate, boxed £500. Siltech HF6 0.5m £50. Musical Fidelity Lifeline speaker cable, Monster interconnect.
Tel: Simon 0171 915 9208

WANTED: QUAD 66FM tuner. For Sale. Quad FM4 tuner £250 o.n.o.
Tel: 01883 653 165 (Surrey).

PINK TRIANGLE DA CAPO, 1307 filter £1050; Audioquest Video z 1m BNC £35; Townshend Seismic Sink £70; Chord Solid 1/C 0.6m phono £60.
Tel: 01534 66238

PERCEPTION PHONO Stage £265; Air Pods (3) £145; Kudos stands £75; Isopods (2 sets) £15; Sil Sounds 12/4 1/C £85; Kinber Oigilink £70. Plenty of speaker cables in short lengths.
Tel: Steve 01685 385 898 (after 6pm)

SPENDOR SPI Speakers. Teak finish. Cabinets in fair condition. Sound quality excellent. £375. Spendor stands £75. Also 'Slate Audio' 12" high slate stands. (cost £345) £250
Tel: 0181 302 9063

DPA (DELTEC) T1 transport DPA Bigger Bit DAC also 2 x The Power Mains Filter £850 o.n.o., Black Slink interconnect £100 o.n.o., Mint, boxed, instructions.
Tel: 01900 826 400 daytime or 01900 826 294 evenings

MAGNAPLANER MG3, legendary panel speakers + foundation stands + separate crossover £895; Audioquest Midnight 2 Hyperlitz speaker cable 2 pairs of 8ft lengths £90 each; Meridian 203 DAC £170.
Tel: 0171 281 0821

LINN ISOBARIKS black, panel stands, active or passive use, mint £900. Linn Klouts - £1300 each. Naim 110 power amp £150. Naim Nait £120. Delivery possible.
Tel: 01622 858 085

KEF REF 107 MkII Rosewood bi-wired with Kube hoods and box's. Mint, cost new £4000, sell £2,200 o.n.o. Wanted: Kenwood LI000T tuner. Wanted: Tannoy Buckingham or Windsor.
Tel: 0121 628 3423

CLASS E DR10 Power-amp, retail £2300, black finish, mint condition, purchased (listening rooms) 23/05/95 on dem. Owner now upgrading £995. Delivered.
Tel: 00 3531 459 1432

ROGERS LS7T with stands, excellent condition, £160, JPW AP3, excellent condition £120 with Atacama stands £40, or together £150.
Tel: 01494 716 909 (High Wycombe)

SONY MDS-302 Mini Disc player. Unwanted Christmas present, unused, boxed and still under warranty. 3 blank discs. £350.
Tel: 01323 485 654

TEAC A3440HS Professional tape deck 10.5", 4 channel c/w DBX processor, mixer boxes, remote, mint, light domestic use only. Unused since service £550. Matching mint Teac 450 cassette deck £100.
Tel: 01202 823 818 (Bournemouth)

NAKAMICHI 700ZXE Auto cassette deck, Dolby/C. Improvement on Dragon. Mint, unmarked, occasional use, unused since B+W service, original packing, manual £800. Consider exchange for mint Ferrograph 722D.
Tel: 01202 823 818 (Bournemouth)

HAFLENER SE100 pre-amp, SE240 power amp, mint £500. Better than Audiolab. Swordsman Plus speakers and stands £150. Rotel RCD R965 CD £160. Boxed and instructions.
01592 265 096 (Scot).

LINN HELIX II Loudspeakers complete with KU Stone stand, boxed £200.
Tel: 01564 777 725 (West Midlands).

MONITOR AUDIO Studio Fifty speakers Ebony Piano lacquer finish, six months old £3950 (£4950). Target B5 equipment rack £100 (£175)
Tel: 01797 253 073 (East Sussex)

PINK TRIANGLE PTTOO, Black, separate power supply in matching plinth, SME 309 tonearm, ATOC9 cartridge, superb sound and condition £695. Kit loudspeakers, slim, floorstanders, Focal Kevlar bass/tweeters, custom made spiked stands, 4 x 5m DNM cable (bi-wired) very rigid, very heavy design in unfinished MDF. Excellent sound. Bargain at £275.
Tel: 01603 663 649 (Norwich).

KRELL KST 100 Mint boxed still guaranteed £1750. Gradient-Quad Xover balanced £275.
Tel: 01923 826 830

RE-OFFERED Immaculate Tandberg Series 12 stereo twin track integrated tape recorder. Fully renovated. Cash offer please. Consider exchanges. WHY? Nakamichi DR-2? Vinyl equipment? 7" recording tapes for sale.
Tel: 01286 831 340 (North Wales).

NAIM 72, 82, HiCap, 250, CD1, IBL, SBL, ARO, NACA5; LP12, Kabers, Troika, Koetsu, Lingo, Helios, Orion, Fi-Rax, Equipment, Rack, Onix amplifier, Rega speakers. May split p/x swap.
Tel: 0114 248 6493

GARRARD 301/401, Quad 22, Leak, Troughline, Sterio 20, JBE, Slate, Turntable, Mana, Table, Various interconnects, cartridges, arms, Siesmic, Sink, Nakamichi Receiver. Split pre/power, full remote. May swap, p/x W.H.Y?
Tel: 0114 248 6493

WANTED Large Wharfedale corner units!
Tel: 0181 9808149

STAX LAMBDA Signature headphones with SRM-1/Mk-2 Pro energiser. Boxed, complete with instructions and leads. Excellent condition. Cost £1300, sell for £590. Stax SR-3 headphones £40.
Tel: 01604 832862 (Northampton)

MORDANT-SHORT 5.40 + 8" Stands, mint, cost £370, £220 or exchange for EPOS ES II. Denon PMA 450 SE amplifier, mint, £190 o.n.o.. Arcam Delta 90.2, £190
Tel: Richard 01908 563737

NAIM 32.5 Pre-Amp, fitted K board phono. Good condition. £175
Tel: 01623 759264 (after 6pm)

LOWTHER CORNER Horns with refurbished speaker units. Highly sensitive. £550. Concordant Exhilarant line level pre-amp, wooden and/or metal case. Superb sound quality £400.
Tel: John 0181 202 3307

WANTED: LINN K18. Either alone or with late model Ittok. Also wanted, Hi Fi World 12" record storage cubes. Milton Keynes area.
Tel: 01908 647798

BEARD BB100 Mk II, 50 watts/channel valve amp. Mint condition, boxed with instructions. Stunning sound and looks. £650. Wanted: Teac P500/D500, SD Acoustics Ribbons, original Roksan DPI.
Tel: Noel 01628 521885 or 0956 688506

WANTED: MARANTZ SX-72 Digital noise suppression unit or something similar.
Tel: 01843 587732

MARK LEVINSON Madrigal HP interconnect cable, 7 metre stereo pair £450 (£995). Peter Sanhen SP 1.5 pre-amp, unusual but highly regarded design, very rare high resolution pre-amp with phono stage £850 ono (£2350 new)
Tel: 0181 291 1744

QUAD ESL Lovely pair £395. Spendor SPI mint £375. Grace G707 arm boxed £65. Kmal M9BA arm new £45. Leak Stereo 30 as new £75. Wanted: Naim; ARO, NAC72, Prefix, Armageddon. Linn: Ekos, Lingo. SME IV.
Tel: Peter 01203 713501 (Coventry)

M A X Midland Audio Exchange

181 Franche Road
Kidderminster
Worcs DY11 5AD

Telephone: 01562 822236
Mobile: 0421 605966

ROKSAN: Upgrades for all Roksan products in stock:
XPS 3.5 £169 (Please state Xerxes or Xerxes 10)
XPS V 3325
D.S.U. £139

Artemiz Upgrade £99.95
Artemiz/Tabrizi Ultra Armcable 3115
Ojan 3X Upgrade £549.95
DP1.5 Upgrade £299.95
DP 2P Mk. II Upgrade £249.95

Please call with any aspect of upgrading Roksan products.

As always, Midland Audio Exchange (M.A.X.) have some limited SPECIAL OFFERS on certain ROKSAN Products:

1 x ROKSAN L1 PRE AMP (SILVER)	Was £2250	Now £1295
1 x ROKSAN L2 PRE AMP (SILVER)	£995	£595
1 x ROKSAN 51.5 Power amp (silver)	£1495	£995
1 x ROKSAN DA1 D/A Converter (silver)	£495	£229
1 x ROKSAN COGNESCENTI XERXES (wood)	£1695	£995

NEW PRODUCTS

from Apogee Acoustics
Ribbon mini monitors in black ash (truly Holographic) £995
Audio Alchemy - Digital Drive System III (use as a Cd player or Transport) £699
Affordable High End Quality.
QLN Signatures/Splitfields (Watch out Wilson Audio!)
Remarkable openness and depth of image, inc. crossovers £1495
Analogue Utopia, a new phono stage MM/MC switchable £449 inc. P.S.U.
Battery P.S.U. available for £399

last, But Not least, some second hand/ P.X. Bargains:

Rega 3/RB200 A+ R P77 MG	£120
Linn LP12 Afrosmosia Valhalla	£350
Michaelson Odysseus	3495
Roksan L2 Pre-amp (black)	£550
Roksan Cognescenti Xerxes Piano Lacquer/RB300	£795
Alphason Sonata/Atlas P.S.U. HR 100S/ Kiseki blue	£695
World Audio 5881	£450
Aura VA80 (new)	£179
Marantz p.m. 55 SE	£195
Project o.5 (OM10) new	3109
Project 1.2 (510) new	£139
Project 2.1 (MC1) new	£179
Project 6.1 (540) new	£299
Heybrook HB1 inc. stands	£319
Nottingham Analogue Space deck	£395 inc. tonearm

MIDLAND AUDIO EXCHANGE BUY Hi-Fi for cash.

Open 9.30 - 6.30 seven days a week. CALL NOW ON:
01562 822236



GRAMEX 520 VALVE MONO-BLOCK AMPLIFIERS
EXCELLENT VALUE AT £600.00 PER PAIR
WE HAVE A CONTINUALLY CHANGING STOCK
OF CLASSIC SECOND HAND AUDIO:
GARRARD 301/401 MOUNTED AND UNMOUNTED
QUAD AND LEAK VALVE EQUIPMENT.
NEW AND USED S.M.E. ARMS SUPPLIED.
BESPOKE EQUIPMENT CONSTRUCTED TO ORDER.
AUDIO-VISUAL INSTALLATIONS UNDERTAKEN.
SATELLITE EQUIPMENT SUPPLIED AND FITTED.

WE ARE ALWAYS INTERESTED IN OBTAINING
CLASSIC BRITISH HI-FI EQUIPMENT.

DROP IN FOR A CHAT AFTER ONE O'CLOCK
TUESDAY TO SATURDAY. OPEN UNTIL SIX.

WE LIVE AT
25 LOWER MARSH,
WATERLOO,
LONDON SE1 7RJ
ENGLAND

TEL +44 0171 401 3830 FAX +44 0171 928 3999

HEATHERDALE AUDIO LTD.

HEATHERDALE PRE-OWNED GUARANTEED
EQUIPMENT. EXPORT FACILITIES AVAILABLE.

STUCER A807 Pro. tape recorder MINT	£3750	QUAD 405 Mk 1 power amp	£1195
AUDIO RESEARCH D200 (£3248) offered for	£2495	DIAMOND ACOUSTICS (Lumley) Ref 2 speakers	£895
LUMLEY 120 monoblocks (with cages)	£2195	PIONEER 4 Chan. receiver QX 949A	£395
PRO AC Tablette II Banded MINT	£295	MARANTZ Quadratic 4 receiver	£295
AUDIO ALCHEMY DAC-in-the-box	£125	THORENS TD 126 MK 3 turntable	£250
SOLSTICE AAD speakers with stands	£650.	CLEARAUDIO turntable/arm/cartridge (demo)	£2795
AUDIO RESEARCH D400 power amp (ex-demo)	£4750	BRAUN A1 int. amp/TI tuner	£495
CLEARAUDIO Gamma S (ex demo)	£400	AUDIONOTE M7 tube pre-amp (£14650)	£5995
NAKAMICHI 1000 ZXI cassette deck	£1995	NAIM HiFi integrated amplifier	£1195
AUDIO RESEARCH Litzlink interconnect (from)	£200	AUDIO TECHNICA OC 9 MC cartridge, mint	£75
MAGNEPAN SWSB speakers (new) reduced to	£765	APOGEE Contour minor speakers	£750
NAKAMICHI Dragon, based.	£1195	REGA RB 250 (silver wire) tonearm.	£195
ROGERS LS 35s walnut MINT	£475	BASE platforms	£40
QUAD 33 pre-amp based	£95	REVOX A700 Tape Recorder (semi pro)	£650
		MAF heavy turntable stand	£250
		DYNAVECTOR DV 6A Silver MC transformer	£495
		DYNAVECTOR Karat Ruby MC cartridge (new)	£295

RARE OPPORTUNITY
MCINTOSH 1 MAC 40 MONOBLOCKS (PAIR) PLUS MCINTOSH C22 PRE-AMPLIFIER.
O.I.R.O. £2500.

202 FINDON ROAD, WORTHING, WEST SUSSEX. BN14 0EJ
TEL. 01903-872288 OR (AFTER HOURS) 0860 660001 FAX. 01903-872234

FIDELITY MC201 MC cartridge	£295	LINN LX 100 power amps x 2	each £350
ADC Phase 2 Phono cartridge	£49	LINN Isobanks with stands	3795
ADC Phase 1 Phono cartridge	£45	STEREO KT88 40 watt valve amp.	£750
LINN Karma MC cartridge	£195	NAKAMICHI DR3 cassette deck	£250
FIDELITY Research FR-101 SE cartridge	£40	MICROMEGA STAGE 1 CD player	£295
NAD 9200 cartridge	£25	AUDIONOTE ANJ speakers	£495
GRACE F-9 cartridge	£95	AUDIO INNOVATIONS 200 power amp	£195
GRADO G-1 cartridge	£45	APOGEE Contour minors	£795
SYSTEMDEK II with Linn basic LV X arm	£375	SYSTEMDEK P 50 integrated amp	£2195
CAMBRIDGE P 50 integrated amp	£50	AUDIO RESEARCH SP 11 Mk 2 pre-amp	£1695
TRANSPARENT Ref. interconnect 15' pair	£1595	AUDIO RESEARCH Classic 30 amplifier	£1295
TRANSPARENT Ref. interconnect 1 mtr. pair	£1295	ORACLE Alexandria turntable	£795
TRANSPARENT Ultra bi-wire sp. cable 12' set	£2195	S.M.E. IV tonearm	£595
TRANSPARENT Phono cable 2.5 mtr.	£395	COUNTERPOINT SA 7 pre-amp	£495
GENESIS model III speakers, mint	£2495	MICROMEGA DUO BS 2 DAC	£495
JADES Duly 7 stereo amp, mint	£3695		
LINN Aktiv X over + DIRAK psu	£450		

MAIN DEALERS FOR QUAD.
VISA - SWITCH - MASTER CARD - DINERS CLUB WELCOME.
WE TAKE PART EXCHANGE ON NEW & USED STOCK

HOT-ROX U.K.

QUALITY VALVES

FOR ALL DEDICATED
ENTHUSIASTS IN SEARCH OF
PERFECTION

MAIN SUPPLIERS OF
SOVTEK

OUR EXTENSIVE RANGE OF VALVES INCLUDE:

6L6WC	6L6WXT	6550	* FAST FREINDLYSERVICE
EL34G	EL34G+	6CA7	* 24HR DELIVERY
6V6	5Y3	KT88	* NO MIN ORDER
12AX7	12AT7	6SN7	* BEST PRICES
EL84M	GZ34	6SL7	* P&P JUST £1.50
12AU7	5U4G		* VALUE FOR MONEY

PLUS NEW SVETLANA SV6550C

ALL ENQUIRIES WELCOME
CHEQUES, VISA
POSTAL ORDER

HOT-ROX U.K.

10 AVONDALE ROAD
CARLTON, NOTTINGHAM, NG4 1AF

TEL/FAX: 0115 9873163 MOBILE: 0468-118375

HOT-ROX U.K. A SOUND INVESTMENT!



ORANGES & LEMONS

Juicy fruit from London's freshest
hi-fi/home cinema retailer. Free home installation + credit cards,
0% credit finance available.

B & W, CABLETALK, CHORD CO, DENON, EPOS, KEF, MARANTZ,
MICROMEGA, NAD, NAIM, NEAT, QUAD, REGA, ROKSAN,
ROTEL, ROYD, RUARK, SOUNDSTYLE, STANDS UNIQUE

Now in our second fruitful year

THE INNOVATIVE
AUDIO RETAILER

0171 - 924 2040

61/63 WEBBS ROAD, CLAPHAM SW11

TRILOGY AUDIO 918 Pre-amplifier, one year old in as new condition (boxed) £1950 ovno (£2950 new)
Tel: 0181 291 1744

MUSICAL FIDELITY F22 pre-amp (phono) £650; and F15 power amp £1390, both as new. Meridian 206 CD player £450. Roksan Xerxes XPS2 £390.
Tel: 0181 337 2544 (eves)

MERIDIAN 200 Transport, 203 DAC, excellent condition, very little used, two years from new, bargain £595 for quick sale. Metre pair Chord First Interconnects £75
Tel: 0123 732828 (Eastbourne)

QUAD 67 Mint condition, hardly used, brilliant sound. Dual 435 turntable + 510, mint both boxed and manual £650 the lot.
Tel: 0385 783900

TANNOY BERKELEY loudspeakers, excellent condition £550.
Tel: 0191 281 0260

BREUER DYNAMIC Tone arm in perfect working order £750
Tel: 0191 281 0260

SONIC FRONTIERS SFDI DAC (balanced) HD CD compatible, amazing sound, boxed as new, 1 year old - 4 years warranty remains. Bargain at £1800 OR will sell together with Theta Data Basic, 1 year old £3450. A fabulous combination.
Tel: 01623 871950

REVOX B77 Stereo reel to reel tape recorder. Speeds 3 3/4 and 1/2. Hardly used and recently serviced c/w remote, instruction book and cover. £595.
Tel: 01383 821873

QUAD 34 PRE-AMP and 303 power amp £250. B&W Acoustitone subwoofer £100. Wanted: Linn Karik CD player and Linn K400 speaker cable.
Tel: 01622 858085

AUDIO INNOVATIONS Classic 25W amplifier (factory built) plus 834 P phono stage. Approx 20 months old, 1st class condition, 16 months guarantee outstanding. £600
Tel: 01277 220 761

ALLBARY 408 mono blocks (£475 ono). van den Hul silver, 3 off 0.5m pieces; gold 2 off 0.5m pairs. Offers for cables considered. Call Mike.
01482 666910

MARK LEVINSON ML 12A pre-amplifier with PLS-124 power supply and MLII power amplifier. Original boxes and manuals. Happy to demonstrate £1500.
Tel: 0191 281 0260

LOWTHER LONDON TPI corner horns incredible dynamics from these full scale classic speakers. PM2C drive units. Cabinets Teak and Black. A bargain at £750 ovno. Buyer collects.
Tel: 01736 798393 (Cornwall)

TANDBERG TUNER 3011 or 3011 wanted for parts, perhaps lying forgotten in your attic.
Tel: Martin 01837 840438

WANTED: SUGDEN A21a with phono stage.
Tel: 01287 625166

LINSLEY HOOD HART monoblocks, approx 100wpc, handbuilt with silver wire throughout £425 ono.
Tel: Geoff Mackenzie 01293 771542

NEAR 10M SPEAKERS Won in Jan comp. Unused. (£499) £399 ono. Swap my Roksan DAC DAI for your Meridian 203 DAC. Wanted: Bass-mid for orig Heybrook HB2.
Tel: 01203 469363

WANTED: TWO LEAK Sandwich loudspeakers. Must be 8 Ohm impedance and in good condition/working order, within easy reach of Oxford please.
Tel: Bob 01865 62554

NAIM 135s WANTED or 4 pack, also matched pair NAP 250s (follow on serial nos) Black SBLs, may consider system any age or condition. Cash waiting, can collect, meet half way, whatever.
Tel: Paul 01924 271043 (eves)

NAIM HICAP, 2 factory reconditioned old style mint, boxed Naim guarantee £385 each - 1 new style £440. New Ekos, boxed, highest offer secures, latest Sumiko SMO cartridge, 3 point mount for Ekos/ARO on demo.
Tel: 01924 271 043 (eves)

LEAK TL12+ (pair) mint £495; Quad II (pair) £295; Quad II (pair) rebuilt £395; Leak TL25+ £295; Quad FMII Tuner £40; Leak Troughline £95; Leak Point One Pre £45.
Tel: 01444 459196

REVOX A77 MINT £395. Revox A77 fair £150. Revox B77 mint £595. Garrard 401 SME arm/plinth £225. Roger Junior fair £95, Leak Stereo 30 plus and Stereofetic Tuner in Teak sleeve £125.
Tel: 01444 459196

LINN KAIRN phono £650. Linn Klout £1000, both excellent and as new.
Tel: 01248 712276

NAIM NAIT 2 amp, new design, mint condition, boxed £250. Arcam Alpha 5 CD player, remote, mint condition, boxed £295. Garrard AP76 turntable £35.
Tel: Brian 01904 490796

TOWNSHEND ROCK MkII Merlin power supply. Rega RB 300 Decca Gold cartridge £450 ono. Garrard 401 £140. Both decks in mint condition, unmarked.
Tel: 01707 372652 (Welwyn Garden City, Herts)

GARRARD 301 TURNTABLE, White with original manual. Both mint. £195. SME 3009 arm with standard & Decca head shells £35. Audiomaster mono valve power amplifier, v.g. condition, revalved. £100
Tel: 0161 283 1689

BOOKS. VALVE. DATA: Iliffe (1966) £15; Bernards 157 (1963), 178 (1965) and 193 (1966) £5 each. Circuits: Mullard (1960) £10; Pre-Amp Cookbook (new) £10; Wireless Servicing, Cocking (1963) £15. Loudspeakers: Briggs (1958) £15; Design Cookbook (new) £12, or offers.
Tel: 01354 56217 (eves)

MICHELL GYRODEC with Rega RB 300 £600. Perspex PSU £50. As new condition, 2 years old. Spondor SP2 speakers £125.
Tel: 0181 427 6936

SONUS FABER Minima Amator £850. Lecson HLI horns £185. IMF professional monitors £450. All good condition. Phone for full details, maybe swop for large Maggies.
Tel: 01993 883882 (Oxon)

AUDIOLAB 8000 C/P £450. Target HJ15 stands £65. Mission DAD Sharkwire - 5m x 2, 10 awg x 0.08 speaker. 6m phono Neutrik, 91 x 0.08 OFC. Ditton 121s £30, NAD items.
Tel: 0121 553 4777

LINN LP12 WALNUT, Ekos, Troika £1050; Sara 9s, stands £385. Perfect condition, very little use. Exchange or purchase LK100, Klout.
Tel: 01492 650053 (eves/w/ends)

MISSION DAC5 + free QED Digiflex £110 ono.
Tel: 0115 929 8789

WANTED LINN LK100 amplifiers Active Cards for Kabers. Must be in good condition. For Sale: Linn LK 280 power amps, in mint condition.
Tel: 01206 212023

LINN SONDEK LP12. Full specification, Cirkus, Lingo, Ekos, Arkiv, Trampolin £1750. Linn Kairn pre/A phono £800. Linn LK280 P/amp £350. All immaculate condition.
Tel: 01793 850847 (Swindon)

LINN AXIS turntable, K9 cartridge £225. Nakamichi amplifier 2, 50W £225. Both owned from new. Excellent condition. Makers boxes, manuals. Will sell separately.
Tel: 01243 606053

LINN ISOBARIKS, Walnut, 1987 spec, beautiful condition c/w stands and panels £875. Rotel pre/power 870, MA R352 speakers black c/w stands, offers, all mint.
Tel: 01530 831574

THE VOYD TURNTABLE mint condition with Rega RB300, new Denon DL304 cartridge, cost £1850 sell £850. Denon DRM 44 cassette new heads and capstans, spent £100, accept £120.
Tel: 01598 760247

QUAD 606 POWER AMP, Avondale Audio modified, boxed, instructions, mod details. Denon DR-M12 cassette deck, light use, boxed, instructions. AudioQuest Ruby interconnects, Exposure speaker cable 4 x 5m. Offers
Tel: Colin 01734 610485 (Reading)

LINN SARA, Black, spiked stands, boxed, can demo vgc £200 ovno.
Tel: 01342 324306

SPENDOR SP2/2 Loudspeakers, black, mint condition, original packaging £375. Quad 44/405 pre/power amp £250. Carriage paid.
Tel: 01232 843663

LINN ISOBARICS DMS, recent dealer service £550. Naim 250 old style, good vintage £550. Sony Walkman Pro with dedicated Naim power supply £225. Snaps £50. Would consider PX late Mk2 Kans Naim 160.
Tel: 01422 372063 answerphone (Halifax)

FOR SALE: Sony Walkman Pro, excellent condition £150. Wanted: Naim 160 and CR5E
Tel: 01422 372063 answerphone (Halifax)

MARK LEVINSON ML2 Mono power amps balanced £2895.
Tel: 01323 410816 (after 6pm)

AUDIO RESEARCH CLASSIC 120 mono block balance condition: mint. 2 1/2 years old. £2580 (£5200 new) Speaker KEF REF 3, black, 3 weeks old, very new £1300 (£2000 new)
Tel: Cherry 0973 842016 or 0171 235 5371

DPA 50S pre/power psu, highly recommended with Black Slink cables, exceptional sounding £950. Enlightenment DAC £495 (£850)
Tel: Adam 01268 711536 (Mon-Fri 11am-6pm)

WANTED: HARBETH LS3/5A or HLP3 and Leak Troughline.
Tel: 01450 870786

ADCOM MONOBLOCKS GFA565 (mint, boxed with manuals) 300 WPC, bi-wire capability. Wonderful sound, ideal for difficult speaker loads. Will demonstrate. £1020 ono.
Tel: 01492 580201 (North Wales after 6pm)

hi Best prices for new, xdem & s/h equipment ^{fi}

Conrad Johnson Prem 8A monoblocks	mint s/h	£7950	Linn Helix LS 150	mint s/h	£195
Audio Research V140 monoblocks	mint s/h	£4995	Infinity Irs Beta	mint s/h	£4995
Gryphon S100 power amp	mint s/h	£3500	Wharfedale Harewood	mint s/h	£395
Nestorovic Alpha 1 150w monoblocks	mint s/h	£1495	Gamma Acoustics Epoch Five	x dem	£90a
Electro Companiet AW100	mint s/h	£1295	Meridian M1	mint s/h	£695
Proceed amp 2	mint s/h	£1295	Soundlab Pristine III	mint s/h	£3995
Audiomote Ongaku	mint s/h	£23995	Alon V mkII		£90a
Goldmund Mimesis 3	mint s/h	£2250	Pink Triangle Ventrical	as new	£595
Jadis JA500 monoblocks	mint s/h	£8995	Kel 103.4	mint s/h	£695
Jadis JA80 monoblocks	mints s/h	£4995	Quad ESL 57	mint s/h	£395
Meridian 605 monoblocks	mint s/h	£1395	Alon 0.5	x dem	£750
Copeland CTA 501	mint s/h	£895	Magnaplanner SMGA	mint s/h	£350
LFD PA1/LS1	mint s/h	£895	martin logan CLSII z/Arcici stds	mint s/h	£2995
Boulder 500 AE	x dem	£90a	Kingereitics Sub woofer SW 800	mint s/h	£2995
Adcom GFA 535	mint s/h	£1195	Gallo Acoustics Reference system	mint s/h	£2750
Gamma Acoustics Space Reference 300B	x dem	£90a	Castle Chester	mint s/h	£495
Exposure VIII	mint s/h	£250	Castle Durham	mint s/h	£195
Krell KSA 250	mint s/h	£3500	meridian A500	mint s/h	£495
Exposure XVIII + XIX	mint s/h	£995	Naim SBL's	mint s/h	£795
Exposure XI + XII	mint s/h	£750	Epos ES 14 + stds	mint s/h	£395
Jeff Rowland Model 3	mint s/h	£2495	Denon DCD S1	mint s/h	£2995
Naim NAP 250 (new)	mint s/h	£950	Mark Levinso 30.5/31	mint s/h	£14995
Primare 928 monoblocks	mint s/h	£3995	Wadia 22 transport	as new	£1650
Unison research Smart 845	as new	£2195	Wadia 26 dac	as new	£1995
Audio Reasearch SP15 mkII (black)	mint s/h	£2895	Wadia 12 dac	as new	£1195
Audio Research SP 14 mkII (black)	mint s/h	£1895	DPA T1 transport	mint s/h	£450
Jadis JP 80 mc	as new	£7995	AVI 2000 dac	mint s/h	£295
Jadis JPL	as new	£2495	PS Audio Ultralink	mint s/h	£1095
Musical Fidelity F22	mint s/r	£695	Audio Research DAC 1	mint s/h	£995
Chronos pre-amp and psu	mint s/r	£1495	Wadia 6	mint s/r	£2250
Gryphon Bel Canto	mint s/h	£2495	Theta TLC	mint s/h	£135
Tesseract Tapa line/phono	x dem	£3995	Orelle DA180	mint s/h	£295
Tesseract Tala line	x dem	£795	Accuphase DP80	mint s/h	£2995
Exposure XIV + IX	mint s/h	£1495	Denon DASI/DPSI	as new	£9950
Heybrook Signature	mint s/h	£395	Micromega Stage 3	mint s/h	£650
Burmester 808 line/phono	mint s/h	£1995	Kenwood DP-X9010	mint s/h	£395
Nakamichi CAS pre-amp	mint s/h	£495	Pioneer DP-S901	mint s/h	£295
Conrad Johnson Prem 7B	mint s/h	£6500	McCormack DAC I	as new	£795
Meridian 201/209	mint s/h	£400	Theta DATA/GENIII	mint s/h	£4995
Gamma Acoustics Gemini	x dem	£450	Wadia 32 AT+T	mint s/h	£795
Jadis JP80 mc	mint s/h	£5995	Voyd Valdi/RB300	mint s/h	£450
Jeff Rowland Consumate	mint s/h	£3500	VPI TNT mkII/Triplaner II	mint s/h	£2795
McCormack ALD-1	as new	£1495	Ortolon MC3000 mkII	mint s/h	£395
McCormack Micro	as new	£395	Audio Research PH2	mint s/h	£1995
Cal SL1	mint s/h	£2495	Tesseract Taha	x dem	£895
Tube Technology Prophet	mint s/h	£795	Pioneer F93 tuner	mint s/h	£350
Maim NAC 52	mint s/h	£3100	Transiguration Supreme	as new	£995
Mark Levinson No. 28	mint s/h	£1800	Day Sequerra FM studio	mint s/h	£2995
Alon V	x dem	£3495	Jadis JPP200 head amp	mint s/h	£2495
Alon I	e dem	£995	Lynx Tuner	mint s/h	£295
Soundlab A3	mint s/h	£3995	Creek T40 tuner	mint s/h	£145
Sonus Faber Amator	as new	£2250	Goldmund Reference (late model)/		
Sonus Faber Minima Amator	as new	£1150	Clavis de Capo mandrake cable	mint s/h	£11500
Wilson Watt 3 Puppy 2 + Paws	mint s/h	£5995	Nakamichi CR7E	mint s/h	£995
Sonus Faber Extrema + stds	mint s/h	£4500	Michell Gyrodek	mint s/h	£395
Sonus Faber Guarneri	mint s/h	£4500	Stax SR Gamma + SRD	mint s/h	£295
Neat Critique	mint s/h	£250	VPI TNT MKIII	P.Q.A.	
NEF 105.3	mint s/h	£1295	Rockport Arm Series 6000	P.Q.A.	

MINT S/H - Second hand as good an example as we've seen anywhere

AS NEW - Typically less than 4 months old in new condition

X-DEM - Typically 'as new' but may be older

G.C.V.G.C - In perfect working condition but may be marked

hi CHOICE ^{fi}
(0181) 392 1959
(0181) 392 1994 phone/fax
 Equipment bought or part exchanged
 Full demonstration facility - by appointment
 Major credit cards accepted
 9.30am - 8.00pm 7days

DESPERATELY SEEKING TOP QUALITY HI-FI
due to the success of
The Hi-Fi Exchange
we have clients looking to
purchase your equipment
Call now for best prices
0181 392 1963

audio arts

HI-FI CONSULTANTS
 01784 461406 or 0973 317325

Audiomote Miphrats	£1 599	Mirage M1	£1 400
YBA CD2	£1 499	Triangle Atlas	£1 499
Audiomeca Kreatura	£950	Wilson Watts 3 2	£6 500
Mark Levinson 31 transport	£4 450	Mirage M3	£2 380
Counterpoint IIE	£1 499	Sonic Frontiers Transport DAC	£500
EAD 7000 Transport AT&T	£1 350	VPI TNT III	£3 450
Micromega Drive Variodac	£699	Rockport Arm	£3 995
EAD 700 DAC	£899	Eminent Tech ETII	£450
Teac VRDS 10	£999	Ortolon MC500	£800
Audio Note DAC 3S1G	£1 599	Soundlab A3	£3 650
Proceed 1 Transport	£999	Proac Response II	£1 250
CAT SL1 Phono	£2 850	Sola Sapphire RB300	£350
Counterpoint SAII	£3 450	Proceed Amp 2+Pre	£2 900
Audio Research SP14	£1 550	LFD MCI Phono Stage	£750
Trilogy 901	£499	Audio research PH2	£1 850
LFD PA1/LS1	£899	Audio note ANJ	£3500
Jadis JP 80	£6 250	Audio Note ANE SPX	£1 450
Adyton Pre Amp	£1 900	Pink Triangle Anniversary	£1 100
Arion Pre Amp	£799	SME V	£699
Krell KSA 100	£1 699	Lume JISL5	£2 200
Counterpoint SA4	£3 900	Audio Physic Tempo	£1 599
Jadis Delay 7	£3 099	Meracus Transport	£3 400
Audio Research LS3	£1 250	CT Premier 3	£1 450
Marantz SC2 Monoblocks	£900	Magnaplanner MG3A	£1 695
Marantz SC2	£550	Audio Research D250	£1 850
NRG 401S	£2 700	PT Export SME IV Red Koetsu	£1 150
NRG PA1	£2 300	Magnaplanner MGA3	£1 650
Krell KSA 250	£3 250	Marantz 94 II & CDA	£650
Jadis JA80	£4 450	Theta Generation III DAC	£2 650
Mesa Barron	£2 850	Theta Data Universal Transport	£1 499
Adyton Cordis 1.6	£2 950	Theta Data Mark II Transport	£2 999
Adyton Opera	£1 950	Audio Research D125 Balance	£1 750
Audio Note Meishu	£2 250	Audio research BLI	£475
Audio Note OT0	£950	Audio innovations Series 500	£320
Arion Tycho	£950	Thel 1.2 Piano black	£699
Deatoc 2x50S+Pre	£999	Accuphase Integrated Amp	£750
MF A370 mkII	£999	Agathon Horning Signature	£2 200
Lumley Rel 120 Chrome	£2 450	Copland CSA 1.4	£825
Audio Innovations Ser 1000	£1 200	Counterpoint SA2	£399
EAR 834	£950	GEN III	£3 299
Kelvin LABS M30 Monos+Absolute + Pre	£500	Yamamura 211 Valve Amp	£4 000
Sonus Faber Amator	£1 599	Koetsu Chang	£1 400
Audio Physic Virgos	£2 995	Theta Data II	£3 499
Sonus Faber Minima Amators	£1 100	Garrard 401 + Plinth & Arm	£225
Audio Physic Illaps	£799	Elite Rock	£550
Cadencia speakers	£2 750	SD3+ Target stands	£275

If the product you want is not here we usually can locate it. Please Ring

WANTED: YOUR HI-FI BEST PRICES PAID
Full demonstrations by appointment
Many Hi End cables. Credit card facilities

AUDIO ILLUSION
 23 Langley Broom
 Langley
 Berkshire SL3 8NB
 (2 mins June. 5 off the M4)
 Tel: (01753) 542761 Fax: (01753) 772532
OPENING HOURS
 10 am-8pm Monday-Saturday (By appointment)

CLASSE AUDIO
KORA TRIODE AMPLIFICATION
MIRAGE BIPOLAR LOUD SPEAKERS
ENLIGHTENED AUDIO DESIGNS

* Mail Order Service
 * Export Facilities
 ** All Major Credit Cards Accepted

EX. DEMONSTRATION and SECONDHAND BARGAINS:

Theta Progeny (£1200)S/HandMint	£750
Arcam Delta 70.3 CD Player (£700)S/HandMint	£325
Audio Research V T60 Power Amp (£2,650)Ex DemoMint	£1795
Densen DM10 Integrated Amplifier 70w (£1,300)Ex DemoMint	£850
Copland CSA14 Integrated Amp (£1,100)Ex DemoMint	£850
Mark Levinson 38S Line Stage Preamp (£6,500)S/HandMint	£3950
Audio Research L.S3B Line Preamp (£2,250)Ex DemoMint	£1650
Musical Fidelity Pre 3A PreampS/HandMint	£175
Classe 30 Remote Preamp Bal. (£1,370)Ex DemoMint	£799
Audion Reference PreampS/HandMint	£395
Audion 300B Silver Knight Export.S/HandMint	£1495
Gold Mono Blocks (£2,500)S/HandMint	£395
Infinity Modulus (piano Bk) including standsEx DemoMint	£1050
Sonus Faber Minima Amators (£1,500)S/HandMint	£450
Magnaplanner MG 1.4 Panel LoudspeakersEx DemoMint	£250
Mirage M-290 Audiophile Monitor (£399)Ex DemoMint	£165
Mirage M-190 Audiophile Monitor (£299)Ex DemoMint	

QUAD 66 PRE-AMP £550, Quad 306 £220, Quad 66 CD £300. Spare remote for 66 pre-amp £60. Tel: Day 01203 216650 or eves 01203 460729

QUAD II POWER AMPS (3) boxed, with various spare valves. Some mods carried out, superb sound, will demonstrate £400. Garrard 301 decks (2) £130 each. Tel: 01274 667347 (West Yorkshire)

NAIM NAC52 £2950. Naim NAP 250 £795. Naim NAT 01 £950. New style. Linn Isobarik DMS £675. Linn Arkiv £250. Nighthale NM1 £175. Heybrook HB3 £195. Sony TC377 £95. Tel: 01453 885032

ION NEXUS SP1 pre-amp/XPAK-2 power supply/four MA40 monoblock power amps £1100. ION FMT2 tuner £150. Denon DCD 1560 CD player £300. Tel: 01244 345461 (Chester)

LEAK TL12 near mint, early Troughline, Armstrong ST3/2 tuners. Large quality enclosure with Goodmans speaker. Technics SL110. all vgc. Also 3 boxed new GEC TT21 valves plus others. Offers. Tel: 01842 812895

LINN AKTIV SYSTEM. Kabers, Aktiv cards, Kairn, Three Klouts, Karik, Numeric, LP12, Lingo, Ekos, Troika, Cirkus, all cables inc. Mint condition. Boxed, hardly used. £7700 ono. Tel: 01992 640021 (eves)

KRELL KSA 50/II £850 ono. (May P/Ex your Naims) Musical Fidelity (The PreAmp) £120. Zeta Tonearm, boxed (mint) £225. Philips CD 850 (boxed mint) £180. Tel: 0191 422 3415

KENWOOD DP9010 CD Transport with Trichord clock 2 mod £290. Audio Alchemy Power Station: One, suitable for DITB or Dacman £25. AR EB101 turntable plus Arcam E77mg £145. Tel: 01279 659948

SNELL KII Speakers, Walnut cabinets with Standesign stands, excellent, manual, boxed £325. Quad 33-303 pre/power vgc, manuals, boxed £125. Buyer collects. Tel: 0114 237 8731 (Sheffield)

EPOS ES 14 SPEAKERS with Epos stands to match in excellent condition. Boxed, instructions, genuine sale due to upgrading. £395. Tel: 01886 821577

CONRAD JOHNSON PV10A pre-amp, exc cond £750. LFD PA2M mono blocs, exc cond £900. Tel: 01604 766124

LINN KAN II Speakers with Linn Kan stands, black, boxed and bi-wireable. Mint condition £260. Tel: 01277 622130 (Essex)

ITS THE DAC Ken Kessler raved about. (Hi Fi News March). Marantz DA12LE. Compatible with high grade transport. Very good, now modified. The best! Boxed, leads, instructions vgc. Rare. Offers. Tel: 0141 954 8030

AUDIO INNOVATIONS Series 200 pre-amp, MM/MC, excellent condition and sound £325 ono. Sugden A48 MkII, recent factory service £120. AKG 340 headphones £80. Tel: 01423 507266

RADIO DESIGNERS handbook, fourth edition 1953. Also Hi-Fi World magazines, Feb 93-Dec 94. Offers. Tel: 01222 889083 (Cardiff)

MISSION 770 FREEDOM speakers, black, integral stands, excellent sound and condition £175. Sansui 222 Mk2 turntable £25. Tel: 01977 684343 eves (Yorks)

QUAD 33/303 FM3 tuner £150 ono. Complete with instruction books. Tel: 01254 886185 before 2pm or after 6pm

BANG & OLUFSEN Stereo receiver £70. Bang & Olufsen stereo cassette deck £50. Haffler stereo pre-mpifier £75. Pair KEF Choral speakers £75. Teac DBX noise reduction unit. £60 vgc. Tel: 0181 686 7996 (Craydon)

AUDIOLAB 8000A amplifier £250. Marantz CD MkII. QED digit plus Positron power supply £70. Sony ST444 ES tuner £100, serious upgrade causes sale. Tel: 01844 354287

DENON POA 6600 Monobloc power amps 250 watts into 8 Ohms. Real powerhouses. Mint condition, boxed £675. also matching Digital pre-amp POA 5500 £450 or £1075 together. Tel: 01279 724804

TANNOY LANCASTER Conner 12. Reds £650. Radford STA25 mint £450. Leak ST20 £250. Micromega Duo v.3.0 plus Marantz CDA 94 DAC both mint £950. Decca Radiogram £30. Tel: 0181 296 8538 (daytime or after 10pm)

AUDIOLAB 8000A Only 4 months old boxed and hardly used. Unwanted gift £395. IPL Acoustics A2 Aerogel speakers using Audax 6.5 inch Aerogel bass/mid similar to Mission 752 £325. Mission DAD 7000 CD player £75. Tel: 01902 374786 (nr Wolverhampton)

LINN KARIK III CD player £1050. Mana 4 tier table, Soundstage, Ref. Top and speaker stands £750 ono. Tel: Tim - Pager No. 0941 119432 (Please leave a contact telephone number)

JOHN SHEARNE 2 amp, vgc £350 ono. Croft SV power amp, 35 wpc, vgc £325. STD 305, 774, Shure, superb £160 ono. Arcam 2 speakers, modified £140 ono. Panel speakers £80. Tel: Paul 01895 446713

CAMBRIDGE AUDIO CD3, Pioneer A400 amp, TDL RTL2s £350 the lot, or split. Buyer collects. Tel: 01279 504926

MVT Mk3, Musical Fidelity pre-amp, MC and MM inputs, separate power supply as new £585. Tel: 01945 581111 (Wisbech)

FM/AM STEREO TUNER, Sumo Aurora, high end product imported by ATC. Cost £700, now £310 or exchange for 35mm SLR camera. Cash adjustment. Boxed, demonstrated with Galaxy 17 aerial! Tel: 0181 651 5711

AUDIOLAB 8000A, 5 months old (receipt) perfect £380. Audio Alchemy DAC-in-the-box, 11 months old £135. Tel: 0116 234 5019 day or 01530 831357 eves (Leicestershire)

SONY TA-N55ES Power amp, 110W per channel stereo (300w mono-bridged). Exc condition with instructions £215. Entre-I m/coil cartridge £35. Tel: 01908 260112 eves

PIONEER A400 Stereo amplifier as new £150. Marantz CD 63 compact disc, new condition £150. JVC top-loading quality cassette deck, vgc £40. Pioneer PL12 turntable vgc £25. Pair early Decca speakers £30. Sugden stereo tuner vgc £60. Tel: 0181 681 1054 (Croydon)

LINN ISOBARIKS PMS black ash with stands, new style, boxed, as new £1050 ono. Project 05 turntable as new £70. Tel: 01494 866487

NAIM NAP 90, 10 months old, Naim NAC 92, 3 months old £600. Tel: Tim-Pager No. 0941 119432 (Please leave a contact tel. no.)

UNITY AUDIO SIGNATURE 3 EDC speakers. A unique blend of beautiful looks and sound. Rave stereophile reviews. Mint condition and boxed. List (£2000) will accept £1150 ono. Tel: 01206 844855

TOWNSHEND ROCK RB250 arm £275. Snell JII loudspeakers (walnut), Foundation stands £295. Thorens TD150, Grace arm £65. Denon TU260 tuner £55. Thorens TD150 £30. LNB loudspeakers (dual concentric) £25. Notts Analogue Tracer cartridge MkII £50. Can Opener Headphone adaptor £45. Beyer 911 Headphones, as new £100. NAD tuner £225 £50. Marantz ST320L tuner £25. Leak Troughline Mk3 stereo tuner £55. Tel: 0114 273 8153 or 272 3621

MANA ACOUSTICS Reference Phase Three special table, including brass finished mini table. This set is one of only two made, Mana Acoustics owns the other. £300 ono. Tel: 01772 719267 eves

DPA (DELTEC) TI Transport, DPA Bigger Bit DAC, also 2 x The Power Mains Filters £850 ono. Black Slink Interconnect £100 ono. Mint, boxed, instructions. Tel: 01900 826400 daytime or 01900 826294 eves

WANTED: QUAD 66 FM tuner. For Sale: Quad FM4 tuner £250 ono. Tel: 01883 653165 (Surrey)

ELITE ROCK TURNTABLE with Mission 774 arm, Linn K9 cartridge £350. Jecklin Float 2 headphones £75. Marantz CD40 CD player £70. Quad valve FM mono tuner £60. Tel: 01423 507266 (Harrowgate)

THORENS TD124 turntable with SME 3009 series II arm, £195. Teak plinth £25. One Leak Sandwich speaker, Teak, £25. Original owner all items. Tel: 0181 908 0087, anytime, Wembley.

SITUATIONS

GRADUATE (25) seeks work within Hi-Fi market. As sales rep or in sales. Excellent product knowledge. Leicester/Midlands area. Tel: Dale 0116 281 2074

CAMBRIDGE UNIVERSITY Engineering undergraduate seeks summer vacation employment in audio engineering before entering 3rd year. Please contact Michael Burcher, Sidney Sussex College, Cambridge CB2 3HU

MAKE ME HAPPY. Give me a job. Hard working design graduate with sense of humour and power Macintosh would like a position in the Audio Visual industry. Tel: Adam 01873 811619

MSc in Audio Engineering? Yes, two analogue buffs, into amp/speaker design, soon to finish unique course at Essex University. Don't delay, or else we advertise abroad! Tel: Jon 01206 242099 or Malcolm 01206 867317

LIVING VOICE

LIVING VOICE POWER TRANSMISSION AND ANALOGUE INTERCONNECT CABLES

Purchase these world renowned products by mail order. The sonic benefits are comprehensive. If you think otherwise your payment is returned in full, minus postage within 20 days of your purchase

LIVING VOICE LVPC-POWER CABLE

A substantial large diameter screened power transmission cable. Silver plated fuse holder and moisture proof encapsulation. For all audio components fitted with a standard IEC mains input. Replacing your conventional or custom power cable with LVPC will dramatically increase dynamic range and bandwidth, provide a silent black background and vivid believable tone colours.

1.2 metre terminated. £69 per unit

LIVING VOICE LV4P-DISTRIBUTION UNIT

As above but terminated with a 4 way distribution unit. One piece brass and phosphor bushbars, polycarbonate casing, silver plated fuse holder. If you are using a conventional extension lead you will have a high noise floor creating a grey hazy background. Densely figured music is often illegible and fatiguing, and tone colours bleached and pale. LV4P will banish these characteristics and provide a clear, calm well ordered presentation.

2.0 metre terminated. £99 per unit

LIVING VOICE LVAL-TONE ARM LEAD

Discover the true quality of your tonearm, For SME 309, 310, 312, IV, V and Wilson Benesch ACT1, ACT 2. Terminated to RCA phono or BNC £189

LIVING VOICE LVC-INTERCONNECT CABLE

Analogue music signal interconnect cable. Low inductance, low capacitance, RF screened. Natural free dynamics with fine low level resolution. Consistent tone character and dynamic proportioning across the full band width - the best interconnect in an overcrowded marketplace.

RCA phono to phono. 1 metre - £165 1.5 metres - £227 2 metres - £290

LIVING VOICE LVDC DIGITAL INTERCONNECT

Terminated with RCA phonos, BNC (or a combination) or AES/EBU.

1.5 mtrs RCA/BNC	£114	AES/EBU	£130	1 mtr RCA/BNC	£82	AES/EBU	£99
				2 mtr RCA/BNC	£144	AES/EBU	£161

Order Form

Please add £3.50 for orders of 1 & 2 items, and £4.50 for 3 items and over. Overseas please add £10.00

Type of termination	Length	Quantity	Price	
LVPC				
LV4P				
LVAL (SME)				
LVAL (WILSON B)				
LVDC				
LVC				

P & P
TOTAL

Please make cheque payable to Living Voice or pay by Visa/Amex/Mastercard.

Card No

Name as printed on the card

Billing address

Expiry Date:

Signature

Post Code

Please allow 14 days for delivery

Cut out form and send to: Living Voice. PO Box No. 247. Nottingham NG2 7TX

CLASSIQUE SOUNDS (LEICESTER) VINTAGE HI-FI SPECIALIST

WANTED

VINTAGE AND MODERN VALVE HIFI

TOP PRICES PAID

FREE COLLECTION OR CARRIAGE PAID.

WORKING OR NOT.

AMPLIFIERS

QUAD, LEAK, RADFORD, ROGERS, AVANTIC, LOWTHER, BEARD, AUDIO INNOVATIONS, CHAPMAN, CROFT, EAR, AUDIONOTE, LUMLEY, REVOX ETC.

SPEAKERS

QUAD ELECTROSTATIC, LOWTHER, TANNY, IMF ETC.

TURNTABLES

GARRARD 301, GARRARD 401, THORENS 124/224 ETC.

VALVES

MULLARD, OSRAM, BRIMAR, GEC, KT66, KT88, EL34, EL84, GZ32/34, 300B, PX4, PX25 ETC.

RECORDS

CLASSICAL, JAZZ, BLUES ETC
FULL OR PART COLLECTIONS.

MISCELLANEOUS

HIFI YEAR BOOK. OLD CAPACITORS. OLD CARBON RESISTORS.

ALSO WANTED

QUALITY MODERN/TRANSISTOR HIFI EQUIPMENT.
SPEAKERS, RECORDS DECKS, AMPLIFIERS, TUNERS ETC.

FOR SALE

1970-1993 HIFI NEWS/RECORD REVIEW BINDERS. COMPLETE £150.

VINTAGE VALVE AMPLIFIER REBUILDS. FROM £100.00. ADD
£20.00 FOR SAME DAY SERVICE. I.E., DELIVER 9AM COLLECT 5PM
SAMEDAY. 12 MONTHS GUARANTEE ON ALL PARTS FITTED

20 % off
products marked *

FOR SALE

PRE-POWER AMPLIFIERS

PAIR QUAD11s	£350	DPA CT480 PRE-AMPLIFIER	£200
RADFORD STA25	£200	CROFT MICRO A	£200
LEAK STEREO 60. EX COND	£200	AVANTIC SPA11	£200
LEAK STEREO PRE AMPLIFIER	£200	MUSICAL FIDELITY P140 PWR AMP	£195
ROGERS CADET POWER	£200	DNM PRE AMP + POWER SUPPLY	£595
PAIR LEAK TL12+. EX COND	£200	PAIR ROGERS JUNIOR AV COND	£200
LEAK STEREO 20	£200	CROFT SERIES 6. NEW	£1500*
QUAD 405/2 MINT BOXED	£200	QUAD 33/303 PRE-POWER	£195
ROGERS CADET MONOS. PAIR	£225	LUMLEY 1030. 15W. CLASS A. MINT	£695*
EAR 859 13W S/ENDED. NEW	£1000	CROFT EPOCH. NEW. 2YRS GTEE	£550
AUDIO INNOVATION S300 EXPT	£299	PIONEER M73 CLASS A PWR AMP	£395
NVA. A40/P50 PRE/POWER	£295*	ROSE RV235 PRE-AMPLIFIER	£375
KON OBELISK 3X + X PACK 1 MINT	£300	BEARD P300 PRE-AMPLIFIER	£299
PYE HF25	£200	BEARD C35 PRE-AMP. MINT. BXD	£450
AUDIONOTE OTO. VALVE	£695	BEARD P35 MK2 POWER AMP. MINT	£695

TURNTABLES

GARRARD 301/401	£400	THORENS TD160/MAYWARE	£149*
THORENS TD160 MISSION 774	£149*	ROKSAN XERXES/PEGA RB300 MINT	£599
PINK TRIANGLE TOOHMELIUS	£500	THORENS 124. VARIOUS	£200
THORENS TD160	£80	GARRARD 401/SME PLINTH/SME 3012	£400

SPEAKERS

QUAD ELECTROSTATICS	£200	MERIDIAN M30/STANDS.ACTIVE	£650
IMF TL550 MINT. BOXED	£399*	WHARFEDALE HAREWOODS. (£1000)	£399*
BOSE 305M EX COND. (£430.00)	£225	LINN SARA ISOBARICS + STANDS	£399*
TANNY CANTERBURY/SILVER UNIT	£425	JAMO SILOUETTE MINT. BOXED	£250*
CASTLE KENDAL	£70	ROGERS LS36 MONITORS 15 OHM	£250
FANE QUARTET PAIR VERY RARE	£100	AUDIONOTE ANJs	£400

OTHER ITEMS

GARRARD 301/401/124 PLINTHS, READY TO VENEER/PAINT VERY HEAVY	£149*		
NAKAMICHI ST-7E TUNER	£400	LINN ITTOCK LV11. BOXED	£60
ACOS LUSTRE ARM. BOXED	£50	SME 3009	£60
LEAK TROUGHLINE 2	£200	SME 3009 IMPROVED BOXED	£100
QUAD FMI LW MW SW	£200	LENTEK MC PRE-AMPLIFIER	£49
LEAK TROUGHLINE 3. VARIOUS	£200	REVOX A77 R.REEL	£120

MAF STANDS FOR OLD ELECTROSTATIC SPEAKERS NOW STOCKED @ £175.00 PAIR.

MAF STANDS FOR NEW ELECTROSTATICS @ £275.00 PAIR

TRANSLUCENT

99.99% PURE SILVER INTERCONNECT CABLES.

.5 METRE.....£60 1 METRE.....£80

7 DAY MONEY BACK GUARANTEE IF NOT BETTER THAN YOUR EXISTING CABLE.

99.99% PURE SILVER WIRE. 0.5MM.....£4.95 PER METRE.
SUITABLE FOR AMPLIFIER OR SPEAKER REWIRE.

TEL/FAX PAUL GREENFIELD ON 0116 2835821 OR 0802 213740 ANYTIME
CLASSIQUE HOUSE, 61 AYLESTONE DRIVE, AYLESTONE, LEICESTER, LE2 8QE

ORDER FORM

SPECIAL OFFER! Now you can advertise in the Classified Section for only £10 or £15 in a display black box (incl. VAT). Maximum length is thirty words, each additional word 50p extra. Telephone and model numbers are treated as one word. All advertisement copy should be typed or written in block capitals and accompanied by the form on this page.

SPECIAL OFFER!
BOOK 1 MONTH GET 1 MONTH FREE.
OFFER APPLIES TO PRIVATE ADVERTISERS ONLY.

Cheques should be made payable to **Audio Publishing Ltd.** Please send your copy to: **Hi-Fi World Classified Ads., Audio Publishing Ltd., 64 Castellain Road, London W9 1EX.** Classifieds will be published in the first available issue after receipt.

HI-FI WORLD CLASSIFIED ADS

Please write your advertisement copy on a separate sheet of paper and return with this completed form.

Name _____

Address _____

Post Code _____

Daytime Tel No: _____

Private Advertiser Trader Situations Wanted (Tick where applicable)

Display (boxed £15 inc. VAT.)

I enclose cheque/postal order for £ _____ Made payable to **Audio Publishing Ltd.**

Please debit my VISA/ACCESS Card No.

Expiry Date: _____

Send to: **Hi-Fi World Classified Ads., Audio Publishing Ltd., 64 Castellain Road, London W9 1EX.**



UNIQUE OFFER!
Looking for a job in the hi-fi/audio market? Hi-Fi World can help you. Advertise yourself free for one month in these pages under the heading SITUATIONS WANTED.
Maximum length 30 words.

TRADE

BUY-SELL-EXCHANGE. Vintage wireless and classical audio. Repairs, spares, restoration, modifications to all valve equipment. Quad II, Leaks, etc. Visit us for collectable audio and gifts. 17 Bell Street NW1 5BY
Tel: 0171 258 3448

AUDIO VALE Electronics specialist. Amplifiers and power supplies, design, construction, repair, restoration. Tel: Theo 0181 881 1623 9-6pm Mon-Sat

UPGRADE YOUR CD PLAYER or Transport with the Taurus Digital Supply which improves sound quality by independently powering critical decoder electronics. Upgrade comprises modification to CD player and state-of-the-art external power supply. Fitted via socket, all for £250. Contact Taurus Systems for details. 9am-6pm Mon-Sat.
Tel: 0181 599 3196

TRADE

HIGH PERFORMANCE Stereo Decoder for valve tuners. Mains powered unit, ready built £48.50. Kit £28.50. Ready to use, no alignment needed. Studio 12 Nanjivey Tce, St Ives, Cornwall TR26 1BQ.
Tel: 01736 798393

SUGDEN AU51cr (remote control) pre-amplifier (new, ex-dem) £745. Sugden SDT-1 (new, ex-dem) £695. DPA-Deltec T1 + Bigger Bit + 2 mains filters £795. DPA-Deltec Black Slink £95. Audio Research Classic 30 (inc new Groove Tubes) £1350. Linn Ittok LVIII £95 (or £325 with full Linn rebuild). Michell Iso (mc) £250. Naim Nait £170. Castle Severn £250. Rega Ela £260. Naim NAC32.5 + Hicap + NAP250 £1195. Linn Kremlin £1195. Audiolab 8000T £395. Castle Howard £595. Arcam Alpha 5 CD £245.
Tel: Steve 01922 640300

TRADE

ARCAM DELTA 170.3 Transport with black box 50 £599; Quad 34/306 £459; Rogers JR150 very rare £199; LS7 £229; Ruark Sabres £199; Eppo ESII £269; Naim SBL £1329; IBL £499; Linn Kabers £899; Tannoy 615 £450; Hi-Fi purchased. Tel: Objective Audio 01279 426647 or 0973 452368

M.A.S. CONSTRUCTION. Improve or build your own speakers cabinets with speaker notes using Viroc or hardwood. New spikes for floor standers incorporating a damping system, silver-plated PTFE cable at £1.28 per metre.
Tel: 01670 354726 after 5pm

TRADE

LUMLEY REFERENCE 120 Monoblocks as new £1500. Audion Silver Night export monoblocks £1350. Elite Rock turntable £300. Part exchange welcome. Equipment bought for cash
Tel: 0121 784 8765

ELITE ROCK Turntable boxed as new £300. Garrard 401, excellent £100. Quad Electrostatic loudspeakers £350. Alon loudspeakers, boxed £800. Lumley Reference 120 monoblocks £1500. Audion Silver Night export monoblocks £1350. Scott valve integrated £200. Part Exchange welcome. Equipment bought for cash
Tel: 0121 784 8765

MARANTZ HI-FI at low prices. For Example CD63 SE KI Signature £399.99. PM55SE amplifier £199.99 and more... CD17 £699.99. Castle, AudioQuest, van den Hul. Ring for more details. Tel: Loughton Audio 0181 508 6000

ABSOLUTELY VINYL

For our latest free catalogue of used Rock/Jazz/Classical Vinyl LPs send 19p SAE to:
P.O. Box 55, Reading RG4 0UE.

WANTED

SLATE AUDIO are looking for Garrard 301s and 401s. Fair prices paid for fair examples, better prices paid for fine examples. We can arrange collection if necessary. Telephone Peter Soper on 0525 384174

WANTED - EARLY HI-FI
Tannoy, Lowther, Parmeko, Voigt, Vitavox, RCA, WE, Garrard, BBC301, EMT, SME, Ortofon, Decca, AEI, Leak, Rogers, PYE, Quad

CLEAR CRYSTAL SYSTEMS
John Petrie-Baker
Tel: 0171 328 9275
Fax: 0171 833 3008

Advertisers' Index

MAIN ISSUE		KEF		IFC	THE POWER PLANT	115
		KJ WEST ONE		52	TRY ME & SEE	102
ALCHEMIST	22	KLIPSCH		88	UK DISTRIBUTION	12
ANGLIA AUDIO	116	LIVING VOICE		128	V AUDIO	62
APOLLO FURNITURE	94	LORICRAFT		88	VICKERS HI-FI	86
ART AUDIO	104	MANA ACOUSTICS		115	WHARFEDALE	18
AUDIO ARTS	126	MANTRA		122	WILMSLOW AUDIO	96
AUDIO CONSULTANTS	40	MARTON MUSIC		118	WILSON BENESCH	22
AUDIO ILLUSION	12/126	MAY AUDIO		48	WILSON STEREO	
AUDIO JUMBLE	120	MICHELL ENGINEERING		98	LIBRARY	96
AUDIO MASTERS	80/115	MIDLAND AUDIO			WIRRAL HI-FI	96
AUDIO SYNERGY	46	EXCHANGE		124		
AUDIO SYNTHESIS	40	MORDAUNT SHORT		60	D.I.Y. SUPPLEMENT	
AUDIOLAB	64	MUSICAL IMAGES		14/15		
AUDIOPHILE FURNITURE	19	ORANGES & LEMONS		124	AP ELECTRONICS	12
AUDIOPHILE		ORCHID PRECISION		62	AUDIO LABORATORY	
INTERNATIONAL	110/111	ORTOFON		22/68/76/98	LEEDS	10
B&W	6/54/55	OXFORD AUDIO CONS		112	AUDIOLINKS	10
CABLE TALK	113	PM COMPONENTS		32	AUDIONOTE	18/19
CAMPAIGN AUDIO DESIGN	22	PORTFOLIO MARKETING		58	BILLINGTON EXPORT	4
CHOICE HI-FI	126	PROGRESSIVE AUDIO		113	CHELMER VALVE CO.	I.F.C.
CLASSIQUE SOUNDS	128	PURE SOUNDS		114	DECADE ENGINEERING	22
CR DEVELOPMENTS	34	RINGMAT		88	DEFINITIVE AUDIO	
CREEK AUDIO	46	ROGERS		19/24	BRIGHTON	6
CUSTOM CABLES	104	ROOM ACOUSTIC SERVICES		112	FALCON ACOUSTICS	10
DEFINITIVE AUDIO	114	SDAY		86	GLASS AUDIO	16
DIVERSE MUSIC	122	SERIOUS KIT		117	HART ELECTRONICS	I.B.C.
DOUG BRADY	22	SLATE AUDIO		108	IPL ACOUSTICS	22
DPA DIGITAL	10	SONIC FRONTIERS		116	KIT & COMPONENT	
EDICRON ELECTRONIC		SONNETEER		104	SUPPLIERS	26
COMPONENTS	118	SOUND CONNECTIONS		113	LANGREX	14
ENCORE	104	SOUND ORGANISATION		94	LORICRAFT AUDIO	16
FRIENDS TO THE STARS	122	SPALDINGS		46	MAY SHAREHOLDERS	24
GAMMA ACOUSTICS	116	SPECTRA DYNAMICS		76	N.V.A.	6
GLOTTA AB	86	STUDIO ONE		98	RIVERSIDE AUDIO	10
GRAMEX AUDIO	124	SUGDEN		I.B.C.	RUSS ANDREWS	B.C.
GROOVE TUBES	113	SUSSEX SURPLUS		120	SEAS	24
GT AUDIO	8	SYSTEMDEK		88	SJS ELECTROACOUSTICS	22
HARBETH ACOUSTICS	40	TANNOY		B.C.	SONIC FRONTIERS	14
HARROGATE HI-FI	112	TECHNICAL & GENERAL		114	TECHNICAL & GENERAL	6
HEATHERDALE AUDIO	124	THE AUDIO ECLAT		117	THE ELECTRONIC ENGINEER	
HI-FI CORNER	106	THE CHORD COMPANY		19	AND CONSULTANT	10
HOT ROX UK	124	THE ELECTRONIC ENGINEER			VINTAGE AUDIO	16/24
IAN EDWARDS	86	AND CONSULTANT		113	WILMSLOW AUDIO	6
IAN HARRISON HI-FI	120	THE EMPORIUM		122		
IMPULSE LOUDSPEAKERS	34	THE SOUND FOUNDATION		68		
JEM DISTRIBUTION	76	THE SOUND GALLERY		78		

SUGDEN

HAND CRAFTED ■ FAIT A LA MAIN

OPTIMA COMPACT DISC PLAYER



SIGNATURE 41R PRE/POWER AMPLIFIER



OPTIMA 200R LINE AMPLIFIER



DESIGNERS & MANUFACTURERS OF HI-FI & AUDIO EQUIPMENT

J. E. SUGDEN & CO. LTD.

Valley Works,

Station Lane, Heckmondwike,

West Yorkshire WF16 0NF

Tel. Heckmondwike 01924 404088/9

Fax No. 01924 410069



MODEL: DEFINITION D700

EXPERIENCE THE SCALE, EXCITEMENT AND IMPACT OF LIVE MUSIC
WITH THE 'DEFINITION' SERIES FROM TANNOY

TANNOY

MARANTZ HI-FI UK LTD.

575-583 BATH ROAD, LONGFORD, MIDDLESEX. UB7 0EH. TEL: 01753 680868. FAX: 01753 680428