

£2.00
HAPPY XMAS

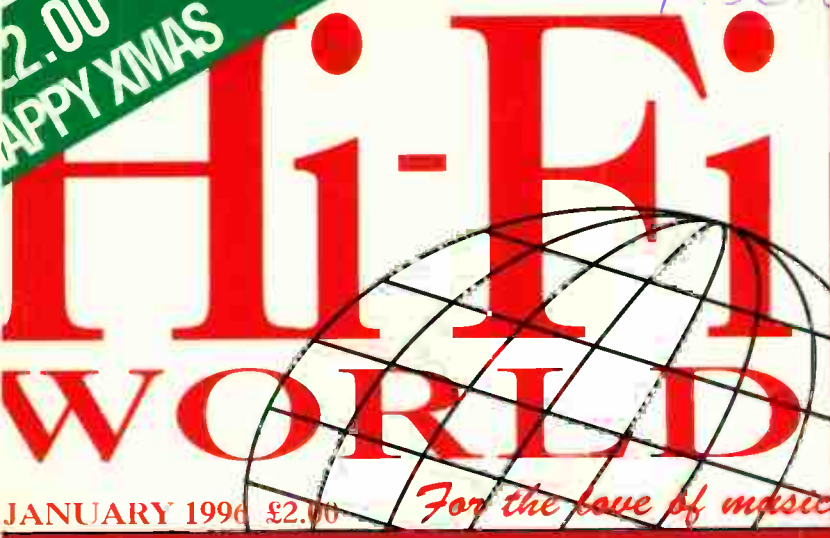

NAD HAVE IT TAPED WITH
THEIR NEW 613
CASSETTE DECK

WE TEST SIX OF THE BEST NEW £200 SPEAKERS

CHRISTMAS SUPPLEMENT
(overseas - inside)
free with this issue.

NEW FROM
ARCAM -
ALPHA 6 CD
PLAYER &
ALPHA 6+
AMPLIFIER



COMPETITION - WIN EVERYTHING WE REVIEW
IN THIS ISSUE - OVER £6500 WORTH OF HI-FI



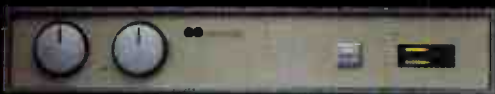

AV1 HOME CINEMA PROCESSOR

Naim's SFX digital signal processing system produces a surround sound that brings realistic concert and film performance into your home.



Explore ^{a new}
dimension
in
sound

With the definitive Home Cinema, sound reproduction focuses into absolute reality. An impression which envelops the senses with consummate precision. Explore this astonishing new world with the AV1 Processor from Naim. It's a living experience.

'EVERYTHING YOU HEAR IS TRUE'

naim

HAPPY CHRISTMAS FROM HI-FI WORLD

To celebrate Christmas, Hi-Fi World is once again holding a massive Christmas Competition, where everything reviewed in this issue can be won. As you can see from the list below there's plenty to win, from a new pair of loudspeakers to state of the art interconnects and loudspeaker cables. In all, there are over £6,500 worth of prizes on offer, so make sure you don't miss out this Christmas - turn to page 66.

Acoustic Energy AE100 loudspeakers	£199.50
B&W DM601 loudspeakers	£199.95
KEF Coda 8 loudspeakers	£189.00
Celestion Impact 15 loudspeakers	£199.00
Mordaunt Short MS20i loudspeakers	£199.99
Revolver Purdey loudspeakers	£199.90
Sonneteer Champion amplifier	£579.00
NAD 613 cassette deck	£229.95
Castle Isis loudspeakers	£229.90
TEAC CD-5 CD player	£349.95
Arcam Alpha 6 CD player	£599.90
Arcam Alpha 6+ amplifier	£349.90
Chameleon Ruby amplifier	£995.00
Denon DCD-315 CD player	£149.99
NEAR 10M loudspeakers	£499.00
Van den Hul cables	£314.94
Light Metal cables	£830.00
Audiophile Base	£480.00
Total	£6794.87

For competition details and entry form see page 66.

Distributed by:
COMAG, Tavistock Road,
West Drayton, Middlesex,
UB7 7QE
Tel: 01895 444055

Origination by:
Ashford Scanning, 2 Norfolk
Drive, Fairwood Industrial
Park,
Asford, Kent TN23 2FB
Tel: 01233 622042

Printed by:
Southernprint, Poole, Dorset.
Tel: 01202 622226

All unsolicited submissions are
made
at the owners risk. We accept
no
responsibility for such
submissions,
nor do we undertake to
return them.

No material may be
reproduced
from this magazine without
the publisher's written
permission.
© Audio Publishing Ltd

EDITORIAL

Editor

Noel Keywood

Assistant Editor
Dominic Baker

Editorial Assistant
David Price
Laura Martin

PRODUCTION

Production Editor
Ferewini T. Michael

ADVERTISING

Advertising Manager
Caroline Knott
Tel: 01245 443555

Advertising Executive
Rosalind Day

MARKETING

Marketing Manager
Jon Dolan

Technical Assistant
Nick Lucas

Contributors
Eric Braithwaite
Douglas Floyd-Douglass
Andy Grove
Dominic Todd

Music Reviewers
Peter Herring
Simon Hopkins
Giovanni Dadomo
Jon Clarke

CONTACT NUMBERS

10 am - 6pm
Tel: 0171-289 3533
Fax: 0171-289 5620
Individual queries cannot
be answered by
telephone.

MAIL ORDER

Tel: 0171-266 0461
(24 hour
answerphone)

SUBSCRIPTIONS

see page 68 for details

AUDIO

PUBLISHING LTD
64 CASTELLAIN ROAD,
MAIDA VALE,
LONDON W9 1EX.



THIS MONTH'S REVIEWS

AMPLIFIERS

SONNETEER CAMPION 20

From new boys Sonneteer, the Champion looks set to be a champion. Eric's rhapsodies are far from terse, but in prose, alas, not in verse.

CHAMELEON RUBY 41

Douglas Floyd-Douglass assesses how the Chameleon Ruby from the professional world adapts to domestic surroundings.

ARCAM ALPHA 6+ AND ALPHA 6 CD PLAYER 33

Dominic Todd meets the newest additions from old friends Arcam - the Alpha 6+ amplifier and Alpha 6 CD player.



LOUDSPEAKERS

GROUP TEST 13

This month's group test promises to be a clean fight, as budget loudspeakers attain increasingly high standards.

Acoustic Energy AE100

B&W DM601

KEF Coda 8

Celestion Impact 15

Mordaunt Short MS20i

Revolver Purdey



CASTLE ISIS 26

The Isis is Castle's replacement for the Trent. Its feet aren't on the ground, but should it be left on your shelf? Eric Braithwaite tells all.

NEAR 10M 57

New England Audio Research claim to being 'the leader in metal speaker technology' thanks to their in-house designed and built metal alloy cone drivers. We audition their 10Ms, a high quality miniature.



CASSETTE DECK

NAD 613 24

Noel Keywood - the man with the Nak - shows how NAD's new 613 measures up.



COMPACT DISC

TEAC CD-5 29

Joining in the fiercely competitive £350 CD player battle, does TEAC's CD-5 pack enough punch to beat off the competition from NAD and Marantz?

DENON DCD-315 49

Denon's low budget £150 DCD-315 offers Eric Braithwaite more quality than he bargained for.

CHRISTMAS SUPPLEMENT

This month's free supplement carries our World Winners listing, a selection of equipment we've reviewed over the last year that stood out sonically above the crowd. You'll also find Christmas music ideas as well as puzzles and games to keep you amused over the festive period.

WORLD VERDICT



OUTSTANDING - Superb sound, something we'd use ourselves.



GOOD - Has strong merit. Well worth an audition.



ADEQUATE - Mediocre in vital areas. May be worth auditioning.



POOR - Seriously flawed. Not worth considering.

REGULARS

NEWS Monthly update on the industry and the market.	7	MEET YOUR MAKER Who makes what and how to get in touch.	81
QUERIES Experts expound, explain and explore.	42	WORLD AUDIO DESIGN Be constructive with a World kit.	82
LETTERS Capital letters from World readers.	52	DIAL-A-DEALER Who sells what, and how to get in touch.	89
COLUMNS Straight, upright and to the point: our columns.	61,63,69,72	HI-FI WORLD LIBRARY An ideal present for your hi-fi friends; affordable and educational.	99
NEXT ISSUE You won't know what's issuing forth if you don't buy our forthcoming issue.	60	MEASURED PERFORMANCE World measures up.	113
SUBSCRIPTIONS Get involved - subscribe to our issues.	68	READERS' CLASSIFIED ADS Pages and pages of bargain used equipment.	134
SPECIALIST HI-FI DEALERS Purveyors of fine quality merchandise and potential paradise, at your disposal.	77	ADVERTISER'S INDEX	146

FEATURES

VAN DEN HUL AND LIGHT METAL CABLES 65
Two interesting loudspeaker/interconnect cables that take a step away from the norm. Van den Hul use a carbon hybrid construction whilst Light Metal have developed a special metal alloy conductor.



MALAYSIAN HI-FI SHOW 36
Noel Keywood recounts his latest visit to the land of the hi-fi enthusiast.

AUDIOPHILE BASE 71
David Price gets to grips with Audiophile Furniture's BASE system, an isolation rack for your equipment.

MUSIC

Some excellent new releases for your perusal.

ROCK RECORD OF THE MONTH:

Pulp: Different Class

CLASSICAL RECORD OF THE MONTH:

Franz Josef Haydn: Six Strings Quartets Op50 (The 'Prussian' Quartets)

ROCK AND POP 73

JAZZ 86

CLASSICAL 93

COMPETITION

A chance to win everything reviewed in this issue. 66



STREETMENTS



PUT SOME SPACE BETWEEN YOU AND THE NEIGHBOURS



VALDUS



With over 63 years experience in producing loudspeakers for recording, for rock concerts, for discos, for instruments ranging from the wickedest rock guitar to thunderous church organs; only Wharfedale has the ability to give your music the power, the realism, the drama that you really deserve. VALDUS speakers are efficient so you get more sound out into the room for each watt of power delivered by the amplifier. VALDUS takes loudspeaker design into a new era; a new age; a new dimension. Connect-up; Power-up; Volume-up; and say goodbye to your neighbours.

Wharfedale

BRITAIN'S MOST FAMOUS LOUDSPEAKERS

Wharfedale International Limited, Sandeas Way, Leeds LS15 8AL, England.
Telephone: 0113 260 1222 Fax: 0113 260 0267



100
£89.95



200
£109.95



300
£149.95



400
£199.95



500
£299.95

AUDIOLAB AMP ARRIVES

Audiolab have announced a new line level integrated amplifier, the 8000S. With six line level inputs, three tape monitors and a healthy output of 60watts, as well as being remote controlled, the 8000S should prove a popular addition to Audiolab's range. It is flexible too, with two pre-amplifier outputs and a power amplifier input. A second power amp. can be added for bi-amping, or it can be used as a stand alone preamp.

The pre-amplifier is a discrete component Class A design and the power amplifier is capable of delivering a peak current of 25 amps. The new 8000S should be in the shops as you read this, retail price 649.90.



Cambridge Systems Technology
Spitfire Close, Ermine Business Park,
Huntingdon, Cambs. PE18 6XY
☎ 01480 52521

THANK Q REL

The Q-Bass is a new addition to REL's range of subwoofers, and is the most affordable to date at £350. Unlike the rest of the range, the Q-Bass uses a sealed box, rather than reflex loading. The 12" long throw bass driver is powered by a 40watt in-built amplifier, and the gain and upper roll off point can be set to suit a wide range of loudspeakers.

The Q-Bass subwoofer is the first in REL's range to use their 'Set-Safe' system. This monitors the output from the power amplifier and automatically reduces gain if the system is overloaded, preventing damage to the amplifier and drive unit, making it near indestructible.



Harman International Industries
Unit 2, Borehamwood Industrial Park,
Rowley Lane, Borehamwood,
Herts. WD6 5PZ
☎ 0181 207 5050

REDESIGN FOR HARBETH'S P3

Harbeth has produced a new version of the five-year-old HL-P3 miniature loudspeaker, to be known as the HL-P3ES. A deeper cabinet than the original holds a redeveloped 110mm plastic cone bass/mid driver, screened for AV and personal computer use. Also changed is the tweeter, now with a black anodised dome, and the 13-element crossover has been redesigned to accommodate the new units. The new cabinet uses damping methods developed from the larger HL-Compact 7, whence comes the new grille design, which slots over the baffle without the need for any fixing plugs. Price is £799.



Harbeth Acoustics
Unit 1, Bridge Road, Haywards Heath,
W.Sussex. RH16 1UA.
☎ 01444 440995

BOOTHROYD STUART
MERIDIAN



The Meridian Audio system has been designed to provide a musical performance in your home - the equal to a live concert. The benefit is that you can choose when to listen and you can build a system from just a CD player to a complete digital home theatre surround sound system. All the products are matched which means that they are easy to use and can even be networked around the house.

If you are looking for the best in sound quality and convenience, call **Meridian Audio Ltd** 13 Clifton Road Huntingdon Cambridgeshire PE18 7EJ

Tel 01480 52144 Fax 01480 459934

HFW 5.95



PROAC PROGENY

New from ProAc is a three-way floorstanding loudspeaker, the 150. Tall and only seven inches wide, it uses two 5in polycarbon drive units upgraded from those in the new Tablette 50 and an uprated fabric dome tweeter from the Studio Three. High density cabinet walls are heavily damped, while a plinth and spikes are included in the £1399 asking price.

ProAc

1 Highpoint House, Riding Road, Buckingham Road Industrial Estate, Brackley, Northants. NN13 1AA
☎ 01403 753180

NEW TO NAD

NAD have been busy expanding and updating their range. The well known and loved 302, developed from the long line of infamous 3020 integrated amplifiers, has now been replaced with the new 312. The 312 is really a development of the 302, in true NAD fashion, building and improving on the strengths of the previous model. There is also a new 512 CD player, a 414 RDS tuner which we hope to review in our February issue, a 412 tuner - the replacement and further development of the superb 402, a 712 receiver, 114 preamplifier and the 118 digital preamplifier with inputs for four digital and four analogue inputs.

Audio Club

401-405 Nether Street, London. N3 1QG
☎ 0181 343 3240

HITTING THE RIGHT NOTE

A new range of compact power amplifiers is now available from Audio Note. The £1599 Conqueror stereo power amp uses one 300B valve per channel to produce an output of 8W. The Quest monoblock, at £2750, also a 300B design, has an output of 9W. At the pinnacle of the new group is the Conquest monoblock at £4450, with two 300Bs per channel and an output of 18W.

Audio Note

Unit C, Peacock Industrial Estate,
125-127, Davigdor Road,
Hove, East Sussex. BN3 1SG

MORE AUDIO ALCHEMY

Audio Alchemy's new CD player, the DDS 111 features a new Sony mechanism and a single-bit DAC. A buffered low-jitter digital output is provided for adding a separate digital-analogue converter later. Novel design elements include a 'concentric chassis' which isolates the transport mechanism and electronics from each other. A digitally-controlled servo compensates for variations in the refractive index of discs. The detachable AC mains cord has integrated line filtering. Retail price, including remote control is £699.95.



Path Premier

Unit 2, Desborough Industrial Park,
Desborough Park Road, High Wycombe, Bucks. HP12 3BG
☎ 01494 441736

FLOORED ON IMPACT

Celestion's latest offering in the Impact series is the Impact 23 floorstander. Boasting a sensitivity of 90dB and power handling of 100W, the 23 is a two-way, with a 155mm long-throw bass driver and 25mm ferrofluid-cooled tweeter. Retail price is £299.

Celestion International

Ipswich. IP3 8JP
☎ 01473 322222
☎ 01273 220511





Prepossessing

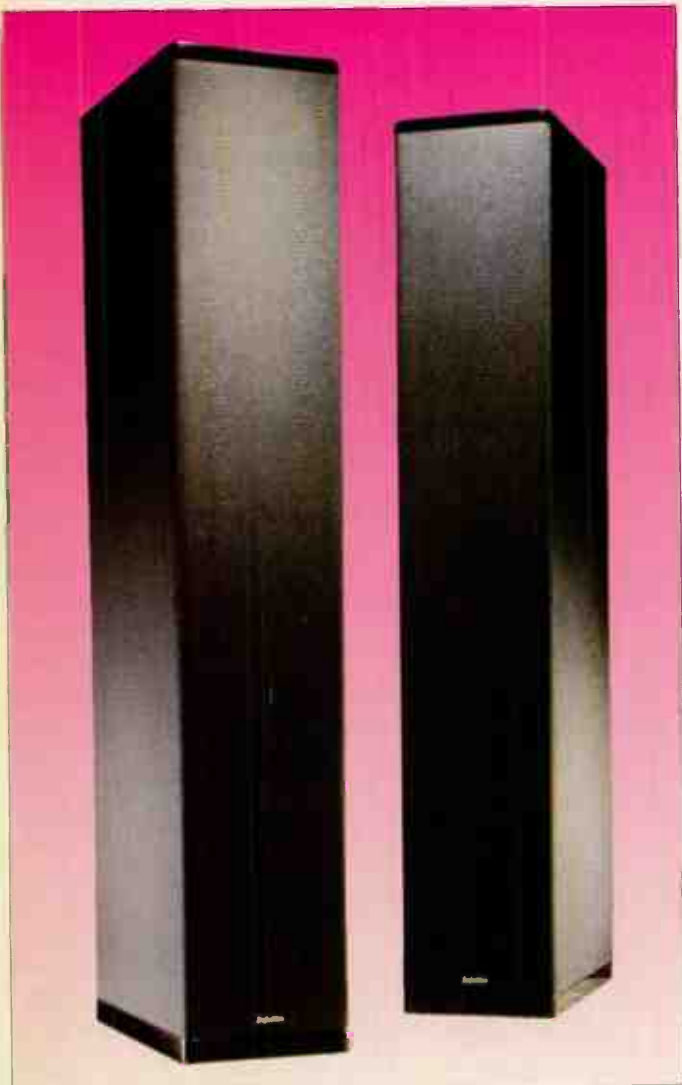

CASH AND CARY

Cary is making valve amplifiers more affordable. The MkII version of the EL-34-based Class A SLA-70 stereo power amplifier offers 30W per channel for £1495. A line-level pre-amplifier to partner it, the SLP-74, now comes in at £1295 with a separate power supply. A phono module is available for £375, while remote control is anticipated as an upgrade. Cary has also branched out into producing high-efficiency loudspeakers for low-output valve power amplifiers. The SP301 is a floorstanding bass reflex design, featuring a Scanspeak tweeter and 6.5in Vifa driver. Power handling is 12-50W, efficiency is rated at 91.5dB. Price is £2295.

The Audiophile Club
PO Box. 6477,
London. N13 4AY
☎ 0181 882 2822

INSERT A BANANA

Insert Audio is producing two new versions of its IA4 24-carat gold-plated 4mm banana plug. With large entry holes, suitable for cable diameters up to 7mm, they are available in screw-fixing or self-solder form. Both versions cost £3.95 per pair.

Glaive
25 Totterdown Street,
London. SW17 8TB
☎ 0181 336 0110

SEVENOAKS SOIREEs

Wine will flow and prizes are on offer at the next batch of musical evenings at Sevenoaks stores in February. At Croydon, Meridian will be promoting their active A/V system and components. Watford will welcome Cyrus to demonstrate some of their audiophile products and new A/V system. In Essex, Audiolab and Monitor Audio will get together to demonstrate some of the best hi-fi to come out of Cambridge.

For dates and times, watch the Musical Expressions ad or phone 01732 742299.

POLES APART

USA manufacturer Definitive Technology's bipolar loudspeaker flagship is now being imported into the UK. The BP2000 sports six drivers (three fore and aft to create a bipolar speaker) along with a massive 15in subwoofer powered by a 300W amplifier. Definitive Technology claims a bottom end response of below 15Hz and 92dB sensitivity. Retail price £3,600.

The Mafia Trading Company
70 Mitcham Park,
Mitcham, Surrey. CR4 4EB
☎ 0589 325363

PETER J. BAXANDALL

On 8th September Peter J. Baxandall passed away. he was 74. Best known as the inventor of the standard tone control he was a prominent member of the audio design community. Frequent contributions to the audio electronics press included his infamous series of articles called 'Audio Power Amplifier Design'. These shed some much needed light on the idea of using, the too often neglected, control theory in audio engineering design. A Silver Medalist of the Audio Engineering Society and a Fellow of the I.E.E., he will surely be missed.





sense of touch



VRDS-10SE

The sense of occasion - it all starts when your touch reaches the Open button and the interior of the superb VRDS mechanism presents itself. You will know to anticipate music in glorious detail - detail your last player could never find for you. You will also know why: Nothing is able to touch the VRDS mechanism for stability and musicality, and nothing else can touch the DAC which, in the VRDS-10 Special Edition, comes straight from the acclaimed TEAC D-T1. It is your TEAC. Only you can touch it.

alert your *senses*

TEAC

TEAC 5 Marlin House The Croxley Centre Watford Herts WD1 8YA
Call Gill Walker on the **BROCHURE HOTLINE 01923 819630 NOW**

All of the speakers in this group test are new to the shops and to consumers. There has been an explosion of what the industry terms "affordable models" lately, because they sell so well. A bird in the hand is worth two in the bush, manufacturers appear to be deciding! We couldn't resist the temptation of comparing no fewer than six models.

In making my reviewing debut the Mission 731LEs I have at home acted as a yardstick, giving these young pretenders a lot to live up to. It seems that you get ever more for less money these days; hi-fi is becoming like the computer business. It's nice to see that those of us on low budgets are not automatically palmed off with duff products - well not in every case.

This group of six loudspeakers covers a wide range of tastes, both visually and musically, so there should be something for everyone. The smallest are Acoustic Energy's AE100s. Styled in similar fashion to their popular, upmarket metal cone AEs, they use a small 4in paper-cone bass driver reflex-loaded by two ports and a 1in fabric dome tweeter. Forward firing ports and compact dimensions make this suitable for bookshelf mounting.

Revolver's Purdey is the only floorstander in the group, quite an achievement at £200. The Purdeys again use a traditional combination of small 4in doped-paper bass driver, reflex-loaded, along with a 19mm soft dome tweeter. A small cavity in the bottom of the cabinets can be filled for extra mass; we used some Sound Bytes filling which improved bass and definition to a worthwhile degree.

KEF's Coda 8s and Celestion's Impact 15s are essentially very similar animals. Both use larger 5.5in paper drivers along with 1in fabric dome tweeters. Both are reflex-loaded and are noticeably larger than the other standmounters in the group, especially the Impact 15s, which look as if they're on steroids. Both KEF and Celestion have smaller, cheaper miniatures in their ranges, but at £200 you are one step above the bottom of the range, so purchasers expect to see - physically - more for their money.

The last two models, B&W's 601s and Mordaunt Short's MS20is, occupy the middle ground. They are both attractively proportioned, both move away from the standard paper cone/soft dome line up. The two use aluminium dome tweeters, gold anodised to give

an impression of quality. B&W are using a Kevlar cone in the 601s, their preferred material and one they have enjoyed success with in their more upmarket products. Mordaunt Short have opted for a plastic driver cone, moulded in one piece to the surround.

SIX SPEAKER SET-TO

Laura Martin sets out to pick the best of six £200 loudspeakers.





Acoustic Energy AE100

Acoustic Energy's AE100s were the smallest 'speakers in this test and probably the only ones that would suit a bookshelf. When I entered the listening room a Grace Jones track featuring Ian McShane talking was playing. I immediately picked up a bit of sibilance in McShane's voice, but otherwise the AE100s seemed to have quite a good balance, sounding neither too bright nor too dull.

I use Oasis' 'Married With Children' as a test of general clarity because it's an uncomplicated acoustic set. The uncluttered charm of this song, although natural, was marred by slightly splashy treble and vague focus, which tended to blur upper harmonics. Chords merged into each other to create a similar impression lower down the scale. Overall though, the sound was quite smooth, melodies allowed to flow freely.

With the Stones' 'Under Cover of the Night' Jagger's vocals sounded natural enough. But in between verses his animalistic yelps, which are normally highly charged, were softened, losing impact. I longed for the decadent party liveliness of Stones rock to come across more forcefully. The AE100s were too polite. Electric guitar didn't really squeal as it should, but on the plus side it wasn't overly forward or aggressive.

Ashkenazy's recording of the Rachmaninov concertos was quite well captured, the piano having good tone

and each note satisfactory definition. The sound stage, although not as large as the best, was wide enough to create a good sense of scale, but individual instruments were spread wide, lacking real focus. I could hear the individual orchestral sections as they entered the performance and integrated nicely into the overall scheme of things, but it wasn't so easy to pinpoint where they had arrived from. Overall this piece could have done with a more forthright presentation, allowing strings to project better on a rousing crescendo or through a sweeping movement.

The AE100s were basically well balanced across the frequency spectrum, with surprisingly good bass extension for their size. Although Wyman's powerfully played bass line, a buoyant and complicated example of his expertise on 'Under Cover of the Night', sounded a touch slow, this was countered by solidity and power, impressive from such a small cabinet.

Possessing a natural and uncoloured sound, they have a lot going for them, but their lack of projection made music sound constricted, held back. They could do with an injection of energy.

Dominic says

The AE100s have good bass for their size, but they are a little lacking in upper bass punch. I felt they also had a dry and neutral midrange, plus well balanced treble. The sound stage was good, and tonal colour, although a touch on the dull side, seemed natural enough. They were certainly not the most captivating 'speakers I have heard, even with the vibrant and colourful melodies of Primal Scream. This was not helped by a touch of sibilance to lower treble and a lack of projection in the upper midrange. The latter was smooth, but not especially clear. The AE100s were a little too smooth and polite for me.

KEF Coda 8

KEF's Coda 8 loudspeakers are two-way stand-mounters which are small, yet solid in appearance. KEF have gone for a simplicity of style, the result being a smart-looking box.

These KEFs had more presence



than most, possessing the ability to be relaxing or compelling company. Their bass was tight, propelling and musical - all at the same time. It rolled along cleanly, forming a solid floor beneath any tune. It was powerful and the path of its progress was drawn clearly.

I found guitar tracks particularly vibrant with these speakers. Pace was fast and there was a crisp biting quality to strings that never became grating. Black Grape's 'Tramazi Parti' had a really festive atmosphere. The vocals were appropriately catchy, but never messy. Brass trilled above the guitars, sounding sparkling and bluesy at the same time. The pace of the track was involving and the organised chaos of vocalists and musicians irresistible.

I found the sweetness of the Codas was welcome when listening to Ella Fitzgerald. I have heard her vocals sound clearer, but I felt the KEFs treated them with great respect. There was an atmospheric lilt in the performance and a sense of poignancy that other budget speakers fail to capture. The soundstage was large, too, for a small speaker, placing woodwind and strings behind her. They were full bodied and lyrical.

Hideko Udagawa's violin was not striking in its clarity, but it was portrayed with a general sense of ease, notes in the highest register showing no strain. Although the Codas' bright tone wasn't strictly accurate, I was still charmed by their smoothness.

Piano was a similar story. The right and left hand could be heard working

separately in complement to each other. There was a sense of musicianship and performance that I found involving. Lyrical passages were alternately hesitant and passionate. Although imaging was not a strong point and the performance couldn't be called life-like, it was persuasive.

KEF's Coda 8s stand out among most budget loudspeakers due to their lack of inhibition. I danced and sang and was completely taken in by their conviction and general vibrance. They are determinedly good-humoured and broad-minded, taking on every sort of music and bringing it to life.

Dominic says

The Coda 8s have quite a large and open sound that filled the room well with Oasis' 'Supersonic'. Bass was good and tight, adding scale and weight to bass lines. Lower midrange instruments were smooth and focused, but higher up, they became a bit more confined and nasal a trait especially noticeable on vocals. Treble was natural and smooth, the best of the group in fact, giving a clean decay to cymbals. Overall though, for me they lacked the focus and immediacy to convey music with really strong expression.



B&W DM601

The B&W DM601s are compact, two-way standmounters. They are discreet enough to look acceptable in any kind of room, unless you remove the grilles

to reveal the bright yellow Kevlar bass/midrange drive unit.

With vocals the DM601s' restraint steered them away from sharpness or harshness and kept things in order. Trumpets in Brenda Lee's 'Speak to Me Pretty' sounded clear and lively. Her vocals were a little distant though. On 'Married With Children' from Oasis' Definitely Maybe album, guitar was resonant and clear, but vocals didn't stand out in sufficient relief against it.

On the more rock-oriented Oasis tracks bass was tuneful and drums tight; both helped to propel tracks along nicely. The 601s also did justice to John Lee Hooker's bass heavy R&B. When bass lines really started to kick, the 601s remained impressively musical; they didn't give up.

Rachmaninov was captured well by the 601s, but at the same time they didn't appreciate the rousing magnificence of his work. Subtleties were dealt with well, the piano was detailed and arresting and remained compelling even in its highest register. Individual instruments could be easily discerned. Ultimately, this made the 601s very well behaved.

Female backing singers and whistles on a Donna Summer CD were well focused and clean in their delivery. The 601s kept a tight grip here, preventing sibilance or splashiness from creeping in. Their ability to project was emphasised on Santana's 'Evil Ways': the keyboard leapt out and whirled around psychedelically. Whilst the 601s didn't project this effect as far as I'd have liked, they stayed clear of being too far forward or hard.

My overriding impression of the B&W DM601s was that they have a clean, detailed and insightful sound. Their bass is wonderfully musical and everything about them is melodic.

Dominic says

B&W's DM601s have an engaging sound that does its best to draw you into the music. Their tight, solid and tuneful bass helps a lot here, delivering a strong performance with Black Grape. They have a clean and pure tonal quality which, despite a midrange that is a little laid back, gives them a surprisingly wide

and open sound stage. Their midrange quality does ensure they don't become too forward though. Treble could become sharp with lesser recordings, but was otherwise of good quality.



Celestion Impact 15

The Celestion Impact 15s are bigger than the other stand-mounters in this test and in many ways they had a bigger and better sound. They are the most in-your-face speakers of the group and the most distinctive.

Although relatively large, the cabinet is neither solid nor well damped, making them susceptible to boom. I was especially conscious of this throughout the audition because the first piece of music we played, Wagner, featured powerful double bass that thrummed madly and ruined the piece.

This problem did not affect electric bass guitar in rock so strongly; it sounded bouncy and leant real life to the rhythm. The Beatles' 'Come Together' was alive and danceable. The prominent bass drum was clear and rounded, propelling the song along nicely. Percussion was resonant, clear and natural. Guitars were nicely defined against bass and vocals sounded rich.

Listening to Ella Fitzgerald exposed some shortcomings. On top of the boxiness, her voice lacked its customary sweetness and I felt that a little of the beautiful intonation was lost. There was

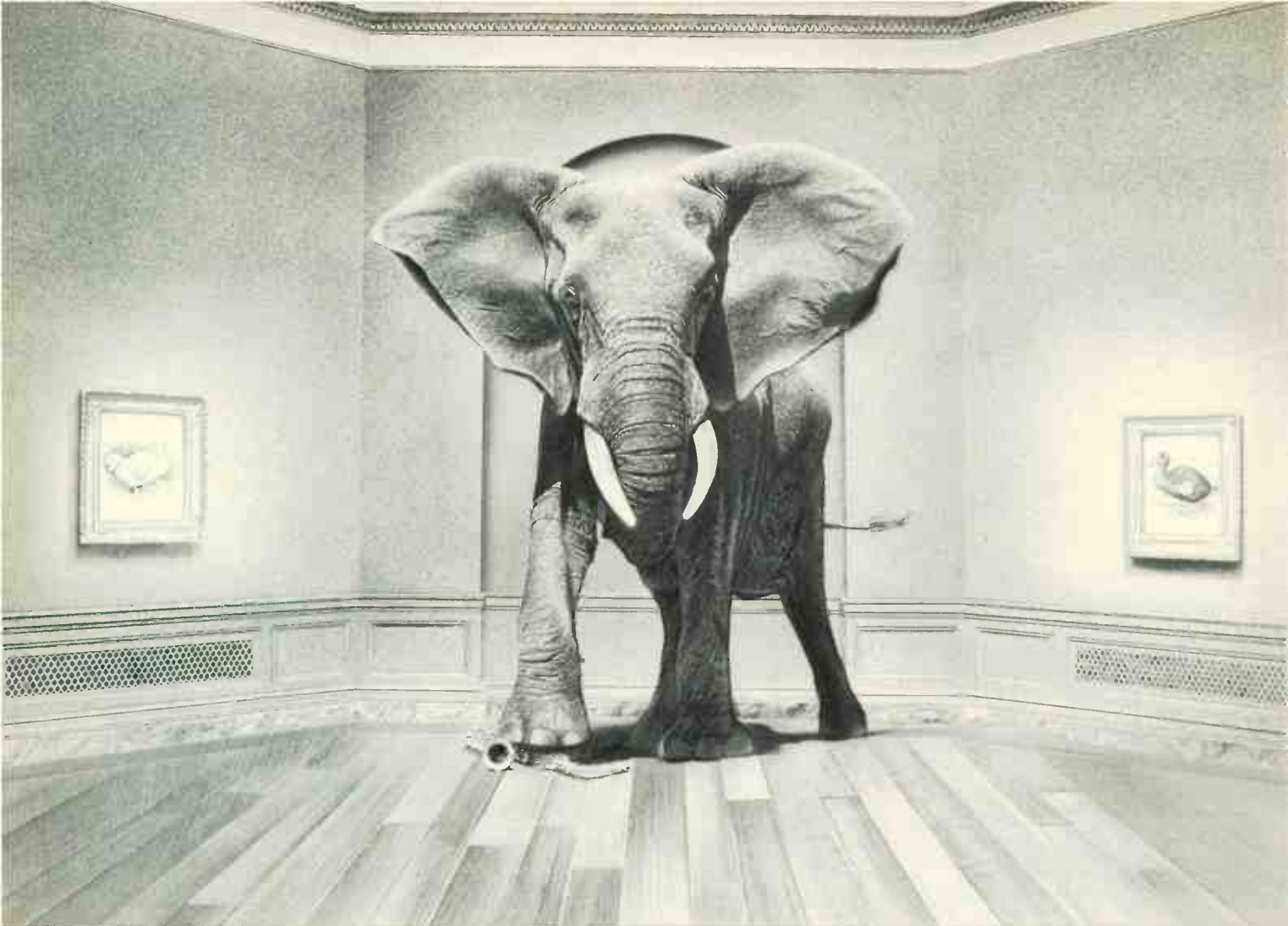

*“To Doctor Livingstone’s surprise,
someone had swapped his Brubeck CD for Beethoven.”*

Only the finest systems bring your music to life.

For a brochure, call 0500 888909.

LINN HI-FI
music for life[™]

World Radio History

a disappointing lack of delicacy and lilt in the whole performance of 'Every Time We Say Good-bye'. With a Rachmaninov piano concerto this translated into some sharpness on prominent piano notes, which contrasted against fuzzy treble.

Strings were fine in terms of dynamic contrast, rising and falling competently, but they weren't detailed or crisp enough. Nevertheless the soundstage was big enough and there was a general ease and conviction that made listening pleasurable.

After doubts were raised over the treble I decided to embark upon the dreaded Donna Summer test. Her own vocals in their ordinary register sounded fine, but higher pitched backing singers were indistinct. These 'speakers were decidedly reticent in the presence of high female vocals or violins.

In defence of the Impact 15s, their generally open and honest character is attractive. Whilst they are unashamedly boxy sounding, they also sound large without becoming screechy or painful; they remained musical throughout the session.

Dominic says

Wagner caught the Impact 15s out early on, revealing a big, boxy 'boof' in the lower octaves. Long, sustained bass notes caused their cabinets to resonate, but on punchier rock material this wasn't so noticeable, adding a nice enough spring to bass lines. Above this their midrange was smooth, dry and impressively open. Yet I also heard some phasiness and a lack of focus in the upper midrange. Treble was sharp and insightful, adding a good sense of detail without harshness. Overall I found the Celestions' big, full and weighty sound impressive.

Mordaunt-Short MS20i

The new MS20i from Mordaunt-Short was an erratic little minx, one minute exciting, the next disappointing. The appeal of this speaker will depend more than usual on what you want it to do.

Upper bass was tuneful and strong



rhythmically, an unusual combination for a budget product. This gave most tracks an entertainingly musical feel, with good pace and dynamics. But there was little evidence of deeper bass, necessary to create the physical sensation of a performance. They need to be placed close to a rear wall.

The midrange was a let-down, with a synthetic, quacky colouration affecting guitar. Brass instruments in the lower registers - trombone and French horn - seemed a little messy and coloured. Black Grape's 'Tramazi-Parti' suffered a certain temporal flatness, the 20is unable to catch leading edges cleanly, softening definition. Marr's guitar in 'There is a Light and It Never Goes Out' had an uneven tone and was blurred; it should propel forwards cleanly. Although it was brightly lit, it also seemed uneven and even a little turgid of tone.

On the positive side, with simple acoustic and vocal tracks the MS20is were strikingly natural and clear. Singers moved impressively close through these speakers, reaching further forward towards me than usual. Female vocals were consistently handled well, Brenda Lee sounding wonderfully velvety.

Acid jazz kings Santana exposed a lot of the MS20is' drawbacks. Tom-toms did not sound adequately hollow or resonant and consequently lost a lot of their groovy influence. Keyboards were not well sustained, lacking the hurdy-gurdy swirl they should display. Nothing jumped out, came alive or had the power to surprise. It seemed that

when the music became more complex, the MS20is got confused and withdrew.

Moving on to classical, Hideko Udagawa's violin was projected clearly, even if its strings sounded a little thin and bright. The instrument ebbed and surged effortlessly under her playing; it was conveyed strongly. All-in-all, the treble registers came across well on this recording.

Ashkenazy's piano work was less pleasurable. He was very much swamped by the orchestra's strings which seemed to be playing over him. The piano should have been more prominent, sitting firmly centre stage and there was insufficient weight to give full expression to his left hand.

There was a lot I liked about the MS20is. Their treble was solid and clear, although a trifle bright. Bass was satisfyingly tight and vocals among the best within this price range. But their midrange was not sufficiently forceful or clear enough with more complex pieces and it had a strange tone. The MS20is are not all-rounders.

Dominic says

Mordaunt-Short's MS20is are all about rhythm and impact. They have a light but fast upper bass and lower midrange, which exaggerates musical tempo to get your feet tapping. Sadly, they have no real deep bass; although rounded enough to sound balanced, I missed bottom end power. Their midrange was clean and forward, giving them an immediate sound that grabbed my attention with Steve Earle's dry vocal and crisply struck guitar chords. The treble could occasionally become excited, ringing on hard struck cymbals, but it didn't become sharp enough to qualify as unpleasant.

Revolver Purdey

The Purdey is a two-way floorstander with a solid, sober appearance. The good thing about floorstanders is you don't need stands, so the Purdey represents good monetary value.

There aren't two ways to say this: the Purdey has little bass. Obviously this offends individual taste to varying degrees, but it does tend to create a

SIREN

THE NEW CHORD COMPANY INTERCONNECT

sīr'en n. 1. (Gk Myth.)
creatures half woman,
half bird,
living on rocky
isle to which
they lured
seafarers with
enchancing
singing.
2. sweet singer.



RRP £65.00
AVAILABLE
NOW AT YOUR
CHORD
COMPANY
DEALER



SILVER-PLATED
COPPER
AIR FOAM
DIELECTRIC
SILVER-LAPPED
SCREEN

BRITAIN'S FAVOURITE CABLE COMPANY

Please send AV info to:

NAME _____
ADDRESS _____



The Chord Company Ltd., 30 Sarum Business Park, Portway, Salisbury, SP4 6EA. Tel (01722) 331674 Fax (01722) 411368

Rogers®

GREAT BRITISH HI-FI

WORLDWIDE

- AUSTRALIA Insignia Project Group PTY Ltd.
- CANADA Plurison
- CROATIA Audio Centar
- DENMARK Audio Consult
- FRANCE Professional Product Line
- GERMANY Pirol Audio Systeme GMBH
- GREECE Temet S.A.
- HONG KONG Cornwall Ltd.
- ISRAEL Audition Stereo Ltd.
- ITALY British Sound
- JAPAN Odex Japan Company
- KOREA Bando Pro Audio
- MALAYSIA Wo Kee Hong Electronics SDN BHD
- NEW ZEALAND Denco Audio Ltd.
- POLAND Hi Fi Sound
- PORTUGAL Esoterico LDA
- RUSSIA Esoterica Ltd.
- SINGAPORE Wo Kee Hong (M) PTE Ltd.
- SPAIN J Clavell
- SWEDEN Hi Fi Art
- TAIWAN Pai-Yuing Co. Ltd.
- THAILAND Kang Yong Co.
- UNITED KINGDOM Rogers International (UK) Ltd.
- VIETNAM Wo Kee Hong (M) PTE Ltd.

For distribution enquiries & dealer information:

+44 181 640 2172

Rogers International Ltd.,
310 Commonsides East,
Mitcham, Surrey
CR4 1HX

FAX: +44 181 685 9496

E-MAIL:

gloots@rogerinter.win-uk.net



VIBRATION ISOLATION PLATFORMS
AND THE MODULAR AUDIO
SUPPORT SYSTEM

MUCH MORE THAN JUST A STAND!

The Reviewer Choice
As a piece of functional furniture the
BASE Racks and Platforms together
are a work of art - Dave Wiley,
Audiophile Magazine.

The Customer Choice
It's refreshing to find a complete
isolation system that values aesthetics
as highly as it does sonic benefits -
Mr P M Rodwell, Cornwall.

Thanks!! The improvement is
astounding and after hearing and
trying other audio stands, the
performance of BASE is second to
none - Mr M Slattery, Sussex.



I could not
have bought
better, I think
it's the most
cost effective
rock on the
market. A
truly satisfied
customer - Mr
R Bosio, Kent.

"The Audiophile support brings the
sound I hear at home one step closer
to the sounds we create in the concert
hall. Bravo".....Dr. K Murphy
(Classical Musician)



For more
details
and a
product
portfolio
please
telephone

Tel: 01342 826262

Audiophile Furniture Limited
The Square, Forest Row,
East Sussex RH18 5SE.



sense of listlessness and there is little to underpin the music.

This omission was offset by their strikingly good portrayal of vocals. Listening to the Stones' 'Brown Sugar' was a pleasurable experience, highlighted by the clarity of Jagger and Richards' harmonising. Their voices were forward and sounded really natural. But the boogy-woogy piano was not prominent enough and brass could have been richer and brighter tonally.

Guitars on The Levellers' 'Hope Street' crashed without becoming messy, showing good focus and integration. This track's melody rose clearly above the rhythm section, where it could be followed easily. Instruments were clean and nicely separated, if a little lacking in body and brightness. There was a nice bite to guitars, but also a frustrating lack of power.

Hideko Udagawa's strings in Bruch's Violin Concerto No.1 benefited from the Purdeys' clean quality. The character of the violin was not sufficiently penetrating and seemed rather distant. There was a nice sense of proportion, but these speakers were not formidable enough to be able to strongly convey its character or intent with any force. A larger sound stage and greater projection would have been particularly beneficial here.

Although dry, the Purdeys did not rasp, but their character did not suit music which was syrupy and smooth, such as Ella Fitzgerald ballads or Harry James's sentimental swing. The

atmosphere of such performances was not well captured and they could sound clinical at times. On the positive side there is nothing cloying about these speakers. They strike a good balance between detail and smoothness.

With Harry James, clarinet was more resonant and natural than trumpet, and cello more luxurious than violin, but all were surprisingly well reproduced for a 'speaker of this price.

Although these Purdeys were unbalanced, they managed to redeem themselves in some area of every recording I played. So despite a slight dullness and anaemic bass, I was forced to look on the bright side.

Dominic says

With Teenage Fanclub's 'Mellow Doubt' the Purdeys impressed with their crisp and open sound and super vocal projection, but their weak bass was immediately noticeable. They go quite low, but with no real power behind notes. Treble was a little untuneful, but bright and clear, giving good insight and detail. The Purdeys have too little bass to sound properly balanced and really need the help of a subwoofer.

CONCLUSION

And now for the final reckoning. No one speaker had everything, so it was a case of choosing which attributes were most desirable.

The B&W DM601s came top of the list for me. The more I thought about them and listened to them the happier I was with this choice. Ultimately, the 601s had the least restricted and the cleanest sound, one I found the most satisfyingly musical. Their subtlety was engaging. These were the 'speakers I would most want to own.

From the outset, KEF's Coda 8s vied for first prize. They had a breezy presence, good dynamics and a sense of fullness to their performance. They didn't beat the B&Ws for clarity and weren't as free from the box either, which ultimately decided against them.

The MS20is automatically went into the top half of the ranking. They had a big sound and were really tight in the bass, but they could also sound a little

sharp and uncomfortable in the midrange. Their lack of deep bass was a disappointment. But a forward and assertive character will commend them to rock fans looking for clarity of beat and metronomic timing.

Celestion's Impact 15s were pushed down into the bottom half of the group by fierce competition. They were marked down by their confined and boomy quality. Although they had a big presentation, it seemed to travel from a distance and sounded a bit synthetic.

Revolver's Purdey floorstanders didn't convey the scale of sound their much larger size promised. In the end their absence of deep bass could not be forgiven. The result was that many kinds of music were left dangling in mid-air. Very clear vocals though.

The AE100s came bottom of the pile for me. Although basically well balanced, they failed to inspire with all types of music. They were reasonably neutral, but also messy in a splashy and sibilant way. They smoothed out dynamic variations, making for a lacklustre performance ●

Acoustic Energy	01285 654432
KEF Audio	01622 672261
B&W	01903 750750
Celestion	01473 322222
Mordaunt-Short	01705 407722
Revolver	0161 9730505

WORLD VERDICT

B&W DM601
 KEF Coda 8
 Mordant Short MS20i
 Celestion Impact 15
 Revolver Purdey
 Acoustic Energy AE100



Measured Performance
 see p113-121

SUPREME CAMPION

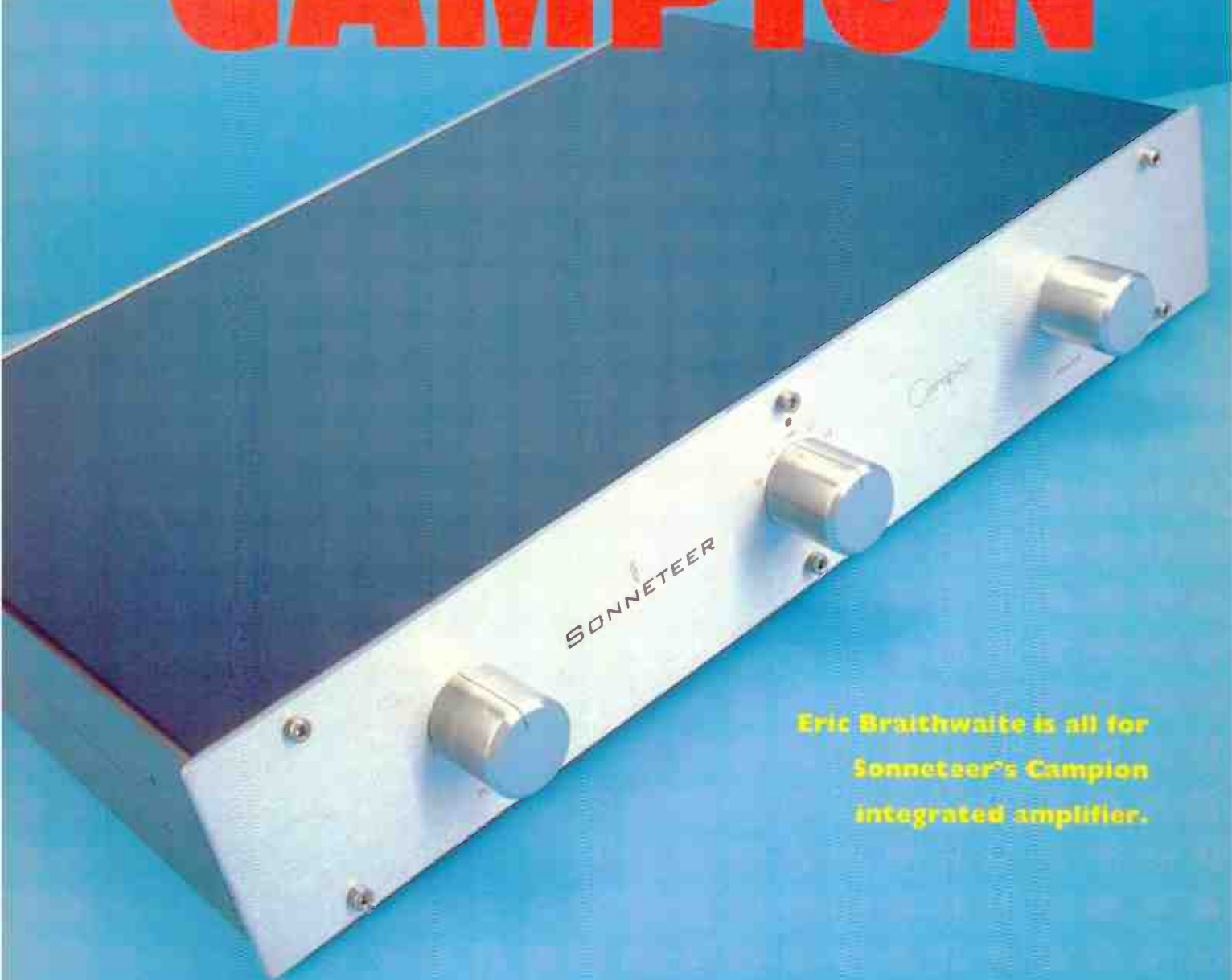

Eric Braithwaite is all for Sonneteer's Campion integrated amplifier.

Excuse me for turning philosophical for a moment. The hi-fi business is not exactly

flourishing. The profits would scarcely attract the attention of a water board or electricity company chairman for

more than a couple of seconds before being dismissed. It's not the kind of business Rothschilds would suggest

putting their capital gains into. Yet there are still young men - the two behind F.T.M. Marketing, for example - who have this notion that designing and building a thoroughly traditional British amplifier is a worthwhile occupation.

Judging by results, they are not as crazy as they might seem. First of a planned small range of amplifiers, the Champion integrated amplifier shows externally all the traditional values: a simple, uncluttered thick fascia plate with three knobs (on/off, source selection and volume) with a chunky quality-finish, adorned only by a blue power LED that reflects off the satin sheen of the middle control. In keeping with other mid-price components from these isles, even the output is a fairly traditional 30watts, so it's not even a stunning powerhouse for the masses. It is, however, one of the most attractive-sounding integrateds these shores have seen for a while.

I am very much one for clarity and lucidity in amplifiers, firmly believing that the work a good recording engineer and producer puts in ought not to be wasted. One of the examples of some fine studio work that needs top-quality amplification to give of its best is the Tafelmusik Haydn Symphony No 41, a Sony SBM recording. The band was perfectly spaced between the speakers, with a breadth that almost defied the boundaries of the room. Within a clean studio space every instrument was pristine and perfect.

In the Second Movement there is some counterpoint of considerable complexity, but the Sonneteer never glazed over the timbre of violas against violins nor submerged the slightly coarse edge of the valveless horns in the brass. Most surprising was the perfection of the flute, along with the clicking of the keys caught by the miking, discernible as it ought to be but not obtrusive. Even with the trickiest

piano and harpsichord recordings, the Champion worked wonders, delivering near-studio definition, even allowing for it lacking studio amplifier power. If King George had heard his own harpsichord in Martin Souter's Isis recording through the Sonneteer, he would probably have given up playing in despair. A virtuosic hour of performing, and recording, it was utterly gripping.

Serious amplification ought to be able not only to keep time, but to change tempo as instantaneously as a real musician. All too often, all but the 'high-end' falls at this musical fence. Not the Champion, however, whose timing was exemplary.

“ Somehow, the Champion is one of those very rare amplifiers that puts everything together and a tingle in all the vertebrae, especially the ones that keep a listener fully upright on the edge of the seat. ”

Nor is all this true for just classical recordings. The same innate truthfulness came across with The Pretenders' 'I'll Stand by You', Chrissie Hynde's voice nicely up front, with that inspiring sensation that you could practically see the tape unwinding before your very eyes. Somehow, the Champion is one of those very rare amplifiers that puts everything together and a tingle in all the vertebrae, especially the ones that keep a listener fully upright on the edge of the seat.

Take the Rob Wasserman/Rickie Lee Jones 'The Moon is Made of Gold' from Duets. No, it wasn't just 180gm vinyl or being tracked with an Ortofon MC7500 playing through Michell's Iso external phono stage, that caught the tension between the two duetists. Through the Sonneteer, there was that sense of the interplay between two musicians and a near-tangible live feeling of the two watching each other bar by

bar that you seldom hear on a recording. Every single momentary vocal twitch was caught like a fly fluttering as the amber set. So was every twang of Wasserman's double bass, with a resonance that made the thing extraordinarily lifelike. True quality stuff, this.

It's almost too good to be true, isn't it? All I would wish for would be a bit more wattage. All the same, clearly, this is an amplifier designed by people who are keen on music and it bodes well for the future generation of British hi-fi design. One day, if there are hi-fi company flags dangling in cathedral naves like those of famous regiments, Sonneteer's name deserves to be among them.

Thomas Campion, by the way, was a kind of Elizabethan Andrew Lloyd Webber. He composed masques and songs, combining the lyricism and the drama his hi-fi descendant has in abundance. He wrote this amplifier's epitaph (if we can allow amplifiers to be female, like ships) as it left:

*All that I soong still to her praise did tend,
Still she was the first, still she my songs did end. . .*

Then let my Noates pursue her scornfull flight:

It shall suffice that they were breath'd and dyed for her delight ●

Sonneteer Champion

£579

F.T.M. Marketing
PO Box 163c,
Esher.
KT10 0YH
☎ 01372 468676

WORLD VERDICT 

Highly detailed and smooth sound.
Worth searching out.

Measured Performance
see p113-121

TRUE MUSICAL

quality hi fi products with style and value for

arcam



ALPHA 6 CD

Arcam's reputation has long been established for class leading performance with the remarkable ALPHA 1 and ALPHA 5+ CD players. The new ALPHA 6 carries on from these.

The secret is Arcam's all new 20bit digital audio board, which delivers a musical presentation with more detail, clarity and depth than ever before. The ALPHA 6 also offers slimline styling and a minimalist layout, ensuring ease of operation as well as making it an ideal aesthetic match for Arcam's Alpha series of amplifiers, especially the new ALPHA 6+. These two models combine to provide the convenience of remote control operation as well as outstanding sound quality. However, the astounding sonic performance of the ALPHA 6 means that it will also complement more expensive ancillary products, like the superb Delta series from Arcam.

At Sevenoaks Hi Fi you will discover the new ALPHA and DELTA series.

cyrus



III

Following the success of the original Cyrus range, the new Cyrus III was developed. Inside the familiar shoe-box casing, this remarkable amplifier incorporates the very latest technology, including full remote control operation. By adding the PSX-R power supply you isolate the Cyrus III from the mains, reducing the chance of extraneous noise and glitches. The end result is an audiophile product, adept at reproducing all types of music with great reality. The recent award from the Federation of British Audio enhances the CYRUS III's reputation further. For more details on the Cyrus range, including the DISCMASTER, DACMASTER, DAD7, FM7 and the new PRE/POWER amplifiers, contact your local Sevenoaks Hi Fi-Cyrus branch.

ruark



PALADIN

Craftsmanship, style and refined musical presentation is evident with all Ruark loudspeaker's. This is the result of years of experience and dedication to design. As a member of the Guild of Master Craftsmen they refuse to accept compromise. The Ruark PALADIN's are a two-way floorstanding loudspeaker that incorporate a new long throw driver and a

Vifa tweeter, ensuring superb mid range clarity and the dimension of extended bass. This means that when the PALADIN's are partnered with suitable amplification they are sure to enhance all music lovers' enjoyment for many years to come.

To audition the Ruark range, including the **TEMPLAR**, **TALISMAN II**, **CRUSADER II** and the new **ICON**'s, contact your local Sevenoaks Hi Fi branch.

meridian



506

All Meridian components, from the simplest to the most complex, are designed to be operated by the touch of a single button on the MSR remote control.

The 506 CD player is no exception. It provides the levels of performance you expect from models within the superb Meridian range.

Utilising a high mass drawer mechanism and steel chassis means that CD transportation is exceptional. An 18bit Delta Sigma conversion stage ensures that bass notes are delivered with real slam, while detail is incredibly natural. These are characteristics common to all Meridian CD players including the new 20bit 508 and the remarkable 500 and 563 CD transport and DAC.

However, the real benefits of the 506 materialise when it is used with other Meridian components, like the 551 integrated amplifier and 504 digital tuner. Creating an advanced an flexible, full remote control system.

audiolab



8000S

The new 8000S, stereo amplifier, offers the same flexibility and outstanding sound quality as every Audiolab product. At the turn of a switch it will perform as an integrated amplifier delivering 60 watts per channel, or by connecting a second power amplifier act as the pre-amplifier in an audiophile pre/power combination. As a high performance stand alone pre-amplifier the 8000S delivers many of the features found on the remarkable new 8000Q, such as Zq technology and remote control operation. With the addition of the 8000PPA, vinyl replay is superb.

The 8000S also caters for the addition of an Audio Visual Decoder and an active sub-bass system. This ensures that the 8000S is an ideal amplifier for the present and the future. For more details on the Audiolab 8000S, 8000A, 8000P, 8000C, 8000CDM, 8000DAC, 8000Q and 8000PPA, then contact your local Sevenoaks Hi Fi branch.

quad



77 CD

0%
finance

AVAILABLE ON A WIDE RANGE OF HI FI SEPARATES

Spread the cost of buying your quality hi fi separates over 5, 9 or 12 months - Details on request

authorised dealers for quality brands of hi fi separates

Sevenoaks Hi Fi have been at the forefront of Hi Fi retail in the UK for over 23 years. We sell quality products to discerning customers and we firmly believe in a meaningful demonstration and helpful unbiased advice.

All the products we sell are brand new, fully guaranteed and maintained by our own service department. We also offer *Peace of Mind* with our own 'No Quibble' extended warranty. We are able to install the products you purchase, ensuring their optimum performance.

World Radio History

EXPRESSION

hi fi connoisseurs and music lovers

The new **77** CD player is available in two guises. The first is a conventional, mains powered CD player, which offers all of the hallmarks of performance and style you expect from Quad products. The second is a bus powered CD player, which must be connected to the revolutionary **77** integrated amplifier and operated by the new intelligent remote control. The introduction of this second model enables Quad's new **77** system to offer almost limitless expansion capabilities, and with the addition of a **77** digital tuner, this exciting family of components will soon be complete. This ensures that Quad will continue to offer their rare breed of innovation and tradition.

rotel



RC/RB970BXII

Designed and developed in the UK, the amazing **RC** and **RB970BXMII** pre and power amplifiers deliver audiophile sound quality. By adding a second power amplifier, you can bridge the two in mono, providing incredible control with a wide range of quality loudspeaker's. The **RC** and **RB970BXMII** offer the same slimline styling and characteristically solid build as all Rotel products. A separate record and listening facility with tone defeat and a split volume control means you have almost finite adjustment. While the addition of the **RQ970BX** phono equaliser ensures vinyl replay of the highest standard. For further details of the Rotel range, including the **RCD970BX** CD player and the **RA970BX** integrated amplifier, visit your local Sevenoaks Hi Fi.

monitor audio



STUDIO 20SE

The breathtaking **STUDIO** series of loudspeaker's from Monitor Audio, offer a no compromise approach to design and construction. This is obvious the first moment you see them. Whether they are finished in a standard satin veneer or a luscious grand piano lacquer, they cater for a discerning palette. Incorporating a gold anodized tweeter and an aluminium alloy bass/mid range driver. The superb **STUDIO 20SE** deliver remarkable transparency and the necessary focus to reproduce complex passages of music with such accuracy that they are used in many reference systems. To experience the stunning Monitor Audio **STUDIO** series of loudspeaker's, including the new **STUDIO 12**'s, just visit your Sevenoaks Hi Fi branch.

michell



GYRODEC

The **GYRODEC** has always been a class act. Beautifully styled in either a gorgeous bronze or a standard silver finish, it looks like no other turntable. Like all of the products designed and built by John Michell, it offers outstanding performance, extracting every last nuance from a variety of music. The **GYRODEC** incorporates a three point suspension system, so it is very easy to set up. It can also be used with a multitude of tonearms and cartridges, making it one of the most flexible turntables available. Over the years the **GYRODEC** has evolved. With the addition of the new **QC** power supply it provides vinyl replay normally associated with more expensive turntables.

marantz



CD63SE

Marantz are one of the audio manufacturers that enjoys making recorded sound as realistic as is possible. This development of pure hi-fidelity has led the Hi Fi press to bestow numerous Best Buys and Recommendations upon models within their range. The latest being the 1995 What Hi Fi Award of CD player Best Buy. The **CD63SE** offers sparkling performance. With its high mass drawer mechanism and copper screening ensuring unrestricted CD transportation and air flow, all music from classical to rock, jazz to blues is reproduced faithfully. The **CD63SE** also offers a logical upgrade path, via its coaxial and digital outputs. With this pedigree the superb **CD63SE** represents exceptional value for money.

REAL



SEVENOAKS
01732 459555
109-113 London Road



ABERDEEN
01224 587070
491 Union Street



BARROW-IN-FURNESS
01229 838757
46 Cavendish Street



BRIGHTON
01273 733338
55 Preston Street



BURY ST EDMUNDS
01284 753776
47 Churchgate Street



CANTERBURY
01227 462787
20a Lower Bridge St



CHATHAM
01634 846859
4 Railway Street



CHELSEA
0171 352 9466
403 Kings Road, SW10



CHELTENHAM
01242 241171
24 Pitville Street



CROYDON
0181 665 1203
373 London Road



ENFIELD
0181 342 1973
7 Genotin Road



ESSEX 01376 501733
1 The Grove Centre
Witham



GUILDFORD
01483 36666
73b North Street



LEICESTER
0116 255 7518
94 Granby Street



OXFORD
01865 241773
41 St Clements



TUNBRIDGE WELLS
01892 531543
28-30 St Johns Rd



WATFORD-Open Sunday
01923 213533
478 St Albans Road



WOOLWICH
0181 855 8016
162 Powis Street



WORCESTER
01905 612929
2 Reindeer Court

MAIL ORDER 01732 458985

ring any one of our branches for a competitive quote

Simply ask your local branch for details.

If you thought this level of service might be expensive - then you would be wrong. We always try to ensure that our prices are competitive.

However, in the unlikely event a competitor within 30 miles advertises an identical product as available from stock at a lower price, even in a sale, we will **match that price!**

Added value offers not available on price match sales.

World Radio History



Whilst the battle for the world's tape market stays unresolved, manufacturers tentatively release new models. But with Philips pitching Digital Compact Cassette at the cut-throat price of £250, there's no room to manoeuvre. At £270 the NAD 614 I tested in the September 1995 issue was as expensive as a DCC recorder. The new 613, following hard on its heels looks more attractive. It worked well and comes for just £230 - dead competitive.

You'd be forgiven for being unable to see meaningful differences between the 614 and 613; I was uncertain at first. The simpler 613 lacks Car, a compressor facility for making car tapes. It also lacks the zero-stop Memory of the 614. Beneath the skin the 613 has a lower quality head, but the 614's was no great shakes. Neither recorder can fully exploit the performance of metal tapes but that's the way of things now; no deck at this price point manages better. Quality has suffered with the rise of the Yen, since cassette deck heads come almost exclusively from Japan; from Canon, TDK and the like.

There are few other important differences. Actually, the 613's transport measured far better than the 614's. Doubtless, this is down to variability in the mechanism, which the decks share.

NAD design their decks themselves. This company knows what it's doing, but they are in battle with the Japanese, and Philips who are throwing their weight around in hi-fi again (not that I'm against a good old scuffle!).

The 'clunk - clunk' of the 613 when it stopped and started did not make it seem very slick. Nor did the undamped cassette door which drew the cassette back into a murky gloom, frustrating a quick visual check of how much tape is left.

Those were the 613's obvious weak points. But it had plenty of strengths to compensate. Control ergonomics were good, there was a big, clear tape counter and automatic tape type selection. Thankfully, NAD have retained both Play Trim and variable

NAD GET IT TAPED



Bias. The former tweaks pre-recorded tapes into proper tonal balance, getting rid of muffled or (sometimes) sharp treble. It actually alters treble level like a tone control, but before the Dolby system acts to decompress. Consequently, Dolby tracks more accurately. Only NAD and Yamaha bother to use this idea.

Bias adjustment similarly affects tonal balance, but only whilst recording.

In effect, it matches a tape to a deck. Many decks, especially budget models, don't vary metal bias and manufacturers slyly conceal this fact. The 613 does: tests showed it tuned in TDK MA perfectly. It also tuned in ferrics and chromes, as expected.

Tests also showed the head struggles to cope with the flux levels needed for metal tapes, so distortion sets in much above 0VU, when

Noel Keywood
auditions NAD's 613
cassette deck to
discover it is a
formidable
competitor - even
against the 614.



recording. Music peaks shouldn't be pushed much past this point. With ferrics especially though, the head is happier, giving cleaner bass and midband quality. Treble will get muddled then soften when it's prominent in music, even though the 613 has Dolby HX Pro to lessen this. Only metal tape can offer clean treble, but to avoid obvious hiss Dolby B must be used.

SOUND QUALITY

Although good music transcends the medium it's played on, good reproduction highlights its qualities. You might think a pre-recorded cassette of a (mediocre) 1965 recording wouldn't add up to much, but the clean opening bass line and sheer zest of the Beatles' 'Drive My Car', were a delight on the 613. It has a strong enough bass performance to sound meaty and full at low frequencies, which gave weight and substance to rhythm sections.

Extended treble gave a ring to triangles, cymbals and tambourines, and fine speed stability freed them from phase jitter and vague positioning on

“The clean opening bass line and sheer zest of the Beatles' 'Drive My Car', were a delight on the 613.”

the sound stage. Play Trim couldn't provide enough lift, being compromised by other losses. Whilst it balanced most recordings, others - amongst them James Brown's 'Gravity' and Diana Ross' 'Eaten Alive' - remained a little dull. Newer recordings, like Dream Harder from the Waterboys, generally came across superbly though. Fine speed stability was apparent in the crisp control maintained over rhythm and the sense of general cleanliness and clarity achieved.

A gruelling test of speed stability was applied by recording Chopin's Opus 48, No 1 at the start of a tape (TDK SA). The 614 disgraced itself here; the 613 flew. It held sustained notes near perfectly. I just hope that the near-Nakamichi like speed stability of my sample wasn't a one-off. It's impossible to tell without testing an unrealistic number of samples I'm afraid.

I jumped between TDK AR ferric tape and TDK MA metal when recording, deciding ultimately that MA had it, ignoring price differences. TDK AR gave cleaner and stronger bass of the two, but it sounded coarse and messy across the upper midband and treble, where MA sounded stable, clear and sweet. Providing record level was kept down to 0VU on peaks (with both tapes, but for different reasons), Dolby B was used and bias cranked back to minimum, TDK MA made great recordings. The sense of cleanliness and precision of the 613 undoubtedly came from fine speed stability, but I felt that NAD's circuitry was making its contribution too. Incidentally, chrome tape in the form of TDK SA, generally sounded turgid on this deck. It wasn't ideal.

I got a fine performance all round from the NAD 613. It might not match my own Nakamichi ZX-9 for replay quality, but it got respectably close. I couldn't say the same with recording quality, where a Nak. is unsurpassed. But the NAD still did a really good job here; I enjoyed listening to it. So I've no hesitation in recommending the new 613 - it's better value than rivals - and even the 614 (whoops!) ● NK

NAD 613

£230

NAD Marketing Ltd.,
NAD Building, 401-405 Nether Street,
Finchley, London N3 1QG.
☎ 0181 343 3240

WORLD VERDICT



Fine playback performance and good recording quality when used carefully. Better than most at the price.

Measured Performance
see p113-121

MINI ISIS

Does the new Isis loudspeaker live up to its lofty ambitions, or is it just a Castle in the sky? Eric Braithwaite and Haider Bahrani give their verdicts.

Why Castle would name their loudspeakers after their version of castles is clear now. The Tansley's compare to pre-war castles, soaring with nobility under Giles Threl's watch, and showing their staid, old-fashioned personality.

Named after the 1930s Orkney Islands, the Isis is a small, square, light-colored wooden speaker with a black grille. It's a small, square, light-colored wooden speaker with a black grille. It's a small, square, light-colored wooden speaker with a black grille. It's a small, square, light-colored wooden speaker with a black grille.

AUDIO ∞ LINKS

AUTUMN 1995 CATALOGUE

SPECIALIST COMPONENTS AT
REALISTIC PRICES

TEL/FAX 01724 870432

If you think that CD sounds
brash compared to analogue,
put the cartridge before
the hoarse



ortofon 01753-889949

SPECTRA Dynamics **DEFLEX** acoustic PRODUCTS

The simplest & most cost effective way to upgrade your system

A. DEFLEX ACOUSTIC PANEL

You need at least 2 Deflex panels for a pair of small bookshelf speakers, 4 panels for a pair of Tannoy 6's, and at least 6 panels for larger cabinets. Deflex panels are re-usable and transferable.

Standard Panel 28cm x 21cm £7.95 each
Small Panel (LS3/5A) 24 x 13cm £5.95 each
Sub-woofer Panel 34cm dia. £14.95 each

B. FOCULPODS

Foculpods are high performance vibration absorbing supports designed to be placed under Compact Disc Players, Turntables, Amplifiers, Loudspeakers and All other Audio, Video & Computer equipment. The spherical surface provides even contact and uniform energy distribution.

Foculpods £14.95 pack of 4

C. TURNTABLE PLATTER ISOLATION MAT

This turntable mat has been carefully designed to incorporate 3 layers of Deflex material, all of differing hardness. Top layer 25°A hardness (anti-static); Sandwich layer 0-1°A hardness (shock absorbing); Base layer 15°A hardness (support).

Turntable Mat 12" diameter £55.50 each
All prices inclusive of V.A.T

NOW AVAILABLE FROM MOST GOOD HI-FI SHOPS
PHONE FOR YOUR NEAREST STOCKIST
(Prices may vary from those shown)

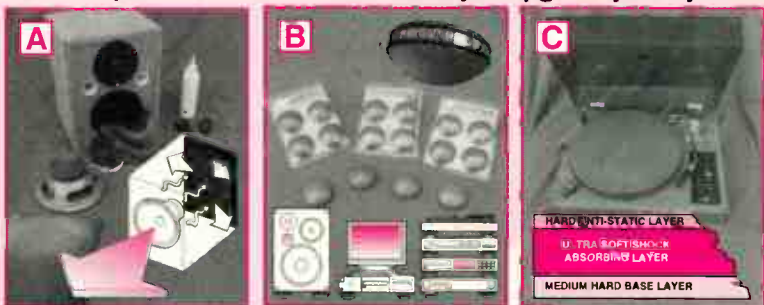

For a FREE information pack and details of all products from SPECTRA DYNAMICS

Tel (01745) 571600 Fax (01745) 570194

VISA • ACCESS • AMEX

(Please add £5.00 P&P on orders less than £50)

Spectra Dynamics Limited, Talargoch Trading Estate, Meliden Road, Dyserth, Clwyd LL18 6DD

Sound Investment

If you have invested expertise and money in building up a sound system to your own unique specifications, then why compromise with indifferent housing units?

Fi-Rax offers a new dimension in audio visual racking - from a range of standard designs to the flexibility to custom create a unit to suit your particular sound system and lifestyle.

- *High quality aluminium construction.
- *Finishes available to your choice.
- *Fully adjustable 6mm glass shelving.
- *Sound isolation on shelving/feet.
- *Custom created to suit your system.
- *Free delivery throughout the UK.

Fi-Rax - a sound investment for those who want the best from their equipment.



Audio Visual Furniture

For further information or a free brochure contact: JEM Distribution,
Springfield Mills, Spa Street, Ossett Wakefield WF5 0HW.
Tel: 01924 277626 Fax: 01924 270759

Timed to perfection, TEAC's £350 CD-5 hits the streets a couple of months before Christmas, traditionally when the hi-fi season begins. Marantz's CD-63SE and NAD's 514, both key competitors against the CD-5, have been around for a while now, and TEAC will be looking to pick up any potential customers not

already taken by these two.

Continuing in similar fashion to their more upmarket players, the CD-5 has a simple, uncluttered fascia with large buttons - full marks for ergonomics. Only the simplest functions are available on the front panel, facilities such as numeric keypad, program, search etc. are found on the remote control. Also

on the remote is a variable output facility which is a nice touch, providing remote volume to the armchair bound. For those looking towards future upgrades, an external CD convertor can be connected to its optical digital output.

To compete with the CD-63SE, which sports Marantz's HDAM audio

TEAC FIVE



**TEAC introduce their new
CD-5 and Dominic Baker is
where the action is.**

SL SonicLink

Make the World's Finest HiFi Cables From the Highest Quality materials

By researching, identifying and using the very best conductors, insulators and connectors for the reproduction of music, SonicLink produces the World's finest HiFi Cables for appreciating and enjoying music.

SonicLink's use of innovative conductor and insulating materials has produced cables which achieve a quality of sound unequalled at their price.

ON THE FIFTH ANNIVERSARY OF THE LAUNCH OF SONIC LINK VIOLET

SonicLink now brings another breakthrough in Cable Technology



SL SonicLink

VIOLET HPMC

The unique Conductor Technology of SonicLink VIOLET brought you new gains in low colouration, clarity and rhythmic flow.

Recommended
HiFi Choice July 1992

★★★
What HiFi November 1993

SonicLink AST150 uses aerospace technology insulation material developed to work reliably where other technologies show deteriorating performance.

SL SonicLink

AST 150

The result is a loudspeaker cable of outstanding clarity and musical enjoyment.

Leading edges and decays of all notes are more clearly heard.

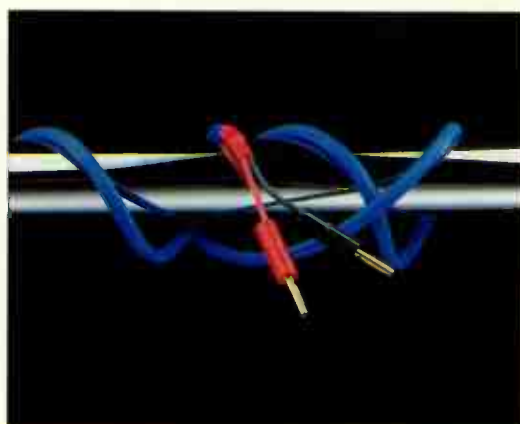

SonicLink AERO SPACE TECHNOLOGY Loudspeaker Cables
The most important cables breakthrough of 1995

SonicLink AERO SPACE TECHNOLOGY Loudspeaker Cables AST150	£3.95/m
SonicLink AERO SPACE TECHNOLOGY BiWire Loudspeaker Cables AST775x2	£4.95/m
SonicLink AERO SPACE TECHNOLOGY BiWire Loudspeaker Cables AST150 x2	£7.95/m

SonicLink AERO SPACE TECHNOLOGY Loudspeaker Cables
The most important cable breakthrough of 1995

SonicLink, 15 Derwent Business Centre, Clarke Street, Derby, DE1 2BU

Tel: 01332 674929

Fax: 01332 298836

output amplifiers and a sprinkling of audiophile grade components in critical locations, and the NAD514 which again uses high grade output devices and quality components throughout, TEAC have had to add their own audiophile status tweak to the CD-5. Sadly, the budget couldn't extend to their VRDS transport, but the CD-5 does have the highly regarded Philips DAC-7 convertor at its heart, and a vibration-resistant foot design.

These gold pointed feet look a bit, well er, silly, as if added as an afterthought. Sadly, this was confirmed when I tried to install the CD-5 into a system; the feet not only made it too wide to fit between the uprights of the stand, but they were also so far outside the footprint of the player that it didn't fit on top either. So, one prerequisite to purchase of the CD-5 is an oversize table to put it on. Odd how TEAC should seem so concerned about vibration, and then make sure that their player can't fit on a normal size isolation table; but then again, the isolation feet are joined to the flimsy pressed steel outer case and not the actual chassis, so maybe they're not as concerned as it would seem at first glance.

Anyway, once all this was aside, the player resting on a wide, solid window ledge, things were under way. The basic balance of the TEAC was very reminiscent of the CD-63SE with which it will compete. Black Grape's 'In The Name of The Father' was produced with a lean and taut presentation. Bass was firm and well rounded, if a little lacking in weight. The initial punch was strong, but the force of the follow through seemed lacking. 'Kelly's Heros' showed the CD-5's ability to catch hold of the deepest notes and produce them to good effect, the near subsonic thud at the intro. sending the Mission 752s' drivers sharply towards their end stops. Again, although the note was well described, it didn't really have enough scale.

Where the CD-5 performed particularly well was with messy or

complicated pieces. The Charlatan's 'Just Lookin' is a typical indie rock track, complete with electric guitar, vocals and percussion all in harmony. Often this kind of mixture can sound ill defined, blurring into a melded mix. The CD-5 showed clear focus here, separating the instruments well and making the performance more succinct.

With strong treble, such as fiercely struck cymbals, the CD-5 could develop a little metallic harshness that gave it an almost mechanical character. It could do with being a little smoother and more natural here. Having said that, it gave great insight and a crisp bite to the more softly played 'Bullet Comes'.

Vocals had a dry, lean character, leading the CD-5 more towards

“It doesn't have the velvety smooth presentation of the CD-63SE . . . but it does seem more ruthless when it comes to extracting the last ounce of detail.”

demanding pieces where its analytical nature allows it to take control. With simpler acoustic tracks, like Steve Earle's Train A Movin' album, the CD-5 could be accused of stripping the music too bare in its search for detail. Like many CD players it lacks any real stage depth, which combined with a lack of warmth can remove some of the body and character so important to these simpler recordings. It doesn't have the velvety smooth presentation of the CD-63SE, which can be a real charmer, but it does seem more ruthless when it comes to extracting the last ounce of detail.

With Wagner's Tannhauser, horns



were full and powerful, if a touch reticent and held at the back of the stage. Tonally, strings were a touch on the bright side, showing a little sharpness on the highest notes. This wasn't unpleasant, and didn't grate badly, but it was noticeable all the same.

All in all the CD-5 is a clean and tidy sounding player, with a good eye for detail and fine insight. It doesn't quite have the magic of the CD-63SE, which, with its smoother and richer midrange and treble brings a more fluent and musical touch. This is in a well balanced system though, and those who find their's a bit too rich or thick, would do well to audition the CD-5 where they'll also be able to take advantage of the extra detail it is capable of resolving ●

TEAC CD-5

£349.95

TEAC UK

**5 Marlin House,
The Croxley Centre,
Watford,
Herts. WD1 8YA
☎ 01923 819630**

WORLD VERDICT

Clean and dry sound, but a little sterile compared to the competition.

**Measured Performance
see p113-121**

SUMO

The Power of Music.



THE ARTEMIS

Sumo presents the Artemis, a totally new concept in preamp design featuring:

- Fully discrete Class A circuitry
- Non-feedback line stage
- Balanced in/out
- RISC microprocessor control
- Infrared remote
- Post gain stepped attenuator
- Separate DC power supply
- Plug in upgrade (MM/MC phono/DAC)

Sumo engineers developed for the Artemis, a proprietary RISC computer program that, in conjunction with the very high voltage non-feedback line stage, allows relay stepped attenuators to control volume levels, with absolutely no degradation of Signal to Noise regardless of the music level.



THE POLARIS III

The Sumo Polaris III: "Highly Recommended" by HiFi Choice 8/95, an 120 watt amp, comes with true balanced inputs and can be easily run as a 350-watt monoblock.



THE FIVE

The Sumo Five: 60 watts of pure Class A power, delivering over 150 peak amps of available current, including fully balanced, XLR connectors and easily configurable as a 200W monoblock.



THE TEN/M

The new Ten/M monoblock, featuring the most advanced Class A balanced circuitry in Sumo history.

Delivering 240 W into 8 ohms, it runs with no overall negative feedback, yet has superior damping factor and low distortion.

Each Ten/M chassis contains two fully balanced differential power amps, one each for the positive and negative signals.

The Ten/M boasts a 1 KVA transformer and can deliver over 150 amps of current.



AUDUSA & Co.

LAT INTERNATIONAL

World Class Audio Equipment

4 Arundel Road, Kingston Upon Thames, Surrey KT1 3RZ

Tel: 0181-642-6221 Fax: 0181-305-3733 Mobile: 0900 230055 E-Mail: shujan.weerasinghe@uk.conqueror.co.uk

KALYPSO

World class quality engineering and workmanship, superb finish, unique electronic design and a true 15 Watts RMS per Channel both channels driven. Don't settle for anything less.



TEL: 01702 469055
FAX: 01702 601883



QUALITY
INSIDE



RRP £549.00

Supplied complete with cover

CRDEVELOPMENTS LTD, Unit 8, Craftsman Square, Temple Farm Ind. Est., Southend-on-Sea, Essex, SS2 5RH

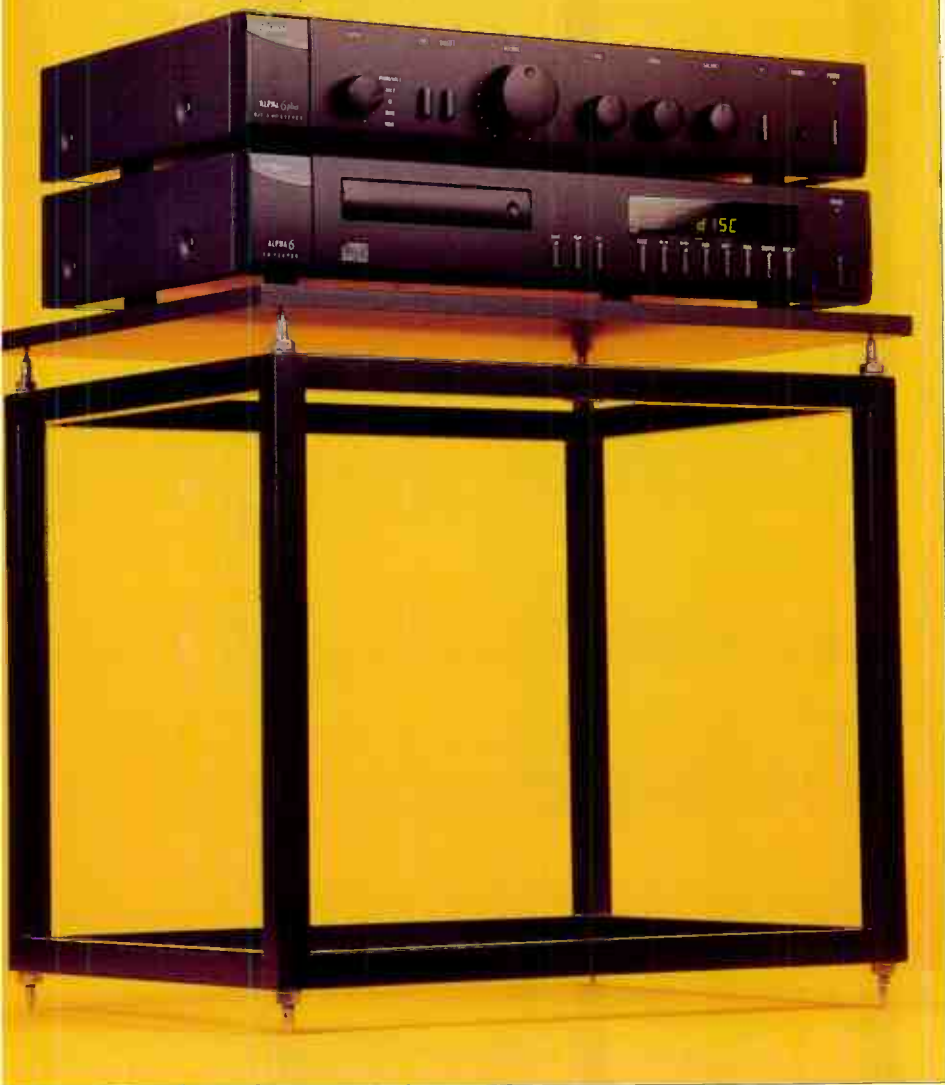

Dominic Todd's journey through hi-fi started with an Arcam Alpha amplifier. Down the road a bit, he listens to Arcam's latest version, the Alpha 6+, partnered with the new Alpha 6 CD player.

there, but it was not meticulously unravelled and presented.

A 12" vinyl disc, Fraiser Ray, presented the Arcam with fewer problems. The powerful bass lines were well integrated with the rest of the mix, and it had little problem dealing with the near sub-sonic notes. If anything, it could become a little soft, making tight bass control a necessity in a partnering 'speaker. The depth of music could have been better portrayed, but I had no complaints with the expansive stereo width. Instrumental timbre was generally well revealed, although the brass sections could sound just a little too laid back.

The Cranberries' 'No need to argue' portrayed the Arcam in possibly its worst light. Although vocals were delicate and free from any sibilance, the whole affair lacked emotion and was too refined. The sound was not well projected, giving the impression of a lack of transparency and instrument separation. Drum transients were softened too.

ROUTE 66

Before I go any further, let me declare an interest here. You see, my very first piece of 'proper hi-fi' was an Arcam Alpha amplifier. This time, however, it's an Alpha 6+, complete with a power hike to take it to a claimed 50 watts. At £349.90, it can hardly be called a budget amp. Neither can its £600 CD brother. It will be interesting to see if this Arcam can compete with the present crop of 'super' machines at almost half the price (Marantz CD-63SE and NAD514).

Both new Alphas are solidly constructed and neatly finished, with a lot of attention given to detail under the bonnets too. The CD player uses a 1-bit PWM (Pulse Width Modulation) DAC with a 20-bit digital filter. This is a break from Arcam's previous Alpha 5+ which uses a multi-bit DAC.

ARCAM ALPHA 6+ AMPLIFIER

When listening to the Alpha amplifier, I used the matching CD player as the primary source (as well as my own sources), and coupled up a pair of Royd 'The Minstrel' 'speakers (a typical combination).

First impressions, with Tricky's album, were of restraint and good manners, but also a slight blandness. Vocals were velvety smooth, and despite refinement there was still fair detail retrieval. It picked up the bass heart beat that runs though one track, although not as clearly other amplifiers might have done. The sound was seamless, but occasionally two-dimensional and slightly veiled. The detail was



One of life's more rewarding decisions.



KEF Reference Series

If only all decisions in life were as straightforward as this.

The fact is that if you want the purest sound and the most uncompromising specification, it simply has to be New KEF Reference.

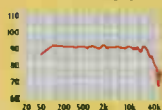

Every speaker must match our engineers' 'reference' prototype to an almost unbelievable

tolerance of 0.5 decibels. This means you can be sure that the sound KEF created will be recreated in your home. Exactly.

Our breakthrough Uni-Q® technology delivers an astonishing stereo image, its unique point source design, with the tweeter at the exact acoustic centre of the mid-range cone, lets you visualise the precise location of every performer on the stage. What's more, because of Uni-Q's smooth, even dispersion you'll hear that incredible realism throughout the room. From speakers this good you'd expect outstanding

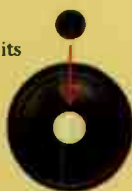

bass performance. With KEF's famous 'coupled cavity' bass system, now further improved with interports, you get it. We go to similar extremes in perfecting every detail.

Some you can't see, like Oxygen-Free Copper internal wiring or magnetic shielding (vital in Home Theatre). Some you can - sumptuously veneered cabinets with heavily gold-plated feet and terminals, for example.

In other words, each pair of Reference speakers is as close to perfection as KEF can make it.

When you know you can choose the best, would you willingly settle for anything less?



The experience of sound

KEF Reference Series Authorised Dealers

ABERDEEN	Holburn Hi-Fi	01224 585713
BISHOP STORTFORD	Audio File	01279 506576
BLOXWICH	Sound Academy	01922 473499
BOURNEMOUTH	Suttons Hi-Fi	01202 555512
BRISTOL	Radford Hi-Fi <i>(head office)</i>	01172 428247
CARDIFF	Audio Excellence <i>(head office)</i>	01222 228565
CHANDLER'S FORD	Hampshire Audio	01703 252827
CHELTENHAM	Sevenoaks Hi-Fi	01242 241171
CONGLETON	Congleton Hi-Fi	01260 297544
COVENTRY	Frank Harvey Hi-Fi	01203 525200
EDGBASTON	Music Matters	0121 4292811
EDGWARE	Musical Images <i>(head office)</i>	0181 958 8777
GODSTONE	Surrey Hi-Fi	01883 744755
GUILDFORD	P J Hi-Fi	01483 504801
HEREFORD	English Audio	01432 355081
KINGS LYNN	Martins Hi-Fi	01553 761683
KNUTSFORD	Wilmslow Audio	01565 650605
LEEDS	Audio Projects	01132 304565
LONDON NW6	Studio 99	0171 624 8855
LONDON W1	HiFi Experience	0171 580 3535
LONDON W1	K J Leisuresound	0171 486 8262
LONDON W5	Audio Concept	0181 567 8703
MAIDSTONE	Speakers Corner	01622 677773
NEW MALDEN	Unilex Audio	0181 942 9567
NEWCASTLE	J G Windows	0191 2321356
NORWICH	Martins Hi-Fi	01603 627010
NOTTINGHAM	Nottingham Hi-Fi	01159 786919
OTLEY	Aston Audio	01943 467689
OXFORD	Audio T <i>(head office)</i>	01865 742044
PETERBOROUGH	The HiFi Company	01733 341755
PORTSMOUTH	Jeffries Hi-Fi	01705 663604
SALISBURY	Salisbury Hi-Fi	01722 322169
SHEFFIELD	Sound With Style	01142 737893
SHREWSBURY	Creative Audio	01743 241924
SOLI HULL	Music Matters	0121 742 0254
SOUTH CROYDON	Zebra	0181 688 2491
ST LEONARDS	Adams & Jarrett	01424 437165
WORCESTER	Severoaks Hi-Fi	01905 612929
WORTHING	Phase 3 Hi-Fi	01903 245577

IF YOUR TOWN ISN'T LISTED PLEASE CONTACT:

KEF AUDIO (UK) LIMITED, ECCLESTON ROAD,
TOVIL, MAIDSTONE, KENT ME15 6QP.
TELEPHONE (01622) 672261.

Far better was the Alpha's reproduction of Classical music. Corelli's Concerto da Chiesa No 8 in G minor proved the point. Smooth treble suited violins, which sounded sweet and fulsome. Despite intricate twists and turns in the music, it was held together. Although the soloists occasionally got lost when pitted against the larger orchestral group, the end result was one of ease. The amplifier had a good sense of timing, the faster quartets of Pachelbel sounding more open than the rendering of acoustic music.

ARCAM ALPHA 6 CD PLAYER

I began listening to the Arcam Alpha 6 CD player with Classical music first, Johann Pachelbel's Canon 'a 3 Violinis con suo Basso', as it happens. I know I'm pigeon-holing a bit here, but Arcam owners are rather sophisticated and conservative people. Perhaps fond of Pachelbel, but defiantly not into Pulp.



The Alpha 6 CD had the distinctive Arcam family sound. Smooth, refined and totally unruffled by whatever the music had to offer. It was, perhaps, just a little less reticent than previous Arcam CD players though. Strings had a coarse edge to them. This is exactly how they should sound, to a degree, but if you prefer a more beguiling presentation, it's something to be wary of. Separation of instruments was excellent and the finely etched quality of solo performances reminiscent of the Marantz CD-63SE. The music also ebbed and flowed in the same effortless manor as other really well engineered PDM Bitstream machines.

As Arcam listeners do (occasionally) listen to rock music, I changed the pace a little with Supergrass. The Arcam lent

the same expansiveness to the sound as it had previously. Unfortunately, the same coarseness that had been apparent with stringed instruments listened to earlier, manifested itself as a slight edginess with vocals this time. By the same token, the excellent guitar definition didn't quite have the same attack demonstrated by some other machines. Bass lacked the presence of a good two-box design of this price, yet was as tight and articulate as one could wish for.

Dina Carroll's powerful vocals were

“ Whilst the Arcam wasn't particularly stunning in any one area, the seamless nature of its sound meant the player never really got in the way of the music ”

expressed with the vigour and the lack of compression they deserve. Her voice had excellent projection from the 'speakers, without sounding shouty and harsh. Bass wasn't especially deep, but the electric bass being played was portrayed with tangible realism, such was the definition extracted from the disc. The experience was one of completeness. Whilst the Arcam wasn't particularly stunning in any one area, the seamless nature of its sound meant the player never really got in the way of the music.

Julia Fordham's 'China Blue' is an atmospheric piece in an acoustic blues context. The Alpha provided plenty of depth to the track, and oozed atmosphere out of every pore. Fordham's voice displayed slight sibilance, but not excessively so. Her vocals were generally beguiling and presented to the listener within a rock-solid sound stage. The double bass had a natural resonant timbre and hi-hat cymbals appeared from an inky darkness. Once again, the Arcam caught the feel of the music, and involved the listener, even though it may not be as technically accurate and transparent as some.

CONCLUSION

It's clear that both Alpha amplifier and CD players are competent hi-fi components that are a fine choice for someone looking for long term satisfaction from their hi-fi. However, the amplifier's sound quality isn't as good, relatively, as that of its CD brother. Whilst they make an excellent pairing, and the CD player is worthy in its own right, there are better sounding amplifiers available for £350.

In the quest for refinement, it seems Arcam have gone too far and taken the raw edge off the music - so often the key to a really involving hi-fi system. Care must also be taken when matching the Alpha 6+ amp. with 'speakers. Those with a loose sounding bass could contribute toward a ponderous end result.

The CD player is more successful in its own right. Reminiscent of the CD-63SE, the Alpha can almost justify its extra cost on account of its excellent build, plus a sonic performance that remains unruffled by whatever type of music is thrown at it ●

Arcam Alpha 6+ amplifier £349.90
Arcam Alpha 6 CD player £599.90

A&R Cambridge,
Pembroke Avenue,
Denny Ind. Centre, Waterbeach,
Cambridge. CB5 9PB
☎ 01223 440964

WORLD VERDICT

Alpha 6 amplifier - Full and smooth sound, with loose bass. ●●●●●

Alpha 6 CD player - Smooth and seamless, with a little coarseness at times ●●●●●

Measured Performance
see p113-121

MALAYSIA AUDIO &

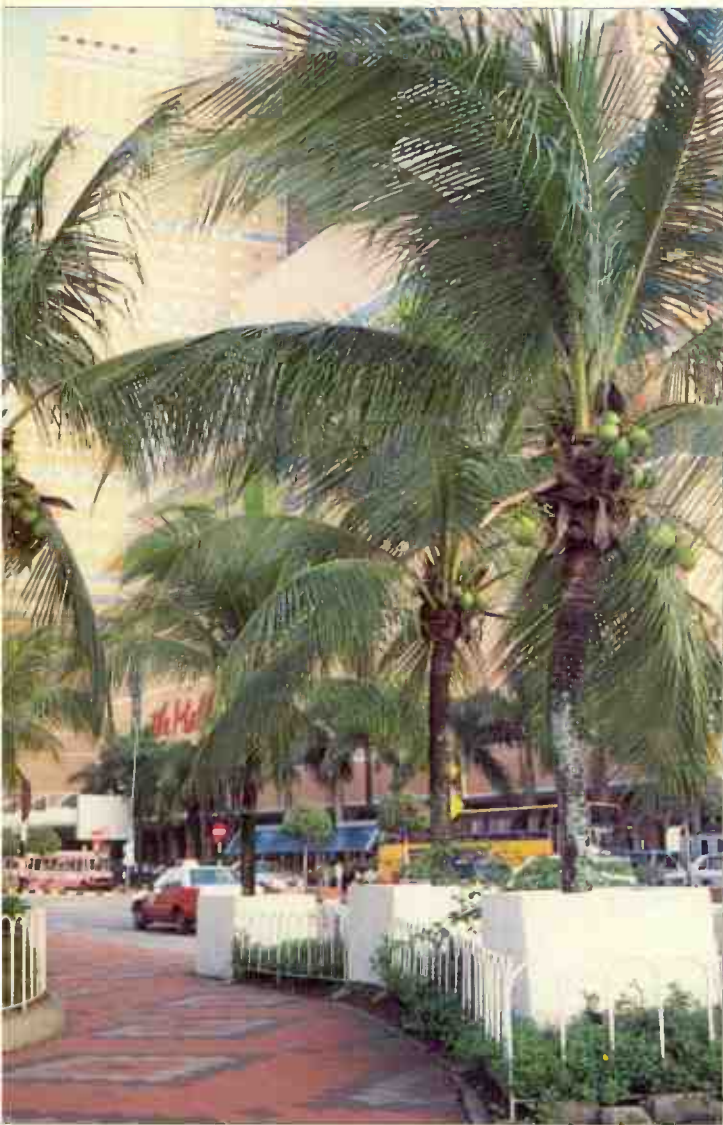

Noel Keyword heads East to Kuala Lumpur, capital of Malaysia, to discover the delights of the Orient. Yes - there were valves everywhere - oh, and a great hi-fi scene, full of surprises.

Not that we aren't in there. Demand for our kits in Malaysia has been growing steadily and we needed a distributor to provide customer support. Recently we tied up with Octave Electronics, one of the few importers able to offer the sort of specialised backup, like loudspeaker measurement, we demand for our kits. So I was on my way to discuss technical matters, as well as meet Hi-Fi World readers and kit builders and, of course, tour the show

in the capital Kuala Lumpur.

This show was full of the mysteries of the East: the good, the bad and the extraordinary. I saw some fantastic high-end products - especially valve amplifiers - yet to be seen in Britain, plenty of awful AV loudspeakers and, most extraordinary of all, fake British amplifiers. There were tales of large scale commercial 'importing' techniques that would interest Her Majesty's Customs & Excise and I even discovered things I never knew about Brit. operations, like the tie up between KEF, Onkyo and NAD. This was one fascinating show!



The Legend Hotel, Kuala Lumpur, venue for the show.

Lying about 120 miles north of the equator, KL is a trifle warm and humid. Steam was rising from the dark green jungle as the jumbo coasted in. Having been brought up in one of Singapore's darkest corners, this was no surprise to me. Mind you, I did wince at the tale of a man recently eaten by a 10ft Python which, thoughtfully crushed him first. This was cheerfully related to me by show organiser Dick Tan. Suddenly the concrete of the



Audionote amplifiers in the State of Art room. Ongaku single-ended 211 triode on top and a 9W 300B equipped Meishu with its cover off below.

Hotel looked all the more inviting.

Malaysia has a strong electronics industry and it's a popular manufacturing base for the Japanese. With a population of 20 million in full employment, the show, spread over three floors of the hotel, was thronging. I was taken aback by the number of British hi-fi products and the absolute

VIDEO SHOW '95



The slim and beautifully veneered Unity Audio Signature I loudspeakers from America, claimed to be sensitive and of smooth impedance.

conviction shown by Malaysians that British is best. As in the U.K., the Japanese have largely abandoned hi-fi, moving instead to AV where undifferentiated black box production commands enough sales to keep their factories going. This has left a vacuum, currently filled by companies like KEF, NAD, Rogers, Celestion, Mission, Tannoy, Mordaunt Short and many, many more household names in the U.K.

I was fascinated to get my first glimpse of Rogers' new valve amplifiers, the 20watt E-20a and the 40watt E-40a, the latter being given pride of place by their importers. Perhaps I should point out that much of the top equipment was valve. I found heavily chromed Australian Micrex and Audionote valve amplifiers in the State of Art room. Desmond Poon told me "Audionote is our biggest brand. In the last six months or so we sold easily over \$1 million of Audionote products. We sold seven Ongakus and a pair of Gaku-Ons. We

are showing 300B Meishu here. Business is very good for us". You might be surprised to know that worldwide distribution of AudioNote, a Japanese company, is handled by Audionote UK. Micrex have yet to appear in Europe though.

Chatting to enthusiastic Malaysians about our kit valve amps and loudspeakers - building your own is a new idea in their market - I realised that there was a strong interest in hi-fi and a lot of knowledge around too. When an elderly gent, surrounded by his son, grandson and great-grandson, chatted animatedly to me about his Leak Stereo 20 valve amplifier, which he bought for a few ringgits 30years ago, I realised that the market was an informed one. There was plenty of interest in LP and cartridges too and as much conviction about its superiority as you'd find in the U.K. It seemed to me that Malaysia could easily support an indigenous hi-fi business and on my tour of the hotel I



The MP211 (centre) and MP30B valve amplifiers from China, imported by David Cheah and Kathy Lam of VT System Enterprise.

found its beginnings.

Menthor valve amplifiers are designed and built in Malaysia, using Japanese Tango transformers. "We have three models", I was told, "KT88, 300B and UV211, all created by Japanese designer Mr Sakai. We use cathode follower drive on KT88 and 211. We use no feedback on 211 and 300B,

because it gives warmer, more open sound. 300B is softish and smooth. 211 is more forward and has stronger bass".

I'd noticed rare UK brands like NVA, Exposure and Onix were well represented and getting plenty of coverage in the press. When I spotted Angel Heart (UK) amplifiers the rare moved into the unknown.

"It is a co-operation like NAD", I was told by a Taiwanese gentleman sporting natty braces and a reluctance to give me his name. He was even less happy when I asked for his picture.

"The factory is in Taiwan, the designer is British and the head office is in Hong Kong" he told me.



Heavily chromed Micrex valve amplifiers from Australia.

"Who's the designer", I asked innocently.

"He's employed by a company so I cannot give you his name" came the reply.

"I'm learning things here and . . ."

"No, no, don't tell me that because you ask me too many secrets" he suddenly blurted out.

"Angel Heart is a Taiwanese name" Sun editor Jeffrey Tan whispered in my ear as we left the room. I got the feeling the chrome plated Angel Heart was as British as Schezuan duck.

PERFECTION IS A PASSION



"...PASSION took over the reference position... substantially ahead of the best active line pre-amps. PASSION's switched, discrete attenuator is clearly more accurate, more dynamic and transparent than the pot alternative. When audio products are as good as this, there is little more to say, save to endorse them with a firm recommendation... Now better still in all Vishay mode with a record score of 37".

*Review of PASSION - Martin Colloms
HiFi News April '93 and November '94*

For further details, brochures and prices please contact:
Audio Synthesis P.O. Box 100, Ilkley, West Yorkshire. LS29 9XW.
Tel: +44 (0) 1943 600404 Fax: +44 (0) 1943 600383

IT'S CURTAINS FOR THE COMPETITION



ALCHEMIST
AXIOM

RRP: £299.95

ELEMENTAL AUDIO

For full details of products and stockists, 'phone 0181-883 3008

Infidelity

indecently good hi-fi

NAIM, ARCAM, DENSEN, DYNAVECTOR, EPOS, LINN, MICROMEGA,
NAKAMICHI, NEAT, REGA, ROTEL, ROYD, SHAHINIAN, XLO and more
9 High Street, Hampton Wick, Kingston upon Thames, Surrey KT1 4DA
Telephone: 0181-943 3530



Open Tuesday - Friday 10.30am - 7pm,
Saturday 10am - 6pm. Closed Monday

LANGFORD & SMITH Radio Designer Handbook AND A FREE COPY OF THE Vintage Audio Receiving Tube Encyclopedia

We are now taking orders for the above Book LANGFORD & SMITH Radio Designers Handbook. This book is recognised as being the Bible. We are reprinting this much sought after work to order only. This beautiful book is printed in Hardback 3 volumes 1500 pages. With every order we are giving away a FREE copy of the Vintage Audio Receiving Tube encyclopedia. This book contains data on 18000 Tubes and is a much sought after work in its own right.

Price £63

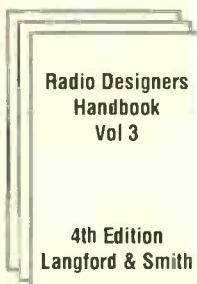

FOR MORE INFO.
PLEASE CALL - or - FAX US ON
TEL & FAX

(01239) 891448

Vintage Audio
BRYNHLYGEN
EGLWYSWRW, CRYMYCH,
DYFED, WALES. SA41 3SS

DO NOT SEND ANY MONEY
(PRINTED TO ORDER ONLY)



Malaysia's own Menthor valve amplifiers, with designer. At left is KT88, centre UV211 and right 300B. Using Japanese Tango transformers, they'll be expensive.

Another Malaysian hi-fi company, Fine Audio Technologies, have developed a small 'speaker, simply titled The 1. Their traditional business was the manufacture of car audio drivers, but they were proudly demonstrating their first hi-fi product, developed using the Leap/LMS measurement package. It uses a coated 5in paper cone bass/mid unit and a silk dome tweeter. A brief listen told me this was a smooth and well integrated little speaker, nicely balanced and with fine imaging. It deserves to do well.



Fine Audio Technologies' first mini hi-fi speaker, called The 1, with designer. Designed and built in Malaysia, it sounded very good.

drive units. VT also imported Chinese Shuguang Golden Dragon valves into Malaysia and director David Cheah told me he has a house in Sussex too.



The fascinating A30 and A60 Angel Heart (UK) amplifiers, chromed and fitted with grab handles. Origin not so much UK as UnKlear.

Some people get around.

That goes for NAD too. Once manufactured in Taiwan by AMC, NAD have been doing the rounds of subcontractors in the East, I was told. They've now tied up with Onkyo and Gold Peak (KEF & Celestion) for their manufacturing. When I asked NAD UK where the 613 cassette deck was made they declined to comment, saying it was



Octave Electronics import Audax loudspeaker components and our own World Audio Design kits. Proprietor Michael Loke sits (bottom right) with a very happy team.



secret. It didn't take long at this show to find that it is in fact made by Onkyo at their factory in Johor Bahru, in the south. Gold Peak are a battery manufacturer whose GP batteries are found throughout the East. Owner Kevin Lo is a hi-fi enthusiast too, which is why he bought KEF and Celestion. Now, I'm told, he has a 15% stake in NAD too. All three brands were strongly represented at the Malaysian show.

Malaysia has a booming economy and a vibrant hi-fi market. Commerce in Asia is brisk - but without its mysteries I found. The Malaysian Hi-Fi Show was one fascinating experience ●



Rogers new E-40a valve amplifier. It uses paralleled pairs of 6L6 output valves to give 40watts per channel.

Another interesting loudspeaker was the Unity Audio Signature 1, imported by Fuli Audio & Trading from America. It's a tall, slim three-way unit with concealed downward firing

campaign audio design



Getting a better more involving sound often means spending a lot of hard earned money. It's such a waste, because every system can benefit from our cables and accessories, at a fraction of the cost of some new "black box". Here are some of the ways we can help.

We have Oxygen Free Copper interconnects (£12.48) up to High Purity Silver cables (£89.00) and high definition

loudspeaker cables in Silver plated Copper or Pure Silver. Our mains cables add weight, power and scale, and with non inductive RF filtering (£10.00) and over voltage protection (£3.00) enhance performance still further. Gold plated AV cables, both RF (£19.95) and Scart (£23.52), help bring picture quality in line with NICAM sound resolution.

Valves, capacitors and transistors are all microphonic, they cannot perform optimally if vibrated. Our set of three Brass Isolation cones (£5.00) are worth their weight in gold - revealing low level resolution and dynamics hitherto hidden beneath electronic noise. We also have a cure for your noisy fridge or central heating motor (£3.50), enabling you to throw away your big mains noise suppressor, which has been giving you that "sat upon sound" for years. There's lots we can do to bring you closer to the emotion and energy of the performance. So confident are we, that we offer a 14 day money back guarantee.

Ring or write for details:-

CAMPAIGN AUDIO DESIGN
Llandudno Road (HW)
Cardiff CF3 8PG
Tel:- 01222 779401

Trade and International Enquiries Welcome.

Hazlemere Audio

CONSULTANTS

ARION
ART AUDIO
ATC
AUDIOMECA
AVI
BASIS
BRIGHT STAR
CONRAD
JOHNSON
FOUNDATION
AUDIO
GRAHAM
KINSHAW
LFD
LUMLEY
REFERENCE
MUSE
NOTTINGHAM
ANALOGUE
ORTOFON
PROJECT
SD
ACOUSTICS
SILVER
SOUNDS
SONIC LINK
TEAC
TRIANGLE
TRILOGY
VPI

CONRAD is to help music lovers increase their enjoyment of music in their homes.

The advice we offer is objective and given to help YOU decide what you like best.

TNT REFERENCE TURNTABLE

SUPERB AVI/ATC COMBINATION

TRILOGY VALVE AMPS

MIRAGE SPEAKERS

We are the Lumley Reference Centre for Buckinghamshire

To listen to the beautiful music produced by the world's finest audio equipment call for an appointment, day or evening:

High Wycombe

(01494) 437892



the AUDIO CONSULTANTS

dealers with a difference

We are pleased to add two amplifiers and two speakers to our select systems.

Arion from Ireland and Unison Research from Italy. The Smart 845 is the first single-ended amplifier to impress us with its controlled bass. Visually stunning too.

The Impulse Lali speakers team well with low powered amplifiers and like walls!

Alon speakers from the U. S. A. have an open baffle design which produce a wonderfully open and transparent sound.

The new V - Damp isolation feet system is by far the best way of eliminating unwanted vibration, feedback and distortion from any system. The result of many years of research, they clean up the sound like no other elastomer can.

Incredible value for money, easy to install. Phone for details.

A genuine consultancy offering totally independent advice providing audio systems for those that appreciate music rather than hi-fi

Alon Speakers
Analysis Ribbon Speakers
Analogue Tracer Cartridges
Arion Audio
Art Audio
Audio Note
Cartridge Man's Grado
Concordant Audio
Groove Tubes
Impulse Speakers
Klipsch
Nottingham Analogue Turntables
Paragon Linear Tracking Arms
Parasound
The Vamp
Trilogy
Unison Research

Demonstrations by appointment only

0171 380 0866

Richard's Audio Visual

Stockists of

Arcam, Audio Innovations, Audioquest, Aura, Beyer, B&W, Bose, Celestion, Cyrus, Denon, Marantz, Mission, Moth, Musical Fidelity,



Heybrook, Nakamichi, Ortofon, Pioneer, Project, Rotel, Royd, Ruark, Sennheiser, Systemdek, Target, Thorens, Van den Hul & more!

Expert friendly service: Listening room
Pioneer Reference Point
4 Greyfriars, Bedford

Tel: 01234 365165



COLOUR CHAMELEON

**This studio amp
doesn't live up to its
name, says Douglas
Floyd-Douglass: it isn't
coloured! But is it
monotonic?**

Chameleon are well known in the recording industry for producing monitor amplifiers of high quality, high power and practical design. I can vouch for the consistency and reliability of Chameleon amps - both essential credentials in the studio industry. However, making a truly successful crossover product or hybrid these days (hi-fi and professional audio) is not as easy as it sounds. Many commercial manufacturers have attempted to market their domestic wares with 'studio straplines' applied to the front panel, only to fail abysmally. The Chameleon Ruby is compact, rugged and functional. Its domestic appeal lies purely in its plain aesthetics and distinctive sound quality.

Electronically, the Chameleon is a well behaved and well controlled amplifier. I found the 200watt per channel Ruby produces a sound which is tight, fast and tonally flat.

This amplifier is not inviting or enticing in the way that, for example,

good valve designs can be, inducing you to listen. It offers a critical presentation, most revealing of an inferior source. This characteristic is an offshoot of the necessity for studio products to deliver power and neutrality, for accurate monitoring. However it may not suit the domestic audiophile.

Because of its stability at high power levels, the Ruby can appear to be biased towards a powerful midrange, but this is the result of its design. With its new A/B switching circuitry the Ruby is quiet (a cooling fan is no longer used, as in the original version), and possesses virtually inaudible distortion. It is well suited to erratic and woolly loudspeakers that require consistency and efficient power distribution to operate best.

Being really critical, in hi-fi terms, the Ruby lacks the depth, sound stage and pure ballsy musicality of the (albeit more expensive) Focusrite 4 which I have also been auditioning. I draw your attention to the bass slide after the first verse in Seal's 'New Born Friend'. On the Focusrite you hear and feel it, but on the Chameleon, it sounds like the instrument needs tweaking or has been attenuated. The sound characteristic is tremendously sober.

I tried a blast of heavy metal, as this amp is more than capable of pumping a tight bass drum and delivering a soaring lead midrange. The Scorpions' 'Love at first Sting', was a corking example.

Impressive guitar tonality contrasted with the heavy dynamics of the Ludwig drums.

Chopin's Prelude Op.28 no 8 in F sharp minor performed by Ivo Pogorelich (Deutsche Gramophone) is a good reference disc for pianoforté, especially in the lower mid-band. With the Ruby, the lower register sounded muted, the midband thin and note definition was bland and uninvolved. Chamber music lacked semblance of timbre.

On string based performances, violin sounded natural enough, although decay occurred prematurely. At the best of times, it was difficult to tell the different string sections apart. There was not much depth to the orchestral sound stage, although stereo separation was good, and provided a clean, focused image. I actually got up to check the phasing of the loudspeakers. Treble was too harsh and at times, almost sibilant. I tried the Ruby with at least four different 'speaker designs, including a nearfield and main monitor of repute. There is no doubt of its studio suitability. However, its hi-fi sonics are subject to strong competition.

I would say the Chameleon was perfectly at home in the best of critical applications, especially with near-field monitors where electro-acoustic control is so important. However, in my view it lacks the personality to add musical life to a home system ●

Chameleon Ruby

£995

**Michael Stevens & Partners Ltd.,
Invicta Works,
Elliott Road, Bromley,
Kent. BR2 9NT
☎ 0181 460 7299**

WORLD VERDICT



Well specified and powerful, but dry and short of life. Suits rock on bass heavy 'speakers.

**Measured Performance
see p113-121**



readers' queries

A VEHICLE FOR VINYL

After my Technics amplifier of fifteen years standing reached its last legs I decided to review what was new in the market and bought the Aura VA-80, which pleases me no end.

This step has naturally renewed my interest in all things musical, since I'd felt as if I had been given a new set of ears to play with. However, being more of a vinyl collector I have had to compensate temporarily by using the phono stage from my old amplifier, which still works but has left me with a phono stage three times the size of my Aura. Obviously, I would like to find a smaller separate phono stage, and possibly a new turntable as well.

I've considered purchasing the EAR 834P which sounds excellent and might give a slightly warmer feel to my Aura which can sound at times rather too cool and detached with certain types of music. On the other hand, I'm at a loss to know what would make a suitable turntable in such a partnership. A wise and trusted friend suggested replacing the 'starter' cartridge (Ortofon FF15 EO MXII) that came with my Trio KD-1033 with a brand

Write in with your problems to Hi-Fi World, 64 Castellain Road, Maida Vale, London W9 1EX. Our panel of experts will endeavour to solve them, or at least offer some practical advice.

new one, an idea I find very appealing. There is very little information in the instruction manual concerning the effective mass of the arm, so I cannot make any decision on an effective cartridge, or even as to whether this is a possibility (I have enclosed a copy of the instruction manual)

Could you also make any recommendations regarding a suitable set of speakers for a bookshelf.

I'm looking forward to hearing from you.

**John Witt
Foxhill,
Bath.**

The Aura VA-80 has a smooth and warm balance which is why it is one of

our favourites too. As you seem very keen to continue playing vinyl, as you should be, this is what I would suggest. Rather than blow the best part of £300 on a specialised valve phono stage, I'd go for something like the Rotel RQ-970BX, which at £129.95 is an absolute bargain. This has a super sound, with fine detail and good dynamics. It is also a low noise design, and works well with moving coil cartridges which I find more detailed, clean and lively in their sound. The money you will have saved will go a long way towards something like the £299.95 Pro-ject 2 turntable, which comes complete with an Ortofon MC10 moving coil. This should give you an excellent vinyl front end which will match the VA-80 well.

You don't mention what kind of budget you have for loudspeakers, but a good choice for bookshelf working with your Aura VA-80 would be Mission's £150 731LEs. These have a crisp and detailed sound, and work well on a bookshelf. They are also quite efficient, so the Aura will drive them well too. DB

I have been using and, importantly, testing cartridges since well before CD was thought of - since the early seventies in fact. Ironically, even though sales are now a shadow of what they were, some of the latest designs, especially Ortofon and Goldring's, offer magnificent performance. The Ortofon moving coils especially can only be described as deeply impressive in every respect. Once, MMs could always outperform MCs. The latest Ortofon MCs blow MMs away in all areas of performance. They have better low frequency, midband and high frequency tracking, a flatter frequency response, loads of output and styli that really reach into the groove to extract a wealth of fine detail, even on inner grooves where mechanical wavelengths are short. It makes a lot of sense to ensure you have a preamp that can handle them, because LPs have never sounded so good as they do nowadays. I have to say that irrespective of all technical arguments, I find LP more amenable, impressive and involving than CD with playback equipment of this stature -

at a cost of less than £500 for the Project and Rotel combo. As sources go, it's got to be a bargain. NK

SECOND COMING

I wrote to you in 1992 from Australia for advice on a new system and at the time you

recommended a Meridian CD, Audiolab pre/power and KEF 103.4 speakers. After auditioning in the UK for nearly six months I ended up with a TEAC VRDS-10, Tube Technology Unisis amp and ProAc Studio I Mk II speakers on Foundation stands, with Furukawa cable

and Radlett Audio interconnect. C'est la vie! I was absolutely captivated by this system, the amp in particular, but my first audition was with the larger ProAc Supertowers, sadly now discontinued. The sound with the Supertowers was so intense that I think I was a

little overwhelmed, and anyway they were over budget.

Now to the problem: though I am very happy with the clarity and the truly wonderful tone of my system, especially midband, I recognise that the imaging, soundstage and bass

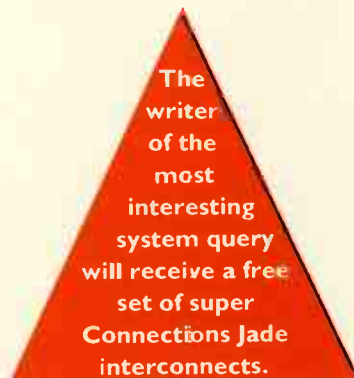
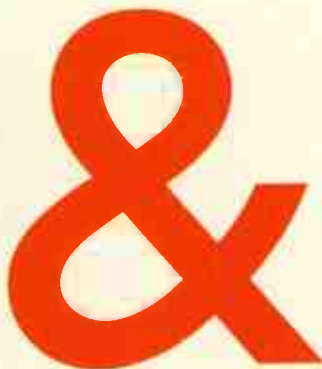

The writer of the most interesting system query will receive a free set of super Connections Jade interconnects.

o f t h e M o n t h

MORE BASS FOR LS3/5A

I would greatly appreciate some assistance with a problem I am having with my hi-fi. I have at the moment a Meridian 200/203 CD player with a Musical Fidelity A100X amplifier and Rogers LS3/5a speakers, pre-bi-wire. The midrange and treble of the system are excellent but the overall sound is very thin. There is little bass to speak of. I have a dedicated hi-fi room which unfortunately is a loft conversion made up of plasterboard walls and a wooden floor. The speakers are on very heavy stands and concrete slabs but still have no bottom end. I have tried the system in the lounge and it was perfect, but I also have a wife, need I say more?

To this end I have decided to change the amplifier for something a bit warmer and more colourful. I would really like to get involved with valve amplification, but I can't see

a valve amp for £1500 that would drive LS3/5as. They all seem to be very low powered units, so I guess I am stuck with transistor amps for the time being.

I am at the moment considering the Musical Fidelity E200/E300 and the Audiolab 8000C/P. Have you any better suggestions as you are the ones with the experience? I prefer not to change the speakers as the midrange is awesome on these little wonders and over the years I have grown attached to them.

My music tastes are very wide ranging but my favourites are mainly female vocal/female folk, Sting type male vocal and 70s type prog rock like Yes and early Genesis. Unfortunately, I am a bass freak but I accept the limitations of miniature speakers knowing that quality is always better than quantity. Many thanks in anticipation.

**Shaun Haselden
Grimby,
Lincolnshire.**

lasterboard walls and a suspended floor are almost certainly the main culprits of your bass light sound. These large panel areas are free to vibrate tend to suck-out any real bass, and if they are quite bare will reflect midrange and treble energy to exaggerate the effect. Heavy curtains and such like may well go some way to improving your situation here.

For deeper, more powerful bass, and without upsetting what you like about the LS3/5as, I'd recommend adding a REL Strata. This is capable of crisp, fast, detailed bass, and certainly carries all the punch you could ask for in the lower registers. It has its own built-in power amplifier and active crossover, so can be tuned in to blend harmoniously with your 3/5as. This also means that the drive

characteristics of the 3/5As won't be affected, important if you are considering valve amplification.

Although the 3/5as are insensitive, suggesting they will need a lot of power, this is not the case. They have a high overall impedance, so do not draw much current, and if driven too loud will easily bottom out - the BBC recommended power handling for the 3/5as is 25watts. It is well worth trying a valve amplifier with the 3/5as, a good push-pull design capable of 20watts or more should drive them well. Try auditioning Audio Innovations' Classic 25 at £1099. This produces a healthy 25watts which should be adequate in a normal domestic situation. It is a line level integrated too, so is quite neat. DB



audio T

Great Value Sound & Vision

OXFORD

Tues-Fri 10-6
Sat 9.30-6
Thurs eve open late until 8
Easy parking at rear

19 Old High St., Headington, OX3 9HS
Tel: (01865) 65961
Jon & Ashley

CHELTENHAM

Tues-Fri 9.30-6
Sat 9.30-5.30
Easy parking near

40/42 Albion Street, Cheltenham, Glos GL52 2RQ
Tel: (01242) 583960
Jon & Andy

ENFIELD

Tues-Fri 9.30-6
Sat 9.30-5.30
Car Park at rear

159a Chase Side, Enfield, Middx EN2 0PW
Tel: 0181-367 3132
David, Maggie & Jason

GANTS HILL

Tues/Thur/Fri 10-7
Wed/Sat 9.30-5.30
Easy Parking near

442-444 Cranbrook Rd., Gants Hill, Ilford, Essex IG2 6LL
Tel: 0181-518 0915
Mark & Burak

SWINDON

Tues-Sat 9.30-6
Easy parking near

60 Fleet Street, Swindon, Wilts SN1 1RA
Tel: (01793) 538222
Andy, Wayne & David

BASINGSTOKE

Tues-Sat 9-5.30
Easy parking near

4 Feathers Lane, Basingstoke, Hants RG21 7AS
Tel: (01256) 24311
Simon & Alan

W. HAMPSTEAD

Tues-Sat 10-6
Thurs eve open late until 8

190 West End Lane, West Hampstead, London NW6 1SQ
Tel: 0171-794 7848
Graham, Felix & John

AMONGST THIS MONTH'S SPECIAL OFFERS...

Basingstoke

Item	Type	Price New/Sale £
CELESTION One	Speakers	New 119 99
LINN Aktiv Kaber	Boards	Ex-dem 749 549
Speakers	Ex-dem	998 798
MERIDIAN 506	CD player	Ex-dem 875 799
PANASONIC NVHD100	Nicam Video	Ex-dem 500 439
PROJEKT 5 shelf Vook	Eqpt. rack	Display 240 175
ROTEL RCD965	CD player	S/hand 299 199
RCD945	CD player	S/hand 229 175
SONY KVX2952	29" Nicam TV	Ex-dem 829 699
SOUNDSTYLE X053	Eqpt. rack	Display 199 149

Cheltenham

AURA CD50	CD player	Ex-dem 400 319
VA80	Amplifier	Ex-dem 280 240
CASTLE Durham/stands	Speakers	S/hand 345 199
EPOS ES11/stands	Speakers	S/hand 540 299
LINN Klout	Amplifier	Ex-dem 1995 1495
MICROMEGA Junior	CD player	Ex-dem 299 199
QUAD 67	CD player	Ex-dem 825 745
66	Pre-amp	Ex-dem 863 790
66	Tuner	Ex-dem 532 480
RUARK Swordsman	Speakers	Ex-dem 329 199

Oxford

CANON S50	A/V Spkrs	Ex-dem 349 149
KODAK PCD865	Photo CD	S/hand 75 75
MONITOR AUDIO MA202	Speakers	New 450 349
NAKAMICHI CR1	Cass. Deck	S/hand 200 200
PANASONIC NVHD100	Nicam video	Last One 500 449
PIONEER PDS801	CD player	S/hand 150 150
TANNOY 636	Speakers	Ex-dem 440 375
YAMAHA NSAC85	Centre spkr	New 99 79

Enfield

ARCAM Alpha CD	CD Player	S/hand 350 199
CELESTION 5.2	Speakers	Ex-dem 190 160
KEF 101.2	Speakers	Ex-dem 550 375
LINN Keilidh	Speakers	Ex-dem 775 650
MARANTZ CD53SE	CD player	Ex-dem 350 295
MERIDIAN 508	CD player	Ex-dem 1475 1250
MICROMEGA CD3.1	CD Trans.	Ex-dem 1500 1250
MISSION 763	Speakers	S/hand 400 200
SONY TAF442	Amplifier	S/hand 250 159

Price Promise

- We know you won't find better service.
- We know you won't find a better sound.
- But if you find a better price, let us know and we'll be more than happy to match it. Plus you will still get our 3 YEAR Guarantee*.

* 2 Year on TV/Video/Mini Systems • 1 Year on Portables

Please check availability before travelling. We can transfer products to a branch near you.

SOUND-BYTES

high density filler material for hi-fi speaker stands



Transform your speaker performance with Sound Bytes.

Four times the density of sand it costs only £29.95 to fill most stands.

Recommended by Soundstyle, Target, Sound Organisation, Atacama and Apollo, filling your stands will enhance bass response, vocal reproduction and imagery.

EXCLUSIVELY FROM AUDIO T
in Oxfordshire, Hampshire, Wiltshire, Gloucestershire and North London

ARCAM OFFERS

Alpha 5	Amplifier	New 229 199
Alpha 6	Amplifier	New 329 299
Alpha 5	Tuner	New 219 199
Delta 290	Amplifier	New 479 429

Available at all branches

W. Hampstead

ARCAM Alpha PlusCD	CD Player	S/hand 450 295
Delta 2	Speakers	Ex-dem 330 275
Delta 70.2	CD Player	S/hand 700 350
AURA VA80	Amplifier	Ex-dem 279 229
DENON DCD 1700	CD Player	S/hand 500 295
MISSION 770/HJ10	Spks/stands	S/hand 570 350
QUAD 77	Amplifier	S/hand 595 530
AUDIOLAB 8000C	Pre-amp	Ex-dem 520 469
AUDIOPLAN Contrast	Speakers	S/hand 2750 1250

MEGA MICROMEGAS!
Stage 1 CD Player, Updated software, B Grade
Normal price £549 Now £449
Available at all branches

Gants Hill

CELESTION One	Speakers	New 120 99
LINN Intek	Amplifier	S/hand 450 289
MERIDIAN 208	CD/pre-amp	S/hand 1500 695
MICROMEGA Leader	CD player	B grade 800 399
Leader 2	CD player	B grade 800 449
MUSICAL FIDELITY Synthesis	Amplifier	S/hand 389 89
ROTEL RCD965discrete	CD Player	Ex-dem 350 299

Swindon

ARCAM Delta 270	CD player	Ex-dem 799 675
Alpha 6	Amplifier	S/hand 330 230
Delta 70.3	CD player	S/hand 699 449
EPDS ES11	Speakers	Ex-dem 490 375
LINN Klout	Power amp	Ex-dem 1995 1650
LK1/Dirak/LK100	Pre/power	Ex-dem 2038 799
NAIM CDi	CD Player	Ex-dem 1997 1697
YAMAHA DSP200	A/V process	Ex-dem 370 225

MAIN BRANDS STOCKED:

- AUDIOQUEST
- ARCAM
- AUDIO TECHNICA
- ATACAMA
- AUDIOLAB
- B&W
- CELESTION
- CHORO
- CYRUS
- DENON
- DUAL
- EPOS
- GOLDRING
- KEF
- KENWOOD
- LINN
- MARANTZ
- MAXELL
- MICHELL
- MERIDIAN
- MICROMEGA
- MISSION
- MONITOR AUDIO
- MOTH
- NAD
- NAIM
- NAKAMICHI
- ORTOFON
- PANASONIC
- PIONEER
- PROAC
- PROJECT
- QED
- ROTEL
- RUARK
- SENNHEISER
- SOUND STYLE
- SONY
- TANNOY
- TARGET
- TOK
- TECHNICS
- THORENS
- VAN DEN HUL
- YAMAHA

Not all products are stocked by every shop so please check with your local branch before travelling

We are authorised dealers for all products

- ★ Demonstration rooms at all branches ★ Part Exchange
- ★ 7 Day Exchange of goods and 30 day Free Upgrades
- ★ Mail Order and Export service
- ★ 3 year guarantee on all hi-fi separates (transferable to any BADA member)
- ★ We are founder members of BADA and your deposits are fully BADA Bonded
- ★ We offer Interest Free Credit (0% APR) on selected items



HOME CINEMA SPECIALIST

Home Cinema products available at all branches

E&OE

All shops are closed on Mondays

.... Continued from page 43

response could be better and I cannot forget the awesome experience with the Supertowers. I feel I am wasting the potential of the amp in particular. My dealer, Radlett Audio, recommend upgrading to ProAc Studio 200s but these are £1800+ and I'd rather spend less if I can! I've listened to second-hand Impulse H2s (impressive, but a bit warm and woolly), ProAc Studio 100s (a sideways step) and KEF Reference 1s (too hi-fi).

Can I achieve my goal in other ways, i.e. upgrading to Gold Aero tubes and adding a DAC, or can you suggest a worthy successor to the Supertowers without the Studio 200 price tag? I'd rather buy new and I listen mainly to jazz, R&B and female vocalists.

Dr Tim Ward
Exeter,
Devon.

P. S What ever happened to the Studio 200 review you promised us? *There's good news and bad news. ProAc have recently launched a new addition to the Studio series, the 150s. These are basically a compact Studio 200, using a smaller pair of 5.5 inch drivers and at a more affordable price of £1300. The bad news is that, like the Studio 200s, we still haven't had a chance to review them formally - it seems they're selling too fast and there aren't enough spare pairs around for us.*

Another alternative would be to add a REL Strata to your system. One of the best sounds I've ever had in my listening room was with a pair of Studio 100s and a REL Strata, and I suspect that you'd get similar results with the Studio 1s. The Strata has super bass, deep, tight and articulate. Using a subwoofer allows you to

pull the main 'speakers further out into the room (you no longer need room reinforcement to add weight to the bass) where they will image better and create a better sound stage, as well as becoming clearer through the midrange. This will be the most cost effective approach and wouldn't affect the basic qualities of the system you seem so happy with. DB

DRIVING GAMES

Thank you for your piece in the October issue of the magazine. And from one cultural theorist to another, isn't the word that you're looking for 'Postmodernism'?

I write as a fellow vinyl addict and as someone who shares an appreciation of second-hand chassis (after all, as with cars, why not let someone else take the depreciation!).

It was the LS3/5as mentioned in your piece that prompted me to write. Mine (marked 15Ω on the back) are currently being driven by a Leak Stereo 30, chosen for its 16Ω output taps and liquid midrange. Source is PT One/Ittok/Corus Black and pre-amp is a Croft Super Micro III. Having just heard the Pink through a Naim 72/140 into the 3/5as, I can say that the drive and grunt is missing with the Leak.

The 3/5as have definite strengths that make me want to keep them, the question is what to drive them with? I would appreciate your comments on second-hand (sorry, 're-owned') Musical Fidelity PI80 (perhaps with CRPS if funds allow) or any other choice of many sweet and affordable watts. Please don't mention the Quad 606 - not transparent enough.

Chris Moorhouse
Sheffield.

First of all, try using your Leak Stereo 30 on the 8Ω tap, where it will be better load matched to the

LS3/5as. At 1kHz the 3/5as may well be 15Ω, but as far as an amplifier is concerned they are closer to 10Ω, as confirmed by our own measurements using a 20Hz-20kHz pink noise signal which closely represents the energy spectrum of a music signal.

If you still feel the need for improvement, greater dynamics, control and detail would come from a Sugden A21a integrated, replacing both the Croft pre and Leak power. Although only 20watts, this class A design has plenty of weight behind it. You won't get deafening levels, but then the 3/5as have a tendency to bottom out quite early on anyway. Make sure they are on good solid stands and that you are using good 'speaker cables, both areas which influence the 3/5a's performance strongly.

If you still find the sound lacking, it is also worth taking a look at the more powerful Sugden AU51 power amplifier. It shares many of the same qualities of the integrated A21a, but has a very healthy 100watts on tap. It should match your Croft preamplifier well too. DB

Here's a note about valve

amplifier load matching.

The impedance of a loudspeaker is reflected back into the primary load which the output valve 'sees'. Because valve amps are 'load matched' devices, for optimum power transfer they must see optimum load. For 15Ω, assuming the designer has done his homework properly, the amplifier should see exactly that figure, right across the audio band. If it sees a lower figure, then the primary impedance goes down, which affects performance, usually for the worse our tests show: power decreases but distortion rises.

However, go in the other direction, connecting up a load higher than nominal (i.e. more than 15Ω), power will again go down, but distortion will decrease too.

So, as Dominic states, if in doubt, try the lower impedance tap. Or in other words, if you have a speaker that you think is 8Ω, but are not certain, the 4Ω output is likely to give better results than the 15Ω output.

Out of interest, we optimise the 8Ω output of our valve amplifiers for 6Ω. The impedance of a



Although insensitive, the BBC LS3/5as don't really need a lot of power to drive, and are only rated at 25 watts power handling.

Still in the dark when it comes to hi-fi and video?

It's time to get Switched On.

Just a few 'sound' reasons to visit **Switched On 96, The Consumer Electronics Show of 1996...**

Admission - only £5 (adults) & £12.50 (family of 4) • **Easy Access** - plenty of parking and the famous Manchester Tram Service every few minutes, direct to the venue • **More to see** - *Switched On* is made up of a series of shows - Photographic & Video, Hi-Fi & Audio, In-Car & Security, Computers etc - each with all the leading names & major retail sponsors • **Buy everything** - unlike other 'consumer' shows, everything you see will be for sale • **Special Offers** - there will be many 'once only' show offers • **Advance Tickets** - on sale from 1.1.96. Includes free 'goody bag' on the day, entry into 3 prize draws, plus many privileges & offers (including many on future purchases) unique to you as a *Switched On* customer • **Location** - provides the first major consumer electronics show for the North of England • **Activity areas** - unique interactive displays to inform, educate & entertain • **Facilities** - From the high quality listening rooms to state of the art home cinema, the show will entertain & excite • **The Cyber Library** - whatever your interest you can dial up the latest info on the internet • **Meet the Media** - each event is sponsored by leading media titles • **Oh yes!** - There will be an awful lot of exhibitors - probably more than ANY similar event before!



Feb 10th & 11th
G-Mex Centre
Manchester



For fuller details call Top Events:

01829 770884 or 01829 770880 • Fax 01829 771258

FOR PEOPLE WITH EARS!

THE AUDIO ÉCLAT CAN MUSICALLY ENHANCE YOUR TREASURED VALVE AMPLIFIER (OR SOLID STATE DESIGNS)

HIGH VOLTAGE ELNA CERAFINE CAPACITORS AVAILABLE NOW PREFERRED BY KONDO SAN FOR THE ONGAKU, KEGON ETC

SILVER CHRISTMAS OFFER IMTR PAIR SOLID SILVER/TEFLON INTERCONNECTS GOLD/TEFLON PHONO PLUGS WONDER SOLDERED ONLY £75 (LIMITED PERIOD)

THE AUDIO ÉCLAT
PHONE: 01642 559543
FAX: 01642 535655

HIGH END Export discount
50% or more

SALE

Only few units left!
Some prices negotiable

AUDIO RESEARCH

DAC1 D/A converter - LS1, SP15 preamplifiers - D250 MkIIS, M300 MkII, Classic150 power amplifiers

WELL TEMPERED

Record Player, Classic, Signature

export price from

£590



GOLDMUND

Studietto turntable - T5 tonearm - Mimesis 8 power amplifier - Apologue speakers

Also: Berning TF-10 preamplifier, Breuer tonearm, Cotter ultra-/subsonic filter, Eureka 1 and 2 step-up devices, MarkLevinson MLC-1 cartridge, Moersch tonearms

Call for catalogue!

Glotta AB, phone +46 8345251, fax +46 8346533

'speaker can go down to 4Ω without distortion rising significantly, yet up at 8Ω, there's little power loss.

Here's another snippet. Many British loudspeakers have impedances of 12-15Ω nominal, we find from pink noise measurement. Running them from the 16Ω tap of a valve amplifier will get more power into them, making them go louder, than an equivalently rated solid-state amplifier. For example, if a transistor amp. swings 15V maximum, it will push 28watts into 8Ω, but only 19watts into 12Ω and 15watts into 15Ω. A 28watt valve amp. like our 300B will swing 25-28watts into all these loads. You can effectively gear up or down the output of a valve amplifier with an output transformer, to match any load. NK

ACTIVE OF PASSIVE!

For more than a year, I have been dithering over the



The Quad 34/306 pre/power amplifier has a smooth musical sound, it's not worth upgrading just for the sake of it.

possibility of replacing my Quad 34 pre-amp with a passive pre-amp. (Passion or Russ Andrews). My

uncertainty arises from the unqualified pleasure that my Quad 34-306 has always given and my inability to derive any worthwhile information from all the reviews of the Passion I have read.

Other factors are the unavailability of a dealer demonstration or a home test of these products, and an advertisement for a cable which, it was claimed, would put 'guts' into passive pre-amps, a quality I have never considered absent from my Quad.

Could you please offer advice on the respective merits of active and passive pre-amps. (I am sure an article describing the effects of substituting passives for particular actives would be of interest to readers) and, if possible, describe some of the differences and improvements (if any) which might be expected from my proposed change.

Peter Williams
Rayleigh,
Essex.

As you seem to be enjoying the sound of your Quad set-up I'd leave well alone.

You may gain a little extra detail with a high quality passive preamplifier, but the balance of the system may also change and you could find it less rewarding musically. If you do decide that you want to try a passive preamplifier, there are a few things to watch out for.

The input sensitivity of the 306 power amplifiers is 375mV. That means to be able to drive the power amplifier fully, your source will need to be producing at least 375mV. This is fine with CD, most

players delivering the Philips standard of 2V or more. But some tuners, cassette decks etc may

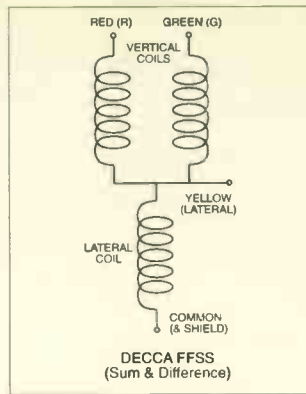

have outputs that fall below this. Also it is best to keep the interconnect between passive preamp and power amp as short as possible, say under 2m. Over longer cable runs the increased capacitance of the cable may well result in some treble roll-off, softening the sound.

Quite honestly though, I suspect that any improvement that a passive preamplifier will bring to your system will be small and the pleasure that the extra albums you can buy instead would be far greater. DB

TANDBERG SPARES

A very quick query. Are there any people around who carry Tandberg tape recorder spares? I am enclosing a stamped addressed envelope in the hope that your readers will turn up trumps.

G. Liles
Harpenden,
Herts.

Tandberg spares are available from Esoteric Audio Imports, 6 Castleman Road, Chichester, W. Sussex. Po19 4TL. Tel: 01243 533030. DB

DECCA CONNECTION

I have tried to install a DECCA FFSS Mk2 head, using a DUAL TA-Kopf TK 15 (Pick-up head TK) mounted in the arm of a DUAL 1229 turntable. I employ several other cartridges using this

technique.

I am unable to resolve stereo separation or channel identification satisfactorily. (Overall reproduction of music is good). I have been using several test records without success.

Accidentally I have arrived at a compromise leaving the output from one slider unconnected. Hum levels are not good.

Can you advise on current suppliers/service engineers of this range of cartridges, please?

A. Jamieson
Caernarfon,
Gwynedd.

The Decca cartridges were designed to cope with early hill-and-dale stereo records, where the modulation axes were at 45degrees to those on the LP as we know it, as well as today's format. There are three sensing coils, instead of two, one for lateral movement sensing and two for vertical movement sensing. The vertical coils are connected out of phase with each other, so when one is in-phase with the horizontal coil (summing with it) the other is out of phase (subtracting with it). This gives what is known as a sum and difference construction of 45degree modulation. For hill and dale, the lateral and vertical coils were used independently, hence the need for the Y connection.

You must connect both Blue and Green ground leads on your headshell to the Common or Shield pin, then run the 'hot' signal wires, Red and White, to Red and Green respectively on the FFSS.

Confusion arises from Decca's use of Green for hot. Modern convention makes this Right channel Ground, so if you connect Green to Green you get zilch. NK



THE INDUSTRY CHOICE

VIVANCO



SR 2000 ifi SR 1000 ifi SR 909 SR 850 SR 606 SR 250

Call 01442 231616 for more details

...and tune into the experience of latest In-Front Localisation sets, or the transparent sound quality of the SR 850s. For pure acoustic pleasure, comfort and durability - from £25 to £140 - make your choice...

...you won't turn Vivanco down.

Vivanco hi-fi headphones. Whatever your favourite sounds, whatever the decibel level, Vivanco make the 'phones you'll prefer. Head for a natural sounding impression of space with the

WHILE, TURN UP THE VOLUME
JUST ONCE IN A WHILE, TURN UP THE VOLUME



Why go for Vivanco?

SR 250 "A real bargain and an obvious Best Buy..." - Hi-Fi Choice, Mar '95

SR 606 "It sounds open and clean, with warmth and graciousness denied most of its competitors" - Hi-Fi Choice, Aug '94

"An excellent buy" - What Hi-Fi?, Dec '93

SR 850 "An all-round giant-killer" - Hi-Fi Choice, Mar '95

SR 909 "...an articulate midband and the good price win through to make the SR909s a bargain" - What Hi-Fi?, Dec '92

SR 1000 ifi "Able to open out the music and bring much-needed depth to listening..." - What Hi-Fi?, Nov. '95

SR 2000 ifi "The sound of the Vivanco's is beautifully crisp and clear with a fast and powerful bass..." - What Hi-Fi?, Sept '95

SR 250 SR 606 SR 850 Call 01442 231616 for more details SR 909 SR 1000 ifi SR 2000 ifi



VIVANCO

THE INDUSTRY CHOICE



DELIGHTS OF DENON



**Eric Braithwaite finds plenty
of delight in Denon's new
DCD-315 CD player.**

XTC

CD TRANSPORT	£1250
DAC	£1000
PREAMPLIFIER	£800
POWER AMPLIFIER	£2000



The ultimate music experience. Indulge yourself call 0181 810 9388



For sounds that are
out-of-this-world call in at
your favourite Earth store...



65 Castle Street, High Wycombe, Bucks HP13 6RN ☎ 01-494 531682



"All CD players at a certain price sound the same". They don't, any more than Berlioz sounds the same when played by a brass band or a full orchestra, even though the tune is the same.

Another fallacy is that budget hi-fi can sound as good as what we fondly term 'high-end' at ten times the price. It can't, any more than Berlioz... etc. etc.

Where Denon's DCD-315 - price a mere £150 - comes into all this is that it makes no pretence at being a high-end player for pennies; but it does all the things a £300 player should do and not so many noticeably wrong things.

I hereby eat the words I had adapted from the famous Morecombe and Wise/Andre Previn sketch: "Most CD players under £250 played most of the instruments of an orchestral recording, but not necessarily in the right order".

The Denon plays all the instruments, in the right order, right down to the bottom of the scale and with impeccable timing to boot. That makes it not only well worth a hundred and fifty brass rounds, it nearly makes it a miracle as well.

This little player wears seven-league

bass boots. Yet inside them - you can tell the pantomime season is approaching - is a pussycat as well. Putting Morrissey's 'Spring-Heeled Jack' in the drawer, the opening bass notes simply thundered out over the floorboards, tight, strong and rhythmical. The bass isn't just noise, however. Kettle drums in a Malcolm Arnold piece had a leading edge to them that while a trifle blurred was better than can be heard issuing out of

"The Denon plays all the instruments, in the right order, right down to the bottom of the scale and with impeccable timing to boot."

many pricier players.

Nor was there any of the hard edge on strings associated with the treble from budget players. It came almost as a surprise to hear a proper array of orchestral strings between the speakers, and, withal, a reasonable amount of spatial discrimination between them.

More remarkable was that the Denon achieves both a good semblance of real orchestral dynamics and acoustic space, which can be a rarity even among

players at three times this price. A Decca Ravel recording was held by the Denon in a commendably amphitheatre-like semi-circle, with each orchestral section firmly in place. Violins were sweet, ditto the woodwind and flutes, if just a trifle short on the full harmonic range. Trumpets in Arnold's Serenade rose over the rest of the orchestra, while the strings played busily away, without being shoved into the background.

It's only in the subtle nuances of recorded music that the 315 gave away much ground to higher-priced players. Listening to Chrissie Hynde on the Pretenders' 'I'll Stand By You', there was a noticeable reverb around the vocal, but more of an impression than a truly definable acoustic. As with Bryan Adams' 'Please Forgive Me', singers had the extra breathing and subtlety in changes of volume of more expensive players, including Denon's own DCD-825. Backing vocals tended to meld with the lead, rather than be a few paces back. But these are the things you have to pay rather more for, and there was nothing wrong with the music in between.

There are so-called CD players on the market - mostly on the market stalls! - for a bit less money and a hell of a lot less sound. Pity the poor idiot who hasn't discovered this Denon and will never have a taste of what real hi-fi and real music can sound like for a mere £150 ●

Denon DCD-315

£150

**Hayden Labs,
Hayden House, Chiltern Hill,
Chalfont St Peter,
Bucks. SL9 9UG
☎ 01753 888447**

WORLD VERDICT 🌐🌐🌐

Great sound at the price, getting all of the basics right. A bargain.

Measured Performance
see p113-111



CASSETTE WARS

I read the feature about Elcaset in the November issue of Hi-Fi World with interest and amazement. I didn't even know that this format had ever existed. It's a shame that seemingly technically superior formats should die through lack of research and marketing.

This brings me to the point of my letter. I am a proud owner of the Philips DCC 951 Digital Recorder and I must take exception to the negative and dismissive comments made about DCC at the end of the feature. Firstly you mention 1963 access speeds. Sure, they are not as quick as CD or MiniDisc but the latest DCC machines search at speeds three times that of analogue units. In terms of looks, the DCC 951 is a very smart and modern looking unit which would complement any system. Finally, the sound is indeed impressive, its 18-bit technology effectively giving better than CD quality.

I have always been a keen fan of the Compact Cassette and have recorded hundreds of hours worth of music and memories over the years, complete with hiss, wow and flutter. Many people see DCC as a significant but natural progression from analogue Compact Cassette and feel comfortable with that. In fact, you can still play analogue tapes on the DCC machine, and with their advanced electronics and superior Dolby noise reduction circuit, my old ACCs never sounded so good. Other benefits include the ability to name tracks and insert markers for easy searches, together with real time display. With hardware

and software prices that would barely buy a reasonable quality analogue machine or a decent metal tape, I don't think that DCC can be consigned to the scrap heap yet.

**Robert Snowden
Easingwold,
N. Yorkshire.**

Neither do we. In fact the latest generation of machines are sounding

better than ever. But let's face it, who's heard of DCC? Or MiniDisc for that matter. The general public just aren't aware that it exists.

Out of DCC and MiniDisc, I must say the DCC looks to have the greater potential, serving as an analogue cassette deck for your old tapes, whilst making noise free high quality recordings on

new DDCs. But I feel its potential has been strangled by a number of factors. Record companies and equipment retailers are not keen to push a new format in the time of recession, since there is simply not the money there for 'luxury' new technology.

On top of this, anyone

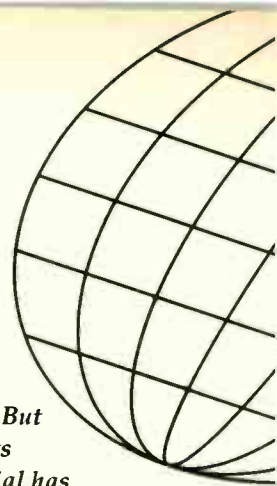

Letter of

WHY ELCASET?

I enjoyed David Price's look at one of Sony's great failures: the Elcaset. Why on earth anyone at Sony thought the public would buy these cumbersome contraptions instead of a Revox A77, Tandberg TD20 or indeed any of Sony's own very fine open reel machines, we will never know.

Cassettes were coming along in leaps and bounds with machines like the Nakamichi brothers' Tri-tracer 700 & 1000. Open reel had the significant advantages of longer uninterrupted recording time, editability, and higher quality available through faster tape speeds. Elcaset fitted neither the convenience of Compact Cassettes (have you tried to fit an Elcaset into your pocket) or the flexibility of a conventional open reel. It appealed to no-one. All of which was a shame.

The basic recipe of an open reel in a cassette was good. Take state of the art tape formulations, add a state of the art head system and mix in a jewel of a mechanism: result Elcaset. The electronics were as simple and plain as they could be (although for some strange reason Sony seem to have limited the performance almost on purpose, perhaps so as not to embarrass their more expensive open reel machines?). Your signal passes through literally only a handful of transistors, and not one IC. Dolby was a redundant function on these decks.

Technics and TEAC also made Elcasets, although I have only ever owned the Technics and Sony machines. The Technics is a huge affair, 19" rack mount, twice the height of the EL5 - and sadly half of the quality, even though it's a no frills, minimalist dream (literally

tape monitor switch is the only switch to twiddle) auto tape selection, and Dolby free zone. The cassette mechanism is the court jester in comparison to the princely EL5, never mind the incredible EL7 King.

Ahh, the EL7. What a machine! The ultimate Elcaset. I would go as far as to say it is better than a Revox A77 running at the same speed. The reason for Elcasets supremacy at the time was the refined tape formulation, and straight out-and-out quality of the transport.

The portable EL-D8 is also a very fine machine, as good as the EL5. It suffers one major problem: it eats its batteries at an alarming rate. I used one to bootleg a concert once - damned thing only managed half an hour!

Ultimately, like Sony, I have given up on Elcaset. My little Sony Walkman Pro and UHER 4200 portable

Send your letters to Hi-Fi World Letter Page,



writes

clued up enough to know about the DCC/MiniDisc debate, almost certainly knows about DAT and the several new formats proposed for CD, and are reluctant to commit to anything. I don't think anyone really knows which way to turn at the moment, irrespective of quality concerns. DB

JAZZ CONFUSION

I have gained an inordinate amount of pleasure from reading your magazine for the last three years, even though I cannot understand why I never win the competitions. You introduced me to one of the great joys of my life, the Tube Technology Unisis amplifier, and for that I can forgive you almost anything. Nevertheless, I am finding it

increasingly difficult to excuse the antics of Simon Hopkins in his Jazz reviews, although I must confess to a sneaking admiration and no small measure of envy for one who is so obviously passionate and knowledgeable about his music.

As a Jazz neophyte however, struggling at the edges of enlightenment and in desperate need of guidance, I find his reviews unnecessarily arcane and deeply frustrating. His latest effort (October '95) was, I admit, milder than most. He didn't mention John Zorn once, an achievement in itself, but I remained baffled by phrases such as "its inchoate agonies rip out from the music around it" and "a swirling tone poem...at times a thick impasto spattered across urgent loping rhythms". I have an impression of John Coltrane meets Beowulf; was this the image Simon was attempting to convey?

Imagine my excitement therefore to read his review of Spirit and the Blues by Eric Bibb and Needed Time. At last, a lucid account of music I was sure I could relate to and enjoy. Imagine my utter frustration to find that after visiting four mainstream record shops, two specialist shops and telephoning three specialist suppliers, I was unable to find anyone who could find evidence of the existence of Mr Bibb, or indeed the Opus3 label. Isn't life difficult enough without reviewing music that no one can get hold of?

Dr Tim Ward
Exeter,
Devon.

Opus3 recordings can be purchased from Pentacone, contact them on Tel: 01924 445039. They are the same people who make the Opus3 turntable reviewed in the same issue. DB

THE VINYL LIGHT

Somewhere around the mid-sixties there was a cartridge available that used a beam of light in place of the usual diamond stylus. I am not absolutely sure but I think it was made by Trio and I believe that it was very expensive. Presumably it was not successful as it did not survive.

One advantage claimed for the cartridge was that it would not wear the record. Any clicks already on the disc would be reproduced exactly as they would with a conventional cartridge but there would be no further wear.

I have no idea how the light beam was made to follow the groove in the disc. Electronics was by no means as advanced at that time and this may have been one of the problems.

I am surprised that this idea has not been explored further using modern electronics. My guess is that the electronic circuitry used to keep the laser of a CD player on the track could be used to control a phono cartridge - possibly without any modification. It is also possible that a laser similar to those used in a CD player could be used as the light source rather than a beam of conventional light.

Maybe the large manufacturers consider that

continued on page 55... ▶▶

the Month

open reel have replaced the EL-D8. A Studer B62 and B&O 9000 the EL7. This happened by accident, without me realising it. If I wanted something small I would use the Walkman Pro, if I wanted the best quality, the B62. The Elcaset no longer figured.

A dealer friend of mine remembers Sony launching the poor format, and it was rumoured that Sony did a bit of a Brent Spar when it totally flopped, dumping thousands of brand new, boxed, but totally unsaleable machines into the Pacific Ocean.

Even up until a few years ago, the last remains of UK Elcasets could be found. Anchor Supplies had new, boxed EL5s; Richer Sounds had a big stack of wired remote controls, and of course Shadoos still have enough cassettes for another trip to the Pacific!

Elcasets have their followers, but I have to

conclude that at the end of the day Elcaset was a totally misconceived idea. If they had launched it five years earlier, and if the prices of the machines had been similar to cassette (impossible) rather than open reel, it may have stood a slight chance. Instead it was virtually still born, and disappeared almost without trace.

The sad part of this tale is what it must have taught Sony. They launched a no holds barred attempt to produce the best audio quality - and nobody wanted it. So now we have to put up with Sony "miniature novelties" such as MiniDisc, which offers lowest common denominator sound quality in a tiny package. Thankfully, nobody in hi-fi seems to want them either!

Haden Boardman
Audio Classics
Mellotone,
Lancs.

Francinstien

STEREO ENHANCEMENT SYSTEM



Try the CD Filter with a difference in your own home

When we listen to music, both the high and low frequency sounds help our brains to paint a 3 dimensional stereo picture. But when we listen to CD, the high and low pictures do not perfectly realign. With their clinically clean electronics, CD players lack the beneficial, subtle signal handling of analogue equipment which can actually "re-converge" the two stereo images. So creating the convincing illusion that is the hallmark of good analogue systems.

Francinstien, designed by Hi-Fi World columnist Richard Brice, breathes life into digital stereo. By simulating the best aspects of analogue equipment, it restores the sense of depth - and even height - to digital recordings. And it does it without introducing any of analogue's vices!

Simply plug **Francinstien** between your CD player and pre-amplifier (or integrated amplifier) and you can have your cake and eat it. Analogue imaging and "involvement" with the clarity and "bite" of digital. But you don't have to believe us because you can try **Francinstien** on home trial.

"It's a gentle elegant effect - and a very even one...One simply becomes more aware of the music."

— **Eric Braithwaite** - Hi-Fi World

"CDs sounded better defined, the soundstage having a more definite shape. It was as if there was more air around each strand in the mix, allowing you to hear it more distinctly, more separately...I didn't immediately want to switch the CD player off and relax with some LPs, instead I went on to make further explorations of my CD collection"

— **Andrew Cartmel** - Hi-Fi Choice

Let the **Francinstien** improve the audio quality and stereo imaging of your system. To send you a demonstration unit we require either cheque or credit card payment for £7.00, to cover postage and administration. If you wish to purchase a **Francinstien** please call us and £7.00 will be deducted from the total price of £150 inc. VAT. However, if you do not wish to keep the **Francinstien** then simply return the unit to us within 10 days.

Title: _____ First Name: _____ Surname: _____

Address: _____ Post Code: _____

Francinstien unit for home demonstration Further information on Perfect Pitch Music products

Credit card payment — I authorise you to debit my credit card account for the cost of goods despatched.

Visa Mastercard Tick one box

Credit card number: _____ Credit card expiry date: _____

N.B Goods will be despatched only if the above address is the cardholder's address.

Cardholder's signature: _____ Date: _____

Select Systems Ltd. Dept. HFW/8 Hanworth Trading Estate Hampton Road West Feltham Middx. TW13 6DH
Tel: +44 (0)181-893-8662 Fax: +44 (0)181-893-4318

World Radio History

VISA

MasterCard



Perfect Pitch Music is a trademark of Select systems™

.... continued from page 53

LPs are obsolescent and that the cost of developing players would not be justified. However, the advantages of using some form of light to recover the information in the grooves of LPs go far beyond the absence of wear. A player could have all the features found in CD players. Some tracks could be programmed to play and others omitted, or just one track selected by number, or a track could be repeated.

If such an idea is feasible and, if a player were developed, it could give the millions of LPs currently collecting dust a new lease of life.

**Brian Darling
Winchmore Hill,
London.**

There have been several attempts in the past to create a record deck that uses light to read the groove. But none have been commercially successful, due to the complexity and cost of such a system. An unexpected problem of any no-contact system is that it reads dirt particles effectively, rather than pushing them out of the way like a stylus. The result is high surface noise, a surprising drawback. Both Trio and Toshiba have in the past experimented with cartridges that used the stylus to wiggle a grating that modulated a light beam, but these were very complex and were never a commercial success.

More recently, in 1992, an Audio Engineering Society paper was presented by three Swiss engineers describing a turntable using an optical fibre to track the grooves. The light emitted by it was collected by a lens and fed to an optoelectronic detector. This system was

especially interesting because it could play a damaged record as if it was new. The signal was picked-up in a normally unused section of the groove and the profiled optical fibre could track the groove accurately. The system was developed for archiving precious recordings rather than every day use though. DB

**WELCOME BACK
WESTERN ELECTRIC**

I really liked the advertisement for Western Electric on the inside cover of HFW Supplement No. 17 and it occurred to me that a framed print would make a fitting addition to my listening room.

The 300B triode no doubt deserves all the praise heaped upon it by so many, even though 'cheap' versions are quite expensive when compared to other valves. The 300B has eclipsed all

other triodes, apparently, and demand is obviously high or Western Electric would not have resumed production.

What about more affordable triodes? In your forthcoming article on output valves, I hope you will consider available examples, if there are any, and an appraisal of the various methods of connecting tetrodes and pentodes would also be useful.

I am too young to remember the debate about triode Vs pentodes, but I would appreciate a clear outline of the arguments for and against these options.

**Aron Proctor
Eastoft,
Scunthorpe.**

Of the power triodes currently available, the 300B, 2A3, 211 and 845 are probably the best known and all are in current manufacture. The 211 and 845 are huge bright emitter

triodes, but are relatively affordable considering their power, costing around half that of the 300B. Unfortunately, typical operating voltage is between 800-1200V, making them expensive to use, more often than not outweighing the cost saved on the valve.

The 2A3 is essentially a 1/2pint 300B, developing less power. It is cheaper, but to get the same power you'd have to use more of them, making the difference in cost small. The 300B is popular because of a combination of factors. It is extremely linear and can be used without feedback. It develops good power, 30watts or so for a push-pull pair, 12watts for one in single-ended mode, and can run with an HT line of 350-550V, making the power supply simpler and more cost effective than with a 211 or 845. Yes the

300B is expensive, but for your money you are getting one of the most linear amplifying devices ever made. DB

And don't forget the newly developed Svetlana 811 triode specially developed for modern audio amplifiers. It has 65watts anode dissipation, making it capable of handling more power than even the excellent 300B. Our experience of the 300B, now considerable, is that it deserves its reputation for sound quality. It's delightfully smooth and silky in its presentation, a real honey. NK

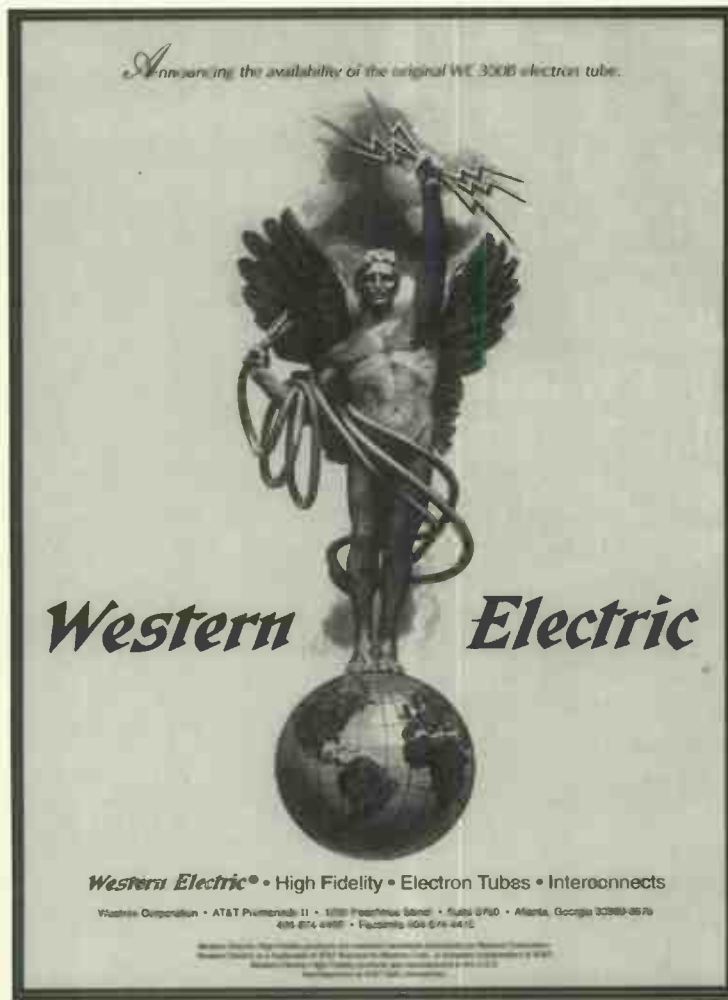

Audiolab 8000S Stereo Amplifier



Imagine an amplifier which offers the simplicity of an Integrated Amplifier and the flexibility of a separate Pre-Power Amplifier. It is the new Audiolab 8000S Stereo Amplifier.

At the turn of a switch you can use it as an Integrated Amplifier, as a Pre-Power Amplifier together with the Audiolab 8000P Stereo Power Amplifier in a bi-amplified system, as a high performance stand alone Pre-amplifier, with an external surround sound processor, or with a sub-woofer. It has remote control and outstanding sound quality. We couldn't think of anything else an Amplifier needs to do!

Ask your Audiolab dealer for a demonstration.



- 8000A Integrated Amplifier
- 8000C Pre-amplifier
- 8000P Stereo Power Amplifier
- 8000M Monobloc Power Amplifier
- 8000T Tuner
- 8000Q Pre-amplifier
- 8000PPA Phono Pre-amplifier
- 8000CDM Compact Disc Transport
- 8000DAC Digital-Analogue Converter
- 8000S Stereo Amplifier



Audiolab 8000A

Audiolab 8000C/P

Audiolab 8000CDM/DAC

Audiolab 8000T

For more information about Audiolab products and details of your Audiolab dealer, call or write.



Hear the difference.

AUDIOLAB

Cambridge Systems Technology Ltd
Spitfire Close, Ermine Business Park
Huntingdon, Cambs PE18 6XY

Telephone 01480 52521
Fax 01480 52159

World Radio History

NEARLY

Dominic Baker tells of his close encounter with NEAR's 10M loudspeakers.



New England Audio Resource pride themselves on their in-house designed and built metal alloy cone drive units, which give them

close control over their loudspeaker design. The 10Ms reviewed here are the entry level into NEAR's range, coming in at £499.

This model is a compact two-way design, using a 5.25" bass/midrange driver and a 1.1" titanium dome tweeter. The bass driver is loaded by a

MICHELL GYRODEC AND QC POWER SUPPLY



A SYMBOL OF PRECISION



"THE MOST DESIRABLE DECK BELOW £1500"

Ken Kessler - Hi-Fi News & Record Review August '94

Michell Engineering, 2 Theobald Street, Borehamwood, Herts WD6 4SE
Tel:- 081 953 0771

You can follow the digital
revolution or you can follow the
Groove



"The sounds from the Pro-ject 1 had the famous engaging bloom and warmth so characteristic of LP, which is either caused by analogue's inherent superiority over digital or a mixture of distortion, crosstalk and microphony according to your viewpoint. Anyway, I liked it ..."

John Borwick, Gramophone

Project 1 Turntable

PRO-JECT
AUDIO SYSTEMS

Pro-ject record playing systems are available for between £150 and £2,000
For more details and stockists, phone ORTOFON UK on 01753-889949

Studio One

We are flexible with our opening times
Free parking available by appointment.

117-119 HAMMERSMITH ROAD
LONDON, W14 0QH.
Tel: 0171 371 3037
Fax: 0171 371 1790
We are open Mon-Sat 9.30 -6.30

Mail Order



SONNETEER CAMPION

Presents:
QUAD
CD's Tuners,
Integrated Amps and
Pre-Power Amps.



We offer home
demos on Hi-Fi
equipment and
cables.
So you can make
your choice.

AVAILABLE NOW

Agents for:- Alchemist, Audio Innovations, Audiolab, Aura, Alphason, Atacama, Audio Technica, Boston, B&W, Chord Company, Castle, Denon, Dynavector, Harmon-Kardon, JBL, Jecklin, Jamo Oriol, Orelle, Kinshaw, KEF, L.A. Audio, LFD, Michell, Moth, Musical Fidelity, Nakamichi, Ortofon, Pro-ject, S.M.E., Sequence, Stemsford, Sugden, Teac, Thorens, Totem, Tannoy, Townshend, Tube Technology, Van - Den - Hul, TDL Electronics. Studio series and many more.

- * Home Installations*
- * Free Local Deliveries*

"Introducing a new brand of
amplifiers exclusive to Studio
One The Sonneteer Campion
Integrated amplifier."

"Call Joseph or Ossie now for Free advice"
Audition The ECA Servo A Point 2 True Ribbon
Loudspeakers "Be Amazed"!

"Records cleaned and sleeved on Nagaoka antistatic
for £1.50 per album"

Pay us a visit, we are near Olympia

small rear-firing reflex port, so a few inches of space must be left behind them if they are to be used on a bookshelf. The tweeter dome is inverted in similar fashion to Focal's tweeters, seeming to narrow dispersion and giving a stronger sweet spot. The upside though is that these inverted domes tend to give more precise imaging, at least in properly sorted designs.

The 10Ms are characterised by strong presence through the midrange which really helps vocals project well. With Pulp's 'Common People' Jarvis Cocker's closely miked vocals became extremely intimate as he spoke in a menacing tone. His voice was perhaps a little too exaggerated to be entirely natural, but it made for an exhilarating and informative balance.

At first listen, the 10Ms can come across as sharp and sibilant, due to a combination of light bass which lacks any real weight, plus strong treble. I had started my listening sans grilles, but after a few tracks the powerful treble

“On simpler pieces things improved, a violin and piano spotlighted well with a good sense of acoustic surrounding them.”

got the better of me and back they went. This took a little of the edge off cymbals, but they retained their essentially bright nature.

Lack of bass combined with a forward balance robbed the 10Ms of any real warmth or character. I used them close to a rear wall, room reinforcement serving to help counteract their lack of bass power to a



certain degree. Unfortunately, in this position, deep bass notes could cause an unpleasant thrum from the cabinet, which was more annoying than the lightweight bass I was trying to cure. In the end, they found greatest favour around 1ft off the back wall.

The metal cone drive units and presence given to vocals by the 10Ms gave an especially realistic presentation to Oasis' 'Wonderwall'. There was a hard, nasal quality to upper male vocals, sounding a little megaphonic, and I suspect that there is either a peak in their response or the cone is starting to break up here (I wrote this before measurement).

'Cast no Shadow' again had the cabinet singing, adding a boxy, hollow quality to bass. The sound stage was reasonably wide and open though, giving a more realistic character through the midrange and treble. The focus of individual instruments could have been sharper; they sounded dispersed across the stage.

With Tchaikovsky's 'Allegro con Grazia' strings had a pure tone and sounded both smooth and unrestrained. Higher notes did gain a graininess though, and were sometimes overly accentuated by the 10Ms.

The NEAR 10Ms again lost out with larger scale pieces where the full power of the orchestra was suppressed by a slightly constricted sound stage and weak bass. On simpler pieces things improved, a violin and piano spotlighted well with a good sense of acoustic surrounding them.

Overall, a bright and thin balance and a hard quality with vocals can make the NEAR 10Ms too demanding at high levels or over extended listening periods. A subwoofer would add much needed warmth and depth to the sound, so they shouldn't be written off all together. And some of their

qualities are endearing, the sharp and fast treble lending them a real sense of precision ●

NEAR 10M

£499.00

Picture The Sound
13 Weston Road,
Guildford,
Surrey. GU2 6AU
☎ 01483 454991

WORLD VERDICT

A thin and hard sound, but precise with it.

Measured Performance
see p113-121

FREE DIY HI-FI
SUPPLEMENT WITH
THE FEBRUARY
ISSUE

IN THE FEBRUARY ISSUE

Winter is well and truly with us now, and what better way to spend it as the nights draw in than relaxing to your favourite music? Well, one way would be to add the February issue of Hi-Fi World, which will entertain you long into the evenings. Full of all the latest equipment, news, features, letters and Q&A, classified adverts where you can pick up a bargain, a super competition, music reviews and more. Here's just some of what we hope to bring you in the February issue.



FOCUSRITE RED 4/5

Focusrite are a familiar name to studio engineers, manufacturing a range of superbly built and finished electronics for studio monitoring. Now they're looking to take the domestic market by storm, with their stunningly styled Red 4/5 pre/power amplifier.

AUDIO INNOVATIONS P2

An all-valve phono stage, the P2 has long been regarded as one of the best external phono stages around. With a sprinkling of top grade audiophile components such as paper-in-oil capacitors, Audio Innovations have certainly paid attention to fine details. We listen closely.

PHILIPS CD 721

The latest budget player to come from the inventors of CD. Philips' budget players have been received with enthusiasm in the past, usually combining the strengths of good quality engineering with the latest technology. Could the new CD 721 be the one to watch in '96?

SYSTEMDEK 165

A £300 floorstander with a quality finish and drive units, the Systemdek 165s look good value. Competition is tough though these days, so the battle isn't so easily won. Find out if Systemdek are to be victorious.

CASTLE COMPETITION

A chance to win one of three pairs of Castle loudspeakers, all exquisitely finished in real wood veneers. 1st prize is a pair of Castle Howard SII loudspeakers, 2nd prize a pair of floorstanding Severns and for the runner up, a pair of the recently launched Isis.

DIY SUPPLEMENT No. 20

Also FREE with the February is DIY hi-fi Supplement No. 20. They'll be plenty to keep enthusiasts busy, including a single-ended solid state amplifier.

Hi-Fi World is still only £2, but with more editorial than most rivals. With the most enthusiastic and expert editorial team in hi-fi journalism, can you afford to miss it? Make sure you don't by filling in this order form and handing it to your newsagent.



Please reserve/deliver* Hi-Fi World on a regular basis, commencing with the next issue, until further notice.

Name: _____

Address _____

Signed: _____ Date: _____

* Delete as appropriate

Distributed to the news
trade by

COMAG
MAGAZINE MARKETING

I didn't know quite what to expect from the Malaysian hi-fi show. Not so much in products and size, because that was predictable to a degree, but in outlook. Would this show reflect a passive and undiscerning market, importing black boxes indiscriminately from Asia's many automated plants, mostly Japanese. Or would it have its own perspective and dynamic? Would it have its own hi-fi culture? I got a shock.

Brought up in Singapore, with an occasional python in the shower, flying foxes (fruit bats) gliding overhead in the evening and the monsoon rains pounding the shiny, corrugated iron roof of our bungalow on stilts, the area held few surprises for me in this respect. My only wonder was: where have all the mosquitoes gone? Somehow the tropics doesn't seem the same without the whine of those little so-and-sos.

But of course, Malaysia and Singapore have changed. Their economies are expanding so fast, they're termed the "Asian tigers", with growth rates of up to 20% per annum. There's a shortage of labour, so the difficult jobs are carried out by labour from Bangladesh, Indonesia and the Philippines. That means Malaysians have good employment, which makes them relatively well off - and it shows. It also accounts for a roaring hi-fi business. Or does it?

I'd argue not. The usual commercial view is: where there's wealth, there are consumer sales. But the average Briton now believes hi-fi comes from Japan, in one box free of unsightly wires, and can be bought for £600, "with everything". I was worried about finding a similar view in Malaysia. What a wonderful surprise to fly into a country free from this depressing outlook.

In Malaysia two national newspapers, *The Star* and *The Sun* (both English language) regularly carry supplements on hi-fi! Having written the occasional piece on hi-fi for *The Sunday Times*, I well know how reluctant British newspapers are to approach the subject. In Malaysia it's a popular one that intrigues people.

Standing in the Octave Electronics room, answering questions about our kits and speaking to people in general about their hi-fi, I soon realised that Malaysians have a great knowledge of the topic, not just a superficial interest. The last thing I ever imagined was to have older guys approach me about their Leak and Quad valve amps, but even this happened. Kits are a new idea, but since the country is industrially strong in electronics, the circuit and the soldering iron hold few fears. Building something of quality is a very satisfying leisure time activity. It's also educational and, best of all, it enables the builder to tweak until his heart is content. All of this went down well.

I'm glad it did, because Malaysia struck me as a country with a great potential future in audio engineering. Funnily, the colonial connection plays a part. Although the British press in its parochialism seldom looks far past

Reflections from Noel Keyword

Blighty's shores nowadays, Malaysia remembers and preserves its links with Britain. One of the biggest surprises of my visit was to find in just what regard our audio industry is held. Another surprise was to find just how large its presence is, alongside those modern-day masters, the Japanese. However, whilst Japan does have its true specialists, like AudioNote, by and large, their hi-fi comes from large conglomerates for whom mass production is everything, the black box its finest creation.

This is steadfastly not the British way. Just about all UK hi-fi manufacturers are founded by audio enthusiasts, even though most do by necessity go on to embrace the rigours of commercial production.

Malaysia sits between the two, with some fascinating consequences. They have the Japanese transplants, like Aiwa and Onkyo, which have large scale manufacturing capacity with low production costs. When I tested the NAD613 cassette deck (p24) I spotted "Made in Malaysia" on the back. But they also have a great love of real hi-fi, which demands more than computerised design and automated production. There's art in this science, and it will remain there until links between

hearing and emotion can be understood.

Audio engineering demands an imaginative approach that goes beyond the purely theoretical and this is in short supply around the world.

It struck me that Malaysians are conveniently situated on the geographical crossroads here, enjoying close links with Britain, strengthened by their near universal use of English (many Malaysians speak three languages: Malay, Mandarin and English), whilst being close enough to Japan and its Asian markets to attract their modern factories. This puts them in a superb position for the future, since audio products do demand industrial technology. I'm reminded that Philips recently moved the headquarters of their Audio Division out of Europe altogether, relocating it in Singapore. I've just found out why.

Whilst so many in Britain now believe hi-fi is a black box from Japan, ironically people in the East are having none of it. That's why Celestion, KEF, Mission, Rogers, Acoustic Energy, NAD, Wharfedale and Quad - and doubtless there are more - now all receive investment from one or other of the Asian tigers. British hi-fi isn't dead, but I wonder whether it's the British keeping it alive ●



Over the years he'll take your car, your hard earned cash and years off your life. Do you really think it will be any different with your Arcam?

We can confidently predict that you will enjoy the top quality sound of your Arcam Hi-Fi separates for many years to come.

It's a simple enough prediction, when you consider just how hard we work to produce Hi-Fi of the highest quality.

Like any good parent, we ensure that our little treasures go out into the world with every advantage.

So, before we bid a tearful farewell, the Hi-Fi produced at our Cambridge factory must pass the most rigorous set of tests, checks and double checks. This means that each Arcam separate is blessed with a long, active and productive life.

Then again, sonic excellence and reliability are bound to feature on all Arcam products, since we design them in from the outset.

A very pleasing aspect of all this dedication is that year after year our products make us rather proud with lots of top Hi-Fi industry awards.

So, do keep a close eye on Junior. He also knows quality when he hears it. (Well, you can't really blame the little angel for inheriting your good taste!)

On the other hand, you could invest in a lesser Hi-Fi system than Arcam...

But why deprive yourself, never mind future generations?

ARCAM

Return the coupon below to: Arcam, Pembroke Ave.
Waterbeach, Cambridge CB5 9PB, England.
Or telephone: (01223) 440964 (24 hours)

Please send me information on: (Please tick)

Arcam amplifiers Arcam CD players

Arcam tuners Arcam home cinema

Arcam DACs all Arcam products

and the name of my nearest authorised dealer.

First Name(s)

Surname

Address

Postcode

HFW 1/96

Son

“One day son,
all of this will
be yours”

In Australia: Stolmack Audio Pty. Ltd., P.O. Box 39, St. Ives, N.S.W., 2075. Tel: (2) 440 8755.

In Canada: Emerald Audio Resources, Sussex P.O. Box 19016,

720 Spadina Avenue, Suite 100A, Toronto, Ontario, M5S 3C9. Tel: (416) 596 7657.

In New Zealand: Avalon Audio, 587 Mount Eden Rd., Auckland. Tel: (649) 638 9000.

In South Africa: Hi-Fi Specialists, Durban Road 155, Bellville, 7535. Tel: (21) 946 1411.

In USA: Audio Limited Corporation, P.O. Box 381, Hightstown Lakes, NJ 07422. Tel: (201) 764 8938.

WorldRadioHistory



Dominic Baker

dB on the level

Yet another hi-fi year has passed by, so now's the time to reflect on all that's happened. The beginning of the year got off to quite an exciting start, with Pacific Microsonics announcing their HDCD high definition CD system, and Pink Triangle beating everyone to it by adding an HDCD filter module to their discrete Da Capo CD Convertor. The HDCD system used a higher resolution recording process, but the information was then encoded onto a normal 16-bit CD to ensure compatibility with existing players. But there was also a hidden recorded code, which an HDCD equipped CD player could decode for 20-bit resolution.

We were first to demonstrate this technology to the public, at the Edinburgh Hi-Fi Show, the general consensus being here was a system that took CD quality to a new level. A year later, only a handful of manufacturers have taken up HDCD. Others are still holding back, for reasons that became clearer as the year progressed.

February 1995 was also

“The biggest surprise though, came from Technics, and their SB-M300 loudspeaker. The Japanese aren't renowned for their success in this field, but the SB-M300s will have produced a worried look on many a UK designer's face.”

the beginning of a new range of electronics for QUAD, starting with the 77 amplifier complete with microprocessor remote control. Later on the matching 77CD player joined it, but only just in time to see Verity Group, the holding company for Mission, buy them up. This secures a strong future for QUAD, but at the same time it was a sad moment

seeing a British hi-fi company with such a great heritage finally get swallowed up.

In April we carried a test between KEF's new Coda 7 and its closest rival, the Mission 731. The KEF just piped it, staying on the throne until Mission replied with their super little 731LE, in November. But the Coda 7 was to set the scene as far as loudspeakers went for 1995, with the manufacturers who were still surviving in the recession becoming leaner and meaner, and their products more competitive. This issue

sees a round up of six new £200 loudspeakers all launched in the last couple of months!

If one product stood out above all else in 1995, it was Marantz's CD-63SE. We reviewed this player in our May issue, and were deeply impressed with its sound quality. This £350 CD player set new standards below £1000, and is still being raved

about now as the year draws to an end. If you were a manufacturer of a CD player in '95, the CD-63SE was the one you had to beat.

Mid-year, around June-August, the hi-fi scene traditionally goes quiet. But with Audiolab launching their new 8000Q preamplifier, DPA their one-box discrete convertor CD player, Heybrook revealing an updated version of their Sextet loudspeakers, Linn's new Karik III CD player and NAD's 514 CD player - the first real rival to the CD-63SE, it was far from quiet for us. Also auditioned for the first time by the Hi-Fi World camp was the Unison Simply 2, a superb sounding integrated, single-ended valve amplifier from Italy.

Since HDCD appeared in the early months of the year, there had been a multitude of rumours around the industry about an all-new CD format. In our September issue we came across the Acoustic Renaissance for Audio, a group of engineers determined to push CD quality forwards. Another format war was on the horizon, between Toshiba/Warner with their 5 Gigabyte video CD system, and Philips/Sony with their 3.7Gig system. The Acoustic Renaissance for Audio were determined that audio shouldn't play second fiddle to video, proposing a music coding

scheme for these new discs that could give 143mins of music with 24-bit resolution. This really would be a step forwards for the future of CD.

The last few months of the year, as ever, saw a flurry of activity as everyone geared up for the season, new models appearing all over the place. The biggest surprise though, came from Technics, and their SB-M300 loudspeaker. The Japanese aren't renowned for their success in this field, but the SB-M300s will have produced a worried look on many a UK designer's face.

Using a form of coupled-cavity bass loading developed by KEF and used in their Reference Series, the SB-M300s were a compact 3-way, 4-driver loudspeaker. Combining a fast and detailed sound, with good bass, in a compact enclosure and at a reasonably affordable £350, here was something UK loudspeaker manufacturers hadn't bargained for.

So 1995 was an exciting and varied year in audio, the quality of equipment reflected by our World Winners list, which has expanded from eighteen products to twenty-nine we felt worthy of accolade. Lets hope that '96 sees even more new and exciting equipment and developments in the world of audio. It seems likely, because UK Hi-Fi plc is as active as it has ever been ●

CD UPGRADE

Why go out and buy a new CD player at great expense for only minimal improvement in performance? Trichord's highly renowned 'Clock 2' and dedicated 'Clock 2 Power Supply' modifications will dramatically improve the sound quality of your existing CD player, or CD transport. Hear the potential that the CD medium really has to offer.

- ♦ High accuracy (5 ppm) low jitter performance master clock.
- ♦ Up to five times reduction in data related jitter.
- ♦ Increased transparency, resolution and sound staging.
- ♦ Greater dynamics and sheer listening pleasure.
- ♦ Can be fitted to most players or transports regardless of price. The level of improvement is just as significant with expensive transports as it is with inexpensive players.

These modifications can be carried out by Trichord Research Ltd, or by your local Trichord dealer. Also available in kit form with instructions for the technically competent.

We are so confident in these upgrades that we offer a complete refund and return your player back to its original state if not satisfied.

Clock 2 Trichord or Dealer fitted	£141.00 inc. VAT
Clock 2 Kit for self fit	£ 95.00 inc. VAT
Clock 2 Power Supply Trichord or Dealer fit	£ 80.00 inc. VAT
Clock 2 Power Supply Kit for self fit	£ 55.00 inc. VAT

for more information:

Trichord Research Limited

Tel: (01684) 573524 Fax: (01684) 577380

FOR THOSE WHO ARE TRULY SERIOUS ABOUT THEIR MUSIC

73 CHURCH STREET, MALVERN, WORCS, WR14 2AE

STUPENDOUS Stimulation STRAIGHTAWAY!

STRATA II STORM STADIUM II STENTOR STOCKED

Dealer	Town	Contact No.	Dealer	Town	Contact No.
Narthwood Audio	Aylesbury	01296 28790	Bartletts	London N7	0171 607 2296
Audio Farnham	Basingstoke	01370 435952	Hi-Fi Experience	London W1	0171 580 3535
The Audio File	Bishops Stortford	01279 506576	K J Leisuresound	London W1	0171 486 8262
Dawsons	Bournemouth	01202 764965	Kamia	London W1	0171 323 2747
8 G Audio	Bury St. Edmunds	01284 755227	Hobbs	Luton	01582 20907
The Audio File	Cambridge	01223 68305	Dooleys	Macclesfield	01625 423 158
Audio Excellence	Cardiff	01222 228565	The Hi-Fi Room	Manchester	0161 832 0888
Peter Tyson	Carlisle	01228 25891	V J	Margate	01843 226977
Rayleigh Hi-Fi	Chelmsford	01268 779762	Technosound	Milton Keynes	01908 561551
L. C. Down	Crawley	01293 520150	Unilet	New Malden	0181 336 0012
Sevenoaks Hi-Fi	Croydon	0181 631 1109	Rapkin	Northampton	01604 37515
The Hi-Fi Studios	Doncaster	01302 781387	A & W Pounds	Ponders End	0181 804 3000
Music Matters	Eggbaston	0121 429 2811	Norman Audio	Preston	01772 253057
Audio Design	East Grinstead	01342 314569	Rayleigh Hi-Fi	Rayleigh	01268 779762
Musical Images	Edgware	0181 952 5535	Helen Koczur	Rochdale	01706 42107
Hispek	Finchley	0181 445 3267	Sounds Expensive	Rugby	01788 540772
V J	Folkestone	01303 256860	Sevenoaks Hi-Fi	Sevenoaks	01732 459555
Lintone Audio	Gateshead	0191 477 4167	Music Matters	Solihull	0121 742 0254
Hailey Audio	Hailey	01992 442425	Rayleigh Hi-Fi	Southend	01702 435255
Adams & Jarrett	Hastings	01424 437165	Darbys	St Albans	01727 51596
Musical Images	Hounslow	0181 569 5802	Burden Electronics	Swindon	01793 613733
Fanthorpes	Hull	01482 223096	Take Two	Uxbridge	01895 231488
Anglian Home	Ipswich	01473 288211	Bradys	Warrington	01925 820009
Entertainment			Sevenoaks Hi-Fi	Watford	01923 212736
Leicester Hi-Fi	Leicester	0116 539753	Sevenoaks Hi-Fi	Whittham	01376 501733
Nicholls Hi-Fi	Lewisham	0181 852 5780	Bartletts	Woking	01483 771175
Musical Images	London	0171 497 1346	Bowers & Wilkins	Worthing	01903 230558
	(Covent Garden)		Vickers	York	01924 629659

RINGMAT FOR RECORD LOVERS

First record support to be properly designed

"All theory aside, the RINGMAT really works."

Robert Deutsch (Stereophile, Vol. 17 No. 5, May 1994)

"Better than ever is what I have to report about the MkII... Buy a RINGMAT and turn your AR into a killer table. It almost seems too good to be true."

Sam Tellig (Stereophile, Vol. 18 No. 1, January 1995)

"Essentially, RINGMAT helps give LPs the kind of firmness and stability normally only available from master tapes... Given the excellence of the original RINGMAT, I was a bit sceptical about whether or not the MkII would provide a worthwhile improvement - it did!"

Jimmy Hughes (Hi-Fi Choice, February 1995)

"This product really does have to be heard to be believed. On most turntables the bass seems to instantly reach down an octave lower, with noticeably better control and extension too... What's more, none of these improvements are ones you'd have to listen hard for and, as yet, I've found no adverse effects."

Dominic Todd (Hi-Fi World, January 1995)

RINGMAT continues to provide music lovers around the world with significant improvements in LP sound quality. Have you tried RINGMAT yet? *But be warned; if you let your best friend borrow it, you will finish up buying another!*

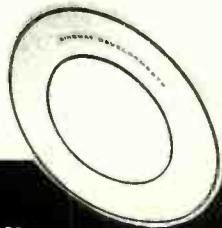

PRICES For all turntables with tonearm height adjustment and for those without height adjustment but using a moderately thick mat:

RINGMAT 330 MkII £40.00

For other turntables without tonearm height adjustment:

RINGMAT 200 (raising the record by about 1.8mm) **£27.50**

RINGMAT 250 (raising the record by about 2.4mm) **£30.00**

RINGMATS can be obtained through good hi-fi retailers.

There is an exchange and upgrade scheme for original RINGMATS. For more information on the above or on the product generally, or for mail order (including VISA/Mastercard), Contact:

RINGMAT DEVELOPMENTS

PO BOX 200 BRENTWOOD ESSEX CM15 8QG UK

Tel: 01277 200 210 Fax: 01277 201 225

(Mail order p&p: additional £2.50 UK; £5.50 outside UK)



REL Storm



HOME ENTERTAINMENT
awards

WINNER REL Storm - Best Subwoofer

REL ELITE DEALERS

For further information contact Harman Audio 0181 207 5050



CABLEOLOGY

Dominic Baker takes a close look at van den Hul's carbon hybrid and Kin Company's silver alloy construction cables, both of which steer away from convention.

Both van den Hul and Kin Company have looked past the familiar copper, silver plated copper or pure silver world of conductors in the quest for a more neutral and transparent sound. Both have been researching their respective technologies for many years now, and Kin Company's Silver Alloy and vdH's Carbon Hybrid cables tested here are the latest to hit the streets.

Van den Hul's Magnum HB loudspeaker cable and Thunderline HB interconnect both use a hybrid construction of silver plated copper and their Linear Structured Carbon conductor (first seen in their First interconnect a few years back). This is an interesting approach, where three different materials, silver, copper and carbon are used together in a fine balance to get the best of all worlds.

Kin Company's Silver Alloy is a closely guarded secret, designed and assembled in the UK, but produced in the States. Both their Silver Signal 200 interconnect and Silver Loudspeaker 240 cables are of a coaxial construction. The multi stranded silver alloy conductors are Teflon coated. Teflon is used because of its low dielectric constant, important for low capacitance. Because the cable is a silver alloy and doesn't corrode like copper, screw and crimp-on connectors are used which

make a direct link between the cable and plug, without the need for solder which could degrade the signal.

After living with each of these cables over a period of time, I must say that both write a very good case for themselves. The van den Hul Thunderline interconnect and Magnum HB loudspeaker cable bring a smoothness to any system they are inserted into.

I used the vdH cables in a very revealing and transparent Ensemble system, high-end equipment made in Switzerland and now imported by PM Components. The Ensemble Elysia loudspeakers I used have a three position treble level control which gently, very gently, either lifts or cuts treble either side of flat. With the van den Hul hybrid cables, the sound was so smooth and rich that I found a little lift preferable, adding useful sparkle and insight.

Through the midrange a lot of this character remained, giving a full bodied tone to strings and vocals. They have quite a damped sound, which makes them a good match in CD based systems and where metal dome tweeters are found, preventing any sibilance or harmonic ringing from being exaggerated.

A van den Hul hallmark it seems, bass was big and beefy, with real force behind notes. It could become a little too full at

times though, the sharpest crack of leading edges softened just a little. But the vdH cables will suit cold and dry systems well, adding useful body and depth.

Kin Company's Silver Loudspeaker 240 is a bi-wire cable, supplied with one pair of 4mm plugs at the amplifier and two pairs at the loudspeaker end. So the Elysia loudspeakers were bi-wired, which affords a slight improvement.

Where with the vdH cables a little treble lift had been preferred from the Elysia loudspeakers, the Kin company cables were better balanced with the 'speakers set flat. There seemed to be so much detail and upper treble resolution, the slight lift made the balance too bright, although surprisingly clear and smooth.

Where the character differs most from the vdH carbon hybrid though, is a dryer, more neutral tonal balance through the midrange and treble. The air and space around violins for example was better captured, allowed to expand, whereas the vdH cables tended to give a closer acoustic. And the thwack of bass guitar strings was faster, biting more clearly into the mix.

Both Kin Company and van den Hul have shown that there is room for new technology with these novel cables. They offer a different balance to more conventional cables; in the case of vdH's Carbon Hybrid a richer, more textured sound, and Kin Company's silver alloy is one of the most neutral and uncoloured cables I've come across. They are expensive, but the influence they have on the sound of a system is nearly as strong as the components themselves ●

Precious Metals by Kin Company

Silver Signal 200	£170/m
Silver Loudspeaker 240 terminated	£660/3m

Picture The Sound, 13 Weston Road, Guildford, Surrey. GU2 6AU
☎ 01483 454991

Van den Hul Carbon Hybrid Thunderline HB	£109.99/0.8m
Magnum HB	£204.95/2.5m terminated

van den Hul, Unit 12, I-Mex House, 6 Wadsworth Rd, Perivale, Middx.
UB3 7JS ☎ 0181 810 9388

CHRISTMAS COMPETITION

WIN EVERYTHING

REVIEWED IN THIS ISSUE!



Rub your eyes. Are they clear now? Yes, it's that time of the year when we go mad and give away everything we review in our bumper January Christmas issue. You won't find another competition like it, and for all you audiophiles out there it's a dream come true. There are eighteen superb prizes on offer, and you can have

the chance to win one for the cost of a postage stamp.

Please state your order of preference with the prizes. We will be grading the winners on the quality of the tie-breaker and allocating the highest selected prize available. So, winner No.1 gets their first choice. Winner No.2 gets their first choice too, unless winner

No.1 has already selected it, in which case they'll get their 2nd choice. Winner No.3 will get their first choice too, unless No.1 or No.2 have already selected it. And so on.

Arcam Alpha 6 CD player
 Arcam Alpha 6+ amplifier
 Castle Isis loudspeakers

Take a look at what's happening in hi-fi retailing at the moment and it's plain to see there is a shift of emphasis towards hi-fi separates. Larger retailers, like Currys and Comet, are paying far more attention to separates than before, possibly spurred on by the conspicuous success of Julian Richer and his Richer stores. Catalogue shops are creeping into the separates domain too. Argos buyers are being shown that there is life after Goodmans and Alba, and Maplin have started stocking hi-fi separates.

There is concern amongst specialist retailers - as you'd expect - about the 'big boys' getting in on the act, and from manufacturers too, though for a different reason. Attaining a useful working knowledge of hi-fi separates is quite a task, but to be knowledgeable about all electrical goods, as the bigger operations need to be, is a tall order. Many stores may have separates departments, but there is always the worry that products won't get the expert attention they deserve when being set up and then demonstrated. With catalogue shops this goes one stage further, the consumers buying completely 'blind', relying totally on reviews or specifications.

Still, the point is hi-fi separates are becoming a more common sight in the high street. Big department stores also seem to be stepping things up a notch or two. Many big name stores are refitting hi-fi departments and putting greater emphasis on quality separates.

Such stores don't just invest money like this on a whim. There are many possible reasons why department stores, chains

and catalogue shops are paying more attention to hi-fi. A bruising battle has been fought on the high street between Japanese majors like Aiwa, Sony, Pioneer, Hitachi, Panasonic et al, in the midi-system market. Margins were cut to the bone and casualties resulted, the most notable being Rumbelows. It's been said many times that this madness benefits no one, except the consumer. But if victory means the whole world now possesses a cheap midi-

“One thing's for sure, the next eighteen months or so look like being the most important for hi-fi retailing since the advent of CD.”

system, it may be pyrrhic.

Whilst there's little profit to be had from a midi-system, that's not the case with hi-fi separates. There's little doubt that the higher margins available from separates are now making severe commercial sense to the larger retail groups, and big stores that may have been uninterested perhaps now want another go.

Greater public

*- from Dominic
Todd, our man in
retailing*



awareness comes also from the increasingly numerous hi-fi shows, as well as national advertising from hi-fi companies like Linn, and I feel the Real Hi-fi campaign has played its part too. It may not have been as successful as hoped, yet it focused individuals in the industry, whether they agree with the scheme or not, on promoting hi-fi separates as they deserve.

The Real Hi-Fi campaign sought to underline the superior sound quality and flexibility of hi-fi separates. It used an advertising campaign, leaflets and smart black on gold (or silver for A/V) stickers for manufacturers to display on their equipment. The idea was that where shops sold both separates and systems, the public would be able to distinguish between the 'real hi-fi' and the rest via the symbol.

At the time the campaign was launched it was hoped that it would make hi-fi separates more available to the public through the larger electrical retailers (as they had been in the past).

Eighteen months on, drawbacks are evident. For a start, not all manufacturers and retailers joined up with the scheme due to a shortage of resources, disapproval, or because they wanted to sit on the fence.

This got the campaign off to a poor start by causing customer confusion. How come a £100 budget amplifier could carry a Real Hi-Fi sticker, but a £1000 valve amplifier did not? Specialist dealers tended to find the campaign of less use because they only sold 'real hi-fi' separates anyway. Leaflets tended to hang around in the corner of shops and not all products were properly labelled.

Now the scheme is to be relaunched and this Christmas sees a new campaign to further raise consumer awareness. You may have already seen the cartoons graphically depicting what you're missing out on if you don't purchase separates. We'll know whether they'll further the cause or not after the Christmas boom.

One thing's for sure, the next eighteen months or so look like being the most important for hi-fi retailing since the advent of CD. We may see hi-fi separates really catch on again in the high street.

Or will a lack of understanding see the big retailers getting their fingers burnt and, once again, pulling out of the market.

Whatever the outcome, it's going to be a turbulent time in hi-fi retailing and there are bound to be some bargains about for the astute customer. Happy shopping!

Loricraft Audio

Specialists in Garrard, Thorens and SME.

PSU II Power Supply

Now in its second year of production PSU II mkII is a power supply that mimics a perfect mains supply, allowing Garrard 301/401 TD124 to be used anywhere in the world, and was developed as a result of our more technically minded customers requiring a more advanced PSU over our successful active PSU I. Whilst PSU I cleans and reshapes the incoming wave from PSU II generates a low distortion wave from which is both voltage and frequency stable. PSU II can also be used with CD players pre amps and tuners.

PSU I £149.00 PSU II £400.00

Supply and service of Garrard, Thorens, and other high quality turntables using genuine and newly manufactured part to original specifications.

Also manufacturers of the world finest Plinth for Garrard 301/401 Thorens TD124 now with 5mm covers and finest hinges if required.

Loricraft PRC 1 Record Cleaning machine as used by the professionals. Please send for details.

Loricraft Garrard 401s with SME arms and record cleaning machines are in use with recording studios and record dealers.

T.M. O'Sullivan

4 Big Lane, Goose Green Lambourn,
Berks RG16 7XQ

• New 1995 catalogue available •

Fax /
Ansaphone: **01488 72267**

Suppliers of Art Audio Amplifiers, Goldring, Ortofon, & SME

SELECT AUDIO

LONDON

for

RESTEK

MIRAGE VPI

ORTOFON CARTRIDGES

MARK LEVINSON

JEFF ROWLAND

PROCEED

SUMIKO TRANSFIGURATION

MAGNEPAN

LYRA AUDION AUDIO MECCA

TRIANGLE OMAK

"Plus more"

3 Single Speaker listening rooms
by Appointment only

0181 986 8788

10-7pm

closed Wednesday & Sunday

.....

o v e r t u r e

For a great performance

◆ Linn Products ◆ Arcam ◆ Naim Audio ◆

◆ Meridian ◆ Quad ◆

◆ Nakamichi ◆ Denon ◆

◆ Heybrook ◆ Mission ◆

◆ Yamaha ◆ NAD ◆

◆ Record cleaning service ◆

◆ Repairs ◆ Cables ◆

◆ Open 6 days ◆ 10.00 to 18.00 ◆ BADA ◆



Overture HiFi Specialists

3 Church Lane

BANBURY

OXON

(01295) 272158

Vintage Audio Valves/Tubes

ECC81	(New Boxed MULLARD)	£2.50
ECC82	(New Boxed MULLARD)	£2.50
ECC83	(New Boxed MULLARD)	£3.25
E188CC	(New Boxed MULLARD)	£3.85
12BH7	(Limited Stock)	£2.85
6J5GT	(USA)	£2.85
6080WA	(New Boxed MULLARD)	£6.50
6L6A	(USA)	£11.10
VT4C	(USA)	£28.00
VT104T	(300B Substitute Octal Base)	£32.00
6B254A	(807 EQUIV)	£4.50
TT21	(GEC KT 88 With Top Cap)	£32.00
828	(USA VERY RARE)	£125.00
T1427	(Forget the 300B this is the ULTIMATE)	£200.00
5U4G		£3.60
5R4GY		£5.75

NOTE All Tubes come with full data sheet and are only sold in Matched Pairs or Quads Minimum order value £20.00 plus VAT carriage at cost

We are always looking to buy the following TUBES
13E1 (New or Ex Equipment), 813, 805, 7241, 6C33, 6336, TBY 350, 613, 6146, PT15, DA100

CALL - or - FAX
US ON
TEL & FAX
(01239) 891448

Vintage Audio
BRYNHLYGEN
EGLWYSRWR, CRYMYCH,
DYFED, WALES. SA41 3SS



TWEAKY CORNER (SLIGHT RETURN)

David Price finds not all equipment supports are created equal with Audiophile furniture's BASE system.

The BASE system comprises an Isolation Platform which sits atop a Starter Pack, onto which extra layers of shelves, each with their own isolation platform, can be added. The isolation platform is the business end, featuring two metal beams running parallel underneath, with Sorbothane feet enabling the platform to be 'tuned', effectively de-coupling it from the room, and reducing resonances likely to degrade sound quality.

Trying the £65 01 Isolation Platform under my CD player, standing on a standard welded steel frame table, the sound took a definite turn for the

better. Low frequencies saw the greatest change, bass lines becoming more supple and better separated from the rest of the mix. Midband was a touch clearer, and improved imaging - especially front to back - lent the acoustic greater depth. The improvement wasn't dramatic, but consistently smoothed and eased the sound, improving low level detail and depth.

I then tried the same platform on top of the £70 SP01 Starter Pack, onto which my Michell Gyrodec was placed, effectively making it a £130 turntable table. The height-adjustable cones made

turntable levelling a breeze, essential for Gyros which are super-sensitive to height and suspension balancing. Changing from a cheaper Target support to the £30 BASE system brought a far more musical sound, with bass lines ebbing and flowing like never before. The soundstage solidified and instruments gained more autonomy, separating out better. Leading edges were faster and notes decayed better. Cymbals struck at the beginning of a bar could be heard falling off gently and crisply, instead of just disappearing into the mix.

Finally, I built up the system to make a four tier (BASE recommend up to 8) rack system, using S120 Shelf Units (120mm height between shelves; 170mm and 270mm shelves are also available). At £430 for a four tier rack with isolation platforms, it's getting expensive, but if you've got the funds it's worthwhile. Duly installed, with cables routed through special holes at the back, the system looked handsome and performed accordingly.

If it's value-for-money upgrades you're looking for, the BASE in its first two guises is an essential audition. They work well across the board, and if you've enough money for an entire rack system, I suspect you won't be disappointed either.

BASE 01 Isolation Shelf	£65
SP01 Platform	£70
S120 Shelf Unit	£50

Audiophile Furniture Ltd.,
The Square,
Forest Row,
East Sussex. RH18 5ES
☎ 01342 826262

WORLD VERDICT

Great build and finish, and it sounds great too

The truth was disgraceful, but we all have features of our pasts that are better forgotten. My initiation into the world of hi-fi was brought about by a pair of Mission 731LE speakers, Linn's Mimik CD player and Magik-I amplifier. Now I'm embarrassed to reveal what I was playing music on before. It would bring me disgrace. What I can proudly claim is that my enthusiasm for music has always been large, even if it was perhaps disproportionately larger than my knowledge of what to play it on.

To be fair to myself, I am sorely limited in terms of space in my matchbox of a bedroom and anything too large would be unrealistic in terms of storage and also the power of the bass potentially given. Dominic assured me that this equipment would suit me perfectly because it was simple to use and small. I wasn't quite sure what he was implying, but I am truly chuffed with my new toys.

The Linn CD player and amplifier are compact and very smart. The speakers can only be described as dinky, and although they are designed for small living spaces, they are quite capable of terrorising the neighbours. The sound they give out, while not room-shaking, is powerful enough, and most importantly, coherent and cohesive. Not knowing my tweeter from my tweak, I was rather anxious about reviewing quality equipment, but the truth is that with good stuff you don't need to be discerning, simply because your ears are opened for you.

The first thing that struck me when I left the room while music was playing was that I could detect its quality throughout the flat. This is not an achievement in itself considering how small the flat is, but I

The fairer view

mean that all the detail of a song carried effortlessly through walls and down passages so that I could listen to it at a distance if need be. In the bad old days only an unintelligible noise could be distinguished if you weren't sitting on the system.

In songs such as the Beatles' 'Come Together' from the Abbey Road album, where Paul's bass line propels the song, I found that it was tuneful and tight, rather than powerful, and that was fine by me. The drum solos were very contained and rounded, although perhaps lacking resonance.

With music of a faster tempo that required harder treatment, the Levellers' 'Hope Street' for instance, the bass was not as prominent as it may be in hefty equipment, but this was compensated for by really good pace that propelled the song nicely, creating the appropriate sense of eruptive life.

With more acoustic music such as Don McClean (I wish I had been cool enough to think about putting some Bob Dylan on) these speakers really came into their own. The detail of the piano at the beginning of 'American Pie' was truly life-like, and the sound was bright in a listenable, clear way. The vocals were sweet and assumed just the

right prominence to convey his enigmatic lyrics.

On the subject of vocals I would like to recommend these speakers to those who listen to music in small dark rooms - preferably a sordid bedsit, but usually in your Mum's house - and really appreciate the poetry and emotional charge of lyrics.

Now, I never was a Smiths fan and am far too sensible to become one now, but I did just happen to put on 'There's a Light That Never Goes Out' from The Queen is Dead album and couldn't help registering that if you were into adolescent angst and if you did like Morrissey's lyrics, then these speakers did a wonderful job at portraying the desperation and latent savagery in his singing.

The more conventional melodic vocals of Ella Fitzgerald were startlingly natural, revealing even more in her voice than I had ever heard before. However, on more jazz oriented numbers, I felt perhaps that trumpets and brass generally were a little too bright and ran the risk of becoming thin and tinny. It was the same with cymbals and tambourines on other CDs. Romantics will be glad to know that ballads are definitely the forté of this system, and guitar based music is fine,

...of

Laura

Martin



but perhaps jazz enthusiasts would like something a little less warm to get the most enjoyment out of music which is meant to cook in a harsher way than the Mission speakers allow.

The Mission 731LEs perform magnificently. In fact, if I didn't believe that they're unlikely to fit in with my inevitable and impending move into a penthouse in Belgravia, I would rush straight out and buy a pair. The Linn electronics behind them has a dry, neutral and revealing presentation. I find the Majik-I injects a level of detail and clarity that helps bring music to life.

Having only been at 'World a couple of months now, I can't claim to be an expert about anything. The most valuable lesson so far has been that it's fine for me to have an opinion about equipment on the basis of how it sounds, even if I don't know how it works.

I had thought very little about hi-fi previously, except that I couldn't afford anything decent. Now I find it's a wonderful medium because it encourages the development of the senses in so many different ways. The ears are much more complex and revealing than I'd realised. I had no idea of the world they can introduce you to. Now, I'm not being disgraceful any more.

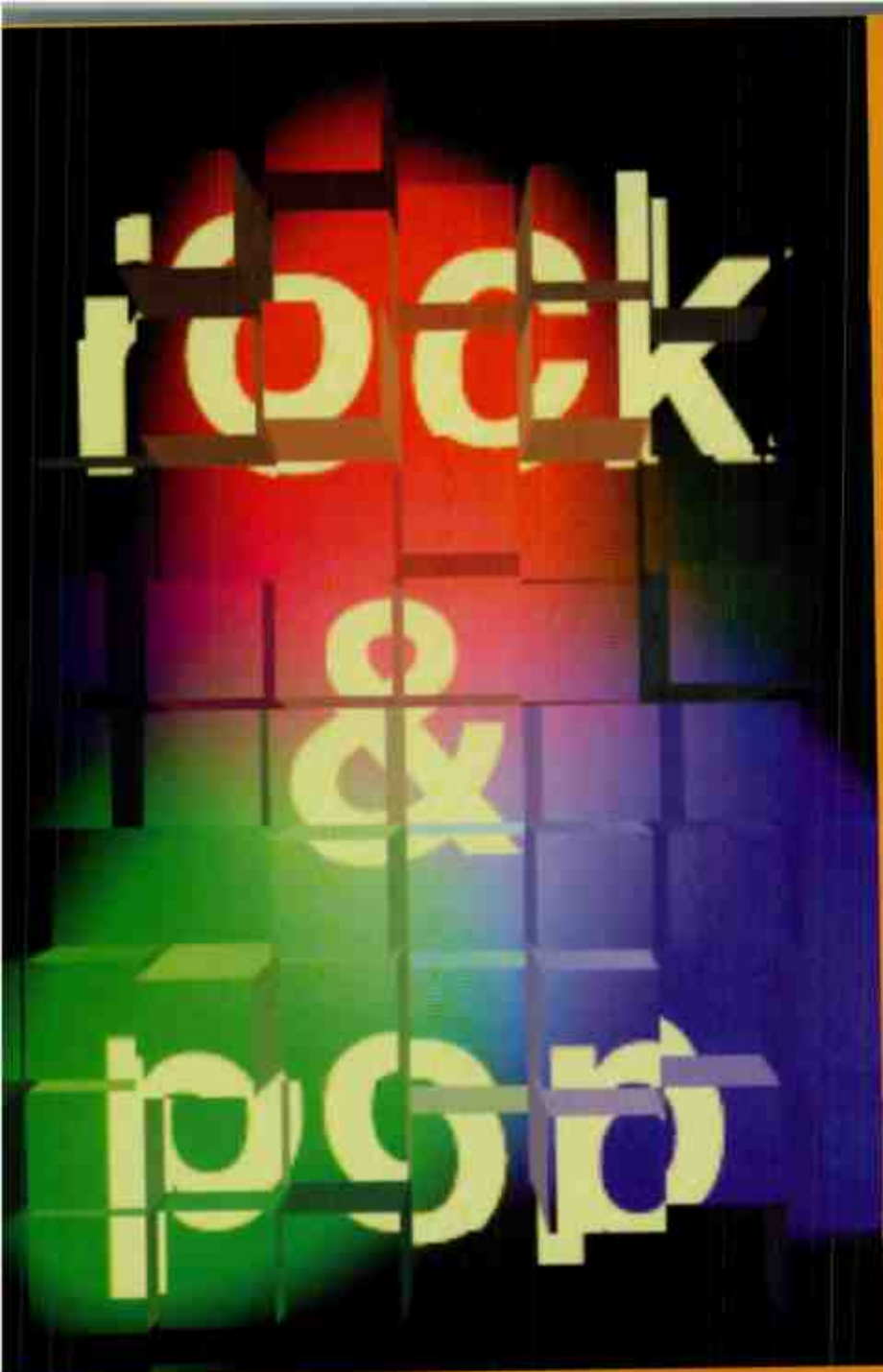

Echobelly and so on. But so what? They do it with gusto and class - two hit singles under their belts already in 'Finetime' and 'Alright', and doubtless many more to come.

Put together last year by John Power (late of the LA's, one of the great lost bands of the era) early last year and including Liam Tyson (guitar, backing vox) Peter Wilkinson (bass) and drummer Keith O'Neill. This is a tough, abrasive sound that has a lot in common with early Who or Jam, particularly in the guitar department. There's also the odd delicate ballad - for instance, 'Walkaway' - sparsely instrumented and laden with dulcet harmonies.

More typical are items like the pounding 'Sandstorm' or the chunksome near-funk of 'History' with its gloriously slippery eel of a guitar sound. This is indeed classic contemporary British pop of the new breed. Ironically the band are said to even have an Oasis/Blur-style mini-war going with Menswear, chuckle chuckle.

These four lads will, as they say, go a long way. And I don't mean Newcastle either. Brilliant John Leckie production - but then his always are. Excellent.



**THE SMASHING PUMPKINS
Mellon Collie And The Infinite Sadness**

HUT DCD 30

● A double, containing a vast 28 songs and clocking in at over two hours, this is certainly the longest rock album of the past couple of decades. It's an impressive body of work, packed with beautifully crafted songs of all shades and colours, the entire thing superbly played by Corgan (vox, guitar) along with fellow veggies James Iha (guitar also), D'Arcy Wretzky on bass and the superb percussion/drum work of Jimmy Chamberlin.

As with another relatively recent double album - The Red Hot Chili Peppers' Blood, Sugar, Sex, Magik - this

Giovanni Dadomo

INDEX

RECORD REVIEWS

ROCK & POP73

Giovanni Dadomo
Jon Clarke
David Price

JAZZ86

Simon Hopkins
Simon Cooke

CLASSICAL93

Peter Herring



CAST
All Change
POLYDOR 529312-2

● Well, yes, you're absolutely right, Cast are yet another of those cheery Britpop bands, like Blur, Oasis,

STOP PRESS!



PRICE BUSTERS!!

E. & O. E.
Not valid with any other offers or interest free credit.



- | | |
|-----------------------------|--------------------|
| Main Authorised Dealer For: | Mitsubishi |
| Acoustic Energy | Monarchy |
| Aiwa | Monitor Audio |
| Akai | Monster Cable |
| AKG | Mordaunt-Short |
| Alphason | Musical Fidelity |
| Arcam | NAD |
| ATC | Nakamichi |
| Audio Alchemy | Ortofon |
| Audio Innovations | Panasonic |
| Audioquest | Philips |
| Audio Technica | Pink Triangle |
| Aura | Pioneer |
| AVI | Polk |
| B & W | PROAC |
| Beyer Dynamic | Project Turntables |
| Bose | QED |
| Boston | Quad |
| Cabletalk | REL |
| Canon | Restek |
| Castle | Rogers |
| Celestion | Roksan |
| Cerwin Vega | Rotel |
| Chord | Royd |
| Creek | Ruark |
| Cyrus | SD Acoustics |
| Denon | Sennheiser |
| DPA | Sharp |
| Dual | Shure |
| EPOS | SME |
| Exposure | Sony |
| GLL | Soundstyle |
| Goldring | Stands Unique |
| Harman Kardon | STAX |
| Heybrook | Systemdek |
| Infinity | Tannoy Prestige |
| Ixos | Target |
| Jamo | TDK |
| JBL | TDL |
| JPW | TEAC |
| JVC | Technics |
| KEF | Thorens |
| Kenwood | Toshiba |
| LaserDiscs | Trichord |
| Lexicon | Van den Hul |
| Marantz | Wadia |
| Maxell | Wharfedale |
| Meridian | XLO |
| Michell | Yamaha |
| Mission | and many more |

We always try to ensure that our prices are competitive. If you find a better price quoted by an Authorised Dealer (and in stock!), let us know and we will gladly match it.

We are committed to our customers.

With three locations, Musical Images offers you an unparalleled choice, outstanding product knowledge and the promise to you of a service that is second to none.

Simply the best!



**45 High Street, Hounslow
Middlesex. TW3 1RH
Tel: 0181 569 5802
Fax: 0181 569 6353**



**173 Station Road, Edgware
Middlesex. HA8 7JX
Tel: 0181 952 5535
Fax: 0181 951 5864**



**18 Monmouth Street, Covent
Gdn, London. WC2H 9HB
Tel: 0171 497 1346
Fax: 0171 497 9205**

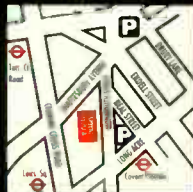

MUSICAL IMAGES

**THE POWER
HOUSE OF CHOICE**
**Hi-Fi and Home Cinema
Specialists**

RECORD OF THE MONTH

PULP
Different Class
CID 8041/524165-2

● Pulp are pop. And with Jarvis Cocker at the helm, pop of a quite exceptional quality.

Mr Cocker has, this year, become a Class A, top rank, high-earning pop professional. In fact he IS this year's pop star.

Different Class, a follow up to last year's excellent His 'N' Hers, is an album of immeasurable quality. While His 'N' Hers was nominated for the Mercury best album of the year prize, this might well win it.

Unsurprisingly the two best tracks on Different Class are the two singles, 'Common People' and 'Sorted for Es and Wizz'. The remainder is a series of seedy songs dredged from the depths of Jarvis's sick mind. Slightly addled, cynical and ironic, the words are always clever and the music sparkling.

The album opens with 'Mis-Shapes', B side to 'Sorted for Es and

Wizz', and the next track 'Pencil Skirt' is probably the worst on the record. The third track, 'Common People', is a

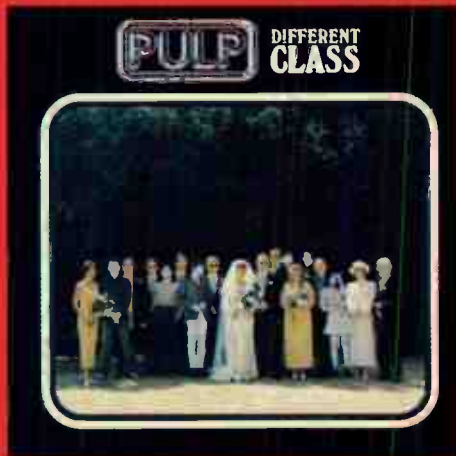

real landmark. A real singalong classic, with funny, yet savage lyrics.

It tells us a lot about Jarvis and his background. Scummy working class boy from the North comes to London to study film at trendy St Martins College. Meets posh rich gal who loves

his awkwardness and common airs.

This class conscious theme continues in the sinister 'I Spy', a track which Cocker wrote at a low ebb some years ago, while smouldering on the Sheffield dole. It tells of Cocker's then fantasy to sleep with a rich man's wife in order to cause both him and her maximum pain.

In contrast the groovy singalong 'Disco 2000' is about an old flame Deborah, who goes off and gets married. 'Live Bed Show' is at once a perverse and brilliantly moving lament for a lost lover.

"This bed has seen it all and the good times only cost £10 from the shop just down the road."

'Something Changed' is another tearjerker, before the cheerful and best song of the year, Sorted For Es and Wizz: "Is this the way the future is meant to feel, 20,000 people standing in the field?"

Suede with balls, Blur without laddishness, Bowie with a sense of humour. Different Class is, well, exactly that!

is a transitory step for another former grunge band. In fact by far the greater bulk of the material here consists of finely-wrought ballads with just the odd blast of thunder to leaven the mixture a little. Perhaps the most surprising of these is 'Cupid De Locke', whose lyrics are almost Byronic a la Stones' 'Lady Jane'.

Of course - and perversely so - it's a few cuts away from the delicately titled 'F*** You (An Ode to No-one)'. This is one of the thunderous, angry ones of course, carrying hints of Iggy & The Stooges' proto punk. Similar explosions occur sporadically - the pumping 'Love', the booming 'Bodies' (which does admittedly overdo it a bit) or 'Tales Of A Scorched Earth' which may just blow your system to smithereens. But it's the slow songs that grab you hardest - the likes of the gentle 'Galapagos' or the luscious 'Thirty Three'. Of course 28 songs ain't no picnic, and there is the inevitable odd clanger (the droning blandness of 'To Forgive') but overall this is one majestic and admirable achievement. Corgan's vocal range is as awesome as the breadth of his song-writing. And if, as already stated, it's no picnic, it's certainly a banquet.

Personally, listening to the entire opus all the way through is something I can't

see myself doing too often but then that's what Program buttons were made for. And finally, top marks for the aptly clean and luminous production c/o the band and Messrs Flood and Alan Morgan. A diamond.

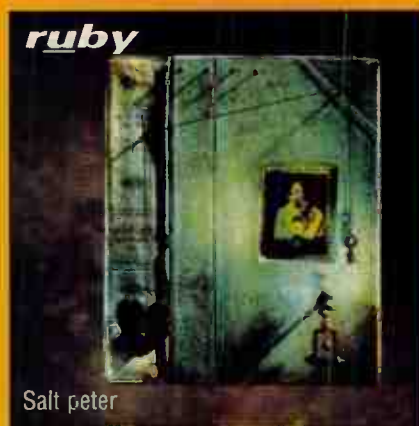

RUBY
Salt peter

● Spicier than a Ruby Murray and more twisted than Jack Ruby, Lesley Rankine's Ruby is a damn sight better than previous band Silverfish.

Salt peter is America's version of the 'Bristol sound' and breathes its own

particular brand of weirdness while still - like Tricky or Portishead - cleverly sitting on the commercial fence.

Often like a film score, Rankine's first solo LP moves in strange and atmospheric ways. Being almost completely put together in a Seattle studio by herself, substituting band members with computers, it paints the picture of a rather lonely and eccentric woman. But after years of sweaty clubs, stage-diving and backbreaking tours, that is probably quite understandable.

Salt Peter is a remarkable record considering the only help she got was from producer Mark Walk. While comprising a fine range of hardcore beats it also picks on some interesting melodies - particularly with the fine 'Paraffin'.

Lyrically the album's sentiments appear destructive and cynical, often hinting at a hatred of men, but the fusing of hardcore with catchy rhythms is creative and appealing.

Rock + Pop.

Miraga

AUDIO ILLUSION
 22 Longley Avenue
 Langley, Bristow, G3 8NF
 TEL: 01753 541761 FAX: 01753 772512
 OPENING 10:30am
 Mon - Sat, Sun - Sat (By Appointment)

Miraga and Exceptional Audio Designers

At Last an experience

HIGH END AUDIO & HOME THEATRE

Investment of the Lifetime For The Music

and Sound and Vision Seeker

Please call for further information

Exceptional Audio Designers

HAZLEBEE AUDIO
 High Wycombe
 0494 41962

AUDIO GALLERY
 Epsom
 01753 60114

KAMEL
 211 Longway Road
 Liphook W1
 01253 2307

SELECT AUDIO
 248 Longway Avenue, Epsom
 01753 60114

M.A.F. AUDIO
 South of Tees
 01227 138000

MIDLAND HiFi STUDIO
 Birmingham
 0121 30009

For those of you that think
 that modern life has been
 immeasurably improved by
 the advent of nuclear power,
 soap operas and the ending
 of all wars, you should replace
 all your records with CD's.

ortofon
 MC 3000
 Mk II

ortofon

01753-889949

Specialist Hi-Fi Dealers

LONDON & SOUTH EAST

hi-fi in the CITY

Auditorium

ARCAM CYRUS
BANG & OLUFSEN
DENON EPOS KEF
DYNAVECTOR
REL MICROMEGA
NAIM MISSION
NEAT WTT XLO
SHAHINIAN
SYSTEM AUDIO

119 Middlesex Street, Bishopsgate, London E1 7JF
Telephone 0171 247 5000
Facsimile 0717 247 0990
TWO MINS WALK FROM LIVERPOOL STREET STATION

**"One of the 5
best hi-fi shops
in the world"**

GRAHAM'S HI FI

Canonbury Yard, 190a New North Road
London N1 7BS, ☎ 071-226 5500
Ring for a chat, an appointment and a map!

BADA



*Best place in town
for Hi-Fi and
Home Cinema*

- ★ Six superb demonstration rooms
- ★ Interest Free Credit
- ★ all Leading Brands
- ★ OPEN SUNDAYS

UNILET SOUND & VISION

35 High Street, New Malden, Surrey KT3 4BN
Tel 0181 942 9567 Fax: 0181 336 0820

HI-FI & COMPONENTS LTD

Established Over 30 Years

- ◆ All Leading Makes Of Equipment
- ◆ Hi-Fi & Video Repairs & Servicing
- ◆ Stockists Of All Accessories & Those Hard To Find Ones
- ◆ Large Range Of Chassis Spkrs
- ◆ AUTHORISED DEALERS

Open Mon - Sat
10-6pm.

Switch and major
credit cards
accepted.

FOR... NAO, DENON, MO, TANNY, KENWOOD
(To Name But A Few)

0171 223 1110
84 Battersea Rise, London SW11

LONDON & SOUTH EAST

The Hi-Fi Shop
GUILDFORD'S SPECIALIST SINCE 1950

We are at:
3 BRIDGE STREET, GUILDFORD
(By the traffic lights - next door to Alfred Works)
0483 504801 • 0483 304756
Access • Visa • Switch
Open Monday - Saturday 9am-6pm (later by appointment)

Spaldings

ESTABLISHED IN SOUND

☎ 081-654 1231/2040
352/4 LOWER ADDISCOMBE RD.,
CROYDON, SURREY

MIDLANDS

STEVE
HANNAH
AUDIO
— of —
WALSALL

neat
j m lab
slate audio
stemfoort
sugden

01922 640300

WELL ENGINEERED PRODUCTS FOR
ACCURATE SOUND REPRODUCTION FROM:

Arcam, ATC, Audioquest, Audio Technica, AVI, Beyer, Cable Talk, Castle, Chord, CRD (Valve), Denon, Dual, Klipsch, Michell, Nakamichi, Ortofon, QED, Quad, Revox, Sennheiser, Sequence Design, S.M.E., Spendor, Target, TDK, TDL, Thorens, Triology (valve) etc., Keith Monks Record Cleaning Machine.

FIVE WAYS HI-FIDELITY LTD (Est. 1972)
12 Islington Row Edgbaston, Birmingham B15 1LD
0121-455 0667 (closed Mondays)

MIDLANDS

MUSIC
MATTERS



**AUTUMN
EX-DEN AND
SECOND-
HAND
CLEARANCE
SALE**

SECONDHAND

MERIDIAN 208 £650; MERIDIAN 207
£450; ARCAM DELTA 70.3 CD
£395; ARCAM DELTA 170.3
£350; DENON DCD1560 £250;
MUSICAL FIDELITY 8200 £140;
KENWOOD DP3050 £95; SONY
TAF446E £140; MONITOR AUDIO
R352 £200; ROGERS LS7 £200;
MARANTZ PM45 £100; AA X06
RECEIVER £125; MATCHING AA CD-
04 £125; ROTEL RT950RX £120;
MUSICAL FIDELITY MKLPRE £350
ROTEL RT950RX TUNER-PRE £200;
ROTEL RB960RX £155; ARCAM
ALPHA PLUS CD £250; MUSICAL
FIDELITY PRE3AK/P140R PRE-
POWER £400; YAMAHA AX440 £99;
CELESTION SL65 £180;
WHARFEDALE S15 £140; B&W DM4
£50; CASTLE PEMBROKE CD STANDS
£300; QUAD 33/40S £135; QUAD 33
/303 £135; SONY TAF446E £140;
KENWOOD DP3050 £95; etc,
etc.....

EX-DEMONSTRATION

MUSICAL FIDELITY PRE3AK65 RRP
£1200, SALE £999; MUSICAL
FIDELITY THE PREAMP/TTPHOON
RRP £569 SALE £499; MUSICAL
FIDELITY T1MKII RRP £299, SALE
£249; MARANTZ PH700Y RRP
£449, SALE £349; ROTEL RCD965LE
DISCRETE RRP £425, SALE £375;
MARANTZ CD11 RRP £2800, SALE
£1150; AURA TUSO CHROME RRP
£349.95 SALE £299; AURA CDSO
RRP £399, SALE £349; ARCAM DELTA
70.3 RRP £799, SALE £549; KEVOX
EVOLUTION SYSTEM RRP £2800,
SALE £1600; KEWOOD KAV7700
RRP £599, SALE £499; KEWOOD
HD1000 RRP £999, SALE £869;
KENWOOD KES040S RRP £249, SALE
£199; SD ACOUSTICS SD1 WALNUT
RRP £1500, SALE £999; RUARK
TALISMAN II £699, SALE £580;
TECHNICS NST1777 RRP £299, SALE
£249; MISSION 7641 RRP \$499,
SALE £250, ... etc.....
Please call.....

OPENING TIMES

TUESDAY TO SATURDAY 10.30 TO 6PM. LATE NIGHT
FRIDAYS TILL 8PM. CLOSED MONDAY.

Branches at:

- Birmingham : 363 Hagley Road, Edgbaston, Tel: 0121 429 2811
 - Solihull : 93-95 Hobs Moat Road, Tel: 0121 742 0254
 - Stourbridge : 156/157 Lower High Street, Tel 01384 444184
- ~Demonstrations By Appointment~

Peter Ellis Audio

A wide range audio products always in stock including :
Denon, Marantz, Arcam, Sugden, Tannoy, Castle, Nakamichi,
Yamaha, TDL, Jamo, Musical Fidelity, JVC, Kenwood, Pioneer,
Dolby ProLogic & Cinema in stock

- Demonstration Room
- Free delivery & installation

29, KIRKGATE, NEWARK,
NOTTINGHAMSHIRE NG24 1AD
01636 704 571



the powerplant

BRIGHTON'S LEADING HI-FI SHOP

Cyrus, Roksan, Micromega, Audionote, Audiolab, Rega,
Arcam, Exposure, Aura, Epos, Thiel, Rjpark, Rotel,
Marantz and other fine equipment.

66 Upper North Street, Brighton
Telephone 0273 775978

FRANK HARVEY Hi-Fi EXCELLENCE

163 Spon Street, Coventry, CV1 3BB Tel : 0203 525200.

Mon to Sat 9.30 till 5.30. Closed Thursday

MUCH MORE
THAN HI-FI

WE ARE A
BADA DEALER

3 Floors, 3 Dem rooms, 3000 sq feet in the pursuit of Hi-Fi Excellence

Audiolab - Audio Alchemy - Arcam - Alphason - Bose - Bang & Olufsen - Celestion - Cyrus - Denon - Dugl - Foundation
Kef - Marantz - Monitor Audio - Mission - Musical Fidelity
Nakamichi - Nad - Quad - Rega - Rogers - Rotel - Target
Tripod - Tannoy - Thorens - Van Den Hul - Yamaha

MAILORDER - EXPORT - HOME TRIALS



**SOUTH
ACADEMY**

Audio Equipment from leading and specialist
brands for you to listen to and choose from.

Tel: 01922 493499/473499

- 3 Hi-Fi Studios
- Home Trials
- Home Cinema Theatre
- Audio Visual Equipment
- Inhouse Service Department
- Mail order available

• Interest Free Credit (On Selected Items,
APR0% - written details on request)

Hi-Fi for those with
an eye for Quality



WE ARE HERE
Sharing the ASDA Carpark
with ample free parking.
Off High Street, Blenheim,
New Walsall, West Midlands
Open 6 Days, 9am - 6pm
Late night Friday

ARCAM AUDIO LAB CHORD NAIM KESWICK AUDIO RESEARCH ALSO-APOLLO A.T. AUDIO ALCHEMY AUDIO QUEST B&W BOSE BEYER CABLE TALK CHORD COMPANY CYRUS
CELESTION DPA EPOS EXPOSURE KEF REFERENCE KENWOOD MARANTZ MICHELL MORDAUNT SHORT MERIDIAN MICROMEGA MISSION MOTU MUSICAL FIDELITY NAKAMICHI ORTOFON PROJECT
QUAD ROKSAN ROGERS ROTEL SENNHEISER SONY SUMIKO SYSTEMDEK TARGET TDL TUBE TECHNOLOGY VAN DEN HUL YAMAHA

Specialist Hi-Fi Dealers

MIDLANDS

CREATIVE AUDIO

9 DOGPOLE, SHREWSBURY,
SHROPSHIRE
Tel: (01743) 241924
Closed Mondays

- Comfortable listening rooms
- Home demonstrations available
- Part exchange welcome
- Free home installation
- Interest free credit

Authorised retailer for:

A&R ARCAM, AUDIOLAB,
CELESTION, CYRUS, DENON, DUAL,
MERIDIAN, MISSION, MONITOR AUDIO,
QUAD, REVOLVER, ROKSAN, ROTEL,
YAMAHA, EPOS, NAIM, KEF, NAD

NORTH WEST

audio excellence



CHESTER

86-90 Boughton,
Chester CH3 5AQ
(01244) 345576

CHESTER

TUESDAY - SATURDAY 9.00 - 5.30
CLOSED MONDAY

WEST & WALES

audio excellence



WHERE THE MUSIC MATTERS

Bristol

65 Park Street
Bristol BS1 5PB
(01179) 264975

Cardiff

134/6 Crwys Road
Cardiff CF2 4NR
(01222) 228565

Gloucester

58 Bristol Road
Gloucester GL1 5SD
(01452) 300046

Swansea

9 High Street
Swansea SA1 1LE
(01792) 474608

TUESDAY - SATURDAY 9.00 - 5.30
CLOSED MONDAY

WEST & WALES

V'AUDIO

Tel: 0117 9686005

36 Druid Hill
Stoke Bishop

ATC AVI Acoustic Energy, Aanalysis Alon,
Audiomeca Audio Technica, AMC Analogue
Electronics, Cadence Valve, Chord Amps,
Electrocompaniet, Exposure, Goldring, Harman
Kardon, Heybrook, Jamo, LFD, Lyra, Ortofon,
Perception, Pink Triangle, Ruark, Michell, REL,
Sansui, SME (inc. 20A), Sonic Link, Stax,
Sugden, Sumiko, Townshend, Triangle, Wadia.

Demos by appointment only. Home trial facilities.
Free installations. Servicing facilities.
We are not a shop

ENGLISH audio



CYRUS CENTRE

PINK TRIANGLE-AUDION-SYSTEMDEK-HEYBROOK-
MICHI-KEF-REFERENCE-MICROMEGA-NAKAMICHI-
CHORD-ARCAM-ROGERS-NAD-ROTEL-DENON-
TANNOY-MARANTZ-MISSION-STAX-DUAL-TDL-JPW-
EXPOSURE-YAMAHA-JOHN SHEARNE-AND OTHERS

Free installation. Credit facilities. Service department

Mon - Sat 9.30 - 5.30

37 Whitecross Road, Hereford. HR4 0DE

Technics

AUTHORISED HI-FI SPECIALIST

BUDD WISER HI-FI

Probably the best Hi Fi shop in the World!

104 ALBANY ROAD CARDIFF TEL 01222 493535

NORTH

HI-FI EXPERIENCE

Arcam • Audiolab • Audioquest • Bang & Olufsen • Chord • Cyrus
Denon • KEF • Marantz • Meridian • Mission • MF • NAD • Quad
REL • Rotel • Spondor • Tannoy • TDL • Yamaha • Sony

Award Winning Hi-Fi from stock - Sales or Service - WE CAN HELP

Tel: (01325) 481418

Fax: (01325) 382982

Britain's Top Specialist Hi-Fi Stores



17 Coniscliffe Road,
Darlington DL3 7EE.

Send or call for your FREE Magazine and Catalogue. BADA Bonded

HI-FI YOU
CAN'T
AFFORD
not to listen to

EQUIPMENT BY ABSOLUTE SOUND

AUDIO INNOVATIONS, SUGDEN, IMPULSE, MICHELL, ROKSAN,
PINK TRIANGLE, ACCUPHASE, THIEL, COUNTERPOINT, SONIC
FRONTIERS, TRICHORD RESEARCH ETC.
By appointment only

SERIOUS KIT

061-707 4823

SCOTLAND

ANCRUM

ELECTRONICS

YOUR LOCAL HI-FI SHOP

PIONEER, TECHNICS, PROLOGIC AMPS + LASER

DISC FOR HOME ENTERTAINMENT

TEL: (01382) 480030

39 GRAY ST., BROUGHTY FERRY DUNDEE

EIRE

• REL • Audiolab • Arcam • B&W •

A Passion for Excellence

CLONEY

Audio
for those who demand the best

55 Main St Blackrock

Tel: 2889449 • 288477

Open: Tue-Sat 10AM-6PM. Thu/Fri 'till 9PM

• EAR • Classé • Meridian • TDL •

• Naim • Castle • Epos • Technics •

• Audioquest • Pink Triangle • Rega •

OVERSEAS



Get on our list -
to get closer to this list.

• MIT MultiCap • Wonder Cap • Kimber Kap • Solo • Hovland MusiCap
Solen • Siemens • Wima • Holco • Rel-Cap • Dralonc • IRC • Allen-Bradley
Jensen • Resista • Vishay • Caddock • Mills • Matsushita • TKD • Noble
Cardas • Kimber Kable • van den Hul • Discovery • Audioquest • MIT
Alps • Bourns • Shalco • Elma • Electroswitch • Nichicon • Gold Aero • RAM
Mallory • Panasonic HFO • Nichicon • Elna • New Old Stock • Ruby Tubes
UltraAnalog • Burt-Brown • Crystal • Linear Technology • Analog Devices
Edison Price • International Rectifier • Hitachi • Motorola • UCC
MagneQuest • Sonic Frontiers • Pearl • Tube Sockets • WBT • Neutrik
Sound Coat • Curcio Audio Engineering • Assemblage and other kits
And it's growing and growing. To order The Parts Connection
1995 Catalog & Resource Guide, send £7 and mailing informa-
tion. You'll also receive a Discount Coupon worth \$10 off a pur-
chase over \$100 or \$25 off a purchase over \$250* as well as
The Breadboard bulletin to keep you updated on our latest
news, information and growth spurts.

*or \$10 US, or credit card information
*discount coupon values are in US Dollars

THE PARTS CONNECTION

A DIVISION OF BONO FRONTIERS INC

2790 Brighton Road, Oakville
Ontario, Canada L6H 5T4

Toll Free Order Line

1-800-769-0747

(U.S. & Canada only)

Tel (905) 829-5858

Fax (905) 829-5388

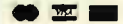

Retailers of Fine Audio Equipment

Congleton

- ▶ LINN
- ▶ ARCAM
- ▶ B&W
- ▶ DENON
- ▶ EPOS
- ▶ KEF
- ▶ MISSION
- ▶ NAKAMICHI
- ▶ PIONEER
- ▶ TARGET
- ▶ TRIPOD
- ▶ YAMAHA
- ▶ LOUSY COFFEE

▶ SUPERB DEMO
FACILITIES

▶ FULL INSTALLATION
& HOME DEMO
SERVICE

OPEN 6 DAYS A WEEK
OTHER TIMES BY
APPOINTMENT

01260
297544

1/4 Duke St Congleton Cheshire CW12 1AP

THE BEST ON TEST

DENON DCD315 CD PLAYER £149.99
ROTEL RA 930 AX mkII AMP. £149.95
TDL RTL2 SPEAKERS £299.99
QED QUDVS SPEAKERS CABLE MET. £2.00
CHORD/CO. COBRA INTERCONNECT £49.00

ALL WITH 5 STAR RATINGS AND ON DEMONSTRATION AT

THE AUDIO SHOP

6, HILL STREET, RAUNDS, NORTHANTS, NN9 6NN
TEL: 01933 622325

• SOUNDS AROUND •

NEW & USED HI-FI

Professional Service Repairs and
Accessories

146A Clarendon Park Road, Leicester
Telephone: 0533 702442

Specialist Hi-Fi Dealers

REPAIRS/DIY

GT AUDIO

Fully guaranteed top quality repairs, servicing & upgrading carried out to all types of audio equipment (including valve). Also agents for:- Unison Research, UKD Opera, Croft, Nottingham Analogue, and Posselt. Contact Graham Tricker for details on **01895 833099**

THE Service Specialists

From classic VALVES [we'll happily re-align your HRO] to the latest DIGITAL LASERDISC You supply the problem... We supply the solution! REVOX • LEAK • QUAD • RADFORD • ALTOBASS • GRANT • RCA • PIONEER • YAMAHA • LUMLEY etc. Our services are already widely used by Professionals and Enthusiasts: ring now for more details **VALVE AMPLIFIER KIT ASSEMBLY** HAVE your amp kit professionally built. We'll assemble it, wire it, de-bug it & provide you with an individual test report **PLEASE RING FOR DETAILS** **AUDIO LABORATORIES (LEEDS)** **0113 2440378**

Russ Andrews

Russ Andrews Ltd.
Edge Bank House, Skelsmergh, Kendal,
Westmorland, LA8 9AS, ENGLAND
Tel: 01539 823247 Fax: 01539 823317

If you like the Hi-Fi equipment you have but want a better performance, don't change it -

UPGRADE IT!

You can build better than you can buy and we offer kits, parts and instructions for anything from simple component upgrades to complete rebuilds, plus kits to build high end equipment from scratch.

New Upgrading Service.

If you are daunted at the prospect of taking the lid off your prized possession, send it to us and we can do the upgrade for you. We will advise on feasibility and cost before starting work and upgrade to the level of performance you require and can afford. We have a secure, low cost collection and delivery service within the UK.

Upgrades to: Audio Research, Celestion, KEF, Krell, Linn, Marantz, Meridian, Naim Nyltech, Pioneer, Quad, Leak, Radford, Rotel etc....

To receive your copy of our 1994/95 catalogue, just Mail, Phone or Fax the address above.

RESTORATION OF CLASSIC EQUIPMENT

ELECTRONICS ENGINEER (DEGREE/MAES) WITH OVER 40 YEARS EXPERIENCE AND SPECIALIST KNOWLEDGE OF QUAD, RADFORD, LEAK, ROGERS, AND ARMSTRONG, ETC. EXTENSIVE FACILITIES ENABLE ORIGINAL STANDARDS WITH DETAILED REPORTS OF WORK CARRIED OUT. APPARATUS IS DEMONSTRATED PRIOR TO CLIENTS DEPARTURE AVAILABLE 7 DAYS PER WEEK. VALVE TESTING A SPECIALITY.

CIRCUIT DATA AND AUDIO EQUIP. ON OFFER... PLEASE ENQUIRE

TEL 0181 504 5467 WOODFORD, ESSEX

Sowler Transformers
EA Sowers Ltd
PO Box 36
Ipswich IP1 2EL
0473 219390/252794

Output and mains transformers for GEC KT88 circuits. Can also make any other transformer to order. Send SA for lists and data.

REPAIRS/DIY

TECHNICAL & GENERAL

THE ORIGINAL TURNTABLE SPECIALIST for the Great Classical Turntable, Arms, Cartridges, Styli **CONNOISSEUR • GARRARD • GOLDRING • LENCO • ORTOFON • SHURE • S.M.E • THORENS • WATTS**

All available Genuine spares and our own re-manufacture of obsolete parts Servicing and Overhuls, to original technical specifications.

NO ILLUSORY 'IMPROVEMENT' NO DUBIOUS OR HARMFUL 'MODIFICATIONS' Remedial Services available

Cartridges and styli, correct radius diamonds, for early recordings - 78s & Lps

TECHNICAL & GENERAL

P.O.Box 53 Crowborough, East Sussex TN6 2BY
Tel: 0892 65 45 34

VALVES/TUBES

CVC Chelmer Valve Company for Audio Valves

Buy CVC PREMIUM Hi-Fi valves direct from us. All valves processed for improved performance. We also have Stock of MAJOR BRAND types including: MULLARD, GEC, BRIMAR, RCA, GE, etc
130, New London Road, Chelmsford, Essex, CM2 0RG
Tel: 01245 265865 Fax: 01245 490064

SOVTEK VALVES

6550WA. 6L6WGC/5881. EL34G.
12AX7WB/7025. EF86/6267
Over 1000 different types of valves stocked S.A.E. for list DEPT. HFW
Wilson Valves, 28 Banks Ave, Golcar,
Huddersfield, West Yorks, HD7 4LZ
Tel: 0484 654650/420774 Fax: 0484 655699
Mail order only. Visa etc.

MUSIC

CD SELECTIONS

The UK's leading suppliers of bargain CDs and music for your free catalogue contact

CD SELECTIONS
PO BOX 1011
DORCHESTER DORSET D12 7YG
Tel. 0305 848 725

SERVICES & CONSULTANTS

LORICRAFT AUDIO

Required Garrard 301/401, Thorens TD124, Goldring GL75 any condition or any parts from new to completely used

Tel/Fax/Answer phone -
01488 72267

R. J. F.

AUDIO VISUAL

Tel: 01209 612260 Fax: 01209 710777

A.K.G., Audio Innovations, Audio Analysis, Atacama, Audio Mech, Audionote, Audioquest, Audio Technica, Beyer, Cable Talk, Denon, Foundation, Goldring, Harman Kardon, Impluse, JBL, JPW Klipsch, Micromega, Monitor Audio, Musical Fidelity, NAD, Nakamichi, Onkyo, Ortofon, Precision, Project, QED, S.D. Acoustics, SME, Sonic Link, Soundstyle, Sugden, Target, TDL, Teac, Triangle, Trichord, Vivanco

To ADVERTISE IN THIS SECTION PLEASE CALL HI-FI WORLD ADVERTISING SALES ON 0171 289 3533 01245 443555

Hi-Fi World Specialist Dealer Directory Order
Book 12 Months For A 30% Discount!!
Or 6 Months For A 20% Discount.

I wish to be included in Hi-Fi World's Specialist Dealer Directory starting the _____ issue for a total of _____ insertions.

Please find enclosed my artwork/copy details.

I wish to book _____ column centimetres at £12.50 per col. cm.

Name _____
Company _____
Address _____

Postcode _____
Telephone No. _____

Please return to
Hi-Fi World, 64 Castellain Road,
London W9 1EX

A reference guide to Britain's Manufacturers and Distributors.

ACOUSTIC ENERGY, 3a Alexandra Road, London W13 0NP. Tel: 0181 840 6305. Acoustic Energy manufacture the award winning Reference Series AE1 and AE2 loudspeakers and the new Aegis Series Model 1, all of which feature the unique AE metal cone drive units. The AE distribution division offers superb high end products from WADIA, GRYPHON ENSEMBLE and TARA LABS.

ACOUSTIC SOLUTIONS is a bespoke manufacturing and design company. We specialise in tailor made loud speakers and interconnects. We have ongoing development projects in loudspeaker design. All products are continually reviewed in order to maintain an unequivocal service. Please us for a chat or advice on 0973 149392. ASL, 18 Tamar Rise, Chelmsford, Essex.

ALCHEMIST PRODUCTS, 4 Rosebury Mews, London N10 2LG. Call us for a list of our dealers in many areas including: London, Kent, Hampshire, Wilts, Milton Keynes and N. Ireland and for product information on the Kraken, Freya, Braqi, Odin, Genesis and more Tel: 0181 883 3008

ALEMA UK LTD., 25 Montflore Road, Hove, BN3 1RD. Tel: 01273 202637. Audion 'Edison' Anderson 'I' Trade enquiries welcome for our newly extended range.

APPOLLO. The UK based designers and manufacturers of high quality speaker stands and equipment racks have now added to their comprehensive range a modular system ideal for housing audio visual products and CD storage. Please send for our free brochure to Zenith Crown Ltd Tipton Rd, Dudley, West Midlands DY14 Tel: 0121 520 5070. Fax: 0121 522 2055. - All export trade enquiries welcome

ARCAM, Pembroke Ave, Denny Industrial Centre, Waterbeach Cambridge, CB5 9PB. Tel: 01223 440964 or Fax: 01223 863384. Manufacturers of the Delta 290 Amplifier and the Delta 280 Digital FM Tuner. The two together produce a sound that has been described as 'subtle and intriguing' and that provide 'real clout' - discover this for yourself. For information on not only these products but also the Arcam CD Players, Speakers, Cassette Decks etc. - Phone or write in to request a brochure - The pleasure is all yours!

ATACAMA AUDIO SUPPORTS from Sambell Engineering Ltd. We are the sole manufacturers of the SE range of speaker stands, consisting of an 8", 12", 16", 20" and the award winning 24" high stand. Also three specialist models for the Tannoy sixes Loudspeakers.

AUDIIONOTE CO. Unit 1, Block C, Hove Business Ctr Fonthill Road, Hove BN3 6HA. Tel: 01273 220511. Audionote supply a range of very high quality and very expensive audiophile components including valve output transformers.

AUDIOPHONICS - The Art of Sound Reproduction. Bespoke design and manufacture of audio systems including: Loudspeakers with metal cone drivers; CA50 spheroidal speakers in hand carved marble with matching FBX150 Bass. New Athens range coming soon. Amplification, Zeus semiconductor zero feedback push-pull or single ended output transformer monoblock power amplifiers and pre-amplifiers.

3 Meldone Close, Surbiton, Surrey KT5 9HO 0181 390 6480. Email: info@apnix.demon.co.uk

From **AUDIO SYNTHESIS**, manufacturers of the outstanding DAX digital to analogue converter, comes DAX-2, a new Hi-End reference converter able to dig deeper into the digital source than ever before! A new addition to the superb PASSION series of all Vishay controllers has just been introduced in the form of PASSION 8, a fully remote controlled uniquely transparent passive preamplifier, the perfect match for DESIRE. For 1996 brochures and full details please contact: Audio Synthesis, PO Box 100, Ilkley, West Yorkshire LS29 9XW. Tel: 01943 600404 Fax: 01943 600383

CABLE TALK PO Box 413, Woking, Surrey, GU22 8YZ. Telephone 01483 750667 Fax 01344 360866. Designers and manufacturers of British made high quality value for money, interconnect and speaker cables. Phone or fax for a free full colour brochure on our What Hi-Fi? 5 star rated products.

CAMPAIGN AUDIO DESIGN, Llandudno Road, Cardiff CF3 8PG. Tel: 01222 779 401. Supplies / manufactures mailorder, high purity silver interconnects, loudspeaker cables, internal wires and bespoke mains cables. Generous two week trial period.

CANFORD AUDIO PLC, Crowther Road, Washington, Tyne & Wear, NE38 0BW. UK Sales 091 415 0205. Admin 0191 417 0057 Fax 0191 416 0392. UK's leading manufacturer and distributor of professional audio equipment 9000+ products are detailed in a bi-annual catalogue which is available free of charge to professional users. Next day deliveries when possible.

CHORD ELECTRONICS LIMITED, 3 Bower Mount Road, Maidstone Kent ME16 8AX. Telephone: 01622-764874 Fax: 01622-688480. We have recently complemented our highly acclaimed SPM

range of power amplifiers with 2 superb pre-amps - the CPA 2800 + CPA 4000a as well as the BBC qualified LS5/12A loudspeaker & LF5/12 bass extension system. Call us for copies of reviews that will leave you wanting details of your nearest retailer.

CREEK AUDIO LTD 2 Bellevue Road, Friern Barnet, London N11 3ES. Tel: 0181 361 4133. Fax: 0181 361 4136. Manufacturers of the 4240 Integrated Amp, P42 and A42 Pre/Power Amps, CD42 CD Player. Please write for further details.

The Exultant Power Amp fitted to Quad II Hardware.

CONNECTIONS U.K. Custom made interconnects direct the manufacturer, all individually made in our Cambridgeshire workshop. Range includes the five star rated 'Jade' (£21 inc.p+p) and new updated 'Jade Ultra' (£28 inc.p+p). To order send cheque/P.O. payable to Connections U.K. to 49 Bishops Road, Peterborough PE1 5AP Tel/Fax 01733 897379. Orders normally dispatched within 10 working days.

DBS AUDIO, P.O. Box 91, Bury St Edmunds, Suffolk, IP30 0NF. Tel: 01284 828 926 Fax: 01284 828 026. DBS Audio supply quality loudspeaker kits designed by Dave Berriman. The DBS 6, features a custom-built 8-inch cast-chassis woofer with high-power voice coil, Morel high-power tweeter, and ready-assembled crossover with Van den Hul cable ICW 630V polypropylene capacitors and bi-wired with gold-plated terminals. By popular demand DBS411 is now upgraded to MKIII (upgrade kit available). New designs are planned. Also, UK distributor for the CLIO professional quality (but easy to use) PC-based audio measuring system. Access/Visa accepted.

O H M DESIGN, - BUNDEE CD REPAIR PROTECTION SYSTEM - Tred and tested on Tomorrow's World. Repairs and protects over 50 CD's, even those scrubbed with steel wool. Effective for all laserdisc formats including CD ROM, MiniDisc and CD-R. RRP £14.95. Why buy a new one when you can clean, repair and protect fifty? Contact David Mather for details of your nearest stockist or distributor. Export enquiries welcome. DHM Design Ltd, Studio 6, Bentinck Court, Bentinck Road, West Drayton, Middlesex, UB7 7RG. Tel: 01895 449559 Fax: 01895 420540

ECA DISTRIBUTION: For the "naturally neutral" chain. Nothing added, nothing taken away. The VISTA line-amp; The LECTERNS S power-amp (Awarded Best Buy - Hi-Fi Choice August '95) and the SERVO A.2 speakers. Resulting from their own Research and Development, the ECA Design Team provides a 'super-symmetry' circuit with the barest minimum of wiring in the amps vacuum impregnated air-coils in the custom-made midrange unit for the speakers. P.O.Box 3023 London NW2 7RW. Tel: 0181 830 5128

ELECTROFLUIDICS, 27 Fournier Street Spitalfields London E1 6QE Tel: 0171 247 0813. Makers of the acclaimed Sonolith loudspeaker series and Monolith 20/20 cable. Mineral polymer enclosures, controlled - flexure alloy - coned drive units, ultra - low impedance wide - band feeds: extraordinary clarity, control and resolution.

ELYTON ELECTRONICS (Yuetone), c/o Don Fordy Ltd, 4 Abertawe House, Ystrad Road, Swansea, SA5 4JS. Tel: 01792 - 588862 or Fax: 01792 - 588865. Elytone Electronics (formerly Yuetone Industrial) are Taiwanese OEM manufacturers of high quality Loudspeaker Crossover Networks and associated components. Don Fordy Ltd, are the UK agents for Elytone.

EMF 2a Bellevue Road, Friern Barnet, N11 3ES. Tel: 0181 361 6734. Manufacturer of Sequel 50w integrated amplifier and the Crystal D2A converter Amplifier and DAC. Please write in for details.

FALCON ACOUSTICS LTD., Tabor House, Norwich Road, Mulbarton, Norwich, Norfolk, NR14 8JT. Tel: (01508) 78272. U.K. distributors of FOCAL drive units and SOLEN (chateauroux) polypropylene capacitors and the largest inductor manufacturer in the U.K. Comprehensive range of DIY Speaker Parts and Kits, Sub-Bass and Electronic Filters. 'Everything but the wood'

FULLERS AUDIO, 20 Tunbridge Road, Southend on Sea, Essex SS2 6LT. Tel: 01702 612116. Fuller's audio produce a range of innovative products. Amplification - a10 a single ended class A semiconductor power amplifier - £1200. b70 a mosfet power amplifier of high standard - £599. prei and prei + matching pre-amplifiers - £599/£649. genii phono stage for mm and mc cartridges £299. Loudspeakers - Pharaoh system, upgradeable from 1 pair of cabinets to 3 pairs for truly extended bass, passive/active options £649-£2499. Sphinx a 3 way floor standing unit £849. Sultan H.E. - 98dB sensitivity £439. matching Sub Woofer £559. Sultan, 91 5dB sensitivity £309

IAN EDWARDS, The Old Chapel, 282 Skipton Road, Harrogate, Yorks. Tel: 01423 500442. Somebody Somewhere must make better storage units for CDs, Music, LPs, HiFi, Books, etc. than Ian

Edwards. BUT until he appears, why not send for the brochure showing a selection of HAND MADE units. To do this please send 3 x 2nd class stamps.

JORDAN WATTS ACOUSTICS LTD, Cyntia Place, 201 Mare Street, Hackney, London E8 3QE. Tel: 0181 985 1646. Jordan Watts Acoustics for Sight AND Sound.

KESWICK AUDIO RESEARCH, 54 Coach Road, Outwood, Wakefield, W Yorks, WF1 3EX. Tel/Fax 01924 870606. I'd say that the Figaro is the best miniature speaker I have heard! Audiophile March 1993. Write in or call for details on our full product range and your nearest stockist.

"KLIPSCH. The Horn loudspeakers of Immortal Foresight!" Call for more information on 0121 4307817.

KRONOS DISTRIBUTION, 35 Farlough Road, Dunganon, N. Ireland, BT714 DU. Tel: 01868 748632. Fax: 10868 448281. Kronos is the UK distributor of some of the finest Hi Fi products in Europe. These include Audiomeca digital products and turntables; Lieder silver speaker and interconnect cables; Pro-Ject turn-tables and amplifiers; Triangle speakers and electronics; and YBA amplifiers. We also handle Frameworks equipment tables; Arion valve amplifiers and mains filters and Essex Audio digital products from the UK. Please telephone or write for product details and dealer lists.

LANGREX SUPPLIES LTD. 1, Mayo Road, Croyden, Surrey CR0 2DP. Tel: 0181 684 1166. Fax: 0181 684 3056. We are one of the largest stockists and distributors of electronic valves, tubes and semiconductors in the UK. Over 6,000 types in stock. We specialise in obsolete types including original UK and USA made audio valves. Telephone or fax for an immediate quotation.

LINN PRODUCTS LTD, Floors Road, Waterfoot, Glasgow, G76 0EP, Scotland. Customer Helpline 0500 888909. LINN HI-FI faithfully captures the source signal, nurturing and protecting it through every stage of the playback chain. All you have to do is listen to decide for yourself how good a sound you want. Call the LINN Customer Helpline free for further information on LINN HI-FI and LINN RECORDS, or to find your nearest retailer.

LORICRAFT AUDIO 4 Big Lane, Goose Green, Lambour, Berks RG16 7SU. Tel: 01488 72267.

Specialist restoration of 301's and 401's using genuine spares and re-manufactured parts to original pristine standards in our newly built work shops designed primarily for these purposes.

MAY AUDIO MARKETING U.K. LTD 83 Main Street, Burley in Wharfedale, North Yorkshire, LS21 7BU. Tel: 01943 864930. Distributors of High Quality audio products from Fusion Electronics, Totem Loudspeakers, Jecklin Float Headphones and quality recordings from Proprius, Prophone, Opus, MAP and Swedish Society. IF ITS MUSIC YOU LOVE, TELEPHONE OR WRITE FOR LITERATURE.

MICHELL 2 Theobald Street, Boreham Wood, Herts, WD6 4SE. For full information on our full range of excellent products including the Gyrodec, Alecto, Iso, Argo and others please telephone us on 0181 953 0771. Michell - Symbol of Precision

MONITOR DIRECT, Unit 80, Woolmer Trading Estate, Bordon, Hants GU35 9QF. MONITOR, the best in home Hi-Fi cables and connections is now available direct (mail order only). Call 01420 476767 or fax 01420 477137 for your free catalogue. Cable prices vary from 0.35p to £14.50. We are now offering a "try before you buy" service for our more expensive cables.

NOTTINGHAM ANALOGUE STUDIO, Tel: 01773 762947. Design and manufacture of quality analogue audio. We're in the business because we realise how important music is. Our turntable arms and cartridges sell the world over a commitment to providing all our customer's with the best of analogue we love music.

PLATFORM 7. High density marble ISOLATION PLATFORMS for all makes of equipment RACKS/STANDS. An elegant way to UPGRADE. Improves clarity, better BASS control. 3 Abbotts Drive, North Wembley, Middlesex HA0 3SB. Tel: 0181 904 2646. Also NEALGAR DISTRIBUTION. Tel/Fax 01296 24756.

PREMIER MARBLE LIMITED, Uncover the true sound quality and potential of your system. Use the natural benefits of granite and marble. These natural materials offer better base definition, clarity, and natural sound staging capabilities. CD/Turn-table platforms, custom made stands, shelves or anything you desire cut and polished to any shape or size required. Tel: 01603 721 995

QUANTUM AUDIO LTD, PO Box 26, 1 Oliphant Drive, Kilmarnock KA3 7JA. Tel: 01563 71122 Fax 0563 71133. Quantum's craftsmen produce the £899 99 MINSTREL 30 Watt, Ultra Linear, zero feedback controller, integrated, line level, valve amplifier. Don't buy any old fashioned valve amplifier before hearing the unique improvements modern technology provides to valve sounds. AAN audition will immediately convince the listener of the

Minstrel's superiority.

SELECT SYSTEMS (PERFECT PITCH MUSIC), Hanworth Trading Estate, Hampton Road West, Feltham, Middlesex, TW13 6DH. Tel: 0181 893 8662. Fax: 0181 893 4318. We manufacture the Franciscan CD enhancement system, The Dacula DAC and Perfect Digital and Analogue interconnects. Perfect Pitch also provide freelance design, manufacture, prototyping and test, also valve and solidstate specials. Trade enquiries welcome.

J E SUGDEN & CO LTD., Valley Works, Station Lane, Heckmondwike, West Yorkshire, WF16 0NF. Tel: 01924 404088. Manufacturers of hand crafted audio products. 'A world of Music'. Call or write in for information on our SDA-I Digital to Analogue Converter, SDT-I CD Player, A21a Class 'A' Amplifier, A25B Intergrated Amplifier, A48 Intergrated Amplifier, A051c Pre Amplifier, A051P Power Amplifier and more.

REL ACOUSTICS, Unit 2, New Street, Bridgend Ind Est. Bridgend, Mid Glamorgan, CF31 3UD. UK. Tel: 01656 768 777, international +44 656 768 777. Fax: 01656 766 093. international. +44 656 766 093. The UK's only specialist sub-bass speaker manufacturer. 'The only one that works'. Get your dealer to give you a home demo and find out what the fuss is all about.

REL HARMAN AUDIO, Unit 2, Borehamwood Ind. Park, Rowley Lane, Borehamwood, Herts, WD6 5PZ. Tel: 0181 207 5050, Fax 0181 207 4572. Sub Base Systems - Rel Strata, Stadium, Stentor, Studio

RICHARD ALLAN AUDIO, Bradford Road, Gomersal, Cleckheaton W Yorks, BD19 4AZ. Tel: 01274 872442 Fax 01274 869933. Manufacturers of very high quality loudspeaker enclosures and drive units. Examples being the £270 RA8 series 2 as supplied to the BBC and the 5" reviewed Minette 2 at £120.

SEQUENCE DESIGN LTD, 83 Main Street, Burley-in-Wharfedale, Yorkshire, LS29 7BU. Tel: 071 495 0775. Fax 0171 495 0281. Slim loudspeakers which stand close to a wall or hang like pictures. Likely to catch a glint in the audiophile's eye (Audiophile): 'the answer to a prayer...a bargain in the extreme' (HiFi News). Available with light or dark grilles and various solid wood finishes. From £199.95 a pair. Call or write in for an information kit and reviews reprints.

SHEARNE AUDIO P O BOX 22, Stevenage, Hertfordshire SG2 8HF, England. Tel: 01438 740953. New from Shearne Audio the Phase 3 power amplifier 450 watts per channel designed as an upgradeable path for the Phase 2 integrated. Owners of the Phase 2 can bi amp via the pre outs on the back of both units connecting the Phase 2 to the tweeters of both speakers and Phase 3 to the bass units. The Phase can also be used to complement different systems.

TARGET AUDIO PRODUCTS PLC, Britannia House, Leagrave Road, Luton, LU3 1RJ. The Audio equipment, rack and speaker stand specialist. For information on our products please telephone or write.

TECH-LINK distributes some of the best performing hi-fi and a/v accessories currently available in the U.K. These include: Puresonic, best known for its range of high performance interconnects and connectors, and cable adapters for a wide variety of hi-fi and a/v applications in its range; Tech-Link's own brand Switch Boxes are the perfect solution to multiple applications - for example, its highly acclaimed TAS-1 is a very practical and inexpensive way of switching your speakers between hi-fi and home cinema systems; and Shark - a range of very exclusive high quality cables, interconnects and connectors.

For more information, contact: Tech-Link at Units 1/2, 76a Farnley Road, London, SE25 6NX. Tel: 0181 771 8388, Fax: 0181 771 1840.

TRICHORD RESEARCH LIMITED Following on from the highly acclaimed CD clock oscillator modifications the Pulsar Series One digital to analogue converter. This unique design is part multibit and part bitstream to give absolute linearity over an extremely wide dynamic range. Switchable between 18 or 20 bit resolution this converter will become the standard for CD replay. For details telephone (0684)573524

WILMSLOW AUDIO LTD, Wellington Close, Parkgate Trading Est. Knutsford, Cheshire, WA16 8DX. Tel: 01565 650605. Extensive range of drive units and over 30 different designs of self-assembly kits. Everything required for the loudspeaker builder and four dem rooms to listen to the kits in build-up form.

REPAIRS & DIY

SOUNDS AROUND, 146A Clarendon Park Road, Leicester. Tel: 01533 702442. New and used Hi-Fi. Professional service repairs and accessories.

KITS HAVE NEVER BEEN SO GOOD!

NEW - K6L6 35W INTEGRATED £295

K6L6 - A high performance 35watt integrated valve amplifier using 6L6 beam tetrode valves. It has four line inputs and a tape output. It is a compact design that will fit into any system, bringing valve transparency, warmth and detail. See p7 in this month's supplement for further details.



CHRISTMAS SPECIAL OFFER
£100.00 OFF
IF YOU ORDER
300B WITH EITHER KLP1 OR
KLPP1 PREAMPLIFIERS
OFFER ENDS 29/2/96

300B VALVE AMPLIFIER



300B VALVE AMPLIFIER KIT

£850

This is a specialised 28watt amplifier based on the highly linear 300B triode valve. Our 300B runs in Class A, giving one of the most sweet, open and neutral sounds possible today. Matched with good loudspeakers, it is unsurpassed. All parts are included in the kit, except valves since different 300B makes are available.

KLP1/KLPP1 PREAMPLIFIERS



KLP1 VALVE LINE PREAMPLIFIER

£345

The KLP1 line level preamplifier uses one of the simplest and most elegant circuits to give a sound with remarkable clarity and detail. The components are all high quality and include Military Spec. Russian valves, Alps potentiometer, polypropylene signal capacitors, silver plated copper wire etc.

KLPP1 VALVE PHONO PREAMPLIFIER

£495

KLPP1 has five line inputs, a tape input with monitor, and a unique low noise valve MM/MC phono stage. There is a switchable subsonic filter to prevent output transformers of valve amplifiers saturating. The line stage has gain, so it will drive any power amplifier. Audio grade components are used and many parts are custom made for highest quality. KLPP1 has a super clear sound, sweet and detailed through line and phono inputs.



World Audio
design

Tel: 0171 289 3533

WARNING

THESE ARE EXPERT KITS, NOT FOR THE INEXPERIENCED.

World Radio History



4W SINGLE-ENDED VALVE AMP KIT £385

The 4W Single-Ended amplifier kit is a line level integrated amplifier. It comes with three line level inputs and a tape output. High quality components are used throughout, including polypropylene signal capacitors, Alps volume control, custom C&K gold plated selector switch etc. Valves are included.

KLS3 THREE WAY CARBON-FIBRE DRIVER LOUDSPEAKER

KLS3 uses extremely light and stiff carbon fibre cone drive units for a fast and accurate sound. A dedicated 4inch carbon fibre midrange drive unit provides the cleanest, smoothest and most detailed midrange characterised by superb projection. Its high 90dB sensitivity and near flat 8Ω impedance make it one of the easiest loudspeakers to drive.

Drive Unit & Crossover kit etc £350
Drive Unit Pack £230

KLS4 TWO WAY CARBON-FIBRE DRIVER LOUDSPEAKER

A two way standmounter using stagger-tuned reflex loading for good bass, plus light and fast carbon fibre drivers.

Drive Unit & Crossover kit etc £230
Drive Unit Pack £120

KLS6 ADVANCED TECHNOLOGY THREE WAY LOUDSPEAKER

KLS6 is our most advanced loudspeaker to date. It uses a combination of Audax's HD-3P gold piezo-electric dome tweeter and High Definition Aerogel (HDA) midrange and bass drivers. To provide super bass depth and dynamics, an 8" HDA bass driver is used in a large, efficient reflex enclosure. With 89dB sensitivity, and a smooth impedance curve, KLS6 can be easily driven with amplifiers capable of producing 20watts or more.

Drive Unit Pack £640
Drive Units & Crossover kit etc. £825

KLS7 TWO WAY CARBON FIBRE DRIVER FLOORSTANDER

A compact and affordable two way reflex loudspeaker. KLS7's slim dimensions make it easy to accommodate, but it uses light and fast carbon fibre drivers, so performance isn't compromised. An audiophile bargain.

Drive Unit Pack £110
Drive Units & Crossover kit etc. £195



K588I KIT £395

A superb, Class A, 20watt stereo power amplifier that uses the Russian 588I output valve, a military version of the American 6L6, designed for low distortion audio work.

Designed for long life, low running costs and excellent sound quality, K588I is sensitive enough to be used with a simple passive pre-amp. or our own line-drive pre-amp, and it matches modern loudspeakers well.

K588I PSE KIT £650

An audiophile parallel-single-ended valve amplifier at an affordable price. K588I PSE uses the reliable Russian 588I output valve in parallel-single-ended mode for outstanding detail and atmosphere. It produces 17watts, enough to drive most loudspeakers, making high-end sound quality and design available to everyone. Can be easily monoblocked to give 32watts.



NEW KLS7 £195



HIGH TECH AUDAX DRIVE UNITS

This range of Audax drive units sees many modern high tech materials and technologies that would normally be unavailable to the home constructor. We offer a small range of the highest quality drivers, including High Definition Aerogel (HDA) units, carbon fibre and three superb soft dome tweeters.

CAST CHASSIS UNITS

	3inch mid	4 inch mid	6.5inch bass/mid	8inch bass
HDA	HM100Z0	HM130Z0	HM170Z0	HM210Z0
=CARBON FIBRE		HM130C0	HM170C0	HM210C0

FABRIC DOME TWEETERS

- TW025M0 (25mm 92dB suitable for 2-way systems)
- TW025M1 (25mm 92dB suitable for 3-way systems)
- TW034X0 (34mm 93dB a large dome with powerful sound)
- OVAL GOLD DOME TWEETER HD-3P (complete with crossover. Works extremely well with HM100Z0 - ultra flat response from 400Hz to 20kHz.)

DEMONSTRATIONS!!

Selected World Audio Design Products are on demonstration at:

2nd Audio
17 Maritime Court,
Harboro Rd,
Sale.
Tel: Andy on
0161-969-0460

Horsham Hi-Fi
28 Queensway,
Horsham,
W. Sussex.
Tel: Jeff on
01403-251587

Please 'phone before you visit



World Audio
design

Tel: 0171 289 3533

WARNING

THESE ARE EXPERT KITS, NOT FOR THE INEXPERIENCED

World Radio

See page 85 for order form...

MERRY CHRISTMAS FROM LINN RECORDS!



For a taste of the Linn Records Jazz catalogue why not try

LINN JAZZ 1995

CD SAMPLER : PRICE ONLY £4.99

CALL US NOW FOR A FREE CATALOGUE OF ALL LINN RECORDINGS

tel: 0141 303 5029 or fax: 0141 644 4262

Linn Records, Floors Road, Waterfoot, Eaglesham, Glasgow G76 0EP

TOP QUALITY VINYL SPECIAL OFFER!

The following top quality titles are available to HiFi World customers at the special price of **ONLY £7** including postage and packing

Classical

- | | | |
|---------|-------------------------------------|---------------------------------|
| CKH 007 | NEW LONDON CONSORT | Columbus |
| CKH 011 | NEW LONDON CONSORT | Elizabethan & Jacobean |
| CKH 010 | PALLADIAN ENSEMBLE | An Excess of Pleasure |
| CKH 013 | NIGEL NORTH | Bach on the Lute Vol 1 |
| CKH 029 | NIGEL NORTH | Bach on the Lute Vol 2 |
| CKH 006 | NIGEL NORTH | The Baroque Lute |
| CKH 001 | POLISH CHAMBER ORCHESTRA | Live Concert |
| CKH 002 | WILLIAM CONWAY / PETER EVANS | Poulenc Cello Sonatas |
| CKH 003 | ENGLISH CLASSICAL PLAYERS | Mozart Symphony 40 |
| CKH 004 | LENINGRAD SYMPH ORCHESTRA | Shostakovich Symphony No 5 |
| CKH 005 | JILL FELDMAN | 17th Century Italian Love Songs |

Jazz

- | | | |
|---------|--------------------------|------------------------------|
| AKH 030 | MARTIN TAYLOR | Spirit of Django |
| AKH 020 | MARTIN TAYLOR | Artistry |
| AKH 022 | MARTIN TAYLOR | Reunion |
| AKH 016 | MARTIN TAYLOR | Change of Heart |
| AKH 014 | MARTIN TAYLOR | Don't Fret |
| AKH 006 | CAROL KIDD | Nice Work |
| AKH 007 | CAROL KIDD | The Night We Called It a Day |
| AKH 017 | CAROL KIDD | I'm Glad We Met |
| AKH 026 | CAROL KIDD | Crazy for Gershwin |
| AKH 018 | CLAIRE MARTIN | The Waiting Game |
| AKH 021 | CLAIRE MARTIN | Devil May Care |
| AKH 028 | CLAIRE MARTIN | Old Boyfriends |
| AKH 024 | TOMMY SMITH | Reminiscence |
| AKH 040 | TOMMY SMITH | Misty Morning & No Time |
| AKH 013 | DAVID NEWTON | Victim of Circumstance |
| AKH 015 | DAVID NEWTON | Eye Witness |
| AKH 025 | DAVID NEWTON | Return Journey |
| AKH 019 | STEVE GIBBONS | Birmingham to Memphis |
| AKH 023 | JON STRONG | Follow Me |
| AKH 034 | RAY GELATO GIANTS | The Full Flavour |

All these titles and many more are also available on CD - price **£13** including postage and packing

"All I need is the right lead... "

- Sam Spade-Connector during his undercover investigations into the Mystery of the Lost Chord. He subsequently solved the case by utilizing a pair of ORTOFON SPK100 speaker cables.

SPK100

ortofon

01753-889949

Simon Hopkins

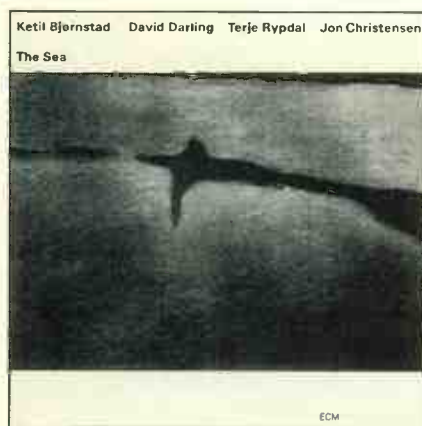

KETIL BJORNSTAD/DAVID DARTLING/TERJE RYPDAL/JON CHRISTENSEN

The Sea

ECM 521 718-2

● Well, here's a supergroup that's actually worthy of the description; an *ad hoc* gathering of uniquely talented

musicians, the sort of 'production group' ECM brings together with startling frequency - and yes, sometimes disappointing results.

Guitarist Terje Rypdal should need little introduction in this column. The Norwegian is one of an all-too-small handful of jazz rock guitarists to have grasped the potential power and lyricism of the genre and subsequently used it as a platform for some of the most expressionistic jazz of the last two-and-a-half decades. Albums like his eponymous debut, *Odyssey*, and *Whenever I Seem to be Faraway*, easily stand alongside the best work of Weather Report, Herbie Hancock and, of course, Miles Davis, while exerting an undeniable European identity.

Fellow Scandinavian and drummer Jon Christensen is another stalwart of the European jazz scene. His is, for my money, one of the most overlooked styles in contemporary jazz drumming, a compelling melding of hard, driving swing and graceful colour. While drumming for ECM, he's played alongside some of the most original voices to have emerged in jazz: saxophonist Jan Garbarek (since last year a major classical cross-over star), the Indian violinist L. Shankar, Keith Jarrett, cult bassist and composer Eberhard Weber and Terje Rypdal himself.

American cellist David Darling is another matter. While he too has a long-standing association with the German label, and has recorded with the likes of Garbarek, increasingly his solo work - beautiful, reverberating multi-tracked suites performed purely

on the cello - has demonstrated more of an affinity with Minimalist composition than with jazz improvisation.

Ironically, pianist Ketil Bjornstad, presumably this group's leader and certainly the composer of all twelve parts of the suite which makes up *The Sea*, is the least well-known of all these players, a largely undiscovered composer and player whose music - a highly melodic, lyrical, Romantic affair - is a natural environment for these highly expressive improvisers. *The Sea* is certainly a record I personally approached with great excitement and, to be frank, found bitterly disappointing. Actually, that's too strong. *The Sea* is certainly a very beautiful record. In particular, Rypdal's richly distorted guitar - at the best, and most psychedelic I've heard it in ages on Part 2 - and Darling's gorgeous cello are a supreme combination of sounds, one I certainly hope they repeat in other circumstances. And Bjornstad's dark, melancholy writing is rich pickings for these players.

Yet there's something subdued about the proceedings, as though these musicians are avoiding treading on each others' toes. At moments Rypdal in particular sounds like he's about to break out, but never really does. And for such a compelling player, Christiansen is oddly muted here, his dynamic drumming really limited to colouring and punctuation - almost an afterthought. Sure, this music is stately, but I can't help but thinking that the whole affair is a bit of a lost opportunity.

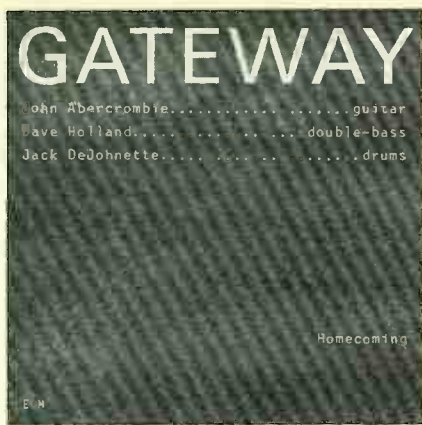

JOHN ABERCROMBIE/DAVE HOLLAND/JACK DeJOHNETTE
Gateway - Homecoming
 ECM 527 637-2

● Gateway is certainly a group with both individual pedigree and a collective history. The trio of American guitarist John Abercrombie, English double bassist Dave Holland and American drummer Jack de Johnette first came together in 1975 to record the now classic ECM album Gateway. At that time De Johnette and Holland were well known for their time in Miles Davis' great electric band; both had played on Bitches Brew and could therefore genuinely lay claim to having been part of one of the most important and decisive moments in the history of recorded music. Abercrombie, meanwhile, was an unknown quantity, a young guitar player with a load of Tal Farlowe and Jim Hall jazz chops and a very noisy fuzzbox.

The results of that first coming-together were astounding. One might have expected some kind of post-Miles psychedelic funk workout, but Gateway was a revelation: an irresistible, really dirty blend of gritty folk melodies and the kind of melodious free jazz that obliquely recalled Atlantic-period Ornette Coleman. They repeated the experience on 1977's equally impressive Gateway 2, but remarkably - given these musicians' huge individual output in the intervening time - Homecoming is the group's first recording in over eighteen years.

Now this isn't, I feel, a completely successful enterprise. Abercrombie in particular is a much different player to the young gun he was in 1975; his recent work has shown an ever more refined approach, his style representing, somehow, an almost 'classical' jazz-rock guitar technique. This is probably inevitable. Think of any really astounding musician involved in jazz-rock in the seventies, and no matter how hard, aggressive, freely experimental or searching their work

was then, you can guarantee that their music now is a good deal less challenging. Compare Wayne Shorter's new album Hi Life with the Weather Report of, say, Sweetnighter; put John McLaughlin's current work alongside Birds of Fire or The Inner Mounting Flame.

And maybe it's just me, but this regression seems to affect guitar players most of all. Whole generations of trailblazing jazz guitar players - McLaughlin and Abercrombie among them, and Sonny Sharrock and Terje Rypdal and a whole bunch more - have been thoroughly eclipsed by the younger and more wildly experimental jazz guitar players who've emerged since. Guitar players like Raoul Bjorkenheim and Bill Frisell and Jimi Sumen and others strictly from outside the jazz tradition (Elliot Sharp, Caspar Brotzmann, Keiji Haino) possess improvising brilliance that makes them vital to the scene.

But enough already, I'm sure you get the picture. Homecoming isn't, and probably couldn't ever be the incendiary work of its predecessors. But, but, but. . . It is, at least in part, a hugely enjoyable record. For one thing, Holland and De Johnette are undeniably one of the finest rhythm sections to grace contemporary jazz. It's instructive to compare De Johnette's work with this group with his playing in Keith Jarrett's mightily prolific Standards group. There De Johnette is complemented by bassist Gary Peacock, a very different player to Holland indeed. With Standards, De Johnette does swing hard, but with a certain graceful poise he keeps in check with Gateway, and a good thing too, in my book. Here he plays fiercely, really hard.

Holland's the key, I reckon. You can hear it in the way he drives De Johnette. And the standout tracks here, the tracks where this group burns, coming closest to the energy of the older albums - are Holland's compositions. For what it's worth, Holland has consistently played with some of the most challenging younger jazzers during his career, and his association with Brooklyn's M-Base collective in particular seems to have paid dividends. There's an incredible combination of angular abstraction and earthy drive in both his writing and playing that drives Gateway fantastically.

And these players can and sometimes do fire off each other in an almost alchemical way, with the kind of telepathic second-guessing that can make this music priceless.

So, eighteen years on, some reservations, but really a welcome return.

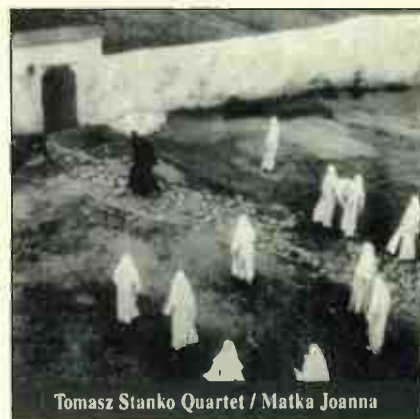

TOMASZ STANKO QUARTET
Matka Joanna
 ECM 1544

● I can't help but feel that the Polish trumpeter and composer Tomasz Stanko is one of the most criminally neglected musicians to have been working in European jazz for three decades or more. Stanko has a long history of building bridges between the absolute spontaneity of free jazz, the heady drive of hard bop and the expressiveness of post-John Coltrane modal improvising.

Now if that sounds like some altogether intellectual enterprise, think again. Genre separatism has arguably crippled jazz for decades. Sure, movements like 70s fusion and the 80s NYC downtown capital-E-Eclecticism have taken jazz on board, but always as part of something else. Meanwhile, in Europe in particular, as documented on labels like, yes, ECM, but also on Soul Note and Black Saint and Scandinavia's Leo and elsewhere, a whole bunch of both American and European jazzers have been trying to make sense out of the legacy of last few decades of jazz history, often with hugely important results. Stanko's work, from his 1975 classic as bandleader, Balladyna, to altogether stranger projects like the proto-New Age solo album recorded at the Taj Mahal, has been central to this development.

Surprisingly, despite numerous appearances on ECM albums as sideman, Matka Joanna is Stanko's first album on the label as leader since Balladyna. He brings to it a superb band: pianist Bobo Stenson, drummer Tony Oxley and bassist Anders Jormin. It's interesting hearing this set back-to-back with Bjornstad's The Sea. A similar sense of melancholy pervades the

music, but there's an urgency at the heart of this music - either group improvisations or pieces written by Stanko - absent from the pianist's. The rhythm section here flits deftly from floating, free rubato to strident rhythms with absolute conviction. Meanwhile, Stanko's trumpet playing is at once lyrical and aggressive; the sound of a musician supremely in control of his improvising. Highly recommended stuff.

Simon Cooke



KATIA LABEQUE
Little Girl Blue
FDM 36/86-2

● Better known as half of the classical piano duo Katia and Marielle Labeque, this is the pianist's first foray into the realms of jazz. She is supported by and playing with such stalwarts as Herbie Hancock, Chick Corea and Joe Zawinul, among others.

This selection includes mainstream standards such as the Rodgers/Hart title track 'My Funny Valentine' and Bill Evans' 'Turn Out the Stars'. There are also more rhythmic tracks such as Skylar/Velazquez's 'Besame Mucho' and Joe Zawinul's 'Volcano For Hire'.

The recording is technically excellent and the presentation of the booklet very professional. This album is a showcase for the slickness of the performers as a whole, but the package sounds safe and sterile. Labeque is obviously an excellent pianist, but sheer expertise is no guarantee of a good jazz album. Labeque has yet to serve her time as a jazzier and learn the language. All I could think of when listening to this CD was the oft-quoted line, ascribed to various musicians: 'My, but you play so many notes!'

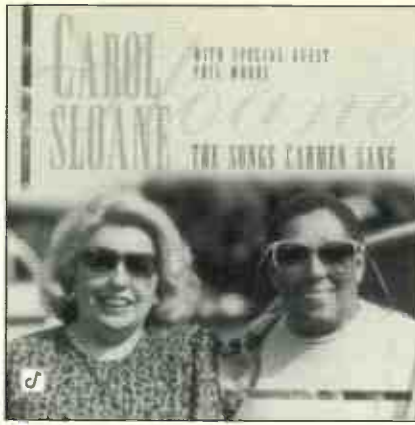

CAROL SLOANE
The Songs Carmen Sang
CCD-4663

● There are plenty of tribute releases around, often works by lesser-known artists basking - or trying to - in reflected glory. This is definitely, unequivocally, not that kind of release. Sloane has a delivery and style equal to the greats and can honestly claim - I quote Carmen McRae from the sleeve notes - to have a 'perfect voice'. Sloane is ably supported by Bill Charlap on piano, Michael Moore on bass, and Ron Vincent on drums, with the inestimable Phil Woods playing sax or clarinet on seven of the thirteen tracks. These thirteen tracks are pretty damn fine in their own right.

Donaldson/Lyman's 'What Can I Say (After I Say I'm Sorry?)', Berlin's 'Supertime', and Arken/Mercer's 'That Old Black Magic' are simply a few of the songs that really highlight the strengths of Sloane's voice. After those the other ten are simply a bonus bundle for mainstream jazz fans.



NEW JERSEY KINGS
Stratosphere Breakdown
JAZID 123

● Jazzy, funky, luscious and very, very sixties, a lost recording of the New Jersey Kings now released on the Acid Jazz label. While some strange goings-on in the mix - peripatetic instruments particularly - won't please hi-fi purists, it is a party piece par excellence. Good groove.

Incidentally, another release on the same label worth mentioning is the Athletico Series I compilation (JAZ 1311) of jazz-house-techno. My copy has already been commandeered. This is serious jazzed up dance.



BARUNGWA
The Messengers
BW 070

● The best of B&W's variable World Music CDs in the last few months coming from Moses Taiwa Molelekwa. He supplies keyboards on this similarly outstanding release of sounds, which encompasses the cultural melting-pot of the new South Africa. Far from tribal music, far from mainstream white sounds, this album is recognisably a product of both these influences and many others. This really is something different, as well as being superbly mastered. Not to be missed.



AVON

AUDIO EXCELLENCE 65 Park Street, Bristol BS1 5PB. Tel. 01179 264975 Fax 01179 251327 All that's best in hi-fi carefully selected and demonstrated by friendly knowledgeable staff, at prices to suit all budgets. Delivery and installation, home dems, part exchange, in house workshops, full credit facilities with interest free on selected items. Tuesday - Saturday 9.00 - 5.30. Closed Monday.

PAUL GREEN HI-FI LTD. Kensington Showrooms, London Road, Bath. Tel. (01225) 316197. Musical Fidelity, Krell, Creek Rogers, Quad, Cust. car park. Best selection in the West.

V'AUDIO, 36 Druid Hill, Stoke Bishop, Bristol, BS9 1EJ. Tel. 01272 686005. ATC, Acoustic Energy, Ruark, AVI, Exposure, Pink Triangle, Wadia, Audio Innovations, SME (incl 20A), Chord Amps, Michell, AMC, Analogue Electronics, Cadence Valve, Jamo, LFD, REL, Sansui, Sonic Link, Stax, Townsend, Audio Technica, Goldring, Ltra, Ortofon, Sumiko. Demos by appt only. home trial facilities, free install. service facilities.

THE RIGHT NOTE, We specialise throughout the West Country and Wales in giving advice and demonstrations in your own home, where you can best judge the benefits. Your long-term satisfaction is our aim. Brands stocked for their excellent sound (not just a passing review), their reliability and suppliers' back-up: Lumley Reference (amps and speakers), Michell, Orelle, CAT, Stratosphere, Graaham, Magnum Cynalab, Transfiguration, NEAT, Sequence, Cogan Hall, Silver sounds, MAF, Atacama Air Pods etc... Tel: 01225 874728 and 01426 315092

BEDFORDSHIRE

RICHARD'S AUDIO VISUAL, 4 Greyfriars Bedford. Tel: 01234 365165. Stockists of: Arcam, Audio Innovations, Audioquest Aura, Beyer, B&W, Bose, Celestion, Cyrus Denon, Heybrook, Marantz, Mission, Moth, Musical Fidelity Nakamichi, Ortofon, Pioneer, Pro-Ject, Rotel, Royd, Ruark, Sennheiser, Systemdek, Target, Thorens, Van den Hul & more! Expert friendly service - Listening room. Pioneer Reference Point. Visa / Access.

BERKSHIRE

NEWBURY AUDIO, 2 Weavers Walk, Northbrook Street, Newbury, Berks, RG13 1A1. Tel. 01635 33929. Linn, Creek, Epos, Denon, Nakamichi, Shahinian, Marantz, Micromega, JPW, Ruark. Single speaker dem room. Appt. necessary. Home trial facilities, free install. service dept. late appts. Access/Visa, interest free credit subject to status. 6 days 9.30am - 6.00pm.

ASTLEY AUDIO, Wallingford, 01491 839305. See our entry under OXFORDSHIRE

AUDIO ILLUSION 23 Langley Broom, Langley, Berks, SL3 8NB. (2 mins. Junc 5 off the M4). Ample free parking. Tel. (01753) 542761; Fax. (01753) 772532. Air Tangent: Apogee: Audio Alchemy: Audio Research: Classe: Copland: Davidson Roth: Denon: Earmax: Jadis: Koetsu: Kora: Krell: Lineaum: Martin Logan: Micro Seiki: Mirage: PS Audio: Sonus Faber: Sumiko: Target: Theta: Wilson: Puresonic, Siltech and Transparent Cables: WBT. 10.00AM-10.00PM Monday - Saturday (by appointment). Dedicated listening room, Home demonstrations, Free installations. Part exchange, Mail order service. All major credit cards accepted. We can tailor a system at a price you can afford - for friendly expert advice give us a call. For a current list of Second hand and Ex. Demo bargains see our monthly ad.

BUCKS

D.L. CHITTENDEN LIMITEQ, 59-61 The Broadway, Chesham, Bucks, HP5 1BX. (Opposite Boots). Tel. 01494 784441. Phillips, Denon, Kenwood, Canon Audio, Koss, Wharfedale, Mitsubishi, Target, Grundig, QED, Mordaunt-Short, Toshiba, Dolby Pro-logic Systems, Nicam TV and Video, Surround Sound, AV Systems. Showroom Demonstrations from expert and friendly staff. No appointments necessary. Service Department. Credit facilities available. Open 8.30 to 5.30 Mon-Sat.

AUDIO INSIGHT - 53 Wolverton Rd, Stony Stratford, Milton Keynes, Bucks - 01908 561551 - See our main entry under Technosound.

OEJAC HI-FI Consultants, 21 The Broadway, Old Amersham, Bucks, HP7 0HL. Tel. (01494) 433173. AMC, Arcam, Bose, Meridian, Quad, Denon, NAD, Tannoy, Mission, TDL, 2 dem rooms, Appts necessary, Free installation, Tricity finance. Instant credit, open 9.30-5.30 pm. including Saturdays.

NORTHWOOD AUDIO II, 98 Cambridge St, Aylesbury, Bucks HP20 1BA. Tel. 01296 26790 (A/P). Selected sounds from Alchemist, Aura, Boston, B & W, Cabellak, Castle, Celestion, Denon, Exposure, Gyrodek, Harman Kardon, Heybrook, Marantz, Micromega, Monitor Audio, Moth, NAD, Nakamichi, Rose, Rotel, Royd, Ruark, Systemdek, Tannoy, TDL, Thorens etc ect. Export orders welcome. 2 Dem rooms. Credit facilities available.

CAMBRIDGE

CAMBRIDGE HI-FI, 1-3 Hawthorne Way, Chesterton, Cambs CB4 1AT. Tel. 01223 67773. Kenwood, Pioneer, Ariston, Kef, Technics, Yamaha. Marantz. B&W, AR, Mordaunt-Short, Bose. Single speaker dem room. Tues-Sat 9.30-5.30pm. Closed Monday. Free install, service dept. Vis/Access credit facilities.

UNIVERSITY AUDIO, 1-2 Peas Hill, Cambridge. 01223 354237. Mission-Cyrus, Arcam, Rotel, Denon, Meridian, Ruark, ATC, AVI, Quad, Linn. E dems, 1 single speaker. Home trial, free install, Service Dept. VISA ACCESS, AMEX, Credit Terms. Open 9-5.30

CHESHIRE

CONGLETON HI-FI, 1/1A Ouke St, Congleton, Cheshire CW12 1AP. (01260) 297544. Arcam, B&W, Denon, Epos, Kef Reference, Linn, NAD, Nakamichi, Onix, Royd, Target, Yamaha, etc. Superbly appointed single speaker demo facilities. No appointment necessary, home trials, free installation. 2 year guarantee on all equipment. Access, Visa, Amex, all usual credit facilities. Open Mon-Sat 9.30-6pm.

SWIFT HI-FI, St. Annes Parade, Wilmslow. 01625 526213. Aura, B&W, Denon, Kenwood, Marantz, Nad, Pioneer, Rotel, Systemdek, Tannoy, Revolver, J.P.W., M. Short, Mission, Celestion, Technics, Audiobal, Castle. Open 9.30-6. Dem room. No pressure. BADA member.

THE HI-FI SHOWROOMS, 12A West Str, Congleton, Cheshire (01260) 280017, 1 Stanley St, Leek (01533) 383780, Celestion, Creek, Exposure, Royd, Naim Audio, Musical Fidelity, Project, Rotel, Ruark, Tannoy, Technics, 5 Dem Rooms. No appts nec. Home trial, Free install, Service dept. Access, Visa, Lombard Tricity. Open 9-5.30, Closed Wed.

HALE HI-FI, 2 Bold St, Hale Road, Altrincham, Cheshire WA14 2ER. Tel: 0161 929 0834. Open Mon - Sat 10am-6pm & later by appointment. Specialising in equipment by: Naim, Quad, Royd, Nad, Denon plus selected others. Large range of quality accessories. On site service department. Installation & delivery. Home demonstrations a pleasure

ASTON AUDIO, 4 West Street, Alderley Edge, Cheshire. Tel. 01625 582704. Products include: Bang & Olufsen, Arcam, Audiobal, B&W, Cyrus, Denon, Epos, Meridian, Micromega, MF Mission, Nakamichi, Quad, Rotel, TDL & other leading brands. Demonstration Rooms, Installation Service, Interest Free Credit, Access, Visa. Open Mon-Sat

CHRIS BROOKS AUDIO, 29 Gaskell Street, Stockton Heath, Warrington, Cheshire, WA4 2UN. Tel (01925) 261212. Tues-Sat 10.00-6.00. 2 dem-rooms. credit facilities. All credit cards. Established 1978. Total absence of bulls**t. Linn Specialist.

PRACTICAL HI-FI, 88 Bridge Street, Warrington, WA1 2RF. Tel: 01925 632179. See our main entry under Preston, Lancs.

THE AUDIO COUNSEL, 14 Stockport Road, Cheadle, Cheshire. Tel (0161) 428 7887 and 12 Shaw Road, Oldham, Manchester OL1 3LQ Tel (0161) 633 2602. Linn, Arcam, Naim, Audio Research, Martin Logan, Yamaha, Creek, Nakamichi, Denon, JPW, Marantz, Royd, Lexicon. 3 dem rooms, free install, VISA/ACCESS Full multi-room and A.V. installation 10:00 - 5:30pm Mon-Sat, till 8:00 Thursday.

NORMAN AUDIO LTD. 106 Victoria Street Crewe CW1 2JT Tel. 01270 211091 Fax 01270 250794 See main ad also under Lancs. for our agencies

CHRIS BROOKS AUDIO, 29 Gaskell Street, Stockton Heath, Warrington, Cheshire, WA4 2UN. Tel (01925) 261212. Tues-Sat 10.00-6.00. 2 dem-rooms. credit facilities. All credit cards. Established 1978. Total absence of bulls**t.

AUDIO EXCELLENCE, 86/90 Boughton, Chester, CH3 5AQ. Tel. 01244 345576. All that's best in hi-fi carefully selected and demonstrated by friendly knowledgeable staff, at prices to suit all budgets. Delivery and installation, home dems, part exchange in house workshops, full credit facilities with interest free on selected items. Tuesday - Saturday 9.00 - 5.30. Closed Monday.

ACOUSTICA, 17 Hoole Rd., Chester CH2 3NH Tel: 01244 344227. All that's best in Hi-Fi from Linn, Naim, Arcam, Audiobal, Ruark, Rotel and many more. Multi room systems from Linn Knekt. Superb demonstration facilities, home demonstrations and installation a pleasure. We offer the best products, the best service and the best sounds. Open Tuesday to Saturday, evenings by appointment.

CLEVELAND

GILSON AUDIO LTD, 172 Borough Rd., Middlesbrough. (01642) 248793. Micromega, Exposure, Arcam, Mission, Cyrus, Denon, Marantz, Rotel, Pioneer, Audiobal, Tannoy. Demonstration facilities in main shop and one demonstration room. Appointments necessary. Home trial facilities. Free install on request. Service department. Access, Visa, H.P. 10-5-6 days.

ACTION ACOUSTICS, 155-157 High St., Redcar, Cleveland TS10 3AN. 01642 480723. Audio Innovations, Audio Note, Denon, Harman Kardon, JBL, Michell, Musical Fidelity, Pink Triangle, Rogers, Sugden, SonicLink, Townsend, TDL, Thorens etc. Dem room appointment nec. Home Trial, Free installation, service dept. Int. free credit facility. Access, Visa & HP. Open 9.15-5.30

CORNWALL

RIF AUDIO VISUAL, 84 Pendarves Street, Tucking Mill, Camborne, Cornwall. TR14 BNJ. 01209 710777/612260. Audio Analysis, Audio Innovations, JBL, Teac, TDL, Monitor Audio, Musical Fidelity, NAD, Nakamichi, B&W, SME, Micromega, Pink Triangle, Project, Perception, Sugden, Harman Kardon, Triangle. Integral dem/showroom and special home dems. Appts nec, home trial, free install, service dept. All Cards Switch and Transax. Open Mon-Sat 9.30-5.30.

CUMBRIA

MISONS SOUND & VISION, Viaduct House, Victoria Viaduct, Carlisle, CA3 8AN. Tel (01228) 22620. Aura, Bang & Olufson, B & W, Castle, NAD, Quad, Rotel, Sony, Sugden, Yamaha, Demo Suite. No appts nec. Home trial facilities. Free installation. Service Department Mon - Sat. 9 - 5.30

PETER TYSON, 6 Abbey Street, Carlisle, Cumbria, CA3 8TX. 'Cumbria's premiere hi-fi centre'. Part exchange welcome. (01228) 467556. Linn, Musical Fidelity, Cyrus, Marantz, Denon, Philips, Nakamichi, Technics, Pioneer, Creek and more. Dem Rooms. Demos without obligation. Home trial. Free installation. In-house service dept. Access, Visa, HP. 9-5.30pm

PRACTICAL HI-FI, 106 English Street, Carlisle, CA3 8ND Tel: 01228 44792 See our main entry under Lancaster.

DEVON

THE HI-FI ATTIC, 58 New George St., Plymouth, Devon. PL1 1RR. 01752 669511. We stock most leading brands including Linn, Arcam, Denon, Pioneer, Musical Fidelity amongst others, and have an expert enthusiastic staff. Premises include attractive hi-fi and home cinema demonstration rooms. We offer free installation and credit facilities (written details on request) also a fully equipped service department. We can also provide a mail order service for all your LaserDisc requirements. We accept Visa, Access, Amex.

UPTON ELECTRONICS, 31 Torquay Road, Paignton, Devon TQ3 3DT Tel- 01803 551329. Pioneer Reference Point Dealer, Sony, Technics, Harmon-Kardon, Orelle, Kinshaw, Creek, Quad, NAD, Target, Alphason, Tannoy, Morduant-Short, Castle, TDL, JPW, Royd, Sequence, Canon, Monitor-Audio,

Micromega, Project, Chord, Van Den Hul, Jamo. Full range of accessories etc. Demonstration room, Home dems. Free delivery and installation. PX available. Own In-house service dept. Compact Discs, Access, Visa, Amex. Credit facilities. 9.00-5.30 9.00-1.00 Wed.

DERBY

STRAO TRADITIONAL AUDIO, 29 Meadowfield, Whaleybridge, nr Buxton, Derbyshire. SK12 7AX. Tel. 01663 733383. We construct custom made reproductions of classic 1950's loudspeaker enclosure designs using authentic blueprints. These have never been bettered for valve amplification. Requests for specific designs considered and researched. Superb new speaker units from Richard Allan and Lowther are used.

ACTIVE AUDIO, 12, Osmaston Street, The Spot, Derby. Tel. 01332 380385. Fax: 0332 385185. We have three studios including a dedicated Audio Visual studio for the demonstration of quality equipment from the largest range in the Midlands. Open six days per week. Own service department. Free local delivery, home trial facility. Current special offers and buyers fact pack and quotation on request.

DORSET

SUTTONS HI-FI, 18 Westover Road, Bournemouth, Hants. Tel. 01202 555512. Arcam, Audiobal, Audiotecnica, Chord, Celestion, Denon, Infinity, Kef Reference, Linn, Mission, NAD, Qed, Rotel, Rel, Sennheiser, Sony, Target, Yamaha and others. 2 listening rooms. Home Cinema Free delivery and installation. Home demonstrations. Open Mon-Sat 9.00-5.30. BAOA Member. Two year guarantee on Hi-Fi.

ESSEX

AUDIO T, 442-444 Cranbrook Road, Gants Hill, Ilford. (0181) 518-0915. Great Value on Aiwa, Arcam, Audiobal, Cyrus, Denon, Kenwood, Linn, Marantz, Meridian, Mission, Micromega, Rotel, Sony, Technics, Yamaha & more. Tues/Thur/Fri 10-7. Wed/Sat 9.30-5.30. 3 year Hi-Fi guarantee. 30 day free upgrades. PX. Selected Interest Free Credit. 2 listening rooms. Home Cinema. BADA Bonded.

BRENTWOOD HI FIDELITY, 2 Ingrave Road, Brentwood, Essex. CM15 8AT. Tel: 01277 222120. Aura, Audio Innovations, Castle, Chord, Crimson, Denon, DNM, E.A.R., Impulse, Marantz, Mission, Micromega, NAD, Pink Triangle, Project, QUAD, Ruark, Rehdero, Sheame Audio, Systemdek, Tannoy, TDL, Thule Audio Single speaker dem rooms, home trials, dems and installations. Mon-Sat 9.30-5.30. Access, Visa, service facilities. Simply THE place to visit if you're serious about music.

RAYLEIGH HI-FI, Chelmsford, 216 Moulsham St. 01245 265245. RAYLEIGH HI-FI, Rayleigh 44a High Street. 01268 779762. RAYLEIGH HI-FI, Southend, 132/4 London Rd. 0702 435255. Over 21 years experience of supplying the best. The best dealer, the best Hi-Fi equipment, the best service. Carefully selected Hi-Fi from: Arcam, Audiobal, Cyrus, Denon, Epos, Linn, Meridian, Mission, Naim, Nakamichi, Quad, Rega, Roksan, etc. etc. 3 years guarantee on Hi-Fi systems. 0% credit facilities.

COLVILLE HI-FI - RHYTHMS, 8, Market Square, South Woodham Ferrers, Chelmsford, Essex. CM3 5XA. Tel: (01245) 325125/Fax: (01245) 328748 Products:- Yamaha/Marantz/Musical Fidelity/Tannoy/Morduant Short/TDL/Toshiba/Cable Talk/ixos/ Alphason/ Sennheiser/Pioneer & More. Tv, Video, Cinema Sound. Friendly Advice. Dem Rooms. See It Hear It And Believe It At Rhythms - For Beautiful Sound & Vision Without The Blues!

WORCESTERSHIRE

PAGE 97

WEST MIDLANDS, YORKSHIRE (SOUTH), YORKSHIRE (WEST), SCOTLAND, EDINBURGH, ABERDEEN, AYRSHIRE, GLASGOW, INVERNESS, TAYSIDE, IRELAND, DUBLIN, BELFAST, COUNTY DOWN, LONDONDERRY, WALES, NORTH WALES, GLAMORGAN (SOUTH), GLAMORGAN (WEST), GWYNEDD

PAGE 89

AVON, BEDFORDSHIRE, BERKSHIRE, BUCKS, CAMBRIDGE, CHESHIRE, CLEVELAND, CORNWALL, COUNTY DURHAM, CUMBRIA, DEVON, DERBY, DORSET, ESSEX

PAGE 90

GLOUCESTERSHIRE, HAMPSHIRE, HEREFORDSHIRE, HERTFORDSHIRE, HUMBERSIDE, KENT, LANCASHIRE, LEICESTER, LINCOLNSHIRE

PAGE 91

LONDON, GREATER MANCHESTER, MERSEYSIDE, MIDDLESEX, NORFOLK, NORTHAMPTON, NOTTINGHAMSHIRE, OXFORDSHIRE

PAGE 92

SHROPSHIRE, SOMERSET, STAFFORDSHIRE, SUFFOLK, SURREY, SUSSEX (EAST), SUSSEX (WEST), TYNE & WEAR, WARWICKSHIRE, WEST MIDLANDS, WILTSHIRE,

SEVENDAKS HI-FI 1 The Grove Centre, Witham, Essex. Tel 01376 501733. The UK's leading independent hi-fi and home cinema retailer, specialising in quality products for discerning customers. Open six days, with dedicated single speaker and audio visual demonstration rooms. Major credit cards accepted, 0% finance available (details upon request), home trial and installation by arrangement. Major brands stocked include Arcam, Audioblab, Castle, Denon, KEF, Marantz, Meridian, Mission, Monitor Audio, Musical Fidelity, Quad, Rotel, Ruark, TEAC, and Yamaha.

GLoucestershire

AUDIO EXCELLENCE, 58 Bristol Road, Gloucester, GL1 5SD. Tel. 01452 300046 Fax. 0452 310680 All that's best in hi-fi carefully selected and demonstrated by friendly knowledgeable staff, at prices to suit all budgets. Delivery and installation, home dems, part exchange, in house workshops, full credit facilities with interest free on selected items. Tuesday - Saturday 9.00 - 5.30. Closed Monday.

AUDIO T, 40-42 Albion Street, Cheltenham. (01242) 583960. Great Hi-Fi on Aiwa, Arcam, Audioblab, Denon, Linn, Marantz, Meridian, Micromega, Mission, NAD, Nakamichi, Pioneer, Quad, Rotel, Sony, Technics, Yamaha & many more. Tues-Fri 9.30-6. Sat 9.30-5.30. 3 year Hi-Fi guarantee. 30 day free upgrades. Home demonstrations. Part exchange. Selected Interest Free Credit. Listening room. BADA Bonded.

SEVENDAKS HI-FI 24 Pittville Street, Cheltenham, Gloucs. Tel 01242 241171. The UK's leading independent hi-fi and home cinema retailer, specialising in quality products for discerning customers. Open six days, with dedicated single speaker and audio visual demonstration rooms. Major credit cards accepted, 0% finance available (details upon request), home trial and installation by arrangement. Major brands stocked include Arcam, Audioblab, Castle, Cyrus, Denon, Epos, KEF, Marantz, Meridian, Mission, Monitor Audio, Quad, Rotel, Ruark, TEAC and Yamaha.

THE RIGHT NOTE - Bath for specialist advice and home demonstrations. See Avon.

Hampshire

HOPKINS HI-FI, 'FOR THE BEST SEAT IN THE HOUSE' experience home cinema sound with Technics, Denon and Kenwood. Award winning products. Now on demo at HOPKINS HI-FI. 38-40 Fratton Road, Portsmouth, Hants, PO1 5BX. Tel. 01705 822 155, Fax. 0705 830 753

AUDIO T, 4 Feathers Lane, Basingstoke. (01256) 24311. Great Value on Aiwa, Arcam, Audioblab, Cyrus, Denon, Linn, Marantz, Micromega, Mission, Naim, Nakamichi, Sony, Technics, Yamaha & many more. Tues-Sat 9-5.30. 3 year Hi-Fi guarantee. Free delivery & installation. 30 day free upgrades. Home demonstrations. PX. Selected Interest Free Credit. Listening room. BADA Bonded.

HAMPSHIRE AUDIO LIMITED, 2-12 Hursley Road, Chandlers Ford, Hants, SO53 2FU. Tel Southampton (01703) 252827/265232. 3 Hi-Fi and 2 Home Cinema/Dolby Surround Sound Demonstration Rooms, one with Projection TV and an 8' wide screen. Brands stocked include ARCAM (incl. Xeta), Audioblab, Audioquest, Celestion, Cyrus, Denon, Gradient, Infinity, KEF, Marantz, Meridian, Mission, Polk, Quad, Rotel, Selec, Sennheiser, Soundstyle, Tannoy, Target Audio, Thorens, & Yamaha. Established 1969, we offer a 2-year Guarantee covered by our own well-equipped Service Dept. We have a large FREE car parking facility and we are located within 3 miles from Junction 14 (M3/M27 Interchange) and Junctions 13 (M3) and 5 (M27). Closed Mondays, except in December. Late Night: Thurs to 8pm. BADA Founder Member. All deposits fully covered by BADA Bonding.

Herefordshire

ENGLISH AUDIO, 37 Whitcross Road, Hereford, HR4 0DG. (01432) 355081. Arcam, A.T.C., Audioblab, Audion, B&W, Castle, Celestion, Cyrus Centre, Denon, Exposure, KEF, Marantz, Michi, Micromega, Mission, Musical Technology, NAD, Nakamichi, Pink Triangle, Pioneer, REL, Rotel, Ruark, John Shearne, SME, Stax, Systemdeck TDL. Yamaha. Single speaker dem room, home trial facilities, free installation, service dept. Access/Visa, Credit arranged. Open Mon-Sat, 9.30-5.30pm. BADA members.

SEVENDAKS HI-FI 478 St Albans Road, Watford, Herts. Tel 01923 213533. The UK's leading independent hi-fi and home cinema retailer, specialising in quality products for discerning customers. Open six days, with dedicated single speaker and audio visual demonstration rooms. Major credit cards accepted, 0% finance available (details

upon request), home trial and installation by arrangement. Major brands stocked include Arcam, Audioblab, Castle, Cyrus, Denon, KEF, Marantz, Meridian, Michell, Mission, Monitor Audio, Musical Fidelity, Quad, Rotel, Ruark, TEAC and Yamaha.

HERTFORDSHIRE

DAVID ORTON AUDIO VISUAL, 6-8 Bancroft, Hitchin, Herts. Tel: 01462 - 452248. Mission, Cyrus, Denon, Pioneer, Marantz, Aura, Kenwood, Rotel, Ruark, Celestion, JVC, Polk and many more. Open Mon-Sat 9.30-5.30. All major credit cards accepted. Finance available. (See our main advert pg 106).

DYNAMICS, Welwyn, Herts - Europe's largest stockist of ex-dem and second hand equipment. High End Audio - Bought, Sold or Exchanged. Many items in stock. (see our main ad pg. 128). Efficient servicing Dept. All items guaranteed. All major credit cards accepted. Please telephone 01438 - 714038 for appointment.

GOSPEL MUSIC AUDIO, 32a High Street, Kington, Herefordshire, HR5 3BJ.(01544) 230254. Alphonson, Allison, Revolver, Luxman, Yamaha, OEO Audio, Systemline.

STUDIO 82, 82 High Street, Harpenden, Herts AL5 2SP. 01582 764246. Fax 0582 467022. ATC, AVI, Arcam, Aura, Audioblab, B&Q Denon, Epos, Marantz, Mission, Naim Audio, Nakamichi, Quad, NAD etc. Quiet single speaker dem room. Appts nec. Home trial, free installation. Service dept. Visa, Access and finance terms. 9-5.30 Mon-Sat.

THE AUDIO FILE, 27 Hockerill St., Bishop's Stortford, Herts, CM23 2DH. Tel 01279 506676. Fax 0279 506638. Linn, Naim, Roksan, Quad, Rega, Mission, Arcam, ProAc, Marantz, Sony etc. 4 dem rooms, installation service. Min 3 year warranty, 0%, BADA.

REVOX Service & Repairs, Suite 10, Smugook Business Centre, Lye Lane, Bricketwood, Herts. AL2 3UG. Tel 01923 893711. Seventeen years experience, ex-Bauch. Authorised agents for Revox products, sales and spares. All repairs carried out are guaranteed. Fast turnaround. Any enquiries telephone: 01923 893711.

RADLET AUDIO, 9 Holywell Hill, St. Albans, Herts, AL1 1EU. Tel. 01727 855577. Mark Levinson, Proceed, Proac, Tube Technology, Teac, Audioblab, Stax, ATC, Audio Alchemy, EAR, Sumiko, Quad, JBL, Denon, Creek, Michell, Micromega, XLO, Alchemister, B&W, Ruark, LFD and many others. Home trial facilities, free installation, Service Dept., Visa/Access, Open 9.30 - 5.30 Mon - Sat.

HUMBERSIDE

Zen Audio George Street Hull Tel. 01482 587397. "Comfortable listening rooms. Home dems. Free installations. Agencies include: Audioblab, Audio Innovations, Aura, Audion, Denon, DNM, D.P.A., Cable Talk, Heybrook, JPW, Kar, Net Petite, Micromega, Michell, Harmon Kardon, Impulse, Ruark, Rotel, Royd, Sugden and many more."

KENT

JOHN MARLEY HI-FI CENTRES, Dover - 01304 207562. Arcam, Audioblab, Aura, B&W, Heybrook, JPW, Proac, Pioneer, Rotel, Ruark, Tannoy, Technics. Dem rooms and home trial facilities. Mon-Sat, 9-5.30 clos. Thurs. Free install. Credit to £1,000. Access, Visa and credit charge. Service Dept.

KIMBERLEY HI-FI, 193 Broadway, Bexleyheath, Kent. Tel 0181 3043272. Pioneer, Technics, Kenwood, Marantz, Denon, NAD, Aiwa, Tannoy, Mission, Rotel, Wharfedale, Castle. Separate dem room, no appt necessary. Free installation, service dept, instant credit facilities. no early closing.

V.J. HI-FI, 29 Guildhall St. Folkstone Kent Tel: 01303-256860. Stockists of: Mission, Tannoy, J.B.L., Pioneer, Philips, Aiwa, Marantz, Musical Fidelity, Quad, Yamaha, Denon and much more besides. Full audio and home cinema demonstration facilities. Fully bonded BADA members. Interest free credit available (subject to status). Open Mon-Sat 9:00-6:00

V.J. HI-FI, 119 High St Margate Kent Tel: 01843-226977. Stockists of: Mission, Cyrus, Quad, Tannoy, J.B.L. Sound Effects Range, Musical Fidelity Yamaha, Denon Meridian, Sound style and Target Equipment Racks. Full audio and home cinema demonstration facilities. Fully bonded BADA members. Interest free credit available (subject to status) Open Mon-Sat 9:00-5:30

THE WESTGATE HI-FI, 2 Station Road West, Canterbury, Kent. 01227 769329. Suppliers of quality hi-fi equipment including: Arcam, Akai, Aura, B&W, Denon, Jamo, JPW, Mordaunt Short, NAD, Panasonic, ProAc, Quad, Rotel, RuArc, TDL, Technics, Tannoy. Part exchange. Listening room. Service and repairs. Credit facilities. Access/Visa. Open 6 days 9-5.30.

DOVER HI-FI, 43 High Street, Dover. Tel: Dover 207562. Suppliers of quality hi-fi equipment including: Arcam, Akai, Aura, B&W, Denon, Jamo, JPW, Mordaunt Short, NAD, Panasonic, ProAc, Quad, Rotel, RuArc, TDL, Technics, Tannoy. Part exchange. Listening room. Service and repairs. Credit facilities. Access/Visa. Open 6 days 9-5.30.

ELECTRICAL DISCOUNT CENTRE, EDC, 138 pelham Road Gravesend, Kent DA11 0JH. Tel: 01474 569601. Pioneer, Marantz, Technics, Akai, JVC, Jamo.

ELECTRICAL DISCOUNT CENTRE, EDC, 109 The Broadway Bexley Heath Kent DA6 7JH. TEL: 0181 298 7880. Pioneer, Marantz, Technics, Akai, JVC, Jamo.

SEVENDAKS HI-FI 28 St Johns Road, Tunbridge Wells, Kent. Tel 01892 531543. The UK's leading independent hi-fi and home cinema retailer, specialising in quality products for discerning customers. Open six days, with dedicated single speaker and audio visual demonstration rooms. Major credit cards accepted, 0% finance available (details upon request), home trial and installation by arrangement. Major brands stocked include Arcam, Audioblab, Castle, Denon, KEF, Marantz, Meridian, Mission, Monitor Audio, Quad, Rotel, Ruark, TEAC, and Yamaha.

SEVENDAKS HI-FI 4 Railway Street, Chatham, Kent. Tel 01634 846859. The UK's leading independent hi-fi and home cinema retailer, specialising in quality products for discerning customers. Open six days, with dedicated single speaker and audio visual demonstration rooms. Major credit cards accepted, 0% finance available (details upon request), home trial and installation by arrangement. Major brands stocked include Arcam, Audioblab, Castle, Denon, KEF, Marantz, Meridian, Michell, Mission, Monitor Audio, Musical Fidelity, Quad, Rotel, Ruark, TEAC, and Yamaha.

SEVENDAKS HI-FI 20a Lower Bridge Street, Canterbury, Kent. Tel 01227 462787. The UK's leading independent hi-fi and home cinema retailer, specialising in quality products for discerning customers. Open six days, with dedicated single speaker and audio visual demonstration rooms. Major credit cards accepted, 0% finance available (details upon request), home trial and installation by arrangement. Major brands stocked include Arcam, Audioblab, Castle, Denon, KEF, Marantz, Mission, NAD, Pioneer, Quad, Rotel, Ruark, TEAC, and Yamaha.

SEVENDAKS HI-FI 109-113 London Road, Sevenoaks, Kent. Tel 01732 459555. The UK's leading independent hi-fi and home cinema retailer, specialising in quality products for discerning customers. Open six days, with four dedicated single speaker and audio visual demonstration rooms. Major credit cards accepted, 0% finance available (details upon request), home trial and installation by arrangement. Major brands stocked include Arcam, Audioblab, Castle, Cyrus, Denon, KEF, Marantz, Meridian, Michell, Mission, Monitor Audio, Musical Fidelity, Quad, Rotel, Ruark, TEAC and Yamaha.

LANCASHIRE

MARTON MUSIC, 5 Masterson Ave, Read, Burnley BB12 7PL. Tel: 01282 773198. Demonstrations of stereo and A/V systems in large comfortable lounge using equipment from AVI, ATC, RUARK, YAMAHA, MARANTZ, SEQUENCE, plus a range of custom built speakers, including Transmission Lines; home demo's encouraged before buying, free installation when required. Agent for LIBERTY INSTRUMENTS IMP/m and AUDIOSUITE loudspeaker testing systems. Ring anytime for appointment, free advice or chat... we never close.

ORPHEUS AUDIO ... Less between you and the music ... Arion Acoustics • Audiomeca (Pierre Lourné) • Audio Alchemy • AudioNote • Audio Synthesis • Burmester • E.A.R. • Cabasse • Lieder • Ortofon • Project • QED • Teac • Triangle • YBA • Boulder • Acarian Systems • Sonic Link • Beyer • Sennheiser • Audio Quest • Demonstrations by arrangement in Standish • Lancs. or in your own home without obligation Tel: 01257 473175 (evening calls welcome)

PRACTIAL HI-FI, 43 Friargate, Preston. Tel:- 01772 883958. The audio visual specialist, expert advice, instant demonstrations, best prices, instant free credit, part exchange welcome. Extended warranty. Stockists of Yamaha, Kenwood, Denon, Sony, Technics, Onkyo, Marantz, Pioneer, Mission, Kef, Jamo, Celestion, B&W. Also stockists of LaserDiscs.

PRACTICAL HI-FI, 84 Penny Street, Lancaster, LA1 1XN Tel:- 01524 39657 - See our main entry under Lancaster.

PRACTICAL HI-FI , 33/35 Knowsley Street, Bolton, Lancs Tel:- 01204 395789 - See our main entry under Lancaster.

PRACTICAL HI-FI, 10 Preston New Road, Blackburn, BB2 1AW Tel:- 01254 691104. See our main entry under Lancaster

PRACTICAL HI-FI , 81 Whitegate Drive, Blackpool, FY3 9DA Tel:- 01253 300599. See our main entry under Lancaster.

NORMAN AUDIO, 131 Friargate, Preston, Lancashire, PR1 2EE. Tel. 0772 253057. Fax. 0772 562731. Marantz, Pioneer, Yamaha, Audioblab, Arcam, Mission, Cyrus, B & W, Kef. Send for your catalogue. Home cinema dem room plus three sales areas. No appt necessary, free install. service dept. instant credit subject to status. Open 9.30-5.30, late night Wed- 8pm.

LEICESTER

LISTENING INN, 6 Hotel Street, Leicester. Tel. 01162 623754. fax. 01162 623758. Arcam, Audioblab, Cable Talk, Chord Co, Creek, Denon, Epos, Heybrook, Kef, Linn, Micromega, Nakamichi, Onix, Rotel, Royd, 4 Dem Rooms. Open 10.00-5.30 (Six days.)

ENCORE! Nr. Melton Mowbray. Tel. 01664 823282. Sugden, Densen, Unison, Tube Technology, Ruark, UKD Opera, Kewick Audio Research and Fi-Rax. As you can see from our agencies, we are open-minded and able to present diverse options for your appraisal. Unbiased and unhurried demonstrations by appointment incl. evenings and weekends.

SEVENDAKS HI-FI 94 Granby Street, Leicester. Tel 0116 255 7518. The UK's leading independent hi-fi and home cinema retailer, specialising in quality products for discerning customers. Open six days, with dedicated single speaker and audio visual demonstration rooms. Major credit cards accepted, 0% finance available (details upon request), home trial and installation by arrangement. Major brands stocked include Arcam, Audioblab, Castle, Denon, KEF, Marantz, Meridian, Mission, Monitor Audio, Quad, Rotel, Ruark, TEAC, and Yamaha.

HARROW AUDIO, 27 Springfield Road, Harrow. Tel: 0181 863 0938 or Fax: 0181 863 2443. We stock scores of leading brands including Arcam, Audioblab, Aura, Denon, KEF, Mission, Marantz, TDL, Tannoy and Yamaha. Next Day Carriage Free Mail Order (UK). M&S Voucher scheme. Free Colour Brochure upon request. Knowledgeable staff with 90 years combined experience! Plus 2 year Guarantees and BADA Bonded. TOP TAPE mail dealer with 1000's of tapes and also a "Simply The Best" member.

CLASSIQUE SOUNDS, "Vintage Hi-fi Specialist". Stockists of: Garrard 301/401, Thorens, Quad, Leak, Rega, Shirley Labs, Spondor, Wharfedale, Rogers, Arcam, SME, Decca, Pioneer, UKD, Sugden, Musical Fidelity, + much more." Tel/ Fax Paul Greenfield on UK + 0116 283 5821 or 0800 213 740 (mobile) any - time Classique Sounds or Demos, Classique House, 61 Aylestone Drive, Leicester, LE2 8QE.

LINCOLNSHIRE

BOSTON HI-FI CENTRE, 65a Wide Bargate, John Adams Way, Boston, Lincs PE21 6SG. Tel: 01205 365477. Quad, Nakamichi, Arcam, Marantz, NAD, Castle, Tannoy, Rogers etc. Separate demonstration studio incl. home cinema. Free installation. Access, Visa, Tues-Sat 9-5 pm.

COTTAGE AUDIO, 17 Bridge Street, Saxilby, Nr Lincoln. LN1 2PZ. Tel: (01522) 702834. Evenings: (01522) 696708. ATC, AVI, Chord amplifiers, Harbeth, LFD, Michell, Origin Live, Kinshaw, QED, Royd, Sansui. Sequence, Something solid, Sonic Link, etc. Demonstration rooms. Home trial facilities. Free installations and above all a personal, friendly service.

STAMFORD HI-FI CENTRE - 9 Red Lion Square, Stamford, Lincs. PE9 2AL. (01780) 62128. Pioneer, Technics, Cyrus-Mission, Rotel, NAD, Yamaha, Kenwood, Marantz, Quad plus all major speaker manufacturers. Expert Advice, Comparator demonstrations, part-exchange Hifi purchased for cash. No appts necessary. Home trial facility, free installation. Service Dept. Mastercard, Visa and credit charge. Mon-Sat 9-5.30 pm. Closed Thursdays.

LONDON

TIME & TUNE, For T.V. video, Hi-Fi, and in-Car Hi-Fi. We are dealers of: Aiwa, Bose, Hitachi, Jamo, Kenwood, Marantz, Mitsubishi, Nad, Panasonic, Pioneer, Sony, Technics. For these and more come and see us at Time & Tune, 218-220 Whitechapel Rd, London, E1 1BJ. Or call 0171 377 2000

ANALOG AUDIO, 849 High Road, Finchley, N12. (0181) 445 3267 For friendly service and advice. AR, AKG, Allison, AT, Cerwin, Vega, Denon, Dual, Harmon Kardon, Jamo, Infinity, Marantz, NAD, Pioneer, Rotel, Revolver, Sonab, Teac, Thorens, Tannoy, Wharfedale, Yamaha. Speaker cables and accessories. Free installation. service

AUDIO CONCEPT, 27 Bond Street, Ealing, W5 5AS. Tel: (0181) 567 8703. Acoustic Energy, Audiolab, Aura, B&O, B&W, Boston Acoustics, Canon, Castle, Denon, Dual, Evolution, Infinity, JPW, KEF, Marantz, Mission, Monitor Audio, Musical Fidelity, NAD, Nakamichi, Onix, Quad, Revox, Rogers, Rotel, Systemdek, Target, Teac, Thorens, Van den Hul. Two dem rooms. Interest free credit, free local delivery & installation, service department. 'Hi-Fi Specialists without the attitude'

AUDIO T, 190 West End Lane, West Hampstead. (0171) 794-7848. Great Value on Aiwa, Arcam, Audiolab, B&W, Denon, Linn, Marantz, Meridian, Micromega, Mission, Nakamichi, Rotel, Sony, Technics, Yamaha & many more. Tues-Sat 10-6 Late Thurs until 8.00. 3 year Hi-Fi guarantee. 30 day free upgrades. Home demonstrations. PX. Selected Interest Free Credit. 2 listening rooms. BADA Bonded.

AUDITORIUM, 119 Middlesex Street, Bishopsgate, London E1 7JF. Tel: 0171 247 5000. Full range of equipment from Arcam, Bang & Olufsen, Cyrus, Denon, Dynavector (amplifiers & cartridges), Epos, Kef, Micromega (including 3.1, 2.1, transports, BS2, Pro2 DACs and Stage) Mission, Naim, Neat, REL, Shahinian, Well Tempered Turntables, and Xlo. Open Monday to Friday 10.30am to 7.00pm and Saturday 11.00am to 4.00pm. Two minutes walk from Liverpool Street Station

GOLF ELECTRONICS, 311 Kentish Town Road, NW5 2TJ Tel 0171 482 2518. Fax 071 284 3381. Authorised dealers for: Sony, Panasonic, Aiwa, Akai, Mitsubishi, Philips, Grundig, Bose. We carry an extensive range of hardware from Walkmans to camcorders, including a wide range of TV and video equipment. Free local delivery & installation on selected items. Open 10-6 Mon-Sat. We regularly have special offers on different products. A visit to GOLF ELECTRONICS could save you £££s

HIFI & COMPONENTS, 84 Battersea Rise, London, SW11 1EH. (0171) 223 1110. Denon, Tannoy, NAD, Rotel, Bose, Dual, QED, Wharfedale, Jamo, Celestion, Kenwood, Ortofon, Infinity, Shure, to name but a few! Established over 29 yrs. Appts necessary. Service dept. 10-6 (closed Weds)

HIFI EXPERIENCE, 227 Tottenham Court Road, London W11. 0171 580 3535. Arcam, Audiolab, Mission, Cyrus, Quad, Celestion, Kef, Meridian, Rogers, Tannoy, Yamaha, TDL, Thorens, Marantz, Nakamichi, Musical Fidelity and many more. Open 10.00-7.00 Mon-Fri. 9-6 on Sat. Service dept. Credit facilities, delivery and free installation.

KAMLA ELECTRONICS, 251 Tottenham Court Road, London W1P 9AD. Telephone: 0171 323 2747. Fax: 071 637 2690. Acoustic Research, Aiwa, Akai, Albarry, Alchemist, Alphason, Audio Alchemy, Audio Innovations, Audio Technica, Audioquest, Aura, Audiogistic, B&W, Cerwin Vega, Conrad Johnson, Coppenhagen, Furukawa, Goldring, Infinity, IXOS, JPW, JVC, KEF, Kenwood, Kuzma, Lynwood, Maxell, Micromega, Mitsubishi, Monster, Mordaunt Short, Moth, Nakamichi, Oracle, Ortofon, Panasonic, Pioneer, Project, QED, Rotel, Ruark, Sansui, Stax, TDK, and many more!!

K J WEST ONE, 26 New Cavendish St., London W1M 7LH. 0171 486 8262/63. Fax 0171 487 3452. Two hi-fi & two home cinema dem studios. Appts pref. Home trial. Installation by arrangement. Service dept. Major credit cards. Interest free credit on selected items. Major brands stocked: Arcam, Audio Alchemy, Audio Innovations, Audio, Audiolab, Audio Research, B&W Castle, Chord, DPA, Harbeth, Harman Kardon, KEF, Klipsch, Krell, Marantz, Martin Logan, Meridian, Michell, Micromega, Mission, Musical Fidelity, Nitty Gritty, Pink, ProAc, Quad, Rel, Rotel, Sonus Faber, Stax, Tannoy, Theta. Open 6 days.

CONNECTIONS, 13 John Prince's Street, London W1M 9AH. Tel: 0181 348 5676. Dealers in: Absolute, Audio Note, Audioquest, Deltac, Harmonix, Kimber, Mandrake, MIT, Sitech, Symo, Van den Hul, WBT and others.

THE LISTENING ROOMS, 161 Old Brompton Road, London SW5 0LJ. (0171) 244 7750/59. Fax (071) 370 0192. Linn, Quad, Meridian, Nakamichi, Arcam, Audiolab, Acoustic Energy, SME, Audio Research, Krell, Wadia, Theta, Apogee, Martin Logan, Pioneer, Tannoy, Systemdek, Stax, Pink Triangle, Michell, Monitor Audio, Yamaha, Marantz, Kef, Bose, Celestion, Epos, Mission, Denon, Neat Petite. Mon-Sat 10-6pm.

THE CORNFLAKE SHOP, 37 Windmill Street London W1P 1HH. Tel.(0171) 631 0472 Fax (0171) 436 7165. Tues-Sat 10-6, Thurs 10-7. The specialists for the highest quality of sound, for one room or many more. Full advice & installation service available. Multiroom specialists & worldwide mail order service. Brands carried include: ATC, AVI, Rega, Naim, Mark Levinson/Proceed Royd, and many more.....

MUSICAL IMAGES, 173 Station Road, Edgware, Middlesex. Tel. (0181) 952 5535. See advert under Middlesex for more information.

MUSICAL IMAGES, 45 High Street, Hounslow, Middlesex. Tel.(0181) 569 5802. See advert under Middlesex for more information.

AUDIO T, 190 West End Lane, West Hampstead, London, NW3 1SQ. (0171) 794 7848. Fax (071) 431 3570. Great Hi-Fi from Adcom, Arcam, Audiolab, B&W, Denon, Epos, Marantz, Meridian, Michell, Mission, Philips, Rotel, Proac, Micromega, Nakamichi, Yamaha, & many more. Mon-Sat 10-6. 3 year guarantee on Hi-Fi. Free delivery & installation. 30 day free upgrade scheme. Home demonstrations. Part exchange. 2 listening rooms. BADA Bonded.

ORANGES & LEMONS, 61-63 Webbs Road, Battersea, SW11. Tel: 0171-924 2040. Juicy fruit from London's newest, freshest Hi-Fi/Home Cinema retailer. Telephone demonstrations, or just up in. All the usual ie. friendly and efficient service, free home installation, credit cards, 0% credit finance available, plus... all the very best from Cable Talk, Chord Co, Denon, Epos, Kef, Micromega NAD, Naim, Quad, Rega, Roksan, Rotel, Royd, Ruark, Soundstyle, Stands Unique and more.

ZEBRA, 18-24 Brighton Road, South Croydon. Tel: 0171 - 688 2093. The UK's First and Finest Home Cinema Store. 3 Demonstration Rooms. Laser Disc CRT and Projection TV Centre. Many brands stocked including Arcam, Audiolab, Meridian, Lexicon, Kef, Pioneer, Rotel, Yamaha, REL and Panasonic. Mon-Sat 9.30-6.00pm. All major credit cards accepted. Finance available. Evening demonstrations by appointment.

SELECT AUDIO, London for Mirage, VPI, Ortofon cartridges, Mark Levinson, Jeff Rowland, Proceed, Sumiko Transfiguration, Magnepan, Lyra plus more, 3 single speakers Listening room by appointment only. Tel: 0181 986 8788, 10-7pm closed wednesday.

RECITAL, 289 New Kings Road, London SW6 4RE Tel 0171-731 0340. To unlock the potential in your music collection hear it through one of our carefully chosen hi-fi systems. equipment by: Adyton, Alchemist, Arion, ATC, Audio Alchemy, Audiomecca, Audio Physic, AVI, Boulder, Cat, Celestion, Chario, Chord Co, CRD, Densen, Graham, Harman, Heybrook, Lumley, Michell, Micromega, Musical Fidelity, NAD, Orelle, Ortofon, Ruark, Triangle, Trilogy.

SEVENOAKS HIFI 403 Kings Road, Chelsea, London. Tel 0171 352 9466. The UK's leading independent hi-fi and home cinema retailer, specialising in quality products for discerning customers. Open six days, with dedicated single speaker and audio visual demonstration rooms. Major credit cards accepted, 0% finance available (details upon request), home trial and installation by arrangement. Major brands stocked include Arcam, Audiolab, Castle, Cyrus, Denon, KEF, Marantz, Meridian, Michell, Mission, Monitor Audio, Musical Fidelity, Quad, Rotel, Ruark, TEAC, and Yamaha.

SEVENOAKS HIFI 162 Powis Street, Woolwich, London Tel 0181 855 8016. The UK's leading independent hi-fi and home cinema retailer, specialising in quality products for discerning customers. Open six days, with dedicated single speaker and audio visual demonstration rooms. Major credit cards accepted, 0% finance available (details upon request), home trial and installation by arrangement. Major brands stocked include Arcam, Audiolab, Castle, Denon, KEF, Marantz, Meridian, Mission, Monitor Audio, Quad, Rotel, Ruark, TEAC and Yamaha.

ALPHABEC LTD, 392 Finchley Road, London, NW2 2HR. Stockists of Bose, Boston, Clifford, Denon, Jamo, JVC, Grundig, KEF, NAD, Onkyo, Panasonic, Sony, Vivanco and Yamaha. Specialists in Multi-Room Installations. Full service facilities. Credit terms available. Open Mon-Sat 10am-6pm. Thurs 10am-1pm. Tel: 0171 431 9133.

GREATER MANCHESTER

THE AUDIO COUNSEL, 12 Shaw Road, Oldham, Manchester DL1 3LQ Tel (0161) 633 2602 and 14 Stockport Road, Cheadle, Cheshire. Tel (0161) 428 7887. Linn, Arcam, Naim, Audio Research, Martin Logan, Yamaha, Creek, Nakamichi, Denon, JPW, Marantz, Royd, Lexicon. 3 dem rooms, free install, VISA/ACCESS Full multi-room and A.V. installation 10:00 - 5:30pm Mon-Sat, till 8:00 Thursday.

ORPHEUS AUDIO, Less between you and the music ... Arion Acoustics • Audiomecca (Pierre Lourme) • Audio Alchemy • Burmester • E.A.R. • Cabasse • Kinshaw • Lieder • Ortofon • Project • Teac • Triangle • YBA • Boulder • Acarian Systems • Sonic Link • Beyer • Sennheiser • Audio Quest • Demonstrations by arrangement in Standish, Lancs. or in your own home without obligation Tel: 01257 473175 (evening calls welcome)

PRACTICAL HI-FI 65 Bridge Street, Manchester M3 3BO Tel: 0161 839 8869 See our main entry under Lancaster

BILL HUTCHINSON HIFI, 50-52 Deansgate, Manchester M3 2FE. (0161) 8321600. For the largest selection of HiFi and audio visual equipment in the North West. Specialist A.V. demonstrations of the highest quality. Best prices guaranteed. Minimum 2 year warranty and an optional 5 yr guarantee available. Instant credit and mail order service on offer throughout the U.K. Pioneer, Denon, Kenwood, Yamaha, Technics, Marantz, Mission, Tannoy plus many more.

MERSEYSIDE

WIRRAL HIFI (Audio Consultants) 17 Shore Bank, Wirral, L62 1DB Tel/Fax: 0151 645 4621. We believe in value for money. That's why we only stock audio equipment that has been carefully selected for its price, build, & most important excellent sound quality. The following manufacturers offer all this: DPA, Gamma, Magnum, Monarchy, Moth, Orelle, Rose, SDA, Sonilith, Teac, Tube Technology, XLO, Audio Synthesis, Audio Alchemy, Bass, Castle, Ethereal Pure Silver Cables. For friendly advice, free local delivery, & installation, demonstration facilities by appointment.

MIDDLESEX

PURE SOUND/ THE AUDIO ROOM, We specialise in high quality valve and solid state amplification, with matching quality speakers and signal source components, and we cover London and the South East. Call us for a personnel demonstration of some of the finest equipment around. We offer too many brands to list here but they include Audio Note, Arion Acoustics, Audio Innovations, Lumley, Impulse, Townsend, Pink Triangle, Audiomecca, XLO, Micromega, Frameworks... 01784 458176/ 0181 893 4485

AUDIO T, 159A Chase Side, Enfield. (0181) 367-3132. Great Hi-Fi from Arcam, Audiolab, Cyrus, Denon, Linn, Marantz, Meridian, Micromega, Mission, Rotel, Yamaha and many more. Mon-Fri 10-6. Sat 9.30-5.30. 3 year Hi-Fi guarantee. Free delivery & installation. 30 day free upgrades. Home demonstrations. PX. Selected Interest Free. 2 Listening Rooms. Home Cinema Specialists. BAOA Bonded.

MUSICAL IMAGES, 45 High Street, Hounslow, Middlesex. Tel.(0181) 569 5802. Fax. (081) 569 6353.

MUSICAL IMAGES, 173 Station Road, Edgware, Middlesex. Tel. (0181) 952 5535. Fax (081) 952 5535. Most brands available - see full page advert. Interest free credit, ask for details. Demo rooms. Repairs & Service. Sunday opening - Open all week. A Home Cinema Specialist. Mail order. Part exchange.

AUDIO T, 159A Chase Side, Enfield. (0181) 367-3132. Great Value on Aiwa, Arcam, Audiolab, Celestion, Cyrus, Denon, Linn, Marantz, Meridian, Micromega, Mission, NAD, Nakamichi, Rotel, Sony, Yamaha & many more. Tues-Fri 9.30-6. Sat 9.30-5.30. 3 year Hi-Fi guarantee. 30 day free upgrades. PX. Selected Interest Free. 2 listening rooms. Home Cinema specialists. BAOA Bonded.

SEVENOAKS HIFI 7 Genotin Road, Enfield, Middlesex. Tel 0181 342 1793. The UK's leading independent hi-fi and home cinema retailer, specialising in quality products for discerning customers. Open six days, with dedicated single speaker and audio visual demonstration rooms. Major credit cards accepted, 0% finance available (details upon request), home trial and installation by arrangement. Major brands stocked include Arcam, Audiolab, Castle, Denon, KEF, Marantz, Michell, Mission, Monitor Audio, Quad, Rotel, Ruark, TEAC and Yamaha.

NORFOLK

BASICALLY SOUND, The Old School, School Road, Bracon Ash (Nr Norwich), Norfolk, NR14 8HG. Tel:(01508) 570 829. Stockists of the following leading Hi-Fi: Arcam, Audiolab, Audio Alchemy, Denon, Naim, Epos, Micromega, Heybrook, Nakamichi, Rotel, Royd, TDL, Beyer, Grado, Sennheiser, Dynavector, and more. Bada members, 2 comprehensive demo rooms.

PROTECT-A-DISC, Unit 4, Elvin Way, Sweetbriar Industrial Estate, Norwich, NR3 2BB. Tel: 01603 482193. Producers and suppliers of finest quality card record and CD sleeves with taped edges, poly-lined or unlined, mailers and cruciforms etc. Please send SAE for full current price list. Trade enquiries welcomed. Tel: 01603 482193.

NORTHAMPTON

CLASSIC HI-FI, At Classic Hi-Fi we cover the best in quality sounds. Be it a question of taste, a question of balance or a question of price, we're the one to help. We stock: Marantz, Nad, Pioneer, Aura, Yamaha, Heybrook, LFD, Suggden, Rotel, Kenwood, B & W, Kef, Rogers, Monitor Audio, JPW, Shearpe Audio, Royd, Audio Alchemy, Teac and many more. For more details call: 01536 310855

THE AUDIO SHOP, 6 Hill Street, Raunds, Northants, NN9 6NN. Tel: 01933 622325. Rotel, Denon, Marantz, Philips, Kinshaw, Moth, Pro-ject, Royd, TDL, JPW, Bose, Wharfedale, Goldring, Ortofon, Chord Co., Van Den Hul, Audioquest, QED, Sound Org., Beyer, Sennheiser, etc. Service dept., Home Demos., Free Installation, Easy Parking, Open 9.30am to 5.30pm (closed Wednesdays).

LISTEN INN, 32 Gold Street, Northants NN1 1RS. Tel. 01604 37871. Fax 0604 601430. Naim, Linn, Rega, Audiolab, Arcam, Cyrus, Royd, Nakamichi, Mission, Denon, Rotel, NAD, Heybrook, Marantz, Chord Co. etc. etc., Open 10.00 - 5.30 (Closed Thurs)

THE AUDIO SHOP, Hi-Fi Specialists. Appointed stockists of:- Arston, Creek, Denon, Dual, Goodmans, JPW, Mordaunt-Short, Rotel, Royd, Tannoy, 6 Hill Street, Raunds, Northamptonshire. Tel:- 01933 622325

NOTTINGHAMSHIRE

PETER ELLIS AUDIO, 29 KIRKGATE NEWARK NOTTS NG24 1AD Tel 01636 704571. C astle. Arcam, Suggden, Tannoy, T.D.L., Musical Fidelity, Heybrook, Morduant Short, Teac, Marantz, Stemfoort, Yamaha, Denon, + more - Demo room, P-ex, Service Dept, free installation. Access, Visa, Amex, Switch. Mon - Sat 9.00-5.30 closed Thurs pm.

CHANTRY AUDIO, 18-18a Eldon Street, Tuxford, Nr Newark, Notts, NG22 0LH. Tel. 01777 870372. Pink Triangle, Absolute Sounds, Micromega, DPA, Alchemist, CD developments, SME, Meridian, Ruark, Rotel/Michi, Audion, Monitor Audio + much more. Three demo rooms inc. Home Cinema, home trial, free installation, service dept. Access, visa, credit facilities, Mail order. Mon-Sat 9.30-6.00, Sun and evenings by appointment.

NOTTINGHAM HI-FI CENTRE, 120-122 Altretton Road, Nottingham. Tel: 01602 786919. Over 25 years experience, superb demo rooms, extensive range, free parking. Mon-Sat 9-5.30

OXFORDSHIRE

AUDIO T, 19 Old High Street, Headington, Oxford (01865) 65961. Great Value on Aiwa, Arcam, Audiolab, Cyrus, Denon, Linn, Marantz, Meridian, Micromega, Mission, NAD, Pioneer, Rotel, Sony, Technics, Yamaha & more. Tues-Fri 10-6. Sat 9.30-5.30. Thurs until 8.00. 3 year Hi-Fi guarantee. 30 day free upgrades. PX. Selected Interest Free. 2 listening rooms. Home Cinema. BADA Bonded.

OVERTURE HIFI, 3 Church Lane, Banbury, Oxfordshire. Tel: 01295 272158. Consult the experts for the best advice on matters Audio. Choose from Arcam, Audioquest, Bose, Denon, Epos, Heybrook, Kef, Linn, Mission, Naim, Nakamichi, Quad, Yamaha. 2 to 5 year warranty. Installation specialists. Superb demonstration facilities. Open six days. Members of the Guild of Master Craftsmen and BADA

WESTWOOD & MASON, 46 George Street, Oxford. Tel. 01865 247783. Creek, Marantz, Naim, Arcam, Rotel, Rega, Epos, Tannoy, Mission, Nakamichi, Denon, Aiwa, Quad, Yamaha, Monitor Audio. Open 9.30-5.00pm. Dem room. Closed Thursdays.

Diaries

ASTLEY AUDIO LTD, 3 Marketplace, Wallingford (3 miles from Berkshire border). 01491 839305. Aura, B&W, Technics, Panasonic, Pioneer, Kenwood, Sony, Yamaha, Denon, Quad, Marantz, Mission, Tannoy. 1 listening room. Home trial, free installation. Service department. Access, Visa, Amex, Diners. Instant credit. Tues-Fri 9-5.30, Sat 9-5. Records & CDs stocked.

SEVENOAKS HIFI 41 St Clements, Oxford. Tel 01865 241773. The UK's leading independent hi-fi and home cinema retailer, specialising in quality products for discerning customers. Open six days, with dedicated single speaker and audio visual demonstration rooms. Major credit cards accepted, 0% finance available (details upon request), home trial and installation by arrangement. Major brands stocked include Arcam, Audiolab, Castle, Denon, KEF, Marantz, Mission, Monitor Audio, Musical Fidelity, Quad, Rotel, Ruark, TEAC and Yamaha.

SHROPSHIRE

AVON HIFI, 12 Barker Street, Shrewsbury, Shropshire, SY1 1QJ. Tel. 01743 355166. Aiwa, Beyer-Dynamic, NAD, Quad, B&W, Mordaunt-Short, Kenwood, Bose, Nakamichi, Onkyo, Teac, Sennheiser. Dem room. Home trial. Free install. Service dept. Access/Visa. £1,000 instant credit. Mon, Tues, Wed, Fri, Sat 9 - 5.30.

SHROPSHIRE HIFI, St Michael Street, Shrewsbury, Shrops. SY1 2ES. Tel. 01743 232065. Stockists of Musical Fidelity, Mordaunt Short, Sony, Kenwood, Pioneer, Rotel, Denon, B&W, Proac. Audio Visual. Products available. Open 9.30 - 5.30pm Mon-Sat.

W. Owen Est 1901 58 Market Street Oakengates Telford Shropshir. Tel. 01952 613818. "Audio/Video specialists. Pioneer, Reference Phont, Kenwood, Sony, Akai, B & W, Bose. Dolby Pro-Logic Specialist- 16:9 screens in stock. Free installations and home deliveries."

STAFFORDSHIRE

ACTIVE AUDIO, 95, Stafford Street, Hanley, Stoke-on-Trent. Staffs. Tel: 01782 214994. Fax: 0782 283346. We have four studios including a dedicated Audio Visual studio for the demonstration of quality equipment from the largest range in the Midlands. Open six days per week. Own service department. Free local delivery, home trial facility. Current special offers and buyers fact pack and quotation service on request.

ACTIVE AUDIO, 29, Market Street, Tamworth, Staffs. Tel: 01827 53355. Fax: 0827 59513. We have two studios including a dedicated Audio Visual studio for the demonstration of quality equipment from the largest range in the Midlands. Open six days per week. Own service department. Free local delivery, home trial facility. Current special offers and buyers fact pack and quotation service on request.

SUFFOLK

AUDIO IMAGES, 7 All Saints Road, Pakefield, South Lowestoft, Suffolk, NR33 6JL. Tel/fax: 01502 582853. Quad, Triangle, Arcam, Castle, Rotel, Moth, JPW, Sugden, Mission, Project, Denon, Yamaha surround sound. Audio Innovations, plus the amazing ROTHWELL range. Separate dem room, no appts nec. 10-6.30 Tues-Thurs, 7pm Fri. 6pm Sat.

SIGNALS Martlesham Heath, Ipswich. Tel: (01473) 622866. See display advertisement for brands. Turntables, high end CD drives/DAC's as well as integrated players, valve and solid state amplification, wide range of cables and loudspeakers. Home demonstrations/equipment trial service. Please telephone for directions and to book appointment.

BURY AUDIO, 47 Churchgate Street, Bury St Edmunds, Suffolk, IP33 1RG. Tel. 01284 724337. Arcam, Audio Alchemy, Heybrook, Marantz, Michell, Meridian, Nakamichi, Pink Triangle, Quad, Rotel, Sonus Faber, Stax, Tube Technology, Single speaker dem room. Free install. Credit facilities. Mon-Sat 9.30-6.00, closed Wed. Evening dems by appointment.

EASTERN AUDIO, 41 Bramford Road, Ipswich, Tel. 01473 217 217. Fax 0473. 215705. Quad, Arcam, Audiolab, Meridian, Mission, Onon, Rotel, Marantz, NAD, Sony, Rogers, Nakamichi, Systemdek, Technics, Celestion, B&W, Tannoy, Morel Thorens and Top Tape. Also stock a wide range of accessories. usual credit facilities. A BADA dealer.

ANGLIA AUDIO Dedicated to top quality HiFi since 1971. Near Beyton Bury St Edmunds IP30 9AZ. Quality systems built to your specification. Telephone (01359)270212. Open 9-6 closed Thursday. Open other times by appointment and evening dems can be arranged.

SURREY

SPALDINGS HI-FI, 352-4 Lower Addiscombe Rd., Croydon, Surrey. 0181 654 1231/2040. 3 dem rooms and home dem. Free installation/credit. Linn, Naim, Quad, Arcam, Audiolab, Mission, Onon, Tannoy, Marantz, Ruark. Mon-Sat 9-6, Tues 9-8, Service dept. (3 Dem rooms incl. A.V. 0% credit).

PJ HIFI, The HIFI Shop, 3 Bridge Street, Guildford, Surrey GU1 4RY. Tel. (01483) 504801. 9-6 Mon-Sat. Linn, Meridian, Rega, Arcam, Quad, Revox, Musical Fidelity, Rotel, NAD, Nakamichi, Marantz, KEF, Reference etc.

ROGERS HIFI, 13 Bridge Street, Guildford, Surrey, (01483)61049. Aiwa, Creek, Denon, Dual, JPW, Marantz, Onix, Pioneer, Systemdek, Ruark, Tannoy, Teac. Dem facilities available, no appts necessary, free installation, service dept. Access/Visa. Instant credit upto £1,000 subject to status. Monday-Saturday, 9.30-6pm, later by appt.

SURREY HIFI, 45 High Street, Godstone, Surrey, RH9 8LS. (01883) 744755. Specialist Hifi outlet, demonstration room and parking available. Quad, Audiolab, TDL, Tube Technology, Rel Acoustics, Nakamichi, Kef, Thorens, Musical Fidelity, Van Den Hul cables, Bose, Sennheiser, Beyer headphones, Marantz, Denon, Michell, Van den Hul, Musical Fidelity, Tannoy, Target, JPW. Single speaker dem rooms. Free installation service dept. Access /Visa /Mastercard. Open 9-6pm. Closed all day Wednesday.

SEVENOAKS HI-FI 369-373 London Road, Croydon, Surrey. Tel 0181 665 1203. The UK's leading independent hi-fi and home cinema retailer, specialising in quality products for discerning customers. Open six days, with dedicated single speaker and audio visual demonstration rooms. Major credit cards accepted. 0% finance available (details upon request), home trial and installation by arrangement. Major brands stocked include Arcam, Audiolab, Castle, Cyrus, Denon, KEF, Marantz, Meridian, Michell, Mission, Monitor Audio, Musical Fidelity, Quad, Rotel, Ruark, TEAC, and Yamaha.

SEVENOAKS HIFI 73b North Street, Guildford, Surrey. Tel 01483 36666. The UK's leading independent hi-fi and home cinema retailer, specialising in quality products for discerning customers. Open six days, with dedicated single speaker and audio visual demonstration rooms. Major credit cards accepted, 0% finance available (details upon request), home trial and installation by arrangement. Major brands stocked include Arcam, Audiolab, Castle, Denon, KEF, Marantz, Michell, Mission, Monitor Audio, Musical Fidelity, Quad, Rotel, Ruark, TEAC and Yamaha.

SUSSEX (EAST)

THE POWERPLANT "Brighton's Leading Hifi Shop". 66 North Street, Brighton, Tel. 01273 775978. Comfortable listening rooms. Knowledgeable and approachable staff. Roksan, Micromega, Exposure, Audiolab, Epos, Rotel, Marantz, Cyrus, Regal, Arcam, Mission and more.

WORTHING AUDIO, 20 Treville Gate, W Sussex, BN11 1VA. Tel 01903 212133. "The friendly shop with the best sound systems in the South". Friendly advice, 3 yr guarantees, easy parking, open Mon-Sat 9-6pm. Late night Wed. Arcam, Exposure, Naim Audio, Marantz, Ruark, Restek, Clear Audio, Audio Technica, Target, Tripod, Sennheiser, AR and many more.

CHURCHERS HI-FI, 154 Montague St. Worthing, Sussex. BN11 3HH. Tel. 01903 821595. All major well know brands of Hi-Fi stocked. Please call for details.

ADAMS & JARRETT, Hi-Fi and Home Cinema Specialist. Phone or visit us at 6-18, Norman Road, St. Leonards-on-Sea, E.Sussex. (01424) 437165/432398. Stockist of quality equipment including: Audio Innovations, Meridian, KEF, Ruark, Marantz, NAD, JBL, Royd, Dali, Jamo, Onkyo, Rel, Traget, Cable Talk, Technics, Yamaha, Kenwood. Air conditioned listening rooms, on site service and repair facilities.

SEVENOAKS HI-FI 55 Preston Street, Brighton, Sussex. Tel 01273 733338. The UK's leading independent hi-fi and home cinema retailer, specialising in quality products for discerning customers. Open six days, with dedicated single speaker and audio visual demonstration rooms. Major credit cards accepted, 0% finance available (details upon request), home trial and installation by arrangement. Major brands stocked include Arcam, Audiolab, Castle, Denon, KEF, Marantz, Meridian, Mission, Monitor Audio, Musical Fidelity, Quad, Rotel, Ruark, TEAC, and Yamaha.

SUSSEX (WEST)

CHICHESTER HIFI, 7 St Panchras, Chi, W Sussex. PO19 1SJ. Tel. 01243 776402. Linn, Naim, Rega, Creek Nakamichi, A&R, Denon, Roksa, Epos, JPW, Ruark, Rotel, Quad, Sendor. Evening appts available.

CRAWLEY AUDIO, 1 Silkin, Dalton Close, Broadfield, Crawley, West Sussex. Tel: 01293 531190, Mob: 01860-911640. RCA "Living Voice" Recordings, Alchemic, Burmester, Manhattan Acoustic, German Physiks, Chord Co, Cable Talk, Systemdek, Gravis Subwoofer, WAD, Apollo, CAD, Ortofon, Fullers Audio, Loricraft (Garrard) SME, Denon cartridges, Polk Audio, Atacama, Magneplanar. Purpose Built Dem Rooms, Home Dems available. Part Exchange, Credit Cards Accepted.

HORSHAM HI-FI, 28 Queensway, Horsham, West Sussex RH13 5AY. Tel 01403 251587/0831 418619. Suppliers of quality audio equipment including:- Magneplanar Loudspeakers, TEAC, Michell, Opera Loudspeakers, Unison Research, S.D. Acoustics, Fanlare Tuners, World Audio Design products, Vintage Radio Restoration Valve Amps, Gravis Subwoffers, Audio Technica, Target, Alchemic Products. Large comfortable demonstration room, home trial facility. Free installation. Part exchanges welcome. Servicing and repairs. Open mon-sat 10am - 7pm.

HEATHERDALE AUDIO LTD, 202 Findon Road, Worthing, Sussex. Tel:- 01903 872288 or 01860 660001 eves. Three comfortable demonstration lounges where you can audition: Audionote, Krell, Audio Research, Klipsch, Martin Logan, Apogee, Sonus Faber, Theta, S.M.E. Copland, Voyd, Magneplanar, E.M.F., Lumley Reference, Creek, Rotel, Heybrook, Clearaudio. Phone for used stock list. 'We are the South Coast's Premier Hi-Fi Specialist'

TYNE & WEAR

FERROGRAPH SPARES & SERVICES, Reel to reel tape recorder servicing facilities, spare part and refurbished equipment suppliers. Main brands supported: Ferrograph and Revox.. In total, around 90% of the entire range of Ferrograph spare parts are still available from stock. Our service department also covers all Ferrograph recorders from the range. Call today for further information. Suite 7, Cookson House, River Drive, South Shields, Tyne and Wear, NE33 1JX. Tel: 0191 427 7774 Fax: 0191 427 5566 E-mail lee@ferrograph.win-uk.net.

BILL HUTCHINSON HIFI, 87a, Castle Street, Newcastle-Upon-Tyne, (0191) 230 3600. For the largest selection of HiFi and audio visual equipment in the North East. Specialist A.V. demonstrations of the highest quality. Best prices guaranteed. Minimum 2 year warranty and an optional 5 yr guarantee available. Instant credit and mail order service on offer throughout the U.K. Pioneer, Denon, Kenwood, Yamaha, Technics, Marantz, Mission, Tannoy plus many more.

WARWICKSHIRE

SOUNDS EXPENSIVE 12 Regent St, Rugby, Warwks CV21 2OF. Tel: 01788 540772. Agents for: Arcam, Audiolab, Aiwa, Castle, Celestion, Cyrus, Denon, Dual, Kef, Heybrook, Mission, Marantz, Meridian, Mordaunt-Short, NAD, Quad, Rotel, Tannoy, TDL, Yamaha & many more. @ year warranty on all hi-fi separates. 2 Demonstration rooms, Home Trials, All Major Credit Cards Accepted, Mail Order Welcome. Ring Now For Keenest Prices. Open Monday - Saturday 9-5.30. If We Haven't Got It It's Probably Not Worth Having.

WEST MIDLANDS

MIDLAND VALVE HIFI, Specialising in true fidelity systems built around valve amplification:- Audion 300B Silver Nights, Audio Innovations, Impulse, Audio Note, KAL, Townsend Audio, Ortofon, Voyd, Micromega, Edison, Stax, Apollo, Dynavector, Seismic Sink, Valves. Home demonstrations and part exchange. Also vintage: Leak, Quad, Croft, Radford, etc. Flexible opening 7 days. 'phone Gary 0121 722 2317.

MUSIC MATTERS, 351 Hagley Road, Edgbaston, Birmingham, B17 8DL. Tel 0121 429 2811. Roksan, Nakamichi, Arcam, Audiolab, Kenwood, DPA, Tannoy, Royd, Heybrook, Michell, Panasonic, Aura, Celestion, Musical Fidelity, Mission/Cyrus, Meridian, Kef, Monitor Audio, Pink Triangle, Ruark, Epos, Exposure, Pioneer and many, many more! 2 single speaker dem rooms. Appts necessary. Home trial facilities and free install. Service dept. Access/Visa/Instant credit upto £1,000. Interest free credit available also. Tues-Thurs 10.30-6pm, Friday 10.30-8.00pm, Saturday 10.00-5.30pm. Check out the new branch in Solihull - Phil works there so it can't be bad! 0121 742 0254

COVENTRY HI-FI, 126, Church Lane (off Walsgrave Road), Coventry. CV2 4AJ. Tel: 01203 440529. Quad sales & service agent, Pioneer Reference Point, Kenwood, Aiwa, T.O.L. B&W, Tannoy etc. Private listening room. 2 year guarantee on all new hi-fi. Open 9.30-5.30 Mon-Sat Closed Thursday.

ELMDON AUDIO, Tel 0121 784 8765. Reference Imports Lumley, Alon etc. Esoteric Audio Research 834 integrated on demonstration. Home demonstration can be arranged. Top part exchange prices, lots of used bargains, Quad, Leak, etc. Valves and valve testers, new GEC KT66s available.

FIVEWAYS HI-FIDELITY LTD. 12 Islington Row, Edgbaston, Birmingham, B15 1LQ. 0121 4550667. Arcam, ATC, Audioquest, Audio Technica, AVI, Beyer, Cable Talk, Castle, Chord, CRD (Valve), Denon, Dual, Klipsch, Michell, Nakamichi, Ortofon, OED, Quad, Revox, Sennheiser, Sequence Design, SME, Sendor, Target, TDK, TDL, Thorens, Trilogy (Valve) etc. Keith Monks Record Cleaning Machine. Closed Mondays.

SOUND ACADEMY, The ultimate experience for those seeking HiFi. Ac. En., Arcam, Audiolab, AudioQuest, B&W, Bose, Chord, Cyrus, Cable talk, DPA, Epos, Kef, Ref, Marantz, Meridian, Mission, Mus. Fid, Nacamichi, Ortofon, Project, Quad, Roksan, Tube Tech, Rotel, Micromega, KAR, Kenwood, Lexicon, Cannon, Celestion, Beyer & more. 3 Single speaker dem. room on two floors incl. AV Cinema. Open 6 days a week. Mon-Sat. All major credit cards taken. Part exchange, enquiries welcome. Just off the High Street, Blaxwich, Walsall, W. Midlands. Tel. 01922 493499. (ample free parking)

AMADEUS SOUND & VISION, 10 Boldmere Road, Sutton Coldfield, West Midlands, Tel. 0121 354 2311. Audio Innovations, B&O, Castle, OED, Wharfedale. Single speaker demo, appts preferred, service available, installations, B&O link install, home trials, Access/Visa, interest free credit available subject to status. 9.30-6.00pm 6 days.

GRIFFIN AUDIO, 94 Bristol St., Birmingham, B1 2PT. 622 2230/0121 692 1359. Tues-Sat 10 a.m.-6 p.m. Enjoy music at home with a system from Griffin Audio. We demonstrate and install the very best hi-fi, with systems from £500 to £25,000. Ask for Bob, Tim or Alex. Linn, Naim, Shahinian, Quad, Arcam, Rega, Denon, Marantz, Rotel.

ELECTRO CENTRE, 244 Soho Rd, Handsworth, Birmingham. Tel 0121 554 1878. Full range of HiFi: Pioneer, Technics, Kenwood, JVC, Sony, Aiwa, Akai. "Guaranteed the lowest prices in the UK". 24hr Mail Order facility available.

FRANK HARVEY HI FI EXCELLENCE 163 Spon Street Coventry Tel: 01203 525200 Fax: 01203 631403 Audiolab - Audio Alchemy-Atacama Aura - Arcam - Audio Quest - Alphon - Apollo - Bang & Olufson - Bose - Castle - Canon - Cable Talk - Celestion - Chord - Cyrus - Denon - Dual Foundation - Heybrook - IXOS - Kef Reference - JBL - JPW - Jamo - Kenwood - Lasor Disc Marantz - Meridian - Monitor Audio - Micromega - Mission - Michell Gyrodek Monster - Mordaunt Short - Musical Fidelity - Nakamichi - NAD - Ortofon - Onkyo - Panasonic - Pioneer - Polk Audio - Quad - OED - REL - Rega - Revolver - Rogers - Rotel - Royd - Sennheiser - Systemdek - Target - Teac - Technics - Tannoy - Thorens - TDL - Van Den Hul - Wessex - Yamaha Much Much More In Store on 3 floors 4000 SQ Feet with 3 Dedicated Hi Fi Oemo Rooms of the very Best Hi Fi Plus 2 AV Demo Rooms. Nice staff Nice coffee. Appts Nec. Service Dept. Free Install & Home Trial. All Credit Facilities. Plus Interest Free Credit. Open 9.30am to 5.30pm Monday to Saturday.

WILTSHIRE

AUDIO T, 60 Fleet Street, Swindon. (01793) 538222. Great Value from Aiwa, Arcam, Audiolab, Denon, Linn, Marantz, Meridian, Micromega, Mission, NAD, Naim, Nakamichi, Rotel, Sony, Technics, Yamaha & many more. Tues-Sat 9.30-6. 3 year Hi-Fi guarantee. Free delivery & installation. 30 day free upgrades. Home demonstrations. PX. Selected Interest Free Credit. 2 listening rooms. Home Cinema specialists. BADA Bonded.

P.R. SOUNDS 58 Castle Street, Trowbridge, Wilts BA14 8AU Tel: 01225 777799. Authorised dealer for Pioneer, Technics, Marantz, Kenwood, Mission, Jama and many more. Cinema Sound Specialists with Listening Room. "For all that's best in Hi-Fi at a Price you can afford" Open Mon-Sat 9-6 Credit Cards accepted. Finance available.

Continued on page 97...

Peter Herring

If there is a common thread linking this selection, which ranges from the fourteenth to the twentieth centuries, it is one of relationships. Relations between composer and royal patron, which benefited both J.S. Bach and Joseph Haydn; the often stormy relationships endured by Puccini's fragile heroines; and the even more unpredictable co-existence between the artist and the state, nowhere better viewed than in the fluctuating fortunes of Dmitri Shostakovich

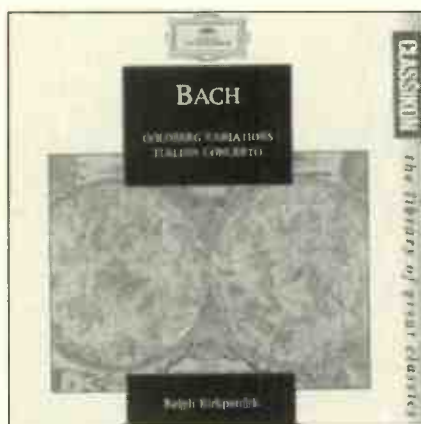

JOHANN SEBASTIAN BACH

Goldberg Variations BWV988/Fantasia in C minor BWV906/Italian Concerto BWV971/Fantasia and Fugue in A minor BWV904 Ralph Kirkpatrick, harpsichord Deutsche Grammophon Classikon 439 465-2 (ADD/68.37)

● According to legend, Bach wrote the 'aria with thirty ornamentations' (as the Goldberg Variations were known until the end of the eighteenth century) for the Russian ambassador to Dresden, Count Hermann Carl von Keyserlingk. It seems the Count was an insomniac and asked Bach for music to help him while away his sleepless hours. The resident harpsichordist at the Count's court also happened to be one of Bach's pupils, one Johann Gottlieb Goldberg.

There is just one flaw in this charming tale: at the time, Johann Gottlieb Goldberg was barely fourteen years old and hardly likely to have been sufficiently competent to tackle what was to be Bach's most complex work for the keyboard. Most probably, Bach made a gift of the work to the Count in 1741, as a gesture of thanks for the

Count bringing his influence to bear on Bach's behalf five years earlier when he wanted to leave Leipzig for the post of Kapellmeister at the court of the Prince-Elector of Dresden.

Bach published the work - without any formal dedication - in Nuremberg in 1742, the fourth part of the series of exercise pieces he entitled *Clavier-Ubung* (Keyboard practice). Some practice pieces! The elegant, straightforward theme - the 'aria' - inspired Bach to extraordinary compositional virtuosity and expressive range. The theme is reworked in all manner of permutations, including various dance forms (minuet, gigue, siciliana) and nine canons, each one built on a different degree of the scale, and two of them in contrary motion. All thirty variations are written in the same key, either G Major or G minor, which requires the player - aside from the technical demands - to find the colour, articulation and ornamentation to bring out the individual character of each piece.

The number of variations - thirty - suggests Bach may have been prompted to produce the work by the appearance, in 1739, of Domenico Scarlatti's thirty *Essercizi Per Gravicembalo*. Bach was acquainted with Scarlatti's effort, and appreciated its originality both in terms of style and technique. In the Goldberg Variations, he assimilated the new ideas of the Italian school and combined them with the proven styles of fugue and canon, and to unsurpassed effect.

The first complete public performance of the Goldberg Variations in modern times was given by Wanda Landowska in 1933. One of Landowska's pupils was the American-born Ralph Kirkpatrick and, twenty-five years on, Kirkpatrick was to make a famous recording of the work for DG's

In 1765, Joseph Haydn began to draw up a catalogue of his works, commencing each category - symphonies, trio sonatas, and so forth - on a fresh page. However, anyone today with more than a passing knowledge of Haydn's canon will notice an apparently serious omission from the list. There is no mention of the early essays in the medium we now know as the string quartet. Yet Haydn is often described as having invented the form. However, a close study of Haydn's entries soon explains the anomaly: he collates all his early works for strings under the general heading of 'divertimenti' - background music to accompany dinner parties and similar functions and entertainments. True, one or two are identified as 'divertimento a quattro' but there is no attempt to give them a separate significance. Haydn, one suspects, would have been as astonished as anyone at the evolution the 'divertimento a quattro' was to undergo in the ensuing four decades before his death in 1809, not only at his own hands, but those of his younger contemporaries, Mozart and Beethoven.

Yet Haydn was by no means the first composer to write music for strings in four parts. The form was already being explored by Italians such as Tartini, Pugnani and the Sammartini

brothers. These works were no 'equal partnerships': generally the second violin, viola and cello merely supplied a backdrop to the virtuosity of the first violin. Meanwhile, in Mannheim, Johann Stamitz was producing works for four string players where none was relegated to an accompanying role: each part was as complex, ornate and florid as the other. However, these works could not be described as string quartets either.

During Haydn's early years, the most popular form of chamber music was the trio sonata, where two violins and a string bass were accompanied by a harpsichord continuo which supplied a kind of 'wash' of background colour. However, the harpsichord's lack of portability made this a strictly indoor musical form, and in the Vienna of Haydn's youth there was an increasing demand for music for outdoor occasions. Musicians such as Haydn, living on casual earnings, were happy to supply the music for these diversions, writing for whatever combinations of strings and wind instruments were available. Thus Haydn learned how to dispense with the 'filling out' of the texture which the harpsichord continuo had provided, and how to spread the harmonic interest throughout all the instruments. And, doubtless, he came to like the end result.

The defining moment seems to have come sometime during the summer of 1755 when a Viennese nobleman, Count Furnberg, mustered four string players, including Haydn, for an evening's music-making. For this event, Haydn drew on his experience of street serenading - for him, four strings made up an orchestra. He wrote music that comprised of a succession of short movements with the emphasis on dance forms, thus breaking with the traditional three-movement structure of the chamber sonata. It was these early divertimenti for strings which gradually revealed to Haydn the expressive potential of the combination of two violins, viola and cello, and by the Op9 set of 1769, the solo quartet had manifestly established an identity quite distinct from that of the divertimento. With the Op20 set of 1772, the transformation is complete, but then Haydn - for whatever reason - wrote no more string quartets until the so-called 'Russian' quartets (Op33) of 1781. Did he feel he needed more time to fully master the medium? Certainly the Op33 set displays a total command of the quartet texture; now Haydn could concentrate on developing his ideas for structure and design, something triumphantly achieved in the next series of six, which he dedicated to the King of Prussia.

Archiv label. This is the performance which has now been reissued in the Classikon series, and it is still readily apparent why it was so acclaimed thirty-seven years ago. Kirkpatrick, who died in 1984, was always regarded as more of a scholarly, cerebral player than an intuitive one, and there are recordings which suffer from a lack of spontaneity. But not here; Kirkpatrick employs a light and subtle registration which brings welcome benefits in terms of colour and translucency. His tempos are finely-judged, lively and exuberant where required; stately and serene in the slower variations with their elaborate counterpoint. Above all there is a sense of pleasure in making the recording and of communicating Bach's genius in all its glory.

The instrument used, which is not identified, has a fine, full sound which is captured in all its detail by the

recording, made in Berlin's Jesus-Christus Kirche, a favourite venue of the DG engineers. However, the harpsichord is also recorded very closely and a little more air around the instrument would have been welcome. The volume setting has to be carefully judged, and I fear the digital remastering has inevitably brought out the undesirable aspects of the original master - some 'muddying' of the lower end, for example - as well as the desirable. Overall, though, given its vintage, the recording has aged well and while the performance may not displace more modern efforts by Trevor Pinnock, Gustav Leonhardt and Ton Koopman, it more than merits its new incarnation, especially with the inclusion of Kirkpatrick's fine studio recordings of the everpopular Italian Concerto and the two short fantasias.

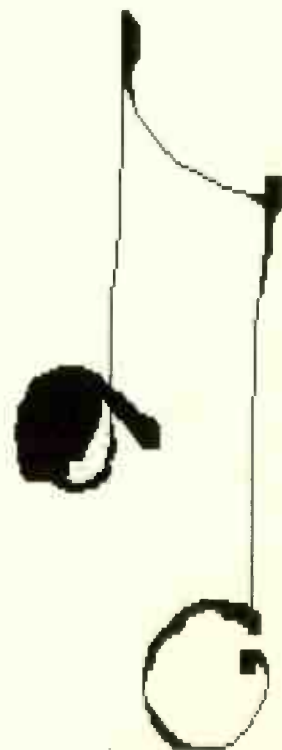

FRANZ JOSEF HAYDN

Six String Quartets Op50 (The 'Prussian' Quartets) The Salomon Quartet Hyperion CDA66821 (DDD/75.18)
CDA66822 (DDD/63.20) (AVAILABLE SEPARATELY)

● The Salomon Quartet's award-winning Haydn quartet series on period instruments continues in similarly inspired vein with these two CDs bringing together the six works of Op50, for which Haydn accepted an offer of three hundred florins from his publishers in April 1784, but did not deliver the completed scores until the autumn of 1787. He dedicated the works to one of the most enthusiastic patrons of music in eighteenth-century Germany, King Frederick William II of Prussia. The monarch was a competent amateur cellist. Mozart's 'Prussian' quartets K575, K589 and K590 were also written to a commission from the King, who also engaged the services of composer-cellist Luigi Boccherini. While not supplying elaborate cadenzas for the cello, Haydn did acknowledge his patron's musical skills by releasing the cello from its familiar role of supplying the underlying comparatively simple bass parts. The

instruments bass parts shine in the adagio of the second quartet, and the andante of the third, and the first work in the set, in B flat Major, opens with two bars from the cello alone.

Here, the 'regal' cellist is Jennifer Ward Clarke and, like her three colleagues (Simon Standage and



Micaela Comberti, violins; Trevor Jones, viola) she is wholly at ease with Haydn's scores. This is relaxed, genial music-making, as it should be. Although generally in a more serious vein than their predecessors, the Op50 quartets are not without the moments of wit and humour which punctuate much of Haydn's music.

Perhaps the most extraordinary passage is to be found in the finale of the sixth quartet in D Major where a 'bariolage' (repeated notes produced by alternating adjacent strings) produces an effect akin to the croaking of a frog (and earned the work an appropriate nickname).

The Salomon Quartet captures the essentially conversational tone of these quartets, retaining the individual voice of each instrument as they explore each musical idea. The players are attentive to the detail but never at the expense of spontaneity. The flow and vitality of these performances are exactly the qualities which made the Salomon's earlier Haydn recordings for Hyperion so captivating and characterful. They seem to have got to the heart of 'Papa Haydn'.

This is music to quietly relax to, and to discover at an unforced pace. Appreciation is helped no end by the truthful, naturally-balanced and crisply-focused recordings, a sound which brings out all the nuances and of colour these instruments. These players are capable of conveying the true meaning of Chamber music which has been described as the 'music of friends'. Listening to the Salomon Quartet play Haydn, the accuracy of that observation becomes abundantly clear.



GIACOMO PUCCINI

The Puccini Experience (excerpts from Le Villi, Edgar, Manon Lescaut, La Boheme, Tosca, Madame Butterfly, La Fanciulla del West, La Rondine, Il Tabarro, Suor Angelica, Gianni Schicchi, Turandot) Angela Gheorghiu, Nina Rautio sopranos; Johan Botha, Francis Egerton, tenors; Anthony Michaels

Moore, Robin Leggate, baritones; Michael Druiett, Eric Garrett, basses; Royal Opera Chorus; Orchestra of the Royal Opera House, Covent Garden; conductor, Sir Edward Downes Royal Opera House Records 75605 55013 2 (DDD/78.42)

● There have been previous Puccini compilations, but this is different; indeed, it's quite unlike any 'best bits' pot-pourri you will have come across. First-and-foremost, all the tracks were especially recorded for this CD, not culled from existing recordings. Second, the selection has been made with far more thought and purpose than to merely present some Puccini 'lollipops' and showcase up-and-coming singers. What singles out this very generously-filled disc is that its eighteen tracks embrace all of Puccini's operas, and in chronological order, from Le Villi of

1884 to the unfinished Turandot of 1926.

The excerpts have been well chosen: vocal and melodic effects introduced in the early operas such as Edgar and Manon Lescaut reappear to even more telling effect in the mature masterpieces, Tosca, Madame Butterfly, Gianni Schicchi and, of course, Turandot. And then there is the recurring Puccini character of the fragile, deserted heroine: Mimi, Lui, Butterfly, Suor Angelica. Here, these famous roles are entrusted to two exceptionally promising young sopranos, the Romanian Angela Gheorghiu, and the Russian Nina Rautio; the former is making her recording debut here, singing five arias. Similarly outstanding is one of the most promising male voices to be heard at Covent Garden recently, the intense and powerful baritone of Anthony Michaels-Moore; his Scarpia is

especially impressive, as is the Calaf of the South African bass Johan Botha. They receive first-rate support from the likes of Robin Leggate and Francis Egerton, and the Covent Garden chorus and orchestra, under the direction of that often under-rated opera conductor, Edward Downes, who is in top form.

Puccini's music is not without its detractors - *Tosca* was once described as a "nasty little shocker"! - but he was a master of dramatic music theatre, and possessed a rare gift for beautiful, deeply touching melody - and both these qualities are richly evident here. Puccini knew precisely how to touch the emotions and thrill the senses, but without descending into mawkishness. He also knew how to deploy orchestral forces, something which comes over supremely well in this stunning recording.

Conifer Records, who produce recordings on behalf of the Royal Opera House, used the sympathetic acoustic of the Henry Wood Hall for this production, and a recording team headed by the ever-excellent Tryggvi Tryggvason. The recording was made using 20-bit analogue-to-digital converters, with 20-bit resolution maintained throughout the editing process, all employing Conifer's proprietary EDR (Extended Dynamic Range) system. Even reduced to a 16-bit CD, the exceptional quality of the sound is immediately evident, both in the purity of the vocal sound, and in the range and clarity of the orchestral textures.

New ideas to 'package' classical music seem to be abounding these days; few have the integrity of this one from Conifer, or I would guess, offer such enduring pleasure. Now for the 'Verdi Experience'?

DMITRI SHOSTAKOVICH
Symphony No 1 in F minor
Op 10 Concerto for Piano,
Trumpet and Strings in C
minor Op 35* Mikhail Rudy,
piano*; Ole Edvard Antonsen,
trumpet*;

Berlin Philharmonic Orchestra;
conductor, Mariss Jansons
EMI CLASSICS 5 55361 2 (DDD/54,51)

● EMI have assembled a starry cast indeed for this Shostakovich coupling. The works are well enough known, but I cannot recall a previous recording combining both the First Symphony and the First Piano Concerto, the latter with its significant concertante role for solo trumpet. Here, the Russian conductor,



Mariss Jansons, is teamed with his compatriot, the pianist Mikhail Rudy, and the Norwegian-born trumpeter Ole Edvard Antonsen. Add the incomparable Berlin Philharmonic, and a top-notch British production team (David Murray and Mike Clements) and you have all the elements for a highly successful recording. I'm delighted to say the promise is amply fulfilled.

Shostakovich completed his First Symphony when he was just nineteen and still a student. There can have been few finer graduation pieces in all music. After the first performance in 1926, under the baton of Nikolai Malko, the work was promptly taken up by Toscanini, Stokowski and a host of other eminent conductors. The young composer, who had been playing piano accompaniments to silent films at three Leninfrag cinemas to earn money for his family, was suddenly catapulted to international prominence.

The First Symphony is remarkable not just for its craftsmanship and coherence, but also for its depth of expression. It is heard at its best in the poignant, and disquieting slow movement, a clear pointer to the epic musical landscapes of, for example, the Eighth and Tenth Symphonies. Shostakovich was fortunate that he was honing his symphonic skills in the years before the Soviet cultural apparatchiks closed the door on new music from abroad. He would still have had access to scores by the likes of Hindemith, Berg and the emigre Stravinsky, and there are echoes of both Hindemith's angularity and the burlesque of Stravinsky's *Petrushka* in the First Symphony.

The debt to Mahler and Tchaikovsky

is evident too, but the sum total is far more than the clever, if lightweight, pastiche of Prokofiev's symphonic debut, his so-called 'Classical Symphony'. Shostakovich's grasp of symphonic form is already strong, and the development of his own individual style resolutely underway.

The influence of Stravinsky, and of *Petrushka* in particular, is even more strongly felt in the First Piano Concerto, not least because of the telling contribution of the solo trumpet. This might seem like mere parody, until you recall the macabre and disturbing undertones of the puppet tale. The concerto dates from the spring and early summer of 1933, immediately after Shostakovich had completed his 24 Piano Preludes Op 34 and while he was preparing the staging of the opera *Lady Macbeth of Mtsensk*, the work which was to see official disapproval heaped upon his head, and force dramatic changes that would permanently affect his career, and his thinking.

There are links between the Preludes and the Concerto, which is in four linked movements, each characterised by glorious themes and teeming invention. While there are many sudden and dramatic changes of mood, the work is unified by its innate lyricism, a quality which comes over well in this performance. The finale is a tour-de-force for both soloists as Shostakovich revels in his compositional wizardry, with quotations from Beethoven ('Rage over a lost penny'), Haydn (the D Major Piano Sonata), folksong, and his own incidental music to *Hamlet*. It is a miracle that it all comes together as a seamless whole, but it does and as this recording ably demonstrates, in a most enjoyable fashion.

In both works, Jansons obtains outstanding playing from the Berliners and the recordings are first-rate, that of the symphony being of demonstration quality. I don't know if this is the precursor of a Shostakovich series from these forces, but Jansons's perceptive and finely-shaped reading of the First Symphony suggests he could offer worthwhile insights into the major works of the composer's middle and later years.

Classical

WORCESTERSHIRE

LYNDEN AUDIO, 01527-873766. Exclusive Midlands Audio Synthesis Dealer, Audio Physic, Adyton, Essex Audio, LFD, Sequence Design Wall Speakers, Harman Kardon, JBL, REL, etc. Specialist Engineering Dept. offers Custom Design and Upgrades, all Kits etc., built to Customers requirements. Open Tues -Sat. 10am-5pm. Evenings by appointment. Tel: 0121 4455057

SPAINS HI-FI 2 & 2a New rd., Bromsgate Worcs Tel: 01527 872460. Aura, Apollo, Audioquest, B&W, Denon, Harmon Kardon, JBL, JVC, Kef, Kenwood, Marantz, Mission, NAD, Nakamichi, Onkyo, Pioneer, QED, REL, Revolver, Rotel, Sennheiser, Sony, Tannoy, Thorens, etc. 2 Demonstration Rooms, Home Cinema Specialists, 0% Finance available on selected products. Part Exchange welcome, on site service dept; wide range of television, video, mini systems etc. in stock.

COLORAMA H-FI, 27 Kingfisher Walk, Kingfisher Centre, Redditch, Worcs B97 4EY (0527) 597260. Aura, NAD, Onkyo, Kenwood, Denon, TDL, Polk Audio, B&W, Tannoy. Full Pro-logic products. In-store integrated dem facilities. No appts required, service dept. Access, Visa. Open 9-5.30, closed Thursdays.

SEVENDAKS HI-FI 2 Reindeer Court, Worcester. Tel 01905 612929. The UK's leading independent hi-fi and home cinema retailer, specialising in quality products for discerning customers. Open six days, with dedicated single speaker and audio visual demonstration rooms. Major credit cards accepted, 0% finance available (details upon request), home trial and installation by arrangement. Major brands stocked include Arcam, Audiolab, Castle, Cyrus, Denon, Epos, KEF, Marantz, Meridian, Mission, Monitor Audio, Quad, Rotel, Royd, Ruark, TEAC and Yamaha.

Midland Audio Exchange 181, Franche road, Kidderminster, Worcs, DY11 5AD. Tel: 01562 822236. Mobile. 0421 605966. Open seven days a week, 9.30am to 6.30pm. By appointment. Evening demos arranged 2 demo rooms, home demos. Part exchange always welcome, service facility, free delivery. Analogue Hi-End specialist. Agencies include Rokan, Rega, NAD, KEF, Aura, Nakamichi, B+W + many more. Access and Visa finance on request.

WEST MIDLANDS

WEST MIDLANDS AUDIO, 158 Ombersly Road, Worcester WR3 7HA. Tel 01905 458046. Fax. 0905 457585. Naim, Rega, Rotel, Marantz, Nakamichi, NAD, Audiolab, Roksan, Meridian, B&W, Audio Research, Krell, Martin Logan, Arcam. 9-5.30 Mon-Sat, eve's by appt only. Free

YORKSHIRE (SOUTH)

HIFI STUDIOS DONCASTER The best range of quality hi-fi in the north of England - Unison valve amps and phono stages, Michell Gyrodec and Orbe - Alchemist amplifiers, Electrocompaniet, Sugden, John Shearman amplifiers, TDL, Audio Alchemy, Proac, Ruark, Castle, Teac, Impulse Horns, Densen Amplifiers, Apogee, Stemoort, Kinshaw, Pink Triangle, Moral Speakers, Heybrook, Monitor Audio, Harbeth, Keswick Audio Research Speakers, AMC, CR Developments (Valves), Art Audio (Valves), REL Subwoofers, Exposure, Target, Sonic Link, Chord, Audio Quest + Yamaha & Klipsch Home Cinema Demonstrations. BADA members. Phone Jeff or Neil on 01302 781387

TRC HIFI, 3 Kings Cross Street, Halifax, HX1 (01422) 366832. Agents for Kenwood, Denon, Castle, Rotel. Demonstrations and advice a pleasure. Call at any time to audition some of the best HiFi and pro-logic systems. Delivering and installation free within 20 miles. "The family firm where the customer matters most."

YORKSHIRE (NORTH)

AUDIO CLINIC, 22 Lord Mayors Walk, Yorks, YO3 7HA. Tel. (01904) 646309. Revox - Qed - Audio Innovation - Allison - Celestion - Yamaha - Teac - Revolver - JPW - Kenwood - Bose - Thorens - Mission - Snell - B&W - Heco - Cannon - NAD - JVC - Musical Fidelity - Wharfedale - Micromega - Ruark - Heybrook. Surround sound and demo rooms, free installation. Service Dept. Credit facilities on request. Access, Visa, Open 10am - 5pm 6 days a week.

HARROGATE HI-FI 15 Commercial Str, Harrogate, N Yorks (01423) 504274. One of the best ranges of quality hi-fi in the North of England including:

Lumley valve amplification, Audio Research, Musical Fidelity, Martin Logan, Sonus Faber, Castle, Orelle, Michell, Ruark, Stax, Copland, Tannoy, NAD, Alchemist, Onkyo, Rotel, Marantz, Quad ESL, Lexicon, Project, Silversounds, Cogan Hall, DNM. Home cinema dems. Home dems (appts not always req'd). Service Dept. All major credit cards accepted. Credit facilities available. Open 10-6pm. Why? Because music matters.

THE SOUND ORGANISATION (YORK) 2b Gillygate, York, YO3 Tel. (01904) 627108. Linn, Meridian, Micromega, Naim, Rega, Arcam, Creek, Nakamichi, Mission, Denon, Epos, Royd, Rotel. 3 single speaker dem rooms, appts. preferred, home trial facilities, free install, service dept. Credit facilities on request. Access/Visa. 10.00am-5.30pm. Tues-Sat. Sony dealer award nominated '86, '87 and '88.

VICKERS HIFI, 24 Gillygate, York. (01904) 629659. Audio Innovations, A, E, Audiolab, Beyer, Harmon Kardon, JBL, Kef, Kenwood, Marantz, Michell, Mission, Monitor Audio, Mordant Short, Pickering, Pink Triangle, Pioneer, Quad, Rogers, Systemdek, Tannoy, Technics, Heybrook, TDL, Thorens, Dual and lots more. Dem Rooms 4. (3 by appointment). Superb showrooms. 2 yr guarantee on all hi fi products. Appts. as above. Home trial facilities, free install. service dept. Qualified and experienced staff, over 25 yrs experience. 12 mths interest free credit. 10.30-5.30 Mon-Sat.

CLARITY HI-FI - PHONE MIKE ON 01723 503432. Friendly polite new business, free estimates / advice, no vat. All work guaranteed specialist in Repairs, Servicing, all makes including Valve Equipment. Audio upgrades V.C.R.S. All work considered. Plugs, sockets, tapes, headphones, microphones etc. Brand names like Q.E.D. / Goldring / Demon / Audio Quest / etc. To find out more feel free to phone between 9.00 am / 9.00 pm Mon to Sat.

YORKSHIRE (WEST)

AUDIO REFLECTIONS: For friendly advice from one of the UK's longest established, truly independent audio consultants. Addition some of the world's finest equipment. Chord pre-power amps, Spondor, SP9/1, SP7/1, SP1/2, SP2/3, ATC, AVI, Sumo, Castle, Harbeth, Chameleon, Bryston, TEAC, Van Den Hul etc. Demonstrations by arrangement in Leeds, or in your own home without obligation. For further details contact *John Bleakley. Phone/Fax Leeds (0113) 252 8850 (evening calls welcome.) Generous part exchange and second hand equipment available.

BILL HUTCHINSON HIFI, 26-28 Woodhouse Lane, Leeds (01532) 427777. For the largest selection of HiFi and audio visual equipment in the Yorkshire. Specialist A.V. demonstrations of the highest quality. Best prices guaranteed. Minimum 2 year warranty and an optional 5 yr guarantee available. Instant credit and mail order service on offer throughout the U.K. Pioneer, Denon, Kenwood, Yamaha, Technics, Marantz, Mission, Tannoy plus many more.

HUDDERSFIELD HI-FI CENTRE, 4 Cross Church St, Huddersfield. (01484) 544668. B&W, Cyrus, Kenwood, Denon, Rotel, Arcam, Musical Fidelity, Quad, Audio Lab, Marantz, Mission, ect. Dem facilities - appointment reqd. Mon-Sat 9-5.30, Thurs 9-8. Closed Wed. Free installation, credit facilities. Access, Visa.

AUDIO PROJECTS, 45 Headingly Lane, Leeds 6. Tel: (0113) 2304565. Linn, Arcam, Quad, Audiolab, Musical Technology, Teac etc. Installation. Home Trials. Home Cinema. Multi-room. Tues-Fri 9.30-6.00, Sat 10.00-5.00.

ASTON AUDIO, 19 Crossgate, Otley, Leeds. LS21 1AA 01943 467689. Products: Naim, Arcam, Audiolab, Cyrus, Denon, Epos, Meridian, Micromega, MF, Mission, Nakamichi, Quad, Rotel, TDL & other leading brands. Demonstration Rooms, Installation Service, Interest Free Credit. Access, Visa, Open Tues - Sat.

SCOTLAND

EDINBURGH

BILL HUTCHINSON HIFI, 43 South Clark Street, Edinburgh. (0131) 667 2877. For the largest selection of HiFi and audio visual equipment in Lothian Specialist A.V. demonstrations of the highest quality. Best prices guaranteed. Minimum 2 year warranty and an optional 5 yr guarantee available. Instant credit and mail order service on offer throughout the U.K. Pioneer, Denon, Kenwood, Yamaha, Technics, Marantz, Mission, Tannoy plus many more.

MUSIC MILL - 72 Newhaven Road, Edinburgh EH6 5QG. Tel: 0131 555 3963. Stockists of Micromega, Proac, Audio Innovations, Lumley Reference, Tube Technology, DNM, B&W, Systemdek, Nottingham Analogue, Nakamichi, Rehdeko, Dali, Crimson, Harmon Kardon, Goldring, DPA, Royd, Alchemist, Beyer Dynamic. Mon-Sat 10-6.00 pm by appt. Closed Wednesdays. All Major Credit Cards Accepted. Contact Fraser or Mark

*ABERDEEN

HOLBURN HI-FI, 441 Holburn Street, Aberdeen. Tel: 01224 585713. Arcam, Audiolab, B&W, Celestion, Denon, Dual, Epos, Heybrook, ION, Kenwood, Creek, Marantz, Meridian, Mission, Cyrus, M.S., NAD, Nakamichi, Pioneer, QED, Quad, Revox, Rotel, Ruark, Tannoy, Technics, Wharfedale, Yamaha. 9.30-5.30 Mon-Sat.

HI-FI EXCELLENCE, Hi-Fi innovators & product designers with 15 years experience. Very much in the business for the music. Musical Fidelity key dealer. Largest Rotel retailer in the area. Particularly keen to make the buying of Hi-Fi a fun experience. Situated in the West End away from the bustle of the City centre - the perfect environment to enjoy quality Hi-Fi. Full time service engineer. Open Mon-Tues 10-6, Wed 10-1, Thurs 10-7, Sat 10-5 or later by appointment. Hi-Fi Excellence, 233 Union Grove, Aberdeen. Tel: 01224 322520

AYRSHIRE

LASER AUDIO, Now at new premises : 1 St Marnock Place, Kilmarnock KA1 1DT. Tel: 01563 40292. Audiolab, Aiwa, Celestion, Cyrus, Denon, Dual, Marantz, Mission, Philips, Pioneer Systemdek and Tannoy. 2 demonstration rooms, AV dem room. Appointments preferred, home trial facilities. Free installation, service facilities. Access, Visa and written credit. Open Tues- Fri 10-5.30 Sat 9.30-5.30.

THE SOUND FOUNDATION, 22 Nelson St., Kilmarnock, Ayrshire. KA1 1BA 01563 74185 Agents for Sugden, Pink Triangle, Micromega, Audio Innovations, Harman Kardon, Castle, Revolver, Michell. Single speaker dem. room. Home dems. & delivery installation service available. Full credit facilities available. For more info, phone Kevin. Be Different Pay Us a Visit.

GLASGOW

STEREO STEREO, 278 St Vincent Street, Glasgow, Scotland. Tel 0141 248 4079. Closed Tuesdays. Installations throughout Scotland. Credit facilities available.

BILL HUTCHINSON HIFI, 43 Hope Street, Glasgow, (0141) 248 2857. For the largest selection of HiFi and audio visual equipment in South West. Scotland Specialist A.V. demonstrations of the highest quality. Best prices guaranteed. Minimum 2 year warranty and an optional 5 year guarantee available. Instant credit and mail order service on offer throughout the U.K. Pioneer, Denon, Kenwood, Yamaha, Technics, Marantz, Mission, Tannoy plus many more.

STEREO STEREO 278 St Vincent Street, Glasgow, Tel: 0140 248 4079 E mail Stereo @ cix. compulink.co.uk We will supply the most musical sound for your budget and if you take the time to visit us we will take the time to return the compliment with free installation of your chosen equipment. Open 10-6.00pm closed Sunday, Tuesday Installation Nationwide Interest free credit available

COLLIN MACKENZIE'S HIFI CORNER 52 Gordon Street Glasgow 0141 248 2840. Rose St Edinburgh 0131 220 1535, 1 Haddington Place, Edinburgh 0131 556 7901 and 44 Cow Wynd, Falkirk 01324 629011. Audiolab, Cyrus, Sound-Bytes, Meridian, etc. Most major Brands stocked. Free five year guarantee on all loudspeakers, keen prices.

JAMES KERR & Co., 145 Bath St, Glasgow 0141 226 5711. Glasgow's oldest established hifi specialist, now at new larger premises.

INVERNESS

THE MUSIC STATION, 49 Church Street, Inverness, IV 1DR. Tel: 01463 225253. Beyer Dynamic, Celestion, Denon, Jamo, Kef, Kenwood, Mission, Marantz, Musical Fidelity, Pioneer, Rotel, Sony. Listening room, service department, free local delivery, part exchange, full range of credit facilities.

IRELAND

DUBLIN

CLONEY AUDIO, 55 Main Street, Blackrock, Co Dublin, Tel. 2889449/2888477 Fax. 2834887. Products include: Arcam, Classe, Philips, Rogers, Epos, B&W, Naim Audio, Meridian and others. Open Tues/Sat 10am-6pm. Thurs/Fri 'til 9pm Closed Mondays.

PETER DAND & CO LTD. 111 Clonskeagh Road, Dublin 6. Tel. 0103531 2694433. Products include: B&O, Quad, KEF, Thorens, TEAC & many more! 2 demonstration rooms and 2 year guarantee.

BELFAST

LYRIC HIFI, 163 Stanmills Road, Belfast (01232) 381296. Linn, Naim, Rega, Arcam, Denon, Rotel and more. Mon-Sat, 10.00-6.00pm. Late night Thurs.

ZEUS AUDIO, 6 Hope Street, Belfast, (01232) 332522, Audio Innovations, Pink Triangle, Roksan, Marantz, Celestion, Meridian and more. Mon-Sat 10.00-5.30pm. Late night Thursday.

COUNTY DOWN

ASTON AUDIO, Unit 8, Kings Road Shopping Centre, Kings Road, Belfast. (01232) 402220. Akai, Technics, JVC, Samsung, Toshiba, Panasonic and many more. Demos. Open Mon-Frid 10-8pm Sat 10-5pm.

LONDONDERRY

ZEUS AUDIO, 23a Kingsgate Street, Colrairie, BT52 4LB. Tel. (01265) 56634. Marantz, Mission Cyrus, Aiwa, Akai, Alphason, Sony, Pink Triangle, Celestion, Rotel. Mon-Sat 10-5.30pm. Closed Thurs.

WALES

NORTH WALES

ACTON GATE AUDIO, 4 Ruabon Road, Wrexham, North Wales, Tel 01978 364500. Audio Visual Specialists. Aiwa, Arcam, Aura, Bose, B&W, Beard, Canon, Celestion, Castle, Denon, Jamo, Marantz, Michell, Mission, Mordaunt Short, Pro-Ject, Musical Fidelity, NAD, Nakamichi, Micromega, QUAD, Radford, Rotel, Rega, Ruark, Tannoy, Thorens, UKD, Yamaha, DSP Club Member, Demo Room, installation service. Easy Parking and Motorway access. All major credit cards accepted. 9.30 - 5.30 daily. Closed Weds pm.

ELECTRO TRADER, 19 Colwyn Crescent, Rhos on Sea, Colwyn Bay, Clwyd, Wales, LL28 4RN. (01492) 548932. NOW APPOINTED SUGDEN DEALER FOR THE NORTH WEST. Rotel, Yamaha, NAD, Harman, Kardon, Teac, Alphason, Heco, Infinity, KEF, JBL, Sugden, Tannoy, Rotel, Michi, Haybrook, Acoustic Research, RUarc and Soundstyle tri-pod racks etc. Dem room appts. preferred. Home trial. Free install Access, Visa. Open 9.30 - 1.00, 2.00 - 5.30 Mon-Sat.

GLAMORGAN (SOUTH)

AUDIO EXCELLENCE, 134-6 Crwys Road Cardiff CF2 4NR, Tel. 01222 228565 Fax. 0222398201. All that's best in hi-fi carefully selected and demonstrated by friendly knowledgeable staff, at prices to suit all budgets. Delivery and installation, home dems, part exchange, in house workshops, full credit facilities with interest free on selected items. Tuesday - saturday 9.00 - 5.30. Closed monday.

GLAMORGAN (WEST)

AUDIO EXCELLENCE, 9 High Street, Swansea, SA1 1LE. Tel. 01792 474608 Fax. 0792 645087. All that's best in hi-fi carefully selected and demonstrated by friendly knowledgeable staff, at prices to suit all budgets. Delivery and installation, home dems, part exchange, in house workshops, full credit facilities with interest free on selected items. Tuesday - saturday 9.00 - 5.30. Closed monday.

GWYNEDD

TOP TAPE, 1 Crystal Way, Elmgrove Road, Harrow, Middlesex, HA1 2BJ. Tel: 0181 427 1404. The UK's oldest and largest Tape Mail Order Service. TDK, Maxell, Sony, Ampex audio cassettes plus Fuji, JVC, Konica, Memorex, Scotch & TDK video tapes. Send for complete list of latest prices and offers including Video 8, VHS-C, S-VHS, OAT, MiniDisc and Open Reel and tape accessories including Allisop. Local Dealer Listing available. Telephone orders on 081 427 1404 Mastercard, Visa & Switch accepted

TO ADVERTISE IN THIS SECTION FOR JUST £10.00 PER MONTH

CALL HI-FI WORLD ADVERTISING SALES ON 0171 289 3533.



INTRODUCING THE NEW 600 SERIES

Don't believe all that
you read in the press...



just this bit:

B&W has pulled the stops well and truly out for these speakers, and boy does the result sound good... the 601's sound like the voice coils of God. Up-to-the-minute design, gold-plated biwirable sockets: they're a bargain - magnificent for £200.



What Hi-Fi, November 1995



L I S T E N A N D Y O U ' L L S E E

For details and stockists of the 600 range of loudspeakers, phone B&W UK on 01903-750750

Hi-Fi World WORLD LIBRARY

NEW VALVE BOOKS

PRINCIPLES OF ELECTRON TUBES, by Herbert J. Reich
£29.95

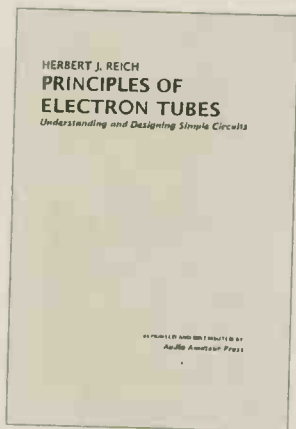

Principles of Electron Tubes first appeared in 1941 as a textbook for beginners studying valves for the first time. The book starts with the basics of how a vacuum tube actually works, including how construction and materials effect performance. Once this basic understanding is in place, Herbert Reich goes on to explain the principles of the simple diode valve, the triode and multi-grid valves. Familiar with the various valve types and their operating principles, the book continues to show how a simple circuit is designed and on to amplifiers, transformers and power supplies. A must for budding valve enthusiasts and an invaluable reference for hobbyists.

70 YEARS OF RADIO TUBES AND VALVES, by John W. Stokes
£19.95

New Zealand author John Stokes, with over fifty years experience, outlines the evolution of radio receiving tubes and the part they played in the domestic radio

receiver in this beautifully illustrated (B&W) book. An ideal reference for those interested in the history and development of valves and for collectors alike.

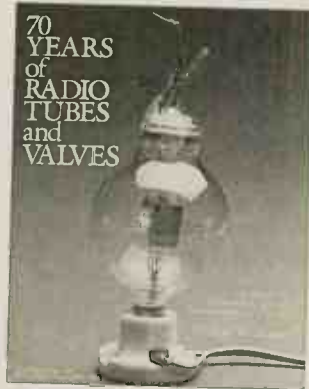

ELECTRONIC UNIVERSAL VADE-MECUM, by Piotr Mikolajczyk & Bohdan Paszkowski
£49.95

This sizeable data book contains no fewer than 5693 valves divided into 442 groups. It contains connection details, operating parameters, load lines, example circuits and more making it one of the most comprehensive reference books we've seen, although there are some omissions, such as 300B and 211 valves.



LOUDSPEAKER BOOKS

BULLOCK ON BOXES, by Robert M. Bullock
£12.95

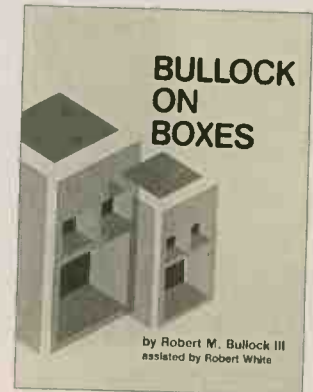

This book relies on manipulation of Thiele-Small parameters (supplied with all drive units) to optimise reflex box design, but with a calculator and at high school level. With lots of helpful tables and graphs, this straightforward book is every beginners best bet for getting to grips with sizing the box and port of a reflex loudspeaker.

ACOUSTICS, by Leo L. Beranek
£39.95

From analogous electrical circuits important for modelling, the author moves through to microphones then loudspeakers. He covers design factors, showing how theory influences practice in drive units. Loudspeaker enclosure types covered include sealed, ported and horn. The behaviour of sound in rooms, very important for hi-fi, is also covered extremely well here.



QUICK & EASY TRANSMISSION LINE SPEAKER DESIGN by Larry D. Sharp
£10.95

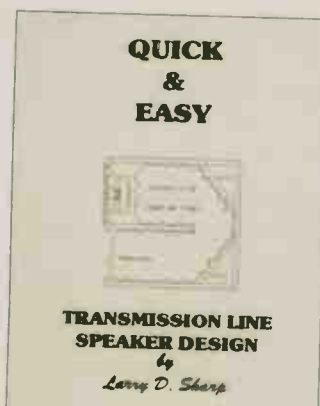

A practical approach to designing and building your own transmission line loudspeaker. Covers the background theory, but is very practical in approach. Design examples and equations, even a computer package to run under Lotus 123 which takes care of the maths.

THEORY AND DESIGN OF LOUDSPEAKER ENCLOSURES by J. E. Benson.
£23.95

This book covers loudspeaker enclosure design; infinite baffle, reflex, passive radiator etc in great detail, with a highly mathematical approach, making it unsuitable for beginners, but highly authoritative to experienced designers with a good foundation in acoustics.

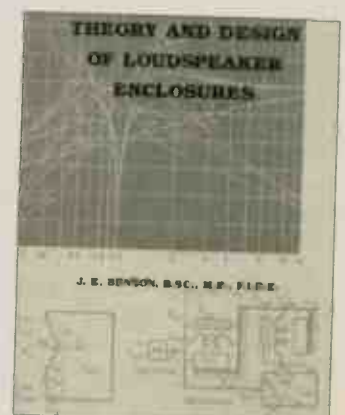

Hi-Fi World WORLD LIBRARY

SOLID STATE ELECTRONICS

THE ART OF ELECTRONICS, by P. Horowitz and W. Hill. £35

The definitive electronics book. The Art of Electronics is an ideal book for the beginner through to the engineer. Written in easy to understand English, each chapter takes you from basic first principles through to full design exercises and practical circuits.



THE ART OF LINEAR ELECTRONICS, by J. Linsley- Hood. £16.95

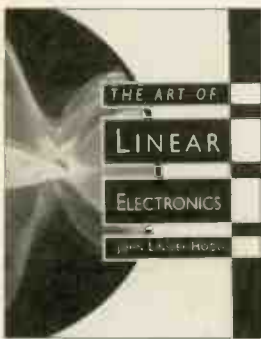

Concentrates specifically on analogue electronics for audio and goes into detail on obscure topics like the drawbacks of feedback, as well as its advantages. Covers mainly solid state but

also includes valves. A must for serious enthusiasts and budding designers.

AUDIO ANTHOLOGIES

Audio Anthologies - When Audio Was Young

There are five volumes of the Audio Anthologies, listed below with a brief description and guide to their contents. They cover one of the most exciting and important eras of hi-fi, from the end of the second world war, through the introduction of stereo magnetic recording, binaural recording and the FM Multiplex decoder. They contain many ground breaking circuits and theory covering all aspects of hi-fi design. A must for valve enthusiasts.

Volume One - May 1947 to December 1949

The first new audio amplifiers, tuners and speakers designed after the long delays of the Great Depression and World War II.

Summary of Contents: 9.5watt, 5watt and 6.5 watt 6AS7G amplifiers, 30watt 300B amplifier, valve FM tuning indicator, 30watt 211 power amplifier, cathode follower amplifier using 6V6, an adaptation of the Williamson amplifier, valve phono preamplifier, several horn and reflex loudspeaker designs and much more.

Volume Two - January 1950 to July 1952

More great amplifiers, preamps, loudspeaker designs, and the first glimmer of the stereo revolution plus magnetic recording aids.

Summary of Contents: Ultra linear 6L6 design and operation of the Williamson, a direct coupled amplifier, Williamson type amplifier using 6A5s, 40watt 845 push-pull amplifier, valve phono and line preamps, valves and loudspeaker damping, design and construction of reflex and horn loudspeakers.

Volume Three - August 1952 to June 1955

Seven power amplifiers, eighteen preamps, twelve loudspeaker designs, including four horn types and binaural recording techniques.

Summary of Contents: Simple valve phono stage, transformerless amplifier using 6082, 20watt 5881 amplifier, 10watt 6V6 amplifier, stereo valve preamp, high quality valve phono stage, a preamp for the Williamson, low distortion tone control preamp, binaural or stereophonic?, transistor phono amp, corner horn loudspeaker, concrete horn loudspeaker.

Volume Four - July 1955 to December 1957

How to plan an audio system, twelve amplifiers and preamps, solid state techniques and circuits introduced and six loudspeaker designs.

Summary of Contents: 18watt 5881 amplifier, 4watt single-ended tweeter amplifier, budget 11 watt amplifier, versatile bass/treble control, transistor theory, transistor preamp, transistor techniques, battery powered transistor phono preamp, loudspeakers explained.

Volume Five - January 1958 to December 1959

Stereo comes to full flower with four FM Multiplex decoder designs, seven power amps, eleven preamps, a commercial killer, five loudspeakers, and theory articles by Olson, Crowhurst and McProud.

Summary of Contents: Stereo valve multiplex decoder, 7watt EL84 amplifier, valve active crossover and 20watt treble amp/50watt bass amp., monaural, binaural, monophonic and stereophonic explained,

heterodyne FM multiplex adapter, transistor preamp, 60watt EL34 amplifier, high power audio amplifiers, hi-fi loudspeaker enclosure.

Price
All five for

£14.95each
£69.95



VALVE BOOKS

AN APPROACH TO AUDIO FREQUENCY AMPLIFIER DESIGN, seventeen circuits from 5 to 1100watts. General Electric Co. £19.95

Seventeen high quality amplifier designs from the Research Laboratories of the General Electric Company (UK). Designs range from 5 to 100watts, using KT66s, KT88s, DA100s, etc.

Also includes two valve pre-amplifiers complete with valve phono stages.

AN APPROACH TO
AUDIO FREQUENCY
AMPLIFIER DESIGN
Seventeen Circuits from 5 to 1100-watts

MULLARD TUBE CIRCUITS FOR AUDIO AMPLIFIERS. £13.95

First published in 1959 by Mullard, this book includes full designs for eleven power and control amplifiers, including the 5-20, using valves. This book begins with a four-chapter tutorial on getting the best sound from valve amplifiers.



THE WILLIAMSON AMPLIFIER,

HQ

Audiophile International Presents

Recommended Vinyl

Pressings By Selected Labels

Audiophile International present a small selection of labels we carry

Analogue Productions,
Analogue Audio Association,
ATR,
B&W,
Cisco Music,
Clarity,
Classic Records LSC,
Verve jazz & CBS,
Concord,
DCC Compact Classics,
Discovery,
EMI,
Enja,
Golden String,
Grapevine,
Impulse jazz,
JMO,
Klavier,
MCA,
Mobile Fidelity,
Mosaic,
Opus,
RCA,
Reference Recordings,
Warner,
Three Blind Mice.

For The UK's Best Selection Give Us A Call.



PHILADELPHIA JERRY RICKS

Empty Bottle Blues

There are a few terms that could describe the sound of this album, one of them would be 'in the room'. If you like that relaxed traditional blues, one man, his guitar, and the bare acoustics of a room, then this is for you. For such a simple arrangement there is so much in this recording, but it is the subtly of air resonating in the body of his guitar the shape of the lyrics that make this simple Radioton pressing, an equal to any audiophile release.

LP only £12



PINK FLOYD

Pulse (4LP Deluxe Box Set)

It was worth the wait, way better than I thought EMI were capable of achieving. Recorded in 'Q-sound' with an all analogue chain and pressed on 4x165gm vinyl with a fantastic full colour hard back book, this set embodies Floyd's latest concert. From 'Wish You Were Here' to there latest album 'Division Bell' to the complete rendition of the 'Dark Side Of The Moon' album this is a must have.

4LP Box only £44



LSC 2446 RIMSKY-KORSAKOV

Scheherzade

A personal favourite among the RCA living stereos. Fritz Reiner drives the Chicago Symphony Orchestra at a perfect pace throughout and the musicians rise to the occasion, most notably concertmaster Sidney Harth who's violin solo at the end of 'Festival in Baghdad' may bring tears to your eyes. Richard Mohr, in writing the original liner notes, said of the CSO "Under Dr. Reiner's direction (they) have achieved what can only be termed a musical revelation and that in the most literal sense"

HQ 180gm LP £28

Available Now From Audiophile International

To Order Visa / Access Call

24 Hour Fax

'Classic Records' Dealer inquiries welcome

01276 855578

01276 855580

01276 855530

BUY 2 OR MORE LSCs FOR £25 EACH

- LSC 1934 BARTOK - Concerto For Orchestra £28
- LSC 2201 MUSSORGSKY - Pictures At An... £28
- LSC 2222 DEBUSSY - Iberia (Reiner) £28
- LSC 2225 WITCHES BREW (Gibson) £28
- LSC 2449 GOUND - Faust/BIZET - Carmen £28
- LSC 2456 LALO - Symphonie Espagnole £28
- LSC 2285 WALTON - Facade £28
- LSC 2298 BORODIN - 2nd Symphony £28
- LSC 2343 REINER - Festival (Chicago S.O) £28
- LSC 2500 STRAUSS - Waltzes (Reiner, C.S.O) £28
- LSC 2541 LISZT - TODTENTANZ £28
- LSC 2436 RESPIGHI - Pines Of Rome (Reiner) £28

- LSC 1817 OFFENBACH - Gaité Parisienne £28
- LSC 2446 RIMSKY-KORSAKOV - Scheherzade £28
- LSC 2134 OVERTURE! OVERTURE! £28
- LSC 2150 PROKOFIEV - Lt. Kije (Reiner, CSO) £28
- LSC 2183 THE REINER SOUND £28
- LSC 2418 ELGAR - Enigma Variations £28

CLASSIC RECORDS VERVE JAZZ

- ELLINGTON & HODGES - Back To Back £25
- COLEMAN HAWKINS ENCOUNTERS £25
- COLEMAN HAWKINS - Alive At The Village Gate £25
- BILLY HOLIDAY - Songs For Distingue Lovers £25
- ELLA FITZGERALD - Let No Man Write My... £25
- BILL EVANS - Live At Montreux £25
- ELLINGTON & HODGES - Side By Side £25

Audiophile International Ltd.

P.O. Box 303, Chobham, Surrey, GU24 8RX.

We are now the official importers and distributors for Classic Records - RCA classical, Verve jazz, as well as DCC Compact Classics, King Super Analogue, Analogue Audio Association, Edition Open Window

If you really like music and want the latest releases on standard vinyl, gold CD and audiophile vinyl and the reassurance that your order will reach you safely you ought to join our world wide data base. Send £3 in postage stamps for our '95 gloss catalogue which contains the UK's largest selection of audiophile recordings, then every month receive free of charge 'update' catalogues containing new releases and used mint condition LPs.

Audiophile International Presents

LP's, CD's & Accessories

Audiophile International

THIS MONTHS RECOMMENDED

Vinyl Pressings

MARY BLACK - Circus	New Release	£10
BJORK - Post		£9
DAVID BOWIE - Excerpts From Outside		£10
BLUR - The Great Escape		£9
SAM COOKE - Night Beat	U.S. Import	£12
COUNTRY - Country by Vinyl Junkie	2LP	£12
THE CRANBERRIES - Now Need To Argue		£9
BOB DYLAN - MTV Unplugged		£12
EAGLES - Hell Freezes Over	2LP	£17
EMMYLOU HARRIS - Wrecking Ball	New Release	£10
JETHRO TULL - Root To Branches	2LP	£14
JIM MORRISON - An American Prayer Music By The Doors		£12
VAN MORRISON - Days Like This		£10
MORRISSEY - Southpaw Grammar		£10
OASIS - Definitely Maybe	2LP	£12
OASIS - (What's The Story) Morning Glory ?	2LP	£12
BOB SEGER & THE SILVER BULLET BAND - Greatest Hits	2LP	£17
PAUL WELLER - Stanley Road		£10
NEIL YOUNG - Mirror Ball	2LP U.S. Import	£15
FRANK ZAPPA - We're Only In It For The Money		£12
FRANK ZAPPA - Strictly Commercial	2LP U.S. Import	£15

EMMYLOU HARRIS



DISCOVERY RECORDS

180gm HQ Vinyl Pressings

DIS 79001 JAZZ AT THE MOVIES - Body Heat	£25
DIS 79002 JAZZ AT THE MOVIES - A Man And A Woman	£25
DIS 79003 JAZZ AT THE MOVIES - White Heat (Film Noir)	£25
DIS 79004 OREGON - Out Of The Woods	£25
DIS 79005 DEXTER GORDON - American Classic.	£25
DIS 79006 LEE RITENOUR - Rit	£25

ACCESSORIES - TORUMAT

All accessories prices include postage charges.

TC-2 TORUMAT CONNECTION CONDITIONER
This is a special formula that promotes conductivity between metals for improved audio - and video - performance. £15.95

TM-7XH TORUMAT SUPER RECORD CLEANING SOLUTION
Our most popular and highly recommended detergent-based non-alcohol cleaning formula. Torumat TM-7XH is safe for all vinyl records and all types of vacuum powered machines, including Nitty Gritty, Record Doctor, VPI, Moth, Keith Monks and more. £15.95

CDX-15 TORUMAT CD CONDITIONER LIQUID
CDX-15 Cleans and conditions the surfaces of laser discs for better sound without loss of musical information. Stunning reviews in all US Hi-Fi magazines. £15.95

COOKIN'/WITH THE MILES DAVIS QUINTET



ANALOGUE PRODUCTIONS

180gm HQ Vinyl Pressings

ART PEPPER - Meets The Rhythm section	£25
SONNY ROLLINS - Way Out West	£25
LIGHTNIN' HOPKINS - Goin' Away	£25
BILL EVANS - Waltz For Debby	£25
DUKE ELLINGTON - This Ones For Blanton	£25
CHET BAKER - Chet	£25
THE DON EWELL QUARTETTE - Yellow Dog Blues	£25
RAY BROWN - Super Bass	£25
MILES DAVIS - Cookin'	£25
DOC & MERLE WATSON - Pickin' The Blues	£25
BASIE JAM	£25
COUNT BASIE - Farmers Market Barbecue	£25
CHARLIE BYRD - The Guitar Artistry Of...	£25
JANIS IAN - Breaking Silence	New £25
JOHNNY ADAMS - Sings Doc Pomus	New £25

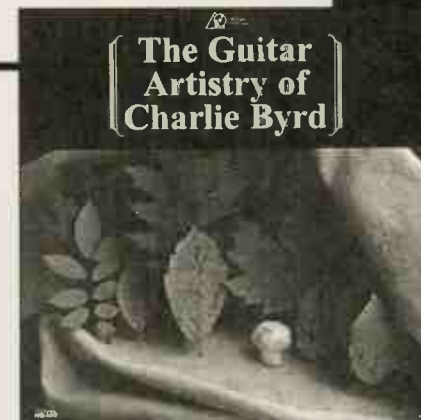

P.O. Box 303, Chobham, Surrey, GU24 8RX. For the UK largest catalogue of Audiophile Vinyl and gold CDs, send £3 in postage stamps or 5 International Response Coupons, you will join our data base and receive free monthly update catalogues containing new releases and used LPs. Free catalogue with every £20 order from this advert, if you seriously like music then you should join our data base. U.K. postage £3 first LP 75p per additional, £2 first CD 50p per additional, we send every U.K. order First Class Recorded Superpacked. Overseas customers call.

Worldwide Mail Order

Retail Orders 01276 855578
Fax 24 Hours 01276 855580
Wholesale 01276 855530

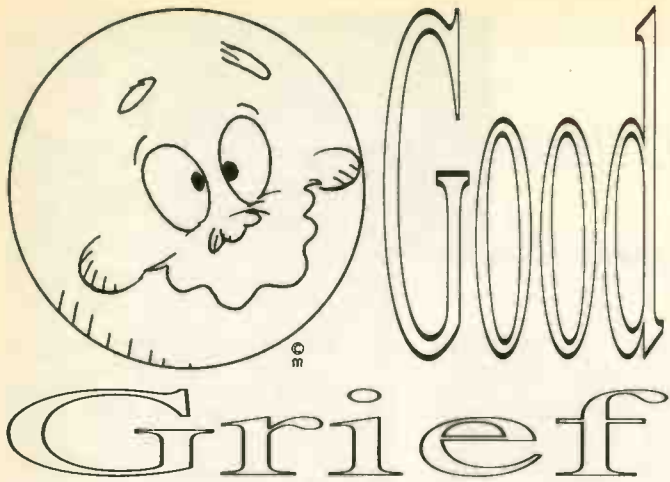

Good Grief

What is it about Hi-Fi World that makes "enthusiast" dealers produce endless newsletter adverts. A dearth of customers to talk to? Mind you scanning through some of the other dealers output I gather that we are all busy sorting problems, superman-style, far and wide.

I suppose my last advert was really a thinly disguised newsletter, this one is more overt: My name is Alastair Gardner, no I'm not unbiased and yes I'm a retailer.

As a frustrated Hi-Fi journalist, oops, retailer, I've been pondering the actual link between technology and amplifier sound quality. Many claims are made. Valve amps tend to offer class A. Transistors predominantly class AB or B. The resultant sound qualities rarely meet expectation (in either direction). It is usually the negative qualities of a given technology that provide a suitable framework on which to hang your prejudices.

The quality of the execution seems more important than any theoretical advantages offered by a particular technology. This conclusion is reached because the name applied to the technology is often misleading. In reality, for example, few "class A" or even "pure class A" amplifiers - valve or transistor - genuinely operate as claimed.

J E Sugden are... unusual (I nearly said virtually unique - but that is as bad as "virtually class A") in making the distinction of pure class A versus class AB - and actually meaning it. In recent years only one of their products - the A21a - has offered true, pure, unadulterated class A. Critical acclaim has been universal.

And now there's another.

The new Sugden Symetra monoblock power amplifiers (they have a name rather than number in common with the new Optima range) manage to transcend arguments about valves versus transistors and confirm the innate superiority of pure class A operation. The link with the A21a is evident yet the Symetras are in a different league.

The Symetras show that just forty watts per channel is no limitation. With the right ancillaries they produce a sound-stage with air, space, colour, subtlety, speed and slam. Those familiar with seriously good (read seriously expensive) valve amplifiers will recognise the free, open, dynamically unconstrained quality. They won't recognise the ease of loudspeaker matching, the bass control, lack of colouration or the price tag.

If you aspire to a top flight music system it's hard to see the point of buying upgradable boxes of electronic lego when around £1500 allows you to enter the "serious" league in one go. After all you have freedom of choice over passive controllers and pre-amplifiers, including some fine remote controlled ones from Sugden. An upgrade path can be constructed by starting with a basic, inexpensive (even passive) controller and working up.

In my opinion you cannot afford to ignore a product of this quality.

Call me and I'll be pleased to demonstrate audio utopia by Sugden.



hi-fi for grown-ups

arion audio innovations audion audiovector
 audio synthesis chord company densen
 ear grado harbeth heybrook jocklin keswick a
 udio research lyra michell morel moth
 ortofon pierre lurne project qed royd
 sennheiser spendor sugden sumiko teac
 triangle trichord voyd and more

ipswich 01473 622 866
 mobile 0802 176319

Pure Sound

We want your used quality kit!

A selection from this month's used and ex-dem bargains - call us for list with your wants and disposals!

AMPS

DPA 50s power, pre and phono stage, balanced cables	£1300
Copland CSA 14 (as new condition)	£750
Jadis Dely (as new condition)	£3350
Lumley Reference passive preamp (chrome)	£250
Alchemist Karaken two poweramps, one pre	£699
Audion Silver Knights	£1599
Arion Tycho 50W chrome	£1650
YBA power 3	£899
Audio Note OT0 Line SE	£999
Arion Elektra export	£999
Audio Innovations 2nd Audio Amp	£599
Adyton Opera integrated amp	£1995

DACS

Audio Note DAC2 (pure, valve sound)	£600
Counterpoint DA10 DAC with 20 bit Ultra Analog DAC - crisp, clean sound	£160
Wadia Digimaster X 32 dac, slightly marked	£650

CD Transports

Audiomeca Kreatura CD transport with Trichord relock - beats £2,000 transport	£799
Audiomeca Damnation transport	£775
YBA CD2 player	£1650
Marantz 94 player	£325

Speakers

Triangle Altinis (beautiful speaker, sensitive for low power valve amps)	£1199
Triangle Alcante speakers (sensitive, good match to valve amplifiers)	£550
Triangle Scalene speakers (smaller, but also excellent with valves)	£350
ProAc towers - 3ATC drive units, superb, clear, dynamic sound	£1300
Lumley reference 4s - bookshelf speaker - amazing value	£210
Audio Physic Step (slightly marked)	£799
Ruark Crusader (special finish, mint condition)	£699

01784 458176

0831 178740

(London, west)

MANTRA AUDIO

- HI-FI/VIDEO ACCESSORIES
- MAIL ORDER DIRECT 1-10 DAYS
- COMPETITIVE PRICE (inc P&P)

MAKE	MODEL	CARTRIDGE	STYLUS	ADC	QLM 30, RQ 3/4	£9.00
Arcam	C 77, C77 Mg	N/A	£18.00		R20 XE, QLM, 39/36, X1 3/4	£12.50
	E77, E77 Mg	N/A	£36.00	Alwa	AN 5/11/30/50/8745	£8.00
	P77, P77 Mg	N/A	£47.00		AN 2/50/70/77/10/4932/8743	£10.00
Audio	AT 95E	£21.00	£12.50	Alkal	RS 33/35/38/84/85/90	£8.00
Technica	AT 110 E	£26.50	£16.00	BSR	ST 14/15/16/17/19/21	£3.00
	AT OC 5	£125.00	£90.00	Dual	DN 145/155/165/E DN 149 S	£12.50
	AT OC9	£216.00	£155.00	Goldring	G800/20/850 (D110/D120/D130)	£8.00
Denon	DL 110	£85.00	£52.00		G800 Sup E	£12.50
	DL 160	£85.00	£88.00	Hitachi	DS-ST 7/12/14/15/26/30/35/102	£8.00
	DL 304	£185.00	£160.00		DS-ST 5/16/23/24/25/55/103/104	£10.00
Dynavector	DV 50X MK2	£135.00	£108.00	JVC	DT 33/35/36/45/55/60/65, DT Z1 S	£8.00
	DV 104X MK2	£160.00	£128.00	Kenwood	N 47/48/51/53/60/61/63/66/72	£8.00
	DV 23RS MK2	£319.00	£255.00	National	N 36/37/43/45/56/59/62/67/69/71	£10.00
	DV 17D2 MK2	£359.00	£288.00		EPS 23/24/25/30/33/51 CS2/270 D	£8.00
Goldring	ELECTRA	£24.00	£16.00	(Technical)	EPS 43/52/75/76/ STS, P30/33 D	£8.00
	1006	£44.00	£29.00	Ortofon	P30 (Upgrade), EPS 205/207 E	£12.50
	1012 GX	£58.00	£38.00	Philips	FF 15/VMS 10/20 EII, DM/P 20	£8.00
	1022 GX	£76.00	£49.00		GP 371/400/780/400 I/III	£8.00
	1042	£94.00	£61.00	Pioneer	GP 330/370/401/401 I/II/41 II	£10.00
	ERDICA (LX/H)	£90.00	£60.00	Sansul	PN 210/220/240/K65/250/T295T	£8.00
					SN 2728/29/33/34/37/41/50/80/101	£8.00
					ST 80/100/151/5/6/613	£8.00
					ST G 8/9/10, ST 28/29/35/37/40 D	£8.00
					STY 104/111/116/117/118/123/124	£8.00
					N 75-6/C/G, N 91 G, SSS 35 C	£8.00
					N 44 E, N 70 E/J, N 75 ED/EJ T2	£10.00
					N 55 E, N 95 ED/EJ, N 97/105 ED	£12.50
					VN 15E, VN 35E (V 15 IIIIE)	£15.00
					N 95/97 HE, VN 35 HE	£20.00
					ND 133/134/142/150/155/200 G	£8.00
					ND 115/143/148/153/220/250 G	£10.00
					N 53/55/60 DY, N 62/292, N 71/290	£8.00
					PROFESSIONAL/DJ ITEMS	DJ PACK STYLUS
Ortofon	DM5E, OMP 5E	£16.00	£14.00			
	DM 78 (Stylus)	N/A	£26.00			
	OM10, OMP10	£25.00	£16.00			
	DM20	£63.00	£35.00			
	DM30	£81.00	£60.00			
	OM N'CLUB S	£31.50	£18.00			
	510	£31.50	£21.00			
	520	£54.00	£40.00			
	530	£85.00	£63.00			
	540	£112.00	£85.00			
	MC1 Turbo	£58.00	£45.00			
	MC3 Turbo	£112.00	£85.00			
	MC 10 Super	£85.00	£65.00			
	MC 15 Super	£112.00	£85.00			
	MC 25 E	£153.00	£117.00			
	MC 25 FL	£290.00	£193.00			
	MC 10 Supreme	£234.00	£186.00			
	MC 20 Supreme	£340.00	£255.00			
	MC 30 Supreme	£425.00	£319.00			
Shure	VN 35 MR (V15II)	N/A	£90.00			
	VN 45 MR (V15 IV)	N/A	£90.00			
	V15 V MR	N/A	£130.00			
Stanton	500 AL Disco	£30.00	£18.00			
	680 ALX Disco	£44.00	£32.00			
	680 ELX Disco	£54.00	£39.00			
	SWISS QUALITY DIAMOND STYLUS		PRICE			

Exchange any MC *** Over 500 may vary. Tel: (0757) 78652

All items are in excellent condition. Noisy items.

MANTRA AUDIO (HW), 22 GARTH AVENUE, NORTH DUFFIELD, SELBY, NORTH YORKS YO8 7RP

For Hi-Fi & Hi-Fi Bargains Welcome To

HI - FI

Save Upto **40%**
or more

CONFIDENTIAL

Ph. 0171 233 0774

**Why buy elsewhere
when we offer:**

***** Service

- * The best prices
- * 24hrs delivery service (Carriage insurance free)
- * Free professional advice
- * The biggest choice of hi-fi separates / systems, speakers and home cinema
- * Valve amps and pre-amps a speciality.

**AUDIO INNOVATIONS-B&W-BOSE
CASTLE-CONRAD JOHNSON DENON-
DPA-DYNAUDIO-EAR-KEF
KENWOOD-LUMBLY REFERENCE
MARANTZ-MUSICAL FIDELITY-NAD-
NAKANISHI-ORELLE-PINK
TRIANGLE-PIONEER-QUAD
SUGDEN-SPENDOR-TANNOY
TECHNICS-TUBE TECHNOLOGY**

HI-FI CONFIDENTIAL LTD
34 Buckingham Palace Road, London SW1W 0RE
ph. 0171 233 7225 & 0171 233 0774
Fax 0171 233 7226
Showrooms near Victoria Station (1 min walk)

Valve amps available with us.
EAR-Tube Technology-Conrad Johnson-Lumbly Reference-Audio Innovations...

We stock the best selection of *speakers* from:
Quad Electrostatics, Spendor, Castle Acoustics, Tannoy, JBL, Kef, Bose, B&W...

Amplifiers and pre-amps:
Alchemist-Musical Fidelity-Quad-Kenwood-Marantz-Denon-Orelle-Rotel-Pioneer-Technics-Yamaha...

DACs & CD Players:
Pink Triangle, DPA, Orelle, Micromega, Marantz, Yamaha, Pioneer, Musical Fidelity, Sony, Teac

We offer the best prices and the widest selection on
cassette decks, tuners, turntables and home cinema
products from: Rotel, Yamaha, Sony, Technics, NAD,
Pioneer, Marantz, Denon...

OFFERS OF THE MONTH THE WIDE SELECTION OF VALVE AMPS/PRE-AMPS

Lumbly Reference	ST 70	£1799	Audio Innovations	P1 phono	£369
Lunbly Reference	S7 40	£899	EAR 859 integrated		£1999
Audio Innovations	L2 preamp	£629	EAR 509 MK11 mono blocks		£3499
Audio Innovations	S200 poweramp	£429	EAR 834P phono stage		£449
Audio Innovations anniversary	S800 poweramp	£1129	EAR 834 amp		£999
Audio Innovations	S300 integrated amp	£449	Unison Research Simply Two		£995
Audio Innovations	classic 25 integrated amp	£799	Tube Technology unises integrated		£1399
Audio Innovations	L1 preamp	£369	Conrod Johnson PVIOAL preamp		£1125

All major credit cards welcome. OPEN 10am-6pm Mon-Sat Mail order throughout UK Tax-free export worldwide.

MARTIN LOGAN • ALCHEMIST • AUDIO RESEARCH •

• AUDIO ALCHEMY • TEAC • NAD • TRIPOD • ALPHASON • PIONEER •



Audio Note



AUDIO GALLERY

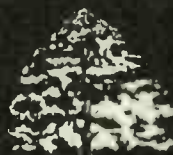

NR PETERSFIELD HAMPSHIRE
MISSION FOR OPENING
MUSICAL FIDELITY HOURS AND
KLIPSCH APPOINTMENTS
DECAPO, AEGIS SPEAKERS PLEASE RING
LYRA CARTRIDGES 9.30am - 7pm
DPA200S HEYBROOK

HOME DEM
AUDIO SYNTHESIS ACOUSTIC ENERGY
WADIA 6 MICROMEGA STAGE DAC IN A BOX
TDL, SME, TEAC
VRDS 10, AUDIONOTE + AV

01730 - 895194

VALVE SPECIALISTS ON A SUPERIOR LEVEL

WADIA • TUBE TECHNOLOGY • DPA •

• DENON • RESTEK • PROAC • JPW • MOTH • PINK TRIANGLE •



The Great British Hi-Fi Show

Saturday 13th & Sunday 14th April 1996
The Palace Hotel, Buxton Derbyshire
9.30am to 5.00pm each day

FREE ENTRANCE

A Warm Invitation is extended to you, your family and friends at this, the 10th year of celebrating all that's Best in British Hi-Fi.

To mark the Show's first decade, you're welcomed to enter our fabulous Free to Enter Draw to win one of the Three Thousand Pounds worth of prizes.!

Be Sure to visit the Great Bazaar where you'll find thousands of records, CDs, Components & Accessories, Furniture, Audio Publications etc, there's a great Valve and Vintage section too.!

Exciting News for 1996... a specialist secondhand equipment section where you can be sure of finding many rare bargains.

A Unique Opportunity to meet the designers in person and have all your questions answered.

See and Hear the newest equipment first hand, in the super atmosphere of the Palace Hotel, where the large demonstration rooms offer some of the best sounds around.

Don't miss some very special 'Show Offers' and save a great deal during the weekend.

Make a note in your diary..... Buxton 13/14 April 1996

Look forward to seeing you at the best event of the Hi-Fi year.!

Enquiries to: The Great British Hi-Fi Show, P O Box 50, Chesterfield S40 4YU
(Formerly 'The Chesterfield Hi-Fi Show')

THE Service Specialists

From **Classic Valve** to **Digital LaserDisc...**

You supply the Problem, We supply the Solution!

QUAD • GRANT • LEAK • RCA • REVOX • ALTOBASS • RADFORD •
PIONEER • LUMLEY • TEAC • YAMAHA • AVANTIC etc.

For over 20 years we have provided un-matched technical services to
Enthusiast and Pro. alike. We've satisfied customers at all points of the
compass - even in Australia!

What makes us so popular? Simply, we're the best!

RESTORATION. Messrs, Leak, Walker, Radford *et al.* got it right!
Yesteryear's great designs are, in the main, fine. They certainly don't need
converting into something else, which seems to be a current trend. We will
carefully restore your classic using modern high-quality components; this
alone frequently improves the sound quality enormously. We will not,
though, alter the original design in an attempt to "improve" it. Enjoy owning
and listening to a Classic... not a latterday fad.

REPAIR/CALIBRATION. Even the finest equipment's will suffer an
occasional breakdown and need meticulous repair, calibration and
alignment. The **only** standards we recognise and work to are Manufacturers
Original. Our Test & Measurement facilities are probably the best in this
sector of the Industry... and we know how to use them!

KIT-BUILDING. There are numerous kits around nowadays. They all
require skill/experience to build satisfactorily and, in the case of valve
equipment, safely. Some designs are good, otherswell, let's just say
their 'designers' would benefit from a sojourn on that celebrated desert
island with only Terman and Langford-Smith for company!

**Whichever kit you choose, though, it will benefit from a professional
build.** We will build it, de-bug it and give you a set of Final Test figures
from your sample.

KIT-RESCUE. In trouble? It won't work? *Nil desperandum.* Contact us
about a rescue/re-furbish.

For more details of our comprehensive services, 'phone or fax:-

(0113) 244 0378

AUDIO LABORATORIES (LEEDS)

TRANSLUCENT



**99.99%
Pure Silver
Interconnects**

**ALL CABLES ARE DOUBLE SCREENED,
PSEUDO BALANCED AND SILVER SOLDERED
USING QUALITY GOLD PLATED PLUGS**

Translucent

Smart grey braid finish 58pf/metre

Half metre **£59.99 (pr)**

One metre **£79.99 (pr)**

Translucent +

Smart grey braid finish, double

silver content 64pf/metre

Half metre **£79.99 (pr)**

One metre **£109.99 (pr)**

Translucent Crystalline

Smart black braid finish, double

silver content, PTFE insulated

74pf/metre

Half metre **£109.99 (pr)**

One metre **£149.99 (pr)**

Please add £3.50 p & p per order
and allow 10 days for delivery.

CLASSIQUE SOUNDS

Classique House, 61 Aylestone Drive, Aylestone, Leicester LE2 8QE

Telephone: 0116 283 5821 or 0802 213740 (mobile)



THE INNOVATIVE
AUDIO/VISUAL
HI-FI RETAILER

SERVING LONDON
FROM BATTERSEA

ORANGES & LEMONS

Juicy fruit from London's newest, freshest
hi-fi/home cinema retailer. Telephone for demonstrations
or just pop in. All the usual,
i.e friendly and efficient service,
free home installation + credit cards,
0% credit finance available.

CABLETALK, CHORD CO, DENON,
EPOS, KEF, MICROMEGA, NAD, NAIM, QUAD, REGA,
ROKSAN, ROTEL, ROYD, RUARK, SOUNDSTYLE,
STANDS UNIQUE,
with more to come.

THE INNOVATIVE
AUDIO RETAILER

0171 - 924 2040

61/63 WEBBS ROAD, SW11

WESTWOOD & MASON



Arcam, Aura, Celestion, Denon,
KEF, Marantz, Mission, Naim,
Nakamichi, Project, Quad, Rega,
Rotel, Royd, Tannoy, TDL, Yamaha,
Cord Co., Goldring, Grado,
Klipsch, JPW, Infinity.

WESTWOOD & MASON (OXFORD) LTD
46 GEORGE ST
OXFORD

TEL OXFORD (01865) 247783
CLOSED THURSDAY

SLATE AUDIO



Esoteric Developments



THE SPEAKERSTAND

The best speaker supports in the world.

State of the art in both performance and design. custom made to suit any loudspeaker. solid slate, supremely rigid and totally stable.

“Immaculately finished, sublimely rigid, on a par with the best stands I've used.” Ken Kessler, Hi-Fi News R/R. “An astonishing degree of instrumental separation, stable and holographic, with great precision and remarkable poise. The ultimate in high fidelity supports.” David Praker, Hi-Fi Answers. “Superbly finished, the sound quality was considered to be first rate.” Martin Colloms, Hi-Fi News R/R. “The sound quality when using the Slate Audio stands proved to be a revelation, something special.” Paul Messenger, Hi-Fi Choice. “The finish is excellent, the sound quality magnificent and breathtaking.” Tom Bryant, The Telegraph. “The Slate stand is unusual and expensive, but if you are after an exceedingly neutral stand it's the leading contender. This stand offers an exceptionally neutral platform for speakers; highly transparent sound leads to musical performances with real insight.” SOUND QUALITY: ■■■■■■ Malcolm Steward Hi-Fi Choice.

SLATE AUDIO GARRARD 301 and 401

The most musical record players in the world.

Our researched Solid Marble Plinth System[®] advances the state of the art and brings the Garrards into the 21st century. All wooden plinths produce unacceptable levels of coloration, microphony and feedback, with poor signal to noise ratios. When dealing with a thoroughbred you must respond with a firm hand, as anybody who has heard the transformation will testify.

Dear Mr. Soper,

Thanks for sending me the plinth for my Garrard 401. I must confess, that I was a bit sceptical about it, when I ordered one - after all, I bought it, without the possibility of listening to it first. But the results I get are really unbelievable. There is no rumbling, instead deep, deep bass and an authority, I never heard before from my records. And believe me, I tried some of the best turntables around (Linn LP 12, Roksan Xerxes). Now I'm waiting for the forthcoming power-supply. The day I place my order for it, I will do so without being a bit sceptical. Thanks again for a marvellous piece of art.

MR TEILINGER - AUSTRIA



Better than a . . .



THE GLASSMAT

The finest platter mat in the world.

The Glassmat was developed to improve the performance of the Garrard 301 and 401 record players. However it also gives astonishing results when used on other turntables. So effective is its performance, we have now made it available as a universal replacement mat. In all cases other mats introduce colorations of their own, robbing the music of large amounts of detail and ambience. In order to achieve maximum information retrieval with optimum damping, a hard and unyielding material is required. Glass is ideal in every respect, damping is complete, the playing surface being quite simply sublime. In terms of detail resolution and sheer three dimensional ability, no other mat comes close. But then you still have to consider the absolute clarity, precision and solidity of the presentation. This is the ultimate platter mat.

£65.00 PLUS £3.50 FREIGHT.

AT LAST THE POWERHOUSE OUR GARRARD 301/401 TD124 AND UNIVERSAL POWER SUPPLY
PHONE NOW FOR A HOME TRIAL OF THE BEST TURNTABLE DRIVE SYSTEM EVER

THE GREEN MONSTER SOLID MARBLE PLINTH SYSTEM[®] FOR THE THORENS TD124.

MICKY MOUSE A VERY SERIOUS UPGRADE FOR THE MICHELL GYRODEC IN SLATE.

BEDROCK SOLID SLATE PLINTH SYSTEM[®] FOR THE REGA PLANAR 2 AND 3.

SLATE AUDIO GARRARD 301 AND 401 AVAILABLE COMPLETE OR MARBLE PLINTH SYSTEM[®] ONLY.

SME/GARRARD 301 AND 401 CELEBRATION ARMS WITH SPECIAL GRAPHICS "GARRARD 301 OR 401 CELEBRATION" 309 £597.00 • 312 £694.00 • IV £869.00 • V £1295.00.

THE TONEARM OUR SPECIAL VERSION OF THE FAMOUS REGA RB300, FITTED WITH GOLD PHONOS £155.00 + £3.50 FREIGHT.

THE SPIKEKIT SPECIALLY DEVELOPED TO FIT DIRECTLY TO FLOOR STANDING LOUDSPEAKERS OR ANY WOODEN SUPPORT ADJUSTABLE AND VERY SIMPLE TO FIT £25.00.

GOLD PHNOS (PAIR) £9.50 • GOLD BANANA PLUGS (FOUR) £8.00 • SORBOTHANE BIG FEET (FOUR) £48.00 • SORBOTHANE CD FEET (FOUR) £30.00 •

SORBOTHANE SHEET (6"x6") £15.00 • SHURE STYLUS PRESSURE GAUGE £18.95 • GARRARD 301 SWITCH SUPPRESSOR £7.50 • TURNTABLE SERVICE £65.00.

WE OFFER A FULL MONEY BACK GUARANTEE IF NOT COMPLETELY DELIGHTED

FOR INFORMATION, SALES OR DEMONSTRATIONS, SPEAK TO PETER SOPER

47 GEMINI CLOSE, LEIGHTON BUZZARD, BEDS, LU7 8UD.

TEL: 01525 384174 or 0421 624429

AUDIO ARTS

HI-FI CONSULTANTS

SYSTEMS FROM £250 000 - £1500



THIS MONTH WE HAVE ON DEMO THE VPI TNT JUNIOR, WE ALSO HAVE THE NEW MERACUS TRANSPORT FROM GERMANY PLUS THE FANTASTIC LFD DAC 3. THIS COMBINATION IS PURE MAGIC.



VALVES WE HAVE THE NEW AUDIONOTE QUEST AND THE NEW ARION NEMESIS. BOTH 300B VALVES

TRANSISTORISED AMPS WE HAVE THE NEW ADYTON OPERA INTEGRATED, A QUITE STUNNING SOUND.



WE ALSO HAVE THE LFD RANGE OF AMPS.

WE ALSO HAVE THE NEW AUDIOPHYSIC ERGO

SPEAKERS AND THE COMPLETE RANGE OF ART



CABLES WHICH WE THINK ARE THE BEST AROUND

AUDIO MECA ATD MERACUS
MCDONALD JACK. AUDIONOTE AUDION ARION TRILOGY MESA/BARRON
ADYTON ELECTROCOMPANIE LFD TRIANGLE AUDIOPHYSIC
IMPULSE ART CABLES VTI TURNTABLES

PART EXCHANGE + CREDIT CARD FAC AVAILABLE
OPEN 7 DAYS A WEEK 10-6pm
FOR MORE INFORMATION ON THESE SUPERB PRODUCTS
DON'T HESITATE TO CALL

TEL/FAX: 01784 - 461406

SOUND-BYTES

High Density Filler Material for Speakers and Stands

As any hi-fi specialist will tell you, to get the maximum benefit from your loud-speaker / speaker stand combination, you should fill your stands with a suitable material. Now available are **SOUND-BYTES**, uniquely shaped steel chips that, once poured into the speaker stand, effectively provide a solid steel core within. This makes the stand an extremely dense heavy platform, ideal for getting the best out of your speaker system.

Once your stands or suitable floorstanding speakers are filled, you will immediately notice an improvement in lower frequencies, in the form of a much tighter, punchier bass response. Available in 4 litre tubs of approximately 20Kgs in weight, each tub will provide enough **SOUND-BYTES** to adequately fill most commonly available speaker stands and floorstanding speakers.

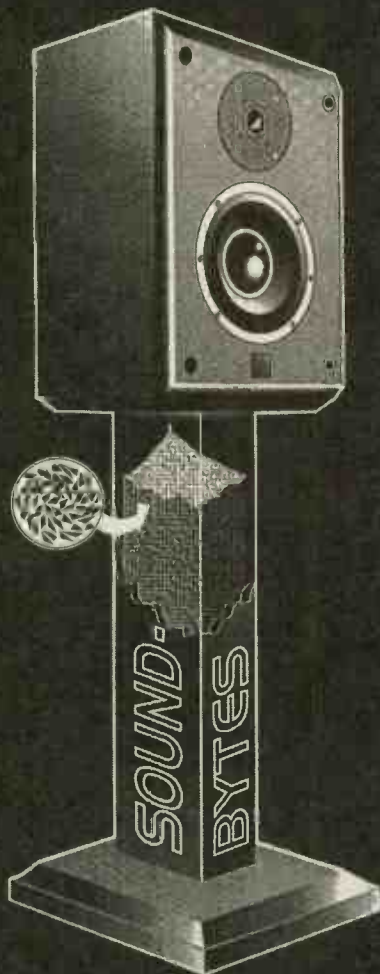

- Interlocking steel delta-shaped bytes
- superb value for money
- superb sound isolation
- suitable for support tables
- very nearly the full density of lead
- four times the density of sand
- suitable for all hollow speaker stands
- suitable for many floor-standing speakers

RECOMMENDED BY THE UK'S LEADING STAND AND LOUDSPEAKER MANUFACTURERS....

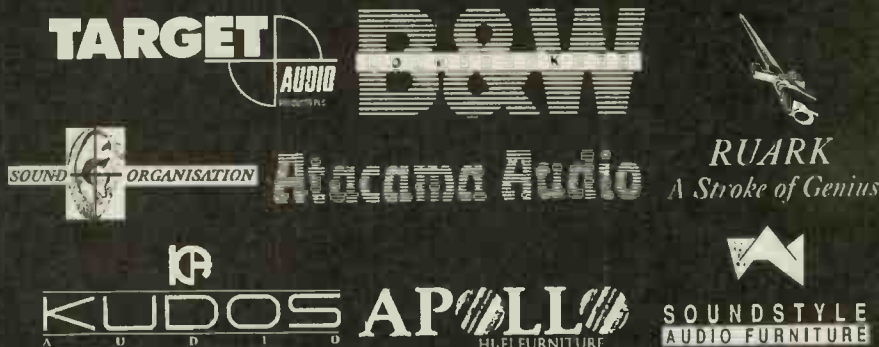

AVAILABLE MAIL ORDER FROM

ALSO AVAILABLE FROM
HI FI CORNER IS

Quality Suppliers of:

- Technics • Denon
- Mission • Arcam
- Wharfedale • Nad
- Micromega • Onkyo

Colin Mackenzie's
HI-FI-CORNER

Scotland's No.1
HI-FI Company

52 Gordon Street,
Glasgow
0141 248 2840

INSTANT CREDIT
AVAILABLE (Subject to Status)
5 Years Guarantee on all Loudspeakers

HOME CINEMA
SPECIALISTS
2 Years Guarantee



- Harman/Kardon
- Kenwood • Tannoy
- Audiolab • Target
- Aiwa • Cyrus • TDL
- and other leading makes

121 Rose Street,
Edinburgh
0131 220 1535

42-44 Cow Wynd
Falkirk
01324 629011

0131 556 7901

Carriage £5.00 Allow 14 Days Delivery.

1 Haddington Pl,
Edinburgh
0131 556 7901

DENSEN
CD MAGIC

£ 9.95

We don't know how it works, but if it doesn't improve your sound we'll give you your money back!

>>> SPECIAL OFFER PRICE £19.95 <<<

The Sound Foundation

SCOTLAND'S PREMIER SPECIALIST HI-FI DEALER

UNBIASED certainly not - that's why people come to us.

The Sound Foundation is a specialist audio retailer offering a traditional service, superb demonstration facilities and expert advice.

We only stock products from the best british companies including Sugden, ProAc, Castle, Michell Engineering and Audio Note UK.....WHY? Because these products are quite simply the best in their respective price a categories.

For example, J.E. Sugden & co have been manufacturing Pure class A amplifiers for over Thirty years, and they just get better and better. The new Symetra monoblocks are 40 watts per channel class A, and combining them with ProAc loudspeakers you will find yourself in Hi-Fi heaven.

Regardless of your budget, please telephone for a chat and see how we can help you enjoy the long winter evenings with some great sounding cerebral Hi-Fi. (If you don't know what cerebral means, don't bother calling!)

01563 574185

22 Nelson St., Kilmarnock, Ayrshire, KA1 1BA

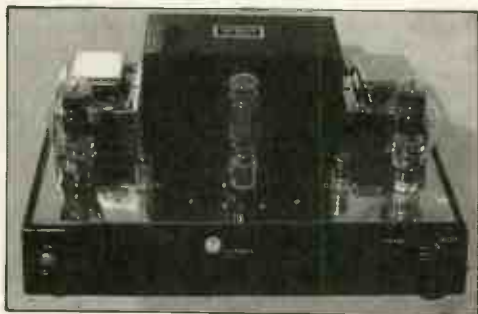

WHY DO I ALWAYS NEED TO COMPROMISE?
AFFORDABLE HIGH END - IS IT TOO MUCH TO ASK?
CALL TO ARRANGE TO HEAR THE ONLY AFFORDABLE
ALTERNATIVE

GAMMA RHYTHM

WE ARE PROUD TO BRING YOU ANOTHER FIRST
211/VT4C PHONO INTEGRATED AMPLIFIER
16 WATTS- PURE SINGLE ENDED
MUSICAL MAGIC

ONLY £2499.00

TRUE HIGH END
ONE DIFFERENCE

AFFORDABILITY!!

Unsurpassed value for money Triode single ended
amplification from £699.00 to £98,000.00

Tel. 01753 26939 Fax. 01753 532262

DISTRIBUTOR/DEALER ENQUIRIES WELCOME
GAMMA ACOUSTICS IVY LODGE 81 SUSSEX PLACE
SLOUGH ROYAL BERKSHIRE SL1 INN ENGLAND.

"The Gamma is especially skilled at placing the listener in the position of a observer at alive event"

This amp has a raw vitality and realism that the others can't match. "(Hi-Fi News & RR March) "

"The Gamma RHYTHM REF (aeon) is a welcome new comer to the single ended fold the design offers the sort of acoustics treasures that are usually the domain of far more expensive amplifiers. "Gamma is to be applauded for this exciting new product!" (Hi-Fi Choice Jan. '94)

"the Gemini is a peach. Switch it on leave it for a couple of minutes to settle down and (once run in) it will give a truly amazing sound. CD, radio broadcast tape can all sound stunning through this devise the Gemini will charm the very best out of your music collection. for £699 you'd be hard pressed to match this design for sheer sound quality and enjoyment (Hi-Fi Choice March '95)

the immediate effect of this new amp was warmth and funkiness.

"Suddenly it had soul" "I had a clearer idea of what they were feeling"

"the Gemini offers a small footprint with a difficult to beat price" (Hi-Fi News & RR Feb. '95)

There's a hugely endearing quality about the Gemini sound, " It has the most attractive price tag: £699 is small money for a decent valve amp, and decent the Gemini is." (What Hi-Fi Feb. '95)

BUT DON'T LET THEIR WORD COME AND BE HAPPILY SURPRISED!

WANTED

CUSTOMERS FOR SERIOUS SOUNDS

AT
SENSIBLE PRICES

NORTHWOOD AUDIO

TELEGRAPH - 01296-28790

REWARDS DEAD or ALIVE

For the Ultimate Sound Experience

98 CAMBRIDGE STREET
AYLESBURY

Mana Acoustics

Music with Life



The MANA 5-tier Amplifier Stand

For information on MANA products please contact:

MANA ACOUSTICS
59 Jubilee Close
Pinner
Middlesex HA5 3TB

Tel/fax: 0181 429 0118 Tel: 0181 868 2788

the **AUDIO CONSULTANTS**
dealers with a difference

We are pleased to add two amplifiers and two speakers to our select systems.

Arion from Ireland and Unison Research from Italy. The Smart 845 is the first single-ended amplifier to impress us with its controlled bass. Visually stunning too.

The Impulse Lali speakers team well with low powered amplifiers and like walls!

Alon speakers from the U. S. A. have an open baffle design which produce a wonderfully open and transparent sound.

The new V - Damp isolation feet system is by far the best way of eliminating unwanted vibration, feedback and distortion from any system. The result of many years of research, they clean up the sound like no other elastomer can.

Incredible value for money, easy to install. Phone for details.

A genuine consultancy offering totally independent advice providing audio systems for those that appreciate music rather than hi-fi

Alon Speakers
Analysis Ribbon Speakers
Analogue Tracer Cartridges
Arion Audio
Art Audio
Audio Note
Cartridge Man's Grado
Concordant Audio
Groove Tubes
Impulse Speakers
Klipsch
Nottingham Analogue Turntables
Paragon Linear Tracking Arms
Parasound
The Vamp
Trilogy
Unison Research

Demonstrations by appointment only
0 1 7 1 3 8 0 0 8 6 6

UPGRADE YOUR AUDIO INNOVATIONS AMPLIFIER WITH A VALVE RECTIFIED POWER SUPPLY

For Audio Innovations Series 500/700/800/1000/
1st Audio and 2nd Audio

Replacing the standard Solid-State supply with an off-board **Valve Rectified Choke Input Filter Power Supply**, will significantly lower **Distortion** and yield substantial improvements in **Dynamics, Bass Control and Resolution**. The slow start characteristic of this supply also increases valve life.

Priced at £550.00 inc. VAT and Shipping this unit offers excellent value in terms of performance improvement per pound and will make your amplifier sound like a much more expensive model.

The conversion is reversible, does not devalue your amplifier and is transferable to other models. Comprehensive conversion instructions are provided but some electrical knowledge is essential as potentially lethal voltages are present! Alternatively, **definitive audio** can do the conversion for an extra £35.00. If you have any doubt about your ability to do this modification safely, please consult us first. **VISA and ACCESS** welcome.

Please telephone

definitive audio

Brighton 01273 208649

Try me & see

U.K.'s No.1 Specialist
Mail Order Company

For the very best deal on any Hi-Fi, Home Cinema, A/V unit - including all Award Winners!

- Try me & see is Britain's first dedicated Hi-Fi mail order company
- 1000s of satisfied customers nationwide

"...
I'm so delighted, that
words fail me. Thank goodness
I contacted you."

- Over half of our business is recommended or repeat
- You phoned the rest, now try the best!

"...
What choice, what advice,
what knowledge.
Wow! What next?"

AMAZING PRICES GUARANTEED!

... you'll get first-class
service
savings
and support

You can always buy from us with the complete confidence that we will never let you down.
We always put our customers first and constantly upgrade and update our systems in order to improve our service.

OUR COMMITMENT TO YOU

- ✓ To supply budget, regular and esoteric equipment.
- ✓ To deliver, insured, anywhere in the world within one week* - or your money back!
- ✓ To accept cheque, cash or major credit/debit cards.
- ✓ To offer a comprehensive warranty on all goods.
- ✓ FREE collection (within 24 hours) and delivery of repairs.
- ✓ To offer extended warranties up to 5 years.

* Subject to stock availability

If you are SERIOUS about
buying hi-fi, phone
(0181) 563 0003
NOW!

Fax (0181) 563 0300

"... no
hesitation in recommending
you to my friends"

... We will be opening a new showroom soon...

Try Me & See Ltd, 5 Rocks Lane, Barnes, London SW13 0DB

MEASURED PERFORMANCE

It's important to measure products to assess performance, find explanations of sound quality and warn of peculiarities or faults. Only Hi-Fi World has an advanced in-house laboratory with digital signal analysis for this purpose. In conjunction with this facility we assess sound quality in our own acoustically treated listening room. We measure most products reviewed. Here's a simple guide on our test results.

LOUDSPEAKERS

Smooth, flat frequency response is important to ensure a balanced sound. Look carefully at overall trends; rising treble will give a bright sound, falling treble a dull sound. A rise through the midrange normally corresponds with good projection.

High sensitivity (better than 86dB) means less power is needed for a certain volume, meaning a low power amp. can be used.

The impedance curve tells us how easy loudspeakers are to drive. Low or wildly varying impedance is bad; a flat impedance around 8Ω is good.

CD PLAYERS

Even small trends in frequency response of CD players can affect their subjective balance. Generally, those with a gently rolled off treble and, more rarely, a rising bass will sound best. Rising treble can produce a sharp sound.

The distortion plot we show is taken at -30dB, to represent a typical music signal. High distortion at this level, combined with rising treble, can result in a harsh sound. Yet other effects have to be considered, especially low level linearity, which we also test for, including -90dB signals with dither applied.

AMPLIFIERS

Distortion from solid state amplifiers should be no more than around 0.2%. Even order (2nd, 4th, 6th etc) distortion is aurally innocuous, but odd order (3rd, 5th, 7th etc) distortion makes for a glassy, hard sound, or grittiness.

Frequency response can be band limited, with bass and treble rolled off just out of the ear's range, or wideband. Each has its own characteristics. Small wideband response variations colour tonal balance.

Power output is easy to understand: the higher the figure, the louder it will go. Just make sure there's enough power output to drive any loudspeakers you intend to use.

TUNERS

Frequency response, as always, says much about tonal balance and character traits, like peaky treble (due to a mismatched MPX filter). Distortion and channel separation need to be less than 0.3% (according to harmonic structure

and better than 25dB.

Hiss level must be lower than -70dB for Radio 3 silences to be just that - silent. And full quieting, the strength of aerial signal needed for optimum results, should be around 1mV or less

Selectivity, the ability to separate stations under the most difficult conditions should be better than 60dB and sensitivity better than 30μV on stereo.

CASSETTE DECKS

Replay performance is measured to IEC 94 Standards using IEC test tapes. This ensures that recordings made on a machine transfer to a car player, personal stereo or another domestic recorder properly, as well as ensuring optimum results with commercially prerecorded tapes. Look for a quoted replay response of 40Hz-10kHz, no more than 1% speed error and hiss in the replay amps lower than -58dB.

Recording quality considers frequency response, bias variation, head performance and alignment. Frequency response should stretch from 40Hz-15kHz or so. Head overload (MOL315) must be above 0dB, reaching around +4dB for good results.

From the transport mechanism look for less than 0.15% wow or flutter. Overall (DIN weighted) wow and flutter should be no more than 0.1% or so.

AMPLIFIERS

SONNETEER CAMPION AMPLIFIER

The Champion is a low power design producing 24watts into 8Ω, so it does need to be partnered with reasonably sensitive loudspeakers. It had no trouble delivering 36watts into 4Ω with little rise in distortion.

The Champion has no phono stage and the CD input has an attenuator on it to match input levels. Sensitivity of the Line input was a satisfactory 250mV, enough to cope with a majority of sources.

Channel separation was good and noise low, although some rectifier spikes were visible in the noise floor. There was little distortion and, interestingly, it did not rise at high frequencies. Third harmonic predominated, measuring around 0.03% - a low value - at normal power outputs.

There was more d.c. offset than usual, around 40mV on each channel. Whilst this

isn't damaging, it's usual to keep offset below 10mV, and most amps nowadays manage 1mV or less.

The Champion was a well engineered amplifier, of modest output. **NK**

TEST RESULTS

Power	24watts
AUX.	
Frequency response	13Hz-130kHz
Separation	78dB
Noise	-99dB
Distortion	0.03%
Sensitivity	270mV
dc offset	-38/-45mV

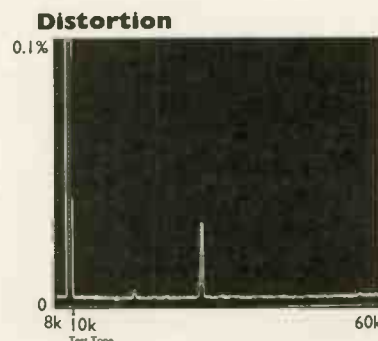

AMPLIFIERS

ARCAM ALPHA 6 AMPLIFIER

The Alpha 6 amplifier has a fair amount of power on offer. It measured 60watts into 8Ω and this rose healthily to 100watts into 4Ω. There was some ripple on clip, suggesting the 10,000μF Rubycon power supply smoothing caps could usefully be increased in size to remove residual 50Hz on the supply lines. Coupling these lines more tightly at low frequencies may well improve the soft bass quality our reviewer heard.

Arcam have given the Alpha 6 a wide audio bandwidth, frequency response measuring 4Hz-84kHz within 1dB limits. I recall earlier models being band-limited, so there seems to be a change in outlook here, extended bandwidth giving a bigger, more open sound, than (generalising) the laid back warmth of band-limited designs. The line stages (CD/tape/tuner, etc) were sensitive, needing just 180mV for full output.

Disc (MM only) was sensitive too at 2mV. Arcam have built in a warp filter which cuts gain below 40Hz, necessary to prevent cone flap now that most 'speakers are reflex ported. Hiss was low at -74dB and input loading correct at 47kΩ and 220pF.

I was surprised to see no d.c. output offset at all (i.e. <<1mV) on either channel, a good performance. Looking inside for output blocking caps (there aren't any!) I noticed that Arcam use a motorised potentiometer for remote volume control, a good system.

Distortion was low, with some rise at high frequencies to a maximum of 0.1% (full output, 10kHz). Third harmonic predominated, but at this level it is difficult to say it could have any subjective effect.

The Alpha 6 measured well. **NK**

Disc	
Frequency response	50Hz-70kHz
Separation	47dB
Noise	-74dB
Distortion	0.04%
Sensitivity	2mV
Overload	90mV

TEST RESULTS

Power	60watts
CD/tuner/aux.	
Frequency response	4Hz-84kHz
Separation	82dB
Noise	-101dB
Distortion	0.04%
Sensitivity	180mV
dc offset	0/0mV

Distortion

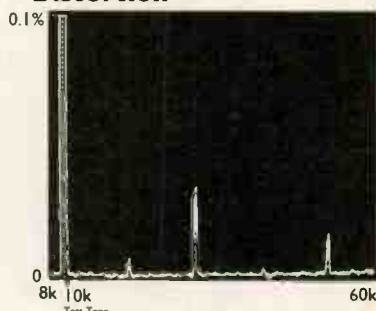

CASSETTE

NAD 613 CASSETTE DECK

Like so many cassette decks these days, the recording head of the 613 isn't too happy with the high flux levels needed for metal tape, getting no further than 0VU in the mid-band before distortion set in, and -2dB at high frequencies. The small difference between the two shows that NAD have set bias on the low side, but record equalisation is such that it needs to be decreased to minimum on the front panel adjuster to get a perfectly flat frequency response with TDK MA metal tape. Otherwise, at median bias, the response exhibits -2dB treble fall, as our response analysis shows.

There was just a little treble peaking with ferric and chrome tapes, but response could be tuned respectably flat with brands and types I found. For decks with so-so heads, I usually recommend a good ferric like TDK AR, because it can take a lot of stick at low frequencies without running into distortion, which produces that soggy bass cassette can suffer. The 613 tuned very flat with AR, one division below median.

Speed stability was very good, total wow and flutter measuring 0.06% - a low value. Our analysis shows capstan sidebands were well suppressed, which helped toward low wow. Long term speed accuracy proved satisfactory too.

NAD have set the 0VU peak record level high at IEC 0dB flux, so recording up to the red actually puts more signal onto tape than most Japanese decks, that generally place it at Dolby flux, -1.8dB lower. The result is a little less noise but more distortion.

The replay response measured flat to 14kHz, by the IEC94 Standard. Play Trim provides 3dB boost or cut (10kHz), enough to counter a little intrinsic roll-off due to EQ or head azimuth error. This facility is very handy for those who play a lot of pre-recordeds and want to hear them sound balanced, not overly muffled or bright.

The new NAD613 gave a balanced performance, displaying no serious weaknesses or misadjustments. It performs as well or better than rivals, which mostly share its head limitations, but lack Play Trim. **NK**

RECORDING (blank tapes)

Frequency response (IEC Primary Refs.)	
ferric (IECI)	18Hz-16kHz
chrome (IECII)	18Hz-17kHz
metal (IECIV)	18Hz-17kHz
Separation (1kHz)	-48dB
Distortion (315H)	2.5%
Hiss (70uS, Dolby out)	-57dB
Speed variations (DIN total)	0.06%
Flutter energy (3-3.13kHz)	-26dB
MOL/SAT (IEC Refs)	315/10k
IEC I (ferric)	3dB/-7.5dB
IECII (chrome)	0dB/-4.6dB
IECIV (metal)	0dB/-2dB

TEST RESULTS

REPLAY (pre-recorded tapes)	
Frequency response (-2dB)	30Hz-14kHz
Speed accuracy	0%
Hiss (70uS, Dolby out)	-60dB

Frequency Response

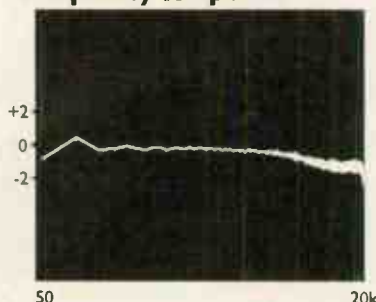

Speed Stability

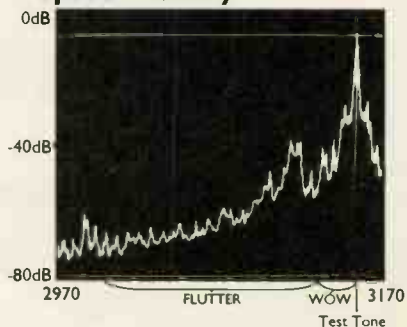

Creative Audio

9 DOGPOLE
SHREWSBURY
SY1 1EN

TELEPHONE
01743 241924

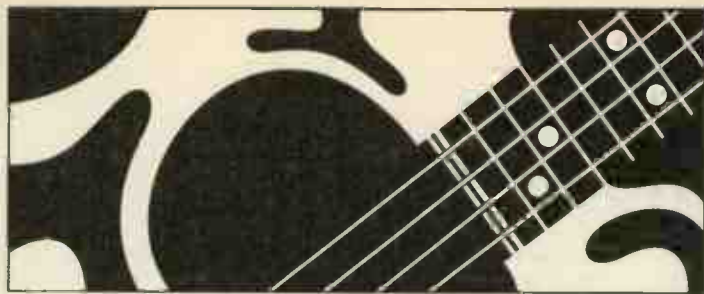

HI-FI SPECIALISTS

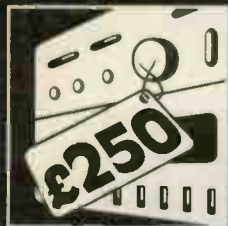

- Systems from only £250

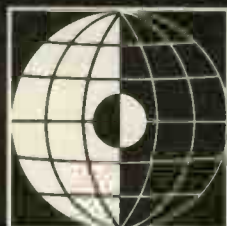

- Large Range of World Acclaimed HI-FI Separates



- Friendly Experienced Staff



- Free Home Delivery and Installation

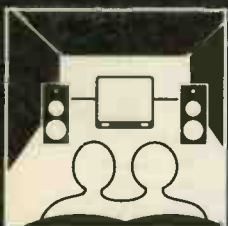

- Comfortable Listening Room



- Part Exchange Welcome



- Free 2 & 5 Year Warranties



- Selected Used Equipment always available



- Home Cinema Specialists



- Interest Free Credit (written details on request)

AUTHORISED RETAILER FOR

ARCAM • AUDIOLAB • CELESTION • CYRUS • DENON • EPOS • KEF • MERIDIAN • MISSION
NAD • NAIM • QUAD • REGA • ROKSAN • ROTEL • SOUNDSTYLE • TRIPODS

CD PLAYERS

ARCAM ALPHA 6

Distortion from the Alpha 6 CD player was high and wide ranging as can be seen from our plot below. The harmonics extend well upwards, becoming predominantly odd order, which may well add a sharpness to the sound. At -60dB, distortion was the highest I can ever remember testing, at 4.7% and 3.1% for left and right channels respectively. The best players manage around 0.4% here, around ten times lower. This restricts dynamic range to a very mediocre 89dB (EIAJ test).

Frequency response of the Alpha 6 shows more favourable traits though. The gentle lift in the bass should give it a solid and powerful bottom end; the slight drop towards high frequencies will aid smoothness. Separation is plenty wide enough and output healthy at 2.39V. Apart from its distortion characteristics, the effect of which can only be judged subjectively, the new Alpha 6 is a well engineered player. **DB**

TEST RESULTS

Frequency response	4Hz-20.8kHz	
Distortion (%)		
-6dB	0.007	0.008
-30dB	0.079	0.058
-60dB	4.71	3.11
-90dB	57.1	46.5
-90dB dithered	31.2	28.9
Separation (dB)	left	right
1kHz	97	79
20kHz	98	78
Noise with emphasis	106dB	
Dynamic range	89dB	
Output	2.39V	

DENON DCD-315

Denon's DCD-315 CD player has an interesting frequency response. In the bass there is a lift; generally a good thing adding weight and power, and the treble has a gentle roll off which should help it steer clear of sharpness. But through the midrange there is a very slight lift, which may well serve to push detail forwards giving better insight.

Distortion was low right across the board, with no visible harmonics at all in our plot below which was taken at -30dB. Distortion stayed low at all levels, which should ensure a smooth and even sound. Low distortion at -60dB corresponds to a wide dynamic range of 108dB (EIAJ test). Output was a little low at 1.83V. This is no real cause for concern though, and the DCD-315 is well engineered in all respects. **DB**

TEST RESULTS

Frequency response	4Hz-21kHz	
Distortion (%)		
-6dB	0.005	0.006
-30dB	0.004	0.004
-60dB	0.46	0.46
-90dB	31.3	31.4
-90dB dithered	8.2	7.9
Separation (dB)	left	right
1kHz	96	102
20kHz	71	77
Noise with emphasis	101dB	
Dynamic range	108dB	
Output	1.83V	

TEAC CD5

The TEAC CD5 has a well engineered frequency response. Generally it is smooth and even, but the gentle lift in the bass should help add weight and power in the lower octaves. Through the midband the response is very flat, but rolls off neatly above 18kHz or so, which should help it steer clear of sharpness.

Distortion was not a pretty sight though, as our plot taken at -30dB, a level picked to represent a typical music signal, clearly shows. Distortion is high and wide ranging which will certainly colour the sound, but most of it was inharmonic, ie. uncorrelated with the signal. Only listening tests will tell what audible form this kind of distortion will take.

Elsewhere the TEAC CD5 measures well enough, with good channel separation, low noise and a dynamic range of 104dB. Output was a little higher than the Philips 2V standard at 2.45V, which allows a little extra headroom for passive preamplifiers. **DB**

TEST RESULTS

Frequency response	4Hz-20.8kHz	
Distortion (%)		
-6dB	0.007	0.007
-30dB	0.022	0.021
-60dB	0.70	0.68
-90dB	33.2	32.4
-90dB dithered	11.2	10.9
Separation (dB)	left	right
1kHz	111	113
20kHz	86	91
Noise with emphasis	102dB	
Dynamic range	104dB	
Output	2.45V	

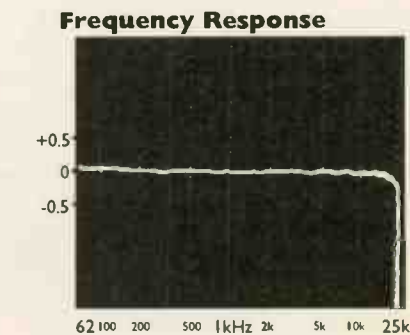
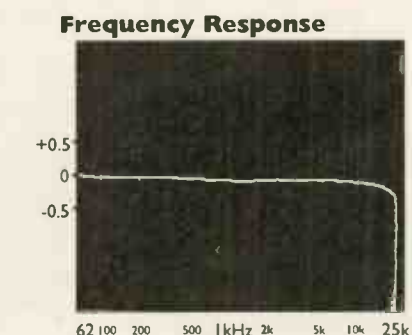
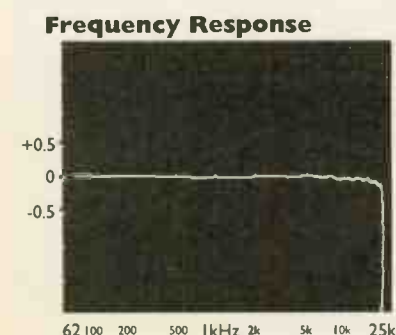
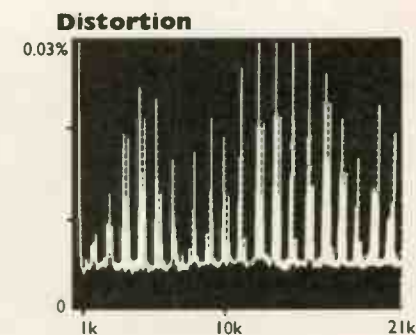
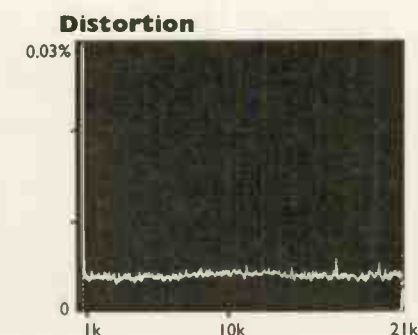
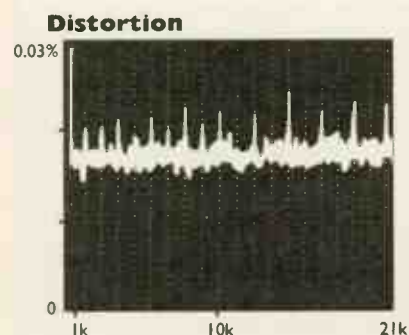

CLASSIQUE SOUNDS (LEICESTER) WANTED AND FOR SALE

VINTAGE HI-FI
SPECIALIST

VINTAGE/VALVE EQUIPMENT BY

LEAK, QUAD, ROGERS, TANNOY, GARRARD, SME, AVANTIC, VITAVOX, THORENS, ARMSTRONG, LOWTHER, PYE, DECCA, CROFT, MULLARD, GEC, BEARD, ETC. WORKING OR NOT

FOR SALE

PRE/POWER AMPLIFIERS	
AUDIO NOTE OTO MINT.....	£750
MUS/FIDELITY E100 ELECTRA.....	£395
ARCAM ALPHA.....	£89
ORANGE PRE-AMP, WAS £1495.....	£695
QUAD 34PRE-AMP, BOXED.....	£200
NVA, A40/P50 PRE/POWER.....	£295
CROFT SERIES 6, NEW.....	£1500
QUAD 33/303, PRE/POWER.....	£195
MISSION CYRUS 2 PSX.....	£300
CROFT EPOCH, NEW, 2 YRS G'NTEE.....	£550
KELVIN LABS INTEGRATED.....	£225
QUAD 66 PRE AMP.REMOTE. MINT.....	£549

TURN TABLES	
THORENS TD280 GOOD COND.....	£125
THORENS TD160/MISSION 774.....	£149
GARRARD 301/401 VARIOUS.....	£POA
THORENS 125/SME2000/SME 3009-£179	
THORENS TD160/MAYWARE.....	£149
STRATHCLYDE STD/SME.....	£99
THORENS 124 VARIOUS.....	£POA
GARRARD 401/BASTIN PLINTH/MOTH.....	£350

SPEAKERS	
QUAD ELECTROSTATICS.....	£POA
IMF TL550. MINT. BOXED.....	£399
BOSE 305M. EX COND. (£430.00).....	£225
ROKSAN HOTCAKES. EX DEMO. BOXED£129	
SPENDOR LS3/5A. BOXED.....	£395
WHARFEDALE HAREWOODS. (£1000).....	£399
LINN SARA ISOBARICKS.....	£450
JAMO SILOUMETTE. MINT. BOXED.....	£250

OTHER ITEMS	
MARANTZ CD40.....	£90
SME 3009.....	£60
REVOX A77 + DBX UNIT.....	£225
MERIDIAN 200/606.....	£1295
MISSION DAC 5. DAC. BOXED.....	£99
QUAD FM3. MINT. BOXED.....	£85

VINTAGE VALVE EQUIPMENT

FOR SALE

PLEASE RING FOR PRICE/AVAILABILITY

LEAK STEREO 20	LEAK STEREO 60	LEAK TL10	LEAK TL12
QUAD 11s/22	ROGERS CADET 3	BTH/AEL PAIR	LEAK TL12+
RADFORD STA15	RADFORD STA25	SHIRLEY LABS	TROUGHLINE 1
TROUGHLINE 2/3	CADET PWR AMPS	LEAK TL25+PR	ROGERS TUNER
HEATHKIT MA12.PR	QUAD FM TUNER	GEC KT66s	NEW/USED VALVES

VINTAGE VALVE AMPLIFIER REBUILDS FROM £100 ADD £20 FOR SAME DAY SERVICE

ALSO WANTED QUALITY MODERN HI-FI EQUIPMENT

TEL/FAX PAUL GREENFIELD ON UK+0116 283 5821 OR 0802 213740 (MOBILE) ANY-TIME CLASSIQUE SOUNDS. CLASSIQUE HOUSE, 61 AYLESTONE DRIVE, AYLESTONE, LEICESTER. LE2 8QE

***** STOP PRESS *****
NOW STOCKING PRODUCTS FROM CROFT
COME AND LISTEN TO THE NEW SUPERB CROFT EPOCH/SERIES 6.

ALPHASON Designs

Fully modular television and hifi supports to suit individual requirements.

SEE THE QUALITY, HEAR THE QUALITY, FEEL THE QUALITY



If you would like to receive further information of our full product range, or wish to know details of your local stockist, please telephone us now, or complete the coupon opposite.

Alphason Designs Limited. Tel: 01942 678000.
Unit D2 D3, Moss Industrial Estate, Fax: 01942 609913
St Helens' Road, Leigh, Lancs.

Please write to: Alphason Designs Ltd, The Quality Centre, 100, St Helens' Road, Leigh, Lancs. L19 9JF

Name: _____
Address: _____
Postcode: _____

PHASE 3 HIFI

213 - 215 Tarring Road, Worthing

West Sussex BN11 4HW Telephone (01903) 245577

Fax. (01903) 505824

THE BEST OF BRITISH!!

ARCAM

ALL NEW PRODUCTS IN STOCK

AUDIOLAB

COMPLETE RANGE IN STOCK

MERIDIAN 'DIGITAL THEATRE'

ON PERMANENT DEMONSTRATION

SHEARNE AMPLIFICATION

ON DEMONSTRATION

Delivered U.K. Mainland 48 hours, F.O.C. Visa, Access and Switch accepted. Products marked * are pre used bargains. All other products are EXDEM.



PHASE 3 HIFI
(01903) 245577



BADA
THE ULTIMATE IN
SOUND ADVICE

AUDIO BY DEVELOPMENT SOMERSET

Serving Local, National and International Enquiries.
Telephone or fax on 01984 623100

At Audio By Development you can relax in a home environment and listen to some of the finest audio equipment available anywhere. We have a wealth of experience in assembling both valve and solid state based systems that genuinely do what they're supposed to do; 'Provide lifelike musical reproduction in your home' We confidently recommend that every product we sell will deliver the best performance, reliability, and value for money in it's particular class, and if you make a purchase then you can rest assured you will get the after sales service and future upgrade advice that you should expect from a reputable independent consultancy.

We supply and recommend the following established products:
AUDIO NOTE • AUDIO INNOVATIONS • UNISON RESEARCH • ECA • SME • ORELLE • MONRIO • REL • CALLAS • OLN • WILSON BENESCH • HOLFI • LFD • AUDIO PHYSIC • ART AUDIO CABLES • TRIPOS • PRIMARE

The following secondhand stock is available this month:-

	WAS	NOW
TOCA class A single ended amplifier (las: one)	£2000	£595
Audio Innovations L2 preamp (boxed unused)	£749	£450
Audio Innovations 2nd Audio triode monoblock		£1295
Amps (ex dem as new)		£1295
Leak Troughline 3 tuner with Studio 12 decoder (totally original, unmarked)		£149
Dali 103 Loudspeakers Stand Mounted 2 way Black		£275
Oracle Delphi Turntable (excellent condition)		£495
Castle Durham Loudspeakers (Mint condition) Black		£150
Alphason HS 100 Tonearm VDHul Wired (Mint condition) (£595)		£375
Leak Stereo 20 Valve Amplifier (excellent condition)		£149
E.A.R. 519 Monoblock Power Amplifiers (V. Good Cond) (£3500)		£1595
E.A.R. 802 Pre Amplifier (V. Good Cond)	£1200	£695
Meridian Tuner 100 Series		£149
Meridian 203 DAC		£199

Large Range of Records and CDs in stock. Next list available January 96.
Audio By Development, Rotton Row, Wiveliscombe, Somerset TA4 2NB.

LOUDSPEAKERS

B&W 601

B&W's 601s have a peak centred around 200Hz which should give them good bass speed and punch. Below this frequency bass extends quite low, and will be helped by room reinforcement, so I'd expect good depth from the 601s. Above this and up until 3kHz the response is very flat, so I'd expect a clean and neutral midrange. From 3kHz upwards there is a plateau lift, around 1.5dB above midband level, which will give the impression of extra detail and insight. These characteristics will give the B&Ws a distinctive sound, one that will sound impressive in a demonstration. Only subjective audition will tell whether they'll stay smooth over longer periods.

Sensitivity was one of the highest in the

group, measuring 88dB (2.83V/1m). This means they will go loud with few watts. Overall impedance measured 7.4Ω, and the impedance curve suggests that they are a reactive load, rising to 35Ω in the midband and falling below 4Ω at frequency extremes.

Impedance

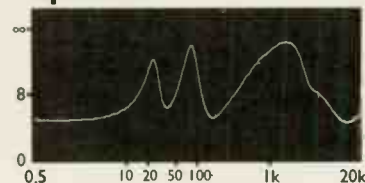

A good 30watt amplifier should drive them well. **DB**

Frequency Response

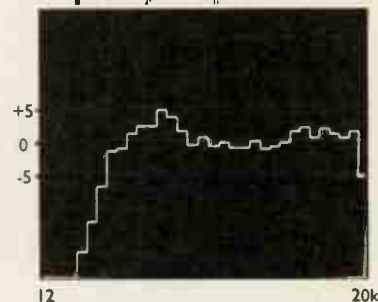

MORDAUNT SHORT MS20I

Mordaunt Short's MS20is have a smooth frequency response, but one that will probably give them a strong character. First of all there is little deep bass, output being 3dB down at 160Hz, so I'd expect them to sound weak in this area. Between 200Hz and 2kHz output is strong, which will tend to push the lower midrange forwards and should give them a punchy sound. Above this output starts to fall, so treble certainly won't be too bright and should remain smooth, but the small peak at 16kHz will add some useful zing.

The MS20is were the least sensitive in our group test, measuring 85dB (2.83V/1m).

Impedance was high overall though at 10.3Ω, so they won't demand high current from partnering amplifiers. The impedance curve is reasonably smooth, so they aren't especially reactive, but a fall to 4Ω in the treble may cause some amplifiers trouble. I'd recommend amplifiers capable of

producing at least 40watts for best results. **DB**

Impedance

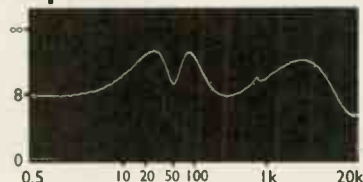

Frequency Response



KEF CODA 8

KEF's Coda 8s have a reasonably flat and smooth frequency response. Through the critical midband they are very smooth, response staying well within 2dB limits. In the bass there is a lift of around 2dB which should ensure a solid bottom end kick.

The Coda 8s are a fraction more sensitive than the smaller 7s, producing 88dB at 1m for a nominal watt (2.83V) pink noise signal. Like the 7s though, impedance isn't the kindest, dropping to 4Ω in places. This drags overall impedance down to 7.3Ω. They will need an amplifier with good current delivery to give their best.

The Coda 8s offer extra bass output over the 7s and a smooth frequency response. I'd recommend amplifiers capable of at least 30watts and with good current delivery. **DB**

Impedance

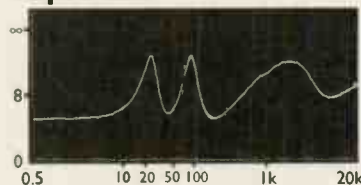

Frequency Response

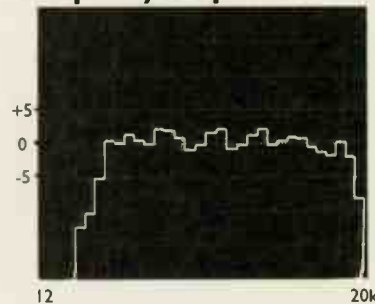

ACOUSTIC ENERGY AE100

The AE100s have a very flat response right the way across the audio band, spoiled only by a sharp dip at 2.5kHz where the crossover fails to mate bass/mid driver with tweeter smoothly. This sharp dip won't be so audible as a wider, shallower dip though, which the human ear is more sensitive to, so potentially they may sound balanced.

Bass extension was surprisingly good for the size, around half that (in volume) of the others. With room reinforcement this should ensure deep and solid bass lines.

Sensitivity was on the low side at 85.5dB (2.83V/1m) so they will need plenty of volts to go loud. Overall impedance was high at 11.1Ω, so they won't demand much current.

The impedance curve holds no surprises either, being reasonably smooth. I'd recommend amplifiers capable of delivering around 40watts or so for best results. **DB**

Impedance

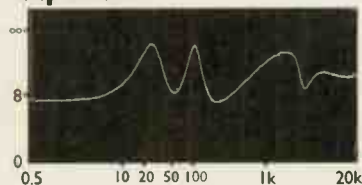

Frequency Response

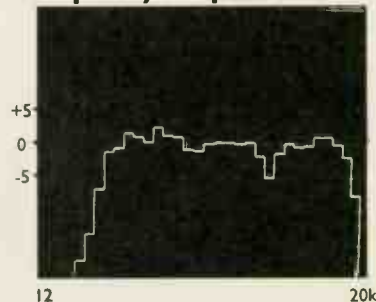

Sound Connections

• Mail Order Suppliers of Quality Hi-Fi Accessories •

• Tel/Fax: 0151 348 1988 •

FOR A WIDE RANGE OF AUDIO ACCESSORIES

Speaker cables • Interconnects • Headphones • Cartridges • Tonearms • DACS • Equipment Tables • Enhancement Products • RCA and Banana Plugs
Records and CD's • CD Storage • Audio Care • Isolation Products • Control Boxes

AGENCIES INCLUDE

Chord Company • Sonic Link • DNM Reson • Audio Quest • QED • Van Den Hul • Ixos • Nordost • Sennheiser • Beyer • Grado • Ortofon
• Sumiko • Goldring • Target • Sound Style • Kontak • Kimber Kable • XLO • Tri Chord • WBT • Moth • Jecklin • Mobile Fidelity

WE OFFER A HOME TRIAL SERVICE ON A SELECTED RANGE OF CABLES AND ACCESSORIES

Please tele/fax for our winter product and price list. Mon-Fri 9.30am to 8.00pm (Sat to 5.00pm)

• MOST MAJOR CREDIT CARDS ACCEPTED •

52, GREEN LANE, GREAT SUTTON, SOUTH WIRRAL, CHESHIRE, L66 4LE.

Are you making the right connections?

Send for Britain's biggest catalogue of specialist cable and connections.

All available by mail order.

Phone 081-9429124 or clip the coupon for your Free copy.

CUSTOM CABLE SERVICE

PO Box 4007, London SW17 8XG

Please send me your FREE Custom Cable Catalogue

Name _____

Address _____

Postcode _____

NO FURTHER INFORMATION REQUIRED

Send to: Custom Cable Service

PO Box 4007

HFV 1/96 London SW17 8XG

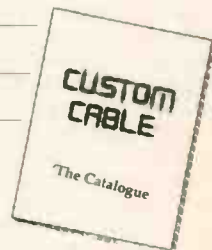

AUDIO LIMITED



New range includes:	4240 Integrated Amp	£279
	P42 Pre-Amplifier	£279
	A42 50W Power Amp	£279
	CD 42 CD Player	£500
	OBH-8 Phono Pre-Amplifier	£99
	OBH-10 Remote Volume Control	£129

Over the last 12 years Creek Audio has designed and constructed Hi-Fi equipment for thousands of enthusiasts. Now that it is once again an independent company the story is set to continue, with a new range of equipment designed for the nineties.

For further information and a list of stockists

Phone 0181 - 361 4133 or send coupon to:

CREEK AUDIO LTD, 2 BELLEVUE ROAD, FRIERN BARNET, LONDON N11 3ER.

Name _____ Address _____

SPALDINGS

The South East's Leading Hi-Fi Specialists
352-354 Lower Addiscombe Road, Croydon, Surrey. CR0 7AF

0181 654 1231/2040

LOUDSPEAKERS

REVOLVER PURDEY

The Purdeys have a smooth and even frequency response. From 200Hz upwards it stays within tight 2dB limits and is free from peaks or troughs. This should give them a clean and balanced midrange and treble. Sadly, bass output was weak, falling off below 160Hz. They will almost certainly sound dry and light in the bass, even allowing for room reinforcement. They'd make the basis of a good three-way design though, with an additional bass driver.

Sensitivity was reasonably high at 86.5dB (2.83V/1m) so they should go reasonably loud with few watts. Impedance was high overall too at 9.6Ω, so they don't need much drive current. Impedance is very smooth,

making them a fine candidate for zero feedback amplification. You'd probably want to add a subwoofer though, to balance the bottom end. **DB**

Impedance

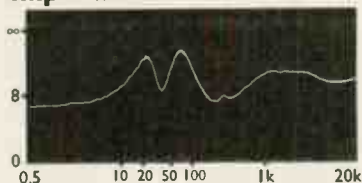

Frequency Response

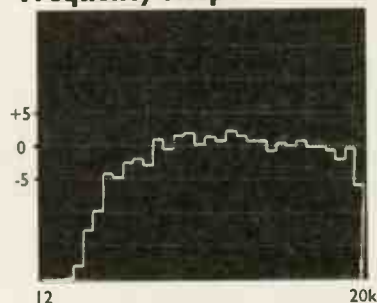

CELESTION IMPACT 15

Celestion's Impact 15s will have a big and powerful sound, a result of their rising bass response. Level is 5dB up at 100Hz, and they have good extension which will be further helped by room reinforcement. This lift tails off gently into a flat and smooth midrange and treble, which should ensure a neutral balance here.

Sensitivity was joint highest in the group at 88dB (2.83V/1m) so they will go loud too. Overall impedance was low at 6.5Ω, so they will draw more current than most of their competitors. Looking at the impedance curve shows why; it falls to around 3.5Ω in the bass. This may not be such a bad thing

though; weaker amplifiers will not be able to deliver full power here, which may balance the bass lift to give a more neutral balance. I'd recommend amplifiers capable of 30watts or so. **DB**

Impedance

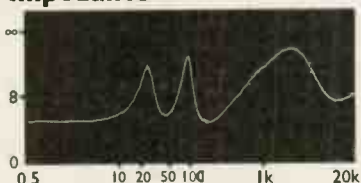

Frequency Response

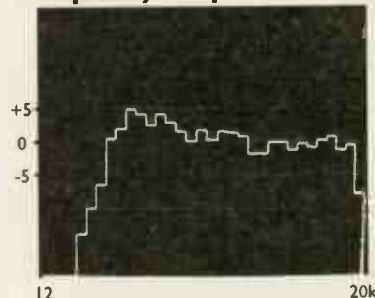

CASTLE ISIS

Castle's new Ises loudspeakers had five of us listening intently over several days; Noel, Eric, Haider, Laura and myself, so intriguing was their sound. Measuring them a week or so later shed a lot of light on what we had heard, and nicely corresponded with our observations. All of us noted a midrange that on some tracks could sound wonderful, projecting vocals well out into the room, but conversely, at times could become too hard and forced. The peak centred around 1kHz explains this, sometimes serving to give useful projection, but also adding a hardness.

Also noted was a bright and insightful sound, but little sense of atmosphere or upper treble extension, and sure enough there is a gentle lift in the low treble

followed by early roll-off. There is a slight peak in the bass, quite high up which adds useful punch and speed to bass lines.

The Ises have reasonable sensitivity for their size at 86dB and a high overall impedance of 12.5Ω means they won't draw

much current either. I'd recommend amplifiers capable of 30watts or so for best results. **DB**

Impedance

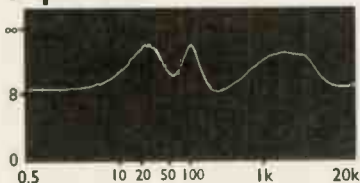

Frequency Response

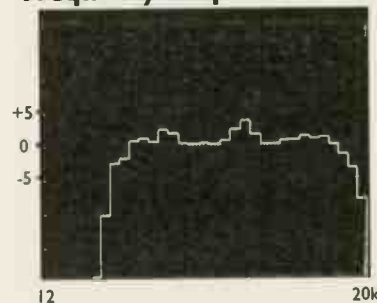

NEAR 10M

When listening to NEAR's 10Ms I quickly discovered they sounded best with their grilles in place, and the response plot below shows why. The upper response was taken without grilles and has a strong peak in the midrange and treble. The plot below, taken with the grilles in place, shows a much smoother characteristic. There is still a peak in the treble, but it is narrow and sharp so won't be so noticeable. Bass output rolls off quite early which usually results in light bass. Again my listening tests confirmed this; they needed to be positioned close to a rear wall, room reinforcement helping to bolster bass output.

Although only just below average sensitivity at 85dB, the 10Ms will need around 50-60watts of power for best results. They have a low overall impedance of 7Ω, and the impedance curve shows dips to 4Ω in the bass and treble. **DB**

Impedance

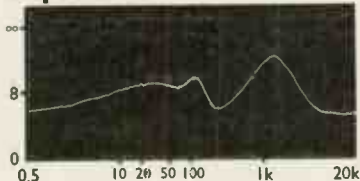

Frequency Response



VALVES

GZ34 MULLARD	£15 ea	2.5H 220MA
GZ37 MULLARD	£7 ea	7.4H 150MA
GZ32 MULLARD	£15 ea	4H 120MA
EL 84 MULLARD	£7 ea	15H 150MA
EF86 MULLARD	£8 ea	3.5H 300MA
ECC81 MULLARD	£6 ea	
ECC82 MULLARD	£8 ea	
ECC83 MULLARD	£10 ea	
M8137 MULLARD	£15 ea	
E88CC MULLARD	£10 ea	
ECC88 MULLARD	£8 ea	

£15	4) PRIMARY	115/230V
£15	SECONDARY	0 - 380V 190MA
£15		0 - 6.4V 4A £20ea
£25		
£15		

OIL FILLED FIL/ TRANSFORMERS

1) PRIMARY	220 - 250V
SECONDARY	

OIL FILLED H.T. TRANSFORMERS

1) PRIMARY	115/ 230V	0 - 4-5-6-3-3A	
SECONDARY		0 - 4-5-6-3-3A	£25 each
	1250 - 0 - 1250 310MA	2) PRIMARY	115/230V
4.6V 100 MA	£75 ea	SECONDARY 0 - 2.5V - 5V - 6.4V 7A	
		0 - 2.5V - 5V - 6.4V 7A	
		6.4V 7A 6.4V 7A	£30ea
2) PRIMARY	230V	3) PRIMARY	115/230V
SECONDARY		SECONDARY	
	375 - 0 - 375 222 MA	0 - 2.5 - 5V - 6.4V 2A	
	6.3V 5A 6.3V 5A 6.3V 2A	0 - 2.5V - 5V - 6.4V 2A	
	5V 4A £40 ea	0 - 2.5V - 5V - 6.4V 2A	
3) PRIMARY	115/230V	0 - 2.5V - 5V - 6.4V 2A	
SECONDARY	640 - 0 - 640 160MA	0 - 2.5V - 5V - 6.4V 2A	
	330 - 0 - 330 225MA	0 - 2.5V - 5V - 6.4V 2A	£25ea

OIL FILLED CHOKES

5H 200MA	£15
5H 400MA	£25
10H 250MA	£30
10H 350MA	£35
16H 120MA	£20
5H 600MA	£30
4.5H 280MA	£15
4.5H 220MA	£15

AVO CT 160 VALVE TESTER, REFURBISHED AND CALIBRATED BY THE M.O.D., PRISTINE CONDITION WITH LEADS AND DATA BOOKS £150ea

PxP £5 PER ORDER UK ONLY, PLUS V.A.T. AT 17.5% TO BE ADDED TO ORDERS.



Vacuum Tubes for Audio Are Back!

Glass Audio brings together yesterday's tube with today's improved components, voltage control, and the exciting new Soviet tubes, to make smooth sound in your livingroom possible again!

YES!

Please send my first issue of *Glass Audio*. I'll pay just \$45.00 for six issues (1 year); \$80.00 for 12 issues (2 years) of the best information on tubes to be found anywhere. I understand that my satisfaction is guaranteed!

Name _____

Street & Number _____

City _____ Postal Code _____

Country _____

REMIT IN US \$ DRAWN ON A US BANK ONLY. PRICE GOOD THROUGH DECEMBER 31, 1995.

We Accept MC/VISA.

Glass Audio

PO Box 176, Dept. HFWS, Peterborough, NH 03458-0176 USA
Phone: (603) 924-9464 or FAX 24 hours a day (603) 924-9467

SERIOUS KIT

21, ALGERNON ST., MONTON, ECCLES,
MANCHESTER, M30 9QA.
0161-707 4823 or 0973 519358

NEWSLETTER NO 7

The summer has been an industrious time for some of the best names in audio. Pro-Ac are one of my favourite loudspeaker manufacturers with possibly the finest choice of quality products available. They have just introduced the new Studio 150 model, which is a small(ish) floorstander using 2 of the company's new bass units and super quality H.F. unit. Elegantly proportioned these speakers are easy to drive requiring from as little as 10Watts (of the right kind of power). I am sure that this product will win many new friends in the future. (Hi-Fi wives will love these as much as the men who will buy them!). Also from Pro-Ac are the incredible and definitely ground breaking Response 2.5. Here is a beautifully crafted piece of furniture that physically is not large, although it is once again a floorstander of the "right dimensions". This speaker is a two way device using the newly developed "carbon loaded bass unit" that Pro-Ac have been working on for some time. The high frequencies are handled by a speak scan unit developed for Pro-Ac. Not only do we have specially developed units but a unique way of aligning the crossover, again developed by hand. One of the main "secrets" of all Pro-Ac speakers is the way in which the cabinets are constructed. This however is to be the subject of a later newsletter.

Audio Note also launch new products with the arrival of the compact series. This is a range of products which offer the usual hi-quality sound and also something different in the way of styling. Traditionally this company's amps have been styled in black box anonymity. The compact series are quite beautiful! The valves are exposed for all to see and tempt the usual array of questions from non audiophiles! On a more technical train the compacts comprise of the Quest which is 9W P.C. 300 output tube. The conquest which is 18W.P.C. 300B. Also units are mono construction with copper cladding (they look like affordable Japanese products). A stereo power amp and pre amp are due before X-mas. All of these products feature the Audionote philosophy of being single ended, direct heated triodes, with no feedback applied. Sugden as mentioned in last months letter, bring us the 40W mono Symetra amplifiers with a reworked AU41 remote pre amp. More goodies on the way.

No longer the brand new item it was in May, but worth a mention,

MicHELL's latest record player the Orb continues to impress in both construction and sound quality. It may be time for you to check this one out!

Impulse I am happy to say are back with us in a definite big way. It is true to say that this company have been concentrating on the overseas markets but are now back with a vengeance to concentrate on the U.K. We have a new range to look at (and listen to). The latest horn speaker is called the Kora and at £1095 represents the entry level, moving up the lali at £500 more. This speaker is related to the older H6 model. The top of the range is the TA"US at £2695 and possibly is the most elegant horn system available. These things definitely have a unique and a "vivid" sound. Anyone who has fallen in love with the single end triode, but requires to fill a large room with sound should look at these speakers seriously! Over the last 18 months or so, Serious Kit has accumulated a number of ex demonstration and secondhand "goodies" which due to space requirements must go. Equipment ranges from Krell to Kinshaw, Audio Innovations to Copland. Please ring for details on how to integrate the "right bargain" into your system.

So with this many exciting new pieces joining us we can certainly be expecting to be pushing back the boundaries of performance. I look forward to hearing from you throughout the dark winter months known professionally as "the season".

Algernon Street, Monton, Eccles, Manchester M30 9QA
Tel 0161 707 4823.

As ever, a musical month to you all.

Kind regards

David W. Speirs
(PROPRIETOR)

STOCKISTS OF THE WORLD'S FINEST AUDIO EQUIPMENT:
ABSOLUTE SOUNDS, AUDIO NOTE, AUDIO INNOVATIONS, MICHELL,
LYRA, J.E. SUGDEN, PRO-AC, IMPULSE, VOYD, WILSON BENESCH,
ORTOFON, KINSHAW, KESWICK AUDIO, STAX, ROKSAN ETC. ETC.

USED EQUIPMENT SALE November 1995

	WAS	NOW
AUDIO INNOV'NS Classic 25 amp	£899	£495
AUDIO INNOV'NS Series 500 amp		£550
AUDIONOTE DAC 2	£1099	£795
EXPOSURE 18 power amp	£795	£525
PIONEER A400X Int amp		£195
KEF Reference 2 speakers	£1500	£1099
KEF Reference 105/3		£795
ROKSAN Xerxes/Tabriz	£1125	£625
SNELL Type J inc Stand (oak)		£550
VOYD Valdi/Helius		£600

The above is a selection of ex-demonstration and trade-in equipment we have currently. A full offers list is available on request. All equipment is guaranteed.

the powerplant 

66 Upper North Street Brighton BN1 3FL
Telephone: 01273 775978 Fax: 01273 748419

ATC, AVI, Audiolab, Arcam, Cyrus, Exposure, Micromega, Marantz, McIntosh, Proceed, Rega, Roksan, Stax and other quality equipment.

Mail order and Worldwide Export service available

AUDIO

ENGINEERING

All of us at Audio Engineering wish everyone a very happy xmas and a sonic new year.

And just to prove it, we will include a very high quality 18 range digital voltmeter complete with manual and test leads, FREE!! With every pair of our single-ended output transformers (excluding headphone OTXS), please remember that. *This offer ends on 30th January 1996.*

**6 KILO SINGLE- ENDED OUTPUT TRANSFORMERS
ALL BUILT ON A 2 1/2 " STACK OF IMPERIAL E & I 120 LAMINATIONS
TOP SHROUDED, DROP THROUGH, INCORPORATING ANTI- MAGNETIC
INSULATORS COMPLETE WITH FIXING BOLTS AND AMPLIFIER CIRCUITS
WHERE POSSIBLE.**

2200 / 8Ω @ 16.58 TO 1	TURNS RATIO
2300 / 8Ω @ 17 TO 1	
2500 / 8Ω @ 17.6 TO 1	KT88 TRIODE CONNECTED
2700 / 8Ω @ 18.5 TO 1	
3000 / 8Ω @ 19.36 TO 1	
3200 / 8Ω @ 20 TO 1	
3500 / 8Ω @ 21 TO 1	
4000 / 8Ω @ 22 TO 1	
5000 / 8Ω @ 25 TO 1	PX25
2200 / 15Ω @ 12 TO 1	
2300 / 15Ω @ 12.4 TO 1	
2500 / 15Ω @ 13 TO 1	
2700 / 15Ω @ 13.4 TO 1	
3000 / 15Ω @ 14 TO 1	
3200 / 15Ω @ 14.5 TO 1	
3500 / 15Ω @ 15 TO 1	
4000 / 15Ω @ 16 TO 1	
5000 / 15Ω @ 18 TO 1	

PRICE £170 PER PAIR

ALL ITEMS INC. P.P. + INS. PLEASE SEND S.A.E.
FOR FURTHER DETAILS, TO P J PERRY
AUDIO ENGINEERING
57 LYNDHURST DRIVE, LEYTON LONDON E10 6JB.
☎ 0181 558 4266

Audio Note

AUDIO NOTE AUDIO COMPONENTS PARTS & PRICE LIST

Audio Note is a company that specializes in high quality audio components. We have a wide range of products available, including speakers, amplifiers, and more. Our products are designed to provide the best possible sound quality, and we are committed to customer service and satisfaction. We offer a variety of options to suit your needs and budget, and we are confident that you will find the perfect audio component for your system. We are proud to be a part of the audio community and we look forward to serving you.

AUDIO NOTE OUTPUT TRANSFORMERS

Model	Power	Impedance	Price
AN-OT-1	10W	16Ω	\$120.00
AN-OT-2	20W	16Ω	\$180.00
AN-OT-3	30W	16Ω	\$240.00
AN-OT-4	40W	16Ω	\$300.00
AN-OT-5	50W	16Ω	\$360.00

COMPLETE TUNING

Our complete tuning service ensures that your audio system is perfectly calibrated for optimal performance. We use state-of-the-art equipment and our expert technicians to adjust all components, from speakers to amplifiers, to achieve the best possible sound. This service is essential for anyone who wants to get the most out of their audio investment. Contact us today to schedule your tuning session.

POSITIVE FEEDBACK

We are proud to have received numerous positive reviews from our customers. Our dedication to quality and customer service has earned us a reputation as a leading audio component retailer. We are grateful for the trust and support of our customers and we are committed to continuing to provide the highest quality products and service. Thank you for choosing Audio Note.

VACUUM TUBE VALVES

Model	Power	Impedance	Price
AN-V-1	10W	16Ω	\$150.00
AN-V-2	20W	16Ω	\$220.00
AN-V-3	30W	16Ω	\$290.00
AN-V-4	40W	16Ω	\$360.00
AN-V-5	50W	16Ω	\$430.00

AUDIO NOTE MAINS TRANSFORMERS

Model	Power	Impedance	Price
AN-MT-1	100W	16Ω	\$120.00
AN-MT-2	200W	16Ω	\$180.00
AN-MT-3	300W	16Ω	\$240.00
AN-MT-4	400W	16Ω	\$300.00
AN-MT-5	500W	16Ω	\$360.00

AUDIO NOTE SILVER FOIL PAPER IN OIL CAPACITORS

Model	Value	Price
AN-SC-1	1000µF	\$1.50
AN-SC-2	2000µF	\$2.00
AN-SC-3	3000µF	\$2.50
AN-SC-4	4000µF	\$3.00
AN-SC-5	5000µF	\$3.50

AUDIO NOTE COPPER FOIL PAPER IN OIL CAPACITORS

Model	Value	Price
AN-CC-1	1000µF	\$1.50
AN-CC-2	2000µF	\$2.00
AN-CC-3	3000µF	\$2.50
AN-CC-4	4000µF	\$3.00
AN-CC-5	5000µF	\$3.50

AUDIO NOTE SILVER FOIL SIGNAL CAPACITORS

Model	Value	Price
AN-SF-1	100pF	\$0.50
AN-SF-2	200pF	\$0.70
AN-SF-3	300pF	\$0.90
AN-SF-4	400pF	\$1.10
AN-SF-5	500pF	\$1.30

AUDIO NOTE MAINS TRANSFORMERS

Model	Power	Impedance	Price
AN-MT-1	100W	16Ω	\$120.00
AN-MT-2	200W	16Ω	\$180.00
AN-MT-3	300W	16Ω	\$240.00
AN-MT-4	400W	16Ω	\$300.00
AN-MT-5	500W	16Ω	\$360.00

AUDIO NOTE SILVER FOIL PAPER IN OIL CAPACITORS

Model	Value	Price
AN-SC-1	1000µF	\$1.50
AN-SC-2	2000µF	\$2.00
AN-SC-3	3000µF	\$2.50
AN-SC-4	4000µF	\$3.00
AN-SC-5	5000µF	\$3.50

AUDIO NOTE COPPER FOIL PAPER IN OIL CAPACITORS

Model	Value	Price
AN-CC-1	1000µF	\$1.50
AN-CC-2	2000µF	\$2.00
AN-CC-3	3000µF	\$2.50
AN-CC-4	4000µF	\$3.00
AN-CC-5	5000µF	\$3.50

AUDIO NOTE SILVER FOIL SIGNAL CAPACITORS

Model	Value	Price
AN-SF-1	100pF	\$0.50
AN-SF-2	200pF	\$0.70
AN-SF-3	300pF	\$0.90
AN-SF-4	400pF	\$1.10
AN-SF-5	500pF	\$1.30

AUDIO NOTE COPPER FOIL SIGNAL CAPACITORS

Model	Value	Price
AN-SC-1	1000µF	\$1.50
AN-SC-2	2000µF	\$2.00
AN-SC-3	3000µF	\$2.50
AN-SC-4	4000µF	\$3.00
AN-SC-5	5000µF	\$3.50

AUDIO NOTE HIGH QUALITY CERAMIC VALVE BASES

Model	Power	Impedance	Price
AN-CV-1	10W	16Ω	\$150.00
AN-CV-2	20W	16Ω	\$220.00
AN-CV-3	30W	16Ω	\$290.00
AN-CV-4	40W	16Ω	\$360.00
AN-CV-5	50W	16Ω	\$430.00

AUDIO NOTE HIGH QUALITY CERAMIC VALVE BASES

Model	Power	Impedance	Price
AN-CV-1	10W	16Ω	\$150.00
AN-CV-2	20W	16Ω	\$220.00
AN-CV-3	30W	16Ω	\$290.00
AN-CV-4	40W	16Ω	\$360.00
AN-CV-5	50W	16Ω	\$430.00

AUDIO NOTE HIGH QUALITY CERAMIC VALVE BASES

Model	Power	Impedance	Price
AN-CV-1	10W	16Ω	\$150.00
AN-CV-2	20W	16Ω	\$220.00
AN-CV-3	30W	16Ω	\$290.00
AN-CV-4	40W	16Ω	\$360.00
AN-CV-5	50W	16Ω	\$430.00

AUDIO NOTE HIGH QUALITY CERAMIC VALVE BASES

Model	Power	Impedance	Price
AN-CV-1	10W	16Ω	\$150.00
AN-CV-2	20W	16Ω	\$220.00
AN-CV-3	30W	16Ω	\$290.00
AN-CV-4	40W	16Ω	\$360.00
AN-CV-5	50W	16Ω	\$430.00

World Radio History

AUDIO NOTE AUDIO COMPONENTS PARTS & PRICE LIST

Audio Note is a company that specializes in high quality audio components. We have a wide range of products available, including speakers, amplifiers, and more. Our products are designed to provide the best possible sound quality, and we are committed to customer service and satisfaction. We offer a variety of options to suit your needs and budget, and we are confident that you will find the perfect audio component for your system. We are proud to be a part of the audio community and we look forward to serving you.

AUDIO NOTE OUTPUT TRANSFORMERS

Model	Power	Impedance	Price
AN-OT-1	10W	16Ω	\$120.00
AN-OT-2	20W	16Ω	\$180.00
AN-OT-3	30W	16Ω	\$240.00
AN-OT-4	40W	16Ω	\$300.00
AN-OT-5	50W	16Ω	\$360.00

COMPLETE TUNING

Our complete tuning service ensures that your audio system is perfectly calibrated for optimal performance. We use state-of-the-art equipment and our expert technicians to adjust all components, from speakers to amplifiers, to achieve the best possible sound. This service is essential for anyone who wants to get the most out of their audio investment. Contact us today to schedule your tuning session.

POSITIVE FEEDBACK

We are proud to have received numerous positive reviews from our customers. Our dedication to quality and customer service has earned us a reputation as a leading audio component retailer. We are grateful for the trust and support of our customers and we are committed to continuing to provide the highest quality products and service. Thank you for choosing Audio Note.

VACUUM TUBE VALVES

Model	Power	Impedance	Price
AN-V-1	10W	16Ω	\$150.00
AN-V-2	20W	16Ω	\$220.00
AN-V-3	30W	16Ω	\$290.00
AN-V-4	40W	16Ω	\$360.00
AN-V-5	50W	16Ω	\$430.00

AUDIO NOTE MAINS TRANSFORMERS

Model	Power	Impedance	Price
AN-MT-1	100W	16Ω	\$120.00
AN-MT-2	200W	16Ω	\$180.00
AN-MT-3	300W	16Ω	\$240.00
AN-MT-4	400W	16Ω	\$300.00
AN-MT-5	500W	16Ω	\$360.00

AUDIO NOTE SILVER FOIL PAPER IN OIL CAPACITORS

Model	Value	Price
AN-SC-1	1000µF	\$1.50
AN-SC-2	2000µF	\$2.00
AN-SC-3	3000µF	\$2.50
AN-SC-4	4000µF	\$3.00
AN-SC-5	5000µF	\$3.50

AUDIO NOTE COPPER FOIL PAPER IN OIL CAPACITORS

Model	Value	Price
AN-CC-1	1000µF	\$1.50
AN-CC-2	2000µF	\$2.00
AN-CC-3	3000µF	\$2.50
AN-CC-4	4000µF	\$3.00
AN-CC-5	5000µF	\$3.50

AUDIO NOTE SILVER FOIL SIGNAL CAPACITORS

Model	Value	Price
AN-SF-1	100pF	\$0.50
AN-SF-2	200pF	\$0.70
AN-SF-3	300pF	\$0.90
AN-SF-4	400pF	\$1.10
AN-SF-5	500pF	\$1.30

World Radio History

AUDIO NOTE AUDIO COMPONENTS PARTS & PRICE LIST

Audio Note is a company that specializes in high quality audio components. We have a wide range of products available, including speakers, amplifiers, and more. Our products are designed to provide the best possible sound quality, and we are committed to customer service and satisfaction. We offer a variety of options to suit your needs and budget, and we are confident that you will find the perfect audio component for your system. We are proud to be a part of the audio community and we look forward to serving you.

AUDIO NOTE OUTPUT TRANSFORMERS

Model	Power	Impedance	Price
AN-OT-1	10W	16Ω	\$120.00
AN-OT-2	20W	16Ω	\$180.00
AN-OT-3	30W	16Ω	\$240.00
AN-OT-4	40W	16Ω	\$300.00
AN-OT-5	50W	16Ω	\$360.00

COMPLETE TUNING

Our complete tuning service ensures that your audio system is perfectly calibrated for optimal performance. We use state-of-the-art equipment and our expert technicians to adjust all components, from speakers to amplifiers, to achieve the best possible sound. This service is essential for anyone who wants to get the most out of their audio investment. Contact us today to schedule your tuning session.

POSITIVE FEEDBACK

We are proud to have received numerous positive reviews from our customers. Our dedication to quality and customer service has earned us a reputation as a leading audio component retailer. We are grateful for the trust and support of our customers and we are committed to continuing to provide the highest quality products and service. Thank you for choosing Audio Note.

VACUUM TUBE VALVES

Model	Power	Impedance	Price
AN-V-1	10W	16Ω	\$150.00
AN-V-2	20W	16Ω	\$220.00
AN-V-3	30W	16Ω	\$290.00
AN-V-4	40W	16Ω	\$360.00
AN-V-5	50W	16Ω	\$430.00

AUDIO NOTE MAINS TRANSFORMERS

Model	Power	Impedance	Price
AN-MT-1	100W	16Ω	\$120.00
AN-MT-2	200W	16Ω	\$180.00
AN-MT-3	300W	16Ω	\$240.00
AN-MT-4	400W	16Ω	\$300.00
AN-MT-5	500W	16Ω	\$360.00

AUDIO NOTE SILVER FOIL PAPER IN OIL CAPACITORS

Model	Value	Price
AN-SC-1	1000µF	\$1.50
AN-SC-2	2000µF	\$2.00
AN-SC-3	3000µF	\$2.50
AN-SC-4	4000µF	\$3.00
AN-SC-5	5000µF	\$3.50

AUDIO NOTE COPPER FOIL PAPER IN OIL CAPACITORS

Model	Value	Price
AN-CC-1	1000µF	\$1.50
AN-CC-2	2000µF	\$2.00
AN-CC-3	3000µF	\$2.50
AN-CC-4	4000µF	\$3.00
AN-CC-5	5000µF	\$3.50

AUDIO NOTE SILVER FOIL SIGNAL CAPACITORS

Model	Value	Price
AN-SF-1	100pF	\$0.50
AN-SF-2	200pF	\$0.70
AN-SF-3	300pF	\$0.90
AN-SF-4	400pF	\$1.10
AN-SF-5	500pF	\$1.30

Cable Talk

Interconnects & Speaker Cables



The full range of our
Award Winning Cables are
available from your
local dealer.



PLEASE TELEPHONE **01252-373434**

FAX **01252-371818** FOR FURTHER INFORMATION

THE EMPORIUM

28 St. Nicholas Street, Diss, Norfolk.

TEL (01379) 650744 FAX (01379) 641932

SALE

LEAK TROUGHLINE II	£75
NVA PASSIVE	£100
GARRARD 401 (60Hz platter)	£60
PROJECT 6 1 turntable & Sumiko arm	£350
SME 3009 II	£50
DECCA KELLY RIBBONS Mk II	£150 pair
LOWTHER PM6A original Alnico magnets with new Hi-Ferric coils	£250 pair
MERIDIAN component amplifier (pre/power)	£300
QUAD 33/303 based	£175
QUAD ELS black pair	£450
QUAD ESL63 PAIR, just serviced	£1350
LEAK STEREO 20 valve amplifier	£250
RADFORD RENAISSANCE STA 25 (Woodside)	£675
MARTIN LOGAN CLSII Full rang electrostatics	£1400 (£4250 new)
CONCORDANT EXULTANT line preamp	£300
TANNoy BERKLEYS, 12" HPD Dual concentrics	£350
BOWERS & WILKINS DM7 (Kevlar 8", Bass radiator, top mounted tweeter)	£325

LINN K9 cartridge, boxed

£50

MICROMEGA MICRODAC	£150
REVOX B77 4 track 3 3/4" 7 1/2" B77 mkl	£550
REVOX B77 2 track 15ips	£500
LEAK TROUGHLINE stereo	£100

WANTED

SINGLES or PAIRS OF LEAK, QUAD or RADFORD valve amplifiers.
ANY GOOD QUALITY VINTAGE HI-FI EQUIPMENT
WE ALSO PURCHASE MODERN BRITISH HI-FI EQUIPMENT and sometimes even Japanese!

PLEASE RING US FOR POLITE SERVICE AND A GOOD QUOTE

Free advice given, but not on Saturdays please.

RECORD, CD & USED HI-FI SHOP OPEN Monday to Saturday 11am to 5pm

ARCAM
CABLE TALK
CELESTION
DYNAUDIO
MARANTZ
MISSION
NAD
PARTINGTON
PINK
TRIANGLE
QED
RESTEK
SYSTEMDEK
TDL
TRIPOD
YAMAHA

WE OFFER

- ★ Home demonstrations (the only way really)
- ★ Free installation on all hi-fi systems
- ★ 2 Year Guarantee
- ★ Single speaker demonstration room
- ★ All cables terminated using silver solder for highest quality signal path

TDL RTL 2 OWNERS
Improve the sound of your system with our own newly developed, spiked stand
ONLY £19.95 RING FOR DETAILS
★★★★★ **WHAT HI-FI?**

KENT'S
LEADING
SPECIALIST

PERFORMANCE SYSTEMS  HI-FI

5 London Road, Riverhead, Sevenoaks, Kent. Tel: 01732 740425

MAKING THE MOST OF THE MUSIC

the
neat
MYSTIQUE



neat
acoustics

UNIT 1A
STAINTON GROVE IND. EST.
BARNARD CASTLE
CO. DURHAM
DL12 8UJ
U.K.
TEL/FAX: 01833 631021

NVA

BLACK BOX RANGE KITS

A range of easy to assemble solid state kit amps, with fully tested and fitted printed circuit boards. If you are competent with a soldering iron these kits should be no problem. A full rebuild and sort out service available.

AP30	Integrated Amplifier	230.00
AP50	Integrated Amplifier	320.00
	Phono Stage Fitted	70.00
A60	Stereo Power Amplifier	300.00
A70	Mono Power Amplifier	570.00 Pair
A80	Mono Power Amplifier	880.00 Pair
P50	4 Input Pre Amp	180.00
P90	6 Input Pre Amp	240.00
	Phono 1 MM or MC Phono Unit	170.00
	Phono 2 MM or MC Phono Unit	240.00
	P.S.U. Power Supply for Phono 2	180.00

EX REVIEW/DEMONSTRATION STOCK BARGAINS, The
Emotive Statement (TES) CD Player 1000.00 RRP 2000.00

NVA, 6 Watmill Ind. Est., Aspenden Road, Buntingford,
Hertfordshire SG9 9JS

Tel: 01763 272707 Fax: 01763 271594

**NEWS
FLASH!**



Gold MEDAL WINNERS do it AGAIN!!!

AN APOLOGY FROM AUDION?

WE MUST SAY SORRY TO ALL OTHER VALVE AMPLIFIER MANUFACTURERS FOR
RELEASING A WORLD CLASS AUDIOPHILE PRODUCT
AT A PRICE WHICH FAVOURS OUR CUSTOMERS

ONLY £599.00 inc.

**A NEW EXTENDED TRIODE SINGLE ENDED "CLASS A" AMPLIFIER
UNBELIEVABLE BUT TRUE!**

THE NEW STERLING "E.T.S.E". STEREO

12 WATTS (18 MAX) 20-20K + 1db

LOW DISTORTION

GOLD R.O.D. EL34M (MULLARD REPLICA)

OPTIMUM TRANSFER TRANSFORMER

SILVER WIRED OUTPUT

AUDION GOLD "POWERLITE" CAPS

AUDION "MAX" SIGNAL TRANSFER

ALPS POTENTIOMETER

COMPLETE WITH AUDION'S FAMOUS "A" RATED GOLD MEDAL WINNING SOUND

AUDION COMMISSIONED EL34M MULLARD REPLICA

AVAILABLE SEPARATELY FOR £38.50 PER PAIR

CONTACT YOUR NEAREST DISTRIBUTOR OR SHOP FOR MORE INFO

LONDON
K J LEISURE
0171 4868 262/3

HERFORD
ENGLISH AUDIO
01432 355081

NOTTS
CHANTRY AUDIO
01777 870372

SUSSEX
JEFFRIES
01273 609431

HEATHROW
AUDIOCRAFT
01895 253340

ABERDEEN
ASTRAL
01224 582825

SURREY
FARNHAM AUDIO
0370 435952

HUMBERSIDE
ZEN AUDIO
01482 587397

NORFOLK
AUDIBLE DIFFERENCE
01379 740227

SOUNDS ADDICTIVE
HARROGATE
01423 536256

OVERSEAS DISTRIBUTORS

SWEDEN
ALEMA
+46-8-7701957

JAPAN
SB INTERNATIONAL
+81-3-34057177

AUSTRIA
LOVING SOUND
+43-316-8228 1044

ITALY
ART OF MUSIC
+39-51-231172

CANADA
CANORUS INC
+1-416-972-1387

HOLLAND
AUDIOVORM
+31-23-322774

SINGAPORE
LANDMARK AUDIO
+65-3383867

PHILIPPINES
UPSCALE
+632-741567

GERMANY
MARVEL HEISS
+49-234-37430

GREECE
EXCLUSIVE
+30-1823622655

SLOVENIA
K.A.T
064-43391

AUSTRALIA
KEDKORP PTY
+61-2-708-4388

HONG KONG
ELITE AUDIO
+852-530-1567

PORTUGAL
LUZESOM
+351-2-9532235

TAIWAN
FOCUS AUDIO
+886 2 8481193

SPAIN
MULTIMEDIA
+34-77-240794

FRANCE
MAGAVOX
+33-59321134

SWITZERLAND
MAR ELECTRONIC
+41-1463-81-05

AMERICAN CUSTOMERS CONTACT CANORUS +416 972 0320

AUDION AMPLIFIERS UNITED KINGDOM

FACT NOT FICTION

ALEMA UK FAX 01273 722250

HART

Hart Audio Kits - Your Value for Money Route to a Better Sound

2 Penylan Mill, Oswestry, Shropshire, UK. SY 10 9AF
Phone 01691 652894 Fax. 01691 662864

Hart Audio Kits and factory assembled units use the very best audiophile components in circuit designs by the renowned John Linsley Hood to give you unbeatable performance and unbelievable value for money.

We have always led the field for easy home construction to professional standards, even in the studios we were using easily assembled printed circuits when Heathkit in America were still using tagboards! Many years of experience and innovation, going back to the early Drinstalle and Bailey classics gives us incomparable design expertise in the needs of the home constructor. The current range of Hart kits is designed to give you all the components for a matching ensemble of audio excellence.



K1100 AUDIO DESIGN 80 WATT POWER AMPLIFIER.

This fantastic John Linsley Hood designed amplifier is the flagship of our range, and the ideal powerhouse for your ultimate hi-fi system. This kit is your way to get EX performance at bargain basement prices. Unique design features such as fully FET stabilised power supplies give this amplifier World Class performance with startling clarity and transparency of sound, allied to the famous HART quality of components and ease of construction. Useful options are a stereo LED power meter and a versatile passive front and giving switched inputs, with ALPS precision Blue Velvet low-noise volume and balance controls. Construction is very simple and enjoyable with all the difficult work done for you, even the wiring is pre-terminated, ready for instant use! All versions are available with Standard components or specially selected Super Audiophile components at £29.60 extra per channel, plus £2.40 if you want to include Gold Plated speaker terminals.

K1100B Complete STANDARD Amplifier Kit	£395.21
A1100B Factory Assembled	£499.21
K1100SC Complete SLAVE Amplifier Kit £	£333.62
A1100SC Factory Assembled	£422.62
K1100M Complete MONOBLOC Amplifier Kit	£261.20
A1100M Factory Assembled	£329.20
RLH10 Reprints of latest Amplifier articles	£4.50
K1100CM Construction Manual with full parts lists	£5.50

K1400 AUDIOPHILE PREAMPLIFIER. A versatile ultra high quality preamp with no less than seven inputs, all switched by sealed high quality relays. Separate tape output selection. Class "A" headphone output for two phones. Lo-Z long line drive facility.

Standard Kit	£343.49
K1400T Kit with Tri-range tone controls	£398.41



"CHIARA" SINGLE ENDED CLASS "A" HEADPHONE AMPLIFIER.

First Module to appear in our new "2000 Range" of kits. This unit provides a high quality phone output for those many amplifiers that do not have one. Easily installed with special link-through facility the unit draws its power from our new Andante Ultra High Quality linear toroidal supply. Housed in the neat, black finished, Hart Mini Box it features the wide frequency response, low-distortion and "musicality" that one associates with designs from the renowned John Linsley Hood. Pre-terminated interconnecting leads and PCB mounted sockets prevent supply polarity reversal and on-board diagnostics provide visual indication of supply line integrity. Volume and balance controls are Alps "Blue Velvet" components. Very easily built, even by beginners, since all components fit directly on the single printed circuit board and there is no conventional wiring whatsoever. The kit has very detailed instructions, and even comes with a roll of Hart audiograde silver solder. It can also be supplied factory assembled and tested. Selling for less than the total cost of all the components, if they were bought separately, this unit represents incredible value for money and makes an attractive and harmonious addition to any hi-fi system.

K2100 Complete Kit	£109.50
K2100SA Series Audiophile version with selected audiophile components	£112.46
A2100SA Factory Assembled and Tested "Chiara"	£149.46



Ordering your HART kit is easy, simply post, telephone or fax your order anytime. Let us know what you require, with your name, address, cheque or credit card number and expiry date. Your daytime phone number is useful in case we need to get back to you. If you need further information on our kits just ask our FREE lists. Overseas order are welcome and we can send anywhere in the World. Post on UK orders up to £20 is £1.50, over £20 - £3.50. Express Courier £10.

K3665 "Andante" Audiophile Power Supply Kit to suit	£85.42
A3665 Factory Assembled and Tested "Andante"	£128.42
Special Offer, Both Units in Kit Form together, with SA version "Chiara" with mains and DC Supply lead	ONLY £184.92
Factory Assembled and Tested	ONLY £267.88

K1450 MAGNETIC PICKUP PREAMPLIFIER KIT features a totally discrete component implementation with the superior sound of the Shunt Feedback concept. High quality components fitting to an advanced double sided printed circuit board make this a product at the leading edge of technology that you will be proud to own. Nevertheless with our step by step instructions it is very easy and satisfying to assemble. The higher current consumption of this unit means that it is best powered by our new Andante Audio Power Supply, itself an advanced piece of technology in a matching case. This supplies the superbly smoothed and stabilised supply lines needed by its sensitive preamplifier and features a fully potted Hi-grade toroidal transformer along with a special shielded earthing system for hum free operation. The K1450 is suitable for all moving coil and moving magnet transducers this unit is especially recommended for, and will extract the very best from the modern generation of low output high quality moving coil transducers. This magnificent kit, comes complete with all parts ready to assemble inside the fully finished 228 x 134 x 63mm case. Comes with full, easy to follow, instructions as well as the Hart Guide to PCB Construction, we even throw in enough Hart Audiograde Silver Solder to construct your kit!

K1450 Complete Kit	£111.58
K1450SA Audiophile Kit	£133.94

Why not buy the reprints and construction manual for the kit you are interested in to see how easy it is to build your own equipment the HART way. The FULL cost can be credited against your subsequent kit purchase.

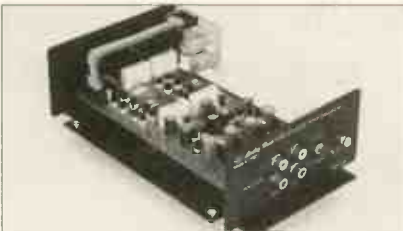

ALPS "Blue Velvet" PRECISION AUDIO CONTROLS.

Now you can throw out those noisy ill-matched carbon pots and replace with the real hi-fi components only used selectively in the very top flight of World class amplifiers. The improvement in track accuracy and matching reality is incredible giving better tonal balance between channels and rock solid image stability.

MANUAL POTENTIOMETERS

2-Gang 100K Lin	£15.67
2-Gang 10K, 50K or 100K Log	£16.40
2-Gang 10K Special Balance, zero crosstalk and zero centre loss	£17.48

MOTORISED POTENTIOMETERS

2-Gang 20K Log Volume Control	£26.20
2-Gang 10K RD Special Balance, zero crosstalk and less than 10% loss in centre position	£26.98

SOLDERING

The size of modern components makes the right soldering equipment essential for good results. Everything we offer we actually use in our own workshop! See our Lists for the full range.

845-820 XS240 ANTEX 240v 25w Soldering Iron. This is the ideal Multi-purpose iron as the bit is designed to totally surround the element giving the best heat transfer. This excellent design also means that although it is small and handy enough for modern components its heating capacity is better than larger irons of conventional construction. Excellent Value	£9.93
845-080 ST4 Lightweight Soldering Iron Stand. This has provision for the classic damp sponge for bit wiping	£3.95

HART SUPER AUDIOGRADE SILVER SOLDER

Hart Super Audiograde Silver Solder has been specially formulated for the serious audiophile. Not only does it give beautiful easy-to-make joints but it is designed to melt at normal soldering temperatures avoiding the possibility of thermal damage to components or the need for special high temperature irons. A very low residue flux makes period joints easy but eliminates the need for board cleaning after assembly.

845-007 3mtrs 22SWG in Hart Mini Tube	£3.90
845-008 100g Reel Special Valve Grade, 20SWG	£12.90
845-009 100g Precision PCB Grade, 22SWG	£14.75
845-110 100g Reel Superfine 24SWG for ultra precise control and easy working	£21.45

PRINTED CIRCUIT BOARD SOLDERING PRACTICE KIT.

Unsure whether you can construct a HART kit?, this is your chance to try! Your HART Printed Circuit Board Soldering Practice Kit comes with a range of modern components, a typical Hart quality PCB, a roll of the correct grade of solder and full instructions. It enables the enthusiast who is uncertain of his, or indeed her, ability to put together and solder a printed circuit to try their hand at minimum cost. The instructions explain the right technique and guide even an absolute beginner through the seemingly daunting, but in fact very simple, art of making a good soldered joint.

Excellent value for money only	£4.99
Super Version with Hart Silver Solder	£6.95

TECHNICAL BOOKSHELF

NEW! "AUDIO ELECTRONICS" And now, hot off the press, yet another classic from the pen of John Linsley Hood. Following the enormous ongoing success of his "Art of Linear Electronics" the latest offering is the all-new edition of "Audio Electronics", now entirely re-written by the master himself.

Underlying audio techniques and equipment is a world of electronics that determines the quality of sound. For anyone involved in designing, adapting or using digital or analogue audio equipment understanding electronics leads to far greater control over the reproduced sound.

The subjects covered include tape recording, tuners, power output stages, digital audio, test instruments and loudspeaker crossover systems. John's lifetime of experience and personal innovation in this field allow him to apply his gift of being so familiar with his subject that he can write clearly about it and make it both interesting and comprehensible to the reader. Containing 240 pages and over 250 line illustrations this new book represents great value for money at only

£18.99

"THE ART OF LINEAR ELECTRONICS."

The definitive linear electronics and audio book by the renowned John Linsley Hood. This 300+ page book will give you an unparalleled insight into the workings of all types of audio circuits. Learn how to read circuit diagrams and understand amplifiers and how they are designed to give the best sound. The virtues and vices of passive and active components are examined and there are separate sections covering power supplies and the sources of noise and hum. As one would expect from this writer the history and derivation of audio amplifier circuitry have an entire chapter, as does test and measurement equipment. Copiously illustrated this book is incredible value for the amount of information it contains on the much neglected field of linear, as opposed to digital, electronics. Instead it must be destined to become the standard reference for all who work, or are interested in, this field. Latest reprinted edition with extended index.

1994 344 Pages, 247 x 190, 1kg, 0-7506-0868-4	£16.95*
---	---------

"DIGITAL AUDIO AND COMPACT DISC TECHNOLOGY"

0-7506-0614-2	£17.95*
---------------	---------

INTRODUCING DIGITAL AUDIO CD, DAT AND SAMPLING.

ISBN 1870775 22 8	£7.95
-------------------	-------

"THE ART OF SOLDERING" 0-89395-324-3, 0

	£3.95
--	-------

"TOWERS' INTERNATIONAL TRANSISTOR SELECTOR"

0-572-01062-1	£19.95*
---------------	---------

"AUDIO" F.A. Wilson BP111

	£3.95
--	-------

"HOW TO USE OSCILLOSCOPES & OTHER TEST EQUIPMENT" R.A. Pentold, BP267

£3.50

"THE LOUDSPEAKER DESIGN COOKBOOK" Vance Dickason (4th Edn) 0-9624-191-7-6

£22.95*

ELECTROSTATIC LOUDSPEAKER DESIGN AND CONSTRUCTION Ronald Wagner BKT6

£18.95

"AN INTRODUCTION TO LOUDSPEAKERS & ENCLOSURE DESIGN"

V. Capel, BP256	£2.95
-----------------	-------

"LOUDSPEAKERS FOR MUSICIANS" BP297

	£3.95
--	-------

"THE HART PRINTED CIRCUIT BOARD CONSTRUCTION GUIDE" This is included FREE

with all complete kits but is available separately	£2.50
--	-------

VALVE & EARLY CLASSIC BOOKS

THE VTL BOOK David Manley BKT1	£17.95
--------------------------------	--------

LOUDSPEAKERS, THE WHY AND HOW OF GOOD REPRODUCTION. G. Briggs 1949 0-	
---	--

9624-1913-3	£8.95
-------------	-------

MULLARD TUBE CIRCUITS FOR AUDIO AMPLIFIERS

BKA27	£13.95
-------	--------

"THE WILLIAMSON AMPLIFIER" 0-9624-1918-4

	£6.95
--	-------

AN APPROACH TO AUDIO FREQUENCY AMPLIFIER DESIGN GEC 1957, 1-882580-05-2

£18.95

AUDIO ANTHOLOGIES, articles from Audio Engineering, Six volumes covering the days

when audio was young and valves were king! BKAA3/1 to 6. All £13.95 each
--

"A SIMPLE CLASS A AMPLIFIER" J.L. Linsley Hood M.T.E.E. 1969 RLH12	£2.50
--	-------

Postage on all books, unless stated, is only £1.50 per book, maximum £4.50 for any number, any size! Starred items are heavy books costing £2.50 to send. No waiting! All listed books are normally in stock!

QUALITY
AUDIO KITS

24hrs SALES LINE
01691 652894

ALL PRICES
INCLUDE
UK/EU VAT

HART

K R O N O S

A stunning range of valve amplifiers
What Hi-Fi Elektra review
"A superb valve amp"

CD at its very best... Transports, Players, DACS.
Exceptional looks... Exceptional sound

Loudspeakers from £325 to £3750
TE60 amp £649
Extreme Neutrality Extreme
Musicality TE60/Comete Tze "There aren't many systems which convey this much detail regardless of price"
HFNRR 1994

AVAILABLE FROM

Practical Hi-Fi Signals	Manchester & Branches 0161 839 8869
Sound Approach	Ipswich 01473 622886 Norwich, Norfolk 01603 622833
Zeus Audio	Belfast N. Ireland 01232 322522
Progressive Audio	Rainham, Kent 01634 38900-

RJF Audio Visual	Camborn, Cornwall 01209 710777
MJS	Barnwell, Leicestershire 01455 846977
Select Audio	Clapton, London 0181 986 8788
Kamla	Tottenham Court Road, London 0171 323 2747



ARION



AUDIOMECA



TRIANGLE

Tel 01868 748632 Fax 01868 748281

CARY SINGLE-ENDED TRIODES

'The Sweetest Feeling'

Transcend into the dream of live music in your home with state-of-the-art amplifiers, CD players (HD/CD, Anti-jitter) and piano-black monolith speakers (bass-reflex) offering 91dB, starting with the SI P 74 pre-amp with separate PS at only £1295

EARMAX at only £375

The all valve OTL triode headphone amplifier, as acclaimed by Ken Kessler.

CARY SINGLE ENDED MAGIC - NOW IN KITS!

Manufactured by Cary Audio Design Subsidiary AES.
Beautifully designed, beautifully finished.

- SE1 300B 7wpc S.T. FREO AMP £749 (assembled £999) excluding 300Bs, but with all other valves -exposed valve design. Inclusive of CEFTRON 300B valves £999 (assembled £1299)
- AE1 All valve line stage pre-amp £549 (assembled £699) exposed valve design - all valves included
- SE1 II 20wpc Stereo Mosfet Zero-Feedback Single-ended amp (40w mono) £749 (assembled £899)
- AE2 Pre-amp with phono stage single ended mostet £449 (assembled £599)

Fun to build - providing hours of listening pleasure without fatigue. After sales build service available. Order today direct from the exclusive supplier:



Exclusive UK Distributor

The Audiophile Club

P.O. Box 6477, London N13 4AY

Tel. 0181 - 882 2822 Fax: 0181 - 372 3772

Oxford Audio Consultants

HI-FI SPECIALISTS



Our superb service is the same, regardless of price.

A STUNNING NEW FLOOR STANDING SPEAKER FROM WILSON AUDIO

- the next best thing to System 5s - must be heard!!

NOW DEMONSTRATING

KRELL - an integrated amp like you've never seen or heard! even with remote control
 SHUN MOOK ACCESSORIES - amazing - from £149 to tune your system
 HARMONIX SPEAKER CABLE - at last a high end cable with discrete looks
 SPENDOR SP 7 FLOOR STANDING SPEAKER - top-class tradition
 UNISON RESEARCH SIMPLY 4 - ITALIAN style with valves
 MICHELL ORBE TURNTABLE & the SME 20 - we still support analogue!
 THORENS AMPLIFIERS - excellent product
 SONUS FABER - a new baby is coming soon - watch out!
 G.M. AUDIO EQUIPMENT TABLES - the ULTIMATE hi-fi table
 B & W CDM 1 & CDM 2 - superb newcomers from B & W to go to with 'P' series
 QUAD 77 SERIES - a big step forward; at last the CD Player is here!
 MARTIN LOGAN SL3 - the new SEQUEL replacement - a stunning advance
 THETA TLC anti-jitter device - try it with the new power supply
 MONARCHY DIP ANTI JITTER DEVICE
 TUBE TECHNOLOGY UNISYS/SYNERGY - gorgeous glowing valves!
 REL STORM/STATA/STADIUM II/STENTOR - redefines our ideas about subwoofers
 B & W THX SPEAKER SYSTEM on dem now
 PINK TRIANGLE DACAP0/DC/CARDINAL
 RUARK PALADIN - A worthy big brother to the Talismans
 LYRA CLAVIS DA CAPO - analogue's still going strong!
 FULL RANGE OF TRANSPARENT CABLES including ULTRA - our new reference
 THETA DATA BASIC CD TRANSPORT - now in Mk 2 form
 AUDIO RESEARCH LS7/VT 60 - a snip at the price!
 WILSON SYSTEM 5 - quite simply state of the art
 COPLAND CSA 14 INTEGRATED AMPLIFIER - still brilliant

EX DEM & P/EX BARGAINS

APOGEE STAGE	£1395
SPENDOR SP 1 TEAK	£395
SONUS FABER MINUETTOS MINT	£695
SONUS FABER MINIMA AMATORS MINT	£1195
SONUS FABER STONEWOOD STANDS MINT	£350
BOSE 501 SPEAKERS AS NEW	£340
LINN KAIRN/3 x LK280s/ ACTIVE KABERS	P.O.A
CHORD 1200 PIANO BLACK POWER AMP	£1495
AUDIO RESEARCH CLASSIC 30 POWER AMP	£1295
QUAD ESL 63 LOUDSPEAKERS	£1295
GRADIENT SUBWOOFER	£950
MAGNEPLANAR 1.4 SPEAKERS	£695
AUDIO RESEARCH LS5 PREAMPLIFIER	£2495
MAGNEPLANAR 2.6	£995
MAGNEPLANAR 2.5 MINT	£950
KRELL PAM 1 PREAMP	£995
OXFORD CRYSTAL SIGNATURE MAHOG TURNTABLE	£995
ROKSAN ATTESSA CD PLAYER	£950
KINSHAW PERCEPTION DAC	£450
THETA DATA BASIC EX DEM	£1595
APOGEE CENTAUR	£995
MAGNEPLANAR MG3.3 AS NEW	£2250
HEYBROOK INTEGRA AMP	£350 (550)
APOGEE CENTAUR MINORS	£695



£995

Oxford Audio Consultants

Oxford Audio Consultants, Cantay House, Park End Street OX1 1JE
 Telephone: Oxford (01865) 790879 Facsimile: Oxford (01865) 791665

VAIC VALVE NEW DESIGN 300B £352.50 PER PAIR

Doncaster Hi-Fi Studios
 Sunnyfields 01302 781387

MAF

Burton-upon-Trent
 01283 530550

Audible Difference
 Diss + Norfolk 01379 740227

Paul Green Hi-Fi
 Bath Avon 01225 316197

Hazelmere Audio
 High Wycombe - Bucks
 01494 4378892

The Hi-Fi Consultants
 London - 0171 380 0866

What do the critics say:

QUINTET

The Art Audio gives you music with a sense of rightness that you don't really question but just get on and enjoy. Sweet open and lucid, the music is produced with an easy sense of naturalness which makes long term listening fatigue free and especially rewarding.

Roy Gregory Hi-Fi Choice

TEMPO

I feel that the Art Tempo amplifiers are among the finest valve power amplifiers currently available. The imagery that the Tempos create is vivid, lifelike and full of space and air.

Alan Sircam, Hi-Fi World

MAESTRO

...they are just so stunningly gorgeous and open to listen to, I can barely imagine anything more alluring.

Noel Keywood, Hi-Fi World

...the Maestro is part of that rare breed of Hi-Fi that makes you forget about the equipment and think about the music. In all, unlike the car, the Maestro lives up to its name

Alan Sircam, Hi-Fi World

AUDIO CABLES DIRECT FROM MANUFACTURER

MAINS CABLES FOR POWER/PRE AMPLIFIERS P.T.F.E. SILVER PLATED MAINS CABLE WITH IEC SOCKET £38/M. + £7/M ADDITIONAL LENGTHS.

SPEAKER CABLES 9 X 0.45MM P.T.F.E. INS.

2 CORE SHEATHED SILVER PLATED, FITTED WITH 4MM BANANA PLUG SPEAKER END AND 4MM STACKABLE BANANA PLUG/ SOCKET AMPLIFIER END FOR BI-WIRING.

CD TRANSWIRE REDUCE THE HARSHNESS IN YOUR CD SYSTEM WITH THIS CABLE THROUGHOUT. FITTED WITH GOLD PLATED PHONO'S £38/METRE - PAIR + £10/METRE FOR ADDITIONAL LENGTHS.

TRANSWIRE SILVER SILVER PLATED COPPER SOLID CORE SCREENED RECOMMENDED FOR LONG INTERCONNECT £45/METRE - PAIR WITH GOLD PHONO'S + £12/METRE A PAIR FOR ADDITIONAL LENGTH.

TRANSWIRE GOLD SOLID CORE SILVER 99.9% OXYGEN FREE TEFLON COATED. £169/METRE - PAIR WITH HIGH QUALITY GOLD PHONOS + OR - £26 FOR 1/2 METRE ADJUSTMENTS.

ALL PRICES INCLUSIVE OF VAT + £3 POST & PACKING.

Art Audio

ART AUDIO 130 MAIN STREET, CALVERTON. NOTTINGHAM NG14 6LU tel: 01159 653604

KEF CONSTRUCTOR SERIES

Wilmslow Audio

KEF Uni-Q Technology, the unique KEF driver design that delivers a sharply focused sound stage throughout a room, is now available to the home constructor.

KEF's Constructor Series of loudspeaker drive units and dividing networks, may be used in systems of your own design, or by following the KEF kit plans below:

KEF Kit 60 - A two-way bookshelf/stand-mounted loudspeaker using a single 8" Uni-Q drive unit in a compact 18 litre reflex loaded enclosure. The DN60 dividing network allows bi-wiring/bi-amping.

KEF Kit 80 - An 8" Auxiliary Bass Radiator augments the output of the main 8" Uni-Q driver used with a DN80 bi-wireable dividing network. This is a floorstanding loudspeaker with exceptional bass response.

KEF Kit 90 - An 8" dedicated bass unit, 8" Uni-Q and DN90 bi-wireable dividing network give this three way floorstander extended bass output down to 35 Hz (-6dB).

KEF have designed a range of drive units and dividing networks which, with simple D.I.Y skills, can be transformed into State-of-the-Art loudspeakers capable of giving years of truly high-fidelity performance.

Kit	60	70	80
Boxed	£215	280	370
Total	£290	370	460

Free DIY speaker catalogue
 export £3.50

Dept. HFW
 Wellington Close, Parkgate Industrial Estate,
 Knutsford, Cheshire WA16 8XL
 Tel: 01565 650605
 Fax: 01565 650080



KEF Kit 60
2-way bookshelf/stand-mounted

KEF Kit 80
2-way floorstanding



KEF Kit 90
3-way floorstanding

Open Tuesdays to Saturdays
 4 demonstration rooms

ACCESS VISA
 AMEX



CHELMER VALVE COMPANY

for
High Quality Audio Valves

We offer below a selection of our CVC PREMIUM range of audio valves. These CVC BRAND valves are from selected world wide sources, processed in our special facility to provide low noise/hum/microphony PRE-AMP valves and POWER VALVES burnt-in for improved stability and reliability. Use this sheet as your order form. If you require matched pairs, quads or octets etc. Please allow £1.00 extra per valve for this service and mark alongside the valve type number 'M2,M4, M8' etc as required.

Price list and Order Form for CVC PREMIUM Audio Valves

PRE-AMP VALVES				RECTIFIERS																							
	Unit Price	Qty	Total Price		Unit Price	Qty	Total Price																				
ECC81/12AT7WA	5.00			EZ80	4.00																						
ECC82/12AU7WA	4.50			EZ81	4.25																						
ECC83/12AX7WA	5.00			GZ32	7.00																						
ECC85	5.00			GZ33	7.00																						
ECC88	4.50			GZ34	6.00																						
ECF82	5.00			GZ37	6.00																						
ECL82	5.00			5U4G	5.00																						
ECL86	5.00			5V4GT	4.00																						
EF86	4.50			5Y3GT	3.50																						
E80F Gold Pin	9.00			5Z4GT	3.50																						
E81CC Gold Pin	6.20																										
E82CC Gold Pin	6.20			SOCKETS ETC																							
E83CC Gold Pin	6.20			Unit Price	Qty	Total Price																					
E88CC Gold Pin	7.20			B9A (Chassis or PCB)	1.60																						
6EU7	6.00			B9A (Ch or PCB) Gold	3.00																						
6SL7GT	4.00			Octal (Ch or PCB)	1.80																						
6SN7GT	4.50			Octal (Ch or PCB) Gold	4.20																						
6922	5.00			4 Pin (For 2A3, 300B)	3.30																						
7025	6.20			4 Pin Jumbo (For 211 Etc.)	11.00																						
				4 Pin Jumbo Gold (For 211 Etc.)	15.00																						
				5 Pin (For 807)	3.00																						
				7 Pin (For6C33C-B)	4.50																						
				Screening Can (For ECC83 Etc.)	2.00																						
				Anode Connector (For 807 Etc.)	1.50																						
				Anode Connector (For PL519 Etc.)	1.60																						
				Retainer (For 6L6WGC Etc.)	2.00																						
POWER VALVES				Unit Price	Qty	Total Price																					
EL34/6CA7	7.50			MATCHING CHARGES £																							
EL34 (Large Din)	8.50			POST & PACKING (UK) £3.00																							
EL84/6BQ5	4.00			TOTAL EXC VAT £																							
E84L/7189A	5.50			VAT @ 17.5% (UK/EEC ONLY) £																							
KT66	9.20			TOTAL TO PAY £																							
KT77	12.00			Please make cheques payable to: 'CHELMER VALVE COMPANY' or pay by ACCESS/MASTERCARD/VISA Please give details: <table border="1" style="width:100%; height:20px;"> <tr> <td></td><td></td><td></td><td></td><td></td><td></td><td></td><td></td><td></td><td></td><td></td><td></td><td></td><td></td><td></td><td></td><td></td><td></td><td></td><td></td> </tr> </table>																							
KT88	12.50																										
KT88 (Gold Special)	19.80																										
2A3 (4 or 8 Pin)	14.50																										
211	22.00																										
300B	50.50																										
6C33C-B	27.00																										
6L6GC	6.50																										
6L6WGC/5881	8.00																										
6V6GT	5.00																										
6080	12.00																										
6146B	10.20																										
6336A	46.00																										
6550A	11.00																										
6550WA	13.50																										
6550WB	13.50																										
7581A	11.00																										
807	8.00																										
811A	10.50																										
812A	34.00																										
845	30.00																										
Total carried forward ...				SIGNATURE: EXP. DATE: NAME: ADDRESS: Post Code:																							

VALVE AMPLIFIERS SOUND BETTER STILL WITH CVC PREMIUM VALVES!

130 New London Road, Chelmsford, Essex. CM2 0RG. Tel: 01245 355296/265865 Fax: 01245 490064

Records at Cost

Now you
can buy
your CDs
at dealer's
cost price

As a member of the WSL Records at Cost Service you can buy **any brand CD** (subject to availability) at cost price plus a small handling charge of only 50p.

Now you have no need to shop around for the best discounts. Here at last clearly stated are CDs at the ultimate saving - **The Dealer's cost price.**

Only WSL - offering a mail order service for more than 30 years - can offer you such low cost listening.

So why not see what savings you really can make by checking our prices?

Return the coupon or write to us now and we'll send you full details of the Records at Cost Service, together with a special promotional membership offer.

Please send me full details of the new Records at Cost Service. Without obligation (I enclose two first class stamps for speedy reply).

Name:

Address:

.....

.....

.....

Postcode:

To: Bill Wilson Stereo Library
PO Box 32 St. Leonards-on-Sea East Sussex TN38 0UZ
Telephone: (01424) 718254 Fax: (01424) 718262

Est  1961

HFV 1/96

AUDIO ILLUSION

23 Langley Broom
Langley Berkshire SL3 8NB
(2 mins Junc. 5 off the M4)
TEL: (01753) 542761 Fax: (01753) 772532
MAIL ORDER AVAILABLE
ALL MAJOR CREDIT CARDS ACCEPTED

AGENCIES:

Air Tangent: Audio Alchemy :Audio Research: Classe: Copland:
Davidson Roth: Densen: Earmax: Enlightened Audio Designs: Jadis:
Koetsu: Kora: Krell: Martin Logan: Mirage: PS Audio: Sonus Faber:
Target: Theta: Thule: Wilson: Siltech and Transparent Cables: WBT

- * Free Installation
 - * Home Demos by appointment
 - * Dedicated Listening Room
 - * Mail Order Service
 - * Export Facilities
 - * Part Exchange Welcome
- ** All Major Credit Cards Accepted

EX. DEMONSTRATION and SECONDHAND BARGAINS

Roksan Xerxes / Artemiz TT/Arm.....	S/Hand	£895
Theta Data Basic (£2,000).....	Ex.Demo	£1595
Musical Fidelity FCD CD Player (£1,500).....	Ex. Demo	£1,095
Dnsen DM10 Integrated Amplifier 70w. (£1,300).....	Ex.Demo	£1,075
Classe 30 Remote Preamp Bal. (£1, 370).....	Ex. Demo	£850
Magnaplanar MG 1.4.....	Mint	£650
Mirage PS-12-90 Active Subwoofer (£549).....	S/Hand	£325
Mirage M-490 Audiophile Monitor (£599).....	Ex.Demo	£399
Mirage M-290 Audiophile Monitor (£399).....	Ex.Demo	£275
Mirage M-190i Audiophile Monitor (£299).....	Ex.Demo	£175
Audion 300B Silver Knight Export, Gold Mono Bloes £2,500).....	S/Hand	£1,850
Audion Reference Preamplifier.....	S/Hand	£595
Wadia X32 DigiMaster DAC.....	S/Hand	£795

M
•
A
•
X Midland
Audio
Exchange

181 Franche Road
Kidderminster
Worcs DY11 5AD

Telephone: 0421 605966
01562 822236

ROKSAN. We have now taken delivery of the new Xerxes 10. There are a few surprises in store for old Xerxes owners. You can now upgrade your old Xerxes to Xerxes 10 specification, or we would be glad to offer you a part exchange on a new turntable. Please ring for more details and prices. Xerxes 10 complete £1495.00.

Also, we have a few Roksan products which are very slightly imperfect on finish, but not on sound quality at amazing prices:

T.M.S. Piano Lacquer (Artemiz cut)	£1995.00
T.M.S. Piano Lacquer (S.M.E. cut)	£1995.00
T.M.S. V.T.I. grey finish (Artemiz cut)	£1750.00
Ojan 3 black ex-demo	£549.00
Xerxes Special Edition piano lacquer	£995.00
M1 Power Amps (Black) S/Hand	£2500.00
L1 Pre-omp (Black) S/Hand	£1195.00
DS4/DA1 Digital Convertor/Power supply S/Hand	£495.00
Xerxes Walnut XPS 2 S/Hand	£395.00

OTHER NEWS. Midland Audio Exchange have now taken the new B. and W. speaker ranges into stock:

D.M. 601	£199.95	D.M. 602	£269.95
C.D.M. 2	£399.95	P4	£599.95

REGA. Still haven't heard the new amplifier range from this formidable British Manufacturer.

As one of the four Dedicated Rega Dealers in U.K., we have in stock the new:

Hal remote controlled pre-amplifier	£998.00
Exs. Stereo Power amplifier	£598.00
Exon. Mono power Amplifier (pair)	£1196.00

and also the amazing Rega Planar 9, with finishes including Light Ash, Black, Rosewood £1598.00 including RB900 tonearm and power supply.

We stock Rega, Roksan, KEF, Aura, Marantz, B&W, Nakamichi.

For a different audio experience ring John Roberts on

01562 822236

Open 9.30 - 6.30 seven days a week.

GOODS DIRECT

Mail Order Limited
HOW CAN YOU SAVE HUNDREDS OF £££s
WITHOUT LEAVING YOUR HOME?

By shopping with Goods Direct!
We have tons of surplus and ex-catalogue stock to clear. Everything from top designer label clothing to cameras, toys, video recorders, TVs, personal stereos, camcorders - you name it, we stock it. Nearly all stock is brand new and boxed and all at a fraction of the retail cost. Take a look at our prices and see for yourself

NO TRICKS - THESE ARE GENUINE PRICES

Stock	Condition	Retail Price	Our Price
Levis 501 jeans	As New	£49.99	£14.99
Adidas torsion running shoes	As New	£59.99	£18.99
Canon Compact Camera	As New	£119.99	£39.99
Olivetti typewriter	As New	£169.99	£49.99
Kenwood Personal CD player	As New	£199.99	£59.99
Philips Video Recorder	As New	£299.99	£99.99

Plus: Packs of 4 blank videotapes from 99p, CDs from £1.50,

Seiko watches from £5 and many more items at silly prices!

All goods sold by mail
Minimum order only £25
Trade Enquiries Welcome

30 DAY MONEY-BACK GUARENTEE
you're money back if you're not completely satisfied

To receive our bumper information pack and current list of stock, please send a cheque/PO for £3 (refundable with first order) made payable to Goods Direct to

Goods Direct Mail Order
37b, New Cavendish Street
London W1M 8JR

STOCK IS LIMITED
SO SEND FOR YOUR LIST TODAY!

hi Best prices for new, xdem & s/h equipment fi

CELLO PERFORMANCE monoblocks (4 chassis)	mint S/H	£7500	KEF 103.4	mint S/H	£795
AUDIO RESEARCH M300	mint S/H	£4995	RUARK CRUSADER II	mint S/H	£895
MUSICAL FIDELITY P270 mkII	mint S/H	£795	WILSON WATT 3 PUPY 2 + PAWS	mint S/H	£6995
BEARD P100 mkII	mint s/h	£695	APOGEE CALIPER SIG	mint S/H	£1495
BOULDER 509M	P.O.A.		DYNAUDIO AUDIENCE 10	mint S/H	£325
JADIS DEFY 7	mint S/H	£3500	APOGEE STAGE	mint S/H	£1295
CHORD SPM 1000	mint S/H	£995	APOGEE STAGE (LATEST)	mint S/H	£2250
JADIS JA 30 monoblocks	mint S/H	£2250	ATC SCM 100 passive	wgc	£1795
ELECTROCOMPACT AW100	as new	£1395	MERIDIAN DSP 6000	mint S/H	£5495
PROCEED AMP 2	as new	£1395	ATC SCM 50A	as new	£3950
JADIS JA 500 monoblocks	mint S/H	£8995	PROAC RESPONSE II	as new	£1495
KRELL KSA 100S	as new	£4495	MAGNEPLANAR 1.4	mint S/H	£95
MERIDIAN 205 monoblocks	mint S/H	£495	SONUS FABER AMATORS	mint S/H	£1795
TUBE TECH GENESIS monoblocks	mint S/H	£1895	AUDIO PRO SUBWOOFER	mint S/H	£350
Mc CORMAC DNA 1	P.O.A.		LINN KABERS +stds	mint S/H	£795
KRELL KSA 50S	as new	£2995	TANNOY CHEVIOTS	mint S/H	£295
NAIM 250	mint S/H	£650	STAX FB1X	mint S/H	£4995
NAIM HI-CAP	mint S/H	£295			
GOLDMUND MIMESIS 3	mint S/H	£2300	DENON DCO S1	mint S/H	£3250
CDNRAD JOHNSON MV5C	mint S/H	£750	MARK LEVINSON No 31 transport	mint S/H	£4750
QUAD 606	g.c.	£350	MERIDIAN 602/606	mint S/H	£1495
EXPOSURE VIII monoblocks	mint S/H	£595	PHILIPS CD 850	mint S/H	£175
AUDIO INNOVATIONS 2mc AUDIO	mint S/H	£1495	SONY X333 ES	mint S/H	£395
CADENCE M2/M2	x-dem	£1695	CAMBRIDGE CD3	mint S/H	£395
LFD PA1/L51	mint s/h	£995	WADIA 22 transport	as new	£1650
TRILGY 901/958	mint S/H	£2495	WADIA 26 D to A	as new	£1995
MUSICAL FIDELITY F15/#22	mint S/H	£1995	WADIA 12 D to A	as new	£1195
AUDIO INNOVATIONS S800 mkI	mint S/H	£350	AUDIOLAB 8000 dac	mint S/H	£995
EXPOSURE dual IV (x3)	mint S/H	£595	DPA T1 transport	mint S/H	£450
QUAD 33/303	mint S/H	£175	WADIA 2000 transport/dac	mint S/H	£4900
MERIDIAN 605 monoblocks	mint S/H	£1495	AUDIO RESEARCH DAC 1	mint S/H	£995
AUDIO RESEARCH SP11 mkII	mint S/H	£2895	WADIA 64 dac	mint S/H	£1995
JADIS JP 90 MC	as new	£7995	MARK LEVINSON No 35 dac	mint S/H	£3750
JADIS JPL	as new	£2995	WADIA 15 dac	x-dem	£1995
CLASSE DR6	as new	£2495	P.S. AUDIO ULTRALINK	mint S/H	£1195
TESSERAC TAP-A Line/Phono	x-dem	£3995			
TESSERAC TALA Line	x-dem	£995	VPI TNT mkII	as new	POA
HEYBROOK SIGNATURE	as new	£395	ALPHASON SYMPHONY/ATLAS	mint S/H	£1295
AUDIO INNOVATIONS L2	mint S/H	£450	VPI TNT mkII/TRIPLANAR III	mint S/H	£2795
AUDIO INNOVATIONS L1	mint S/H	£195	ROKSSAN XERXES/ARTEMIZ/SHIRAZ		
AUDIO RESEARCH L2SB mkII	mint S/H	£2750	ARTA XERXES/CHORUS BLACK	mint S/H	£1095
EXPOSURE XVII Line/Phono	as new	£495	VOYD "THE VOYD"	mint S/H	£995
EXPOSURE IX + XIV	mint S/H	£1495	SME SERIES 20/V	as new	POA
BURMESTER 808 Line/Phono	mint S/H	£1995	KUZMA STOGI/STABI + psu	mint S/H	£995
			LUMLEY STRATOSPHERE ST1	as new	£POA
CREEK 4240	mint S/H	£160	VOYD VALDI/RB 300	mint S/H	£450
AUDIO INNOVATIONS S500	mint S/H	£495	KOETSU RED	mint S/H	£495
NAIM NAIT II	mint S/H	£250	AUDIO NOTE I/O	as new	£795
			ORTOFON MC 7500	as new	£1495
ALON V	x-dem	£3495	DENON DL 304	as new	£145
SPENDOR SP 9/1	mint S/H	£2395	MICHELL ISO/HERA	mint S/H	£395
SOUNDLAB A3	mint S/H	£3500	TESSERAC phono mm/mc	x-dem	£995
SONUS FABER MINIMA AMATORS	mint S/H	£1095	TESSERAC GYRODEC power supply	x-dem	£295
NEAT PETITE	mint S/H	£395	QUAD FM4 (grey)	mint S/H	£275
SONUS FABER EXTREMA + stds	mint S/H	£4495	SEQUERA PANELIZER TUNER	mint S/H	£4500

MINT S/H - Second hand as good an example as we've seen anywhere

AS NEW - Typically less than 4 months old in new condition

X-DEM - Typically 'as new' but may be older

G.C/V.G.C - In perfect working condition but may be marked

hi CHOICE fi

(0181) 392 1959

(0181) 392 1994 phone/fax

Equipment bought or part exchanged
Full demonstration facility - by appointment
Major credit cards accepted
9.30am - 8.00pm 7days

**DESPERATELY SEEKING
TOP QUALITY HI-FI
due to the success of
The Hi-Fi Exchange
we have clients looking to
purchase your equipment
Call now for best prices
0181 392 1963**



THE APEX 100 SERIES SOUND EXPERIENCE



FEATURING
PASSIVE CROSSOVERS
ACTIVE CROSSOVERS
ALUMINIUM CONES
WOOD VENEERS
OFC CABLING
STANDS

Q.T.A. SYSTEMS
 2 WHEATSHEAF WAY · LINTON
 CAMBRIDGESHIRE · CB1 6XB
 TEL: 01223 891091

CHORD, ATC, AVI, HARBETH, ROYD,

**BUYING OR SELLING?
 THEN USE OUR DATABASE!**

LFD, MICHELL, ORIGIN LIVE, KINSHAW,

Apogee	Centaur Minor loudspeakers (b/ash)	£750
ATC	SCM 50A loudspeakers (Black)	£2450
Audio Pro	Active sub-woofer (black-Ash)	£250
AVI	S2000MA 70wpc stereo power amp	£325
AVI	S2000MC cd player	£699
AVI	S2000MD doc	£375
AVI	S2000MI integrated amplifier	£699
B&W	801 loudspeakers no acoustic hood B/ash	£1500 ono
Delph	Da Capo Stereo Amp	£799
Harmon Kardon	655 int amp 40 wpc	£100
Kimber	Cable	£100
Kinshaw	Overture integrated amp	£295
Kinshaw	Perception preamp	£350
LFD Audio	MMO phono stage mm/mc	£270
Linn	Kaber loudspeakers	£700
Linx	Pulsar 130 wpc stereo power amp	£399
Meridian	203 doc	£250
Michell	Argo 1JR/Hem power supply	£895
Musical Fidelity	A100 integrated amplifier	£250
Musical Fidelity	F15 stereo power amp 7mths old	£1250
Musical Fidelity	MVT preamplifier MM/MC	£399
Origin Live	OL2 loudspeakers (black Ash)	£375
Origin Live	OL1 loudspeakers (black Ash)	£290
Pink Triangle	Export turntable, arm & cartridge	£725
QED	Digit	£95
Quad	606 mk1 power amp	£400
Rogers	LS3/5A loudspeakers (black Ash)	£250
Royd	A7 seriesII Loudspeakers (b. ash)	£75
Royd	Minstrel Loudspeakers (grey)	£175
Sansui	AV7000 DSP Pro Logic A/V amp	£399
Sequence	Model 30 loudspeakers (dark)	£130
Sequence	Model 30 Loudspeakers (light)	£140
Sony	715E CDP cd player as new	£195
Spendor	SP/3 loudspeakers in Walnut	£600
Target	Open Frame 20" stands	£35
Target	Single Column 22" stands	£65
TDL	Monitor Loudspeakers inc stands (b/ash)	£1200
Thorens	166 mkVI turntable & AT95 Cartridge	£199

Cottage Audio

17 Bridge Street, Saxilby, Nr. Lincoln. LN1 2PZ

Tel/Fax (01522) 702834

DELPH, QED, PROJECT, THORENS

SANSUI, SEQUENCE, SONIC LINK,

Classified Ads

For details on how to place a Classified Advertisement, please see page 145

QUAD 405-2 power amplifier, mint condition £225; Quad 34 pre-amp, mint condition £175. Linn Majik integrated amplifier, six months old, mint £150. Celestion Diction 44 loudspeakers £100, Revox A77 Mk III high speed 2 track mint £350
Tel: 01403 251587 or 0831 418619

NAKAMICHI ZX7 3 head cassette deck, remote control, independently variable bias and level controls, azimuth adjustable £500
Tel: Trevor 0191 2813805

AUDIOLAB 8000A Mk II, 12 months old, 1 year guarantee left, receipt boxed £330. 3 metres Chord Flatline twin professionally terminated, cost £120, sell £65. Mission 780SE still guaranteed £150.
Tel: 01206 867614

IPL ACOUSTICS STL transmission line speaker, excellent condition £200, medium size replica transmission line excellent condition £125. SD Acoustics SDI new ribbon tweeters good condition £450, offers to Mike
Tel: 01734 693377

THORENS TD124 mint boxed, Garrard 301 (white or grey) Audio Innovations Second Audio monoblocks with custom valve pre-amp. Thorens TD160 Formula 4 Ultimo 20A, Ariston RD80, Linn LVV, KS
Tel: 01642 559543

AUDIO INNOVATIONS Series 500, mint condition, rebuilt to latest spec and unused £650. Watchet, Somerset.
Tel: 01984 633905

MERIDIAN 208 CD pre-amp 209 remote, boxed, mint £675.00; 215 phono module £70.00; Rotel RB990 BX power 200 wpc £295.00. WANTED Lift Jumbo CD trays.
Tel: 01276 710605

REL STRATA subwoofer £300; Mission 751 speakers in rosewood with deflex panels £165, or £425 together. All items vgc and include postage.
Tel: 01534 66238

SUPERB ION NEXUS active system comprising SP1 pre-amp two SAM 40 stereo modules, three XPAKZ PS, one FMT1 tuner £2,400 new; £1150.00. Roksan DPI transport, mint £650.00, Roksan Xerxes, Tabriz ATOC9 £375.00
Tel: 01905 455355

EPOS ES14 speakers with Epos stands, boxed, mint condition £295 or p/x Quad 606 or similar power amp.
Tel: 01734 425451 (eves)

AUDIO ALCHEMY DDE V10 digital recording engine with upgraded p.s.u. power station one. Will post if required. Price £190
Tel: Selby 01757 638194 (ansaphone)

LINN ITTOK LVII (silver) £150; Linn Klyde (almost new) £200; Dave Billinge, Portsmouth.
Tel: 01705 293 646

REL STADIUM SUB £550; KEF 10172 reference speakers with Atacama stands (all black Ash) £320
Tel: 0181 773 3798 after 6pm

SUGDEN AU51 power amplifier (original model) £300. Celestion SL600 speakers plus Foundation stands £250
Tel: 01702 588216 (Southend on Sea, Essex)

EVERYTHING MUST GO! Aura CD 50 £100; JPW Sonata speakers £30; Celestion DL311 speakers £40.
Tel: 01202 475781

DELTEC (DPA) FDM1 Series I DAC £95. Tel: Mike 01664 392722 (daytime) 01684 561526 (evening, before 9pm)

MUSICAL FIDELITY F22 pre-amp £650; F15 power amp £1200; AVI S200 MM monoblocks £700; ATC SCM 20 speakers & stands, black £1100. All new & boxed.
Tel: 0181 870 3630

QUAD 606 amplifier 140 wpc excellent condition £360 o.n.o.
Tel 01843 587732 (Kent)

TDL STUDIO 1 loudspeakers finished in black Ash complete with dedicated spiked stands, little used £300.
Tel: Chris 01992 587848 daytime or 01438 721909 evenings (Hertfordshire area)

APOGEE CENTUR Minor hybrid ribbon panels speakers with dedicated stands £650 incl packaging. VdH The Wind speaker cable 5m pair £220, cost £380. Sonic Link Violet interconnects 1/2m £20; 1m £40
Tel: 0956 230056

AUDIO INNOVATIONS Second Audio triode mono-blocks £900; Audio Innovations L1 pre-amplifier only had one hours use £200; Albarray AP4 pre-amplifier latest grey finish £175; absolutely no offers
Tel: 01904 763157 (York)

SONY ST700ES AM/FM tuner, excellent sound & condition £125; Ortofon pure copper interconnect phono/phone 1m pair £95; Kenwood pro-logic centre speaker, never used £50; Kimber mains lead 1/14m £28.
Tel: 01422 206495 (Halifax)

REGA ELA speakers v.g.c. £300; Naim NA03 tuner as new £350; original Koetsu Rosewood cartridge needs retipping £250.
Tel: 01670 368510 after 1pm (Blyth, Northumberland)

NAIM ACTIVE ISOBARIK system, NAC 82. 3 x Hi Cap. 3 x NA250. Linn Isobariks walnut mint condition £6,000 o.n.o. May split.
Tel: 0181 546 2881 (evenings)

WANTED: Linn LP12 Walnut Valhalla Ittok or Ekos arm with Cirkus if possible. FOR SALE: Dunlop Systemdek II, Rega RB300 arm, Nagaoka N-IIMP Boron cartridge ex condition £100
Tel: 01933 626170

AUDION 300B Silver Knights, triode, pure class 'A', zero feedback, monoblocks, variable gain, cost £2500, nearly new, £1550 o.n.o. Impulse Horn H2 94 dB sensitivity, rosewood, cost £2500 v.g.c. £1450 o.n.o.
Tel: 01634 365153 (N. Kent)

SUMO ATHENA PRE £350; LFD LSI lineage (not white) £480; Castle York in Yew £180; Audio Technica AT1130 tonearm £70. All boxed and as new.
Tel: 01626 334068 (evenings)

MUSICAL FIDELITY F15/F22 review models £1950; P270.2 £650; Nakamichi CR7E, warranty £900; Leak Troughline II 'Acrylic'/Paravacini decoder £300; Meridian 605 monos latest spec. 20hrs use £995; VPI TNMkII/ Eminent Technology II/Visa Pump £2,250. All mint, boxed
Tel: 01734 313032

WANTED: Radford STA 50 power amplifier, SC22 control unit in excellent condition. FOR SALE: Leak Stereo 30 Plus amplifier, Leak Delta tuner, £15 each or £25 both plus postage.
Tel: 01273 583675

QUAD 67 CD player boxed mint condition £95.
Tel: 01527 835769

MERIDIAN 605 £1200; Meridian 603 £800; Quad ESL63s £1500. As new, boxed, little used, retired owner.
Tel: 01202 470789

AVI CD PLAYER £875; AVI tuner £500; Cyrus 21" speaker stands £65; Soundstyle Tri-Pod, 5 shelf, blue £190; Galaxie 14 aerial £55. All six months old.
Tel: 01462 458527

PINK TRIANGLE Ventricle speakers £600; Linn Kairn pre-amp £730; Teac VRDS 10 CD player £450; Sumo Athena pre-amp £350; A.V.I. mono block power amps £550; Keswick Audio Aria speakers £180; Professional Monitor Co TBI speakers with Target R3 stands £425.
Tel: 01977 643629

AUDIOPHILE LPs: reference recordings, Mobile Fidelity, ATR, Gale, Sheffield, special Japanese pressings, plus Weaver's, in excellent condition, from £6 per LP. List available.
Tel: 0181 883 5618

KLIPPSCHORN CORNER horn speakers (pair) Australian Walnut, purchased 1952. Radford STA 25 amplifier and SC22 control unit, plus Garrard 301 turntable, all in excellent condition. Deceased sale, best offer secures.
Tel: 0115 939 3139

AURA VA 40 amplifier v.g.c. £110 onvo; B & W DM 600 loudspeakers v.g.c. £85; Atacama S24 stands (mint condition) £50; Target HS25 stands £35; 2 x 10m AudioQuest (Indigo Blue cable) £55; 2 x 5m Cable talk (biwire) £20. Contact evenings or Sunday or Monday.
Tel: 01908 605617

EPOS ES14s on dedicated stands finished in black Ash, absolutely immaculate condition with boxes and receipts, can demonstrate £400.
Tel: Dave 0589 132007 (day) 0181 270 9393 (night)

LINN LP12, Black Ittok, K18, £495; Exposure 15 £350; Ruark Templars £280, all as new, boxed. Swordsman with stands £95. WANTED: Exposure 7/8, Micromega Leader 2
Tel: 01792 205598

ROTEL RT850AL tuner FM/MM/LW, auto/manual preset memory tuning, excellent sound, mint condition, boxed with instructions £75.
Tel: 01638 507694

KOETZU ROSEWOOD, serviced and re-tipped by expert pickups - three sides only £275. "Caruso" by Stanley Jackson plus discography by Carl Brun £30.
Tel: 01249 812565

KEF SPEAKERS reference series model 103/4, black, boxed as new mint condition £695.
Tel: 01332 751392 (Derby)

T.D.L. STUDIO 3 transmission line speakers, Walnut finish new 1992 (£1000) First sensible offer over £400, will demonstrate, buyer collects, Surrey area.
Tel: 0181 661 2886

NAKAMICHI ZXL 1000 Dolby unit £995, Tannoy 15" HPDs, studio cabinets £350, Reslo valve mono blocks £200, Audiolab tuner £400, Revox B126 CD player, faulty transport £285. WANTED: Avantic Beam Echo, etc.
Tel: 0161 860 5532

MERIDIAN 500 transport + 563 DAC £1500 + AES-EBU lead. Audiolab 8000Q pre-amp £800; Audiolab 8000M monoblocks x 6 £1200 per pair; 4 x Van Den Hul "Magnum" speaker cable 6 x 2 metre lengths terminated with WBT connectors £400; Alphason rack £200; Ruark Accolades "Dark Walnut" £2300. All are brand new with boxes, manuals etc. No time wasters, can deliver.
Tel: 01622 746863 after 6.30pm mon-fri anytime w/ends

TANNOY BERKELEY speakers 15 inch dual concentrics rosewood cabinets £650 o.n.o.; Leak TL-50 valve power amps new valves £550 o.n.o.; Lowther corner Acoustas, new PM6Cs in folded horns £325. Pair Lowther PM7Cs £200; Quad 33/303 £120
Tel: 01709 555403 (eves)

LINN KAMS + LINN stands £180 o.n.v.o.; B & W sub woofer £75 (all black Ash); Technics SL 1400 Mk2 with Ortofon cartridge £125; Audio Technica arm with Ortofon cartridge £25. All excellent condition
Tel: 01453 546191 (Glos)

TOWNSEND ROCK MkII no arm/no lid, excellent £250; Goldring Eroica as new £55; 1006 stylus new £20, 3 shelf rack (sand filled) £20, buyer collects/cash transaction.
Tel: 0181 777 5423

FOR SALE RCA high fidelity Orthophonic pre and power amplifier £200, commercial Williamson amplifier pair KT66 huge output and mains transformers £200, pair Marconi PX25 new boxed 100 each Warfedale super 12 driver 23
Tel: Alan 01661 852874

MICHAELSON AUDIO Odysseus intergrated valve amp 45w per channel, demonstration, excellent condition £500
Tel: 0181 889 6457

PIONEER TX9800 tuner mint £70; Leak Delta 70 amp Teak sleeved £50; Leak Varislope stereo pre-amp £35; Connoisseur BD1 turntable kit brand new unused £20; Isophore KK8 tweeters £5 each.
Tel: Tony 01472 878919

2 REVOX A77 Mk3 high and standard speed 2 track £295 each; Teac A3340S H.S. 4 track £295; Ferrograph series 7 model 724 £155, all in perfect condition
Tel: 01275 835334 (Bristol)

NAIM 72-hi cap with MC boards, 180 power amp, boxed as new only one year old, cost over £2400, accept £1700
Tel: 01633 222538

QUAD 34 PRE-AMP with MM/MC boards £170, REL Strata subwoofer £260, Goldring Eroica low output MC £40. All boxed.
Tel: Andrew 01483 291335 (work) 01737 832789 (home) (Surrey)

ATC SCM10 speakers full six year guarantee £750; Audio Innovations Second Audios new Dragon 2A3s 1000 pre-amp, incredibly dynamic £1,275 (going single ended!) Meridian 203DAC £195! All immaculate.
Tel: 01379641584

SPENDOR SP2/2 speakers Teak finish mint condition with boxes, manual etc £425.
Tel: 01422 203057 after 6pm (W. Yorks)

GLENN MILLER Moonlight Serenade Nos 15-179 (5 missing), books, mags, LPs inc 10", limited editions 1 & 2 AEF set, eps, 78s, associated bands etc
Tel: 01279 724216 (Essex)

1940s BIG BANDS, classic jazz LPs inc 10", eps, some vocals, comedy, classical, Readers Digest boxed sets, books etc, selling private collection formed 1950s/70s
Tel: 01279 724216 (Essex)

SUGDEN AU41 pre + power amps, boxed vgc £550.
Tel: 0181 509 0455

MARK LEVINSON Madrigal HT interconnect cable, 7 metre stereo pair £495 (£995); 1.5 metre stereo pair £150 (£300); XLO PL10 mains cables, 3 feet lengths £65 each (£125); 4 feet lengths £80 each (£150); Mana Acoustics amp stand tables, single tier £80 each (£125)
Tel: 0181 291 1744

PINK TRIANGLE DaCapo converter with DC battery power supply. Fitted with Philips 1307 filter module. DC has new battery cells fitted. 18 months old, mint condition and boxed cost new £3150 will accept £2150. Will consider splitting.
Tel: 0181 291 1744

PROAC RESPONSE ONES 'S' (Rosewood) latest specification £650. Proac Tablette III (Teak) £310. All items boxed and in mint condition.
Tel: 01952 406759 (eves or w/ends)

SME 3009 SERIES II brand new boxed £100; Garrard Music Recovery Module £40; Motion Electronics TV sound monitor £40; Leak 1950s Troughline mono valve tuner £95.
Tel: 01372 467 264 (Esher)

MUSICAL FIDELITY MA50 power amps pair (excellent reviews) £395 o.n.o. WANTED: Denon DL300/301 cartridges any condition.
Tel: 01634 387686

PERCEPTION PHONO centre £285; NVA Soundpipe £80, Silver Sounds 12/4 £85; Audioplan Super AF £65; Kimber KCAG Digilink £75.; Masterlink Digital £45; Loads of speaker cables.
Tel: Steve 01685 385898 after 6pm

MARANTZ CD94 superb looking two box design immaculate £750; Arcam Alpha 5 £200; Linn Ekos, Troika £800; Epos ES14 plus stands £275; Marantz PM71 IAV pro-logic amplifier £300.
Tel: 01952 502097 (Telford)

QUICKSILVER monoblocks 60 wpc; 8-4-1 ohm taps, gleaming chrome, run KT88 or 6550, boxed as new including spare tubes £795 o.n.o.
Tel: 0151 722 4526

MANTICORE MAKE MORE MUSIC

Turntable Servicing - all makes - please ring for details.

ARISTON - LOGIC - THORENS SPARES

Arm rewiring - Manticore standard cable	£80.00
Arm rewiring - Van den Hul. Isoda	£160.00
Arm rewiring - Cardas	£160.00
Silver plated mains cable with IEC socket	£50.00
Aerolam equipment support	£54.00
Fibrebram equipment support - superior performance	£130.00
Mantra replacement belt - supplied in twos	£22.00
Logic DM101 belt - supplied in twos	£22.00
Logic DM101 spring sets	£23.00
Rega armspacers - polished aluminium 1mm increments	£11.00
Impex motor, pulley and PCB	£90.00
Manticore Jazz turntable - choice of tonearms	POA
Manticore Magister with 12" Magician	£3,800.00
Manticore Mantra turntable - the classic - no arm	£495.00
Manticore Musician tonearm	£395.00
Manticore Magician tonearm	£695.00
Manticore 12" Magician tonearm	£795.00
<i>Part-ex available against all other tonearms</i>	
MB5i off-board power supply "suits most decks"	£290.00
MB6 off-board power supply	£490.00
Motor rebuild	£150.00
RIAA and preamplifier "system Integrity wiring"	£690.00
Active crossovers and AV amplifier	POA

Please telephone or write for more information and a copy of Mumbo Jumbo



MANTICORE AUDIO VISUAL

MAV Shareholders Ltd.
The Courtyard, 56c Shortmead Street,
Biggleswade, Beds. SG18 0AP
Tel: 01767 318437 (office) and 0585 583653 (mobile)

TECHNICAL INFORMATION BULLETIN No. 1

MANTICORE TURNTABLE POWER SUPPLIES

Manticore Audio Visual's range of power supplies suit all turntables fitted with the Philips Impex range of AC synchronous motors. This includes Manticore (of course!). Linn, Rega, Logic, Ariston (not all models), Systemdek and many more. Our power supplies can also be adapted to other AC synchronous motors and we have built up a lot of experience over the years in this area.

The entry level model, the MB5i, is a quartz crystal based amplifier that runs at 33 and 45 RPM. The highly sophisticated MB6 in addition, has a computer referenced phase lag and separate amplification for each set of poles of the motor.

Manticore has the policy of helping our customers to progress along the upgrade path, and we will always take an MB5, or MB5i in part exchange at full cost price against an MB6. Consequently, we often have pre-owned MB5 or Mb5i in stock at very good prices.

A detailed specification sheet is available for both current models.

We believe the MB6 to be the finest turntable power supply on the market. Our customers agree, and we have many testimonials to that effect. A sample of these is contained in the product information pack.

Our products are very reliable. At the time of placing this advert, no production MB6s have ever gone wrong in the field.

All Manticore Audio visual products come with a lifetime guarantee. This is qualified in the following way - electronic components, such as transistors, are guaranteed until the end of their reasonable working lifetime. Mechanical assemblies for the most part manufactured by us are guaranteed until the reasonable end of their specified design life. The first Mantra was produced 12 years ago and is still in fine shape.

PROGRESSIVE AUDIO

Telephone
(01634) 389004. 5
mins from J4 on
the M2 in Kent

Autumn sale of ex demonstration equipment

Loudspeaker		CD	
Origin Live OL2(Black)	£425	Orelle CD-102 Transport	£595
Monitor Audio Studio 6 (Piano Black Laquer)	£895	Orelle DA 180 DAC	£395
Ruark Crusader (Walnut)	£1075	Micromega Duo BS DAC	£400
Ruark Broadsword (Walnut)	£495	Kinshaw Perception DAC (Twin case)	£595
Soundlab (Black)	£1725	Turntables	
Acoustat Spectra 11 (Black)	£450	Alphason Sonata + Atlas	
Acoustat Spectra 1100 (Beige)	£500	Power Supply (Black)	£795
Spica TC50 (Black)	£250	VPI HPW 19 Mk III (Piano black)	£1250
Impulse H7	£395	Voyd with reference bearing + platter plus splitphase P/S (Black)	£1795
Alon 1 (Light Oak)	£995	Eminent Technology tonearm + Weisa pump	£750
Audiostatic HS100 Electrostatics	£2150	Decca Super Gold Cartridge (Unused)	£195
Snell "E" s	£800	Secondhand	
Snell "J" s	£550	SME Series V	£750
Amplifiers		Micromega Stage 1CD Player (2 weeks old)	£400
Sonographe SA 135 power amp	£750	Aura V100 II Amp (2 weeks old)	£250
Sonographe SC22 Pre (Phono)	£650	Agencies	
Conrad Johnson PFI Pre (Phono)	£1150	Audionote, Audio Innovations, Sugden, unison Research, Conrad Johnson, Audio Alchemy, ProAc, TDL, Origin Live, Impulse, Audion, Densen, Morel, SME, VPI, Chord, Tube Technology, Quantum Audio, Alon, Mark Levinson, Van Den Hul, SD Acoustics, Ortofon, Systemdek., Audiomeca, Arion, Trichord Research., Voyd, Audioquest, Stax, Cable Talk, Target, Soundstyle, Grado, Lyra, Silversounds, Audiostatic, Moth, Stemfort, Goldring etc.	
Mark Levinson 28 Pre amp (Hi gain phono)	£2350		
Conrad Johnson Premier			
Ten Line Stage	£2500		
Audio innovations 200 Pre (MC phono)	£400		
Audio Innovations S200 Power	£275		
Audio Innovations S200 Power (2)	£295 Each		
Audio Innovations 1st Audio	£1250		
Moth Series 30 Stereo Power	£160		
Moth Series 30 40W Monos	£350 Pr		
Moth Series 30100W Monos	£625 Pr		
LFD LSI Linestage (White)	£525		
LFD PA2 Power amp (White)	£825		
Kinshaw Perception Pre amp (Twin case)	£550		
Conrad Johnson MF 80 Power amp	£1250		

Unless otherwise stated all the above items are virtually mint condition, boxed and warranted. Telephone (01634) 389004, anytime. Demonstrations strictly by appointment. Please call for details of full itinerary of brands stocked.

AMADEUS

Audio Innovations,
Aura,
Bang & Olufsen,
Castle Acoustics,
Marantz,
Musical Fidelity,
NAD, Pioneer,
Quad, Technics

SOUND & VISION

10 BOLDMERE ROAD

SUTTON COLDFIELD, WEST MIDLANDS

Tel: 0121 - 354 2311

MITCHELL ARGO HR pre-amp as new 1 yr old, bargain at £795 o.v.n.o.
Tel: 01623 871950

MICROMEGA LOGIC CD player; Crimson Electric pre/power; EPOS ES14s speakers; Linn/Teac interconnects; Cable Talk 3; stands: £1000 o.n.o. Can deliver or swap for van camper.
Tel: Pete 01227 769723 (Canterbury)

MUSICAL FIDELITY A100 integrated amplifier (boxed) £200; Technics RS885 cassette deck £165; Technics ST-G50L tuner £80; Panasonic NV870 Hi-fi VHS player £180.
Tel: Rod 0121 705 1142 between 5pm & 7pm weekdays

AUDIOLAB 8000A amplifier, winner of various Hi Fi awards, only one year old vgc £300 o.n.o. Also Monitor Audio MA3 speakers, powerful (3 way big box) £150 o.n.o.
Tel: 01245 224024

NAIM IBL loudspeakers black Ash vgc £350
Tel: 01980 633362

PROAC EBS speakers with stands walnut vgc £750
Tel: 01703 466853 (eves) 01703 445090 (days)

MARANTZ AV500 pro logic pre amp £350; Mission DACS £60; Kenwood GE-1001 parametric equaliser £90; Denon DCD-1420 £150; Goldring Audio Rack with 5 shelves, adjustable spiked feet in base £60
Tel: 0181 316 1033

LUXMAN K112 3 head HX Pro cassette deck £120 o.n.o.; Carver TX-10 tuner £135 o.n.o. Both in excellent condition, Dynavector Karat 23 RS Mk II cartridge unused new £280. Sale £130
Tel: 0181 658 2490

WHARFEDALES WANTED. 507.2 speakers in Rosewood finish.
Tel: 0141 339 7595 (Glasgow)

REVOX A77/4 half track N.S. suitcase model, built in amps/speakers; 2 x p.z. mikes NAB adaptors £275; Quad 33/303 £150; Leak Troughline III + decoder £60; B & W LM1s £90. Hi Fi News complete (4 copies missing) 1966-1994. Some earlier copies to 1958. Offers.
Tel: 01983 297903

WANTED: MERIDIAN MPA power amp - needed to match my existing MPA for bridging. Must be in mint condition.
Tel: 0113 2530627 after 6pm

LINN LP12, LVX Grace F9 £300; Magnum MP250 pre & power (modified by designer) £400; 10m Linn cable £10; Rotel 965LE Discrete & Trichord 2 (6 months) £175; JBL 18Ti £250.
Tel: 01628 27406

MERIDIAN 508 CD player £995; 501V preamp £495; 555 power amp £395; A500 speakers in rosewood £495 all boxed, mint, less 3 mths old. Upgrading.
Tel: 0121 783 8214

WANTED: TOWNSHEND Rock Reference turntable. Cash waiting. FOR SALE: Naim 42.5/110 pre/power boxed £300 o.n.o.; Audio Technica ATH70 Electret headphones inc energiser unit £75.
Tel: 0181 989 6434

WANTED: OLD WHARFEDALE SFB3 speaker cabinets (mid to late 50s) in reasonable condition. (Drive units do not have to be working)
Tel: 0171 5384020

LINN KAIRN LK280 pre/power amplifiers £995; Yamaha DSPE200 surround sound processor £195; Denon TU260L £65; Jamo 100 centre speaker £75. Offers considered.
Tel: 01423 528256 (Harrowgate)

MINROYD SINTRAS in real wood veneer. Boxed complete with (Royd) dedicated spiked stands. Will demo for serious buyer £180.
Tel: 01782 515602 eves

AURA CDS0 CD player. Must be heard! In nearly new condition. Upgrading to CD transport! £265 o.n.o.
Tel: 01275 856360

KEF BBC MONITOR speakers LS5/1AE 84x43x48cm 15" bass units Celestion 1500 HF units 1960s superb sound, offers. Revox G36 valve tape machine offers. Wanted: Quality valve power amp.
Tel: Steve 0181 391 0229

QUAD 66 PRE-AMP £475; 606 power-amp £400; FM4 tuner £200; all o.n.o. Boxed, recently serviced.
Tel: 01995 671426 (eves) (Lancs)

NAIM NAI40 (new style) boxed £475 + EPOS ES14 & stands (black Ash) boxed £450 + Linn LP12 Valhalla, Basic LVX, Goldring 1020 cart £300.
Tel: 01702 354946 (Essex)

WANTED: B & W 804 or 805 speakers Musical Fidelity MA50/MA65 amps + pre-amp. Offered Hitachi HCA 8300 preamp HMA 7500 power 75wpc black boxed Superfi £250 (SE)
Tel: 01322 524381

T.D.L. STUDIO 3 loudspeakers with walnut finish dedicated stands, boxed and in good condition. Can demonstrate £450 o.n.o.
Tel: 01492 879547

AUDIO SYNTHESIS DAX "Ultra-Analogue" D/A converter with built-in "Passion" all Vishay/Silver attenuator (Colloms Reference). Cost new £2,500 Audiophile bargain at £1000.
Tel: Robert 01909 479203 (evenings)

DPA200S pre/power, justly acclaimed by HF World and HF Choice. Immaculate condition, boxed, over one year guarantee. Hesitant upgrade sale. Happily demonstrated. £950 o.n.o. (£1270)
Tel: 01635 867135 (anytime) (Newbury)

RESTEK CHALLENGER amplifier 130w per channel, unused £650; JPW Ruby 2 speakers plus stands, as new £550.
Tel: 01225 833765

NAIM SBL SPEAKERS, black Ash, immaculate, active £895; passive £995. WANTED: 5 tier Mana Acoustic tables and Sony Walkman Pro record/playback leads.
Tel: 0161 432 0744

ACOUSTIMAS 5s (in white). Excellent condition £500 o.n.o.
Tel: 0171 6380104

LOWTHER ACOUSTAS, PM6s, refurbished £250; Pioneer A-9 massive intergrated amp, 110w rms £90; Yamaha CT800 silver fronted analogue high quality tuner £50. WANTED: Leak 3900A and Leak TL-12 (KT66 type) amps.
Tel: 01273 684424 (Brighton)

ROGERS LS7 loudspeakers, excellent condition, includes stands QED cables with gold connectors £175.
Tel: 01325 320584

MISSION POWER amplifier model 772 Mk 2 class A/B design, 150 watts rms per channel, 3 sets of loudspeaker terminals, powerful sound, boxed £200.
Tel: 01902 782015 (Wolverhampton)

SYSTEMDEK II/900AP, MP11 Boron £200; Musical Fidelity A100 £200; Musical Fidelity MC2 £150; Naim NAC62 Hicap, old style £450; Deltac Little Bit £173; Arcam Alpha CD £185. All vgc.
Tel: 01926 831388

DELTEC DSP50S pre amplifier. Three box. Mint. All original packaging, instructions and press reviews. (Nice one Noel). Genuinely good value £695
Tel: 01652 636086

VALVE EQUIPMENT FOR SALE. Various amps from Leak (inc TL50s) Quad, Rogers, Radford etc. Also Quad Electrostatics, black, immaculate, serviced. WANTED: TL10, TL12 and Snell Ks.
Tel: 01548 821360

MICHELL FOCUS 1 deck with Linn Basik arm and AT-25 cartridge. Black and silver finish with three point suspension. Immaculate condition offers around £90.
Tel: 0161 485 1634

NOTTINGHAM ANALOGUE SPACEDECK with Mentor arm and Tracer 3 MM cartridge £600 complete. LFD linestage LS2 pre-amp £400. Kelvin Labs M60 monoblocks £400.
Tel: 0116 2811736

TANDBERG 3015 A CD player, mint, boxed. Offers or swap for mint Arcam Delta 270.
Tel: 01482 666313

APOGEE STAGES: excellent only £1495. Audiolab 8000C&P £550. Musical Fidelity E100 superb reviews only £425. May p/x (o.n.o.)
Tel: 01225 337821

MAGNEPAN 1.5SE white, 2 years old, great sound, no wife acceptance, cheap £550; turntable Heybrook TT2 with AT-Tonearm and Elac cartridge £250, 5 pairs XLO-pro150 £30 each.
Tel: Michael 0171 4397986 (work) or 0171 9377935 (home)

REVOX B77 MkII high speed, 2 track, excellent condition £2300 new £750.
Tel: 01347 838852 (N. Yorkshire)

LINN LP12 (black) Linn. Itrok, K9 - 3 years old and little used. Superb for £800, A & R Cambridge amp £30. Linn Kans plus cable and stands £200.
Tel: 01706 290094

AUDION 300B monoblocks export model new £2500, £1750 o.n.o. Audion Reference preamp (modified) £450 o.n.o. Both for £2000.
Tel: Alan 01223 420204

AUDIOLAB 8000A latest spec, few months old, boxed little use £300. Revolver turntable, Linn LVX arm, AT95E cartridge. Boxed as new £200
Tel: 0161 445 7657 after 6pm (Manchester)

CELESTION 300, transmission line speakers 9 months old, boxed, excellent condition, press recommended, genuine reason for sale £700.
Tel: 01553 636 800 eves (Norfolk)

CELESTION 5L6-S speakers + dedicated stands £200; Rotel RCD963BX CD player £100 less than three years old. Trio pre power L08-C & 2x L08-M power amp mono blocks 180 watts of high quality power. A bargain at £600.
Tel: Richard 0115 9376212 day (Nottingham)

PINK TRIANGLE 22 BIT DaCapo/Cardinal (2350) £1500; Sonus Faber Minima Amators (1500) £950. Orelle CD10T/DA180 (1400) £850; Orange valve preamp superb (1000) £350; Hugens stands (300) £100
Tel: Roy 0121 427 6661

PAIR QUAD ELS black with Mahogany trim, plus REL sub woofer. The ultimate transducer system £600.
Tel: 0121 478 3672 or daytime 01675 467432

QUAD FM4 TUNER £250; Quad 34 control unit £175; Quad 33/300 amplifier £150, boxed plus manuals.
Tel: 0121 478 3672 or daytime 01675 467432

EXPOSURE 17/18 pre/power immaculate boxed £900 (£1700); EPOS ES14 speakers, dedicated stands, excellent condition £300 (£700); Pioneer PD 73 reference CD player, immaculate, boxed £360 (£800)
Tel: 01695 557957

THORENS 124/1 plinth/cover £225; Revox G36 chassis £195; Fidelity research FR64S £360; STOGI superb £250; Meridian 605 amplifier; mint boxed £1195; Lumley reference ST70 amplifier mint boxed £1195; Audioplan Konzept loudspeakers laquered black £1195; Neat Petites £325; Aura TU50 tuner £175; Revox B750 amplifier £495; Voyo Valdi Rega OC7 £495; Sony PCMF1/SLF1 digital recording £695; WANTED: Marantz CD10, Nakamichi 505/CR3/CR7, Naim Nat 01, Troughline/TDP decoder VPI HW19, MFA200 amplifier.
Tel: 01747 851747 (Dorset)

LINN KLOUT power amplifier 2 years old boxed £995. Will straight swap for Naim 250 power amplifier new facia. Any age.
Tel: Mark 0161 456 1024 (Manchester)

QUAD 405/2 power amplifier £150; Canon S-50 loudspeakers and stands boxed £175. Stone loudspeaker stands £20.
Tel: 0850 416752 (Winchester)

LINN SARAS (black) with stands (mint) £325 o.n.o. Meridian 506 CD (latest spec) £650 o.n.o. Thorens TD 160 £60 o.n.o. Yamaha CT810 tuner (mint) £85 o.n.o. Pye HF111 valve tuner £25 o.n.o. QED M/C head amp (boxed) £20. May p/x
Tel: 0191 4877796

QUAD FM11 tuner (the one with valves but matches Quad 33) Very rare. As new condition £95.
Tel: 01902 606268 evenings

MERIDIAN CDS06 Trichord clock 2 stunning £650; REL Strata £395; Yamaha DS200 £230; C90 Centre speaker £50; Rogers studio 3 speakers £230; Goldring Lenco turntable/Rega Elys cartridge £85. All excellent, little use.
Tel: 01883 330063

EXPOSURE AMPLIFIER XI pre-amplifier; XII power supply; VIII (mono) power amplifier. Original price £2600 will accept £1500 o.n.o. all boxed and in excellent condition, baby forces sale.
Tel: 01932 345416 (eves after 6pm) (Woking)

MISSION CYRUS TWO amplifier (with balance control) and PSX power supply No. 70 £350. Cyrus (Two) tuner, remote control £170, brand new B & W 620i floorstanding speakers (boxed) cost £485 for £240. Excellent sounding system all for £695 together. Real Bargain!
Tel: 01422 370206

QED DIGIDAC with twin positron power supply £200 o.n.o. JPW subwoofer rarely used £50
Tel: 01704 566258

PROAC SUPER TOWER speakers £600
Tel: 0181 386 4753

LINN LK1 pre amp £200; Yamaha CT1010 FM/AM tuner £95. WANTED: Linn Spark, may p/x
Tel: 01423 734846 (Harrowgate)

COGAN HALL reference interconnect 1.5m £140; speaker cable 8ft £170; Isoplat £10; Fluxbuster £10; Ringmat £20; Apollo stand £20; Standesign wall shelf £20; ArQ dampers £40; 200 Hi-Fi magazines.
Tel: 0115 9308100

READY ASSEMBLED KLS4s, cabinets plus stands. All that is needed are speaker units to complete. Sensible offers please. (O.W.H.Y.)
Tel: Pete 0115 9294060 (Nottingham)

LINN/LP12/VALHALLA/TITOK/ASAKA, recent rebuild, Rosewood £550; Naim NAC 32.5 NAP110 £500; Audioquest Quartz 1m phono to BNC. Sports car restoration forces sale.
Tel: 0117 909 8736 after 7pm (Bristol)

ARCAM TWO PLUS speakers (real black Ash veneer) good condition quick sale hence £110. Naim NAC 42 pre-amp as new bargain £90.
Tel: James 01280 813037/0585 457092

NAIM 03 CD player, brand new, boxed, guaranteed £745 o.n.o. Naim 72 pre-amp new style and Hi-Cap (old style) both comparatively new and mint £725.
Tel: 00 3531 4591432 (Dublin)

WANTED: TDL REFERENCE standard speakers, any condition considered.
Tel: Paul 01274 879608 day or 01274 587111 night

ORDINAL DAC by Pink Triangle, 18 bit, 18 months old, as new, receipt and box £500.
Tel: 01874 665488 (eves S.Wales)

AKAI GX325D cassette deck wanted. Any condition at all.
Tel: Sandy 01292 314190 (eves or w/ends) or 01563 544550 during working hours.

"Music is more than a bunch of sine waves."

ORCHID

PRECISION AUDIO

It was 1822 when Jean Baptiste Joseph Baron De Fourier invented the Fourier transform, the powerful and elegant mathematics which can describe a complex signal such as music in terms of a collection of simple sine waves, and in so doing laid the foundations for the way we now measure the fidelity of a hi-fi component in terms of its "frequency response".

But there was always more to the Baron's theory than that, there is the phase response, the forgotten part. And leaving out the phase response provides just half a description. Perhaps nowhere more so than with loudspeakers.



ORCHID PRECISION AUDIO – THE PHASE LINKED LOUDSPEAKER

So here's the test that nobody shows you, the square wave test. A square wave contains a very rich spectrum of harmonics. If a loudspeaker can reproduce these harmonics without altering either their amplitude or phase, a square wave will be obtained at the microphone. The first photograph is the response of a respected American loudspeaker trying to reproduce a 300 Hz square wave. You could be forgiven for remarking that the output (on the lower trace) looks nothing like the input (on the upper trace). This is phase distortion. If this measurement was of an amplifier, it wouldn't even merit a review.

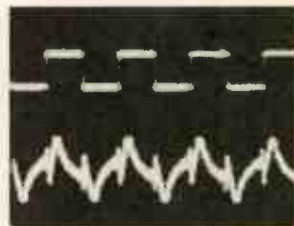

Surprisingly, some manufacturers actually state that loudspeakers are generally incapable of reproducing a square wave, due to all sorts of reasons. We don't feel that way, as the lower photograph shows. With enough care, which we have, this higher level of fidelity can be obtained.

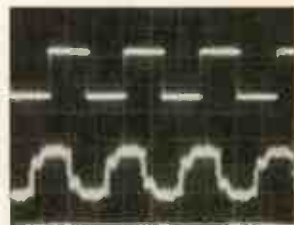

But what does it all mean? It means that these loudspeakers reproduce music on a grand scale and preserve all the subtle nuances that contribute to a realistic stereo image, both in width and depth. These loudspeakers are passionate, demanding, and addictive. They fulfil the only criterion left at the high end, that you can just forget about them, be convinced by the music, and not have to work at it. If you would like to know more, write to us at our address below, better yet listen to them at our distributor's and hear real music.

Freq resp: +/- 3 dB,
24 Hz - 22 KHz
Sensitivity: 87 dB/watt / 1M
Impedance: 4 ohms, nom
Min power: 100 watts
Size (inch): 39 x 14 x 15
Price: £4750.00

Our distributor is:
Westwood and Masons
46 George Street
Oxford
Oxfordshire
01865 247783

We are:
Orchid Precision Audio
Compton Court
Long Compton
Warwickshire
CV36 5JW

ARCAM DELTA 150 Nicam stereo TV tuner £175 o.n.o. mincondition; also pair LS3/5a speakers built from Wilmslow audio kit, teak veneer finish £60. Tel: 0181 508 3909 (evenings)

LINN: EKOS (Full rebuild with new arm and bearings 6/95 MkII) £700; Klyde (3/95) £200; LP12 Black (Cirkus 3/95) £330. Naim: Prefix (6/95) £225; Armageddon (8/95) £410. All mint/excellent condition. Tel: 01761 410625 (Avon)

MAGNEPLANER MGI 5 QR mint condition £650 cost £1600 new. REL Strata subwoofer £280 cost new £500 Tel: 01582 573477

OLD BUT LOVINGLY cared for Linn Isobarks (Walnut-DMS) on Russ Andrews Torlyte stands with Naim A5 cable. Baby and immlent house force sale. £450. Tel: 01525 851508 (Beds)

FURUKAWA FA-2010 interconnect cables £75, Pioneer F-401L tuner £95. Both items boxed and in perfect condition. Tel: 0973 245508 (days) 01952 883490 (eves)

TWO NAIM NAP250s, 1994, £1100 each including postage. SBLs (black, passive) £1050 o.n.o. Tel: 0191 4166866 (Washington Tyne & Wear eves or weekends)

WESTERN ELECTRIC 594A microphonic HF driver, spare DIA £450. Pair RCA LMI-9458 HF X throats £220. Pair BT-H ESA HF X throats £90. Buyer collects. Tel: Martin 0121 476 0071 (7-7.30 pm)

WANTED. SONUS FABER loudspeaker stands Walnut/Marble type. Good price paid. Tel: 0181 5053851

TRIODE MONO-BLOCKS based on 1st Audio £750. Quad EL557 bronze, protection, £325. Valve line pre-amp £220. EL84 power amp extensively modernised £220. Tel: 01403 891349 (Sussex)

BEARD CA35 VALVE pre-amp. Recent service, excellent, boxed, £250. Croft 45A power amplifier, 6550 output valves, recent service, excellent £375. Tel: 0161 283 1689

VINYL LOVERS dream pre-amplifier, the world famous Primare Series 928, user adjustable for any cartridge, absolute phase and cartridge channel balance £1850 o.n.o. (£3750) Receipts, reviews, manuals, boxed as new. Tel: 01943 466381 (now!)

LINN LK1 pre-amp with remote control, boxed. £200. Tel: 01734 730379 (Wokington)

B&W P4 Compact floorstanders in Rosenut, complete with plinths. 2 months old. Boxed. £500. Tel: John 0171 278 9396 (day) 0181 848 4967 (eves)

AUDIO ALCHEMY DDE V1.0 DAC still under warranty, former Hi-Fi Choice best buy. Sell £170 o.n.o. (new £400) Tel: David 01908 678628 (home) 01908 342552 (work) Milton Keynes

WANTED: RADFORD STA15, STA25 series 3 + SC22 control unit. Will pay an excellent price and collect for mint amp, pre-amp. Private buyer. Tel: 01302 724384

NAIM 140 and Walnut IBLs. Marantz CD-94 and CDA-94 DAC. Offers i.r.o. £400 each. Audiotech table £85. 2 Target TT2 tables £40 each. Tel: 0181 668 9040 (Croydon) or 0836 696096 (mobile)

LINN HELIX speakers, in black Ash, perfect condition, boxed £175 Tel: 0121 681 1224

ROKSAN XERXES P.S.U. 3, Artemiz, Shiraz (2 yrs old) plus Roksan stand. Walnut, new condition £900. Mission Cyrus One, latest £150. Arcam black box 3 £150. Quad 34/405-2 £350. Tel: 01952 502097 (Telford)

MERIDIAN 563 DAC mint condition, 9 months old, boxed with owners manual and receipt of purchase £550. Tel: 01970 627583 (eves) (Mid Wales)

AUDIO INNOVATIONS 800 II power amp, mint, boxed, just serviced £425. Sony Professional Walkman WM-D6C, boxed, little used, power supply and leather case, £165 o.n.o. Tel: Tim 01629 733634 or 0378 165764

DENON TU260L tuner £100 o.n.o. Denon DCD 810 CD player £200 o.n.o. Denon DRS 810 tape player £200 o.n.o. Denon PMA 520 amp £250 o.n.o. Excellent condition. Tel: 01252 811978

COLLECTORS ITEM - HMV Melstersinger stereophonic radiogram (1950s) Model 1645. Very good burr Walnut case and separate speakers £150 o.n.o. Tel: 01582 760050 (Harpندن)

LINN PRETEK pre-amplifier, boxed with Linn extended warranty £165. Linn K18 II moving coil cartridge £50. Tel: 01744 614562 (Merseyside)

TAPE RECORDERS Brenell TR Mk 5 c/w Reslo RBH/T mic £150. Tandberg model 75b stereo c/w mini-lab £125. Philips DCC 600 digital cassette recorder £150. Hanimex 2040 AV slide synchronizer, new £50. Tel: 01922 691553

MAGNEPLANAR 1.4 panel ribbon speakers. These have excellent sound quality. The wife says exchange for Ribbon Hybrid wood finish floor standers "Heybrook", "SD" etc. Wanted: old 100 watt plus amps. Tel: 01626 774 246

AUDIO INNOVATIONS L2 valve pre-amp. Serviced and boxed, excellent condition £420. Tel: Simon 01484 429844 or 534890 (West Yorks)

MICHELL GYRODEC Rega RB300. 7 months old, used twice, boxed since, receipts etc. Genuine reluctant sale. £700 o.v.n.o. Mitchell Gyro power supply mint £85. Wanted: Quad 405 Mk2 late model. Tel: 01582 573286 (Luton)

B&W MPA 1 monobloc power amps 120 wpc, as used in recording studios. Good condition £425 o.n.o. Tel: 0131 229 4739 (answerphone before 6pm)

ROTEL 850 STEREO tuner (fm/mw/lw) and owners manual; excellent condition and sound £50. Tel: 01929 551 338 (Wareham Dorset)

NAIM NAIT 2 integrated amplifier, boxed as new £130. Tel: 01234 215598 (Beds)

TDL MONITOR SPEAKERS (new £3,600) £1,800. Finestra pre-amp (new £1,200) £500. NAD tuner 4300 (new £360) £120. Time Window model 1A speakers (new £1,000) £500. All perfect condition. Tel: 01766 523342

LEAK STEREO 20 with Varislope stereo pre-amp and Troughline II tuner. All working and in clean condition. With some spare valves. £180. Tel: 0161 483 8409 (eves) (Stockport)

TREAT YOURSELF THIS XMAS Revox G36 2T 15ips. Just serviced, recalibrated. Brand new heads! with 2 studio capacitor mics (inc psu) Cables and 10 blank tapes £800. Tel: 01243 553531

FOR YOUR XMAS SOCK Art Audio VPI pre £300; Incatech 50w amp ex-con £130; Naim Nait 2 mint £350; Garrard 301, plinth, trough, RB300, K9, good example £250. Tel: 01243 553531

SON OF SANTA Rare American HK valve integrated UK transformer, superb for £250. Leak Troughline 3 v.g.c. £120. Stereofetic £80. Ortofon MC transformer £80. TD166, grunge, armless £20 Tel: 01243 553531

TANNOY PAIR G.R.F. Memory loudspeakers in excellent condition £1,595 Tel: Paul 0181 6603170

LINN INTEK AMP £200; Linn Helix speakers with Rogers stands £200 Both items o.n.o. Tel: Steve 0181 684 9815 (Croydon)

TEAC P500/D500 CD transport & DAC VRDS, mint, champagne finish, audiophile equipment, upgrade forces sale, cost new £1,050 sell for £600 Tel: 0161 626 0879

LOGIC DM101 MkII Helios arm, Elite cartridge £150. Quantum 102 pre-amp/402 power supply. 207DA 80w power amp, numerous leads £170, Audiomaster LS3/5A with stands £175. All o.n.o. Tel: 01773 826170 (Derbys)

RARE OPPORTUNITY - CROFT Series X OTL power amp - 20 watt output, also Croft Charisma valve pre-amp, MM plus 3 line inputs. Both boxed as new with spare valves £950. Tel: 01905 641 385

MARK LEVINSON preamplifier No. 38 and D/A converter No. 36. Both in perfect condition. The No. 38 preamplifier features full remote control and balanced inputs and outputs. The No. 36 D/A converter has 6 inputs, balanced outputs and HDCD. Superb value at £2000 each. Krell KSA 50 Mk2 Class A stereo power amplifier in very good condition only £850. Tel: 01943 603 493

QUAD ESL-63 speakers, 4 yrs old, latest spec, brown, mint condition, reluctant sale, £1450 (new £2970) Garrard 401/3009/SME type plinth, excellent condition £225 Tel: 0121 602 2591 (Birmingham)

FOR SALE, EPOS ES14 speakers with EPOS stands to match in perfect condition. Boxed, instructions, genuine sale due to upgrading £455 Tel: 01886 821 577

PROAC RESPONSE 3 speakers, Mahogany finish £1,950 Tel: 01274 817 035

MANTICORE MANTRA turntable, Musician arm and ATOC5 cartridge. ION Obelisk 2 amplifier. Monitor Audio R300MD speakers with stands. Five shelf tripod stand. All in excellent condition. £750 o.n.o. Tel: 01908 506 400

CROFT MEGA MICRO 2 box valve pre-amp with single ended outputs £750. Recently serviced. Tel: 01305 263 702

LINN MMIIK 2 CD latest spec, surface mount. 10 months old, over 4 years Linn warranty, mint boxed £595. Original Linn Kan 2 stand, good condition £200 Tel: 0113 262 9661

TANNOY DC2000 £195; Systemdek IIX (w/o arm) £60. (RB300 if required) All boxed. QED Digiflex £9 Tel: 01843 593 958

GRANT PRE-AMP; NAIM 82; 62; Hi-Cap; 250; 135s; QUAD 33; FM2; FM4; CROFT 3R power; Audio Research LSI pre-amplifier; Royd Abbott loudspeakers; Marantz CD 94. May swap or p/x Tel: 0114 248 6493

TURNTABLES: Ariston RDIIS; Systemdek; Rega 3; Garrard 301 & 401; Various arms & cartridges; Naim IBL speakers; Nytech amp & matching tuner; Nytech active crossovers. Wanted Naim, Linn or Quad Tel: 01990 550 534 or 01909 550 534

PS AUDIO PHONO pre-amp, switchable loading £95. Jecklin Float headphones £55. Teac PD3200 CD £90. All mint, boxed. Wanted: early Revox; Manual for Mozart tuner; Beyer ET1000 headphones. Tel: 01280 706 488

KEF REFERENCE 104aB, Teak finish, complete with Target stands. Sand filled and fitted with spikes. Classic speakers in excellent condition for £150. Tel: 0181 660 1148 (Surrey)

P.S. AUDIO 4.6 pre-amp. Active/Passive MC/MM. Better than an Argo/ISO. V. good condition, boxed £494 (£1000) AT-OC30 cartridge part worn £85 (£619) Save £100 traded in against a new one! Tel: 01342 712 653 (Gatwick)

WADIA 3200 CD transport. Excellent condition £675 Tel: 01604 766124

AUDIO RESEARCH VALVE Pre SP8, mint £695. STD 305 deck, 774 arm, Shure, v.g.c. £155. Valve phono stage £120. Arcam speakers £125. Goodmans panel speakers £75. Tel: Paul 01895 446 713

AUDIO RESEARCH SP10 MkII pre-amplifier. Groove tubes in output stage and power supply. Modified to give "bypass" CD input (similar to phono bypass) £800 Tel: 0161 432 6120 (Stockport)

LINN EQUIPMENT: Kairn (phono) £925, Kremlin £1100, Klouts £1300 each, Kaber Aktiv cards £495, Majik (phono) £420. Possibly deliver/install. WANTED: LK100 power amps, LK400 speaker cable Tel: 01622 858 085

MUSICAL FIDELITY F22/15 pre/power amplifiers as new and guaranteed with phono input. Cost £3000, accept £1995 o.v.n.o. Siltech and Translucent silver cables for sale - 0.5m to 2.5m lengths. Tel: 0181 949 6723

QUAD II amp, 22 pre-amp, FM tuner, ELS speaker, Garrard 301 deck, all in good working order. £650 may split Tel: 0121 745 4283

PIONEER STEREO amplifier £40; Goldring GL85 turntable £30; Panasonic top loading stereo cassette deck £20; Fisher stereo tuner £30; Kenwood CD player £55. Wanted KEF speaker units vgc Tel: 0181 681 1054 anytime

UKD CALLAS SPEAKERS superb sound cost £750 sell for £380. Mint and boxed. Target 4 pillar type stands £90. Arcam Delta 70-3 CD player boxed as new £350. Tel: 01978 860 332 (Clwyd)

CHORD SPM 1000B power amp 250 wpc/8 ohms. 8 months old. Transferable 28 month guarantee. Boxed, mint (new £2600) £1250 o.n.o. Concordant Excelsior pre-amp mm/4 x line inputs excellent condition (new £1150) £550 o.n.o. Tel: David 0181 741 3119 days or 0181 348 0612 eves/ans



You want the finest range of quality interconnects, cables and connectors... but you want them at affordable prices... then look no further than **SHARK**.

Now in stock are the new T-26CX *Phono Plugs*:

- high grade gold plating
- teflon insulating
- thick shoulder for extra grip
- fully lathed body design
- compact size for easy installation



AMAZING INTRODUCTORY OFFER

25% off for Hi-Fi World readers!
T-26CX normally £40.00 per set of 4
Now only £30.00!



Add £1.50 per set post, packing & insurance. For details of the complete range of SHARK products contact: **SHARK**

Unit 1 • 76^a Farnley Road • London • SE25 6NX
Tel: 0181 • 771 8388 Fax: 0181 • 771 1840

diverse vinyl

est 1988

A vinyl service aiming to cover the whole music spectrum
12 Upper Dock Street Newport Gwent NP9 1DF
9am - 5.30pm Mon - Sat

phone/fax 01633 259661 P&P £1.00 per order

Catalogues available for all categories Mastercard Visa Amex Switch JCB

Exclusive Re-Releases (limited)

Janis Ian	Between the lines/stars	each £5.50
Joan Baez	Ring Them Bells	£8.90

New And Expected Releases

Alice in Chains	Alice in Chains	£9.90
Beatles	Anthology	£21.50
Beatles	Audiophile LP's-US imports	£15.90
Bruce Springsteen	Ghost of Tom Joad	£9.90
Cypress Hill	Temple of Boom-Triple Ltd.	£14.50
David Bowie	Singles Triple Vinyl	£16.90
Hawkwind	Alien	£10.90
John Coltrane	Stellar Regions	£14.90
Linda Lewis	Second Nature	£7.90
Mavericks	Music For You-import	£10.90
Pharoah Saunders	Karma	£14.90
Pulp	Different Class	£8.90
Queen	Made In Heaven	£8.90
Rolling Stones	Stripped Live	£12.90
Runrig	Mara	£9.90
Sam Cooke	At The Copo-import	£9.90
U2/Eno/Passengers	Original Soundtracks 1	£8.90
Van Morrison/G'Fame	How long has it been	£8.90

Some Diverse Vinyl Favourites of 1995

Black Grape	It's Great When You're Straight	£8.90
Ballistic Brothers	London Hooligan Soul	£11.90
Ben Harper	Fight For Your Mind	£13.90
Donald Byrd	Kafi-Reissue	£9.50
Garbage	Garbage	£8.90
High Llamas	Gideon Gaye	£8.90
Jackie Leven	Forbidden Songs	£12.90
Janis Ian	Revenge	£8.50
Jethro Tull	Leftism	£13.90
Living Fin Killie	Houdini	£8.50
Matt Doughton	Villager	£8.90
Neil Young	Mirrorball	£13.90
Nightmares On Wax	Smokers Delight	£10.90
Oasis	Morning Glory	£10.90
Outside	The Rough and the Smooth	£9.30
PJ Harvey	To Bring You My Love	£8.90
Paul Brady	Spirits Colliding	£9.90
Radiohead	The Bends	£9.50
Rancid	And Out Came The Wolves	£8.50
Salif Keita	Folon	£8.50
Sam Cooke	Nightbeatre-issue	£10.90
TLC	Crazy Sexy Cool	£9.90
Teenage Fanclub	Grandprix	£8.90



Get on our list - to get closer to this list.

- MIT MultiCap • Wonder Cap • Kimber Kap • Solo • Hovland MusiCap • Solen • Siemens
- Wima • Holco • Rel-Cap • Dralonic • IRC • Allen-Bradley • Jensen • Resista • Vishay • Mills
- Caddock • Matsushita • TKD • Noble • Cardas • Kimber Kable • van den Hul • Discovery
- Audioquest • MIT • Alps • Bourns • Shalco • Elma • Electroschick • Nichicon • Gold Aero
- RAM • Mallory • Panasonic HFQ • Nichicon • Elna • N.D.S. • Ruby Tubes • UltraAnalog
- Burr-Brown • Crystal • Linear Technology • Analog Devices • Edison Price • Motorola • UCC
- International Rectifier • Hitachi • MagneQuest • Sonic Frontiers • Pearl • Tube Sockets
- WBT • Neutrik • Sound Coat • Curcio Audio Engineering • Assemblage and other kits

And it's growing and growing. To order The Parts Connection 1995 Catalog & Resource Guide, send £7 and mailing information. You'll also receive a Discount Coupon worth \$10 off a purchase over \$100 or \$25 off a purchase over \$250* as well as The Breadboard bulletin to keep you updated on our latest news, information and growth spurts.

*or \$10 US, or credit card information
*catalogue discounts are in US Dollars

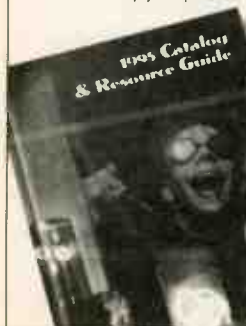

THE PARTS CONNECTION®

A DIVISION OF SONIC FRONTIERS INC

2790 Brighton Road, Oakville
Ontario, Canada L6H 5T4

Toll Free Order Line 1-800-769-0747
(U.S. & Canada only)

Tel (905) 829-5858 Fax (905) 829-5388

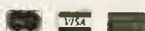

IAN HARRISON HI-FI TEL: 01283 702875

9am-9pm

CARTRIDGES	CASSETTE DECKS	TUNERS
ORTOFON AUDIO TECHNICA DENON TRANSFIGURATION BENZ MICRO SHURE GOLDRING	***TRADE IN YOUR OLD MOVING COIL CARTRIDGE (ANY AGE MAKE OR CONDITION) AND SAVE UP TO 40% OFF THE NORMAL SELLING PRICE	TRANSFORMERS & PHONO STAGES ORTOFON SOWTER EXPRESSIVE TECHNOLOGIES
CD PLAYERS	CASSETTE DECKS	TUNERS
TEAC, SONY MARANTZ	AIWA, TEAC, NAKAMICHI, SONY, MARANTZ	QUAD, MARANTZ, SONY, DENON
AMPLIFIERS	HI-FI FURNITURE	CABLES
QUAD, CONRAD JOHNSON, MUSE, MARANTZ, SONY, TECHNICS, TEAC	SOUND ORGANISATION, APOLLO, SOUND FACTORY TRIPOD, SOUNDSTYLE, PROJECT	AUDIOQUEST, COGAN HALL SONIC LINK, SILVER SOUNDS, QED GOLDRING
BLANK TAPES	HEADPHONES	ACCESSORIES
TDK, MAXELL, SONY BASF, FUJI, AMPEX, SCOTCH, JVC, KONICA	SENNHEISER, BEYER, AKG, KOSS	QED, DISCWASHER, GOLDRING
TEST CASSETTES & CD'S		
PHONE OR WRITE FOR DETAILS		

MAIL ORDER ONLY
PLEASE PHONE TO CONFIRM PRICE AND AVAILABILITY
PRIOR TO ORDERING. ALL GOODS ARE BRAND NEW WITH
FULL UK GUARANTEES.

GOODS ARE NOT SUPPLIED ON APPROVAL.
MAIL ORDER FROM: IAN HARRISON HI FI, 7 MILL HILL, REPTON,
DERBY, DE65 6GQ.

TEL: 01283 702875 9am-9pm. Inc. Sunday

MUSICAL FIDELITY 'pre-amp 8' limited edition as new boxed (Chrome facia) £200
Tel: Bill 01738 635 968

KRELL KSA 150 £2200; Krell KSA 80 £1895; ATC 20T rosewood speaker £1750; Infinity reference 2B speaker with crossover £1500
Tel: 01344 777 516

KEF Q30 £369 sell £299; TDL RTL 2 £299 sell £220 Mission 761 £129 sell £90. All boxed as new will demo. No timewasters please
Tel: Steve - 01865 59737 (Oxford)

MAGNAPLANER MG1C panel speakers, white, excellent condition, superb soundstage £550. Also Hitachi FT5500 Mk2 stereo tuner, hardly ever used £90.
Tel: 01222 891 314 (Cardiff)

DPA PDM2 mint boxed £995; DPA Bigger Bit mint boxed £350; DPA mains filter £95; Pioneer 295D LD player as new £595, REL subwoofer unwanted unopened box
Tel: 0370 435 952 anytime

NAIM SBL loudspeakers and 18" cables not 3 years old £700
Tel: 01686 413782

AUDIO INNOVATIONS S1000 monos & L2 pre at £1500. Its a belter.
Tel: Ralph Tyneside 2724180 or leave your name & number so I can get in touch.

NITTY GRITTY Automatic record cleaner. This is the top model. The mini pro. Cleans both side at once. Rarely used and half price at £350
Tel: 0181 325 2585

QUAD 22 FM TUNER and control unit with multiplex decoder. 2 Quad II power amplifiers sell complete £350 o.n.o. Plus Pioneer PLI 120 turntable any reasonable offer.
Tel: 01438 362 027

TURNTABLE MICRO SEKI DD-20; Yamaha Quadriser amp UD-500; Harmon Kardon 430 twin powered receiver; Sansui SC 3000 stereo cassette tape deck; 4 - AR/16 speakers, need att. £150 o.v.n.o.
Tel: 0181 737 9950 eves

NAIM IBLs, Walnut finish £450
Tel: 01509 215 622 (Loughborough)

PROAC RESPONSE 2 speakers in Mahogany, with silver Van den Hul internal wiring (dealer upgrade) £1090; Target R2 stands for above £159; Counterpoint DA-11E CD transport with masterclock upgrade, latest model £1325.
Tel: 01284 769 985 (Suffolk)

MAGNEPAN SMGb speakers £500; Classe 30 pre-amp £750; Classe 70 power amp £750; Croft Super Micro and pre £275. All boxed and perfect.
Tel: 01252 311 016

WANTED PRIVATELY: NAIM NAC 72, Hi Cap, NAP 180 or 250.
Tel: 01598 760 247 after 6pm

EPOS ES14s and stands, 2 months old £500; Naim NAC72 (new style) £350; Mana Reference table £250.
Tel: 01234 341 943 evenings

NAIM NAIT 2 intergrated amplifier £275. Excellent condition and sound (Genuine) Two years old, upgrade causes sale.
Tel: Jon 0117 973 9004 (Bristol)

MACDONALD HFN Transmission line speakers. Real wood Mahogany finish, brown grill cloth "Room Tuneable" £300 o.n.o. Luxman analogue tuner £20 o.n.o. Buyer collects.
Tel: 01203 310 343 (evenings only)

LINN LK280 AMP; Linn LK1 pre-amp with remote. Both mint condition £500 pair. Linn Kellidh speakers with stands and bi-cable. Mint condition (warranty) £500 pair. Can demonstrate.
Tel: Gary 01494 715 673 (Bucks)

SPENDOR SP2/2 Walnut speakers, full Deflex treatment including Heybrook HBS1 stands £400 no offers.
Tel: 01565 733 525 (Cheshire)

ALL NEW, UNUSED, BOXED. Half current retail price plus postage. Beyer DT911 headphones; Linn K5 cartridge; Sony semi auto turntable (45/33) QED switching boxes (various)
Tel: 0114 245 4586 (Sheffield)

HEYBROOK HB1 loudspeakers including dedicated stands £150. Linn Akito tonearm and K9 cartridge £120.
Tel: 01737 241 675

ACOUSTIC ENERGY AE1 speakers, black, boxed with AE1 stands, excellent condition £500. Carriage extra.
Tel: Mike 0121 430 3416 (Birmingham)

GARRARD 401 turntable. This deck is in pristine condition. Due to occasional years of non-use due to absence it is thus in an excellent mechanical state.. £100 o.n.o.
Tel: 01785 823 204 (Stafford)

ROGERS BBC Studio monitors (3 units) as new in original package including stands. £300. Goodmans Axiom 80 (9 1/2"), Audiom 70 bass (12 1/2") 15 ohms. Sensible offer.
Tel: 01424 844 932 (Bexhill)

LUMLEY REFERENCE 120 monoblocks, latest spec, mint condition with triode switching facility plus Pearl tube coolers £1750 o.n.o.
Tel: 01403 733 055

AUDIO ALCHEMY CD transport, 2 box - top loading, remote, mint £400 (£1099). Tripod wall mounted hi-fi stand, tinted glass spiked support, beautiful new + boxed £60 (£140). Senheisser HD545 reference new £70 (£120)
Tel: 0181 372 2584

APOGEE SCINTILLA panel speakers, Antracite vgc, boxed £1600. Krell KMA100 MkII monoblock amplifiers, vgc, boxed £1900. If both items bought together £3,300.
Tel: 0181 840 1471 or 0973 323 169

NAIM 72/140 HICAP £1300 new style, may separate. Radford SC25 pre-amp £450. Audio Alchemy DST digital cable £150. Plexchange!
Tel: 0181 0595 or 0181 559 9562

LINN LK1/280 £400; Linn Intek £350; Quad 67 £475; Musical Fidelity pre 3A £175; plus T1 tuner £175. Epos ES11 (black) Foundation Audio Designer stands (£324) £450
Tel: 01952 502 097 (Telford)

DIAMOND ACOUSTICS Reference 2 speakers, mint condition, unusual design, Volts, Audax, Bandor drive units £2250 new £990 cash and part-ex considered. Leak TL12+ monoblocks modified. Regulated power supplies, revalved £350 for quick sale.
Tel: 01709 851 993 (Rotherham)

QUAD 606 power amp mint £295; Quad 34 pre-amp mint £175. Both boxed. Thorens turntable - offers
Tel: 01942 718 366 (Lancashire)

MISSION 752 Rosewood, 8 months old, excellent condition, boxed £390. Sansui AUX-911 intergrated amp, on board DAC, remote control, 100 wpc, breathtaking sound for the money. Cost £900 asking £200
Tel: John 01480 463 938

NAIM CD3 compact disc player 18 months old little used, as new complete with box and lead. £600
Tel: 01256 461 453 (Hants)

MERIDIAN 601 DSP pre amp, Meridian 602 transport CD, Meridian 605 mono amps. All mint condition with a remote. £3750 for all or nearest reasonable offer.
Tel: 01527 543 442

AMC CVT 3030 intergrated valve amp, unused, boxed £450. Sugden A25, as new, boxed £100. New lid for LP12 £25. Leak Delta tuner £50. Target TT2 shelf £35
Tel: 0181 386 0935 (Watford)

LINN MAJIK phone £400, LK100 £375, free Linn interconnects and LK400 cables if bought together. Naim 72 (S,K,V, boards) £400, immaculate, boxed, manuals.
Tel: 01705 690 093 (Portsmouth)

LINN LP12 (Valhalla, Nirvana) Ittok and Asaka £525. Naim 32.5/110 amplifier £475, Arcam Delta 80 tuner £150. Soundstyle 4 shelf, record storage etc £105. Mission 737 speakers £60.
Tel: 01233 611 171 (Kent)

NAKAMICHI Soundspace 7 includes multi CD player, tuner, amplifier, speakers £1500. New. Casework needs respray or £150 for new parts from Nakamichi hence £250.
Tel: 0302 782 722 (Doncaster)

SPENDOR SPI loudspeakers "An exceptional all rounder" (Hi Fi Choice) Excellent condition £450.
Tel: 01621 778 859

EXPOSURE XX integrated amp £325 o.n.o.; Arcam Alpha 3 integrated amp £100 o.n.o. Both immaculate and boxed.
Tel: 0121 357 9561

QUAD 44/405-2/FM3 with manuals, leads and boxes £330; Thorens TD 125-2/SME 3009-2 DH with plinth, cover, cartridge, leads, manuals and box £175; Leak Sandwich speakers £85.
Tel: 01582 715 560 (Herts)

SYSTEMDEK IIX Acrylic platter, metal armboard, Rega RB250 silver wired; Goldring 1022 £240 o.n.o.. Audio Innovations series 300 Mk 1 valve amp £150. Snell type K IIs black Ash with Pirate stands £250. 4 x 2.5 metres of Audionote AWB speaker cable £35. 2 x 5ft lengths of Cogan Hall speaker cable cost £345 - £45. Audionote ANV pure silver interconnect cost £225 £75
Tel: Andy 01323 841 472

KEF 104/2 Speakers. Walnut, bi-wired £600. Quad 34/606 (Mark 1) £500. Thorens TD 125/2, SME 3009/2, A & R P77 cartridge £200. Sony TC-K 1010 computer controlled Dolby C cassette deck £50.
Tel: 01895 271 953 (Uxbridge)

KITS BUILT AND RESCUED. Intimidated? Frustrated? Valve amp problems solved to get you up and running. Performance report or completed kit will be provided.
Tel: 01322 386 560 (Gravesend Area)

ARCAM 170.3/BB5 combo for £700 in very condition.
Tel: Jon 0181 348 9535

PIONEER A400 amplifier. 85 watts per/ch. Bargain at £140. Mint condition. Also: Marantz CD-52 mint condition £125. Please allow £7.20 (inc. insurance) to cover each item if posted.
Tel: 01491 825 534

AUDIO INNOVATIONS L2 pre-amp. Absolutely mint £400. A400 Trichord mod £150, 2 x 5m Audionote ANB speaker cable £65, sound Factory tripod base unit and record box £50.
Tel: 01242 577 060

HFV 4WSE (performance checked by HFV) £425. Leak Troughline 3 stereo (GT Audio) £250 Troughline 3 mono £50. Leak Stereo 30 £30
Tel: 01834 860 681 (Dyfed)

COLLECTORS ITEM - Garrard 401/SME 3009 II in SME 2000 plinth, excellent condition, complete with original instruction manuals £350 o.n.o. Pair Goodmans Magnum K-2 speakers £100
Tel: 01279 871 461 (Essex)

KEF REFERENCE Model 3 in Rosetta Burr. Just run in. Superb but too big for my room. £1750. Naim NAT 101 + Snaps £400. Townshend Glastonbury II £500.
Tel: 01286 871 629 (day) or 870 246 (eve)

AUDIO RESEARCH SPI4 pre-amp/classic 60 power amp silver £2900, may split. Impulse H6 horn speakers, burr Oak late model £750
Tel: 01384 265 058

MERIDIAN 206B mint condition little use £299. Also Mordaunt Short MS30 black mint boxed with stands only £95. Can happily demonstrate.
Tel: 01256 463 539 after 6pm

REVOX HS 7.5 & 15 ips, 2 track. Suitcase model with built in amplifiers and speakers. Excellent condition, light use only. Ideal Christmas present
Tel: 01425 653 623 (Hampshire)

BEAUTIFULLY CONSTRUCTED passive pre-amp. Alps "Black Beauty" volume pot, silver plated selector switch, silver plated cable/silver solder, gold/PTFE phonos, 5 inputs £135.
Tel: Mark 01224 210 875

MICHELL GYRODEC. Zeta black arm, Supex cartridge £675
Tel: 01235 769 603

DELTEC WANTED: DPA 50S or 100S pre/power amplifier required. Early model preferred, with phono input.
Tel: 01442 396 761

EAR 859 intergrated valve amplifier £950. Single-ended heaven! Hi-Fi News kit, deluxe version built to a high standard. Upated with Alps pots. A fantastic bargain.
Tel: 01923 247 197 (Eves) Watford

EXPERIMENTAL RIBBON loudspeaker with crossover network Ortofon type C pickup with transformer, Jason JTV tuner. Pye HF25A (25 watt) valve amplifier £60, all manuals
Tel: 01522 531 243 (Lincoln)

AUDIO PRO B120 subwoofer. Black Ash, built in amplifier and crossover. Few hours use. Immaculate, boxed with manual £275
Tel: 01903 750 962 (Sussex)

IMPULSE H6 Horn speakers, black, fair condition & serviced £550. Audio Innovations S500, mint & boxed £425.
Tel: Paul 01702 467 757 or 0589 807 375 (mobile) Essex

LINN KEILIDH speakers (wainut) & ceramic plinth £450, Kenwood 9010 CD transport (upgraded) £250, QED Digit DAC & power supply £100. Marantz 50 SE CD player £135
Tel: 0114 243 5651 (Sheffield)

DPA BIGGER BIT DAC-7 and Kenwood DPX-9010 CD transport (boxed) mint condition £500
Tel: 01225 833 473 (Bath)

PINK TRIANGLE Da Capo £890, P10 CD transport (Trichord Clock) £690. Marantz CD94 II (Trichord Clock) £450. Michell Argo pre-amp £310. QED Digit DAC £70. Proac Tablette II speakers £230. Target speaker stands £50. Standesign equipment stand, 5 shelves £80. All in excellent condition.
Tel: 01483 503 618 (Surrey)

TECHNICAL & GENERAL

Some Necessities - From the Original Classic Turntable Specialists

			P&P
Connoisseur	BD1/2 Drive Belt	10.25	1.85
	BD1/2 Motor Suspension kit	13.95	2.45
	SAU.2 Headshell	16.75	2.55
	SAU.2 Connecting lead	15.95	3.55
Garrard	Standard Models		
	Wired arm tubes	from 12.75	2.55
	Cartridge carriers (sliders)	10.25	1.85
	Idler Wheels	9.85	2.25
	301/401 Transcription Models		
	Original Thrust pad assembly	10.25	2.25
	Original Idler tension spring	2.95	1.85
	Original Speed control disc - 401	13.75	2.20
	Xeroxcopy Owners Manual 301 incl. full size mounting template	7.85	1.85
	Xeroxcopy Owners Manual 401 incl. full size mounting template	5.70	1.85
	Replacement Intermediate drive wheel	19.95	2.85
	Replacement 301 control knobs On-Off/Speed select	pair 20.25	2.55
	Replacement 301 suppressor unit	5.65	2.25
	Replacement 301 motor pulley (-2%), (-1%), (Std), (+1%)	each 12.65	2.25
	Replacement 301 Chrome plated mounting bolts	set 4.70	2.25
	Recommended Lubrication set - early 301 or 301/401 (specify)	5.60	1.85
	Goldring/Lenco	Idler wheel (lock-nut or clip fixing)	19.95
Arm Pivot bearings with instructions		8.25	1.85
Spindle/Main bearing assembly complete		24.85	3.85
Headshells		from 21.95	2.55
Instruction books		from 4.20	1.85
Thorens	TD 124 series		
	Idler wheel original	27.50	2.85
	Idler wheel our redesigned replacement	15.35	2.55
	Drive belt	15.25	1.85
	Chassis spring suspension (replaces 'mushrooms')	13.85	2.55
	150/160 series		
	Drive belt	10.25	1.85
	Suspension springs (-1%), (Std), (+1%)	set 11.85	2.55
	Suspension bushes	set 12.50	2.25
	Armboards for most models	from 16.90	2.55
Cecil Watts Dustbugs/Paralats/ (spares incl. Preener wicks)			
Cartridges and styli for 78s & Mono LPs in addition to current Stereo LP			
TECHNICAL & GENERAL PO Box 53. Crowborough, E.Sussex. TN6 2BY Tel:- 01892 654534			

Gramex

25 Lower Marsh (by Waterloo Station)
London SE1 7AB (UK)
Hours. Tues-Sat 12.30-6.00
Tel: 0171 401 3830 or
0932 570080 Fax: 0171 928 3999

A
u
d
i
o

SELECTED USED
QUALITY HI-FI



KIT BUILDING
AND BESPOKE
EQUIPMENT



RELAXED
COMFORTABLE
ENVIRONMENT

Dynamics

HIGH END AUDIO BOUGHT/SOLD EXCHANGED

	SALE		LIST
MARK LEVINSON ML7A PREAMP. - MINT	2995	S/HAND	£6800
CAMBRIDGE CD1 CD PLAYER HEAVILY MODIFIED WITH MASSIVE POWER SUPPLY SUPERB	£1 295	S/HAND	PHONE
METAXIUS ICARUS INTEGRATED AMPLIFIER CHROME - MINT	£595	EX/DEMO	£895
PINK TRIANGLE PIP 2 MK2 VISHAY MODIFIED PREAMP - MINT	£1 795	S/HAND	£4,500
MARK LEVINSON ML3 POWER AMP. - MINT	£3,995	S/HAND	£8,250
CONRAD JOHNSON MV75 VALVE POWER AMP - MINT	£1,295	S/HAND	£2,500
CELLO AMATI SPEAKERS TWIN MOUNTED PAIR IN OAK ON GRANITE STANDS SUPERB V.G.C.	£5 500	S/HAND	£20,000
MERIDIAN ARGENT 3 SPEAKERS ROSEWOOD - MINT	£995	NEW	£1,495
PROAC PROSTATIC ELECTROSTATIC SPEAKERS RARE V.G.C.	£1,995	S/HAND	PHONE
SNELL A3 SPEAKERS WALNUT V.G.C.	£4 495	S/HAND	£8 995
METAXIUS IRAKLIS MK2 POWER AMP CHROME - MINT	£895	EX/DEMO	£1 500
METAXIUS CHARISMA PREAMP CHROME - MINT	£895	EX/DEMO	£1 500
EQUATION ZERO SPEAKERS PIANO BLACK - MINT	£695	S/HAND	£1 300
CARY 300B VALVE MONO POWER AMPS 40 WATT TRIODE	£2,995	EX/DEMO	£4 800
HELVIS CYALENE ARM - MINT	£795	S/HAND	£1 400
CABSSE IROISE MIC SPEAKERS CHERRYWOOD MINT.	£1,995	EX/DEMO	£2 700
NEW IN THIS MONTH			
RESTEK CHALLENGER INTEGRATED AMP - MINT NEW	£799		
CITATION 18 TUNER ORIGINAL AMERICAN V.G.C.	£295	S/HAND	£650
SUGDEN AUS1C PREAMP 2 BOC MODIFIED BY AVONDALE V.G.C.	£895	S/HAND	£1800
SOTA COSMOS VACUUM PLATTER - MINT	£1995	S/HAND	£4400
CRYSTAL REFERENCE TURNTABLE (WALLMOUNT)	£1495	S/HAND	£2500
NAKAMICHI QMS 7E CD PLAYER VGC	£795	S/HAND	£1500
GRYPHON LTD EDITION PREAMP BALANCED - MINT	£3995	S/HAND	£8000
SNELL TYPE C SPEAKERS WALNUT - MINT	£1295	S/HAND	£2550
CRYSTAL SIGNATURE TABLE TOP TURNTABLE BRUAR 8 ARM	£2995	S/H	£6450
MERIDIAN 606 DAC 7 MK2 DAC - MINT	£2495	E/D	£1450
AUDIO RESEARCH V70 HYBRID VALVE AMP - MINT	£2495	S/H	£4480
ARAGON 2004 POWER AMP - MINT	£695	S/H	£1295
DYNAUDIO SPECIAL ONES SPEAKERS ROSEWOOD - MINT	£795	E/D	£1249
AUDIO RESEARCH LS2B BALANCED PREAMP MINT	£1995	S/H	£3355
MERIDIAN 605 MONO POWER AMPS BALANCED MINT	£1550	E/D	£1900
KHILL KR8BP REFERENCE PREAMP BALANCED MINT	£4995	S/HAND	£11500
QUILDMUND MIMESIS 3 POWER AMP BALANCED MINT	£1995	S/HAND	£9000
TANDBERG TPA 3009A MU2 MONO POWER AMP MINT	£10955	S/HAND	£2195
WILSON WATT 3 PUPPY2 & PAWS MINT	£7495	S/HAND	£13645
MAGNUM DYNALAB ETUDE TUNER GOLD MINT	£995	E/D	£1390
MERIDIAN 506 CD PLAYER MINT	£680	E/D	£875
CREEK 6080 INTEGRATED AMP MINT	£275	S/H	£500
MARK LEVINSON ML12A PREAMP PLS 124 SUPPLY	£995	S/H	£2400
CAT SL1 SIGNATURE PREAMP & PHONO MINT	£2995	S/H	£6800
PS AUDIO 4 PREAMP & SUPPLY V.G.C.	£295	S/H	£950
EXPOSURE 7 PRE 9 PRO SUPPLY 4 REG AMP MINT	£1250	S/H	£2750
NAD 214 POWER AMPS LATEST 2 AVAILABLE MINT	£295	S/H	£370
MARK LEVINSON ML II POWER AMP MINT	£995	S/H	£2700
LUMLEY REFERENCE M120 VALVE MONOS MINT	£1795	E/D	£3200
MERIDIAN A500 SPEAKERS BLACK ASH MINT	£450	E/D	£695
SCINY 337 ESD CD PLAYER MINT	£295	S/H	£600
GRYPHON BEL CANTO PREAMP LATEST MINT	£2495	S/H	£3500
GRYPHON S100 POWER AMP BALANCED MINT	£3995	S/H	£5975
JADIS DEFY 7 MK3 VALVE POWER AMP MINT	£3495	S/H	£5290
KEF 102 2 SPEAKERS ROSEWOOD + KUBE + STANDS	£295	S/H	£1150
APOGEE STAGE SPEAKERS + STANDS MINT	£1695	S/H	£3454
ACOUSTIC ENERGY AE3 SPEAKERS & STANDS MINT	£995	E/D	£2075
COUNTERPOINT SA 3000 VALVE PREAMP MINT	£995	S/H	£2169
AVI PREAMP, PHONO STAGE REMOTE PAIR MONO AMPS	£1395	S/H	£2148
ADCOM GFA 565 MONO AMPS BALANCED VGC	£1250	S/H	£2000
MERIDIAN D600B ACTIVE SPEAKERS BLACK MINT	£1795	E/D	£2995
WHARFDALE OPTION 1 4 WAY ACTIVE SPEAKERS GREY & WHITE			
1 OF ONLY 5 PAIRS SUPERB VGC	£1995	S/H	PHONE
CARVER AMAZING SPEAKERS PIANO BLACK VGC	£895	S/H	£2300
CELESTION SL600 S1 SL6000 SUBWOOFER	£1295	S/H	£2400
MARK LEVINSON ML2 MONO POWER AMPS G.C.	£2995	S/H	£15000
LUMLEY MEGAVOX M150 SIGNATURE VALVE AMPS V.G.C.	£1595	S/H	£3800
MERIDIAN M1 ACTIVE SPEAKERS WALNUT LAST TYPE	£795	S/H	£1700
HALES SIGNATURE 2 SPEAKERS ROSEWOOD MINT	£3495	S/H	£6800
MUSE 18 ACTIVE SUBWOOFER ROSEWOOD BALANCED MINT	£2495	S/H	£4000
PROAC SUPERTOWERS SPEAKERS MAHOGANY MINT	£695	S/H	£1226
PIONEER PD75 CD PLAYER MINT	£395	S/H	£800
MERIDIAN 508 SUPER CD PLAYER BALANCED MINT	£995	E/D	£1475
MARRANTZ CD 65 MK 2 SE CD PLAYER MINT	£175	S/H	£350
VOYO 5 REFERENCE TURNTABLE ROSEWOOD CYALENE ARM & POD SUPPORT MINT	£3250	S/H	£5580
AUDIO RESEARCH SP9 MK2 VALVE PREAMP MINT	£1095	S/H	£1998
KRELL KSP 7B PREAMP BALANCED MINT	£1295	S/H	£3200
MICHELL 150 HR PHONO STAGE MINT	£495	S/H	£979
ROWLAND MODEL 3 MONO AMPS BLACK BAL. MINT	£2250	S/H	£4000
MARK LEVINSON NQ20 REF MONO AMPS BAL. MINT	£4995	S/H	£1100
CHORD 1200 POWER AMP MINT	£1595	S/H	£3000
PIONEER C73 PRE & M73 POWER AMP MINT	£795	S/H	£1300
MARK LEVINSON NO 23 POWER AMP BALANCED MINT	£2750	S/H	£5295
APOGEE CENTAUR MINORS SPEAKERS MINT	£895	S/H	£1345
APOGEE CALIPER SIGNATURE SPEAKERS ANTHRACITE MINT	£1595	S/H	£3998
QUAD ESL 63 PROFESSIONAL SERIES SPEAKERS BLACK MINT	£2500	S/H	£3358
GRADIENT SUBWOOFERS FOR ESL 63 BLACK MINT	£1295	S/H	£1995
GALE 302 SPEAKERS BLACK ASH MINT	£275	S/H	£440
THIEL CSIII SPEAKERS PIANO BLACK MINT	£7995	S/H	£12300
JANUARY SALE			
TEAC P10 D10 CD TRANSPORT & DAC MINT	£995	S/H	£2300
CAL TEMPEST 2 CE VALVE PLAYER MINT	£1500	S/H	£3900
MICHELL ARGO HR PREAMP LATEST & SUPPLY MINT	£895	S/H	£1340
MARK LEVINSON ML10A PREAMP MINT	£1250	S/H	£3800
ROWLAND MODEL 5 POWER AMP BALANCED MINT	£2500	S/H	£5250
QUAD 606 POWER AMP MINT	£395	S/H	£679
CLASSE AUDIO DR15 POWER AMP BALANCED MINT	£1695	S/H	£3400
CONRAD JOHNSON PREAMP 4 VALVE AMP MINT	£1795	S/H	£500
SOTA STAR SAPHIRE 3 TURNTABLE - MINT	£995	E/D	£2500
MARK LEVINSON ML7 PREAMP - MINT	£1995	S/H	£5800
NRS A20 IS STEREO AMP 200W CLASS A - MINT	£2995	S/H	£6600
AUDIO PLAN KONTRAST 2 SPEAKERS ROSEWOOD - MINT	£1295	S/H	£2800
SUNHO ARIA PANEL SPEAKERS OAK VGC	£795	S/H	£3000
GENESIS 8300 SPEAKERS & STANDS PIANO BLACK - MINT	£995	E/D	£1895
MERIDIAN 204 TUNER - MINT	£395	E/D	£695
BURMEISTER 838 PHONO STAGE BALANCED - MINT	£495	S/H	£1500
DYNAUDIO KRAFT SPEAKERS & STANDS V.G.C.	£1295	S/H	£2720
VESTROVIC A1 VALVE MONO AMPS BALANCED - MINT	£1595	S/H	£6670
MARK LEVINSON ML2 REFERENCE MONO AMPS	£3750	S/H	£19000
DYNAUDIO CONSEQUENCE MK2 SPEAKERS FINISHED IN CHERRYWOOD			
LOOKS & PERFORMANCE	£9250	E/D	£15275
CONRAD JOHNSON SYTHESIS REFERENCE 4 TOWER SPEAKERS			
SYSTEM FINISHED IN OAK	£2995	S/H	£8000
DUNTECH CROWN PRINCE SPEAKERS BLACK VGC	£2500	S/H	£6500
APOGEE MINI GRAND OS SPEAKERS PIANO BLACK MINT	£4900	S/H	£8995
"ODDLES OF HIGH END CARTRIDGES AVAILABLE RING FOR DETAILS" MANY MORE ITEMS IN STOCK, EFFICIENT SERVICING DEPARTMENT. WE ARE LOCATED IN WELWYN, HERTS			
ALL ITEMS GUARANTEED - ALL MAJOR CREDIT CARDS ACCEPTED RING FOR DETAILS AND DEMONSTRATION 01438 714038			
10.00 AM - 7.00 PM MON - SAT 10.00 AM - 1.00 PM SUN			
Mobile Tel. 0831 250985			

BRAND NEW ATOC9 cartridges £180. Naim NAC 42.5 NAP 90 £450. Deltac DPA 50S pre amp three box set mint cond £800. Heybrook HB1s brand new sealed box £220
Tel: Jules 01792 280 061

TANNOY 609 Mk I loudspeakers with fitted Atacama stands £170; also NAD monitor series 5000 CD player £110. All boxed as new
Tel: 01543 274 674 (Birmingham area)

AUDION 300B SE Stereo, Silver Night, power amplifier, immaculate, genuine reason for sale, bargain at £695. Rose RV23 valve pre-amp, excellent £350, Dynaco SCA 35 valve integrated with the original instruction book £180
Tel: 0171 281 1208 eves

EPOS ES11 loudspeakers, with stands £250. Naim 32 pre-amp (choice of phono boards) £150. Mission 774 tonearm, on Linn LP12 arm board £45
Tel: 0113 279 1337 (Leeds)

KOETSU URUSHI immaculate accept £1100 o.n.o. Koetsu Black unused, accept £300 o.n.o. Michell Transcription Reference with SME III's - pristine accept £375 o.n.o. Meridian 103Ds with pre-amp only £275 o.n.o. Sonus Faber Electas unused £1100 o.n.o. Philips 37" home cinema immaculate £1250 o.n.o.
Tel: 01280 824 517

CELESTION 7 MkII speakers excellent budget speaker. See What Hi-Fi and Hi-Fi News buyers guides. £240. 5 months ago, still under warranty £140. Also Target stands £20
Tel: 01780 64149 (Stamford Lincs)

AUDIONOTE OTO integrated valve amplifier, push pull version, excellent first valve amp, perfect condition, boxed £650. Naim NAT101 FM analogue tuner, it's weird but works brilliantly £350
Tel: 01730 263 473

TRIANGLE ALCANTE floorstanding speakers 91dB sensitivity, Audio Note silver wired internally. Big fluid sound, a perfect valve match. Would cost £1600 new, asking £799
Tel: 01296 437 314 eves (Aylesbury)

REGA PLANAR 3 turntable £150. NAD 3020E amp £150. Denon DRM07 cassette deck £50. Yamaha T09 tuner £35. All items boxed in mint condition
Tel: 01708 523 545 anytime

AUDIO RESEARCH SP8 valve pre-amp £550. Yamaha NS-1000 speakers plus stands £600. Yamaha CT7000 classic tuner £350. Sonc Frontiers Golden arm plus spare valves (£3000) £995. Gold Gyrodec plus Southern Parallel tracking arm (£1700) £500
Tel: 01386 446 756

LINN KABER passive loudspeakers. Black. 4 years old, little use. Boxed. £525
Tel: 01785 850 535

BRAND NEW AUDIO Technica OC9s £180. Quad 34/606 mint cond £670. DPA Little Bit MkIII new £285. Naim 42.5 NAP 90 £450. Roxsan Xerses T.T. Artimix Shiraz mint cond £1200
Tel: Jules 01792 280 061

TUBE TECHNOLOGY Genesis monoblocks 100 wpc, recently serviced, re-valved with gold standard Gold Aero tubes, new black grilles, boxed, guarantee 7 years, Warm powerful open sound, excellent condition £1600
Tel: 0181 309 5644

SONUS FABER Minima Amators with Target R/3 stands £1100. Musical Fidelity A1000 amplifier £780. Linn Trampoline Base £70
Tel: Richard 0171 586 2390 eves/w/ends or ansaphone

WANTED: AUDIOLAB 8000P power amplifier, must be in good condition
Tel: 01491 825 534 (evenings)

FULL RANGE Ribbons, floor standing speaker panels, Hi Fi Liner Field Transducers III, H-56" x W-26" x D-2". Cost £5000. Will sell for £2350. Poss p/x W.H.Y.
Tel: 01843 850 263

NOTTINGHAM Space Acoustics analogue record deck, Nottingham pick up with Mission 773 m/c cartridge. Mint condition, worth £2000, will sell for £1000. Poss p/x W.H.Y.
Tel: 01843 850 263

CHRIS ROGERS PRO 9 transmission line speaker £250, willing to part exchange or swap. KEF Concertos nice condition £120 o.n.o.. Rega RB250 arm £40, Pioneer A400 boxed etc £150, AR60 amp £75, Stax Lambda Pro, SR6 energiser £300
Tel: 0114 273 8153 or 0114 272 3621

CELEF DOMESTIC 2 speakers, Teak veneer finish, Seas drive units, mint condition, boxed c/w 16" Partington open frame stands £90
Tel: Mark 01543 414 936 (Staffs)

ELITE ROCK, EXCALIBUR, Merlin, Seismic. Totally serviced, upgraded, valeted by Townshend. Extras, armboards, spare power supply, silicone clamps, outriggers, mint, hardly used. £895 the lot. Ortofon MC7500 5 hrs use £895. Both £1450
Tel: 01482 842 740

NAIM AUDIO Active system, NAC 72 £395, Naxo 2-4 £250, Hi Cap £325 (2 No.), NAP 250 £750 (2 No.) SBLs £850, can demonstrate.
Tel: 01734 588 251

WORLD AUDIO DESIGN phono stage with passive preamp and power supply £200. Clearaudio battery powered phono preamp £100, Neat Petite speakers on Atacama SE24 stands £400
Tel: 01244 660 946

TECHNICS ST-G90L tuner, excellent sound, sensitivity and selectivity, ideal for difficult reception areas £150 o.n.o. Can demonstrate in high quality system. Drive units and crossovers for TDL Studio 2 £25 o.n.o.
Tel: 01962 851 802

QUAD ESL-63 mint condition £1150 (£2860) C R Developments Kalypso valve amp beautiful mirror finish, exceptional performance & value, as new £369 (£535) Audio Note ANJ/D speakers, superlative sound, superb with valves £449 (£899)
Tel: 0181 372 2584

B&W MODEL 70 speakers. Teak, Bass units rebuilt by B&W 1990, 701 Electrostatic units in excellent condition. Ideally suited to classical music. Will demonstrate £200
Tel: 0117 924 3210 after 9pm

VPI TNT superb, ring. CAT 5L1 preamp superb. Just serviced. £2295. Musical Fidelity 370.2 amplifier £895. Revox B77.2 4 track Dolby mint boxed £725. Quad FM4 tuner, boxed £200. Leak Troughline Paravicini decoder superb £300. Voyd Valdi split phase PSU, Lexan Platter, Tabriz. Superb £695. Linn Klyde 20 hours use mint boxed £200. Denon 3300, SME 3009, Denon Superb £295. Wanted: Nakamachi Dragon amplifier, Koetsu cartridge
Tel: 01747 853 372 (Shaftesbury, Dorset)

KEF REFERENCE 104/2 floorstanding speakers in rosewood, excellent condition £1700 new. Accept £750
Tel: 01903 716 275 (West Sussex)

QUAD ELECTROSTATIC speakers, Leak Troughline II tuner & Tim de Paravicini de-coder.
Tel: 01299 402 022

GARRARD 301 Leak Variscope control TL12+ power amplifier, custom Oak cabinet with matching enclosure containing Goodmans Axiom 201; Offers. Also numerous technical reports, articles for early Hi-Fi equipment
Tel: 01842 812 895

ELS 57s BRONZE, completely re-built by Quad this year, new covers, original wooden feet and 15" Quadropod stands. Reluctant sale £550.
Tel: 01865 63160

WANTED NAIM ARO ARM - may consider with Sondek. Wanted Naim CDS/CD1 - CD player. Wanted: Naim 250 - old type. For sale: Naim SBL new factory matched units complete with crossovers £885
Tel: 019 242 74887 day or 019 242 71043 eves

SWISS REFERENCE power amplifier, dual mono, 100 wpc, cost £4400 in 1990. Rolex quality, mint condition. Fault on one channel will cost £250 to repair. Service manual provided £600
Tel: 0181 883 5618

MERIDIAN 602 transport 606 DAC £1395, 201 MkIII pre, 209, £450. 204 tuner £375. Both latest specification. 206B £375, 263 DAC £275. 555 amp £400. Michealson Audio Chronos valve pre/psu (Hi-Fi News Feb 91) £1395, Linn Theta tuner £200, EAR 834P £300, VPI TNT III offers on p/sex
Tel: 01734 313 032

PENTACHORD SPEAKERS and stands with passive subwoofer and active crossover cost £1100 accept £400. Naim preamp 100 poweramp Avondale 3 channel power supply £400
Tel: 01803 297 891 (Devon)

ROKSAN XERKES Rega RB300 arm Linn K9 cartridge. Excellent condition, boxed £500 o.n.o.
Tel: 01223 510 453 (Cambridge)

EXPOSURE XX amplifier £295. Marantz CD-65IIE £75. Arcam Black Box (with TDA 1541A/N2/S1 converter chip) £60. Pioneer TX301 FM tuner £25. DAC in the Box £100
Tel: 01734 473 266 (Reading)

NAIM NAC82 pre-amp, 7 months old £1390, HiCap £450, both new style, boxed and in mint condition. Mission 770 MkII, vgc £110, Target stands (suit Missions) £40 (cost £113)
Tel: 01622 820 716

WANTED: NAIM CDI and Naim amps (new style) plus Ruark Talisman II speakers. Must be vgc. Collection can be arranged
Tel: 01705 788 694

TANNOY III L2s (Gold units) £165, Tandberg TCD310 cassette deck (poss attention required) £30; Armstrong 625 FM tuner £25. £200 the lot. WANTED: Mordant Short 442 loudspeakers
Tel: 01452 750 242 (Glos)

LP12 VALHALLA/Basik Plus/Ortofon S10 £249, NVA three box pre-power £299. Linn Intek £199. Arcam 170/Balck box £349. Beyer DT 311s £20. Mostly mint, boxed, swaps! p/x?
Tel: 0191 414 1852

LINN LP12/Lingo/ARO/Troika (Cartridge under 100 hrs use). Naim 32-5 (72spec)/HiCap/250. NAT101 tuner / Snaps. EPOS ES11 + Foundation stands + NACS bi-wired cables. Little used. Boxed. Superb condition £2500
Tel: 0121 453 4023

Impulse H6 loudspeakers. Latest spec (pre Lal) approx 60 hrs use £850. Also PLA45D record deck. Good condition. Sitting in the attic for 5 years! £50
Tel: 01628 476 836

PHILIPS CD850 MkII bitstream player. Excellent condition. Boxed with instructions Cost £400 Sell £175
Tel: 01275 835 172 after 7pm

BOWERS & WILKINS Series P2/H updated monitor loudspeakers £450. Tandberg series 6X tape recorder £150. Garrard 201 turntable with Rothermel arm in original J + A Margolin 'Plus-A-Gram' cabinet £75
Tel: 0171 435 4177

AUDIOLAB 8000A II integrated amplifier in excellent (as new) condition. Purchased Oct 1993, boxed with mains lead £295
Tel: 01369 703077

MUSICAL FIDELITY complete Audiophile Amplification. 2 P180 stereo power amps, switchable for mono block application 160w., 2 external power supplies. Choke regulated power supply. P173 pre amp with separate power supply. Solid state dependability with traditional Antony Michaelson valve sound. Mint £1500
Tel: 01785 850 535

TOWNSHEND ELITE Rock Rega RB 300 Decca Gold Pod. Townshend Merlin power supply. All in mint condition. Offers invited.
Tel: 01707 372 652

G.E.C. KT88 Gold Lion valves very limited supply. Mullard CV1377 (Mil Spez GZ34) Audio Innovations 2nd Audio Monoblocks 51000 pre, 51000 transformer, Audioplann Konzepts, Era turntable. Wanted Lowther speakers.
Tel: 01642 559 543

NAIM 72 pre-amp and 140 power amp 10 months old as new, boxed, plus cables. Cost £1300 - sell for £800.
Tel: 01753 554 635 eves/w/ends (Slough)

RADFORD SC22+STA25/3 £600. STA25/3 £450. Leak: ST-50 £450, ST-20 £250, TL-12+ 2xVarislope/3 mint £500. 3xTL-10.1 3xpreamps £400. Troughline/3: Mono £80, Stereo £130. Mullard 4xEL-37(KT-66) £140
Tel: 0171 372 3724

ROGERS EXPORT Monitors £175 Lowther PM-6 Acoustas £350. Quad 33/303/FM3, £250 2xELS Bronze £290. Garrard 401 chassis £140. Mission 774LC arm £40. Sugden A-48 £145. 2 off C-51/P-51 £185 each. T-51 tuner £95
Tel: 0171 372 3724

WANTED: Goodmans 12" Axiom 300. 8" Axiette 3 ohms. Thomson Houston 18" dual concentric. Pair Tannoy x-overs. Quad II near Ser.No. 2727. Leak TL-10. Leak TL 12.1. SME 3012
Tel: 0171 372 3734

BURMESTER 785A preamp, Black £645. Nakamichi 620 poweramp 2x100Wrms £345. Technics SL-110/SME III/Eroica £345. Rogers LS-6, Black £275 pair. JBL L-100 Century £395 pair. Yamaha NS-1000M monitors £550 pair. Quad FM4 £250
Tel: 0171 625 8966

HEALS CABINETS For wall mounting Quad valve systems £70. Matching cabinet with Thorens TD-124/Shure M212 arm £230. Sugden Connoisseur Craftsman 3 turntable chassis £70. KEF Kantor ultra slim 2 way £75 pair
Tel: 0171 625 8966

definitive audio nottingham quality and integrity

Tel/Fax +44 (0)115 9813562

DEFINITIVE AUDIO has a formidable, worldwide reputation for achieving sound quality benchmarks. A reputation earned by the consistent and intelligent application of it's holistic, system based approach.

Experienced audio journalists have described our systems as:- "Good enough to represent the country" (HiFi Choice, Nov 95) and "so real it makes a mockery of conventional stereo." (Jon Kettle, Audiophile Feb. 93) "A sense of shape and substance to music that usually only live performances achieve" (Jason Kennedy, HiFi Choice April 95). One of our modest systems was described as 'Sobering', with "an uncanny ability to suck you into the musical experience" (Paul Messenger HiFi Choice Aug 95).

These comments speak volumes for the depth and breadth of experience we offer. Whether you are a first time buyer or seasoned audiophile your contact with us will prove both rewarding and stimulating. You will also find our back up and service second to none.

DEFINITIVE AUDIO is situated 20 minutes from East Midlands International Airport and junction 24 - M1.

Deliveries nationwide and worldwide. VISA/MASTERCARD/AMEX

Living Voice. Horning. Dali. Audio Innovations. Monarchy Audio. Wadia. Audio Alchemy. XLO. Impulse. Systemdek. Micromega. Klyne. Wilson Benesh. Lyra. Stax. EMT. SME. SATI. Border Patrol. Goldring. Lowther. Vitavox. JBL. Ortofon. (inc SPU Gold Reference) Yamaha. Pioneer.... and other selected agencies.

Second hand/sale items. (Deliveries nationwide/worldwide. Prices excl. carriage).

	Import/Export	
	SALE	RRP
SME Series V	£790 inc. full warranty	£1250
SME Model 220 Boxed, unopened, unused current spec	£2755 inc. full warranty	£3240
Micromega Duo CD2 Transport	£1375 inc. full warranty	£2750
Micromega Duo Pro DAC	£1500 inc. full warranty	£700
Stax Lambda Nova Sig. Pro Headphone new	£380 inc. full warranty	£450
Snell All Loudspeaker system.		
Mahogany Boxed	£1750	£4500
Snell JII Loudspeaker system.Walnut	£450	£800
Audio Innovations S500 x 2 full warranty	£500/600	£1200
Audio Innovations S800 Mk.I Stereo	£450 inc. full warranty	—
Audio Innovations S1000 Silver		
Passive Pre	£270 inc. full warranty	£150
Rega RB300 Tonearm. Boxed.	£95 inc. full warranty	£140
Helius Scorpio II	£75	£190
Helius Scorpio I	£50	£150
Audio Note ANB Speaker cable 4 metre bi-wireset	£150	£304
Audio Note ANV silver i/c .4 metre/.7metre/.9 metre	POA	—
NVA mc. phono stage	£100	—
Rogers FM Valve tuner. Needs attention	£35	—
Impulse H5 Ash	£1400 inc. full warranty	£1850
Various I/C cables and EQ. supports to clear	POA	—
Pink Triangle Anniversary turntable current spec. Ash	£800	£1750

Lowther drive units and cabinet drawings available from stock.

Phone or fax direct +44 (0)1159-813562



V' audio

Hi-Fi Consultants

Ian C. Vaudin
36 Druid Hill, Stoke Bishop,
Bristol BS9 1EJ
Tel/Fax: Bristol
(0117) 9686005

MYRIAD OF MINIS

Strictly speaking myriad means tens of thousands, so

I am exaggerating somewhat, but it came to mind because of a new integrated amp we have just evaluated, by a company called Myriad whose MI 120 remote controlled amp was launched at the London Sound & Vision Show last month. As you can see from the picture this is a very nice looking amplifier for only £530, and offers 60 Watts/CH. It's not just that I am lazy, but I do find a remote volume control a tremendous bonus, especially as the equipment is usually at the other end of the room from where I sit. Particularly with classical music, it is not always easy to get the volume right and if you don't wish to disturb neighbours, it's handy to be able to turn down those climaxes! This is one of the reasons why we invariably use the R/C AV1 pre-amp, apart from the fact that it's one of the best we know anyway. Customers buy the AV1 integrated simply because it has R/C, when other fine amps are cheaper but haven't got R/C. So it's nice to welcome the Myriad, which looks good, sounds good, is cheaper than the AV1 and has an

optional phono stage and pre-amp outputs to bi-amp with the MA120 power amp (not yet available) and there are CD player, pre/power amps, tuner and 250W power amps on the way.

So with the above amp, the AV1 Shearne Phase II, Heybrook Integra, Triangle TE60, and Electrocompaniet EC1-2, we have quite a range of excellent integrated amps, which sound best with our equally excellent range of small speakers, you must decide for yourself. But with the exciting new Electrocompaniet Qube (amazing for a first speaker from an amplifier manufacturer) and the Alon Petite (the first box speaker from Alon), to add to our existing range of ATC SCM 10, AE1, Triangle Titus and Comete, and Jamo Cornet 30/40 (still amazing for around £100). We can produce some really big sounds from such small items. Of course you need a good stand to allow these speakers to perform at their best and we recommend the Foundation Apprentice and Designer 23" stands; they may not be cheap but are as vital to the sound as using good interconnects and speaker cable. We also will be stocking the stands unique equipment stands and speaker stand, but haven't yet heard how the latter sounds. More next time.



SUGDEN

HAND CRAFTED ■ FAIT À LA MAIN

DESIGNERS & MANUFACTURERS OF HI-FI & AUDIO EQUIPMENT

J. E. SUGDEN & CO. LTD.

Valley Works,

Station Lane, Heckmondwike,

West Yorkshire WF16 0NF

Tel. Heckmondwike 01924 404088/9

Fax No. 01924 410069

MISSION

75^{centre}

1 9 8 5

HOME ENTERTAINMENT
awards

WINNER

MISSION 75C • Best Centre Speaker



Mission Group, Huntingdon. PE18 6ED Tel: 01480 451777 Fax: 01480 432777