



APR. 1966

Radio-^{INC}Electronics

TELEVISION • SERVICING • HIGH FIDELITY

HUGO GERNSBACK, Editor-in-chief

A
GERNSBACK
PUBLICATION

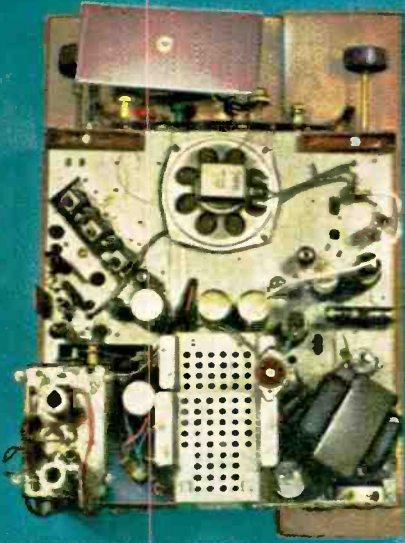

REPAIR TV's
fast with the WHATSIT!

CONTROL

high power
with SCR's!

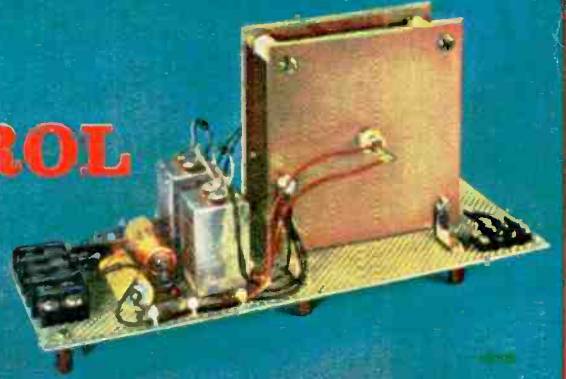

BUILD
a self-balancing
transistor voltmeter!

ENJOY

talking on a
light beam!

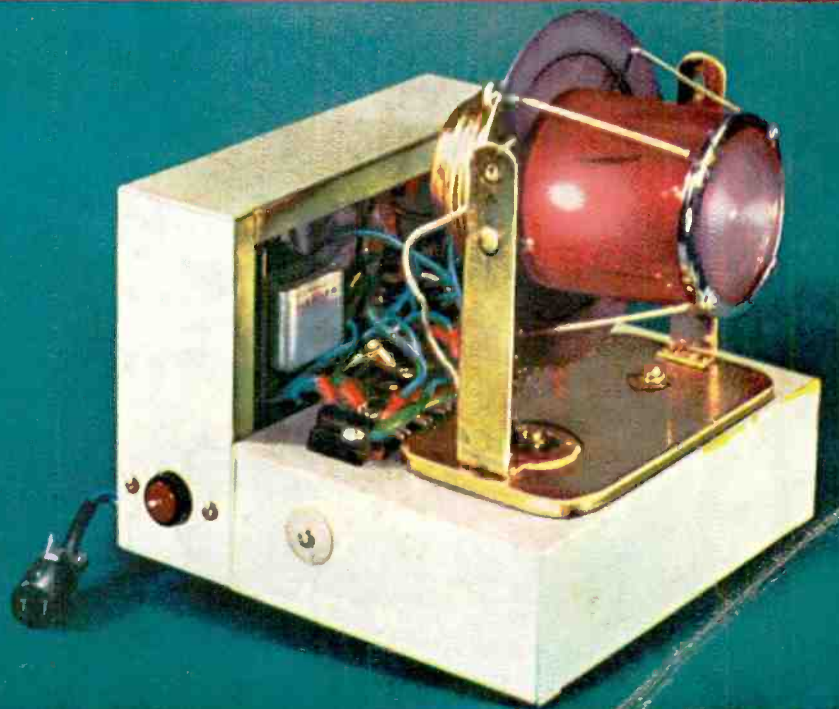

**WORLD'S LARGEST SELLING
AND WORLD'S NEWEST**

Hand Size v-o-m's

TRIPLET

MODEL 310-C
World's Newest
Volt-Ohm-Milliammeter

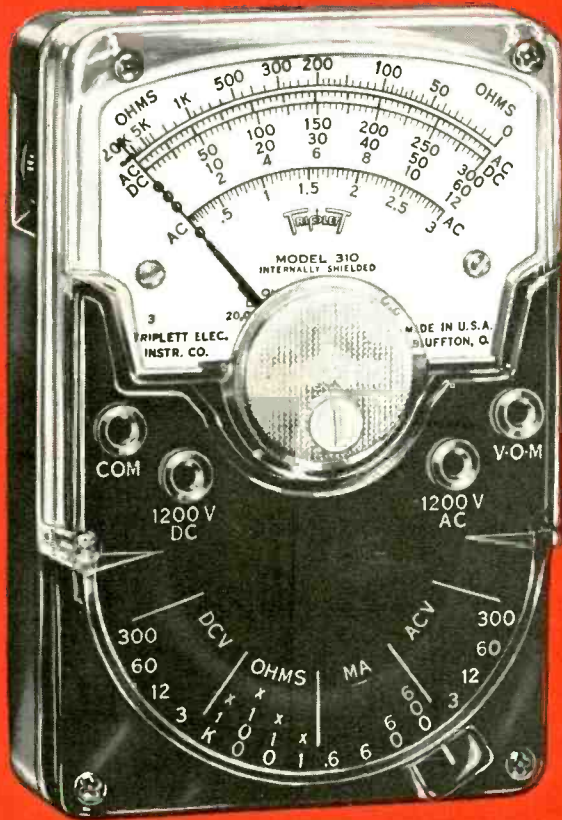

MODEL 310
World's Largest Selling
Volt-Ohm-Milliammeter

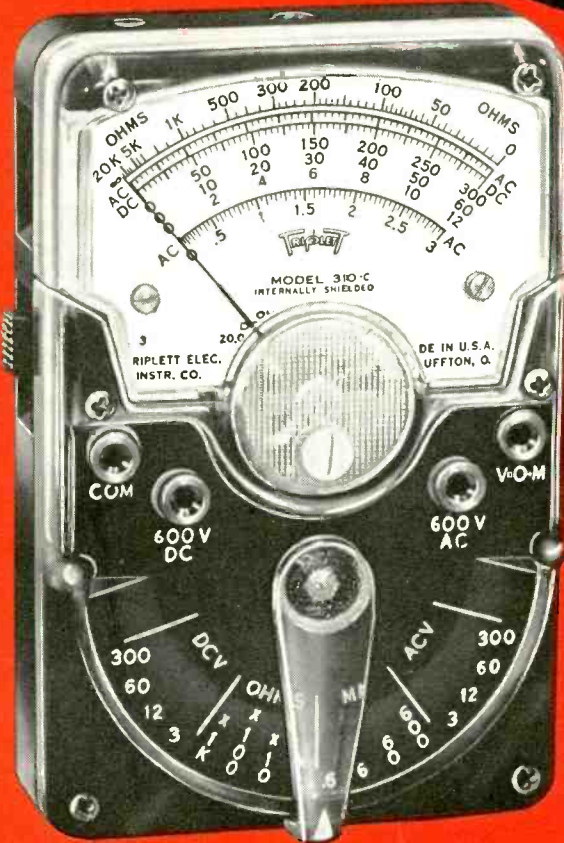

**BOTH TESTERS
SHOWN
ACTUAL SIZE**

- 1** HAND SIZE AND LIGHTWEIGHT, but with the features of full-size V-O-M's.
- 2** 20,000 OHMS PER VOLT DC; 5,000 AC (310)—15,000 AC (310-C).
- 3** EXCLUSIVE SINGLE SELECTOR SWITCH speeds circuit and range settings. The first miniature V-O-M's with this exclusive feature for quick, fool-proof selection of all ranges.

SELF-SHIELDED Bar-Ring instrument; permits checking in strong magnetic fields. FITTING INTERCHANGEABLE test prod tip into top of tester makes it the common probe, thereby freeing one hand. UNBREAKABLE plastic meter window. BANANA-TYPE JACKS—positive connection and long life.

Model 310—\$40.00 Model 310-C—\$50.00 Model 369 Leather Case—\$3.50

ALL PRICES ARE SUGGESTED U.S.A. USER NET, SUBJECT TO CHANGE

THE TRIPLET ELECTRICAL INSTRUMENT COMPANY, BLUFFTON, OHIO

Circle 7 on reader's service card

310-C PLUS FEATURES

1. Fully enclosed lever range switch
2. 15,000 Ohms per volt AC (20,000 O/V DC same as 310)
3. Reversing switch for DC measurements

MODELS 100 AND 100-C

Comprehensive test sets. Model 100 includes: Model 310 V-O-M, Model 10 Clamp-on Ammeter Adapter; Model 101 Line Separator; Model 379 Leather Case; Model 311 leads. (\$73.50 Value Separate Unit Purchase Price.)

MODEL 100—U.S.A. User Net. \$70.00
MODEL 100-C — Same as above, but with Model 310-C. Net.\$80.00



USES UNLIMITED: FIELD ENGINEERS • ELECTRICAL, RADIO, TV, AND APPLIANCE SERVICEMEN • ELECTRICAL CONTRACTORS • FACTORY MAINTENANCE MEN • ELECTRONIC TECHNICIANS • HOME OWNERS, HOBBYISTS
THE WORLD'S MOST COMPLETE LINE OF V-O-M's • AVAILABLE FROM YOUR TRIPLET DISTRIBUTOR'S STOCK

If the Electro-Voice Model 664 picks up sound here...

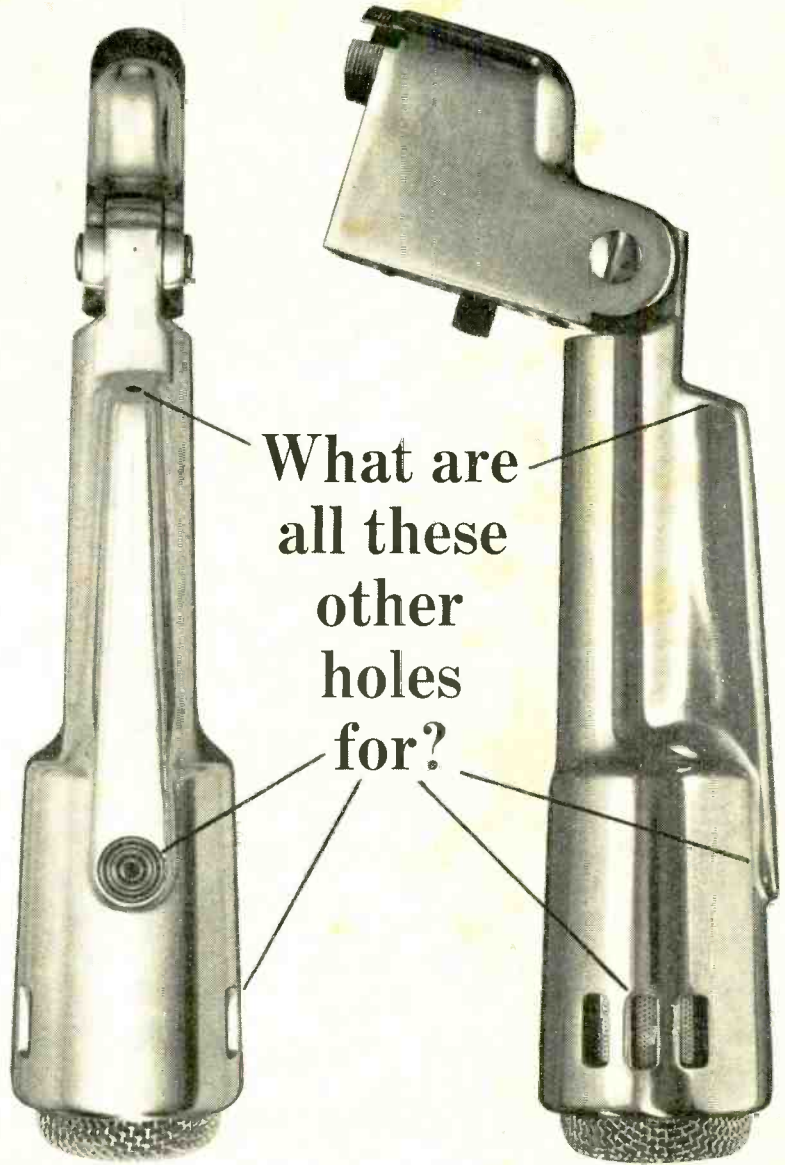
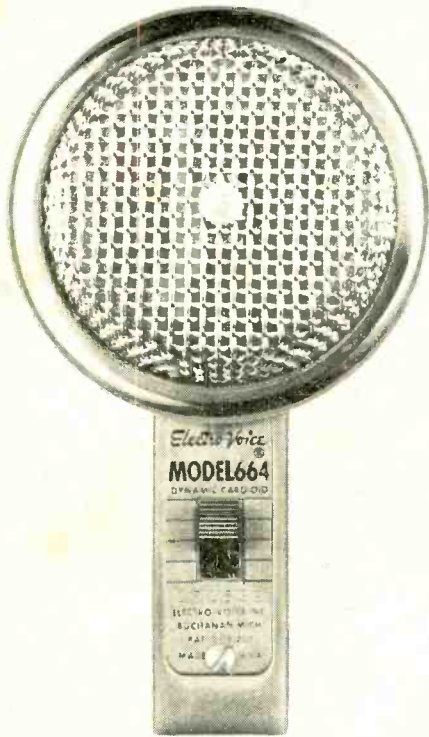

What are
all these
other
holes
for?

Ⓔ The holes in the top, sides and rear of the Electro-Voice Model 664 make it one of the finest dynamic cardioid microphones you can buy. These holes reduce sound pickup at the sides, and practically cancel sound arriving from the rear. Only an Electro-Voice Variable-D[®] microphone has them.

Behind the slots on each side is a tiny acoustic "window" that leads directly to the back of the 664 Acoustalloy[®] diaphragm. The route is short, small, and designed to let only highs get through. The path is so arranged that when highs from the back of the 664 arrive, they are cut in loudness by almost 20 db. Highs arriving from the front aren't affected. Why two "windows"? So that sound rejection is uniform and symmetrical regardless of microphone placement.

The hole on top is for the mid-range. It works the same, but with a longer path and added filters to affect only the mid-frequencies. And near the rear is another hole for the lows,

with an even longer path and more filtering that delays only the bass sounds, again providing almost 20 db of cancellation of sounds arriving from the rear. This "three-way" system of ports insures that the cancellation of sound from the back is just as uniform as the pickup of sound from the front—without any loss of sensitivity. The result is uniform cardioid effectiveness at every frequency for outstanding noise and feedback control.

Most other cardioid-type microphones have a single cancellation port for all frequencies. At best, this is a compromise, and indeed, many of these "single-hole" cardioids are actually omnidirectional at one frequency or another!

In addition to high sensitivity to shock and wind noises, single-port cardioid microphones also suffer from proximity effect. As you get ultra-close, bass response rises. There's nothing you can do about this varying bass response—except use a Variable-D

microphone with multi-port design* that eliminates this problem completely.

Because it works better, the E-V 664 Dynamic Cardioid is one of the most popular directional microphones on the market. It has both high and low impedance outputs available at the plug. Frequency range is peak-free from 40 to 15,000 Hz (cps). Output is -58 db. To learn more about Variable-D microphones, write for our free booklet, "The Directional Microphone Story." Then see and try the E-V 664 at your nearby Electro-Voice microphone headquarters. Just \$85.00 in satin chrome or non-reflecting gray, or \$90.00 in gold finish (list prices less normal trade discounts).

*Pat. No. 3,115,207

ELECTRO-VOICE, INC., Dept. 462E
613 Cecil Street, Buchanan, Michigan 49107



Circle 8 on reader's service card

EDITORIAL

- 33** To Know An Editor *Forest H. Belt*

TEST INSTRUMENTS

- 44** East Side, West Side *Jim McCormick*
Build this ingenious transistor meter with its own calibration source
- 48** The Whatsit: A Sub Set for TV Service *John Fitzgibbon*
Functioning "junk" set is test source from dc to 40 MHz!
- 66** Equipment Report: EICO 369 TV/FM Sweep Generator
- 82** Continuity Tester Finds Low-Resistance Circuits *Tommy N. ...*
Those tiny 2-transistor "toy" radios are good for something!

AUDIO-HIGH FIDELITY-STEREO

- 34** Talk Over a Hi-Fi Light Beam *Virgil L. McCarty*
Simple, quick-to-build system uses parts and amplifiers you may have on hand
- 40** A Transistor "Line Transformer" *Peter E. Sutheim*
Impedance matcher with gain will feed long low-impedance lines
- 56** What Would You Do? *George D. Philpott*
Shopowner takes young benchmark aside, explains some facts of life, multiplexwise
- 67** Equipment Report: Dual 1019 Auto/Professional Turntable

RADIO

- CAREER SERIES** **36** The Two-Way Radio Technician *Jack Darr*
Investigate a field many TV men have switched to
- 53** An Afternoon at CB Repair *Charles B. Randall*
Don't miss out on profitable CB transceiver service

ELECTRONICS

- 38** High Power SCR Controls for You *Ronald L. Ives*
Put SCRs to work to replace bulky variable transformers and rheostats
- 61** Case of the Open Cathode Resistor *J. Chamkis*
Test your knowledge of basic electronics
- 57** Light-Meter Quandaries *Notes on February's "Ultra-Sensitive Light Meter"*

GENERAL

- 22** Service Clinic *Jack Darr*
- 42** Finding Buried Stuff *Cecil Beeler*
How metal locators work, and how to work with them
- 47** Equipment Report: Heath Fotoval Computer, PM-14 *Elmer Carlson*
- 50** Potentiometer Facts and Trickery *F. H. Frantz*
For a 3-terminal passive device, a pot can do some remarkable things

- 60** What's Your EQ?

TELEVISION

- 52** Tynecolor Coming, But Not Here Yet
- 58** Put 'em Up and Keep 'em Up! *Jack Darr*
Antenna towers, that is...
- 62** Inventors of Television: Boris Rosing

THE DEPARTMENTS

- | | | |
|--------------------------|--------------------------------------|-------------------------------|
| 16 Correspondence | 75 New Products | 92 Not-Worthy Circuits |
| 93 New Books | 86 New Semiconductors & Tubes | 84 Technotes |
| 81 New Literature | 4 News Briefs | 88 Try This One |
| | | 60 50 Years Ago |
- 72** Reader's Service Page



Member,
Institute of High Fidelity
Radio-Electronics
is indexed in
Applied Science
& Technology Index
(Formerly
Industrial Arts Index).

HUGO GERNSBACK, editor-in-chief. M. HARVEY GERNSBACK, publisher. FOREST BELT, editor. Robert F. Scott, W2PWG, technical editor. Peter E. Sutheim, associate editor. Jack Darr, service editor. I. Queen, editorial associate. Wm. Lyon McLaughlin, technical illustration director.

ELECTRONICS

WHERE CAN YOU EQUAL THIS OPPORTUNITY

TO EARN A GOOD PAYING JOB IN A FAST GROWING FIELD?

DeVRY'S "BIG 3" AIDS TO PROGRESS ARE DESIGNED TO SPEED YOU QUICKLY TO A REAL FUTURE IN ELECTRONICS

1. EFFECTIVE TRAINING!
Learn **AT HOME** in spare time, or day or evening in one of our **RESIDENT SCHOOLS**.

2. INDUSTRY RECOGNITION!
DeVry programs, prepared with industry's help, are **"JOB-AIMED."**

3. EMPLOYMENT SERVICE!
for **ALL** graduates through our contacts with many large, respected companies across North America.

ELECTRONICS is one field that spells OPPORTUNITY in big capital letters for many men 18 to 45. This widespread but FAST GROWING field offers trained men some of today's finest, good-paying job opportunities — or a chance to start a profitable servicing shop!

Even if you don't have previous technical experience or an advanced education, DeVry's "BIG 3" aids to progress may very well be YOUR stepping stones to a BETTER FUTURE. You can learn at home in your spare time, while keeping your present job. Or, in a day or evening program in our U.S. or Canadian resident school, you can develop the very skills needed to make wonderful progress. We even work to get resident students part-time jobs to help with tuition or living expenses, if necessary!

Regardless of how you complete your educational program with DeVry, you can count on industry-recognized, effective training aimed directly at providing on-the-job-type "know-how." This is followed by actual EMPLOYMENT SERVICE to help you get started in Electronics. Or, if you are in the field already, remember that a DeVry recommendation has meant plenty of ADDED DOLLARS in income to many who made themselves more valuable to employers.

See for yourself how you, too, may prepare for the INCOME, the PRESTIGE and the FINE FUTURE that goes with the title of Electronics Technician. Mail the coupon NOW for facts without obligation.

WE PREPARE YOU NOT FOR ONE JOB BUT FOR JOBS IN MANY DIVISIONS OF THE FASCINATING FIELD OF ELECTRONICS



SPACE & MISSILE



TV — RADIO

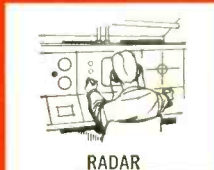

RADAR

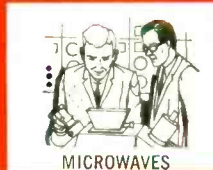

MICROWAVES



AUTOMATION



COMMUNICATIONS



COMPUTERS



BROADCASTING



INDUSTRIAL ELECTRONICS



ELECTRONIC CONTROL

MOVIES, TEXTS AND EQUIPMENT HELP YOU LEARN FASTER



DeVry includes training movies **AT HOME**, "programmed" texts and many shipments of Electronic parts — to help you learn quickly, remember more.

FREE

Send coupon for these two factual booklets NOW!



MAIL COUPON TODAY!

DeVRY TECHNICAL INSTITUTE

4141 Belmont Avenue, Chicago, Ill. 60641 Dept. RE-4-W

Please give me your two free booklets, "Pocket Guide to Real Earnings," and "Electronics in Space Travel"; also include details on how to prepare for a career in Electronics. I am interested in the following opportunity fields (check one or more):

- | | |
|--|---|
| <input type="checkbox"/> Space & Missile Electronics | <input type="checkbox"/> Communications |
| <input type="checkbox"/> Television and Radio | <input type="checkbox"/> Computers |
| <input type="checkbox"/> Microwaves | <input type="checkbox"/> Broadcasting |
| <input type="checkbox"/> Radar | <input type="checkbox"/> Industrial Electronics |
| <input type="checkbox"/> Automation Electronics | <input type="checkbox"/> Electronic Control |

Name _____ Age _____

Address _____ Apt. _____

City _____ State _____ Zip Code _____

Check here if you are under 16 years of age.

HOME STUDY AND RESIDENT SCHOOL TRAINING AVAILABLE IN CANADA

2101

DeVry Technical Institute

4141 Belmont Avenue
Chicago, Illinois 60641

Accredited Member of National Home Study Council

NEWS BRIEFS

COLOR TV TAPE RECORDER SHOWN BY SONY

A color TV tape recorder for the home was demonstrated by Sony in Tokyo, and shortly thereafter at the company's showrooms in New York City. Sony's vice president, Akio Morita, said that production for the market would not begin till the fall of 1967.

Owners of Sony black-and-white recorders can have them modified for color, Mr. Morita stated. The price of the new color recorders could not be guessed too closely, but it will be "less than twice the price of present black-and-white recorders." The new color prototype resembles the present Sony recorder very closely, not only in its appearance but in most of its specifications.

A. W. HULL DIES AT 85

The inventor of the magnetron and screen-grid tube and developer of "probably more types of vacuum tubes than any other man" died at Schenec-



tady Jan. 22. Dr. Hull had been assistant director of the General Electric Research Laboratory from 1928 until his retirement in 1949. He remained a consultant and visited the office daily till his final illness.

Dr. Hull's outstanding achievements in the vacuum-tube field also included development of the dynatron and thyratron. He was a pioneer in the analysis of crystals by X-rays, for which he received the Potts Medal from the Franklin Institute in 1923. He was the recipient of many other honors, including the Liebman Prize (1930) for his work on vacuum tubes, and the Presidential Certificate of Merit. He held 94

patents and was the author or co-author of 72 technical publications.

RADIO BILLIONS OF YEARS OLD?

Radio waves that may have originated at the creation of the universe have been picked up by scientists at Bell Labs and Princeton University. These waves come from all directions and are picked up on radar and radio-astronomy receivers. They may even be responsible for a small fraction of the noise visible on the screen of your uhf TV set.

According to a widely held theory, the universe was at one time compacted into a cosmic fireball, possibly ten times the size of our own galaxy. Some billions of years ago the fireball "exploded," in what has been called the Big Bang. Radiation emitted at that time may still be coursing through the universe.

Measurements of the intensity of this type of radiation at 7.3 and 3.2 centimeters have yielded results that fit the theoretical spectrum of radiation emitted at the time of the Big Bang. Additional measurements are being made to see whether the radiation intensity does indeed follow this theoretical spectral curve.

IEEE ISSUES TEN AWARDS

The Institute of Electrical and Electronics Engineers has announced the recipients of ten awards, five of which are major awards in the electrical and electronics field. The Medal of Honor of the IEEE went to Dr. Claude Shannon, pioneer in communications mathematics; the Edison Medal to Dr. Wilmer L. Barrow, Sperry Gyroscope Co.; the Founders Award to Dr. Elmer Engstrom of RCA, leading developer of color television, and the Lamme Medal Award to Rene Andre Baudry, Westinghouse consultant in Paris, France, for "significant contributions to the design of large electric generators."

The Education Medal was awarded to Dr. William H. Huggins of Johns Hopkins University; the Harry Diamond Memorial Award to John J. Egli of the U.S. Army Electronics Command; the Vladimir Zworykin Award to Ray Davis Kell of RCA Laboratories in Princeton, and the W. R. G. Baker Prize Award to Robert Gallager of the Massachusetts Institute of Technology. The Browder J. Thompson Memorial Prize, given for the best paper in an IEEE publication by an author under

the age of 30, went to Kenneth M. Johnson of Sylvania Electronics Systems, and the Institute Student Prize to Roy Schwartz, Bronx, and Robert Spindel, Jamaica, N. Y., for their paper entitled "Design of an Instantaneous Display Correlator."

NEW COMMUNICATIONS LASER IS POWERED BY SUNLIGHT



The experimental sun-pumped laser, as used to transmit television pictures over a light beam in its first experimental use. RCA physicist Richard J. Tarzaïski is seen reflected in the parabolic mirror as he adjusts the equipment.

The first step toward a 50-million-mile communications link between space craft and earth was announced by RCA. The device is a "sun-pumped" laser—a communications laser that takes its only power from the sun.

Sunlight is concentrated by a 31-inch parabolic mirror. The rest of the equipment consists of the laser (a double-doped yttrium aluminum garnet [YAG] crystal type), a modulator, optical elements and an optical receiver. The equipment is installed on an equatorial mount so that it tracks the sun automatically, and the sun's rays will be continually reflected from the mirror onto the laser. It is expected that the laser will make it possible to communicate between spacecraft in the vicinity of Mars and ground stations on earth.

U. S. ENGINEERS FORM TECHNICAL PEACE CORPS

A group of American engineers have banded together in an association

RADIO-ELECTRONICS

A New Electronic Slide Rule with Instruction Course

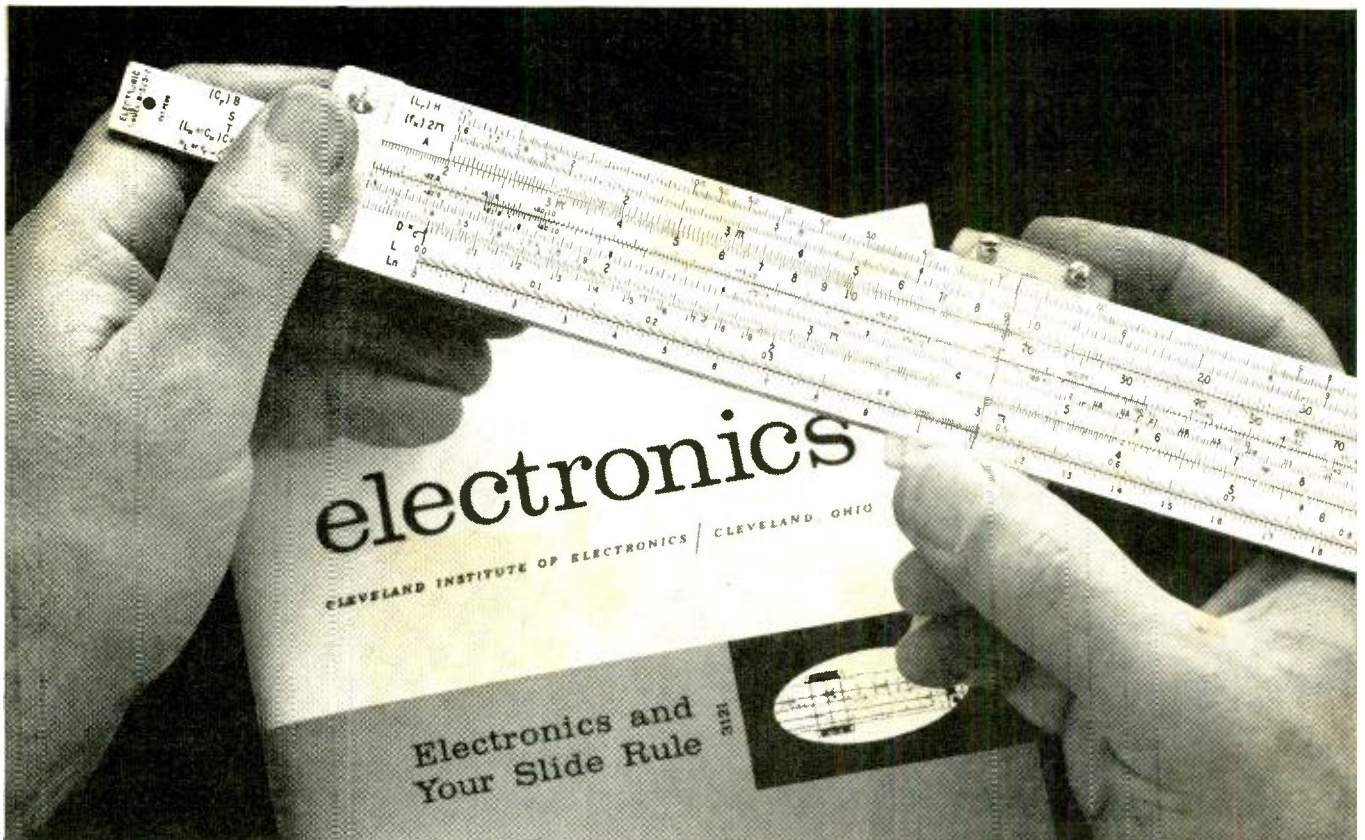

Why didn't someone think of this before?

Here's a great *new* way to solve electronic problems accurately . . . easily. The Cleveland Institute Electronics Slide Rule* is the only rule designed specifically for the exacting requirements of electronics computation. It comes complete with an illustrated Instruction Course consisting of four AUTO-PROGRAMMED* lessons . . . each with a short quiz you can send in for grading and consultation by CIE's expert instructors. With this personal guidance, you'll soon be solving complex electronics problems in seconds while others still struggle along with pad and pencil.

Here's what Mr. Joseph J. DeFrance, Head of the Electrical Technology Dept., New York City Community College, has to say about it:

"I was very intrigued by the 'quickie' electronics problem solutions. It is an ingenious technique. The special scales should be of decided value to any technician, engineer, or student. The CIE slide rule is a natural."

See for yourself. Learn how to whip through all kinds of reactance, resonance, inductance, AC and DC circuitry problems in seconds . . . become a whiz at conventional computations too!

This all-metal 10" rule is made to our tough specs by Pickett, Inc. . . . comes complete with top grain leather carrying case *and* Instruction Course. A \$50 value for less than \$20. Send coupon for FREE illustrated booklet *and* FREE Pocket Electronics Data Guide. Cleveland Institute of Electronics, 1776 E. 17th St., Dept. RE-121, Cleveland, Ohio 44114.

*TRADEMARK

GET BOTH FREE!

ELECTRONICS SLIDE RULE

Send coupon today →

Cleveland Institute of Electronics

1776 E. 17th St., Dept. RE-121 • Cleveland, Ohio 44114

Please send FREE Electronics Slide Rule Booklet.
SPECIAL BONUS: Mail coupon promptly . . . get FREE Pocket Electronics Data Guide too!

Name _____ (Please Print)

Address _____ County _____

City _____ State _____ Zip _____

A leader in Electronics Training . . . since 1934

Circle 10 on reader's service card

NEWS BRIEFS continued

called the Volunteers for International Technical Assistance (VITA). Its purpose is to enlist the technical community to help solve the problems of developing nations.

VITA is firmly convinced that a successful technical assistance program must spring from needs that are seen on the spot in the developing countries. It seeks therefore to work in direct partnership with individuals and groups in those countries. Most of this assistance consists of free technical advice or solutions to technical problems

sent to VITA's head office by the Peace Corps, the American Friends Service Committee and by UN Technical Assistance workers.

All members donate their time and services in the conviction that enduring peace can be achieved only by eliminating great disparities between the living standards of the various nations of the world. VITA is interested in recruiting American scientists and engineers in this work. For information on how you can use your engineering ability to aid developing nations without going overseas, write to Benjamin Coe, VITA, 230 State St., Schenectady, N. Y.

RUSSIAN "INVENTOR OF TV" DIES

Boris Grabovsky, credited by the Russians with being the first person to transmit TV, died at the age of 85, according to a Ukrainian newspaper. Grabovsky sent pictures by wireless on July 26, 1928, from a camera to a receiver 40 yards away in Tashkent, Uzbekistan. (Boris Rosing's experiments were strictly closed-circuit TV, with the receiver's synchronism controlled directly from the transmitter.)

Other countries will dispute the Russians' claim of an absolute first. Experimental work by Baird in England and Jenkins, Alexanderson, and the Bell Laboratories in the United States was considerably earlier. Baird had, in fact, actually succeeded in transmitting television pictures that were received across the Atlantic by February 1928. One of the "first" dates in the United States was April 27, 1927, when a TV transmission took place from Whippany, N.J., to Bell Labs in New York City—a distance of 30 miles.

In August, 1928, Hugo Gernsback initiated a regular scheduled daily television program from his station WRNY, New York.

N. J. COURT SAYS HUSBAND CAN CONTROL OWN TV

A New Jersey judge has firmly established the right of a husband to adjust the volume of the domestic TV set, and further to enforce his right with the rabbit ears, if necessary. Mrs. Erika Weckenmann, Paterson, N. J., charged her husband with assault and battery, claiming that he turned the set down twice after she'd turned it up. Finally, she said, he broke an indoor antenna over her head. Her husband claimed that she had attacked him.

After hearing both sides, the judge
Continued on page 12

Jackson ... IT'S THE FINEST

Ask

30,000 servicemen
what they think
about their
Model 648
DYNAMIC
TUBE TESTER

IF IT'S A JACKSON...IT'S THE FINEST

IF IT'S A JACKSON...IT'S THE FINEST

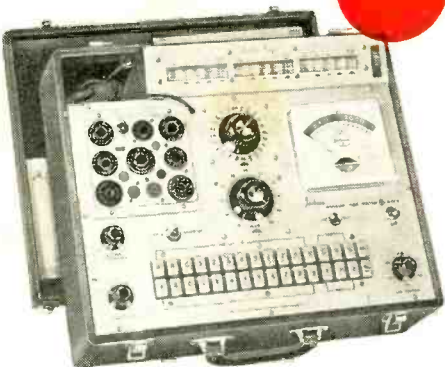

**Model 648-1
DYNAMIC TUBE TESTER \$179⁹⁵_{Net}**

Check all the Model 648-1 features at your Jackson distributor, or write for catalog

JACKSON ELECTRICAL INSTRUMENT COMPANY

35 Windsor Avenue, Mineola, New York 11501

In Canada: William Cohen Corp.
Export: Morhan Exporting Corporation
458 Broadway, New York 13, N. Y.

IF IT'S A JACKSON...IT'S THE FINEST

Circle 11 on reader's service card

Over 30,000 Model 648 Tube Tester owners are Jackson's greatest boosters. They speak with authority, because they have used the Model 648 right in the field and found it provides more accurate checking of all tube types. *It's a fact!* Thousands of Model 648s are providing more years of service than any other tube testers in its price class as it is completely versatile for all new and old tube types. Jackson engineers have designed the tube socket layout to simplify changing, thereby practically eliminating obsolescence. Model 648 owners particularly appreciate the exclusive color keyed panel and push-button sequence switching which makes set-up time less than warm-up time... the angled view zig-zag exclusive color-coded roll chart conveniently located on upper part of panel. Why not put the Model 648-1 to work now? You too will become its greatest booster.

RADIO-ELECTRONICS is published by Gernsback Publications, Inc. Chairman of the Board: Hugo Gernsback President: M. Harvey Gernsback Vice President-Secretary: G. Aliquo Vice President-Treasurer: Charles A. Raible Editorial, Advertising, Subscription and Executive offices: 154 West 14th Street, New York 10011. Subscribers: When requesting change of address please furnish an address label from a recent issue. Allow one month for change of address. ADVERTISING REPRESENTATIVES: East: John J. Lamson, Eastern Sales Manager. RADIO-ELECTRONICS, 154 West 14th Street, New York 10011, 212 AL 5-7755; Midwest: P. H. Dempers Co., 5555 N. Lincoln Ave., Chicago, Illinois, 60611, 213 561-0220; South Central: Media Representatives, Inc., 7900 Carpenter Freeway, Dallas, Texas 75247, 214 ME 1-4480; West Coast: J. E. Publishers' Representative Co., 8380 Melrose Avenue, Los Angeles, California, 90069, 213-653-5841; 420 Market Street, San Francisco, California, 94111, 415-981-4527; United Kingdom: Publishing & Distributing Co., Ltd., Mitre House, 177 Regent St., London W.1, England.

SONY[®]

CAPTURES THE TOTAL DIMENSION OF SOUND

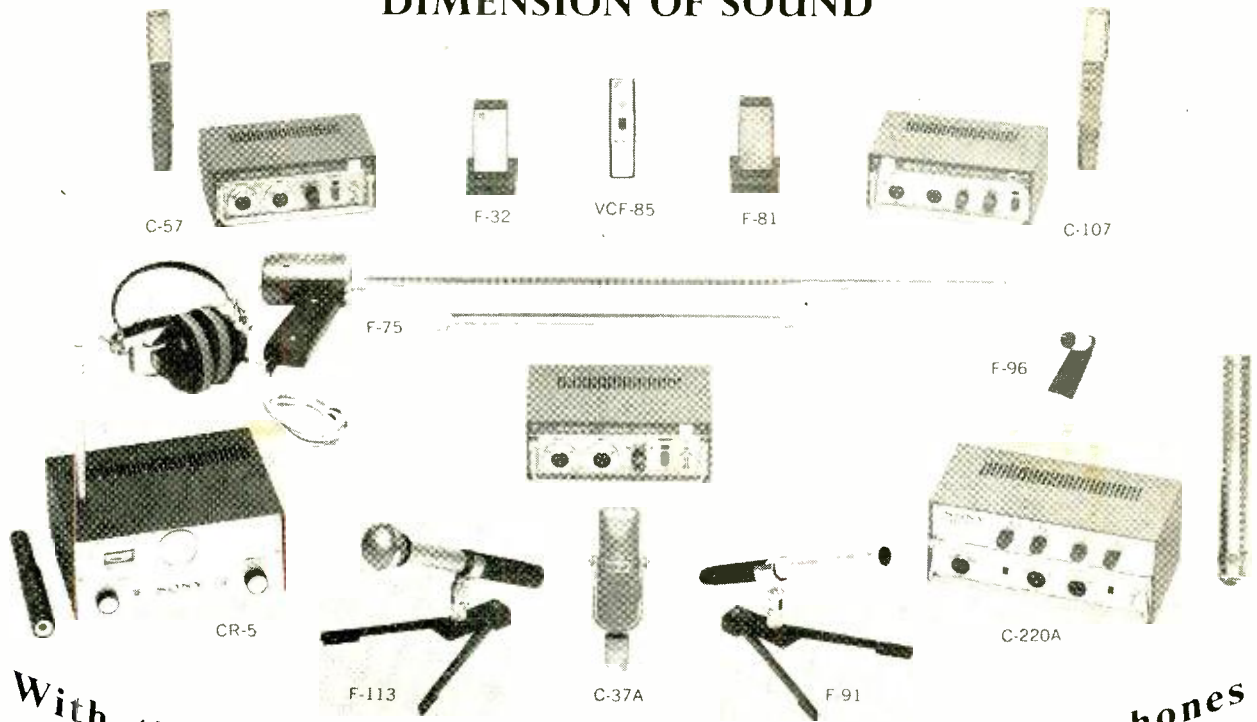

With the World's Most Complete Line of Microphones

Once again, Sony concentration on research and design establishes product leadership. Sony microphones are universally preferred for their capability of transmitting the full natural range of the sounds of music and the human voice. No other manufacturer offers Sony's breadth of selection. Whether Professional or Consumer, there is a Sony microphone for every requirement, priced lower than any other comparable instrument.

PROFESSIONAL MICROPHONES—designed for use in TV and radio stations, recording studios and theatres.
Model C-37A Variable Directivity Condenser Microphone: The standard within the broadcasting and recording industry, \$295.
Model C-57 Variable Directivity Condenser Microphone: Wide frequency response, low distortion and rapid selection of directional characteristics, \$375.
Model C-107 Continuously Variable Polidirectional Condenser Microphone: Ideal for recording studios or broadcast requiring remote control, exceptional uniformity and high front to back rejection, \$525.
Model C-220A Uni-axial Stereo/Monaural Condenser Microphone: 2 complete microphones contained within a single case, independent selection of each polar pattern, \$625.
Model F-75 Super Directional Telemicrophone: 18" probe for use up to 75 feet, 34" probe for use up to 150 feet, \$395.
Model CR-5 Wireless Microphone: Consists of FM transmitter and receiver, mike

hand-held or lavalier-worn, operates up to 300-foot radius, \$365.
Model F-91 Slim Styled Dynamic Microphone: Ideal for TV staging, "on-the-spot" interviews, audience participation, \$149.50.
Model F-113 Uni-directional Dynamic Microphone: For difficult acoustical environments where feedback or background noise are a problem, \$249.50.
CONSUMER MICROPHONES—developed for the home recording enthusiast.
Model F-81: Premium quality, high impedance, cardioid dynamic microphone, less than \$29.50.
Model F-32: Same as F-81 but incorporates bass attenuation switch for Voice Public Address, less than \$27.50.
Model VCF-85: Cardioid dynamic microphone with voice activating feature, less than \$22.00.
Model F-96: General purpose, dynamic microphone, ideal for instrumentalists, singers, public address, less than \$17.50.
 For literature or nearest franchise dealer, write to Superscope, Inc., Sun Valley, California, Dept. 58

SONY SUPERSCOPE The Tapeway to Stereo[®]
 8150 VINELAND AVENUE • SUN VALLEY, CALIFORNIA • 91353

Circle 12 on reader's service card

**Discover the ease
and excitement of NRI's**

3 DIMENSIONAL METHOD



of ELECTRONICS TV-RADIO TRAINING

10 HOME-STUDY PLANS TO CHOOSE FROM

Ask men whose judgment you respect about NRI's three dimensional method of home-study training. Ask about the new, remarkable NRI Achievement Kit. Ask about NRI custom-designed training equipment, programmed for the training of your choice to make Electronics come alive in an exciting, absorbing, practical way. Ask about NRI "bite-size" texts, as direct and easy to read as 50 years of teaching experience can make them. Achievement Kit . . . training equipment . . . bite-size texts . . . the three dimensions of home-study training; the essentials you must have to make

learning easier, more interesting, more meaningful. You get them all from NRI

Whatever your interest . . . whatever your need . . . whatever your education . . . pick the field of your choice from NRI's 10 instruction plans and mail the postage free card today for your free NRI catalog. Discover just how easy and exciting the NRI 3-DIMENSIONAL METHOD of training at home can be. Do it today. NATIONAL RADIO INSTITUTE, Electronics Division, Washington, D.C. 20016.

**BEGIN NOW AN ABSORBING
ADVENTURE—LEARN ELECTRONICS
THE EASY NRI WAY—MAIL CARD TODAY**

OUR 50TH YEAR OF LEADERSHIP



IN ELECTRONICS TRAINING

1 Start Fast with NRI's New Remarkable Achievement Kit

The day you enroll with NRI this new starter kit is on its way to you. Everything you need to make a significant start in the Electronics field of your choice is delivered to your door. It's an outstanding way of introducing you to NRI training methods . . . an unparalleled "first dimension" that opens the way to new discoveries, new knowledge, new opportunity. The Achievement Kit is worth many times the small payment required to start your training. No other school has anything like it. Find out more about the NRI Achievement Kit. Mail the postage-free card today.



2 NRI "Bite-Size" Lesson Texts Program Your Training

Certainly, lesson texts are a necessary part of any training program . . . but only a part. NRI's "bite-size" texts are simple, direct, well illustrated, and carefully programmed to relate things you read about to training equipment you build. Here is the "second dimension" in NRI's training method. Here are the fundamental laws of electronics, the theory, the training of your choice, presented in a manner you'll appreciate. And in addition to lesson texts, NRI courses include valuable Reference Texts related to the subjects you study, the field of most interest to you.



3 Custom-Designed Training Kits Make Learning Come Alive

Electronics becomes a clear and understandable force under *your* control as you get your hands on actual parts and build, experiment, explore, discover. Here is the "third dimension". . . the practical demonstration of things you read about in NRI texts. NRI pioneered and perfected the use of training kits to aid in learning at home in spare time. *Nothing is as effective as learning by doing.* NRI invites comparison with equipment offered by any other school, at any price. Prove to yourself what three-quarters-of-a-million NRI students could tell you . . . that you get more for your money from NRI than from any other home-study Radio-TV, Electronics school. Mail postage free card for your NRI catalog. (No salesman will call.)

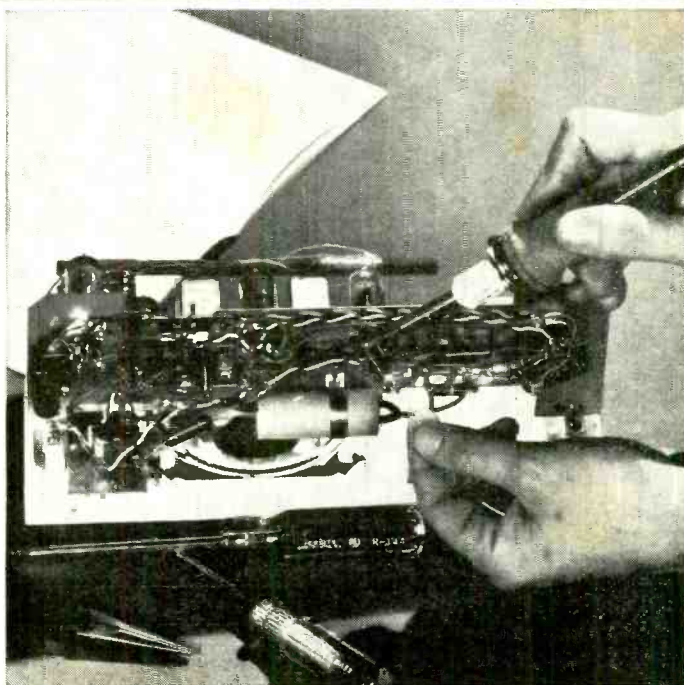

Complete TUNER REPAIR

\$950

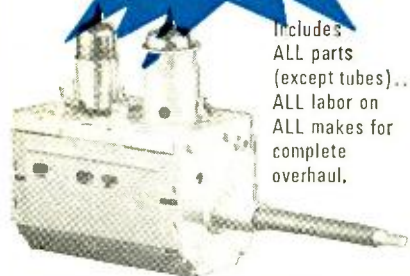

Includes
ALL parts
(except tubes)...
ALL labor on
ALL makes for
complete
overhaul.

FAST, 24-HOUR SERVICE with FULL YEAR WARRANTY

Sarkes Tarzian, Inc., largest manufacturer of TV and FM tuners, offers unexcelled tuner overhaul and factory-supervised repair service.

Tarzian-made tuners received one day will be repaired and shipped out the next. More time may be required on other makes. Every channel checked and realigned per original specs. And, you get a full, 12-month guarantee against defective workmanship and parts failure due to normal usage. Cost, including labor and parts (except tubes) is only \$9.50 and \$15 for UV combinations. Replacements at low cost are available on tuners beyond practical repair.

Always send TV make, chassis and Model number with faulty tuner. Check with your local distributor for Sarkes Tarzian replacement tuners, parts or repair service. Or, use the address nearest you for fast, factory-supervised repair service.

SARKES  TARZIAN

TUNER SERVICE DIVISION

537 S. Walnut St., Bloomington, Ind.
Tel: 812-332-6055

10654 Magnolia Blvd., N. Hollywood, Calif.
Tel: 213-769-2720

TUNER SERVICE  CORPORATION

(Factory-supervised tuner service
authorized by Sarkes Tarzian, Inc.)

547 Tonnele Avenue, Jersey City, N.J.
Tel: 201-792-3730

Manufacturers of Tuners, Semiconductors,
Air Trimmers, FM Radios, AM-FM Radios,
Audio Tape and Broadcast Equipment

NEWS BRIEFS continued

announced: "The master of the house has the right to turn down his own television set, especially on his day off," and dismissed the case.

REVISED FCC EXAMINATIONS

FCC field examination offices are now using a revised Commercial Examination Element Three (required for Second-Class Radiotelephone licenses). A revised Element Four (for First-Class Phone) is being prepared and will be announced. The revised examination will contain the usual 100 questions of the multiple-answer type, and 75% remains the passing grade.

CALENDAR OF EVENTS

IEEE International Convention, March 21-25; Coliseum and New York Hilton Hotel, New York, N. Y.

Institute of High Fidelity Los Angeles Show, March 27-Apr. 3; Ambassador Hotel, Los Angeles, Calif.

Institute of High Fidelity San Francisco Show, April 18-25; Civic Auditorium, San Francisco, Calif.

NATESA (National Alliance of TV & Electronic Service Associations) Spring Conference, Apr. 23-24; St. Louis, Mo.

AES (Audio Engineering Society) Thirteenth Annual Convention, Apr. 25-28; Hollywood Roosevelt Hotel, Los Angeles, Calif.

1966 INTERMAG (International Conference on Magnetism), Apr. 20-22; Liederhalle, Stuttgart, Germany

SWIEEEO (Southwestern IEEE Conf.), Apr. 20-22; Dallas Memorial Auditorium, Dallas, Tex.

NATIONAL ELECTRONICS ASSOCIATION ANNOUNCES CONTEST RESULTS

The regular quarterly meeting of the National Electronics Association (NEA) was held Jan. 15-16 in Louisville, Ky. The 2½-month "Ask 'Em to Join" membership contest was formally closed, and prizes ranging from television sets through Playboy Club keys to "Legal Service Invoices" were given out.

First-prize winner was William G. Norman of Winston-Salem, N.C. Second prize went to W.G. Tucker, Hutchinson, Kan., and third to Donald Offet, Great Bend, Kan. Other winners were Vince Lutz, St. Louis; John Hemak, Minneapolis, Minn.; John Graham, Co-

Radio-Electronics Adopts Hertz

RADIO-ELECTRONICS is now using the term *Hertz*—recently adopted officially in the United States—in place of cycles in all references to frequency. This term has been used for many years in other countries. Hz, KHz and MHz, abbreviations for Hertz, kilohertz and megahertz, are replacing cycles, kc and mc in all recently edited material. You may run across the older abbreviations in copy set in type before the change.

lumbus, Ohio; Emmet Hughes, Hutchinson, Kan., and Clark Pohl, Perry, Iowa.

A "Leadership Training School" session, in which a number of business, government and organization speakers addressed the delegates, was a feature of the meeting. A certification program, to provide for testing and registering electronic technicians, was approved for use on the state level.

LASER RADAR DETECTS CLEAR-AIR TURBULENCE

A new ruby laser, designed and manufactured by the Laser Systems Center of Lear Siegler, Inc., has given tangible evidence that clear-air turbulence can be detected by optical radar. A report by University of Michigan physicists covers a year of flying into areas of severe turbulence.

The laser transmitter is operated at an output level of 3 megawatts with a repetition rate of 4 pulses per minute. The optical receiver uses a 4-inch diameter reflecting telescope. A photomultiplier changes the light into an electric signal and increases its strength. The return signal from the photomultiplier is fed directly to an oscilloscope in an A-scope type radar of display.

INFRARED TESTS COMPONENTS

A new mode of inspection is about to be added to testing by X-ray, ultrasonics and, of course, the human eye. Lockheed Aircraft has asked all its subcontractors on a recent bid for equipment to supply two sets of bids: one including the cost of infrared testing, and one without that expense.

Infrared photography will often show up hot spots (uneven distribution of heat) in a piece of equipment that passes all other tests. Yet those weaknesses might be crucial.

Infrared is also being investigated by the Boeing Co. and Raytheon is studying a variation of the technique.

BRIEF BRIEFS

The FCC's announcement that it expects to control practically all forms of CATV specifically exempts systems serving fewer than 50 installations or those used as one-building master-antenna systems. No new systems may be installed in larger cities, however, without the FCC's approval after open hearings.

Persons who work with high-power radar equipment in some cases show accelerated aging in their eye lenses, two New York University Medical Center investigators have discovered. There was no indication of a greater proportion of eye defects or cataracts, however.

Engineered for Professional Quality and savings up to 50%

Whether you want the creative pleasure and thrift of build-it-yourself, or factory-assembled professional quality equipment ready-to-use—you save up to 50% with EICO

no-compromise engineering. Be super-critical. Compare EICO with anybody else. The more critically you judge, the more you'll see for yourself that your best buy is EICO.



COLOR TV LAB

Three compact portable instruments for shop or home Color TV servicing. Add one more and you're set for FM-MPX stereo.

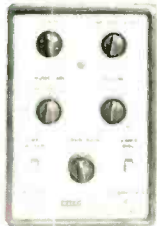

New Model 380 Solid State NTSC Color Generator generates exact NTSC color signals individually and all required dot-bar patterns. Super-compact, 4 pounds light, instant operation. \$159.95 wired only.

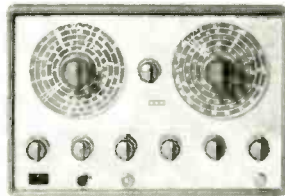

Model 369 Sweep/Marker Generator for easiest, fastest visual alignment of color or B&W TV and FM RF and IF circuits. Five sweep ranges from 3-225mc. Crystal marker oscillator. Post Injection of markers. \$89.95 kit, \$139.95 wired.

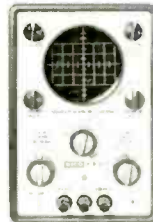

New Model 435 Direct-Coupled Wideband Scope. Top-quality DC-4.5mc scope with 3" flat-face CRT. Zener calibrator: Outperforms 5" scopes three times its size, facilitates on-location color TV and other servicing. \$99.95 kit, \$149.95 wired.

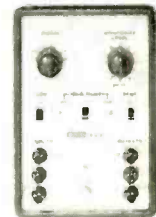

New Model 342 FM Multiplex Signal Generator. Design lab quality. Both composite audio and FM RF outputs. Inputs for stereo audio source for store demonstrations, critical A/B listening tests. \$149.95 wired.



New Model 1030 Regulated Power Supply. Speeds troubleshooting, design work, production line testing, electronics teaching. Variable bias and plate sources regulated to 1/3 of 1%: 0-150V @ 2ma; 0-400V @ up to 150ma. Ripple less than 3mv rms. Unregulated fil. volts of 6.3V & 12.6V, @3A. Switchable, monitoring milliammeter and voltmeter. \$59.95 kit, \$99.95 wired.



New Model 378 Audio Generator. Near-distortionless sine wave generator (<0.1% 20-20,000c) providing fast, convenient switch-selection of frequencies from 1c to 110kc (1c steps 1c-100c, 10c steps 100c-1kc, 100c steps 1kc-10kc, 1kc steps 10kc-110kc). 8-pos. 10db/step output attenuator & fine attenuator. Output meter (4 1/2" 200ua) with 8 voltage ranges & db scale. \$49.95 kit, \$69.95 wired.



New Model 965 FaradOhm Bridge Analyzer. "Unusually versatile" — Electronics World. 9-range, low-voltage capacitance-resistance bridge safely measures even 1-volt electrolytics. Metered bridge balance, leakage test voltage (6 DC VTVM ranges 1.5-500V), leakage current (11 DC VTAM ranges 0.15ua-15ma). DC VTVM & VTAM externally usable. \$129.95 wired.



Model 460 Wideband Direct-Coupled 5" Oscilloscope. DC-4.5mc for color and B&W TV service and lab use. Push-pull DC vertical amp., bal. or unbal. input. Automatic sync limiter and amp. \$89.95 kit, \$129.50 wired.



Model 232 Peak-to-Peak VTVM. A must for color or B&W TV and industrial use. 7-non-skip ranges on all 4 functions. With Uni-Probe.® \$29.95 kit, \$49.95 wired.



New Model 779 Sentinel 23 CB Transceiver. 23-channel frequency synthesizer provides crystal-controlled transmit and receive on all 23 channels. No additional crystals to buy ever! Features include dual conversion, illuminated S/R/F meter, adjustable squelch and noise limiter, TVI filter, 117VAC and 12VDC transistorized dual power supply. Also serves as 3.5 watt P.A. system. \$169.95 wired.



New Model 3566 All Solid-State Automatic FM MPX Stereo Tuner/Amplifier. "Very satisfactory product, very attractive price"—Audio Magazine. No tubes, not even nuvistors. Delivers 112 watts IHF total to 4 ohms, 75 watts to 8 ohms. Completely pre-wired and pre-aligned RF, IF and MPX circuitry, plus plug-in transistor sockets. \$219.95 kit (optional walnut cabinet \$14.95), \$325.00 wired including walnut cabinet. UL approved.



New Model 753 The one and only SSB/AM/CW Tri-Band Transceiver Kit. "The best ham transceiver buy for 1966"—Radio TV Experimenter Magazine. 200 watts PEP on 80, 40 and 20 meters. Receiver offset tuning, built-in VOX, high level dynamic ALC. Unequaled performance, features and appearance. Sensationally priced at \$179.95 kit, \$299.95 wired.

FREE 1966 CATALOG

EICO Electronic Instrument Co., Inc.
131-01 39th Ave., Flushing, N.Y. 11352 RE-4

Send me **FREE** catalog describing the full EICO line of 200 best buys, and name of nearest dealer. I'm interested in:

- test equipment ham radio
 stereo/hi-fi Citizens Band radio

Name _____

Address _____

City _____ State _____

1945-1965: TWENTY YEARS OF LEADERSHIP IN CREATIVE ELECTRONICS

Circle 15 on reader's service card



Again from **JFD**[®]

the first major VHF antenna advance
since the invention of the JFD LPV Log Periodic!

Developed at the JFD Antenna-Research Laboratories, Champaign, Illinois under the
direction of Dr. Paul E. Mayes, co-inventor of the acclaimed LPV Log Periodic concept.

the remarkable new

JFD[®] **LPV-TV**[®]
COLOR
LOG PERIODIC

for channels 2 to 13 and FM/Stereo

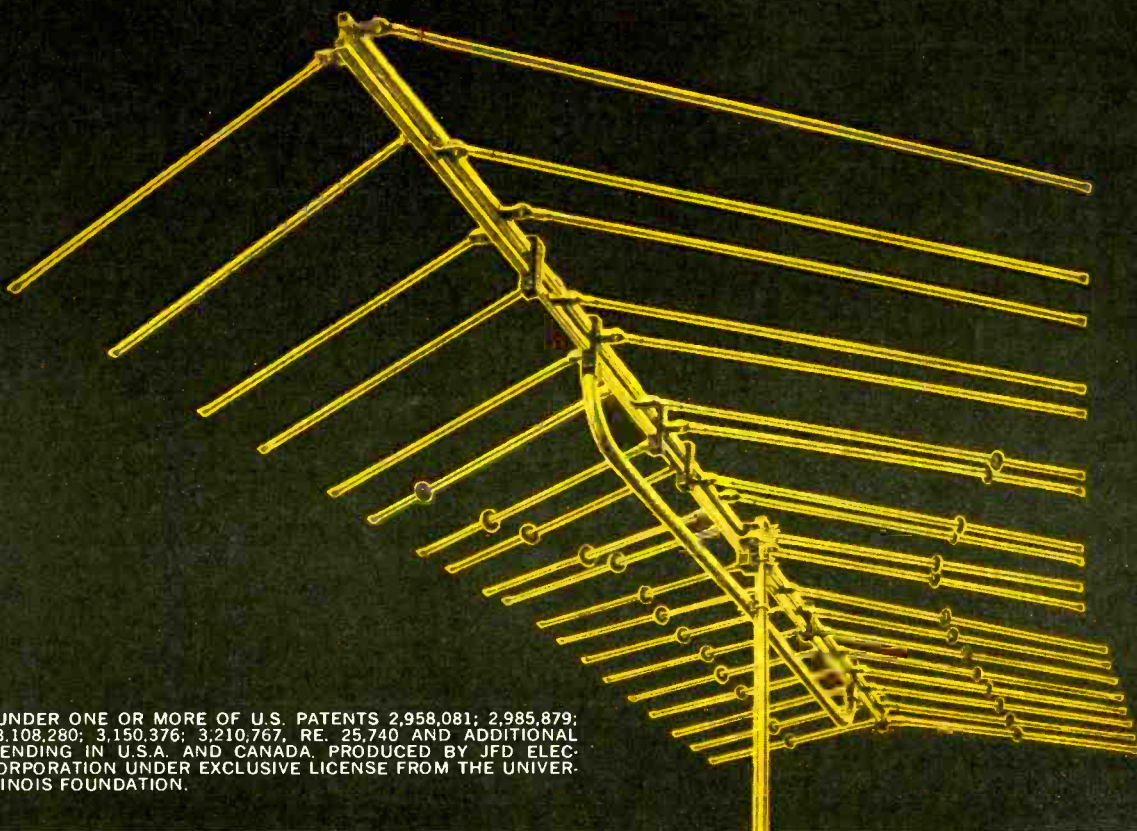

LICENSED UNDER ONE OR MORE OF U.S. PATENTS 2,958,081; 2,985,879;
3,011,168; 3,108,280; 3,150,376; 3,210,767, RE. 25,740 AND ADDITIONAL
PATENTS PENDING IN U.S.A. AND CANADA. PRODUCED BY JFD ELEC-
TRONICS CORPORATION UNDER EXCLUSIVE LICENSE FROM THE UNIVER-
SITY OF ILLINOIS FOUNDATION.

Circle 16 on reader's service card

WIFIJECH

While our LPV-TV series was undergoing development in Champaign, Ill., it was assigned the code name: WIFIJECH.

For good reason.

Its performance objectives were to surpass every competitive make—model for equivalent model—in gain, directivity, response, V S W R, & F/B ratio.

Did the new LPV-TV come through?

—All the way! Its performance is the proof!

Now at your JFD LPV distributor.

Seven LPV-TV models to choose from — meet any location or budget needs!

Write for LPV-TV brochure 1039.



BY FAR—the best antenna for VHF COLOR performance because it combines...

- The electronic perfection of the patented frequency independent Log Periodic concept of the University of Illinois Antenna Research Laboratories.
- New capacitor-coupled Cap-Electronic elements that respond on the third harmonic mode for highest effective gain. More harmonically resonant elements mean higher signal-to-noise ratios, better ghost rejection, sharper directivity on high VHF band—where it's most needed, especially in color.*
- True dual-band directors separately tune to high and low bands for added gain and directivity on all channels.
- Flat frequency response ($\pm \frac{1}{2}$ db across entire channel) for studio-quality color regardless of channel tuned.

New LPV-TV Log Periodic antenna series incorporates new capacitor-coupled element concept for improved response, especially in color, on channels 2 to 13.

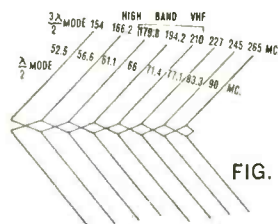

FIG. 1 (Note that only three dipoles resonate at frequencies in the high VHF band.)

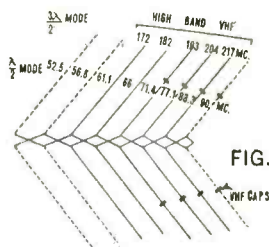

FIG. 2

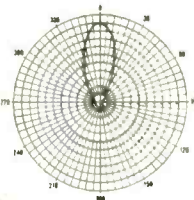



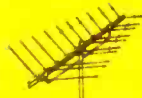

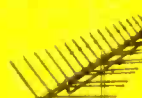



FIG. 3

Fig. 1 shows how a VHF log periodic with eight conventional V-dipoles might look. The resonant frequencies of the dipole elements in the low VHF band are indicated near midpoint of each dipole. The $3/2$ wavelength resonant frequencies are indicated near the ends of each dipole.

However, by introducing parallel plate capacitors into the dipoles and by carefully adjusting the value of this capacitance and its position on the dipole, as shown in Figure 2, the resonant frequencies of the dipole can be shifted in the $3/2$ wavelength mode. In this way, the dipole can be made to resonate at two desired frequencies: e.g., 88 and 216 mc.

Result: the active region in the high band extends over five of the eight original dipoles instead of three, as in Fig. 2, with a performance improvement of $66\frac{2}{3}\%$. The new capacitor-coupled dipoles also present more capture area on the low band than ordinary dipoles. Thus LPV-TV antennas offer, on both bands, higher and more uniform gain, lower side-lobe levels, narrower beamwidths, for vastly improved ghost rejection (see Fig. 3).

 <p>VHF — up to 50 miles FM — up to 30 miles Model LPV-TV3 3 Cell System (single-crossarm) With electronic "ghost-killing" trap \$14.95 list</p>	 <p>VHF — up to 75 miles FM — up to 40 miles Model LPV-TV5 6 Active Cell & Director Cap-Electronic Element System \$23.95 list</p>	 <p>VHF — up to 100 miles FM — up to 50 miles Model LPV-TV7 8 Active Cell & Director Cap-Electronic Element System \$31.95 list</p>	
 <p>VHF — up to 125 miles FM — up to 50 miles Model LPV-TV10 10 Active Cell & Director Cap-Electronic Element System \$41.95 list</p>	 <p>VHF — up to 150 miles Model LPV-TV13 13 Active Cell & Director Cap-Electronic Element System \$49.95 list</p>	 <p>VHF — up to 175 miles Model LPV-TV16 16 Active Cell & Director Cap-Electronic Element System \$59.95 list</p>	 <p>VHF — up to 200 miles Model LPV-TV19 19 Active Cell & Director Cap-Electronic Element System \$79.95 list</p>

JFD ELECTRONICS CORPORATION

15th Avenue at 62nd Street, Brooklyn, N.Y. 11219
JFD International, 64-14 Woodside Ave., Woodside, N.Y. 11377
JFD Canada, Ltd., Canada

See what's NEW from JFD at BOOTH #2101 in San Francisco Parts Show June 3, 4, 5

color coded nutdrivers

now in new, handy kits

FOR BENCH, WALL OR TOOL BOX

Sturdy, new pebble-grain plastic cases provide handy means for keeping nutdrivers in good order on the workbench or in tool box for service calls. Lids snap shut, lock tight to protect tools. No. 77 case has hole in lid lock for wall hanging . . . molded compartments keep tools from tumbling out.



No. 77
SOLID SHAFT
NUTDRIVER KIT

7 Hex Openings: 3/16", 7/32", 1/4", 9/32", 5/16", 11/32", 3/8"



No. HS6-18
HOLLOW
SHAFT
NUTDRIVER KIT

10 Hex Openings: 3/16", 7/32", 1/4", 9/32", 5/16", 11/32", 3/8", 7/16", 1/2", 9/16"

PROFESSIONAL QUALITY

Precision fit, case-hardened sockets; polished and plated steel shafts; shockproof, breakproof, color coded plastic (UL) handles.

WRITE FOR CATALOG 162



XCELITE, INC., 10 BANK ST., ORCHARD PARK, N. Y.
Canada: Charles W. Pointon, Ltd.,

Circle 17 on reader's service card

Correspondence

MORE TOP-CAP-CATHODE TUBES

Dear Editor:

First let me say I think you have a great magazine. I was surprised at you, though, when I saw the letter from Mr. J. W. Clarke, and your answer, on top-cap-cathode tubes (January 1966, Correspondence, p. 14). I can think of at least four in addition to the ones you mentioned, without even looking at a tube manual: the 6- and 12AF3, the 6V3, the 16AQ3 and the 6-RK19. The 6V3 was used as far back as 1950 in most of Philco's TV receivers. Some early G-E sets used the 6V3. The 6AF3 and 16AQ3 have been used for several years by Motorola, and the 6-RK19 is used in most Curtis-Mathes receivers. All are dampers.

ELVIN D. SLATER

Charleston, W. Va.

[We've received more correspondence on this one subject than we've gotten sometimes about a whole issue. Mr. Al Yeager, the reader who started this whole thing way back in the October, 1965, Correspondence column, stated sarcastically, in reference to the diabolic inventiveness of tube manufacturers, that he hadn't yet seen a tube with its cathode connection on top, and asked why makers didn't exploit that wrinkle.

Mr. Clarke wrote us (January 1966, Correspondence) about the 6AL3. At the end of that letter, we mentioned the new 6EC4, just announced by Amperex. Mr. Slater, above, mentions four more types. Mr. Joseph Shaw (Speed TV) of Bellmore, N. Y., contributed a piece of genuinely useful information by saying that you can check the 6AL3, 6AF3 and any other dampers with similar characteristics and the same base on any tester that will check a 6V3. —Editor]

COLORGAN GREMLINS

Dear Editor:

Gremlins have crept into a few readers' circuits in duplicating the Colorgan [Oct. 1965 RADIO-ELECTRONICS]. Most of these stem from use of larger,

hand-wired circuitry and possibly the use of surplus diodes. Here are some of the troubles and some of the cures:

Symptom: Each channel works OK as a dimmer but operates erratically when following the audio. This may happen to only one channel, two, or all three.

Cause: Poor high-frequency response of diodes D7, D8, D9.

Cure: Change capacitors C6, C7 and C8 from .001 μ F to .005 μ F. Ceramic discs work well.

Symptom: Interaction of background controls at low levels.

Cause: Coupling of signals from SCR gate to gate. This is much more prevalent in wired circuitry and is made worse by neatly lacing the three gate leads together.

Cure: Replace C6, C7, and C8 as above. Reroute gate leads to minimize interaction. If both these steps do not reduce the interaction to a negligible level, add a 2,200-ohm resistor between gate and cathode of each SCR.

Symptom: At settings below the minimum brightness setting, bulbs jump on to half brilliance or some other erratic brightness level.

Cause: Skip cycling of SCRs when C3, C4, or C5 fail to discharge completely at low brightness settings.

Cure: Add a 5,000-ohm, 5-watt wirewound (no lower rating) from anode to cathode of each SCR. These can put out 3 watts or so of heat, so place them accordingly.

Symptom: Background controls fail to reduce minimum brightness to an acceptably low level.

Cause: C3, C4 and C5 slightly too big for avalanche diode used.

Cure: Change to .082 or .068 μ F to obtain desired range.

I would be interested in hearing from any readers having any further difficulty and any who have made any successful changes to the circuit.

DONALD LANCASTER

Phoenix, Ariz.

[Several readers have written to say they couldn't find the 10-ampere, 200-volt bridge rectifier (RECT) called for in the Colorgan article. The exact unit specified, a Motorola MDA962-3, is listed in the middle of page 46 of the 1966 Allied Industrial Electronics Catalog and costs \$4.85. You can order it for that amount, plus postage, from Allied Radio Corp., 100 N. Western Ave., Chicago, Ill. 60680. Motorola industrial distributors in larger cities should also have the rectifier (check your Yellow Pages).

[Any other bridge of similar ratings should work as well, or you can even use four separate 10-amp, 200-volt diodes connected in a bridge configuration.—Editor]

NOTES FROM OUR GHOST FILE

Dear Editor:

The "Rabbit's Foot" antenna on page 8 of the August 1965 issue really tickled me. It encourages me to put my own idea on the market.

Recently I was aligning my TV set with a file tang when I happened to touch the antenna terminal momentarily with the tip of the file. All of a sudden the picture was ghost-free. Now I know why. A ghostly image can't enter the set through a file because the file removes the rough edges.

A rabbit-ear dipole type of antenna made of two files should bring in a clear, sharp picture. Different kinds of files should shape some of the uglier pictures into neater ones. Made with machinists' finishing files, the antenna would eliminate the need for a fine-tuning control.

As I joke about this I think many might be fooled if the idea were explained to them in a more technical style. Remember older TV's with inside antennas? People paid quite a bit more for sets with a piece of wire tacked inside the cabinet.

PETER LEGON

Malden, Mass.

HOW WE LOCATE BASS TONES

Dear Editor:

Re Eric Barschel's letter in the August, 1965, RADIO-ELECTRONICS: The fact that he can tell without looking where the tuba player is located does not negate the nondirectional character of bass notes.

Pure low-frequency tones are virtually non-directional, and directivity becomes more and more pronounced as the frequency is increased. Therefore, the location of the source of a pure low-frequency tone could not be determined simply by listening to the tone.

However, no ordinary musical instrument is capable of producing pure tones at any frequency. The tuba, for example, produces sounds having a relatively low fundamental frequency, which is what we identify as its characteristic voice and which allows us to distinguish it from other instruments. This nondirectional fundamental frequency is accompanied by higher-frequency harmonic tones. These are directional, and our ears use them to locate the instrument. We are usually not aware of these harmonics, so we attribute a strictly low-frequency voice to the tuba.

I hope this is the clarification Mr. Barschel was looking for!

WILLIAM C. PARKER

Boonville, N. Y.

END

KWIKETTE SOLDERING AIDS...

the revolutionary new connectors that make **QUICK** work of parts replacement!

WIRE + FLUX + SOLDER, ALL in One!

The 3-in-1 KWIKETTE is not just another wire spring connector... Copperweld wire inner core, a layer of flux, and an outer jacket of solder... all you need is heat!



Ten times actual size

Once again, Sprague helps the TV-radio service industry by solving difficult servicing problems... parts replacement on printed wiring boards, in "inaccessible" chassis nooks, and on crowded terminal lugs. Mechanically sturdy and electrically reliable, the KWIKETTE provides quick, expert, "one-handed" soldered connections as easy as A-B-C!

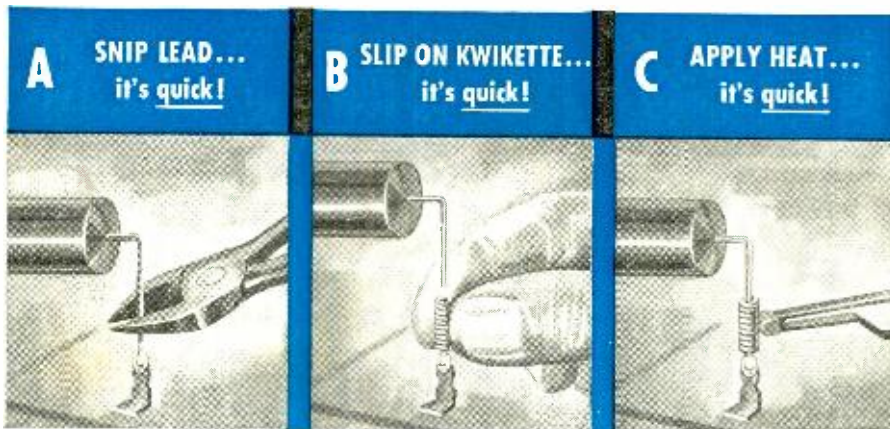

NOBODY ELSE HAS KWIKETTE CONNECTORS... YOU GET 'EM ONLY FROM SPRAGUE PRODUCTS!

KWIKETTES are now being packed with Sprague Atom® Capacitors at no extra cost to you! Whenever you need tubular electrolytics, insist on pre-packaged Sprague Atoms from your parts distributor and you'll automatically get your KWIKETTE component connectors... the biggest boon to the service technician since the soldering gun!

*Trademark



WORLD'S LARGEST MANUFACTURER OF CAPACITORS

65-5116

Circle 18 on reader's service card

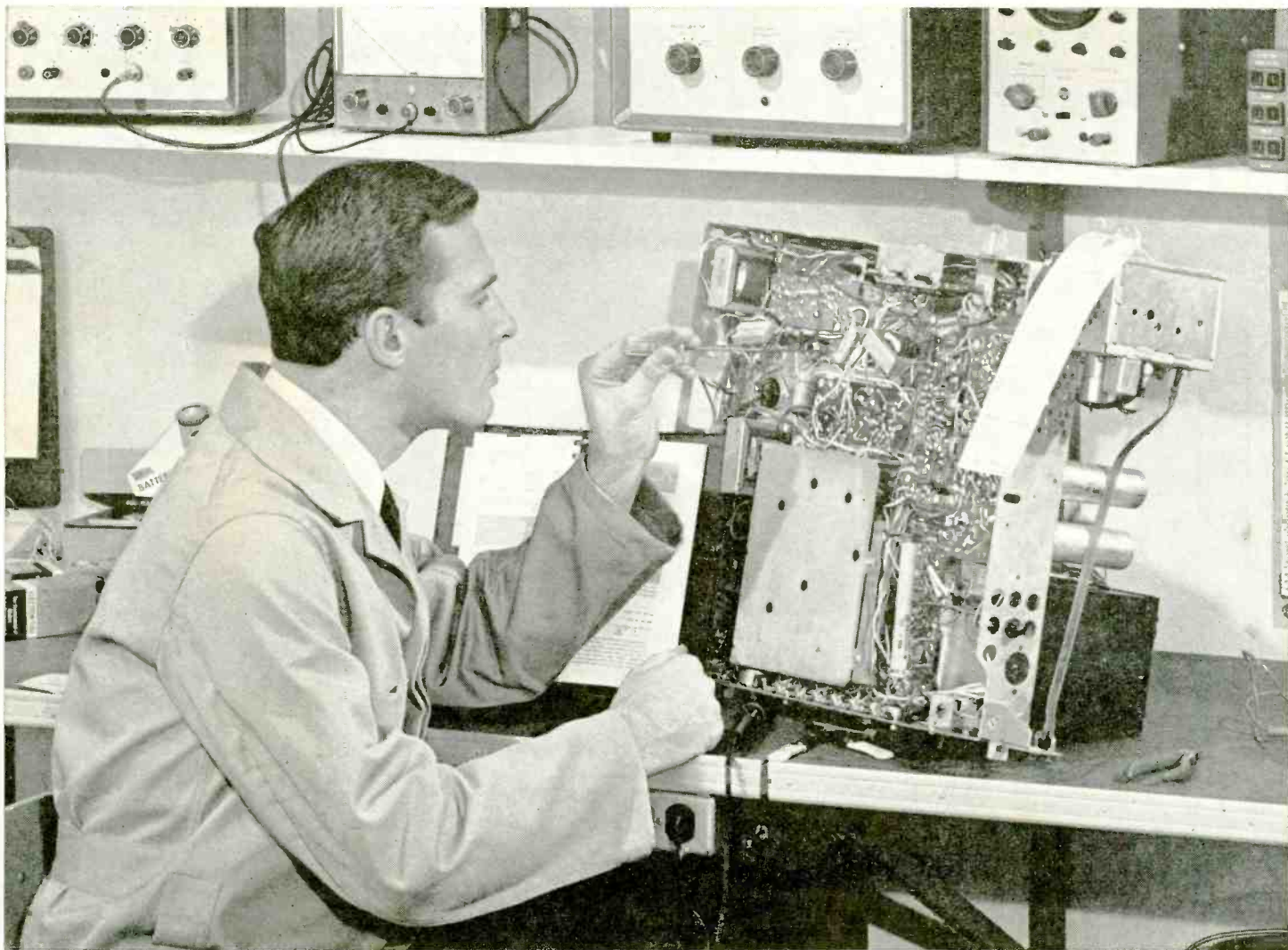

RCA TRAINING **can be the smartest investment you ever made!**

**Start building a profitable career in electronics now!
New RCA "AUTOTEXT" programmed instruction will help you
learn faster and easier!**

If you're considering a future in electronics, now is the time to start! A great new teaching aid—"AUTOTEXT" programmed instruction developed by RCA and introduced by RCA Institutes will help you master the fundamentals of electronics almost automatically. Even people who have had trouble with conventional home training methods are finding it easier and more fun to start their training in Electronics Fundamentals the RCA way. Prove

it to yourself as others throughout the country are now doing. An interest or inclination in electronics is what you need. RCA "Autotext" helps you to do the rest. You'll be ready to go on to advanced training sooner than you ever thought possible! The future is unlimited; the jobs are available. The important thing is to get started now.

Founded in 1909, RCA Institutes is one of the largest technical schools in the United States devoted princi-

pally to electronics. The very name "RCA" means dependability, integrity, and scientific advance. RCA Institutes offers the finest facilities of home training. A Service of the Radio Corporation of America, RCA Institutes gives you the technical instruction you need to plan, build and realize the career you want in today's fastest growing field.

Investigate your future now at RCA Institutes. It can be the smartest investment you ever made.

HOME TRAINING COURSES

RCA Institutes offer this complete selection of Home Training Courses

- Electronic Fundamentals
- Electronic Fundamentals (in Spanish)
- TV Servicing
- Color TV Servicing
- Transistors

- Communications Electronics
- FCC License Preparation
- Mobile Communications
- Automation Electronics
- Automatic Controls

- Industrial Applications
- Nuclear Instrumentation
- Digital Techniques
- Computer Programming
- Drafting

Liberal Tuition Plan. All RCA Institutes Home Study courses are available under a Liberal Tuition Plan. This plan affords you the most economical possible method of home study training. You pay for lessons only as you order them. If, for any reason, you should wish to interrupt your training, you can do so and you will not owe a cent until you resume the course. No other obligations! No installment payments required.

RCA Personal Instruction. With RCA Home Study training you set your own pace in keeping with your own ability, finances and time. RCA Institutes allows you ample time to complete the course. Your lesson assignments are individually graded by technically trained personnel, and helpful comments are added where required. You get theory, experiment, and service practice beginning with the very first lesson. All lessons are profusely illustrated. You get a complete training package throughout the entire course.



You Get Prime Quality Equipment. All kits furnished with the course are complete in every respect, and the equipment is top grade. You keep all the equipment furnished to you for actual use on the job... and you never have to take apart one piece to build another.

Free Placement Service. RCA Institutes graduates are now employed in important jobs at military installations with important companies such as IBM, Bell Telephone Labs, General Electric, RCA, and in radio and TV stations all over the country. Many other graduates have opened their own businesses. A recent New York Resident School class had 93% of the graduates who used the FREE Placement Service accepted by important electronics companies... and had their jobs waiting for them on the day they graduated!

CLASSROOM TRAINING IN NEW YORK CITY

No previous training required. You are eligible even if you haven't completed high school.

RCA Institutes Resident School in New York City offers training that will prepare you to work in rewarding positions on research and production projects in fields such as automation, transistors, communications, technical writing, television, computers, and other industrial and advanced electronics applications. If you did not complete high school, RCA will prepare you for such training with courses specially designed to provide the basic math and physics required for a career in electronics. Check classroom training on attached card, and full information will be rushed to you.



Coeducational Day and Evening Courses. Day and Evening Courses are available at RCA Resident Schools in New York City. You can prepare for a career in electronics while continuing your normal full-time or part-time employment. Regular classes four times each year.

**SEND POSTCARD FOR FREE ILLUSTRATED BOOK TODAY!
SPECIFY HOME TRAINING OR CLASSROOM TRAINING.**

RCA INSTITUTES, INC. Dept. RE-46 A SERVICE OF RADIO CORPORATION OF AMERICA, 350 WEST 4TH ST., NEW YORK, N.Y. 10014



The Most Trusted Name in Electronics

Circle 19 on reader's service card

SERVICE CLINIC

By **JACK DARR** Service Editor

The Great Game of Diagnosis

LET'S PLAY GAMES. YOU KNOW YOU LIKE to work puzzles, or you wouldn't be in this business! I never knew an electronics technician yet that wasn't fascinated by the puzzle aspect of this kind of work. And what more interesting puzzle can you find than a good intermittent or a

circuit with a mysterious trouble? I know that's one of the main reasons I'm in this field, and I suspect that you are too.

Electronics servicing is like detective work. We have to take certain clues, put them together and come up with a solution to the crime—a diagnosis—and

then put it to work to find the criminal.

So, let's put some highly useful information in the form of one of the oldest quiz games, "Twenty Questions." In this case, you won't have to guess whether it's animal, vegetable or mineral, or whether it's bigger than a breadbox; you already have that. (Except in the case of the little transistor portable TV's. They aren't as big as a breadbox.)

Now let's play the game. If you can answer all these questions to yourself as you go through a service job, you'll make more money out of it, for it will be a lot faster. The basic idea is to establish a *logical sequence of testing*, and, since all electronic gear is built and works on a strictly logical foundation of laws, it ought to make the thing a lot simpler to fix.

You might not like my list. If you don't, make up one of your own, along the same lines, and in the same logical order. If you've been repairing TV's for a good while, the chances are you use this method whether you realize it or not.

1. Is the thing plugged in?
2. If so, are the line cord, interlock, socket and switch OK?
3. Are all the tubes lit?
4. Is there a raster?
5. How about the sound?
6. How's the B+ voltage?
7. Are the operating voltages OK over the whole set?
8. Got any high voltage?
9. Did the fuse blow? If so, why?
10. How's the horizontal output tube cathode current?
11. Did you check the boost?
12. Picture OK? (Out of sync, weak, etc.)
13. Is it the tuner or the i.f. strip?
14. Did you check the age?
15. What *section* is the trouble in? (raster, sweep, video, sync, sound, etc.)
16. What *stage* is it in?
17. What *circuit* is it in?
18. What *part* is it in?
19. What happened? (Resistor burned, etc.)
20. Why?

NEW B & K MODEL 606 DYNA-JET
TESTS
LATEST
TUBES
QUICKLY
AND
ACCURATELY
PORTABLE/LOW COST/PROFESSIONAL

This new B&K Tube Tester provides the sockets and the features you need to test the latest color and compactron receiving tubes, as well as older types.

You can test for all shorts, grid emission, leakage and gas; and check cathode emission the accurate way—under simulated load conditions! Each section of a multiple section tube is checked. With the Model 606, you won't reject the good tubes, and you'll quickly find the bad ones, reducing call backs, selling more tubes, and increasing service profit.

You'll find "tough dogs" and weak tubes with the exclusive adjustable grid emission test, which has a sensitivity of over 100 megohms. Tube sockets have phosphor bronze contacts for long, trouble-free life. Complete tube listings are provided in a handy reference index.

This efficient instrument, in a small, handsome, leatherette covered carry case, will perform professionally on house calls or the service bench. Its low price will soon be paid for with increased profit.

Net \$7995

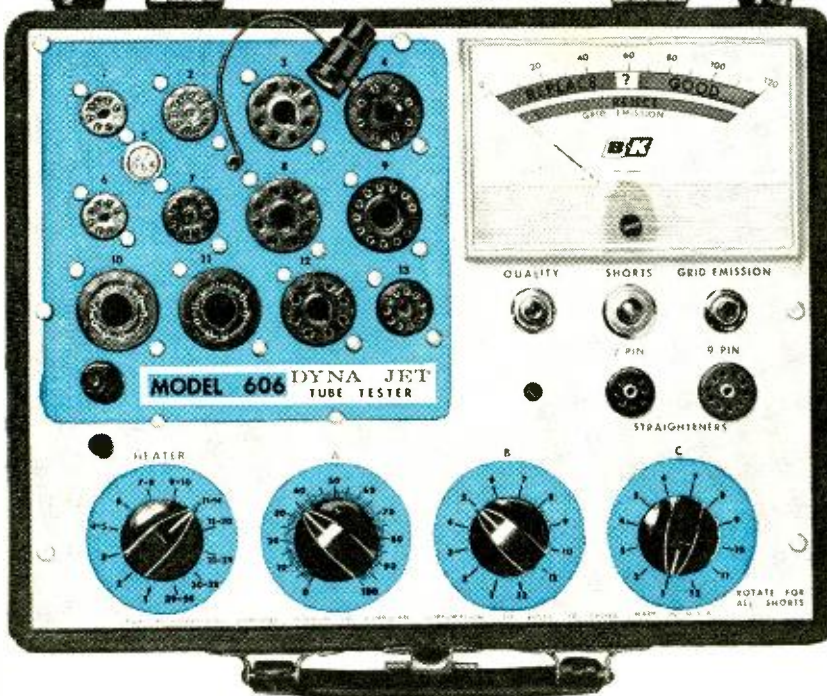

For additional information write for Catalog AP-22.



B & K MANUFACTURING CO.
 DIVISION OF **DYNASCAN CORPORATION**
 1801 W. BELLE PLAINE AVE. - CHICAGO, ILL. 60613
 Canada: Atlas Radio Corp.
 Export: Empire Exporters, 123 Grand St., New York 13, U.S.A.

Circle 20 on reader's service card

This column is for your service problems—TV, radio, audio or general and industrial electronics. We answer all questions individually by mail, free of charge, and the more interesting ones will be printed here.

If you're really stuck, write us. We'll do our best to help you. Don't forget to enclose a stamped, self-addressed envelope. Write: Service Editor, Radio-Electronics, 154 West 14th Street, New York 10011.

Why does one of these men earn so much more than the other?

More brains? More ambition?

No, just more education in electronics.

You know that two men who are the same age can work side-by-side on the same project, yet one will earn much more than the other.

Why? In most cases, simply because one man has a better knowledge of electronics than the other. In electronics, as in any technical field, you must learn more to earn more. And, because electronics keeps changing, you can never stop learning if you want to be successful.

But your job and family obligations may make it almost impossible for you to go back to school and get the additional education you need. That's why CREI Home Study Programs are developed. These programs make it possible for you to study advanced electronics at home, at your own pace, on your own schedule. You study with the assurance that what you learn can be applied on the job to make you worth more money to your employer.

CREI Programs cover all important areas of electronics including communications, servomechanisms, even spacecraft tracking and control. You're sure to find a program that fits your career objectives.

You're eligible for a CREI Program if you have a high school education and work in electronics. FREE book gives all the facts. Mail coupon or write: CREI, Dept.1404-D, 3224 Sixteenth Street, N.W., Washington, D.C. 20010

Send for Free Book

Accredited Member of the National Home Study Council

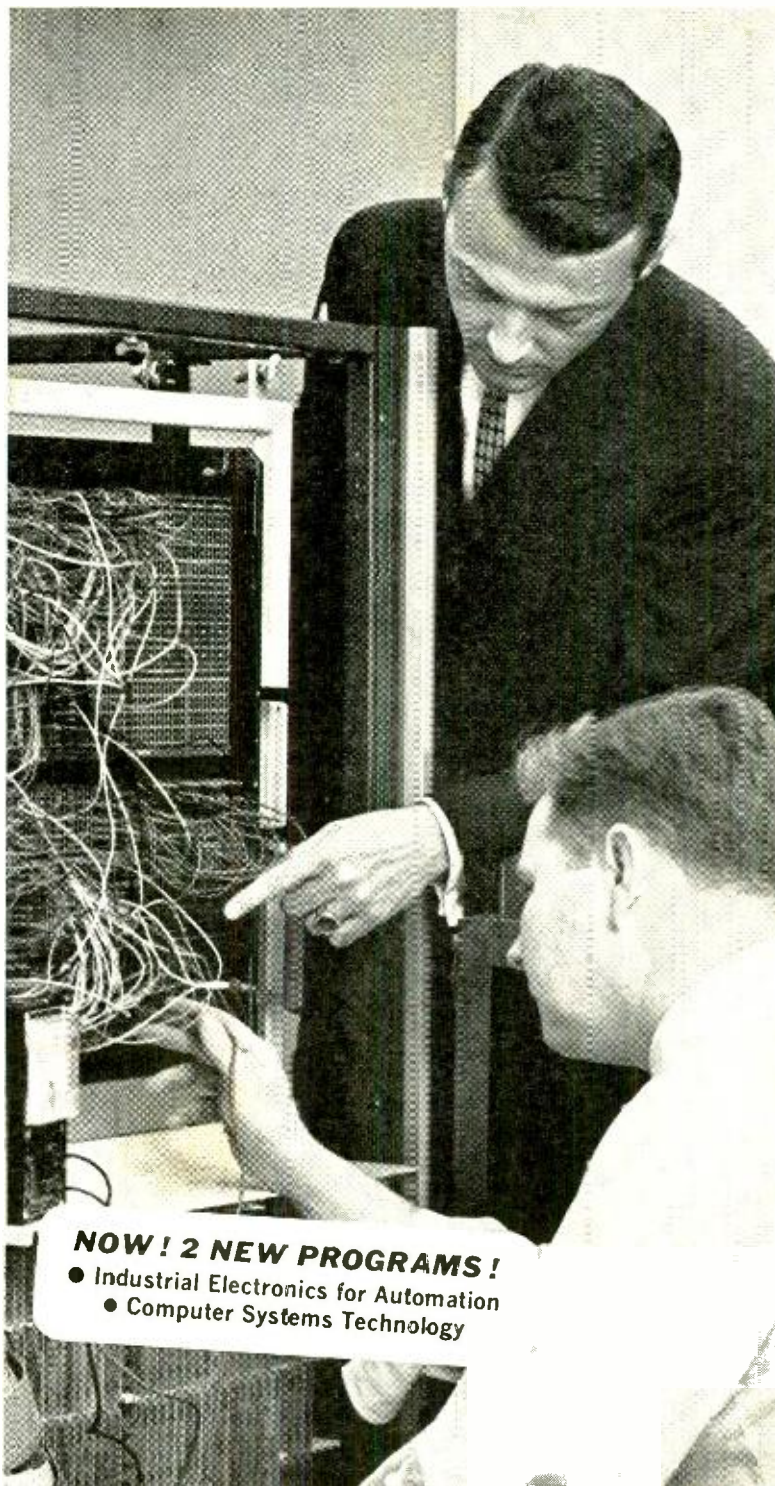

NOW! 2 NEW PROGRAMS!
 • Industrial Electronics for Automation
 • Computer Systems Technology

The Capitol Radio Engineering Institute

Dept 1404-D, 3224 Sixteenth Street, N.W.
 Washington, D.C. 20010

Please send me FREE book describing CREI Programs. I am employed in electronics and have a high school education.

NAME _____ AGE _____

ADDRESS _____

CITY _____ STATE _____ ZIP CODE _____

EMPLOYED BY _____

TYPE OF PRESENT WORK _____

- I am interested in Electronic Engineering Technology
 Space Electronics Nuclear Engineering Technology
 NEW! Industrial Electronics for Automation
 NEW! Computer Systems Technology

SERVICE CLINIC continued

And there you are. By the time you answer No. 20, you've got the set fixed. You can probably think of several other questions for that list, so go ahead.

This is a TV list. You can make up one for radio, hi-fi equipment or anything else. As long as it's the same type of list and covers the basics—primary power supply, secondary power supply, amplifiers, voltage distribution, and output signals—it's OK. This is the order in which everything ought to be checked, based on long experience, and the probability of failure.

First, find the faulty function, then the faulty stage, then the faulty circuit, then the faulty part. Replace that and the job is over. It's a logical sequence of operation and the one that works best.

6BK4 Plate Red-Hot, Heathkit Color TV

I've built a Heathkit color TV set, and I'd like an explanation of something I noticed. The plate of the 6BK4 rectifier tube gets red hot if I turn the brightness control up. At normal brightness, it cools off, but there is still red at the bottom. Capacitors and resistors check good. The tube tests OK.—M. C., Paterson, N. J.

The 6BK4 is not a rectifier, although it's a big bottle. This is the high-voltage regulator tube. Its plate is connected directly to the 25,000-volt line (filament of the 3A3 HV rectifier—see diagram.)

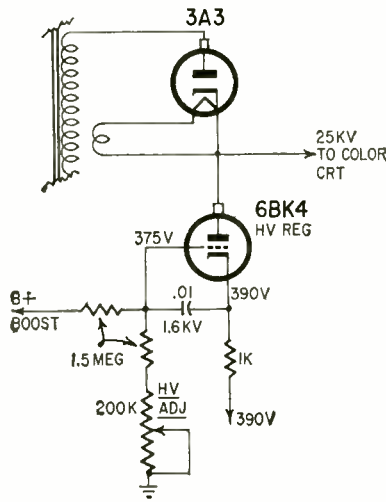

The cathode is connected to 390 volts; and the grid, through a 1.5 megohm resistor, back to the boost. The resistors make up a voltage divider circuit in the grid. So, the actual grid bias on the tube depends on the boost voltage. The actual bias runs somewhere

around -12 to -15 volts, but this is ordinarily measured as the difference between grid and cathode voltages. You'll find about 390 volts on the cathode and about 375 on the grid. This can be adjusted with the HV ADJ CONTROL. Of course, changing the bias changes the plate current drawn by the tube; so, it takes more or less current from the high-voltage line. By doing this (automatically) it controls the high voltage.

The setup procedure for this is given in your instruction manual. Follow it exactly, and the chances are you'll come out all right. In your case, the plate is getting red hot because the bias is off, and the 6BK4 is drawing too much plate current. There is a remote possibility that the tube itself is bad; I ran into some trouble last summer with a few defective 6BK4's, but this situation has been corrected now. For a reliable check, read the plate current; it should be between 0.85 and 1.05 mA. Seems pretty small for a big tube, but that comes out to some 25 watts dissipation, with 25 KV on the plate!

Recording-Meter Trouble, Norelco 401

I have a Norelco 401 transistor tape recorder with a bug in the recording-level meter. Recording is normal.

MR.

SERVICEMAN

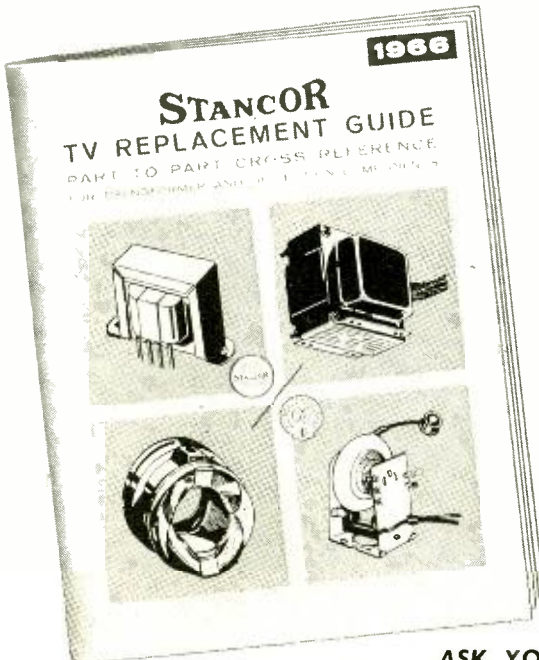

HERE IS YOUR NEW 1966 STANCOR PART-TO-PART CROSS REFERENCE GUIDE

COMPLETE FROM A..... to Z.....*



MONOCHROME AND COLOR are included in the 1966 Stancor Cross Reference Guide. Over 12,000 Manufacturers' Part Numbers Cross Referenced to Stancor Standard Replacement Transformers and Sweep Components.

* With 151 other brands in between.

ASK YOUR DISTRIBUTOR FOR YOUR COPY!

SOLD NATIONALLY THROUGH ELECTRONIC DISTRIBUTORS BY ELECTRONIC MARKETING DIVISION

3501 W. Addison Street • Chicago, Illinois 60618

Circle 21 on reader's service card



FINCO[®]-AXIAL COLOR-KIT



FINCO-AXIAL COLOR-KIT, Model 7512 AB

High performance Indoor and Outdoor Matching Transformers convert old-fashioned and inefficient 300 ohm hook-ups to the new Finco-Axial 75 ohm color reception system.

List price for complete kit . . .
7512A3 \$8.95

7512-A Mast mounted matching transformer . . . list \$5.40

7512-B TV Set mounted matching transformer . . . list \$4.15

FINCO-AXIAL SHIELDED COLOR CABLE, CX Series

Highest quality, 75 ohm swept coaxial cable (RG 59/U) complete with Type F fittings, weather boot ready for installation.

Available in 25, 50, 75 and 100 foot lengths. List price . . . \$5.55, \$8.65, \$11.50 and \$14.20.

Write for Color Brochure # 20-349

the
complete
color TV
reception
system

For the best color TV picture

*eliminates color-fade, ghosting and smearing!
Improves FM and Stereo, too!*

QUICK, EASY INSTALLATION

ENJOY brilliant "TV-Studio" color reception today by changing over to the new Finco-Axial Color Reception System. NOW, color fade, ghosts and smears are a thing of the past. Finco-Axial shields color sets against signal loss . . . eliminates outside interference and mismatch problems.

THE FINNEY COMPANY 34 WEST INTERSTATE STREET, DEPT. RE BEDFORD, OHIO

ASSEMBLE YOUR OWN ALL-TRANSISTOR *Schober* ELECTRONIC ORGAN



3 NEW MODELS

Recital	\$1500
Console II	\$850
Spinet	\$550

This is the all-new, all-transistor Schober

Recital Model...the most versatile electronic organ available today. Its 32 voices (plus amazing "Library of Stops"), 6 couplers and 5 pitch registers delight professional musicians...make learning easy for beginners. Comparable to ready-built organs selling from \$5000 to \$6000.

The pride and satisfaction of building one of these most pipe-like of electronic organs can now be yours...starting for as low as \$550. The Schober Spinnet, only 39¼ inches wide, fits into the smallest living room. The new, all-transistor Schober Console II is the aristocrat of "home-size" organs...with two full 61-note manuals, 17 pedals, 22 stops and coupler, 3 pitch registers and authentic theatre voicing.

AND YOU SAVE 50% OR MORE BECAUSE YOU'RE BUYING DIRECTLY FROM THE MANUFACTURER AND PAYING ONLY FOR THE PARTS, NOT COSTLY LABOR.

It's easy to assemble a Schober Organ. No special skills or experience needed. No technical or musical knowledge either. Everything you need is furnished, including the know-how. You supply only simple hand tools and the time.

You can buy the organ section by section...so you needn't spend the whole amount at once.

You can begin playing in an hour, even if you've never played before—with the ingenious Pointer System, available from Schober.

Thousands of men and women—teenagers, too—have already assembled Schober Organs. We're proud to say that many who could afford to buy any organ have chosen Schober because they preferred it musically.

Send for our free Schober Booklet, describing in detail the exciting Schober Organs and optional accessories; it includes a free 7-inch "sampler" record so you can hear before you buy.

THE Schober Organ CORPORATION

43 West 61st Street, New York, N.Y. 10023
Also available in Canada, Australia, Hong Kong, Mexico, Puerto Rico, and the United Kingdom

THE SCHOBOR ORGAN CORP., DEPT. RE-42
43 West 61st Street, New York, N.Y. 10023

Please send me FREE Schober Booklet and free 7-inch "sampler" record.

Enclosed find \$2.00 for 10-inch quality LP record of Schober Organ music. (\$2.00 refunded with purchase of first kit.)

Name _____

Address _____

City _____ State _____ Zip No. _____

Circle No. 23 on reader's service card

SERVICE CLINIC continued

but the meter reading slowly rises until the meter needle is pegged! The reading fluctuates, especially on speech recording, but sometimes the needle sticks at full scale; I can flip it with a finger and it comes back, though. What is this?—H. N., Greensboro, N.C.

Since your recording is normal, that eliminates the chance of a slowly increasing signal, and leaves only the metering circuit itself. In this stereo recorder, only one meter is used, and it reads a combination of the signals on both heads. The drawing shows the metering circuit, with switches omitted for clarity.

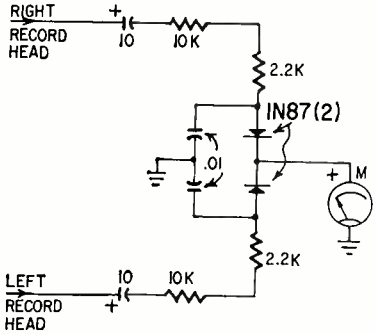

I'd suspect a leaky electrolytic capacitor, from the "slow-rise" symptom. Of course, it could be a heat-sensitive resistor, but these aren't as common as leaky electrolytics in transistor equipment. (Don't overlook them, though; nothing is impossible.)

For a fast check, disconnect either diode from the meter, and run the recorder. If you still get the symptom, the trouble is in the side that's still in-circuit. If the trouble is gone, it's in the side you disconnected!

**Signal, No Raster;
No Signal, Raster!**

I have a Canadian Admiral 21F1 with no raster. I took the antenna off, and the raster came back. I replaced the horizontal oscillator tube, output, etc. without results. Checked all parts in afc—nothing. What's this?—G. B., Wingham, Ont.

This is afc trouble. Without an input signal, your oscillator is able to free-wheel, and drive the output tube. When a signal is fed in, something in the afc circuit is doing just the opposite of what it's supposed to! It's throwing the horizontal oscillator so far off frequency that it's effectively killing it.

Possibilities: leakage in one of the capacitors that feed in the sync or comparison pulses, a resistor that has drifted far off value, or even a defective 6AL5 afc tube. This can happen to any type of afc circuit, and does. Check the dc voltages around the afc without a signal;

then recheck with a signal, and you'll get an idea of where to look.

Missing Tuning Slug

I just picked up an old FM radio. It wouldn't work until I put an iron screw into one of the coils! I can find a place where the coil works, by juggling the screw. Also, the set uses a 19T8 tube. I've got several 6T8's. Can I work out an interchange between them? They're the same, aren't they?—L. T., Brooklyn, N.Y.

I think you've found the trouble! There must be an iron core slug missing from this coil. Not an unusual thing: I found a long lag-bolt in the sound i.f. coil of an old TV one day, being used as a slug! A little big, but it worked fairly well! So check the size of the coil; you can get replacement cores at your radio parts store. Try several until you find one that makes the set work best.

Unfortunately, this is a series-heater circuit, so I'm afraid you're out of luck on the tube replacement. The 6T8 and 19T8 are exactly the same *except* for the heaters. 6T8's have a 6.3-volt, 450-mA heater; 19T8's use only 150 mA. Only way to convert here would be to add a 6.3-volt filament transformer for the 6T8, and put a resistor in place of the 19-volt heater to complete the string. 19T8's are listed in the current radio mail-order catalogs for \$1.85.

Diagnosing Vertical Troubles

Is there any way I can tell whether the trouble is in the vertical oscillator or the sync, without pulling the chassis?—Y.L., Montreal, Quebec.

Yes, there is. Try the vertical hold control; if this makes the picture roll up and down, then the oscillator is capable of running on-frequency. If it will roll in only one direction (either up or down), then something's wrong in the oscillator circuit.

While rolling the picture down, watch the blanking bar as it nears the bottom of the screen. If it suddenly snaps out of sight about 2–3 inches before it gets to the bottom, then there is definitely sync. If the picture rolls smoothly past the bottom without even slowing up, there's no sync. END

All about HOME TV RECORDERS

Catch up on the most exciting entertainment idea since television! Several machines at prices from \$500 to \$2,000 are already on the market—more are coming soon. Learn how they work, what sort of picture quality they give, how much they cost to use . . .

. . . all in May Radio-Electronics

New Professional DC 'Scope Heathkit® IO-14

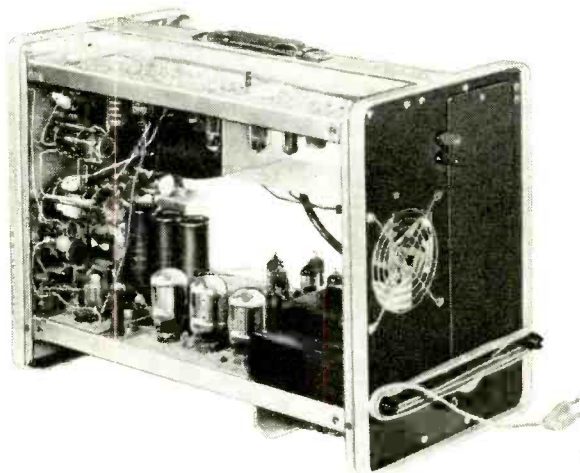

Kit **\$299**
Factory Assembled **\$399**

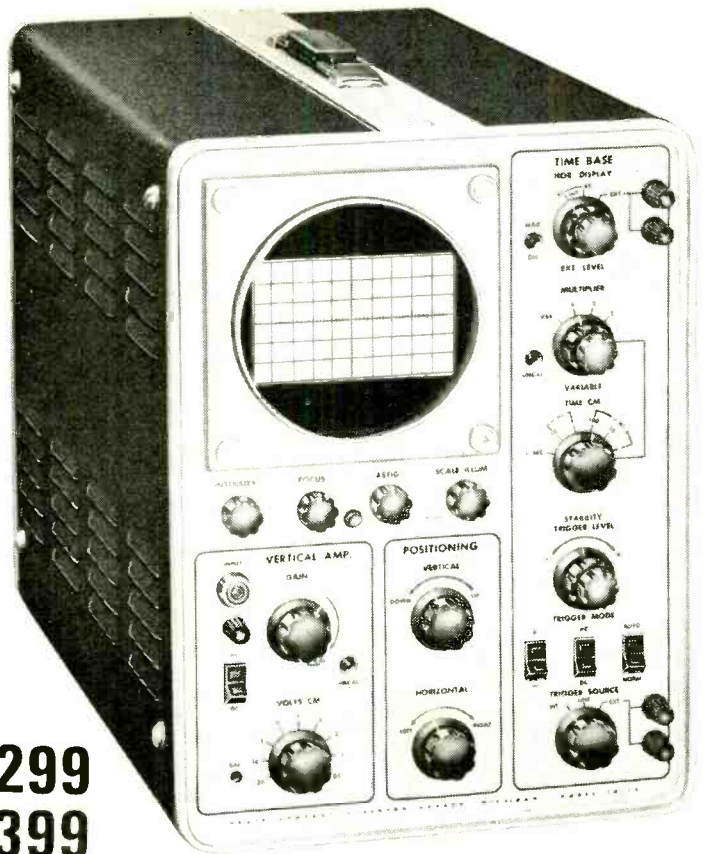

Eighteen Years Ago Heath Broke The Price Barrier On Oscilloscopes With A Low-Cost Scope For Hams, Hobbyists, And Service Technicians. Now Heath Breaks The Price Barrier Again! . . . With A Precision, Fast-Response, Triggered Sweep, Delay Line Oscilloscope For The Serious Experimenter, Industrial Or Academic Laboratory, And Medical Or Physiology Research Laboratory.

- A high stability 5" DC oscilloscope with triggered sweep • DC to 8 mc bandwidth and 40 nanosecond rise time • Vertical signal delay through high linearity delay lines—capable of faithful reproduction of signal waveforms far beyond the bandwidth of the additional circuitry • Calibrated vertical attenuation—from 0.05 v/cm to 600 volts P-P maximum input • Calibrated time base • 5X sweep magnifier • Forced air cooling • Input for Z axis modulation • Input for direct access to vertical deflection plates • Easy circuit-board construction & wiring harness assembly • Components are packaged separately for each phase of construction • Easy to align • Fulfills many production and laboratory requirements at far less cost than comparable equipment—particularly scopes capable of fast-rise waveform analysis • No special order for export version required—wiring options enable 115/230 volt, 50-60 cycle operation

Here Is A Truly Sophisticated Instrument . . . designed with modern circuitry, engineered with high quality, precision-tolerance components, and capable of satisfying the most critical demands for performance. The IO-14 features precision delay-line circuitry to allow the horizontal sweep to trigger "ahead" of the incoming vertical signal. This allows the leading edge of the signal waveform to be accurately displayed after the sweep is initiated.

The IO-14 Provides Features You Expect Only In High Priced Oscilloscopes. For example, switches are quality, ball-detent type; all major control potentiometers are precision, high-quality sealed components; all critical resistors are 1% precision; and circuit boards are low-loss fiber glass laminate. The IO-14's cabinet is heavy gauge aluminum. Its CR tube is shielded against stray magnetic fields, and forced air ventilation allows the IO-14 to be operated under the continuous demands of industrial and laboratory use.

Kit IO-14, 45 lbs. \$299.00
Assembled IO-14, 45 lbs. \$399.00

IO-14 SPECIFICATIONS—(Vertical) Sensitivity: 0.05 v/cm AC or DC. **Frequency response:** DC to 5 mc, —1 db or less; DC to 8 mc, —3 db or less. **Rise time:** 40 nsec (0.04 microseconds) or less. **Input impedance:** 1 megohm shunted by 15 uuf. **Signal delay:** 0.25 microsecond. **Attenuator:** 9-position, compensated, calibrated in 1, 2, 5 sequence from 0.05 v/cm. **Accuracy:** ±3% on each step with continuously variable control (uncalibrated) between each step. **Maximum input voltage:** 600 volts peak-to-peak; 120 volts provides full 6 cm pattern in least sensitive position. **(Horizontal) Time base:** Triggered with 18 calibrated rates in 1, 2, 5 sequence from 0.5 sec/cm to 1 microsecond/cm with ±3% accuracy or continuously variable control position (uncalibrated). **Sweep magnifier:** X5, so that fastest sweep rate becomes 0.2 microsecond/cm with magnifier on. [Overall time base accuracy ±5% when magnifier is on.] **Triggering capability:** Internal, external, or line signals may be switch selected. Switch selection of + or — slope. Variable control on slope level. Either AC or DC coupling. "Auto" position. **Triggering requirements:** Internal: ½ cm to 6 cm display. **External:** 0.5 volts to 120 volts peak-to-peak. **Horizontal input:** 1.0 v/cm sensitivity (uncalibrated) continuous gain control. Bandwidth: DC to 200 kc —3 db. **General:** 5ADP31 or 5ADP2 Flat Face C.R.T. interchangeable with any 5AD or 5AB series tube for different phosphor characteristics. 4250 V accelerating potential. 6 x 10 cm edge lighted graticule with 1 cm major divisions & 2 mm minor divisions. **Power supply:** All voltages electronically regulated over range of 105-125 VAC or 210-250 VAC 50-60 cycle input. [Z Axis] Input provided. DC coupled CRT unblanking for complete retrace suppression. **Power requirements:** 285 watts, 115 or 230 VAC 50-60 cps. **Cabinet dimensions:** 15" H x 10 1/2" W x 22" D includes clearance for handle and knobs. **Net weight:** 40 lbs.

FREE! 1966 Heathkit Catalog



108 pages . . . many in full color . . . describe over 250 Heathkits for the lab, hobbyist, and industry.

Heath Company, Dept. 20-4
Benton Harbor, Michigan 49022

Enclosed is \$ _____, plus shipping for model (s) _____
 Please send FREE Heathkit Catalog & full IO-14 specifications.

Name _____

Address _____

City _____ State _____ Zip _____

Prices & specifications subject to change without notice.

TE-142



Circle 24 on reader's service card

You can earn more money if you get an FCC License

...and here's our famous CIE warranty that you will get your license if you study with us at home

NOT SATISFIED with your present income? The most practical thing you can do about it is "bone up" on your electronics, pass the FCC exam, and get your Government license.

The demand for licensed men is enormous. Ten years ago there were about 100,000 licensed communications stations, including those for police and fire departments, airlines, the merchant marine, pipelines, telephone companies, taxicabs, railroads, trucking firms, delivery services, and so on.

Today there are over a million such stations on the air, and the number is growing constantly. And according to Federal law, no one is permitted to operate or service such equipment without a Commercial FCC License or without being under the direct supervision of a licensed operator.

This has resulted in a gold mine of new business for licensed service technicians. A typical mobile radio service contract pays an average of about \$100 a month. It's possible for one trained technician to maintain eight to ten such mobile systems. Some men cover as many as fifteen systems, each with perhaps a dozen units.

Coming Impact of UHF

This demand for licensed operators and service technicians will be boosted again in the next 5 years by the mushrooming of UHF television. To the 500 or so VHF television stations now in operation, several times that many UHF stations may be added by the licensing of UHF channels and the sale of 10 million all-channel sets per year.

Opportunities in Plants

And there are other exciting opportunities in aerospace industries, electronics manufacturers, telephone companies, and plants operated by electronic automation. Inside industrial plants like these, it's the licensed technician who is always considered first for promotion and in-plant training programs. The reason is simple. Passing the Federal government's FCC exam and getting your license is widely accepted proof that you know the fundamentals of electronics.

So why doesn't everybody who "tinkers" with electronic components get an FCC License and start cleaning up?

The answer: it's not that simple. The government's licensing exam is tough. In fact, an average of two out of every three men who take the FCC exam fail.

There is one way, however, of being pretty certain that you will pass the FCC exam. And that is to take one of the FCC home study courses offered by the Cleveland Institute of Electronics.

CIE courses are so effective that better than 9 out of every 10 CIE-trained men who take the exam pass it...on their very first try! That's why we can afford to back our courses with the iron-clad Warranty shown on the facing page: you get your FCC License or your money back.

There's a reason for this remarkable record. From the beginning, CIE has specialized in electronics courses designed for home study. We have developed techniques that make learning at home easy, even if you've had trouble studying before.

In a Class by Yourself

Your CIE instructor gives his undivided personal attention to the lessons and questions you send in. It's like being the only student in his "class." He not only grades your work, he analyzes it. Even your correct answers can reveal misunderstandings he will help you clear up. And he mails back his corrections and comments the same day he receives your assignment, so you can read his notations while everything is still fresh in your mind.

It Really Works

Our files are crammed with success stories of men whose CIE training has gained them their FCC "tickets" and admission to a higher income bracket.

Mark Newland of Santa Maria, Calif., boosted his earnings by \$120 a month after getting his FCC License. He says: "Of 11 different correspondence courses I've taken, CIE's was the best prepared, most interesting, and easiest to understand."

Once he could show his FCC License, CIE graduate Calvin Smith of Salinas, California, landed the mobile phone job he'd been after for over a year.

Mail Card for Two Free Books

Want to know more? The postpaid reply card bound-in here will bring you free copies of our school catalog describing opportunities in electronics, our teaching methods, and our courses, together with our special booklet, "How to Get a Commercial FCC License." If card has been removed, just send your name and address to us.

THESE CIE MEN PASSED... NOW THEY HAVE GOOD JOBS

**Matt Stuczynski,
Senior Transmitter
Operator, Radio
Station WBOE**



"I give Cleveland Institute credit for my First Class Commercial FCC License. Even though I had only six weeks of high school algebra, CIE's AUTO-PROGRAMMED™ lessons make electronics theory and fundamentals easy. After completing my CIE Course, I took and passed the 1st Class FCC Exam. I now have a good job in studio operation, transmitting, proof of performance, equipment servicing. Believe me, CIE lives up to its promises. I really enjoy my work and I'm on my way up."



**Chuck Hawkins,
Chief Radio
Technician, Division
12, Ohio Dept.
of Highways**

"My CIE Course enabled me to pass both the 2nd and 1st Class License Exams on my first attempt...I had no prior electronics training either. (Many of the others who took the exam with me were trying to pass for the eighth or ninth time!) I'm now in charge of Division Communications. We service 119 mobile units and six base stations. It's an interesting, challenging and rewarding job. And incidentally, I got it through CIE's Job Placement Service...a free lifetime benefit for CIE graduates."

**Glenn Horning,
Local Equipment
Supervisor, Western
Reserve Telephone
Company**



"There's no doubt about it. I owe my 2nd Class FCC License to Cleveland Institute. Their FCC License Course really teaches you theory and fundamentals and is particularly strong on transistors, mobile radio, troubleshooting and math. Do I use this knowledge? You bet. We're installing more sophisticated electronic gear all the time and what I learned from CIE sure helps. Our Company has 10 other men enrolled with CIE and take my word for it, it's going to help every one of them just like it helped me."

CIE **Cleveland Institute of Electronics**
1776 E. 17th St., Dept. RE-16, Cleveland, Ohio 44114

Accredited by the Accrediting Commission of the National Home Study Council, and the only home study school to provide complete coverage of electronics fundamentals plus such up-to-date applications as: Microminiaturization • Laser Theory and Application • Suppressed Carrier Modulation • Single Sideband Techniques • Logical Troubleshooting • Boolean Algebra • Pulse Theory • Timebase Generators...and many more.



Cleveland Institute of Electronics

WARRANTY

of success in obtaining a
Government FCC License

The Cleveland Institute of Electronics hereby warrants that upon completion of the Electronics Technology, Broadcast Engineering, or First-Class FCC License course, you will be able to pass the FCC examination for a First Class Commercial Radio Telephone License (with Radar Endorsement) ;

OR upon completion of the Electronic Communications course you will be able to pass the FCC examination for a Second Class Commercial Radio Telephone License ;

AND in the event that you are unable to pass the FCC test for the course you select, on the very first try, you will receive a FULL REFUND of all tuition payments.

This warranty is valid for the entire period of the completion time allowed for the course selected.

G. O. Allen

G. O. Allen
President

You'll star in TV Guide

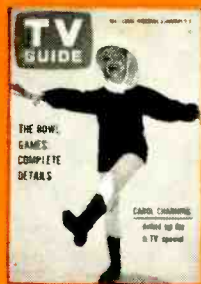

If you're "the right TV serviceman?"

Get the jump on profitable color set repairs.

Your Sylvania distributor will put your name, your town, your phone number in *TV Guide* as many as four times this year. If you're the right TV serviceman.



The right TV serviceman—Mr. Right—is any Independent Service Dealer who carries the most advanced replacement parts: our *color bright 85™* picture tubes and our color receiving tubes. He may also carry competing brands. So he's in a position to give unbiased opinions on color set repairs.

This is what our double-page, full-color localized ads explain to *TV Guide* readers. Just see your Sylvania distributor and the ads will tell all those TV set owners about you. How about it, Star?

Sylvania Electronic Tube Division, Electronic Components Group, Seneca Falls, New York 13148.

SYLVANIA
SUBSIDIARY OF
GENERAL TELEPHONE & ELECTRONICS **GTE**

Circle 25 on reader's service card



To know an editor

... and to help him know you.

How can a new Editor become acquainted with his readers and introduce himself to them? I feel I know many of you already, since some are readers of two magazines I formerly edited. But many more of you are new to me, and I to you.

One help is the fact that my career has been devoted to electronics. Your satisfactions, hopes, and problems are similar to what mine have been. I've known the thrills (and disenchantments) of servicing sets for the public; the satisfaction of discovering new ways to troubleshoot a complicated piece of equipment; the fascination of watching electronics technology grow to the highly skilled professional vocation of the Space Age. I have known the feeling that comes when something you've built works the first time you turn it on. I've watched the light of understanding spring into the eyes of a student who suddenly grasps some electronic principle that has eluded him for days.

Tough dogs have stumped me as they have you from time to time, and believe me there are tough dogs in every field of electronics. I solved mine the same way you do: by reading and studying and getting into the circuitry with a meter, scope, and solder gun, and sweating until the fault is found. So you see, we have much in common.

The most rewarding experience of all for me, however, has been my work in writing and preparing articles for magazine publication. For any Editor, the highest praise he can receive is to learn from his readers that the leadership of his publication is being felt; that his efforts and those of his staff are proving valuable; that his magazine is both read and understood by a sometimes astonishing variety of readers. The thrill of serving an industry in this manner surpasses any other I can imagine.

And what an industry this one is! The field of electronics, notwithstanding its spectacular growth already, has really only begun to blossom. Where it goes from here, and at what phenomenal rate, depends on people like you. Whether you're a technician, an engineer, a home-lab experimenter, an electronics student, or a teacher—whatever your connection with electronics, the future of the indus-

try depends on how well informed and knowledgeable you stay. It isn't enough any more to be expert in one facet of electronics; if you and the industry are to develop, you need to recognize the *whole* picture, the latest up-to-date picture, and that's what I plan to bring you over the next months and years in RADIO-ELECTRONICS.

Some of the goals I'll be aiming at in these pages will be difficult to achieve, some not so difficult. All will be centered on the primary theme of helping you. I expect RADIO-ELECTRONICS to lead you well in the industry; to keep you the best informed group of readers ever to pick up and read a specialized publication such as this; to teach you not only the techniques you need right now to profit from and enjoy your work with electronics but also the advanced concepts necessary to understand the future of this exciting and expanding technology; to help you make the most of electronic knowledge you already have, for a rich and rewarding career. In other words, I plan that RADIO-ELECTRONICS will continue to be the best all-around value you can get for your magazine money.

And so we come back to the problem: How do I become better acquainted with you? There are too many of you for me ever to meet you all individually, although on field trips I'll meet some of you. I can put questionnaires in the magazine or send them in the mail, and I shall; but in those you can only answer questions—there's still not much chance to get acquainted.

So, of course, the best answer is for you to introduce yourself to me through your letters. You'll be surprised how well this works. You'll get to know me through this editorial page every month and through whatever answers we print in our Correspondence department, and I'll get to know you from the letters you write. You can tell a lot about yourself on just one typewritten page.

So write! Write when you have a troubleshooting problem. Write if you need management advice for your electronics business. Write when you need information; if we don't have it, we can often suggest where to look. Write when there's something wrong in the magazine. Write and tell me when you see something done especially well. Write with article ideas, when you have them.

If none of those reasons is sufficient, just write occasionally to let me know you're still reading RADIO-ELECTRONICS. Tell me what you think of the magazine, of its authors (good and bad), of new features you'd like to see. Tell me your specific interest in electronics, and your part in the field.

With this help from you, the staff of RADIO-ELECTRONICS can give you a really top-grade publication.

—Forest H. Belt

Talk Over A Light Beam

Steady, flickerless beam of white light carries voice or music across your basement or back yard

By VIRGIL L. McCARTY

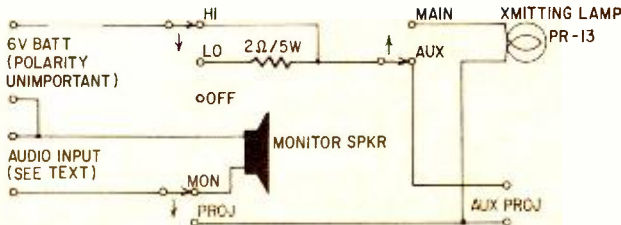

Fig. 1—Wiring diagram of transmitter. Monitor speaker and switch, resistor and Hi-Lo switch, and auxiliary projector terminals and switch, are all optional.

Fig. 2 — Receiver circuit. Other generating photocells will work, but may require more amplifier gain. Solar Systems type 10-8L has high output.

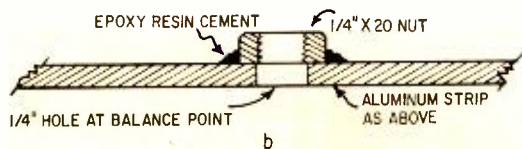
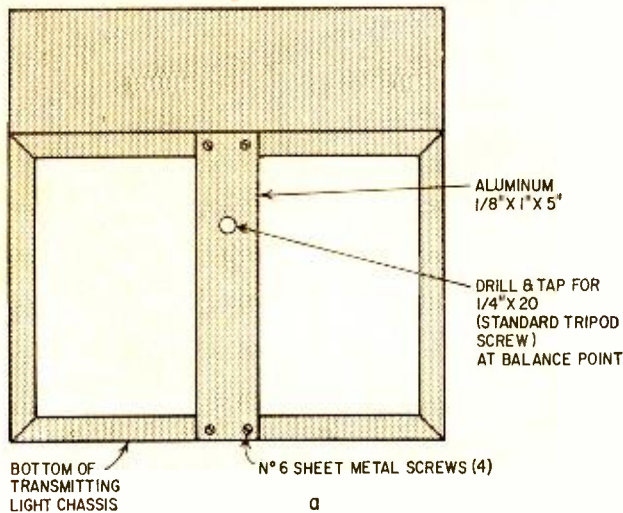
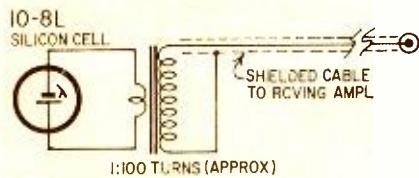

Fig. 3—*a*—Suggested tripod mount for light-beam transmitter. Threaded hole should be at center of gravity of completed chassis, to reduce accidental shifting of aim. *b*—Alternate method of making a threaded hole, if suitable tap is not available.

THERE'S SOMETHING ABOUT COMMUNICATING OVER A LIGHT BEAM (even if it isn't a laser) that has thrilled thousands ever since it was first thought of. Sending voice or music via an apparently steady beam of light is an ever-popular project at school science fairs around the country, and it's an exciting way to spend spare hours in the yard or basement.

The simplest way to modulate a light beam for communicating intelligence is simply to switch it on and off (either electrically or with light shutters). Morse code is sent this way between ships at sea. But for voice or music, a different kind of modulation is necessary.

The most obvious approach is to connect a lamp across the output of an audio amplifier. The varying ac signal power would vary the light intensity in proportion, modulating the beam. It turns out, though, that for all but a few recent flea-size lamps, the thermal lag of the filament is so great that the light intensity can't change fast enough to follow the audio. The filament can't heat and cool fast enough.

To overcome this problem, I chose to heat the filament to approximately its normal light output with dc, and then to superimpose the ac signal on the dc. As long as the peak-to-peak ac is only a small percentage of the steady dc, the lamp will follow the modulating signal faithfully. When the modulating voltage is 1% of the dc voltage, frequencies up to 15 KHz can be carried on the beam.

Keeping the modulation percentage small also has an extra advantage: the beam doesn't flicker visibly—which adds an element of mystery to the operation!

To put the principle to work, I built a light-beam transmitter out of a Sears 6-volt lantern. The unit shown on the cover and in the photo at the top of the next column was simply detached from its battery and mounted without changes on 5 x 7 x 2-inch chassis. The barrier terminal block behind it is for various connections between lamp and power

WHAT YOU'LL NEED

- Sears 6-volt Sportsman Lantern (Sears, Roebuck & Co.) or Eveready 106 camp lantern, or similar
- 2-ohm, 5-watt resistor (optional—to reduce light intensity and battery drain)
- 2 spdt toggle switches (Eagle 479 or equivalent)
- Single-pole 3-position rotary switch (Cutler-Hammer 8122K4, Centralab 1461 or equivalent)
- 3-inch PM speaker (optional—monitor speaker)
- 6-volt lantern battery (Eveready 731, Burgess TW1, Ray-O-Vac 918 or equivalent)
- Audio transformer (input, line-to-grid, mike-to-grid or intercom type), approx. 100:1 turns ratio (Knight 61 U 492, Stancor A-4744; Stancor A-4705)
- Silicon solar cell (Solar Systems 10-8L, available Allied Radio Corp., 100 N. Western Ave., Chicago, Ill., 60680, \$3.60. See Allied Catalog 250B [1965], page 245)
- Concave mirror (see text). Circular two-side shaving mirror with one concave (magnifying) side is available in department and drug stores. Also called "vanity mirror." Author used 10-inch-diam., 36-inch focal length size
- Amplifier for transmitter—4- or 8-ohm speaker output, 1 watt minimum. Input and gain suitable for desired source (mike, phono, etc.)
- Amplifier for receiver—high-gain, high-impedance input. Output for ear-phones or speaker, as desired

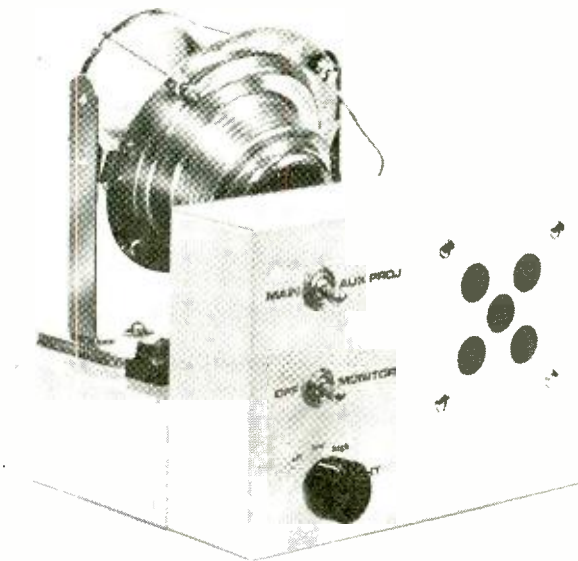

Dressed-up version of light-beam transmitter built by RADIO-ELECTRONICS. You can simplify panel by omitting switches.

source, and to the other parts of the system. (The photos here show an earlier version, built of wood, with a 1/4-inch clear plastic panel.)

Another 5 x 7 x 2 chassis, mounted upright against the lamp chassis, as shown in the cover photo, makes a "cabinet" for the monitoring speaker and for switches and controls. Construction and layout are not critical; the prototype of this design was built out of wood and clear plastic. Fig. 1 shows the transmitter circuit, Fig. 2 the receiver.

A sturdy camera tripod is the most convenient equipment for mounting the light-beam unit. A strip of aluminum 1 inch wide and 1/8 inch thick can be drilled and tapped as shown in Fig. 3-a as a tripod mount. Or a 1/4 x 20 nut can be cemented over a hole in the strip as shown in Fig. 3-b if tapping the hole is inconvenient.

To modulate the beam, almost any amplifier with a power of a watt or more is sufficient. I used one channel of a Sony TC-200 tape recorder.

Because the power of the transmitting light is limited by the size of lamp filament that can still follow the audio variations, the distance this system can cover depends heavily on the receiving end, and on the optics between.

I used a silicon solar cell (Fig. 2) as the receiving element, with a stepup transformer to boost the signal voltage, and a high-gain amplifier. The more concentrated the light beam from the transmitter (the less it spreads in a cone), and the more accurately it is aimed at the receiving cell, the greater will be the distance you can cover with the system. Increasing amplifier gain will also improve the transmission range, but only up to the point where amplifier noise, stray hum pickup and other noise sources begin to mask the signal.

In the first version, the stepup transformer was mounted in a can with the silicon cell, but this means a relatively high-impedance line between the transformer secondary and the amplifier input. That calls for shielded cable not more than 10 or 15 feet long. If you put the transformer at the amplifier, the leads from the silicon cell can be any convenient length and don't need shielding. It's important, though, to keep the transformer from picking up hum from the amplifier power transformer. In a word, use whichever arrangement is most convenient and gives you the least noise pickup.

The simplest and least expensive optics to help gather light for the photocell is a shaving mirror with one concave (magnifying) side, mounted with the photocell housing on a long adjustable arm (bottom photo at right). More effective

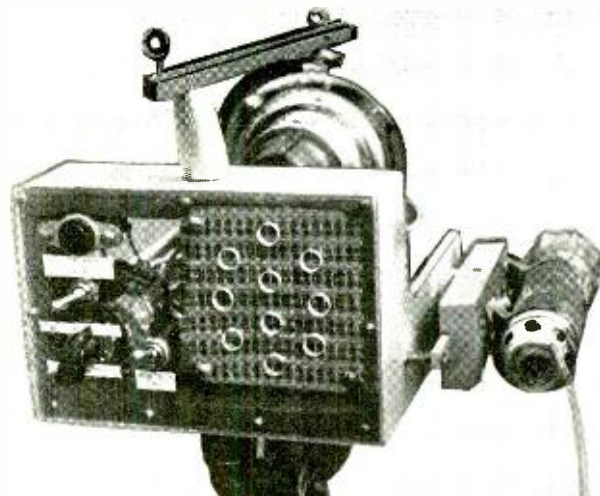

Panel of experimental light-beam transmitter was made of 1/4-inch clear acrylic plastic. "Chassis" proper was built up out of wood.

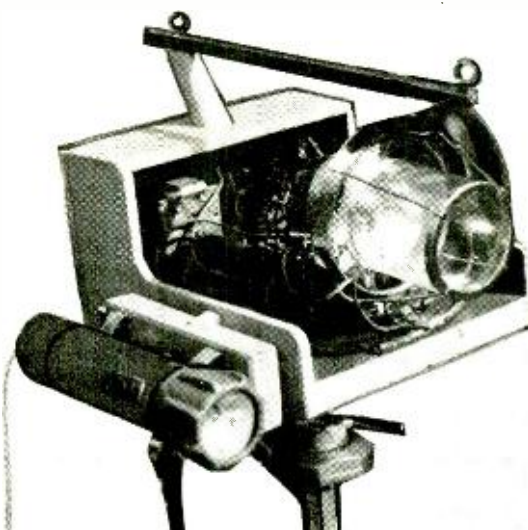

Flashlight on side of transmitter chassis is auxiliary light, on elaborate pivoted mounting to permit exact alignment. It is not essential to the system.

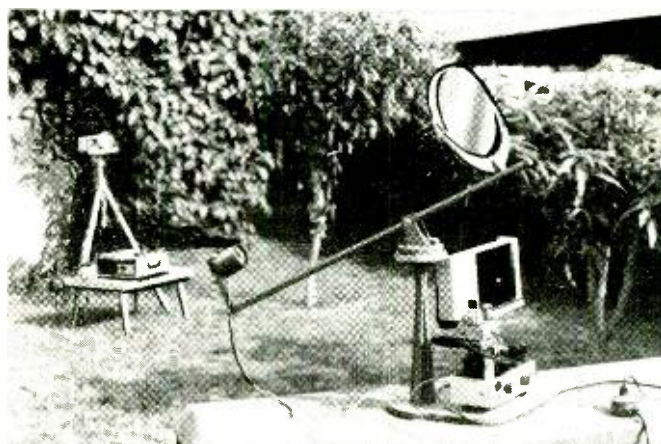

Receiving end consists of photocell and transformer shielded in tin can (far end of arm) and shaving mirror, plus high-gain audio amplifier.

(and complicated) systems may suggest themselves to those of you who are interested in optics.

Even in its simplest form, though, this light-beam communications link will provide many happy hours of experimenting. It could very likely win someone a prize at the next science fair!

END

The Two-Way Radio Technician

Look in on a growing field, hungry for men, that offers high returns and real independence

By JACK DARR SERVICE EDITOR

THE FCC ITSELF DOESN'T KNOW HOW MANY STATIONS IT HAS licensed in the Mobile Radio Services! If someone there walked across the room to get the answer, the figure would be obsolete before he got back to his desk. This tremendous growth has created a demand for highly skilled technicians to keep this equipment up to the exacting standards of the FCC.

To get the facts about it, we interviewed a full-time technician. Meet Joe Bollinger. Joe's a lean, fit-looking 6-footer, tanned to a healthy color. He smokes a curved-stem pipe and speaks with a pleasant drawl, full of humor—a valuable asset when you're asked impertinent questions on a broiling summer day!

Joe got his basic electronics training in the Army, at a Signal Corps school in Little Rock. Its 48 hours of classes per week covered material equivalent to a 4-year college course! After getting out of the Army in 1946, he got his FCC First-Class radiotelephone license, and went to work for the Arkansas State Forestry Service.

After some years at that, which wasn't as demanding as his present job (the state didn't have nearly as many radios then as it does now), he found himself doing more independent work than official. So he opened his own shop and has been very successful ever since.

Joe is affiliated with Motorola Communications & Electronics, as an MSS (Motorola Service Station). He does not work for Motorola, but is a factory-authorized service sta-

This is Joe Bollinger, a full-time two-way radio man with his own business. Like many others, he got his start by working for someone else.



tion for all Motorola two-way radio products. He also services several other makes in the same capacity.

Home, shop and headquarters are in Nashville, Ark., a small town in the south central part of the state, but his service area goes far and wide. He'd like to cut it down a little; he covers about 60 miles in every direction.

After some trouble in running him down, I finally caught him one hot Saturday afternoon, at his comfortable home, and we sat down to talk.

"How do you like this work?" I asked.

"Fine!" He grinned. "It's a headache once in a while, like everything else, but I like it."

"Keeps you moving, doesn't it?"

"Yep. I'll drive seven or eight hundred miles a week, in the busy season, and that seems to be most of the time."

"How many hours a week, at a guess?"

"Oh, from 50 to 60 hours. It varies."

"How about your test equipment?" I asked.

"That's really important," he answered seriously. "I've got about \$3,000 worth out there in the truck now, and about that much more in the shop. Your equipment has to be accurate, to meet the new FCC standards, and that makes it a lot more expensive. A signal generator that's 1% accurate is about \$100, but one that's .0002% accurate gets up around \$2500! It sure is expensive to move that decimal point in the tolerance!

"Then, there are special 'set testers' that cost from \$175 on up, but they're worth it. It'd take all day to make the tests you can make with just one twist of the selector switch, so they pay for themselves. Anything that saves time makes money."

"You're so right," I agreed. "The faster you do each job, the more jobs you do in a day."

"This stuff is expensive, but it's rugged," he said. "I do have to bring it all into the shop every couple of weeks and tighten up all the bolts I've shaken loose hauling it around. But it's easy to keep calibrated. Most of the frequency meters, signal generators and monitors can be self-calibrated by checking them against WWV. That way, you don't have to send them off for recalibration, the way we used to.

"Good test equipment is built to take it. It'll last for a long time if you give it any care at all. So, in the end, the best test equipment is the cheapest."

"What would you pick as the minimum test equipment to get started?" I asked.

"Well, let's see. A good vom, a set tester, a frequency and deviation meter and a good rf wattmeter. Say about \$1600-1700, plus your hand tools and parts stock, which won't be very big—tubes and vibrators and so on. Make it about \$2,000 total."

"How about transportation?"

"Use the family car, at first," he said. "You can carry all the stuff on the back seat. That's what I did. Later, you can use any of the van trucks, a good pickup or almost anything."

"OK. Now, how about the most important part of all, the training. How much do you need?"

"All you can get!" he answered. "And you've got to keep on studying if you're going to keep up. I'd say that your technical training ought to be about the same as, say, a radio station engineer's or a really good TV technician's. You've got to have a thorough background in electronics fundamentals. With that, it won't take long to pick up the details of this kind of work."

"A lot of correspondence schools have specialized courses for two-way radio servicing now," I pointed out.

"Yep. Motorola's got a training course aimed especially at it, and so have a lot of the other makers. I have seen some sample lessons from that course, and from some of those correspondence schools, and they're written a lot plainer than the books you and I had to work on!"

"Yea, verily!" I agreed, remembering a lot of midnight oil.

"Once you finish your course and get your FCC First or Second-Class license, you're all set, as far as paperwork goes," Joe went on.

"Do you think it's as hard to get a ticket now as it was when we got 'em?" I asked.

"Not really," Joe said. "There's more stuff in the FCC exam, but if a fellow studies as he ought to, he won't have any real trouble. After all, all you really *need* is a Second-Class phone ticket, so if you bust your First-Class element you can always take it over again until you pass it!" I grinned sheepishly. That was the way I got mine!

"Now, how about some practical stuff?" I asked. "How would you go about getting into two-way radio work right now, if you were a young fellow?"

"Well," he answered thoughtfully, "there are two ways. Start in for yourself as an independent, or get a job with one of the outfits with a lot of two-way radios: state police, game and fish commission, forest service or one of several companies around here that have lots of two-way radios on trucks. A lot of them need a full-time technician just to take care of their radios. Just send in an application, stating your qualifications, and you'll have a pretty good chance."

"As usual, the hard way would be to start in for yourself, as an independent," I said.

"That's true in any business, isn't it? You can't just sit down, open up your test equipment and say, 'Here I am, folks! Come get me!' You have to make a survey of the area where you plan to start. Find out how many two-way radio systems there are, and how many of them *you* can get. Most of the owners already have some kind of maintenance agreement; they have to. But, if their present man is a long way off, and you're right there, you could get the job because you can give quicker service. Most of this stuff is 'emergency'; they want it fixed right now! But you have to let them know you're around—you have to go after the business; it won't come to you.

"I'd say that a territory with about 150–175 mobile units in it, within about a 30–40-mile radius of your headquarters, would be fine. Varies, of course—in big-city areas,

WHAT THE INDUSTRY SAYS

This story is written from the technician's viewpoint. To confirm Jack Darr's conclusions, we checked with some of the leading manufacturers of two-way FM radios.

The service manager of the largest maker of two-way radios said, "We have 800 shops in our organization. These are all independently owned. We could use many more licensed technicians to handle the existing volume of work."

Another large radio manufacturer: "We have about 5,000 men now, in 900 franchised shops, all independents. The need for qualified men is great, and it's enlarging."

From a major maker of components for two-way radios, "I think there are at least 2–3,000 qualified two-way radio technicians, and we need to double that number! The need is particularly great in the smaller towns; I feel that TV technicians can qualify easily, handling both entertainment products and two-way radio servicing profitably."

This article deals exclusively with business type two-way FM radio; we have deliberately left out Citizen's-band radio repairing. There's a large and steadily growing market for services here, too.

there are a lot more units per square mile than there are out around here."

Then we got to reminiscing about how some of our mutual friends had started in two-way radio. Joe, after getting out of the Army, started with a state agency. I'd been more or less dragged into two-way service. Police cars and such kept coming around to the radio-TV shop for repairs, and I was the only one with an FCC license.

One man had gone from a small radio station to work in the two-way radio section of the US Forest Service, and

another engineer at the same station had gone to a big oil pipeline company. A TV-radio technician in another town had also worked into two-way radio gradually, while another had gone to work for a big lumber company which had a large fleet of radio-equipped trucks, and so on. All these jobs resulted from applying to the bigger companies.

"OK. Now, just for the record, exactly what does your job involve?"

"Well, you're expected to be able to repair anything in the whole radio system," he answered. "Base station, mobile units, antennas, remote control systems, and everything. Not as hard as it sounds, for most of your troubles will be pretty simple.

Marion Bufkin, technician for a large lumber company, watches the meter on a specialized "set-tester" — designed especially for rapid work on a particular make. Also on the floor of the truck is his frequency meter.

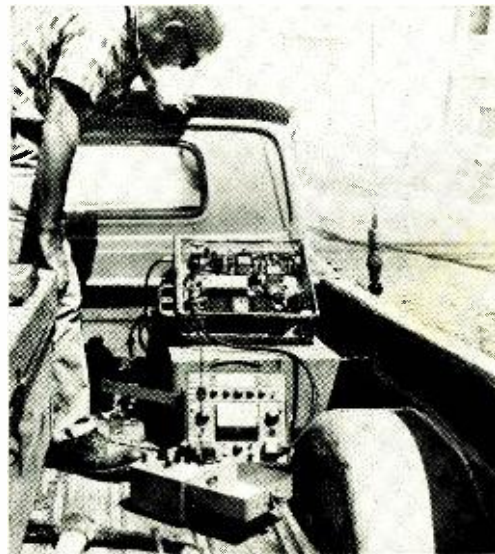

"Your base stations will be indoors, unless they're remote-controlled; then, they'll be in a little house up on a mountaintop. Mobile units you fix in the car or truck; most of the time, you have to go to them. Only a few will be able to come to the shop. With the right test equipment, though, it doesn't take long to find the trouble and fix it.

"You'll make installations, too, of course—base and mobile units. Mobile units are easier if you've got a garage space in your shop, but they usually don't take too long, and you can do 'em outdoors."

"Service data?" I asked.

"Plenty! Nowadays, you get a really complete service manual with every new radio set, and I do mean complete! Gives you everything you need, with plenty of diagrams, parts lists, everything. A lot of manufacturers send out regular monthly mailings of new radio schematics, service hints and so on. It's easier than TV in that respect. Manufacturers don't put out yearly models, but stick with basically the same model until something comes along that is really better. Like the time when they made the change from tubes to transistors, for instance. By the way, they sent me a big batch of stuff on transistor theory then, I remember, and it sure did help!"

About then, the phone rang and Joe picked it up. "Yep. OK. OK. Be right with you," he said and hung up. "Sheriff's office at Ashdown's all broke down!" he grinned. "Gotta get 'em back on the air. Saturday night's the busy night in any small town!" He checked his test equipment, hopped into the station wagon, and was off.

Two-way radio service is one of the fastest-growing branches of electronics today. As you can see, it takes a bit of travel, good test equipment and ready technical knowledge and skill. The pay is good and the work is never monotonous. In one day, you may go from a police department to a dam site, from a forest to a city. You're almost certain to meet a new lot of interesting people every day! END

THE SILICON CONTROLLED RECTIFIER, or thyristor, is the solid-state version of the thyatron. In many applications, it performs considerably better than its electronic equivalent. Briefly, the SCR is a silicon rectifier equipped with a trigger. When operated within its rated voltage limits, it will not conduct until the trigger is energized by a short positive pulse. Once conducting, it will not stop until the supply is interrupted.

SCR's are now available over the counter at voltages up to 400 rms, and for currents from a few milliamperes to 50 amperes. They have recently been used in a wide variety of low- and medium-power hand-tool speed controls, lamp dimmers and other devices. The higher-power (10 amps and up) SCR's are ideal for controlling theatrical and photographic lights, replacing heavy and costly faders, saturable reactors and variable transformers. They have the added advantage that the control can be some distance from the power circuits, and can be electrically isolated from it quite simply.

An SCR, if triggered at the beginning of a positive half-cycle, passes to the load pretty nearly all the power in that half-cycle. If triggering is delayed until a part of the cycle has passed, power supplied to the load is proportionally reduced.

This happy property is demonstrated in Fig. 1, a circuit that is excellent at all power levels but too costly for currents above about 2 amperes.

Here, alternating current from the line is full-wave-rectified in the bridge, giving the SCR a pulsating dc supply. *This must not be filtered, or the circuit will not shut off.* SCR and load are in series across the bridge output.

Pulses to trigger the SCR, and an R-C delay circuit to permit varying the timing of the pulses, are supplied by a unijunction transistor, Q. When timing potentiometer R3 is set at a low value, the R-C delay is slight, and vice versa.

Capacitors C1 and C2 protect both the control circuit and the load from incoming line spikes and from outgoing spikes produced by triggering the SCR. C1 can be considerably larger than shown; C2 cannot be increased much without impairing the control operation.

Zener diode D1 and the ordinary diode D2 prevent overvolting the unijunction. They may be omitted where the line voltage is free of spikes and surges, but are very desirable on ordinary industrial power lines.

A resistive load is shown. If an inductive load is used, hang a reversed diode across it to absorb flybacks, which sometimes cause unwanted and unscheduled SCR conduction.

Input, trigger and output waveforms in this circuit are sketched in Fig.

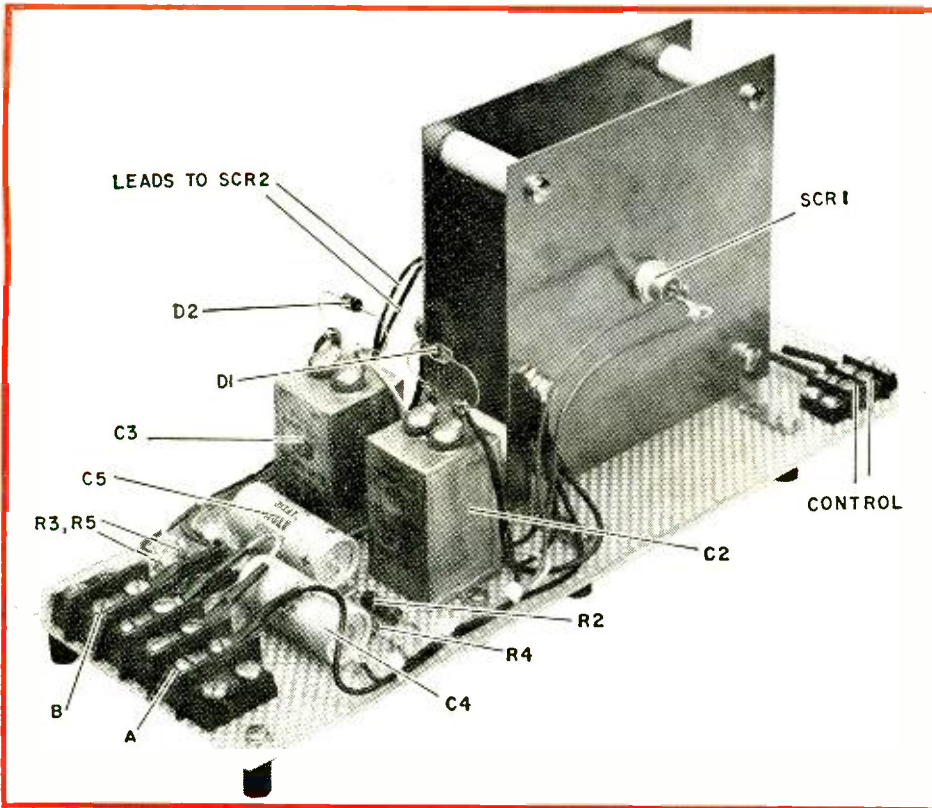

A 1-kw SCR power control unit, out of its housing.

HIGH-POWER SCR CONTROLS FOR YOU

Simple, compact, inexpensive circuits handle up to 10 amperes, switched or continuously variable, for remote-controlling theater or photo lights

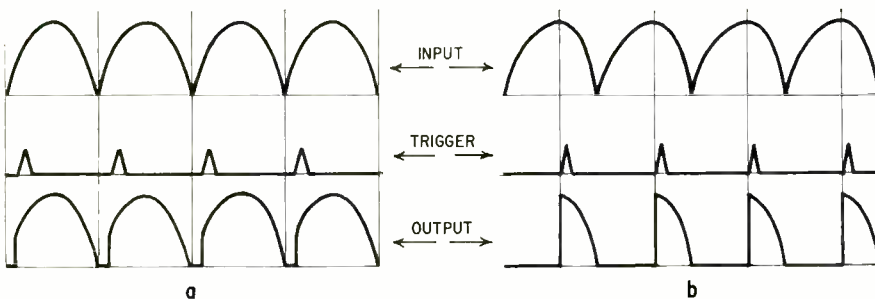
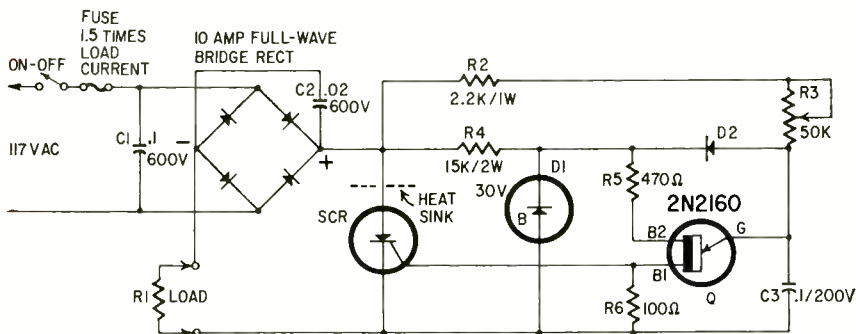

Fig. 1—A basic and simple SCR and control circuit for loads of 2 amps or less. (It gets expensive for higher loads.) Waveforms show almost full power (a) and less than half power (b), depending on when in each cycle SCR is triggered. R3 determines that.

1. In *a*, the trigger delay is slight, and the control resistance (R3) is set at a low value. So triggering takes place very close to the beginning of each half-cycle, and the output (load) receives almost full power. In *b*, triggering takes place much later in each cycle, the greater delay being produced by a higher-resistance setting of R3. The load now receives less than half maximum possible power. With the constants shown, load power can be varied from 0% to about 98% of maximum.

This is a relatively simple and troublefree circuit, ideal for night lights, small photographic printers and other light loads.

When the load demands are great, the simple circuit of Fig. 1 is costly: a 10-ampere bridge rectifier costs considerably more than an additional 10-ampere SCR. For higher currents, an inverse-parallel arrangement of two SCR's is most economical. Fig. 2 shows how it is done.

Here, the supply is raw ac from the line. Gating is also supplied from the line through a rectifier-resistor-capacitor network. The control, to be discussed later, is the firing-delay element, and permits anything from 0% to more than 98% of available power to be delivered to the load.

To see how it works, assume that point A (Fig. 2) is at zero potential, at the beginning of a positive-going half-cycle. As the cycle progresses, the cathode of SCR1 and the anode of SCR2 become positive. SCR1, being back-biased, cannot conduct. SCR2, not being triggered, also does not conduct. At the same time, through diode D1, a positive potential is applied, through the control circuit (a resistance) to C3, and thence, through the network R3, C5 and R5 to the gate of SCR2. When this potential rises to the trigger voltage (about 4), the SCR conducts, and the load receives power. It stays energized for the rest of the half-cycle. At the end of the half-cycle, SCR2 has no potential across it and goes out of conduction.

During the following negative half-cycle, point B (Fig. 2) goes positive, and SCR1 goes into conduction with a mirror reversal of the process just outlined. As soon as either SCR conducts, voltage across the trigger and control network drops very low ($\frac{2}{3}$ of a volt or so), and the trigger circuit is inactive until the next half-cycle begins.

The simplest control device, obviously, is a switch. An SCR permits turning on and off a high-power load with a pretty flimsy switch, because the switch carries only triggering currents (a few milliamperes—seldom over 25). This arrangement is useful for controlling large lamp loads, whose turn-on in-rush currents may be 10 or more times their steady-state current, making welded

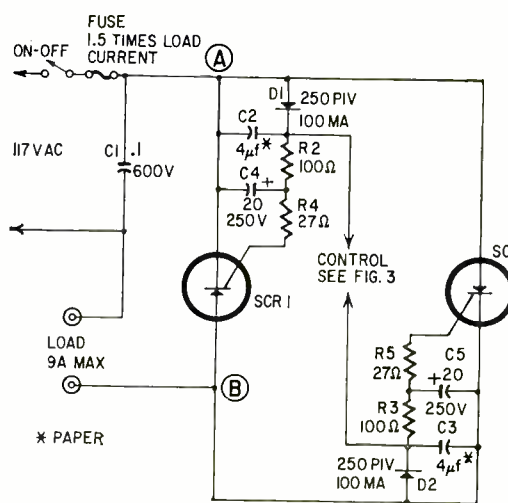

Fig. 2—Full-wave SCR control circuit that requires no rectifier. Note that it's symmetrical.

- C1—0.1 μ f, 600 volts
- C2, C3— μ f, 150 volts, paper (can also use 5- μ f 250-volt electrolytic)
- C4, C5—20 μ f, 250 volts, electrolytic
- Load—minimum hot resistance, 12.9 ohms
- R2, R3—100 ohms, $\frac{1}{2}$ watt
- R4, R5—27 ohms, $\frac{1}{2}$ watt
- D1, D2—250-volt min piv, 100 ma or greater silicon diode (Sarkes Tarzian F-6 or equivalent)
- SCR1, SCR2—5-amp, 200-volt (min) SCR's (International Rectifier SCR-04 or equivalent)

switches and similar annoyances quite common. A 1,000-watt lamp, for example, if turned on at the peak of a cycle, has an instantaneous current drain of about 110 amperes, even though its steady-state current is only 8.7 amperes. Some photographic floodlamps have even higher turn-on surge currents.

The most common control device is a variable resistor, which permits gradual turn-on of the load, preventing turn-on surges. It also permits operating the load at any value less than full. Circuit and values for a suitable resistive control for the SCR circuit of Fig. 2 are shown in Fig. 3-a. This control may be placed any distance up to several hundred feet from the SCR's. The control leads must be adequately insulated; they are hot to ground by the full line voltage for a part of each cycle. And they should be adequately shielded, as the steep wavefronts caused by triggering the SCR's are rich in harmonics, and produce very strong radio interference up into the megacycle range.

Both these troubles can be reduced by using a photoelectric control, outlined in Fig. 3-b. The photocell is placed close to the SCR's, in a light shield, and its resistance is varied by changing the illumination on the cell. The lamp control is a potentiometer, which can be put any reasonable distance away.

Constructing an SCR power control is relatively simple and straightforward, and requires no special techniques. The only critical construction is that of the heat sinks for the SCR's, which must be adequate, or the SCR's will have a short life. Where two SRC-04's (International Rectifier Corp.) handle a kilowatt, each should have a sheet-copper heat sink about 5 by 5 by $\frac{1}{16}$ inch. These must be insulated from ground, and arranged so that they cool by natural convection (plates vertical, air flow unobstructed).

A 1-kilowatt load control using the circuit of Fig. 2 is shown in the photo. Note that the SCR's are bolted directly

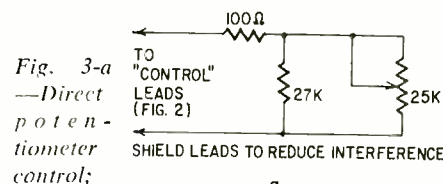
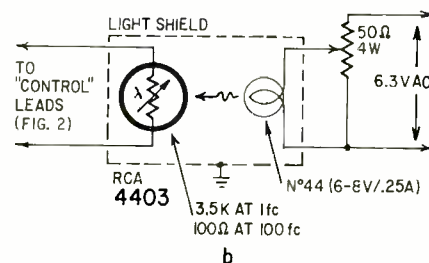

Fig. 3-a
—Direct potentiometer control;



b—Control via light-dependent resistor. Such devices as Raytheon's Rayistors, which incorporate lamp and LDR in same housing, could also be used.

to the heat sinks, to give maximum heat conduction. This control is normally housed in an amplifier case with a perforated top to give adequate ventilation.

Used with a group of high-intensity photographic lights, the power control's performance was excellent. With immediate turn-on (switch), the old bugbears of switch failure and contact welding immediately vanish. In this use, the SCR control performs slightly better than a heavy-current relay.

When used as a proportional control (Fig. 3), dimming lamps during focusing is possible, and is obtained with the light, compact SCR control as easily as with a massive variable transformer. The remote-control feature is also a great convenience. A slow turn-on, easily attainable with a potentiometer control, eliminates warmup surges, so that a 1-kilowatt lamp load can be fused at 10 amperes. Higher-rated or slow-blow fuses are no longer necessary.

When the slow turn-on is used, other equipment connected to the same line is not disturbed by the lamp load. Lamp life seems to be extended, and catastrophic lamp failures reduced. END

A Transistor "Line Transformer"

Low-cost impedance-changer with power gain

By **PETER E. SUTHEIM**
ASSOCIATE EDITOR

THIS TWO-TRANSISTOR CIRCUIT IS THE equivalent of a high-impedance-to-low-impedance line transformer—only better. First, it costs less than a transformer of similar characteristics. Second, its impedance ratio is higher than that of any practical transformer. Third, it has power gain.

Response at maximum output is within 1 dB or better from 20 to 30,000 Hz. (At 1 volt output, it is flat within 1 dB from 10 to 60,000 Hz). Distortion is extremely low—just how low depends, along with output voltage and gain, on how the "transformer" is used. More later.

tial even with the negative feedback. This makes it possible to raise the input impedance still further (if we're willing to throw away gain) by connecting build-out resistor R_A between the signal source and the base of Q1. R_A and the input impedance of Q1 make a voltage divider; by selecting R_A , the overall gain can be varied from less than 1 (attenuation) up through the full amount available from the stage.

In this particular design, the value of R_A for unity gain is about 1.2 megohms. So, the total resistance seen by a signal source looking into the input of the amplifier is about 1.25 megohms (1.2 meg + 50,000 ohms).

One further detail before we look

over a wide range of temperatures and makes it pretty well independent of manufacturing variations in transistors.

The actual output impedance (source impedance) of the output is extremely low—a few ohms. But—as with tube cathode followers—you cannot ex-

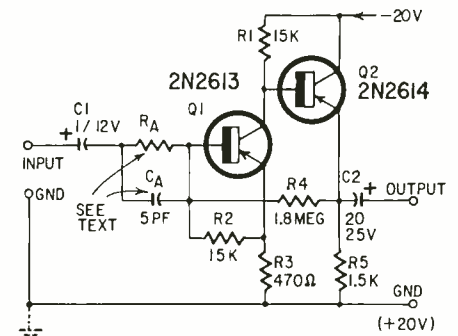

Fig. 1—Circuit of the "line transformer". Input impedance can be greater than 1 megohm.

C_A —approx. 5 pF (see text)
C1—1 μ F, 12 volts, electrolytic
C2—20 μ F, 25 volts, electrolytic
(0.5 μ F paper or ceramic is enough if following stage has input impedance of 100,000 ohms or higher)

Q1—2N2613 (RCA)
Q2—2N2614 (RCA)
 R_A —see text
R1, R2—15,000 ohms
R3—470 ohms
R4—1.8 megohms
R5—1,500 ohms

pect such a stage as this to work into a load equal to its own impedance and still have low distortion. This point has been stressed often in RADIO-ELECTRONICS articles and elsewhere, so I won't belabor it here; just don't expect to drive 8-ohm earphones with this amplifier! It does work well into 600 ohms, or anything higher, which makes it a natural for broadcast and PA applications. Its output, of course, is unbalanced, which might not matter for many applications (try it and see). For low-level balanced-line installations where there is trouble with crosstalk and hum as soon as some-

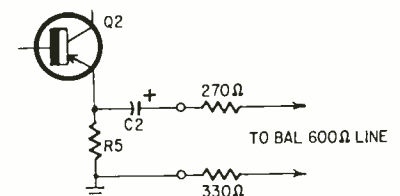
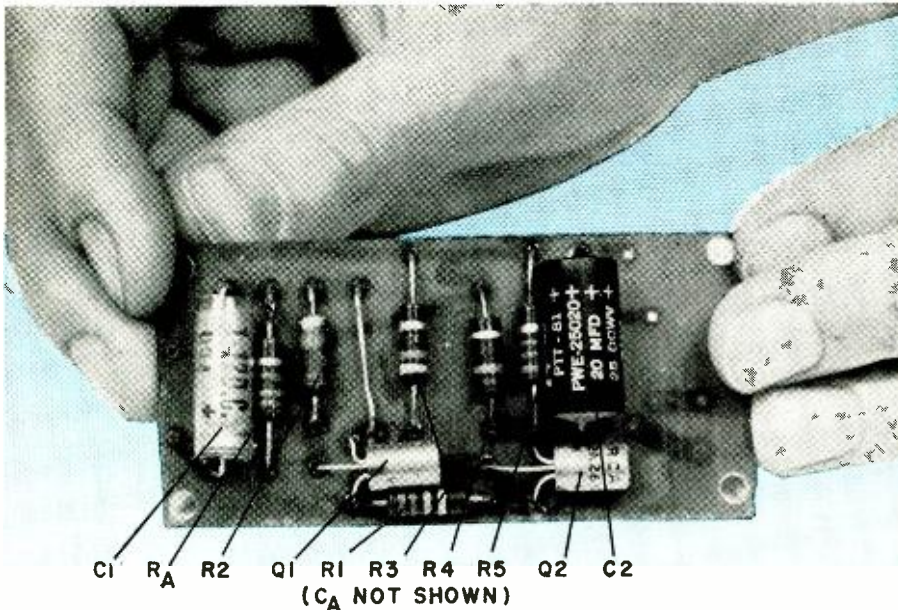

Fig. 2—Simple trick for feeding balanced lines with single-ended output works well for many broadcast installations.



"Line Transformer" on home-made etched circuit board. Photo shows it about actual size.

The "transformer" (Fig. 1) is a two-stage transistor amplifier. The first stage (Q1) is a cross between an emitter follower and a common-emitter stage, giving a voltage gain of about 15. The unbypassed emitter resistor raises the input impedance to more than 50,000 ohms. The second stage (Q2) is just a simple emitter follower with a voltage gain slightly less than unity.

Q1's input impedance of about 50,000 ohms is already much higher than that of a plain common-emitter amplifier. Because of the high current gain of the 2N2613, the stage gain is substan-

at the output. The input impedance is inevitably slightly capacitive. As R_A is made larger and larger, the input network begins to look more and more like a low-pass filter section (series resistance plus shunt capacitance). To overcome that, at values of R_A greater than about 50,000 ohms, connect a 5-pf capacitor across R_A . This flattens the overall response to what it would be with no R_A at all.

The output stage, Q2, is direct-coupled to Q1. A dc and ac negative feedback loop via R4 stabilizes the operating parameters of the whole amplifier

SPECIFICATIONS

Frequency response
Harmonic distortion
Intermodulation } see curves →

Hum and noise: more than 80 dB below 0 VU (.775 volt across 600 ohms) with input shorted. Hum depends on shielding, and on filtering of power supply

Input impedance: 50,000 ohms plus resistance of R_A (see text and schematic)

Gain ($R_A = 0$): approx. 20 dB with 600-ohm source and load; approx. 50 mV in for 1 volt out with high-impedance (100,000-ohm) load

R_A value for unity gain: approx 1.2 megohms

Power requirements: 20 volts, 10 mA well filtered dc

Temperature stability: amplifier meets specs from 40°F to 90°F; distortion increases with temperature

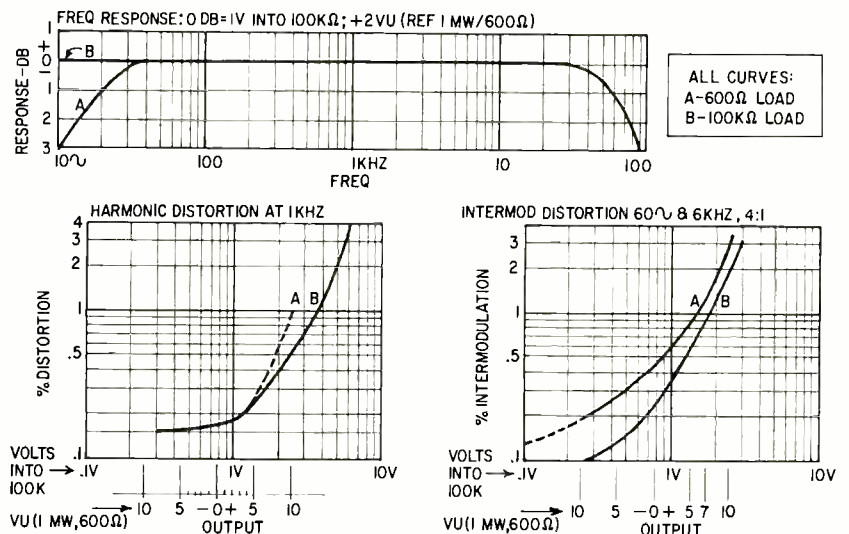

one breathes at a ground lug, you will want to try the output padding arrangement of Fig. 2. (This causes a 6-dB loss, but that's life.)

The performance of the "line transformer" is shown in the specifications, and curves above. Using all new parts from standard supply houses, the amplifier can be built for about \$3 (not counting the printed-circuit board, which of course is optional—you can build the circuit on a chassis, a perforated phenolic board, or free-standing and self-supporting, or not, or whatever.)

Power requirements are modest: about 20 volts at 10 mA. The voltage is near the design maximum for the 2N2613 (Q1), so don't go any higher. Lower voltage will reduce the maximum output for a particular distortion figure, or increase the distortion for a particular output voltage. A suitable supply can be built with junkbox parts, or the voltage can be tapped off an existing source. Since the amplifier is entirely class-A, the supply need not be well regulated. (It should be well filtered, though.)

Applications

I first conceived the amplifier because I wanted to run long lines (about 50 feet) from my FM tuner in the living-room to a terminal block at the workbench, so I could have a high-quality program source there for testing, or just for listening. I have also used one as a left-plus-right mixer for feeding a sum center-channel amplifier from a stereo preamp through a long line. A professional recording friend of mine, when I told him casually about the design, said "Hey, would you build me a couple?" He wanted to use them as mixing amplifiers—taking medium or high-impedance sources, one to each amplifier, and mixing the outputs through 1,000-ohm po-

tentiometers for each source (a sort of poor man's broadcast mixing console).

One of the amplifiers did a job for me as a scope preamp: short leads from a high-impedance, low-level signal I wanted to examine; long leads run conveniently to a scope.

Another fruitful application for a pair of these is in feeding transistor power amplifiers (such as the T-40/40 described in the March 1965 RADIO-ELECTRONICS). They often have a comparatively low input impedance—anywhere from 1,000 to 50,000 ohms. Many common tube preamps like loads of 100,000 ohms or more. For such a job, these "line transformers" are ideal. Resistor R_A can be chosen to make the "transformer" give some gain as well as raise the load on the preamp.

Or: Adjust the input impedance to 47,000 ohms for phono pickups. Gain will then be about 10 to 15, meaning you will be feeding approximately a 100- to 150-mV signal at low impedance through a line. The line can now be any length up to a couple of hundred feet, consistent with acceptable noise level. Deterioration in high-frequency response is no longer a factor.

Recently, several manufacturers announced low-cost silicon transistors with small-signal current gains of up to 500. The high gain and low leakage of these transistors make possible input impedances 10 times the figures given for this circuit—that is, 0.5 megohm or more *without* R_A and without any special tricks like "bootstrapping". The transistors (such as G-E's 2N2925 and 2N3391) cost only about 50% more than 2N2613 used here. If there seems to be enough interest, we'll describe a higher-impedance (or higher-gain) silicon "line transformer" in a future issue. Please let us have your comments. END

1966 NATIONAL BOAT SHOW

The 56th Annual National Boat Show, held in January at the New York Coliseum, displayed a wealth of marine electronic gear from depth sounders to short-range, high-definition radar sets.

Amateur boaters who visited the show seemed most pleased by the increased choice of vhf FM radiotelephones. Although in use on the Great



Lakes for a few years, they have been generally ignored by pleasure-craft users, even though the Coast Guard urges boaters to use vhf FM to relieve congestion in the hf band. Now that prices are down, the sets are expected to become more popular.

Short-range radar sets at the show were priced from \$2,200 up. Transistors reduce power drain to as little as 160 watts with some models.

Enac-Triton—the marine division of Narco—exhibited a marine Omnigator, which uses aircraft VOR (vhf omnidirectional range, usually called "omni") stations for marine navigation. A wide selection of other navigation aids were also displayed.

Hf AM radiotelephones on display ranged in power from 35 to 1,000 watts, and included SSB units. Citizens-band transceivers were few. They are not essentially marine, but CB sets are used on some pleasure boats and small commercial vessels.—James A. Belt

First of two articles on metal locators and how they work

By CECIL BEELER

THIS CITY'S POLICE DEPARTMENT CALLED on a metal locator to find, in 4 inches of trampled snow, a spent bullet that figured in a murder case. A refinery east of town used a locator to stake out a dogleg run of buried feeder conduit that blew out in a power surge. A contractor likes to use a locator to sweep for known and unknown gas, water and telephone lines ahead of his digging machines.

Each job needed a different type of instrument, handled in a different way. There are only three types of metal locators in common use.

The *search-coil* type (Fig. 1-a) commercialized from the wartime mine detector, is best at finding small bits of metal not buried very deep.

Its coil, worked in a horizontal plane near the ground, is a field-sensitive component in a *Hughes balance circuit*. The frequency is usually between 20 and 100 KHz.

The pickup and oscillator coils are mounted in the detector head and oriented so there is no signal transfer from the oscillator to the receiver coil when there is no metal in the vicinity. The receiver is a straight rf amplifier-detector with a couple of stages of audio amplification. As the coil is brought nearer to a piece of metal, or any material more conductive than the soil, the operator hears a rising beat note in his headset.

You can expect excellent work within a bowl-shaped range to a depth of about the radius of the search coil, falling off to good at the diameter of the coil, and usable results under favorable con-

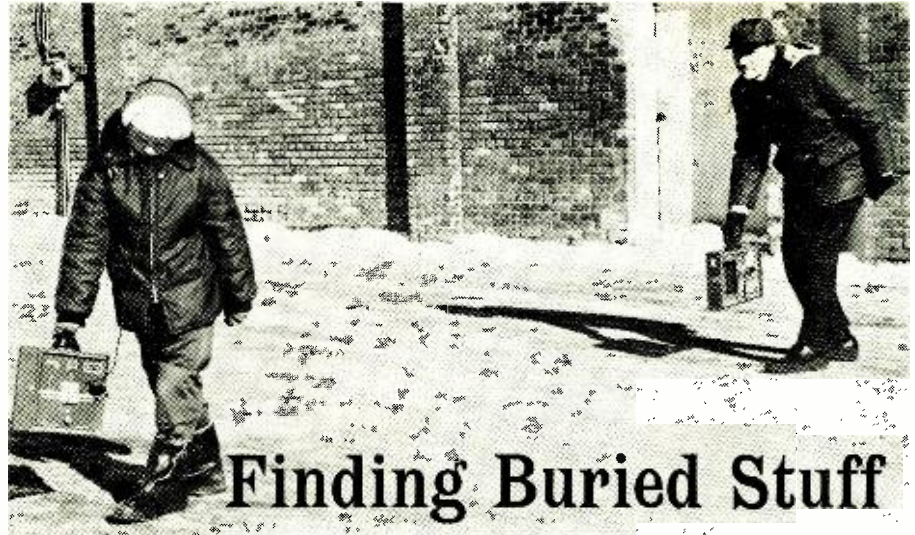

Tracking a buried line with separate rf transmitter and receiver is a two-man job. Often, a simpler audio-frequency locator can be used, but only if the sound source can be connected directly to some point along the pipe to be traced.

ditions to 2 or 3 feet with a 10-inch coil.

The *rf transmitter-receiver* (Fig. 1-b) needs bigger stuff to work with, but will oblige with a depth range from 6 feet to 20 or more under best conditions.

Used in the petroleum industries as a pipe locator, one of these consists of separate transmitter and receiver units tuned to each other at a frequency between 20 and 100 KHz through built-in loop coils. The working principle is to transmit a signal into or toward any buried stuff and then pick it up with the receiver as a beat note of audio frequency.

Three arrangements are possible with the same instrument. For a one-man search unit, the transmitter and receiver may be clipped in a mutual null position on a carrying shaft so that only reflected or secondary signals from the transmitter can be picked up by the receiver. Or the transmitter may be carried or set down over one point of a buried pipe or cable while the receiver, 20 to

100 feet away, is used to locate the pipe's course with an accuracy of a few inches. In a third method, the transmitter may have a switch to send the signal to a terminal post which can be wired to an accessible part of the otherwise buried pipe or what-have-you.

The *af transmitter-receiver* (Fig. 1-c) is also known as a *pipe locator*. The receiver is simply a very uncomplicated audio amplifier whose pickup may be a search coil of a few hundred turns on a 6- to 12-inch form. The transmitter is generally a vibrator or sine-wave generator working at 100 to 1,000 Hertz. Some have selectable frequencies. Other (external) sources of af can be used.

An af locator is at its best on long lines. Up to 5 miles is quite practical, with excellent accuracy and reliability. Lower frequencies carry farther and confuse less, but lose the radiation feature of rf.

The best locator, in case you're going to ask, is determined more by the job

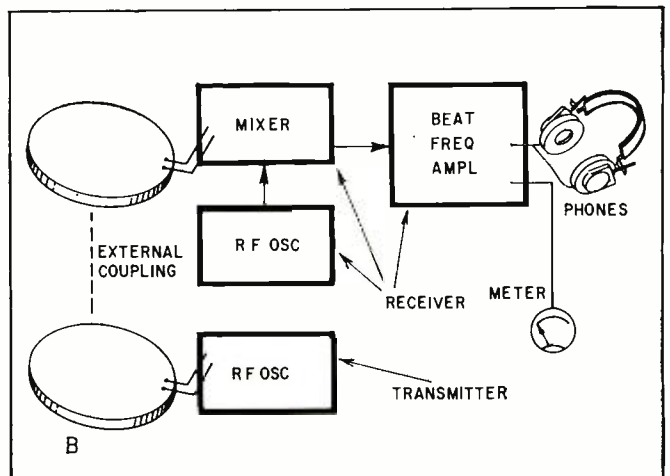
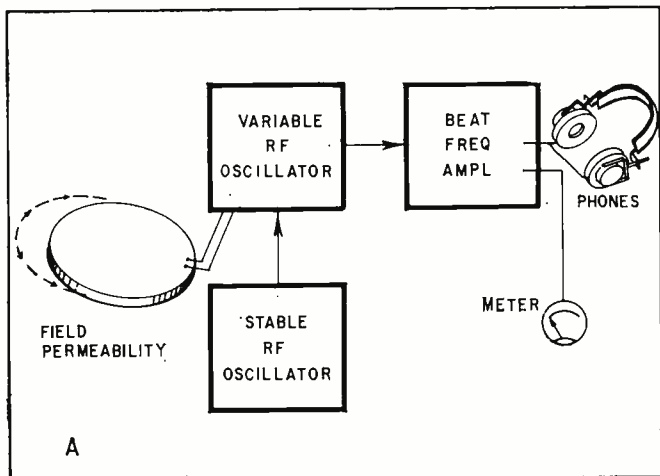



Coupled together, rf transmitter and receiver can be used by one man for finding large, deeply buried objects.



Search-coil locator is ideal for disclosing small buried objects under mud, paving or snow.



How deep?—a simple measurement at a 45° slant from the point indicated by the receiver pinpoints depth of located metal.

at hand than by the locator's price tag, which may be from \$100 to \$1,000. Anything from a hairy-spaghetti did-it-yourself to a glossy big geophysical set can be counted on to do a good job within the limits of its design.

To clear your head on the matter of locators, try a 15-minute workout using the running motor of your car, a pocket transistor radio and a length of buried stuff such as a water or sewer line under your basement floor or underground wiring to a garage or to a garden light.

Clamp or twist a wire of any size to an exposed part of the pipe or cable for a good electrical connection. Insert the other end of the wire, bared and possibly looped, into a sparkplug lead of your car. Start the car, turn on the radio, which must be tuned off any station, and search for the raucous pulses of the ignition.

You should find them very loud within 3 or 4 feet of the ignition wire

and your wire lead. They should also be very apparent along the buried stuff for several feet to either side and for its whole length, or for 50 feet of it at least.

Don't be surprised if the signal is also apparent in other house wiring, water and other facilities.

As you play around with the radio you'll learn many things. You'll find that you can't locate the line any better than within a broad band about as wide as the depth of the metal. Your sharpest results will be with the volume turned down to a barely audible level. An ear-phone is better than the speaker.

A little more study and you'll see that the radio would perform better if the AVC were cut out—AVC tends to dull the sharp edges of signal areas—and if it had a sharply directional pickup, such as a loop. More, the ignition type transmission with both AF and RF components and a hashy trail between could be better for some purposes if it made up its mind one way or another.

In short, this experiment will lead you to a conclusion that a metal locator, like every instrument in your kit, will do work that nothing else can; but its use still depends on that well known button at the top of your spine.

In an early issue we'll show you more details of commercial metal locators—enough so you can build your own. And more also on how to set yourself up in business—either servicing locators or using them to find things for other people.

END

**COMING SOON:
A METAL LOCATOR
THAT WORKS UNDER WATER!**

Easy to build, this detector helps salvage sunken boat motors, wrecks, anchors—even treasure chests!

**CALIFORNIA COURT ENJOINS
BACKGROUND MUSIC PIRATE**

The Los Angeles Superior Court has awarded the Muzak franchise in the Los Angeles cash damages and a permanent injunction against concerns manufacturing and distributing devices that intercept private broadcasts intended only for background-music subscribers. These broadcasts are on S.C.A. (Subsidiary Communications Authorization) subcarriers transmitted simultaneously with FM radio broadcasts. The Communications Act forbids all third parties from using for their own profit or divulging any transmitted material. But prior to this court ruling the law in the matter of manufacture, sale and use of S.C.A. tuners and adapters has been somewhat vague.

END

Fig. 1—Three basic types of metal locators: search coil (a), rf transmitter/receiver (b), and af transmitter/receiver (c).

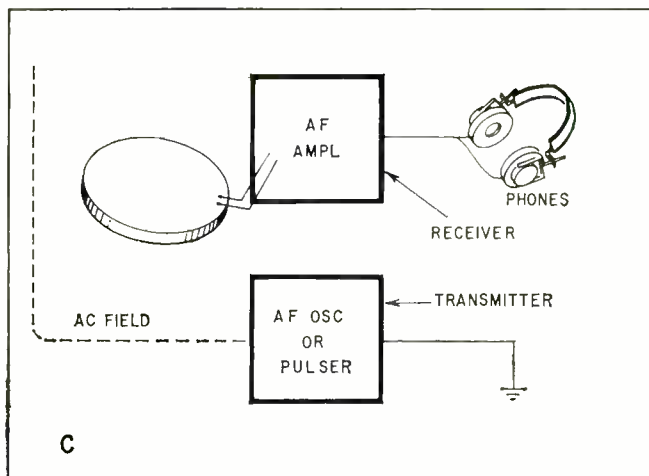

EAST SIDE, WEST SIDE

A Stable 400,000-Ohm-Per-Volt DC Meter

By JIM McCORMICK

A multipurpose story: build this highly stable, sensitive voltmeter with its own calibrator, and learn a lot about transistor dc amplifiers in the bargain!

THIS YARN, ALTHOUGH AIMED AT EXPERIMENTERS WHO LOVE zany viewpoints, also describes a low-loading voltmeter useful to anyone who works or plays with transistor circuits. It's a thoroughly practical device for shack or shop—but not as an aid to be carried on service calls. This crack will be explained later.

While experimenting with the first haywire version of the dc amplifier, I found myself whistling *The Sidewalks of New York*. Result: the contraption was named East Side–West Side. Fig. 1 shows how apt the name is. You can see that it is really two amplifiers, each with its own power supply, but sharing a common meter.

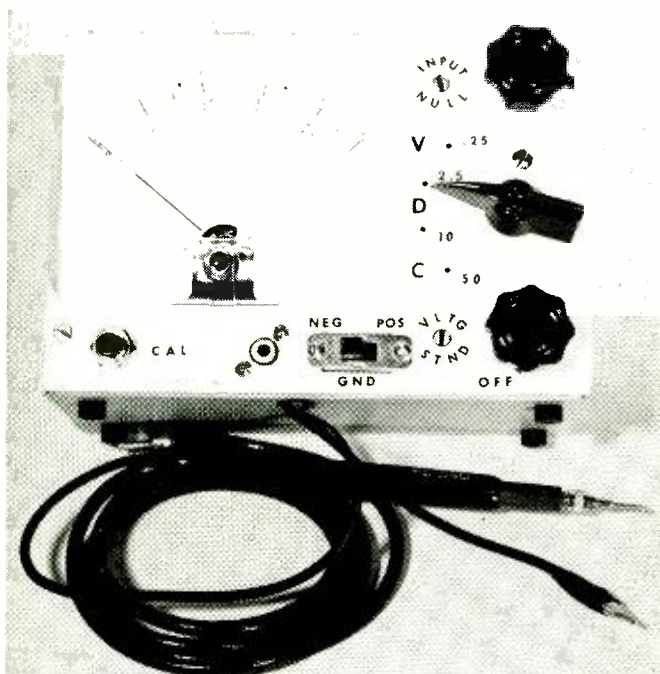

This unusually versatile transistor voltmeter has "flexible" ranges. The text explains.

Lest there be any confusion about the relationship of the two dry cells, they are in series. Fig. 2, an oversimplified equivalent circuit, makes this clear. Because B1 and B2 are in series, it will be seen that if west-side current exceeds east-side current, the difference must pass through the meter. The idea behind the whole thing is to make thermal drift impossible.

Look at R1 and R2. They could be called limiting resistors. They don't limit current; the transistors do that. R1 and R2 limit the voltage drop across Q1 and Q2, which in turn limits the microwatts dissipated by the pair. So what?

Well, R1 and Q1 are in series and share the 1.5 volts of B1 between them. Let's suppose that drift begins and current

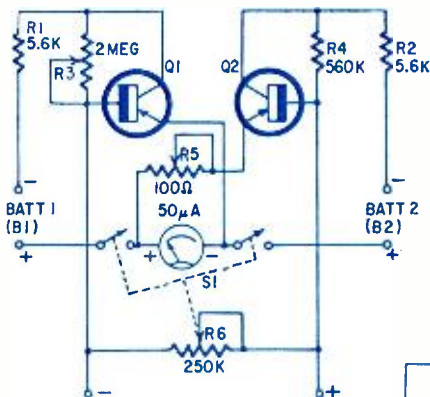

Fig. 1—Basic "East Side, West Side" amplifier stabilizes sensitive instrument against temperature and voltage changes.

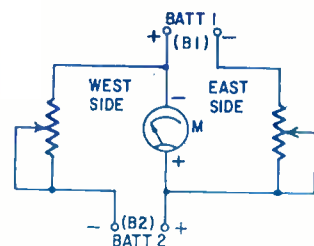

Fig. 2—Ultrasimplified bridge used in ES–WS meter shows the principle behind the idea.

risers. The increased current causes an increase in the voltage drop across R1. Thus R1 is subjected to a rise in both voltage and current so that it assumes more than its share of the increased power dissipation. It assumes so much more, in fact, that Q1, which experienced a drop in voltage equal to R1's increase, is actually dissipating less power than before.

Get the drift? Or rather, the lack of it? The increased current has caused Q1 to cool—not heat—and its now decreased conductivity stops the current rise, and the drift. The same thing is true in reverse. A current decrease causes the transistor to heat rather than to cool.

The two circuits, east and west, are linked through the meter and, because of the drop across the meter's resistance, affect each other. With R6 linking the bases of Q1 and Q2, the meter becomes an emitter resistor for both circuits. Thus any change in current originating in one circuit only (east or west), is duplicated in the other. This matching of currents makes the aberration imperceptible in the output, resulting in excellent linearity. In other words, the negative feedback through the meter resistance forces one transistor to correct the mistake of the other.

The meter resistance, by the way, amounts to a large part of the input resistance. To the output, the meter looks like 2,000 ohms—or whatever the actual meter resistance happens to be. But if the gain is 40 or 50, a 2,000-ohm meter will look like 80,000 or 100,000 ohms at the input.

As to the controls: R3 (made large to allow for the extreme individuality of transistors) is the zero control. It controls the forward bias of Q1 so that it can be made to match that of Q2, biased by R4, and equalize east-side and west-side currents. R3 and R4 also provide some negative feedback, working with R1 and R2, and helping these resistors in their limiting function.

R5 brings Q2's base to the same potential as the base of Q1. This is necessary to permit adjusting the calibrating resistor without affecting the zero setting of the meter. If R5 doesn't work, transpose the two transistors.

R6, shunting the input, is the calibrating resistor. It de-

An R-E editor writes:

"This instrument performs as described in article. It was checked on each scale and found to be correct within 3% (better than most vtvm's). Zero drift was very small. The only possible improvement I could think of would be to separate the calibration control from the battery switch. As it stands, it is necessary to recalibrate each time the meter is turned on."

termines the effective gain of the amplifier.

Going to Fig. 3, which shows the complete voltmeter circuit, we find three capacitors and a potentiometer added to the basic amplifier circuit. The pot, in series with the meter, adjusts the total resistance of the lowest range to exactly 100,000 ohms. The capacitors squelch any ac component of the input current.

Also in Fig. 3 is a dpdt pushbutton, a transistor, some diodes and another dry cell. This is a voltage standard, adjusted to exactly 0.25 volt, used to calibrate the instrument each time it is turned on—as with an ohmmeter. Rather than

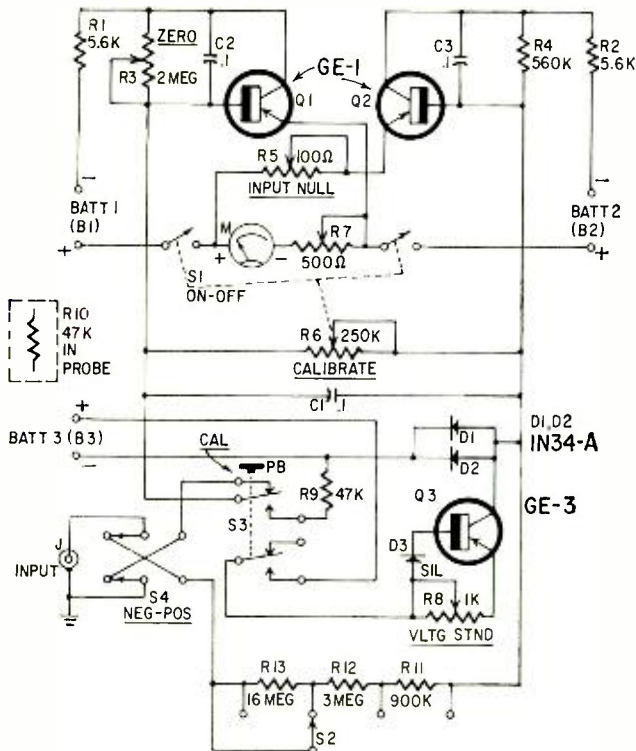

Fig. 3—Complete circuit of the voltmeter with its "variable" ranges and built-in pushbutton calibrating source.

- R1, R2—5,600 ohms, 1/2 watt, 10%
- R3—pot, 2 megohms
- R4—560,000 ohms, 1/2 watt, 10%
- R5—pot, 100 ohms
- R6—pot, 250,000 ohms with dpst switch
- R7—pot, 500 ohms
- R8—pot, 1,000 ohms
- R9, R10—47,000 ohms, 1/2 watt, 5%
- R11—900,000 ohms, 1/2 watt, 1%
- R12—3 megohms, 1/2 watt, 1%
- R13—16 megohms, 1/2 watt, 1%
- (Some 1% resistors can be made up from lower 1% values connected in series.)
- C1, C2, C3—0.1 μf disc, 25 volts
- B1, B2, B3—1.5-volt size-AA (pen-light) cells
- D1, D2—1N34-A
- D3—silicon diode (piv and current rating unimportant)
- J—RCA-type phono jack
- M—2,000-ohm 50-μa meter, 4 1/2 in. (Knight 67 Z 205, 67 Z 237 or equivalent)
- Q1, Q2—GE-1 (General Electric universal replacement series)
- Q3—GE-3 (General Electric universal replacement series)
- S1—(See R6)
- S2—single-pole, 4-position switch, shorting or nonshorting
- S3—dpdt pushbutton switch (Mallory 1016 or equivalent)
- S4—dpdt slide (or toggle) switch
- Misc.—5 x 7 x 3 aluminum chassis, 1/8-in. Masonite panel, 4 13/16-in.-square perforated phenolic board, 3-cell battery holder, transistor sockets (2), phono plug, test leads or shielded cable, clip and probe, knobs, screws, etc.

being a nuisance, I think you will find this reassuring. The button can be pushed even while you are reading, to confirm accuracy of calibration.

The voltage standard works this way: A forward-biased diode tends to be a constant-voltage device because a slight increase in voltage causes an enormous decrease in resistance. It is not *truly* constant-voltage—some change in voltage must occur to make the resistance drop. A reverse-biased diode, including the collector diode of a transistor, tends to be a constant-current device. A slight increase of current increases the resistance enormously.

When the two are combined, a forward-biased diode in series with a reverse-biased diode, the forward-biased one comes much closer than before to being truly constant in its voltage drop. And if a transistor is used to supply the near-

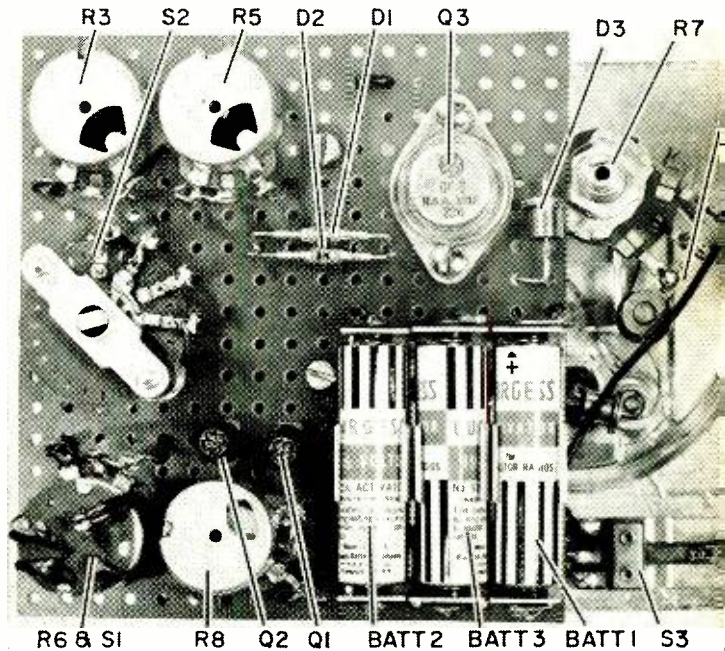

Back-of-panel shot shows all major parts. Author writes: "That is a forward-biased silicon diode across the meter terminals. I put it there (and I buckle my safety belt) because I'm chicken." Good idea.

constant current, the current level is adjustable—with a catch: the collector diode, the near-constant-current element, must not be shunted by a forward-biasing resistor.

So I used a power transistor, with a high current plateau, even though the current required is less than a milliampere. The current plateau of the collector is adjusted downward to suit the need.

The standard actually used in the instrument evolved from Fig. 4-a to Fig. 4-b. Fig. 4-a held the output constant within 1% of 0.25 volt regardless of battery condition other than complete exhaustion, but was too wildly temperature-sensitive to be acceptable. The difficulty arises because the transistor amplifies the temperature-caused current changes and takes wider excursions than the diode.

In Fig. 4-b, another germanium diode is added in parallel with D1. This of course doubles the current necessary to achieve the 0.25-volt drop, but it also means that any given current deviation produces only half as much deviation as before in the output voltage. D3, a silicon diode, is in series with the collector diode of the transistor, and tends to be a constant-voltage device, thus pinning down the base voltage. It allows considerable remaining forward bias because of its relatively high forward resistance. R8 now becomes an emitter resistor to oppose current change with the D3 diode—and the diode's temperature—determining the forward bias.

The Fig. 4-b version is quite acceptable for use at any temperature likely to be found in shack or shop. But don't bring the instrument into the shop from your parked car on a cold winter day and expect it to be accurate.

If your design should require a 0.5-volt standard, substitute a pair of cheap top-hat silicons for the 1N34-A's.

To upset tuned circuits as little as possible, the lowest-range resistor is in the probe, as an isolating resistor. The four switched ranges all provide 400,000-ohm-per-volt loading on the measured circuit. These four ranges are 0.25, 2.5, 10 and 50 volts.

By tricks of calibration, more ranges are obtainable. With the range switch set at 0.25 volt, and calibration adjusted to half instead of full scale, a 0.5-volt range is obtained. The ohms-per-volt figure here is about 140,000. Adjusting to quarter scale gives a 1-volt range, and the 60,000 (approximately) figure is still sizable considering that this range is likely to be used in measuring the drop across a relatively low-value emitter resistor.

This calibration trick (half or quarter scale) can be used on the lowest range only, because it lowers the 100,000-ohm value of the initial range and makes the multiplier arrangement meaningless. Nevertheless, two more ranges, 100 and 250 volts, are possible on the 50-volt position of the range switch. Calibration marks added to the meter face guide the operator. The ohms/volt figure is 200,000 ohms for the 100-volt range, and 80,000 for the 250-volt range.

The front panel is 1/8-inch Masonite; the rear panels, perforated phenolic board. The panels are held apart by three 1 1/2-inch lengths of dowel stick, held together by screws through the panels and into the ends of these sticks.

Two of the three screwdriver adjustments are on the front panel. There is no good reason for this. Relegate them to the rear panel.

Aluminum foil, snaffled from the kitchen, is glued to the back of the front panel with Goodyear Pliobond adhesive. This glue deserves a plug. Although it seems to be a sort of rubber cement, it is unbelievably tough. It adheres to any dry, nongreasy surface and, once dry, is nonconductive and waterproof. Several coats of white enamel from a spray can pretty up the front panel.

Solder the three disc capacitors directly to the transistor sockets. The rest of the wiring can be done in any convenient manner. Leads which must go from one panel to the other are left long, and joined, taped and tucked in when the panels are finally assembled.

The meter you buy will likely have 50 scale divisions, and be marked 10, 20, 30, 40, 50. Above these figures, and at the same places, ink in 5, 10, 15, 20 and 25. Under them, ink in 20, 40, 60, 80 and 100.

An RCA type phono jack for the input is not the point-less whim that it might seem. If you use ordinary test leads, one of them will carry the isolation resistor. No one will accidentally use this lead on the wrong instrument if the two leads are attached to a phono plug at one end. If you make up rectifying probes for peak or peak-to-peak indications, shielded cable will help to avoid unwanted pickup. Don't forget to include the 47,000-ohm resistor in such probes.

Initial calibration

Get a vom with a low-voltage range around 0.5 or 0.6 volt. First turn R6 to the right to the end of its travel. Bring the meter needle to zero by adjusting R3. Now turn R6 back to the left stop, but not far enough to turn off the switch. Adjust for zero this time with R5. You may find it necessary to swap transistors. R6 can now be moved to any position without affecting the meter's zero.

Set the range switch at the 50-volt position, and the vom to its proper range and connect both meters to a

45-volt battery. Adjust R6 to make the ES-WS meter agree exactly with the vom. Leaving R6 alone, connect both meters to a pot (voltage divider) across a dry cell. Set the meters to their lowest range. Adjust the pot until the vom indicates 0.25 volt exactly. Still leaving R6 alone, adjust R7 to bring the ES-WS meter to full scale, or 0.25 volt.

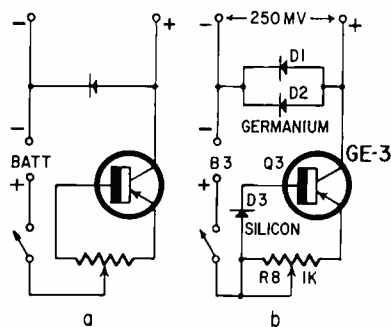

Fig. 4-a—Simple constant-voltage calibrator is satisfactory but temperature-sensitive. Improved version (b) is the one actually used in meter.

Repeat this, switching the meters alternately to the 45- and the 0.25-volt source—being careful to trim with R6 at 45 volts and R7 at 0.25 volts. When no further trimming is possible, the amplifier is calibrated and all that remains is to set the standard at 0.25 volt.

This is easy. Being careful to touch neither R6 nor R7, push the calibration button and adjust R8 so that the needle rests exactly at full scale. Return the instrument to its case.

If you want the 100-volt and 250-volt ranges previously mentioned, get a 90-volt battery. With the range switch at the 50-volt setting, attach both meters to the battery and use R6 to make the meters agree, reading the 100 scale on the ES-WS meter. Now push the calibration button and note the exact point on the scale to which the needle comes to rest. Remove the meter cover and ink a dot just above the scale at this point. This dot is your future calibration guide for the 100-volt range. For the 250-volt range, add voltage to your battery, if you can, and repeat the procedure, using the 25 scale instead of the 100.

Suggestions

If you use transistors other than GE-1's for Q1 and Q2, select ones that have a current plateau (base open) in the neighborhood of 100 μ a. (Transistors with higher current plateaus can be used, with greater battery drain.)

D3 can be the cheapest top-hat in your junkbox. Test it with your ohmmeter to see that it isn't open, shorted or leaky.

Almost any nonleaky power transistor will do for Q3. To test it for leakage, measure the collector current (emitter open) at 1.5 volts and again at 9 volts. If this sixfold increase in voltage causes the current to rise more than 30%, consider the transistor too leaky for this purpose.

And a suggestion to the reader who has never before worked with transistors in dc circuits: When making adjustments with the case removed, results will be puzzling if you fail to keep your (literally) hot little fingers off the transistors and diodes. Also, shade these components from your work lamp or other source of radiated heat. If you do handle the Q's and D's, give them plenty of time to return to room temperature. They have to cool by convection—a much slower process than the conductive heating from your fingers.

Although its resistance is 100,000 ohms, your instrument is essentially a microammeter at its lowest range, and 2.5 μ a brings it to full scale. With the aid of an external battery and Ohm's law, you can measure resistance. If the resistance measured is over 10 megohms, you needn't bother to subtract the 100,000 ohms of meter resistance. END

Heath Fotoval Computer, PM-14

Easy-to-build kit version of Mitchell Fotoval saves time, paper, money

THE PURPOSE OF THE FOTOVAL IS TO DETERMINE accurately the grade of photographic printing paper whose contrast limits most nearly match the extremes of light projected through a negative in an enlarger. It indicates the correct exposure for optimum enlargements every time.

A photoresistive cell is mounted in a probe positioned on the image projected by an enlarger. The amount of light falling on the photocell determines the resistance of the sensitive element. A magnet on the bottom of the probe case holds the probe in position for readings.

The basic circuit (Fig. 1) is similar to that used in the more sensitive expo-

sure meters. It is protected by a diode, which bypasses excessive current when too much light for that particular range falls on the probe.

The ranges of the meter are calibrated separately on white plastic strips that fit into clips in front of the meter face. Enough scales are included so you can calibrate a separate one for each grade of photographic paper you use.

Once the computer has been calibrated, any change in illumination, such as from the varying density of the negative film, or enlarger-lamp brightness, will be measured accurately. The Fotoval will compute a specific answer in terms of contrast and exposure for that negative. Each negative can then be

produce a correct print at a given enlarger-lens aperture, lamp brightness and printing-paper grade.

Each new batch of printing paper should be checked against the calibra-

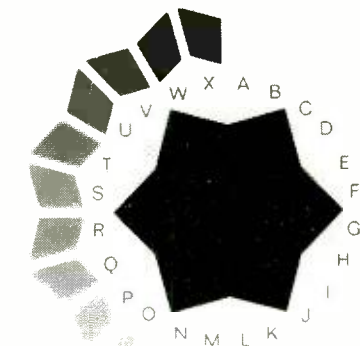

Fig. 1—Basic photoresistive-cell light-measuring circuit used in light meters.

tion of the Fotoval scales. Trial prints have to be made and the results checked against the calibration scales.

Installing a new enlarger lamp means that the master calibration scale must be checked. Even though the computer will compensate for differences in intensity, the color of the light can vary from one lamp to another—even with lamps of the same brand and type. And, of course, any change in the developing process will change the final results, just as without the Fotoval.

Keeping the computer in calibration may sound like a lot of extra work but it is worth it if the computer is to do its job properly. Even with recalibration, the Fotoval saves times and money.



Heathkit version of Fotoval costs \$89. Above, positive print made from test negative in kit. In negative, each patch is distinguishable from every other.

sure meters. Alone, it is not sufficiently versatile, or sensitive, for darkroom processing.

The Fotoval circuit (Fig. 2) uses higher, more accurate voltages than an exposure meter. Seven voltage dividers (potentiometers) supply voltages for 10 ranges—the five positions of the PAPER SPEED selector switch are doubled to 10 by the SHADOW and HIGHLIGHT selector positions in the probe. Two of the calibrating potentiometers supply voltage for both the SHADOW and the HIGHLIGHT positions of the switch in the probe. The 255-volt dc supply is taken directly from across the regulator tubes.

To increase the sensitivity of the circuit further, a 0–20- μ A meter is used

printed on the exact grade of paper that will give the best print.

The calibration standard for the computer is a 35-mm negative that consists of a circle of shaded patches surrounding a testing star (above). The testing star is actually a star within a star. The overall test negative is opaque (black). In the center of the circle of shaded patches is an area of clear film in the shape of a six-pointed star—in the center of the clear area is a smaller, slightly grayed testing star. When this negative is properly exposed, the slightly grayed star will be just distinguishable in the heavier black of the area overexposed through the clear portion of the negative. Only one exposure time will

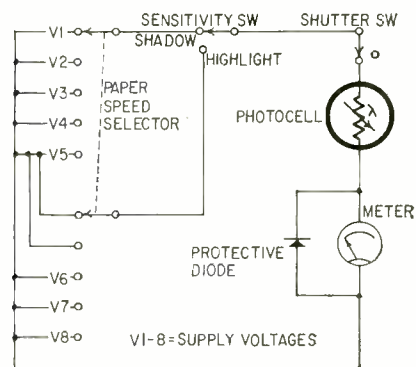

Fig. 2—More advanced circuit, similar to Fig. 1, used in Heathkit Fotoval.

Fewer test prints are needed to calibrate the computer than for try-and-try-again printing. In a given time, more good enlargements will be made with a properly calibrated Fotoval than without one.—*Elmer C. Carlson*

THE WHATSIT: A SUB-SET FOR TV SERVICE

By JOHN FITZGIBBON

WHAT HAS 18 TUBES, COSTS ABOUT \$5 AND CAN SAVE YOU twice that much every day? A Whatsit. Fig. 1 shows one. Looks like a hunk of junk, you say? It is! But *this* piece of junk can be a valuable piece of test equipment! Its uses are limited only by your own ingenuity.

What *is* it? An old TV chassis—one of the better makes, in good shape, but with its picture tube blown out. Your friendly neighborhood distributor usually has lots of them in his trade-in pile. Not good enough to repair and sell, but plenty good for this. Actual cost depends on your horse-trading ability.

What can you *do* with it? Anything! The best source of any kind of test signal is the signal itself (or an *exact* duplicate). And that's just what we have in a good Whatsit.

It should meet *some* specs, though: a power transformer, a 40 MHz i.f. video signal fed to CRT cathode, and fairly good high voltage, say about 10–12 KV. Get one with a plug-in yoke if you can; otherwise, you'll have to add a yoke plug and socket (Fig. 2).

Now, you've got to have the "auxiliary equipment." Fig. 3 shows a full set of it: two test leads with alligator clips on each end, another with a plate clip on one end and a plate cap on the other, and a pilot-light socket in the middle. That's all you need, although you can add other stuff later, as we'll see.

Let's see a few of the things we can do with the Whatsit. One of the most important tests, and one we have to make often, is flyback checking. Say you have a set for repair (called from now on "the set") and you want to know if the flyback is OK. You're not too sure about the horizontal output tube, oscillator and so on.

Take off the plate caps from the set and the Whatsit. Us-

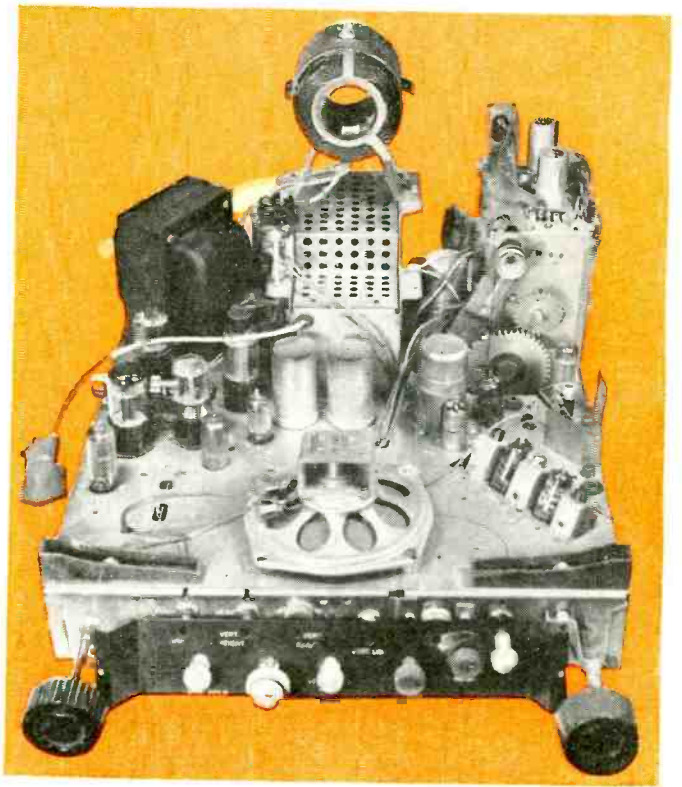

Fig. 1—The Whatsit ready to go, with dirt, cabinet and pic tube removed, speaker bolted to chassis and high-voltage cable covered. This is a Zenith 19K23, but anything like it will do. (Be sure it has a power transformer!)

ing the lead with the pilot light in series, connect the plate cap of the Whatsit's horizontal output tube to the flyback plate lead of the set (Fig. 4). Ground both chassis together with a clip lead, and turn them on. The Whatsit's known-good horizontal output tube, power supply, etc., are now driving the set's flyback. If these important parts are good, you'll get high voltage, a raster, and so on, on the set you are testing.

You can measure the plate current by putting a suitable pilot light in the socket. Since this is hot at all times, please use an insulated socket! A No. 47 pilot light draws 150 ma, so you can use it for common horizontal output tube types. After a bit of experience, you'll learn to judge the current

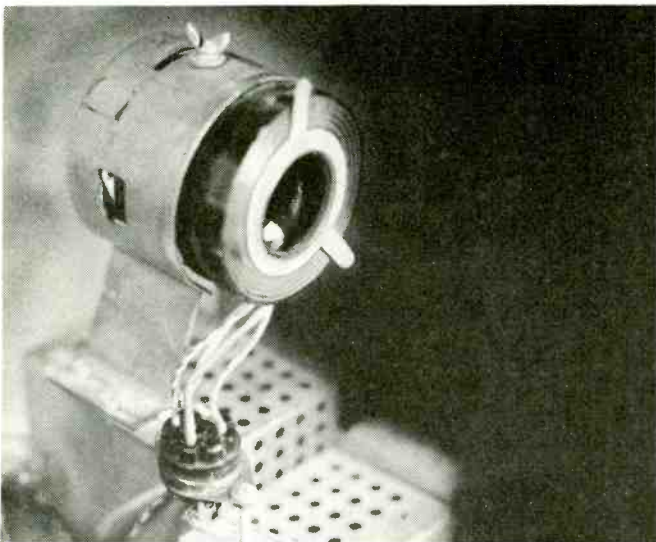

Fig. 2—If your Whatsit doesn't have a plug-in yoke cable, add one. Use an octal socket, or whatever you like. The yoke was reversed to get more lead length, but it is still fastened in the original brackets.

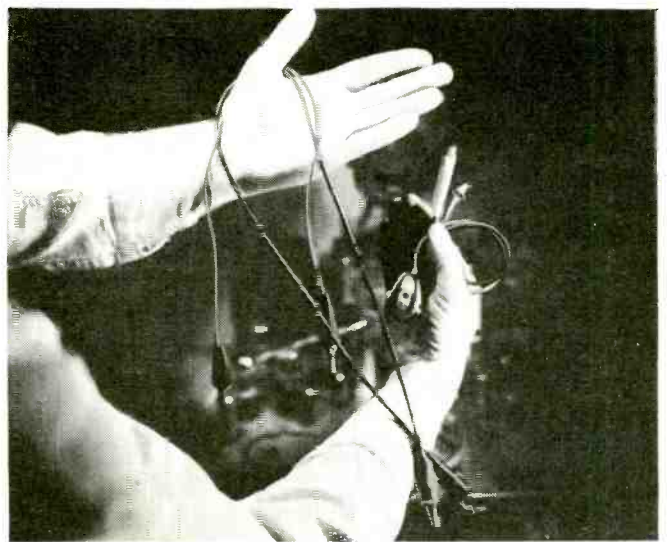

Fig. 3—Two clip leads and a plate connector are the only extras you need. (Better use an insulated pilot-lamp socket instead of the bare one shown. If you don't, you'll find out why you should have!)

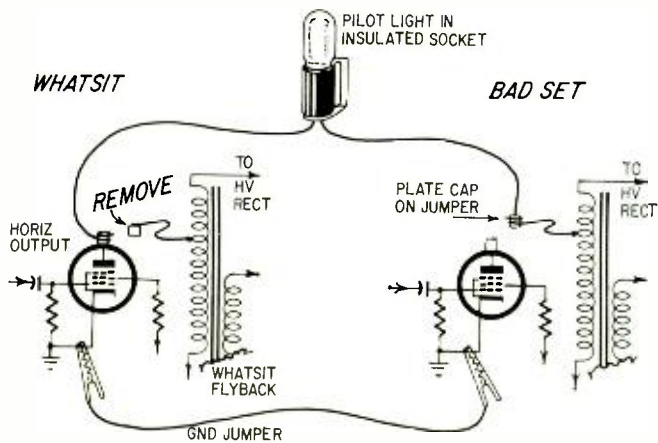
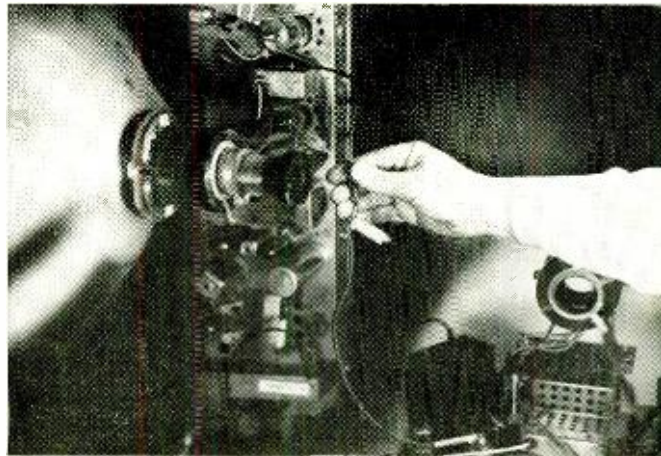

Fig. 4—Connect the Whatsit's good output tube to the suspected flyback. This is plate drive. Both sets must be on and their chassis connected. Pilot indicates plate current.



quite accurately by watching the glow. For color sets and others with heavy plate current, use a heavier lamp.

To check a horizontal oscillator, simply connect the grid of the Whatsit's horizontal output tube direct to the grid of the set's horizontal output tube with a clip lead. In most cases you won't even have to use a blocking capacitor. (Check the grid voltage on the schematic to see.) Now turn both sets on. This is a "voltage" feed, and a good horizontal oscillator will always drive at least *two* sets at the same time! Put an antenna on each set, so that you'll have sync and pictures—checking is easier this way.

Suppose the set doesn't pass the first test, and you suspect yoke trouble? Make up a socket and cable to fit the yoke socket of the Whatsit, as in Fig. 5. You won't need the vertical coils, in most cases. Put clips on the ends, and put a tag on the hot lead (top) of the horizontal yoke as shown. Disconnect the horizontal yoke of the set, and clip the Whatsit's horizontal yoke in its place.

What if it doesn't match? Chances are it won't, but that makes no difference for this test. The Whatsit's yoke will probably be in the medium range of inductance, and it will very likely be within the tolerance for yokes, which is pretty wide anyhow. In any case, if you *do* have a bad yoke in the set, you'll have no boost voltage, and probably no high voltage, with the set's own yoke. Hook up the sub-yoke from the Whatsit, connect your voltmeter to either the boost voltage source or the high voltage lead. Now turn the set on and watch: if the set yoke *is* bad, you'll get a definite *increase* in boost, or some high voltage. Boost will always increase enough to give you a definite indication.

How about another one? Suppose you have a set with a burned-out power transformer, and you want to know how many *other* things are wrong, before you stick your neck out on an estimate of the total repair cost? Easy. In the Whatsit's good power supply circuit, add an old fuse-holder in each circuit, as in Fig. 6. One's in the B+, and the other in the heater line. You can disconnect the bad power transformer, take out the fuses in the Whatsit (which are not used for circuit protection, since we use a 20-ampere or so, but merely as a cheap "quick disconnect"). With your clip leads, hook up to the set's power supply, fire it up, and you can tell how the thing is going to work. You can locate any shorts, bad tubes, bad picture tube, etc., without having to replace the power transformer first!

There isn't space to list all the tests possible with this gizmo. That's up to you. I will say that there isn't a function, signal or voltage in the average TV set that you can't find in a good Whatsit! Video signals, i.f. signals, sound, all kinds of dc voltages of either polarity—you name it, there's one in there somewhere.



Fig. 5—Make up socket and cables to fit Whatsit's yoke plug. Put clips on the ends of the wires and mark the hot lead of the horizontal deflection coils with a tag.



Fig. 6—Put a couple of old fuse holders in the power supply circuits of the Whatsit, one in B-plus and the other in the heater circuit. Use 20-amp fuses—they aren't for protection, just simple quick disconnects. Clip to the ends of the fuse holders to pick off power.

You can add milliammeters and gussie it up as much as you want. But one thing I definitely recommend: put a good conspicuous pilot light on the thing, so that you *know* when it's turned on! If the chassis is pretty filthy, you can hide it under the bench and "remote-control" it. It may not be too ornamental, but after all, the "beauty of utility" is pretty pretty, if you ask me!

END

Potentiometer Facts & Trickery

You can do some interesting things by connecting potentiometers to generate special voltage-vs-rotation curves—even find square roots or take tangents.

By F. H. FRANTZ*

THE SIMPLE POTENTIOMETER IS FREQUENTLY taken for granted, because it's relatively simple and straightforward. Yet potentiometers are the heart of many electronic sensing, computing, instrumentation and control devices. In advanced applications, they are much more important as sensing elements (motion or position to voltage converters) and computing elements (position to special voltage function converters) than they are as mere voltage dividers. Several frequently neglected facets of potentiometers and the trickery possible with them should prove useful to anyone in electronics.

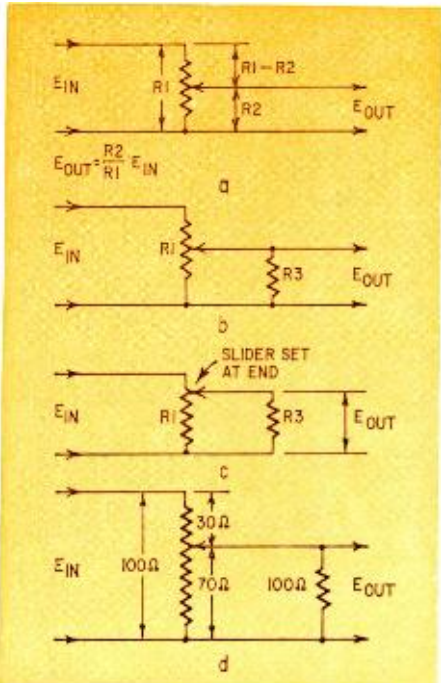

Fig. 1—How loading affects a pot. Fig. 1-a is usually wishful thinking; in most applications, pot arm is loaded by external circuit resistance— R_3 in Fig. 1-b. If R_1 and R_2 (Fig. 1-c) are equal, loading on source E_{in} is double that in an ideal situation. In 1-d, actual transfer function is quite different from the expected one. Power dissipation holds some surprises, too!

In Fig. 1-a, output voltage E_{out} is the input voltage E_{in} times R_2/R_1 , where R_1 is the total potentiometer resistance and R_2 is the resistance be-

tween the common terminal and the slider arm. R_2/R_1 is the *transfer function* of the potentiometer. The slider-arm position determines the resistance of R_2 , of course. This circuit arrangement is commonly called a *voltage divider* because E_{in} is divided by R_1/R_2 to produce an output voltage E_{out} less than E_{in} .

Actually, the assumption that E_{out} equals E_{in} times R_2/R_1 isn't true in the strictest sense when the potentiometer is used in a circuit.

Why?

Because any attempt to use the output involves parallel-connecting another resistance R_3 across the section we labeled R_2 (Fig. 1-b). This *loading* invalidates the ideal no-load condition. If R_3 is much (100 or more times) greater than R_1 , the error in assuming E_{out} equals R_2/R_1 times E_{in} is small—negligible in practical applications. If R_3 is about 10 to 50 times R_1 , the loading is still relatively small, but must be considered in many applications. The importance of taking loading into account increases with precision requirements. And, of course, loading effect becomes more serious as R_3 becomes smaller with respect to R_1 .

For instance?

Loading considerations can become important in relatively simple circuit applications. In Fig. 1-c the potentiometer is set full up (E_{out} equals E_{in}). Assume, for example, that R_1 is 100 ohms and R_3 is 100 ohms. If E_{in} is 10 volts, there is a current of $10/100$ or 0.1 ampere through R_1 and a current of 0.1 ampere through R_3 . That's a total of 0.2 ampere, or twice the current from the source E_{in} that would be required if R_3 were infinite. Obviously, if load R_3 had been neglected, the circuit would not perform to the design requirements.

Now, let's take a look at the effect of loading on E_{out} relative to E_{in} , neglecting the effect that loading might have on E_{in} itself. We'll assume again that E_{in} is 10 volts and that R_1 and R_3 are 100 ohms. *But we'll assume the potentiometer is set so that R_2 is 70 ohms* (Fig. 1-d). The parallel combination of 70 and 100 ohms has an equivalent resistance of about 41 ohms. Then E_{out} is E_{in} times $41/(41 + 30)$ or in this case $10 \times 41/71$. Therefore E_{out} is about 5.6

volts instead of 7, as predicted by the assumption of no loading. The circuit transfer function for this particular circuit is 0.56 instead of 0.7!

So what?

The effect of loading on the potentiometer transfer function is unimportant for most simple circuit applications.

But, the effect of loading is important if the output voltage E_{out} is to be related to shaft position as in:

1. Potentiometers with calibrated dials where the operator sets shaft position to obtain a given output. Typically, many instrumentation and control schemes, including even some simple signal generator attenuation schemes, fall into this category. So do applications in analog computers and calculators.

2. Potentiometers used to translate shaft position from another instrument into a voltage proportional to position. The shaft position may be a function of another quantity such as pressure, valve displacement, liquid level or distance. See Fig. 2.

If potentiometer loading is severe but neglected in these applications, the precision of control or measurement is degraded.

But potentiometer loading has its blessings. Loading may be used to arrive at a pocketful of fancy transfer functions that might otherwise require a large batch of electronics (or mechanics). **A little understanding of potentiometers and potentiometer loading principles will go a long way toward saving time and dollars in designing or modifying your equipment. And they'll go a long way toward helping an industrial electronics technician get the "wizard" award from his customers.**

Before we get into this trickery, let's review some often neglected potentiometer facts. Unless we're together on those, it's futile to attempt potentiometer trickery expecting happy results.

Potentiometer facts

Total resistance is the commonest electrical characteristic in that it is basic to the electronic or electrical circuit. Total resistance is R_1 in Fig. 1. The total resistance accuracy is not too important if the voltage source E_{in} is independent of loading or if the load on the potentiometer (R_3 in Fig. 1) is negligible. If

*Project engineer, Vought Electronics, Arlington, Tex.

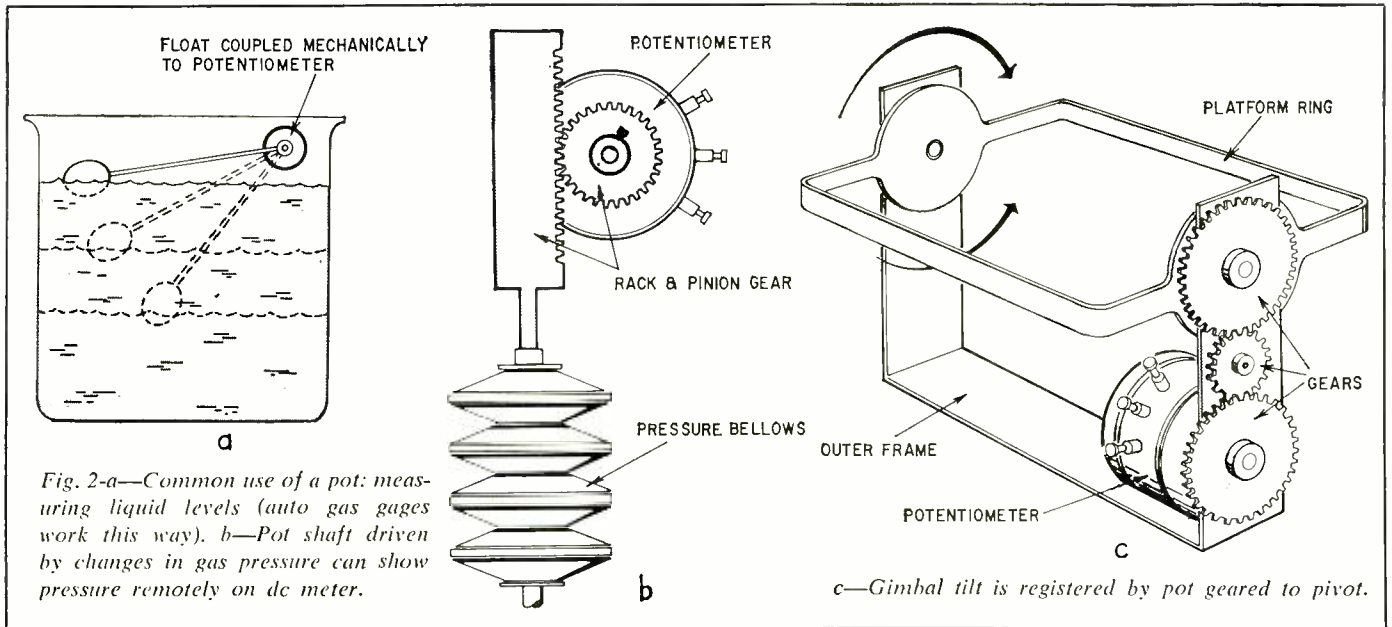

loading design is to be intelligent, the tolerance of the total resistance must be considered. If you're building one instrument only, you can measure total potentiometer resistance with a bridge and base your design on the measurement. If you are designing for production, you'll have to specify the tolerance of total resistance. The total resistance tolerance for most inexpensive commercial wirewound potentiometers is 5% to 10%. Precision potentiometers with 1% or smaller tolerances are available at considerably higher prices.

Taper is an important potentiometer characteristic that relates the voltage transfer function to shaft position. The *linear taper* potentiometer (output voltage directly proportional to shaft position) is most commonly used in applications of the type discussed in this article. *The trickery of loading is to change the taper from linear to some other form.*

Independent linearity is the accuracy of the taper or transfer function without regard to the total potentiometer resistance tolerance. Inexpensive commercial potentiometers which have independent linearity tolerances of about 1% to 3% are easy to obtain. The Clarostat 58C1 series has an independent linearity of 1%. The Clarostat 58 series has an independent linearity of about 2%.

Dissipation rating is another characteristic. A potentiometer should be operated *below* its power rating. Bear in mind that loading increases potentiometer dissipation and must be considered.

Resolution of a potentiometer refers to the smallest percentage increment of change that can be obtained by shaft movement. Resolution is obviously a function of the number of turns on a wirewound pot and the

number of turns the wiper arm covers at one fixed position.

Mechanical rotation refers to the number of degrees the shaft can be ro-

tated from one end stop to the other.

Electrical rotation refers to the number of degrees from the point where the arm leaves zero resistance to the point where the arm first reaches maximum resistance. Electrical and mechanical rotation are rarely the same because part of the mechanical rotation is over the relatively broad metal contact connection ends of the pot. The Clarostat 58 series has 280° of electrical rotation and 300° of mechanical rotation. Obviously, if you're going to calibrate a dial scale, it should cover a span of only 280°.

Potentiometer trickery

Fig. 3-a shows the effect of heavy loading in a conventional loading circuit. The ratio R_2/R_1 is proportional to percentage of electrical rotation and can be readily transferred to a dial scale. Thus if 280° represents full electrical rotation ($= 1$), 0.1 corresponds to 28°. Note that when R_3 is one-tenth of R_1 ($R_1/R_3 = 10$), the potentiometer-load taper differs considerably from a linear taper.

A particularly interesting relationship exists for the case where R_3 is half of R_1 . If E_{out}/E_{in} is multiplied by 10, this quantity approximates the *antilogarithm* of R_2/R_1 for values of R_2/R_1 from 0.15 to 1.0 to a reasonable degree of accuracy. The dotted curve in Fig. 3-a is the antilogarithm plot. This arrangement might be used in an instrumentation or computer application where a shaft rotation represented a logarithm and a voltage proportional to the antilog is desired. Obviously the general basic loading principle may be used to obtain unusual transfer functions where a "droop" in the curve is desired.

If you want to get "bulge" in the transfer curve, simply load the opposite

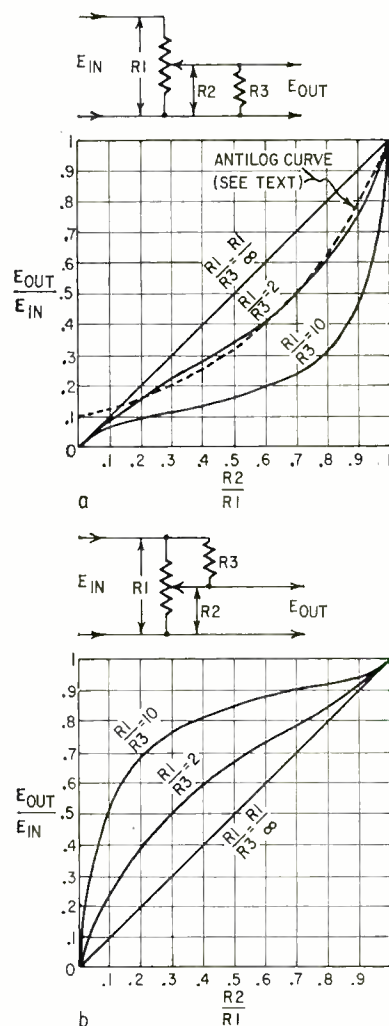

Fig. 3-a—Loading a pot to get a "drooped" curve. You can approximate a logarithmic function. b—A "bulged" curve.

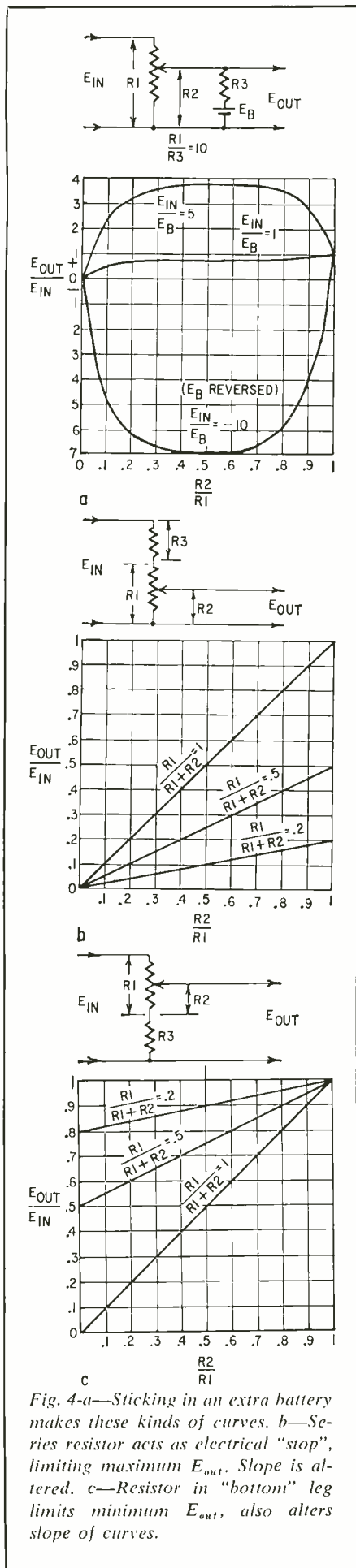

Fig. 4-a—Sticking in an extra battery makes these kinds of curves. b—Series resistor acts as electrical “stop”, limiting maximum E_{out} . Slope is altered. c—Resistor in “bottom” leg limits minimum E_{out} , also alters slope of curves.

side of the pot, as shown in Fig. 3-b.

In Fig. 4-a we've added to the trickery by putting a bias battery (E_B) in the circuit. Note the effect of changing the battery voltage ratios and polarities. This set of curves is for the condition $R_1/R_3 = 10$. By varying this ratio, you can generate still other functions.

Another basic potentiometer trickery scheme is to employ fixed resistance

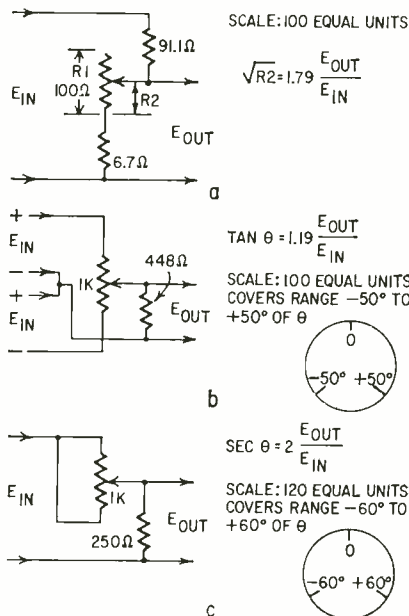

Fig. 5-a—This circuit approximates a square-root relationship—1.79 times the ratio of E_{out} to E_{in} (each of which can be measured) is the square root of the resistance value of R₂ (which could be marked off on a dial). b—Values of tangents of angles between +50° and -50° come out of this circuit. Angle θ and angle of pot rotation are not necessarily same thing. Angle θ refers to electrical rotation. c—A secant circuit.

in series with one of the potentiometer end legs. Note that the connection arrangement of Fig. 4-b changes the slope and maximum output voltage. The arrangement of Fig. 4-c changes the minimum voltage and the slope of the transfer function curve. In each case the curve is a straight line.

The basic methods of Fig. 3 and 4 can be combined to derive an almost limitless number of variations. I'll leave the number to the enthusiastic reader. But I'll throw in a few special tricks as a wind-up gesture. In Fig. 5-a I've shown the circuit for a square-rooter. The pot scale should be divided into 100 equal units. The relationships are shown in the figure. A tangent solver good over a range of -50° to +50° is shown in Fig. 5-b. A secant solver is shown in Fig. 5-c.

END

Tinycolor Coming; But Not Here Yet

In recent weeks, “tinycolor” has merited mention in newspapers over the country, made the cover of a “popular” magazine, and drawn action from the US Securities and Exchange Commission. Trouble is . . . these little sets aren't available yet, except as prototypes!

This premature excitement is probably the result of pictures that were shown of mockups—dummies intended only to show what is envisioned for future tinycolor receivers. Photos have been released of *proposed* tinycolor sets to be built around a two-gun flat-type tinycolor CRT. The idea is fine, and steps are under way to get the tubes manufactured, but finished sets are NOT on the market and probably won't be this year.



Other companies have developed mockups for tinycolor, too, such as this photo of an RCA conception. But, an RCA official points out, sets are *not* available at this time; the dummies only portend what is to come.

Announcements by Admiral and RCA, and hints by others, that their Spring 1966 lines of TV receivers will use integrated circuits in a few applications, have placed the whole tinycolor concept far closer to actuality—and has probably lent credence to the misunderstanding that tinycolor sets are presently available.

Hopes for 1966 tinycolor have been dampened further by Video Color Corp., which holds rights to the Kaiser-Aiken flat-tube patent (RADIO-ELECTRONICS, March 1957, page 43). They told *Television Digest* they don't feel a consumer version of that tube is anywhere near ready.

So far, one thing seems sure: Unless some major manufacturer is carefully guarding a secret, you'll not be seeing tinycolor sets on the market for some months to come.—Forest H. Belt

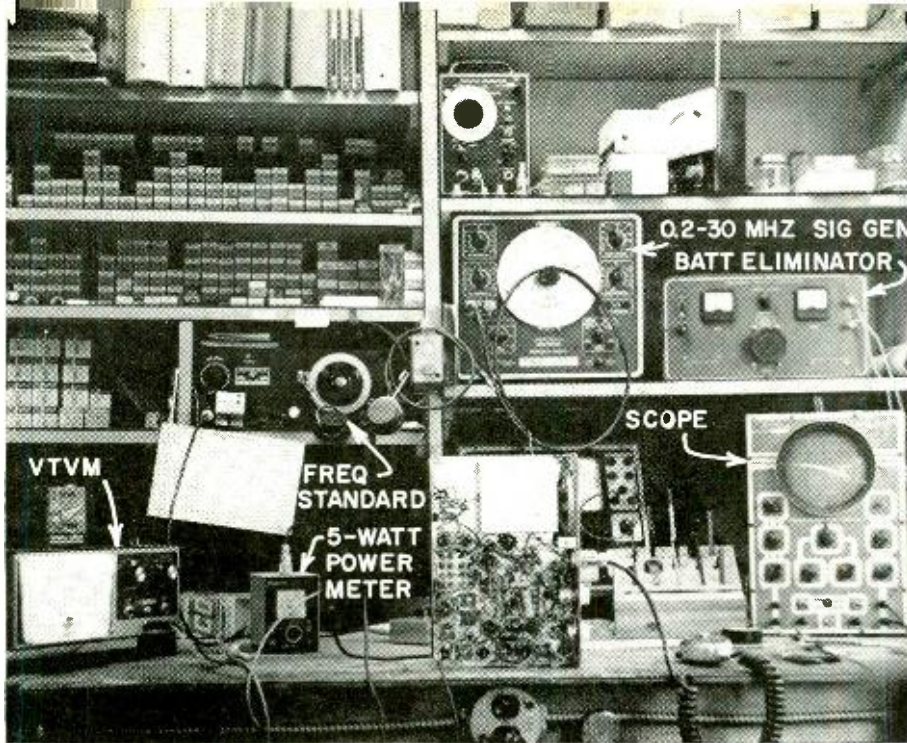

By CHARLES B. RANDALL

How fast you can move
CB units in and out of
your shop is everything.
Here's one man who
has mastered the art

*Essentials of quick, effective
and profitable CB service.
Note how everything is
in easy reach, yet doesn't
clutter the work space.*

An Afternoon At CB Repair

I REMEMBER READING WITH ONLY PASSING interest about the opening of the 11-meter Citizens band. That must have been in '57 or '58. By 1960 I found myself confronted by more and more CBers who wanted to have their rigs repaired. Not one to turn away a customer, I accepted a Globe 100 for service. Immediately I discovered how little I knew about transceiver operation.

I fixed that unit. Then I decided to see about developing CB service into a profitable sideline in my TV repair shop. After a few years and a few thousand more rigs repaired, the sideline has paid off not only in dollar profits but in many hundreds of new friends.

My test setup includes the basic instruments needed for proper CB servicing, arranged for quick, accurate work. The heart of it is a .002% frequency standard with calibrated output. This is used for checking the transmitter and for precise alignment of receivers.

Up front is a 5-watt power meter and dummy load with an earphone for monitoring modulation, a vtvm and a scope for visual checks of the carrier. A battery eliminator and a 200 KHz to 30 MHz signal generator complete the setup.

Nearby is a mutual-conductance tube tester with an accurate grid emission test. A thorough check of each tube is an important step in getting the most out of the critical circuits of a transceiver. Finally, a second-class FCC Radiotelephone license on the wall lets me do a complete job on each set that crosses the bench.

A kit assembled by the do-it-yourself fan can be very good practice for a technician. It takes real sleuthing to locate some of the mistakes. If the builder follows instructions carefully, I usually find only alignment is necessary. However, the first thing I see in a Heath GW-10 (just finished, but absolutely dead) is a terminal left unsoldered. I quickly check over the rest of the connections, applying solder where needed. Not a very promising start.

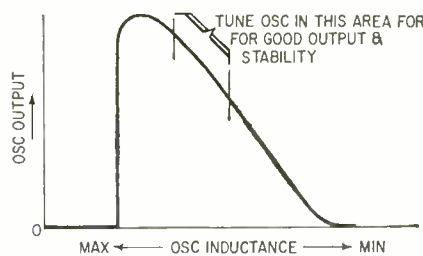

Fig. 1—Remember always to adjust oscillator plate tank slightly on the high-frequency side of resonance for best stability.

I hook the set to the dummy load and fire it up. There is a rush from the speaker and the squelch cuts out the audio as it is advanced. So far OK. When I depress the mike button the relay closes but the needle on the power meter doesn't budge. Squeezing the mike switch I quickly back the slug out of the oscillator coil and she kicks off.

The proper adjustment for the oscillator coil is approximately a quarter turn out (counterclockwise) from peak.

This is on the sloping side of the response curve (Fig. 1) and will give the most stable operation.

Next I install the extra transmit crystals the customer ordered and check them for on-frequency operation. Peaking the rf output coil produces the normal (for this model) 2-watt carrier.

When I check the modulation with the earphone, I get nothing but a loud squeal. The two yellow secondary leads from the audio output transformer have been reversed. The directions clearly indicate that the top lead goes to the speaker, the lower one to the relay. The first time I ran into this it took me a lot longer to locate the trouble. Now, speaking into the mike, I hear a strong clear signal. A scope check shows the modulation peaks hitting around 95% with strong response even at a whisper (Fig. 2). That takes care of the transmitter.

To check out the receiver I first hook the dc probe from the vtvm to the age line. After pushing the CRYSTAL-TUNABLE switch to the CRYSTAL position, I install a channel 11 receiving crystal. (I always peak both transmitter and receiver on 11 unless the customer definitely wants to favor some other channel.) A change in the rush (or in the age level) lets me know the oscillator is working. However, feeding 27.085 MHz from the frequency standard into the antenna jack, I get no response from the age, even at full output.

At this point I'll try to bring the i.f.'s into range with the regular signal generator. This is necessary only in cases where the adjustments have been thrown

way off. After roughing-in the i.f.'s around 455 KHz. I switch back to the frequency standard and quickly peak each i.f. and the rf input, cutting back the output as I go to prevent overload.

Before final speaking I switch back to TUNABLE and set the dial on 11. Starting with the tunable oscillator slug all the way in (clockwise), I slowly back it out until I get a signal. Noting the age reading, I switch back to crystal and again check the age. If there is a difference in response from tunable to crystal, I balance it out with a slight adjustment of the crystal oscillator coil. This assures

First I hook the mobile rig to the power meter, and, whistling into the mike, monitor with the earphone. The modulation is definitely intermittent. By moving the mike cord I can get it to cut off and on at will. A new coil cord seems to be called for in this case. After the new cord is on, I make a quick recheck of the modulation. The job is completed.

The other Globe 100 is due for a routine overhaul. With the set hooked to the outside antenna for a preliminary air check, it seems to be picking up a number of signals. However, when a calibrated signal is fed into the receiver,

making good contact. To correct this trouble I remove the relay, clean all contacts and carefully reset the contact springs. (If any of the contacts appear burned, I install a new relay.) I replace the relay and trigger it a number of times to check the alignment of the springs. This completes the repair.

Next I check all the tubes in the set, replacing any that are weak or gassy. Then I align the receiver completely, using the crystal nearest the center of the band. After alignment, I feed in a signal for the rest of the crystals in the set, making sure each is receiving on channel. The transmitter is peaked and each crystal checked for on-frequency operation.

The modulation sounds clear in the earpiece but the scope shows up some trouble. The carrier can be fully modulated but only with a sharp whistle or very loud speech. I clip a test mike across the present one and see an immediate improvement. There had been no complaint about getting out but the old ceramic cartridge is definitely weak. Since the unit is used only as a base station, a good quality crystal could be used. A phone call to the customer results in the sale of a more practical desk type mike.

Off-frequency operation

The next job in line is a Johnson Viking. A citation from the FCC for off-frequency operation on channel 9 brought this one in. The customer had



Trapezoid pattern is good speedy modulation check (see Fig. 2). For information on how to interpret it, try Radio Amateur's Handbook or other books on transmitter design and maintenance.

that signals read on tunable will be as strong as those on crystal. To obtain maximum sensitivity, I cut the frequency standard back to a few microvolts output and, in the CRYSTAL position, carefully touch up each i.f. and the rf coil.

While I'm wrapping up the Heath-kit, a driver from a local fuel-oil company carries in two of the firm's Globe 100's for a checkup. One of the units (a mobile) is said to be breaking up on transmit, while the other (the base) is not receiving properly. "I'll try to get them out as soon as possible," I said, taking them right to the bench. Businesses often depend heavily on their communications, so it's important to get them back on the air promptly.

Checking back in the file, I noted that the mobile rig had been in less than 3 months ago, while the base hadn't needed work for over a year. With sets that are serviced routinely, we run frequency checks only if 6 months have passed since the last check. To insure good sensitivity, receivers are realigned at least once a year. The circuits of a CB receiver are much more sharply tuned than those of a table radio or television, and slight changes in a tube or part can cut performance. Of course, all new repair jobs get the full treatment.

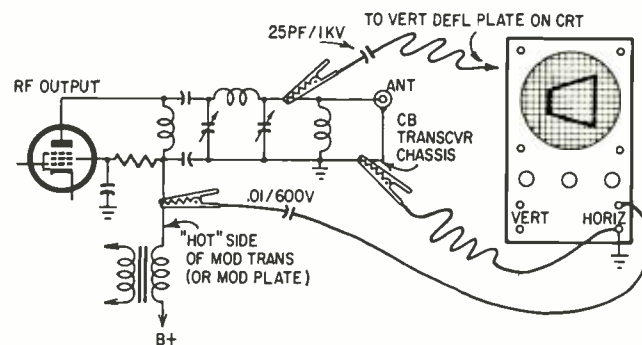

Fig. 2—How to connect a scope to get a trapezoidal modulation pattern. The rf connection must be made directly to one vertical deflection plate of scope.

I immediately notice the lack of sensitivity. The age responds only to a signal level of 20 μ V or more where normally it should be sensitive to less than 1 μ V.

In a small indexed booklet I jot down hints and kinks about each set as I go along. I reserve a space for receiver sensitivity readings to be expected of each model. I make a note of the normal age reading (from a specified test point) at 10 μ V. Also the lowest signal level at which the age will respond. I get my figures by averaging the readings from a number of new rigs (if possible) or older sets that have been repaired and realigned.

I track the trouble in the Globe to the relay; the antenna return was not

also mentioned that the receiver did not seem up to par. A frequency check indicates channel 9 is more than 2,500 Hz low, or about 1,200 Hz out of tolerance. However, when I check the other four channels, I find them all 2,000 to 3,000 Hz low! New tubes make no difference; nor does a double check with a couple of new crystals.

By adjusting the oscillator grid coil I can bring all channels within 500 Hz of the correct frequency. The set had evidently been operating out of adjustment and off frequency for some time. The next step is to fill in the repair-correction form furnished by the FCC. Before turning to the receiver I peak the transmitter and check the modulation.

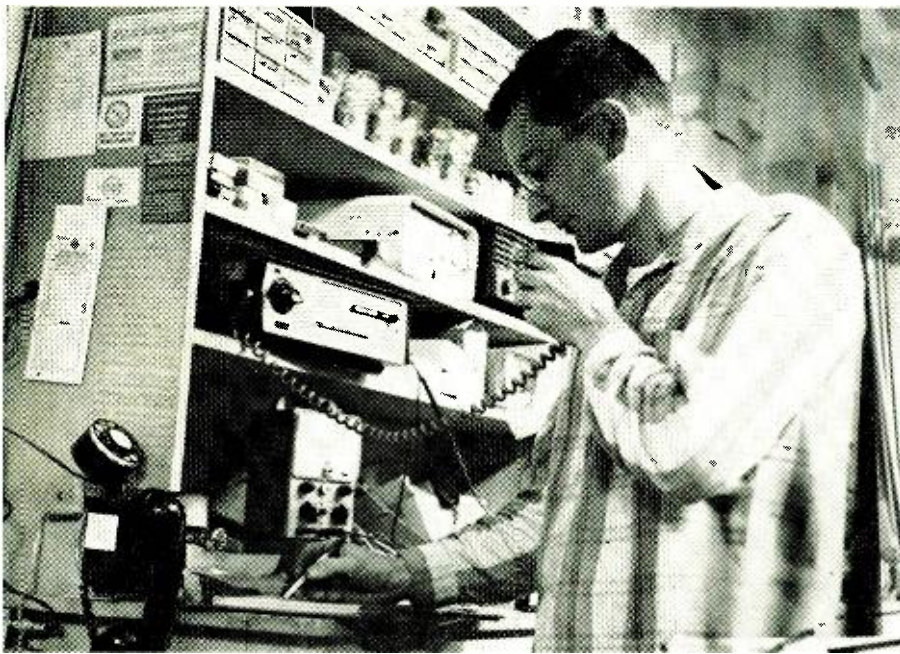

Base rig is busy during the day as customers call on channel 7 for parts and information. *Vivm* makes sensitive S-meter for on-the-air transmitter checks.

Just as I was hooking up the dc probe to the receiver agc, a CB'er pulled up in front of the store. I walked out to the counter. "I wonder if you'll take a look at my mobile rig," he said, "I'm not getting out." "Give me a call from out front." I told him, and walked over to listen on my base rig. He had trouble. Modulation sounded clear but his carrier was much too low. (I keep my meter adjusted so a mobile in front of the store gives full-scale deflection.)

I went outside and connected my power meter to the rig's output. His set pushed my power meter needle over 3 watts, so nothing was wrong there. But I find a dead short from center conductor of the antenna lead-in to ground. The center hole in the fender hadn't been cut large enough, and the bolt supporting the ball, spring and whip was shorting. I enlarge the hole with a rattail. This time when the customer throws on his carrier, the S-meter on the store rig climbs right to the top.

Back in the store, he asks me what he can do to prevent his steel whip from slapping around so much while he drives. "I came pretty close to hitting a pedestrian with it a couple of times," he said.

"Try one of these 96-inch glass jobs," I advised. "They're much more rigid than steel. They don't take a set and don't lay back, even at high speeds."

"Sold," he said. "Can I borrow an adjustable wrench to put it on?"

Getting back to the bench I resume the repair of the Johnson by checking each tube in the receiver. The 6BE6 oscillator-mixer is weak and shorting; the rest are OK. The first step in the alignment is to check the receive oscillator for on-frequency operation. I check this

whenever I suspect tampering. Or, as in the case of this Johnson, when the oscillator tube or some critical component has been replaced. I loop a piece of wire loosely around the oscillator coil and feed the other end into the frequency meter. I then adjust the slug for zero beat with the proper frequency.

Now I feed 27.085 MHz to the antenna jack and peak the i.f. The adjustment of the rf transformer is critical. The top slug has to be peaked to channel 1 and the bottom slug to channel 22. (It is very important in aligning many sets to follow the manufacturer's prescribed procedure.) Peaking i.f.'s is usually routine, and most rf stages are properly aligned if you use a channel near the center of the band. However, a number of units, like Johnson, require a different alignment procedure. Finally, using 27.085 MHz, I touch up the i.f.'s and peak the antenna coil.

I price my repairs on an hourly basis. There is a minimum charge (\$5) for the first half hour's work, and an additional \$3.50 charge for each half hour after that. The average repair takes less than half an hour to complete. A general overhaul usually runs about an hour.

Being able to service a CB transmitter competently is the most important part of a successful enterprise. If you can land some warranty service contracts, you'll pull in many new customers. Sales of new units and accessories can be profitable. Trade-ins can be put into top shape and resold at a good markup. There are many opportunities in this expanding field for an alert technician. END

THE CASE OF THE MISSING HIGH VOLTAGE

ONE OF THE MOST FRUSTRATING TV repair jobs I ever did was on a Magnavox series 105 chassis. This is a 20-inch set made to slide into a cabinet that already housed a radio-phono combination. The set owner had left the TV chassis with a repairman for over a year, but it hadn't been fixed.

There was no high voltage and no raster, the boosted B-plus was low and the other B-plus voltages were slightly low. A suspicion that the filament in the 1B3-GT high-voltage rectifier was not lit crossed my mind, but I rejected the thought since the previous service technician surely had checked it.

After checking and substituting tubes, measuring voltages, checking various capacitors and resistors I decided to check the high-voltage rectifier socket assembly. This consisted of a tube, a socket, a 1-megohm resistor in series with the high voltage, two paralleled 10-ohm resistors in series with the 1B3-GT filament, and the usual doorknob capacitor. Every thing was in order, but there was still no high voltage.

Then I took out the 1B3-GT and put it into a spare socket, connected a 1.5-volt flashlight battery across the filament pins, and connected a capacitor from a filament pin to the boosted-B-plus circuit. When I again connected the plate cap of the 1B3-GT and turned on the set, I had a raster and all the high voltage I needed. This proved that the 1B3-GT hadn't been lit when it was plugged into the socket in the set.

What was wrong? I unsoldered the filament loop at one tube-socket lug and checked it through the flyback for continuity. It was good. The 1-megohm resistor was good. The two 10-ohm resistors were good. The capacitor was good. I resoldered the filament wire, and there was the raster and high voltage. After adjusting the horizontal circuits I had a picture. The set was still operating several months later.

This experience taught me a lesson. Never ignore the obvious symptom for it may save you hours of work when troubleshooting TV receivers.—James A. Fred

NARROW-BAND SCOPE FOR COLOR TV?

Impossible? Not at all! An inexpensive scope with response to only a few hundred KHz can do many of the jobs often left for 5-MHz scopes. TV service expert Bob Middleton explains how in May RADIO-ELECTRONICS.

WHAT WOULD YOU DO?

Lucky & Super tackle FM multiplex

By GEORGE D. PHILPOTT

THE HARD THUMP OF A CAR BUMPER against the back wall of Lucky's TV Shop brought Lucky back to reality in a hurry. He had been drifting and dreaming in a musical trance, listening to multiplex stereo on his most recent repair job.

"That's my protege! Super-Sonic has returned!" Lucky exclaimed to a nonexistent audience. He stopped to retrieve a coil of lead-in wire bumped from its nail in the wall and muttered, "I'll fire that . . .", just as the younger technician barged into the room through the back door, loaded with chassis and tools. The lad brushed on by, grunting, and deposited his load on top of the bench.

"One of these days you're gonna drive that truck right onto my bench!" shouted Lucky, often having pictured such a scene. Then he saw the newly arrived chassis and sputtered, "Is this Mr. Fump's stereo outfit? I thought you would fix it there."

"I tried," said Super, rather weakly. "But the actual trouble wasn't in the phono section like it was marked on the

call sheet. The multiplex adapter has a bug in it, and I'm afraid that's your department. I haven't enough experience with stereo multiplex. After all, it's new here. . . ."

Lucky gave his helper a benevolent grin. He appreciated the fact that he had not shown ignorance in front of the customer.

"I'll buy your excuse this time—but it's time for you to catch up on multiplex. It's not one bit more mysterious than any other branch of electronics. In fact, it's a lot like intercarrier TV sound. Let's clear off the bench a little and I'll explain some of the simpler details."

The phone rang; Lucky answered it and wrote down another service call. Finally, he turned to the workbench and perched on his stool. "It might sound naive," he began, "but, the first thing to think about when you repair a stereo set is to identify the multiplex section. Any technician who knows the general layout of a receiver can spot the additional coils, tube or tubes, and the extra diodes. Some manufacturers stick a chassis layout chart to the cabinet. Find the multi-

plex section, or adapter, and check the tubes. Shorted tubes cause half the trouble, and sometimes they're troublemakers because they only short after being on an hour or longer. Am I being emphatically clear on this one simple point?"

"Sure thing, boss—you test the tubes. But I always do that. In fact, most of the customers have them tested at the drugstore before they call. I need technical stuff—for instance, how does stereo work, so I'll have confidence in myself when I go on a job."

Lucky shifted himself uneasily on the seat. "Super, I'll get to the screwdriver aspects of the case *after* drilling one important fact into your mind, if you don't mind?"

"Okay."

"Make certain the right tubes are in the right sockets. As you say, a customer may have tested them—and put them back in the wrong sockets. Second, if a tube is defective, replace it with an *exact* replacement. Don't jam in the first substitute that comes into your mind and expect it to work right. You can't see the results on a screen like in television. Your ear will often fool you, but the customer *knows* how his set should sound."

"I don't believe in hit-or-miss tube substitution anyhow," said Super. "If there wasn't *some* difference in tubes, the manufacturers wouldn't number them different."

"Seems to be the general idea," Lucky agreed, smiling a little. "The next suggestion is to carry a pair of stereo phones with you on the job. Connected into the headset jack or across the speaker terminals, they give you a chance to determine stereo quality, channel separation and quality of the receiver in general. I put a pair in the truck for just that reason."

"I'll use them, now that I know," said Super.

"Now for the theory," Lucky continued. "Multiplex starts at the station, where two input signals, left and right, from a stereo setup—mikes, records or tape—are mixed to form a composite audio waveform which modulates the FM transmitter. Also mixed as part of the modulation is a 19-kc sine wave, called the *pilot signal*. At the receiver, the 19-kc signal is detected along with

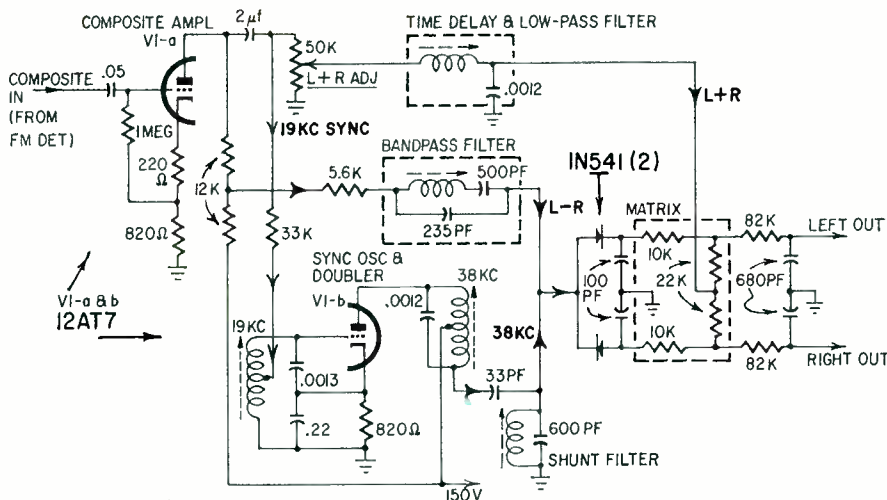

This G-E circuit is probably the simplest practical multiplex decoder—only one tube. It has three basic signal paths, which split off after VI. One path carries the L + R sum signal (plain audio, from 30 to 15,000 cycles), which is just what any FM receiver would pass to its audio stages. Second path carries the L - R signal—sidebands of suppressed-carrier 38-kc AM signal that (as a whole) frequency-modulates the main carrier. These are frequencies between 23 and 53 kc; all others must be kept out, hence the bandpass filter. Third path regenerates 38-kc carrier, dropped at transmitter. All paths re-unite at detectors and matrix.

the audio and used to phase-lock the individual stereo channels.

"A composite stereo signal is more complex than you might think. There's the main-carrier modulation, which is the *sum* of left and right channels, the 19-kc pilot and a 38-kc suppressed-carrier AM subcarrier that provides the *difference* of left and right channels. In short, the receiver has three detecting jobs to handle perfectly at the second detector before you get *stereo*."

"Could you run over me again with that mess?" Super pleaded.

"It's worth a try," said Lucky, grinning. "Maybe if you can visualize the studio—two microphones placed a few feet apart in front of an orchestra and picking up music, an audio signal generator turned low at 19-kc between the mikes, and an instrument capable of supplying a mixed left-minus-right signal voltage from both mikes, amplitude-modulating a 38-kc wave, all going directly into the input line, exactly phased and in proportion to the sound level of the music in the room. That's a rough analogy of a stereo signal.

"The combination voltage from both sources, frequency-modulating the main carrier, is sometimes known as the left-plus-right signal or the *main* channel. Being a straightforward sum voltage from both microphones, alone it sounds just like ordinary single-channel, non-stereo FM on a set without multiplex circuits. That's what we mean by compatible. Properly detected and mixed with the left-minus-right *difference* component which is transmitted as suppressed-carrier by the 38-kc subcarrier, you have the two channels for stereo reception."

Super-Sonic crossed his legs the other way, scratched his head and whistled softly. "Let's see now," he said. "Yeah, the 19-kc is the pilot signal. The 38-kc signal is a subcarrier modulated with the difference voltages between the two mikes, in the suppressed-carrier mode. Am I right?"

"You're beginning to find the range."

"It's really interesting, Boss . . . and as simple, once you understand it, as a double-rank shift regulator on the discriminating end of a linear burnout back spacer."

"You won't think it's so funny after you tangle with a few," Lucky jabbed. "In fact, it might be a good idea to let you sweat over the set you just brought in."

"Getting the chassis out of the cabinet was no cinch, by itself."

Lucky grinned, got up and examined the three separate units. Unplugged and tangled with various wires and cables, the receiver more closely resembled a discarded telephone switchboard assembly than a radio. "The manufactur-

ers sure don't care what happens to their product once it leaves the factory," Lucky sighed. "A fly in a spider's web is better off than an electronics technician these days."

"You ain't kidding," said Super.

Examining the units thoughtfully, Lucky arranged them on the bench, connected bench speakers, hooked an antenna to the FM antenna terminals and installed the cheater plug. The tubes warmed up and stations began to come in strong. "Sounds very good on monaural," he commented. Tuning from station to station, he did notice a faintly discernible distortion on the weaker carriers. The Suburba station seemed acceptable on straight FM. But when he switched to stereo, the customer's complaint became apparent immediately: highs were completely distorted. "Sounds more like a scratchy record played with a dull needle in a bad crystal pickup," Lucky remarked.

"It's rough all right," Super agreed.

Lucky removed the tubes from the stereo adapter, tested them and replaced them in their sockets. Looking a bit apprehensive, he tuned the receiver back and forth slowly across the station carrier. "This is a locked-oscillator type circuit," he advised Super. "Notice the 'plopping' sound as I tune into the signal? Some stereo receivers use a different system for getting exact 38-kc phasing. Instead of using the 19-kc pilot to phase-lock a free-running oscillator, which then is used for frequency-doubling into an amplifier stage, they merely amplify the pilot and inject it as grid drive into a class-C amplifier stage tuned to 38 kc. Both systems have their advantages. The nonoscillating kind isn't as sensitive to frequency drift in the tuned circuits."

"Can't we put a scope on the adapter and find the trouble?" Super queried.

"We can and will," Lucky replied, "if for no other reason than to get you acquainted with the proper test points and waveforms. In this case, we can find our trouble without even connecting a scope. Watch close and I'll show you what I mean." He then very carefully tuned the receiver to one side of the stereo carrier and back into it. "Notice the solid 19-kc locking effect on this side?"

"Seems real solid, Boss."

Lucky tuned the receiver to the other side of the carrier and gradually brought it back a considerable distance beyond the edge of the carrier before the locking 'plop' could be noticed. "It's pretty weak on this side of the carrier," he commented, watching his rather surprised helper. "Got any ideas yet?" he grinned.

"I'm beginning to center in on something," Super said hesitantly.

"This repair job is practically fin-

ished," said Lucky, as he reached for a tool and began to work on the set.

What kind of tool did Lucky use to repair the receiver, and what did he do?

Answer to Lucky's repair problem:

He used an alignment tool. By tuning the receiver across the FM carrier and observing the unsymmetrical locking, he recognized that the receiver's discriminator or ratio detector must have been mistuned at least enough to distort the 38-kc suppressed-carrier waveform, which in turn affected proper reinsertion of the left-minus-right signal in the adapter matrixing network. Of course, ordinary FM and the 19-kc pilot would also be affected, but not as much. END

Light-Meter Quandaries

Readers have questioned the specifications of two components in the parts list of the "Ultra-Sensitive Light Meter" on page 50 of the February issue. One reader noted that the dimensions of the photocell ($\frac{1}{2}$ in. dia, $\frac{1}{8}$ in. thick) differ from those listed in the Lafayette catalog. A Lafayette representative says the dimensions given by the author are correct and the catalog dimensions are wrong.

Some readers have been confused by the fact that switch S1 is listed in the Lafayette catalog as a shorting type and are afraid that the instrument won't work with this type of switch. The switch listed is a shorting type and is the correct one for the light meter. The confusion is caused by some readers' unfamiliarity with switch nomenclature.

Rotary switches are made in three basic types. In a *nonshorting type*, the switch arm or wiper leaves one contact before it reaches the other. In relay and switch terminology this is called a Form C or *break-before-make* contact. A *shorting type* switch is one in which the arm or wiper blade is wide enough to touch the next contact in line just before it leaves the other. This is a Form D or *make-before-break* arrangement. It is often specified in cases where some components might be damaged if the circuit is momentarily opened. For example, a shorting switch should be used to switch meter shunts. The meter is then always protected by a shunt, even while switching from one range to another. If a nonshorting switch is used for this application, the meter might be damaged if it is passing current when the range is switched.

The third type of rotary switch is a *progressive-shorting type*. The arm or wiper is generally a "fan" or circular type that shorts successive contacts until, in the last position, all contacts are connected to a common terminal. Some readers may have been confusing this type with the shorting type.

PUT 'EM UP AND KEEP 'EM UP!

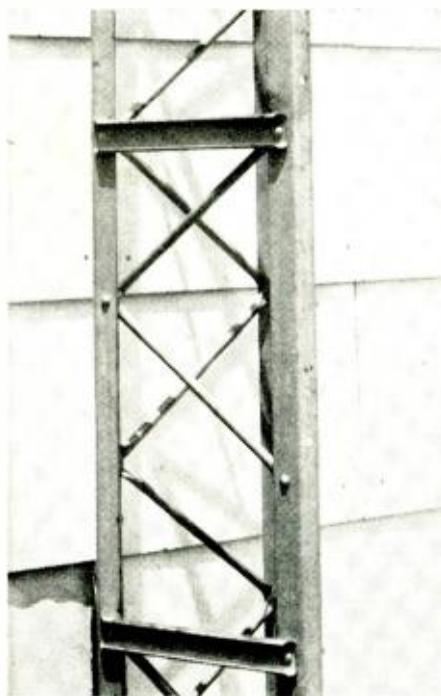

Fig. 1—Stamped-steel tower, 9 inches on a side, is typical for home installations.

By **JACK DARR**
SERVICE EDITOR

YOU CAN PUT UP A HOME TV ANTENNA tower so strong that it will *not* blow down. It will ride out any windstorm that doesn't blow away some of the house! You can do it with ordinary materials, not special hurricane-proof stuff. The secret is in the guying and installation. Even the lightest home type tower has ample strength, *if* it is properly rigged. I've done this for 15 years, and never yet lost a tower to wind—yet! Some towers, although used far beyond recommended lengths, have ridden out gusts of over 105 mph!

The magic formula is proper load

distribution. Using standard sizes of guy wire, we set them on the tower to give a liberal safety factor, and spread the load out among more wires. If we use only two heavy wires, and one breaks, we'd lose half of our strength; with four small wires of the same *total capacity*, if one breaks we still have three-fourths of the capacity left.

TV towers

Least expensive is the stamped-steel tower of Fig. 1. The 9-inch size (across) is recommended for heights up to 36 feet, and the 11-inch above that, up to about 75 feet.

We'll take as an example a tower of 50 feet, since this will be about the tallest "home" tower you'll get. Now, to rig this tower so it will withstand high winds without coming down we have to provide enough guy wires to carry the total load, and install them so that they will give maximum strength. These guy wires do two jobs: they hold the tower *up*, and also hold it *straight*. A triangular tower is actually a "truss" section. It has tremendous strength under a "compression" load, straight down. Even the thin stamped-steel legs will carry extremely heavy loads. Sidewise, though, because of the great length-to-width ratio, towers are comparatively weak. This is where we come in with our little rolls of guy wire! Let's see how to figure guying points and wire sizes.

Tower loading

There are two loads on a tower: the straight-down push of the weight of antenna, rotator and guy wire; and, second, push from wind loading—most of this is converted into a downward push by the action of the guy wires. Much more to be feared are the forces in a side wise direction (where the tower is weak-

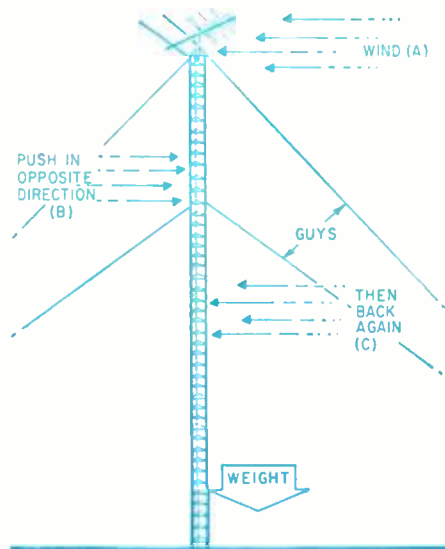

Fig. 3—Approximation of forces acting on tower. Base supports weight of installation, also carries part of wind load, translated into downward push by guy wires.

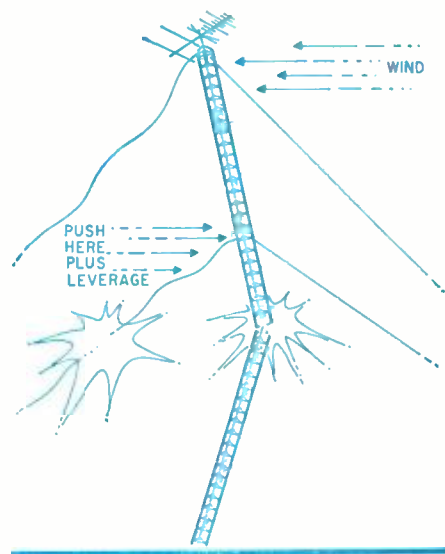

Fig. 4—Only way to go from here is down!

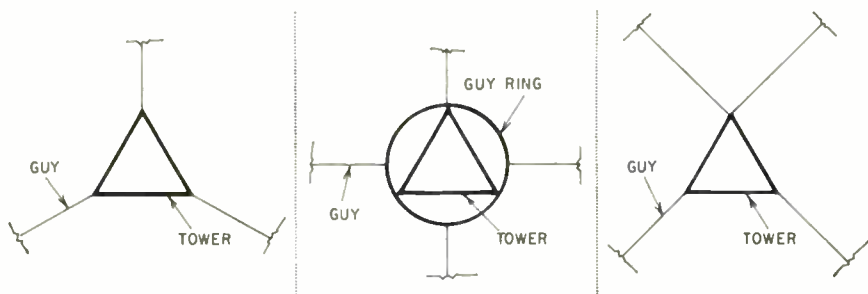

Fig. 2—Three-guy and four-guy patterns, viewed from top of tower. Equal spacing is best, and easiest to figure.

est) exerted by winds. As long as we can hold the structure straight, it's strong. Try driving a bent nail, then a straight one!

There are two patterns for guy wires—three-guy and four-guy (Fig. 2). I prefer the four-guy, for the obvious reason that you've got one more wire! One broken wire in a three-guy system, and you've lost it. Also, each guy can pull against another one directly oppo-

site, making tension adjustments simpler.

The forces acting on a tower under wind loading are far from "linear." We do *not* get a straight downward push nor a straight sidewise push, but a weird combination of forces, because of the *leverage* that we set up in the tower structure when we attach the guy wires. In Fig. 3, wind pushing on the antenna at A may be transformed into a push *upwind* at B, because of the leverage acting around the fulcrum formed by the top guy-wire attachment point. In the next section, this can be reversed again, and so on.

So, if our guys aren't spaced correctly, here's what happens (Fig. 4). I found this out many years ago, by losing two identical installations on the same night: tubular masts, not towers. Both went the same way: the mast buckled in two places, and down they went. Not a single guy wire broke, and the antenna fell *upwind*. (This made a deep impression, because I had to replace both of 'em free. I'd guaranteed 'em!) Replaced with heavier masts, and relocated guys, they're still standing. That showed me where the unsuspected forces show up in masts and towers.

The lesson I got was "Don't skimp on guy wires! Use more of 'em, and space 'em closer." So, from then on, I've used a layout like that in Fig. 5. For a 50-foot tower, guys are tied at 50, 40, 30 and 20 feet from the top. By doing this, we break up that most vulnerable part into very short levers, shortening the "moment arms" up there.

Also, by using four-guy patterns, we can make the tower into a truss section. This gives maximum *rigidity*: the closely spaced guy wires hold the tower in its position of maximum strength—vertical and straight.

The top guys should be set at least 80% of the tower height from the base. Right at the top is better.

For the last step in all installations, look straight up the tower from the base (Fig. 6). It'll probably look like a three-

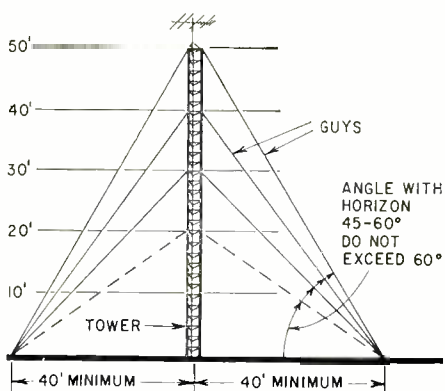

Fig. 5—Side view of guy wires on 50-foot tower. Often, first 20 feet can be braced against building.



Fig. 6—Looking up along tower will tell you whether or not it's straight.

cornered metal snake! Pull guy wires to adjust it, until you can see that it is absolutely straight. A bend in the tower can be the starting point for a disastrous buckle. Plumb it, for appearance if nothing else. Use the old lineman's trick: hang a weight on a string, hold it up and sight past it at the tower. This will help get it exactly vertical. The old linemen used their pocket watch and chain for this!

Figuring wind loads

We need to know the wind loading—the push of the wind on tower and antenna—so we can choose the right guy wire. To figure this, take the total area of the tower, on the largest side. In a 50-foot tower of this type, it figures out to 12.5 square feet. (That's for flat-leg towers. In tubular-leg welded-steel towers, it's quite a bit less.) The side area of even the largest fringe-area TV antenna with rotator comes out at about 2 square feet. So, let's use 15 square feet for total area. In working these problems, always round off figures *up*, to increase the safety factor.

Multiply this by your wind pressure in pounds per square foot, and you have the total push on the whole thing. Commercial tower erectors use a figure of 30 lb/sq ft, in figuring for towers up to 300 feet. This is the maximum wind force found over almost 95% of the US, except for a very thin strip along the Gulf Coast and up the Atlantic seaboard. In these "hurricane" areas, 35 and 40 pounds are used. These figures correspond to 87-, 94- and 100-mph winds. A table of these figures and a map of average wind velocities can be found in

EIA Standard RS-222. So, let's use an 87-mph wind, at 30 lb/sq ft, to be safe.
 $15 \text{ sq ft} \times 30 \text{ lb/sq ft} = 450 \text{ lb}$

The standard also recommends a safety factor of 1.5, based on the projected area of the tower. So, $450 \times 1.5 = 675 \text{ lb}$. To make it worse, let's say that this whole thing is concentrated in one flat area at the top of the tower (Fig. 7). And let's pretend we have only one guy wire, and it will have to carry the load all alone.

Guy-wire strengths

The most popular guy wire is 6/18 steel: six strands of No. 18 wire, galvanized. Load-carrying ability of this is rated at 650–675 lb. Comes out even, but no safety factor. So, in this case, let's use the next size. The 8/18 is rated at 850–900 lb; 6/18 Copperweld, 1,100 lb. For very heavy loads, an 8/18 Copperweld goes to 1,450 lb.

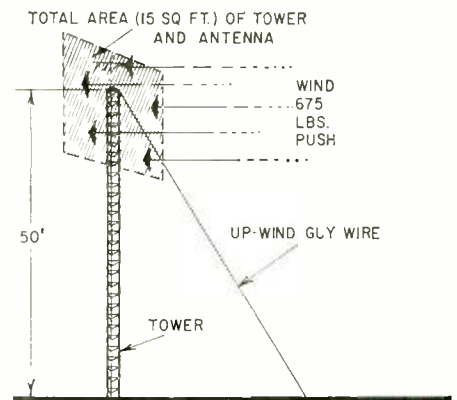

Fig. 7—As an example of conservative "worst-case" load calculations, pretend that tower's total effective surface is concentrated at top, where wind force has greatest leverage, and that only one wire has to hold it all!

Let's see what the actual strength would be, in a typical installation like that of Fig. 5, using 6/18 steel guys, in four sets of four each. With four guys on each side, at 650 lb apiece, we'd get a total of 2,600 lb. load-carrying capacity. A wind of 140 mph develops only 80 lb/sq ft pressure. Using the true area with a safety factor of 1.5, we can carry a load of 110 lb per sq ft! I don't know what that is. The table only goes to 141 mph!

Guy anchorage

The real strength of a guy depends on three things: breaking strength of the wire, strength of the anchorage and the way the wire is fastened. Unless *all* these are correct, you won't get maximum strength.

We ran tests on a calibrated hydraulic press with typical materials—6/18 guy wire, No. 4 (¼ inch) screw-eyes, etc. Some of the results surprised

Unraveling Wire Specs

Specifications for stranded cables (also called wire rope) are confusing to the layman. Antenna guy wire supplied by Birnbach, Saxon Metal Products, South River Metal Products and others is specified by a fraction-type number that shows the number of strands (wires) and the wire gage.

In construction, industrial and mechanical trades, stranded wire is specified by a number such as 6 x 19 x 1/4. The first number is the number of strands, the second is the number of wires per strand and the third is the total diameter in inches. Breaking strength and the diameter depend on the core material and on the gage of wire used in each strand.

If an installation requires wire stronger than that ordinarily sold for antennas, consider some of the smaller industrial types. For example, a 6 x 7 x 3/16 galvanized-iron sash cord has a breaking strength of 688 lb; 6 x 7 x 1/4 breaks at 1,225 lb.

With less than seven or eight turns, the wire will slowly unwrap and let go. The safest way is to use cable clips.

In setting these screweyes in wood roofs, trees, etc., run them up until all threads are covered, for maximum strength. In frame houses, be sure that screweye goes *through* the roof and into one of the framing members. Roofs are covered with 1-inch board: while the screweye will hold, a high wind could pull boards off the roof! So, look for a roof rafter, and be sure you hit it; this is easy at the eaves.

Trees? Use only large ones, so that the sway of the trunk won't pull on the tower. Set guy-wire anchors at least 6

feet above ground, so you won't decapitate an unwary walker some night!

In fastening to the tower itself, use the special rings made for the purpose, with thimbles. *Don't* wrap wires around the sharp-cornered legs of stamped towers: this can cause failure. Even on the round-leg towers, use the correct guy-wire attachments.

Pull guy wires only tight enough to take up the slack. Never pull them tight enough to "ping." This puts an extra load on the tower. Pull them just tight enough to hold the tower absolutely straight and take up the sag.

On a tower with four guys up each side, put the top guy on a separate anchorage. The three lower guys can be tied to the same anchorage, if it is strong enough.

Our load-carrying ability is developed over the whole tower, guy wires and anchorages. Every little detail is important. It would take 47 pages of math to work out the exact proportion carried by each member, and in cases like that it isn't important. What we have to know is the maximum load that will be carried, under "worst-case" conditions, so that we can give ourselves a liberal safety factor. If in doubt, add a little! My motto has always been "50 cents worth of guy wire is cheaper than \$500 worth of tower!"

By using smaller guy wires, and dividing the load so that they are set closer to each other, we gain a lot in added rigidity of the flexible towers, and by the old "bundle of sticks" analogy, gain in total strength. For a final verification of your work, do what I do: climb the thing. From your airy perch 50 or 60 feet in the air, you'll soon learn to guy right and tight!

END



Fig. 8—Screweyes such as this must be screwed in all the way to eye and into solid structural material, not just shingles or decking. Wire here is wrapped only about 7 times; 10 is better. Note ferrule (or thimble) around wire loop, to reinforce it.

even me. Running these screweyes into pine boards, more than 1,000 lb pull was needed to make them let go. Even then, they didn't break, but slowly straightened out! We had to use a triple 6/18 wire to make them break. The wire, in each case, took more than its rated load before failure.

The manner in which the wire is tied is very important. For maximum strength, always use a "thimble" and make the tie as shown in Fig. 8. Be sure to take *at least ten turns* of wire around the guy after going through the thimble.

WHAT'S YOUR EQ?

Conducted by E. D. CLARK

Two Currents

Rheostat R2 can be adjusted to two different values at which it will dissipate

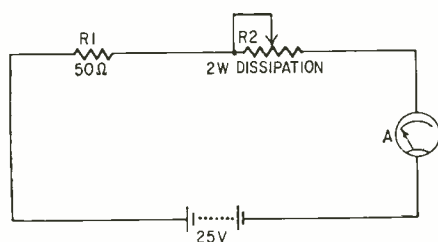

2 watts. What are the two circuit currents?—C. A. Kelly

Rise Time

A circuit is designed to produce a square wave with a rise time of 10 μsec. However, when the waveform is viewed

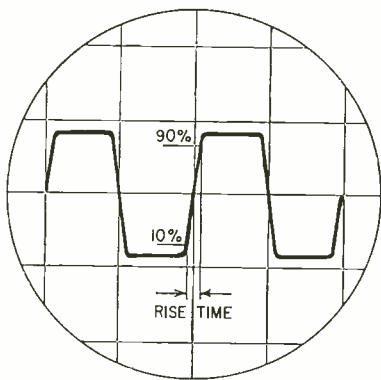

on a scope (type with a changeable vertical preamplifier), the rise time appears longer than that.

After checking the setup, it is found that the long rise time is the fault of the scope. Why?—Donald Ludwig

Two puzzlers for the student, theoretician and practical man. Simple? Double-check your answers before you say you've solved them. If you have an interesting or unusual puzzle (with an answer) send it to us. We will pay \$10 for each one accepted. We're especially interested in service stinkers or engineering stumbers on actual electronic equipment. We get so many letters we can't answer individual ones, but we'll print the more interesting solutions—ones the original authors never thought of.

Write EQ Editor, Radio-Electronics, 154 West 14th Street, New York, N. Y. 10011.

Answers to this month's puzzles are on page 91.

50 Years Ago

In Gernsback Publications
In April, 1916
Electrical Experimenter

Radio Range and Direction Now
Found by Instruments
Sealed-Point Electrolytic Detector
Hints

Weather Forecasts by Wireless
How to Organize a Radio Club

Case of the Open Cathode Resistor

By J. CHAMKIS

Let us assume you are taking a test to demonstrate your knowledge as an electronics technician, and you are asked this question:

A 12AU7-A is wired in a circuit as a class-A self-biased amplifier (Fig. 1). You are aware that this stage is inoperative because R1 is open. The tube is known good and its heater is glowing normally. What voltage would you expect to read on a vtvm from point A to ground?

1. 200 or very slightly less?
2. 18?
3. 0?

Most technicians would choose answer 1 without hesitation. If you picked answer 2, you probably hesitated a moment to take a closer look at the circuit. Let's see just what happens when operating potentials are applied to the circuit. Since the tube is good and there is no fault in the heater circuit, we would expect the tube to have a fairly low internal resistance if the plate is made 200 volts positive with respect to the cathode. This is in fact the case; the internal resistance of the tube is a few thousand ohms under those conditions. It would then seem logical that we would have a simple series circuit as in Fig. 2, and we should read only slightly less than the applied plate voltage of 200.

That would indeed be true were it not for the cathode bypass capacitor. C1 in Fig. 1. Before cathode resistor R1 opened, we would have measured 3.16 volts at point A—the normal operating bias of the stage. At the instant R1 opened, point A would have begun to rise toward 200 volts. But observe what happens when point A reaches 17.5 volts. A normal 12AU7-A happens to cut off at -18 grid volts with a plate voltage of 200. That is to say, with 200 volts applied from plate to cathode, the tube will stop conducting when its grid is 18 volts negative to the cathode. The grid in the circuit of Fig. 1 is at ground potential, and we left the charge on C1 at 17.5 volts. Therefore, the grid is 17.5 volts negative to the cathode, and the tube is almost cut off. Its internal resistance is now very high, and the charge on C1 will slowly rise to the 18 volts that it takes to cut off the tube and continue very slowly somewhat higher.

In first steps of troubleshooting an inoperative amplifier like that of Fig. 1, it would certainly not be uncommon to measure the voltages at the tube socket of the faulty stage. If you were to read 199 volts at the cathode, you would immediately suspect an open cathode resistor; but would you immediately reach

the same conclusion if you read 18 volts at the cathode? You might if you have a schematic that tells you the normal voltage at point A is 3.16, but if the correct voltage is not known, 18 volts at point A may not seem a very spectacular symptom.

So the voltage at the cathode of a tube is not always a reliable indicator of the condition of the cathode circuit. If a circuit similar to that of Fig. 1 is not op-

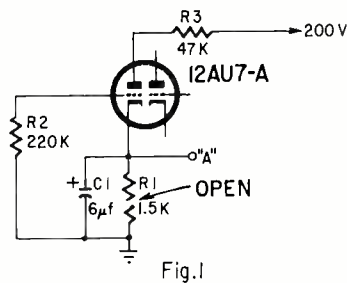

Fig. 1

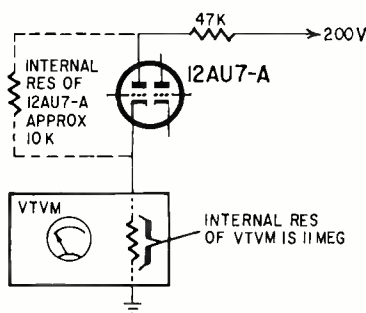

Fig. 2

erating properly, measure the potentials at the plate and cathode and compare them with the B+ voltage for the stage before selecting any components for closer investigation. In the circuit of Fig. 1, 199 volts would be measured at the plate of the tube—a dead giveaway that the tube is not conducting. However, the 18 volts measured at the cathode may tend to confuse you if you don't immediately think of the cathode bypass capacitor.

In practice, the measured voltage will depend on the capacitance and leakage resistance of C1, the leakage resistance of the tube and tube socket, the type of tube, the plate voltage and how long it has been applied, as well as the internal resistance of the voltmeter.

The circuit of Fig. 1 is also an extremely simple method of measuring the cutoff voltage of a specific tube under given operating conditions. This is useful for designing a class B or C amplifier, but take care to duplicate the potentials that will be used in the final version of the circuit. Variations in plate voltages as well as screen and other grid voltages have a profound effect on the control-grid-to-cathode voltage needed to cut off a tube.

END

Buy the BEST!
Buy in KIT form!



MARK® TEN

SCR CAPACITIVE DISCHARGE
IGNITION SYSTEM

ONLY \$29.95 PPD.!

Why settle for less in motor vehicle ignition systems when you can buy the very BEST from Delta, the originators, the leaders in capacitive discharge (SCR) systems. Delta pioneered this electronic marvel. Thousands have installed this remarkable electronic system. Now YOU can purchase at low, LOW cost, and in easy-to-build kit form, the king of them all, the DELTAKIT. Low price due simply to high production levels at no sacrifice in peerless Delta quality.

Operate Any Motor
Vehicle More Efficiently

Compare these proven benefits:

- ▲ Up to 20% Increase in Gasoline Mileage
- ▲ Installs in Only 10 Minutes on any Car or Boat
- ▲ Spark Plugs Last 3 to 10 Times Longer
- ▲ Instant Starts in all Weather
- ▲ Dramatic Increase in Acceleration and General Performance
- ▲ Promotes More Complete Combustion

Literature and complete technical information sent by return mail.

BETTER YET — ORDER TODAY!

DELTA PRODUCTS, INC.

P.O. Box 1147 F • Grand Junction, Colo.
Enclosed is \$_____. Ship prepaid.
 Ship C.O.D.

Please send:
 Mark Tens (Assembled) @ \$44.95
 Mark Tens (Delta Kit) @ \$29.95

SPECIFY — Positive Negative
 6 or 12 Volt

Car Year _____ Make _____
Name _____
Address _____
City State _____ Zip _____

DP 6-2

Circle 29 on reader's service card

Inventors of Television

Boris Rosing

AT THE BEGINNING OF THIS CENTURY, all the necessary elements for television were at the disposal of scientists. Karl F. Braun perfected the Crookes tube in 1897. The great English savant, J. Thomson, introduced deflection plates. In 1899, the German E. Vichert showed that one could concentrate electron beams with a winding concentric to the axis of the tube. And finally in 1902 the Russian A. A. Petrovski suggested that two windings at right angles to each other could be used for deflection. Scanning with mirrors had also been proposed.

Boris Lvovitch Rosing was born on the 23rd of April, 1869, in St. Petersburg. In 1887 he entered the Department of Physics and Mathematics of the University of St. Petersburg, where he was a student of F. F. Petrouchevski, himself a student of Lenz. At his graduation he was invited to remain as assistant to the Chair of Physics. Later he worked in physics at the Technological Institute of St. Petersburg. This placed excellently equipped laboratories at his disposition. In 1897 he became the director of the physics department there, where he worked until 1917.



Boris Lvovitch Rosing, 1869-1933

Rosing's researches included work on the telescope, on the "photography" of sound, equipment intended for the blind, a motion-picture projector and a transformer for direct current. Thus he was led to the study of what he called "electric telescoping." At the International Congress of Electrotechnique in Paris in 1900, he presented a report entitled "The Present Position of the

Problem of Television." It appears that this was the first use of the word "television."

In 1902 Rosing started experimenting with a cathode-ray tube for the transmission of images, beginning with a writing technique in which simple designs and letters could be traced on the face of the tube.

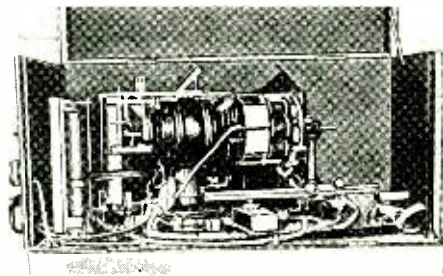

Rosing's transmitter. Much is unclear, but one drum and sync coils can be seen.

In 1907 he developed the first electronic television device, using two drums with mirror surfaces, mounted with their axes perpendicular to each other (Fig. 1). The light from the image fell first on the horizontal drum, which turned at a speed of 50 revolutions a second. It then went to the vertical drum, which had a speed of 12 turns per second, and from there to the photoelectric cell. (One of his patent application drawings showed the light going first to the vertical, then the horizontal drum.) The current of that cell modulated the strength of an electronic beam that fell on the fluorescent screen. This was done by deflecting this electronic stream across a small orifice through a capacitor (pair of deflecting plates), in such a way that a greater or smaller number of electrons went through the orifice. In the earliest models the two drums carried potentiometers with sliding arms that developed sawtooth vertical and horizontal deviation voltages, now supplied electronically. (Later models used the coils shown in Fig. 1.) These were applied to the vertical and horizontal deviation windings, which of course were in perfect synchronism with the transmitter.

This development was patented by Rosing on July 25, 1907, ten years after he began his first experiment. Rosing applied for and received an English patent in 1908 and a German patent in 1909, and finally, in October 1910, a patent in his own country.

The first model of the equipment, considerably improved over the original design, was finished in 1908 in the laboratories of the Technological Institute in St. Petersburg. A little later he developed the idea of modulating the brightness of the spot by changing its velocity, and in 1911 applied for a patent covering that idea.

On May 9, 1911, Rosing succeeded for the first time in obtaining an image on the screen of his rudimentary televisor. It consisted of four white bands on a black background. The photo at left shows the first transmitter. This success of the "electric telescope" brought Rosing the gold medal of the Russian Technical Society and several other honors.

World War I forced Rosing to abandon his experiments and devote himself to work in connection with national defense. After the Revolution he published numerous articles, and in 1922 the 25th anniversary of his work in the domain of television was celebrated. In 1924 the experimental electronic laboratory of Leningrad was placed at his disposition, and here he developed improved equipment, using a drum with 48 mirrors for horizontal scan and an oscillating mirror controlled by an eccentric cam for vertical scan. In this way he was able to produce an image of 2,400 elements. The time bases were developed with capacitors and resistors, much as is done today. Finally, the intensity of the beam was modulated by applying the video voltage to the cathode.

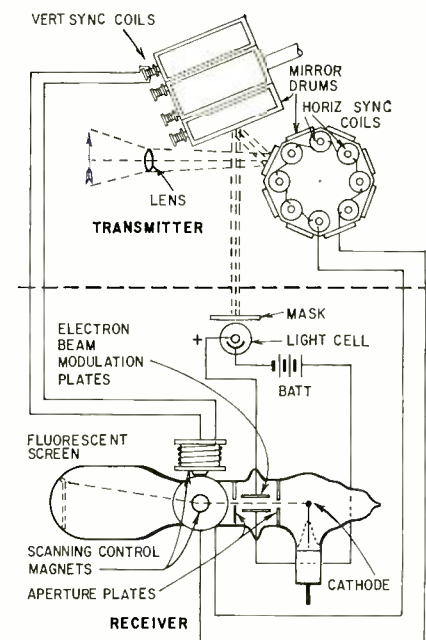

Fig. 1—Transmitter-receiver detail.

This activity was interrupted in 1931 when, with many other scientist victims of the Stalin terror, Rosing was arrested and deported for 3 years into the regions of the north. Continuing his work under great difficulties, he succeeded in preparing a number of articles. At Arkhangelsk he was able to use the physics laboratories of the Forester Institute, where he continued with his studies. There, on April 20, 1933, at the age of 64, he was struck down by a cerebral hemorrhage. END

FREE CATALOG

250 "Do-It-Yourself"
Electronic Kits At
Up To 50% Savings

Why Build Heathkit Electronics? A desire for top-quality products at 50% savings, to be sure. But it goes beyond that. The reason people choose Heathkit is pride. Not just the pride of owning something new, but something a bit better that you have created yourself. From watching your Heathkit grow and take shape from your own efforts. It's a labor of love and a lot of fun. The large pictorial diagrams and simple, step-by-step instructions make it easy. And when you finish and turn it on you'll know that unique self-satisfaction that comes with "do-it-yourself". You will have joined the millions of people, from ages 11 to 79, people with no special electronic skills or knowledge, who successfully build Heathkits. People like you! Give it a try. Your FREE Heathkit catalog is waiting for you now.

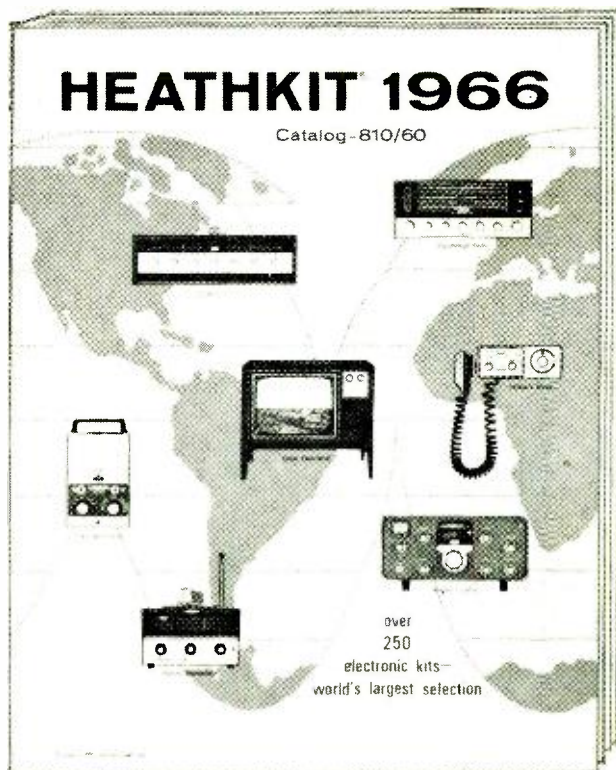

Complete Test Line For Every Servicing Need NOW AVAILABLE KIT OR ASSEMBLED



VTVM...Kit IM-11,
\$24.95; Assemb.
IMW-11, \$39.95



Service Bench VTVM
...Kit IM-13, \$32.95;
Assemb. IMW-13,
\$49.95



Audio Generator
Kit IG-72, \$41.95; As-
semb. IGW-72, \$64.95.



5" Oscilloscope ...
Kit IO-12, \$79.95;
Assemb. IOW-12,
\$134.95

- **AC VTVM** . . . Kit IM-21, \$33.95; Assemb. IMW-21, \$52.95
- **Deluxe Transistor Tester** . . . Kit IM-30, \$54.88; Assemb. IMW-30, \$84.95
- **RF Signal Generator** . . . Kit IG-102, \$27.95; Assemb. IGW-102, \$54.95
- **Variable Voltage Regulated Power Supply** . . . Kit IP-32, \$56.95; Assemb. IPW-32, \$84.95
- **Regulated DC Power Supply** . . . Kit IP-20, \$72.95; Assemb. IPW-20, \$114.95
- Plus many more test & lab instrument kits

World's Largest Selection Of Electronic Kits



Home & Hobby
Items . . . radios,
intercoms, or-
gans, tools, color
TV (now only
\$375) . . . many
with new low
prices



Citizen's Band
Radio . . . trans-
ceivers, walkie-
talkies, acces-
sories for effi-
cient shop to field
communications.



**Marine Electron-
ics** . . . full com-
plement of marine
gear for more fun
and safety afloat

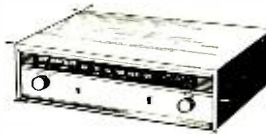

Stereo/Hi-Fi . . .
tuners, amplifi-
ers, changers,
speakers, furni-
ture . . . many
with new low
prices



Amateur Radio . . .
full line of trans-
mitters, receivers,
transceivers . . .
world's largest
ham line



Automotive . . .
ignition analyz-
ers, tester sets,
timing light for
fast, efficient auto
servicing

HEATHKIT 1966



Mail Card
Or Coupon
For Your
FREE
Copy!

Heath Company, Dept. 20-4
Benton Harbor, Michigan 49022

Please send FREE 1966 Heathkit Catalog.

Name _____

Address _____

City _____

State _____

Zip _____

Prices & Specifications subject to change without notice.



CL-218R

"HI"

refers to performance
...not price with

OXFORD

Hi-Fi Speakers

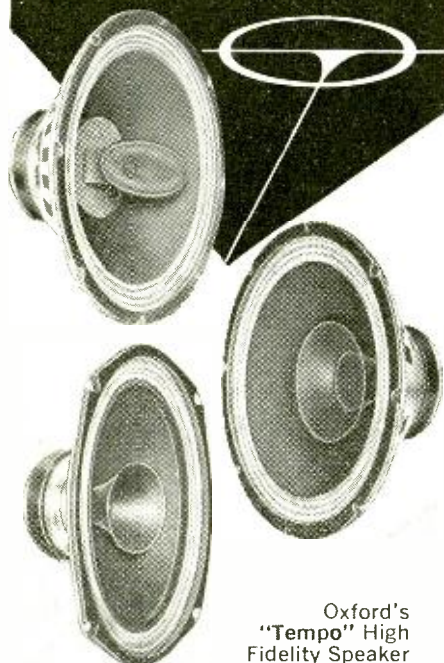

Oxford's "Tempo" High Fidelity Speaker line has established new "highs" in performance... new "lows" in price in the realm of high fidelity speakers. They embody all the fine high quality features that are needed for critical performance. Extremely heavy ceramic magnets give the extra power handling capacity needed for today's wide range reproduction. Units also feature Oxford's exclusive, "Floating Suspension Surround", a resilient, permanently flexible edge which extends the low frequency spectrum without undesirable "hangover". Clean transient responses are assured with smooth mid-range and brilliant high frequency response.

Various models available including: 12-in. with built-in electrical cross-over; 12-in. with built-in whizzer and mechanical cross-over; 8-in. with built-in electrical cross-over; 8-in. with built-in whizzer and mechanical cross-over, and a 6 x 9-in. with a built-in whizzer and mechanical cross-over. For a new high in high fidelity speaker performance at a new low in prices, write for complete information today!

OXFORD TRANSDUCER COMPANY
A Division of
Oxford Electric Corporation

3911 S. Michigan Ave.
Chicago, Ill. 60653

Visit Display Booth No. 407
San Francisco Parts Show
June 3-5

Circle 31 on reader's service card

EQUIPMENT REPORT

EICO 369 Sweep and Post-Injection Marker Generator

Circle 27 on reader's service card

MOST TV AND FM RECEIVERS WILL MAINTAIN their factory-set alignment if they are not touched by some screwdriver mechanic. But a sweep generator is still important as a troubleshooting instrument. It is not just something to be dusted off when a defective i.f. transformer is replaced and things still don't work exactly right afterward.

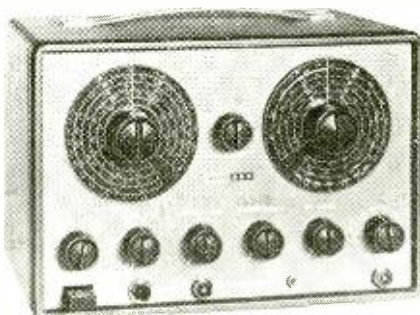

Many obscure reception problems can be solved with a sweep generator. Chirps, whistles and buzzes can often be traced to oscillation in the rf. mixer or i.f. stages. It doesn't take long when you can see a dip or a wiggle in the response curve. Such things can sneak past the fixed-frequency generator setup.

Sweep generators of the past have been a bother, mostly because the marker pips were difficult to adjust and often interfered with alignment, or just because a separate generator had to be connected to the sweep generator to provide the markers.

Except for the laziest technicians, these objections are removed by the Eico 369 sweep and post-injection marker generator. The variable-marker generator and the crystal marker are in the same case, along with the sweep gen-

erator. The crystal marker is turned on and off by plugging the crystal into the panel socket or pulling it out. The variable marker is controlled by a front-panel switch. *These markers do not go through the chassis under test. They cannot upset critical circuits.*

Much of the confusion over which cable is connected where is also eliminated. The hookup for the Eico 369 is simple. (See the diagram.)

The 369 is the only instrument that has to be close to the chassis under test. The scope can be placed farther away to give a little more elbow room while you work, since most adjustments are made at the panel of the 369.

With the instruments and chassis under test turned on, and the scope set for external sweep, a trace will appear on the screen of the scope. If the chassis under test is not completely dead and the Eico 369 is tuned to a point near the input frequency of the chassis, the scope trace will be more than just a horizontal line. It's that simple!

Of course it will be necessary to adjust some of the Eico 369 controls to

MANUFACTURER'S SPECIFICATIONS

Frequency ranges & output: A, 75-220 MHz, 0.1 v \pm 1 db; B, 36-95 MHz, 0.2 v \pm 0.5 db; C, 16-42 MHz, 0.3 v \pm 0.5 db; D, 6-16 MHz, 0.3 v \pm 0.5 db; E, 3-7.5 MHz, 0.3 v \pm 0.5 db

All ranges fundamental; 6:1 tuning ratio for center frequency; 350° tuning scale

Output impedance: 50 ohms

Output attenuation: 4-step decade plus continuously variable level

Sweep width: continuously variable to 20 MHz, depending on range. Minimum on all TV channels and i.f.'s, 10 MHz

Phasing: narrow-range control at rear of chassis adjusts horizontal deflection signal for accurate phase alignment

Marker ranges: A, 2-6 MHz; B, 6-20 MHz; C, 20-75 MHz; D, 60-225 MHz (3rd harmonic of range C)

Fixed-frequency marker: 4.5-MHz crystal supplied; plugging it into panel socket starts oscillator. Other crystals can be used. Fixed-freq. marker mixed internally with variable-freq. marker.

Marker post injection circuit: sweep signal only supplied to device under test. Demodulated, low-pass-filtered sweep output from device under test is mixed with marker inside instrument, amplified and fed to scope.

Power: 105-125 Vac, 50 watts

Size: 8½ x 12½ x 7 in.

Weight: 16 lb

Price: \$89.95 kit, \$139.95 wired

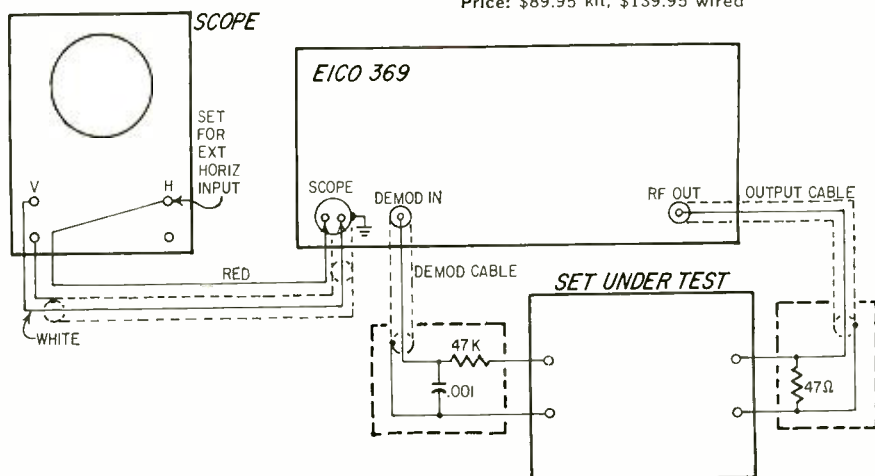

obtain a recognizable trace that can be compared to the one in the service manual.

Whether the trace goes up or down from the horizontal center line will depend on the output polarity of the diode in the demodulator circuit of the chassis under test. Generally this is negative (downward) because the same voltage is used to supply age to the front-end and i.f. circuits.

The instruction manual for the Eico 369 gives the basic procedures for front-end, i.f., trap and intercarrier alignment. Typical response curves are given. The manual also covers mechanical adjustments and calibration, and has voltage and resistance charts. There is also a troubleshooting chart for a number of possible defects (which will probably never occur, unless you deliberately ignore directions in the construction manual).

Ready-wired or in kit form, this sweep generator will simplify alignment for all frequencies between 3 and 220 MHz.—*Elmer C. Carlson*

Dual 1019 Auto/Professional Turntable

Circle 28 on reader's service card

A CASUAL EXAMINATION OF THE NEW Dual 1019 reveals little that wasn't on the highly successful Dual 1009. If you look carefully, you'll see an arm cue mechanism, a mysterious adjustable gage at the base of the arm, a smaller cartridge head and a generally superior trim.



A price of \$129.50 is dangerously close to what you would have to pay for the fanciest manual turntable. Is this automatic really as good? Let's see.

This 1019 does share the automatic change mechanism with the 1009 and 1010. That system consists of a readily removable center spindle that supports the record stack on triangular supports sticking out of the spindle shaft. At the proper moment, the three supports retract, a collar lifts and grips all of the stack but the bottom disc. That one falls to the turntable. It is all very gentle. This sort of mechanism means minimum wear and tear on the record surfaces and center hole.

If you prefer to play records sin-

gly, you exchange the long spindle for a short one. This short spindle is different from those supplied with earlier units. It now fits tightly into the center hole and thus revolves firmly with the turntable.

A slider toward the front of the chassis controls all operation. With either spindle in place, the Dual can be set to lift its arm automatically and set it down gently at the beginning of a record. (A separate slider selects disc size: 7, 10 or 12 inches.) If the main slider is moved in the opposite direction, it sets the table for manual operation. The arm must then be placed on the record by hand or by the automatic arm lift. In all cases,

the arm is raised and returned to rest, the table shut off and the idler disengaged when a record is finished.

As with the 1009, the new arm is fully balanced before stylus force is set. The rear counterweight assembly is moved in or out for approximate balance. Final balance adjustment is made by turning the counterweight on a screw thread. This arm is the easiest I have yet found to balance precisely.

Once the arm is balanced, the desired stylus force is simply dialed on a wheel mounted coaxially to the arm's vertical-motion bearings. A coiled spring bears on them to provide the force. The

continued on page 70

First One-Piece All-Channel Antenna with Individual UHF and VHF Orientation

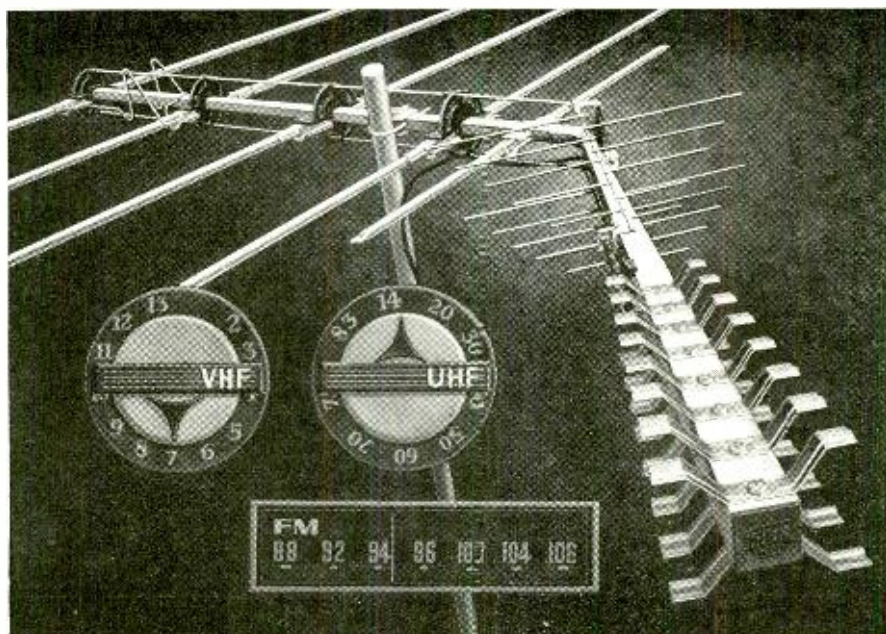

New JERROLD Coloraxial™ *Pathfinder*™

Take advantage of the growing UHF and FM stereo markets by selling the antenna to answer every home reception need from metropolitan to deep-fringe areas... Jerrold's new Coloraxial PATHFINDER.

Look at the advanced design of the PATHFINDER (Series PAB and PXB): a cascaded periodic VHF section plus a radically new UHF section hinged for individual orientation and maximum directivity. Here's all the flexibility of separate antennas, without the splitter losses from coupling separate antennas to a common downlead.

Both 75-ohm Coloraxial and 300-ohm standard outputs for every taste and budget. Prices as low as \$21.95. Rugged square-boom construction and Golden Armor corrosion-resistant finish assure long life. Flat response across all 82 channels, low VSWR, excellent front-to-back ratio make PATHFINDER a natural for quick sales and satisfied customers. Send coupon for complete information.



JERROLD ELECTRONICS CORPORATION
Distributor Sales Division, Dept. RE-4
401 Walnut Street, Philadelphia, Pa. 19106
Please send me complete information on
PATHFINDER all-channel TV and FM antennas.

Name _____
Company _____
Address _____
City _____ State _____ Zip _____

Circle 32 on reader's service card

NOW! Save up to \$60 per year on the

JOIN THE NEW PHOTOFACT-OF-

STARTING IN JULY, 1966!
6 New Photofact Sets per month—20% more coverage than ever before—FOR ONLY \$10 PER MONTH!

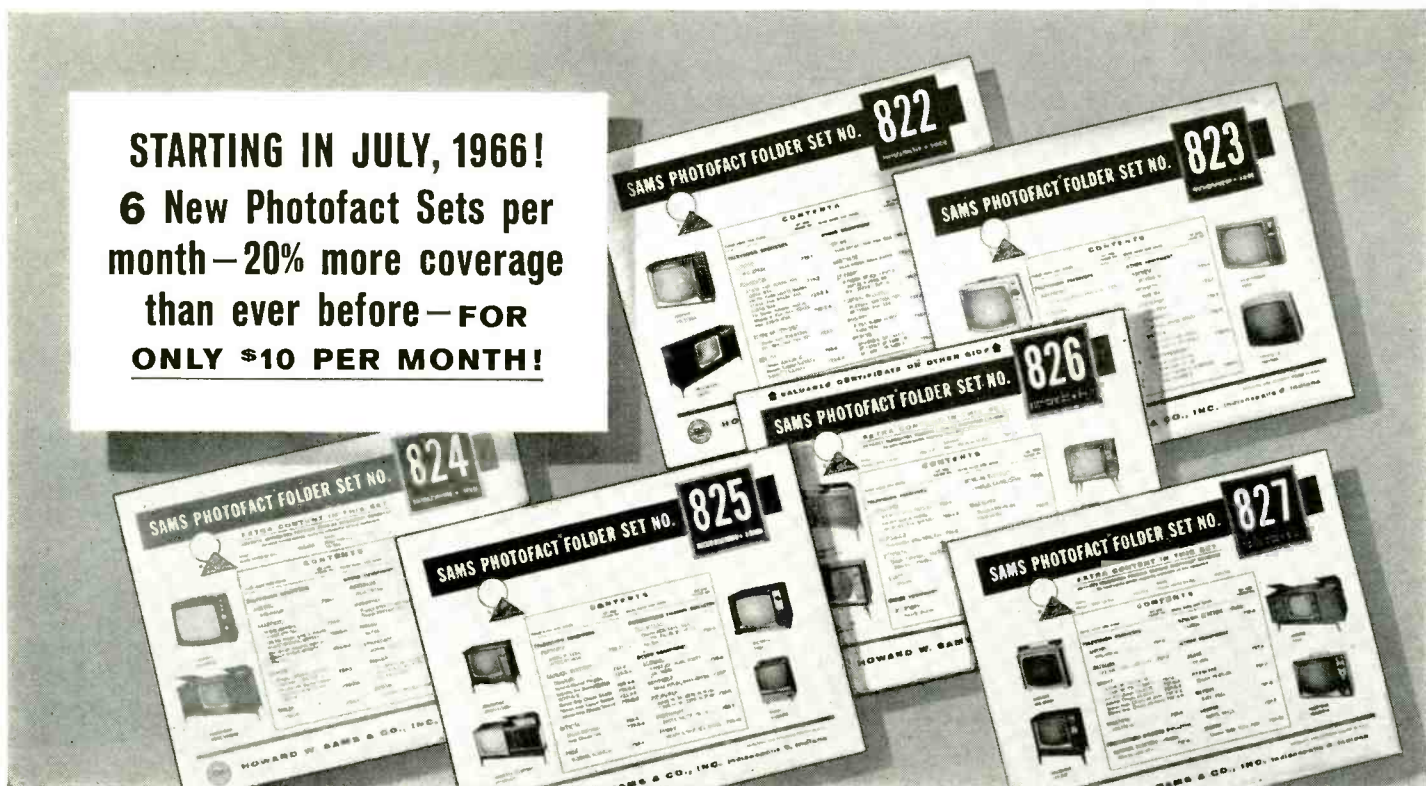

Now! maximum coverage of equipment you service most!

★ **MORE TV COVERAGE**
5 Color TV models per month
More Black & White TV coverage

★ **MORE AC-DC COVERAGE**

★ **MORE AM-FM MODELS**

★ **MORE STEREO HI-FI COMBINATIONS**

★ **MORE RECORD CHANGER COVERAGE**

★ **MORE PHONOGRAPH COVERAGE**

complete service data on at least 50 chassis each and every month to meet all your service needs!

now only \$10 per month

Membership in the new Photofact-of-the-Month Club now brings you 20% more coverage monthly—saves you \$5 per month, up to \$60 per year! You get *more* of the famous PHOTOFACT time-saving, troubleshooting help—*everything* you need to earn more daily. Take the *right* step to faster, more profitable servicing—enroll now with your Sams Distributor as a member of the new Photofact-of-the-Month Club—or send in the membership form today!

ENROLL TODAY IN THE PHOTOFACT-OF-THE-MONTH CLUB

use the
handy coupon

Circle 33 on reader's service card

RADIO-ELECTRONICS

world's finest TV-radio service data!

THE-MONTH CLUB — membership starts in July, 1966

only \$10 per month brings you 20% more monthly current Photofact service data coverage to boost your daily earnings

How the Photofact-of-the-Month Club benefits you

more for your service data dollar

Starting in July, 1966, as a member of the P.O.M. Club, you get 6 new Photofact Sets monthly (20% more coverage) for just \$10 per month! You save \$5 per month—\$60 per year (regular price for individually purchased Photofact Sets is \$2.50, effective July 1, 1966). Now you can keep right up with the flood of current equipment output. Now you get the world's finest service data on at least 50 different chassis each month—to help you turn out more repairs daily, with a bigger profit on every job.

IMPORTANT NEWS FOR OUR THOUSANDS OF PRESENT PHOTOFACT SUBSCRIBERS

Your loyalty through the years is deeply appreciated. You will automatically be enrolled as a charter P.O.M. Club member. Starting in July, 1966, you will receive 6 Photofact Sets monthly (20% more coverage), and pay only \$10 per month. Your subscription to Photofact becomes more valuable than ever.

how this is possible

We have explained the new Photofact-of-the-Month Club plan to hundreds of electronic technicians. From what they have told us, and from their enthusiastic response, we expect to add substantially to the thousands of present monthly subscribers to Photofact. This means we can effect greater economies through large-volume production, and that's what makes possible not only lower costs to P.O.M. Members, but greater coverage than ever before. It's as simple as that!

HERE'S ALL YOU DO TO BECOME A MEMBER OF THE NEW PHOTOFACT OF THE MONTH CLUB

See your Sams Distributor today, or fill out and mail the membership form below. That's all there is to it. Do it today! It's the opportunity you've been looking for—the chance to be a regular Photofact subscriber at the price you can afford. Get started on the road to the kind of profits you've always wanted.

DO IT TODAY...



Current COLOR TV coverage

Now—as a P.O.M. Club member, you will get a minimum of 5 Photofact Color TV Folders per month—you keep right up with the biggest growing profit opportunity in the service field.

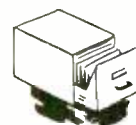

BONUS File Drawers

As a P.O.M. member, you are also eligible for the Bonus Photofact File Drawer offer.

Fill Out This Form For Membership In The Photofact-Of-The-Month Club

HOWARD W. SAMS & CO., INC.

4300 West 62nd Street, Indianapolis, Indiana 46206

Dept. REF-4

Please enroll me as a new member of the Photofact-of-the-Month Club. I agree to pay \$10 per month for my membership, and understand my subscription will begin with the July, 1966

issue, consisting of 6 current Photofact Sets, to be delivered by my Sams Distributor (named below).

Name _____

Business Name _____

Address _____

City _____ State _____ Zip _____

My Sams Distributor is: _____ Sign here: _____

**sign up now
and save!**

ATTENTION! CB OPERATORS

save on citizens radio equipment

Discontinued Models From International Radio Exchange

Select that extra transceiver for mobile or base installation, or equip a new station. Our stock includes International types as well as other makes.

Write Today for A
Complete List of
Equipment in Stock



RADIO EXCHANGE
18 NO. LEE, OKLA. CITY, OKLA. 73102
Division Of International Crystal Mfg. Co.
Dealing In Used Citizens
Radio Equipment

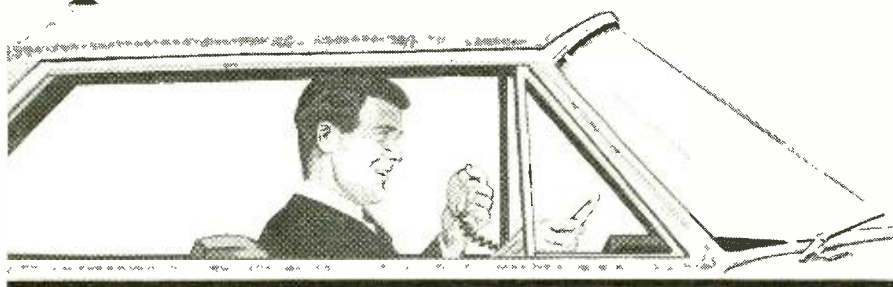

Circle 35 on reader's service card

LATEST and GREATEST!

NEW *Brach* UHF/VHF TV ANTENNAS FOR Black/White & Color

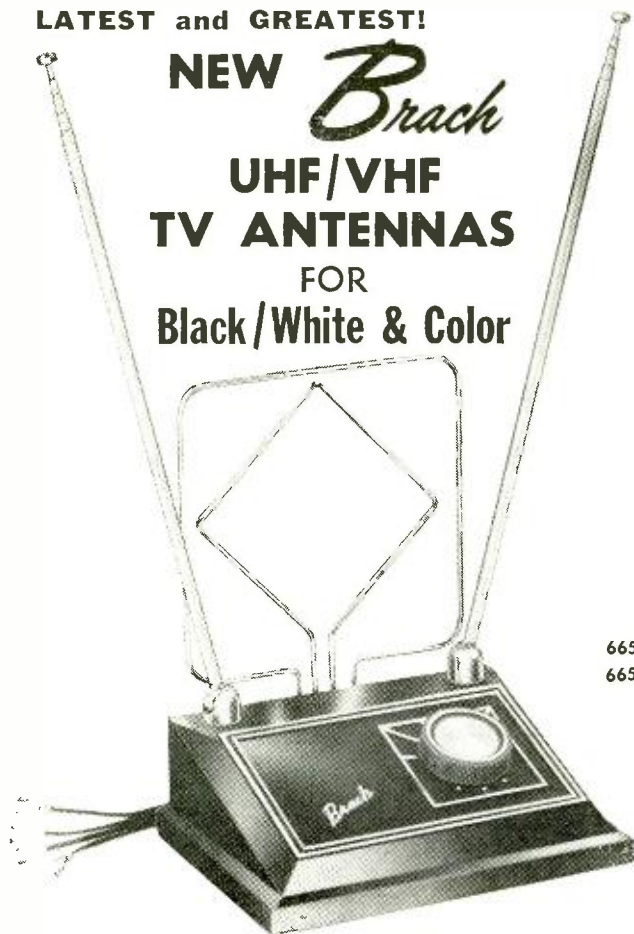

- Ultimate in Design!
- Unequaled in Performance!
- Outstanding in Value!

6651 Gold Finish
6652 Chrome Finish

SEND FOR our latest
catalog with our complete
line of antennas

BRACH MFG. CORP. DIV. of General Bronze Corp.
899 Main Street, Sayreville, N.J. 08872

Circle 36 on reader's service card

EQUIPMENT REPORT continued

force gage is accurate to within 1/4 gram.

At the base of the arm is a second gage—the one mentioned at the beginning. This dials the correct *skating compensation* to overcome the force generated by the head offset angle and stylus friction. The gage is calibrated for a stylus of 0.6 mil. Other sizes, including ellipticals, are covered in the excellent manual that accompanies the unit. Thus, this arm can be exactly compensated against most of the forces that try to wrench the cartridge out of the groove.

Finally, there is the arm-lift device. As with the rest of the 1019, this mechanism shows the thought that has gone into the design. It lifts or lowers the arm with a feather touch. The descent is very slow; a gentler entrance into a record groove cannot be imagined. This hydraulic arm drop can be used with manual or automatic play.

This new Dual measured a total unweighted rumble of 40 dB below a 1 KHz recorded velocity of 3.54 cm/sec. Most of this rumble was subsonic. That figure knocks 3 dB off the 1009 model and is *as good* a figure as I have seen for any table—and *better* than any I have seen for any automatic. This combination of low intensity and low frequency results in a *practical* rumble that is inaudible.

Flutter in the 1019 measured a low .08% rms. Again, this is slightly lower than the 1009 and the equal of virtually anything on the market.

A hysteresis synchronous motor is *not* the only kind capable of accurate speed at widely varying voltages. The induction motor of the Dual was able to keep the turntable speed virtually constant from 100 to 130 volts. In addition, the 1019 has a speed vernier control for a $\pm 3\%$ adjustment around each of the four standard speeds. Pitch purists will never have a quarrel with Dual.

The removable tone-arm head allows the cartridge to be slid forward or back for minimum tracking error. There's a gage for that, too. Adjusted, the Dual showed 1.25° error at the outer edge of the disc.

Arm resonance proved difficult to measure because of excellent damping. It was an ill-defined rise at about 18 Hz. Low enough never to be a problem.

Also worth mentioning is that from the first to the eighth record there was less than a 0.1-gram rise in stylus force.

There are no cartridge restrictions for the Dual. My tests, in fact, were conducted entirely with a Shure V-15 cartridge, tracking as low as we have tracked this cartridge in an SME arm. That is a great deal to say about an automatic!

This is a high-priced unit, but well worth it.—*Leonard Silke*

Price: \$129.50 less base.

END

If you don't know how to service radios but you'd like to learn fast—

Get these two great books . . . a \$9.90 value

only **99¢**

by joining the Electronics Book Club today!

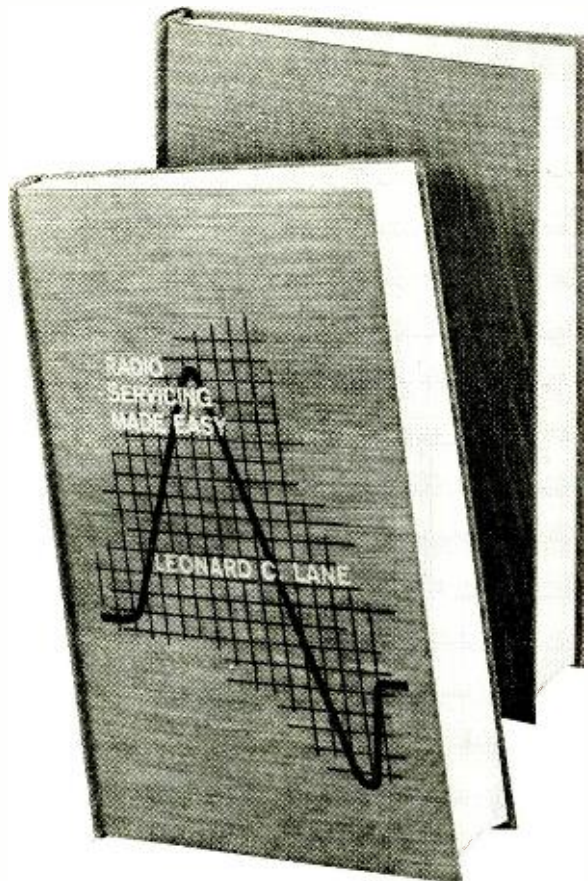

RADIO SERVICING MADE EASY—by Leonard C. Lane.

Here is a wonderfully helpful set of two handbooks written by an expert with years of practical servicing experience. He tells you everything you want and need to know about radio servicing today. Nothing is left out. You get down-to-earth facts and techniques you can use at once, including many tricks-of-the-trade never put in print before. Just a few of the eye-opening things you'll discover: Working With Transistors/Getting started. What is a reference point? Approaching the transistor. Pairs of diodes. Testing Transistors and Printed Circuits/Checking transistors. In-circuit transistor testing. Troubles. Measurements. Replacing resistors and capacitors. Servicing Transistor Radios/Batteries. Stage-by-stage analysis. Typical circuits. Servicing Auto Radios/Installation and removal. Servicing. Using signal generator. AM Receivers/Frequency range. Ac-dc power supplies. Troubleshooting. FM Receivers/AM-FM Tuners/Communications Receivers/Tuning troubles. Receiver analysis. Noise limiters. Marine receivers/Marine frequencies. Receiver circuitry. Checking the direction finder. Rf amplifier stage. Mobile Radio. Plus many other subjects.

Here is an extraordinary offer to introduce you to Gernsback Library's famous Electronics Book Club, specially designed to help you increase your know-how and earning power.

WHY SHOULD YOU JOIN!

Whatever your interest in electronics—radio and TV servicing, audio and hi-fi, industrial electronics, communications, electronics as a hobby—you'll find that the Electronics Book Club will help you get the job you want, keep it, improve it, or make your leisure hours more enjoyable. By broadening your knowledge and skills, you'll build your income and electronics enjoyment as well.

WHAT BOOKS ARE OFFERED?

From Gernsback Library and other leading publishers come the country's most respected books in the field of electronics. All are deluxe, hard-covered books of permanent value, offered at considerable cash savings to members, regardless of higher retail prices.

TYPICAL CLUB SELECTIONS:

Servicing AGC Circuits
Reg. \$6.00—Club price \$4.95
(You save \$1.05)

Probes For Test Instruments
Reg. \$4.60—Club price \$3.35
(You save \$1.25)

Diode Reference Book
Reg. \$6.25—Club price \$4.95
(You save \$1.30)

TV Sweep Oscillators
Reg. \$6.00—Club price \$4.95
(You save \$1.05)

Color TV Repair
Reg. \$4.60—Club price \$3.25
(You save \$1.35)

Handbook of Electronic Tables
Reg. \$4.95—Club price \$3.50
(You save \$1.45)

Elements of Electron Physics
Reg. \$5.65—Club price \$4.45
(You save \$1.20)

Transistor Reference Book
Reg. \$6.00—Club price \$4.50
(You save \$1.50)

Audio Design Handbook
Reg. \$5.00—Club price \$3.75
(You save \$1.25)

Electronics Data Handbook
Reg. \$4.60—Club price \$3.25
(You save \$1.35)

Mandl's Television Servicing
Reg. \$8.95—Club price \$7.95
(You save \$1.00)

Electrical Appliance Service Manual
Reg. \$6.75—Club price \$5.75
(You save \$1.00)

Basic Math Course for Electronics
Reg. \$6.45—Club price \$5.15
(You save \$1.30)

The V.T.V.M.
Reg. \$4.60—Club price \$3.35
(You save \$1.25)

Basic Transistor Course
Reg. \$5.75—Club price \$4.50
(You save \$1.25)

Industrial Electronics Made Easy
Reg. \$5.95—Club price \$4.35
(You save \$1.35)

Horizontal Sweep Servicing Handbook
Reg. \$5.75—Club price \$4.50
(You save \$1.25)

The Oscilloscope
Reg. \$5.20—Club price \$3.95
(You save \$1.25)

HOW THE CLUB WORKS

The Electronics Book Club will send you, every other month, the News Bulletin describing a new book on a vital area of electronics. As a member, you alone decide whether you want a particular book or not. You get 2 books now for 99¢ and need take only 4 more within a year, from a wide selection to be offered. And the Club saves you money on the books you take, regardless of higher retail prices.

HOW TO JOIN

Simply mail the coupon today. You will be sent your two-handbook set—RADIO SERVICING MADE EASY, which regularly sells for \$9.90. We will bill you 99¢ (plus a few cents postage). If you are not pleased with the set, send the books back within 10 days and membership will be cancelled. Otherwise, you will enjoy all these benefits:

- * Get two books immediately for 99¢
- * Free 10-day examination privilege.
- * Continuous cash savings.
- * Free charts given with many books.
- * You alone decide which books you want. Books are returnable.
- * Club books are practical working tools, written by experts.

Gernsback Library, Inc., Electronics Book Club, Dept. RE46
154 West 14th Street, New York, N.Y. 10011

Please enroll me in the Electronics Book Club and send me the TWO-HANDBOOK SET: RADIO SERVICING MADE EASY. Bill me only 99¢ plus shipping. If not pleased, I may return both books in 10 days and this membership will be cancelled.

As a member, I need only accept as few as 4 additional books a year—and may resign any time after purchasing them. All books will be described to me in advance, every other month, in the Club Bulletin, and a convenient form will always be provided for my use if I do not wish to receive a forthcoming book. You will bill me the special Club price for each book I take (plus a few cents postage)—regardless of higher retail prices.

Name
(please print)

Address

City State Zip Code

SAVE! Enclose your 99¢ now with this coupon and we will pay postage. Same return guarantee privilege.

The following free advertising material is available through

RADIO-ELECTRONICS READER'S SERVICE

- | | |
|--|---------------|
| ALLIED RADIO CORP. (Pg. 76)
Catalog. | Circle 107 |
| AMPEREX (Third Cover)
List of replacement tubes. | Circle 149 |
| ARROW FASTENER CO. (Pg. 90)
Literature available on staple gun tackers. | Circle 126 |
| B & K MANUFACTURING CO. (Pg. 22)
Test equipment catalog AP-22. | Circle 20 |
| BRACH MFG. CORP. (Pg. 70)
Catalog on TV antennas. | Circle 36 |
| BROOKS RADIO & TV CORP. (Pg. 88-89)
Information sheets and price lists of tubes and parts. | Circle 124 |
| CASTLE TV TUNER SERVICE (Pg. 76)
Information on complete tuner overhaul by mail. | Circle 108 |
| CENTRALAB (Pg. 77)
Information on Fastatch II exact replacement control combinations. | Circle 109 |
| CHARLES ENGINEERING (Pg. 79)
Information on Wizard 300 TV-FM antenna coupler. | Circle 111 |
| CLEVELAND INSTITUTE OF ELECTRONICS (Pg. 5)
Electronics slide rule booklet and data guide. | Circle 10 |
| CONAR INSTRUMENTS (Pg. 75)
Catalog on kits. | Circle 106 |
| CORNELL ELECTRONICS CO. (Pg. 96)
Catalog and price list of tubes and parts. | Circle 137 |
| COYNE ELECTRONICS INSTITUTE (Pg. 93)
Booklet: "Your Opportunities in Electronics." | Circle 134 |
| DATAK CORP. (Pg. 92)
Folder and sample of "instant lettering." | Circle 131 |
| DELTA PRODUCTS INC. (Pg. 61)
Literature and complete technical data on Mark Ten SCR capacitive discharge ignition system. | Circle 29 |
| DE VRY TECHNICAL INSTITUTE (Pg. 3)
Booklets "Pocket Guide to Real Earnings" and "Electronics in Space Travel." | Circle 9 |
| EICO ELECTRONIC INSTRUMENT CO. (Pg. 13)
Catalog. | Circle 15 |
| ELECTRO-VOICE (Pg. 1)
Booklet: "The Directional Microphone Story." | Circle 8 |
| ELECTRONIC CHEMICAL CORP. (Pg. 87)
Information on "No-Noise" aerosol service chemicals. | Circle 120 |
| ELECTRONIC COMPONENTS CO. (Pg. 94)
Information on rectifiers and transistors. | Circle 135 |
| FINNEY CO. (Pg. 25)
Brochure 20-349 on Finco-Axial Color Kit for TV antennas. | Circle 22 |
| GRANTHAM SCHOOL OF ELECTRONICS (Pg. 93)
Brochure on FCC license preparation. | Circle 133 |
| GENERAL RADIOTELEPHONE CO. (Pg. 89)
24 page catalog on all equipment available. | Circle 125 |
| HEALD'S ENGINEERING COLLEGE (Pg. 91)
Catalog and registration application. | Circle 130 |
| HEATH COMPANY (Pg. 27, 65)
Catalog. | Circle 24, 30 |
| INTERNATIONAL CRYSTAL MFG. CO. (Pg. 98)
Catalog of Citizens Band transceivers and dealer list. | Circle 139 |
| INTERNATIONAL RADIO EXCHANGE (Pg. 70)
List of traded-in equipment in stock. | Circle 35 |
| JACKSON ELECTRICAL INSTRUMENT CO. (Pg. 6)
Complete catalog on test instruments. | Circle 11 |
| JERROLD ELECTRONICS CORP. (Pg. 67)
Information on Pathfinder all-channel TV & FM antennas. | Circle 32 |
| JFD ELECTRONICS CORP. (Pg. 14-15)
Brochure 1039 on LPV-TV log periodic antennas. | Circle 16 |
| MICROFLAME INC. (Pg. 88)
Information on hand-held gas welding torch. | Circle 123 |
| MULTICORE SALES CORP. (Pg. 86)
Information on Ersin Multicore 5-core solder. | Circle 118 |
| MUSIC ASSOCIATED (Pg. 90)
Information on Music Associated's Sub Carrier Detector for "music only" programs on FM Broadcast Band. | Circle 127 |
| OXFORD TRANSDUCER CO. (Pg. 66)
Information on Tempo high-fidelity loudspeakers. | Circle 31 |
| POLY PAKS INC. (Pg. 97)
Information on semiconductors. | Circle 138 |
| RCA INSTITUTES (Pg. 18-21)
Brochures on homestudy and classroom study. | Circle 19 |
| RYE SOUND CORP. (Pg. 85)
Information on 5-reel tape file. | Circle 116 |
| SAMS, HOWARD W. CO. INC. (Pg. 68-69)
Information on new Photofact-of-the-month plan. | Circle 33 |
| SAMS, HOWARD W., CO. INC. (Pg. 78)
Booklist. | Circle 110 |
| SCHOBER ORGAN CORP. (Pg. 26)
Booklet and 7" sampler record. | Circle 23 |
| SENCORE (Pg. 79)
Information on Mighty Mite tube checker. | Circle 112 |
| SONAR RADIO CORP. (Pg. 84)
Information on Fr-101/102 FM emergency band monitor receivers. | Circle 114 |
| SPRAGUE PRODUCTS CO. (Pg. 17)
Information on Sprague Atom capacitors and KWIK-ETTE connectors. | Circle 18 |
| SQUIRES-SANDERS INC. (Pg. 87)
Information on FM Alert emergency band receivers. | Circle 121 |
| STANCOR (Pg. 24)
Stancor part-to-part cross reference guide for transformers and sweep components. | Circle 21 |
| SUPERSCOPE INC. (Pg. 7)
Information on Sony professional and consumer microphones. | Circle 12 |
| SYLVANIA ELECTRONIC TUBE DIVISION (Pg. 32)
Information on how independent service dealers can get listings in TV Guide. | Circle 25 |
| TRIPLETT ELECTRICAL INSTRUMENT CO.
(Second Cover)
Information on complete line of V-O-M's. | Circle 7 |
| UNITED RADIO CO.
Parts catalog. | Circle 13 |
| UNIVERSITY SOUND (Pg. 81)
Microphone catalog. | Circle 113 |
| WARREN ELECTRONIC COMPONENTS (Pg. 92)
Information on silicon rectifiers. | Circle 132 |
| WELLER ELECTRIC CORP. (Pg. 84)
Information on Marksman pencil soldering irons models SP 23 and 23K. | Circle 115 |
| WINEGARD CO. (Pg. 91)
Fact-finder #242 with information on Chroma-Tel antenna. | Circle 129 |
| XCELITE INC. (Pg. 16)
Catalog 162 on nutdrivers. | Circle 17 |

Here's how you can get manufacturers' literature fast:

1. Tear out the post card on the facing page. Clearly print or type your name and address.
2. Circle the number on the card that corresponds to the number appearing at the bottom of the New Products, New Literature or Equipment Report listing in which you are interested. For literature on products advertised in this issue circle the number on the card that corresponds to the number appearing at the bottom of the advertisement in which you are interested, or use the convenient checking list in the column at the left.
3. Mail the card to us (no postage required in U. S. A.)

NEW PRODUCTS

More information on new products is available free from the manufacturers of items identified by a Reader's Service number. Turn to the Reader's Service Card facing page 72 and circle the numbers of the new products on which you would like further information. Detach and mail the postage-paid card.

Hz = Hertz = cycles per second; KHz = kilocycles; MHz = megacycles

5-CHANNEL CB TRANSCEIVER, the S5S, has 0.5- μ V receiver, 8-KHz selectivity through 4-crystal lattice filter. Channel selectivity better than 50 dB. Squelch adjustable from 1-50 μ V. Audio output: 4-dB rise from 1- μ V to 0.1-V signals. 3 x 5 front-facing speaker. Legal transmitter input of 5 watts; built-in speech booster. 25



silicon transistors, 5 diodes, 1 Zener diode. Battery drain less than 200 mA dc on receive. Adjustable π network for optimum antenna match to antennas of 30 to 75 Ω . 8 x 3 $\frac{1}{2}$ x 7 in., less than 4 lb. May be used on government 27.575-MHz, CAP 26.620 as well as 27-MHz business frequencies, subject to FCC type approval.—Squires-Sanders, Inc.

Circle 46 on reader's service card



75 Ω COAXIAL CABLE, Rainbow Series 59/U, available in gray, white or beige for dressing up second TV installations.—Viking Industries

Circle 47 on reader's service card



3-BAND MARINE RADIO, and radio direction finder, the *Nova Pal*, model P-300. Receive ship-to-ship, ship-to-shore, Coast Guard, May Day, police calls, hams. Monitor 24-hr weather reports for 200 miles. 9 transistors, leather case, batteries, carphone, mounting stand. 9 x 5 x 2 $\frac{1}{2}$ in., 2 $\frac{1}{2}$ lb.—Nova-Tech, Inc.

Circle 48 on reader's service card

STEREO AM/FM TUNER, latest in *Superba* series, the KG-790, has 22 transistors and 14 diodes. FM section: 2.5 μ V for 30 dB quieting usable IHF sensitivity; 2 dB capture ratio; i.f. rejection 80 dB min.; image rejection over 70 dB, 87.5-108.5 MHz; -60 dB hum/noise; i.f. bandwidth 300 KHz; \pm 2 dB 50 Hz to 15 KHz response; less than 0.75% output distortion at 1V; unbalanced 300 Ω input. Multi-



plex: 55 dB min. 19-KHz suppression; 50 dB min. 38-KHz suppression; separation exceeds 40 dB at 1 KHz. AM section: 3.5 μ V for 20 dB s/n, 1.5 μ V for 10 dB s/n. 7.5 KHz i.f. bandwidth; 60 dB min. i.f. rejection; 70 dB min image rejection at 1 MHz; 40 dB min 10 KHz rejection; 535-1620 KHz tuning.—Allied Radio Corp.

Circle 49 on reader's service card

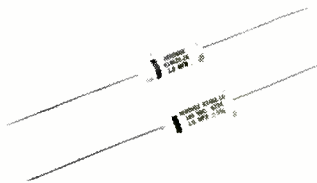

METALLIZED POLYCARBONATE CAPACITORS, types K146Z and K146ZR,

one cylindrical and the other flattened. Voltage ratings: 100, 200, 300, 400, 600. Capacitance values range from .01 to 5.0 μ F. Temperature range: -65°C to +125°C.—Aerovox Corp.

Circle 50 on reader's service card

PIHOTIMER, the PT-15, kit form, lets you control exposure time of both contact and enlarging operations in tenths of a second up to 9.9 seconds, and in full seconds up to 99 seconds. Uses two switch-selected ranges which allow accurate re-



setting of any interval any time. Styled to match Heathkit/Mitchell Fotoval computer. Ac outlets for enlarger and safelight; solid-state; time-focus switch so you can turn off enlarger manually; stop switch to halt exposure process.—Heath Co.

Circle 51 on reader's service card

AUDIO GENERATOR, model 378, kit or factory-wired. Setable to any frequency between 1 Hz and 110 KHz. Output level adjustable from 0 to 10 volts rms



Your new copy is waiting

FREE! For fun and pride in assembly, for long years of pleasure and performance, for new adventures in creative electronics mail the coupon below and get Conar's brand new catalog of quality do-it-yourself and assembled kits and equipment. Read about items from TV set kits to transistor radios . . . from VTVM's to scopes . . . from tube testers to tools. And every item in the Conar catalog is backed by a no-nonsense, no-loopholes, money-back guarantee! See for yourself why Conar, a division of National Radio Institute, is just about the fastest growing entry in the quality kit and equipment business.

CONAR

MAIL THIS COUPON NOW

CONAR 3939 Wisconsin Ave., Washington 16, D.C. DC6C

Please send me your new catalog.

Name _____

Address _____

City _____ State _____ Z-Code _____

Circle 106 on reader's service card



FREE

send for your
MONEY-SAVING
508-page

1966 ALLIED CATALOG

SAVE MOST ON:

- Stereo Hi-Fi
- Tape Recording
- CB 2-Way Radio
- Shortwave & Ham Gear
- Automotive Electronics
- FM-AM & AM Radios
- Portable TV & Phono
- Test Instruments
- TV Tubes & Antennas
- Power Tools, Hardware
- Parts, Tubes, Transistors

See the world's largest selection of top money-saving buys, including exclusive Knight-Kits and products available only from ALLIED. Get fastest service, easy-pay terms, satisfaction guaranteed or your money back. Send coupon today for your FREE 1966 ALLIED Catalog.

EASY TERMS: Use the Allied Credit Fund Plan.

ALLIED RADIO

free
catalog

ALLIED RADIO, Dept. 2D
100 N. Western Ave., Chicago, Ill. 60680

Send FREE 1966 ALLIED Catalog.

Name _____
PLEASE PRINT
Address _____

City _____ State _____ Zip _____

Circle 107 on reader's service card

COMPLETE TUNER OVERHAUL

9.95

ALL LABOR AND PARTS
(EXCEPT TUBES & TRANSISTORS)*



COLOR TUNERS

REPLACEMENTS
ALIGNMENT
ADDITIONAL
COLOR
NO CHARGE

Simply send us the defective tuner complete, include tubes, shield cover and any damaged parts with model number and complaint. Your tuner will be expertly overhauled and returned promptly, performance restored, aligned to original standards and warranted for 90 days. UV combination tuner must be single chassis type; dismantle tandem UHF and VHF tuners and send in the defective unit only. Exact Replacements are available for tuners unfit for overhaul. As low as \$12.95 exchange. (Replacements are new or rebuilt.)

And remember—for over a decade Castle has been the leader in this specialized field... your assurance of the best in TV tuner overhauling.

CASTLE
TV TUNER SERVICE, INC.

5715 N. Western Ave., Chicago 45, Illinois
41-96 Vernon Blvd., Long Island City 1, N. Y.

For service in Canada write to Chicago or use reader service card in this magazine.
*Major parts are charged extra in Canada.

Circle 108 on reader's service card



on 4½-in. meter. Switch-selected internal 600Ω load below 1-volt rms output. Switch-selectable frequency output, attenuated output in 8 steps, metered output voltage. Output: 1–10 Hz (1-Hz steps), 10–100 Hz (10-Hz steps), 100 Hz–1 KHz (100-Hz steps), 1–10 KHz (1-KHz steps), 10–100 KHz (10-KHz steps) accuracy ±5%. Distortion less than 0.1% 20–20,000 Hz. Output voltage ranges: 0–3, 10 V into hi-z (10K min.); 0–.003, .01, .03, .1, .3, 1 V into ext. 600Ω load, or with internal load into external hi-z. Power: 120 volts, 50–60 Hz, 40 watts. 8½ x 12½ x 9 in., 13 lb.—EICO Electronic Instrument Co.

Circle 52 on reader's service card

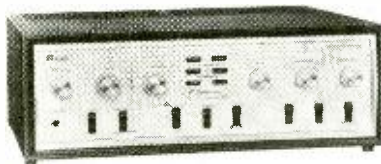

120-WATT STEREO AMPLIFIER, Knight-Kit KG-895. Power output: 60 watts per channel IHF, 40 watts per channel, continuous sine wave; frequency response ±1 db, 18–30,000 Hz at full output. Harmonic distortion less than 0.7%. Power output, rated output or greater, 20–20,000 Hz with less than 1% distortion. Hum and noise, magnetic phono input, 65 db below rated output. 5 x 16½ x 15 in.—Allied Radio Corp.

Circle 53 on reader's service card

RECTIFIERS, series 401HF, with applications from household appliances to vending-machine power supplies. 15 to

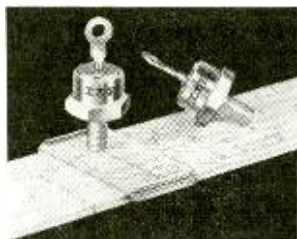

40 amps; 100 to 400 volts PRV. Double diffused junction; hermetic sealing; hard-solder assembly; corrosion-resistant case.—International Rectifier

Circle 54 on reader's service card



FM EMERGENCY RECEIVER, the FM Alert. Choice of 2 frequency ranges:

FM Alert 152 from 152 to 175 MHz; FM Alert 30, 30–50 MHz. Mode switch selection of variable tuning or 2 crystal-controlled receive channels. Sensitivity: 3 μV or less for squelch control and 10 db S/N. About 2 watts audio output. Illuminated slide-rule dial calibrated in 2-MHz divisions. 117 volts, 60 Hz ac, 30 watts. Solid-state silicon rectifier. 4½ x 10½ x 6 in., 6½ lb. Separate matching 3 x 5 in. PM speaker.—Squires-Sanders, Inc.

Circle 55 on reader's service card

2-CHANNEL CITIZENS-BAND RADIO, model T-2.

14 transistors, crystal-controlled. Hand-held, 2-watt input. Compatible with all existing systems. Built-in meter for modulation and battery test. Adjustable squelch. Class-B modulation. Self-contained rechargeable NiCad batteries. Earphone and mike jacks. Telescoping antenna. 117-Vac charger, leather case. 3½ x 10¼ x 2 in., 2 lb.—Sonar Radio Corp.



Circle 56 on reader's service card

MICROCIRCUIT VEROBOARD.

1/32-in. thick phenolic board with series of parallel copper strips each pierced with matrix of holes spaced at .050, corresponding to .050 spacing of flat packs and connectors for microcircuit applications.

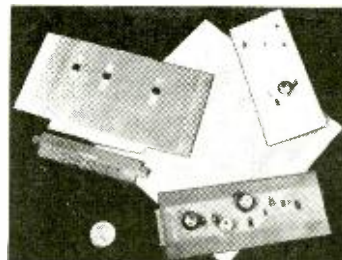

Available in single-sided board and double-sided on which copper strips on reverse side run at 90° to front of board. Insertion of pin in hole makes XY connections, giving program of 101 x 101 on 6-in. square board.—Vero Electronics Inc.

Circle 57 on reader's service card

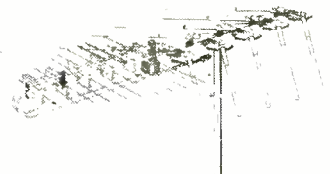

UHF, VHF, FM ANTENNA KIT, model AA-156. Multiple drive Vee-log design for all channels 2–83 plus FM. 1-in. square boom, 57 in. long. High-impact, low-loss polystyrene insulators, spring-temper aluminum snap-lock brackets, spring-temper aluminum drive lines. Solid-rod aluminum ulf elements. Range: vhf to 120 miles, FM 70, ulif 60. Color-approved for all channels.—Olson Electronics, Inc.

Circle 58 on reader's service card

CABINET SPEAKER SYSTEM, 8400 Convertible Grenadier, designed for shelf or its own bench. Lowered front

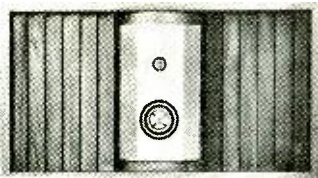

panels, satin walnut finish. Low-frequency hyperbolic horn; mid-range direct radiator, ultrasonic domed tweeter coupled to die-cast acoustic lenses. Response: 25-20,000 Hz; nominal impedance 8 Ω ; power-handling capacity maximum undistorted 100 watts.—Empire Scientific Corp.

Circle 59 on reader's service card



6-INCH SPEAKER, SP6D-M1, fits into rear seat of General Motors convertibles and sports models, which have rear-seat grilles as original equipment. Can be used with Delco (8-10 Ω), Automatic (20 Ω), or Motorola (40 Ω) radios because it has two voice coils which can be wired in series or parallel. Peak power 6.5 watts.—Utah Electronics

Circle 60 on reader's service card



WALKIE-TALKIE, HA-70B, aimed at younger market. 3 transistors. Superregenerative receiver, crystal-controlled transmitter; effective range of $\frac{1}{4}$ mile. Push-to-talk button, on-off switch, telescoping antenna. No license required. 9-volt battery, plastic carrying case. 5 x 2 $\frac{1}{2}$ x 1 $\frac{1}{2}$ in., 1 lb.—Lafayette Radio Electronics Corp.

Circle 61 on reader's service card

DC REGULATED POWER SUPPLY, model PS-3A. 0-25 volts dc at 0-200 mA, .02% line or load regulation. Maximum ripple 0.5 mV. 12 to 1 ratio for output

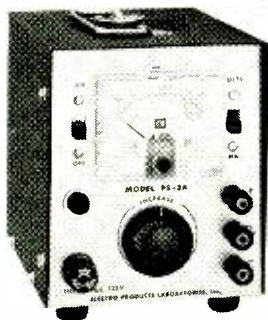

APRIL, 1966

Need an Exact Replacement Control?

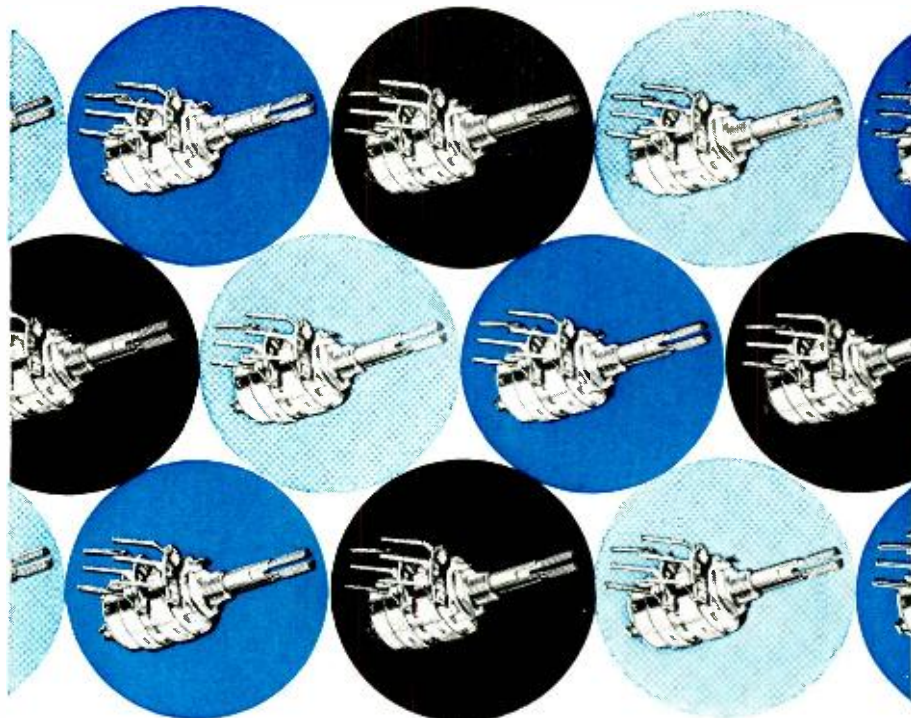

**Your Centralab Fastatch® II Distributor
Has Over**

9 BILLION*

In Stock!

* With the Fastatch II system, your Centralab distributor can supply any of 9,938,500,000 different *exact replacement control* combinations. You'll see that these replacements look like the original, because they have:

EXACT length shafts for single, dual concentric and twin controls.
EXACT shaft end (round, half round, knurled, slotted, etc.)
EXACT mounting hardware (doghouse, twist-tab, reverse, etc.) and, of course, exact resistance and taper.

Although they look like the original, these controls will outperform the original—thanks to Centralab's patented snap-together *permanent-locking, anti-backlash* construction.

See your Centralab Fastatch II distributor whenever you need a replacement control. Whether for color or black and white TV, hi-fi, stereo, or radio, he can supply it!!

For additional information on the Fastatch II Control System, write to Centralab, Distributor Products, P. O. Box 591, Milwaukee, Wisconsin 53201, TWX: 414-731-8731. (In Canada: Centralab Canada Ltd.)



B6509

DIVISION OF GLOBE-UNION INC.

Circle 109 on reader's service card

NEW SAMS BOOKS

BRAND-NEW Enlarged 9th Edition of the famous HOWARD W. SAMS

Tube Substitution Handbook

2-IN-1 PACKAGE!

One copy for your bench... Compact copy for your caddy



Here's what you get in this great low-priced package: 1. Latest 9th edition handbook (5½ x 8½"), for bench use—lists 11,500 direct substitutions for all types of receiving and picture tubes. 7 sections: 1. Cross-reference of all American receiving types. 2. Picture tube substitutions. 3. Cross-reference of miniature tubes. 4. Industrial substitutes for receiver tubes. 5. Substitutions for communications and special-purpose tubes. 6, 7. Cross-reference of American and foreign tubes. 2. Caddy-size tube substitution guide—now contains all of the above 7 sections, making it an ideal handy reference for outside calls. Each handbook tells you when and how to make proper substitutions. Both handbooks in one vinyl-wrapped package. Order TUB-9P, both for only \$225 TUB-9. 5½ x 8½" handbook only \$150

ABC's of Antennas

by Allan Lytel. Covers basic theory of radio-wave transmission and reception, and fundamental antenna design principles. Describes basic antenna types, construction, uses, radiation characteristics. Includes antennas for business and amateur communications, microwaves, radio-navigation, etc. Invaluable for students, amateurs, and technicians. 96 pages; 5½ x 8½". Order AAL-1, only \$195

First-Class Radiotelephone License Handbook

by Edward M. Noll. Revised 2nd edition, completely updated to cover the latest revision of the FCC Commercial License Examination Element IV. Serves not only as an invaluable preparation for the exam, but is also a thorough textbook for broadcast engineer training. Subjects cover: Frequency assignments; duties and license requirements; broadcast microphones; record and tape machines; studio and control room facilities; remote facilities; a-m transmitters, antennas, lines; f-m transmitters; f-m stereo broadcasting; monitor and test equipment; proof of performance measurements. Invaluable appendices for permanent reference. 384 pages. 5½ x 8½". \$495 Order BON-2, only

Color TV Trouble Clues. Vol. 2

by the PF Reporter Editorial Staff. Practical procedures for servicing color TV sets; all-new material; emphasis on late models. Describes typical color troubles and shows how experts troubleshoot and repair them. Clearly explains how to tackle each problem. A great aid for seasoned as well as new technicians. 128 pages. 5½ x 8½". \$195 Order COL-2, only

Electronic Corrosion Control for Boats

by John D. Lenk. Invaluable for boat owners and marine technicians. Describes latest commercial systems designed to reduce and eliminate metal corrosion—a major problem in boat operation. Explains unwarranted causes of corrosion (improper wiring, poor bonding, bad paint, wrong metals), and how to remedy them. Includes data on impressed-current corrosion-control systems. 128 pages; 5½ x 8½". Order CCL-1, only \$195

Basic Piezoelectricity

by John Potter Shields. Covers theory and application of unusual metals that produce electricity when subjected to pressure. Describes both natural and synthetic materials and their properties. Discusses phono cartridges, sonar, ultrasonic cleaning, high-voltage power supplies, and ceramic filters. Includes 10 practical experiments. Many photos, schematics and drawings. 128 pages; 5½ x 8½". Order BPS-1, only \$250

HOWARD W. SAMS & CO., INC.

Order from your Sams Distributor today, or mail to Howard W. Sams & Co., Inc., Dept. RE-4 4300 W. 62nd Street, Indianapolis, Ind. 46206

Send me the following books:

TUB-9P AAL-1 COL-2 BPS-1

TUB-9 BON-2 CCL-1

Send FREE Sams Booklist. \$_____ enclosed

Name _____

Address _____

City _____ State _____ Zip _____

My Distributor is _____

Circle 110 on reader's service card

voltage adjustment. Dc voltages remain constant regardless of ac input supply voltage fluctuations between 105–125 V ac, 60 Hz. Internal reference and stabilization circuitry; floating output terminals with separate chassis ground terminal; 2% accuracy d'Arsonval meter; 1-year guarantee, 6¼ x 5 x 6 in., 3½ lb.—Electro Products Labs

Circle 62 on reader's service card

PROBE, the Tri-Probe, does three jobs—demodulation, direct, low-capacitance—by dialing section you need. Low-capacitance section provides 10 to 1 at-



tenuation when used with scope having input resistance of 1.3 megohms. Needle point. Combined operating range: 0 to 250 MHz.—Far Hills Design, Div. of Kastle Electric Co.

Circle 63 on reader's service card

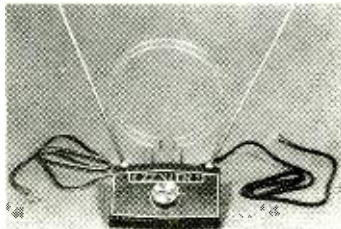

ALL-CHANNEL INDOOR TV ANTENNA, the Wavemagnet, has separate vhf and uhf sections. Vhf section has adjustable rabbit ears dipole with special network for lower swr. On uhf, full-size uhf loop array. Front-to-back ratio up to 15 dB.—Zenith Sales Corp.

Circle 64 on reader's service card

3 NEW SCREWDRIVER KITS, called Prestige, in stiff blue plastic case with extra pockets and 16-page suggestion book. No. SP-10 Deluxe contains: 3/32 x 2-in. round pocket clip; ½ x ½-in. stubby;

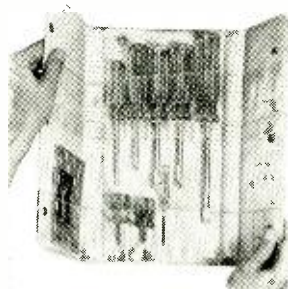

No. 1 stubby Phillips; 3/16 x 4-in. round; ¼ x ½-in. round; 5/16 x 6-in. square; No. 2 Phillips. 2 lb, 11 oz.—Vaco Products Co.

Circle 65 on reader's service card

REGULATED POWER SUPPLY, model 780. Regulated dc output: voltage 0–400 V, continuously variable; current 0–150 mA continuous from 200–400 V,

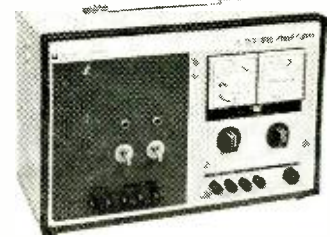

0–100 mA continuous from 0–200 V, 0–125 mA intermittent from 0–200 V; regulation 0.33% or 0.3 V (whichever is greater) from no load to 100-mA load, 0.4% or 0.5 V for ±10-V line variation; ripple less than 3 mV rms; output impedance less than 10Ω from dc to 1 MHz. Bias output: voltage 0 to –150 V continuously variable, current 2 mA max. Unregulated ac output: output 1, 6.3 V, 3 amps center-tapped; output 2, 6.3 V, 3 amps no center tap (1 and 2 used independently or connected in series or parallel). Input: 117 V ±10%, 50–60 Hz ac, 160 watts. Meters: dc volts, 0–400 V, 0–200 V; dc mA 0–200 mA, 13 15/16 x 8 15/16 x 7 in., 20 lb.—Precision Electronics

Circle 66 on reader's service card

TWO SCREWDRIVER KITS for driving Scrulox square recess screws. Interchangeable blade kit 99SL has Service Master handle and five 4-in. Scrulox blades, plastic case. Compact convertible set PS44 (illus.) includes 5 color-coded

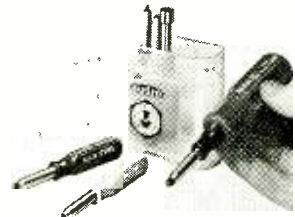

midget Scrulox screwdrivers and ½-in. hex midget nutdriver. Piggyback torque amplifier handle slips over top of midget drivers for larger gripping surface. Case has flat base for use as bench stand.—Xcelite Inc.

Circle 67 on reader's service card

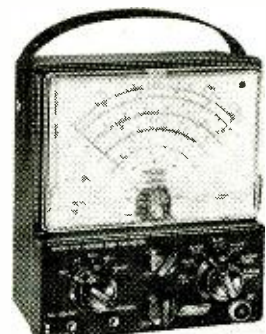

VTVM, model 1700, ac/dc ranges: 0–1.5, 5, 15, 50, 150, 500, 1,500 volts. Output –20 to +65 dB, 0 dB = 1 mW across 600 Ω. Input impedance 1.4 MΩ and 11 MΩ. Response: 30–500,000 Hz within 3%. Power consumption 10 watts.—Mercury Electronics Corp.

Circle 68 on reader's service card



TRANSISTOR IGNITION SYSTEM, the *Octopulse*, can be mounted on engine next to original coil with safe operation up to 400°F. 3-year, no-mileage-limit guarantee. Extends life of points to 75,000 to 100,000 miles.—Unigas, Inc.

Circle 69 on reader's service card

STEREO MAGNETIC HEADSET, model L, No. 56-15. Four-conductor cord, two 2-circuit plugs, 8-, 16-, and 6,000Ω



impedance. Braided nylon over-the-head cord, Bakelite shell and cap. Response to 9,000 Hz—Trimm, Inc.

Circle 70 on reader's service card

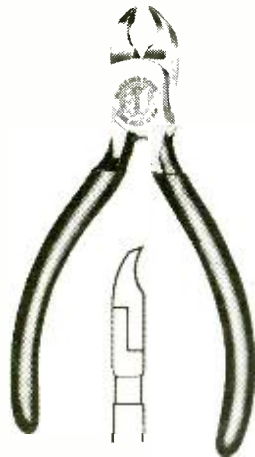

MATRIX CUTTER, 4-in. and 5-in. size. Combines advantages of end cutter and diagonal cutter. Extra hard, curved blade. Plier has no bevel. Coil spring keeps handles open. Red dipped plastic handles.—Mathias Klein & Sons, Inc.

Circle 71 on reader's service card

MAGNETIC TAPE RECORDER/REPRODUCER, the *R70*. 1 to 8 separate

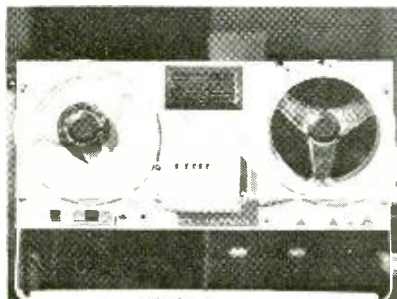

tracks can be recorded on 1/2-in. tape, 8 3/4-in. reel, any single speed 15/32 to 7 1/2 ips. 3 motors; 2 special direct-drive torque; 1 drive (reversible), 1, 2 or 4 (8 on special order) channels. Response: 15/32 ips ±3 dB 250-2,500 Hz, better than 30 dB S/N; 7 1/2 ips ±2 dB 50-12,000 Hz, better than 50 dB S/N. Less than 2% harmonic distortion at 3 3/4 ips and above. Flutter and wow: less than 0.5% rms at 15/32 ips with decreasing amounts at higher speeds. Stop time less than 50 milliseconds at lower speeds. Unmounted: 32 lb with all amplifiers for 4 channels.—Stancil-Hoffman Corp.

Circle 72 on reader's service card



12-INCH SPEAKER, the *SK-500*. Custom-built in England. 25-20,000 Hz with less than 1% distortion. 3-way axial design: pneumatic air-suspension woofer, dome-lens-compression type multicellular radial treble horn, balanced midrange radiator, single die-cast frame. Built-in 2,000- and 5,000-Hz crossover, high-frequency 1-pad control, 1 3/4-lb magnet. Woofer voice-coil diameter 1 1/2 in., tweeter 1 in. Free-air cone resonance 22 to 27 Hz. Rated impedance 8-16Ω. Power-handling capacity of 30 watts.—Lafayette Radio Electronics Corp.

Circle 73 on reader's service card

TUNED ON THE LINE

for maximum flow of signal to the set.



That's right!—and that's why Wizard 300 coupling instantly improves both the range and quality of TV-FM signal response—and that's why Wizard 300 couplers immediately convert ordinary reception to excellent reception—why weak, "out of reach", TV-FM signals frequently come into focus—**That's why** (without amplification) no difficulty is experienced in serving up to twenty TV receivers from a single antenna in medium to strong signal areas—and that's why the only limitation to the number of TV receivers which can be effectively operated in a non-amplified master antenna system is the signal strength available at the antenna—and that's why Wizard 300 couplers are regarded as the most valuable means of signal transfer in the distribution of TV-FM signals—and that's why hundreds of thousands of Wizard 300 couplers have been sold—why this uniquely versatile coupler is used in homes, duplexes, motels, apartments, TV sales rooms and housing projects—why professional master antenna system installers as well as the two-three-four-set families use Wizard 300 couplers—Wizards have many astonishing performance advantages—"Tuned on the line for maximum flow of signal to set".

WIZARD COUPLERS contain no moving parts nor thermionic devices—no resistors—no capacitors—no inductances. Its case is of premium weather-resistant plastic material—it is therefore, literally indestructible and maintenance free—designed expressly for twinlead (ribbon)

If you are unable to obtain Wizard couplers from your dealer, order directly from us—List \$1.95 ea.—

CHARLES ENGINEERING INC., 3421 N. Knoll Dr., Los Angeles, Calif. 90028

NAME _____

ADDRESS _____

CITY _____ STATE _____

Circle 111 on reader's service card

THE CHAOS OF CAPACITOR COLOR CODES

Buttons and pellets, cans and globs, tubes and cubes! All with colored stripes and dots, each according to a different system. AT LAST—find out how to decode capacitor color codes, how they started why they're used. Big drawings, handy clip-out charts—coming in . . .

May Radio-Electronics

MY BACK IS KILLING ME! I'VE LUGGED THIS STUFF ALL DAY AND STILL HAVE TWO CALL-BACKS TO GO! MY TUBE CHECKER LIED TO ME AND I RAN OUT OF TUBES FOR SUBSTITUTION!

WISE UP OLD BUDDY! GET YOURSELF A MIGHTY MITE... NEVER LETS YOU DOWN AND IS AS EASY TO CARRY AS YOUR LUNCH BOX! I MADE 10 CALLS ALREADY AND SOLD FIVE EXTRA TUBES I WOULDN'T HAVE CAUGHT BY SUBSTITUTION!

YE OLDE TUBE TESTER

YE OLDE BEAT UP TON AND A HALF TUBE CADDY

JOE'S TV SERVICE

MIGHTY MITE

"Finds 'em Fast... Checks 'em All!" **SENCORE MIGHTY MITE** TUBE CHECKER

NOW CHECKS OVER 3,000 TUBES

Circle 112 on reader's service card



Take your toughest electronics problems to the Gernsback Book Rack at your parts distributor — for instant answers!

When you need immediate answers to thorny electronics problems, go directly to the Gernsback Library Book Rack at your favorite electronics parts distributor. This unique information center will automatically give you accurate answers to every imaginable electronics problem you may face. You'll find answers on radio and TV servicing, transistors, hobby projects, test instruments, audio, hi-fi, stereo, tape recording, communications, industrial electronics, to name just a few areas. Each book is written by an expert and designed to give you practical assistance in the field you desire. So check the Gernsback Rack at your parts distributor when you have a question. You'll increase your know-how and get more fun out of electronics as well.

Servicing AGC Circuits

By Harry E. Thomas. This practical how-to-do-it manual first shows you everything that can go wrong with AGC circuits and then goes on to reveal all you need to know to correct the trouble. Enables you to locate breakdowns quickly, in AGC circuits, and then make your repairs rapidly and intelligently. Specific service approaches are plainly spelled out so you can use them immediately. Special emphasis is placed on TV troubleshooting, giving you the devices and techniques used in modern circuitry. Easy-to-read explanations, helpful illustrations, readily understood charts give you the information you need to start servicing AGC circuits as soon as you've read the book. 204 pages, softbound, available through parts jobbers only.

Order #126 \$3.95

Color TV Repair

By 10 Servicing Experts. Top technicians like David R. Anderson, Ed Bukstein, Jack Darr, Homer L. Davidson, Art Margolis, Robert Middleton and Warren Roy have created here, an important tool for the profit-minded service technician. Tells you clearly and concisely just what can go wrong in color TV receivers and how to fix them. First each trouble symptom is described in detail, then a perfect solution is provided for the problem. Book covers color circuits, ABC's of color TV servicing, antennas and boosters, replacing the color picture tube, how to pinpoint the defective color section fast, servicing the chroma circuits, unexpected causes of TV color failure, troubleshooting with a color bar generator, color servicing tips, plus a glossary of color TV terms. In addition, the volume is crammed with photos and schematics. 160 pages, softbound.

Order #123 \$2.95

TV Sweep Oscillators

By Harry E. Thomas. A giant reference and practical working tool for every service technician and engineer who wants to know what can go wrong with sweep oscillators and how to repair them. Covers relaxation oscillators, pulse techniques, transistorized oscillators, failure analysis, sawtooth generators, synchronization, sweep oscillator servicing, AFC in horizontal circuits, multivibrators and blocking oscillators. Completely illustrated. 226 pages, softbound, available at parts jobbers only.

Order #119 \$3.95

Horizontal Sweep Servicing Handbook

By Jack Darr. Gives you fast, simple methods of locating and repairing troubles in the sweep sys-

tem. Shows you lots of practical shortcuts developed on the bench for the rapid isolation of trouble. Written by an expert in the field and packed with schematics to help you do a better job. 224 pages, softbound.

Order #115 \$4.10

The Handbook of Electronic Tables

By Martin Clifford. Here is an effective new approach to solving electronics problems. You don't have to make mathematical computations, or carry a slide rule or memorize any formulas whatsoever. Every answer you will ever need is worked out for you in 160 fact-packed pages of accurate electronic tables. Simply take the figures of your electronics problems and turn to the appropriate table. Then move your finger across the table and read the answer, instantly. You'll find these tables are easy to use, offer a wide choice of solutions and provide a high degree of accuracy. Softbound.

Order #125 \$2.95

Electronics Data Handbook

By Martin Clifford. Gives you the most-needed formulas and data in electronics. Tells exactly which formula to use to solve a problem. Provides an easier formula if there is one. Shows what substitutions, if any, can be made in formulas. 160 pages, softbound.

Order #118 \$2.95

Hi-Fi Troubles

By Herman Burstein. High fidelity is complex and sophisticated and the more complex it is, the more apt it is to develop troubles. This book tells you how to maintain your audio system to keep it in peak condition for peak performance. It shows you why you have troubles, how to locate them, how to fix them. Most important, it shows you what *not* to do. *Hi-Fi Troubles* saves both time and money and helps solve problems like these: excessive hum; deteriorating equipment; noise in switches, tubes, resistors, etc.; distortion; bass and treble problems; installation; problems faced by kit builders; stereo and tape completely illustrated, softbound.

Order #120 \$3.95

Probes for Test Instruments

By Bruno Zucconi and Martin Clifford. A probe is a link. It is a device you connect between a test instrument like a scope or v.t.v.m. and a radio or TV set being repaired. The finest scope or v.t.v.m. is limited by the *kind of probe* you use, and by *how much* you know about putting probes to work for you. Now comes this valuable handbook showing you in clear detail exactly what probe to use for a particular job. Covers

crystal-demodulator probes, voltage-doubler probes, balanced probes, low-capacitance probes, high-voltage probes, isolation probes, direct probes, specialized probes, vacuum-tube and semiconductor probes. 224 pages, softbound. Newly Revised.

Order #54 \$2.50

The Oscilloscope

By George Zwick. Enables technicians to become masters of the scope. Incorporates newest uses and techniques. Covers waveforms, the cathode-ray tube, sweep systems, typical oscilloscopes, alignment, oscilloscope techniques, tests and measurements, experiments using the oscilloscope. The book is fully illustrated. 224 pages, softbound.

Order #108 \$3.65

The V.T.V.M.

By Rhys Samuel. Get the most out of this electronic workhorse. Explains V.T.V.M. circuits and how and why they work. Gives many new time-saving uses. Eleven important chapters tell all: instrument characteristics, how the V.T.V.M. works, meter scales, probes and cables, using the V.T.V.M., TV troubleshooting, AM-FM alignment and repair, servicing audio amplifiers, the V.T.V.M. in the ham shack, miscellaneous applications, troubleshooting the V.T.V.M. 224 pages, completely illustrated, softbound.

Order #57 \$2.50

How to Get the Most out of your VOM

By Tom Jaski. Get more mileage out of this versatile instrument. A complete analysis including theory and practical usage, plus important chapters on construction. 224 pages, illustrated, softbound.

Order #85 \$2.90

Order from your Parts Distributor or Mail to:

Gernsback Library, Inc., Dept. RE 46

154 West 14th Street, N.Y., N.Y. 10011

Please send the following books.

I enclose \$

123 (\$2.95) 54 (\$2.50)

115 (\$4.10) 108 (\$3.65)

125 (\$2.95) 57 (\$2.50)

118 (\$2.95) 85 (\$2.90)

120 (\$3.95) Prices 10% higher in Canada.

Name

Address

City State Zip

My Distributor is

Get these books at your parts distributor or mail ➤

NEW LITERATURE

All booklets, catalogs, charts, data sheets and other literature listed here are free for the asking with a Reader's Service number. Turn to the Reader's Service Card facing page 72 and circle the number of items you want. Then detach and mail the card. No postage required!

HI-FI CATALOG. 16 punched pages, photos and some specs on line of consoles, portables, tape recorders, components.—**Voice of Music (V-M Corp.)**

Circle 74 on reader's service card

TWO CATALOGS. One (8 pages) on gold-bonded germanium diodes; the other (16 pages) on germanium transistors. Curves and specs.—**General Instrument Corp., Semiconductor Products Group**

Circle 75 on reader's service card

4-PAGE BROCHURE describes *Claro-Dec* miniature precision resistance-decade boxes designed for lab, school, experimenters, hobbyists.—**Claro-stat Mfg. Co., Inc.**

Circle 76 on reader's service card

SHORT-FORM CATALOG, No. 66, 22 punched pages: basic listing of complete product line of electrical switching and connecting components and accessories. 19 new items featured.—**Switchcraft, Inc.**

Circle 77 on reader's service card

CATALOG, No. 620, on TACO line of antenna-system mounting components, including clamp assemblies, masts and booms, couplers, guy-wire kits, mounting ring kits, adjustment bearings. 4 pages, specs and illustrations.—**Jerrold Electronics Corp.**

Circle 78 on reader's service card

DATA SHEETS, A.I.A. File 31-i-7, on commercial/industrial sound equipment, describe the modularized Galaxy line of amplifiers. 22 pages, photos.—**Harman-Kardon**

Circle 79 on reader's service card

ILLUSTRATED BOOKLET, D602-3003, 4 pages, describes line of silicon-transistor vidicon cameras for closed-circuit TV.—**Diamond Electronics**

Circle 80 on reader's service card

BROCHURE, ET 2931, "75 Milliwatts Dissipation—T-2 Photoconductive Cells," 4-page data sheet with curves, temperature range on T-2 photoconductive cells.—**Sylvania Electric Products Inc.**

Circle 81 on reader's service card

CATALOG, No. 6X6, 6-page foldout with cross-reference page on terminal blocks. Eby Sales has purchased physical assets of Exceller Electronics and this is the catalog.—**Eby Sales Co.**

Circle 82 on reader's service card

PRODUCT DATA SHEET on 7067/68 LVDT's, details new subminiature linear variable differential transformer series capable of ultra-sensitive measurement.—**Pickering & Co. Industrial Products Div.**

Circle 83 on reader's service card

CATALOG, L-161F, the Digest of Indicator Lights. 16 pages, illustrated. Miniature and large

fittings, for use with neon or incandescent sources. Lamp charts.—**Dialight Corp.**

Circle 84 on reader's service card

1966 SPRAY DATA SHEET, No. 11, describes line of antistatic compounds. 4 pages. Prices.—**Merix Chemical Co.**

Circle 85 on reader's service card

Write direct to the manufacturers for information on the items listed below:

APPLICATION REPORT to communications design engineers. No. S-124: "Designing Varactor Triplers Using the 1N4885/H4A"; No. S-125, "24 Watts at 450 MHz by Coupling the Amperex 8458 Driver to the 1N4885/H4A Varactor Tripler." Both reports in one 14-page booklet.—Write on company letterhead to: **Amperex Electronic Corp., Slatersville, R. I. 02876**

BIG CATALOG

World's "BEST BUYS" in GOV'T. SURPLUS Electronic Equipment

FULL OF TOP QUALITY ITEMS—
Transmitters, Receivers, Power Supplies, Inverters, Microphones, Filters, Meters, Cable, Keys, Phones, Antennas, Chokes, Dynamators, Blowers, Switches, Test Equipment, Headsets, Amplifiers, etc., etc. **SEND 25¢ (stamps or coin) for CATALOG and receive 50¢ CREDIT on your order.** Address Dept. RE.

FAIR RADIO SALES
P.O. Box 1105 • LIMA, OHIO • 45802

Let's Look Inside The Dynamic Microphone

THIS is no ordinary microphone. It's a University Dynamic. Its manner of working is no less complex than a modern day computer. Its system of elements is a carefully integrated electromechanical network in a critical acoustical area. Without showing it, it's really quite a bit more than it appears to be — you have to listen to know the results of its performance.

For example—you move toward a flurry of activity on a busy street corner and witness a man-on-the-street interview. To you and other observers the conversation is barely audible above the noise of people and traffic. But to radio listeners the conversation is clear and unaffected by the sounds of the city . . . They are remote . . . in the background where they belong. This is the distinct advantage of a microphone with a good directional pick-up pattern.

To demonstrate another case in point — Imagine yourself an unseen observer in a conference room of a large organization. A tape recorder, fed by a single microphone in the center of the conference table, is in use to store all that is said. Many speak at once; some face away from the microphone; it appears that all that is said may never be recorded, but every word is captured on the magnetic tape for later review.

Both are University Dynamic

Microphones, but they are different in design, to serve different applications. The first is a highly directional (cardioid) dynamic microphone, sensitive only to the areas of sound intended for radio transmission or recording . . . proportionally attenuating sounds emanating from adjacent unwanted areas. The second is a highly omnidirectional dynamic microphone sensitive to sounds in all surrounding areas, specifically designed to pick up all sounds.

University makes only dynamic microphones, and they have the precision and reliability of modern day computers. Look at the inside to confirm this. The bullet shaped dome of the directional cardioid is a precise and significant component of the system. It smoothes the vital mid-range to provide a more dynamic, natural quality of sound. Filters, in a special configuration, soften sudden bursts of sound, minimize sibilants and protect the inner components from dust, dirt and the elements. A series of ducts further extends the performance of the microphone's transducer element providing gross and fine tuning (similar to the bass ducts of a speaker system) to sharpen the directional characteristics and reinforce the bass response.

Model 2040 Omnidirectional With Switch

Model 2020 Omnidirectional

Model 2050 Omnidirectional With Swivel & Switch

The unusual, rugged, yet highly sensitive characteristics of the exclusive University UNILAR diaphragm are responsible for the remarkable high frequency performance of the University Dynamic Microphone — sharp, bright, clear and transparent. The UNILAR diaphragm is not easily seen in the precision cut-a-way shown above. It is extremely light and sliver thin, rugged and virtually indestructible. It could easily withstand torturous bursts of sound and vibration, even without the "extra-measure-of-protection" blast filter screen in the assembly. This feature alone guarantees continued distortion-free and trouble-free performance . . . and, it is only one of many features that make the University Dynamic Microphone the choice of professionals and recording buffs. No matter what the nature of sound, University captures the live natural quality that makes the difference right from the start . . . better than other microphones costing \$10, \$15 or even \$20 more. And, the exclusive University warranty gives you five times as long to enjoy this "lively sound." Stop at a franchised University Dealer today and try for yourself. Get more info too! Write to Desk D-69.

UNIVERSITY SOUND, P. O. Box 1056, Oklahoma City, Oklahoma 73101. . . . we'll send you a FREE copy of "MICROPHONES 66."

Circle 113 on reader's service card

CONTINUITY TESTER FINDS LOW-RESISTANCE CIRCUITS

Build this versatile little gadget in less than an hour and for less than \$4

By Tommy N. Tyler

IN SERVICING INDUSTRIAL EQUIPMENT, we often have to test continuity through cable harnesses, relay and switch contacts or terminal boards. Usually we want to distinguish between direct circuit paths—through a wire or other conductor—and “sneak” paths through a low-resistance circuit such as a relay coil or transformer winding.

This continuity tester does just that. Its audible tone can identify a change in circuit resistance as small as 1 ohm. It operates on low voltage and current, so is virtually incapable of damaging semiconductors or other components.

The circuit of the continuity tester is simply a Hartley oscillator direct-coupled to a miniature speaker. Feedback comes from the secondary winding of the output transformer instead of via the usual tapped primary.

The frequency of oscillation depends heavily on the amount of resistance in the emitter circuit. If the circuit is adjusted to oscillate at about 1,000 Hz with the probes shorted, inserting a 1-ohm resistor between the probes increases the frequency by about 50 to 100 Hz, which is easily detected by the ear. Ten ohms of resistance sounds about an octave higher, and the tone rapidly becomes inaudible as the resistance between the probes approaches 50 to 100 ohms.

No sound is heard when the probes are applied to transformers or inductors with very low dc resistance, because of their high reactive impedance at the oscillator frequency. A circuit through a large electrolytic capacitor can be identified by a characteristic rising tone as the capacitor charges from the small current through the probes.

The unit shown in the photos was constructed by modifying an inexpensive two-transistor radio. These “toy” radios can usually be found for about \$2 to \$4, and although they lack a bit in performance, they represent a substantial bargain in parts value. While models may differ slightly, they invariably use a basically similar reflex circuit, and the many parts can be the basic ingredients for construction projects such as this one.

Begin by stripping the circuit board

of all components except the volume control, the output transistor and the output transformer. Do this very carefully to avoid peeling the copper from the board. Next, examine the board pattern to see how it may be adapted to the circuit shown in the diagram. You will probably find most of the component mounting holes and conductor patterns you need already available. The unit I built required drilling only one new mounting hole and adding one jumper.

If you don't feel you will ever want to use the tester with the earphone, use the phone plug and jack for connecting the test probes. I decided to keep the earphone feature on my unit, so I installed another miniature phone plug and jack for the probes. Other connectors could be used, but this type is small and polarized. Remove the antenna socket and ream out the hole slightly to mount the probe jack. One of the photos shows the inside of the completed tester. The volume control knob has been removed so that the oscillator frequency, once set, will not be disturbed.

Wiring the battery through the on-off switch is optional, since no current



Once a midget transistor radio, this is now a light, compact continuity tester.

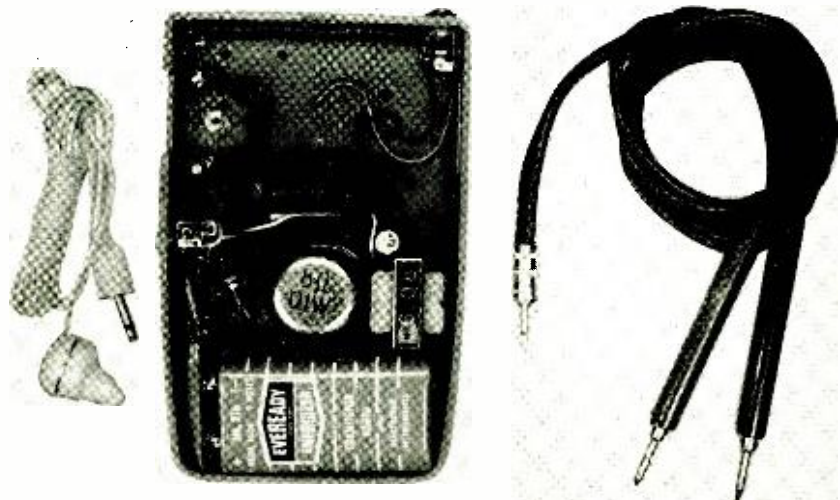

Inside the tester, with its probes and optional earphone.

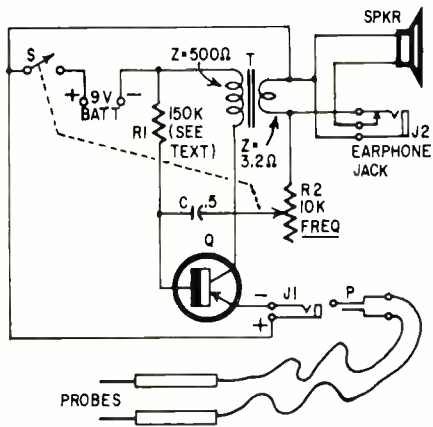

Circuit of the continuity tester. Nearly all parts are supplied by the "toy" radio.

- C—0.5 μ F paper
- J1, J2—miniature phone jacks (Switchcraft TR-2A or equivalent)
- P—miniature phone plug to fit J1 (Switchcraft 850 or equivalent)
- Q—p-n-p audio transistor (almost any medium- to high-gain replacement or "bargain" type)
- R1—150,000 ohms (see text)
- R2—10,000-ohm "Trimpot" or miniature volume control
- S—spst switch, part of R2 if desired, or separate
- T—transistor output transformer, 500 ohms to 3.2 ohms
- Battery—9-volt transistor-radio type (Burgess 2U6 or equivalent)
- SPKR—1 1/2-inch miniature speaker
- Probes (G-C Electrocraft "Klipzon" Miniprods, or equivalent)
- Case and hardware (see text)

is drawn unless the probe circuit is closed. If the probes are unplugged when the tester is not in use, the batteries cannot be discharged accidentally. You may prefer to attach the probe leads to the tester permanently and use the on-off switch instead.

Select R1 for about 2 to 4 mA of collector current with the probes shorted and no feedback applied to the base. Usually a value somewhere between 100,000 and 300,000 ohms will do.

Adjust R2 until the tester oscillates at the desired frequency when the probes are shorted. If the circuit doesn't oscillate, reverse the connections to either of the transformer windings. Experiment will usually disclose a frequency range in which the tester is most sensitive to resistance between the probes.

As the battery voltage tapers off, it will be necessary to readjust R2 slightly. At 2 mA, and with intermittent use, the usable life of the battery is more than 100 hours.

This little device comes in handy for making quick checks for burned-out diodes and transistors. For example, if the negative probe is applied to the base of a p-n-p transistor, a tone should be heard when the positive probe is applied in turn to the emitter and collector leads, and no tone should be heard when the probe polarity is reversed. The opposite is true for n-p-n transistors. END

APRIL, 1966



Look what's happened to the RCA WR-51A FM Stereo Signal Simulator

...it got to be the WR-52A...

NEW, REDESIGNED AND IMPROVED

Last year we decided to make a few improvements in our WR-51A Stereo FM Signal Simulator... for two years THE established test instrument for multiplex stereo servicing. We intended to call it the WR-51B. But one thing led to another and we made so many extensive improvements that we virtually had a new instrument on our hands. You're looking at it: the NEW RCA WR-52A STEREO FM SIGNAL SIMULATOR.

We've added an RF Deviation Meter to measure the modulation level of both stereo and monaural FM signals. The meter is also used to accurately establish the level of the 19 Kc subcarrier.

We've included provisions for modulating left or right stereo signals with an external monaural source.

We've added a switch to disable the 19 Kc oscillator to provide a low-distortion monaural FM output.

We've added a new frequency (72 Kc)... required, along with the 67 Kc frequency, for trap alignment in some sets.

These features, together with numerous internal circuit design changes have resulted in a vastly improved, almost completely new instrument. And, the RCA WR-52A includes all those features that made its predecessor such a valuable servicing tool.

■ COMPOSITE STEREO OUTPUT—for direct connection to multiplex circuit

Choice of left stereo and right stereo signals

■ RF OUTPUT—for connection to receiver antenna terminals

100 Mc carrier, tuneable

Choice of FM signals—left stereo, right stereo, monaural FM, internal test and 60 cycle FM sweep

FM stereo deviation adjustable from 0-100%

100 Mc sweep signal adjustable from 0 to more than 750 Kc at a 60 cps rate

RF output attenuator

■ CRYSTAL-CONTROLLED 19 Kc SUBCARRIER ($\pm 0.1\%$)

■ SINE WAVE FREQUENCIES

Three low-distortion frequencies—400 cps, 1 Kc, 5 Kc

Two crystal-controlled frequencies—19 and 38 Kc

Additional frequencies—67 and 72 Kc for trap alignment

■ READILY PORTABLE—weighs only 12 3/4 pounds, measures 13 1/2" by 10" by 8"

■ COMPLETE WITH WIRED-IN CONNECTING CABLES

We also raised the price... just 50 cents. The WR-52A is now \$250.00.* Ask to see it at your Authorized RCA Test Equipment Distributor.

*Optional distributor resale price, subject to change without notice. May be slightly higher in Hawaii and the West.

RCA ELECTRONIC COMPONENTS & DEVICES, HARRISON, N.J.



The Most Trusted Name in Electronics

TECHNOTES

EICO 435 SCOPE KIT ADJUSTMENTS

To adjust the vertical amplifier according to step 4-4c of the operating manual, resistor R23 must be unsoldered temporarily from pin 1 of the tube V4 and a vom connected to measure the cathode current of tubes V3 and V4.

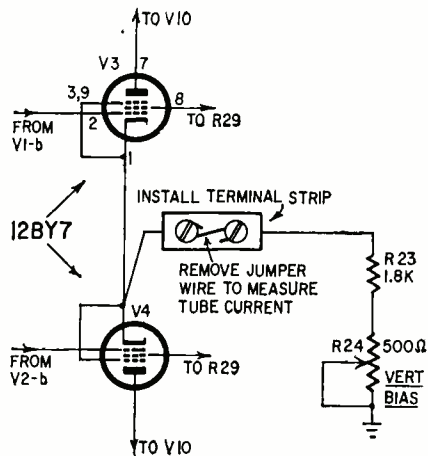

If this is done a few times as the tubes age, the pin and resistor leads may be damaged because of repeated operations.

A better way is to install permanently a two-screw terminal strip in series with the resistor. Mount it directly above R23, fastening it to the rear panel with small metal brackets. Remove the jumper and connect the vom leads to the terminals to measure the tube current.

Also, to assure the proper bias in tubes V1-a and V2-b, adjust the dc balance (step 4-4e) before making the rest of the vertical amplifier adjustments (steps 4-4a through 4-4d).—Donald R. Hicke

LEEDS & NORTHRUP 101042 INDUSTRIAL RECORDING AMPLIFIER

When the fail-safe relay sounds off with a noise like an ordinary house-door buzzer, the cause is the failure of the tubular 50- μ F 25-volt capacitor under the chassis.

Very erratic operation of an instrument using the 101042 and 101040 chassis is usually due to failure of part No. 032122 (4-4-25- μ F) and No. 023123 (4-25-25- μ F) plug-in type capacitors. These are not available at most local distributors. They are readily obtainable from the manufacturer for about \$2 apiece.—F. Jusaites

STEELMAN TRANSITAPE AND AIRLINE 7111 RECORDERS

If it isn't possible to switch tapes recorded at 1 7/8 ips from portable to portable, even of the same manufacture, without noticeable tone difference, check the large brass flywheel for overuse of oil.

Wash flywheel and drive rollers clean of grease and oil. Do not slosh cleaner on; some oil is necessary in the bearings. After cleaning, use a drop of Non-Slip or similar frictive on the idler wheel in both high- and low-speed positions.

The idler wheel should be free to move sideways and float against the motor drive shaft and the brass flywheel. The idler itself should be examined for wear. When replacing, replace the entire assembly. (Steelman part No. 155006).

To check the motor, use a stroboscope with the motor under load. Erratic current draw, overly high current draw,

BE ON THE ALERT! with SONAR FM MONITOR RECEIVER

Wired for "Tone Alert."

HAND WIRED
LOW COST & GIVES HIGH PERFORMANCE

Monitor the calls and know the facts as it happens.

NOW!—8 Super Deluxe FM communication receivers to meet your particular needs for home, office or car. Powerful and dependable. Engineered for rugged service under all operating conditions. Featuring High frequency oscillator, temperature compensated for stability, RF amplifier for maximum sensitivity, illuminated dial, safety rated components and ALL Aluminum construction plus many other outstanding features. Operates on 110 VAC. Includes power cord, mounting bracket.

Model FR-101—(25-50 mc)
Model FR-102—(150-175 mc)

\$89⁹⁵ TUNABLE RECEIVER AC Only

Slightly higher prices for DC and XTAL control

SONAR RADIO CORPORATION
73 Wortman Ave., Brooklyn 7, N. Y. Dept. 464
Please send me information on Model FR101/102 Monitor Receiver.

Name.....
Address.....
City.....Zone.....State.....

Perfect for

- Police • Fire
- Other Law Agencies
- Tow Trucks
- Civil Defense
- Weather
- Ship to Shore

Circle 114 on reader's service card

Now you can solder tuners, planes, pre-amps and trains with the finesse of a production-line pro



New
MARKSMAN
PENCIL
Soldering Iron

Featherweight precision tool has stainless steel long-reach barrel with replaceable tip. Handle remains cool. Tip runs up to 750°F. Complete with cord. Model SP-23. **\$2⁹⁸** list
Also available in kit with two extra soldering tips, handy soldering aid and supply of solder. Model SP-23K. **\$4⁴⁴** list

WELLER ELECTRIC CORP., Easton, Pa.
WORLD LEADER IN SOLDERING TECHNOLOGY
Circle 115 on reader's service card

and excessive noise in the speaker are fair indicators of the need to replace (Steelman part No. 311183 for the motor, No. 155006 for the bracket).

The distance from the motor shaft to the face of the flywheel is critical. From the back edge of the motor shaft to the face of the flywheel, the distance should be exactly 17/32 inch. Use a steel rule; do not guess.—*Max Ath*

STRAY RF PICKUP IN FM PORTABLES

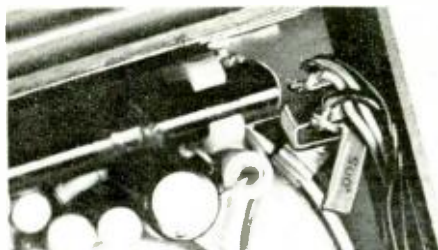

Long phone leads used with portable transistor FM receivers occasionally pick up rf and feed it back into the receiver, cancelling or reducing the signal from the regular whip antenna.

A cure for this problem in receivers such as the Webcor model 310 is to connect a .005- μ F miniature capacitor in parallel with the audio output leads, effectively shorting out rf, but not affecting audio. A convenient mounting place is across the phone jack as shown in the accompanying photo. Other values may be appropriate for other conditions.—*Jon H. Larimore*

ADMIRAL G11, G13 COLOR CHASSIS

Alternate audio tubes were used in early G13 production. The 6Y10 and 6AD10 tubes are *not* interchangeable because of circuit and voltage differences. Always replace with the same type as originally used, *even though both numbers are stamped on the chassis.*

The 6CD3 damper tube used in early G13 and G11 chassis will be replaced by a 6CG3. These two types are interchangeable.

A vertical stripe may appear on some sets when an

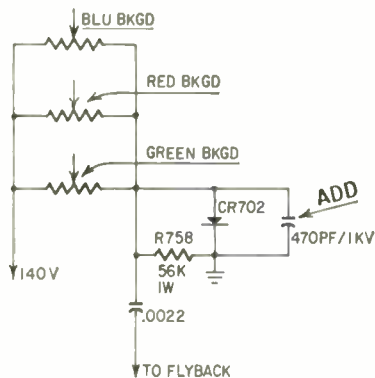

early-production G13 is operating nearby. This can be corrected by connecting a 470-pF 1,000-volt ceramic capacitor (Admiral part No. 65D10-350) across CR702.

If you need additional center-convergence range, transfer the end of R616 (5,600 ohms, 3 watts) on the back of the board from point T to ground (next terminal to the right, looking at the back of the convergence board.)

If you encounter high-voltage arcing through the high-voltage socket cap to the metal screen under the chassis on the G11 sets, add an Admiral part No. 33C206-5 or 33C206-4 HV Cup Cover inside the original. The 33C206-5 is now used in current production. With the added cover, the assembly will withstand 50,000 volts.—*Admiral Service News Letters*



A clever tape file

Stores 5 reels in one sturdy plastic case with swing-out compartments. Protects these valuable tapes, keeps them handy, indexed and orderly. Stacks horizontally or vertically, comes in three sizes (for 3-, 5-, 7- inch reels). Handsome two-tone beige. (A neat 8-mm film file too!)

3": \$2.99
5": \$4.45
7": \$4.95
(all prices less reels)



Available through your local distributor, or write to:
RYE INDUSTRIES INC.
127 Spencer Place, Mamaroneck, N.Y. 10543
Circle 116 on reader's service card

EIGHT INSTRUMENTS IN ONE

- Out-of-Circuit Transistor Analyzer
- Dynamic In-Circuit Transistor & Radio Tester
- Signal Generator
- Signal Tracer • Voltmeter
- Milliammeter
- Battery Tester
- Diode Checker

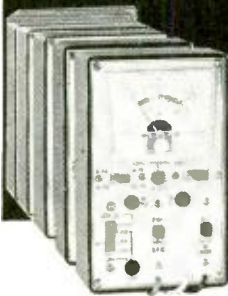

Transistor Analyzer Model 212

Factory Wired & Testec — \$18.50
Easy-to-Assemble Kit — \$13.50

YOU DON'T NEED A BENCH FULL OF EQUIPMENT TO TEST TRANSISTOR RADIOS! All the facilities you need to check the transistors themselves — and the radios or other circuits in which they are used — have been ingeniously engineered into the compact, 6-inch high case of the Model 212. It's the transistor radio troubleshooter with all the features found only in more expensive units. Find defective transistors and circuit troubles speedily with a single, streamlined instrument instead of an elaborate hook-up.

Features:
Checks all transistor types — high or low power. Checks DC current gain (beta) to 200 in 3 ranges. Checks leakage. Universal test socket accepts different base configurations. Identifies unknown transistors as NPN or PNP.

Dynamic test for all transistors as signal amplifiers (oscillator check), in or out of circuit. Develops test signal for AF, IF, or RF circuits. Signal traces all circuits. Checks condition of diodes. Measures battery or other transistor-circuit power-supply voltages on 12-volt scale. No external power source needed. Measures circuit drain or other DC currents to 80 milliamperes. Supplied with three external leads for in-circuit testing and a pair of test leads for measuring voltage and current. Comes complete with instruction manual and transistor listing.

EMC, 625 Broadway, New York 12, N. Y.

Send me FREE catalog of the complete value-packed EMC line, and name of local distributor.

NAME _____ RE-4

ADDRESS _____

CITY _____ ZONE _____ STATE _____

EMC

ELECTRONIC MEASUREMENTS CORP.
625 Broadway, New York 12, New York
Export: Pan-Mar Corp., 1270 B'way, N.Y. 1



**ERSIN
MULTICORE**

ONLY 69¢

BUY IT AT RADIO-TV PARTS STORES
MULTICORE SALES CORP. WESTBURY, N.Y. 11590.
Circle 118 on reader's service card

for your convenience

over
600
electronic
parts
distributors

now sell
Radio-Electronics
in the United States
and Canada

NEW SEMI- CONDUCTORS AND TUBES

THE TINIEST DIODES— THE BIGGEST SCR

At the small end of the electronic components range (and we mean *small*) is the "beam lead" diode developed by General Instrument Corp. The whole silicon diode is about the size of a period at the end of this sentence. There are 4,000,000 of them in a pound. They can be used in hybrid circuitry (separate, or *discrete*, components plus integrated circuits), or packaged as discrete components themselves.

The construction technique is at least as interesting as the diode itself. It is expected to lend itself to transistor and integrated-circuit production, and to diodes and rectifiers as well. Some 15,000 diodes are manufactured simul-

taneously on a half-dollar-sized slice of silicon. As an integral part of the structure, two gold bonding leads ("Hercu-



leads") are firmly attached to the diode chip and cantilevered out from it. The diode itself is an epitaxial silicon chip measuring less than .015 x .020 x .002 inch, with a diffused p-n junction.

Because of the small mass of brittle silicon compared to the large mass of resilient gold, the diode is practically indestructible in normal handling. For that reason, it lends itself very nicely to automatic production, because it doesn't need to be coddled like some other semiconductor devices.

At the other end of the scale is a silicon controlled rectifier that is certainly the highest-power single SCR ever built. It can handle up to 550 amperes rms at up to 1,200 volts. The across-the-flats dimension of the stud-mounting case is only 1 1/16 inches. The SCR is intended for a variety of high-power industrial work in such things as locomotives and other electric traction vehicles,

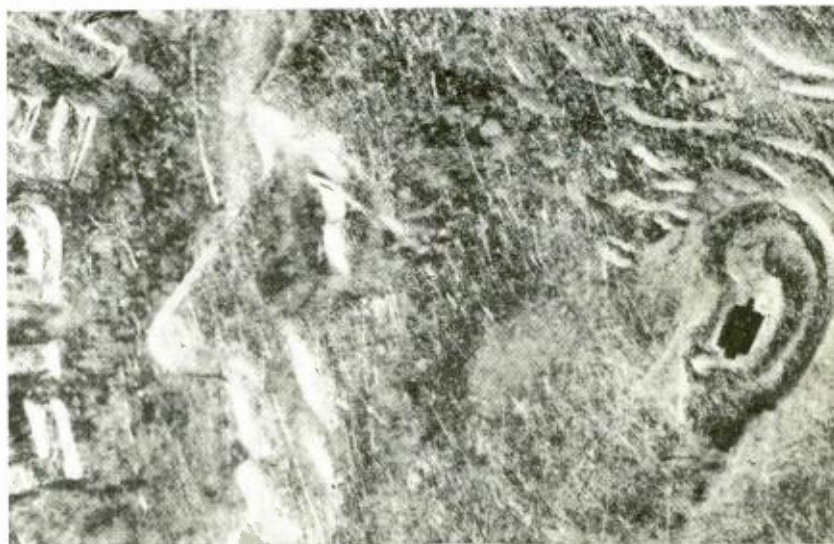
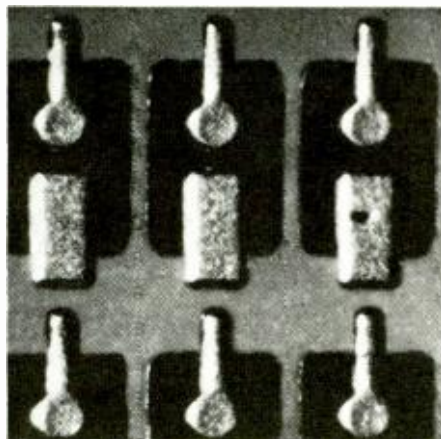

machine tools, electric furnaces and ovens. Prices vary according to breakdown voltage ratings; the 1,200-volt SCR costs over \$600.

"ANNULAR" PROCESS BRINGS VERY-HIGH-VOLTAGE SILICON TRANSISTORS

A new transistor manufacturing process developed by Motorola Semiconductor engineer Jack Haenichen is responsible for raising the breakdown rating of passivated p-n-p silicon transistors to 300 volts. Even higher voltages are predicted for the near future.

Four US patents were granted to Motorola in December for the new design, which, according to Dr. C. Lester Hogan, vice president and general manager of Motorola's Semiconductor Products Div., is the only practical method known for making passivated high-voltage p-n-p transistors.

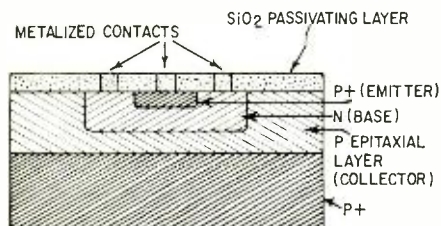

Fig. 1—Cross section of conventional passivated p-n-p silicon transistor.

So what is "passivated"? A *passivating layer* is a thin film of (usually) silicon dioxide created on the surface of active semiconductor silicon during processing, to protect the active silicon from contamination and to insulate it electrically (Fig. 1). The passivating layer does its job very nicely until the resistivity of the collector region is increased to raise the breakdown voltage. Then the characteristics change drastically, unfavorably—and unpredictably.

Apparently this effect is caused by impurities in the passivating layer. It keeps *most* contaminants from reaching the sensitive semiconductor junctions. But if it contains (or transmits) impurities that have electric charges, there can be trouble. Also, at the interface (meeting surface) of the silicon and the silicon dioxide, positive charges can accumulate. They attract free electrons in the p-type collector region toward the Si/SiO₂ interface. (True, the majority carriers in p-type material are holes, not electrons, but quite a few electrons do float about due to thermal agitation.)

Now, as long as the collector region contains a substantial number of holes (that is, has low resistivity), the only effect of the concentration of electrons near the interface is to reduce the hole concentration there. *But*—when the collector material is made with high resistivity, as is done for high-voltage transistors, the electrons outnumber the holes and convert a shallow layer of the collector surface to n-type material.

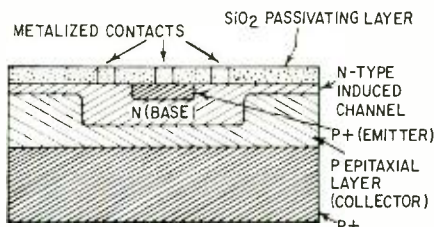

Fig. 2—Passivated p-n-p silicon transistor with induced n-channel out to edges.

Not good. This "inversion layer" amounts to a channel under the passivating layer of silicon dioxide that goes right out to the unprotected edges of the device (Fig. 2). This channel causes the unpredictable degrading of the transistor's characteristics.

Briefly, the annular design prevents this trouble by introducing a ring (annulus) of low-resistivity p-type material surrounding the n-type base region. Since this low-resistivity material is not channel-prone, it terminates the channel safely under the protective oxide coating (Fig. 3). Almost immediately, it becomes possible to double the voltage rating of this kind of transistor.

There are other advantages to this type of construction, which we don't have space to expand on. One of the principal ones is lower total series resistance for a particular device at a given voltage. Among other things, this means less power dissipation.

The annular construction is not limited to high-priced computer transistors, by the way. Motorola's new plastic-encapsulated silicon transistors for radios and hi-fi/stereo sets are annular.

In annular structure, p-type ring around base terminates channel under passivated layer.

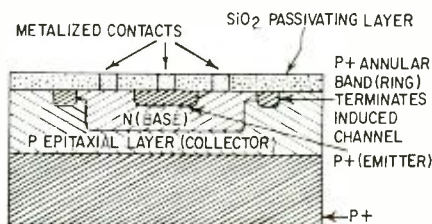

Fig. 3—In annular structure, p-type ring around base terminates channel under passivated layer.

The annular process is not completely new—Motorola has been making such transistors for about 3 years. Its cheapness plus its advantages make it likely to replace older processes. All Motorola's small-signal silicons, both p-n-p and n-p-n, have been converted to the annular structure.

An example of the high-voltage transistors possible with the annular type of construction is the 2N3743, introduced just a year ago, with a collector-emitter breakdown voltage (base open-circuited) of 300. END

Every No-Noise Aerosol Product

Guaranteed

**Non-Flammable
Non-Toxic and
Won't Affect Plastics**

"NO NOISE"

Insist On This Trusted
NAME BRAND
Avoid Risky "Private Labels"

"No Noise" PRODUCTS ARE
PERFECT FOR COLOR TV

- Volume Control & Contact Restorer
- Tuner-Tonic with Perma-Film
- EC-44 For Electrical Contacts
- Tape-Reco Head Cleaner

FREE 5" plastic extender push-button assembly for pin-point application with all No-Noise products.

ELECTRONIC CHEMICAL CORP.
813 Communipaw Avenue, Jersey City 4, N. J.

Circle 120 on reader's service card

**Police, fire,
ambulance emergency
calls, CD, weather...**

tune in on the Squires-Sanders FM Alert

First crystal FM emergency receiver at a down-to-earth price. Two crystal receive channels plus tunable control. Sensitive, selective, stable receiver. Smooth, adjustable squelch. Choice of two models: FM Alert 152—152 to 174 mc; or FM Alert 30—30 to 50 mc. Only \$89.95. Matching speaker \$9.95. Sold by communications specialists, or write Squires-Sanders Inc., Martinsville Rd., Millington, N. J. 07946

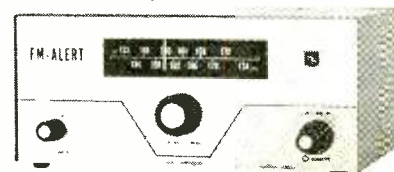

Squires Sanders



Circle 121 on reader's service card

GAS WELDING TORCH

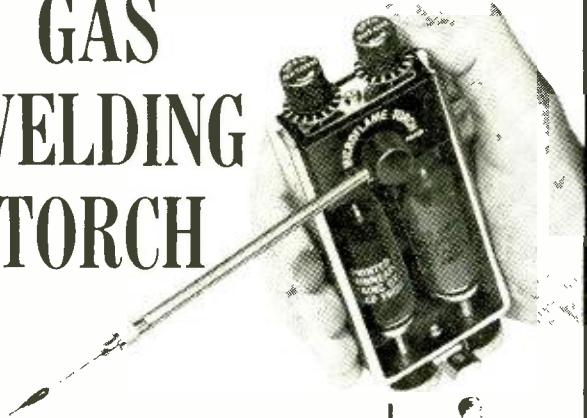

Uses **OXYGEN** and **LP GAS**

- Completely self-contained.
- Produces 5000° pin-point flame.
- Welds, brazes, solders.
- Hundreds of lightweight uses.
- Suggested list — \$19.95.

GET COMPLETE DETAILS AT MOST INDUSTRIAL DISTRIBUTORS, OR WRITE TO MICROFLAME, INC.

MICROFLAME, INC.
7800 COMPUTER AVENUE
MINNEAPOLIS, MINNESOTA 55424

Circle 123 on reader's service card



TRY THIS ONE

LEAVE SOME INSULATION ON THE END

When you strip insulation off the end of a piece of stranded wire to make a screw-terminal connection, push the scrap along by 1/2 or 3/8 inch, but don't slide it off completely. That way, enough wire is exposed to make the connection, but the strands won't separate and cause shorts.

If you like to tin stranded wire before connecting it, this trick makes that easier, too. No twisting. Slide off the insulation scrap, tin the bare wire, then snip off the end, insulation and all, with your cutters.—*Harry J. Entrican*

HEMOSTATS FOR TWEEZING

Few tools are as handy as a set of straight and curved surgeon's mosquito hemostats, obtainable at medical supply houses.

Smaller than any needlenose pliers, these instruments can't be beat for snagging tiny wires deep inside a crowded chassis. An added advantage is that having once latched onto a wire, the hemostat can be locked on it.—*Henry Mullen*

BEAT THE BAD-CHECK ARTISTS

When a stranger in our shop presents a check he wants cashed, we use our effective "stall" technique.

We pretend to examine the check very carefully, then duck out of sight. The honest person will wait, but the bad-check passer—thinking we're tipping the police—simply won't sweat out our stall for more than a few minutes.—*H. Muller*

"MOVING OUT SALE" PORT OF N. Y. AUTHORITY TAKING OVER 13 BLOCKS FOR TRADE CENTER & WE'RE IN IT!

We must unload 3 BULGING WAREHOUSES . . . at the GREATEST PRICE SLASH in Electronic History!

We will have 2 Places to serve you — Uptown at 2271 Broadway, Downtown still pending — Sale may end soon — HURRY, HURRY, HURRY.

FREE \$1 BUY WITH EVERY 10 YOU ORDER

Only applies to "\$1" Buys

FREE GIFT WITH EVERY ORDER

- | | |
|--|--|
| <input type="checkbox"/> 1000—ASST. HARDWARE KIT \$1
screws, nuts, washers, rivets, etc. | <input type="checkbox"/> 100'—MINIATURE ZIP CORD \$1
2 conductor, serves 101 uses . . . |
| <input type="checkbox"/> 250—ASST. SOLDERING LUGS \$1
best types and sizes | <input type="checkbox"/> 10 SETS — DELUXE PLUGS & JACKS \$1
asst. for many purposes . . . |
| <input type="checkbox"/> 250—ASST. WOOD SCREWS \$1
finest popular selection | <input type="checkbox"/> 10 — SETS PHONO PLUGS & PIN JACKS \$1
RCA type |
| <input type="checkbox"/> 250 — ASST. SELF TAPPING SCREWS \$1
#6, #8, etc. | <input type="checkbox"/> 10 — SURE-GRIP ALLIGATOR CLIPS \$1
2" plated |
| <input type="checkbox"/> 150—ASST. 6/32 SCREWS and 150 6/32 HEX NUTS \$1 | <input type="checkbox"/> 4—50' SPOOLS HOOK-UP WIRE \$1
4 different colors |
| <input type="checkbox"/> 150—ASST. 8/32 SCREWS and 150—8/32 HEX NUTS \$1 | <input type="checkbox"/> 200'—BUSS WIRE #20 tinned for hookups, special circuits, etc. . . \$1 |
| <input type="checkbox"/> 150—6/32 HEX NUTS and 150—8/32 HEX NUTS \$1 | <input type="checkbox"/> 100 — STRIPS ASSORTED SPAGHETTI \$1
handy sizes |
| <input type="checkbox"/> 150—ASST. 2/56 SCREWS and 150—2/56 HEX NUTS \$1 | <input type="checkbox"/> 100—ASSORTED RUBBER GROMMETS \$1
best sizes |
| <input type="checkbox"/> 150—ASST. 4/40 SCREWS and 150—4/40 HEX NUTS \$1 | <input type="checkbox"/> 50—ASSORTED PRINTED CIRCUIT SOCKETS \$1
best types |
| <input type="checkbox"/> 150—ASST. 5/40 SCREWS and 150—5/40 HEX NUTS \$1 | <input type="checkbox"/> 20—ASSORTED VOLUME CONTROLS \$1
less switch |
| <input type="checkbox"/> 500—ASSORTED RIVETS \$1
most useful selected sizes | <input type="checkbox"/> 7—ASSORTED VOLUME CONTROLS \$1
with switch |
| <input type="checkbox"/> 500—ASSORTED WASHERS \$1
most useful selected sizes | <input type="checkbox"/> 15—RADIO OSCILLATOR COILS \$1
standard 450ke |
| <input type="checkbox"/> 100 — ASST. RUBBER & FELT FEET FOR CABINETS \$1
best sizes | <input type="checkbox"/> 20—ASST. PILOT LIGHTS \$1
#41, 46, 47, 51, etc. |

- | | |
|--|---|
| TV BARGAIN COLUMN | RCA 110² FLYBACK TRANS |
| <input type="checkbox"/> TV TUNERS — VHF, UHF, COLOR new & complete closing out odds & ends by asst & get all 3 types ea \$4 | <input type="checkbox"/> 110° TV DEFLECTION YOKE \$ |
| <input type="checkbox"/> 90° FLYBACK TRANSFORMER \$1
for all type TV's incl schematic | <input type="checkbox"/> 90° TV DEFLECTION YOKE \$1
for all type TV's incl schematic |
| <input type="checkbox"/> 70° FLYBACK TRANSFORMER \$1
for all type TV's incl schematic | <input type="checkbox"/> 70° TV DEFLECTION YOKE \$1
for all type TV's incl schematic |
| <input type="checkbox"/> 4 — TV ALIGNMENT TOOLS \$1
most useful assortment | <input type="checkbox"/> 20—ASSORTED TV COILS \$1
I.P. video, sound, ratio, etc. |
| <input type="checkbox"/> 40—ASSORTED TV KNOBS \$1
all standard types, \$20 value . . . | <input type="checkbox"/> 20—ASSORTED GRID CAPS \$1
for 1B3, 1N2, 6BG6, 6BQ6, etc. . . |
| <input type="checkbox"/> 100 — ASSORTED TV PEAKING COILS \$1
all popular types | <input type="checkbox"/> \$15.00 TELEVISION PARTS \$1
"JACKPOT" best buy ever |
- We scooped the Market Latest type—standard for all 110° TV's

RCA's design of large Coil produces 18KV—assuring adequate width

Incl Schematic Diagram application for any TV

List price \$13.90

Your price . . . \$3

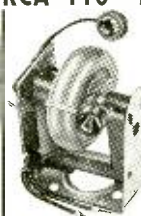
- | | |
|--|--|
| <input type="checkbox"/> 1—LB SPOOL ROSIN-CORE SOLDER \$1
40/60 top quality | <input type="checkbox"/> 2—G.E. PIECES OF EQUIPMENT \$1
stacked with over 200 useful parts |
| <input type="checkbox"/> \$14 QUAM 12" PM SPEAKER \$5
Top quality 100z ceramic mag. . . . | <input type="checkbox"/> 10—ASSORTED DIODE CRYSTALS \$1
1N34, 1N48, 1N60, 1N61, 1N82 |
| <input type="checkbox"/> 10—TOP BRAND TRANSISTORS \$1
NPN & PNP 2N404, 2N414, etc. | <input type="checkbox"/> TRANSISTOR RADIO <i>asst type</i> \$1.50
good, bad, broken, as-is, potluck |
| <input type="checkbox"/> 1 — SQ. YARD GRILLE CLOTH \$1
most popular brown & gold design | |

IMMEDIATE DELIVERY . . . Scientific light packing for safe delivery at minimum cost. **HANDY WAY TO ORDER:** Pencil mark or write amounts wanted in each box, place letter F in box for Free \$1 BUY. Enclose with check or money order, add extra for shipping. Tearsheets will be returned as packing slips in your order, plus lists of new offers.

Name Cost of goods
Address Shipping
 estimated
 TOTAL

Please specify refund on shipping overpayment desired: CHECK POSTAGE STAMPS MERCHANDISE (our choice) with advantage to customer

Circle 124 on reader's service card

STRIPPING RIBBON LEAD

To strip insulation off the end of a length of 300-ohm antenna lead, make a

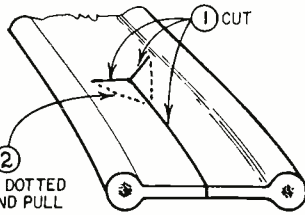

GRASP TABS AT DOTTED LINES, TWIST AND PULL

cut with a pair of diagonal cutting pliers up the center of the ribbon, and two small cuts toward the wires, as shown in the drawing. Grasp the upper end of the resulting tabs with the diagonals, using enough pressure to pull but not cut. Then simply twist the tab away from the wire for a clean strip.—Robert W. Larson

QUICK COMPARISON CHECK FOR HOME TAPE RECORDERS

Thorough speed and sound quality tests on a tape recorder are time-consuming, but they are often unnecessary when all you want is to verify a customer's complaint or check the effects of a repair. The method here is fast and easy, and though it applies mainly to speed checks, it will also give you clues about the recorder's frequency range.

distortion and noise.

All you need is a good-quality record player and a good record of some kind of music—preferably piano. (The record player turntable should be checked out for accuracy and constancy of speed. Test records are available for this; some turntables have built-in stroboscopes. However, most hi-fi turntables are accurate enough for this check.)

Set up the tape recorder for the speed you want to test. Record the record from the phonograph for about five minutes. Rewind the tape to the beginning of the recording. Disconnect the phono from the tape deck. Now simultaneously place the stylus at the beginning of the record and start the tape recorder, allowing each to play back through its own speaker. With a little manipulation you'll be able to do this on the third or fourth try.

By listening to the record on the phonograph (as your standard) and comparing it to the simultaneous playing of the identical sound on the tape you'll find it easy to detect any wow or gain or loss of speed. In this fashion you can check all speeds of the tape deck.

For complete tests, record at the very beginning of the tape reel, then duplicate the test midway on the reel, and finally another at the tail end of the tape, where wow often appears.

Obviously this test is applicable

WANTED DEAD OR ALIVE SERVICE DEALERS

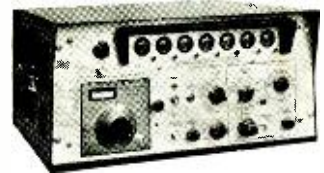

IS YOUR SERVICE DEPARTMENT DEAD? REVIVE IT WITH A GENERAL CG-3 \$75 PER MONTH

Take advantage of 2-way communications sales which have hit an all-time high of over \$50 million. As we both know, service is the backbone of the 2-way communications industry. Time and knowledge is what you sell. Increase your gross profits by giving quicker service—

TRY AND BUY

GENERAL Direct Readout Frequency Counter—it is the fastest instrument in the industry—

SAVE TIME—MAKE MONEY

GENERAL is the only company that will take a trade. Submit now and be ready. Send for 24 page catalog.

GENERAL RADIOTELEPHONE CO.
3501 W. Burbank Blvd., Burbank, California

Circle 125 on reader's service card

CANADIANS: Ordering is easy . . . we do the paperwork . . . try a small order

SARKES TARZIAN TV TUNER 41mc



Latest Compact Model—good for all 41 mc TV's. BRAND NEW—MONEY BACK GUARANTEE

Best TUNER "SARKES TARZIAN" ever made—last word for stability, definition & smoothness of operation. An opportunity—to improve and bring your TV Receiver up-to-date.

COMPLETE with Tubes & Schematic . . . \$7.95

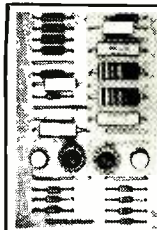

IBM COMPUTER SECTIONS

8 assorted Units we sell for \$1 are loaded with over 150 valuable parts.

Incl. — Transistors, Condensers, Resistors, Heat Sinks, Diodes, Etc.

8 for \$1
100 for \$10

HIGHWAVE AM-FM PORTABLE RADIO

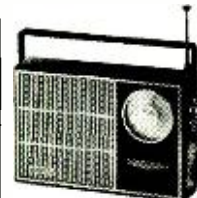

Elegance in Ebony & Chrome
14 Transistors — A Powerhouse of Quality Reception with AFC Operates on 4 "C" Cells
22" Telescoping FM Antenna & Personal Listening Attachment
Money refund — if not better than any Known Brand selling for even twice the price
8"x5 1/4"x2 1/4" — 4 lbs

COMPLETE . . . \$19.50

- | | | | |
|--|--|---|---|
| <input type="checkbox"/> 50 — ASSORTED MYLAR CONDENSERS popular selected types . . . \$1 | <input type="checkbox"/> TELEPHONE JACK or PLUG make any telephone portable ea \$0.60 | <input type="checkbox"/> 100 — ASST. CERAMIC CONDENSERS Some in 5% . . . \$1 | <input type="checkbox"/> UNIVERSAL 2" PM SPEAKER Alnico 5 magnet, quality tone . . . \$29.60 |
| <input type="checkbox"/> 50 — RADIO & TV SOCKETS all type 7 pin, 8 pin, 9 pin, etc. \$1 | <input type="checkbox"/> TELEPHONE RECORDING DEVICE place it under telephone . . . \$1 | <input type="checkbox"/> 100 — ASST. MICA CONDENSERS some in 5% . . . \$1 | <input type="checkbox"/> UNIV. 3" x 5" PM SPEAKER Best type for Radios, TV, Etc. \$75.00 |
| <input type="checkbox"/> CLEAN UP THE KITCHEN "JACKPOT" High Deal only one to a customer . . . \$1 | <input type="checkbox"/> CRYSTAL LAPEL MICROPHONE high impedance, 200-6000 cps . . . \$1 | <input type="checkbox"/> 100 — ASST. 1/4 WATT RESISTORS stand. choice ohmages, some in 5% . . . \$1 | <input type="checkbox"/> UNIVERSAL 4" PM TWEETER SPEAKER for FM, Hi-Fi, etc. . . . \$59.60 |
| <input type="checkbox"/> 4 — TRANSISTOR RADIO EARPIECES wired complete with plug \$1 | <input type="checkbox"/> TAPE RECORDER — assorted types good, bad, broken, as-is, potluck \$4 | <input type="checkbox"/> 100 — ASST. 1/2 WATT RESISTORS stand. choice ohmages, some in 5% . . . \$1 | <input type="checkbox"/> UNIVERSAL 4" PM SPEAKER Alnico 5 magnet, quality tone . . . \$69.60 |
| <input type="checkbox"/> 510 QUAM 8" PM SPEAKER Top quality 10 oz. ceramic Mag. . . \$3 | <input type="checkbox"/> 4 — SHOCKPROOF SCREWDRIVERS best sizes incl Philips . . . \$1 | <input type="checkbox"/> 35 — ASST 2 WATT RESISTORS stand. choice ohmages, some in 5% . . . \$1 | <input type="checkbox"/> 3 — AUDIO OUTPUT TRANSFORMERS 50L6 type . . . \$1 |
| <input type="checkbox"/> 50 — G.E. FLASHLIGHT BULBS #PR-9, 2.7 volts . . . \$1 | <input type="checkbox"/> 50 — BALL POINT PENS Retractable, assorted colors . . . \$1 | <input type="checkbox"/> 50 — PRECISION RESISTORS asst. list-price \$50 less 98% . . . \$1 | <input type="checkbox"/> 10 — SPEAKER PLUG SETS deluxe type, 2 conductor, wired \$1 |
| <input type="checkbox"/> 10 — ASSORTED SLIDE SWITCHES SPST, SPDT, DPDT, etc. . . . \$1 | <input type="checkbox"/> 100 — MIXED DEAL "JACKPOT" Condensers, Resistors, Surprises . . . \$1 | <input type="checkbox"/> 20 — ASST'D WIREWOUND RESISTORS, 5, 10, 20 watt . . . \$1 | <input type="checkbox"/> \$15.00 RADIO PARTS "JACKPOT" handy assortment . . . \$1 |
| <input type="checkbox"/> CHAPT ZU DI MITZIA "JACKPOT" double your money back if not completely satisfied . . . \$1 | <input type="checkbox"/> 300 — ASST. 1/2 W RESISTORS Top Brand, Short leads, excellent \$1 | <input type="checkbox"/> 100 — ASST. TERMINAL STRIPS all types, 1-lug to 6-lug . . . \$1 | <input type="checkbox"/> 50 — ASST. TUBULAR CONDENSERS .001 to .47 to 600v . . . \$1 |
| <input type="checkbox"/> 10 — ASST. RADIO ELECTROLYTIC CONDENSERS . . . \$1 | <input type="checkbox"/> 100 — MOLDED TUBULAR COND. Top brand, short leads, excellent \$1 | <input type="checkbox"/> 25 — INSTRUMENT POINTER KNOBS selected popular types . . . \$1 | <input type="checkbox"/> 20 — IIT SELENIUM RECTIFIERS 65ma for Radios, Meters, Chargers, Transistors, Experiments, etc. . . . \$1 |
| <input type="checkbox"/> 7 — ASST. TV ELECTROLYTIC CONDENSERS popular selection . . . \$1 | <input type="checkbox"/> 50 — ASSORTED #3AG FUSES popular assorted ampere ratings . . . \$1 | <input type="checkbox"/> 50 — ASST. RADIO KNOBS all selected popular types . . . \$1 | <input type="checkbox"/> 20 — ASSORTED TUBES Radio, Television and Industrial . . . \$1 |
| <input type="checkbox"/> 3 — ELECTROLYTIC CONDENSERS 50/30-150v . . . \$1 | <input type="checkbox"/> 5 — I.F. COIL TRANSFORMERS sub-min for Transistor Radios . . . \$1 | <input type="checkbox"/> 5 — PNP TRANSISTORS general purpose, TO-5 case . . . \$1 | <input type="checkbox"/> 50 — WHITE TUBE CARTONS asst. for all 4 important sizes . . . \$1 |
| <input type="checkbox"/> 3 — STANDARD SAPHIRE NEEDLES for all thumbcrew cartridges \$1 | <input type="checkbox"/> 5 — AUDIO OUTPUT TRANSFORM Sub-min for Trans Radios \$1 | <input type="checkbox"/> 5 — NPN TRANSISTORS general purpose, TO-5 case . . . \$1 | <input type="checkbox"/> ALL AMERICAN TUBE KIT \$2 Top Standard Brand — 12BA6, 12REG, 12AV6, 50C5, 35W4 . . . \$1 |
| <input type="checkbox"/> 20 — STANDARD TUBULAR CONDENSERS .047-600v . . . \$1 | <input type="checkbox"/> 4 — TOGGLE SWITCHES SPST, SPDT, DPST, DPDT . . . \$1 | <input type="checkbox"/> 2 — POWER TRANSISTORS No. 1 Replace 2N155, 2N176, 2N301, etc. \$1 | <input type="checkbox"/> 3 — TOP BRAND 35W4 TUBES \$1 |
| | <input type="checkbox"/> 15 — ASST. ROTARY SWITCHES all popular types \$20 value . . . \$1 | <input type="checkbox"/> 10 — ASST DUAL CONTROLS for Radio, TV, Hi-Fi, Stereo, etc. \$1 | <input type="checkbox"/> 5 — RCA 1U4 TUBES brand new boxed, also serves as a 1T4 . . . \$1 |

BROOKS RADIO & TV CORP., 84 Vesey St., Dept. A, New York 7, N.Y. TELEPHONE COrtlandt 7-2359



EFFICIENT!
SAFE!
FAST!

AUTOMATIC STAPLE GUNS

For Fastening Any
Inside or Outside
Wire Up to 1/2" in Diameter

- UP TO 3/16"
No. T-18
- UP TO 1/4"
No. T-25
- UP TO 1/2"
No. T-75

- Telephone wire
 - Intercom wire
 - Bell wire
 - Thermostat wire
 - Radiant heating wire
 - Hi-Fi, Radio & TV wires
- Tapered striking edge gets into close corners!
- Available in:
Brown, Ivory, Beige,
Monel, Bronze, Natural

ARROW FASTENER COMPANY, INC.

1 JUNIUS STREET • BROOKLYN 12, N. Y.

Circle 126 on reader's service card

Enjoy the "music-only" programs now available on the FM broadcast band from coast to coast.

- NO COMMERCIALS •
- NO INTERRUPTIONS •

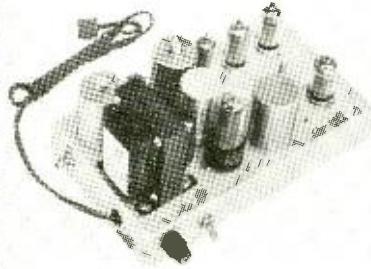

It's easy! Just plug Music Associated's Sub Carrier Detector into multiplex jack of your FM tuner or easily wire into discriminator. Tune through your FM dial and hear programs of continuous commercial free music you are now missing. The Detector, self-powered and with electronic mute for quieting between selections, permits reception of popular background music programs no longer sent by wire but transmitted as hidden programs on the FM broadcast band from coast to coast. Use with any FM tuner. Size: 5 1/2" x 6". Shipping weight approx. 7 lbs.

KIT \$49.50

(with pre-tuned coils, no alignment necessary)

WIRED \$75.00 (Covers extra \$4.95 ea.)

Current list of FM Broadcast stations with SCA authorization \$1.00

MUSIC ASSOCIATED

65 Glenwood Road, Upper Montclair, N. J.
Phone: (201)-744-3387

Circle 127 on reader's service card

only on home recording and does not apply to commercial prerecorded tapes. The tape recorder under test may have a built-in speed deficiency and in such a case would have to be checked out by a qualified serviceman.—*Albert L. Sohl*

HINGE FOR PIPE MAST

When a pipe flagpole or antenna mast is to be taken down from time to time, it is convenient to hinge the base.

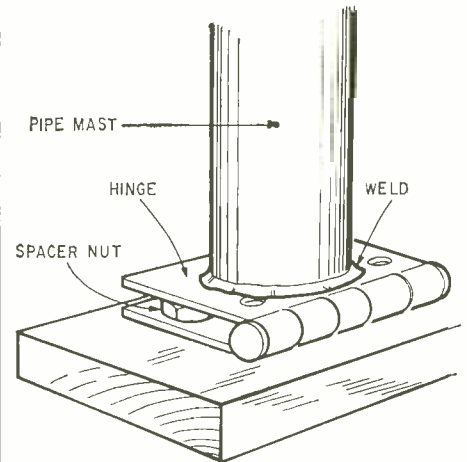

Use a large hinge with one leaf welded to the end of the pipe. Also weld a spacer between the leaves to keep them even (the spacer may be a nut).—*Hugh Lineback*

MULTIPLE SOLDERING TIP

A job that requires soldering many phono plugs can be done in less time with the aid of the rig described. A 250-watt gun is clamped into a vise with the trigger taped down. The gun is con-

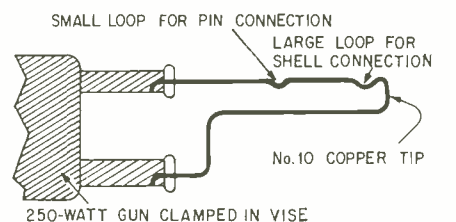

250-WATT GUN CLAMPED IN VISE

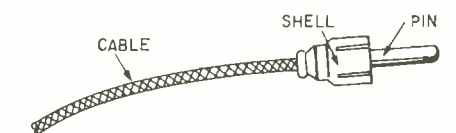
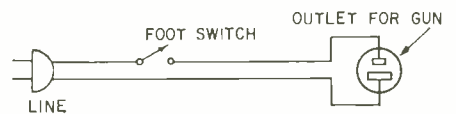

nected to a foot switch. A tip made of No. 10 copper wire is formed as shown. When soldering phono plugs, step on the foot switch and first solder the end (shield) connection. Next move over to the tip (pin) connection and solder it. A buffing machine fitted with a wire brush removes excess solder and flux. Be sure to use a good grade of solder; poorer grades will soon corrode the copper tip.—*Steve P. Dow* END

INNOVATION
INNOVATION
INNOVATION
INNOVATION



In Electrical Electronics Engineering

- 80 Technical sessions, 300 papers — all at the New York Hilton
- 4 floors of exhibits — all at the New York Coliseum. Four days only — Monday - Thursday
- Gala IEEE Banquet—Wednesday, 7:15 p.m., New York Hilton Grand Ballroom — \$15.00
- Free shuttle busses between the Hilton and the Coliseum — every few minutes
- Registration — Members \$2.00 — Non-members \$5.00. Ladies \$1.00. Good for all days — Technical Sessions and Exhibits. In and out privileges.

EXHIBITS (4 days only)

Monday through Thursday
11:30 a.m. - 9:30 p.m.

NEW YORK COLISEUM

TECHNICAL SESSIONS

Monday through Friday
NEW YORK HILTON

MARCH 21-25, 1966

Students (over 14) accompanied by adult will be admitted to Exhibits Thursday only. \$2.00. (Not more than 3 per adult)



IEEE EXHIBITION

WHAT'S YOUR EQ?

These are the answers. Puzzles are on page 60.

Two Currents

Combining Ohm's Law and a power formula, we get $50I^2 + 2 = 25I$. This is a quadratic equation ($ax^2 + bx + c = 0$) In this equation: $a = 50$, $b = -25$ and $c = 2$.

$$50I^2 - 25I + 2 = 0$$

The general quadratic formula is:

$$x = \frac{-b \pm \sqrt{b^2 - 4ac}}{2a}$$

$$\text{Therefore, } I = \frac{25 \pm \sqrt{625 - 400}}{100}$$

$$I = \frac{25 \pm 15}{100}$$

$$\frac{25 + 15}{100} = 0.4 \text{ and } \frac{25 - 15}{100} = 0.1 \text{ amp.}$$

Rise Time

The rise time of the square wave is faster than the rise time of the scope. To find the Answer rise time of a scope, use the formula:

$$t_r = \sqrt{t_s^2 + t_a^2}$$

In the formula, t_r is the rise time of the display seen on the scope, t_s is the rise time of the scope (usually given in the specs) and t_a is the given rise time of the vertical preamplifier.

For example, if t_s is 20 μsec and t_a is 15 μsec , t_r equals 25 μsec .

$$t_r = \sqrt{20^2 + 15^2} = \sqrt{400 + 225} = \sqrt{625} = 25 \mu\text{sec.}$$

Another Way

Here's Mr. Phil Stein's approach to the solution of the "Printed Circuit" puzzler in the December, 1965 column.

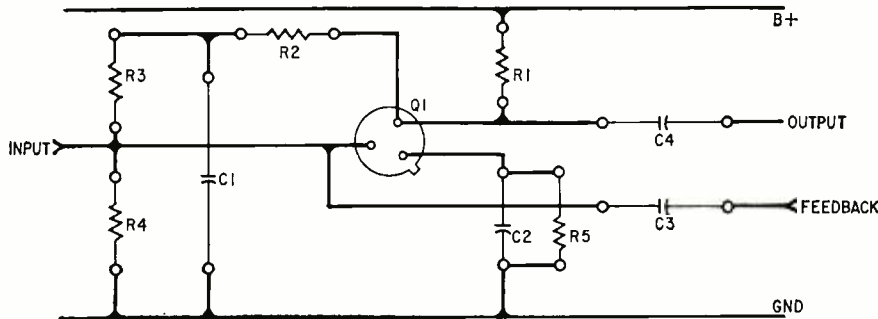

Another Solution

An alternate solution to the puzzle "Which Row?" (October 1965) is to connect the resistor strings in parallel as shown, and to measure total resistance between A and B.

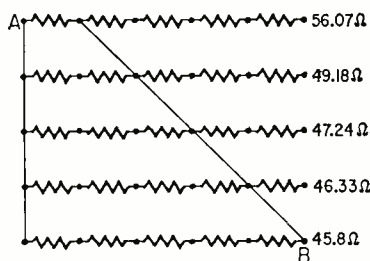

ance between A and B. Total resistance values are indicated opposite the string with the 200-ohm resistors.—Robert H. Yager

Radio-Electronics Is Your Magazine!

Tell us what you want to see in it. Your suggestions may make it a better magazine for the rest of the readers as well as yourself. Write to the Editor, RADIO ELECTRONICS, 154 West 14th St., New York, N. Y. 10011.

Meet Winegard Chroma-Tel

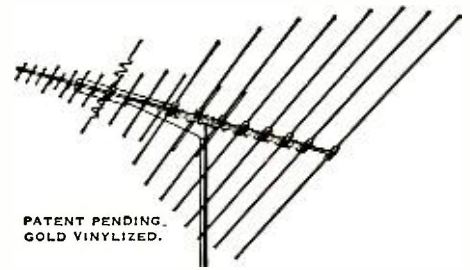

PATENT PENDING. GOLD VINYLIZED.

First 1/2 size all-band (UHF, VHF, FM) antenna with full size power

- Delivers Brilliant Color, Beautiful Black and White, Full-Tone FM Sound
- Brings in All the UHF, VHF and FM Stations in Your Area

Now there's an All-Band (UHF, VHF, FM) antenna that is actually half the size of most other all-band antennas. It eliminates half the bulk, half the wind loading, half the storage space, half the truck space and half the weight of ordinary all-band antennas... without sacrificing one bit of performance! Features Winegard's new Chroma-Lens Director System and impedance correlators.

Compare size, cost and performance... you'll choose Winegard Chroma-Tel every time. Ask your distributor or write for Fact-Finder #242 today.

3 Models from \$17.50 list.

Winegard Co. ANTENNA SYSTEMS
3000 Kirkwood • Burlington, Iowa

Circle 129 on reader's service card

ELECTRONICS

Engineering-Technicians



The Nation's increased demand for Engineers,

Electronic Technicians, Radio TV Technicians is at an all time high. Heald Graduates are in demand for Preferred High Paying Salaries. Train now for a lucrative satisfying lifetime career.

Bachelor of Science Degree, 30 Months
Save Two Years' Time

- Radio-Television Plus Color Technician (12 Months)
- Electronics Engineering Technology (15 Months)
- Electronics Engineering (B.S. Degree)
- Electrical Engineering (B.S. Degree)
- Mechanical Engineering (B.S. Degree)
- Civil Engineering (B.S. Degree)
- Architecture (B.S. Degree) (36 Months)

Approved for Veterans

DAY AND EVENING CLASSES

Write for Catalog and Registration Application. New Term Starting Soon.

Your Name
Address
City
State

HEALD'S

ENGINEERING COLLEGE

Est. 1863—103 Years
Van Ness at Post, RE
San Francisco, Calif.

Circle 130 on reader's service card

Because you've got to SEE it to BELIEVE it
.....we will send you a FREE sample!

instant lettering®

DATAMARK

— the easy new way to label your projects!

Just rub over the pre-printed words or symbols with a ballpoint pen and they transfer to any surface — looks like finest printing! Label control panels, meter dials, letter on anything!

LOOK FOR **instant lettering**®

DATAMARK SETS only \$1.25 each — at leading electronic distributors

DATAMARK SETS AVAILABLE FOR:

- Amateur Radio, CB
- Audio, Hi-Fi, TV
- Experimenter Home Intercom
- Industrial Test Equipment
- Switch & Dial Markings
- Alphabets & Numerals in 1/8", 1/4" and 1/2"

— each set has black, white, and gold

SEND FOR FREE SAMPLE RE-4

THE DATA CORPORATION

85 HIGHLAND AVENUE • PASSAIC, N. J. 07055

Circle 131 on reader's service card

SILICON RECTIFIER SALE

IMMEDIATE DELIVERY

FULLY GTD AMERICAN MADE



NEWEST TYPE FULLY TESTED

750 MA-SILICON "TOPHAT" DIODES
LOW LEAKAGE FULL LEAD LENGTH

PIV/RMS	PIV/RMS	PIV/RMS	PIV/RMS
50/35	100/70	200/140	300/210
.05 ea.	.07 ea.	.10 ea.	.12 ea.
400/280	500/350	600/420	700/490
.14 ea.	.15 ea.	.23 ea.	.27 ea.
800/560	900/630	1000/700	1100/770
.35 ea.	.45 ea.	.60 ea.	.75 ea.

ALL TESTS AC & DC & FWD & LOAD
SILICON POWER DIODE STUDS

D.C. AMPS	50 PIV 35 RMS	100 PIV 70 RMS	150 PIV 105 RMS	200 PIV 140 RMS
.3	.08 ea.	.12 ea.	.16 ea.	.22 ea.
.12	.25	.50	.65	.75
.25	.65	.90	1.40	1.40
.50	1.50	1.75	2.20	2.60
1.00	1.60	2.00	2.40	3.00

D.C. AMPS	300 PIV 210 RMS	400 PIV 280 RMS	500 PIV 350 RMS	600 PIV 450 RMS
.3	.27 ea.	.29 ea.	.37 ea.	.45 ea.
.12	.90	1.30	1.40	1.40
.25	2.00	2.35	2.60	3.00
.50	3.25	4.00	4.75	6.00
1.00	3.60	4.50	5.25	7.00

"SCR" SILICON CONTROLLED RECTIFIERS "SCR"

PRV AMP	7	16	25	PRV AMP	16	25
.25	.50	.75	1.00	.25	1.75	2.15
.50	.60	.90	1.25	.50	2.00	2.40
1.00	.80	1.25	1.50	1.00	2.40	2.75
1.50	.90	1.60	2.00	1.50	3.20	3.80
2.00	1.25	1.80	2.25	2.00	3.40	4.50

SPECIALS! SPECIALS!

100 Different Precision Resistors 1/2—2 Watt 1/2%—1% TOL \$1.25

Asst transistor Kit, P.N.P.—N.P.N. All popular types. Unchecked 100 for \$2.95 500 for \$9.95

TEXAS INSTRUMENT—POWER TRANSISTOR—85 WATT—DIFFUSED NPN, SILICON MESA TYPE 2N424 FACTORY NEW \$1.50 EA

Computer Grade Condenser 15,500 MFD 15 VDC American Mfg. .75 ea.

Type IN34 DIODE GLASS .07 ea 100 for \$5

Money Back guarantee. \$2.00 min. order. Plus shpg charge. Include check or money order. C.O.D. orders 25% down.

Warren Electronic Components

230 Mercer St., N. Y., N. Y. 10012 • OR 3-2620

Circle 132 on reader's service card

NOT-WORTHY CIRCUITS

Not to be built before April 1

VOLTAGE DUD-LER

A little-known low-current power supply circuit is based on the simple

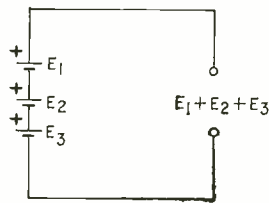

Fig. 1

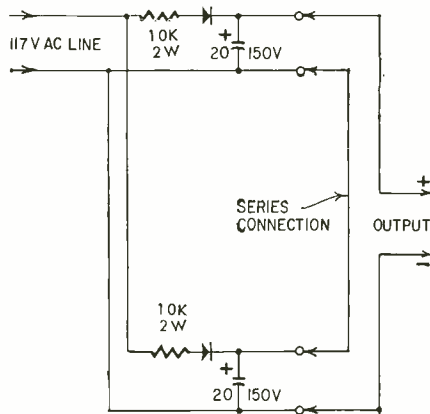
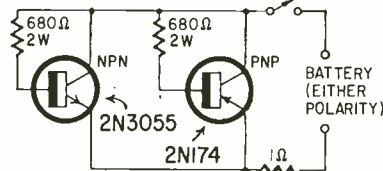

Fig. 2

uses two 15-amp complementary power transistors, connected as shown in the diagram. Resistor values are not critical. Both transistors should be mounted on heat sinks (a common heat sink will do and the transistors need not be insulated from it).

High-power transistors are somewhat expensive, but the convenience in



being able simply to connect any battery without observing polarity outweighed cost considerations for this particular job. If you are willing to sacrifice that convenience, a single p-n-p or n-p-n transistor will work equally well as long as the battery to be discharged is connected with its negative side to the collector of the transistor.—Strom Kurzschluss

ACCURATE 60-Hz DRIVE FOR SYNCHRONOUS CLOCK

Synchronous motors run at rated speed only when driven from a source of the correct frequency. Clocks, for instance, will not keep time unless the line frequency is exactly 60 Hz.

The circuit shows a simple oscillator-amplifier with enough 60-Hz sine-wave output to drive an ordinary electric clock motor. Q1 and Q2 are a phase-shift oscillator, with Q2 included to reduce the source impedance for the phase-shift network and also to provide current drive for Q3, the output stage. The phase-shift oscillator's normal free-running frequency is slightly above 60 Hz; a resistor from one side of power transformer T2 feeds in enough 60-Hz line voltage to synchronize the oscillator to the power line frequency.

T1 is an ordinary 6.3-volt filament transformer connected to

ALL-TRANSISTOR BATTERY DISCHARGER

This quickly built battery discharger will drain off any kind of battery, either polarity, any voltage up to 12. It

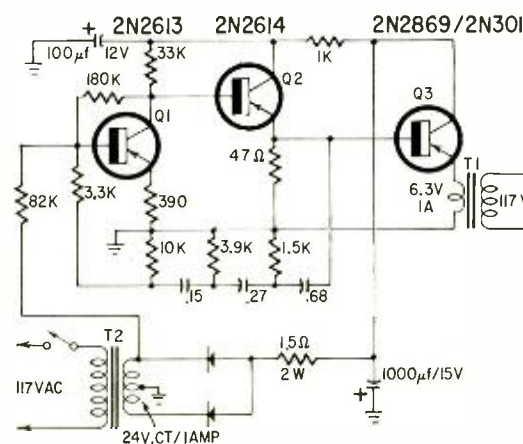

SELECT TO RESONATE T1 AT 60~

step up the voltage to just over 100. Total power output is approximately 3 watts. Capacitor C (paper) resonates the transformer to 60 Hz for more efficient operation.—C. E. Leakage.

SCHOOL DIRECTORY

Get Your First Class Commercial F.C.C. LICENSE QUICKLY!

Get your first class F.C.C. license in 4 months of resident classes—or at your own pace by correspondence. Grantham training in communications electronics leads you *step-by-step* to your third, second, and first class F.C.C. license, and to success in your electronics career.

Resident courses (day or evening) are available in Washington, D.C.; Seattle, Wash.; and Hollywood, Calif. Laboratory training is optional—recommended for beginners, and not so important to those who have practical experience.

Correspondence instruction is highly satisfactory for those who wish to study at their own pace. Grantham correspondence lessons are "programmed" for maximum learning efficiency—in your own home, in your leisure time.

Grantham lessons are constantly revised to keep up with the latest F.C.C. changes, and are written so you can understand them. Get the facts on Grantham F.C.C. License Preparation. Write or phone any school location listed below, and ask for "Brochure 67-D".

Grantham School of Electronics

1505 N. Western Ave., Hollywood, Cal. 90027
(Phone: HO 9-7878)

408 Marion Street, Seattle, Wash. 98104
(Phone: MA 2-7227)

818-18th St., NW, Washington, D.C. 20006
(Phone: 298-7460)

Circle 133 on reader's service card

GET INTO ELECTRONICS

V.T.I. training leads to success as technicians, field engineers, specialists in communications, guided missiles, computers, radar and automation. Basic & advanced courses in theory & laboratory. Electronic Engineering Technology and Electronic Technology curricula both available. Assoc. degree in 29 mos. B.S. also obtainable. G.I. approved. Graduates in all branches of electronics with major companies. Start Sept., Feb., Doms. campus. High school graduate or equivalent. Catalog.

VALPARAISO TECHNICAL
INSTITUTE
Department C, Valparaiso Indiana



start your career here

Tri-State graduates hold important engineering and business administration posts throughout the U. S. Tri State is a small professionally oriented college in the beautiful lake section of NE Indiana. Excellent faculty . . . well-equipped labs . . . new library and residence halls . . . 300-acre campus . . . small classes . . . rich tradition. Modest costs. Four-quarter year permits degree in three years. One year Drafting-Design Certificate program. For Catalog, write Director Admissions indicating career interest. Graduate placement outstanding!



TRI-STATE COLLEGE

2446 College Avenue, Angola, Indiana

ENGINEERING DEGREES



Associate—Bachelor
Electronics—Mechanical
earned by

HOME STUDY

Resident Classes Also
Available if Desired
Specify course preferred

PACIFIC
INTERNATIONAL
COLLEGE OF ARTS
& SCIENCES

Primarily a correspondence school
Chartered 1935

5507M Santa Monica Blvd. Hollywood, Calif., 90038

Learn Electronics for your SPACE-AGE EDUCATION

at the center of
America's aerospace industry

No matter what your aerospace goal, you can get your training at Northrop Tech. in sunny Southern California.

COLLEGE OF ENGINEERING. Get your B.S. degree in engineering in just 36 months by attending classes year round. Most Northrop Tech graduates have a job waiting for them the day they're graduated!

A & P SCHOOL. Practical experience on real aircraft. One-year course prepares you for F.A.A. A&P certificate. WRITE TODAY FOR CATALOG.

NORTHROP INSTITUTE OF TECHNOLOGY

1199 W. Arbor Vitae, Inglewood, Calif.



A JOB or a POSITION ?

The difference is ELECTRONIC MATHEMATICS

NOW! A NEW WAY TO LEARN—I. H. S. I. WAY. A complete home study course in electronic math to help you get the position you want—MORE MONEY—MORE RESPECT.

COURSE PREPARED BY
COLLEGE PROFESSORS

who have lectured to thousands of men on math and engineering. You learn at home quickly, easily —AS FAST as you want.

YOU SIGN NO CONTRACTS

Pay only if satisfied—you owe it to yourself to examine the INDIANA HOME STUDY INSTITUTE COURSE IN ELECTRONIC MATH. FREE BONUS—if you join now, a refresher course in basic arithmetic.

Write For Brochure—No Obligation

THE INDIANA HOME STUDY INSTITUTE

Dept. RE-4, P.O. Box 1189
Panama City, Fla. 32402

LEARN

ELECTRONICS

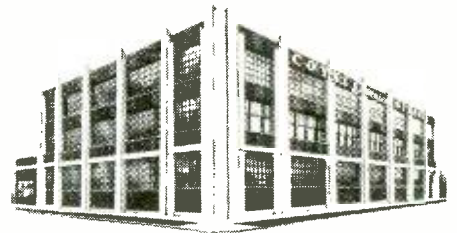

FOUNDED 1899

NOT-FOR-PROFIT

COYNE ELECTRONICS INSTITUTE

Electronics Engineering Technology	—	Degree (2 Yrs.)
Electrical-Electronics Technician	—	Diploma (40 Wks.)
TV-Radio-Electronics Technician	—	Diploma (40 Wks.)
Combined Electronics Technician	—	Diploma (80 Wks.)
Practical Electrical Maintenance	—	Diploma (32 Wks.)
Practical Refrigeration Air Conditioning and Appliance Repair	—	Diploma (24 Wks.)
Specialized Industrial Electronics	—	Diploma (16 Wks.)
Introduction to Electricity-Electronics	—	Certificate (8 Wks.)
FCC First Class Radiotelephone	—	Certificate (100 Hrs.)

Special finance plans. Part time employment service while in school. Also Free graduate employment service.



Use this coupon to get our FREE BOOK
"YOU OPPORTUNITIES IN ELECTRONICS"

COYNE ELECTRONICS INSTITUTE, Dept. of Electronics 46-N
1501 W. Congress Parkway, Chicago, Illinois 60607

Name _____ Age _____

Address _____ Phone _____

City _____ Zone _____ State _____

Unlike most other schools, we do not employ salesmen

Circle 134 on reader's service card

LEARN Electronics AT HOME

Fix TV, design automation systems, learn transistors, complete electronics. College level Home Study course taught so you can understand them. Earn money in the highly paid electronic industry. Computers, Missiles, theory and practical. Kits furnished. Over 30,000 graduates now employed. Resident classes at our Chicago campus if desired. Founded 1934. Catalog.

AMERICAN INSTITUTE OF ENGINEERING
AND TECHNOLOGY

1139 W. Fullerton Pky., Chicago, Ill. 60614

NEW BOOKS

SERVICING AGC, by Harry E. Thomas. Gernsback Library, 154 W. 14 St., New York, N. Y. 10011. 5½ x 8½ in., 204 pp. Paper, \$3.95

A reprint of a book originally published by Prentice-Hall in 1962. This work devotes a full 195 pages to the single subject of automatic gain control servicing. The reader will agree that every paragraph of this extensive treatise is useful.

SOUND AND HEARING, by S. S. Stevens, Fred Warshofsky and the Editors of Life. Time-Life Books, Time & Life Bldg., New York, N. Y.

10020. 8½ x 11 in., 200 pp. Cloth, \$3.95

A beautifully illustrated book that deals chiefly with hearing, with the emphasis on the physics of that phenomenon. Only the first chapter deals with sound itself. The problems of the deaf are considered in a chapter, as is also noise control. The discussion is not limited to human hearing. Bats, dolphins and insects are also included.

BASIC ELECTRICITY, THEORY AND PRACTICE, by Kenneth G. Shultz. St. Martin's Press, 175 5th Ave., New York, N. Y. 10010. 6 x 9 in.,

214 pp. Cloth, \$2.60

Interesting, well-illustrated and very simply written book on electrical fundamentals. Also contains a little material on electric wiring and electronics.

INTRODUCTION TO ELECTRONICS, prepared by Bureau of Naval Personnel. Dover Publications, 180 Varick St., New York, N.Y. 10014. 6½ x 9¼ in., 145 pp. Paper, \$1

A basic work covering the subject from an equipment point of view (describes "amplifiers" rather than "amplifier circuitry"). Covers not only tubes, amplifiers and oscillators but transistors, servosystems, radio (transmitting and receiving), radar and sonar.

END

MARKET CENTER

ADVERTISING INDEX

RADIO-ELECTRONICS does not assume responsibility for any errors which may appear in the index below.

Allied Radio Corp.	76
Amperex Electronic Corp.	Third Cover
Arrow Fastener Co., Inc.	90
B & K Manufacturing Co. (Div. of Dynascan Corp.)	22
Brach Manufacturing Corp. (Div. of General Bronze Corp.)	70
Brooks Radio & TV Corp.	88-89
Capitol Radio Engineering Institute, The	23
Castle TV Tuner Service, Inc.	76
Centralab (Div. of Globe-Union Inc.)	77
Charles Engineering, Inc.	79
CLASSIFIED	94-97
Cleveland Institute of Electronics	5, 28-31
Conar (Div. of National Radio Institute)	75
Cornell Electronics Co.	96

Data Corporation, The	92
Delta Products, Inc.	29
DeVry Technical Institute	3
EICO Electronic Instrument Co., Inc.	13
Electro-Voice, Inc.	1
Electronic Chemical Corp.	87
Electronic Measurement Corp. (EMC)	85

Fair Radio Sales	81
Finney Co.	25
General Radiotelephone Co.	89
Gernsback Library, Inc.	71, 80
Heald's Engineering College	91
Heath Company	27, 63-65

I.F.E.E.	90
International Crystal Mfg. Co.	98
International Radio Exchange	70

Jackson Electrical Instrument Company	6
Jerrold Electronics Corporation (Distributor Sales Division)	67
JFD Electronics Corp.	14-15

Microflame, Inc.	88
Multicore Sales Corp.	86
Music Associated	90

National Radio Institute	8-11
--------------------------	------

Oxford Transducer Company (A Division of Oxford Electric Corporation)	66
---	----

Poly Paks	97
-----------	----

RCA Components & Devices	
Test Equipment	83
Tubes	Fourth Cover
RCA Institute, Inc.	18-21
Rye Sound Corporation	85

Sams & Co., Inc., Howard W.	68-69, 78
Sarkes-Tarzian, Inc. (Tuner Service Div.)	12
Schober Organ Corp., Inc.	26
Secore	79
Sonar Radio Corporation	84
Sprague Products Company	17
Squires-Sanders, Inc.	87
Stancor Electronics (Essex Wire Corporation)	24
Superscope, Inc.	7
Sylvania (Subsidiary of General Telephone & Electronics)	32

Tarzian, Inc. Sarkes (Tuner Service Div.)	12
Triplett Electrical Instrument Company, The	Second Cover

United Radio Co.	95
University Sound (Div. of LTV Ling Allee, Inc.)	81

Warren Electronic Components	92
Weller Electric Co.	84
Winegard Co.	91

Xcelite, Inc.	16
---------------	----

MARKET CENTER	94-97
Chemtronics	
Edmund Scientific Corp.	
Electronic Components Co.	
Eurotech Service Co.	
TAB	
Tape-Mates	

SCHOOL DIRECTORY	93
American Institute of Engineering & Technology	
Coyne Electronics Institute	
Grantham School of Electronics	
Indiana Home Study Institute	
Northrop College of Science & Engineering	
Pacific International College	
Tri-State College	
Valparaiso Technical Institute	

GENERAL

TV SERVICE ORDER BOOKS for use with your rubber stamp. Duplicate or triplicate. Low cost. Write for FREE 32 PAGE CATALOG and Special Rubber Stamp Offer. OELRICH PUBLICATIONS, 6556 W. Higgins, Chicago, Ill. 60656.

SAFEGUARD PRIVACY! New instrument detects electronic "bugs", wire-tapping and snooping devices. Free information. DEE EQUIPMENT, Box 7263-E8, Houston 8, Texas.



BLACK/WHITE OR COLOR

THE ONLY SAFE NON-DRIFT TV TUNER CLEANERS

AVAILABLE AT ALL DISTRIBUTORS

CHEMTRONICS

BROOKLYN, N. Y. 11236

PARTS

SERVICE FOR ALL

GERMAN

RADIOS-PHONOGRAPHS
TAPE RECORDERS
EUROTECH SERVICE CO.
 66-44 FOREST AVENUE
 BROOKLYN 27, N.Y. HY 7-1448

FREE CATALOG!

148 PAGES • NEARLY 4,000 BARGAINS
 OPTICS • SCIENCE • MATH



Completely new 1966 edition. New items, categories, illustrations. 148 easy-to-read pages packed with nearly 4000 unusual items. Dozens of electrical and electronic parts, accessories. Enormous selection of Astronomical Telescopes, Microscopes, Binoculars, Magnifiers, Magnets, Lenses, Prisms. Many war surplus items, for hobbyists, experimenters, workshop, factory. Write for catalog "E1".

CLIP AND MAIL COUPON TODAY

EDMUND SCIENTIFIC CO., Barrington, N. J.
 PLEASE SEND ME FREE CATALOG "E1"

Name

Address

City

State

Astonishing!

- **3 HOUR STEREO ALBUMS**
- **CLASSICS / POP / JAZZ / VOCAL VARIETY / SHOW / DANCE**

\$1.195*

*SUGGESTED RETAIL PRICE
 Ask your local dealer or write for complete catalog information to TAPE-MATES, 5280 W. Pico Blvd., Los Angeles, Calif. 90019.

Rectifiers & Transistors

		SILICON DIODES			
Amps		50 PIV	100 PIV	150 PIV	200 PIV
.75*		.05	.0710
3		.08	.14	.16	.22
15		.35	.50	.65	.75
18**		.26	.45	.60	.70
35		.60	.80	1.15	1.30

Amps		300 PIV	400 PIV	500 PIV	600 PIV
.75*		.12	.14	.18	.21
3		.25	.28	.35	.40
15		.90	1.30	1.40	1.65
18**		.85	1.25	1.85	2.50
35		1.90	2.25	2.50	2.90

Amps		700 PIV	800 PIV	900 PIV	1000 PIV
.75*		.25	.32	.40	.55
3		.49	.58	.67	.78
15		1.90	2.30	2.50	2.70
35		3.65	4.40	4.65	4.90

* Top Hat, Epoxy or Flangless ** Press Fit pkg.

1100 PIV, .70 1200 PIV, .85 (75A TH Epoxy, Flangless)
 10 Watt Sil. Zener Stud 12-200 v, 20% .95¢ ea.
 1 Watt Zener diode, axial leads 8-200v, 20% .50¢ ea.
 Sil. diode, 1500 PIV, 50ma, axial leads .35¢ ea.
 Hoffman Hi-Voltage Sil. Epoxy Diode, 2 1/2 x 3/8 x 1/2
 200 ma. 3000 PIV \$1.49 ea 6000 PIV \$3.49
 Thermistor, bead, 900 or 1200 ohms, 600°F, 2/\$1.00

150 w GER POWER. T0-5

2N1021	\$1.00	2N9022	\$1.25
2N458A	90¢	2N511	\$1.50

2N3075 300 mc, 150 mw, 2 ma, 40 volt Germanium 75¢
 Silicon Power Transistors, 85 w, 2N1724 \$1.50
 Philco Sil., NPN, 2N2479, new 3 for \$1.00
 HF Silicon, 2N702, 100 mc 40¢; 2N703-150 mc 60¢
 2N1038 Germanium, 10 for \$1.00
 30 oil capacitors wt 5 lbs. \$1.00
 10 Radio & TV Tubes \$1.00
 Sil. diodes, 1N200 series, asst'd., new 15 for \$1.00
 Ger. diodes, glass—1N34A 15/\$1.00
 Nickel-Cadmium Battery, 9 1/2 oz., 8 amp-hr. \$1.95

Varicap-Voltage Variable Capacitor
 27, 47, or 100 pf, 4v, 4-1, new \$1.25 ea.

Silicon Controlled Rectifiers

PRV .75A	1A	7A	16A	PRV .75A	1A	7A	16A
25	.20	.28	.48	200	.80	.90	1.15
50	.40	.48	.70	300	1.20	1.30	1.80
100	.55	.70	1.20	400	1.70	1.85	2.20
150	.60	.70	1.50	500	1.95	2.05	3.00
.75A Tophat—1A T0.5—7A	600	2.30	2.50	3.20	3.30		

& 16A Stud
 Money back guarantee. \$2.00 min order, include postage.
 Catalog 25¢.

Electronic Components Co.
 Box 2902 Baton Rouge, La. 70821

Circle 135 on reader's service card

CONVERT ANY TELEVISION to sensitive Big-Screen Oscilloscope. Only minor changes required. No electronic experience necessary. Illustrated plans \$2.00. **RELCO-A25**, Box 10563, Houston 18, Texas.

PRINTING PRESSES. Type, Supplies, Lists 5¢. **TURNBAUGH SERVICE**, Mechanicsburg, Pa.

LOSING Hair? Balding? Dandruff? Free copyrighted booklet. **DR. SHIFFER LABORATORIES**, 529 Euclid Arcade, Cleveland, Ohio 44115.

"300 Tricks you can do" book—dollar. Free catalogue. **MANDEL**, 2912D Neptune Avenue, Brooklyn, New York 11224.

WANTED

QUICK CASH . . . for Electronic EQUIPMENT, COMPONENTS, unused TUBES. Send list now! **BARRY**, 512 Broadway, New York, N. Y. 10012. 212 WALKER 5-7000.

CASH, SONY TRANSISTOR TV's etc. swapped for G-R, H-P, L&N etc. equipment, special tubes, manuals, military electronics. **ENGINEERING ASSOCIATES**, 428 Patterson Road, Dayton, Ohio 45419.

WANTED Cleveland Institute of Electronics course called "Electronics Technology". **RON LOSIE**, 1208 Page St., Toledo, Ohio 43608.

SERVICES

METERS—MULTIMETERS REPAIRED and calibrated. **BIGELOW ELECTRONICS**, Box 71-B, Bluffton, Ohio.

TRANSISTORIZED products dealers catalog. \$1. **INTERMARKET**, CPO 1717, Tokyo, Japan.

SAMS PHOTOFACETS. Radio \$1. Television \$2. Old Radio Diagrams \$1. **SERVICAIDE**, Box 3412B, Harrisburg, Pa. 17105.

ALL MAKES OF INDUSTRIAL ELECTRONIC INSTRUMENTS AND TEST Equipment Repaired/Calibrated. Fast Service. Ship or Send for Details. **ELECTRONICS SERVICE**, P.O. Box 1037, Spring Valley, California 92077.

AUDIO — HI-FI

RENT STEREO TAPES—over 2,500 different—all major labels—free brochure. **STEREO-PARTI**, 1616 Terrace Way, Santa Rosa, Calif.

WRITE for highest discounts on components, recorders, tapes, from franchised distributors. Send for FREE monthly specials. **CARSTON**, 1686-R Second Ave. N.Y.C. 10028

HI-FI COMPONENTS. Tape Recorders, at guaranteed "WE will not be undersold" prices. 15-day moneyback guarantee. Two-year warranty. NO Catalog. Quotations Free. **HI-FIDELITY CENTER**, 239R East 149th St., N.Y., N.Y. 10451.

TAPE RECORDER SALE. Brand new, latest models, \$10.00 above cost. **ARKAY SALES**, 1028-E Commonwealth Ave., Boston, Mass. 02215.

HI-FIDELITY COMPONENTS. Ham Marine and Communication equipment at considerable savings. If you want to save money write us for our low prices on all your needs. **AIREX RADIO CORP.**, 85 (RE) Cortlandt St., N.Y., N.Y. 10007

STEREO TAPES. Save up to 60% (no membership fees, postpaid anywhere USA). Free 60-page catalog. We discount batteries, recorders, tape accessories. Beware of slogans "not undersold." as the discount information you supply our competitor is usually reported to the factory. **SAXITONE**, 1776 Columbia Road, Washington, D. C. 20009

HI-FI Equipment at largest discount. Catalog. **MENDOTA FURNITURE CO.**, Mendota, Minnesota.

LOW LOW QUOTES Dyna, Garrard, AR, Eico HI-FI, Roslyn, Pa. 19001.

BUSINESS AIDS

JUST STARTING IN TV SERVICE? Write for FREE 32 PAGE CATALOG of Service Order books, invoices, job tickets, phone message books, statements and file systems. **OELRICH PUBLICATIONS**, 6556 W. Higgins, Chicago, Ill. 60656. New Hyde Park 5, N.Y.

1,000 Business Cards. "Raised Letters" \$3.95 postpaid. Samples. **ROUTH RE12**, 2633 Randleman, Greensboro, N. C. 27406.

CLASSIFIED COMMERCIAL RATE (for firms or individuals offering commercial products or services): 60¢ per word . . . minimum 10 words.

NON-COMMERCIAL RATE (for individuals who want to buy or sell personal items): 30¢ per word . . . no minimum.

Payment must accompany all ads except those placed by accredited advertising agencies. 10% discount on 12 consecutive insertions, if paid in advance. Misleading or objectionable ads not accepted. Copy for June issue must reach us before April 11th.

WORD COUNT: Include name and address. Name of city (Des Moines) or state (New York) counts as one word each. Zone or Zip Code numbers not counted. (We reserve the right to omit Zip Code if space does not permit.) Count each abbreviation, initial, single figure or group of figures or letters as a word. Symbols or groups such as 8-10, COD, AC, etc., count as one word. Hyphenated words count as two words. Minor over-wordage will be edited to match advance payment.

HARD-TO-GET TUBES IN STOCK

BRAND NEW—1 YR. GUARANTEE

TYPE	PRICE	TYPE	PRICE	TYPE	PRICE	TYPE	PRICE	TYPE	PRICE	TYPE	PRICE
OOA	3.50	5X8	1.40	6CX8	1.68	6X5GT	.77	12AT7	1.05	25C5	.75
O1A	2.75	5Y3	.61	6CZ5	1.48	6X8A	1.20	12AU6	.74	25CD6	1.40
OD3	.75	5Y4	1.45	6D4	1.75	6Y6GA	1.45	12AU7	.86	25DN6	2.28
1A7	1.75	5Z3	1.54	6D6	2.50	6Z4/84	1.25	12AV6	.58	25L6	.97
1AX2	.95	5Z4	3.00	6DA4	1.03	7A4	2.25	12AX4	.92	25Z5	1.64
1B3	.95	6A7	3.05	6DN6	3.05	7A5	2.05	12AX7	.89	25Z6	1.10
1H5	1.50	6A8	2.49	6DN7	1.45	7A6	2.69	12BA6	.59	26	1.60
1L6	2.60	6AB4	.92	6DQ4	.96	7A7	2.70	12BE6	.61	27	1.75
1LA4	1.30	6AB7	2.50	6DQ5	3.10	7A8	2.95	12BH7	1.04	30	1.40
1LA6	1.98	6AC5	2.24	6DQ6	1.39	7AD7	1.25	12BQ6	1.58	32	1.25
1LC5	1.05	6AC7	1.75	6E5	2.25	7AF7	2.34	12BR7	1.14	32ET5	.88
1LC6	1.80	6AF3	1.18	6F4	4.75	7AG7	2.85	12BY7	1.15	33	1.15
1LD5	1.95	6AG5	1.03	6F5GT	1.72	7AH7	1.95	12CU5	.94	33JV6	1.67
1LE3	1.25	6AG7	2.25	6F6G	1.95	7AU7	.93	12K7	2.49	34	1.25
1LH4	2.80	6AH4	1.25	6F7	3.95	7B4	2.52	12K8M	2.95	35A5	2.10
1LN5	2.25	6AK5	1.69	6F8	3.08	7B5	3.00	12L6	1.32	35L6	.92
1N5	1.85	6AL3	1.05	6GJ5	2.18	7B6	1.90	12L8	.50	35W4	.39
1P5	2.00	6AL7	2.45	6GK5	1.50	7B7	2.85	12Q7	1.50	35Y4	1.70
1R4	.80	6AM8	1.25	6GK6	1.12	7B8	2.14	12SA7	1.59	35Z3	1.74
1R5	1.10	6AN8	1.43	6H28	2.10	7C4	1.15	12SC7	1.92	35Z5	.72
1S5	1.10	6AQ7	1.59	6J5G	1.34	7C5	1.25	12SF5	1.40	36	1.50
1T5	.80	6AR5	.94	6J6A	.95	7C6	2.75	12SF7	2.33	37	1.25
1U4	1.05	6A55	.99	6J7	1.88	7C7	1.28	12SG7	1.72	38	1.25
1U5	.98	6A57	2.85	6J7G/GT	1.75	7E5	2.00	12SH7	1.85	39/44	1.25
1V	2.00	6AT6	.72	6J8	2.50	7E6	1.25	12SJ7	1.50	41	1.50
1V2	.83	6AT8	1.49	6K6GT	.93	7E7	1.95	12SK7	1.40	42	1.50
2A3	3.75	6AU4	1.28	6K7	1.90	7F7	2.84	12SL7	1.33	43	1.94
2A5	2.50	6AU5	1.75	6L6G	1.10	7F8	3.10	12SQ7	1.35	43	2.75
2A6	4.50	6AU6	.74	6L6GC	1.65	7G7	2.25	12SR7	1.79	46	.95
2B7	1.95	6AU8	1.68	6L7M	2.58	7H7	1.95	12V6	1.35	47	3.50
2X2A	1.95	6AW8	1.35	6M7M	1.85	7HG8	1.25	12W6	1.35	48	4.00
3.3	1.18	6AX4	.96	6P5	2.50	7J7	2.50	13GF7	1.36	49	3.50
3A5	1.10	6AX5	1.23	6Q7	2.05	7K7	3.05	13J10	1.93	50	1.75
3AU6	.82	6AX7	1.25	6S7	1.95	7L7	1.99	14A4	1.45	50A1	3.50
3B7	2.39	6B4	5.95	6S8GT	1.60	7N7	2.71	14A5	1.35	50A5	2.20
3BN4	1.08	6B7	2.75	6SA7M	1.60	7Q7	1.85	14A7	1.85	50C5	.74
3BZ6	.83	6B8	2.66	6SB7Y	2.25	7R7	2.25	14AF7	1.85	50L6	.83
3CB6	.82	6BA6	.70	6SD7	1.49	7S7	1.79	14B6	1.90	50X6	2.10
3DG4	1.48	6BA8	1.48	6SE5	1.10	7V7	1.74	14B8	1.95	50Y6	1.55
3DT6	.88	6BE5	.81	6SF7	2.40	7W7	2.49	14C5	1.75	50Y7	1.52
3Q5	2.00	6BH6	.95	6SG7	1.69	7X6	1.35	14C7	2.33	53	3.50
3V4	.95	6BH8	1.54	6SH7	1.50	7X7	2.85	14E6	1.39	55	2.75
4BQ7	1.52	6BK5	1.35	6SJ7GT	1.49	7Y4	2.35	14E7	1.39	56	1.45
4BU8	1.39	6BK7	1.38	6SJ7M	1.65	7Y7	1.79	14F7	3.10	57	1.75
4BZ7	1.45	6BQ6	1.59	6SK7	1.60	7Z4	2.35	14F8	2.23	58	1.75
4CB6	.82	6BQ7	1.43	6SK7M	1.58	8AU8	1.46	14H7	1.95	59	3.50
5AM8	1.50	6BX7	2.10	6SL7GT	1.25	8BQ5	1.03	14J7	1.95	70L7	.99
5AN8	1.64	6C4	.64	6SN7GT	.90	8CG7	.86	14N7	1.95	71A	1.25
5AQ5	.89	6C5M	1.95	6SQ7GT	1.33	8FQ7	.92	14Q7	2.25	75	2.60
5AS3	1.64	6C6	2.50	6SR7	1.50	8GJ7	1.28	14R7	2.50	76	1.75
5AT8	1.44	6C8G	2.95	6S57M	1.88	8GN8	1.42	14S7	1.95	77	2.00
5AZ4	2.00	6CA7	2.20	6T8	1.20	8JV8	1.38	14W7	1.85	78	1.75
5BQ7	1.49	6CG7	.95	6T9	1.46	9A8	1.33	14X7	1.75	80	1.75
5BR8	1.59	6CG8	1.15	6U5	2.75	9GV8	1.45	14Y4	1.75	83	1.75
5CG8	1.19	6CL6	1.45	6U8	1.18	9U8	1.14	15FM7	1.28	5881	3.00
5J6	1.25	6CL8	1.40	6V6GT	.76	10DE7	1.23	19	1.00	6146	2.75
5U4	.73	6CM7	1.05	6V6M	2.25	10DR7	1.56	19X8	1.50	6336	4.75
5U8	1.19	6C08	1.29	6W4	.86	12AB	2.95	22	1.15	6550	4.00
5V4	1.35	6CS7	1.10	6W6GT	1.02	12AH7	1.99	22JU6	2.20	807	.95
5W4	1.75	6CW4	1.80	6X4	.59	12AT6	.63	24A	1.50	KT-88	4.95

This is a partial list of our stock of T.V.—Radio, Special Purpose, Industrial & Transmitter Catalog.

Send For Complete Catalog **MINIMUM ORDER \$5.00** ADD POSTAGE
UNITED RADIO CO. P.O. BOX—1000 R4, NEWARK, N.J.

Circle 13 on reader's service card

MARKET CENTER

FREE CATALOG of 200 special slide rules and calculating aids. DYNASLIDE, 600 South Michigan, Chicago, Illinois 60605.

TRANSISTOR ignition kits, components. Free diagrams. ANDERSON ENGINEERING, Epsom, N.H. 03239

RADIO & TV TUBES 33¢ each. One year guaranteed. Plus many unusual electronic bargains. Free catalog. CORNELL, 4217-E University, San Diego, California 92105

TUBES. "Oldies", latest. Lists free. STEINMETZ, 7519 Maplewood, Hammond, Indiana, 46324.

FREE Catalog. Electronic parts, tubes. Wholesale. Thousands of items. Unbeatable prices. ARCTURUS ELECTRONICS RE, 502-22 St., Union City, N. J. 07087

METERS—Surplus, new, used, panel and portable. Send for list. HANCHETT, Box 5577, Riverside, California 92507.

TV TRADES wanted "as is" Hi Prices paid. TV WHOLESALE OUTLET CORP., 467 Columbus Avenue, N.Y., N.Y.

BEFORE You Buy Receiving Tubes, Transistors, Diodes, Electronic Components & Accessories... send for Giant Free Zalytron Current Catalog, featuring all STANDARD BRAND TUBES all Brand New Premium Individually Boxed. One Year Guarantee—all at BIGGEST DISCOUNTS in America! We serve professional servicemen, hobbyists, experimenters, engineers, technicians. WHY PAY MORE? ZALYTRON TUBE CORP., 469R Jericho Turnpike, Mineola, N. Y. 11502

JAPAN & HONG KONG Electronics Directory. Products, components, supplies. 50 firms—just \$1.00. IPPANO KAISHA LTD., Box 6266, Spokane, Washington 99207.

Silicon Power Diodes		Studs & P.F.*	
D. C. Amps	50Piv 35Rms	100Piv 70Rms	200Piv 140Rms
12	.30	.50	.70
18	.20	.85	.75
35	.65	1.35	1.85
150	2.50	2.90	3.50
240	3.75	4.75	7.75

D. C. Amps	400Piv 280Rms	500Piv 350Rms	600Piv 420Rms	750Piv 525Rms
12	1.10	1.30	1.55	1.75
18	1.50	2.00	2.70	3.40
35	2.25	2.90	2.90	3.50
150	5.40	6.50	7.50	12.00

5U4 Silicon Tube Reu. \$2 @ 6 for \$10
5R4 Silicon Tube Reu. \$5 @ 2 for \$9

"TAB", SILICON 1-AMP* DIODES Factory Tested
*NEWEST TYPE! LOW LEAKAGE Gld.1

Piv/Rms	50/35	100/70	200/140	300/210
	.07	.10	.12	.15

Piv/Rms	400/280	500/350	600/420	750/490
	.20	.25	.30	.35

Piv/Rms	800/560	900/630	1000/700	Send 25¢ for Catalog
	.40	.50	.55	

*ALL TESTS AC & DC & FWD & LOAD!

1700 Piv/1200Rms @ 750Mas1.20 @ .10 for \$10
same 1100Piv/770Rms 75¢ @ .16 for \$11

"TAB" TERMS: Money Back Guarantee. Our 21st year. 52 Min. order prepaid 48 states U.S.A.
111 G-A Liberty St., N. Y. 6, N. Y.
SEND 25¢ Phone: REctor 2-6245 for CATALOG

BUSINESS OPPORTUNITIES

New scientific transistor instrument detects buried coins, treasures. Will detect gold, silver, copper, iron, etc. \$19.95 up. Free catalog. RELCO-A-25, Box 10563, Houston 18, Texas.

ELECTRONICS

BARGAINS in Canadian Electronic equipment and surplus. Send \$1.00 for giant catalogs. ETCO, Dept. R, 520 Fifth Avenue, New York 36, N.Y.

PROFESSIONAL ELECTRONICS PROJECTS — Organs, Timers, Computers, etc.—\$1 up. Catalog 25¢. PARKS, Box 25565, Seattle, Wash. 98125.

NEON AC DC ELECTRIC TESTER FOR HOME AUTO SHOP

Special! 59¢

Special! With every \$10 Order

25¢ per tube

(No Limit) from this list.

6AG5 6SN7
6AU6 6J6 6S4
6AQ5 6K6 6W4

CORNELL TUBES

1 YR. GUARANTEED

Mutual Conductance Lab-tested, Individually Boxed, Brand and Code Dated. Tubes are new, or used and so marked

21 PICTURE TUBES 1 Yr. Guar. Aluminized Pay Dud Deposit C.O.D. or Send Dues with Order

1395 plus shipping

Prestige & Success are yours as an ELECTRONIC EXPERT

FOR CORNELL CUSTOMERS ONLY by special arrangement with the publisher, these amazing bargains are available.

COMPLETE RADIO SERVICING AND BASIC ELECTRONICS COURSE ONLY \$3.00 (50¢ to \$300+ value of parts)

NEW PRACTICAL TV TRAINING COURSE ONLY \$3.50 (50¢ to \$300+ value of parts)

Both above courses \$6.00

33¢ PER TUBE

30¢ PER TUBE

100 TUBES OR MORE:

all purpose ELECTRONIC CLEANER

89¢ plus shipping

ELECTRONIC CLEANER LUBRICATES RESTORES TUBES & CONTROLS CORNELL

024	6A55	6CD6	6K6	6X4	12BF6
1B3	6AT6	6CF6	6K7	6X8	12BH7
1J3 1K3	6AT8	6CG7	6Q7	7A7	12BL6
1H5	6AU4	6CG8	6S4	7A8	12BY7
1L4	6AU5	6CM7	6SA7	7B6	12C5
1T4	6AU6				12CA5
1U4	6AV6				12SN7
1X2	6AW8				12SQ7
3BZ6	6AX4				25L6
3DG4	6BA6				25Z6
5U4	6BC5				35W4
5U8	6BD6	6CZ5	6SH7	7C5	35Z3
5V4	6BG6	6D6	6SJ7	7N7	50L6
5Y3	6BJ6	6DA4	6SK7	7Y4	24
6A6	6BL7	6DE6	6SL7	12AD6	27
6A8	6BN4	6DQ6	6SN7	12AE6	27
6A84	6BN6	6EA7	6SQ7	12AF6	77
6AC7	6B06	6EM5	6SR7	12A77	78
6AG5	6BZ6	6F6	6U7	12AU7	84/624
6AK5	6B26	6GH8	6Y6	12AX7	5687
6AL5	6C4	6H6	6VB	12BA6	6350
6AN8	6C6	6J5	6W4	12BD6	6463
6AQ5	6CB6	6J6	6W6	12BE6	7044

Other tubes at low prices—send for free list
NO SUBSTITUTIONS WITHOUT YOUR PERMISSION

HIGH GLOSS CLAY COATED TUBES WITH BEAT-UP DIMENSIONAL PARALLELS

FOR TUBE SIZE PRICE PER 10 CARTONS PER 100 CARTONS shipping in shipping in

MMK 6AU6	29	2.50
GT 6SN7	29	2.40
6E 6Y 6U4A4	50	5.20
6E 6Y 6U4B	50	7.00

11.000 TUBE SUBSTITUTES \$1.25

ABC TV \$100

LET AHEAD OF THE FIELD

PICTURE EXPANDER

99¢

SPECIAL LOW PRICE \$2.99

EASY TO HANDLE HOT SHOT THE ALL PURPOSE ELECTRIC SOLDERING GUN

Electronic SOLDER

SENSATIONAL VALUE! 29¢

CORNELL ELECTRONICS CO.

Dept. RE 4 4217 University Ave., San Diego, Calif. 92105

TERMS: Add 3¢ per tube shipping. Orders under \$5.00 add 3¢ per tube shipping plus 50¢ handling. Canadian orders add approximate postage. Send 25¢ deposit on C.O.D. orders. No C.O.D. orders under \$5.00 or to Canada. No 24 hr. free offer on personal check orders. 5-DAY MONEY BACK OFFER!

TV CAMERAS, transmitters, converters, etc. Low-est factory prices. Catalog 10¢. **VANGUARD**, 196-23 Jamaica Ave., Hollis, N.Y. 11423.

SURPLUS PARTS CATALOG. Send for free catalog listing hundreds of up-to-date electronic components at down-to-earth prices. **ELECTRONIC CONTROL DESIGN COMPANY**, P.O. Box 1432-P, Plainfield, N.J. 07061.

TV Tuners Rebuilt and Aligned per Manufacturers specifications. All Makes—Color-B&W. Only \$9.50. We ship COD Ninety Day written guarantee. Ship complete with tubes or valve for free mailing kit and dealer brochure. **VALLEY TUNERS**, 5641 A Cahuenga Blvd., North Hollywood, California.

MESHNA CONVERTER KITS, converts car radio for shortwave reception. Police, fire, marine. 30-50mc, 100-200mc, marine. Any kit \$5.00. Completely wired for use \$15.00. **MESHNA**, Lynn, Mass. 01904.

APPLIANCE-LAMP PARTS. Wholesale catalogue 35¢. **SECO** 112 South 20th Street, Birmingham, Alabama 35233.

MAGNETS—Alnico-Ceramic-Flexible-Assemblies. What you need, we have. Special—Five assorted magnets, \$1.00. **MARYLAND MAGNET**, 5412-G Gist, Baltimore, Maryland 21215.

BEGINNERS, BUILDERS Giant catalog—25¢, refundable. **LABORATORIES**, 993-B, Redwood City, California 94064.

FREE ELECTRONICS catalog. Tremendous bargains. **ELECTROLABS**, Department C-250C, Hewlett, New York 11557.

NEW, used Hickok radio, T.V. test equipment. **PAUL CAPITO**, 637 West 21st St., Erie, Pa.

TV CAMERA KITS including printed circuit and transistor models, \$16.95 up! Send 10¢ for latest catalog. **ATV RESEARCH**, Box 396-R, So. Sioux City, Nebr. 68776.

SLEEP LEARNING. Hypnotism! Tapes, records, books, equipment. Details, strange catalog **FREE.** **RESEARCH ASSOCIATION**, Box 24-RD, Olympia, Wash.

BROADCASTING, Communications Electronics taught quickly—resident classes; correspondence. Free details. Write: Dept. 4, **GRANTHAM SCHOOLS**, 1505 N. Western, Hollywood, Calif. 90027

NEW CONCEPT in Electronic Training Aids for schools, for information write **ELECTRO-SCHMATIC**, 4708 Alabama Street, El Paso, Texas 79930.

B.Sc. DEGREE (Engineering) or College Entrance by home study. Send \$1 for 1966 prospectus. **CIST**, Suite 655, 263 Adelaide Street W., Toronto, Canada.

REI First Class Radio Telephone License in (5) weeks Guaranteed. Tuition \$295.00. Job placement free. **RADIO ENGINEERING INSTITUTE**, 1336 Main Street, Sarasota, Fla.

FIX ANY TELEVISION RECEIVER. Become expert repairman on Black/White, Color TV sets. "Work bench" method used by thousands of "pros". Write specifying black/white, or color. **NATIONAL TECHNICAL RESEARCH LABS**, 6412 S. Western Avenue, Whittier, Calif.

EMPLOYMENT OPPORTUNITIES

FOREIGN EMPLOYMENT information. Construction, other work projects. Good paying overseas jobs with extras, travel expenses. Write only: **FOREIGN SERVICE BUREAU**, Dept. RE, Bradenton Beach, Florida 33510.

SPRING DOUBLE BONUS

\$25

Radio, TV Parts. Add 25¢ for handling

—PLUS—
CHOOSE ANY \$1 ITEM FREE

BOTH "GIFTS" FREE WITH \$10.00 ORDERS

FREE WORTH OF
Transistors
Rectifiers
Condensers
Diodes
Knobs
Coils, etc.

FIRST TIME IN U.S.A!
"ONE PRICE" SCRS!

Imagine 7-amp, 16-amp and 25-amp at one price! Just check the proper amp and PRV blocks.

7-Amps		16-Amps		25-Amps	
PRV	Sale	PRV	Sale	PRV	Sale
25	.25	150	.75	400	1.95
50	.45	200	1.00	500	2.50
100	.65	250	1.35	600	2.75

750 MIL TOP HAT AND EPOXIES

PIV	Sale	PIV	Sale	PIV	Sale
50	5¢	600	19¢	1400	95¢
100	7¢	800	24¢	1600	1.10
200	9¢	1000	31¢	1800	1.35
400	13¢	1200	49¢	2000	1.50

SILICON POWER STUD RECTIFIERS

AMPS	25 PIV	50 PIV	100 PIV	200 PIV
3	5¢	7¢	12¢	19¢
15	15¢	22¢	40¢	65¢
35	39¢	50¢	75¢	1.19
AMPS	400 PIV	600 PIV	800 PIV	1000 PIV
3	75¢	35¢	45¢	69¢
15	90¢	1.35	1.59	1.79
35	1.90	2.50	2.75	2.95

GOVERNMENT SURPLUS

GOVERNMENT SURPLUS Jeeps from—\$52.50, Voltmeters from—\$1.05, Transmitters from—\$6.18, Oscilloscopes, Walkie-Talkies, Multimeters. Typical "As Is" Bid Bargains from Uncle Sam. Tremendous variety. Exciting free list. Write: **ENTERPRISES**, Box 402-F8, Jamaica, New York 11430.

72 page illustrated Government Surplus Radio, Gadgets Catalog 25¢. **MESHNA**, Nahant, Mass.

EDUCATION/INSTRUCTION

LEARN ELECTRONIC ORGAN SERVICING. New home study course covering all makes electronic organ including transistors. Experimental kits—schematics—trouble-shooting. Accredited NHSC-GI Approved. Write for free booklet. **NILES BRYANT SCHOOL**, 3631 Stockton Blvd., Dept. F, Sacramento 20, Calif.

HIGHLY—effective home study review for FCC commercial phone exams. Free literature! **COOK'S SCHOOL OF ELECTRONICS**, Craigmont, Idaho 83523.

FCC LICENSE in 6 weeks. First Class Radio Telephone. Results Guaranteed. **ELKINS RADIO SCHOOL**, 2603E Inwood, Dallas, Tex.

SEMI-KON-DUCTORS

- FACTORY TESTED
- 85 WATT 2N424 PLANAR, silicon, TO-53 npn \$1
 - 30 "KLIP IN" DIODES, made by Sylvania \$1
 - 1 IGNITION SWITCHING TRANSISTORS, 10-AMP \$1
 - 4 2N336 NPN SILICON transistors, Transistron \$1
 - 10 ZENERS REFERENCES stud, ass't types \$1
 - 2N998 TYPE, 1000 GAIN, npn silicon, planar \$1
 - "MICRO-T" TRANSISTOR, like TMT-1613, \$1
 - 6 TRANSISTRON TRANS'RS, 2N311, no test, npn \$1
 - 4 "TEXAS" 20 WATTERS, 2N1038-1042, w/sink \$1
 - 4 2N170 TRANSISTORS, by GE, npn for gen'l rf \$1
 - 6 TRANSISTOR RADIO SET, osc-ifs, driver-pup \$1
 - 25 GERMANIUM & SILICON DIODES, no test \$1
 - 25 TOP HAT RECTIFIERS, silicon, 750ma, no test \$1
 - 10 1000 MC-1N251 GERMANIUM DIODES \$1
 - 5 30MC TRANSISTORS, like 2N217, Sylvania \$1
 - 3-2N705 MESA, 300 mc, 300 mw, pup, TO18 \$1
 - 1 3N35 TETRODE, 150mc transistor, silicon \$1
 - 10 PNP SWITCHING TRANSISTORS, 2N 141, TO5 \$1
 - 10 PNP SWITCHING TRANSISTORS, 2N338, 410 \$1
 - 15 PNP TRANSISTORS, CK722, 2N315, 107 no test \$1
 - 15 PNP TRANSISTORS, 2N35, 170, 440, no test \$1
 - 30 TRANSISTORS, r.f./audio osc-ifs, P05 no test \$1
 - 4-2N996 PNP PLANARS, 100MC, TO18 case \$1
 - 4 2N117 TRANSISTORS, npn silicon, TO22 \$1
 - 10 FAMOUS CK722 TRANSISTORS, pup \$1
 - 5 2N107 TRANS'RS, by GE, pup, pup, audio pak \$1
 - 2 40W NPN SILICON MESA, 2N1648, 2N1048 \$1
 - 10 ZENERS GLASS SILICON DIODES, axial, leads \$1
 - 5 SUN BATTERIES TO 1 1/2" sizes, lite sensitive \$1
 - 2 2N718 NPN SILICON PLANARS, by Fairchild \$1
 - 4 2N213 TRANSISTORS, mixer-cony, TO22 \$1
 - 3 2N706 500MW, 300MC NPN PLANAR, TO16 \$1
 - 10 30-MC TRANSISTORS, w/shield, P05, no test \$1
 - 3 2N255 POWER TRANSISTOR EQUALS, TO8 case \$1
 - 2-500MC, 2N708 NPN Silicon planar TO16 \$1
 - 3 2N711 300MW, 300 MC, PNP MESA, TO18 \$1
 - 15 1AMP 200V epoxy rectifiers, made by Sylvania \$1
 - 25 "EPOXY" SILICON DIODES, untested \$1
 - 4 ZENER REFERENCES, 1N429, 6-volt, silicon \$1
 - 2 "TINY" 2N1613 2W, 100MC, TO16 case, npn \$1
 - 2 500MC TRANS'RS, 2N964, mesas, pup, TO18 \$1
 - 1 85W SILICON PWR TRANSR, by GE, pup, 2N1212 \$1
 - 4 2N43 OUTPUT TRANSISTORS, by GE, pup, TO5 \$1
 - 4 2N333 NPN SILICON transistors, by GE, TO5 \$1
 - 10 2-6amp RECT's, studs, silicon, 50 to 400V \$1
 - 6 TRANSISTOR RADIO SET, osc-ifs-driver, pup \$1
 - 3 2-WATT PLANAR TRANS'RS, 2N697, 100mc \$1
 - 4 2N35 TRANSISTORS, npn, by Sylvania, TO22 \$1
 - 4 "MICRO" TRANSISTORS, 2N131's, 1/16", rf \$1
 - 4 CK721 TRANSISTORS, pup, aluminum case \$1
 - 3 2N721 PNP PLANAR, 2W, 75MC, TO-18 \$1
 - 3 2N735 NPN MESA, 500MW, 135MC, TO-18 \$1

WORLD'S MOST POPULAR \$1 PARTS PAKS

ZENER VOLTAGE REGULATORS 1 watt

3 For \$1

Volts	Volts	Volts	Volts	Volts	Volts	Volts	Volts
6.8	10	15	22	33	47	68	100
7.5	11	16	24	36	51	75	150
8.2	12	18	27	39	56	82	180
9.1	13	20	30	43	62	91	200

10-WATT ZENER Stud, photo 3-200V 70¢ ea.

- 10 TUBULAR ELECTROLYTICS, to 500 mf \$1
- INFRA-RED PHOTO DETECTOR TRANSDUCER \$1
- INFRA-RED PARABOLIC REFLECTOR & FILTER \$1
- 40 WORLD'S SMALLEST COND., to .05mf \$1
- 4 TRANSISTOR TRANSFORMERS, ass't, worth \$25 \$1
- 2 CLAIREX PHOTO ELECTRIC CELL, CL607 \$1
- \$25 RELAY SURPRISE, sealed, tiny types \$1
- 3 INFRA-RED DETECTORS, with leads \$1
- \$25 SURPRISE PAK: transistors, rect, diodes, etc \$1
- 40 PRECISION RESISTORS, 1/2, 1, 2W, 1% values \$1
- 30 CORNING "LOW NOISE" resistors, ass't \$1
- 60 TUBULAR CONDENSERS, to .5mf to 1KV, ass't \$1
- 40 DISC CONDENSERS, 27mf to .05mf to 1KV \$1
- 60 TUBE SOCKETS, receptacles, plugs, audio, etc \$1
- 30 POWER RESISTORS, 5 to 50W, to 21 Kohms \$1
- 50 MICA CONDENSERS, to .1mf, silver, tool \$1
- 10 VOLUME CONTROLS, to 1 meg, switch tool \$1
- 10 ELECTROLYTICS, to 500mf, ass't PP & tubular \$1
- 50 RADIO & TV KNOBS, ass't, colors & styles \$1
- 10 TRANSISTOR ELECTROLYTICS: 10mf to 500mf \$1
- 50 COILS & CHOKES, rf, ant, osc, & more \$1
- 35 TWO WATTERS, ass't incl. A.B., 5/2 tool \$1
- 75 HALF WATTERS, ass't incl. A.B., 5/2 tool \$1
- 60 HI-O RESISTORS, 1/2, 1, 2W, 1% & 5% values \$1
- 10 PHONO PLUG & JACK SETS, tuners, amps \$1
- MAGNETIC REED SWITCH, glass sealed \$1
- 30 "YELLOW" MYLAR CONDENSERS, ass't val \$1
- 60 CERAMIC CONDENSERS, discs, npn's, to .05 \$1
- 40 "TINY" RESISTORS, 1/10W, 5% tool \$1
- 10 TRANSISTOR SOCKETS for pup-npn transistors \$1
- 30 MOLDED COND'S, mylar, pore, black beauty \$1
- 3 GEIGER COUNTER DETECTOR, tubes, ass't \$1

10¢ FOR OUR "SPRING" BARGAIN CATALOG ON:
Semiconductors Poly Paks Parts

POLY PAKS

TERMS: send check, money order, include postage—avg. wt. per pak 1 lb. Rated, net 30 days. CDS 2500

P.O. BOX 942R
SO. LYNNFIELD, MASS.
"PAK-KING" OF THE WORLD

Circle 138 on reader's service card

WELCOME ABOARD!

International's "FLYING SHOWROOM 66" will visit your area soon. Welcome aboard this fabulous electronic flying display.

During 1966, International's Martin 202 Flying Showroom will tour cities throughout the United States, bringing with it displays of International electronic equipment and products, plus a technical staff available for consultation. ■ A space age electronic show for Citizens Radio dealers and users, Amateur Radio operators, users of commercial 2-way radio, manufacturers requiring special electronic products, radio experimenters and hobbyists. ■ If you are a manufacturer, radio equipment dealer, Amateur or Citizens Radio Club, or other interested groups, we will attempt to schedule a specific time and date to visit your area. Watch for announcement or write International Crystal Manufacturing Co., Inc. for details.

Discuss your technical and engineering requirements with International's staff. See how International electronic products can work for you.



INTERNATIONAL
CRYSTAL MFG. CO., INC.
18 North Lee
Oklahoma City, Okla. 73102



Circle 139 on reader's service card

If you think
all replacement tubes are alike,
you've got a surprise coming

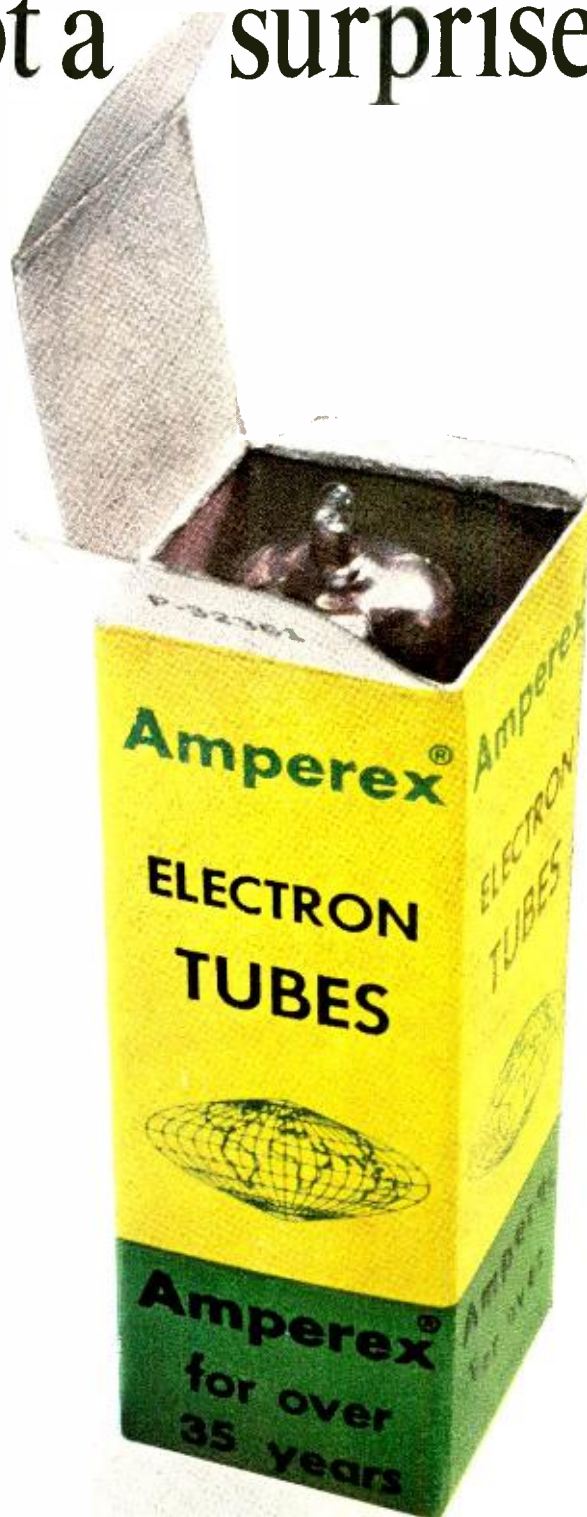

© 1966, AMPEREX ELECTRONIC CORP., HICKSVILLE, L. I., NEW YORK 11802

Circle 149 on reader's service card

RCA rare-earth

Hi-Lite

Color TV Picture Tubes

for every smart
customer who wants
a superior color picture

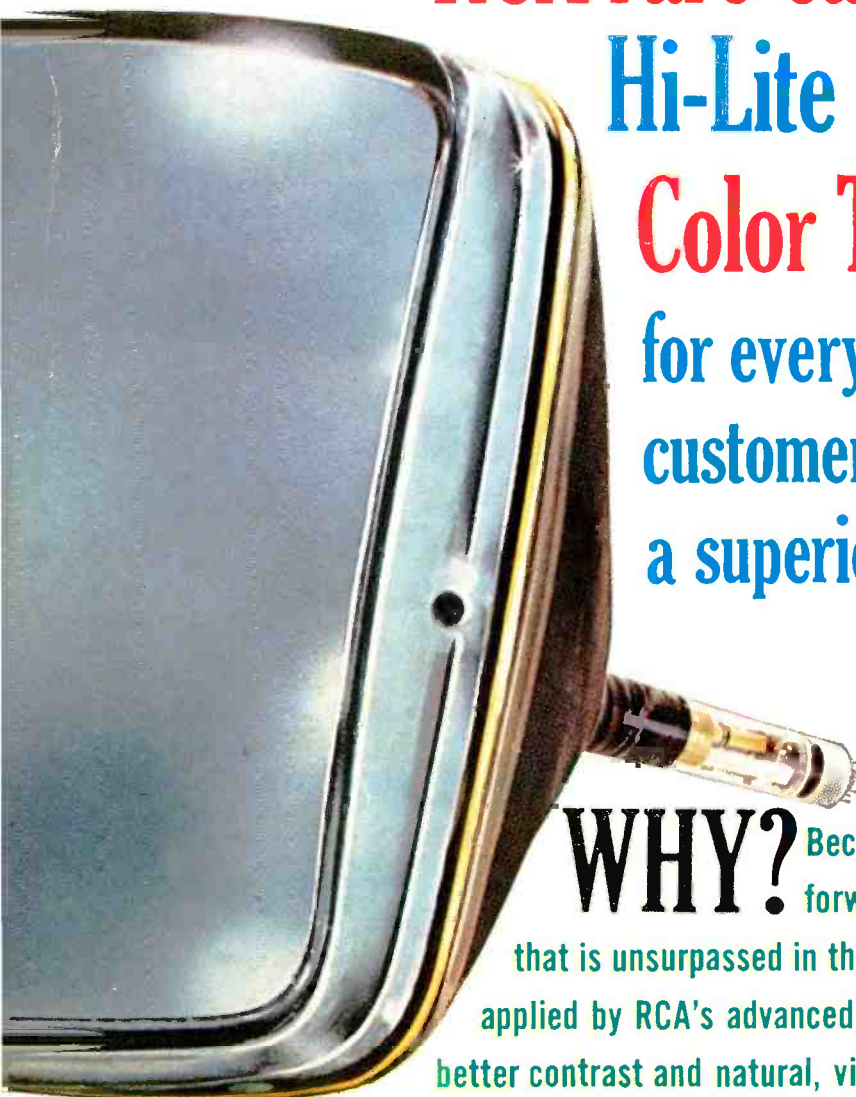

WHY?

Because RCA's Hi-Lite line represents a big step forward in color picture brightness—brightness that is unsurpassed in the color TV industry. Rare-earth phosphors applied by RCA's advanced screening methods create brighter reds, better contrast and natural, vivid colors . . . Everything the smart customer wants. Are you ready to service your smart customers? Keep posted. See your RCA Distributor today.

RCA ELECTRONIC COMPONENTS AND DEVICES, HARRISON, N.J.



The Most Trusted Name in Electronics

