

THE PROFESSIONAL MAGAZINE FOR ELECTRONICS AND COMPUTER SERVICING

ELECTRONICTM

Servicing & Technology

JUNE 1993/\$3.00

VCR troubleshooting tips

Troubleshooting an unusual Magnavox TV problem

Test equipment update



TONE READING IMPROVED!!!

DECODE...CTCSS-50, DTMF-16, DCS-105



OPTOELECTRONICS

Monitoring off-the-air signalling tones such as private line and DTMF (Touchtones®) has always involved compromises—tiny displays, ambiguous readouts and poor response time. *No Longer!*

Optoelectronics has applied world class engineering to the problem and set a new standard for inexpensive tone reading equipment. This unit was designed to fill a function, not meet a price—yet it is competitive with other, less featured units. A micro-processor measurement system makes the unit precise and enables future expansion of capabilities.

- Off-the-air reading of CTCSS, DCS and DTMF tones
- Simultaneous indication of DCS/CTCSS and DTMF data
- Scrollable display storage of 127 DTMF digits
- Stores most recent CTCSS or DCS tone

- Convenient front panel controls
- Upgrade older service monitors
- Use with scanner or receiver (may require internal connection for CTCSS)
- Direct connection to Optoelectronics R10 Interceptor
- Ideal for two-way service technicians, hams and monitoring hobbyists
- 2 line by 16 character backlit LCD display
- Low power battery operation optional
- Precise Switched Capacitor audio filtering
- OE10 INSIDE high speed frequency counter ASIC
- Made in USA



DC440
with R10
Package
Price \$549.
Includes
DC440, R10
& Cable

SPECIFICATIONS

Function:	CTCSS and DTMF decoding and display
Display:	2 x 16 character LCD dot matrix/EL Backlight
Controls:	Power, Mode, Recall
Inputs:	1/8" Phone jack, greater than 400 kΩ impedance
Output:	Serial Data (I/O)
Power Req.	7 - 15 VDC
Size:	1.8"H x 4.5"W x 4" D
OPTION:	NiCad 44 \$39.
PRICE:	\$259.

Factory Direct Order Line
1-800-327-5912

305-771-2050 • Fax 305-771-2052

5821 NE 14th Ave, Ft. Lauderdale, FL 33334
5% ship/ Handling (Max \$10) U.S. & Canada. 15% outside continental U.S.
Visa, Master Card, C.O.D., Cash or Money Order only.

Circle (12i) on Reply Card



page 14

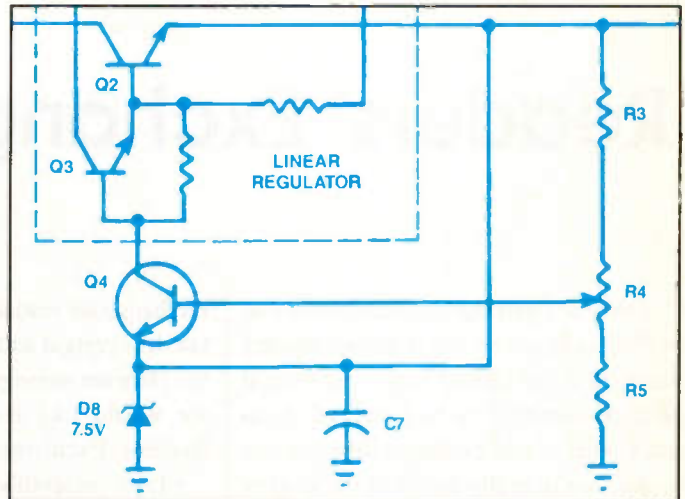

page 48

FEATURES

- 8 **Test equipment update: Understanding measurements in horizontal output stages**
By Glen Kropuenske
This article describes troubleshooting of problems in horizontal output/deflection circuits of a typical TV set and describes some of the measurements a technician can make to determine the causes.

- 14 **Test equipment update: Analog signature analyzers—Part I of three parts**
By Vaughn Martin
This is the first of a three-part article examining the theory of operation, as well as applications of this piece of electronic test equipment.

- 24 **Tape backups for IBM compatible computers**
By Sheldon Fingerman
What's the most expensive part of your computer? How about the data? In the event of a computer disaster, you can replace any part of your computer in less time than it would take you to retype all of the data back in. The best way to save much grief is to install an efficient data backup system.

- 28 **Servicing an unusual Magnavox TV problem**
By Homer Davidson
The screen showed a half-circle image at the top center. The circle was darker at the bottom and lighter at the top. The remainder of the screen was black. This article takes a close look at this very unusual problem in a Magnavox T815-02AA chassis and at how this problem was solved.

- 44 **Servicing monochrome televisions**
By Dale Shackelford
Years ago it was not uncommon for electronics servicing technicians to service black and white television sets. Today, for a number of reasons, the monochrome set is considered disposable. However, the technician who can and will still repair monochrome receivers has additional sources of revenue that other technicians often let slip by.

- 48 **TV power supply troubleshooting**
By Brian E. Jackson
This article will discuss the operation and troubleshooting of the linear power supply for a TV receiver.

- 53 **VCR servicing**
By Victor Meeldijk
The Electronics Industries Association reports that 43% of five year old VCR's have required service. This article takes a look at the most com-

mon problems and describes how to narrow down the problem areas by analyzing the failure symptoms.

DEPARTMENTS

- 2 **Editorial**
- 3 **News**
- 4 **Literature**
- 6 **Products**
- 23 **Test Your Electronics Knowledge**
- 31 **Profax**
- 59 **What Do You Know About Electronics?**
- 62 **Computer Corner**
The CD-ROM primer—the conclusion of a three-part series.
- 64 **Audio Corner**
Lightning protection for audio gear
- 65 **Readers' Exchange**
- 68 **Advertisers' Index**

ON THE COVER

As consumer electronics products become more diversified and sophisticated, the test equipment and skills employed by technicians also must become more diverse and sophisticated. (Photo courtesy Pacific Electro Data)

Readers' Exchange guidelines

Readers' Exchange is a free feature that we're really proud of. It allows readers throughout the United States and several foreign countries to buy and sell from each other to and exchange information.

And we're really proud of the readers who use the Exchange. The instances in the past fifteen years where someone used Readers' Exchange to take unfair advantage of someone else, at least those that have been brought to our attention, can be counted on the fingers of one hand. And even in those cases, it's doubtful if the problem was intentional. That's fantastic.

But there are a few things about Readers' Exchange that may not be well understood, and we'd like to clear them up here.

No dealers

Readers' Exchange is a free service. Its purpose is to allow individual service centers to offer to sell a piece of equipment that it no longer needs, or to advertise for a piece of equipment that it would like to buy used, at reasonable cost. And it allows readers to share information: for example, if someone has been unable to obtain some schematic, he may advertise in Readers' Exchange asking if another reader has a copy that he's willing to let him borrow, or make a copy of.

Once in a while, however, an item sent in by a reader is obviously to buy or sell for a commercial business that makes its livelihood by buying and selling those products. Items such as that are not welcomed in Readers' Exchange. Those should be advertised in a paid type of advertising: classified or display.

Neatness and completeness count

Most items we receive for Readers'

Exchange are readable. But some of them tax the eyesight and ingenuity of the editor. Here are some general guidelines that we would like readers to follow for Readers' Exchange:

- Type, preferably, or print legibly, your item on a sheet of 8-1/2 by 11, white paper.

- Abbreviate only when the abbreviation is commonly accepted in the industry. We're not charging by the word or the length of the item, and sometimes abbreviations make the meaning unclear. So please refer to Part Number, not P/N, and Model Number, not Mod. No.

- Be accurate. Check spelling. For example, we frequently receive items looking for Photofact folders. The company that publishes Photofact is Howard W. Sams; not SAMS or Sam's. Tektronix is spelled with an x at the end, not cs. If you misspell the name of a company or a product, a potential buyer or seller may not recognize it. If we're not familiar with the company, or name of the instrument, we will spell it just as you spelled it.

- Include a full name, address and telephone number, including area code. And please use the postal abbreviation for your state. If you would prefer that we leave any of that information out of the item we will respect your wishes, but we need all of this information in order to process your item.

- We are not under any obligation to publish any Readers' Exchange item, so if the editor can't read or interpret an item, it will be discarded.

It will take a while

We work approximately two months ahead. For example, as I'm writing this the date is April 30, 1993, and all Readers'

Exchange items for this issue were typed up by the editor several weeks ago. The May issue is long gone to the printer. So please don't send us an item expecting it to be in the very next issue.

No guarantees

Because Readers' Exchange is a free service, we can't afford to take the kinds of precautions that are taken with a paid ad. And, again, we don't make any promises that any item will be published. It's rare, but occasionally an item is lost. If you can't afford not to have your item published, in a specific issue, don't send it to Readers' Exchange. Take out a paid classified ad.

Caveat emptor

One final note. Readers' Exchange is a free service designed to let readers get together to buy, sell and exchange products and information. We can't and don't check the background of anyone who uses it. In our experience, most people who use Readers' Exchange are honest and above-board, but you can never be sure.

Before you send a piece of equipment, or a check, make sure you're dealing with someone you can trust. We simply print Readers' Exchange items. Once you choose to deal with someone who has submitted an item, or has responded to your item, you're on your own.

Nile Conrad Penner

Fiber optic installer conference

The first-ever fiber optic conference to offer a full week of hands-on training in the design and installation of fiber optic networks will occur in Nashville, TN on July 25-31, 1993. Over thirty fiber optic vendors have joined to offer this unique opportunity to fiber optic installers.

Fotec, Inc., the conference organizer is a manufacturer of fiber optic test equipment. According to Fotec President and Founder, Jim Hayes, a "pioneer" in the fiber optic industry, the response to the conference has been phenomenal.

"It was our customers who kept asking where they could get comprehensive training in fiber optic installation. The enthusiastic response to the conference from both our vendor participants and installers has shown this to be an industry-wide need.

"I have read many magazine articles that say fiber is too fragile, too hard to install or too expensive. This conference will help put that myth to rest. A well-trained installer can make fiber cost competitive with most of the "exotic" copper wire schemes proposed for high speed communications."

A brochure on the conference is available, listing all the cosponsors. For more information, contact Louise Downing at 800-537-8254.

Appliance technicians certified

Sixteen appliance technicians received the "Certified Appliance Technician" title following examinations conducted at the first annual Major Appliance Servicer Convention, held February 12-14, in Denver, CO. The convention was sponsored by Precision Trax, Inc., publishers of Appliance Tech Talk magazine.

The successful technicians, who were among a group of 32 who sat for the exam, passed a rigorous examination given by the International Society of Certified Electronics Technicians (ISCET). The exam consists of 100 multiple-choice questions covering electrical circuits and components, refrigeration systems, laundry equipment, cooking equipment, and dishwashers and trash compactors.

Successful applicants receive a wall certificate designating them as Certified Appliance Technicians and are eligible for associate membership in ISCET.

A seminar preparing the technicians for the exam was given at the convention by Al Pruess CAT, San Diego, CA. Pruess is the new chairman of the CAT Committee, who is preparing a study guide/practice test for the exam.

In other developments at the three-day convention, the assembled appliance servicers decided to form an independent organization affiliated with NESDA (National Electronics Service Dealers Association). The group expects to have its newly elected Board of Directors seated at the NESDA Convention, August 2-7, in Louisville, KY.

The Certified Appliance Technician exam is available from ISCET test administrators located throughout the nation and abroad. To receive a list of test sites, technicians should contact ISCET, 2708 West Berry, Fort Worth, TX 76109, or call 817-921-9102.

Color TV sales gain

Strong sales of color televisions 26 inches and over and 13 inches and under, helped sales of video products continue the category's solid sales pace in the second month of 1993, according to the statistics released by the Electronic Industries Association's Consumer Electronics Group (EIA/CEG).

Color TV sales posted the category's best ever two month start to a year on the strength of a nearly 22 percent gain in February, compared to the same period in 1992. Sets 26 inches and over rose 22 percent from the same period last year, and sets 13 inches and under rose 19 percent during the same period.

According to research by the investment houses Dean Witter Reynolds Inc., and Salomon Brothers, the nation's retailers saw sales increase from one to 1.5 percent in February, compared to the same period in 1992.

Many analysts attributed the sluggish growth to the snow storms which racked the United States—particularly the Western half of the country—during

February. The same analysts do not expect sales to continue to be flat, but, instead, expect a rebound in March. That would be more welcome news for an already strong video market.

Sales to dealers of video products in February totaled 2.7 million units, up 14 percent over the same period last year. A combination of the February gain and a 15 percent increase in January pushed video sales to their best ever two month start to a new year.

Video sales have started 1993 strongly as consumers have shown an increased tendency to loosen their spending belts. The amount of outstanding consumer credit, a good indicator of consumer willingness to make big ticket purchases, rose for the fifth straight month in January. Analysts caution, though, that this does not indicate a return to the consumer spending patterns of the 1980s, but does indicate an increased willingness for consumers to spend their money for products with real value.

Sales of camcorders have taken off in the first two months of this year, jumping 20 percent in February versus the same period last year. Camcorder sales have grown 14 percent during the first two months of this year. Growth in sales of full-size units outpaced the growth of compact units during February—sales of full-size units rose 27 percent from the same period last year, while compact units climbed 17 percent.

TV/VCR combination unit sales continued to be hot in February, rising 72 percent over February 1992. Sales in the first two months of this year rose 41 percent over the same period last year.

Projection television sales continued to climb, rising 14 percent in February. Growth during the month was strongest for sets 55 inches and over, as sales of these units grew 69 percent compared to February 1992.

Laserdisc players rebounded from a disappointing January 1993 to record a gain of 19 percent in February. Sales of VCR decks declined slightly in February, but still remain three percent ahead of the record pace set through the first two months of 1992. ■

ELECTRONIC

Servicing & Technology

Electronic Servicing & Technology is edited for servicing professionals who service consumer electronics equipment. This includes service technicians, field service personnel and avid servicing enthusiasts who repair and maintain audio, video, computer and other consumer electronics equipment.

EDITORIAL

Nils Conrad Persson, *Editor*
Linda Romanello, *Assistant Editor*

CONSULTING EDITORS

Homer L. Davidson, *TV Servicing Consultant*
William J. Lynott, *Business Consultant*
Victor Meeldijk, *Components Consultant*
John E. Shepler, *Audio Consultant*
Sam Wilson, *Electronics Theory Consultant*

PRODUCTION

Elizabeth Ryan, *Art Director*
Barbara Terzo, *Assistant Art Director*
Susan Reale, *Artist*
Edmond Pesonen, *Electronic Composition Mgr.*
Dorothy Kehrwieler, *Production Manager*
Emily Kreutz, *Production*
Pat Le Blanc, *Phototypographer*

BUSINESS

Richard A. Ross, *Publisher*
Jonathan C. Kummer, *Associate Publisher*
Dorothy Kehrwieler, *General Manager*
Frank V. Fuzia, *Controller*
Catherine Ross, *Circulation Director*
Melissa Kehrwieler, *Data Processing Manager*
Carol Licata, *Data Processing*
Denise Pyne, *Customer Service*

SALES OFFICE

Electronic Servicing & Technology
76 N. Broadway, Hicksville, NY 11801
516-681-2922; FAX 516-681-2926

Jonathan Kummer, *Advertising Manager*
Emily Kreutz, *Sales Assistant*



Member, Electronic Servicing Dealers Association



EDITORIAL CORRESPONDENCE

P.O. Box 12487
Overland Park, KS 66212
913-492-4857

Electronic Servicing & Technology (ISSN 0278-9922) is published 13 times a year by CQ Communications, Inc. 76 N. Broadway, Hicksville, NY 11801. Telephone (516) 681-2922. Second class postage paid at Hicksville, NY and additional offices. Subscription prices (payable in US dollars only): Domestic—one year \$24, two years \$40. Foreign countries—one year \$30, two years \$52. Entire contents copyright 1993 by CQ Communications, Inc. Electronic Servicing & Technology or CQ Communications, Inc. assumes no responsibility for unsolicited manuscripts. Allow six weeks for delivery of first issue and for change of address. Printed in the United States of America.

Postmaster: Please send change of address notice to Electronic Servicing & Technology, 76 N. Broadway, Hicksville, NY 11801.

CQ Communications, Inc. is publisher of CQ The Radio Amateur's Journal, Popular Communications, ComputerCraft, CQ Radio Amateur (Spanish CQ), CQ Amateur Radio Equipment Buyer's Guide, CQ Amateur Radio Antenna Buyer's Guide, Popular Communications Communications Guides, and Electronic Servicing & Technology.

Literature

New parts catalog

Dalbani Corporation has released its newest 176-page catalog for 1993. The catalog features the company's vast line of semiconductors, connectors, audio/video cable assemblies, VCR heads (also belts, accessories), flybacks, computer connectors and accessories, as well as telephone accessories and batteries, cordless telephones and camcorders and many other parts.

The catalog provides an easy-to-read format for part listing, as well as extensive cross references to the major manufacturers part numbers. The newest addition is a cross reference between original semiconductor manufacturer numbers and replacement type numbers, which should facilitate price/option comparison for the buyer.

Circle (40) on Reply Card

Catalog of cable tools

Cablematic Division of Ripley Company offers a new catalog on its CATV and telecommunication cable preparation tools. Operations from jacket or sheath stripping, to simultaneous coring and stripping with a single tool, to hex or round full-cycle crimping are performed with these tools. The catalog presents the company's full product line including information on tools for specific cables, such as Quantum Reach, MC² and TX cables. Tools for stripping and crimping fiberoptic cable are also included, plus several specialty tools, like a cable expanding tool kit, connector insertion tools, a duct cutter, and an antenna hole saw.

Circle (41) on Reply Card

Solvent selection guide

An all-new, updated Solvent Selection Guide is now available from Dynaloy, Inc., a manufacturer of specialty chemicals and solvents serving industries such as telecommunications, computer electronics, plastics processing/molding, automotive, avionics/aerospace, medical, audio/video, and converting/laminating. The six-page, full color guide cross references the company's solvents with applications for removal of urethanes, silicones, epoxies, acrylics, conformal coatings, photoresists, isocyanates, mold releases, and other adhesives and polymers. The brochure contains two

selection guides: one for industrial applications, the other for electronic applications. Also included is a solvent applications table; descriptions of all of the company's solvents, including new products for solving industries' concerns of health, safety, disposal, and the environment; and several before and after application photos.

Circle (42) on Reply Card

Tips on optics pocket guide

The Broadcast and Communications Products Division of Fujinon, Inc., has released the Tips on Optics Pocket Guide, a reference piece that provides a simple overview and general description of various optical subjects.

The booklet provides information on 17 different areas, ranging from basic terms to more complex optical issues. Subjects such as T-number, F-number, modulation transfer function, optical coatings, and depth of field are covered. The information provided is concise, but completely thorough in giving you an understanding of the various lens terminology.

The information provided in Tips on Optics also gives the reader an understanding of why a lens performs the way it does and what to look for when purchasing a lens.

Circle (43) on Reply Card

Catalog of computers, accessories, and components

Spring 1993 catalog of discounted computers and accessories is now available from American Design Components of Secaucus, NJ.

Geared to meet the needs of small and large manufacturers, research and development, schools, universities, hobbyists, students, and computer buffs; the 40-page fully-illustrated catalog is filled with low cost computer systems, motherboards, disk drives, monitors and a wide variety of computer accessories. Also featured are lead acid and nickel-cadmium batteries, power supplies, adaptors, integrated circuits, connectors, switches, relays, fans, blowers, motors and pumps, electronic kits and books, test equipment, CCTV systems, telephones, electronic gadgets and lighting for special effects.

Circle (44) on Reply Card

Catalog of test equipment, tools and supplies

A 204-page catalog from Contact East lists hundreds of new test instruments and tools for plant and facilities operation, maintenance directors, engineers, production managers, and purchasing agents. Featured are products from brand-name manufacturers like Fluke, Tektronix, Weller, 3M, Microtest, Simpson, etc. for testing, repairing, assembling, and maintaining electronic equipment.

Product highlights include insulated hand tools, cordless power tools, thermometers, DMMs, power line monitors, UPS (uninterruptible power supplies), telecom tools and test equipment, tool kits, safety cabinets for storing flammable and corrosive materials, portable digital storage scopes, network testers and ESD-safe ergonomic chairs.

Also included are DMMs, communication test equipment, clamp meters, hand tools, soldering/desoldering systems, measuring tools, frequency counters, shipping containers, static protection products, batteries, ozone safe cleaners, adhesives, inspection equipment, workbenches, tool kits, cases and more.

Circle (45) on Reply Card

Brochure for TDR short range cable/fault locator

A brochure featuring the benefits and specifications of the new Biddle 511 Time Domain Reflectometer (TDR) is available from AVO International. A short-range, hand-held TDR featuring a full trace display (LCD) the tester is designed to locate and identify cable faults as close as six inches or as far away as 950 feet with accuracy.

The four-color brochure contains important product benefits and features, highlights the unit's simple five-key operation, identifies options, and diagrams the types of circuit impedance changes or faults typically displayed on the LCD.

Circle (46) on Reply Card

PC accessories and service products supplement

Jensen Tools has introduced an 84-page catalog supplement featuring new PC network accessories and service products.

Illustrated in full color, Supplement P showcases the IBM PS/2 Monitor Kit, a new Mac-Users Tool Set, new programming and diagnostic systems from Data I/O, Datatran and other major manufacturers, recent additions to Jensen's full line of LAN and fiber optic service products, and latest technical service guides.

Many unique specialty tools are also included: ergonomic hardware cutter, tiny

and effective coax cable stripper, insulated burnisher and other hand tools. Also PC tool kits, cases and foam filled shipping containers, programming and diagnostic systems and software, soldering stations, bench accessories, test leads, cable accessories, power monitors, probes, meters and a wide range of other test instruments.

Circle (47) on Reply Card

ELESCO & HITACHI & B+K PRODUCTS

AT DISCOUNT PRICES

TO ORDER
CALL TOLL FREE
1-800-292-7711
1-800-445-3201 (Con.)

48 HOUR
SHIPPING

ELESCO OSCILLOSCOPES

S-1325 25MHz \$349

Dual Trace Oscilloscope

S-1340 40MHz \$495

Dual Trace Oscilloscope

S-1360 60MHz

Dual Trace, Delayed Sweep

\$775

- Automatic beam finder
- Built-in component tester
- 1mV sensitivity
- Dual time base

B+K OSCILLOSCOPES

- 2120 - 20MHz Dual Trace \$395
- 2125 - 20MHz Delayed Sweep \$539
- 1541B - 40MHz Dual Trace \$749
- 2160 - 60MHz Dual Trace, Delayed Sweep, Dual Time Base \$949
- 2190 - 100MHz Three Trace Dual Time Base, Delayed Sweep \$1,395
- 2522 - 20MHz / 10MS/s Storage \$895
- 1442 - 20MHz Portable \$1,229
- 1443 - 40MHz Battery / AC operated with Cursor & Readouts \$1,439

Digital Capacitance Meter

CM-1508

\$58.95

9 Ranges
1pF-20,000uF
5% basic accuracy
Zero control w/ Case
Big 1" Display

Digital LCR Meter

LC-1801

\$125

Measures
Coils 1uH-200H
Caps 1pF-200uF
Res. 01-20M

Multimeter with Capacitance & Transistor Tester

\$55 CM-1500B

Reads Volts, Ohms
Current, Capacitors,
Transistors and
Diodes / with case

CALL US FOR ALL YOUR COMPONENT NEEDS

Soldering Station

Temperature Controlled

SL-30 \$99

Digital Display
Temp Range:
300F-900F
Grounded Tip
Overheat Protect

Video Head Tester

HT-200

\$44.95

Tells you if
VHS head
is defective
or worn.

Quad Power Supply

XP-580

\$69.95

2-20V @ 2A
12V @ 1A
5V @ 3A
5V @ 3A

Fully regulated and short circuit protected

Triple Power Supply

XP-620

Assembled \$75

KR \$50

2 to 15V @ 1A,
2 to 15V @ 1A
(or 4 to 30V @ 1A)
and 5V @ 3A

All the desired features for doing experiments.
Features short circuit protection, all supplies

AM/FM Transistor Radio Kit

with Training Course

Model AM/FM 108

\$27.95

14 Transistors & 5 Diodes
Makes a great school project

Sweep/Function Generator with Freq. Counter

\$259

Elenco Model GF-8026

Sine, Square, Triangle, Pulse, Ramp
2 to 2MHz, Freq Counter: 1-10MHz
Internal Linear & Logic Sweep

Function Generator

Blatz #9600

\$28.95

Provides sine, triangle, square wave from 1Hz to 1MHz
Kit \$26.95 AM or FM capability

True RMS 4 1/2 Digit Multimeter

M-700T

\$135

0.5% DC Accuracy
1% Resistance
with FREQ. Counter
Data Hold

Learn to Build and Program Computers with this Kit

Model MM-8000

\$129.00

Starting from scratch you build a complete system. Our Micro-Master trainer teaches you to write into RAMs, ROMs and run a 8085 microprocessor, which uses similar machine language as IBM PC

Elenco Wide Band Signal Generators

SG-9000 \$129

RF Freq 100K-450MHz AM Modulation of 1KHz Variable RF
SG-9500 w/ Digital Display & 150 MHz built-in Counter \$249

XK-500 Digital / Analog Trainer

A complete mini-lab for building, testing, prototyping analog and digital circuits
Elenco's Digital/Analog Trainer is specially designed for school projects. With 5 built-in power supplies. Includes a function generator with continuously variable, sine, triangular, square wave forms. All power supplies are regulated and protected against shorts.

Power Supplies

- Variable Power Supply
- +1.25 to 20VDC @ 3 Amp
- +1.25 to 15VDC @ 1 Amp
- -1.25 to 20VDC @ 3 Amp
- +1.25 to 15VDC @ 1 Amp
- +12VDC @ 1 Amp
- -12VDC @ 1 Amp
- +5VDC @ 1 Amp
- 30VAC Center tapped
- 15VAC @ 1 Amp

Analog - Section

- Function Generator Sine
- Triangular, Square wave forms
- Frequency adjustable in five ranges from 1 to 100kHz
- Fine frequency adjust
- Amplitude adjust
- DC offset
- Modulation: FM AM

Digital - Section

- Eight data switches
- Test no bounce logic switches
- 4 LED readouts TTL, DCM, etc
- Clock frequency 1 to 100kHz
- Clock amplitude 5VPP square wave

Breadboards

- 2 breadboards, each contains 640 test points (not 1,000)

Assembled \$129.95 Kit

WE WILL NOT BE UNDERSOLD

UPS SHIPPING: 16 STATES 5'
IL RES 7.5% TAX (\$3 min \$10 max)
PROBES INCL ALL SCOPES & METERS

C&S SALES INC.

1245 ROSEWOOD, DEERFIELD, IL 60015
FAX: 708-520-0085 • (708) 541-0710

15 DAY MONEY BACK GUARANTEE

FULL FACTORY WARRANTY

WRITE FOR FREE CATALOG

(NO. 15 SUBJECT TO CHANGE)

Circle (20) on Reply Card

June 1993 Electronic Servicing & Technology 5

Hand-held meters measure true RMS and temperature

Two new Test Bench multi-function DMMs have been unveiled by *B&K Precision*. The Model 391 is a 4-1/2 digit, true RMS reading DMM, with 0.05% dc accuracy. The Model 390 offers 3-3/4 digit, 0.1% dcV accuracy and a 42-segment analog bar graph.

Both meters are ruggedized and feature drop-resistant cases with impact absorbing rubber boots. The rubber boot also provides test lead storage. Internal circuitry is protected by overload protection and high-energy fusing on both $\mu\text{A}/\text{mA}$ and 20A current ranges.

The Model 390 measures temperature from -50C to +1300C, $\pm 2\text{C}$. The Model 391 has a full 4-1/2 digit, 20,000 count LCD display; the 390 is 4000 count. DC and ac current measurement capabilities extend to 20A, with resistance measurement to 20M Ω on the 391 and to 40M Ω on the 390. Frequency counter capability reaches 50kHz on the Model 390 and 200kHz on the 391. On the Model 390, five capacitance ranges extend to 40 μF .

Circle (25) on Reply Card

Digital scope with oversampling

A low-cost 100MHz digital real-time oscilloscope has been introduced by *Tektronix, Inc.* An advanced technique called "oversampling" is used to boost the single-shot bandwidth to the full analog bandwidth of the scope. The latest addition to the TDS family, the TDS 320 is designed primarily for service as well as education and design.

The input circuitry on each of the scope's two channels digitize at the rate of 500 million times-per-second (500 MS/s).

At slower sweep speeds, the peak-detect acquisition mode enhances the scope's



ability to faithfully capture and display waveform activity.

The product's intuitive interface captures the simplicity of the traditional analog interface while supporting a wide range of digital functionality.

A communications option, including GPIB and Centronics-type interfaces, enables the user to have hardcopy at the push of a button. This option also enables users to download waveforms for documentation or analysis.

Circle (26) on Reply Card

New software for field service

DiagSoft, Inc. has introduced the newest release of QAPlus/FE, version 5.1. QAPlus/FE is a PC diagnostic tool for field engineers, service/support professionals and power users. QAPlus/FE is designed to provide comprehensive, in-depth testing and tuning capabilities, enabling users to pinpoint system problems down to the component level.

In addition to the advanced diagnostic tools included in QAPlus/FE, the new release includes the following features: identification of the latest hardware technologies, upgraded component tests, enhanced information system reporting, new and enhanced system utilities, new virus detection and remote control software, and new networked PC support.

Circle (27) on Reply Card

Dual-display portable LCR bridge

A new hand-held LCR bridge with dual digital readouts has been introduced by *B&K Precision*, a division of Maxtec International Corp. Designed for field service or general industrial applications, the Model 878 measures inductance, capacitance and resistance at a basic accuracy of 0.7%.

The unit has a wide range of features designed to speed such operations as component testing and sorting. When testing capacitors, it displays capacitance and dissipation factor simultaneously. For inductors, inductance and Q can be read at the same time. To further speed component sorting, a relative mode stores the value of a reference part, then shows a plus or minus difference between the reference and measured value. This makes it easy to spot out-of-tolerance



components. The tester can be set to beep when a component is outside of a preselected 1%, 5%, or 10% tolerance around the reference value.

A data hold function is also available to freeze any displayed reading. A minimum/maximum/average function keeps track of the running average of readings and records the highest and lowest running values.

The bridge measures capacitance from 0.1 pF to 10,000 μF . Resistance measurements span from 0.1 Ω to 20M Ω . Inductance values can be read from 0.1 μH to 2,000 H. Tests may be conducted at either 120Hz or 1kHz. This microprocessor-based unit even tells you when calibration is needed. Self-calibration is initiated by a pushbutton switch.

The display features separate four and three digit LCD readouts with function annunciators. Other features include auto or manual ranging and operation from batteries or from a supplied ac adapter.

Circle (28) on reply Card

Non-contact temperature probe

The 80T-IR Infrared Temperature Probe from *John Fluke Mfg. Co.*, allows users to make non-contact temperature measurements using a digital multimeter (DMM). The probe is useful for situations where it is difficult to make measurements, such as when the subject is electrically live, moving, hard to reach, or can be contaminated by touch.

The rugged design of the product makes it suitable for harsh environments, and its temperature range of 0F to 500F and accuracy of 3% of reading allow it to



be used in a wide variety of temperature measurement applications, including predictive and preventative maintenance. Emissivity is preset at 0.95, which is adequate for most industrial applications. The ergonomic design of the probe makes it easily held and used with one hand.

The unit works with any digital multimeter. Operation is simple, requiring only that the probe be plugged into the V/Ω input jacks of the meter, the meter be set to mVdc, and the probe be pointed at the subject. The temperature is shown on the multimeter's display within 1 second.

Circle (29) on Reply Card

Linear power supplies

American Reliance introduces five

models of linear programmable dc power supplies with power output ranging from 30W to 165W. Each model of the LPS series is controlled by an internal microprocessor and all data entry is performed via a front-panel keypad to simplify operations. The output voltage and current can be monitored by the built-in LCD panel and an optional RS-232 interface allows remote talk and listen control. Other key features include a voltage/current step up/down function, power-off memory for voltage and current settings, output enable/disable, and an intelligent forced-fan



cooling system (except the LPS-301).

The series includes two models which are dual-range single-output designs rat-

ed at 30V/1A or 15V/2A for the LPS-301 and 30V/2A or 15V/4A for the LPS-302. The LPS-303 is a single-output unit rated at 90W with a voltage output of 30V and a current output of 3A. The LPS series also includes two triple-output models with two independently variable channels and a fixed-output channel; the LPS-304 offers two 30V/1A outputs along with a fixed 5V/2A output while the LPS-305 offers two 30V/2.5A outputs in addition to a 5V or 3.3V output at 3A.

Circle (30) on Reply Card

Voltage probe

Amprobe announces the introduction of Model VP-440 VoltProbe, a pocket-sized instrument that will safely indicate the presence of ac voltage. This is a professional tool that can protect the user from the hazard of an electrical shock. No current needs to be flowing, nor is contact with the conductor required. By placing the plastic tip along an insulated or uninsulated cable, the tip will illuminate red if ac voltage is present. There is no need to disconnect cables, wall sockets, or fuses to detect the voltage.

Circle (31) on Reply Card

72 new ECG® semis, 8,100 new crosses in guide supplement.

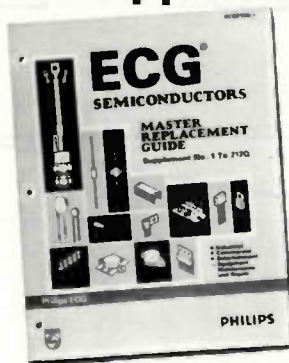

Supplement to ECG Master Guide details newest replacement modules, ICs and discretes for use in entertainment and industrial equipment, adds 8,100 more part-number cross references to the industry's most complete semiconductor line.

At 900 Philips ECG distributor locations or call 1-800-526-9354.



Philips ECG



PHILIPS

Circle (10) on Reply Card

New ECG® parts, tools bring A/V line to over 350.

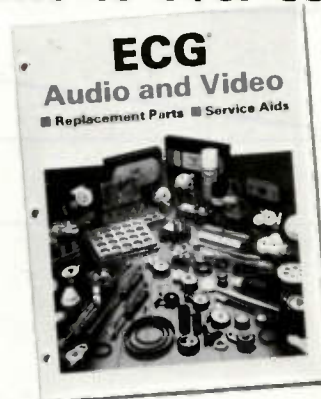

Replacement parts that meet or exceed OEM specs for 31 popular VCR brands, VHS and Beta. Catalog: over 3,500 crosses; industry's best source for replacement parts and tools. Ask for a copy.

At 900 Philips ECG distributor locations or call 1-800-526-9354.



Philips ECG



PHILIPS

Circle (11) on Reply Card

Test equipment update:

Understanding measurements in horizontal output stages

By Glen Kropuenske, CET

The article, "Understanding TV horizontal output/deflection circuits," published in the May 1993 issue of *ES&T*, described the operation of the horizontal output circuits in a typical TV set. This article describes troubleshooting of prob-

lems in those circuits, and in particular describes some of the measurements that a technician can make to determine the causes of problems.

The components in the horizontal output stage are under considerable stress from high currents and voltages. Because of this stress, this stage has one of the

highest component failure rates of any television or monitor circuit.

Troubleshooting horizontal output stage problems and symptoms is difficult for several reasons. The horizontal output stage operates with high levels of sawtooth flyback and yoke currents. These currents are easily influenced by power

Kropuenske is an applications engineer for Sencore.

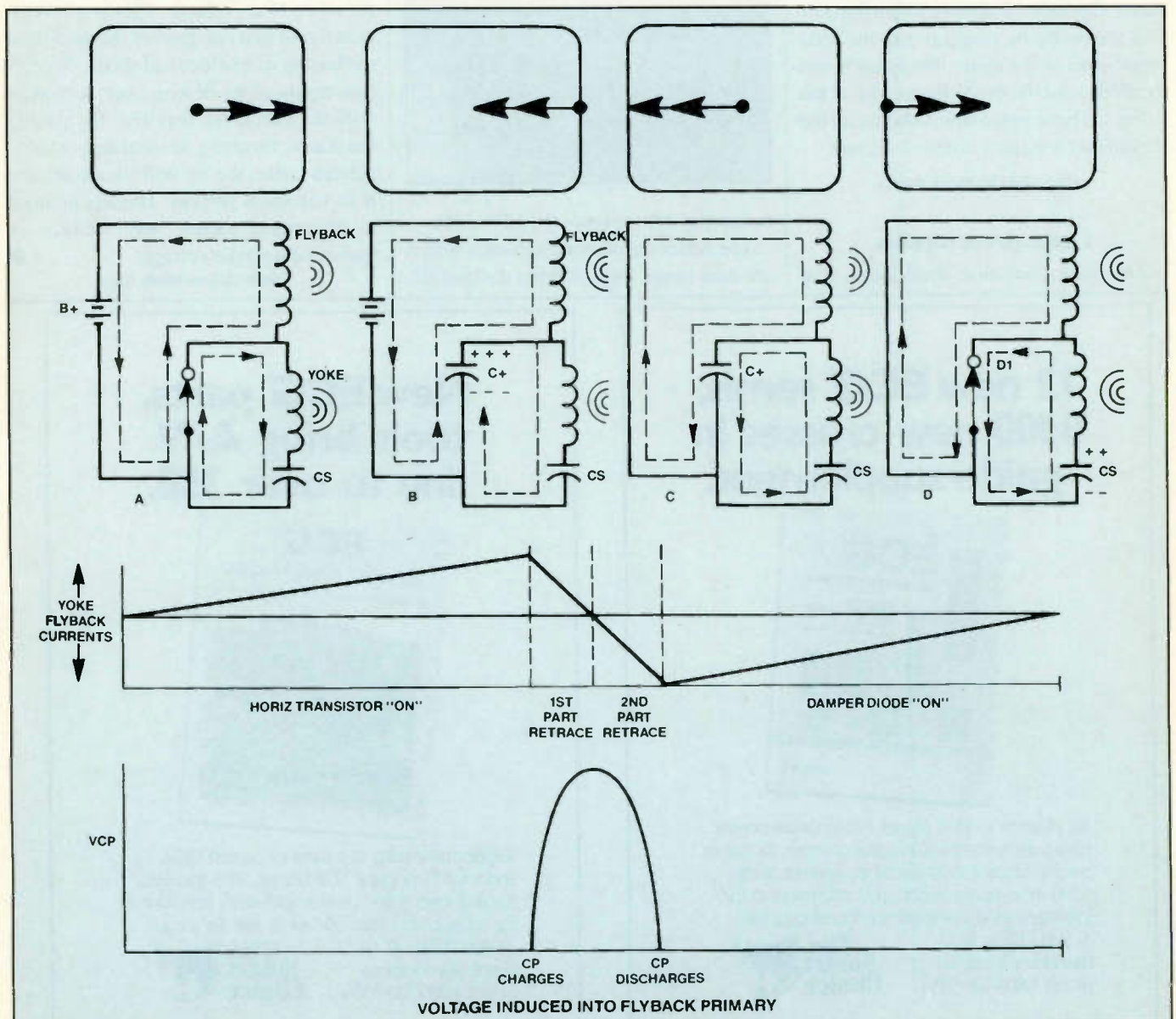

Figure 1. Key components and resulting currents and waveforms in the horizontal output stage.

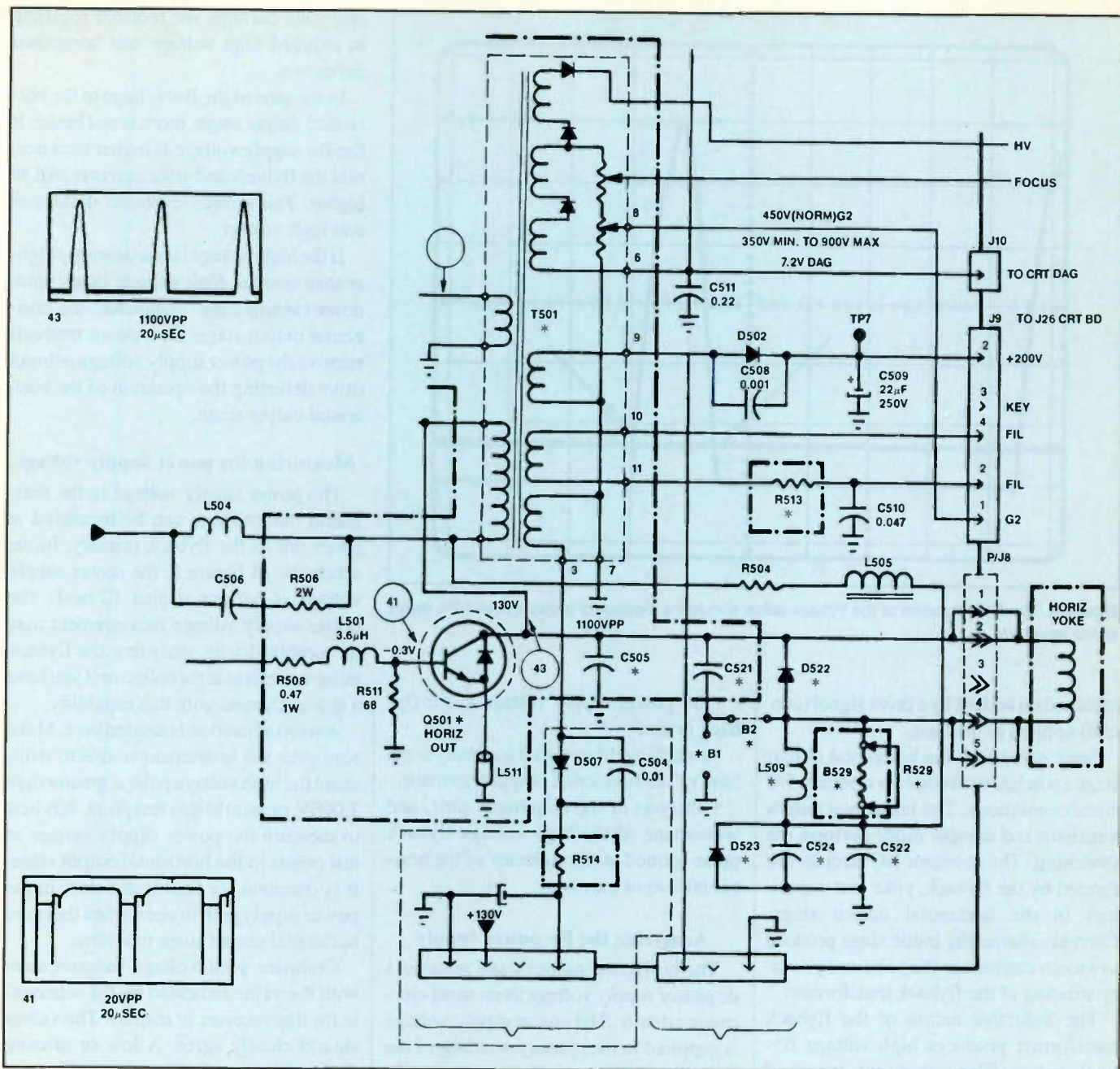

Figure 2. Horizontal output stage and waveforms of one TV set shown in the service literature provided by Philips Consumer Electronics. (Courtesy of Philips Consumer Electronics)

supply voltages, input drive to the horizontal output transistor (HOT), and fly-back secondary circuit problems. These currents cannot be easily viewed or interpreted with conventional test instruments. Furthermore, many test instruments are not designed to withstand the high voltage pulses present in the horizontal output stage.

This article will define the key measurements needed to analyze problems associated with horizontal output stages, and examine how to interpret these measurements so you can better isolate the

problem stage or defective horizontal output stage component.

A review of the horizontal output stage

The article that appeared in the May issue described the role of the six key horizontal output components and examined the currents and voltages within the horizontal output stage. You'll recall that the horizontal output circuit consists of six basic components:

- horizontal output transistor (Q1);
- flyback transformer (flyback);

- retrace timing capacitor or "safety cap" (Ct);
- damper diode (D1);
- horizontal yoke;
- yoke series capacitor (Cs).

Figure 1 illustrates the basic components and resulting currents and voltages within the horizontal output stage.

During normal operation, the horizontal output stage is energized by a B+ power supply. Current flows through the primary winding of the flyback transformer when the horizontal output transistor is conducting. The transistor is

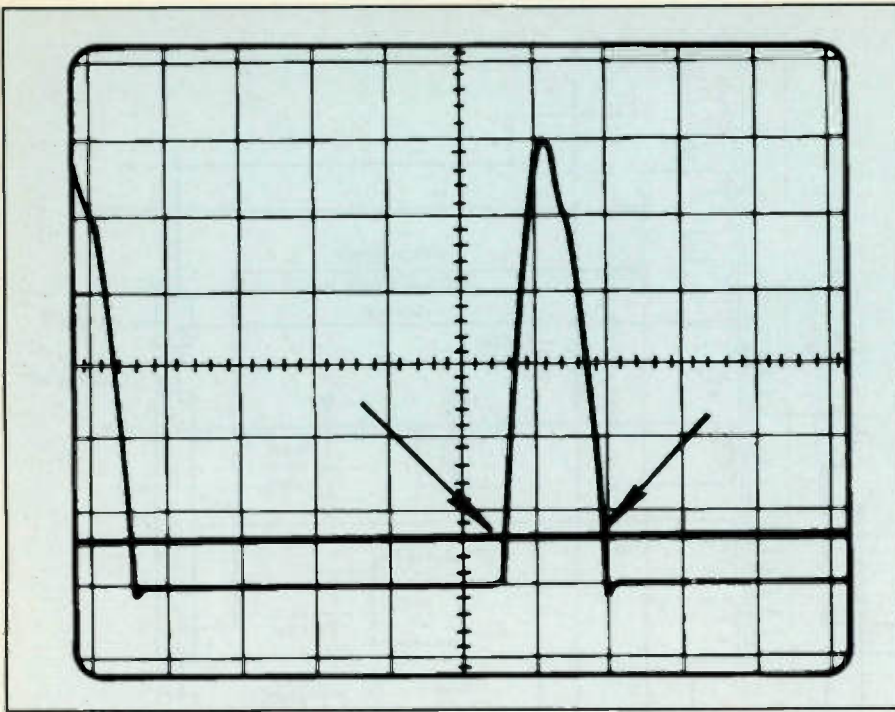

Figure 3. The time duration of the flyback pulse should be measured between the 10% levels of the waveform.

switched on and off by a drive signal (current) applied to the base.

Once energized, the horizontal output stage switches between two resonant LC circuit conditions. The horizontal output transistor and damper diode perform the switching. The resonant LC circuits are formed by the flyback, yoke and capacitors in the horizontal output stage. Currents alternating in the stage produce sawtooth currents in the yoke and primary winding of the flyback transformer.

The inductive nature of the flyback transformer produces high voltage flyback pulses. The pulses are produced when the horizontal output transistor abruptly turns off causing a fast decrease in current in the flyback primary. The flyback's magnetic field collapses quickly, producing a large induced voltage pulse into the flyback windings.

Key horizontal output measurements

Three key measurements are needed when analyzing horizontal output/high voltage/deflection problems in television receivers or monitors. The first two measurements check for proper inputs required by the horizontal output stage for normal operation. The third measurement analyzes the operation of the horizontal output stage itself.

The three key measurements are:

- B+ power supply voltage to the flyback primary
- switching drive signal (current) to the base of the horizontal output transistor
- analysis of the amplitude, time, and waveshape of the high voltage flyback pulse formed at the collector of the horizontal output transistor.

Analyzing the B+ power supply

The horizontal output stage requires a dc power supply voltage as do most electronic circuits. The power supply voltage is supplied to the primary winding of the flyback transformer. The power supply serves as a source of power for the horizontal output stage. The voltage ranges from approximately 120V in small monochrome displays to 160V in larger color displays. The power supply must be capable of delivering currents of up to approximately 1A.

The power supply voltage directly determines the flyback and yoke current levels. In turn, the currents determine the resulting high voltage and horizontal deflection. Therefore, regulating the power supply voltage acts to regulate the high voltage and horizontal deflection (width). If the B+ voltage is missing, the horizontal output stage will not produce flyback or yoke currents. If the B+ voltage is lower than normal, both the flyback

and yoke currents are reduced resulting in reduced high voltage and horizontal deflection.

In the case of the B+ voltage to the horizontal output stage, more is not better. If the B+ supply voltage is higher than normal the flyback and yoke currents will be higher. This causes increased deflection and high voltage.

If the high voltage is considerably higher than normal, high voltage safety shutdown circuits may "shutdown" the horizontal output stage. Shutdown methods remove the power supply voltage or input drive defeating the operation of the horizontal output stage.

Measuring the power supply voltage

The power supply voltage to the horizontal output stage can be measured at either pin of the flyback primary. In the schematic of Figure 2, the power supply voltage is present at pins 12 or 1. The power supply voltage measurement may be combined with analyzing the flyback pulse waveform at the collector if you have a test instrument with this capability.

A word of caution is needed here. Make sure your test instrument is able to withstand the high voltage pulses, greater than 1,000V, present at this test point. It is best to measure the power supply voltage at test points in the horizontal output stage. It is common for fusible resistors in the power supply path to open when there are horizontal output stage problems.

Compare your voltage measurement with the value indicated by the schematic for that receiver or display. The values should closely agree. A low or missing dcV indicates a bad power supply or a direct short on the power supply. Use an ohmmeter to identify and correct a direct dc short to ground. If no short exists, troubleshoot the power supply.

Some problems result in a higher than normal B+ voltage. This usually means one of two things: either that the power supply is not regulating properly or that the current demand of the horizontal output and subsequent circuits has decreased. A reduction in current demand will increase the voltage from a non-regulated supply and also in some regulated power supplies if the regulating range is exceeded. To isolate the cause of increased voltage, substitute a known load with a power resistor or light bulb and test the power supply voltage. If the voltage

is reduced to near its proper level the supply is regulating properly.

Testing for input drive

The second input requirement of the horizontal output stage is a switching drive signal to the base of the horizontal output transistor. A drive signal is required to switch the horizontal output transistor on and off.

The transistor's switching action produces flyback and yoke currents. If the transistor is not receiving a drive signal, the horizontal output stage cannot produce yoke and flyback currents.

To test for an input drive signal to the horizontal output stage, connect an oscilloscope to the base of the horizontal output transistor. Figure 2 shows a typical horizontal input drive waveform. Note that it is shaped similar to a squarewave with deep negative voltage spikes.

Input drive waveforms typically range from 5Vpp to 30Vpp. Much of the drive waveform amplitude consists of negative voltage spikes on the waveform. These spikes are characteristics of the transistor's on/off switching transitions.

The presence of an input waveform tells you that the horizontal oscillator and driver stages are functioning. However, it does not tell you if the drive current is adequate; scope waveforms are voltage waveforms, whereas the horizontal output transistor is a current operated switch.

Horizontal output problems

Defects in the drive signal (base current) can reduce the transistor's collector current, reducing high voltage and horizontal deflection. Drive current irregularities can also cause poor transistor switching, thus creating excessive heat. These drive signal (current) problems are caused by problems in the drive signal path and are difficult to detect when viewing the drive waveform.

The frequency of the horizontal drive input is also important. The resonant timing of the horizontal output stage must work in harmony with the horizontal output transistor's switching action. If the input drive frequency has changed considerably from normal, the timing of the flyback and yoke currents may seriously conflict with the horizontal output transistor's switching.

Problems with the input drive signal to the horizontal output stage are the most

difficult to detect. Problems commonly alter the operation of the output stage making it appear to be defective. The best way to confirm problems with the drive signal is to substitute a known-good drive signal and check to see if the horizontal output stage operates normally.

Analyzing the high voltage flyback pulse

The high voltage flyback pulse provides a wealth of information regarding the operation of the horizontal output stage. This waveform more than any other measurement lets you identify horizontal output stage problems and isolate suspect components.

You will recall that the high voltage flyback pulse is produced when the magnetic field of the flyback primary collapses. A charging current to the retrace capacitor produces a rising voltage waveform. Once the flyback's magnetic field has fully collapsed, the capacitor begins to discharge producing a falling waveform. The resonant action of the horizontal output stage produces this flyback voltage pulse each cycle.

The high voltage flyback pulse is developed across Ct or at the horizontal output transistor's collector. You can analyze this high voltage waveform by connecting an oscilloscope or analyzer designed for this purpose to the collector of the horizontal output transistor.

A word of warning! Before connecting your scope or meter to the horizontal output stage be sure your test instrument is designed to withstand and measure peak-peak voltage pulses greater than 1000V. Many test instruments or accessory X10 probes will be damaged by these high voltage pulses.

When analyzing the high voltage flyback pulse, you should measure its amplitude (PPV) and pulse time (μ S), and check for waveshape defects. Each parameter provides you with important circuit information and clues when isolating problems associated with the horizontal output stage. Let's take a close look at what each parameter indicates when analyzing the horizontal output stage.

Interpreting flyback pulse amplitude (PPV)

The presence of flyback pulses at the collector of the horizontal output transistor indicates that power supply voltage

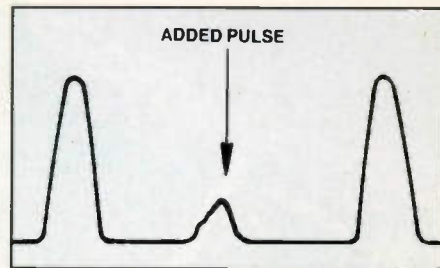

Figure 4. A common waveform deformity shows up in the horizontal output waveform as an added pulse approximately half way between the normal flyback pulses.

and drive are present. It indicates that current is alternating in the flyback and the retrace capacitor, confirming that these circuit paths are functioning.

If flyback pulses are missing, the horizontal output stage is dead. Possible causes of a dead horizontal output stage include a short in the stage, absence of B+ supply voltage or input drive, a short circuit to ground, or an open in the flyback current path.

To analyze the flyback pulse amplitude, measure the peak-to-peak voltage and compare the measured value to the amplitude specified by the service literature. Figure 2 shows a collector waveform pictured in the service literature.

The measured value should be close to the amplitude shown in the service literature. However, it is not unusual for PPV levels to vary 50Vpp between chassis of the same model. Flyback pulses among color TV and monitors range in peak-to-peak values from 500Vpp to 1100Vpp.

The amplitude of the flyback pulse reflects the levels of current in the horizontal output stage. To better understand what an amplitude (PPV) change indicates let's look at what determines the amplitude of the flyback pulse. The amplitude of the flyback pulse depends on two things: the intensity of the flyback transformer's magnetic field and the rate at which the magnetic field collapses.

The intensity of the magnetic field is determined by the amount of current flowing through the flyback primary during the conduction of the horizontal output transistor. This current is a result of the B+ power supply voltage, flyback inductance and horizontal output transistor collector current.

The amplitude is also influenced by the time or rate at which the magnetic field collapses into the flyback windings. The faster the rate of collapse the greater the

Imagine If You Could Divide Every TV Into Its Functional Blocks!

- Productivity would rise.
- Profits would increase.
- Inventory would decrease.
- Estimates would be more accurate.

Physically cutting the TV chassis into the functional blocks isn't practical, but there is a way you can electrically isolate them. There's a way that will help you determine defects by simply watching the CRT. And there's a way to isolate horizontal circuit (startup/shutdown) faults without risking damage to replacement components - or your pride.

Sencore has been designing instruments that allow servicers to use signal injection for troubleshooting for many years. Now, with the new TVA92 TV Video Analyzer, TV servicing actually pulls the entire TV together while isolating individual stages.

Now you can isolate TV defects, troubleshoot startup/shutdown problems, test expensive TV components, plus accurately estimate TV repair costs in minutes with:

- Exclusive "TV OFF" horizontal output load test
- Dynamic tests through a simple 3 lead hook-up to the H.O.T.
- Horizontal output transistor sub and drive
- Universal substitute TV signals
- Patented ringer test to pinpoint shorted turns in flybacks, IHVTs, yokes, and switching transformers
- An exclusive yoke drive signal
- DC biasing supply
- Built-in monitor for all sub-signal results and making DCV and PPV measurements

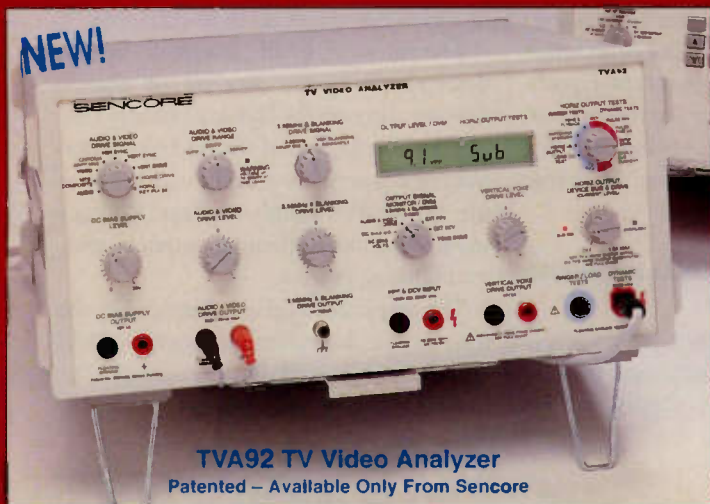

If you're looking for the only complete TV Analyzer to help build your TV servicing business - reserve your new TVA92 TV Video Analyzer today. Act now and lock-in special limited introductory pricing. (New video demonstration tape available upon request.)

Call 1-800-SENCORE ext. 608
(736-2673)

THE CHOICE
SYSTEM

SENCORE

3200 Sencore Drive, Sioux Falls, SD 57107
Direct (605) 339-0100 Fax (605) 339-0317

Circle (16) on Reply Card

pulse amplitude. We'll look at the pulse duration or retrace time measurement next. For now, let's look at what causes amplitude changes when the timing of the horizontal output stage is normal.

If the flyback pulse PPV amplitude is considerably low compared to the schematic but the pulse duration (time) is normal, the cause is a decrease in flyback primary current. This can result from reduced B+ voltage, insufficient horizontal output transistor gain (beta) or insufficient base drive current. Test the power supply voltage and transistor gain to isolate the problem.

If the flyback pulse amplitude is considerably high but the pulse duration (time) is normal, the cause is an increase in flyback primary current. The most likely cause is an increase in the B+ power supply voltage from improper regulation.

Interpreting flyback pulse durations (retrace timing)

The duration of the flyback pulse provides additional information regarding the operation of the horizontal output stage. The duration of the flyback pulse is the retrace time. This time is determined by the critical timing components of the horizontal output circuit including the flyback, retrace capacitor Ct, yoke and series yoke capacitor.

To measure the flyback pulse time, calculate the time between the 10% amplitude points of the waveform as shown in Figure 3. Compare this measurement to the normal pulse duration indicated by the service literature. Use the scope timebase setting and divisions of the pulse as pictured in the service literature to determine the normal pulse duration.

If the flyback pulse duration isn't listed in the service literature, you can estimate it by considering the horizontal sync period of the input video or RGB signal. The flyback pulse time should be slightly longer than the horizontal sync period.

For example, the horizontal sync period of an NTSC TV signal is approximately 11.1 μ S. Typical television receivers have flyback pulse durations (retrace times) ranging from 11.3 μ S to 13.5 μ S. If the measured time varies considerably from a determined normal time, a timing problem is indicated.

If the flyback pulse time is considerably longer than normal, suspect an open yoke current path, or reduced yoke or

yoke capacitor values. A long flyback pulse time is usually accompanied by a reduced amplitude. This lowers all the voltages and currents induced into the flyback secondaries. Check the yoke and components in series with the yoke current path to isolate the defect.

A flyback pulse time that is unusually shorter than normal indicates a reduction in flyback inductance or retrace timing capacitance. This symptom is usually accompanied by an increase in flyback pulse amplitude. When the amplitude increases so do the voltages and currents in the flyback secondaries.

Reduced timing may be caused by a shorted turn in the flyback, a short turn in the yoke, or reduction in capacitor values of retrace timing capacitors. Loading on the secondary of the flyback transformer also effectively reduces the inductance of the flyback transformer, reducing the flyback pulse time.

Interpreting the flyback pulse waveshape

Waveform deformities indicate a problem associated with the horizontal output stage or flyback secondary circuitry. Deformities may or may not change the timing or amplitude of the flyback pulse. The flyback pulse waveform should be a symmetrical pulse with a flat baseline between pulses. See Figure 3. Defects cause waveshape changes. Analyzing the waveshape can help you determine where to look for horizontal output problems.

A common waveform deformity shows up in the horizontal output waveform as an added pulse approximately half way between the main flyback pulses. This is illustrated in Figure 4. With this problem, the flyback pulse timing is normal but a slight reduction in amplitude is typical. The receiver or monitor symptoms with this waveform vary from only minor reductions in high voltage and deflection to more visible reductions, depending on the severity of the problem.

The added baseline pulse corresponds to the end of damper diode time. During this time the flyback and yoke magnetic fields are collapsing, producing currents in the horizontal output stage. If the collapsing magnetic fields cannot sustain current until the horizontal output transistor is switched on, the damper diode opens and Ct becomes part of the circuit. The presence of Ct interrupts the normal

circuit resonant action producing this unwanted pulse.

The added baseline pulse indicates that the horizontal output stage does not have adequate power (currents) to satisfy the power losses or demands of the flyback secondaries. There are three possible causes of this symptom:

- a slightly higher power is demanded because of a defect in a flyback secondary circuit (flyback loading)
- the horizontal output stage has added power losses from a leaky component
- the stage lacks adequate flyback primary current when the HOT conducts.

A good guideline when analyzing waveform deformities is to consider at what time during the horizontal cycle they occur. Rarely do problems occur along the baseline before the horizontal flyback pulse when the horizontal output transistor is conducting. Problems in this area would point to transistor or power supply problems. Deformities on the falling edge of the flyback pulse or damper period are common. These deformities usually point to severe flyback loading or defects in the horizontal output stage. Consider these changes along with the amplitude and timing to theorize possible causes. ■

Parts Express
International Inc.

FREE CATALOG
CALL TOLL FREE
1-800-338-0531



Parts Express is a full-line distributor of electronic parts and accessories, geared toward the consumer electronics industry and the technical hobbyist. We stock an extensive line of replacement parts for TV and VCR repair. Call for your FREE 148 page catalog today.

Free catalog is sent via bulk mail. For express delivery, please send \$2.50 to cover 1st class postage. Foreign destination customers send \$5.00 to cover postage.

340 E. First St., Dayton, Ohio 45402

Circle (9) on Reply Card

Test equipment update:

Analog signature analyzers - Part I

By Vaughn Martin

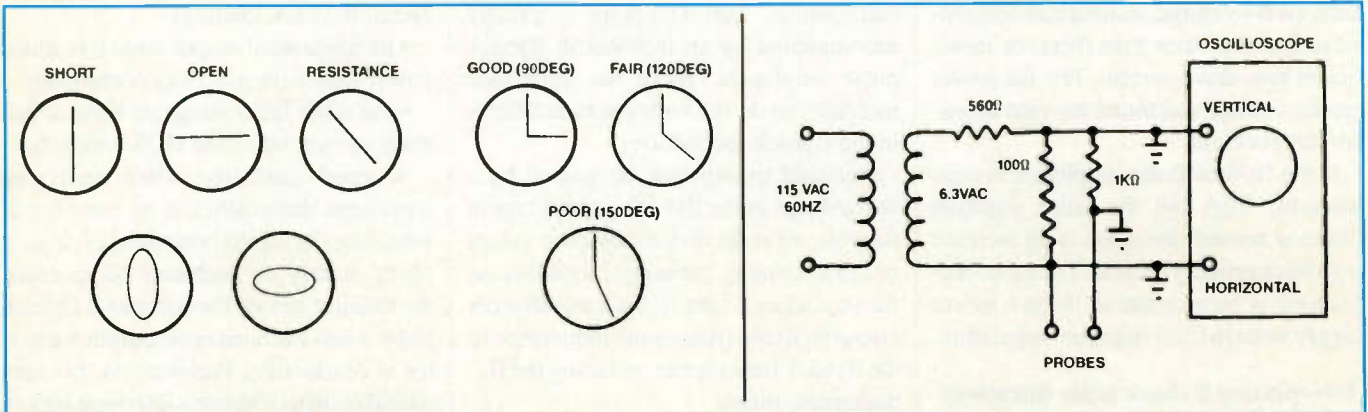

Figure 1. A typical greatly simplified analog signature analyzer and representative signatures.

An analog signature analyzer is an electronic test instrument that is used to pinpoint defective components with no power to the circuits in the unit under test. This three-part article examines the theory of operation, as well as numerous applications of this valuable piece of equipment.

This instrument checks each component, with the power off, while they are still mounted on the circuit board. This allows you to see if components exhibit normal characteristics.

The analyzer displays a curve, called a "signature." This signature, (hence the instrument's name) represents the operat-

ing characteristics of the component connected to the analog signature analyzer.

Even though this instrument is primarily designed for analog troubleshooting, it can also troubleshoot digital TTL 7400 series IC's, memories, and even selected features on a microprocessor. These features include checking the data, address, reset and INTE pins.

Getting acquainted with analog signature analyzers

An analog signature analyzer is a specialized piece of electronic test equipment, even though it has a relatively simple theory of operation. You can actually build a very simple analog signature analyzer with only a few components. It is

used in conjunction with an oscilloscope (for its CRT and horizontal and vertical amplifiers). See Figure 1.

Many Navy ETs (Electronic Technicians) remember making these test fixtures, commonly called an "octopus" because the hanging wires resemble the legs of an octopus.

However, we are more interested in commercially available instruments. One of the first and simplest of the three signature analyzers covered here was the Heath model IT-2232 (Figure 2). This analog signature analyzer cost about \$239 in kit form.

Today there are essentially two companies building analog signature analyzers in more traditional, already assem-



Figure 2. Heath's model IT-2232 analog signature analyzer.



Figure 3. The B&K Precision model 545 circuit analyzer

If you enjoy Amateur Radio, you'll enjoy CQ.



It's a different kind of ham magazine. Fun to read, interesting from cover to cover, written so you can understand it. That's CQ. Read and enjoyed by over 90,000 people each month in 116 countries around the world.

It's more than just a magazine. It's an institution.

CQ also sponsors these thirteen world famous awards programs and contests: The CQ World Wide DX Phone and CW Contests, the CQ WAZ Award, the CQ World Wide WPX Phone and CW Contests, the CQ World Wide VHF WPX Contest, the CQ USA-CA Award, the CQ WPX Award, the CQ World Wide 160 Meter Phone and CW Contests, the CQ Five Band WAZ Award, the CQ DX Award, and the highly acclaimed CQ DX Hall of Fame. Accept the challenge. Join the fun. Read CQ.

Also available in Spanish language edition. Write for rates and details.

SUBSCRIBE TODAY!



The Radio Amateur's Journal
76 North Broadway
Hicksville, NY 11801

Please start my CQ subscription with the next available issue.

Enclose payment or charge information with order.
Term and Rate (check one):

	USA	VE/XE	Foreign
1 Year	<input type="checkbox"/> 22.95	<input type="checkbox"/> 25.	<input type="checkbox"/> 27.
2 Years	<input type="checkbox"/> 43.	<input type="checkbox"/> 47.	<input type="checkbox"/> 51.
3 Years	<input type="checkbox"/> 63.	<input type="checkbox"/> 69.	<input type="checkbox"/> 75.

Paid by: Check Money Order VISA MasterCard
 American Express



Card Number:

--	--	--	--

Allow 6-8 weeks for delivery of first issue

Name _____

Street _____

City _____

State or Country _____ Zip _____



Figure 4. The B&K Precision model 5030 autotracer. ↑

Figure 5. A B&K Precision model 5030 autotracer showing pin 1 on its cable. →

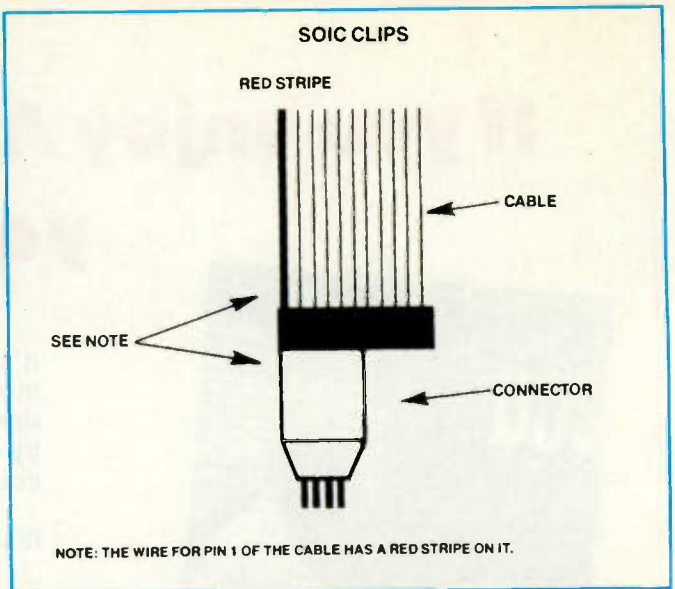

bled, (manufactured) end products: B&K Precision and Huntron. Let's look at two B&K Precision analog signature analyzers. These are the model 545 Circuit Analyzer (Figure 3) and the PL 5030 Autotracer (Figure 4).

You will note that B&K Precision and Huntron have many similarities.

Comparing signatures

The B&K Precision Model 545 Circuit Analyzer tests approximately 98% of all

electrical components in-circuit with power off. It produces a voltage-versus-current (V-I) curve on the CRT. The signature of a component that is suspected to be faulty can be compared against the V-I curve (also called a signature) of a known-good component.

This is made possible because the instrument has A and B inputs, and internal circuitry that switches back and forth between the two inputs at a rate of approximately 2Hz, controlled by an internal

oscillator set at that frequency. This switching allows the two signatures to be superimposed upon one another, allowing the operator to quickly and easily detect any differences in components.

The Model 545 offers four voltage ranges and five source impedances at four frequencies. There is also an AUTO-SCAN mode which automatically sequences a series of tests. For example, all pins on an IC (up to 40 pins) can be checked. You can set an acceptance tol-

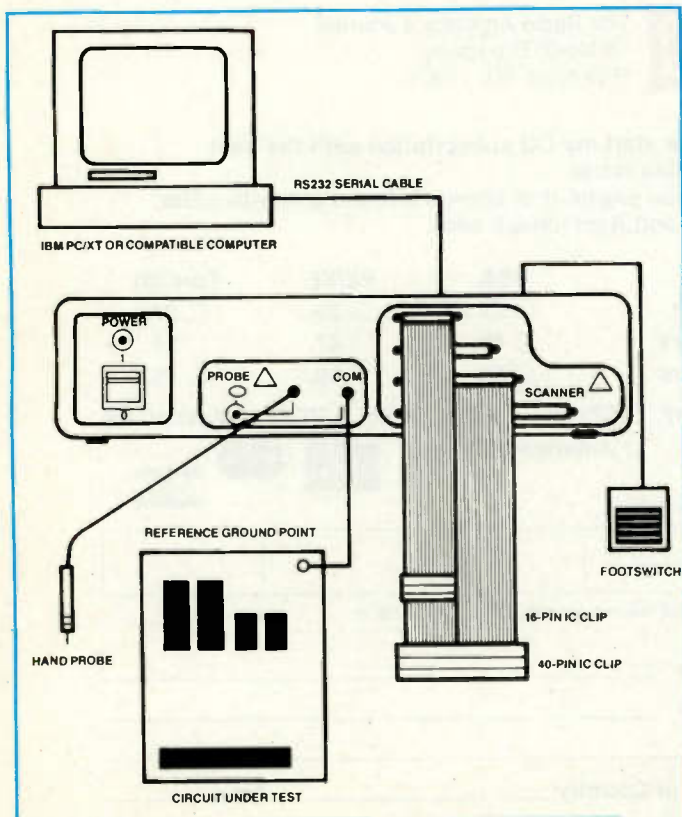
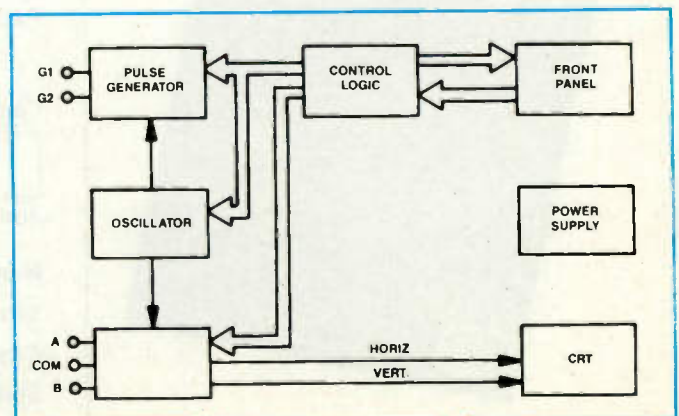

Figure 6. A typical equipment set-up using a B&K Precision model 5030 autotracer. ←

Figure 7. An analog signature analyzer's block diagram. ↓



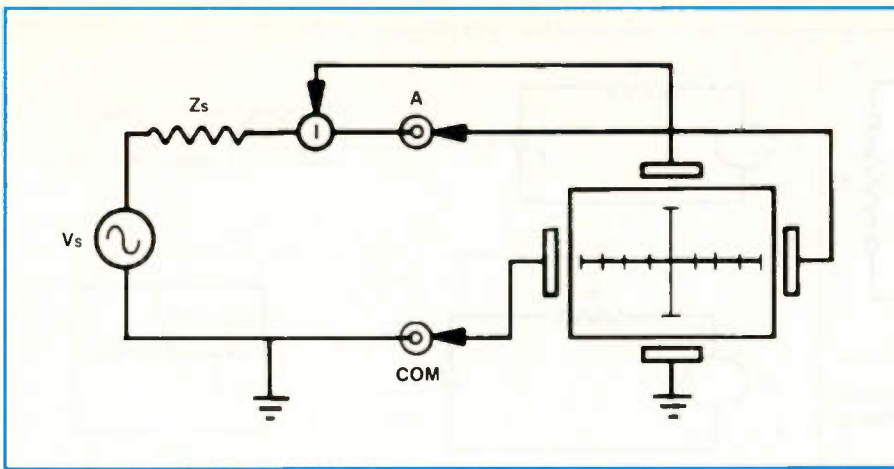

Figure 8. An analog signature analyzer's ac source in series with a source impedance.

erance between 2% and 100% between the two inputs (A and B). This would be ideal for hand selecting diodes in a precision clamping or active rectifier circuit.

This unit comes with an RS-232 port so signatures can be stored on a computer and compared at a later date. The software (AK545) adapts an IBM or compatible computer to the signature analyzer.

The B&K Precision Model PL 5030 Autotracer is a board level tester type of analog signature analyzer. This analog

signature analyzer compares a suspect board (rather than a single component), to a known-good board. It stores up to 64 nodes in computer memory. You may measure node-by-node manually in the traditional manner. Alternatively, you may elect to scan through the 64 nodes via a computer interface. The Auto Tracer is completely menu driven.

The Model PL 5030 comes with four cables: one each of 40 pins, 28 pins, 20 pins and 16 pins. Pin 1 of each cable is

identified with a red stripe. See Figure 5. Table 1 shows some of this analog signature analyzer's standard commands.

Setting up

Figure 6 is a typical equipment set up. When you begin, observe the usual precautions about static discharge or you may damage the delicate circuitry associated with the RS-232 interface port. The set up is as follows:

1. Connect the serial cable to the RS-232 serial port. Computer models such as the IBM PC/XT, Personal System/2, and compatibles require a 25-pin connector. IBM PC/ATs require a 9-pin connector. For a 25-pin computer connection, use the 25-to-9-pin adapter.

2. Carefully plug in the appropriate IC test clips that will be used to scan the ICs under test.

3. Plug the black probe (with alligator clip) into the black banana jack labeled "COMMON" and connect this to a reference point on the circuit under test (typically ground). Plug the red probe into the red banana jack designated "PROBE". These two test probes may be substituted by a single BNC terminated probe. The

ATTENTION SERVICE MANAGERS

PTS is the NATION'S LARGEST source for Exact Replacement Parts and Service.

Check out our savings on major brands of television...

- TUNERS
- MAIN BOARDS
- MODULES
- COMPLETE CHASSIS

Exact replacements for RCA, GE, ZENITH, NAP and many more!

Call **1-800-844-7871** for more information and a FREE Price Guide.

PTS Electronics



- TUNERS • MODULES • MONITORS •
- SATELLITE RECEIVERS • CAMCORDERS

4941 ALLISON STREET #11
ARVADA, COLORADO 80002
Customer Service: 1-800-331-3219
Local: 303-423-7080
Fax: 303-422-5268

Corporate Headquarters:
5233 HIGHWAY 37 SOUTH
BLOOMINGTON, INDIANA 47401
Customer Service: 1-800-844-7871
Local: 812-824-9331
Fax: 1-800-844-3291

110 MOPAC ROAD
LONGVIEW, TEXAS 75602
Local: 903-757-6200
1-800-264-5082

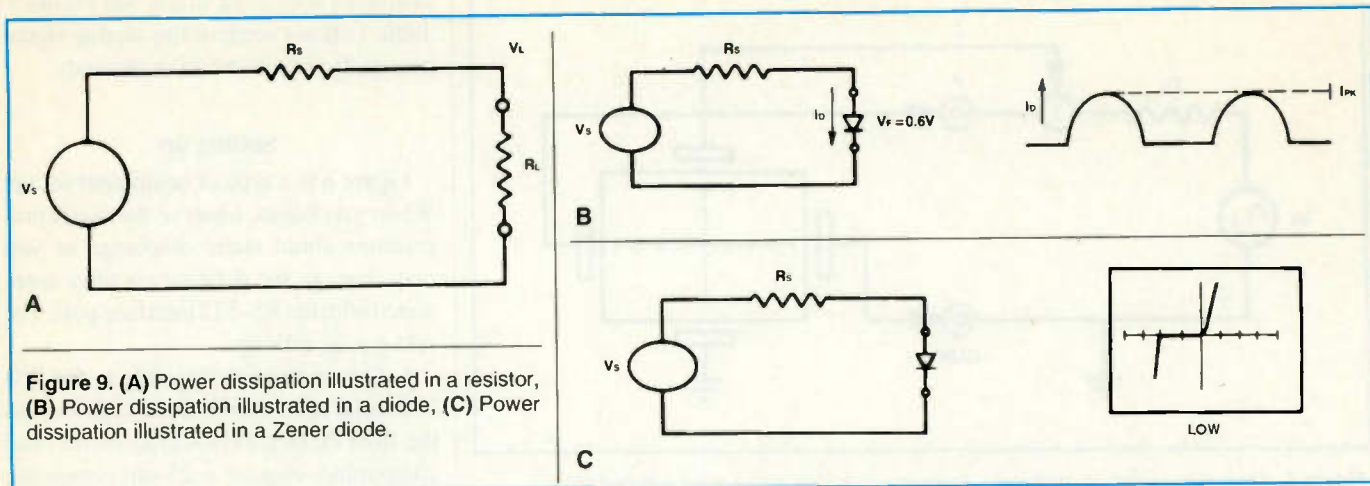

outer shield of the BNC connector becomes the reference point, or common, of the circuit under test.

4. Connect the footswitch to the input jack on the rear panel.

5. Turn on the computer and let DOS load (refer to the IBM DOS reference guide). Before examining actual applications of an analog signature analyzer, let's see what makes all of this possible.

Signature analyzer operation

Figure 7 is the block diagram of an analog signature analyzer. This is a Huntron Tracker Model 2000. This is a representative analog signature analyzer. Although it is one of the most advanced units in the industry, it still illustrates the fundamental principles of operation.

As an overview, the control logic selects the appropriate channel, frequency, impedance range, and pulse generator mode through front panel pushbuttons. The oscillator provides the test signal used by both the signal section and the pulse generator.

In the signal section, the test terminals

are driven by the test signal. Signal conditioners monitor the terminals and produce the horizontal and vertical signals used for the component signature on the CRT.

The pulse generator provides an added source of stimulus for testing the terminal devices. The power supply provides voltages for CRT acceleration, deflection, and filament as well as the low voltage general purpose supply used by all other sections of the circuit.

Actual operation

There are four major groups of con-

trols on the front panel from which to select

- Range
- Frequency
- Channel
- Pulse generation mode features.

The Range consists of four selections, LOW, MED1, MED2, and HIGH. The range selected controls the CRT's horizontal sensitivity. See Table 1. The Channel Select feature selects Channel A or B. In the ALT position it switches back and forth between each channel for comparison purposes. The Frequency Selection section enables 50Hz to 60Hz



Figure 10A. A Huntron tracker model 2000.

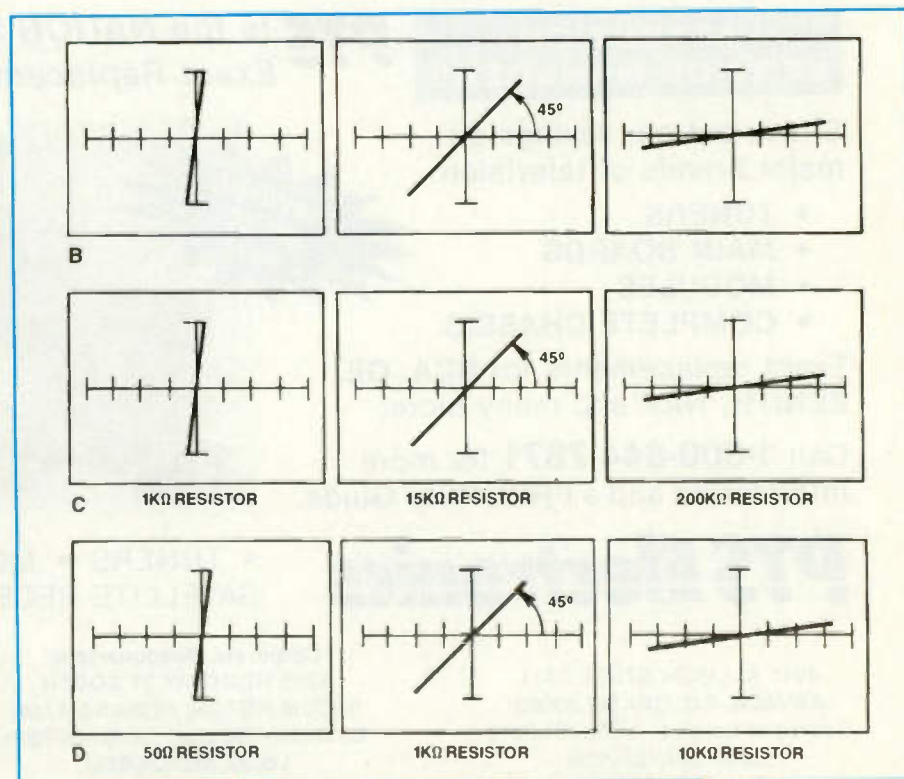

Figure 10 (B) A generalized resistance example, (C) A comparison of the same resistance taken on the MED 2 range, (D) A comparison of the same resistance taken on the MED 1 range.

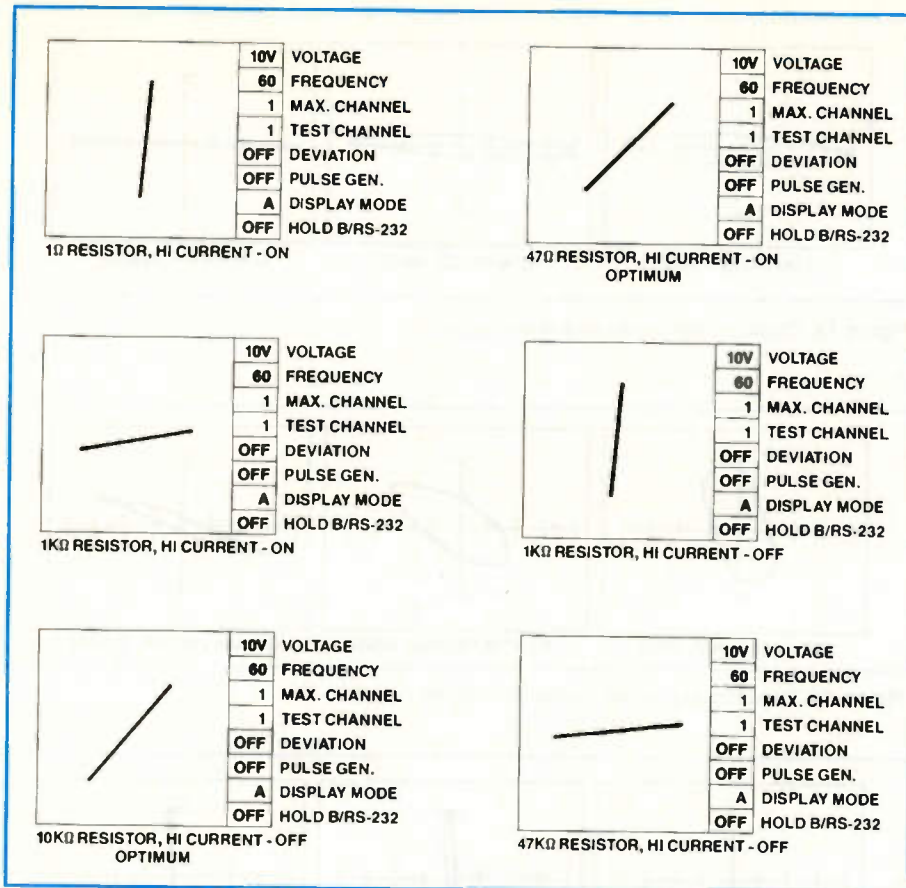

Figure 11. A comparison of what similar resistances look like on a model 545 B&K precision circuit analyzer.

to be selected, (depending on line frequency) or fixed frequencies of 400Hz or 2,000Hz.

If the instrument is used with a 400Hz power source, such as exists on aircraft, an 80Hz test signal is provided. The Pulse Generation section allows selection of a dc or a Pulsed mode. It also selects the polarity of the signal.

Troubleshooting examples

There are at least 25 different types of electronic components you can troubleshoot with this instrument. These include both passive and active devices. These active devices can be either analog

or digital IC's, as well as triacs, optoelectronic devices and many speciality ICs such as LASCRs (Light Activated SCR's).

We will examine three passive devices here, a resistor, a capacitor, and an inductor. Then we'll examine an ordinary NPN bipolar silicon transistor, an SCR, a triac, and some optoelectronic devices. We'll conclude with 7400 series TTL digital ICs and some microprocessor related topics, such as "stuck" buses.

Forming the signatures

To gain an appreciation of how the X-Y deflection driver sections of the CRT form

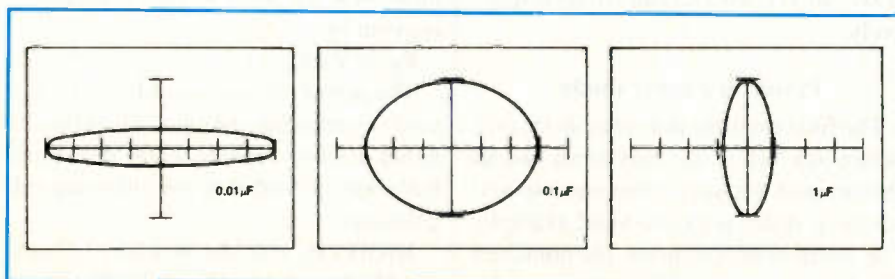

Figure 12. A generalized illustration of a larger capacitor's signature.

these signatures, let's review some basic trigonometry and electronics theory.

The voltage $V(t)$ across a capacitor at a given time is:

$$V(t) = a \sin(\omega t)$$

The current in the loop is 90 degrees out of phase with the voltage and is:

$$I(t) = b \cos(\omega t)$$

a and b , in these two equations are both constants.

If you divide both sides of these equations by their constants, square each equation, and add them together, you get:

$$\frac{V^2(t)}{a^2} + \frac{I^2(t)}{b^2} = \sin^2(\omega t) + \cos^2(\omega t) = 1$$

This, you may recall, is the equation of an ellipse. Under the special condition that constants a and b are equal, the ellipse is a circle.

Interpreting the signatures

Realizing that the constants, a and b , are affected by the test signal frequency and the selected impedance range is the basis of interpreting the CRT's signature.

This becomes even more apparent when we observe actual CRT signatures taken on different frequency ranges. We will observe the distorting of a circle, squashing it to make it fatter, and elongating it to make it taller. We will also see straight lines being rotated on the CRT.

What is actually occurring is we are changing these constants, a and b . As these change, they reflect changing component characteristics. The analog signature analyzer's CRT deflects and displays signatures in a manner which corresponds to these changes. The value of the signature analyzer is in the interpretation of these signatures.

Before you become truly comfortable using this new kind of instrument, you may need reassurance that you will not overstress a component. Let's examine three passive components, a resistor, a diode and a zener diode. Later we'll again address overstressing in a small signal bipolar transistor application.

First, the analog signature analyzer is essentially an ac voltage source in series with a source impedance, Z_s (Figure 8). The ac source is purposely not regulated; therefore, as you draw more current from it, its voltage decreases dramatically.

Power in a resistor

With a purely resistive load, the maximum power transfer occurs when load

impedance is matched to the source impedance ($R_L = R_S$). See Figure 9A.

When $R_L = R_S$ the source voltage, V_S , is divided in half at the terminals so that:

$$\text{equation (1) } V_L = V_S/2$$

and when V_S is a sine wave, the power dissipated in R_L is:

$$\text{equation (2) } P_D = V_L^2/2R_L$$

where V_L is measured in peak volts.

Using equation (1) and substituting V_L in equation 2:

$$P_D = [V_S/2]^2/2R_L = V_S^2/8R_L$$

This is the equation for maximum power into R_L . Using this equation and data for V_S and R_S from Table 2, the maximum power transfer for each of the Huntron Tracker's four ranges is as follows:

$$\begin{aligned} \text{HIGH} - P_{\text{MAX}} &= (60 \text{ V})^2/8(74\text{k}\Omega) \\ &= 6.08\text{mW} \\ \text{MED 2} - P_{\text{MAX}} &= (20 \text{ V})^2/8(27\text{k}\Omega) \\ &= 1.85\text{mW} \\ \text{MED 1} - P_{\text{MAX}} &= (15 \text{ V})^2/8(1.2\text{k}\Omega) \\ &= 23.4\text{mW} \\ \text{LOW} - P_{\text{MAX}} &= (10 \text{ V})^2/8(54\Omega) \\ &= 231\text{mW}. \end{aligned}$$

Note where 54 Ω , 1.2k Ω , 27k Ω and 74k Ω are the source impedances of LOW, MED1, MED2, and HIGH respectively.

Power in a diode

A small signal diode rectifies ac test signals so that the current flowing in the diode is a half-wave rectified sine wave. See Figure 9b. The average power dissipated in a diode is approximately equal to the product of forward voltage and average current. The average current for a half-wave sine wave is:

$$\text{equation (1) } I_{\text{AVE}} = I_{\text{PK}}/\pi$$

the peak diode current in the test circuit in Figure 9b is:

$$\text{equation (2) } I_{\text{PK}} = (V_S - 0.6) / R_S$$

(0.6V is the junction drop).

By using equations (1) and (2) and the formula for power in a diode, we get equation (3):

$$\text{equation (3) } P_D = V_F I_{\text{AVE}}$$

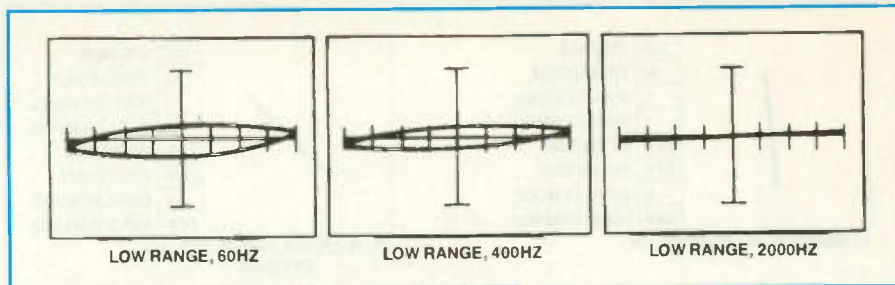

Figure 13. Capacitor signatures on the low range.

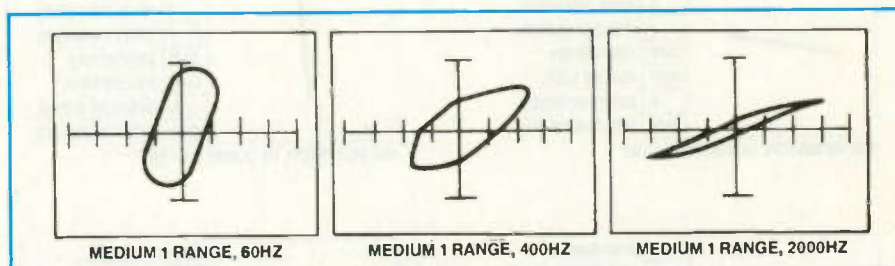

Figure 14. Capacitor signatures on the MED range.

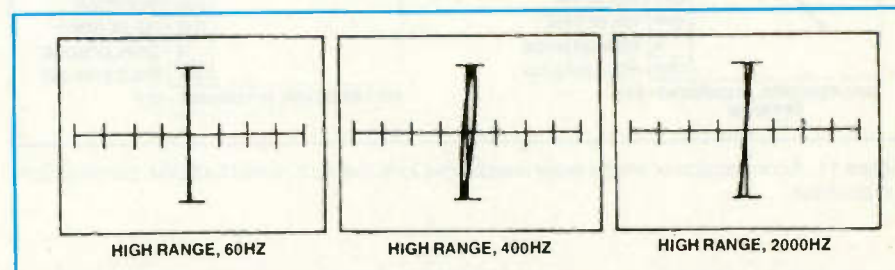

Figure 15. Capacitor signatures on the high range.

$$= 0.6V[I_{\text{PK}}/\pi] = 0.6V(V_S - 0.6V) / \pi R_S$$

Using Table 2 again, diode power can be determined for each range as follows:

$$\begin{aligned} \text{HIGH} - P_{\text{MAX}} \text{ DIODE} &= 0.6(60 - 0.6V)^2/\pi(74\text{k}\Omega) = 0.15\text{mW} \\ \text{MED 2} - P_{\text{MAX}} \text{ DIODE} &= 0.6(20 - 0.6V)^2/\pi(27\text{k}\Omega) = 0.14\text{mW} \\ \text{MED 1} - P_{\text{MAX}} \text{ DIODE} &= 0.6(15 - 0.6V)^2/\pi(1.2\text{k}\Omega) = 2.3\text{mW} \\ \text{LOW} - P_{\text{MAX}} \text{ DIODE} &= 0.6(10 - 0.6V)^2/\pi(54\Omega) = 33\text{mW} \end{aligned}$$

Note again where 54 Ω , 1.2 k Ω , 27 k Ω and 74 k Ω are the source impedances of LOW, MED1, MED2, and HIGH respectively.

Power in a zener diode

The final example is a zener diode (see Figure 9c). While this may seem like an obscure and not very often encountered device, it really is a quite valid example. The basic semiconductor phenomenon which occurs in an IC's junction under these tests by an analog signature ana-

lyzer is identical to the discrete zener's action. Therefore, this is a representative and realistic example of power dissipation in common devices (zeners and ICs).

The actual power in a zener naturally depends on a few factors, its zener voltage being one of the most salient. In our examples, we're going to use 5V as our reference zener breakdown voltage.

In the forward direction, a zener is equivalent to the silicon diode just covered. In the reverse, or breakdown direction, it is necessary to add the power contribution for the half cycle when the diode turns on at the zener voltage. This power is given by:

$$P_D = V_Z(I_{\text{AVE}})$$

The power calculation of I_{AVE} for this case is somewhat complex. Therefore, to avoid a lot of tedious math, the values have been provided in the following calculations:

$$\begin{aligned} \text{HIGH} - P_Z &= 0.15\text{mW} + 5V(0.23\text{mA}) \\ &= 0.15\text{mW} + 1.15\text{mW} = 1.3\text{mW} \\ \text{MED2} - P_Z &= 0.14\text{mW} + 5V(0.15\text{mA}) \end{aligned}$$

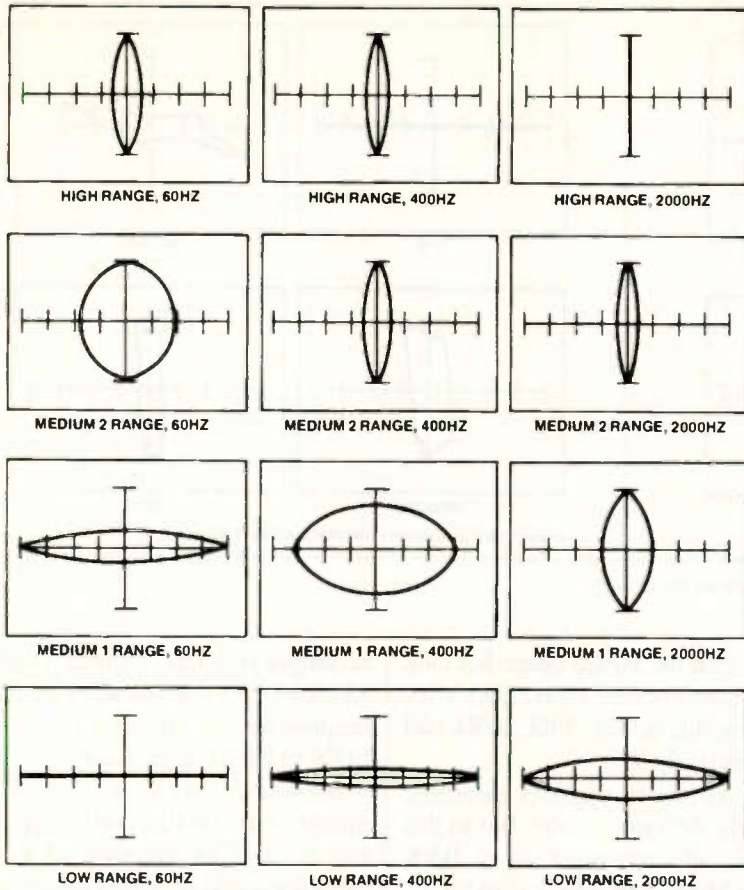

← **Figure 16.** A signature of a 0.22 μF capacitor on various ranges and tested at various frequencies.

$$\begin{aligned}
 &= 0.14\text{mW} + 0.75\text{mW} = 0.89\text{mW} \\
 \text{MED1} - P_Z &= 2.3\text{mW} + 5\text{V}(2.1\text{mA}) \\
 &= 2.3\text{mW} + 10.05\text{mW} = 12.8\text{mW} \\
 \text{LOW} - P_Z &= 33\text{mW} + 5\text{V}(20.2\text{mA}) \\
 &= 33\text{mW} + 101\text{mW} = 134\text{mW}.
 \end{aligned}$$

Again, you will note that the worst case power occurred on the LOW range and even that was small, less than 1/5W.

Resistance measurements

Figure 10 is a Huntron Tracker Model 2000, the instrument which will be used to demonstrate the principle of operation of a signature analyzer.

Because voltage and current are in phase when measuring a pure resistance, the signature curve becomes a straight line. But note that, as resistance increases, the straight line deflects from a straight up vertical line to a flat horizontal line. This makes sense, because as resistance increases the current through the resistance becomes smaller.

Next, refer to Figure 10b and note that the resistances start to cause the signature

MCM has the right combination for you!

TENMA® Universal Test System

The TENMA Universal Test System combines four of the most commonly used pieces of test equipment into one economical unit. Designed for use in service, design and education.

Features: • Triple output power supply 0-30VDC(0-2A variable), 5VDC fixed(2A), 13.8VDC fixed(3A) • Full function 4½ digit DMM • 250MHz frequency counter • 2MHz sweep function generator • Comes complete with test leads and owners manual • Power requirements: 110/220VAC, 50/60Hz • Dimensions: 14½" (W) x 6½" (H) x 12½" (D) • Weight: 38½ lbs. • Call your MCM sales representative for complete specifications and order yours today!

#72-1005 \$419⁹⁵ (ea) \$399⁹⁵ (2-up)



MCM is now a RCA/GE Premier Distributor

For a FREE Catalog Call:
1-800-543-4330
 To Order by FAX:
1-513-434-6959



90 Days same as cash!



MCM ELECTRONICS
 650 CONGRESS PARK DR.
 CENTERVILLE, OH 45459-4072
 A PREMIER Company

ES-72

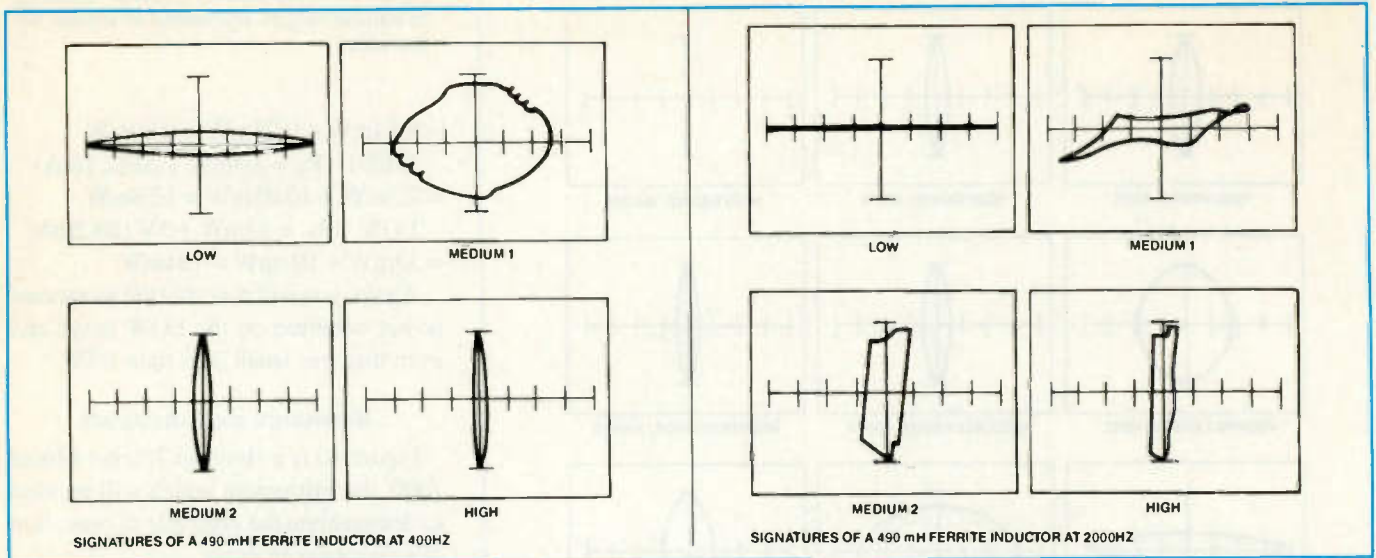

Figure 17. A 490 mH inductor's signature at various frequencies and ranges.

to assume a more horizontal posture as they increase. The resistances in this case are 50Ω, 1kΩ, and 20kΩ respectively, taken on the LOW range. The resistances taken on the MED 2 range are shown in Figure 10c. To reiterate, as the resistance increases, the line approaches closer to a straight horizontal line or X-axis. Refer to Figure 10d and note that on the MED1 range the same deflections occurred as in

Figure 10c on the MED2 range, but look at the resistances causing this effect. They are far less, that is, only 50Ω, 200Ω, and 10Ω respectively.

Figure 11 shows resistors measured with nearly the same results. But in this case, they are measured on a B&K Precision Model 545 circuit analyzer.

Capacitance measurements

In testing capacitors you will note as we go from the LOW to the HIGH ranges we are testing smaller value capacitors (Table 2). This is just the opposite of what we did with resistors, but remember the equation from which we derived the ellipse. Refer to Figures 12 through 15 and note how much fuller the ellipse is on the HIGH range. The reason for this difference in signature on the different ranges is that capacitance values of less than 1.0μF appear as open circuits in the LOW range while capacitance values greater than 1μF appear as short circuits in the MEDIUM and HIGH ranges.

Figure 12 is a generalized illustration showing how a larger value capacitor first widens then contracts again into an ellipse; however, note the 90-degree shift

accompanying this. Figures 13 through 15 show the same capacitor at different frequencies on differing ranges, from LOW to HIGH respectively.

However, since you'll be working mostly with smaller value capacitors, Figure 16 is an overview of a 0.22μF capacitor tested at various ranges and frequencies. Try to memorize this effect and compare it against inductors.

Inductance measurements

Let's look at a 490mH inductor in the three ranges. Refer to Figure 17 and note that this small value inductor, which is designed to operate at higher frequencies, saturates at lower frequencies and shows marked distortion. Next, refer to Figure 18, this is a 6H inductor (a healthy chunk of copper) and note that it does not saturate at all and there is virtually no distortion present here.

This concludes the first part of this three-part article. In parts II and III we will examine the pulse generator within an analog signature analyzer. We'll also look at more active devices, and finish with more sophisticated totally computer generated operations. ■

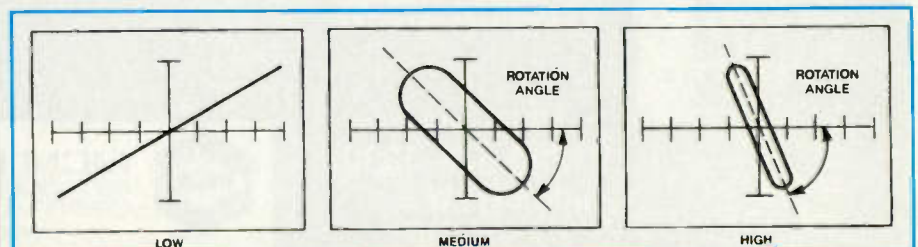

Figure 18. A 6 Henry inductor showing no saturation nor any distortion under test.

To Order Back Issues

Send \$3.50 Per Issue

(Check, Money Order, Mastercard, VISA, and AMEX).

Send All Correspondence To:

CQ Communications
76 North Broadway
Hicksville, NY 11801

Or Call

516-681-2922

FAX 516-681-2926

ORDER YOUR
BACK ISSUES
TODAY!

Test your electronics knowledge

By J.A. Sam Wilson, CET

See the TYEK correction in this month's 'What do you know about electronics?'

In this issue, and the next few issues, I am going to give questions that appeared in one of the first CET tests. This test dates back to the 1960's so there is some older technology and timeless technology involved. Lew Edwards helped get the CET program started by writing the first CET tests.

(Note: questions in the first tests were limited to broadcast TV and TV receivers. The questions were not all multiple choice as they are today.)

1. The rating "6 by 20" for stranded guy wire means:
 - A. number 6 wire, 20 strands.
 - B. number 20 wire, 6 strands.
 - C. manufacturer's designation of wire material.
 - D. reel number.
2. The video signal is frequency modulated.
() true () false
3. A picture tube is most likely to implode if you
 - A. knock off the neck of the tube.
 - B. break off the spot under the base where the vacuum was introduced.
 - C. punch a hole in the face plate.
 - D. handle it carefully.
4. Capacitive reactance is given in
 - A. henries.
 - B. microfarads.
 - C. ohms.
5. A quick check to determine if the high-voltage circuit is operating properly is to measure the
 - A. horizontal drive voltage.
 - B. horizontal screen voltage.
 - C. B plus boost voltage.
 - D. horizontal output cathode current.
6. In a standard 44mc (now abbreviated 44MHz) IF TV receiver at what frequency is the
 - A. audio carrier _____?
 - B. video carrier _____?
 - C. color carrier _____?
7. In color TV receivers, what purpose does the delay line serve?
 - A. delays chrominance signal
 - B. delays color burst
 - C. delays luminance signal
 - D. delays RY/BY amp
8. A square wave generator is used for testing amplifier circuits to
 - A. check rise time for low-frequency response.
 - B. check ability to pass a high frequency.
 - C. check accurately exact gain.
 - D. check low- and high-frequency response.
9. An oscilloscope is normally calibrated to measure
 - A. RMS voltage.
 - B. peak value.
 - C. peak-to-peak value.
 - D. only ac voltage.
10. In high-powered transistor amplifiers, silicon grease is used to make a good _____ bond between the transistor and heat sink.
 - A. electrical
 - B. thermal
 - C. mechanical
 - D. insulating

Bonus Question—Which radio company introduced the first small car in 1939?

(Answers on page 47)



Join Us

on the ETA-SDA Pro Show

Satellite S3, ch. 21, 5.8 mHz
Sunday evening tech show: 9-11 p.m. EST

On the ETA-SDA RBBS
through the GENie Network
1-800-638-8369
to sign up on GENie

For TechniTips - job openings - Association Journal - Tech Training monographs - regional tech & business seminars (with college credit) - Certification - local chapters - a voice in your profession - 1993 national convention and satellite trade show in Moline - August 1993.

For Information Call:
317-653-8262
602 North Jackson
Greencastle, IN 46135

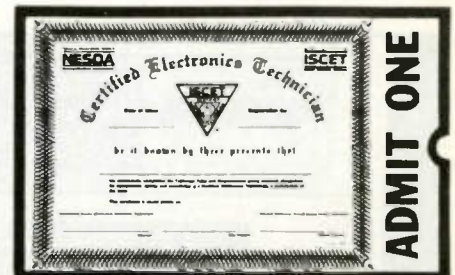

Your Ticket To SUCCESS

Over 28,000 technicians have gained admittance worldwide as certified professionals. Let your ticket start opening doors for you.

ISCET offers Journeyman certification in Consumer Electronics, Industrial, Medical, Communications, Radar, Computer and Video. For more information, contact the International Society of Certified Electronics Technicians, 2708 West Berry Street, Fort Worth, TX 76109; (817) 921-9101.

Name _____
Address _____
City _____
State _____ Zip _____

Send material about ISCET and becoming certified.

Send one "Study Guide for the Associate Level CET Test." Enclosed is \$10 (inc. postage).

Tape backups for IBM compatible computers

By Sheldon Fingerman

What's the most expensive part of your computer? The hard drive? The monitor? The CPU? The CD-ROM? Actually, it's none of the above.

How about the data? I assure you that you can replace any part of your computer in less time than you can retype all of the data back in. A lot less time! In the event of a computer disaster, the best way to save much grief for yourself or for your customers is to install an efficient data backup system.

Many ways to back up

There are many ways to backup data.

Fingerman is an electronics and computer consultant and servicing technician.

The first is to use the BACKUP command that comes with the disk operating system (DOS). Since you already have it, the price is right. BACKUP's most troublesome problem is that you need to store all of your data on floppy disks; the more data, the more disks you need. It also takes a loooooong time.

Regardless of how fast your computer is, floppy drives move at a pace all their own. Still, it's better than nothing.

Your next choice might be to use one of the more popular "aftermarket" backup programs. You will still have to use floppies, but these programs will give you a wealth of information that DOS's BACKUP does not.

The programs will allow you to easily

select, or "tag" files and subdirectories that you want to backup. Many of these programs not only tell you how many disks you will need, but how long it will take to complete the backup before you start; a real advantage over DOS, but you still have to feed disk after disk into your computer. Using either of these programs isn't all that bad.

If you only need to backup your "data," you may be able to get everything on one or two disks. Should you encounter a failure however, you would have to rebuild your entire hard disk using all of your original disks. You do have all of your original disks, don't you?

Assuming that the answer is yes, you would have to reinstall all of your soft-



Figure 1. Colorado Memory's Jumbo 120 internal tape drive, installed in a full tower system. The photo shows a tape being inserted. As you can see, the backup physically installs just like a floppy drive.

Figure 2. An older Archive 40 megabyte tape backup (internal). Even the inside resembles a floppy drive. At the rear of the drive you can see the jumpers, the edge connector, and the terminating resistor.

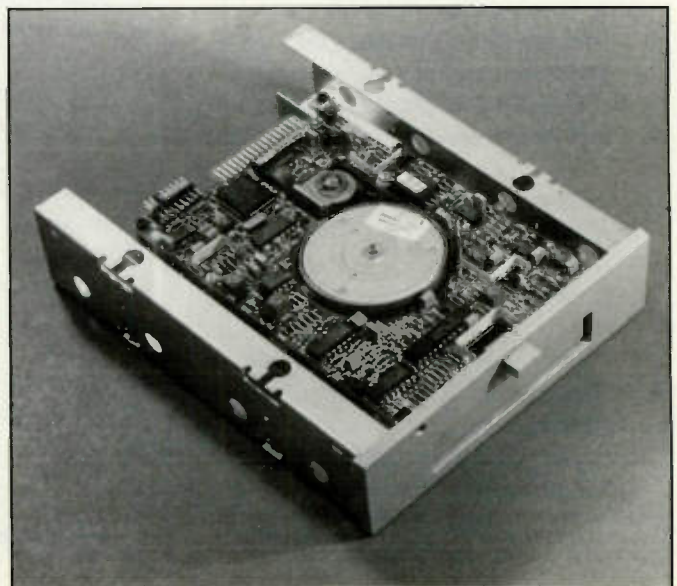

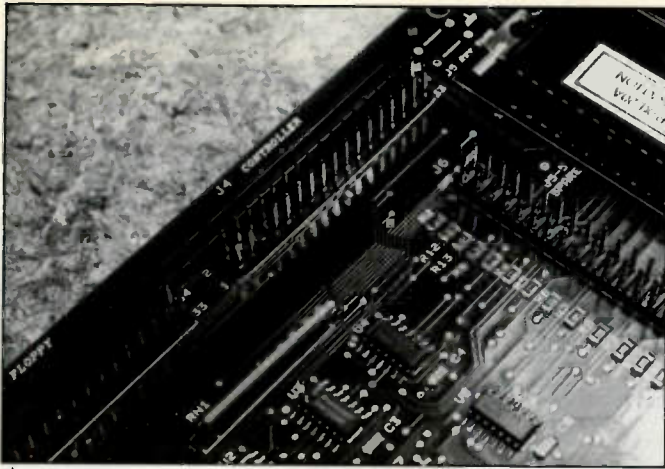

▲ **Figure 3.** A detail of an external backup card (older Archive). You can see that the connectors for both the floppy drives and the controller are clearly labeled. Also, if you look closely you can see that pin 5 is missing on connector J4. This is the "key" which matches the ribbon cable.

Figure 4. Colorado Memory's latest, the Trakker 250. This external tape drive merely plugs directly into your parallel (printer) port. The black cord is the power cord, since there is no way for this type of drive to access power from a parallel port. This software company has three computers on site, and another 15 at test locations, making this backup a real bargain for them. ▶



ware. Even the ones that took you a week to figure out. And if you "borrowed" the software from a friend—we don't even want to get into that one.

Installing a tape backup

So what's a person to do? Install a tape backup system, that's what. They're not as expensive as they used to be, they are much faster than they used to be, and they are extremely reliable. You can record up to 250 megabytes on a cartridge that's smaller than a cigarette pack. Not only that, you can go out and have lunch while all this is happening. Or, you can have it happen in the middle of the night when you aren't even there. Try to do that with your floppies!

The most popular sizes for modern tape backups are 120 and 250 megabytes. Should you opt for the 120Mbyte size, and need more space, you can always add tape after tape. Same thing goes for the 250. When trying to decide which size you should get, think of convenience, and the total cost of the backup with the number of tapes you will require.

Types of tape backup systems

The three most popular tape backup systems are the internal, the external, and,

the latest in technology, backups that plug directly into your parallel port, requiring only that you install the software.

The internal tape backup will fit in virtually any half-height drive bay. Some models simply replace your B: drive, and require no special cables. If you already have both an A: and B: drive, you may require an extra cable to complete the installation, usually included with the backup. This extra cable replaces the floppy drive cable, where it attaches to the floppy controller card. The other end goes directly to the backup.

Because most modern computers combine the floppy and hard drive controller on one card, simply follow the cable from the floppy drive(s) to get the right one. You now have a free cable coming from your floppy drives that you just removed from the controller.

No problem. There is another "socket" on the new backup cable that you plug the floppy cable into. This is a relatively easy procedure; just be sure to double check that the cables are installed correctly. Every ribbon cable inside your computer is marked on one side, usually by a red or blue line.

Before removing any cable, check that the colored line is referenced to pin one (1) of anything it's connected to. You may

find that the cable is reversed. This is acceptable, as long as it's the same on both sides (pin one to pin one).

Since ribbon cables angle up or down when installed on a device, some installers may reverse the cables to make installation easier. Again, when all cables are connected, they must all be in harmony. A good analogy is connecting speakers to a stereo amplifier. It makes no difference whether the red wire goes to plus or minus, as long as it's the same on both channels.

Keyed cables

Another problem you may encounter is that many manufacturers "key" their cables. Normally this is fine, and helps the installer avoid mistakes. Conversely, it is not uncommon that these "keys" will prevent you from obtaining proper polarity with a particular system.

A "key" will be evident in one of two ways. You may find a slot on an edge connector that allows the cable to be attached one way only. On pin connectors you may find that the cable has one hole in the socket filled, matching a missing pin. Reversing these types of cables is not impossible. If necessary, a sharp pointed object, or some pliers will remove most of these "keys" with ease. It's certainly a

lot easier than waiting for a new cable.

Never cut off a pin to reverse a cable. If you are installing an internal backup in place of a B: drive, you have to consider two things. First, make sure to eliminate the B: drive from your setup menu. The backup software will find it with no problem, but you don't want the computer thinking it's a second floppy drive. Second, most computers need what's called a terminating resistor in the last floppy drive in the chain, and the backup may come with one installed.

A terminating resistor usually looks like a thin IC with a bunch of pins in a single row. It's about an inch long, and just plugs in. One thing it does not look like is a resistor. Check the documentation to see if this resistor needs to be removed, or added, and where it is located.

External tape backups

External tape backups reside outside of your computer. They have their own self-contained cases, and most get power from the computer itself, while some require external power. If you have no extra drive bays in your computer, an external backup would be the best choice.

Installing an external backup requires that you install an adapter card inside your computer. The card can be inserted into just about any open "slot." Make sure it is seated fully, and secured with the proper screw. If applicable, attach one of the plugs from the power supply to the card.

Many of these kits come with a Y adapter, in case the power supply in your system doesn't come with enough plugs. Once again, you will have to remove the cable from the floppy controller. A new cable will be connected from the controller to the new adapter card, and the cable from your floppy drive(s) will also be connected to the new adapter card.

Be sure not only to observe proper polarity, but that the floppy drives and controller are attached to the proper connectors. As you can figure, the odds on getting this one right are 50/50. This new card will also have a large connector on it facing out the back of your computer. The external drive's cable will attach to it quite easily. Extra adapter cards may be purchased, allowing you to use one backup with several computers.

When you purchase an external backup, you may find that the backup and the case are shipped separately (internal drive

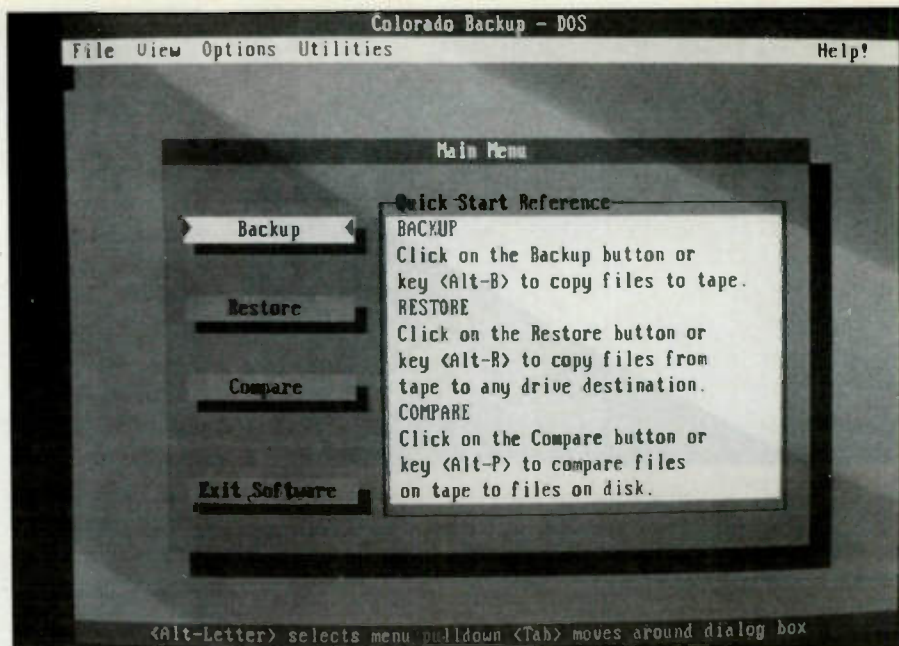

Figure 5. The main menu of a typical backup system. Either a mouse, or the keyboard can be used to run this software. This particular software even has a Help option (upper right corner).

and external kit). Assembly is quite easy, and if you decide you would like to use your external as an internal someday, you are all set.

An external drive with no adapter card

The latest in tape backups is an external backup that attaches to the parallel (printer) port. These have no adapter card. As a matter of fact you don't even have to open your computer at all. Just plug it in and install the software. They are an ideal choice for laptops, an office that has many computers, and the computer servicer who wants to back up his customer's data before starting any repairs.

Although the most costly of the three types (as of this writing) they can be quite cost effective, especially in a large office environment with lots of individual workstations. This is because an adapter card is not required for each computer. It can also be an excellent choice for the person who has a computer at home, as well as the office or shop.

Because this type of backup uses your printer port, a port is provided at the rear of the backup case, allowing you to "chain" your printer, should you choose to leave the backup in place.

I expect that we will soon see prices drop on these new external backups, phasing out the ones requiring an adapter card. Even though an internal backup

becomes conveniently a part of your computer, the advantages of these new external models should not be overlooked.

Software for tape backup systems

Running any of these models will require that you install some software. Each brand of software is unique to the brand of backup that it comes with, with some exceptions.

Loading the software may be as simple as putting in a floppy and typing "INSTALL." You may be required to make a subdirectory on your hard disk, and simply copy the files from the floppy over to it. You can even run the software directly from the floppy; and you will have to, should you encounter a crash.

Always make sure you have a copy of the backup software handy, as well as a disk with the operating system on it. If everything goes according to plan, running the software should bring the system to life.

On some models, merely putting the tape in the drive will provoke activity. You should see the light on the backup come on, and hear all kinds of whirring noises as the tape "initializes" itself. Hardware problems can almost always be traced to improper installation, and improper jumper settings. Double check your work, and even though the products can usually be installed straight out of the box, check the jumper settings against the documentation.

One common problem is that your computer tries to access the backup, when it is really looking for a hard or floppy drive. If this happens, see if the problem is caused by starting the computer with a tape in it. You may have to change the jumper settings, however.

Compatibility considerations

When purchasing a backup, new or used, make sure it's compatible with your computer. Backups for models 286 and up may not work with an older XT. And to my knowledge, you cannot use an IBM compatible backup with a Macintosh computer, and vice-versa.

Software problems are usually very simple. However, they often imitate hardware problems. Every software problem that I have encountered, which wasn't caused by improper installation, was incompatibility between the software and DOS 5.0, especially if you've purchased a used backup. You can spend hours trying to troubleshoot a backup system, not realizing that a newer version of the software is the answer. Most manufacturers are constantly updating their software, either because of "bugs," convenience, or updating for use with Windows.

If you have spent a reasonable amount of time trying to sort out a backup problem, call the manufacturer. Newer software may be the answer. Always know the "version" of the software when calling (1.2, 2.5, etc.). Updates are often provided free of charge.

Newer versions of software can cause problems as well. If you install the latest version on an existing backup system, be sure it's "backwards" compatible with the earlier version being replaced. You could find that version 4.5, for example, may not read tapes that were backed up with version 4.0. Either keep both versions of the software on hand, or simply make another backup using the newer version.

A final note

The documentation that comes with today's backup systems is well written. Reading it *before* you begin can save you hours of frustration, and solve many problems after the installation is completed. If you are still having trouble, call. Most major manufacturers have excellent support systems.

Backup your data as often as necessary. If you backup every day, you would only have to re-enter a days work. If you back-

up once a week, you would have to re-enter a weeks work. And so forth.

As you see, the easier you can make this procedure, the more inclined you are to use it. Most people backup the entire hard disk at chosen intervals, and then back up only their data files on a daily basis. Virtually all backup systems allow you to backup only the "files that have changed" since the last backup.

A good backup system is like health insurance. You don't want to ever use it, but if you have to, you're glad it's there. And if you haven't been backing up at all, you may need your "health" insurance if the system crashes. So, back up your hard disk, put the tape (or disks) under your pillow tonight, and sleep well knowing that your data is safe and snug.

Seeing the light

During the writing of this article I received a phone call. One of my customers had a hard disk crash. Even though she had backed up her data, it still took over four hours to rebuild everything on her hard disk, except for the program she had "borrowed" from a friend. We didn't have the disks for that one. (I swear, I'm not making this story up.)

When I finally finished, I installed a used tape backup that I knew was available. If you are in the business of servicing computers, this is one of the easiest upgrades to sell. Especially after a crash. With street prices for internal tape backups at less than \$200, there's no excuse for anyone who uses a computer for serious business not to have one. ■

**Save Your Copies Of
Electronic Servicing & Technology
Order Your Binders Today!
Call Jesse Jones Industries.
Call Toll FREE 7 days, 24 hours
1-800-825-6690**

DO YOU HAVE OVER 25 PERSONAL COMPUTERS? DO THEY EVER BREAK? THEN WE CAN SAVE YOU BIG BUCKS!

HOW? By doing the following: ■ Reduce Downtime ■ Cut Inventory Cost
■ Cut Actual Repair Time
■ Increase Technician's Job Satisfaction

These drives cost \$120 to replace. You can fix 90% of them with a ten minute adjustment.



NAC TEACHES TECHNICIANS ADVANCED HANDS-ON REPAIR AND MAINTENANCE OF PC AND PS/2 HARDWARE, NOVELL NETWORKS, AND PRINTERS.

This PS/2 Monitor could cost you \$40 or less to repair. Are you currently paying \$300 to get this repaired?

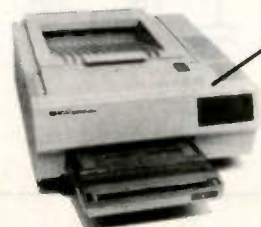

Laser printer problems can cost you \$350 per visit. Let us show you how to do your own service for under \$20!

For More Information Call:

**National
Advancement
Corporation**

2730-J South Harbor Blvd.
Santa Ana, CA 92704

National 800-832-4787
California 800-443-3384

Servicing an unusual Magnavox TV problem

By Homer Davidson

In my years of servicing television sets, I have never seen another set with the unusual symptom that I encountered in this Magnavox T815-02AA chassis. The screen showed a half-circle image at the top center. The circle was darker at the bottom and lighter at the top. The remainder of the screen was black (see Figure 1).

The half circle would oscillate and pulse forward, then collapse. It acted somewhat like a motorboating problem. Only the outline of the half circle would change with the black raster. There was no sign of movement inside the circle.

The sound was good, which indicated that high voltage was present. There was no sign of color in the half circle. Operation of the front controls had no effect on the circle. You would have bet that this symptom was caused by a defective picture tube.

In the beginning

The service center picked up the set and brought it in for service on the bench. Over a two-week period two technicians worked on the chassis with no results. Their investigation did reveal that someone had replaced the safety capacitor and horizontal output transistor.

One of the problems they found was two burned resistors in the picture tube circuits. These resistors, R3 and R4, which provide grid voltage to pin 9 of the CRT from the 247V boost power source, were replaced (Figure 2).

Once R3 and R4 were replaced, the set was turned on. It still exhibited the same symptoms. Measurement with the high-voltage probe revealed that high voltage (28.3KV) was normal. All other voltages at the picture tube connections were fairly normal, except the voltages at the color output transistors. Voltages on these transistors, Q1, Q2 and Q3 were high at 209V. The technicians assumed that the picture

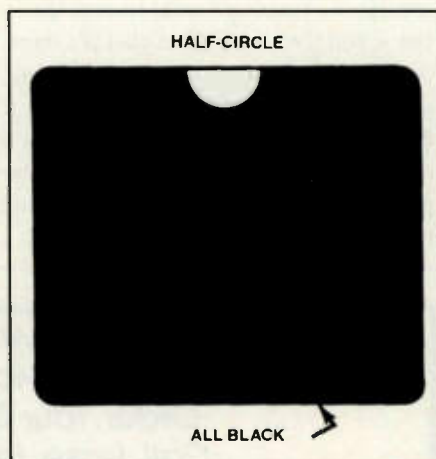

Figure 1. The entire screen was black except for a half circle at the top of the screen in a Magnavox T815-02AA chassis.

tube gun assembly was defective and ordered a new picture tube (25EUP22).

Snapped necks

The CRT arrived within a week and was installed at once. When the set was turned on, the same half circle was still at the top of the screen. Off and on the technicians

checked circuit after circuit with no results. They did notice when the red lead of the yoke was removed the pulsating action stopped. Then one morning while the technician was working on the set, he heard a light snapping sound and the neck of the picture tube dropped off, including the yoke assembly (Figure 3).

Inspection of the neck of the picture tube revealed that the glass had broken above the area where the new gun assembly had been attached in the rebuilding process. Perhaps the yoke assembly was tightened too tight on the neck of the tube. Then again, with all the checking and moving of the chassis, the tube might have received a bump, cracking the neck of the tube. Or perhaps the tube was damaged in shipment.

Another tube, another loss

Although the service center might have simply reinstalled the old tube and returned the defective set, they decided to rise to the challenge presented by this unusual symptom. They ordered another picture tube. After this tube was installed,

(Continued on page 41)

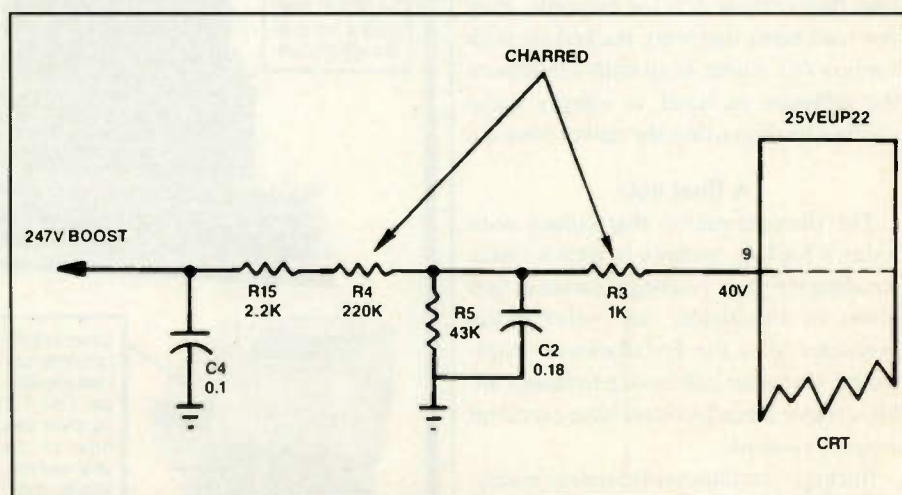

Figure 2. Resistors R3 and R4 on the main PC board feeding voltage to pin 9 of the CRT were charred.

Davidson is a TV servicing consultant for ES&T.

JUNE 1993

Profax
Number

SHARP
Video Cassette Recorder Models VC-A503U, VC-A504U/C 3104

**SCHEMATIC DIAGRAM:
MAIN(1) CIRCUIT VC-A503U)**

Product safety should be considered when component replacement is made in any area of an electronics product. A star next to a component symbol number designates components in which safety is of special significance. It is recommended that only exact cataloged parts be used for replacement of these components.

Use of substitute replacement parts that do not have the same safety characteristics as recommended in factory service information may create shock, fire, excessive x-radiation or other hazards.

This schematic is for the use of qualified technicians only. This instrument contains no user-serviceable parts.

The other portions of this schematic may be found on other Profax pages.

SCHEMATIC DIAGRAM: MAIN(1) CIRCUIT VC-A503U)

Product safety should be considered when component replacement is made in any area of an electronics product. A star next to a component symbol number designates components in which safety is of special significance. It is recommended that only exact cataloged parts be used for replacement of these components.

Use of substitute replacement parts that do not have the same safety characteristics as recommended in factory service information may create shock, fire, excessive x-radiation or other hazards.

This schematic is for the use of qualified technicians only. This instrument contains no user-serviceable parts.

The other portions of this schematic may be found on other Profax pages.

All integrated circuits and many other semiconductors are electrostatically sensitive and require special handling techniques.

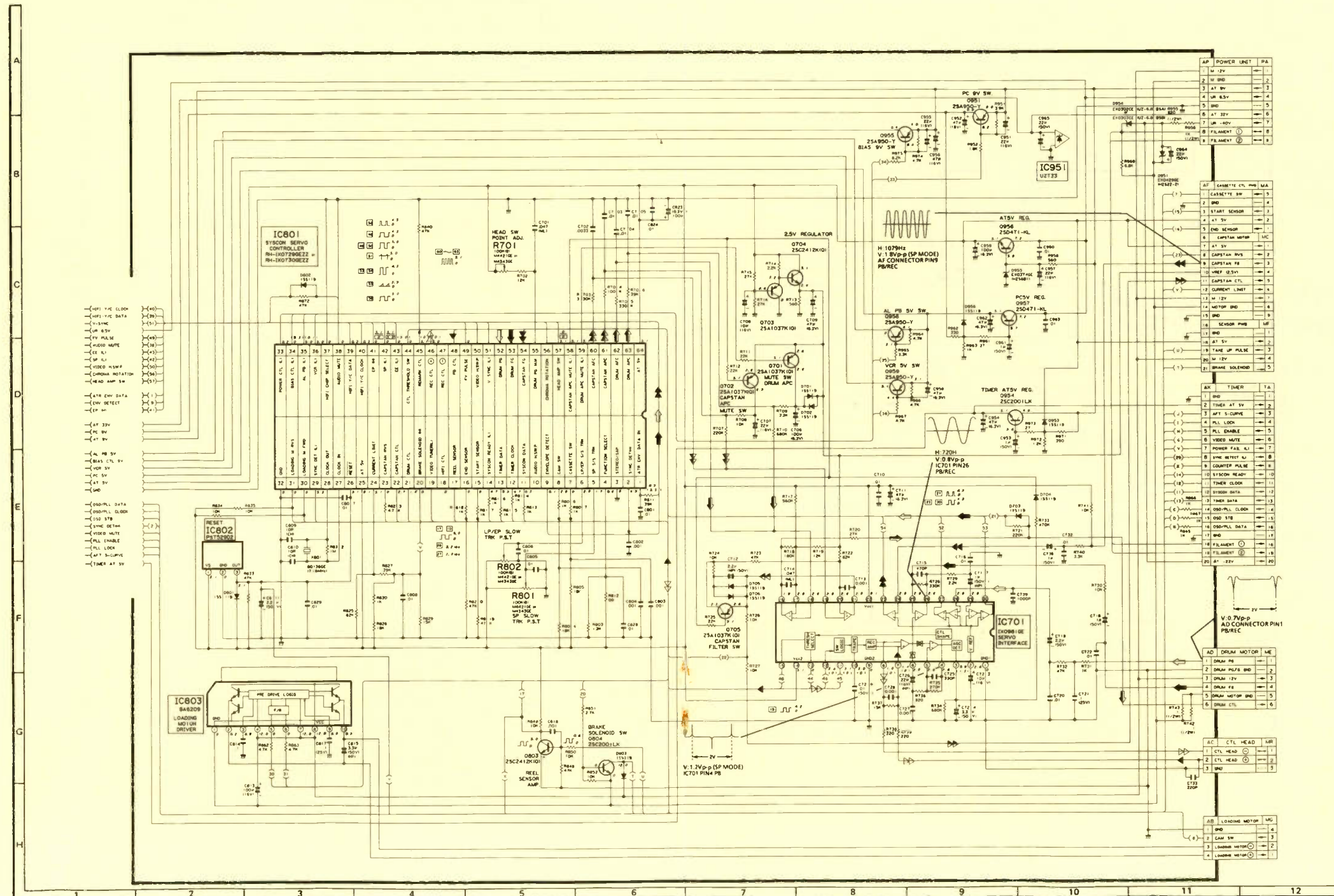

SCHEMATIC DIAGRAM: MAIN(2) CIRCUIT (VC-A503U, A504U/C)

Product safety should be considered when component replacement is made in any area of an electronics product. A star next to a component symbol number designates components in which safety is of special significance. It is recommended that only exact cataloged parts be used for replacement of these components.

Use of substitute replacement parts that do not have the same safety characteristics as recommended in factory service information may create shock, fire, excessive x-radiation or other hazards.

This schematic is for the use of qualified technicians only. This instrument contains no user-serviceable parts.

The other portions of this schematic may be found on other Profax pages.

All integrated circuits and many other semiconductors are electrostatically sensitive and require special handling techniques.

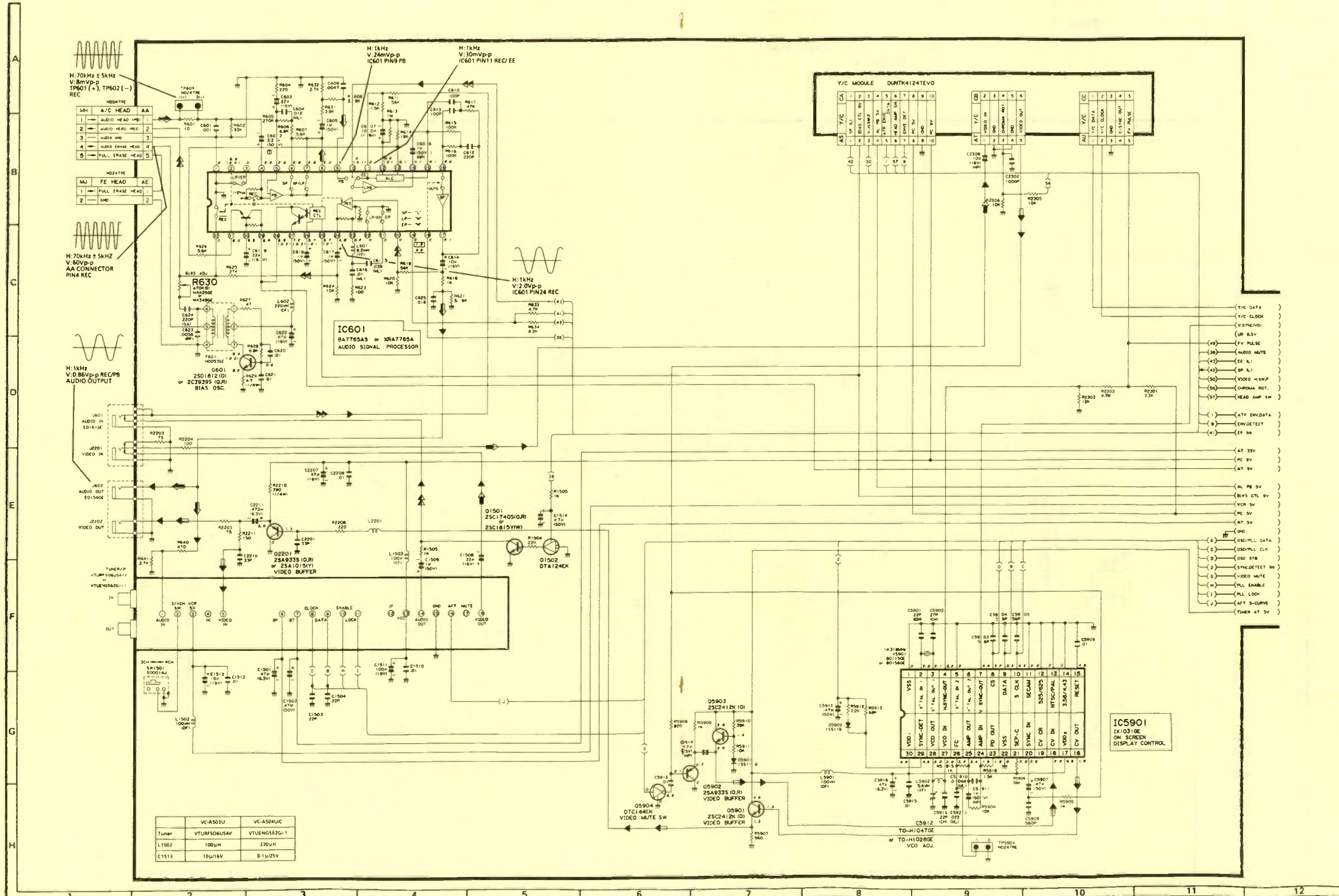

SCHEMATIC DIAGRAM: MAIN(2) CIRCUIT (VC-A503U, A504U/C)

Product safety should be considered when component replacement is made in any area of an electronics product. A star next to a component symbol number designates components in which safety is of special significance. It is recommended that only exact cataloged parts be used for replacement of these components.

Use of substitute replacement parts that do not have the same safety characteristics as recommended in factory service information may create shock, fire, excessive x-radiation or other hazards.

This schematic is for the use of qualified technicians only. This instrument contains no user-serviceable parts.

The other portions of this schematic may be found on other Profax pages.

All integrated circuits and many other semiconductors are electrostatically sensitive and require special handling techniques.

SCHMATIC DIAGRAM: MAIN(1) CIRCUIT (VC-A504U/C)

Product safety should be considered when component replacement is made in any area of an electronics product. A star next to a component symbol number designates components in which safety is of special significance. It is recommended that only exact cataloged parts be used for replacement of these components.

Use of substitute replacement parts that do not have the same safety characteristics as recommended in factory service information may create shock, fire, excessive x-radiation or other hazards.

This schematic is for the use of qualified technicians only. This instrument contains no user-serviceable parts.

The other portions of this schematic may be found on other Profax pages.

All integrated circuits and many other semiconductors are electrostatically sensitive and require special handling techniques.

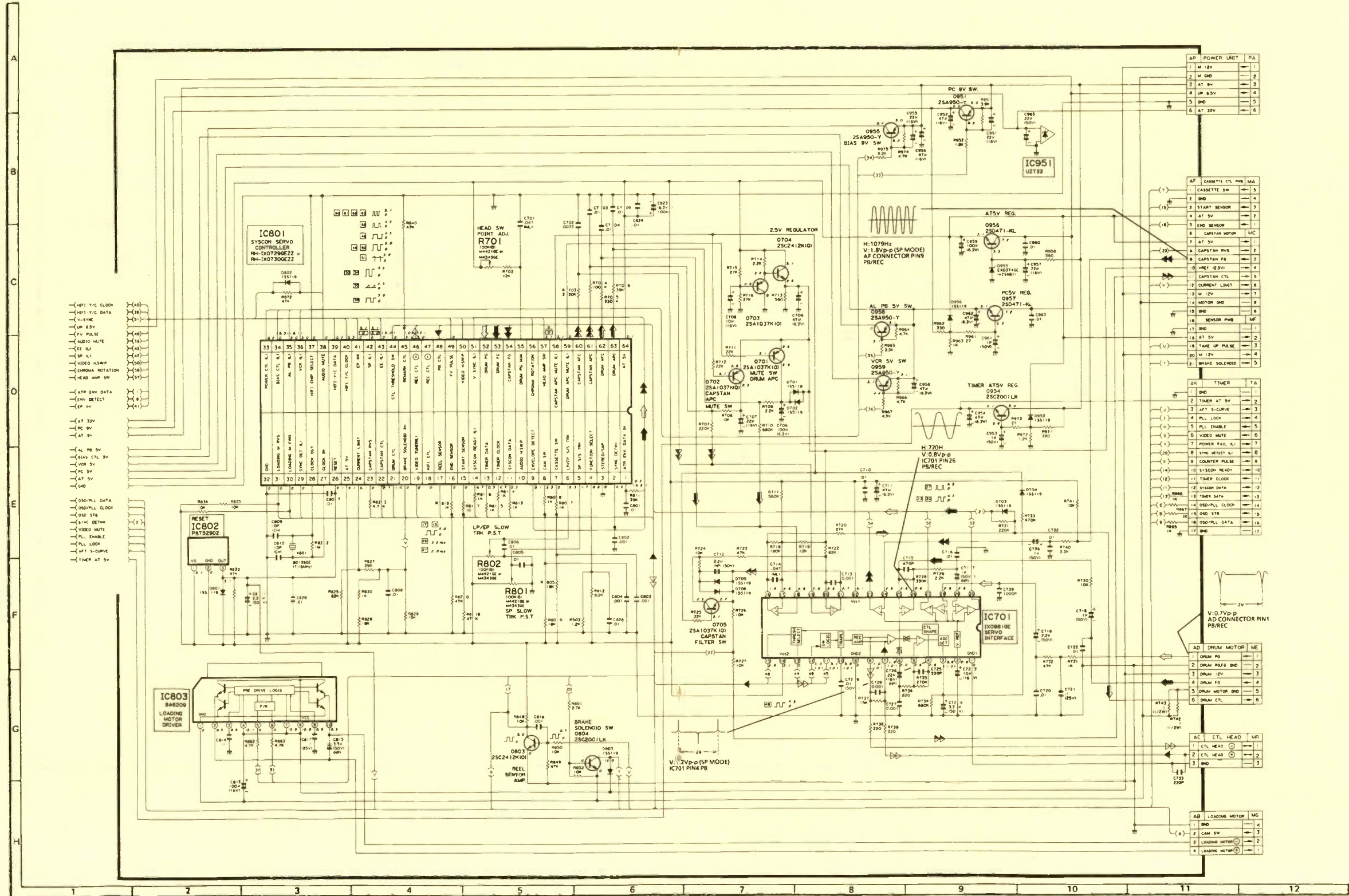

SCHMATIC DIAGRAM: MAIN(1) CIRCUIT (VC-A504U/C)

Product safety should be considered when component replacement is made in any area of an electronics product. A star next to a component symbol number designates components in which safety is of special significance. It is recommended that only exact cataloged parts be used for replacement of these components.

Use of substitute replacement parts that do not have the same safety characteristics as recommended in factory service information may create shock, fire, excessive x-radiation or other hazards.

This schematic is for the use of qualified technicians only. This instrument contains no user-serviceable parts.

The other portions of this schematic may be found on other Profax pages.

All integrated circuits and many other semiconductors are electrostatically sensitive and require special handling techniques.

AP	POWER UNIT	PA
1	M 12V	1
2	M GND	2
3	AT 5V	3
4	UP 6.5V	4
5	GND	5
6	AT 32V	6

AT	CASSETTE CTL	PH	MA
1	CASSETTE SW	1	1
2	IND	2	2
3	START SENSOR	3	3
4	AT 5V	4	4
5	END SENSOR	5	5
6	CAPSTAN MOTOR	6	6
7	AT 5V	7	7
8	CAPSTAN PWS	8	8
9	CAPSTAN FG	9	9
10	VREF 2.5V	10	10
11	CAPSTAN CTL	11	11
12	CURRENT LIMIT	12	12
13	M 12V	13	13
14	MOTOR GND	14	14
15	IND	15	15
16	SENSOR PWS	16	16
17	IND	17	17
18	AT 5V	18	18
19	TAKE UP PULSE	19	19
20	M 12V	20	20
21	BRAKE SOLENOID	21	21

AT	TIMER	TA
1	IND	1
2	TIMER AT 5V	2
3	APT S-CURVE	3
4	PULL LOCK	4
5	PULL ENABLE	5
6	VIDEO MUTE	6
7	POWER PULL L	7
8	SYNC TEST L	8
9	COUNTER PULSE	9
10	SICRON READY	10
11	TIMER CLOCK	11
12	SICRON DATA	12
13	TIMER DATA	13
14	DSO/PLL CLOCK	14
15	DSO STR	15
16	DSO/PLL DATA	16
17	IND	17

AD	DRUM MOTOR	ME
1	DRUM PG	1
2	DRUM PWS GND	2
3	DRUM 12V	3
4	DRUM FG	4
5	DRUM MOTOR GND	5
6	DRUM CTL	6

AC	CTL HEAD	MR
1	CTL HEAD	1
2	CTL HEAD	2
3	IND	3

AB	LOADING MOTOR	MG
1	IND	1
2	CAN SW	2
3	LOADING MOTOR	3
4	LOADING MOTOR	4

Y/C CIRCUIT (VC-A503U, A504U/C)

Product safety should be considered when component replacement is made in any area of an electronics product, A star next to a component symbol number designates components in which safety is of special significance. It is recommended that only exact cataloged parts be used for replacement of these components.

Use of substitute replacement parts that do not have the same safety characteristics as recommended in factory service information may create shock, fire, excessive x-radiation or other hazards.

Y/C CIRCUIT (VC-A503U, A504U/C)

This schematic is for the use of qualified technicians only. This instrument contains no user-serviceable parts.

The other portions of this schematic may be found on other Profax pages.

All integrated circuits and many other semiconductors are electrostatically sensitive and require special handling techniques.

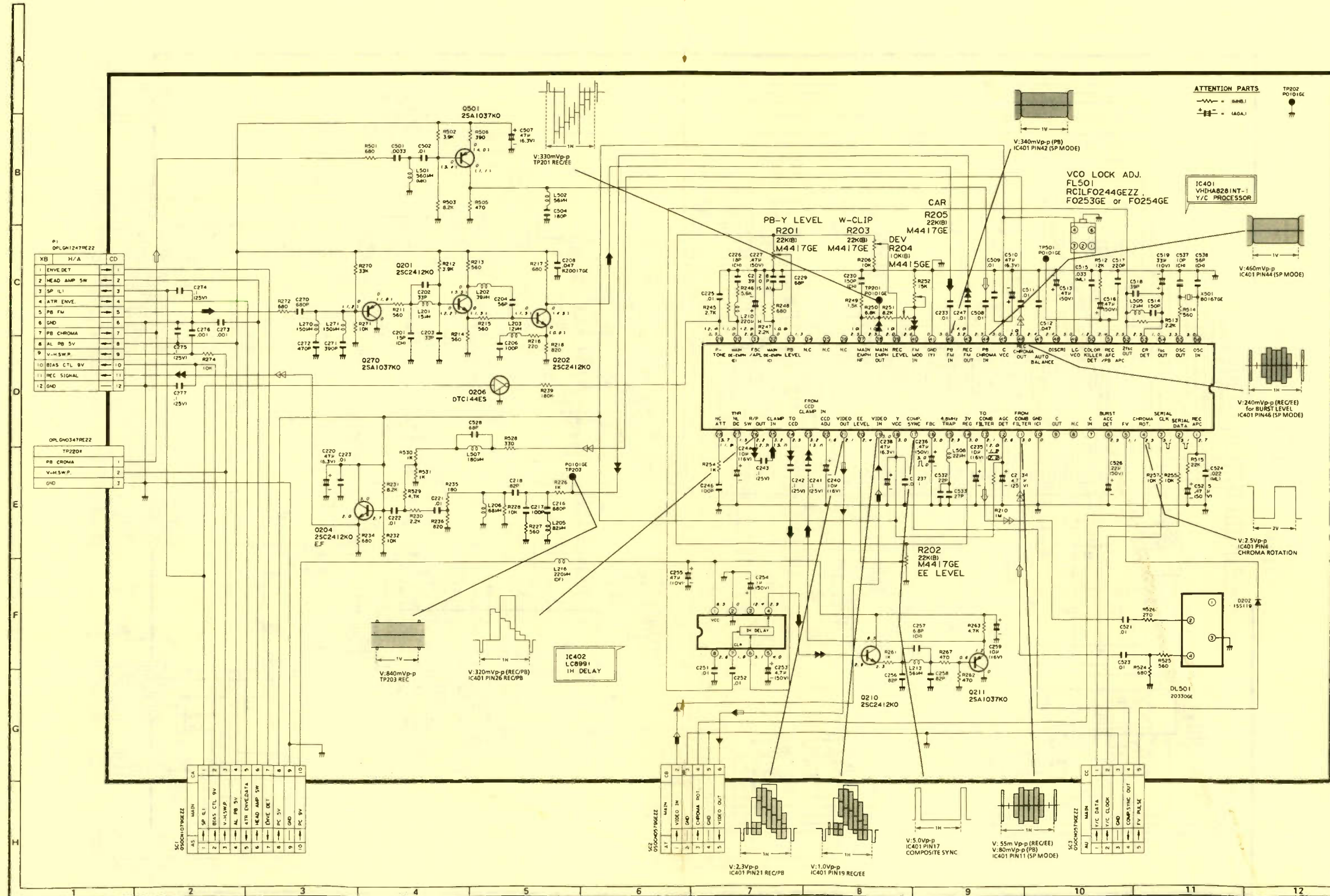

the same half-circle appeared. There was now no doubt that the problem was somewhere other than in the picture tube.

The technicians replaced the retrace and pin cushion modules but noted no improvement (Figure 4). Continuity measurements of the yoke assembly and fly-back were normal. Finally they replaced the horizontal/driver module. The image on the screen did not change.

While measuring voltage sources feeding the video section, one of the technicians heard a snap and the neck of this picture tube dropped off. Now they had two new broken picture tubes and several replaced modules and the same unusual symptom.

Another day

When I was first told about the unusual raster and broken picture tubes, I had to see for myself. After getting a description of all of the problems from the two technicians who had worked on the chassis, I started by making several voltage measurements on the CRT and the picture tube circuits (Figure 5). All voltages appeared normal, and inspection of the CRT board revealed no defects.

Before proceeding any further, I checked the voltages within the low-voltage power supply. All voltages from the power transformer circuits were normal. The +120V feeding the horizontal stage was normal at +119V.

The 26V (sound module), 24.3V (IF module), 24.3V and 8.6V (horizontal oscillator/driver module), 24.3V and 19V (comb filter), 24.1V (low level video module), 24.3V and 12.6V (chroma module) were all within one volt of the values specified on the schematic.

After lunch we reinstalled the original picture tube. The problem persisted. Because there was no video or picture within the half circle, I decided to check out the video circuits.

The oscilloscope showed a normal video signal from the video output transistor, Q4, to the comb filter module. I found a luminance signal at Q1 on the low level module feeding the video/chroma output circuits. In desperation I installed a new video module, but this didn't cause any change on the screen. No doubt the original video and luminance circuits were normal.

The only voltage that was high appeared on the color output transistors.

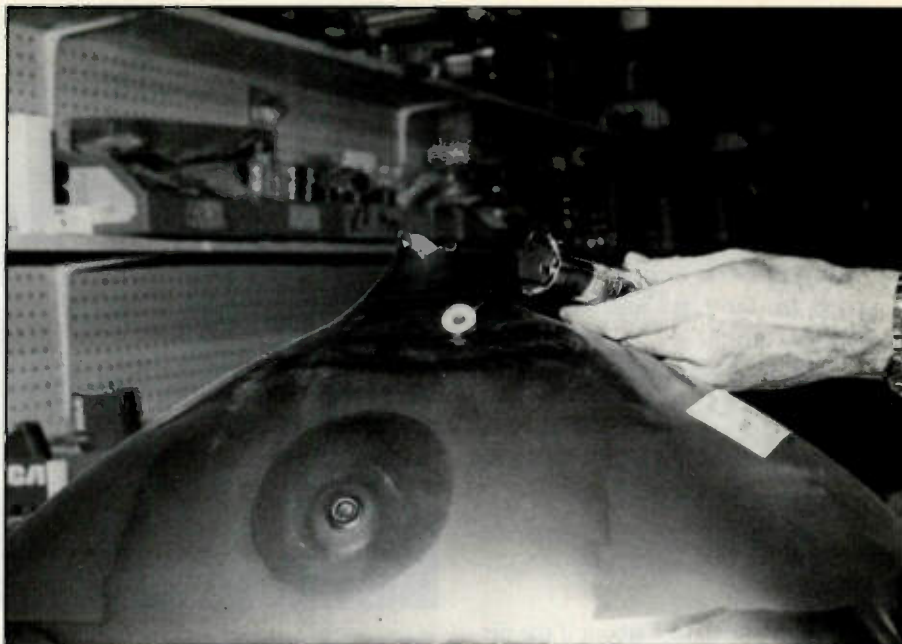

Figure 3. The picture tube snapped at the neck area, ahead of the gun assembly.

I assumed that this was because no video was applied to the CRT circuits.

Another circuit

In checking back through the many cases I have encountered in the past in which the picture tube neck was broken, I found that in most cases it was a Zenith chassis. In each case, the safety capacitor had become faulty. These capacitors, which have four legs, would become open, resulting in high voltage on the

CRT. Replacing these hold-down capacitors solved those problems.

I wondered if in this case the safety capacitor was breaking down for only a few seconds, allowing excessively high voltage to destroy the picture tube. Ordinarily when this happens, however, you hear a loud cracking sound of high-voltage arc-over.

To determine if the high voltage was becoming excessive intermittently, I monitored the high voltage supply with

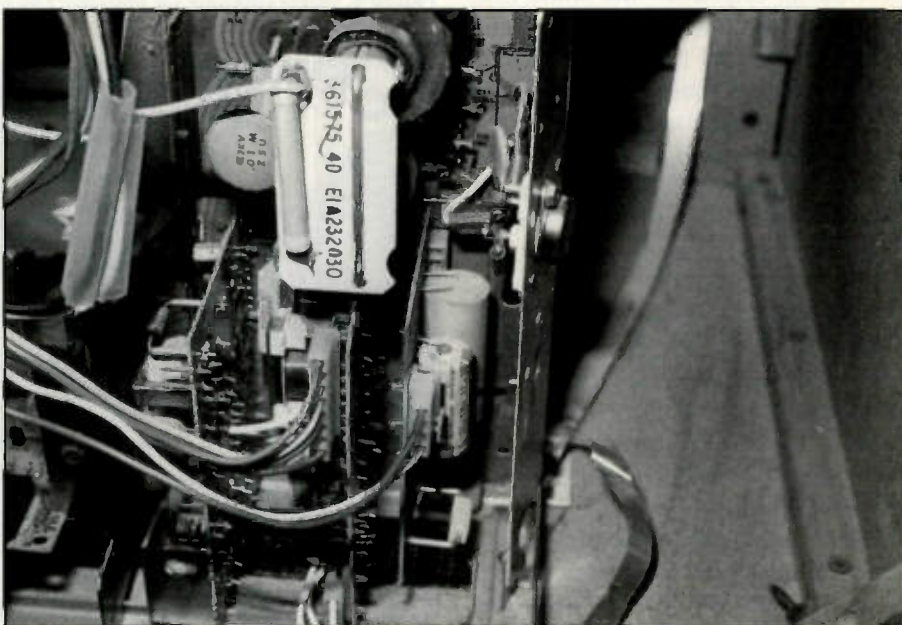

Figure 4. The retrace module with four-legged hold down or safety capacitor was replaced, but this had no effect on the symptoms.

the HV probe over a period of time, but this revealed only slight fluctuations.

Although C2 had been replaced at one time, I replaced the retrace module with a universal replacement (Figure 6). In this chassis the horizontal output transistor is mounted on the chassis metal heat sink, while the safety capacitor is located on the retrace module nearby. The chassis operated for the remainder of the day without any change.

The next morning I tackled the chassis once again to try to determine what had damaged the two picture tubes. Of course, the half circle didn't go anywhere overnight. Maybe I had missed some of the voltages in the picture tube circuits. So I went through the whole process again without any luck.

I was determined to find out if the picture tube circuits were at fault by raising and lowering the brightness and screen controls. I looked all over for the service switch to collapse the raster to a thin white line. I finally found the switch, on the vertical module instead of the chassis.

When I switched the service switch to the service position, nothing happened. No white line appeared on the raster, even though all screen controls and the master screen control were wide open. Perhaps the service switch was dirty or defective.

The vertical module was matted with dirt and dust. I could see only the tops of the electrolytic capacitor and the vertical hold control. I worked the switch back and forth without any results. There was no video or brightness, nor white line, only good sound.

After I removed the vertical module and cleaned it, I squirted cleaning fluid down into the switch area (Figure 7). The picture was the same after replacing the module. Perhaps the module was not properly seating. I again removed the vertical module and reinserted it. There was still no change.

If the ground terminal of the vertical module is not making good contact, it may not let the service switch ground out the picture tube and vertical oscillator circuits, so I removed the vertical module and cleaned all contacts with a pencil eraser and cleaning fluid.

While cleaning the vertical module, I noticed a small burned resistor. A closer inspection revealed that a diode had become overheated. No doubt this was why the service switch did not have any

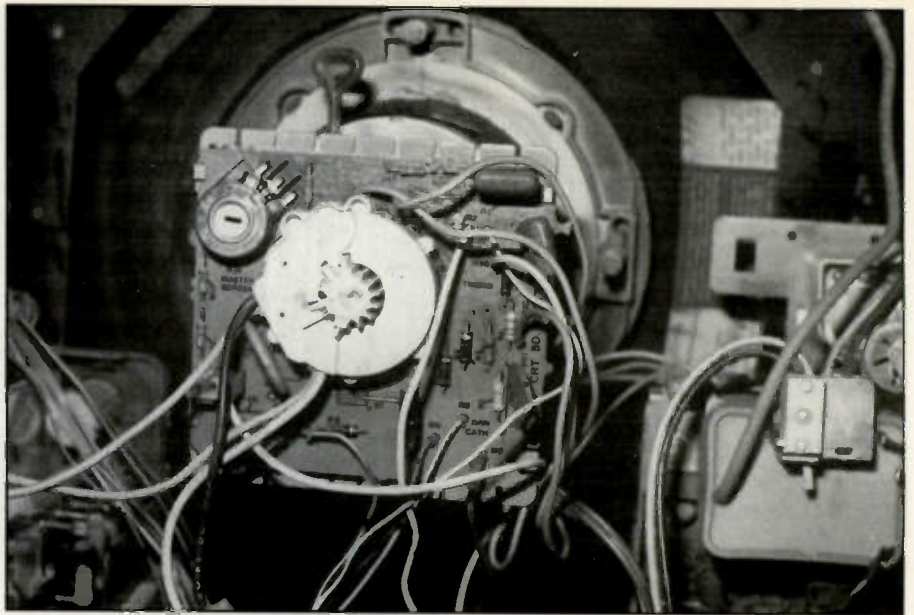

Figure 5. All voltages at the CRT socket were fairly normal.

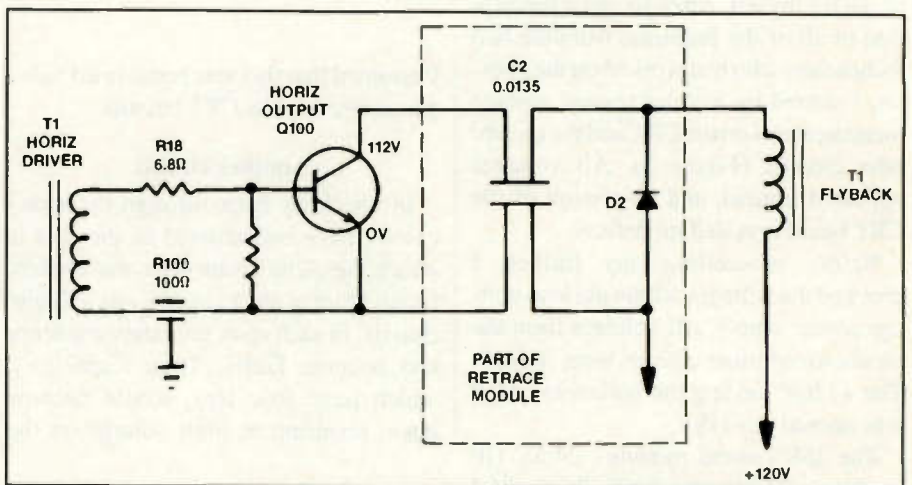

Figure 6. Safety capacitor C2 (0.0135F) on the retrace module was replaced.

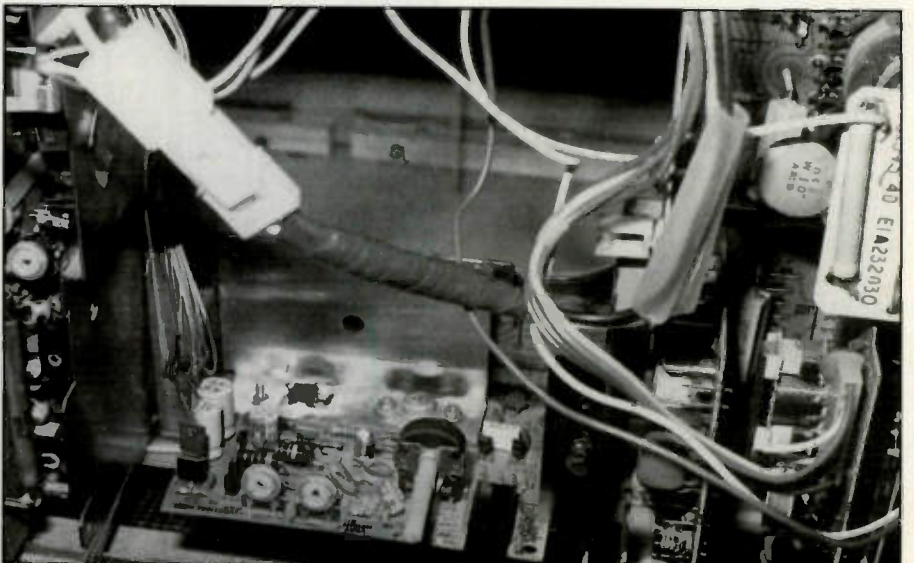

Figure 7. The vertical module was removed, dust and dirt blown off, and cleaning fluid was sprayed down into the switch area.

effect. But could these parts result in a half circle raster if defective? I didn't think so.

Unusual problems

I did not have a replacement for the vertical module, so I decided to remanufacture the existing module. I checked D4 and D5 with the diode test of the DMM. D4 was leaky. I checked both L1 and L2 for continuity. L1 was open.

I checked vertical output transistors Q8 and Q9 in the circuit. Q8 measured high leakage. From the schematic, I found that L1 and D4 were part of the 15Vdc vertical output power source. A flyback winding was the source of this vertical supply (Figure 8).

I replaced Q4 with a GE-511 universal diode and R4 with a 1Ω, 1W resistor. Instead of ordering a replacement for L1 and waiting for it to arrive, I decided to refurbish the existing coil. I removed the burned coil from the chassis. After removing the old winding and cleaning off the coil form, I wound 4 turns on the same coil form using wire from a discarded yoke winding (about 30-gauge enameled wire).

After checking the parts list on the Sams Photofact for this set and consulting the semiconductor manual, I replaced Q8 with an ECG-291 replacement transistor. R26 (1Ω) and Q9 tested good, so I left them alone.

I reinstalled the refurbished vertical module and switched the service switch to the service position. A white horizontal line appeared on the screen.

Although I had expected to see a white line, because the vertical switch, S1, shorts out the vertical oscillator and amp to chassis ground, I didn't expect to have cured the problem.

But, when I changed the position of the service switch to its operating position I was pleasantly surprised. The screen was filled with a great picture; in excellent color. Lowering the master screen control returned the picture to normal. I'm still wondering what the half-circle had to do with a defective vertical section.

I can understand the motorboating or oscillating of the half-circle, maybe caused by the leaky parts in the vertical section, from flyback to the vertical yoke section. But how does the failure of the vertical section produce a half circle?

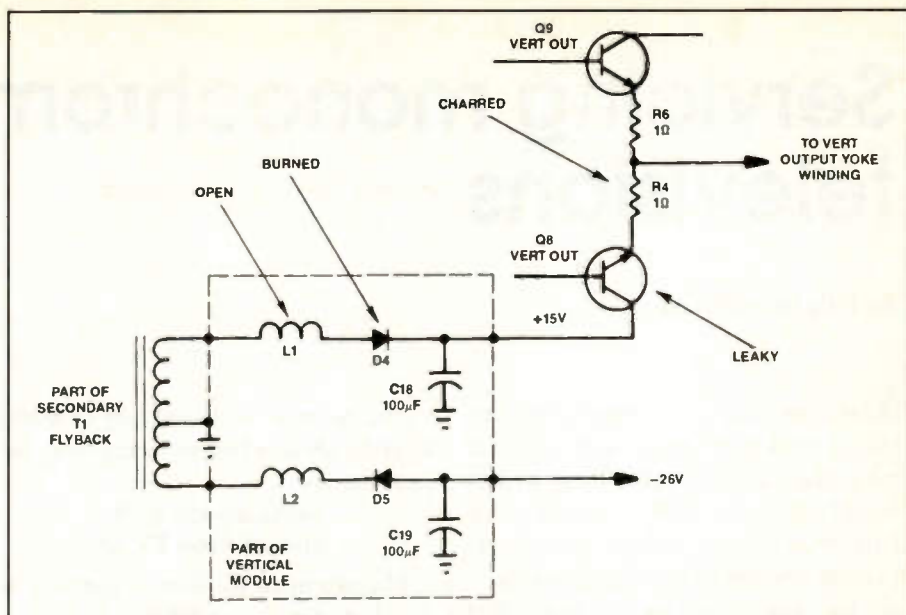

Figure 8. Q8 was leaky, and R4, D4, and L1 were burned.

I also wonder why both picture tube necks broke above the gun assembly. Is it possible both tubes were defective? You may find one tube defective, but not two in a row.

Sometimes we never actually know why some circuits or problems react the way they do in electronics servicing. Perhaps that's why the next one is a greater challenge. ■

TUBES • TUBES • TUBES
World's Largest Range
 Over 2,000 Types, Domestic & Foreign
UP TO 85% OFF Ask for price list
International Components Corporation
 Toll Free 800-645-9154 • N.Y. State 516-293-1500
 105 Maxess Road, Melville, New York 11747

Circle (5) on Reply Card

Tech's Guide To Pricing
NEW
"Sperry Tech's Pricing Guide"
 Updated new 6th edition... a framework for setting rates that apply to Hi-Tech products... a formula that guarantees SUCCESS!
 Call Toll Free for details
 1-800-228-4338

Circle (18) on Reply Card

Free PHOTOFACTS!

PHOTOFACT. Technical Service Data

SPECIAL OFFER

Twelfth month free with every new subscription

Only \$3.35 per PHOTOFACT!

14 PHOTOFACTS for the low price of \$46.95 a savings of over \$90.00!

Why spend up to \$250.00 on manufacturers' service literature when you can get 14 PHOTOFACTS for only 46.95?

Begin your subscription by contacting your local Sams distributor, or call 1-800-428-7267. Your PHOTOFACT-of-the-Month packages will be delivered to your Sams distributor each month.

Offer good through July 31, 1993

Howard W. Sams & Company
 2647 Waterfront Parkway East Drive
 Indianapolis, Indiana 46214-2041

Phone 1-800-428-7267
 FAX 1-800-552-3910

Circle (15) on Reply Card

Servicing monochrome televisions

By Dale Shackelford

Years ago it was not uncommon for electronics servicing technicians to service as many black and white televisions as they would color sets. Today, with the popularity of color sets, coupled with the extremely low cost of monochrome receivers, the monochrome set, like many other goods in this day and age, are considered disposable.

Technicians who will still accept monochrome televisions for service realize that too much time spent on the diagnosis can not be justified on the bottom line. The technician who can and will repair monochrome receivers in a matter of minutes, however, has additional sources of revenue that other technicians often let slip by.

Another reason to read an article on the servicing of monochrome sets, even though they may frequently not be worth servicing, is that the diagnostic and ser-

vic-ing processes followed may be useful to know about when servicing more expensive sets.

Servicing the KTV monochrome TV set

Manufactured by Korean Electronics Co., Ltd., the 12-inch KTV monochrome receiver is fast becoming a popular consumer device. Two models of this set (the KT1210A and the KT1230) both use the exact same circuit boards, tuners and CRTs, though the KT1230 is capable of being powered by an external 12Vdc source in addition to the standard 120Vac line voltage. Both models are equipped with internal line voltage transformers and standard (mono) earphone jacks.

Component failure is common

As is usually expected with most of the lower priced appliances, component failure in the two KTV models being discussed is quite common. Fortunately, however, the same components in almost all cases seem to be causing the same

symptoms/problems in about 95 percent of the sets. When one works with an average of five sets per week, all the same model and all exhibiting the same symptoms, one becomes familiar with servicing them.

Noisy volume control is chief complaint

In most cases, the chief complaint with these sets is a scratchy or intermittent volume control. In an attempt to quickly rectify this problem, a liberal amount of a brand name tuner cleaner was sprayed into R620 (potentiometer), making sure that the set was unplugged (the power switch is connected to the pot), and that any run-off liquid was absorbed by a rag.

This particular brand of tuner cleaner, according to the claims written on the side of the can, removes dirt, grease and oils from tuners, potentiometers and other such components, and leaves a lubricating film as well.

Because of these claims, and success

Shackelford is an independent electronic servicing technician.

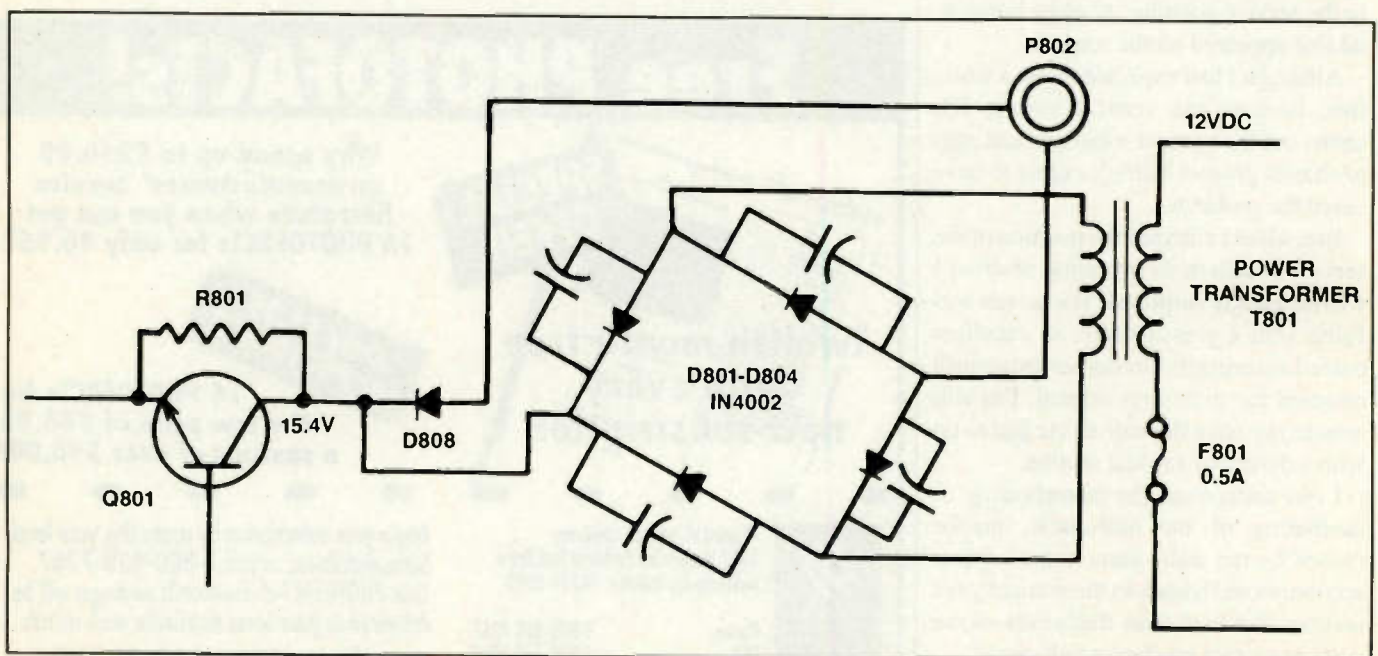

Figure 1

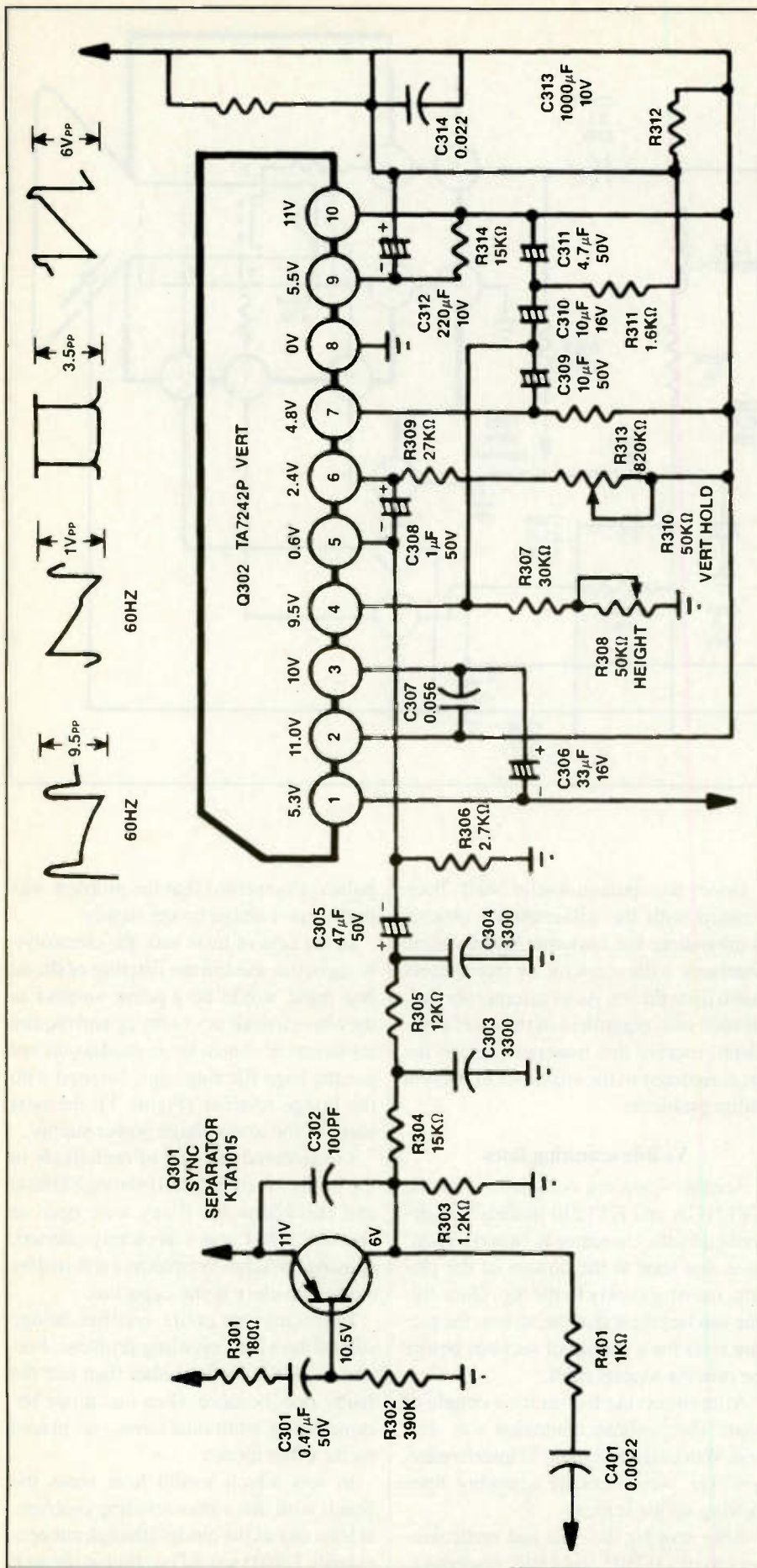

Figure 3

If the customer continues to operate the set with a bad diode in the rectifier bridge, a second, and possibly third diode will go bad, causing F1 to open, resulting in a dead set when it arrives at the shop. Approximately 90 percent of the dead KT-1210A and KT1230 models which come into the shop are due to an open line fuse (F1) as a result of bad rectifier diodes.

Retrace lines

As with most other brands of television receivers, monochrome or color, KTVs are sometimes plagued by retrace lines over some, or most of the screen, even though the video signal, minus the retrace lines, looks fairly good.

In most instances, retrace lines covering the entire screen would lead the servicing technician to check the video amp circuit (see Figure 2). In this case, voltage tests revealed 2.4V on the emitter of Q201 and approximately 2.8V on the base; pretty close to the desired voltages.

At the collector of Q201, however, little or no voltage was present, where the schematic specified that there should be 72.2V. Voltage measurements were then made on the Q201 side of L202 (peaking coil), where the 72.2V should also be present, but it wasn't.

When I measured the voltage on the other side of L202, there was 72.2V present. Because the 72.2V was found on one side of the peaking coil, but not on the other (Q202) side, the inductor was removed from the circuit and tested with an ohmmeter. It was open. Replacing the peaking coil solved the recurrent full-screen retrace problems, and has solved the same problem in many other sets with the same symptoms since.

Improper vertical deflection

The lack of full vertical deflection in any television set can be a nightmare for any technician, and these sets, though relatively simple are no exception. In these KTV models, the vertical circuits are controlled by, and consist primarily of, a single IC package, identified in the schematic of Figure 3 as Q302.

In cases where the top or bottom half of a raster is missing, the fault can usually be traced to the corresponding (top or bottom) vertical output transistor. When the set uses an IC package for both top and bottom vertical circuits, the simple

TV power supply troubleshooting

By Brian E. Jackson

A power supply is an electronic circuit that performs some type of power conversion. Modern TV sets use switching power supplies to furnish dc power to most of the circuits. However, these sets also contain one or more linear power supplies.

These linear power supplies are used for operating the switch-mode dc/dc converter and for powering standby circuits such as the remote-control receiver and microprocessor. This article will discuss the operation and troubleshooting of the linear power supply for a TV receiver.

DC to dc converter

A dc to dc (dc/dc) converter converts dc of one voltage into a dc voltage of another value. For example, a dc/dc converter might be used to convert +5V into +12V and -12V as shown in Figure 1. A +5V supply is common in many pieces of electronic equipment. Instead of building in additional +12V and -12V supplies, these voltages can be derived from the +5V supply by using a dc/dc converter.

A dc/dc converter uses pulse and switching circuits to achieve the voltage translation. We refer to this as a switch-mode supply because the output of the supply is generated by using transistor switches to convert this dc into a high-frequency ac signal.

This ac is then passed through a transformer to step up or step down the voltage to the desired level. Then another rectifier converts the square-wave pulses into pulsating dc, which is then filtered into a constant dc by a capacitor filter.

Switch-mode power supplies have become popular because the use of high-frequency ac as the input to the voltage translation transformer allows much smaller, lighter, less expensive (less copper) transformers to be used.

DC/dc converter components

Figure 2 shows the basic components of a dc/dc converter. The dc supply is any

Jackson is an electronics servicing technician specializing in VCR service.

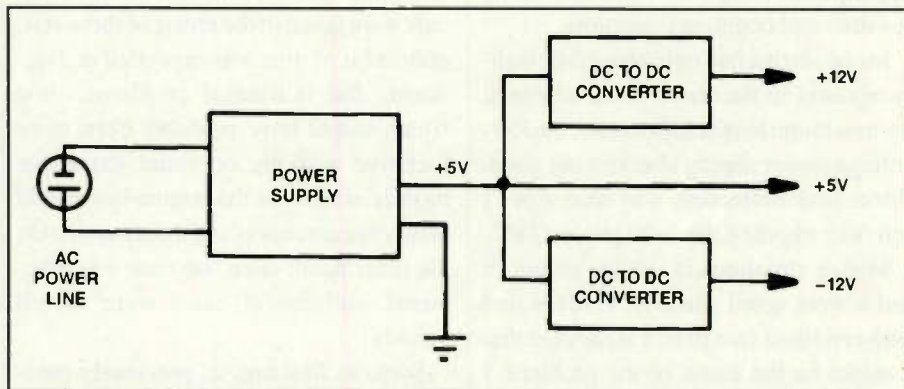

Figure 1. A dc to dc converter converts dc of one voltage to dc of a different voltage.

normal driven power supply. Its voltage is passed through Q1, a high power switching transistor.

This transistor is driven by an astable multivibrator. When the transistor turns on, current flows through the primary winding of transformer T1, and a magnetic field builds up. When Q1 switches off, the magnetic field collapses.

The changing magnetic field induces a voltage into the secondary of T1. The transformer is set to deliver the required voltage across the secondary. These pulses are rectified by the bridge rectifier into a pulsating dc. The capacitor filters this into a constant dc voltage.

Horizontal output supply

As you saw in the previous section on the dc/dc converter, a main source of dc is required to operate the oscillator, power switches and regulators that generate the ac pulse signals that are ultimately rectified into the dc voltages used to power most TV circuits. In modern TV sets, the horizontal output stage is the base of this dc/dc conversion.

Figure 3 shows the supply that is used to power the horizontal sweep and output circuits. Most manufacturers use this circuit or some variation of it.

The ac from the line cord is first applied through a fuse to two inductors, L1 and L2. These inductors along with C1 form a low-pass filter that serves two purposes.

First, it keeps high-frequency noises on the power line from reaching the other circuits in the set. Second, it prevents high-frequency noise and signals developed inside the set from getting back onto the power line.

Notice that this circuit does not use a power transformer. Some power supply circuits use a transformer to isolate the ac from the rectifier and to either step up, or step down the ac line voltage to the desired level before rectification. In this circuit, the ac line voltage is applied to a bridge rectifier circuit. Capacitors C2 through C5 suppress any high-frequency noise. The dc across filter capacitor C6 is about 150V unregulated.

This voltage is often referred to as "raw" dc, because it is unregulated. This voltage is frequently called B+. Some sets apply this raw dc voltage directly to the horizontal output stage. But usually some kind of series regulator circuit is used between the filter output and the horizontal stages as shown in Figure 3.

Note that the B+ is applied through a separate fuse to the series linear regulator. R4 allows you to set the output voltage to the precise value desired. Diode D8 is used as the reference to which the output voltage sample is compared. Q4 in Figure 3 generates an error signal that drives the base of the series pass element, which is a Darlington transistor. Physically, this device looks like a regular power

transistor and is usually mounted on a heat sink to help dissipate the heat it generates.

The two transistors, Q2 and Q3 are connected internally along with the bias resistors and the reverse protection diode, D7. The output is a constant 140Vdc, which serves as the main power source for the horizontal circuits and all of the scan derived voltages. C8 is a small electrolytic that provides final filtering.

Also note in Figure 3 that a degaussing circuit is shown. Most degaussing coils use a positive temperature coefficient (PTC) thermistor. When the circuit is first turned on, R2 has a very low resistance so maximum current flows in the degaussing coil and the resulting magnetic field does the degaussing. The thermistor heats up fast and its resistance increases to a very high value, effectively reducing the current flow to a very low level.

Standby supply

Modern TV receivers usually produce standby voltage for remote control operation. Standby voltage is available even when the set is turned off. In Figure 3, the relay contact, RY1, connected in series with one side of the ac line, is driven by standby voltage. When you turn the set on using the remote control, a coded signal is sent to a remote receiver which is then interpreted by a microprocessor.

The remote receiver and microprocessor are also powered by standby voltage. The microprocessor generates a logic signal which is sent to the base of Q1 through R1. Q1 turns on and causes current to flow in the relay coil. This creates a magnetic field that closes the relay contact. This ac is applied to the bridge rectifier and the main supply turns on.

A standby supply is a power supply used to power standby circuits. The main standby circuits are the remote-control receiver and the microprocessor that interprets inputs from the remote and issues control signals to the rest of the set. The remote receiver must, of course, be turned on all the time so it can respond to a signal from the remote control.

The standby supply is usually a half-wave rectifier diode, D1, connected to the ac input right after the input filter (See Figure 4). The take-off point is shown in Figure 3. A Resistor, R1, is used to drop the unused voltage produced by the line. C2 filters the 60Hz pulses from the rectifier into a steady dc. Next, this dc is ap-

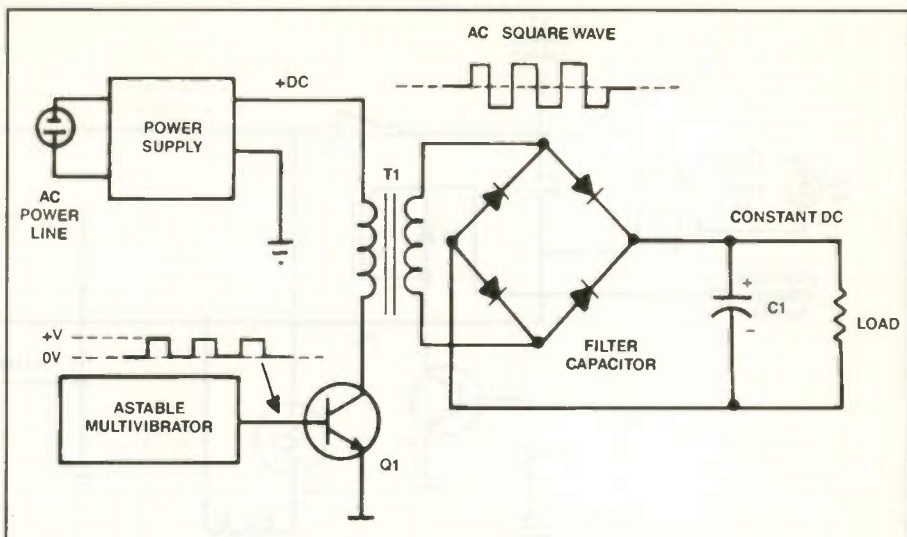

Figure 2. This dc to dc circuit uses an astable multivibrator to convert the dc output of a power supply to an ac square wave. The ac square wave is then transformed in voltage by the transformer, rectified and filtered. The output is a dc voltage that is different in level from the original power supply output voltage.

plied to two series pass transistors. The two output voltages are +5 and +12 volts. The +5V powers the single-chip microcomputer and any auxiliary circuits. The +12V powers the remote receiver circuits.

Power supply troubleshooting

A multimeter with a high voltage attachment and an oscilloscope are usually all you need to troubleshoot various power supplies, including switch-mode power supply circuits.

Common symptoms

Most TV sets made since 1982 use some type of switching power supply arrangement. Because this circuit uses feedback, the usual symptom when something goes wrong with the power supply is a completely dead set. However, it is also possible to have a power supply problem with the set partially functional. For example, if a rectifier diode in one of the circuits that operates the tuner is open, the entire power supply wouldn't shut down.

A picture with no audio suggests the possibility of a partial power supply failure: you might have a bad power supply circuit for the audio section. On the other hand, the audio circuits themselves could be bad. In any case, you should always check the dc voltage supplying a circuit first before you try troubleshooting anything else. If the voltage is present, you troubleshoot the inoperative circuit. If the voltage is absent, you check the power supply to see why.

Other symptoms that suggest a bad power supply include distorted audio or hum, a shrunken or dim picture, or lack of horizontal or vertical sync. These can sometimes be caused by reduced power supply voltages or an increase in ripple. This means that the power supply is working, but not as it should.

Defective components

One thing that will help you quickly find the faulty part is the knowledge that some parts are more likely to fail than others. After years of keeping track of TV set failures, most manufacturers have found that statistically you can almost predict what the problem will be. And these problems are the same for any manufacturer.

Listed are the parts that are most likely to fail, given in the order from the most likely to the least likely:

- bad power transistors (horizontal output or driver, series pass regulator, etc.)
- bad rectifier diodes (usually shorted)
- defective IC voltage regulators
- open power resistors (wattage rating of 2W or more)
- defective flyback transformer
- bad filter capacitor (electrolytic)
- broken wire or bad connector
- bad off/on switch

In many cases, you will experience two or more of these problems at the same time. For example, if a filter capacitor shorts, it usually takes out several other components, such as a power transistor, rectifier diode and power resistor. Don't

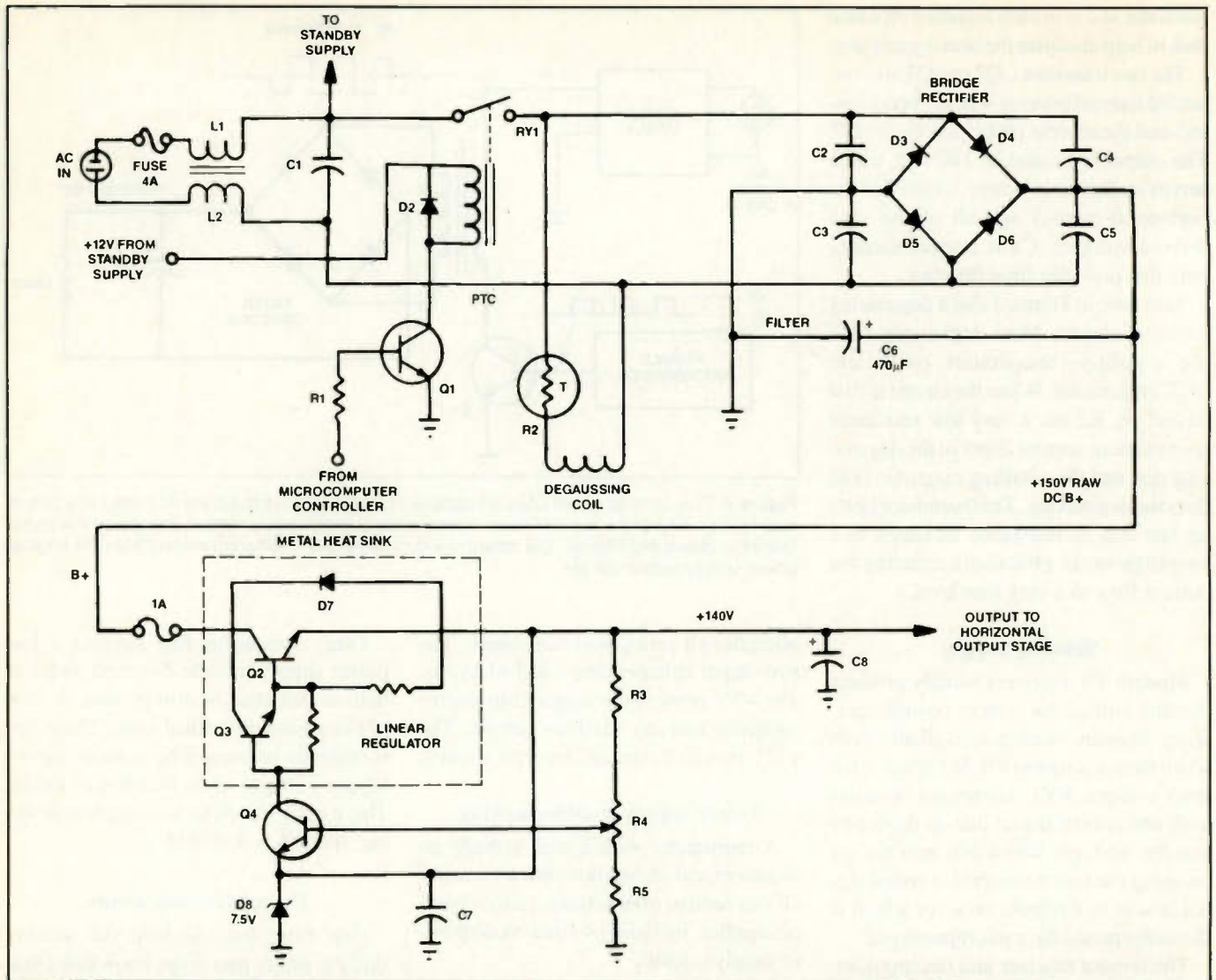

Figure 3. Most TV manufacturers use this circuit, or some variation of it, to power the sweep and output circuits.

stop your troubleshooting when you have located one bad part; look at other parts associated with the bad one.

The following segments present a recommended troubleshooting procedure.

Verify the problem

The first thing you should do is to try to validate the customer's complaint and attempt to duplicate the symptoms. You really must see the problem yourself just to be sure you are getting all of the data you will need to figure out where the problem is. The customer's complaint may contain some useful information, but always check the symptoms yourself.

Perform a visual analysis

You should first check the most obvious problems. Is the line cord to the set really plugged in? If it is, is there ac at the

outlet. A fuse or circuit breaker may have opened, shutting off power to the outlet.

When you are satisfied that you are getting ac power to the set you can continue. Next, you should open up the set and look around inside. Refer to the manufacturer's service literature to find your way around inside the set. Locate the power supply circuit boards and any related assemblies, such as the flyback transformer.

Now, visually inspect these items. Look for broken or burned parts. Check for broken wires and dirty or unseated connectors. Look for melted wax that has flowed out of a transformer, indicating that this part has overheated. Of course, if you locate a defective part, then you are on the right track. Remember, though, that the damage to a burned out or defective part may have been caused by the failure of another part.

Check circuit breakers and fuses

All power supplies contain some type of circuit breaker that protects the circuitry if something goes wrong. A fuse, for example, will blow if the current demand on the circuit is greater than usual. A shorted part or circuit usually causes this. You can usually tell if a fuse is good just by looking at it.

Most TV fuses are small glass cylinders containing a thin wire. If the wire is still there, most likely the fuse is still good. Keep in mind, though, that on rare occasions there may be a bad connection within the fuse, and it will not pass current even though it appears to be intact.

If the wire is missing, or the fuse glass housing is blackened, then the fuse is bad. If you aren't sure, check the continuity with your ohmmeter.

Replacing a fuse can be tricky, partic-

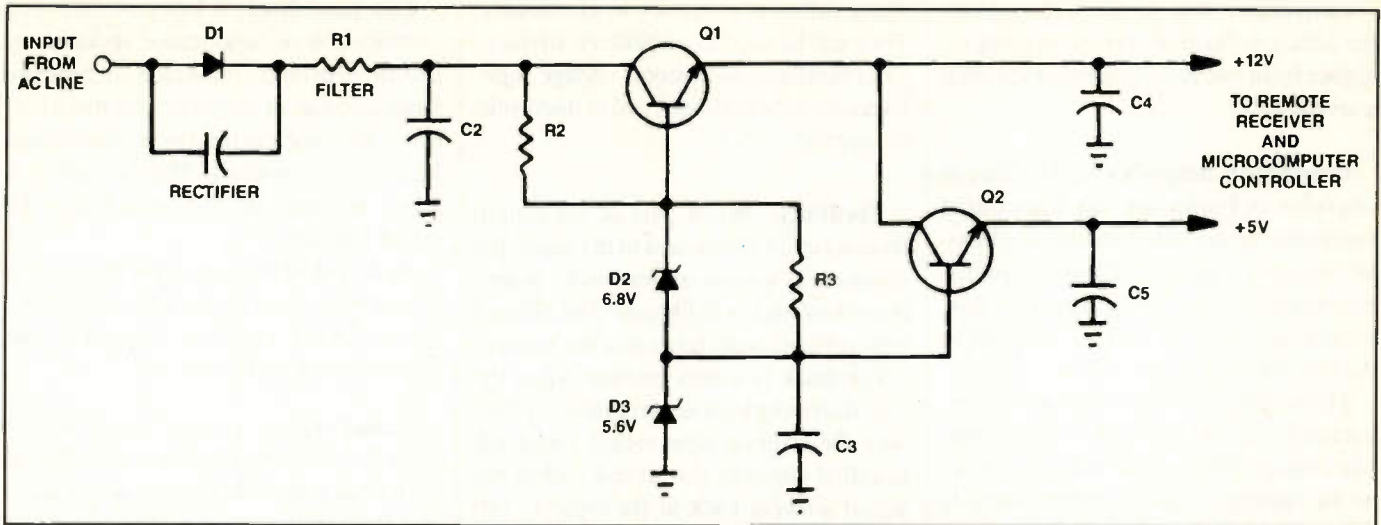

Figure 4. The standby power supply in a TV set is usually a half-wave rectifier diode (D1 in this circuit) connected to the ac input right after the input filter.

ularly if they are soldered in place. In any case, just be sure you replace the fuse with the exact value of the original.

Perform a voltage analysis

Voltage analysis is a step-by-step procedure for isolating a defective part by tracing the voltages in a particular section of the receiver with a multimeter. This will usually lead you to the bad circuit. Then you can make some component tests with your ohmmeter to pinpoint the bad part or parts.

A good starting point for a voltage analysis is to measure the regulated output voltage of the linear supply. It should be around 140V. Remember to refer to the service manual to locate parts that are inside the receiver.

In addition, the manufacturer will often provide troubleshooting charts to help you locate the problem. Refer to these charts often and apply deductive reasoning to guide you in the repair.

High voltage problems usually require some special troubleshooting procedures. Generally, the procedures for troubleshooting any scan-derived supply apply. If the horizontal output transistor (HOT) fails, the HV will be lost. If the horizontal oscillator, countdown IC, or driver fail, no pulses will reach the HOT, so there will be no scan-derived voltage, HV included. Verify these circuits first.

To verify the absence of high voltage, measure it using an HV probe or with an HV meter. This typically comes in the form of a large, insulated probe that contains a small analog meter which reads directly in KV. These are not too expen-

sive, and they are handy if you plan to do a lot of TV service work. They are also safe, provided you read the manufacturer's suggested HV value, and use it only in the manner recommended.

Make the repair

Once you have identified and removed the bad component, check it with the ohmmeter to be sure. However, to make sure that the identified component is the only defective one, substitute a good component for the defective one in the circuit, and check to see if normal operation is restored. If normal operation is restored, you've solved the problem.

Glossary

Some of the terms used in this article may not be familiar to all readers. The following is a glossary of the most important terms used.

Astable multivibrator: An astable circuit is a form of oscillator. The word astable means unstable. An astable multivibrator consists of two tubes or transistors arranged in such a way that the output of one is fed directly to the input of the other. The astable multivibrator is frequently used as an audio oscillator, but is not often seen in RF applications because it is extremely rich in harmonic products.

B plus: The term B plus (B+) refers to the positive high voltage dc supply used for the operation of a vacuum tube circuit. Since tubes are becoming less and less common in modern electronics, the ex-

pression B+ is heard less often today than a few years ago, but sometimes is applied to the voltage source in transistors. B+ voltages are frequently high enough to be dangerous.

Bridge rectifier: A bridge rectifier is a form of full-wave rectifier circuit, consisting of four diodes. Bridge rectifier circuits are commonly used in modern solid-state power supplies. Some integrated circuits are built especially for use as bridge rectifiers; they contain four semiconductor diodes in a bridge configuration, enclosed in a single package.

Capacitor: A capacitor is a device designed for providing a known amount of capacitance in a circuit. Capacitors are available in values ranging from less than 1pF to hundreds or thousands of μ F. It is rare to see a capacitor with a value approaching 1F. Capacitors are also specified according to their voltage-handling capability; these ratings must be carefully observed, to be certain that the potential across a capacitor is not greater than the rated value. If excessive voltage, either from a signal or from a source of direct current, is applied to a capacitor, permanent damage can result.

Continuity: In an electrical circuit, continuity is the existence of a closed circuit, allowing the flow of current. A simple device called a continuity tester may be used to check for circuit continuity. The continuity tester consists of a power source and an indicating device, such as a battery and a lamp.

Converter: Any device that converts frequency, voltage or current, or computer data from one form to another is called a converter.

Darlington amplifier: a Darlington amplifier, or Darlington pair, is a form of compound connection between two bipolar transistors. In the Darlington amplifier, the collectors of the transistors are connected together. The input is supplied to the base of the first transistor.

The emitter of the first transistor is connected directly to the base of the second. The emitter of the second transistor serves as the emitter for the pair. The output is generally taken from both collectors.

The amplification of the Darlington pair is equal to the product of the amplification factors of the individual transistors as connected in the system. This does not necessarily mean that a Darlington amplifier will produce far more gain than a single bipolar transistor in the same circuit. The impedances must be properly matched at the input and output to ensure optimum gain.

Some Darlington pairs are available in a single case. Such devices are called Darlington transistors. The Darlington amplifier is sometimes called a double emitter follower or a beta multiplier.

Degaussing: Degaussing is a procedure for demagnetizing an object. A device called a degausser or demagnetizer is used for this purpose. Sometimes the presence of a current in a nearby electrical conductor can cause an object to become magnetized.

This effect may be undesirable. Examples of devices in which degaussing is sometimes required include TV picture tubes, tape recording heads and relays. By applying an alternating current to produce an alternating magnetic field around the object, the magnetization can usually be eliminated. Another method of degaussing is the application of a steady magnetic field in opposition to the existing, unwanted field.

Diode: A diode is a vacuum-tube or semiconductor device intended to pass current in only one direction. The positive terminal of a diode is called the anode, and the negative terminal is called the cathode, under conditions of forward bias. Semiconductor diodes are used for

many different purposes in electronics. They can be used as amplifiers, frequency controllers, oscillators, voltage regulators, switches, mixers, and in many other types of circuits.

Feedback: When part of the output from a circuit is returned to the input, the situation is known as feedback. Sometimes feedback is deliberately introduced into a circuit; sometimes it is not wanted.

Feedback is called positive when the signal arriving back at the input is in phase with the original input signal. Feedback is called negative (or inverse) when the signal arriving back at the input is 180 degrees out of phase with respect to the original input signal.

Positive feedback often results in oscillation, although it can enhance the gain and selectivity of an amplifier if it is not excessive. Negative feedback reduces the gain of an amplifier stage, makes oscillation less likely, and enhances linearity.

Filter capacitor: A filter capacitor is used in a power supply to smooth out the ripples in the dc output of the rectifier circuit. Such a capacitor is usually quite large in value, ranging from a few microfarads in high-voltage, low-current power supplies to several thousand μF in low-voltage, high-current power supplies. Filter capacitors are often used in conjunction with other components such as inductors and resistors.

The filter capacitor operates because it holds the charge from the output-voltage peaks of the power supply. The smaller the load resistance, the greater the amount of capacitance required in order to make this happen to a sufficient extent.

Filter capacitors in high-voltage power supplies can hold their charge even after the equipment has been shut off. Good design practice recommends that resistors of fairly large value be placed in parallel with the filter capacitors in such a supply so that the shock hazard is reduced. Before servicing any high-voltage equipment, the filter capacitors should be discharged.

Half-wave rectifier: A half-wave rectifier is the simplest form of rectifier circuit. It consists of a diode in series with one line of an alternating-current power source, and a transformer (if necessary) to obtain the desired voltage.

Low pass filter: A low pass filter is a combination of capacitance, inductance, and/or resistance, intended to produce large amounts of attenuation above a certain frequency and little or no attenuation below that frequency. The frequency at which the transition occurs is called the cutoff frequency.

At the cutoff frequency, the attenuation is 3dB with respect to the minimum attenuation. Below the cutoff frequency, the attenuation is more than 3dB.

Scan-derived power supplies: A scan-derived power supply is a dc/dc converter that uses the horizontal output stage and flyback transformer. The term scan refers to the sweep circuits used to generate the ac pulses that are rectified into dc voltages. These voltages are used to power all of the circuits in the TV set.

Step-down transformer: A step-down transformer is a transformer in which the output voltage is smaller than the input voltage. The primary-to-secondary turns ratio is the same as the input-to-output voltage ratio. The input-to-output impedance ratio is equal to the square of the input-to-output voltage ratio.

Step-up transformer: A step-up transformer is one in which the output voltage is larger than the input voltage. The input-to-output voltage ratio is equal to the primary-secondary turns ratio. The input-to-output impedance ratio is equal to the square of the input-to-output voltage ratio.

Temperature coefficient: Many electronic components are affected by fluctuations in temperature. Resistors and capacitors, especially, tend to change value when the temperature varies over a wide range. The tendency of a component to change in value with temperature variations is known as temperature coefficient.

If the value of a component decreases as the temperature rises, that component is said to have a negative temperature coefficient. If the value increases as the temperature rises, a component has a positive temperature coefficient.

A few components exhibit relatively constant value regardless of the temperature; these devices are said to have zero temperature coefficient. The temperature coefficient is usually expressed in percent per degree Celsius. ■

VCR troubleshooting tips

By Victor Meeldijk

In a study conducted by the Electronics Industries Association (EIA), 43% of five year old VCR's have required service. Of the two most often cited reasons for service, head cleaning was the first (30% of units brought in for service) and rewind mechanism problems was the second (15%).

The owner of a service center in New York estimated that 70% of his VCR service involved mechanical parts. The other 30% was attributed to electrical problems. This article discusses the reasons for VCR problems, and describes how to narrow down the problem areas by analyzing the failure symptoms.

Frequent VCR failures

A high percentage of VCR repairs involves mechanical parts. One typical manufacturer's 10 most likely causes of warranty failure are:

• Belts	21.5%
• Idlers and pulleys	4.4%
• Motors	2.5%
• Switches	1.5%
• Loading mechanism	1.6%
• Relays	1.0%
• Tape heads	4.6%
• Circuit card assemblies	3.9%
• IC's	8.8%
• Remote unit	1.3%

Beyond the warranty period, mechanical wear-out is one of the biggest problems along with slow rewind problems, belt failures, head clogging and physical VCR damage. In cases of electronics failures, the microprocessors are cited as the high failure item.

Troubleshooting by symptom analysis

Analyzing the symptoms of a malfunctioning VCR can often help in isolating the cause of the problem. The remainder of this article provides possible causes and suggested areas to check. They are listed by general, then specific, problem areas.

Meeldijk is the Reliability/Maintainability Engineering Manager for Diagnostic/Retrieval Systems, Inc. Oakland, NJ.

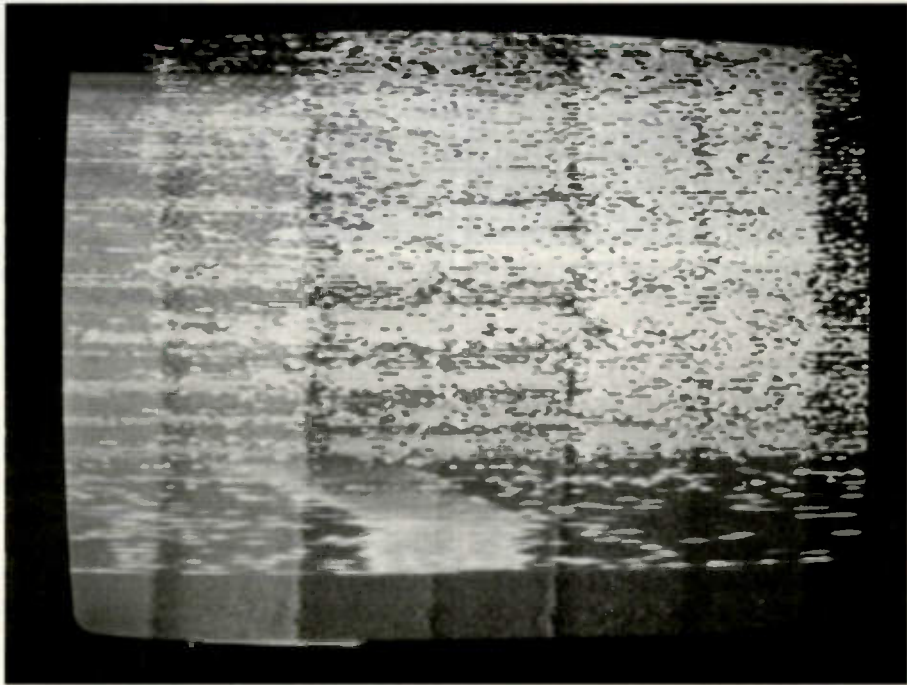

Figure 1. A snowy picture can be a symptom of the heads rotating at the wrong speed (the cylinder head motor is binding or needs lubricating or worn video heads (in this case, the bottom portion of the picture looks clear, but poor video quality, only because of extreme tracking misadjustment in a four head machine).

Picture problems (general)

Remember that proper playback requires that both the position and speed of the video heads across the tape, and tension and position of the tape as it is fed past the heads, are correct. Following are some typical picture problems, possible causes, and areas to check.

Picture out of sync

An out of sync picture is characterized by rolling/jittering or noise bar running vertically (up and down) through the picture, non-hi-fi audio good.

The audio quality depends on the rate at which the tape is pulled by the capstan across the audio head. If the non-hi-fi sound is good, then you know that tape speed is correct, so check the following areas in the servo circuit.

- Pulse width modulation signal
- Capstan frequency generator signal

- Cylinder pulse generator signal—(a constant frequency signal based upon cylinder movement)

- Control track logic pulses
- 30Hz Reference Signal—(29.97Hz square wave)

One way to check servo lock is to mark the top of the cylinder (sometimes referred to as the scanner) with a grease pencil. Use a fluorescent light, which will act as a strobe, to look at the cylinder while it is spinning. If the pencil mark does not appear as an almost stationary blurred pattern (in other words, if the mark is spinning around) it means that the servo is not locked.

If the servo locks in record, but not playback, this is a timing reference problem; check the tracking circuit. If lock doesn't occur in either record or playback, check the 30Hz feedback pulse from the video cylinder. Note: it may be difficult

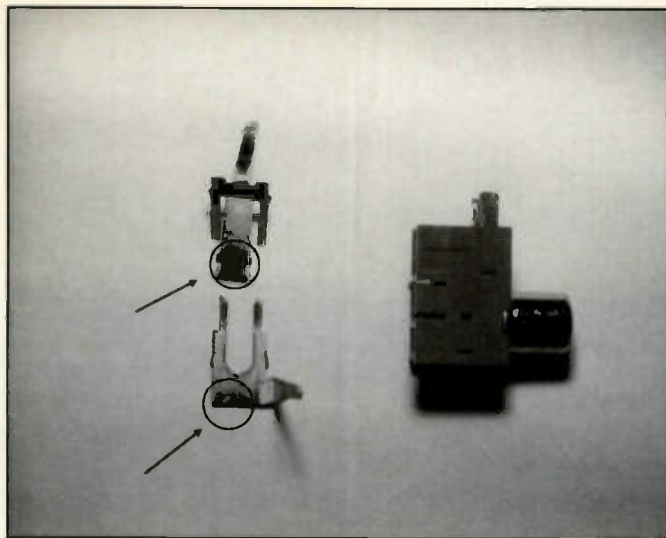

Figure 2. Oxidized input jacks can result in loss of audio or video signals when making recordings.

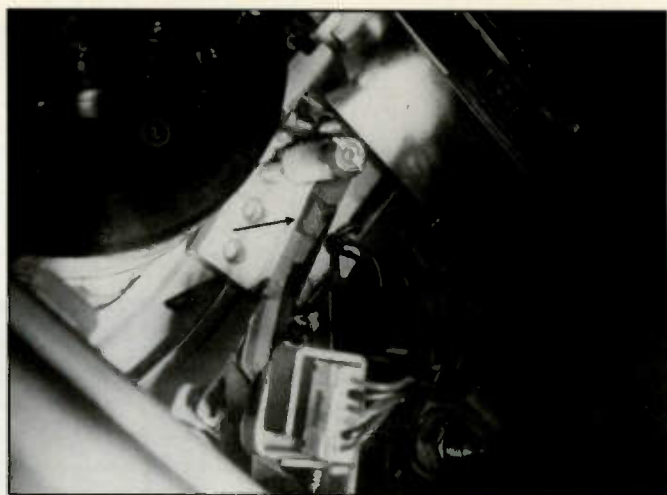

Figure 3. Irregular roller movement (leading to picture jitter and distorted audio) can be detected by looking at the reflections in the moving tape. If any jitter at all is noted in the reflection, the roller needs to be adjusted or replaced.

to see the pencil mark, so another way to perform this test is to note some reference mark on the top of the cylinder, such as a screw, or hole, and see if that reference appears to stand still under the fluorescent light.

Snow bar or alternating clear/snowy picture

If the problem is either a snow bar, or an alternating clear/snowy picture, check the following areas.

- Tracking control settings
- Capstan phase: the video heads may be tracing the wrong azimuth track or the guard band
- Video head relay (or switching circuit). The heads may not be switching in or out of the circuit
- Back (tape) tension (especially if there are a lot of dropouts)

If in SP mode the top portion of the picture is clear, or in EP mode the bottom portion of the picture is clear, the heads are not the problem (provided the alignment potentiometers are not so misadjusted as to cause worn heads to track in such a way as to cause a portion of the picture to be clear as in Figure 1) and the video head relay has to be checked.

If the unused head (for a particular mode) is not shorted out, it will also read data and distort the picture. In SP mode the SP heads read the video tape first and then the EP heads contact the tape. If the EP heads are not shorted out the bottom

portion of the picture is distorted. Similarly in EP mode the SP heads contact the tape before the EP heads and again if they are not shorted, the top part of the picture is affected.

Noisy picture or absence of video

When you observe a noisy picture, or if there is no video at all, check the following possible causes.

- Video heads (if the problem occurs at all speeds)
- If the problem occurs only at one speed, or if a portion of the picture is clear, check the head switching circuits and pre-amplifier

In general, check:

- Video head preamplifiers
- Playback/record switching transistor
- RF modulator
- Luminance (B/W picture) circuits
- Rotary transformer
- Power supply
- Chrominance (color) circuits
- 3.58MHz oscillator
- 4.2MHz conversion circuit
- 30Hz and 15Hz reference signals
- 629 kHz color subcarrier. For Beta, this is 688 kHz.

Note: It is possible for a worn (marginal) head to record a tape which plays back acceptably on another machine (although the picture may be somewhat degraded) but will exhibit noise when it plays back its own tapes.

On older VCR's with fine tuning chan-

nel controls, if the problem does not affect all channels, check the thumbwheel setting. The thumbwheel may be improperly set or may be intermittent due to dust and dirt.

Luminance problems, or a poor definition picture lacking sharpness may be related to the video preamp circuit or the noise canceller circuit.

Noise or snow may indicate problems in the tracking control circuit, or dirty heads. If the snow is coarse grained check for dirty heads. Dirty heads account for about half of the noise or snow associated with VCR problems.

A herringbone pattern on the screen when playing a known good tape may be the result of a carrier leak, check the FM demodulators and limiters. If the herringbone pattern occurs in a color picture but not in a B/W picture (turn TV color controls off to check this) check color/luminance circuits for leakage.

A narrow band of noise at the bottom of the picture indicates that the heads are switching too soon. If you encounter this symptom, check the 30Hz control track logic pulses and 30Hz reference signal.

The function of the delay line is to replace missing data, generally caused by tape oxide defects, with data from the previous horizontal scan line. This circuit will not affect recordings. It only functions in playback.

If a recorded tape has a lot of random dropouts (not a snowy picture) but plays

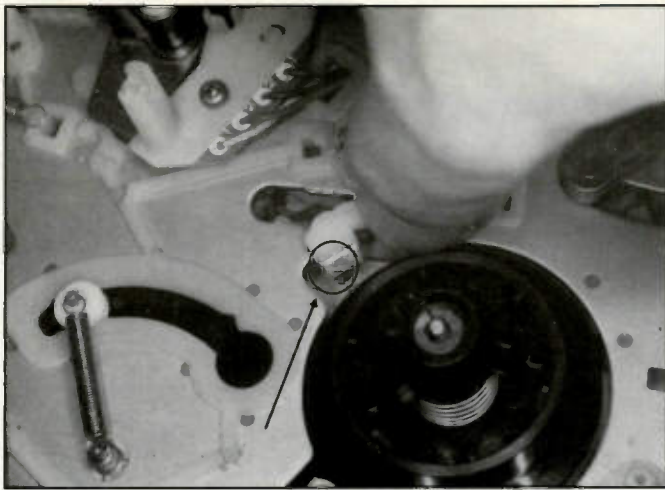

Figure 4. Dirty reel tension brakes can cause erratic reel movement which can result in picture jitter and audio garbling.

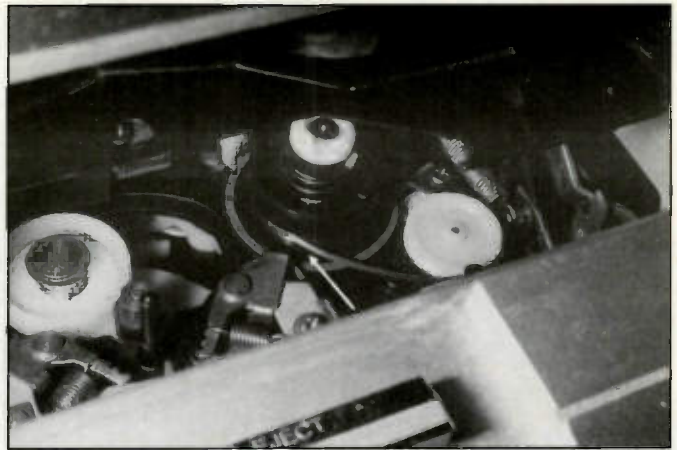

Figure 5. A loose footage counter belt will cause VCR shutdown in machines without reel sensors (the system microprocessor will not receive signals through the footage counter feedback circuitry and think the take up reel is not turning).

well on a known good VCR suspect the delay line circuitry.

Flagging

If you observe flagging, that is the upper part of the picture is skewed or bent over (a wave in the top part of the picture), check:

- Tape back tension
- TV AFC circuit

TV's built before 1978 have a lower video sync tolerance and the AFC circuit may not follow the VCR playback. If this is the problem, the TV AFC circuit needs to be modified (capacitor values changed).

Some prerecorded tapes with copy protection can also cause this if the output level is reduced by going through a switching system or another VCR.

No picture in TV mode

When the VCR is in TV mode, and there is no picture, check:

- TV/VCR switch
- TV/VCR switching relay

Either may have dirty or worn contacts.

No picture in stop mode

When the VCR is in stop mode, and there is no picture, check:

- Tuner/IF
- Video input connector (see Figure 2)
- Mode switch

Color-related picture problems

Defects in VCR circuits frequently cause color-related problems in the playback picture such as absence of color,

flickering of color, or other picture defects in which color is incorrect. Here are some typical symptoms accompanied by suggested areas to check.

1. No color. Check:

- Color playback or reference circuits
- AFC circuit

- Dropout compensation circuit (if this problem occurred after a severe dropout)

2. Loss of color lock, barber pole effect. Check:

- FC and horizontal sync pulses
- VCO frequency

3. Flickering of color in playback. Check:

- Automatic color control circuit
- Video heads (especially if the problem shows up in a B/W picture as well)
- Video head preamplifier balance

4. Color change in playback. Check:

- Color subcarrier frequency

5. Bands of color several lines wide, other colors saturated, check:

- Automatic phase control circuits
- 3.58MHz oscillator frequency

Audio problems

In addition to video problems, VCRs may also exhibit audio problems. If the unit has a hi-fi sound system, the audio problems may be related to either the linear audio or the hi-fi audio. The problem may be related to the record/playback heads, or may be caused by the circuitry. Following are some typical audio problems you may encounter along with suggestions of areas to investigate.

1. Non-hi-fi audio problem but hi-fi audio normal. Check:

- Stationary audio/servo head

- Audio circuit, especially record/playback relay (contacts may be dirty) if recorded tapes made on the problem machine play normally on a different VCR.

2. No sound from TV program in stop mode. Check:

- TV/VCR relay (dirty or worn)
- Tuner/IF
- RF converter
- Mode switch
- Audio input connector (Figure 2)

3. Hi-fi sound problem on playback, standard audio good. Check:

- Hi-fi audio heads (on cylinder)
- Rotary transformer
- Audio preamplifiers
- Audio head switching relay

4. Hi-fi audio sounds raspy. Check:

- Head switching relay and circuitry
- Audio dropout detection circuitry

The audio heads in a hi-fi VHS machine are located on the cylinder along with the video heads, and are switched at a 30Hz rate. The audio heads are 120 degrees around the head cylinder from the adjacent video head, and have an azimuth angle of +30 degrees. Audio head switching is delayed slightly from the video head switching by an audio phase shifter circuit. Incorrect audio head shifting results in loss of, or noisy, hi-fi audio.

In operation, the audio signals are recorded first, then the video signals recorded over them. The different head gaps enable this depth multiplexing where the audio signals are recorded deep into the tape, with the video signals only recorded to a shallow depth. The audio

Business Is Not A Game Of Chance!

**You Either Win Or You Lose -
There's No Two Out Of Three!**

All too often a servicer is forced to place the profits on the line based solely on the flip of a coin or an educated guess. What happens to your productivity when you go down the wrong circuit, or spend time diagnosing the heads when the servos aren't tracking correctly? You lose the gamble, right?

Don't take that chance! Here's the answer . . .



Thousands of satisfied customers have invested in the VC93 All Format VCR Analyzer for various reasons: servo analyzing, head checking, luminance/chrominance circuit troubleshooting, audio and Hi-Fi circuit analyzing, plus the simple ability to add an additional \$2-\$5 of profit on each VCR coming through their service center.

And they can do all of these things because the VC93 provides:

- ◆ Dynamic VCR head signal substitution
- ◆ Exclusive Hi-Fi Stereo head substitution
- ◆ Innovative VCR luminance, chrominance, and audio circuit analyzing
- ◆ Automatic servo analyzer
- ◆ Stand-alone ability or can be integrated with the new "Tech Choice System" instruments
- ◆ Complete all-format troubleshooting, including:
 - Servo bias supply
 - Standard video & audio line outputs
 - Autoranging DCV and PPV meter
 - Output signal monitor

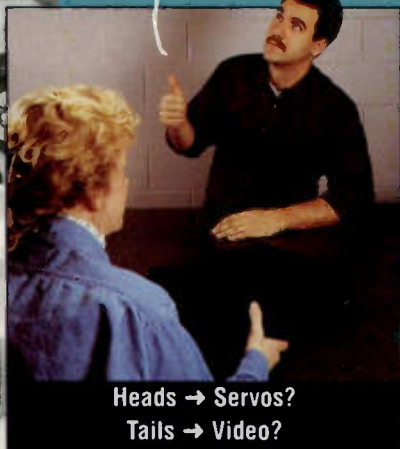

Heads → Servos?
Tails → Video?

New!

If you'd like to learn more about the VC93, call your Sencore Area Sales Representative today, and find out why the VC93 is one of the best investments you'll make in your 1993 VCR servicing.

VC93 All Format VCR Analyzer
Patented - Exclusively From Sencore

Call 1-800-SENCORE Ext. 607
(736-2675)

Circle (17) on Reply Card



SENCORE

3200 Sencore Drive, Sioux Falls, SD 57117
Direct (605) 339-0100 Fax (605) 339-0317

heads reject video data due to their +30-degree azimuth and further video signal rejection is done by bandpass filtering of the audio head signals.

In Beta machines the FM luminance frequency is moved up a small amount so that the sidebands of audio converted to FM signals will not overlap with the sidebands of the FM luminance and down-converted chroma. Therefore, different head azimuths are not needed to keep the audio converted FM signals separate from the video FM.

Beta machines use the video heads to also record hi-fi audio using four different audio-to-FM frequencies. Filters switch in during playback to prevent audio tracks from interfering with the video information.

Audio and video problems

1. Noise bar in the picture; sound intermittent, absent or garbled. Check:
 - Audio/control head
2. Garbled or off-pitch audio, out of sync picture. Check:
 - Capstan
3. Picture pulsates in and out at a steady rate, no audio. Check:
 - Capstan servo lock (the absence of audio is caused by the VCR cutting off the sound because the servo is not locked)
4. Playback speed seems incorrect, picture noisy and sound pitch too high or low. Check:
 - Mode switch
 - Servo head (look for this in the audio/servo head stack)
 - Capstan servo circuit

5. Jittery video and garbled audio. Check:

- Tape movement (Figures 3 and 4)

Tape interchange problems

If known-good tapes from other VCRs play poorly, or the tracking control can not be adjusted to eliminate white streaks in the picture, the tape path probably needs to be adjusted.

VCR control problems

1. VCR remains in, or goes into, Stop mode. Check:
 - Dew sensor circuit
 - End of tape sensors
 - Movement of reels when loading tape
 - Reel sensors
 - Tape slack sensor (microswitch)
 - Counter belt (Figure 5)
 - Counter circuit (and check Hall Effect sensors under reels)
 - VCR cassette sensor switch
2. VCR accepts cassette (front load unit) but will not load tape. Check:
 - End of tape sensors
 - Cylinder rotation for servo lock
3. VCR accepts cassette but then loads and unloads tape continuously (or shows these symptoms when play or record mode selected), or the VCR will not accept cassette, check:
 - End of tape sensors
 - Rewind sensor
 If you hear the tape loading motor. Check:
 - Tape loading gears (check to see if they are worn or broken)
 - Cassette eject switch (they may be

mechanically stuck "on" or shorted)

- Mode switch
 - Cassette tray (stage) motor and belt (Figure 6)
4. VCR goes into Stop mode and unloads tape. Check:
 - Record tab switch (if this switch is intermittent it may cause these symptoms, especially in Matsushita, Panasonic, GE and Magnavox VCR's.)
 - The play pulley
 - The play roller
 - Felt clutch (in some RCA and Panasonic units, improper torque can cause this symptom.)
 5. VCR does not respond to input switches. Check:
 - Power supply
 - State switch
 - System control circuits
 - Sensors (especially the end of tape sensor lamp)
 - Motors
 6. VCR will not go into record mode or on-timed recordings did not record. Check:
 - Record tab (see below)
 - Record tab Microswitch
 When the problem is intermittent, it is important to verify that it was not actually caused by one cassette used intermittently. This problem occurred in one VCR because a cassette had a tab that was slightly out of tolerance and did not always activate the record tab switch. Thus the VCR would not always record in the timer mode when this cassette was being used.
 7. VCR does not fast forward or rewind,

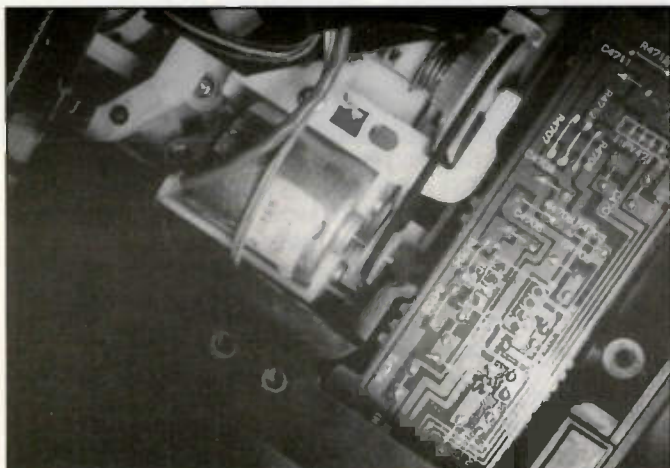

Figure 6. The marks on the belt pulley, and debris under the pulley indicate that this belt is dried out and needs replacement.

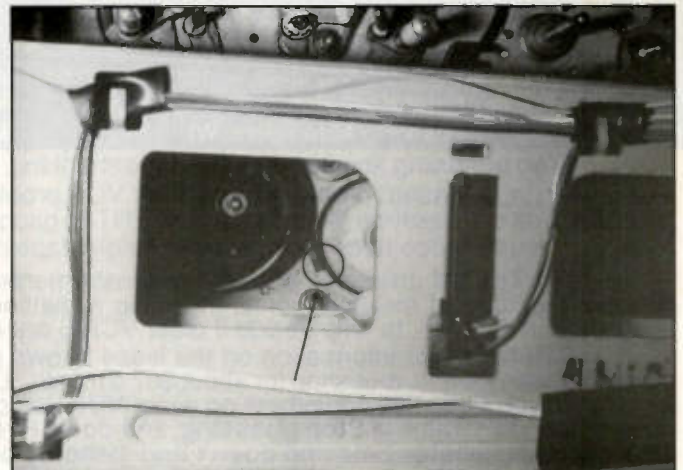

Figure 7. This piece of a broken cassette lodged under the supply reel causing play, fast forward and rewind problems.

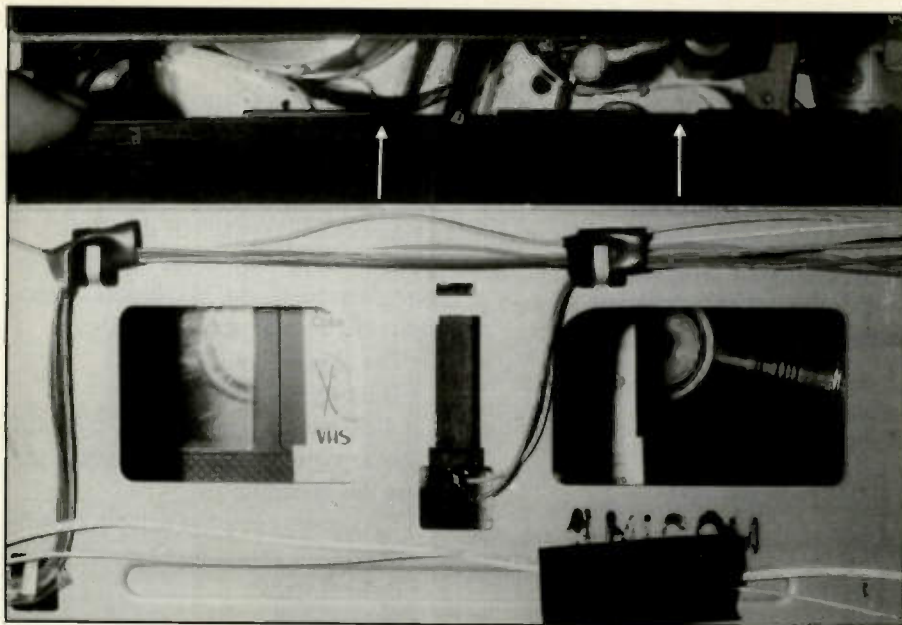

Figure 8. A common VCR problem is "eating tape" caused by tape not retracting back into the cartridge. This can be caused by a worn clutch tire, idler mechanism or objects lodged in the machine (see Figure 7).

or is slow in these modes (cue/review function normal). Check:

- Clutch tires (Figure 8)
- Idler assembly

In addition to mechanical problems, cheap no name type video cassettes may have poor hub lock mechanisms that do not fully disengage, making it hard, if not impossible for the VCR to turn the cassette tape reels.

Another possibility is foreign objects that are interfering with the mechanism. Inspect the interior of the VCR carefully for foreign objects (Figure 7).

8. VCR eats tape because the tape is not drawn back into the cassette. Check:

- Clutch tires
- Idler assembly

The idlers are usually found between the reels on the top of the chassis, and are therefore relatively easy to service (on some models the idler can be lifted out of the VCR after a spring is removed. On other models, a chassis part may have to be removed to provide enough room to maneuver the idler out of the VCR. Some Fisher units have the idlers mounted underneath the chassis thus causing longer more complicated repairs, and some Emerson models require that a circuit board above the chassis be removed.

Rubber revitalizer is only a temporary

fix for belts and clutch tires which show wear but are not at the replacement stage (with a cracked or glazed shiny surface). The most the rubber revitalizer will do is add a few months to the tire or belt and is not an alternative to the replacement of these items.

Miscellaneous symptoms

Low power supply voltages, or spikes on the dc outputs can cause problems that appear to be sensor related. Low voltages can reduce signals into uncertain areas between definite high and low logic switching and front panel control may no longer operate, or may be erratic. Spikes can upset sensor circuitry into thinking sensor pulses are present. For example, some VCR's may shut off during a lightning storm as power line spikes cause transients that fool the VCR circuitry into thinking a turn off signal occurred.

Intermittent record tab switches, especially in Matsushita, Panasonic, GE and Magnavox units may produce a variety of symptoms depending on contact resistance. These symptoms include:

- Loss of timer control
- Loss of one-touch recording
- VCR going in and out of record mode but front panel indicators do not show this happening
- Snowy picture
- Hissing audio with noises, clicks or motorboating sounds

• New video is recorded but the original audio remains (when recording over a recorded tape). This can also be caused by poor contacts in an audio input jack. ■

If You Knew How Much TENTEL Gauges Improve VCR Repair - You'd Already Have Them!

More confidence in repairs being done right the first time. **Peter Kosovich**

Peko TV- Milwaukee, WI

Bench time has been cut in half! **Fred Jolley**

Beverly, N.J.

Don't know how we managed as long as we did without the gauges. **Peggy Miller**

Miller's Elect's-Butler, PA

Stop guessing about sources of video streaking, tracking problems, flagging video, tape edge damage, video head wear, tape "eating" problems, and other VCR problems. 9 out of 10 VCR malfunctions are due to mechanical problems that can easily be diagnosed with TENTEL gauges. Electronic methods just don't work for guide height, tape tension, torques, video head wear, spindle height, tape edge damage, and other critical measurements.

TENTEL's 4 universal, powerful test instruments allow YOU to do 28 different mechanical measurements; including a method to determine video head wear in microns, to help decide if older VCR'S are even worth repairing.

Call today for information on the lease to own program that puts the power of these tools in your shop for about \$67 a month. Less than one VCR per month, yet you'll use this equipment on every VCR you do, and know it's been done right! Isn't it time to Stop guessing, and do VCR repair better and faster. Trial and error wastes time and doesn't find pending problems. Often there are 2 or 3 other problems along with each major problem. Can you find them now?? We can! Your satisfaction is 100% guaranteed!



CALL TOLL FREE: 1-800-538-6894 / 916-939-4005
TENTEL 4475 Golden Foothill Pkwy. El Dorado Hills, CA 95630

What do you know about electronics?

More about tunnel diodes

By J.A. Sam Wilson, CET

TYEK gremlins

When I typed the February 1993 "Test Your Electronics Knowledge" column I incorrectly copied question #1 from my notes. It should have read: "The highest number of decimal digits that can be represented by eight binary bits is:"

Answer: 256

Many thanks to Charles C. Spiro, CET of Middletown, VA and Lyn Schaeferle of NY for their letters about the error.

More on the tunnel diode

Ask a scientist to explain how a tunnel diode works and you will very likely get an answer like this: "In a tunnel diode some of the negative charge carriers move from the N-type material into the P-type material by virtue of quantum mechanical tunneling."

For some reason that explanation reminds me of the answers I got when I asked Ray questions about technology or science (Ray is a friend in Akron, OH).

Sam—How is it possible for a heavy ship made of iron and steel to float on top of the ocean?

Ray—It's simple. They just make the sides high enough so that the water can't get over the top.

Like the scientist's answer to the way tunnel diodes work, Ray's answer isn't wrong. However, there are a lot of important details left out.

In the most-recent issue of *ES&T* I gave a simplified model to explain the tunnel effect. That explanation is sufficiently accurate to make it possible to analyze tunnel diode circuits.

Tunnel diodes are not new devices. They were first introduced by the discoverer, Dr. Leo Esaki in 1958. In an article titled *New Phenomenon in Narrow Germanium P-N Junctions*, Dr. Esaki described the tunnel effect. That's why tunnel diodes are sometimes referred to as Esaki Diodes.

Note that the original tunnel diode was

Wilson is the electronics theory consultant for *ES&T*.

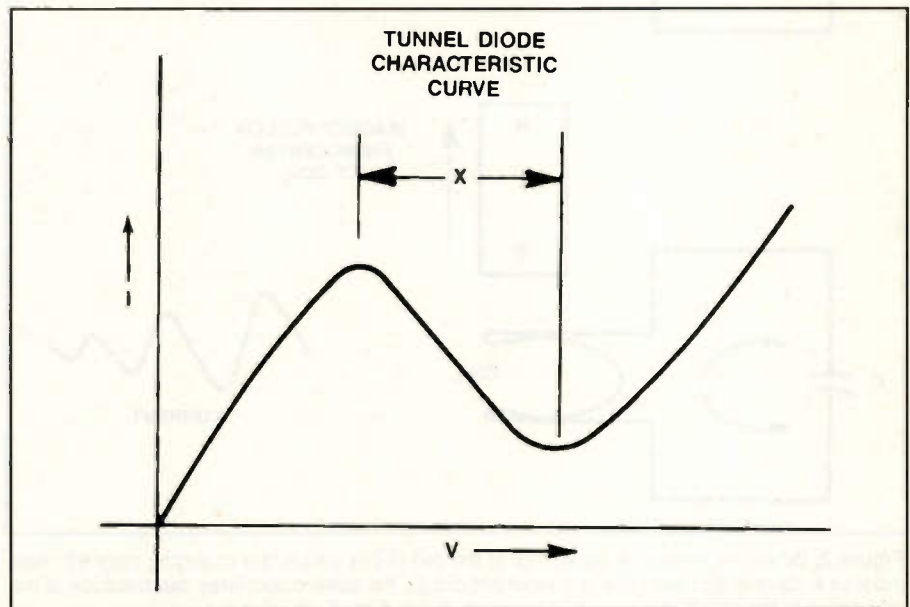

Figure 1. This is the characteristic curve of a tunnel diode. In the region marked with an "X," an increase in voltage results in a decrease in current. Ordinarily when voltage is increased across a resistive device the current increases. Therefore, the tunnel diode is said to exhibit "negative resistance" over part of its characteristic curve.

made of germanium. However, more recent versions have been made of silicon and gallium arsenide.

The negative resistance idea given in tunnel diode theory is not new and it has been utilized in some very old tetrode tube circuits. In your study of basic theory you likely were told that there is no such thing as negative resistance. Later, when you studied more advanced technology you probably heard such statements as "the device exhibits negative resistance." Later, when you studied more advanced technology you probably heard such statements as "the device exhibits a negative resistance characteristic."

Do not jump over the word "characteristic." Devices like the tunnel diode act like they have negative resistance. However, what you were first told is true: There is no such thing as real-world negative resistance.

In the real world whenever you increase the voltage across a resistor there is an increase in current through it. Refer to the tunnel diode characteristic curve of Figure 1. In the region marked with an 'X'

an increase in voltage results in a decrease in current. That is the reason for the term negative resistance. So, the tunnel diode acts like it has negative resistance. I explained the reason for that in the previous article.

Here is a good place to restate a very important thing about this discussion on tunnel diodes. I'm leaning on models to get the theory across. If you want a full-blown explanation of quantum mechanical tunneling you will have to go to an advanced physics book. My models give a perfectly plausible idea of how the tunnel diode works. However, when I talked to a physicist about my model he fell to the floor, tore his clothes, and threw dirt all over himself.

One difference between the model of the tunnel diode that we are using and the rigid scientific explanation of the action is in the speed with which tunneling electrons cross the depletion region. In the model, I have described the motion as being a drift across the junction. In the actual device the electrons are said to cross the junction "at the speed of light."

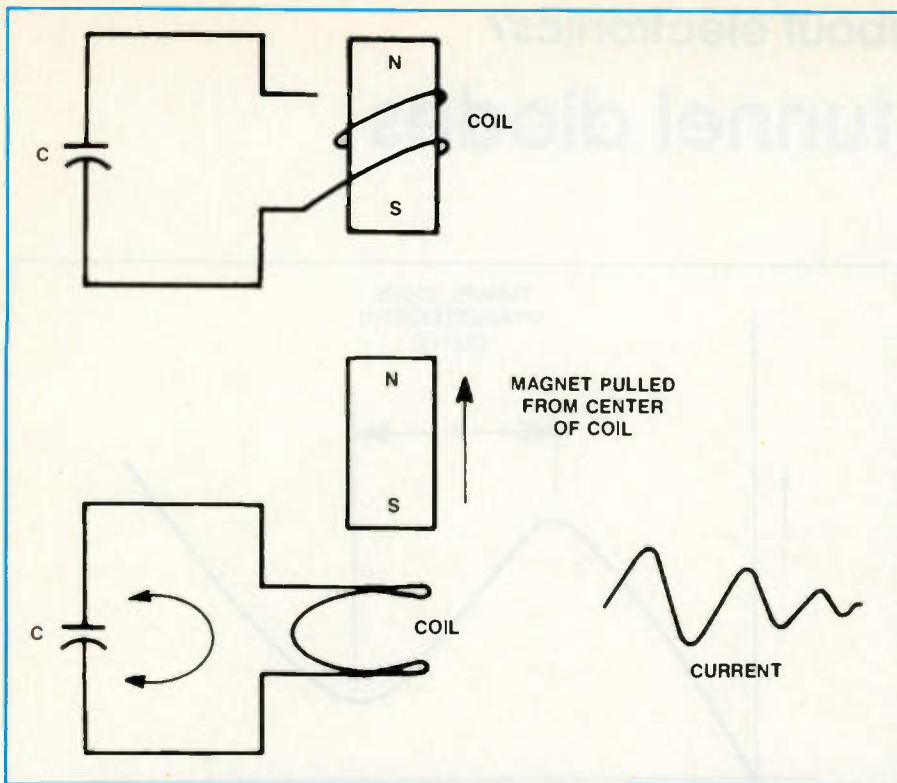

Figure 2. When the magnet is pulled out of the coil in this circuit, the changing magnetic field induces a current. Because this is a resonant circuit, the current oscillates, but because of the resistance in the circuit, the current is damped; that is it gradually dies out.

That does not alter the action of the device as it is described in this series.

How is a tunnel diode different from other diodes?

The N- and P-regions in the tunnel diode are more heavily doped compared

to those regions in rectifier diodes. In our model we would say that when there are more negative charge carriers there is a greater chance that some of them will get enough energy to sneak through the depletion region and get into the P-region. My physics book says "It has been deter-

mined experimentally that heavier doping of the semiconductor materials results in an increase in quantum mechanical tunneling." (Note: I have paraphrased that line from the original.)

The junction in a tunnel diode is much thinner than the junction in rectifier diodes. In fact, the junction is less than a millionth of an inch across. In our model we would say that the thin depletion region makes it easier for an electron to get up enough energy to cross the junction without the need for an external voltage.

Because of the thin dielectric and heavy doping the tunnel diode has a higher reverse current than rectifier diodes.

A tunnel diode oscillator circuit has very good temperature stability. In other words, the operating characteristics of a tunnel diode do not change with reasonable changes in temperature.

A tunnel diode circuit also has great frequency stability. So, once the frequency is established it stays put. There won't be any change in frequency when there is a slight change in supply voltage.

Support for the model

At this time I want to offer further support to the model I have given for the tunnel diode.

Think about this. In any material the atoms and/or molecules are in constant motion. (That motion is called Brownian Motion.) The motion occurs at all temperatures above absolute zero. If you increase the temperature of a material, the amount of motion increases. If you decrease the temperature, the amount of motion decreases.

In an experiment that has been performed a number of times, two pieces of material are clamped together and maintained at room temperature. In one of those experiments the materials were gold and lead. After a given lapse of time the metals are separated. It has been found in these experiments that some lead migrates into the gold and some gold migrates into the lead.

That experiment shows that at room temperature there is a certain amount of energy in each atom/molecule. In fact, the energy is high enough to permit the atom/molecule to cross the gold and lead interface. If the atoms and molecules have that much energy, then surely the electrons in them also have enough energy to escape their bonds and cross the depletion region.

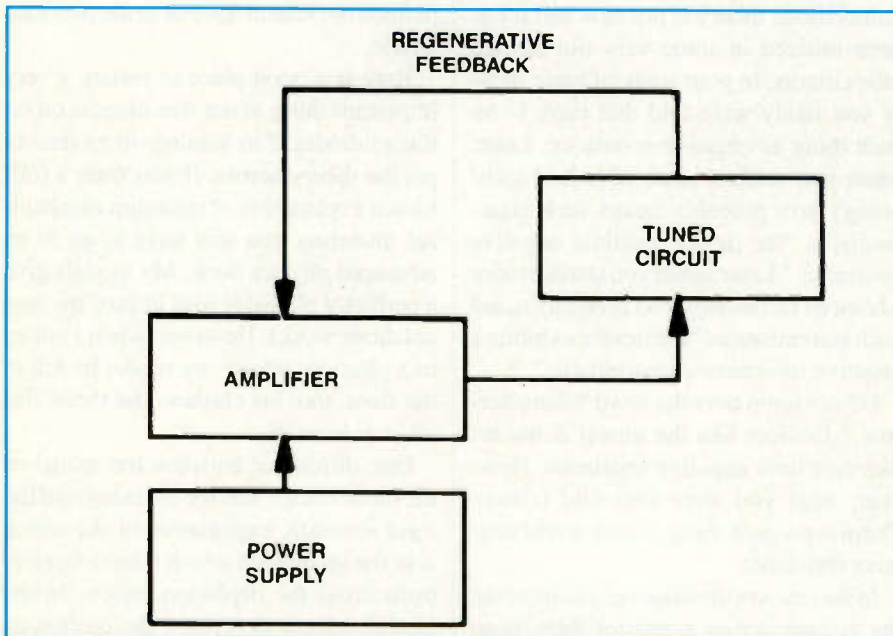

Figure 3. In order to get continuous oscillation in a circuit such as that in Figure 2, it is necessary to introduce an amplifier and a switching device, such as a tunnel diode, that can switch power supply energy into the circuit at precisely the right time to sustain the oscillation.

It turns out that an electron cannot just sneak into a higher energy level. To go from one energy level to the next higher level requires a specific amount of energy increase. That amount of energy is called a quantum.

Once an electron gets enough energy to get away from its atom or molecule it has energy by virtue of its motion.

That is a form of mechanical energy called kinetic energy.

The electrons in a tunnel diode are able to move from the N-type material to the P-type material without a forward bias on the device. That is not supposed to be possible. If the basic idea of the junction is correct they have to be restricted to their N-type material. You can explain that they get across the line by tunneling under—or through—the junction.

Put the underlined words together and you get quantum mechanical tunneling.

Oscillator review

I didn't get to the tunnel diode oscillator circuit in this issue. It will definitely be in the next issue.

This is a good place to review a basic concept about oscillators. Refer to the

simple series circuit in Figure 2. When the magnet is pulled out of the coil center a voltage is induced in the coil. That starts an oscillating current. The operation of the circuit is sometimes referred to as the "flywheel effect."

The result is a damped waveform.

The reason the amplitude decreases is that energy is lost—that is, radiated in the form of heat. The heat is the result of the circulating current flowing through the circuit resistance.

In order to get continuous sinewave oscillation it is necessary to frequently replace the lost energy. An amplifier is usually used for that purpose. A tube, or transistor, or FET is often used as the amplifying device. See Figure 3.

Basically, the only purpose of the amplifying device is to continually deliver energy at the right moment to replace the energy lost in the form of heat.

In a tunnel diode sinewave oscillator circuit the tunnel diode switches power supply energy into the system at the exact proper time. It is the power supply that actually supplies the replacement energy. That is also true for other types of sinewave oscillator circuits. ■

THE SOURCE . . . for quality Electronic Parts & Accessories.

"We'll get your parts to you as fast as you need them!"

Call today and ask about our **PREMIUM DELIVERY** and for your **FREE** copy of our catalog . . .

1-800-558-9572

or for 24 hour ordering call FAX 414-473-4727

"First in Quality, Service and Delivery"

PREMIUM PARTS+
ELECTRONICS COMPANY

P.O. Box 28 • Whitewater, Wisconsin 53190

Circle (13) on Reply Card

Use Your Free Reader Service Card For More Information On Companies Advertising In This Issue.

Come Out of the Dark.

Highlight this opportunity to enrich your skills at the 1993 National Professional Electronics Convention, August 2-7, Louisville KY. Programs will include:

- Hands-On Technical Training. • Certification.
- Management Seminars. • Industry Trade Show.
- Register and pay by June 30 to **SAVE UP TO \$80 PER PERSON.**

For a registration form or more information, rush the following to NESDA:

Name _____

Business _____

Address _____

City _____ State _____

Zip _____

Phone _____

National Electronics Service
NESDA
Dealers Association, Inc.

2708 W. Berry St.
Ft. Worth, TX 76109
(817) 921-9061

The Industry's Most Complete Line of Flyback Transformers.



Over 100 Types - All Available from Stock
Same Day Delivery - Call for Catalog
Call for the Distributor Nearest You

EVG A DIVISION OF
russell industries, inc.

Suppliers of High Quality Electronic Components for Over 30 Years

3000 LAWSON BLVD. • OCEANSIDE, NEW YORK 11572 • 516-536-5000 • 800-645-2202 • FAX 516-764-5747

Circle (14) on Reply Card

The CD-ROM Primer - Part 3

By Vaughn D. Martin

CD-ROM is short for Compact Disc-Read Only Memory. This new technology for storing and quickly retrieving large masses of data has created a keen interest in the field of personal computers. This is the third of three articles in Computer Corner that will describe this recently developed computer technology.

Viewing a CD-ROM-generated document

Once a search of the CD-ROM is complete, the user will want to view the results. Scrolling allows the user to move immediately to where keywords occur. Illustrations may also be referenced within the document. The user can call these up as well.

A printer provides for hard copy. Certain software programs even insert the graphics into the text where they were placed in the original document.

Another option is to copy information from the CD-ROM to a floppy or hard disc as an ASCII file which can be edited with a word processor or put into a spreadsheet. These are but a few of the possibilities of what can be done with CD-ROM data. The one immediate limitation, though, is after you edit or merge data within other documents, you can't write them back onto the CD-ROM disc.

How CD-ROMs are developed

The first step in developing a CD-ROM is data preparation. All data must be electronic, that is, machine readable for a processor. In order that text not appear just as a continuous stream of words, it has to have such things as organized chapters, section headings, paragraph labels, and other more subtle indicators such as italics and boldface, as well as centered texts.

There are conventions defined for han-



Figure 1

dling graphics as well. One way to handle graphics is the way word processors do; they insert special codes or tags into the text. After all of the data is in the proper format, tagged appropriately and checked, indexes are made from all the text, except the stopwords. The last step here is to send all of these files and indexes to a disc production facility on a nine-track magnetic tape which serves as the first step in making the master.

The next phase is called mastering in which the error correction codes are calculated and placed along with the information already on the nine-track tape.

Mastering follows and begins by having a glass disc coated with photoresist. A laser cuts away part of this photoresist where each pit is to appear on the finished CD. This leaves a spiral track of pits, just as they will appear on the final CD-ROM disc. A series of intermediate steps fol-

low in which a metal stamper is produced which is then used to duplicate the pits when the actual discs are made.

Mass production is carried out by injecting polycarbonate resin into a mold. The stamper impresses the pits in the surface of the transparent discs. The discs are then coated with the layer of aluminum through an evaporation process in a special vacuum chamber. After the aluminum is deposited, the disc is coated with resin and labels are printed and placed on the discs.

Multiple CD-ROM discs

It may be inconceivable that any application could require more than one CD-ROM of data; however, there are some such applications. In these cases you may use multiple disc drives daisy-chained together. The Amdek LASERDRIVE-1 allows daisy-chaining of up to four such

Martin is Chief Engineer in the Automatic Test System Division at Kelly Air Force Base.

----- Travel Directions -----

02/28/89

Start:

Go south 0.020 mile(s). (10.00 mph)

Turn left on WEDDINGTON ST and go east 0.542 mile(s). (30.00 mph)

Turn left on CEDROS AV and go north 0.160 mile(s). (30.00 mph)

Turn right and go east 0.050 mile(s). (10.00 mph)

Stop:

Finish.

Totals:

Travel Distance: 0.772 mile(s) = 1.243 kilometer(s).

Travel Time: 0 hr(s), 1.82 min. (= 0.030 hrs)

Gas Usage: 0.03 gallons = 0.13 liter(s).

Travel Cost: \$0.19

Based on:

Travel Cost: \$0.25/mi

Mileage: 23.0 mi/gal

Figure 2

devices. A device called a "jukebox" may also be used. This device reduces the manual switching of discs, just as its namesake does with discs you pay to hear.

An application that might use more than one CD-ROM is typically represented by Hewlett-Packard, the test equipment and computer manufacturer. By subscribing to their new CD-ROM support service you would receive regular mailings of updated CD-ROM discs. As a customer of this service these discs enable you to gain access to up-to-date reference manuals, application notes, and solutions to known problems concerning HP products and services.

While this process began as a service just for HP 3000 business computer users including the new commercial RISC-based Precision Architecture computers, HP's Applications Support Division, recently announced another 10 new products. Further ones are planned to be added to this service soon. It definitely represents a move toward the "paperless" information society. Other companies are following suit and offering similar services with related products throughout the modern world.

Some other computer-based information systems

CDI stands for Compact Disc Interactive and refers to a system that combines features of both CD-audio and CD-

ROMs. You can play audio and perform data retrieval as well.

DVI (Digital Video Interactive) promises to take the integration of audio and video one step further by recording full-motion video on a CD-ROM disc.

The challenge of using CD-ROM for this is that extremely large amounts of data are required to be compressed and then decompressed again to play the video. An hour's worth of video could be contained on one disc. DVI is being developed as a computer peripheral and not as part of a consumer electronics entertainment system.

WORM, which stands for Write Once, Read Many, refers to 5.25 inch optical discs and drives which directly enter data, rather than going through a manufacturing process. The discs can be removed from the drive, providing security. They are also well suited for the recording of transactions.

Compared to CD-ROMs, WORM discs have lower capacity, and both the discs and the drives are more expensive. But they serve different purposes. The CD-ROM is a distribution medium. The WORM is a writeable, permanent mass storage of transactions.

An automotive navigation system using a CD-ROM

There are a number of automobile navigation systems coming on board today or

nearly available to the public. The CAR-INS system in Europe is being pushed by Philips of Holland. This system uses a satellite to constantly update a map that is on a console between the two front seats. You can select the most direct economical or the most scenic route for a trip, and updates are given as you drive, warning of accidents or road repairs underway.

A more modest system here in America is called "Streets on a Disc" and uses a number of city maps, all supplied on discs, and a car compass. Refer to Figure 2 and note this city map of Los Angeles. Figure 3 shows how you can see how far you have driven and what it costs in gas and actual cash outlay.

Maps are very labor intensive and require the entry of massive amounts of data. This has been an impediment until now, but once the data has been entered, this high density medium is absolutely ideal for handling map data, and guiding you and making intelligent decisions and calculations nearly automatically for you.

I.C.S! TRANSISTORS!

Largest selection of original RADIO, T.V. & VCR semiconductors. Call or write for free catalog.

PRELCO ELECTRONICS DISTRIBUTOR
605 CHESTNUT STREET • UNION, N.J. 07083
TEL: 1-908-851-8800 • FAX: 1-908-886-4658

Circle (12) on Reply Card

Resolve Monitor Repair Database

900 Repairs

75 Monitors

30 Manufacturers

Component Sources

Manufacturer's Cross Reference

4 Updates per year

Call for FREE Demo

1-800-999-0304

ANA TEK
CORPORATION
PO Box 1200 / 4 Limbo Lane / Amherst, NH 03031

Circle (1) on Reply Card

Lightning protection for audio gear

By John Shepler

The thunderstorm season is upon us. This is often a particularly viscous time of year for damage to electronic devices caused by lightning. Let's review some of the measures we can take to protect valuable gear, and why lightning isn't always the culprit.

Most of us are careful not to get caught in the open during a thunderstorm. We've all heard the stories of people who have become human lightning rods or made the mistake of standing under the tallest tree on the golf course. Likewise, we assume that it's the equipment hooked to tall towers or sitting out in the open that is most vulnerable. Unfortunately, that is a false assumption.

A lot of equipment damaged by thunderstorms is sitting high and dry on living room shelves or wooden service benches. Many test setups and audio gear, other than receivers, don't even have antenna connections. Yet, a violent storm can race through your area and destroy a room full of equipment in a matter of minutes.

As you probably have guessed, the lightning strike isn't coming through the air in the building to do its damage. It has a much easier path through the power wiring. What happens is that lightning will hit an exposed nearby power line and cause an instantaneous voltage surge.

That surge has a fairly fast rise time and may persist for tens of milliseconds before fading out. Otherwise it looks like any other power line voltage. This means

that the surge will pass right through transformers, along underground wires, into any building, and through the wiring and outlets into vulnerable equipment. The high voltage surge exceeds the ratings of semiconductors only for an instant, but it only takes microseconds to destroy solid state diodes, transistors, and integrated circuits.

Rural areas seem to get hit harder than cities. Storms at night also seem to do more damage. Most likely, this is due to the lower loading of the power lines at night and in the country. All those industrial motors and electric lights in the city help to absorb the excess energy caused by a lightning strike. Where there are fewer loads, the remaining equipment sees a larger transient.

This suggests some easy protection methods. Turn off electronic gear not needed, especially during a storm. The line switch will break the surge path for most equipment. Better yet, unplug anything particularly sensitive . . . especially anything remotely controlled that is always powered. High priced televisions, stereo receivers, and personal computers are too valuable to risk operating during a storm. Also note that computers tend to crash during thunderstorms anyway, due to momentary power outages.

A good safety feature is the surge protected outlet strip. Most of these use a device called a MOV or Metal Oxide Varistor. This is a semiconductor that acts like back to back Zener diodes connected across the power terminals. The MOV draws little current until its rated voltage

is exceeded. At that point the device resistance instantly drops and conducts current until the voltage goes below the lower threshold. MOVs work by "shorting" the transient before it gets farther into the equipment.

There are other semiconductor devices that provide the same action, perhaps clamping a bit faster. When the surge absorbing components are combined with coil and capacitor filters, you have a line protector that will also help filter out RFI and other hash on the power lines.

Surge protectors are also a good investment because not all power line transients are caused by lightning. When power companies switch from one feeder to another, lightning-like voltage surges are created on the lines.

Don't forget those antenna inputs. Cable TV lines and any outdoor antenna should have an antenna discharge unit or grounding block connected to a grounding rod that is driven into the soil. Cable installers generally provide these right where the line enters the house. People installing their own TV, FM, or scanner antennas may neglect this important connection. While the equipment will work just fine normally, blown RF preamplifier stages can result when a big storm comes overhead and causes high voltage static charges to build up on the antenna.

Now the most important point. Besides protecting the equipment, installing antenna discharge units, line surge protectors, and grounded outlets can help keep you and your customers alive. Now, that is well worth the cost and effort. ■

Shepler is an engineering manager and broadcast consultant. He has more than twenty years experience in all phases of electronics.

Readers' Exchange

Readers' Exchange has been reinstated as a free service.

The following restrictions apply to Readers' Exchange:

- Only individual readers may use Readers' Exchange, and items must be restricted to those that are ordinarily associated with consumer electronics as a business or hobby. If you're in business to sell the item(s) you want to offer for sale, the appropriate place for your message is in a paid advertisement, not Readers' Exchange.
- Readers' Exchange items must be restricted to no more than three items each for wanted and for sale, and may be no more than approximately four magazine column lines in length (about 20 words).
- All submissions must be typed or printed clearly!

Send your Readers' Exchange submissions to:

Readers' Exchange
Electronic Servicing & Technology
76 N. Broadway
Hicksville, NY 11801

WANTED

Looking for two each: A Pioneer power amp, IC part #SI-1125HDP. Warren Shukis, 510-651-5112, 1479 Prince Edward Way, Sunnyvale, CA 94087.

Radio Riders #'s 22, 23; "Mosquito" transistorized signal injector pen, 6 inches long, mfg. by Don Bosco Electronics, MS-130; early tube radios, esp. Wards Airline and Movie dials. Harry W. Hughes III, HCR 31 Box 241, Sandy Valley, Nevada 89019. 702-723-1102.

High voltage divider P/N 7615407 and H/V Quad-rupler P/N 761634 for Barcovision 2 VSTAR 5 projector. Will pay for used functional or overstock parts. Call 614-899-9049.

Service manual/schematics for a Technics model SA1010 FM receiver. Copies OK. Please state price. John Walker, 10839 Linden St., Tequesta, FL 33469.

Schematic and service information for Radio Shack STA-11 stereo. Will copy and return or pay for copies. Ray Heffner PSC #1, Box 4228, APO AA 34001.

Schematic service info. on Technics Receiver model SA-850. Erik Stephens, 1005 Vernon St., La Grange, GA 30240.

Lafayette/Allied Radio catalogs of 60s/70s, Burwen 700 transient noise eliminator, Burwen 1201A Dynamic Noise Filter. Kevin Parks, 3532 W. Patterson Pl., Littleton, CO 80123-2831.

Sams Photofact set or partial set, prefer microfiche. Action TV-VCR, Glendale, AZ 602-842-4200.

Non-working color TVs, 1978 and up. Complete sets, not robbed of parts. Call 1-417-924-3350 or write David Lehmann, RR2, Box 104, Mansfield, MO 65704.

Working or not: need main boards but will buy whole unit if boards are in good physical shape. Sony Beta VCR model SL2001, main board Hitachi camcorder model Vm 3000, A-main board Marantz power amp model 250m-need one complete output board part #200-1071-100. Flenings TV, 42 Main St. Camden, NY 13316. Call 315-245-0992.

Service lit. Emerson VCR 900 and Capstan motor, p/n 288 PO52010. Inexpensive RF sweep gen. Phone/fax 907-789-5017, 8209 Cedar Dr. Juneau, AK 99801.

Sencore FT46 super cricket in good condition. Tim Sedgwick, 5510 W. Clearwater #2-E, Kennewick, WA 99336. 509-783-2709.

Schematic, or any information, on FANON Model FMW Wireless Interoffice Communicator. Will pay for copy or original. Orlo Hudson, 816-356-6309.

FOR SALE

Heath IB-2A impedance bridge, Sencore TR-129 transistor tester, both in good condition. Each unit \$400.00 plus shipping. Bob Kramer, 919 Grove St., Aurora, IL, 60505, 708-898-4044.

Sencore SC61 scope, like-new condition, \$2450.00. OBO. 602-926-4157.

Sams Photofacts 30 thru 1675. Some missing total 1390. \$1.00 each plus shipping or make offer for all. Willy Fleeman, 4145 Suisun Valley Rd., Suisun, CA 94585, 707-864-8237.

Sencore SC61 waveform analyzer. Unit is in mint condition rarely ever used on field service. Have probes, manuals and box. Was just calibrated by Sencore in July 92. Asking \$1700.00 or best offer. If interested, please call 701-663-5331. Ask for Pete.

Free tubes, you pay shipping. Approx. 26 assorted tubes. Electrical cond. unknown. Send SASE for list of tube types. Mike Roberge, 66 Thrush Dr., Milton, VT 05468.

Boonton Q-Meter, with spare tube & manual, good condition. Price includes UPS pre-paid anywhere in continental U.S.: \$55.00. Bob Kramer, 919 Grove St., Aurora, IL 60505, 708-898-4044.

Sencore VC93 VCR analyzer with all leads, manual, VHS servo test tape and packaging. Mint condition! \$1950.00. Call 814-239-2761.

Sencore VA62, VC93, NT64, and EX231 expander. Complete set, manuals and cables. \$2500.00. 402-476-8164 day, 402-423-2635 evs.

B&K MOD 430 signal level meter, 1 year old, excellent condition, \$795.00. General Instrument Videocipher II Satellite Receiver, excellent condition with remote (no module), \$200.00. Call Centreville Electronics, 703-631-0202, 13810B Braddock Rd., Centreville, VA 22020. Ask for Bob.

Sencore PA81 w/field battery and SG80. Both complete with all accessories and covers. Hardly used 2 1/2 yrs. old. \$4000.00 for both. Coastal TV Service, PO Box 352259 Palm Coast, FL 32135-2259. 904-437-4450.

Sencore SC3080 80MHz waveform analyzer. One year old, light use. Excellent condition. \$2500.00. Call Kent at 314-845-0010.

Light box kit w/glass chart set for camcorder service—new in box \$375.00—call Ken at 404-451-9132.

Sencore CM2000 computer monitor analyzer with most adapters. Also, Sencore SC61, VA62A, VC63, NT64, & PR57. All equipment is in excellent condition. Manuals and all standard cables included. Call Carl at 702-828-5474 to make an offer on any item. Photofacts (76), 1009-2040. \$1.75 each. (\$125.00 lot). B&K 2160 dual trace 60 MHz scope, manual/probes \$700.00. 40 new RCA 6BK7B tubes \$2.50 each (\$80.00 lot). Bob, 919-444-1660.

Sams Photofacts 1726, 1881, 1519, 1641, 1601, 1840, 1778, 1766, 1319, 2073. N. Young, 214 East Robertson St., Brandon, FL 33511.

630 original Mfr's service TV manuals. Mostly mid-80's Hitachi, Sharp, Mitsubishi, Panasonic, NAP, Quasar, Teknika, \$1.00 each. Freight prepaid on 100. \$400.00 for all. Bob Nelson, 602-855-5400.

Sencore VA62 with cover, VC63, NT64 for \$2000.00. Also, Sencore SG165 AM/FM stereo analyzer \$1000.00. All in excellent condition, used only once. Call John 201-432-7635.

Sencore VA62 video analyzer, VC63 VCR test accessory, NT64 color pattern generator, SC61 waveform analyzer-dual trace scope with digital display, more. Like new. Call 205-983-6237.

Sencore #TC28, \$175.00; SG169, \$80.00; FE20, \$25.00; Hickok tube tester #6000, \$55.00; B&K #747, \$200.00; Simpson #312, \$50.00; #260, \$25.00; Triplett #630, \$25.00; #603, \$40.00. Some with manuals. Price plus shipping. For more info., 415-334-7927.

May 1990 to March 1993 complete ES&T. Offer plus shipping. Simpson AM/FM signal generator. B&K television analyst. Will sell both items very cheap, plus shipping. Excellent condition. Call 219-522-0262.

Thermabins, used parts bins 2x12, 4x12, 6x12, etc. Call for details. Keith, 703-368-1300.

Service manuals, paper and microfiche, Sams. Send large SASE to 20th Century TV & Stereo, 1615 W. Montrose Ave., Chicago, IL 60613.

Laser power meter (never used) \$150.00. Upper drum assembly \$100.00 plus misc. boards for Fisher FVH-839 (VCR). The Camera Clinic, 236 E. First St., Weston, WV 26452.

Sencore SC61, recent calibration at factory, like new, \$1500.00. VA 48 needs minor repair, \$400.00. ST66, never used, make offer. Also have SC60, new and Sylvania CK3000 test signal. All prepaid shipping. R. Bailey, 410-486-4323.

Conar TV pattern generator model 682, B&K 1076 television analyst, B&K 415 solid-state sweep/marker generator, Conar Model, 255 solid-state oscilloscope. N. Young, 214 East Robertson Street, Brandon, FL 33511. 813-685-1900.

Laser power meter—like new. Used once. \$125.00. Call Rich, 304-269-7850.

Sencore VA62, NT64, \$1200.00; ST66, \$500.00; Heathkit audio load \$50.00. Bud Schlegel, 1079 Homestead Ave., Holyoke, MA 01040. 413-533-7566. ■

Classified advertising is available by the word or per column inch.

By-the word. \$1.65 per word, per insertion, pre-paid Minimum charge is \$35 per Insertion. Initials and abbreviations count as full words. Indicate free category heading (For Sale, Business Opportunities, Miscellaneous, Wanted). Blind ads (replies sent to ES&T for forwarding) are \$40 additional. No agency discounts are allowed for classified advertising by the word. Contact Emily Kreutz at 516-681-2922 to place your classified ad (by-the-word). Mastercard, VISA, American Express and Discover are accepted for phone or mail orders.

Per column inch (classified Display): \$235 per column inch, per insertion, with frequency discounts available, 1" minimum, billed at 1/4" increments after that 10" maximum per ad. Blind ads are \$40 additional. Reader Service Number \$25 additional to cover processing and handling costs. (Free to 4-inch or larger ads.) For more information regarding classified display advertising please contact Jonathan C. Kummer at 516-681-2922. Optional color (determined by magazine) \$150 additional per insertion.

Send your order, materials and payments to:

Electronic Servicing & Technology
76 North Broadway
Hicksville, New York 11801
Attn: Emily Kreutz
Phone: 516-681-2922
FAX: 516-681-2926



FOR SALE

*****TIPS*****TIPS*****TIPS***** The **TIP** computer Program is the **BEST** technical database program on the market today. Why is it the BEST? 1). **Easy to use** - developed with the technician in mind. 2). **One of the largest technical tip databases in the country** - over 12,000 tips related to consumer electronics (that's not a misprint that's over twelve thousand tips)!!! 3). **Our clients say it is the BEST** (and who are we to argue). **INCREASE your PROFITS** by reducing troubleshooting time. **ONLY \$295.00 HIGHER INTELLIGENCE SOFTWARE, INC., 60 Farmington Lane, Melville, NY 11747 (516) 643-7740.**

VCR AND TV SERVICERS** Make those hard repair jobs easy with our up to date symcure information **1800 item VCR symcure file and 1200 item TV tough dog symcure file available on IBM compatible disk and print out. VCR disk w/pc \$85.00 print out only \$45.00. TV/dog, disk w/pc \$85.00 print out only \$45.00. VCR Tune Up Center, 2610 Bay Road, Redwood City, CA 94063.

TEST EQUIPMENT SALES has what you are looking for, Quality Equipment at low prices! Scopes, meters, counters, Sencore PR57's and more. Call now (603) 434-2544 or write, Test Equipment Sales, PO Box 986, Londonderry, NH 03053.

WAVEFORM ANALYZER - 1,500.00, VA-62 Universal Video Analyzer - 1,500.00, VC-63 VCR Test Set - 100.00, FS-74A TV-RF Signal Analyzer - 25.00. Sadello Digital F.S. Mtr Mod #200 - 400.00. RC ELECTRONICS INC. 508-477-0771.

NAP A340309-1002/1003 TUNER CURE! Repair yourself and save! For complete instructions send \$15.00: TEK Enterprises, 212 Marabou Drive, Newark, DE 19702.

ATTENTION CONSUMER ELECTRONICS TECHNICIANS! "The Dog Catcher" is a new program which gives instant access to the largest repair tips from a network of America's finest technicians. Monthly updates, and your own tips can be added to the database of VCR, Camcorder, TV and Stereo repairs. Take advantage of the introductory price now! \$99.95 DataBasic 1-800-967-5924. See our ad on page 67.

REDUCED 85%. Diehl Mark 111 \$69, Diehl Mark V Horizontal circuit tester \$179. New. Conductive coating for remote control keypads \$9.99 ppd. WEEC, 2805 University Ave., Madison, WI 53705. 608-238-4629, 608-233-9741.

VHS-VCR Repair Solution Sets I, II, III IV, V, VI, VII, VIII. Each contains 150 symptoms and cures, updated cross reference chart, free assistance, \$11.95 each, all eight \$79.95. Schematics available. Visa/MC. Eagle Electronics, 52053 Locks Lane, Granger, IN 46530.

SENCORE: VA48 \$600, SG165 \$800, SC61 \$2,200, VA62,63,64 \$2,200, AC CRICKET \$150, DC CRICKET \$150, SUPER MACK CRT RESTORER W/DANDY DAPTER \$600. ALL LIKE NEW 914-687-4309.

THE ONLY ANSWER TO REPAIRING ELECTRONICS PROFITABLY (this should have been done years ago) **GET SMART!** Someone somewhere has already repaired your next repair **YOUR TOP TECHNICIAN**, who's training you have paid for **JUST LEFT TODAY!** **YOU'RE THE BOSS** and now you have to put on your old rusty technician's cap. **TODAY YOUR BANK** sent you three NSF checks your customers so graciously gave you, and you don't have time to chase them down to collect, **THEY LEFT TOWN. IT'S TAKING YOU LONGER** to assess the repairs and your customers are now coming to collect their units. You promised to give them a **FREE** estimate, but you just realized you don't have a schematic or time to do it. **NOW YOU ARE DOING NIGHT REPAIRS** because during store hours the phone rings off the hook with nuisance questions about setting VCR clocks and you have parts to order, bills to pay and service literature to file. **CIRCUIT CITY JUST MOVED IN** and your wife say's there's no money in repairs **FRIEND!! YOU DEFINITELY HAVE AN EMERGENCY!!** Program start up of 10,000 repairs occurring today through out the world with our annual updates of an additional 2,000 tips 1987 thru March 1993. **I CAN ASSURE YOU THESE TECH-TIPS ARE NOT DUSTY OLD REPAIRS YOU'LL NEVER SEE.** Other programs don't even come close to comparing. **CALL NOW (305) 474-2677 FOR A "FREE" DEMONSTRATION DISK OR PAPER FORMAT** or mail request to **TV-MAN SALES & SERVICE, 8614 SR-84, FT. LAUDERDALE, FL 33324**

SENCORE VA62A, ST65, MT64, \$2,250, like new, VA62 has been updated. Johnson's Video Service, 10321 South DeAnza Blvd, Cupertino, CA 95014. 408-252-6200

COMPUTER AIDED TV/VCR REPAIR SOLUTIONS: 5 1/4" IBM compatible disks, 1,000 VCR, Printout \$83, Disks \$72. 5,400 TV, Printout \$135, Disks \$113 (Harddrive). Add to or quick scan by chassis, model and stage. Two solutions pays for it. Electronic Solutions, 407 W. Ave. "N", San Angelo, TX 76903.

TV-VCR SHOPS: Now fix those tough dogs! A program of over 2800 fixes on disk. One fix could pay for all. Only \$99.95. TECH-DAT, 212 Earth Row, Waynesville, MO 65583. To order call 1-800-280-2100. VISA & Mastercard Accepted.

SENCORE EQUIPMENT - Shop closing VC93, SC3080 take over payments or make loan pay-off. Ray Brewington, 1687 New Eastwood Circle, Morsanton, N.C. 28655. 704-437-9241.

SENCORE VA62 & VC63 \$1,500, VA62A & VA63 & NT64 \$1,750, LC75 \$650, Tektronix 200MHz Oscilloscope \$1,000, all mint condition. Alex 1-408-738-4206, Fax 1-408-736-6946.

SENCORE SC-61 waveform analyzer, never used, with manual \$1500, BK Precision digital IC color generator, never used, with manual \$75. Guy 303-674-5389.

TV CASE HISTORIES: Booklet with 1,750+ histories. Satisfaction assured. Only \$35 (first-class shipping add \$1.50). Mikes Repair Service, P.O. Box 217, Aberdeen Proving Ground, MD 21005. Same mailing address 29 years. Send SASE for samples.

BUSINESS OPPORTUNITIES

MOVE TO LAS VEGAS: Fastest growing area in USA. Computer & VCR sales & service business. Inventory, Parts, equipment. Call for details. 702-435-3201.

TV SALES & SERVICE SW Fla coast! Owner retiring from 17 yr old, profitable, well equipped business strategically located in fastest growing county in U.S. Ideal operation for 2 techs or can be expanded to meet demands of rapidly growing market. Priced at \$95,000 with seller financing. Call Ted Aughey - Five Star Realty 1-800-788-1203.

ESTABLISHED SERVICE SHOP: good reputation, great potential. Will sell or possibly partner with the right person. Central WV 304-269-7850.

TV/VCR SERVICE ST. PETERSBURG FLORIDA. Fully equipped shop with Sencore/Sams/Tools & Parts. Open for business. \$10,000 includes all. Phone: 813-546-7060.

MOVE TO SUNNY SOUTH FLORIDA: A Turn of the key guarantees minimum take home of \$100,000. Owner retiring. Fully staffed in largest growth area of Ft. Lauderdale. Established 12 years, no competition. Authorized 15 major brands. 100 percent computerized. Simple to operate business. Owner financing available. Call for details 305-474-3588.

BUILDING and 22 year consumer electronics retail national franchise business in New Mexico near lake. Principals only. Contact Whittington, Box 932, Williamsburg, NM 87932.

WANTED

WANTED: Service manuals for the following EUMIG equipment; FL-1000 cassette deck, T-1000 FM tuner, C-1000 preamp, M-1000 power amp. Call Jon Kummer 516-681-2922 work, 718-428-9070 home.

EXPERIENCED ELECTRONIC TECHNICIAN interested owning own shop opening to inherit my shop as I retire after 63 years. Wichita Falls, TX 817-767-5490, evenings.

Manufacturers Parts and Literature Directory

This monthly section is sponsored by manufacturers to help you find the parts and technical literature needed to service their equipment. Call them for replacement parts or for the name of their nearest distributor.

Hitachi Home Electronics 401 W. Artesia Blvd. Compton, CA 90220 800-HITACHI	Mitsubishi Electronics America 5757 Plaza Drive Cypress, CA 90630 800-553-7278 fax 800-825-6655	NEC Tehcnologies 1255 Michael Drive Wood Dale, IL 60191 800-366-3632
Panasonic 50 Meadowlands Parkway Secaucus, NJ 07094 800 545-2672	Philips ECG 1025 Westminister Drive Williamsport, PA 17701 800-526-9354 fax 800-346-6621	Quasar 50 Meadowlands Parkway Secaucus, NJ 07094 800-545-2672
Technics 50 Meadowlands Parkway Secaucus, NJ 07094 800-545-2672	Thomson Consumer Electronics 2000 Clements Bridge Road Deptford, NJ 08096 800-257-7946 fax 800-524-1498	Zenith Electronics Corp. 1900 N. Austin Avenue Chicago, IL 60634 312-745-2000

Call Jonathan Kummer at 516-681-2922 to reserve space in this special section.

Improve Your Form.

3-Part

A continuous feed form used for customer c.o.d. service or parts/accessory sales receipts (N3CN). Not for warranty billing. Computer generated software to be available soon.

5-Part

Available in snapout (N5SN) or continuous feed (N5CN). Matching fields with N3SN, except for customer estimate and receipts. For warranty billing.

7-Part

A universal snapout form (N7SN) designed for both customer service c.o.d. and manufacturer warranty billing. Complies fully with the requirements of state and local ordinances, including California.

Discounts

Carbonless NESDA Forms are available to NESDA members at additional savings. For pricing information and samples, or information regarding other NESDA membership benefits, write to NESDA, 2708 W. Berry St., Ft. Worth, TX 76109; or call (817) 921-9061.

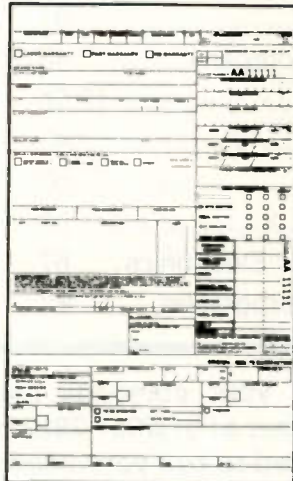

The NESDA Form

NESDA, 2708 W. Berry St.
 Fort Worth TX 76109
 Phone: (817) 921-9061

The Dog Catcher 2.0

For PCs
A Repair Tip Program

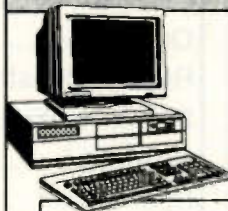

**Our Software Will Save
You Time and Money!**

Mouse/Menu driven!

Thousands of Tips!

Updated monthly with tips from technicians just like you!

One Price covers VCR, TV, Stereo, and Camcorder tips!

Easy Searches by any part of model number, similar model number, or chassis!

Lets your shop network with other shops nationwide!

The Dog Catcher 2.0 - \$99.95
 Evaluation Version - \$10.00

DataBasic

1-800-967-5924

1631 Babcock Rd,
 San Antonio Texas 78229

Circle (3) on Reply Card

Test your electronics knowledge

Answers to the quiz (from page 23)

1. A. There were still a lot of high antennas used for TV reception in fringe areas in those days.

2. False. Remember, this was written in the pre-VCR days.

3. C. In the very early days of TV (1948) at least one company required technicians to knock off the neck of the defective tube while it was mounted face-down in a safe box.

Then, they had to bury the box.

4. C. NOT microfarads!

5. C. Regarding choices B and D, you do remember tubes don't you?

6. A 41.25 Megahertz
B 45.75 Megahertz
C 42.17 Megahertz

7. C. In the very early days of color TV the delay line consisted of a length of coaxial cable looped around the inside of the cabinet.

8. D. Before you can run this test you first have to determine if your oscilloscope can pass the testing square wave without introducing distortion.

9. C. Don't jump over the word "normally." Scopes can be used to measure current, and, the RMS value of a sine wave. Also, if you can measure peak-to-peak voltage, you can often determine the peak voltage.

10. B. Also, the transistor must be mounted with sufficient torque to assure good physical contact. However, that is NOT done with silicon grease.

Answer to the bonus question: Crosley.

Advertiser's Index

Company	Page Number	Reader Service Number	Advertiser Hotline
Anatek	63	1	800/999-0304
C & S Sales	5	20	800/292-7711
Dalbani Corporation	47	2	800/325-2264
Databasic	67	3	800/967-5924
Electronic Technician Association	23	317-653-8262
Fluke Manufacturing, John	BC	100	800/87FLUKE
Hitachi Home Electronics	67	800/545-2672
International Components Corp.	43	5	800/645-9154
Iscet	23	817/921-9101
MCM Electronics	21	6	800/5434330
Mitsubishi Electronic America	67	800/553-7278
NEC Technologies	67	800/366-3632
NESDA	61,67	817/921-9061
National Advancement Corp.	27	7	800/832-4787
OPTOelectronics	IFC	121	800/327-5912
PTS Corporation	17	8	812/824-9331
Panasonic	67	800/545-2672
Parts Express	13	9	513/222-0173
Philips ECG	7,67	10,11	800/526-9354
Plaza Distributing	47	21	813-392-9168
Prelco Electronics	63	12	908-857-8600
Premium Parts +	61	13	800/558-9572
Quasar	67	800/545-2672
Russell Industries	61	14	800/428-7267
Sams, Howard & Company	43	15	800/429-7267
Sencore	12,56	16,17	800/SENCORE
Sperry Tech	43	18	800/228-4338
Technics	67	800/545-2672
Tentel	58	19	800/538-6894
Thomson Consumer Electronics	67	800/257-7964
Zenith Electronic Corporation	67	312/745-2000

We'd like to see your company listed here too. Contact Jonathan C. Kummer at 516/681-2922 to work out an advertising program tailored to suit your needs.

SALES OFFICE
PHONE:(516) 681-2922
FAX (516) 681-2926



**CQ's new videos
bring the exciting world of
amateur radio into your
living room!**

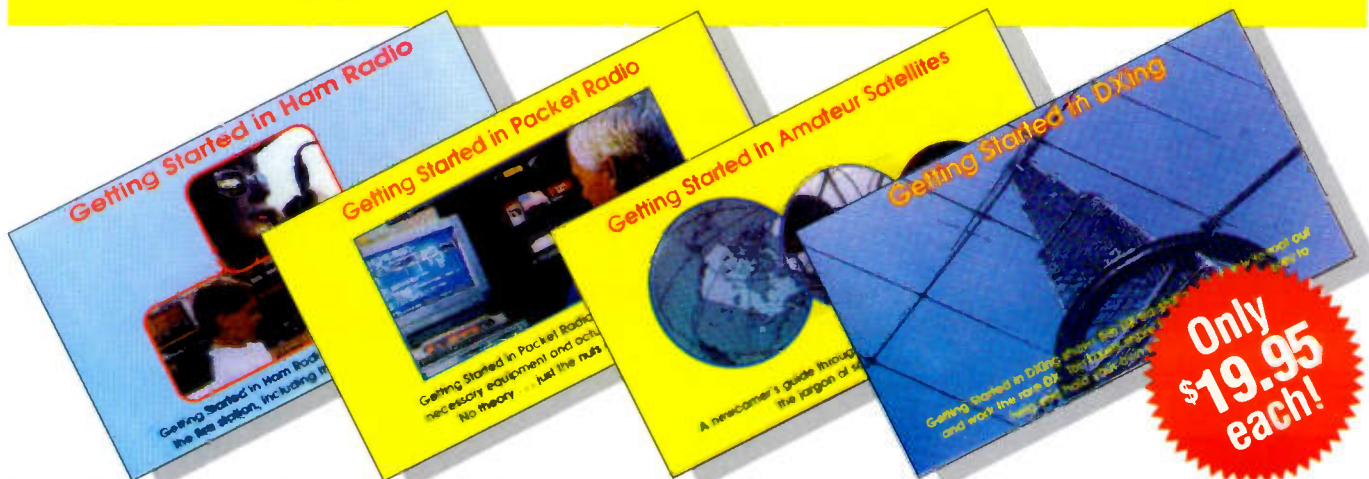

Getting Started in Ham Radio.

The authoritative fast paced video introduction to the fascinating world of ham radio. Shows how to select equipment and antennas. How to use repeater stations for improved VHF coverage. The importance of grounding and the basics of soldering. How to get the most out of your station, whether it's home-based, mobile or hand held!

Getting Started in Packet Radio.

This video will help de-mystify the exciting but sometimes confusing world of packet radio. Shows you how to get started in using your computer on the radio. Includes step-by-step instructions on making packet contacts and using packet bulletin boards, networks and satellites.

Getting Started in Amateur Satellites.

Shows you how veteran operators set up their satellite stations and how to find and track ham satellites with ease. How to access current satellites and contact far ranging countries around the world. This video is filled with easy to understand advice and tips that can't be found anywhere else.

Getting Started in DXing.

Top DXers share their experience on equipment, antennas, operating skills and QSL-ing. See hams work rare DX around the world. If you're new to DXing this video is for you. All the valuable information presented here may well give you the competitive edge you need to master the exciting world of DXing.

The New CQ Video Library!

Now, for the first time, CQ brings you all our experience in an exciting new format. Our videos will help you get started and improve your existing skills in amateur radio with our informative, helpful and easy-to-follow instructional videos.

Whether you're a new ham or just getting started in Packet, Satellite or DXing we've got your video. Each tape gives you first-hand tips from hams who are on the air. You'll get advice from some of our hobby's most experienced users. They take you under their wing and show you just what it takes to get on the air!

Filled with step-by-step tips in setting up your first station, operating satellites, using packet radio, maximizing your DXing potential, these videos offer insights for beginners and experienced operators alike. You can order just the ones you want, or all four. It's up to you.

Send for your first video today and start growing now in the exciting and adventurous world of amateur radio!

CQ Communications
76 North Broadway, Hicksville, New York 11801
For Faster Service Call 516-681-2922 or FAX 516-681-2926

Multi-Choice.

Whether you're doing first-level troubleshooting or component-level diagnosis, Fluke meters offer you one of the widest choice of capabilities and price ranges in the industry. Choices ranging from the basic Fluke 12 with auto function V-Chek™ and Continuity Capture™. To the classic Fluke 77

with Auto Touch Hold® and current measurements.

Fluke 77
The classic
Multimeter
\$169.00

To the advanced Fluke 83 with Min/Max/Average recording,

Frequency, Duty Cycle and Input Alert™. Plus a full

line of quality accessories to extend those

capabilities even further. No matter which Fluke

meter you choose, you can count on precise, reliable, consistent performance year in and

year out. Plus, strong customer support and product warranties that measure up to any

in the industry. Make the choice

that gives you the most choices.

Look to Fluke

for the tools you need to get the job done right.

See your Fluke distributor, or call 1-800-87-FLUKE

for a catalog and the name of the

distributor nearest you.

Fluke 12
Auto-function
Multimeter
\$95.00



Fluke 83
Full-featured
Multimeter
\$255.00



FLUKE 12	FLUKE 77	FLUKE 83
The Fluke meters listed above feature DC/AC voltage, resistance, audible continuity and diode test.		
Capacitance measurements	Auto Touch Hold®	Auto Touch Hold® and Relative modes
V-Chek™ (auto function)	Current measurements	Current measurements
Min/Max Record with Relative Time Stamp	Analog/Digital display	Analog/Digital display
Two-year warranty	Three-year warranty	Three-year warranty
Continuity Capture™	Yellow holster with Flex Stand™	Yellow holster with Flex Stand™
Basic accuracy 0.9%	Basic accuracy 0.3%	Input Alert™
	For measurements to 4800 V-A	Capacitance measurements
		Frequency and Duty Cycle
		Min/Max/Avg. Recording
		Basic Accuracy 0.3%

John Fluke Mfg. Co., Inc.
P.O. Box 9090, Everett, WA 98206
For more information call:
(416) 890-7600 In Canada
(206) 356-5500 from other countries

©Copyright 1993, John Fluke Mfg. Co., Inc. All rights reserved. Prices subject to change. Suggested U.S. list price. Ad No 00377

FLUKE®

Circle (100) on Reply Card