

# Electronics World

FEBRUARY, 1970  
60 CENTS

**NEW CIRCUIT DESIGNS IN 1970 COLOR-TV SETS**  
**REGULATED POWER SUPPLIES: Design and Construction**  
**ELECTRONICS AND THE HEART**  
**ELECTRONIC DICE—For Games of Chance**



## 4-CHANNEL STEREO



**The New**  
**Surrou**

514700 HND 2724L097 OCT76 1 M  
M J HINDMAN  
2724 E LINWOOD  
SPRINGFIELD MO 65804



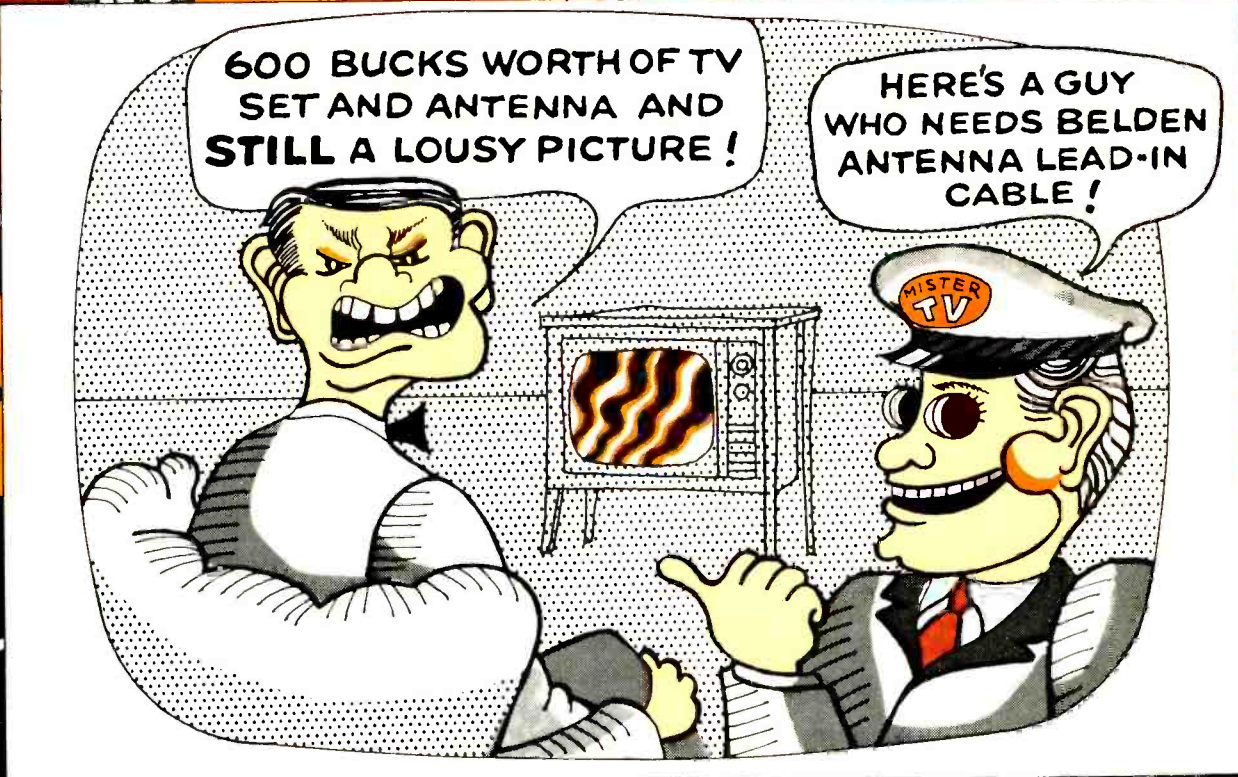

Color or UHF set perfect? Antenna perfect? Then obviously there's a missing link. Check that antenna lead-in cable. Old, worn-out, weather-beaten cable, or the ordinary flat ribbon kind designed for black and white VHF, causes more fuzzy, distorted pictures than you can count. It's your opportunity to upgrade these customers to a cable matched to their particular signal reception situations. One of Belden's Big Four—the link to perfect reception.

FOR CONGESTED AREAS...  
**8290 SHIELDED PERMOHM®**



In congested, in-city areas, stray electrical interference and noise are at their worst. For perfect, all-82 channel reception—color or B/W—replace old cable with Belden's 8290 Shielded PermoHM. Its aluminum Beldfoil® shielding prevents pickup of ghost signals and electrical noise by the lead-in. Weather-proof and water-proof. You can tape it right to the mast. Or install it underground, in conduits—even in rain gutters.



AWG & (Stranding)	Color	Nom. O. D. (inch)	Nom. Velocity of Propagation	Nom. Capacitance (mmf/ft.)	Nom. Attenuation per 100'		Standard Package Lengths in ft.
					mc	db	
22 (7 x 30)	Brown	.305	69.8%	7.8	57	1.7	50', 75', 100' coils have terminals attached. Available in counter dispenser. 250', 500' spool.
		x			85	2.1	
		.515			177	3.2	
					213	3.5	
					473	5.4	
					671	6.6	
	887	7.7					

Copperweld, 2 conductors, orange polyethylene insulation and web between conductors, cellular polyethylene oval insulation, Beldfoil shield, stranded tinned drain wire, polyethylene jacket.

BELDEN 8285 - PERMOHM

FOR FRINGE AREAS...

## 8285 PERMOHM®

Antenna cable in uncongested or fringe areas picks up little electrical interference. But does get a lot of weathering, which degrades an already weak signal. These customers need encapsulated cable. Belden 8285 PermoHM. Its special polyethylene jacket protects the energy field, regardless of weather conditions. It delivers the strongest signal of any unshielded twin lead under adverse conditions. Requires no matching transformers and connectors. For all 82 channels, color or B/W.



AWG & (Stranding)	Color	Nom. O. D. (inch)	Nom. Velocity of Propagation	Nom. Capacitance (mmf/ft.)	Nom. Attenuation per 100'		Standard Package Lengths in ft.
					mc	db	
22 (7 x 30)	Brown	.255 x .468	73.3%	5.3	100	1.4	50', 75', 100' coils have terminals attached. Available in counter dispenser. 250', 500' coils and 1000' spool.
					300	2.8	
					500	3.8	
					700	4.8	
					900	5.6	

Copperweld, 2 conductors parallel, orange polyethylene insulation and web between conductors, cellular polyethylene oval jacket.

FOR LOCAL BLACK AND WHITE...

## 8275 CELLULINE®



Cracked, corroded, weathered cable, full of dirt and moisture, loses signal strength; prevents any TV set from delivering a quality picture. Upgrade B/W VHF and local UHF customers to Belden 8275 Celluline. Performance is improved because all possible moisture between conductors has been eliminated. Abrasion-resistant and weather-resistant for a long, long service life. And, it requires no end sealing.

AWG & (Stranding)	Color	Nom. O. D. (inch)	Nom. Velocity of Propagation	Nom. Capacitance (mmf/ft.)	Nom. Attenuation per 100'		Standard Package Lengths in ft.
					mc	db	
20 (7 x 28)	Brown	.300 x .400	80%	4.6	100	1.05	50', 75', 100' coils in counter dispenser. 250', 500', 1000' spools.
					200	1.64	
					300	2.12	
					400	2.5	
					500	2.98	
					700	3.62	
900	4.3						

Bare copperweld; 2 conductors parallel, polyethylene jacket with inert gas filled unicellular polyethylene core.

BELDEN DUOFOIL

FOR MATV AND CATV...

## 8228 DUOFOIL® COAX

Got an apartment or townhouse complex in your area? Motels or hotels? Or is CATV coming? Use Belden's new 75 ohm coaxial cable—8228 Duofoil. Shielding is 100%—sweep tested 100%. Spiral wrapped drain wires provide long flex life. Small diameter saves space in conduit installations. Use Duofoil for all coaxial color and B/W VHF, UHF and CATV applications.



AWG & (Stranding)	Color	Nom. O. D. (inch)	Nom. Velocity of Propagation	Nom. Capacitance (mmf/ft.)	Nom. Attenuation per 100'		Standard Package Lengths in ft.
					mc	db	
18 Solid, Bare	Black	.242	78%	17.3	50	1.5	100', 500', 1000' spools.
					100	2.1	
					200	3.1	
					300	3.8	
					400	4.5	
					500	5.0	
					600	5.5	
					700	6.0	
					800	6.5	
					900	6.9	

Don't forget to ask them what else needs fixing.

See your local Belden distributor for full details or to order. For a free copy of the recent reprint article, "Electronic Cable," write: Belden Corporation, P.O. Box 5070-A, Chicago, Illinois 60680.

**BELDEN**

8-6-84

CIRCLE NO. 144 ON READER SERVICE CARD

# Our 1¼ oz. alarm will blast you with 80db of the most irritating noise in the world.

Nothing can drown out or cover up the persuasively piercing sound of the Mallory Sonalert®. It's made to be heard.

The light, compact Sonalert is of solid state design for maximum efficiency and reliability and requires as little as 3 milliamps current. No arcing. No RF noise. No mechanical wear.

Consider Sonalert for use with electronic equipment where voltage control is critical. Because the Sonalert generates no RF, there is no danger of its introducing extraneous and spurious signals into the system. Important not only for use



with computers, but with aircraft systems as well. Other uses include instrumentation, communications, medical electronics.

Sound intensity range is 68db @ 6VDC to 80db @ 28VDC. Sound frequency levels are 2900 hertz  $\pm$  500 Hz and 4500 hertz  $\pm$  500 Hz, depending on model.

For further information on the Mallory Sonalert, ask your Mallory Distributor for "idea folder" No. 9-406. Or write Mallory Distributor Products Company, a division of P. R. Mallory & Co. Inc., Indianapolis, Indiana 46206.

**MALLORY**

**MALLORY DISTRIBUTOR PRODUCTS COMPANY**

a division of P. R. MALLORY & CO. INC.

Box 1558, Indianapolis, Indiana 46206; Telephone: 317-638-5353

Batteries • Capacitors • Controls • Resistors • Semiconductors **Sonalert®** Switches • Timers • Vibrators • ICs

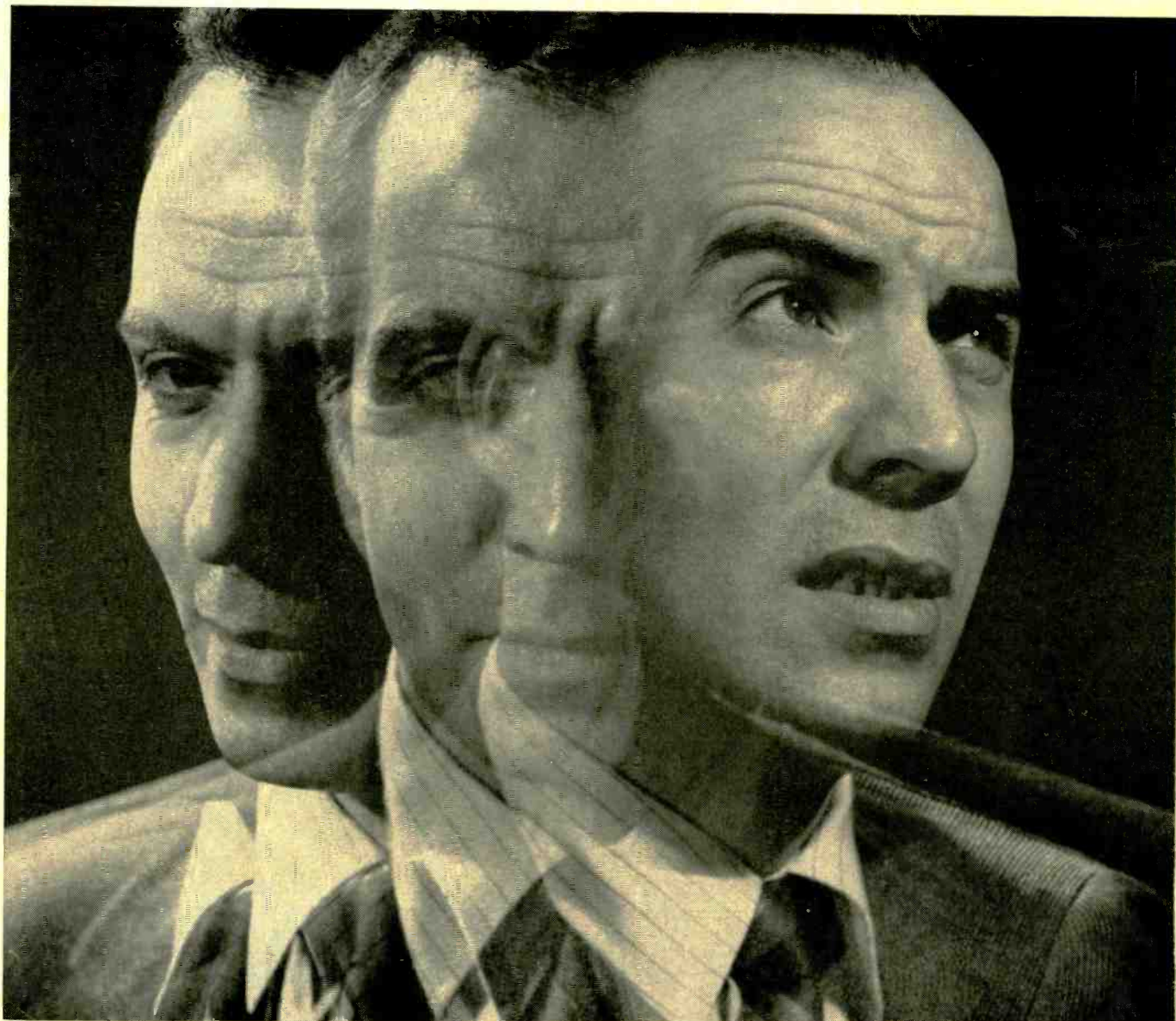

CIRCLE NO. 125 ON READER SERVICE CARD



THIS MONTH'S COVER symbolizes a topic that is causing much excitement in the high-fidelity industry today—4-channel stereo. There are a small number of 4-channel, 4-track reel-to-reel tapes available from Vanguard, one of which is shown on the cover. To play such a tape requires a special 4-track, in-line tape head, such as the Nortronics record/play head shown. Along with four loudspeakers you need four channels of amplification, either from a pair of stereo amplifiers or from a special combination unit, such as the Scott 499 Quadrant 4-channel amplifier shown. This unit delivers 35 W/channel continuous power and is priced at \$600. An article on 4-channel stereo appears in this issue and a follow-up story is due next month.



**Publisher**  
LAWRENCE SPORN

**Editor**  
WM. A. STOCKLIN

**Technical Editor**  
MILTON S. SNITZER

**Associate Editors**  
P. B. HOEFER  
MURRAY SUNTAG

**Contributing Editors**  
WALTER H. BUCHSBAUM  
Prof. ARTHUR H. SEIDMAN  
FOREST H. BELT

**Art Editor**  
RICHARD MOSS

**Technical Illustrator**  
J. A. GOLANEK

**Advertising Manager**  
JOSEPH E. HALLORAN

**Marketing Manager**  
ROBERT UR

**Advertising Service Manager**  
MARGARET DANIELLO

**Group Vice President  
Electronics & Photographic**  
FURMAN H. HEBB

February, 1970

# Electronics World

FEBRUARY 1970

VOL. 83, No. 2

## CONTENTS

- 25 Electronics and the Heart** *Fred W. Holder*  
Here are some of the latest electronic equipment used by the medical profession to save and prolong the lives of victims of heart disease.
- 28 Recent Developments in Electronics**
- 30 Design and Construction of Regulated Power Supplies** *Richard H. Dutton*  
Looking for a low-cost, very stable, 20-volt, 1.5-ampere regulated power supply? The author thoroughly describes the design and construction of a supply that has better than 1-percent regulation.
- 34 Electronic Dice** *R. W. Fox*  
Build this electronic die or roulette wheel for use in board games or games of chance. New G-E complementary SCR's are used in ring-counter circuit to light indicator lamps.
- 36 Air Traffic Control Transponder Identifies Radar Targets** *D. J. Holford*  
This device makes flying safer by allowing the air-traffic controller to accurately identify the radar blips from aircraft under his control.
- 39 Four-Channel Stereo—the New Surround Sound** *Robert Berkovitz*
- 42 Hybrid Technology Regains IC Spotlight** *Lothar Stern*
- 46 Ferroresonant Transformer Improves Color TV** *Neil Ferency*
- 48 Color TV for 1970** *Forest H. Belt*
- 74 C.E.T. Test, Section #1** *Dick Glass*
- 76 Portable Dual-Range IC Frequency Standard** *Frank H. Tooker*

- 6 EW Lab Tested**  
Marantz Model 16 Power Amplifier  
Dual 1219 Automatic Turntable
- 56 What Price Independence?** *John Frye*
- 64 Test Equipment Product Report**  
Eico Model 443 Semiconductor Curve Tracer  
Honeywell "Digitest 500" Digital V.O.M.  
Mercury Model 1101C Tube Tester

## MONTHLY FEATURES

- 4 Coming Next Month** **23 News Highlights**
- 12 Letters** **84 New Products & Literature**
- 15 Radio & Television News** **94 Books**

Electronics World: Published monthly by Ziff-Davis Publishing Company at One Park Avenue, New York, New York 10016. One year subscription \$7.00. Second Class Postage paid at New York, New York and at additional mailing offices. Subscription service and Forms 3579: Portland Place, Boulder, Colorado 80302.

Copyright © 1969 by Ziff-Davis Publishing Company. All rights reserved.

# Build this exciting Schober Console Organ for only \$1040!\*

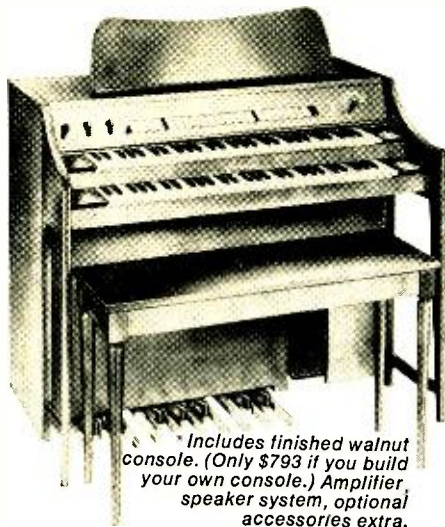

\*Includes finished walnut console. (Only \$793 if you build your own console.) Amplifier, speaker system, optional accessories extra.

You couldn't touch an organ like this in a store for less than \$1800—and there never has been an organ of the Console II's graceful small size with 22 such pipelike, versatile voices, five-octave big-organ keyboards, and 17 pedals! It sings and schmaltzes for standards, pops, old-time favorites, speaks with authority for hymns and the lighter classics, all with a range of variety and satisfying authenticity you've never found before in an instrument under church or theatre size. If you've dreamed of an organ of your own, to make your own beautiful music, even if your home or budget is limited, you'll get more joy from a Schober Console II than any other "home size" organ—kit or no kit.

You can learn to play it. And you can build it, from Schober Kits, world famous for ease of assembly without the slightest knowledge of electronics or music, for design and parts quality from the ground up, and—above all—for the highest praise from musicians everywhere.

Send right now for the full-color Schober catalog, containing specifications of all five Schober Organ models, beginning at \$499.50. No charge, no obligation. If you like music, you owe yourself a Schober Organ!

The *Schober* Organ Corp., Dept. RN-74  
43 West 61st Street, New York, N.Y. 10023

- Please send me Schober Organ Catalog and free 7-inch "sample" record.  
 Enclosed please find \$1.00 for 12-inch L.P. record of Schober Organ music.

NAME \_\_\_\_\_

ADDRESS \_\_\_\_\_

CITY \_\_\_\_\_ STATE \_\_\_\_\_ ZIP \_\_\_\_\_

## COMING NEXT MONTH

SPECIAL FEATURE ARTICLE:

### IC MEMORIES

In Part I of a two-part series, Dale Mrazek of National Semiconductor describes the technical operation of integrated-circuit memories. These new devices, which are finding wide application in all types of computer systems, have an IC capacity of 256 to 2048 bits. The concluding part will appear in our April issue.

#### 4-CHANNEL STEREO RECORDING & TRANSMISSION

*Daniel von Recklinghausen, H. H. Scott's chief research engineer, offers his analysis of this newest development in the hi-fi field—the problems which will have to be solved and possible solutions. Don't miss this penetrating article.*

#### 1937—A NEW DEVICE TO DETECT AIRCRAFT

*Harold A. Zahl, who until his recent retirement was Director of Research at Fort Monmouth's Labs, recalls the historic May 26, 1937 demonstration of our early radar and heat detector system. It all sounds rather primitive now,*

*but was a tremendous breakthrough as the world stood poised on the brink of World War II.*

#### TELEVISION'S BUILT-IN TEST SIGNALS

*Ivan Mertes of Heath describes how the vertical-interval test signals transmitted by TV networks can be used to evaluate TV receiver performance and provide a quick alignment check of the set.*

#### COMPUTER TIME-SHARING

*Want your own computer? Here are some of the pertinent facts about time-sharing systems that make a computer available to you.*

*All these and many more interesting and informative articles will be yours in the March issue of ELECTRONICS WORLD . . . on sale February 19th.*

### ZIFF-DAVIS PUBLISHING COMPANY

William Ziff  
President

W. Bradford Briggs  
Executive Vice President

Hershel B. Sarbin  
Senior Vice President

Stanley R. Greenfield  
Senior Vice President

Phillip T. Heffernan  
Vice President, Marketing

Philip Sine  
Financial Vice President

Walter S. Mills, Jr.  
Vice President, Circulation

Frank Pomerantz  
Vice President, Creative Services

Arthur W. Butzow  
Vice President, Production

Edward D. Muhlfeld  
Vice President, Aviation Division

Irwin Robinson  
Vice President, Travel Division

George Morrissey,  
Vice President

Sydney H. Rogers,  
Vice President

Editorial and Executive Offices  
One Park Avenue  
New York, New York 10016 212 679-7200

NEW YORK OFFICE 212 679-7200  
Joseph E. Halloran, Adv. Mgr.  
Michael E. Kelman

MIDWESTERN OFFICE  
307 North Michigan Avenue  
Chicago, Illinois 60601 312 726-0892  
George B. Mannion, Jr.

WESTERN OFFICE  
9025 Wilshire Boulevard  
Beverly Hills, California 90211  
213 CRestview 4-0265; BRadshaw 2-1161  
Western Advertising Manager, Bud Dean

JAPAN: James Yagi, Ishikawa Mansion,  
#4, Sakuragooka Shibuya-ku, Tokyo 462-2911-3

CIRCULATION OFFICE  
Portland Place, Boulder, Colorado 80302



Member  
Audit Bureau of  
Circulations

Radio & TV News • Radio News • Radio-Electronic Engineering Trademarks Reg. U.S. Pat. Off.  
**SUBSCRIPTION SERVICE:** Forms 3579 and all subscription correspondence should be addressed to Electronics World, Circulation Department, Portland Place, Boulder, Colorado 80302. Please allow at least six weeks for change of address. Include your old address, as well as new—enclosing if possible an address label from a recent issue.  
**EDITORIAL CONTRIBUTIONS** must be accompanied by return postage and will be handled with reasonable care; however publisher assumes no responsibility for return or safety of art work, photographs, or manuscripts.  
**ELECTRONICS WORLD** (February, 1970, Vol. 83, No. 2). Published monthly at One Park Avenue, New York, New York 10016, by Ziff-Davis Publishing Company—also the publishers of Airline Management and Marketing, Boating, Business & Commercial Aviation, Car and Driver, Cycle, Flying, Modern Bride, Popular Electronics, Popular Photography, Skiing, Skiing Area News, Skiing Trade News, Stereo Review, and Travel Weekly. One year subscription rate for U.S., U.S. Possessions, and Canada, \$7.00; all other countries, \$8.00. Second Class postage paid at New York, N.Y. and at additional mailing offices. Authorized as second class mail by the Post Office Department, Ottawa, Canada and for payment of postage in cash.

ELECTRONICS WORLD

# TV-Radio Station Engineers Needed—At High Pay!

Television and radio broadcasting is growing at a fast pace. More and more station engineers are required, at salaries of \$800 to \$1000 and more per month. If you would enjoy working in broadcasting and taking home a handsome paycheck for your efforts, investigate Grantham training. For 18 years, Grantham Schools have specialized in training for broadcast engineering jobs.

To be a broadcast engineer, it is essential that you hold an FCC first class radiotelephone license. And to earn the big money in the better jobs, you need *not only* the license *but also* a solid knowledge and understanding of electronics. Complete theoretical and laboratory training is offered in resident classes in Washington. Also, home-study training is available from our Home Study Division in Hollywood. Both are G.I. Bill approved. For free information, write:

**Dept. B, Grantham School of Electronics**  
818 - 18th Street NW, Washington, D.C. 20006 (Telephone: 202-298-7460)

In ONE Educational Program Earn BOTH Your

## F. C. C. LICENSE

And Your

## A. S. E. E.

(Associate in Science in Electronics Engineering)

## DEGREE

In an electronics career today, an FCC license is important — sometimes essential — but it's not enough! Without further education, you can't make it to the top. Get your FCC license without fail, but don't stop there. To prepare for a still better position, continue your electronics education and earn your *Associate in Science Degree in Electronics Engineering*.

This is the common-sense approach for those who want to make both money and reputation in the expanding field of electronics. Also, it makes good sense to prepare for your FCC license with the School that gives degree credit for your license training — and with the School that can then take you from the FCC license level to the Degree level.

The *home-study* program which accomplishes *both* of these objectives is the Grantham Associate-Degree Program in Electronics Engineering. This educational program consists of a total of 370 correspondence lessons, followed by a two-week period of review and evaluation

### Grantham School of Engineering

• Established in 1951 •



1505 N. Western Ave.  
Hollywood, Calif. 90027

Telephone:  
(213) 469-7878

at the School. The prerequisite for enrollment is high school graduation (or equivalent) and at least one full year of experience as an electronics technician. Upon completion of the first 160 correspondence lessons, you are prepared for your first class FCC license and radar endorsement. Then, upon completion of the remainder of the program, you are awarded the ASEE Degree.

This *accredited* ASEE Degree program covers a review of basic electronic circuits and systems, applied engineering mathematics (including algebra, trigonometry, analytic geometry, and calculus), classical and modern physics, technical writing, computer systems, electrical networks, and semiconductor circuit analysis and design. The ASEE Degree is awarded upon satisfactory completion of the 370 correspondence lessons and the final two-week residency at the School.

For those who wish to continue their engineering studies beyond the ASEE Degree level, Grantham offers a BSEE Degree program in Hollywood. The Grantham ASEE Degree or other equivalent background is prerequisite to enrollment in the BSEE Degree program.

#### Accreditation and G.I. Bill Approval

The Home Study Division of Grantham School of Engineering is accredited by the Accrediting Commission of the National Home Study Council. Both the Home Study Division and the Resident Division are approved under the G.I. Bill, and both divisions are legally authorized to grant academic degrees.

Mail the coupon below for our free Bulletin.

#### Grantham School of Engineering

EW-2-70

1505 N. Western Ave., Hollywood, Cal. 90027

Gentlemen:

Please mail me your free Bulletin which explains how the Grantham educational program can prepare me for my FCC license and Associate Degree in Electronics Engineering. I understand no salesman or counselor will call.

Name \_\_\_\_\_

Address \_\_\_\_\_

City \_\_\_\_\_ State \_\_\_\_\_ Zip \_\_\_\_\_

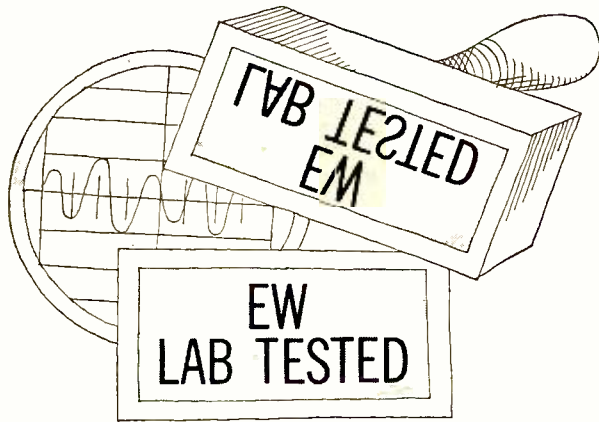

# HI-FI PRODUCT REPORT

TESTED BY HIRSCH-HOUCK LABS

## Marantz Model 16 Power Amplifier Dual 1219 Automatic Turntable

### Marantz Model 16 Power Amplifier

For copy of manufacturer's brochure, circle No. 1 on Reader Service Card.



IN testing some of the better amplifiers recently, we have found that our distortion-measuring equipment was not equal to the task of showing how good the amplifiers really were. The residual distortion level of our test equipment (about 0.06 percent), although more than adequate for most amplifiers, did not permit us to measure the distortion of amplifiers rated at 0.05 percent or less.

One of the earliest amplifiers that brought us face-to-face with this problem was the Marantz Model 15, which we tested in 1967. The company has now replaced the Model 15 with a higher-powered version, the Model 16,

which is rated at 80 watts per channel continuous power output with both channels driven into 8-ohm loads. At full power, for any frequency between 20 and 20,000 Hz, its rated distortion is less than 0.1 percent, and is typically 0.05 percent. Its input impedance is 47,000 ohms, and it requires an audio input of about 1 volt for full power output.

The Model 16 consists of two completely separate mono power amplifiers, each with its own power supply. Each channel is contained in a black-finned housing that serves as an efficient heat radiator. The use of separate power supplies guarantees that the

power output and distortion of one channel will be unaffected by the operating condition of the other channel. We are pleased to note that Marantz does not use a "music-power" rating for the Model 16, merely stating unequivocally that it will deliver full power from 20 to 20,000 Hz with less than 0.1-percent distortion—a most conservative claim, as we found in our tests.

The measurement problem mentioned above has been solved by our recent acquisition of an ultra-low distortion audio oscillator and a distortion analyzer, manufactured in Great Britain by Radford. This equipment has a residual distortion of about 0.002 percent, and is, as far as we know, the only commercial test equipment capable of accurately measuring distortion levels below 0.01 percent.

At its rated output of 80 watts per channel, we measured the harmonic distortion of the Model 16 at less than 0.05 percent from 20 to 20,000 Hz, and less than 0.02 percent of all frequencies below 16,000 Hz. At half power or less, the distortion was about 0.01 percent at frequencies below 15,000 Hz.

With a 1000-Hz test signal, amplifier harmonic distortion was under 0.01 percent up to about 95 watts output, and actually reached its minimum value of 0.0025 percent at 80 watts! Below 1 watt the distortion was masked by high-frequency noise, which was totally

(Continued on page 68)

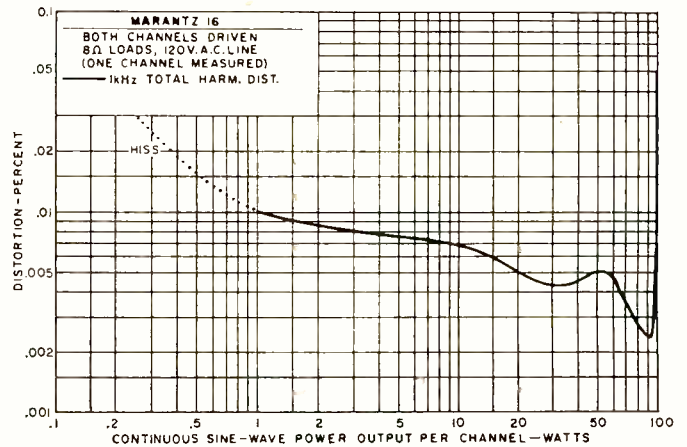
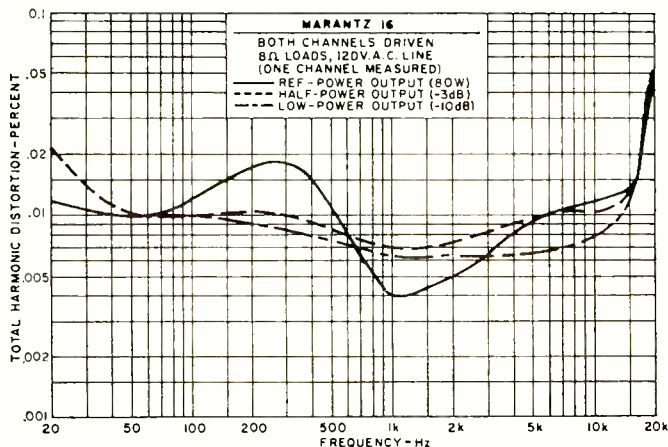



Shocked? Don't be. Does this man *look* like a criminal?

He's not. This man is in the business of *preventing* crime. (One of the fastest growing industries today.) He's a Radar Sentry Alarm dealer representative.

What could this possibly mean to you? Perhaps nothing. On the other hand, it could change your entire life.

As a Radar representative, you could make \$1,200 a month if you sold only one system each week. Most of our dealers make much more. Two sales a week would net you \$28,000 a year; five a week, \$46,000 a year. We make the finest solid state microwave burglar alarm system available; one that's easy to install and easy to service...for both home & business. We're presently expanding our organization of dealer representatives. We'll train you, provide you with leads and offer continuing counsel. You can operate full-time or part-time. Later, you may want to expand and organize your own sales staff.

But for now, let's get better acquainted. Fill out the coupon. In a few days, you'll receive complete details about how you can live a life of crime-and make it pay, *handsomely*.



## Radar Sentry Alarm. The Crimebuster.

RADAR DEVICES MFG. CORP.  
22003 Harper Ave., St. Clair Shores, Michigan 48080  
Rush me RSA Distributor Info.  
I understand there is no obligation. EW-2

Name \_\_\_\_\_

Address \_\_\_\_\_

City \_\_\_\_\_ State \_\_\_\_\_ Zip \_\_\_\_\_

# Live a life of crime, honestly.



# EXPERIENCE IS STILL YOUR BEST TEACHER

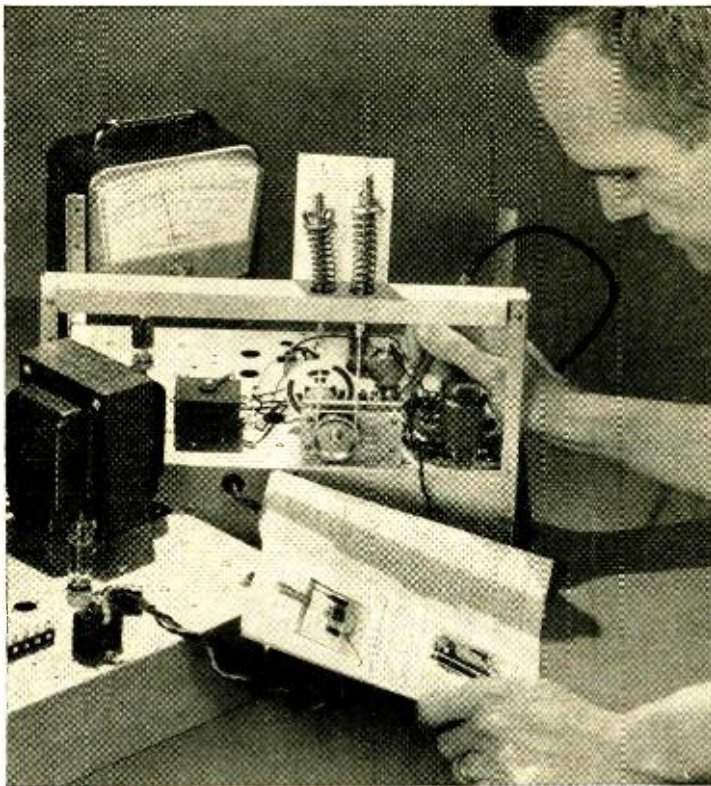

**NRI designed-for-learning training equipment gives you priceless confidence because your hands are trained as well as your head.**

**Learning Electronics at home the NRI way is fast and fascinating. Read opposite page.**



**OLDEST AND LARGEST  
SCHOOL OF ITS KIND**

Accredited by the Accrediting Commission of the National Home Study Council

**ELECTRONICS WORLD**

# You get more for your money from NRI

—more value, more solid experience so essential to careers in Electronics. NRI's pioneering "discovery" method is the result of more than half a century of simplifying, organizing, dramatizing subject matter. In each of NRI's major courses you learn by doing. You demonstrate theory you read in "bite-size" texts programmed with NRI designed-for-learning professional lab equipment. Electronics comes alive in a unique, fascinating way. You'll take pleasure in evidence you can feel and touch of increasing skills in Electronics, as you introduce defects into circuits you build, perform experiments, discover the "why" of circuitry and equipment operation.

Almost without realizing it, the NRI discovery method gives you the professional's most valuable tool—practical experience. You learn maintenance, installation, construction and trouble-shooting of Electronic circuits of any description. Whether your chosen field is Industrial Electronics, Communications or TV-Radio Servicing, NRI prepares you quickly to be employable in this booming field or to earn extra money in your spare time or have your own full-time business. And you start out with training equivalent to months—even years—of on-the-job training.

## NRI Has Trained More Men for Electronics Than Any Other School

—By actual count, the number of individuals who have enrolled for Electronics with NRI could easily populate a city the size of New Orleans or Indianapolis. Over three-quarters of a million have enrolled with NRI since 1914. How well NRI training has proved its value is evident from the thousands of letters we receive from graduates. Letters like those excerpted below. Take the first step to a rewarding new career today. Mail the postage-free card. No obligation. No salesman will call. NATIONAL RADIO INSTITUTE, Electronics Division, Washington, D.C. 20016.



L. V. Lynch, Louisville, Ky., was a factory worker with American Tobacco Co., now he's an Electronics Technician with the same firm. "I don't see how the NRI way of teaching could be improved."



G. L. Roberts, Champaign, Ill., is Senior Technician at the U. of Illinois Coordinated Science Laboratory. In two years he received five pay raises. Says Roberts, "I attribute my present position to NRI training."



Don House, Lubbock, Tex., went into his own Servicing business six months after completing NRI training. This former clothes salesman just bought a new house and reports, "I look forward to making twice as much money as I would have in my former work."



Ronald L. Ritter of Eatontown, N.J., received a promotion before finishing the NRI Communication course, scoring one of the highest grades in Army proficiency tests. He works with the U.S. Army Electronics Lab, Ft. Monmouth, N.J. "Through NRI, I know I can handle a job of responsibility."

**APPROVED UNDER NEW GI BILL. If you served since January 31, 1955, or are in service, check GI line on postage-free card.**

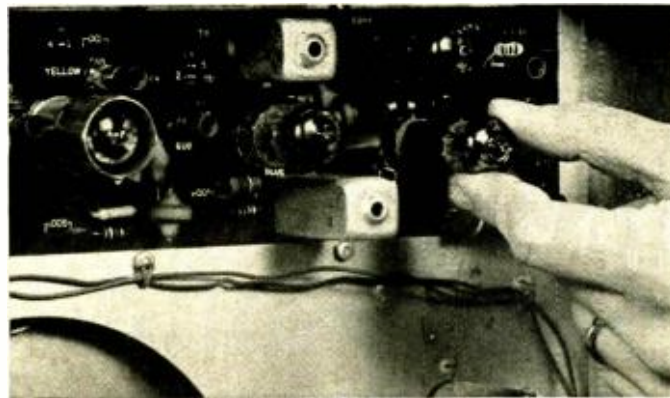

## COLOR TV CIRCUITRY COMES ALIVE

as you build, stage-by-stage, the only custom Color-TV eng.need for training. You grasp a professional understanding of all color circuits through logical demonstrations never before presented. The TV-Radio Servicing course includes your choice of black and white or color training equipment.

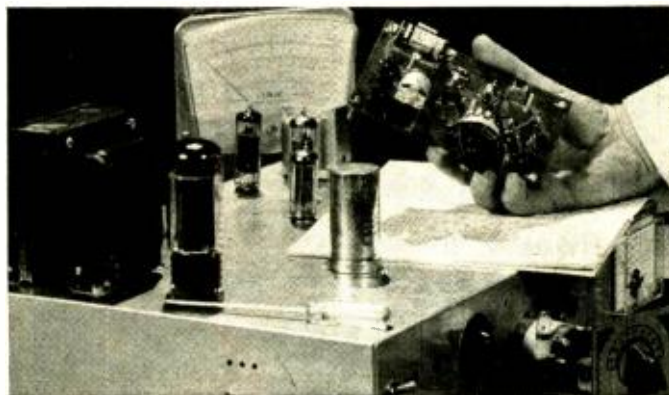

## COMMUNICATIONS EXPERIENCE

comparable to many months on the job is yours as you build and use a VTVM with solid-state power supply, perform experiments on transmission line and antenna systems and build and work with an operating, phone-cw, 30-watt transmitter suitable for use on the 80-meter amateur band. Again, no other home-study school offers this equipment. You pass your FCC exams—or get your money back.

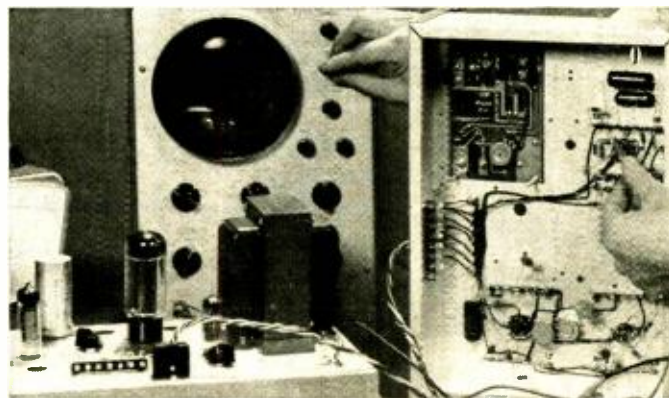

## COMPETENT TECHNICAL ABILITY

can be instantly demonstrated by you on completing the NRI course in Industrial Electronics. As you learn, you actually build and use your own motor control circuits, telemetering devices and even digital computer circuits which you program to solve simple problems. All major NRI courses include use of transistors, solid-state devices, printed circuits.

LAUNCHING  
THE  
SPECTACULAR

70<sup>th</sup>



IN ELECTRICAL and  
ELECTRONICS ENGINEERING

4 Floors of Exhibits  
NEW YORK COLISEUM

50 Technical Sessions  
NEW YORK HILTON

Monday  
through  
Thursday



IEEE  
70

INTERNATIONAL  
CONVENTION and EXHIBITION  
MARCH 23-26, 1970

CIRCLE NO. 132 ON READER SERVICE CARD

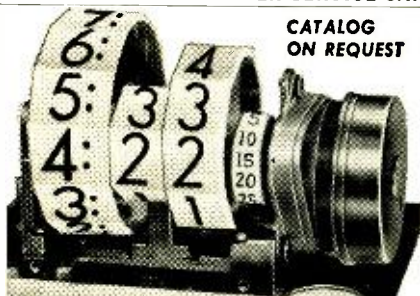

CATALOG  
ON REQUEST



**CLOCK MOVEMENTS**

DIGITS RESETTABLE INDIVIDUALLY

Available in 50, 60 cy., all voltages, AC. UL approved motor, cord. One Year Guarantee.

#130...12-HOUR #131...24-HOUR

Made in U.S.A.



#110

SECOND BY SECOND 12 and 24 Hour  
READ OUT DIGITAL CLOCK

Complete Line: Delay, Interval  
and Cycle Timers, Digital Computers

**PENNWOOD NUMECHRON CO.**  
**TYMETER ELECTRONICS**

7249 FRANKSTOWN AVE., PITTSBURGH, PA. 15208

CIRCLE NO. 121 ON READER SERVICE CARD

12

## LETTERS FROM OUR READERS

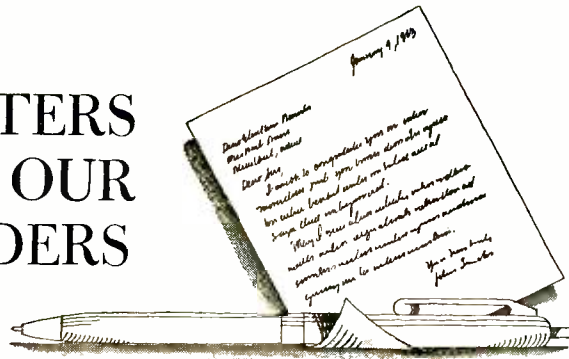

### MULTICHANNEL RECORDING

To the Editors:

Your article on page 38 of the September, 1969 issue, "Multichannel Recording for Creating the 'New Sound,'" did not carry the correct title, in my opinion. You should have called it "Our Problems with the Ampex MM-1000-16." The major portion of the article was concerned with the operation of the Ampex machine. There are other 16-track recorders available: Gauss and 3M Company. So I think my title would have been better.

There was only a brief and sketchy description of some of the techniques used in multichannel recording. Perhaps this studio does not utilize some of the "standard" procedures in use at most studios: phasing (flange) effects, delayed echo and reverb, direct pick-up of instruments, etc.

No mention was made of the importance of a good producer or A&R man. Most engineers today could not turn out a good product without the assistance of the A&R man, and if the latter knows what he is doing the results can be beautiful.

SIDNEY FELDMAN  
Mastertone Recording Studios  
New York, N. Y.

*The Ampex machine was used only as an example. Space limitations prevented us from covering the other standard techniques used.*

*Also, while we agree that a good A&R (artists and repertoire) man is important, we are sure that Sid Feldman would agree with us that good engineering, including mastering and mixing, are equally important in order to get a good, top-quality recording. We should not overlook the importance of manufacturing and production as well in obtaining a good, final product that reproduces the artistry of the original performers.—Editors.*

\* \* \*

### A UNITED SERVICE ASSOCIATION

To the Editors:

I have read and re-read the great editorial "A Plea for a United Service Association" by Mr. R. W. Woodbury on page 13 of the November, 1969 issue of your very fine magazine. It is a most worthwhile article. His points are

very clear and we should take what he has said into very serious consideration and do something about it.

In the sixth paragraph, he clearly brings out a true statement about the professional service technicians being divided. This has been true from the beginning of consumer electronics and I have personally been actively involved in this field since 1926. Technicians, as a whole, have very strong individualistic attitudes and most uncooperative egos. No doubt there are many reasons for this attitude and it has been developed over a period of many years. The service technician has been the "whipping boy" of the industry. He has been belittled, berated, downgraded, browbeaten, kicked, and booted by the press, the distributor, and the manufacturer. The result has been a great exodus of many good technicians from the consumer electronics field and into the other fields of industrial and government electronics.

However, we can be somewhat optimistic, as a number of service associations have been and are forming throughout the nation. Here in Florida, for example, we now have a young, aggressive organization, Florida Electronic Service Association (FESA). It is composed of a number of local organizations and individual technicians and dealers with strong, positive, cooperative attitudes. They are knowledgeable and have good academic and technical backgrounds. They are seeking ways to better serve the consumer, manufacturer, distributor, and of course each other. The many faults of the servicing profession can be laid at the feet of all of us in electronics—manufacturer, distributor, dealer, and technician—and not just one segment.

How are we going to attempt to survive? The only foreseeable way is for each of us to do the following:

1. We each, as individual technicians or shop owners should join a local organization. For it to be successful each of us should take an active part in the organization. We should attend all meetings and be heard. We should have open, friendly, positive minds toward our fellow technician, shop owner, and dealer, and be willing to work together with the distributor and manufacturer.

2. All the local organizations should join a state organization and actively participate in the state organization in order to make it a success for all concerned.

3. The state organization should join a national group and work for growth and strength. Only through a strong, united, national organization can we be heard and work for the betterment and good of all concerned.

4. The national organizations we now have are all fine. I am a CET and a member of NEA. I would be a member of NARDA and NATESA but don't know where to write. I think NARDA, NATESA, and NEA should merge for their own good. The manufacturer should endorse and publicize the CET program, for what is good for the technician is good for the consumer and manufacturer.

CHARLES B. COUCH, JR.  
Couch's Inc.  
Gainesville, Fla.

*There's no doubt that a single, strong, unified national service association that could speak for all service technicians would be more effective than a number of separate organizations. For Reader Couch and others who have written to us, the addresses of NATESA, NARDA, and NEA are as follows: NEA, 12 So. New Jersey St., Indianapolis, Ind. 46204. NATESA, 5906 S. Troy St., Chicago, Ill. 60629; and NARDA, 634 Merchandise Mart, Chicago, Ill. 60654. We are certain that these organizations will be glad to send details about their operation.—Editors*

\* \* \*

#### SPEAKER-MATCHING PROBLEMS

To the Editors:

I would like to point out a slight error in the article on speaker-matching problems by Abraham Cohen in the October, 1969 issue of EW. Mr. Cohen makes a special effort to point out the fact that a dynamic loudspeaker has a frequency-dependent impedance and behaves as an inductor at high frequencies. However, when he considers connecting a tweeter to a woofer, he completely ignores this fact and calculates the combined impedance as if only pure resistances were involved. Thus, if a tweeter whose high-frequency impedance is 8 ohms, is connected (through a capacitor) in parallel with a woofer whose 400-Hz impedance is 8 ohms, Mr. Cohen calculates a resulting high-frequency impedance of 4 ohms. The true impedance will be closer to 8 ohms, assuming that the woofer behaves as a pure inductance at frequencies above about 500 Hz.

It has always been my understanding that the inductor in the crossover network is not there primarily to match impedances but to remove the high-frequency contributions of the woofer cone,

which is not usually designed to reproduce high frequencies and, therefore, does so in an irregular manner and with higher distortion. The tweeter then serves to make the system as efficient at high frequencies as at the lower frequencies.

In many texts the writers imply that at the crossover frequencies the impedances to be used in calculating the component values are the rated impedances of the speakers, but the true impedances at the crossover frequencies may be three or four times greater than the rated impedances of the speakers involved. Perhaps the difference is considered too academic for practical purposes, but I feel that a good crossover network should be designed with a knowledge of the true impedances of the speaker used at the crossover frequencies.

FORREST C. GILMORE  
Milford, Pa.

*A portion of the reply from Author Cohen follows.—Editors*

To the Editors:

The point raised by Mr. Gilmore is quite valid under many circumstances where the woofer has a sharply rising impedance. In these instances, the resultant impedance will be closer to 8 ohms rather than 4 ohms as indicated in the example given. However, one must realize that the rising impedance slope of cone loudspeakers varies widely, and the illustration seems adequate in making the point that the over-all performance of such a system must be considered as resulting from the combination of the speakers and the network rather than from the loudspeakers themselves.

While the paragraph referred to by Mr. Gilmore was entitled "Impedance Correction," the intent of the paragraph was not to infer that we were changing the impedance of the elements for matching purposes, but for ensuring that the final impedance of the woofer-tweeter system continues to show the same 8 ohms over the operating range relatively independent of the operating frequency.

It was not feasible in a short article to explore all the intricacies of the crossover network. However, where space is possible, these networks are treated much more fully, with attention paid not only to the electrical roll-off of the speaker, but to the acoustic roll-off of the component itself in its acoustic baffle or horn. For these details may I suggest that Chapter 8 "Networks in Multi-Speaker Systems" of my book "Hi-Fi Loudspeakers and Enclosures," Second Edition, published by Rider, be examined for a broader picture of the problem of crossover networks.

ABRAHAM B. COHEN  
Syosset, N. Y. ▲

# ENGINEERS

- Evaluation and Test
- Manufacturing
- Others

Automatic Electric, a leading innovator of computerized electronic switching systems and the largest producer of communications equipment for the independent telephone industry, has numerous entry level and experienced technical positions available in the following areas: EVALUATION & TESTING Electronic and electrical engineers to initially learn the design of new electronic and computer systems and then perform prototype and/or field evaluation thereon. Entry level requirements — BS degree in EE, ET, or computer science with some knowledge of programming. Higher level positions exist for those with experience in electronic common control systems.

MFG. ENGINEERING Degreed electronic or electrical engineers (new or experienced) initially learn new computerized electronic telephone switching systems, design test equipment and associated test procedures and troubleshoot the mass production of this equipment.

*Additional Positions currently available include:*

- Software and Hardware Design Engineers
- Automation Engineers
- Ceramic Engineers
- Switching System Planning Engineers
- Traffic Analysts

If you are interested in a progressive, growing company that offers well equipped modern facilities, a policy of promotion from within, and a pleasant West suburban location (15 miles from downtown Chicago), send your resume in confidence to:

Larry Wisniewski

Professional Employment Representative

**AUTOMATIC ELECTRIC**

Subsidiary of General Telephone & Electronics

400 North Wolf Rd., Northlake, Ill. 60164  
An Equal Opportunity Employer

CIRCLE NO. 147 ON READER SERVICE CARD

# ? what next?

*after you've designed*

general purpose vidicon cameras  
high performance vidicon cameras  
IR/UV sensitive vidicon cameras  
low lag, non burn PbO cameras  
low light image orthicon cameras  
low light image isocon cameras  
integrating image orth systems

*of course,*

# a silicon matrix television camera



by

**mti**

Division of KMS Industries, Inc.

57 Dodge Avenue

North Haven, Connecticut 06473

Phone 203-239-5341 • TWX 710-465-3077

write or phone for  
sc-20 series camera brochure

CIRCLE NO. 124 ON READER SERVICE CARD

## Cable TV Moves Faster Than Ever

Now sanctioned officially by the Federal Communications Commission, cable television is getting into high gear. The biggest moves now relate to programming and getting into large cities. The term "CATV" is obsolete. The modern cable system is no longer a "community antenna" project. It's cablecasting—an entertainment and information medium of its own.

The top-50 television markets contain around 70 percent of the TV sets in the U.S. Although it's expensive to string cable in these urban localities, there are more customers per mile. *Manhattan Cable Co.* has almost 20,000 subscribers hooked on in New York City; *TelePrompTer*, the other franchisee in Manhattan, has about that many. Almost weekly, another city announces it is getting ready for cable TV. Recent ones are Louisville, Ky. and El Paso, Texas.

The lure in such markets is more channels. There is equipment now to distribute 20 v.h.f. channels—more than present TV sets can accommodate. We expect one manufacturer to soon announce a color receiver designed especially for high-capacity cable systems—probably by the end of this year. And the set is likely to be for lease rather than for sale.

With that many channels, programs to fill them is the next problem. The FCC approves program originations, in fact insists on it for systems with over 3500 subscribers. The cable owner can sell advertising time on channels on which original programs are shown. So, there will be money available to buy program material.

One approach is syndication. *H & B Communications*, the largest cable firm at present, is negotiating to merge with *TelePrompTer*, which is third largest. When the deal is completed, the new firm expects to develop a distribution arrangement by which new, fresh programs can be supplied to other cable systems as well as its own. The FCC has already okayed microwave for relaying cablecasts. There's even talk of using a satellite for distribution. The plan is an ambitious projection, but it's likely to run into the same paucity of entertaining ideas that plagues conventional TV. It won't be any easier to fill cable channels with lively material than it is to do the same for TV networks.

Much ado has been made about pay-TV over cable. Until lately, cablecasters said it wasn't going to happen. One recent report has it that *Television Communications*, the ninth largest system owner, proposes a per-channel fee added onto the monthly system charge if that subscriber wants channels with special programming. One channel would have three feature movies a week, another education and instruction, and so on. That's pay-TV, however you disguise it.

Anyway, the fat is in the fire. This year will see, month by month, dozens of new schemes tried in cable TV. We'll try to tell you about some of the more interesting experiments in this column.

## Integrated Circuits Go Slow

Three years ago, when *RCA* put the first integrated circuit into a television receiver, industry-watchers expected that event to trigger a rush to IC's in all sorts of consumer products. It just hasn't happened. Oh yes, every few months, a new IC shows up here and there in a hi-fi unit, a TV set, a phonograph. But that's only a drop in the bucket. The Japanese, who usually jump into any new miniature technology with both feet, have shied away from this one, too. One Japanese firm displayed an all-IC pocket-sized TV set last year, but nothing more has been heard or seen of it.

One factor is undoubtedly cost. And it's going to take some momentum to overcome that holdback. If IC's were cheaper, demand would be greater. If demand were greater, they would be cheaper, etc.

Integrated circuits haven't had the fanfare that accompanied, say, the transistor when it began making inroads into home-entertainment electronics. No glamor has attached itself to the idea of having a set with IC's in it. Again, the round-robin syndrome may be partly to blame; IC's aren't popular because there aren't many of them used, and few of them are used because they're not especially popular. So, the rate of introducing and using IC's that are consumer-oriented is slow.

*Motorola* has done quite a bit to promote IC's in the consumer market. The HEP (for Hobbyist, Experimenter, Professional) line of low-cost IC's has spread the word about IC's. *RCA* has distributed samplers and kits of hobby-type IC's; that familiarizes a few more people. Other companies have rushed into and backed out of the consumer-product IC business. Public's response to technical promotions has been sluggish.

It looks like three things are needed to get an IC revolution under way—if, indeed, it is ever to come

about at all. (1) We need products that are all-IC. Then buyers will look on IC's as more than just a one-shot fancy. (2) We need some real razzle-dazzle promotion to call attention to IC's, to alert the public to the advantages of IC's. (3) We need more kinds of IC's for consumer products. This means IC-makers will have to stick their necks out, pushing lines that are unprofitable for awhile. (That's how the color-TV industry was built.)

IC's are reliable now—more so than transistors, if failure statistics are to be believed. Perhaps it's time to start making the integrated circuit as popular as the transistor.

## Two-Pole Convergence

There are fewer dynamic convergence adjustments than usual on the new portable color chassis from *Zenith*, the 12A8C11. That's because of a new two-pole convergence system. It also changes the old "cloverleaf" appearance of the convergence yoke assembly on the neck of the picture tube.

The new convergence system is used with the 15ACP22 picture tube, which has the blue gun on bottom (like other recent *Zenith* color CRT's) instead of on top. The former *Zenith* three-pole system has separate static-magnet adjustments for red and green, spaced at 10 o'clock and 2 o'clock on the picture-tube neck. The two-pole system has a single combined red/green magnet assembly located at the top. A red/green lateral magnet moves the red and green dots sideways, either away from or toward each other. A red/green vertical magnet moves both dots up or down. Blue vertical and lateral magnets, located at 6 o'clock on the neck, work the same as before. The new system of handling red and green eliminates some of the red/green waveshaping controls on the dynamic convergence panels.

## "Back to the Factory" Repairs

From time to time, we investigate complaints we hear over and over from customers who buy home-entertainment equipment and the technicians who service it. One complaint that has come up a lot lately refers to imported sets, particularly TV. The story goes something like this.

A customer buys an import brand (not a U.S.-branded import). When trouble crops up, which happens just as often as with domestic brands, he tries to get his favorite service shop to repair it. The shop operator often turns it down. If he accepts it, then he may not be able to dope out some of the unusual circuits because he has no service literature for the set.

If he does happen to find the trouble, and it's some special part, there are none handy. Written pleas to the national service department of the importer (if it has one), asking for circuit and parts information—are, with few exceptions, ignored. Phone calls are shunted away from responsible executives by secretaries or "assistants." When the customer finally gets steamed up enough to take matters over, the best answer he can get is "Take it to our authorized service agency." When, as often happens, the "authorized agency" doesn't have parts or information either, the suggestion is: "Return your set to our national service department for repairs." (That's usually located in the New York area.) This situation prevails whether the set is in warranty or not.

This philosophy of "taking care" of customer needs for service leaves a lot to be desired. What customer is going to pack up his color TV and ship it to New York or any other out-of-town point, for repair? What customer has the facilities, or saves the carton? And, even if he does all that, how much damage is going to be done when it's shipped back? And who pays the freight? And who today will put up with the weeks of waiting? That's a lot of inconvenience.

One improvement would be to make service information and parts available to independent shops that are willing to work on imported sets. We'd be glad to tell our readers about any importer who has really licked this problem, who does cooperate with independent servicers, who does have parts available quickly, and who has some convenient way for owners to get service when it's needed. Our inquiries haven't turned up any like this so far.

## Parts Availability

To clarify what was said about this in last month's column: It is not fair to a technician who has to service a particular brand of set when the distributor of parts for that brand carries only *some* of the replacement parts. It is also unfair to the TV owner who bought that brand and unfortunately he often blames the technician. There is no excuse a set-owner will listen to; indeed, is there any real excuse at all? If the set is available, parts to repair it should be available. This is not always the case, as proven by spotchecks we reported last month. Weeks of waiting—even days, for that matter, do not set well with either customer or technician. Almost for sure, technicians are going to fall back on their chief weapon against such problems: suggesting customers buy some other brand. ▲



# The New 1970 Improved Model 257 **A REVOLUTIONARY NEW TUBE TESTING OUTFIT**

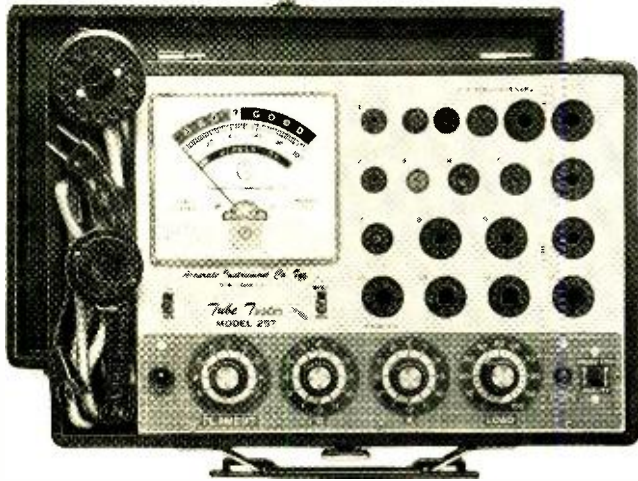

**COMPLETE WITH ALL ADAPTERS AND ACCESSORIES, NO "EXTRAS"**

### STANDARD TUBES:

- ✓ Tests the new Novars, Nuvistors, 10 Pins, Magnovals, Compactrons and Decals.
- ✓ More than 2,500 tube listings.
- ✓ Tests each section of multi-section tubes individually for shorts, leakage and Cathode emission.
- ✓ Ultra sensitive circuit will indicate leakage up to 5 Megohms.
- ✓ Employs new improved 4½" dual scale meter with a unique sealed damping chamber to assure accurate, vibration-less readings.
- ✓ Complete set of tube straighteners mounted on front panel.

The Model 257 is housed in a handsome, sturdy, portable case. Comes complete with all adapters and accessories, ready to plug in and use. No "extras" to buy. Only .....

### BLACK AND WHITE PICTURE TUBES:

- ✓ Single cable used for testing all Black and White Picture Tubes with deflection angles 50 to 114 degrees.
- ✓ The Model 257 tests all Black and White Picture Tubes for emission, inter-element shorts and leakage.

### COLOR PICTURE TUBES:

- ✓ The Red, Green and Blue Color guns are tested individually for cathode emission quality, and each gun is tested separately for shorts or leakage between control grid, cathode and heater. Employment of a newly perfected dual socket cable enables accomplishments of all tests in the shortest possible time.

**\$52<sup>50</sup>**

## NOTICE

We have been producing radio, TV and electronic test equipment since 1935, which means we were making Tube Testers at a time when there were relatively few tubes on the market, 'way before the advent of TV. The model 257 employs every design improvement and every technique we have learned over an uninterrupted production period of 34 years.

Accurate Instrument Co., Inc.

# SEND NO MONEY WITH ORDER PAY POSTMAN NOTHING ON DELIVERY

Pay Cash or in EASY MONTHLY PAYMENTS AFTER 15 Day Trial!

Try it for 15 days before you buy. If completely satisfied remit \$52.50 plus postage and handling charge. (If you prefer you may PAY MONTHLY ON OUR EASY PAYMENT PLAN.) If not completely satisfied, return to us, no explanation necessary.

ACCURATE INSTRUMENT CO., INC. Dept. 729

2435 White Plains Road, Bronx, N. Y. 10467

Please rush me one Model 257. If satisfactory I agree to pay at the terms specified at left. If not satisfactory, I may return for cancellation of account.

Name \_\_\_\_\_

Address \_\_\_\_\_

City \_\_\_\_\_ State \_\_\_\_\_ Zip \_\_\_\_\_

Save Money! Check here and enclose \$52.50 with this coupon and we will pay all shipping charges. You still retain the privilege of returning after 10 day trial for full refund.

**“Get more  
education  
or  
get out of  
electronics  
...that’s my advice.”**



**IN-DEPTH  
COVERAGE OF  
SOLID STATE  
ELECTRONICS  
...including  
integrated circuits!**

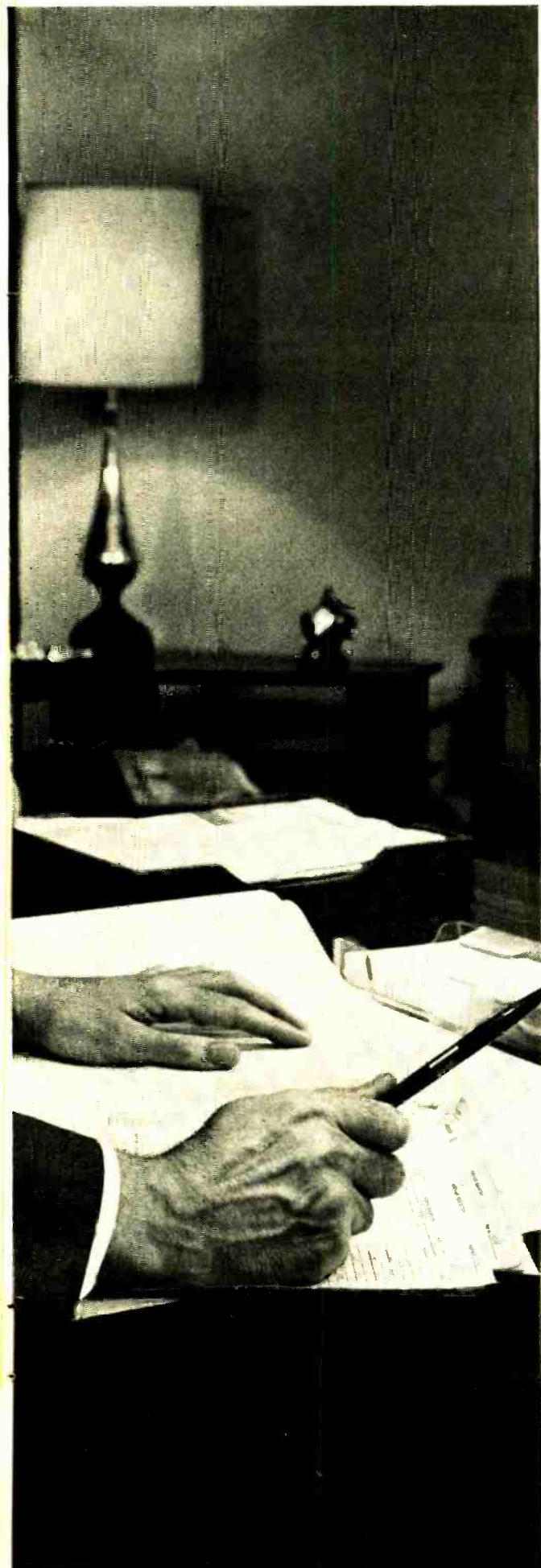

**Ask any man who really knows the electronics industry.**

Opportunities are few for men without advanced technical education. If you stay on that level, you'll never make much money. And you'll be among the first to go in a layoff.

But, if you supplement your experience with more education in electronics, you can become a specialist. You'll enjoy good income and excellent security. You won't have to worry about automation or advances in technology putting you out of a job.

How can you get the additional education you must have to protect your future—and the future of those who depend on you? Going back to school isn't easy for a man with a job and family obligations.

CREI Home Study Programs offer you a practical way to get more education without going back to school. You study at home, at your own pace, on your own schedule. And you study with the assurance that what you learn can be applied on the job immediately to make you worth more money to your employer.

You're eligible for a CREI Program if you work in electronics and have a high school education. Our FREE book gives complete information. Mail postpaid card for your copy. If card is detached, use coupon below or write: CREI, Dept. 1102A, 3224 Sixteenth Street, N.W., Washington, D.C. 20010.

Founded 1927



Accredited Member of the National Home Study Council



**CREI, Home Study Division  
McGraw-Hill Book Company  
Dept. 1102A, 3224 Sixteenth Street, N.W.  
Washington, D.C. 20010**

Please mail me FREE book describing CREI Programs. I am employed in electronics and have a high school education.

NAME \_\_\_\_\_ AGE \_\_\_\_\_

ADDRESS \_\_\_\_\_

CITY \_\_\_\_\_ STATE \_\_\_\_\_ ZIP CODE \_\_\_\_\_

EMPLOYED BY \_\_\_\_\_

TYPE OF PRESENT WORK \_\_\_\_\_  G.I. BILL

I am interested in

Electronic Engineering Technology  Computers

Space Electronics  Nuclear Engineering Technology

Industrial Automation  NEW! Electronics Systems Engineering

**APPROVED FOR TRAINING UNDER NEW G.I. BILL**

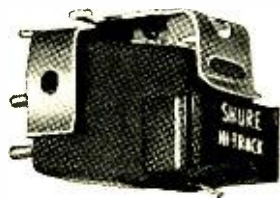

# Second to one...

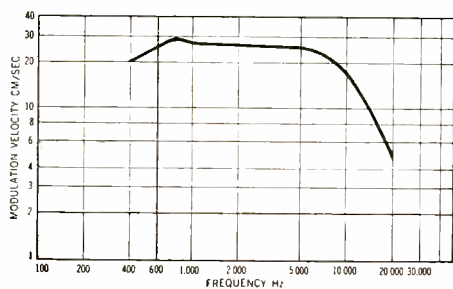

TRACKABILITY CHART FOR M91E  
Measured At One Gram

If it were not for the incomparable Shure V-15 Type II (IMPROVED) Super-Track, the Shure M91E Hi-Track would be equal or superior to any other phono cartridge in trackability . . . regardless of price! The astounding thing is that it costs from \$15.00 to \$50.00 less than its lesser counterparts. And, it features an exclusive "Easy-Mount" design in the bargain. Trade up to the M91E now, and to the V-15 Type II (IMPROVED) when your ship comes in. Elliptical Stylus.  $\frac{3}{4}$  to  $1\frac{1}{2}$  grams tracking. \$49.95. Other models with spherical styli, up to 3 grams tracking, as low as \$39.95.

**SHURE**

## M91E HI-TRACK PHONO CARTRIDGE

© 1969, Shure Brothers Inc., 222 Hartrey Ave., Evanston, Illinois 60204  
CIRCLE NO. 108 ON READER SERVICE CARD



# NEWS HIGHLIGHTS

## More on Home Video Recorders

Continuing our coverage of home video recorder announcements (see our January issue "Radio & Television News"), we were present when *Sony Corporation* unveiled for the American public what it calls "the most practical, economical, reliable, and easy-to-use Color Videoplayer in the world." Our opinion: Very good. If production models are as good as display models, you couldn't ask for better quality. Scheduled to go on sale in Japan by late 1970 and make the American scene in late 1971, it can be used with any standard color or black-and-white TV set. Long time lapse due to *Sony's* attempt to build up large video cassette library by inviting TV-oriented industries (movies, music, sports, etc.) to make their programs available for TV audiences. . . . Each cassette will contain 900 ft of  $\frac{3}{4}$ " two-sound-track (stereo) magnetic tape, and can be programmed to play up to 90 minutes. Projected 1971 price for Videoplayer between \$350-\$400 and \$20 for an individual cassette that, for a nominal fee, can be returned to program supplier for re-recording another program. For additional \$100, adapter will be available to allow home recording of black-and-white or color-TV programs.

## Communism's Loss—Our Gain

In October 1969, thirteen years after Hungarian Revolution, the original equipment used to establish standards for stereo-FM broadcasting in U.S. was presented to the Smithsonian Institution by *G-E*. What's the connection? Well, Antal (Tony) Csicsatka, advanced product engineer with *G-E*, who was responsible for development of the pilot-tone system that made stereo-FM broadcasting possible, was one of the more fortunate individuals to have escaped Budapest as the Russian tanks entered the city. Equipment, presented to the Smithsonian by Mr. Csicsatka himself, will be placed on public display along with other pioneering broadcasting achievements.

## Stork Outpaces Electronics

The premature birth of quintuplets to a London mother, Mrs. Irene Hanson, on Thursday, November 13, put engineers of three countries in a dither. The engineers, all working for *Beckman Instruments Co.*, although aware of the impending multiple birth, were caught with their equipment down when stork delivered two weeks early. Babies had arrived but promised electronic instruments for monitoring their physiological responses were still sitting in main plant in Fullerton, Calif. Cramming three days' work into three hours, a team of scientists, engineers, and executives miraculously completed the systems and air-shipped them to London. By late Friday the units, that use a TV-like physiological oscilloscope to display waveforms of each child's breathing, heartbeat, and temperature, and sound an alarm when trouble is indicated, were put into operation by the combined efforts of an English and French engineering team. Seems like a message here—whereby men of three different countries and two different continents can successfully overcome all barriers when confronted by a common humanitarian challenge.

## WWV and WWVH in Transition

Formats of radio stations WWV in Fort Collins, Colorado and WWVH in Maui, Hawaii, which transmit accurate time and frequency information, are being reviewed by the Na-

tional Bureau of Standards (NBS) for possible changes and modifications. To develop most useful format, a survey of WWV users is currently under way. Users of WWV, who have not received questionnaire and who wish to participate can, by writing to WWV 1969, National Bureau of Standards, Boulder, Colorado 80302.

## Pollution Control—Connecticut Leads Way

Although we continuously hear admonitions about pollution, whether it be of the air, water, or noise variety, very little is actually being done about it on governmental level, that is—until now. *CBS Laboratories*, under contract from Connecticut Research Commission and with full cooperation of Governor Dempsey and state police and highway departments, has developed a highway noise monitor that measures noise levels that exceed an acceptable threshold while simultaneously producing a split-screen photograph of offending vehicle's license and noise-level recording. What makes this noise-abatement plan unique is that Connecticut will be the first state to be able to actually produce *prima-facie* evidence that will stand up in court when a driver has been cited for violation of the State's traffic noise ordinance. Tests are currently being conducted to determine maximum acceptable noise level that will be enacted into law by state legislature. Hopefully, pioneering effort by Connecticut to control insidious highway noise pollution problem will act as a catalyst for development of other pollution control systems.

## New Cable-TV Association Head

On January 1, 1970 Donald V. Taverner, Pittsburgh educational television executive, took over reins as president of the National Cable Television Association from Frederick W. Ford, who had been in office since 1965. Heralding choice made by NCTA Presidential Selection Committee from some 60 persons considered for job as ". . . the right man for the right job at the right time," Mr. M. William Adler, national chairman of the NCTA Board of Directors, announced Mr. Taverner's acceptance.

## Overseas Business

*RCA* goes continental. Anticipating expanding European semiconductor market to approach \$650-\$700 million in sales by 1972, *RCA* recently started construction of a \$10.7-million ultramodern semiconductor manufacturing plant in Liege, Belgium. Completion date, of what represents *RCA's* first electronics manufacturing facility on the European continent, is mid-1970. Facilities will provide European market with latest semiconductor components used in television, automobiles, data processing, industrial, military, and aerospace electronic equipment. . . . America's faith in South Korea paying off. Last November 10 marked opening of Korea Electronics Industry Promotion Office at 1212 Avenue of the Americas, New York and second step of an 8-nation tour by 15 Korean electronics manufacturers. Intent is to improve coordination of export and import opportunities and to induce foreign investment in Republic's growing electronics industry. Director of KEIPO, In Kyun Lah, attributes electronic industry's growth and its major role in Korean economy to government's Foreign Capital Inducement Law, which offers investment incentives. American investment in Korean electronics industry accounted for exports of \$15 million in 1968. ▲

# How man's conquest of the moon helped Scott develop the world's most advanced AM/FM Stereo Receiver



The billions of research dollars expended towards America's race to the moon helped foster the development of many entirely new electronic devices. Alert Scott engineers realized that the adaptation of some of these devices could result in significant advances in the performance of high fidelity components . . . a realization that inevitably led to the development of the 386 AM/FM stereo receiver.

The 386 represents a level of sound quality and performance characteristics that is a giant-step ahead of any stereo component ever before available . . . utilizing entirely new features that help you control incoming signals with a degree of accuracy never before possible . . . incorporating new assembly techniques that guarantee superb performance over periods of time previously thought unattainable.



There are 7 ultra-reliable Integrated Circuits in the 386 . . . more than in any other receiver now on the market. These 7 circuits include a total of 91 transistors, 28 diodes, and 109 resistors!

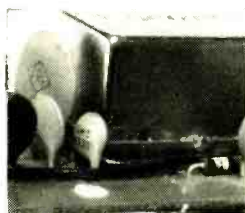

Quartz crystal lattice filter IF section, never before found in a receiver in this price class, ends the need of IF amplifier realignment, and gives very low distortion and high selectivity.

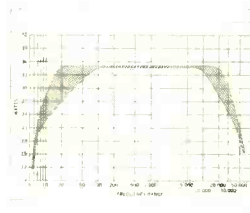

Higher power at lower distortion: The shaded area indicates where competitive receivers tend to rob you of full response in the extreme lows (organ, bass drum) and highs (flutes, triangles, etc.)



Perfectune, a computer logic module, decides when you've reached the point of perfect tuning and lowest distortion, then snaps on the "Perfectune" signal light.

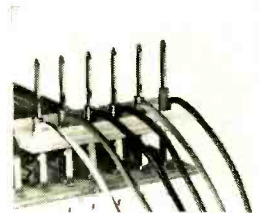

Wire-wrap terminal connections and plug-in printed circuit module construction result in the kind of reliability usually associated with aerospace applications.

© 1969, H. H. Scott, Inc.

## 386 Specifications

Total power ( $\pm 1$  dB) 170 Watts @ 4 Ohms. IHF Dynamic power, 67.5 Watts/channel @ 4 Ohms; Continuous power, both channels driven, 42 Watts/channel @ 4 Ohms, 35 Watts/channel @ 8 Ohms; Distortion  $< 0.5\%$  at rated output; Frequency response ( $\pm 1$  dB), 15-30 KHz; IHF power bandwidth, 15-25 KHz. FM usable sensitivity (IHF), 1.9  $\mu$ V; FM selectivity, 42 dB. Price, \$349.95.

CIRCLE NO. 115 ON READER SERVICE CARD

# SCOTT®

For detailed specifications, write:  
H. H. Scott, Inc., 111 Powdermill Road, Maynard, Mass. 01754  
Export: Scott International, Maynard, Mass. 01754



A surgeon is shown performing minor surgery to implant a cardiac pacemaker system in heart patient.

# ELECTRONICS and the HEART

By FRED W. HOLDER/Supervisor Technical Writing,  
Bendix Field Engineering Corp.

*Although electronic instrumentation has helped save and prolong many a heart patient's life, the steady increase in deaths due to heart disease gives mute testimony for the need of further research along these lines.*

**I**N the past ten years, we have learned enough to send a man to the Moon and bring him back, but we haven't managed to slow the growth of heart disease. The death rate from heart disease has increased more than 15 percent over this period, so that more than half of all deaths in the U.S. are attributed to heart ailments. In Los Angeles County alone, heart attacks kill 30 persons each day.

The American Heart Association reports that 40 percent of all persons who die from heart attacks do so within the first hour. Another 45 percent die within the first day. New technology is allowing something to be done about this. For example, miniaturization has made electronic heart-care equipment small enough to be taken to the patient; sophisticated patient-monitoring and treatment equipment is available once the patient reaches the intensive-care room in the hospital; and the miniaturization, which made mobile heart care possible, now enables many heart patients to return to a nearly normal, productive life. In this article, we will investigate some of these new items.

## Mobile Coronary Equipment

In 1968, *Schaefers Ambulance Service* of Los Angeles adapted medical instrument techniques developed by

NASA for its test pilots to provide heart-rate information on ambulance patients to doctors awaiting their arrival at the hospital. If the patient gives his permission, *Schaefers'* attendants attach small bare wires to his chest with a special gun. This gun sprays and dries a silver-glue combination to form electrodes for monitoring the electrical activity of the patient's heart. Information from these electrodes is picked up by special electronic instruments and relayed, as an audio tone, by short-wave radio and telephone lines, to the UCLA Medical Center. At the Medical Center, the information is used to drive a standard electrocardiograph record, providing a visual display of the patient's heart activity for the waiting doctors. With such advance information available, the doctor can make the necessary preparations before the patient arrives and gain many valuable minutes needed to save a life.

In a similar move, Los Angeles County started operating a new mobile, electronically equipped coronary rescue unit in June 1969. This unit is expected to save the lives of 300 Southern Californians annually, who might otherwise have died of heart attacks. This unit, called a myocardial infarction rescue unit (MIRU), uses a *General Motors Step-Van* to house and transport the electronic instrumentation.



Fig. 1. Patient monitoring system gives doctor on-the-spot data and allows one nurse to monitor up to eight patients.

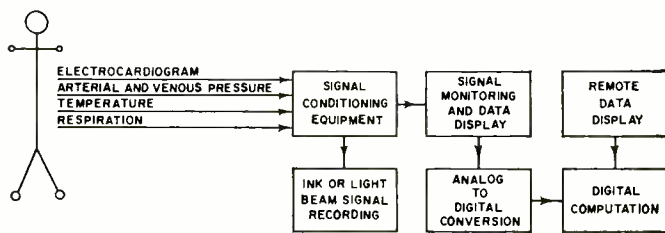

Fig. 2. Block diagram of typical patient-monitoring system.

The electronic equipment used in MIRU is made by *Dalsons Instruments*, a division of *International Rectifier Corp.* MIRU has a cardioscope, to display the patient's heart activity; a heart-rate meter with alarm settings to trigger other equipment when an extreme is reached; and an elapsed-time meter to measure the crucial time between heart beats. Information from these instruments is transmitted to a nearby hospital where a cardiologist diagnoses it and radios instructions to the nurse and technician in MIRU.

The cardiologist can prescribe the use of a defibrillator, which gives an electric shock to stimulate heart activity, or a pacemaker which either replaces or supplants the heart's normal timing mechanism. With such useful "tools" out in the field, the doctor's fight against a heart attack has a better chance of being won. Estimates show that MIRU will be able to answer the average call within 10 to 15 minutes. The actual value of MIRU will be determined during its two-year pilot program now under way.

### Hospital Coronary-Care Equipment

Patient-monitoring equipment has proved to be of great value in the treatment of coronary patients. Intensive care

Fig. 3. Arrhythmia Monitor system, consisting of a trend recorder and arrhythmia monitor, records patient's heart activity and provides the necessary alarms when arrhythmia occurs.

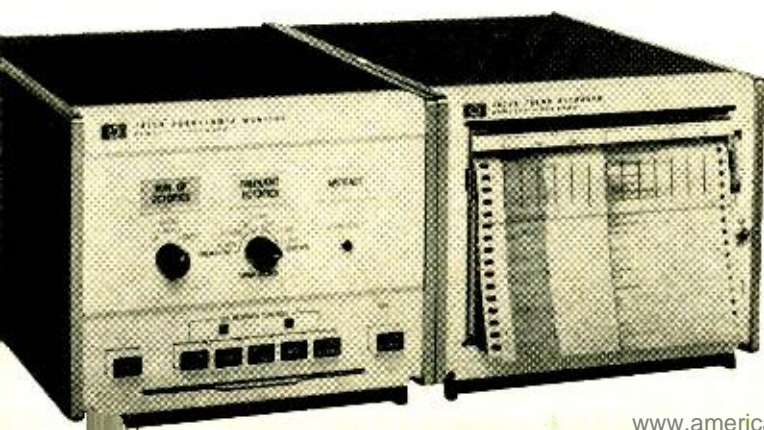

of these patients is aided and indeed enhanced through the use of electronic instruments which continuously monitor various physiological parameters, such as arterial and venous pressures, temperature, and respiration. Such systems are not new to the medical profession since some 400 hospitals are currently using electronic patient-monitoring equipment. Such systems do not replace a nurse or any other member of the hospital staff, but serve to supplement the staff and to increase the nurse-to-patient ratio in coronary-care units of the hospital. Experience has shown that patient-monitoring systems reduce the mortality rate of coronary patients.

*Honeywell*, *Hewlett-Packard*, and *General Electric* are among the firms making patient-monitoring systems to perform the functions shown in Fig. 2. Most of these systems are modular so that they may be tailored to fit the requirements of a specific hospital. Such systems normally consist of electrodes and transducers which attach to the patient and gather information for display and recording. The signals from the electrodes and transducers are routed through signal-conditioning equipment where they are used to drive display devices (both graphic and digital) and recording equipment. The signals picked up from the electrodes and transducers may be recorded on moving charts or magnetic tapes and may also be routed to analog-to-digital equipment for conversion and further processing by computer equipment and then forwarded to remote locations where the data may be displayed for consulting physicians.

The newest patient-monitoring system from *Honeywell* consists of one or more bedside units and a central control console (Fig. 1). The bedside unit provides an electrocardiogram monitoring channel, an oscilloscope for displaying data, a beat-to-beat cardiometer, a precision meter display with high and low adjustable alarm settings, and a push-button control-indicator board. The bedside monitor works in conjunction with the central control console so that one nurse can monitor up to eight patients. The central console contains one or two multi-trace oscilloscopes to display data from up to eight individual bedside units; a direct-write recorder with automatic selection, control, and identification features; and keyboard and meters identical to those in each of the bedside units.

*Hewlett-Packard* also has a number of new modular patient-monitoring units, such as the Model 7803A Monitor-scope which provides one- or two-channel monitoring on a five-inch display. This display is large enough to be seen from a distance and compact enough (less than 1/3 cubic foot) to be used at the patient's bedside or at a central station. The unit features automatic brightness control and two sweep speeds.

Another *Hewlett-Packard* unit, the Model 7825A Trend Recorder, provides a 24-hour record of up to four physiological variables on a six-by-ten inch chart. This compact unit (6 1/2" x 7 3/4" x 11"), weighing only 13 pounds, permits wide flexibility in chart format. For example, four channels may occupy equal portions of the chart, a single channel may use the entire chart, or two channels may each appear on one-fourth of the chart while a third channel occupies the remaining half of the chart. To ensure reliable, unattended recording, the unit uses inkless electric writing to provide permanent, reproducible recordings.

When the Trend Recorder is combined with an arrhythmia monitor, the system (Fig. 3) provides the necessary alarms and a permanent record of the patient's abnormal heart beats. The arrhythmia monitor measures the width of the over-all pulse, representing a complete heart beat (known as the QRS) rather than the beat-to-beat interval, Fig. 4. Clinical trials have shown that a widening of the QRS is a more reliable indicator of heart arrhythmias than the detection of premature beats based on variations in the beat-to-beat interval.

Finally, a coronary patient in intensive care must be protected against electrical shock, because it has been found



that a small current at the point of contact with the heart can induce ventricular fibrillation (the heart muscles contract independently and without rhythm). A new pressure transducer (Fig. 5) has been developed that provides electrical isolation of cardiac-catheterized (where a tube has been inserted into the heart through a vein) patients. The electrical isolation provided by this transducer will not permit more than 0.5 microampere of current to flow with potentials up to 800 volts, which is well below the 10 microamperes considered safe. If the voltage should exceed 500 volts, a protective circuit in the transducer automatically bypasses the excess current to ground.

### Portable Coronary Equipment

When a coronary patient's heart slows down (known as heart block) or stops beating (known as Stokes-Adams syndrome) because of damage to the nerve that pulses the heart muscle, it may be necessary to provide these electrical pulses artificially to keep the patient alive. Stokes-Adams disease was once invariably fatal. However, the advent of the electronic pacemaker changed all this, making it possible to keep the patient alive with external electronic pulses. Today, thousands of Americans have been given a new lease on life by electronic pacemakers such as those manufactured by *General Electric*.

According to *General Electric*, approximately 25,000 people have had tiny electronic pacemakers implanted in their bodies since 1960. The smallest pacemaker now available weighs about four ounces and fits easily into the palm of your hand. The unit consists of an electronic generator, powered by long-life mercury batteries, and two electrodes which are attached to the heart muscle. The generator is normally set to pulse 70 times per minute but a unit is available which can be adjusted to 85 pulses per minute for younger or more active patients.

In cases where treatment of the patient requires monitoring of his blood pressure during his normal daily activities, the *Remler* portable blood-pressure recorder is the answer. This unit consists of an inflation bulb, a blood-pressure cuff, a portometer to measure pressure, a microphone, an indicator light, and a tape deck (Fig. 6). The patient wearing the blood-pressure cuff operates the blood-pressure recorder by systematically squeezing the inflation bulb until the signal light informs him that the upper range of pressure has been reached. He then releases the pressure until the signal light indicates that the lower pressure has been reached. The tape recorder, controlled by the inflation pressure, records the cuff pressure, artery sounds, and the heart rate. In this operation, the microphone serves the same purpose as the doctor's stethoscope.

The information recorded by the tape recorder is translated into graphic form by a calibrated decoder in the laboratory to furnish a permanent record which can be evaluated by the physician. Measurements made under these conditions not only determine the presence of hypersensitive complications, but are of significance in assessing the efficacy and dosage of medications, and can guide the physician in prescribing additional medication for the patient.

A new device for automatically recording heart-rate activity over a given period of the normal work day has been developed by *T. E. M. Instruments Ltd.* of Sussex, England. This tiny instrument, known as SAMI/HR (Socially Acceptable Monitoring Instruments/heart rate), obtains its signal from two adhesive chest electrodes. The electrical heart-beat signal is amplified and filtered by the circuits in the SAMI/HR and converted to a constant-current charge pulse. This pulse is recorded in an electro-chemical integrator or E-cell, manufactured by *The Bissett-Berman Corp.* of Los Angeles. The E-cell recordings may later be decoded by an E-cell replay machine to determine the number of times the wearer's heart beats in a given period of time. Currently, SAMI/HR's are being used in clinical follow-up,

in work study programs, and in estimating psychological stress.

Professor William Einthoven developed the electro-cardiograph almost 70 years ago and gave the world its first heart-monitoring device. Since then, technology has come a long way in the development of electronic medical instrumentation. But the continuing increase in the death rate from heart disease tells us we still have a long way to go. ▲

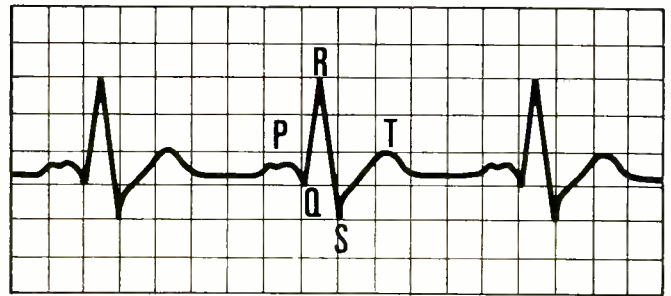

Fig. 4. Electrocardiogram waveform showing a complete heartbeat, called a QRS.

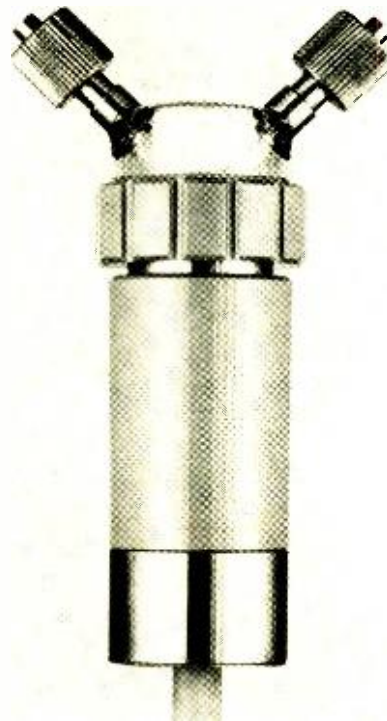
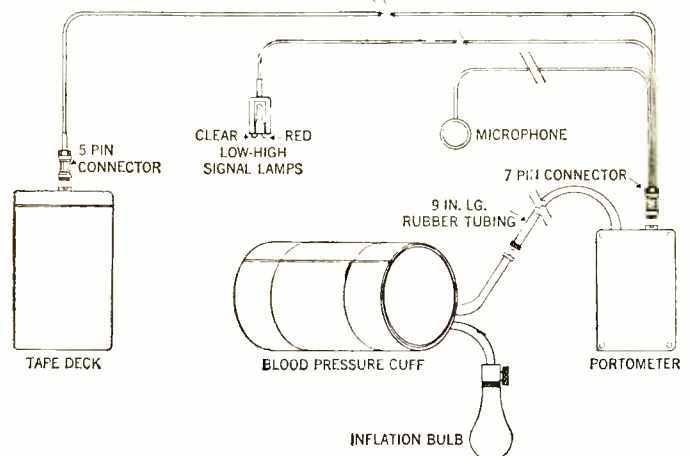
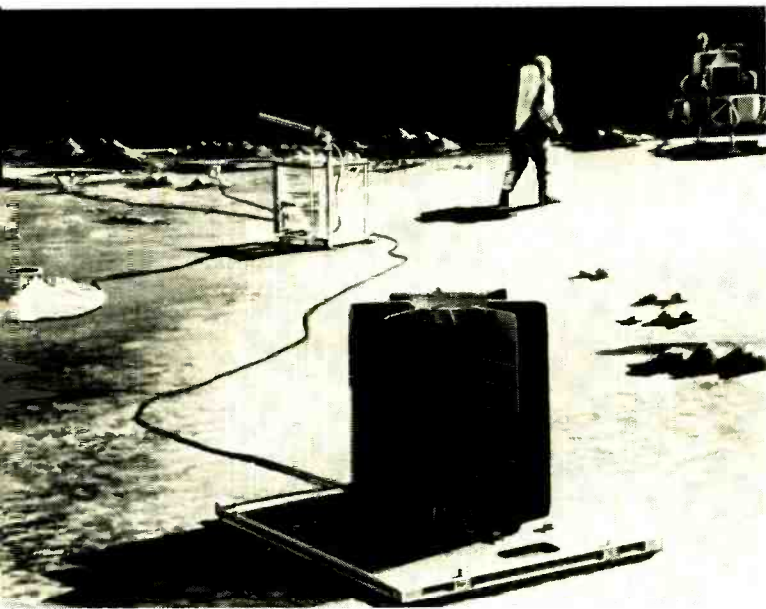

Fig. 5. Pressure transducer that's used to protect heart patients against electric shock while undergoing cardiac catheterization.

Fig. 6. Remler portable blood-pressure recorder used to monitor patient's blood pressure during normal daily activities.





# RECENT DEVELOPMENTS IN ELECTRONICS

**Nuclear Power on Moon.** (Top left) The recent Apollo-12 mission marked the first use of a nuclear electric power system on the Moon. The device, called SNAP-27 (Systems for Nuclear Auxiliary Power), is a radioisotope thermoelectric generator, or atomic battery. It is designed to produce all the electricity for continuous one-year operation of the array of scientific instruments left by the astronauts on the lunar surface. The generator, fueled with plutonium-238, is designed to produce 63 electrical watts of power. The unit is about 18-in high and 16-in in diameter, including radiating fins. The spontaneous radioactive decay of the plutonium within its protective graphite fuel cask produces heat. An assembly of 442 lead telluride thermoelectric elements then converts this heat—1450 thermal watts—directly into at least 63 watts of electrical energy. There are no moving parts in the generator. Long, ribbon-like connecting cables interconnect the output of the generator to the various experiment packages. The unit was designed by G.E.



**Flash Three Times for Highway Help.** (Center) The stranded motorist whose car is at the extreme left is being helped by a police officer summoned to the scene by the flashing headlights of a passing motorist. The system was recently installed along a 50-mile stretch of Interstate Highway 4 passing through Lakeland, Florida. Along this stretch of road, there are 20 light detectors, mounted on 4-ft poles, and located near major interchanges. Signs along the test section of road ask drivers who spot stalled vehicles to flash their bright lights three times at the next Flash sign. This generates a signal over interconnecting telephone lines to a panel of lights and alarms at the local Highway Patrol station. The trooper monitoring the panel radio-dispatches a patrol car to the area to investigate. The system was developed by AIL, while the interconnections were provided by GT&E. Presently experimental, the system will be tested for a year. The installation was financed by the Federal Bureau of Roads.

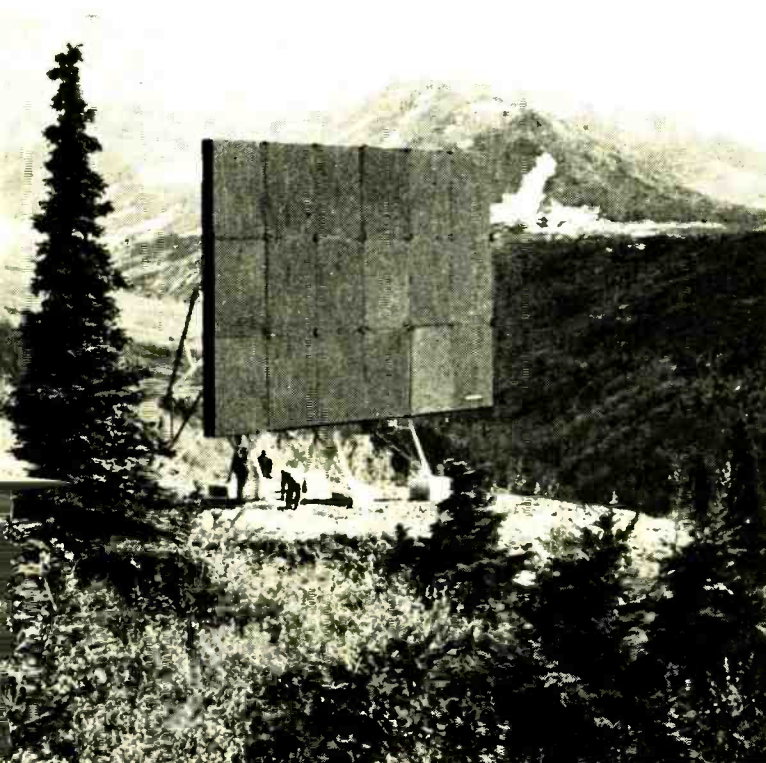

**Passive Reflector for Microwave Communications.** (Bottom left) This 30- by 48-ft passive reflector has recently been installed near Anchorage, Alaska for a new microwave communications system. The huge billboard-like flat reflector is illuminated by a transmitting antenna some 7 miles away. It then redirects the 6700-MHz, 300-voice-channel signals to a receiving antenna which is located 48 miles away. Most of this path is over the waters of Cook Inlet, so that it would have been impractical to install closely spaced active repeaters with their small dish antennas. The reflector is painted black to retard ice build-up in the severe Alaska winter. This turns the reflector into a black-body radiator so that any sunlight that occurs is turned into heat and dissipated to melt the ice. The passive element bounces the reflected energy off at a horizontal angle of 36 degrees with respect to the incident energy, and it provides a gain of 118 decibels at the operating frequency. The reflector was installed by the Microflect Co. for RCA.

**Video Mappers Aid Air Traffic Control.** (Top right) The controller is watching radar blips from aircraft on a screen with a superimposed geographical map. The video-mapper system scans a film negative of the map (up to 8 can be push-button-selected), and then transmits the resultant video for the radar display. Various landmarks, checkpoints, airways, and airports can be shown so that the planes can be located exactly. The video-mapper system has been developed by General Time Corp. for the Air Force and is now being produced for the North Atlantic Defense Ground Environment program for use in all NATO nations. The company has recently received a \$2.8-million award from Air Force for a number of these systems.

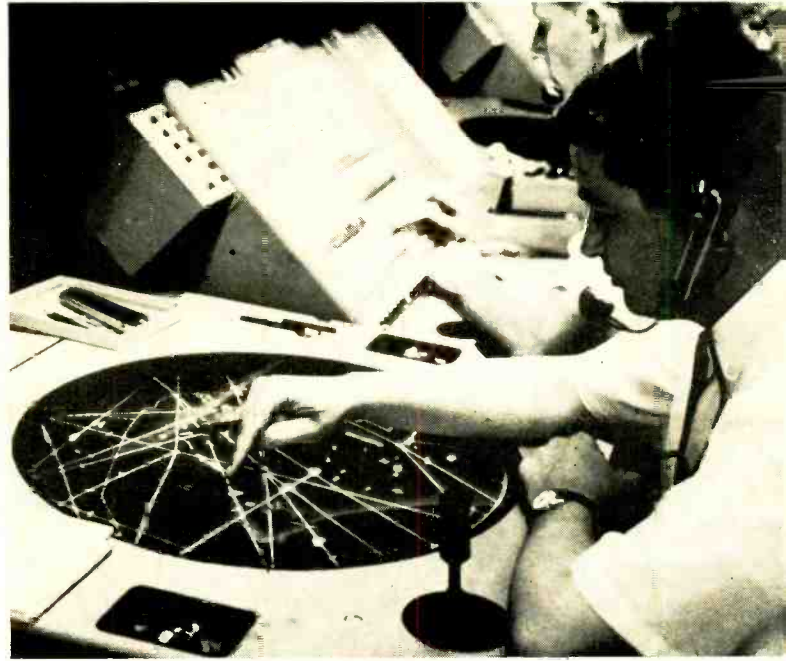

**Solid-State Comes to the Farm.** (Center) This new International Harvester farm combine uses a dozen magnetic transducers, and some 60 or 70 transistors and diodes to monitor such things as rotation speed of shafts, volume of material passing through the combines, pressures, and temperatures. Any abnormal function lights one of a series of red warning lights on the read-out panel in the cab. Since the operator rides in an air-conditioned, dust-proof, broadcast-radio-equipped cab, he is isolated from many of the sights, sounds, vibrations, and smells that signal trouble or a need to make an adjustment. The new solid-state monitoring system is needed then to bring such important information directly to the attention of the operator.



**Electron Beam Used as Test Probe.** (Below left) An electron beam is being used to test the connective wiring on a printed-circuit board. The beam first charges the circuit and then scans the board. The secondary electron emission produced by the scanning is received by a special photomultiplier device and converted to the CRT display shown. Test points on the circuit are darkened on the display by the greater secondary emission resulting from the initial charging. The white spots are points on the circuit that are not connected to the selected circuit. System is being used experimentally at IBM Laboratory.

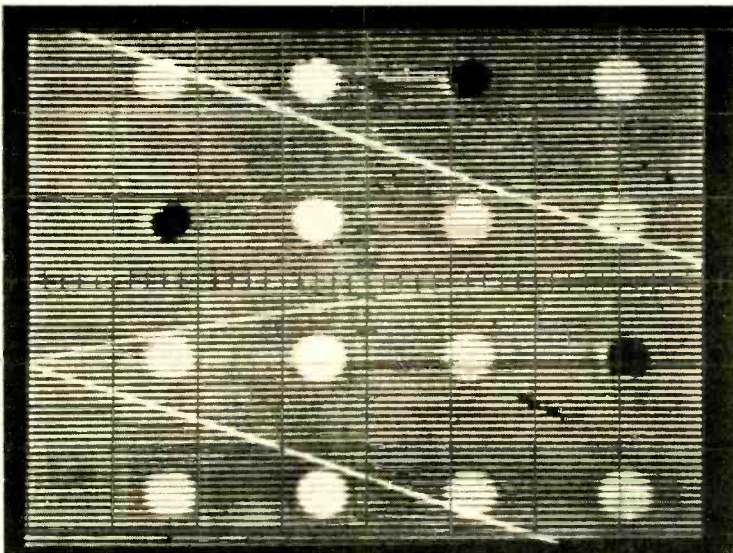

**TV in the Classroom.** (Below right) A lecture in transistor theory is being given with the help of a new instructional-TV system at Monroe Community College (Rochester, N.Y.) The system is said to be the most extensive ever installed in a junior college; it has the capability of providing up to 17 simultaneous programs. Programs can originate at any point on campus and be fed via a cable by two subcarrier channels to the college's TV center for distribution or taping. Equipment includes 11 cameras and a dozen video-tape recorders. The cable system interconnects 156 classrooms, lecture halls, laboratories, and learning carrels. The elaborate instructional-TV system was designed by Jerrold Electronics Corporation.

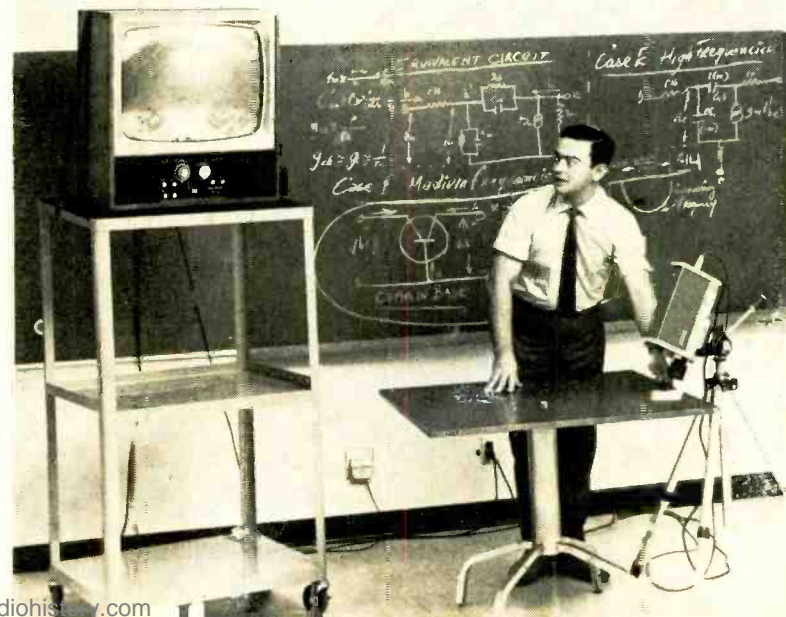

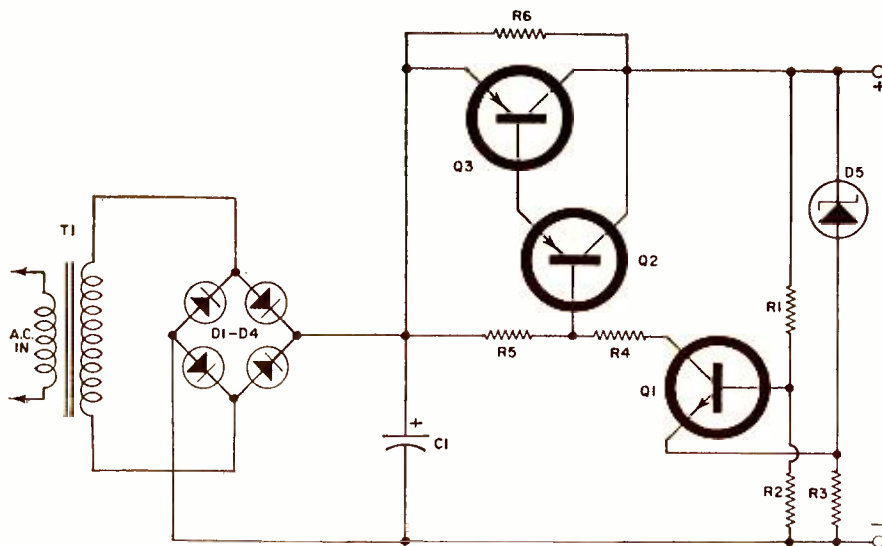

Fig. 1. Basic regulated power-supply circuit showing bridge-rectifier circuit, reservoir capacitor, regulator circuit.

# Design and Construction of Regulated Power Supplies

By RICHARD H. DUTTON

*Construction hints and design criteria for building some inexpensive, but very stable, series-pass regulated power supplies. The fabrication of a 20-volt, 1.5-ampere regulated power supply with a dynamic impedance under 0.4 ohm and with regulation better than 1 percent is described thoroughly.*

**N**EARLY all experimental projects need a power supply of one kind or another. Batteries are convenient for experimental and portable use but are not adequate when large amounts of power are required for extended periods of time.

Most a.c. power supplies function with a simple rectifier and choke-capacitance or resistance-capacitance filter. The choke filter (Fig. 2A) is bulky and relatively costly while the resistance filter (Fig. 2B), to be really effective, wastes considerable power. Neither power supply is regulated and, when high currents are drawn from the supply, output voltage falls while ripple increases. Some improvement in power-supply output can be obtained by the addition of the simple emitter-follower stabilizer shown in Fig. 3. However, the output impedance of this device is still on the order of several ohms so that unwanted feedback and cross coupling can still occur when several amplifier stages are placed in parallel on the same power-supply bus.

The power supply described in this article tends to over-

Fig. 2. Two filter networks, (A) choke-capacitance and (B) resistance-capacitance, commonly used with power supplies.

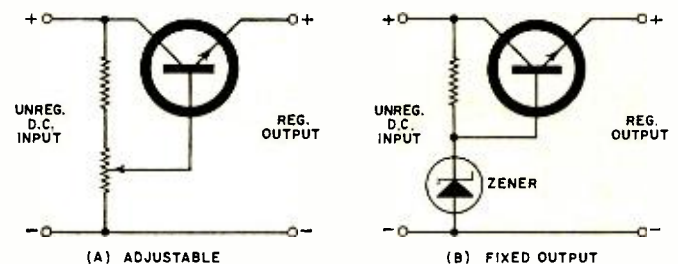
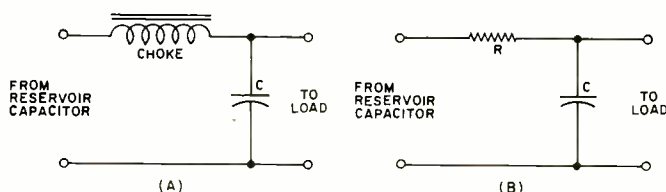

Fig. 3. (A) Adjustable and (B) fixed type of emitter-follower stabilizers used to regulate output of power-supply units.

come the disadvantages mentioned by being efficient, using only inexpensive non-critical parts which are readily available, and by being of very low impedance and fully regulated. Using only spare parts, the 20-volt, 1.5-amp version described is presently powering both channels of a home stereo center with both the power amplifier and preamp power-supply lines connected in parallel. The measured power-supply dynamic impedance is less than 0.4 ohm, regulation is better than 1 percent, and there is no trace of audible hum, line noise, nor channel crosstalk.

## Basic Circuit

Two unusual features of this power supply are shown in Fig. 1. First, no choke or smoothing component of any kind, other than the usual reservoir capacitor and the regulator itself, is included. Second, series-pass transistor Q3 is used in the collector-follower mode instead of the more commonly

used emitter-follower configuration, thus contributing quite significantly to the voltage gain of the regulator loop and maintaining a low output impedance without the need for additional amplification stages. There are, in fact, only two voltage-amplifying stages, Q1 and Q3, with phase inversion occurring in Q3 only, so that undesirable interstage feedback is eliminated and excellent output voltage stability is maintained.

### How it Works

Transformer T1, diodes D1 through D4, and capacitor C1 form a standard bridge-rectifier circuit with reservoir capacitor. If the available transformer secondary is center-tapped, a standard full-wave configuration can be used instead of the bridge. The remainder of the circuit forms the regulator proper with Q1 functioning as a differential voltage amplifier. Any voltage change appearing at the top of the voltage dividers, formed by R1 and R2 and by D5 and R3, is sensed at the base and emitter of Q1, respectively. Since the emitter of Q1 is connected to the voltage source through zener diode D5, the full amount of the change appears at the emitter because the zener maintains a constant voltage drop within its operating range. However, the voltage change at the base of Q1 is less than the change at the emitter because of the voltage-divider effect of R1 and R2. The voltage across the emitter-base junction of Q1 is, therefore, the differential between these two changes, resulting in Q1 tending to carry more current if the output voltage falls and less if it rises.

The collector current of Q1 flows through R4 and through R5 which is in parallel with the base-emitter junction of Q2.

The change at the base of Q2 is current amplified, in phase, by emitter-follower action of Q2, and appears as a larger current change at the base of Q3. The increased current in the base-emitter junction of Q3, originally caused by the amplification of the drop in voltage at the output terminal by Q1 and Q2, causes Q3 to conduct more, reducing the voltage drop between collector and emitter and thus effectively raising the output voltage by the amount necessary to cancel out the original change. Since the loop is completely d.c.-coupled and there are no RC time constants, this correction is, in effect, instantaneous with only a minute residual change in output voltage. Basically, the operation can be compared with that of a high-gain power amplifier with virtually 100 percent negative feedback, as shown in the block diagram of Fig. 4.

### Function of R6

At this point, to explain the function of R6, we must first consider the basic circuit with R6 removed. Then, at switch on, the rectified d.c. voltage would appear across C1, in parallel with the load and Q3, which are in series. However, with this setup there is initially no voltage across the load itself and Q1 remains cut off because of the absence of a differential between its emitter-base junction. As a result, no current will flow in the base-emitter junctions of Q2 and Q3 so that these transistors remain at cut-off. Consequently, no current will flow and all of the voltage will appear across the pass transistor, Q3.

This situation can be rapidly corrected by introducing sufficient voltage at the base of Q1 to overcome the emitter-base junction bias and turn it on. As soon as Q1 turns on, voltage appears across the load and the normal loop gain takes over, stabilizing the output voltage at the selected level. The voltage required to turn Q1 on can be introduced by a flashlight battery connected through a diode to the base of Q1, with the other battery terminal grounded. At switch-on current would be drawn and then, during normal operation, the connecting diode would back-bias and disconnect the battery. However, it is more convenient to tap the unregulated supply for the necessary starting potential by adding R6. With R6 in the circuit, the starting potential is the voltage across C1, dropped by R6, R1, and R2 and by R6, D5, and

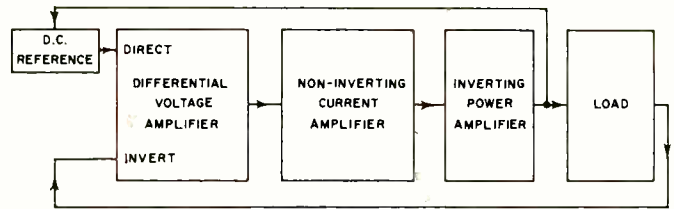

Fig. 4. Block diagram of high-gain, 100 percent negative feedback power amplifier used as analog of regulated power supply.

R3, to the base and emitter of Q1, respectively. Since the zener is initially non-conducting and R3 is small compared to R2, the differential across the emitter-base junction at Q1 is initially quite large, causing the supply to turn on very quickly.

Once the supply has turned on, the voltage across the starter resistor (R6) and therefore the current through it, drops to a very low value and has no effect on the regulation or the output voltage. This action emphasizes a couple of other things that can be done with the supply if we want to. First, we can place a normally open push-button, relay contacts, photocell, or other control device in series with R6. Even though a.c. power is applied, d.c. power will not come on until the control device is activated either locally or remotely, and once on will stay on regardless of the operating condition of the control.

A similar device across R2 can operate as a remote cut-off, and variation of R2, within the limits discussed later in the article under "Construction Hints," can be used to adjust the output voltage. Second, the output terminals can be short-circuited without causing any damage since there is no capacitive storage at the output and the current surge through the short circuit will last only long enough for Q1 to react and turn Q2 and Q3 off. However, if R6 is in the circuit the output voltage will be restored immediately when the short or overload condition is removed. This is very important when using the supply to power a construction project where accidental short circuits may occur.

### Final Circuit Design

The final circuits, Figs. 5 and 6, show three components not in the basic circuit (Fig. 1). Although the circuit will work perfectly well without these components they provide protection against inadvertent thermal runaway. D6 provides a d.c. bias on Q2 which reduces the necessary amount of swing at the collector of Q1 and thereby increases the loop gain. At the same time, the potential drop across D6 varies inversely as its temperature, thus reducing the bias on Q2 and the current through Q3, as the resistance of Q3 also falls with temperature. R7 is a positive temperature-coefficient resistor whose value increases with temperature, thus having

Fig. 5. Schematic diagram of the 20-volt, 1.5-ampere regulated power-supply unit showing the components (D6, R7, and R8) that provide protection against inadvertent thermal runaway.

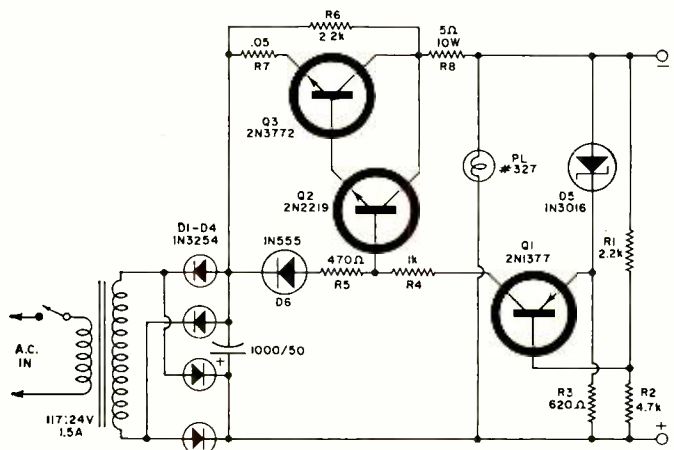

the same effect of reducing the forward bias. *R8* is a "power waster" and need only be used when the rectified d.c. voltage at the emitter of *Q3* is significantly higher, with respect to ground, than the desired output voltage. By inserting *R8* the power dissipation in *Q3* can be considerably reduced while not affecting the regulation of the supply, because *R8* is within the feedback loop.

### Construction Hints

Parts placement for the construction of the power supplies shown in Figs. 5 and 6 is non-critical except that *Q3* must be mounted on an adequate heatsink and be capable of dissipating the maximum necessary power; that is, the product of the maximum voltage across *Q3* times the maximum current through it should be no greater than the transistor power rating, even though these two conditions are unlikely to occur together. The voltage rating should be at least one and a half times the expected output voltage, or about 10 percent greater than the no-load voltage across *C1*, whichever is larger. If in doubt, select a "bigger" transistor and check it for leakage by connecting base-to-emitter, putting it in series with a milliammeter and, making sure that the polarity is correct, connect it across a 12-volt battery.

If the leakage current is less than 1 mA, mount *Q3* to the heatsink, using an appropriate mounting kit and plenty of silicone grease. *Q3* can be either silicon or germanium, according to which is handy, and either of the TO-3 or door-knob-size package. Silicon is preferred because of its higher temperature capability but germanium is perfectly satisfactory if it is adequately cooled. Mount *R7* and *D6* to the heatsink about 1 to 1½ inches from *Q3*, and on opposite sides of it if possible to compensate for uneven heat distribution in the heatsink. Closer mounting is permissible if space is particularly tight. Don't use a silicon diode with a germanium transistor but, if you don't have a silicon diode handy when using a silicon transistor, use two germanium diodes in series.

Fasten diode *D6* to the heatsink with a spot of epoxy or use a small stud-mounted type, insulated from the heatsink with a mica washer. *R7* can be a bolt-on type resistor of any value that will provide a voltage across it that is less than 0.5 volt at maximum current when *Q3* is silicon, or less than 0.25 volt when *Q3* is germanium. *R7* can be replaced by either a 1-ampere slow-blow fuse seated in a clip bolted to the heatsink or by about 15 inches of #26 magnet wire wound around the body of a 1-watt resistor and epoxied to the heatsink. The other components should be mounted on a piece of phenolic, perfboard, etc. and spaced at least ½ inch from the heatsink. Using a separate heatsink, if necessary, mount the transformer and rectifier bridge so that they don't contribute to or are affected by the heat generated by *Q3*. Select a transformer that is rated to carry the maximum current required at a voltage rating about 5 volts higher than the

maximum output rating, and connect it to the rectifier assembly and to *C1*.

If the voltage across *C1* is much greater than 5 volts higher than the output voltage desired, calculate the value of *R8* that would be necessary to drop the additional voltage at maximum rated current, leaving about 5 volts across *Q3*. Use a high-wattage resistor for *R8* and mount it where it will be adequately ventilated. The proper selection of *R8* will reduce the power dissipation in *Q3* and lengthen its life. However, if *R8* isn't necessary then leave it out and connect the output terminal and divider chains directly to the collector of *Q3*. *Q2* can be any convenient transistor of the same polarity and material as *Q3* and capable of providing the necessary base current to *Q3*. A collector current rating of 150 mA for *Q2* is usually adequate.

The differential amplifier, consisting of *Q1*, *R1*, *R2*, *R3*, and *D5* is the most sensitive part of the regulator and any drift in this area will cause a corresponding output voltage change. It is more desirable to use a germanium transistor for *Q1* because the junction potential is less than silicon, thereby requiring a smaller differential. However, when making an adjustable power supply use a silicon transistor and a trimmer to offset the increased differential.

For a fixed-voltage output the calculation of resistor values must take into account the junction differentials. Since *R1* limits the collector current of *Q1* to less than 10 mA, the transistor current can be neglected when calculating *R3*. To calculate *R3* first select a zener or reference diode with a zener voltage between one-quarter and three-quarters of the design output voltage. High values within this range will improve the regulation slightly by increasing the relative base-emitter change across *Q1*, while low values will reduce zener dissipation and long-term drift. Make sure the reference zener is of good quality since the stability of this device determines the stability of the power supply. Subtract the zener voltage from the required output voltage and, using Ohm's Law, calculate the resistance value of *R3* that will draw the current which will cause the zener to run about one-third of its maximum rating. Do not starve the zener or its voltage will not be constant with time.

When building a variable supply, calculate *R3* so as not to cause more than 90 percent of the rated dissipation in the zener at the highest voltage and not less than 15 percent at the lowest voltage. Use a 1-watt zener for power supplies in the 12-volt-and-up range and a 400-milliwatt zener for lower voltages. Very low voltage supplies, such as a 4.5-volt IC supply, can use three or four forward-biased silicon diodes in series as a reference instead of a zener. Always be sure to use diodes of large enough current capacity so that the current through *R3* will be at least five times the emitter current of *Q1*. Next, calculate those values of *R1* and *R2* which, together, will permit a current flow of 3 to 5 mA at the desired

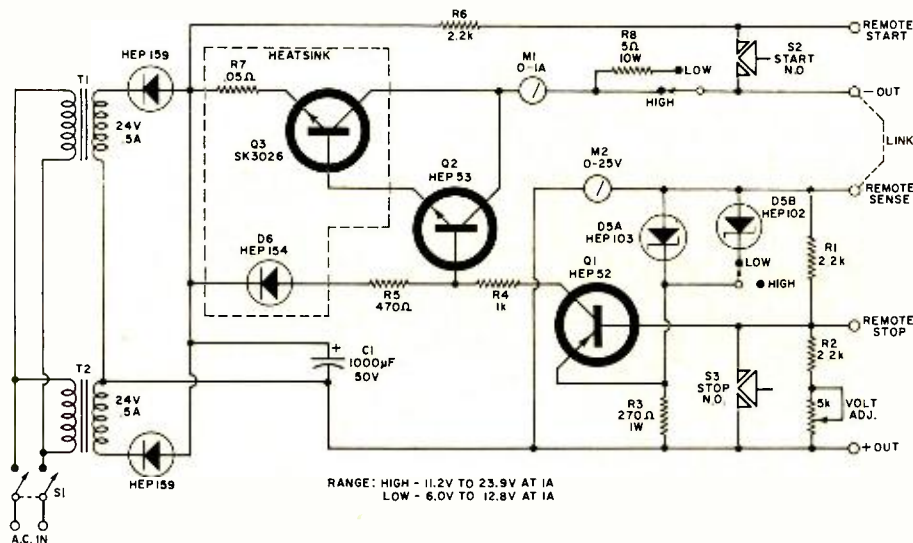

Fig. 6. Schematic diagram of laboratory version of closely regulated power supply. When remote start/stop is not required, leave connections open; when required, connect N.O. push-button switches at terminals in parallel to internal push-button. If local start/stop is not required, remove push-buttons and bridge remote start lead internally to negative output terminal and use power switch *S1* to control. Length of remote leads is not critical if resistance is small. Twisted pair of leads, connected together at the load, should be used for remote sense and negative bus. The supply is floating, therefore either bus may be grounded. All transistors must be of the low-leakage type for the various "remotes" to function correctly.

OUTPUT VOLTAGE FOR SINGLE-ENDED SUPPLY (nominal)	RANGE OF TRANS. SEC. VOLTAGE (r.m.s.)	ZENER DIODE 400 mW RATING (volts)	RESISTORS $\pm 10\%$		
			R1	R2	R3
5	6.3	3.6	270	180	47
6	6-10	3.6	510	510	56
9	12	6.2	680	1100	68
12	12.6-18	9.1	1200	510	68
18	18-24	12.0	1100	1000	390
30	28-36	12.0	2000	3300	1200

Table 1. Alternate component values for outputs other than that shown in Fig. 7.

output voltage while dropping a voltage across R2 that is equal to the voltage across R3 plus the junction potential of Q1. The junction potential will be between 0.2 and 0.4 volt for a germanium transistor and close to 0.6 volt for a small-signal silicon transistor. Ignore the base current of Q1, since it is too small to influence the calculation.

It is unlikely that calculated values for R1 and R2 will exactly match the normally available quarter-watt 10-percent tolerance resistor scale, so the trick is to increase or decrease both calculated values in the same ratio to the nearest standards. If the tolerances add up incorrectly or the junction potential of Q1 is not quite what it was indicated to be, the power-supply output voltage will be slightly different from the design value, but otherwise operation will be normal. If the discrepancy is troublesome, reduce the value of R2 by, say, 500 ohms, connect a 1000-ohm miniature potentiometer in series with it, and "trim" the supply to the desired voltage.

### Adjustable Supplies

An adjustable supply can be obtained in the same way. Calculate the value of R2 alone, for the lowest voltage obtainable within the zener-current limits described before and then the value of R2 plus potentiometer that will give the highest voltage. The potentiometer can be connected either locally or remotely. If a remote pot is used it is better to put it in series with R1 rather than R2 because then, if the remote line is opened, the supply will switch off rather than swinging to highest voltage. If more than one "range" is required, the zener diode can be switched. Use a make-before-break switch or switch the lower voltage zener in parallel with the higher one so that the emitter of Q1 never loses voltage. If you wish to package the power supply for bench use, with meters, and without losing regulation because of meter impedance, simply connect the voltmeter across the output terminals and the current meter within the feedback loop between the collector of Q3 and the junction of R1 and D5. If R8 is used, the meter can be placed on the side of R8 that is most convenient. The slight amount of current drawn by the voltmeter and voltage-amplifier chains may shift the zero on the ammeter a little if it is sensitive enough, but this can be overcome by resetting the pointer to zero with the power supply on and no load connected. A #327 pilot lamp, connected as shown in Fig. 5, draws very little current and provides a good visual indication of power-supply operating conditions, especially when meters are not included in the design.

### Dual Supplies

Fig. 7 shows a dual power supply with positive and negative outputs symmetrical about the common point. This type of supply is useful for servo-motor drive and similar applications where symmetrical outputs are desired. It can also be used to power complementary-transistor type OTL audio amplifiers, permitting the normal amplifier output blocking capacitor to be eliminated by connecting the amplifier to the positive and negative power-supply terminals and the speaker between amplifier output and power-supply common. Typical component values are given in Fig. 7 for 6-volt

operation and alternate component values for other popular outputs are listed in Table 1. It is not essential that the positive and negative voltages be equal but the transformer must be capable of supplying the total current of both halves at the voltage necessary for the higher output bus. Be sure that semiconductor ratings are adequate for the maximum voltage that can appear across them under "worst-case" conditions. Transistors should be rated for at least 1.5 times the r.m.s. voltage of the transformer secondary, as should the capacitors, with adequate rectifier p.i.v. ratings as well.

Multiple voltage supplies can be readily obtained by designing the regulator for the requirements of the main bus and then using this bus as the input for one or more emitter-follower regulators of the type shown in Fig. 3. This method provides closely stabilized collector and base potentials for the emitter-follower, thus improving its stability over the unregulated input version by several orders of magnitude. The current drawn from such a device should be small and nearly constant, otherwise it might be better to provide a separate fully regulated supply, in order to maintain a low dynamic impedance. (Continued on page 89)

Fig. 7. Dual polarity power supply used for servo-motor drive and similar applications where symmetrical outputs are required. The component values shown are typical for  $\pm 6$ -volt operation.

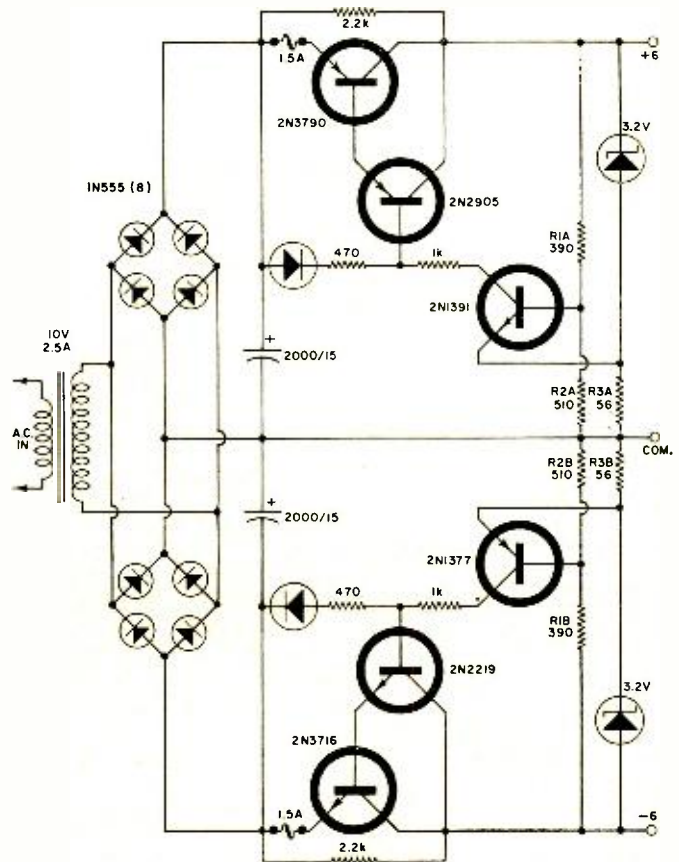

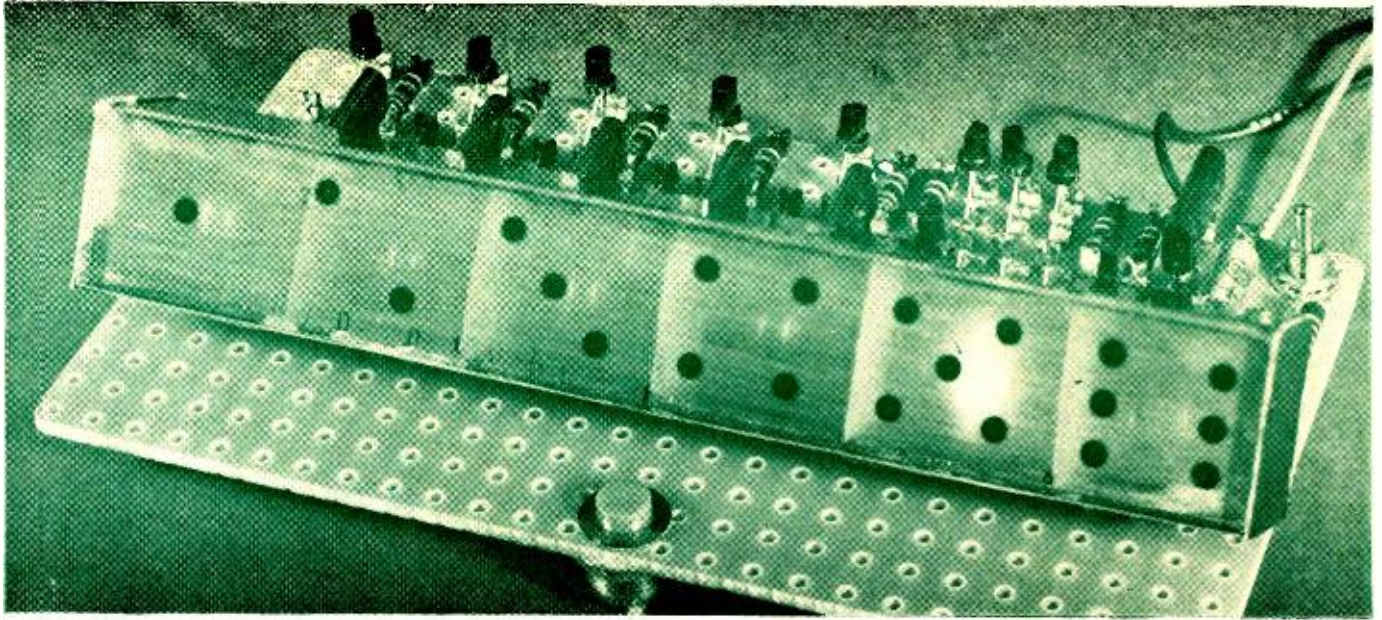

To roll the electronic die, simply press the button for a second or so and let go. One of six lamps will light up.

# ELECTRONIC DICE

By R. W. FOX/Application Engineering  
Semiconductor Products Dept., General Electric Co.

*Design and construction of an electronic die using SCR's in ring-counter circuit which is used to actuate indicator lamps.*

**D**ICE are used in a multitude of gambling, board, and various fun games. In each case, the dice help us enjoy these games by introducing the element of chance. The time has come for the "old-fashioned" die to catch up with the space age, so we present here a circuit for an electronic die.

With an investment of as little as ten dollars and a few hours of time, you can make your own electronic die or roulette wheel. This die can be used in a game such as Monopoly or as a spinner in other board games. Use it as a challenge to your friends to prove it is random, or as a source of random numbers for mathematical analysis, as a roulette wheel or as a wheel of chance like the one found at the local bazaar.

Basically, this electronic die is a low-voltage ring counter

circuit. It is a series of identical circuit stages which turn each other "on" and "off" in a predetermined sequence. When a given stage is on, it represents a given number. The probability of a given stage being on will be  $(1/n)$ , where  $n$  is the number of stages, if all stages remain on for the same length of time. This means that each number has an equal chance of coming up a winner.

In the heart of this circuit (see Fig. 1) is a complementary SCR, which has its gate tied into the anode. A new, inexpensive *General Electric C13Y* is used. Its unique characteristics make possible the construction of this low-power ring counter with only five components per stage, in addition to the load. It is interesting that the lamp loads ( $L_1-L_6$ ) are in the gate circuits of the SCR's rather than in the anode or cathode.

Fig. 1. Complete schematic of triggered ring counter circuit that is used for the electronic die.

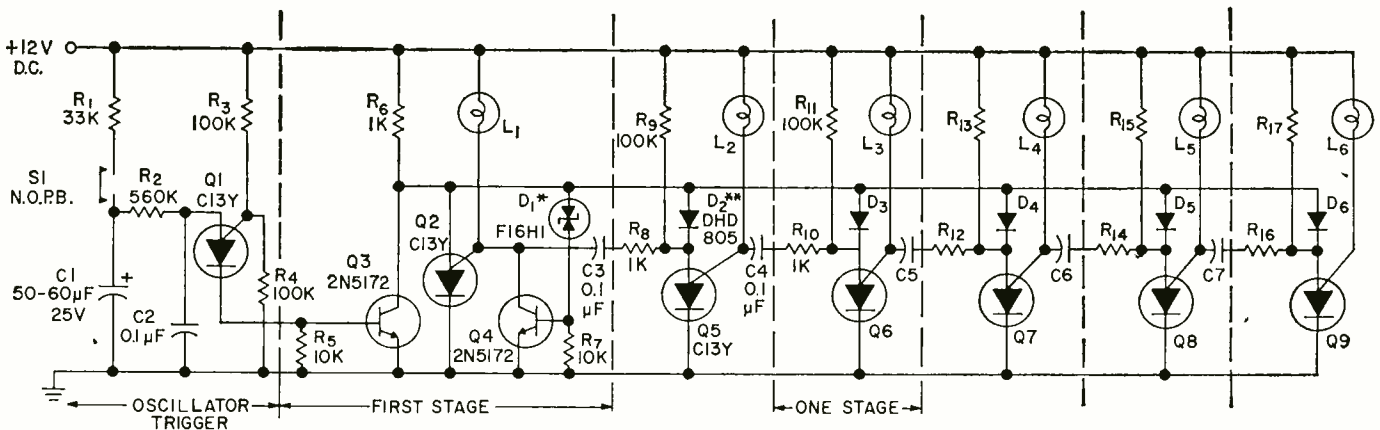

TO OPERATE, DEPRESS PUSHBUTTON FOR A SECOND OR SO AND RELEASE.  
FOR ROULETTE, USE 36 LAMPS / STAGES.

\* CAN BE ANY 6.2V ZENER

\*\* CAN BE IN914

$L_1-L_6$  - #53 LAMPS



The circuit can be classed as a triggered ring counter, that is, on each input pulse the ring counter steps up to the next stage. For example, if Q5 is assumed to be conducting, then current flows through L2 and the gate-cathode circuit of the C13Y. Current also flows through R6, D2, and the anode-cathode circuit of Q5. Since the gate-cathode circuit of the C13Y is at low impedance when the device is on, C4 becomes charged to 12 V through R10 and R11. This, then, sets the system for the next shift pulse at the base of oscillator transistor Q3.

When a positive pulse appears on the base of Q3, the current through R6 is shunted away from Q5 and flows through the collector-emitter circuit of Q3. Then, the anode current of Q5 drops below the holding current, the device turns off. When Q5 turns off, the gate current ceases and the gate rises to a potential of 12 volts. Since C4 is charged to 12 volts, the anode voltage of Q6 is now at a potential twice that of the gate. As this is the equivalent of a 12-volt gate signal, Q6 turns on and starts to discharge C4 through R11. The signal is removed from the base of Q3 before C4 discharges below the holding current of Q6; hence, Q6 remains on until the next shift pulse at Q3.

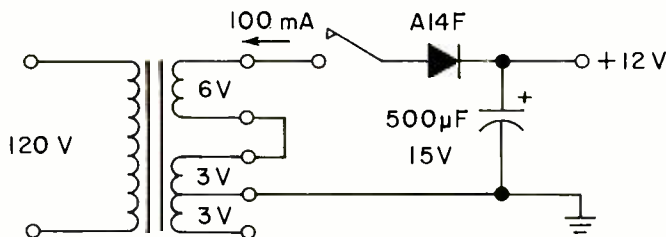
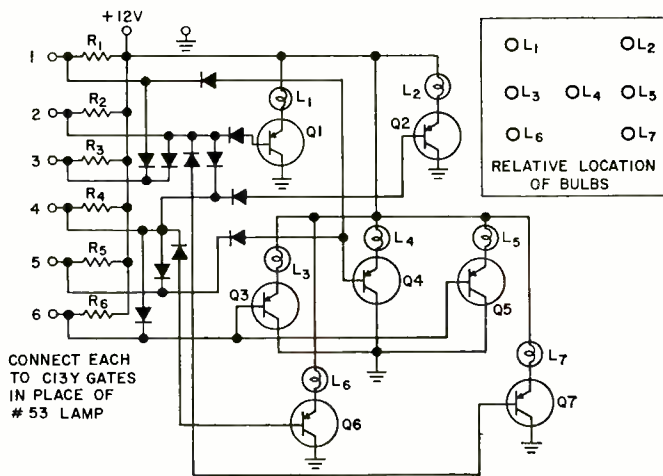

Fig. 2. Power supply can use any 100-mA diode. Can also use 8 penlight cells or 2 lantern batteries, connected in series.



- ALL DIODES : DHD805 OR IN914
- TRANSISTORS : 2N5354
- LAMPS : # 680 OR # 756
- RESISTORS : 1 K, 1/2 W

Fig. 3. Diode-transistor encoder permits display to resemble face of die. Circuit is connected directly to Fig. 1 circuit.

Fig. 4. Output display for circuit shown in Fig. 1. For a set of dice two circuits and two displays can be used or else the number of stages can be doubled to give reading up to 12.

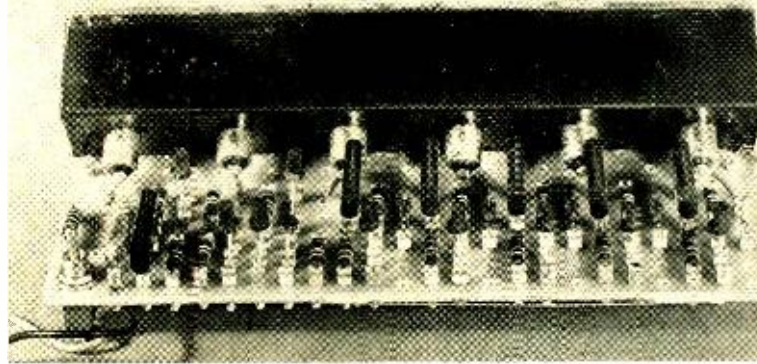
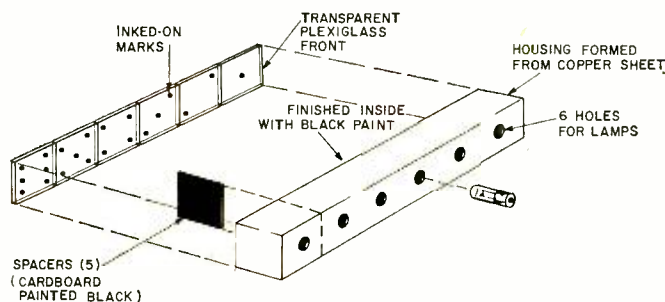

Rear view of six-lamp display unit used as electronic die.

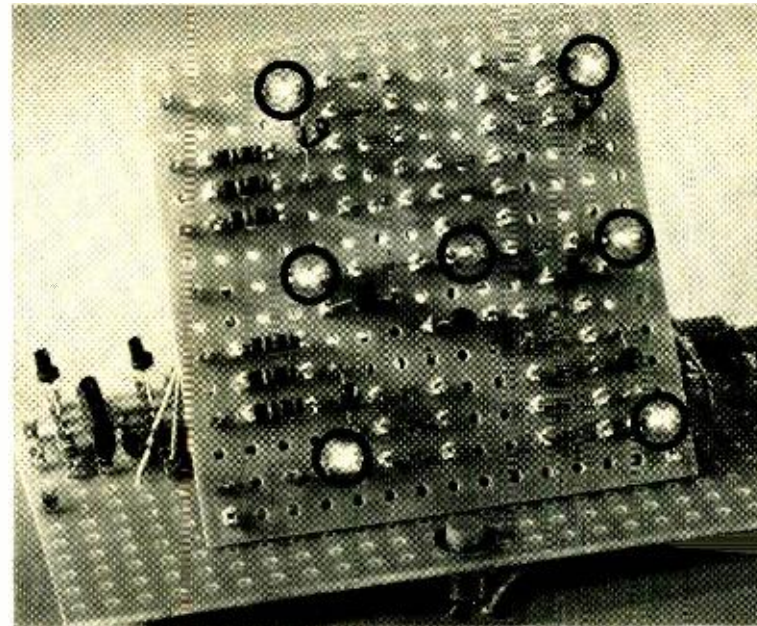

This display uses the circuit of Fig. 3 to simulate die face.

The shift pulses come from a relaxation oscillator made up of Q1, Q3, and Q4. When S1 is closed momentarily, C1 charges through R1. When the voltage on C1 exceeds the voltage needed to trigger Q1, the SCR turns on and discharges capacitor C2 through R5 and the base circuit of Q3. When S1 is opened, the relaxation oscillator will continue to run until the charge remaining on C1 is insufficient to allow peak current to flow to Q1. At this time shift pulses stop and the "winning number" appears as the final lighted stage. By changing the value of C1, the length of time of the "roll" can be controlled; the larger C1, the longer the roll.

Fig. 2 shows a simple power supply that can be used for the electronic die.

### Randomness of the Circuit

Since the die is a ring counter, one winning number will always precede another specific one. However, the randomness is built into the circuit in another way. The winning number is dependent upon several factors. First is the charge on capacitor C1, and second, the stage that is on when S1 is opened. To make it extremely difficult to fix the system, the time constant to charge C1 has been made long (with the values shown, about 2 seconds). This makes it difficult to open the switch at a given spot on the charging curve, except at full charge. Since the ratio of C1 to C2 is more than 500-to-one, a 0.2% change in the voltage of C1 when the switch is opened will cause an extra step in the ring counter. To charge C1 to a point within 0.2% of full voltage would take over 500 time constants or over 16 minutes.

Another factor that determines which stage is on when the switch is opened is extremely difficult to control. When the relaxation oscillator is running, its frequency is about 20 pulses per second. This means (Continued on page 79)

# Air Traffic Control TRANSPONDER Identifies Radar Targets

By D. J. HOLFORD

*Description of the ATC transponder that allows the air traffic controller to accurately identify the radar blips from aircraft under his control.*

*Editor's Note: The recent mid-air collision over Indianapolis involving a small private plane and an Allegheny Airlines jet, in which 83 persons lost their lives, called attention to the ATC transponder. According to news reports, the small plane did not appear on the ground controller's radar. Had this plane been transponder-equipped, as was the commercial jet, chances are that it would have been spotted so that the accident might have been avoided. Some private planes do have radar transponders to produce an identifiable radar return on the controller's radar screen. However, since the cost of these units may be \$1000 or more, quite a few private planes do not have them but instead rely on "see and be seen" visual flight rules. After the accident occurred, there was talk of requiring all planes that fly near major airports to be transponder-equipped. As of this writing, the investigation is not concluded.*

**T**HE air traffic control transponder system is an outgrowth of the wartime radar-beacon IFF (Identification Friend or Foe) system, which enabled military radar operators to distinguish between friendly and hostile radar targets.

The modern air traffic control system permits rapid identification, ease of tracking desired targets, and at the same time allows the controller to display only those targets with which he is concerned. It also permits the complete elimination of weather returns and false targets encountered with normal primary radar equipment.

The system consists of a ground transmitter (interrogator), which transmits a coded signal to all aircraft, and an airborne transmitter-receiver (transponder), which receives and decodes the interrogation signal. If the interrogation signal contains one or more of the codes for which the transponder is set, a coded reply will be transmitted. This reply is received and processed by the ground receiver and is used to generate a synthetic, readily identified target on the radar display.

There are available four different modes of operation. Mode A is the one presently used for civil and military air traffic control; mode B is coming into use and serves the same function as mode A. Mode C, which will soon be enter-

ing service, is used for automatic reporting of aircraft altitude; while mode D is reserved for future development, possibly as a data relay system.

## Sequence of Operation

The trigger pulse to initiate transmission of the interrogation signal is provided by the associated radar system (Fig. 1). The ground-based interrogator is pre-triggered, that is, the interrogation is transmitted before the primary radar pulse. This is necessary because processing of the signal by the transponder involves a time delay which would result in the transponder target being displayed at a different (and incorrect) range than the radar target.

An FAA air traffic control radar site. The main surveillance radar antenna is on the two-story tower. The horizontal white bar atop this antenna is the rotating directional antenna for the ground-based interrogator unit which sends out pulses that trigger the transponder units located in the aircraft.

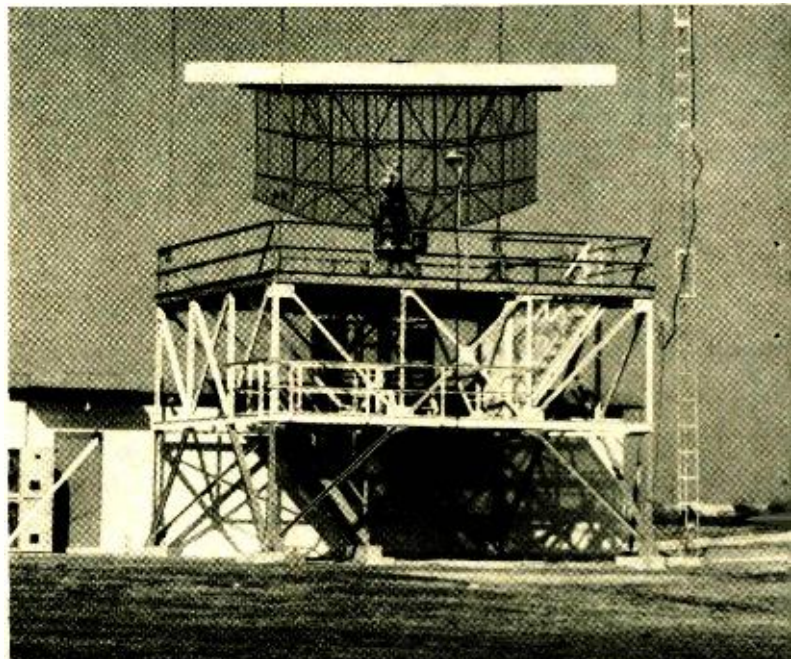



An FAA traffic controller seated at his radarscope. On the vertical panel behind the scope are the code-selector wheels along with code-assignment identifications which are employed to simplify identification of transponder-equipped aircraft.

The pulse-repetition frequency of the interrogator is the same as that of the associated radar. The interrogation signal consists of two 0.85-microsecond pulses, whose spacing is dependent on the mode of operation selected. In some cases a third pulse is inserted.

If it is desired to interrogate in more than one mode at the same time, the pulses are interlaced or transmitted alternately. All ground transmission takes place on a frequency of 1030 MHz.

The airborne transponder receives the interrogation signal (Fig. 2). If the spacing coincides with a mode to which the transponder has been selected to reply, a pulse is generated and used to trigger the coding circuits. These generate a train of pulses appropriate to the reply selected by the pilot, or reporting altimeter in the case of mode C. At the same time a pulse is applied to a blanking gate, which prevents further trigger pulses from reaching the coder until code generation is completed. This prevents garbling of the reply. The coder output is applied to the modulator and transmitted on a frequency of 1090 MHz.

One other circuit of interest in the transponder is the over-interrogation control. This limits the replies transmitted to a number which will not exceed the duty cycle of the output tubes. If the number of interrogations becomes too great, a cut-off signal is applied to the blanking gate in order to limit replies to a safe level.

The ground receiver then amplifies the replies and passes them to a unit known as a "defruiter." This removes the non-synchronous replies (those triggered by other interrogators). From the defruiter the replies are passed to a common decoder, which decodes the basic signal to indicate that a reply is being received without indicating its code. The only codes which it will decode are those indicating a communications failure or an in-flight emergency.

After being processed by the common decoders, the signals are passed on to the non-common decoders, one of which is provided for each radar display. These units decode only those particular codes that have been selected at the associated control box, up to a maximum of 10 codes at each position.

The decoders generate synthetic signals which are dis-

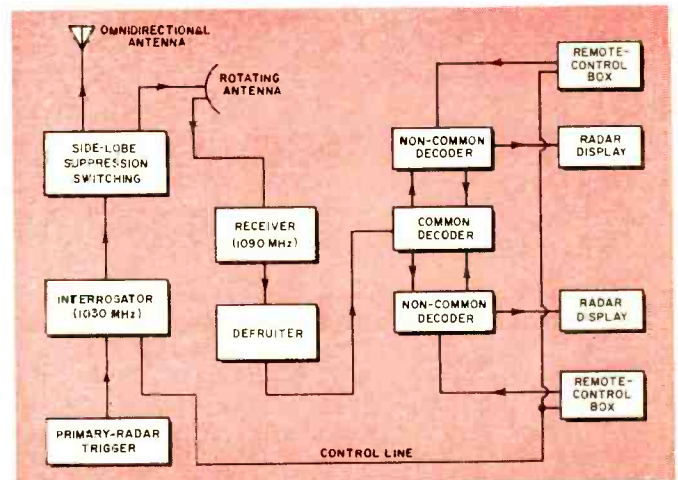
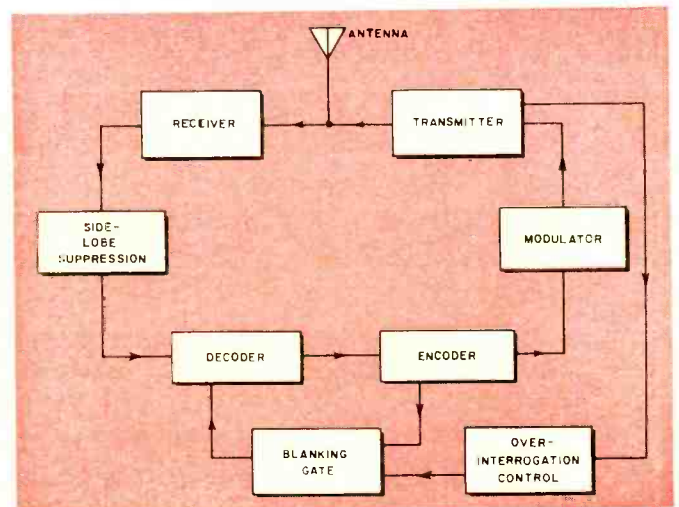

Fig. 1. Simplified block diagram of ground installation.

Fig. 2. Block diagram of the airborne transponder unit.



played on the radar indicator in the same position as the primary radar target.

The coding employs a 12-bit information code, enabling 4096 discrete codes to be generated. The basic reply consists of a pair of pulses, termed the start and stop pulses, separated by 20.30 microseconds. Between these pulses are the twelve 0.45-microsecond-wide information pulses, spaced 1.45 microseconds apart. (There is room for 13, but the seventh or center pulse is omitted in civil transponders.) The information pulses are divided into four interleaved groups of three each, making up a four-digit code with each digit having a maximum value of seven. Code 7600 is reserved for notification of in-flight communications failure and 7700 for indicating an in-flight emergency; leaving 4094 codes available for routine assignment.

The start, stop, and information pulses are known as the pulse train. When requested to "squawk ident" by the controller, the pilot pushes a button on his control box, which for a period of twenty to thirty seconds causes an additional pulse to be transmitted 4.35 microseconds after the stop pulse. This pulse is known as the "caboose," or identification pulse. It serves to generate a distinctive change in the displayed target, in order to provide rapid and positive identification of a specific target.

The defruiter, which removes undesired replies, operates on a storage system. The received signal is stored by one of a pair of storage tubes and compared to the reply from the next interrogation. If the replies are identical and are from targets at the same position, they are passed on to the decoders. While this process is being carried out, the new reply is being written on the other storage tube for comparison with the next reply. If the replies are not identical, they are rejected. A pair of storage tubes is provided for each mode in use.

### Control Box and Display

Each traffic-control position has a control box which, in addition to controlling the associated non-common decoder, provides for selection of the defruiter and of desired interrogation modes. The control box also contains a number of pilot lights which indicate status of the ground equipment.

The control boxes permit each controller to select a num-

Close-up of air traffic control radar display. The display lines indicate the approach paths to the various runways. Both single- and double-slash targets from transponder-equipped planes can be seen. Frequently other information is displayed on the radarscope, including location of check points, holding areas, certain airways, and digital printout identifying flights and altitudes.

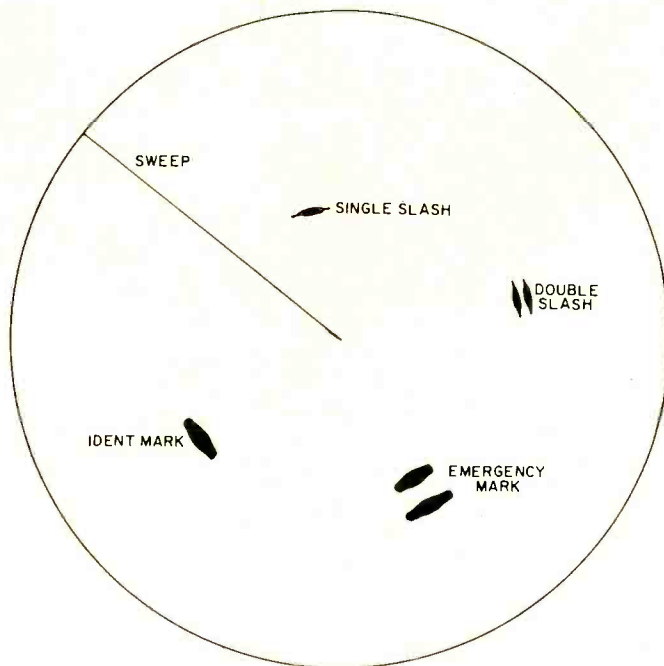
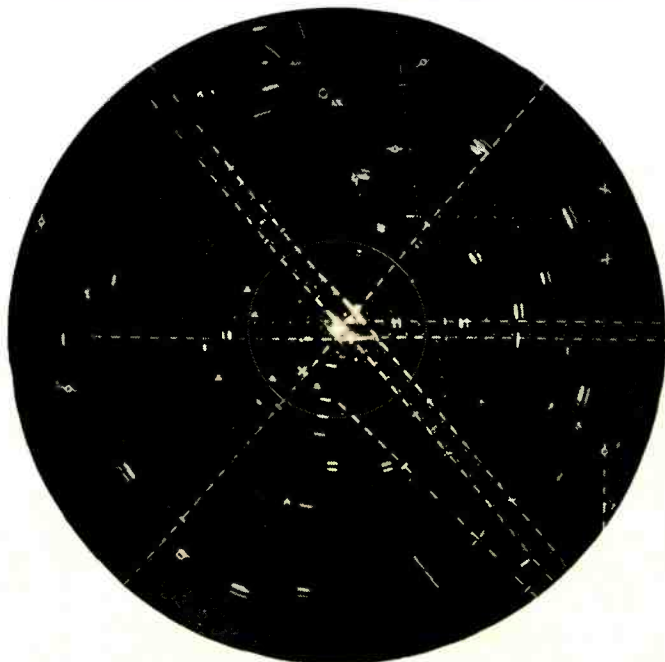

Fig. 3. Simplified radar display. A single-slash blip is produced by a transponder-equipped aircraft. This is in contrast to a smaller, single-point blip produced by the primary radar. Without a transponder, there may be no radar indication at all. A specific grouping of planes, such as those within the jurisdiction of one controller, will transmit a coded reply that shows up on the radarscope as a double-slash target. When the traffic controller wishes to identify one plane in the group of planes under his control, he requests the pilot to "squawk ident." The pilot then pushes a button on his transponder and the double slash fills in producing the ident mark. In the event of an airborne emergency, the pilot uses special code which produces emergency mark on all displays.

ber of codes (usually 10) for his own use. This enables him to display on his radarscope only those targets in which he is interested. If desired, he may select display of all aircraft which are equipped with transponders regardless of code, or he may display only selected targets. Also, if required, he may display all targets but cause selected ones to be displayed in a distinctive manner. This is achieved by causing selected targets to be displayed by two short lines (or slashes) and all other transponder-equipped aircraft by a single slash (Fig. 3). Other possible displays are the identification mark, where the space between the two slashes fills in. This provides a very distinctive mark, enabling identification of a specific target from among a group with the same coding.

One final display is the emergency mark, which consists of two wide slashes similar to a double identification mark. This is triggered by reception of codes 7600 or 7700. Simultaneously with the display of the emergency mark, a buzzer sounds to alert the controller and one of two warning lights on the control boxes is illuminated. These lights carry the legends "Emergency" or "Communications Failure," and serve to identify which code is being received.

Since the codes are not assigned in a random manner, but indicate information about the aircraft (whose control it is under or its altitude), there may be occasions when a controller wishes to determine the code of an unidentified aircraft. Since it is not practicable for the controller to work his way through 4096 codes, a means is provided for him to rapidly determine the code of unknown targets. The equipment consists of a four-digit readout indicator, a light gun, and associated counting circuits. The light gun contains a photocell, and a light source which generates a small circle of light.

In operation the light gun is positioned so that the circle of light surrounds the target. As the sweep passes through the target it causes the

(Continued on page 78)

# Four-Channel Stereo

## – the New Surround Sound

By ROBERT BERKOVITZ / Acoustic Research, Inc.

*If you want to be immersed and surrounded by sound or reproduce the ambiance of a concert hall, try 4-channel stereo. Here are the principles and techniques used for a system that is causing much excitement in the high-fidelity industry.*

**F**OUR-CHANNEL stereo, an exciting new feature of the recent Los Angeles Hi-Fi Show, is a technique of recording, broadcasting, and playback which permits sounds to be presented to the listener from any direction in the horizontal plane. Although the resulting reproduction cannot match the resolution of which the ear and brain are capable and is not independent of the acoustics of the listening room, the system works well and creates an interesting illusion. The number of channels and the present state of electronic technology make possible 4-channel professional and amateur recording systems, as well as home-playback components which are within economic reach of many music listeners. Since multichannel recording is not new, it is the possibility of its availability to home listeners, and not the system itself, which is causing all the excitement.

The importance of 4-channel systems can best be realized by considering the essential nature of high-fidelity recording and playback. Properly made 2-channel stereo recordings are capable of satisfying even critical listeners, as long as the recording engineer wishes to produce the effect, upon playback, that the instruments are in the same room as the listener. The success of this illusion, however, involves eliminating from the recording the acoustics of the recording hall. Otherwise, the presence of this reverberation, superimposed upon that of the listening room, would quickly betray to the listener the artificiality of the presentation. The apparent source of sound is limited, of course, to a location (or locations) between the two speaker systems. But, since it is usually easy to separate these adequately in most listening rooms, the distance between speakers is

Fig. 1. Sound-image map for Jordan Hall at New England Conservatory of Music (Boston), where AR first made 4-channel music recordings. The dashed line represents the front edge of the stage. The various images of the hall experienced by a listener at the position shown are the result of sound reflections from the walls. Clearly no two microphones could record all the positional information in such a case, nor could any number of loudspeakers arranged in one straight line reproduce it.

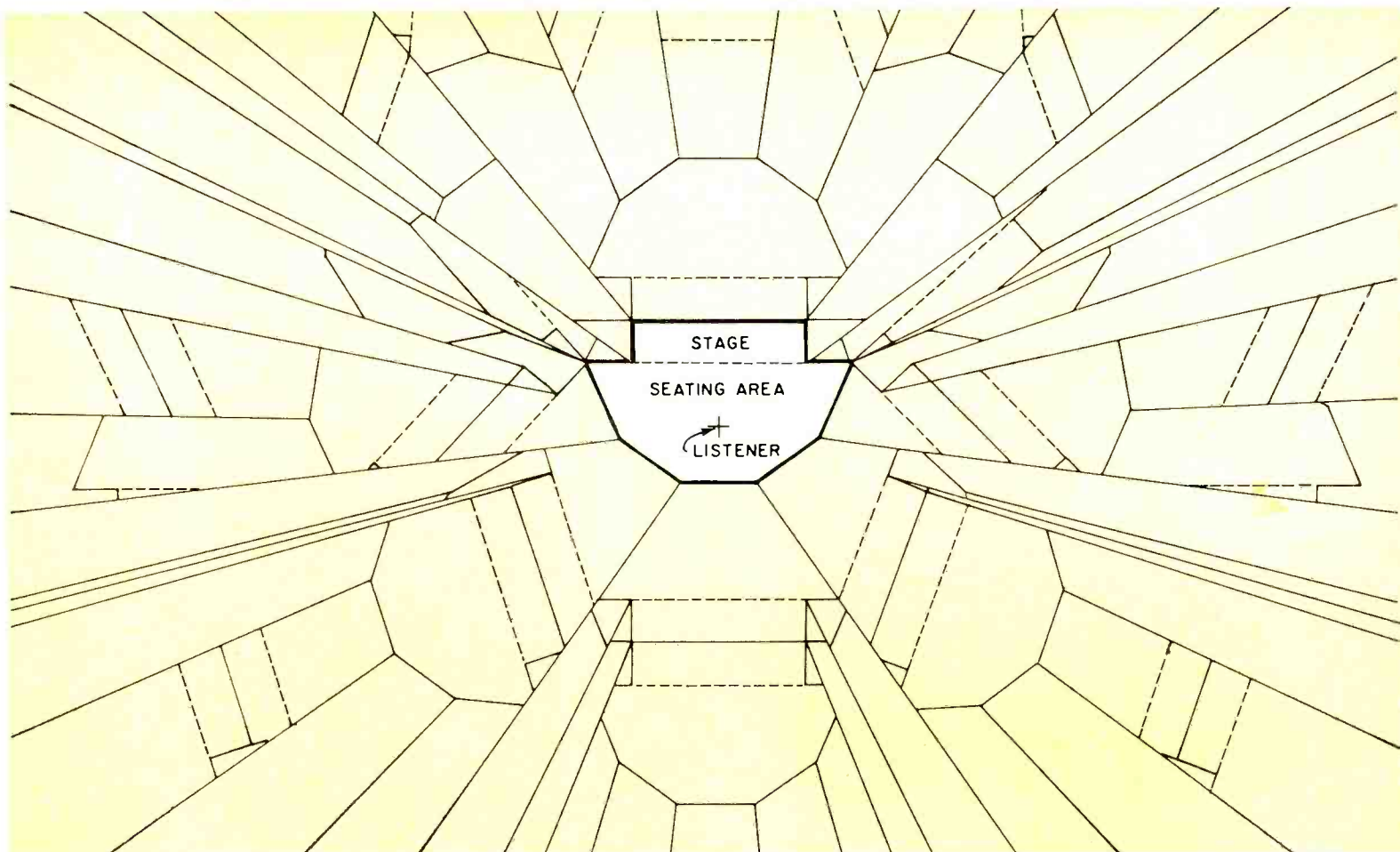

rarely a limitation in 2-channel stereo.

Limitations arise if we want to record or reproduce an *acoustic field*, that is, to recreate for the listener the sensations produced by hearing the real performance in the acoustic setting of the concert hall. The acoustic properties of any room or hall are really the total effect of the time delays, amplitudes, directions, and frequency spectra of the reflections of the original sound as they come to the listener from the walls of the room (Fig. 1). The acoustic field at the concert-goer's seat is a region in which not only the sound level but the direction of the source of sound is constantly changing. Just as monophonic recording is able to produce only a linear array of sources, one behind the other, 2-channel stereo can only represent a plane with the edge closest to the listener formed by a line between the two speakers (Fig. 2).

Sounds originating outside this sector may be recorded by using additional or omnidirectional microphones to mix this sound with that from the primary area being recorded. However, this additional sound cannot be recorded in a way which will permit it to be recovered correctly, as to direction, by the listener; nor can any types or combinations of speaker systems or other components regenerate it from a 2-channel recording.

To represent sound sources or their images in *any* direction with respect to the listener, more than two elements (microphones, loudspeakers) are needed, because we need to surround the listener. We need a set of points which will form a closed-plane figure, and two points will do no more than form a line. The closed figure requiring the least number of points is, of course, a triangle. However, a triangular array of speaker systems has a somewhat smaller satisfactory listening area, and imposes rather difficult domestic problems in terms of speaker placement, compared to a rectangular array. Four channels offer less resolution than an even greater number, of course, but four have the advantage of relative economy and the possibility of using pairs of 2-channel components in experimentation. Such a system, by making possible the recording and playback of directional information over the entire 360 degrees surrounding the listener, can produce an excellent reproduction of the acoustics of a concert hall, about as effectively as two channels are now able to represent one-fourth of this acoustic setting.

It is reasonable to ask how the ear/brain system is able to function as a direction-sensing mechanism using only two detectors, if it is necessary to use at least three detectors to record the same information electronically. The answer, in part, is that the two biological detectors (ears) are constantly shifted by minute movements of the head, so that they sense sounds from more than two fixed positions. In addition, the shadowing effects of the head and pinnae aid by causing spectral changes in sounds from some directions.

It is possible to use knowledge of the reverberant properties of a room or concert hall to artificially prepare, with the use of a digital computer, four-channel tapes which simulate the results which would be obtained by placing a sound source in such a concert hall. The programming techniques for this are quite simple. By slightly "tampering" with the data for real concert halls, acoustic presentations may be created which are entirely new, and perhaps impossible to achieve architecturally.

#### Tape as a Signal Source

One of the fortunate aspects of 4-channel systems is that



Bethany Beardslee, soprano, is shown here during the preparations for the 4-channel recording by AR of "Philomel" by Milton Babbitt. Eight widely spaced microphones were used in chapel of General Theological Seminary, New York.

all of the components needed for experimentation are readily available, and have been for many years. Foremost among these is the multitrack tape recorder, available in many professional recording studios in 3-, 4-, and up to 24-channel versions. Lower cost reel-to-reel machines for home use are also now available, requiring only the added amplifier and pair of speakers for a full 4-channel record/play system. An informal standard already exists for pre-recorded tapes for this use, in which channel 1 is left front, 3 is right front, 2 is left rear and 4 is right rear.

Multichannel studio machines are customarily used only to permit easier mixing and balancing of 2-channel releases, rarely and experimentally for multichannel playback or for acoustic-field recordings. The first 4-channel recordings of this type known to the author were made by *Acoustic Research* in 1968 at the New England Conservatory of Music, followed shortly by others, also produced by AR, at Harvard University's Loeb Drama Center. In March, 1969, a 4-channel recording was made at the Eastman School of Music by Thomas Mowrey, at the author's suggestion. Later, Mowrey produced the first recording in the AR Contemporary Music Project Series: a four-channel recording of "Philomel" by Milton Babbitt. After hearing some of Mowrey's Eastman tapes, Seymour Solomon of *Vanguard Records* made a series of tape recordings which were demonstrated to the press in June, 1969.

In a parallel but unrelated series of developments, *Columbia Records* and *CBS Laboratories* investigators had prepared a number of 4-channel tapes from material originally recorded for 2-channel release. Experimental acoustic-field recordings by *Columbia* began early in 1969, and continue as part of a program of study and development of 4-channel systems without specific plans for the future. Earlier experiments than those listed here took place elsewhere but this, to the author's knowledge, is the most recent part of the chronology.

The appearance of cartridge and cassette 4-channel tape systems will signify that manufacturers of recordings have serious expectations of the system, and these are likely to be rather straightforward modifications of existing packages in both cases. The cassette and cartridge present compatibility problems which do not arise in the case of the 4-channel disc discussed below. These tape compatibility problems arise when important information appears on all four channels, as is the case when the 4-channel medium is fully exploited rather than being used only for acoustic-field recordings.

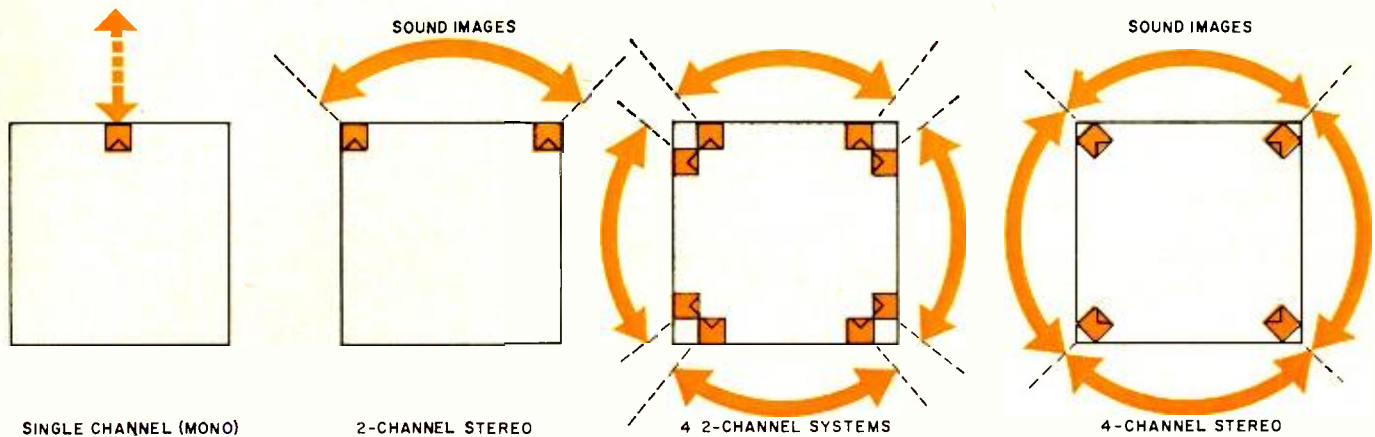

Fig. 2. A one-speaker system reproduces all sounds as if they were located somewhere on a line extending behind the speaker. Two speakers are able to give the effect of a sound field in the space behind and between the speakers. Four sets of two speakers each, one on each wall of a rectangular room, can cover a 360° plane field. In practice, four loudspeakers are used.

Playing only the front two channels in such cases gives the listener only half the information in the recording. It is desirable to mix the information from the rear channels into those in front so that it will not be lost when the tapes are played by a listener with a 2-channel system. To do so, the information must be recorded and played with a double matrixing system, similar to that now used for FM multiplex broadcasting. This will allow present owners of 2-channel machines to play 4-channel tapes when they appear. Alternatively, the two additional signals may be routed through a switch which mixes them with the other two signals.

#### Four-Channel Discs

Disc systems are the potential basis for widespread use of 4-channel recorded material. This is both because of their compatibility (a recently demonstrated 4-channel disc can be played immediately on 2-channel systems with no changes in equipment and no loss of information), and because of their low cost compared to tape media. To this must be added their continued high popularity with the listening public. A long-playing record costs about 25 cents to manufacture and runs about 45 minutes, whether 2- or 4-channel. The same playing time on 1/4-inch tape, at 3 3/4 inches per second, costs the manufacturer about a dollar, or a half dollar if an 8-track format is used—still twice as much as a disc. Add to these factors the need for even present recorder owners to buy a new tape player of some sort, in contrast to the continued usefulness of their present turntables, and the disc seems a potent competitor to tape formats.

The only disc system which has been widely demonstrated to members of the audio industry at the time of writing is that proposed by musician-inventor Peter Scheiber and Thomas Mowrey, a producer of classical music recordings well-known in the industry. The system was first heard by the author some time prior to its general presentation to members of the audio press and industry. At that time it showed excellent performance in reproducing one voice from one channel at a time, using an ordinary 2-channel cartridge playing through a special "decoder" required with the system. Separation was very good, although it appeared to decrease somewhat when complex 4-channel material was substituted for the single voice in the program. Further work on the system has been done, and listeners at later demonstrations have reported that the system works quite well.

Although the method used in the Scheiber-Mowrey disc has not been revealed by its proponents, it is clear that some sacrifice in channel capacity must be made, since the encoded 4-channel information on the disc is stored in only two channels. Since the storage capability of an audio channel—whatever the medium—is restricted, it is likely that some difference will be detectable if the Scheiber-Mowrey disc is compared to a 4-channel tape of the same program. The difference,

however, may be unimportant, or even less than would be heard were another disc system employed.

(Editor's Note: Scheiber and Mowrey have applied for patents on their system and have formed the Audiodata Co. to exploit their technique. It is claimed that neither frequency response nor a dynamic range has been compromised in their disc. Nor is a subcarrier technique employed for the two additional channels.)

#### FM Broadcasts

Apart from the public demonstrations which are presented at the *Acoustic Research Music Rooms* in New York and Cambridge, the largest number of listeners have heard 4-channel stereo through the medium of FM broadcasts in the Boston area. There, every Saturday night, AR is presenting the entire Boston Symphony season live in 4-channel stereo, transmitted on two FM stations, WCRB and WGBH.

Various experimental microphone locations have been tested, both before and during the broadcast season, with the object of providing the best possible service for 2-channel listeners, who are the vast majority of the audience, while allowing the most effective 4-channel transmission. The arrangement currently favored, and scheduled to be adopted in the first 1970 broadcast and continued thereafter, will allow home listeners to hear 4-channel stereo or to tune in one of the two FM stations for either a near or medium "seat" in the reproduced acoustic setting of (Continued on page 58)

Fig. 3. Comparison of optimum listening areas for ideal speakers in 2- and 4-channel systems. The boundaries enclose critical areas within which lateral movement of listener will not produce more than 2 dB of imbalance. Since other factors also operate, actual areas are larger. When four channels are used, the four critical areas overlap to form a smaller ideal listening zone. In order to increase the size of this area, it may be necessary to exaggerate the separation of recordings made for 4-channel stereo. However, even if the listener is not in this ideal central area, note that most of the locations within the room are within either two or three of the optimum listening areas for two or three pairs of speakers. Hence, the listener at the back wall, for example, will receive sound images produced by the front two speakers as well as by the rear two speakers.

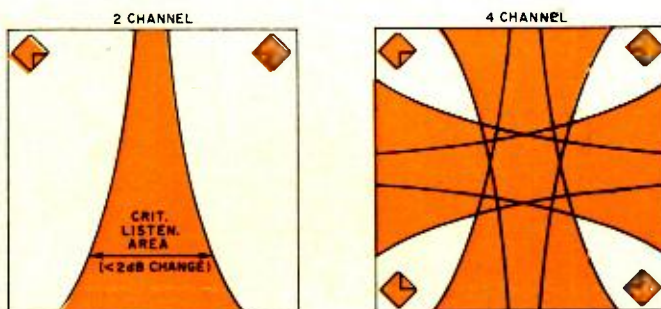

# Hybrid Technology Regains IC Spotlight

By LOTHAR STERN/Manager, Technical Information Center,  
Motorola Semiconductor Products Inc.

*Hybrid IC's aren't new, but a growing awareness of their potential, and the advent of new processing techniques gives renewed impetus to IC revolution.*

A DECADE or so ago, when the industry first investigated a technology called "integrated circuits," it did so on a very modest scale. While thinking in terms of depositing and interconnecting dozens of components on a single (monolithic) chip of silicon, what was actually produced was a number of hybrids—circuits in which a number of individual diffused resistors, capacitors, transistors, and diodes are soldered onto a ceramic substrate (Fig. 1) and interconnected (with a gold-film pattern and bonding wires) to form a functioning circuit.

As experience was gained and as manufacturers developed formulas for depositing and insulating active and passive components in combination on a single substrate, monolithic circuits began to take over and hybrids faded into the background. But they didn't disappear altogether. Although waning in importance, the hybrids still provided certain advantages under specific conditions. For example, they were easier and cheaper to build than monolithics if only small quantities were needed. The turn-around time from order placement to delivery of custom circuits was reduced considerably. They were capable of performance in some application areas that could not be duplicated with monolithic circuits.

Today, although technological maturity has resulted in production monolithics with hundreds of interconnected parts, and thousands of parts in the R&D stage, hybrids are still very much in evidence. Even more surprising, they are suddenly growing in importance—so much so, that they are beginning to exert an increasing influence on equipment design and production.

## Why Hybrids?

The reasons for the strong resurgence of an all-but-dead

hybrid technology are the same as those that kept it from being abandoned completely in the first place—only with some new twists. It is suddenly dawning on manufacturers that, no matter how complex a monolithic chip, it will always be possible to make a more complex circuit by putting two or more monolithic chips in a single package in the form of a hybrid structure. What's more, monolithic circuits can be combined with discrete component chips, e.g., power transistors, to extend the performance capability of a single-package circuit. Finally, equipment manufacturers are finding that while they cannot normally make monolithic circuits, they can assemble hybrids with a relatively small investment in equipment. By doing so, they increase their "contributed value" to the equipment and reduce to a minimum the possibility of "leaks" of their proprietary designs.

Hybrids, of course, cannot compete with monolithics in the latter's own domain. Where a particular circuit is technically practical in monolithic form and is required in large enough quantities for a production run, a hybrid would not be economically feasible. But there are enough exceptions to these two criteria to make the hybrid endeavor one of the most interesting trends in electronics today.

## Extending IC Capability

Commercially, hybrid devices—as an extension of the microcircuit art—are available in varying complexity and a wide range of package types. Typical of a simple but useful circuit is the two-transistor, Darlington-connected amplifier (Fig. 2, top) which provides current gain of more than 1000 at current levels of 5 amperes. The device, type MCH2005, is intended as a high-speed pulse power driver. It is packaged in a quarter-inch ceramic flat pack, similar to those used for many monolithic circuits; but no monolithic

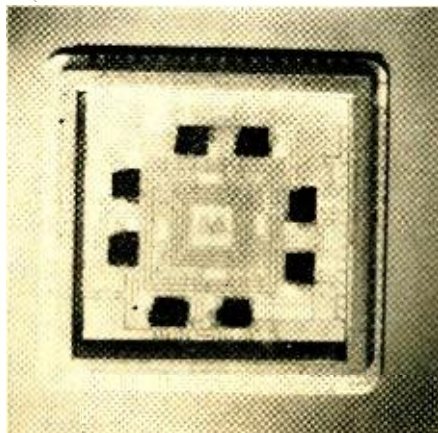
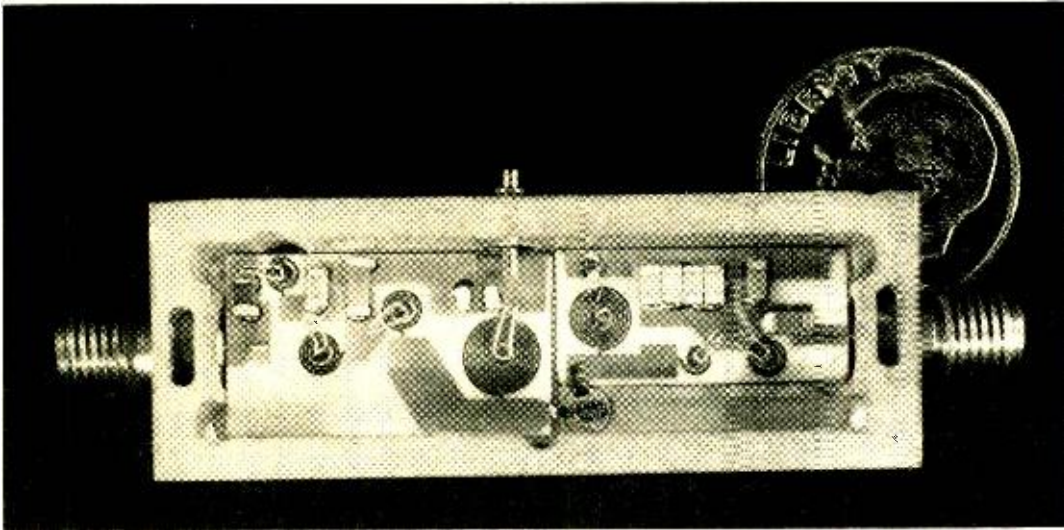

Fig. 1. Some examples of hybrids. (Left) Early 1960's crude hybrid circuit and (right) today's sophisticated hybrid.





Advanced microwave (225 to 440 MHz) r.f. power amplifier developed using hybrid techniques. Thin-film techniques are used for depositing conductors and spiral inductors. Chip capacitors and balanced-emitter r.f. power-transistor chip are also included in this hybrid.

circuit to date is capable of operating at this high a current level.

An example of a more complex type of hybrid circuit is MCH1002P dual power driver (Fig. 2, center) which contains a separate monolithic dual logic gate, two discrete power transistor chips, and four resistors. Designed for relay or lamp-driving applications requiring up to 1 ampere of current, it is encapsulated in a 14-lead (in-line) plastic package measuring approximately  $\frac{1}{2}'' \times 1\frac{1}{2}'' \times \frac{1}{4}''$ . Thus, hybrid structures are employed to provide small size and single-package utility in applications where the monolithic cannot meet technical requirements.

Another application category difficult to service in monolithic form is microwaves. Here, again, circuit manufacturers are turning to hybrids, not only to save space (compared with discrete circuitry) but also to achieve performance improvement as a result of close component spacing and reduction of parasitics. A device of this type is the 500-MHz amplifier (Fig. 2, bottom). It is anticipated that the microwave-microcircuit market will grow rapidly in the next few years and that only hybrid circuits will be able to meet the requirements in the foreseeable future.

#### Made-to-Order Custom Circuits

The real impact of hybrid technology is not in the standard circuits being introduced as a result of this "mix and match" technique, but rather in the fact that a significant hybrid capacity will free individual system designers from the restrictions inherent in monolithic IC capability. For example, the designer may choose one or more standard monolithic IC's from the large number of catalogued items and have these combined with discrete component chips to obtain a specific function. A monolithic sense amplifier, in conjunction with a couple of power transistor chips, could provide enough power to trip solenoids or perform other work functions. Simple standard digital building blocks, such as gates or flip-flops, can be combined in different ways for made-to-order functions that more elaborate monolithic circuits cannot handle. A customer's needs can be met, even in small quantities, because the job principally involves assembly and packaging operations using standard, inventoried components. True, such a custom hybrid circuit would probably cost somewhat more than the same circuit in monolithic form (if quantity and technology permit monolithic fabrication) but it should be less costly than a similar circuit built with discrete components.

Then, too, the much wider range of passive component values available with hybrid processes makes it practical to convert many existing discrete circuits into hybrids, whereas the conversion to monolithic structures would require com-

Fig. 2. Hybrid circuits vary in complexity from simple (top) 2-transistor, high-current Darlington amplifier, (center) combination of monolithic IC's and discrete chip components, to (bottom) 500-MHz amplifier used in microwave field.

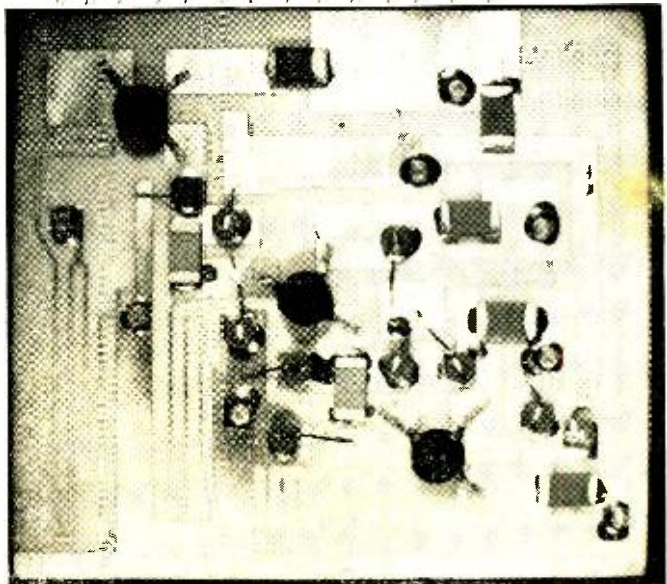
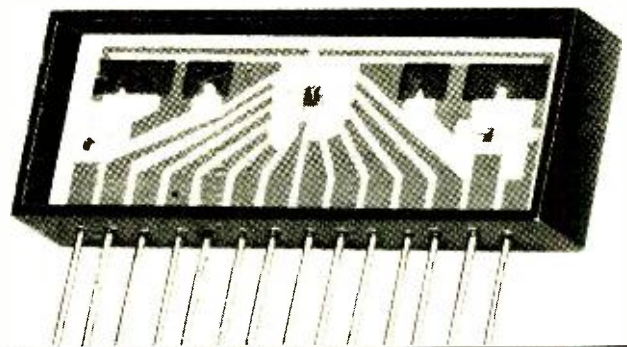
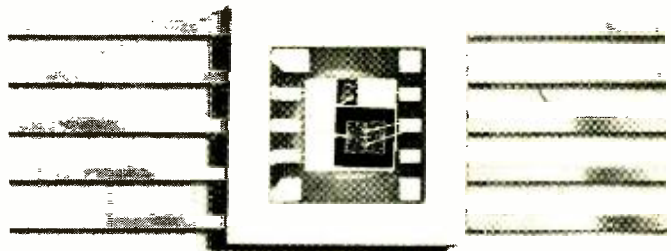

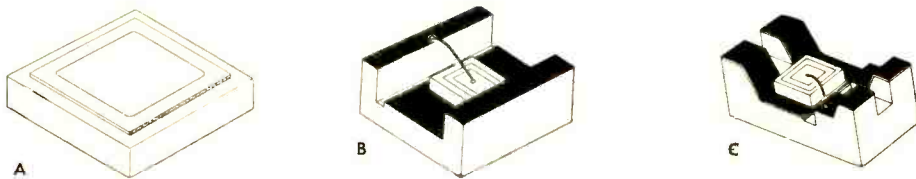

Fig. 3. Standard off-the-shelf zeners are now available in forms of (A) ordinary chips, (B) chips mounted on ceramic U-channels that provide electrical isolation and ease-of-handling, and (C) chips on four-post ceramic carriers that require no wire-bonding and facilitate soldering to hybrid substrate.

plete redesign of the circuit. Thus, an active hybrid capability makes it practical to re-evaluate every remaining discrete circuit with a view towards microminiaturization and cost savings.

It is not surprising that large semiconductor manufacturers should turn to hybrids to augment their monolithic lines. With their normal inventories of monolithic IC's and discrete semiconductor devices, and their obvious capability for die bonding, wire bonding, and packaging, they claim to have an edge over other types of manufacturers in low-cost custom hybrid production. And, on the basis of this claim, they are actively soliciting such custom business.

But not all equipment manufacturers agree with this premise. This is exemplified by a growing industry demand for unencapsulated active and passive devices, called chips. While semiconductor firms openly deplore this trend, they are quick to meet the market demand. So much so that today's equipment manufacturer can purchase, for assembly in his plant, not only a wide variety of discrete and integrated-circuit chips, but a whole host of matching diffused

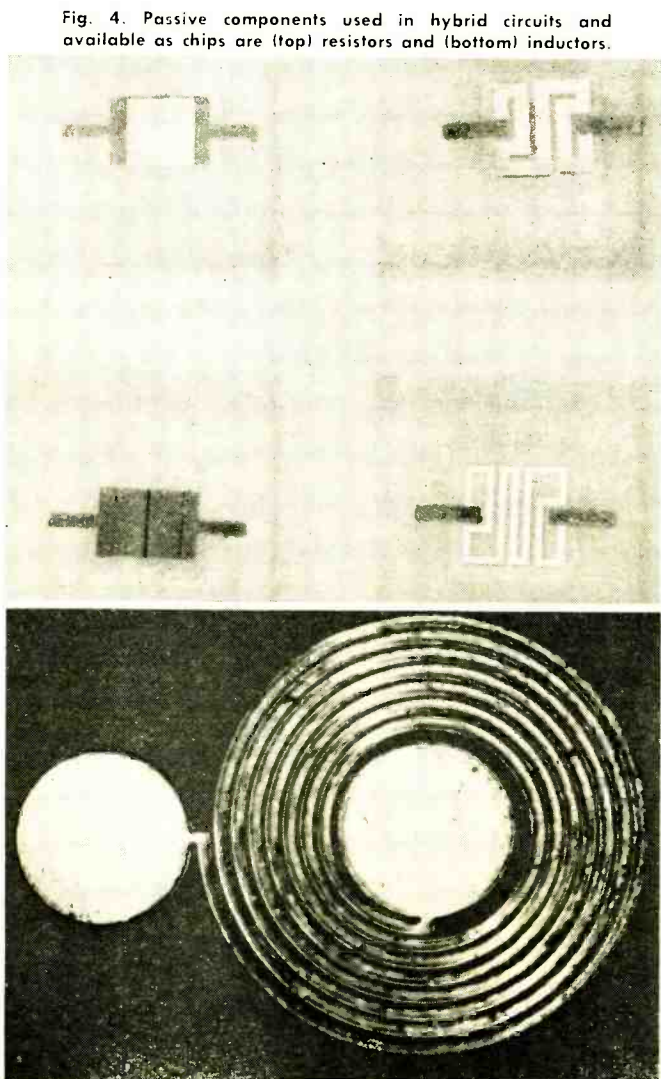

Fig. 4. Passive components used in hybrid circuits and available as chips are (top) resistors and (bottom) inductors.

and film-type passive elements as well. Some of these are available only through specially negotiated contracts with the manufacturer, but others can be bought just like any other standard catalogue item. Says *Motorola's* Tom Connors, the Semiconductor Division's outspoken marketing director, "I don't like selling chips. It's a nasty, ulcer-type business. Many customers who insist on buying chips don't know how to use them, or

how to test them, or how to work with them. This causes a whole raft of communications problems that drive prices up. In many cases I could sell a completely wired circuit for the price I have to charge for the unencapsulated components alone. But as long as customers insist on buying chips, we might as well go whole hog and make it as easy as possible on both of us."

To Connors, going "whole hog" means making available as many chips as possible to as many customers as possible on a standard, off-the-shelf basis—accompanied by a data sheet with complete specifications. In this way the customer knows exactly what he is buying and the communications problems that attend many special orders are reduced. To date, more than 70 different small-signal and power transistors as well as a half-dozen FET's and a whole range of zener diodes have become standard data sheet items—and other discrete components and even IC's are being readied for this kind of off-the-shelf market. To make it easier for concerns without chip-handling experience, some standard active component chips are being made available in three ways:

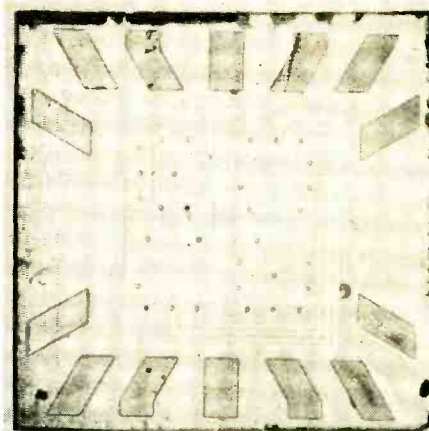
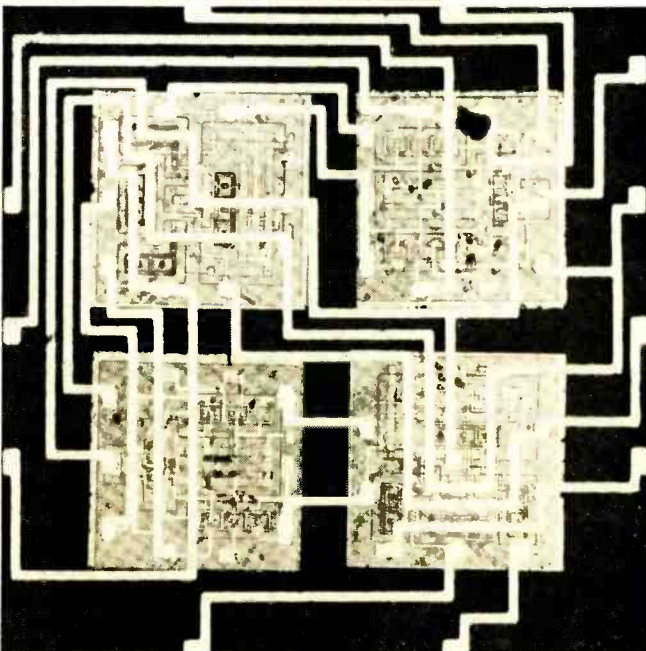

Fig. 5. One variation of flip-chip technique, a method for eliminating wire bonds, involves deposition of metallic "bumps" (top) on substrate, patterned with an interconnecting conductive film, that mates with (bottom) metallized pads on upside-down-mounted chips to form a 4-chip IC.



**Fig. 6. Processing Steps Used to Fabricate I.F. Amplifier Strip.**



(A) Gold metalization patterns for die and wire bonding are screened and fired onto a thermally conductive substrate.

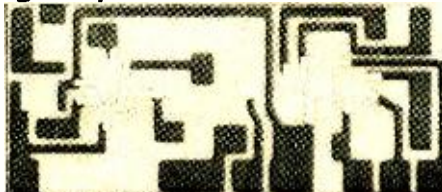

(B) Conductive paste is used to screen on all of the interconnecting patterns that are required by the circuit configuration.

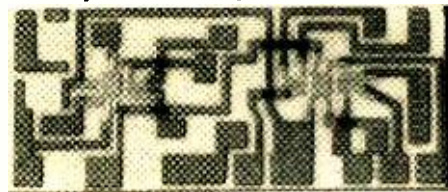

(C) Crossovers are formed by depositing glass film over bottom conductors and followed by conductive film over glass.

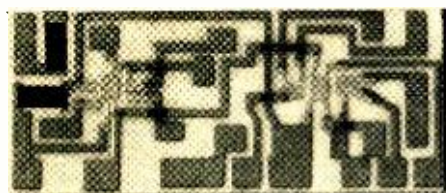

(D) The resistor patterns, designed to yield a lower-than-desired resistor value, are screened on by resistive pastes.



(E) Sand blasting or laser trimming removes portion of resistor pattern, increasing the resistance to the desired value.

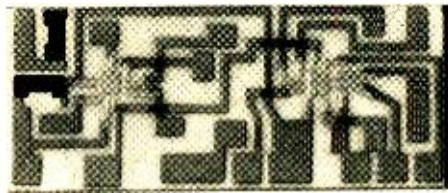

(F) Die and wire bonding is used to interconnect monolithic and/or discrete chips with the wiring pattern on the substrate.

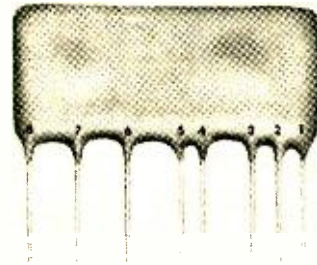
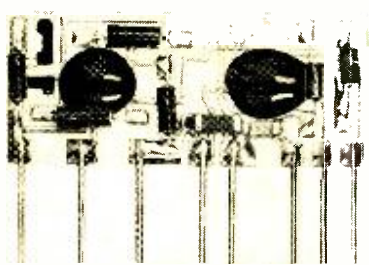

(G, on left) Chips and wiring are encapsulated by drop of epoxy and dip soldering prepares conductive pattern on substrate to accept discrete components and external leads, while (H, on right) shows the final encapsulation that results in the complete i.f. amplifier strip package.

1. As ordinary chips, much as they are used in ordinary semiconductor packages (Fig. 3A).

2. Chips on channels—where the chips are premounted and wire bonded onto a carrier which is then soldered onto the hybrid substrate. This makes chip handling much easier, although at a sacrifice of space (Fig. 3B).

3. Chips on carriers that require no wire bonding on the part of the user. With such devices, the carrier is simply turned upside down and its posts are soldered directly to metalized lands on the hybrid substrate (Fig. 3C).

As a further concession to the hybrid market, *Motorola* has introduced a series of passive devices (Fig. 4), including not only resistors and capacitors, but film-type inductors as well. These were developed for the company's internal microwave hybrid effort and have joined the ranks of OEM products.

### Problems and Solutions

Emphasis on hybrids has contributed its share to the advancement of the technology. Although it is generally recognized that large-scale systems, at present, can be more easily implemented with hybrid circuits than by increasing the complexity of monolithic circuits, hybrids, too, have had their drawbacks. One of these is the fact that when a number of monolithics are combined on a hybrid-type substrate, the interconnection of such devices by conventional wire-bonding techniques causes both economic and reliability problems, due to the large number of individual wire bonds needed. An early attempt to reduce the number of wire bonds resulted in a technique known as flip-chip bonding. With this method, raised areas, or bumps, are manufactured on the substrate (or on the chip) to coincide with interconnecting metalization pads on the chip (or metalized "lands" on the substrate), Fig. 5. By placing the chip upside down on the substrate (with the metalized surface facing the substrate) all solder connections can be made simultaneously.

Although a number of different flip-chip techniques are

used commercially, they have not received wide industry acceptance. More prominent is a relatively recent technique, developed by *Western Electric*, called "beam-lead technology." With beam-lead technology, interconnecting wires for an integrated circuit (or other semiconductor component) are fabricated right on top of the chip itself and the ends of the leads are permitted to extend beyond the boundaries of the chip. Where the device is incorporated in a hybrid circuit, the beam leads are lined up with a conductive pattern on the substrate and, with appropriate equipment, are soldered in place in a single operation.

However, beam leads are not necessarily limited to integrated circuits. When intended for hybrid circuits, even discrete component chips, *i.e.*, transistors, resistors, capacitors, etc., can benefit from this type of construction—and such devices are indeed finding their way into the market. It is true that they are normally more expensive than an equivalent conventional chip, since beam-lead processing requires additional sequence steps, but marketing people are already projecting prices to be realistically competitive with other types as sales volume increases in the future.

Still another method of circumventing individual lead bonding is a process called "spider bonding," developed by *Motorola*. Spider bonding, like beam leads, utilizes a set of leads from the chip for simultaneous attachment to a film pattern on a substrate. Unlike the chemically processed beam leads, however, the spider-bond leads are mechanically affixed to the chip after the circuit processing is finished. This is done automatically, of course, so that the cost involved is nominal compared to the attachment of individual bonding wires. Although spider-bonding techniques are currently in large-scale commercial use for fabrication of standard, plastic-packaged circuits, the process has not yet been made available for chip-type components. Nevertheless, it has a good potential for hybrid-circuit applications.

### Fabricating Hybrid Circuits

Apart from the various methods (*Continued on page 53*)

# Ferroresonant Transformer Improves Color TV

By NEIL FERENCY/CV Product Manager, Sola Electric,  
Div. of Sola Basic Industries

*Description of a ferroresonant constant-voltage transformer for home color-TV use that keeps the applied line voltage steady.*

**I**N some areas of the United States, day-to-day measurements of line voltage to private residences, especially those closest to a utility's distribution facilities, have reportedly been as high as, or higher than, 128 volts a.c. This frequently results in a short life cycle for color-TV components, household light bulbs, and certain appliances with resistive-type electric heating elements. On the other hand, homes located on the outskirts of a utility's service area have been reported to experience relatively low median line-voltage conditions, say approximately 106 volts a.c. This condition has been found to reduce the effective strength of components found in color-TV receivers by as much as 60 percent. Consequently, to bring the picture quality of many color sets on such low-voltage up to standard, maximum power adjustments are required that actually place more stress on these components.

In addition to basic line-voltage excursions outside the home, another factor considered detrimental to color-TV components are line spikes which are produced whenever other household appliances start up, cycle, and shut down. It is feasible for these line spikes to have magnitudes of 200 to 300 percent of nominal, depending upon the line supply voltage level stability, the load the appliance requires for opera-

tion, and whether or not the appliance is on the same circuit as the color TV. With the growing number of electrical appliances in the home—air-conditioners, clothes dryers, dish washers, washing machines, etc.—power drain on many low-level distribution lines is too great for the supply. The use of these appliances results in extremely low supply-line voltage dips during start-up and only somewhat less severe dips during cycling.

Although only a few milliseconds in duration, line spikes strain nearly all color-TV components to some extent, and noticeably disrupt picture quality by causing the hue to fade and the picture to collapse, flip, and roll.

Higher-than-design voltages into the rectifier tube—and possibly the CRT—are known to be the basic cause of x-radiation from color-TV receivers. With a line source of 128 volts a.c., the high-voltage input to the regulator tube in most new color-TV sets would be approximately 27 kV and in older or perhaps less expensive models the input could climb to as high as 32 kV. According to reliable industrial sources, the x-radiation threat increases roughly in proportion to the square of the voltage increase.

To remedy some of the problems caused by both over- and under-voltage conditions, a ferroresonant constant-voltage

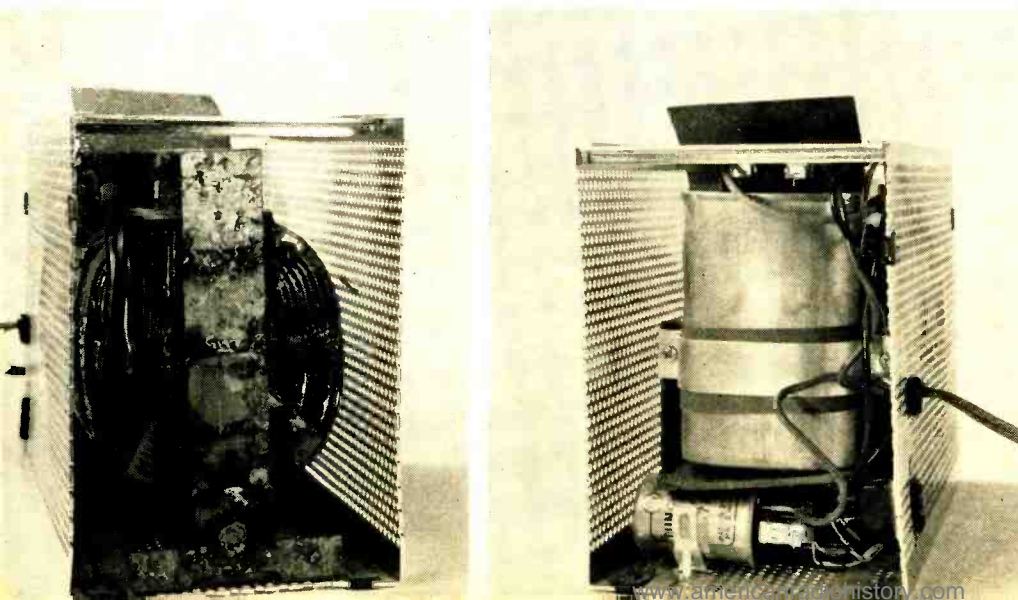

Views of "Colorvolt" ferroresonant constant-voltage transformer with the ends removed, showing (left) the transformer and (right) the electrolytic capacitor and thermal switch.

transformer—familiar in a variety of industrial applications—has been developed for home use.

### Constant-Voltage Transformer

Dubbed "Colorvolt," the adaptation consists of a basic industrial core/coil/capacitor assembly plus an automatic thermal switch (Fig. 1). The total unit is packaged in an attractive metallic housing with a wood-grain finish.

The constant-voltage (or CV) transformer is a single-core structure with a separate capacitor that combines the functions of both linear reactor and saturable transformers, except that the Colorvolt units have a magnetic shunt path added (Fig. 2).

The shunt cross section, with appropriate air gap, provides paths for some of the primary and secondary flux to return directly to their respective windings without inducing coupling. When a capacitor is across the secondary winding as shown in Fig. 2, the voltage induced in the secondary by the primary flux causes a capacitive current flow in the secondary. The secondary flux, induced by the secondary ampere-turns, is in phase with the primary flux, causing a flux addition to occur in the core under the secondary winding. Within this reinforcement, it becomes possible to saturate the core under the secondary winding only, the core under the primary is operated well below saturation.

The Colorvolt's magnetic shunt enables the secondary to act as a saturable transformer, while the primary acts as a conventional transformer; result is that the primary doesn't draw excessive line currents, even though the secondary may be saturated.

When the secondary's center leg has been saturated, it operates above the knee of the magnetization curve (see Fig. 3)—hence, a large change in primary voltage,  $\Delta E_p$ , produces a small change in the secondary voltage,  $\Delta E_s$ . Because the magnetization curve always retains a positive slope, there will always be a change of output voltage with a change in input voltage. The change, however, is at a much lower proportionate rate.

To reduce the total amount of output voltage variation, a small winding on the primary, in series with but opposing the secondary winding, is added. As the primary voltage increases, voltage in the compensating winding increases, canceling the voltage increase in the secondary winding.

### Tests Performed

To determine the effectiveness of the ferroresonant transformer in protecting color-TV receivers, an independent testing laboratory ran a series of tests.

The results clearly indicated that the TV set with Colorvolt was affected the least when the various appliances were initially started up. The worst case example was when a ten-inch table saw was turned on which caused the voltage input to the set with the Colorvolt to drop from 117 volts to between 104 and 107 volts and the unregulated set to drop to 89 volts. Under low voltage line conditions (106 volts), the effect was more severe, with the input to the set with the Colorvolt only dropping to 99.6 volts and the unregulated set to a low 76 volts.

The results of additional input/output tests conducted to determine the voltage regulating capability of the Colorvolt are listed in Table 1.

Assuming then that the radiation problem is directly proportional to input voltage going to the high-voltage section of the receiver, Colorvolt would alleviate the radiation threat by pulling voltages as high as 130 volts a.c. down to within the nominal performance range of most new color sets.

### Conclusion

A model of the Colorvolt that the color-TV receiver can be plugged directly into is available direct from *Sola Electric*, Div. of *Sola Basic Industries*, Elk Grove Village, Ill., at a cost of \$39.95.

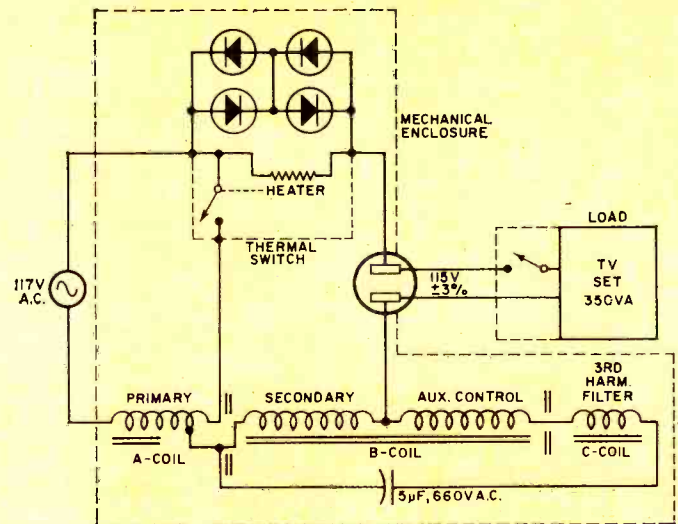

Fig. 1. Schematic diagram of modified ferroresonant transformer used to maintain a constant line-voltage input to color-TV sets.

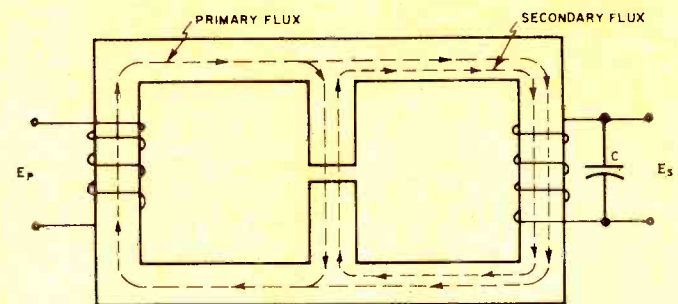

Fig. 2. Constant-voltage transformer used in the "Colorvolt." Note that the core structure has a magnetic shunt path, with an air gap, that enables the secondary to act as a saturable transformer and the primary as a conventional transformer.

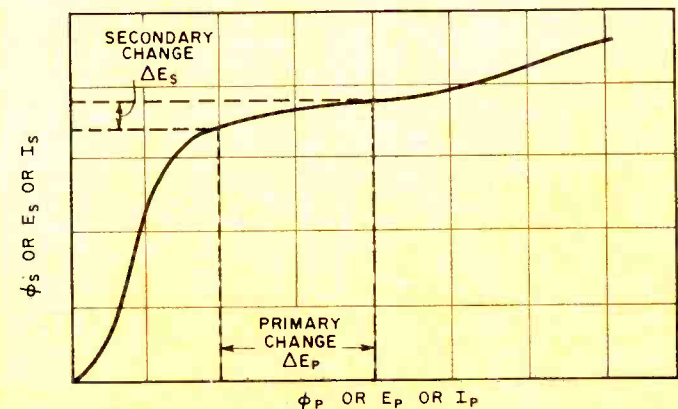

Fig. 3. Magnetization chart, used in evaluating performance characteristics of constant-voltage transformer, shows that when secondary's second leg has been saturated (operates above the knee of the magnetization curve) a large change in primary voltage causes a small change in secondary voltage.

Table 1. Test results showing "Colorvolt" regulating capability.

INPUT TO COLORVOLT (V a.c.)	OUTPUT FROM COLORVOLT (V a.c.)
130	113
125	113
120	113
115	112.3
111	111.8
105	110.8
100	109.5

# COLOR TV for 1970

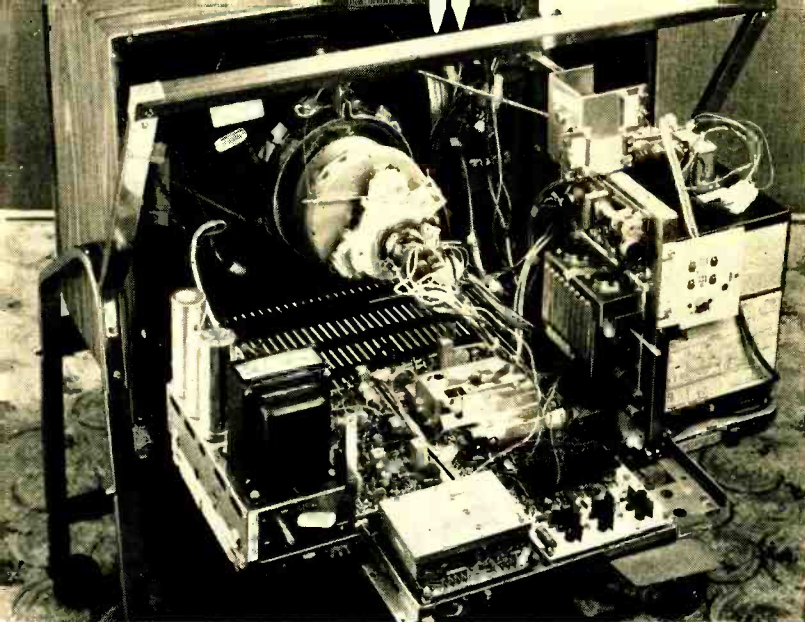

Fig. 1. The "Fast-Back" arrangement used by Motorola.

THE year just past—the last of the sixties—has practically broken the long chain of yearly increases in color-TV sales. The number of sets sold seems to have hit a plateau. Here's the statistical picture:

1964—1.4 million color sets sold  
1965—2.7 million  
1966—4.7 million  
1967—5.2 million  
1968—5.8 million  
1969—5.7 million (est.)

At press time, final figures for the year aren't in, but the trend is fairly well established.

Sales through 1969 were erratic; that is, seasonal patterns of prior years meant little. Week by week, as the year progressed, sales went above normal, then below, then high again, then low again. Seasonal forecasts became tough.

By mid-July, one thing was obvious: 1969 would be disappointing in over-all sales of color TV. Big yearly gains were apparently at an end.

Market saturation can't be blamed, at least not directly. True, 97 percent of all U.S. homes have television of some sort. But only 32 percent (a little higher now) had color last July.

Some analysts say the *actual* market is saturated. It's a matter of prices. Color sells best to middle- and upper-income groups. That market is near its limit—is in fact becoming a second-set market. That explains the popularity of portable color sets. But medium- and lower-income families still wait for an under-\$100 color set. They'll have a long wait.

Others who study the color-sales picture blame 1969's "poor" showing on bad publicity. Servicing, warranty, x-rays—all got bad headlines. Worst was the x-ray thing. It ran out of hand until late in the year. That's when the Bureau of Radiological Health finally did two things: (1) Established standards and procedures for measuring x-radiation from color-TV receivers, and (2) concluded there is no danger to the average viewer from normal color-set radiation.

But newspaper stories had taken their toll. Doubt—and even outright fear of damage to eyes, skin, unborn offspring, and health in general—kept prospects away from showrooms. Unfair and unnecessary though it was, the x-ray worry had a real dampening effect on color-TV enthusiasm. And it continues into 1970.

Extra effort has gone into planning color sets for 1970. Prices aren't lower, but aren't much higher either. More meaningful, selling prices for color TV are rising much slower than for other consumer goods. Inflation is rolling along, but isn't affecting color TV too much.

Instead of skimping and trying to lower prices for 1970, manufacturers—especially lesser known ones—have piled

on innovations to woo the hesitant buyer. Some chief attractions are discussed in this article. *Solid-state* is the big word; and simplicity of operation is probably next in importance, giving rise to lots of automatic circuits. Finally, extra attention is being given to safety, dependability, and ease of servicing.

There's extra promotion effort too. There are lots more brands, and heavy advertising budgets are planned by those who will discuss it. Some are even boasting about it, to boost enthusiasm among dealers (and attract more).

Designers cater to every need, real or created, they can think of. There's almost every screen size (except, oddly enough, for those two favorites of long ago, 17 and 21). There are 9, 11, 12, no 13 of course, 14, 15, 16, 18, 19R (formerly 21 inch round), 20, and 23. A 10 inch is expected.

*(Editor's Note: The above are all actual diagonal picture sizes, which are apt to be an inch or two smaller than the diagonal measurement of the entire picture-tube faceplate, as designated in the tube-type number. This is in accordance with a FTC ruling, which also permits picture size to be given in terms of square inches. For example, a 23-in picture is 295 sq in, a 20-in picture is 227 sq in, an 18-in picture is 180 sq in, and a 14-in picture is 102 sq in.)*

So, what to expect for 1970? Technical features, we know about. Sales are something else. Our educated guess is that sales will hold about the same, maybe rise just a little. It's pointless to expect a revival of the boom years. So let's say about 6 million sets will be sold in 1970.

Now, if you're selling or buying, here are some of the things you'll run into.

## The Trend is Solid

Transistors are what's happening this model year. The trend is manifest in several ways. In the first place, there are more hybrids—receivers that use several transistors in jobs formerly handled by tubes. Only about 40 percent of the color chassis listed in our 1969 model chart (January, 1969 issue) were of hybrid construction. This year almost half are hybrids. (See January, 1970 issue.)

More significant, the hybrids this year contain more transistors than ever. In 1969 hybrids, transistors averaged only 18 per set. In 1970 hybrid chassis, the average is 22. There are correspondingly fewer tubes; they averaged more than 14 in 1969 hybrid models, fewer than 12 in 1970.

How come set makers stick with hybrids instead of going all-transistor? For several reasons. Cost is the most important. Semiconductor prices are lower than ever and dropping steadily, but some transistors for color still cost more than tube equivalents.

Another reason: It takes time and research to design new transistor circuits—and some companies are far behind others. With a basic hybrid design, tubes can be replaced one or two at a time by solid-state designs. The expensive or critical stages are kept with tubes: horizontal sweep and high voltage, vertical sweep, video output, color-difference amplifiers, blanker, and some audio-output and sync-separation stages. The i.f. sections in hybrids are mostly transistor, but most v.h.f. tuners are still tube versions.

Tooling up is another holdback on all-solid-state color. It costs a lot of money to make drastic changes in assembly

By FOREST H. BELT/ Contributing Editor

### Part 1. More solid-state components and a number of IC's, are being used in the new models. Here are circuit details.

lines and set-makers understandably hesitate. The small improvement in performance and dependability doesn't sound glamorous enough to be salable—except of course in models that would be high-priced anyway.

In the meantime, an occasional transistor or two is used in tube chassis. Some examples: Dozens of receivers use a transistor or even an IC a.f.t. stage.

The *Arvin* 60K34 chassis has a transistor second video amplifier. Its 80K54 uses three transistors; one triggers a light to signify the need for fine tuning, and the other two are audio amplifier and output.

In the *Magnavox* T940 chassis, predominantly a tube design, five transistors are used in the unique new automatic tint control (a.t.c.) board. (See article in September, 1969 issue.)

There are other examples. *Motorola* has a two-transistor pincushion-corrector stage in some versions of the TS-921 chassis. *Packard-Bell* uses a transistor for a noise inverter and gate stage in the sync section of its CQ-634 chassis; three transistors are used in the CQ-622 chassis, but no detailed information was supplied for this chassis. Two transistors in the *Westinghouse* V8001 chassis, an imported version since that company has decided to quit making its own, are color killer and automatic chroma control (a.c.c.).

Despite the trends, there seems little likelihood of a grand rush to solid-state. Instead, set designers and manufacturers continue to peck away at the vacuum tube, replacing it with transistors, integrated circuits, and other solid-state devices as they become available in dependable quantities and at practical prices.

#### New All-Transistor Color Chassis

You may recall that for 1969 there were only two transistor color-TV chassis. One was the *Motorola* "Quasar" TS-915/919 chassis series, a modular design in which all stages relating to a function are grouped on a plug-in printed-circuit module; *Motorola* scooped the industry back in 1967 with its introduction (for the 1968 model year). For the 1969 model year, *RCA* brought out its all-transistor CTC 40 (it has a tube h.v. rectifier).

For 1970 at least seven all-transistor sets are promised.

*Motorola's* popular works-in-a-drawer chassis, the TS-915 "briefcase" version, continues the same. The chassis is laid out vertically and slides out to the front for easy access to both sides of all the modules. The early TS-919, which is electronically the same as the TS-915, was virtually discontinued over a year ago; its flat-chassis horizontal layout wasn't as popular as the TS-915. However, a new idea in chassis accessibility, called the "Fast-Back", has revived the TS-919. The concept, shown in Fig. 1, was tried successfully with last year's TS-921 tube type. It makes servicing as convenient as with the "drawer" idea.

Also continued in 1970 is the now well-known *RCA* CTC 40. Almost no changes have been made. Technicians all over the country are at least acquainted with this chassis, through an extensive program of seminars and clinics carried on by *RCA* field engineers and distributors. The CTC 40 contains the most unusual innovation of last year: a horizontal-deflection system using silicon controlled rectifiers (SCR's) as the main sweep drivers. So far, no one has duplicated the feat.

The system works well as long as *RCA* hand-picked switching diodes and SCR's are used for any repairs.

The other five transistor color chassis promised for 1970 are from outside the U.S. Four are from Japan and one from Canada. At press time, none of the five is available in quantity. Two of the Japanese chassis are from *Hitachi*, the only company which supplied data on the new transistor chassis.

One *Hitachi* set is a 14-inch portable, the CFA-450; the other, the CWA-200, is a 12-inch. Both use ordinary shadow-mask picture tubes, with color-dot triads arranged about the same as in larger screen U.S. color sets.

One difference between the CWA-200 and what you might expect starts in the video i.f. amplifier section. See Fig. 2. There are four video i.f. amplifier transistors. Two of them amplify the entire video i.f. signal. However, past the second, the signal is split up. One of the third amps is aligned for a band-pass curve that accentuates the 45.75-MHz i.f. picture carrier and the vestigial sideband frequencies for about 2.75 MHz below it—down to about 43 MHz. Sound and chroma i.f. carriers are almost eliminated by this i.f. stage. It feeds a video (or luminance, if you prefer) detector, which feeds video (Y) signal to video amplifiers.

The other, third video i.f. amp is aligned for a response that accentuates both 42.17 and 45.75 MHz. The 42.17-MHz frequency, as you probably know, is the i.f. "center" for the color-subcarrier sidebands. This video i.f. stage must also pass the 45.75-MHz picture carrier so the subcarrier sidebands have something to "beat" against in the chroma detector that follows. The 42.17-MHz sidebands become 3.58-MHz sidebands. From the chroma detector, the sidebands go to band-pass amplifiers as in any other color set.

The 41.25-MHz i.f. sound carrier also gets through the wide-band video i.f. stage. In the chroma detector, it beats with the 45.75-MHz i.f. picture carrier and creates a 4.5-MHz intercarrier sound signal, just as in a conventional video detector. (They don't beat in the video detector of this set because the narrow bandwidth of the i.f. stage preceding that detector won't pass the 41.25-MHz signal.) The 4.5-MHz signal accompanies the 3.58-MHz chroma sidebands through the first band-pass amplifier and then is taken off and fed to the usual 4.5-MHz sound i.f. amplifier stages.

There isn't much information available at press time about the other two Japanese brands. *Panasonic* insists it will have a 9-inch all-transistor color portable ready for U.S. import early in 1970. The company has displayed a prototype.

*Sony*, too, has shown some 12-inch color portables using the unusual Trinitron color picture tube. The Trinitron uses shadow-mask construction, with grids instead of holes. The color phosphors are deposited in vertical stripes instead of dot triads. The tube has only one gun but three beams. The set is solid-state. This is the third year *Sony* has promised an all-transistor set for U.S. sale; a number of sets were in the country at press time.

A couple of other Japanese companies have talked about a set, but have neither shown a set nor given details. *Haya-kawa* is one; it even described an on-screen indicator for setting chroma hue accurately. None of the sets was available at press time.

Fig. 2. Video section of Hitachi CWA-200 12-in. set.

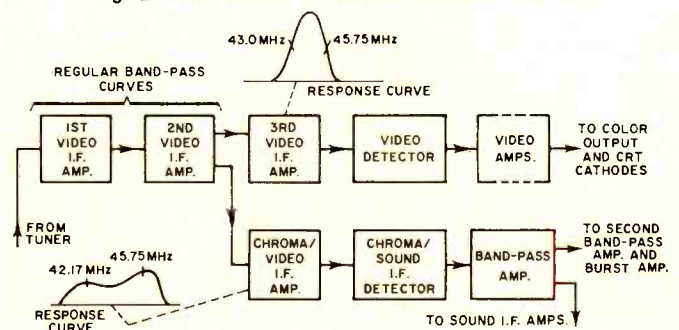

Philco-Ford—all chassis  
 RCA—CTC 40, CTC 47 (2000 series)  
 Sylvania—D12  
 Toshiba—all chassis

Some of these tuners include a varactor diode or a backward-biased transistor junction to control oscillator frequency with a d.c. voltage from the a.f.t. system in the chassis.

The *Electrohome* C8 chassis has a tuner that is completely varactor-tuned. A finger-resistance-activated diode switching system permits touch tuning; a fingertip between a terminal and bus bar triggers tuner logic circuits, which in the blink of an eye tune the set to the desired channel. There are terminals for all twelve v.h.f. channels; six additional ones permit a choice from among six pretuned u.h.f. channels.

A special diode-switched transistor tuner is used in a limited-run RCA called the "2000" series, using the CTC 47 chassis. The chassis is put into a fancy cabinet with a special high-brightness color CRT, a special instant-action remote-control system, and a price tag of \$2000. The advanced technology is interesting. Only 2000 are to be produced.

All of a sudden, several chassis sport transistor color demodulators. In past years, demodulators have been limited to tube versions of several types, and a few kinds of diode demodulators.

One transistor demodulator is shown in Fig. 3; it's in the *Sylvania* D12 chassis. Chroma sidebands are applied to both bases in parallel or in the same phase. The 3.58-MHz c.w. signal from the reference oscillator is applied to the emitters, but it is phase-shifted about 80 degrees by C1-L2 before it is applied to Q2.

Here's what happens. The high-amplitude c.w. signal applied to the emitters drives each transistor as a grounded-base amplifier. The output, in the collector circuit of each, is a large-amplitude 3.58-MHz signal. Remember, though, the signal across R9 is 80 degrees out-of-phase with the signal across R8. Chroma sidebands in the base circuit of each "modulate" the 3.58-MHz c.w. signals. The outputs are different, however, because of the phase difference in the c.w. signals.

The mixed signals are smoothed out by a low-pass filter in the output of each demodulator stage. All r.f. products of the mixing are eliminated, and the demodulated chroma signal is passed along to the color amplifier that follows. The coupling capacitors in Fig. 3 are C4 and C6. The signals in Q1 produce, after filtering, a red or R-Y signal; the signals in Q2, since the c.w. has an 80-degree phase difference, produce a blue or B-Y signal.

Small portions of the color signals are fed back from the collector to the bases of the two demodulators. This is done by resistors R10 and R12. A sample of R-Y signal is phase-shifted by C7 and L5 and fed to the G-Y amplifier by C5.

Other chassis have transistor X-Z demodulators, too. All *Broadmoor* color chassis and the *Philco-Ford* 19FT60 chassis use circuits similar to the one just described. The demodulation angle may vary slightly, but is chosen to render best color for that chassis. The *Admiral* K10 chassis have transistor demodulators, too, working on the R-Y and B-Y axes. There's almost no difference in operation.

There's something different in the *Packard-Bell* 98C21 and 98C22 demodulators. They have field-effect transistors—dual-gate FET's, in fact. They're shown in Fig. 4. The c.w. signal goes directly to gate 1 of Q2 but is phase-shifted by L1-C3 before it gets to Q1. The chroma sidebands are applied to gate 2 of both FET's, equally and in the same phase. Operation is similar to Fig. 3.

All *Zenith* chassis for 1970, except the 16Z8C19, have an integrated circuit for the color demodulator. The IC is a *Fairchild*  $\mu$ A737. Operation is very much like the 6LE8 type of beam-switching demodulator. The diagram is shown in Fig. 5.

One set of switching amplifiers inside the IC receives a

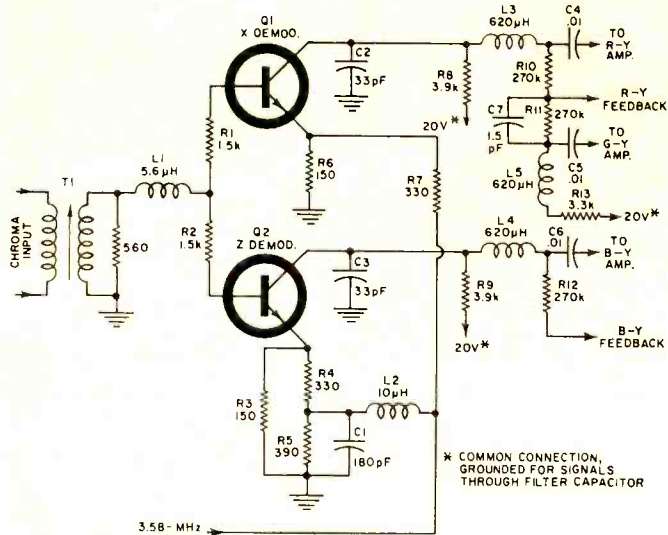

Fig. 3. Transistor demodulator in Sylvania D12 chassis.

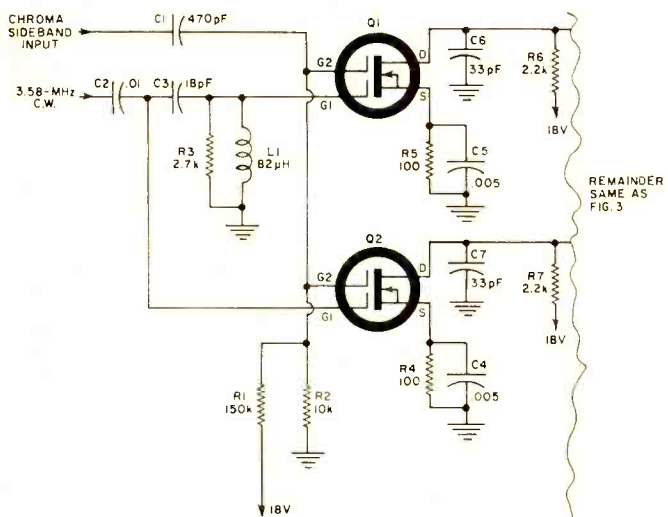

Fig. 4. Demodulator in Packard-Bell's 98C21 and 98C22 employs dual-gate field-effect transistors as shown here.

*Clairtone* of Nova Scotia, Canada, has shown a transistor color receiver that may be as big an event as the Quasar was. The unique feature is modular construction. The modules are in the form of circuit cards, similar to those used in computers. These are about 6 inches square, made of fiber glass, with etched wiring. The chassis frame is oblong and horizontal, and the cards slide into it vertically. The boards, eight of them, contain 80 transistors and diodes and four integrated circuits. *Clairtone* spokesmen express high hopes the new MSS 71 chassis will be available, in a cabinet with a 23-inch picture tube, by early spring of 1970.

And then there are the many odds and ends of new solid-state gimmicks. One example is several transistor v.h.f. tuners. For 1969 only eight brands of color sets had transistor v.h.f. tuners (u.h.f. tuners have been solid-state since 1964). The 1970 lineup shows 13 brands with transistor v.h.f. tuners in more than 30 chassis. That's a healthy increase. Here are the brands and the chassis numbers:

- Admiral*—all K10 chassis
- Broadmoor*—all chassis
- Clairtone*—MSS 71
- Electrohome*—C8
- Hitachi*—CWA-200, CFA-450
- Magnavox*—T936, T947
- Motorola*—TS-915, TS-919
- Packard-Bell*—CQ-322, CQ-522, CQ-524
- Panasonic*—CT-23P, -24W, -64P, -65W, -991



# TWO NEW BELL RINGERS FROM DELTA

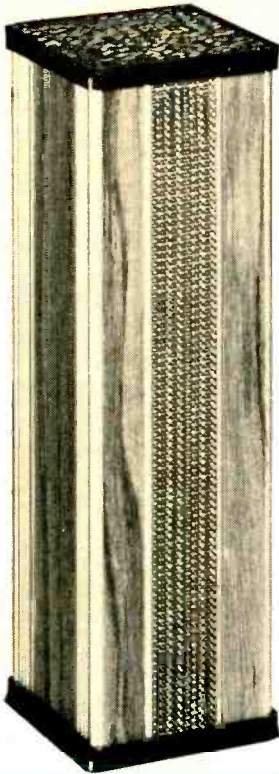

## DELTALERT

### Ultra Sonic Silent Sentry System

The all new economical-to-use DELTALERT, is more than a total motion detection and intrusion alert system. Use it as a convenience item to turn on lights, ring bells, alarms or monitor any area, indoors or out. Merely plug the system into any wall socket and plug the light, bell or alarm into the back of the unit. DELTALERT's Extra Feature variable sensitivity control and adjustable timing features provide you the most advanced sentry system on the market. Unit comes in handsome walnut finish, complete with 110-130V drop cord.

#### SPECIFICATIONS:

- ▲ Ultrasonic Frequency: 35 KHZ
- ▲ Area Coverage: 10-30 feet (depending on environmental conditions such as shape of area)
- ▲ Controls: On-Off Switch; Built in Timer; Variable Sensitivity Control
- ▲ Output: 110-130V at 1 Amp.
- ▲ Power Requirements: 110-130V, 60 HzAC

ONLY **\$59<sup>95</sup>**  
For Complete Unit, Ready to Use **ppd.**

## HIGH VOLT ANALYST

### Complete Auto Analyzer

Delta brings you a new concept in automotive tune-up — The High Volt Analyst. A unique and complete auto analyzer, it provides all the primary advantages of a scope and yet is completely portable.

#### SPECIFICATIONS:

- ▲ Accuracy — Tachometer  $\pm 2\%$  of full scale (all ranges) • Dwell Meter  $\pm 1\%$  (both ranges) • OHMS Scale  $\pm 5\%$  • Low Voltage  $\pm 2\%$  of full scale • High Voltage  $\pm 5\%$  of full scale
- ▲ General — Fully protected meter circuit\* • Size: 6 $\frac{1}{2}$ W x 8H x 3 $\frac{1}{2}$ D • Weight: 3 $\frac{3}{4}$  lbs.
- ▲ Ranges — DC Volts 0-15V, 15KV and 45KV • OHMS: 0-1 Meg. (10K center scale) • Dwell: 4, 6 and 8 cylinders • Tachometer: 0-1500 RPM, 6000 RPM

\*Batteries (8 Type AA cells) included. Comes complete with standard lead set, a special probe, and high tension lead.

**\$79<sup>95</sup>** ppd.  
Assembled

**\$59<sup>95</sup>** ppd.  
kit form

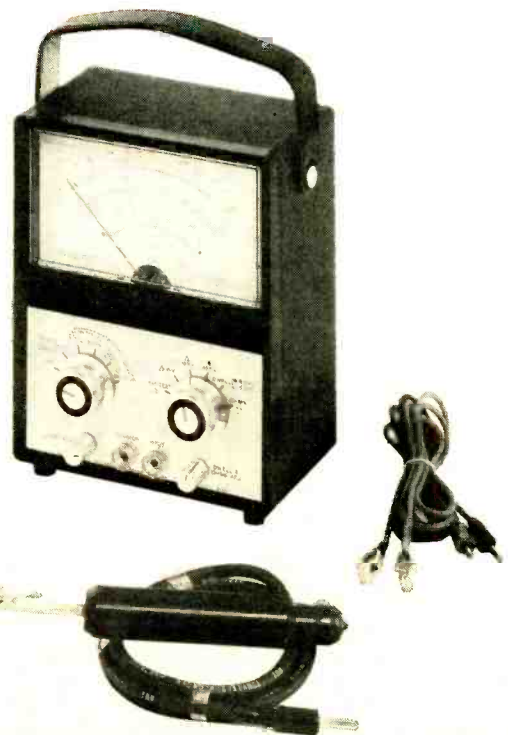

DELTA: Please send me literature immediately.

I am enclosing \$\_\_\_\_\_ for items checked.

- DELTALERT
- High Volt Analyst, Assembled
- High Volt Analyst, Kit form

Please ship immediately.

Name \_\_\_\_\_ Dept. EW

Address \_\_\_\_\_

City/State \_\_\_\_\_ Zip \_\_\_\_\_



**DELTA PRODUCTS, INC.**

P.O. BOX 1147 • GRAND JUNCTION, COLORADO 81501

CIRCLE NO. 140 ON READER SERVICE CARD

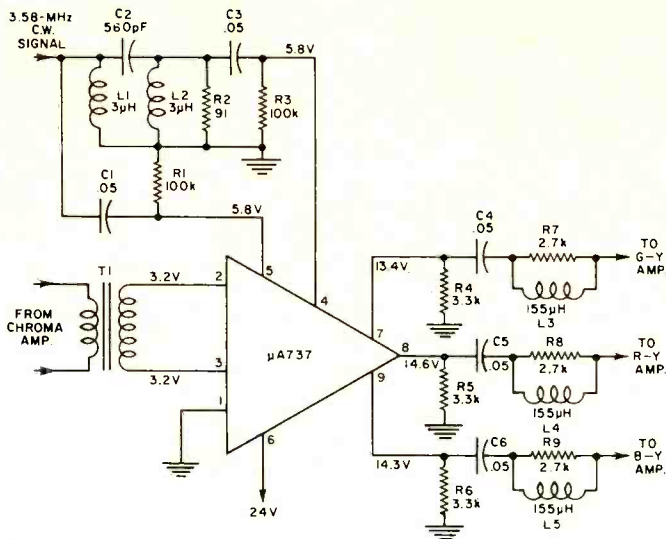

Fig. 5. Zenith color demodulator uses integrated circuits.

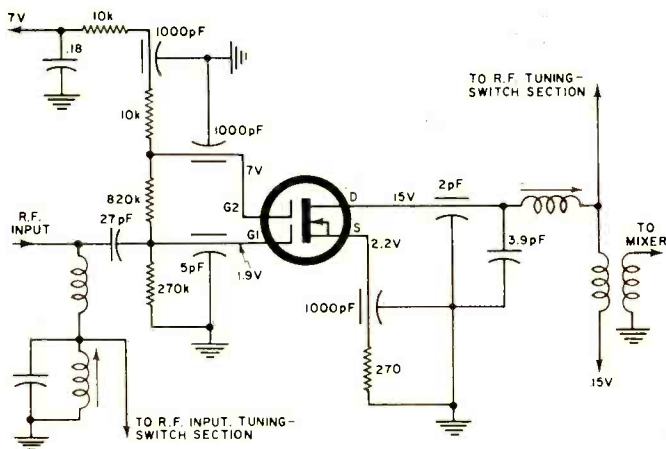

Fig. 6. The r.f. amplifier in RCA's CTC 40 is a simple circuit with dual-gate field-effect transistor.

3.58-MHz signal through C1 and terminal 5. Their job is to switch a pair of differential amplifiers alternately on and off at the 3.58-MHz rate. Phase-shift network L1-C2-L2 alters the phase of the 3.58-MHz signal applied through C3 to terminal 4 of the IC. This phase-shifted signal goes to another set of switching amps, which control a second pair of differential amplifiers.

Chroma signals are applied to terminals 2 and 3 of the IC, with both sides balanced to ground. Inside the IC, the chroma sideband signals are applied to the two pairs of differential amplifiers in parallel, in the same phase. Since the halves of the differential amps are being alternately switched off and on at 3.58 MHz, their outputs are a product of mixing 3.58-MHz signals with the chroma sidebands.

What remains is a demodulated color signal. From the differential amplifier that gets the c.w. signal directly, a B-Y signal is developed. From the one that gets the phase-shifted signal through terminal 4, an R-Y signal results. A resistive matrix inside the IC extracts a G-Y signal, too. Each color-difference signal is amplified by a single-ended transistor amplifier inside the IC and brought to an external terminal. B-Y comes to terminal 9, R-Y to terminal 8, and G-Y to terminal 7. Resistors R4, R5, and R6 are external load resistors for the color-difference amplifiers.

The 3.58-MHz signal is naturally eliminated in this balanced-type demodulator. However, a rather strong second harmonic is generated near 7.2 MHz. That's the reason for trap chokes L3, L4, and L5 in the output circuits.

Field-effect transistors, which we've already mentioned in the Packard-Bell demodulator stage, are new to color

TV. We know of only two other chassis that employ FET's.

The r.f. amplifier in the RCA CTC 40 is a dual-gate field-effect transistor. Its circuit is simple—see Fig. 6. The dual-gate FET is like two FET's in "cascode." The r.f. signal is applied to gate 1, and is amplified. A d.c. voltage on gate 2 is for gain control of the r.f. amplifier. Notice that gate 2 is decoupled by 1000 pF of capacitance, but the coaxial capacitor at gate 1 is only 5 pF—part of the input tuning.

The other chassis that has an FET is the Admiral K10. The field-effect transistor is a reactance control stage for the 3.58-MHz oscillator. The dual-gate units in the RCA above are insulated-gate FET's or IGFET's. The one in this Admiral chassis is a junction FET, or JFET. See Fig. 7.

In effect, the n-channel of the JFET is in series with the 220-pF capacitor. The d.c. voltage on the gate, coming from the burst phase detector, controls effective resistance of the channel. When it's low, the capacitor loads down the crystal, altering its frequency slightly. When it's high, the capacitor has little effect on the crystal. The stage's nominal effect on frequency of the c.w. oscillator is set by the Reactance Adjust control in the source circuit of the JFET. It merely sets the bias voltage between gate and source.

Speaking of new solid-state technology being used in the 1970 color chassis, the Broadmoor sets have something that is a first for color sets, as far as we can determine. There are no tuned circuits in the sound i.f. system. A diode detects the 4.5-MHz intercarrier as usual. The signal is then passed to an extremely high-"Q" ceramic filter and coupled by the filter to the integrated circuit that is the sound i.f. amplifier. Another 4.5-MHz ceramic filter follows the IC. It's a special one, with a capacitance tap between the ceramic element and ground. A pair of back-to-back diodes are connected to the tap for phase detection of the FM sound.

A fairly recent solid-state device is the integrated circuit. In 1969, of 63 chassis surveyed, 16 had integrated circuits. This year we surveyed about 100 chassis and found 27 with IC's. On a percentage basis, that's very little increase. Except for a little initial glamor, IC's haven't added much to color TV.

The fact is, it is no more—and often less—expensive to do the job with other solid-state components. Only 13 that we know of use IC's. They are: Andrea, Arvin, Broadmoor, Clairtone (with four IC's in one chassis), Heath, Hitachi, Magnavox, Motorola, Packard-Bell, Philco-Ford, RCA (first brand to use IC's in color sets and with six in one chassis this year), Sylvania, and Zenith. The circuits in which IC's appear are: sound i.f. and discriminator, sound i.f. alone, color demodulator, a.f.t., 3.58-MHz oscillator, and remote receiver. One tuner-maker has an integrated-circuit tuner for v.h.f., but no set-maker has put it into a receiver. The future for IC's in color TV looks slow, at best.

Next month, we will conclude this two-part article with descriptions of circuits that provide a number of automatic features in the new 1970 color-TV models. In addition, we will go into some of the new remote-control units. Finally, we will cover the serviceability of the new color receivers.

(Concluded Next Month)

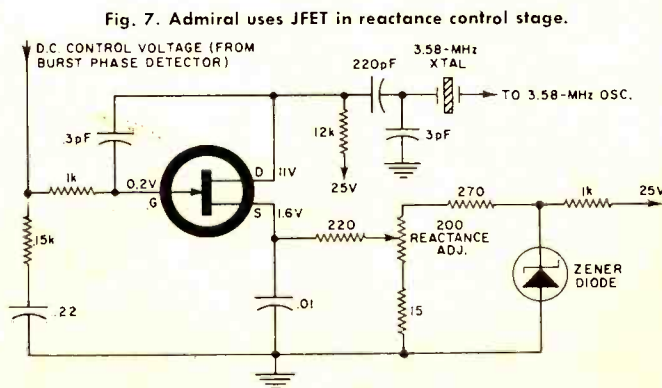

Fig. 7. Admiral uses JFET in reactance control stage.

**Hybrid Technology**  
(Continued from page 45)

of wiring a chip into a circuit, hybrid circuit construction involves two primary processing techniques—thick film and thin film. These deal with the processing of the substrate itself and govern the metalization pattern that interconnects various components as well as, in some cases, the fabrication of some, if not all, of the passive circuit elements.

Actually, the terms thick and thin films are not based primarily on the thickness of the film; rather they describe the processes used in their deposition. Thick films, for example, are applied to the substrate by means of well-developed screen methods whereby a variety of resistive and dielectric inks, or pastes, are deposited on a substrate through a fine metal-mesh screen. The process may be done either manually, with the squeegee that presses the paste through the screen mesh operated by hand, or on automated equipment for large production runs. A process sequence for a typical, although simple, thick-film circuit is shown in Fig. 6.

By varying the resistivity or conductivity of the paste, either resistive or conductive patterns may be deposited. Resistor values ranging from about 1 ohm to several megohms can be obtained. Resistor tolerances of 5 to 10 percent are standard, but extreme accuracy may be obtained through sandblasting or laser trimming after initial deposition. This is accomplished by removing parts of the resistive pattern until the desired end resistance is obtained. Screened-on capacitors require two conductive layers separated by an insulating film; values up to 10,000 pF can be deposited. For higher values, tiny ceramic or tantalum units are normally added in packaged form, although, if space is limited, chip-type capacitors may be needed.

Basically, thin-film circuit fabrication is similar to the thick-film approach, except that the metallic or dielectric films are deposited on the substrate by more sophisticated processes, such as vacuum evaporation, sputtering, gas plating, and a number of other techniques. The resultant films are more closely controllable, resulting in greater uniformity, better definition, and improved geometric control. Moreover, thin-film processing permits the use of a number of different materials, thereby providing a wide range of film characteristics. Indeed, by judicious combination of thick- and thin-film passive components, discrete active component chips, and monolithic circuits in a hybrid structure, it is possible to obtain extreme miniaturization and cost saving while approaching the circuit-design flexibility of discrete-component circuits. ▲

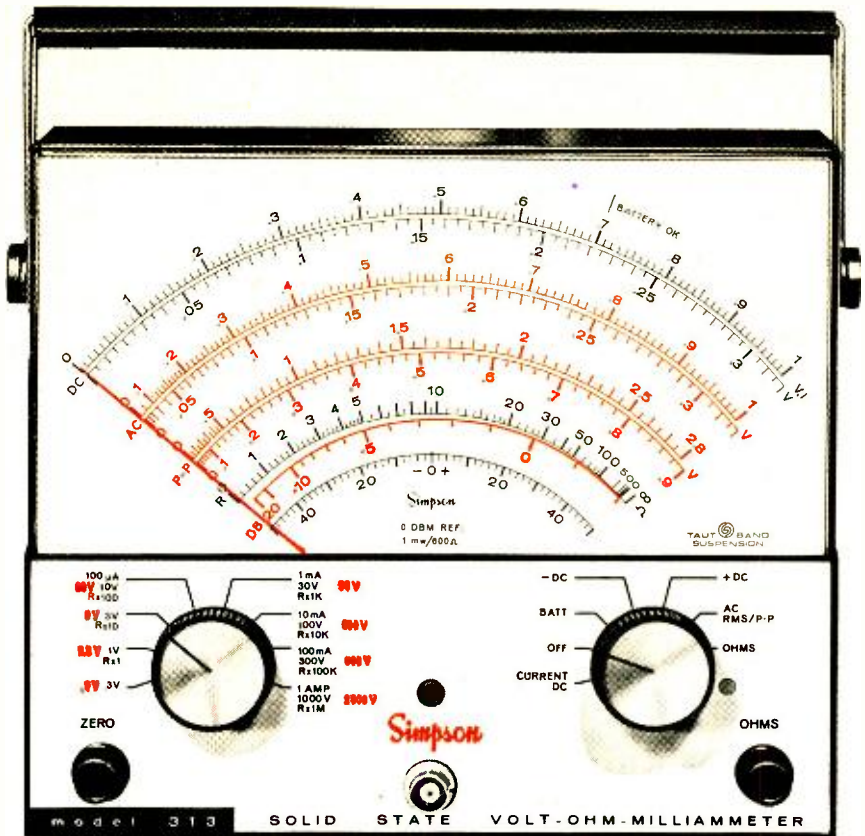

## Simpson's NEW solid-state VOM with FET-Input

- **HIGH INPUT IMPEDANCE...**  
**11 Meg  $\Omega$  DC 10 Meg  $\Omega$  AC**
- **PORTABLE..... battery operated**
- **7-INCH METER..... overload protected**

Simpson's new 313 gives you high input impedance for accurate testing of latest circuit designs . . . free of line cord connections. Over 300 hours operation on inexpensive batteries. And the new 313 is *stable*, which means positive, simplified zero and ohms adjustments. Protected FET-input handles large overloads. DC current ranges to 1000 mA. Sensitive Taut Band movement and 7-inch meter scale provide superior resolution down to 5 millivolts. Write today for complete specifications.

Complete with batteries, 3-way AC-DC-Ohms probe, and operator's manual . . . . . **\$125<sup>00</sup>**

**Simpson** ELECTRIC COMPANY  
GET "OFF-THE-SHELF" DELIVERY FROM  
YOUR LOCAL ELECTRONIC DISTRIBUTOR



5200 W. Kinzie Street, Chicago, Illinois 60644 • Phone (312) 379-1121  
EXPORT DEPT.: 400 W. Madison Street, Chicago, Illinois 60606. Cable Simelco

CIRCLE NO. 107 ON READER SERVICE CARD

**This is 30,000  
solid state replacement parts.**



# So is this.

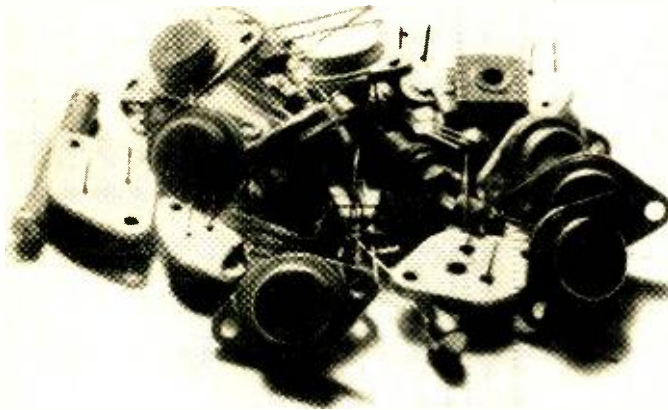

It used to be if you wanted to satisfy everyone, you had to stock over 30,000 different solid state replacement parts.

Well, everyone realized that was ridiculous. So some enterprising people came up with a bunch of universal replacements.

Then you only had to stock about eleven or twelve hundred.

That was a lot better, but we still thought it was a little ridiculous.

So two years ago (when we went into this business), we figured out how to replace all 30,000 with only 60.

Now all you have to do is stock 60 of our diodes, transistors, integrated circuits, etc., and you can replace any of the 30,000 JEDEC types manufacturer's

part numbers, foreign types, etc., now in use.

That means you invest less money.

You don't tie up valuable space.

You do away with complicated inventory control.

And you operate more efficiently.

To make life even easier, we've got a new book that gives you all the cross references you need to figure out which part replaces which.

It's available from your nearest Sylvania distributor.

If the whole thing sounds rather incredible, you're right. But why not give your distributor a call and let him narrow the incredibility gap.

**SYLVANIA**  
GENERAL TELEPHONE & ELECTRONICS



# J OHN FRYE

*An attempt to understand why service technicians, as well as farmers and automobile mechanics, are so hard to organize.*

## WHAT PRICE INDEPENDENCE?

IT was a day in which snarling winter bared all her fangs. Alternating snow, freezing rain, and sleet, accompanied by a bitter howling wind, made life miserable outside and tried to follow Barney through the door of the service shop when he returned from a protracted trip to the wholesaler's for parts.

"Get stuck in the snow?" Mac asked his employee with mock concern.

"Nope," Barney replied, putting his shoulder to the door to help the automatic closer shut out the buffeting wind, "I got stuck in a discussion. You'll admit this is not the sort of day to make you want to button up your overcoat and hurry back out into the storm, and there was a whole gang of technicians there sopping up free coffee and shooting the bull. They started talking about why service technicians were so hard to organize. Naturally I had to stay and give them the benefit of my thoughts."

"But naturally!" Mac agreed with thick sarcasm. "I hope you'll share those thoughts with me for I've a few ideas myself. What did you decide?"

"Truthfully, I can't say we decided anything, but several ideas came out. First we agreed we're not alone in our stubbornness. Other groups, notably farmers and automobile mechanics, also are difficult to organize; so we tried to discover what all three groups have in common that makes them resist organization—at least as compared with barbers, plumbers, electricians, dock workers, railroaders, factory workers, and other groups that seem to clump together as effortlessly as butter particles agitated in a churn."

"What did you conclude?"

"For one thing farmers, mechanics, and electronics technicians seldom take up their line of work primarily to make money. Not that they have anything against money or are averse to making same, I hasten to add; but the original primary attraction of the farmer, mechanic, or technician to his life's work is seldom pecuniary. The farmer becomes a farmer because he was reared on a farm or likes the outdoor life. The mechanic and the technician likely got 'hooked' on their respective lines of work because they started fooling around with cars or radios and discovered there was something deeply satisfying about being able to make broken or poorly functioning pieces of equipment work. And don't jump to the conclusion there's anything wrong with this kind of motivation. It probably is the moving force behind every really great scientist, surgeon, and inventor. A man must love his work to become a master at it."

"No argument," Mac conceded.

"The second thing is all three occupations are what you might call 'loners.' The farmer works alone, with nature for his antagonist. He pits his brains and brawn against the flood and the drought and the insects. He makes his own decisions and abides by the consequences. The mechanic with his head under the hood or sprawled on a creeper beneath the car is very much aware that it is just he and the car. A wrench slips off and barks his knuckles; he swears soulfully and wipes the grease from his eyes; but he never forgets for a moment he must repair that perverse collection of nuts and bolts or admit

personal defeat. And the technician working on an intermittent is in precisely the same situation. No matter if he is standing elbow to elbow with other technicians, that TV set in front of him is *his* responsibility. Its problems are his problems, and either he repairs it or acknowledges—at least to himself—shameful failure.

"The fellow on a production line does not have this feeling of lonely personal struggle. He makes only a small contribution to the finished product and accepts only a small part of the responsibility, if any. What fellow workers do on the line ahead of him affects the difficulty of his job, and what he does will be seen and criticized by those following him. He cannot think about his work without thinking about the group with which he works; so organizing him is comparatively easy."

"It seems to me," Mac said thoughtfully, "that what you are saying is that some occupations, such as those mentioned, attract a particularly independent type of person, a person who enjoys working alone, who likes to make his own decisions, and who is willing to accept a considerable amount of return for his work in the form of personal satisfaction with what he is doing and freedom from interference."

"Hey, you sure you weren't there eavesdropping?" Barney demanded. "That's precisely the conclusion we reached. We decided we were a pretty independent bunch of knuckleheads who preferred having our individual technical ability recognized to having the cash income of the whole group raised. This has been just as true of farmers and auto mechanics as it has of us. All three resent our low pay and lack of recognition, but we're not willing to sacrifice our jealously guarded independence to get better pay. Like the fiercely independent old river pilot, we have demanded that the boat be ours to run as we please, even if that means running it into the bank!"

"This is good?"

"That's what we finally got around to asking one another. We soon agreed it's becoming harder and harder to be independent. High cost of farm machinery, high taxes, the impossibility of securing farm labor, and low farm prices are making it virtually impossible to make a living on a small farm. Complexity of modern cars with their tricky wheel suspensions, complicated automatic transmissions, air conditioning, and temperamental high-compression engines are forcing the one-man alley garages out of business. One man cannot do enough service, no matter how good he is, to earn a decent living and to afford all the expensive equipment required to work on today's cars. And we know the variety and complexity of modern electronic equipment is exerting the same kind of pressure on the small service shop. To be able to do a first-class job of servicing transistor and tube radios, black-and-white and color TV, AM and FM receivers and tuners, stereo and hi-fi equipment, CB radios, automobile radios, tape recorders and tape players, you must invest a small fortune in equipment and service data. Technical competence cannot substitute for this equipment and cannot grow without it."

"Don't forget," Mac reminded, "the shop owner's dollar income must keep rising for him to maintain the same standard of service and of personal income. When he has to pay

two to three dollars for a haircut, a dollar and a half for a pound of steak, forty cents for a gallon of gasoline, and put a mortgage on the house before he dares call a plumber, electrician, carpenter, bricklayer, or doctor, he begins to wonder if his independence is worth the price he is paying for it—especially when he considers the amount of time it took him to learn his trade, the money he has invested in equipment, and the hours he works.

"So why does he still shy away from joining an organization?"

"A fellow at the store asked the same question of an executive of a service technician's organization. The latter said one reason was many service technicians have an unfounded fear their lack of technical knowledge will be exposed if they meet and talk and plan together with other technicians, some of whom are more experienced. Service organizations are designed to enable members to pull together, not to pit one member against another; and the least experienced member stands to learn the most from association. The second reason was the same the maiden lady gave when asked why she never married: 'No one asked me.' This man is convinced a great number of service dealers have not joined an association simply because they have never been personally approached by an enthusiastic member who could explain the advantages."

"Do you think these are the reasons only one out of four or five service technicians is a member of any organization?"

"They are not the only reasons. Many technicians do not join because they are repelled by the squabbling that has taken place over the years among rival organizations. The name-calling, accusations, and counter-accusations have bewildered and disgusted potential members. Also some of the smaller local organizations have tried to fix prices and dictate hours—a real hobgoblin to the independent service technician. Finally, the independent technician wants to be shown the *quid pro quo*, as the lawyers like to call it. What is he going to get for his membership dues?"

"Well, what *will* he get?"

"A strong national organization can do a great deal to improve the public image of the service technician—and believe me that image can stand it. Such an organization can bring strong pressure to bear on the manufacturers to make their products more serviceable. It can protect his interest at all levels of local, state, and federal legislation."

"Sounds like a big order," Mac said; "and I'm not sure but that the whole discussion is largely academic. It may well be the service fraternity has put off organization too long to save the independent technician. Only in recent

months have there been encouraging signs the association ball is starting to roll, but for a long time the independent technician has been slowly but surely going the way of the independent grocer, the Mom and Pop motel, the corner drugstore, and the small farmer. Independence is rapidly becoming a luxury few workers can afford. The modern idea is to work simply to make money to be used pursuing an interesting avocation. The old ideal of doing work you enjoy—combining your work and your chief interest—is becoming less and less practicable."

"More's the pity," Barney commented. "However, if the independent technician goes down the drain, he'll not be the only loser. Manufacturers will be forced to do their own servicing, something they really don't want. They know the advantage of having the service dealer as a buffer between them and irate customers. If service technicians are forced to work in the service shops of manufacturers, they will be unionized just as are production workers and will demand much higher pay. This will result in greatly increased service costs, which the manufacturer can either absorb or pass on to the customer. Guess which he will do! If the independent closes his doors, wholesalers will not be far behind. Who will be buying replacement parts or general service data or service magazines? Each manufacturer will supply his own service department with these materials tailored just for his own products."

"It seems, then," Mac concluded, "that it behooves the service technicians, manufacturers, wholesalers, and publishers to help the technicians create a strong, democratic national organization *now*. All will benefit from such a move, and the customers will benefit most of all. Only a strong, fully supported service organization can make electronic service work sufficiently attractive to hold the caliber of men we need to keep the electronic equipment of this electronics-oriented country going!" ▲

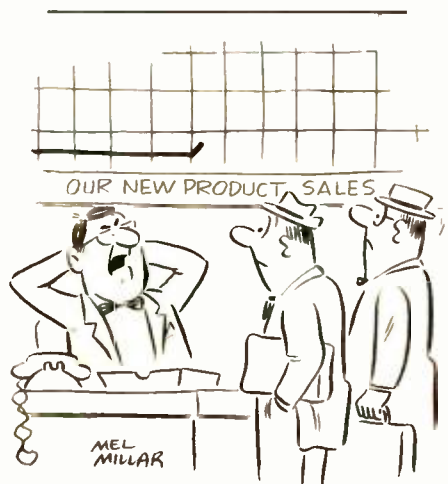

"So far it hasn't exactly been put into orbit!"

**In 1948, University Sound made home high fidelity possible.**



**In 1970, we made it perfect.**

In 1948, University unveiled the world's first popularly priced, full fidelity speaker — the 6201.

In 1970, University unveils the finest, fullest line of component speakers in the world. For example —



**THE PREMIER SERIES** / Custom built multi-speaker components reproduce the full frequency range without distortion or coloration. Award-winning one-piece die-cast baskets assure long life, troublefree operation. Astounding depth and clarity from all five models in the Premier Series: 315-C, 312, 6201, the Diffusicone 12 and Diffusicone 8. Send for complete details on University's entire component speaker line, and on PSE—University's Planned Speaker Expansion program, brochure full of construction details, specs, hints, blueprints—simplified so anyone can build a fine speaker system.

**UNIVERSITY TY SOUND** — the world's leading manufacturer of electroacoustics products.

It's yours  
**free**

for the  
asking!

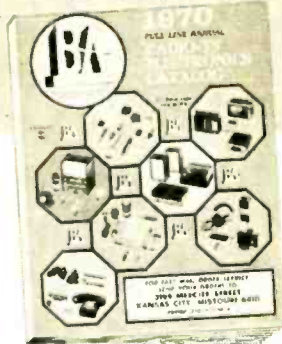

**GIANT 274 PAGE  
1970  
RADIO-TV  
ELECTRONICS  
CATALOG**

**YOUR BUYING GUIDE FOR . . .**  
TV's, Radios, Recorders, Phonos, Amateur and CB equipment,  
electronic parts, tubes and test equipment . . . featuring B-A's  
famous big bargain packed section!

Write to:

**BURSTEIN-APPLEBEE CO.,**  
DEPT. EW-2 3199 MERCIER ST.,  
KANSAS CITY, MO. 64111

Name \_\_\_\_\_  
Address \_\_\_\_\_  
City \_\_\_\_\_  
State \_\_\_\_\_ Zip Code \_\_\_\_\_



CIRCLE NO. 143 ON READER SERVICE CARD

**NEW!** . . . from Lampkin Laboratories  
**TYPE 107 DIGITAL FREQUENCY METER**  
FAST - ACCURATE - PORTABLE



Designed to meet today's  
mobile-radio service needs -

- ★ ONE PART PER MILLION ACCURACY!
- ★ ALL-CHANNEL COVERAGE - TO 500 MHZ
- ★ READ FREQUENCY DIRECT - NO CHARTS!
- ★ EASIER - MORE FLEXIBLE - FASTER!

\$2,390 F.O.B. Bradenton, Florida

For complete specifications - Mail coupon today

Name \_\_\_\_\_  
Address \_\_\_\_\_  
City \_\_\_\_\_ State \_\_\_\_\_ Zip \_\_\_\_\_

**LAMPKIN LABORATORIES, INC.**  
MFM Div., Bradenton, Fla. 33505

Symphony Hall, long-considered one of the world's finest concert halls. Optionally, listeners may add one more channel to their 2-channel systems by tuning in WGBH on a monophonic radio and placing it at the back of the room. Those with no stereo equipment at all can enjoy a reverberant effect by listening to WCRB on a monophonic AM radio and WGBH on a monophonic FM set. In addition, regular 2-channel stereo reception has been improved as a direct result of the work undertaken in the 4-channel experiments.

(In New York City, WNYC-FM and WKCR have transmitted a number of programs using 4-channel tape.—Editor)

The only multiplex FM system thus far proposed publicly has been that of William Halstead, using additional subcarriers for compatible transmission of the necessary four channels. A compatible multiplex system would be superior to the two-station approach for the reasons outlined in the discussion of tape above, since the listener with only one stereo system would then hear all the information presented.

**Amplifiers and Speaker Systems**

Since a 4-channel stereo system can be thought of as four 2-channel systems, one on each wall of a room, it is not surprising that the same criteria as apply to the 2-channel technique should also influence setting up a 4-channel system. However, the need to provide optimum results from all four directions simultaneously does make somewhat more care necessary in choosing and placing speaker systems, while some types of speaker systems may not lend themselves to 4-channel use. If audio systems which employ a "center-fill" speaker are used, then eight speaker systems, rather than four, will be needed. Reflecting-type speakers, which create images which are intense additional sound sources, cause "sound effects" which do not result from reverberant information in the recording.

Microphone setup in Busch-Reisinger Museum at Harvard during Columbia recording of organ music performed by E. Power Biggs. Five microphones were used; front center information from fifth mike was mixed into front left and right.

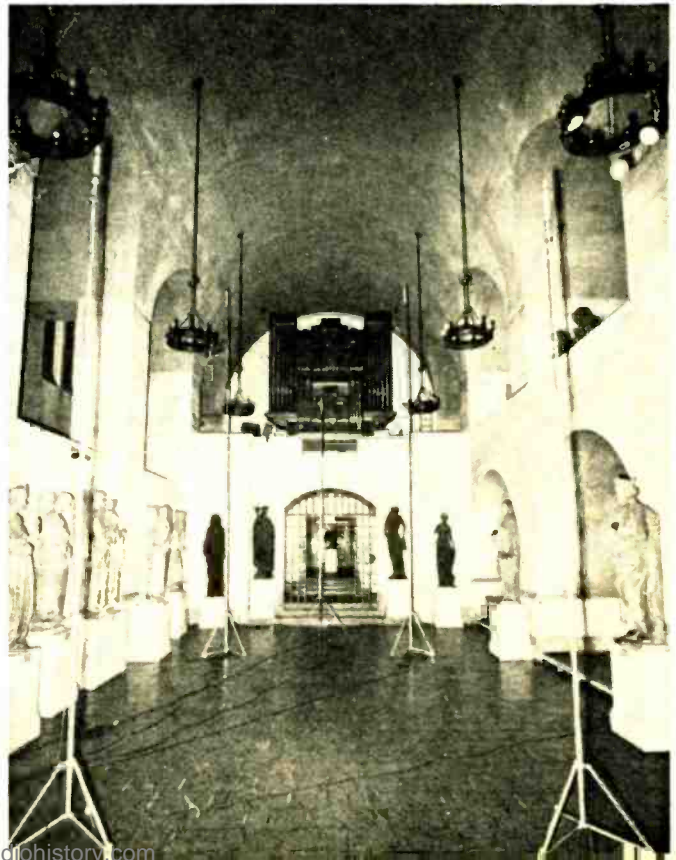



The optimum listening area is that which includes the region in which the optimum areas for the four "pairs" of speakers overlap (Fig. 3). A simple computer program was used to prepare the diagram showing ideal locations for listening to acoustic-field recordings with minimum balance error. The arrangement giving the largest effective listening area for such recordings is a square, as large as can be arranged in a given room, preferably with the speaker systems near the corners, for best channel separation and directional accuracy.

All rooms, including concert halls, tend to absorb high frequencies more than middle or low frequencies. As a result, the recording of a piano in a concert hall will contain an over-all deficiency of high frequencies when compared to a recording of the piano made, say, outdoors at the same volume level. This is because the sound in the concert hall is the total of direct sound (correct high-frequency balance) and reflected sound (attenuated high frequencies), while an anechoic recording contains only the direct sound of the instrument.

In reproducing the concert-hall recording, we wish to hear the balance as it is in the concert hall, that is, with slightly attenuated high frequencies. However, the room in which such a recording is played is also somewhat reverberant and therefore dilutes high-frequency content slightly further. It is therefore desirable to apply slight treble boost to compensate for listening-room losses when playing acoustic-field recordings made in the concert hall. If 2-channel recordings of the "presence" type are played, the treble boost should be removed, and listening room acoustics allowed to play their normal part.

Acoustic-field recordings are not the only kind which can be made with 4-channel recorders, however. The least critical recordings, from the home listener's viewpoint, are those in which each channel carries its own unique signal. In these cases, there is little or no restriction on the type of speaker system which may be used, except for the usual requirement that the speaker display some semblance of accuracy if the playback is to reflect the intention of the recording's producer.

Naturally, all the speakers used will have to be in phase with one another. To achieve this is a slightly more time-consuming activity than is the case when only two speaker systems need to be matched with each other.

Multichannel systems have been available before this time, and several different formats have been proposed in the past. Usually, even when three or four channels were used, these have been proposed to cover only the front one-fourth of the listening field. Whether the most recent series of experiments will lead to any more substantial development than the earlier proposals will undoubtedly depend to some extent upon the public's reaction to the 4-channel presentations it is able to hear and upon the outcome of experiments made both by professionals and amateurs.

Audio is a field which owes a great deal of its vitality and progress to individual efforts at exploration and development, of which the Scheiber-Mowrey 4-channel disc is only a recent example. Perhaps other individual investigators, spurred by industry interest, will now support and develop techniques of 4-channel stereo just as they aided in the development of 2-channel stereo a decade ago. ▲

**EDITOR'S NOTE:** Last month we promised our readers we would keep them abreast of developments on 4-channel stereo. Bob Berkovitz' article in this issue is such an all-inclusive presentation that it's rather difficult to say any more at this time. We had hoped to include an article by Russ Molloy of The Telex Corp. also, giving his opinions on 4-channel stereo, but due to business commitments, his article has not materialized. In line with keeping our readers up-to-date, however, we have planned a rather extensive story on 4-channel stereo by Daniel von Recklinghausen of H. H. Scott, Inc., which will appear next month.

February, 1970

**Telex writes  
new specs  
on sensitivity  
and ruggedness  
in headphones.**

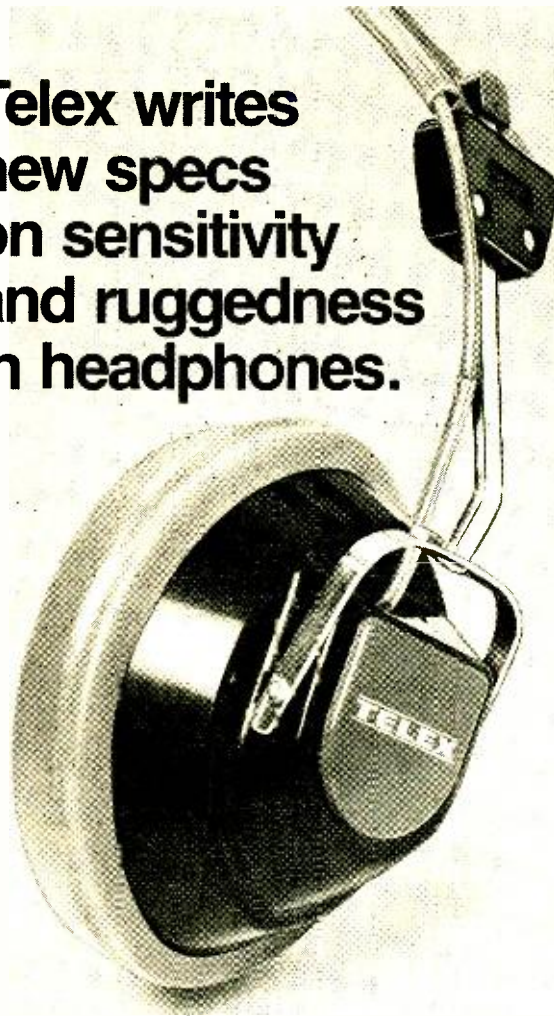

## the Communicator Series

**HIGH SENSITIVITY AND LOW OPERATING POWER.** The new Communicator Series of headphones is designed around a dramatic new driver unit that requires only absolute minimal operating power. This added efficiency allows for a substantial increase in sensitivity without any increase in distortion, making the Communicator Series the most sensitive and versatile headphones available today.

**RUGGED. CONSISTENT PERFORMANCE.** Unlike the soft aluminum or paper cones in most of today's headphones, the Communicator's rugged new cone is made of special material that will provide peak performance without being affected by temperature or humidity. This means that you get consistent, high quality performance, day in and day out, under the most demanding communications conditions.

For more information on Telex's new Communicator headphones, contact your nearest Telex dealer or write.

PRODUCTS OF SOUND RESEARCH  
**TELEX**<sup>®</sup>  
COMMUNICATIONS DIVISION  
9600 Aldrich Avenue South  
Minneapolis, Minnesota 55420



CIRCLE NO. 104 ON READER SERVICE CARD

59

Second in a series...

# Can you solve these problems in electronics?

They're a cinch after you've taken RCA Institutes' new communications electronics program.

It includes new preparation for the FCC license plus the assurance of your money back if you fail to get it.

This one is quite elementary.

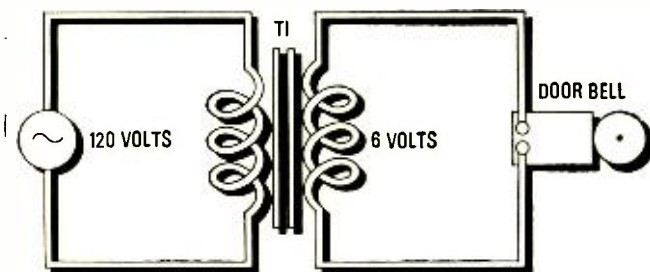

**In this door bell circuit, which kind of transformer is T<sub>1</sub>, — step-up or step-down?**

Note: if you had completed only the first lesson of any of the RCA Institutes Home Study programs, you'd easily solve this problem.

This one is more advanced.

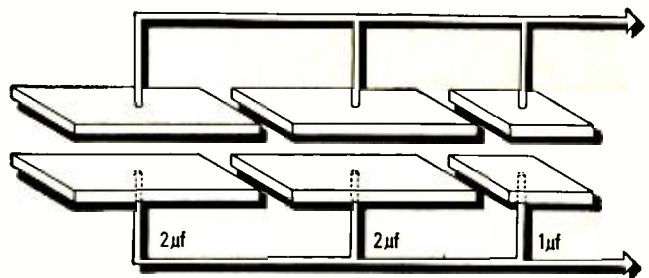

**What is the total capacitance in the above circuit?**

Note: you'd know the solution to the problem if you'd taken only the first two lessons in RCA's new Communications Electronics Program.

These are the lessons that prepare you step-by-step for an FCC License.

This license is a requirement for servicing all types of transmitting equipment and can help open doors to jobs commanding high income in communications, radio and broadcasting, aerospace, industrial automation and many others.

**For a rewarding career with good pay, take that first step now. Send for complete information—mail the attached card.**

Answers: Step-down.

# RCA Institutes Autotext learning method makes problem-solving easier... gets you started faster towards a good-paying career in electronics

Are you just a beginner with an interest in electronics? Or, are you already making a living in electronics, and want to brush-up or expand your knowledge? In either case, RCA has the training you need. And Autotext, RCA Institutes' own method of Home Training will help you learn more quickly and with less effort.

## Wide Range of Courses

Select from a wide range of courses. Pick the one that suits you best and check it off on the attached card. Courses are available for beginners and advanced technicians.

- Electronics Fundamentals
- Black & White Television Servicing (Transistorized TV Kit Available)
- Color Television Servicing (Color TV Kit Available)
- FCC License Preparation
- Automatic Controls
- Automation Electronics
- Industrial Electronics
- Nuclear Instrumentation
- Electronics Drafting
- Computer Programming

## Plus these new up-to-the-minute courses

- Semiconductor Electronics
- Digital Electronics
- Solid State Electronics
- Communications Electronics

## Prepare for good paying positions in fields like these

- Television Servicing
- Telecommunications
- Mobile Communications
- CATV
- Broadcasting
- Marine Communications
- Nuclear Instrumentation
- Industrial Electronics
- Automation
- Computer Programming
- Solid State
- Electronics Drafting



Build and keep this valuable oscilloscope.



In the new program on Solid State Electronics you will study the effects of temperature and leakage characteristics of transistors.



## Variety of Kits—Yours to Keep

A variety of RCA Institutes engineered kits are included in your program of study. Each kit is yours to keep when you've completed the course. Among the kits you construct and keep is a working signal generator, a multimeter, a fully transistorized breadboard superheterodyne AM receiver, and the all-important oscilloscope. These 4 kits are at no extra cost. Compare this selection with other home study schools.

## Two Convenient Payment Plans

Pay for lessons as you order them. No contract obligating you to continue the course. Or, you can take advantage of RCA's convenient monthly payment plan. No interest charges!

## Classroom Training Also Available

RCA Institutes operates one of the largest technical schools of its kind. Day and evening classes. No previous training is required. Preparatory courses are available. Classes start four times a year.

## Job Placement Service, Too!

Companies like Bell Telephone Labs, GE, Honeywell, IBM, RCA, Westinghouse, Xerox, and major radio and TV networks have regularly employed graduates through RCA Institutes' own placement service.

**All RCA Institutes courses and programs are approved for veterans under the new G.I. Bill.**

**Send Attached Postage Paid Card Today. Check Home Study or Classroom Training.**

Accredited Member National Home Study Council.

IF REPLY CARD IS DETACHED, SEND THIS COUPON

### RCA Institutes Inc.

Home Study Dept. 240-002-0  
320 West 31 Street  
New York, N.Y. 10001

Please send me FREE illustrated career catalog.

Name \_\_\_\_\_ Age \_\_\_\_\_  
(please print)

Address \_\_\_\_\_

City \_\_\_\_\_ State \_\_\_\_\_ Zip \_\_\_\_\_

Enjoy Relaxing Background  
Music at Home with . . .  
**NO COMMERCIALS!**

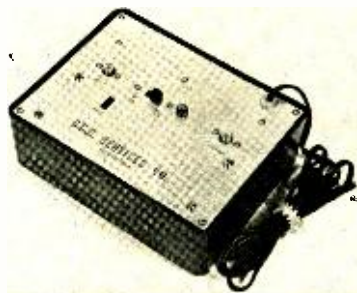

Our SCA-1 Decoder makes possible reception of this "private" musical programming, transmitted by nearly 400 FM stations around the country. YOUR FM tuner or receiver can recover this "hidden" music with the simple addition of an SCA-1.

Hook-up in minutes—full instructions supplied. SCA-1 is self-powered . . . uses all solid-state circuitry (FET's, IC's, NPN's). Works with any quality FM Tuner or receiver.

Send check or m.o. for either . . .  
**SCA-1 (Wired, ready to use) . . . \$64.50**  
**SCA-1K (Kit, all needed parts) . . . \$49.95**  
**Etched, drilled P.C. Board plus special IC and full construction plans . . . \$12.50**

(New York State Residents Add 5% Sales Tax)

One year parts guarantee

Prohibited for commercial use

FREE National S.C.A. station list supplied with every order.

**SCA Services Co., Inc.**

Box 601, Port Washington, N.Y. 11050

(516) 883-5694

CIRCLE NO. 117 ON READER SERVICE CARD

ENJOY THE "MUSIC ONLY" FM PROGRAMS

**M. A. D.**

MUSIC ASSOCIATED'S DETECTOR  
NO COMMERCIALS—NO INTERRUPTIONS



It's easy! Just plug Music Associated's Sub Carrier Detector into multiplex jack of your FM tuner or easily wire into discriminator. Tune through your FM dial and hear programs of continuous commercial-free music you are now missing. The Detector, self-powered and with electronic mute for quieting between selections, permits reception of popular background music programs no longer sent by wire but transmitted as hidden programs on the FM broadcast band from coast to coast. Use with any FM tuner. Size: 5½" x 9". Shipping weight approx. 7 lbs.

**KIT \$49.50**

(with pre-tuned coils, no alignment necessary)

**WIRED \$75.00**

COVER \$4.95 EXTRA

List of FM Broadcast Stations with SCA authorization \$1.00

**MUSIC ASSOCIATED**

65 Glenwood Road, Upper Montclair, N.J. 07043  
Phone: (201) 744-3387



# TEST EQUIPMENT

## Product Report

### Eico Model 443 Semiconductor Curve Tracer

For copy of manufacturer's brochure, circle No. 3 on Reader Service Card.

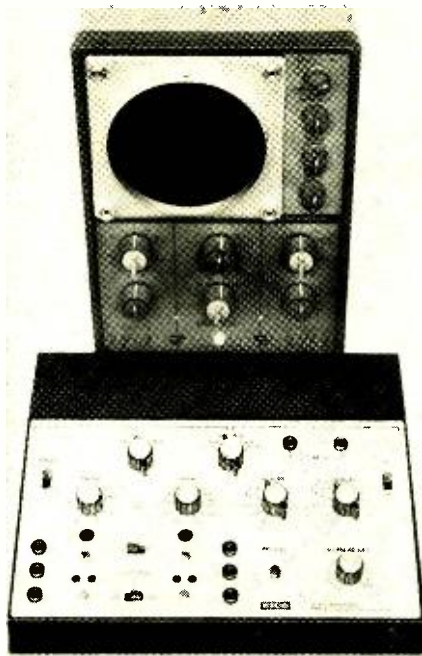

control that determines the size of the base-current steps for the proper display size. Now, the transistor *beta* can be read directly on the curve-tracer control. What is more, many other transistor characteristics, including leakage current, breakdown voltage, resistance, and *beta* linearity can be determined graphically right from the oscilloscope display.

Separate tests are available for signal and power transistors. Signal transistors are checked over a *beta* range of 15 to 500 at a voltage of 10 volts and maximum collector current of 12 mA. Power transistors are checked over a *beta* range of 0 to 300 at the same voltage but with a maximum current of 1 A.

The curve tracer also does a fine job of displaying the *V-I* characteristics of diodes. Both signal and rectifier diodes can be checked. Two basic tests are performed: the peak inverse voltage and the forward current. Maximum inverse voltage applied to a diode is 1400 volts at 1 mA, while maximum forward current is 1 A. During the time that the high reverse voltage is applied to the diode under test, a flashing neon lamp on the panel signals its presence. At the same time, the user must press a momentary-contact push-button to apply the test voltage, so there is little chance of getting a shock from the equipment.

When we used the curve tracer to check a number of similar rectifier diodes we had on hand, we were surprised to observe the variation in peak inverse voltages. Although our diodes were rated at a p.i.v. of 600 volts and most of them checked out around this figure, we found one that would only handle 300 volts before breakdown occurred. Naturally, we discarded this one immediately.

Two separate sets of transistor sockets and banana jacks are provided. The instrument can be switched back and forth from one to the other when it is desired to match a pair of transistors.

In addition to the various switches and operating controls on the front panel of the curve tracer, the unit contains a small printed-circuit board on which are mounted 8 transistors and associated components. These transistors generate

**T**HE conventional transistor checker is fine if you want to get a quick reading of *beta* and leakage currents. But if you want to really *see* how the transistor operates, you need a curve tracer. This device, working along with an oscilloscope, produces a display of the transistor's *V-I* characteristics on the screen. The most popular curve tracer we know is a *Tektronix* unit that is fairly expensive. Now, along comes *Eico* with a real first in the much lower-priced test-equipment field with their new Model 443 curve tracer.

The tracer is designed for use with any general-purpose oscilloscope. What it does is to generate a horizontal sweep signal proportional to the transistor's collector voltage along with a vertical sweep proportional to the collector current. At the same time, four levels or steps of base current are applied to the transistor under test. Each step lasts for the duration of a single sweep. As a result, four *V-I* curves are traced on the oscilloscope and these curves depict a family of characteristics of the transistor. After the instrument is properly calibrated to produce a display of given size, it is only necessary to advance the con-

For the **SERVICEMAN**  
who is also  
a **Businessman...**

For the **HOBBYIST**  
who is also  
a **Perfectionist...**

The **1970 ELECTRONICS INSTALLATION & SERVICING HANDBOOK**  
is the handy guide you need  
and will use daily.

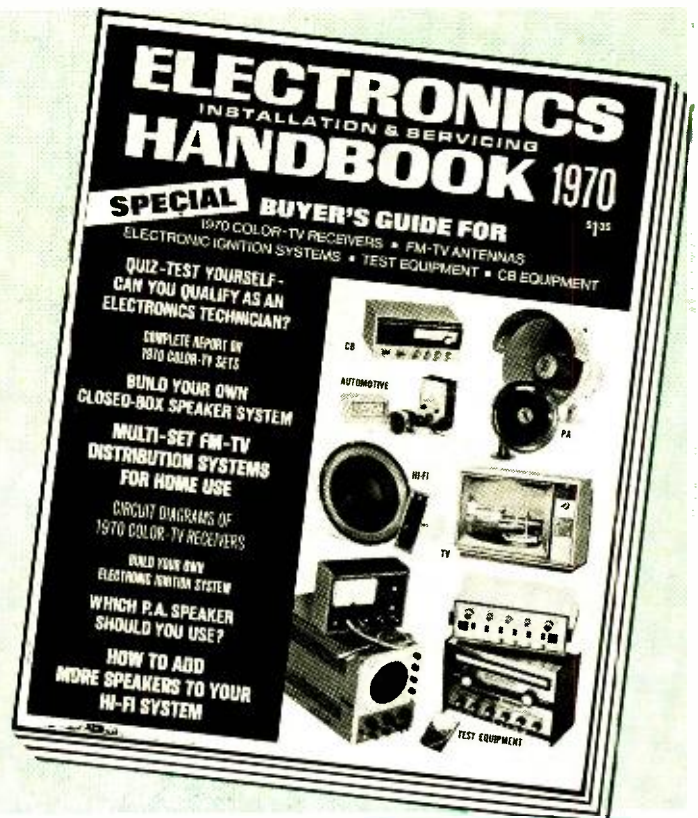

This is the industry's "how-to" book for installing and servicing consumer electronics equipment. From the basic tools and test equipment to advanced techniques. Color TV . . . TV/FM antennas . . . Stereo HiFi . . . CB . . . Electronics Ignition Systems . . . Radio and TV test equipment . . . P. A. systems. All in clear, concise, complete detail.

**KEEPS YOU AHEAD OF YOUR COMPETITION**

You'll find valuable special features in your 1970 ELECTRONICS INSTALLATION & SERVICING HANDBOOK. Like a "Do-it-yourself" test: Can you qualify as an electronics technician? And up-to-the-minute articles on Multi-set FM-TV distribution systems for home use . . . 1970 Color-TV sets . . . How to add more speakers to your HiFi system. And many more.

**YOU'LL BENEFIT FROM THE EXPERIENCE OF OTHERS**

You'll be advised on what you can—and can't—handle, based on the experience of experts. You'll have hundreds of charts, circuit diagrams and tables at your fingertips—all designed to help you do a better job in the least amount of time. You'll become a better serviceman and a better businessman.

Don't put it off. Start now to make every working hour more profitable. Use the coupon to order your copy. Only \$1.35.



**GET THE DELUXE LEATHERFLEX-BOUND EDITION**  
for just **\$3.50 POSTPAID!**

The 1970 ELECTRONICS INSTALLATION & SERVICING HANDBOOK is also available in a splendid deluxe edition. Rugged Leatherflex cover provides lasting protection yet is softly textured and gold-embossed for the look of elegance. A collector's item—a superb addition to your permanent reference library. And it's yours, for just **\$3.50** postpaid, when you check the appropriate box on the order form.

**Bring Your Reference Library Up to Date!**

If you've missed any of these current and previously published handbooks, a wide selection is still available. Just circle the corresponding numbers on the coupon below.

**ELECTRONIC EXPERIMENTER'S HANDBOOK**—148 pages of the most fascinating and challenging construction projects for electronics hobbyists.

1970 Winter—#97    1969 Spring—#88    1969 Winter—#85  
1968 Spring—#84    1968 Winter—#50    1966 Spring—#36  
1966 Fall—#39    1965 Fall—#9

**TAPE RECORDER ANNUAL**—Covers every aspect of tape recording . . . plus complete buyer's guide.

1970—#99    1969—#81    1968—#59

**STEREO/HI-FI DIRECTORY**—Giant buyer's guide complete with photos, specs, prices.

1970—#98    1969—#82    1968—#56

**ELECTRONICS INSTALLATION & SERVICING HANDBOOK**—Covers all 8 areas of consumer electronics servicing—for the serviceman and hobbyist.

1969—#83    1968—#58    1967—#43

**COMMUNICATIONS HANDBOOK**—Fact-packed pages for the CB, SWL, or HAM . . . plus equipment buyer's guide.

1969—#86    1968—#53    1967—#47

**ZIFF-DAVIS SERVICE DIVISION, Dept. IS • 595 B'way • N.Y., N.Y. 10012**  
Please send me the 1970 ELECTRONICS INSTALLATION & SERVICING HANDBOOK. I want the:

- Regular Edition—\$1.35 plus 25¢ for shipping and handling. (\$2 postpaid, for orders outside the U.S.A.)
- Deluxe Edition—\$3.50, postpaid. (\$4.50 postpaid for orders outside the U.S.A.)

I've circled the numbers of additional annuals I wish to receive.

<b>\$1.25</b>	9	36	39	43	47	50	53	<b>\$1.35</b>	81	83	86
each	56	58	59	82	84	85	88	each	97	98	99

I am enclosing a total of \$\_\_\_\_\_ for the annuals ordered above. I've added an additional 25¢ per copy for shipping and handling. (For orders outside the U.S.A., all regular editions are \$2.00 per copy, postpaid. Deluxe editions are \$4.50 per copy, postpaid.) EW-2-70

print name \_\_\_\_\_

address \_\_\_\_\_

city \_\_\_\_\_

state \_\_\_\_\_ zip \_\_\_\_\_

**PAYMENT MUST BE ENCLOSED WITH ORDER**

## DON'T SETTLE FOR A HIT AND MISS IGNITION SYSTEM



### Install a **JUDSON** ELECTRONIC MAGNETO

It offers the combined advantages of both the standard transistorized and capacitive discharge systems in one simplified patented circuit. Provides better performance, a smoother running engine and keeps your car in tune. Installed in twenty minutes.

Write Today for Literature



CIRCLE NO. 130 ON READER SERVICE CARD

## MR. SCA OPERATOR

NEED A RELIABLE SOURCE FOR HIGH QUALITY, LOW COST SCA RECEIVERS, OR SCA DEMODULATOR UNITS?

A new and proven sub-carrier demodulation scheme using old established principles is now practical due to recent component developments and mass production. The resultant reduction in cost is passed on to you.

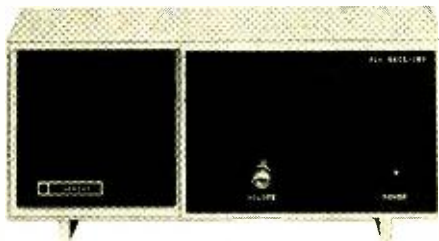

MODEL SCA-6137 SINGLE FREQUENCY FM RECEIVER. Size: 12" x 5½" x 4½". Price: \$69.95 (Quantity 1-9)

SCA-6137 FM Receiver Features:

- Range: 88 to 108 MHz • Frequency Field Adjustable • All Solid State Devices • RF Stage
- 3 IF Stages • Automatic Frequency Control
- Two 67 KHz Amplifier Stages • 67 KHz Ratio Detector • Adjustable Muting • Main/Sub-Carrier Switch • One Watt Audio Output • 4" Monitor Speaker • Provision for External Speaker • 117 Volt AC Operated.

Also available: SCA-3 sub-carrier demodulator PC Card with muting control. Size: 2½" x 3" x ¾". Operates on 6 to 12 Volts DC at 6 ma. Available from stock. Price: \$39.95 (Quantity 1-9)

Quantity discounts and detailed specifications are available to SCA operators.

Send orders and inquiries to:

JanZac Company; P.O. Box 177;  
Stamford, Conn. 06904

KenZac Company; P.O. Box 66251;  
Houston, Texas 77006

CIRCLE NO. 129 ON READER SERVICE CARD

the various stepping currents applied to the transistors under test.

The *Eico* Model 443 measures about 11½-in wide, 9½-in deep, and just under 3-in high. It is furnished along

with a special engraved graticule for a 5-in scope, in case your scope doesn't already have one. The tracer sells for \$69.95 in kit form or for \$99.95 factory-wired. ▲

### Honeywell "Digitest 500" Digital V.O.M.

For a copy of manufacturer's brochure, circle No. 4 on Reader Service Card.



SEVERAL years ago at the IEEE Show in New York, *Fairchild* created quite a stir with a really low-cost (under \$300) digital voltmeter. (See our July, 1967 Test Equipment Product Report.) Quite a few other manufacturers have tried to crack what they consider to be a fairly lucrative test-equipment market with an instrument of this type. A new instrument in this class is the *Honeywell* "Digitest 500" digital v.o.m. *Honeywell* has had a "Digitest 333" before this (see our April, 1968 Test Equipment Product Report), priced at just over \$500. But the new unit is more compact, lighter in weight, and it sells at less than half the cost of the previous digital v.o.m. The Model 500 is priced at \$250.

*Honeywell's* Test Instruments Div. marketing people are very enthusiastic about the new instrument. They have predicted a sale of more than 400 of these units during 1970. This would raise the company's percentage of units sold in the 3-digit multimeter market to 40 percent or more, compared with 18 percent last year.

One look at the unusual appearance and styling of the Model 500 seems to indicate that it was not designed in the U.S. The instrument is actually a French design and was manufactured by *Schneider Radio Television*, Ivry-Seine,

France. It was introduced earlier in Europe and will be marketed in the U.S. by *Honeywell*.

The 3-digit instrument has 17 ranges of a.c. and d.c. voltage, current, and resistance with accuracies ranging from 0.2 percent to 1.5 percent, and low-range sensitivities of 100 microvolts and 100 nanoamps. Input impedance is 2 to 50 megohms. The unit operates from 117 V a.c. or 11 to 18 V d.c. power sources.

One reason for the size and weight reduction is the use of LSI (large-scale integrated) circuitry. A 16-pin, dual in-line IC provides counting and logic functions in addition to some analog-to-digital conversion and switching normally done by transistors.

The Model 500 weighs only 2½ lbs and is packaged in a case 9-in long, 5-in wide, and under 3-in high. The unit's small size permits it to be held easily in one hand and operated by the other. Yet the instrument is still large enough to permit the user to conveniently select the ranges and functions by means of its push-button matrix keyboard. Readout is on three Nixie-type indicator tubes mounted behind the sloping panel. The simplicity and ease of operation, as well as its \$250 price, should attract many users to this test instrument. ▲

### Mercury Model 1101C Tube Tester

For a copy of manufacturer's brochure, circle No. 5 on Reader Service Card.

THERE are still plenty of tubes being used in electronic equipment. Even though TV set makers are using more and more transistors and IC's these days, most of the color-TV and black-and-white receivers now in use employ vac-

uum tubes and these will continue to be in use for years to come. That's why test-equipment manufacturers keep coming out with new or modified tube testers, such as the *Mercury* Model 1101C described here.

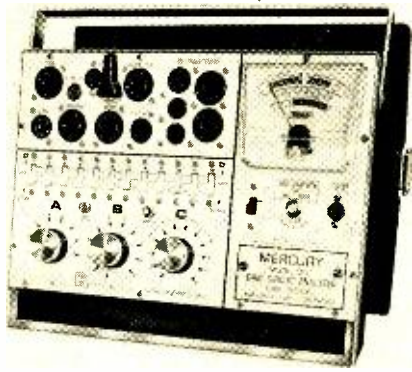

This new tube tester performs the usual short-circuit and cathode-emission tests. In addition, it uses a 12AU7 v.t.v.m. circuit to check on grid emission and leakage of the tube under test. When the grid-emission meter scale indicates less than 0.5 microampere, the tube is satisfactory with respect to this test. A grid current of 0.5 to 2 microamperes indicates a questionable tube, while higher grid currents are excessive and the tube should not be used. Sockets are provided to test not only octals 7-, 9-, and 10-pin miniature tubes, but also novistors, compactrons, decals, magnovals, and novars. There are five other sockets on the front panel for use as pin straighteners.

The tester is light in weight (only 7 lbs) and the controls have been arranged for simple ABCD operation. Hence, it should be possible to test all the tubes in a TV set in not much more than several minutes. As a matter of fact, it takes longer to look up the tube type in the data chart than it does to set up the tube tester to check a given tube.

Price of the Model 1101C is \$69.95, factory-wired. The company also has available a subscription service to keep the tube-test data always up-to-date. The price of this service is \$4.50 for a year's subscription, including the latest revised tube-data chart plus all supplements. ▲

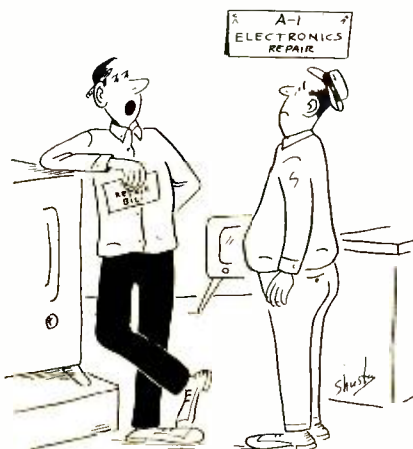

"Sorry, we got a deal with the bank—they don't repair television sets and we don't give credit!"

# 2

## ALIGNMENT OSCILLATORS DESIGNED TO MAKE SERVICING EASIER BOTH NEW FROM INTERNATIONAL

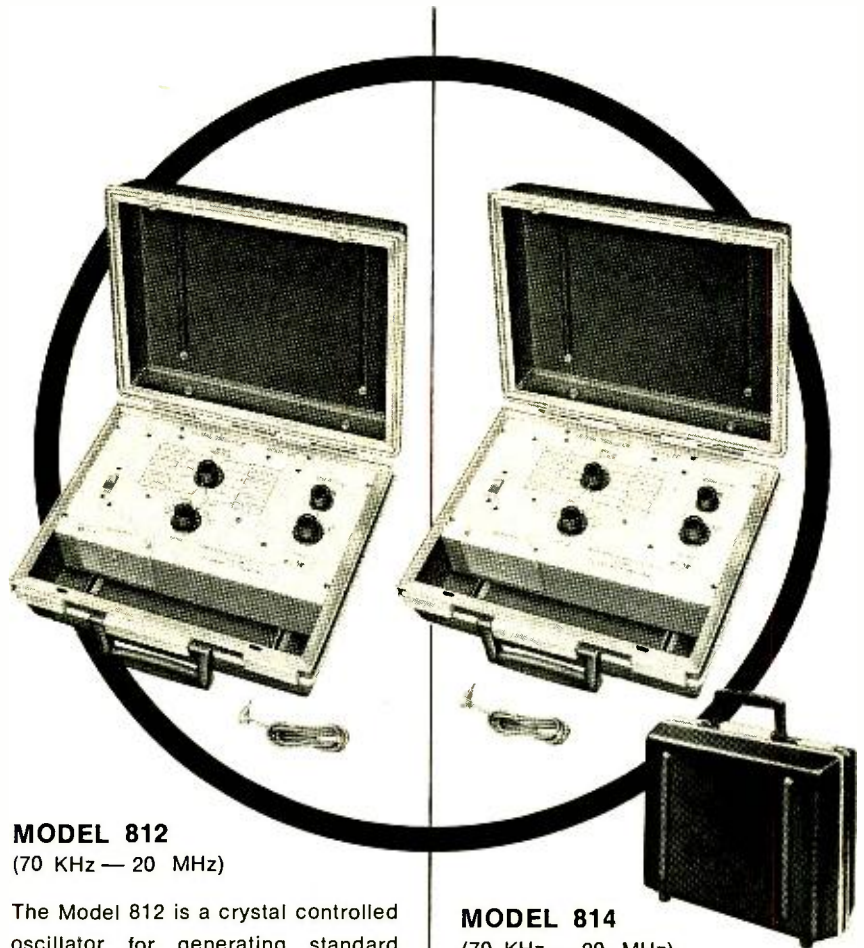

### MODEL 812 (70 KHz — 20 MHz)

The Model 812 is a crystal controlled oscillator for generating standard signals in the alignment of IF and RF circuits. The portable design is ideal for servicing two-way radios, TV color sets, etc. This model can be zeroed and certified for frequency comparison on special order. Individual trimmers are provided for each crystal. Tolerance .001%. Output attenuators provided. Battery operated. Bench mount available.

Complete (less crystals) \$125.00

### MODEL 814 (70 KHz — 20 MHz)

The Model 814 is identical in size to the 812. It does not have individual trimmers for crystals. Tolerance is .01%. Battery operated. Bench mount available.

Complete (less crystals) \$95.00

*Both the Model 812 and Model 814 have positions for 12 crystals and the entire frequency range is covered in four steps.*

Write for catalog



**CRYSTAL MFG. CO., INC.**  
10 NO. LEE • OKLA. CITY, OKLA. 73102  
CIRCLE NO. 131 ON READER SERVICE CARD

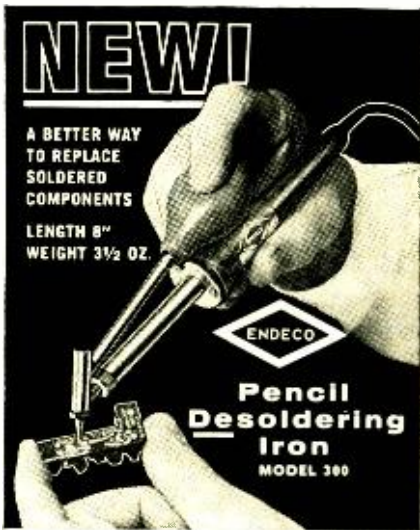

Now—remove miniature soldered components in seconds—without damage

Hollow tip fits over connection; vacuums all solder for easy removal of component. Leaves terminals and mounting holes clean. Then, with 360° contact, it resolders faster, better than regular irons. Handles miniature and standard components in PC boards and conventional wiring. Self-cleaning. All parts replaceable. 40 watts, 120-v. Standard tip supplied, 6 other tip sizes. Pays for itself. \$10.95 net East of the Rockies.

Larger model available. See your distributor or write:

ENTERPRISE DEVELOPMENT CORPORATION  
5149 E. 65th • Indianapolis, Ind. 46220  
CIRCLE NO. 138 ON READER SERVICE CARD

**Olson**  
ELECTRONICS

FREE

Catalog

---

Fill in coupon for a FREE One Year Subscription to OLSON ELECTRONICS Fantastic Value Packed Catalog — Unheard of LOW, LOW PRICES on Brand Name Speakers, Changers, Tubes, Tools, Stereo Amps, Tuners, CB, Hi-Fi's, and thousands of other Electronic Values. Credit plan available.

NAME \_\_\_\_\_  
ADDRESS \_\_\_\_\_  
CITY \_\_\_\_\_ STATE \_\_\_\_\_  
GIVE ZIP CODE \_\_\_\_\_

If you have a friend interested in electronics send his name and address for a FREE subscription also.

**OLSON ELECTRONICS**  
562 S. Forge Street, Akron, Ohio 44308

CIRCLE NO. 123 ON READER SERVICE CARD

## EW Lab Tested

(Continued from page 6)

inaudible and nearly unmeasurable (better than 85 dB below 10 watts). Although the distortion increased slightly as power was reduced from 80 watts, this can hardly be criticized in view of the fact that it rose from 0.0025 percent to a "high" of 0.01 percent.

We could not get significant IM distortion measurements since we read only the residual 0.07 percent distortion level of our IM analyzer up to nearly 100-watts output. For that reason no IM-distortion curve is included on the graph.

The power output into 8-ohm loads at the clipping point was about 93 watts per channel. Into 4 ohms, it was 89 watts, and it dropped to 56 watts with 16-ohm loads. The frequency response was as flat as our test meters could read—within less than 0.5 dB from 20 to 20,000 Hz. By driving the Model 16 beyond its clipping level (over 100 watts per channel) we did

manage to make it misbelieve to the extent of producing a sharp spike near the peak of the output waveform, accompanied on one channel by a short burst of what looked like ultrasonic oscillation caused by the unit's protective circuitry. Obviously, however, in any practical, real-life situation, this amplifier can be considered unconditionally stable and distortion free.

The Marantz Model 16 is a relatively compact unit, measuring 15 $\frac{5}{8}$  inches wide, 5 $\frac{3}{4}$  inches high, and 8 inches deep, and weighing 30 pounds. It is an enormously powerful, ultra-low-distortion unit that can do justice to the finest home music systems, even when driving the lowest-efficiency speaker systems. We could not fault it in listening tests, during which our threshold of pain was exceeded long before the amplifier reached its limits. The Model 16 sells for \$395. The Model 16M, which is one channel of the unit, sells for \$239. Optional accessories include a rack-panel mounting kit (available at \$50) and a walnut cabinet (\$29.95). ▲

## Dual 1219 Automatic Turntable

For copy of manufacturer's brochure, circle No. 2 on Reader Service Card.



CONSIDERING their present high level of performance, it is difficult to imagine how the better automatic turntables could be significantly improved. Nevertheless, the Dual 1019, widely regarded as one of the finest record players available, has now been superseded by the new Dual 1219. The 1219 has a 7-pound nonferrous platter 12 inches in diameter. The turntable has a nominal  $\pm 3$  percent vernier adjustment for each of its three (78, 45, and 33 $\frac{1}{2}$  r/min) speeds. It has a new motor with a "continuous-pole" section to bring the turntable up to speed in half a revolution, and a synchronous section to lock its speed to the line frequency independent of line-voltage variations.

The very accurate and effective anti-skating compensation of the 1019 has been retained in the 1219, with a minor improvement in convenience; it is no longer necessary to look up the proper setting for the compensator in a separate table when an elliptical stylus is being used (they require a different amount of correction than conical styli). The anti-skating dial has two scales, calibrated in grams to correspond to

the tracking force in use. One is used for 0.7-mil conical styli, the other for 0.2 x 0.9-mil elliptical styli. A table in the instruction manual provides setting information for other stylus dimensions.

The 8 $\frac{3}{4}$ -inch tonearm, which is claimed to be the largest presently being used on any automatic record player, is pivoted on low-friction gimbals. The pivots of the 1019 were already about as good as one could wish; the new ones are claimed to be even better (although we don't know how we could measure the improvement). At any rate, the new arm can operate at the lowest force that any cartridge can use, and will in no way limit the user's choice of cartridges, now or in the foreseeable future.

A new feature of the Dual 1219 is its provision for corrections of vertical stylus angle for single-play or automatic play. When playing single records, a short manual spindle that rotates with the platter is inserted in the turntable center hole. A mode-selector lever next to the arm base is set to SP (single play), and this adjusts the arm height so that the cartridge and arm are parallel to the record surface. If the cartridge is correctly designed and installed (a plastic jig supplied with the 1219 makes this a simple matter), it will have the required 15-degree vertical-tracking angle for lowest distortion. Single-play operation can be initiated either by pressing the Start lever, which causes the arm to index to the selected



record diameter, or by picking up the arm and cueing it manually (the turntable starts as the arm is moved toward the record).

For automatic operation, an automatic spindle is inserted in the center hole, and the mode selector is moved to MP (multiple play). This raises the entire arm structure so that the 15-degree vertical angle will be obtained on the third record of a six-record stack. The actual variation in vertical angle over the full stack is a negligible  $\pm 1.5$  degrees.

An interlock system helps to prevent operation of the unit with the mode selector in an incorrect position. If it is set to SP and the automatic spindle is installed, no record will drop, and the arm will not index. If it is set to MP with the single-play spindle installed, the cueing control level will not function. The cueing lever, like that of the 1019, is viscous-damped on both lift and drop, and operates with impressive smoothness. Unfortunately, the cueing function does not operate with the changer spindle in place. This is a slight inconvenience in that it cannot be used to achieve a momentary pause when there is a stack of records on the spindle.

When we tested the 1219, we found its performance to be much like that of the 1019. Its rumble was  $-37$  dB in the lateral plane, and  $-33$  dB including vertical components. Wow and flutter were 0.09 and 0.03 percent, respectively, at the two lower speeds, and slightly less at 78 r/min. The arm's tracking-force calibration scale was accurate to within 0.2 gram, and the anti-skating correction was optimum for equal distortion in both channels, which is the proper criterion for its adjustment. The arm tracking error was less than 0.8 degree per inch of record radius, a good figure.

Obviously, the *Dual* 1219 has a high degree of operating refinement, plus the fine performance that has long been associated with the *Dual* name. It is quite expensive—\$159.50 plus the base—and undoubtedly will have greatest appeal to those who dislike any compromise in their audio components. Its added cost has gone largely into technical and operating refinements; essentially the same performance is available in the much less expensive *Dual* 1209, as the manufacturer readily admits. At any rate, the 1219 is a good illustration of how an already superior product can be further improved by intelligent and imaginative engineering. ▲

**EDITOR'S NOTE:** Readers of this test report on the *Dual* 1219 automatic turntable will also be interested in a report on the lower-priced *Dual* 1212 automatic turntable. This report appeared on page 80 of our November, 1969 issue.

# Introducing the world's only \$339 triggered scope.

Before you say you don't need a triggered scope, look what's happening to TV servicing: tubes are out, transistors and IC's are in.

With tubes you could play hit-or-miss, knowing the tube would take the overload. Try the same thing now, and good-bye transistors.

For new-era circuitry, Leader introduces a new-era troubleshooter. A triggered scope, just like the ones the TV designers use.

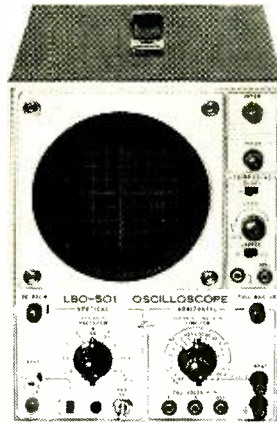

Now the wave shape is locked in and continuously displayed. Now you can look at a waveform containing high and low frequency components. Now you can determine voltage directly and instantly.

Before you say \$339 is a lot of bread, look what it buys: Leader's LBO-501 5-inch triggered scope, with a bandwidth of DC to 10MHz and a solid state package.

Going like hotcakes at your Leader distributor.

## Seeing is believing.

### LEADER INSTRUMENTS

37-27 27th Street, Long Island City, N.Y. 11101, (212) 729-7411

CIRCLE NO. 127 ON READER SERVICE CARD

## The brand for all reasons

BSR McDONALD 600



Every BSR McDonald automatic turntable is precisely made in Great Britain to the most exacting specifications. Upon their arrival in the U.S., every model is unpacked and retested under actual playing conditions. That's why BSR service calls are the lowest in the industry—and perhaps that also explains why BSR sells more turntables than anyone else in the world.

E  
BSR (USA) LTD.  
BLAUVELT, N.Y. 10913  
Please send FREE detailed literature  
on all BSR McDonald automatic turntables.

Name

Address

City

State

Zip



McDONALD

**We pack your electronics course with kits to make your training fast. You'll enjoy every minute of it.**

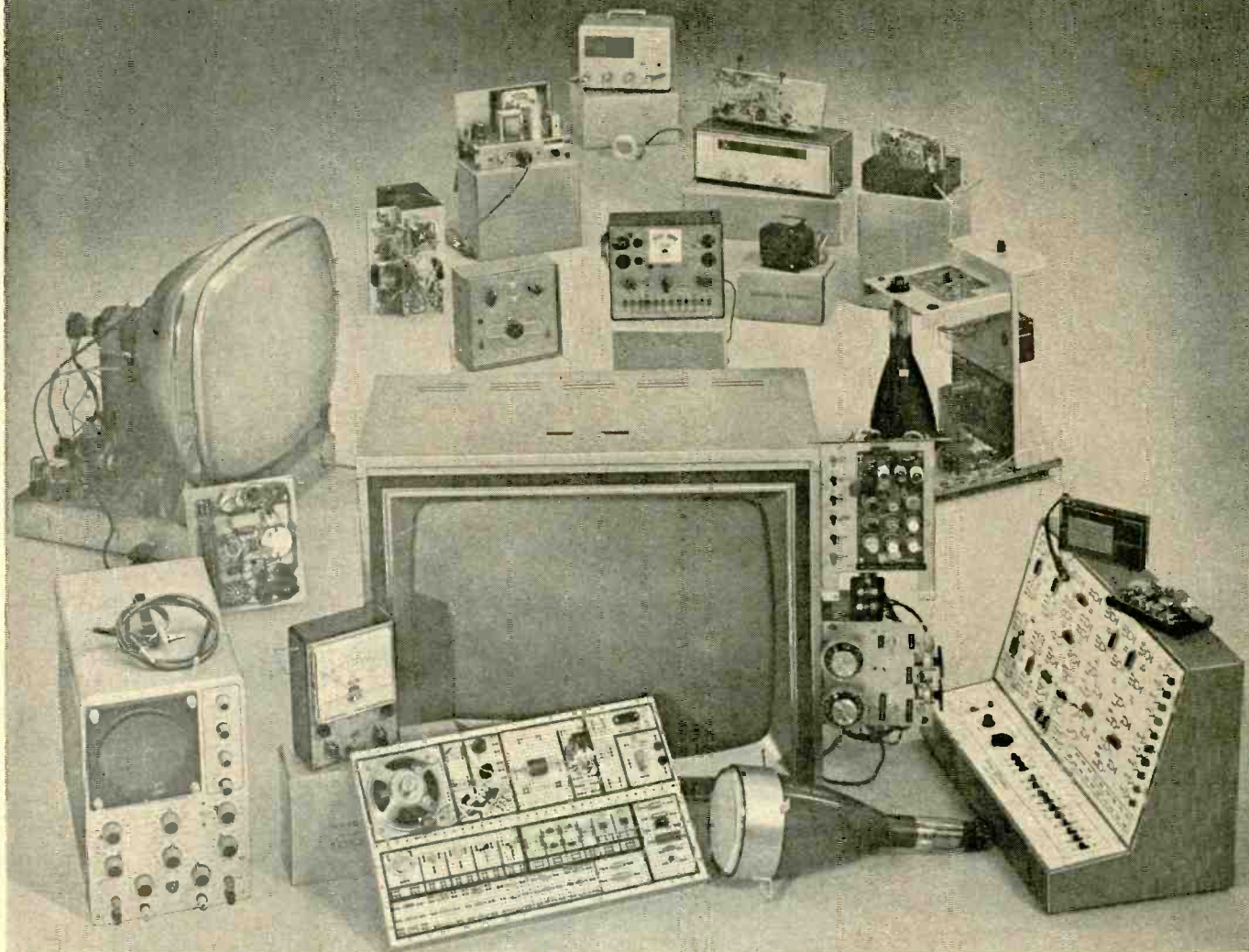

## **Your NTS success package**

Choose a career in electronics: Computers. Color TV Servicing. Automation. Communications. Whatever the field, NTS has a complete home-study package to get you to the top *faster*. 10 thorough training courses. Each includes *everything* to give you the *working* knowledge required of successful technicians.

NTS Project-Method Training is the practical way to learn elec-

tronics. It's a proven combination of lessons and the best professional kit equipment available. NTS provides the *biggest selection of kits ever offered in home-study . . . all at no extra cost*. You'll construct these exciting kits to fully understand electronic circuits, components, and concepts. Our Project-Method lets you build skills by putting theory into practice . . . by working with your hands, as well as your head.

The NTS "learn and practice" approach makes training at home really easy. All it takes is a few hours a week . . . whether you're starting from scratch or in advanced courses. This is the all-inclusive success package that put thousands of men into the best paying jobs . . . or into their own business. If "just a living" isn't good enough for you, now is the time to get something better going for you!

## NTS COMPUTER ELECTRONICS

This is the future. And it's happening now. The number of computers will *increase many times* in the next few years.

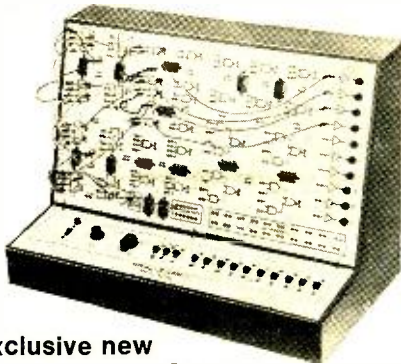

### Exclusive new Compu-Trainer®

NTS offers a solid grounding in computer operation, wiring, data processing and programming. One of the 10 important kits included is our exclusive Compu-Trainer®. It's a fully operational computer logic trainer — loaded with integrated circuits — the first ever offered in home study. It introduces you quickly to how, what, when and why of computers . . . from theory to practical servicing techniques. This unit is capable of performing 50,000 operations per second. And it's sent at no extra cost.

## NTS COLOR TV SERVICING

This is a broad, easily understood

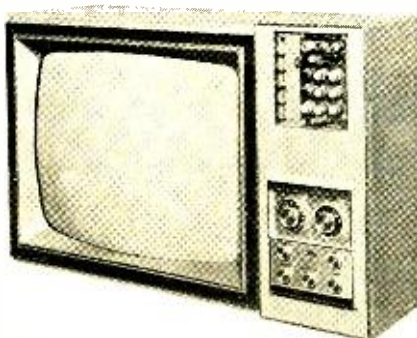

### COLOR TV 295 SQ. IN. PICTURE

program designed to make you a complete home-entertainment service technician. Included, at no extra cost, is a color TV that has more features than any

set on the market. You also learn all about stereo, hi-fi, multiplex systems, and become a specialist in Color TV Servicing. Kits also include AM-SW radio, solid-state radio, field-effect transistor volt-ohmmeter, electronic tube tester.

## NTS AUTOMATION/ INDUSTRIAL ELECTRONICS

You're trained in the "push-button" electronics that keep industry going and growing . . . from relay type controls to highly advanced systems essential to production. You receive 16 kits including a 5" wide band oscilloscope, and the new NTS electronics lab: a fascinating NTS exclusive experimental laboratory. A complete workshop which makes you familiar with solid-state, miniature, and integrated circuits.



5"  
Oscilloscope

## NTS ELECTRONIC COMMUNICATIONS

The use of 2-way radio systems in private and commercial applications is skyrocketing. NTS prepares you for the big-money opportunities in the field of transmitting and receiving equipment. *Your tuition will be refunded in full if you cannot pass the FCC exam for a 1st Class Commercial Radio-Telephone License within*



5 Watt AM Transmitter & Receiver

*six months after successfully completing this course.* You build valuable kits including Amateur-Phone 6 Meter VHF Transceiver, solid-state Radio, and a field-effect transistor volt-ohmmeter.

## CLASSROOM TRAINING AT LOS ANGELES

You can take classroom training at Los Angeles in sunny Southern California. NTS occupies a city block with over a million dollars in facilities devoted exclusively to technical training. Check box in coupon.

## NATIONAL TECHNICAL SCHOOLS

World-Wide Training Since 1905  
4000 South Figueroa Street  
Los Angeles, Calif. 90037, U.S.A.

## APPROVED FOR VETERANS

Accredited Member: National Association of Trade and Technical Schools, National Home Study Council.

**TODAY, MAIL  
COUPON  
FOR FREE  
COLOR  
CATALOG  
AND SAMPLE  
LESSON.**

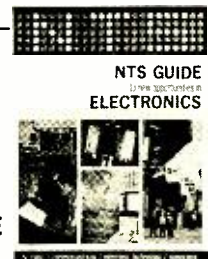

**NATIONAL TECHNICAL SCHOOLS**  
4000 S. Figueroa St., Los Angeles, Calif. 90037

Please rush Free Color Catalog and Sample Lesson, plus information on field checked below. No obligation. No salesman will call.

- MASTER COURSE IN COLOR TV SERVICING
- COLOR TV SERVICING
- MASTER COURSE IN TV & RADIO SERVICING
- PRACTICAL TV & RADIO SERVICING
- MASTER COURSE IN ELECTRONIC COMMUNICATIONS
- FCC LICENSE COURSE
- MASTER COURSE IN ELECTRONICS TECHNOLOGY
- INDUSTRIAL AND AUTOMATION ELECTRONICS
- COMPUTER ELECTRONICS
- BASIC ELECTRONICS

Name \_\_\_\_\_ Age \_\_\_\_\_

Address \_\_\_\_\_

City \_\_\_\_\_ State \_\_\_\_\_ Zip \_\_\_\_\_

- Check if interested in Veteran Training under new G.I. Bill.
- Check if interested ONLY in Classroom Training at Los Angeles. Dept. 240-020

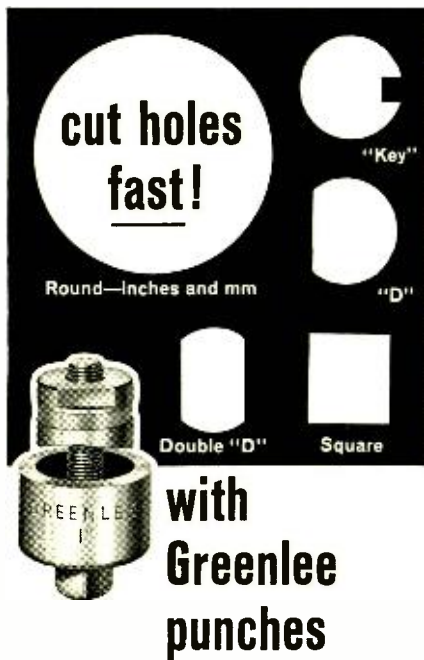

with  
**Greenlee  
punches**

Here's the simple speedy way to cut smooth, accurate holes in metal, hard rubber, plastics, epoxy, etc.

Save hours of hard work . . . punch clean, true holes in seconds for sockets, controls, meters, and other components. Easy to operate. Simply insert punch in a small drilled hole and turn with a wrench. For use in up to 16-gauge metal. Available at leading radio and electronic parts dealers.

**GREENLEE TOOL CO**  
DIVISION OF GREENLEE BROS. & CO.

1866 Columbia Avenue, Rockford, Ill. 61101

A Unit of Ex. Cell-C Corporation

CIRCLE NO. 135 ON READER SERVICE CARD

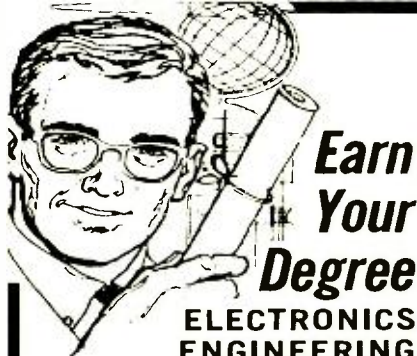

**Earn  
Your  
Degree**

**ELECTRONICS  
ENGINEERING**

**through HOME STUDY**

HIGHLY EFFECTIVE

HOME STUDY COURSES IN:

- Electronics Engineering Technology

- Electronics Engineering Mathematics

Earn your Associate in Science Degree in Electronics Engineering and upgrade your status and pay to the engineering level. Complete college level courses in Electronics Engineering. We're a forward looking school. Outstanding lesson material—thorough and easy to understand. Engineering taught on the basis of application and understanding rather than on the basis of memorization. Up to date in every respect. Acquire the knowledge and ability that means the difference between a low paying technician job and a high paying engineering position. Low tuition cost with low monthly payments. Free engineering placement service for our graduates. Write for free descriptive literature. Ask for bulletin J. no salesman will call on you.

**COOK'S INSTITUTE**  
of Electronics Engineering

Forest Hill Road

P. O. Box 10634

Jackson, Miss. 39209

Established 1945

Formerly Cook's School of Electronics

CIRCLE NO. 141 ON READER SERVICE CARD

74

# C.E.T. Test, Section #1 Antennas

By DICK GLASS\*

**What is your electronics servicing I.Q.?  
You must get 75% on entire exam to pass.**

This is the first in a series of 12 test sections to be published monthly, which are representative of the Certified Electronic Technician (C.E.T.) examinations given by NEA, a national association for radio and television service technicians.

(Answers will appear next month.)

- Which of the following lead-in cables normally has the greatest loss per 100 ft?
  - encapsulated foam twin-lead
  - open 2-wire
  - shielded twin-lead
  - standard RG-59U coax
- Standing waves on a transmission line might be caused by:
  - wrong number of reflectors
  - signal too strong
  - not enough antenna height
  - incorrect impedances
- TV antenna distribution systems usually try to supply a minimum of ..... of signal to each receiver.
  - 6 dB
  - 100 microvolts
  - 0 dBm
  - 1 volt
- A simple dipole antenna has a d.c. resistance at the terminals of:
  - practically zero ohms
  - infinity
  - 300 ohms
  - 72 ohms
- The best antenna for eliminating reflected signal problems is:
  - a yagi
  - a conical
  - rabbit ears
  - stacked conical
- In an antenna distribution system, a 2-way splitter might be expected to have a loss of:
  - 1 dB
  - 4 dB
  - 8 dB
  - no loss
- One way to correctly connect a 72-ohm antenna to a 300-ohm receiver is to:
  - use a balun at the set and 300-ohm lead wire
  - use a balun at the antenna and 72-ohm lead wire
  - use a matching transformer at both ends
  - use a matching transformer at the antenna and 300-ohm lead
- Which of the following would most likely not be used to eliminate an antenna interference problem?
  - shorted-end stub trap
  - 4<sup>3</sup>/<sub>4</sub>" 300-ohm, shorted-end (with trimmer) trap
  - open-end stub trap
  - 4.5-MHz trap
- An auto antenna, shorted to the car's body, would usually cause:
  - excessive spark-plug noise pick-up
  - blown radio fuse
  - cross-modulation
  - burned-out antenna input coil
- The least important TV antenna characteristic is usually:
  - directivity
  - horizontal polar pattern
  - sensitivity
  - vertical polar pattern

\*Executive V.P., NEA, 12 South New Jersey St., Indianapolis, Ind. 46204, assisted by Lew Edwards, chairman of Test Make-up Subcomm.

# NOW YOU CAN EASILY ADD SOUND

TO YOUR SLIDE AND FILM SHOWS  
WITH POPULAR PHOTOGRAPHY'S  
EXCLUSIVE AND EXCITING

## "SOUND FOR A PICTURE EVENING" RECORD ALBUMS, Vols. I through IV

Expressly created for film and slide shows



No matter how good your film and slide shows are, sound will make them better . . . more entertaining and certainly more professional. But, it has to be the right kind of sound. Although any musical record can be used as a background, few, if any, can match the variety of action, situations and scenes inherent in most shows. That's why Popular Photography created these albums. They're ideal for almost every mood captured by your camera. Whether your show is simple, elaborate or somewhere in-between—"Sound For A Picture Evening" provides a final, professional touch to make it a complete success.

This complete set, Volumes I through IV, offers you the most extensive selection of background music and sound effects available anywhere. Produced by the Editors of Popular Photography exclusively for our readers, these records cannot be purchased in any store and are available by mail only to the readers of Popular Photography and other Ziff-Davis Magazines.

**FREE**

A comprehensive instruction booklet comes with EACH record, showing you how to make a successful sound-and-music tape track for your slide or movie show, or to use the record alone as background, even if you're a rank beginner. An ingenious band pointer which fits on top of each record instantly locates any band you want. No guessing. no wasted motion, no false starts.

FOUR 12" VINYL 33 $\frac{1}{3}$  RPM HIGH-FIDELITY ALBUMS offering you more than 2 $\frac{1}{2}$  hours of playing time consisting of 66 specific mood music backgrounds, 40 tracks for special sound effects and 16 tracks featuring "National Portraits"—a total of 122 tracks of sparkling, mood-setting off-beat music and hard-to-find sound effects—for use "as is" by playing the appropriate tracks as your slide or movie show proceeds or for editing your selections and recording them on tape. "Sound For A Picture Evening" adds another dimension to your photography—high-fidelity sound.

### ALBUM CONTENTS

#### VOLUME I

17 music backgrounds . . . 8 sound effects tracks: themes to match your subjects . . . perfectly! 3 film openings: grandiose, sweet and gentle and dramatic • 3 film closings: epic finale, Hollywood style and gentle • happy-go-lucky • gay party • vacation tempo • traveling • happy birthday party • pomp of a parade • sound of a carousel • circus time • sentimental moments • children's playtime • Christmas time • ocean waves • train • jet planes • baby crying • crowd in stadium • traffic • dog barking • thunder and rain.

#### VOLUME II

19 music backgrounds . . . 11 music effects tracks: majestic • backyard nature • experimental • mysterious • music of the spheres • vive la France • German village band • soul of Spain • American west • English countryside • buon giorno, Italia • bass drum • bassoonery • cathedral bells • galloping horses • zoo noises • children at play • cocktail party • birds on a spring morning • outboard motor • oars in water • skis on snow • trumpet fanfare • solo violin • music from silent movies • music for slow-motion movies • music for speeded-up motion • music for stop-motion movies • underwater music • music for old-time footage.

#### VOLUME III

25 music backgrounds . . . 10 sound effects tracks: music for time-lapse photography • liquidity • music to fly by • music to take a trip by • fiddle faddle • jungle themes • music for the bull ring • way out • farm machinery • chicken clucking and rooster crow • cows • horse whinny • pigs grunting • wind in the trees • sleigh bells • cat meowing and purring • hammering and sawing • Japan • Scandinavia • South America • Jamaica • Middle East • bowling • jogging • little league • rally and drag racing • horseback riding • tennis • ice skating • Russian balalaika • Indian sitar • Viennese zither • steel band music • square dance music with caller • drum and bugle corps music.

#### VOLUME IV

23 music backgrounds . . . 9 sound effects tracks: music to make portraits by • music for historic places • music to zoom by • monochromatic moods in color • music to orbit by • music to graduate by • music to scale cliffs by • gypsy violin • Japanese koto • mariachi band • bagpipes • rock 'n' roll • German band • Russia • Holland • Africa • Switzerland • Greece • boating • gardening • golfing • musicians at work • dancing • carnival "outside talker" • plane captain on the intercom • jetting down the field for take-off • cruise ship departure • corks popping, liquid gurgling • shotgun blasts • wood chopping • crickets chirping • fireplace sounds.

This complete set of 4 individually jacketed records, a \$19.92 value, is available to you at the special discount price of only \$14.98, postpaid—a savings of \$4.94.

For those of our readers who may have purchased Volumes I and II when they were originally produced, Volumes III and IV are available at the special discount price of \$7.96 for both, postpaid—a savings of \$2.00.

Volumes I, II, III and IV may be purchased individually @ \$4.98 each, postpaid.

They're a must for every slide and film show impresario and albums you will enjoy for many years to come.

RECORDS • Ziff-Davis Service Division  
595 Broadway • New York, N.Y. 10012

EW-2-70

My check (or money order) for \$\_\_\_\_\_ is enclosed. Please send:

\_\_\_\_\_ Complete sets, Volumes I through IV @ \$14.98 each, postpaid.

\_\_\_\_\_ Sets Volumes III and IV only @ \$7.96 each set, postpaid.

\_\_\_\_\_ Volume I; \_\_\_\_\_ Volume II; \_\_\_\_\_ Volume III; \_\_\_\_\_ Volume IV @ \$4.98 each, postpaid.

(Outside U.S.A. please send \$20 for complete set; \$12 for each set of 2; \$7 for 1 record ordered.)

print name \_\_\_\_\_

address \_\_\_\_\_

city \_\_\_\_\_ state \_\_\_\_\_ zip \_\_\_\_\_

**PAYMENT MUST BE ENCLOSED WITH ORDER**

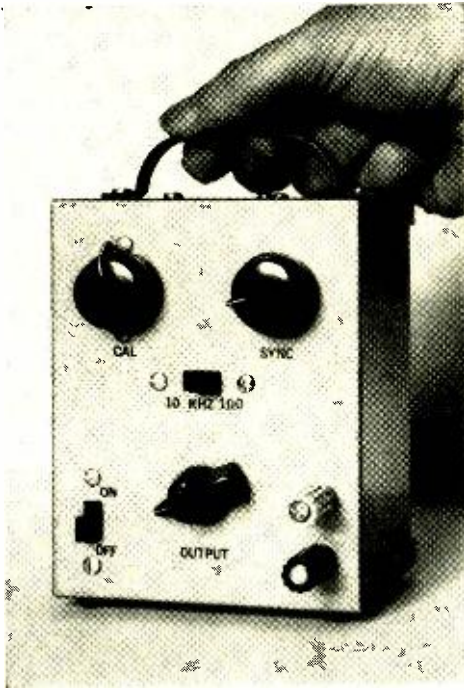

# Portable Dual-Range IC Frequency Standard

By FRANK H. TOOKER

*The design, calibration, and operation of a solid-state version of a crystal oscillator with frequency divider is described. Ideal for accurate frequency spotting.*

Fig. 1. Front view of the portable dual-range IC frequency standard showing the controls used in calibrating the instrument for 10- and 100-kHz signals.

WHEN vacuum tubes were the main source of amplification, prior to the discovery of the transistor, frequency standards were made by combining a synchronized 10-kHz multivibrator with a 100-kHz crystal oscillator.

The vacuum-tube frequency standard, because of its inherent characteristics, had certain disadvantages. Primarily, because it was a heat generator as well as a generator of radio frequencies, it had to be operated continuously if drift were to be kept to a minimum. In addition, the multivibrator was somewhat erratic in that it did not always react spontaneously to the sync pulses, and portability was more a matter of how one defined the word, rather than a reality.

Noticeably, since the advent of transistor technology, there has been a dearth of frequency standards combining a crystal oscillator with a multivibrator frequency divider. Quite likely, much of this has been due to the fact that a transistor multivibrator operates at its best only when the pair of transistors used in the circuit are properly matched, the technique of which has always presented somewhat of a problem to design engineers. With the development of the integrated-circuit manufacturing process, where the characteristics of transistors can be closely matched, this problem has been eliminated.

The frequency standard described in this article uses a pair of Fairchild  $\mu$ L914 IC's, one as a 100-kHz crystal oscillator, the other as the 10-kHz synchronized multivibrator. Power-supply requirement is only 3 volts at 14 mA maximum, and the entire setup, including a signal-squaring amplifier and an emitter-follower output stage, mounts easily in a 5" x 4" x 3" aluminum cabinet (Fig. 1)

so that portability is obtained. Heat generation is insignificant, thus frequency drift is negligible. Furthermore, the multivibrator in this instrument synchronizes easily—thanks in large measure to the component values used in the multivibrator and the rectangular waveform of the crystal-oscillator output signal. Lock-in is obtained over an angle of at least

Fig. 2. Schematic and parts list of the frequency standard discussed in text. IC1 and crystal make up the 100-kHz crystal oscillator and IC2 the 10-kHz multivibrator. Q1 and Q2 function as amplifier and emitter-follower output stages, respectively.

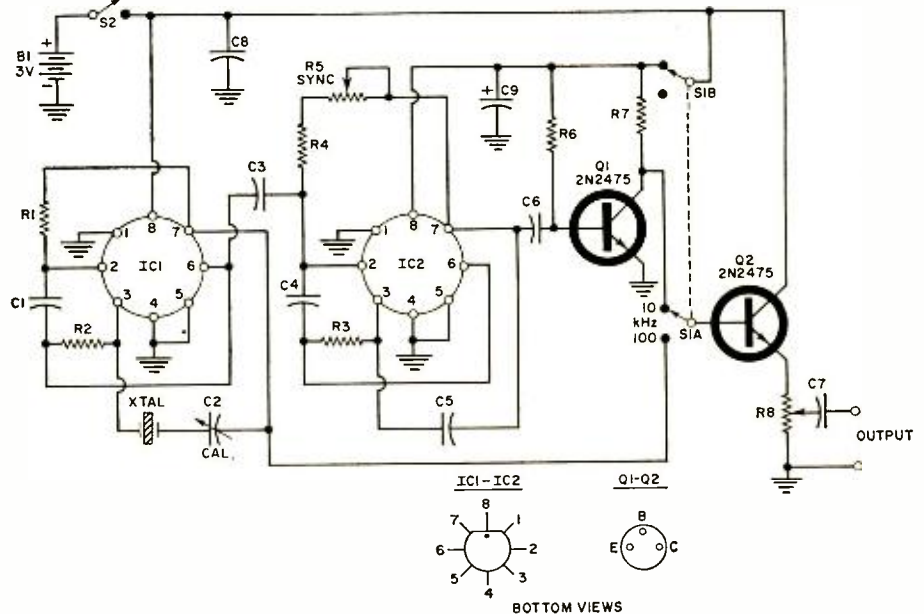

- R1—15,000 ohm, 1/2 W res.  $\pm 5\%$
- R2—22,000 ohm, 1/2 W res.  $\pm 5\%$
- R3—2700 ohm, 1/2 W res.  $\pm 5\%$
- R4—1200 ohm, 1/2 W res.  $\pm 5\%$
- R5—2500 ohm linear-taper pot
- R6—6800 ohm, 1/2 W res.  $\pm 5\%$
- R7—3300 ohm, 1/2 W res.  $\pm 5\%$
- R8—500 ohm linear-taper pot
- C1—5000 pF polystyrene capacitor
- C2—50 pF ceramic-insulated variable capacitor
- C3—6.8 pF zero-temp coeff. ceramic capacitor
- C4, C5, C6—0.022  $\mu$ F Mylar capacitor

- C7, C8—0.1  $\mu$ F Mylar capacitor
- C9—5  $\mu$ F, 3 V elec. capacitor
- S1—D.p.d.t. slide switch
- S2—S.p.s.t. slide switch
- Xtal—100-kHz frequency-standard crystal
- B1—3-volt battery (2 "C" cells in series)
- IC1, IC2—Dual two-input gate IC ( $\mu$ L914 or HEP584)
- Q1, Q2—Silicon "n-p-n" transistor (2N2475)

20 degrees of rotation of the front-panel "Sync" control.

The  $\mu$ L914 IC, designed for use in computer circuitry, is actually a dual 2-input gate that contains four transistors, two collector load resistors, and current-limiting base resistors. Only two of the transistors in each IC are used in the present circuit and the base of each of the two other transistors is grounded.

### Operation

A schematic diagram of the frequency-standard instrument is shown in Fig. 2. The crystal oscillator, together with IC1, is actually a multivibrator circuit. Coupling between the two active transistors in this IC is obtained through capacitor C1 and feedback occurs through crystal and calibration capacitor C2. The crystal operates in a series-resonant (low-impedance) mode.

Synchronizing pulses to lock the 10-kHz multivibrator (IC2) in step with the crystal-oscillator signal are obtained at pin 6 of IC1 and fed to pin 2 of IC2 via capacitor C3. Note especially the low value of this capacitor. Such a low value of capacitance, together with the low resistance of the circuit that follows it, sharply differentiates the crystal oscillator signal. A value significantly larger than 6.8 pF can cause the crystal oscillator signal to pull the multivibrator frequency too vigorously, inhibiting satisfactory operation of the multivibrator at 10 kHz.

The 10-kHz multivibrator is of the conventional cross-coupled kind, using capacitors C4 and C5. Base current for one side of the circuit is obtained through resistor R3, while current for the other side is obtained through resistor R4 and potentiometer R5. Adjusting R5 varies the multivibrator's frequency sufficiently to permit it to be locked in with every 10th cycle of the crystal oscillator signal. Actually, the proper adjustment of R5 (the "Sync" control) sets the multivibrator frequency slightly lower than 10 kHz. The multivibrator is, therefore, primed to switch itself from one state to the other when the sync pulse arrives and triggers it. Synchronized operation cannot occur if the free-running frequency of the multivibrator is somewhat faster than 10 kHz.

Output from the synchronized multivibrator is taken at pin 7 of IC2 and fed through capacitor C6 to the base of Q1, the signal-squaring amplifier. Switch section S1A selects either the signal at Q1's collector (10 kHz) or the signal at pin 7 of IC1 (100 kHz), and feeds the selected signal directly to the base of Q2, the emitter-follower output stage. The signal at the output terminals is obtained from the slider of potentiometer R8, the "Output" level control, via capacitor C7.

Switch section S1B disconnects d.c. power from IC2 when the instrument is being operated at 100 kHz. S2 is the instrument "On-Off" switch. Battery B1 consists of two "C" cells, preferably the kind made specifically for use in transistor circuits, connected in series.

### Construction

The prototype instrument is assembled in a 5"  $\times$  4"  $\times$  3" gray-hammertone-finished aluminum box. Neither the stator nor the rotor of the calibration control capacitor, C2, can be grounded, so it is essential that all its metal parts be well insulated from the cabinet front. The capacitor used in the unit mounts on a pair of insulated, threaded spacers.

All of the small components, except C7, are mounted on a 2 $\frac{7}{8}$ "  $\times$  2 $\frac{3}{16}$ " glass-epoxy-base printed-circuit card. Components not visible in the rear view (Fig. 3) are mounted on the reverse or foil side of the card.

### Calibration

When the instrument has been completely assembled and checked out for errors, connect its output terminals to the vertical input terminals of an oscilloscope. Set calibration ("Cal") control C2 at about midposition, "Sync" control pot R5 in its maximum counterclockwise position (maximum resistance in the circuit), and "Output" level control R8, for

maximum output. Set switch S1 to its 100-kHz position and turn the instrument on by closing switch S2. A rectangular waveform signal should be observed on the scope screen, and, although the horizontal portions of the waveform may not be entirely flat and there may be some slight overshoot, this is of no consequence.

Having confirmed that the crystal-oscillator stage is functioning properly, set switch S1 in its 10-kHz position. With the scope set for a display of two or three cycles at 10 kHz, inspect the horizontal portion of the positive-going alternations of the waveform. If there are four tiny, sharply defined pips above the horizontal line, and four below the line, the 10-kHz multivibrator is synchronized with the crystal-oscillator signal.

Now set the "Sync" control of the scope at as low a position as possible, and advance the "Sync" control, R5, of the frequency standard slowly—until the waveform observed on the scope screen begins to run out of control. Note the position of the knob on R5, and return the setting of the control to a position about midway between this point and the fully counterclockwise position. This setting results in maximum stability.

In the event that the multivibrator is not synchronized with the signal from the crystal oscillator when R5 is set in its maximum counterclockwise position, advance the control slowly until synchronism is just obtained. Note the setting of the control. Now advance the setting until synchronism is lost, as described in the preceding paragraph, and again note the setting of the control. Make the final setting of R5 about midway between these two positions.

### Final Check

As a final check on the synchronized multivibrator, tune in the standard's 10-kHz signal at any clear point on the dial of a broadcast-band receiver. The signal should sound smooth and, if it is rough or modulated, the "Sync" control is improperly adjusted. Stations on the broadcast band are located at 10-kHz intervals. Thus, tuning across the band and finding a heterodyne which can be brought to zero beat on every station indicates proper 10-kHz operation of the frequency standard.

The crystal oscillator may be calibrated precisely by tuning a short-wave receiver to NBS's station WWV and, when WWV's signal is unmodulated, carefully adjust the calibration control, C2, for zero beat of the standard's output signal with WWV's signal. Broadcast-band stations maintain their carrier frequency quite accurately; therefore, closely approximated calibration may be obtained by zero-beating the standard's signal with the signal of a station on the broadcast band. The carrier frequency must, of course, be a multiple of 100 kHz. Switch S1 should always be in its 100-kHz position during calibration. ▲

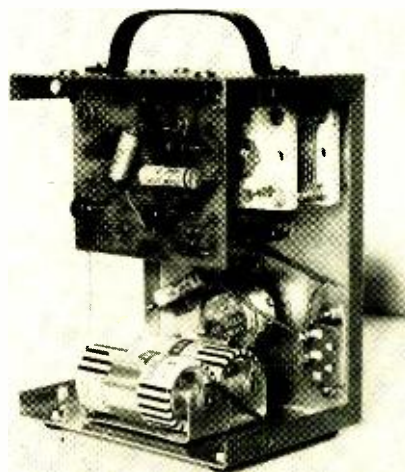

Fig. 3. Rear view of the dual-range IC frequency standard, showing the location of most of the components.

# MANUFACTURING ENGINEERING

**Test Equipment Design  
Production Troubleshooting**

Automatic Electric, a leading innovator of computerized electronic switching systems and the largest producer of communications equipment for the independent telephone industry, has numerous entry level and experienced positions available for **MANUFACTURING ENGINEERS**.

We are seeking new and experienced degreed electronic or electrical engineers (or equivalent work experience) to initially learn new computerized electronic telephone switching systems, design test equipment and associated test procedures and trouble-shoot the mass-production of this equipment.

If you are interested in a progressive, growing company that offers well-equipped, modern facilities, a policy of promotion from within, and a pleasant Suburban location (17 miles West of downtown Chicago), send your resume in confidence to:

**Larry Wisniewski**  
Professional Employment Representative

**AUTOMATIC ELECTRIC**  
Subsidiary of General Telephone & Electronics  
400 North Wolf Rd., Northlake, Illinois 60164

An equal opportunity employer

CIRCLE NO. 146 ON READER SERVICE CARD

## SELECTION WORKS!



### IMPROVES SOLDERABILITY

- **SOLDERING PROBLEMS**—Selection simplifies soldering to aluminum, stainless, refractories, glass, without acid fluxes.
- **PRINTED CIRCUITS**—Selection repairs breaks; gold or rhodium plates tabs; plates flexible cable.
- **MACHINING**—Selection builds mismachined parts back to tolerance.
- **CORROSION RESISTANCE**—Selection replates selected areas with chromium, nickel, tin, etc; refurbishes rejects.

SELECTION MEETS ALL MILITARY SPECIFICATIONS

## SELECTIONS, LTD.

116 EAST 16th STREET ● NEW YORK, N.Y. 10003

Tel: (212) CA 8-6800

CIRCLE NO. 110 ON READER SERVICE CARD

## Air Traffic Control Transponder (Continued from page 38)

photocell to trigger the counting circuits. These, in turn, activate the readout indicator providing a digital readout of the target code.

### Side-Lobe Suppression

The only significant problem with this equipment is a condition known as "ring around," where the transponder replies to side lobes of the interrogation signal. This can create a serious problem for the controller as the target then occupies a large arc on the display, and determination of actual position becomes difficult.

The first solution to this problem was to provide for lowering the sensitivity of the transponder receiver. This helped but did not eliminate the problem. However, later equipment is provided with side-lobe suppression circuitry which has solved the problem completely.

Side-lobe suppression introduces a third pulse into the interrogation signal, 2 microseconds after the first pulse. This pulse is transmitted from a separate omnidirectional antenna, and at a level slightly below that of the main portion of the main lobe of the rotating signal. The transponder receiver compares the level of the side-lobe suppression pulse with the other two pulses, and initiates a reply only if the interrogation pulses are of greater amplitude than the suppression pulse.

The ATC transponder system provides the controller with the following advantages over conventional primary radar: longer reliable range, ease of identification and tracking, reduced communications workload, automatic alerting of communications failure or emergency, and automatic reporting of aircraft altitude. ▲

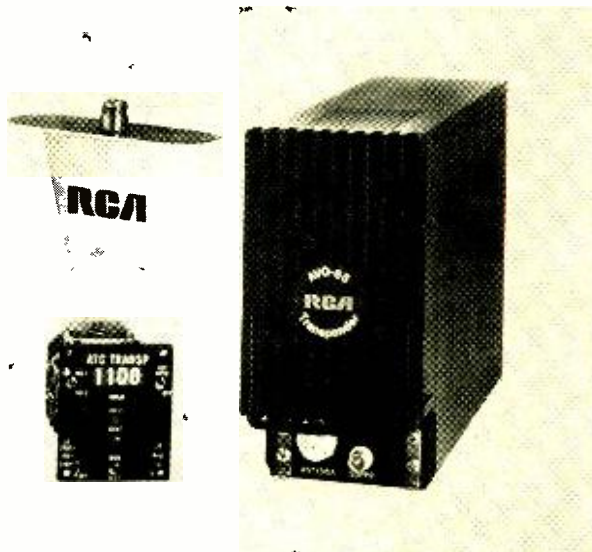

Airborne equipment consists of antenna, control unit, and the black box containing electronic circuitry for the transponder.

Airborne transponder control unit showing 4141 code set up by the four knobs. Ident pushbutton is at lower left while the reply light, which flashes when transponder is responding to interrogations, is above function selector switch at the left.

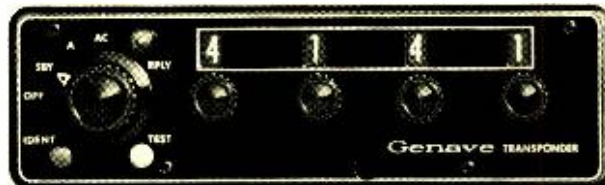



**Electronic Dice**  
(Continued from page 35)

that a person has a specific 1/20th of a second in which to open the switch. This is rather difficult.

To prove the difficulty of fixing the circuit and the lack of a recognizable pattern in the sequence of winning numbers, 200 sample runs were made. The results of the runs were subjected to several tests for randomness, and it was shown that the system appears to be truly random.

**Variations**

There are two interesting variations of this circuit. One is a more complex display and the other is expanding the die into a roulette wheel.

Fig. 3 shows a diode-transistor encoder which will change the output from a single lamp into a display which duplicates the actual face of a die. For example, when a stage is on number 3, terminal 3 is dropped to near-ground potential. This allows the diodes whose cathodes are connected to terminal 3 in Fig. 3 to conduct and provide base drive for the transistors Q1, Q4, and Q7. This then lights three lamps in a diagonal line as on the "three" side of a die. The 1000-ohm resistors R1-R6 serve to insure that, when a stage is to be off, the gates of the C13Y SCR's are returned to the 12-volt line through a finite impedance.

The second variation is that of roulette wheel or a wheel of chance. If 36 stages are constructed as in Fig. 1 and the lamps are placed in order in a circle, the resultant display is equivalent to a roulette wheel.

Construction of the circuit is straightforward, as shown in the photos. The model shown was constructed with Vector board. Fig. 4 shows the construction of the readout used in the lead photograph which is the simple display diagrammed in Fig. 1. ▲



"It's an electronic lip reader!"

**CONTROL CENTER** Switches Speakers

ORDER BY MAIL

For Stereo, Input Mixing, Monitoring

1st Time!

Alco Control Center allows your choice of up to 6 stereo speaker systems to be selected simultaneously. Push-on & push-off switches enable you to optionally select your choice of speaker pairs. Easy access rear panel connectors to match your particular system. No external power required; no impedance match problems. Useable with low or high impedance circuits. Leather-styled black metal with brushed aluminum trim. Size: 5 7/8" x 2 1/8" x 3 9/16". For home, professional use.

Model	No. Pcs.	Connector Type	Each
CC4RCA	4	RCA	\$19.95
CC4PHM	4	Phone (Miniature)	21.95
CC4PHS	4	Phone (Standard)	22.95
CC6RCA	6	RCA	26.95
CC6PHM	6	Phone (Miniature)	28.95
CC6PHS	6	Phone (Standard)	29.95

CHOICE OF 6 MODELS

**ALCO** Buy Direct: BOX 1348W LAWRENCE, MASS. 01842

We ship shipping extra short arrangements and etc.

CIRCLE NO. 100 ON READER SERVICE CARD

**LIBERTY PAYS MORE!**  
**WILL BUY FOR CASH**

ALL TYPES:

- ★ ELECTRON TUBES
  - ★ SEMICONDUCTORS
  - ★ TEST EQUIPMENT
  - ★ Military Electronic Equipment
- WIRE—WRITE—PHONE COLLECT!  
We pay freight on all purchases—

**LIBERTY OFFERS MORE!**  
**PRESTEL FIELD STRENGTH METER**

(Model 6T4G)

Only \$120.00

F.O.B. New York

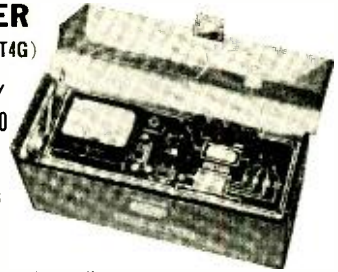

- ★ Never Anything Like It!
  - ★ 1-Man Can Do A Better Job than 3 in the Same Time!
  - ★ A Gold-Mine for Antenna Installers!
- Calibrated from 40 to 230, and 470 to 860 in 4 Bands Megahertz, from 10 to 50,000 Microvolts. Nothing makes it easier to properly and speedily find the correct place to install TV, FM and Communication Antennas. You can measure and hear the signals with this 4 1/2 volt battery economically powered unit.

**LIBERTY ELECTRONICS, Inc.**

548 Broadway, New York, New York 10012  
Phone (212) 925-6000

CIRCLE NO. 126 ON READER SERVICE CARD



Precision has led the field in quality and dependability for 25 years.

**Greatest value in sound for every PA application**

Most trouble-free line in the industry, Precision offers a complete range of amplifiers in every power range including mobile, and a complete line of accessories. From the smallest office to large auditorium or industrial installations, Precision gives maximum flexibility and performance.

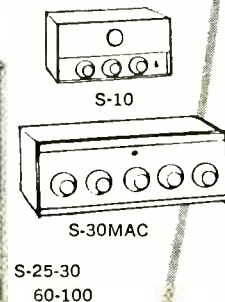

DIVISION OF PRECISION ELECTRONICS, INC.  
9101 KING STREET, FRANKLIN PARK, ILLINOIS 60131

NAME \_\_\_\_\_

ADDRESS \_\_\_\_\_

CITY \_\_\_\_\_ STATE \_\_\_\_\_ ZIP \_\_\_\_\_



CIRCLE NO. 119 ON READER SERVICE CARD

# How to become a “Non-Degree Engineer”

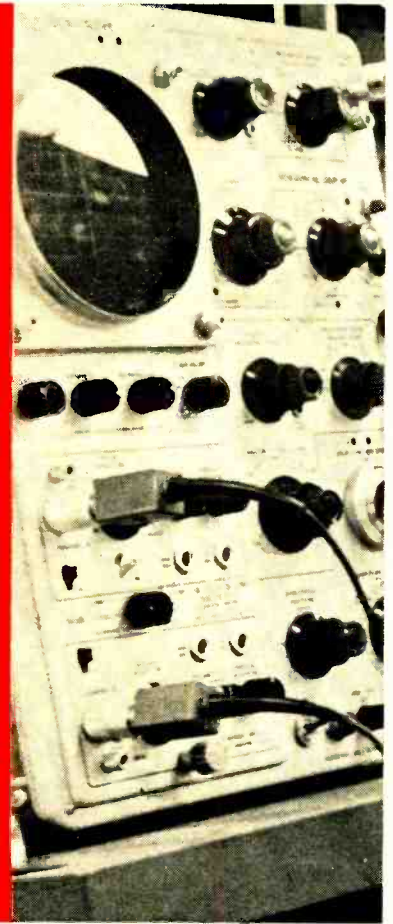

**In today's electronics boom the demand for men with technical education is far greater than the supply of graduate engineers. Thousands of real engineering jobs are being filled by men without engineering degrees—provided they are thoroughly trained in basic electronic theory and modern application. The pay is good, the future is bright... and the training can now be acquired at home—on your own time.**

**T**HE ELECTRONICS BOOM has created a new breed of professional man—the non-degree engineer. Depending on the branch of electronics he's in, he may "ride herd" over a flock of computers, run a powerful TV transmitter, supervise a service or maintenance department, or work side by side with distinguished scientists on a new discovery.

But you do need to know more than soldering connections, testing circuits and replacing components. You need to really know the fundamentals of electronics.

How can you pick up this necessary knowledge? Many of today's non-degree engineers learned their electronics at home. In fact, some authorities feel that a home study course is the *best* way. *Popular Electronics* said:

"By its very nature, home study develops your ability to analyze and extract information as well as to strengthen your sense of responsibility and initiative."

#### **Cleveland Method Makes It Easy**

If you do decide to advance your career through home study, it's best to pick a school that *specializes* in the home study method. Electronics is complicated enough without trying to learn it from texts and lessons that were designed for the classroom instead of the home.

Cleveland Institute of Electronics concentrates on home study exclusively. Over the last 30 years it has developed tech-

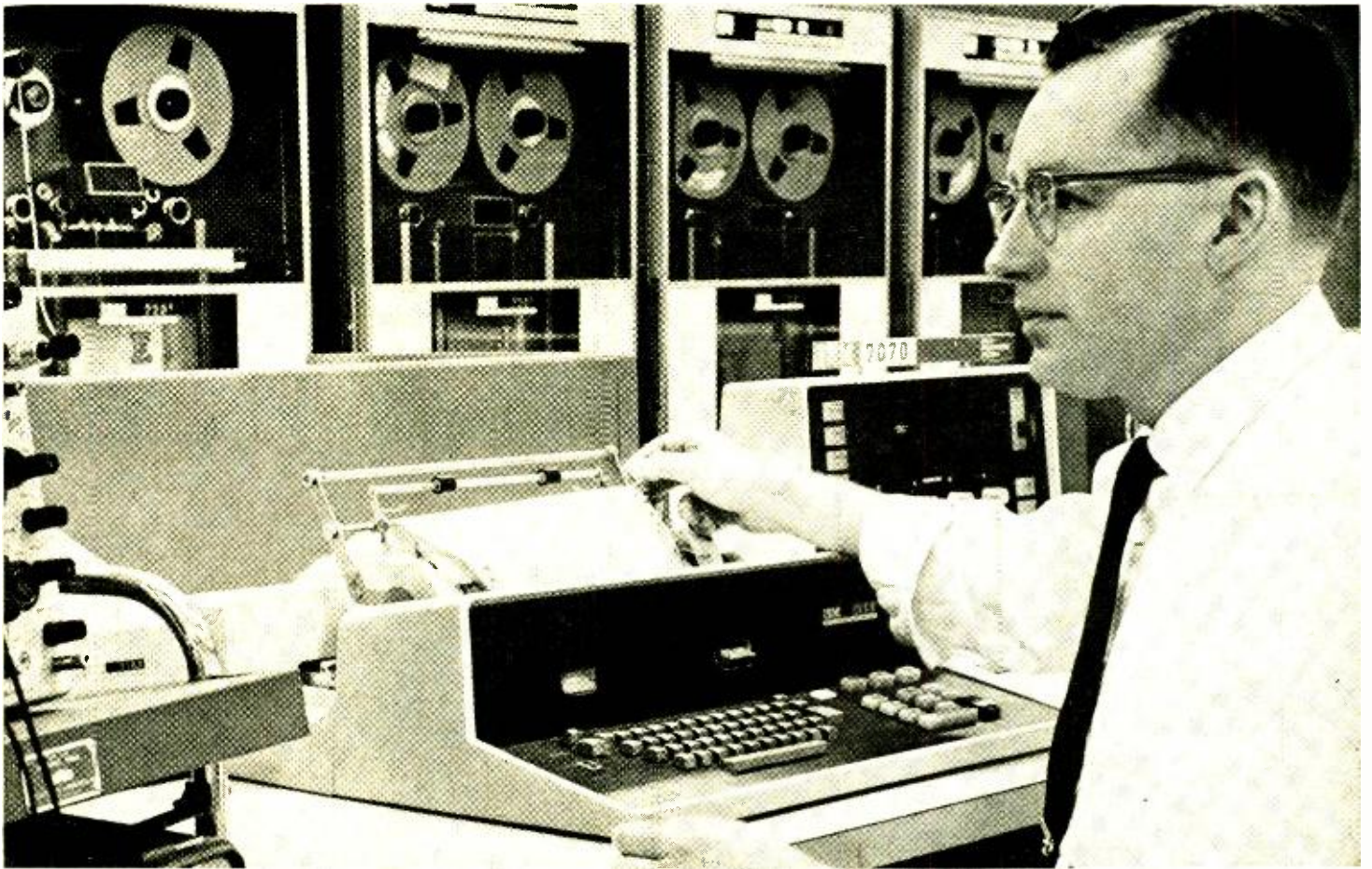

niques that make learning at home easy, even if you once had trouble studying. Your instructor gives the lessons and questions you send in his undivided personal attention—it's like being the only student in his "class." He not only grades your work, he analyzes it. And he mails back his corrections and comments the same day he gets your lessons, so you read his notations while everything is still fresh in your mind.

Students who have taken other courses often comment on how much more they learn from CIE. Says Mark E. Newland of Santa Maria, Calif.:

"Of 11 different correspondence courses I've taken, CIE's was the best prepared, most interesting, and easiest to understand. I passed my 1st Class FCC exam after completing my course, and have increased my earnings by \$120 a month."

#### Always Up-to-Date

Because of rapid developments in electronics, CIE courses are constantly being revised. This year's courses include up-to-the-minute lessons in Microminiaturization, Laser Theory and Application, Suppressed Carrier Modulation, Single Sideband Techniques, Logical Troubleshooting, Boolean Algebra, Pulse Theory, Timebase Generators...and many more.

#### CIE Assures You an FCC License

The Cleveland method of training is so successful that better than 9 out of 10 CIE

graduates who take the FCC exam pass it. This is despite the fact that, among non-CIE men, 2 out of every 3 who take the exam fail! That's why CIE can promise in writing to refund your tuition in full if you complete one of its FCC courses and fail to pass the licensing exam.

#### This Book Can Help You

Thousands who are advancing their electronics careers started by reading our famous book, "How To Succeed in Electronics." It tells of many non-degree engineering jobs and other electronics careers open to men with the proper training. And it tells which courses of study best prepare you for the work you want.

If you would like to cash in on the electronics boom, let us send you this 44-page book free.

Just fill out and mail the attached post-paid card. Or, if the card is missing, mail the coupon at right.

### NEW COLLEGE-LEVEL CAREER COURSE FOR MEN WITH PRIOR EXPERIENCE IN ELECTRONICS

**ELECTRONICS ENGINEERING**...covers steady-state and transient network theory, solid state physics and circuitry, pulse techniques, computer logic and mathematics through calculus. A college-level course for men already working in Electronics.

## CIE Cleveland Institute of Electronics

1776 East 17th Street  
Cleveland, Ohio 44114

Please send me without cost or obligation:

Your 44-page book "How To Succeed in Electronics" describing the job opportunities in Electronics today, and how your courses can prepare me for them.

Your book on "How To Get A Commercial FCC License."

I am especially interested in:

- Electronics Technology
- Broadcast Engineering
- First Class FCC License
- Electronic Communications
- Industrial Electronics
- Electronics Engineering

Name \_\_\_\_\_ (PLEASE PRINT)

City \_\_\_\_\_

Address \_\_\_\_\_

State \_\_\_\_\_

Zip \_\_\_\_\_ Age \_\_\_\_\_

**ENROLL UNDER NEW G.I. BILL.** All CIE courses are available under the new G.I. Bill. If you served on active duty since January 31, 1955, or are in service now, check box on card or in this coupon for G. I. bill information.

EW-70

# NEW PRODUCTS & LITERATURE

For additional information on items identified by a code number, simply fill in coupon on Reader Service Card. In those cases where code numbers are not given, may we suggest you write direct to the manufacturer on business letterhead.

COMPONENTS • TOOLS • TEST EQUIPMENT • HI-FI • AUDIO • CB • COMMUNICATIONS

## "REFLECTIVE" SPEAKER SYSTEM

A reflective speaker system, the W80 "Vari-flex", is fully adjustable so that a pair of units may be placed anywhere in a room, any distance

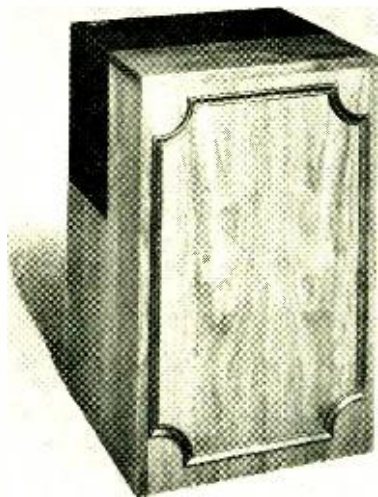

apart, and still offer controlled stereo sound. Sound dispersion is fully controlled by means of a unique movable variplanular reflector. The sound is adjusted specifically for the acoustical characteristics of the room and the decorating layout.

The speaker measures 17" x 17 1/4" x 29" in its furniture-style cabinet. Wharfedale

Circle No. 6 on Reader Service Card

## IMPROVED COLOR-TV KIT

The new 1970 line of color-TV kits incorporate three important improvements over earlier models.

All of the new sets feature increased video bandpass for greater resolution and sharper, more detailed pictures. This circuit modification is also available to builders of earlier models in the form of a modification kit GRM-681-1.

The second improvement involves the use of new brighter picture tubes as standard in all sets. The third improvement involves increased safety for the builder and user. All cabinets now have an a.c. interlock. Owners of earlier models can obtain a free modification kit to incorporate this feature in their sets. Model GRM-100 is the designation for this kit. Heath

Circle No. 7 on Reader Service Card

## MULTI-PURPOSE EPOXY

A new multi-purpose epoxy which has a complete curing time of less than 60 seconds is now available as "Minit-Cure." The new material is suited for jobs requiring fast curing time at room temperature (75° F) and can be used to bond metals, woods, plastics, rubber, and glass.

Applied with a brush, the epoxy can be used for repairs, maintenance, lab work, and even production. It has a tensile strength of 2900 psi. Tescom

Circle No. 8 on Reader Service Card

## INTRUSION DETECTOR

The Model DS300 intrusion detector does not require a reflector or a receiver and is insensitive to the environmental problems which often trigger false alarms.

The unit operates by emitting a pulsed beam

of invisible light while simultaneously measuring the amount of invisible light which is bouncing off room surroundings. When an intruder enters a protected room, he disturbs the reflection pattern and sets off the alarm signal.

The detector is housed in a furniture-type cabinet which will blend in with any decor. Full operational details are available on request. Detection Systems

Circle No. 9 on Reader Service Card

## ELECTRONIC SPRAY CHEMICALS

A selection of nine of the "most needed" electronic spray chemicals have been put on the market, packaged in a rainbow assortment of color-coded cans. Each chemical was selected for a specific application intended to cut service cost and provide greater profits for the technician.

The array features cleaners, coolers, lubricants, insulators, and protectors. They are designed to meet the requirements of technicians in TV, radio, record player, tape recorder repair as well as in computer, office machine, industrial, and broadcast servicing. Six of the cans feature a snap-on extension spray nozzle, included for precise application of the chemical to a specific circuit area. RCA Parts & Accessories

Circle No. 10 on Reader Service Card

## SOLID-STATE TAPE DECK

The Model 407 is a two-speed (7 1/2 & 3 3/4 in/s) solid-state tape deck incorporating three motors—one each for supply and take-up reels and a hysteresis synchronous capstan drive motor. The deck has four heads, push-button solenoid-operated controls, automatic reverse, dual vu meters, automatic tape lifters, and an automatic shut-off switch.

Because the unit has a separate playback head,



the machine can record sound-with-sound, sound-on-sound, and echo effects. Frequency response is 30-20,000 Hz at 7 1/2 in/s.

The deck measures 21" wide x 14 1/2" high x 10 1/2" deep. Complete specifications are available on request. Astrocom/Marlux

Circle No. 11 on Reader Service Card

## TURNTABLE/CARTRIDGE

The "Troubador" Model 598 turntable system has been specifically designed for the new low-tracking-force cartridges and features the 990 playback arm and new 1000<sup>2</sup> stereo calibration standard cartridge.

The turntable operates at three speeds, has push-button power control, a built-in 45 r/min spindle, and measures 17 1/2" w. x 15 1/8" d. x 8" high with base and dust cover. It can track as low as 0.1 gram.

The cartridge is individually calibrated to have a flat frequency response within ±1 dB from 20 to 20,000 Hz. There are no electrical or mechanical resonant peaks and total IM distortion at the standard 3.54 cm/s groove velocity does not exceed 0.05% at any frequency within the full spectrum, according to the company. Stereo separation is better than 35 dB at 1000 Hz and remains at least 25 dB or better all the way out to 20,000 Hz. Over-all frequency response is 4 to 40,000 Hz. Empire

Circle No. 12 on Reader Service Card

## INTEGRATED PREAMP/AMP

The new 1A-1200 integrated preamplifier/amplifier has an IHF music power rating of 120 watts but instead of separating this power into



two 60-watt channels, the amplifier feeds into four channels of 30 watts each. Switch selection on the front panel permits combinations of four 30-watt channels for complex speaker systems, two 30-watt channels plus a 60-watt center channel, two 60-watt channels, or one mono channel of a full 120 watts.

Power output selection makes the unit compatible with all kinds of speakers. Power output is selected on the front panel.

The unit is fully transistorized and its output stages are protected against damage from thermal shock due to overload or accidental shorting. The amplifier and preamplifier may be operated separately if desired. Hitachi

Circle No. 13 on Reader Service Card

## R/C GARAGE-DOOR OPENER

A deluxe solid-state RC garage-door opener is now being offered as a semi-kit. Employing a factory assembled and aligned u.h.f. transmitter and receiver, the unit will operate garage doors from up to 150 feet away without interference from similar neighborhood units.

The mechanism can be assembled and installed in a single day. Soldering has been eliminated by using push-on connectors. The 7' screw mechanism with its 1/4-hp motor is designed to operate all 7' overhead-track garage doors as well as jam and pivot doors (with accessory adapter).

Additional details on the new GD-209A kit are available on request. Heath

Circle No. 14 on Reader Service Card

## IC AMP/PREAMP

The Sinclair IC-10 monolithic integrated hi-fi amplifier and preamp is now available in the U.S. Designed as a full-performance amp-preamp requiring only the addition of the usual tone and



volume controls and a power supply, the circuit can be used in other applications including car radios, electronic organs, servo amps, etc.

Output is 10 watts peak, 5 watts r.m.s. continuous and frequency response is 5-100,000 Hz  $\pm 1$  dB. Total harmonic distortion is less than 1% at full output. Load impedance is 3 to 15 ohms. The circuit can be powered at 8 to 18 volts. The chip measures 1 x 0.4 x 0.2 inch.

A complete spec sheet on this unit will be supplied on request. Audionics

Circle No. 15 on Reader Service Card

#### AUTOMATIC TURNTABLE

The new Model 750 Elac/Miracord turntable is identical to the Miracord 50H except that it has



a special four-pole induction motor instead of a Papst hysteresis synchronous motor and a different trip.

It has push-button operation, a 12-inch one-piece die-cast turntable, precision silicone-damped cueing, and a metal main cam that insures long life, according to the company. Benjamin

Circle No. 16 on Reader Service Card

#### COMPACT MUSIC SYSTEMS

The new "Slimline" compact music system line consists of four separate models: Model SL1012 is an AM-FM stereo receiver/speaker combination with omnidirectional speakers; Model SL1112 has the same features except includes a mini record changer; the Model SL1312 consists of an AM-FM stereo receiver/speaker combination plus mini record changer/stereo tape cassette recorder; and the Model PC13, a mini changer/tape cassette module, which is available separately.

All of the units are ultra-compact and can fit into a small space on a bookshelf or table top. Harman-Kardon

Circle No. 17 on Reader Service Card

#### COLOR GENERATOR

A miniature color generator that is small



enough to fit into a tube caddy has been introduced as the "Caddy Bar," Model CG19.

The generator has standard keyed-rainbow color bars, crosshatch, white dots, and vertical and horizontal lines. The new circuitry reduces the current drain, allowing full voltage regulation on all circuits rather than just the timer circuits. Reduced current also increases battery life. Timer range on the unit has been doubled over that of earlier models. Sencore

Circle No. 18 on Reader Service Card

#### FOUR-WAY SPEAKER SYSTEM

The Model IV is a 14-speaker, high-efficiency four-way non-resonant system designed and engineered with inverse-feedback electronic suspension and room gain control for improved sound reproduction in large auditoriums, music halls, amphitheaters, dormitories, and large living rooms. The unit is also being offered in a kit version for custom applications.

February, 1970

# NOW - CHECK ALL TRANSISTORS IN OR OUT OF CIRCUIT ...

Flick function switch to left to check all regular transistors.

Flick function switch to right to check any FET.



... plus the new FIELD EFFECT TRANSISTORS too!

LARGE 6" METER

You won't be stopped when you run into the new FETs that are wired into the latest hi-fi, newest TV receivers and nearly every other new device coming on the market. For the very first time, you can check them all, in or out of circuit. The TF151 works every time using tried and proven signal injection techniques. New, improved tests on special RF transistors and the latest high power transistors, mean that the TF151 is the only up-to-date transistor tester on the market. A new, exclusive setup book in rear compartment guides you to every test for over 12,000 transistors and FETs. The book is not needed for general service troubleshooting. Regular transistors are checked for beta gain and  $I_{cbo}$  leakage. FETs are checked for transconductance and  $I_{gss}$  leakage. only \$129<sup>50</sup>

NEW SENCORE TF17 compact in and out of circuit transistor FET tester. Same as TF151 except in new Sencore Handi case and with 4-1/2" meter. . . \$109.50

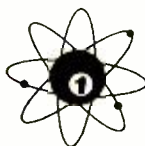

**SENCORE**  
NO. 1 MANUFACTURER OF ELECTRONIC MAINTENANCE EQUIPMENT

426 SOUTH WESTGATE DRIVE, ADDISON, ILLINOIS 60101  
CIRCLE NO. 109 ON READER SERVICE CARD



The speakers in the new system include four 15" woofers, four 8" mid-bass, four 6" mid-range, and two 5" horn-type tweeters. They are housed in an air-tight wooden cabinet measuring 51½" high x 36¼" wide x 20" deep including the kick base. Frequency response is 20-20,000 Hz ± 3 dB with crossovers at 150,1000, and 4000 Hz. Nominal impedance is 4 ohms and power handling capacity is 200 watts r.m.s. with 100 watts r.m.s. per channel minimum power requirement.

A brochure describing this and other speakers in the company's line is available on request. LWE Div.

Circle No. 19 on Reader Service Card

#### 12-POSITION ROTARY SWITCH

Daven, Grenier Field, Manchester, New Hampshire 03103 has announced the availability of ½-inch diameter rotary switches with 12 positions. The firm's Series "G" and "K" switch lines have



been expanded to include 12-position shorting and non-shorting models in the same 0.500-inch diameter as the 10-position switches.

MIL-Spec and commercial versions are available, with choice of flatted-pierced or PC terminations, from 1-pole 12-position up to 4-pole 3-position. The switches are explosion-proof and carry current up to 3 amps and switch up to 1 amp. Rotation life is 25,000 cycles at 200 mA, 85° C.

The company will forward a copy of data sheet SG-79 to those making their requests on their business letterheads.

#### SOLID-STATE STEREO RECEIVER

The new SX-990 solid-state, AM-FM multiplex stereo receiver uses an all-silicon semiconductor quasi-complementary circuit to provide a push-pull output of 100 watts of audio power across a speaker impedance of 8 ohms (IHF) or a continuous audio power output, with both channels driven, of 28 watts per channel across the 8-ohm voice coils of speakers.

Speaker control from the front panel permits individual selection of speakers A, B, or both sets of speakers. The bass and treble controls supply positive action bass and treble adjustments. Completely flat response is also available to the user.

The front panel also features two push-button filter controls and a loudness-contour control which is switchable to on or off. The front panel features a black rectangular face plate. Glow

lights come on when the function selector is turned to various positions. Pioneer

Circle No. 20 on Reader Service Card

#### MULTI-PURPOSE TOOL KIT

A 100-piece multi-purpose tool kit, JTK-17, includes virtually every standard tool required in the field for maintenance of complex electronic and data processing equipment.

Housed in an attaché-type case, most of the tools are mounted on two removable pallets. These pallets hold the tools securely in a well-organized manner, yet present them to the view of the user. There is room in the case for housing large tools, spare parts, and an optional v.o.m.

A brochure describing the kit and its contents is available on request. Jensen Tools

Circle No. 21 on Reader Service Card

#### DESOLDERING TIP

Weller Electric Corporation, 100 Wellco Road, Easton, Pa. 18042 has added a new accessory tip for the desoldering and removal of dual in-line flat packs from PC boards to its industrial line.

The style DIT-1 tip assembly is a low-cost accessory for use with the company's Models W-TCP-L and W-TCP soldering station and complements a previously introduced style FPT-1 tip for removal of flat-packs.

The tip is wide enough to span all fourteen leads of a dual in-line pack simultaneously. The DIT-1 is available either as an accessory or with a complete soldering station.

The Industrial Products Division of the company will supply full details upon letterhead request.

#### COLOR-CODED CASSETTE

A color-coded cassette designed to meet the special requirements of the educational market is now available. The audio/visual cassettes are white on one side and black on the other. This configuration enables an instructor to tell at a glance if the entire class is listening to the correct side of the tape, which is essential in foreign language classes.

The cassettes are screw fastened and have a viewer window for seeing how much tape has been used or remains to play. They are available in a wide choice of playing times—10, 20, 30, 40, 60, 90, and 120 minutes. Audio Magnetics

Circle No. 22 on Reader Service Card

#### RADAR DETECTOR

A new miniature radar detector is designed to alert drivers well in advance of radar speed zones. It is completely transistorized, weighs only 8 ounces, and operates on two penlight batteries. The unit can be clipped to the sun visor.

The device picks up the radar signal and "beeps" a warning to the driver to slow down to



the posted speed limit. The detector is a receiver only and will not interfere with any transmitting beam and is only heard when picking up radar signals.

This unit is legal in all states except Virginia and Massachusetts. Additional details will be supplied on request. Mutronic

Circle No. 23 on Reader Service Card

#### NEW INTERCOMS

Three new series of solid-state intercoms have been introduced: the IM17 (seventeen-station) and IM-9, (nine-station) units which feature a

6-watt peak output power and provide operation with optional hands-free reply when called by other master units; the IE series which is available in the IE-13, an all-master system, and a six-station model, IE-7; and a special two-station package, the IE-4S system.

Various remotes and accessories are available for use with the new systems. Full details on these new units will be forwarded on request. Bogen

Circle No. 24 on Reader Service Card

#### STEREO CASSETTE DECK

A new stereo record/playback cassette-type deck is now being offered as the Model LP-1. It is unique in that it has been designed to allow for future conversion to play and record simultaneous 4-track stereo which will be released on prerecorded cassettes in the near future.

The unit has foolproof interlocking controls, a four-pole synchronous motor, three-digit counter, dual vu meters with separate input level

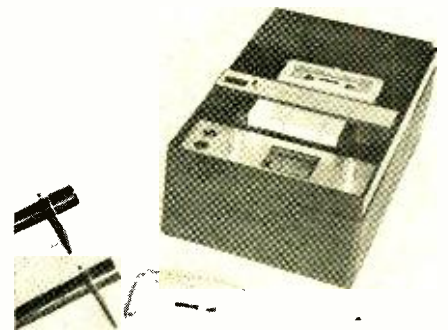

controls, and all interconnecting cables ready to plug in and operate. The unit measures 12½" d. x 7½" w. x 4½" h. A walnut base and a matched pair of microphones are available extras. Lumistor

Circle No. 25 on Reader Service Card

#### NEW SPEAKER SYSTEM

A new speaker system which incorporates a special control system that can be adjusted to help fit the speakers into various listening environments has been introduced. Response can be controlled at three different frequency ranges—the tweeter level and the 100-200 Hz and 1000-2000 Hz ranges in the woofer. Crossover frequency is 2000 Hz.

Both the 8-inch specially designed woofer and the 1-inch tweeter have smooth frequency response in the ±3 dB range. According to the company, the mid-band distortion is very low due to a new edge suspension and spider, making possible greater linear cone travel. 3M

Circle No. 26 on Reader Service Card

#### FOUR-CHANNEL STEREO AMP

The 499-Quadrant amplifier is the first commercial unit specifically designed to reproduce four-channel stereo. It has been designed for immediate use with the new four-channel prerecorded tapes and playback units, providing the necessary controls for convenient operation and optimum acoustic channel balancing of both left-right as well as front-rear. In addition, the 499 is compatible with existing two-channel systems, as well as any future four-channel FM or phono applications.

Power at 0.5% distortion with all four chan-



nels driven is 35 watts per channel at 8 ohms; power bandwidth is 15-25,000 Hz and frequency response is 15-30,000 Hz  $\pm$  1 dB.

A brochure giving full details on this amplifier is available on request. H. H. Scott

Circle No. 27 on Reader Service Card

#### AN ENDLESS CASSETTE

A new accessory for cassette recorders is now available as an endless cassette, which operates continuously in any standard cassette recorder or player. Supplied pre-loaded with blank tape, the unit can be recorded by anyone and played back continuously for point-of-purchase displays, language study courses, museum displays, on-the-job training, automatic telephone answering, or in-store announcements.

The cassette is available with tape lengths ranging from 70 seconds to 30 minutes. Sheldon Recording

Circle No. 28 on Reader Service Card

#### FREQUENCY CONTROL SYSTEM

A new, highly flexible stereo tonearm control system which can be added to most component amplifiers and receivers, has been introduced as the Frequency Balance Control. The unit incorporates all-solid-state circuitry and is designed to improve the tonal balance of recordings and stereo

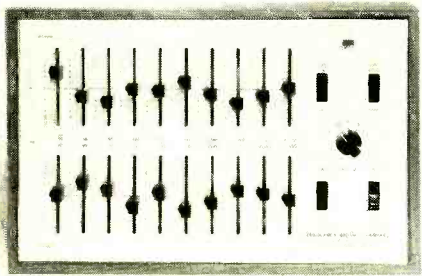

equipment and to compensate for varying room acoustics.

The control consists of twenty linear controls (ten per stereo channel), each of which adjusts the output of a single octave in the audio spectrum over a range of  $\pm$  12 dB. In all, ten octaves from 20 to 20,480 Hz are covered. In addition to the octave control, switching is provided to bring the control in or out of the circuit on each channel. A means of comparing left and right channels instantaneously is also provided. Advent Corp.

Circle No. 29 on Reader Service Card

#### PORTABLE/MOBILE SOUND SYSTEMS

A series of four portable/mobile sound systems for public address and other commercial institu-

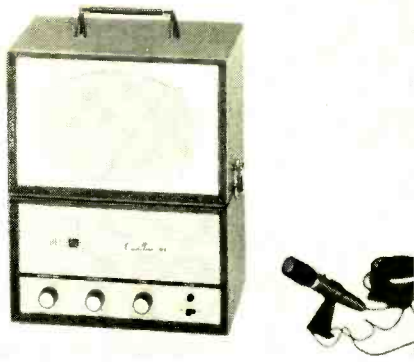

tional applications is now available. Ranging from 10 to 35 watts power output and including standard and solid-state amplifier circuits, these systems are designed for direct user application at indoor and outdoor meetings, lectures, auctions, trade shows, and other activities where quick set-up and operation are needed.

A 30-watt, all-weather car-top system with mounting bracket is included in the line. All sys-

tems, except the car top, include carrying case with handle. Amplifiers and speakers are sized and matched for particular crowd capacities.

Detailed product literature will be forwarded on request. Bell P/A

Circle No. 30 on Reader Service Card

## MANUFACTURERS' LITERATURE

#### TAPE-HEAD REPLACEMENTS

A new short-form Tape Head Replacement and Conversion Guide covering 218 manufacturers and over 2100 tape recorder models is now available for distribution.

The guide provides complete tape-head replacement data for both popularly priced and professional recorders, domestic and imported. The listing also includes a cross-referencing of Shure and Michigan Magnetics tape-head replacements with those of the firm. Nortronics

Circle No. 31 on Reader Service Card

#### RECORDERS AND COMPACTS

A 16-page, 4-color illustrated catalogue which provides specifications, features, and application data on a complete line of portable cassette tape recorders, Radiocorders, home-entertainment systems, and reel-to-reel stereo tape decks, receivers, speakers, and an 8-track cartridge player is now available for distribution. Concord

Circle No. 32 on Reader Service Card

#### TRANSISTOR CROSS-REFERENCE

Fairchild Semiconductor, Box 1058, Mountain View, California 94040, has issued an 8-page brochure which gives a complete listing of all standard dual, Darlington, and differential amplifier transistors available in today's market. The guide provides important electrical specifications for all registered devices in these categories for easy selection. For each device described, a Fairchild equivalent product is indicated.

The listings include 131 differential amplifiers

## The Most Spectacular Sound Exhibition of STEREO FIDELITY Ever Available on one Disc.



This record is the result of two years of intensive research in the sound libraries of Deutsche Grammophon Gesellschaft, Connoisseur Society, Westminster Recording Company and Cambridge Records Incorporated. The Editors of Stereo Review have selected and edited those excerpts that best demonstrate each of the many aspects of the stereo reproduction of music. **The record offers you a greater variety of sound than has ever before been included on a single disc.** It is a series of independent demonstrations, each designed to show off one or more aspects of musical sound and its reproduction. Entirely music, the Record has been edited to provide self-sufficient capsule presentations of an enormous variety of music arranged in a contrasting and pleasing order. It includes all the basic musical and acoustical sounds that you hear when you listen to records, isolated and pointed up to give you a basis for future critical listening.

#### WIDE RANGE OF DEMONSTRATIONS

- Techniques of Separation & Multiple Sound Sources
- Acoustic Depth
- Ambiance of Concert Hall
- Sharp Contrasts of Dynamics
- Crescendo & Diminuendo
- Very High & Very Low Pitched Musical Sounds
- Polyphony (2 or more melodies at once) With Both Similar & Contrasting Instruments
- Tonal Qualities of Wind, String & Percussion Instruments
- Sounds of Ancient Instruments
- Sounds of Oriental Instruments
- Sound of Singing Voice, Both Classically Trained and Untrained
- Plus a Large Sampling of Finger Snapping, Hand Clapping, Foot Stamping & Other Musical & Percussive Sounds.

#### 13 SUPERB SELECTIONS

**STRAUSS:** Festive Prelude, Op. 61 (excerpt) DGG  
**DEBUSSY:** Feux d'artifice (excerpt), Connoisseur Society.  
**BEETHOVEN:** Wellington's Victory (Battle Symphony) (excerpt from the first movement) Westminster Records.  
**MASSAINO:** Canzona XXXV à 16 (complete) DGG Archive.  
**CORREITE:** Concerto Comique Op. 8, No. 6, "Le Plaisir des Dames" (third movement) Connoisseur Society.  
**KHAN:** Raga Chandranandan (excerpt) Connoisseur Society.  
**RODRIGO:** Concert—Serenade for Harp and Orchestra (excerpt from the first movement) DGG.  
**MANITAS DE PLATA:** Gypsy Rhumba (complete) Conn. Soc.  
**MARCELLO:** (arr. King) Psalm XVII "The Heavens are Telling" (complete) Connoisseur Society.  
**PRAETORIUS:** Terpsichore: La Bourrée XXXII (complete) DGG Archive.  
**BERG:** Wozzeck (excerpt from Act III) DGG.  
**BARTÓK:** Sonata for two pianos and Percussion (excerpt from the first movement) Cambridge Records.  
**BEETHOVEN:** Wellington's Victory (Battle Victory) (excerpt from the last movement) Westminster.

ORDER YOUR STEREO DEMONSTRATION RECORD TODAY

Only \$4.98 Postpaid

**FREE**

Descriptive Booklet Enclosed includes discussion of the selections on the record, plus a complete description of each selection and the purpose behind its demonstration.

AVAILABLE IN YOUR CHOICE OF 33 1/3 RPM OR 45 RPM

The Stereo Demonstration Record is processed and pressed on a newly developed, improved vinyl. It is permanently anti-static, repels dust and dirt and promotes longer stylus wear. The use of this material is conducive to low surface noise and contributes to the production of full dynamics and frequency range. The record continually looks new, sounds new and wears longer.

RECORDS • Ziff-Davis Service Division  
 595 Broadway • New York, N.Y. 10012

Please send me \_\_\_\_\_ Stereo Review Stereo Demonstration Record Albums at \$4.98 each, postpaid. My check (or money order) for \$ \_\_\_\_\_ is enclosed.

Check One:  33 1/3 rpm  45 rpm

(outside U.S.A. please send \$7.00 per album ordered.) New York State residents please add local sales tax.

Print Name \_\_\_\_\_

Address \_\_\_\_\_ EW 2-70

City \_\_\_\_\_ State \_\_\_\_\_ Zip Code \_\_\_\_\_

PAYMENT MUST BE ENCLOSED WITH ORDER

# Electronics World SUBSCRIBER SERVICE

Please include an address label when writing about your subscription to help us serve you promptly. Write to: Portland Place, Boulder, Colorado 80302

## CHANGE OF ADDRESS:

Please let us know you are moving at least four to six weeks in advance. Affix magazine address label in space to the right and print new address below. If you have a question about your subscription, attach address label to your letter.

## TO SUBSCRIBE:

Check boxes below.

- New  Renewal  
 5 years \$26  
 3 years \$18  
 1 year \$7

## SPECIFY:

- Payment enclosed—  
 You get 1 extra issue per year as a BONUS!  
 Bill me later.

**→ AFFIX LABEL ←**

state	city	address	name
zip-code			please print

**↑ If you have no label handy, print OLD address here ↓**

[Add 1 postage: \$1 per year outside U.S., its possessions & Canada.]

name please print c324

address

city

state zip-code

## For a SOUND INVESTMENT... you need SOUND ADVICE

### 1970 STEREO HI-FI DIRECTORY



It's the most complete, most reliable guide to virtually every new component on the market — amplifiers ● tuners ● receivers ● changers and turntables ● home TV-tape recorders ● cartridges-arms and accessories ● tape machines-cartridge, cassette and reel-to-reel ● speaker/cabinets ● hi-fi systems ● miscellaneous accessories.

You'll know what to look for, what to listen for, how to buy, what to pay—before you set foot into the store. You'll be armed with full technical specs, photos, model numbers, dimensions, special features, optional accessories, and prices for each piece of stereo equipment put out by the world's leading manufacturers.

Even if you plan to buy just one piece of equipment in the next 12 months, the 1970 Stereo Hi-Fi Directory is your most important first step. A must for anyone concerned with good listening... and sound buying!

Ziff-Davis Service Division, Dept. SD  
595 Broadway, New York, N.Y. 10012 EW-2-70  
YES. Send me the new 1970 STEREO HI-FI DIRECTORY as checked below:

\$1.35 enclosed, plus 25¢ for shipping and handling. Send me the regular edition. (\$2.00 for orders outside the U.S.A.)

\$3.50 enclosed. Send me the Deluxe Leather-bound edition, postpaid. (\$4.50 for orders outside the U.S.A.) Allow three additional weeks for delivery.

print name

address

city

state zip

**— PAYMENT MUST BE ENCLOSED WITH ORDER —**

while other listings are devoted to unmatched dual amplifiers, complementary dual amplifiers, "n-p-n" and "p-n-p" Darlington amplifiers, and "n-p-n" military transistors.

Write on your business letterhead for a copy of this publication.

### THE METRIC SYSTEM

American National Standards Institute, Inc. has just published a 45-page illustrated booklet covering the history of measuring systems, growth of the metric system, and recent changes in metric units of measure. Also covered in "Measuring Systems and Standards Organizations" are national and international organizations active in the field of standards of measure and commercial standards.

Copies of this new booklet are available for \$1.25. Orders, with payments, should be sent to the ANSI at 1430 Broadway, New York, N.Y. 10018.

### TIME-DELAY RELAYS

A complete line of solid-state variable time-delay relays, featuring external knob adjustment for a delay range of 0.1 to 10 seconds, 0.6 to 60 seconds, or 1.8 to 180 seconds—is described in a new 8-page catalogue published by Ohmite Manufacturing Company, 3601 Howard Street, Skokie, Illinois 60076.

Write on your business letterhead to the above address if you would like a copy.

### CRIMPING TOOLS

Crimping tools for a wide variety of applications, including Class I and Class II specifications of MIL-T-22520, are described and pictured in Catalogue T103. A separate section of the loose-leaf catalogue explains crimp-tool phraseology and lists better crimping techniques.

The line is available in standard and miniature sizes; 4- and 8-indent; automatic and manual feed, and C-frame configurations. An assortment of crimping tool kits is also covered. Buchanan

Circle No. 33 on Reader Service Card

### HOME-STUDY SCHOOL LIST

A "Directory of Accredited Private Home Study Schools" is now available in a handy pocket-sized booklet. There is a listing of the various subjects taught by accredited schools, cross-referenced to the schools.

The listing of 120 schools on the accredited list provides the name, address, and a short resumé of courses being offered. A Business Reply card for obtaining additional information is also included. National Home Study Council

Circle No. 34 on Reader Service Card

### TAPE-RECORDER CATALOGUE

A colorful 52-page catalogue listing the complete line of Sony tape recorders, decks, accessories, and cassette units has just been issued.

Each model is pictured and described in considerable detail, with information on suggested accessories that can be used with each unit. A glossary of features, expanding the notations in the catalogue section, is also included. Super-scope

Circle No. 35 on Reader Service Card

### HIGH-PERFORMANCE MOTORS

A new illustrated 88-page catalogue describing a full line of induction, synchronous, and torque motors for the OEM market has been issued by IMC's Eastern Division, 570 Main St., Westbury, New York 11591.

Drawings, curves, performance data, electrical and mechanical specifications are provided for more than 2000 designs, each pre-tooled and engineered to highest industry standards.

There are individual sections devoted to induction, torque, hysteresis, reluctance, and polarized synchronous motors. In addition, a thorough explanation of motor design and operation, as well as selection factors and application information is provided.

Write on your business letterhead to Peter Koehler of the Marketing Division at the above address for your copy.

### ELECTRONIC PARTS

A new 56-page general catalogue listing an extensive line of batteries, capacitors, controls, IC's, resistors, switches, etc. is available.

The catalogue clearly defines all product types and has new illustrations and drawings for both established components as well as new ones. The new products are clearly indicated in the tabular listings on each page. Ample space is provided for the user to make notes. For ease of use, in addition to an alphabetically arranged table of contents, there is a product index arranged alphabetically and numerically. Mallory Distributor

Circle No. 36 on Reader Service Card

### PRECISION INSTRUMENTS

Catalogue No. TIC 3515 is a 36-page publication which provides detailed information on an extensive line of general-purpose test equipment and special two-way radio test equipment and service aids.

Extracted from the company's Buyer's Guide, the catalogue lists frequency meters, v.o.m.'s, signal generators, scopes and accessories, voltmeters, multimeters, diode testers, audio oscillators, etc. Each unit is pictured and described in minute detail. Motorola Communications

Circle No. 37 on Reader Service Card

### RECEIVER SPECS

A 6-page, 4-color brochure outlining the various features of the SEL-200 stereo-FM receiver is now available for distribution. In addition to calling out the front-panel controls and switches, complete amplifier, tuner, and general specs are provided, along with performance graphs. Sherwood

Circle No. 38 on Reader Service Card

### CB ANTENNAS

A 20-page catalogue which lists and describes an extensive line of "Hustler" antennas and accessories for CB service has been published.

Included are co-linear, ground-plane, and beam antennas for base stations and an extensive line of mobile antennas, portable antennas, mounts, springs, and bases. New-Tronics

Circle No. 39 on Reader Service Card

### HAND TOOL BROCHURE

A line of precision hand tools is pictured and described in an 8-page, 2-color brochure which is available for distribution.

There are screwdriver and awl sets, drivers and Allen-type wrench sets, tap drills, screwdrivers of various types, scribers, precision dies, pocket magnets, specialized repair kits, among the products covered. Moody

Circle No. 40 on Reader Service Card

### SEMICONDUCTOR CATALOGUE

A 24-page catalogue which covers silicon semiconductors including chip devices, zener regulators, reference diodes, solar cells, and photovoltaic assemblies is off the press and ready for distribution.

Featured in this listing is a unique new kit of chip zener regulators which comes complete with 1500 of the 30 most popular zener regulator chips. It is designed for prototype development work.

A table of contents, an interchangeability table, a regulator quick-reference chart, as well as a detailed index, makes this catalogue convenient to use. There are photos of all part number series as well as dimensioned drawings and detailed performance specs. Centralab

Circle No. 41 on Reader Service Card

### INDUSTRIAL INSTRUMENTS

Bulletin 2080 is a 14-page listing of a broad line of industrial electronic and electrical test instruments. Complete specifications on equipment for servicing industrial electronic and electrical



gear, radio and TV sets, communications, automotive, air conditioning, refrigeration, and heating appliances are included. Simpson Electric

Circle No. 42 on Reader Service Card

#### YOUR FUTURE IN ELECTRONICS

A 60-page booklet on "How to Prepare for Tomorrow's Jobs in Electronics" has been issued. It outlines the various college-level home-study programs offered in electronic engineering technology and nuclear engineering technology, outlines the opportunities available to qualified personnel, and lists the various courses (both elective and required) the school is prepared to offer. CREI

Circle No. 43 on Reader Service Card

#### SUBMINIATURE LAMPS

A new 21-page catalogue from Chicago Miniature Lamp Works contains valuable basic design information, technical discussions of the various parameters involved in lamping, and a usable cross-reference guide to lamp substitution.

Catalogue CMT-3 features a revised layout of technical data on each lamp, giving the all-important design voltage for each lamp first, allowing the engineer to tailor his lamp selection to the voltage required.

For a copy of this valuable data, write on your business letterhead to the company at 4433 N. Ravenswood Ave., Chicago, Ill. 60640

#### QUARTZ CRYSTALS

Reeves-Hoffman Division, 400 W. North Street, Carlisle, Pa. 17013 has issued a 16-page product brochure describing its complete line of coldweld and solderseal crystal units.

Included in the brochure in technical data covering individual crystal types providing frequencies from 850 Hz to 125 MHz. Wide-ranging applications for these crystals include computers, telephone systems, radio transmitters and receivers, aircraft navigation aids, and space and missile guidance systems.

Address your letterhead request for this brochure to the attention of Jim Harlin, sales vice-president, at the above address.

#### PRECISION SWITCHES

Cherry Electrical Products Corporation, 1650 Old Deerfield Road, Highland Park, Ill. 60035 has just issued a 44-page catalogue covering its long-life line of precision switches.

Included in the line are leverwheel/thumb-wheel rotary switches, matrix selector switches, low-energy switches, and snap-action switches. The catalogue also provides a switch-selector locator and a glossary of snap-switch terminology.

A request on your business letterhead will bring you a copy of Catalogue C-70.

#### RESONANT REEDS

Motorola's Communications Division, 4501 W. Augusta Blvd., Chicago, Ill. 60651 has issued a one-page brochure on "K1000A Vibrasponder Resonant Reed."

The brochure describes these contactless resonant reeds which are now available to the OEM market. They are suited for applications in supervisory control, aerospace, military, and telemetry or wherever selective tone signaling or stable audio tones are required.

For a copy of No. TIC 3521, send your letterhead request to the attention of the Component Products Department at the above address.

#### COMPONENTS & SUBASSEMBLIES

Microwave Associates, Inc., Burlington, Mass. 01803 is now distributing its 120-page "Master Catalogue" covering a comprehensive line of components and subassemblies. Included are semiconductors and diodes, microwave power tubes, duplexers and duplexer tubes, ferrite devices, solid-state r.f. sources, solid-state amplifiers and control devices, transmission line devices, and custom engineered subassemblies.

In addition to providing complete product information, the catalogue includes sales, shipping, and service information; R&D data; U.S. and international sales representatives; semiconductor distributors; and a product index.

Those desiring a copy of this catalogue should make their requests on their business letterheads to the company at the above address. ▲

### Regulated Power Supplies

(Continued from page 33)

It will be evident to the more experienced experimenter that several additional features could be incorporated into the design of this type of power supply. The addition of meters as shown in Fig. 6 is a case in point. Other features include both fine- and coarse-voltage control, presettable current limiting, and a means of overcoming the nominal 1.5-volt minimum voltage output inherent in the basic design. However, it was felt that the basic premise of this article would be violated by the additional complexity and expense involved in incorporating such features. Hence no attempt has been made to do more than acknowledge the feasibility of such features and to suggest their incorporation only when the additional cost is justified. The basic design described here is more than adequate for its purpose, having been used to power audio systems, experimental musical instruments, and electric trains and slot cars (for which its constant voltage-variable current characteristic at each setting of the speed control is ideal). In no case has the minimum voltage offset been a problem. Additional uses, besides general-purpose bench service, include power for IC circuits, regulation of inverter output, brightness adjustment of a low-voltage-type reading lamp, and constant-speed motor control using tachometer feedback. The HO train version includes a switch to disconnect C1. This provides "pulse power" with the amplitude of the flat-top pulses controlled by the throttle potentiometer.

Additional uses will no doubt occur to the reader, for which this simple, stable regulator will more than justify its very nominal cost. ▲

#### PHOTO CREDITS

Page	Credit
25, 28 (top)	General Electric Co.
26 (top)	Honeywell
26 (bottom), 27	Hewlett-Packard
28 (center)	General Telephone & Electronics
28 (bottom), 78 (top)	RCA Corp.
29 (top)	General Time Corp.
29 (center)	International Harvester
29 (bottom left)	IBM
29 (bottom right)	Jerrold Electronics Corp.
36, 37	Official FAA Photo
38	Bendix Corp.
40, 58	Acoustic Research, Inc.
42, 43, 44, 45, 46	Motorola Semiconductor Products Inc.
46	Sola Electric
48	Motorola Inc.
78 (bottom)	General Aviation Electronics, Inc.

**LAFAYETTE**  
RADIO ELECTRONICS

**FREE!**

1970 CATALOG NO. 700  
JUST OFF THE PRESS!!  
SEND FOR YOUR EXCITING COPY NOW!



**LATEST RELEASES!**  
**BEST BARGAINS!**  
**496**  
Pages

YOUR 1st GUIDE TO  
EVERYTHING IN  
ELECTRONICS

- \* CITIZENS BAND 2-WAY RADIO
- \* STEREO/HI-FI COMPONENTS
- \* MUSICAL INSTRUMENTS AND AMPLIFIERS
- \* PUBLIC ADDRESS
- \* AMATEUR RADIO
- \* TEST EQUIPMENT
- \* PARTS
- \* PORTABLE AND TABLE RADIOS
- \* PHOTO EQUIPMENT
- \* TOOLS BOOKS
- \* AUTO ACCESSORIES
- \* EDUCATIONAL AND OPTICAL
- \* TV AND ANTENNAS

Mail the Coupon Today for your FREE 1970 Lafayette Catalog 700

LAFAYETTE Radio ELECTRONICS Dept. 01020, P.O. Box 10 Syosset, L.I., N.Y. 11791

Please Send the FREE 1970 CATALOG 700 01020

Name .....

Address .....

City ..... State .....

Zip ..... (please include your Zip Code No.)

CIRCLE NO. 128 ON READER SERVICE CARD

Cooperate With The  
Zip Code Program  
of The Post Office  
Department.  
Use Zip Code  
In All Addresses

# NEW IMPROVED 1970 HEATHKIT® COLOR TV

## New Lower-Than-Ever Prices

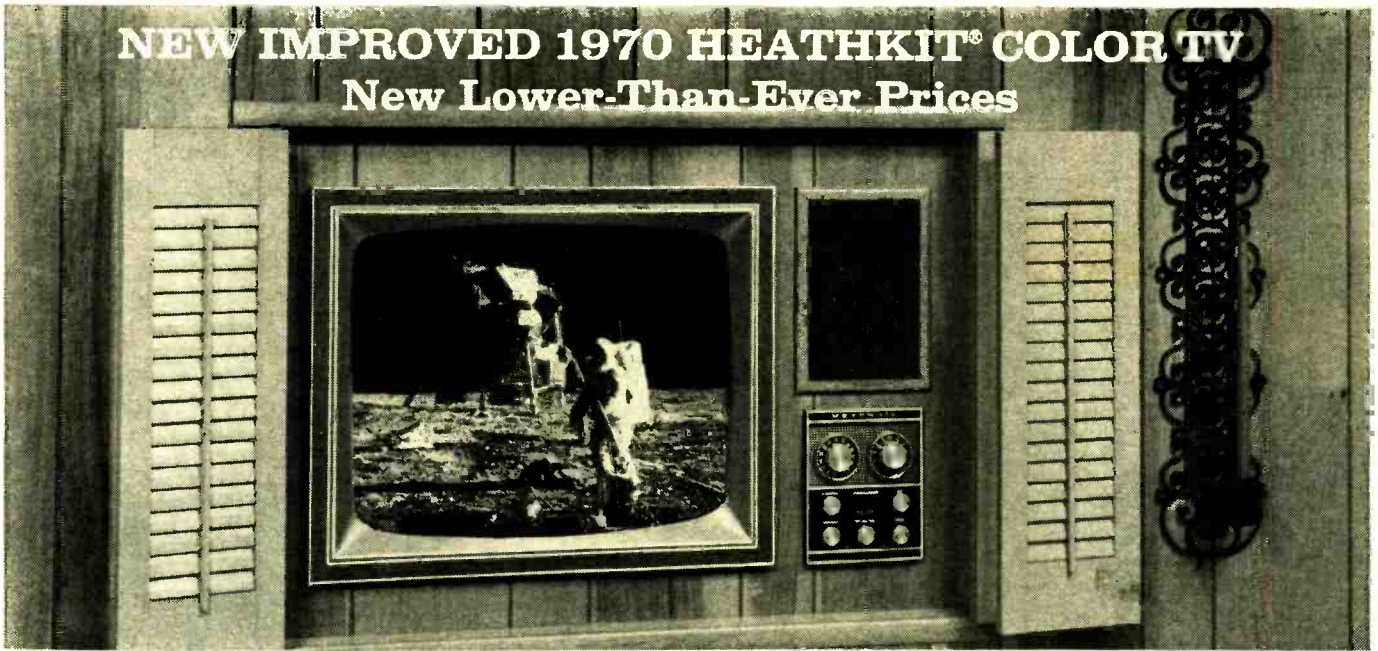

### Here's How The Color TV That Thousands Call Best Became Even Better and Lower In Price

Since the very first model was introduced, thousands of owners, electronic experts, and testing labs have praised the superior color picture quality and extra features of Heathkit Color TV. Now Heath has made improvements that make the 1970 models even better.



**Sharper, More Detailed Pictures.** Latest design improvement in the circuitry of Heathkit Color TV video amplifiers has increased their bandpass capabilities. The result is an increase in the number of lines of resolution . . . greater than in any other brand of color TV we have tested. This improvement means you get sharper, more detailed pictures as shown by test pattern measurements. You not only get the superior color pictures Heathkit Color TV has always been noted for, but you also get sharper pictures.

**New Brighter Tube.** Now all Heathkit Color TV models include the new brighter picture tube you've read so much about. These new tubes produce noticeably brighter pictures with more life-like, natural colors and better contrast. (We also offer the RCA Hi-Lite Matrix tube as an extra-cost option for the Heath GR-681 and GR-295 kits.)

**New Safety Features.** As an added safety precaution, AC interlocks have been added to all Heathkit Color TV cabinets.

**Now The Best Costs Less.** How can Heath make improvements in its Color TV Models and still reduce the prices? We have passed on to you the savings which have accrued due to reduced picture tube prices. The result is your 1970 Heathkit Color TV will cost you \$20 to \$55 less depending upon which model you choose . . . proof that Heathkit Color TV is a better buy than ever.

#### All Heathkit Color TV's Have These Superior Features

- New brighter American brand rectangular color tube with bonded-face, etched anti-glare safety glass
- Exclusive built-in self-servicing aids so you can adjust and maintain the set for best performance always
- Automatic degaussing plus mobile degaussing coil
- New broader video bandwidth for better resolution
- 3-stage video IF
- Improved retrace blanking
- Gated automatic gain control for steady pictures
- Automatic color control
- Exclusive Magna-Shield surrounds picture tube for better color purity
- Deluxe VHF tuner with "memory" fine tuning and precious metal contacts (models with automatic fine tuning also are available in all 3 picture tube sizes)
- 2-speed UHF solid-state tuner
- Completely shielded hi-voltage supply
- Extra B+ boost for better definition
- 2 hi-fi sound outputs for built-in speaker or your hi-fi system
- 300 ohm & 75 ohm antenna inputs
- Circuit breaker protection
- Optional wireless remote control can be added anytime
- Factory assembled and adjusted tuners, IF section, and hi-voltage supply
- Exclusive 3-way installation capability — in a wall, custom cabinet or Heath cabinets

Choose Your Heathkit Color TV Now . . .

It's Better Than Ever in Performance . . . and A Better Buy Than Ever

### New Lower-Than-Ever Prices On All Models

Heathkit GR-681  
(295"-AFT)  
save \$30

Now only **\$469<sup>95</sup>\***



Heathkit GR-681MX  
(with Matrix tube)  
save \$55

Now only **\$479<sup>95</sup>\***



Heathkit GR-295  
(295")  
save \$30

Now only **\$419<sup>95</sup>\***



Heathkit GR-295MX  
(with Matrix tube)  
save \$55

Now only **\$429<sup>95</sup>\***

cabinets from \$65\*

Heathkit GR-581  
(227"-AFT)  
save \$20

Now only **\$399<sup>95</sup>\***



Heathkit GR-227  
(227")  
save \$20

Now only **\$359<sup>95</sup>\***

cabinets from \$39.95\*

Heathkit GR-481  
(180"-AFT)  
save \$30

Now only **\$329<sup>95</sup>\***



Heathkit GR-180  
(180")  
save \$30

Now only **\$299<sup>50</sup>\***



cabinets from \$27.50\*

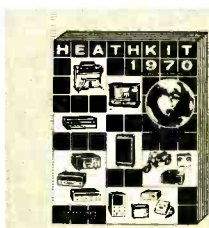

### NEW FREE 1970 CATALOG!

Now with more kits, more color. Fully describes these along with over 300 kits for stereo/hi-fi, color TV, electronic organs, guitar amplifiers, amateur radio, marine, educational, CB, home & hobby. Mail coupon or write Heath Company, Benton Harbor, Michigan 49022.

HEATH COMPANY, Dept. 15-2  
Benton Harbor, Michigan 49022

Enclosed is \$ \_\_\_\_\_, plus shipping.

Please send model (s)

Please send FREE Heathkit Catalog.

Please send Credit Application.

Name \_\_\_\_\_

Address \_\_\_\_\_

City \_\_\_\_\_

State \_\_\_\_\_

Zip \_\_\_\_\_

\*Mail order prices; F. O. B. factory.

Prices & specifications subject to change without notice.

CL-376



a Schlumberger company

# This NEW Sweep-Marker Generator Does Every Color Alignment Job That Needs Doing—and Saves You Up To \$260



**Heathkit® IG-57A Kit \$135\*—Assembled \$199\***  
**Now With Video Sweep Modulation & Second Bias Supply**

**Compare the Features — Compare the Cost**

- **New Video Sweep Modulation**.....allows you to inject chroma sweep directly into the IF amplifiers or through the antenna terminals... permits more accurate matching between color bandpass amplifiers and IF and observation of overall response.
- **Exclusive Heathkit Attenuator**.....lets you quickly and accurately determine 6 dB points without guessing. Gives up to 70 dB total attenuation in 1, 3, 6, 10 and 20 dB steps.
- **15 Crystal-Controlled Markers**.....provide all the most used marker frequencies... 3 for color bandpass, 1 for TV sound IF, 8 at the IF frequencies from 39.75-47.25 MHz including special markers for B&W bandpass. Markers also included for picture & sound carriers on channels 4 & 10. The 15th crystal marker is at 10.7 MHz for FM IF. A coil-tuned 100 kHz marker is also provided. A front-panel input accepts an external marker generator.
- **New Built-In Bias Supplies**.....two individually adjustable bias supplies can be switched for either positive or negative output... up to 15 V at 10 mA.
- **400 Hz Modulated Or CW Output**.....of any individual marker for fast, simple trap alignment and FM tuner adjustment.
- **Proven Saturable Reactor Circuitry**.....produces stable, linear sweep signals that cover the five most used frequency ranges.
- **Complete Scope Matching Controls**.....switchable Retrace Blanking enables accurate Phase Control adjustment. Just switch on Retrace Blanking for convenient zero output base line. Trace Reverse function permits display of markers in proper sequence.
- **Quick-Disconnect BNC Connectors**.....for quick, easy set-up changes.
- **Complete With All Probes, Test Leads & Terminated Cables**.....includes terminated RF cable with built-in DC blocking capacitor... Demodulator Probe for envelope detection in color circuits... shielded Scope Vertical lead... shielded Clip Lead cable... Scope Horizontal lead... two Bias Leads.
- **How-To-Use**.....the famous Heathkit manual includes a comprehensive, well-illustrated Applications Section that shows you how to align TV IF, Traps and Color Bandpass... how to do IF & RF Video Sweep Alignment, VHF Tuner checking, FM Tuner Tracking & IF alignment.

Compare The New Heathkit IG-57A With All Others... you get more useable features, better performance, more versatility per dollar with the IG-57A. Order your IG-57A now... and keep up to \$260 in your pocket.



All Cables, Leads, & Probes are included. Nothing extra to buy.

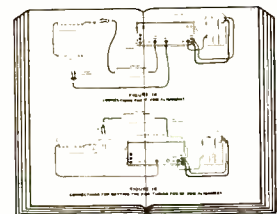

26 pages of Instructions and Illustrations — show you exactly how to use your IG-57A for greater efficiency, greater profit.



**NEW**  
**FREE 1970 CATALOG!**  
 Now with more kits, more color. Fully describes these along with over 300 kits for stereo/hi-fi, color TV, electronic organs, guitar amplifiers, amateur radio, marine, educational, CB, home & hobby. Mail coupon or write Heath Company, Benton Harbor, Michigan 49022.

**HEATHKIT**  
*a Schlumberger company*

HEATH COMPANY, Dept. 15-2  
 Benton Harbor, Michigan 49022

Enclosed is \$ \_\_\_\_\_, plus shipping.

Please send model(s)  
 Please send FREE Heathkit Catalog.     Please send Credit Application.

Name \_\_\_\_\_

Address \_\_\_\_\_

City \_\_\_\_\_ State \_\_\_\_\_ Zip \_\_\_\_\_

\*Mail order prices; F.O.B. factory. Prices & specifications subject to change without notice. TE-214

CIRCLE NO. 133 ON READER SERVICE CARD



# BOOKS

**"FUNDAMENTALS OF DIGITAL COMPUTERS"** by Donald D. Spencer. Published by *Howard W. Sams & Co., Inc.*, Indianapolis, Ind. 252 pages. Price \$5.50. Soft cover.

This is a basic text dealing with all phases of electronic computing for those whose lives are touched by computers— which means virtually any citizen with a driver's license, a credit card, an account with a utility company or a department store, children in school, a bank account, etc.

The text is divided into five main parts covering an introduction to and history of computers, computer structure, the computer system, solving problems with a computer, and computer topics.

The writing is informal and the author's command of his subject is such that he is able to convey the important aspects of computer technology to his largely uninitiated audience in easy-to-understand form.

\* \* \*

**"AUDIO SYSTEMS HANDBOOK"** by Norman H. Crowhurst. Published by *Tab Books*, Blue Ridge Summit, Pa. 17214. 189 pages. Price \$7.95.

This is a no-nonsense handbook for the professional audio man or the sophisticated audiophile. The author wastes no time in getting down to basics and deals with his subject in nine information-packed chapters covering amplifiers; equalizers, mixers, and filters; distribution systems; program sources; special devices; the complete system; commercial sound; studios; and loudspeaker systems.

The text is lavishly illustrated with diagrams, graphs, response curves, and floor plans. Since the writing is tight, Mr. Crowhurst has provided a lot of basic information in a relatively few pages.

\* \* \*

**"UNDERSTANDING AND USING UNIJUNCTION TRANSISTORS"** by Stu Hoberman. Published by *Howard W. Sams & Co., Inc.*, Indianapolis, Ind. 92 pages. Price \$2.50. Soft cover.

While this is a rather specialized text, the upsurge in popularity of unijunction transistors in applications ranging from timing and triggering circuits, oscillators, voltage sensors, power-controlling devices, and counters to computer memory systems justifies this specialization.

In five chapters the author covers UJT fundamentals, UJT oscillators, voltage controls, time delays and flashers, and sensing circuits. A table listing UJT characteristics is also included. The text is well illustrated.

\* \* \*

**"DIGITAL ELECTRONICS FOR SCIENTISTS"** by H. V. Malmstadt and C. G. Enke. Published by *W. A. Benjamin, Inc.*, New York. 532 pages. Price \$9.50.

The proliferation of electronic and scientific instrumentation has exposed a whole new group of scientists to the problem of using unfamiliar equipment.

It is for this non-engineering audience that the authors have prepared this text. It offers a systematic introduction to the digital circuits, the concepts, and the systems that are basic to the new instrumentation-computation revolution. In seven chapters the book covers digital measurements, switching concepts and diode circuits; transistors, relays, and other switches; switching logic and logic gates; flip-flops and multi-vibrators; counters, registers, and readout; and digital and analog-digital instruments and systems. The experiments to be performed (warmly recommended by the authors, but not

absolutely essential) are grouped in a special section at the back of the book along with nine appendices and a bibliography.

\* \* \*

**"UNDERSTANDING AND TROUBLESHOOTING SOLID-STATE ELECTRONIC EQUIPMENT"** by Jack Berens and Stephen Berens. Published by *Chilton Book Company*, Philadelphia, Pa. 19106. 171 pages. Price \$7.95.

This is a book for the electronics technician who must troubleshoot and repair various types of equipment using solid-state components. The authors contend that there are certain basic circuits and when the technician is familiar with them he can also handle less familiar circuits which are closely related but not identical.

To this end, the authors cover troubleshooting diodes and their circuits, troubleshooting transistor circuits, and specialized service information and equipment for such work.

The introductory chapters explain the concept, describe semiconductor technology, and provide background material on transistors. The text is illustrated and the presentation is informal.

\* \* \*

**"CONTROL SYSTEMS FOR TECHNICIANS"** by V. G. T. Bryan. Published by *Hart Publishing Company, Inc.*, New York. 326 pages. Price \$12.50.

The shortage of qualified technicians to install and maintain the multiplicity of automatic control systems has moved the author to prepare this elementary text to familiarize students and technicians with the field.

Although the author is British and his material is based on British equipment and standards, he acknowledges the differences in U.S. and British terminology and has provided a glossary and special appendix covering these variations.

The text is wide-ranging, covering the meaning of control; control system components; remote transmission; position control systems; speed control systems; process control; digital techniques and computers; and machine-tool control. The treatment is basic and the author's style is informal and informative.

\* \* \*

**"RCA COLOR TV SERVICE MANUAL"** by Carl Babcoke. Published by *Tab Books*, Blue Ridge Summit, Pa. 17214. 176 pages plus 36-page schematic section. Price \$7.95. Leatherette cover.

This 8½" × 11" manual covers 23 RCA color chassis, with complete schematics supplied for 12 of the chassis. General and specific troubleshooting procedures are covered and the text deals with each section separately and discusses certain problems that might afflict the section. The text is illustrated by photographs, line drawings, partial schematics, scope patterns, and other useful material.

The large, easy-to-read format makes the book useful even on the service bench during an actual repair job.

\* \* \*

**"BASIC TECHNICAL MATHEMATICS"** by Thomas C. Crooks and Harry L. Hancock. Published by *The Macmillan Company*, New York. 467 pages. Price \$8.95.

For technicians and students in technical and vocational schools who have discovered that their mathematical skills are not adequate in this technical age, this would be an excellent means of remedying the situation.

Assuming little or no previous experience with mathematics, the authors have started with basic addition, subtraction, multiplication, and division of natural numbers and then continued with common fractions, decimal fractions, denominator numbers, integers and equations, exponents, percent, involution, and an introduction to plane and solid geometry.

Since review tests, summary tests, and various exercises are included in this book and since the presentation is clear and straightforward, this text can be used as a home-study guide as well as in the classroom. ▲











**STAMPS**

**RUSSIA** high-value collection. 32 different Russia—some over 50 years old! Commemoratives, Czarist Issues, Animals, catalog price \$2.50. Special get-acquainted offer—all for only 10¢! H. E. Harris, Dept. GG-54, Boston, Mass. 02117.

**115 WORLDWIDE 10¢** with approvals. The La-Dows, 631 N. W. 71st Avenue, Hollywood, Fla. 33204.

**WOW! 110 ALL DIFFERENT GERMANY 10¢** Commemoratives, Airmails, High Values, Big catalog, bargain lists. Also, fine stamps from our approval service, which you may return without purchases and cancel service at any time. Jamestown Stamp, Dept. A20EG, Jamestown, N. Y. 14701.

**FREE! BIG BARGAIN CATALOG—NEW EDITION** listing thousands of bargains including U.S. & B.N.A. stamps, packets, albums, accessories and supplies. Also, fine stamps from our approval service which you may return without purchases and cancel service at any time. Jamestown Stamp, Dept. E20EG, Jamestown, N.Y. 14701.

**POSTMARKED MOON!** Valuable Moon Landing First Day Cover postmarked from die taken to Moon and back by Apollo 11 Astronauts. This unique cover features century-old wood cut from Jules Verne's 1869 novel predicting 3 Americans would be first to land on Moon! We'll give you one **FREE** of extra cost to introduce our famous Approval Service. Buy \$1 worth and get extra bonus of 110 stamps including spectacular Space Issues, plus illustrated Album—or buy nothing, return stamps and album, cancel service anytime. Moon Cover is yours to keep in any case! Send 25¢ for postage and handling today. Kenmore, MC-539, Milford, New Hampshire 03055.

**MAGAZINES**

**BACK DATE MAGAZINES!** Send needs. Midtown, Box 917-EW, Maywood, N.J. 07607.

**BUSINESS OPPORTUNITIES**

**FREE CATALOGS.** Repair air conditioning, refrigeration. Tools, supplies, full instructions. Doolin, 2016 Canton, Dallas, Texas 75201.

**I MADE \$40,000.00 YEAR** by mailorder! Helped others make money! Start with \$10.00—Free proof. Torrey, Box 318-N, Ypsilanti, Mich. 48197.

**JAPANESE Electronics** New Products Monthly! Specimen copy \$1, deductible. Dee, 10639-W Riverside, North Hollywood, Calif. 91602.

**FREE BOOK** "999 Successful Little-Known Businesses." Work home! Plymouth 445-T, Brooklyn, New York 11218.

**MAKE BIG MONEY** raising chinchillas, rabbits, guinea pigs for us. Catalog—25¢. Keeney Brothers, New Freedom, Pa. 17349.

**RUBBER STAMPS**

**RUBBER ADDRESS STAMP \$2.00. SIGNATURE \$3.50. FREE CATALOG. JACKSON, BOX 443-G, FRANKLIN PARK, ILL. 60131.**

**MISCELLANEOUS**

**WINEMAKERS:** Free illustrated catalog of yeasts, equipment. Semplex, Box 122-76, Minneapolis, Minn. 55412.

**AS YOU SCAN THESE COLUMNS,** more than 177,000 monthly buyers of **ELECTRONICS WORLD** are doing the same. These men are all Electronics Professionals—individuals involved actively in electronics from a business or hobby viewpoint—they are doubly interested in those advertisements which will enhance their careers or their leisure hours. They look to the pages of the **ELECTRONICS MARKET PLACE** for prime sources of products and services of interest to them. They will buy from you if your advertising appears regularly in their favorite magazine. Send copy and payment now using the handy order form printed in these columns. Or, if you want additional information write today to: Hal Cymes, Classified Advertising Manager, **ELECTRONICS WORLD**, One Park Avenue, New York, New York 10016. **REMEMBER:** April issue, on sale March 19th, closes February 1st.



**\$100,000 INTEGRATED CIRCUIT PENNY SALE!**

Imagine—buy 1 Integrated Circuit at our bargain price get the 2nd one for ONLY 1¢ . . .

Fairchild No.		EACH	1c MORE
900	Buffer	1 for 1.49	2 for 1.50
903-903*	3 Input gate NAND/Nor	2 for 1.98	4 for 1.99
910	Dual Two Input Gate	1 for 1.29	2 for 1.50
910-910	Dual Two Input Gate	2 for 1.98	4 for 1.99
914	Dual Two Input Gate	1 for 1.29	2 for 1.30
914-914*	Dual Two Input Gate	2 for 1.98	4 for 1.99
915	Dual 3 Input Gate NAND/Nor	1 for 1.49	2 for 1.50
915-915	Dual 3 Input Gate NAND/Nor	2 for 1.69	4 for 1.70
923	JK-Flip Flop	1 for 1.49	2 for 1.50
923-923*	JK-Flip Flop	2 for 1.98	4 for 1.99
925	Dual 2 Input Gate, Expander	1 for 1.49	2 for 1.50
927	Quad Inverter	1 for 1.49	2 for 1.50
930	Dual 4 Input Gate NAND/Nor	1 for 1.49	2 for 1.50
933	Dual Input Gate, Expander	1 for 1.49	2 for 1.50
944	Dual 4 Input Power Gate	1 for 1.49	2 for 1.50
945	Clocked Flip Flop	1 for 1.69	2 for 1.70
946	Quad 2 Input Gate NAND/Nor	1 for 1.49	2 for 1.50
948	Clocked Flip Flop	1 for 1.98	2 for 1.99
953	2-2-3-Input and Gate	2 for 1.69	4 for 1.70

**EPOXY SILICON TRANSISTORS**

**5 for \$1**

Type	Sale
2N706	5 for \$1
2N2222	5 for \$1
2N2368	5 for \$1
2N2711	5 for \$1
2N3396	5 for \$1
2N3645	5 for \$1
2N3568	5 for \$1
2N3638	5 for \$1
2N3641-3	5 for \$1
2N3645	5 for \$1
2N3662	5 for \$1
2N3683	5 for \$1
2N3692	5 for \$1
2N3793	5 for \$1
2N4140-1	5 for \$1
2N4248-9	5 for \$1
2N4284-5	5 for \$1
2N4288-9	5 for \$1
2N4290-1	5 for \$1

**INTEGRATED CIRCUIT AUDIO AMPLIFIER!**

★ 8 Transistors ★ Dime Size **149**

Never before offered! Self-contained, integrated circuit—size of a DIME! TO-5 case, 8 leads. Use for phono, tape, intercom & 100's of microminiature audio circuits, mike, phono, tape. Output: 3 to 16 ohm speaker. Complete with data.

**709C OP AMPLIFIER**

**149**

Guaranteed! With Spec. TYPICAL USES: AC AMPLIFIER, RIAA PHONO PREAMP, INTEGRATOR, MULTIPLIER

**2 AMP SILICON 800 P IV RECTIFIERS**

**6 for \$1**

Terms: add postage. Rated: net 30, cod's 25%. Phone Orders: Wakefield, Mass. (617) 245-3829. Retail: 211 Albion, St., Wakefield, Mass.

GIANT SPRING CATALOG ON: Parts, Rectifiers, Transistors, SCRs, I.C.'s, Equipment. **10¢**

**POLY PAKS**

P.O. BOX 942 W LYNNFIELD, MASS 01940

**SALE ON FAIRCHILD COUNTING "ICs"**

**3 for \$15 \$5.95**

No.	Description
958	Decade Counter
959	Quad Latch
960	Decoder-Driver

CIRCLE NO. 120 ON READER SERVICE CARD

**ABOUT YOUR SUBSCRIPTION**

Your subscription to **ELECTRONICS WORLD** is maintained on one of the world's most modern, efficient computer systems, and if you're like 99% of our subscribers, you'll never have any reason to complain about your subscription service.

We have found that when complaints do arise, the majority of them occur because people have written their names or addresses differently at different times. For example, if your subscription were listed under "William Jones, Cedar Lane, Middletown, Arizona," and you were to renew it as "Bill Jones, Cedar Lane, Middletown, Arizona," our computer would think that two separate subscriptions were involved, and it would start sending

you two copies of **ELECTRONICS WORLD** each month. Other examples of combinations of names that would confuse the computer would include: John Henry Smith and Henry Smith; and Mrs. Joseph Jones and Mary Jones. Minor differences in addresses can also lead to difficulties. For example, to the computer, 100 Second St. is not the same as 100 2nd St.

So, please, when you write us about your subscription, be sure to enclose the mailing label from the cover of the magazine—or else copy your name and address exactly as they appear on the mailing label. This will greatly reduce any chance of error, and we will be able to service your request much more quickly.

**FREE Catalog of The WORLD'S FINEST GOV'T SURPLUS ELECTRONIC BARGAINS**

**Now BIGGER and BETTER Than Ever!**

MAIL COUPON TODAY

NAME: \_\_\_\_\_  
 ADDRESS: \_\_\_\_\_  
 CITY: \_\_\_\_\_ STATE: \_\_\_\_\_ ZIP NO: \_\_\_\_\_

**FAIR RADIO SALES** Dept. EW • BOX 1105 LIMA, OHIO 45802

CIRCLE NO. 137 ON READER SERVICE CARD



**GREGORY ELECTRONICS**

**An Extensive Selection of  
General-Electric  
Progress Line 2-Way  
Mobile Equipment**

30-50 MHz Vibrator Power  
14" Case Complete Access.  
Fully narrow-band (Tx & Rx)  
MA/E 13 6/12v, 30w **\$178.**

MA/E 16 6/12v, 60w **\$198.**

MD/Y 16N 6/12v, 60w **\$138.**

Dynamotor Power Supply **\$228.**

MT/16 12v, 60w **\$228.**

Transistor Power Supply **\$228.**

148-174 MHz Vibrator Power  
14" Case Complete Access.  
Fully narrow-band **\$198.**

MA/E 33 6/12v, 30w **\$228.**

MA/E 36 6/12v, 60w **\$188.**

Vibrator Power Supply **\$228.**

FA/E 33 6/12v, 30w **\$248.**

MT/33-6/12v, 30w **\$248.**

MT/36-6/12v, 60w **\$248.**

450-470 MHz 15w Vibrator  
Power Supply MA/E 42,  
with accessories **\$148.**

MT 42 12v, 15w **\$198.**

Transistor Power Supply **\$198.**

**450-470 MHz General-Electric  
Progress Line Accents**

10 watts, 12 volts/transistor power supply; front or  
rear mount. Complete accessories. Model No. EG48S  
Wide Band **\$168** Narrow Band **\$188**  
EG 48CT (Trunk) EG 48CF (Front)

GE Progress Line Receiver Strips 25-50 MHz  
Narrow Band **\$45.** Wide Band **\$35.**

**BRAND NEW**

DUMONT M430RTN 450-470 MHz Special!  
50-watt transistor power supply meets latest  
FCC narrow-banding specifications, 5 K.C.  
deviations.

IN FACTORY-SEALED CARTONS **\$295.**

With tone added, minus reeds **\$345.**

**MOTOROLA X43GGV Special!**

In 10" case. 150-170 MHz. 30 watts with  
accessories. Transmitter N.B., receiver W.B.  
Transistorized receiver power supply and vi-  
brator powered. 2 freq. transmitter. Receiver  
only private line, single squelch, 2 **\$158.**  
freq. receiver.

**Reconditioned & Used FM 2-Way Radio Equipment**

We Buy Late Model Equipment for Cash  
**SEND FOR NEW CATALOG**



**GREGORY  
ELECTRONICS  
CORPORATION**

249 RT. 46, Saddle Brook, N.J. 07662  
Phone: (201) 489-9000

**CIRCLE NO. 134 ON READER SERVICE CARD**

**GET INTO ELECTRONICS**



V.T.I. training leads to success  
as technicians, field engineers,  
specialists in communications,  
guided missiles, computers, ra-  
dar and automation. Basic &  
advanced courses in theory &  
laboratory. Electronic Engi-  
neering Technology and Elec-  
tronic Technology curricula  
both available. Assoc. degree in  
29 mos. B. S. also obtainable.  
G.I. approved. Graduates in all  
branches of electronics with  
major companies. Start Sep-  
tember, February. Dorms, cam-  
pus. High school graduate or  
equivalent. Write for catalog.

**VALPARAISO TECHNICAL INSTITUTE**  
Dept. RD, Valparaiso, Indiana 46383

**ELECTRONICS WORLD FEBRUARY 1970**

**ADVERTISERS INDEX**

READER SERVICE NO.	ADVERTISER	PAGE NO.	READER SERVICE NO.	ADVERTISER	PAGE NO.
150	Accurate Instrument Co.	17	128	Lafayette Radio Electronics	89
100	Alco Electronic Products	79		Lampkin Laboratories	58
148	Arcturus Electronics	96	127	Leader Instruments Corp.	69
147	Automatic Electric	13	126	Liberty Electronics, Inc.	79
146	Automatic Electric	78	125	Mallory, P.R. & Co., Inc.	2
145	BSR	69	124	Maryland Telecommunications, Inc.	14
144	Belden Corporation	SECOND COVER, 1		Music Associated	64
143	Burstein-Applebee Company	58		National Radio Institute	8, 9, 10, 11
	CREI, Home Study Division, McGraw-			National Technical	
	Hill Book Co.	18, 19, 20, 21		Schools	70, 71, 72, 73
142	Cleveland Institute of		123	Olson Electronics	68
	Electronics	80, 81, 82, 83	122	Park Electronic Products	95
141	Cook's Institute of		121	Pennwood Numerchron Co.	12
	Electronics Engineering	74	120	Poly Paks	99
140	Delta Products, Inc.	51	119	Precision Electronics	79
139	Edmund Scientific Co.	98		RCA Institutes, Inc.	60, 61, 62, 63
149	EICO, Electronic		118	Radar Devices Mfg. Corp.	7
	Instrument Co., Inc.	THIRD COVER	117	SCA Services Company	64
111	Electro-Voice, Inc.	FOURTH COVER	116	Schober Organ Corp.	4
138	Enterprise Development Corporation	68	115	Scott, H.H., Inc.	24
137	Fair Radio Sales	99	110	Selectrons, Ltd.	78
	G & G Radio Supply Co.	96	109	Sencore, Inc.	85
136	General Sales Co.	97	108	Shure Brothers, Inc.	22
	Goodheart Company, Inc., R.E.	95	107	Simpson Electric Company	53
101	Grantham School of Engineering	5	106	Solid State Sales	97
135	Greenlee Tool Co.	74	105	Surplus Center	97
134	Gregory Electronics Corporation	100		Sylvania Electric	54, 55
133	Heath Company	90, 91, 92, 93	104	Telex Communications Division	59
132	IEEE	12	103	University Sound	57
131	International Crystal Mfg. Co., Inc.	67	102	University Sound	57
130	Judson Research & Mfg. Co., Inc.	66		Valparaiso Technical Institute	100
129	Kenzac	66			

CLASSIFIED ADVERTISING 95, 96, 97, 98, 99

# The first and only solid-state test equipment guaranteed for 5 years.

Now EICO, because of its emphasis on reliability in engineering and manufacture, offers the industry this breakthrough.

EICO's new line of solid-state test equipment comes with an unprecedented 5-year guarantee of performance and workmanship. (Send

for full details of this EICO 5-year GUARANTEE on factory-assembled instruments.)

Additional advanced features include: new functional design, new color-coordinated esthetics, new PC construction, new easier-to-build kit designs.

## New EICO Solid-State Test Equipment



### EICO 240 Solid-State FET-VOM \$59.95 kit, \$79.95 wired.

One all-purpose DC/AC OHMS Uniprobe®. Reads 0.01V to 1 KV (to 30 KV with optional HVP probe). 7 non-skip ranges, in 10 dB steps. AC or battery operated. RMS & DCV: 0-1, 3, 10, 30, 100, 300, 1000V P-P ACV: 0-2.8, 8.5, 28, 85, 280, 850, 2800V. Input Z: DC, 11 M; AC, 1 MΩ. Response 25 Hz to 2 MHz (to 250 MHz with optional RF probe). Ohmmeter reads 0.2 to 1 MΩ in 7 ranges. 4½" 200 μA movement. HWD: 8½", 5¾", 5". 6 lbs.

### EICO 242 Solid-State FET-TVOM \$69.95 kit, \$94.50 wired.

All the versatility of the EICO 240 plus: AC/DC Milliammeter, 1 ma to 1000 ma in 7 non-skip ranges; single all-purpose DC/AC-Ohms — MA Uniprobe®; and large 6½" 200 μA meter movement.

### EICO 150 Solid-State Signal Tracer \$49.95 kit, \$69.95 wired.

Multi-purpose troubleshooter for TV/FM/AM & Audio Equipment. Independent RF Audio inputs. Speaker and meter output indicators. 400 mW continuous power output. Substitution amplifier, output transformer, speaker. Input for rated output: 1 mV RF, 63 mV audio.

Hum 60 dB below 400 mW, 105-132 VAC, 50/60 Hz, 5VA. HWD: 7½", 8½", 5". 6 lbs.

### EICO 330 Solid-State RF Signal Generator. \$59.95 kit, \$84.50 wired.

5 fundamental bands 100 kHz to 54 MHz. Vernier control 0-100%. Output 300,000 μV into 50-Ohm load. External signal modulation or internal 400 Hz, 0 to 100%. 105-132 VAC, 50/60 Hz, 1.7 VA. HWD: 7½", 8½", 5". 5 lbs.

### EICO 379 Solid-State Sine/Square Wave Generator. \$69.95 kit, \$94.50 wired.

5 sine wave and 4 square wave bands. Low distortion Sultzer feedback FET circuit. Sine: 20 Hz to 2 MHz; 0-7.5V rms into hi-Z, 0-6.5V into 600 ohms Max. distortion 0.25%. Square: 20 Hz to 200 kHz; 0-10V p-p into hi-Z, pos. direction, zero ground. Rise time at 20 kHz less than 0.1 μ sec. 105-132 VAC, 50/60 Hz, 10VA. HWD: 7½", 8½", 8½". 9 lbs.

## New EICO High Performance Instruments

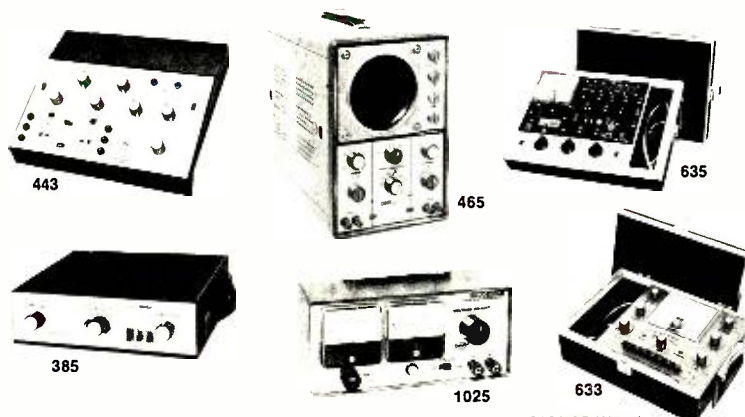

- EICO 385 — Solid-State Portable Color Generator \$79.95 Kit, \$109.95 Wired.
- EICO 465 — Wideband Vectorscope/Oscilloscope \$179.95 Kit, \$249.95 Wired.
- EICO 1025 — Solid-State Power Supply \$34.95 Kit, \$49.95 Wired.
- EICO 443 — Semiconductor Curve Tracer \$79.95 Kit, \$119.95 Wired.
- EICO 633 — CRT Tester & Rejuvenator \$69.95 Kit, \$99.95 Wired.
- EICO 635 — Portable Tube Tester \$44.95 Kit, \$69.95 Wired.

## New EICO Probes for the Pros

### Hi-Voltage Probe HVP-5, Wired \$19.95.

Convenient built-in voltmeter. Barrier sections isolate HV tip from handle and meter. Measures up to 30 KV. Lightweight, compact.

### Solid-State Signal Injector Probe PSI-1, Kit \$5.95, Wired \$9.95.

Pen-size, 1-ounce, self-powered signal generator. Frequency range from 1kHz to 30MHz, with harmonics. Clip it to your pocket — ideal for signal tracing in the field.

### Solid-State Signal Tracer Probe PST-2, Kit \$19.95, Wired \$29.95.

Flashlight-size, 2.2oz, self-powered. Hi-gain amplifier, 50Hz to 200MHz with demod tip. Input Z: 3500Ω, 35KΩ, 350KΩ; Output: 0.3 p-p volts. Noise —45dB. Distortion <5%. Complete with earphone, all probe tips, AA battery, pocket clip.



SEND FREE 1970 CATALOG

Name \_\_\_\_\_  
 Address \_\_\_\_\_  
 City \_\_\_\_\_ State \_\_\_\_\_ Zip \_\_\_\_\_



EICO Electronic Instrument Co., Inc.  
 283 Malta Street, Brooklyn, N.Y. 11207  
 EICO Canada Ltd.  
 20 Millwick Drive, Weston, Ontario

CIRCLE NO. 149 ON READER SERVICE CARD

# 7 arguments in favor of building your own speaker system from scratch.

The easiest way to buy high fidelity speakers may not always be the best. Because a complete pre-packaged system may be far from what you need. Consider some of the advantages of separate component loudspeakers:

1. You choose from an almost infinite variety of sizes and levels of performance. Your system will exactly reflect your specific listening preferences.

2. You save space by building speakers into walls, ceilings, closet doors, even in floors! Or use existing cabinets or custom-built enclosures that better suit your decor than any mass-produced system.

3. You enhance the illusion of "live" music by hiding or disguising the sound source. You listen to the music — not the speakers.

4. You end the conflict between fine sound and handsome decor by making the speaker system an integral part of the room or the furniture.

5. You save money by paying only for performance.

6. You can up-date your component system as often as you wish to meet advances in the state of the art.

7. You can use the building-block method of planned improvement as your budget permits. There's no problem of

being "stuck" with a compact that fits today's budget but can't meet your ultimate listening goals.

Take a few minutes to study the variety of Electro-Voice component speakers. 21 models from \$14.00 to \$250.00. From super-tweeters to giant 30" woofers. Consider how they can aid in creating a speaker system that uniquely expresses your musical needs. And ask your Electro-Voice high fidelity specialist for his recommendation. Finally, take the time to listen carefully.

Freedom of choice. It's at the nub of high fidelity.

ELECTRO-VOICE, INC., Dept. 204N  
629 Cecil Street, Buchanan, Michigan 49107

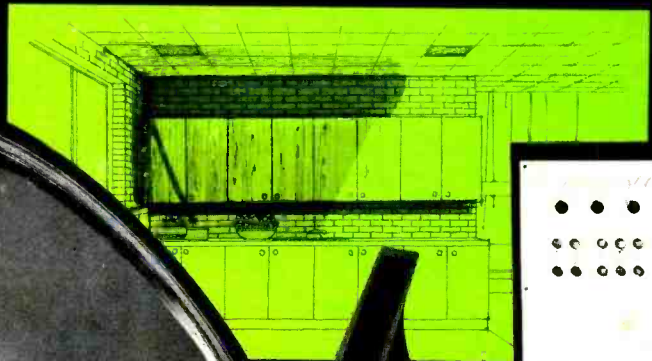
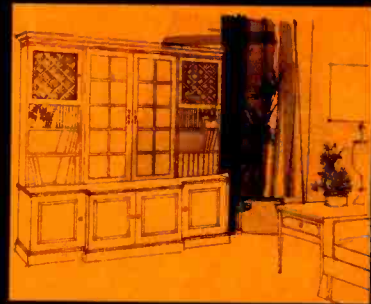
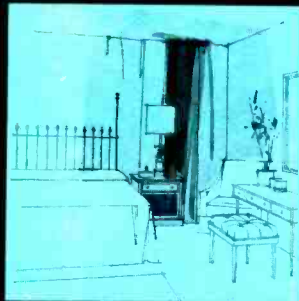

FOR INFORMATION ON E-V PRODUCTS:

Microphones  
**CIRCLE NO. 111 ON READER SERVICE CARD**  
PA Speakers/Accessories  
**CIRCLE NO. 112 ON READER SERVICE CARD**

Musician's speakers/microphones  
**CIRCLE NO. 113 ON READER SERVICE CARD**  
High Fidelity speakers/electronics  
**CIRCLE NO. 114 ON READER SERVICE CARD**

**Electro-Voice®**

A SUBSIDIARY OF GULTON INDUSTRIES, INC.