

Studio • Live • Broadcast • Contracting • Post

PRO AUDIO REVIEW



Eminem
page 114

The Industry's Equipment Authority

February 2003

Vertical text on the left side of the page, likely a list of featured equipment or articles, including names like 'Beyonce', 'Audiobahn', and 'Millennia'.



GEAR GUIDE 2003

PRO AUDIO GROUP Publishing

\$3.95



www.proaudioreview.com

 **DIGICO**

D5 LIVE



The digital system for the analogue engineer

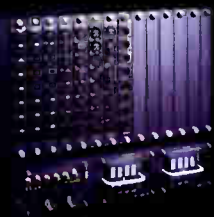

THE FUTURE OF LIVE DIGITAL CONSOLES

WWW.DIGICONSOLES.COM

World Radio History

SHAPING THE INVISIBLE

WORKING WITH AIR

Engineering, producing or performing – you are shaping invisible sound waves while constantly relating to what you hear. AIR 20 is the first 3-way design to take advantage of the revolutionary AIR technology. Combining this technology with Dynaudio two-to-one™ technology, the AIR 20 simply sets new standards for performance and precision in 3-way powered monitors.

New AIR 20

AIR Series Advantages

- ◀ Acoustic Placement Compensation
- ◀ Preset Storage and Recall
- ◀ Programmable Reference levels
- ◀ Level alignment in 0.1dB steps
- ◀ All Monitors factory aligned within +/- 0.2dB precision
- ◀ Integrated Parametric EQ's and Delay in each monitor (via Installer's Package)
- ◀ Central and Remote control of system and parameters
- ◀ Direct Digital Inputs
- ◀ Analog Inputs (optional)
- ◀ Networking in-between all AIR models
- ◀ Dedicated AIR Base subwoofers
- ◀ Bass Management, with selectable crossover frequency points



Leonardo da Vinci was among the first to use science to enhance his art. Being a musician, he also applied his genius to define the phenomenon of sound: "Figurazione dell'invisibile - Shaping the invisible."

Don't take our word for it, trust your ears, work with AIR and shape the invisible...

dynaudio acoustics
IF IT'S THERE - YOU'LL KNOW IT

Call now to arrange a demo in
your facility!

TC ELECTRONIC A/S DENMARK ▶ ☎ + 45 8742 7000
TC ELECTRONIC INC USA ▶ ☎ (805) 373 1828 ▶ [FAX] (805) 379 2648
WWW.DYNAUDIOACOUSTICS.COM

AIR
SERIES

THE ISSUES

PRO AUDIO REVIEW

The Industry's Equipment Authority

Evaluating audio products for professionals in commercial recording, broadcast production, audio for video/film, project studios, live sound, contracting and multimedia.

GEAR GUIDE 2003

- 8 Accessories
- 12 Acoustical Products
- 14 Amplifiers
- 24 Analog Audio Processors
- 32 Consoles/Mixers
- 44 Converters
- 46 Digital Audio Workstations, Plug-ins and Peripherals
- 52 Digital Audio Processors
- 55 Headphones
- 58 Interconnects
- 62 Microphones
- 69 Preamplifiers
- 75 Recorders/Players
- 79 Recording Media
- 80 Speakers/Monitors
- 94 Test Equipment
- 97 Wireless Microphones
- 99 Manufacturers Directory

DEPARTMENTS

- 114 **Single Slice**
Eminem's "Lose Yourself"
by Chuck Taylor

WWW.PROAUDIOREVIEW.COM

PRO AUDIO REVIEW

Vol. 9 Issue 2 • February 2003

Evaluating audio products for professionals in commercial recording, broadcast production, audio for video/film, project studios, live sound, contracting and multimedia.

Publisher, Executive Editor: John Gatski ext. 119
e-mail: jgatski@aol.com

Associate Group Publisher: Nick Humbert
e-mail: n.humbert@audiomedia.com

Managing Editor: Brett Moss ext. 143
e-mail: bmoss@imaspub.com

Technical Editor: Edward J. Foster

Studio Editor: Steve Murphy
e-mail: editor@smurphco.com

Technical Consultant: Tom Jung

Contributors: Bruce Bartlett,
Dr. Frederick Bashour
Nick Bailly, Edd Forke
Edward J. Foster, Carlos Garza
Will James, Bob Katz
Bascom H. King, Daniel Kumin
Carl Lindemann, Russ Long
Glen O'Hara, Alan R. Peterson
Rich Rarey, Andrew Roberts
Alan Silverman, Mark Ulano
J. Arif Verner, Roger Williams
Tom Young

Production Director: Lisa McIntosh
Production Manager: Annette Linn
Ad Traffic Manager: Kathy Jackson
Publication Manager: Davis White
Product Showcase/
Classified Coordinator: Angela Washington
Graphic Designer: Joaquin Araya

President/CEO: Stevan B. Dana
VP: Carmel King
COO/Editorial Director: Marlene Lane
Sales Director: Eric Trabb
National Sales Manager: Alan Carter ext. 111
Northwest Sales: Paul DaCruz 707-789-0263
Ad Coordinator: Joanne Munroe ext. 152
Dir. of Marketing and Circ.: Sheryl Unangst ext. 164
Circulation Manager: Kwentin Keenan ext.108

Extensions refer to office number 703-998-7600



PRO AUDIO REVIEW (ISSN 1083-6241) is published monthly by IMAS Publishing Group, 5827 Columbia Pike, 3rd Floor, Falls Church, Va. 22041.

Phone: 703-998-7600 Fax: 703-998-2966

Periodicals postage paid at Falls Church, VA 22046 and additional mailing offices. POSTMASTER: Send address changes to Pro Audio Review, P.O. Box 1214, Falls Church, Va. 22041.

©2003 by JRS Publishing, Inc. All rights reserved.

REPRINTS: Reprints of all articles in this issue are available. Contact Joanne Munroe (ext. 152) at Pro Audio Review.

Printed In The U.S.A.



A RACK MIXER BUILT TO PERFORM LIKE A PRODUCTION CONSOLE.



THE XRM MONITOR MIXER

One of four X-Rack Series mixers, the compact XRM is built inside and out to deliver high-end console performance for today's in-ear monitoring situations. It features individual circuit boards on each channel for the sonic performance of a sophisticated mixing console, and ease of servicing. Made in the USA, Crest's X-Rack Series includes the exceptional X-Matrix, XR-24, XR-20, and XRM mixers.

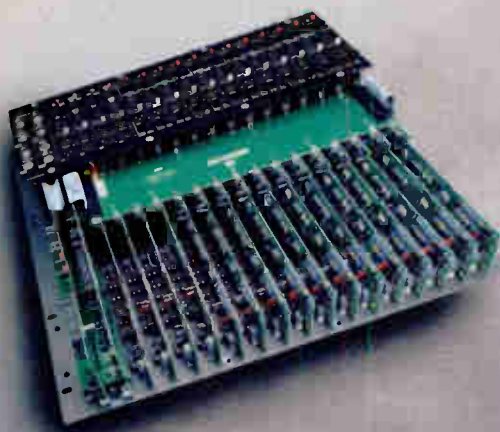

Can Your Mixer Do This?

- Switchable from 12 Mono to 6 Stereo Outputs for In-Ear Mixes
- Built-in XLR/XLR Splitter System with Ground Lift Switches
- 12 Mono and 4 Stereo Inputs, all with Full EQ and Mic Preamps
- 4 Band EQ with 18dB per Octave High Pass Filters
- Inserts on all Outputs Pre Solo System
- XLR Bus Inputs and Solo Link Connectors for Easy Linking to Second XRM (for 40 Inputs) or X-Rack FOH Console
- Five Year Limited Warranty on Crest Audio Mixers and Consoles

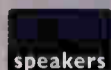

Crest Audio, Inc., 16-00 Pollitt Drive, Fair Lawn, New Jersey 07410
Toll Free: 866.812.7378 • Fax: 201.909.8744 • www.crestaudio.com

GEAR 2003 GUIDE

It's Gear Guide Time!!!

Back in 1998, Pro Audio Review debuted the Gear Guide in the February issue. At the time, there was (and still is) nothing like it. Thousands of detailed listings of products available to every niche of the pro audio industry. Not just studio, but live sound, sound contracting, broadcast production, post production and project studios and multimedia. Along with the detailed specs and prices of individual products, we threw in a comprehensive list of manufacturer information including

web sites, addresses and phone numbers.

Jump to 2003. It is now the sixth annual Gear Guide — with the thousands of listings you have come to expect. And this year Gear Guide Editor (and *PAR*'s hardest working man in pro audio magazines) Brett Moss has singled out a lot of the new gear for 2003, so the readers will know what is new in a glance.

From our perch, the Gear Guide has become well accepted by the readers. According to our latest reader survey, more than 40 percent of the readers refer

to the Gear Guide throughout the year, and I always get calls from the readers thanking me for listing of a microphone or amp, or software they had not heard about. Even manufacturers say it is a great source of info to keep track of the competition — not to mention the handy dandy company directory.

So read on and enjoy. The 2003 Gear Guide is your source — until the 2004 edition comes out.

— John Gatski

ON THE COVER

- 1 - Microtech Gefell M930 X-Y stereo mic set
- 2 - Legacy Silver Screen II speaker
- 3 - Steinberg Nuendo software
- 4 - Yamaha AW-2816HD digital audio workstation
- 5 - Alesis CLX-440 equalizer
- 6 - True Systems P2analog preamplifier
- 7 - Eventide DSP 7000 Ultra-Harmonizer
- 8 - Millennia Media LPE-2 equalizer
- 9 - Peavey XR-696F mixer
- 10 - Bryston 14BSST amplifier
- 11 - Audix D6 microphone
- 12 - Kamesan KS-342 mixer and EQ, submixer modules
- 13 - Digidesign Mbox
- 14 - Crest X-VCA console

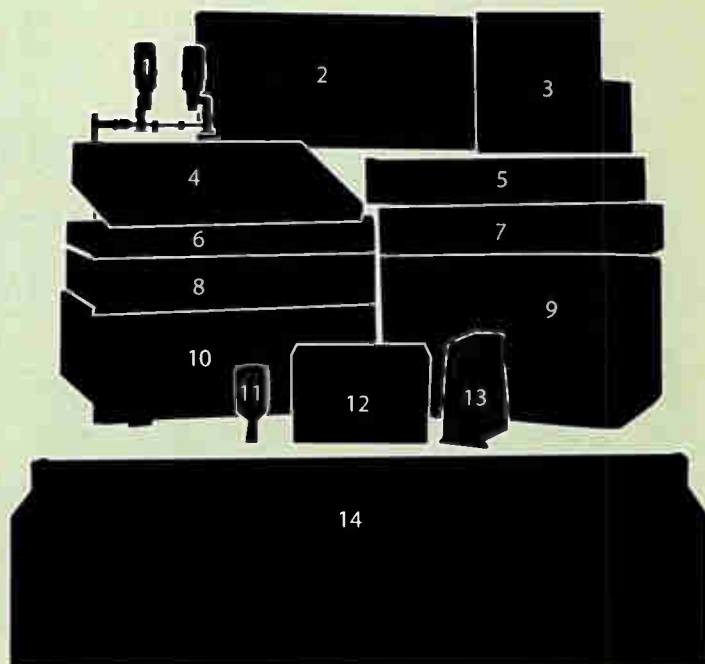

Cover Photo: Alan R. Peterson

SONY

WE GAVE YOU OUR BEST. YOU MADE IT BETTER.



SIU-100 SYSTEM INTERFACE UNIT



SIU-RM101 MIC PRE REMOTE



DMBK-S101 8-CHANNEL
MIC PRE AMP BOARD



DMBK-R109 MADI
INTERFACE BOARD

With the DMX-R100, Sony introduced perhaps the world's finest small-format digital mixer. A professional mixer that works like a pro: fast and intuitive. With a full input module that gives you a knob for every key function, so you don't get lost in menus.

You used it. You liked it. You told us how to make it even better. The result is an improved Sony DMX-R100. With a new MADI board option, for compatibility with MADI-based recorders – and for cascading two R100's together, giving you more than 100 inputs. Plus a new SIU-100 I/O expansion system for remotely controlled mics during both studio and live productions as well as expanded digital I/O. And the SIU-100 also supports I/O networking for multi-room facilities with Ethernet IP remote control.

Of course, we saved all the features that make the R100 so popular. Including easy-to-learn operation, 10-bit precision, touch-sensitive faders and a comprehensive automation system. Even a large color touch-screen, so it's simple to assign I/O, perform surround sound panning and monitoring, and view EQ curves and dynamics settings.

What more could we do? Make new pricing with special financing terms available to qualified customers through Sony Financial Services*. And to meet all your needs, we offer optional R100 operations training through the Sony Training Institute as well as optional on-site support packages through Sony Professional Services.

THE SONY DMX-R100. WE MADE IT GOOD. YOU MADE IT BETTER.
TO FIND OUT HOW MUCH BETTER JUST GIVE US A CALL AT
1-800-472-7669 EXT. R100/2.

DMX-R100



www.sony.com/proaudio

© 2001 Sony Electronics Inc. All rights reserved. Reproduction in whole or in part without written permission is prohibited. Features and specifications subject to change without notice. Sony is a trademark of Sony.
*On approved credit financing available through Sony Financial Services LLC or dealers go to www.sonyfinancial.com

ACCESSORIES

A.P.I.C. Inc.

Pic Stands
Mic stands of differing sizes, 6" - 13".

Ace Products

Rack Porter
Portable Racks. Four, six-rack units; wheels; telescoping handles; housing.

Allen Avionics Inc.

AGL-600
Isolation Transformer One, two-channel; 600 ohm impedance; shielded. XLR.
AGL-600: \$125, AGL-600-2: \$250

MM-020
Pipe-Based Speaker Mounting System. \$75

Multimount Speaker Mounting System
Faceplate/hinge/peg system; flexible angles; pan/tilt. \$75

Steerables
Speaker Aiming System. Wall or ceiling. \$250

U-Bracket Speaker Mounting System
Wallmount; optional adjustable white wallmounts; snap-on cover plates. Starts at \$30

American Audio

ProTek Road Cases
CD/LP Cases. Many sizes; up to 600 CDs; up to 70 LPs. \$69 - \$149

American Recorder Technologies Inc.

AD-1000
ADAT Maintenance Kit. Deluxe ADAT Cleaning kit features 2 ADAT cassette cleaners, 2 ounce bottle of cleaning fluid, 25 chamois swabs, CO-2 duster with six refills and storage case. \$150

AD-311B
ADAT Cleaning Kit. Wet type ADAT cassette cleaner; bottle of cleaning fluid. \$22

C-911B
Cassette cleaner with fluid. \$8

CD-101P
CD/DVD Cleaning Kit. Manual DVD/CD cleaner, cleaning fluid, 3 cotton loops, non-abrasive pads and handle. \$8

DAT-101
DAT Cleaning Kit. Wet type cleaner of DAT recorders. \$30

K-141
Cassette Maintenance Kit. Cassette cleaner, fluid, replacement pads and storage case. \$15

LL-151
CD Lens Cleaner. Dual brush laser lens cleaner. \$8

S-721H
Audio Equipment Cleaner. Professional tape head, capstan, pinch roller cleaning fluid. Two ounces: \$8, Quart: \$24

SNAKESKIN
Cable dressing. Self-wrapping expandable cable dressing. 0.5-inch: \$2.00/foot; 1-inch \$2.50

VS-1
Chamois swab for rotary heads. 10 pack: \$10; 25 pack: \$20

Anvil Case Co.

A.T.A. Cases
Equipment Cases. Meets Air Transportation Association specs.

ArmorLite
Equipment Cases. Aluminum skin and interior; polyethylene core.

Forge II
Equipment Cases.

ASA Productions

Composite ATA Cases
Custom size - console to racks; ATA, mil-specs.

Atlas Sound

All-Purpose Floor Stands
Extendible 34" - 63"; circular metal base.

Desk and Banquet Stands
Desktop/Tabletop Mic Stands. Variety including marble bases, unusually-shaped bases; extendible arms.

Professional Full-Height Stands
Extendible 34" - 62"; wearproof clutch; circular metal base.

Studio Stand With Air Suspension
Extendible 38" - 67"; air suspension; triangular metal base.

Tripod/Boom Combinations
Extendible tripod - 34" - 66"; extendible booms - 23" - 37"; wearproof clutch; Glide'n Lock legs; tripod base.

ATM Fly-Ware

Rigging Systems and Hardware
Live sound, sound reinforcement, installation. Modular loudspeaker rigging; custom made to order.

Audio 2000's

ADL 3101/ADL 3104
Mixer Light, Gooseneck; 12V/5W. BNC or XLR. ADL 3101 (XLRM) \$15.80. ADL 3104 (BNC): \$17.60

Pop Filters
Clip-on, 4", 6" arm. \$15.90 - \$19.90.

Speaker Stands
Extendible tripods - 44" - 77" and 56" - 102"; aluminum tube construction. \$63.80 - \$85.80

Audio Engineering Associates

AEA SMT
Stereo Microphone Template Mount. Twin mountings; Blumlein, near coincident settings. \$145

AEA Stereo Microphone Positioner Series
Array/Positioner. Studio, location. Engraved positioner markings; dual microphone placement; mounting sliders; black anodized aluminum finish. Three sizes: 17" - \$245; 1 m - \$345; 1.25 m - \$395.

Tall Microphone Boom Stands
Studio, field. Lightweight; folding design. Maximum pivot height: 13 1/2'. Booms - 25HDB - 25', 40HDCFB - 40'. Optional quick lock wheel set - \$130. 25HDB ships with 10 lb. counterweight, 40 and 45 HDCFB use sand-bag counterweights. 25HDB - \$635, 40HDCFB - \$1,235

The Tree
Studio. Decca-type three microphone tree; black anodized aluminum. Mini - 33" x 17". Decca - 67" x 34". Super - 84" x 34". Can be stand-mounted or flown. Mini - \$595, Decca - \$795, Super - \$945

Audio-Technica U.S. Inc.

AT8615
Desk Mic Stand. Metal. \$72

AT8646AM
Podium Shockmount. Live sound, installation. Rubber pad; 5/8" threaded mount. \$35

AT8647QMS
Podium Shockmount. Rubber pad; lighted mute switch; requires 48 V phantom power. XLR. \$95

B2 Technologies

Xtra Hand
Solder Aid. 1/4", RCA, XLR male, XLR female holes. \$30

BGW Systems Inc.

Rack Enclosures
24 - 44RU; 48" - 83" high; welded; cable pass-throughs; powder coat finish. Optional locking doors. Optional casters. Optional panel enclosures. Starts at \$575

Bowman Technologies

QSII Digital Studio Timer
LED display; 1/100th second increments; 5' cable; start/stop, reset buttons. Master only: \$249. Master/slave (with 30' connector cable) \$449.

CAIG Laboratories Inc.

CalKleen A/V234
Head Cleaner deoxidizer; removes tape residue; degreaser. \$8.95

CalKleen RBR
Rubber Part Cleaner. \$8.95

CalLube MCL
Metal cleaner and preservative for conductive plastics, carbon-based connectors; choice of applicators. Starts at \$4.95

DeOxit
Aerosol deoxidizer for metal surfaces; choice of applicators. Starts at \$4.95

ProGold GXL
Metal connector enhancer, conditioner, preservative; stabilizes dissimilar metal contacts; safe on plastic parts; nonflammable; choice of applicators. Starts at \$6.95

Calzone Case Co.

Proline
Equipment Cases. Aluminum trim; exceeds Air Transportation Association specs; recessed latches, handles.

Series 50
Equipment Cases. ABS plastic case; carpeted exterior; polyethylene core.

Ultima Series
Equipment Cases. Aluminum case with polytolene laminate; reinforced corners.

Carvin

MS13
Mic Stand and Boom. 30" boom; tripod stand. \$29

MS15
Adjustable Floor Mic Stand. 34" - 62". \$19

SS20
Adjustable Speaker Stands. 3.5' - 6.5'; tripod stand; up to 75 lb. \$49

CE Distribution

JJ Tubes
EL34, EL34L, 6L6GC, KT88, 6BQ5/EL84, 12AT7, 12AX7-S, 12AU7, 6922, 300B, 7027A.

Clark Wire & Cable

Blank A/V
Rack Panels. .068" black anodized aluminum, .500" flanges. 19" wide, single through quadruple RU. Non-standard sizes available.

XLR and BNC Rack Panels
.068" black anodized aluminum, .5" flanges, white silk screened labeling. XLR: 1x8, 1x12, 2x8, 2x12; BNC: 1x16 (50 and 75 ohm), 2x16 (50 and 75 ohm). Custom layouts available.

Conquest Sound

Custom Engraved Wallplates, Rack Panels
Anodized aluminum or stainless steel; choice of colors.

Cubicon Corp.

Speaker Enclosures
Standard and customized speaker enclosures.

Dana B. Goods

Humfrees
Rack Isolation Strips. Eight per bag. \$4.99

Rack Release
Quick-Release Rack Screws. \$6.99

Davicom Technologies Ltd.

DAPD-01 Audio Presence Detector
Threshold control; time control; silence alarm; DPDT relay; TTL contact closures. Terminal. \$400

Dynastar Electronics

LPS-4A, LPS-6A, LPS4ATS, LPS-ATS
Speaker Protection System. Delay, holdout time controls. Neutrik NL2FC. 2RU.

EBTECH/Sound Enhancements

HE-2
AC Hum Eliminator. Studio, sound reinforcement, location. Two-channel. Frequency response: 20 Hz - 40 kHz. THD: <0.005%. 1/4" TRS, RCA adapters. 1.5" x 4.25" x 3.5". Converts balanced/unbalanced. \$895

LLS-2 Line Level Shifter
Studio, sound reinforcement, location. Two-channel; passive design; hum elimination; +4/-10 dB conversion. Frequency response: 10 Hz - 40 kHz. THD: <0.002%. 1/4" TRS, RCA adapters. 4.25" x 3.5" x 1.5". Converts balanced/unbalanced. \$99

Electro-Harmonix

Electro-Harmonix Tubes
12AX7EH; 12AU7EH; EL34EH; EL84EH; 6550EH; 6L6EH; 6V6EH; 300BEH; KT88EH; 6CA7EH; 6NS7EH; 6CG7EH; 5U4GEBEH.

Equipment Emporium

Boompole Holder
Rubber-coated holder. \$25

RoboPole
Boom Pole. Three-section; aluminum/titanium; telescope; internal cable run; disassembles. 7.5": \$329. 12" or 15": \$349.

Esoteric Sound

Disc Stabilizer Clamp
Accommodates LP and 78s; .5 kg. \$39

ROKSGF1
Stylus Force Gauge. Track arm force: 0.25 - 5.75g. \$15

Gator Cases

GM-4
Soft Mic Case. Four mic forms; nylon bag; shoulder strap. \$19

GPA-700
Rolling Speaker Bag. Hard foam case; polyethylene floor; nylon bag; telescoping handle; wheels. \$119

GR
Portable Shallow Racks. Front and rear rack rails; polyethylene case; twist latches. Designed for <14" depth equipment. \$99 - \$109

GRC Slant Top Console Racks
Twist latches; polyethylene construction. \$179 - \$269

GX-20 Cable Caddy
Nylon covered plywood case; lift out trays; wheels; telescoping handle. \$114

Roller Racks
Telescoping handle; built-in wheels; polyethylene construction. 4RU, 6RU, 8RU, 10RU sizes. \$119 - \$149

Groove Tubes

PS79
Tube Pin Straightener. Seven or nine-pin. \$20

Tubes
GT7025, GT12AX7A, GT12AX7R, GT12AX7R2, GT12AU7, GT12AU7A, GT12AY7, GECC83s, GT5751, GT6267/EF86, GT6072-M, GT6201-M, GT5Y3, GT5U4, GT5AR4, GT6L6, GT6L6GE, GTKT88, GTKT90, GT6L34, GT6L84, GT7027, GT6550. Some available as matched pairs.

Har-Ken Specialties

Adapters, Attenuators, Phase Reversers, Pads
1/4", XLR, RCA, BNC, barrier strip, RJ9, RJ11, RJ45.

HK-124
In-Line Attenuator. Up to 30 dB attenuation. RCA. \$36.50

Jan-AI Cases

ATA Cases
Laminated plywood and Finnish birch; casters; latches; reinforced corners; dividers, trays available; stackable; standard or customized cases. Mixer, rolling racks available. Depends on configuration

Jasoni Electronics

Kontroler A-1
Speaker Muting/Warning Light for Mixers. Actuation by audio, 5 - 35V DC, switch. RCA, barrier strip. \$195

WL Series On-Air Signs
"On The Air" or "Recording"; sustain or flash; shadowbox design; wall-mounted; standard lamps. 14" x 3.5" x 2.5". Black/white: \$119; silver or custom color: \$139.

KATA USA

Koala Mixer Case
Cases. Padded shoulder strap; vinyl side panels; other case arrangements made on request. \$179 to \$233

Panda Sound Organizer Pack
Cases. Two section case for audio equipment (mixing board, microphone, cables, etc.) \$183

Littlita/CAE Inc.

Gooseneck Lamps
Lamps. Fully-adjustable dimmer; 6, 12, 18 inch lengths; 5 or 2.4 Watt bulb; 6' cord; snap mount set; 120 or 240 V.

RLX RakItte
Gooseneck Lamp Rack Interface. Studio, sound reinforcement. Two ports; dimmer switch. 1RU.

Manley Laboratories

Starbird Boom
Microphone Stand. Studio, sound reinforcement, field. Horizontal extension: 4' - 8'; vertical extension: 5' - 9'; 16" total extension; air damped vertical extender. \$1,000

MBHO Microphones US/MTC

MBHO - 7000
Jecklin Disc. \$229

MBHO - 7100
Schneider Disc. \$299



INTRODUCING HELIX ONE EQUALIZER ENDLESS POSSIBILITIES



GRAPHIC FADER

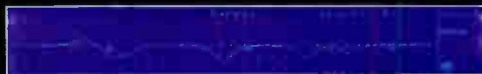

GRAPHIC CURVE



PARAMETRIC

SIMPLICITY FOR THE COMPLEXITY OF TODAY'S SYSTEM DEMANDS.

Klark Teknik, the company that revolutionized system performance and made one-third equalizers an indispensable professional tool, is ready to take you to the next level... in 0.1 dB increments.

The Helix digital equalizer is a no-compromise addition to any audio professional's toolbox.

The 2-channel unit contains:

- ⊕ 31 bands of 1/3-octave digital filters in 5 different filter emulations, per channel
- ⊕ 12 bands, 20 Hz – 20 kHz, of parametric equalization, per channel
- ⊕ 2 bands of Threshold Dependent Equalization (T-DEQ), per channel
- ⊕ (4) 1st to 8th order filters, per channel
- ⊕ 1 second of delay, per channel

For more information on the Most Versatile Audio Equalization system in the world call 1-800-392-3497 or visit www.klarktechnik.com



ACCESSORIES

Middle Atlantic Products Inc.

DM50-Digital Mixer Desk
30" x 50" work surface; steel tube legs, frame; cable pass-throughs. Optional risers, meter bridge. \$500

Edit Center Desk Systems
Edit Station Furniture. Desk, risers, meter/monitor bridges, rackmountable equipment bays, integrated cooling, doors, cable pass-throughs. Power Factor Function controls. Cherry, graphite laminate finishes.

PTRK Series
Portable Rack Enclosures. 16 gauge steel construction; 14 or 21 rack spaces; cushioned heavy duty casters; 11 gauge rack rails; laser cut openings; spring loaded recessed handles; lockable doors with keys. 22 5/8" wide x 23" deep. \$523 (14 spaces), \$556 (21 spaces)

SR-40-22
Swinging Rackmount Enclosure. 7.5' tall rackmount unit that is hinged to swing open for rear access; 350 lb. weight capacity; key lock. \$1,022

Modular Sound/Handi Q

HandiClip HC2
Palm Pilot PDA to MIDI interface. Compatible with HandiQ/HandiFX/HandiMix software; Palm III, V, VII; battery operation. RJ11, XLR. \$149

MultiMic

MultiMic
Multiboom Mic Stand. Up to four mics; up to 5' extension. \$289

O.C. White

61900 BG
Extendible Microphone Boom/Arm. Up to 29". XLR.

Olsen Audio Group

Rapido Microphone Quick Release
Ball bearing mic/stand release.

Windtech Microphone Screens
Variety of sizes.

On-Stage Stands

MS9612B+
Studio Boom. Vertical height: 45" - 76"; Horizontal extension: 43" - 79"; casters; locking headphone clamp. \$97

MY-300 Shock Proof Microphone Clips
Rubber ring isolator. MY-325 (25mm opening). MY-330 (30mm opening). \$12.99

Palmetto Logic Software

Sound Advice v3.0
Sound Reference Software for Palm OS. Terms, measurement formulas; calculator. \$9.95

Panel Authority

Custom Panels
Custom engraved metal panels.

Per Madsen Design

RACKET System 19 Dolly
Solid oak frame; capacity up to 300 lb; casters; part of RACKIT 19 modular studio furniture system. 20.75" x 16" x 4". \$55

RACKIT System 19 CD/DVD/VHS Unit
CD, DVD, VHS cassette storage; oak frame; Finnish birch plywood sides and casings; ball-bearing slides; stackable with other RACKIT System 19 units; oak front. 20.75" x 16" x 15". With optional birch front, \$245. \$265

RACKIT System 19 Component Racks

Equipment Rack. Oak frame; oak plywood shelf; stacks with other RACKIT System 19 units; four sizes. 20.75" x 16" x 5", 7.5", 10", 15". \$90, \$95, \$105, \$110

RACKIT System 19 Disc Cabinet
Stores 115 discs; oak frame; oak plywood shelf; Finnish birch plywood sides and casings. Stackable with other RACKIT System 19 units; laserdisc and LP storage. 20.75" x 16" x 15". \$135; With optional glass door, \$185

RACKIT System 19 Rail Rack
Equipment Rack. Oak frames and cross beams; steel mounting rails; stacks with other RACKIT System 19 units; three sizes. 20.75" x 16" x 10", 15", 30". EIU standard 5U, 8U, 16U racks. \$110, \$125, \$185

RACKIT System 19 Tabletop
Oak veneer plywood with MDF core; part of RACKIT 19 modular studio furniture system. 3/4". \$40

PM of America

Svetlana Tubes
12AX7, EL34, 6550C, KT88, 6L6GC.

Polar Focus

Zbeam
Equipment Rigging System. Flexible azimuth, elevation; aluminum; rigging-holes; 800 lb. capacity. 20" long. \$360

Popless Voice Screens

VAC-6c
Double Microphone Pop Screen. 6" diameter; Variable Acoustic Compression adjustable double removable screen; 15" gooseneck stand/clamp; screens are washable. \$59

VAC-RE20
Double Microphone Pop Screen. 3.5" diameter; Variable Acoustic Compression adjustable double removable screen; screens are washable. Designed for Electro Voice RE20/27 microphones. \$46

Porter Case Inc.

Porter Case
Equipment Case With Wheels. Up to 200 lb carrying capacity; many sizes and models. \$179

Primera Technology

Inscripta Thermal CD Printer
CD/DVD Thermal Printer. Thermal printer; Windows 2000; SureThing CD labeling software; compatible with most printable optical discs. \$2,995

SignaturePro
CD/DVD Printer. Inkjet printer; 2,400 x 1,200 dpi; Windows ME/2000 software; compatible with any printable optical DVD/CD disc. \$1,895

Quik-Lok/Music Industries Corp.

A-399
Microphone Stand. Steel tubing; wobble-free color-coded base; up to 61.5" extended. 35.5" - 61.5", 6 lb. \$30

A-50
Mic/Boom Stand With Casters. Aluminum tubing; solid steel legs; tripod base with locking casters; adjustable counterweight; up to 91.5" extended; 46" - 85" boom with mic cable clips; rubber and nylon gaskets. 53.5" - 91.5", 28 lb. \$180

BS-336, BS-342 Monitor Stands
Steel tubing; sand compartments; wire runs; triangular base; retractable carpet spikes and rubber feet. BS-336 (36" tall); \$150 per pair; BS-342 (42" tall); \$160 per pair.

OM-100
Mixing Console Stand. Steel tube; 25",

34", 44", 55" or 62" wide. Optional risers. Optional caster kit (\$80).

OR-110
Equipment Rack. 10RU unit; glass top; perforated steel side; wire management; optional casters. \$359

OS-136, OS-142 Near-Field Monitor Stands
Steel tubing; sand compartments; wire runs; triangular base; retractable spikes and rubber feet; Optimum series. 36" or 42" high.

S-203
Adjustable Extension Tube for Speakers. For flying satellite speakers from subs with standmounts; steel; polycarbonate Sure-Grip tension collar. 33.4" - 57". \$40

S-225 Steel Tripod Speaker Stand
Steel tubing; adjustable tripod; polycarbonate Sure-Grip tension collar; up to 84.6", 45.3" - 84.6". Optional speaker flange: \$7.95. \$80

R & R Cases and Cabinets

Showtrunks
3/4" birch plywood with fiberglass mat and gel coat; heavy duty casters; for heavy items; truck pack dimensions

Tour Series Cases
Heavy duty interlocking tongue and groove construction; high impact laminate or stucco aluminum; 3/8" seven-ply birch plywood; heavy duty casters. Wide variety of sizes and shapes.

Rackman

Rack Trays, Drawers, Shelves
Various sizes; sliding or fixed.

Racks
Various sizes; rolling, wallmount; open or close-sided.

Raxxess

CBLD
Cable Holder. Steel; 13 slots.

CL
Plug-In Console Light. Gooseneck; 12V. BNC.

CV Converta Rack
Rolling Rack. Front-accessible rack; raisable top rack for mixers; carpeted covering; reinforced nickel corners; casters; butterfly latches.

Panels
Wide variety of rackmountable panels for different functions.

RFM Relay Floor Mount
11-gauge steel; channel stiffeners; three heights available; up to 145 lb. 47.5", 66.75", 79" tall.

SRR Swinging Relay Rack
Rack on hinges. 28.25" or 42.25" high.

Stop-It
Pop Screen. 6", 8" hoop; standmount adapter. Optional gooseneck.

RCI Custom Products

Custom Furniture
Variety of sizes, functions - install, studio.

Custom ID Plates
Customizable ID plates in a variety of sizes and materials - console, wall, rack.

Custom Racks
Variety of sizes, functions, connectors.

Rip-Tie Inc.

Rip-Tie Cable Ties
Velcro connectors; varying colors, lengths, widths.

RPM Optoelectronics

Racklight
Rackmounted Light. LED; red, amber, green, blue, cyan, purple, white. 100,000 hour life. 1RU.

Ruby Tubes/Magic Parts

Ruby Tubes
12AJ7/ECC82; 12AX7A Tesla; 5881R; 5AR4; 5U4GC; 6550; 6L6; 7027A Tesla; E34L Tesla; EL84 Tesla; KT66; KT88.

Rycote Microphone Windshields

Microphone Windscreens
Standard and customized mic windscreens.

Modular Suspension
Modular Microphone Suspension. Four point variable suspension; twin suspension hoops; pistol grip; compatible with most major microphones.

Sabra-Som/K-IV

Shockmounts
Dual ring, rubber elastic bands; available in single, stereo and 5.1 configurations.

Pop Filters
Dual filter; articulated arm.

Selco Products Co.

Knobs
Push-on knobs; screw-on knobs; plastic; aluminum; various sizes and shapes.

Sescom Inc.

IL-19
In-Line Balanced Transformer. Studio, project studio, live sound. Electrostatic shield to prevent ground loops. Frequency response: 20 Hz - 20 kHz. XLR. \$50

IL-29 Ground Isolator
For electret condenser mics/phantom power; eliminates RFI, EMI. \$58

ISO Series
Hum Eliminators. XLR. \$33.75+

TR Series
Audio Transformers. Mono line XLR to various other connectors. \$60 - \$100

Shure Inc.

M25C
Phono Cartridge. Live sound. Type 1; 1/2" tone arm mount; replaceable needle. Track force: 1.5 - 3 grams. Ships with extra headshell wires, stylus cleaning brush, stylus guard, mounting hardware. Optional 78 RPM needle. \$39

M35X
Turntable Cartridge. Type 1 cantilever design. Tracking force: 1.5 - 3 grams. Output: 6 mV. \$75

M44-7
Phono cartridge. Live sound. Type S cantilever design. Frequency response: 20 Hz - 20 kHz. Output: 9.5 mV. Tracking: 1.5 - 3 grams. \$115

M44G
Phono Cartridge. Live sound. Type S cantilever design. Frequency response: 20 Hz - 20 kHz. Output: 6.2 mV. Tracking: 0.75 - 1.5 grams. \$100

M78S
Turntable Cartridge. For 78 RPM units; monophonic; color coded cartridge connectors. \$90

M94E
Turntable Cartridge. Color coded cartridge connectors. P-Mount version, MP94E. \$100

M97xE
Turntable Cartridge. Dynamic Stabilizer damper/destaticizer; color coded cartridge connectors. \$140

SC35C
Phono Cartridge Type 1 cantilever design. Frequency response: 20 Hz - 20 kHz. Tracking: 4 - 5 grams. Output: 5 mV. \$60

WHLB White Label
Turntable Cartridge. \$175

Signal Transport

Swing Track
Customizable Rack System. Studio, broadcast. Standard 19" rack size; hinged swinging design; customizable installation; single or double bay. 12, 15 or 45RU. Starts at \$1,300

SKB Cases

Gig Rig
Case. Rotomolded case; 10U slant rack; 10U front panel; 360 degree rotational locking wheels. \$499

Plastic Equipment Cases
Equipment cases, rack cases. Shock Rock cases; lifetime warranty; variety of sizes and shapes. \$79 - \$600

Rack Drawer
Ball bearing drawer glide; twist lock. 4RU. \$150

Slider Products

Piano Barre
Mic Boom for Piano. Telescopic; two mic clamps. 23" - 55". \$189

Sonifex/Independent Audio

HY-02, DHY-02
Telephone Interfaces. Studio, broadcast. Line hold switching; balanced inputs and outputs; echo cancellation. XLR, telephone jack. 1 and 2 RU. Optional ring detector. HY-02 (analog) - \$1,230 (one channel), \$2,225 (two channels). DHY-02 (digital) - \$2,050 (one channel), \$3,580 (two channels).

RB-SD1
Silence Detection Unit. Broadcast. Level, trim pots. XLR. \$475

Sound Anchors

ADMID
Midfield Monitor Stands. Adjustable height (6" - 46"); welded construction; spikes; sorbothane pads; variable speaker tilt; damped; can be filled with sand. \$425 per pair

DAW
Digital Audio Workstation Furniture. Modular; adjustable keyboard, monitor platforms; heavy duty casters; cable management. Optional platforms. Starts at \$450

MIXER
Mixer Table. Adjustable platform heights, configurations; welded construction; Starts at \$850

PROJ
Monitor Stands. Welded construction; spikes; sorbothane pads; can filled with sand. \$225 per pair

STUDADJ
Monitor Stands. Adjustable height (6" - 45"); welded construction; spikes; sorbothane pads; damped; pre-filled with sand. \$335 per pair

Sound Construction & Supply

Iso Box
Sound Isolation Rolling Equipment Bay 12, 16, 20 spaces; 1" Auralex acoustical foam lining; two-speed cooling fan; glass door. starts at \$750

Stedman Corp.

Proscreen PS100
Pop Screen Filter. Metal screen; washable; attached mic stand adapter. 4.6" x 7.2". \$49

TASCAM DM-24: The Affordable Luxury Console Is Here



Luxury usually comes with a hefty price tag. Not so with the new TASCAM DM-24 32-Channel 8-Bus Digital Mixing Console.

The DM-24's features are usually reserved for super high-end mixers. With 24-bit/up to 96kHz digital audio, the DM-24 blows away the standards in sonic quality for affordable consoles. With its internal automation, you'll get more power at your fingertips than you would from those huge consoles in commercial facilities. With some of the finest spatial and modeling processing from TC Works™ and Antares™, you can create fully polished productions without ever going to the

rack. With incredibly flexible routing, fully parametric EQ, machine control capabilities, touch-sensitive motorized faders, and lots of audio interfaces, you can integrate the DM-24 into any studio environment.

Whether you're working with standalone hard disk recorders, DAW systems, MDMs or analog tape, the DM-24 is optimized to be the very best choice in consoles designed for 24-track recording. Ready to get everything you ever wanted (and more) in a digital console? Get the DM-24 today at your authorized TASCAM dealer.

DM-24 DIGITAL MIXING CONSOLE

NEW! Version 1.6 Software Update!

- 16 more channels at mixdown (total of 48)
- New MIDI Machine Control capabilities, including compatibility with Mackie™ hard disk recorders
- New routing features, including eight more post-fader aux sends, 24-track simultaneous recording, and stereo bus signal routing to the multitrack I/O
- Enhanced user interface
- "Keep" and "Touch" automation features now available

And there's more! Visit www.tascam.com to get all the info on v1.6, download the file and update the DM-24 via MIDI.



The DM-24's rear panel includes AES/EBU digital I/O, S/PDIF digital I/O, MIDI In, Out and Thru jacks, ADAT Optical input and output, external footswitch connector, time code input, GPI port, word sync in, out/thru, DTRS remote port, RS-422 9-pin control port, 24-channel TDIF I/O and more. Shown here with standard interfaces. Not luxurious enough? Customize your DM-24 with two expansion ports for extra analog, TDIF, ADAT or AES/EBU modules.

All trademarks are the property of their respective holders
www.tascam.com

TASCAM

a whole world of recording

ACCESSORIES

Proscreen PS101

Pop Screen Filter. 13" goose neck; stand clamp; metal. 4.6" x 20". \$59

Sterling Modular

E-Z Set-up Console

Console Desk with Bridge. Steel frame; cable passthroughs; cable raceway; 1" plywood. Optional 13RU rack unit. Optional 2RU under bridge rack. Starts at \$2,959

Swivel Wing Console

Console Desk with Movable Wings. Steel frame; hardwood veneer; two slant-faced 13RU lower racks; two movable wings; adjustable keyboard shelf; casters for wings; cable raceways; ball bearing joints. Optional motorized wings. Optional additional racks. Optional noise-reduced glass door rack. Optional extended wings. Optional bridge. starts at \$7,590

Taytrix

Mini-O

Workstation Furniture. Adjustable meter bridge; adjustable speaker wings. Optional maple finish with rubber bumper. Optional keyboard drawer. \$2,875

Oval

Workstation Furniture. Adjustable meter bridge; adjustable speaker wings. 6' x 3'. Optional rack bay. Optional maple finish with rubber bumper. Optional keyboard drawer. \$3,050

RA/RS 12, 14, 16

Equipment Racks. Upright or angled. 12, 14 or 16RU. Maple or cherry wood. Optional casters, doors, back doors or back rails. \$298 - \$429

TBC Consoles Inc.

Freeform Studio Furniture Console

Studio. Curved design; adjustable desktop height; rubber edges; three-bay curved equipment rack bridge; two-bay storage base; choice of finishes. 96" x 52", 650 lbs. \$3,000 - \$5,000

Techflex Inc.

Flexo Expandable Slewing

Braided Cable Slewing. Braided, various sizes, colors; color coding.

Tingler Innovations

SolderBuddy AVC

Standard audio, video, computer connector-sized holes; post and clip; aluminum block base; spare screw holder. \$49.50

Toleto Fasteners International

Cord-Lox

Reusable Velcro Cord Wraps. Organizes and color codes cables of all types and sizes; variety of sizes,

styles and colors. Optional custom fabrication and imprinting.

Ultralife Batteries Inc.

U9VL

Nine Volt Lithium Battery. Lithium-based 9 V battery; 4X greater life than alkaline batteries. \$6

Videoquip Research Ltd.

SD-2

Audio Silence Detector. Two input; defeatable audible alarm; relay contacts. XLR, screw terminal. \$395

Whirlwind

Cast-Base Floor Stands

Mic Stands. 8" - 67" height.

Large Boom Stands

43" - 73" height; 62" fixed boom; air suspension system or wheel base.

Mic Stand Booms

16" - 51.5" lengths; adjustable or fixed sizes.

TRHL Series

Audio Transformers. Special core and housing materials, Faraday shielding. Converts high-impedance signals to low impedance.

Tripod Mic Stands

26" - 63" height.

Winsted Corp.

Equipment Racks

Up to 74.5" high. \$500 - \$700

Media Storage Cabinets

Wide variety; small to facility size; stationary or pullout rolling cabinets.

ACOUSTICAL PRODUCTS

Acoustic Sciences Corp.

Full-Round, Half-Round, Quarter-Round Tube Traps

Bass Wave Traps/Diffusers. Studio, sound reinforcement. Stackable; custom colors; absorbs down to 30 Hz; diffuses +400 Hz; ships in 48" lengths; diameters - 9", 11", 13", 16", 20". \$218 - \$928

Monitor Stand

Sound Absorbing Monitor Stand. Studio. Sound absorbing materials; felt ring insert; choice of colors; 200 lb. capacity. 11", 13", 16", 20" inserts. Choice of height. \$756 - \$1,300 per pair

Sound Flag

Noise Absorbing Flags. Studio. Triangular; edge mounted; custom colors; absorbs down to 150 Hz; custom sizes available. 2" x 16" x 12". \$415 set of 12

Studio Trap

Portable Bass Trap, High-Frequency Diffuser. Studio. Portable; tripod mounted; adjustable height and angle; choice of colors; absorbs down to 110 Hz; diffuses +400 Hz; ships in 4" lengths; 9" diameter. 18 lbs. \$368

Tube Trap

Bass Wave Trap/Diffuser. Studio, sound reinforcement. Stackable; custom colors; absorbs down to 30 Hz; diffuses +400 Hz; ships in 37.5" lengths; diameters - 9", 11", 13", 16", 20". \$228 - \$778

WallDamp Iso-Wall System

Wall/Ceiling Construction System. STC: >60. \$3.00 - \$3.50 per sq. ft.

Acoustic Systems Inc.

Announcer Booths

Standalone Isolation Booths. Prefabricated or customized; acoustically sealed; ventilated; lighting; cable pass-through; casters; windows.

Acoustical Interiors/Systems Development Group

Bass Eraser

Wall-Mounted Bass Trap. Thermoplastic backing; fabric covered rigid fiberglass face; fire rated or non-fire rated; models. 2' x 4'. Custom colors available.

Model F

Wall-Mountable Sound Absorber. Thermoplastic or styrene; absorbed bandwidth: 1kHz - 16 kHz. 2' x 2' x 2.25". Custom colors available.

Acoustical Solutions Inc.

Alpha Linear Acoustical Foam

Acoustic dampening material; 2" x 2', 2' x 4' panels; 2", 3", 4" thicknesses; open cell polyurethane; charcoal, blue, beige, brown, hunter green, burgundy. Optional fire-rated white melamine foam. Starts at \$160 per box

Alpha Wave Form Panels

Acoustic fabric exterior; thermoplastic structure; 2' x 2', 2.25", 4.25" thicknesses; white or black; choice of fabric covering. \$79 - \$99

Modular Recording and Broadcast Booths

Steel exterior; wiring conduits; sound absorbing insulation; prewired jack panel. Starts at \$4,135

Signature Ceiling Tiles

Acoustic dampening ceiling tiles; 1' thicknesses; 2' x 2', 2' x 4' tiles; Class 1 fire rating. Starts at \$15.50

Acoustics First Corp.

Bermuda Broadband BB-44 & Bermuda "Shorts" BS-28

Acoustical absorption material. Studio Absorption averaging 29.3 Sabins at NRC frequencies; absorption coefficients exceeding theoretical limit of 1.00 across the spectrum; available in pairs or 2' or 4' lengths in four colors of urethane or Class 1 Melamine foam. 4' x 1' or 2' x 1.4' BB-44 or 8 BB-28 for \$168

Double Duty Diffuser

Polycylindrical Diffuser. Gelcoat or Guilford of Maine fabric covering; sizes from 2' x 2' up to 4' x 8'. May be wall or ceiling mounted. 2- x 4-foot absorption @125 Hz is 1.00 above 500 Hz - 0.10. Uniform polar dispersion pattern in pper and middle frequencies over 180 degrees. 7" deep sizes 2' x 2' through 4' x 8'; 2-foot x 4-foot: \$200; 4-foot x 8-foot: \$760

First Respond Kits

Sound Absorbing Panels. Studio. Fire retardant fabric covering; fire retardant chemically hardened foam core; choice of edge shapes; includes choice of wall mounting hardware. Depends on configuration

Quiet Louver

Sound Absorbing Panels. Studio. Fire retardant fabric covering; choice of fabric color; exterior wood slats; choice of wood; fire-retardant foam core. AFQL24 - 24" x 48" panel - \$348. AFQL28 - 24" x 96" panel - \$632.

Sound Channels-2

Wall Fabric Absorber Class A flame retardant; fusible clear latex backing; available in bulk - 33 yards per bolt. 54" wide. Choice of 60 colors.

Acoustone

Grille Cloth/Sound Absorbing Fabrics

Wide variety of styles, materials, applications, sizes; fire retardant.

Auralex Acoustics Inc.

LENRD Bass Trap

Corner Bass Trap. Corner or stand mount; 8 per box; Class B flame retardant; 12 colors. 12" x 12" x 17", 24" long. \$259 per box

SheetBlok

Sound Barrier. Comes in 30' x 4' rolls or 10' x 4' sections; 1/8" thick; flame retardant; nontoxic; can be cut with scissors or knife. 30': \$359, 10': \$159.

Studiofoam

Sound Absorbent Wedges and Pyramids. 1", 2", 3", 4" wedge thicknesses; 2", 4" pyramid thickness; Class B flame retardant; 2' x 4' panels; 12 colors. Wedge per box: \$239, Pyramid per box: \$289.

Sunburst-360s

Standmounted Sound Absorber. Broadband absorber; wedge cut; tripod stand included. 12" x 14" x 4'. \$289 per box

T-Fusers

Sound Diffusers. Thermoplastic construction; various shapes and sizes; paintable; Class B flame retardant; 4 per box. 23.75" x 23.75" x 5.5". \$69

U-Boats

Floor Beam Float Channels. U-shaped design; rubber; fits 2' x 4'. 2 1/8" x 1.5" x 2". \$2

ClearSonic Mfg. Inc.

ClearSonic Panel System

Portable Drum Shield System. Modular up to seven panels; 24", 48", 66" x 2' panels; 25" acrylic; cable cutouts. Optional sound absorbing foam attachments. Optional soft cases. Optional scratch-resistant panels. Cleaner available. starts at \$192

Flector

Personal Monitor Disc. 8", 12" diameter; 0.1" acrylic disc. 8": \$10. 12": \$11.

LID System ★ New for 2003 ★

Portable Sound Absorbing Enclosure. Telescoping aluminum frame; choice of ClearSonic SORBER panels and/or clear acrylic panels. SORBER: \$208. Acrylic: \$272.

SORBER Absorption Baffles

Portable Gobo. 1.5" thick; 48" x 48", 66" x 48", 24" x 22" panels; handle. \$24 - \$144

Fabric Wallmount Systems

Wallmate

Wallmounted Framed Sound Absorber. Locking frame.

Illbruck/SONEX

Fabritec

Fabric-Covered Acoustic Panels. 24" x 24", 24" x 48"; 1" thick; four panels per box. 24" x 24": \$140 per box, 24" x 48": \$264 per box.

SONEXclassic Acoustical Panels

Studio. Wedge design; FIBER-FREE material; 2" thickness; eight 2' x 4' sheets per box. White: \$213 per box. Charcoal, beige, brown, blue, gray. \$266 per box.

SONEXpyramid Acoustical Panels

Studio. Pyramid-shaped; FIBER-FREE material; low flammability; several pyramid thicknesses available; 8 - 14 sheets per box depending upon thickness; white, beige, brown, blue, gray. 2' x 2' x 2" or 4" or 6". \$260 - \$293 per box

SONEXsuper Acoustical Wedges

Studio. Anechoic wedge-shaped; FIBER-FREE material; low flammability; custom sizes available. 1' x 1' x 6".

SONEXtextile Acoustical Panels

Studio. Choice of colors; FIBER-FREE material; low-flammability; several thicknesses available. 2' x 4' x 1" or 2" or 3".

Middle Atlantic Products Inc.

AP Wall Panels

Acoustic Wall Treatments. 24" x 24" - 30" x 84" panels; beveled edges; polyester fabric covering. Beige or gray. starts at \$133 per panel

Netwell Noise Control

Columns

Foam Bass Trap. 10" thick; 4' long. \$42

Max Blocks

Wedge Panels. 6", 8"; 1' x 1' panels; polyurethane. Choice of colors. paintable white available. Melamine version available. \$10 - \$12 per panel

Wedges

Egg Carton-Style Foam Panels. 2", 3", 4" thicknesses; 2' x 3' panels; polyurethane. \$19 - \$24

Noren Products

ACL-NC

Rack Isolation Cabinet. Fanless Heat-Pipe technology cooling; airtight; acoustically isolated cabinetry; gaskets; double pane door; cable channels; interior light; 14RU of rackspace.

Black or maple finishes. \$3,200

ACL-RC-PC

Rack Isolation Cabinet. Fanless Heat-Pipe technology cooling; airtight; low-profile; designed for tower PC/Mac. Black or maple finishes. \$2,400

Primacoustic

Australis Corner Trap

Polyurethane foam; absorbs bass to 75 Hz.. 3' x 1' x 1'.

Europa Flutter Wall

Sound Absorbing Panels. 3' x 6", 3' x 6' panels; high-density open cell foam; fire-retardant; variety of patterns.

Primafoam

Sound Absorbing Foam. Panels, wedges, trim tiles; high-density open cell foam; fire-retardant.

Scandia Scatter Blocks

Acoustic Foam Sound Absorbing Blocks. Variety of patterns; designed to control slap echo and chatter.

RPG Diffuser Systems

Abffector

Sound Absorbing Panels. Hinged double panel. 4', 7'. Optional wood feet.

ProCorner

Sound Absorbing Corner Wedges. Choice of several colors. 4'.

Skyline

Sound Absorbing Ceiling Panels. Variable height block surface (156 blocks) per sheet. 2' x 2'.

Taytrix

Stack-It Gobos

Modular; fabric or 1/4" plexiglass or wood sides. 15" or 30" x 46" x 8", 19 - 37 lb. \$306 - \$443

Vocalbooth.com

Silver Series Sound Rooms

Portable Isolation Rooms. Foam-lined interiors; windows; ventilation; cable pass-throughs; lighting. 4' x 4' - 16' x 16'. starts at \$1,650

WhisperRoom Inc.

WhisperRoom SE 2000 Series

Portable Sound Isolation Rooms. Studio, broadcast. Complete room - floor, door, wall; sound absorbing materials; single or double wall; Sound Wave deflection system; window; cable pass-throughs; fan-powered ventilation; ventilation sound damping system. Up to 8.5' x 15.5'. 17 sizes. Optional windows. Optional casters. Starts at \$2,185

Show Your **TRUE COLORS**

Yamaha has been crafting some of the finest creative tools in the music field for a very long time: musical instruments for over 100 years, PM mixing consoles for 30, and digital mixers for 15. Discerning artists worldwide have preferred these tools, because of their ability to paint a musical picture with unparalleled brilliance. Reveal the depth of your musical vision with every sonic shade and hue under your total control. If you're serious about your art, check out Yamaha's outstanding new MG-Series mixers today...and show your true creative colors.

A YAMAHA DESIGNED MG SERIES MIXING CONSOLE
MG10/2 MG12/4 MG16/4 MG16/6FX MG24/14FX MG32/14FX



30th 5th
Anniversary

Mix With the Best
PM (celebrating 30 years)
Digital (celebrating 5 years)

AMPLIFIERS

Agular Amplification

DB 728
Tube-Based Power Amplifier. Monoblock; eight 6550 tubes; impedance switch; twin cooling fans. 1/4". \$2,495

Allen & Heath

GR8A
Eight-Channel Amplifier. Installation. Eight-channel; input level control per channel; onboard thermal management system; headphone jack; bridgeable channels. Power output per channel: 60 W @ 4 ohms, 120 W @ 8 ohms, bridged. XLR, 1/4". 2RU. \$1,399

American Audio

V-2000 Plus
Live sound. Two-channel; level controls; DC, overload, short circuit protection; soft start; high-pass filters; ground lift; limiters; twin cooling fans; heat sink; LED meters. Power output per channel: 280W @ 8 ohms, 450W @ 4 ohms, 650W @ 2 ohms. XLR, 1/4". \$399

V-4000 Plus
Power Amplifier. Live sound. Two-channel; level controls; DC, overload, short circuit protection; soft start; high-pass filters; ground lift; high-pass filters; limiters; twin cooling fans; heat sink; LED meters. Power output per channel: 600W @ 8 ohms, 1,010W @ 4 ohms, 1,400W @ 2 ohms. XLR, 1/4". banana. 1RU. \$999

Apogee Sound

CS-700
Power Amplifier. Installs, live sound, sound reinforcement. Level controls; bridgeable; ground lift switch; temperature, DC, ultrasonic, short circuit protection; turn-on delay; cooling fan; air filter; status LEDs. Frequency response: 20 Hz - 20 kHz. Power output per channel: 520W @ 8 ohms, 720W @ 4 ohms; bridged: 1,240W @ 8 ohms. THD: 0.02%. XLR, barrier strip. 2RU. 35 lb.

DA-800
Power Amplifier. Live sound, sound reinforcement, installation. Level controls; remote controllable; onboard performance analysis programs; bridgeable; ground lift switch; linkable; level control lock; status LEDs; temperature, DC, ultrasonic, short circuit protection; turn-on delay; cooling fan; air filter; LCD; compatible with Apogee Sound AmpNET remote amplifier software system. Frequency response: 20 Hz - 20 kHz. Power output per channel: 660W @ 8 ohms, 975W @ 4 ohms; bridged: 1,880W @ 8 ohms, 1,820W @ 4 ohms. XLR, five-way binding posts. 2RU. \$2,464

MA - Modular Multichannel Power Amplifier Series
Sound reinforcement. Modular; Class D; chassis holds up to eight amp cards/channels; each card offers 200 Watts of power; power, signal present, clipping, fault, emergency LEDs per channel; VCA clip limiting; compatible with Apogee Sound AmpNET amplifier control software. XLR, five-way binding posts. Optional battery back-up. Optional input for paging, background, zone priority. Optional AmpNET amplifier control software interface. Optional 70/100 Volt chassis. \$5,665

SA-700B/CA-700
Power Amplifiers. Live sound, sound reinforcement, installation. Status LEDs; bridgeable; ground lift switch; temperature, DC, ultrasonic, short circuit protection; turn-on delay; cooling fan; air filter; LCD. Frequency response: 20 Hz - 20 kHz. Power output per channel: 545W @ 8 ohms, 775W @ 4 ohms; bridged: 1,550W @ 8 ohms, 1,400W @ 4 ohms. 2RU. SA-700B has front mounted level controls; CA-700 has rear mounted level controls. \$2,179

Applied Research & Technology

SLA-1 Studio Power Amp
Two-channel; cooling fan; heat sink; ground lift; bridgeable; steel chassis; status LEDs. Power output per channel: 100W @ 8 ohms, 130W @ 4 ohms; 260W @ 8 ohms, bridged. Frequency response: 10 Hz - 40 kHz. XLR, 1/4". \$279

Ashdown Engineering/HHB

PM1000
Stereo Amplifier. Studio. Two-channel; level controls; independent channel operation; heat sink; four cooling fans; VU meters. Power output per channel: 320W @ 8 ohms, 500W @ 4 ohms. Neutrik Speakon, 1/4". 2RU. \$1,999

Ashly Audio

FTX-1501
Stereo Power Amplifier. Studio, live sound. Two-channel; MOSFET output devices; Class A full complementary front end; modular construction; stereo/mono/bridging modes; LED meters; thermal, ultrasonic, DC, short circuit protection; protect LEDs; turn-on delay; cooling fan; extruded aluminum heat sink. Power per channel: 200W @ 4 ohms, 300W @ 8 ohms; 600W @ 8 ohms bridged. Frequency response: 20 Hz - 20 kHz. 1/4", XLR, barrier strip, five-way binding posts. 2RU. 46 lb. Optional PowerCard crossover, mixer, transformer, comp/lim module cards. \$859

MFA-8000
Power Amplifier. Live sound, sound reinforcement. Two-channel; bipolar output devices; dual monaural design; Class A full complementary front end; modular construction; stereo/parallel mono/bridging modes; LED meters; short circuit, thermal, ultrasonic, RF, DC protection; clip limit; turn-on delay; protection, limit, thermal LEDs; cooling fan; aluminum heat sink. Power per channel: 750W @ 8 ohms, 1,200W @ 4 ohms; 2,400W @ 8 ohms bridged. Frequency response: 20 Hz - 20 kHz. 1/4", XLR, barrier strip, five-way binding posts. Speakons. 3RU. 68 lb. Optional PowerCard crossover, mixer, transformer, comp/lim module cards. \$2,139

Powerflex 6250
Six-Channel Amplifier. Live sound, sound reinforcement, installation. Four-channel; high-pass filter; MOS-FET output; bridgeable; rear panel trim pots; three-speed cooling fan; steel chassis; status LEDs. Power output per channel: 150W @ 8 ohms, 250W @ 4 ohms. THD: <0.2%. XLR, 1/4", Euroblock, five-way binding posts. 3RU. 45 lb. \$1,799

SRA-120
Power Amplifier. Studio, live sound. Two-channel; switchable stereo/mono/bridging modes; level control; input sensitivity select switch; signal, clip LEDs; Class A front end; toroidal transformer; turn-on delay, instantaneous turn off; thermal protection; convection cooled; stereo headphone jack. Power output per channel: 45W @ 8 ohms, 60W @ 4 ohms, 120W @ 8 ohms, bridged. Frequency response: 20 Hz - 20 kHz. 1/4", barrier strip, five-way binding post. 1RU. 20 lb. \$579

AudioControl Industrial

Architect Model 510
Multichannel/Zone Amplifier. Installs. 12-channel; Lightdrive Protection system; clipping, DC temperature protection; input level controls; Programmable Filter Module bass filtering; bridgeable; ground option switch; remote control. Power output per channel: 50W @ 4 ohms; 100W @ 8 ohms, bridged. THD: 0.12%. Euroblock. 3RU. 35 lb.

Architect Model 950
Multichannel/Zone Amplifier. Installation. 16-channel; five-band EQ per channel; Class H; Lightdrive Protection system; clipping, DC temperature protection; input level controls; bridgeable channels; high-pass filter (40 Hz); bridgeable; remote control. Output per channel: 55W @ 8 ohms, 110W @ 8 ohms, bridged. 4RU. Optional Ethernet remote control.

Pantages
Multichannel Power Amplifier. Installation, studio. Five-channel; Class H; Lightdrive protection circuitry; BiMOS Class A/MOSFET output stage. Power output per channel: 200W @ 8 ohms. RCA, XLR. \$2,100

Benchmark Media Systems Inc.

IFA-3 Stereo Balanced Output Amplifier
Dynamic range: >120 dB. THD: 0.0008%. \$160

VCA-2
Remote Stereo Voltage Controlled Amplifier. Gain control: -100 +20 dB. THD: 0.002%. \$305

BGW Systems Inc.

BGW Millennium 3
Power Amplifier. Sound reinforcement. Modular design; transient free switching; switchable clipping eliminator circuit; adjustable high-pass filter; two-speed fan; heatsink; short circuit, thermal, open circuit, subsonic, RF, DC, start protection; signal presence, clip, power LEDs; detented gain control; bridgeable; THX approved. Power output per channel: 375 W @ 8 ohms, 600 W @ 4 ohms. Frequency response: 20 Hz - 20 kHz. XLR, 1/4", touch-proof binding post. 3RU, 44 lb. \$1,296

GT5600
Live sound, sound reinforcement. Two-channel; level controls; high-pass filter; clip limiter; variable speed cooling fan; bridge mono/stereo/dual stereo switch; ground lift. Power output per channel: 900W @ 8 ohms, 1,500W @ 4 ohms; 2,500W @ 8 ohms, bridged. XLR, 1/4", Neutrik Speakon, five-way binding posts, Euroblock. 3RU. \$2,311

GTA
Power Amplifier. Sound reinforcement. Two-channel; stepped attenuators; forced air cooling; subsonic; bridgeable; signal presence indicator; Ultra Case transistors; 2 ohm operation. Power output per channel: 450 W @ 8 ohms, 850 W @ 4 ohms, 1,350 W @ 2 ohms; 2,900 W @ 4 ohms, bridged. Frequency response: 20 Hz - 20 kHz. XLR, 1/4", five-way binding post. 3RU. 80 lb. \$2,299

Model 750G
Power Amplifier. Broadcast, sound reinforcement, recording studio. Two-channel; stepped attenuators; stereo/mono switch; circuit breaker; DC protection; Ultracase transistors; linkable; LED meters; DC, temperature, clip status LEDs; subsonic filter; fan defeat switch; bridgeable; dual mono mode; ground lift; start delay; 2 ohm operation; THX approved. Power output per channel: 375 W @ 8 ohms, 675 W @ 4 ohms; 1,350 W @ 8 ohms, bridged. Frequency response: 20 Hz - 20 kHz. XLR, 1/4", five-way binding post. 4RU, 61 lb. Optional crossover cards. \$1,949

Performance Series 1
Power Amplifier. Sound reinforcement. Modular design; transient free switching; DC protection; forced air cooling; heatsink; signal presence, clip, power LEDs; detented gain control; 2 ohm operation. Power output per channel: 190 W @ 8 ohms, 290 W @ 4 ohms; 600 W @ 8 ohms, bridged. XLR, 1/4", five-way binding post. 2RU, 31 lb. \$874

VX208
Eight-Channel Amplifier. Installation. Eight-channel; level controls; Class AB-B; high-pass filter; soft start; 70V capable; variable speed cooling fan; bridged mono/stereo/dual mono switch; DC, temperature protection; ground lift; 16-gauge steel chassis. Power output per channel: 200W @ 8 ohms, 300W @ 4 ohms; 600W @ 8 ohms, bridged. XLR, barrier strips, Euroblock. 3RU. \$3,595

VX660
Installation. Two-channel; level controls; Class H; high-pass filter; soft start; 70V capable; variable speed cooling fan; bridged mono/stereo/dual mono switch; DC, temperature protection; ground lift; 16-gauge steel chassis; THX approved. Power output per channel: 660W @ 8 ohms, 1,050W @ 4 ohms; 1,750W @ 8 ohms, bridged, 2,450W @ 4 ohms, bridged. 660W @ 4 ohms, 70V. XLR, barrier strips, Euroblock. 3RU. 58 lb. \$2,032

X3800
Live sound. Two-channel; level controls; clip limiter; variable speed cooling fan; ground lift. Power output per channel: 660W @ 8 ohms, 1,050W @ 4 ohms, 1,500 @ 2 ohms; 1,750W @ 8 ohms, bridged, 2,450W @ 4 ohms, bridged. XLR, 1/4", five-way binding posts. 3RU. \$1,593

Bryston

14B-ST
Studio, live sound, sound reinforcement, broadcast. Two-channel; power/clipping lights; level controls per channel; Quad-Complementary output section; heat sink; convection cooling; twin power supplies; bridgeable; gold-plated connectors. Power output per channel: 600 W @ 8 ohms, 1,000 W @ 4 ohms. THD: <0.004%. XLR, 1/4", RCA, five-way binding posts. 3RU. 90 lb. \$5,495

3B-ST
Studio, live sound, sound reinforcement, broadcast. Two-channel; power/clipping lights; mono/stereo output switch; Quad-Complementary output section; heat sink; convection cooling; twin power supplies; bridgeable; gold-plated connectors. Power output per channel: 120 W @ 8 ohms, 200 W @ 4 ohms, 400 W @ 8 ohms, bridged. THD: <0.007%. XLR, 1/4", five-way binding posts. 3RU. 22 lb. \$1,890

6B-ST
Three-Channel Power Amplifier. Studio, live sound, sound reinforcement, broadcast. Three-channel; power/clipping lights; polarity reverse; heat sink; convection cooling; bridgeable; gold-plated connectors. Power output per channel: 350W @ 8 ohms, 500W @ 4 ohms. 4RU. 85 lb. \$3,800

7B-ST ★ New for 2003 ★
Monoblock Power Amplifier. Studio, live sound, sound reinforcement, broadcast. Single-channel/monoblock; series/parallel switch; Quad-Complementary output section; soft start; heat sink; convection cooling; 1 ohm operation; gold-plated connectors. Power output per channel: 500 W @ 8 and 2 ohms, 800 W @ 1 or 4 ohms. THD: <0.007%. XLR, 1/4", five-way binding posts. 3RU. 42 lb. \$2,630

9B-ST THX
Multichannel Amplifier. Studio, live sound, sound reinforcement, broadcast. Power/clipping lights; level controls per channel; Quad-Complementary output section; heat sink; convection cooling; twin power supplies; bridgeable; gold-plated connectors. Power output per channel: 150 W @ 8 ohms, 275 W @ 4 ohms. THD: <0.002%. XLR, 1/4", RCA, five-way binding posts. 3RU. 75 lb. Two-channel: \$1,850. Three-channel: \$2,750. Four-channel: \$3,300. Five-channel: \$3,880.

Powerpac 60 Monaural Amplifier
Monoblock Amplifier. Studio, live sound, sound reinforcement, broadcast. Monoblock; power/clipping lights; level controls per channel; Quad-Complementary output section; heat sink; convection cooling; gold-plated connectors. Power output: 90 W @ 8 ohms, 150 W @ 4 ohms. THD: <0.002%. XLR, 1/4", RCA, five-way binding posts. 12" x 4" x 7". 4 lb. \$630

Carver Professional

CV2502
Power Amplifier. Installation. Two-channel; level control; switchable high-pass filter (80/120 Hz); limiter; remote operable; parallel; sequential start; plug-in module slot; 25V, 35V, 50V, 70V, 100V transformer; status LEDs. Power output per channel: 250W @ 4/8 ohms or voltage, 500W bridged. Frequency response: 20 Hz - 20 kHz. THD: 0.5%. Phoenix. 2RU. 43 lb. Optional ducking, matrix mixer, DSP, mic preamp modules. \$1,250

pt2400
Power Amplifier. Sound reinforcement. Two-channel; detented level controls; independent channel relays; clipping eliminator; Soft Start/Input mute; LED displays; DC, short, temperature, high frequency protection circuitry; fan cooling; separate L/R power cords; 70 V direct operation. Power output per channel: 750W @ 8 ohms, 1,200W @ 4 ohms, 1,500W @ 2 ohms; 2,400W @ 8 ohms, bridged, 3,000 W @ 4 ohms, bridged. Frequency response: 20 Hz - 20 kHz. THD: <0.5%. XLR, barrier strip, multiway binding posts. 3RU. 48 lb. \$2,779

PXm450
Power Amplifier. Two-channel; detented level controls; high-pass filters (30 Hz, 80 Hz); two ohm stable; clip eliminator; input sensitivity control; bridgeable; variable speed fan cooling; 70 V direct operation. Power output per channel: 150W @ 8 ohms, 225W @ 4 ohms, 335W @ 2 ohms; 450W @ 8 ohms, bridged. XLR, 1/4". 2RU. Optional Speakon, barrier strips. \$665

ZR1000
Power Amplifier. Installation. Two-channel; level controls; switchable high-pass filter (30/80 Hz); limiters; Class D; power-up sequencing; slot for processor modules; cooling fan; thermal, short circuit, overvoltage, overcurrent protection; ground lift; status LEDs. Power output per channel: 225W @ 8 ohms, 350W @ 4 ohms, 500W @ 2 ohms; 700W @ 8 ohms, bridged, 1,000W @ 4 ohms, bridged. Frequency response: 20 Hz - 20 kHz. THD: >1%. Neutrik Speakon. 2RU. 30 lb. Optional crossover, ducking, EQ, mic preamp modules available.

Carvin

DCM1001
Two-channel; level controls; onboard twin nine-band graphic EQs; limiters; stereo/parallel/bridge; status LEDs. Power output per channel: 225W @ 8 ohms, 350W @ 4 ohms, 500W @ 2 ohms. XLR, 1/4", Twist-Lok, binding posts. 2RU. \$469

DCM150
Two-channel; level controls; EQ; bridgeable; status LEDs. Power output per channel: 75W @ 4 ohms; 150W @ 8 ohms, bridged. XLR, 1/4", binding posts. 1RU. \$229

DCM2000
Power Amplifier. Studio, sound reinforcement. Two-channel; level controls; limiter switch; modular components; short circuit, no load, thermal, soft start protection; ground lift; bridgeable; heat sink; cooling fan; clip LED. Frequency response: 20 Hz - 20 kHz. Power per channel: 450 W @ 8 ohms; 700 W @ 4 ohms. Bridged mono: 1,400 W @ 8 ohms; 2,000 W @ 4 ohms. 1/4", XLR,

Raise

Expectations.



Focused. Instrumental. KSM.

There's more than meets the eye to the new instrumental KSM studio condenser microphones from Shure. There's performance, heritage and versatility. The dual-pattern KSM141 switches from cardioid to omnidirectional with the turn of a dial. The studio-workhorse KSM137 powers through percussion and soars with the solos.

And the KSM109 rounds out the KSM instrument line with incredible price performance. These microphones feature transformerless preamplifier circuitry, extended frequency response, and incredibly low self-noise. They provide the technology, so your studio can provide the sound. The KSM line of instrument studio microphones. Only from Shure.

www.shure.com

©2002 Shure Incorporated

SHURE
It's Your Sound[®]

World Radio History

AMPLIFIERS

binding post, banana, Twist-Lok. 3RU. \$539

DCM4000A

Four-Channel Power Amplifier. Four-channel; level controls; limiters; low-cut filters; ground lift; twin cooling fans; short circuit, thermal, SpeakerGuard protection; stereo/parallel/bridge switches. Power output per channel: 425W @ 8 ohms, 700W @ 4 ohms, 1,000W @ 2 ohms; 1,400W @ 8 ohms, bridged (two-channel), 2,000W @ 4 ohms, bridged (two-channel). XLR, Twist-Lok, banana, binding posts. 3RU. 70 lb. \$1,099

Chevin Research North America

A2000

Power Amplifier. Live sound, sound reinforcement. Two-channel; level controls; SoftClip limiter; twin cooling fans; short circuit, RF, DC protection; 2 ohm operation. Power output per channel: 375W @ 8 ohms, 750W @ 4 ohms, 1,200W @ 2 ohms. Frequency response: 2 Hz - 80 kHz. S/N: 125 dB. THD: 0.04%. 2RU, 19" x 3.5" x 15", 27 lbs. \$2,149

A500

Power Amplifier. Live sound, sound reinforcement. Two-channel; level controls; SoftClip limiter; twin cooling fans; short circuit, RF, DC protection. Power output per channel: 200W @ 8 ohms, 350W @ 4 ohms. Frequency response: 2 Hz - 40 kHz. S/N: 125 dB. THD: 0.06%. 1RU, 19" x 1.75" x 8.5", 9 lbs. \$999

A6000

Power Amplifier. Live sound, sound reinforcement. Two-channel; level controls; SoftClip limiter; twin cooling fans; short circuit, RF, DC protection; 2 ohm operation. Power output per channel: 1,200W @ 8 ohms, 2,000W @ 4 ohms, 3,000W @ 2 ohms. Frequency response: 2 Hz - 80 kHz. S/N: 125 dB. THD: 0.04%. 4RU, 19" x 7" x 15", 55 lbs. \$4,700

Q6

Power Amplifier. Live sound, sound reinforcement. Four-channel; level controls; SoftClip limiter; twin cooling fans; short circuit, RF, DC protection. Power output per channel: 350W @ 8 ohms, 600W @ 4 ohms. Frequency response: 2 Hz - 80 kHz. S/N: 125 dB. THD: 0.04%. \$2,849

Crest Audio Inc.

8002

Power Amplifier. Live sound, sound reinforcement. Two-channel; level controls; Class H; TourClass amp protection circuitry; PowerLok power factor correction technology; Twin Tunnel cooling with two variable speed cooling fans; ground lift; bridgeable; activity LEDs; Pro II Series. Frequency response: 20 Hz - 20 kHz. THD: <0.05%. Power output per channel: 750W @ 8 ohms, 1,350W @ 4 ohms, 1,900W @ 2 ohms, 2,700W @ 8 ohms, bridged, 3,800W @ 4 ohms, bridged. XLR, five-way binding posts. 3RU. 42 lb. \$3,560

CA 18

Power Amplifier. Sound reinforcement. Two-channel; level controls; toroidal power transformer; heavy duty power supply; massive aluminum heat sinks; TourClass protection; twin tunnel cooling with two variable speed fans; front panel circuit breaker switch; bridgeable. Power output per channel: 950W @ 8 ohms, 1,700W @ 4 ohms, 2,400W @ 2 ohms, 3,400W @ 8 ohms, bridged, 4,800W @ 4 ohms, bridged. XLR, 1/4", Speakon, binding post. 3RU. 77 lb. \$3,390

CKS Model 100

Power Amplifier. Sound reinforcement. Two-channel; NexSys computer control; speaker load diagnostics; mains power monitor; PowerSave function; sequential power on/off; TourClass

protection circuitry; expansion slots for NexSys signal, EQ, DSP, crossover network modules. Frequency response: 20 Hz - 20 kHz. Power per channel: 75W @ 4 ohms. Barrier strip. 2RU. 27 lb. \$860

CKS Model 1200-2

Power Amplifier. Sound reinforcement. NexSys computer control; speaker load diagnostics; mains power monitor; PowerSave function; sequential power on/off; TourClass protection circuitry; expansion slots for NexSys signal, EQ, DSP, crossover network modules. Frequency response: 20 Hz - 20 kHz. Power per channel: 900W @ 4 ohms. Barrier strip. 4RU. 71 lb. \$2,390

CKS Model 800-2

Power Amplifier. Sound reinforcement. NexSys computer control; speaker load diagnostics; mains power monitor; PowerSave function; sequential power on/off; TourClass protection circuitry; expansion slots for NexSys signal, EQ, DSP, crossover network modules. Frequency response: 20 Hz - 20 kHz. Power per channel: 600W @ 4 ohms. Barrier strip. 3RU. 71 lb. \$2,190

CKV Model 100

Power Amplifier. Sound reinforcement. Two-channel; NexSys computer control; speaker load diagnostics; mains power monitor; PowerSave function; sequential power on/off; TourClass protection circuitry; expansion slots for NexSys signal, EQ, DSP, crossover network modules. Power per channel @ 70V - 50W. Barrier strip. 2RU. 26 lb. For 70V installation. \$860

CKV Model 1600

Power Amplifier. Sound reinforcement. Two-channel; NexSys computer control; speaker load diagnostics; mains power monitor; PowerSave function; sequential power on/off; TourClass protection circuitry; expansion slots for NexSys signal, EQ, DSP, crossover network modules. Power per channel @ 70V - 800W. Barrier strip. 4RU. 71 lb. For 70V installation. \$2,390

CKV Model 800

Power Amplifier. Sound reinforcement. Two-channel; NexSys computer control; speaker load diagnostics; mains power monitor; PowerSave function; sequential power on/off; TourClass protection circuitry; expansion slots for NexSys signal, EQ, DSP, crossover network modules. Power per channel @ 70V - 400W. Barrier strip. 3RU. 50 lb. For 70V installation. \$1,820

CPX2600

Two-channel; GCL clip limiting; thermal, DC protection; soft start; heat sink; two-speed cooling fan; bridgeable. Power output per channel: 1,300W @ 2 ohms; 2,600W @ 4 ohms, bridged. THD: <0.1%. XLR, 1/4", barrier strip, Speakon. 2RU. 49 lb. \$799

CPX900

Two-channel; GCL clip limiting; thermal, DC protection; soft start; heat sink; two-speed cooling fan; bridgeable. Power output per channel: 450W @ 2 ohms; 900W @ 4 ohms, bridged. THD: <0.1%. XLR, 1/4", barrier strip, Speakon. 2RU. 40 lb. \$459

LT1000

Power Amplifier. Live sound, sound reinforcement, installation. Two-channel; level controls; Linear Power Supply; Class D; Tour-Class protection; cooling fan; ground lift. Power output per channel: 500W @ 4 ohms. Frequency response: 10 Hz - 20 kHz. THD: 0.05%. XLR, 1/4", Speakon, binding posts, Phoenix. 2RU. 21 lb. \$1,090

LT1500

Power Amplifier. Live sound, sound reinforcement, installation. Two-channel; level controls; Linear Power Supply; Class D; Tour-Class protection; cooling fan; ground lift. Power output per channel: 750W @ 4

ohms. Frequency response: 10 Hz - 20 kHz. THD: 0.05%. XLR, 1/4", Speakon, binding posts, Phoenix. 2RU. 33 lb. \$1,059

Pro 5200 * New for 2003 *

Two-channel; level controls; Automatic Clip Limiting; AutoRamp soft start; DC, temperature protection; stereo/parallel/bridge; variable speed cooling fan; heat sink; LED meters. Power output per channel: 525W @ 4 ohms. XLR, Speakon, binding posts. 2RU. 25 lb. \$1,600

Pro 8200 * New for 2003 *

Two-channel; level controls; Automatic Clip Limiting; AutoRamp soft start; DC, temperature protection; stereo/parallel/bridge; variable speed cooling fan; heat sink; LED meters. Power output per channel: 1,450W @ 4 ohms. XLR, Speakon, binding posts. 2RU. 25 lb. \$2,630

ST1000

Power Amplifier. Live sound, sound reinforcement, installation. Two-channel; level controls; Class D; Tour-Class protection; cooling fan; steel chassis; ground lift. Power output per channel: 500W @ 4 ohms. Frequency response: 10 Hz - 20 kHz. THD: 0.05%. XLR, 1/4", Speakon, binding posts, Phoenix. 2RU. 22 lb. \$1,099

Crown Audio

CE 1000

Power Amplifier. Sound reinforcement, live sound, installation. Two-channel; level controls; reset switch; variable speed cooling fan; bridgeable; status LEDs; 2 ohm capable; compatible with Crown SST crossover modules. Power output per channel: 275W @ 8 ohms, 450W @ 4 ohms, 560W @ 2 ohms, 900W @ 8 ohms, bridged, 1,100W @ 4 ohms, bridged. Neutrik combo, barrier strip. 3RU. 33 lb. \$731

CE 2000

Power Amplifier. Sound reinforcement, live sound, installation. Two-channel; level controls; reset switch; variable speed cooling fan; bridgeable; status LEDs; 2 ohm capable; compatible with Crown SST crossover modules. Power output per channel: 400W @ 8 ohms, 660W @ 4 ohms, 975W @ 2 ohms, 1,320W @ 8 ohms, bridged, 1,950W @ 4 ohms, bridged. Neutrik combo, barrier strip. 3RU. 40 lb. \$1,043

CH 2

Power Amplifier. Live sound, installation, sound reinforcement. Two-channel; volume control; 70V/100V operation; independent channel operation; comp/lim; high-pass filter (70 Hz); variable speed cooling fan. Power output per channel: 400W @ 8 ohms, 660W @ 4 ohms; 1,320W @ 8 ohms, bridged; 600W @ 70V or 100V. Neutrik combo, barrier strip. 3RU. 48 lb. \$1,240

CL 2

Power Amplifier. Live sound, installation, sound reinforcement. Two-channel; volume control; independent channel operation; comp/lim; variable speed cooling fan; compatible with Crown's SST modules. Power output per channel: 400W @ 8 ohms, 660W @ 4 ohms, 975W @ 2 ohms; 1,320W @ 8 ohms, bridged, 1,950W @ 4 ohms, bridged. Neutrik combo, barrier strip. 3RU. 40 lb. \$1,090

CL 4

Power Amplifier. Live sound, installation, sound reinforcement. Two-channel; volume control; independent channel operation; comp/lim; variable speed cooling fan; compatible with Crown's SST modules. Power output per channel: 600W @ 8 ohms, 1,200W @ 4 ohms, 1,800W @ 2 ohms; 2,400W @ 8 ohms, bridged, 3,600W @ 4 ohms, bridged. Neutrik combo, barrier strip. 3RU. 33 lb. \$2,269

CP660

Six-Channel Power Amplifier. Installation, live sound. Six-channel; channel pair switches; bridgeable. Power output per channel: 60W @ 8 ohms, 75W @ 4 ohms; 150W @ 8 ohms, bridged. THD: 0.3%. Barrier strip, binding posts. 2RU. \$864

CTs 3000

Installation. Two-channel; level controls; selectable high-pass filter (35/70 Hz); input sensitivity switch; bridge/mono switch; Balanced Current Amplifier (BCA) technology; overvoltage, undervoltage protection; 70/100V capable; compatible with Crown Programmable Input Processor PIP2 modules; heat sink; variable speed cooling fan. Power output per channel: 1,200W @ 8 ohms, 1,500W @ 4 ohms, 1,500W @ 2 ohms, 1,500W @ 70V; 2,400W @ 16 ohms, bridged, 3,000W @ 8 ohms, bridged, 3,000W @ 4 ohms, bridged. THD: <0.05%. Phoenix, screw terminals. 2RU. 27 lb. \$3,192

CTs 4200

Multichannel Amplifier. Installation. Four-channel; level controls; high-pass filter (70 Hz); bridge/mono switch; overvoltage, undervoltage protection; Fault Isolation Topology channel protection; 70V capable; compatible with Crown Programmable Input Processor PIP2 modules; heat sink; variable speed cooling fan. Power output per channel: 200W @ 8 ohms, 260W @ 4 ohms, 220W @ 70V; 400W @ 16 ohms, bridged, 520W @ 8 ohms, bridged. THD: <0.05%. Phoenix, screw terminals. 2RU. 27 lbs. \$1,703

CTs 8200

Multichannel Amplifier. Installation. Eight-channel; level controls; high-pass filter (70 Hz); bridge/mono switch; overvoltage, undervoltage protection; Fault Isolation Topology channel protection; 70V capable; compatible with Crown Programmable Input Processor PIP2 modules; heat sink; variable speed cooling fan. Power output per channel: 160W @ 8 ohms, 200W @ 4 ohms, 200W @ 70V; 320W @ 16 ohms, bridged, 400W @ 8 ohms, bridged. THD: <0.05%. Phoenix, screw terminals. 3RU. 36 lbs. \$3,310

D-75A

Studio, broadcast. Two-channel; level controls; AB+B circuitry; bridgeable. Power output per channel: 40W @ 8 ohms, 55W @ 4 ohms; 110W @ 8 ohms, bridged. THD: 0.05%. Neutrik combo, terminal strip. 1RU. 10 lb. \$652

K2

Power Amplifier. Studio, sound reinforcement. Two-channel; level controls; Balanced Current Amplifier (BCA) circuit design; soft start; Thermal Level Control temperature protection; input sensitivity control; bridgeable; convection cooling; status LEDs; 2 ohm capable. Power output per channel: 475W @ 8 ohms, 800W @ 4 ohms, 1,250W @ 2 ohms, 1,600W @ 8 ohms, bridged, 2,500W @ 4 ohms, bridged. XLR, 1/4" TRS, binding posts. 2RU. 38 lb. \$1,872

MA-3600VZ

Power Amplifier. Sound reinforcement. Two-channel; level controls; Output Device Emulation Protection output stage protection; status LEDs; Programmable Input Processor (PIP2) module compatible; 2 ohm capable; Macro-Tech VZ series. Power output per channel: 1,125W @ 8 ohms, 1,625W @ 4 ohms, 1,800W @ 2 ohms, 2,250W @ 16 ohms, bridged, 3,250W @ 8 ohms, bridged, 3,600W @ 4 ohms, bridged. XLR, 1/4" TRS, binding posts. 2RU. 55 lb. \$3,228

MA-5002VZ

Power Amplifier. Sound reinforcement. Two-channel; level controls; Output Device Emulation Protection output stage protection; bridgeable; parallel mono; Quad-Mute protection (short,

open circuit, load mismatch, DC, thermal); Programmable Input Processor (PIP2) module compatible; Input/Output Comparator (IOC) circuitry; Grounded Bridge; Macro-Tech VZ series. Power output per channel: 1,300W @ 8 ohms, 2,000W @ 4 ohms, 2,500W @ 2 ohms. S/N: 105 dB. THD: 0.05%. XLR, 1/4", spade, banana. 3RU. 78 lb. \$4,219

MT-2400

Power Amplifier. Sound reinforcement. Two-channel; Output Device Emulation Protection output stage protection; selectable input sensitivity; dual power supplies; cooling fan; bridgeable; parallel mono; Grounded Bridge; Micro-Tech series. Power output per channel: 520W @ 8 ohms, 800W @ 4 ohms, 1,050W @ 2 ohms; 1,585W @ 8 ohms, bridged, 2,070W @ 4 ohms, bridged. S/N: 105 dB. THD: 0.05% 1/4", five-way binding posts. 2RU. 47 lb. \$1,459

Studio Reference 1

Studio, post production. Two-channel; level controls; bridgeable; parallel mono; ground lift; selectable input sensitivity; Output Device Emulation Protection output stage protection; Programmable Input Processor (PIP2) module compatible; LED meters. Power output per channel: 800W @ 8 ohms, 1,190W @ 4 ohms; 2,375W @ 8 ohms, bridged. S/N: 120 dB. THD: 0.02% 1/4", five-way binding posts. 4RU. \$4,532

XLS 202

Power Amplifier. Sound reinforcement, live sound. Two-channel; detented level controls; cooling fan; status LEDs; steel chassis. Power output per channel: 145W @ 8 ohms, 200W @ 4 ohms, 250W @ 2 ohms. THD: 0.15%. XLR, 1/4", binding posts. 2RU. 21 lb. \$329

XLS 402

Power Amplifier. Sound reinforcement, live sound. Two-channel; detented level controls; cooling fan; status LEDs; steel chassis. Power output per channel: 260W @ 8 ohms, 400W @ 4 ohms, 570W @ 2 ohms. THD: 0.15%. XLR, 1/4", binding posts. 2RU. 25 lb. \$495

DAS Audio of America Inc.

E-2

Two-channel; level controls; Discrete Monolithic Amplifier Technology; short circuit, thermal protection; cooling fan; steel chassis. Power output per channel: 90W @ 8 ohms, 125W @ 4 ohms. 2RU. \$579

Demeter Tube Amplification

VT275HF

Power Amplifier. Recording studio. Two-channel; feedback control; tube-based; four matched Ruby Tubes 6550 tubes; adjustable individual tube bias. Power output per channel: 65 W. THD: 0.05%. RCA, binding posts. 4RU. \$2,299

Denon Electronics

DN-A850 Zone Mixing Amplifier

Powered Zone Mixer. Installation, live sound. Four fully independent channels; master level, music source, mic source controls per channel; ducking function; bass, treble EQ per zone; input level controls; Page Zone attenuation function; overload, DC thermal amp protection. Power output per channel: 50 W @ 4 ohms, 25 W @ 8 ohms. THD: <0.5%. RCA, XLR, 1/4", terminal strip. 3RU. \$999

Electro-Voice

CPS 4

Power Amplifier. Installation. Limiter; short circuit, thermal, overload, surge, overload, DC protection circuitry; variable speed cooling fans. Output: 750 W @ 8 ohms, 1,200 W @ 4 ohms,

NO EXCUSE PERFORMANCE.



The New RMX 4050HD From QSC.

The New RMX 4050HD

In the world of live sound, no excuse means no second takes. With amplification, no excuse means brute force power, pristine audio performance, and high efficiency design. Introducing the RMX 4050HD. Built for the most demanding jobs, this amp delivers "big block" performance capable of driving up to four 8-ohm subwoofers per channel. That's 4000 watts of pulse pounding adrenaline in a 3RU chassis only 16" deep.

Heavy Duty in every respect, QSC "HD" amps work as hard into 2-ohm loads as most competing amps will at 4-ohms. With a three-tier, Class H design, the RMX 4050HD is extremely efficient at real world power levels. Less AC current is wasted and more goes into producing useful audio power. Best of all, this powerhouse uses a standard 15-Amp plug (120V models).

Like all RMX amps, the 4050HD features balanced 1/4" TRS, XLR and barrier strip inputs, binding posts and Neutrik Speakon™ outputs, front-mounted gain controls, plus signal and clip LED indicators to monitor performance. Unique to the 4050HD is a dual mono, high current power supply designed to keep the house rockin' night after night.



RMX 4050HD rear panel view

The RMX 4050HD. Heavy Duty performance with the rock-solid reliability QSC is famous for—at a price that won't break the bank. For more information, visit your authorized QSC dealer, log onto

www.qscaudio.com or call 800-854-4079. The RMX 4050HD—the no excuse amp for no excuse performance.

Both channels driven		20 Hz-20 kHz, 0.1% THD*	1 kHz, 0.1% THD (EIA Watts)
Stereo (W/Ch)	8 ohms	800 watts	850 watts
	4 ohms	1300 watts	1400 watts
	2 ohms	1600 watts	2000 watts †
Bridged Mono	8 ohms	2600 watts	2800 watts
	4 ohms	—	4000 watts †

MSRP: \$1,779

*FTC Watts †1 kHz, 1% THD

Special Features:

- The RMX 4050HD provides improved thermal performance that gives you higher continuous power in 2-ohms stereo or 4-ohms bridged applications
- Dual mono, high current power supply for increased reliability and performance
- High-current toroidal transformers for greater two-ohm power and low noise
- 3RU chassis only 16" deep
- 3-year warranty. An optional 3-year extended service contract is available.



HEAR THE POWER OF TECHNOLOGY.

AMPLIFIERS

1,500 W @ 2 ohms. XLR, Neutrik Speakon. 3RU. 64 lb. \$2,516

Eliminator I Amp

Power Amplifier. Live sound, sound reinforcement. Two-channel; level controls; limiter; bridgeable; LPN processor. Power output per channel: 380 W @ 8 ohms, 600 W @ 4 ohms, 850 W @ 2 ohms; 1,200 W @ 8 ohms, bridged, 1,700 W @ 4 ohms, bridged. XLR. 3RU. \$1,258

Force Amp

Power Amplifier. Live sound. Two-channel; level controls; limiter; bridgeable. Power output per channel: 280 W @ 8 ohms, 450 W @ 4 ohms, 650 W @ 2 ohms; 900 W @ 8 ohms, bridged, 1,300 W @ 4 ohms, bridged. XLR, Neutrik Speakon. \$1,662

P1200 Precision Series

Power Amplifier. Studio, live sound. Two-channel; level controls; Dual Differential Discrete Topology circuitry; bridgeable; temperature, overload, short circuit, DC, RF protection; limiter; fan-cooled; status LEDs. Frequency response: 20 Hz - 20 kHz. S/N: >100 dB. Power output per channel: 350 W @ 8 ohms, 500 W @ 4 ohms, 600 W @ 2 ohms. XLR, Neutrik NL4MP Speakon. 2RU. 36 lb. \$1,662

P3000 Precision Series

Power Amplifier. Studio, live sound. Two-channel; level controls; Dual Differential Discrete Topology circuitry; bridgeable; temperature, overload, short circuit, DC, RF protection; limiter; fan-cooled; status LEDs. Frequency response: 20 Hz - 20 kHz. S/N: >100 dB. Power output per channel: 750 W @ 8 ohms, 1,200 W @ 4 ohms, 1,500 W @ 2 ohms. XLR, Neutrik NL4MP Speakon. 3RU. 62 lb. \$3,766

Px1202

Sound reinforcement, live sound, installation. Two-channel; processor modules; I/O modules; level controls; speaker protection circuitry. Power output per channel: 600W @ 4 ohms. XLR, Speakon. Contractor versions with Phoenix connectors and barrier strips. Processor modules available. \$1,470

FBT North America

HP 1000

Power Amplifier. Live sound, sound reinforcement, installation. Two-channel; volume controls; bridgeable; parallel; link; ground lift; subsonic filter; crossover filter; switchable high-pass filter (35 or 120 Hz); clip indicators; thermal, DC, short circuit protection; soft start; variable speed cooling fan. Frequency response: 20 Hz - 20 kHz. S/N: >105 dB. Power output per channel: 300 W @ 8 ohms, 500 W @ 4 ohms, 650 W @ 2 ohms; 1,000 W @ 8 ohms, bridged. THD: 0.02%. XLR, 1/4", Speakon. 2RU. 31.5 lb. \$979

Symbol 12000

Power Amplifier. Live sound, sound reinforcement, installation. Two-channel; volume controls; Ultra Linear Cascode Circuits; bridgeable; parallel; ground lift; clip indicators; thermal, DC, short circuit protection; soft start; twin variable speed cooling fans. Power output per channel: 600 W @ 8 ohms, 1,000 W @ 4 ohms, 1,500 W @ 2 ohms; 1,800 W @ 8 ohms, bridged, 2,600 W @ 4 ohms, bridged, 3,400 W @ 2 ohms, bridged. Frequency response: 20 Hz - 20 kHz. S/N: >110 dB. XLR, speakon. 2RU. 55 lb. \$2,149

Hafler

9505 Trans'nova

Power Amplifier. Studio, live sound. Two-channel; trans'nova topology; JFET input/MOSFET output; discrete circuitry; lighted power switch; convection cooled; bridgeable. Frequency response: 1.15 Hz - 300 kHz. Power output per channel: 250W @ 8 ohms, 375W @ 4 ohms. Bridged mono:

750W 1/4", XLR, five-way binding post. 3RU, 19" x 5.25" x 12.5", 50 lb. \$2,200

P1000 Trans'ana

Power Amplifier. Studio, installation, broadcast. Two-channel; trans'ana circuit topology; level controls; lighted main power switch; NOMAD protection circuitry; MOSFET outputs; switchable 115/230 voltage; headphone output; signal, thermal, clipping LEDs; convection cooled. Power output per channel: 50 W @ 8 ohms, 55 W @ 4 ohms, 110 W @ 8 ohms, bridged. RCA, 1/4", XLR, barrier strip. 1RU, 19" x 1.75" x 8.5", 12 lb. \$569

P4000 Trans'nova DIAMOND

Power Amplifier. Studio, live sound, installation. Two-channel; trans'nova circuit topology; Diamond transconductance driver stage; MOSFET output devices; level controls; lighted main power switch; electronic fuse; signal, thermal, short, clipping LEDs; modular design; convection cooled; bridgeable. Power output per channel: 200 W @ 8 ohms, 275 W @ 4 ohms, 550 W, bridged, 1/4", XLR, five-way binding post. 3RU, 19" x 5.25" x 11", 34 lb. \$999

P7000 Trans'nova DIAMOND

Power Amplifier. Sound reinforcement, live sound, installation. Two-channel; trans'nova circuit topology; Diamond transconductance driver stage; MOSFET output devices; active crossovers; level controls; lighted main power switch; electronic fuse; signal, thermal, short, clipping LEDs; modular design; twin cooling fans; bridgeable. Power output per channel: 350 W @ 8 ohms, 500 W @ 4 ohms, 1,000 W @ 8 ohms, bridged. 1/4", XLR, five-way binding post. 2RU, 19" x 3.5" x 13", 40 lb. \$1,399

SR2300

Power Amplifier. Live sound, installation. Two-channel; volume controls; trans'nova circuit topology; Diamond transconductance stage; NOMAD protection circuitry; MOSFET output; Class G output stage; twin variable speed cooling fans; bridgeable. Power output per channel: 300W @ 8, 4, 2 ohms; 600W @ 8.4 ohms, bridged. THD: 0.2%. S/N: 100 dB. XLR, 1/4", "touch-proof" five-way binding posts. 2RU. 32 lb. 70V/100V compatible. Cinema-optimized version with plug-in processor cards. GX2300: \$1,749. \$1,599

TA1600

Power Amplifier. Studio, live sound. Two-channel; trans'nova circuit topology; soft start; thermal protection; MOSFET output stage; convection cooled. Power output per channel: 60W @ 8 ohms, 75W @ 4 ohms. 19" x 3.5" x 8.5", 22 lb. \$379

Hot House Professional Audio

Fifteen Hundred

Power Amplifier. Recording studio. MOSFET outputs; fan cooled. Power output per channel: 350 W @ 8 ohms, 500 W @ 4 ohms, 680 W @ 2 ohms. S/N: 105 dB. 48 lb. \$3,499

M500HV

Power Amplifier. Studio. Monoblock; single-channel; convection-cooled; MOSFET output; toroidal transformer. Power output: 375 W @ 8 ohms, 600 W @ 4 ohms, 800 W @ 3 ohms. S/N: 105 dB. 2RU. \$2,499

Six Hundred

Power Amplifier. Studio. MOSFET outputs; convection cooled. Power output per channel: 175 W @ 8 ohms, 275 W @ 4 ohms, 325 W @ 2 ohms. S/N: 105 dB. 3RU. 32 lb. \$2,499

Two Thousand

Power Amplifier. Studio. Dual monoblock; MOSFET outputs; fan cooled. Power output per channel: 390

W @ 8 ohms, 600 W @ 4 ohms, 950 W @ 2 ohms, 1,250 W @ 1 ohm. S/N: 105 dB. 5RU. 95 lbs. \$4,999

Lab.gruppen/TC Electronic

fp2200

Live sound, sound reinforcement. Two-channel; detented level controls; Class AB; switch mode power supply; clip limiter; short circuit, open circuit, thermal, RF, DC, ultrasonic, low-current, overcurrent protection. Power output per channel: 350W @ 8 ohms, 650W @ 4 ohms, 1,100W @ 2 ohms. THD: 0.06%. XLR, Neutrik Speakon, Neutrik Combo. 2RU. 17 lb. \$1,995

fp2400Q

Live sound, sound reinforcement. Four-channel; detented level controls; Class AB; switch mode power supply; clip limiter; short circuit, open circuit, thermal, RF, DC, ultrasonic, low-current, overcurrent protection. Power output per channel: 370W @ 8 ohms, 590W @ 4 ohms, 650W @ 2 ohms. THD: 0.06%. XLR, Neutrik Speakon, Neutrik Combo. 2RU. 19 lb. \$2,395

fp6400

Live sound, sound reinforcement. Two-channel; detented level controls; Class TD; switch mode power supply; clip limiter; short circuit, open circuit, thermal, RF, DC, ultrasonic, low-current, overcurrent protection. Power output per channel: 1,300W @ 8 ohms, 2,300W @ 4 ohms, 2,900W @ 2 ohms. THD: 0.04%. XLR, Neutrik Speakon, Neutrik Combo. 2RU. 22 lb. \$4,495

Legacy Audio

Powerblock2

Power Amplifier. Studio. Two-channel; Class A/AB; 20 hand-matched bipolar transistor outputs per channel. Frequency response: 1 Hz - 100 kHz. THD: <0.03%. S/N: 92.5 dB. Power output per channel: 300 W @ 8 ohms, 600 W @ 4 ohms. Two pair 5-way binding posts per channel. 17" x 6" x 15". 50 lb. \$1,995

Powerblock5

Five-Channel Power Amplifier. Studio, post production. Five-channel; Class A/AB; ten hand-matched bipolar transistor outputs per channel. Power output per channel: 200 W @ 8 ohms, 300 W @ 4 ohms. Frequency response: 1 Hz - 100 kHz. THD: <0.03%. S/N: 92.5 dB. Five-way binding posts. 17" x 5.5" x 14". 58 lb. \$3,250

Ultra Monobloc

Power Amplifier. Recording studio. Single-channel; VU meter. Power output: 600 W @ 8 ohms, 1,200 W @ 4 ohms. RCA, XLR. 17" x 5.5" x 14". 55 lb. \$2,400

Lory Electronics Inc.

5250

Five-Channel Amplifier. Studio. Five-channel; gain trims; status LEDs; separate and isolated power supplies; gold-plated connectors. Power output per channel: 250W. Frequency response: 10 Hz - 50 kHz. THD: 0.005%. S/N: 106 dB. RCA, five-way binding posts. 2RU. 42 lb. \$1,687

PA21A

Power Amplifier. Sound reinforcement. Auto on/off; front panel fuse access; blown fuse indicator; separate and isolated power supplies; FLPT-FET output stage. Power output per channel: 125 W. Frequency response: 20 Hz - 30 kHz. THD+N: 0.01%. S/N: 101 dB. XLR, 1/4" balanced, RCA unbalanced (with adapters). 2RU. Designed for driving midrange and tweeters in multi-amp installations. \$595

Mackie Designs Inc.

M*2600

Power Amplifier. Recording studio, live

sound. Two-channel; variable low-cut filters; sweepable high-pass filter; switchable subwoofer function (60, 90, 120 Hz); constant Directivity Horn EQ; temperature, signal present, overload, level, short circuit LEDs; bridgeable; T-Design Constant Gradient cooling; 2 ohm operation. Power output per channel: 500 W @ 8 ohms, 850 W @ 4 ohms, 1,300 W @ 2 ohms, 1,700 W @ 8 ohms, bridged, 2,600 W @ 4 ohms, bridged. Five-way binding posts, Neutrik Speakon. \$1,199

Manley Laboratories

Studio 240

Tube Power Amplifier. Studio. Monoblock; 10 EL34 output tubes; triode/tetrode switch; soft start; feedback, slope controls. Power output: 240W. 19" x 8.75" x 11". Rackmountable. \$7,500 per pair

Studio 440

Tube Power Amplifier. Studio. Monoblock; 10 KT90 output tubes; triode/tetrode switch; soft start; feedback, slope controls. Power output: 440 W. 19" x 8.75" x 11". Rackmountable. \$9,500 per pair

Marantz Professional

MM9000P

Five-Channel Amplifier. Five-channel; level controls; level indicators; THX approved. Frequency response: 5 Hz - 100 kHz. S/N: 95 dB. Dynamic range: 98 dB. Banana plugs. 4RU. \$1,349

Martin Audio

MA1.6

Sound reinforcement, live sound, installation. Minimum Load Switch speaker impedance matching. Power output per channel: 840W @ 4 ohms. 2RU.

MA4.2

Sound reinforcement, live sound, installation. Minimum Load Switch speaker impedance matching. Power output per channel: 2,100W @ 4 ohms. 2RU.

MC2 Audio

MC1250

Two-channel; linkable level controls; limiter; soft start; DC, short circuit, temperature, in-rush protection; variable speed cooling fan; bridgeable; RS485 port; remote controllable; LED meters. Power output per channel: 1,250W @ 8 ohms, 1,600W @ 4 ohms, 1,800W @ 2 ohms. Frequency response: 20 Hz - 20 kHz. THD: <0.03%. XLR, binding posts. 3RU. Optional crossover cards. \$3,600

MC750

Two-channel; linkable level controls; limiter; soft start; DC, short circuit, temperature, in-rush protection; variable speed cooling fan; bridgeable; RS485 port; remote controllable; LED meters. Power output per channel: 425W @ 8 ohms, 750W @ 4 ohms, 1,100W @ 2 ohms. Frequency response: 20 Hz - 20 kHz. THD: <0.03%. XLR, binding posts. 2RU. Optional crossover cards. \$2,700

T1500

Two-channel; level controls; limiter; DC, short circuit, temperature, in-rush protection; soft start; bridgeable; variable speed cooling fan; heatsink. XLR, Speakon. Optional crossover cards. \$1,700

Metasonix

TM-4 Vacuum Tube Stereo Amplifier

Two-channel; volume controls; 6BM8 tube per channel. Power output per channel: 1W @ 8 ohms. 1/4". Ships with RCA to 1/4" adapters. \$450

Miles Technology

MPR-1K Power Amplifier

Installation. Six-channel; Class D; gain control; filters; limiters; thermal, load protection; activity LEDs. Power output per channel: 170 W @ 4 ohms. 2RU. Choice of inputs and crossovers. \$1,999

Nady Systems Inc.

SPA-2400

Sound reinforcement, live sound, installation. Two-channel; bridgeable. Power output per channel: 750W @ 4 ohms, 1,200W @ 2 ohms; 1,500W @ 8 ohms, bridged, 2,400W @ 4 ohms, bridged. Neutrik Speakon, XLR, 1/4", five-way binding posts. \$519

SPA-850

Sound reinforcement, live sound, installation. Two-channel; bridgeable. Power output per channel: 400 W @ 8 ohms, 425W @ 2 ohms; 600W @ 8 ohms, bridged, 850W @ 4 ohms, bridged. Neutrik Speakon, XLR, 1/4", five-way binding posts. \$429

Pacific Innovative Electronics

KHM-850

Power Amplifier. Studio, post production. Monoblock; Cardas wiring; matched semiconductors; Power Bus circuit board design. Power output: 250 W @ 8 ohms. THD: 0.2%. XLR, 1/4", binding posts, Neutrik NL4P Speakon. 3RU. \$2,700

PS-400

Power Amplifier. Studio, post production. Cardas wiring; matched semiconductors; Power Bus circuit board design. Power output: 125 W @ 8 ohms. THD: 0.2%. XLR, 1/4", binding posts, Neutrik NL4P Speakon. 2RU. \$2,660

Parasound

A 23

Two-channel; gain controls; Class A/AB; ground lift; THX Ultra2. Power output per channel: 125W @ 8 ohms, 200W @ 4 ohms; 400W @ 8 ohms, bridged. XLR, RCA, five-way binding posts. 2RU. 28 lb. \$850

A 51

Five-Channel Amplifier. Five-channel; Class A/AB; ground lift; THX Ultra2. Power output per channel: 250W @ 8 ohms, 400W @ 4 ohms. XLR, RCA, five-way binding posts. 4RU. 80 lb. \$4,000

HCA-2205A Power Amplifier

Studio, post production. Five-channel; Class AB operation; hybrid, modular design; MOSFET drivers; gain control; overload indicator; THX approved. Frequency response: 5 Hz - 100 kHz. THD: <0.03%. Power output per channel: 220 W @ 8 ohms, 300 W @ 4 ohms. RCA, gold-plated five-way binding posts. 19" x 7" x 19.5". \$1,999

HCA-750A High Current Power Amplifier

Two-channel; gain controls; short circuit, overload, thermal protection; heat sink. Power output per channel: 75 W @ 8 ohms, 125 W @ 4 ohms; 250 W @ 8 ohms, bridged. RCA, gold-plated five-way binding posts. \$450

JC 1

Monaural Amplifier. Single-channel; Class A/AB; JFET input stage; MOSFET drivers; ground lift; THX Ultra2. Power output per channel: 400W @ 8 ohms, 800W @ 4 ohms, 1,200W @ 2 ohms. XLR, RCA, five-way binding posts. 64 lb. \$3,000

Pass Laboratories

X1000

Monoblock. Single-channel; Pass Supersymmetry circuit topology; two gain stage; MOSFET design. Power output: 1,000 W @ 8 ohms. THD: <

simplydifferent.

thenewtube



AT3060
phantom-powered tube microphone



30 | series

Never satisfied to rest on their laurels, our engineers were inspired to improve upon the technical excellence and coveted sound of valve design. How? By making it *simpler*.

The new **AT3060** tube microphone offers the convenience and easy setup of a standard studio condenser by operating exclusively on 48V phantom power – no dedicated power supplies and special cables required. Add to that an all-new large-diaphragm cardioid capsule design and you get the warm sound of a vintage tube mic combined with the exceptional quality and consistency you count on from Audio-Technica.

The result is, quite simply, something special, for a lot less than you'd expect.

 **audio-technica.**

AMPLIFIERS

1% XLR, five-way binding posts. 19" x 10.5" x 28", 200 lbs. \$12,000

X150

Stereo Power Amplifier Two-channel; SuperSymmetry circuitry; two-gain stage; MOSFET design. Power output per channel: 150 W @ 8 ohms. THD: <1%. XLR, RCA, five-way binding posts. 70 lb. \$4,000

X3

Three-Channel Power Amplifier. Studio. Three-channel; SuperSymmetry circuitry; MOSFET. Power output per channel: 150 W @ 8 ohms. XLR, RCA, five-way binding posts. 5RU. 85 lb. \$4,250

X5 ★ New for 2003 ★

Five-Channel Power Amplifier Five-channel; SuperSymmetry circuitry; two gain stage; MOSFET design. Power output per channel: 125 W @ 8 ohms. XLR, RCA, five-way binding posts. 85 lb. \$4,500

X600

Monoblock. Single-channel; Pass Supersymmetry circuit topology; two gain stage; MOSFET design. Power output: 600 W @ 8 ohms. THD: <1%. XLR, five-way binding posts. 19" x 10.5" x 22". 150 lbs. \$6,000

Peavey Electronics Corp.

CS 3000H

Sound reinforcement. Two-channel; DDT compression; variable low-pass filters; variable crossovers; twin two-speed cooling fans. Power output per channel: 825W @ 8 ohms, 1,400W @ 4 ohms, 2,150W @ 2 ohms; 3,000W @ 4 ohms, bridged. \$1,399

CS 800H

Sound reinforcement. Two-channel; DDT compression; variable low-pass filters; variable crossovers; twin two-speed cooling fans. Power output per channel: 250W @ 4 ohms, 300W @ 2 ohms; 800W @ 8 ohms, bridged. \$799

GPS 3500

Power Amplifier. Two-channel; volume controls; DDT speaker protection; bridgeable; twin variable speed cooling fans. Power output per channel: 775W @ 8 ohms, 1,200W @ 4 ohms, 1,750W @ 2 ohms. XLR, 1/4". 3RU. \$1,349

GPS 900

Power Amplifier. Two-channel; volume controls; DDT speaker protection; bridgeable; twin variable speed cooling fans. Power output per channel: 200W @ 8 ohms, 330W @ 4 ohms, 450W @ 2 ohms. 1/4", XLR. 3RU. \$699

PV 2600

DDT compression, V-Cooling. Power output per channel: 1,080W @ 8 ohms, 1,600W @ 4 ohms, 2,600W @ 2 ohms. XLR, 1/4", Speakon, barrier strips, binding posts. \$799

PV 900

DDT compression, V-Cooling. Power output per channel: 600W @ 8 ohms, 1,000W @ 4 ohms, 1,500W @ 2 ohms. XLR, 1/4", Speakon, barrier strips, binding posts. \$489

QSC Audio Products Inc.

CX 1102

Power Amplifier. Installation. Two-channel; level controls; PowerWave technology; Class H; limiter; high-

pass filter; DC, ultrasonic, RF, load, thermal, short circuit protection; bridgeable; data port for QSCControl; variable speed cooling fan; security cover; status LEDs. Frequency response: 20 Hz - 20 kHz. Power output per channel: 700W @ 8 ohms, 1,100W @ 4 ohms, 1,700W @ 2 ohms, 1,400W @ 16 ohms, bridged, 2,200W @ 8 ohms, bridged, 3,400W @ 4 ohms, bridged. XLR, terminal, 15-pin D-sub. 2RU. 21 lb. \$2,050

CX 1202V

Power Amplifier. Installation. Two-channel; level controls; PowerWave technology; 70 V operation; Class H; limiter; high-pass filter; DC, ultrasonic, RF, load, thermal, short circuit protection; bridgeable; data port for QSCControl; variable speed cooling fan; security cover; status LEDs. Frequency response: 20 Hz - 20 kHz. Power output per channel: 800-1,200 W @ 70 V; 1,600 - 2,400 W @ 140 V; 700W @ 8 ohms, 1,100W @ 4 ohms, 1,400 W @ 16 ohms, bridged, 2,200 @ 8 ohms, bridged. XLR, terminal, 15-pin D-sub. 2RU. 21 lb. \$1,850

CX 702

Power Amplifier. Installation. Two-channel; level controls; PowerWave technology; Class H; limiter; high-pass filter; DC, ultrasonic, RF, load, thermal, short circuit protection; bridgeable; data port for QSCControl; variable speed cooling fan; security cover; status LEDs. Frequency response: 20 Hz - 20 kHz. Power output per channel: 425W @ 8 ohms, 700W @ 4 ohms, 1,200W @ 2 ohms, 850W @ 16 ohms, bridged, 1,500W @ 8 ohms, bridged, 2,400W @ 4

ohms, bridged. XLR, terminal, 15-pin D-sub. 2RU. 21 lb. \$1,550

CX168

Power Amplifier. Installation. Eight-channel; level controls; PowerWave switching technology; clip limiters; high-pass filter (50, 75 Hz); bridgeable pairs; data port for QSCControl processing; short circuit, thermal, RF, load, DC fault, ultrasonic protection; variable speed cooling fan; security cover; status LEDs. Frequency response: 20 Hz - 20 kHz. Power output per channel: 90W @ 8 ohms, 130W @ 4 ohms; 180W @ 16 ohms, bridged, 260W @ 8 ohms, bridged. Phoenix, 15-pin D-sub. 2RU. 21 lb. \$2,450

CX204V

Power Amplifier. Installation. Four-channel; level controls; PowerWave switching technology; clip limiters; high-pass filter (50, 75 Hz); bridgeable pairs; data port for QSCControl processing; short circuit, thermal, RF, load, DC fault, ultrasonic protection; variable speed cooling fan; security cover; status LEDs; 70V output. Frequency response: 20 Hz - 20 kHz. Power output per channel: 200 - 300W @ 70V, 400 - 600W @ 140V. Euroblocks, 15-pin D-sub. 2RU. 21 lb. \$1,400

ISA 280

Power Amplifier. Installation. Two-channel; rear panel gain controls; high-pass (30 Hz, 70 Hz) filter; stereo/parallel/bridge; DC, ultrasonic, RF, thermal, short, load protection; V2 data port; variable speed cooling fan; status LEDs. Power output per channel: 185W @ 8 ohms, 280W @ 4 ohms, 430W @ 2 ohms; 370W @ 16 ohms, bridged, 600W @ 8 ohms, bridged,

830W @ 4 ohms, bridged. Barrier strips, XLR, detachable Euroblocks. 3RU. 36 lb. \$525

ISA 500T

Power Amplifier. Installation. Two-channel; rear panel gain controls; high-pass (50 Hz, 75 Hz) filter; stereo/parallel/bridge; DC, ultrasonic, RF, thermal, short, load protection; V2 data port; variable speed cooling fan; status LEDs; 25/70/100V output. Power output per channel: 500W @ 70 - 100V, 400W @ 25V; 260W @ 8 ohms, 425W @ 4 ohms, 700W @ 2 ohms; 900W @ 8 ohms, bridged, 1,400W @ 4 ohms, bridged. Barrier strips, XLR, detachable Euroblocks. 3RU. 33 lb. \$799

MX 1500a

Power Amplifier. Live sound, sound reinforcement, installation. Two-channel; Class H; stepped linear output circuit; thermal and short-circuit protection circuitry; balanced inputs; power and clip indicators; Level 1 Open Input Architecture; two speed fan. Power output per channel: 350W @ 8 ohms, 500W @ 4 ohms, 750W @ 2 ohms. 1/4", "touchproof" binding posts. XLRs optional. 2RU. 42 lb. \$1,425

PLX1202

Power Amplifier. Live sound, sound reinforcement. Two-channel; level controls; PowerWave technology; Class AB; limiter; low-frequency rolloff; DC, ultrasonic, RF, load, thermal, short circuit protection; bridgeable; variable speed cooling fan; status LEDs. Frequency response: 20 Hz - 20 kHz. THD: <0.01%. Power output per channel: 200W @ 8 ohms, 325W @ 4 ohms, 600W @ 2 ohms; 400W @ 16 ohms, bridged,

www.passlabs.com **PASS LABS** www.passdiy.com

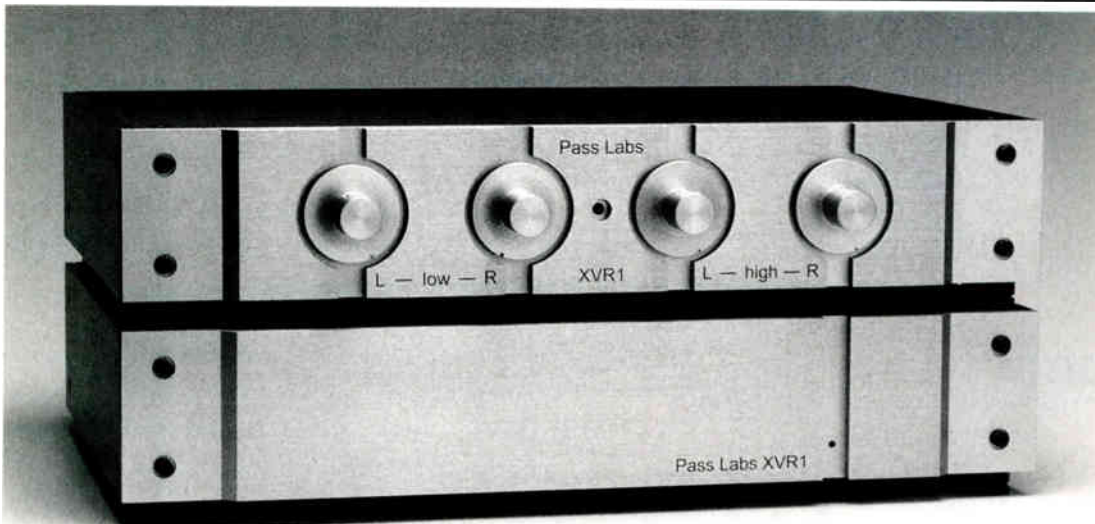

The XVR1 electronic crossover network

Something like 28 million possible settings per filter. Be careful what you wish for.

Pass Laboratories, PO Box 219, 24449 Foresthill Rd., Foresthill, CA 95631 - 530.367.3690

AMPLIFIERS

700W @ 8 ohms, bridged, 1,200W @ 4 ohms, bridged. 1/4", XLR, Neutrik Speakon, five-way binding posts. 2RU. 21 lb. \$838

PLX3002

Power Amplifier. Live sound, sound reinforcement. Two-channel, level controls; PowerWave technology; Class H; limiter; low-frequency rolloff; DC, ultrasonic, RF, load, thermal, short circuit protection; bridgeable; variable speed cooling fan; status LEDs. Frequency response: 20 Hz - 20 kHz. THD: <0.01%. Power output per channel: 550W @ 8 ohms, 900W @ 4 ohms, 1,500W @ 2 ohms; 1,100W @ 16 ohms, bridged, 2,000W @ 8 ohms, bridged, 3,000W @ 4 ohms, bridged. 1/4", XLR, Neutrik Speakon, five way binding posts. 2RU. 21 lb. \$1,398

PowerLight 1.4

Power Amplifier. Studio, sound reinforcement. Two-channel; PowerWave switching technology; independently defeatable clip limiters; detented calibrated gain controls; stereo/parallel/bridge; data port for remote signal processing; amp monitoring; Class H output topology; short circuit, open circuit, thermal, RF, load, DC fault, ultrasonic protection. THD: 0.01%. Power output per channel: 300W @ 8 ohms, 500W @ 4 ohms, 700W @ 2 ohms. Neutrik combo, "touchproof" binding posts. 2RU. 18 lb. Works with QSCControl network audio system. \$1,778

PowerLight 1.5X

Biamp Power Amplifier. Studio, sound reinforcement. Two-channel; PowerWave switching technology; independently defeatable clip limiters; detented calibrated gain controls; stereo/parallel/bridge; data port for remote signal processing; amp monitoring; Class H output topology; short circuit, open circuit, thermal, RF, load, DC fault, ultrasonic protection. THD: 0.01%. Power output: 450W channel one, 200W channel two @ 8 ohms; 700W channel one, 325W channel two @ 4 ohms; 1,000W channel one, 500W channel two @ 2 ohms. Neutrik combo, "touchproof" binding posts. 2RU. 18 lb. Works with QSCControl network audio system. \$1,778

PowerLight 1.6HVX

Biamp Power Amplifier. Studio, sound reinforcement. Two-channel; PowerWave switching technology; independently defeatable clip limiters; detented calibrated gain controls; stereo/parallel/bridge; data port for remote signal processing; amp monitoring; Class H output topology; short circuit, open circuit, thermal, RF, load, DC fault, ultrasonic protection. THD: 0.01%. Power output: 700W channel one, 300W channel two @ 8 ohms; 1,100W channel one, 500W channel two @ 4 ohms. Neutrik combo, "touchproof" binding posts. 2RU. 18 lb. Works with QSCControl network audio system. \$1,948

PowerLight 2.0HV

Power Amplifier. Studio, sound reinforcement. Two-channel; PowerWave switching technology; independently defeatable clip limiters; detented calibrated gain controls; stereo/parallel/bridge; data port for remote signal processing; amp monitoring; Class H output topology; short circuit, open circuit, thermal, RF, load, DC fault, ultrasonic protection. THD: 0.01%. Power output per channel: 650W @ 8 ohms, 1,000W @ 4 ohms. Neutrik combo, "touchproof" binding posts. 2RU. 18 lb. Works with QSCControl network audio system. \$2,198

PowerLight 3.8X

Independent Channel Power Amplifier. Sound reinforcement. Two independent channels; PowerWave switching technology; independently defeatable clip limiters; detented calibrated gain controls; stereo/parallel/bridge; data port for remote signal processing; amp monitoring; Class H output topology; short circuit, open circuit, thermal, RF, load, DC fault, ultrasonic protection. THD: 0.01%. Power output: 900W channel one, 450W channel two @ 8 ohms; 1,400W channel one, 800W channel two @ 4 ohms; 2,400W channel one, 1,400W channel two @ 2 ohms. Neutrik combo, "touchproof" binding posts. 3RU. 30 lb. Works with QSCControl network audio system. \$2,898

PowerLight 6.0 II

Sound reinforcement, live sound. Two-channel; level controls; PowerWave technology; Class H; limiter; low-frequency rolloff; data port for QSCControl; soft start; DC, ultrasonic, RF, load, thermal, short circuit protection; bridgeable; variable speed cooling fans; status LEDs. Power output per channel: 1,300W @ 8 ohms, 2,200W @ 4 ohms, 3,500W @ 2 ohms; 2,300W @ 16 ohms, bridged, 4,100W @ 8 ohms, bridged, 6,500W @ 4 ohms, bridged, Neutrik Combo, Speakon, Phoenix, binding posts, 25-pin D-sub. 3RU. 53 lb. \$5,175

PowerLight 9.0 PFC

Power Amplifier. Live sound, sound reinforcement. Two-channel; level controls; Power Factor Correction technology; Class H; limiter; low-frequency rolloff; data port for QSCControl; soft start; DC, ultrasonic, RF, load, thermal, short circuit protection; bridgeable; variable speed cooling fans; status LEDs. Frequency response: 20 Hz - 20 kHz. THD: <0.01%. Power output per channel: 1,800W @ 8 ohms, 3,200W @ 4 ohms, 4,500W @ 2 ohms. 1/4", XLR, Neutrik Speakon, five-way binding posts, barrier strip. 3RU. 59 lbs. \$6,998

PowerLight PL 218A

Power Amplifier. Sound reinforcement, live sound. Two-channel; PowerWave switching technology; independently defeatable clip limiters (5, 30, 50 Hz); onboard two-way crossover, delay, EQ, limiter controls; detented calibrated gain controls; stereo/parallel/bridge; data port for remote signal processing; security lockout; Class AB output topology; short circuit, open circuit, thermal, RF, load, DC fault, ultrasonic protection. Frequency response: 20 Hz - 20 kHz. THD: <0.01%. Power output per channel: 310W @ 8 ohms, 525W @ 4 ohms, 900W @ 2 ohms. 1/4", XLR, Neutrik Speakon, "touchproof" binding posts, detachable Euroblocks, 15-pin D-sub. 2RU. 21 lb. \$1,350

PowerLight PL 230A

Power Amplifier. Sound reinforcement, live sound. Two-channel; PowerWave switching technology; independently defeatable clip limiters (5, 30, 50 Hz); onboard two-way crossover, delay, EQ, limiter controls; detented calibrated gain controls; stereo/parallel/bridge; data port for remote signal processing; security lockout; Class H output topology; short circuit, open circuit, thermal, RF, load, DC fault, ultrasonic protection. Frequency response: 20 Hz - 20 kHz. THD: <0.01%. Power output per channel: 575W @ 8 ohms, 900W @ 4 ohms, 1,500W @ 2 ohms. 1/4", XLR, Neutrik Speakon, "touchproof" binding posts, detachable Euroblocks, 15-pin D-sub. 2RU. 21 lb. \$1,950

PowerLight PL 236A

Power Amplifier. Sound reinforcement, live sound. Two-channel; PowerWave switching technology; independently defeatable clip limiters (5, 30, 50 Hz); onboard two-way crossover, delay, EQ,

limiter controls; detented calibrated gain controls; stereo/parallel/bridge; data port for remote signal processing; security lockout; Class H output topology; short circuit, open circuit, thermal, RF, load, DC fault, ultrasonic protection. Frequency response: 20 Hz - 20 kHz. THD: <0.01%. Power output per channel: 725W @ 8 ohms, 1,100W @ 4 ohms, 1,850W @ 2 ohms. 1/4", XLR, Neutrik Speakon, "touchproof" binding posts, detachable Euroblocks, 15-pin D-sub. 2RU. 21 lb. \$2,150

RMX 1850HD

Power Amplifier. Sound reinforcement, live sound. Two-channel; independently defeatable clip limiters; low-frequency (30 Hz, 50 Hz) limiters; Class H; Advanced Thermal Management System; variable speed fan; stereo/parallel/bridge; short circuit, open circuit, thermal, RF, load, DC fault, ultrasonic protection. Power output per channel: 360W @ 8 ohms, 575W @ 4 ohms, 900W @ 2 ohms.

straight wire* with gain



* really great-sounding wire

TRUE systems **P2analog** 2-CHANNEL MIC PREAMP

Distributed by NeumannUSA • One Enterprise Drive • Old Lyme, CT 06371
 Phone: 860-434-5220 • Fax: 860-434-3148 • Canada: Tel: 514-426-3013 • Fax: 514-426-3953
 e-mail: info@neumannusa.com • www.neumannusa.com
 Visit the True Systems website: www.micpreamp.com

AMPLIFIERS

THD: <0.03%. 1/4", XLR, Neutrik Speakon, "touchproof" binding posts. 2RU. 44.5 lb. \$649

RMX 4050HD ★ *New for 2003* ★
Live sound, sound reinforcement. Two-channel; level controls; independently defeatable clip limiters; low-frequency (30 Hz, 50 Hz) limiters; Class H; Advanced Thermal Management System; variable speed fan; stereo/parallel/bridge; short circuit, open circuit, thermal, RF, load, DC fault, ultrasonic protection. Power output per channel: 800W @ 8 ohms, 1,400W @ 4 ohms, 2,000W @ 2 ohms; 2,800W @ 8 ohms, bridged, 4,000W @ 4 ohms, bridged. THD: <0.03%. 1/4", XLR, Neutrik Speakon, "touchproof" binding posts. 2RU. \$1,799

Quasted/Q.usa

AP800
Power Amplifier. Studio, post production. Two-channel; level controls; Class AB; selectable peak limiter; mute switch; soft start; variable speed cooling fan; bridgeable. Power output per channel: 450W @ 8 ohms, 770W @ 4 ohms. Frequency response: 20 Hz - 20 kHz. XLR, binding posts. 2RU. 51 lb. Optional crossover cards. Optional remote control network. \$2,995

Rane Corp.

MA 3 Multichannel Amplifier
Installation. Three-channel; input level controls; high-pass filter (80 Hz); SPIKe protection circuitry; load sensitive dynamic limiters; two-speed cooling fan; headroom LED meters. Frequency response: 20 Hz - 20 kHz. S/N: 90 dB. Power output per channel: 40 W @ 8 ohms, 60 W @ 4 ohms. Euroblock. 2RU. 26 lb. \$699

MA 6S
Power Amplifier. Studio, sound reinforcement, installation. Six-channel; input level controls per channel; input overload protection; bridgeable. Power output per channel: 100W @ 8 ohms, 150W @ 4 ohms; 300W @ 8 ohms, bridged. Euroblock. 3RU. \$1,649

RDL, Radio Design Labs

RU-PA518
Power Amplifier. Two-channel; level controls; bridgeable. Power output per channel: 9 W @ 4 ohms; 18 W @ 8 ohms, bridged. \$227

Redwood Music Corporation

V16 Plus 4
Four-Channel Power Amplifier. Live sound, sound reinforcement, installation. Four-channel; level controls; cooling fan; short, thermal protection; soft start; limiter; low-cut filter. Power output per channel: 330W @ 4 ohms, 420W @ 2 ohms; 800W @ 4 ohms, bridged. THD: 0.05%. S/N: 100 dB. XLR, 1/4", binding posts. 3RU. 49.5 lb. Optional Speakon inputs. \$1,119

V-3.5M
Power Amplifier. Live sound, sound reinforcement, installation. Single-channel; level control; nine-band graphic EQ; cooling fan; short, thermal protection; soft start. Power output per channel: 150W @ 8 ohms, 230W @ 4 ohms, 350W @ 2 ohms. THD: 0.05%. S/N: 100 dB. XLR, binding posts, 1/4". 2RU. Optional Speakon inputs. \$399

V8 Plus
Power Amplifier. Live sound, sound reinforcement, installation. Two-channel; level controls; cooling fan; short, thermal protection; soft start; limiter; low-cut filter. Power output per channel: 400W @ 4 ohms, 500W @ 2 ohms; 1,000W @ 4 ohms, bridged. THD: 0.05%. S/N: 100 dB. XLR, 1/4", binding posts. 3RU. 48.5 lb. Optional Speakon inputs. \$649

Renkus-Heinz Inc.

P2400
Power Amplifier. Sound reinforcement. Two-channel; modular; slots for control modules. Power output per channel: 250W @ 8 ohms, 350W @ 4 ohms. XLR, Neutrik Speakon. 2RU. Optional control modules include overload protection, parametric EQ, crossovers. \$975

P3500
Power Amplifier. Sound reinforcement. Two-channel; modular; slots for control modules. Power output per channel: 500W @ 8 ohms, 750W @ 4 ohms, 900 @ 2 ohms. XLR, Neutrik Speakon. 2RU. Optional control modules include overload protection, parametric EQ, crossovers. \$2,325

Rolls Corp.

RA170 70-Volt Power Amplifier
Installation. Volume control. Push terminals, RCA or 1/4".

Samson Technologies Corp.

F800
Live sound, sound reinforcement. Two-channel; cooling fan; bridgeable. Power output per channel: 400W @ 4 ohms; 800W @ 8 ohms, bridged. Frequency response: 10 Hz - 60 kHz. THD: <0.04%. 1/4", RCA, binding posts. 3RU. \$399

S2000
Power Amplifier. Live sound, installation. Two-channel; detented level controls; linkable; variable speed cooling fan. Power output per channel: 1,000 W @ 4 ohms; 2,000 W @ 8 ohms, bridged. XLR, 1/4", banana, Speakon. 3RU. 36 lb. \$749

S500
Two-channel; level controls; linkable. Power output per channel: 150W @ 8 ohms, 250W @ 4 ohms; 500W @ 4 ohms, bridged. Frequency response: 10 Hz - 20 kHz. THD: <0.04%. \$419

Servo 120
Studio. Two-channel; level controls; temperature, overcurrent protection; headphone jack; LED meters. Power output per channel: 52W @ 8 ohms, 60W @ 4 ohms. Frequency response: 10 Hz - 100 kHz. THD: 0.05%. 1/4", RCA, push terminals. 1RU. 16 lb. \$259

Servo 550
Two-channel; level controls; stereo/bridged mono. Frequency response: 10 Hz - 85 kHz. Power output per channel: 235W @ 8 ohms, 275W @ 4 ohms; 550W @ 8 ohms, bridged. 1/4", binding posts. 3RU. 32 lb. \$419

Sony Electronics

SRP-P50
Power Amplifier. Studio, broadcast. Two-channel; level controls; bridgeable. Power output per channel: 50 W @ 8 ohms, 75 W @ 4 ohms; 150 W @ 8 ohms, bridged. XLR, RCA, five-way binding posts. 1RU. 18 lb. \$575

Stewart Audio

DA-70-2
Compact Power Amplifier. Installation, live sound, broadcast, studio. Two-channel; level controls; convection cooling; switch mode power supply; power, clip LEDs. Power output per channel: 35W @ 8 ohms, 70W @ 4 ohms. Frequency response: 20 Hz - 20 kHz. S/N: >93 dB. THD: <0.25%. Phoenix. 1/2RU. Power Factor Correction version, DA-70-2-PFC: \$460

DA-70-4
Compact Power Amplifier. Installation, live sound, broadcast, studio. Two-channel; level controls; convection cooling; switch mode power supply; power, clip LEDs. Power output per channel: 35W @ 8 ohms, 70W @ 4

ohms. Frequency response: 20 Hz - 20 kHz. S/N: >93 dB. THD: <0.25%. Phoenix. 1/2RU. Power Factor Correction version, DA-70-4-PFC: \$695.

PA-200
Power Amplifier. Installation. Two-channel; level controls; IEQ EQ circuit (250 - 400 Hz). Power output per channel: 50 W @ 8 ohms, 90 W @ 4 ohms, 100 W @ 2 ohms; 180 W @ 8 ohms, bridged, 200 W @ 4 ohms, bridged. 1/4". 1.75" x 8.5" x 10.2". 5.5 lb. \$445

World 2.1
Power Amplifier. Installation, live sound, sound reinforcement. Two-channel; level controls; Class H; Harmonic Shift Correction; short circuit protection. Power output per channel: 400 W @ 8 ohms, 630 W @ 4 ohms, 960 W @ 2 ohms; 450 W @ 8 ohms, bridged, 775 W @ 4 ohms, bridged; 1,650 W @ 2 ohms, bridged. XLR, 1/4", five-way binding post. 2RU. 17 lb. \$1,198

World 600
Power Amplifier. Installation, live sound, sound reinforcement. Two-channel; level controls; Class H; Harmonic Shift Correction; short circuit protection. Power output per channel: 130 W @ 4 ohms, 275 W @ 2 ohms; 190 W @ 8 ohms, bridged, 230 W @ 4 ohms, bridged; 390 W @ 2 ohms, bridged. XLR, 1/4", five-way binding post. 1RU. 10 lb. \$749

SWR Sound Corp.

Power 750
Power Amplifier. Live sound, sound reinforcement. Slave output; LED meters. Power output per channel: 750W @ 4 ohms. 1/4", Speakon. 3RU. 32 lb. \$1,199

Symetrix Inc.

420 Stereo Power Amplifier
Installation, studio, broadcast. Two-channel; gain controls per channel; bridgeable; speaker mute; headphone output. Power output per channel: 20 W @ 8 ohms, 20 W bridged mono. 1RU. \$449

TOA Electronics

BG-130
Zone Amplifier. Installation. Three inputs; music/hold output; auto-mute; mic, telephone inputs. Power output per channel: 30 W.

IP-600D
Power Amplifier. Live sound, installation. Two-channel; level controls; variable speed cooling fan; removable air filter; DC, thermal, short circuit, overload protection; bridgeable; activity LEDs. Power output per channel: 400W @ 8 ohms, 600W @ 4 ohms, 1,200W @ 8 ohms, bridged. Screw terminals. 2RU. Optional remote control interface. Optional 2570V transformer. \$1,399

P-906MK2
Power Amplifier. Installation. Single-channel; master level control; module slot; overload, thermal, DC protection; 25/70V-compatible. Frequency response: 20 Hz - 20 kHz. Power output: 60 W. \$680

Tsunami Technologies

HQ-1302S
Power Amplifier. Two-channel; level controls; switching power supply; variable speed cooling fan. Power output per channel: 380 W @ 8 ohms, 600 W @ 4 ohms; 1,200 W @ 8 ohms, bridged. 2RU. 25 lb. \$995

HQ-702S
Power Amplifier. Two-channel; level controls; switching power supply; variable speed cooling fan. Power output per channel: 220 W @ 8 ohms, 350 W

@ 4 ohms; 650 W @ 8 ohms, bridged. 2RU. 21 lb. \$695

Whirlwind

P-12
Monitor Power Amplifier. Two-channel; level controls per channel; headphone/speaker switch. Power output: 11 W @ 8 ohms. Frequency response: 20 Hz - 30 kHz. S/N: >96 dB. XLR, 1/4", push terminals.

PA-1
Two-channel; input switch; balance, volume controls; battery operable. XLR, 1/4".

Yamaha Corp. of America

CP2000
Power Amplifier. Sound reinforcement, install. Two-channel; input gain control; Energy Efficient Engine technology; soft start; DC, temperature protection; stereo/bridge/parallel operation; variable speed cooling fan; MOSFET output section; optimized for Yamaha Club series speakers. Power output per channel: 450W @ 8 ohms, 650W @ 4 ohms, 1,000W @ 2 ohms. Frequency response: 20 Hz - 50 kHz. THD: 0.1%. XLR, 1/4", TRS, five-way binding posts, barrier strip. 2RU. 6.5 lb. \$799

P1600
Power Amplifier. Sound reinforcement. Two-channel; 31-position input attenuator; Energy Efficient Engine power supply; soft start; DC, temperature protection; stereo/mono mode switch; variable speed cooling fan; activity LEDs. Frequency response: 10 Hz - 50 kHz. Power output per channel: 160 W @ 8 ohms, 200W @ 4 ohms, 400W @ 8 ohms, bridged. Barrier strip, XLR, 1/4", five-way binding posts. 19" x 4.25" x 18". 27 lb. \$599

P4500
Power Amplifier. Two-channel; 31-position input attenuator; Energy Efficient Engine power supply; soft start; DC, temperature protection; stereo/mono mode switch; variable speed cooling fan; activity LEDs. Frequency response: 10 Hz - 50 kHz. Power output per channel: 460 W @ 8 ohms, 620 W @ 4 ohms, 1,240 W @ 8 ohms, bridged. Barrier strip, XLR, 1/4", five-way binding posts. 19" x 4.25" x 18". 35 lb. THX certified. \$999

PC4800N
Networkable Power Amplifier. Two-channel; level controls; high-pass filter; EEEngine technology; Cobranet; twin variable speed cooling fans; heat sink. Power output per channel: 550W @ 8 ohms, 800W @ 4 ohms, 1,600W @ 4 ohms, bridged. XLR, Phoenix, five-way binding posts, Speakon, RJ45. 2RU. \$1,399

XH150
Power Amplifier. Broadcast, sound reinforcement. Two channels; switchable 64 ohm and 32 ohm output impedances; built-in low- and high-cut filters for each channel; rear panel attenuators; full circuit protection; variable speed cooling; power, protection, clip and signal indicators. Frequency response: 20 Hz - 20 kHz. Power output per channel: 150 W. Barrier strip, XLR, 5-way binding posts. 3RU. 19" x 5.25" x 12.5". 35 lb. 70/100V operation. \$699

XM4220
Multichannel Installation Power Amplifier. Installation. Four-channel; bridged mono operation; high-pass filter; input attenuators; DC, thermal protection; clip, signal LEDs; variable speed cooling fan; EEEngine technology. Power per channel: 170 W @ 8 ohms, 220 W @ 4 ohms, 440 W @ 2 ohms, bridged. XLR, Euroblock, five-way binding posts. 3RU. 40 lb. 70 V capable. \$899

XM6150
Multichannel Installation Power

Amplifier. Installation. Six-channel; bridged mono operation; high-pass filter; input attenuators; DC, thermal protection; clip, signal LEDs; variable speed cooling fan; EEEngine technology. Power per channel: 120 W @ 8 ohms, 150 W @ 4 ohms. Bridged 3-channel: 300 W @ 8 ohms. XLR, Euroblock, five-way binding posts. 3RU. 40 lb. 70 V capable. \$899

XS350
Power Amplifier. Sound reinforcement, installation. Two-channels; bridged mono operation; built-in variable subwoofer/low-cut filter; rear panel attenuators; full circuit protection; variable speed cooling; bridgeable; power, protection, clip and signal indicators. Frequency response: 10 Hz-50 kHz. Power output per channel: 230 W @ 8 ohms, 350 W @ 4 ohms, 700 W @ 8 ohms, bridged. Barrier strip, XLR, 5-way binding posts. 3RU. 44 lb. \$699

Yorkville Sound Inc.

A4.4
Power Amplifier. Two-channel; level controls; cooling fan; limiter; ground lift; high-pass filter; stereo/mono/bridge switch. Power output per channel: 750W @ 8 ohms, 1,200W @ 4 ohms; 2,400W @ 8 ohms, bridged. XLR, 1/4", Speakon, binding posts. 2RU. 25 lb. \$1,499

AP2020
Power Amplifier. Sound reinforcement, installation. Two-channel; limiter; high-pass filter (20, 40 Hz); DC, load, thermal, breaker protection; ground lift switch; bridgeable; cooling fan; steel chassis; status LEDs. Power output per channel 2 ohm mode: 250 W @ 8 ohms, 400 W @ 4 ohms, 600 W @ 2 ohms, 1,200 W @ 4 ohms, bridged; 4 ohm mode: 400 W @ 8 ohms, 750 W @ 4 ohms, 1,325 W @ 2 ohms, 2,600 W @ 4 ohms, bridged. Frequency response: 20 Hz - 20 kHz. THD: <0.01%. XLR, 1/4", Neutrik Speakon, binding posts. 2RU. 35 lb. \$1,099

AP4040
Power Amplifier. Sound reinforcement, installation. Two-channel; limiter; high-pass filter (20, 40 Hz); DC, load, thermal, breaker protection; ground lift switch; bridgeable; cooling fan; steel chassis; status LEDs. Power output per channel: 750W @ 8 ohms, 1,200 W @ 4 ohms; 2,400W @ 8 ohms, bridged. Frequency response: 20 Hz - 20 kHz. THD: <0.01%. XLR, 1/4", Neutrik Speakon, binding posts. 2RU. 44 lb. \$1,399

AP6040
Power Amplifier. Live sound, sound reinforcement. Two-channel; level controls; limiter; high-pass filter (40 Hz); soft start; DC, load, thermal, breaker protection; ground lift switch; twin variable speed cooling fans; removable air filters; steel chassis; status LEDs. Power output per channel: 1,250W @ 8 ohms, 2,000 W @ 4 ohms. Frequency response: 20 Hz - 20 kHz. XLR, 1/4", Speakon, binding posts. 3RU. 64 lb. \$1,849

CR5
Power Amplifier. Live sound, sound reinforcement. Two-channel; gain controls; limiter; clip indicators; bridgeable. Power output per channel: 250 W @ 4 ohms. XLR, 1/4", touchproof binding posts, barrier strip. 3RU. 23 lb. \$579

SR-300
Power Amplifier. Studio. Two-channel; level controls; peak and average limiter; thermal overload protection; channel, clip and limit LEDs; side-mounted heatsinks; steel chassis. Frequency response: 20 Hz - 20 kHz. THD: <0.015%. Power output per channel: 110W @ 8 ohms, 150W @ 4 ohms, 175 W @ 2.7 ohms. 1/4", push terminals. 2RU. 23 lb. \$499

Wants You For Your Personality

Your voice has a unique personality. You need a pro mic that can appreciate that.

The remarkably responsive, versatile Studio Pro® mics from Peavey can capture every nuance of your voice clearly, no matter your style. The Studio Pro M2 dual diaphragm mic offers three directional characteristics—omni, cardioid and figure-8—and can handle up to 140 dB without distorting. The single diaphragm, cardioid Studio Pro M1 has a wide frequency response and low noise transformer circuitry for use with any instrument. Because Studio Pro mics are interested in what you have to say.

Pick up a Studio Pro today and express *your* personality.



StudioPro M1

StudioPro M2

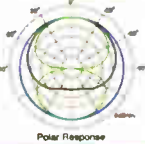

Pressure gradient transducer with double gold-plated membrane capsule

Three directional characteristics: omni, cardioid, figure-8

20 dB front-to-back rejection

Flat frequency response of 30 Hz ~ 20 kHz

16 mV sensitivity

140 dB maximum SPL

Low noise transformer circuitry

Switchable, low frequency roll-off

Switchable, 10 dB pre-attenuation



HK5™ 8



KOSMOS™



RSM™ 1642



VMP™ 2 Tube Preamp



NOW YOU CAN SHOP OR BUY ONLINE @ PEAVEY.COM or CALL toll free 866-443-2333

World Radio History

ANALOG AUDIO PROCESSORS

Aleis

3630 Compressor

Dual-Channel Compressor/Limiter/Gate. Studio, sound reinforcement, broadcast. Two-channel; threshold, ratio, attack, release controls per channel for compressor; threshold, rate controls per channel for gate; input, output level, gain reduction LED meters; Peak/RMS compression; side chain; hard and soft knee; stereo link; bypass; +4, -10 dB operation. Dynamic range: 118 dBA. Distortion: <0.05%. S/N: >100 dB. Attack time: 0.1 - 200 msec. Release time: 20 msec - 3 sec. Compressor ratio: 1:1 - infinity. Gate rate: 20 msec - 2 sec. 1/4". 1RU. \$199

M-EQ 230

Graphic Equalizer. Studio, live sound, sound reinforcement. Two-channel; 30-band; 1/3 octave; Auto Power Muting; boost/cut (12 dB); bypass; status LEDs. Frequency response: 20 Hz - 20 kHz. Dynamic range: 107 dB. 1/4", RCA. 1RU. \$299

Amek USA

Stem Compressor

Eight-Channel Compressor/Limiter Studio. Eight-channel; threshold, ratio, attack, release, gain controls per channel; programmable; bypasses; surround sound-compatible; LED meters; Pure Path series. 1RU. \$6,995

System 9098 Equalizer

Recording studio, live sound. Single-channel; four-band parametric EQ; curve shape control; variable high-, low-pass filters; notch switches; 48V phantom power; phase; linkable; bypasses; Rupert Neve design. 1RU. \$2,269

AMS Neve PLC

33609/J

Compressor/Limiter. Two-channel; threshold, recovery limiter controls per channel; threshold, recovery, gain, ratio compressor controls per channel; fast attack mode; bypass; mono/stereo switch; gain reduction meters. Compressor ratio: 1.5:1 - 6:1. \$3,915

Apex

AQ1

Graphic Equalizer. Two-channel; 15-band; 2/3 octave; 70mm faders; ±12 dB cut/boost; VU meters. XLR, 1/4", RCA. 2RU. \$359

AQ2

Graphic Equalizer. Single-channel; 31-band; 1/3 octave; 70mm faders; ±6/12 dB cut/boost; ground lift switch; bypass; VU meter. XLR, 1/4", RCA. 2RU. \$359

Apex Systems Ltd.

Model 108 Easyrider

Two-Channel Automatic Compressor. Studio, live sound, sound reinforcement, broadcast, video. Two-channel; drive, speed, output controls per channel; bypass, gain reduction LED meter per channel; stereo link; Wave Dependent Compressor circuit; no-Knee compression curve; -10/+4 operation. Frequency response: 10 Hz - 30 kHz. Dynamic range: 94 dB. THD: <0.5%. Ratio: 1:1.1 - 5.5:1. 1/4". 1RU. \$299

Model 109 Parametric Equalizer With Tubessence

Four-Band Mono/Two-Band Stereo Parametric Equalizer. Studio, live sound, sound reinforcement, broadcast, post production. Four-band mono or two-band stereo mode; input, boost/cut (15 dB), frequency (20 Hz - 2 kHz, 200 Hz - 20 kHz), bandwidth (1/5 - 2 octave) controls per channel/band; selectable mode; Tubessence circuit; bypass; peak/shelf switch; -10/+4 dB operation. Frequency response: 10 Hz - 30 kHz. Dynamic range: 105 dB. THD: <0.15%. 1/4". 1RU. \$449

Model 204 Aural Exciter and Optical Big Bottom

Two-Channel Enhancer. Live sound, sound reinforcement, studio, broadcast. Two-channel; Aural Exciter circuit; optical Big Bottom circuit; harmonics, tune, mix Aural Exciter high frequency enhancement controls per channel; drive, tune, mix Big Bottom bass enhancement controls per channel; bypass. XLR, 1/4". 1RU. \$399

Model 250 Aural Exciter Type III

Two-Channel Enhancer. Studio, live sound, sound reinforcement, broadcast, video, film. Two-channel; noise reduction threshold, tune, peaking, null fill, timbre, mix controls per channel; Mode A, Mode B noise reduction modes; Spectral Phase Refractor bass enhancement; solos switches; status LEDs. Frequency response: 1 Hz - 190 kHz. Dynamic range: 114 dB. 1RU. \$995

Model 320A Compeller

Dual Mono/Stereo Processor. Studio, live sound, sound reinforcement, broadcast, video, post production. Two-channel compressor/leveler/peak limiter; drive, process balance, output, threshold controls per channel; Stereo Enhance, Leveling, Leveling & Compression switches; bypasses; leveling speed switch; Dynamic Gate Verification, Dynamic Recovery Computer circuits; status LEDs; LED meters. -10/+4/+8 operation. Frequency response: 10 Hz - 65 kHz. THD: 0.05. XLR. 1RU. \$1,350

Model 720/722 Dominator II

Stereo Multiband Peak Limiter. Studio, live sound, sound reinforcement, broadcast, location, post production. Two-channel; input gain control; LF, HF EQ controls; release, density controls; fine, coarse peak limiter controls; Automatic Limit Threshold (ALT) circuit; Relative Crest Height (RCH) density; crossover switches; stereo band coupling; bypass; peak limit range switch; LED meter. Frequency response: 4.5 Hz - 50 kHz. Dynamic range: >108 dB. THD: <0.006%. Crossovers @ 100/210 Hz, 1.7/3.4 kHz. XLR. 1RU. Model 722 is a broadcast oriented version with broadcast industry equalization curves: \$1,495.

API Audio Products Inc.

2500

Stereo Bus Compressor. Recording studio. Threshold, attack, release, ratio controls; soft, medium, hard knee compression; compression knee type switch; link control; makeup gain output control; switchable VU meter; API 2505 opt-amp. XLR, 1/4". 1RU. \$2,650

Apogee Sound

CRQ-12 Multi-Mode Parametric Equalizer

Live sound, sound reinforcement, recording studio. Modular design; 6/12-channel/band design; each channel/band is full range; range switch, bypass per channel; cooling fan. Frequency response: 20 Hz - 20 kHz. \$3,393

Applied Research & Technology

Dual Leveler Model 256

Vactrol/Tube Compressor Tube Compressor/Leveling Amplifier. Studio, live sound, broadcast. Two-channel electro-optical compressor/leveling amplifier; threshold, output controls; adjustable ratio, release settings; gain reduction LEDs; stereo linkable; 12AX7a tube. Frequency response: 10 Hz - 20 kHz. Dynamic range: >105 dB. THD: <0.1%. EIn: -100dBm. XLR, 1/4". 1RU. \$369

Dual Tube EQ Model 258

Tube-based Parametric Equalizer. Recording studio. Two-channel/mono; four-band stereo/eight-band mono; low-shelving, high-shelving filters; 20 - 200 Hz, 200 Hz - 2 kHz sweepable bands; input, output controls per chan-

nel; 12 dB boost/cut; 12AX7A tubes; bypass. Frequency response: 20 Hz - 20 kHz. Dynamic range: >90 dB. THD: <0.1%. XLR, 1/4". 1RU. \$525

HQ 15

Graphic Equalizer. Two-channel; 15-band; 2/3 octave; Feedback Detection Circuit; level controls; ±6 or ±12 dB cut/boost; bypass; 45mm faders; VU meters. Frequency response: 20 Hz - 20 kHz. THD: 0.01%. XLR, 1/4", RCA. 2RU. \$299

HQ 31

Graphic Equalizer. Single-channel; 31-band; 1/3 octave; Feedback Detection Circuit; level controls; ±6 or ±12 dB cut/boost; high-pass, low-pass filters; bypass; 45mm faders; VU meter. Frequency response: 20 Hz - 20 kHz. THD: 0.01%. XLR, 1/4", RCA. 2RU. \$679

Model 341

Graphic Equalizer. Live sound, sound reinforcement, installation. Two-channel; 15-band; 2/3 octave; 20mm center-detented faders; ±6 or ±12 dB gain. Frequency response: 20 Hz - 20 kHz. THD: 0.01%. S/N: 94 dB. XLR, 1/4", RCA. 1RU. \$249

Pro VLA Model 212

Vactrol/Tube Compressor/Leveling Amplifier. Studio, project studio, live sound, broadcast. Two-channel; electro-optical compressor; threshold, ratio and output controls per channel; attack and release switches; stereo link; bypass; 10-segment gain reduction meter; VU meters; 12AX7a tube per channel. Frequency response: 10 Hz - 20 kHz. Dynamic range: >100dB. THD: <0.1%. Compressor ratio: 2:1 - infinity. XLR, 1/4". 2RU. \$679

Tube EQ Model 128

Tube-Based Parametric Equalizer. Studio, live sound. Single-channel; four-band; 20 Hz - 20 kHz midband sweep; high-, low-shelving bands; input, output level controls. Frequency response: 20 Hz - 20 kHz. Dynamic range: 90 dB. THD: <0.1. XLR, 1/4". 5.25" x 8.5" x 1.75" \$295

Ashly Audio

CLX-52

Stereo Compressor/Limiter. Live sound, sound reinforcement, studio. Two-channel; gain, threshold, ratio, attack, release, output level controls; calibrated threshold control; detector patch point for frequency selective limiting or ducking. I/O level tricolor LED meter and selector switch; gain reduction LED meter; stereo link; bypass. Frequency response: 20 Hz - 20 kHz. THD: <0.1%. Compression ratio: 2:1 to infinite. Attack time: 200 microseconds to 200 milliseconds. Release time: 100 milliseconds - 3 seconds. 1/4", XLR. 1RU. \$539

DPX-200

Parametric Equalizer/Compressor/Limiter. Live sound, studio, installation. Single-channel; four-band parametric EQ; 2/3 octave; high, low-shelf filters; gain, threshold, ratio, attack, release, output level controls; bypass; switchable LED meters. XLR, 1/4". 1RU.

GQX-1502

15-Band Stereo Graphic Equalizer. Studio, live sound, sound reinforcement. Two-channel; 15-band, 2/3 octave; detented metal shaft faders; gain control; Wein bridge filters; constant Q filter design; subsonic filter; balanced inputs; servo-balanced outputs; high-pass filters; bypass; clip LED; ±15 dB boost/cut; selectable 6 dB or 15 dB range; LED meters. Frequency response: 20 Hz - 20 kHz. THD: <0.01%. 1/4", XLR, barrier strip. 2RU. \$569

GQX-3102

Two-Channel 31-Band Stereo Graphic Equalizer. Studio, live sound, sound reinforcement. Two-channel, 31-band, 1/3 octave; detented metal shaft faders; gain

control; Wein bridge filters; constant Q filter design; low-cut filter control; balanced inputs; servo-balanced outputs; high-pass filters; bypass; clip LED; ±15 dB boost/cut; selectable 6 dB or 15 dB range; LED meters. Frequency response: 20 Hz - 20 kHz. THD <0.01%. 1/4", XLR, barrier strip. 3RU. \$1,149

MQX-2310

31-Band Stereo Graphic Equalizer. Live sound, sound reinforcement. Two-channel; 31-band, 1/3 octave; 25mm fader with center off position; switchable low-cut filter; signal present and clip LEDs; Wein bridge filters; constant Q design; selectable 15 dB or 6 dB range. Frequency response: 20 Hz - 20 kHz. Max input level: +23 dBu. Max output level: +23 dBu. EIn: <-92 dBu. THD: <0.01%. 1/4", XLR, barrier strip. 2RU. \$869

PQX-572

Two-Channel Five-Band Parametric Equalizer. Studio, live sound, sound reinforcement. Two-channel; five parametric bands per channel; tunable low- and high-frequency shelving filters; adjustable bandwidth from 3 1/3 octave to 1/20th of an octave; level control per channel; master level control; true reciprocal curves; range switch; bypass per channel; balanced I/O. Frequency response: 20 Hz - 20 kHz. THD: <0.03%. 1/4", XLR, barrier strip. 2RU. \$759

AudioControl Industrial

Bljou

Seven-Channel Theater Equalizer. Installation. Seven-channel; Dolby Digital, Pro Logic; THX approved; constant Q; 1/6 octave filters. Frequency response: 20 Hz - 20 kHz. THD: 0.01%. S/N: 109 dB. RCA, 25-pin D-sub. 17" x 4.75" x 11". 12 lb. Optional rackmount kit. \$995

C-101

Equalizer/Spectrum Analyzer. 10-band graphic EQ (± 15 dB); infra-sonic filter; real time spectrum analyzer; LED panel/meters. Frequency response: 10 Hz - 100 kHz. THD: 0.005%. S/N: 120 dB.

Audio-Technica U.S. Inc.

AT8684 UniMute

Microphone Attenuator. 24 - 48 V phantom power; UniTools series. XLR. \$70

Avalon Design

AD2044

Opto-Compressor. Studio. Dual mono/stereo; ratio, threshold, attack, release, output gain controls per channel; sidechain; bypass; VU meters; Class A operation. XLR. 2RU, 19" x 3.5" x 12". \$3,000

AD2077

Mastering Equalizer. Studio, post production. Two-channel/dual mono; low, mid 1, mid 2, high gain controls per channel; variable frequency controls per band; 108 frequencies per channel; passive and active filters; stepped controls; stepped slope control; Vari-Q; .5, 1 and 2 dB resolution; range and frequency multipliers; Class A operation. Bandwidth - 1 Hz - 500 kHz. XLR. 3RU. \$12,000

VT-747SP

Opto-Compressor/Parametric Equalizer. Studio. Optical compressor/six-band EQ; Twin Signal Path (tube or solid state); EQ pre or post selection for compressor; Class A input, threshold, attack, release, compression, makeup gain, output controls; twin filter controls; side chain threshold contour controls; VU meter. Frequency response: 1 Hz - 200 kHz. THD: 0.5%. XLR. 19" x 3.5" x 12". \$2,495

BBE Sound Inc.

362NR Sonic Maximizer + Noise Reduction

Signal Enhancement Processor.

Project studios, sound reinforcement. Two-channel; contour, process, threshold, release controls; clip LED; switchable noise reduction; bypass. S/N: 108 dB. THD: 0.1%. RCA, 1/4". 1RU. \$349

362SW Sonic Maximizer + Sub

Signal Enhancement Processor for Speakers and Subwoofers. Recording studio, live sound. Two-channel; sub frequency, level, to contour, process controls; LED meter; bypass. S/N: 108 dB. THD: 0.1%. RCA, 1/4". 1RU, 19" x 5.75" x 1.75".

462 Sonic Maximizer

Signal Enhancement Processor. Project studio, sound reinforcement, live sound. Two-channel; contour, process controls; LED meters; bypass. Frequency response: 20 Hz - 20 kHz. THD: 0.025%. RCA, 1/4". 1RU. \$349

862 Sonic Maximizer

Signal Enhancement Processor. Recording studio, sound reinforcement. Two-channel; contour, process controls; LED meters; bypass. Frequency response: 20 Hz - 20 kHz. THD: 0.025%. XLR, 1/4". 1RU. \$599

Behringer

Composer Pro MDX2200

Processor. Two-channel; compressor, limiter, expander, gate; Interactive Knee Adaptation compression; threshold, ratio, attack, release controls; threshold, ratio expander/gate controls; Interactive Gain Control peak limiter threshold control; automatic/manual modes; side chain; bypass; +4/-10 dB operation; LED meters. XLR, 1/4". \$125

Dualflex Pro EX2200

Sound Enhancement Processor. Studio. Two-channel; exciter; enhancer; spatial enhancer; variable Sound Processing circuit; dual mode bass processor; automatic level control. XLR, 1/4", RCA. 1RU. \$85

Multigate Pro XR4400

Expander/Gate. Four-channel; Ultra Transient Response gate; attack, hold controls; parametric side chain filter; Interactive Hold Circuit; Interactive Ratio Control expander; bypass. \$209

Tube Composer T 1952

Tube Dynamics Processor. Studio. Two-channel; stereo/two-channel mono; Ultra Tube Circuitry; compressor, limiter, expander, gate; threshold, ratio expander/gate controls per channel; threshold, ratio, attack, release, output compressor/limiter controls per channel; Interactive Knee Adaptation knee control; contour side chain control; "Warmth" tube sound controls; bypass; +4 dBu/-10 dBV operation; four VU meters. XLR, 1/4". \$399

Tube Ultraflex T 1954

Tube Enhancer. Studio. Two-channel; stereo/surround width controls; "Warmth" tube sound controls; low mix, high mix, tune, sensitivity, process controls per channel; bass mode switch; bypass; noise reduction; VU meters. XLR, 1/4". \$399

Tube Ultra-Q T 1951

Tube Parametric Equalizer. Studio. Two-channel; four-band; frequency, level, bandwidth controls per band; input controls; "Warmth" tube sound controls; 15 dB boost/cut; high-, low-cut filters; shelf filter; two VU meters. XLR, 1/4". \$399

Ultra-Graph Pro GEQ3102

Two-Channel Graphic Equalizer. Live sound, installation, sound reinforcement. Two-channel; 31-band; 1/3 octave; input level control; variable high-cut filter; variable low-cut filter; bypass; ALPS LED faders. Frequency response: 10 Hz - 35 kHz. S/N: 92 dB. XLR, 1/4" TRS. 2RU. \$185

Ultra-Q Pro PEQ 2200

Parametric Equalizer. Studio, post pro-

AC 24

Cross-over crossover.

Our new AC 24 combines the power of Rane DSP with straightforward, simple-to-use analog controls.

With rotary knobs on the front and formidable digital signal processing power inside, the AC 24 does things no other stereo 4-way crossover can.

It gives you the precision of 24 dB/octave slopes — yet maintains perfect filter phase accuracy.

Since HF compression drivers trade even response for wider dispersion, we've included 2 kHz-8 kHz Horn EQ for High and Hi-Mid bands.

All rotary controls merely send data to the internal DSP (instead of actually being in the signal path), so they don't affect sound quality.

Mute switches on each band.

Mid / High crossover point is variable from 160 Hz to 1.6 kHz.

3-Way / 4-Way modes.

When you press the Stereo Link button, the left channel becomes the master and the right channel becomes the slave. LEDs show the status.



Inside, a universal power supply automatically switches to any local voltage.

Link switch applies the same limiting to all channel bands.

Or apply different limiting to each band. LEDs show the status.

Hi-Mid / High crossover point (4-way mode) is variable from 1.25 kHz to 12.5 kHz.

0 ms to 10 ms delay control on each band.

The AC 24's internal DSP lets us include a 0 ms to 10 ms delay on each band so you can time-compensate your drivers.

Individual/linkable limiters let you crank out maximum SPLs. Separate dual-band CD Horn EQs optimize compression driver frequency response.

All this with *perfect phase accuracy*, higher reliability than analog units and top notch RFI immunity.

Visit our website or call us for more information on the digital crossover for people who still like to get their hands on real knobs.

Separate left and right input controls with overload LED.

Low Frequency Mono button.

AC 24

- 4th-Order, 24 dB/octave Linkwitz-Riley alignment
- Stereo 4-way or 3-way operation
- Independent (dual-mono) or linked, (stereo) operation
- Split-band limiters
- Driver alignment delay
- Separate Hi-Mid and High Filter CD horn EQs
- Invert switch for each filter output
- Stereo or mono low output
- Summed output
- Universal internal power supply

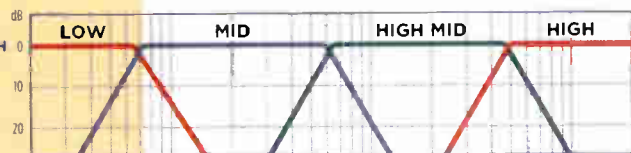

Typical 4-way crossover application. Dial it into the AC 24 without hooking up a computer or (dare we say it?) dragging or dropping anything.

Thank you Siegfried Linkwitz (and Mr. Riley, too). They came up with the filter design; we pioneered its use in pro audio. Maintaining Linkwitz-Riley crossovers' phase accuracy at 24 dB per octave is no easy feat using analog components. It also requires proper delay for each transducer. That's the beauty of the AC 24 — it does its work in the digital domain, maintaining perfect filter phase accuracy and allowing the easy addition of individual delays.

We wrote the book! Buy your

copy of our Pro Audio Reference. 320 pages of RaneNotes,

technical glossary and PC/Mac CD-Rom. Get it direct at www.rane.com.

Rane Corporation • 425.355.6000
Mukilteo Washington USA

www.rane.com

World Radio History

ANALOG AUDIO PROCESSORS

duction. Five-band; Ultra-Q notch filters; 15 dB cut/boost; variable filters; high-, low-cut filters; frequency, bandwidth, level controls; bypass; 4580 op-amps. XLR, 1/4". 1RU. \$125

Bellari/Rolls Corp.

RP583 Studio Tube Compressor/Limiter

Recording studio, project studio. Two-channel; output level, threshold, attack, release, ratio controls per channel; bypass; side chain; tube operation; switchable VU meters. Frequency response: 20 Hz - 40 kHz. THD: < 0.1%. S/N: 90 dB. 19" x 3.5" x 6". \$650

Boas

VT-1 Voice Transformer

Effects Processor. Pitch, formant, mix balance, reverb controls; onboard "robot" processor; vocoder; memory settings; four presets; bypass. 1/4", RCA. \$395

BSS Audio/Harman Pro North America

DPR-402

Compressor/Peak Limiter/De-Esser. Studio, sound reinforcement. Two-channel; compressor/limiter/de-esser; de-ess, frequency, threshold, ratio, attack, release, peak limiter controls per channel; stereo linking; gain reduction, output level LED metering. XLR. 1RU. \$1,599

DPR-504

Four-Channel Noise Gate. Recording studio, live sound, broadcast. Four-channel; key filter, octave width, threshold, release controls per channel; key listen, attack, gate range switches per channel; meter per channel; link; bypass; status LEDs. 1RU. \$1,449

DPR-901 II

Parametric Equalizer. Recording studio, live sound. Four-channel/band; width, frequency, compression/expansion, threshold controls per band; filter, release switches per band; bypass; LED meters per band; bell/shelving filter curves. 1RU. \$1,549

DPR-944

Parametric Compressor/Gate. Live sound, recording studio, installation. Two noise gates, two compressors; key filter, threshold, release, width, frequency, ratio, gain controls per channel; side chain; filter shape, key listen, attack speed, release speed, gate depth switches; progressive knee ratio; linkable; gain reduction LED metering; status LEDs. Dynamic range: >117 dB. Gate distortion: <0.05%. Compressor distortion: <0.005%. XLR, 1/4". 1RU. \$699

FCS-926 VARICURVE

Parametric Equalizer with Real Time Analysis. Studio, sound reinforcement. 12-band mono/6-band stereo; 212 frequencies per filter; ± 15 dB cut/boost; octave/bandwidth control; onboard spectrum analyzer; RTA mic input; LED meter and screen. XLR, 2RU. \$2,999

FCS-960

Dual Mode Graphic Equalizer. Studio, sound reinforcement. Two-channel; 30-band; 45 mm faders; constant Q filters; switchable, sweepable high-pass filter; filter width control; gain control. XLR, 3RU. \$1,799

FCS-966

30-Band Graphic Equalizer. Live sound, sound reinforcement, recording studio, project studio. Two-channel; 30-band; ± 15 dB per band; 45 mm faders; constant Q filters; high-pass filter, gain, HF contour (± 6 dB @ 14 kHz), LF contour (± 6 dB @ 50 Hz) controls per channel; bypass; LED meters; Opal series. Frequency response: 5 Hz - 45 kHz. Dynamic range: >115 dB. THD: <0.005%. XLR, 1/4", screw terminals. 3RU. \$1,095

Carvin

EQ 2015 2/3 Octave EQ

Graphic Equalizer. Live sound, sound reinforcement, studio, installation. Two-channel; 15-band; 2/3 octave; 15 dB cut/boost; gain control, variable high- and low-cut filters per channel; bypass; -10/+4 dB operation; peak LED. Frequency response: 10 Hz - 45 kHz. THD: <0.01%. 1/4", XLR. 2RU. \$199

EQ 2030 1/3 Octave EQ

Graphic Equalizer. Live sound, sound reinforcement, studio, installation. Two-channel; 30-band; 1/3 octave; 15 dB cut/boost; gain controls, variable high- and low-cut filters per channel; bypass; -10/+4 dB operation; peak LED. Frequency response: 10 Hz - 45 kHz. THD: <0.01%. 1/4", XLR. 3RU. \$299

Chandler Limited

LTD-2

Compressor. Release, attack, threshold, gain controls; link; hand wired; modeled on Neve 2254. \$1,599

TG-12413

Compressor/Limiter. Gain, recovery, hold controls; link; based on "Abbey Road" EMI compressor. \$4,500

CLM Dynamics/Wave Distribution

DB5005 The Expounder

Dynamic Equalizer. Recording studio. Two-channel; four-band EQ; 20 parametric bands; variable high-, low-cut filters; ± 20 dB boost/cut; shelf/bell curve switch; gain, frequency controls; bypass; link; LED meters. LF: 40 - 300 Hz; LMF: 200 Hz - 2 kHz; HMF: 1 - 8 kHz; HF: 1.5 - 20 kHz. 3RU. \$1,499

Crane Song Ltd.

IBIS * New for 2003 *

Two-channel; four-band; Class A; discrete; variable low-cut filter; frequency switches, bandwidth, cut/boost controls per band; adjustable "color" control; bypass. 2RU. Optional mastering version. \$4,500

STC-8

Stereo Compressor/Peak Limiter. Studio, broadcast. Two channel; Class A; compressor/limiter; attack, threshold, release, shape, gain, peak limiter controls per channel; presets; "Analog," "tube" effects circuits; side chain; stereo link; toroidal power transformer; switchable LED meters. Frequency response: 5 Hz - 60 kHz. Noise floor: -89 dB. XLR, 2RU. Optional version detented controls: \$5,450. \$4,450

Trakker

Compressor/Limiter. Single-channel; threshold, attack, release, knee gain controls; 16 presets; hard/soft knee compression; tube emulation; linkable; bypass; switchable LED meter. Frequency response: 5 Hz - 55 kHz. Noise: -89 dBm. Max compression ratio: 20:1 XLR. 1RU. \$2,550

D.W. Fearn

VT-4

Vacuum Tube LC Equalizer. Studio. Single-channel; five-band; adjustable gain; Class A operation; triode tubes. XLR. 3RU. 20 lb. \$3,900

VT-5 Stereo Vacuum Tube

LC Equalizer * New for 2003 * Stereo; five-band; LC circuitry; Class A; Jensen transformers; low-cut, low boost, mid cut, high boost, high bandwidth, gain controls. Frequency response: 20 Hz - 20 kHz. THD: <0.1%. Dynamic range: >100 dB. 3RU. \$6,600

DACS Ltd./Independent Audio

FREQUE II

Dual Ring Modulator. Twin ring modulators; "weight," "edge" spectral, wet, dry, gain controls; fine, tune, range controls; onboard twin oscillators (.2 Hz - 16 kHz); frequency shifting; cascaded effects routing; bypass. \$1,400

tor (.2 Hz - 16 kHz); frequency shifting; cascaded effects routing; bypass. \$1,400

Vocoding Filter

Vocoder. 16-band; low-pass filter (100 Hz); high-pass filter (640 Hz); frequency, volume, wet, dry, gain controls; pink noise generator; ramp oscillator. \$1,500

Daking

91579

Compressor/Limiter Recording studio. Single-channel; threshold, ratio, attack, release, makeup gain controls; insert; stereo link; Class A; switchable VU meter. XLR, 1/4". \$1,450

FET Compressor

Class A; threshold, ratio, attack, release controls; switchable VU meter. XLR, 1/4". \$1,995

dbx Professional Products

1046 Quad Compressor Limiter

Studio. Four-channel; threshold, ratio, output gain, limiter controls per channel; PeakStop Plus limiting; True RMS Summing; hard knee or OverEasy compression; stereo couple; selectable input/output level LED metering; gain reduction LED metering; V2 VCAs; bypass; selectable +4 dB/-10 dB operation. 1RU. \$650

120XP Subharmonic Synthesizer

Subharmonic Synthesizer. Studio. Waveform Modeled Synthesis; subwoofers, low frequency boost, subharmonic controls; twin synthesized frequency controls; selectable crossover (80 Hz or 120 Hz). 1RU. \$300

1231

Graphic Equalizer. Two-channel; 30-band; 1/3 octave; selectable 6, 15 dB boost/cut; low-cut filter (40 Hz); 45mm faders; input gain control per channel; bypass; soft start. Frequency response: 10 Hz - 50 kHz. S/N: >90 dB. THD: <0.005%. XLR, 1/4" or barrier strip. 3RU. \$469

160A Compressor/Limiter

Studio, live sound. Single-channel; threshold, ratio, output gain controls; Dec-linear dbx VCA; OverEasy or hard knee compression; bypass; gain reduction LED metering. 1RU. \$460

160SL Stereo Compressor

Studio. Two-channel; threshold, compression, output gain, attack, release, stop level controls per channel; OverEasy or hard knee compression; PeakStop Plus limiting; AutoVelocity dynamics; auto attack and release switches; side chain; stereo couple; bypass; V8 VCAs; VU meters; Blue Series. Dynamic range: 127 dB. Optional Type IV Conversion System. \$2,800

166XL Dual

Compressor/Limiter/Gate. Studio, live sound. Two-channel; stereo or dual mono operation; threshold, release gate/expander controls; threshold, ratio, output gain compressor controls; limiter level control; OverEasy or hard knee compression; PeakStop limiting; soft knee expander gate; True RMS Summing; bypass; stereo link; gain reduction LED metering; status LEDs. 1RU. \$330

2215 Graphic Equalizer

Studio, live sound. Two-channel; 15-band; 2/3 octave; input gain, limiter controls per channel; PeakPlus limiter; dbx Type III noise reduction; low cut filter; nylon faders; bypass; LED metering; LED status lights. XLR, 1/4", barrier strip. 2RU. \$550

2231 Graphic Equalizer

Sound reinforcement, live sound, studio. Two-channel; 31-band. 1/3 octave; input gain, limiter controls per channel; PeakPlus limiter; dbx Type III noise reduction; low cut filter.

ter; nylon faders; bypass; LED metering; LED status lights. XLR, 1/4", barrier strip. 3RU. \$800

266XL Compressor Gate

Studio, live sound. Two-channel; stereo or dual mono operation; threshold, ratio expander/gate controls, threshold, ratio, attack, release, output gain controls per channel; OverEasy or hard knee compression; program-adaptive gates; bypass; side chain insert; gain reduction LED meters; +4 dB/-10 dB operation. 1RU. \$190

3031 Graphic Equalizer

Installation, sound reinforcement, live sound. Single-channel; 31-band; 1/3 octave; gain reduction, low-cut filter controls per channel; long throw faders; switchable ± 6 or 12 dB boost/cut; LED meter. XLR, 1/4". 2RU. \$750

566 Dual Channel Tube Compressor

Studio. Two-channel; tube operation; compression threshold, ratio, attack, release, drive, level, limiter threshold controls per channel; OverEasy compression; PeakPlus limiter; True RMS Power Summing; phase reverse; bypass; switchable VU meters; 12AU7 tubes; +4/-10 operation; Silver Series. XLR, 1/4" TRS. 2RU. \$1,000

Demeter Tube Amplification

RV-1 Real Reverb

Spring Reverb. Studio, live sound. Two-channel; dual tank spring reverbs; phase reverse; high-pass filter; input, mix, output controls; Accutronics tanks; mu metal shielding. Frequency response: 20 Hz - 20 kHz. S/N: >90 dB. Delay/decay Ch.1: 1.5 sec. Delay/decay Ch.2: 3.5 sec. 1RU. \$729

VTCL-2B Stereo Tube Optical

Compressor/Limiter. Studio. Two-channel; tube-based; attack, release, input sensitivity controls. XLR, 1/4", 2RU. Optional Jensen input/output transformers version, VTCL-2BX: \$2,949. \$2,499

Drawmer USA/TransAmerica Audio Group

1961 Vacuum Tube Equalizer

Studio. Two-channel; variable input level; four-band EQ; variable high-pass filter (15 - 500 Hz) with bypass; variable low-pass filter (2.5 - 56 Hz) with bypass; soft clip, overload LEDs; bypass; -10/+4 dB operation. XLR, 1/4". 2RU. \$2,575

DF330 Universal Noise Filter

Two-channel; downward expander section; variable threshold and release; switchable ratio, attenuation; high-pass filter; bypasses. XLR, 1/4". \$1,100

DL251 Spectral Compressor

Compressor/Enhancer/Limiter. Studio. Two-channel; compressor/enhancer/limiter; switchable hard and soft knee; variable threshold, ratio, output gain; auto/manual attack and release, side chain access, side chain listen; Dynamic Spectral Enhancement Circuitry; transparent "Zero Overshoot" limiter; -10/+4 dB operation; stereo linking. XLR. 1RU. \$1,100

DL441 Quad Auto

Compressor/Limiter. Studio. Four-channel; auto compressor/limiter; switchable hard and soft knee compression, threshold, ratio, output gain controls per channel; automatic attack and release; transparent "Zero Overshoot" limiter; -10/+4 dB operation; stereo linking. XLR. 1RU. \$1,200

DL501 Power Gate

Two-channel; high, low-pass filters; Peak Punch; envelope, attack, hold decay, range controls. \$900

DL651 Sixpack

Six-Channel Multiprocessor. Six-channel; compressor/limiter/expander/gate;

Zero Overshoot limiter; gain, attack, ratio, threshold, release controls for compressor; release, threshold controls for gate/expander; LFE filter; channel link. \$2,675

DS201 Dual Noise Gate

Studio. Two-channel; variable high- and low-pass filters; individual attack, hold and release; variable range, ducking; key input; key listen; stereo linking. XLR. 1RU. \$750

MX40 Punch Gate

Studio. Four-channel; "Peak Punch" circuitry; single trigger frequency control; key input; key listen; variable release; auto attack; switchable range; bypass; master/slave configuration. XLR. 1RU. Designed for accentuating the leading edge of percussion instrument signals. \$725

Tube Station 2

Compressor/Limiter. Compressor/limiter; Tube Drive; stereo link; attack, release controls; soft knee compressor; limiter. With 24-bit, 96 kHz AES/EBU, S/PDIF digital output module, \$999. \$750

Electro-Harmonix

Hoiler Grail

Studio Reverb Pedal. Spring, hall, room flerb reverb; length, blend, gate, gate threshold controls; gate speed, reverse switches. 1/4". \$298

Empirical Labs

EL8 Distressor

Compressor. Input, attack, release controls; high-pass filter; switchable compressor ratio; distortion switches; link; LED meter. Frequency response: 5 Hz - 160 kHz. 1RU. Single-channel: \$1,449. Two-channel: \$2,799.

Esoteric Audio Research/Subsonic

Esoteric Audio Research 822Q

Equalizer. Studio, post production. Low, high, band-pass filters; boost, cut, shelf, peak, bandwidth controls; Pultec style; bypass; ECC83 tube operation. XLR, 2RU. Midrange version, 823MQ: \$3,290. \$3,290

Esoteric Audio Research 825Q

Equalizer. Studio, post production. Two-channel; five-band; bass bell, bass shelf, midrange, treble range, treble shelf controls. 3RU. \$4,900

Esoteric Sound

Re-Equalizer

Phonograph Equalizer. Provides phono compensation for old phonograph disks; adjustable rolloff, turnover; RIAA compatible. Frequency response: 20 Hz - 20 kHz. THD: <0.02%. RCA. 1RU. \$295

Surface Noise Reducer

Decracker, declicker, noise reducer. Frequency response: 20 Hz - 20 kHz. THD: <0.02%. RCA. 1RU. \$425

FMR Audio

RNC1773 Really Nice Compressor

Single-channel; threshold, ratio, attack, release, gain controls; bypass; sidechain; LED meter. Compressor ratio: 1:1 - 25:1. Attack: 0.2 - 200 mS. Release: 0.05 - 5 seconds. 1/4". \$2,000

Focusrite Audio Engineering

Platinum ComPounder

Compressor/Limiter/Gate. Studio, post production, broadcast. Two-channel; Bass Expander; hard knee, soft knee compression; LED meters. 1RU. \$775

Platinum MixMaster

Multi-Effects Processor. Stereo spectral compressor; three-band sweepable EQ; limiter; stereo image controller; stereo expander; bypass; LED meters. 2RU. Optional 24-bit/96 kHz A/D module. \$1,095

BRYSTON



www.bryston.ca

14B ST

BRYSTON

Bryston Limited P.O. Box 2170, 677 Neal Drive, Peterborough, Ontario Canada K9J 7Y4
1-800-632-8217 www.bryston.ca

TAKING POWER TO THE NEXT LEVEL.

ANALOG AUDIO PROCESSORS

Red 2
Dual Mono Equalizer. Studio, post production, broadcast. Two-channel; high, low-pass filters; sweepable high and low mid band; transformer balanced I/O. Frequency response: 5 Hz - 200 kHz. XLR. 2RU. \$2,995

Red 3
Compressor/Limiter. Studio, post production, broadcast. Two-channel; threshold, attack, release compressor controls; threshold limiter control; bypass; Class A VCA design; VU meters. Frequency response: 5 Hz - 200 kHz. XLR. 2RU. \$3,295

GML, LLC

GML 8200
Stereo Parametric Equalizer. Two-channel; five-band; bandwidth/Q controls; 15 dB boost/cut; shelf mode. 2RU.

GML 8900 Dynamic Range Controller
Two-channel; crest factor, timing, release hysteresis controls; side chain; tricolor LED meters. 2RU.

GML 9500 Mastering Equalizer
Post production. Dual mono; gain, frequency, Q controls; five-band; 24 frequencies per band. 3RU.

GTC Industries

AGC-2
Automatic Level Control. Live sound, installation. Gated expansion mode; preset response curves; LED meters. RCA. 2.75" x 3.75" x 1". \$100

Guyatone/Godyke Distributing

RTE-3000 Tape Echo
Input volume, echo volume, delay time, delay repeat, output volume controls; six delay settings; Ampex tape loop; 10, 20 dB pad; VU meter. \$1,100

HHB Communications USA LLC

Radius 20
Tube Parametric Equalizer. Studio. Tube operation; four-band parametric EQ; input, output level controls; instrument input; peak LEDs; bypass. Frequency response: 10 Hz - 40 kHz. Dynamic range: 106 dB. XLR, 1/4". 2RU. \$749

Radius 3 Fat Man
Tube Compressor. Studio. Two-channel; input gain, output gain, gain make-up, threshold, ratio controls; attack, release switches; 15 factory presets; 12AX7 tube; bypass; 1/4" front inputs; VU meter. 1/4". \$469

Radius 30
Tube Compressor. Studio. Two-channel/dual mono; tube operation; compressor/expander/gate; input, output gain, threshold, ratio, expander/gate, gain make-up controls per channel; switchable attack, release; front panel instrument input; side chain; link; VU meters. Frequency response: 10 Hz - 40 kHz. Dynamic range: 106 dB. XLR, 1/4". 10" x 3.5" x 8". \$749

ISP Technologies

Decimator Pro Rack
Noise Reducer. Two-channel; threshold controls; +/-10 dB operation; LED meters. Dynamic range: 118 dB. THD: <0.05%. 1/4". 1RU. \$319

Joemeck/PMI Audio

C2 Stereo Compressor
Input gain, compression, attack, release, output volume controls; LED meters. Frequency response: 8 Hz - 30 kHz. THD: 0.01%. S/N: 118 dB. \$400

SC2
Stereo Compressor. Studio. Two-channel; photo optical; input gain, slope, compression, attack, release controls; bypass; VU meter. Frequency

response: 5 Hz - 30 kHz. Attack: 1.5 mS - 10 mS. THD: 0.004%. XLR, 1/4". 2RU. \$1,299

SC2.2
Stereo Compressor. Studio. Stereo; photo optical; input gain, slope, compression, attack, release, output gain controls; bypass; switchable VU meter. THD: 0.004%. Frequency response: 5 Hz - 30 kHz. 2RU. \$799

VC5 Meequalizer
Equalizer. Studio. Two-channel; treble, mid, frequency, bass, gain controls per channel; bypass. 1/4". 1RU. \$400

Klark Teknik

DN300
Graphic Equalizer. Studio. Single-channel; 30-band; 1/3 octave; 45mm oil-dampened faders; MELT filters; 12 dB cut/boost; adjustable high-, low-shelving filters with selectable 6/12 dB octave high cut slope; bypass; ground lift; security cover. Optional transformer balanced output version, DN300B - \$1,331. \$1,295

DN330
Preset Equalizer. Studio, live sound. Single-channel; 30-band; 1/3 octave; rotary pots; MELT filters; 12 dB cut/boost; adjustable high-, low-shelving filters with selectable 6/12 dB octave high cut slope; bypass; ground lift; security cover. \$1,082

DN332
Graphic Equalizer. Studio. Two-channel; 16-band; 2/3 octave; 45mm oil-dampened faders; MELT filters; low-cut (18 dB per octave) filters; security cover; ground lift; bypass. 2RU. Optional transformer balanced output version, DN332B - \$1,356. \$1,132

DN3600C
Programmable Equalizer. Studio. Two-channel; 30-band; 1/3 octave; tunable notches; high-, low-pass filters; backlit LED display; 30 switches/virtual faders; autogain; 66 memories; multiple clip warning levels; slave unit interface. Optional transformer balanced output version, DN3600CB - \$3,452. Slave unit, DN3601C - \$2,492. Slave unit with transformer balanced output, DN3601DB - \$2,644. \$3,300

DN4000
Equalizer with Delay. Studio. Two-channel; delay/five-band parametric EQ; 20-bit A/D-D/A; high-, low-pass filters, shelf filters; frequency, Q, level controls; 32 memories; security lock-out; LCD screen. Maximum delay: 340 mS. Frequency response: 20 Hz - 20 kHz. Dynamic range: 114 dB. Optional AES/EBU interface. Optional transformer balanced output version, DN4000B - \$4,752. \$4,600

DN410
Parametric Equalizer. Studio. Two-channel; five-band or mono 10-band; high-, low-pass filters; frequency overlap; gain, bandwidth, frequency controls per band; I/O switch; status LED per filter; bypass; overload LED; ground lift switch. Optional transformer balanced output version, DN410B - \$1,524. \$1,664

DN500
Compressor/Limiter/Expander. Studio. Two-channel; variable knee compression; autoattack/release; threshold, ratio, knee, attack, release controls per channel for compressor; threshold, ratio, release, gain reduction per channel for expander; separate sidechain for compressor, expander; variable threshold for peak limiter; peak clipping; stereo link. 1RU. Optional transformer balanced output version, DN500B - \$1,396. \$1,244

DN514
Auto Gate. Studio. Four-channel; threshold, release, HF, LF controls per channel; semi-automatic attack modes; sync function; machine con-

trol; sidechain monitor; bypass; status LEDs. Optional transformer balanced output version, DN514B - \$1,448. \$1,444

DN7103
Digital Delay Processor. Studio, post production. Single-channel; 18-bit A/D-D/A, peak limiter, parametric and shelf EQ per channel; 32 memories; input headroom level indicators; MIDI interface; user definable input/output; shuttle wheel; LCD screen. Max delay: 1.4 seconds. Frequency response: 20 Hz - 20 kHz. Dynamic range: >100 dB. Optional transformer balanced output version, DN7103B - \$2,112. \$1,900

Little Labs

IBP
Phase Alignment Tool. Phase adjustment control; phase reverse; phase center, phase adjust; line/instrument; ground lift; 1/4" front panel input. 1/4". \$450

MAM America

CF1
Multiprocessor. Chorus, flanger, modulator; input, output, dry/mix, cutoff, feedback phase, feedback depth, LFO rate, modulation depth, delay, flange, chorus controls; bypass. \$269

Phase 2
Phaser. Stereo; resonance, feedback controls; low-frequency oscillator. 1RU. \$219

VF 11
Vocoder. 11-band; filter bank. 1RU. \$399

WARP 9
High, low filters; notch filters; low-frequency oscillator; key control. 1RU. \$239

Manley Laboratories

Enhanced Pultec EQP-1A Equalizer
Pultec-Style Equalizer. Studio. Low-frequency section (20 - 120 Hz) with cut and boost controls; high-frequency section (1 - 16 kHz) with bandwidth and boost controls; cut section (4 - 20 kHz); phase reverse; 12AU7WA, 6414 tubes; bypass. Frequency response: 10 Hz - 70 kHz. THD: <0.01%. S/N: 116 dB. Balanced XLR and unbalanced 1/4". 1RU, 19" x 1.75" x 10". \$2,150

Langevin All-Discrete Pultec EQP-1A
Single-channel; boost and cut controls per band. Frequency response: 20 Hz - 60 kHz. THD: 0.04%. XLR, 1/4". \$1,275

Langevin Dual Vocal Combo
Two-channel/dual mono; mic pre, two-band EQ, electro optical limiter; 48V phantom power; gain reduction controls per channel; stereo link; bypass; switchable VU meters. XLR, 1/4". \$2,000

Langevin Dual-Channel Electro Optical Limiter
Studio. Two-channel; gain reduction controls per channel; bypass; link; switchable VU meter. THD: 0.04%. XLR, 1/4". \$1,775

Massive Passive Stereo Equalizer
Studio. Two-channel; four-band EQ; bandwidth; frequency controls per band; boost/cut, shelf/bell switches per band; high-pass filters (22, 39, 68, 120, 220 Hz), low-pass filters (6, 7.5, 8, 12, 18 kHz) per channel; bypasses; two 5751 tubes, four 6414 tubes. Frequency response: 8 Hz - 60 kHz. Dynamic range: 120 dB. THD: 0.06%. 3RU. 21 lb. \$4,800

Variable MU Limiter/Compressor
Studio. Two-channel; input, threshold, attack controls, recovery speed switches per channel;

bypass; link; VU meters. Recovery times: 0.2, 0.4, 0.6, 4, 8 seconds. Attack: 25 - 70 mSec. THD: <0.01%. XLR. 2RU. \$4,000

Metasonix

TM-1 Vacuum Tube Waveshaper/Ringmod
Waveform processor; ring modulator; input level control; "pulsar stability," "beam tube screen," "ringmod oscillator pitch" controls; bypass. 1/4". \$399

TM-2
Vacuum Tube Band-Pass Filter. Single-channel; dual tunable filters; level, filter resonance, filter tune, filter modulation controls; bypass. 1/4". \$399

Miles Technology

M86 Multisonic Imager
Stereo to LCR Converter. Installation, live sound. Crossover filters; gain controls; level indicators. Frequency response: 20 Hz - 20 kHz. THD: <0.02%. XLR, RCA. 1RU. \$799

Millennia Media Inc.

MSD-2 The Matrix
M/S Decoder. Twin Millennia Media HV-3D mic preamps; Class A; head-phones controls; bypass. 2RU. \$4,500

NSEQ-2
Parametric Equalizer. Recording studio, mastering, post production. Two-channel; four-band; Twin Topology vacuum tube and solid state signal paths; Class A operation; transformerless; 20 dB coarse/10 dB fine tune; Q adjustment; frequency multiplier; Mogami Nexlex, silver Teflon wiring. 19" x 3.5" x 12.5", 29 lb. \$3,295

TCL-2 Twincom
Compressor/Limiter. Recording studio, mastering, post production. Two-channel; Twin Topology vacuum tube and solid state signal paths; Class A operation; transformerless; threshold, attack, release, ratio controls per channel; master output gain control; VU meters. 19" x 3.5" x 12.5", 28 lb. \$2,995

Nady Systems Inc.

FS-4N
Feedback Suppressor. Four notch filters; 1/60 octave; onboard eight-band spectrum analyzer; bypass. 1/4". 1RU. \$135

GEQ 215
Graphic Equalizer. Two-channel; 15-band. XLR, 1/4", RCA. \$119

GEQ 231
Graphic Equalizer. Two-channel; 31-band. XLR, 1/4", RCA. \$199

PEQ-5B
Parametric Equalizer. 15 dB cut/boost; constant Q; parallel phase filters; high, low-cut filters; bypass. XLR, 1/4". \$139

Oram Professional Audio

OctaEQ
Eight-Channel Equalizer. Eight-channel; five-band British EQ; split band function. \$2,750

Soniccomp Two
Compressor. Recording studio, post production. Two-channel; threshold, output controls; light dependent resistors; VU meters. \$2,590

Peavey Electronics Corp.

CEL-2A
Two-channel; compressor/limiter/expander; side chain; de-esser; low-cut filter. XLR, 1/4". 1RU. \$299

DeltaFex
Stereo Effects Processor. Studio. 16 different effects; seven reverb; four

delays; chorus; flange; phase shift; rotary speaker with morphing speed control; adjustable effect parameters; I/O level controls; clip indicator. 1RU. \$159

EQ 215FX
Graphic Equalizer. Live sound, sound reinforcement, studio. Two-channel; 15-band, 2/3 octave; +/-15 dB cut/boost; constant Q filters; feedback locator, independent bypass, low-cut filters, gain controls and LEDs on each channel. Frequency response: 20 Hz - 20 kHz. 1/4". XLR, 2RU. \$399

kosmos
Bass Processor/Subharmonic Generator. Live sound, studio. Two-channel; subharmonic, bass boost, stereo image, sub output, level controls; bypass. Frequency response: 10 Hz - 40 kHz. XLR, 1/4". 1RU. \$299

Q 231 FX
Graphic Equalizer/Feedback Locating System. Live sound, sound reinforcement, studio. Two-channel; 31-band, 1/3 octave; +/-15 dB cut/boost; constant Q filters; feedback locator, independent bypass, low-cut filters (40 Hz), gain controls and LEDs on each channel. Frequency response: 20 Hz - 20 kHz. THD: 0.003%. S/N: 96 dB. XLR, 1/4". 3RU. \$449

Q1311
Graphic Equalizer. Single-channel; 31-band; 6/12 dB cut/boost; low-cut filter (40 Hz); gain control; constant Q filters; 45mm faders; bypass. XLR, 1/4". 1RU. \$199

Q2151
Graphic Equalizer. Two-channel; 15-band; 6/12 dB cut/boost; low-cut filter (40 Hz); gain control; constant Q filters; 45mm faders; bypass. 1/4", XLR. 1RU. \$199

QF 215
Graphic Equalizer with Feedback Locator. Live sound, sound reinforcement, studio. Two-channel; 15-band, 2/3 octave; 12 dB boost/18 dB cut per band; constant Q filters; feedback locator; independent bypass; low-cut filters (40 Hz), gain controls and LEDs on each channel. Frequency response: 20 Hz - 20 kHz. XLR, 1/4". 2RU. \$284

Pendulum Audio

6386 Variable Mu Vacuum Tube Limiter
Two-channel; input, threshold, output, attack, release controls per channel; variable Mu compressor/limiter; Class A; six compressor presets; fast/manual/preset switch; sidechain; bypass; link; two 6386 tubes; switchable VU meters. Frequency response: 15 Hz - 75 kHz. THD: <0.08%. 2RU. Modeled on Fairchild 660, 670 limiters. \$3,995

ES-8 Variable Mu Vacuum Tube Limiter
Two-channel; input, threshold, output, attack, release controls per channel; variable Mu compressor/limiter; Class A; six compressor presets; fast/manual/preset switch; sidechain; bypass; link; two 6ES8 tubes; switchable VU meters. Frequency response: 15 Hz - 75 kHz. THD: <0.08%. 2RU. \$3,495

OCL-2 Electro-Optical Vacuum Tube Compressor/Limiter
Two-channel; threshold, ratio, output, attack, release controls per channel; soft knee compressor; Class A; six compressor presets; fast/manual/preset switch; sidechain; bypass; link; two 6072A, two 6922 tubes; switchable VU meters. 1/4", XLR. 2RU. \$2,795

Polyfusion Electronics

Mode 755 Frequency Shifting Feedback Controller
Sound reinforcement. Continuous frequency shifting. XLR, 1/4". \$695

NUENDO

frank filipetti



nuendo... untouchable sound.

To capture the sound of their new release *Untouchables*, heavy-hitting band *Korn* turned to digital recording pioneer Frank Filipetti and producer Michael Beinhorn. After painstaking comparisons, the group was unhappy with the way their tracks sounded using other popular DAWs, and found that they could edit and process tracks to their heart's content in NUENDO with absolutely no decrease in fidelity.

"I knew going in that the band was going to be especially vigilant about the sound of their instruments. That's why it was so important for me to find the right digital gear. Nowadays, everyone is accustomed to the manipulations we can perform on a digital platform. But the feature set has to be secondary to the fidelity set. And on that score we found NUENDO second to none."

One might even say.... untouchable.

phil ramone
rory kaplan
chuck ainlay
david tickle
frank filipetti
rob hill
greg ladanyi
elliott scheiner
alan parsons



These world-renowned producers know what it takes to be the best. They also know why NUENDO is the best digital audio production tool available and have partnered with Steinberg to ensure that it will continue to meet the needs of tomorrow.



 **steinberg**
Creativity First

ANALOG AUDIO PROCESSORS

PreSonus Audio Electronics

ACP88
Eight-Channel Compressor/Gate. Studio. Eight-channel; compressor/limiter/gate; hard, soft knee; peak/auto compression; compressor threshold, attack, ratio, release controls per channel; gate threshold, attack, release controls per channel; gain control per channel; sidechain, gate key and bypass per channel; gain reduction metering; linkable; LED meters. Frequency response: 10 Hz - 50 kHz. S/N: >94 dB. THD: <0.006%. Compressor ratio: 1:1 - 20:1. \$1,199

Blue Max
Compressor/Limiter. Studio. Single-channel; input, ratio, attack, release, output controls; 15 preset compression settings; preset limiting settings; bypass; side chain; switchable input/output LED meter; gain reduction LED meter. Compressor: ratio - 1:1 - 20:1; attack - 0.01 - 100 ms; release - 10 - 500 ms. 1/4", 8" x 1.75" x 4.5". \$199

GTX44
Quad Gate/Expander. Four-channel; low-filter, high-filter, threshold, attack, release, ratio, range controls per channel; duck; key input; bypass; side chain; +4/-10 dB operation; LED meters. XLR, 1/4". 1RU. \$599

VXP
Twin Servo Mic Preamp Voice Processor. Recording studio. Single-channel; mic pre, compressor, de-esser, expander, semiparametric EQ; gain, IDSS (tube emulation) controls for mic pre; compression compressor control; threshold, ratio expander controls; threshold, ratio de-esser controls; frequency, level controls for EQ; limiter and master level controls; 48 V phantom power; 20 dB pad. Frequency response: 10 Hz - 50 kHz. Dynamic range: >115 dB. XLR, 1/4". 1RU. Optional digital output card: \$399.

Prism Media Products Inc.

MEA-2 Precision Stereo Equalizer
Equalizer. Studio. Two-channel; four-band; variable Q/shelf, frequency and cut/boost controls on each band; bypass. Frequency response: 19 Hz - 27 kHz. Maximum boost/cut: ±8 dB. Minimum boost/cut: 0.5 dB. THD: <0.001%. 3RU. \$6,320

MLA-2 Compressor
Studio. Two-channel; stepped controls; ratio, attack and release controls; input, output gain controls; dynamic auto-adjustment; non-VCA design; linkable; switchable VU meters. THD: 0.001%. XLR, 19" x 4" x 12". \$3,650

Purple Audio

MC76 Peak Limiting Amplifier
Single-channel; input, output, attack, release controls; Class A; FET; switchable VU meter. Compressor ratios: 4:1, 8:1, 12:1, 20:1. Attack time: 20 - 800 microseconds. Release time: 50 mSec to 1.1 Sec. XLR, 2RU, 19" 3.5" x 8". \$1,195

Rane Corp.

DC 24
Dual Channel Dynamic Controller. Two-channel; gate/expander/compressor/limiter/crossover; threshold, ratio/gate/expander controls; threshold, ratio compressor controls; threshold ratio limiter controls; crossover control; output controls; bypass. XLR, 1/4" TRS. \$599

GE 130
Graphic Equalizer. Single-channel; 30-band, 1/3 octave; +12/-15 dB cut/boost; 45mm sliders; sweepable high-, low-cut filters; master level control; bypass. XLR, Euroblock. 2RU. \$529

GE 30
Graphic Equalizer. Studio, sound reinforcement. Single-channel; 30-band; 1/3 octave; 60mm sliders; boost/cut or cut only; active or transformer output; adjustable high-, low-cut filters; auto-bypass for power failure; security cover. +12 dB boost, -15 dB cut. XLR, screw terminals. 2RU. \$799

GE 60
Graphic Equalizer. Two-channel; 30-band, 1/3 octave; ±12 dB cut/boost; 45mm sliders; sweepable high-, low-cut filters; master level control; bypass. XLR, 1/4" TRS, screw terminal. 3RU. \$899

ME 30B
Graphic Equalizer. Studio, sound reinforcement. Single-channel; 30-band; 1/3 octave; ±6, 12 dB boost/cut; 20mm sliders; level control; bypass; 6 - 12 dB boost/cut. XLR, 1/4". 1RU. \$429

ME 60
microGraphic Equalizer. Two-channel; 30-band, 1/3 octave; 20mm sliders; adjustable high-, low-cut filters; level controls; ±12 dB cut/boost; bypass. XLR, RCA, 1/4" TRS. 2RU. \$699

PE 17
Parametric Equalizer. Studio, live sound, post production. Five-band; four octave sweep per band; bandwidth, octave, level controls per band; variable gain, high-, low-cut filters; bypass. Frequency response: 10 Hz - 20 kHz. Bandwidth: 0.03 - 2 per octave. Filter: -15 - +12 dB. XLR, 1/4". 1RU. \$549

SEQ 302L
Graphic Equalizer. Studio. Two-channel; 30-band; 1/3 octave; level control; 45mm sliders; bypass; 12 dB boost/cut. XLR, 1/4". 2RU. \$599

SEQ 30L/SEQ 30S
30-Band Graphic EQ. Live sound, sound reinforcement, installation, studio. Two-channel; 30-band; constant Q filters; input level control; bypass; ±12 dB cut/boost; overload LED. Dynamic range: 115 dB. XLR, 1/4". SEQ 30L (45mm faders, 2RU); \$599. SEQ 30S (20mm faders, 1RU); \$429.

THX 22 Stereo Equalizer
Installation. THX certified; two-channel; 5:1 surround; 11-band EQ; two parametric EQ bands; security cover. RCA. 1RU. Use with THX 44 for full 5.1 system. \$499

Raven Labs

PMB-1
Effects Processor. Two-channel; three-band EQ; gain controls; output volume control; effects loop control; phase reverse; front panel 1/4" inputs; ground lift; battery operation. 1/4", XLR. \$399

RDL, Radio Design Labs

FP-PEQ3
Parametric Equalizer. Single-channel; three-band; ±15 dB cut/boost; gain controls. RCA. \$275

RU-EQ2
Two-Band Equalizer. Bass, treble controls. \$153

Redwood Music Corporation

VQ-15N
Graphic Equalizer. Live sound, sound reinforcement, installation. Two-channel; 15-band; 2/3 octave; level control; low-cut filter (50 Hz); -10/+4 dB operation. Frequency response: 20 Hz - 20 kHz. S/N: 90 dB. THD: 0.03%. XLR, 1/4". 1RU. \$214

VQ-31N
Graphic Equalizer. Live sound, sound reinforcement, installation. Single-channel; 31-band; level control; low-cut filter (50 Hz); -10/+4 dB operation. Frequency response: 20 Hz - 20 kHz. S/N: 90 dB. THD: 0.05%. XLR, 1/4". 1RU. \$214

Requisite Audio Engineering

L2M Mastering Limiter
Studio. Two-channel; output level, peak reduction, response curve controls; bypass; ratio select (3:1, 5:1); linkable; 12AX7, 6A14, 6AQ5A tubes; switchable VU meters. Frequency response: 10 Hz - 90 kHz. XLR, 3RU. Single-channel mode: \$3,000. \$5,000

Rolls Corp.

CL 151 GLC
Compressor/Limiter/Gate
Single-channel; 12V phantom power; input, output, threshold, ratio, release controls; soft knee compression; side chain; LED meter. XLR, 1/4". \$120

EQ101 10-Band Precision Equalizer
Live sound, installation. Single-channel; 10-band; bypass. 1/4", RCA.

REQ215 Graphic Equalizer
Two-channel; 15-band; ±12 dB; high, low-shelving filters. RCA, 1/4", XLR, 1RU.

REQ231 Graphic Equalizer
Two-channel; 31-band; ±12 dB; high, low-shelving filters. RCA, 1/4", XLR, 2RU.

RP252 Compressor Limiter Gate
Two-channel; threshold, ratio, attack, release controls; side chain; +4/-10 operation. XLR, 1/4". \$749

RP262 Stereo Sonic Exciter
Two-channel; definition, bottom controls; LED meters. Frequency response: 20 Hz - 40 kHz. XLR, RCA, 1/4". 1RU.

Samson Technologies Corp.

S-com 4
Multiprocessor. Four-channel; expander/gate/ compressor/limiter; threshold expander/gate control; threshold, ratio, controls for compressor; output control. 1RU. \$289

S-com plus
Multiprocessor. Two-channel; expander/gate/ compressor/limiter/de-esser; threshold expander/gate control; threshold, ratio, attack, release controls for compressor; output control; de-esser level control; limiter threshold control; link. 1RU. \$279

S-Curve 215
Graphic Equalizer. Two-channel; 15-band; 2/3 octave; ±12 dB; hardwired bypass switches; independent level controls for both channels; high-pass filter; Constant Q; parallel filter design; LED meters. Frequency response: 10 Hz - 80 kHz. THD: 0.0035%. 1RU. \$199

S-Curve 231
Graphic EQ. Sound reinforcement, broadcast. Two-channel; 1/3 octave, 31-band EQ; hardwired bypass switches; ±6, ±12 dB; cut only mode; independent level controls for both channels; parallel filter design; Constant Q; LED meters. Frequency response: 10 Hz - 80 kHz. THD: 0.0035%. XLR, 1/4". 2RU. \$289

S-Gate 4
Four-channel Gate. Four-channel; expander/gate/duck; high, low-pass filters per channel; threshold, attack, hold, release, range controls per channel; LED meters. 1RU. \$339

Smart Electronics/Sunset Sound

C2 Stereo Compressor
Two-channels; threshold, ratio, attack, release, makeup controls per channel; "crush" frequency enhancement mode; link; sidechain; meters. Frequency response: 20 Hz - 100 kHz. THD: <0.005%. Compressor ratios: 1.5:1, 2:1, 3:1, 4:1, 10:1. Attack times: 0.1, 0.3, 1, 3, 10, 30 mSec. Release times: 0.1, 0.3, 0.6, 1.2, 2.4 Sec. 1RU.

19" x 1.5" x 10.25". Optional stereo only and slave units. \$2,995

Sonifex/Independent Audio

RB-SL2
Limiter. Two-channel; stereo/mono switch; gain, limit controls. XLR. \$280

Spatializer Audio Laboratories

Spatializer Retro
3D Audio Processor. Studio, post production. Can be used on individual tracks or entire mix. Frequency response: 22 Hz - 22 kHz. Dynamic range: 90 dB. 1/4", 1RU, 19" x 1.75" x 6". \$649

Speck Electronics

Model ASC
Four-Band Parametric Equalizer. Four-band; level, frequency controls per band; slope controls on mid bands; master gain control; bypass. Frequency response: 2 Hz - 154 kHz. 1/4" TRS, XLR. Version with optional output transformer: \$749. \$645

SPL US

Charisma 2 Model 9733
Tube Emulator. Studio. Two-channel; tube saturation, limiting, drive, charisma, output controls per channel; bypass; ground lift. Frequency response: 30 Hz - 40 kHz. THD: 0.41%. XLR, 1/4". \$749

Classic Vitalizer Model 9215
Multiprocessor. Studio. Two-channel; audiometric and psychoacoustic program EQ; stereo expander; output level control. Frequency response: 20 Hz - 50 kHz. THD: 0.002%. XLR, 1/4". 1RU. \$799

DynaMaxx Model 9735
Compressor/Decompressor/Limiter/Noise Gate. Studio. Two-channel; compressor, decompressor, soft limiter, noise gate; variable compressor times; automatic compression adjustment; decompression; side chain; bypass; ground lift; LED meter. Frequency response: 20 Hz - 100 kHz. THD: 0.002%. XLR, 1/4". 1RU. \$799

Kuitube Model 2049
Compressor/Limiter. Threshold, ratio, attack, release, makeup gain, tube harmonics controls; soft, hard knee compression; decompression; progressive time control; bypass; ground lift. Frequency response: 10 Hz - 100 kHz. XLR, 1/4". 2RU. Optional Lundahl transformers. \$1,999

Qure Model 9738
Three-band Parametric Equalizer. Recording studio, post production. Two-channel; three-band; LC filtering; tube emulation effect; variable high, low-pass filters; input, output controls; bypass; 12AX7LPS tubes; ground lift. Frequency response: 10 Hz - 100 kHz. THD: 0.01855%. XLR, 1/4". 2RU. Optional Lundahl transformers. \$1,949

Stereo Vitalizer MK2 Model 9526
Stereo Enhancer. Studio. Stereo expander; bass compressor; audiometric and psychoacoustic program EQ; intensity control; ground lift; bypass. Frequency response: 10 Hz - 100 kHz. THD: 0.002%. XLR, 1/4". 1RU. 12AX7LPS tube version, Stereo Vitalizer MK2-T Model 9739: \$999. \$699

Transient Designer 4 Model 9842
Envelope Modeler. Studio. Four-channel; Dynamic Envelope Technology independent processing technology; attack, sustain controls; channel link; bypass; ground lift. Frequency response: 20 Hz - 100 kHz. THD: 0.01%. XLR, 1/4". 1RU. \$1,199

Tube Vitalizer Model 9530
Tube-Based Stereo Enhancer. Studio. Tube circuitry; audiometric and psychoacoustic program EQ; two-band

EQ; coil filtering; 12AX7LPS tubes; bypass; VU meters. Frequency response: 10 Hz - 100 kHz. THD: 0.002%. XLR, 1/4". 2RU. \$2,899

Studio Technologies Inc.

Generation II Stereo Simulator
Post production, recording studio, broadcast. film. Stereo intensity, mode controls; LED meters. Frequency response: 20 Hz - 20 kHz. THD: 0.4%. XLR, 1RU. \$829

Summit Audio Inc.

DCL-200
Dual Compressor/Limiter. Studio, live sound, post production, broadcast. Two-channel; gain level control, variable slope, threshold, attack, release controls per channel; stereo link; bypass; side chain; switchable VU meters; three 12AX7A tubes. Frequency response: 5 Hz - 70 kHz. THD: <0.5%. XLR, 2RU. \$3,490

EQ-200
Four-Band Equalizer. Studio. Four-band; digital control; Rupert Neve-designed Class A analog signal path; high, low-pass filters; switchable shelving, peak filters; 25 user memory settings; MIDI compatible; linkable; Element 78 series. THD: <0.001%. XLR, MIDI. Slave version, EQ-200S: \$4,000. \$4,500

EQF-100
Tube Equalizer. Studio. Four-band; frequency, bandwidth, gain controls per band; band bypass; unit bypass. Frequency response: 5 Hz - 100 kHz. \$3,450

EQP-200B
Tube Equalizer. Studio, live sound, post production, broadcast. Two-channel; low-frequency boost/cut filters; high-frequency boost filters; high-frequency cut filters; one low-frequency shelf filter per channel; bandwidth control; transformerless signal path; bypass; three 12AX7A tubes. Frequency response: 5 Hz - 100 kHz. XLR, 2RU. \$2,950

TLA-100A
Tube Leveling Amplifier. Studio, live sound, post production. Single-channel; transformerless signal path; gain, gain reduction controls; switchable attack, release times; soft knee compression; link; side chain; bypass; switchable VU meter; 12AX7A tube. XLR, 1/4". 2RU. \$2,150

TLA-50
Tube Leveling Amplifier. Studio, live sound, post production. Single-channel; transformerless signal path; gain, gain reduction controls; switchable attack, release times; soft knee compression; link; side chain; bypass; switchable VU meter; 12AX7A/EC83 tube. XLR, 1/4". 1/2RU. \$695

Symtrix Inc.

422 Stereo AGC/Leveler
Automatic Gain Controller. Installation, broadcast. Automatic gain controller/limiter; detector, ratio, target level controls; peak limiter controls; bypass; LED meters. 1RU. \$549

532E Graphic Equalizer
31-band Stereo Graphic EQ. Sound reinforcement, broadcast. Two-channel; 31 constant Q bands; controllable high-, low-cut filters; level inputs; switchable cut/boost (6 or 12 dB); 20mm metal shaft faders; servo balanced outputs; direct coupled inputs; LED meters. THD+Noise: <0.002%. Dynamic range: >112 dB. Gold-plated 1/4", XLR, 2RU. \$749

551E
Parametric Equalizer. Studio, live sound, sound reinforcement, broadcast. Single-channel; five-band parametric EQ; controllable high, low-cut filters; frequency, bandwidth, cut/boost

TRUST YOUR MIX TO MIDAS

“Frankly, there is nothing that compares to the Venice in sound quality and size! And believe me, I’ve tried everything...”

Marvin Sutton, FOH engineer, Morgan Sound
Faith Hill/Tim McGraw

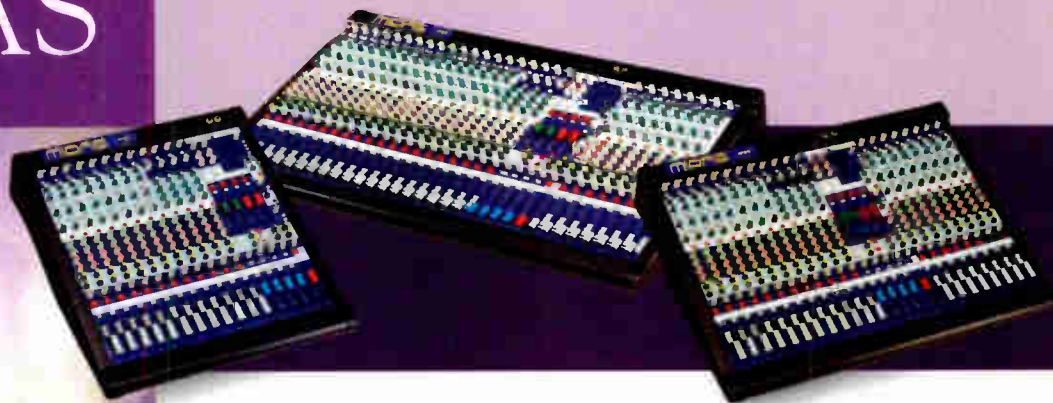

“I can honestly say that this is the sweetest sounding board I have tested.”

Jamie Rio, Technical Reviewer, *Gig Magazine*
Blue Barrel Jazz and Blues Festival

“We auditioned the Venice 240 at AES this year and were blown away!”

Marty Wentz, FOH Engineer
9-piece showband, “Which Doctor”

“I’ve dreamed of something like this, and now Midas has come through with its Venice series.”

Etienne Lemery, Technical Reviewer, *SONO Mag World Edition*

“This is an outstanding console! We’ve had it jammed to the max and it performs wonderfully! Truly a MIDAS!”

Jack Haffamier, Manager, Nelson Sound
Pasadena Pops/Wayne Newton/Jay Leno at Bally’s Events Center

“Keeping the show within budget. Saving the sound. Truly fantastic!”

Robbie McGrath
Peter Dinklage/Weezer US Tour

“This is the money! I had every single hole at the back of the Venice 320 filled with all the toys like Summits, Focusrite® and Drawmers®. I was running three sends back to stage for monitors, two for effects and the last for subs. DI outs to Pro Tools®. I was maxxed out, and it seemed to like it. I did too!”

Cristiano Avigni, FOH Engineer
Abenaa

To get your own Midas, call 1-800-392-3497 or visit us at www.midasconsoles.com

 **MIDAS**
DESIGNED FOR A PURE PERFORMANCE

 **VENICE**

ANALOG AUDIO PROCESSORS

controls per band; servo balanced output, direct coupled inputs. THD+Noise: <0.002%. Dynamic range: >112 dB. Gold-plated 1/4" and XLR. 1RU. \$449

610 Broadcast Audio Delay

Broadcast. Stereo, 3.5 or 7.5 second delay; cough, profanity edit functions; LED delay meter; bypass. 1RU. Remote control, RC-610: \$249. \$1,999

TC Electronic USA

1128

Graphic Equalizer/Spectrum Analyzer. Sound reinforcement, live sound. 28-band; 1/3 octave; programmable, autofeedback search and destroy; onboard signal analysis computer; 99 user presets; security lock and memory functions; LCD screen. Frequency response: 10 Hz - 100kHz. Dynamic range: >110 dB. 1/4" XLR 1RU. Optional SMPTE time code function, SMT128. Optional video interface. \$2,742

1210

Spatial Expander/Stereo Chorus/Flanger. Studio. Two-channel, separate chorus flanging circuits, delay, panning; stereo/mono; input sensitivity, intensity, speed, width, delay controls; bypass; linkable, LED; Haas Principle stereo enhancement. Frequency response: 20 Hz - 20 kHz. 1RU. \$1,684

TL Audio/HHB Communications

C-1 Dual Valve Compressor

Two-channel, tube operation input gain, threshold, attack, release, ratio, gain makeup controls per

channel; 48 V phantom power; high-pass filter (90 Hz); master gain output control; front panel 1/4" inputs; VU meters. Frequency response: 20 Hz - 40 kHz. XLR, 1/4". \$1,599

EQ-1 Dual Valve Equalizer

Two-channel; tube operation; four-band; cut/boost, switchable frequency controls per band; gain controls per channel; 48 V phantom power; front panel 1/4" input. Frequency response: 20 Hz - 40 kHz. 1/4", XLR. \$1,599

EQ-2 Dual Parametric Valve Equalizer

Two-channel; four-band parametric EQ; preamp section; 48 V phantom power, gain control; variable high, low-cut filters; master output control; bypasses per band; front panel 1/4" input. Frequency response: 20 Hz - 40 kHz. 1/4", XLR. \$2,199

Tube Tech

CL 2A Dual Compressor

Studio. Two-channel; optical compressor; side chain. Frequency response: 5 Hz - 80 kHz. Compressor ratio: 2:1 - 10:1. \$3,295

EQ 1AM

Tube Equalizer. Studio, live sound. Single-channel; tube operation; three-band EQ; high-, low-cut filters; high-, low-shelving; gain controls with boost/cut switches; floatable transformers; hard bypasses with clickless relay; three ECC81, one ECC82, three ECC83 tubes; rotary switches. Frequency response: 5 Hz - 60 kHz. XLR 2RU. \$5,695

LCA 2B

Compressor/Limiter. Studio, live sound. Two-channel; tube operation; output, ratio, threshold, attack, release controls per channel; separate compressor and limiter functions per channel; Fairchild 670 attack/release presets; variable compression ratio; two ECC81, two ECC82, two ECC83 tubes; dual LED indicators. Frequency response: 20 Hz - 22 kHz. XLR, 2RU. \$3,495

PE 1C

Tube Equalizer. Studio, live sound. Two-channel; tube operation; tube push-pull amplifier; separate frequency boost and attenuation controls; bandwidth control; attenuation control; ECC82, ECC83 tubes; similar to Pultec EQP-1A. Frequency response: 5 Hz - 40 kHz. XLR, 3RU. \$1,850

SMC 2B

Multiband Compressor. Studio. Two-channel; three-band; optical compressor; gain, threshold, attack, release controls per band. 3RU. \$4,395

Universal Audio

1176LN Solid State Limiting Amplifier

Single-channel; input, output, attack, release controls; selectable compression ratio (4:1, 8:1, 12:1, 20:1); Class A; switchable VU meter; modeled on original 1176 peak limiter. Frequency response: 20 Hz - 20 kHz. THD: 0.5%. \$2,295

Teletronix Model LA-2A

Leveling Amplifier. Studio. Single-channel; gain, peak reduction controls; +4 or +10 dB output; optical attenuation; VU

meters; modeled on original Teletronix LA-2A. THD: 0.5%. \$3,495

Videoquip Research Ltd.

SC-2 Stereo Corrector

Polarity correction; left/right channel reversal; mono sum. XLR. \$350

White Instruments

4400

Equalizer. Single-channel; 28-band; 1/3 octave; 10 dB cut/boost; variable high-, low-pass filters; triamp outputs; optional two-way, three-way, plug-in crossover network cards; metal or plastic security cover. Filter ranges: 31.5 Hz - 16 kHz. \$1,500

4700

1/3 Octave Equalizer. 28-band, 1/3 octave; digital control; 10 presets; 10 memories; 10 dB cut/boost; high-, low-pass filters; security lockout; LCD screen. 1RU. Optional computer controlled version, 4700 XL, \$1,050. Optional SACD/DSD upgrade. \$1,225

4856

Graphic Equalizer. Single-channel; 29-band; gain control; 15 dB cut/boost; variable high-pass filter (15 - 175 Hz); bass rolloff (100 Hz); 45mm sliders; bypass; LED meters; optional security cover. Filter ranges: 31.5 Hz - 16 kHz. 1/4", XLR. Optional gain output control version, 4856SX. \$1,835

XTA Electronics/Group One Ltd.

GQ600

Graphic Equalizer. Two-channel; 30-

band; 1/3 octave; high-pass filter; trim controls; bypass; 45mm faders. \$1,650

Yamaha Corp. of America

GC2020C

Compressor/Limiter. Sound reinforcement. Two-channel; expander/gate, threshold, ratio, attack, release, input, output controls per channel; switch selectable dual-mono and stereo modes; link; side chain; gain reduction LED. Frequency response: 20 Hz - 20 kHz. XLR, 1/4", RCA. 1RU. \$489

GQ1031C

Graphic Equalizer. Sound reinforcement. Single-channel; 31-band, 1/3 octave; high-pass filter (80 Hz); bypass; peak LED; signal LED. Frequency response: 20 Hz-20 kHz. XLR, 1/4", 1RU. \$415

GQ2015A

Graphic Equalizer. Sound reinforcement. Two-channel; 15-band, 2/3 octave; high-pass filter (80 Hz); bypass; peak LED; signal LED. Frequency response: 20 Hz-20 kHz. XLR, 1/4", 2" x 9" x 19". \$449

GQ2031B

Graphic Equalizer. Sound reinforcement. Two-channel; 31-band, 1/3 octave; level controls; automatic muting circuit; 6/12 dB cut/boost; peak LED; variable high-pass filter (20 - 200 Hz); bypass; signal LED. Frequency response: 20 Hz-20 kHz. XLR, 1/4", 2RU. \$769

CONSOLES/MIXERS

Adgil Design/Sascom Marketing Group

The Director

Surround Sound Monitoring System. Modular, stereo, LCRS, 5.1, 6.1, 7.1 surround format compatible; Pec/Direct; various modules for input, output, communication, processing, expansion. Starts at \$2,995

AETA Audio Corp.

Mix2000

Field Mixer. Field, broadcast, film. Four-channel; M/S matrix, level controls, 48V/12V, 12T phantom power, phase reverse, compressor, limiter, low cut filters (80 Hz, 120 Hz), slate, oscillator; on air indicator; LED meters; battery operable. Version with AES/EBU output. \$4,285. \$3,895

AKG Acoustics US

AS 16x12 Automatic Matrix Mixer

Installation. 16-channel mic mixer; Adaptive Proportional Gain, matrix routing, high-pass, low-pass filters; 19 programmable logic outputs, mix-minus; Lectrosonics LecNet PC software, RS232 port, linkable; compatible with AMX, Crestron controllers. 2RU. \$3,783

AS 4x3 Seven Channel Automatic Mixer

Four mic inputs, three line inputs; 24V phantom power, compressor, limiter; ducking, gate, linkable. \$996

Alesis

MultIMix 12R ★ New for 2003 ★

Rackmount. Mixer. Eight-channel; 60mm faders. 3RU. \$349

MultIMix 8FX ★ New for 2003 ★

Four mono inputs, two stereo inputs; three-band EQ; 99 24-bit digital effects, pan, balance controls; LED meters. XLR, 1/4", RCA. \$199

Studio 12R

Rackmount Mixer. Studio, live sound. 12-channel; 60mm faders; inserts; two-band shelving EQ; two aux sends, pan, high-, low-shelving, peak indicator per channel; stereo aux return; 48V phantom power; LED meter; headphone, monitor output. XLR, 1/4", 3RU. \$449

Allen & Heath

DR128

Digital Zone Mixer. Live sound, sound reinforcement. 12 inputs, 8 outputs; two DSP modules - signal processing, mix matrix; gate, compressor, 31-band graphic and parametric EQ; ducking; 12 user-definable memory soft keys, 16 internal memory patches; LCD screen; Windows computer control. \$3,199

GL4000

Live Sound Console. Live sound, sound reinforcement. FOH and/or stage monitor console; 24, 32, 40, 48 channel frames; 100mm faders; four-band fully sweepable British EQ; Control; pan; input gain control; Sys-Link; four groups; phantom power; 20 dB pad on mic pres; high-pass filter; low-cut filter; six auxiliary sends; eight groups; stereo returns; width control on stereo inputs; automated mute; bypasses; PFL/AFL; talkback function; LED meters; direct outs with level control; inserts; phase; gold-plated connectors. XLR, 1/4". \$16,699

GR1

Zone Mixer. Installation, live sound. Six input channels; three-zone; three stereo, three mono outputs; input gain controls; compressor/limiter; emergency paging function; ducking priority buttons; phantom power; LED meters; peak LEDs; remote controllable. XLR 1RU. Sys-Link option. \$1,099

ICON DP1000

Powered Digital Mixer. Live sound. 10-channel; four-band EQ per channel;

10-band master EQ; 100mm faders; onboard effects processor with gates, compressor, flange, chorus, reverb, tremolo; programmable; sequencing function; patch functions; footswitch, MIDI control; LCD screen; 600 W amp; Windows control software. XLR, 1/4", RCA, Speakon, MIDI. \$1,799

ML5000

Console. Live sound. 32, 40, 48-input frames; four-band parametric EQ with sweepable mids; 16 axes; LCR panning; 128 scene memory; onboard 12 x 8 matrix; inserts; talkback function. XLR, 1/4". 24-input sidecars available. \$23,999 - \$31,950

PA20-CP

Powered Mixer. 16 mono inputs, two stereo inputs; 48V phantom power; four-band EQ; onboard DSP effects; four aux sends; background music mode; twin onboard 500W amps; XLR lamp socket; LED meters. XLR, 1/4", RCA, Speakon, S/PDIF. \$2,499

WZ16:2DX MixWizard

Mixer. Live sound, studio. 16-channel; four-band semiparametric EQ; 100mm faders; inserts; 10 dBV/+4 dBu operation; phantom power; low-cut filter; onboard DigTech DSP module; rotating connector section for console or rackmounting. XLR, 1/4". \$1,249

Xone2:464

DJ-Style Mixer. Live sound. Four mic/line inputs; 6 dual stereo inputs; crossfader; four-band EQ; 6 dB boost/25 dB cut; RIAA preamps for turntables; six aux sends; ALPS faders; 100mm, 60mm faders; LED meters. \$2,199

Allen Audio Inc.

VPA-100

Digital Matrix Mixer. Installation, live sound. Eight-channel; full matrix; 20-bit A/D-D/A; six-band parametric EQ, compressor, gate per channel; delay; reverb; 48V phantom power; preset

memories; headphone; PC control software; RS232; LCD screen; jog wheel. XLR, 1/4", RCA, nine-pin D-sub. \$3,000

Ameek USA

9098i Recording and Production Console

Recording studio, post production. 24-120 channels; 24-track bus; 16 aux sends; four-band parametric EQ; adjustable EQ curves; 48V phantom power; Transformer-Like Amplifier (TLA) mic preamps; remote controlled outboard RCMA mic preamps; input trims; phase; LCRS, 5.1 surround sound; Virtual Dynamics DSP; SuperTrue automation; Visual FX automation/machine control; Recall snapshot memory; MMC; control room/studio monitor section; AFL, PFL, solo; talkback function; tone signal generator; 1/4" patchbay; keyboard; motorized 100mm, 60mm faders; tricolor LED meters; VU meters.

Galileo 360V

Broadcast, post production. 40, 56-channel frames; dual signal path; 24-track bus; 16 aux sends; four-band parametric EQ; 48V phantom power; Transformer-Like Amplifier (TLA) mic pres; input trims; phase; LCRS, Dolby, 7.1 surround sound; Virtual Dynamics DSP; SuperTrue V4 automation; Visual FX automation/machine control; Recall snapshot memory; MMC; control room/studio monitor section; AFL, PFL, solo; talkback function; tone signal generator; keyboard; tricolor LED meters; VU meters.

Media 51

Mixing Console. Studio, post production, broadcast. 28, 44-input frames; 48V phantom power; pan controls; phase reverse; variable high-pass filter; variable low-pass filter; four-band EQ; 5.1, 7.1, LCR, LCRR, LCRRS surround formats; Virtual Dynamics processing; Supertrue automation;

Rupert Neve designed mic preamp and EQ sections; effects send/returns; talkback section; 12-bus; AFL; slate. 28-channel: \$49,950. 44-channel: \$69,950.

Recall RN

Console. Live sound, broadcast, installs, recording studio. 40, 56-channel frames; eight-bus; 48V phantom power; phase; four-band EQ with sweepable mids; EQ cut/boost ±18 dB; Virtual Dynamics DSP; SuperTrue automation; Showtime automation; Rupert Neve designed mic/line input modules; high-, low-pass filters; flexible routing options; inserts; eight aux per channel; talkback function; onboard tone generator; PFL, AFL, solo; 100mm faders; tricolor LED meters. Recall RN 40: \$91,000. Recall RN 56: \$109,000.

Rembrandt

Console. Recording studio, post production, film, video. 40, 56-channel frames; dual signal path; 24-track bus; 16 aux sends; four-band parametric EQ; 48 V phantom power; pad; line pad; phase; Virtual Dynamics DSP; SuperTrue automation; Visual FX automation/machine control; Recall snapshot memory; MMC; control room/studio monitor section; AFL, PFL, solo; 1/4" patchbay; keyboard; 100mm, 60mm faders; tricolor LED meters; VU meters. Rembrandt 80: \$129,789. Rembrandt 112: \$167,874.

American Audio

Q-3433/SX

Rackmount Preamp Mixer. Live sound. Q-start; APLS feather fader; gain control; three-band EQ; cue level control; talkover ducking; goose-neck light; zone/boost controls; left/right turntable controls; PFL; rubber knobs. XLR, 1/4", RCA. \$399

Q-MX2BPM

Preamp Scratch Mixer. Live sound. X-Y assignable channels; gain controls;

A complete 1000 watt system!

Whether it's for your band, church or school, Carvin's PA800/PA1200 package systems allow you to run the whole group in stereo while powering your monitors! The lightweight mixer pumps out 1000w RMS from three amps delivering 333w each. You also get two built-in 24-Bit digital multi-effects processors with over 256 effects each!

There has never been a system so easy to use with so much clarity, power and flexibility! Discover the complete line of Carvin sound packages for "matched system" performance.

PA SERIES 8 and 12 CHANNEL MIXERS:

- Three high current power amps – R-L/Monitor
- 1000w RMS – 333w per amp at 4Ω
- Two 24-Bit stereo effects processors
- Assign any channel to effects 1 or 2
- Assignable 9-Band EQ's – mains or main/monitor
- Super quiet, high-headroom mic/line pre-amps
- Three Band channel EQ @ 80Hz, 750Hz and 11.5k Hz
- Balanced XLR line outputs, RCA In/Out connectors
- Easy to use and carry. These compact mixers weigh only 28 lb.
- Engineered with double sided copper FR-4 military spec cards and SMT construction for rock-solid reliability and interference free performance.
- Continuous full RMS power is assured from the 6063-T5 aluminum heat sink cooled by a quiet dual-speed fan.

832 15" SPEAKERS and 722 12" MONITORS:

- Deep bass punch with crystal clear highs for exceptional clarity
- High power handling 832: 400 watts, 722: 300 watts
- Strong, lightweight plywood construction, covered with Duratuff II™ and protected with steel corners and grills • Stand-mount inserts

optional MS13 stands

832 Speakers



optional SS20 stands



722 Monitors

8 CH Mixer PA800 **'669'** 12 CH Mixer PA1200 **'769'**

Package System including monitors
1200P-832-722 '1659'
 • 1000W PA1200 mixer • Two 832 400W speakers
 • Two 722 300W monitors • Two CM50 mics • Two 20ft XLR mic cables • Four PH50 speaker cables

CARVIN
 800.854.2235 .COM

To ORDER, SPECS or for a FREE catalog carvin.com/pro_sound
WORLD'S #1 FACTORY DIRECT MUSIC STORE
 Enter carvin.com/s weekly FREE GEAR giveaway!

CONSOLES/MIXERS

selectable crossfader curve; Q-Start; BPM; three-band EQ per channel; talkover ducking; kill switches; PFL; rubber knobs. \$499

Q-Spand

DJ Preamp FX Mixer. Live sound. Four-channel; fader curve control; Q-start; three-band EQ; gain controls; mic volume controls; onboard sonic enhancement controls; zone volume control; SRS WOW technology; light socket; LED meters. \$399

AMS Neve PLC

88R
Analog; automated faders; 5.1 surround sound. Starts at \$550,000

Digital Film Console (DFC)

Film, post production. Up to 512 inputs; 16, 20-bit A/D-A; track arming controls; Encore dynamics automation; onboard DSP; eight-band graphic EQ; 5.1, 6.1, dubber chain sync controls; setting displays; routing displays; Integrated Machine Control; PEC/Direct; RS422 ports; ES Bus, Sony, Lynx VR3 support; MADI interface; upgradable digital processing cards; compatible with AMS Neve AudioFile systems.

Libra Live II

Digital Console. Broadcast. 16, 20, 24-bit A/D-A; mix-minus; full surround sound monitoring; 44,056, 44.1, 47,952, 48 kHz sample rates; onboard DSP; filters; limiters; gates; delay; talkback, AFL per channel; Scope snapshot automation; On-Air broadcast chain security; split console mode; Flash RAM console control BIOS; upgradable digital processing cards; MADI interface; nine pin compatible; ES bus; jog/shuttle wheel; LCD screen; tricolor LED meters.

Libra Post

Video post production. 12, 24, 48-frame; up to 96 channels; 20-bit I/O; 32-bit processing; eight-channel (7.1) surround monitoring; four-band parametric EQ; Encore Total Dynamic Automation; snapshot memory and setting control; jog/shuttle/rollback control; locate points; onboard delay; PFL; solo; stereo; mono auxes; onboard oscillator; inserts; improved automation; upgradable digital processing cards; MADI interface; ADAT, TDIF interfaces; electronic track scribble pads; twin LCD screens.

Logic MMC

Digital Mixing Console. Film, video, post production. 24-bit; 96 kHz; 48 kHz internal processing sample rate; onboard DSP; Encore automation; scene memory; Dolby approved; qwerty keyboard; LCD; networkable with other AMS Neve products. Starts at \$200,000

VXS Multiformat Post Production Console

Post production, film, video, broadcast. 24 - 96-channel frames; 48-bus; eight aux sends; phantom power; 30 dB pad; mic trims; line trims; phase; four-band parametric EQ; expander/gate, compressor/limiter; high-, low-pass filters per channel; surround sound; dubber support; pan controls; inserts; AFL, PFL, solo; track laying/mixdown/broadcast modes; effects return; oxygen-free wiring; LED meters.

API Audio Products Inc.

7800
Master Control Module Links with API 7600 input channels; solo control; four send masters; control room monitor controls; four bus masters; talkback section; stereo fader. 1RU. \$2,495

Legacy

Console. 64-channel; API 212L mic preamp module; API 550L equalizer module; API 768 input module; moving faders; VU meters. Compatible with

optional API L200 processor modules. Starts at \$140,000

Ashly Audio

XL-308B

Rackmounted Eight-Channel Stereo Line Mixer. Live sound, sound reinforcement 8 stereo or 16 mono inputs; channel 1 and 2 selectable mic or line inputs; level/pan controls, mute switches per channel; stereo output, output controls; clip indicators; stereo output mute switch; stereo headphone output with level control; five-segment LED meters. 1/4" TRS. 1RU. \$612

MX-508

Rackmounted Eight-Channel Stereo Mixer. Sound reinforcement, live sound, broadcast, location. Eight-channel; three-band EQ with sweepable mids per channel; two auxes per channel; input level per channel; level/pan controls per channel; mic/line switches, insert jacks per channel; main output level controls; mono output control; headphone control; two master aux sends and returns; 48V phantom power; 10-segment LED meters. XLR, 1/4". 5RU. \$1,519

ATI Audio Technologies Inc.

MX100

Mic/Line Mixer. Field, broadcast. Three input; mono; tricolor LED meters; external power supply/battery package; NanoAmp series. Frequency response: 20 Hz - 20 kHz. THD: 0.1%. XLR. 1/3RU. Available with switchable peak limiter, MX100C; \$479. Optional rack and desk mount adaptors. Optional 48V phantom power. \$439

MX200

Mic/Line Mixer. Field, broadcast. Three input; stereo; tricolor LED meters; external power supply/battery package; NanoAmp series. Frequency response: 20 Hz - 20 kHz. THD: 0.1%. XLR. 1/3RU. Available with switchable peak limiter, MX200C; \$799. \$779

MXS100

Portable Stereo Mixer. Location. Phantom power; slate mic; switchable limiter; low-cut filters; headphone monitor; tape I/O; stereo out mic/line; test tone oscillator; tricolor LED meters; AC/DC converter; field/battery power package; ships with carrying case. XLR. 1.75" x 5.5" x 5.75". \$969

Audient/ATI

Aztec Live Console

Live sound. 32, 40, 48 channels; 12 x 8 matrix; tube frame; LED meters. \$49,900

Audio & Design Ltd.

DMM-1 Digital Mini Mixer

Four into One Mixer. Four into one; 32, 44.1, 48 kHz sample rates; onboard sample rate converter; 16-24-bit; DAT ID bypass; M/S capable; PAL, NTSC digital frame delay; onboard digital line oscillator; four aux outputs; AES/EBU, S/PDIF; LED meters. \$2,948

Audio Developments Ltd./Independent Audio

AD 146

Mixer. Field, broadcast. Four-track; 6 - 18 inputs; 12V, 24V phantom power; M/S; four output busses; limiter; PFL; talkback function; tone (1, 10 kHz) generators; switchable analog meters. XLR. Depends on configuration. Optional T power. \$6,350 - \$13,000

AD 149

Mixer. Film, live sound. 6 - 12 inputs; three-band EQ; send/returns; slate; M/S decoding; EQ; limiter; switchable analog meters. XLR. Depends on configuration. \$7,775 - \$13,625

AD 261 ENG Mixer

Portable Mixer. Field, broadcast. Four

mic/line; 48V phantom power; 12V Toner; AC/battery power; PFL; M/S decoding; talkback function; limiter; tone (1 kHz, 10 kHz) generator; camera return; switchable analog meters; battery operable. XLR, 1/4". \$3,650 - \$4,550

Audio Toys Inc.

Paragon II

Live Sound Monitor Console. Live sound, install. 64 inputs; up to 20 stereo outputs; four-band parametric EQ, compressor, low-pass filter, high-pass filter, gate per channel; phase; 48V phantom power; three-band EQ on outputs; intercom: wedge and in-ear monitor paths; Penny & Giles faders; LED meters. XLR, 1/4". Optional moving fader automation. Available as a production optimized version. Starts at \$115,000

Azden Corp.

FMX-2 ★ New for 2003 ★

Field. Two-channel; level, monitor control; battery operable (9V). XLR, 1/8". \$350

Behringer

DDX3216

Digital Mixer. 32-channel; four-band parametric EQ; compressor; gate; low-cut filter; DSP effects; MMC; eight auxes; 100mm ALPS motorized faders; Windows software. Optional I/O cards for AES/EBU (\$349), TDIF (\$319), ADAT (\$319). \$1,999

Eurodesk MX3282A

Mixing Console. Studio. 24 mono inputs, four stereo inputs; three-band mono EQ with sweepable mid; four-band stereo EQ; auxes; talkback function; 48V phantom power; PFL; solo; inserts; top-mounted I/O. XLR, 1/4", RCA. \$1,479

Eurodesk MX9000

Console. Studio. 48-input; four-band EQ with sweepable mids; Virtualizer DSP effects; 48V phantom power; 100mm faders; talkback function; gold-plated connectors; LED meter bridge. 1/4", XLR. \$2,399

Eurorack MX2642A

Rackmountable Mixer. Studio, live sound. Eight mono inputs, four stereo inputs; three-band mono EQ with sweepable mid; four-band stereo EQ; low-cut filter (75 Hz); auxes; 48V phantom power; PFL; solo; inserts; LED meters. XLR, 1/4". \$499

Eurorack MX3242X

Console. Studio. 16-channel; 32 mono inputs; 20-bit A/D-D/A; 24-bit onboard Virtualizer DSP; four-band EQ with sweepable mids; reverber, chorus, delay, flange, low-cut filter; 48V phantom power; talkback function; inserts; direct outs; rackmountable. Includes rack-mount kit. \$999

Pro Mixer DX1000

Live sound. Seven input channels; crossfader; 100mm channel faders; three-band EQ; independent subwoofer output; talkover function; PFL; lamp socket. XLR, 1/4", RCA. \$449

Benchmark Media Systems Inc.

IFA-10 4x4 Assignable Mixer

Broadcast, recording studio. Four-channel; gain controls, mix-minus. \$270

IFA-2 Balanced Mix Amplifier

Two into one out. Dynamic range: >120 dB. \$195

Cadac Electronics PLC.

F-Type Live Production Console

Live Sound Mixing Console. Live sound. Modular; up to 256 inputs, 52 outputs. XLR, 1/4".

M-Type Monitor Board

Monitor Mixing Console. Live sound, sound reinforcement. Modular; up to 112 input channels; 52 outputs; 28 mix busses; four-band parametric EQ; variable high-pass, low-pass filters; PC compatible; memory settings. XLR. Wide variety of sizes, input options available. Optional fader automation.

R-Type

Console. Live sound, sound reinforcement, installation. Modular; LCR pan; 48V phantom power; 32 output busses; compatible with Cadac Sound Automation Manager (SAM) software; memory. XLR, 1/4".

S-Type Live Production Console

Live sound, sound reinforcement, installation. 12, 16, 24-input frames; 100mm Penny & Giles faders; XLR, 1/4" TRS. Starts at \$25,000

Calrec Audio Ltd.

Alpha 100

Digital Console. Studio, broadcast. Up to 96-channel; 24-bit; EQ; dynamics; modular processing cards; IFB outputs; mix-minus; 5.1 surround compatible; Dolby E; NTSC/PAL sync; word clock; 44.1, 44,055.9, 47,952, 48 kHz sample rates; Windows NT memory system; electronic scribble strips; LED meters. Optional delay.

M3 Minimizer II

Remote Recording/Production Console. Broadcast. 10 - 42-channel; three-band EQ; high-pass filter; two-band filters; stereo pan, stereo width controls; mix-minus; fader/cue start; rackmountable. Optional meter bridge.

S2

Broadcast Production Console. Broadcast, studio. Up to 72 channels; surround sound functions; mix-minus; four-band EQ; three high-pass, three low-pass filters; eight aux sends; stereo pan; stereo width control; talkback function; expanded monitoring functions; switchable metering.

Sigma 100

Studio, broadcast. 32, 48, 72-channel frames; four-band EQ, compressor, limiter, expander/gate per channel; 12 auxes; Dolby E; 5.1 surround sound; IFB functions.

Carvin

C1644

Mixer. Live sound, studio. 16-channel; twin nine-band graphic EQs; onboard 24-bit digital effects; onboard chorus, reverb, flange; gain control, low-cut filter, three-band EQ with sweepable mid, effects sends, pan control, mute, PFL per channel; phantom power; tape in/out; effects returns; top-mounted I/O; headphone controls; LED meters. XLR, 1/4", RCA. 22.25" x 14.25" x 3.25". 20 lb. Powered version: \$1,099. \$699

C3244

Mixer. Live sound, sound reinforcement. 32-channel; twin nine-band graphic EQs; onboard 24-bit digital effects; onboard chorus, reverb, flange; gain control, low-cut filter, three-band EQ with sweepable mid, effects sends, pan control, mute, PFL per channel; phantom power; tape in/out; effects returns; top-mounted I/O; headphone controls; LED meters. XLR, 1/4", RCA. 38" x 14.25" x 3.25". 40 lb. \$1,199

PA1200

Powered Box Mixer. 12-channel; onboard 24-bit DSP effects; three-band EQ; twin nine-band master graphic EQs; phantom power; effects send; tape return; pan controls; three onboard 333W amps. XLR, RCA, 1/4". 19.5" x 9" x 11". 28 lb. Unpowered rack-mount version: \$459. \$769

PA410

Powered Box Mixer. Four-channel;

onboard 24-bit DSP effects; two-band EQ; seven-band master graphic EQ; phantom power; effects send; tape return; onboard 100W amp. XLR, 1/4", RCA. \$239

S/L Series

Console. Studio. 24, 40, 56-channel frames; 48V phantom power; four-band EQ with sweepable mids; low-cut filter (75 Hz); pan control; eight auxes; 100mm ALPS faders; LED meter bridge. XLR, 1/4", RCA. Speakon. 24-channel: \$1,999. 40-channel: \$3,399. 56-channel: \$4,999.

Cooper Sound Systems Inc.

CS 104 "ENG" Style

Portable Stereo Mixer. Location. Four-channel; high-pass filters; peak indicators; level controls; PFL; slate, oscillator; Jensen transformers on I/O; peak or VU meters; battery tester; headphone monitor section; line/mic gain selectors; tape return/out; monitor in; video sync connector; linkable; battery powered (8 AA cells). XLR. 11" x 6.75" x 2.5". 4.8 lb. \$4,300 - \$4,400

CS 208 Professional Audio Mixer

Film, video. Modular; 8 input channels; battery powered (12 D cells); phantom power; EQ; two high-pass filters, limiter, phase, 20 dB and 40 dB pads, PFL, aux, 83mm Penny & Giles sliders on each channel; peak or VU Sifam meters; slate; talkback feature; oscillator selector; headphone level control; Litterle, XLR, TO9, nine-pin D-sub. 16.5" x 15" x 5". 19 lb. Remote rolls for HHB, Fostex, Nagra recorders. Rackmountable. \$12,500 - \$14,500

Crest Audio Inc.

LMx

Monitor Console. Sound reinforcement, live sound. 22 output busses; three-band sweepable output EQ; four-band input EQ; pad; variable high-pass filter; 100mm faders; Dedicated Room Ambience section; ducking features; VU meter bridge. \$39,400 - \$49,000

V12

Mixing Console. Live sound, sound reinforcement, broadcast. 28, 36, 44, 56 input frames; 12 VCA groups; 48V phantom power; pad; phase reverse; four-band full parametric EQ on input modules; high-pass filter; LCR on mono inputs; 16 aux busses; MIDI-based microprocessor control and muting; eight group busses; left/right stereo and center/mono busses; multi-mode solo; talkback and intercom; VU meter bridge; sidetack expanders available. \$41,000 - \$77,000

X Series

Mixing Consoles. Live sound, sound reinforcement. X-Four (12, 20, 28, 36-channel frames), X-Eight (28, 36, 44-channel frames); four-band EQ with sweepable mids on each input and each output; eight aux sends; switchable stereo on select channels; microprocessor controlled MIDI mute; LCR panning; eight audio groups with discrete bus assignment; 12 x 4 matrix output; flexible group/master options; separate 1/4" jacks for return and send functions; solo, PFL, mute; pink noise generator; VU meters. Customizable for live sound or recording configurations. \$4,950 - \$18,200

XR-20

Rackmount Mixer. Installation, live sound, broadcast. 12 mono inputs; four stereo inputs; 100mm faders; four-band EQ; 48V phantom power; high-pass (70 Hz) filter; six auxes; mute; PFL; pan; linkable; LED meters; lamp socket. 1/4", RCA, BNC, MIDI five-pin. \$2,200

XR-M

Rackmount Monitor Mixer. Installation, live sound, broadcast. Up to 12 mono/six stereo monitor mixes; four-band EQ with sweepable mids; 20-

PYRAMIX V4.1

VIRTUAL STUDIO

THE MOST OPEN DAW IN THE WORLD!

NOW HAS DIRECT PROJECT INTERCHANGE WITH...

- > Akai - DD/DR Series
- > Sonic Solutions
- > Pro Tools

PLUS, INDUSTRY STANDARD INTERCHANGE THROUGH...

- > AES31 - (DAR, Fairlight, SADIE, Waveframe, ...)
- > Open TL - (Logic Audio, Nuendo, Tascam, ...)
- > OMF - (Avid, Incite and most NLE systems)



www.merging.com

SWITZERLAND TEL. +41 (0)21 946 3444
USA: TEL. +1 (847) 272 0500
EUROPE / ASIA: TEL. +44 (0) 1606 692788

World Radio History

MERGING

input mic splitter; high-pass filter; inserts; lamp socket; LED meters. XLR, 1/4", RCA, BNC. \$2,600

X-VCA

Console. Live sound, 24, 32, 40, 48-input channel frames; four-band EQ with sweepable mids; comp/lim; downward expander; eight aux sends; 48V phantom power; pad; phase reverse; microprocessor controlled MIDI mute; LCR panning; eight audio groups with discrete bus assignment; flexible group/master options; talkback function; solo, PFL, mute; 128 scene memory; pink noise generator; VU meters. XLR, 1/4", RCA, MIDI live-pin. Optional 12 x 12 sidecar/matrix, X-Matrix. \$19,000 - \$31,000

D & R North America/SF Corp.

Cinemax 2

Studio, post production, video, broadcast. 5.1, LCRS surround sound; automated joystick panners; stereo returns; PowerVCA automation. Optional PowerFade motorized faders. Optional premix inputs monitor module. Starts at \$38,000

Orion X

Recording studio, post production, 38, 51-input frames; four-band channel EQ; two-band monitor EQ; high-pass filter; 48V phantom power; eight aux sends; LCR routing; stereo returns; onboard patch bay. Optional PowerDynamics limiters, compressor, gates. Optional PowerFade motorized faders. Starts at \$22,000

Dan Dugan Sound Design

Model D-2

Rack-Mounted Automatic Mixing Controller. Broadcast, installation, live sound. Eight-channel; 24-bit A/D-D/A; 48 kHz sample rate; music threshold, gain limit, auto mix controls; bypass; override; RS422 port; Ethernet; LED meters. Frequency response: 10 Hz - 22 kHz. S/N: 100 dB. XLR, optical, terminal strips, nine-pin D-sub, 25-pin D-sub, RJ45. \$11,200

Denon Electronics

DJ-X400

DJ Mixer. Live Sound. Input gain control; three-band EQ; hot start; onboard sampler; track marker; fader control for Denon CD players; fader cue control; effects loop; brake; subwoofer output; 45mm faders; LED meters. RCA, XLR, 1/4", 4RU. \$500

Desk Doctor

Multi Format Monitor Selector

Surround Monitoring Console Upgrade. LCRS, 5.1, 6.1, 7.1 surround formats; MIDI. 1RU.

DiGiCo

D4

Digital Console. Studio, film, post production. Up to 320-channel; 16 - 96 100mm motorized fader frames; 48 - 96 kHz sample rates; 124-buss; four-band parametric EQ; LCRS, 5.1, 7.1 surround sound; dynamics processor; rackmountable I/O; linkable; LCD touch-screen interface; RS422 port.

D5 Live ★ New for 2003 ★

Digital Live Sound Mixer. Live sound. Up to 96 channels; 44.1, 48 kHz sample rates; 40 busses; 38 x 8 matrix; phantom power; four-band parametric EQ; onboard DSP; high, low-pass filters; delay; 5.1 surround sound; word clock; snapshot memory; touch-sensitive LCD screens; LED meters; joysticks; electronic scribble strips; rack-mounted I/O bus; RS422 port; USB data port; VGA output port; XLR, MADI, optical, AES/EBU.

DS-3B

Digital Broadcast Console. Broadcast. 64 - 96-channel; 100mm motorized faders; 48 kHz sample rate; 24-bit; 32-

bit internal processing and DSP; four-band parametric EQ; gate/expander; de-esser; compressor; LCRS, 5.1 surround sound; timecode; talkback function; snapshot automation; LCD touch-screens; LED meters. Starts at \$110,000

Electro-Voice

MA-1212

Rackmount Mixer. Installation. 12 inputs; 24V phantom power; telephone paging input. \$698

PSX 1000

Powered Mixer. Live sound, installation. 14-channel; six mono, four stereo; three-band EQ; pan controls; three aux; phantom power; voice filter; low-cut filter (80 Hz); onboard 18-bit DSP; effects returns; seven-band master graphic EQ; PFL; inserts; lamp socket; top-mounted I/O; LED meters; LED display; onboard two-channel amplifier; amp limiter. Power output per channel (two): 250 W @ 8 ohms, 500 W @ 4 ohms. XLR, 1/4", RCA, Neutrik Speakon. 44 lb. \$2,524

PSX 600

Powered Mixer. Live sound, installation. 10-channel; six mono, two stereo; three-band EQ; pan controls; onboard 18-bit DSP; seven-band master graphic EQ; inserts; top-mounted I/O; LED meters; LED display; onboard two-channel amplifier; amp limiter. Power output per channel (two): 150 W @ 8 ohms, 300 W @ 4 ohms. XLR, RCA, 1/4", Neutrik Speakon. \$1,788

Euphonix Inc.

CS3000

Audio Mixer. Studio, post production, film, broadcast. 12 - 104-channel frames; modular design; automation; digitally controlled analog processing; snapshot memory; Hyper-Surround panning; Status Lock on air security. Balanced TT. Supports 5.1 DTS surround sound mixing. Optional motorized faders. Starts at \$125,000

Max Air

Digital Console. Broadcast. Up to 96-channel; Euphonix System 5 core; modular; four-band parametric EQ; compressor/limiter; side chain; delay; high, low, band-pass, notch filters; 12 aux sends; mix-minus, talkback functions per channel; solo, AFL, PFL; snapshot recall; tone oscillator; digital matrix; LCD touchscreen. S/PDIF, AES/EBU, MADI, TDIF, Pro Digi, Pro Tools.

System 5

Digital Console Studio, broadcast, video, post production. 52 - 310 channels; up to 672 inputs; modular; 44.1, 48, 96 kHz sample rates; 40-bit internal processing; four-band parametric EQ; expander/gate; compressor limiter; high, low, band-pass, notch filters; LCRS, 5.1, 7.1 surround sound; 24 auxes; side chain; machine control; separate rackmount processors, I/O, RCA, XLR, 1/4", BNC, nine-pin D-sub, 25-pin D-sub, multipin, MADI, AES/EBU. Optimization packages for broadcast, post production. Starts at \$250,000

FBT North America

Pickup 14X

14-Channel Mixer. Live sound, studio. 14-channel; three-band EQ; effects send; phantom power; pan, gain controls; inserts; rackmountable; 60mm ALPS faders and potentiometers; LED meters; LCD screen. XLR, RCA, 1/4". 12.5" x 3.5" x 13". 8 lb. \$599

Pickup 18E

18-Channel Mixer. Live sound, studio. 18-channel; three-band EQ; onboard twin 56-bit digital effects processors with 256 presets each; pan, gain controls; two effects send; 48V phantom power; inserts; rackmountable; 60mm ALPS faders and potentiometers; RF

CONSOLES/MIXERS

shielding; LED meters; LCD screen; top-mounted I/O. XLR, 1/4", RCA, Neutrik Speakon. Optional powered version, 18A; \$1,799. \$1,249

Pickup 8A

Eight-Channel Powered Mixer. Live sound, installation. Eight-channel; three-band EQ; onboard 32-bit digital effects processor with 256 presets; effects send; phantom power; pan, gain controls; inserts; monitor section; rackmountable; ALPS potentiometers; LED meters; LCD screen; onboard fan-cooled amp. Power output per channel (two): 100 W @ 4 ohms, XLR, 1/4", RCA. \$849

Renegade 242-E

Portable PA System. Live sound. Four-channel mixer; headphone jack; 48V phantom power; three-band EQ; reverb; onboard DSP; dedicated input channel; two S-122 speakers (10" woofer, horn tweeter); 240W amp; molded polypropylene cabinets. 1/4", XLR. \$999

Fostex Corp. of America

MN-12 12-Channel Utility Mixer

Portable Mixer. Studio, field, live sound, installation. 12-channel; two-band EQ; aux send/return; four mic/line, four stereo ins; stereo out; master level control; pan controls; headphone jack; LED meters. 1/4", 14" x 2" x 7.75". \$279

VM-200

Eight-Track Digital Mixer. Eight-track; four-band parametric EQ; 44.1, 48 kHz sample rates; 32-bit internal processing; 48V phantom power; word clock; MIDI control; 60mm motorized faders; twin Advanced Signal Processing digital processing engines; 50 EQ factory presets; 100 location memory; effects send/return; aux send; scrub wheel; LCD screen. XLR, ADAT lightpipe, 1/4", BNC, RCA. \$1,499

FSR Inc.

ML-400

Zone Audio Combiner. Installation. Up to four rooms; in-room panel control; single mic per room.

Harris Pacific

Integrity Digital Broadcast Console. Digital Broadcast Console. Broadcast. 16 channel; 26 - 52 kHz sample rate; two program busses; four mix-minuses; 10 character individual channel identification; phantom power; talkback function; remote section; caller/IFB interface; control room/studio communications; Windows 95 interface (computer included); memory; large separate LCD display screen. Analog, AES-3, S/PDIF, RS232. 144.25" x 24.75" x 5.5". \$35,000

Harrison by GLW Inc.

Live Performance Console (LPC)

Live sound, installation. 112 input channels per rack unit; up to 64 busses; 48V phantom power; four-band parametric EQ; limiters; gates; high, low-pass filters; IKIS automation and snapshot memory; motorized faders, pots, joystick; 5.1; MMC; MADI; electronic scribble pads per channel; LED meters; LCD screen.

MPC2

Automated Mixing Console. Post production, film. Digitally controlled, fully automated; flexible application-specific layout; digital (40-bit, 96 kHz) or analog paths; up to 768 channels; 64 x 8 summing matrix; multiple automation modes; stereo, LCRS, 5.1, 7.1, SDDS surround mixing; touchscreen interface. AES/EBU, MADI, TDIF, ADAT, analog.

TV5.1

Mixing Console. Broadcasting, live sound. Modular; 24 mix-minus busses; 5.1 surround sound; four CF fuses;

four-band EQ; compressor/gate; eight aux busses; two stereo cue busses; flexible talkback and muting options; assignable remote fader machine controls. Customizable.

Henry Engineering

Micromixer

Line Level Mixer. Studio. Four inputs, two outputs; assignable switching, S/N: 80 dB. Euroblock. 1.75" x 5.75" x 6". \$225

Stereomixer

Line Level Mixer. Studio. Eight inputs; three outputs. S/N - 80 dB. Euroblock. 1.75" x 5.75" x 6". \$275

Innova SON

Compact Digital Console

Live sound, sound reinforcement, installation. 32-input; digital; four-band parametric EQ; low-cut, notch filters; gate/expander; delay; compressor/limiter; PFL, AFL; APL; digital matrix routing/patching. \$45,000

Compact Sy40

Live sound, 40 input channels; 27 mix busses; compatible with Innova SON Stage Box rackmounted I/O unit.

Large Scale Console

96-input; digital; 20-bit; 40-bit internal processing; five-band parametric EQ; eight-band parametric EQ; low-cut, notch filters; gate/expander; compressor/limiter; delay; PFL, AFL, APL; digital matrix routing/patching. Optional I/O modules. Starts at \$115,000

Intellex

AMIX-8

Mic/Line Mixer. Installation. Eight-channel; level controls per channel; master level control; three automatic modes; low-cut filter; 15 V phantom power; XLR. \$1,478

Jasoni Electronics

MB6C

Meter Bridge for Mackie 1604 Mixer. Monitors channels 1 - 4, two-channel stereo; LED. For Mackie 1604 mixers. \$239

JLCooper Electronics

CS-32 MiniDesk

Miniature Mixer/DAW Control Surface. 32-channel; EQ; pan; 20mm faders; jog/scrub wheel; compatible with most DAW software. MIDI, USB, RS232. 8" x 10". 4 lb. \$499

Klotz Digital America Inc.

Spherion

Digital Console. Broadcast. 12, 20-fader frames; machine control; EQ; limiter; gate; compressor; flexible monitoring options; talkback function; separate rackmountable processor; linkable through Klotz DiAN fiber-optic network; mechanical VU meters.

Vadis D.C II

Modular Digital Console. Broadcast, installation, studio. 4 - 24 fader; onboard DSP modules; separate rack-mounted processor; separate rack-mounted I/O; LCD screens. Optional MADI I/O module. Optional Ethernet I/O module. Starts at \$49,000

Lectrosonics Inc.

AM16/12

Automatic Matrix Mixer. Installation, live sound. 16-mic/line inputs/12 outputs; high-, low-frequency boost controls; low-frequency cut controls; mix-minus; phantom power; four room/zone operation; onboard noise generator; Adaptive Proportional Gain; RS232 ports; linkable; compatible with AMX, Crestron control systems; compatible with Lectrosonic LecNet software. Phoenix, TRS, 2RU. \$3,600

AM8/4

Automatic Matrix Mixer. Installation, live sound. Eight-channel; eight-channel in, four-channel out; high, low-shelving filters per channel; Adaptive Proportional Gain; programmable inputs and outputs; internal matrix mixing; RS-232 port; compatible with AMX, Crestron control systems. TRS, Phoenix. 1RU. \$1,650

Level Control Systems (LCS)

Matrix3/LX-300

Live sound, installation. Modular; up to 200 inputs, 512 outputs; dynamics, compressor/limiter, delay, multidimensional panning; acoustic enhancement; SMPTE; machine control; programmable; MIDI-compatible; Ethernet; RS232/422 ports. Starts at \$6,900

Logitek Electronic Systems Inc.

Nunmix

Digital Mixing Console. Broadcast. Modular configuration; accepts analog and digital inputs; 24-bit digital inputs, 20-bit A/D-D/A; audio processing engine and board are separate units; networkable; multiple cards for specific mission uses. \$18,000 - \$38,000

Remora

Modular Digital Control Surface for Audio Engine. Broadcast. Modular; 4.6-fader buckets; programmable buttons; LED meter; LCD screen; Ethernet port. Uses Logitek Audio Engine digital processor/router. \$10,000 - \$25,000

M Audio

MIXIM 10

Mini Mixer. Four mono inputs; two stereo inputs; three-band EQ; phantom power; headphone controls. 1/4", RCA, XLR. \$249

MultiMixer 6

Mini Mixer. Six-channel; pan, gain controls per channel. 1/4". \$99

Mackie Designs Inc.

1402-VLZ PRO

Compact Mixer. Studio, live sound, sound reinforcement. Six line/mic inputs; XDR Extended Dynamic Range mix preamps; four stereo line inputs; three-band EQ; input trim controls; low-cut filter; phantom power; 60mm faders; two aux; pan controls; inserts; control room monitor outputs; PFL, AFL; +/-10 switch; top-mounted I/O; LED meter. \$629

1642-VLZ PRO

Compact Mixer. Studio, post production, sound reinforcement. 16-channel; XDR Extended Dynamic Range mix preamps; 48V phantom power; four-band EQ; three-band EQ with sweepable mids; input trim controls; low-cut filter (75 Hz); 60mm faders; four aux; pan controls; inserts; direct outs; control room monitor outputs; PFL, AFL, solo; LED meter. 1/4". \$999

24.4 VLZ PRO

Mixer, 24-channel; XDR Extended Dynamic Range mix preamps; phantom power; four-band EQ; three-band EQ with sweepable mids; input trim controls; low-cut filter (75 Hz); 60mm faders; six aux; pan controls; inserts; direct outs. \$1,599

32-8

Mixer. Studio, live sound, sound reinforcement. 32 input channels; 48V phantom power; eight busses; 100mm faders; four-band EQ with sweepable mids; low (80 Hz), high (12kHz) EQ shelving; pan controls; input trim controls; six auxes; inserts; direct outs; solo; two headphone systems; talkback function; lamp socket; top-mounted I/O; LED meters. \$4,249

408S

Powered Box Mixer. Live sound. 8

Digital Hybrid Wireless™

US Patent Pending



Digital Hybrid Wireless™ is a revolutionary new technique (US patent pending) that combines a 24-bit digital audio chain with an advanced analog RF link. The result is superb audio quality without a compandor and its artifacts, and the extended operating range of the finest analog wireless systems. This hybrid combination of digital and analog techniques works so well that it is destined to be the basis of all high-end wireless microphone designs for the foreseeable future.

The UCR411 compact receiver can be powered from two internal 9V batteries or external DC. A built-in LCD interface brings all controls to the front panel, and provides a unique RF spectrum analyzer to make finding clear operating frequencies quick and simple.

The MM400A miniature transmitter is a AA battery powered 100 mW design for use with electret lavalier microphones. It is housed in a watertight, featherweight aluminum housing with a corrosion resistant finish and O-ring seals on all external controls and connectors.

The UM400 belt-pack transmitter provides the industry standard configuration for use with any mic or line level signal.

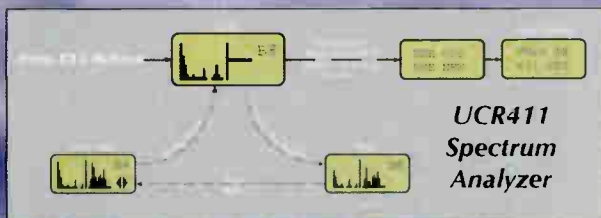

A powerful graphics type LCD interface provides display windows for the RF spectrum analyzer.

Meet the future of high-end wireless...

Visit: www.lectrosonics.com/R/par0203
Or call: (800) 821-1121

LECTROSONICS, INC.

581 Laser Road, Rio Rancho, NM 87124 USA - tel (505) 892-4501 - fax (505) 892-6243 - sales@lectrosonics.com

World Radio History

LECTRO™

The name of wireless in film and television.

mic/line channels; 32-bit onboard DSP effects; three-band EQ; nine-band master graphic EQ; phantom power; mutes; effects returns; onboard twin FR series amps. Power output per channel: 250W @ 2 ohms. XLR, 1/4", RCA. Amps can be run independently as stereo mains. \$899

808M

Powered Box Mixer. Live sound. 8 mic/line channels; 32-bit onboard DSP effects; three-band EQ; nine-band master graphic EQ; nine-band monitor EQ; phantom power; mutes; effects returns; onboard twin FR series amps. Power output per channel: 600W @ two ohms. XLR, 1/4", RCA. \$899

CFX 20

Mixer. Sound reinforcement. 16-channel; 12 mono mic/line, two stereo inputs; three-band EQ with sweepable mids; nine-band master graphic EQ; four-band stereo line EQ; onboard 32-bit DSP effects (reverb, phase, flange, delay, chorus); effects expander; bypass; 48V phantom power; low-cut filter (80 Hz); inserts; headphone controls; BNC lamp jack; subwoofer output. XLR, 1/4", RCA. \$1,099

Digital 8" Bus

Digital Mixer. Studio, post production, sound reinforcement. 72-channel; four-band parametric EQ; compressor/gate; 24-bit A/D-D/A; 32-bit processing; onboard DSP effects; onboard Apogee Electronics UV-22 processing; LCRS, 5.1, 6.1, 7.1 surround sound; snapshot memory; word clock; side chain; 100mm moving faders; hard drive; 3.5" floppy drive; tape-style transport controls; keyboard, mouse ports; Ethernet port; SVGA monitor port; shuttle wheel; LED meters, display. XLR, 1/4", 25-pin, 9-pin D-sub. Optional third party processing effects plug-ins. Starts at \$10,999

SR32.4 VLZ PRO

Console. Studio, sound reinforcement. 32-channel; XDR Extended Dynamic Range mic preamps; phantom power; four-band EQ; three-band EQ with sweepable mids; input trim controls; low-cut filter (75 Hz); EQ for subwoofer channels; 60mm faders; six auxes; pan controls; inserts; direct outs. \$1,999

MAD Labs (Musgrave Audio Design)

CP4, CP8

Center section upgrades for AMS Neve V-Series consoles; includes 5.1, 6.1, 7.1, IMAX, 10.2 surround monitoring; solo; talkback; reassignable tape inputs; bass extension.

Magtrax/Independent Audio

MasterBox

Surround Sound Monitoring Router/Controller. Post production, studio. Onboard preset matrices; LCRS, Dolby Surround, 5.1, 6.1, 7.1, DTS, SDDS; remote control; function buttons; LCD screen. 25-pin D-sub. \$5,500

MixBox

Surround Sound Monitoring Router/Controller. Post production, broadcast. Onboard preset matrices; LCRS, Dolby Surround, 5.1, 6.1, 7.1, DTS, SDDS; remote control; function buttons; LCD screen. 25-pin D-sub. \$8,200

MAM America

LM 122

Rackmount Mixer. 12-channel; volume, pan control; effects send. 1RU. \$259

MM 42

Rackmount Mixer. Four-channel; phantom power; two-band EQ; effects send. XLR. \$239

Manley Laboratories

16 Into 2 Mixer

Rackmount Mixer. Modular; 16 inputs; linkable; pan control; phantom power; VU meters. 5RU. Line version: \$9,000. Mic version: \$9,900. Line/mic (8+8) version: \$9,500.

MartinSound Inc.

ForMAX

Surround Monitoring Routing Matrix Recording studio, post production, film, video. 24 mix bus inputs; 24 recorder return inputs; 24 x 8 cross-point routing matrix; linkable up to five units. TDIF, 25-pin D-sub. 1RU. Companion to MultiMAX. \$3,495

Multimax EX

Multiformat Monitor Controller. Studio, post production, film, video. Eight-channel or Dolby 4-2-4 format; mono, stereo, quad, LCRS, 5.1, 7.1, Dolby AC-3, Dolby Surround EX, MPEG2, IMAX, RSP Circle Surround; PEC/Direct switching; autotune; speaker configuration controls; low-pass filter; pink noise generator; remote control surface. TDIF, 25-pin D-sub. 1RU. \$3,195

Midas

B2000

Broadcast Console. TV broadcast, video production. 24 - 72-channel frames; six auxes; 5.1, 7.1 surround; limiters; mix-minus; VU, bargraph meters. AES/EBU.

Heritage 1000

Console. Live sound. 48 inputs; 26 mix/sends; 13 x 8 output matrix; direct outs; LED meters. XLR. Optional audio follows video facility.

Heritage 3000

Live Sound Console. 48 inputs; 24 mix/sends; 48V phantom power; pad; phase reverse; four-band EQ; variable high-pass filter; inserts; automation; 400 memory settings; four MIDI messages per scene; LCR; Littlites; LED meters. 1/4", XLR.

Legend 3000

Live sound, sound reinforcement, installation. Modular; Midas XL4 preamps; XL3 four-band EQ for monitors; XL3 EQ for FOH; high-pass filter; 12 auxes; Spatial Imaging System; snapshot automation; PFL/AFL; talkback section; LED meters. XLR, RCA, 1/4". Starts at \$29,000

Venice 160

Sound reinforcement, live sound. Eight mono mic/line, four stereo line/mono mic inputs; 48V phantom power; four-band EQ with sweepable mids; effects sends per channel; two auxes per channel; pan control; high-pass filter (80 Hz); ALPS faders; talkback section; light socket; LED meters; rackmountable. XLR, 1/4", RCA. \$3,158

Venice 320

Sound reinforcement, live sound. 24 mono mic/line, four stereo line/mono mic inputs; 48V phantom power; four-band EQ with sweepable mids; effects sends per channel; two auxes per channel; pan control; high-pass filter (80 Hz); ALPS faders; talkback section; light socket; LED meters. XLR, 1/4", RCA. \$5,325

XL250

Mixing Console. Live sound, sound reinforcement. 44, 48-input frames; 20 mix sends; 16 stereo sends; XL-3 preamps; four band EQ with parametric mids; Common Mode Rejection noise reduction; PFL, AFL, solo; designed as a monitor board. Starts at \$44,939

XL4

Mixing Console. Live sound, sound reinforcement. 48 inputs; 16 aux sends; four-band parametric EQ; low-, high-pass filters; snapshot memory; 12

CONSOLES/MIXERS

VCA moving faders; fader automation. Optional broadcast version. Starts at \$112,930

Millennia Media Inc.

Mixing Suite

Modular Mixer. Studio. Modular design: 20 inputs on basic board; aux and line I/O; mic in. Frequency response: 2 Hz - 400 kHz. THD: <0.001%. S/N: 100 dB. 19" x 7" x 12". Optional modules include additional stereo and mono inputs, aux and stereo masters, mic splitters and EQ. \$15,000+

Nady Systems Inc.

CMX-16A

Mixer. Studio, live sound. 16-channel; 48V phantom power; three-band EQ; two auxes; PFL, AFL; LED meters; top-mounted I/O; rackmountable. XLR, 1/4", RCA. \$399

MXE-812

Eight-channel; three-band EQ; onboard DSP effects; 48V phantom power; pan controls. \$259

SPM-835

Powered Mixer. Eight-channel; 48V phantom power; eight-band EQ. Output per channel: 35W @ 4 ohms. XLR, 1/4", RCA. \$229

SPM-8600

Powered Mixer. Eight-channel; seven-band master graphic EQ; onboard DSP; onboard 300 W amp. \$769

SRM-14X

Rackmount Mixer. 14-channel; 48V phantom power; three-band EQ; gain, pan controls; inserts; two auxes; top-mounted I/O; LED meters. XLR, 1/4", RCA. \$289

SRM-8

Rackmount Mixer. Eight-channel; 48V phantom power; three-band EQ; gain, pan controls; inserts; two auxes; top-mounted I/O; LED meters. RCA, XLR, 1/4". \$149

Oram Professional Audio

BEQ Pro 24 Series

5.1 Analog Mixing Console. Studio, post production. 24, 32, 40, 48-channel frames; 5.1 surround sound; OramSonic British EQ; two-band secondary EQ; onboard Hi-Def Sonicomp compressor; eight auxes; 100mm faders; 60mm faders; VU meters; LED meters. BEQ Pro 24-24: \$28,880. BEQ Pro 24-32: \$36,480. BEQ Pro 24-40: \$44,080. BEQ Pro 24-48: \$53,263.

BEQ-48

24, 48, 60, 72-channel frames; Total Operation Recall memory system; 48-bus; 10 aux; onboard DSP; 5.1, 7.1 surround sound; individual micro-processor per channel; Hi-Def EQ per channel; motorized faders; motorized joysticks; trackball; noise floor metering; Flashback nonvolatile memory; LED scribble strips. BEQ48-24: \$256,000. BEQ48-48: \$386,000. BEQ48-60: \$424,000. BEQ48-72: \$512,000.

Peavey Electronics Corp.

AAM 1662

16-channel Rackmount Mixer. 16-channel; three-band EQ; pan; 60mm faders; inserts; mute, PFL; headphone controls. XLR, 1/4".

MMA 875T

Nine-channel Modular Powered Mixer. Nine-channel; eight module slots; bass, treble controls; mute; low-cut filter; SPS protection circuitry; onboard 75 W amp. Frequency response: 20 Hz - 20 kHz. THD: <0.02%. 2RU. 100V, 70V, 25V compatible. Optional I/O and processing modules available

PZS 140

Zone Mixer. Live sound, installation.

Four-zone; five inputs; tone controls; paging features. Power output per zone: 35 W.

RQ 2310

Mixer. Studio, live sound. Eight-channel; 10-input; three-band EQ; pad; phase reverse; PFL; effects send/return; 60mm faders. \$489

RQ 2314

Mixer. Studio, live sound. 12-channel; 14-input; three-band EQ; pad; phase; PFL; effects send/return; 60mm faders. \$599

RQ 4324

24-channel; 48V phantom power; pad; polarity reverse; three-band EQ with sweepable mid; soft knee compressor; low-cut filter; PFL; mute. \$1,649

SRM 2410 HC

Console. Sound reinforcement. 24-channel; four-band EQ; eight mono sub buses; high-pass and notch filters; 60mm faders; 48V phantom power; L/R, mute and PFL on each input; feedback level LEDs on each channel; variable power supply; integrated flight case. \$3,499

XR 1600F

Powered Mixer. Live sound. 20-channel; three-band EQ per channel; dual nine-band master graphic EQ; 48V phantom power; 60mm faders; 16-bit onboard DSP effects; Feedback Locating System; LED meters; DDT speaker protection; three onboard amplifiers. RCA, 1/4". \$1,649

XR 2012

Powered Mixer. 12-channel; three-band EQ per channel; dual nine-band master graphic EQ; 48V phantom power; 60mm faders; 16-bit onboard DSP effects; PFL; pad; aux; Feedback Locating System; LED meters; DDT speaker protection; onboard amplifier. \$1,999

XR 696

Powered Mixer. Live sound. Onboard Feedback Ferret feedback eliminators; onboard Recall 48-bit digital effects; DDT speaker protection; memory; nine-band graphic EQ; low-cut filter; inserts; 25 dB pad. Power output per channel: 1,200W @ 4 ohms. \$1,199

XR 800F+

Powered Mixer. Onboard Deltaflex digital effects; nine-band master graphic EQ; FLS feedback locator system; DDT speaker protection. \$999

Phonic America

MRS1-20

Surround Sound Mixer. 20 mono inputs; three-band EQ; six aux sends per channel; 5.1 surround sound. \$1,700

Polycorn

Vortex EF2241

Conferencing System. Installation, broadcast. Eight inputs, eight outputs; telephone interface; onboard 10W amp; onboard mic matrix. \$3,995

Vortex EF2280

Audio Conferencing System. Installation, broadcast. Multichannel mic matrix; 12 inputs; 12 outputs; AGC; five-band parametric EQ; delay; echo cancellation; user software. \$4,615

Professional Audio Design, Inc.

TDD Surround Panning Module

Surround Sound Upgrade for SSL 4000 Consoles.app. \$550 per channel

Professional Sound Corp.

Alphamix

Portable Mixer. Field, broadcast. Four-channel; 48V phantom power; 12T power; low-cut filter; PFL; headphone controls; LCD meters; battery operable

(NP-1). XLR, 1/8", Hirosa. 10.5" x 7.5" x 2.25". 4 lb. Ships with boom-mountable remote control, Porta Brace case. \$1,895

M4mkl Audio Mixer

Portable Field Mixer. Field, film. Four-channel; 48V phantom power; low-cut filters; recessable pan pots; boom pole remote control; battery operable (NP-1). XLR, ten-pin. 10.25" x 7" x 2". 31 lb. \$1,800

M8 Audio Mixer

Portable Mixer. Field, film. Eight-channel; four bus; three-band EQ with sweepable mid; phantom power; compressor/limiter; channel assignment; four headphone feeds; duplex boom communications; slate; battery powered. XLR, 1/4". 14.75" x 18" x 3". 16 lb. \$9,500

Rane Corp.

CP 31

Zone Mixer. Installation. Stereo or dual mono program; I/O level control; page ducker; page threshold control; mic/line paging with gains trim; adjustable detector; zone control functions; high-, low-cut filters (100 Hz, 7 kHz); LED meters. RCA, Euroblock. 1RU. \$449

CP 64 Commercial Processor

Zone Mixer. Installation. Two-zone; stereo or dual mono program; four inputs; I/O level control; four priority levels; 7-band EQ; page ducker; page threshold control; mic/line paging with gain trim; adjustable detector; zone control functions; LED meters. RCA, Euroblock. 1RU. \$849

DA 26

Zone Mixer. Installation. Six-zone; gain; detect, duck controls; target, ratio controls for AGC; high, low-pass filter per zone; level control per zone; crossover control; LED meters. XLR, 1/4", Euroblock. 1RU. \$549

Empath

DJ Mixer. Three-channel; magnetic crossfader; three-band Accelerated Slope EQ; FlexFX effects loop; Penny & Giles faders; dry/wet pan; Flash Cue cueing; CD triggers; headphone tone controls; LED meters. XLR, 1/4", RCA, 1/8". \$1,199

MLM 103 Mic/Line Mixer

Rackmount Mixer. Installation. 10-channel; 15V phantom power; three-band EQ; level control; A/B assignment meters; switches; LED meters. Euroblock. 3RU. \$999

MLM 82a

Rackmount Mixer. Installation. Four stereo line level inputs; four mono mic/line inputs; two outputs; 15V phantom power; assign switches. XLR, 1/4", 1RU. \$999

MM 8z

DJ-Style Mixer. Live sound. Two mix channels, two channel per mix; three-band EQ; eight stereo inputs; three-band EQ; cueing; active crossfader with contour control; two aux; headphone jack and level, pan controls; meter. XLR, 1/4", RCA. 4RU. Mojo series. \$999

MP 2016 Rotary DJ Mixer

Live sound. Six-channel; four phono/line inputs; two mic/line inputs; input gain, level controls per channel; three-band Accelerated Slope EQ; booth ducking; switchable headphone source and level control; switchable effects loop. XLR, RCA, 1/4". 3RU. \$1,499

MP 22z

DJ-Style Mixer. Live sound, sound reinforcement. Four-band EQ; two-band mic EQ; active crossfader with contour control; effects loops; stereo aux inputs; line and mic inputs; master level fader; output level controls; LED meters. XLR, 1/4", RCA. 4RU. \$999

Production Ready.

ASI5111

- > 4 Stereo PCM Play Streams
- > 2 Stereo PCM record streams
- > Balanced stereo analog I/O
- > AES/EBU or S/PDIF digital I/O
- > Low noise mic input with 48v phantom supply
- > Compressor/Limiter and Parametric Equalizer

YOU DEMAND SERIOUS AUDIO PRODUCTION. So take a look at AudioScience's new ASI5111 audio adapter. This PCI card provides stereo analog and digital inputs and outputs, 2 record streams and 4 play streams, plus a mic preamp with phantom power.

MRX Multi-Rate Mixing™ is included, so you can record, play and mix multiple audio streams to a 1Hz precision. And our SoundGuard™ transient voltage suppression protects against lightning and other high voltage surges. Windows 98, NT, 2000 and XP drivers are included—even Linux! And we even throw in the XLR breakout cables.

For features you demand at a breakthrough price, get the ASI5111. Call +1-302-324-5333 or check us out on the web at www.audioscience.com.

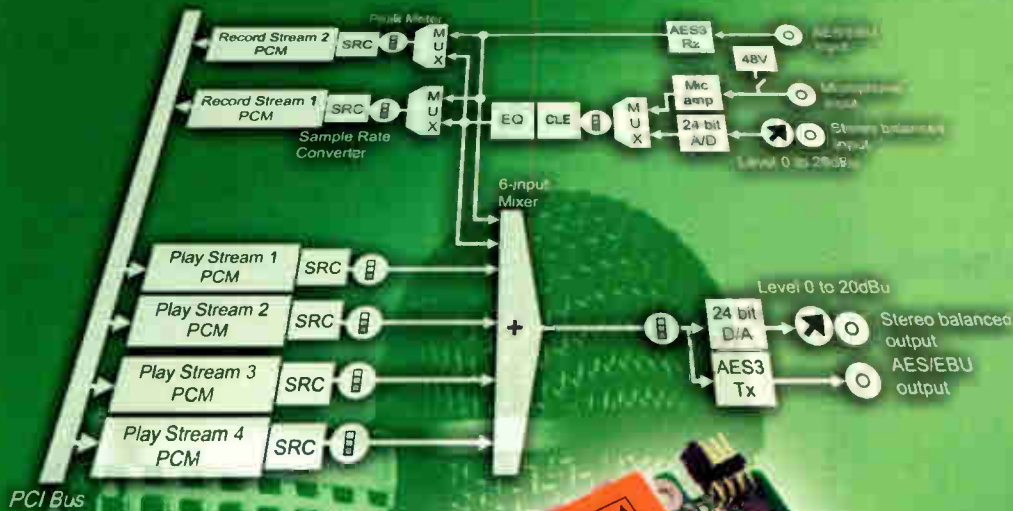

BUILT FOR BROADCAST

ASIOSCIENCE
Sound Engineering
Sonic Excellence

CONSOLES/MIXERS

MP 44
DJ-Style Mixer. Live sound. Four-channel; three-band Accelerated Slope EQ; ducking; output limiter; FlexFx bus; contour switch; monitor controls; active crossfader; LED meters. RCA, XLR, 1/4", Euroblock. 5RU. 17 lb. \$1,999

SM 82
Stereo Line Level Mixer. Eight-channel; send, balance sliders, level control per channel; effects return control; master output level. 1/4" TRS. 1RU. \$599

SRM 66
Zone Mixer. Installation. Six inputs, six outputs; input, output level controls; 24 memory settings; programmable output per channel assignments; limiter; LCD screen. Euroblock. 1RU. \$999

TTM 56
DJ-Style Mixer. Live sound. Two-channel; three-band Accelerated Scope EQ; noncontact magnetic fader; reverse switch; adjustable contours; headphone controls; LED meters. RCA, 1/4", 3" x 9" x 13". 11 lb. \$999

RDL, Radio Design Labs

FP-MX4
Mic/Line Mixer. Four-channel; 24V phantom power; gain switches; mix controls. \$350

RU-MX5
Audio Mic/Line Mixer. Five-channel; level controls per channel; 24V phantom power; LED meter. \$248

Redwood Music Corporation

SM-16SDN
Powered Mixer. Eight mono inputs; four stereo inputs; three-band channel EQ; low-cut filter; three auxes; pan; nine-band master graphic EQ; onboard digital effects; inserts; headphone controls; subwoofer output; top-mounted I/O. Power output: 350 W @ 8 ohms, 600W @ 4 ohms. XLR, 1/4", RCA. 35 lb. \$1,649

VM-11SD
Powered Mixer. Live sound, installation. Nine mono inputs; four stereo inputs; three-band channel EQ; 10 dB pad; seven-band master graphic EQ; effects send; onboard digital effects; delay; reverb; two onboard amps; bridgeable; LED meters. Power output per channel: 300 W @ 4 ohms, 200W @ 8 ohms. XLR, 1/4", RCA. Rackmounted version, VRM 11 SD: \$884. \$869

VM-6SFX
Powered Mixer. Live sound. Six inputs; three-band channel EQ; effects send; three-band master EQ; onboard digital effects. Power output per channel: 100W @ 4 ohms, 70W @ 8 ohms. XLR, 1/4", RCA. 20 lb. \$519

VX-3242N
Mixer. Live sound, installation. 24 mono inputs; 4 stereo inputs; low-cut filter (75 Hz); three-band EQ with sweepable mids; pan controls; four auxes; inserts; PFL; AFL; 100mm faders; top-mounted I/O; headphones control. XLR, 1/4", RCA. \$2,199

Roland Corp. U.S.

M-1000
Rackmounted Digital Line Mixer. 10-channel; 24-bit A/D-D/A; 44.1, 48, 96 kHz sample rates; word clock; USB port; headphone controls; LED meters. XLR, RCA, 1/4", BNC, optical, USB, S/PDIF. 1RU. \$695

VM-7000 V-Mixing Series
Modular Digital Mixers. Up to 94 channels; 24-bit A/D-D/A; 32, 44.1, 48 kHz sample rates; onboard sample rate converter; 5-band EQ; real time analyzer; white, pink noise generators; phase delay; processing delay; COSM microphone and speaker modeling effects; 5.1 surround sound; 100 scene

memory; Flex-Bus routing; talkback function; MIDI compatible; machine control functions; jog/shuttle wheel; LCD screen; rackmountable outboard processor I/O. 1/4", XLR, AES/EBU. Starts at \$4,995

Rolls Corp.

MX442 Field Mixer
Broadcast, ENG, field, film, video. Four-channel; 48V phantom power; trim controls; low-cut filter; 20 dB pad; slate tone (20 Hz); setup tone (400 Hz); limiter; battery operation; aluminum case; VU meters. XLR, 1/4".

MX54s Pro-Mix Plus
Three-channel; level controls per channel; battery operation; aux input. 1/4", XLR.

RM67 Mic/Source Mixer
Zone Mixer. Installation, live sound. Three-channel; 12V phantom power; effects loop; bass, treble controls. THD: <0.003%. S/N: 106 dB. XLR, RCA, 1/4". \$280

Samson Technologies Corp.

MDR 16
Studio. 16-channel; three or two-band EQ per channel; low-cut filter; nine-band master graphic EQ; onboard DSP; phantom power; inserts; two auxes; PFL; solo; 60mm faders; LED meters. XLR, 1/4", RCA. \$639

Mixpad 12
Sound reinforcement, studio, broadcast. 12-channel; two aux sends per channel; two stereo effects returns; two-band EQ; mic trim controls; top-mounted I/O. XLR, 1/4", RCA. 2.5" x 12.75" x 9". \$389

Mixpad 4 Portable Mixer
Four-channel; one aux send per channel; pan control; three-band EQ; phantom power; mic trim controls; battery operable. XLR, 1/4", RCA. \$249

PA324 Powered Mixer
Box Mixer. Live sound, sound reinforcement. Six-channel; three-band EQ; 24-bit onboard DSP effects; twin seven-band graphic EQ; 30 dB pad; phantom power; effects returns; onboard 150W per channel amp; LED meters. XLR, 1/4", RCA. \$499

S63 Powered Mixer
Box Mixer. Sound reinforcement. Six-channel; three-band EQ; two aux sends; 48V phantom power; reverb; 10-band graphic EQ; handle. Frequency response: 20 Hz - 50 kHz. Power output: 130 W into 8 ohms. XLR, 1/4", RCA. \$479

S83 Powered Mixer
Sound reinforcement. Eight-channel; four-band EQ; two aux sends; four effects returns; 48V phantom power; reverb; 10-band graphic EQ; headphone controls; handle. Frequency response: 10 Hz - 28 kHz. Power output: 220 W into 8 ohms. XLR, 1/4", 17" x 5" x 11". \$599

TM300 Stereo Powered Mixer
Studio, live sound. Six-channel; three-band EQ per channel; seven-band master graphic EQ; DSP effects; two aux sends; onboard 150W per channel amplifier. XLR, 1/4", RCA. \$619

Sendit Electronics

Sendit 4x3
Add-On Aux Send Unit. Four-channel, three aux sends; controls; linkable. 1/4". 1RU. \$500

Shure Inc.

AuxPander
8x8 Matrix Mixer/Console Expander. Live sound, studio. 8x8; inserts; direct inputs; balance, level controls per channel. Frequency response: 20 Hz - 20 kHz. Dynamic range: 100 dB. THD: 0.01%. 1/4" TRS. 4RU. \$990

FP 33
Three into Two Mixer. Field, installation, broadcast, video. Three inputs; two outputs; input controls per channel; 12V or 48V phantom power; low-cut filters; tone generator (1 kHz); slate tone; talkback function; headphone jack; peak LEDs; status LEDs; linkable; battery operation (2 9V cells); meters. XLR. \$1,904

FP 410
Automatic Mixer. Installation, live sound, broadcast. IntelliMix; last mic on function; Noise-Adaptive Threshold; EQ; tone generator; signal/clip indicators; selectable LED meter; headphone jack; battery operable. XLR. \$1,750

M367
Mixer. Project studio, field, installation, broadcast, video, live sound. Six-channel; mic/line switches per channel; input controls per channel; adjustable limiter; 12V and 48V phantom power; headphone controls; tone oscillator; peak LEDs; battery operation or 120/230 VAC; VU meter. XLR, 1/4". \$843

SCM268
Microphone Mixer. Installation, live sound. Four-channel; 12V phantom power; level controls; low-cut filters; LED meter. XLR, RCA. \$350

SCM410
Automatic Mixer. IntelliMix; four-channel; 48V phantom power; microphone activation control; antifeedback circuitry; adjustable low-pass filter; peak output limiter; master output level control; linkable. XLR. \$974

SCM810
Automatic Mixer. Installation. IntelliMix; eight-channel; adjustable EQ per channel; 48V phantom power; microphone activation control; linkable. 1/4". \$1,750

Smart Electronics/Sunset Sound

2 Tools
Pro Tools/Solid State Logic Console Interface. SSL console control master control over Pro Tools. \$1,650

Solid State Logic Ltd.

Avant Film Console
Customizable Film Dubbing Console. Film, video post production. 16 - 96 channel frames; six-band EQ; EQ library; 48 digital delays; 24 reverbs; eight aux sends per channel; inserts; delay; automated operation; dedicated control surface; inserts; LCRS, 5.1, 6.1, 7.1 surround sound compatible; 64 x 8 matrix; SSL Hub Router; 32 record busses.

Aysis Air Plus Digital Broadcast Console
Digital Audio Mixer for Broadcast. Broadcast. 48-fader frame; 96-channel; 16-24-bit; dedicated control surface; snapshot automation; LCRS, 5.1, Dolby surround sound; 20 mid-minus sends; SSL Hub Router; onboard EQ, dynamics, delay; AFL, PFL; channel inserts; eight aux sends per channel. Optional smaller mobile version available.

MT Production Digital Production Console
Broadcast. Up to 96-channel; 16 - 24-bit; LCRS, 5.1 surround sound; SSL Hub router; onboard dynamics; AFL, PFL; 8 aux sends per channel; up to 48 mid-minus; surround sound; tactile feedback faders. Optional machine control. Optional dynamic automation. Optional reduced width mobile version.

XL 9000 K Series SuperAnalogue
Large Format Console. Studio, post production. SuperAnalogue technology; compressor, expander/gate, dynamics, four-band EQ per channel; LFE filtering; 5.1 surround sound;

UltiPan surround panning; Total Recal snapshot automation; machine control; SuperAnalogue circuitry; DK Audio meters; solo/cut; AFL, PFL; talkback function. Optional dedicated scoring system. Optional SuperPre remote mic preamps.

Sony Electronics

DMX-P01 ★ New for 2003 ★
Portable Digital Mixer. Field. Four-channel; 24-bit A/D-D/A; 48, 96 kHz sample rates; variable low-cut filter; M/S; 48V phantom power; limiter/compressor; slate; oscillator; scene memory; linkable; backlit LCD; battery operable. XLR, RCA, 1/4", 1/8", 12-pin camera. \$2,800

DMX-R100
Digital Audio Mixer. Studio. 48-channel; 24-bit A/D-D/A; 44.1/48/88.2/96 kHz sample rate; four-band EQ; compressor, limiter, expander, gate; high, low-pass filters; 5.1 surround sound; SMPTE timecode; MTC; NTSC, PAL video sync; word clock; 99 scene snapshot memory; moving faders; touchscreen; LED meters; numeric keypad; linkable (up to 96-channel). XLR, 1/4", BNC, nine-pin D-sub, optical, MIDI five-pin. Various I/O option cards. App. \$16,000

OXF-R3
Digital Recording/Mixing Console. Studio, post production. 96-channel; 120 input sources; 32-bit processing; 24-bit I/O; five-band EQ; compressor; gate; timecode; word clock; control room output; monitor outputs; jog wheel; MADI interface; machine control functions; multiformat architecture; talkback function. Multiple options and configurations.

SRP-V110
Audio Mixer. Project studio. 12-channel; 10 mic inputs; monitor function; 8 stereo line inputs; 4 stereo sub-inputs; 8 aux output; 8 subgroup output; three-band EQ; PFL; tape monitor; 48V phantom power. XLR, 1/4", RCA. \$2,295

SRP-X351P
Rackmounted Powered Mixer. Installation. Four mic inputs; three stereo channels; four video channels; 48V phantom power; level faders; mic group control; bass, treble, balance controls; level trims; echo; RS232 port; remote control; slots for wireless Sony mic receivers. Power output per channel: 170W @ 4 ohms. XLR, RCA, 1/4", 1/8", S-Video, BNC, nine-pin D-sub, binding posts, screw terminals. 3RU. \$1,350

SRP-X700P
Digital Powered Mixer. Installation. Four mic inputs; two mic/line inputs; two line inputs; 48V phantom power; 70V; video switcher; onboard feedback control; parametric EQ; compressor/limiter; scene memory; USB port; RS232 port; parallel port; slots for Sony wireless mic receivers; compatible with Sony video recorders, players, projectors; PC remote control software. Power output per channel: 150W @ 8 ohms, 200W @ 4 ohms. 3RU. 28 lb. \$2,700

Sound Devices LLC

442
Field Mixer. Four-channel; phantom power (12V, 48V); T power; M/S; level controls; limiter; PFL; high-pass filter; headphone controls; battery operable (4 AA); LED meters. XLR, 1/4", 1/8".

Soundcraft USA

328XD
Digital Mixer 16/32-channel; 24-bit A/D-D/A; three-band parametric EQ; gate, compressor/limiter per channel; twin Lexicon effects processors; 100mm motorized faders; 44.1, 48 kHz sample rates; UltraMic+ preamps; 48V phantom power; high-pass filters;

effects sends; word clock; pan; solo; PFL, AFL; undo/redo functions; snapshot memory; SMPTE, MTC compatible; ADAT, TDIF format compatible; linkable; RS422 port; top-mounted I/O; LED meters. XLR, BNC, AES/EBU, S/PDIF, TDIF, ADAT. \$4,995

FIVE Monitor
Live Sound Monitor Console. Sound reinforcement, live sound. 40, 44, 48, 52, 56, 60-channel frames; 24 or 32 bus; four-band parametric EQ, sweepable high, low-pass filters, 48V phantom power, mic sensitivity control, input level metering per channel; 100mm faders; talkback function; matrix section; pink noise/tone generator; wedge monitor section; VU meters; compatible with BSS VariCurve system. Starts at \$54,995

K2
Live Sound Console. Sound reinforcement, live sound, installation. 24, 32, 40, 48, 56-channel frame sizes; 48V phantom power; 100mm faders; mic sensitivity control, pan/balance control, eight aux sends, four-band EQ, LED meter, cut, solo per channel; eight stereo returns; eight bus; LCR; MIDI control; talkback function; two-track replay function; mono, PFL, AFL; FX return section; mute control section; 11 x 4 matrix section; VU meter bridge. Starts at \$10,091

MH4
Multipurpose Console. Live sound, sound reinforcement, install. 24, 32, 40, 48, 56 inputs; four-band EQ; high-pass filter; 48V phantom power; LCR panning; 16 aux busses; 20 x 8 matrix; inserts; talkback function; ClearCom compatible; machine control for dbx DriveRack and BSS Varicurve processors; pink noise, test tone generator; 100mm faders; snapshot automation; PFL, AFL; color-coded aux send faders; LED, VU meters. XLR, 1/4", 24-channel: \$23,995. 32-channel: \$28,495. 40-channel: \$32,995. 48-channel: \$37,295.

Powerstation 600
Mixer. Studio, live sound. Eight-channel; 60mm faders; Lexicon effects unit; seven-band dual graphic equalizer; three-band EQ per channel; subsonic filter (40 Hz); UltraMic preamps; 48V phantom power; inserts; patchbay; LED meters; two-channel 300 W amplifier; amplifier protection. XLR, 1/4". Optional rackmount kit. \$1,650

Series FOUR
Live sound/installation console. Live sound, theater. 24, 32, 40, 48-channel frames; four-band EQ with parametric mids; LCR panning; 10 auxes; direct outs; VU meter bridge; 16x8 onboard matrix; eight VCA subgroups. Starts at \$31,995

Series TWO
Live Sound Console. Live sound, installation. 24, 32, 40-channel frames; 48V phantom power; phase reverse; four-band EQ; variable high-pass filters; eight mono auxes; eight group busses; four stereo returns; LCR; 11 x 2 matrix; talkback function; PFL, SIP-1 kHz tone generator; insert points; meter bridge; LED meters. XLR, 1/4". 24-channel: \$6,395. 32-channel: \$7,695. 40-channel: \$9,395.

SM12
Live Sound Monitor Console. Sound reinforcement, live sound. 32, 40, 48-channel frames; four-band EQ, pan control, 12 sends, cut, LED meters per channel; talkback function; 100mm faders; AFL, PFL, solo; pink noise/tone generator; LED meters. Starts at \$18,587

Spirit F1
Mixer. Live sound, studio. 6, 8-channel; UltraMic preamps; 48V phantom power; three-band EQ; 100mm faders; three auxes; PFL, AFL; integral carrying handle. XLR, RCA, 1/4". Six-channel: \$500. Eight-channel: \$600.

THE PROFESSIONAL'S CHOICE

"Whether listening in the studio to a live master mix or kicking back at home - Legacy's quality of sound is UNPARALLELED."

-FOGHAT Guitarist, Bryan Bassett, has engineered over 100 CD releases including FOGHAT's upcoming "FAMILY JOULES".

Foghat



Tony Stevens

Bryan Bassett

Whisper
Handcrafted by



Get to know us and our dealers  www.legacy-audio.com

Legacy Audio, Inc., 150 Locust St. Macungie, PA 18062 800-283-4644 Fax: 610-965-4915

CONSOLES/MIXERS

Spirit FX16

Audio Mixer. Studio, live sound, sound reinforcement. 16-channel; UltraMic preamps; programmable onboard Lexicon effects; three-band British EQ; 100mm faders; solo, PFL; direct outs; high-pass filter; stereo returns; 48V phantom power; LED meters. XLR, 1/4". Optional rackmount kit. \$1,300

Spirit Live 42

Mixing Console. Live sound. UltraMic+ preamps; four mute groups; phase reverse; four-band EQ; EQ I/O switch; aux sends; separate -10 dBV section; stereo inputs; stereo effects return; direct outs; high-pass filter; 48V phantom power; talkback function. XLR, 1/4". 12-channel - \$1,800; 16-channel - \$2,200; 24-channel - \$3,000; 32-channel - \$4,000; 40-channel - \$5,000.

Spirit M4

Mixer. Live sound, studio. Four mono channels; four stereo channels; three-band EQ with sweepable mid; two-band EQ; PFL, AFL; high-pass filter (100 Hz); inserts; direct outs; mute; pan; S/PDIF digital output; 100mm faders; top-mounted I/O; rackmountable. XLR, RCA, 1/4". \$559

Spirit Notepad

Portable Mixer. Live sound, studio. Four-channel; two-band EQ; aux sends; 48V phantom power; separate mix and monitor outputs; peak and VU metering; headphone output; rotary controls; mic and phono preamps. XLR, 1/4", RCA. \$230

Speck Electronics

XTRAMIX-V5

Rackmount Mixer. Studio, sound reinforcement. 76 inputs; 8-bus; 8 effects sends and returns; effects pan and level controls; level and balance controls; subgroup assign; master sections; talkback function; solo; activity LEDs; switchable LED meters. 1/4" TRS, 4RU. \$3,390

SPL US

MMC1 Model 2160

Mastering Console. Post production. 5.1, 6.1, 7.1 surround sound; DVD-A, SACD-compatible; SUPRA op-amps; correlation, phase, surround analysis; vectorscope; RTA; onboard patch bay; VU, LED meters. XLR. \$89,900

Studer North America

Vista 7

Digital Mixing Console. Studio, post production. 48 - 148 channels; modular; expandable DSP processing core; 96 kHz; Visonic touch control surface; DSP dynamics; LCR, LCRS, 5.1 Virtual Surround Planning; automation; talkback section; 100mm faders; machine control; LCD monitor; LED meters. Optional 6.1, 7.1 surround sound packages. Optional AES/EBU, ADAT, TDF, MADI I/O.

Tamura Corporation

izm125

Portable Digital Mixer. Field, film, video, broadcast. Eight-channel; 24-bit A/D-D/A; 44.1, 48, 88.2, 96 kHz sample rates; 48V phantom power; gain, trim controls; LTC; Dolby Headphone monitoring; PFL, mute; mLAN; Ethernet; LCD screen; LED meters; battery operable. \$10,000

TASCAM

DM-24

24-Channel Digital Mixing Console. 24-channel; 24-bit; 96 kHz; 100mm motorized faders; dual digital effects processors per channel; gate, four-band parametric EQ, compressor per channel; delay; reverb; spatial effects; inserts; MMC; LCD. XLR, 1/4", RCA, 25-pin D-sub, TDF, S/PDIF, optical, I/O options. Compatible with TDF I/O hard disk recorders. \$2,999

DS-M7.1 ★ New for 2003 ★

Surround Sound Monitor Controller. Studio, post production. Eight-channel; LCRS, 5.1, 6.1, 7.1 surround sound; up to 96 kHz sample rate; bass management functions; pink noise generator; delay compensation. AES/EBU, TDF, ADAT. \$1,899

X-9 Professional DJ Digital Mixer

Live sound. Four-channel; onboard effects (reverb, delay, echo, flange, pan); three-band parametric EQ; fader curve control; onboard sampler; low-fi filter; pitch control; parametric EQ; memory. RCA. \$1,375

TechNec

IM-1

BeltPack Audio Mixer. Field, broadcast. Two inputs/two outputs; mix control; minibox housing; belt clip. XLR, 1/4". \$149

IM-2

BeltPack Audio Mixer. Field, broadcast. Two inputs/one output; mix control; level control; minibox housing; belt clip. XLR, 1/4", 1/8". For Sony, Panasonic camcorders. \$195

Telect Inc.

2065

Audio Summing Amplifier. Installation. Four-zone; four mic/line inputs; two paging mic inputs; four line inputs; four remote gain interfaces; phantom power; mute, ducking functions; rumble filter (30 - 400 Hz); activity LEDs; compatible with Telect VersaFrame modular AV signal management system. Frequency response: 50 Hz - 20 kHz. THD: <0.1%. 4.5" x 1.5" x 5.75". \$1,495

TL Audio/HHB Communications

M-3 Tubetracker 8/2 Valve Mixer

Rackmountable Eight-Channel Tube Mixer. Studio. Eight-channel; four-band EQ with sweepable mids; two aux sends; tube (12AX7A) preamps; 48V phantom power; phase reverse; low-cut filter (90 Hz); tube stereo mix buss; pan; PFL; 100mm ALPS faders; LEDs; VU meters, XLR, 1/4", RCA, TOSLink, BNC, 15-pin D-sub. Optional 24/96 digital output. \$3,549

VTC

Tube Console. Recording and mixing. 16, 24, 32, 40, 48, 56-channel; modular; 8 bus mixer with tube (12AX7A) stages in mic preamps, monitors, groups and stereo master; 8, 16, 24-channel sidecars for expansion; 48V phantom power; high-pass filter (90 Hz); four band EQ per channel with parametric mids (± 15 dB); one stereo and six mono sends; faders on both channel and monitor signal path, 16-channel: \$24,995; 24-channel: \$29,995; 32-channel: \$34,995; 40-channel: \$42,995; 48-channel: \$45,995; 56-channel: \$52,995.

Trident Audio USA

Series 80 5.1 Console

24, 32, 40, 48, 56, 72-channel frames; 48V phantom power; phase reverse; two-band EQ; four-band EQ; 5.1 surround sound; Oram Sonicomp compressor/limiter; 100mm, 60mm faders; LED meters; VU meters. 24-channel: \$41,000. 32-channel: \$51,000. 40-channel: \$61,000. 48-channel: \$73,000. 56-channel: \$86,000. 72-channel: \$98,000.

Tsunami Technologies

MX-102

Mixer. Six mic/line channels; two stereo inputs; three-band EQ; low-cut filter (100 Hz); phantom power; PFL. XLR, 1/4", RCA. \$425

SE-1075P

Powered Box Mixer. Eight mic/line channels; two stereo inputs; three-band EQ; twin nine-band master

graphic EQs; 48V phantom power; LED meters; three onboard 250 W amps. XLR, 1/4", RCA. \$1,099

Whirlwind

MIX-6

Stereo Mixer. Four-channel; 48V phantom power; volume, pan controls per channel; master volume controls; mic/line switch per channel; LED meters. 1/4", XLR, RCA. 1RU. \$699

MIX-8S

Stereo Mixer. Eight stereo line level inputs; independent volume controls; aux send on channels 1-4; front-panel pan pot on channels 5-8; headphone jack with volume control; clip LED. Frequency response: 30 Hz - 20 kHz. THD: 0.05%. \$699

MPM-1

Rackmounted Three-Channel Mixer. Installation, live sound. Three-channel; input volume, master volume, line priority, mic priority controls; four-band EQ; ground lift; remote control. RCA, 1/4", XLR. \$1,249

Yamaha Corp. of America

O2R96 ★ New for 2003 ★

56-channel; 24-bit; 96 kHz; 32-bit internal processing; four-band parametric EQ; channel delay; compressor; gate; DSP effects; 5.1 surround sound; word clock; 16 programmable function keys; four mini YGDAI slots; 100mm motorized faders; joystick; LED meters; Yamaha Studio Manager Mac/Windows software; compatible with Digidesign Pro Tools, Steinberg Nuendo. RCA, XLR, 1/4", TOSLink, MIDI five-pin, BNC, 25-pin D-sub, 68-pin D-sub Optional mini YGDAI cards for ADAT, TDF, AES/EBU I/O, Apogee Electronics converters, Waves Y56K effects. \$9,999

DM1000 ★ New for 2003 ★

Digital Console. Studio, broadcast, post production. 48-channel; 24-bit A/D-D/A; 96 kHz; 32-bit internal processing; four-band parametric EQ; delay; onboard DSP; surround sound; 100mm motorized faders; scene memory; programmable hot keys; pan; joystick; compatible with Pro Tools, Steinberg Nuendo, Emagic Logic automation; two mini YGDAI slots; LCD screen. XLR. Optional AES/EBU, ADAT, TDF, analog I/O. Starts at \$5,000

DM2000

Digital Production Console. Studio, broadcast. 96-channel; 24-bit; 96 kHz; 44.1, 48, 88.2, 96 kHz sample rates; 31-band EQ; compressor; gate; delay; onboard DSP; 14 Yamaha DSP 7 LSI processor chips; eight DSP 6 LSI effects processor chips; 52 onboard effects factory presets; LCRS, 5.1 surround sound; routing matrix; word clock; SMPTE timescode; MTC; Pro Tools, Steinberg Nuendo control; Studio Manager Windows/Mac control software; MMC; scene memory; tape-style transport controls; track arming; linkable; mLAN compatible; 100mm motorized faders; joystick; shuttle wheel; electronic scribble strips; LCD screen; cooling fan; mini YGDAI I/O slots; SmartMedia card drive; RS422 port; USB port; tricolor LED meters. XLR, 1/4", RCA, BNC, MIDI five-pin, USB, 25-pin D-sub, nine-pin D-sub, 68-pin D-sub. \$18,300

EMX3000

Powered Mixer. Sound reinforcement. 12 inputs; three-band EQ; 48V phantom power; 16 onboard effects; seven-band master graphic EQ; top-mounted I/O. Power output per channel: 300W @ four ohms. XLR, RCA, 1/4". \$1,000

EMX660

Powered Box Mixer. Sound reinforcement. Six-channel; 15V phantom power; onboard digital reverb; limiter; seven-band master graphic EQ; seven-band monitor EQ; effects return;

LED meter; Energy Efficient Engine technology; onboard 600 W amp. Frequency response: 20 Hz - 20 kHz. XLR, 1/4", RCA. 19.5" x 11" x 11". 35 lb. \$650

GA24/12

Mixing Console. Sound reinforcement. 24-input; 12-bus architecture; G/A Diversity system; two matrix mixes; 48 V phantom power; pad; phase; high-pass filter; 6+ aux; pan/balance controls; four-band EQ with sweepable mid; EQ in/out switch; talkback function; 100mm faders; PFL switch; tricolor LED meters. XLR, 1/4", RCA. \$2,599

GF16/12

Console. Sound reinforcement. 16-channel; 12-bus; 48V phantom power; three-band EQ with sweepable mid; LED meters. XLR, 1/4", TRS, RCA. \$1,249

M3000

Mixing Console. Sound reinforcement, live sound, installation. 24, 40, 56-input frames; 16-channel bus with G/A Diversity system; 8 VCA groups; 128 scene memory; 48 V phantom power; adjustable high-pass filter; inserts; instant recall; four-band sweepable EQ; talkback function; pink noise/sine wave generator; VU meters. XLR, RCA, 1/4". M3000-24: \$10,995; M3000-40: \$13,995; M3000-56: \$17,495.

MC24/12, MC32/12

Consoles. Sound reinforcement, live sound, installation. 24, 32-channel; 12-bus; four-band EQ with sweepable mid; 48V phantom power; pad; phase; high-pass filter; pan; talkback; six auxes; 100mm faders; PFL; tricolor LED meters. Frequency response: 20 Hz - 20 kHz. THD: <0.1%. RCA, XLR, 1/4", TRS. MC24/12 (24-channel): \$2,599. MC32/12 (32-channel): \$3,199.

MV20/6

Mixing Console. Sound reinforcement. 20 inputs; six-bus; three-band EQ; 48V phantom power; onboard DSP; reverb; independent monitor and effect send controls, seven-band master graphic EQ on stereo outputs. XLR, 1/4", RCA. \$949

MV800

Rackmounted Zone Mixer. Eight-track; two-zone; gain controls, two-band EQ, gate, gate gain controls per channel; duck/paging controls; compressor; ratio, threshold compressor controls; master output controls per zone; 48V phantom power; linkable; LED meters. Frequency response: 20 Hz - 20 kHz. THD: <0.1%. XLR, 1/4", RCA, Euroblock. 2RU, 16 lbs. \$699

MX12/6

Mixing Console. Sound reinforcement. 12 inputs; six-bus; three-band EQ; 48V phantom power; onboard DSP; reverb; independent monitor and effect send controls, seven-band master graphic EQ on stereo outputs. Frequency response: 20 Hz - 20 kHz. THD: <0.1%. XLR, RCA, 1/4". \$799

PM1D

Digital Live Sound Console. Sound reinforcement, live sound, installation, broadcast. 48, 96-channel frames; up to 192 inputs; 28-bit A/D, 27-bit D/A; 44.1, 48 kHz sample rates; 1,000 scene memory; onboard DSP; 31-band EQ; compressor, limiter, delay, gate; high-pass filter; phase reverse; six-band PEQ; SMPTE; separate rackmountable processor engines; pink noise generator; talkback functions; 100mm motorized faders; separate rackmountable modular I/O boxes; PCMCIA drive; USB port; PS2 ports; LCD screen; LED meters. XLR, 1/4", RCA, USB, 25-pin D-sub, 15-pin D-sub, nine-pin D-sub. Additional mini YGDAI cards for preamps, A/D, D/A, AES/EBU, ADAT, TDF I/O.

PM4000

Mixing Console. Sound reinforcement, live sound. 24, 32, 40, 48-input frames; eight busses; eight VCA grouping; master muting; four-band parametric EQ; 48V phantom power; adjustable high-pass filters; pink noise/sine wave generator; talkback function; VU meter bridge. XLR, 1/4", 13.5" x 44" x 53" - 82" PM4000-24: \$54,999. PM4000-32: \$60,999. PM4000-40: \$65,999. PM4000-48: \$74,999.

PM4000M

Monitor Mixing Console. Sound reinforcement. 44, 52 inputs; eight VCA groups with mute capability; 18 group mixing busses; two pair of stereo mixing busses; continuously variable 50 dB gain trim; 48V phantom power; switchable 30 dB pad; four-band parametric EQ; talkback function; VU meter bridge. XLR, 1/4", 13.5" x 44" x 62.5" - 82". PM4000M-44: \$65,999. PM4000M-52: \$74,999.

Yorkville Sound Inc.

AP812

Powered Mixer. Live sound, sound reinforcement. 12-channel; two nine-band graphic equalizers; three-band channel EQ; 255 onboard 16-bit digital effects; 24V phantom power; 60mm faders; footswitch jack; cue monitoring; top-mounted I/O; cooling fan; twin onboard 400W amplifiers. 1/4", RCA, XLR, Neutrik Speakon. 19" x 18" x 5.5". Rackmount option. \$1,299

M8

Powered Mini Mixer. Eight-channel; phantom; three-band EQ; two-band EQ; four-band master EQ; onboard twin 85W amps. Power output per channel: 85W. XLR, 1/4". \$549

MM4/MM4R

Powered Box Mixer. Sound reinforcement, live sound. Four-channel; input controls; effects loop XLR, 1/4", RCA. 21" x 11" x 6". 25 lb. Rackmountable version, MM4R. \$379

MP10DS

Powered Mixer. Sound reinforcement, live sound. 10-channel; 6 mono, two stereo; 24V phantom power; three-band EQ; nine-band graphic master EQ; gain, balance, effects level, monitor controls; 255 onboard 16-bit digital effects; clip LEDs; thermal, load, DC protection for amp. XLR, 1/4", RCA. 21" x 10" x 11". 38 lb. \$769

PowerMAX22

Powered Mixer. Sound reinforcement, live sound. 22-channel; 18 mono, two stereo; 24V phantom power; semiparametric EQ; nine-band graphic EQ; switchable high-pass filter; 255 onboard 16-bit DSP effects; aux sends; inserts; AFL, PFL, mute, solo; lamp socket; top-mounted I/O; LED meters; twin two-channel amps; thermal, load, DC protection; variable speed cooling fan. XLR, 1/4", RCA. 63 lb. \$3,199

Zaxcom Inc.

Arria HD

Digital Audio Mixer. Broadcast, video, recording studio. Eight-channel; time-line; gate; compressor; limiter; five-band EQ; sample rate converter; time compression; reverb; pitch shift; 5.1 surround sound; ESAM II editing protocol; 22 AES/EBU inputs. Optional -10 fader extension. \$20,950

DMX 1000

Digital Audio Mixer, Video, Timeline; internal RAM recorder; EQ; gate; pan; compatible with GVG, CMX, Axial, Sony 9100 editors; GVG, HEDCO, NVision, Utah Scientific, PESA routers. Digital and analog. \$26,950

CONVERTERS

Apex Systems Ltd.

Model 212 A/D-D/A Converter

Two-channel; 32, 44.1, 48, 64, 88.2, 96 kHz sample rates; 16, 18, 20, 24-bit; Apex Drift Stabilized A/D conversion; A/D thermal recalibration; word clock, Superclock; headphone controls; LED meter. XLR, RCA, BNC, Toslink, AES/EBU, S/PDIF. 1RU. \$995

Apogee Electronics Corp.

AD16

A/D Converter. 16-channel; 24-bit; 44.1, 48, 88.2, 96 kHz; Apogee UV22HR redither; soft limiter; Sonorus S/MUX; word clock; LED meters. Toslink, BNC, ADAT, TDIF, 25-pin D-sub. 1RU. \$2,995

AD-8000

A/D Converter. Recording studio, post production, project studio. Eight-channel; 24-bit; Soft Limit limiter; Apogee UV-22 mastering/bit reduction; 44.1, 48 kHz default sample rates; variable sync sample rates (32-54 kHz); video, film sync; Apogee Low Jitter Clock; word clock I/O; calibration functions; onboard digital router; headphone monitor; LED meters; optional expansion modules available. Dynamic range: 114 dBA. THD: -110 dBA. XLR, RCA, BNC, AES/EBU, S/PDIF. 2RU, 19" x 3.5" x 14.25". Optional interface modules include ADAT, TDIF, SDIF, Digidesign, Sonic Solutions, Toslink, MADI, eight-channel AES, Solid State Logic I/O cards. Optional microphone preamplifier. Optional Special Edition upgrade version - \$7,995. \$5,995

PSX-100

Two-channel A/D-D/A. Recording studio. Two-channel; 24-bit; 44.1, 48, 88.2, 96 kHz sample rates; 32-106 kHz chase sample rates; UV-22; bit splitting; Soft Limit circuitry; confidence monitor, analog monitor, digital copy functions; two onboard Apogee low-jitter clocks; word clock; channel mute; LED meter. Dynamic range: 119 dB (A/D), 112 dB (D/A). XLR, ADAToptical; BNC, 25 pin TDIF D-sub; AES/EBU, S/PDIF, ADAT optical, TDIF. 19" x 1.75" x 12.5". Optional 96 kHz sampling rate model. \$1,295

Rosetta AD

Analog to digital converter. Recording studio. Two-channel; 44.1, 48 kHz sample rate; 24-bit; UV-22HR bit splitting; Soft Limit circuitry; word clock; +4/-10 dB operation; LED meter. Frequency response: 10 Hz - 20 kHz. Dynamic range: 120 dB. XLR, AES/EBU, S/PDIF, ADAT optical, TDIF. 19" x 1.75" x 12.5". Optional 96 kHz sampling rate model. \$1,995

Applied Research & Technology

DIO

A/D-D/A Converter. 24-bit; 44.1, 48, 88.2, 96 kHz sample rates; tube warmth circuit (12AX7 tube) controls; input gain controls. 1/4", RCA. \$199

Audio & Design Ltd.

ProBox 4

Digital Audio Converter. Two-channel; 16, 24-bit; 32, 44.1, 48 kHz sample rates; word clock; level, sample rate controls; redither. XLR, RCA, BNC. 1RU. \$2,123

Benchmark Media Systems Inc.

AD 2008

Converter. Studio. Eight-channel; 20-bit; variable external sampling rates (28-54 kHz); 44.1, 48 kHz sampling rate; phase lock; eight LED meters with selectable metering scales. THD: 0.0004%. Gold-plated XLR, BNC, AES/EBU, S/PDIF. 1RU. \$4,030

AD 2408-96

A/D Converter. Studio. Eight-channel; 16, 20, 24-bit; 44.1, 48, 88.2, 96 kHz sampling rate; supports variable external sampling rates; phase lock; word

length reduction; eight LED meters with selectable metering scales. Dynamic range: 117 dB. THD: 0.00032%. Gold-plated XLR, BNC, AES/EBU, S/PDIF. 1RU. \$5,095

AD2K+

Portable A/D Converter. Two-channel; 44.1, 48, 88.2, 96 kHz sample rates; 16, 20, 24-bit; word length reduction; level control; switchable; LED meters; battery operable. XLR, BNC. 1/2RU. \$1,795

ADA 2008

A/D-D/A Converter. Studio. Eight-channel; 20-bit; A/D-D/A; 44.1, 48 kHz sampling rates; sample rates autosensing; phase lock; eight LED meters with selectable metering scales. Gold-plated XLR, BNC, AES/EBU, S/PDIF. 1RU. \$4,285

DAC 2008

D/A Converter. Studio. Eight-channel; 20-bit; 44.1, 48 kHz sampling rates; sample rates autosensing; phase lock; eight LED meters with selectable metering scales. THD: 0.0004%. Gold-plated XLR, BNC, AES/EBU, S/PDIF. 1RU. \$4,285

DAC1 ★ New for 2003 ★

D/A Converter. Two-channel; 24-bit; 96 kHz; UltraLock anti-jitter technology. THD: 0.0005% XLR, RCA, BNC, Toslink. 1/2RU. \$795

CreamWare US Inc.

A16 Ultra

16-channel; 24-bit; 32, 44.1, 48, 88.2, 96 kHz sample rates; word clock; SMUX; FireWire port; VU meters; LED meters 1/4", Toslink, BNC, FireWire, ADAT. 1RU. Optional TDIF, ADAT multiplex interfaces. \$999

dCS/Independent Audio

dCS 904 A/D Converter

16, 24-bit; 44.1, 48, 88.2, 96, 176.4, 196 kHz sampling rates; antialiasing filters; three types of noise shaping; input level adjustment; digital tone generator; master/slave; LED display. Compatible with Sony Direct Stream Digital (DSD). XLR, BNC, nine-pin D-sub. 1RU. \$6,000

dCS 952 Digital to Analog Converter

Studio. 16, 24-bit; 32, 44.1, 48, 88.2, 96 kHz sample rates; mute; phase; de-emphasis, output level trim; digital volume control; four anti-imaging filters; digital tone generator; LED display. XLR, BNC, RCA, nine-pin D-sub. \$5,600

dCS 954 D/A Converter

16, 24-bit; 32, 44.1, 48, 88.2, 96, 176.4, 192 kHz sampling rates; mute; phase; de-emphasis; onboard sample rate/format converter; output level trim; digital volume control; four anti-imaging filters; digital tone generator; LED display. Compatible with Sony Direct Stream Digital (DSD). XLR, RCA, BNC, nine-pin D-sub. 1RU. \$6,000

dCS 955 Digital to Analog Converter

Studio. 32-96 kHz sample rates; up to 192 kHz; DSD-compatible. \$6,995

dCS 972 Digital to Digital Converter

Studio. Sample rates from 11.025, 12, 16, 22.05, 24, 32, 44.1, 48, 88.2, 96, 176.4, 192 kHz sample rates; 8 - 24-bit; 1st, 3rd, 9th order noise shaping; word clock; video sync; AES, dual AES, S/PDIF, SDIF-2 cross conversion. XLR, BNC, RCA, Toslink, nine-pin D-sub. \$5,435

dCS 974 D/D Converter

Sample Rate Converter. 11.025 - 192 kHz sample rates; AES/EBU, S/PDIF; DSD-compatible. \$5,940

Digital Audio Denmark

ADDA 2402

A/D-D/A Converter. Two-channel; 16, 18, 20, 24-bit; 32, 44.1, 48, 64, 88.2, 96 kHz sample rates; word clock; LED meters. XLR, RCA, optical, BNC, S/PDIF, AES/EBU. \$6,000

ADDA 2408

A/D-D/A Converter. Eight-channel; 24-bit; 44.1, 48, 88.2, 96 kHz sample rates; word clock, Superclock; NTSC, PAL, SECAM video sync; Windows, Mac software for remote control; MIDI I/O thru; USB port; LED meters; LCD screens. XLR, BNC, MIDI five-pin, USB, AES/EBU, TDIF, ADAT. Optional ADAT, TDIF, S/PDIF. Pro Tools I/O cards \$6,000

Drawmer USA/TransAmerica Audio Group

DC2496 Masterflow High Resolution A/D Converter

16, 18, 20, 22, 24-bit; 44.1, 48, 88.2, 96 kHz sample rates; sample rate phase; word clock; gain control; four mode limiter; LED meters. AES/EBU, ADAT, TDIF, S/PDIF. \$5,625

Euphonix Inc.

Euphonix Converters A/D and D/A Converters Choice of formats: analog, AES/EBU, MADI; sample rate convert; bit reduction. \$5,000

FC727 Digital Audio Format Converter

56-channel; full duplex; 16, 20, 24-bit; 44.1, 48, 88.2, 96 kHz sample rates; redither; onboard digital format converter; onboard sample rate converter; word clock, XLR, BNC, Toslink, MADI, D-sub, 25-pin D-sub, 50-pin, TDIF, SDIF, ADAT, ProDigi, AES-EBU, Pro Tools. 2RU. Version without Pro Tools compatibility, FC726: \$12,000 \$17,000

IZ Technology

UFC-24

Universal Format Converter. 24-channel; 32-48 kHz sample rates; 24-bit; supports TDIF, SDIF, AES/EBU, ADAT, PD (ProDigi); MIDI I/O thru; bidirectional; word clock; status LEDs. Optical, 25-pin D-sub, 50-pin D-sub, BNC, MIDI five-pin. \$1,995

Jünger Audio/G Prime

b44 SDI Audio Converter/Router

Four-channel; 16, 20-bit A/D-D/A; 16, 20, 24-bit; 44.1, 48 kHz sample rates; onboard sample rate converter; four x four matrix. XLR, BNC, nine-pin D-sub, AES/EBU. Optional SDI/video interface. \$249

Kramer Electronics USA Inc.

465

Digital Audio Converter. Toslink S/PDIF to AES/EBU and vice versa; 32, 44.1, 48, 96 kHz sampling rates. Toslink, Euroblock, S/PDIF, AES/EBU. \$495

Lavry Engineering

dB4496

Modular A/D-D/A Converter System. Up to eight-channel; 24-bit; 44.1, 48, 88.2, 96 kHz; Varispeed; Acoustic Bit Correction T technology; tape emulation; jitter removal; peak detector; redither. \$7,500

Leitch Inc.

ADC-880, ADC-6880

AES/EBU A/D Converters. Conversions Two-channel; AES11/AES3; 20-bit, 110 ohm balanced, 75 ohm coaxial, terminal strip, BNC. Card in 6800 or 7000 frame. ADC-880: \$895, ADC-6880: \$875

MXA-6800AES

Audio Multiplexer. Multiplexing audio into the serial digital interface; trans-

porting video and audio on single cable Four SDI outputs, full EDH capability, 20 bit resolution, 24 bit processing, audio is synchronized with adjustable delay to correct lip-sync problems. Four outputs; one video input; two AES (one group, four channels) or 2 analog (stereo pr.) audio inputs \$1,495

Lucid

AD9624

Analog to Digital Converter. Two-channel; 24-bit; 32, 44.1, 48, 88.2, 96 kHz sample rates; level controls; 16-bit noise shaping; word clock; LED meters; headphones control. Frequency response: (@ 88.2, 96 kHz) 20 Hz - 40 kHz; (@ 44.1, 48 kHz) 20 Hz - 20 kHz; (@ 32 kHz) 20 Hz - 15 kHz. Dynamic range: >114 dB. XLR, 1/4", BNC, optical, AES/EBU, S/PDIF, Toslink. 8" x 1.75" x 8.5". \$899

ADA 1000

A/D-D/A Converter. Studio, archiving, mastering, CD-burning. Simultaneous input and output; 20-bit delta sigma conversion; 32-48 kHz sample rates; stereo link; LED meters; input level controls; compatible with most AES/EBU, S/PDIF capable computer cards. S/N: 95 dB. XLR, 1/4", AES/EBU, S/PDIF. 1RU. \$499

DA9624

Digital to Analog Converter. Two-channel; 24-bit; 96 kHz capable; output control; LED meters; headphones control. Frequency response: (@ 88.2, 96 kHz) 20 Hz - 40 kHz; (@ 44.1, 48 kHz) 20 Hz - 20 kHz; (@ 32 kHz) 20 Hz - 15 kHz. Dynamic range: >114 dB. XLR, 1/4", optical, AES/EBU, S/PDIF, Toslink. 8" x 1.75" x 8.5". \$749

Freedom

A/D-D/A Converter. Field. Two-channel; 24-bit; 96 kHz; phantom power; clip limiter; USB port; battery operable

SRC9624

Sample Rate Converter. Studio, post production. 30 - 100 kHz input sample rates; 32, 44.1, 48, 88.2, 96 kHz output sample rates; 16, 20, 24-bit redither; word clock; status LEDs. XLR, RCA, BNC, optical, AES/EBU, S/PDIF. 1RU. Accepts consumer-grade signals. \$1,499

M Audio

CO3

Digital Audio Converter. AES/EBU, S/PDIF, Toslink conversion; 24-bit; up to 100 kHz sample rates; defeatable SCMS; activity LEDs. XLR, RCA, Toslink. \$249

Super DAC 2496

A/D Converter. 128X oversampling; 16, 18, 20, 24-bit; 22-100+ kHz sample rate phase; activity LEDs. S/N: 117 dB. Frequency response: 20 Hz - 20 kHz. Dynamic range: 115 dB. XLR, 1/4", RCA, Toslink, S/PDIF, AES/EBU. \$299

Manly Laboratories

The WAVE

Preamplifier/Converter. 24-bit, 96 kHz; tube line stage; volume control; insert; return; separate power supply; remote control. XLR, RCA, optical, AES/EBU, S/PDIF. \$7,500

Merging Technologies

DUA II

Converter/Audio Interface. Studio, broadcast, post production. Four-channel; 24-bit A/D-D/A; word clock; linkable; headphone controls; status LEDs. XLR, 1/4", AES/EBU, optical. Compatible with Merging Technologies Pyramix DAW. \$999

Sphynx Modular High Resolution Audio Interface

Converter/Interface. Modular; eight-channel; 24-bit A/D-D/A; 96 kHz; video,

word clock; activity LEDs. XLR, BNC, optical, RCA. 2RU. Configurable modular I/O: ADAT, AES/EBU. Starts at \$3,995

Metric Halo Laboratories

Mobile I/O 2882

FireWire Interface. FireWire; eight-channel; Mac/Windows/ASIO; 24-bit A/D-D/A; 96 kHz; linkable up to 128 channels at 96 kHz; word clock; LED meters. XLR, 1/4", BNC, optical, AES/EBU, S/PDIF, ADAT, FireWire. 1RU. With optional DSP package: \$2,195. \$1,495

Mytek Digital

8X96 ADC

A/D Converter. Studio, post production. Eight-channel; 24-bit; 96 kHz sample rate. AES/EBU. 2RU. Optional ADAT, TDIF, Sonic I/O available. \$2,795

8X96 DAC

D/A Converter. Studio, post production. Eight-channel; 24-bit; 96 kHz sample rate. AES/EBU. 2RU. Optional ADAT, TDIF, Sonic I/O available. \$2,795

Stereo 96 ADC

Analog to Digital Converter. Eight-channel; 44.1 - 96 kHz sample rates; 24-bit; word clock; battery operable. XLR, BNC, AES/EBU, S/PDIF. 1RU. \$995

Stereo 96 DAC

Digital to Analog Converter. Eight-channel; 44.1 - 96 kHz sample rates; 24-bit; word clock; battery operable. XLR, BNC, 1/4", AES/EBU, S/PDIF. 1RU. \$995

Otari Corp.

FS-96

Format/Sample Rate Converter. 24-channel; 32 - 96 kHz; 16, 24-bit; onboard router; linkable; memory. TDIF, SDIF, ADAT, AES/EBU, 2RU. Optional MADI interface: \$995. Optional mLAN (FireWire/IEEE-1394) interface: \$995. \$3,495

Prism Media Products Inc.

ADA-8 ★ New for 2003 ★

Eight-Channel A/D-D/A Converter. Eight-channel; 16, 24-bit; 44.1, 48, 88.2, 96 kHz sample rates; Overkiller peak limiter; MR-X word mapping; Prism Sound SNS noise-shaping; Prism Sound DRE encoding; word clock, Superclock; flexible routing; RS232, RS485 port; expansion slots; LED meters; LCD screen. XLR, RCA, BNC, D-sub, AES/EBU, S/PDIF, 2RU. Pro Tools-compatible. \$9,745

Dream DA-2 ★ New for 2003 ★

A/D Converter. Studio. 32, 44.1, 48, 64, 88.2, 96 kHz sample rates; AES 3 interface; high jitter attenuation; 24-bit; DRE decoding for hi-bit DAT recording; status LEDs. Dynamic range: 115 dB. THD: 0.0006%. AES 3, AES 3i, S/PDIF, Toslink. \$7,990

RME/X-Vision US

ADI-8 PRO

A/D-D/A Converter. Eight-channel; 24-bit; 44.1, 48 kHz sample rates; word clock; Yamaha O2R bit-splitting function; format conversion. 1/4", optical, 25-pin D-sub, ADAT, TDIF. \$1,775

SEK'D America

ADDA 2496 S

A/D-D/A Converter. Studio. 24-bit; 44.1, 48, 96 kHz sample rates; two-channel; gain controls. RCA, XLR, AES/EBU, S/PDIF. 1/2RU. \$899

Sonic Sense

AD2K+

A/D Converter. Two-channel; 44.1, 48, 88.2, 96 kHz sample rates; 16, 20, 24-

CONVERTERS

bit; word length reduction; level control; switchable; LED meters; battery operable. \$1,795

Sonifex/Independent Audio

RB-ADDA

A/D-D/A Converter. 16, 24-bit; 32, 44.1, 48, 88.2, 96 kHz; AES/EBU, S/PDIF, XLR, RCA. \$715

RB-DAC1

D/A Converter. Studio, broadcast, installation, 24-bit; 96 kHz; level control; headphone output. XLR, RCA, 1/4", AES/EBU, S/PDIF, 1RU. \$635

RB-SC1

Sample Rate Converter. AES/EBU I/O; S/PDIF input. Dynamic range: 120 dB. XLR, RCA. \$530

Steinberg North America

DD 8

AES/EBU/ADAT/TDIF Format Converter. 44.1, 48, 96 kHz sample rates; SyncCheck; SyncAlign; onboard sample rate converter; sample split; word clock; status LEDs. XLR, BNC, 25-pin D-sub, AES/EBU, ADAT, TDIF. 1RU. \$1,150

Nuendo 8 I/O 96K Digital Converter

Digital Audio Converter for Steinberg Nuendo System. Eight-channel; 24-bit A/D-D/A; 44.1, 48, 88.2, 96 kHz sample rate; word clock; Intelligent Clock Control; SyncCheck; SyncAlign; digital patch bay function; Yamaha bit/split function; AKM, Analog Devices chips. Optical, BNC, 1/4" 25-pin D-sub, ADAT, TDIF. \$2,250

Nuendo AD-8000

Digital Audio Converter for Steinberg Nuendo System. Eight-channel; 24-bit; UV-22 bit reduction mode; Soft Limit limiter; AKM chips; modular AMBus I/O slots. Nuendo-optimized version of Apogee Electronics AD-8000. \$7,699

Swissonic America

AD96mk2

Four-Channel A/D Converter. Studio. Four-channel; 16, 18, 20, 24-bit; 44.1, 48, 88.2, 96 kHz; matrix; word clock, Superclock; ADAT lightpipe output; AES/EBU; bit splitting; LED meters and status lights. ADAT, AES/EBU. 1/2RU. \$999

DA96mk2

Four-Channel D/A Converter. Studio. Four-channel; 16, 18, 20, 24-bit; 44.1, 48, 88.2, 96 kHz; word clock, Superclock; matrix; LED meters and status lights. AES/EBU, ADAT. 1/2RU. \$999

TC Electronic USA

ADA 24/96

A/D-D/A Converter Card for M5000 Processor. 24-bit; 64, 88.2, 96 kHz sample rates; onboard 100 MHz SP processor; soft clip; conversion filters. XLR, RCA, TOSLink.

Troisi Design Ltd.

DC224ADC

Digital Audio Converter. Studio. Two-channel; switchable 24-, 20-, 16-bit; 44.1, 48, 88.2, 96 kHz sampling rates; variable sample rate input; LED meters; word clock in. Frequency response: 20 Hz - 20 kHz. THD: 0.0003%. Dynamic range: 120 dB. XLR, RCA, TOSLink, BNC, S/PDIF, AES/EBU. 7" x 9" x 1.5". \$2,050

DC8-224ADC

A/D Converter. Studio. Eight-channel; four channels analog stereo in; four digital channels out; 44.1 - 96 kHz sampling rates; external sync lock; sample rate/sync source, clip; LED indicators; word clock in; switchable +4 dB, -10 dB inputs. XLR, BNC. 1RU. \$3,920.

DC8-224DAC

D/A Converter. Studio. Eight-channel; four channels analog stereo out; four digital channels out; 44.1 - 96 kHz sampling rates; sample rate, error LED indicators; switchable +4 dB, -10 dB inputs. XLR, 1RU. \$3,890

Universal Audio

2192 Dual DA/AD Converter

Up to 192 kHz; Class A. AES/EBU, S/PDIF, ADAT. 1RU.

Videoqup Research Ltd.

A2D-1

A/D Converter. 32, 44.1, 48 kHz; 20-bit; AES/EBU, S/PDIF; clip LED. XLR, RCA. \$795

D2A-1

D/A Converter. Two-channel; 20-bit; 32, 44.1, 48 kHz sample rates; AES/EBU, S/PDIF; status LEDs. XLR, RCA. \$795

FC-1

S/PDIF to AES/EBU Converter. 32, 44.1, 48 kHz sample rates; status LEDs. RCA, TOSLink, XLR. \$249

FC-2

Digital Audio Format Converter. Dual converters; S/PDIF to AES/EBU or AES/EBU to S/PDIF; 32, 44.1, 48 kHz sample rates; status LEDs. XLR, RCA. \$350

SRC-1 Sample Rate Converter ★ New for 2003 ★

32, 44.1, 48, 96 kHz sample rates; AES3, video; external sync; bypass; RS422 port; status LEDs. XLR, BNC, RCA, TOSLink, nine-pin D-sub. \$850

Weiss Engineering/G Prime

DAC1-MK2

D/A Converter. 24-bit; 44.1, 48, 88.2, 96, 192 kHz sample rates; jitter reduction. XLR, TOSLink.

Hydra

AES3 Dual Line Sample Rate Converter. Converts dual line sample rates to single line and vice versa. XLR. Optional version with jitter eliminator, Hydra-X: \$1,300. \$950

SFC 2

Sampling Frequency Converter. Two-channel; 44.1, 48, 88.2, 96 kHz sample rates; 16, 20, 24-bit; auto-black. 1RU. \$3,400

Z-Systems Audio Engineering

z-3arc

Sample Rate Converter. 32 - 96 kHz; 16 - 24-bit; word clock; internal/external sync; bypass. XLR, BNC, TOSLink, AES/EBU, S/PDIF. 1RU. \$1,500

z-link96/z-link96+ Sample Rate Converters

32 - 96 kHz; 16 - 24-bit. S/PDIF. z-link96+ has external sync. z-link96: \$475, z-link96+: \$630

Truthful

DAC1

Power Error Non PCM Coaxial XLR Optical

PAR REVIEWER'S PICK 2002

Digital Audio Reviewer's Pick 2002

"The Benchmark is a killer!

It sounds:

- 1) spacious (excellent width and depth)
- 2) clean
- 3) robust
- 4) solid
- 5) pure

It sounds like it costs more than \$2000, not \$795. I've NEVER heard a \$795 DAC that sounds as good as this Benchmark. It has definitely established a new price/performance ratio. I've never heard a \$2000 DAC that sounds as good with jittery sources. None, period."

Bob Katz - Mastering Engineer - Digital Domain, Orlando, FL

The two-channel DAC1 is perhaps one of the more significant recent advances in digital-audio conversion technology.

It provides some of the finest digital-to-analog conversion through 96-kHz, and will play back 192-kHz with a 48-kHz analog bandwidth. The performance of the DAC1 is unrivaled. THD+N is an astonishing -108 dB measured at -3 dBFS, at any playback frequency, at any sample rate, with any degree of input jitter. You can now hear detail that was previously masked by jitter induced artifacts. If the recording was exceptional, you'll hear it; if it wasn't, you'll hear that as well. The secret? *UltraLock™* technology.

The DAC1 is essential equipment for any location that requires uncolored monitoring. Locations such as mastering and recording studios, broadcast facilities and even high-end home audio environments. The price? An unbelievably low \$795. Call today and experience what is certainly one of the finest DACs in the world.

BENCHMARK MEDIA SYSTEMS, INC.
800-262-4675
www.BenchmarkMedia.com

Benchmark
...the measure of excellence™

DIGITAL AUDIO WORKSTATIONS/PERIPHERALS/PLUG-INS

360 Systems

Short/Cut Personal Audio Editor
Studio, broadcast, location. Two-track; 16-bit, 44.1, 48 sampling rates; cut/copy/insert/paste editing; hotkeys; function keys; edit, solo buttons; variable scale waveform/alphanumeric LC display; keypad; jog/shuttle/scrub dial; tape style transports; onboard speakers; LED meters. Frequency response: 20 Hz - 20 kHz. XLR, BNC. 3.75" x 17.25" x 12.75". Optional Zip drive. \$3,495

Aardvark Computer Systems

Direct Pro 24/96
DAW/Studio Interface. PCI slot card; four-channel breakout box; Windows 95/98, ASIO drivers; 48 V phantom power; full duplex; 24-bit; 96 kHz; onboard mixer software; onboard DSP software programs; MIDI; word clock; headphone jack. 1/4", XLR, RCA, MIDI, S/PDIF, 25-pin D-sub. Rackmount kit: \$49. \$699

Direct Pro Q10

Interface Box. Rackmount I/O box; PCI card; Windows 95/98/Me/2000, Mac; ASIO, GSIF, MME, DirectSound; 24-bit A/D-D/A; eight preamps; 48V phantom power; two Hi-Z inputs; word clock; MIDI I/O; headphone control; linkable; +4-10 dB operation. XLR, 1/4", MIDI, BNC, S/PDIF. Ships with Cakewalk Pro Audio 9 DAW software. \$1,099

Akai Musical Instrument Corp.

D.C. Vocoder
Vocoder Plug-in. Windows, Mac; VST; 50-band; onboard six-voice synth; MIDI. \$149

Deca Buddy

Harmony Generator Plug-in. Windows, Mac; VST; 10-voice; formant; pitch correction; gender; delay; scale presets; random program; MIDI. \$149

Pitch Right!

Pitch Correction Plug-in. Windows, Mac; VST; ratio, smoothing, calibration controls; presets; programmable; MIDI. \$149

Rotator

Rotary Speaker Emulation Plug-in. Windows, Mac; VST; speed, distortion, balance controls; virtual mic function. \$149

Antares Audio Technologies

Auto-Tune 3 DX
Pitch Correction Plug-in for DirectX-Based Systems. Automatic and manual modes; pitch control; bass mode; 96 kHz-compatible; Windows DirectX. \$299

Auto-Tune 3 TDM

Pitch Correction Plug-in for Pro Tools. Automatic and manual modes; pitch control; bass mode; 96 kHz-compatible; Mac; TDM, Audio Suite. \$599

Microphone Modeler Plug-In

TDM, MAS, DirectX, Mac VST, RTAS; Spectral Shaping Technology; dozens of models available; MIDI SysEx, TDM; \$599. Mac VST; \$399. RTAS; \$399. MAS; \$399. DirectX; \$299.

Antex Electronics Corp.

LX-44

Computer Audio Card. Installation, broadcast, archive. PCI slot; Windows 98/NT, Alpha drivers; four-channel; full duplex; 20-bit A/D-D/A; linkable. 25-pin D-sub. Optional XLR connectors. \$720

Apogee Electronics Corp.

Native Tools
Hardware/Software Hard Disk Recording System. Apogee AD-16, DA-16 converters; Steinberg Nuendo software with Steinberg 96/52 PCI card. \$7,995

Arboretum Systems Inc.

Harmony
Formant-Based Pitch Processor and Harmonizer. Mac; formant-pitch shift; automatic pitch correction; automatic harmonization; eight voice harmony; waveform graphs. Minimum requirements: Power Mac 200 MHz. \$349

Hyperprism

DSP Software. Studio, post production, video, film. Power Mac; real time effects; reverb, ambience simulation, pitch shifter, compressor, soft knee compressor, gate, parametric EQ, high- and low-pass filters, flange, phase, delay, vibrato, echo, pan, chorus, analog-style vocoder, tremolo, Z-Morph "talk box" effect, frequency shifter, Doppler effect, M/S matrix, Granulator, stereo dynamics, Sonic Decimator, HyperVerb, Echo Tranz, pitch time changer, formant pitch shifter, HyperPhaser, harmonic exciter, bass maximizer, tube/tape saturator; nondestructive drag and drop editing; multitasking; supports AIFF, Sound Designer II files. Minimum requirements: Power Mac 120 MHz, System 7.6, 16 MB RAM, 22 MB hard disk space. \$299

Audio Processing Technology Ltd. (APT)

ADK200
Computer Audio Card. Studio, broadcast. Four-channel; Windows 95/NT, DOS 6; ISA slot; 20-bit; 8 - 48 kHz sample rate; MPEG Layer 1 and 2 decode; apt-X 100 coding; full duplex; time stretch. Optional MPEG Layer 1 and 2 encoding daughterboard; optional analog daughterboard. \$299

AudioScience

ASI5111 ★ *New for 2003* ★
Audio Card. Broadcast. PCI card; two record channels, four playback channels; Windows 98/ME/NT/2000/XP, Linux drivers; 24-bit; 11 - 96 kHz sample rates; MRX sample rate conversion; 48V phantom power; three-band parametric EQ; compressor/limiter; SonicGuard protection; linkable up to eight cards; breakout cable. 1/4", XLR, nine-pin D-sub, AES/EBU, S/PDIF. \$549

Bader

51A
Surround Mix/Monitor Controller for Digidesign ProControl. Stereo/5.1 surround mixing and monitoring; 192 kHz-compatible. XLR, 3RU. \$1,995

BIAS Inc. (Berkley Integrated Audio Software)

BIAS Studio
Software Bundle. Mac; recording, editing, mastering software bundle; 250 MB sample library; OS X-compatible. Includes BIAS Peak VST, BIAS Deck, BIAS Vbox, Roxio Toast Lite. \$799

Deck 3.5
Digital Audio Workstation Software. Mac; VST; up to 64-track; cut and paste, drag and drop editing; nondestructive editing; onboard DSP; graphic EQ, parametric EQ, delay, chorus; QuickTime support; syncs to OMS MIDI programs; SMPTE, MIDI time code; CD-R burning function; ADAT compatible; OMF; OS X-compatible. Ships with BIAS Vbox SE, BIAS Peak LE, Roxio Toast Lite, variety of VST plug-ins. \$399

Peak 3.1
Digital Audio Workstation Software. Mac; recorder/editor/mixer software; 16 - 32 bit; waveform editing; nondestructive editing; unlimited undo; playlist; batch file processing; sample editing; QuickTime compatible; video window; SMPTE sync; loop function; 250 MB sample library; MIDI sampler support; MP3; Shockwave; SCSI-compatible; CD-R burning program; com-

patible with VST, ASIO, Premiere; OS X-compatible. Ships with BIAS Vbox SE, Freq EQ, various VST plug-ins, Roxio Toast Lite. \$499

Sound Soap

Noise Reduction Plug-in. Mac OS X, Windows XP; DirectX, VST; hiss, hum, rumble removal; adaptable filters; QuickTime, AVI, DV, MP3, MP4, AIFF, SDII, WAV files. \$399

Bitheadz

Phrazer
Loop Sequencer/Editor. Mac software; sample editor; effects controls; MIDI trigger; volume, pan, tempo controls; onboard loop library; AIFF, WAV, SDII files; OMS, ASIO, ReWire, MAS 2.0, DirectConnect, Direct I/O, FreeMIDI, QuickTime compatible. Compatible with Sonic Foundry ACID files. \$399

Unity Session Digital Sampler

Mac 9x, OS X, Win 95/98; 24-bit; 96 kHz; 256-voice; onboard sample library; compatible with Akai S1000, S3000, SampleCell, Sound Font, DLS, WAV, AIFF, SDI, SDII, ASIO, MPU-400, Direct Sound; two insert effects, two assignable filters per voice; 13 filters; six-stage envelope modulators; MIDI clock; ReWire, RTAS, VST, DXi, MAS 2.0, DirectConnect compatible. Ships with 2GB of samples. Synth plug-in package available. \$649

Cakewalk

SONAR
Digital Audio Workstation Software. Windows 98/98SE/ME/2000/XP; recorder/mixer/editor software; unlimited tracks; nondestructive waveform editing; reverb, flange, chorus, delay, time compression, expansion, pitch shifting; SMPTE timecode; parametric EQ; metering options; AVI, QuickTime, MPEG 2/3, ACID, AIFF, AU, SND, DXi; CD burner; MIDI section; advanced MIDI FX; DirectX8 support for plug-ins; RealSystem G2; Windows Media Advanced Streaming Format; onboard sampler; multiprocessor compatible; ships with third party plug-ins, sample library. SONAR XL: includes more DSP effects, third party plug-ins, loop libraries - \$599. \$479

Carillon Audio Systems

AC1
Turnkey Digital Audio Workstation. Pentium IV processor; hot-swappable hard drives; heavily damped components and aluminum, steel case; tech help. Optional front-mounted inputs, tape-style transport controls. Preloaded with choice of Pro Tools, Nuendo, Cakewalk Sonar. starts at \$1,199

CEDAR AUDIO USA

DNS2000
Dialogue Noise Suppressor for Pro Tools Systems. 32, 44.1, 48 kHz sample rates; USB port. 1RU. \$6,525

Coleman Audio

TB4 DAW Talkback Module
Passive, cue, talkback mic level controls; headphone output. XLR, 1/4", 1RU. \$1,150

Cool Stuff Labs Inc.

Generator X
Signal Generator Plug-in. TDM; ASIO; 24-bit signal generator; programmable and variable signal controls. \$70

CreamWare US Inc.

Luna II
DAW System. Windows, Mac; PCI card; three Analog Devices SHARC DSP chips; ASIO, EASI, DirectSound, MME, Gigasampler, OMS, Sound Manager, tripleADT; onboard 32-bit DSP (chorus, flange, compressor, phase, reverb, limiter, gate); 24-bit, 96

kHz; 5.1 surround sound; Z-Link; MIDI I/O; compatible with CreamWare Pulsar/SCOPE systems. \$399

PowerPulsar

PC, Mac; PCI card; 15 Analog Devices SHARC DSP chips; 24-bit, 96 kHz; 32-bit internal processing; onboard 32-channel digital mixer; STS-3000 sampler; onboard DSP effects (EQ, dynamics, delay, chorus, flanger, vocoder); onboard modular synthesizers; MIDI interface; compatible with CreamWare SCOPE system; ASIO, VST, EASI, MME, DirectSound, OMS, Sound Manager-compatible. \$3,399

SCOPE/SP

Digital Audio Workstation System. Windows, Mac; modular; recorder/mixer/editor; PCI card; 24-bit, 96 kHz; 15 SHARC DSP chips (2.7 gigaflops); 32-bit internal processing; onboard 48-channel digital mixer; onboard V2 modular synthesizer; STS-5000 sampler; onboard DSP effects; compatible with Cubase systems; third party plug-ins available; upgradable. Optional expansion boards. \$3,399

Cube Technologies/Sascom Marketing Group

AudioCube 5
Digital Audio Workstation. Post production, archiving, video, film. Turnkey system; Windows NT; twin 850 MHz Pentium III processors; 24/96; up to 192 kHz sample rate; 32/64-bit processing; editor; de-noise; de-click; de-buzz; de-esser; de-scratch; azimuth correction; EQ, tape machine simulation; phase linear EQ; DVD-compatible. \$15,000

Cycling '74

Pluggo
Plug-in Package. Mac VST, RTAS; synchronization; delay; filters; pitch; distortion; granular synthesis; dynamics; reverb; panning; modulation; sampling. VST: \$74, RTAS: \$199

delaydots.com

Sound Designers
Windows 9x/NT/2000/XP; VST, DirectX; Phat low-frequency synth; PitchShift; daBomb distortion; Phat Pro DX. \$55

Spectral
Windows 9x/NT/2000/XP; VST, DirectX; Shaper FFT-based 4,096-band EQ; Morphor; eXtractor band-pass filter. \$55

Digidesign

1622 I/O
16-Channel A/D for Pro Tools Systems. 16-channel; 20-bit A/D; 24-bit D/A; +4/-10 dB operation. 1/4", S/PDIF, 1RU. \$1,595

192 Digital I/O
Digital Interface for Pro Tools HD. Up to 16 channels; up to 192 kHz sample rate; word clock; slave clock; linkable; Legacy peripheral port; compatible with Digidesign 888/24, 882/20, 1622, 24-bit ADAT Bridge interfaces. XLR, RCA, BNC, optical, 25-pin D-sub, AES/EBU, S/PDIF, TDIF, ADAT. \$2,495

192 I/O
Pro Tools HD I/O Interface. Eight-channel; 44.1, 48, 88.2, 96, 176.4, 192 kHz sample rates; 24-bit; onboard sample rate converter; limiter; word clock; expansion card slot; Legacy Port for compatibility with Pro Tools 888/24, 882/20, 1622, ADAT Bridge; LED meters. XLR, RCA, Toslink, BNC, 25-pin D-sub, AES/EBU, S/PDIF, TDIF, ADAT. Optional eight-channel 192 kHz A/D, D/A cards. \$3,995

Control 24
Control Surface for Pro Tools Systems. For TDM/LE systems; 24 motorized faders; 16 Focusrite mic preamps;

onboard dynamics/EQ; machine control; scribble strips; 5.1 surround sound monitoring; Ethernet port. \$7,995

Crane Song Phoenix

Tape Emulation Plug-in. TDM; tape emulation; five "flavors."

Digi 001

Digital Audio Workstation. Mac, Windows 98SE; PCI card; 24-bit rack-mountable breakout box with two mic preamps; MIDI-compatible; headphone controls; ships with Pro Tools LE software; DigiRack RTAS plug-ins. XLR, RCA, 1/4", optical, S/PDIF, ADAT, 1RU. \$995

Digi 002

Digital Surface/DAW Software Bundle. Eight motorized faders; four mic preamps; up to 32-track software; Pro Tools LE software; 24-bit; 44.1, 48, 88.2, 96 kHz sample rate; transport controls; scribble strips; MIDI-compatible; FireWire port. XLR, RCA, 1/4", five-pin DIN, S/PDIF, ADAT. Ships with plug-in bundle. \$2,495

Mbox

USB Interface. USB-based box; Mac, Windows; two-channel; 24-bit; 44.1, 48 kHz sample rates; Focusrite mic preamps; headphone controls; ships with Pro Tools LE 1/4", XLR, RCA, USB, S/PDIF. Compatible with Digidesign DigiStudio. \$495

Pro Tools HD

Modular DAW. PCI base card; 32-channel; up to 192 kHz, 64-bit; TDM/TDM II; Mac, Windows software; LCRS, 5.1, 6.1, 7.1 surround sound; MIDI functions and control; compatible with Avid video products and OMF files; waveform editing; punch-in editing; onboard multitrack recorder; digital video track; digital video window; ADR-compatible; multiformat ruler; online sound file library access; TDM, TDM II, RTAS, AudioSuite-compatible; plug-ins available; compatible with control surfaces; third party plug-ins available. With additional HD Process PCI card: \$9,995. With two additional HD Process PCI cards: \$11,995. Ships with software tools and plug-ins bundle. starts at \$7,995

ProControl

Dedicated Control Surface for Pro Tools System. Modular, up to 48-channel; 100mm DigiFader touch sensitive faders; routing buttons; monitor controls; pan controls; scrub wheel; electronic scribble strips; dedicated function buttons; DSP assign section; channel matrix; talkback section; numeric keypad; LED meter bridge; Ethernet. Optional fader expansion sidebar: \$6,495. Optional "Edit Pack" control surface expander: \$7,495. \$11,995

Soft SampleCell

Sample Editor. Mac; AIFF, WAV, SDI, SDII files; OMS, DirectConnect; envelope, filter controls; loop points; track generator; low-pass filter; up to 96 voices; compatible with Pro Tools HD. \$345

Virus Indigo

Synthesizer Plug-in. Pro Tools HD-compatible; 96 kHz. Upgrade for registered Virus TDM users: \$95. \$795

Digigram Inc.

VX442
Audio Card. PCI card; 24-bit; 96 kHz; four-channel I/O. AES/EBU. \$789

VXpocket 440

Windows, Mac drivers; PCMCIA card for laptop computers; 24-bit; four-channel I/O; breakout cable; balanced mic/line analog inputs. Breakout cable with XLR, RCA, 1/8". \$650

Dissidents

Sample Wrench 24/96
Sample Editing Software. Windows 95/98/NT; 24-bit; 96 kHz-compatible;

PRISM SOUND ADA-8 FOR DIGIDESIGN™ PRO-TOOLS|HD™

THE PRISM SOUND ADA-8 IS THE KEY THAT WILL UNLOCK THE TRUE SONIC POTENTIAL OF YOUR WORKSTATION.

- ADA-8 is now available with a Pro-Tools|HD™ interface
- Connect up to four Prism Sound ADA-8 units per Digidesign™ Pro-Tools|HD Core™ or HD Process™ card
- Analogue and digital ports can be fitted for all channels
- Combinations of Digidesign™ I/O units and Prism Sound ADA-8 units can be configured
- A Prism Sound ADA-8 interface card is also available for the Digidesign™ Pro-Tools|24 Mix™ family



CALL NOW TO ARRANGE YOUR DEMO!



PRISM MEDIA PRODUCTS LIMITED
William James House
Cowley Road
Cambridge CB4 0WX
UK

Tel : +44 1223 424 988
Fax : +44 1223 425 023

Web: <http://www.prismsound.com>

PRISM MEDIA PRODUCTS INC.
21 Pine Street
Rockaway
NJ 078566
USA

Tel : (973) 983 9577
Fax : (973) 983 9588

Web: <http://www.prismsound.com>
Email: sales@prismsound.com

Prism Sound

NOTE: Digidesign do not endorse or support the Prism Sound ADA-8 unit. Not all Pro-Tools™ controls or configurations are supported by the Prism Sound ADA-8. Prism Sound reserve the right to amend their own product specifications without notice.

Digidesign, Pro-Tools, Pro-Tools|HD, HD Core, HD Process and Pro-Tools|24 Mix are trademarks of Digidesign, a division of Avid Technology Inc.

World Radio History

DIGITAL AUDIO WORKSTATIONS/PERIPHERALS/PLUG-INS

waveform cut, paste editing; EQ; reverb; time stretch; pitch shift; envelope controls; noise gate; convolution; compressor; filtering; factory; user presets; undo; log function; compatible with WAV, AIFF, AU, RM, VOC, SDI file formats. 16-bit version, Sample Wrench Classic: \$99 \$149

Echo Digital Audio

Echo Indigo

Laptop Computer Audio Interface. Windows 98/Me/2000/XP, Mac OS X; 24-bit, 96 kHz. \$139

Gina24

Computer Audio Interface. PCI slot card; breakout box; eight-channel; Windows 98/Me/2000/XP, Mac OS X, OS X; 24-bit, 96 kHz; headphone jack, 1/4", 25-pin D-sub, RCA, optical, S/PDIF, ADAT. Bundled with Steinberg Cubase. \$495

Mona

Computer Audio Interface. PCI slot card; breakout box; level controls; Windows 98/Me/2000/XP, Mac OS X, OS X; 24-bit, 96 kHz; word clock; headphone jack; LED meters. XLR, 1/4", RCA, BNC, optical, nine-pin D-sub. 1RU. Bundled with Steinberg Cubase. \$995

Ego Sys

Audioterminal 010

Computer Audio Card. PCI slot card; 32, 44.1, 48, 64, 88.2, 96 kHz sample rates; MMC, MTC; word clock; Windows 98SE/Me/2000/XP drivers. Optical, five-pin MIDI, 25-pin D-sub, S/PDIF, ADAT, TDIF, R-Bus. Optional daughterboard. \$399

WaMi Rack 192L

Computer Recording System. PCI card; breakout box; 48V phantom power; headphone control; level controls; 5.1, 6.1, 7.1, Dolby/DTS surround sound; 24-bit A/D-D/A; 96 kHz A/D; 192 kHz D/A; 32, 44.1, 48, 88.2, 96, 176.4, 192 kHz sample rates; Windows 98SE/Me/2000/XP drivers; ASIO, GSIF, 1/4", XLR, RCA, MIDI five-pin. \$499

Elemental Audio Systems

Firium

Paragaphic EQ Plug-in. Mac OS X, OS X; VST; modular EQ parameters; spectrum analyzer; EQ history comparator; up to 192 kHz sample rate; Altivec optimization. \$129

Emagic

Logic Audio

Digital Audio Workstation Software. Mac; VST, DirectX, Audio Suite, Rex2, MicroLogic AV-compatible; 24-bit; up to 128 tracks; POWr dither; onboard software synths; 32-bit internal processing; 7.1 surround sound; MIDI sequencer; parametric EQ; plug-ins; Rocket Network-compatible; Apple multiprocessor, Velocity Engine-compatible; TDM-compatible; SSE/SIMD-compatible; OS X-compatible. Compatible with most Emagic software synths. \$599

Event Electronics

EZbus Computer Audio Recording Interface

USB Control Surface/Mixer/Preamplifier/Computer Interface. Eight-fader; trim pots; 48V phantom power; 24-bit, 96 kHz A/D-D/A; onboard DSP; word clock; 32 scene memory; USB port; tape-style transport controls; jog/shuttle wheel; LCD screen. XLR, 1/4", RCA, optical, BNC, five-pin MIDI, S/PDIF, ADAT. \$849

Fairlight

DREAM Console

48-track hard disk recorder/editor/mixer; up to 192-chan-

nel; 32, 44.056, 44.1, 48, 96 kHz sample rates; six-band EQ; onboard DSP; 7.1 surround sound; 48-busses; Fairlight QDC processing engine; MediaLink-compatible; up to 84 faders; twin LCD screens; jog/shuttle wheel; joy stick; function buttons; tape-style transport controls. Third party plug-ins available. Starts at \$100,000

DREAM Satellite

Digital Audio Workstation. 16, 32, 48-track; 24-bit; 32, 44.056, 44.1, 48, 96 kHz sample rates; Fairlight QDC processing engine; MediaLink-compatible; jog wheel; function buttons; LCD screen; tape-style transport controls. Third party plug-ins available. Starts at \$20,000

FAME2

Audio Mixer/Editor. Studio, post production, broadcast. Recorder/mixer/editor; 24-track; mixed bit (16, 20, 24-bit) length clip capable; 40-bit processing; 32, 44.056, 44.1, 48 kHz sample rates; 36-input mixer with 12 busses; 12 insert sends and returns; moving fader automation; four-band EQ; VST plug-ins-compatible; TimeFX time compression/expansion; compressor/limiter; M/S decoder; 5.1 surround sound; machine control; snapshot memories; Open Media Framework (OMF), Tektronix Lightworks, WaveFrame, TimeLine compatible. Expandable to 48-track. Starts at \$98,000

Prodigy II

Digital Audio Workstation. 24-track; 16, 20, 24-bit; 24-bit A/D-D/A; 36-channel mixer (expandable to 48-channel); QDC processing engine; 5.1 surround sound; four-band parametric EQ; dynamics module per channel; compressor/limiter; M/S decoding; 40-bit DSP processing; motorized faders; machine control; memory; automated joysticks; LCD screens; QWERTY keyboard. Optional MediaLink networking. Compatible with VST plug-ins.

Frontier Design Group

Dakota

PCI Soundcard. PCI slot; Windows 95/98, Mac; 44.1, 48 kHz sample rates; 16, 20, 24-bit operation; SoDA SMPTE time code; time code chase; sync converter; MTC; MIDI I/O; ADAT sync; compatible with most major DAW programs; ASIO 2.0 driver; Direct GigaSampler XP; connection for Montana expansion card; connection for Sierra MIDI SMPTE expansion box.. ADAT, S/PDIF I/O. Bundled with Tango24 converter: \$899. \$449

Glyph Technologies

X-Project

Expansion Hard Drive for Digidesign Digi 001 System. 30 GB; FireWire interface; audio-optimized; Mac, PC compatible; table top or rackmounted. Ships with FireWire cable. \$599

JEMS Data Unlimited

Desktop FireWire Drives

External Drives. 40 - 80 GB; FireWire interface. Starts at \$349

FireCOR

Rackmounted FireWire Drive Interface. Two-bay; hot swappable; FireWire interface; options of hard drive, CD-RW, DVD-RAM, VXA tape. Starts at \$949

JLCooper Electronics

MCS3 - Media Control Station3

Control Surface. Mac, Windows versions; ADB, USB, RS-232, RS-422, MIDI interface versions; jog/shuttle wheel; tape-style transport controls; dedicated function buttons; compatible with Adobe Premiere, Avid Media 100, Macromedia. \$599

MCS-3800

Modular Control Surface System.

Eight 100mm touch-sensitive motorized faders; numeric keypad; jog/shuttle wheel; programmable function buttons; LCD screen; tape-style transport controls; SMPTE time code; MTC; MMC; 60 memory setting; five rotary encoders; RS232, RS422, RS485, GPI ports; two expansion slots. Optional color LCD/TFT touchscreen controller, MCS-Viewpoint: \$1,199. \$2,999

Joemeek/PMI Audio

MQ1 MicroMeek

Computer Audio Interface. Computer-mountable 5.25" bay break-in box; PCI card; preamp/compressor/EQ; input, output, compressor controls; three-band Meequalizer EQ; 48V phantom power; front panel 1/4" input, XLR, 1/4", RCA. Ships with Sonic Foundry Sound Forge, ACID software. \$249

Korg USA Inc.

D1600V40

Standalone DAW/Recorder. 24-channel; 44.1 kHz sample rate; 16 - 24-bit; onboard 40 GB removable hard drive; CD-RW drive; three-band EQ; onboard DSP effects; TMC; MIDI compatible; WAV files; tap tempo; onboard chromatic tuner; SCSI port; built-in mic; tape-style transport controls; shuttle wheel; LCD touchscreen. XLR, 1/4", RCA, S/PDIF. \$2,000

PXR4

SmartMedia Workstation/Recorder. Two-track; SmartMedia format; 16-bit; 32 kHz sample rate; onboard DSP effects; onboard chromatic tuner; onboard mic; USB port; LCD screen. 1/4", 1/8", USB. \$500

Kurzweil/Young Chang America Inc.

K2600X

Digital Audio Workstation/Keyboard Synthesizer Eight-channel sampler; 88-key synthesizer; onboard DSP; internal hard drive; expandable ROM (up to 44 MB); expandable RAM (up to 128 MB); 512 k P/DRAM; 600mm ribbon controller; 20m ribbon controller; SCSI port. 5.4" x 18" x 5", 73 lb. Compatible with Kurzweil K2500 sound ROMs, KDFx and CDs. Smaller 76-key rackmountable version available. starts at \$6,820

Laird Telemedia

DVora Pro Tools Digital Audio Workstation

Turnkey Systems. Pro Tools LE software; Digidesign Digi 001 or 002 interfaces; 40GB or larger hard drive; Pentium IV 2 GHz processor; RAID; Matrox dual head video card; ADS Pro FireWire capture card; 512 MB RAM; Soundblaster sound card. Numerous upgrade options. Optional powered speakers. Optional mixer. Starts at \$5,999

Lynx Studio Technology

L22

Computer Audio Card. PCI card; 24-bit; 192 kHz; Windows 98/Me/NT/2000/XP, MME, ASIO, Mac drivers; onboard mixer; breakout cable. AES/EBU, S/PDIF. Optional ADAT, AES/EBU, S/PDIF I/O modules. \$749

LynxTWO

PCI slot; 24-bit A/D-D/A; 8 - 32-bit file depths; 24, 25, 29.97, 30, 32, 44.1, 48, 88.2, 96 kHz sample rates; sample rate chase; SMPTE, LTC; NTSC, PAL video sync; word clock; SyncClock; Windows 98/Me/NT/2000/XP, MME, ASIO, Mac; MIDI-compatible; breakout I/O cable; breakout sync cable; +4 - 10 dB operation. 15-pin D-sub, 25-pin D-sub, RCA, XLR. Ships with mixing software. Optional ADAT, AES/EBU, S/PDIF I/O modules. Starts at \$995

M Audio

Audiophile 2496

Computer Audio Interface. PCI slot; 24-bit, 96 kHz; breakout cable with four inputs; four outputs; defeatable SCMS; Windows 95/98/Me/NT/2000/XP, Mac, Mac OS X, Linux drivers; ASIO, EASI, GSIF, DirectX, OMS; MP3, RCA, five-pin MIDI, S/PDIF. \$229

BiPort 2x4s

MIDI Interface. Windows 98/Me/NT, Mac drivers; 32 MIDI channels in/64 MIDI channels out; SMPTE timecode; MIDI timecode; status LEDs; GeoPort-compatible. \$179

Delta 1010

Computer-Based Recording System. PCI slot card; 24-bit, 96 kHz; breakout box; Windows 95/98/Me/NT/2000/XP, Mac, Mac OS X, Linux drivers; ASIO, EASI, GSIF, DirectX; mixing software; MIDI; word clock; +4-10 operation. 1/4", RCA, BNC, five-pin MIDI, S/PDIF. \$799

Delta 66

Computer-Based Recording System. PCI slot card; 24-bit, 96 kHz; breakout box; Windows 95/98/Me/NT/2000/XP, Mac, Mac OS X, Linux drivers; ASIO, EASI, GSIF, DirectX; mixing software; +4-10 operation. 1/4", RCA, S/PDIF. \$500

Omni Studio

Computer-Based Recording System. PCI slot card; 24-bit, 96 kHz; four-channel breakout box with effects sends; separate mic preamps; inserts; headphone controls; Windows 95/98/NT/2000/XP, Mac, Mac OS X, Linux drivers; ASIO, DirectX, GSIF, EASI; mixing software; +4-10 operation. XLR, 1/4", RCA, S/PDIF. \$599

USB Duo

USB Mic Preamp/Converter. USB; mic preamp; 48V phantom power; 20 dB pad; 24-bit A/D converter; 44.1, 48, 88.2, 96 kHz sample rates; level control; headphone controls; S/PDIF output; Windows 98/Me/2000/XP, Mac, Mac OS X drivers; ASIO, DirectX; +4-10 dB operation. RCA, XLR, 1/4", S/PDIF. \$349

USB Midisport 2x2

USB/MIDI Interface. USB; two MIDI ins/two MIDI outs; Windows 98/Me/2000/XP, Mac, Mac OS X drivers; OMS. Five-pin MIDI, USB. Ships with USB cable. \$89

USB Quadro

USB I/O Box. USB; MIDI; up to four-in, four-out; up to 24-bit, 96 kHz; Windows 98/Me/2000/XP, Mac, Mac OS X drivers; ASIO, DirectX, OMS; +4-10 operation. 1/4", MIDI five-pin, USB. \$349

Mackie Designs Inc.

HDR24/96

Standalone DAW/Hard Disk Recorder. 24-track; 96 kHz-compatible; 44.1, 48 kHz current sample rates; onboard 20 GB hard drive; onboard editing software; WAV, AIFF files; word clock; SMPTE; black burst; NTSC/PAL; MIDI-compatible; rackmountable recorder; SVGA monitor port; 3.5" floppy drive; Ethernet port; tape-style transport controls; LED meters, display, 25-pin D-sub, nine-pin D-sub, BNC, 1/4". \$4,999

Mackie Control

Control Surface. Eight-channel; 100mm faders; programmable buttons; jog/shuttle wheel; tape-style transport controls; Lexan program-specific overlays; compatible with Mackie Soundscape, Steinberg Nuendo, Cubase, MOTU Digital Performer, Cakewalk SONAR, Syntrillium Cool Edit Pro Optional Mackie Control Extender sidecar: \$1,099. \$1,299

Magix Entertainment Corp.

Samplitude Producer 2496

Windows 95/98/Me/NT/2000/XP; recording/mixer/editor software; 32-bit internal processing; waveform editing; nondestructive editing; graphic EQ; parametric EQ; compressor/expander; noise gate; distortion effects; reverb; FFT filter/analyzer; up to 999 tracks; SMPTE, MIDI time codes; punch in/out; WAV, BWF, AIFF file formats; 5.1 surround sound; MPEG audio compatible; DirectX compatible; CD mastering/burning utilities; compatible with Radikal Technologies SAC-2k controller. Lite version: \$399 \$ 675

Mark Of The Unicorn (MOTU)

896

FireWire-based I/O Box. Eight-channel; Mac, Windows Me/2000/XP; 24-bit, 96 kHz; 44.1, 48, 88.2, 96 kHz sample rates; onboard sample rate converter; 48V phantom power; volume controls; +4-10 dB operation; word clock; ADAT Sync; linkable; LED meters. XLR, 1/4", BNC, optical, nine-pin D-sub, FireWire, AES/EBU, ADAT. Ships with Mac AudioDesk software. Compatible with other MOTU hardware and software. \$1,295

Digital Performer

DAW Software. Mac; hard disk recording, mixing, editing; waveform editing; 24-bit; compressor, expander, limiter, gate; echo, flange, chorus, reverb, tube simulation; DSP effects; fully MIDI compatible; TDM-compatible; SMPTE; QuickTime; up to 10.2 surround sound; Pro Tools-compatible; compatible with Mackie HUI, Radikal Technologies SAC-2K control surfaces; proprietary plug-ins available; third party plug-ins available. Third party plug-ins available. \$795

HD192

Hard Disk Recording System. PCI card (PCI-424) and rackmounted interface; Mac, Windows 98SE/Me/2000/XP; 12-channel; 44.1, 48, 88.2, 96, 176.4, 192 kHz sample rates; linkable up to 48 channels; word clock; SMPTE; video sync; CueMix matrix; FireWire port; compatible with VST, MAS, DirectX, Premiere; headphone jack and control; LED meters. 1/4", RCA, BNC, TOSLink, FireWire. 2RU. Ships with AudioDesk DAW software. \$1,895

MOTU Audio 2408

Hard Disk Recording System. PCI card (PCI-324) and rackmounted interface; Mac, Windows 98SE/Me/2000/XP; 24 inputs; expandable I/O; 20-bit A/D-D/A; word clock; sample rate, format converter; supports WAV, AIFF, SDII, GSIF file formats; compatible with Digital Performer, VST, ASIO, Cakewalk, Cool Edit Pro, SEK'D Samplitude, IQS SAW, Logic Audio, RCA, TDIF, ADAT optical, 1/4", BNC. Ships with AudioDesk workstation software. Minimum system: Power Mac G04, 32 MB RAM, OS 7.6.1; 200 MHz Pentium, 32 MB, Win 95/98. \$995

MOTU Audio 24I/O

Hard Disk Recording System. PCI card (PCI-424) and rackmounted interface; Mac, Windows 98SE/Me/2000/XP; 24 inputs; 24-bit A/D-D/A; 44.1, 48, 88.2, 96 kHz sample rates; word clock; SMPTE; video sync; CueMix matrix; FireWire port; compatible with VST, MAS, DirectX, Premiere; headphone jack and control. 1/4", RCA, BNC, TOSLink, FireWire. Ships with AudioDesk DAW software. \$1,495

McDowell Signal Processing

Analog Channel

Analog Emulation Plug-in. TDM, AudioSuite, RTAS; tape emulator; gain control; analog saturation. \$495

DIGITAL AUDIO WORKSTATIONS/PERIPHERALS/PLUG-INS

Compressor Bank

Compressor Plug-in. Audio Suite/TDM/RTAS; multiple peak detection; Bi-directional Transient Enhancement bite and knee controls; pre-EQ filter; post static dynamic EQ; LA2A, UREI, 1176LN, dbx165, Neve 2254/33609C emulation. \$495

Filter Bank

EQ/Filter Plug-in. Audio Suite/TDM/RTAS; programmable equalizer; 22-band; high, low-pass filters; band-pass filters; parametric EQ; tube, solid state emulation. Compatible with Digidesign ProControl and Mackie HUI. \$495

Medea Corp.

AudioRack LP

Rackmountable SCSI Array. Windows NT, Mac; 24-bit, 96 kHz capable; desktop or rackmountable arrays; four UltraSCSI2 LVD drives; networkable; up to 300 GB. Starts at \$1,849

Merging Technologies

Mykerinos

PCI Audio Card. PCI card; modular; daughtercards provide I/O options; NTSC, PAL, HDTV video sync; LTC, VITC; timecode generator; Windows 95/98/Me/2000/NT; onboard DSP (parametric EQ, reverb, graphic EQ); up to 128 tracks; 24-bit; 96 kHz; up to 384 kHz sample rate; word clock; Philips Trimedia processor. ADAT, S/PDIF, AES/EBU, TDIF, SDIF, MADI I/O options.

PyraMix Virtual Studio 4.1 ★ New for 2003 ★

Digital Audio Workstation. Studio, post production. Mykerinos PCI card; Windows 95/98/2000/NT DAW software; 24 - 96 tracks; 32 - 192 kHz; onboard mastering software; 5.1, 7.1 surround sound; CD mastering software; LTC, VITC, NTSC, PAL HDTV; onboard DSP; 32-bit internal processing; reverb; networkable; DirectX, VST, ASIO, OMF, CMX/EDL, SDII, WAV, AU, AIFF, MP3, AC3 files; MMC; Sony P9; 24/96-compatible; up to 384 kHz sample rate. Optional I/O daughtercards - ADAT, MADI, TDIF, S/PDIF, SDIF, AES/EBU, DSD/SACD optimized package; \$9,000. Starts at \$1,995

Metric Halo Laboratories

ChannelStrip

Software Channel Strip. Six-band EQ; six-band parametric EQ; compressor; delay; polarity reverse; expander/gate; high, low-cut filters; bandpass filters; peak, RMS, VU meters; TDM, RTAS, MAS versions; Lite Version, ChannelStrip SP, ChannelStrip TDM. \$699. ChannelStrip/SP TDM: \$349. ChannelStrip RTAS: \$345. ChannelStrip/SP TDM: \$175. ChannelStrip MAS: \$345. ChannelStrip/SP MAS: \$175.

Minnetonka Audio Software

discWeider Chrome

DVD-A Authoring Software. DVD Audio format; Windows 98/NT/2000/XP; 24-bit; 96/192 kHz; surround sound; MLP-compatible; video_ts-compatible; DLT export. \$2,495

discWeider Steel

DVD-A Authoring Software. DVD Audio format; Windows 98/NT/2000/XP; 24-bit; 48/96/192 kHz; surround sound. \$495

SurCode DVD Professional for DTS

DTS Surround Sound Encoder for DVD. Post production. Windows 95/98/2000/NT; WAV or AIFF file format; DTS format for DVD-Video; six track. \$1,995

SurCode for Dolby Digital

Dolby Digital Surround Sound Encoder. Post production. Windows 95/98; WAV or AIFF file format; Dolby Digital (AC-3); six track. \$995

Mixed Logic

M24

Control Surface. 24 100mm motorized faders; automation; EQ, dynamics; software plug-in control; jog/shuttle wheel; LCD screen. MIDI, USB. Compatible with Pro Tools, Cakewalk Sonar, Steinberg Nuendo, Cubase, MOTU Digital Performer, Emagic Logic. \$3,499

Mixman

Studio Pro

DJ Mixing/Processing Software. Windows 95/98 software; 16-channel; Wide Band Audio Real-time Processing DSP effects; filter sweep; reverb; delay; pass filters; flange; compatible with WAV, MP3, RealPlayer G2, SoundFont files; ships with SFX library; compatible with Cubase 3.7. \$90

Native Instruments

NI-Spektral Delay

Multiband Delay. Windows, Mac; VST2, DirectX, ASIO, DXi, MME, DirectSound, Sound Manager; up to 160 bands per channel; up to 1,024 virtual bands; up to 12 second delay; LFO; feedback matrix; real time FFT; real time sonograms; input modulator; input filter; sine, triangle, square, sawtooth waves. RTAS/HDTM Pro Tools version, NI-Spektral Delay PTE: \$449. \$289

Reaktor

Synthesizer Software. Windows 98/2000/XP, Mac; ASIO, VST2, DirectConnect, DirectSound, Logic, MME, DXi, MAS; OMS; FreeMIDI; mixers; oscillators; filters; onboard modular synth;

sequencers; envelope controls; 64-voices per instrument; 32-bit processing; programmable; MP3; compatible with Native Instruments libraries and other programs; Akai sampler-compatible. SSE instruction, Altivec-optimized. \$599

PreSonus Audio Electronics

FIREstation

FireWire-based Interface. Eight-channel; 24-bit A/D-D/A; 48V phantom power; 20 dB pad; tube drive circuit for preamp; onboard mixer; word clock; MIDI; FireWire ports; mLAN; ASIO drivers; linkable; headphone controls. XLR, 1/4", TOSlink, BNC, FireWire, nine-pin D-sub, S/PDIF, ADAT, 1RU.

Propellerheads Software

Reason 2.0

Mixer/Sequencer/Synth/Sampler Software. Windows, Mac; ASIO, MME, DirectX, Sound Manager drivers; 24-bit, 96 kHz; REX file format; 32-bit processing; AIFF, WAV-compatible; ReWire slave support; onboard synths; onboard mixer; onboard samplers; onboard DSP; onboard library; MIDI-compatible; OS X-compatible. \$399

RME/X-Vision US

DIGI9652 Hammerfall

Audio Card. PCI slot; 24-channel; PC, Mac; 24-bit, 96 kHz; ASIO2 drivers. ADAT optical, S/PDIF. Optional daughter-cards for additional I/O. \$775

THE AZDEN 411DRH

The Professional's Choice

The 63-channel UHF 411DRH system delivers everything you've come to expect from an Azden wireless system: high quality audio, with 2 complete front ends for "real" true diversity, and moderate pricing. All backed by our outstanding QC, technical support, and customer service. When you add it all up, we know you'll agree that the Azden 411DRH is the "real deal!"



Receiver: True diversity, with 2 complete front ends. Rugged metal half-rack case. 63-channel user-selectable crystal-controlled and PLL synthesized. 1/4" and XLR output jacks on rear, with rear-mounted detachable antennas and squelch control. Rack-mountable with HR-1 or HR-2 rack kits.



Transmitters:

Body-pack (41BT) with 4-pin Hirose mini-connector, available with omni (EX-503H), uni (EX-505UH), Sony ECM-44H, or, headworn mics: uni (HS-11H), omni (HS-9H).

Plug-in universal (41XT)

Handheld w/uni (41HT)



147 New Hyde Park Road
P.O. Box 10, Franklin Square, NY 11010
(516) 328-7500 • FAX: (516) 328-7506
E-Mail: AZDENUS@AZDENCORP.COM
Web site: www.azdencorp.com

DIGITAL AUDIO WORKSTATIONS/PERIPHERALS/PLUG-INS

Roland Corp. U.S.

MC-909 Sampling Groovebox

DSP, dynamics; COSM effects; onboard mixer; pitch shifter; LFO; filters; turntable emulator; BPM counter; 16-track sequencer; upgradable 16MB sampler; 64-voice synth; twin beams; shuttle wheel; 16 velocity pads; tap pad; V-Link; USB port; LCD screen, 1/4", RCA, MIDI five-pin, optical, USB, S/PDIF. Optional SmartMedia drive. \$1,795

VS-1880HD

Digital Audio Workstation. Recorder/editor/mixer; hard disk; 18-track; 288 virtual tracks; eight track playback; pan controls per channel; 24-bit A/D-D/A; 24-bit recording; 32, 44.1, 48 kHz sample rates; sample rate chase; nondestructive editing; onboard DSP; onboard special effects; MIDI time code; MIDI machine control; MIDI I/O thru; SCSI port; tape style transport controls; jog wheel; LCD screen; modular; linkable; table top, non-PC standalone unit. RCA, 1/4", XLR, optical. Optional CD recording function. Optional DSP processor cards with effects. \$2,795

Rorke Data Inc.

Galaxy 50 Series Fibre Channel RAID

72 GB - 2.4 TB; hot-swappable drives; Fibre Channel/SCSI interface. Starts at \$40,000

Galaxy-i

IDE/SCSI RAID Storage Network, IDE/SCSI Ultra 3; RAID 0, 3, 5; up to 80 MBps; up to 450 GB.

StudioNet-FC

Fibre Channel Storage Network. Fibre channel network; up to 200 MBps; compatible with Sun, Windows, Mac, SGI workstation systems; compatible with all RAID levels.

Roxio

Easy CD Creator 5

CD Recording Software. Windows 98/Me/2000/XP. \$99

Toast 5 Titanium

CD Recording Software. Mac OS X. \$89

SADIE, Inc.

Apogee UV22 Plug-in

Word Length Reducer. Studio, post production. Variable bit rate, 8-24 bits; based on Apogee Electronics UV technology. \$495

DSD Mastering Editor

Digital Audio Workstation. SACD/DSD-compatible; turnkey system; 16-bit, PCM, 64fs, Scarlet Book, Red Book standard-compatible; nondestructive editing; unlimited undo; DirectX-compatible; AIT drive. Starts at \$16,000

DVD-A Direct

DVD Audio Authoring Software. Windows software; DVD-A format; DVD-R, DLT cassette-compatible; NTSC, PAL-compatible. Optional Meridian MLP encoding.

SADIE 24.96 Digital Audio Workstation

Digital Audio Workstation. Studio, post production, video, film. Windows 98/2000/NT; 24-bit recording; 32-bit processing; processing; 20-bit A/D-D/A; 96 - 192 kHz; modular; 8 - 32 channels; onboard DAW mixing/editing software; time compressor/expander; PQ editor; LCR, LCRS, 5.1 surround sound; CAT time code generator; SMPTE I/O; DVD compatible; AES31, OMF compatible; PCI cards; breakout box; RS422 ports; SCSI ports. Turn key system with Pentium processor, 17" monitor, removable hard drive. \$12,995

SEK'D America

ProdiF Plus

Audio Card. Studio. PCI slot; 10-channel; Mac, Windows 95/98/NT/2000/XP; 20-bit, 48 kHz; full duplex; 20-bit A/D-D/A; autosync; ships with Samplitude Basic DAW software. ADAT lightpipe, 1/4", RCA, S/PDIF, AES/EBU. \$549

PRODIFT 2496 Pro

TDIF Audio card. PCI slot; Windows

95/98/NT/2000; 16-channel; 24-bit; 96 kHz; TDIF sync; ASIO, MME; breakout cable. TDIF. \$689

Sonic Foundry Inc.

Sound Forge 6.0

Windows 95/98/2000/NT; DirectX; drag and drop, cut and paste editing; nondestructive editing; graphic EQ; parametric EQ; chorus, echo, flange, distortion, compress, gate, pitch bend, reverb, time compress/expand, enhance; DC offset; spectrum analyzer; NTSC/PAL sync; loop editing; Active Streaming Format, RealMedia encoding; RealSystem G2; MPEG/MP3 encoding; Windows Media Technology; batch converter; spectrum analysis; SMPTE, MIDI time code; Acoustic Mirror acoustic modeling; Wave Hammer mastering tools; DirectX plug-in manager; compatible with DirectX, NetShow, WAV, AU, AVI, AIFF and most major file formats. Includes Vegas Video 3.0 LE. \$399 for download. \$499

Vegas Pro

Digital Audio Workstation Software. Windows 98/2000/NT; multiprocessor with Windows NT; 24-bit, 96 kHz; waveform editing; mixing; EDL functions; onboard DSP (compressor, gate, four-band EQ); envelope controls; video window; MTC; WAV, AIFF, AVI, MP3, MOV, MPG, BMP files; DirectX; Windows Media Technology 4.0; RealSystem G2; MPEG/MP3 encoding. Ships with Sonic Foundry XFX plug-in bundles. Minimum system: Pentium 200, 32 MB RAM. \$449

Sonic Studio LLC

HD 1.8

Turnkey Digital Audio Workstation. Eight-channel; 24-bit/96 kHz; HDSP EQ; timecode. Optional DSD/SACD Scarlet Book package. Optional DVD-A package.

Steinberg North America

Audiolink 96 DigiSet

FireWire-based Computer Audio Interface. Breakout box; word clock; ADAT sync; Windows 98/Me/2000/XP, Mac drivers; ASIO, GSIF, RCA, BNC, optical, MIDI five-pin, FireWire, nine-pin D-sub, S/PDIF, ADAT. Needs Audiolink 96 PCI or Audiolink 96 Mobile I/O card. \$650

Cubase VST 5.0

Digital Audio Workstation Software. Windows, Mac; recorder/editor/mixer; VST/ASIO system; 24-bit; 48 kHz; up to 128 tracks for onboard digital mixer; four-band EQ; onboard DSP effects; onboard MIDI sequencing/editing; RealAudio support; Web network (InWire/Rocket Network) support; compatible with GM Module synths, ReWire2; numerous proprietary and third party plug-ins available. \$399

Cubasis VST 2.0 for Mac

Digital Audio Workstation Software. Recorder/editor/mixer/MIDI sequencer; 48-track; DSP effects/processing; QuickTime-compatible; VST, ASIO; compatible with InWire network; TRK, REX file compatible; third party plug-ins available. \$99

Houston

DAW Control Surface. USB; MIDI; VST; 100mm motorized faders; function buttons; LCD screen; jog/shuttle wheel; numeric keypad; compatible with Steinberg Nuendo, Cubase systems. \$1,499

Nuendo

Digital Audio Workstation Software. Post production. Windows 98/NT/2000, Mac; VST2/ASIO2, DirectX compatible; Virtual Studio Instruments-compatible; recording/mixing/editing functions; up to 200 tracks; 24-bit, 96 kHz; EDL functions; unlimited undo/redo; onboard DSP; video sync; QuickTime, AVI support; 5.1, 7.1 surround sound; time code; Apogee UV-22 redifier; test/analysis functions; multiprocessor-compatible; MIDI compatible; OMF-compatible; joystick control; proprietary and third party plug-ins and hardware available. \$1,295

Nuendo 96/52

PC Audio Card for Steinberg Nuendo System. PCI slot; Windows 98/NT; up to 52-channel input; 32, 44.1, 48, 88.2, 96 kHz; 24-bit; AutoSync; SyncCheck; SyncAlign; ASIO; word clock; breakout daughterboard; breakout cable. BNC, optical, 25-pin D-sub, AES/EBU, S/PDIF. \$649

Stomp!

RecordNow Max

CD Burning Software. Windows 95/98/Me/NT/2000/XP; Red Book; DVD burning; track editing. \$49

Storage Concepts Inc.

FibreBlock

Modular Fibre Channel-Based Network. Fibre Channel; modular; 300GB; upgradable/expandable. Transfer rate: 80 - 85 MBps. Starts at \$5,995

Studio Network Solutions

A/V SAN

Standalone Fibre Channel-based Network. Fibre Channel; up to 400 MBps; up to 576 GB; compatible with most DAWs; Mac, Windows. 1RU. Starts at \$3,900

Fibredrive

Outboard Fibre Channel Drive. Fibre Channel; 72GB or 144GB; PCI host card; Mac, Windows. Ships with cables. \$2,200

Symbolic Sound Corporation

Kyma.5 / Cqybara 320

Sound Design Software System. Studio, project studio, film, video. Software/hardware; 24-bit, 96 kHz; real time processing; analysis; vocoder; spectral analysis/morphing; additive and granular synthesis; graphical spectrum interface; timeline interface; filters; reverb; MIDI compatible; word clock; VITC; LTC; Mac and Windows compatible; modular design for expansion of processing. Analog and digital - S/PDIF, AES/EBU. \$3,300

Synchro Arts Limited

VocAlign Project

Audio Alignment Software. Windows, Mac; RTAS. \$299

Syntrillium Software Co.

Cool Edit Pro 2.0

DAW Software. Studio. Windows 95/98/NT/XP; up to 128 tracks; 32-bit DSP; 192 kHz processing; onboard mixing package; graphic EQ, parametric EQ; echo, compressor, expand, limit, delay, reverb, flange, noise and hiss reduction, pitch shift, etc; video sync; CD burning; sample rate converter; multiple file format support; ActiveMovie, DirectX plug-in support; onboard pink, white and brown noise generators; sine, square, saw tones; multiple redo/undo; batch processing; MIDI, SMPTE synchronization; RealAudio G2 support; onboard audio restoration; frequency analysis and editing; level meters. Download: \$249. Upgrade: \$79 - \$229 depending on original version. \$279

TASCAM

GigaStudio 96

Windows 95/98; 96-voice polyphony; 32 MIDI channels; 32-channel mixer; 16, 24-bit; 44.1, 48, 96 kHz sample rate; 32-bit internal processing; instrument editor; reverb; onboard Akai S sampler converter; GSIF; QuickSound database; GigaStudio; RetroDrums; DirectSound. \$399

SX-1 Integrated Audio Production Station

Standalone Digital Audio Workstation. Recorder/mixer/editor; 16-fader control surface; 48 kHz; 24-bit; onboard 128-track MIDI sequencer; 5.1 surround sound; onboard CD-RW drive; onboard effects from TC Works, Antares; SMPTE, LTC, MTC; word clock; 100mm faders; jog/shuttle wheel; two LCD screens; SCSI port; Ethernet. XLR, 1/4", optical, MIDI. Expansion slots for expanded I/O options. \$8,999

US-224

USB Digital Audio Workstation Control Surface. USB; four-channel; Windows/Mac compatible; 24-bit A/D-D/A; two preamps; jog wheel; faders; tape-style transport controls; MMC; MTC; linkable. XLR, 1/4", USB. Ships with Steinberg Cubasis VST. \$375

US-428

USB DAW Control Surface. USB; eight-channel; Windows/Mac compatible; 24-bit A/D-D/A; 44.1, 48 kHz sample rates; four-band EQ; jog wheel; faders; tape-style transport controls; MMC; MTC; linkable. XLR, RCA, 1/4", 14" x 11.5" x 3.5". Ships with Steinberg Cubasis VST. \$625

Proudly Introducing the Quartet



Four Element Class A Tube Recording Channel

The Quartet is the ideal front end for high resolution recording. Our modern tube design adds larger-than-life detail and depth to any source. Its features include:

- The tube Mic/DI Preamp from the MDP-1
- The tube Opto-Compressor/Limiter from the OCL-2 using our proprietary optoelectronic cell
- A new three band tube EQ with HI and LO shelving and six frequency MID band
- A new de-esser design using opto-inductive filtering and a highly selective inductive detector
- Transformerless or transformer-balanced outputs

Pendulum Audio

(908) 665-9333
www.pendulumaudio.com

DIGITAL AUDIO WORKSTATIONS/PERIPHERALS/PLUG-INS

TC Works

Assimilator for PowerCore

Windows, Mac; VST, MAS; 2,000+-band EQ; 24-bit, 96 kHz. \$249

Master X3 3.0

Mastering Plug-in for Pro Tools MIX/HD Systems. Pro Tools MIX/HD; compressor, expander, limiter; up to 96 kHz. \$599

PowerCore

DSP Card for Mac Systems. Windows, Mac; PCI slot card; VST, MAS, ASIO; 24-bit, 96 kHz; four Motorola DSP 56362 chips; one PowerPC chip. Minimum system requirements: Mac G3, OS 8.6, 128 MB RAM. Ships with Spark LE, TC Tools, TC Master, MegaReverb, other software. Third party plug-ins available. \$1,299

Spark XL

Digital Audio Workstation Software. Mac; 24-bit, 96 kHz; waveform editor; onboard parametric EQ, reverb, notch filter, high, low-cut EQ, band-pass EQ, three-band EQ, delay, compressor, limiter; time stretch; tube emulation; system performance monitors; phase correlation meter; real time analyzer; AIFF, SDII, QuickTime, WAV files; compatible with most samplers; TDM-compatible; OS X-compatible. Ships with TC Native Bundle. \$599

TC Tools 3.5

Reverb/EQ Plug-In for Pro Tools. Studio. Five-band EQ; three parametric bands; TC Works MegReverb; chorus; 18 dB boost/cut; analog simulation effect; 24-bit. Free upgrade from 2.0 or \$199 for 1.0 users. Version for Pro Tools MIX/HD systems. \$999

Tracer Technologies/EnhancedAudio.com

Diamond Cut LIVE

Audio Restoration/Noise Reduction Software. Paragraphic EQ; tube emulator; reverb; dynamics processor; delay (up to 100 ms); click, pop, noise, hiss, hum, buzz removal; high, low-pass filters; band-pass filters; azimuth correction; de-esser. \$995

Universal Audio

ReaVerb 5.1

Reverb Plug-In for Surround Sound. Post production, film, video. TDM; room shape, texture controls; direct path, early reflection, late reverb controls. Compatible with DAV-Audio. \$795

SmartCode Pro

Surround Sound Encoder. AudioSuite; 44.1, 48 kHz; data rate; DTS, Dolby AC-3; includes ReaVerb 5.1, TweeTie, WooTie plug-ins. Dolby Digital: \$995. DTS-DVD: \$1,495. DTS-CD: \$495.

SmartPan Pro

Surround Sound Plug-in for Pro Tools. Post production, film, video. TDM; LCRS, 5.1; pan, divergence, azimuth, LFE, gain controls; low-pass filter. \$349

UAD-1 Powered Plug-Ins

PCI Card and Software Package. PCI DSP card; Windows 98/Me/2000/XP, Mac software; VST; includes DSP plug-ins, notably LA-2A, 1176LN and Pultec emulators. \$995

Voyager Sound

GraphiMix 01

Control Software for Yamaha ProMix 01 and 01V Mixers. Win 95/98/NT/2000/XP; MIDI; surround sound; presets; memory; automation. \$129

Wave Arts

WaveSurround

Spatial Enhancer Plug-in. Windows, Mac; VST, DirectX; spectral shaping 3D filter; crosstalk cancelling; mono-stereo enhancement; reverb; HRTF binaural processing. \$89

Waves

360 Surround Toolkit

TDM/HD Surround Sound Plug-in. TDM/HD; dynamics, calibration, mixdown, pan, rotation, width controls. \$2,400

Masters Bundle Native

Software Bundle. RTAS, AudioSuite, MAS, VST, DirectX; Mac, Windows; includes L2 Ultramaximizer, Linear Phase Equalizer, Linear Phase Multiband plug-ins. \$900

Masters Bundle TDM

TDM/HD Software Bundle. TDM/HD; includes L2 Ultramaximizer, Linear Phase Equalizer, Linear Phase Multiband plug-ins; Pro Tools HD compatible. \$1,800

Restoration Bundle

Audio Restoration Plug-in Bundle. Mac/Windows; RTAS, AudioSuite, MAS, VST, Direct X; X-Noise noise reduction; X-Click declicker; X-Crackle declicker; X-Hum hum eliminator. \$1,200

Restoration Bundle HD

HD Plug-in Bundle. Mac/Windows; Pro Tools HD; X-Noise noise reduction; X-Click declicker; X-Crackle declicker; X-Hum hum eliminator. \$2,400

Yamaha Corp. of America

AW2816 ★ New for 2003 ★

Hard Disk Recorder/Mixer/Editor. Studio, live sound. 28 input channels; 16-track; 24-bit A/D-D/A; 16, 24-bit; 44.1, 48 kHz sample rates; 32-bit DSP processor; compressor, gate, ducking, expander, limiter per channel; four-band parametric EQ; reverb, delay, echo, chorus, pitch, rotary, tremolo, flange, phase; editing functions; CD-RW drive; word clock; MTC; MIDI in/out/thru; nine motorized faders; tape-style transport controls; shuttle wheel; onboard sampler; scene memory; SCSI port; LCD screen, meters; LCD, XLR, 1/4", RCA, MIDI five-pin. Choice of I/O cards - AES/EBU, ADAT, XLR, RCA, TDIF. \$2,399

AW4416 Professional Audio Workstation

Hard Disk Recorder/Mixer/Editor. Studio, live sound. 44 input channels; 16-track; 24-bit A/D-D/A; 16, 24-bit; 44.1, 48 kHz sample rates; dual 32-bit DSP processors; compressor, gate, ducking, expander, limiter per channel; four-band parametric EQ; reverb, delay, echo, chorus, pitch, rotary, tremolo, flange, phase; editing functions; CD-RW drive; word clock; MTC; MIDI in/out/thru; 16 60mm motorized faders; tape-style transport controls; shuttle wheel; onboard sampler; scene memory; SCSI port; LCD screen, meters; LCD; FLASH ROM operating system memory for upgrades. RCA, 1/4", XLR, nine-pin D-sub, five-pin MIDI, 22" x 18" x 6". Choice of I/O cards - AES/EBU, ADAT, XLR, RCA, TDIF. \$3,799



The world's only compact, affordable tube mixer

Designed and manufactured in Britain, TL Audio's M3 TubeTracker delivers vintage tube sound at a project studio price.

For full details of TL Audio M3 and VTC tube mixers, and Classic tube processors, contact HHB or your nearest dealer.

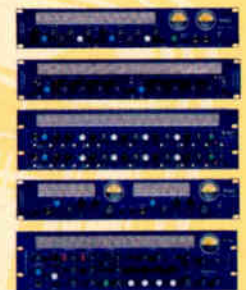

FIRST WE LISTEN

HHB USA: 805 579 6490
HHB Canada: 416 867 9000

www.hhbusa.com

DIGITAL AUDIO PROCESSORS

AETA Audio Corp.

HIFIScoop 3

ISDN Codec Broadcast, location. ISDN: 2, 4, 6-channel; G:7.22, J.52, MPEG Layer 2, MPEG Layer 3, ADPCM; ITU-T J52 compliant; full duplex; headphone jack and volume control; Lexan cover; LCD. 64 - 384 kbps. AES/EBU. 2RU. \$4,800

Akai Musical Instrument Corp.

HV1 Duo Buddy

Harmony Generator. Single-voice; formant; gender; delay; pitch change; random program; 12 presets; memory; input, harmony controls. XLR, 1/4", RCA. 1RU. \$379

HV10 Deca Buddy

Harmony Generator. 10-voice; input, output level controls; pitch correction; scales/chord; formant; gender; delay; up to 100 program memory; program edit; MIDI in/out/thru; bypass; LCD screen. 1/4", XLR, RCA, MIDI five-pin. 1RU. \$499

S6000

Digital Sampler. Studio. 64-voice; optional 128 voices; WAV file format; 3.5" floppy drive; Quickload function; Assignable Program Modulation onboard DSP; 16 outputs (upgradable); two SCSI ports; word clock; LCD panel; shuttle wheel; dedicated function keys; programmable keys; numeric pad; detachable front panel. 1/4". Optional ADAT interface. \$2,999

Z8

Digital Sampler. Studio, live sound. 64-voice; 20 GB hard drive; 272 MB RAM (up to 512 MB RAM); 16, 24-bit; 44.1, 48, 96 kHz sample rates; 36 filter types; three filters per voice; onboard effects processor; Q-Link modulation; IntelliSample automation; word clock; MIDI I/O/thru; onboard DSP; SCSI port; ak.SYS PC/Mac network software; USB port. 1/4", RCA, MIDI five-pin, BNC, 50-pin D-sub, USB, ADAT. \$2,299

AKG Acoustics US

DFM 4x4 Digital Audio Signal Processor

Installation. 24-bit A/D-D/A; up to 12 filters per channel; delay; limiter; parametric EQ; 4x4 matrix router; Automatic Digital Feedback Eliminator; Windows software; eight logic outputs; compatible with AMX, Crestron controllers. \$1,733

Alesis

CLX-440

Compressor/Limiter/Expander. Two-channel; threshold, ratio, attack, release, detect, knee compressor controls; threshold, ratio, attack, release, hold, knee expander controls; threshold, output limiter controls; look-ahead mode; side chain; bypass; +4/-10 dB operation; LED meters. 1/4", 2RU. \$399

MicroVerb 4

Programmable Effects Processor. Studio, sound reinforcement. Two-channel; 18-bit operation; 100 presets; 100 user programs; input, mix, output controls; pitch, chorus, delay, tremolo, pan, Leslie, hall and room reverb plates; decay, high-cut, depth, feedback; shuttle wheel; MIDI modulation; 46.875 kHz sampling rate; program change; footswitch jack; LED display and meter. Frequency response: 20 Hz - 20 kHz. Dynamic range: >90 dB. THD: <0.02%. 1/4", 1RU. \$199

MidiVerb 4

Programmable Effects Processor. Studio, sound reinforcement. Two-channel; 18-bit A/D-D/A; 24-bit operation; 128 presets; 128 user programs; 32 effects algorithms; 48 kHz sample rate; chorus, flange, pitch, delay, tremolo, Leslie, pan effects; concert, room, nonlinear reverbs; Auto Level

Sensing; shuttle wheel; MIDI control/I/O/thru; program change; help functions; footswitch jack; LCD. Frequency response: 20 Hz - 20 kHz. 1/4", 1RU. \$299

NanoCompressor

Stereo Compressor/Limiter. Studio, sound reinforcement. Stereo; threshold, ratio, attack, release, output level controls; Peak/RMS compression; sidechain; hard and soft knee; bypass; input, gain reduction LED meters. Dynamic range: >118 dB. THD: <0.08%. S/N: >100 dB. Attack time: 0.1 - 200 msec. Release time: 50 msec - 3 sec. Compressor ratio: 1:1 - infinity. 1/4", 5.5" x 1.75" x 4.5". \$119

NanoVerb

Digital Effects Unit. Studio, sound reinforcement. Two-channel; 18-bit operation; 16 presets; flange, chorus, delay, Leslie, hall and room plate reverb; stereo I/O level, parameter mix, adjust controls; 46.875 kHz sampling rate; bypass footswitch jack. Frequency response: 40 Hz - 20 kHz. Dynamic range: >90 dB. THD: <0.02%. 1/4", 5.5" x 1.5" x 4.5". \$135

PEQ-450

Parametric Equalizer. Two-channel; five-band; frequency, gain, Q controls per band; input, output controls; stereo link; bypass; +4/-10 dB operation; LED meters. 1/4", 2RU. \$399

Antares Audio Technologies

AMM-1 Microphone Modeler

Microphone Emulator. Spectral Shaping Technology; programmable; editable parameters; tube saturation control; low-cut filter; bypass; dozens of models available; LED meter. XLR, five-pin MIDI. 1RU. \$999

ATR-1a Auto-Tune Intonation Processor

Pitch Correcting Processor. Studio, post production. 20-bit; 56-bit internal processing; scale, speed controls; factory presets; Bass Mode; memory settings; bypass; MIDI SysEx. 1RU. \$549

Applied Research & Technology

DMV-Pro Model 416 Dual True-Stereo 24-Bit Studio Effects Processor

Recording studio. Four-channel, dual stereo; 24-bit; twin DSP engines; 72 algorithms; 100 user presets; 20-bit A/D-D/A; shuttle wheels; LED display; LCD. Dynamic range: >93 dB. 1/4", MIDI five-pin. 1RU. \$525

Quadra/Fx Model 415

Digital Effects Processor. Studio, live sound, project studio. Four-channel/twin stereo; 24-bit DSP; 20-bit A/D-D/A; DEA software technology; 46 kHz sample rate; 100 user presets; 72 algorithms; reverb, delay, pitch, shape, pitch, mix, rotary, pan, tremolo, decay, pitch, chorus; selectable cascade signal path; LED display. Dynamic range: >93 dB. THD: 0.01%. 1/4", 1RU. \$349

Ashly Audio

Protea 4.24C

Digital Crossover/System Processor. Live sound, sound reinforcement, installation. Four ins, eight outs; 24-bit; 48 kHz sample rate; full matrix; crossover; parametric EQ; delay (up to 680 ms); compressor/limiter; Linkwitz-Riley, Butterworth, Bessel filters; high- and low-pass filters; remote PC control via RS232 interface; MIDI compatible; LCD screen. Dynamic range: >110 dB. XLR, five-pin MIDI. 1RU. \$2,475

Protea 4.24G

Four-Channel Digital System Processor. Sound reinforcement, live sound, studio, broadcast. Four-channel compressor/limiter/EQ/DSP; 24-bit; 28-band, 1/3 octave EQ; EQ gain controls; constant Q/reciprocal design; ±15 dB cut/boost; programmable delay/time alignment (up to 680 ms);

high- and low-pass; master level control; 128 preset locations; RS232 interface; MIDI compatible; LCD screen. Frequency response: 20 Hz - 20 kHz; THD: <0.01%. Dynamic range: >100 dB. 1/4", XLR, five-pin MIDI, nine-pin D-sub. 2RU. Optional slave version (4.24GS) - \$1,899. Optional full function remote with display (4.24RD) - \$999. Two-channel slave version - Protea 2.24GS - \$1,199. \$2,249

Audio & Design Ltd.

ProBox 12 Senior

Reference Signal Generator. AES/EBU/word clock signal generator; compatible with NTSC/PAL video sync; 32, 44.1, 48, 88.2, 96 kHz sample rates; DVD compatible. \$2,995

Behringer

Feedback Destroyer Pro DSP 1124P

Feedback Eliminator/Parametric EQ. Studio, live sound, sound reinforcement. Two-channel; 24-bit A/D-D/A; 24-bit; 46.875 kHz sampling rate; 24-band parametric EQ; 24 programmable filters; memory; bypass; MIDI compatible; Windows software. XLR, 1/4", 1RU. \$159

Shark DSP110

Feedback Suppressor/Processor. Live sound, installation, sound reinforcement. Programmable; feedback suppressor, delay, compressor, noise gate, preamp; 48V phantom power; 24-bit A/D-D/A; 46.875 sample rate; variable high-pass filter; LED meters. Delay: up to 2.5 seconds. Frequency response: 10 Hz - 21 kHz. S/N: 92 dB. XLR, 1/4". \$85

Ultra-Curve Pro DSP 8024

Digital Multi-Effects processor. Studio. Two-channel; 24-bit A/D-D/A; 24-bit processing; 31-band graphic/parametric EQ; 16 dB boost/cut; programmable EQ curves; 110 user memories; stereo link; feedback eliminator; limiter; gate; delay (up to 2.5 sec.); MIDI control; bypass; real time analyzer; white/pink noise/sine wave generator; updatable; LCD. XLR, 1/4". \$499

Ultramizer Pro DSP1400P

Loudness Maximizer Two-channel; 20-bit A/D-D/A; 24-bit; compressor; limiter; enhancer; noise reduction; LED meters. \$109

Boss

VF-1

Multi-Effects Processor. 24-bit A/D-D/A; 200 presets; 200 user programs; COSM guitar, mix amp modeling; MMC; front panel 1/4" Hi-Z input; LCD screen. Dynamic range: 97 dB. 1/4", MIDI five-pin. \$495

BSS Audio/Harman

ProSys PS-8810

Installation. Eight inputs, 10 outputs; EQ; gate; compressor; delay; routing matrix; compatible with Crown's IQ for Windows software; CobraNet. 2RU. \$499

Carvin

XP2 Dual Engine Effects Processor

Two-channel; two 24-bit DSP engines; reverb, chorus, flanger, phaser, echo, delay, rotary speaker; MIDI. 1/4", MIDI five-pin. \$199

XP4 Quad Engine Effects Processor

Two-four-channel; four 24-bit DSP engines; reverb, chorus, flanger, phaser, echo, delay, rotary speaker; MIDI. 1/4", MIDI five-pin. 1RU. \$299

CEDAR Audio USA

DCX Declicker

Studio, post production. Scratch and click removal; 40-bit processing; sensitivity control; 24-bit I/O; real-time;

bypass; CEDAR Series X. AES/EBU, S/PDIF. 1RU. \$5,925

DXH Dehisser

Hiss and Noise Reducer. Hiss and noise reduction; 40-bit processing; level, attenuation, variance controls; 24-bit I/O; real-time; bypass; CEDAR Series X. AES/EBU, S/PDIF. 1RU. \$6,725

DNS1000 Dynamic Noise

Suppressor Standalone Noise Reduction System. Post production, broadcast. 24-bit A/D-D/A; 40-bit internal processing; 32, 44.1, 48 kHz sample rates; faders. \$5,895

Comrex Corp.

Matrix

Codec. Broadcast. POTS/GSM wireless; 15 kHz/10 kHz; onboard ten minute audio storage; programmable dialing features; headphone controls; numeric keypad; LCD screen. XLR, 1/4", mini, RJ11. Rackmountable or portable versions. Optional battery kit, \$450. \$3,700

Vector

Codec. Broadcast. POTS; three input channels; autodial; autodial; memory; up to 15 kHz; programmable dialing features; numeric keypad; three headphone outputs; headphone controls; LCD screen. XLR, 1/4", 1/8", RJ11. \$4,500

Crane Song Ltd.

HEDD - 192

Multiprocessor. Studio. 24-bit A/D-D/A converter; 24-bit DSP processing; word clock; 16, 20-bit redither; 44.1, 48, 88.2, 96, 176.4, 192 kHz sample rates; adjustable "Triode," "Pentode" tube emulation circuits and controls; word clock; bypass; LED meter. XLR, optical, RCA, AES/EBU, S/PDIF digital. 1RU. \$3,495

Crown Audio

IQ-USM 810

Digital Processor/Mixer/Router. Installation. Eight inputs, 10 outputs; 24-bit A/D-D/A; delay, gate, compressor, limiter; crossover; output filters; ambient level compensation; IQ for Windows software; 6x6 mix matrix; room combining; compatible with Crown Programmable Input Processor (PIP2) modules; 32 memory settings; Ethernet; RS232/422 port. Barrier block, RJ45, nine-pin D-sub, 37-pin D-sub. 2RU. 13 lb. \$3,360

dbx Professional Products

DDP Digital Dynamics Processor

Studio, live sound, installation. Two-channel; gate/compressor/limiter/deesser/EQ; 24-bit A/D-D/A; input gain, output gain controls per channel; OverEasy, VariKnee, hard knee compression; True RMS Power Summing; dbx Type IV Conversion System; Tape Saturation Emulation; side chain; jog wheel; LCD screen; input/output LED meters. 1RU. \$600

DriveRack PA

System Processor. Installation. Two inputs, four outputs; 28-band graphic EQ; crossover controls; parametric EQ; compressor/limiter; Advanced Feedback Suppression; dbx 120A Subharmonic Synthesizer; real time analyzer; parameter controls; programmable; computer remote control operable; Windows software; LED meters; linkable; display screen. \$499

Quantum

Digital Mastering Processor. Two-channel; compressor, limiter, expander, gate, five-band parametric EQ, de-esser; Type IV Conversion System; 24-bit A/D-D/A; 44.1, 48, 88.2, 96 kHz sample rates; TSE tape saturation emulation; high, low-shelving filters; Q control; True Power Summing;

Variable Transient Capture Mode gating; threshold, ratio, gain, auto, attack, hold, release compressor controls; OverEasy with VariKnee compression; gain, attack, release, hold controls for limiter; VariKnee limiter; 50 factory presets; 50 setting memory; side chain; LED meter; LCD screen. XLR, 1/4", 1RU. \$2,000

Digital Domain

DD-2 Ambience Recovery Processor

Digital Stereo Processor. Post production. "K-Stereo" process; left, right, shelf filter, bell curve, ambience controls; presets; MIDI control-compatible; bypass. \$3,500

Dolby Laboratories Inc.

DP564 Multichannel Audio Decoder

Broadcast, post production. Compatible with all Dolby formats; onboard SRC; 32, 44.1, 48, 88.2, 96 kHz input; LTC; Ethernet; headphone output; fluorescent display. XLR, BNC, 1/4" RJ45, optical, eight-pin DIN, nine-pin D-sub, 37-pin D-sub. 2RU. \$4,900

DP570 Multichannel Audio Tool

Digital, Dolby E, Dolby Surround Monitor. Broadcast, post production. Dolby Digital, Dolby E, Dolby Surround formats; 24-bit; eight-channel (7.1) router; creates and monitors metadata; onboard decoder; Windows software. 2RU. Optional surround mix output card. \$6,495

DP572 Dolby E Decoder

Broadcast, post production. Dolby E/AES3; eight-channel; 48 kHz sample rate; audio/video frame sync; SMPTE timecode; NTSC/PAL; remote control, status, auxiliary, metadata ports; LCD screen. Frequency response: 20 Hz - 20 kHz. THD: 0.02%.

Draemer USA/TransAmerica Audio Group

DC2476A Masterflow Pro Digital Mastering Processor

Studio, broadcast. 24-bit A/D-D/A; 32, 44.1, 48, 88.2, 96 kHz sample rates; five-band EQ; three-band stereo width; Dynamic Spectral Enhancement; three-band "bootstrap" compressor; three-band expander; word clock; MIDI I/O/thru; PC/MCIA drive; LCD screen; LED meters. 1RU. \$3,100

DTS-Digital Theater System

CAD-4 Decoder

DTS Surround Sound Decoder. Post production. DTS (5.1) format; 24-bit. XLR. 1RU.

CAE-4 Encoder

DTS Surround Sound Encoder. Post production. DTS (5.1) format; 24-bit; timecode defeat; LFE mute; surround bypass; headphone jack. XLR.

Dynatron/G Prime

255

Reverberator. Five-channel; 44.1, 48 kHz sample rates; reverb decay, low-frequency decay, high-frequency decay controls; based on EMT 250. XLR. 2RU. \$5,995

Euphonix Inc.

Model Two HDCD Processor

Post production, studio. Two-channel; 16, 20, 24-bit; 44.1, 48, 88.2, 96, 176.4, 192 kHz sample rates; HDCD Dynamic Decimation Filtering Conversion; onboard sample rate converter; word clock; linkable XLR, BNC. \$25,000

Eventide Inc.

DSP7000

24-bit A/D-D/A; 56-bit processing; 147 effects modules; keypad; shuttle

DIGITAL AUDIO PROCESSORS

wheel; 44.1, 48, 88.2, 96 kHz sampling rates; clip indicator; modular; input modules; 128-band parametric EQ; pitch shift, reverb, bandpass, chorus, flange, delay; 6-band EQ, tube simulation; dynamics processor; 500 presets; foot pedal interface; compatible with Eventide EVE/NET software. Optional effects expansion board.

Orville

Digital Audio Processor. Eight-channel; 24-bit; 44.1, 48, 88.2, 96 kHz sample rates; pitch shift; compressor; limiter; 16-band EQ; time compression; delay (up to 87 seconds); onboard sampler; onboard presets; A/B comparative operation; MIDI compatible; PC/MCIA card drive; numeric keypad; LED screen; LED meters; compatible with Eventide DSP4000 presets and cards. XLR, RCA, 1/4", MIDI five-pin D-sub, nine-pin D-sub, AES/EBU, S/PDIF. 2RU. Optional AES/EBU, ADAT I/O boards. \$5,695

Gold Line/TEF

EQ-2

Digital Parametric Equalizer. Two-channel; 10-band parametric EQ; high-, low-pass, shelving, feedback notch filters; delay (up to 170 mSec. in 28-microsecond steps); nonvolatile memory; computer remote control; RS232 port; preset buttons; compatible with Gold Line RTAs. XLR, RCA. \$1,279

Inovonics Inc.

Omega

Digital Audio Dynamics Processor. Post production, broadcast. 24-bit; four-band leveler, four-band compressor; peak control; automatic gain control. 2RU. \$5,880

Joemeek/PMI Audio

SC4 Digital Stereo Compressor

Studio. Two-channel; 24-bit; 44.1, 48 kHz sample rates; input gain, slope, compression, attack, transient release, release, output gain controls; image width control; M/S insert point; digital bypass; word clock; bypass; VU meter. XLR, Toslink, BNC, AES/EBU, 2RU. Optional AES/EBU interface - DC4: \$300.

Jünger Audio Studioteknik GmbH/G Prime

accent2

Digital Dynamic Range Processor. Studio, post production, broadcast, video. Digital expander/limiter/compressor/limiter; 24-bit processing; 44.1 - 96 kHz sample rate; A/D-D/A; configurable routing; 50 settings memory; sample rate converter. AES/EBU, XLR, BNC. 1RU. \$5,100

Model e07

Digital Parametric Equalizer. Studio, post production, broadcast, video. Four-band parametric EQ; dynamic filters; timecode; snapshot; 44.1, 48, 88.2, 96 kHz sampling rates; 24-bit processing; digital limiter; frequency, range, width controls; RS232 port. XLR, RCA, AES/EBU, S/PDIF. 1RU. \$4,750

Klark Teknik

DN2360

Digital Graphic EQ. Installation. Two-channel; 30-band; constant-Q; notch, PEQ, high-pass filter, low-pass filter controls; 24-bit A/D-D/A; 96 kHz; Windows 95/98/2000/NT software; RS-232 port; RS-485 network ports. XLR, Phoenix, nine-pin D-sub. 1/2RU. Compatible with AMX, Crestron, Smart-Pro, Palm Pilot, Stardraw Audio controllers. \$1,491

DN7454

Digital Delay/Multiprocessor. Live sound, installation, sound reinforcement. Two inputs, four outputs; 24-bit A/D-D/A; 24-bit Motorola processors;

seven-band parametric EQ on input; six-band parametric EQ on outputs; compressor; limiter; MIDI in/thru/out; RS-232 port. Frequency response: 20 Hz - 20 kHz. Dynamic range: >112 dB. Delay: up to 4,500 ms on inputs, up to 900 ms on outputs. XLR, nine-pin D-sub, five-pin MIDI DIN. 1RU. \$2,384

DN9340 Helix ★ New for 2003 ★

Digital Equalizer. Live sound, installation, sound reinforcement. Two-channel; 31-band graphic EQ; 12-band parametric EQ; Threshold Dependent Dynamic EQ; four filters (high, low-pass, shelf, notch) per channel; delay (up to 1 sec); touch panel; linkable up to 64 channels; LED meters; compatible with Midas Legend and Heritage consoles. XLR, nine-pin D-sub, RS232. 2RU. \$3,663

Kurzweil/Young Chang America Inc.

KSP8 Multi-bus Effects Processor

Eight-channel; 24-bit; reverb, flange, rotary speaker, chorus, distortion, EQ, filter, et al; SmartMedia card drive. Optional TDF, lightpipe or AES/EBU I/O. \$2,995

Lectrosonics Inc.

DSP44

Digital Signal Processor. Installation, live sound. Four-channel; Automatic Digital Feedback Eliminator; 12 filters per channel; compressor; attack, release, threshold, ratio compressor controls per channel; limiter; attack, release, threshold limiter controls per channel; delay; 4X4 routing matrix; RS232 port; ships with LecNet software; compatible with AMX, Crestron systems. Phoenix, 15-pin D-sub, 8-pin DIN. 1RU. Single and dual versions available. single: \$1,650, dual: \$2,950

Lexicon Inc.

960L

Digital Effects Processor. 16-channel; 24-bit; 44.1, 48, 88.2, 96 kHz; Lexicon 3D Preceptual Modeling; reverb; 5.1 surround sound; 240 factory presets; 500 user memory scenes; onboard hard disk; onboard 3.5" drive, CD-ROM; separate control surface with joystick, motorized faders, LCD screen; word clock. Digital I/O only version: \$11,995. \$15,000

MPX 200

Digital Effects Processor. Two-channel; 24-bit; Lexichip; 240 presets; ambience, plate, chamber, inverse reverbs; compressor; tremolo, rotary, chorus, flange, pitch, detune, echo; delay (up to 5.5 seconds); MIDI-compatible; tempo display; 64 user memories. 1RU. \$399

MPX 550

Digital Effects Processor. Two-channel; 24-bit; Lexichip3 processor; 240 factory presets; 64 user presets; ambience, plate, chamber, inverse reverbs; tremolo, rotary, chorus, flange, pitch, detune, echo; compressor; delay (up to 5.5 seconds); MIDI-compatible; tempo display. RCA, S/PDIF. \$649

MPX G2

Guitar Effects Processor. Lexichip processor; 32-bit; overdrive; analog speaker emulation; vintage stomp box emulation; pitch shift, parametric EQ, tap delay, chorus, flange, rotary speaker, reverb, ambience; noise gate; 250 programs; bypass. 1RU. \$1,499

PCM 91 Digital Reverberator

Two-channel; Lexichip processor; 450 presets; search function; PC/MCIA drive. XLR, RCA, AES/EBU, S/PDIF. 1RU. \$2,995

Line 6

Studio Modelers

Digital "Classic" Effects Processor. 24-bit A/D-D/A; echo, filter, chorus, tremo-

lo, phaser, delay; 99 memory settings; MIDI. S/N: >105 dB. 1/4", XLR, MIDI five-pin. 1RU. \$699

Manifold Labs

Plugzilla

Rackmounted Dedicated Software Plug-in Player. VST 2.0 plug-ins; up to four-channel; 24-bit; 96 kHz; 32 MIDI channels; programmable; Pentium processor; CompactFLASH port; USB port; LED screen. 2RU.

Martinsound Inc.

FilterMAX

Surround Low-Frequency Effects Filter. \$999

ManagerMAX

5.1 Surround Bass Manager. Six filters; filter controls.

MUSICAM USA

CDQ Prima Model 210

Digital Audio Codec. Broadcast, studio. Bidirectional 20 kHz stereo; ISO/MPEG Layer II, III, G.722; up to 3 ISDN TA modules; AES/EBU I/O; SMPTE timecode; 256 presets; RS232 remote control; RS485 port; keypad; LEDs. AES/EBU I/O. 2RU. Wide variety of interface, analysis, processing options available. \$3,750 base price

CDQ Prima Model 220

Digital Audio Codec. Broadcast, studio. Bidirectional 20 kHz stereo; ISO/MPEG Layer II, III, G.722; up to 3 ISDN TA modules; AES/EBU I/O; SMPTE timecode; 256 presets; RS232 remote control; RS485 port; cue keypad; LEDs, LCD, VU meters. AES/EBU I/O. 2RU. Wide variety of interface, analysis, processing options available. \$4,700 base price

CDQPrima LT

Digital Audio Codec. Broadcast, project studio. 24-bit A/D-D/A; MPEG Layer II, III, G.722; includes TA module. Dynamic range: 95 dB. Up to 384 kbps. 2RU. Optional AES/EBU, S/PDIF I/O. \$3,495

Prima LT Plus

Digital Audio Codec. 24-bit A/D-D/A; MPEG Layer II, III, G.722; ISDN dual line; Prima Logic Language; three plug-in card slots. Up to 384 kbps. 2RU. Optional SMPTE timecode. Optional V.35, X.21, RS-422, RS-535 interfaces. \$4,995

Nady Systems Inc.

SDP-20

Digital Sound Processor. Two-channel; twin processing engines; 256 presets; reverb, gate, delay, echo, chorus, flange, Leslie, pitch shift, distortion. \$174

Peavey Electronics Corp.

Feedback Ferret II

Feedback Eliminator. Live sound, sound reinforcement. Two-channel/dual mono; 16/32 filters; user presets; RS232 port. XLR, 1/4". \$499

PreSonus Audio Electronics

DEQ624

Digital Equalizer/Multiprocessor. Two-channel; graphic EQ/compressor/gate; 31-band; 24-bit A/D-D/A; high, low-cut filters; compressor, ratio, gate, gain controls; hum removal; security lock-out; LED meters. \$2,295

Princeton Digital

Reverb 2016

Digital Reverberator. 24-bit; 44.1, 48 kHz sample rates; input, output, mix, pre-delay, decay, position, diffusion, low EQ, high EQ controls; stereo, room, high density plate reverbs; 99 user presets; copy of Eventide SP2016

reverberator. 1/4", XLR, S/PDIF.

Quantec/HHB Communications

Yardstick 2402 Room Simulator

Reverberator. Quantec Room Simulator algorithm; LCD screen; RS232 port; LED meters. XLR, AES-EBU, nine-pin D-sub. \$2,999

Rane Corp.

AD 22d

Delay Unit. Studio, post production, film. Two-channel; memory; sensitivity controls per channel; display in milliseconds, meters, feet; bypass; lock-out switch; LED display; XLR balanced output. Delay: 1.5 - 999.99 mSec. 1RU. \$849

RPE 228d

Remote Controlled Equalizer. Studio, broadcast, sound reinforcement. Two-channel; 28-band; 1/3 octave; high-, low-cut filters (± 10 dB); level controls; 16 memory settings; compatible with RaneWare; RaneWare software included; Windows-based. RS232, Euroblock. 1RU. \$749

RPM 22

Programmable Multifunction Processor. Two-channel; 24-bit; 48V phantom power; 24 memory settings; remote/computer operable via DragNet Windows software; Ethernet port; RW485 port; LED meters. XLR, Euroblock, RJ45, AES3. 2RU. \$1,749

RPM 26z

Remote Programmable Multifunction Processor. Two-channel; crossover/compressor/delay/parametric EQ; 24-bit A/D-D/A; 32, 48-bit processing; adjustable high, low-cut filters; pink noise/sine wave generators; Bessel, Butterworth, Linkwitz-Riley filters; compatible with Rane Drag Net software; RS232 port; Windows-based. Frequency response: 20 Hz - 20 kHz. THD: <0.05%. Limiter attack time: 1 - 100 mSec. Limiter release: 1 mSec - 5 Sec. Compressor ratio: 1:1 - 20:1. Compressor attack time: 0.5 - 100 mSec. Compressor release: 1 mSec - 5 Sec. RS-232, Euroblock, AES/EBU. 1RU. \$1,199

RPM 44

Programmable Multifunction Processor. Eight-channel; 24-bit; 48V phantom power; 24 memory settings; remote/computer operable via DragNet Windows software; Ethernet port; RW485 port; LED meters. XLR, Euroblock, RJ45, AES3. 2RU. \$2,149

RPM 88

Programmable Multifunction Processor. Installation. Eight-channel; 24-bit; 48V phantom power; 24 memory settings; remote/computer operable via DragNet Windows software; Ethernet port; RW485 port; LED meters. XLR, Euroblock, RJ45, AES3. 2RU. 13 lb. \$3,499

Roland Corp. U.S.

RSS-303 Ambience System

3D Reverb Processor. Installation, live sound. Roland Sound Space; 16 wall, 16 surface types; three-band EQ; MIDI I/O thru; Roland COSM speaker modeling; LCD screen. XLR, nine-pin D-sub, screw terminal. \$2,295

Sabine Adaptive Audio Products

FBX-1020Plus, FBX-2020Plus

Feedback Processors. Studio, live sound, sound reinforcement, installation. 12 FBX Feedback Exterminator feedback digital notch filters per channel; additional dynamic filters: 1/10th, 1/5th octave filtering; ClipGuard clip control; 20-bit performance. Frequency response: 20 Hz - 20 kHz. S/N: >100 dB. Dynamic range: >105 dB. FBX-1020Plus (single-channel): \$599. FBX-2020Plus (two-channel): \$1,099.

Power-Q ADF-4000

Multi-Effects Processor. Studio, sound reinforcement, live sound, installation. Two-channel; 31-band graphic EQ; adjustable filter widths; 12-band parametric EQ; high-, low-pass filters; 24-bit operation; FBX Feedback Exterminator feedback eliminator; real time analyzer; compressor/limiter; delay; noise gate; ClipGuard; 99 memory settings; PC/Windows interfaces; linkable. Frequency response: 10 Hz - 20 kHz. S/N: >105 dB. Dynamic range: >110 dB. THD: <0.01%. 2RU. Optional AES/EBU I/O (\$410). Two-channel slave unit (ADF-4SLU) - \$1,549. \$1,799

Real-Q2

Real Time Adaptive Equalizer. Live sound, sound reinforcement. Two-channel; 31-band; 1/3 octave; real time analyzer; pink, white noise generators; compressor/limiter; delay; noise gate; 24-bit processing; programmable high-, low-pass filters; reference microphone; automatic room mapping/equalization; 99 memory settings; PC/Windows interfaces. Frequency response: 20 Hz - 22 kHz. S/N: >105 dB. Dynamic range: >110 dB. THD: 0.02%. Optional Jensen transformers. \$1,999

Shure Inc.

DFR11EQ Version 5

Feedback Reducer/Equalizer. Live sound, sound reinforcement. PC-controlled; 24-bit; 48 kHz sample rate; fully programmable; ten notch filters; 10-band parametric equalizer; 30-band 1/3 octave graphic EQ; delay; high-, low-pass filters; limiter; scene recall; frequency response monitor; linkable; RS232 port. Frequency response: 20 Hz - 20 kHz. Dynamic range: 104 dB. THD: 0.05%. Delay: up to 1,300 milliseconds. XLR, 1/4", nine-pin D-sub. \$780

Sintefex Audio

FX 8000 Replicator

Digital Audio Effects Multiprocessor. Compressor; EQ; programmable effects replicator; 24-bit; 96 kHz; 32-bit internal processing; memory settings; word clock; MIDI I/O; ten SHARC processing chips; USB port. XLR, 1/4", BNC, RCA, optical, USB. 2RU. Optional 5.1, 7.1 surround output versions. \$6,000

Sony Electronics

DRE-S7772

Sampling Digital Reverberator. Studio, post production. Two-channel; real-time DSP; 24-bit processing; seven standard reverb programs; 44.1, 48, 88.2, 96 kHz sampling; variable reverb time: 0 to 0.5 second pre-delay in 1 ms steps; word clock; front panel LCD and jog dial; onboard CD-ROM drive; self diagnostics; RS232 port; MIDI I/O. Frequency response: 20 Hz - 20 kHz. S/N: >105 dB. BNC, XLR, AES/EBU. 2RU. Optional software expansion, optional analog I/O board, DABK-S700: \$2,350. Optional CD-ROM sample discs. \$9,000

Spatializer Audio Laboratories

Digital Spatializer

3D Audio Mastering System. Studio, post production. Can be used on individual tracks or on entire mix; 24-bit processing; dithering options; mono-stereo synthesis; word length and format control. Frequency response: 22 Hz - 22 kHz. Dynamic range: 90 dB. RCA, XLR, 1/4". S/PDIF, AES/EBU. 1RU, 19" x 1.75" x 7". Based on db Technologies Model 3000 sample rate converter. \$3,999

SRS Labs

SRS Pro 220

SRS Processor. Sound Retrieval System 3D sound system. \$249

DIGITAL AUDIO PROCESSORS

Symetrix Inc.

372 SPL Computer

System Processor. Installation. Automatically senses ambient noise and adjusts installation sound system; ducking priority control; ratio control; adjustable sensors; calibration functions; AGC; LED meter; speaker-based sensor system; headphone control. Euroblock. 1/2RU. \$549

SymNet

Mixer/Router/Processor. Installation. Eight-channel; 24-bit; 48 kHz sample rate; Windows SymLink, SymNet Designer software; 32-bit SHARC processor; EQ, AGC, comp/lim, gate, dynamics, delay; crossover; phantom power; signal generator; duck; linkable; remote controllable; RS232/485 port; CobraNet-compatible. Euroblock, nine-pin D-sub, RJ45. Optional eight-channel input unit: \$3,599. Optional eight-channel output unit: \$3,399. \$3,999

TC Electronic USA

1380

Multitap Digital Delay. Sound reinforcement. 18-bit A/D-D/A; three output channels; four preset memory bank; nonvolatile memory; feet, meter, frame measurement; security lock. Frequency response: 20 Hz - 20 kHz. Dynamic range: >100 dB. Maximum delay: 20 seconds. XLR, 1RU. Designed for speaker alignment in biamped, triamped and four-way systems. \$2,466

2290

Digital Delay/Effects Control Processor. Studio, broadcast, live sound, sound reinforcement. Variable delay modulations; programmable chorus, ducking, gating, panning; stereo panning; pitch shift; 5 effects loops; MIDI I/O thru; LED displays. Frequency response: 20 Hz - 20 kHz. 1/4", XLR, 2RU. \$1,995

D22 Digital Broadcast Delay

Broadcast. Two-channel; 24 A/D-D/A; up to 1300 millisecond delay; frame, subframe, millisecond, microsecond measurement; tap delay; nudge control function; 32, 44.1, 48 kHz sample rates; sample rate converter; word clock; security lockout; RS485 port; LCD screen. \$1,999

DB Max

Digital Broadcast Maximizer. Broadcast. 24-bit A/D-D/A; 24-bit D/D; FM/AM/TV/DAB compatible; five-band limiter/compressor/expander; dynamic equalization; 48, 44.1, 32 kHz sampling rates; automatic gain control; LCRS surround mode; oscillator; LEDs; bypass; memory; PCMCIA slot; shuttle wheel. Frequency response: 10 Hz - 20 kHz. AES/EBU, S/PDIF, XLR, RCA, BNC, MIDI, 1/4". 1RU. \$3,995

Finalizer 96K

Mastering/Multi-Effects Processor. Studio, post production. Two-track; 24-bit A/D-D/A; 24-bit D/D; de-esser/Digital Radiance Generator/compressor/limiter/normalizer/expander/EQ; three-band stereo width control; presets; 32, 44.1, 48, 88.2, 96 kHz sample rates; RAM memory; phase meter; word clock; calibration tone generator; peak hold meter; MIDI I/O thru; 48, 44.1, 32 sampling rates; M/S encode/decode; word clock; memory; PCMCIA drive; analog compatible; LED meters; LCD screen. Frequency response: 10 Hz - 20 kHz. AES/EBU, S/PDIF, XLR, RCA, ADAT optical, BNC, MIDI, 1RU. \$2,995

Finalizer Express

Mastering Processor. Post production, studio. Two-track; 24-bit A/D-D/A; 16, 20-bit dithering; 44.1, 48 kHz sample rates; auto makeup gain; soft limiting; look ahead delay; three-band spectral balance controls; fade in/out control; soft clip; presets; bypass; MIDI

I/O thru; PCMCIA drive; LCD screen. XLR, RCA, MIDI, TOSlink. 1RU. \$1,595

G-Major

Effects Processor. Studio, live sound. Up to seven simultaneous effects; 24-bit A/D-D/A; 44.1, 48 kHz sample rate; three-band EQ, pitch, phase, delay, chorus, flange, reverb, tremolo, modulation; compressor; gate; 100 factory presets; 100 user presets; chromatic tuner; LCD screen. 1/4", RCA, five-pin MIDI. Optional MIDI foot controller, G-Minor - \$159. \$699

Intonator

Vocal Intonation Processor 24-bit; 44.1, 48, 88.2, 96 kHz sample rates; pitch corrector; de-esser control; vocal-optimized low-cut filter; window, attack, amount controls; MIDI note link; word clock; PCMCIA drive XLR, RCA, AES/EBU, S/PDIF, BNC, ADAT optical. \$1,500

M2000

Effects Processor. Studio, broadcast, live sound. Two simultaneous effects; 20-bit A/D-D/A; 24-bit D/D; analog compatible; pitch shifter, CORE reverb, chorus, delay, stereo enhancement; Dynamic Morphing; tap tempo; flexible signal routing; 250 factory presets; memory; instrument optimization settings; 32, 44.1, 48 kHz sampling rates; PCMCIA drive. Frequency response: 10 Hz - 20 kHz. AES/EBU, S/PDIF. 1RU. \$1,500

M300 Dual Engine Processor

Multiprocessor. Two-channel; 24-bit A/D-D/A; 24-bit processing; 15 reverb; MTC; 256 factory presets; 99 user presets. \$299

M3000 Studio Reverb Processor

Twin processing channels/engines; 24-bit A/D-D/A; 16, 20-bit dithering; Virtual Space Simulator 3 technology; CORE reverb, delay, chorus, flange, tremolo, dynamic EQ, pitch, soft compression, gate, expander, limiter, five-band parametric EQ; 250 presets; 200 memories; MIDI I/O thru; onboard RAM; PCMCIA drive; LCD screen. XLR, RCA, AES/EBU, S/PDIF, BNC, ADAT optical. 1RU. \$2,495

M-One XL Dual Effects Processor

Multieffects Processor. Two-channel; 24-bit A/D-D/A; dual 24-bit effects engines; 25 effects algorithms; reverb, chorus, tremolo, pitch, delay; 44.1, 48 kHz sample rates; MIDI mapping; input, mix, effects balance controls; 200 factory presets; 128 user presets; LED screen. XLR, 1/4", MIDI. \$699

P2 Level Pilot ★ New for 2003 ★

Video/Broadcast Post Limiter. Video, broadcast, post production. 24-bit; 32, 44.1, 48 kHz sample rates; brickwall limiter; delay; compressor; EQ; five-band optimizer; loudness controller; onboard sample rate converter; 48-bit internal processing; NTSC, EBU, SMPTE specs; presets; word clock; PC remote software; RS232 port; LED meters. XLR, RCA, BNC, nine-pin D-sub, AES/EBU, S/PDIF. \$2,995

System 6000

Multichannel Digital Audio Processor. Control surface, rackmountable processor/I/O unit; modular/expandable; up to 24/96; four-band multiband processing; VSS-5.1 reverb; multichannel pitch change; expander; compressor; brickwall limiter; chorus; delay; phaser; Massenburg MDW HiRes EQ; de-esser; 100 factory presets; 3.5" disk drive; motorized faders; touchscreen; word clock; Pro Tools, Cubase compatible automation; SMPTE timecode; Ethernet port; USB ports. Eight-channel AES/EBU I/O card: \$1,995. Starts at \$7,295

Triple C

Multiband Compressor/Envelope Processor. Multiband; 44.1, 48 kHz sample rates; 8, 16, 20, 24-bit; threshold, ratio, attack, release controls; low-

high-band spectral envelope controls; makeup gain control; look ahead mode; soft limiter; Digital Radiance Generator; de-esser; 50 factory presets; MIDI I/O thru. 1/4", RCA, MIDI five-pin, S/PDIF. Single-channel: \$699. Two-channel: \$999.

TC Helicon

VoiceOne

Voice Pitch/Modeling Processor. 24-bit A/D-D/A; 44.1 kHz, 48 kHz sample rates; Hybrid Pitch shifting; Pitch Recognition pitch shift; FlexTime inflection algorithm; VoiceModeling modeler; harmonization controls; 100 factory presets; 50 user presets; MIDI-compatible. S/PDIF. \$1,299

VoicePrism

Vocal Formant/Pitch Processor. Four-voice harmony; 48V mic preamp; lead, harmony, effects, input controls; onboard DSP effects (compressor, delay, flange, reverb); pre, post effects; jog wheel; MIDI I/O thru. 1/4", MIDI five-pin. 2RU. With optional VoiceCraft Human Voice Modelling DSP card, VoicePrism Plus: \$1,598. \$999

Waves

L2 Ultramaximizer

Limiter/Converter. Studio, post production. Two-channel; 24-bit A/D-D/A; 96 kHz; 44.1, 48, 88.2, 96 kHz sample rates; 16 - 24-bit; 48-bit internal resolution; digital peak limiter; threshold, ceiling, release controls; increased Digital Resolution redithering; three noise shaping curves; Auto Release Control level maximizer; word clock; LED meters. RCA, XLR, 1/4", BNC, 2RU. \$2,395

Weiss Engineering/G Prime

DS 1-Mk2

Digital De-Esser/Compressor/Limiter. 24-bit; 96 kHz; 40-bit internal processing; de-esser; split band operation; linear-phase filters; compressor/limiter; soft-knee compression; soft knee, threshold, ratio compressor controls; gain makeup control; bandwidth, frequency controls; attack, release/delay, release/fast, release/slow, release/average controls; double sampling; bypass; dither; MIDI, RS232, RS422 controls. LCD. XLR, EAS/EBU. \$5,500

EQ1-MK2

Digital Parametric Equalizer. Studio, post production. Seven full range bands; 24-bit; 96 kHz sampling rate; boost/cut, frequency, Q/slope controls on each band; M/S functions; SHARC DSP chip; LCD; expandable; MIDI, RS232, RS422 controls. XLR, AES, 2RU. \$4,500

POW-R

Redithearing Processor. Psycho-acoustically Optimized Word Length Reduction (POW-R); 44.1, 48, 88.2, 96 kHz sample rates; 8, 16, 20, 24-bit; 16-bit master bit length; auto-black. \$2,995

White Instruments

ParaMedic 26

Digital Signal Processing Matrix Live sound, installation. Two-input, four-output; 24-bit A/D-D/A; SHARC 32 - 40-bit DSP; delay; pink noise generator; Bessel, Butterworth or Linkwitz-Riley filter slopes; 100 assignable filters; 6-48 dB per octave; RS-232. Dynamic range: >110 dB. XLR, Phoenix, nine-pin D-sub. 19" x 3.5" x 10.1". \$2,499

ParaMedic 48

Digital Parametric Equalizer/Limiter/Crossover. Installation, live sound, sound reinforcement. Four inputs, eight outputs; delay; crossover controls; parametric EQ; high, low-pass filters; matrix router; 24-bit A/D-D/A; password security. Dynamic range: >112 dB. XLR, Phoenix. Optional RS-232/485 ports. \$3,270

ParaMedic Code Pink

Digital Parametric Masking Generator. Installation, live sound, sound reinforcement. Two-channel; 1/3 octave equalizer; high, low-pass filters; 70 filters; 1 Hz filter steps; 32-bit white/pink noise generator; Windows 95/98/NT and White Windows software. Optional version with input/output transformers, ParaMedic Code Pink-T: \$2,000. \$1,750

XTA Electronics/Group One Ltd.

DP100

Audio Delay Processor. Studio, live sound, broadcast. Two input/four-output; stereo, split modes; 80 memory settings; three-band EQ on each output; LCD screen. Frequency response: 20 Hz - 20 kHz. Dynamic range: 103 dB. XLR, five-pin MIDI. 1RU. Optional memory expansion, relay bypass. Optional transformer balanced inputs, outputs. Optional AES/EBU I/O. \$2,595

DP202

Digital Signal Processor. Studio, live sound, broadcast. Eight-band parametric EQ/limiter; variable high-and-low-pass filters at 12 or 24 octave slopes; twin limiters; high- and low-shelving filters; AudioCore Windows software; two inputs/two outputs; LCD screen; LED meters. Frequency response: 20 Hz - 20 kHz. XLR, five-pin MIDI. 1RU. Optional relay bypass. Optional transformer balanced inputs, outputs. Optional AES/EBU I/O. \$2,475

DP324 SIDD

Studio, live sound, broadcast. Two-input, four-output; 24-bit A/D; EQ, delay, compressor, limiter, gate/expander; AudioCore software; high, low-pass filters; PCMCIA card slot; LED meters; LED screen. Frequency response: 20 Hz - 20 kHz. Dynamic range: >110 dB. XLR, nine-pin D-sub, RS232, RS485, five-pin MIDI. 1RU. Optional transformer balanced inputs, outputs. Optional AES/EBU I/O. \$2,795

E2

Parametric Equalizer. Four-band; frequency, level controls per band; high, low-shelving filters; high, low-pass filters; bypass; LED meters. 1RU. \$1,795

Yamaha Corp. of America

D1030

Digital Delay. Sound reinforcement. Onboard EQ; 1-in/3-out configuration; 18-bit A/D-D/A; 50 kHz sampling rate; input level controls; independently programmable delays; 15 memory locations; LCD. Frequency response: 20 Hz - 20 kHz. XLR, nine-pin D-sub, five-pin MIDI. 1RU. \$1,399

D5000

Digital Delay. Sound reinforcement, studio. Two channels; 20-bit A/D-D/A; 50 kHz sampling; input, mix controls; parameter switches; dual delay, single delay; freeze record and playback; sample and hold effects programs; jog wheel; LCD screen. Frequency response: 20 Hz - 20 kHz. XLR, 1/4", five-pin MIDI. 1RU. \$1,599

ProR3

Digital Reverberator. Studio, sound reinforcement. Two-channel; 32-bit DSP; 20-bit linear A/D-D/A conversion; 44.1 kHz sampling rate; frequency, gain controls for low frequency section; frequency, gain controls for mid frequency section; frequency, gain controls for high frequency section; parameter buttons; 90 presets and 90 user memories; MIDI I/O thru; numeric keypad; LCD screen; LED display. Frequency response: 20 Hz - 20 kHz. XLR, 1/4", five-pin MIDI. 2RU. \$1,399

REV500

Digital Reverberator. Studio, sound

reinforcement. Two-channel; 20-bit 64x oversampling A/D conversion; 20-bit 8x D/A conversion; 32-bit processing; independent left and right channels; hall, room, plate, special reverb categories; 100 preset programs; 100 user programs; onboard snare and rim shot samples. Frequency response: 20 Hz - 20 kHz. In: XLR, phone jack; Out: XLR, phone jack. 1RU. \$549

SPX1000

Multieffects Processor. Sound reinforcement, studio. Two-channel; 16-bit A/D-D/A conversion; 44.1 kHz sampling; input level controls; 40 preset effects; 59 user presets; individual two-band parametric EQ and dynamic filter parameters on each effect program; reverb, gate, flange, chorus, phase, pitch, tremolo, pan, stereo dynamics, expander, exciter, compressor programs; MIDI I/O thru; LCD screen. Frequency response: 20 Hz - 20 kHz. 1/4", 8-pin DIN, five-pin MIDI. 1RU. \$1,949

SPX990

Multieffects Processor. Sound reinforcement, studio. Two-channel; 20-bit A/D-D/A; 44.1 kHz sampling rate; input level control; true stereo configuration; reverb, gate, flange, chorus, phase, pitch, tremolo, pan, stereo dynamics, expander, exciter, compressor programs; MIDI I/O thru; PCMCIA port; LED display; LCD screen. Frequency response: 20 Hz - 20 kHz. 1/4", XLR, five-pin MIDI. 1RU. \$1,259

SREV1 Sampling Reverberator

Programmable Digital Sampling Reverberator. Four-channel; programmable; CD-ROM drive; samples editable via PC; word clock; PCMCIA slot; separate controller and rack-mountable processor; LCD screen; motorized faders, jog/shuttle dial on controller; serial ports; RS422 port; XLR, BNC, MIDI five-pin, eight-pin DIN, nine-pin D-sub. Optional DSP expansion board. Optional CD-ROM sampler libraries. \$9,585

YDP2006

Digital Parametric Equalizer. Studio. Two-channel, six-band, single-channel, 12-band; 20-bit A/D-D/A; input level controls; 50 user programs; gain, frequency and Q settable on all bands; high-pass filter; low-pass filter; four notch filters; MIDI I/O thru; LCD screen. XLR, five-pin MIDI. 1RU. \$1,399

Zoom

RFX-300

Multiprocessor. Two-channel; 24-bit processing; 18-bit conversion; 44.1 sample rate; reverb, chorus, delay, flange, phase, comp/lim, pitch; factory presets; mic simulator; tap key; battery operable. 1/4", RCA. \$174

Z-Systems Audio Engineering

z-CL6

Digital Compressor/Limiter. Six-channel; compressor; limiter; ratio, attack, release, threshold, makeup gain controls; POW-R word length reduction. \$8,250

z-K6 K-Surround Processor

Two-channel into 5.1. "K-Surround" process. \$12,500

z-Q2

Digital Parametric Equalizer. Two-channel; six-band; four bell curves, two shelves per channel; 16, 20, 24-bit; 96 kHz; 40-bit internal processing; MIDI; POW-R wordlength reduction; M/S. XLR, AES/EBU, SMPTE. \$3,000

z-G6

Digital Mastering Processor. Post production. Six-channel; 24-bit; 88.2, 96 kHz sample rates; level controls per channel; four-bell, two shelving filters per channel; six-band parametric EQ. AES/EBU, S/PDIF. \$8,250

HEADPHONES

AKG Acoustics US

IVM-1 In-Ear Monitoring System

Live sound, sound reinforcement System includes IP 1 In-ear phones, SPR 1 Stereo Bodypack Receiver, SST 1 Stationary Stereo Transmitter; 16-channel FM system (766 - 952 MHz); Individual Virtual Acoustics (IVA) customized binaural processing technology. \$2,714

K 240 Studio

Headphones. Studio, broadcast. Varimotion XXL diaphragm; circumaural design; self-adjusting headband; 10' oxygen-free copper cable. Frequency response: 15 Hz - 20 kHz. Sensitivity: 91 dB 1W/1m. Ships with 1/8" to 1/4" plug adapter. \$179

K 270S

Headphones. Studio, broadcast. Circumaural, closed design; Parabolic Transducer Array; automatic mute function; self-adjusting headband. Frequency response: 20 Hz - 28 kHz. Impedance: 75 ohms. \$340

K 501 Professional Headphones

Studio. Circumaural open air design; "acoustically porous" large diaphragm transducer; neodymium magnet; oxygen-free copper cable; Acoustic Supported Digital Filters; self-adjusting headband; removable leather ear pads; gold-plated connector. Frequency response: 15 Hz - 35 kHz. Impedance: 120 ohms. 1/4". \$245

Applied Research & Technology

HPFX Headphone Monitor System

Four-outputs: 20-bit A/D-D/A; 24-bit DSP; level, mix, effects controls; battery operation. \$299

ATI Audio Technologies Inc.

HDA100

Headphone Amplifier. Stereo/mono switch; volume control; selectable +4/-10 dB inputs; NanoAmp series. THD: 0.05%. 1/4", XLR. 1/3 RU. Battery operated version, HDA100-BAT. \$269. Optional rackmount adaptors. Power supply sold separate. \$229

HDA600

Headphone Distribution Amplifier. Broadcast. Six outputs; direct inputs to each output; mic/line cue input. THD: 0.01%. XLR, 1/4". 1RU. \$599

Audio-Technica U.S. Inc.

ATH-COM2

Stereophone/Dynamic Microphone Headset. Open-back design, 40mm diameter drivers; headphones; flexible mic boom; dynamic; neodymium mic magnet; two connectors; two adaptors. Frequency response: 30 Hz - 20 kHz. Phone sensitivity: 91 dB. Impedance: 40 ohms. Maximum input: 50 mW. 3.5mm mini plugs, 1/4" adaptors. 5' cable. \$60

ATH-D40fs

Studio. Dynamic; closed-back design; 40mm diameter drivers; neodymium magnets; copper-clad aluminum wire voice coils; field replaceable cables, drivers, earpads; oxygen-free copper Litz wire cables; rotatable earpieces. Frequency response: 20 Hz - 28 kHz. Sensitivity: 102 dB. Impedance: 66 ohms. Maximum input: 1,600 mW. 1/4". 11' cable. \$150

ATH-M30

Studio. Circumaural design; 40mm driver; neodymium magnet; copper-clad voice coil; 11' cable. Frequency response: 20 Hz - 20 kHz. Impedance:

65 ohms. 1/8". 1/4" adapter. \$119

ATH-M40fs Studiophones

Studio. Dynamic; closed-back design; 40mm diameter drivers; neodymium magnets; copper-clad aluminum wire voice coils; field replaceable cables, drivers, earpads; oxygen-free copper Litz wire cables; rotatable earpieces. Frequency response: 5 Hz - 28 kHz. Sensitivity: 100 dB. Impedance: 60 ohms. Maximum input: 1,600 mW. 1/4". 11' cable. \$150

Behringer

Powerplay Pro HA4000

Headphone Distribution System. Four-channel; mix, level controls per channel; mute, mono switches per channel; front panel I/O. 1/4". \$95

Benchmark Media Systems Inc.

IFAe7 Stereo Headphone Amplifier

Level control. 1/4". \$200

beyerdynamic Inc.

DT 150

Closed back; padded headband. \$289

DT 250

Studio Monitoring Headphones. Studio. Closed back. Frequency response: 5 Hz - 30 kHz. Impedance: 250 ohms. Output: 98 dB. Isolation: 16 dB(A). 1/4". \$239

DT 297 PV

Headset. Broadcast. Closed-back headphone; neodymium magnet; padded headband; electret condenser mic; shockmounted gooseneck mic stalk; single-sided cable. \$489

DT 931 Open Back Headphone

Recording studio, project studio. Open

back; Neodymium magnet; viscose earpads. Mini, 1/4" adapter. \$329

Carvin

H40M

Closed back design, neodymium magnet; padded headband; 1/4" adapter. Frequency response: 20 Hz - 22 kHz. Impedance: 64 ohms. 1/8". \$49

PM1000 Professional In Ear Monitor System

UHF system; includes PM1000 transmitter and PM1001 backpack receiver; earbuds; microphone input; crystal oscillator; 16 frequencies. Frequency response: 100 Hz - 10 kHz. \$299

Clear-Com Intercom Systems

MS-232

Intercom Main Station. Studio, live sound. Two-channel; 60 headset/20 speaker station operation; short circuit protection; speaker; call signaling; program input; channel combine function. Frequency response - 150 Hz - 18 kHz \pm 2 dB. XLR. 19" x 1.75" x 6.5". Optional gooseneck mic or headset. \$995

Q700

Intercom System. UHF system; 2,400 frequencies; compander; backpack monitoring on master station; up to six channels per master station; compatible with Clear-Com, RTS intercoms; controllable via PC. Frequency: 470 - 740 MHz, 835 - 865 MHz. Range: up to 1,500'. XLR, 1/4". Master station with six backpacks: \$20,850

COMTEK Inc.

BST-25

VHF Wireless Base Transmitter. Studio, broadcast, field, installation.

VHF system; 119 selectable channels; range up to 1,000'; level control; EG; compander; test tone generator (400 Hz); security lockout; mic/line switch; battery operable; LED display. Frequency: 76.2 - 87.8 MHz. Frequency response: 80 Hz - 15 kHz. XLR, BNC. Works with Comtek PR-25 receiver. \$1,425

DACS Ltd./Independent Audio

HeadLife

Headphone Amplifier. Four-channel; level controls, input selector per channel; front panel outputs; compatible with in-ear monitors. Frequency response: 1Hz - 20 kHz. S/N: 124 dB. THD: <0.002%. 1/4". \$675

Denon Electronics

AH-D350

Headphones. 40mm drivers; neodymium magnets; oxygen free copper cables; polymer film diaphragms; low-resonance housing; gold-plated connector. Frequency response: 4 Hz - 26 kHz. Impedance: 35 ohms. 1/4", 1/8". \$65

AH-D550P

Headphones. 50mm driver; neodymium magnets; oxygen free copper cables; polymer film diaphragms; oval earpads. Frequency response: 3 Hz - 28 kHz. Impedance: 35 ohms. 1/4", 1/8". \$80

AH-D750P

Headphones. 50mm driver; neodymium magnets; pure copper voice coils and cables; vaporized titanium diaphragms; oval earpads. Frequency response: 2 Hz - 30 kHz. Impedance: 30 ohms. 1/4", 1/8". \$135

Hear What The Hype Is All About

"The C-3 is THE HIP new guitar mic. It gives your Marshalls that phat-gut-punch we all crave. I'll never cut another record without one."

Scott Rouse - Producer, Grammy Nominee, Nashville, Tennessee

I have a microphone "wish list". You have allowed me to check off both the U87 with the C1 and the C12 with the T3.

Ted Perlman - Producer/Arranger/Composer

Bob Dylan, Chicago, Kaci, Zgether, Young MC

One of the best vocal mics in the world is the \$300 Studio Projects C1. You can spend way more for "one of those" mics from Germany if your ego demands it, but the C1 is certainly the sonic equivalent.

Pete Leoni - Producer Engineer, Tech writer and reviewer



C1

Single-pattern
Cardioid
List \$299

C3

Multi-pattern
Cardioid, Pad, Filter
List \$599

T3

Variable-pattern
Tube
List \$1099

All models include shockmount and case.

PAR
REVIEWER'S
PICK 2002



StudioProjects™

P M I
AUDIO GROUP

PMI Audio Group

23773 Madison St., Torrance, CA 90505 USA

toll-free 877 563 6335 fax 310 373 4714

Visit Us Online at www.studioprojectsusa.com



VT-1

Tube Mic Pre, Discret Class A/B switching,
with variable Tube Drive. List \$299

HEADPHONES

Doc's Pro Plugs Inc.

Doc's Earsaver
Foam Earplugs. \$4.50 per five

Protune Earphone Enhancer
Flexible Earphone Holder. Variety of sizes; occludes loud exterior sounds; Maxi Bass Super Resonator Duct; compatible with 15mm - 18mm buds. \$15 per pair

Etymotic Research

ER-20 High Fidelity Earphones
Earplugs. Patented tuned resonator; acoustic resistor. \$10

ER4 MicroPro Earphones
Insert Earphone. Frequency response: 20 Hz - 16 kHz. Sensitivity: 98 dB. Isolation: 20 - 25 dB. Ships with stereo plug adaptor, three pairs of rubber earplugs, five pairs of foam earplugs, carrying pouch, shirt clip, storage box. \$330

Fostex Corp. of America

PH-50 Headphone Amp Distributor
Five-channel; level controls per channel; master input, aux controls; linkable. 1/4", XLR, RCA. \$279

T-50RP
Printed ribbon diaphragm design; neodymium magnet; copper foil. \$199

Furman Sound Inc.

HDS-16
Headphone Distribution System Hub. Eight mono inputs, four stereo inputs; up to 6 output channels; RJ11/Ethernet ports; status LEDs; front panel inputs. 1/4", RJ11. Requires HRM-16. \$799

HDS-6
Headphone Distribution System. Rackmounted; four submixes; gain trims; overload LEDs per channel; Ethernet connection to HR-6 studio module; ground lift. \$349

HRM-16
Personal Headphone Mixer. Eight mono channels, four stereo channels; talkback function; source controls; effects send, pan controls per channel; effects return; master control 1/4", 50-pin. Requires HDS-16. \$699

Future Sonics

Ear Monitors
Custom-molded stereo earphones; low frequency vents; optional colors. Frequency response: 26 Hz - 18 kHz. Max SPL: 112 dB. 1/8".

Grace Design

Model 901
Headphone Amplifier. Level control; analog or digital; 24-bit, 96 kHz digital audio converter. Frequency response: 4 Hz - 600 kHz. THD: <0.005%. Dynamic range: 121 dB. XLR, RCA, 1/4", optical. \$1,495

GTC Industries

AP-1 Amp-Plug Studio Headphone Amplifier
Two-channel; level control; three-position EQ; mono/stereo switch; 1/4" plug housing. Output: 1.4 W/1/4". \$99

MAM America

HP 48
Headphone Distribution Amplifier. Four-channel. 1RU. \$159

Mytek Digital

Private Q Headphone System
Studio. 12-channel; Class A; individual level control per channel. 12" x 3" x 7". \$595

Nady Systems Inc.

PEM-500
In-Ear Monitor System. Live sound, sound reinforcement. 16-channel; linkable; 300 operating range. Frequency: 696 - 865 MHz. Frequency response: 50 Hz - 12 kHz. \$399

QH 560
Headphones. 40mm diaphragms; neodymium magnet; self-adjusting headband. Frequency response: 20 Hz - 20 kHz. 3.5mm, 1/4" adapter. \$54

Phonic Ear Inc.

OnWave
FM Transmitter/Receiver System. Installation. FM system; 1,000 range; 50 frequencies; 10 wide or 6 narrow band channels; digital audio synthesis; input, output level, bass cut controls; ships with four bodypack receivers. Frequency range: 72 - 76 MHz. XLR, 1/4". \$1,200

Precision Laboratories Inc.

Challenger Monitor Earphones
In-Ear Monitor. Compatible with most in-ear monitor systems.

ER Musician's Earplugs
Choice of 9 dB, 15 dB, 25 dB attenuation. \$199

Quantum Technologies

Talk Back Model 200
Talkback Controller. Talkback level, control room monitor level, headphone volume controls. 1/4", XLR, 1RU. \$599

Talk Back Model 600
Talkback Controller. Talkback level, control room monitor level controls. 1/4", XLR, 1RU. Optional wireless remote: \$199. \$799

Rane Corp.

HC 4
Headphone Amplifier. Studio, live sound. Four-channel; master input level control; individual channel level controls and overload indicators; stereo/mono; 32-600 ohm headphone. 1/4". 1RU. \$299

Redwood Music Corporation

VH6
Six-Channel Headphone Distribution Amplifier. Six-channel; level controls. 1/4", 1RU. \$299

Rolls Corp.

HA43 Headphone Amp
Four outputs; volume controls per output. S/N: >90 dB. THD: <0.008%. 1/4".

RA62 Headphone Amplifier

Six-channel; level controls per channel; master pan control; mono/stereo switch; linkable. S/N: >90 dB. THD: <0.008%. 1/4".

WPM61

Wireless Personal Monitor System. Four-channel; transmitter; bodypack receiver; battery operable (9V). 1/8". \$150

Samson Technologies Corp.

CH700 Studio Headphones
40mm Mylar drivers. Frequency response: 20 Hz - 20 kHz. \$54

C-que8

Four-channel Headphone Distribution Amp. Four-channel; volume control per channel; EQ; balance control; LED meters. 1/4". \$159

Q5

Stereo Headphone Amplifier. Studio, broadcast. Five stereo headphone channels; independent volume controls; stereo thru jacks; mono/stereo switch. Frequency response: 20 Hz -

20 kHz. Balanced 1/4" inputs. 1.75" x 8.5" x 7". \$199

RH300
Open ear; 40mm drivers; neodymium magnets; gold-plated connectors. Frequency response: 20 Hz - 22 kHz. Mini. 1/4" adapter. \$54

S-phone

Headphone Distribution Amplifier. Four-channel; treble, bass, balance, volume controls per channel; two-channel mode. 1/4". 1RU. \$259

UHF EarAmp

In-Ear Monitoring System. UHF system; 128 frequencies; rackmountable transmitter; remote controllable. \$1,249

Sentit Electronics

HDPH-4
Headphone Box. Constant impedance; linkable up to 33 headphones. Balanced I/O version: \$500. \$400

Sennheiser Electronics Corp.

3050 Series In-Ear Monitoring System
Studio, live sound, sound reinforcement, broadcast. UHF system; stereo; 16 switchable frequencies; Hi-Dyn plus noise reduction; headphone jack; power status LEDs. Frequency: 450 - 960 MHz. S/N: >105 dB(A). Range: 500 - 1,000 feet. Transmitters - 17.5" x 8.5" x 1.75". Series consists of EK3052-U bodypack receiver and SR3054-U single-channel transmitter and SR3056-U dual-channel transmitter. EK3052 - \$1,600, SR3054 - \$2,400, SR3056 - \$3,800

EK3053-U

Wireless Bodypack In-Ear Monitor. Live sound, broadcast. UHF system; stereo; 16 switchable frequencies; Hi-Dyn plus noise reduction; headphone jack; power status LEDs. Frequency: 450 - 960 MHz. S/N: >105 dB(A). Frequency response: 45 Hz - 15 kHz. Range: 500 - 1,000 feet. Lemo \$1,600

evolution wireless 300 In-Ear Monitor Systems

Wireless In-Ear Monitoring System. Eight-channel; 1,280 frequencies; true diversity; HDX compander; FOCUS function switch; safety limiter; battery operation; LED display.

HD 280 Pro

Headphones. Broadcast, field, studio. Compact folding design; neodymium magnet; circumaural. Frequency response: 8 Hz - 25 kHz. SPL: 113 dB. THD: <0.1%. 1/8", 1/4" adapter. \$199

HD 600

Dynamic Headphones. Open air, dynamic circumaural design; Duofol diaphragm; aluminum voice coils; computer optimized neodymium-ferrous magnets; steel mesh grille; 10' oxygen-free Kevlar reinforced copper wiring cable. Frequency response: 12 Hz - 39 kHz. Sensitivity: 97 dB. THD: <0.1%. Impedance: 300 ohms. Mini-1/4" adapter included. \$450

Shure Inc.

E5
Ear Buds. Dual-driver; compatible with Shure personal in-ear monitor systems. 1/8". \$600

FP 22

Headphone Amplifier. Level control; loop though; belt clip; battery operation (9 V). XLR, 1/4". \$451

P4MTRE1

Wired Personal Monitor System. Live sound. P4HW hardwired monitor; P4M four-channel mixer; level, pan controls; EQ; limiter; E1 earphones. Combo; XLR, 1/4". Components available individually; P4HW hardwired monitor - \$374; P4M mixer - \$458; E1 earphones - \$202. \$1,030

P6HWE1 Wired In-Ear Monitor System

Live sound, studio. Wired system; MixMode monitor mix technology; limiter; high-frequency boost; 15 dB pad; bodypack receiver; input cable; earpieces; extra foam tips. Frequency response: 20 Hz - 20 kHz. S/N: 85 dB. \$891

P6TRE1 Wireless In-Ear System

Live sound, Wireless system; MixMode monitor mix technology; limiter; high-frequency boost; 15 dB pad; bodypack receiver; rackmountable transmitter; earpieces; extra foam tips. S/N: 80 dB. \$1,687

PSM600 Personal Stereo Monitor Hardwired System

Bodypack receiver; E1 in-ear monitors; MixMode technology; up to 10 mixes. Frequency response: 20 Hz - 20 kHz. \$891

PSM600 Wireless Personal Stereo Monitor System

Bodypack receiver; transmitter; E1 in-ear monitors; MixMode technology; up to 10 mixes. Frequency range: 626 - 662 MHz. \$1,687

PSM700 Personal Monitor

Wireless In-Ear Monitor System. Live sound. UHF system; 32 switchable frequencies; stereo/mono/mix mode; input, volume, headphone level controls on P7T transmitter; open frequency locator; dynamic overload control; pad; LED meters; linkable; Shure dual driver E5 earphones; balance, frequency controls on P7R bodypack receiver. Frequency range: 722 - 745 MHz. 1/4", 1/8", BNC, XLR. starts at \$3,172

Simon-Kaloi Engineering

CB-4
Headphone Distribution Unit. Two cue sends; four outputs; level controls per output. \$375

Sonifex/Independent Audio

RB-DHD6
Digital Headphone Distribution Amplifier. Broadcast, studio. One input; six outputs; level controls. XLR, RCA, 1/4", AES/EBU, S/PDIF. 1RU. \$799

RB-HD1

Stereo Headphone Amplifier. Studio, broadcast. XLR, 1/4". 1RU. \$279

RB-HD6

Headphone Distribution Amplifier. One stereo input, six stereo outputs or one mono input, 12 mono outputs; volume controls. XLR, 1/4". \$400

Sony Electronics

MDR-7506
Headphones. Studio. Folding construction; 40 mm driver; closed-ear design; gold connectors. Frequency response: 10 Hz - 20 kHz. Sensitivity: 104 dB 1W/1m. 1/4", 1/8". \$130

MDR-7509

Headphones. Studio. Closed ear; 50mm Aura-Nomic driver; neodymium magnet; gold connectors. Frequency response: 5 Hz - 30 kHz. Sensitivity: 107 dB 1W/1m. \$260

MDR-V700DJ

DJ-Style Headphones. Live sound. Closed ear; rotating earcup; 50 mm driver; neodymium magnet; gold connectors. Frequency response: 16 Hz - 22 kHz. Sensitivity: 107 dB 1W/1m. \$150

Special Projects

HPH-610 Stereo Headphones
Neodymium driver; 40mm driver; adjustable headband; 4' oxygen-free copper cable. Frequency response: 20 Hz - 20 kHz. Sensitivity: 110 dB. Impedance: 32 ohms. 1/4". \$49

Symtrix Inc.

304 Headphone Amplifier
Four-channel; volume controls per channel; pass thru; input level control; front panel inputs; mono/stereo. 1/4". 8.5" x 1.75" x 6.5". \$299

506E

Headphone Amplifier. Broadcast, installation. Three inputs, six outputs; gain controls per channel. XLR, 1/4", 1RU. \$529

Telex Communications Inc.

BTR-300
Wireless Intercom System. VHF system; up to four base stations, 16 belt-pack transmitters; filter controls; channel assignment controls; battery operated belt-pack transmitters; compatible with Telex RTS ADAM, RTS TW, AudioCom and Matrix Plus intercom systems.

BTR-800

UHF Wireless Intercom System. UHF system; two-channel; relay closure function; IFB; ClearScan; primary user override. \$4,395

PH-44

Headset. Monoaural; moleskin-covered earpieces; noise-canceling mic on a boom. XLR4. \$155

PST-16

16-Channel Portable Beltpack Transmitter. Installation. VHF system; 16-channel; battery operation; part of SoundMate personal listening system products. Frequencies: 72.1 - 72.9 MHz. 74.7 MHz. 75.3 - 75.9 MHz. TA4M.

Videoquip Research Ltd.

HA-2B Stereo Headphone Amplifier

Two-channel; volume controls. 1/4". \$295

Westone Laboratories

ES1

Customized In-Ear Monitor. Single-driver; stereo Y cord; carrying case; dehumidifier. Frequency response: 40 Hz - 16 kHz. Up to 25 dB ambient noise reduction. 1/8". Requires custom user ear impression. \$375

UM1

In-Ear Monitor. Single-driver; stereo Y cord; padded storage pouch; wax loop; three pair foam tips. Up to 25 dB ambient noise reduction. 1/8". \$139

Whirlwind

Headphone Breakout Box

Passive headphone distribution system divides standard power amplifier output signal into six separate headphone outputs. \$109

Williams Sound

PPA 275

Personal PA FM Assistive Listening System. T4 transmitter; three R30 receivers; audio processor on transmitter; battery operable. \$907

WIR-TX900

Four-Channel IR Listening System. Four-channel; compression controls; 22,000 sq. ft. area. Frequency: 2.3 - 3.8 MHz. \$3,436

www.bhphotovideo.com



The Professional's SOURCE for all your PRO-AUDIO and RECORDING needs

- Built To Order Computer Based Turnkey Systems for Macintosh or Windows
- Expert Advice from Working Professionals!
- World's Largest In-Stock Inventory!



The Professional's Source
When in New York City
Be Sure To Visit Our
SuperStore



420 Ninth Ave.
Between 33rd & 34th Streets,
New York, N.Y. 10001

For Information Call:
800-947-1182 • 212-444-6682
or Fax (24 Hours):
800-947-7008 • 212-239-7770

Store and Mail Order Hours:
Sun. 10-5, Mon. thru Thurs. 9-7
Fri. 9-1, Sat. Closed
WE SHIP WORLDWIDE

INTERCONNECTS

Alpha-Core

Goertz Speaker Cables

Oxygen-free copper and/or solid silver cables; choice of gauge, length, spade or banana termination.

Aphex Systems Ltd.

Model 124A 10/4 Interface

-10/+4 dB Interface/Converter. Studio, broadcast. Two-channel; -10 input/+4 output conversion; output controls per channel; power/clip LED; 600 ohm terminate switch. RCA, XLR, 1/2 RU. \$229

ATI Audio Technologies Inc.

AMM200

Line Amplifier/Meter. Headphone controls; switchable LED meters. THD: 0.01% XLR, RCA, 1/4". Rackmount kit available. Power supply sold separately. \$399

BI100

Bidirectional +4 dB/-10 dB Interface. Bidirectional; stereo; +4 dB/-10 dB; NanoAmp series. THD: 0.005%. RCA, XLR, 1/3 RU. Optional rack and desk mount adaptors. Optional rack and desk mount adaptors. Power supply sold separately. \$239

DA103 Distribution Amplifier

Single line input, three outputs; master gain, output level controls; balanced I/O; NanoAmp series. THD: 0.005%. Screw plug. 1/3 RU. Optional rackmount adaptors. Power supply ordered separately. \$239

DDA112-XLR

Digital Audio Distribution Amplifier. Single channel in, 12 channels out; 27 - 96 kHz sample rate; data reclock; data regeneration; loop through; cable equalization; status LEDs, error LEDs; LED display. Output jitter: <3 nanosec. Propagation delay: <100 nanosec. XLR, 1RU. \$959

DDA124-BNC

Digital Audio Distribution Amplifier. Single channel in, 24 channels out; 27 - 96 kHz sample rate; data reclock; data regeneration; cable equalization; status LEDs, error LEDs; LED display. Output jitter: <3 nanosec. Propagation delay: <100 nanosec. BNC, 1RU. \$699

DM200

AES/EBU Monitor/D-A Converter. 24-bit, 96 kHz compatible; 32, 44.1, 48, 82.2, 96 kHz sample rate; LED meters; PPM; headphone monitor; NanoAmp series. XLR, BNC, RCA, 1/4". 1/3 RU. Power supply sold separately. Optional rack and desk mount adaptors. \$599

DMM100 Digital Match-Maker

Digital Interface AES/EBU Lines. Signal present LED; choice of I/O; NanoAmp series. AES/EBU, S/PDIF, XLR, RCA, BNC, Toslink, 1/3RU. Power supply sold separately. Optional battery operated version, DMM100-BAT: \$299. \$259

DP100 Disc-Patcher

Unidirectional Unbalanced/Balanced Stereo Interface. Unbalanced input, balanced output. Frequency response: 20 Hz - 20 kHz. THD: 0.005%. Dynamic range: 102 dB. XLR, RCA, 1/2 RU. \$299

DXA112-XLR

Digital Distribution Amp. One in/12 outs; transformer isolated. Output jitter: <3 nanosec. Propagation delay: <100 nanosec. XLR, AES/EBU, 1RU. \$699

DXA124-BNC

Digital Distribution Amp. One in/four outs. Output jitter: <3 nanosec. Propagation delay: <100 nanosec. BNC, AES/EBU, 1RU. \$659

MM100 Match-Maker

Bidirectional Balanced/Unbalanced Stereo Interface. Bidirectional; balanced/unbalanced; transformer isolated outputs. THD: <0.02%. Dynamic range: +98 dB. XLR, RCA, 1/2 RU. \$339.

Audio Accessories Inc.

1/4" Long Frame Maxi

1/4" Patch Bay, 20, 24, 26 pairs; 1/4" format; with or without normal; gold alloy contacts; tie bar. starts at \$145

SHORTI Quick-Switch Patchbay

Patch Bay, 48 pairs; 1/4" TRS, TT, bantam formats; three-pin EDAC rear connectors; normalled per jack pair. 2RU. Also available as 1/4" long frame. \$799

Belden Wire & Cable Co.

7880A

AES/EBU Digital Audio Cable. Eight pairs of 26AWG tinned copper conductor; data/ene insulation; capable of connecting with 25-pin D-sub without stripping.

9451D

Dual Analog Audio Cable. Twisted pair; 22AWG tinned copper conductor; foil shield; PVC jacket.

Brilliance AES/EBU Digital Audio Cables

Digital Audio Cable. Single, double and snake multi-pair digital audio cables. High flex, non-conduit Plenum, individually shielded and jacketed, and individually shielded arrangements. 1, 2, 4, 8, 12, 16, 24 pair: 26, 24, 22 gauges. Multi-Pair snake: 24 gauge.

Benchmark Media Systems Inc.

Audio World Interface

Two-channel; input level, output level controls; line amp, mono mix modes; channel reverse; status LEDs. THD: 0.0011%. Dynamic range: 127 dB. XLR, RCA. \$230

IFA-8 Quad Input Amplifier

Dynamic range: >120 dB. \$225

IFA-9

Distribution Amp. One in/six outs; channel, master input gain controls; status LEDs. \$230

Bittree Inc.

969 Series

Patch Bays. 96-point; 1/4" or TT; choice of rear connectors - ELCO/EDAC, E3F.

Brainstorm Electronics Inc.

SR-26

Timecode Distributor. Six outputs; level controls per output. 1RU. \$549

BTX

BTX Professional XLR and 1/4" Cable Assemblies

Custom and standard lengths; Mogami cable; Neutrik connectors.

Carvin

Adapter Plugs

Choice of XLR, 1/4", RCA to XLR, 1/4", RCA, male and female. \$3.99 - \$15.99

MS2

Mic Splitter. One input, two outputs. XLR. \$23

PB48 Patch Bay

48-point. 1/4". 1RU. \$49

PH Series Cable

Speaker Cable. 16 gauge. 1/4". PH4 (4'): \$6. PH8 (8'): \$7. PH25 (25'): \$13. PH50 (50'): \$17.

XLR Series Cable

Shielded Mic Cables. XLR8 (8'): \$10. XLR25 (25'): \$14. XLR50 (50'): \$18.

Clark Wire & Cable

700 Series Audio Snake Cable

3 - 28-channel; 22-gauge; color-coded; numbered; PVC jacket.

AES/EBU Cable

Bulk Digital Audio Cable. Dual pair; color-coded; easily stripped. \$410 per 1,000'

Coleman Audio

LS3 Line Level Selector

3 x 1; passive switching; bidirectional. 1/4". \$125

MS6 Monitor Switcher

Six-channel; six stereo inputs, one stereo output. XLR. Optional passive level control: \$599. Optional passive level control and headphone: \$655. Optional active level control and headphone: \$545. \$425

PS1 Monitor Controller

Router. Four inputs, three outputs; selector buttons; output control. XLR. 1RU. \$640

SR5.1 Surround Level Control

Six balanced inputs; six balanced outputs; stepped attenuator; trim. XLR. 1RU. \$675

DACs Ltd./Independent Audio

MIDI Patch Bay

Mono; interconnects 10 MIDI devices. \$275

Dangerous Music

Dangerous Monitor

Studio Monitor Router. 24-bit D/A; volume control. XLR. \$4,500

dCS/Independent Audio

dCS 988

AES/EBU Distribution Box. 96 kHz compatible. \$2,150

dCS 992

Master Clock. AES/EBU, SDIF-2; 32, 44.1, 48, 88.2, 96 kHz sample rates. \$5,250

Digigram Inc.

EtherSound ES8in/ES8ou Ethernet Audio Bridges

Ethernet-based Sound Distribution Modules. Up to 64-channel; EtherSound network; Ethernet. XLR, RJ45. \$1,500

DiMarzio Inc.

Chrome Microphone Cables

Overbraided; chrome. 20': \$53.25. 30': \$69.

High Definition Interconnect Cables (RCA)

16 gauge OF copper; overbraided; silver soldered termination; gold-plated connector. RCA. .5m, 1m, 1.5m, 2m. Per pair. .5m: \$90, 1m: \$90. 1.5m: \$100. 2m: \$110.

Drawmer USA/TransAmerica Audio Group

LA12 Line Distribution Amplifier

Studio. One input, 12 outputs; individual volume controls on each output; aux (linkable) stereo output. RCA. 1RU. \$735

Evidence Audio

The Siren

Speaker Cable. 1/4', 10': \$35. 20': \$71.

Frontier Design Group

Apache

Lightpipe Patch Bay. 12 optical inputs, 12 optical outputs; 16, 24-bit; memory; ADAT, S/PDIF. 1RU. \$799

FSR Inc.

EA1X4

Audio Switching Module. One input, four outputs. Screw terminals.

MIC1

Microphone Switcher Module. Screw terminals.

TAI Tape Audio Interface

Consumer to pro (+4 dB) interface. RCA, screw terminal.

Lavry Engineering

(formerly dB Technologies)

dB4496 Converters



Features: Modular A/D-D/A system; up to 8 Channels per rack; 44.1, 48, 88.2, 96kHz sampling; Varispeed; Set word length with Acoustic Bit Correction; Soft saturation; Tape emulation; Reference bridge.

Comments: "I have been a fan of your wonderful products for many years." Frank Filippetti

206-381-5891 www.lavryengineering.com

INTERCONNECTS

Galaxy Audio

JIB C
Combiner. Two inputs; one output; Jacks In The Box series. XLR. \$50

JIB Y
Splitter. One input, two outputs; phantom power block; Jacks In The Box series. XLR. \$50

Gepco International Inc.

3BP Male/Female XLR/Binding Post Adapters
Color-coded. XLR, binding posts.

5526GFC Multi-pair Series
AES3 Digital Audio Cable. For breakout or XLR snakes; color-coded pair jackets; 26AWG tinned copper conductors; foam polypropylene dielectric; easy strip foil shield; 4, 8, 12, 16, 24 pairs available.

GSC 132
High-Definition Speaker Cable. 13 gauge, two conductors, high strand bare copper.

X-Band Audio Cable
Studio, installation, live sound. 24-gauge oxygen-free copper; braid shield with drain wire; G-Flex jacket; very flexible.

Gotham Audio

Gotham Shielded Audio Cables
Double Reussen shielded.

Gotham Shielded Digital Cables
Double Reussen shielded. AES/EBU spec.

Hannay Reels Inc.

AV, AVC
Cable Reels. Single wheel; legs, handle.

AVX
Cable Reel. Dual-wheel; storage tray; feet; handle.

Henry Engineering

Matchbox II
Level/Impedance Converter. Studio. Converts -10 dB to +4 dBm; four-channel; bidirectional; active circuitry; Hi Gain mode for use with computer sound cards. S/N: 90 dB. Maximum output: +26 dBm. XLR, RCA. 1.75" x 5.75" x 6". \$225

MoniSwitch
Stereo Audio Switcher. Four inputs, two outputs; gain controls per input; remote controllable. Euroblock. 1.75" x 5.75" x 6". \$225

The Patchbox
Audio Splitter. Five balanced, six unbalanced outputs. 1/4", XLR, RCA. 5" x 7" x 2". \$195

Hosa Technology Inc.

CMK Series
Microphone Cables. 20-AWG inner conductors; 98% braided shield. XLR. 3', 5', 10', 15', 20', 25', 30', 50', 75', 100'.

Fiber-Optic Cables
Fiber-optic. Toslink. 2', 3', 2m, 5m.

MXP Series
XLR to 1/4" Mic Cables. 24-AWG inner conductors; 98% braided shield. XLR, 1/4". 3', 5', 10', 15', 20', 25', 30', 50', 75', 100'.

Patch Bay Cables.
Various connectors; various lengths. RCA, 1/4", TT. 6", 1', 1.5', 3', 5'. Choice of colors.

PHB-184, PHB-185, PHB-186
Patch Bays. 32-point; choice of connectors front and back. RCA, 1/4" (TRS, phone). 1RU.

Intelix

Psychologist
Remote Controlled Monitor Mixing System. Studio, live sound. Main and a minicontrol for each user; 8 - 32-channel; variable VCA matrix mixing system; multiple remote controls for different feeds from the same unit; customizable. Phoenix, nine pin D-sub. 19" x 3.5" x 14" (main unit). App \$5,000 but depends on configuration

Kimber Kable

4PR
Speaker Cable. Pure copper cable. Banana. 8'. Also available by the foot: \$1.80 per foot. \$84

8TC
Speaker Cable. 16 TCSS copper cable. Banana. 8'. Also available by the foot: \$14 per foot. \$288 per pair

AGDL
Digital Cable. Silver tribrid geometry; silver-plated connectors. XLR, RCA. 1m. \$240

Hero
Copper cable; Gyroquadratic geometry; WBT connectors. RCA or XLR. 1m. \$150 per pair

KCAG
Silver tribrid geometry; WBT connectors. RCA or XLR. 1m. \$460 per pair

KS 1011
Orthogonally braided copper; WBT connectors. 1m. \$460 per pair

KS 2120
AES/EBU Cable. Silver cable; silver-plated connectors. XLR. .75m. \$950 per .75m

Monocle X
Speaker Cable. 16 VariStrand copper cable; WBT connectors. Banana or spade lugs. 8'. \$630 per pair

OPT-1
Optical Cable. Polished. 1m. \$60

PBJ
Copper tribrid geometry; Ultraplute connectors. RCA or XLR. 1m. \$84

TAK Cu
Phono Cable. Copper Orthogonal Gyroquadratic2 braiding. 1m.

\$250

V21
Digital Cable. Copper cable; 75 ohm coax. BNC, RCA. 1m.

\$48

Little Labs

AES Digital Audio Mastering Router
Five inputs. XLR, BNC. 1RU. Additional output channel: \$200. Surround package (three routers): \$3,500. \$1,250

Lucid

GENx6-96
Clock/Sync Generator. Six outputs; 44.1, 48, 88.2, 96 kHz sample rates; word clock, Superclock. BNC. \$499

SSG192 Studio Sync Generator
32, 42,336, 44,056, 44.1, 44,144, 45,937, 46,080, 47,952, 48, 48,048, 50, 88.2, 96, 100, 176.4, 192 kHz sample rates; word clock; Superlock; Lucid UltraClock; video blackburst; NTSC, PAL; pull-up/pull-down; status LEDs. XLR, BNC. 1RU. \$1,799

M Audio

MIDI Cable
6.6'. \$4.95

Standard Optic Cable
Fiber optic; 6.6'. \$14.95

Thru 1x4
MIDI Thru Box. Single input/four outputs. MIDI five-pin. \$59

Merging Technologies

Onouris Long Distance Converter
Optical Cable Extender. Allows optical cable runs of up to 600 yards/meters; two-inputs. Toslink. \$495 per pair

Nermal Electronics International Inc.

NE3700 Series
37-pin Audio Connector. 12-channel; one piece aluminum body; optional strain reliefs for different cable sizes. \$75

Neutrik USA Inc.

Easy-Patch
Programmable Patch Bay. 96-point; TT jacks; gold-plated jack terminals; choice of 56-pin, 90-pin Elco/Edac connectors, 50-pin D-sub, IDC push terminal, solder lug connectors. 1RU. Solder lug version: \$750. Starts at \$900

LF48
1/4" Long-Frame Patch Bay. 48-point; 1/4"; solder termination; palladium switch contacts; rear stress bar. 1RU. Available in black, red, silver, blue. \$344

Patchlink SPL
1/4" Patch Bay. 48-point; no-solder design, 1/4". 1RU. \$100

Otari Corp.

Lightwinder LW-50 Colosseum Series
Powered Optical Cable Interconnect System. Live sound, sound reinforcement, installation. Up to 128 channels; modular; 44.1, 48

TELEFUNKEN Elektronakustik

Now Available Ela-M 251



"A tribute to the
classic microphone"



Telefunken North America
300 Pleasant Valley Rd., (Suite E)
South Windsor, CT 06074

ph: 860-882-5919
fax: 860-882-5980

info@telefunkenusa.com
www.TelefunkenUSA.com

INTERCONNECTS

kHz sampling rates; 24-bit A/D-D/A; test tone generator; Windows 95/98/NT software; remote control; compatible RTS, Clear-Cor, Telex systems; RS-232/422 port; MIDI. Frequency response: 10 Hz - 22 kHz. THD: <0.005%. Dynamic range: >108 dB. XLR, 25-pin D-sub, AES/EBU. \$28,000 - \$45,000 depending on configuration

Planet Waves

Adapters

Various genders; various connectors. XLR, RCA, 1/4", 1/8", banana, Speakon.

Digital Cable

Clad reflective layer; overmolded connectors. Optical. 2' - 30'. \$14 - \$74

Microphone Cables

Jacketed solder points; dual layer shielding; dual layer insulation; copper conductor; color-coded O-ring; gold plated connectors. XLR, 1/4", 3' - 50'. \$32 - \$72

Patch Cables

Spring-loaded plug; jacketed solder points; dual layer shielding; copper conductor; color-coded O-ring. 1' - 2'. Mono, stereo and right angle connectors available. \$43 - \$47 per pair.

Speaker Cables

12-gauge oxygen-free copper; overmolded connectors; gold-plated connectors. 1/4", banana, Speakon. 5' - 50'. \$30 - \$106

Swivel XLR Cables

Cable with Swivel Angle XLR Connector. Double-insulated; double shielding; overmolded connectors; swiveling XLR connector. XLR, RCA, 1/4", 5' - 25'. \$32 - \$59

Radial Engineering

1/4" Patch Cables

1/4", 1/4" TRS; 12", 18", 24", 30", 36", 6', 10', 15', 20', 25', 30'.

Box

Splitter. Eight-channel; 15 dB pad, ground lift per channel; Jensen transformers; 14-gauge steel case; scribeable strip. Phoenix, 25-pin D-sub.

Mic Adapter Cables

XLR to 1/4", XLR to RCA; 3', 6', 10', 15', 20', 25'.

Mic Cables

XLR, 3', 6', 10', 15', 20', 25', 30', 50', 75', 100'; standard, vintage, quad options.

Multi-Channel 110 Ohm AES/EBU Cable

4, 8, 12-channel assemblies; 8', 16', 24' lengths. XLR.

Plug Adapters

Choice of plug adapters; RCA, XLR, 1/4", 1/8", right angles; male, female.

Radial Digital Audio Cables

3' to 100' lengths. RCA, XLR, MIDI five-pin, AES/EBU, S/PDIF, TDIF.

RCA Cables

RCA connectors; 3', 6', 10', 15', 20', 25'; standard, dual-head, high definition options.

Speaker Cables

Live sound, sound reinforcement, studio. 12 - 18 gauge; 3' - 100' lengths. 1/4", banana, Speakon, Amphenol AP, Amphenol EP.

TASCAM T-DIF

Custom cable for TDIF; 3', 6', 10', 15', 20', 30', 50', 100'. 25-pin D-sub.

TT Patch Cables

TT connectors; Neutrik connectors; 12", 18", 24", 30", 36", 48", 60", 72'.

Y-Cables

Single Connector Split to Double Connector Cable. 1', 2', 3', 6' lengths.

1/8" TRS, RCA, 1/4" TRS, XLR.

Rane Corp.

BB-44X Balance Buddy

Signal transformer. Studio. Two-channel; -10 dBV to 4 dB and vice versa conversion; nickel core "80" Ni transformers. XLR, RCA. 1RU. Expandable to eight-channel. \$299

DA 216a

Distribution Amplifier. Studio. Eight stereo or 16 mono channel output; mic/line input switch; 40/60 dB gain switches; phantom power; master input level control; individual output level control. Screw terminal. 1RU. \$499

RCI Custom Products

BM-16D

Portable Active Mult Box. Field. Two inputs; mic/line switch; 16 isolated outputs; Jensen transformers; Zero Halburton case; VU meter. XLR, 1/4", RCA, 1/8". Available as rackmounted version. \$2,346

BM-24

Portable Mult Box. Field. One input/24 output; input level meter; ABS suit-case. XLR, 1/8". Available in rack-mount version. \$689

RDL, Radio Design Labs

FP-BUC2

Balanced to Unbalanced Converter. Two-channel; gain control. RCA, XLR. \$177

RU-LA2D

+4/-10 dB Converter. Bidirectional. XLR, RCA. \$274

RU-MDA3

Microphone Distribution Amplifier. One input, three outputs; gain control on input; phantom power. XLR. \$240

Rosati Acoustics

Monitor Man SS

Rackmountable Speaker Selector. Up to six pairs; mil-spec components; gold-plated connectors; compatible with AMX, Creston systems. XLR, banana, multipin.

Rosendahl Studiotechnik/HHB

MIF3 MIDI Timecode Interface

MTC; LTC; duplex; MTC jitter filter; LED screen. RCA, five-pin DIN. 1RU. \$549

Nanoclocks Digital Audio Clock Server

Studio Word Clock Distributor. 12 clock outputs; word clock, Superclock; 44.1 - 192 kHz; transformer isolated inputs. \$1,299

Signal Transport

PP-96-1, Project Patch 96 Point TT Patch Bay

Studio, live sound. 96 TT jacks; full grounding; cable tray; plug and play wiring; no tools/solder installation. 2RU. \$795

Signex/Independent Audio

CPJ48P - Isopatch

Patch Bay. 48 point; selectable half or full normalizing per connector; 1/4", RCA or solder rear connectors; support bar. 1/4" TRS. 1RU. \$232

CPU16

Multiconnector Interface Bay. Modular rack for various connectors - XLR, RCA, 1/4", 1/8", BNC. 1RU. Connector modules sold separately. \$76

Sonifex/Independent Audio

RB-DA6

Six-Channel Distribution Amplifier. Six-channel stereo/12-channel mono. XLR. \$415

RB-DDA6A

AES/EBU Digital Distribution

Amplifier. Six outputs; 32, 44.1, 48, 64, 88.2, 96 kHz sample rates; 16, 20, 24-bit. XLR. \$530

RB-SP1

Digital Splitter and Combiner. Duplex operation, AES/EBU, S/PDIF. XLR, RCA. \$630

Studio Technologies Inc.

Model 85

AES/EBU Digital Audio Distribution Amplifier. Two inputs, eight stereo outputs. 1RU. \$549

Model 90

Microphone Switcher. Eight inputs; two outputs; USB port. Optional rackmount kit: \$54. \$699

Sundance Systems, Inc. Fibox Products Div.

FBAl-M/FBAl-SL

Fiber Optic Transmission System. Studio, broadcast, installation, facility. Modular; two-channel; linkable up to 12 channels; 20-bit A/D-D/A; gain controls; 48 kHz sample rate; 48V phantom power; phase reverse; SMPTE; RS232/422/485 port. XLR, 15-pin D-sub, fiber optic, AES/EBU. 1/3RU. FBAl-SL is a slave model.

Switchcraft Inc.

3502RA Series

Right Angle RCA Connectors. Right-angle; heavy-duty cable clamps, handles; black/gold, nickel/gold, nickel/nickel finishes.

MTP Series Patch Bays

PTP punch down terminals. 1/4", ban-tam. 1 or 2RU.

Symetrix Inc.

303 Interface Amplifier (Bi-directional)

Level matching interface/amplifier. -10/+4 dB operation. XLR, RCA. 8.5" x 1.75" x 6.5". \$199

581E Distribution Amplifier

Four inputs, 16 outputs; four-channel; input, four output controls per channel; LED meters. Frequency response: 20 Hz - 20 kHz. THD: <0.009%. S/N: >125 dB. Euroblock. 1RU. \$549

TASCAM

IF-TAD

DTRS/ADAT Format Converter. DTRS/ADAT format conversion; 25-pin TDIF port; ADAT optical I/O; word clock out. ADAT optical, 25-pin D-sub, BNC. \$250

TecNec

AES/EBU Digital Audio Converter Patch Bays

8, 16 port. BNC, XLR. 8-port: \$330. 16-port: \$550.

Combo Patch Bay

8, 16-point. Neutrik combo. 8-point: \$79.99. 16-point: \$149.

Digital Audio Patch Bay

12 front, 12 back ports; Neutrik connectors. XLR. \$349

OTL-1S

Impedance Converter. Two-channel; unbalanced RCA to balanced XLR. RCA, XLR. \$90

Rack Mount RCA Patch Bay

32-point. RCA. 1RU. \$149

RJ45 Feed-Thru Patch Bay

16, 32-point. RJ45. 16-point: \$169. 32-point: \$224.

Telect Inc.

Longframe Patchbay with Punch-Down Connectors/Harness

1/4" Patchbay. 48-point; 1/4"; punch-down connectors; 4 harness connec-

tion cable; normaled or half-normaled. \$755 - \$950

Tice Audio Products

TPT Treated Cables

Audio Cables. OFHC high purity copper; black high gloss sleeve; available balanced; choice of connectors. RCA, spades, XLR.

Transparent Cable

Custom Cables

XLR, RCA terminations; noise filters. Starts at \$50

Videoquip Research Ltd.

ADA-204A

Distribution Amplifier. Installation. Two inputs; four outputs; trim pots. Screw terminals. \$325

DDA-104

Digital Audio Distribution Amplifier. One input; four outputs; AES/EBU; 32, 44.1, 48 kHz sample rates; status LEDs. XLR. \$315

MS-102 Microphone Splitter

One input, two outputs; ground lift; impedance switch. XLR. \$275

RS-41D Longitudinal Time Code/ Data Routing System

Four inputs, one output; for output. Nine-pin D-sub, screw terminal. \$375

S-41AV Audio/Video Switcher

Two-channel; four inputs, one output per channel; parallel remote port. XLR, BNC, nine-pin D-sub. \$795

TCR-1 SMPTE Time Code Reshaper/Distribution Amplifier

Two inputs; nine outputs; trim pots. XLR, RCA, 1/4", screw terminal, \$350

WBT-USA

Banana Plugs

Expandable lip; CE approved. \$17.50 - \$35

Binding Posts

CE approved. \$17.50 - \$50

RCA Connectors

Male or female; solder or crimp. \$17.50 - \$35

Whirlwind

AES/EBU Cables

Gold-plated connectors; 3', 6', 10' lengths. XLR.

Console Insert Cables

1/4" TRS plug to dual 1/4" TS plugs. 5', 10', 15', 25'.

DA-2

Distribution Amplifier. Four stereo, eight mono outputs; volume controls per output; headphones control. Frequency response: 20 Hz - 20 kHz. THD: 0.004%. XLR, 1/4". 1RU.

Imp Splitter 1X2

One-input/two-output; transformer isolated outputs; ground lift.

Longframe Patch Cables

Two-conductor or quad; red or black. Neutrik NP3TB 1/4".

MIDI Cables

3', 6', 10', 20' lengths. MIDI five-pin.

MK4 Series

Microphone Cables. Accusonic+2 two-conductor cable, Whirlwind XLR connectors, flexible and resistant to handling noise. 3, 6, 10, 15, 20, 25, 30, 50 and 100 foot lengths.

Multiselect

Input Selector. Four-input/single-output or single-input/four-output.

PB Series

Passive Press Boxes. 6, 12, 16, 24 output. XLR.

Phono Cables

1', 3', 5', 10', 15', 20', 25' lengths. RCA.

PressMite

Portable Press Feed System. 12 transformer isolated mic level outputs; two fixed gain transformer isolated line outputs; headphone monitoring, selectable 18V phantom power. Powered by two 9 V batteries. \$1,000

Quad Series

Mic Cables. Belden 1192A cable; 6', 10', 15', 20', 25', 30', 50', 100' lengths. XLR.

S/PDIF Cables

Gold-plated connectors. RCA

Selector

A/B Box. A/B or combined; battery operable.

Split 6

Single female XLR, six male XLRs. \$99

TOS Link Optical Cables

1m, 2m, 5m lengths.

Y Cables

Male or female; 1/4" or XLR.

Wireworks Corp.

MusiLUX

Microphone Cable. Two 22 AWG conductors; thermoplastic shielding; easily stripped jacket; multiple colors.

SpeakerLUX

Satin finish; 13-gauge copper strands; 2, 4, 6, 8-conductor.

StudioLUX

Interconnect Cable. 4, 8-conductor.

Yorkville Sound Inc.

1/4" Patch Cables

Neutrik 1/4". 10': \$7.25. 20': \$9.25.

12-Gauge Round Speaker Cables

12-gauge. 1/4". 25': \$29.50. \$43. 100': \$89.

16-Gauge Round Speaker Cables

16-gauge. 1/4". 25': \$15.25. 50': \$23.95.

Balanced Patch Cables

Balanced TRS; shielded. 1/4" TRS. 3': \$9.75. 6': \$10.75. 10': \$13.75. 20': \$16.50.

Microphone Cables

Switchcraft connectors. 5': \$12.95. 15': \$15.50. 25': \$17.50. 50': \$24.50.

MIDI Cables

Four-core. 1': \$2.50. 3': \$3.50. 6': \$4. 10': \$4.50. 20': \$5.75. 30': \$7.50.

RCA to 1/4" Patch Cables

Shielded. 1/4", RCA. 3': \$7.25. 6': \$8.25. 10': \$9.20. \$13.95.

XLR - 1/4" Patch Cables

Shielded. 25' XLR male - 1/4" male: \$22.95. 25' XLR female - 1/4" male: \$19.95.

Z-Systems Audio Engineering

OptiPatch Matrix Audio Router

ADAT Lightpipe Router. Eight eight-channel lightpipe channels; 99 routing settings. Lightpipe. 1RU. \$399

z-8.8a Lightpipe Detangler

Eight-channel; duplex; routing matrix. Lightpipe. \$1,500

z-8.Br/z-16.16r/z-32.32r/z-64.64r/z-128.128r Digital Detanglers

Remote-Controlled Digital Routers. 8 x 8, 16 x 16, 32 x 32, 64 x 64, 128 x 128; rackmounted; remote control surface; jog wheels; memory settings; RS422 port; full routing flexibility. 25-pin D-sub, nine-pin D-sub. z-8.Br: \$1,100. z-16.16r: \$1,600. z-32.32r: \$5,000. z-64.64r: \$12,000. z-128.128r: \$25,000.

HIGH PERFORMANCE CABLE DIRECTORY

interconnects		
KS 1030	\$1,300.00	Orthogonally braided silver WBT® RCA type topline connectors
KS 1021	\$820.00	Orthogonally braided silver & copper WBT® RCA type topline connectors
KS 1011	\$460.00	Orthogonally braided copper, WBT® RCA type topline connectors
KS 1130	\$1,500.00	Dual concentric grounding, silver, XLR type connectors
KS 1121	\$960.00	Dual concentric grounding, silver & copper, XLR type connectors
KS 1111	\$600.00	Dual concentric grounding, copper, XLR type connectors
KCAG	\$460.00	Silver in tri-braid geometry, WBT® RCA type or XLR type connectors
SS-BAL	\$330.00	Silver and copper in tri-braid geometry, XLR type connectors
SS-SE	\$240.00	Copper and silver in tri-braid geometry, WBT® RCA type connectors
HERO	\$150.00	Copper, GyroQuadratic™ geometry, WBT® RCA or XLR type connectors
PBJ	\$84.00	Copper in tri-braid geometry, Ultraplate™ RCA or XLR type connectors
TONIK	\$56.00	Copper in tri-braid geometry, Ultratrike™ RCA or XLR type connectors
Video		
S/mtr pair	S/meter	
S-Video Ag	\$350.00	Silver conductors in MST geometry
S-Video Cu	\$190.00	Copper conductors in MST geometry
DV-75	\$180.00	75 ohm coax, silver plated, "F", BNC or RCA type connectors
DV-75-RGB	\$540.00	75 ohm coax, silver plated, "F", BNC or RCA type connectors
DV-30	\$75.00	75 ohm coax, solid-core copper, "F", BNC or RCA type connectors
DV-30-RGB	\$225.00	75 ohm coax, solid-core copper, "F", BNC or RCA type connectors
V-21	\$48.00	75 ohm coax, solid-core copper, "F", BNC or RCA type connectors
V-21-RGB	\$144.00	75 ohm coax, solid-core copper, "F", BNC or RCA type connectors
Digital		
S/mtr pair	S/meter	
KS 2120 .75 Meter	\$950.00*	Silver AES/EBU digital cable, silver plated XLR type connectors
KS 2020 .75 Meter	\$650.00*	Silver S/PDIF digital cable, silver RCA type or BNC connectors
ORCHID	\$660.00	AES/EBU cable with silver plated XLR type connectors
AGDL-Bal	\$240.00	Silver in tri-braid geometry, silver plated XLR type connectors
D-60	\$290.00	Silver, twin, helically wound shields, BNC & RCA type connectors
DV-75	\$180.00	75 ohm coax, silver plated, "F", BNC or RCA type connectors
DV-30	\$75.00	75 ohm coax, solid-core copper, "F", BNC or RCA type connectors
OPT-1	\$60.00	Uniquely polished high-quality optical/digital link
Phono		
S/mtr pair	S/meter	
TAK Ag	\$600.00	Silver with OGQ/2™ braiding, termination options
TAK H	\$400.00	Copper & silver with OGQ/2™ braiding, termination options
TAK Cu	\$250.00	Copper with OGQ/2™ braiding, termination options
Speaker		
S/8ft pair	S/8ft pair	
KS 3038	\$7,500.00	Hyper-pure silver, WBT® bananas or spades
KS 3035	\$3,680.00	Hyper-pure copper and silver, WBT® bananas or spades
KS 3033	\$1,680.00	Hyper-pure copper, WBT® bananas or spades available
BiFocal XL	\$1,920.00	Internally bi-wired w/36 VariStrand™ copper, WBT® bananas or spades
BiFocal X	\$1,300.00	Internally bi-wired w/18 VariStrand™ copper, WBT® bananas or spades
Monocle XL	\$940.00	24 VariStrand™ copper, WBT® bananas or spades
Monocle X	\$630.00	16 VariStrand™ copper, WBT® bananas or spades
8TC	\$288.00	16 Hyper-pure, VariStrand™ copper, priced with single bananas
4TC	\$184.00	8 Hyper-pure, VariStrand™ copper, priced with single bananas
4VS	\$108.80	8 Ultra-pure, VariStrand™ copper, priced w/single bananas
4PR	\$84.80	8 High purity copper, priced w/single bananas
Speaker Bulk		
S/foot	S/foot	
8TC	\$14.00	16 Hyper-pure, VariStrand™ copper, available by the foot or spool
4TC	\$8.00	8 Hyper-pure, VariStrand™ copper, available by the foot or spool
4VS	\$3.30	8 Ultra-pure, VariStrand™ copper, available by the foot or spool
4PR	\$1.80	8 High purity copper, available by the foot or spool
Power Cords		
S/6 feet	S/6 feet	
PK 10 PALLADIAN™	\$1,060.00	10awg copper, SWR Damping, WATTGATE™ 350 IEC & 330 wall connectors
PK 10 GOLD	\$300.00	10awg copper, WATTGATE™ 350 IEC & 330 wall connectors
PK 10	\$180.00	10awg copper, WATTGATE™ 320 IEC & Marinc® wall connectors
PK 14 PALLADIAN™	\$930.00	14awg copper, SWR Damping, WATTGATE™ 350 IEC & 330 wall connectors
PK 14 GOLD	\$270.00	14awg copper, WATTGATE™ 350 IEC & 330 wall connectors
PK 14	\$150.00	14awg copper, WATTGATE™ 320 IEC & Marinc® wall connectors

Special services and options

Y-cords and jumpers quickly manufactured from many of our models
Unusual bi-wire or multi-wiring configurations are routinely manufactured

*KS 2120 & KS 2020 are
priced at .75 meter

801-621-5530

www.kimberkable.com



KIMBER KABLE

MICROPHONES

ADK (Audio DeutchKraft)

A-48 ★ New for 2003 ★
Nine patterns; dual 1.07" diaphragms; Class A, 12AX7 tube; external power supply. Ships with shockmount, aluminum flight case. \$1,195

A-51TC
Microphone. Cardioid pattern; condenser; 1" gold-sputtered diaphragm; 10 dB pad; 6072 tube; brass body. Frequency response: 20 Hz - 20 kHz. Max SPL: 125 dB. Sensitivity: 14 mV/Pa. Ships with aluminum flight case, elastic suspension, power supply, foam windscreens. \$995

Area 51 Large Diaphragm Studio Condenser Microphone
Cardioid pattern; 1" gold-vaporized diaphragm; condenser element; brass body. Version with 10 dB pad and bass rolloff, Area 51s: \$529. \$399

Area 51 TT Tube Transducer
Nine patterns - omni - figure 8; twin 1" six-micron diaphragm; 6072 tube. Frequency response: 20 Hz - 20 kHz. Ships with power supply, windscreens, shockmount, mic cable, flight case. Special Commemorative Edition with GE 6072A tube, \$1,895. \$1,595

Advanced Sonic Concepts

LCM100HL
Instrument Microphone. Live sound, studio, broadcast. Electret condenser element; separate included preamp; bridge clamp. Frequency response: 20 Hz - 20 kHz. Max SPL: 125 dB. For bass. \$329

LCM77
Instrument Microphone. Live sound, studio, broadcast. Electret condenser element; separate included preamp; extended tube mic mount. Frequency response: 50 Hz - 20 kHz. Max SPL: 135 dB. For trumpet, bugle. \$469

LDM94
Instrument Microphone. Live sound, broadcast. Dynamic element; ships with shockmount. Frequency response: 70 Hz - 15 kHz. Max SPL: 155 dB. For saxophone, trombone, high pressure horns. \$369

STM 99
Modular Microphone System. Studio. Preamp body; ships with cardioid pattern screw-on capsule, shockmount. Frequency response: 30 Hz - 20 kHz. Max SPL: 131 dB. Omnidirectional capsule: \$289. Supercardioid capsule: \$289. \$795

AKG Acoustics US

C 12 VR
Tube Condenser Microphone. Studio. Nine step incremental polar pattern including cardioid, hypercardioid, omni, figure 8; twin diaphragm design; 10, 20 dB pad; 10 dB boost; 6072 dual triode tube; power supply includes low-frequency rolloff (75 Hz) and 150 Hz cut. Frequency response: 30 Hz - 20 kHz. Sensitivity: 10 mV/Pa. Maximum SPL: 128 dB. 12-pin Tuchel. Ships with carrying case, windscreens, suspension mount, cables, and power supply. \$4,821

C 2000B
Condenser Microphone. Studio, live sound. Cardioid pattern; condenser element; 10 dB pad; bass rolloff. Frequency response: 30 Hz - 20 kHz. Ships with stand adapter. \$378

C 4000 B
Dual Large Diaphragm Microphone. Studio, live sound, broadcast. Omni, cardioid, hypercardioid patterns; dual large gold-sputtered 6 micron diaphragms; 10 dB pad; bass rolloff (100 Hz); internal shockmount; internal wind, pop screen; 9 - 52V phantom power; ships with spider shockmount,

external windscreens. Frequency response: 20 Hz - 20 kHz; Sensitivity: 25 mV/Pa; Max SPL: 155 dB. \$848

C 411C/411 B Acoustic Pickup MicroMic
Acoustic Instrument Pickup. Live sound, studio, broadcast. Vibration pickup. Frequency response: 10 Hz - 18 kHz. Max SPL: 96 dB. Adheres via adhesive compound. XLR (C 411); 1/8" (C 411 B). Designed for bridge placement on stringed instruments. C 411 - \$248; C 411 B - \$152

C 414 B/U/L/S
Twin Diaphragm Condenser Microphone. Studio, location, broadcast. Switchable patterns - cardioid, hypercardioid, omni, figure 8; dual 1" diaphragms; Ultra Linear Series electronics; 10, 20 dB pad; low-frequency cut filters at 75 and 150 Hz. Frequency response: 20 Hz - 20 kHz. Sensitivity: 12.5 mV/Pa. Maximum SPL: 160 dB. XLR. Ships with carrying case, spider shockmount, clamping stand adapter and windscreens. Nickel-plated stereo Special Edition: \$2,100. \$1,048

C 426 B
Twin Diaphragm Stereo Microphone. Studio, post production, broadcast, location. Twin gold-sputtered paired diaphragms; nine step incremental pattern switch including cardioid, omni, figure 8; polar pattern control box with independent control of each diaphragm capsule pattern; indicator LEDs; 10 dB pad; low-frequency cut switch; capsules can rotate. Frequency response: 30 Hz - 20 kHz. Sensitivity: 11 mV/Pa. Max SPL: 142 dB. S/N: 80 dB. 12-pin miniature DIN. \$4,944

C 4500B-BC
Condenser Microphone. Broadcast, studio. Cardioid pattern; gold-coated large diaphragm; 20 dB pad; internal pop filter; magnetic shielding; rolloff filter (120 Hz). Ships with H100 spider suspension. \$665

C 451 B
Studio. Cardioid pattern; condenser element; 10, 20 dB pad; bass cut off (75, 150 Hz). Frequency response: 20 Hz - 20 kHz. Max SPL: 135 dB. Ships with stand adapter, foam windscreens. \$549

C 5600
Large Diaphragm Condenser Microphone. Live sound, broadcast, studio. Cardioid pattern; condenser element; internal shockmount; switchable low-frequency cut/rolloff filter; die-cast alloy body. Frequency response: 20 Hz - 20 kHz. Sensitivity: 6 mV/Pa. Max SPL: 140 dB. S/N: 76 dB. XLR. \$748

C 5900
Condenser Microphone. Live sound, recording studio. Hypercardioid pattern; TPC-I condenser element; gold-sputtered double-stretched diaphragm; bass rolloff switch; internal four-layer pop filter/windscreens; InterSpider capsule suspension; DuraShell body. Frequency response: 20 Hz - 22 kHz. Max SPL: 140 dB. \$622

C 747 Condenser Pencil Microphone
Installation, live sound, location. Hypercardioid pattern; pencil-style body; bass rolloff. Frequency response: 30 Hz - 18 kHz. Max SPL: 133 dB. XLR. Ships with windscreens, shock mount/adapter, mini gooseneck, mounting clip, thread link. \$659

C 900
Live sound. Cardioid pattern; condenser element; Mylar membrane; internal shockmount; presence boost adapter; wire mesh grille; Emotion II series. Frequency response: 20 Hz - 20 kHz. Sensitivity: 6 mV/Pa. Max SPL: 139 dB. XLR. \$250

D 112
Dynamic Microphone. Live sound, studio. Cardioid pattern; built-in

windscreens. Frequency response: 20 Hz - 17 kHz. Sensitivity: 1.8 mV/Pa. Max SPL: 168 dB. XLR. Ships with carrying case and stand adapter. For drums, bass guitar and high SPL brass. \$397

D 230
Microphone. Broadcast. Omnidirectional pattern; die-cast, non-reflective body. Frequency response: 40 Hz - 20 kHz. Designed for electronic news gathering. \$164

D 3900
Microphone. Live sound. Hypercardioid pattern; Maximum Flux neodymium/iron boron; presence peak; Moving Magnet Suspension internal capsule suspension; high boost switch; bass rolloff switch; internal/removable wind screen and pop filter. Frequency response: 40 Hz - 22 kHz. Max SPL: 156 dB. \$308

D 430
Instrument Microphone. Cardioid pattern; condenser element; MicroMic III series. Frequency response: 20 Hz - 20 kHz. Sensitivity: 7 mV/Pa. Ships with stand adapter, windscreens. Compatible with AKG B 15 battery. \$238

D 50 S
Dynamic Microphone. Live sound. Dynamic element; directional; on/off switch; removable grille; Performer Series. 1/8" Ships with 1/4" adapter, 16' cable, leatherette case. \$81

D 550
Instrument Microphone. Live sound. Cardioid pattern; wire mesh grille; Emotion II series. XLR. \$238

D 880D 880 S
Dynamic Microphone. Live sound, studio. Supercardioid pattern; dynamic element; NdFeBr magnets; Tietzlieh Varimotion System diaphragm; DoubleFlex antivibration system; gold-plated connectors; Emotion Series. Frequency response: 60 Hz - 20 kHz. Sensitivity: 2.5 mV/Pa. Max SPL: 147 dB. XLR. Ships with carrying case and stand adapter. For vocals. S version has on/off switch. D 880 - \$142, D 880 S - \$155

SOLIDTUBE
Tube Microphone. Studio. Cardioid pattern; 12AX7 tube; 20 dB pad; low-frequency cut filter at power supply; 1" gold sputtered 6 micron mylar membrane; ground lift; window on mic body for viewing tube. Frequency response: 20 Hz - 20 kHz. Max SPL: 145 dB. 16 and 3 pin XLR. \$1,165

Audio 2000's

ACM 193
Cardioid pattern; condenser element. Frequency response: 50 Hz - 18 kHz. \$95

Audio Engineering Associates

AEA R44C
Bidirectional Ribbon Microphone. Studio, broadcast. Modern replica of classic RCA R44; new-old stock ribbon. Custom built. High output version, AEA R44CX: \$4,000. Limited edition NAMM 100th Anniversary model, R44 CNE: \$3,000. \$3,550

AEA RB4
Ribbon Studio Microphone. Studio. Figure 8 pattern; ribbon element; hardwired 9' mic cable. XLR. Ships with shockmount, mic stand adapter, case. \$999

Coles/AEA 4038
Bidirectional Ribbon Microphone. Studio. Ribbon element - 0.6 microns; Western Electric connectors. Frequency response: 30 Hz - 20 kHz. Classic studio ribbon microphone. Repair and service available AEA for older 4038s. \$1,135

Audio-Technica U.S. Inc.

AE2500 ★ New for 2003 ★
Instrument Microphone. Live sound. Condenser/dynamic hybrid; 10 dB pad; high-pass filter (80 Hz); Artist Elite series. Designed for kick drums. Ships with isolation mic clamp. \$699

AE3000
Instrument Microphone. Live sound. Cardioid pattern; side address; condenser element; 10 dB pad; high-pass filter (80 Hz); Artist Elite series. Ships with isolation mic clamp. \$379

AE4100
Live sound. Cardioid pattern; dynamic element; internal shockmount; Artist Elite series. Ships with stand clamp. \$289

AE5100
Instrument Microphone. Live sound. Cardioid pattern; condenser element; 10 dB pad; high-pass filter (80 Hz); Artist Elite series. Ships with isolation mic clamp. \$379

AE6100
Live sound. Hypercardioid pattern; dynamic element; internal shockmount; Artist Elite series. Ships with stand clamp. \$289

AT3031 Cardioid Condenser Microphone
Studio. Cardioid pattern; condenser element; 10 dB pad; rolloff (80 Hz). Frequency response: 30 Hz - 20 kHz. Impedance: 250 ohms. Max SPL: 158 dB. Dynamic range: 132 dB. XLR. Ships with mic clamp, windscreens, carrying pouch. \$259

AT3035 Cardioid Condenser Microphone
Studio. Cardioid pattern; condenser element; gold-coated diaphragm; 10 dB pad; rolloff (80 Hz). Frequency response: 20 Hz - 20 kHz. Impedance: 250 ohms. Max SPL: 158 dB. Dynamic range: 136 dB. XLR. Ships with shockmount, carrying pouch. \$349

AT4033/CL ★ New for 2003 ★
Cardioid Condenser Microphone. Studio, broadcast, live sound. Cardioid pattern; condenser element; high-pass filter (80 Hz); 10 dB pad switch; gold-plated diaphragm; isolated interior. Frequency response: 30 Hz - 20 kHz. Maximum SPL: 145 dB. S/N: 77 dB. Dynamic range: 128 dB. Impedance: 100 ohms. XLR. Ships with shockmount, dust cover, protective case. \$595

AT4040
Cardioid Condenser Microphone. Studio. Cardioid pattern; condenser element; vapor deposited gold 2 micron diaphragm; 10 dB pad; high-pass filter (80 Hz). Frequency response: 20 Hz - 20 kHz. Max SPL: 155 dB. XLR. Ships with AT8449 shockmount, dust cover, protective case. \$495

AT4047/SV
Cardioid Condenser Microphone. Studio, live sound, broadcast. Cardioid pattern; condenser element; gold-plated dual diaphragm; 10 dB pad; switchable high-pass filter (80 Hz). Frequency response: 20 Hz - 18 kHz. Max SPL: 149 dB. Dynamic range: 140 dB. S/N: 85 dB. XLR. Ships with shockmount, dust cover, carrying case. \$695

AT4050
Multipattern Condenser Microphone. Studio, live sound. Cardioid, omni, figure 8 patterns; large diaphragm; condenser element; high-pass filter (80 Hz); 10 dB pad. Frequency response: 20 Hz - 18 kHz. Maximum SPL: 149 dB. S/N: 77 dB. Dynamic range: 132 dB. Impedance: 100 ohms. XLR. Ships with shockmount, dust cover, protective case. \$995

AT4060
Large Diaphragm Vacuum Tube Condenser Microphone. Studio.

Cardioid pattern; two micron thick vapor deposited gold coating on twin diaphragms; 6922 tube. Frequency response: 20 Hz - 20 kHz. Dynamic range: 131 dB. Max SPL: 150 dB. S/N: 75 dB. Impedance: 200 ohms. Ships with AT8560 power supply, shockmount, 33' cable, power cable, rack-mount adapters for power supply, protective carrying case. \$1,695

AT4073a
Shotgun Condenser Microphone. Broadcast, film, video, live sound. Line + gradient, condenser element; high-pass filter (150 Hz); 9" barrel; patented A-T directional circuitry; aluminum alloy body. Frequency response: 30 Hz - 20 kHz. Maximum SPL: 126 dB. S/N: 80 dB. Dynamic range: 112 dB. Impedance: 100 ohms. XLR. \$850

AT804
Handheld Dynamic Microphone. Broadcast, live sound, location. Omnidirectional pattern; dynamic element; steel body. Frequency response: 50 Hz - 15 kHz. Impedance: 600 ohms. XLR. Ships with stand clamp, protective pouch. \$110

AT813a
Handheld Condenser Microphone. Studio, live sound. Cardioid pattern; condenser element; battery or phantom power. Frequency response: 30 Hz - 20 kHz. Maximum SPL: 137 dB (phantom), 123 dB (battery). S/N: 70 dB. Dynamic range: 113 dB (phantom), 99 dB (battery). Impedance: 200 ohms (phantom), 270 ohms (battery). XLR. \$210

AT825
OnePoint X/Y Stereo Field Recording Microphone. Location, broadcast. Cardioid patterns; twin condenser elements; switchable low-frequency rolloff (150 Hz); battery or phantom power. Frequency response: 30 Hz - 20 kHz. Maximum SPL: 126 dB. S/N: 70 dB. Dynamic range: 102 dB. Impedance: 200 ohms. XLR. \$525

AT831R
Miniature Lavalier/Instrument Microphone. Studio. Cardioid pattern; condenser element; power module; phantom power. Frequency response: 40 Hz - 20 kHz. Maximum SPL: 141 dB. Dynamic range: 112 dB. Impedance: 200 ohms. XLR. \$225

AT835ST
Stereo Shotgun Condenser Microphone. Field, studio, broadcast, film. Line cardioid, figure 8 patterns; M/S; 9.25" barrel; 11 - 52V phantom power; low-frequency rolloff (80 Hz); two stereo matrix modes; 24' cable; windscreens; carrying case. Frequency response: 40 Hz - 20 kHz. Max SPL: 127 dB. S/N: 72 dB. Dynamic range: 102 dB. XLR. \$899

AT849
Stereo Condenser Boundary Microphone. Studio, live sound, installation, broadcast. Boundary-style shell; cardioid pattern; twin condenser elements; X/Y configuration; stereo/mono; switchable rolloff (150 Hz) rubber bottom pad; ships with 25' cable, protective pouch. Frequency response: 30 Hz - 20 kHz. S/N: 67 dB. Dynamic range: 110 dB. Max SPL: 137 dB. \$450

AT853R
Miniature Hanging Microphone. Live sound, broadcast, studio. Cardioid pattern; condenser element; interchangeable directional elements; switchable rolloff (150 Hz); power module; 25' attached cable. Frequency response: 30 Hz - 20 kHz. Maximum SPL: 138 dB. S/N: 67 dB. Dynamic range: 111 dB. Impedance: 200 ohms. XLR. Ships with foam windscreens, steel hanger. \$239

AT857AM
Double Gooseneck Microphone. Live sound, broadcast, studio. Cardioid pat-

MICROPHONES

tern; condenser element; interchangeable directional elements; low-frequency rolloff (150 Hz); alternating gooseneck; power module. Frequency response: 30 Hz - 20 kHz. Maximum SPL: 138dB. S/N: 67 dB. Dynamic range: 111 dB. Impedance: 200 ohms. XLR. \$290

AT8801
Phantom Power Supply. 48 V. XLR. \$75

AT895 Adaptive-array Microphone System

Directional Microphone. Field, broadcast. Full-field adaptive, planar adaptive, line+gradient patterns; Microline element; five condenser elements; four noise-canceling elements with pre-amps; DSDA-Pro digital noise canceling processing; onboard processor/controller; high-pass, band-pass filters; ships with cable. Frequency response: 60 Hz - 12 kHz. Max SPL: 117 dB. XLR. Available as Remote Kit with pistol-grip shockmount, zepelin, battery housing (\$2,995) or Mount Kit with shockmount/stand clamp (\$2,595). \$2,995

ATM23HE
Instrument Microphone. Studio, live sound. Hypercardioid pattern; Hi-ENERGY neodymium dynamic element; integral stand clamp; ships with protective pouch. Frequency response: 70 Hz - 16 kHz. Impedance: 600 ohms. XLR. Designed for snare drum. \$235

ATM35
Clip-On Instrument Microphone. Studio, live sound. Cardioid pattern; condenser element; low-frequency rolloff (150 Hz); UniMount clip mount; 25' attached cable; power module;

phantom or battery power. Frequency response: 30 Hz - 20 kHz. Maximum SPL: 145 dB. S/N: 67 dB. Dynamic range: 118 dB. Impedance: 200 ohms. XLR. \$350

ATM63HE
Handheld Microphone. Live sound. Hypercardioid pattern; Hi-ENERGY neodymium dynamic element; patented floating diaphragm; ships with stand clamp, windscreens, protective pouch. Frequency response: 50 Hz - 18 kHz. XLR. \$189

ATM89R
Handheld Microphone. Live sound. Hypercardioid pattern; condenser element; internal shock mounting. Frequency response: 70 Hz - 20 kHz. Maximum SPL: 138 dB. S/N: 67 dB. Dynamic range: 111 dB. Impedance: 100 ohms. XLR. Interchangeable polar pattern heads available. Ships with stand clamp, protective pouch. \$325

KP-DRUMS KitPak
Drum Microphone Package. Live sound, studio. Four mics - two for snare/toms, two for kick/toms; cardioid pattern; dynamic element; adjustable stand mounts. Snare/tom - frequency response: 100 Hz - 12 kHz. Kick/tom - frequency response: 60 Hz - 12 kHz. XLR. \$500

MB4000C
Microphone. Live sound. Cardioid pattern; condenser element; Midnight Blues series. Frequency response: 100 Hz - 18 kHz. Max SPL: 128 dB. Impedance: 200 ohms. XLR. \$125

PRO 25
Hypercardioid Instrument Microphone.

Hypercardioid pattern; dynamic element; high SPL. Frequency response: 30 Hz - 12 kHz. Impedance: 600 ohms. XLR. \$150

PRO 35x
Cardioid Clip-On Microphone. Cardioid pattern; condenser element. Frequency response: 50 Hz - 17 kHz. Max SPL: 149 dB. Impedance: 200 ohms. XLR. \$165

PRO 45
Hanging Microphone. Installation. Cardioid pattern; condenser element; 9 - 52 V phantom power; high SPL. Frequency response: 70 Hz - 16 kHz. Max SPL: 134 dB. Impedance: 100 ohms. XLR. Optional white version. \$115

PRO 49QL
Gooseneck Podium Microphone. Cardioid pattern; condenser element; 9 - 52 V phantom power; gooseneck; quickmount; high SPL. Frequency response: 70 Hz - 16 kHz. Max SPL: 134 dB. Impedance: 100 ohms. XLR. \$120

PRO 95
Acoustic Instrument Microphone. Condenser element. Frequency response: 80 Hz - 13 kHz. Max SPL: 105 dB. Dynamic range: 67 dB. 1/4". \$149

ADX-20i
Instrument Microphone. Cardioid pattern; condenser element; ships with mic clip. Frequency response: 40 Hz - 20 kHz. XLR. For horns, saxophone. Optional hypercardioid module. \$199

ADX-50
Cardioid Instrument Microphone. Cardioid pattern; condenser element; electret capsule; ships with stand adapter. Frequency response: 40 Hz - 18 kHz. Max SPL: 132 dB. \$299

CX-111
Large Diaphragm Condenser Microphone. Studio, live sound. Cardioid pattern; condenser capsule; 1" gold vapor-deposited large diaphragm; 10 dB pad; bass rolloff switch. Frequency response: 20 Hz - 20 kHz. Max SPL: 145 dB. Dynamic range: 109 dB. S/N: 83 dB. Optional power supply. Matched pair available: \$1,325. \$599

D1
Dynamic Instrument Microphone. Live sound, studio, broadcast. Hypercardioid pattern; transformerless design; dynamic element. Frequency response: 46 Hz - 18 kHz. Max SPL: 144 dB. Designed for snares, toms, high hat, flute and other high SPL instruments. \$219

D6 ★ New for 2003 ★
Drum/Percussion/Bass Microphone. Cardioid pattern; Very Low Mass (VLM) capsule; dynamic element; machined aluminum housing. Frequency response: 30 Hz - 15 kHz. Max SPL: 144 dB. XLR. \$349

Micro-D
Miniature Condenser Instrument Microphone. Live sound. Hypercardioid pattern; condenser element; rubber shockmount. Frequency response: 40 Hz - 20 kHz. Max SPL: 140 dB. Ships with three specialized mic clips. \$249

OM5
Dynamic Vocal Microphone. Studio, live sound. Hypercardioid pattern; dynamic element. Frequency response: 48 Hz - 19 kHz. Impedance: 200 ohms. Maximum SPL: 144 dB. Ships with stand adapter and carrying pouch. \$265

OM7
Dynamic Vocal Microphone. Studio, live sound. Hypercardioid pattern; transformerless capsule design; dynamic element. Frequency response: 45 Hz - 19 kHz. Max SPL: 144 dB. \$359

SCX-1
Microphone Preamp for SCX Capsules. Studio, live sound. Handheld mic pre for modular system; optional screw-on capsules; brass housing. \$299

SCX-25
Lollipop-Style Microphone. Studio. Cardioid pattern; condenser element; gold-sputtered large diaphragm; isolated capsule; internal shockmount; brass body. Frequency response: 20 Hz - 20 kHz. Max SPL: 138 dB. Sensitivity: 29 mV/Pa. Dynamic range: 124 dB. XLR. \$799

SCX-c
Cardioid Microphone Capsule. Studio, live sound. Cardioid pattern screw-on capsule for SCX series. Frequency response: 40 Hz - 20 kHz. \$299

SCX-hc
Hypercardioid Microphone Capsule. Studio, live sound. Hypercardioid pattern screw-on capsule for SCX series. Frequency response: 40 Hz - 20 kHz. \$329

Audix Corp.

THE ENGLISH CHANNEL

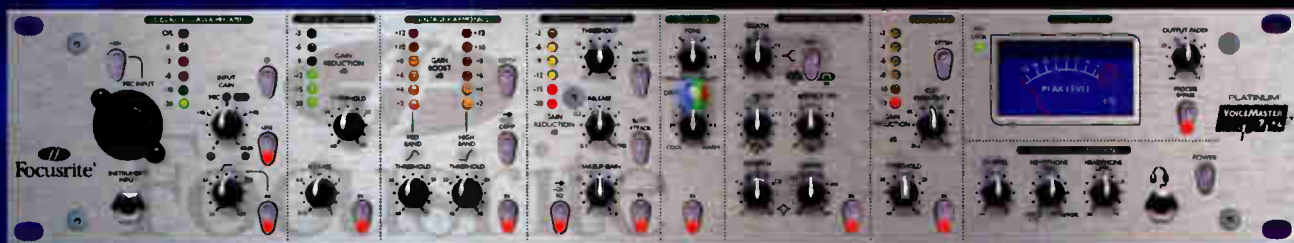

THE NEXT GENERATION VOICEMASTER HAS ARRIVED

- Award-winning Focusrite Class-A mic pre
- Real-time, latency-free stereo monitoring
- Vintage Harmonics processor for classic vocal effects
- Optional 24-bit/96kHz A-D with Word Clock for seamless digital connectivity
- ISA430 De-esser with "listen" feature

- Improved versions of the VoiceMaster Tube Sound, Optical Expander, EQ & Compressor
- Unmatched flexibility with insert points, FX send/returns and DI functionality

The New VoiceMaster Pro Vocal Channel, the famous Focusrite sound with incredible features and an outstanding price to match.



digidesign
NORTH AMERICAN DISTRIBUTOR
www.digidesign.com

For a demo, call toll-free
1-866-FOCUSRITE or visit
www.focusrite.com for
more information.
World Radio History

Focusrite

MICROPHONES

UEM-81s

Shotgun Microphone. Broadcast, location. Cardioid/supercardioid pattern; prepolarized condenser; shotgun style. \$329

VX-10

Live sound. Cardioid pattern; 16mm gold-vaporized diaphragm; steel mesh grille. Frequency response: 40 Hz - 20 kHz. Max SPL: 140 dB. Ships with mic stand adapter, foam windscreens. \$599

Azden Corp.

SGM-2X

Shotgun Microphone. Live sound, broadcast. Switchable omnidirectional and supercardioid barrels; integrated shockmount; camera shoe mount; mic stand mount; foam windscreens. Frequency response: 100 Hz - 18 kHz. XLR. \$300

Baltic Latvian Universal Electronics (BLUE)

Baby Bottle

Cardioid Microphone. Studio. Cardioid pattern; gold/aluminum sputtered six-micron Mylar diaphragm. Frequency range: 20 Hz - 20 kHz. Sensitivity: 33.5 mV/Pa. Max SPL: 133 dB. Ships with cherry wooden box, velvet mic pouch, mic clip. Optional Cranberry mic cable: \$44.95. \$649

Blueberry

Microphone. Recording studio. Cardioid pattern; tunable large gold coated Mylar diaphragm; condenser element; Class A; brass backplate. Frequency response: 20 Hz - 20 kHz. Sensitivity: 20 mV/Pa. Max SPL: 133 dB. XLR. Ships with cherry wood mic case. External pop filter/shockmount: \$279. External shockmount: \$99. Optional Blueberry cable: \$44.95. \$1,299

Cactus

Tube Condenser Microphone. Studio. Cardioid, omnidirectional, figure 8 patterns; condenser element; gold coated 6 micron Mylar diaphragm; slow start; AC701 or same tube. Frequency response: 20 Hz - 20 kHz. Sensitivity: 18 mV/Pa. Max SPL: 130 dB. Ships with BLUE Champagne mic cable, flight case, shockmount/pop filter, BLUE 9601 power supply. Optional Kiwi cable: \$54.95. \$3,295

The Bottle Mic

Studio. Tube based amplifier with switchable pattern heads; EF 86 tube; slow start. Available heads: B0 - large diaphragm cardioid with single backplate; B1 - small diaphragm cardioid; B2 - figure 8; B3 - medium diaphragm cardioid; B4 - omnidirectional small diaphragm perspex sphere; B5 - omnidirectional large diaphragm; B6 - large diaphragm cardioid with dual backplate; B7 - large diaphragm with single backplate. Max SPL: 134 dB. Ships with B6 capsule, large ATA flight case, BLUE Champagne mic cable, BLUE Model 9610 power supply. Additional heads - \$750 each except B4 which is \$1,500. \$4,995

The Mouse

Microphone. Recording studio. Cardioid pattern; Class A; gold-sputtered Mylar diaphragm; condenser element; rotatable capsule; internal shockmount. Frequency response: 20 Hz - 20 kHz. Sensitivity: 21 mV/Pa. Max SPL: 134 dB. XLR. Ships with cherry wood box. Optional external Pop pop filter: \$200. Optional external Shock shockmount: \$350. Optional Cranberry cable: \$44.95. \$1,699

Bayview Pro Audio

Cascade M-55

Cardioid pattern; 1" gold-sputtered

diaphragm; 12AX7A tube. Frequency response: 20 Hz - 20 kHz. Ships with power supply, shockmount, flight case. Optional 6072A tube. \$349

Cascade MX-56 * New for 2003 *

Variable omnidirectional - figure 8 patterns; 1.07" gold-sputtered diaphragm; 6072A tube. Frequency response: 20 Hz - 20 kHz. Sensitivity: 12 mV/Pa. Ships with separate power supply. \$569

Behringer

B-2

Microphone. Studio, broadcast. Omnidirectional, cardioid patterns; gold-sputtered 1" dual diaphragms; 10 dB pad; high-pass filter (150 Hz); nickel-plated brass body. Frequency response: 20 Hz - 20 kHz. Max SPL: 145 dB. S/N: 76 dB. Sensitivity: 16mV/Pa. XLR. \$329

beyerdynamic Inc.

M 88 TG

Moving Coil Microphone. Recording studio, live sound. Polar, hypercardioid patterns; moving coil; high SPL; vocal, brass, drum oriented. Frequency response: 30 Hz - 20 kHz. Impedance: 200 ohms. Output: 2.3 mV/Pa = -53 dBV. XLR. \$399

MC 740

Large Diaphragm Condenser Microphone. Studio. Omni, figure 8, cardioid, hypercardioid, supercardioid patterns; 10 dB pad; bass rolloff. Frequency response: 20 Hz - 20 kHz. XLR. General studio mic. \$1,899

MC 801/MC 803/MC 805

Modular Condenser Microphone System. Studio. Modular system; CV 800 preamp/body; optional pattern heads. MC 801 - CK 1 (omnidirectional) and CV 800 preamp. MC 803 - CK 3 (cardioid) and CV 800 preamp. MC 805 - CK 5 (supercardioid) and CV 800 preamp. \$899 each

MCD 100

Digital Condenser Microphone. Cardioid pattern; condenser element; high SPL; AES3 digital output signal. Max SPL: 150 dB. Dynamic range: > 113 dB. \$2,500

MCD 801/MCD 803/MCD 805

Modular Digital Condenser Microphone System. Modular system; 24-bit; AES3 digital output; CVD 800 preamp/body; optional pattern heads. Dynamic range: > 100 dB. MCD 801 - CK 1 (omnidirectional) and CVD 800 preamp. MCD 803 - CK 3 (cardioid) and CVD 800 preamp. MCD 805 - CK 5 (supercardioid) and CVD 800 preamp. MCD: \$1,499 each; CK: \$699 each

MCE 91

Condenser Vocal Microphone. Studio, live sound. Cardioid pattern; condenser element; high SPL. Max SPL: 139 dB. \$699

Opus 59

Vocal Microphone. Live sound. Supercardioid pattern; dynamic element; internal shockmount. Ships with bag, mic clip. \$199 Opus 83 Instrument Microphone. Cardioid pattern; electret condenser. Frequency response: 40 Hz - 20 kHz. Impedance: 190 ohms. XLR. \$339

Opus 87

Drum Microphone. Electret condenser element; gooseneck; shockmount clamp. \$399

TG-X 10

Moving Coil Percussion Microphone. Studio, sound reinforcement. Supercardioid pattern; moving coil; reinforced diaphragm for high SPL; Neodymium magnet. Frequency response: 50 Hz - 15 kHz. Impedance: 300 ohms. Output: 2.5 mV. XLR. Designed for drums and percussion instruments. Ships

with shockmount.

\$289

Brauner Microphones/ Transamerica Audio Group

Phantom C

Cardioid pattern; FET. Frequency response: 20 Hz - 22 kHz. Sensitivity: 28 mV/Pa. Max SPL: 142 dB. Ships with shockmount and aluminum carrying case. \$1,380

Valvet

Tube Microphone. Studio. Cardioid, omnidirectional patterns; dual large diaphragms; Class A; EF 86 tube; Lundahl transformer; RF filter; phase reverse; groundlift switch. Frequency response: 20 Hz - 22 kHz. Sensitivity: 28 mV/Pa. Max SPL: 142 dB. S/N: 81 dB. \$2,695

VM1 KHE

Studio. Multiple patterns; condenser element; Class A; Telefunken EF 806S tube; pattern control from power supply; 10 dB pad and ground lift on power supply; custom modifications by Klaus Heyne. \$7,000

VM1S

Stereo Tube Microphone. Studio. Multiple patterns; condenser element; dual large diaphragms; Class A; Telefunken EF 806S tube; pattern control from power supply; twin 10 dB pads and ground lift on power supply. Tüchel, XLR. \$7,999

CAD Professional Microphones

C195

Condenser Vocal Microphone. Cardioid pattern; electret condenser element; INR-3 internal shockmount; FlexForm grille; multistage pop filter. Frequency response: 50 Hz - 18 kHz. Sensitivity: 18 mV/Pa. Max SPL: 132 dB. Ships with swivel mount, vinyl pouch. \$239

E350

Multipattern Microphone. Omnidirectional, cardioid, figure 8 patterns; 1.1" Optema capsule; side address; 20 dB pad; high-pass filter (80 Hz); phantom power/nickel metal hydride battery (NiMH) operation. Frequency response: 10 Hz - 20 kHz. Dynamic range: 137 dB. Max SPL: 148 dB. Sensitivity: 17.8 mV/Pa. Ships with shockmount, metal case. \$899

M 179

Variable Pattern Condenser Microphone. Studio, live sound. Variable pattern - omni, cardioid, wide cardioid, figure eight, etc; 1.1" capsule; 20 dB pad; high-pass filter (80 Hz); 24 - 48V phantom power. Frequency response: 10 Hz - 20 kHz. Sensitivity: 15 mV/Pa. Max SPL: 143 dB. XLR. Ships with swivel mount and case. \$399

M9 EH

Tube Condenser Microphone. Studio, live sound. Cardioid pattern; 1.1" gold-sputtered capsule; servo valve coupled electronics; 20 dB pad; high-pass filter (80 Hz); 12AX7 tube. Frequency response: 10 Hz - 20 kHz. Sensitivity: 16 mV/Pa. Max SPL: 154 dB. XLR. Ships with MV200 power supply, 30' cable, shockmount, swivel mount, case. \$599

VSM

Tube Condenser Microphone. Cardioid pattern; 1.1" Optema gold-sputtered diaphragm capsule; condenser element; 8, 16 dB pads; high-pass filter (80 Hz). Frequency response: 10 Hz - 20 kHz. Dynamic range: 123 dB. Max SPL: 138 dB. Ships with shockmount. \$1,099

VX2

Dual Valve Condenser Microphone. Recording studio. Dual valve design; cardioid, omni, figure 8 patterns; interchangeable 1.25", 1.1" capsules; gold sputtered, 3 micron polymer film diaphragm; 8, 16 dB pads; side

address; separate tube head amp and tube output circuit; custom wound humbuck output transformer; 80 Hz rolloff; 12AX7, 12AU7 tubes. Frequency response: 10 Hz - 20 kHz. Dynamic range: 123 dB. Max SPL: 152 dB. S/N: 81 dB. \$2,249

Carvin

CM 50

Dynamic Microphone. Live sound, sound reinforcement, studio. Cardioid pattern; dynamic element; internal pop filter; on/off switch. Frequency response: 50 Hz - 14 kHz. Maximum SPL: 120 dB. XLR. \$49

CM 67 Instrument Mic

Dynamic Microphone. Live sound, sound reinforcement, studio. Cardioid pattern; dynamic element; internal pop filter. Frequency response: 40 Hz - 15 kHz. Maximum SPL: 120 dB. XLR. Ships with 20' XLR cable, stand adapter, leatherette zipper pouch. \$79

CM 90E Studio Condenser

Condenser Microphone. Live sound, sound reinforcement, studio. Cardioid pattern; condenser element; internal pop filter. Frequency response: 30 Hz - 20 kHz. Maximum SPL: 132 dB. XLR. \$114

CM-87S

Large Diaphragm Condenser Microphone. Studio. Cardioid pattern; six micron gold-sputtered diaphragm; 10 dB pad; low-cut filter (80 Hz). Frequency response: 30 Hz - 20 kHz. Dynamic range: 133 dB. XLR. \$219

CM98ST

Tube Condenser Microphone. Studio. Variable pattern, omnidirectional - figure eight; dual 1" gold-sputtered five micron diaphragms; 10 dB pad; low-cut filter (120 Hz); tube. Frequency response: 20 Hz - 20 kHz. Dynamic range: 133 dB. Ships with aluminum flight case, shockmount, cable, foam windscreens, carrying pouch, power supply. \$499

CMBD1 * New for 2003 *

Bass Drum Microphone. Stand mount; metal windscreens. Frequency response: 30 Hz - 15 kHz. Max SPL: >140 dB. \$59

CMST1 * New for 2003 *

Snare Drum Microphone. Stand mount; metal windscreens. Frequency response: 70 Hz - 15 kHz. Max SPL: >130 dB. \$49

Coles Microphones/ Independent Audio

4038

Studio Ribbon Microphone. Broadcast, recording studio. Figure 8 pattern; ribbon element; monel mesh; brass body; BBC design. Frequency response: 30 Hz - 15 kHz. XLR. Ships with carrying case, mic mount, jack plug. \$1,240

4040

Studio. Ribbon element; internal shockmount. XLR. \$1,399

Core Sound

Binaural Microphone Set

Binaural Microphone Pair. Omnidirectional/binaural; DPA 4060 capsules; bass rolloff; battery box power supply. Frequency response: 20 Hz - 20 kHz. Max SPL: 144 dB. 3.5mm, XLR, 1/4". \$980 (per pair)

Countryman Associates Inc.

B6

Ultrasmall Lavalier Microphone. Live sound, broadcast. Omnidirectional pattern; electret condenser; available for wired and wireless systems; replaceable caps. Optional three-pin Lemo connector: \$438. \$389

EM-301

Conference Table Microphone. Omnidirectional pattern; moisture-resistant; 25' cable; designed for mounting in holes. Frequency response: 50 Hz - 15 kHz. Max SPL: 130 dB. XLR.

IsoMax EMW Lavalier Microphone

Very Small Lavalier Microphone. Omnidirectional; frequency optimized versions available - shelved, peaked, flat; choice of clips - tie clip, tie tack, Viper Grip pin clip, iron on. Max SPL: 130 dB. Wireless version available.

IsoMax TVH

Miniature Lavalier Microphone. Hypercardioid pattern; high-pass filter; ships with rotatable clip, belt clip, windscreens and carrying case. Frequency response: 70 Hz - 18 kHz. Max SPL: 120 dB. XLR.

Crown Audio

CM-150

Microphone. Recording studio, acoustical measurement. Omnidirectional pattern; condenser element; titanium diaphragm; ships with foam windscreens, stand clamp. Frequency response: 20 Hz - 20 kHz. Sensitivity: 10 mV/Pa. XLR. Available in matched pairs. \$899

CM-700

Condenser Microphone. Sound reinforcement, studio. Cardioid pattern; two position low-frequency rolloff. Frequency response: 40 Hz - 20 kHz. XLR. Ships with stand adapter, foam windscreens and foam two-stage pop filter. Available in matched pairs. \$299

GLM-200

Miniature Microphone. Live sound. Hypercardioid pattern; electret condenser element; miniature design; ships with universal mount, tie bar. Frequency response: 60 Hz - 20 kHz. Sensitivity: 6 mV/Pa. XLR. \$249

LM-300A

Podium Microphone. Installation. Supercardioid pattern; gooseneck; foam pop filter; low-cut filter. Frequency response: 80 Hz - 15 kHz. Sensitivity: 6 mV/Pa. XLR. \$289

MB-A Mini Boundary Microphone

Miniature Boundary Microphone. Half-supercardioid pattern; works with standard mic preamp/mixer. Frequency response: 50 Hz - 15 kHz. XLR. \$159

PCC-170

Boundary Microphone. Installation. Boundary-style; half supercardioid pattern; 15' cable. Frequency response: 50 Hz - 20 kHz. Sensitivity: 22 mV/Pa. XLR. Black or white. With on/off switch, PCC-170SW. \$289

PZM-30D

Plate-Mounted Microphone. Live sound. Hemispherical pattern; pressure zone mic; switchable rising/flat response. Frequency response: 20 Hz - 20 kHz. Sensitivity: 7 mV/Pa. XLR. \$349

PZM-6D

Plate-Mounted Microphone. Live sound. Hemispherical pattern; pressure zone mic; switchable rising/flat response; 15' cable. Frequency response: 20 Hz - 20 kHz. Sensitivity: 7 mV/Pa. XLR. \$349

Curtis Technology

AL-2 Microphone System

Matched twin tube condenser microphones with 1" diaphragms; dual rack-mounted power supply; ground lift switch; matched 12AU7 tubes. Frequency response: 20 Hz - 30 kHz. Max SPL: 125 dB. Ships with shockmounts, Canare cable. \$3,495

DPA Microphones

3532T

Large Diaphragm Tube Microphone

75 years later... Nothing has Changed!



2003 - UM92.1S capsule.



1957 - UM57 capsule.



The original 'Baby-bottle'.

Gefell microphones are still hand made in Germany with the care and precision that one can only equate with old-world craftsmanship and a commitment to excellence. From the early days with Georg Neumann, through the relocation of the factory during the 2nd World War, and the many years separated behind the Iron Curtain, Gefell has remained true to its roots. And these roots run deep...

From the 1st generation multi-pattern UM57 to the fabulous UM92.1S, Microtech Gefell continues the tradition with the legendary 'tube sound' that is only possible with the original M7 capsule. That's right, the original M7, with gold sputtered PVC, hand made in the Gefell factory.

That's not to say we have rested on our laurels... Since the beginning Gefell has set the pace for microphone innovation and continues to elevate the bar: The Gefell UM900 Phantom, the world's only 48V phantom powered tube mic; the Gefell M930 Compact, a large-diaphragm studio condenser with optical isolation and the lowest self-noise in the business; and now the Gefell MV230 digital for better than 140dB performance. But wait, there's more...

Today, Gefell measurement microphones lead the world in metal diaphragm technology. For those 'in the know', nothing compares to the precision of an ultra-thin 0.8-micron pure nickel membrane for true, full bandwidth performance. This incredible technology is now available with the new Gefell M295, a low profile cardioid that will absolutely blow you away.

Of course there are lots of mics to choose from and for the average person, a mass-produced copy is just fine. But if you want something truly special and a cut above, visit one of our exclusive Gefell Dealers and listen to the difference that quality, tradition and pride can make. You may be surprised at how good a hand-made microphone can truly be.



(Left to Right) Tube mics: Original UM57 (1957), UM57 V.E.B. (1972), and today's Gefell UM92.1S



Gefell M930 Stereo X/Y



Gefell UM900

Gefell - Quality, Tradition and Innovation

 www.gefell-mics.com

GefellTM
the original hand-made German microphone

DISTRIBUTED BY C-TEC - CABLETEK ELECTRONICS LTD. - 1638 KEBET WAY, PORT COQUITLAM BC V3C 5W9 TEL: 604-942-1001 FAX: 604-942-1010 EMAIL: info@gefell-mics.com

MICROPHONES

Stereo Kit. Studio, live sound, broadcast. Two microphones; omnidirectional pattern. Frequency response: 10 Hz - 20 kHz. Max SPL: 144 dB. XLR. Ships with preamps, power supply, cables, suspension mounts, stereo boom, windscreens, pop filters. Solid state version, 352S: \$10,000. \$10,200

DPA 3541

Modular Vocalist/Microphone System. Studio, location, broadcast, live sound. Omnidirectional pattern; modular system; soft boost (4-6 dB @ 8 kHz); ships with preamp, power supply, cable, suspension, windscreen, pop filter. Frequency response: 10 Hz - 20 kHz. Max SPL: 144 dB. Other pattern heads available. \$5,000

DPA 4015/4016

Wide cardioid pattern; prepolarized condenser element. Frequency response: 40 Hz - 20 kHz. Max SPL: 158 dB. 4016 requires a microphone preamplifier; 4015 requires standard 48V phantom power. \$1,850

DPA 4060/4061/4062

Miniature Microphones. Broadcast, film, live sound. 5.4mm prepolarized condenser cartridge element with vertical diaphragm; two different protection grids; designed for wireless systems. Frequency response: 20 Hz-20 kHz. Max SPL: DPA 4060 - 134 dB; DPA 4061 - 144 dB; DPA 4062 - 154 dB. Choice of colors. Wide variety of connectors available. DPA 4062: \$589. \$399

DPA 4065

Miniature Headworn Microphone. Broadcast, film, live sound. 5.4mm prepolarized condenser cartridge element with vertical diaphragm; two different protection grids; bendable headband; designed for wireless systems. Frequency response: 20 Hz - 20 kHz. Max SPL: 144 dB. Choice of colors, connectors. \$475

Earthworks Audio Products

FM500

Gooseneck Microphone. Studio, live sound, contracting. Cardioid pattern; 19" long gooseneck. Frequency response: 50 Hz - 20 kHz. Max SPL: 145 dB. Sensitivity: 10 mV/Pa. XLR. \$400

SR77

Microphone. Recording studio, live sound. Cardioid pattern; 48V phantom power. Frequency response: 30 Hz - 30 kHz. Max SPL: 145 dB. Sensitivity: 10 mV/Pa. XLR. Matched pair in cherry box: \$1,600. \$750

TC30K

Microphone. Studio. Omnidirectional pattern; 48V phantom power. Frequency response: 9 Hz - 30 kHz. Max SPL: 150 dB. Sensitivity: 8 mV/Pa. XLR. High SPL, drums, guitars. \$600 each, \$1,300 matched pair

Electro-Voice

Cobalt Co9

Dynamic Vocal Microphone. Cardioid pattern; dynamic element; neodymium magnet; cobalt blue finish. Frequency response: 50 Hz - 18 kHz. XLR. Ships with mic stand adapter, gig bag. \$169

ENG 618

Boom/Shotgun Microphone. Broadcast, field, film, video. Hypercardioid pattern; condenser element; attached graphite fiber extendible K-Tek boom (up to 6'); built-in head-phantom amp; bass rolloff (200 Hz); phantom power or battery (9V) operation. Frequency response: 50 Hz - 20 kHz. XLR. Ships with large carrying pouch, windscreen. \$1,534

N/DYM 468 Instrument

Microphone. Studio, live sound. Supercardioid pattern; dynamic element; neodymium magnet. Frequency response: 30 Hz - 22 kHz. Ships with stand adapter, gig bag. \$334

N/DYM 767a Lead Vocal

Microphone. Studio, live sound. Supercardioid pattern; dynamic element; switched low-frequency rolloff; VOB bass enhancement technology; Memraflex grille; Warm grip handle. Frequency response: 35 Hz - 22 kHz. \$252

PolarChoice

Microphone. Installation. Switchable omnidirectional, hypercardioid, supercardioid, cardioid patterns; electret element; quickmount; gooseneck; steel casing; ships with windscreen. Frequency response: 75 Hz - 15 kHz. XLR. Optional flange mount. Optional shockmount. With 12" gooseneck: \$316. With 18" gooseneck: \$326.

RE1000 Studio Condenser

Microphone. Studio. Supercardioid pattern; condenser element; rolloff switch; two stage pop filter; hard shell case. Frequency response: 70 Hz - 18 kHz. XLR. Optional shock mount. \$630

RE20 Variable-D Dynamic

Microphone. Studio, broadcast, live sound. Cardioid pattern; dynamic element; Variable-D anti-proximity effect technology; built-in pop/wind filter; rolloff switch. Frequency response: 45 Hz - 18 kHz. \$798

RE27ND Dynamic

Microphone. Broadcast, live sound, studio. Cardioid pattern; dynamic element; rolloff switch; N/DYM high output technology; Variable-D anti-proximity effect technology. Frequency response: 45 Hz - 20 kHz. \$840

RE510

Handheld Microphone. Live sound, studio. Supercardioid pattern; condenser element; low-frequency boost; low-frequency rolloff; internal pop filter; Warm Grip handle; Memraflex grille. \$420

Fostex Corp. of America

M11RP

Cardioid pattern; Fostex Printed Ribbon technology ribbon element. Frequency response: 40 Hz - 18 kHz. Impedance: 600 ohms. Ships with leatherette case, swivel mount, cable. \$1,199

M88RP

Figure 8 pattern; Fostex Printed Ribbon technology ribbon element. Frequency response: 40 Hz - 18 kHz. Impedance: 600 ohms. Ships with leatherette case, swivel mount, cable. \$1,399

Global Audio by CAD

M37

Cardioid pattern; 1" condenser element; 20 dB pad; high-pass filter (80 Hz). Frequency response: 20 Hz - 20 kHz. Sensitivity: 16 mV/Pa. Max SPL: 143 dB. \$159

Groove Tubes

GT55

Cardioid pattern; 1" 3-micron gold-evaporated diaphragm; condenser element; FET; Class A. Ships with hard mount, shockmount, pouch. Optional omnidirectional (\$199), hypercardioid (\$199) capsules. \$599

GT66

Cardioid pattern; 1" 3-micron gold-evaporated diaphragm; condenser element; GT6025 tube; Class A. Ships with power supply, 25' cable, hard mount, shockmount, pouch. \$1,099

Josephson Engineering

C700S

Microphone. Studio. Omnidirectional - figure 8 patterns; three capsules; 16mm pressure element; two 26mm gradient elements; multiple outputs. Ships with cables, fiberglass case. Matched pairs available. \$6,500

Lawson Inc.

L251

Tube Microphone. Studio. Variable pattern; Telefunken ELAM 251 capsule reproduction; 6922/6N1P tube; low-frequency contour (6 dB @ 100 Hz); cardioid only pattern boost; internal shockmount; 10 dB pad on power supply. Frequency response: 20 Hz - 20 kHz. Max SPL: 144 dB. Sensitivity: 18mV/Pa. Ships with mic cable, carrying case, swivel mount. \$2,495

Lawson L47SH

Large Diaphragm Microphone. Studio. Cardioid pattern;

U47/M49 1" capsule reproduction; 48 V phantom power; 3 micron gold sputtered diaphragms; internal shockmount; 10, 20 dB pad; low-frequency rolloff switch. Frequency response: 20 Hz - 20 kHz. Sensitivity: 11 mV/Pa. Maximum SPL: 165 dB. XLR. Ships with shockproof carrying case, swivel mount. \$995

M Audio

Groove Tubes Model 1B

★ **New for 2003** ★
Cardioid pattern; 1.1" 3-micron gold-evaporated diaphragm; Disk Resonator technology; tube, condenser element; 10 dB pad; low-frequency rolloff (75 Hz); Class A. XLR. Ships with 25' mic cable, shockmount, hard mount. Matched pairs available. \$699

Groove Tubes Model 1B-FET

★ **New for 2003** ★
Cardioid pattern; 1.1" 3-micron gold-evaporated diaphragm; Disk Resonator technology; condenser element; 10 dB pad; low-frequency rolloff (75 Hz); Class A. XLR. Ships with 25' mic cable, shockmount, hard mount. Matched pairs available. \$399

GT 33 ★ **New for 2003** ★

Cardioid pattern; .75" 6-micron gold evaporated diaphragm; condenser element; 15 dB pad; low-frequency rolloff (75 Hz); FET; Class A. XLR. Ships with 25' mic cable, shockmount, hard mount. Optional supercardioid, omnidirectional capsules available. Matched pairs available. \$399

GT 67 ★ **New for 2003** ★

Side-Address Microphone. Omnidirectional, cardioid, supercardioid, figure 8 patterns; 1.1" 3-micron gold-evaporated diaphragm; condenser element; FET; Class A. Ships with 25' mic cable, shockmount, hard mount. Matched pairs available. \$999

Manley Laboratories

Langevin CR-2001

Cardioid pattern; FET; 10 dB pad; bass rolloff. Ships with shockmount, carrying case. \$800

Reference Cardioid

Large-Diaphragm Tube Microphone. Studio. Cardioid pattern; 1" 6-micron gold diaphragm; 10 dB pad; brass backplate. Frequency response: 10 Hz - 30 kHz. Sensitivity: 17 mV/Pa. Max SPL: 150 dB. XLR and 4-pin power supply. Ships with swivel, shockmount, leather capsule pouch, mic carrying case. \$3,000

Stereo Reference Gold

Multipattern Large-Diaphragm Tube Stereo Microphone. Studio. Continuously variable omnidirectional, cardioid, figure 8 patterns; stereo; dual rotatable capsules with 1" gold diaphragms; 10 dB pads; individual capsule pattern controls; gold plated brass body. Frequency response: 10 Hz - 30 kHz. Sensitivity: 17 mV/Pa. Max SPL: 150 dB. XLR and 4-pin power supply. \$8,000



Model 710 multi-zone amplifier

12 Channel, 3 Rack Spaces, 600 Watts Compact, efficient, and cost effective

- 12 channels, 50 watts each, all channels driven
- Low current draw, high efficiency, no fan
- Anti-clipping circuits, adjustable high pass filter
- Two-stage thermal protection
- Protection on each channel pair, automatic resets
- Signal sense turn on, 12v trigger
- Balanced euro block inputs with bussing
- Input gain control on rear of product
- Proven from the Russian Tea Room to the Beverly Hills Hotel

For more info contact:

AudioControl Industrial

22410 70th Avenue West • Mountlake Terrace, WA 98043

Phone 425-775-8461 • Fax 425-778-3166 • www.AudioControlIndustrial.com

Also available without six
band eq per channel -
Model 510



MICROPHONES

Marshall Electronics Inc.

MXL 2001-P
Studio Condenser Microphone. Recording studio, project studio. Cardioid pattern; condenser element; 1" gold sputtered 6-micron diaphragm; 48V phantom power. Frequency response: 30 Hz - 20 kHz. Sensitivity: 15 mV/Pa. S/N: 80 dB. Max SPL: 130 dB. \$200

MXL 2003
Studio Condenser Microphone. Recording studio. Cardioid pattern; 1.06" 3-micron diaphragm; 10 dB pad; bass rolloff (150 Hz); 48V phantom power; ships with shockmount. Frequency response: 20 Hz - 23 kHz. Sensitivity: 16 mV/Pa. S/N: 77 dB. Max SPL: 140 dB. \$400

MXL V67G Gold Edition
Cardioid pattern; 1" gold-sputtered 6mm diaphragm; condenser element; double screen grille; FET circuitry. Frequency response: 30 Hz - 20 kHz. Max SPL: 130 dB. Sensitivity: 15 mV/Pa. Ships with mic stand adapter. \$279

MXL V69 Mogami Edition
Cardioid pattern; Mogami wiring. Frequency response: 20 Hz - 20 kHz. Max SPL: 140 dB. XLR, Mogami seven-pin. \$399

MXL V77
Tube Condenser Microphone. Cardioid pattern; 1" diaphragm; condenser element. Max SPL: 122 dB. Ships with shockmount. \$699

MBHO Microphones US/MTC

MBHO/MBNM-608
Lollipop-Style Microphone. Omni, cardioid, figure 8 patterns; double gold-sputtered large diaphragms. Frequency response: 5 Hz - 20 kHz (omni); 10 Hz - 20 kHz (cardioid); 40 Hz - 18 kHz (figure 8). XLR. \$1,355

MBHO/MBNM-621
Plate-Mounted Microphone. Omnidirectional; electret condenser element. Frequency response: 10 Hz - 26 kHz. Sensitivity: 5 mV/Pa. XLR. \$322

MBHO/MBNM-622
Jeklin Disc-Mounted Stereo Mic System. Recording studio. Twin mics; Jeklin Disc; stereo system; omnidirectional pattern; battery operable. Frequency response: 10 Hz - 26 kHz. Sensitivity: 5 mV/Pa. XLR. \$572

MBNM 440 CLS
Cardioid pattern; condenser element; 10 dB pad; high-pass filter. Matched pairs available. \$439

Microtech Gefell/C-Tec

M 940
Studio Condenser Microphone. Studio, broadcast. Supercardioid pattern; condenser element; large gold Mylar diaphragm; internal shockmount; ships with wooden case and stand adapter. Frequency response: 40 Hz - 18 kHz. Max SPL: 141 dB. Sensitivity: 23 mV/Pa. XLR. \$795

UM 900 The Phantom
Microphone. Recording studio, broadcast, film. Omnidirectional, cardioid, wide cardioid, hypercardioid,

figure 8 patterns; tube condenser; bass rolloff switch (70 Hz); built-in isolation mount. XLR. \$2,995

UM 92.1S
Tube Microphone. Studio, broadcast. Omni, cardioid, figure 8 patterns; tube condenser; twin gold sputtered plastic diaphragms; pattern select switch on power supply; EF 86 tube. Frequency response: 40 Hz - 18 kHz. Dynamic range: 103 dB. Maximum SPL: 120 dB. Impedance: 200 ohms. Sensitivity: 15 mV/Pa. XLR, seven pin Tuchel. M-7 capsule. \$2,200

Nady Systems Inc.

SCM 1000
Microphone. Studio. Cardioid, omnidirectional, figure 8 patterns; gold-sputtered diaphragm; 10 dB pad; low-cut filter; condenser element; internal shockmount. \$179

SPC-10
1" diaphragm; condenser element; low-cut filter. Dynamic range: 112 dB. Max SPL: 140 dB. Sensitivity: 8 mV/Pa. \$129

TCM 1050
Studio Vacuum Tube Condenser Microphone. Variable pattern; 1" gold-sputtered Mylar diaphragm; 6072/12AT7 tube. \$369

Neumann/USA

KK 105-S
Capsule. Live sound. Supercardioid pattern; K55 capsule; triple acoustic noise filter. For use with Sennheiser SKM 5000 handheld transmitter. \$650

KM 184
Miniature Condenser Microphone. Studio, broadcast. Cardioid pattern; transformerless circuitry; phantom power. Frequency response: 20 Hz - 20 kHz. Self-noise: 16 dB(A). Dynamic range: 122 dB. Maximum SPL: 138 dB. XLR. Ships with clip, windscreen, wooden box. Optional stereo set. \$729

KMR 82 i
Shotgun Microphone. Field, film, broadcast. Supercardioid pattern; interference/pressure gradient element; shotgun-style; HF boost; high-pass filter (120 Hz). Frequency response: 20 Hz - 20 kHz. Max SPL: 128 dB. XLR. 16" long. \$1,775

KMS 105
Live Performance/Vocalist Microphone. Live sound, broadcast. Supercardioid pattern; K55 capsule; condenser element; triple acoustic noise filter. Frequency response: 20 Hz - 20 kHz. Sensitivity: 4.5 mV/Pa. Max SPL: 150 dB. Dynamic range: 132 dB. Nickel, matte black finish. \$595

M 147 Tube
Condenser Studio Microphone. Studio, broadcast. Cardioid pattern; K 47/49 dual diaphragm capsule; transformerless. Frequency response: 20 Hz - 20 kHz. Dynamic range: 122 dB. Sensitivity: 20 mV/Pa. Impedance: 50 ohms. Ships with aluminum carrying case, swivel mount, power supply and cable. \$1,995

M 149 Tube
Dual Diaphragm Tube

Microphone. Studio. Nine switchable polar patterns; transformerless circuitry; pressure gradient transducer; seven-position low-frequency rolloff switch. Frequency response: 20 Hz - 20 kHz. Dynamic range: 101 dB. 8 pin DIN, XLR. Classic microphone. \$4,250

TLM 103
Large Diaphragm Condenser Microphone. Studio, broadcast. Cardioid pattern; single diaphragm capsule; transformerless. Frequency response: 20 Hz - 20 kHz. Self-noise: 7 dB(A). Dynamic range: 131 dB. Maximum SPL: 138 dB. XLR. New K 103 capsule. Ships with swivel mount, wooden box. \$995

TLM 170 R
Condenser Microphone. Studio, broadcast, film, video. Omni, cardioid, wide cardioid, hypercardioid, figure 8 patterns; transformerless; remote control; double membrane capsule; switchable low-frequency rolloff; 10 dB pad; ships with bracket mount. Frequency response: 20 Hz - 20 kHz. Dynamic range: 130 dB. Maximum SPL: 144 dB. XLR. Optional N 48 R-2 power supply. \$2,695

TLM 50 S
Studio Microphone. Omnidirectional pattern; nickel diaphragm; 10 dB pad; high-pass filter (100 Hz). Frequency response: 20 Hz - 20 kHz. Max SPL: 146 dB. XLR. \$5,300

U 87 AI
Dual Diaphragm Condenser Microphone. Studio, broadcast, film, video. Omni, cardioid, figure 8 patterns; switchable low-frequency rolloff; 10 dB pad. Frequency response: 20 Hz - 20 kHz. Dynamic range: 105 dB. XLR. Classic microphone. Recommended for vocal, orchestra. \$2,695

U 89 i
Large Diaphragm Microphone. Omnidirectional, cardioid, figure eight, hypercardioid, wide cardioid patterns; dual diaphragm design; front address; 10 dB pad; switchable low-frequency rolloff (80 Hz or 160 Hz). Frequency response: 20 Hz - 20 kHz. Max SPL: 134 dB. Sensitivity: 8 mV/Pa. \$2,825

Pearl Microphone Labs/Independent Audio

CO 22
Studio, location. Omnidirectional pattern; condenser element. Frequency response: 40 Hz - 25 kHz. Max SPL: 126 dB. Sensitivity: 16 mV/Pa. XLR. \$1,700

DS 60
Stereo Condenser Microphone. Recording studio, field, broadcast, film. Multipattern; twin membranes mounted 90 degrees apart; M/S, X/Y, Blumlein capable. Frequency response: 18 Hz - 25 kHz. Sensitivity: 16 mV/Pa. Max SPL: 126 dB. 9 pin Lemo, XLR. \$4,450

MM50
Compact Cardioid Microphone. Installation. Cardioid pattern; compact body. Frequency response: 90 Hz - 12 kHz. XLR. \$175

MSH 20
Shotgun Microphone. Field, broadcast, film, video. Stereo; short shotgun; modified M/S output. \$1,675

TL 44
Studio Condenser Microphone. Recording studio. Cardioid main pattern; omnidirectional, figure 8 patterns obtainable through panning the outputs of the dual membranes; condenser element; mono/stereo. Frequency response: 20 Hz - 20 kHz. Sensitivity: 16 mV/Pa. Max SPL: 126 dB. Five pin XLR. \$1,950

TL 6K/TL 6C
Studio Condenser Microphone. Recording studio, broadcast. Transformerless; TL6K - omnidirectional pattern; TL 6C - cardioid pattern. Sensitivity: 80 mV/Pa. Max SPL: 132 dB. XLR. \$500

TLC 90
Live Sound Condenser Microphone. Live sound, broadcast. Cardioid pattern; internal shockmount; power LED. Sensitivity: 8 mV/Pa. Max SPL: 144 dB. \$475

WCM 90/AMP
Wind Instrument Microphone. Recording studio. Cardioid pattern; included amplifier. Sensitivity: 12 mV/Pa. Max SPL: 144 dB. Ships with mic clamp. \$482

Rode Microphones

Classic II
Studio. Variable polar patterns (hypercardioid - figure 8); 1" gold-sputtered diaphragm; high-pass filter; 10, 20 dB pads; ground reverse; internal shockmounts on tube and diaphragm; Jensen transformers; 6072 twin triode preamp; power supply. Frequency response: 20 Hz - 20 kHz. Max SPL: 131 dB. Sensitivity: 13 mV/Pa. XLR. \$1,999

NT1-A
Cardioid pattern; condenser element; 1" gold-sputtered Mylar diaphragm; transformerless; internal shockmount; internal windscreen. Frequency response: 20 Hz - 20 kHz. Max SPL: 137 dB. \$349

NT4
XY Condenser Microphone. Studio, field. Fixed XY pattern; .5" capsules; condenser elements; power switch; phantom or battery power. Frequency response: 20 Hz - 20 kHz. Dynamic range: 128 dB. Max SPL: 143 dB. XLR, 1/8". \$849

NTK
Tube Microphone. Cardioid pattern; 1" gold-plated diaphragm; Class A; internal shockmount. Max SPL: 158 dB. \$999

Royer Labs

R-121
Ribbon-Velocity Microphone. Studio, broadcast. Figure 8 pattern; 2.5 micron aluminum ribbon; neodymium magnet; stainless steel damper; nickel finish. Frequency response: 30 Hz - 15 kHz. Max SPL: >135 dB. Sensitivity: 53 dB. XLR. Ships with wood mic case, mic clip. \$995

R-121A
Active Ribbon Microphone. Symmetrical figure 8 pattern; 2.5-micron aluminum ribbon; neodymium magnet; ships with wood case, mic sock. Frequency response: 30 Hz - 15 kHz. XLR. Optional shockmount, windscreen. \$1,495

SF-12
Stereo Coincident Ribbon-Velocity Microphone. Studio. Symmetrical figure 8 pattern; stereo; dual 1.8 micron aluminum ribbons; offset 45 degrees; XLR Y cable for dual outputs. Frequency response: 30 Hz - 15 kHz. Max SPL: 130

dB. XLR. Ships with wood mic case, 18' cable, mic clip. \$2,150

Samson Technologies Corp.

Q1 Condenser Microphone
Cardioid pattern; condenser element; internal shockmount. Frequency response: 50 Hz - 20 kHz. Max SPL: 142 dB. XLR. \$399

Q7
Live sound, studio. Dynamic element. Frequency response: 20 Hz - 18.5 kHz. XLR. \$199

R11 Hypercardioid Dynamic Microphone
Hypercardioid pattern; dynamic element; neodymium magnet; zinc body; steel mesh grille; on/off switch. Frequency response: 60 Hz - 18 kHz. Max SPL: 130 dB. XLR. \$199

S12
Microphone. Sound reinforcement. Hypercardioid pattern; neodymium magnet; Omic shockmount; heavy-gauge mesh; silicone anti-dent ring; carrying case and clip. Frequency response: 60 Hz - 18 kHz. XLR. \$149

Sanken Microphones

CMS-10
Camera-Mounted Shotgun Microphone. Shotgun; camera mount; stereo; M/S; polyethylene sulfide diaphragms. Ships with suspension holder, windscreen, replacement rubber ring, cable. \$2,195

CS3
Short Shotgun Microphone. Supercardioid pattern; three capsules. \$1,350

Schoeps/Redding Audio

CCM2HLg
Compact Microphone. Omnidirectional pattern; condenser; high-frequency emphasis. Ships with 16' cable. \$1,145

CCM41SLg
Compact Microphone. Supercardioid pattern; condenser; LF rolloff. \$1,205

CCM5Lg
Multipattern Compact Microphone. Cardioid, omnidirectional patterns; condenser. Ships with 16' cable. \$1,380



Microphonic solutions for Big Band, Orchestral and Acoustic solo instruments for live and studio applications.

— Unique custom microphones and mounting systems for Brass, Woodwinds and Strings. Endorsed by players of all musical styles: Classical, Jazz, Rock and Pop. Call for a free brochure and specifications. Experience SD Systems microphones, delivering the pure, natural, clean sound of your chosen instrument.

Advanced Sonic Concepts, Inc. is the pre-authorized distributor of SD Systems Instrument Microphones in the US and Canada.

ADVANCED SONIC CONCEPTS, INC.
PO Box 237 Chatsworth, NJ 08019 • Ph: (609) 726-9202 • Fax: (609) 751-3681

MICROPHONES

CCM8Lg
Compact Microphone. Figure eight pattern; condenser. Ships with 16" cable. \$1,305

KFM6
Sphere Microphone. Twin omnidirectional mics set in 8" diameter globe; onboard 12 - 48V preamp; ball socket mount. \$4,655

MSTC64
ORTF Microphone. Twin MK4 cardioid capsules on T-shaped preamplifier body; 12 - 48V. \$2,000

SE Electronics

SE5000
Cardioid pattern; condenser element; 1" gold-evaporated diaphragm; 12A77 tube. Frequency response: 20 Hz - 18 kHz. THD: <0.5% at 120 dB. Ships with power supply, SHM6 elastic suspension mount, cable, case.

Sennheiser Electronics Corp.

E604
Instrument Microphone. Studio, live sound. Cardioid pattern; glass fiber body; high SPL; for drums. Evolution Series. Frequency response: 40 Hz - 18 kHz. Sensitivity: 1.8 mV/Pa. XLR. Ships with velour pouch, mic clip. \$249

E608
Instrument Microphone. Studio, live sound. Supercardioid pattern; humbucking coil; glass fiber case; clip on gooseneck; for winds and horns. Evolution Series. Frequency response: 40 Hz - 16 kHz. Ships with velour pouch, mic clip. \$299

E825-S
Microphone. Studio, live sound. Cardioid pattern; dynamic element; optional on/off switch; zinc casing. Evolution Series. Frequency response: 80 Hz - 15 kHz. Sensitivity: 1.5 mV/Pa. XLR. Ships with velour pouch, mic clip. \$129

Evolution 609 Silver
Instrument Microphone. Studio, live sound. Supercardioid pattern; humbucking coil; for guitar cabinets, toms. Evolution Series. Frequency response: 40 Hz - 18 kHz. Sensitivity: 1.5 mV/Pa. XLR. Ships with velour pouch, mic clip. \$199

MD42 II
Dynamic Microphone. Studio, broadcast, sound reinforcement. Cardioid pattern; large diaphragm with aluminum/copper coil; glass composite body; on/off switch; neodymium magnet; humbucking coil; five-position low-frequency rolloff switch. Frequency response: 30 Hz - 17 kHz. XLR. \$485

MD441
Microphone. Broadcast, studio, live sound. Supercardioid pattern. Frequency response: 30 Hz - 20 kHz. Classic microphone. \$895

ME 104
Lavalier Microphone. Broadcast, live sound, film. Cardioid pattern. Frequency response: 100 Hz - 20 kHz. \$275

MKE2-4 Gold
Miniature Lavalier Microphone. Broadcast, live sound, film. Omnidirectional pattern; subminiature size; swivel clamp. \$425

MKH 40
Microphone. Studio, live sound, broadcast, film. Cardioid pattern; pressure gradient; rolloff; pad; MKH series. Frequency response: 40 Hz - 20 kHz. Sensitivity: 25 mV/Pa. XLR. \$1,350

MKH 416/RF Condenser
Shotgun Microphone. Broadcast, film. Hypercardioid pattern; short shotgun style; MKH series. Frequency response: 40 Hz - 20 kHz. Sensitivity:

25 mV/Pa. XLR. \$1,275

MKH 80
Microphone. Studio, broadcast, film. Omnidirectional, modified cardioid, cardioid, supercardioid, figure 8 patterns; pressure gradient; rolloff; switchable treble emphasis; MKH series. Frequency response: 10 Hz - 20 kHz. \$2,950

MKH 800-P48
Multipattern Condenser Microphone. Studio. Omni, figure 8, cardioid, wide cardioid, supercardioid patterns; condenser element; 8, 12 dB pads; low-cut filter (50 Hz); presence boost (10 kHz); MKH series. Frequency response: 30 Hz - 50 kHz. Sensitivity: 40 mV/Pa. Max SPL: 142 dB. \$2,950

Shaker Microphone

Madcat
Harmonica Microphone. Hand-shaped body design; volume control; resin body. \$149.95

Shure Inc.

14A
Microphone. Live sound. Cardioid pattern; dynamic element; neodymium magnet; internal shockmount; internal windscreen; on/off switch; metal mesh grille. Frequency response: 80 Hz - 14 kHz. \$55

545SD-LC Unidyne III
Microphone. Installation, live sound. Cardioid pattern; condenser element; dual impedance switch; on/off switch. Frequency response: 5 Hz - 15 kHz. \$162

55SH Series II
Microphone. Live sound, recording studio, broadcast. Cardioid pattern; dynamic element; retro shell; on/off switch. Frequency response: 50 Hz - 15 kHz. \$284

Beta 58A
Dynamic Microphone. Studio, live sound. Supercardioid pattern; pneumatic shockmount. Frequency response: 50 Hz - 16 kHz. For vocals. \$300

Beta 87A
Condenser Microphone. Recording studio, live sound, broadcast. Supercardioid pattern; three-stage pop filter. Frequency response: 50 Hz - 18 kHz. \$463

Beta 98D/S Drum Microphone
Live sound, sound reinforcement. Supercardioid pattern; condenser element. Frequency response: 40 Hz - 20 kHz. Max SPL: 144 dB. \$458

Beta 98HC
Clip-on Instrument Microphone. Supercardioid pattern; internal shockmount; attached preamplifier; integrated mic clip; gooseneck. Frequency response: 20 Hz - 20 kHz. \$397

KSM137/SL ★ New for 2003 ★
Studio, live sound. Cardioid pattern; condenser element; 15/25 dB pad; variable low-frequency filter; ships with Popper Stopper foam windscreen, mic clip, carrying case. Frequency response: 20 Hz - 20 kHz. XLR. \$575

KSM141/SL ★ New for 2003 ★
Studio, live sound. Omnidirectional, cardioid patterns; condenser element; 15/25 dB pad; variable low-frequency filter; ships with Popper Stopper foam windscreen, mic clip, carrying case. Frequency response: 20 Hz - 20 kHz. XLR. \$770

KSM32 Studio Condenser Microphone
Recording studio. Cardioid pattern; side address; condenser element; onboard Class A preamp; gold-layered 2.5 microneter Mylar diaphragm; 15 dB pad; internal shockmount; switchable low-frequency filter. Frequency

response: 20 Hz - 20 kHz. Dynamic range: 126 dB. S/N: 81 dB. XLR. KSM32/SL is champagne-colored and ships with ShureLock elastic suspension shockmount. \$997

KSM44/SL
Studio Microphone. Studio. Omnidirectional, cardioid, figure 8 patterns; 1" gold-layered Mylar diaphragms; dual capsules; 15 dB pad; condenser element; three-position filter; three-stage pop filter; Class A preamp; internal shockmount; steel grille. Frequency response: 20 Hz - 20 kHz. Ships with aluminum carrying case, ShureLock suspension shockmount, swivel mount, carrying pouch. \$1,394

Microflex MX202B, MX202P, MX202W, MX202WP
Miniature Condenser Overhead Microphones. Live sound, installation. Interchangeable condenser patterns - cardioid, supercardioid, omnidirectional; 4" gooseneck mount; cable; phantom powered; in-line or plate amplifier choice. Frequency response: 50 Hz - 17 kHz. \$277

SM57
Microphone. Live sound, recording studio. Cardioid pattern. Frequency response: 40 Hz - 15 kHz. For drum, percussion and instrument amplifiers. \$146

SM58
Microphone. Live sound. Cardioid pattern. Frequency response: 50 Hz - 15 kHz. \$188

SM63
Dynamic Microphone. Broadcast. Omnidirectional pattern; dynamic element; internal mechanical isolation; Veraflex grille. Frequency response: 80 Hz - 20 kHz. \$198 - \$225

SM81
Condenser Microphone. Studio, live sound. Cardioid pattern; condenser element; 10 dB pad; switchable low-frequency rolloff (6/18 dB); phantom power only. Frequency response: 20 Hz - 20 kHz. Ships with windscreen. \$562

SM87A
Condenser Microphone. Live sound. Supercardioid pattern; condenser element; three-stage pop filter. Frequency response: 50 Hz - 18 kHz. \$372

SM89
Shotgun Microphone. Broadcast, film, field. Shotgun style directional microphone; condenser element; low-frequency rolloff. Frequency response: 60 Hz - 20 kHz. \$1,180

VP88
Stereo Microphone. Studio; broadcast. Stereo pattern; M/S condenser; adjustable stereo spread; low-frequency rolloff; mono mode; phantom or battery power. Frequency response: 40 Hz - 20 kHz. Ships with windscreen, swivel adapter, Y cable. \$1,266

Sony Electronics

C-48
Studio Large Diaphragm Condenser Microphone. Studio. Cardioid, omnidirectional patterns; phantom and battery power; 10 dB pad. Frequency response: 30 Hz - 16 kHz. Dynamic range: 106+ dB. Impedance: 150 ohms. Maximum SPL: 128 dB. Ships with carrying case, stand adapter. \$1,625

C-74/76
Shotgun Condenser Microphones. Broadcast, video, film. Supercardioid pattern; two-way powering; RF condenser design; shotgun style mic. Frequency response: 40 Hz - 16 kHz. Max SPL: 126 dB. XLR. C-74: \$1,245. C-76: \$1,445.

C-800G/PAC
Vacuum Tube Studio Microphone.

Studio, film, post production. Cardioid, omnidirectional patterns; large diaphragm; Peltier device for tube temperature control. Frequency response: 20 Hz - 18 kHz. Dynamic range: 113+ dB. Impedance: 200 ohms. Maximum SPL: 131 dB. \$7,350

ECM-44B
Omnidirectional Lavalier Microphone. Video, sound reinforcement. Omnidirectional pattern; electret condenser capsule; battery powered; black finish. Frequency response: 40 Hz - 15 kHz. XLR. \$250

ECM-66B
Lavalier Microphone. Studio, sound reinforcement. Unidirectional pattern; electret condenser capsule; two-way powering; black finish. Frequency response: 70 Hz - 14 kHz. Max SPL: 130 dB. XLR. \$440

ECM-88 ★ New for 2003 ★
Lavalier Microphone. Live sound, studio. Omnidirectional pattern; electret condenser element; dual diaphragm; 8' cable; water resistant. Frequency response: 20 Hz - 20 kHz. Dynamic range: 99 dB. SPL: 125 dB. \$440

ECM-M55
Stereo Microphone. Broadcast, sound reinforcement, recording studio. Mid-Side stereo microphone; six-position stereo angle selector; electret condenser capsule; two-way powering. Frequency response: 70 Hz - 20 kHz. Max SPL 130 dB. 5-pin XLR. \$1,575

F-780/9X
Dynamic Microphone. Studio, live sound. Cardioid pattern; dynamic element; copper clad aluminum voice coil; Alnico magnet. Frequency response: 50 Hz - 18 kHz. Impedance: 400 ohms. Ships with stand adapter. \$390

Soundelux

E47
Studio. Variable pattern; modeled on Neumann U 47 microphone. Frequency response: 20 Hz - 20 kHz. Sensitivity: 16.5 mV/Pa. Max SPL: 134 dB. Ships with power supply, spider-mount, mic clip, wood box. \$3,500

ELUX 251
Tube Microphone. Studio. Cardioid, omnidirectional, figure 8 patterns; copy of Telefunken ELAM 251. Ships with power supply, shockmount, aluminum flight case. \$4,999

ifet 7
Studio. Cardioid pattern; low-cut filter; pad; "vocal" mode; "instrument" mode; dual electronics modeled on U 47 fet and U 87 electronics. Frequency response: 20 Hz - 16 kHz. \$2,100

U99
Multipattern Tube Condenser Microphone Studio. Sweepable omnidirectional-figure 8 patterns; tube condenser; dual membrane capsule; gold/aluminum sputter; internal shockmount; EF86 tube; Teflon/silver wiring. Frequency response: 20 Hz - 20 kHz. Max SPL: 130 dB. Dynamic range: 120 dB. Sensitivity: 20 mV/Pa. \$2,500

SoundField Research/TransAmerica Audio Group Inc.

Mark 5 Microphone System
Four Capsule/Single Point Microphone System. Recording studio, broadcast, post production, film, video. Four capsule array; variable polar patterns - omni through figure 8; controllable X/Y, M/S output; zoom, mic orientation controls; multichannel output. Frequency response: 20 Hz - 20 kHz. Max SPL: 145 dB. \$8,000

Soundman/Independent Audio

OKM II Studio Classic
Stereo Headset/Binaural Microphones. Omnidirectional pattern;

condenser elements; binaural; adaptor with pad, rolloff filter, battery check. Frequency response: 20 Hz - 20 kHz. Mini. \$130 - \$325

Special Projects

SP-12 Handheld Vocal Microphone
Studio, live sound. Hypercardioid pattern; windscreen; steel mesh grille. Frequency response: 60 Hz - 18 kHz. Max SPL: >130 dB. \$99

SP-H20 Waterproof Headworn Microphone
Live sound, field. Bidirectional noise canceling; electret condenser element; detachable cable; water resistant. Frequency response: 200 Hz - 6 kHz. Max SPL: 120 dB. Sensitivity: 8 mV/Pa. \$279

SPL US

Nugget 2275
Cardioid pattern; condenser element; 1" diaphragm; internal baffle; 10 dB pad; high-pass filter (50 Hz); transformerless; ships with shockmount, thread adapter. Frequency response: 20 Hz - 20 kHz. S/N: 78 dB. Max SPL: 145 dB. XLR. \$428

Studio Projects/PMI

B3
Omnidirectional, cardioid, figure eight patterns; twin 1" 3 micron Mylar diaphragms; 10 dB pad; high-pass filter. \$199

C1
Microphone. Studio, live sound, broadcast. Cardioid pattern; condenser element; 1" Mylar diaphragm. \$299

C3
Microphone. Studio, live sound, broadcast. Omnidirectional, cardioid, figure 8 patterns; 1" dual gold-sputtered Mylar diaphragm; high-pass filter; 10 dB pad. \$499

LSD-2 ★ New for 2003 ★
Stereo Microphone. Dual 1" diaphragm capsules; rotatable upper capsule; X-Y, M/S, Blumlein. \$999

TB1
Tube Microphone. Cardioid pattern; 1" 3 micron Mylar diaphragm; 6072 tube. Ships with power supply, cable, road case. \$399

T.H.E. (Taylor Hohendahl Engineering)

Professional Series
Modular Microphone System. KA-04 preamp body; KR-1D 1/2" omni diffuse field capsule (\$348); KR1F 1/2" omni free field capsule (\$348); KR-2W 1/2" subcardioid capsule (\$348); KR-2C 1/2" cardioid capsule (\$348); KR-3H 1/2" hypercardioid capsule (\$348); KR-6M omni measurement capsule (\$349); KR-25A 1" lollipop cardioid capsule (\$568); KR-33A 33mm lollipop cardioid capsule; TT-3M titanium omni measurement capsule (\$1,350); BS-3D binaural recording sphere (\$2,648). Capsules require KA-04 preamp body (\$398).

Telefunken USA

Ela-M251 ★ New for 2003 ★
Omnidirectional, cardioid, figure 8 patterns; CK-12 capsule; copy of original AKG-built Telefunken 251 mic. \$10,125

Whirlwind

Micpower
Portable Phantom Power Supply. Works with most electret condenser mics; supplies +12 to 18 V DC; AC coupled output; LED battery power indicator. Powered by two 9 V batteries. \$119

GEAR GUIDE

PREAMPLIFIERS

A Designs

MP-2

Two-channel; phase reverse; phantom power; level controls; EF86 tube; VU meters. XLR 1/4". 2RU. \$1,499

Aardvark Computer Systems

Direct Pro LX6

Preamp/Processor. Onboard DSP effects; headphone controls. 1/4". \$349

AETA Audio Corp.

PSP 3

Preamp/Processor. Field, broadcast. Two-channel; M/S matrix; 48V/12V phantom power; phase reverse; low cut filters (80 Hz, 120 Hz); gain, balance, M/S, headphones controls; battery operable. Frequency response: 20 Hz - 20 kHz. THD: 0.1%. \$800

Agular Amplification

DB 659

Tube Preamp. Jensen transformer. \$975

Amek USA

Channel In A Box

Rackmountable Channel Strip Studio. Mic/line input; low, high-pass filters; compressor; four-band parametric EQ; 48V phantom power; phase reverse; gain, trim controls on mic preamp; input control, phase reverse on line input; low, high-pass filter controls; threshold, ratio, attack, release, gain controls on compressor; master output controls. 1RU. \$3,250

Apex Systems Ltd.

Model 1100

Two-Channel Tube-Based Preamp

and A/D Converter. Studio. Two-channel; 24-bit A/D; 44.1, 48, 96 kHz sample rates; triode tube circuit; 48V phantom power; 20 dB pad; polarity reverse; mic mute; MicLim limiter; switchable low-cut filters (30, 36, 44, 53, 63, 77, 92, 111, 134, 162, 195 kHz); gain control; word clock; +/-10 dB operation; tricolor LED meters. XLR, 1/4". 1RU. \$2,495

Model 1788

Eight-Channel Remote Controlled Microphone Preamp/Processor. Broadcast, live sound, studio. Eight-channel; remote or local control operation; 48V phantom power; 20 dB pad; polarity reverse; low-cut filter (75 Hz); onboard limiter; tricolor LED meter, gain display, status LEDs per channel; 32, 44.1, 48 kHz sample rate; switchable sync clock; headphone monitor; MIDI control; RS232, RS422 ports. \$4,995

Model 207

Mic/Instrument Preamp/Processor. Two-channel; gain controls; output trim; 48V phantom power; 20 dB pad; low-cut filter; phase reverse; MicLim limiter per channel; Reflected Plate Amplifier tube circuitry; 1/4" front panel input; +/-10 dB operation; LED meters. 1/4", XLR. 1RU. \$649

API Audio Products Inc.

7600

Rackmountable Input Channel Strip. Recording studio, broadcast. Includes 212L mic preamp, 225L comp/lim, 550A three-band EQ; gain control; 48 V phantom power; 20 dB pad; LED meter for mic pre; threshold, ratio, release controls; switchable fast attack mode; LED meter for comp/lim; master channel pan; four send controls; master

output control; master bus assignment. 1RU. \$2,995

Applied Research & Technology

D/O Preamp System

Tube Preamp/Digital Audio Converter. Two-channel; Variable Valve Voicing; 12AX7A tube; gain, output controls; Output Protection Limiter, up to 96 kHz A/D; analog meters. XLR, 1/4". \$399

Pro MPA Model 210

Tube Microphone Preamp/Processor. Studio, live sound, broadcast. Two-channel; input/output level controls; switchable variable high-pass filter (15, 65, 150 Hz); 20 dB pad; 48 V phantom power; phase reverse; 10-segment tube character meter; 12AX7 tube; VU meters. Frequency response: 20 Hz - 40 kHz. Dynamic range: >100 dB. THD: <0.1%. XLR, 1/4". 2RU. \$679

Tube MP OPL

Preamp/Processor. 12AX7A tube; phantom power; phase reverse; Output Protection Limiter; analog meters. \$114

Tube MP Studio V3

Preamp/Processor. Single-channel; input, output level controls; 48V phantom power; phase reverse; 20 dB pad; Variable Valve Voicing technology; Output Protection Limiter; VU Meter. \$149

Tube PAC Model 131

Tube-Based Preamp/Compressor. Studio, live sound. Single-channel preamp/compressor; input, output level controls; phantom power; phase reverse; compression and limiting ratio controls; bypass; two 12AX7a tubes. Frequency response: 20 Hz - 20 kHz. Dynamic range: >90 dB. XLR, 1/4".

5.25" x 8.5" x 1.75". Doubles as a direct box. \$295

ATI Audio Technologies Inc.

ML200

Dual Microphone to Line Amplifier Studio, broadcast. Two-channel; gain controls; 20V phantom power; peak LED. Frequency response: 20 Hz - 20 kHz. THD: 0.05%. XLR. 1/3 RU. Optional rackmount adaptors. Optional 48V phantom power. Power supply ordered separately. \$299

MMA400-1/MMA400-2

Multichannel Microphone Preamps. Four-channel; gain trim pots. THD: 0.005%. Barner strip with fan strips. 1RU. Transformer isolated, MMA400-1: \$597. Active balanced, MMA400-2: \$479.

P100S

Turntable Preamp. RIAA curve; subsonic warp filter. RCA, barrier block. \$359

Audio Engineering Associates

MS38 Mark II

Stereo Microphone Processor. Studio, post production. field. MS stereo matrix decoder; adjustable stereo width; switchable insert loop; bypass. XLR, 1/4". 8.5" x 1.75" x 7". \$585

Audio Toys Inc.

BMX2 Mic Preamp/Mixer

Preamp/Mixer. Studio, live sound, broadcast. Eight-channel. 48V phantom power, pan control, phase, cue select, mic gain, limiter threshold control, channel level control, mix assign per channel; LED meter; headphone jack. Frequency response: 10 Hz - 50

kHz. THD: 0.008%. EIN: -132 dBm. XLR, 1/4", 25-pin D-sub. 1RU. Interface cables with analog and digital recorders, consoles, processors and DAWs available. \$2,795

Audio-Technica U.S. Inc.

AT8681 UniMix

Mic Combiner. Two inputs, one output; balance control; 24 - 48 V phantom power; UniTools series. \$70

Avalon Design

AD2022

Preamp/Processor. Box. Studio. Two-channel/dual mono; Class A operation; 48V phantom power, 20 dB pad, filter, polarity switches, input, output, mic impedance, high-pass filter controls per channel; front panel Hi-Z inputs; VU meters. Frequency response: 1 Hz - 120 kHz. THD: 0.05%. EIN: -126 dBu. XLR, 1/4". 2RU. \$3,000

VT-737SP

Tube Signal Path/Processor. Studio, post production. Single-channel; microphone preamp/EQ/optical compressor; preamp gain, compression ratio, threshold, attack, release controls; variable high-pass filter control; four-band EQ with bass, low mid, high mid, treble, output controls; variable EQ band frequency controls; bass, low mid, high mid, treble controls; 48 V phantom power; phase; stereo link; Class A operation; 1/4" front panel DI; stereo chain; status lights; VU meter. Frequency response: 10 Hz - 120 kHz. XLR, 1/4". 2RU. \$2,295

BBE Sound Inc.

DI-100 ★ New for 2003 ★

Studio, project studio, live sound.



Maximize Your Mix™

plug-in the

Sonic Maximizer™



"The BBE plug-in offers the same no-fuss openness and detail of the hardware units, earning it a place on my must-have list of audio plug-ins."

Loren Alldrin, PRO AUDIO REVIEW



Pro Audio Review Magazine 2002 "Reviewer's Pick Award"



Get it in stores now!

5381 Production Drive • Huntington Beach, CA 92649 • 714-897-6766 • www.bbessound.com

PREAMPLIFIERS

Direct box; single-channel Sonic Maximizer; contour, process controls; 15 dB pad; bypass. S/N: 100 dB. THD: 0.05%. XLR, 1/4". \$159

Behringer

Tube Ultragain T 1953

Tube Preamp/Studio. Two-channel; tube-based mic/line preamps; Ultra Tube Circuitry; mic trim; phantom power; phase reverse; DI box function; level controls; "Warmth" tube sound controls; high-pass filter; four VU meters. \$399

Bellari/Rolls Corp.

RP520 Studio Tube Mic Preamp

Recording studio, project studio. Two-channel; tube operation; gain, volume controls; phantom power; 30 dB pad; phase; VU meter. Frequency response: 20 Hz - 40 kHz. THD: 0.1%. S/N: >107 dB. 19" x 3.5" x 6". \$600

VP129 Tube Phono Preamp

Level controls; RIAA equalization; rumble filter; mute; headphone output; tube operation. \$120

Benchmark Media Systems Inc.

Mic Man Jr.

Portable Mic Preamp. Recording studio. Two-channel; gain controls; 12V phantom power; battery powered. \$435

MPS-400

Microphone Preamp/Studio. Broadcast, video, film. Four-channel; phantom power; 20 dB pad. THD: 0.0009%. Dynamic range: >120 dB. XLR, 1RU. \$1,395

MPS-420

Microphone Preamp/Studio. Broadcast. Four-channel; phantom power; 20 dB pad; headphone controls. THD: 0.0009%. Dynamic range: >120 dB. XLR, 1RU. \$1,595

Boss

DI-1

Direct Box. Live sound, recording studio. Phantom power; 20, 40 dB pad; phase; ground lift. Frequency response: 20 Hz - 40 kHz. THD: <0.05%. 1/4", XLR. \$150

Bryston

SP-1 ★ New for 2003 ★

Preamp/Studio/Surround Sound Processor. Six inputs (four digital inputs); Dolby Digital, Dolby Pro Logic, DTS, THX; bass redirection; "smart" subwoofer output. \$3,800

BSS Audio/Harman Pro

AR-133

Active DI Box/Line Balancer. Live sound, recording studio, project studio. Single-channel; 20 dB, 40 dB attenuation; ground lift; optional battery operation. XLR, 1/4". \$185

Carvin

D83

Direct Box. Three inputs. XLR, 1/4". \$25

FDR60

DI Box. Input control; ground lift. 1/4", XLR. \$24

Chandler Limited

1073EX

Single-channel; preamp/EQ; 48V phantom power; phase reverse; DI; output fader; based on Neve 1073. \$1,999

LTD-1

Single-channel; preamp/EQ; 48V phantom power; phase reverse; DI; output fader; hand wired; based on Neve 1073. \$2,799

CLM Dynamics/Wave Distribution

DB8000s

Eight-Channel Microphone Preamp/Studio. Eight-channel; 48V phantom power; 20 dB pad; M/S-compatible; SoftStop limiter; gain, limiter controls; high-pass filter; +4/-10 dB operation; LED meters. XLR, 1/4". 3RU. With digital output: \$2,249. \$1,999

Countryman Associates Inc.

Type 85

DI Box. Input switch; ground lift; Class A; battery operable. Frequency response: 20 Hz - 20 kHz. XLR, 1/4".

Crane Song Ltd.

Flamingo

Two-Channel Microphone Preamp/Studio. Two-channel; Class A discrete; phantom power; phase; gain, attenuation controls per channel; "Iron" and "Sound" effects switches; LED meter. Balanced I/O. 1RU. \$3,125

Spider

Eight-Channel Mic Preamp/Studio. Eight-channel; Class A; 15-24-bit dither; 44.1, 48, 88.2, 96 kHz sample rates; gain, pan, level controls; 48V phantom power, phase, low-cut filter; word clock; tape emulator. AES/EBU, TDIF, optical. \$7,500

Curtis Technology

Opred8 Microphone Preamp/Studio

Eight-channel; level control; 48V phantom power, 20 dB pad, phase, pan control, Class A; Lundahl input transformers; LED meter per channel. XLR. Two-channel version, Opred2: \$1,495. \$3,495

D.W. Fearn

VT-2 Dual Channel Vacuum Tube Microphone Preamp

Recording studio. Two-channel; Class A operation; triode tubes; polarity reverse; VU meter. XLR, 3RU. Single-channel version, VT-1: \$2,000. \$3,500

DACS Ltd./Independent Audio

MicAmp

Microphone Preamp/Studio. Two-channel; switchable bass rolloff (30, 80 Hz); gain control trim per channel; phase; phantom power. \$2,125

Daking

Mic-Pre EQ

Single-channel; 48V phantom power; phase reverse; pad; gain, output level controls; four-band EQ; low-pass, high-pass filters; polycarbonate front panel overlay. \$1,995

Dan Alexander Audio

Mic Preamp

Two-channel; 48V phantom power; phase reverse; 1/4" front panel amp and DI inputs; Class A. XLR, 1/4", 1RU. \$1,150

Davisound

TB-1 Inner Tube Tube Amp

Preamp/Studio. Two-channel; tube operation; Class A; transformerless; 48V phantom power; front panel 1/4" input; wooden case; 12AX7 tube. RCA, 1/4", screw terminals. \$950

dbx Professional Products

376 Tube Channel Strip

Preamp/EQ/Compressor/De-Esser/DA. Single-channel; tube mic preamp; three-band semi-parametric EQ; de-esser; compressor; onboard DA converter; Type IV conversion; 44.1, 48, 88.2, 96 kHz sample rates; 16, 20, 24-bit; 12AU7 tube; OverEasy compressor; threshold, ratio compressor controls; frequency, amount de-esser controls; 48V phantom power; 20 dB pad; phase reverse; low-cut filter

(75 Hz); preamp drive control; word clock; LED meters. AES/EBU, S/PDIF, 1/4", XLR, RCA, BNC. 1RU. \$600

576 Combination Mic Preamp/Compressor

Studio. Single-channel; tube operation; three-band parametric EQ; 48V phantom power; 20 dB pad; phase invert; low-cut filter; insert loop with send level control; compression threshold, ratio, attack, release, drive, level, limiter threshold controls per channel; OverEasy compression; PeakPlus limiter; True RMS Power Summing; phase reverse; drive controls, level, limiter threshold controls; bypass; switchable VU meters; 12AU7 tubes; +4/-10 operation. XLR, 1/4". 2RU. \$1,000

Demeter Tube Amplification

HXM-1

Stereo Tube Microphone Preamp/Studio recording. Two-channel; input, gain, volume controls; low-cut filter; 20 dB pad; phantom power; phase; switchable LED meter; all tube front end; Jensen transformers; hybrid design; output uses chip for balance; 12AX7A tubes; H Series. Frequency response: 20 Hz - 20 kHz. S/N: >120 dB EIN. XLR, 1/4". \$1,399

VTBP-201s Tube Bass Preamp

Live sound, studio. Passive and active inputs; three-band EQ; volume, presence controls; effects loop controls; 60/120 Hz boost/cut; treble (2 kHz) boost switch; 12AX7LPS tubes; Jensen transformers. Frequency response: 10 Hz - 40 kHz. S/N: >80 dB. THD: <0.1%. 1/4", 1RU. \$799

VTMP-2B

Stereo Tube Microphone Preamp/Studio. All tube; variable tube gain control; pad; phase; low-cut filter; Jensen input transformers; pin 2-3 hot switch. 1/4", XLR, TT. \$2,299

Desk Doctor

DI Active

24-Channel DI Unit. Recording studio. 24-channel. Frequency response: 15 Hz - 40 kHz. THD: 0.003%. 1/4", 25-pin D-sub, TDIF. 1RU.

Digidesign

PRE

Eight-Channel for Pro Tools HD. Eight-channel; 48V phantom power; phase reverse; 18 dB pad; high-pass filter; limiter; front panel DI; MIDI I/O thru; remote controllable via Pro Tools DAW or control surfaces. XLR, 1/4", five-pin DIN, 25-pin D-sub. \$2,495

Drawmer USA/TransAmerica Audio Group

1960 Vacuum Tube Preamp/Mic Preamp

Studio. Two-channel; 48V phantom power; two mic preamps; variable gain; 50 Hz/100 Hz high-pass filters; clip LED; soft knee compression with variable threshold, attack, release and output gain; side chain access, side chain listen; bypass; stereo linking; instrument tube preamp with variable gain, EQ, switchable low/high gain stage, brightness boost, EQ bypass. XLR, 1/4", 2RU. \$2,675

1969 Mercenary Edition

Tube Mic Preamp/Compressor. Studio. Two-channel; 48V phantom power; two mic preamps; variable gain; 50 Hz/100 Hz high-pass filters; clip LED; soft knee compression with variable threshold, attack, release and output gain; side chain access, side chain listen; bypass; stereo linking; +4 dB and -10 dB inserts; instrument tube preamp with variable gain, EQ, switchable low/high gain stage, brightness boost, EQ bypass; Burr-Brown op-amps. XLR, 1/4". 2RU. \$2,950

MX60 Front End One

Preamp/Compressor/Limiter/Equalize

r. Single-channel; mic preamp; hard, soft knee compressor; peak limiter; three-band EQ with sweepable mid; de-esser; front panel DI; LED. \$725

Tube Station 1

Preamp/Compressor/A-D Converter. Preamp/compressor; 24-bit A/D converter; 96 kHz; Class A; variable high-pass filter; soft knee tube compressor; Tube Drive; phantom power; insert; side chain 1RU. \$749

Earthworks Audio Products

1022

Two-channel; 48V phantom power; phase reverse; gain controls, variable output controls per channel; standby mute. Frequency response: 2 Hz - 100 kHz. Distortion: <0.0001%. XLR, 1/4". \$2,000

Esoteric Audio Research/Subsonic

Esoteric Audio Research 824MM

Studio. Dual mono; 48V, 130V phantom power; gain controls; tube operation. XLR, 2RU. \$5,345

Esoteric Sound

Professional Moving Magnet

Preamp/Studio. RIAA curve; separate power supply. Frequency response: 20 Hz - 20 kHz. THD: 0.05%. S/N: 85 dB. Sensitivity: 3.5 mV. RCA. 5.5" x 1.5" x 3". \$79

Focusrite Audio Engineering

ISA 220 Session Pack

Preamp/Multi-processor. Single-channel; preamp/EQ/compressor/limiter; four-band EQ; de-esser; three-band limiter; high, low-pass filters; side chain; bypasses; VU meter. XLR, 1/4". Optional 24-bit/96 kHz A/D board. \$525. \$2,295

ISA 430

Preamp/Studio. Post production. Single-channel; EQ; gate/expander; de-esser; frequency-adaptive limiter; bypass; Class A. 1RU. \$3,495

OctoPre

Eight-Channel Preamp/Processor. Eight-channel; compressor/brick wall limiter. Optional AES/EBU, S/PDIF, ADAT outputs. \$1,169

Platinum 6 TrakMaster

Preamp/Multi-processor. Single-channel; Class A preamp; phantom power; high-pass filter; three-band EQ; compressor; tube emulation; +4/-10 dB operation; LED meters. 1RU. \$450

Platinum VoiceMaster Pro

★ New for 2003 ★
Mic Preamp/Processor. Studio, post production, broadcast. Single-channel; noise reducing expander/vocal saturator/opto-compressor/EQ/opto de-esser; mic/line switch; 48 V phantom power; phase; variable high-pass filter gain control; threshold, depth controls for expander; drive, tuning controls for vocal saturator; treble, threshold, release, output controls for opto-compressor; warmth, tuning, presence, breath controls for voice-optimized EQ; threshold, cut frequency controls for opto de-esser; Frequency response: 10 Hz - 200 kHz. THD: 0.002%. XLR, 1/4", RCA, BNC. \$675

Red 7

Microphone Preamp/Studio. Post production, broadcast. Single-channel; compressor/de-esser/exciter; 48V phantom power; threshold, attack, release compressor controls; high-pass filter; VU meter. Frequency response: 10 Hz - 140 kHz. XLR, 2RU. Optimized for vocals. \$2,395

GML LLC

Model 2020 High Resolution

Discrete Input Channel. Single-channel; preamp/limiter/parametric EQ/dynamics processor; phantom power; phase reverse; gain control; four-band parametric EQ; threshold, timing, release, crest factor, output, ratio dynamics controls. Power supply: \$650. \$6,000

Gordon Instruments

Gordon Microphone Preamp/Converter

System. Two-channel; 48V phantom power; phase reverse; Hi-Z input; ground lift. Bandwidth: 0.7 Hz - 700 kHz. 1RU. Optional floor stand outriggers. \$3,500

Grace Design

Lunatec V3 ★ New for 2003 ★

Preamp/Converter. Two-channel; level, trim controls; 24-bit A/D; 44.1, 48, 88.2, 96, 176.4, 192 kHz sample rates; 48V phantom power; high-pass filter (50/100 Hz, 75/150 Hz); ANSR word length reduction; word clock; M/S decoder; battery operable. XLR, BNC, RCA, AES/EBU, S/PDIF. \$1,695

Model 101

Single-Channel Preamp/Studio. Single-channel; gain, trim controls; 48V phantom power; high-pass filter; 1/4" front panel Hi-Z input. Frequency response: 4.5 Hz - 400 kHz. XLR, 1/4". \$695

Model 801

Eight-Channel Microphone Preamp. Recording studio, live sound. Eight-channel; gain control; 48V phantom power; phase reverse; 20 dB pad. Frequency response: 4.5 Hz - 1 MHz. THD: <0.015%. XLR, 2RU. \$4,795

Great River Electronics

MP-2NV Mercenary Edition

Two-Channel Microphone Preamp/Studio. Two-channel; Class A; Hi-Z input. XLR, 1/4". 1RU. \$2,499

MP-4

Microphone Preamp/Studio, location. Four-channel; transformer input; phantom power; Hi-Z input. XLR, 1/4". 1RU. Optional output transformers. \$2,275

Groove Tubes

DITTO ★ New for 2003 ★

Preamp/DI. Tube operation. \$399

VIPRE

Variable Impedance Microphone Preamp/Studio. Single-channel; input type, impedance (300, 600, 1,200, 2,400 ohms), gain, rise time controls; switchable VU meter; 48V phantom power; phase reverse; high-pass filter (100 Hz); variable rise time; mute; Class A; two 6DJ8 tubes; four 12AT7 tubes; GT6508 tube; two 6AQ5 tubes; front panel 1/4" input; switchable VU meter. XLR, 1/4". \$2,999

HHB Communications USA LLC

Radius 10

Tube-Based Microphone Preamp/Studio. Four-channel; tube operation; input, output controls per channel; 48 V phantom power; phase; low-cut filter (90 Hz); peak LEDs. XLR, 1/4". 2RU. \$749

Radius 40

Tube Voice Processor. Studio. Single-channel; tube operation; preamp/compressor/EQ/expander/gate; 48V phantom power; instrument input; low-cut filter; attack, release, threshold, ratio, gain makeup compressor controls; threshold control for expander/gate; four-band EQ; master output gain control; link; side chain; peak LEDs; switchable VU meter. XLR, 1/4" 10" x 3.5" x 8". \$749

Millennia
Music & Media Systems

ORIGIN STT-1

FOUR Award Winning
Millennia Products
Inside the **STT-1**



HV-3D Eight Channel Solid State Preamp



M-2B Stereo Vacuum Tube Preamp

Over 130
product combinations...
Class A vacuum tubes
or
Class A discrete transistors
...at the touch
of a button



Vintage platinum crackle finish shown (optional) Also available in mirror black finish

VACUUM TUBE

SOLID STATE



NSEQ-2 Four Band Parametric EQ



TCL-2 Opto-Compressor / Limiter

Based faithfully upon
Millennia's acclaimed
recording products (the
HV3, the M2B, the TCL, &
the NSEQ), the **ORIGIN** is

designed for the engineer /musician/producer
who would rather not spend large blocks of
time patching and repatching racks of analog
front-end gear to achieve "that sound."

Now, it's possible to quickly and easily patch
the widest range of sonic color available in one
chassis. **ORIGIN** is the *ultimate* expression
of Millennia performance, vastly expanding the
range of every artist's sonic palette at a price /
performance level previously unknown in world-
class audio. Discover why Millennia is the first
choice of top artists, engineers, and producers
worldwide. Visit our website for Millennia's
key user list, technical specs, news and reviews.



www.mil-media.com
530.647.0750
Fax 647.9921

PREAMPLIFIERS

Radius 5 Fat Man 2

Tube Preamp/Compressor. Single-channel; preamp/compressor; 48V phantom power; low-cut filter (90 Hz); gain input, output, make-up controls; threshold, ratio, controls for compressor; 12AX7A tube; VU meter. XLR, 1/4". Optional rackmount kit. \$469

Hosa Technology Inc.

DIB-307

DI Box. Instrument/mic switch; battery operable. 1/4", XLR. \$80

Joemeek/PMI Audio

TwinQCS Dual Studio Channel

Two-channel; mic pre/opto-compressor/EQ; Current Sense preamp; 48V phantom power; phase reverse; low-cut filter; front panel 1/4" input; compression, slope, attack, release compressor controls; three-band Meequalizer EQ; VU meters. \$999

VC1QCS Studio Channel

Preamp/Multiprocessor. Studio. Single-channel; microphone preamp/photo-optical compressor/EQ/enhancer; compression, attack, release controls, slope switch for compressor; input gain, output gain, drive, Q, enhance controls; three-band EQ with sweepable mid; 48V phantom power; front panel 1/4" Hi-Z input; high-pass filter; mic/line input switch; VU meter. XLR, 1/4", 2RU. \$799

VC2 Tube Channel

Preamp/Multiprocessor. Studio. Single-channel; microphone preamp/photo-optical compressor/enhancer/tube gain make-up amplifier; compression, ratio, attack, release, input gain, output gain, drive, Q, enhance controls; 48V phantom power; 20 dB pad; high-pass filter; mic/line input switch; VU meter. XLR, 2RU. \$1,999

VC3Q Pro Channel

Preamp/Multiprocessor. Studio. Single-channel; microphone preamp/compressor/EQ; input gain, compression, attack, release, output volume controls; three-band EQ; 48V phantom power; compression speed switch; line/instrument input; LED meter. Frequency response: 10 Hz - 50 kHz. XLR, 1/4". \$400

VC6Q British Channel

Preamp/Multiprocessor. Studio, sound reinforcement. Single-channel; microphone preamp, photo-optical compressor, EQ; input gain, compression, slope, attack, release controls; three-band EQ with sweepable mid; output volume control; 48V phantom power; 20 dB pad; phase reverse; sweepable compression ratio; high-pass filter; front panel 1/4" Hi-Z input; bypass; LED meter. XLR, 1/4", 1RU. \$600

Jünger Audio Studioteknik GmbH/G Prime

VAMP1

Microphone Preamplifier/Processor. Studio, post production, broadcast, video. 24-bit A/D; preamplifier/compressor/expander/de-esser/limiter; filter; level control; source selector; automated ducking; sample rate converter; monitor section; headphone controls; RS232 port; LED display. AES/EBU, S/PDIF, XLR, 1RU. \$4,150

Klark Teknik

DN1414

Multichannel DI Box. 14-channel; 30 dB pad; 15 dB output attenuator. XLR, 1/4", 3RU. \$2,662

DN422M

Mic Preamplifier/Equalizer. Two-channel; XLR mic preamp; four-band parametric EQ; variable high-pass filters; insert. 1RU. \$1,624

LBB100 Active DI Box

Studio. 48V phantom power; 30 dB

input pad; 15 dB output pad; switchable ground lift. XLR, 1/4". \$196

Lavry Engineering

MSPA-1000 ★ *New for 2003* ★ Microphone Side Pre Amplifier. 48V phantom power; gain control. XLR. \$560

Line 6

POD

DI Box/Guitar Processor. Analog amp cabinet emulator; 32 historical amp models; programmable settings; A.I.R. cabinet/speaker/mic emulation; SoundDiver library 1/4". \$359

POD Pro

Analog amp cabinet emulator; 24-bit digital output; 32 historical amp models; programmable settings; 36 memory settings; A.I.R. cabinet/speaker/mic emulation; SoundDiver library software; word clock. XLR, 1/4". \$899

Little Labs

Multi Z DI

DI Box. Single-channel; Hi, Mid, Lo-Z; Z controls; level controls; bypass; 48V phantom power; ground lift. XLR, 1/4". \$550

M Audio

Audio Buddy

Preamp/DI Box. Two-channel; level controls; phantom power. Frequency response: 5 Hz - 50 kHz. XLR, 1/4". 5.5" x 3.5" x 1.75". \$119

TAMPA

Preamp/Compressor/Converter. Studio. Single-channel; preamp/compressor/A-to-D converter; Temporal Harmonic Alignment technology; threshold, ratio, attack, release controls for compressor; Class A; mic gain, impedance controls; 20 dB pad; low-cut filter (80 Hz); 24-bit; 44.1, 48, 88.2, 96 kHz sample rates; phase reverse; bypass; 20 dB output pad; VU meters. XLR, 1/4", RCA, AES/EBU, S/PDIF. \$799

Manley Laboratories

Dual Mono Mic Pre

Studio. Two-channel; 48V phantom power; input attenuation controls; gain switch; phase; front panel 1/4" input; tube operation. XLR, 1/4", 1RU. \$2,400

Langevin Dual Mono Mic Preamp With EQ

Recording studio. Two-channel/dual mono; input, two-band EQ controls per channel; 48V phantom power. Frequency response: 10 Hz - 20 kHz. THD: 0.05%. \$1,475

Mic/EQ-500 Combo

Differential Tube Preamp and Equalizer. Studio. Single-channel; 48V phantom power; phase; mic/line switch; mic input, line input controls; LF (40, 100 Hz), HF (3, 5, 7, 10, 15 kHz) controls; cut/boost controls; shell/peak switch; VU meter. 2RU. \$2,900

SLAM!

Electro Optical/FET Limiter/Mic Preamp. Two-channel; electro optical limiter; FET limiter; preamp; 48V phantom power; DI input; input, output, release controls; link; switchable VU meters. 1/4", XLR. \$6,600

VOXBOX

Multiprocessor. Studio. Single-channel; mic preamp, opto-compressor, Pultec EQ, de-esser, peak limiter; 48V phantom power; phase; preamp input control, gain switch; compressor threshold control, attack, release setting switches; de-ess threshold, frequency setting switches; EQ peak, dip controls, frequency setting switches; bypasses; front panel 1/4" input; linkable; tube operation; switchable VU meter. XLR, 1/4", 3RU. \$4,000

Martech

MSS-10

Microphone Preamplifier. Studio, film. 48V phantom power; mic gain, line out controls; 20 dB pad; phase reverse; custom input transformer; discrete amplifiers; VU meter. Frequency response: 10 Hz - 20 kHz. THD: <0.0015. XLR. \$1,995

Midas

XL42

Preamplifier/Parametric Equalizer. Two-channel; 48V phantom power; 25 dB pad; phase; variable low-cut filter; mic gain, bass, low-mid, high-mid, treble, level/pan controls per channel; full frequency controls; bell/shelf EQ switches; LED meters; modified from Midas XL4 console channel strip. 1RU. \$1,416

Millennia Media Inc.

HV-3

Stereo Microphone Preamplifier. Studio. Discrete hybrid topology. Frequency response: 1 Hz - 300 kHz. THD: 0.0005%. XLR, 2RU. \$1,895

HV-3D

Microphone Preamplifier Studio, location. Four and eight-channel. 2RU. Four-channel: \$2,995; Eight-channel: \$3,995

LPE-2 Analog Legacy

Phonographic Preamplifier/Equalizer. Studio, post production. Two-channel; low-frequency compensation controls per channel; high-frequency rolloff controls per channel; low-frequency, high-frequency filters and gain controls per channel; RIAA curve; Class A; moving coil, moving magnet inputs; polarity reverse. XLR, RCA. 2RU. \$9,500

Origin STT-1

Preamplifier/Compressor/EQ/De-Esser. Single-channel, Twin Topology vacuum tube and solid state signal paths; Class A; preamp gain controls; 48V phantom power; phase reverse; threshold, attack, release, ratio controls for compressor; de-ess controls; direct input; bypasses; VU meter. 2RU. \$2,895

TDB-1 Twin Direct ★ *New for 2003* ★

DI Box. Twin Topology vacuum tube and solid state signal paths; N5EQ two-band parametric EQ; Class A operation; input impedance control; 20 dB pad; polarity reverse. Optional HV-3 preamp upgrade. \$1,295

Nady Systems Inc.

TMP-3 Tube Channel

Preamp/Multiprocessor. Two-channel; preamp/EQ/compressor; three-band EQ; 48V phantom power; phase reverse; limiter; input, output gain controls; 12AX7A tube; VU meter. XLR, 1/4". \$259

Oram Professional Audio

Octasonic

Mic Preamplifier. Eight-channel; Oram Sonics group delay; 48V phantom power; phase. \$2,118

Palmer Direct Recording Devices

PDI 09 The Junction

DI Box. Mellow, bright, normal tone switch; 15/30 dB pad. 1/4", XLR. \$120

Parasound

P3

Two-channel; RS232 port; remote control. Frequency response: 5 Hz - 55 kHz. THD: 0.01%. 2RU. \$800

Pass Laboratories

X2

Line Stage Preamplifier. Single MOS-FET gain stage; single ended Class A.

XLR, RCA. 17" x 3.5" x 12". \$2,500

XO.2

Dual Mono Line Stage Preamplifier. Pass Supersymmetry circuit topology; volume control, remote control. XLR, RCA. 17" x 3.5" x 12". \$10,000

Peavey Electronics Corp.

TMP-1

Tube-based Mic Preamp. Studio. Class A; high-pass filter; 24V phantom power. Frequency response: 20 Hz - 20 kHz. THD: <0.2%. XLR, 1/4". 1RU. \$289

Pendulum Audio

MDP-1

Vacuum Tube Mic/DI Preamp. Two-channel; 48V phantom power; phase; 20 dB pad; Class A; gain, output controls per channel; variable low-cut filter (20 - 180 Hz); Jensen transformers; soft start; front panel variable 1/4" input; two 12AX7A, two 6922 tubes; switchable VU meters. XLR, 1/4", 2RU. \$2,495

Quartet

Four Element Tube Recording Channel. Studio. Single-channel; mic pre/EQ/Opto-compressor/limiter/de-esser; 48V phantom power; 20 dB pad; low-cut filter (75, 150 Hz); gain, output controls for mic pre; three-band modified Baxandall EQ; EQ-comp/limiter stage reverse; threshold, ratio, output, attack, release, mode controls for comp/lim; threshold, frequency, depth controls for de-esser; bypasses at most stages; front panel 1/4" input; switchable VU meter. 2RU. \$3,250

Phoenix Audio

DRS-2

Two-channel; 48V phantom power; phase reverse; gain controls; front panel 1/4" Hi-Z input; high-pass filter (80 Hz); Class A. 1RU. \$2,495

GTQ2

Preamplifier. Studio. Two-channel; 48V phantom power; phase reverse; gain control; front panel 1/4" Hi-Z inputs; high-pass filter (80 Hz); three-band EQ; Class A. 1RU. \$1,995

PreSonus Audio Electronics

Acousti-Q

Tube Acoustic Instrument Preamp/EQ/Blender. Twin tube preamps; 12V phantom power; phase reverse; internal mixer; notch filter, EQ, brilliance, gain, level controls; foot switch input; mute; LED meter. 1/2RU. \$299

DigiMax

Eight-Channel Preamplifier/Multiprocessor. Eight-channel; 24-bit A/D-D/A; level controls; 32, 44.1, 48, 96 kHz sample rates; 48V phantom power; 20 dB pad; phase reverse; limiter; EQ; front panel 1/4" Hi-Z, Lo-Z inputs; word clock. XLR, RCA, 1/4", TOSlink, BNC. \$1,699

DigiMax LT

Eight-channel; 24-bit A/D; level controls; 32, 44.1, 48 kHz sample rates; 48V phantom power; 20 dB pad; inserts; word clock. XLR, 1/4", BNC, TOSlink, ADAT. \$999

M80

Eight-Channel Microphone Preamplifier. Studio. Eight-channel; Class A; pan, IDSS tube emulation, gain controls, phase reverse; 48V phantom power; 20 dB pad; 80 Hz low-cut filter per channel; master output control; aux send/return; headphone output and controls; Jensen transformers; LED meters, clip indicators. XLR, Neutrik combo, RCA. \$2,299

MP20

Microphone Preamplifier. Studio. Two-channel; Class A; pan, IDSS tube emulation, gain controls, phase

reverse; 48V phantom power; 20 dB pad; 80 Hz low-cut filter per channel; master output control; aux send/return; headphone output and controls; Jensen transformers; LED meters, clip indicators. XLR, Neutrik combo, RCA. \$699

Prism Media Products Inc.

MMA-4 Four Channel Mic-Preamp Four-channel; 48V phantom power; phase reverse; gain controls. Frequency response: <1 Hz - >200 kHz. THD: 0.0006%. XLR. \$3,160

Radial Engineering/CableTek Electronics

Radial JD4 Quad

Four-Channel Direct Box. Live sound, studio. Four-channel; phase, ground lift switches; 15 dB pad; high-frequency filter; front panel 1/4" input; throughput; routing jacks; Jensen transformers. Frequency response: 10 Hz - 80 kHz. 1/4", XLR. 1RU. \$849

Radial JDV MK3 Super DI

Class A Preamp & DI Box. Live sound, recording studio. Class A; dual recessed switches; 15 dB pad; four outputs; ground lift; heavy duty construction; carrying pouch. Frequency response: 10 Hz - 80 kHz. 1/4", XLR. \$450

Rane Corp.

AP 13 Acoustic Instrument Processor

Live sound, studio. Separate master input, piezo, mic, input controls; master output control; adjustable low-cut filters; seven-band EQ; pan, cut, level sliders; phantom power; phase; send, return loops; headphone controls. 1/4", XLR. \$569

DMS 22

Dual Channel Microphone Preamp. Studio. Two-channel; 48 V phantom power; three-band EQ with sweepable midrange; pan controls; input gain, output level controls; stereo output level control. XLR, 1/4" TRS. 1RU. \$549

NIM 84 Network Mic Preamp

Installation. Eight-channel; 24-bit; 48V phantom power; low-cut filters (40 - 160 Hz); high-cut filters (7 - 20 kHz); limiter; Ethernet/CobraNet connection; SNMP, ActiveX/PC control software; RS-232 port; Memory Recall Port; LED meters; LCD screen. XLR, RS-232, RJ-45. \$3,995

PS 1

Phono Preamp. RIAA phono to line level conversion; rumble filter; selectable cartridge loading. RCA, screw terminal. \$229

VP 12 Voice Processor

Mic/Line Preamplifier. Single-channel; mic preamp/de-esser/gate/expander /two-band parametric EQ/compressor; high, low-cut filter, frequency, threshold de-esser controls; frequency, level bandwidth controls for parametric EQ; gate/expander threshold control; threshold, ratio controls for compressor; master input gain, output level controls; 48V phantom power; configurable processing order. XLR, 1/4", terminal strip. 1RU. \$599

Raven Labs

APD-1

Direct Box. Live sound, studio. Two-channel; phase reverse; 10, 20 dB pad; 6 dB boost; effects loop control; mute; front panel 1/4" inputs; ground lift; oxygen-free copper wiring; battery operation. \$349

PHA-1

Preamplifier/Headphone Amplifier. Two inputs; three-band EQ; level controls; master volume control. 1/4". Ships with headphones, patch cord. \$299

ADK

MICROPHONES

"I have had the opportunity to use a variety of ADK Microphones in a wide range of applications. The sound is huge and wide open when tracking vocals. The clarity and detail is incredible! The accurate and transparent sound reproduction, especially on the acoustic grand piano, is nothing short of amazing! You really owe it to yourself to give ADK Microphones a serious listen."

*Dale Sticha - Recording & Live Sound Engineer/
Piano Tech for Sir Elton John*

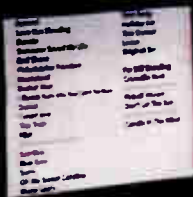

ADK

MICROPHONES

Ridgefield WA USA

TEL (360) 566-9400 FAX (360) 566-1282
www.adkmic.com info@adkmic.com



**The New ADK Studio
Twin Packs Are Here!**

ADK has a Strict Policy Regarding Endorsements and Testimonials.
 All Web and Advertised Comments or Use of Photographs are Unpaid.

ADK is Not Sold in National Chains. Available at Independent Pro Audio and Better MI Dealers.

World Radio History

PREAMPLIFIERS

RDL, Radio Design Labs

FP-MP1
Two-channel; 12/24V phantom power; gain control; low-cut filter(80 Hz); XLR. \$225

RU-MP2
Adjustable Stereo Mic Preampifier. Two-channel; mic preamp; mic to line; gain controls. Frequency response: 25 Hz - 20 kHz. THD: <0.05%. Impedance match : 150 ohms to 600 ohms. XLR \$299

Requisite Audio Engineering

PAL PLUS
Preampifier and Limiter Studio. Single-channel; tube operation; 48V phantom power; 20 dB pad; input gain reduction, peak reduction, output level, limiter response, feedback controls; switchable compressor/limit ratio (3:1, 10:1); LA2A-style limiter; link; front panel 1/4" input; mic/line switch; 12AY7, 12AX7, 6414, 6AQ5A tubes; switchable VU meter. Frequency response: 10 Hz - 90 kHz. THD: <0.03%. XLR, 1/4". 2RU. \$3,000

Rogue Audio

Ninety-Nine
Preampifier. Two-channel; gain, volume controls; headphone jack; 6SN7GT tubes; mute; remote. Optional moving magnet/moving coil phono input. \$1,995

Rolls Corp.

SE 162 Red Square
DI Box. Live sound, recording studio. Level, bottom, definition controls. 1/4", XLR. \$80

Samson Technologies Corp.

C-valve
Tube Mic Preamp. 48V phantom power; phase reverse; gain, saturation, output volume controls; enhancer; limiter; LED, VU meters. \$159

S-direct
DI Box. 48V phantom power; ground lift; battery operable. 1/4", gold-plated XLR. \$124

Schoeps/Redding Audio

VMS 5 U
Preampifier with M/S Matrix. Two-channel; M/S matrix; gain, balance, width controls; 48V phantom power; low-cut filter (150 Hz); headphone controls; battery power meter. XLR, five-pin binder. \$1,305

Sendit Electronics

DB-1
Direct Box. Jensen transformers; pad; filter; ground; phase reverse. 1/4", XLR. \$299

Shure Inc.

FP 23
Battery Powered Mic Preampifier. Field, broadcast. Single-channel; gain control; high-pass filter (80, 100 Hz); limiter; battery operation. Frequency response: 20 Hz - 50 kHz. Dynamic range: >120 dB. \$420

FP 24
Portable Preampifier. Field, broadcast, film, video. Two-channel; level controls; high-pass filter; headphone controls; slate; LCR; tone generator (1 kHz); tape return; LED meters; battery operable. Frequency response: 10 Hz - 50 kHz. Dynamic range: >110 dB. XLR, 1/4". \$855

Simon- Kaloi Engineering

RDB-400
Active Direct Box. Live sound, studio. Four-channel; transformerless; output level controls; attenuation trim controls;

speaker level pad. Frequency response: 10 Hz - 150 kHz. XLR, 1/4". \$995

Smart Electronics/Sunset Sound

Guitar Deluxe D.I. System
D/I Distribution System. Live sound, studio. Send and receive unit; balanced outputs. XLR, 1/4". \$450

Sonifex/Independent Audio

RB-DMA2
Two-channel; level controls; 48V phantom power; high-pass filter; word clock. XLR, RCA, BNC, AES/EBU, S/PDIF. 1RU. \$799

RB-MA2
Two-Channel Microphone Preampifier. Two-channel; low-frequency rolloff (125 Hz); 48V phantom power; gain control. XLR. \$325

Sound Devices LLC

MixPre
Field Mixer/Preampifier. Field, film. Two-channel; 48/15V phantom power; gain controls; LCR pan; high-pass filters (80, 160 Hz); limiter; tape return; slate; slate mic; headphone control; switchable LED meter; two AA batteries. Frequency response: 20 Hz - 50 kHz. Dynamic range: 110 dB.

USBPre
USB Preampifier. Two-channel; Windows, Mac; USB port; 8 - 24-bit; 32, 44.1, 48 kHz sample rates; 48V phantom power; mix control; headphone controls; LED meters. Frequency response: 10 Hz - 20 kHz. Dynamic range: 106 dB. XLR, 1/4", RCA, USB. \$695

Speck Electronics

MicPre 5.0
Single-channel; gain, trim, controls; 48V phantom power; 20 dB pad; phase reverse; variable high-pass filter; linkable mix level control; pan; bypass; LED meter. Frequency response: 10 Hz - 200 kHz. THD: 0.002%. XLR, 1/4". \$998

SPL US

Area 5.1 Model 2047
Surround Microphone Preampifier. Five-channel; phantom power; pad; phase reverse; low-cut filter; mute, pan, stereo level, gain controls; ground lift; LED meters. XLR, 1/4". 3RU. \$4,599

Track One Model 2058
Channel Strip. Studio. Single-channel; 48V phantom power; low-cut filter; three-band EQ; compressor/limiter; de-esser; gain, output level controls; switchable LED meter. XLR, 1/4". 1RU. \$899

Stewart Audio

ADB4
Four-Channel DI Box. Four-channel; ground lift; input sensitivity switch (± 20 dB). 1/4", XLR. \$379

Studio Projects/PMI

VTB-1
Preampifier/DI Box. Single-channel; 48V phantom power; phase reverse; mic gain, tube drive, output level controls; high-pass filter (70 Hz); front panel 1/4" Hi-Z input; 12AX7 tube; LED meter. XLR, 1/4". \$299

Submit Audio Inc.

2BA-221 Microphone and Line Module
Single-channel; solid state and tube stages; input gain, tube output, mic gain controls; 48V phantom power; 20 dB pad; phase reverse; variable high-pass filter; Hi-Z input; 12AX7A/ECC83 tube. XLR, 1/4". 1/2RU. \$695

MPC-100A

Microphone Preampifier/Compressor/Limiter. Studio, live sound, post production. Single-channel; 48V phantom power; preamp gain control; switchable attack/release switches; gain, threshold, slope, output controls; input impedance control; 20 dB pad; phase; Jensen input transformers; mic/line inputs; front panel 1/4" Hi-Z input; +4 dB/-10 dB inputs; stereo link; bypass; clip LEDs; VU meter; two 12AX7A tubes. XLR, 1/4". 2RU. \$2,290

TD-100
Preampifier/DI Box. Live sound, studio. Single-channel; level, output gain controls; variable input impedance; phase reverse; ground lift switch; Hi-Z input; 12AX7A/ECC83 tube. 1/4", XLR. 1/2RU. \$495

Swissonic America

USB Studio/D
USB Interface/Preamp. Project studio. Two mic inputs; two Hi-Z instrument inputs; four stereo line inputs; auxiliary inputs; USB port; headphone jack; 20-bit A/D-D/A; 48V phantom power; phase reverse; 44.1, 48 kHz sample rates; Windows/Mac compatible. XLR, 1/4", USB, RCA. \$989

Symetrix Inc.

528E Voice Processor
Analog Voice Processor. Studio, sound reinforcement, live sound, broadcast. High gain mic preamp, compressor, limiter, expander, gate, de-esser, three-band parametric EQ; mic gain control; de-ess frequency, threshold controls; expander threshold, compressor threshold, ratio controls; frequency, bandwidth, cut/boost controls per band; master gain output control; phantom power; pad; mic and line level inputs; LED meters; Voice symmetry function. XLR I/O, 1/4" TRS output. 1RU. \$749

628 Digital Voice Processor
Studio, broadcast. Mic preamp, expander, gate, compressor, de-esser, three-band parametric EQ; de-ess frequency, threshold controls; expander/gate threshold, ratio, release controls; compressor threshold, ratio, release controls; frequency, bandwidth, cut/boost controls per band; master gain output control; 128 presets; mic and line level inputs; phantom power; 15 dB pad; 20-bit A/D-D/A; MIDI I/O; LED display. XLR, 1/4" TRS, AES/EBU, S/PDIF. 1RU. \$1,249

TC Electronic USA

1140
Preampifier/Parametric Equalizer. Studio, sound reinforcement. Single-channel; four-band parametric equalization; band overlap; ± 20 dB cut/boost; input gain, output, EQ match controls; center, bandwidth, function controls per band; bypass. Frequency response: 10 Hz - 100 kHz. Dynamic range: >116 dB. 1RU. \$760

Gold Channel
Digital Preampifier/Processor. Two-channel; preampifier, expander, compressor, equalizer, de-esser, dynamics processor; 44.1, 48, 96 kHz sample rates; 24-bit A/D-D/A; 48V phantom power; phase; low-cut filters; 20, 40 dB pad; parameter, value controls; M/S encoder/decoder; time alignment function; Digital Radiance processing; 100 factory presets; MIDI I/O/ thru; PCM101A drive; LCD screen. XLR, RCA, 1/4", TOSlink, MIDI. 1RU. \$2,495

TDL Technology

Model 407
Stereo Phonograph Preampifier. Gain, turnover, rolloff controls; rumble filter (20 Hz); battery operable. RCA. Designed for use with 78 rpm records. Designed for use with computer sound card. \$237

The John Hardy Co.

M-1 Microphone Preamp
Studio. Modular - up to four-channel; Jensen transformers; adjustable gain; polarity reverse switch; phantom power; VU meter. XLR. 1RU. One-channel: \$1,120. Two-channel: \$1,715. Three-channel: \$2,310. Four-channel: \$2,905.

M-2 Microphone Preamp
Studio. Modular - up to four-channel; Jensen transformers; metal film resistors; adjustable gain; polarity reverse switch; 48 V phantom power; choice of 20 dB pad or 20 ohm mic switch. XLR. 1RU. ptonal transformer upgrade. One-channel: \$1,165. Two-channel: \$1,805. Three-channel: \$2,445. Four-channel: \$3,065.

TL Audio/HHB Communications

5051 Mono Valve Voice Processor
Single-channel; tube operation; pre-amp/compressor/expander/gate/four-band equalizer; input gain control; mic/line switch; 48 V phantom power; high-pass filter threshold, ratio, gain makeup controls on compressor; last attack mode; fast release mode; expander/gate control; front panel 1/4" input; link; switchable VU meter. XLR, 1/4". \$749

PA-1 Dual Pentode Valve Pre Amp
Two-channel; tube operation; 48 V phantom power; phase reverse; gain switches; output level controls; front panel 1/4" inputs; switchable high, low-pass filters; ground lift; 12AX7A tubes. Frequency response: 30 Hz - 40 kHz. 1/4", XLR. \$1,149

VP-1 Tube Processor
Preamp/Compressor/Equalizer Studio. Preampifier, compressor, parametric EQ, de-esser, peak limiter, expander/gate; phantom power; 30 dB pad; phase reverse; variable high-pass filter; four-band EQ; threshold, ratio, attack, gain make-up controls for compressor; frequency, bandwidth controls for de-esser; threshold, attack, release controls for expander/gate; EF86, 12AX7A tubes; VU meter. Optional word clock input. \$2,999

Trident Audio USA

AI Schmitt Pro-Channel
Single-channel; preamp; six-band EQ; soft knee compressor; phantom power; phase reverse; VU meter. \$8,525

S20 Dual Microphone Preampifier
Two-channel; 48V phantom power; phase reverse; gain, low-cut filter controls. \$1,299

True Systems/Neumann USA

P2analog
Two-channel; level controls; high-pass filter (40/80 Hz); M/S; phase meter; front panel 1/4" DI inputs; LED meters. XLR, 1/4". 1RU. \$1,750

P2digital ★ New for 2003 ★
Two-Channel Digital Preampifier. Studio. Two-channel; 16, 20, 24-bit; 44.1, 48, 88.2, 96 kHz sample rates; 48V phantom power; phase reverse; gain controls; high-pass filters; M/S; stereo correlation meter; LED meters. XLR, 1/4", optical, AES/EBU, ADAT. 1RU. \$1,995

Precision 8
Eight-Channel Microphone Preampifier. Eight-channel; 48V phantom power, phase, level controls, LED meters per channel; peak hold control; M/S decoding; DI inputs. Frequency response: 1 Hz - 500 kHz. XLR, 1/4", 25-pin D-sub. 1RU. \$2,850

Tube Tech

MEC 1A
Microphone Preamp/EQ/

Compressor. Studio, live sound. Single-channel; tube operation; three-band EQ; high-, low-shelving filters; optical compressor; manual and fixed attack and release controls; two mic inputs; 48V phantom power; 20 dB pad; phase reverse; high-pass filter; three ECC81, one ECC82, three ECC83 tubes; switchable VU meter; bypasses. Frequency response: 5 Hz - 70 kHz. XLR. 2RU. \$3,495

Uncle Albert's Amplifier Inc.

VDT-2A
Vacuum Tube Direct Box. Live sound, studio. DC filament heater; buffered output; 12AX7 tube; ground lift. Frequency response: 20 Hz - 40 kHz. XLR, 1/4". \$449

Universal Audio

2-610 Vacuum Tube Microphone Preampifier
Studio. Two-channel; gain controls; phantom power; phase reverse; EQ, boost controls; Hi-Z inputs; 12AX7, 6072 tubes; modeled on 610 input module. XLR, 1/4". 2RU. \$2,295

6176
Channel Strip. Single-channel; Universal Audio 2-610 preamp section; Universal Audio 1176 compressor section; VU meter. \$2,495

M610
Vacuum Tube Microphone Preampifier. Studio. Single-channel; gain controls; phantom power; phase reverse; EQ, boost controls; Hi-Z input; 12AX7, 6072 tubes; modeled on 610 input module. XLR, 1/4". 2RU. \$1,295

Videoquip Research Ltd.

MP-2
Dual Channel Microphone Preampifier. Two-channel; 48V phantom power; level controls; dual outputs per channel. XLR, screw terminals. \$395

Weiss Engineering/G Prime

ADC1-MK2
Preamp/A/D Converter. 24-bit; 44.1, 48, 88.2, 96 kHz sample rates; level controls; soft clip; phantom power; pad; 16, 20-bit redither; word clock; LCD screen; LED meters. XLR, BNC, nine-pin D-sub. 1RU. \$5,000

Whirlwind

Director
Passive Direct Box. Hi-Z bridging input; 30 dB pad; ground; switchable low pass roll-off filter; switch lift switch; TRH-LM transformer. Frequency response: 20 Hz - 20 kHz. Impedance: 20 kohm. 1/4", XLR. \$109

HotBox
Direct Box. Studio, live sound. Instrument/mic/amp switch; 48V phantom; battery power; power LED; ground lift switch. Frequency response: 20 Hz - 20 kHz. \$169

MD-1
Microphone Preamp/Headphone Monitor. Mic/line input stage; transformer-isolated line driver; independent headphone amp; phantom power; belt clip. Line level balanced output. Powered by two 9V batteries. \$399

Yamaha Corp. of America

HA8 ★ New for 2003 ★
Microphone Preampifier. Studio. Eight-channel; 48V phantom power; gain controls. Frequency response: 20 Hz - 40 kHz. THD: <0.05%. XLR. 2RU. \$1,869

Yorkville Sound Inc.

YDI-1A
Active Direct Box. Single-channel \$75

GEAR GUIDE

RECORDERS/PLAYERS

360 Systems

DigiCart/E

Hard Disk Recorder. Broadcast, studio. Two-channel; hard disk; onboard 250 MB Zip drive; 16, 24-bit; 44.1, 48, 88.2, 96 kHz sample rates; onboard sample rate converter; WAV, BWF, AC2 files; basic track editing functions; programmable hot keys; jog wheel; linkable; Ethernet port; RS422/485 port; LCD screen. XLR, BNC, 1/4", nine-pin D-sub, RJ45, AES/EBU. Compatible with Ethernet Audio network. Compatible with other Digi-Carts. \$3,995

Instant Replay

Digital Audio Clip Recorder/Player. Studio, broadcast. Onboard hard drive; 16-bit; 44.1, 48 kHz sample rates; alphanumeric pad; basic editing functions; LED display; hotkeys; 1,000 cut library; printer port; onboard sample rate converter; Dolby AC-2 encoding; up to 24-hour recording. Frequency response: 20 Hz - 20 kHz. Dynamic range: >90 dB. XLR, RCA, AES/EBU. 5" x 15" x 9". \$3,250

Aardvark Computer Systems

Aark 24

Multitrack Hard Disk Recording System. PCI card; 10 input/output 1/4" analog, RCA digital breakout box; Windows 95/98 software; 24-bit A/D-D/A; 32, 44.1, 48 kHz sample rate; 30 - 50 kHz sample rate chase; word clock; full duplex; calibration tone; linkable; compatible with major DAW programs, Steinberg Wavelab, VST, IQS SAW family, Cool Edit Pro, Cakewalk, Sonic Foundry Sound Forge, SEK'D Samplitude; ASIO compliant. 1/4", RCA, S/PDIF, ADAT, MIDI. \$899

Akai Musical Instrument Corp.

DPS24

Portable Digital Recorder/Mixer. Studio, production, broadcast. 24-track random access disk recorder; 250 virtual tracks; 44-channel digital mixer; 16, 20, 24-bit; 32, 44.1, 48, 88.2, 96 kHz sampling rates; onboard sample rate converter; 56-bit internal processing; 60 GB hard drive; CD-RW drive; time stretch; pitch shift; BPM; dynamics; word clock; CD burn software; inserts; phantom power; talkback function; LCD; 5.1 surround mixing; SCSI interface; USB port; 100mm motorized faders; jog wheel. XLR, 1/4", RCA, MIDI five-pin, USB, 68-pin SCSI D-sub, BNC, optical. \$5,499

Alesis

ADAT-XT20

Eight-Track ADAT Type II Recorder. Studio. ADAT Type II format; eight-track; 20-bit; 44.1, 48 kHz sample rate; track copy; tape offset; track delay; 10 locate points; LED panel/meter. Frequency response: 20 Hz - 20 kHz. Dynamic range: 102 dB. THD: 0.003%. RCA, ADAT optical, 56-pin ELCO, 9 pin D-sub ADAT sync. 3RU. 20 lb. \$1,699

HD24

Hard Disk Recorder. Hard disk format; 24-track; 24-bit; 44.1, 48 kHz; basic editing functions; word clock; upgradeable 10 GB drive; hot-swappable drives; ADAT/FST file format; MTG; Ethernet; LED meters; linkable; ADAT sync; compatible with Alesis ADAT recorders, BRC remote controllers. 1/4", TOSlink, BNC, five-pin DIN, nine-pin D-sub, ADAT. Optional 88.2/96 kHz upgrade. \$1,999

MasterLink ML-9600

Hard Disk Recorder/CD-R Burner. Studio, post production. Two-channel; 24-bit; 96 kHz; 24-bit A/D-D/A; 44.1, 48, 88.2, 96 kHz sample rates; sample rate converter; selectable 16, 20, 24-bit word length; bit rate converter; 3.2 GB internal hard drive; 4X CD-R burner; Red Book standard; basic editing functions; tape-style transport controls; headphone controls. Frequency response: 20 Hz - 40 kHz. S/N: 113 dB. THD: <0.002%. XLR, RCA, AES/EBU, S/PDIF. 2RU. \$1,699

American Audio

DCD PRO 400 Dual CD Player

Live sound. Dual-well; independent operation; faders; Seamless Looping; 10 memory cues; fader start; automatic sleep mode; pitch bend; pitch control ($\pm 16\%$); jog wheel; beat counter; search function; digital output; LCD screen; rackmountable. RCA, S/PDIF. \$679

Power Drive 2.2

Turntable. Direct drive; pitch control ($\pm 20\%$); 33/45/78 rpm; forward/reverse spin; tone arm counterweight; stylus target light; lift lever; 45 adapter; adjustable feet. \$399

ATR Service Co.

Ampex ATR102 Recorders

Remanufactured Ampex Tape Recorders. Recording studio, post production, broadcast. 1/2", 1" two-track; fully remanufactured; new transports.

Boss

BR-532

Mini Digital Recording Studio. SmartMedia (32MB) format; four-track; 32 virtual tracks; 24-bit A/D-D/A; 32-bit

internal processing; COSM effects; onboard drum tracks; jog/shuttle wheel; LCD screen; battery operable. XLR, optical, RCA, 1/4", MIDI five-pin. \$495

CD Cyclone Duplication Systems

T-8

Standalone CD Duplicator. Eight-bay; one touch duplication; premastering function; internal hard drive; 12X duplicator drives; LCD touchscreen; compatible with autoloader and CD color printer; CD Audio, CD-ROM (Mode 1,2), CD-ROM XA, CD-I, CD-I Bridge, CD-I Ready, CD-Extra HFS, Joliet, Photo-CD, Video CD, USF, Hybrid, Mixed Mode, Expandable to 16 drives. Upgradeable to DVD drives. \$6,795

Contemporary Research Corp.

232-FMA Stereo FM Tuner

Installation. FM; programmable presets; auto stereo/mono; DX; mute; search function; software controllable via RS232 port; LED display. RCA, BNC, nine-pin D-sub, 1/2RU. Optional rackmount. \$495

Denon Electronics

AVR-1062P

Receiver. Installation. Seven-channel; 5.1, 6.1, 7.1 surround sound; 32-bit SHARC processing; Denon DDSC-D circuitry; Denon 7.1 Widescreen DSP; DTS Extended Surround; DTS Neo; Dolby Digital, Pro Logic II, EX; DVD-A, SACD compatible; 40 station AM/FM tuner memory; remote control; two-zone mode. Power output per channel: 110W. RCA. 4RU. \$1,100

CDR-W1500P

Dual Drive CD Recorder/Player. Installation, studio. Dual drive; one

HDCC capable CD player drive; one CD-R/CD-RW recorder drive; 24-bit; 2X dubbing; onboard sample rate converter; CD text-compatible. RCA. 2RU. Rackmount kit included. \$649

DN-2100F

DJ Style Dual Drive CD Player. Dual drive; A-B looping; pitch bend; memory; brake; switchable pitch; pitch bend; instant start; end of message; large DJ-style illuminated buttons; jog/shuttle wheel; 10 second shock memory, two hot starts per drive; Digi-Scratch; stutter; separate control and transport units. RCA, S/PDIF. 2RU each. \$1,150

DN-780R

Dual Well Cassette Recorder. Studio, installation. Analog cassette format; twin independent wells; pitch control ($\pm 12\%$); AGC; auto tape selector; autoreverse; 2X duping; Dolby B, C, HX; MPX filter; search; -10/+4 operation; RS232 port; remote control. RCA, 1/4", 1/8", nine-pin D-sub, 25-pin D-sub. 3RU. \$699

DN-961FA

CD Player. Studio, broadcast. Cart style player but doesn't use cart; play-back speed control; pitch control ($\pm 3\%$); cue button; search function; end monitor; end of message; instant start; fader start; RS422 port; LED display; parallel remote port. XLR. 5.75" x 5.25" x 16". Plays CD-R discs without TOC and CD Extra discs. \$1,500

DN-C550R

Dual Drive CD Recorder. Studio, installation, broadcast, live sound. CD-R/CD-RW format; dual drive; 24-bit A/D-D/A; onboard sample rate converter; 44.1 kHz sample rate; multisection capable; 2X duplication speed; defeatable SCMS; CD Text; remote control. XLR, RCA, S/PDIF. 2RU. \$899

GRACE

Presents the **model 901** Reference Headphone Amplifier



"We're blown away with the accuracy, detail and ability to deal with both analog and digital inputs that the 901 provides. In the final stages of quality control, both stereo and 5.1 music projects are monitored through a high-end headphone monitoring chain. The 901 has become the new headphone reference standard here at Gateway."

-Bob Ludwig, President Gateway Mastering and DVD

- ★ 120 dB dynamic range ★ AES, S/PDIF and TOSLINK digital inputs ★ 10dB gain boost switch for -10dB sources ★ Ultra low distortion 24-bit DAC accepts sample rates from 32 to 96kHz ★ Sealed gold contact relays for input select and gain boost switching ★ Balanced XLR, unbalanced RCA analog inputs ★ 24 position level attenuator with .05dB channel level matching ★

for more information, visit WWW.GRACEDSIGN.COM
Boulder, CO USA tel 303.443.7454 fax 303.444.4634

RECORDERS/PLAYERS

DN-C630
CD Player. Studio. Index search; 18-bit; A-B repeat; instant start; cue; pitch control ($\pm 9.9\%$) program play; memory; end monitor; end of message; parallel port; headphone controls. XLR, RCA, S/PDIF. 2RU. Plays CD-R discs without TOC. \$599

DN-D9000
Dual-Well DJ-Style CD Player. Live sound. Dual-well; ALPHA dual track playback; 15-second sampler per drive; hot start; cue point memory; jog/shuttle wheel; programmable play; loop playback; 14 programmable preset buttons; 16-second memory buffer; onboard effects; five platter control modes; scratch effects; BPM counter; compatible with CD-RW discs; compatible with Denon DN-X400 and X800 DJ mixers. RCA, S/PDIF. 3RU/2RU. \$1,800

DN-F20R
Solid State Media Recorder. Field, studio, broadcast. IC/CompactFlash memory card format; 16-bit; MPEG1, MPEG2, WAV files; 24, 48 kHz sample rates; low-cut filter; 20 dB pad; limiter; headphone jack; LCD; battery operable. XLR, RCA. \$1,299

DN-H800
Five-Disc CD Carousel and AM/FM Tuner. Installation. Five-disc carousel; AM/FM tuner; Radio Data System (RDS); text screen; 30-station preset; $\pm 12\%$ pitch control; programmable play; random play; volume control; headphone jack. RCA, XLR. 3RU. \$499

DN-M1050R
MiniDisc Recorder. Studio, broadcast. Comprehensive editing functions; cue tally; instant start; leader start; pitch control ($\pm 9.9\%$); end monitor; end of message; RS232, RS422 port; PS2 keyboard port; undo function; buffer memory. XLR, RCA, AES/EBU, S/PDIF. 3RU. \$1,999

DN-M2300R
Dual Drive MD Recorder/Player. Live sound, studio. MiniDisc format; twin MiniDisc drives; one drive records; undo/redo; dubbing function; five cue points; A-B loop; hot start; autocue; pitch control ($\pm 8\%$); pitch bend ($\pm 12\%$); dual jog/shuttle wheels; shock memory; separate control and transport units; DJ-style deck; fluorescent display. RCA, S/PDIF. 3RU/2RU. \$1,499

DN-T645
Installation, live sound. CD player/cassette recorder; pitch control ($\pm 12\%$); Dolby B, C, HX Pro; CD-RW-compatible; MP3-compatible; autoreverse; back cue; program play; CD repeat play; linkable; -10/+4 operation. RCA, XLR, 1/8", nine-pin D-sub, 25-pin D-sub. 3RU. \$750

DN-V1700
Network Audio/Video Player. Installation. Removable 40GB hard drive; PCMCIA slot; CompactFlash, MicroDrive-compatible; RS232 port, RS422 port; S-Video, component, composite; SMPTE, VITC timecode. XLR, RCA, BNC, S/PDIF, nine-pin D-sub, 15-pin D-sub. 1RU. \$2,500

DJ-DJ151
DJ-Style Turntable. Quartz synthesized; direct drive; 33.3/45/78 rpm; key adjust; pitch control ($\pm 12\%$); high torque start; pop up light; S-shaped tone arm; VTA adjustment; three speed brake effect. RCA, S/PDIF. \$499

DRA-685P
Receiver. Installation. Two-channel; auto preset memory; multiroom/multisource; video switching; two remotes. Power output per channel: 100 W. Banana, RCA. 4RU. \$549

DRW-585P
Dual Well Cassette Recorder. Studio.

Analog cassette format; dual well; autoreverse; high-speed dubbing; Dolby B, C; HX Pro. 3RU. \$299

DVD-1600P
DVD/CD Player. Installation. CD-RW, VCD-compatible; 3:2 pull-down; Faroudja DCDI; 3MB buffer memory; MP3-compatible; S-Video; composite; component. RCA, optical. 2RU. \$550

TU-1500RDP
AM/FM Tuner. AM/FM/Stereo FM; Radio Data System display; character input function; 40 station memory. RCA. 2RU. Ships with rackmount kit. Optional remote. \$399

Disc Makers

Elite Pro 1
Automated Disc Duplication/Printing System. CD-R/DVD-R; single duplication drive; onboard computer; Windows XP; Padius DiscJuggler software; 125-disc bin capacity; 1200 dpi inkjet printer; robotic arm; automated duplication/printing. Additional duplication drive available. CD-R: \$4,690; DVD-R: \$5,290

EliteMicro
Automated Disc Duplicator. CD-R/DVD-R; single duplication drive; 125-disc bin capacity; Padius DiscJuggler software; robotic arm; automated duplication/printing. Ships with FireWire card and cables. Additional duplication drive available. CD-R: \$1,590; DVD-R: \$1,990

Esoteric Sound

REK-O-KUT Rondine 3 Turntable
Bell-drive; 16, 22.5, 33, 39, 45, 68.5, 71, 76, 78, 80, 85, 90 RPM; accepts 16" radio transcription discs; Delrin platter; adjustable aluminum/magnesium Rek-O-Kut Transcribe arm; vertical/lateral switch; pitch control ($\pm 15\%$). Wow and flutter: <0.09%. Rumble: <75 dB. Includes dust cover. \$1,200

Euphonix Inc.

R-1
Multitrack Hard Disk Recorder. Hard disk format; 48-track; modular; 24-bit recording; 40-bit SHARC DSP processing; 44.1, 48, 96 kHz sample rates; random access; cut and paste editing; nondestructive editing; multiple undo/redo; TransferStation file translator; dedicated function keys; track destination buttons; tape style transport controls; variable speed; keyboard; jog/scrub wheel; FireWire interface; MAADI interface; SCSI ports; word clock; video sync, blackburst; timecode; MTC; compatible with MMC devices; includes rackmountable outboard processor, studio hub router, recorder deck. starts at \$24,000

Fairlight

Merlin
Hard-Disk Multitrack Recorder. 24-bit; 96 kHz; up to 48-track; 16, 20, 24-bit; editing functions; time code; word clock; dedicated control surface; tape-style transport controls; programmable function buttons; MediaLink networking; LCD monitor; onboard editing functions.

Fanfare Electronics Ltd.

FT-1AP
FM Tuner. Broadcast, installation, studio. FM band; composite output; DX; wide/narrow settings; station presets; shielded; fluorescent display; 16-gauge steel case. S/N: 75 dB. THD: 0.3%. RCA, XLR, BNC. 2RU. Optional remote control. \$1,395

Fostex Corp. of America

D-160v2
Hard Disk Recorder. Studio, broadcast. Hard disk format; 16-track; eight virtual tracks; simultaneous recording/editing; basic editing functions;

MIDI sync; jog wheel; 16-bit processing; 18-bit A/D, 64X oversampling; 20-bit D/A, 128X oversampling; 44.1 or 48 kHz sample rates; varispeed ($\pm 6\%$); no compression; 6.4 GB hard drive; SCSI port; 99 nameable partitions. Frequency response: 20 Hz - 20 kHz. RCA, S/PDIF, optical ADAT. 19" x 5.75" x 15". \$2,195

D2424LV
Multitrack Recorder. Hard disk format; 24-track; 56 virtual tracks; 16, 24-bit A/D, 48, 96 kHz sample rates; 24-bit A/D-D/A; MIDI functions; separate control surface with LCD screen, jog/shuttle; transport controls; basic editing functions; video sync; SCSI port; RS422 port. 1/4", BNC, TOSlink, five-pin DIN, nine-pin D-sub, ADAT. \$2,495

DV40
DVD-RAM Recorder. Studio, post production, installation. DVD-RAM format; four-track; 44.1, 48, 88.2, 96, 176.4, 192 kHz; 16, 24-bit; word clock; slate; basic editing functions; SMPTE timecode; UDF, BWF, SDII; Avid ALE compatible; +4-10 operation; jog/shuttle wheel; keyboard port; VGA output. XLR, 1/4", MIDI five-pin, BNC. \$5,995

FD-8
Multitrack Hard Disk Recorder. Project studio, recording studio. Hard disk format; eight-track; internal hard drive or external storage solutions; ADAC encoding; 44.1 kHz sample rate; 20-bit; three-band EQ, pan per channel; master level controls; aux sends; basic editing; undo; preview; tempo map; MMC, MTC; varispeed ($\pm 6\%$); MIDI time code; jog wheel; Fostex Disk Management System-3; SCSI port; LCD screen. XLR, 1/4", RCA, Lightpipe. \$899

PD-6 DVD Location Recorder
Field. DVD-RAM format; six-track; 44.1, 48, 88.2, 96 kHz sample rates; onboard mixer; M/S; limiter, high-pass filter per track; word clock; LTC, SMPTE timecode; drop frame; BWF files; 100 cue points; slate mic; tone generator; FireWire port; USB port; battery operable (NP-1). XLR, BNC, 1/4", 25-pin D-sub, 10-pin Hirose; AES/EBU, S/PDIF.

VF-160
Hard Disk Recorder/Mixer. Hard disk format; 16-track; 20GB hard drive; 44.1 kHz sample rate; three-band EQ; compressor; onboard CD-RW drive; onboard DSP effects; ADAT-compatible; onboard mic preamps; BPM delay; 99 scene memory; scrub zoom; 60mm faders; jog/shuttle wheel; tape-style transport; LCD screen. XLR, 1/4", RCA. Without CD-RW drive: \$799. \$999

X-24
Multitrack Cassette Recorder. Studio. Four-track; analog cassette format; aux send/return; bouncing; punch in editing; pitch control ($\pm 15\%$); 3 3/4 IPS; high bias; Dolby B, XLR, 1/4". 16" x 4" x 125". \$389

Genex Audio

GX9000
Digital Audio Recorder. Twin removable hard drives; eight-channel; 24-bit; up to 192 kHz; PCM, DSD/SACD formats; onboard mixer; onboard sample rate converter; tape-style transport controls; jog/shuttle wheel; mLAN networking; PC-compatible control, logging software; RAID formatting; USB port; FireWire port; SCSI port. XLR, BNC, AES/EBU. Choice of I/O: analog, AES3, optical MAADI, FireWire, PCM, DSD, AES3d, SDIF. Starts at \$3,950

GX9048
Digital Audio Recorder. Twin removable hard drives; up to 48-channel; 24-bit; up to 192 kHz; PCM, DSD/SACD formats; onboard sample rate converter; tape-style transport controls; jog/shuttle wheel; mLAN networking; PC-compatible control, logging soft-

ware; RAID formatting; USB port; FireWire port; SCSI port; remote control. XLR, BNC, AES/EBU. Choice of I/O: analog, AES3, optical MAADI, FireWire, PCM, DSD, AES3d, SDIF. 24-track; \$7,250; 48-track: \$12,200

Graff Electronic Machines

Turbotrax 3
Cassette Duplicator. Three copy wells; 16X duplication; choice of mono or stereo. Optional long-life heads. Optional erase heads.

HHB Communications USA LLC

CDR830 BurnIT PLUS
Compact Disc Recorder. Studio, post production, broadcast. CD-R/CD-RW format; 24-bit A/D-D/A; 32 - 48 kHz sample rate converter; 44.1 kHz master record sample rate; CD Text; multi-ple record modes; defeatable SCMS; Stable Platter Mechanism; headphone controls; remote control. Frequency response: 10 Hz - 20 kHz. THD: 0.003%. RCA, XLR, 1/4", optical, AES/EBU, S/PDIF. 3RU. \$649

PORTADRIE
Portable Hard Disk Recorder. Field. Hard disk format; eight-track; 24-bit, 96 kHz; onboard mixer; limiter; delay; high-pass filter; phase reverse; onboard slate mic; onboard oscillator; timecode; video sync; word clock; M/S decoding; BWF, SDII file formats; headphone controls; battery (Li ion) operable; SCSI port; RS422 port; LCD screen. XLR, optical, BNC, nine-pin D-sub, 25-pin D-sub, AES/EBU, S/PDIF. App. \$10,000

PP-MDP500 PORTADISC
Portable MiniDisc Recorder. Field, studio, broadcast. MiniDisc format; ATRAC 4.5; 32 - 48 kHz sample rates; 44.1 kHz master sample rate; 48V phantom power; bass rolloff; limiter; time/date stamp; six second buffer memory; onboard speaker; USB port; LCD; battery operable. Frequency response: 10 Hz - 20 kHz. Dynamic range: >96 dB. XLR, RCA, S/PDIF, optical. Ships with soft case, carrying strap, battery caddy, AC adaptor; MiniDisc. \$1,545

IZ Technology

RADAR 24 Nyquist
Multitrack Hard Disk Recorder. Hard disk format; 24-track; 24-bit; 32, 44.1, 48, 64, 88.2, 96 kHz sample rate; removable 36 GB hard drive; DVD-RAM drive; WAV, BWF files; editing functions; MTC; SMPTE; LTC; video sync; word clock; MIDI I/O thru; SCSI port; linkable; Ethernet; remote control; meter bridge. XLR, RCA, BNC, MIDI five-pin, nine-pin D-sub, 25-pin D-sub, S/PDIF, AES/EBU, S/PDIF, TDIF. 4RU. \$12,995

RADAR 24 Project
Multitrack Hard Disk Recorder. Hard disk format; 24-track; 24-bit; 32, 44.1, 48 kHz sample rate; 80 GB hard drive; WAV, BWF files; editing functions; MTC; SMPTE; LTC; video sync; word clock; MIDI I/O thru; SCSI port; linkable; Ethernet. XLR, RCA, BNC, MIDI five-pin, nine-pin D-sub, 25-pin D-sub, S/PDIF, AES/EBU, S/PDIF, TDIF. 4RU. \$5,995

RADAR 24 Project D
Multitrack Hard Disk Recorder. Hard disk format; 24-track; 24-bit; 32, 44.1, 48 kHz sample rate; 80 GB hard drive; WAV, BWF files; editing functions; MTC; SMPTE; LTC; video sync; word clock; MIDI I/O thru; SCSI port; linkable; Ethernet. AES/EBU, S/PDIF, TDIF, lightpipe. \$3,995

Mackie Designs Inc.

MDR24/96
Hard Disk Recorder. Studio. 24-track; 24-bit, 96 kHz; onboard 20 GB hard drive; removable drive bay; 3.5" drive; word clock; blackburst; Ethernet port;

LED meters; tape-style transport controls. 25-pin D-sub. Optional AES/EBU, ADAT, TDIF I/O cards. \$3,499

Marantz Professional

CDR300
Portable CD Recorder. CD-R/CD-RW format; 48V phantom power; level control; three-band EQ; high, band-pass filters; onboard speaker; headphone controls; shuttle wheel; CD Text. XLR, 1/4", RCA, S/PDIF. \$849

CDR500
Dual Well CD Recorder/Player. Studio, live sound, installation, broadcast. CD-R/CD-RW format; dual well (one record/one play only); 44.1 kHz sample rate; onboard sample rate converter (11 - 56 kHz); defeatable SCMS; memory buffer; CD/MD/DAT sync mode; programmable; CD Text; 2X duplication; remote control; AMX, Crestron compatible. Frequency response: 20 Hz - 20 kHz. S/N: 100 dB. Dynamic range: 86 dB. THD: 91 dB. XLR, RCA, optical. 2RU. \$849

PMD222
Portable Cassette Recorder. Field. Mono; three heads; built-in mic, speaker; two record speeds; tone control; pitch control ($\pm 20\%$); half-speed playback; 10, 20 dB pad; limiter; level control; peak indicator; VU meter; RJ11 telephone jack; low battery indicator; battery power (3 D cells). Frequency response: 40 Hz - 15 kHz. S/N: 57 dB. RCA, XLR, RJ11. 2" x 9" x 6.5". 3 lb. \$519

PMD340
CD Player. Studio, installation, live sound, broadcast. Compatible with CD-RW discs; cue; programmable playback; keypad; search functions; frame by frame search; fader start; instant start; 10-second buffer memory; jog wheel; rubber buttons; 21 programmable presets; pitch control ($\pm 12\%$); pitch bend; CD-TEXT display. RCA, XLR. \$789

PMD371
Five Disc CD Player. Installation. CD-R/CD-RW format; peak search; intro scan; fade in; syncs with Marantz cassette recorders; edit mode; remote control. Frequency response: 20 Hz - 20 kHz. Dynamic range: 96 dB. S/N: 100 dB. RCA. 3RU. \$369

PMD430
Portable Stereo Cassette Recorder. Field. Three heads; built-in mic, speaker; two record speeds; Dolby B, dbx NR; MPX filter; bias adjustment; tone control; pitch control ($\pm 6\%$); half-speed playback; 15, 30 dB pad; limiter; level control; peak indicator; VU meters; RJ11 telephone jack; low battery indicator; battery power (3 D cells). Frequency response: 35 Hz - 17 kHz. S/N: 50 - 75 dB. RCA, XLR. 2" x 9" x 6.5". 3 lb. \$699

PMD511
Dual-Well Cassette Recorder. Dual independent wells; two heads per well; separate pitch controls ($\pm 15\%$); optically sensing autoreverse; normal/high speed recording; Dolby B, C, HX Pro NR; dubbing levels controls; ALC; music search; headphone level control; LED peak meters. Frequency response: 20 Hz - 18 kHz. S/N: 56 - 72 dB. RCA. 3RU. \$749

PMD650
Portable MiniDisc Recorder. MiniDisc format; two-track/mono recording; basic editing functions; 32, 44.1, 48 kHz sample rates; 20-second (stereo), 40-second (mono) buffer memory; 48V phantom power; 15, 30 dB pad; ambient noise cancelling filter; defeatable SCMS; battery operable. Frequency response: 20 Hz - 20 kHz. XLR, RCA. 10.5" x 2.25" x 7.5". \$1,249

PMD690
Portable PC FLASH RAM Card Recorder. Field, studio, broadcast.

Langevin
by Manley Laboratories Inc.



Langevin

DUAL VOCAL COMBO

STEREO MICPRE • DI • EQ • ELOP LIMITER
BY MANLEY LABORATORIES, INC.



The Langevin Dual Vocal Combo is a 2 channel microphone preamplifier with 2 shelf equalizers plus 2 channels of electro-optical limiters. Full-on STEREO, baby!

This combo is the result of suggestions from our customers to combine two of our most popular Langevin products and make the price irresistible, half the price of the Voxbox in fact, for 2 channels of great sounding all-discrete channel strips. Sound interesting?

The DVC includes real VU meters, individual phantom power, limiter linking, and time proven circuitry. This is an ideal box for musicians and engineers on a budget and is equally at home in a big league studio, mobile recording truck, or live gig. It has the reliability, functionality, and the sound without the any of the complexity— the essential features without the “sea of knobs.” Easy on the wallet, easy to love.

Built with precision and pride by:

Manley Laboratories, Inc.

13880 Magnolia Ave. Chino, CA. 91710 USA

tel: (909) 627-4256 fax: (909) 628-2482

→ www.manleylabs.com ←



GEAR GUIDE

RECORDERS/PLAYERS

FLASH RAM card format; two-channel; 16-bit; 48 kHz sample rate; MP2/3, WAV, BWF files; high-pass filter; cue marks; limiter; built-in mic; telephone jack; headphone jack. 1/4", RCA, XLR, S/PDIF. 2" x 10.5" x 7.5". 3 lb. Also uses IBM Microdrives. Ships with strap, AC adapter, battery holder. \$1,499

MicroBoards Technology Inc.

Orbit II
Standalone CD/DVD Duplicator. CD/DVD; single read drive; robotic arm; single 40X CD duplication drive. Upgradeable DVD-R drive.
Starts at \$2,495

StartREC

CD Rackmountable Recorder/Editor/Duplicator. Five-bay (one reader, four writers); 4.2 GB hard drive; basic editing functions; programmable recording functions; 44.1 kHz sample rate; sample rate converter; 16-bit; record level controls; 8X record drives; SCMS; CD-DA, CD-ROM (Mode 1/Mode 2), XA (Form 1/Form 2), ISO9660, HFS, UFS, Hybrid, Enhanced CD, XLR, RCA, AES/EBU, S/PDIF, optical. 4RU. 30 lb. \$2,995

Mytek Digital

D-Master DSD Digital Master Recorder
Computer Hard Disk Recorder Interface. Post production. Two-channel; onboard A/D-D/A; SCSI interface; RS422 port; headphone controls; LCD screen; VU meters. XLR, BNC, nine-pin D-sub, SCSI. 1RU. \$5,995

Nagra USA Inc.

ARES-P
Handheld Solid State Recorder. Location, broadcast. PCMCIA FLASH media; 20-bit A/D-D/A; 16, 24, 32, 48 kHz sample rates; Automatic Level Control; shuttle search; G7.22, MPEG 2 compression; headphone jack; battery operation; LCD screen. \$1,750

Nagra Area-C
Portable Digital Recorder/Editor. Field, film. PCMCIA Flash media format; two-channel; 48V, 12V phantom power; level controls per channel; out, paste, copy editing; 16-bit A/D-D/A; MPEG, G7.22, G7.11, A Law, u Law compression; 16, 24, 32, 48 kHz sampling rates; telephone adapter; AC/battery operation; tape style transport controls; scrub wheel; LCD screen; VU meter. Frequency response: 30 Hz - 20 kHz. XLR. \$5,900

Nagra-D II
Portable Digital Audio Recorder. Field, studio, film. 1/4" reel-to-reel format; two or four-channel; 24-bit; 96 kHz; four hours recording; confidence monitor function; AC/battery operation; SMPTE/EBU time code; 32 - 96 kHz sampling rates available; headphone jack; RS422 port; LCD screen; VU meters. Frequency response: 20 Hz - 47 kHz. S/N: >110 dB. THD: <0.05%. XLR. \$22,000 - \$30,000

Otari Corp.

MX-5050 BIII
Reel-to-Reel Tape Recorder. 1/4" reel-to-reel tape format; 3.75, 7.5, 15 ips; level controls; pitch control ($\pm 20\%$); tone generator; VU meters. Frequency response: 30 Hz - 20 kHz. XLR. Optional 1/4 track head. \$4,452

Primera Technology

Bravo Disc Publisher
CD/DVD Duplicator/Printer. Single duplication drive; Windows 2000/XP; 2400 dpi disc printer; automated operation; 25 disc hopper; compatible with mini CD, business card CD.
CD-R: \$1,995, DVD-R: \$2,495.

ComposerMAX Optical Disc Duplicator
CD/DVD Duplicator. Two/four drives;

Windows ME/2000/XP; Pioneer DV-R drives; fully automated operation; 50 disc hopper; Prassi PrimoDVD 2.0 mastering software; compatible with Primera Signature, Inscripta disc printers. 2 CD-R drives: \$6,495. 4 CD-R drives: \$7,995. 2 DVD-R drives: \$9,995. 4 DVD-R drives: \$12,995.

Rimage Corp.

Producer II Amigo II
CD Duplication System. Windows 98/NT workstation; Everest CD/DVD printer; fully automated; networkable; compatible with most major CD formats. \$11,450

Roland Corp. U.S.

VSR-880HD Digital Studio Recorder
Hard Disk Recorder. Eight-channel; 128 virtual tracks; 24-bit; 32, 44.1, 48 kHz sample rates; three-band EQ; 999 levels of undo; full duplex; COSM microphone, guitar amp, speaker modeling; R-BUS port; SCSI port; tape-style transport controls. 1/4", RCA, MIDI 5-pin, R-Bus. 2RU. \$1,795

Soniflex/Independent Audio

Courier CO-USB
Portable Hard Disk Recorder. Field, broadcast. PCMCIA card media format; 16, 22, 025, 24, 32, 44.1, 48 kHz sample rates; scrub editing wheel; cut and paste editing; MPEG Layer 2, WAV, BWF, AIFF files; ISDN; Enco DADPro32 compatible; single stereo/mono channels; modem; 48 V phantom power; high-pass filter; limiter; battery power; compatible with Digigram, Artex broadcast audio cards. XLR, RS232. \$2,800

Sony Electronics

CDP-D11
Rackmounted CD Player. Studio, live sound, installation. Cue functions; $\pm 12.5\%$ pitch; Instant Start; three second shock buffer; jog/shuttle dial; RS232 port; headphone control; remote control. XLR, RCA, optical, nine-pin D-sub. 1RU. \$770

CDR-W66
CD Recorder. CD-R/CD-RW; 24-bit; onboard sample rate converter; onboard DSP programs (EQ, limiter, Super Bit Mapping); word clock; 2X duplication; CD Text; PS2 port; remote control. XLR, RCA, optical, AES/EBU, nine-pin D-sub. 2RU. \$1,150

MDS-E12
MiniDisc Recorder/Player. Live sound, broadcast, installation. 24-bit; ATRAC Type R; MD ATRAC 3 long play; RAM edit; pitch control; autolock; 10 hot starts; A-B erase; PS2 port; RS232 port; linkable; ships with remote. RCA, XLR, S/PDIF, nine-pin D-sub. \$945

MXD-D40
CD Player/MiniDisc Recorder/Player Combo. Broadcast, live sound, installation. 4X CD to MiniDisc copy function; 20-bit A/D; long play mode; pitch control; CD Text, scale factor editing; ATRAC 3, 4.5. RCA, optical. \$360

PCM-M1
Portable DAT Recorder. Studio. DAT format; two-channel; Super Bit Mapping; 20-bit converter; 32, 44.1, 48 kHz sample rates; adjustable recording levels; automatic volume limiter; automatic gain control; switchable SCMS; NiMH battery. \$1,075

PCM-R300
Rackmountable DAT Recorder. Studio. DAT format; two-channel; Super Bit Mapping; 16-bit; 32, 44.1, 48 kHz sample rates; two-speed recording; auto head-cleaning; sync threshold level; switchable SCMS; A/D, D/A monitoring; error readout; remote control. RCA, S/PDIF. \$345

PCM-R700
DAT Recorder. Studio. DAT format; two-channel; four heads; four motor direct drive transport; confidence monitoring; Super Bit Mapping; menu system; auto head-cleaning; variable speed cue/shuttle knob; -10/+4 dB operation; headphone controls; remote control. XLR, RCA, coaxial, AES/EBU, S/PDIF. 19" x 14" x 6". 16 lb. \$3,150

TCD-D10 Pro II
Portable DAT Recorder. Field. DAT format; 16-bit; 32, 44.1, 48 kHz sample rate; built-in speaker; low-cut filter; mic attenuator; battery or AC operation; LCD screen; AC adapter. RCA, XLR, AES/EBU. 10" x 7.75" x 2.25". \$4,750

Superscope Technologies Inc.

PSD300
Portable CD Recorder/Player. Live sound. CD-R format; dual well; CD-R recording drive, CD playback drive; three-band EQ; pitch control; tempo control; onboard mic preamps; onboard speaker; headphone controls. RCA, XLR, 1/4". \$1,099

TASCAM

122MKIII
Cassette Deck. Studio, broadcast, post production, installation. Four-track; three cobalt amorphous heads; Dolby B, C, HX Pro; auto tape selection; tape bias control; tone level calibration; memory functions; two motor IC logic transport; electronic tape counter; MPX filter; pitch control ($\pm 12\%$); headphone controls; parallel port; VU meters. XLR, RCA. 2RU. \$1,499

202MKIII
Dual Well Dubbing Deck. Dual-well; analog cassette format; Dolby B, C, HX Pro; sync reverse; autoreverse; input, balance controls; record mute function; continuous loop; two speeds; headphone controls. \$525

322
Analog Cassette Recorder. Installation. Analog cassette format; optical leader sensor; autoreverse; pitch control ($\pm 10\%$). RCA. \$799

788 Digital Poststudio
Eight-track Mixer/Recorder. Eight-track; hard disk format; 24-bit; eight faders; onboard DSP (reverb, chorus, delay, noise gate, de-esser, multi-effects); three-band EQ; MMC; MTC; pitch control ($\pm 6\%$); tape-style transport controls; SCSI port. 1/4". \$1,149

BR-20
Two-Track 1/4" Tape Recorder. Studio, post production, broadcast. Two-track; 1/4" analog tape format; three-head design; fader/event start; dual speed (15, 7 1/2 IPS); 20 dB pad; cue; input level controls; pitch control ($\pm 12\%$); calibration; 10 1/2" reel compatible; tape counter; splicing block. XLR, RCA. \$3,699

CC-222
CD-RW/Cassette Deck Combo Unit. CD-R, CD-RW, analog cassette formats; defeatable SCMS; Dolby B; pitch control ($\pm 12\%$); RIAA equalization; 1 - 24 second fade in; wired remote. RCA, optical. 3RU. \$875

CD-450
Compact Disc Player. Studio. Autolock; autoready; fader/event start; programmable; pitch control ($\pm 12\%$); timer; numeric keypad; headphone controls. RCA. 2RU. \$799

CD-D1x4
Rackmounted CD Duplicator. Four TEAC 16X CD duplicator drives; CD-RW-compatible; CD-R-DA, CD-RW-DA; verify; linkable. 4RU. \$1,999

CD-RW2000
Compact Disc Recorder. Studio, broadcast. CD-R/CD-RW formats; 24-bit A/D-D/A; sync start; auto, manual

track increment; onboard sample rate converter; 44.1 kHz master record sample rate; RAM buffer; word clock; defeatable SCMS; input level controls; output level trim control; headphone controls; 25-track program play; wired remote. XLR, RCA, optical, BNC, AES/EBU, S/PDIF. 2RU. \$1,125

CD-RW402
Dual Drive CD Recorder/Duplicator. CD-R/CD-RW formats; 4X duplication; 24-bit A/D-D/A; TOC edit; stutter scrub; pitch control ($\pm 9.9\%$); onboard sample rate converter; RAM buffer; defeatable SCMS; locate points; CD Text; headphone controls; PS2 keyboard port; headphone controls; wired remote. XLR, RCA, optical, AES/EBU, S/PDIF. \$1,249

CD-RW4U
Outboard CD-RW Drive. CD-R, CD-RW formats; defeatable SCMS; 20-bit A/D-D/A; onboard sample rate converter; mute; shuffle; input level control meter; LED screen; wireless remote. RCA, 1/8". \$479

DA-40
Digital Audio Tape Recorder. Studio, broadcast. DAT format; two-channel; 32, 44.1, 48 kHz sample rates; 12 - 16 bit; input controls; variable speed jog wheel; two record speeds; defeatable SCMS; selectable copy ID; switchable balance/unbalance. XLR, RCA, AES/EBU, S/PDIF, 15-pin D-sub. 3RU. \$1,399

DA-60MKII
Four-Head Time Code DAT Recorder. Studio, post production, video. DAT format; four-head; multiple time code format support; Sony P2 compatible; memory function; subcode edit; word clock; video sync; pitch control ($\pm 12\%$); confidence monitoring; calibration; heavy-duty transport system; jog wheel; headphone controls. XLR, RCA, nine-pin D-sub. \$6,999

DA-78HR
DTRS Recorder. Studio, post production. Eight-track; 16 - 24-bit, 128X oversampling; delta-sigma A/D-D/A; 44.1, 48 kHz sample rates; Auto Track Finding; SMPTE timecode; word clock; onboard oscillator; pitch control ($\pm 6\%$); digital patch bay; jog/shuttle wheel; Application Specified Integrated Circuit. TDIF, RCA, S/PDIF, 25-pin D-sub. 3RU. \$3,399

DA-98HR
DTRS Recorder. Studio, post production. Eight-track; 24-bit; 44.1, 48 kHz sample rate; four track 88.2/96 kHz performance; two-track 176.4/192 kHz performance; pitch control ($\pm 6\%$); MMC; SMPTE timecode; video sync; word clock; confidence monitoring; jog/shuttle wheel; LCD panel; RS422 port; connect 16 machines for 128 tracks. RCA, 25-pin D-sub, TDIF, XLR, BNC. 4RU. \$6,999

DA-P1
Portable DAT Recorder. Field, broadcast. DAT format; limiter; 20 dB pad; 48V phantom power; 32, 44.1 kHz sample rates; defeatable SCMS; built-in LCD; quick change battery operation. Frequency response: 20 Hz - 20 kHz. THD: 0.004%. S/N: 92 dB. Dynamic range: 93 dB. XLR, RCA, S/PDIF. \$2,199

DSD-98
DSD/SACD Recorder. Studio, post production. DTRS format; eight-track; DSD two-track; 24-bit; 44.1, 48, 88.2, 96, 176.4, 192 kHz sample rate; four track 88.2/96 kHz performance; two-track 176.4/192 kHz performance; pitch control ($\pm 6\%$); MMC; SMPTE timecode; word clock; confidence monitoring; jog/shuttle wheel; LCD panel; RS422 port. XLR, BNC, 25-pin D-sub, TDIF, SDIF. \$9,500

MD-801RMKII
MiniDisc Recorder. Studio, installation,

broadcast, live sound. Two-channel; 20-bit A/D-D/A; sample rate converter; 44.1 kHz master record sample rate; ATRAC 4.5 recording; pitch control ($\pm 9.9\%$); editing functions; input level controls; incremental play; track replace; Sound Sync automatic record function; autolock; word clock; PS2 keyboard port; RS232 port; headphone controls; jog wheel. RCA, XLR, BNC, AES/EBU, S/PDIF, nine-pin D-sub. 3RU. \$699

MX-2424
Multitrack Hard Disk Recorder. Studio, post production, broadcast. 24-track; 16, 24-bit; 44.056, 44.1, 44.144, 47.952, 48, 48.048, 88.112, 88.2, 88.288, 95.904, 96, 96.096 kHz sample rates; 9 GB hard drive; jog/scrub wheel; SMPTE; LTC; MTC; MMC; NTSC, PAL video sync; drop frame rates; word clock; SCSI 3 port; compatible with AIFF, BWF, SDII files; ViewNet Windows/Mac controller software; LED meters; linkable up to 32 units. Frequency range: 20 Hz - 48 kHz. TDIF, ADAT optical, AES/EBU, S/PDIF, RCA, MIDI, BNC, XLR, 25-pin D-sub. 4RU. \$3,999

Pocketstudio 5
Portable Multitrack Recorder. CompactFlash format; four-track; 100 effects; basic editing functions; MIDI, MP3; tape-style transport controls; USB port; shuttle wheel; LCD screen; battery operable. 1/4", 1/8". \$499

Telex Communications Inc.

SpinWise 1-16
CD Duplicator. Two-bay; one record bay; rackmountable; 16X drives. \$699

SpinWise 6-16
CD Duplicator. Six-bay; six recording drives; internal hard drive; verification; programmable operation; rackmountable; 16X drives. 3RU. \$3,195

Yamaha Corp. of America

MD8
Multitrack MD Mixer/Recorder. Studio. Up to eight tracks of simultaneous recording and playback; 44.1 kHz sampling; ATRAC compression; jog/shuttle dial; three-band EQ; MIDI in/out thru; MIDI clock out; MTC; MMC receive; part copy, track copy, song copy, song renumbering and tempo map editing functions. XLR, 1/4", RCA. \$1,399

Zaxcom Inc.

Deva II
Portable Digital Recorder/Mixer. Field. Four-channel; 20-bit A/D-D/A; 30/40 GB hard drive; removable media drive; level control per channel; onboard comp/lim, parametric EQ, gate; effects; basic mix functions; SMPTE timecode; 48V phantom power; numeric keypad; cue memory; RS422 remote port; LCD screen; NP1 battery. AES/EBU. 8" x 3" x 7.25". \$9,950

Zoom

MRS-1044
Multitrack Hard Disk Mixer/Recorder. Hard disk format; 10-track; 24-bit A/D-D/A; two-band EQ; onboard effects; 84 Variable Architecture Modeling System effects; onboard drum/rhythm machine; touch sensitive drum pads; tape-style transport controls; shuttle wheel; 20 GB hard drive; basic editing functions; scene memory; marker points; bounce mode; LCD screen. XLR, RCA, 1/4", optical, five-pin MIDI, S/PDIF. Optional SCSI, USB interfaces. Version with 40 GB hard drive and CDR-RW burner, \$1,999. \$1,199

PS-02 Personal Studio
SmartMedia Format Handheld Recorder. Three-track; onboard DSP effects; onboard sampler library; battery operable; LCD screen; 20-bit A/D-D/A; onboard mic; headphone control. 1/4", mini. \$539

GEAR GUIDE

RECORDING MEDIA

FujiFilm USA Inc.

CD-R Audio

CD-R format; compatible with consumer and pro; 80 minute.

DPA

ADAT format; library case; 42-minute length.

DPD

DTRS format; Advanced Super Thin Layer and High Output Magnetic Media tape; lubricant; library case; 30, 60, 113 minute lengths.

DVD-R

DVD-R Authoring Disc. 4.7 GB.

DVD-RAM

DVD-RAM Disc. 4.7 GB, or 9.4 GB.

Professional Digital Audio Tape

DAT format; Super Fine Metallix particles; Flexible 3-D Network Binder; Ultra-smooth Polyester Base; 15, 34, 48, 64, 94, 124 minute lengths.

HHB Communications USA LLC

ADAT 4S/ADAT 60

ADAT Type II format; ultrafine cobalt ferric oxide particles; high density binder. 45, 60 minute lengths.

CDR80 Silver

CD-R format; silver reflective layer; phthalocyanine dye recording layer; exceeds Orange Book standards. 80-minute; inkjet or thermal printable surfaces.

Digital Audio Tape

DAT format; anti-static lid; ships with shatterproof polypropylene case. 15, 35, 50, 65, 95, 125 minute lengths.

DTRS Tape

DTRS-AH-8 format; Hi-pack metal magnetic particles; flexible base; metal binder. 30, 60, 113 minute lengths.

DVD Discs

DVD-R, DVD+R, DVD-RW, DVD+RW formats; general and authoring discs; purple cyanine dye; inkjet printable surface. 4.7 GB capacity.

DVD-RAM Single Sided

DVD-RAM format disc; Type 2; phase-change rewritable disc; double sided; protective cartridge. 4.7 GB capacity.

MD74/MD80

MiniDisc. 74, 80-minute versions; UV coating; loil shutter; lubricated; 1+ million read/write cycles.

Maxell Corp. of America

48X CD-R

48X-compatible; 700MB.

4X DVD-R

DVD-R format; 4X-compatible; 4.7GB.

ADAT 400A

ADAT format; Anchor Effect Interaction binder; black magnetite particles; Smooth Winding Reel.

DAT Certified Digital Audio Tape Cassettes

DAT Cassette. 19, 34, 49, 64, 94, 124-minute lengths.

DRS-1130

DTRS format; high-output magnetic particles; dust-resistant case.

DVD-RAM Disc

DVD-RAM II; 4.7GB single side, 9.4GB double side.

MD-PRO

MiniDisc format; lubricated surface; 1,000,000+ write/erase cycles; sealed shell; 74 minute length.

MS Studio

Analog Cassette. Type II; 20, 30, 60, 90-minute lengths.

Ultrium 2

Linear Tape Open (LTO) format; 200GB; 20 - 40 MBps.

XLI

Analog 1/4" Reel-to-Reel Tape. Polyester binding; Epitaxial particles; carbon backcoating; 550m, 1100m lengths.

Mitsui Advanced Media

Gold Archive

Optimized for audio; gold reflective layer; phthalocyanine dye; Diamond Coat protective surface; 700MB; 24X.

Inkjet CD-Rs

Varieties compatible with inkjet printers; 650 MB.

Pro Audio CD-R 80 Mins.

CD-R Disc. Phthalocyanine dye; UV-resistant; Diamond Coat protective surface; 700MB; 24X.

Quantegy Inc.

467

Open Reel DASH Tape. DASH format; 1/4", 1/2", 1" widths; polyester base; each 1/2" and 1" reel is tested. 4,800', 7,200', 9,700' lengths.

472

Analog Cassette. High bias; polycarbonate shell. 10, 20, 30, 45, 60, 90

minute lengths.

ADAT

Cassette. 42, 60-minute lengths.

DA8

DTRS Cassette. 30, 60, 113 minute lengths.

DAT

DAT Cassette. Special carbon backing; 16, 34, 48, 64, 94, 124 minute lengths.

DAU Digital Audio Mastering

Cassette U-Matic Cassette. U-matic cassette format; 30, 60, 75, 83-minute lengths.

Gold CDR

CD-R Disc. Gold phthalocyanine dye reflective layer; writable surface.

Grand Master 456

Reel-to-Reel Tape. 1/4", 1/2", 1", 2" widths. 1,200', 2,500', 5,000' lengths.

MDR Recordable MiniDisc

MiniDisc. 74-minute length.

Ricoh Disc Media Systems Center

CD-R

CD-R format; phthalocyanine dye; 12X; 80 minute; 700 MB; Orange Book standard.

Sony Media Solutions

DASH Open Reel Digital Tape

DASH Reel-to-Reel Tape. DASH format; 1/4" and 1/2" widths.

DASV Series

ADAT Cassette. 40, 60-minute lengths.

DAT Cassettes

DAT format; ultrafine "Crystal Art" metal particle; locking cassette lid. 30, 74, 90, 120 minute lengths.

DTRS-MP Digital Multitrack Tape

DTRS format; metal particle; ABS plastic shell cassette; antistatic lid; 30, 60, 113-minute lengths.

Pro MiniDisc

MiniDisc format; jewel case; 80-minute length.

TASCAM

TEAC CD-R/CD-RW

CD-R/CD-RW format; 12X CD-R, 4X CD-RW; 700MB/74 min.; phthalocyanine; silver reflective layer. Available single, three-pack, 25-disc spindle.

TDK Data Storage Media

DAT

DAT Cassette. 16, 60, 90, 120, 180-minute lengths

Hi-8 Pro

DTRS Cassette. 25, 50, 75, 100-minute lengths.

MA

Analog Tape Cassette. Type IV; 60, 90, 110-minute lengths

MD-XG

MiniDisc. 74-minute.

SA-X

Analog Tape Cassette. Type II; 60, 90, 100-minute lengths.

ST-CM

ADAT Cassette. 10, 20, 40-minute lengths.



Fat Man. The easy, affordable way to add tube warmth to your mix

With 16 stunning presets configured for everything from vocals to drums, the original HHB Radius 3 Fat Man stereo tube compressor makes it easy to add the unique sweetness of vacuum tubes to your mix. And with a new low price* the Fat Man stereo tube compressor has never been more affordable. So if your tracks could use some vintage tube warmth, get down to your nearest HHB dealer and make a date with the Fat Man.

* Ask dealer for details.



FIRST WE LISTEN

HHB USA: 805 579 6490
HHB Canada: 416 867 9000

www.hhbusa.com

GEAR GUIDE

SPEAKERS/MONITORS

ADAM Audio USA

P11-A
Active Closefield Monitor. Studio, post production. Two-way; 7" Nomex woofer; Accelerated Ribbon Technology folded ribbon tweeter; room EQ, gain controls; onboard twin 80W amps; shielded; bass port. Frequency response: 48 Hz - 35 kHz. XLR. 13" x 8.25" x 11". 22 lb. \$1,700 per pair

S2-A
Active Studio Monitor. Studio. Two-way; 7.25" Hexacone Kevlar-treated Nomex woofers; Accelerated Ribbon Technology folded ribbon tweeter; gain, room EQ controls; twin onboard 150W amps; bass port. Frequency response: 35 Hz - 35 kHz. XLR. 15" x 9" x 13". 29 lb. Passive version, S3: \$1,700 per pair. \$2,900 per pair

S3-A
Active Studio Monitor. Studio. Three-way; twin 7.25" Hexacone Kevlar-treated Nomex woofers; Accelerated Ribbon Technology folded ribbon tweeter; gain, room EQ controls; three onboard 150W amps; bass ports. Frequency response: 32 Hz - 35 kHz. XLR. 24" x 14" x 18". 35 lb. Passive version, S3: \$2,800 per pair. \$4,400 per pair

S4C-A
Active Studio Monitor. Studio.

Three-way; twin 9" Hexacone Kevlar-treated Nomex woofers; Accelerated Ribbon Technology folded ribbon tweeter; gain, room EQ controls; four onboard 150W amps; bass ports. Frequency response: 28 Hz - 35 kHz. XLR. 14.5" x 27" x 18". 71 lb. Passive version, S4: \$5,700 per pair. Available in upright column configuration: \$8,200 per pair (powered), \$6,200 per pair (passive).

Sub-P
Powered Subwoofer. Studio, post production. 11" coated paper woofer; level, crossover, satellite crossover controls; phase control; onboard 200W amp; bass port. XLR, RCA. 20" x 12" x 16". 70 lb. \$1,500

Adamson Systems Engineering

MH121.5
Loudspeaker. Sound reinforcement, live sound, installation. 2-way active or passive models; 12" AW12 low-frequency driver; 1.5" compression high-frequency driver; Adamson Acoustic Waveguide; Baltic birch trapezoidal cabinet; socket mount; 14 gauge steel grille; dual component resin finish. Frequency response: 55 Hz - 18 kHz. Max SPL: 136 dB. Crossover @ 1.5 kHz. Neutrik NL4 Speaker. 26" x 17.5" x 15.25". 63 lb. \$2,995

RA3B
Subwoofer. Sound reinforcement, live sound, installation.

Three 18" Kevlar AW18 low-frequency drivers; Baltic birch cabinet; flypoints; rigging; steel frame; steel grille; dual component resin finish. Frequency response: 30 - 200 Hz. Max SPL: 134 dB. Neutrik NL8 Speaker. 42" x 28" x 29.5". 235 lb. Ships with dolly. \$6,200

Agular Amplification

GS112
Speaker. Two-way; 12" woofer; tweeter. Power handling: 300W. 1/4", Speaker. \$449

Alesis

M1 MKII Active Bi-amplified Reference Monitor
Bi-amplified Monitor. Studio. Two-way; 6.5" carbon fiber woofer; 1" silk dome ferrofluid-cooled tweeter; shielded; 75 W LF amp; 25 HF amp; time adjusted; input level control. Frequency response: 38 Hz - 23.5 kHz. Crossover @ 1.5 kHz. XLR, 1/4". 8.5" x 15" x 9.75". 19.5 lb. \$649 per pair

ProLinear 820
Powered Speaker. Two-way; 8" polypropylene woofer; 1" cloth dome tweeter; onboard DSP functions; four-band parametric EQ; high-pass filter; factory presets; memory; magnetic shielding; onboard 100W LF amplifier; onboard 50W HF amplifier; Windows/Mac software; RS232 port; LCD screen. XLR, 1/4", nine-pin D-sub.

\$1,299 per pair

Allen Audio Inc.

Corinthian
Speaker. Installation, live sound, sound reinforcement. Two-way; 6.5" cone woofer; 1" selenium tweeter with 40 degree x 60 degree horn; trapezoidal cabinet. Frequency response: 100 Hz - 20 kHz. Impedance: 8 ohms. Binding posts. 25" x 9" x 7.5". 25 lb. \$550

Foundation
Subwoofer. Installation, live sound, sound reinforcement. Twin 12" woofers; bass port. Frequency response: 40 - 400 Hz. Impedance: 4 ohms. 32.75" x 17" x 19". 70 lb. Choice of black, white or wood finish. \$1,250

Ambiance Acoustics

California Cube
Closefield Monitor. Studio. Four 4.5" full range treated paper cone drivers; outboard active equalization; bass rolloff; tape monitor loop; bypass. Frequency response: 45 Hz - 17 kHz. Sensitivity: 90 dB 1W/1m. Impedance: 8 ohms. Five-way binding posts. 13.5" x 13.5". \$1,295

Amplivox Portable Sound Systems

SW122A/SW132A Wireless Roving Rostrum
Portable PA System. Live sound. Two speakers; onboard

50W amp; onboard wireless mic receiver; wired mic inputs; aux input; ships with lapel mic and wireless transmitter. With onboard CD and cassette players, SW132A: \$1,054 \$944

Anchor Audio/Communications

Xtreme MPA-5600
Powered PA System. Live sound. Onboard CD player, Shure Wireless mic system, 130W amp; bass, treble, volume controls; automatic music, speech modes. 15.25" x 12.25" x 26.75". 40 lb. \$1,060

Apogee Sound

FS-2
Stage Monitor. Live sound. Two-way; 12" fluid-cooled woofer; 2" fluid-cooled compression driver coupled to polyurethane horn; biamped; wedge-style cabinet. Frequency response: 50 Hz - 19 kHz. Max SPL: 132 dB. Power handling: 1,600 W. Neutrik NL-4. 22.5" x 13.75" x 19.25". 55 lb. Weatherized version, \$2,452. \$2,043

Applied Research & Technology

SLM-1 Studio Monitor
Closefield Monitors. Two-way; 6.5" woofer; 1" soft dome ferrofluid-cooled tweeter; magnetic shielding. Frequency response: 40 Hz - 20 kHz. Power handling: 70W, program. Binding posts. \$299 per pair

ATC Studio Monitors/Transamerica Audio Group

SCM10ASL Pro
Two-Way Monitor. Studio. Two-way; 5" bass cone with 1.75 soft dome mid; Super Linear Magnet System; 1" tweeter. Frequency response: 65 Hz - 20 kHz. Max SPL: 103 dB. Crossover @ 2.8 kHz. Sensitivity: 80 dB 1 W/1 m. Impedance: 8 ohms. 4mm. 15" x 7" x 10". 22 lb. \$3,000 per pair

Sub 1/12 Pro
12" ATC SL woofer; crossover, contour, level, phase controls; onboard 1,000W amplifier. 23" x 19.75" x 23". 114 lb. \$4,900

Atlas Sound

1015
Two-Way Speaker. Sound reinforcement. Two-way; 15" subwoofer; 2" x 6" high-frequency horn; Power Sentry horn protection circuit; ten degree trapezoidal cabinet with interlocking dado construction; interlocking trap protective corners; steel grille. Frequency response: 36 Hz - 30 kHz. Impedance: 8 ohms. 1/4", five-way binding post. 28.75" x 22" x 16.5". 62 lb. \$330

20115S
Subwoofer System. Sound reinforcement. 15" bandpass design; die cast sub with 3" voice coils; 3" sound ports; dado interlocking construction; interlocking corners; grip bar handles; pole mount. Frequency response: 35 Hz - 145 Hz. Impedance: 8 ohms. 1/4", five-way binding post. 28.75" x 22.75" x 17.5". \$340

Audix Corp.

PH5-vs
Two-Way Powered Speaker. Studio, broadcast. Two-way; 5.25" polycarbonate woofer; 75" ferrofluid-cooled polycarbonate dome tweeter; shielded; 25 Watt

per channel amp; volume control; ABS molded composite cabinet. Frequency response: 75 Hz - 20 kHz. Impedance: 4 ohms. Sensitivity: 90 dB 1 W/1m. RCA, 1/4". 6.3" x 9.3" x 6.5. 11 lb. \$299

Bag End

Crystal-R Time-Align
Speakers. Sound reinforcement, live sound. Two-way; twin 12" cone with 3" voice coils; 3" titanium diaphragm with 1.4" compression driver with waveguide; time aligned; 14-gauge steel grille; 13-ply birch plywood cabinet; integral flypoints; integral handles; ATM FlyWare compatible. Frequency response: 80 Hz - 18 kHz. Sensitivity: 103 dB 1 W/1 m. Impedance: 8 ohms. Power handling: 800 W. Crossover @ 1.9 kHz. Banana, 1/4", Neutrik NL4MP Speaker. 38" x 14" x 16". 110 lb. Optional install version, Crystal-I, \$2,880. \$3,160

Infrasub-18
Powered Subwoofer. Studio, post production. 18" front firing cone woofer; onboard Extended Low-Frequency processor; 400 W amp; overload amp protection; 3/4" MDF cabinet. Frequency response: 8 - 95 Hz. RCA, spring terminals. 23.5" x 21.25" x 18.25". 92 lb. Optional finishes. \$1,670

MM-6 Time-Align
Nearfield Monitor. Studio, post production. Two-way; Time Aligned 8" coaxial low-frequency cone driver with 1" aluminum compression high-frequency driver; three EQ settings. Frequency response: 100 Hz - 20 kHz. Power handling: 150 W. Sensitivity: 93 dB 1m/1 W. THD: <1%. Crossover @ 1.9 kHz. Five-way binding post. 17.5" x 12.25" x 8". 31 lb. \$1,320

TA5000-C Time-Align
Speaker. Live sound, sound reinforcement. Two-way; 15" low-frequency cone; 1" compression driver; Time Aligned. Sensitivity: 101 dB 1W/1m. Power handling: 200 W. Impedance: 8 ohms. Banana, 1/4", Neutrik NL4MP Speaker. 28" x 22.5" x 19". 70 lb. Optional install version, TA5000-I, \$1,150. \$1,140

Behringer

Truth B2031
Active Studio Monitor. Studio. Two-way; 8.75" woofer; 1" ferrofluid-cooled titanium dome tweeter; input trim control; 150W onboard amp. Frequency response: 50 Hz - 21 kHz. XLR, 1/4". \$490 per pair

BGW Systems Inc.

M2200I
Powered Subwoofer. Installation, live sound, sound reinforcement. Four 15" drivers with copper edge wound voice coils; selectable SwitchSet crossover/Linkwitz Riley filters (63, 71, 80, 89, 100, 112, 125, 140, 160, 180 Hz); onboard BGW GTA amp; variable speed cooling fan; heat sink; 14 gauge steel grille; 1" MDF cabinet; carpeted. Frequency response: 25 - 180 Hz. Max SPL: 130 dB. Amp power output: 1,900 W. XLR, terminal strip. 33.75" x 42.75" x 31". 454 lb. Touring version, M2200T: \$8,600. \$7,000

Acoustics First® Materials To Control Sound And Eliminate Noise

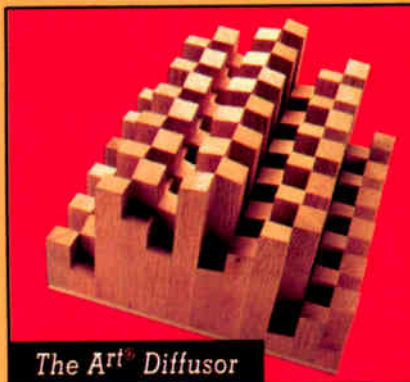

The A^{RT} Diffusor



Respond Absorber Panels

Sound
Absorbers

Noise
Barriers

Sound
Diffusers

Noise
Isolators

Toll Free

1-888-765-2900

Web: <http://www.acousticsfirst.com>

SPEAKERS

Blue Sky International/Group One

Sky System One

Powered Speaker/Subwoofer System. Studio. Separate speaker and subwoofer; two-way satellite: 6.5" woofer, 1" tweeter; 12" woofer for powered subwoofer; onboard bass management module for subwoofer. XLR. Stereo and sub, 2.1 configuration: \$1,595. 5.1 configuration: \$3,795.

BSS Audio/Harman Pro North America

9088II

Digital Network Sound System Processor. Installation. Modular system; eight outputs, eight analog inputs; choice of digital inputs; 200 MIPS processing power; networkable; Soundweb designer software. 1RU. Optional AES/EBU I/O card. \$4,999

Califone International

PA-300 Plus Amplified Speaker

Two-way; 5.25" woofer; 13mm Mylar dome tweeter; phantom power; two-band EQ; onboard amplifier; infrared remote control; LED meter. Frequency response: 60 Hz - 20 kHz. Max SPL: 104 dB. XLR, RCA, 1/4". 6.25" x 10" x 8.5". 10 lb. \$349

Carvin

1562

Speaker. Sound reinforcement, live sound. Twin 15" woofers; horn protection; seven-ply poplar plywood cabinet; handles; Duratuff II finish. Frequency response: 40 Hz - 19 kHz. Sensitivity: 102 dB 1W/1m. Power handling: 600 W. Impedance: 4 ohms. 1/4", Speakon. 17" x 15.25" x 44.25". 75 lb. \$369

FH1801

Folded Horn Subwoofer. 18" woofer with 4" voice coil; kolded horn design; casters; pole mount; steel corners; steel grille; DuraTuff II exterior coating. Frequency response: 50 - 350 Hz. Sensitivity: 102 dB 1W/1m. Impedance: 8 ohms. 1/4", Twist-Lok. 24.25" x 30" x 40.25". 116 lb. \$549

S400 StageMate

PA Powered Speaker. Live sound. Two-way speaker; onboard four-channel mixer; two-band EQ, effects loop per channel; onboard digital effects; master input level controls; onboard 100 W amp; battery operable. Frequency response: 65 Hz - 16.5 kHz. 1/4", RCA, XLR. 12.75" x 11.5" x 18.5". 34 lb. \$399

SRS6.5

Studio. Two-way; 6.5" woofer; magnetic shielding; contour/flat switch; DuraTex finish. Frequency response: 50 Hz - 20 kHz. Sensitivity: 92 dB 1W/1m. Power handling: 125W, program. Five-way binding posts. 9.25" x 9" x 14.75". 21 lb. \$149 each/\$279 per pair

SW1802

Subwoofer. Sound reinforcement, live sound. Twin 18" woofers with 4" voice coils; handles; Duratuff II finish. Frequency response: 35 Hz - 1 kHz. Sensitivity: 97 dB 1W/1m. Power handling: 1,600 W. Impedance: 4 ohms. 1/4", Speakon. 48" x 24" x 31". 159 lb. \$699

TCS115M

Stage Monitor. Two-way; 15" woofer; flypoints; 13-ply Baltic birch cabinet; DuraTex exterior coating. Frequency response: 55 Hz - 15 kHz. Impedance: 8 ohms. 29.25" x 17" x 17". 68 lb. \$439

CE Distribution

Jensen Speakers

Raw Drivers. 8", 10", 12", 15"; alnico; ceramic. \$40 - \$100

Celestion Professional/Group One.

CX11022

Two-way; 10" Kevlar impregnated cone woofer; 2" tweeter on a rotatable NoBell resonance inhibited horn; 60 x 40 degree coverage pattern; birch plywood cabinet; flypoints. Frequency response: 120 Hz - 20 kHz. Sensitivity: 102 dB 1W/1m. Impedance: 8 ohms. \$1,799

CX11811

Subwoofer. 18" woofer with 4" voice coil; horn-loaded; birch plywood cabinet; flypoints; mounting hardware. Frequency response: 45 - 450 Hz. Sensitivity: 104 dB 1W/1m. Impedance: 8 ohms. \$1,499

KR1

Installation. Two-way; 5.25" coaxial woofer with polymer HF driver; PowerGuard protection circuitry; steel grille. Frequency response: 90 Hz - 20 kHz. Sensitivity: 90 dB 1W/1m. 25V/70V/100V version, KR1/T: \$229 per pair. \$199 per pair

Cerwin-Vega

AB-36 Afterburner

Subwoofer. Live sound. 18" woofer; horn-loaded; heat sink; carpeted exterior. Sensitivity: 108 dB 1W/1m. 1/4", Speakon. 36" x 24" x 36". 166 lb. Painted finish: \$1,400. \$1,300

S-36 Earthquake

Live sound. 18" woofer; horn-loaded; handles; casters; carpeted exterior. Sensitivity: 107 db 1W/1m. 1/4", Speakon. 36" x 24" x 36". 166 lb. Painted finish: \$1,100. \$1,000

Sub-15 MKII

Subwoofer. Live sound. 15" woofer; pole mount; carpeted exterior. Sensitivity: 101 dB 1W/1m. 1/4", Speakon. 24" x 18" x 19". 51 lb. Painted finish: \$600. \$500

T-36/750

Subwoofer. Live sound. 18" woofer; horn loaded; carpeted exterior; trapezoid cabinet. Sensitivity: 108 dB 1W/1m. 1/4", Speakon. 36" x 24" x 36". 148 lb. Painted finish: \$1,400. \$1,300

V-253 MKII

Two-way; twin 15" woofers; carpeted exterior. Sensitivity: 106 dB 1W/1m. 1/4", Speakon. 49" x 24" x 19". 115 lb. Painted finish: \$1,300. \$1,200

Community Professional Loudspeakers

CPL27

Speaker. Two-way; twin 8" low-frequency drivers; 1" high-frequency dome 100 x 100 degrees; PowerSense Dynamic Driver Protection; trapezoidal cabinet; steel grille. Frequency response: 40 Hz - 20 kHz. Power handling: 500 W program. Barrier strip. Ships with yoke bracket. Optional 70V version, CPL27T: \$410. \$365

CSV38M

Stage Monitor System. Sound reinforcement. Two-way; 15" low-frequency ferrofluid-cooled driver; PZT high-frequency driver; PowerSense Dynamic Driver protection; high-density particle board cabinet; threaded insert mounting points; oak laminate finish. Frequency response: 60 Hz - 18 kHz. Power handling: 375 W program. Neutrik, 1/4". 41 lb. \$658

CSV52

Speaker System. Sound reinforcement. Three-way; 15" ferrofluid-cooled low-frequency driver; 6.5" medium-frequency driver; PZT high-frequency driver; PowerSense Dynamic Driver protection; high-density particle board cabinet; threaded insert mounting points; oak laminate finish. Frequency response: 40 Hz - 18 kHz. Power handling: 500 W program. Neutrik, 1/4". 88 lb. Optional mounting kits. \$1,028

MVP35

Live sound, sound reinforcement. Two-way; 15" woofer; .75" ferrofluid-cooled tweeter; 90 x 40 degree coverage pattern; Thermal-Link driver protection; recessed handles; 16-gauge steel grille; rigging points; rubber feet; black carpet exterior. Frequency response: 65 Hz - 16 kHz. Sensitivity: 95 dB 1W/1m. Impedance: 8 ohms. 46 lb. \$437

MVP38

Floor Monitor. Live sound, sound reinforcement. Two-way; 15" woofer; LM20 ferrofluid-cooled tweeter; Thermal-Link driver protection; recessed handles; wedge cabinet; 16-gauge steel grille; black carpet exterior. 1/4". \$437

MVP40

Subwoofer. 18" woofer; Thermal-Link driver protection; high-pass filter (150 Hz); recessed handles; 16-gauge steel grille; black carpet exterior; pole mount; mounting pole. Frequency response: 40 - 250 Hz. Max SPL: 123 dB. Sensitivity: 98 dB 1W/1m. 1/4". 18" x 15" x 34". \$684

R1-66

Weather Resistant Speaker System. Installation, live sound, sound reinforcement. Two-way; horn-loaded coaxial system; 12" ferrofluid-cooled low-frequency driver; 1" titanium ferrofluid-cooled high-frequency 60 x 60 degree horn; PowerSense Dynamic Driver Protection; fiberglass cabinet; WeatherStop grille. Frequency response:

Jelly-Fish™ Surround Sound Monitor

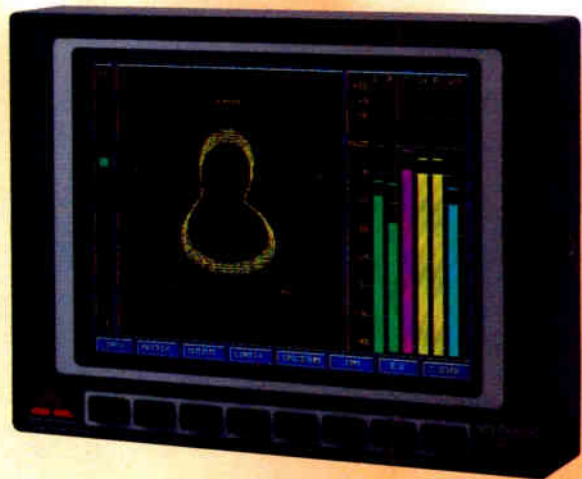

MSD600M Master Stereo Display

- Jelly-Fish™ Surround Sound indicator
- Phase Meter, Audio Oscilloscope and Multi-channel PPM
- User configurable up to 32 input channels
 - Analogue and digital operation
 - Built-in 18(32)x16 audio matrix
 - 96 kHz input option
 - VGA output
 - Spectrum Analyser
- Signal Generator w/white and pink noise



DK-AUDIO AMERICA Inc.

4417 East Villa Rita Drive • Phoenix, AZ 85032 • USA
Tel.: +1 (602) 765-0532 • Call Toll-Free: +1 (800) 421-0888
Fax: +1 (602) 765-1473 • jdt@dk-audio.com

DK-AUDIO A/S

Marielundvej 37 D • DK-2730 Herlev • Denmark
Tel.: +45 44 85 02 55 • Fax: +45 44 85 02 50 • info@dk-audio.com

www.dk-audio.com

SPEAKERS/MONITORS

100 Hz - 18 kHz. Power handling: 500 W program. 50 lb. \$1,224

R6-BASSHORN

Low-Frequency Horn. Installation. Six horn-loaded 12" ferrofluid-cooled drivers; fiberglass horn enclosure; WeatherStop grille; electronic crossover required. Frequency response: 45 - 500 Hz. Power handling: 3,000 W. SJOW input cable. 204 lb. \$3,360

SL5918

Speaker System. Sound reinforcement. Three-way; ferrofluid-cooled low-frequency 12" driver; twin 6.5" medium-frequency drivers; 1" VHF100 ferrofluid-cooled high-frequency 90 X 50 degree horn; electronically controlled; PowerSense Dynamic Driver Protection; passive/biamp modes; molded fiberglass waveguide; trapezoidal; 13-ply Baltic birch cabinet; steel handles; steel grille. Frequency response: 50 Hz - 18 kHz. Power handling: 500 W program. Neutrik, dual banana. 88 lb. \$1,758

SL5980

Low-Frequency Driver Loudspeaker System. Sound reinforcement. Three-way; twin ferrofluid-cooled low-frequency 15" drivers; 2" M200 ferrofluid-cooled medium-frequency driver; 1" VHF100 ferrofluid-cooled high-frequency 65 X 40 degree horn; electronically controlled; PowerSense Dynamic Driver Protection; passive/biamp modes; molded fiberglass waveguide; trapezoidal; 13-ply Baltic birch cabinet; steel handles; steel grille. Frequency response: 60 Hz - 18 kHz. Neutrik, dual banana. 243 lb. \$4,120

TVLF218 ★ New for 2003 ★

Subwoofer Live sound, sound reinforcement, installation. Dual 18" ferrofluid-cooled drivers; 13-ply Baltic birch cabinet; built-in wheels; recessed handles; 16-gauge steel grille; electronic crossover require. Frequency response: 40 - 150 Hz. Power handling: 2,000 W. Neutrik Speakon. 45" x 22.5" x 30". 178 lb. \$2,179

WET112

Weather-Resistant Subwoofer. 12" low-frequency driver; mounting points; fiberglass cabinet; WeatherStop grille. Frequency response: 45 - 150 Hz. 52 lb. \$1,450

WET312

Weather-Resistant Speaker. Three-way; 12" ferrofluid-cooled low-frequency driver; 2" midrange driver; 1" high-frequency driver; 90 x 50 degree horn; PowerSense Dynamic Driver Protection; mounting points; fiberglass cabinet; WeatherStop grille. Frequency response: 70 Hz - 18 kHz. 62 lb. \$1,950

XLT41E

Monitor. Two-way; 12" ferrofluid-cooled low-frequency driver; 1" titanium high-frequency 60 x 40 or 90 x 40 degree horn; high-frequency level switch; PowerSense Dynamic Driver Protection; passive/biamp modes; 13-ply Baltic birch cabinet; two-position wedge; steel handles; steel grille. Frequency response: 60 Hz - 18 kHz. Power handling: 500 W program. Neutrik, 1/4". 50 lb. \$851

XLT51E

Subwoofer. 15" low-frequency driver; PowerSense Dynamic Driver Protection; high-pass filter (150 Hz). Frequency response: 40 - 150 Hz. Power handling: 300 W program. 59 lb. \$773

Crest Audio Inc.

LH1

Live sound, sound reinforcement. Two-way; 15" woofer; 2" titanium compression driver; 3/4" plywood cabinet; han-

dles; metal grille. Frequency response: 48 Hz - 20 kHz. Speakon. 106 lb. \$1,499

LH4

Subwoofer. Live sound, sound reinforcement. Twin 18" woofers; 3/4" plywood cabinet; handles; metal grille. Speakon. 144 lb. \$1,599

LQ-10P

Powered Speaker. Sound reinforcement, live sound. Two-way; 10" water-resistant cone woofer; 1.4" titanium compression driver with Quadratic Throat Horn; 90 x 45 degree pattern; biamped; 150W onboard LF amp; 50W onboard HF amp; CD horn EQ; low-cut filter; contour control; signal loop through; volume control; injection molded polypropylene cabinet; perforated metal grille; stand mount. Frequency response: 80 Hz - 20 kHz. XLR, 1/4". 19" x 14" x 13". 36 lbs. \$650

Dale Pro Audio

B25

Powered Subwoofer. Seismic 8196 driver; 17-ply birch cabinet; onboard QSC 1,000 W amp. Frequency response: 20 - 120 Hz. 40" x 24" x 30", 200 lb. Some customization options. \$3,500 - \$5,000

DAS Audio of America Inc.

Compact 1

Three-way; 15" G-354 woofer; 6" B-6 cone midrange; 2" M-5 titanium diaphragm tweeter on a CD horn; onboard 1,000W Class D amp; birch plywood cabinet; steel grille. Max SPL: 133 dB. 39.75" x 20.5" x 16.5". 114.5 lb. \$1,195

DS-12A Active Power Loudspeaker Live sound, sound reinforcement. Two-way; 12" speaker; 1" high-frequency driver; biamped; onboard 150 W amplifier; onboard 50 W amplifier. Frequency response: 60 Hz - 19 kHz. 23" x 16" x 12". 45 lb. \$599

Monitor 6

Closefield Monitors. Studio. Two-way; 6" woofer; 1" ferrofluid-cooled aluminum tweeter on a Linear Quadratic Spherical waveguide. 13.5" x 6.5" x 10.5". 15 lb. \$399

ST-112A

Powered Speaker. Live sound, sound reinforcement. Three-way; 12" woofer with 4" copper voice coil with horn and phase plug; 4" titanium compression driver with 1.5" exit midrange; ND-10 neodymium tweeter; onboard 400 W and 200 W amps; flyware. Frequency response: 125 Hz - 95 kHz. Max SPL: 139 dB. 33 x 22" x 24". 146 lb. \$3,195

ST-15

Floor Monitor. Live sound, sound reinforcement. 15" woofer; 4" titanium compression driver with 1.5" exit; Finnish birch plywood trapezoidal cabinet; steel grille; rigging points; Sound Touring Series. Frequency response: 50 Hz - 20 kHz. Max SPL: 129 dB. Impedance: 8 ohms. Sensitivity: 100 dB 1W/1m. Crossover @ 1.25 kHz. 20" x 28" x 15", 73 lbs. \$1,399

ST-18

Subwoofer. Live sound, sound reinforcement. 18" low-frequency woofer; Finnish birch plywood trapezoidal cabinet; steel grille; rigging points; Sound Touring Series. Frequency response: 35 - 300 Hz. Max SPL: 130 dB. Impedance: 8 ohms. Sensitivity: 100 dB 1W/1m. Crossover @ 160 Hz. 20" x 28" x 28.5". 110 lb. \$1,249

Dynastar Electronics

Speaker Knife II

Speaker Driver Protector. Prevents speaker driver overload; adjustable high speed power rating. \$90

Dynaudio Acoustics/TC Electronic

Air 15

Powered Monitor System with Onboard DSP. Studio, broadcast, post production. Master/slave configuration; two-way; 10" polypropylene cone woofer with 4" voice coil; 1" Esotec soft dome tweeter; onboard DSP: 32, 44.1, 48, 64, 88.2, 96 kHz sample rates; 24-bit A/D; word clock; TC Link; PC remote control; onboard 200W amp. Frequency response: 33 Hz - 22 kHz. Crossover @ 2.15 kHz. XLR, BNC, RJ45. 17" x 11" x 15.5". 42 lb. Optional 5.1 and digital only packages. \$3,620 per set

Air Base 1

Active Subwoofer. Studio, post production. 10" polypropylene cone woofer with 4" voice coil; onboard 200W amp; word clock; 32, 44.1, 48, 64, 88.2, 96 kHz sample rates; TC Link. Frequency response: 25 - 120 Hz. XLR, BNC, RJ45. 12.5" x 19" x 16.5". 48 lb. \$1,350

BM6

Two-Way Nearfield Monitor. Studio. Two-way; 7" magnesium silicate impregnated polypropylene cone with 3" Dynacoll voice coil; 1" Esotec soft dome tweeter with ferrofluid-cooled aluminum voice coil; magnetically shielded; gold-plated connectors. Frequency response: 43 Hz - 20 kHz. Sensitivity: 86 dB 1W/1m. Crossover @ 3.1 kHz. Impedance: 4 ohms. Five-way binding posts. 12.25" x 8" x 10", 15 lb. \$999 per pair

BM6A

Two-Way Powered Nearfield Monitor. Studio. Two-way; 7" magnesium silicate impregnated polypropylene cone with 3" Dynacoll voice coil; 1" Esotec soft dome tweeter; variable Q limiting on LF; trim control; slow attack optical high-frequency limiter; magnetically shielded; dual 100 W MOSFET amps; electronic phase-aligned crossover. Frequency response: 42 Hz - 21 kHz. Max SPL: 118 dB. Crossover @ 2.2 kHz. XLR. 13.25" x 8.5" x 12.5". 24 lb. Available as a surround package with BX30 subwoofer: \$9,497. \$1,999 per pair

BX30

Compact Active Subwoofer. 12" low-frequency driver with 4" Dynacoll voice coil; low-pass crossovers @ 80, 95, 120 Hz; phase alignment system; 140 W amplifier. Frequency response: 22 - 120 Hz. Max SPL: 115 dB. XLR. 16" x 24" x 21". \$2,200

M1 Monitor

Console Top Monitor. Studio. Two-way; twin 6" magnesium silicate impregnated polypropylene cone bass drivers with 3" Dynacoll aluminum voice coils; 1" Esotec soft dome tweeter with aluminum voice coil; high SPL; thermal tweeter protection. Frequency response: 50 Hz - 20 kHz. Sensitivity: 88 dB 1W/1m. Max SPL: 122 dB. Max power: 1,000 W. Impedance: 4 ohms. Gold-plated five-way binding posts. 8.5" x 17.75" x 12.25". 31 lb. \$3,199 per pair

E. M. Long

NFM-6C Time Align Nearfield Monitor

Studio. Two-way; 6.5" woofer; 1" coaxially-mounted tweeter; shielded; Time Align. Frequency response: 60 Hz - 20 kHz. 14" x 9" x 9". 14 lb. \$690

E.T.I. Sound Systems Inc.

BP-18X

Subwoofer. Live sound, installation. B-52 18-200S woofer with 4" polyamide voice coil; seven-ply .75" plywood cabinet; steel handles; metal corners; rubber feet; pole mount; 16 gauge steel grille; Plexiglas window; casters; carpet exterior. Frequency response: 30 - 130 Hz. Power handling: 1,000 W program. Max SPL: 132 dB. Sensitivity: 101 dB 1W/1m. Impedance: 8 ohms.

Neutrik Speakon, 1/4", 24" x 33" x 22", 107 lb.

FX-1818S

Subwoofer. Live sound, installation. Twin B-52 18-200S 18" woofers with 4" polyamide voice coils; seven-ply .75" plywood cabinet; metal corners; steel handles; casters; carpeted exterior. Frequency response: 35 - 250 Hz. Power handling: 2,000 W program. Max SPL: 133 dB. Sensitivity: 102 dB 1W/1m. Impedance: 4 ohms. Neutrik NL4 Speakon. 23" x 42" x 20", 105 lb.

MI-1515

Speaker. Live sound, installation. Two-way; twin B-52 15-80 15" woofers; 1" titanium tweeter with a 90 degree x 40 degree horn; pole mount; metal handles; 16-gauge perforated steel grille; rubber; metal corners; casters; carpeted exterior. Frequency response: 40 Hz - 19 kHz. Power handling: 600 W program. Sensitivity: 99 dB 1W/1m. Max SPL: 130 dB. Impedance: 4 ohms. Crossover @ 1.6 kHz. 1/4". 19" x 45" x 18". 100 lb.

MI-MN 15

Stage Monitor. Live sound, installation. Two-way; 15" woofer with 2.5" polyamide voice coil; 1" titanium tweeter with a 90 degree x 40 degree horn; metal handles; 16-gauge perforated steel grille; rubber; metal corners; carpeted exterior. Frequency response: 40 Hz - 19 kHz. Power handling: 300 W program. Sensitivity: 97 dB 1W/1m. Max SPL: 128 dB. Impedance: 8 ohms. Crossover @ 1.6 kHz. 1/4". 23" x 18" x 21". 56 lb.

PA-1515X

Speaker. Live sound, installation. Two-way; twin 15" woofers with 4" polyamide voice coils; 2" Beyma titanium compression HF driver on a 90 degree x 40 degree horn; Airport rear-firing bass ports; 13-ply Baltic birch cabinet; handles; flyware; scratch-resistant acrylic coating. Frequency response: 35 Hz - 19 kHz. Power handling: 1,300 W program. Max SPL: 131 dB. Sensitivity: 101 dB 1W/1m. Impedance: 4 ohms. Crossover @ 1.4 kHz. Neutrik NL4 Speakon. 21" x 46" x 21". 143 lb.

PA-BP 12

Band-Pass Subwoofer. Live sound, installation. 12" woofer; MDF cabinet; scratch resistant acrylic coating. Frequency response: 30 - 130 Hz. Power handling: 400 W program. Max SPL: 132 dB. Sensitivity: 101 dB 1W/1m. Impedance: 8 ohms. Gold-plated five-way binding posts. 17" x 17" x 17". 60 lb.

Earthworks Audio Products

Sigma 6.2

Monitor. Studio. Two-way; 6.5" Vita woofer; Vita tweeter; magnetic shielding; silver solder; oxygen-free copper wiring. Frequency response: 40 Hz - 40 kHz. Sensitivity: 87 dB 1W/1m. Power handling: 150W program, 400W peak. Impedance: 8 ohms. Speakon, gold-plated five-way binding posts. 9.5" x 16.75" x 15.5". 32 lb. Cherry cabinet: \$5,000 per pair. \$3,300 per pair

Eastern Acoustic Works (EAW)

BH760

Subwoofer. Live sound, sound reinforcement. Twin 12" woofers; bent horn; skirts. 30" x 30" x 45". 273 lb. Optional castor pallet. \$3,670

JJFX590

Live sound, installation. Two-way; 15" woofer; 1.4" compression HF driver on a CD horn; 90 x 45 degree pattern; biampable; mounting points; pole mount cup; integrated handle. 25.2" x 18" x 19". 90 lb. \$1,997

KF760

Line Array Speaker. Three-way; twin 12" woofers; twin 10" cone midrange

drivers; twin 2" compression HF drivers; bent horn; VA4 technology. 14.5" x 45" x 31". 235 lb. \$8,167

Electro-Voice

Eliminator I Sub

Subwoofer. Live sound. 18" DL188FH woofer; built-in crossover; black carpeted exterior. Frequency response: 40 - 100 Hz. Power handling: 400 W. 1/4". \$598

Eliminator II

Speaker. Live sound, sound reinforcement. Two-way; twin 15" DL158FH woofers; twin DH2010A compression drivers on a High-Q 60 x 40 degree constant directivity horn; Ring-Mode Decoupling technology; black carpeted exterior. Frequency response: 50 Hz - 20 kHz. Power handling: 600 W. Neutrik Speakon. \$798

EVID 12.1

Installation Subwoofer. 12" woofer; onboard filters; satellite output. Frequency response: 40 - 140 Hz. Sensitivity: 100 dB. Max SPL: 122 dB. Impedance: 8 ohms. Spring terminals. 48 lb. \$480

EVID 3.2

Installation Speaker. Two-way; twin 3.5" woofers; 75" titanium dome tweeter; magnetic shielding; perforated steel grille; paintable ABS cabinet; aluminum Strong Arm Mount; hemispherical design. Frequency response: 85 Hz - 20 kHz. Sensitivity: 87 dB 1W/1m. Max SPL: 108 dB. Impedance: 8 ohms. Spring terminals. 8.5 lb. Mounting options. 70V/100V version available: \$280 per pair. \$256 per pair

Force I

Speaker. Live sound. Two-way; 15" woofer; DH2010A 1.25" titanium compression high-frequency driver with a constant directivity horn; 80 degree x 55 degree pattern; Ring-Mode decoupling technology; Barrier Port technology; PRO driver protection; RoadWood cabinet; socket mount; mounting pole. \$1,198 - \$1,248

FRI-152

Install speaker. Installation, live sound. Two-way; 15" woofer; rotatable horn; Ring-Mode Decoupling technology; biampable; 13-ply birch trapezoidal cabinet; steel grille. Frequency response: 42 Hz - 16 kHz. Crossover @ 1.6 kHz. Barrier strip. 26" x 19" x 23.25". 70 lb. Choice of finishes. Available with 60 x 40 degree, 90 x 40 degree or 60 x 60 degree horns. \$1,198 - \$1,248

FRI-28LPM

"Low-Profile" Floor Monitor. Two-way; twin 8" woofers; 1" voice coil compression driver; 100 degree x 100 degree CD horn; Ring-Mode Decoupling technology; low-profile slant angle cabinet. Sensitivity: 93 dB 1W/1m. 8.75" x 24.5" x 14". 40 lb. \$718

FRX-640, FRX-940

Installation Speakers. Installation. Two-way; 15" woofer; Ring-Mode Decoupling technology; Duplex point source technology; 60 x 40 degree or 90 x 40 degree horns. Max SPL: 124 dB. 31" x 28.5" x 26". 152 lb. Choice of finishes. FRX-640: \$2,208, FRX-940: \$2,250

QRx-115/75

Speaker. Live sound, sound reinforcement. Two-way; 15" woofer; DH7 HF driver on a 75 degree x 50 degree rotatable CD horn; protection circuitry; Ring-Mode Decoupling technology; pole mount; Safe-Grip handles; five-sided modified wedge cabinet. \$1,598

QRx-218S

Subwoofer. Live sound, sound reinforcement. Twin EVX180B 18" woofers; recessed handles; pole mount. Max SPL: 127 dB. Optional flyable version, 218SF: \$2,098. \$1,798

So,

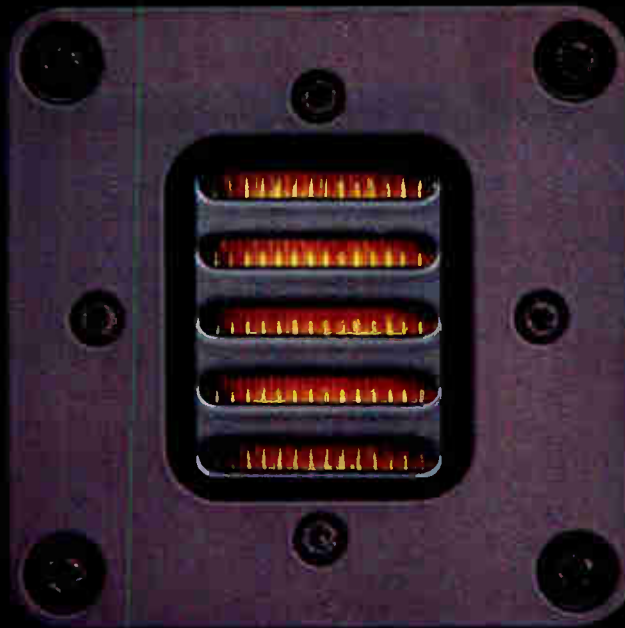

what's with the **striped** tweeter?

It's not striped.

It's an A.R.T. – **Accelerated Ribbon Technology** – folded ribbon tweeter, and it actually represents the first departure from the traditional voice coil principle used by every other pro speaker manufacturer.

You'll instantly notice an unprecedented degree of sonic clarity and detail, resulting in an image so lifelike that that you'll swear you can almost reach out and touch the musicians. You'll track and mix more effectively than ever before, and your work will translate to any other system flawlessly – from the smallest boombox to the most high-end audiophile rig. You'll even hear new things in pieces of music that you've been listening to literally your whole life long...ever notice the squeaking door sound in the first verse of the Beatles song "Yesterday"? You will...

Distributed in the United States by ADAM Audio USA (805) 413-1133



Come meet the entire ADAM family at www.adam-audio.com



SPEAKERS/MONITORS

S-80A Monitor

Studio, broadcast, live sound, sound reinforcement. Two-way; 8" woofer; 1" high-frequency driver; Direktor high-frequency dispersal horn. Frequency response: 80 Hz - 15 kHz -3 dB. Sensitivity: 91 dB 1W/1m. Crossover @ 2 kHz. 16" x 10.75" x 8.5". 17 lb. \$300

Sx100+

Speaker System. Live sound. Two-way; 12" EVG woofer; 1" DH2005 titanium compression horn high-frequency driver with 65 x 65 degree constant directivity horn; Ring-Mode Decoupling; polypropylene structural foam enclosure. Frequency response: 80 Hz - 25 kHz -3 dB. Sensitivity: 99 dB 1W/1m. Crossover @ 1.5 kHz. 23" x 17" x 12.3". 32 lbs. \$546

Sx300A

Powered Speaker System. Live sound. 12" DL12RMD Kevlar composite mica impregnated cone woofer; DH2010A 1" horn high-frequency driver on a 65 x 65 degree constant directivity Varipath horn; Ring Mode Decoupling technology; onboard 300 W power amplifier. Frequency response: 80 Hz - 25 kHz. XLR. 23" x 17" x 12.3". 49 lbs. \$1,422

T221

Stage Monitor. Live sound. 12" woofer; 1" tweeter; High-Q 60 x 40 degree horn. Frequency response: 75 Hz - 16 kHz -3 dB. Sensitivity: 100 dB 1W/1m. Crossover @ 1.2 kHz. Power: 400 Watts program. 28" x 16.5" x 19". 55 lb. \$1,240

TL880D Subwoofer

Sound reinforcement, post production. Twin 18" woofers; THX approved. Frequency response: 23 Hz - 1.8 kHz -3 dB. Sensitivity: 98 dB 1W/1m. 47.5" x 30" x 24". 160 lb. \$3,308

X-fil

Line Array Speaker. Live sound, sound reinforcement. Three-way; twin 15" EVX 155 woofers; twin 8" neodymium midrange drivers; three ND5A

high-frequency drivers with vertical waveguides; X-Line series.

XVLS

Line Array Speaker. Live sound, sound reinforcement. Three-way; twin 15" EVX 155 woofers; twin 8" neodymium midrange drivers; three ND5A high-frequency drivers with vertical waveguides; X-Line series.

Event Electronics

20/20 Direct Field Monitor

Studio. Two-way; 8" mineral-filled polypropylene cone with 1.5" voice coil; 1" ferrofluid-cooled silk dome tweeter; 5/8" vinyl laminate MDF cabinet. Frequency response: 50 Hz - 20 kHz \pm 2 dB. Power handling: 200 Watts peak. Sensitivity: 88 dB 1W/1m. Crossover @ 2.6 kHz. Impedance: 4 ohms. Five-way binding post. 10.25" x 14.75" x 11.75". 22 lb. \$399 per pair

Project Studio 6 Bi-amplified Direct Field Monitors

Studio. Two-way; 6.5" mineral-filled polypropylene cone with 1.5" voice coil; 1" ferrofluid-cooled silk dome tweeter; magnetic shielding; subsonic filter; onboard 70 W LF amp, 30 W HF amp; RF, thermal amp protection; limiter; fuse. Frequency response: 45 Hz - 20 kHz. 8.25" x 12.5" x 10". 23 lb. \$699 per pair

Tuned Reference 8 Bi-amplified Direct Field Monitor System

Studio. Two-way; 8" mineral-filled polypropylene cone woofer with 1.5" voice coil; 1" ferrofluid-cooled soft dome tweeter; magnetic shielding; gain control; subsonic filter; fuse; 5/8" MDF cabinet. Frequency response: 35 Hz - 20 kHz. SPL: >108 dB. 1/4". XLR, RCA. \$599 per pair

FBT North America

Esprit 3.0A

Powered Monitor. Project studio, live sound, installation. Two-way; 10" woofer; 1.25" compression

tweeter; onboard Class G amplifier (200 W); two-band EQ; gain, volume controls; mic, line inputs; ground lift; thermoplastic resin cabinet. Frequency response: 70 Hz - 19 kHz. Max SPL: 120 dB. XLR, 1/4". 11.5" x 17" x 11.25". 33 lb. Optional wallmount, speaker stands. Gray or white finish. \$750

Jolly 3

Speaker. Studio. Two-way; 5" woofer; .75" dome tweeter; thermoplastic resin cabinet. Frequency response: 80 Hz - 20 kHz. Max SPL: 112 dB. Crossover @ 3.5 kHz. 1/4". 6.5" x 10" x 6.25". 6.5 lb. Gray, white or brown finish. Optional wall-mount hardware. \$189

K-250

Speaker. Installation, live sound. Two-way; 15" K-Series woofer; 1" K-Series driver with 90 x 60 degree horn; link; 13-ply birch plywood cabinet; heat resistant carpet exterior; stand socket; handles. Frequency response: 60 Hz - 18 kHz. Max SPL: 123 dB. 1/4". 16.5" x 25" x 16.5". \$449

Maxx 2

Speaker. Live sound, installation, studio. Two-way; 10" B&C woofer with neodymium magnet; 1" B&C compression driver; 90 x 60 degree pattern; ground lift switch; onboard speaker cabinet. Frequency response: 50 Hz - 20 kHz. Max SPL: 121 dB. 13.75" x 21.5" x 12". 22 lb. Optional ceiling or wall-mount kits. \$439

Maxx 2A

Powered Speaker. Live sound, installation, studio. Two-way; 10" B&C woofer with neodymium magnet; 1" B&C compression driver; gain, volume controls; three-band EQ; 90 x 60 degree pattern; ground lift switch; onboard Pulse Wave Modulation 200W LF and 50W HF amps; polypropylene cabinet. Frequency response: 50 Hz - 20 kHz. Max SPL: 121 dB. XLR, 1/4". 13.75" x 21.5" x 12". 25 lb. Optional ceiling or wall-mount kits. \$749

PSM-215

Stage Monitor. Live sound, sound reinforcement. Two-way; 15" woofer with 4" voice coil; 3" neodymium HF compression driver in a 90 x 45 degree horn; ADAP component protection circuitry; 13-ply Baltic birch plywood cabinet; Black Rhino finish. Frequency response: 55 Hz - 18 kHz. Sensitivity: 98 dB 1W/1m. Max SPL: 130 dB. Impedance: 8 ohms. Speakon. 19" x 16.75" x 18". 65 lb. \$1,500

PSR-215

Live sound, sound reinforcement. Two-way; 15" woofer with 4" voice coil; 3" neodymium HF compression driver in a 80 x 60 degree horn; biampable; ADAP component protection circuitry; flying points; 13-ply Baltic birch plywood cabinet; Black Rhino finish. Frequency response: 45 Hz - 18 kHz. Sensitivity: 98 dB 1W/1m. Max SPL: 131 dB. Crossover @ 1.6 kHz. Speakon. 18.5" x 29.5" x 19". 93 lb. \$1,700

Studio 4-B

Studio, live sound. Two-way; 5" woofer; .75" poly-carbonate dome tweeter; thermoplastic resin cabinet; ships with mic stand mounts. Frequency response: 80 Hz - 20 kHz. Sensitivity: 93 dB 1W/1m. Max SPL: 110 dB. 1/4". push terminals. 6.25" x 10" x 6". 6.5 lb. Optional wall mounting brackets. \$199

Fender

118sA

Subwoofer. Live sound, sound reinforcement, installation. 18" woofer with 2.5" voice coil. Frequency response: 42-110 Hz. Sensitivity: 99 dB 1W/1m. Impedance: 8 ohms. Power handling: 900 W program. Max SPL: 125 dB. 1/4". 24.75" x 31.5" x 24.75". 87 lb. \$479

1270P Powered Monitor

Live sound, sound reinforcement, installation. Two-way; 10" woofer with a 2" voice coil; 1.5" compression driver; molded ABS cabinet; onboard mic preamp; level control; tone control; 110 W amp. Frequency response: 110 Hz - 20 kHz. Max SPL: 109 dB. 13.5" x 13.5" x 9.25". 20 lb. \$399

Artist 112xp

Two-Way Loudspeaker. Live sound, sound reinforcement, installation. Two-way; 12" woofer; twin 1.5" HF compression drivers coupled to a CD horn; trapezoidal cabinet. Frequency response: 60 Hz - 20 kHz. Sensitivity: 95 dB 1W/1m. Power handling: 400 W (peak), 200 W (program). Impedance: 8 ohm. 1/4". 21.25" x 18.25" x 18.75". 50 lb. \$299

Passport 250

Powered PA System. Live sound. Two-piece; six-input; digital reverb effects loop; switchable line voltage; Vocal Priority control; twin 6.5" full range drivers in each cabinet; onboard 250 W amp. Power output per channel: 125 W. XLR, 1/4", RCA. Ships with two microphones, cable. \$950

Fostex Corp. of America

6301BEAV

Personal Monitor. Studio. Full-range 3.5" driver; die-cast aluminum frame; shielded; 10W amp. Frequency response: 80 Hz - 13 kHz. 1/4". 6.5" x 4" x 5". \$229

PS-3.1

Powered Monitoring System. Project studio. Two-way, three box system - twin mid/high range satellite speakers (3" mid, 1" tweeter with 5 W amps) and bass/subwoofer (5.25" driver with 15 W amp); shielded. Frequency response (whole system): 70 Hz - 20 kHz. THD: <0.1%. RCA, five-way binding posts. Subwoofer - 10" x 11.25" x 8 1/4". Satellites - 8 1/4" x 4" x 4". \$349

Furman Sound Inc.

MS2A1

Rackmounted Speaker. Two speakers; two-channel (input); magnetic shielding; volume, balance controls; headphone controls; onboard twin 20W amps; switchable LED meters. XLR. 1RU. \$1,049

MS4AD-1

Rackmounted Speaker. Two speakers; four-channel (input); 24-bit/96 kHz digital input; magnetic shielding; volume, balance controls; headphone controls; onboard twin 20W amps; switchable LED meters. XLR, BNC. 1RU. \$1,499

Galaxy Audio

Hot Spot

Speaker. Twin 5" ferrofluid-cooled drivers; ABS plastic cabinet; stand adapter; handle. Frequency response: 150 Hz - 15 kHz. Sensitivity: 96 dB 1W/1m. Max SPL: 123 dB. Impedance: 16 ohms. 1/4". Optional volume control. \$159

Genelec Inc.

1030APM

Active Closefield Monitor System. Studio, post production. Two-way; 6.5" polymer composite woofer; 3/4" metal dome Directivity Control Waveguide tweeter; magnetic shielding; bi-amplified; 80 W LF amp; 50 W HF amp. Frequency response: 52 Hz - 20 kHz. Maximum output: 115 dB. XLR. 12.5" x 7.25" x 9.5". 15 lb. \$2,098 per pair

1034B Active Monitoring System

Studio, post production, broadcast. Three-way; twin 12" low frequency drivers; 5" midrange; 1" metal dome Directivity Control Waveguide tweeter; bass, midrange, treble controls; twin 400 W LF amps; 350 W midrange amp; 120 W HF amp; separate rackmountable amp unit. Frequency response: 32 Hz - 22 kHz. Max SPL: 125 dB. 28.75" x 25" x 15". 161 lb. Amp: 66 lb. Vertical or horizontal orientation. \$9,999 per channel

1036A Active Monitoring System

Studio, post production, broadcast. Three-way; twin 18" woofers; twin 5" midrange Directivity Control Waveguide cone drivers; 1" compression HF driver; rotatable Directivity Control Waveguide; triamplified; two 1,100 W LF amps; 600 W midrange amp; 300 W HF amp; separate rackmountable amp unit. Frequency response: 21 Hz - 20 kHz. Max SPL: 136 dB. 33.75" x 46.5" x 25.5". 400 lb. Amps: 155 lb. Horizontal or vertical orientation. \$27,000 per channel

1038AC Active Center Channel Speaker

Three-way; twin 10" woofers; 5" midrange driver; 1" metal dome Directivity Control Waveguide tweeter; magnetic shielding; triamplified; two 200 W LF amps; 120 W midrange amp; 120 W HF amp; separate rack-mountable amp unit. Frequency response: 33 Hz - 20 Hz. Max SPL: 124 dB. 36" x 14" x 22". 130 lb. Amp: 30 lb. For surround sound environments. \$7,499

2029B Digital Stereo Monitoring System

Active Closefield Speakers. Studio. Two-way; 5" woofer; .75" metal dome Directivity Control Waveguide tweeter; magnetic shielding; volume control; 24-bit/96 kHz D/A; bi-amplified; twin 40 W amps; heat sink; right speaker is the master, left is the slave. Max SPL: 110 dB. XLR. 9.75" x 6" x 7.5". \$1,375 per pair

Anyone who has heard it knows ...



Dual Channel

VT-2
Vacuum Tube
Microphone Preamplifier

D. W. FEARN

(610) 793-2526

P.O. Box 57 • Copcon, PA • 19366 • Fax (610) 793-1479
www.dwfearn.com

SPEAKERS

7060A

Active Subwoofer for Multichannel 1029AP System. Studio, post production, film. 10" woofer; LCR I/O; LFE in; phase control; onboard 6.1 bass manager; Laminar Spiral Enclosure vented enclosure. Frequency response: 29 - 85 Hz. Max SPL: 108 dB. XLR. 21" x 18" x 14". 59 lb. Designed for use with Genelec 1029A monitor. \$1,650

S30D

Active Closefield Monitor System. Studio, post production, broadcast. Live sound. 8" woofer; 3" midrange; 2.5" ribbon tweeter; bass, midrange and tweeter controls; tilt and low-frequency rolloff controls; 24-bit/96 kHz digital interface; three 120 W amps. Frequency response: 38 Hz - 50 kHz. Maximum output: 122 dB. XLR. 19.5" x 12.75" x 11.5". 44 lb. Either vertical or horizontal layout. \$2,850 per channel

Genz Benz

CMP-115H

Live sound, sound reinforcement. 15" woofer; constant directivity horn; metal grille; recessed handles; corner protectors; carpeted exterior; trapezoid cabinet; speaker stand adapter. Frequency response: 56 Hz - 15 kHz. Max SPL: 125 dB. Crossover @ 3.5 kHz. 1/4". Speakon. 28.5" x 19" x 15.5". 50 lb. \$429

TAC-EX-218SUB

Subwoofer. Live sound, sound reinforcement. Twin 18" woofers; .75" plywood cabinet; corner protectors; metal grille; recessed handles; carpeted exterior. Frequency response: 42 Hz - 1.5 kHz. Max SPL: 131 dB. 1/4". Speakon. 23" x 46" x 22.5". 137 lb. \$1,099

Hafler

M5

Monitor. Studio, broadcast. Two-way; 5.25" polypropylene cone; 1" soft dome waveguide tweeter; tweeter control; bass port; shielded. Frequency response: 70 Hz - 21 kHz. Crossover @ 3.2 kHz. Impedance: 6 ohms. Five-way gold-plated binding posts. 12.25" x 6.75" x 7". 12 lb. \$125

TRM12s V2F Trans'ana Powered Subwoofer

Studio. 15" cellulose fiber cone; onboard 200 W Class G trans'ana amp circuitry; MOSFET output stage; adjustable input sensitivity; adjustable crossover (40 - 100 Hz); phase control. Frequency response: 25 - 110 Hz. S/N: >100 dB. Max SPL: >115 dB. 19.5" x 18" x 19.25". 94 lb. \$845

TRM8.1

Powered Studio Monitor. Studio, installation, broadcast. Two-way; 8" polypropylene cone; 1" soft dome waveguide tweeter; Diamond series trans'nova circuit topology; high-frequency drive - 75 W amp @ 6 ohms; low-frequency - 150 W @ 4 ohms; subsonic filter (30 Hz); bass level control; magnetically shielded. Frequency response: 45 Hz - 21 kHz. THD: <0.5%. S/N: >100 dB. Crossover @ 2.5 kHz. RCA, 1/4", XLR. 10.25" x 15.5" x 13". 35 lb. \$1,850 per pair

HHB Communications USA LLC

Circle 3 Active

Powered Monitor. Two-way; 5.5" polymer cone with a 1" aluminum voice coil; 1" ferrofluid-cooled soft dome tweeter with aluminum voice coil and neodymium magnet; polyswitch tweeter protection; magnetic shielding; Sallen, Key midband filters; two-channel amp; heat sink. Frequency response: 70 Hz - 20 kHz. XLR, RCA. 10.75" x 7" x 8". 11 lb. \$799 per pair

Circle 5 Passive

Studio Monitors. Recording studio, project studio, broadcast. Two-way; 8" polymer cone with an 1" aluminum voice coil; 1" ferrofluid-cooled soft dome tweeter with aluminum voice coil; polyswitch tweeter protection; magnetic shielding. Frequency response: 48 Hz - 20 kHz. Impedance: 8 ohms. Power handling 120 W. Crossover @ 2.6 kHz. Binding posts. 16.5" x 10" x 12". 22 lb. \$749 per pair

Hot House Professional Audio

ARM 265 Active Reference Monitor

Studio Monitor. Recording studio. Two-way; twin 6.5" woofers; 1" recessed dome tweeter; biampified. Frequency response: 30 Hz - 20 kHz. Max SPL: 126 dB. S/N: 102 dB. 1/4", XLR. 14" x 25" x 12". 52 lb. Choice of black, red or golden oak finish. \$6,499

ASB 115

Powered Subwoofer. Studio. HV 15 low-frequency driver; high-, low-pass filters; 600 W MOSFET amp. Peak SPL: 122 dB. \$3,999

PRM 165 Passive Reference Monitor

Nearfield Studio Monitor. Recording studio. Two-way; 6.5" woofer; 1" recessed dome tweeter; shielded. Frequency response: 49 Hz - 20 kHz. Impedance: 8 ohms. 12.5" x 8.5" x 13". 25 lb. \$1,299

ISP Technologies

SA115

Powered Subwoofer. Live sound. 15" woofer with 3" voice coil; onboard DCAT amplifier; thermal protection; slave output. Frequency response: 45 - 100 Hz. Max SPL: 127 dB. XLR. 24" x 20" x 19". 95 lb. \$1,326

Tripower 900

Powered Speaker. Live sound. Three-way; 15" woofer with 3" voice coil; 10" midrange driver; 2" titanium compression HF driver; onboard DCAT three-channel amplifier; thermal protection. Frequency response: 45 Hz - 20 kHz. Max SPL: 129 dB. XLR, 1/4".

40" x 20" x 18.5". 135 lb.

\$1,830

Triwedge

Powered Stage Monitor/Speaker. Live sound. Three-way; 12" woofer; 10" midrange driver; 2" titanium compression HF driver; onboard DCAT three-channel amplifier; thermal protection. Frequency response: 60 Hz - 18 kHz. Max SPL: 127 dB. XLR, 1/4". 16.5" x 30.5" x 19". 85 lb. \$1,428

JBL Professional

4208

Closefield Studio Monitor. Studio. Two-way; 8" woofer; 1" tweeter; magnetic shielding. Frequency response: 60 Hz - 20 kHz. Sensitivity: 89 dB. Impedance: 8 ohms. Crossover @ 2.6 kHz. 17.75" x 11.25" x 12". 21 lb. \$279

4645C

Subwoofer. Studio, post production. 18" JBL 2242 SVG Super Vented Gap woofer; THX approved. Frequency response: down to 22 Hz. Sensitivity: 97 dB 1W/1m. Power handling: 800 W. Impedance: 8 ohms. 39" x 25.5" x 17.75". 138 lb. \$1,203

4890A

Two-Way Stage Monitor. Live sound. Two-way; 14" woofer; 1.5" high-frequency driver with a rotatable 40 degree x 60 degree Optimized Aperture Flat-Front Bi-Radial horn; 16 gauge steel grille; Duraflex coating; horizontal orientation; Array Series. Frequency response: 70 Hz - 18 kHz. Sensitivity: 98 dB 1W/1m. Power handling: 600 W. Max SPL: 132 dB. Impedance: 8 ohms. 8-pin Neutrik. 15" x 27" x 15". 65 lb. \$3,323

4893A

Subwoofer. Live sound. Twin 14" woofers; 16 gauge steel grille; Duraflex coating; Array Series. Frequency response: 38 - 400 Hz. Sensitivity: 98 dB 1W/1m. Power handling: 1,200 W. Impedance: 8 ohms. 8-pin Neutrik. 42" x 15.5" x 14.25". 100 lb. \$2,097

AC2215/64, AC2215/95, AC2215/00

Installation, live sound. Two-way; 15" woofer; rotatable Progressive Transition Waveguide; biampable. Frequency response: 50 Hz - 17 kHz. Speakon, barrier strip. 25" x 16.5" x 20". Choice of 90 x 50 degree coverage, 60 x 40 degree coverage or 100 x 100 degree coverage patterns. /64, /95 - \$860; /00 - \$890

AL6125

Low-Frequency Cabinet. Installation, live sound. Twin 15" VGC woofers. Frequency response: 42 Hz - 2.1 kHz. Speakon, barrier strip. 38" x 16.5" x 20". 98 lb. Designed for AM6200 series. \$1,680

AM4200/64, AM4200/64

Installation, live sound. Two-way; 6" CMCD midrange driver; 1.5" compression driver; rotatable Progressive Transition Waveguide. Frequency response: 400 Hz - 20 kHz. Speakon, barrier strip. 21.5" x 22" x 26". 61 lb. Choice of 90 x 50 degree coverage or 60 x 40 degree coverage patterns. \$1,800

ASB4128

Subwoofer. Installation, live sound. Twin 18" VGC woofers. Frequency response: 40 Hz - 1 kHz. Speakon, barrier strip. 43" x 22" x 32.25". \$1,875

EON 15 G2

Powered Speaker System. Sound reinforcement, live sound, installation. Two-way; 15" neodymium Differential Drive low-frequency driver; 1.75" titanium diaphragm compression driver; polypropylene cabinet; 100 W HF amplifier; 300 W LF amplifier. Frequency response: 39 Hz - 18 kHz. Power output: 300 W/100 W biampified. Maximum SPL: 129 dB. XLR, 1/4". 27.5" x 17" x 17.5". 46 lb. \$869

EVOi.324

Processor/Powered Speaker System. Live sound, installation, sound reinforcement. Two-way; twin 14" woofers; horn; onboard twin 600W amplifiers; onboard 100W amplifiers; onboard speaker processor integrates with controller system. Speaker: \$3,499. Controller system: \$999. Available as full package with mixer, mics, cables, mic stands: \$11,499. \$3,499

LSR25P

Compact Biampified Monitor Studio, broadcast, post production. Two-way; nearfield; 5.25" SFG woofer; 1" titanium composite tweeter with elliptical oblate spheroidal waveguide; high-pass filter; volume control; 100W LF amplifier; 50W HF amplifier; magnetic shielding; LSR - Linear Spatial Reference series. Crossover @ 2.3 kHz. XLR, RCA. 7" x 10.75" x 9.5". 17 lb. \$399

MP215

Speaker. Live sound, sound reinforcement. Two-way; 15" woofer; 1" titanium HF driver; Laminar Flow Baffle; SonicGuard HF driver protection; carpeted exterior; 16-gauge steel grille; pole socket mount; metal handles. Frequency response: 45 Hz - 16 kHz. Power handling: 250W, program, 1/4", Neutrik NL4 Speakon. 28.5" x 18.5" x 13.75". 49 lb. \$499

MP255S

Subwoofer. Live sound, sound reinforcement. Twin 15" woofers; carpeted exterior; low-pass filter; 18-gauge steel grille; 24" steel mounting pole; pole socket mount; metal handles. Frequency response: 32 - 180 Hz. Power handling: 500W, program. Neutrik NL4 Speakon. 37.5" x 20.75" x 37". 115 lb. \$759

SF15

Live sound, sound reinforcement. Two-way; 15" woofer; Progressive Transition Waveguide; SonicGuard HF driver protection; recessed



Cable Ready.

Blue, the leader in cutting-edge microphone technology, is proud to announce three distinctive microphone cables. Built to Blue's rigid specifications, these microphone cables offer the recordist and performer a signal path of outstanding sonic quality and high durability. Although recommended for our entire award-winning microphone line, these cables will enlighten the performance of any studio or live performance microphone. Consult your authorized Blue Microphones dealer for the cable that best suits your needs. We think you'll agree that it's the best cable install around.



Microphones

Think you can't afford the best? Think again.™

• www.bluemic.com •

SPEAKERS/MONITORS

metal handles; 18-gauge metal grille; 3/4" MDF cabinet; carpeted exterior. Neutrik NL4, 1/4". 27" x 18.25" x 17". \$369

SP222
Speaker. Installation, live sound. Two-way; twin 12" Vented Gap Cooled (VGC) low-frequency drivers; compression driver on an Optimized Aperture Bi-Radial horn; bi-amp/passive switch; 13-ply birch cabinet; paintable DuraFlex finish; horizontal orientation. Sensitivity: 98 dB 1W/1m. Impedance: 4 ohms. Neutrik NL4 Speakon. 22.75" x 28" x 18.75". 110 lb. \$2,520

SR4718X
Subwoofer. Sound reinforcement, live sound. 18" VGC low-frequency transducer; 13-ply Baltic birch cabinet. Frequency response: 42 - 300 Hz. Power handling: 600 W @ 4 ohms. Sensitivity: 98 dB 1W/1m. Neutrik NL4. 24.5" x 24" x 24". 88 lb. \$1,029

SR4725X
Speaker. Sound reinforcement, live sound. Two-way; 15" VGC low-frequency transducer; 1.75" titanium compression driver on an Optimized Aperture horn; 13-ply Baltic birch cabinet. Frequency response: 35 Hz - 18 kHz. Power handling: 600 W @ 8 ohms. Sensitivity: 92 dB 1W/1m. Speakon. 28.5" x 24.5" x 17.82 lb. Flyable version, SR4725XF: \$1,629. \$1,329

VT4881
Line Array Subwoofer for VerTec Series. Live sound, installation, sound reinforcement. 15" woofer with dual voice coils; DuraFlex exterior; rigging. Frequency response: 22 - 125 Hz. NL8. 22" x 31" x 27". 120 lb. \$2,636

VT4889 VerTec Line Array
Live Sound Speaker Array. Live sound, installation. Three-way; twin 15" dual-coil neodymium woofers; four 8" dual-coil neodymium midrange drivers; three 1.5" high-frequency drivers with beryllium diaphragm and coupled to wave guide; Radiation Boundary Integrator; composite cabinet; aluminum bracing; steel grille; Duraflex coating; onboard rigging; front cover; dolly; VerTec series. Frequency response: 50 Hz - 18 kHz. Power handling: 3,000 W. Eight-pin Neutrik. 19.25" x 47.75" x 21". 152 lb. \$11,627

Z32S
Contractor Speaker Zone Controller. Installation, live sound. Three input, two output; AutoWarmth processing; LevelGuard volume control; ducking controls; subwoofer crossover; stereo/mono control; Soundzone series. \$699

Klark Teknik

DN9848
Loudspeaker Processor. Live sound, installation, sound reinforcement. Four inputs, eight outputs; phase reverse; Butterworth, Bessel, Linkwitz-Riley filters; eight-band input parametric EQ; six-band output parametric EQ; high-pass filters; low-pass filters; compressor; delay; limiter; RS-232 port. Frequency response: 20 Hz - 20 kHz. Dynamic range: 113 dB. Delay: up to 1 second on inputs, up to 300 ms on outputs. XLR. 1RU. Compatible with Stardaw Audio controllers. \$5,539

KRK Systems Inc.

Expose E7
Blamp Studio Monitor. Studio, post production, broadcast. Two-way; 7" Kevlar woofer; 1" Kevlar tweeter; self-powered. Frequency response: 54 Hz - 19 kHz. Maximum power handling: 140 W. XLR. 15" x 13.75" x 12". 50 lb. Hexagon shaped. Shielding optional. \$1,900

KRoK II
Studio Monitor. Studio, post production. Two-way; 8" DLDA aluminum

woofer; 1" silk dome tweeter; bass ports; magnetic shielding. Frequency response: 52 Hz - 20 kHz. Sensitivity: 90 dB 1W/1m. Impedance: 8 ohms. Five-way binding post. 15.25" x 10.5" x 9.75". 26 lb. \$250

M1-18
Studio Monitor. Three-way; 18" cone woofer; 7" Polykevlar midrange; 1" carbon ring diaphragm tweeter; separate 24-bit, 96 kHz DSP processor with crossover filters, digital delay, parametric EQ. Frequency response: 19 Hz - 22 kHz. Max SPL: 121 dB. Gold-plated binding posts. 37" x 22" x 24.5". 200 lb. \$9,000

M7000B
Closefield Monitor. Studio, post production, broadcast. Two-way; 7" Kevlar woofer; 1" Kevlar tweeter. Frequency response: 50 Hz - 20 kHz. Crossover @ 3 kHz. Sensitivity: 91 dB, 1W/1m. Maximum power handling: 150 W. Maximum SPL: 110 dB. Impedance: 8 ohms. Binding post. 14.25" x 11" x 11". 50 lb. Shielding optional. \$750

RoKit II
Studio Monitor. Studio, post production, broadcast. Two-way; 6.5" DLDA aluminum woofer; 1" silk dome tweeter; bass ports; magnetic shielding. Frequency response: 62 Hz - 20 kHz. Sensitivity: 89 dB, 1W/1m. Maximum power handling: 100W. Five-way binding post. 13" x 9.75" x 8.75". 21 lb. \$199

S12
Powered Subwoofer. 12" woven Kevlar woofer; grille; gain control; variable low-pass filter; high-pass filter (80 Hz); phase control; onboard 175 W amp; ships with spikes. Frequency response: 31 - 130 Hz. Max SPL: 115 dB. XLR. 15" x 22" x 20". 72 lb. \$1,500

V4
Powered Monitor. Studio, Two-way; 4" Kevlar woofer; 1" silk dome tweeter; input sensitivity control; bass port; 30W low-frequency amp; 15W high-frequency amp; shielded. Frequency response: 65 Hz - 20 kHz. Max SPL: 104 dB. Neutrik combo. 9.25" x 6" x 7.75". 11 lb. \$400

KS Audio USA

T-4
Digitally Controlled Speaker System. Live sound, sound reinforcement. Two-way; 12" woofer; 2" high-frequency driver; 1,400 W amp; onboard digital processing (EQ, time adjust, phase coherence, crossover); 24-bit A/D. XLR. Optional control, processing cards. \$695. Speaker: \$3,295. Matched amplifier: \$4,750.

L-Acoustics US

ARCS
Speaker. Sound reinforcement, installation. Two-way; 15" weatherproof cone with 3" voice coil; 1.4" high-frequency driver on a DOSC waveguide; Wavefront Sculpture Technology; Baltic birch trapezoidal - arrayable cabinet; flying hardware. Frequency response: 63 Hz - 18 kHz. Neutrik Speakon. 32.25" x 17.5" x 25.75". 126 lb. \$3,600

Legacy Audio

Classic
Four-Way Monitor System. Studio. Twin 10" carbon-poly woofers; 7" Kevlar midbass driver; 1.25" soft dome; ribbon tweeter; internal bracing. Frequency response: 22 Hz - 30 kHz. Sensitivity: 92 dB. Power handling: 400 Watts. Crossovers @ 120 Hz, 2.8 kHz, 10 kHz. Impedance: 4 ohms. Gold-plated 5-way binding posts. 44" x 12" x 12". Rosewood finish optional. \$2,000. \$2,895 per pair

Deep Impact ★ New for 2003 ★
Powered Subwoofer. Twin 12" woofers; frequency, level controls; onboard amplifier. \$1,495

Studio

Two-Way Monitoring System. Studio. Two-way, 7.5" dual voice coil Kevlar driver; 1" titanium dome tweeter. Frequency response: 39 Hz - 22 kHz. Sensitivity: 90 dB. Power handling: 200 W. Crossover @ 2.8 kHz. Gold-plated 5-way binding post. 13" x 10" x 10". Rosewood finish optional. \$100. \$995 per pair

Lightspeed Technologies Inc.

WA-2002
Portable PA System. Three-way speaker; up to two UHF wireless mic receivers; onboard CD player; onboard cassette recorder/player; onboard 75 W amp; battery operable; casters; retractable trolley. \$2,625

M Audio

SP-BX8 ★ New for 2003 ★
Powered Monitor. Two-way; 8" mineral-filled polypropylene cone woofer; 1" silk dome ferrofluid-cooled tweeter; level control; magnetic shielding; onboard 130W amp. Frequency response: 37 Hz - 20 kHz. XLR, 1/4". 15" x 10" x 12". \$599 per pair

Studiophile SP-5B
Powered Monitor. Two-way; 5.25" mineral-filled polypropylene cone woofer; 7.5" ferrofluid-cooled silk tweeter; volume control; magnetic shielding; onboard 42W LF amp; onboard 33 HF amp; rear-firing bass port. Frequency response: 33 Hz - 22 kHz. XLR, 1/4". 10" x 6.5" x 8". \$399 per pair

Mackie Designs Inc.

Fusion 1800SA/1800S
Subwoofers. Live sound, sound reinforcement. Twin 18" woofers with 4" voice coils; onboard 2,500W amp; output to slave on 1800SA; 18mm birch cabinet; compatible with Fusion 3000. Frequency response: 38 - 160 Hz. Max SPL: 139 dB. 33" x 23.75" x 23.75". 1800S is an unpowered slave: \$1,249. \$2,999

HR624 Active Studio Monitor
Powered Monitor. Two-way; 6.7" mineral-filled polypropylene cone woofer; 1" aluminum alloy dome high-frequency driver; high-pass filter (80 Hz); Acoustic Space controls; bass port; low, high-frequency controls; twin power amps; 100 W LF Mackie FR series amp; 40 W HF Mackie FR series amp; THX certified. Frequency response: 49 Hz - 22 kHz. XLR, RCA, 1/4". 13" x 8.25" x 10.5". 25 lb. \$599

HR824
Powered Monitor. Studio. Two-way; 8.75" mineral-filled polypropylene cone woofer; 1" aluminum alloy dome high-frequency driver; high-pass filter (80 Hz); Acoustic Space controls; twin power amps; 150 W LF Mackie FR series amp; 100 W HF Mackie FR series amp. Frequency response: 39 Hz - 20 kHz. Max SPL: 121 dB. XLR, 1/4". 10" x 15.75" x 12.25". 34 lb. Optional padded nylon carrying case: \$200 per pair. \$799

HRS120 Active Subwoofer
12" RCF Precision woofer with 4" voice coil; 12" passive radiator; 110 Hz filter; crossover, polarity, input sensitivity controls; onboard 400W FR series amp; .75" MDF cabinet; THX certified. Frequency response: 21 - 150 Hz. XLR, 1/4", RCA. 21" x 18" x 21.5". 94 lb. \$1,499

SA1232
Live Sound Speaker. Live sound, sound reinforcement. Three-way; 12" woofer; 6" midrange driver; 1" RCF compression driver; onboard EQ; onboard time adjustment; handles. Frequency response: 45 Hz - 18 kHz. Max SPL: 136 dB. Crossovers @ 700 Hz, 3 kHz. XLR. 42.25" x 19" x 14". 132 lb. \$1,699

SR1530

Self-Powered Stage System. Live sound, installation. Three-way; triamplified; 15" woofer; 6" horn-loaded midrange; 1" tweeter; high flux magnetic circuit; time correction; phase alignment; thermal protection; onboard 500 W FR series amp. Frequency response: 45 Hz - 18 kHz. Max SPL: 126 dB. Crossovers @ 700 Hz, 3 kHz. 44" x 19" x 18". 100 lb. \$999

SRM450 Self-Powered Sound Reinforcement Loudspeaker

Live sound. Two-way, 12" woofer with 2.5" voice coil; 1.75" titanium tweeter; level control; low-cut filter (100 Hz); contour EQ; power down timer; thermal protection; modified trapezoidal cabinet; integral handles; flypoints; onboard 300 W LF and 100 W HF FR series amps. Frequency response: 45 Hz - 20 kHz. Crossover at 1.6 kHz. XLR. 26" x 15.5" x 14.75". 51 lb. \$899

MacPherson Inc.

AXIA
Speaker. Live sound, sound reinforcement, installation. Three-way; 15" woofer; twin 8" midrange drivers; 2" compression driver in a constant directivity horn; 90 x 55 degree coverage pattern; biampable; tri-ampable. Frequency response: 50 Hz - 17 kHz. 18.5" x 38" x 13.25". 128 lb. Optional line array rigging. Optional installation rigging. Optional dollyboard, cover. \$3,790 - \$4,750

IS15X
Speaker. Installation. Two-way; 15" woofer; 2" compression driver in a rotatable constant directivity horn; 90 x 55 degree coverage pattern. Frequency response: 85 Hz - 15 kHz. 30.25" x 17.25" x 8.5". 73.5 lb. \$1,885

KS115
Low-Profile Subwoofer. Live sound, sound reinforcement, installation. 15" woofer; skid rails. Frequency response: 30 - 120 Hz. 18" x 22" x 22.5". 72.5 lb. \$1,325 - \$1,825

LPX Version 2
Floor Monitor. Live sound, sound reinforcement. Two-way; 15" woofer; 2" compression driver in a constant directivity horn; 90 x 55 degree coverage pattern; biampable; wedge-style cabinet. Frequency response: 80 Hz - 15 kHz. 19" x 17.25" x 23.25". 69 lb. Optional weatherproofing. Optional road case. \$2,375

M2B
Speaker. Live sound, sound reinforcement, installation. Two-way; 15" woofer; 1" compression driver; 90 x 50 degree coverage pattern; biampable; trapezoid cabinet. Frequency response: 90 Hz - 14 kHz. 24.75" x 17.5" x 16.5". 62.5 lb. Optional weatherproofing. Optional road case. Optional pole mount. Optional overhead suspension spreader plate. \$1,760 - \$1,925

Monolith Version 2
Speaker. Live sound, sound reinforcement, installation. Three-way; 18" woofer; twin 6.5" midrange drivers; 2" compression driver in a constant directivity horn; 90 x 55 degree coverage pattern; biampable; tri-ampable. Frequency response: 44 Hz - 17 kHz. 43.5" x 22.5" x 8.5". 128 lb. Optional installation rigging. Custom colors. Optional weatherproofing. Optional cover. \$3,695 - \$4,495

Scholar Model 118 Subwoofer
Arrayable Subwoofer. Live sound, sound reinforcement, installation. Self-Cornering Horn-Loaded Array technology; skid rails. Frequency response: 30 - 120 Hz. 23.25" x 36" x 30". 163 lb. Optional road version. Optional dollyboard. Optional road cover. \$1,725 - \$1,975

Martin Audio

C516
Loudspeaker. Sound reinforcement. Ceiling speaker system; ported baffle; 6.5" ICT; metal grille. Impedance: 4 ohms. Frequency response: 80 Hz-20 kHz. Max SPL: 111 dB. \$199

EM15
Loudspeaker. Sound reinforcement. Mini trapezoid; 5" Inductively Coupled Transducer; 5" low-frequency driver; 80 x 80 degree pattern. Max SPL: 113 dB. \$329

EM150
Subwoofer. Sound reinforcement. Twin 10" low-frequency drivers. Frequency response: 45 Hz - 200 Hz. Max SPL: 129 dB. No crossover required. \$1,069

F15
Speaker. Live sound, installation, sound reinforcement. Two-way; 15" woofer; 1.4" compression driver; 80 x 50 degree rotatable constant directivity horn; steel grille; BlackLine series. \$1,649

H3
Speaker. Live sound, installation, sound reinforcement. Three-way; 15" woofer with folded horn; 10" midrange driver; 1" compression driver; 70 x 40 degree constant directivity horn; tri-amped; steel grille; flypoints; castors; BlackLine series. \$2,999

LE12JB
Wedge Floor Monitor. Sound reinforcement. Two-way; 12" woofer with a 3" voice coil; 1.5" titanium tweeter; steel grille; used with DX1 or MX5 controllers. Crossover @ 1.3 kHz. \$1,979

LE700A
Active Monitor. Sound reinforcement. Two-way; 15" low-frequency driver with 4" voice coil; 2" compression high-frequency driver; birch floor wedge cabinet; steel grille; differential HF. Frequency response: 60 Hz - 18 kHz. Max SPL: 131 dB. Speakon 28" x 19.5" x 15". 97 lb. \$2,139

S15
Compact Subwoofer. Live sound, installation, sound reinforcement. 15" woofer; steel grille; BlackLine series. \$1,349

McCauley Sound

Monarc MLA5
Line Array. Three-way; twin 15" woofers; twin HX32 Carbon-Honeycomb Nomex Composite midrange drivers; one Unified Titanium Diaphragm compression driver; InterCell Summation Aperture technology; Perfect90 baffles; stainless steel hardware; Powerlink rigging; 12-ply 5/8" birch cabinet; Procoat finish. NL8. 14" x 58" x 28". 250 lb.

SM950-2
Stage Monitor. Three-way; 15" woofer; 10" Integrated PointSource midrange driver with Ultra-High Definition UTD HF compression driver; 80 x 80 degree pattern; triamp/biampable; steel grille; 12-ply void-free Finnish birch laminate; ProCoat Elastomeric finish; wedge-style cabinet. Frequency response: 73 Hz - 23 kHz. NL8. 17" x 28.5" x 15". 78 lb.

Meyer Sound Laboratories Inc.

650-P
Powered Subwoofer. Sound reinforcement. Twin 18" drivers; 360 x 180 degree coverage pattern. Frequency response: 28 Hz - 100 Hz. Max SPL: 136 dB. 221 lb. \$5,140

CQ-2
Powered Speaker. Sound reinforcement. Arrayable. 15" LF; 4" HF compression driver; 50 x 40 degree coverage pattern; complementary MOSFET amplifiers; auto voltage selection; Tripower limiting. Frequency

ON THE ROAD AGAIN

From the makers of the original Leviathan™ Touring System,
Community is at it again



T-CLASS

Quality
you will come
to expect

Community

www.loudspeakers.net

SPEAKERS/MONITORS

response: 40 Hz - 18 kHz. Max SPL: 139 dB. 130 lb. \$7,010

HD-1
Closefield Monitor. Studio. 8" low-frequency cone driver; 1" silk dome high-frequency driver; 60 x 60 degree pattern. Frequency response: 32 Hz - 22 kHz. Max SPL: 125 dB. 51 lb. \$3,420

HM-1S Powered Studio Monitor
Studio, post production. Two-way; 7" graphite cone low-frequency driver; 1" soft dome concentric mounted tweeter; 100 x 100 degree constant directivity horn; phase correction; magnetic shielding; 400 W MOSFET amplifier. Frequency response: 42 Hz - 20 kHz. Maximum SPL: 116 dB. 11.5" x 9" x 9.75". 11 lb. Requires PS-1A power supply. \$1,340

M1D Ultra-Compact Curvilinear Array
Powered Line Array. Live sound, sound reinforcement. Two-way; Twin 5" cone woofers; three neodymium dome tweeters; 100 degree horizontal pattern; onboard 225W LF amp, 125W HF amp; QuickFly rigging. Frequency response: 60 Hz - 18 kHz. Max SPL: 125 dB. XLR. 23" x 7" x 8.5". 40 lb.

M2D Compact Curvilinear Array
Powered Line Array. Live sound, sound reinforcement. Two-way; twin 10" woofers; Ribbon Emulation Manifold with 1.5" tweeter; 90 degree horizontal pattern; onboard 400W MOSFET LF amp, 200W MOSFET HF amp. Frequency response: 60 Hz - 16 kHz. Max SPL: 136 dB. XLR. 39" x 12" x 17.5". 114 lb.

MSL-6
Powered Speaker. Sound reinforcement. Arrayable; dual 12" low-frequency drivers; three 2" HF compression drivers; 30 x 25 degree coverage pattern; complementary MOSFET amplifiers; auto voltage selection; Trupower limiting. Frequency response: 65 Hz - 16 kHz. Max SPL: 145 dB. 475 lb. \$21,220

MTS-4A
Powered Loudspeaker. Sound reinforcement. 12", 15" and 18" low-frequency drivers; 4" high-frequency compression driver; 70 x 60 degree coverage pattern. Frequency response: 32 Hz - 16 kHz. Max SPL: 140 dB. 280 lb. \$11,100

PSM-2
Powered Stage Monitor. Sound reinforcement. 12" low-frequency driver; 4" high-frequency driver; 50 x 50 degree coverage. Frequency response: 50 Hz - 18 kHz. Max SPL: 139 dB. 90 lb. \$6,800

PSW-6
Powered Cardioid Subwoofer. Sound reinforcement. Two 18" and four 15" drivers; cardioid frequency pattern coverage. Frequency response: 30 Hz - 125 Hz. Max SPL: 140 dB. 442 lb. \$15,450

UM-100P
Powered Stage Monitor. Live sound, sound reinforcement. Two-way; 12" cone low-frequency driver; 3" compression driver; 100 x 40 degree coverage pattern; phase correction; automatic voltage selection; surge protection; MOSFET amplifier. Frequency response: 60 Hz - 18 kHz. Maximum SPL: 132 dB. Crossover @ 1,200 Hz. 77 lb. \$4,900

UPA-2P
Powered Loudspeaker. Sound reinforcement. Two-way; 12" low-frequency cone driver; 3" high-frequency compression driver; 45 x 45 degree coverage pattern; phase corrected; MOSFET amplifiers; auto voltage; surge protection; crossover/processor card. Frequency response: 60 Hz - 18 kHz. Maximum SPL: 132 dB. 77 lb. \$4,900

UPM-2P
Powered Loudspeaker. Sound reinforcement. Twin 5" low-frequency drivers; 1" high-frequency driver; 45 x 45 degree coverage pattern. Frequency response: 60 Hz - 20 kHz. Max SPL: 123 dB. 21 lb. \$2,100

X-10
Monitor. Studio. Two-way; 15" woofer with 4" voice coil; 4" high-frequency compression driver. Frequency response: 16 Hz - 20 kHz. Max SPL: 135 dB. 87 lb. \$15,000

Miller & Kreisel Professional

MPS-1525
Triple Surround Monitor. Studio, post production. One 5.25" polypropylene woofer; twin 3.5" ferrofluid-cooled mid range cones; 1" soft dome tweeter; Phase-Focused crossover; dipole or tripole mode; THX approved. Frequency response: 100 Hz - 20 kHz. Five-way binding post. 10.5" x 8" x 6.5". 11 lb. \$1,399 per pair

MPS-1610
Monitor. Studio, post production. Two-way; 6.5" polypropylene woofer; 1" soft dome ferrofluid-cooled tweeter. Frequency response: 80 Hz - 25 kHz. Five-way binding posts. 12.5" x 8.5" x 7.5". 12 lb. \$650

MPS-1625
Triple Surround Monitor. Three-way; tripole design; 6.5" polypropylene woofer; four 3.5" midranges; 1" soft dome ferrofluid-cooled tweeter. Frequency response: 80 Hz - 20 kHz. Five-way binding posts. 12.6" x 10.5" x 8". 14 lb. \$499

MPS-2510P
Powered Monitor. Studio, post production. Two-way; twin 5.25" polypropylene woofers; three 1" soft dome ferrofluid-cooled tweeters; switchable wide/narrow vertical directivity; onboard 200 W LF amp; onboard 150 W HF amp; THX approved. Frequency response: 80 Hz - 20 kHz. XLR, RCA. 12.5" x 10.5" x 12". 43 lb. \$1,999

MPS-2525
Triple Surround Monitor. Studio, post production. Three-way; tripole design; twin 5.25" polypropylene woofers; four 3.5" midranges; three 1" soft dome ferrofluid-cooled tweeters; THX approved. Frequency response: 80 Hz - 20 kHz. Five-way binding posts. 12.5" x 10.5" x 12". 26 lb. \$1,399

MPS-5310 Subwoofer
THX Powered Subwoofer. Studio, post production. Two 12" long-throw drivers; push-pull design; adjustable low-pass filter; low-pass Linkwitz-Riley filter; 350 Watt amplifier; shielded; THX approved. Frequency response: 20 - 125 Hz. XLR. 23" x 15.25" x 19.75". \$1,999

Musikelectronic Geithain/G Prime

Basis 1
Powered Subwoofer. 11" woofer; high-pass filter; bass output level control; MOSFET amplifier; MDF cabinet. Frequency response: 28 - 80 Hz. Max SPL: 110 dB. XLR. 40 lb. Optional magnetic shielding. \$2,995

RL 906
Powered Closefield Monitor. Studio, broadcast. Two-way; 5" woofer; 1" metal dome tweeter; coaxial design; bass ports; MDF cabinet. Frequency response: 50 Hz - 20 kHz. Max SPL: 104 dB. Crossover: 3 kHz. XLR. 10 lb. \$1,250

Nexo USA

Alpha E-F
Two-Way Speaker. Live sound, sound reinforcement, installation. Two-way. Frequency response: 40 Hz - 19 kHz.

PS8 Loudspeaker System
Live sound, sound reinforcement. Two-

way; 8" neodymium long excursion woofer; 1" neodymium compression driver; asymmetrical constant directivity horn. Frequency response: 58 Hz - 21 kHz. Amplifier output per channel: 430W @ 8 ohms. XLR. 16" x 10" x 9". 20 lb. PS8 controller: \$2,995. PS8 amplifier: \$2,895. \$925

NHTPro

A-20
Amp/Speaker System. Studio. Two-way; 6.5" treated paper cone; 1" aluminum dome tweeter; magnetic shielding; separate rackmountable 250 W amp with gain, proximity controls, LED display. Frequency response: 40 Hz - 20 kHz. Max SPL: 117 dB. XLR, 1/4". \$1,800 per pair

B-20
Powered Subwoofer System. Twin 14" cubs; 10" polypropylene woofer; 250 W separate rackmountable amp with controls; switchable low-pass filter; switchable high-pass filter; sensitivity, boundary, phase, gain controls. Frequency response: 25 - 110 Hz. Max SPL: 110 dB. XLR, 1/4". \$1,900

C-20
Powered Center Channel Speaker Project studio, broadcast. Two-way; 6.5" treated paper cone woofer; 1" aluminum dome tweeter; magnetic shielding; separate rackmountable 250 W amp with sensitivity, boundary, position controls; for A-20 system. Frequency response: 48 Hz - 20 kHz. Max SPL: 117 dB. XLR, 1/4". \$1,000

OAP Audio

C-3.0
Loudspeaker. Sound reinforcement. Two-way; 15" coaxial woofer; 1" titanium diaphragm compression driver on a 60 x 30 degree constant dispersion horn; twin 1" titanium diaphragm compression drivers; biamped; L-pad for horn; 3/4" plywood cabinet. Frequency response: 64 Hz - 16 kHz. Power handling: 350 Watts, program. Impedance: 8 ohms. Five-way binding posts. 36" x 29.5" x 18.5". 115 lb. Choice of grille cloth. Optional biamp. \$2,500

CM-110
Floor Monitor. Two-way; 10" woofer; 1" compression driver on a 90 x 90 degree horn; 3/4" MDF cabinet; 16-gauge steel grille. Frequency response: 95 Hz - 14 kHz. Power handling: 300 watts, program. Impedance: 8 ohms. 1/4". 35 lb. \$370

CPX-1250
Loudspeaker. Sound reinforcement. Three-way; two 15" woofers; 10" horn-loaded midrange; 2" titanium diaphragm compression driver on a constant dispersion horn; Select Frequency Tuning; 3/4" plywood cabinet; OAP Safety First Internal Truss System; 16-gauge steel grille; rigging points. Frequency response: 45 Hz - 18 kHz. Power handling: 1,600 W program (low-frequency), 600 W program (midrange), 120 W (high-frequency). Neutrik NL4 Speakon. 40" x 23.25" x 26.5". 225 lb. Choice of finishes. Weatherizing available. \$5,400

LF-118
Subwoofer. Sound reinforcement. 18" woofer; 3/4" plywood cabinet; internal bracing; pole socket; 16-gauge steel grille. Frequency response: 45 Hz - 200 Hz. Power handling: 800 W program. Impedance: 8 ohms. 1/4", barrier strip. 22.5" x 24" x 25.5". 95 lb. Optional Neutrik NL4 Speakon connectors. Choice of finishes. Weatherizing available. \$1,020

MT-152
Loudspeaker. Sound reinforcement. Two-way; 15" woofer; 1" titanium diaphragm compression driver on a 90 x 40 degree constant dispersion horn; passive crossover; speaker stand socket; 3/4" plywood cabinet; internal

bracing; 16 gauge steel grille. Frequency response: 55 Hz - 16 kHz. Power handling: 400 W program. Impedance: 8 ohms. 1/4", barrier strip. 25.5" x 16" x 19". 85 lb. Optional Neutrik NL4 Speakon connectors. Optional bi-amp. Choice of finishes. Weatherizing available. \$860

NF-241
Install Speaker for Stair Risers. Two-way; twin 4.5" woofers; 1" compression driver on a 90 x 90 degree horn. Frequency response: 128 Hz - 15 kHz. Impedance: 16 ohm. 14.5" x 8.75" x 5.25". Designed for mounting in stair risers. \$700

SM-115
Stage Monitor. Live sound, sound reinforcement. Two-way; 15" woofer; 1" titanium diaphragm compression driver on a 90 x 40 degree constant dispersion horn; 3/4" plywood cabinet; 16-gauge steel grille. Frequency response: 60 Hz - 16 kHz. Power handling: 400 W program. Impedance: 8 ohms. 1/4". 19.25" x 25.5" x 17.3". 80 lb. Optional Neutrik NL4 Speakon connectors. Optional biamp. Choice of finishes. Weatherizing available. \$850

T-1002
Loudspeaker. Sound reinforcement. Two-way; 10" woofer; 2" titanium diaphragm compression driver on 70 x 50 degree constant dispersion horn; 3/4" plywood cabinet; OAP Safety First Internal Truss System; 16-gauge steel grille; rigging points. Frequency response: 78 Hz - 18 kHz. Power handling: 600 W program (low-frequency), 120 W (high-frequency). Impedance: 8 ohms. NL4 speakon, barrier strip. 22" x 11.75" x 15.5". 64 lb. Optional biamp. Choice of finishes. Weatherizing available. \$1,760

OWI Inc.

Landscape Garden Speaker System
Omnidirectional Installation Speakers. Installation. 360 degree pattern; weatherproof; rock finish; green, grey, taupe, granite finishes. Optional 70 V transformers. Optional onboard lights. \$499

Panaramic Sound/800
Speaker. Sound reinforcement; installation. Two-way; direct radiator; 5.5" polypropylene coated woofer; 1" waveguide soft dome tweeter; strontium magnet; power selector; weatherized; aluminum cabinet. Frequency response: 100 Hz - 22 kHz. Sensitivity: 89 dB 1W/1m. Crossover @ 3.5 kHz. 10" x 6" x 6.25". Optional foreground/background. Optional mounting hardware. Choice of finishes. Available in 8 ohm or 70 V models. \$499 per pair

PAS (Professional Audio Systems)

MF-218
Subwoofer. Live sound, sound reinforcement. Twin 18" woofers; handles; Baltic birch cabinet; three pole mounts. Frequency response: 34 - 300 Hz. Power handling: 1,200 W program. Neutrik NL4. 21" x 42" x 24". 150 lb. \$1,495

SW-1.2
Stage Monitor. Live sound. Two-way; 15" woofer; 2" compression driver; Time Offset Compression; 40 x 60 degree coverage pattern; Baltic birch cabinet; handles. Frequency response: 50 Hz - 17 kHz. Power handling: 500 W program. NL4. 21.25" x 17.25" x 15.25". 71 lb. \$1,520

T-2540
Speaker. Live sound, sound reinforcement. Two-way; twin 15" woofers with 4" edgedwood voice coils; 2" compression driver; 60 x 40 degree coverage pattern; integrated handles; 3/4" plywood cabinet; carpeted exterior; T series. Frequency response: 40 Hz - 16 kHz. Max SPL: 132 dB. Sensitivity:

102 dB 1W/1m. Power handling: 1,000 W program. Neutrik NL4. 46" x 21.5" x 19". 145 lb. \$1,499

Peavey Electronics Corp.

112PM
Powered Floor Monitor. Live sound. 12" woofer; bullet-style tweeter; onboard 75W amp; four-band EQ; wedge-style cabinet; carpeted exterior; metal corners; metal grille. Frequency response: 100 Hz - 17 kHz. Sensitivity: 96 dB 1W/1m. Impedance: 8 ohms. \$439

Impulse 1012
Weather Resistant Speaker System. Sound reinforcement. Two-way; 12" Black Widow BWX woofer; RX22 titanium compression driver with molded 90 x 45 horn; Sound Guard high-frequency driver protection; Versamount mounting points; stand mount adapter; handles; weather resistant construction; 8 or 4 ohm versions. Frequency response: 74 - 78 Hz - 18 kHz. Power handling @ 8 ohms: 500 W continuous, 2,000 W peak. @ 4 ohms: 700 W continuous, 2,800 W peak. Sensitivity: 100 dB 1W/1m. Impedance: 8 ohms. Horn dispersion: 90 degrees x 45 degrees. 23.5" x 18" x 13.75". 45 lb. Trapezoidal design. \$549

Impulse 1012 Subwoofer
12" weather resistant Black Widow BWX woofer with field replaceable basket; hypervent port; integral stand-mount; Versamount mounting points; carrying handles. Frequency response: 52 Hz - 3.5 kHz. Power handling: 500 W program. Impedance: 4 ohms. 1/4", Neutrik Speakon. 23.5" x 18" x 13.75". 40 lb. \$449

Impulse 1012P
Two-way; 12" BWX Black Widow woofer; RX22 compression HF driver with DDT protection; field replaceable basket. Frequency response: 62 Hz - 18 kHz. Max SPL: 128 dB. \$899

Q-W ML/Q0W MR
Monitors. Two-way; 15" Pro Rider woofer with 4" voice coil; 4" 44XT titanium compression HF driver on CH942qt Quadratic Throat Waveguide CD horn; field replaceable baskets. Frequency response: 65 Hz - 12 kHz. Power handling: 2,000W, program. Neutrik Speakon. \$1,099

SP 4X
Speaker System. Sound reinforcement. Two-way; twin 15" BWX Black Widow woofers with Kevlar impregnated cone; 4" voice coil; field replaceable basket; RX22 compression driver; external voicing switch. Frequency response: 51 Hz - 16 kHz. Power handling: 1,000 W program. Sensitivity: 100 dB 1W/1m. 49" x 21" x 22.75". 125 lb. Trapezoidal design. \$849

PMC/Bryston

AB2
Monitor. Studio. Two-way; 10" woofer with 4" voice coil; silk dome tweeter; oxygen-free copper wiring; double veneered 3/4" MDF cabinet. Frequency response: 25 Hz - 25 kHz. Sensitivity: 89 dB 1W/1m. Maximum SPL: 116 dB. Power: 400 W. Crossover @ 2 kHz. Impedance: 6 ohms. Binding post. 4mm banana. Neutrik Speakon. Optional magnetic shielded model. Black ash/walnut veneers. Rosewood extra. \$3,800 per pair

AML-1
Powered Monitor. Studio, post production. Two-way; 6" carbon fiber/Nomex flat piston woofer; 1" silk dome tweeter; oxygen-free copper wiring; onboard 150 W LF amp; onboard 100 W HF amp; 3/4" MDF cabinet. Frequency response: 25 Hz - 25 kHz. Sensitivity: 91 dB 1W/1m. Maximum SPL: 115 dB. \$5,300 per pair

BB-5
Three-Way Monitor. Studio, post pro-

The Professional's Source



The Professional's SOURCE for all your PRO-AUDIO and RECORDING needs

- Built To Order Computer Based Turnkey Systems for Macintosh or Windows
- Expert Advice from Working Professionals!
- World's Largest In-Stock Inventory!



The B&H on line SuperStore is open 24 Hours for your Convenience



420 Ninth Ave.
Between 33rd & 34th Streets,
New York, N.Y. 10001

For Information Call:
800-947-1182 • 212-444-6682
or Fax (24 Hours):
800-947-7008 • 212-239-7770

Store and Mail Order Hours:
Sun. 10-5, Mon. thru Thurs. 9-7
Fri. 9-1, Sat. Closed
WE SHIP WORLDWIDE

SPEAKERS/MONITORS

duction. Three-way; 15" radial woofer; 3" fabric midrange; 1" silk dome tweeter; oxygen-free copper wiring; 3/4" MDF cabinet. Frequency response: 17 Hz - 25 kHz. Sensitivity: 91 dB 1W/1m. Maximum SPL: 127 dB. Power: 1,000 W. Crossover @ 3.8 kHz. Impedance: 4 ohms. Neutrik NL4 Speakon. Black ash/walnut veneers. Rosewood extra. Optional horizontal orientation. \$19,200 per pair

DB1
Two-way; 5.5" woofer; aluminum alloy ferrofluid-cooled tweeter; transmission line; biampable. Frequency response: 50 Hz - 25 kHz. Sensitivity: 87 dB 1W/1m. Crossover @ 3 kHz. Binding posts. 11.5" x 6" x 9.25". 20 lb. Cherry, oak, black ash, studio black finishes. Shielded version available. Center channel version available. \$745 per pair

IB-HS
Monitor. Studio. Three-way; 10" carbon fiber/Nomex woofer; 3" doped fabric midrange; 1" silk dome tweeter; oxygen-free copper wiring; 3/4" MDF cabinet. Frequency response: 25 Hz - 25 kHz. Sensitivity: 89 dB 1W/1m. Maximum SPL: 116 dB. Power: 500 W. Crossover @ 380 Hz, 3.8 kHz. Impedance: 4 ohms. Optional magnetic shielded model. Optional self-powered model. Optional horizontal orientation. \$4,950 per pair

LB1
Monitor. Studio. Two-way; 4.5" woofer with 3" voice coil; silk dome tweeter; oxygen-free copper wiring; double veneered MDF cabinet. Frequency response: 35 Hz - 25 kHz. Sensitivity: 87 dB 1W/1m. Maximum SPL: 114 dB. Power: 300 W. Crossover @ 2.5 kHz. Impedance: 4 ohms. Binding post, 4mm banana, Neutrik Speakon. Black Ash/Walnut veneers. Rosewood extra. \$2,360 per pair

TB2S
Monitor. Studio. Two-way; transflex loaded 7" cast magnesium alloy woofer; 1" aluminum alloy ferrofluid tweeter; oxygen-free copper cable; silver solder; 3/4" MDF cabinet. Frequency response: 40 Hz - 25 kHz. Sensitivity: 90 dB 1W/1m. Maximum SPL: 113 dB. Power: 150 W. Crossover @ 3 kHz. Binding post, 4mm banana. 16" x 8" x 12". \$900 per pair

XB1
Subwoofer. Studio. 10" dual voice coil woofer; oxygen-free copper wiring; 3/4" MDF cabinet. Frequency response: 25 - 200 Hz. Sensitivity: 90 dB 1W/1m. Maximum SPL: 116 dB. Power: 200 W. Crossover @ 100 Hz. Binding post, 4mm banana. \$1,250

QSC Audio Products Inc.

215PCM/215PSB/215SB
Powered Subwoofer. Twin facing 15" woofers with 4" voice coils; onboard 3,000W QSC Class H amp; two QSC DSP-3 processor modules; weather resistant Composite carbon fiber cabinet; recessed handles; pole mount; QSCControl; onboard rigging; casters; rubber feet; RS232 port. Frequency response: 36 - 360 Hz. Max SPL: 141 dB. XLR, Neutrik NL4MP. 40" x 26" x 30". 230 lb. 215SB is unpowered. 215PSB adds additional internal 3,600W QSC amp for output to satellite. \$900 per pair

Quested/Q.usa

F11P
Speaker. Recording studio, project studio, broadcast. Two-way; 6.5" woofer; 1" soft dome high-frequency driver; shielded. Frequency response: 65 Hz - 20 kHz. Max SPL: 98 dB. Sensitivity: 84 dB 1W/1m. Impedance: 8 ohm. 9" x 12.5" x 11.5". 26 lb. \$595

F19
Powered Subwoofer. 10" woofer; onboard 200W Class D amp.

Frequency response: 29 - 120 Hz. Max SPL: 107 dB. 18.5" x 11.5" x 14.25". 42 lb. Optional bass management control module.

VH3208

Three-Way Speaker. Studio, broadcast, installation. Three-way; twin 8" woofers; 3" midrange; 1" soft dome tweeter; input sensitivity switch; 1" MDF cabinet. Frequency response: 45 Hz - 20 kHz. Max SPL: 110 dB. Sensitivity: 92 dB 1W/1m. Impedance: 8 ohm. 19" x 24.25" x 16.5". 84 lb. \$2,295

VS1115

Powered Subwoofer. Studio, broadcast, installation. 15" woofer; onboard 400 W amp; phase, bass management controls. XLR. 27" x 21.25" x 27.5". 137 lb. \$3,675

VS3208

Three-Way Powered Monitor. Studio, broadcast, installation. Three-way; twin 8" woofers; 3" midrange; 1" soft dome tweeter; input sensitivity switch; three-band EQ; onboard twin 230 W LF amps; onboard 110 W midrange amp; onboard 100 W HF amp. Frequency response: 40 Hz - 18 kHz. Max SPL: 112 dB. 19" x 24.25" x 16.5". 104 lb. \$3,700

Radian Audio Engineering

365

Installation. Two-way; 6.5" woofer with coaxially-mounted .75" Mylar dome tweeter. Frequency response: 60 Hz - 12 kHz. Sensitivity: 91 dB 1W/1m. Optional 25/70/100V transformer: \$113. \$83

MicroFill RMF-1122

Installation, live sound, sound reinforcement. Two-way; 12" woofer; 2" horn compression driver; 50 x 70 degree pattern; biampable; 13-ply Baltic birch cabinet; rigging hardware; pole mount. Sensitivity: 96 dB 1W/1m. Neutrik NL4. 25" x 16.5" x 15". 72 lb.

MicroWedge RMW-1122

Stage Monitor. Live sound. Two-way; 12" woofer; 2" compression driver; coaxial design; biampable; 3/4" 13-ply Baltic birch low-profile cabinet; Duradur finish. Frequency response: 60 Hz - 20 kHz. Power output: 123 dB, continuous. \$1,995

RCX-215P/B

Speaker. Sound reinforcement, installation. Two-way; twin 15" low-frequency drivers; 2" compression high-frequency driver; Zolotone finish. Frequency response: 45 Hz - 20 kHz. Power handling: 2,000 W. Sensitivity: 102 dB 1W/1m. Max SPL: 135 dB. 37.5" x 20" x 21.25". 128 lb. RCS-215B is a biamp version: \$2,095. \$2,195

RPX-108P

Stage Monitor. Live sound, sound reinforcement. Two-way; 8" low-frequency driver; 1" compression high-frequency driver; wedge-style monitor; 13-ply Baltic birch cabinet; weather/scratch resistant Duradur finish; metal grille; built-in flypoints. Frequency response: 80 Hz - 20 kHz. Power handling: 400 W. Sensitivity: 96 dB 1W/1m. Max SPL: 125 dB. Neutrik NL-4. 12" x 17.5" x 12". 32 lb. \$790

Randall Amplifiers

Randall Isolation

Speaker Isolation Box. 12" woofer. 1/4". Optional Celestion 12" woofer model: \$499. Smaller 10" model for bass: \$399.

Rane Corp.

AC 24 ★ New for 2003 ★

Active Crossover. Live sound, sound reinforcement, installation. Two-channel; four-way; mute, delay, limit controls per band; CD horn EQ; Linkwitz-Riley filters; stereo link. XLR. 2RU. \$999

SAC23 Three-Way Stereo

Crossover

Live sound, sound reinforcement. Input level control; three output level controls; frequency controls (80 Hz - 1 kHz, 350 Hz - 7 kHz); Linkwitz-Riley filters. XLR. 1RU. \$399

Redwood Music Corporation

SP-112AP

Powered Speaker. Sound reinforcement, live sound, installation. Two-way; SK12100 12" woofer; SK20ST tweeter; onboard four-channel mixer; level controls; five-band EQ; onboard 100W amplifier; pole mount; 3/4" Road Wood cabinet; Warnex coating. Frequency response: 70 Hz - 18 kHz. Sensitivity: 100 dB 1W/1m. Impedance: 8 ohms. Crossover @ 3.3 kHz. \$589

SP-152L

Speaker. Sound reinforcement, live sound, installation. Two-way; SK15200 15" woofer; SK20HST tweeter; biampable; 3/4" Road Wood cabinet; metal handles; pole mount; Warnex coating. Frequency response: 60 Hz - 18 kHz. Sensitivity: 101 dB 1W/1m. Impedance: 8 ohms. Crossover @ 2.5 kHz. \$529

Renkus-Heinz Inc.

CDT350 Series

Speaker Horns. Sound reinforcement. CoEntrant design, 1" high-frequency drive, 8" midrange driver; variable coverage patterns; weather resistant. Frequency response: 350 Hz - 17 kHz. Maximum output: 129 dB. Screw terminals, 4" pig tails. 32" x 28" x 32". Designed as horn upgrades. \$1,485

CT4212

Three-Way Speaker. Three-way; twin 12" SSL12-7 fiber cone woofers; 8" SSL8-9 treated paper cone midrange driver; 2" CDT-1K CoEntrant driver; Complex Conic horn; biampable. Frequency response: 55 Hz - 18 kHz. 38" x 17" x 20". 133 lb. \$3,595

DRS18

Subwoofer. Sound reinforcement. Long throw magnetic 18" woofer; heavy duty 13-ply hardwood construction. Frequency response: 32 - 100 Hz. Maximum SPL: 127 dB. Screw terminals, Neutrik Speakon. 32.5" x 21" x 32". 152 lb. Portable or fixed installation. \$1,735

SR6/6 and SR 6/9

Three-Way Loudspeakers. Sound reinforcement. Compact three-way CoEntrant/Complex Conic driver system; 12" woofer; 2" Complex Conic horn; built-in mid/high crossover for biamping; optional control modules. Frequency response: 60 Hz - 17 kHz. Maximum output: 123 dB. Screw terminals, Neutrik Speakon. 26.5" x 14" x 16". Horns may be rotated. Coverage choice - 60 x 40 or 90 x 40. Optional passive version. Optional control modules for crossover, response, overload protection and phase equalization. \$2,085

TCR152

Two-Way Speaker. Two-way; twin 12" SSL15-6K cone woofers; 2" SSD3302-8 compression driver; Complex Conic horn. Frequency response: 40 Hz - 18 kHz. 48.75" x 16.5" x 23.25". 138 lb. \$2,545

Requisite Audio Engineering

Cantilever Reference Monitor

Powered Monitor. Studio. Three-way; 12" woofer; 7" magnesium cone midrange driver; dual ring radiator tweeter; onboard amps. Frequency response: 25 Hz - 40 kHz. \$12,000 per pair

Rexroat Sound

MPT-48

Speaker Array. Two-way; twin 15" woofers; twin 12" mid/high drivers with

1" compression drivers; horn loaded; 13-ply 3/4" Baltic birch trapezoidal cabinet. Neutrik NL8MPR. 48" x 21" - 48" x 54". 500 lb. \$5,295

Roland Corp. U.S.

DS-90A Powered Monitors

Studio. Two-way; 24-bit A/D; 6.5" polypropylene woofer; 1" soft dome tweeter; input level, trim controls; onboard 60 W amp for woofer; onboard 30 W amp for tweeter; magnetic shielding; optical input; status LEDs. Frequency response: 48 Hz - 20 kHz. XLR, 1/4", RCA, optical. 9" x 15" x 14.75". 33 lb. For use with Roland COSM speaker modeling. \$595

SSM-151 Floor Monitor

Live sound. Two-way; 12" woofer; horn tweeter; tweeter protection; recessed handles; floor wedge. Frequency response: 58 Hz - 16 kHz. Sensitivity: 98 dB 1W/1m. Impedance: 8 ohms. Crossover @ 4 kHz. Max power: 450 W. 1/4", Speakon. 24.5" x 15.75" x 14.25". 32 lb. \$399

Samson Technologies Corp.

dB500a

Powered Speaker/Floor Monitor. Live sound. Two-way; 15" Celestion Truvox Kevlar impregnated cone woofer; 1" titanium compression tweeter; onboard 400W Class AB LF amp; onboard 100W Class AB HF amp; limiter; bass, treble controls; flypoints; steel grille; pole mount. Neutrik Speakon. \$699

DMS80 Desktop Monitor System

Studio. Two two-way speakers, separate integrated preamp/amp unit; five-band graphic EQ; volume, balance, level controls; 5.25" woofer; dome tweeter; front panel 1/4" input; LED meters. 1/4", RCA. \$299

Expedition Express

Portable PA System. Live sound. Two-way; 12" woofer; 1" titanium compression driver; onboard 125W per channel amp; onboard four-channel mixer; onboard DSP; casters. XLR, 1/4", RCA. Includes second passive slave speaker cabinet, dynamic handheld mic, cables, cases. Optional cassette recorder. Optional battery. Optional wireless mic system. \$949

Resolv 65 Reference Monitor

Speaker. Two-way; 6.5" copolymer woofer with butyl surround; 1" aluminum dome tweeter. Frequency response: 40 Hz - 20 kHz. THD: <0.05%. Gold-plated binding posts. 13.75" x 8.5" x 10". \$279 per pair

XP300

Powered Speaker. Two-way; 12" Celestion woofer; 1" titanium compression driver; onboard mixer; onboard DSP; volume control; VU meter; handle; wheels; Expedition Pro series. Frequency response: 60 Hz - 15 kHz. XLR, RCA. Optional cassette recorder. Optional wireless mic system. \$799

Servo Drive/Sound Physics Lab

BassTech 7

Servo Motor Driven Subwoofer. Sound reinforcement. Twin 15" woofers; servo motor-driven. Frequency response: <28 Hz. Max SPL: 136 dB. 22.5" x 45" x 45". 230 lb. Heavy-duty version, BassTech 2K: \$4,795. \$4,315

ContraBass

Servo Motor Driven Subwoofer. Twin 15" woofers; servo motor-driven. Frequency response: 14 - 125 Hz. Sensitivity: 92 dB 1W/1m. 18" x 22.5" x 37". 120 lb. \$2,995

SPL TRIK

Floor Monitor. Three-way; two 12" woofers; four 4" midrange drivers; 1" compression driver. Max SPL: 133+ dB. 16" x 40" x 20". 80 lb. \$2,795

SPL12d1

Speaker. Three-way; two 12" woofers; four 5" midrange drivers; 1" HF horn; Unity Summation Aperture technology; Baltic birch cabinet. Frequency response: 65 Hz - 20 kHz. Sensitivity: 103 dB 1W/1m. Crossovers @ 300 Hz, 1.2 kHz, NL8, NL4, 23" x 29" x 19". 130 lb. Can be rigged as active. \$2,795

Shure Inc.

P4800

System Processor. Installation, live sound, sound reinforcement. Soundplex software; 48 kHz sample rate; DFR 11 feedback reduction; graphic EQ; parametric EQ; gate; limiter; compressor; expander; delay; AGC; crossover controls; Butterworth, Bessel, Linkwitz-Riley slopes; RS232, RS422 ports; compatible with AMX, Crestron controllers. Phoenix, MIDI five-pin, nine-pin D-sub. 1RU. \$2,665

SLS Loudspeakers

112R

Speaker. Live sound, sound reinforcement, installation. Two-way; 12" woofer; 6" ribbon driver; 110 x 40 degree pattern; birch cabinet; steel grille; NeverMar finish. Frequency response: 52 Hz - 20 kHz. Power handling: 500W, program. MAX SPL: 132 dB. Sensitivity: 98 dB 1W/1m. Crossover @ 1.8 kHz. Impedance: 8 ohms. Neutrik NL4FC. 25.25" x 16.5" x 13". 70 lb. Optional rigging version, 112R-I: \$1,795. \$1,695

112RM

Stage Monitor. Live sound, sound reinforcement, installation. Two-way; 12" woofer; 6" ribbon driver; 80 x 40 degree coverage pattern; 13-ply Baltic birch semi-wedge cabinet; steel grille; NeverMar finish. Frequency response: 58 Hz - 18 kHz. MAX SPL: 132 dB. Sensitivity: 98 dB 1W/1m. Crossover @ 1.6 kHz. Neutrik NL4FC. 15.5" x 28" x 14.5". 70 lb. Smaller version with 40 x 100 degree coverage pattern, 112RMV: \$1,850. \$1,995

LS8695 True Planar Ribbon Line

Source Array Installation, live sound, sound reinforcement. Two-way; eight 6.5" woofers; nine SSL PRD500 5" ribbon drivers; 100 degree coverage pattern; 13-ply Baltic birch plywood cabinet; NeverMar finish. Frequency response: 80 Hz - 20 kHz. Sensitivity: 104 dB 1W/1m. Max SPL: 128 dB. Crossover @ 1.3 kHz. Neutrik NL4. 55.5" x 11.5" x 12". 110 lb. \$3,495

RLA/1

Line Array. Live sound, sound reinforcement. Three-way; twin 15" woofers; quad 6.5" midrange drivers; twin SSL PRD1000 ribbon HF drivers; NeverMar finish. Frequency response: 45 Hz - 20 kHz. Speakon NL8. 17" x 50" x 21". 250 lb. \$6,000

S8R

Speaker. Studio. Two-way; 8" woofer; 5" ribbon HF driver; 120 x 40 degree dispersion pattern. Frequency response: 44 Hz - 20 kHz. Power handling: 125W, program. Max SPL: 110 dB. Sensitivity: 90 dB 1W/1m. Crossover @ 2.5 kHz. Binding posts. 19" x 10.5" x 11.25". 25 lb. Natural oak or black oak finish. \$775

T3R

Speaker. Live sound, sound reinforcement, installation. Three-way; 15" cone woofer; 10" horn-loaded cone; 6" ribbon tweeter; 13-ply birch cabinet; steel grille; NeverMar finish. Frequency response: 48 Hz - 18 kHz. Crossovers @ 300 Hz, 1.8 kHz. Neutrik NL8FC. 48" x 22" x 23.5". 170 lb. With flypoints, T3R-I: \$3,950. Optional dolly. Optional Cloud Nine covers. Optional fully horn-loaded version, T3RH-I: \$4,895. \$3,850

UB28R

Horizontal Speaker. Two-way; twin 8" woofers; 5" ribbon driver; 13-ply Baltic

Groove Tubes™

www.groovetubes.com

Vipre™

Variable
Impedance
Preamp



WHAT MICROPHONES DREAM ABOUT.

VOG: Vipre Owners Group

"I heard the Vipre demo at the NY AES show in New York and I bought one right away...and gotten great results I would not have been able to obtain otherwise. This is not just another first class mic pre - this box can help you get sounds out of your mic's that have eluded you up until now."

Walter Becker,
Steely Dan

"I've used it on voice, guitar, and bass, all with stunning results!"

Frank Fillpetti,
James Taylor, Carly Simon, Elton John, Barbara Streisand, Pavarotti, Celine Dion, others

"After extensive listening tests comparing it to all other mic preamps at my studio, the Vipre came out way on top in terms of sound clarity and depth."

Michael Wagener
Dokken, Ozzy Osbourne, Janet Jackson, Stryper, Alice Cooper, many others

"This Vipre is just too good to send back! I gotta have it! Here's the check."

George Petersen
MIX Editor, "Mr. Mix"

VARIABLE IMPEDANCE INPUT

Custom-wound transformers load mics at 300, 600, 1200 or 2400 ohms, multiplying the performance potential of every microphone. Additional transformerless balanced bridged, line and instrument inputs.

VARIABLE RISE TIME

Select between five amplification styles ranging from Smooth-and-Classic (Slow) to Bright-and-Modern (Fast). These first two exclusive Vipre features alone provide 25 unique tone-shaping combinations from any single mic!

ALL TUBE, BALANCED CLASS A

Eight Groove Tubes in a fully differential signal path dramatically lowers noise and distortion - while expanding bandwidth (flat from 7Hz to over 100kHz!).

PRECISION GAIN CONTROL

No pots! Custom-built ceramic deck attenuators control Vipre's incredible 75dB of total gain in 5dB and 1dB stepped increments for precision gain while maintaining the integrity of Vipre's fully balanced signal path.

AUTHENTIC VU METERING

Custom-built, back lighted VU meter with five switchable viewing ranges.



Stop dreaming, Wake up your mics.

Only Vipre does what no other preamp can.

Visit our website or call us at 818 361 4500 for complete specs and a list of Groove Tubes Vipre dealerships.

GROOVE TUBES LLC CUSTOM SHOP PRODUCTS™

©2002 Groove Tubes LLC. All rights reserved. Groove Tubes, the GT in a circle logomark, Groove Tubes Custom Shop Products and Vipre are trademarks of Groove Tubes LLC.

SPEAKERS/MONITORS

birch cabinet; flypoints; steel grille; NeverMar finish. Frequency response: 65 Hz - 20 kHz. Power handling: 200W, program. Max SPL: 114 dB. Sensitivity: 96 dB 1W/1m. Crossover @ 2.2 kHz. Impedance: 4 ohms. Binding posts. 10" x 29.75" x 10.75". 38 lb. \$1,149

Sony Electronics

SRP-F300
Digital Speaker Processor. Live sound, sound reinforcement, installation. Two-input; six-output; 24-bit; 96 kHz; 11-band master parametric EQ; 31-band master graphic EQ; compressor; delay; high, low-cut filters; three-band parametric EQ; Butterworth, Bessel, Linkwitz-Riley filters; high, low-pass filters; pink noise/oscillator generator; phase reverse; 50 memory settings; PC software for remote operation; security lockout; linkable; RS232 port. XLR, nine-pin D-sub. 1RU. \$1,950

Sound Advance Systems Inc.

CT73 SpeakerTile
Flat Panel Ceiling Speaker. Installation. Planar Diaphragm technology; Expanded PolyStyrene surface; customizable finishes and colors. Frequency response: 40 Hz - 19 kHz. Variety of mounting options.

CT8F
Flat Panel Installation Speaker. Full-range driver; mounting hardware; 8 ohm, 70V models; paintable. Frequency response: 80 Hz - 15 kHz. \$91

Sound Bridge Acoustic Labs

SB2112HT
Speaker. Live sound, sound reinforcement, installation. Two-way; 12" woofer; 1" compression driver with ABS horn; high-frequency protection; steel pole mount; 16 gauge metal grille; 3/4" plywood trapezoid cabinet; Ozite exterior coating. Frequency response: 60 Hz - 18 kHz. Sensitivity: 98 dB 1W/1m. Power handling: 350 W, 700 W peak. Impedance: 8 ohms. 1/4". \$379

SB2112W Floor Monitor
Live sound, sound reinforcement, installation. Two-way; 12" woofer; 1" compression driver with ABS horn; high-frequency protection; 16 gauge metal grille; 3/4" plywood wedge-style cabinet; Ozite exterior coating. Frequency response: 68 Hz - 18 kHz. Sensitivity: 98 dB 1W/1m. Power handling: 300 W. Impedance: 8 ohms. 1/4". \$379

SB2118SW Subwoofer
Live sound, sound reinforcement, installation. 18" woofer; 16 gauge metal grille; 3/4" plywood cabinet; Ozite exterior coating; designed for use with SB2000 series speakers. Frequency response: 35 - 600 Hz. Sensitivity: 99 dB 1W/1m. Power handling: 300 W. Impedance: 8 ohms. 1/4". \$419

SoundTube Entertainment

CM81
Ceiling Installation Speaker. Installation. Two-way; 8" treated fiber cone; three 1.35" ferrofluid-cooled polypropylene tweeters; Omni360 dispersion lens; Zero Reflection cabinet; 360 degree pattern. Frequency response: 84 Hz - 16.5 kHz. Crossover @ 2.6 kHz. Impedance: 8 ohm. 16 gauge leads. Optional 70/100V model. \$365

FP633 SoundDome
Installation Speaker. Installation. Two-way; 5.25" treated fiber woofer; 1" polypropylene tweeter; Zero Reflection cabinet; Coaxial

Parabolic Lens circular directional dispersion system. Frequency response: 140 Hz - 13.2 kHz. Impedance: 4 ohm. Gold-plated five-way binding posts. 30.5" x 15". 10 lb. \$535

RS65

Installation Speaker. Installation. Two-way; 5.25" polypropylene driver; 1" dome tweeter; Omni360 dispersion lens; Zero Reflection cabinet; 8 ohm or 70/100V. Frequency response: 55 Hz - 19.7 kHz. Crossover @ 3.1 kHz. Impedance: 8 ohm. Optional hanging model. Custom colors available. \$355

SP Technology

Timepiece 2.0
Studio. Two-way; 8" aluminum cone woofer with phase plug; 1" ferrofluid-cooled cloth dome tweeter. Frequency response: 30 Hz - 16 kHz. Sensitivity: 85 dB 1W/1m. Impedance: 8 ohms. Neutrik Speakon, binding posts. 21.5" x 12.75" x 15.75". 65 lb. \$2,495

Stage Accompany USA

Champ C 27
Speaker. Live sound, sound reinforcement, installation. Two-way; SA 1502 LF driver; SA 8535C ribbon tweeter midrange/HF driver on a 70 x 40 degree waveguide; biampable; kick-proof grille; water repellent grille cloth; UNI-RIG flyware; horizontal or vertical orientation. Frequency response: 55 Hz - 30 kHz. Max SPL: 129 dB. Impedance: 8 ohms. Neutrik Speakon. 30" x 20.5" x 18". 90 lb. \$2,625

Entertainer E 27
Live Sound Speaker. Live sound, sound reinforcement, installation. Two-way; SA 1513 LF driver; SA 8535 ribbon midrange/tweeter; trapezoidal cabinet. Frequency response: 45 Hz - 30 kHz. Max SPL: 126 dB. Impedance: 8 ohm. Speakon, spring terminals. 17" x 23" x 13.5". 64 lb. \$2,007

Master M 57
Studio Monitor. Studio, post production. Two-way; twin 12" SA 1205M LF drivers; SA 8535 ribbon tweeter midrange/HF driver; Controlled Acoustic Dispersion baffle; biampable. Frequency response: 35 Hz - 30 kHz. Max SPL: 130 dB. Impedance: 16 ohms. Neutrik Speakon. 35.75" x 21.5" x 17". 163 lb. \$3,477

Sunfire Laboratories

True Subwoofer
Subwoofer Onboard 2,700 amplifier; bass level, crossover frequency, phase controls; armar. 25 - 100 Hz. XLR, RCA. \$1,499

Tannoy

CMS110BC
Corner-Mounted Subwoofer Installation. 10" woofer; Class A fire rating; 80 Hz high-pass output; trapezoidal corner cabinet; status LEDs. Frequency response: 31 - 150 Hz. Max SPL: 110 dB. XLR. 18" x 30" x 13.25". 42 lb. \$599

CMS501CT

Ceiling Speaker. Installation. 5" full-range driver; Inductive Coupling Technology; can body. Frequency response: 85 Hz - 22 kHz. Barrier strip. Optional 70/100V 30W transformer version: \$170. Optional 70/100V 60W transformer version: \$186. \$155

Ellipse 10

Powered Studio Monitor. Three-way; 10" Dual Concentric woofer and tweeter; separate Tannoy SuperTweeter; Tannoy Wideband technology; EQ controls; time-adjusted; laminated elliptical birch cabinet; onboard amp.

I5MP

Weatherized Install Speaker.

Installation. 5" ICT full range driver; onboard 30W amp; molded polyethylene cabinet; choice of gimble or yoke mounting hardware. Frequency response: 80 Hz - 22 kHz. Max SPL: 113 dB. RCA, Phoenix. 9" x 7" x 6". 8 lb. Optional shielding. White or dark gray finish. \$320

Proto-J

Studio Monitor Studio, broadcast. Two-way; 6.5" woofer; .75" soft dome tweeter; wall-mountable. Frequency response: 60 Hz - 20 kHz. Impedance: 8 ohms. Sensitivity: 90 dB 1W/1m. Crossover @ 3 kHz. 13.75" x 8.25" x 9.25". 24 lb. \$279 per pair

Reveal

Studio Monitors. Studio, broadcast. Two-way; 6.5" woofer; 1" soft dome tweeter; 40mm baffle; magnetic shielding. Frequency response: 65 Hz - 20 kHz. Sensitivity: 90 dB 1W/1m. THD: <0.8%. Impedance: 6 ohms. Crossover @ 3 kHz. Five-way binding posts. 13.5" x 8.25" x 10.25". \$399 per pair

System 1200

Closefield Monitor. Studio, broadcast. 12" Dual Concentric driver; bass-reflex loaded LF design; MDF cabinet construction. Frequency response: 40 Hz - 23 kHz. Power handling: 350 W program. Sensitivity: 95 dB. Impedance: 8 ohms. Crossover @ 1.3 kHz. Frequency response: 15.5" x 25.5" x 16". Optional magnetic shielding: \$200. \$2,495 per pair

V15

Speaker/Stage Monitor. Live sound, sound reinforcement. Two-way; 15" PowerDual concentric driver; biampable; 2/3" birch plywood cabinet; foam-covered steel grille; mounting points. Frequency response: 50 Hz - 23 kHz. Sensitivity: 100 dB 1W/1m. Max SPL: 132 dB. Crossover @ 1.4 kHz. Impedance: 8 ohms. Speakon NL4MP. 23.25" x 17.75" x 16.5". 70 lb. \$2,150

Technomad Inc.

Berlin 15H
Weatherproof Loudspeaker. Installation, live sound. 15" low-frequency driver; 2" compression high-frequency driver; second and third order filters; weather resistant cabinet; stainless steel hardware; WeatherTech stainless steel grille; flypoints; stand-mount socket. Frequency response: 50 Hz - 17.5 kHz. Sensitivity: 102 dB 1W/1m. Maximum SPL: 121 dB. Impedance: 8 ohms. Neutrik NL4MP Speakon. 33" x 21" x 10.5". 94 lb. \$1,679 - \$1,879

Vernal 15

Weatherproof Installation Speaker. Installation, live sound. Two-way; 5" polypropylene woofer; 1" horn-loaded ceramic HF driver; WeatherTech stainless steel grille; flypoints; 1/2" molded polyethylene shell. Frequency response: 100 Hz - 18 kHz. Max SPL: 100 dB. Impedance: 8 ohms. Terminal blocks. 9" x 6" x 6". 10 lb. Optional cabinet colors. \$229

TOA Electronics

DP-0206 DACsys

Digital Speaker Processor. Live sound, sound reinforcement, installation. Two-in, six-out; crossover/parametric EQ/limiter/delay/compressor/graphic EQ/gate; 24-bit A/D/A; 48 kHz sampling rate; 16-band parametric EQ; 1/3 or 2/3 graphic EQ; CD horn EQ; RS232, RS485 ports; linkable; Windows 3.1/95 software. Optional I/O expansion modules. \$3,198

Truth Audio/Wave Distribution

TA-1
Closefield Monitor. Studio. Two-way; twin 5" woofers; 1" tweeter. Passive: \$499 each, active: \$899 each.

Turbosound/Sennheiser

Flashlight TFS-780W/TFS-780L

Speaker Array. Live sound, sound reinforcement, installation. Four-way; horn-loaded; 21" TFS-780L low frequency driver with 6" voice coil; 12" low midrange cone; 6.5" high midrange cone; 1" compression driver with waveguide horn. Frequency response: 50 Hz - 20 kHz. Sensitivity: 109 dB 1W/1m. Max SPL: 136 dB. EP6, XLR. 32.5" x 22.75" x 30.5". 191 lb. TFS-780H: \$5,830, TFS-780L: \$4,185

Floodlight TFL-760H

Speaker. Live sound, sound reinforcement, installation. Three-way; 12" low-midrange cone driver on proprietary horn; 6.5" high-midrange cone driver on proprietary horn; 1" compression driver on proprietary horn. Frequency response: 180 Hz - 20 kHz. Sensitivity: 107 dB 1W/1m. Max SPL: 133 dB. EP6. 32.5" x 22.75" x 20.25". \$5,511

HiLight THL-2

Speaker. Live sound, sound reinforcement, installation. Three-way; 15" low-frequency driver; 6.5" proprietary horn-loaded midrange cone driver; 1" compression driver on a waveguide horn. Frequency response: 55 Hz - 20 kHz. Sensitivity: 100 dB 1W/1m. Max SPL: 126 dB. Neutrik NL4 Speakon. 33.75" x 20.25" x 16.25". 97 lb. Available in horizontal orientation, THL-2H. \$2,865

Impact-80

Install Speaker. Live sound, sound reinforcement, installation. Two-way; 8" low-frequency cone driver; tweeter; 3rd order crossover network; rotationally moulded cabinet. Frequency response: 70 Hz - 20 kHz. Sensitivity: 91 dB 1W/1m. Max SPL: 125 dB. Power handling: 250 W. Spring terminals, banana plugs. 17.5" x 11.75" x 9.5". 18 lb. Choice of colors. Available 70 V model - Impact-80T. \$699. \$595

TQ-440SP

Powered Three-Way Speaker. Live sound, sound reinforcement, installation. Three-way; concentric 12" low-frequency cone driver with 1" high-frequency compression driver; 6.5" TurboMid horn-loaded midrange; onboard Class AB amp; Finnish birch cabinet; pole mount. Frequency response: 75 Hz - 17 kHz. Power handling: 800 W. 23" x 16" x 14.3". 85 lb. \$4,447

Westlake Audio

BB10-SWP

Subwoofer System. Ported 18" woofer; high-resolution HLX crossover. Frequency response: 26 Hz - 18 kHz. Sensitivity: 96.5 dB. Crossover @ 55 Hz. Five-way binding posts with hi and low inputs; high output. 30" x 28.6" x 23.5". 275 lb. Dedicated subwoofer system for BBSM-10; dual tuned port enclosure can be bi- or triamplified. \$12,987 per pair

BBSM-12

Closefield Monitor. Studio, broadcast. Three-way; ported dual 12" woofers; 6.5" midrange in nonresonant enclosure; 1.25" soft dome tweeter. Frequency response: 45 Hz - 18 kHz. Sensitivity: 96 dB. Crossovers @ 500 Hz, 4 kHz. Barrier strip. 19" x 24" x 23". 220 lb. Biwired inputs for passive biampification. \$9,499 per pair

HR-1

Monitor System. Studio. Four-way; ported dual 15" woofers; 10" mid-bass; 2" compression horn midrange; 1" compression horn tweeter; biamp. Frequency response: 34 Hz - 18 kHz. Sensitivity: 99 dB. Crossovers @ 1 kHz, 4.5 kHz, 30" x 44" x 20". 415 lb. With optional quad-amp crossover available, \$34,500. \$34,990 per pair

Lc24.75

Monitor/Center Channel Speaker. Two-way; twin 4" woofers; .75" tweeter;

magnetic shielding. Frequency response: 65 Hz - 20 kHz. Five-way binding posts. 6.5" x 16.5" x 7.25". 18 lb. Center channel speaker for surround sound system and stereo monitoring. \$1,999 per pair

Lc265.1

Monitor/Center Channel Speaker. Studio, installation, post production. Three-way; two 6.5" propylene woofers; 5" midrange driver with a 1" coaxially mounted tweeter; shielded; biampable. Frequency response: 48 Hz - 18 kHz. Sensitivity: 91 dB. Power handling: 125 W continuous program. Crossovers @ 180 Hz, 4 kHz. Banana, five-way binding posts. 8.5" x 22" x 11". 42 lb. Center channel speaker for surround sound system and stereo monitoring. \$1,897

Lc3w12

Three-way Speaker. Studio, broadcast. Three-way; 12" paper woofer; 6" midrange driver; 1" dome tweeter; horizontal orientation; biampable. Frequency response: 40 Hz - 18 kHz. Sensitivity: 91 dB. Power handling: 100 W continuous program. Crossovers @ 160 Hz, 4.5 kHz. Banana, five-way binding posts. 15" x 25" x 15.5". 102 lb. \$5,087 per pair

Lc6.75

Closefield Monitor. Studio, broadcast. Two-way; 6.5" polypropylene woofer; .75" soft dome tweeter; time-adjusted front baffle; dual front firing ports. Frequency response: 60 Hz - 18 kHz. Sensitivity: 88 dB. Power handling: 80 W continuous. Crossover @ 4 kHz. Five-way binding posts. 16" x 8" x 10". 22 lb. Shielded version available. \$1,498 per pair

Lc8.1

Closefield Monitor. Studio, broadcast. Two-way; 8" polypropylene woofer; 1" soft dome tweeter; time-adjusted cabinet, dual front ports. Frequency response: 55 Hz - 18 kHz. Sensitivity: 90.5 dB. Power handling: 85 W continuous. Crossover @ 3.6 kHz. Five-way binding posts. 18" x 10" x 11.75". 31 lb. Shielded version available. \$1,948 per pair

Lc8.1SW

Subwoofer. Two 10" polypropylene woofers; dual ports; biampable. Frequency response: 34 Hz - 18 kHz. Sensitivity: 90.5 dB. Power handling: 160 W continuous program. Crossover @ 68 Hz. Banana, five-way binding posts. 28" x 13.75" x 14.75". 100 lb. For use Lc8.1 monitors. \$5,299 per pair

TM-3

Monitor. Studio. Three-way; ported dual 15" woofers; horn-loaded compression, 1" tweeters; 2" midrange driver; biamp/triamp. Frequency response: 34 Hz - 18 kHz. Sensitivity: 99 dB. Crossovers @ 800 Hz, 4.5 kHz. Biwire terminals. 20" x 44" x 20". 389 lb. Optional electronic crossover for tri-amp configuration. \$29,950 per pair

XTA Electronics/Group One Ltd.

DP226

Speaker Management System. Studio, live sound, broadcast. Two inputs, six outputs; three-way stereo crossover; 2 x 8-band parametric EQ; 6 x 5-band parametric sections; high and low shelving filters; PCMCIA card driver; MIDI, RS232, RS485 interfaces; AudioCore Windows software; LCD screen; LED meters. Frequency response: 20 Hz - 20 kHz. Delay: 2.6 us. XLR, five-pin MIDI, 1RU. Optional transformer balanced inputs, outputs. Optional AES/EBU I/O. \$3,995

Yamaha Corp. of America

Club Series S112 IV

Loudspeaker. Sound reinforcement, installation. Two-way; 12" cone LF driver; 2" titanium high-frequency compression driver; 90 degree x 40 degree dispersion pattern; integral handles;

SPEAKERS/MONITORS

steel grille. Frequency response: 60 Hz - 16 kHz. Power handling: 300 W program. Sensitivity: 97 dB 1W/1m. Impedance: 8 ohms. Crossover @ 2 kHz. 1/4". 15.75" x 24.5" x 12.5". 42.5 lb. Installation version, S112 IVS: \$399. Floor monitor version, SM12 IVS. \$399

Club Series SM15 IV

Floor Monitor. Sound reinforcement, installation. Two-way; 15" cone LF driver; 2" titanium high-frequency compression driver; integral handles; floor wedge; steel grille. Frequency response: 55 Hz - 16 kHz. Sensitivity: 99 dB 1W/1m. Power handling: 500 W program. Impedance: 8 ohms. Crossover @ 1.7 kHz. 1/4". 27.5" x 19" x 13.5". 57 lb. \$459

Club Series SW215 IV

Subwoofer. Sound reinforcement, installation. Dual 15" drivers; metal corner protectors. Frequency response: 33 Hz - 2 kHz. Sensitivity: 98 dB 1W/1m. Power handling: 1,000 W program. Impedance: 8 ohms. 1/4". 21" x 44" x 24". 140 lb. \$799

MS1011

Powered Speaker. Studio, sound reinforcement, live sound. 4" full-range cone driver; onboard 10 W amplifier; magnetically shielded; master volume control; tone controls; power switch. Frequency response: 75 Hz - 18 kHz. 1/4", RCA. 5.75" x 7.5" x 8.5". 5 lb. \$175

MS400

Powered Speaker. Live sound, sound reinforcement. Two-way; 15" woofer; 2" titanium tweeter; biampified; onboard 300W and 100W amps; two-band EQ; master, mic, level controls; EEEngine technology; pole mount. Frequency response: 50 Hz - 16 kHz. 1/4", XLR. 17.75" x 27" x 15". 53 lb. \$849

MSP10 Studio

Powered Speaker. Studio. Two-way; 8" cone woofer; 1" titanium dome tweeter; biampified; 120W LF amp; 60W HF amp; trim controls; low-cut filter 60 Hz; magnetic shielding. Frequency response: 40 Hz - 40 kHz. XLR. 10.5" x 13" x 16.6". 44 lb. Optional wallmount brackets.

MSP5

Biampified Nearfield Monitor. Studio. Two-way; 5" woofer; 1" titanium dome tweeter; equalization control; power LED; onboard twin amplifiers; magnetic shielding; trim switches. Power output: 40 W to LF driver, 27 W to HF driver. XLR, 1/4". 6.5" x 11" x 8.75". 17 lb. \$319

S112IVA-Oak

Loudspeaker. Sound reinforcement. Two-way; 12" cone low-frequency driver; 2" titanium high-frequency compression driver on a 90 x 40 degree constant directivity horn; oak finish. Frequency response: 60 Hz - 16 kHz. Power handling: 300W, program. Sensitivity: 97 dB 1W/1m. Impedance: 8 ohms. 17.5" x 20.75" x 14.75". 33 lb. \$399

S12Me

Floor Monitor. Sound reinforcement, installation. Two-way; 12" low-frequency driver; 1" compression driver with 90 x 40 degree horn; pole socket; carrying handles; steel grille. Frequency response: 65 Hz - 14 kHz. Sensitivity: 97 dB 1W/1m. Power handling: 250 W program. Impedance: 8 ohms. 1/4". 22.5" x 12.5" x 16". 31 lb. \$269

S15e

Loudspeaker. Sound reinforcement, installation. Two-way; 15" low-frequency driver; 1" compression driver with 90 x 40 degree horn; pole socket; carrying handles; steel grille. Frequency response: 65 Hz - 14 kHz. Sensitivity: 98 dB 1W/1m. Power handling: 250 W program. Impedance: 8 ohms. 1/4". 19" x 14.5" x 26.5". 48 lb. \$319

SW10

Powered Subwoofer. Studio. 10" woofer; onboard 180 W amp; low-pass filter; magnetic shielding; volume control; power, clip LEDs. Frequency response: 25 - 150 Hz. Max SPL: 111 dB. XLR. 13" x 18" x 18.75". 57.5 lb. \$849

Yorkville Sound Inc.

C120

Install Speaker. Installation. Two-way; 5" woofer; adjustable tweeter; weather-resistant ABS cabinet; Coliseum Mini series. Frequency response: 70 Hz - 19 kHz. Sensitivity: 92 dB 1W/1m. Push terminals, 1/4". Available in black or white. 70V version: \$79. \$69

E160P

Powered Speaker. Live sound, sound reinforcement. Two-way; 10" woofer; 1" high-frequency driver; 100 degree x 30 degree horn; onboard 160W LF amp; onboard 30W HF amp; stand adapter. Frequency response: 50 Hz - 20 kHz. Max SPL: 122 dB. Crossover @ 4 kHz. 1/4", XLR. 13" x 16" x 17.5". 38 lb. \$789

E604

Speaker. Live sound, sound reinforcement. Two-way; twin 10" woofers; 1" high-frequency driver; 60 degree x 40 degree ABS waveguide horn; CTL high-frequency protection; carpeted exterior; stand adapter; handles. Frequency response: 50 Hz - 16 kHz. Max SPL: 129 dB. Sensitivity: 101 dB 1W/1m. 1/4", Speakon. 16.25" x 17" x 30" x 8". 84 lb. \$999

EF500P

Powered Speaker. Live sound, sound reinforcement. Two-way; 15" woofer; 2" high-frequency titanium driver; 60 degree x 40 degree horn; two-band EQ; trim control; biampified; onboard 650W LF Class D amp; onboard 150W HF Class H amp; .75" Baltic birch cabinet. Frequency response: 50 Hz - 19 kHz. Max SPL: 127 dB. Crossover @ 2.1 kHz. XLR, 1/4". 28" x 18" x 15". 94 lb. With flying hardware and black, EF500PBLK: \$1,499. \$1,399

EF508

Speaker. Live sound, sound reinforcement. Two-way; 15" woofer; 2" high-frequency driver; 60 degree x 40 degree horn; biampable; ATP high-frequency protection; carpeted exterior; stand adapter; handles; flypoints. Frequency response: 50 Hz - 19 kHz. Max SPL: 126 dB. Sensitivity: 99 dB 1W/1m. 1/4", Speakon. 18.75" x 14.5" x 26.25" x 11". 89 lb. With Baltic birch cabinet and black finish, EF508BLK: \$799. \$1,349

EM378

Stage Monitor. Live sound, sound reinforcement. Two-way; 12" B&C 12" woofer with 3" voice coil; 2" B&C HF driver on a 40 x 60 degree horn; biampable; stand mount adapter; metal grille; recessed handles, carpeted exterior; metal corners. Frequency response: 65 Hz - 19 kHz. Power handling: 350 W (program). Crossover @ 1.2 kHz. Max SPL: 127 dB. Sensitivity: 102 dB 1W/1m. 1/4", Neutrik Speakon. 25" x 16" x 15.25". 71 lb. \$799

ES700P

Powered Subwoofer. Live sound, sound reinforcement. Twin 10" woofers; level control; thermal, overcurrent protection; onboard 700W amp. Frequency response: 45 - 125 Hz. Max SPL: 131 dB. 1/4". 24" x 24.5" x 17.5". 93 lb. \$1,099

L368

Speaker. Live sound, sound reinforcement. Three-way; 12" neodymium woofer; 6" horn-loaded cone midrange with phase plug; 1" high-frequency Mylar driver on 60 x 40 degree horn; MSP self-resetting protection; biampable; 5" cabinet; handles; flypoints. Frequency response: 55 Hz - 15 kHz. Sensitivity: 101 dB 1W/1m. Max SPL: 126 dB. Crossovers @ 325 Hz, 3 kHz. 1/4", Speakon. 25.75" x 23.25" x 18.5" x 14.5". 58 lb. \$799

LS1208 Basspipe

Subwoofer. Live sound, sound reinforcement. 18" ceramic magnet woofer with 4" voice coil; basspipe horn; 3/4" plywood cabinet; metal corner protectors; perforated metal grille; handles; black carpeted exterior. Frequency response: 35 - 200 Hz. Sensitivity: 105 dB 1W/1m. Max SPL: 136 dB. 1/4", Speakon. 26.5" x 28" x 43.5". 188 lb. \$999

NX20

Stage Monitor. Two-way; 12" neodymium woofer with 2.5" voice coil; 1" Mylar high-frequency driver; 90 x 60 degree horn; CTL horn protection; fly-ware; pole mount; injection molded plastic trapezoid cabinet; handles. Frequency response: 65 Hz - 17 kHz. Sensitivity: 98 dB 1W/1m. Max SPL: 124 dB. Crossover @ 2.5 kHz. 1/4". 14" x 16" x 24" x 7.5". 26 lb. \$499

NX520P

Powered Speaker/Stage Monitor. Live sound, sound reinforcement. Two-way; 12" neodymium woofer; 1" high-frequency horn; trim control; EQ; biampified; onboard 450W LF amp; onboard 100W HF amp; high-pass filter; trim control; fly-ware; pole mount; injection molded plastic trapezoid cabinet. Frequency response: 65 Hz - 17 kHz. Max SPL: 124 dB. Crossover @ 2.5 kHz. XLR, 1/4". 24" x 16" x 14". 38 lb. \$999

NX88

Speaker/Floor Monitor. Two-way; 8" woofer with 1.5" voice coil; 1" Mylar tweeter; CTL horn protection; 90 x 30 degree pattern; recessed handles; metal grille. Frequency response: 70 Hz - 16 kHz. Sensitivity: 96 dB 1W/1m. Max SPL: 117 dB. Crossover @ 2 kHz. Impedance: 8 ohms. 17.5" x 12" x 10".

PM12

Floor Monitor. Sound reinforcement, live sound. Two-way; 12" Eminence woofer; 1" RCF tweeter; ABS waveguide horn; current-to-light signal overage protection; metal grille; flush-mounted handles; .75" seven-ply plywood; internal support. Frequency response: 70 Hz - 16 kHz. Maximum SPL: 120 dB. Sensitivity: 98 dB 1W/1m. Power handling: 150 W, program. Crossover @ 2.8 kHz. 1/4", Neutrik Speakon. 21.3" x 15.5" x 18". 40 lb. \$369

PS18

Subwoofer. Sound reinforcement. 18" Eminence woofer; metal grille; flush-mounted handles; 3/4" seven-ply plywood; internal support. Frequency response: 50 - 150 Hz. Maximum SPL: 124 dB. Sensitivity: 100 dB 1 W/1m. Power handling: 300 W, program. Crossover @ 150 Hz. 1/4", Neutrik Speakon. 32" x 23" x 24". 90 lb. \$559

PS210P

Powered Subwoofer. Sound reinforcement. Two 10" Eminence woofers; line/speaker switch; ground lift switch; level and satellite level control; overcurrent, thermal, clip protection; switchable crossover (80 Hz, 110 Hz, or 150 Hz); two 300 W amps; metal grille; flush-mounted handles; 3/4" seven-ply plywood; internal support. Frequency response: 50 - 120 Hz. Maximum SPL: 124 dB. Power handling: 300 W program for sub and 300 W for satellites. 1/4", XLR. 20" x 22.5" x 22". 81 lb. \$1,049

TM12

Stage Monitor. Two-way; 12" woofer; 1" high-frequency driver; 60 degree x 40 degree horn; pole mount; Ultra-thane coating; Pulse series. \$369

TX2M

Stage Monitor. Sound reinforcement. Two-way; 12" woofer with 3" voice coil; 2" high-frequency driver mounted on a 60 x 40 degree waveguide horn; high-pass filter; limiter; matched aperture horn/throat ratio; biampified; 13-ply Baltic birch cabinet; recessed carrying handles; metal grille. Frequency response: 60 Hz - 19 kHz. Power handling: high-frequency - 120 W @ 8 ohms; low-frequency - 350 W @ 8 ohms. Maximum output: 125 dB. Neutrik Speakons. 15" x 25.25" x 15.75". 77 lb. Requires TX2P processor. \$1,349

TX4

PA Speaker. Sound reinforcement, installation. Two-way; 15" B&C low-frequency woofer; 4" B&C high-frequency driver and 60 x 40 degree horn; high-pass filter; limiter; 13-ply Baltic Birch cabinet; ATM FlyWare; internal bracing; recessed handles; metal grille. Frequency response: 50 Hz - 19 kHz. Power handling: high-frequency - 120 W @ 8 ohms; low-frequency - 500 W @ 8 ohms. Maximum output: 127 dB. Neutrik Speakon. 28.25" x 18.3" x 14.75" x 11". 99 lb. Requires TX4P processor. \$1,449

Y150

Two-way; 15" woofer; 1" high-frequency driver; 60 degree x 40 degree horn; carpeted exterior; Performance series. With flypoints, YF150: \$469. \$449

Y150M

Stage Monitor. Two-way; 15" woofer; 1" high-frequency driver on 60 degree by 40 degree horn; carpeted exterior; wedge cabinet; Performance series. \$449

YSM1P

Powered Monitor. Studio. Two-way; 6.5" woofer; 1" soft-dome, ferrofluid-cooled tweeter; 2" tuned bass port; onboard 70W LF amplifier; onboard 30W HF amplifier; limiter; filter; 75" MDF cabinet; magnetic shielding. XLR, 1/4". \$320

CASCADE M-55 1" Vacuum Tube Condenser

Specifications

Frequency Response: 20Hz to 20kHz
Polar Pattern: Cardioid
Diaphragm: 1" 24K gold-sputtered
Sensitivity: >14m V/Pa
Tube Type: 12AX7 (6072A optional)
Output Impedance: <200 ohm
Output Noise: <17 dB (A weighted)
THD: <0.5% at 125 dB SPL
Power requirement: Dedicated Power Supply, includes switchable 115V to 220V
Security: Serial number is engraved into the body on all Cascade microphones.

Includes shock-mount, power supply, and case as see in the photo below!

Limited time!
\$349.00



Includes SHM5500 shock-mount



Toll Free 888.718.0300

<http://bayviewproaudio.com>

CASCADE MICROPHONES a division of Bayview Pro Audio, Inc.

TEST EQUIPMENT

ACO Pacific Inc.

4012RA, 4012RAL7

Right Angle 1/2" Mic Preamplifiers. Compatible with 4012 family of measurement mics; compatible with IEC 1094 mics. Frequency response: 0.5 Hz - 200 kHz. XLR or Lemo. 4012RA (XLR): \$595. 4012RAL7 (Lemo): \$670.

511ES124

Microphone Level Calibrator. 1 kHz signal at 94 dB or 124 dB; ships with 1/2" mic adapters; for low sensitivity microphones. 1/4", 1", 10mm, 20mm mic adapters available. \$595

7023

Measurement Microphone. Pressure, polarized, 1"; stainless steel diaphragm; stainless steel casing; Type 1; meets IEC, ANSI specs. Frequency response: 3 Hz - 10 kHz. Sensitivity: 50 mV/Pa. \$725

7046

Measurement Microphone. Free field, polarized, 1/2"; stainless steel diaphragm; stainless steel casing; Type 1; meets IEC, ANSI specs. Frequency response: 3 Hz - 20 kHz. Sensitivity: 50 mV/Pa. Phased matched pair available: \$1,550 per pair. \$650

Model 3024 Very Random Noise Generator

White/Pink Noise/Tone Generator. White/pink noise generator; 1 kHz tone generator; amplitude, attenuation controls; crystal controlled; two hour 20 minute random cycle; speaker output; AC/battery operation. Ships with AC adapter. \$695

PS9200KIT

Measurement Microphone Package. Complete Type 1 kit; two-channel; choice of ACO Pacific 7012, 7013, 7046, 7047 1/2" measurement mics; ACO Pacific PS9200 power supply; ACO Pacific PS9 or PS29 power adapters; windshield; foam padded storage case. With 1/4" measurement mic: \$1,955. \$1,650

Acoustic-X Software Corp.

Acoustic-X

Room Acoustics Design Software. Recording studio, live sound venues. Windows 95/NT; onboard acoustic treatment, acoustic behavior and speaker measurement programs - Modal Response, Speaker Boundary Interface, Ray Trace, Acoustic Calculator. \$399

AcoustiSoft Inc.

ETF 5.xxx

Audio Analyzer Software. Windows 95/98/2000/NT; 32-bit; impulse response; frequency response; Energy Time Curve; mic/speaker distance; reverb time. Ships with sound card. Optional measurement mic and pre-amp: \$249. \$149

ATI Audio Technologies Inc.

BGD400

Quad Bargraph LED Meter. Quad bargraph; tri-color LED; VU or PPM versions. Screw plug connectors. 1/3 RU. Optional rackmount adaptors. Power supply sold separately. \$469

Audio Engineering Associates

SS220 Stereo Scope

Stereo Phase Measurement System. Gain trim; LED; rack or panel-mountable; 7-15 V operation; 120 VAC adapter. In - 10 kohm. Screw terminals. 3.25" x 4" x 7". \$475

Audio Precision

ATS-2

Audio Analyzer. Audio Precision Dual Domain system; FFT spectrum analysis; jitter analysis; signal/noise generator; multitone; ATS-2 Windows software. XLR, BNC, TOSLink, AES/EBU, S/PDIF. Optional serial digital audio interface upgrade. \$9,995

System Two Cascade Plus

Digital Audio Analyzer. 96 kHz capable; single or dual connector; 96 kHz I/O; 8 - 24-bit; 8 - 100 kHz sample rates; SMPTE; CCIF, DFD, DIM test signals; sine burst; square wave; white, pink noise generators; FFT analyzer; quasi-anechoic acoustic tester; multitone analyzer; headphone jack; APWIN 2.0 software; increased DSP power. XLR, BNC, TOSLink, RCA, AES/EBU, S/PDIF, D-sub. Starts at \$22,800

AudioControl Industrial

lasys

System Analyzer. Portable; version 3; amplitude, phase, coherence, frequency, crossover, thermal compression measurement and analysis; fuzzy logic analysis; RT-60 reverb time measurement; limiter; 1/48 octave filter; programmable sweep/sine/noise; delay; polarity; dual input; sine, sweep sine, pink noise output; 12 V phantom power; memory; shuttle wheel; LED screen. Wave generators: 20 Hz - 20 kHz. XLR, RCA. 4" x 10" x 13.5". Ships with omnidirectional measurement electret condenser microphone. Home theater optimized version, lasys HT: \$3,995. \$3,995

SA-3051/3052

Real Time Spectrum Analyzer. 30 1/3 octave bandwidth filters; fourth order ANSI filters; input sensitivity calibration and controls; pink noise generator; four display speeds; LED display; digital SPL display; memory settings. Maximum measurement SPL: 44 - 136 dB, 0.1 dB accuracy. XLR, RCA, 1/4", SA-3052 comes with soft carrying case, primer interface and internal battery pack. Optional accessories for both include test signal CD and 175 dB SPL upgrade. SA-3051 - \$995, SA-3052 - \$1,359

Audix Corp.

TR40

Test Microphone. Lab, studio. Omnidirectional pattern; 1/4" pre-polarized condenser capsule; gold-plated connector; brass body. Frequency response: 20 Hz - 20 kHz. Max SPL: 128 dB. Dynamic range: 102 dB. Sensitivity: 14 mV/Pa. XLR. Stereo matched pairing available. \$249; stereo matched pair - \$549

Benchmark Media Systems Inc.

SPM-220/SPM-320

Stereo Program Meters. Peak hold; switchable discrete stereo or matrix metering; switchable VU/PPM metering; VU meters per channel; clip LED; BNC scope outputs; headphone output. SPM-320 has a third VU meter for SCA, SAP or additional monitoring: \$1,895. \$1,410

Bruel & Kjaer

2260 Observer Sound Level Analyzer

Handheld Real Time Analyzer. RTA; 1/3 octave; A, C, Lin weighting; white/pink noise generator; IEC61672 Class 1, ANSI Type 1; 32MB memory; RS232 port; battery operable. Frequency response: 6.3 Hz - 20 kHz. Ships with Type 4189 measurement mic. \$6,495

DIRAC/7841

Windows-based Room Acoustic Measurement System. Windows 95/98/ME/2000/XP; onboard room editing/CAD; A weighting; reverb time, strength; clarity; early decay; lateral energy fraction; Inter Aural Cross correlation; speech transmission; impulse response; S/N; 1/3 octave; scale model; IEC1260/60268-16, ISO3382-compliant. \$2,695

Channel D. Corp.

Mac the Scope

Mac-Based Audio Signal Generator/Analyzer. Mac; two-channel; signal generator; real time analyzer; oscilloscope; sonogram; signal level triggering; sine, square, triangle, pulse, ramp waves; burst; sweep; time base; time trace, scale; spectrograms; Lissajous displays; random, chirp, sinusoidal, custom waveforms. \$89 - \$449

Cliff Electronic Components

Qualkit PRO 32 CD

Audio Equipment Calibration Test Signals. Audio/video test signals; sine wave; sweeps; reference square wave; 0-100% 1 kHz amplitude ramp; white noise; pink noise; stereo phase; reference frequencies; concert pitch phase; 1/3 octave noise bands; 1/3 octave warble tones. \$75

Coleman Audio

CA7 Cable Tester

Continuity, phase check. XLR, RCA, MIDI, 1/4", BNC, F connector, bantram. \$130

MB4

Quad Rackmount VU Meters. Four path switchable VU meters; input trims; internal power supply. XLR. \$650

Conex Electro Systems

ToneJack

Signal Generator. Sweep; burst; sine, square waves; RS-232; volume control; LCD; battery operated. \$229

Denon Electronics

C397147

Technical Test CD. 99 tracks; test signals; demos. \$20

DK Audio

MSD 100 AES-SA

Master Stereo Display. Studio. Two-channel operation; LED overload indicator; FFT spectrum analyzer; audio vector oscilloscope; level meter; multiple PPM scales; LCD; VU scale. AES/EBU. Available without spectrum analyzer as MSD 100. \$1,208

MSD 200

Master Stereo Display. Studio. Two-channel operation; stereo; LED overload indicator; peak hold; reference level select; audio vector oscilloscope; level meter; scale - 7 PPM; RS232 port; tone, white, pink noise generator; electroluminescent display. XLR, AES/EBU, D-sub. Optional spectrum analyzer. \$2,729

MSD 600C-SA

Master Stereo Display. Studio. Four-channel operation; built-in signal generator; correlation meter; FFT spectrum analyzer; audio vector oscilloscope; level meter; scale - 7 PPM; color LCD. XLR, AES/EBU. \$4,754

MSD 800/SA8

Master Stereo Display. Studio. Eight-channel operation; built-in signal generator; correlation meter; FFT spectrum analyzer; audio vector oscilloscope; level meter; scale - 7 PPM; electroluminescent display. D-sub. \$3,884

MSD600M

Surround Meter. Post production. Multichannel discrete metering and analysis; phase meter; surround audio vectorscope; loudness meter; multichannel peak program meter; 2-, 4-, 6- and 8-channel versions; "Jelly-Fish" image display; Dolby Pro Logic, 4, 5.1, 6.1, 7.1 surround sound; color LCD screen. Optional FFT spectrum analyzer. Optional SDI module. \$3,976

Dolby Laboratories Inc.

DM100 Bitstream Analyzer

Handheld Dolby Digital, Dolby E, PCM Monitor. Broadcast, post production, installation. Dolby Digital, Dolby E, PCM, AES formats; signal generator; eight-channel; pass-through; LCD screen; battery operation. \$1,995

Dorough Electronics Inc.

400-A2

Extra Large Analog Loudness Meter. A or C scale; large numbers; tricolor LED segments. 23" x 8". \$1,995

Model 1200

Stereo Signal Test Set. Stereo measurements of level, balance, crosstalk, phase, separation, headroom and signal-to-noise; 100 dB range; simultaneous peak & average; L/R or sum/diff modes; calibration; range control; 2 B scale loudness meters; tricolor LEDs. \$1,650

Model 12-DAES/EBU

Digital Audio Meter. 32, 44.1, 48, 96 kbs; alarm phase lamp; AES/EBU; SMPTE; arc meter. XLR, BNC. \$950

Model SUR6-B

5.1 Surround Sound Monitor. Six-channel. Desktop or rack versions. Optional 7.1 surround sound version. \$2,970

LEARN the ART of RECORDING



RECORDING WORKSHOP

- The Original, founded 1971
- Effective, Hands-On Approach
- 2 Months, 300+ hrs Training
- 3 to 6 Students per Class
- 8 Studio Facility, Latest Gear
- Affordable Tuition
- Job Placement Assistance
- On-Campus Housing



RECORDING WORKSHOP
School of Audio & Music Production

Contact us for a Free Brochure

800-848-9900

www.recordingworkshop.com

email: info@recordingworkshop.com

Outside USA: 740-663-2544 Fax: 740-663-2427

455-P Massieville Road, Chillicothe OH 45601

Ohio State Board of Proprietary School Registration #80-07-0696T

Of all the reasons to buy the affordable new ATS-2, one stands out:

- Unsurpassed Multitone Analyzer speeds testing
- Analog and digital inputs and outputs for comprehensive connectivity
- Independent analog and digital generators provide maximum flexibility
- Jitter generation and analysis for digital interface characterization
- Harmonic Distortion Analyzer finds problems quickly
- Performance option increases bandwidth to 120 kHz



• It's from Audio Precision

**"An ideal test unit
for portable use."**
- *Pro Audio Review*
September 2002



Some brands are legends. The new ATS-2 delivers the Audio Precision quality and performance you've been yearning to afford. The ATS-2 audio testing system speed and flexibility lets you do more — and do it faster — without **breaking** your budget. But with capabilities like those listed above, it's clear the ATS-2 doesn't cut corners to cut costs.

You don't just buy a product. You buy expertise. Designed by the company who builds the acclaimed System Two Cascade Plus system, the ATS-2 is backed by Audio Precision's unmatched technical application know-how. It's one more solid solution to help you engineer the best audio performance.

Intrigued? Go to audioprecision.com/par202
to learn more about what the ATS-2 can do for you.

**Audio
precision**®

Testing for Optimal Results

TEST EQUIPMENT

Earthworks Audio Products

M30
Measurement Microphone. Omnidirectional pattern; compatible with SMAART, TEF, MLSA, RTA; 48V phantom power. Frequency response: 9 Hz - 30 kHz. Max SPL: 150 dB. Sensitivity: 8 mV/Pa. XLR. Optional matched pair in cherry box. \$600 each, \$1,300 matched pair

EBTECH/Sound Enhancements

Swizz Army 6 in 1 Cable Tester
Continuity check, intermittent detect/display, cable wiring pin-out, phantom power detect, ground shield detect, cable test: 440 Hz/1 kHz test tone generator. XLR, 1/4", 1/8", RCA, MIDI \$179

Electro-Voice

RTM-1000
Wireless Test Microphone System. Bodypack transmitter, true diversity receiver; 950 channels; Advanced ClearScan; compander; battery operable; choice of frequencies. Frequency: 566 - 662 MHz. Frequency response: 30 Hz - 15 kHz. SN: 110 dB. Lemo, XLR. With phantom power: \$1,800. \$1,700

Galaxy Audio

Check Mate CM100 SPL Meter
IEC 651 Type II meter; level range display; AC signal output; selectable level range; A, C-weighting; standard applied IEC651 Type 2; ANSI S1.4 Type 2; onboard electret condenser measurement mic; windscreen; battery (9V) operable; LCD screen. Resolution: 0.1 dB. Frequency range: 35 Hz - 8 kHz. Dynamic range: 50 dB. \$149

Gold Line/TEF

DSP30
Real Time Analyzer. 1/3 octave; front panel numeric display; up to 30 memory settings via EPROM; 10x30 LED matrix with 85 dB range; automated sum and average function; 1/4 to 5 dB scales; keypad-selectable filters; electret condenser microphone; serial port; computer control, analysis software. Optional computer controlled/slave version: \$1,200. \$1,625

PN-3B
Pink Noise Generator. Level control; 1 kHz tone generator; gated output for RT60; battery operation. \$195

SPL120
Sound Level Meter. Portable; battery operated; built-in microphone; digital numeric display; sound level readings based on ANSI S1.4 standards; readings provided in "FLAT, IECA or C; battery operation." \$336

TEF 20 SHIP System
Acoustic Analyzer. Time delay spectrometry; maximum length sequence; FFT RTA; polar plots; waterfall; phase/Nyquist; electrical vs. acoustical energy; test tone generator; sweep generator; EQ; THD; noise measurement/analysis; serial, host and parallel interfaces. \$3,595

GTC Industries

Tone Plug
Audio Test Signal Generator. 11 functions; 5 sine wave tones; multiple frequency burst; amplitude sweep; frequency sweep; auto frequency stepping; subwoofer test; phantom powered. Sine wave tones: 100 Hz, 250 Hz, 400 Hz, 1 kHz, 10 kHz. XLR. \$50

Josephson Engineering

C550
Measurement Microphone. Choice of line, mic, high SPL capsules; choice of free or diffuse field; 5" capsule; 3.5mm polyester diaphragm; nickel chromium

alloy body. Can withstand temperatures up to 150 degrees. \$480

Klark Teknik

DN6000
Real Time Audio Spectrum Analyzer. 1/3 and 1/6 octave; 48 V phantom power; sum and difference display options; A, C weighting filters; adjustable display range, level, response time; sine wave, pink noise generators; burst, frequency sweep; 32 memory stores; RT60, Leq, Let measurement; printer port; DN3600 interface. Optional microphone. \$4,065

Leitch Inc.

DAR-6880 Digital Audio Reference Signal Generator
Choice of housings - frame card or minibox; 24-bit. Lockable to AES3 standard; compatible with AES11 Grade 2 (44.1, 48 kHz sample rates); video standard compatible; tone selectable (500 Hz, 1 kHz), tone dedicated, word clock dedicated outputs. Tone frequency: 500 Hz or 1 kHz. Tone level: 0 - 31 dBFS. Jitter: <1ns. BNC \$995

Liberty Instruments

Audiosuite 3
Measurement and Development System. Measurement and development software for loudspeakers and audio electronics; multitone intermodulation and harmonic distortion analysis instruments; central spectrum processing of loudspeaker/room frequency responses; group delay display for phase responses; linear or log-frequency display formats; frequency response curve averaging; variable viewing angles for waterfall plots; persistent "hold" reference curve. Ships with PC sound card. Software only: \$389. \$800

Lineax Systems Inc.

LMS Loudspeaker Measurement System
Sweep Sine Wave Analyzer. Windows 95/98/2000/NT/ME; ISA slot card; programmable frequency range over 10 Hz - 100 kHz; 32-bit; frequency resolution of up to 200 points per decade; frequency response and impedance measurement; RLC meter; full system utilities; own macro programming language; calibrated measurement microphone. SPL range: 35 - 125 dB. THD: 0.015%. Frequency range: 10 Hz - 100 kHz. \$1,395

Listen, Inc.

SoundCheck
PC-Based Electroacoustic Measurement System. Windows software; frequency, distortion measurement up to 100 kHz; stepped sine wave; log sine sweep; WAV file excitation; 500 k line FFT; RS-232 port. USB, AES/EBU, S/PDIF, nine-pin D-sub. Starts at \$6,950

Logitek Electronic Systems Inc.

Bright-VU
Audio Meters. Studio, broadcast, post production, 20-segment LED bargraph audio meters; loop through for digital inputs; simultaneous VU and true peak display; IEC standard ballistics. 0.1 dB accuracy. XLR, analog and/or digital. 1RU. Available in single, double or triple stereo pairs. \$470 - \$1,145

SV51/JV51/SV71/JV71
Surround Sound Meters. 5.1, 7.1 surround sound channel formats; 300 ms ballistics; simultaneous peak indicator; user selectable reference points; tri-color LEDs per channel (40-segment for SV51, 63-segment for JV51 and JV71). \$2,095 - \$4,400

Tru-VU
Stereo LED Meter. Two or four tri-color LED VU-style meters; 300 ms ballistics; digital or analog

inputs. XLR. 2RU. \$675 - \$1,025

Ultra-VU

Precision Audio Meter. Studio, broadcast, post production. 63-segment tri-color LED bargraph audio meters; simultaneous display of multiple functions - peak, stereo image, phase; mono sum display. 70 dB range. XLR, RCA, 1/4". 1RU. Also 7.1 surround version available. \$1,080 - \$2,300

Metric Halo Laboratories

SpectraFuo
Audio Analysis/Measurement Software. Mac; standalone or plug-in; modular; Lissajous phase; stereo balance; history meters; audio spectrum analysis; Spectrogram spectral history meter; PhaseTorch frequency phase meter; digital level meter; correlation meter; bit range and matrix meters/scope; signal generator; oscilloscope; capture, looping functions; compatible with Sonorus STUDIO/O, Korg 1212/O, Digigram PCXPocketAD and Digidesign boards. \$400 - \$800

Metrosonics

Chameleon
Handheld Sound Level Meter. Onboard 3/8" electret mic; speed, impulse controls; A, C-weighting; calibration; battery operation; touchpad; LCD screen. Range: 40 - 140 dB. Resolution: 0.1 dB. optional computer interface packages. \$525

Neutrik USA Inc.

Digilizer DL1
Portable Digital Audio Analyzer. 32 - 96 kHz sampling rate; 8 - 24-bit; digital audio analysis; carrier signal analysis; signal level, sweep; full-scale; bit measurement; THD measurement; event log; onboard speaker; LCD screen; battery operable (AA). XLR, RCA, BNC, optical, AES3, S/PDIF, ADAT. \$2,000

Minirator MR1
Audio Signal Generator. Sine wave; sinusoidal signal; sweepable; square wave; white, pink noise; polarity test; LCD screen. Frequency: 20 Hz - 20 kHz. XLR. \$268

Novatech Instruments Inc.

DDS8m
100 MHz Quadrature Synthesizer Module. Circuit board; s/cosine, ACMOS/TTL output; frequency sweep, FSK, BPSK, chirp, single tone modes; 1 microHertz - 100 MHz resolution; RS-232 port. BNC. \$575

Precision Audio Labs

SRD-1
Sample Rate Detector. Up to 52 MHz; word clock, slave clock; LCD. \$150

Prism Media Products Inc.

DSA-1
Handheld Digital Audio Tester. Digital audio generator, analyzer; eight-channel status editor; MS-DOS/Windows software; 24-bit; 48 and 44.1 kHz sampling rate; AES/EBU specifications; jitter, sample rate measurement; sine, ramp, square wave. XLR, AES/EBU, S/PDIF, optical, RS232. 5" x 9" x 2.5". \$4,770

dScope Series III
★ New for 2003 ★
Analog and Digital Audio Test System. Digital, analog; portable; two-channel; 32, 44.1, 48, 88.2, 96, 176.4, 192 kHz sample rates; 64-bit; analog and digital analysis; time domain analysis; FFT; trace; sweep; degradation analysis; bit measurement; jitter measurement; onboard signal generator; NTSC, PAL, Secam; Windows 95/98/NT software; separate I/O box. Frequency response: <10 Hz - 86 kHz. XLR, BNC, optical, 1/4". \$8,795

Rane Corp.

RA 30 ★ New for 2003 ★
Real Time Analyzer. 30-band; ANSI Class II filters; A, C-weighting; pink noise generator; SPL meter; master level control; three-color LED meter per band; 6 dB/3 dB/1 dB scale; +4/-10 dB calibration; measurement mic included; 25" mic cable. XLR, 1/4". 1RU. \$549

RCI Custom Products

CT-2
Cable Tester. Detects shorts, open circuits; probes; alligator clips; belt clip; battery operable. XLR, RCA, 1/4", 1/8", BNC. \$163

Rhintek Computer Engineering

CARA Release 2.1 PLUS
CARA - Computer Aided Room Acoustics. Windows software; room analysis; room design tool; materials database/calculator; acoustics property library/analysis; loudspeaker configurator; acoustic response simulator; 2D, 3D graphing, analysis. \$49.95

Rohde & Schwarz/ Tektronix/Measurement Business Div

UPL06
Audio Analyzer. Low-distortion analyzer; analog and digital operation; increased voltage input range; modified low-distortion generator; input voltages up to 100 V; jitter susceptibility measurement. \$14,000

RPG Diffuser Systems

Room Optimizer
Speaker/Listener Placement Design Software. Windows 95/98; configuration design; wizards; response spectra; SBIR, Modal.

Ruby Tubes/Magic Parts

Maxi-Matcher Digital Tube Tester
Tests for short circuits, plate current, transconductivity; octal base sockets. Adapters available for EL84, 7591, 7868, 807, 811, 845, 12AX7 tubes. \$495

SIA Software

Smaart Acoustic Tools
Windows; decay, reverb, spectrograph, time domain, frequency domain, impulse response; FFT measurements; 8 - 24-bit; 11,025 - 48 kHz sample rates; STI, RSTI, ALCons.

Sound Alignment-System By Checkpoint

Pro Tech Kit 2.05
Laser-based Alignment Kit. Includes LG120 laser, DLT 675.05 inclinometer, Ultra-Mag level, RD22 rotary base, P770 laser, base plate, beam splitter, layout sheets, carrying case. \$1,240

SurgeX

DSP 2010-EX
Audio Analysis Tool. DSP based; two-channel FFT; log and linear spectrum; oscilloscope; logarithmic sweep, energy/time modes; LTP; MIDI and calibration modes; phantom power; printer port. Frequency response: 20 Hz - 20 kHz. RS232. MIDI I/O. XLR. 1/4". 1RU. \$2,995

Test 1-2-3
Audio/Video Signal Tracer/Analyzer. Detects mic, line, speaker, RGB, composite video signals; 1/4" phone plug; 3 indicator LEDs. 1/4" \$90

Sysid Labs

TES 1350 A Sound Level Meter
A, C weighting; peak/hold response; calibration mode; foam windscreens; LCD screen. \$259

TecNec

RX-1 Cable Tester
Short, open circuit, phase detection. XLR, 1/4", RCA. \$49.95

VUM-RM 4-Channel Audio VU Meter
Four-channel; onboard tone generator/calibrator (1 kHz); peak LEDs; VU meters per channel. Frequency response: 10 Hz - 60 kHz. 1/4". 2RU. \$495

TerraSonde

Audio Toolbox Plus
Onboard mic; real time analyzer; SPL measure; RT60; speaker/mic polarity; reverb decay; phase; tuner; energy/time graph; sound study graph; SMPTE reader/generator; MIDI data; hum canceller; signal generator; noise generator; impedance meter; S/N; frequency response; distortion meter; cable tester; headphone amp; phantom power checker; battery operable; LCD. XLR, RCA, 1/4". \$1,799

Digital Audio Toolbox
Digital Audio Test System. Bitstream analyzer; bitscope; sample rate converter; digital signal generator; clock counter; jitter meter; latency tester; transparency tester; FFT analysis; cable tester; Windows/Mac interface; digital headphone monitor; battery operable. Ships with cables, hard case. \$2,490

True Audio

TrueRTA 2.0
Windows 9x/NT/2000/XP; RTA; sine wave, pink noise generator; RMS voltmeter; oscilator; mic calibrator. Free basic download. 1/3 octave resolution: \$39. 1/6 octave resolution, sound card calibrator: \$69. 1/24 octave resolution, white noise generator: \$99.

Videoquip Research Ltd.

DSG-1 Digital Analog Signal Generator
32, 44.1, 48, 96 kHz sample rates; 400 Hz, 1 kHz, 10 kHz, sweep tones; level controls; battery operable; status LEDs. XLR, RCA, TOSlink, AES/EBU, S/PDIF. \$750

VP-2 Extended Range VU/PPM Meter
Two-channel; switchable VU, PPM meters; multicolor LEDs. XLR. \$425

Whirlwind

Qbox
Audio Line Tester. Microphone; speaker; test tone generator; standard headphone outputs; 1/4" line in jack or 2 kohm earpiece out; "voltage present" LEDs; belt clip. Powered by one 9 V battery. \$199

Tester
Audio Cable Tester. Checks most varieties of audio cables; any combination XLR, 1/4" or RCA phono plugs for shorts, opens and phase; hands-free design; on/off switch; belt clip. Battery powered. \$109

White Instruments

Model 155 Pink Noise Tube
Pink Noise Generator. Pink noise; 9 - 52V phantom power; 47 minute digital word repeat. XLR. \$197

Wireworks Corp.

TE-3 Plus Cable Tester
Detects shorts, opens, phase; status LEDs; battery operable. XLR, 1/4", BNC

TEN-4 Speaker Cable Tester
Detects opens, shorts, phase; status LEDs. 1/4", Speakon.

WIRELESS MICROPHONES

AKG Acoustics US

CK 55 L
Lavalier Microphone. Live sound, installation. Cardioid pattern; ships with clip, wind-screen; compatible with AKG WMS wireless mic systems. Frequency response: 150 Hz - 18 kHz. Compatible with MPA III L phantom power adapter, B29 L phantom power supply. \$168.40

GB 40 MicroTools GuitarBug
Wireless Guitar Mic Transmitter. 1/4" FlexJack; power switch; gain control. Frequency response: 40 Hz - 20 kHz. S/N: 103 dB. 1/4". \$178

MP 40 MicroTools MicroPen
Miniature Vocal Transmitter. Detachable C 407 lavalier microphone; clip; rechargeable; power/mute switch. \$198

PR 81 Pocket Receiver
Miniature Camera-Mountable UHF Receiver. Field, broadcast, live sound. UHF system; 15 frequencies; twin antennae; headphone controls; battery operable. Frequency: 710 - 865 MHz. Compatible with AKG WMS 80, WMS 81 wireless systems. \$610

SO 40 MicroTools SnapOn
For use with dynamic mics; power/mute switch; gain control. \$178

WMS 300
Wireless Microphone System. Live sound, installation, broadcast, studio. UHF-based system; 32-channel; networkable with up to 16 units; SR 300 true diversity receiver with twin antennae; battery operation option; reception, RF, peak, squelch, audio and mute LED indicators; HT 300 handheld transmitter, PT 300 bodypack transmitter; low battery indicator, sensitivity control on transmitters; handheld screw-on capsule options include D3700 mic, D3800 mic, C5900; bodypack transmitter capsules include C411 stringed instrument mic, C416 instrument mic, C417 lavalier, C419 instrument mic, C410 and C420 headset mics, CK7 twin diaphragm lavalier, CK97 directional lavalier. Frequency: 766 - 805 MHz. Options available. Prices depend on options and mic combinations. Starts at \$1,316

WMS 61
VHF Wireless Microphone System. Live sound, installation. VHF-based system; 15-channel; 8 optional capsules; SR 61 receiver unit; HT 61 handheld transmitter; PT 61 bodypack transmitter; channel, volume controls on receiver; Tone Code Squelch control; removable dual antennae; low battery indicator, sensitivity control on transmitters; handheld capsule options include capsules from AKG D880, D3800 dynamic mics and C535EB condenser mic; bodypack transmitter capsules include C417 lavalier, C419 instrument mic, C410 and C420 headset mics. Frequency: 169 - 216 MHz. Ships with carrying case, power supply for multiple units. Prices depend on options and mic combinations. Starts at \$740

WMS 81
UHF Wireless Microphone System. Live sound, installation. UHF-based system; 15-channel; 8 optional capsules; SR 61 receiver unit; HT 61 handheld transmitter, PT 61 bodypack transmitter; channel, volume controls on receiver; Tone Code Squelch control; removable dual antennae; low battery indicator, sensitivity control on transmitters; handheld capsule options include capsules from AKG D880, D3800 dynamic mics and C535EB condenser mic; bodypack transmitter capsules include C417 lavalier, C419 instrument mic, C410 and C420 headset mics. Frequency: 710.2 MHz - 745.6 MHz. Ships with carrying case, power supply for multiple units. Prices depend on options and mic combinations. Starts at \$862

Audio 2000's

AWM 6514P
UHF Wireless Microphone System. UHF system, single-channel; 16 frequencies; PLL. XLR, 1/4". \$290 - \$370

AWM 6524P
UHF Wireless Microphone System. UHF system; two-channel; 16 frequencies; PLL. XLR, 1/4". \$554

Audio Ltd.

CXIR
Miniature UHF Wireless Mic Receiver. Live sound, film, video. UHF system; 32 frequencies; true diversity; infrared control; battery operation; camera mountable. Six-pin Lemo. Infrared controlled by Audio Ltd. SwitchIR controller. \$2,550

HXIR
UHF Handheld Transmitter. Live sound, film, video. UHF system; 32 frequencies; compatible with Schoeps Collette capsules; infrared control; battery operation. Frequency range: 470 - 1000 MHz. Infrared controlled by Audio Ltd. SwitchIR controller. \$1,500

Audio-Technica U.S. Inc.

200 Series Freeway Wireless Systems
VHF Wireless Microphone Systems. VHF systems; fixed frequency; volume control; adjustable squelch; removable docking power supply; twin antennae; ATW-201 UniPak Body-pack transmitter with choice of PRO 8HECW headworn mic, AT829CW lavalier mic, guitar cable; ATW-202 Handheld transmitter. Frequencies: 169.505 MHz, 170.245 MHz, 171.905 MHz. ATW-201 UniPak Body-pack system: \$149. ATW-201/G Guitar system: \$174. ATW-201/H Headworn system: \$249. ATW-201/L Lavalier system: \$224. ATW-202 Handheld Microphone system: \$174.

ATB31CW
Miniature Cardioid Lavalier Microphone. Cardioid pattern; condenser element; works with any A-T UniPak bodypack transmitter. Four-pin. Ships with clothing clip, windscreen. \$114

ATB89CW
Headworn Noise-Canceling Microphone. Condenser element; adjustable head and neck bands; cushioned ear pieces; cable clip; windscreen; moisture-resistant. Four-pin. \$229

ATM73CW
Headworn Microphone. Cardioid pattern; condenser element; works with any A-T UniPak bodypack transmitter. Four-pin. \$170

ATW-0328 Handheld Wireless Microphone System
Live sound. ATW-R03 receiver - 10 VHF frequencies; InvisibleLink sound quality circuitry; ATW-T28 handheld mic/transmitter; dipole antenna. \$250

ATW-1128 Handheld Wireless Microphone System
Live sound. VHF system with 20 frequencies; true diversity; InvisibleLink sound quality circuitry; dual power battery-save switch; ground lift switch; squelch control; ATW-T28 handheld mic/transmitter with Hi-ENERGY dynamic element and internal shock mount. 1RU. \$549

ATW-1235 UniPak Bodypack Wireless Microphone System
Live sound. VHF system with 20 frequencies; true diversity; two RF sections; ground lift switch; ATW-T35 UniPak transmitter includes Super Hi-Z input. 1/2RU. \$550

ATW-1237 Handheld Wireless Microphone System
Live sound. VHF system with 20 frequencies; true diversity; two RF sections; ground lift switch; ATW-T37C condenser mic/transmitter accepts interchangeable polar pattern elements. \$798

ATW-1453 Dual Transmitter Wireless Mic System
Live sound. UHF system; true diversity; ten frequencies; squelch control; ground lift; ATW-R14 receiver; ATW-T51 bodypack transmitter; ATW-T52 handheld transmitter; AT831CW lavalier microphone. Frequency: 732 - 746 MHz. Frequency response: 100 Hz - 15 kHz. 1/4". \$919

ATW-7376 Handheld Wireless Microphone System
Live sound, installation. UHF system (728.125 - 740.5 MHz); true diversity; 100 PLL-synthesized channels; ATW-R73 receiver; InvisibleLink circuitry, twin receiver stages, squelch control, ground lift switch, two flexible

UHF antennae; ATW-T76 Handheld Microphone/Transmitter; unidirectional pattern, Hi-ENERGY dynamic element, internal shock mount, stand clamp. Frequency response: 100 Hz - 15 kHz. Range: 300'. Frequency stability: ±0.005%. 1/4", XLR. Ships with rackmount adapters \$879

ATW-U102 Camera-Mounted Plug-On Wireless Microphone System
Field, broadcast. UHF system; 100 PLL-synthesized channels; ATW-R100 receiver; true diversity; dual antennae; output level control; status LEDs; headphone jack with volume control; battery power; ATW-T102 plug-on transmitter. Range: 300'. Frequencies: 656 - 668 MHz, 728 - 740 MHz. Frequency response: 100 Hz - 15 kHz. XLR. \$950

ESW-T212
UHF Wireless Plug-on Transmitter. Installation. UHF system; plug-on; Tone Lock squelch; level control; power switch; frequency control; 9V battery; Engineered Sound series. Frequency: 728 - 740.5 MHz. Frequency response: 100 Hz - 15 kHz. Range: 300'. \$835

PRO 100 Series VHF Wireless Microphone System.
Live sound, installation. VHF system; R1 receiver; dipole antenna; squelch control; ATW-T28 handheld mic/transmitter; Hi-ENERGY dynamic element; external shockmount; ATW-T27 UniPak transmitter; ships with carrying case. Range: >200'. Frequency: 169 - 207 MHz. PRO 128 Handheld Microphone System: \$278. PRO 127G UniPak Guitar System (with 1/4" input cable): \$242. PRO 127L UniPak Lavalier Microphone System (with AT829CW cardioid condenser lavalier mic): \$278. PRO 127H UniPak Headworn Microphone System (with PRO8HECW hypercardioid dynamic headworn mic): \$332.

Azden Corp.

1000URX
Camera Mountable UHF Wireless Mic System Receiver. UHF system; true diversity/Diversity Logic Control reception; 121 selectable frequencies; output level control; twin antennae; battery operable; LCD screen; camera mountable. Frequency: 723 - 735 MHz. XLR, 1/8". Version with Anton Bauer Gold Mount: \$1,100. \$900

1000XT
UHF Plug-on Transmitter. UHF system; 121 selectable frequencies; phantom power switch; level control; on/off switch; battery operable. XLR. \$420

400 UDR Camera Mountable UHF Wireless Microphone Receiver
Video, broadcast. UHF system; single-channel; 63 selectable frequencies; true diversity; PLL; crystal oscillator; output level controls; tone squelch; twin antennae; low battery indicator; RF, AF levels; antenna switch; headphone controls; channel, group select switches. Frequency: 794 - 806 MHz. XLR, BNC. \$480

411DRH
UHF Wireless Mic System Receiver. UHF system; single-channel; 63 selectable frequencies; diversity reception; PLL; crystal oscillator; output level control, squelch controls. 1/2RU. \$475

41BT Bodypack UHF Wireless Microphone Transmitter
Live sound, installation. UHF system; 63 selectable frequencies; input level control; standby switch; tone squelch; battery operation (2 AA cells); compatible with Azden 422, 411, 400 UDR wireless microphone receivers. Frequency: 794 - 806 MHz. \$200

41HT
UHF Wireless Handheld Microphone Transmitter. Live sound, installation. UHF system; supercardioid pattern mic capsule; 63 selectable frequencies; tone squelch; battery operation (2 AA cells); compatible with Azden 422, 411, 400 UDR wireless microphone receivers. Frequency: 794 - 806 MHz. \$260

41HT3
UHF Handheld Microphone Transmitter.

Bruce says

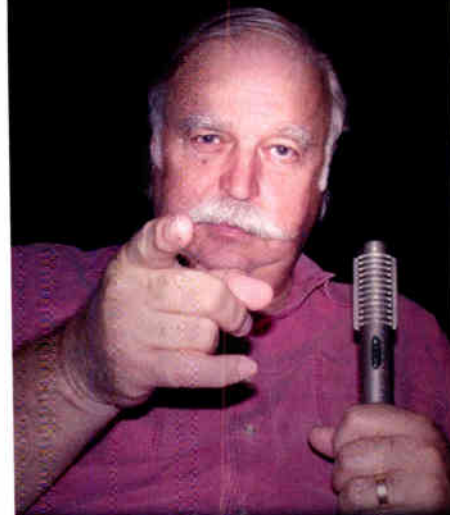

"I've never heard anything better in a ribbon microphone than Royer's new R-122, ever! Something happened when they put that amp and larger transformer in there and this has become my new favorite ribbon microphone. I always use ribbon mics for their warmth and sweet high frequency response characteristics, but there is something truly unique about the powered R-122's sound quality. My pal Omar Hakim was bouncing off the walls when he heard the first playback with R-122's on overheads on his drum set - they just sound absolutely fantastic! Royer really nailed it with the R-122."

Bruce Swedien

(Grammy winner, Jennifer Lopez, Michael Jackson, Quincy Jones, Duke Ellington, Count Basie)

Visit royerlabs.com to hear Bruce speak about ribbons and to see photos of his current recording session.



www.royerlabs.com
813.760.8472

81 in e series

WIRELESS MICROPHONES

Live sound, sound reinforcement. UHF system; 63 frequencies; Audix OM-3 element; tone squelch; battery operation (2 AA cells); compatible with Azden 422, 411, 400 UDR, 411 DRH wireless microphone receivers. \$360

422 UDR UHF Wireless Microphone Receiver OBS

Live sound, sound reinforcement. UHF system; two-channel; 63 selectable frequencies; group selection switch, channel selection switch, output level controls per channel; tone squelch; twin antennae; LED meters. Frequency: 793 - 806 MHz XLR, 1/4", BNC. \$1,200

500UDR

Camera Mountable UHF Wireless Mic System Receiver. UHF system; true diversity; 63 selectable frequencies; PLL; crystal oscillator; output level control; tone squelch; twin antennae; battery operable; camera mountable. Frequency: 793.75 - 805.75 MHz. Compatible with Azden 41BT, 41HT, 41XT transmitters. \$825

beyerdynamic Inc.

U 400 UHF

UHF Wireless Microphone System. Live sound. UHF system; 16 frequencies per channel; PLL synthesis tuning; LCD; NE 400 receiver; optional transmitters: SDM 400 handheld transmitter, SEM 400 handheld transmitter, TSG 400 guitar transmitter, TSP 400 beltpack transmitter. Frequency: 798 - 822 MHz. U 400 HD: \$1,999. U 400 HE: \$1,999. U 400 PW: \$1,899. U 400 G: \$1,899.

Crown Audio

CM-311A

Headworn Microphone. Live sound. Differoid pattern (modified cardioid); bendable headband; includes CM-311 beltpack transmitter. Frequency response: 50 Hz - 17 kHz. XLR. Optional model for mounting on Sony MDR-V6, MDR-7506 headphones, CM-311AHS. \$329

Electro-Voice

N/DYM SCU Receiver

UHF Wireless Microphone System Receiver. Installation, live sound. UHF system; 10-channel; ClearScan auto-channel select; SecurePhase diversity; squelch control; detachable antennae; meters; rackmount hardware; security lockout; compatible with EV N/DYM wireless systems. XLR. \$544

NRU-H1 Headset

Headset Mic/Beltpack Wireless Mic Transmitter System. Live sound. UHF system; HM2 headset microphone; whip antenna; compatible with EV N/DYM wireless series. \$804

NRU-L20 Cardioid Lavalier

Mic/Beltpack Wireless Mic Transmitter System. Live sound. UHF system; cardioid pattern; EV ULM-20 microphone; whip antenna; compatible with EV N/DYM wireless series. \$828

NRU-N1 Handheld

Handheld Wireless Microphone Transmitter. Live sound. UHF system; cardioid pattern; EV N/DYM 167 microphone capsule; compatible with EV N/DYM wireless series. \$754

NRU-N7

Handheld Wireless Microphone Transmitter. Live Sound. UHF system; supercardioid pattern; EV N/DYM 767a microphone capsule; compatible with EV N/DYM wireless series. \$838

R200 Diversity Wireless Microphone System

UHF Wireless Microphone System. Live sound, installation. UHF system;

Secure-Phase true diversity circuitry; HTU handheld transmitter has a choice of EV BK-1 cardioid condenser mic or EV N/D157 cardioid mics. The BPU beltpack transmitter works with EV ULM20 cardioid condenser mic, HM2 headset or a 1/4" guitar connection. Frequency: 710.1 - 721.35 MHz. XLR, 1/4", TA4F.

RE-1

UHF Wireless Microphone System. Live sound. UHF system; 950 channels; Advanced ClearScan; Auto Channel Select; DSP PosiPhase diversity; sound check; up to 16 systems per receiver; bodypack, handheld transmitters; tone code; adjustable amplitude squelch; rackmount hardware. XLR, 1/4". Handheld transmitter package: \$1,550. Beltpack package: \$1,490.

Jensen Music Industries

JW801R.DV

UHF Wireless Microphone Receiver. Live sound, sound reinforcement, installation. UHF system; dual front-mounted antennae; available as handheld transmitter or beltpack system with lavalier, headset or instrument cable. 1/4", XLR. Ships with carrying bag. \$369 - \$399

Lectrosonics Inc.

CR187

VHF Compact Wireless Receiver. Field, video. VHF system; output level control; six-section helical resonator front end filters; Unichannel IF filtering; headphone jack; machined aluminum body; battery operable. Frequency: 169 - 216 MHz. Compatible with Lectrosonics H187, M187 transmitters. \$1,060

H175DC

VHF Wireless Handheld Transmitter. Live sound, broadcast, installation. VHF system; battery operable; Digital Code squelch system. Frequency: 169 - 216 MHz. XLR. Compatible with Lectrosonics R175/DR175 receivers. \$460

MM400

Miniature UHF Digital Wireless Beltpack Transmitter. UHF; Digital Hybrid Wireless; 24-bit A/D; 256 frequencies; soft limiter; DSP-based pilot tone; watertight stainless steel case; screw-on bronze wire antenna; battery operable (AA), 2.5mm micro. Designed for electret lavalier mics. \$1,250

UCR201

Compact UHF Wireless Receiver. UHF; 256 frequencies; SmartSquelch; SmartDiversity reception; dual-band compander; constant group delay SAW filters; onboard RF spectrum analyzer; aluminum housing. XLR. \$1,525

UCR411

Compact UHF Digital Wireless Receiver. UHF; Digital Hybrid Wireless; 256 frequencies; SmartSquelch; SmartDiversity reception; constant group delay SAW filter; DSP-based pilot tone; digital pulse counting detector; onboard RF spectrum analyzer; aluminum housing. XLR, BNC. \$2,575

UDR200C

UHF Wireless Microphone System Receiver. Live sound, broadcast, installation. UHF system; 256 selectable frequencies; Opti-Blend ratio diversity reception; RS232 port for remote control; battery voltage display; built-in RF spectrum analyzer; 16-character ID strip; security lockout; LED meters; compatible with LecNet software. Operating frequencies: 537.6 - 588.7 and 614.4 - 767.9. XLR, 1/4", BNC, RS232. \$3,565

UH100

UHF Wireless Handheld Microphone Plug-On Transmitter. Live sound,

installation. UHF system; 256 frequencies; dual band compander; limiter; machined aluminum body; battery operation. Frequency: 537.6 - 767.9 MHz. XLR. Compatible with Lectrosonics UCR100 receiver. \$995

UH200C

UHF Wireless Handheld Microphone Plug-On Transmitter. Live sound, broadcast, installation. UHF system; 256 selectable frequencies; attenuator; level control; mute switch; 9V battery operation. Frequency: 537.6 - 767.9 MHz. XLR. \$1,025

UM200C

UHF Wireless Beltpack Transmitter. Live sound, broadcast, installation. UHF system; 256 selectable frequencies; audio level control; low-frequency rolloff; 9V battery operation; removable flexible antenna. Frequency: 537.6 - 767.9 MHz. TASF five-pin. \$895

UM400

UHF Digital Wireless Beltpack Transmitter. UHF; Digital Hybrid Wireless; 256 frequencies; dual envelope input limiter; DSP-based pilot tone; soft limiter; battery operable (9V). Frequency response: 35 Hz - 20 kHz. TASF. \$1,250

Nady Systems Inc.

401

VHF Wireless Microphone System. VHF system; four-channel/four separate receivers; option of handheld or bodypack transmitters; operating range: 250' - 500'. Dynamic range: 120 dB. \$579 - \$619

UHF-16

UHF system; 16 frequencies; DigiTRU Diversity reception; tone squelch; twin antennae; 500' operating range. Handheld or bodypack transmitters. \$449

XR-61/62 Pro VHF Series

VHF Wireless Microphone System. VHF system; DigiTRU Diversity reception; handheld transmitter, instrument, lavalier or headworn mic bodypack transmitter options; operating range: 250' - 500'. Frequency: 169 - 216 MHz. Dynamic range: 120 dB. 1/4", XLR. XR-61 - single receiver. XR-62 - dual receiver. \$259 - \$599

Posthorn Recordings

Sonotrim STR-BPS

Miniature Lavalier Microphone Family. Live sound, broadcast, film, video. Choice of connectors/terminations; various mounting clips; battery or phantom powered depending on transmitter; compatible with Audio Ltd., Comtec, Lectrosonics, Sennheiser, Shure, Sony, Telex, Vega transmitters. Available in black, gray, tan, white. \$294 - \$491

Sabine Adaptive Audio Products

SWM-3000 30-Channel Wireless UHF System

Live sound. UHF system; 30 frequencies; handheld, beltpack transmitters; onboard FBX Feedback Extremator feedback controller for receiver; compressor ratio, threshold, attack control for receiver; output level control for receiver; PLL synthesis; true diversity; dual antennae; dual battery compartment. Frequency range: 800 - 960 MHz. S/N: 95 dB. THD: <0.3%. Handheld package (SWM-3000H): \$950. Lavalier package (SWM-3000L): \$950. Headset package (SWM-3000D): \$970. SW-30R receiver only: \$600. SW-30H handheld mic/transmitter only: \$360. SW-30T beltpack transmitter only: \$300.

Samson Technologies Corp.

UHF Series One UHF Wireless Microphone Series.

UHF system; Phase Lock Loop; crystal oscillator; UT1G beltpack transmitter; UT1L beltpack transmitter; UH1 handheld transmitter; UR1 receiver with Surface Acoustic Wave circuitry, activity LEDs, squelch, volume controls; operating range: 300'. Frequency: 800 - 806 MHz. UT1G beltpack transmitter: \$220. UT1L beltpack transmitter: \$240. UH1 handheld transmitter: \$320+. UR1 receiver: \$310.

UHF Synthesized

UHF Wireless Microphone Series. UHF system; 74 selectable frequencies; UT5 beltpack transmitter; UH5 handheld transmitter; UR5 receiver with true diversity reception, dbx noise reduction, activity LEDs, volume, group, channel controls; operating range: 300'. Frequency: 794 - 800 MHz. UT5 beltpack transmitter: \$800. UH5 handheld transmitter: \$820. UR5 receiver: \$1,450. UR5D two-channel receiver: \$2,250.

UR6D

UHF Wireless Microphone System Receiver. Live sound, broadcast. UHF system; two-channel; double superheterodyne true diversity reception; 95 selectable frequencies; Phase Lock Loop; dbx noise reduction; level controls; LCD screen. Frequency: 794 - 806 MHz. Frequency response: 40 Hz - 15 kHz. \$2,200

Sennheiser Electronics Corp.

Digital 1000 Wireless Microphone System

Live sound, broadcast. UHF system; Quadiversity receiver - four internal receivers; 16-bit A/D-D/A; choice of handheld, bodypack or instrument transmitters. 900 MHz frequency. 1/2 RU. Optional external antennae. Handheld transmitter - 1091 Digital: \$895. Instrument/bodypack transmitter - 1092 Digital: \$795. Lavalier/bodypack - 1093 Digital: \$895.

EM 1046

Modular Eight-Channel Wireless Microphone Receiver. Broadcast, live sound. Modular; up to eight-channels per frame; linkable; VHF or UHF; computer controllable through software; compatible with all Sennheiser wireless transmitters. app. \$89,581

EM 203

Modular Three-Channel Wireless Microphone Receiver. Broadcast, live sound. Modular; up to three channels per frame; VHF or UHF; compatible with all Sennheiser wireless transmitters. app. \$32,040

EM3532 Wireless Microphone Receiver

Live sound, broadcast, installation. UHF system; two-channel; computer controllable; PLL synthesis; true diversity; HiDyn plus noise reduction; 4800 selectable frequencies; 32 frequency memory; scan function; antenna splitter; headphone output; LCD screen; Sennheiser Mikropot compatible. Frequency range: 450 - 960 MHz. S/N: 116 dB. Frequency response: 45 Hz - 20 kHz. 1RU. \$4,650

evolution wireless 500 Series

Wireless Microphone System 16-channel; 1,280 frequencies; choice of handheld, plug-on, bodypack (with lavalier, instrument or headworn mics) transmitters; true diversity; HDX compander; rackmountable, camera-mountable; battery operation; LED display. \$1,635 - \$1,776

SK 50-UHF/SK 250-UHF

Bodypack UHF Wireless Microphone Transmitters. Broadcast, field, live sound, video. UHF system; 16 selectable frequencies; battery operation; SK 50 has a 50 mW transmitter; SK 250 has a 250 mW transmitter. S/N: 110 dB. Dynamic range: 108 dB. Optional VHF version of SK50,

\$1,895. SK50-UHF: \$2,925, SK250-UHF: \$3,750

SK3063-U

UHF Bodypack Wireless Microphone Transmitter Broadcast, live sound. UHF bodypack transmitter; PLL; HiDyn plus noise reduction; gain control. Frequency: 450 - 960 MHz. S/N: 108 dB. Lemo. \$2,100

SKM 5000

Handheld Wireless Microphone Transmitter. UHF and VHF systems; interchangeable capsules; 16 selectable frequencies; bass rolloff; high SPL. Frequency: 450 - 960 MHz. S/N: 117 dB. Max SPL: 151 dB. SKM5000 UHF: \$2,500, SKM5000 VHF: \$1,695

SKM3072-U

Handheld UHF Wireless Microphone Transmitter. Live sound, broadcast. UHF; 32 switchable frequencies; switchable supercardioid condenser capsules; integrated antenna; LCD; low battery indicator. Frequency: 430 - 960 MHz. Frequency response: 80 Hz - 20 kHz. S/N: 120 dB. XLR, 10,25" x 2". Compatible with all Sennheiser multichannel receivers. \$1,600

Shure Inc.

LX Wireless Series

VHF Wireless Microphone Series. Live sound, sound reinforcement. VHF system; LX1 bodypack transmitter; LX2 handheld transmitter (compatible with many Shure mic heads); LX3 receiver single antenna receiver; LX4 receiver with MARCAD Diversity reception, level control; autosquelch, LED meters. LX1 bodypack transmitter: \$230. LX3 receiver: \$280. LX4 receiver: \$435.

Performance Gear UHF

UHF Wireless Microphone System. Live sound. UHF system; UT1 bodypack transmitter with 20 dB pad; UT2 handheld transmitter; UT4 diversity receiver with volume control, MARCAD Diversity reception.

Performance Gear VHF

VHF system; fixed frequencies; diversity reception. \$370 - \$520

U1 Bodypack Wireless Microphone Transmitter

Live sound, broadcast, installation. Adjustable audio gain; power and frequency lock; battery power (2 AA cells); battery power LED gauge; power/mute LED; LCD; 1/4-wave whip antenna. Tini-Q-G. Optional LEMO connector. Compatible with most Shure products. \$730

U2/58 Handheld Wireless Transmitter

Live sound, broadcast, installation. Shure SM58 capsule with cardioid pattern; adjustable audio gain; power and frequency lock; battery power (2 AA cells); battery power LED; power/mute LED; LCD; 1/4 wave helical antenna. \$838

U2/Beta 58 Handheld UHF Wireless Microphone Transmitter

Live sound, sound reinforcement, broadcast, installation. UHF system; Shure Beta 58A capsule with supercardioid pattern; adjustable audio gain; power and frequency lock; battery power (2 AA cells); battery power LED; power/mute LED; LCD; 1/4 wave helical antenna. \$944

U2/Beta 87 Handheld UHF Wireless Microphone Transmitter

Live sound, sound reinforcement, broadcast, installation. UHF system; Shure Beta 87A capsule with supercardioid pattern; adjustable audio gain; power and frequency lock; battery power (2 AA cells); battery power LED; power/mute LED; LCD; 1/4 wave helical antenna. \$1,050

WIRELESS MICROPHONES

UA888

Wireless UHF Microphone Network Interface System. Live sound, installation, broadcast. 32 channels; PC/Windows software; audio level, RF, frequency, diversity signal, battery level monitors; A/B antenna. Group/channel, frequency, squelch, lock, ID controls; signal strength monitor/analyzer; frequency scanner; memory; password protection; RS232 port; Shure Link circuitry, 25 pin D-sub. Compatible with all Shure wireless mic systems \$2,110

UC Wireless System

Installation, live sound, UHF system; frequency agile; UC1 bodypack transmitter; UC2 handheld transmitter (compatible with many Shure mic heads); UC4 receiver with MARCAD Diversity reception, level control, two-band EQ, LED meter and display. Frequencies: 692 MHz - 716 MHz; 782 MHz - 802 MHz.

ULX Wireless Systems

UHF system; 1,440 frequencies; Predictive Diversity reception; autodetection; frequency agile; frequency grouping function; detachable antennae; security lockout; LCD screen; up to 20 systems; bodypack, handheld transmitter packages. Frequencies: 554 - 865 MHz. Compatible with many Shure wireless transmitters. Optional antenna distributor, UA844. Optional line amplifier, UA830WB. Optional directional powered antenna, UA870WB.

UP4

Camera-Mounted Wireless Microphone Receiver. UHF system; PLL; Predictive Diversity; tone key; group, channel controls; dual antennae; camera mount; headphone jack; battery operation; compatible with Shure UC wireless mic series. Frequencies: 692 MHz - 716 MHz, 782 MHz - 806 MHz. XLR, 3.5mm, BNC. \$1,248

WH20 Headworn Dynamic Microphone

Live sound, installation, broadcast. Cardioid pattern; condenser element; swiveling, bendable gooseneck stalk; Croakies headband. Options include 1/4" connector or Tini OG connector for wireless systems or hardwired XLR version. Ships with windscreens and cloth clip. \$127

WL50 Series

Lavalier Microphones. Live sound, broadcast. Subminiature; omnidirectional pattern; black, beige, white; EQ caps; condenser element; compatible with Shure UHF, UC, SC, LX wireless systems. Pigtail or TA4F. Ships with magnet mount, swivel lapel clip, dual tie clip, pin mount, foam windscreens. \$316 - \$353

Sony Electronics

CU-F780/G780

Wireless Mic Capsule. Live sound. Supercardioid pattern; dynamic element. For use with WRT-847B handheld transmitter. CU-G780 has reduced proximity effect and increased range. CU-F780: \$325, CU-G780: \$575

ECM-77BMP

Electret Condenser Microphone. Sound reinforcement. Omnidirectional pattern; electret condenser element. \$305

WRR-802A

UHF Wireless Microphone Receiver. Live sound. Single-channel; Space Diversity reception; Phase Lock Loop; output volume control; 10 dB pad; channel skip; linkable; LCD; battery monitor alarm; front mounted antennae. Frequency response: 100 Hz - 15 kHz. XLR, TRS. \$920

WRR-861B

Portable UHF Wireless Mic Receiver. Field, broadcast, video. UHF system; two-channel diversity reception; 188 selectable frequencies; magnesium alloy body; headphone jack; LCD; battery operation; camera mountable. Ships with breakout cable, case, bracket assembly, two antennae. \$1,575

WRR-862B

UHF Synthesized Diversity Wireless Microphone Receiver. Broadcast, sound reinforcement, field. UHF system; two-channel diversity reception; 188 selectable frequencies; RF squelch; headphone jack; LCD; battery operation; camera mountable. XLR. \$3,600

WRT-805B

UHF Synthesized Bodypack Transmitter. Live sound, sound reinforcement. UHF system; bodypack; channel, attenuator and accumulat-

ed time LCD; 188 PLL-synthesized frequencies; guitar/mic switch; helical antenna. Frequency response: 70 Hz - 15 kHz. Frequency: 758 - 806 MHz. \$510

WRT-807B

Handheld Wireless Microphone. Live sound, broadcast. UHF; 188 PLL synthesized frequencies; locking power switch; LCD; battery operation. \$840

WRT-822B

UHF Synthesized Bodypack Transmitter. Sound reinforcement. UHF system; 188 selectable frequencies; PLL synthesized control transmission; lavalier microphone capability; 8 hours continuous battery operation; LCD; magnesium casing. Frequency: 758 - 806 MHz. Frequency response: 100 Hz - 15 kHz. \$1,125

WRT-847B

UHF Wireless Handheld Transmitter. Broadcast, sound reinforcement, field. UHF system; 188 selectable channels; compander; selectable signal output level; LCD. Frequency: 794 - 806 MHz. Frequency response: 70 Hz - 15 kHz. Max SPL: 142 dB. \$1,050

WRT-860A

UHF Synthesized Bodypack Transmitter. Sound reinforcement. UHF system; 94 selectable frequencies; PLL synthesized control transmission; detachable antenna; battery level meter. Frequency: 770 - 806 MHz. Frequency response: 70 Hz - 15 kHz. \$1,970

WRT-867A/X

UHF Wireless Handheld Microphone and Transmitter. Sound reinforcement. UHF system; cardioid pattern; dynamic element; 94 selectable frequencies; PLL synthesized control transmission; 4 hours continuous battery operation; LED power monitor. Frequency: 794 - 806 MHz. Frequency response: 50 Hz - 15 kHz. Max SPL: 142 dB. \$1,720

WRT-8B

Bodypack Transmitter. UHF; phase locked loop; switchable input levels; attenuator; magnesium body; battery alarm; LCD screen; LEDs. Ships with mic cable, soft case, spare battery

case.

\$1,945

WRU-806B

UHF Synthesized Diversity Tuner Module. Live sound, broadcast. UHF; 188 frequencies; single-channel; Space Diversity Tuning; Phase Lock Loop; auto channel scan; channel and battery alarm on LCD; output volume control; front mounted antenna; compact unit. Frequency response: 100 Hz - 15 kHz. Frequency: 758 - 806 MHz. Compatible with MB-806A wireless module rack. \$540

Telex Communications Inc.

ENG-100

Portable UHF Receiver. Broadcast, location, installation. UHF system; 100 channels; mic, volume controls; phase diversity; headphone jack; battery operation; camera-mountable. Frequency: 668 - 746 MHz. XLR, 1/4". \$525

FMR-1000

UHF Wireless Microphone System. UHF system; 950 channels; Auto Channel Select; Posi-Phase diversity; Advanced ClearScan; tone code amplitude squelch; HT-1000 handheld transmitter; WT-1000 magnesium bodypack transmitter; twin antennae, USB port on receiver. Compatible with AD-450 antenna distributor. \$1,250

S.A.F.E.

Encrypted Wireless Microphone System. Installation. UHF system; BTR600 encryption; RS-1 receiver; LS-1 bodypack transmitter; HS-1 handheld transmitter. Frequency: 668 - 746 MHz.

UR-700

UHF Wireless Microphone System. Live sound, installation. UHF system; Posi-I-Phase diversity; UR-700 receiver with LED level meter and squelch control; HT-700 handheld transmitter; WT-700 bodypack transmitter with WL-50 lapel mic. Frequency: 690 - 720 MHz. Optional Audix OM-3 capsule. \$635 - \$695

USR-100

UHF Wireless Microphone System. Live sound, installation. UHF system; microprocessor-controlled; choice of 100 channels; RF, audio level LED meters on

receiver; USR-100 receiver with Posi-I-Phase Smart diversity reception; SH-100 handheld transmitter; LT-1000 bodypack transmitter. Frequencies: 668.1 - 679.5 MHz, 734.1 - 745.5 MHz. Handheld transmitter available with Audix OM-3 capsule. \$1,125 - \$1,590

UT-102

Handheld Plug-on Wireless Transmitter. UHF system; frequency agile; Posi-phase diversity; compatible with Telex ENG-100 receiver. XLR.

TOA Electronics

Password Series

UHF Wireless Mic System. Installation. UHF system; true diversity; frequency scan; squelch control; dynamic handheld transmitter; lapel mic for bodypack transmitter; twin antennae; linkable. Frequency: 690 - 722 MHz. Starts at \$1,000

Vega/Clear-Com

U2020

UHF Wireless Microphone System. Live sound, broadcast, installation. UHF system; 100 selectable channels; DX20 audio processing; dual squelch mode; receiver self-noise squelch; 30 dB pad; choice of handheld capsules for HT-2020 handheld transmitter; BT-2020 bodypack transmitter; linkable; LED meter, display. Frequency range: 672 - 782 MHz. Range: 1,000'. Frequency response: 50 Hz - 15 kHz. XLR, 1/4", BNC. Starts at \$1,029

Zaxcom Inc.

Zaxcom Digital Wireless Miniature Digital UHF Wireless Microphone System. Film, video, field. UHF system; 24-bit A/D-D/A; digital dropout compensation; scramble transmission mode; DSP; miniature bodypack transmitters; networkable receivers; lithium ion battery; compatible with Zaxcom Cameo II mixer and DEVA II recorder. Frequency: 500 - 1,000 MHz. Dynamic range: 117 dB. Basic system includes transmitter, receiver, battery charger.

MANUFACTURER DIRECTORY

A

A Designs

P.O. Box 4255
West Hills, California 91304
818-716-4153
www.adesignsaudio.com

Aardvark

202 E. Washington, Suite 306
Ann Arbor, Michigan 48104
734-665-8899 F) 734-665-0694
www.aardvark-pro.com

Ace Products

630 Las Gallinas Avenue, #215
San Rafael, California 94903
415-492-9600 F) 415-492-5959
www.aceproducts.com

ACO Pacific

2604 Read Avenue
Belmont, California 94002
650-595-8588 F) 650-591-2891
www.acopacific.com

Acoustic Sciences Corporation

P.O. Box 1189
Eugene, Oregon 97440
541-343-9727 F) 541-343-9245
www.tubetrap.com

Acoustic-X Software Corporation

376 Queen Street East
Toronto, Ontario M3N 1M3
Canada
416-868-0809 F) 416-861-0620

www.pichner-schoustal.com

Acoustical Interiors/Systems Development Group

5744 Industry Lane, Ste. J
Frederick, Maryland 21704
301-846-7990 F) 301-688-4683
www.acousticalinteriors.com

Acoustical Solutions

2852 E. Parham Road
Richmond, Virginia 23228
804-346-8350 F) 804-346-8808
www.acousticalsolutions.com

Acoustics, Inc.

720 Greenwich Street
#2C
New York, New York 10014

Acoustics First

2247 Tomlyn Street
Richmond, Virginia 23230
804-342-2900 F) 804-342-1107
www.acousticsfirst.com

Acoustisoft/ETF

463 King Street
Upper Apartment
Peterborough, Ontario K9J 2T1
Canada
800-301-1423
www.etfacoustic.com

Adamson Systems Engineering

332 Fairall Street
Ajax, Ontario L1S 1R6

Canada

905-683-2230 F) 905-683-5414
www.adamsonproaudio.com

ADAM Audio USA

3717 E. Thousand Oaks Blvd., #215
Westlake Village, California 91362
805-413-1133 F) 805-413-1134
www.adam-audio.com

ADC Telecommunications

125 Crown Point Court
Grass Valley, California 95945
530-265-1000 F) 530-265-1021
www.adc.com

Adgii Design/Sascom

34 Nelson Street
Oakville, Ontario L6L 3H6
Canada
905-469-8080 F) 905-469-1129
www.sascom.com

ADK

18016 NW 69th Avenue
Ridgefield, Washington 98642
360-566-9400 F) 360-566-1282
www.adkmic.com

Advanced Sonic Concepts

P.O. Box 237
Chatsworth, New Jersey 08019
609-726-9202
www.advancedsoniconcepts.com

AETA Audio Corp.

75 Fleetwood Drive, Ste. 200

Rockaway, New Jersey 07866
973-659-0555 F) 973-659-9555
www.aetausa.com

Agular Amplification

599 Broadway, 7th Floor
New York, New York 10012
212-431-9109 F) 212-431-8201
www.agularamp.com

Akai Professional

4710 Mercantile Drive
Fort Worth, Texas 76137
817-831-9203 F) 817-222-1490
www.akai.com/akaipro

AKG Acoustics, US

914 Airport Center Drive
Nashville, Tennessee 37217
615-620-3800 F) 615-620-3875
www.akg.com

Alesis

12555 Jefferson Avenue
Los Angeles, California 90066
310-821-1500 F) 310-306-7194
www.alesis.com

Allen & Heath/North American Pro Audio

Agoura Business Center East
5304 Derry Avenue, Suite C
Agoura Hills, California 91301
800-431-3129
www.allen-heath-usa.com

Allen Audio

150 Locust Street
Macungie, Pennsylvania 18062
610-966-2202 F) 610-965-3098
www.allenaudio.com

Allen Avionics

224 E. Second Street
Mineola, New York 11501
516-248-8080 F) 516-747-6724
www.allenavionics.com

Allen Products

1635 E. Burnett St.
Signal Hill, California 90755
562-424-1100 F) 562-424-3520
www.allenproducts.com

Alpha-Core

915 Pembroke St.
Bridgeport, Connecticut 06608
203-335-6805 F) 203-384-8120
www.alpha-core.com

Altec Lansing Technologies, Inc.

Route 6 & 209
Millford, Pennsylvania 18337-0277
570-296-4434 F) 570-296-6887
www.alteclansing.com

Attinex Inc.

592 Apollo Street
Brea, California 92821
714-990-2300 F) 714-990-3303
www.attinex.com

Ambiance Acoustics

P.O. Box 27115

MANUFACTURER DIRECTORY

San Diego, California 92198
858-485-7514 F) 858-675-9245
www.ambianceacoustics.com

Amek
1449 Donelson Pike
Nashville, Tennessee 37217
615-360-0488 F) 615-360-0273
www.amek.com

American Audio
4295 Charter Street
Los Angeles, California 90058
800-322-6337 or 323-582-2650 F)
323-582-2610
www.americanaudio.us

American Recorder Technologies
P.O. Box 1450
Simi Valley, California 93062
805-527-9580 F) 805-527-1433
www.americanrecorder.com

Amplivox Sound Systems
3149 MacArthur Blvd.
Northbrook, Illinois 60062
847-498-9000 F) 847-498-6691
www.amplivox.com

AMS Neve
100 Avenue of the Americas, 5th Fl.
New York, New York 10013
212-965-1400 F) 212-965N3739
www.ams-neve.com

Anchor Audio
3415 Lomita Blvd.
Torrance, California 90505
310-784-2300 F) 310-784-0533
www.anchoraudio.com

Antares Audio Technologies
231 Technology Circle
Scotts Valley, California 95066
831-461-7800 F) 831-461-7801
www.antarestech.com

Antex
1125 West 190th Street
Gardena, California 90248
310-532-3092 F) 310-532-8599
www.antex.com

Anthony DeMaria Labs
95 Dubois Road
New Paltz, New York 12561
845-256-0032 F) 845-255-3202
www.adl-tube.com

Antique Electronic Supply
6221 S. Maple Avenue
Tempe, Arizona 85283
480-820-5411 F) 480-820-4643
www.tubesandmore.com

Anvil Cases
15650 Salt Lake Avenue
City of Industry, California 91745-1114
626-968-4100 F) 626-968-1703
www.anvilcase.com

APA Audio Group Intl.
16411 371st Avenue
Green Isle, Minnesota 55338
888-442-8776 F) 320-238-2545

Apex/Yorkville Sound
4625 Wilmer Industrial Estate
Niagara Falls, New York 14305
716-297-2920 F) 716-297-3689
www.yorkville.com

Aphex
11068 Randall Street
Sun Valley, California 91352
818-767-2929 F) 818-767-2641
www.aphex.com

API Audio Products, Inc.
8301 Patuxent Range Road, Ste. A1
Jessup, Maryland 20794
301-776-7879 F) 301-776-8117
www.apiaudio.com

A.P.I.C. Inc.
90 Dayton Avenue
Passaic, New Jersey 07055
973-405-6185 F) 973-405-6189
www.apicstands.com

Apogee Electronics
3145 Donald Douglas Loop South
Santa Monica, California 90405
310-915-1000 F) 310-391-6292
www.apogeedigital.com

Apogee Sound
2180 S. McDowell Blvd.
Petaluma, California 94954
707-778-8887 F) 707-778-6923
www.apogee-sound.com

Arboretum Systems
75 Aura Vista Drive
Pacifica, California 94044
650-738-4750 F) 650-738-5699
www.arboretum.com

ARS Electronics
7110 DeCelle Place
Van Nuys, California 91406
818-997-6279 F) 818-997-6158
www.arselectronics.com

ART - Applied Research and Technology, Inc.
215 Tremont Street
Rochester, New York 14608
716-436-2720 F) 716-436-3942
www.artroch.com

ASA Cases
P.O. Box 244
Yorba Linda, California 92885
909-738-8222 F) 909-738-8221
www.asacase.com

Ashdown Engineering/HHB
743 Cochran Street, Bldgs. E & F
Simi Valley, California 93065-1976
805-579-6490 F) 805-579-8028
www.hbusa.com

Ashly Audio
847 Holt Road
Webster, New York 14580-9103
716-872-0010 F) 716-872-0739
www.ashly.com

ATC Studio Monitors/Transamerica Audio Group
4760 W. Dewey, #129
Las Vegas, Nevada 89118
702-365-5155 F) 702-365-5145
www.transaudiogroup.com

Atlas Sound
1601 Jack McKay Blvd.
Ennis, Texas 75119
800-876-7337 F) 800-765-3435
www.atlassound.com

ATM Fly-Ware
21000 S. Wilmington Avenue
Carson, California 90810
310-834-5914 F) 310-834-3042
www.atmflyware.com

ATR Service
2101 Pennsylvania Ave. Ste. 11
York, Pennsylvania 17404
717-852-7700 F) 717-852-7755
www.atrservice.com

Audience
1525 Brian Place
Escorido, California 92025
760-743-1997 F) 760-743-2192
www.audience-av.com

Audient/ Audio Toys Inc.
8301 Patuxent Range Rd., Ste. A1
Jessup, Maryland 20794
301-776-7879 F) 301-776-8117
www.audiotoys.com

Audio 2000's
650 Flinn Avenue, #4
Moorpark, California 93021
805-523-2759 F) 805-523-2021
www.audio2000s.com

Audio Accessories
Mill Street, P.O. Box 360
Marlow, New Hampshire 03456
603-446-3335 F) 603-446-7543
www.patchbays.com

Audio & Design/G Prime
1790 Broadway, #402
New York, New York 10019
212-765-3415 F) 212-581-8938
www.gprime.com

Audio Developments, Ltd./Independent Audio
43 Deerfield Road
Portland, Maine 04101
207-773-2424 F) 207-773-2422
www.independentaudio.com

Audio Ease
Lagenwood 26
3513 GW Utrecht
The Netherlands
31-30-24-33-606 F) 31-30-24-38-500
www.audioease.com

Audio Engineering Associates
1029 N. Allen Avenue
Pasadena, California 91104
626-798-9128 F) 626-798-2378
www.wesdooley.com

Audio Engineering Limited/Micron
Micron House
3 New Road
London, N8 8TA
England
44-208-341-3500
www.micronwireless.com

Audio Limited
Audio House
Progress Road
High Wycombe, Buckinghamshire
HP12 4JD England
44-1494-511-711 F) 44-1494-539-600
www.AudioLtd.com

Audio Precision
5750 SW Arctic Drive, Suite J
Beaverton, Oregon 97005
503-627-0832 F) 503-641-8906
www.audioprecision.com

Audio Processing Technology
Unit 6 Edgewater Road
BT3 9UJ Belfast
Northern Ireland
44-2890-371-110 F) 44-2890-371-137

Audio-Technica US, Inc.
1221 Commerce Drive
Stow, Ohio 44224
330-686-2600 F) 330-686-0719
www.audio-technica.com

Audio Technologies Incorporated
328 W. Maple Avenue
Horsham, Pennsylvania 19044
215-443-0330 F) 215-443-0394
www.atiguys.com

Audio Toys Inc.
8301 Patuxent Range Rd., Ste A1
Jessup, Maryland 20794
301-776-7879 F) 301-776-8117
www.audiotoys.com

AudioControl Industrial
22410 70th Avenue West
Mountlake Terrace, Washington 98043
425-775-8461 F) 425-778-3166
www.audiocontrolindustrial.com

Audiophile Systems Ltd.
8709 Castle Park Drive
Indianapolis, Indiana 46256
317-849-7103
www.aslgroup.com

AudioScience
42C Read's Way
New Castle, Delaware 19270
302-324-5333 F) 302-235-7110
www.audioscience.com

Audix Corporation
P.O. Box 4010
Wilsonville, Oregon 97070
503-682-6933 F) 503-682-7114
www.audixusa.com

Auralex Acoustics, Inc.
8851 Hague Road
Indianapolis, Indiana 46256
317-842-2600 F) 317-842-2760
www.auralex.com

Avalon Design
1030 Calle Sombra, Suite B
San Clemente, California 92673
949-492-2000 F) 949-492-4284
www.avalondesign.com

Avlex Corp.
10668 Widmer
Shawnee Mission, Kansas 66215
913-906-9216 F) 913-906-9225

AVP Mfg. & Supply
187-2288 Dumries RR2
Cambridge, Ontario N1R 5S3
Canada
519-740-7966 F) 519-740-0131
www.jackfields.com

Azden
147 New Hyde Park Road
Franklin Square, New York 11010
516-328-7500 F) 516-328-7506
www.azdeninc.com

B2 Technologies
12277 Nicollet Avenue South
Burnsville, Minnesota 55337
952-894-5091 F) 952-894-2117

Bader
1040 Stonehill Court
Danville, Kentucky 40422
859-516-5467 F) 859-936-3145

www.baderlk.com
Bag End
22272 Pepper Road, Unit D
Barrington, Illinois 60010
847-382-4550 F) 847-382-4551
www.bagend.com

BAI Distributors
2312 NE 29th Avenue
Ocala, Florida 34470
352-732-7009 F) 352-732-1616
www.baionline.com

Baltic Latvian Universal Electronics
766 Lakefield Rd, Suite D
Westlake Village, California 91361
805-370-1599 F) 805-370-1549
www.bluemic.com

Barbetta Electronics
5345 Commerce Avenue
Moorpark, California 93021
805-529-3607
www.barbetta.com

Bayview Pro Audio
740 Clark Street SW
Turnwater, Washington 98512
360-753-3862 F) 360-352-3802
www.bayviewproaudio.com

BBE Sound, Inc.
5381 Production Drive
Huntington Beach, California 92649
714-897-6766 F) 714-896-0736
www.bbessound.com

BeachTek
53 Bellefair Avenue
Toronto, Ontario M4L 3T7
Canada
416-690-9457 F) 416-690-0866

Behringer
190 W. Dayton Street
Ste. 201
Edmonds, Washington 98020
425-672-0816 F) 425-673-7647
www.behringer.com

Bel Canto Design
212 3rd Avenue, North, Ste. 274
Minneapolis, Minnesota 55401
612-317-4551 F) 612-359-9358
www.belcantodesign.com

Belden Wire and Cable Company
2200 US Highway 27 South
Richmond, Indiana 47374
765-983-5200 F) 765-983-5257
www.belden.com

Bellari/Rolls Corporation
5968 South 350 West
Salt Lake City, Utah 84107
801-263-9053 F) 801-263-9068
www.rolls.com

Benchmark Media Systems, Inc.
5925 Court Street Road
Syracuse, New York 13206
315-437-6300 F) 315-437-8119
www.benchmarkmedia.com

Beyerdynamic North America
56 Central Avenue
Farmingdale, New York 11735
631-293-3200 F) 631-293-3288
www.beyerdynamic.com

BGW Systems, Inc.
13130 Yukon Avenue
Hawthorne, California 90250
310-973-8090 F) 310-676-6713
www.bgw.com

BIAS, Inc.
1370 Industrial Ave., Ste. A
Petaluma, California 94952
707-782-1866 F) 707-782-1874
www.bias-inc.com

BitHeadz Inc.
2850 South County Trail
East Greenwich, Rhode Island 02818
401-886-7045 F) 401-886-7049
www.bitheadz.com

Bittree
600 West Elk Avenue
Glen Dale, California 91204
818-500-8142 F) 818-500-7062
www.bittree.com

Blue Sky/Group One, Ltd.
200 Sea Lane
Farmingdale, New York 11735
310-927-7788 F) 310-927-9220
www.abluesky.com

Bogen Communications
50 Spring Street
Ramsey, New Jersey 07446
201-934-8500 F) 201-934-9832
www.bogen.com

Bomb Factory
3917 W. Burbank Blvd.
Burbank, California 91505
818-588-7171
www.bombfactory.com

Bose
The Mountain
MS 232
Framingham, Massachusetts 01701
508-879-7330 F) 508-872-6640
www.bose.com

Boss/Roland Corporation
5100 S. Eastern Avenue
Los Angeles, California 90040
323-890-3700 F) 323-890-3701
www.bossum.com

Bowman Technologies
2204 Duke Street
Indianapolis, Indiana 46205
317-545-5165 F) 317-547-4668
www.caboospro.com

Brainstorm Electronics, Inc./plus24
1155 N. La Brea Avenue
West Hollywood, California 90038
323-845-1171 F) 323-845-1170
www.plus24.com

Brauner Microphones/Transamerica Audio Group
4760 W. Dewey, #129
Las Vegas, Nevada 89118
702-365-5155 F) 702-365-5145
www.transaudiogroup.com

Bruei & Kjaer
2815-A Colonnades Court
Norcross, Georgia 30071
770-209-6907 F) 770-448-3246
www.bkhome.com

Bryston
1839 Oakwood Avenue
Arcadia, California 91006
626-355-9525 F) 626-355-9565
www.bryston.ca

BSS Audio/Harman Pro North America
1449 Donelson Pike
Nashville, Tennessee 37217
615-360-0277 F) 615-360-0480
www.bss.co.uk

BTX
10 Skyline Drive
Hawthorne, New York 10532
800-666-0996 F) 800-569-4244
www.btx.com

C

C-Tec/CableTek Electronics
1638 Kebet Way
Port Coquitlam, BC V3C 5W9
Canada
604-942-1001 F) 604-942-1010
www.cabletek.ca

CAD Professional Microphones
341 Harbor Street
Conneaut, Ohio 44030
440-593-1111 F) 440-593-5395
www.cadmics.com

Cadac/Group One
200 Sea Lane
Farmingdale, New York 11735
631-249-1399 F) 631-753-1020
www.cadac-sound.com

CAIG Laboratories, Inc.
1220 Thatcher Court
Poway, California 92064-6876
858-486-8388 F) 858-486-8398
www.caig.com

Cakewalk
51 Melcher Street, 8th Floor
Boston, Massachusetts 02210
617-423-9004 F) 617-423-9007
www.cakewalk.com

Callfone International
21300 Superior Street
Chatsworth, California 91311
818-407-2400 F) 818-407-2405
www.callfone.com

Calrec Audio Ltd.
Studio Consultants
321 W. 44th Street, 9th Floor

THE NEW AUDIX D6

FEEL THE POWER



**D-6
SILVER**



**D-6
BLACK**

LIGHTNING FAST RESPONSE
THUNDEROUS SOUND

AUDIX, THE INDUSTRY LEADER IN DRUM
AND PERCUSSION MICROPHONES,
INTRODUCES THE LATEST ADDITION TO
THE D SERIES OF PROFESSIONAL
INSTRUMENT MICROPHONES, THE D6.

- ◆ HUGE, CLEAN, UNDISTORTED SOUND
- ◆ CONVENIENT SIZE, EASY TO POSITION
- ◆ NO EQ REQUIRED
- ◆ PRECISION MACHINED FROM SOLID ALUMINUM
- ◆ FREQUENCY RESPONSE OF 30HZ - 15KHZ
- ◆ CARDIOID PICK-UP PATTERN
- ◆ MADE IN USA



SET UP IS A BREEZE

AUDIX
PERFORMANCE IS EVERYTHING

FOR A DEALER NEAR YOU CALL: 800-966-8261
TEL: 503-682-6933 FAX: 503-682-7114 WWW.AUDIXUSA.COM

World Radio History

AUDIX CORPORATION
PO BOX 4010
WILSONVILLE, OR 97070

IN CANADA, C-TEC
TEL 604-942-1001
FAX 604-942-1010

© AUDIX CORP 2002.
ALL RIGHTS RESERVED.
AUDIX AND THE AUDIX LOGO
ARE TRADEMARKS OF AUDIX
CORPORATION.



MANUFACTURER DIRECTORY

New York, New York 10036
212-586-7376
www.cairec.com

Calzone Cases
225 Black Rock Avenue
Bridgeport, Connecticut 06605
203-367-5766 F) 203-336-4406
www.calzonecase.com

Canare
531 5th Street, Unit A
San Fernando, California 91340
818-365-2446 F) 818-365-0479
www.canare.com

Carver Professional
9300 North Decatur
Portland, Oregon 97203
503-978-3344 F) 503-978-3302
www.carverpro.com

Carvin
12340 World Trade Drive
San Diego, California 92128
858-487-1600 F) 858-487-8160
www.carvin.com

Case Logic
6303 Dry Creek Parkway
Longmont, Colorado 80503
303-652-1000 F) 303-652-1094
www.caselogic.com

CD CyClone Duplication Systems
1582 Park Way Loop, Ste. K
Tustin, California 92780
714-247-0099 F) 714-247-0080
www.cdyclone.com

CE Distribution/Antique Electronic Supply
6221 South Maple Avenue
Tempe, Arizona 85283
480-755-4712 F) 480-820-4643
www.tubesandmore.com

CEDAR Audio USA
43 Deerfield Rd.
Portland, Maine 04101-1805
207-773-2424 F) 207-773-2422
www.independentaudio.com
www.cedaraudio.com

Celestion Professional Products/Group One, Ltd.
200 Sea Lane
Farmingdale, New York 11735
631-249-1399 F) 631-753-1020
www.celestion.com

Cerwin-Vega
555 East Easy Street
Simi Valley, California 93065
805-584-9332 F) 805-583-0865
www.cerwin-vega.com

Chandler Limited/Wave Distribution
1170 Greenwood Lake Turnpike
Ringwood, New Jersey 07456
973-728-2425 F) 973-728-2931
www.wavedistribution.com
www.chandlerlimited.com

Channel D Corporation
9 Highland Avenue
Red Bank, New Jersey 07701
609-393-3600 F) 609-393-6940
www.channeld.com

Chevin/Sennheiser USA
One Enterprise Drive
P.O. Box 987
Old Lyme, Connecticut 06371
860-434-9190 F) 860-434-1759
www.chevinresearch.com

Clark Wire and Cable
1355 Armour Blvd.
Mundelein, Illinois 60060-4401
847-949-9944 F) 847-949-9595
www.clarkwc.com

Clear-Com Intercom Systems
4065 Hollis Street
Emoryville, California 94608
510-496-6666 F) 510-496-6699
www.clearcom.com

ClearSonic Mfg. Inc.
1223-B Norton Road
Hudson, Ohio 44236
330-650-1420 F) 330-650-1445
www.clearsonic.com

Cliff Electronic Components
4876 East 2nd Street
Benicia, California 94510
707-746-8090 F) 707-746-8092
www.cliffcomponents.com

CLM Dynamics/Wave Distribution
1170 Greenwood Lake Turnpike
Ringwood, New Jersey 07456
973-728-2425 F) 973-728-2931
www.clmdynamics.com

Coleman Audio
81 Pilgrim Lane
Westbury, New York 11590
516-334-7109 F) 516-334-1420
www.colemanaudio.com

Coles Microphones/Independent Audio
43 Deerfield Road
Portland, Maine 04101
207-773-2424 F) 207-773-2422
www.independentaudio.com

CommScope
P.O. Box 1729
Hickory, North Carolina 28603
828-324-2200 F) 828-328-3400
www.commscope.com

Communications Specialties
55 Cabot Court
Hauptaugasse, New York 11788
631-273-0404 F) 631-273-1638
www.commspecial.com

Community Loudspeakers
333 East Fifth Street
Chester, Pennsylvania 19013-4511
610-876-3400 F) 610-874-0190
www.community.chester.pa.us

Comrex
65 Nonsent Path
Acton, Massachusetts 01720
978-263-1800 F) 978-635-0401
www.comrex.com

Comtek
357 West 2700 South
Salt Lake City, Utah 84115
801-466-3463 F) 801-484-6906
www.comtek.com

Conex Electro Systems
1602 Carolina Street
Bellingham, Washington 98226
360-734-4323 F) 360-676-4822
www.conex-electro.com/~conex

Conquest Sound, Inc.
26113 South Ridgeland Avenue
Monee, Illinois 60449
708-534-0390 F) 708-534-0398

Contemporary Research Corp.
17630 Davenport, Suite 113
Dallas, Texas 75252
972-931-2728 F) 972-931-2675
www.contemporaryresearch.com

Cooper Sound Systems, Inc.
1411 Marsh Street, Suite 105
San Luis Obispo, California 93401
805-782-9750 F) 805-782-9752
www.coopersound.com

CopyPro
4020 Pike Lane
Concord, California 94520
925-689-1200 F) 925-689-1263
www.copypro.com

Core Sound
574 Wyndham Road
Teaneck, New Jersey 07666
201-801-0812 F) 201-801-0912
www.core-sound.com

Corporate Systems Center
3310 Woodward Avenue
Santa Clara, California 95054
408-588-1110 F) 408-969-2655
www.cddupeit.com

Countryman Associates
417 Stanford Avenue
Redwood City, California 94063-3422
650-364-9988 F) 650-364-2794
www.countryman.com

Crane Song
2117 E. 5th Street
Superior, Wisconsin 54880
715-398-3627 F) 715-398-3279
www.cranesong.com

CreamWare US, Inc.
6879 Russell Avenue
Vancouver, British Columbia V5J 4R8
Canada
604-435-0540 F) 604-435-9937
www.creamware.com

Crest Audio Inc.
16-00 Pollitt Drive
Fair Lawn, New Jersey 07410

201-909-8700 F) 201-909-8744
www.crestaudio.com

Crown International
1718 W. Mishawaka Road
Elkhart, Indiana 46517-1000
219-294-8200 F) 219-294-8329
www.crownaudio.com

Cube Technologies/Sascom
34 Nelson Street
Oakville, Ontario L6L 3H6
Canada
905-469-8080 F) 905-469-1129
www.sascom.com

Curtis Technology
129 S. Phelps Ave.
Suite 526
Rockford, Illinois 61108
815-399-8453 F) 815-399-2559
www.curtis-technology.com

Cycling '74
1186 Folsom Street
San Francisco, California 94103
415-621-5743 F) 415-621-6563
www.cycling74.com

D

DACS, Ltd./Independent Audio
43 Deerfield Road
Portland, Maine 04101
207-773-2424 F) 207-773-2422
www.independentaudio.com
www.dacs-audio.co.uk

Daking/Transamerica Audio Group
4760 W. Dewey, #129
Las Vegas, Nevada 89118
702-365-5155 F) 702-365-5145
www.transaudiogroup.com

Dale Pro Audio
7 East 20th Street
New York, New York 10003
212-475-1124 F) 212-475-1169
daleproaudio.com

Dan Alexander Audio
965 Hilldale Avenue
Berkeley, California 94708
510-527-1411 F) 510-528-8721
www.danalexanderaudio.com

Dan Dugan Sound Design
290 Napoleon Street
San Francisco, California 94124
415-821-9776 F) 415-826-7699
www.dandugan.com

Dana B. Goods
4054 Transport Street, A
Ventura, California 93003
805-856-1701 F) 805-644-6332
www.danabgoods.com

Dangerous Music/Wave Distribution
1170 Greenwood Lake Turnpike
Ringwood, New Jersey 07456
973-728-2425 F) 973-728-2931
www.wavedistribution.com

Dartech, Inc.
7400 Metro Blvd. #350
Edina, Minnesota 55439
952-844-0915 F) 952-844-9025
www.dartpro.com

DAS Audio of America, Inc.
6970 N.W. 50th Street
Miami, Florida 33166
305-436-0521 F) 305-436-0528
www.dasaudio.com

Davisound
1504 Sunset, P.O. Box 521
Newberry, South Carolina 28603
803-276-0639
www.davisound.com

DB Systems
245 Main Street
Rindge, New Hampshire 03461
603-899-5121

dbx Professional Products
8760 South Sandy Parkway
Sandy, Utah 84107
801-568-7660 F) 801-568-7662
www.dbxpro.com

dCS/Independent Audio
43 Deerfield Road
Portland, Maine 04101
207-773-2424 F) 207-773-2422
www.independentaudio.com
www.dcsdtd.com

Delaydots.com
www.delaydots.com

Demeter Tube Amplification
15730 Slagg Street
Van Nuys, California 91406
818-994-7658 F) 818-994-0647
www.demeteramps.com

Denecke
5417 Cahuenga Blvd., Unit B
North Hollywood, California 91601
818-766-3525 F) 818-766-0269
www.denecke.com

Denon
19 Chapin Road, Building C
Pine Brook, New Jersey 07058-9777
973-396-0810 F) 973-396-7459
www.usa.denon.com

Desk Doctor
3316/18 West Burbank Blvd.
Burbank, California 91505
818-848-8065 F) 818-848-2022
www.deskdoctor.com

DigiCo Uk Ltd.
The School House
4 Dorin Road
Epsom, Surrey KT18 7LX
United Kingdom
44-13-7284-5600 F) 44-13-7284-5656
www.digicosoles.com

Digidesign
2001 Junipero Serra Blvd., Ste. 200
Daly City, California 94014
650-731-6300 F) 650-731-6399
www.digidesign.com

Digigram, Inc.
2101 Wilson Blvd., Ste. 1004
Arlington, Virginia 22201
703-875-9100 F) 703-875-9161
www.digigram.com

Digital Audio Denmark/Sascom
34 Nelson Street
Oakville, Ontario L6L 3H6
Canada
905-469-8080 F) 905-469-1129
www.sascom.com

Digital Domain
931 N. State Route 434
Suite 1201-168
Altamonte Springs, Florida 32714
407-831-0233 F) 407-834-1339
www.digidio.com

DIMarzio, Inc.
1388 Richmond Terrace
Staten Island, New York 10310
718-981-9286 F) 718-720-5296
www.dimarzio.com

Disc Makers
7950 N. Route 130
Pennsauken, New Jersey 08110
856-663-9030 F) 856-661-3450
www.discmakers.com

Discount Distributors
1121-20 Lincoln Avenue
Holbrook, New York 11741
631-563-8326 F) 631-563-1390
www.discount-distributors.com

Dissidents
10325 Woods Road
Utica, New York 13502-6723
315-797-0343
www.dissidents.com

DK Audio America
4417 E. Villa Rita Drive
Phoenix, Arizona 85032
602-765-0532 F) 602-765-1473
www.dk-audio.com

Doc's Proplugs
719 Swift Street, Suite 100
Santa Cruz, California 95060
831-425-5920 F) 831-425-0178
www.proplugs.com

Dolby Laboratories Inc.
100 Potrero Avenue
San Francisco, California 94102
415-558-0200 F) 415-645-4000
www.dolby.com

Dorrough Electronics
5221 Collier Place
Woodland Hills, California 91364
818-998-2824 F) 818-998-1507
www.dorrough.com

DPA Microphones
691 Gray Mountain Drive

Lyons, Colorado 80540
303-823-8878 F) 303-823-5830
www.dpamicrophones.com

D & R North America/SF Corporation
Rt. 1, Box 54F
Brashear, Texas 75420
903-485-2535
www.d-r.nl

Drake
230 Industrial Drive
Franklin, Ohio 45005
937-746-4556 F) 937-743-4510
www.drake.com

Drawer/TransAmerica Audio
4760 W. Dewey, #129
Las Vegas, Nevada 89118
702-365-5155 F) 702-365-5145
www.transaudiogroup.com
www.drawerusa.com

DTs
5171 Clareton Drive
Agoura Hills, California 91301
818-706-3525 F) 818-706-1868
www.dtsonline.com

Dukane
2900 Dukane Drive
St. Charles, Illinois 60174
630-584-2300 F) 630-584-2792
www.dukane.com

D.W. Fearn
P.O. Box 57
Pocopson, Pennsylvania 19366
610-793-2525 F) 610-793-1479
www.dwfearn.com

Dynastar Electronics
1531 E. Starpass Drive
Fresno, California 93720
559-433-9700
www.dynastarelectronics.com

Dynatron/G Prime
1790 Broadway
Suite 402
New York, New York 10019
212-765-3415 F) 212-581-8938
www.gprime.com

Dynaudio Acoustics/TC Electronic
742-A Hampshire Road
Westlake Village, California 91361
805-373-1828 F) 805-379-2648
www.dynaudioacoustics.com

E

Earthworks Audio Products
P. O. Box 517
Wilton, New Hampshire 03086
603-654-6427 F) 603-654-6107
www.earthworksaudio.com

Eastern Acoustic Works
One Main Street
Whittinsville, Massachusetts 01588
508-234-6158 F) 508-234-8251
www.eaw.com

Eastman Wire & Cable
1085 Thomas Busch Highway
Pennsauken, New Jersey 08110
856-488-8800 F) 856-662-7555
www.eastmanwire.com

EBTECH/Sound Enhancements
185 Detroit Street
Cary, Illinois 60013
847-639-4646 F) 847-639-4723
www.soundenhancements.com
www.acuverb.com

Echo Digital Audio
6460 Via Real
Carpinteria, California 93013
805-684-4593 F) 805-684-6628
www.echoaudio.com

Electro-Harmonix
32-33 47th Avenue
Long Island City, New York 11101
718-937-8300 F) 718-937-9111
www.ehx.com

Electro-Voice
12000 Portland Avenue South
Burnsville, Minnesota 55337
952-884-4051 F) 952-887-5588
www.electrovoice.com

Elemental Audio
P.O. Box 14544
Research Triangle Park, NC 27709
919-462-3351 F) 919-462-3361
www.elementalaudio.com

MANUFACTURER DIRECTORY

Emagic
13348 Grass Valley Ave. Bldg C
Grass Valley, California 95945
530-477-1051 F) 530-477-1052
www.emagicausa.com

E. M. Long
138 Mt. View Avenue
San Jose, California 95127
408-923-4450 F) 408-923-4355

Empirical Labs/Wave Distribution
1170 Greenwood Lake Turnpike
Ringwood, New Jersey 07456
973-728-2425 F) 973-728-2931
www.wavedistribution.com

EnhancedAudio.com
3600 Board Road
York, Pennsylvania 17402
717-764-9240 F) 717-764-9254
www.enhancedaudio.com

Equi=Tech
18258 Redwood Highway
P.O. Box 249
Selma, Oregon 97538
541-597-4448 F) 541-597-4099
www.equittech.com

Equipment Emporium
15235 Brand Blvd., Ste 110
Mission Hills, California 91345
818-838-4457 F) 818-838-1667
www.equipmentemporium.com

ESI/Ego Sys
3003 N. First Street, Suite 303
San Jose, California 95134
408-519-5774 F) 408-519-5786
www.egosys.net or www.esi-pro.com

Esoteric Audio Research/Subsonic
2333 Hidalgo Avenue
Los Angeles, California 90039
323-667-1899 F) 323-667-0238
www.eapro.com

Esoteric Sound
4813 Wallbank Avenue
Downers Grove, Illinois 60515
630-960-9137 F) 630-960-9137
www.esotericsound.com

ETA Systems
1532 Enterprise Parkway
Twinsburg, Ohio 44087
330-425-3388 F) 330-425-9700
www.etasystems.com

ETI Sound Systems, Inc.
3383 Gage Avenue
Huntington Park, California 90255
323-277-4100 F) 323-277-4108
www.B-52pro.com

Elymotic Research
61 Martin Lane
Elk Grove Village, Illinois 60007
847-228-0006 F) 847-228-6836
www.elymotic.com

Euphonix
220 Portage Avenue
Palo Alto, California 94306
650-855-0400 F) 650-855-0410
www.euphonix.com

Event Electronics
P.O. Box 4189
Santa Barbara, California 93140
805-566-7777 F) 805-566-7771
www.event1.com

Eventide
One Alsan Way
Little Ferry, New Jersey 07643
201-641-1200 F) 201-641-1640
www.eventide.com

Evidence Audio
P.O. Box 73241
San Clemente, California 92673
949-306-7390 F) 949-752-7258
www.evidenceaudio.com

EZQuest Inc.
23311 E. La Palma Avenue
Yorba Linda, California 92887
714-694-0031 F) 714-694-0034
www.ezq.com

Fabric Wallmount Systems
P.O. Box 572134
Tarzana, California 91357
818-772-7770 F) 818-772-7775
www.wallmate.net

Fairlight USA

844 N. Seward Street
Hollywood, California 90038
323-465-0070 F) 323-465-0080
www.fairlightusa.com

Fanfare
6509 Transit Road, H-1
Bowmansville, New York 14026
716-683-5451 F) 716-683-5421
www.fanfare.com

FBT Sound Systems
1940 Wilbur Cross Highway
Berlin, Connecticut 06037-8144
860-829-0434 F) 860-829-1026
www.fbt.it

Fender Musical Instruments
8860 East Chaparral Rd., Ste 100
Scottsdale, Arizona 85250
480-596-9690 F) 480-596-1384
www.fender.com

FMR Audio
2110 Slaughter Ln., Ste. 115
Austin, TX 78748
512-280-6557 F) 512-280-8627
www.fmraudio.com

**Focusrite Audio Engineering/
Digidesign**
2001 Junipero Serra Blvd., Ste. 200
Daly City, California 94014
650-731-6300 F) 650-731-6399
www.focusrite.com

Fostex Corporation of America
15431 Blackburn Avenue
Norwalk, California 90650
562-921-1112 F) 562-802-1964
www.fostex.com

Frazier Loudspeakers
3030 Canton Street
Dallas, Texas 75226
214-741-7135 F) 214-741-7136

Friend-Chip America/plus24
1155 N. La Brea Avenue
West Hollywood, California 90038
323-845-1171 F) 323-845-1170
www.plus24.com

Frontier Design Group
199 Heater Road
Lebanon, New Hampshire 03766
603-448-6283 F) 603-448-6398
www.frontierdesign.com

FSR, Inc.
244 Bergen Blvd.
West Paterson, New Jersey 07424
973-785-4347 F) 973-785-3318
www.fsrinc.com

Fuji Photo Film USA
Magnetic Products Division
555 Taxter Road
Elmsford, New York 10523
914-789-8100 F) 914-789-8295
www.fujifilm.com

Furman Sound Inc.
1997 South McDowell Blvd.
Petaluma, California 94954-6919
707-763-1010 F) 707-763-1310
www.furmansound.com

Future Sonics
1006 Hollicong Road
Pineville, Pennsylvania 18946
215-598-8828 F) 215-598-8827
www.futuresonics.com

G Prime
1790 Broadway, Suite 402
New York, New York 10019
212-765-3415 F) 212-581-8938
www.gprime.com

GAI-Tronics Corporation
40 East Wynnissing Avenue
Mohnton, Pennsylvania 19540

Galaxy Audio
P.O. Box 16285
Wichita, Kansas 67216
316-263-2852 F) 316-263-0642
www.galaxyaudio.com

Gator Cases
3421 N. Lakewood Drive
Tampa, Florida 33618
813-221-4191 F) 813-221-4181
www.gatorcases.com

Gefen Systems
6265 Variel Avenue, Ste. C
Woodland Hills, California 91367

818-884-6294 F) 818-884-3108
www.gefen.com

Gemini Sound
8 Germak Drive
Carteret, New Jersey 07008
732-969-9000 F) 732-969-9090
www.geminidj.com

Genelec Oy
7 Tech Circle
Natick, Massachusetts 01760
508-652-0900 F) 508-652-0909
www.genelec.com

Genex Audio
2116 Wishire Blvd., #210
Santa Monica, California 90403
310-828-6667
www.genexaudio.com

Genz Benz Enclosures
7811 East Pierce Street
Scottsdale, Arizona 85257
480-941-0705 F) 480-946-2412
www.genzbenz.com

Geppo International
1770 Birchwood Avenue
Des Plaines, Illinois 60018
847-795-9555 F) 847-795-8770
www.geppo.com

Global Audio by CAD
341 Harbor Street
Conneaut, Ohio 44030
440-593-1111 F) 440-593-5395
www.cadmics.com

Glyph Technologies
735 West Clinton Street
Ithaca, New York 14850
607-275-0345 F) 607-275-9464
www.glyphtech.com

GML/Transamerica Audio
4760 W. Dewey, #129
Las Vegas, Nevada 89118
702-365-5155 F) 702-365-5145
www.gmlinc.com
www.transaudiogroup.com

Gold Line/TEF
Box 500
West Redding, CT 06896-0500
203-938-2588 F) 203-938-8740
www.gold-line.com

Gordon Instruments
P.O. Box 150644
Nashville, Tennessee 37215
615-665-1005
www.gordonaudio.com

Gotham Service Lab
5 West 36th Street, Ste. 504
New York, New York 10018
212-967-3120 F) 212-967-3126
www.gothamservice.com

Grace Design
P.O. Box 204
Boulder, Colorado 80306-0204
303-443-7454 F) 303-444-4634
www.gracedesign.com

Grado Labs
4614 Seventh Avenue
Brooklyn, New York 11220
718-435-5340 F) 718-633-6941
www.gradolabs.com

Graf Electronic Machines
Woodhill Road, Cillingham
Newark, Nottinghamshire
United Kingdom NG23 7NR
44-1636-893-036
www.grafelectronics.co.uk

Graham-Patten Systems
13366 Grass Valley Avenue
Grass Valley, California 95945
530-273-8412 F) 530-273-7458
www.gpsys.com

Great River Electronics
305 E. 65th Street
Inver Grove Hts., Minnesota 55076
651-455-1846 F) 651-455-3224
www.greatriverelectronics.com

Grommes-Precision, Inc.
9101 King Avenue
Franklin Park, Illinois 60131
847-678-5350 F) 847-678-0511
www.grommesprecision.com

Groove Tubes
1543 Truman Street
San Fernando, California 91340
818-361-4500 F) 818-365-9884
www.groovetubes.com

GTC Industries
P.O. Box 2493
Naperville, Illinois 60567
630-369-9815 F) 630-369-9198
www.gtciindustries.com

Guyatone/Godyke Distribution
328 Mason Avenue
Haledon, New Jersey 07508
973-835-2100
www.guyatone, www.godyke.com

H

Hafler Professional
2055 E. 5th Street
Tempe, Arizona 85281
480-581-3157 F) 480-894-1528
www.hafler.com

Hannay Reels
553 State Route 143
Westerlo, New York 12193-0159
518-797-3791 F) 518-797-3259
www.hannay.com

Har-Ken Specialties
P.O. Box 317
Edgewater, New Jersey 07020
201-886-8020 F) 201-886-9409
www.voice.net/~harken

Harris Pacific
2070 Las Palmas Drive
Carlsbad, California 92009
760-438-3911 F) 760-438-9277
www.harris.com

Harrison by GLW
1024 Firestone Parkway
Laverne, Tennessee 37086
615-641-7200 F) 615-641-7224
www.glw.com

Henry Engineering
503 Key Vista Drive
Sierra Madre, California 91024
626-355-3656 F) 626-355-0077
www.henryeng.com

HHB Communications, LLC
743 Cochran Street, Bldgs. E & F
Simi Valley, California 93065-1976
805-579-6490 F) 805-579-8028
www.hhbusa.com

HK Audio/Akai Professional
4710 Mercantile Drive
Fort Worth, Texas 76137
817-831-9203 F) 817-222-1490
www.akai.com/akaipro

Hosa Technology, Inc.
6920 Hermosa Circle
Buena Park, California 90620
714-736-9270 F) 714-522-4540
www.hosatech.com

Hot House Professional Audio
275 Martin Avenue
Highland, New York 12528
www.hothousepro.com
845-691-6077 F) 845-691-6822

HSE Audio Lab/Northern Lights
2581 Wilson Avenue
Bellevue, New York 11710
516-783-9406

I

Illbruck, Inc.
3800 Washington Avenue, North
Minneapolis, Minnesota 55412
612-520-3620 F) 612-521-5639
www.illbruck-sonex.com

Independent Audio
43 Deerfield Road
Portland, Maine 04101
207-773-2424 F) 207-773-2422
www.independentaudio.com

Industrial Acoustics
1160 Commerce Avenue
Bronx, New York 10462
718-831-9000 F) 718-430-4530
www.industrialacoustics.com

InnovaSon/Sennheiser USA
One Enterprise Drive
Old Lyme, Connecticut 06371
860-434-9190 F) 860-434-1759
www.sennheiserusa.com

Inovonics
1305 Fair Avenue
Santa Cruz, California 95060
831-458-0552 F) 831-458-0554
www.inovon.com

Intelix
8001 Terrace Avenue
Middleton, Wisconsin 53562
608-831-0880 F) 608-831-1833
www.intelix.com

Intelligent Computer Solutions
9350 Elton Avenue
Chatsworth, California 91311
818-998-5805 F) 818-998-3190
www.ics-iq.com

ISP Technologies
7508 ME CAD Blvd., Unit C
Clarkston, Michigan 48348
248-620-6795 F) 248-620-6796
www.isptechnologies.com

IZ Technology Corporation
#214 8988 Fraserston Court
Burnaby, British Columbia V5J 5H6
Canada
604-430-5818 F) 604-430-5828
www.recordingtheworld.com
www.izcorp.com

J

Jan-AI Cases
3339 Union Pacific Avenue
Los Angeles, California 90023
323-260-7212 F) 323-260-4696
www.janai.com

JasonI Electronics
3149 E. Desert Inn Road
Suite 94
Las Vegas, Nevada 89121
702-791-3394

JBL Professional
8500 Balboa Blvd.
Northridge, California 91329
818-894-8850 F) 818-830-1220
www.jblpro.com

Jems Data
52 Stiles Road
Salem, New Hampshire 03079
603-896-6319 F) 603-894-9768
www.jemsdata.com

Jensen Music Industries
P.O. Box 111749
Nashville, Tennessee 37222
615-331-5696 F) 615-331-0339
www.jensenmi.com

Jensen Transformers
7135 Hayvenhurst
Van Nuys, California 91406
818-374-5857 F) 818-374-5856
www.jensen-transformers.com

JJ Tubes/CE Distribution
6221 South Maple Avenue
Tempe, Arizona 85283
480-755-4712 F) 480-820-4643
www.cedist.com

J L Cooper Electronics
142 Arena Street
El Segundo, California 90245
310-322-9990 F) 310-335-0110
www.jlcooper.com

JoeMeek/PMI Audio
23773 Madison Street
Torrance, California 90505
310-373-9129 F) 310-373-4714
www.pmiaudio.com or
www.joemeek.com

Josephson Engineering
329A Ingalls Street
Santa Cruz, California 95060
831-420-0888 F) 831-420-0890
www.josephson.com

Juice Goose/Whitenton Industries
7320 Ashcroft, #104
Houston, Texas 77081
713-772-1404 F) 713-772-7360
www.juicegoose.com

Junger Audio/G Prime
1790 Broadway, #402
New York, New York 10019
212-765-3415 F) 212-581-8938
www.gprime.com

K

Kamesan/HB Communications
743 Cochran Street, Bldgs. E & F
Simi Valley, California 93065-1976
805-579-6490
www.hhbusa.com

Kimber Kable
2752 South 1900 West

MANUFACTURER DIRECTORY

Ogden, Utah 84401
801-621-5530 F) 801-627-6980
www.kimber.com

Klark Teknik
12000 Portland Avenue South
Burnsville, Minnesota 55337
952-887-7444 F) 952-884-0043
www.klarkteknik.com

Klipsch Audio Technologies
3502 Woodview Terrace
Indianapolis, Indiana 46268
317-860-8708 F) 317-860-9170
www.klipsch.com

Klotz Digital America
5875 Peachtree Industrial Blvd.
Suite 340
Norcross, Georgia 30092
678-966-9900 F) 678-966-9903
www.klotzdigital.com

Korg USA, Inc.
316 South Service Road
Melville, New York 11747-3201
516-333-9100 F) 516-333-9108
www.korg.com

Koss Stereophones
4129 North Fort Washington Avenue
Milwaukee, Wisconsin 53212
414-964-5000 F) 414-964-0506
www.koss.com

Kramer Electronics
33 Rupell Road
Hampton, New Jersey 08827
908-735-0018 F) 908-735-0515
www.kramerelectronics.com

KRK Systems, Inc.
5452 Business Drive
Huntington Beach, California 92649
714-373-4600 F) 714-373-0421
www.krksys.com

KS Audio USA
1062 Cephas Drive
Clearwater, Florida 33765
727-447-9656 F) 727-447-9715
www.ksaudioussa.com

Kurzweil/Young Chang America
9501 Lakewood Drive, SW
Lakewood, Washington 98499
253-589-3200 F) 253-588-6809
www.kurzweilmusicsystems.com

KV2 Audio
19501 144th Ave. NE, Ste. F900
Woodinville, Washington 98072
425-402-4600 F) 425-402-4610
www.kv2audio.com

L

Lab.gruppen/TC Electronic
742-A Hampshire Road
Westlake Village, California 91361
805-373-1828 F) 805-379-2648
www.labgruppen.com

L-Acoustics US
2201 East Celsius Way
Oxnard, California 93030
805-604-0577 F) 805-604-0858
www.l-acoustics-us.com

Laird Telemedia
2000 Sterling Road
Mount Marion, New York 12456
845-339-9555 F) 845-339-0231
www.lairdtelemedia.com

Lavry Engineering
824 Post Avenue
Seattle, Washington 98104
206-381-5891 F) 206-381-5835
www.lavryengineering.com

Lawson, Inc.
2739 Larron Ave.
Nashville, Tennessee 37204
615-269-5542 F) 615-269-5745
www.lawsonmicrophones.com

Lectrosonics
581 Laser Road, NE
Rio Rancho, New Mexico 87124
505-892-4501 F) 505-892-6243
www.lectrosonics.com

Legacy Audio
3023 Sangamon Avenue
Springfield, Illinois 62702
217-544-3178 F) 217-544-1483
www.legacy-audio.com

Leitch
920 Corporate Lane

Chesapeake, Virginia 23320
757-548-2300 F) 757-548-4088
www.leitch.com

Level Control Systems
130 E. Montecito Ave., Ste. 236
Sierra Madre, California 91024
626-836-0446 F) 626-836-4883
www.lcsaudio.com

Lexicon Inc.
3 Oak Park
Bedford, Massachusetts 01730-1441
781-280-0300 F) 781-280-0490
www.lexicon.com

Liberty Instruments
6572 Gretel Ct.
Liberty Township, Ohio 45044
513-755-0252
www.libinst.com

Lighthouse Digital Systems
P.O. Box 1802
Grass Valley, California 95945
530-272-8240 F) 530-272-8248
www.lighthousedigital.com

Lightspeed Technologies
11509 S.W. Herman Road
Tualatin, Oregon 97062
503-684-5538 F) 503-684-3197
www.lightspeed-tek.com

Line 6
22901 Agoura Road
Agoura Hills, California 91301
818-575-3600 F) 818-575-3601
www.line6.com

LinearX Systems, Inc.
9500 SW Tualatin-Sherwood Rd.
Tualatin, Oregon 97062
503-612-9565 F) 503-612-9344
www.linearx.com

Listen, Inc.
450 Harrison Ave., Suite 320
Boston, Massachusetts 02118
617-556-4104 F) 617-556-4145
www.listeninc.com

Listen Technologies
8535 South 700 West, Suite A
Sandy, Utah 84070
801-233-8992 F) 801-233-8995
www.listentech.com

Little Labs
6711 Whitley Terrace
Los Angeles, California 90068
800-642-0064 or 323-851-6860
www.littlelabs.com

Littlile/CAE
10087 Industrial Drive
Hamburg, Michigan 48139
810-231-9373 F) 810-231-1631
www.littlile.com, www.caeinc.com

Location Sound Corporation
10639 Riverside Drive
North Hollywood, California 91602
818-980-9891 F) 818-980-9911
www.locationsound.com

Logical
75 Gateway Blvd.
Cottage Grove, Oregon 97424
541-942-3610 F) 541-942-3640
www.logical-co.com

Logitek
5622 Edgemoor Drive
Houston, Texas 77081
713-664-4470 F) 713-664-4479
www.logitekaudio.com

Lory Electronics, Inc.
1436 Paloma Street
Pasadena, California 91104
213-925-0575 F) 626-794-1493
www.loryco.com

LPB, Inc.
28 Bacton Hill Road
Frazer, Pennsylvania 19355
610-644-1123 F) 610-644-8651
www.lpbinc.com

Lucid
14926 35th Avenue W.
Lynnwood, Washington 98037
425-787-3222 F) 425-787-3211
www.lucidaudio.com

Lynx Studio Technology/HHB
743 Cochran Street, Bldgs. E & F
Simi Valley, California 93065-1976
805-579-6490
www.lynxstudio.com

M

M Audio
45 E. St. Joseph Street
Arcadia, California 91006
626-445-2842 F) 626-445-7564
www.m-audio.com

Mackie Designs, Inc.
16220 Wood-Red Road, NE
Woodinville, Washington 98072
425-487-4333 F) 425-487-4337
www.mackie.com

MacPherson, Inc.
5500 W. Touhy Avenue
Skokie, Illinois 60077
847-674-3535 F) 847-674-3548
www.macpherson-inc.com

MAD Labs
10842 Art Street
Shadow Hills, California 91040
818-353-6199 F) 818-353-3290
www.madlabs.com

Magic Parts
1221 N. McDowell Blvd.
Petaluma, California 94954
707-769-5100 F) 707-769-5105
www.magicparts.com

Magix Entertainment Corp./SEK'D
11400 W. Olympic Blvd., Ste. 450
Los Angeles, California 90064
310-477-0241 F) 310-473-2394
www.magix.com

Magma
9918 Via Pasar
San Diego, California 92126
858-530-2511 F) 858-530-2733
www.magma.com

Magtrax/Independent Audio
43 Deerfield Road
Portland, Maine 04101
207-773-2424 F) 207-773-2422
www.independentaudio.com

MAM America/plus24
1155 N. La Brea Avenue
West Hollywood, California 90038
323-845-1171 F) 323-845-1170
www.plus24.com

Manifold Labs
433 Liberty Street
Little Ferry, New Jersey 07643
201-641-7716 F) 360-838-6867
www.manifoldlabs.com

Manley Laboratories
13880 Magnolia Avenue
Chino, California 91710
909-627-4256 F) 909-628-2482
www.manleylabs.com

Marantz Professional
1100 Maplewood Drive
Itasca, Illinois 60143
630-741-0320 F) 630-741-0652
www.marantzpro.com

Mark Of The Unicorn
1280 Massachusetts Ave.
Cambridge, Massachusetts 02138
617-576-2760 F) 617-576-3609
www.motu.com

Marquette Audio Labs
22825 Kings Court
Hayward, California 94541
510-581-3817 F) 510-581-3917
www.marquetteaudiolabs.com

Marshall Electronics
1910 East Maple Avenue
El Segundo, California 90245
310-333-0606 F) 310-333-0688
www.mxmics.com

Martech
1151 W. Valley Blvd.
Alhambra, California 91803-2493
626-281-3555 F) 626-284-3092
www.martinsound.com

Martin Audio
P.O. Box 44019
Kitchener, Ontario N2N 3G7
Canada
519-747-5853 F) 519-747-3576
www.martin-audio.com

Martinsound Technologies
1151 W. Valley Blvd.
Alhambra, California 91803-2493
800-582-3555 or 626-281-3555 F)
626-284-3092
www.martinsound.com

Maxell
22-08 Route 208
Fair Lawn, New Jersey 07410
201-794-5900 F) 201-796-8790
www.maxellpromedia.com

MBHO/MTC
495 Lorimer Street
Brooklyn, New York 11211
718-963-2777 F) 718-302-4890
www.mbho.de

MC2 Audio/Group One
200 Sea Lane
Farmingdale, New York 11735
631-249-1399 F) 631-753-1020

McCauley Sound
16607 Meridian Avenue East
Puyallup, Washington 98375
877-622-2853 or 253-848-0363 F)
253-841-3050
www.mccauley.com

McDowell Signal Processing
Palo Alto, California 94303
650-320-8452 F) 707-220-0994
www.mcDSP.com

Medea
5701 Lindero Canyon Road
Building 3-100
Westlake Village, California 91362
818-597-7645 F) 818-597-7643
www.medeaCorp.com

MediaFORM, Inc.
400 Eagleview Blvd., Suite 104
Exton, Pennsylvania 19341
610-458-9200 F) 610-458-9554
www.mediaform.com

Memorex
10100 Pioneer Blvd, Suite 110
Santa Fe Springs, California 90670
562-906-2800 F) 562-906-2848
www.memorex.com

Merging Technologies
3000 Dundee Road, Suite 316
Northbrook, Illinois 60062
847-272-0500 F) 847-272-0597
www.merging.com

Metasonix
PMB 109
881 11th Street
Lakeport, California 95453
707-263-5343
www.metasonix.com

Metric Halo Laboratories
M/S 601 Building 8
Castle Point Campus
Castle Point, New York 12511
845-831-8600 F) 603-250-2451
www.mhllabs.com

Metrosonics
P.O. Box 23075
Rochester, New York 14692
716-427-7402 F) 716-427-8942
www.metrosonics.com

Meyer Sound Laboratories, Inc.
2832 San Pablo Avenue
Berkeley, California 94702
510-486-1166 F) 510-486-8356
www.meyersound.com

Microboards Technology, Inc.
1721 Lake Drive West
Chanhassen, Minnesota 55317
952-556-1600 F) 952-556-1620
www.microboardsproaudio.com

Microtech Gefell/C-Tec
1638 Kebet Way, #100
Port Coquitlam, British Columbia
Canada
604-942-1001 F) 604-942-1010

Midas
12000 Portland Avenue South
Burnsville, Minnesota 55337
952-887-7445 F) 952-884-0043
www.midasconsoles.com

Middle Atlantic Products
North Corporate Drive
Riverdale, New Jersey 07457
973-839-1011 F) 973-839-1976
www.middleatlantic.com

Milab/Group One Ltd.
200 Sea Lane
Farmingdale, New York 11735
631-249-1399 F) 631-753-1020
www.g1ttd.com

Miles Technology

1826 S. 3rd Street
Niles, Michigan 49120
616-683-4400 F) 616-683-4499
www.milestech.com

Millennia Media
4200 Day Spring Court
Placerville, California 95667
530-647-0750 F) 530-647-9921
www.mil-media.com

Miller & Kreisel Sound
9351 Deering Avenue
Chatsworth, California 91311
818-701-7010 F) 818-701-0369
www.mkprofessional.com

Minnetonka Audio Software
17113 Minnetonka Blvd., Ste. 300
Minnetonka, Minnesota 55345
952-449-6481 F) 952-449-0318
www.minnetonkaaudio.com

Mitsui Advanced Media
10045 Federal Drive
Colorado Springs, Colorado 80908
719-262-2470 F) 719-592-0057
www.mitsuidr.com

Mixed Logic Studio Electronics
6507 E. Vancey Drive
Brook Park, Ohio 44142
440-826-1676 F) 440-826-1399
www.mixedlogic.com

Mixman
2600 South El Camino Real
San Mateo, California 94403
650-295-2300 F) 650-295-2333
www.mixman.com

Modular Sound/Handi Q
1380-C S. Pennsylvania Avenue
Morrsville, Pennsylvania 19067
215-736-8727 F) 215-736-1262
www.modularsound.com

Msoft
6355 Topanga Canyon Blvd., Ste 507
Woodland Hills, California 91367
818-716-7081 F) 818-716-0547
www.msoftinc.com, www.serversound.com

Multimic
6632 Jocelyn Hollow Dr.
Nashville, Tennessee 37205
615-356-3498

MUSICAM
Musicam USA
670 North Beers St., Building 4
Holmdel, New Jersey 07733
732-739-5600 F) 732-739-1818
www.musicamusa.com

Musikelectronic Geithain/G Prime
1790 Broadway, 4th Floor
New York, New York 10019
212-765-3415 F) 212-581-8938
www.gprime.com

Mytek Digital
142 E. 27th Street, 6A
New York, New York 10016
212-245-7800 F) 212-245-8636
www.mytekdigital.com

N

Nady Systems
6701 Shellmound Street
Emoryville, California 94608-1023
510-652-2411 F) 510-652-5075
www.nady.com

Nagra USA
240 Great Circle Rd., Ste. 326
Nashville, Tennessee 37228
615-726-5191 F) 615-726-5189
www.nagra.com, www.nagrausa.com

Native Instruments USA
5631 A Hollywood Blvd.
Los Angeles, California 90028
323-467-5260 F) 323-467-5236
www.native-instruments.com

Nemal Electronics
12240 NE 14th Avenue
North Miami, Florida 33161
305-899-0900 F) 305-895-8178
www.nemal.com

Netwell Noise Control
18525 37th Avenue, North
Minneapolis, Minnesota 55446
800-638-9355 F) 612-939-9836
www.asknetwell.com or
www.controlnoise.com

ORDER 24/7 FROM OUR SECURED WEB SITE

After you order from BSW, no salesperson will call...and call...and

If you've ever ordered from some mail order pro audio companies, you know that once they have your name in their database, you've made a "friend" for life. Or so it seems after the umpteenth unsolicited call you get during dinner.

Broadcast Supply Worldwide hires pro audio veterans, not ex-used car salesmen. They spend their time fielding technical questions instead of bugging folks who've already ordered.

BSW doesn't sell guitars, drums or keyboards. That's another reason we're the Secret Source that radio and television stations, recording studios and post houses rely on for rock-bottom prices on top-name pro audio products.

Give us a try and you'll never call one of those hard-sell places again.



Call for a free 112-pg. catalog!

www.bswusa.com • 1.800.426.8434

ORDER 24/7 FROM OUR FAST-LOADING WEB SITE • RING US UP 6AM-6PM PACIFIC TIME

BSW EXCLUSIVE MONEY-SAVING 5-PACK DEALS!

Collect 'em! Trade 'em with your friends!

Buy in bulk...save in bulk!
Awesome prices on gear you can never have too much of.



ST95MKII PKG
99⁹⁹

AUDIO TECHNICA • ST95MKII PKG
• dynamic handheld mic 5-pack



MS300 PKG
89⁹⁹

Mic Stand • 5-pack



89⁹⁹

AKG • K110M PKG • full enclosure stereo headphone 5-pack



WINDSCREEN
24⁹⁹

Windscreen • 5-pack



CDR300
699⁹⁹
~~\$849.00 list~~

MARANTZ • CDR300 • portable CD recorder • stereo XLR or 1/4" mic/line inputs
• built-in preamp - no external mixer or preamp required • BSW includes 50 FREE CD-Rs!



SLA1
199⁹⁹
~~\$279.00 list~~

ART • SLA1 • studio power amplifier • 100 watts/channel into 8 ohms • XLR and 1/4" inputs



AT3035
199⁹⁹
~~\$349.00 list~~

AUDIO TECHNICA • AT3035 • cardioid condenser mic



B2031 • list \$379.99 / pair
399⁹⁹ / pair

BEHRINGER • B2031 • Active 8.72" monitors
• 75 watt/150 watt power amps • video shielded



HE
59⁹⁹
~~\$89.95 list~~

EBTECH • HE • 2-channel hum eliminator • converts balanced and unbalanced signals



MIA • list \$249.00 / ea
179⁹⁹

ECHO • MIA 24-bit/96 kHz digital audio card • 3 "virtual" outputs

GUARANTEED LOWEST PRICES!



World's Best Source for Pro Audio Products

MANUFACTURER DIRECTORY

Neumann USA
1 Enterprise Drive
Old Lyme, Connecticut 06371
860-434-5220 F) 860-434-3148
www.neumannusa.com

Neutrik USA
195 Lehigh Avenue
Lakewood, New Jersey 08701-4527
732-901-9488 F) 732-901-9608
www.neutrikusa.com

Nexo U.S.A.
2165 Francisco Blvd., Suite E2
East San Francisco, California 94901
415-482-6600 F) 415-482-6110
www.nexo-sa.com

NHT Pro
527 Stone Road
Benicia, California 94510
707-748-5940 F) 707-748-5945
www.nhtpro.com

Noren Products
1010 O'Brien Drive
Menlo Park, California 94025
650-322-9500 F) 650-324-1348
www.acoustilock.com
www.norenproducts.com

Novatech Instruments, Inc.
P.O. Box 55997
Seattle, Washington 98155
206-301-8986 F) 206-363-4367
www.novatech-instr.com

Numark Industries
11 Helmsman Avenue
North Kingston, Rhode Island 02852
401-295-9000 F) 401-295-5200
www.numark.com

O

OAP Audio
310 Peachtree Industrial Blvd.
Buford, Georgia 30518
770-945-1033 F) 770-945-1843
loudspeakers.com

Olsen Audio Group/Windtech
7845 E. Evans Road
Scottsdale, Arizona 85260
480-998-7140 F) 480-998-7192
www.olsenaudio.com

Omnirax
P.O. Box 1792
Sausalito, California 94966
800-332-3393 F) 415-332-2607
www.omnirax.com

On-Stage Stands
P.O. Box 270648
West Hartford, Connecticut 06127
860-236-7134 F) 860-233-6888
www.onstagestands.com

Oram Professional Audio
The Old Forge
Hook Green, Meopham
Meopham, Kent DA13 0JE
England
44-1474-815-300
www.oram.co.uk

Otari Corporation USA
8236 Remmet Avenue
Canoga Park, California 91304
818-598-1200 F) 818-594-7208
www.otari.com

OWI, Inc.
17141 Kingsview Avenue
Carson, California 90746
310-515-1900 F) 310-515-1606
www.owi-inc.com

P

Pacific Innovative Electronics
3012 N. Hollywood Way
Burbank, California 91504
818-845-6153 F) 818-845-6157
www.pacificinnovative.com

Pacific Pro Audio
1100 Virginia, Suite 202
Seattle, Washington 98101
206-264-9386 F) 206-264-0140
www.pacificproaudio.com

**Pacific Radio Electronics/No
Shorts Cable Co.**
969 N. La Brea Avenue
Los Angeles, California 90038
323-969-2035 F) 323-969-2053
www.pacificradioelectronics.com

Palmetto Software Logic
12099 Colonial Drive
Maryland Heights, Missouri 63043
www.palmettologic.com

**Palmer Direct Recording
Devices/Techstar Distributors**
750 Cowan Street, Suite 9
Nashville, Tennessee 37207
615-242-2925 F) 615-242-9528
www.palmerdirect.com

Panamax Corporation
150 Mitchell Blvd.
San Rafael, California 94903-2057
415-499-3900 F) 415-472-5540
www.panamax.com

Panasonic Factory Automation
9377 W. Grand Avenue
Franklin Park, Illinois 60131
847-288-4400 F) 847-288-4430
www.panasoniccia.com

Panatek/Cool Lux
412 San Pablo, #200
Cambridge, California 93012
805-482-4820 F) 805-482-0736
www.cool-lux.com

PanaVise Products
7540 Colbert Drive
Reno, Nevada 89511
775-850-2900 F) 775-850-2929
www.panavise.com

Paradigm
P.O. Box 2410
Niagara Falls, New York 14302
905-632-0180 F) 905-632-0183
www.paradigm.com

Parasound
950 Battery Street
San Francisco, California 94111
415-397-7100 F) 415-397-0144
www.parasound.com

PAS
2270 Cosmos Court
Carlsbad, California 92009
760-431-9924 F) 760-431-9496
www.pas-toc.com

Pass Laboratories
24449 Foresthill Road
Foresthill, California 95631
530-367-3690 F) 530-367-2193
www.passlabs.com

**Pearl Microphone
Labs/Independent Audio**
43 Deerfield Road
Portland, Maine 04101
207-773-2424 F) 207-773-2422
www.independentaudio.com

Peavey Electronics
711 A Street
Meridian, Mississippi 39301
601-483-5365 F) 801-486-1278
www.peavey.com

Pendulum Audio
P.O. Box 339
Gillette, New Jersey 07933
908-665-9333 F) 908-665-9333
www.pendulumaudio.com

Per Madsen Design
P.O. Box 882464
San Francisco, California 94188
800-821-4883 or 415-822-4883
www.rackitfm.com

**Phoenix Audio International/
Transamerica Audio Group**
4760 W. Dewey, #129
Las Vegas, Nevada 89118
702-365-5155 F) 702-365-5145
www.phoenixaudio.net

Phonic America
5411 Johns Road, Suite 605
Tampa, Florida 33634
800-430-7222 F) 813-890-6861
www.phonic.com

Phonic Ear, Inc.
3880 Cypress Drive
Petaluma, California 94954
707-769-1110 F) 707-769-9624
www.phonicear.com

Planet Waves
595 Smith Street
Farmingdale, New York 11735
631-439-3300 F) 631-439-3333
www.planet-waves.com

PM of America
1687 Shelby Oaks Drive, #8

Memphis, Tennessee 38134
901-388-2424 F) 901-388-2405
www.svietanusa.com

PMC/Bryston
1839 Oakwood Avenue
Arcadia, California 91006
626-355-9565 F) 626-355-9525
www.pmc-speakers.com

PMI Audio
23773 Madison Street
Torrance, California 90505
310-373-9129 F) 310-373-4714
www.pmiaudio.com

Polar Focus
217 Russell St. P.O. Box 3
Hadley, Massachusetts 01035
413-586-4444 F) 509-357-5657
www.polarfocus.com

Polycorn
1720 Peachtree Street, NW, Ste 220
Atlanta, Georgia 30309
404-892-3200 F) 404-892-2512

Popless Voice Screens
P.O. Box 1014
New Paltz, New York 12561
845-255-3367 F) 845-255-5271
www.popfilter.com

Porter Case Company
3718 W. Western Avenue
South Bend, Indiana 46619
574-289-2616 F) 574-289-2747
www.porteracase.com

Posthorn Recordings
142 West 26th Street
New York, New York 10001
212-242-3737 F) 212-924-1243
www.posthorn.com

Precision Audio Labs
22307 Hart Street
West Hills, California 91303
818-888-0388 F) 818-704-7614
www.pacificnet.net/~pas3

Precision Earmold Laboratories
303 Sunshine Lane
Altamonte Springs, Florida 32714
407-774-8022 F) 407-774-8133
www.precisionweb.com

PreSonus Audio Electronics
7257 Florida Blvd.
Baton Rouge, Louisiana 70806
225-216-7887 F) 225-926-8347
www.presonus.com

Primacoustic/Cabletek
1638 Kebet Way
Port Coquitlam, BC V3C 5W9
Canada
604-942-1001) 604-942-1010
www.primacoustic.com

Primer Technology
Two Carlson Parkway North
Plymouth, Minnesota 55447
763-475-6676 F) 763-475-6677
www.primertechnology.com

Princeton Digital
407 Prospect Avenue
Princeton, New Jersey 08540
609-497-0328 F) 609-497-0329

PrismSound/Prism Media
21 Pine Street
Rockaway, New Jersey 07866
973-983-9577 F) 973-983-9588
www.prismsound.com

Pro Co Sound, Inc.
P.O. Box 18001
Kalamazoo, Michigan 49019
800-253-7360 F) 616-388-9681
www.procosound.com

PRO Manufacturing Co.
52 South Main Street
Castleton, New York 12033
518-732-7231 F) 518-732-4016
www.promfg.com

ProCases, Inc.
3825 Willat Ave.
Culver City, California 90232
310-841-2340 F) 310-204-6412
www.procases.com

Professional Audio Design
357 Liberty Street
Rockland, Massachusetts 02370
718-982-2600 F) 718-982-2610
www.proaudiodesign.com

Professional Sound Corp.
28085 Smyth Drive
Valencia, California 91355
661-295-9395 F) 661-295-8398
www.professionalsound.com

Propellerheads Software/ M Audio
45 E. St. Joseph Street
Arcadia, California 91006
626-445-2842 F) 626-445-7564
www.propellerheads.se

PS Audio International
3050 Broadway, Suite 201
Boulder, Colorado 80304
720-406-8946 F) 720-406-8967
www.psaudio.com

Purple Audio
38 - 62 Eleventh Street
Long Island City, New York 11101
718-482-8494 F) 718-482-8159
www.purpleaudio.com

QSC Audio Products, Inc.
1675 MacArthur Blvd.
Costa Mesa, California 92626
714-754-6175 F) 714-754-6174
www.qscaudio.com

Quantec/ HHB
743 Cochran Street, Bldgs. E & F
Simi Valley, California 93065-1976
805-579-6490 F) 805-579-8028
www.hhbusa.com

Quantegy
2230 Marvyn Pkwy.
Opelika, Alabama 36801
334-745-7643 F) 800-628-0535
www.quantegy.com

Quantum Technologies
991 Discovery Drive
Huntsville, Alabama 35806
256-922-1200 F) 256-922-1221
www.qtiav.com

Quest Technologies
1060 Corporate Center Drive
Oconomowoc, Wisconsin 53066
262-567-9157 F) 262-567-4047
www.quest-technologies.com

Quested/Q.usa inc.
5816 Hwy. K
Waunakee, Wisconsin 53597
608-850-3600 F) 608-850-3602
www.quested.com

Quik-Lok/Music Industries Corp.
625 Locust Street
Garden City, New York 11530
516-794-1888 F) 516-794-4099
www.quiklok.com

R & R Cases and Cabinets
1217 Rand Road
Des Plaines, Illinois 60016
847-299-8100 F) 847-299-8110
www.rcases.com

Rackman
3120 Damon Way
Burbank, California 91505
818-846-1317 F) 818-846-0359
www.rackman.com

Radial Engineering
1638 Kebet Way
Port Coquitlam, BC V3C 5W9
Canada
604-942-1001 F) 604-942-1010
www.radialeng.com

Radian Audio Engineering
600 N. Batavia Street
Orange, California 92668
714-288-8900 F) 714-288-1133
www.radianaudio.com

Radikal Technologies
696 Palisade Avenue
Teaneck, New Jersey 07666
201-836-5116 F) 201-836-0661
www.radikaltechnologies.com

Radio Design Labs
P.O. Box 1286
Carpinteria, California 93014
805-684-5415 F) 805-684-9316
www.rdlinet.com

Ramtech Industries
3709 SW 42nd Avenue, #13
Gainesville, Florida 32608

352-466-0920 F) 352-466-0906
www.ramtech.net

Randall Amplifiers/Washburn
444 East Courtland Street
Mundelein, Illinois 60060
847-913-5511 F) 847-949-8444
www.randallamplifiers.com

Rane Corporation
10802 47th Avenue West
Mukilteo, Washington 98275
425-355-6000 F) 425-347-7757
www.rane.com

Rapco
3581 Larch Lane
Jackson, Missouri 63755
573-243-1223 F) 573-243-1384
www.rapco.com

Raven Labs
16820 Nanette Street
Granada Hills, California 91344
818-368-2400 F) 818-368-2400
www.raven-labs.com

Raxxess
261 Buffalo Avenue
Paterson, New Jersey 07503
973-523-5105 F) 973-523-5106
www.raxxess.com

RCI Custom Products
20400 Observation Drive
Germantown, Maryland 20876
240-912-0130 F) 240-912-0131
www.rcicustom.com

Redwood Marketing
P.O. Box 901705
Sandy, Utah 84090
801-947-5750 F) 801-947-5752
www.redwoodmusic.com

Remote Audio Products
240 Great Circle Rd., Suite 338
Nashville, Tennessee 37228
615-256-3513 F) 615-259-2699
www.remotefaudio.com

Renkus-Heinz, Inc.
19201 Cook Street
Foothill Ranch, California 92610
949-588-9997 F) 949-588-9514
www.rh.com

Requisite Audio Engineering
2645 East Glenoaks Blvd.
Glendale, California 91206
818-247-2047 F) 818-247-4498
www.requisiteaudio.com

Rexroat Sound
3100 27th Street Drive
Moline, Illinois 61265
309-236-7788
www.rexroatsound.com

Rhintek Computer Engineering
8835 Columbia 100 Parkway
Columbia, Maryland 21045
410-730-2575 F) 410-730-5960
www.rhintek.com

Rimage Corporation
7725 Washington Avenue South
Minneapolis, Minnesota 55439
952-944-8144 F) 952-944-7808
www.rimage.com

Rip-Tie Company
883 San Leandro Blvd.
San Leandro, California 94577
510-577-0200 F) 510-553-0160
www.riptie.com

Riser-Bond Instruments
5101 N. 57th Street
Lincoln, Nebraska 68507
402-466-0933 F) 402-466-0967
www.riserbond.com

RME/X/ision Audio US
5111 Market Street
Boardman, Ohio 44512
330-259-0308 F) 330-259-0315
www.rme-audio.com

Rockustics
5080 Paris Street
Denver, Colorado 80239
303-371-0208 F) 303-371-0604
www.rockusticsinc.com

Rode Microphones
P.O. Box 3279
Torrance, California 90510
310-328-7456 F) 310-328-7180
www.rodemic.com



MANUFACTURER DIRECTORY

Rogue Audio
2827 Avery Road
Slatington, Pennsylvania 18080
570-992-9901 F) 570-992-1978
www.rogueaudio.com

Rohde & Schwarz/Tektronix
Measurement Business Division
14150 SW Karl Braun Drive
P. O. Box 500 M/S 50-220
Beaverton, Oregon 97077
800-835-9433 F) 503-627-5593

Roland Corporation, Inc.
5100 S. Eastern Avenue
Los Angeles, California 90040-2938
323-890-3700 F) 323-721-4875
www.rolandus.com

Rolls Corporation
5968 South 350 West
Salt Lake City, Utah 84107
801-263-9053 F) 801-263-9068
www.rollis.com

Rorke Data
9700 W. 76th Street
Eden Prairie, Minnesota 55344
952-829-0300 F) 952-829-0988
www.rorke.com

Rosati Acoustics, Inc.
123 South Street
Boston, Massachusetts 02111
617-423-5546 F) 617-423-5884
www.rosatiacoustics.com

Rosendahl Studioteknik/HMB
743 Cochran Street, Bldgs. E & F
Simi Valley, California 93065-1976
805-579-6490 F) 805-579-8028
www.hbusa.com

Roxio
461 S. Milpitas Blvd.
Milpitas, California 95035
408-945-8600 F) 408-635-8112
www.roxio.com

Royer Labs
821 North Ford Street
Burbank, California 91505
818-760-8472 F) 818-760-8864
www.royerlabs.com

RPG Diffuser Systems
651-C Commerce Drive
Upper Marlboro, Maryland 20774
301-249-0044 F) 301-249-3912
www.rpginc.com

**RPM Optoelectronics/
Racklight.com**
1724 Corby Avenue
Santa Rosa, California 95407
www.rpmlc.com, www.racklight.com

Ruby Tubes/Magic Parts
1221 N. McDowell Blvd.
Petaluma, California 94954
707-769-5100 F) 707-769-5105
www.magicparts.com

**Rycote Microphone
Windshields/Redding Audio**
97 South Main Street, Unit 10
Newtown, Connecticut 06470
203-270-1808 F) 203-270-2934
www.reddingaudio.com

S

Sabine Adaptive Audio Products
13301 Highway 441
Alachua, Florida 32615
396-418-2000 F) 396-418-2001
www.sabine.com

SabraSom/K-IV
59 Flaming Arrow Road
Mahwah, New Jersey 07430
201-828-9492 F) 201-828-9493
www.sabrasom.com

SADIE Inc.
2218 Metro Center Blvd.
Nashville, Tennessee 37228
615-327-1140 F) 615-327-1699
www.sadie.com

Samson Technologies Corp.
575 Underhill Blvd.
Syosset, New York 11791
516-364-2244 F) 516-364-3888
www.samsontech.com

Sanken Microphones/plus24
1155 N. La Brea Avenue
West Hollywood, California 90038
323-845-1171 F) 323-845-1170
www.plus24.com

SBS Technologies
1284 Corporate Center Drive
St. Paul, Minnesota 55121
651-905-4700 F) 651-905-4701
www.sbs.com

Schertler & Koley
P.O. Box 595
South Dennis, Massachusetts 02660
866-724-3785
www.schertlerusa.com

Schoeps/ Redding Audio
97 South Main Street, Unit 10
Newtown, Connecticut 06470
203-270-1808 F) 203-270-2934
www.reddingaudio.com

**SD Systems/Advanced Sonic
Concepts**
P.O. Box 237
Chatsworth, New Jersey 08019
609-726-9202
www.advancedsonicconcepts.com
www.sdsystems.com

S E Electronics
5850 Commerce Blvd., #C-1
Rohnert Park, California 94928
408-873-8606 F) 408-873-7670
www.tbknics.com

SEK'D America/plus24
1155 N. La Brea Avenue
West Hollywood, California 90038
323-845-1171 F) 323-845-1170
www.plus24.com

Selco Products
605 S. East St.
Anaheim, California 92805
714-917-1333 F) 714-917-1355
www.selcoproducts.com

Sendit Electronics
1722 Rogers Place, Unit 25E
Burbank, California 91504
818-848-5059 F) 818-848-9099
www.senditelectronics.com

Sennheiser
One Enterprise Drive
Old Lyme, Connecticut 06371
860-434-9190 F) 860-434-9022
www.sennheiserusa.com

**Sensaphonics Hearing
Conservation, Inc.**
660 N. Milwaukee Avenue
Chicago, Illinois 60622
312-432-1714 F) 312-432-1738
www.sensaphonics.com

Sensonics
820 Arizona Ave., Suite 203
Trinidad, Colorado 81082
719-845-9820
www.TheSilenzler.com

Servo Drive
1940 Lehigh
Glenview, Illinois 60025
847-724-5500 F) 847-724-1953
www.servodrive.com

Sescom, Incorporated
517 Main Street
Wellsville, Kansas 66092
785-883-3009 F) 785-883-4422
www.sescom.com

Shaker Microphone
P.O. Box 613
Payson, Arizona 85547
928-474-2448
www.shakermicrophone.com

Shure Brothers Incorporated
222 Hartrey Avenue
Evanston, Illinois 60202-3696
847-866-2200 F) 847-866-2279
www.shure.com

SIA Software Co.
One Main St.
Whitinsville, Massachusetts 01588
508-234-9677 F) 508-234-6479
www.siasoft.com

Signal Transport
8 Hammond Drive, Suite 104
Irvine, California 92618
949-859-9615 F) 949-859-9616
www.sigl.com

Signex/Independent Audio
43 Deerfield Road
Portland, Maine 04101
207-773-2424 F) 207-773-2422
www.independentaudio.com

Silent Source
58 Nonotuck Street
Northampton, Massachusetts 01060
413-584-7944 F) 413-584-2377
www.silentsource.com

Simon/Kalol Engineering.
2985 East Hillcrest Dr. #204
Thousand Oaks, California 91362
805-777-1084 F) 805-777-1186
www.skeng.com

Sintefex Audio
S. Marcos da Serra
P-8375, Portugal
351-82-361748 F) 351-82-361749
www.sintefex.com

SKB Cases
1607 North O'Donnell Way
Orange, California 92867
714-283-8118 F) 714-283-0425
www.skbcases.com

Slider Products
P.O. Box 3287
La Mesa, California 91944
619-462-2286 F) 619-462-1831
www.sliderproducts.com

SLS Loudspeakers
3119 S. Scenic Avenue
Springfield, Missouri 65807
417-883-4549 F) 417-883-2723
www.slsloudspeakers.com

Smart Electronics/Sunset Sound
6650 Sunset Blvd.
Hollywood, California 90028
323-469-1186 F) 323-465-5579
www.smartresearch.co.uk

Solid State Logic
320 West 46th St., 2nd Floor
New York, New York 10036
212-315-1111 F) 212-315-0251
www.solid-state-logic.com

Sommer Cable/plus24
1155 N. La Brea Avenue
West Hollywood, California 90038
323-845-1171 F) 323-845-1170
www.plus24.com

Sonic Foundry
1617 Sherman Avenue
Madison, Wisconsin 53704
608-256-3133 F) 608-256-7300
www.sonicfoundry.com

Sonic Sense
2755 S. Gilpin Street
Denver, Colorado 80210
303-753-0201 F) 303-753-0817
www.sonicsense.com

Sonic Studio
12813 Industrial Park Blvd.
Plymouth, Minnesota 55441
763-577-1535 F) 763-577-5950
www.sonicstudio.com

Sonic Studios
1311 Sunny Court
Sutherlin, Oregon 97479
541-459-8839 F) 541-459-8842
www.sonicstudios.com

Sonifex/Independent Audio
43 Deerfield Road
Portland, Maine 04101-1805
207-773-2424 F) 207-773-2422
www.independentaudio.com
www.sonifex.co.uk

Sonotrim/ Posthorn Recordings
142 West 26th Street
New York, New York 10001
212-242-3737 F) 212-924-1243
www.posthorn.com

Sony
1 Sony Drive
Park Ridge, New Jersey 07656
201-358-4109 F) 201-358-4907
www.sony.com/professional

Sony Media Solutions
680 Kinderkamack Road
Oradell, New Jersey 07649
201-930-1000 F) 201-599-3554
www.mediabysony.com

Sound Advance Systems, Inc.
3202 So. Shannon Street
Santa Ana, California 92704
714-556-2378 F) 714-556-5425
www.soundadvance.com

**Sound Alignment
Systems/Checkpoint**
3112 Kashiwa Street

Torrance, California 90505
310-891-1550 F) 310-891-1551
www.checkpoint3d.com

Sound Anchors
2635 Kirby Avenue
Palm Bay, Florida 32905
321-724-1237
www.soundanchors.com

Sound Bridge Acoustic Labs
3501 I-35E
Waxahachie, Texas 75165
972-937-2030 F) 972-935-0539
www.soundbridge.com

Sound Construction & Supply
107 Spence Lane
Nashville, Tennessee 37210
615-884-8257 F) 615-884-8258
www.custom-consoles.com

Sound-Craft
1584 Petit Jean Mountain Road
Morrilton, Arkansas 72110
501-727-5476 F) 501-727-5402

Sound Devices
300 Wengel Drive
Reedsburg, Wisconsin 53959
608-524-0625 F) 608-524-0655
www.sounddevices.com

Sound Enhancements
185 Detroit Street
Cary, Illinois 60013
847-639-4646 F) 847-639-4723
www.soundenhancements.com
www.accuverb.com

**Sound Sculpture Musical
Instrument Products**
4700 Sterling Drive, Suite C
Boulder, Colorado 80301
303-442-1954 F) 303-447-3502
www.soundsculpture.com

Soundcraft, Inc.
1449 Donelson Pike
Nashville, Tennessee 37217
615-360-0471 F) 615-360-0273
www.soundcraft.com

**Soundelux Microphones/
Transamerica Audio Group**
4760 Dewey, #129
Las Vegas, Nevada 89118
702-365-5155 F) 702-365-5145
www.transaudiogroup.com

**Soundfield Research/
TransAmerica Audio Group, Inc.**
4760 West Dewey, #129
Las Vegas, Nevada 89118
702-365-5155 F) 702-365-5145
www.transaudiogroup.com
www.soundfieldusa.com

Stedman/Independent Audio
43 Deerfield Road
Portland, Maine 04101
207-773-2424 F) 207-773-2422
www.independentaudio.com

SoundTech
444 East Courtland Street
Mundelein, Illinois 60060
847-949-0444 F) 847-949-8444
www.soundtech.com

Soundtracs USA/ Fairlight USA
844 N. Seward Street
Hollywood, California 90038
323-465-0070 F) 323-465-0080
www.soundtracs.com

SoundTube Entertainment
6430 N. Business Park Loop
Park City, Utah 84098
435-647-9555 F) 435-647-9666
www.soundtube.com

SP Technology
1405 Woodward Street
LaPorte, Indiana 46350
219-324-6800 F) 219-362-7938

Spatializer Audio Laboratories
900 Lafayette Street, Ste. 710
Santa Clara, California 95050
408-296-0600 F) 408-296-0650
www.spatializer.com

**Special Projects/Audio Group
International**
16411 371st Avenue
Green Isle, Minnesota 55338
320-238-2554 F) 320-238-2545
www.spaudio.net

Speck Electronics
341 E. Alvarado Street

Fallbrook, California 92028
760-723-4281 F) 760-723-3294
www.speck.com

SPL USA
2498 Rikkard Drive
Thousand Oaks, California 91362
805-241-5140 F) 805-435-7455
www.spl-usa.com

SRS Labs
2909 Daimler Street
Santa Ana, California 92705
949-442-1070 F) 949-852-1099
www.srslabs.com

Stage Accompany USA
8917 Shore Court
Bay Ridge, New York 11209
800-955-7474 F) 800-955-9564
www.stageaccompany.com

Stedman Corporation
4167 Stedman Drive
Richland, Michigan 49083
269-629-5930 F) 269-629-4149
www.stedmancorp.com

Steinberg North America
9200 Eton Avenue
Chatsworth, California 91311
818-678-5100 F) 818-678-5199
www.steinberg.net, www.cubase.net

Stephen Paul Audio/ PMI Audio
23773 Madison Street
Torrance, California 90505
310-373-9129 F) 310-373-4714
www.pmiaudio.com

Sterling Modular
2234 Farmington Avenue
Boyertown, Pennsylvania 19512
610-369-5802 F) 610-369-9003
www.sterlingmodular.com

Stewart Audio
1000 Technology Drive
Columbia, California 95310
209-588-8111 F) 209-588-8113
www.stewartaudio.com

STK Electronics
P.O. Box 901705
Scotty, Utah 84090
801-947-5750 F) 801-947-5752
www.redwoodmusic.com

Stomp Inc.
2302 Barranca Pkwy.
Irvine, California 92606
949-263-8550
www.stompinc.com

Studer North America
1947 Leslie Street
Toronto, Ontario M3B 2M3
Canada
416-510-1347 F) 416-510-1294
www.studer.ca

Studio Network Solutions
1986 Innerbelt
Business Center Drive
St. Louis, Missouri 63114
877-537-2094 F) 314-733-0537
www.studionetworksolutions.com

Studio Projects/PMI Audio
23773 Madison Street
Torrance, California 90505
310-373-9129 F) 310-373-4714
www.studioprojectsusa.com

Studio Technologies
5520 West Touhy Avenue
Skokie, Illinois 60077
847-676-9177 F) 847-982-0747
www.studio-tech.com

Summit Audio, Inc.
390 Westridge Drive
Watsonville, California 95076
831-728-1302 F) 831-728-1073
www.summitaudio.com

**Sundance Systems, Fibox
Products Div.**
4925 N. O'Connor Blvd. #101
Irving, Texas 75062
772-717-7441 F) 972-893-0380
www.sundancesys.com

Sunfire Laboratories
P.O. Box 1589
Snohomish, Washington 98291
425-335-4748
www.sunfire.com

Superscope Technologies, Inc.
2640 White Oak Circle
Suite A



nsca2003

SYSTEMS INTEGRATION EXPO®

DALLAS TX - MARCH 13 -15

At the 2003 Systems Integration Expo® thousands of professionals representing many different system components will tear down the walls inhibiting converged technology and discover together the power of integration.

Don't miss the event devoted to

TECHNOLOGY WITHOUT BORDERS

500 exhibits featuring

- Audio
- Video
- Security/Life Safety
- Telecommunications
- Data Networking

400 hours of industry-leading education

- Systems Integration and Convergence
- Building Automation
- Audio
- Video and Control Systems
- Circuits/Cabling/Protocol
- Security and Life Safety
- Business

Send registration information:

Name

Title.....

Company Name.....

Address

City.....State Zip

Phone ().....

Fax ().....

Email.....

Fax to 319.366.4164

PAR

www.nscasexpo.org

Produced and Managed by:



NSCA is the leading association representative of the commercial electronic systems industry.

For more information visit www.nscas.org



MANUFACTURER DIRECTORY

Aurora, Illinois 60504
630-820-4800 F) 630-820-8103
www.superscopetechnologies.com

SurgeX
6131 B Kellers Church Road
Pipersville, Pennsylvania 18947
215-766-1240 F) 215-766-9202
www.surgeX.com

Svetlana Electron Devices/PM of America
1687 Shelby Oaks Dr., Ste. 8
Memphis, Tennessee 38134
901-388-2424 F) 901-388-2405
www.svetlanausa.com

Swissonic America/plus24
1155 N. La Brea Avenue
West Hollywood, California 90038
323-845-1171 F) 323-845-1170
www.plus24.com

Switchcraft, Inc.
5555 North Elston Avenue
Chicago, Illinois 60630
773-792-2700 F) 773-792-2129
www.switchcraft.com

SWR Engineering
9130 Glenoaks Blvd.
Sun Valley, California 91352
818-253-4797 F) 818-253-4799
www.swrsound.com

Symbolic Sound Corporation
P.O. Box 2549
Champaign, Illinois 61825
217-355-6273 F) 217-355-6562
www.symbolicsound.com

Symetrix, Inc.
14926 35th Avenue W.
Lynnwood, Washington 98037
425-787-3222 F) 425-787-3211
www.symetrixaudio.com

Synchro Arts Limited
Global House, Ashley Avenue
Epsom, Surrey KT18 5AD
United Kingdom
44-20-8823-9100
www.SynchroArts.com

Syntrellium Software Company
P.O. Box 62255
Phoenix, Arizona 85082-2255
480-941-4327 F) 480-941-8170
www.syntrellium.com

Sysid Labs
1563 Solano Ave., Suite 211
Berkeley, California 94707
510-559-9075 F) 510-526-8087
www.sysid-labs.com

T

Tamura Corp.
1-19-43 Higashi Ozumi
Nerima-ku, Tokyo
Japan 178-8511
81-3-3978-2242 F) 81-3-3978-2122
www.qolle.com

Tannoy
335 Gage Avenue, Unit 1
Kitchener, Ontario N2M 5E1
Canada
519-745-1158 F) 519-745-2364
www.tannoy.com

TASCAM
7733 Telegraph Road
Montebello, California 90640
323-726-0303 F) 323-727-7635
www.tascam.com

Taylor Hohendahl Engineering
P.O. Box 343
S. Woodstock, Connecticut 06226
860-974-3491 F) 860-974-2635
www.theaudio.com

Taytrix
134 Bay Street
Jersey City, New Jersey 07302
201-222-2826 F) 201-222-5457
www.taytrix.com

TBC Consoles, Inc.
115 Cabot Street
West Babylon, New York 11704
516-293-4068 F) 516-293-4075
www.tbconsoles.com

TC Electronic
742-A Hampshire Road
Westlake Village, California 91361
805-373-1828 F) 805-379-2648
www.tcelectronic.com

TC Helicon
742-A Hampshire Road
Westlake Village, California 91361
805-373-1828 F) 805-379-2648
www.tc-helicon.com

TC Works
742-A Hampshire Road
Westlake Village, California 91361
805-373-1828 F) 805-379-2648
www.tcworks.de

TDK
901 Franklin Avenue
Garden City, New Jersey 11530
516-535-2600
www.tdk.com

TDL Technology
5620 Cochise trail
Las Cruces, New Mexico 88012
505-382-2173 F) 505-382-8810
www.zianet.com/tld

Tech 21
333 52nd Street
New York, New York 10019
212-315-1116 F) 212-315-0825
www.tech21nyc.com

Technical Audio Devices
1925 East Dominguez Street
Long Beach, California 90810
310-952-2168 F) 310-952-2412
www.ta-d-pioneer.com

Technomad, Inc.
1112 Boylson St., Suite 302
Boston, Massachusetts 02115
617-424-9612 F) 617-424-8233
www.technomad.com

TecNec
812 Kings Highway
Saugerties, New York 12477
845-246-0428 F) 845-246-0626
www.tecnec.com

Tektronix
Measurement Business Division
14150 SW Karl Braun Drive
M/S 50-220
Beaverton, Oregon 97077
800-835-9433 F) 503-627-5593
www.tek.com

Telecast Fiber Systems
102 Grove Street
Worcester, Massachusetts 01605
508-754-4858 F) 508-752-1520
www.telecast-fiber.com

Telect
2111 N. Motter Road
Liberty Lake, WA 99019-0665
509-926-8000 F) 509-926-8915
www.telect.com

Telefunken North America
300 Pleasant Valley Rd., Ste. E
South Windsor, Connecticut 06074
800-882-5919 F) 860-882-5980
www.telefunkenusa.com

Telex Communications
12000 Portland Avenue
Burnsville, Minnesota 55337
952-884-4051 F) 952-356-4985
www.telex.com

TerraSonde
2434 30th Street
Boulder, Colorado 80304
303-545-5848 F) 303-545-6066
www.terraSonde.com

The John Hardy Company
1728 Brummel Street
Evanston, Illinois 60202
847-864-8060 F) 847-864-8076

Tice Audio Products
1530 Cypress Drive
Suite C
Jupiter, Florida 33469
561-575-7577 F) 561-575-0302
www.ticeaudio.com

Tingler Innovations
5540 Amber Cove Way
Flowery Branch, Georgia 30542
770-476-5337 F) 770-965-2661

TL Audio/HMB
743 Cochran Street, Bldgs. E & F
Simi Valley, California 93065-1976
805-579-6490 F) 805-579-8028
www.hbusa.com
www.tludio.com/uk

TOA Electronics
601 Gateway Blvd., Suite 300

South San Francisco, CA 94080
650-588-2538 F) 650-588-3349
www.toaelectronics.com

Toleto Fasteners International
1658 Precision Park Lane
San Ysidro, California 92173
619-662-1355 F) 619-662-1486
www.cord-lox.com

Transamerica Audio Group
4760 W. Dewey, #129
Las Vegas, Nevada 89118
702-365-5155 F) 702-365-5145
www.transaudiogroup.com

Transparent Audio
47 Industrial Park Road
Saco, Maine 04072
207-284-1100 F) 207-284-1101
www.transparentcable.com

Trident Audio Ltd. USA
3 Golf Center #219
Hoffman Estates, Illinois 60195
847-530-8161
www.tridentaudio.co.uk

Troisi Design, Ltd.
27 Almeria Circle
Westford, Massachusetts 01886
978-692-7768 F) 978-392-9869
www.troisi.com

True Audio
387 Duncan Lane
Andersonville, Tennessee 37705
865-494-3388 F) 865-494-3388
www.trueaudio.com

True Audio Systems/Neumann
One Enterprise Drive
Old Lyme, Connecticut 06371
860-434-5220 F) 860-434-3148
www.neumannusa.com

Truth Audio
129 Sugar Cove Road
Destin, Florida 32459
850-267-1255
www.truthaudio.com

Tsunami Technologies
459 Geary Street
San Francisco, California 94102
415-776-9705 F) 415-776-9214
www.tsunami technologies.com

Tube Tech
742-A Hampshire Road
Westlake Village, California 91361
805-373-1828 F) 805-379-2648

Turbosound/Sennheiser USA
One Enterprise Drive
Old Lyme, Connecticut 06371
860-434-5220 F) 860-434-3148
www.neumannusa.com

U

Ultimate Support Systems
P.O. Box 470
Fort Collins Colorado 80522-4700
970-493-4488 F) 970-221-2274
www.ultimatesupport.com

Ultralife Batteries, Inc.
242 Washington Avenue
Nutley, New Jersey 07110
973-542-0450 F) 973-542-0455
www.ulbi.com

Uncle Albert's Amplifier, Inc.
8033 46th Street
Indianapolis, Indiana 46226
317-546-7674 F) 317-546-0035
www.unclealberts.com

Under Cover
373 Broadway, #F-5
New York, New York 10013
www.undercovernyc.com

Universal Audio
2125 Delaware Ave. Suite A
Santa Cruz, California 95060
831-454-0630 F) 831-454-0689
www.uaudio.com

Uptown Automation Systems, Inc.
8301 Patuxent Range Rd., Ste. A1
Jessup, Maryland 20794
301-776-7879 F) 301-776-8117
www.faders.com

V

Vega/ClearCom
4065 Hollis Street
Emoryville, California 94608

510-496-6666 F) 510-496-6699
www.vegawireless.com

Velodyne Acoustics
1070 Commercial St., Ste. 101
San Jose, California 95112
408-436-7270 F) 408-436-6181
www.velodyne.com

Verbatim
1200 W. T. Harris Blvd.
Charlotte, North Carolina 28262
704-547-6500 F) 704-547-6609

Verity Systems
6236-A Main Street
El Dorado, California 95623
530-626-9363 F) 530-626-9395
www.veritysystems.com

Videoquip Research Limited
4-595 Middlefield Road
Scarborough, Ontario M1V 3S2
Canada
416-293-1042 F) 416-297-4757
www.videoquip.com

Vocalbooth.com
1631 S.E. Riviera Drive
Bend, Oregon 97702
541-330-6045 F) 801-659-2475
www.vocalbooth.com

Voyager Sound
P.O. Box 115
Weston, Massachusetts 02493
781-893-2574
www.voyagersound.com

W

Wave Arts
99 Massachusetts Ave., Ste. 7
Arlington, Massachusetts 02474
781-646-3794 F) 781-646-7190
www.wavearts.com

Wave Distribution
1170 Greenwood Lake Turnpike
Ringwood, New Jersey 07456
973-728-2425 F) 973-728-2931
www.wavedistribution.com

Wave Mechanics
P.O. Box 528
Burlington, Vermont 05402
802-951-9700 F) 802-951-9799
www.wavemechanics.com

Waves
306 West Depot Ave., Ste. 100
Knoxville, Tennessee 37917
865-546-6115 F) 865-546-8445
www.waves.com

WBT-USA
2752 S. 1900 West
Ogden, Utah 84401
801-621-1500 F) 801-627-6980
www.wbt-usa.com

Weiss Engineering/G Prime
1790 Broadway, #402
New York, New York 10019
212-765-3415 F) 212-581-8938
www.gprime.com

Wenger Corporation
555 Park Drive
Owatonna, Minnesota 55060
507-455-4100 F) 507-455-4258
www.wengercorp.com

West Penn Wire/CDT
2833 West Chestnut Street
Washington, Pennsylvania 15301
724-222-7060 F) 724-222-6420
www.westpenn-cdt.com

Westlake Audio
2696 Lavery Court, Unit 18
Newbury Park, California 91320
805-499-3686 F) 805-498-2571
www.westlakeaudio.com

Westone Laboratories
2235 Executive Circle
Colorado Springs, Colorado 80906
719-540-9333 F) 719-540-9183
www.westone.com/music

Wheatstone
600 Industrial Drive
New Bern, North Carolina 28552
252-638-7000 F) 252-635-1285
www.wheatstone.com

Whirlwind
99 Ling Road
Rochester, New York 14612
585-663-8820 F) 585-865-8930

www.whirlwindusa.com

WhisperRoom, Inc.
116 S. Sugar Hollow Road
Morristown, Tennessee 37813
423-585-5827 F) 423-583-5831
www.whisperroom.com

White Instruments
1514 Ed Bluestein Blvd., #108
Austin, Texas 78721
www.whiteinstruments.com
512-389-3800 F) 512-389-1515

Williams Sound
10399 West 70th Street
Eden Prairie, Minnesota 55344
952-943-2252 F) 952-943-2174
www.williamssound.com

Winsted Corp.
10911 Hampshire Avenue S.
Minneapolis, Minnesota 55438
612-944-9050 F) 612-944-1546
www.winsted.com

Wireworks Corporation
380 Hillside Avenue
Hillsdale, New Jersey 07205
908-686-7400 F) 908-686-0483
www.wireworks.com

Wireworld, Inc.
12349 SW 53 Street, Suite 201
Cooper City, Florida 33330
954-680-3848 F) 954-680-1525
www.wireworldaudio.com

Wohler Technologies
713 Grandview Drive
South San Francisco, CA 94080
650-589-5676 F) 650-589-1355
www.wohler.com

Worx Audio
620 South Elm Street, Suite 315
Greensboro, North Carolina 27406
336-275-7474 F) 336-275-2044
www.worxaudio.com

X

XS Technologies
3001 Curry Ford
Orlando, Florida 32806
888-978-3241 F) 407-895-0122
www.xstech.com

XTA Electronics/Group One Ltd.
200 Sea Lane
Farmingdale, New York 11735
631-249-1399 F) 631-753-1020
www.xta.co.uk

XVision Audio US
5111 Market Street
Boardman, Ohio 44512
330-259-0308 F) 330-259-0315
www.xvisionaudio.com

Y

Yamaha Corporation of America
Pro Audio Products
6600 Orangetherpe Avenue
Buena Park, California 90620
714-522-9011 F) 714-739-2680
www.yamaha.com/proaudio

Yorkville Sound, Inc.
4625 Witmer Industrial Estate
Niagara Falls, New York 14305
716-297-2920 F) 716-297-3689
www.yorkville.com

Z

Zaolla
6920 Hermosa Circle
Buena Park, California 90620
714-736-9167 F) 714-522-4540

Zaxcom Audio
140 Greenwood Ave., Bldg. 2
Midland Park, New Jersey 07432
201-652-7878 F) 201-652-7776
www.zaxcom.com

Zoom/Samson Technologies
P.O. Box 9031
Syosset, New York 11791
516-364-2244 F) 516-364-3888

**Z-Systems Audio Engineering/
Transamerica Audio Group**
4760 W. Dewey Drive, #129
Las Vegas, Nevada 89118
702-365-5155 F) 702-365-5145
www.transaudiogroup.com
www.z-sys.com

PRODUCTS & SERVICES

Now with **LID** Option!



Quick & Easy Isolation



CLEARSONIC PANEL
Drum Shields

SORBER
Absorption Baffles

1.800.888.6360
clearsonic.com

CLEARSONIC
manufacturing inc.

NEW! The Matchbox that mounts in your rack!

- Superb audio specs
- Built-in AC power supply
- Compact 1/3 rack-width



In stock at all Henry Engineering dealers. For dealers and full specs, visit www.henryeng.com



Tel: 626.355.3656
Blueboxes, Inc.



SRC-1
Digital Audio
Sample Rate Converter



The Phase 3 SRC-1 allows any digital audio signal format to be converted to professional AES3 (XLR) or AES3-ID (BNC) formats, up to 96 kHz.

Input signals may be S/PDIF (coaxial or optical), AES3, or AES3-ID, at 32, 44.1, 48, or 96 kHz.

The SRC-1 will lock to the internal clock, the separate AES3 sync input, or to a composite video input (BNC). Dither on the converted outputs may be set to 16, 20 or 24 bits, or disabled completely.

Conversion may also be bypassed completely.

VIDEOQUIP
RESEARCH LIMITED
www.videoquip.com

Phone: 416-293-1042
Fax: 416-297-4757
Toronto, Canada
TOLL FREE 1-888-293-1071

NOW HEAR THIS!

PRO AUDIO REVIEW

PRO AUDIO REVIEW'S Product Showcase is a cost efficient and effective method to sell your products and services.

For more information, call
Tina Tharp at
773-472-2495 • Fax 773-472-2498
Email: Tinatharp1@aol.com

PRODUCTS & SERVICES

SOUND ANCHORS



**SPEAKER STANDS MIXER TABLES DAWS
VIDEO MONITOR STANDS**



Digital Audio Workstation Stand

The Sound Anchor DAW is the perfect solution for your Pro Tools system.

It features:

- ◆ Independently adjustable monitor and keyboard platform heights
- ◆ Compact mobile space saving design
- ◆ Configurable for single or dual monitor systems
- ◆ Special keyboard platform sizes available

SOUND ANCHORS INC. 2835 Kirby Ave. Palm Bay FL 32905
Tel/fax: 321 724 1237 info@soundanchors.com
www.soundanchors.com

FREE CATALOG!

PRO AUDIO & VIDEO INTERFACE PRODUCTS

AUDIO & VIDEO ASSEMBLIES

- Mic
- Patch
- ADAT
- Snake
- Speaker
- Video
- VCA
- Cat5
- MIDI

Custom Lengths Available!

AUDIO & VIDEO BULK CABLE

- Belden
- Mogami
- West Penn

Full Rolls & Cut Footage Available!

AUDIO TECHNICA MICROPHONES

Wired & Wireless
Now In Stock!

THOUSANDS OF CONNECTORS

- XLR
- RCA
- 1/4"
- Mini
- HD15
- DB9

Many More!

BTX

Phone: 800-666-0996
Fax: 800-569-4244
Web: www.btx.com
Email: info@btx.com

Your Source For:
BELDEN
EDAC
MOGAMI
NEUTRIK
SWITCHCRAFT
and many others

CONTACT US FOR A FREE COPY OF OUR CATALOG!

ENCORE SERIES™ HDA400 and HDA600 Stereo Headphone Amplifiers

Complete monitoring solutions for Interview Studios, Broadcast Remotes, Production Rooms, Learning Centers, Live Sound and Recording Studios.

HDA400 Basic 1X4 with front and rear headphone program outputs.

HDA600 Full featured 1X6 includes program, cue and direct channel inputs.

FEATURES:

- Drives most 32 to 600 ohm phones over 120dB SPL
- Master Program inputs
Balanced TRS and XLR*
- Master Mono/Stereo switch and Level control
- Cue* Mic or Line Balanced TRS and XLR input
- Cue Send* Left/Right/Both channel selector
- Direct* inputs, unbalanced stereo or balanced mono
- Signal Present* and Input Overdrive indicators
- Internal 115/230VAC power supply

* HDA600 only



ATI AUDIO TECHNOLOGIES INCORPORATED

See Us At
NSCA 2003
Booth #1629

<http://www.atiguys.com>
Call or write for detailed brochure

328 W. Maple Ave. • Horsham, PA 19044
(800) 959-0307 • (215) 443-0330 • FAX (215)443-0394

Pro Audio Review DISTRIBUTOR DIRECTORY

ARE YOU
A DISTRIBUTOR?
LET OUR READERS KNOW...

ADVERTISE!!!

SPACE AVAILABLE

call

Simone @ 703-998-7600
ext.154

PRO AUDIO REVIEW'S DISTRIBUTOR DIRECTORY

is an efficient, effective and
affordable advertising option!
For more information about
rates and deadlines
call Simone at
1-800-336-3045 ext.154.

2003 Classified Advertising Rates

	(1x)	(3x)	(6x)	(12x)
1-9 column inch	\$95	\$90	\$85	\$80
10-19 column inch	\$90	\$85	\$80	\$75
Distributor Directory	\$145	\$135	\$130	\$125
Professional Card	\$100	\$95	\$90	\$85
Blind Box	\$25			

AD INDEX

This listing is provided for the convenience of our readers.
Pro Audio Review assumes no liability for inaccuracy.

Page No.	Advertiser	Website
80	.Acoustics First	www.acousticsfirst.com
83	.ADAM Audio USA	www.adam-audio.com
73	.ADK	www.adkmic.com
67	.Advanced Sonic Concepts	www.advancedsonicconcepts.com
116	.Alesis	www.alesis.com
111	.ATI (Audio Technologies Inc.)	www.atiguys.com
95	.Audio Precision	www.audioprecision.com
66	.AudioControl Industrial	www.audiocontrolindustrial.com
39	.AudioScience	www.audioscience.com
19	.Audio-Technica	www.audio-technica.com
101	.Audix	www.audixusa.com
49	.Azden Corp.	www.azdencorp.com
57	.B&H Photo-Video	www.bhphotovideo.com
89	.B&H Photo-Video	www.bhphotovideo.com
93	.Bayview Pro Audio	www.bayviewproaudio.com
69	.BBE Sound Inc.	www.bbessound.com
45	.Benchmark Media Systems	www.benchmarkmedia.com
85	.BLUE Microphones	www.bluemicro.com
27	.Bryston Ltd.	www.bryston.ca
105	.BSW	www.bswusa.com
111	.BTX Technologies, Inc.	www.btx.com
65	.CableTek	www.gefell-mics.com
33	.Carvin	www.carvin.com
43	.Cerwin-Vega, Inc.	www.cerwin-vega.com
110	.Clearsonic Panels	www.clearsonic.com
87	.Community Professional Loudspeaker	www.loudspeakers.net
5	.Crest Audio, Inc.	www.crestaudio.com
84	.D.W. Fearn	www.dwfearn.com
81	.DK-Audio A/S	www.dk-audio.com
9	.EVI Audio	www.klarkteknik.com
31	.EVI Audio	www.electrovoice.com
63	.Focusrite USA	www.focusrite.com
75	.Grace Design	www.gracedesign.com
91	.Groove Tubes, LLC	www.groovetubes.com
110	.Henry Engineering	www.henryeng.com
51	.HHB Communications Ltd	www.hhbusa.com
79	.HHB Communications Ltd	www.hhbusa.com
61	.Kimber Kable	www.kimber.com
58	.Lavry Engineering	www.lavryengineering.com
37	.Lectrosonics	www.lectrosonics.com/rpar0203
41	.Legacy Audio	www.legacy-audio.com
77	.Manley Labs	www.manleylabs.com
35	.Merging Technologies	www.merging.com
115	.Midi-Man	www.m-audio.com/tampa57
71	.Millennia Media	www.mil-media.com
108	.NSCA	www.nsca.org
20	.Pass Labs	www.passlabs.com
23	.Peavey	www.peavey.com
50	.Pendulum Audio	www.pendulumaudio.com
47	.Prism Media Products	www.prismsound.com
17	.QSC Audio Products	www.qscaudio.com
25	.Rane Corporation	www.rane.com
94	.Recording Workshop	www.recordingworkshop.com
97	.Royer Labs	www.royerlabs.com
21	.Sennheiser Electronic Instruments	www.micpreamp.com
15	.Shure, Inc.	www.shure.com
7	.Sony Broadcast	www.sony.com/proaudio
111	.Sound Anchors	www.soundanchors.com
2	.Soundtracs	www.digiconsoles.com
29	.Steinberg North America	www.steinberg.net
55	.Studio Projects	www.studioprojectsusa.com
3	.TC Electronic	www.dynaudioacoustics.com
11	.TEAC America, Inc.	www.tascam.com
59	.Telefunken North America	www.telefunkenusa.com
110	.Videquip	www.videoquip.com
13	.Yamaha Commercial Audio	www.yamaha.com/proaudio

Advertising Sales Representatives

East Coast/Midwest Sales

Alan Carter 703-998-7600 ext. 111
Fax: 703-671-7409

West Coast Region Sales

Paul DaCruz 707-789-0263
Fax: 707-789-0251

UK & Ireland, Benelux, Scandinavia, Africa, Middle East

Derek Gregory 44(0)1761-420123
Fax: 44(0)1761-42123

Japan

Eiji Yoshikawa 81-3-3327-2688
Fax: 81-3-3327-3010

Classifieds

Simone Fewell 703-998-7600 ext. 154
Fax: 703-671-7409

Product Showcases

Tina Tharp 773-472-2495
Fax: 773-472-2496

Audio Equipment Exchange

ACOUSTICS

AcousticsFirst™
 Toll-Free Number: **888-765-2900**
 Full product line for sound control and noise elimination.
 Web: <http://www.acousticsfirst.com>

Auralex acoustic www.auralex.com
 1-800-959-3343
 Expert Consultations • Tons Of Famous Clients • Cool, Greatly Expanded Website • Widest Selection • Lowest Prices Anywhere • Dealers Everywhere!
TOTAL SOUND CONTROL

Whisper Room INC.
 SOUND ISOLATION ENCLOSURES
 PH: 423-585-5827
 FAX: 423-585-5831
 E-MAIL: whisper@lcs.net
 WEB SITE: www.whisperrroom.com
 116 S. Sugar Hollow Road
 Morristown, Tennessee 37813
 Vocal Booths
 Broadcast Booths
 etc...

HARDWARE

Industry Standard
 Loudspeaker Rigging
ATM
FLY-WARE CERTIFIED
 (888) RIG-MORE
www.atmflyware.com

The professional's choice
 for product reviews
PRO AUDIO REVIEW
 The Industry's Equipment Authority
 To advertise here,
 call Simone Fewell at
 703-998-7600, ext. 154
 or e-mail:
sfewell@imaspub.com

CONTROL PANELS

CUSTOM PANELS & METALWORK

 Custom panels in Aluminum, Steel, Stainless & Brass. Wide choice of finishes. Silk screened or engraved graphics. Custom wood mounting systems & desktop consoles.

PANEL AUTHORITY INC
 PHONE 815.838.0488 | FAX 815.838.7852 | www.panelauthority.com

EQUIPMENT

ALAN SMART COMPRESSORS

 C-1, C 2 & Multi-channel versions
 available in the U.S. & exclusively distributed by:
Sunset Sound, Hollywood (323) 469-1186
www.sunsetsound.com

Get the Inside Scoop in Gear Technology!

Single Slice: Whitney Houston's Breakout Hit, "One of Those Days"

PRO AUDIO REVIEW
 The Industry's Equipment Authority
 Award Winning Gear and Software 2002
 Capturing the Essence of Recording
 True Systems P2analog Mic Preamp
 Incredible Sounding 24-bit 96 kHz DAC
 On Tour With the Big, Bigger!

Single Slice: Avril Lavigne's Chart Topper, "SK8ER BOI"

PRO AUDIO REVIEW
 The Industry's Equipment Authority
 High-Resolution Recording Special Section
 Live Sound
 Better Than The Original? Lyttelton L251 Classic
 Buyers Guide
 Processor

Single Slice: Norah Jones' Hit "Don't Know Why"

PRO AUDIO REVIEW
 The Industry's Equipment Authority
 Digital Workstations/Plug-Ins issue
 Outstanding DSD
 Systems



Single Slice

BY CHUCK TAYLOR

Eminem "Lose Yourself"

SINGLE: "Lose Yourself"

ALBUM: *8 Mile* soundtrack, (Shady/Interscope)

DATE RECORDED: November 2001

ENGINEERS: Steve King, Michael Strange Jr.

OTHER PROJECTS: King has worked on projects for Nas, D12, 50 Cent, Frank Sinatra *Duets*, 50 Cent, Was Not Was, Sponge, Patty Smith, The Winans, and Eminem's *The Marshall Mathers LP*.

SINGLE SONGWRITERS: Marshall Mathers, J. Bass, L. Resto

SINGLE PRODUCER: Eminem

STUDIOS: 54 Sound, Ferndale, Mich., also worked on the track at a homemade trailer studio booth with keyboards and Pro Tools system on the set of *8 Mile*.

CONSOLE: SSL 4000 G

RECORDER: Pro Tools

MONITORS: Yamaha NS10, KRK V8

MICROPHONES: Sony C800G

MICROPHONE PREAMPS: Neve 1073

PROCESSORS: Avalon 737-SP



Engineer's Diary



Steve King

Eminem has been called a lot of things since gaining fame in the millennium pop world, but in the studio, he's tagged with a nickname you would likely never guess. "We call him 'computer ears,'" says Steve King, who engineered Eminem's monster smash "Lose Yourself," from his acclaimed cinematic bow, *8 Mile*. "His sense of timing is incredible. I'll move something a quarter frame, and he'll notice that it doesn't feel the same. It's wild." King says that like most of Eminem's rap tracks, "Lose Yourself" came together in the studio: "He jams a lot and keeps CDs of a lot of different beats. This one started as a guitar jam with a drum machine, then four or five months later, we came back to and updated it, changed the tempo, and it all fell into place." One constant in the process is the mic used for Eminem's vocals. "There's no question that the Sony 800G is the one for him," King says. "It catches every nuance of his different registers. We never have a problem getting a clear sound." Which counts for a lot, according to King, who says that Eminem is the most intense artist he has ever worked with "in terms of really knowing every little thing about the production. He's very articulate and very careful with the layering of his vocals and the beats. When those are sitting right, everything else just fits around them."

Chuck Taylor, a regular contributor to Pro Audio Review, is senior editor at Billboard magazine in New York.

Put your whole
sound in the
sweet spot.



TAMPA-The Professional Mic Preamplifier and Compressor with Temporal Harmonic Alignment™

TAMPA is a professional microphone/instrument preamp unlike any other. That's because our design team set out to discover just why expensive tube technology sounds so good, and devise a way to land that sound at affordable solid state prices. The result is far beyond tube modeling. It's a whole new technology called Temporal Harmonic Alignment™. TAMPA even comes with direct digital output and world-class dual optical servo compressor built-in.

Unlike most solid state electronics, tube-based devices strike the ear as having such a "warm" sound because the added mid-range harmonics have the same temporal relationship as natural mechanisms like strings, drumheads and vocal chords. This results in a sweet spot that makes vocals, guitars and

other midrange-rich content sound especially pleasing.

TAMPA's revolutionary new Temporal Harmonic Alignment technology produces that same phase relationship found in both tubes and nature.

And unlike tubes, TAMPA's sweet spot spans the full spectrum of your sound from bass to cymbal.

- >> Class A circuitry throughout
- >> Built-in dual optical servo compressor/limiter
- >> Variable impedance optimizes vintage mic performance
- >> Available 66dB system gain
- >> S/PDIF and AES/EBU output to digital recording gear



M-AUDIO
Redefining the Studio™

See the M-AUDIO dealer near you or visit us online: www.m-audio.com/tampa57

DEQ Series

DIGITAL GRAPHIC EQUALIZERS



Curtis works with 240 bands....

SURE, MOST GUYS COULDN'T HANDLE IT. BUT CURTIS OWNS A DEQ830 – the only eight-channel, 30-band 1/3-octave digital graphic EQ with an interface so fast it feels (and looks) analog. With 100 user programs and 100 curve templates, setup's a snap whether it's the fifth club this week or a complex installation.

And 24-bit 1/4" TRS connectors plus digital I/O keep the audio studio-ready, all in an amazingly affordable and compact 1U rack. Of course, sometimes real men need just two channels . . . that's where the OEQ230 and OEQ230D (with digital I/O) come in. Now if only musicians were so easy to control.



DEQ230D with digital I/O shown, DEQ230 with analog I/O available

For more information visit
www.alesis.com, or call 310-821-5000
for a product line brochure.