

MARCH 1985
U.S. \$3.00
CANADA \$3.75
Bipad No. 71613

THE RECORDING INDUSTRY MAGAZINE

Mix

Interview: John Fogerty



**Southeast
Studio Listings
Special Report:
Loudspeakers
Nashville Film & Video
"Cotton Club" Sound
Jim Keltner
Producer Martin Rushent**

Worth Its Wait In Gold.

For Harrison Reliability

Sure, Harrison has waited to enter the U.S. broadcast market. When you're a stickler for precise engineering and a perfectionist when it comes to quality performance – you've got to take your time to get it right. *Get it just right for you.*

No Compromises

It can be tough getting the right console to match your specifications. About as easy as fitting a square peg in a round hole, right? Harrison Systems has anticipated your need for versatility. A good deal of time and research goes into our consoles in order to bring you the smartest, most efficient technology and service. We've got the system that fits the size and scope of your needs, whether it be:

- Teleproduction
- Video Sweetening and Post-Production
- Video Edit Suite
- Film Sound Post-Production
- On-Air Broadcasting
- Broadcast Production
- Live Sound Reinforcement
- Music Recording and Scoring

At Harrison Systems, we give you choices – not excuses or unnecessary fluff. Our systems are designed to bring you long-lasting, clean performance and reliability.

Harrison Puts You In Good Company

Organizations like Swiss Broadcasting and Belgian Radio and Television have believed in the superior quality of Harrison Stereo Broadcast Audio Consoles for years and have chosen Harrison for multiple broadcast installations. Swedish Television has selected 8 TV-3 consoles and has committed to several more. This year's Winter Olympics in Yugoslavia received the main audio feed from a TV-3.

At Last

At Harrison, we take the time to listen to your needs. We design our consoles with the flexibility to fit your operation. And although our standards may be high for our consoles – our prices are very, very reasonable. We think you'll find it's been worth the wait – in golden, Harrison-true performance. Call us for a demonstration and see for yourself.

For Harrison Innovation

Introducing Harrison's TV-3, PRO-7 and TV-4, the broadcast consoles you've been waiting for:

TV-3 For large scale TV audio, remote production, studio production, post-production and sweetening ■ Adapts to wide range of tasks ■ Available in a variety of configurations for customization ■ Plus many options.



Now Available
AIR-7 For on-air stereo radio broadcasting, combining sophisticated technology with simple operation.

PRO-7 Designed for comprehensive use in broadcast, live sound, motion picture teleproduction ■ Two major configurations ■ Simple to operate ■ Cost-effective ■ Independent mix decision capability ■ Long-term performance achieved through thick-film laser-trimmed resistor networks ■ Plus many options.

TV-4 For medium scale on-air production, remote production, studio production, sweetening and post-production ■ Three major, simplified configurations ■ Easy to install ■ High-speed, low noise, low distortion amplifiers allow for best possible electronic performance ■ Plus many options.

Harrison's new VSI Fader Section, which allows for simultaneous interface with automation and video editor switcher, is available for TV-4 and PRO-7 consoles.



Why wait any longer? Call or write Harrison Systems, Inc., P.O. Box 22964, Nashville, TN 37202; (615) 834-1184, Telex 555133.

**Harrison**



Cover: Designed and constructed by the students and faculty of the University of Miami, the school's well-equipped control room features MCI recorders and JH-500 Series console (donated by the manufacturer), as well as 3M and Mitsubishi digital mastering systems. The facility is linked to the 600 seat Gusman Concert Hall and a medium sized recording room which doubles as a classroom.

Photo by: Patricia Fisher

Corner photo of John Fogerty by Michael Utterback



One of our main features this issue is an exhaustive piece on *loudspeaker technology* by Larry Oppenheimer. Rather than taking a strictly historical approach, Larry instead looks at some of the key figures in the field through the years. That story begins on page 12.

DEPARTMENTS

- 5 FEEDBACK
- 6 CURRENT
- 8 SESSIONS
- 94 LUNCHING WITH BONZAI: JIM KELTNER by Mr. Bonzai
- 99 PREVIEW
- 147 PLAYBACK
- 159 CLASSIFIEDS
- 162 ADVERTISERS' INDEX

LISTINGS

- SOUTHEAST RECORDING STUDIOS
- 64 LOCATION INDEX
- 66 4&8 TRACK
- 72 16 TRACK
- 76 24+ TRACK

MUSIC

- 46 JOHN FOGERTY INTERVIEW by Elizabeth Rollins
- 114 SESSION PLAYER: BILLY STRANGE, PART TWO by Carol Kaye
- 134 MUSIC NOTES
 - Gary U.S. Bonds
 - The dB's
 - Grover Helsley Recording
 - Bruce Lundvall
 - Mixwords
 - and more . . .

AUDIO

- 12 SPECIAL REPORT: LOUDSPEAKERS by Larry Oppenheimer
- 26 SOUND FOR THE COTTON CLUB by Nicholas Pasquariello
- 36 STUDIOSCOPE: THE DIGITAL RENTAL BUSINESS by Robert Carr
- 40 FILM AND VIDEO IN NASHVILLE by Rose Clayton
- 52 SOUTHEAST STUDIO REPORT by George Petersen
- 102 FIELD TEST: FOSTEX B-16M by Joe Van Witsen
- 118 PRODUCER'S DESK: MARTIN RUSHENT by John Diliberto
- 122 COMPUTER TOOLS by Ronald G. Ajemian
- 150 INTERNATIONAL UPDATE

VIDEO

- 126 VIDEO NEWS by Mia Amato
- 128 MUSIC VIDEO PRODUCTION: JON ROSEMAN by Lou CasaBianca

For years, Nashville has called itself "Music City." It's still the country music capital of the world, but now the metropolis has an added claim to fame—"Music City" is quickly becoming "*Movie City*." Rose Clayton looks at the burgeoning Nashville film industry on page 40.



Nashville is just one of the many cities we visit in our look at studio activities in the Southeastern region, which starts on page 52. From Memphis to Miami, business is up for *Southeastern recording studios*, and *Mix* writers tell you why in this month's round-up.

You don't get to play with the best unless you are one of the best. That's certainly true in the case of drummer *Jim Keltner*, who has played with everyone from Dylan to Cooder. Mr. Bonzai finds out what makes this super skinsman tick in his "Lunching" on page 94.



THE TRUTH ABOUT DIGITAL AUDIO STATIONARY HEAD RECORDING



After delivering over 100 Mitsubishi X-80 Digital Audio Stationary Head recorders all over the world (over 50 in North America) the Mitsubishi Format is the digital standard.

Will the newcomers to the Digital Audio Stationary Head recorder field be compatible with The Mitsubishi Format? No one knows. They haven't delivered even one recorder yet.

With the finest audio production facilities already recording on Mitsubishi, shouldn't your studio be compatible with the standard format?

Call or write for the truth about Digital Audio Stationary Head recording systems.

THE X-80 by MITSUBISHI



DIGITAL ENTERTAINMENT CORPORATION

A SUBSIDIARY OF MITSUBISHI ELECTRIC SALES AMERICA, INC.

Headquarters: 87 Sand Pit Road, Danbury, Connecticut 06810, Tel: (203) 743-0000, Telex: 703547
• New York City: Suite 1530, 555 W. 57th Street, New York, NY 10019, Tel: (203) 743-0000
• Nashville: 2200 Hillsboro Road, Nashville, TN 37212, Tel: (615) 298-6613 • Los Angeles: 8255 Beverly Blvd., Hollywood, CA 90048, Tel: (213) 658-6881 • Canada (GERR): 363 Adelaide Street E., Toronto, Ont. M5A 1N3, Tel: (416) 868-0528



Circle #002 on Reader Service Card

Mix

PUBLISHER/
EDITOR David M. Schwartz

PUBLISHER/
GENERAL MANAGER Penny Riker Jacob

ASSOCIATE PUBLISHER/
ADVERTISING DIRECTOR Hillel Resner

MANAGING EDITOR Blair Jackson

ASSISTANT EDITOR George Petersen

ASSOCIATE EDITOR Ken Pohlmann

MUSIC EDITOR David Gans

EDITOR AT LARGE Mr. Bonzai

FILM/VIDEO EDITOR Lou CasaBianca

EDITORIAL ASSISTANT Elizabeth Rollins

CONTRIBUTING EDITORS
Mia Amato Joe Van Witsen
Bruce Pilato Tony Thomas
Neal Weinstock

ASSISTANT ADVERTISING DIRECTOR Jeffrey Turner

NO. WEST/NO. CENTRAL ADVERTISING REP Harton Firmin

SO. CAL./SOUTHWEST SALES OFFICE
4000 MacArthur Blvd., Suite 3000
Newport Beach, California 92660
(714) 851-1706

Cecilia (Cece) Hernandez
ADVERTISING REPRESENTATIVE
DIRECTORIES/CLASSIFIED MANAGER Lauri Newman

ART DIRECTOR Tim Gleason

ASSISTANT ART DIRECTOR Bonnie Blair Ofshe

DESIGN & PRODUCTION Dave Marrs

TYPESETTING Linda Dierking

JoAnne Evind Lynn McCormick

PRODUCTION MANAGER Anne Letsch

CIRCULATION MANAGER Mary Holland

CIRCULATION ASSISTANT Allison Hershey

ACCOUNTING DEPARTMENT Mark Elsberg

Linda Simpson Cathy Boyum

TRAFFIC MANAGER Neil McKamey

BOOK DEPARTMENT Craig Wingate Caryl Sherman

OFFICE MANAGER Rachel McBeth

OFFICE ASSISTANT Athena Craig



Dear *Mix*:

It was with mixed emotions that we read the excellent article on Danny Tate and East of Eden in the December issue of *Mix*—the untimely death of the article's writer, Laurice Niemtus, a few weeks before the issue's publication saddened us all. Laurice was a well-respected member of the music press, and deservedly so. Her understanding of and empathy for the artist enabled her to get the most out of an interview, and in turn, take than information and created an article that captured the true spirit of the subject.

Laurice and her writing will be greatly missed by those of us who knew her, and greatly admired and respected her work.

Sincerely,
Jennifer Bohler/
Network Ink, Inc.
Danny Tate and East of Eden
Carl Marsh

Dear *Mix*:

I would like to commend you on your informative update on stereo TV in the November issue. I found the articles on WTTW and the *Tonight Show* to be extremely interesting.

I promise I'll continue reading *Mix* as long as it continues to mirror so many diverse aspects of the industry.

Sincerely,
Keith W. Stiver
San Francisco, CA

Dear *Mix*:

I own a Dokorder 8140 four-channel deck. I was advised that there is a source of parts (and/or service) in the L.A. area. I would appreciate any details you could provide.

Thank you,
Greg Lewis
Hermosa Beach, CA

Dear Greg:

At present we know of no sources for Dokorder parts. If any of our readers know of a parts/service source, drop us a line and we'll pass the information along.

Dear *Mix*:

The Mendocino County Regional Occupation Program presently offers courses in Audio/Video in the Mendocino, CA area. We have an eight track studio and a video studio with separate editing suite. The video program has recently expanded to include three quarter inch technology.

The studios have been in operation for a number of years, but recently moved to new facilities. The audio program's future plans include the possible creation of a small record company.

Sincerely,
Lawrence Bullock
Mendocino, CA

Dear Lawrence:

We are forwarding forms so your program can be listed in our July 1985 Recording School Directory. We encourage other schools to contact us if they wish to be included in that issue.

Dear *Mix*:

I was very impressed with Audio Analysts' sound work on the Styx *Kilroy Was Here* tour, and I am wondering how to contact the company.

Sincerely,
Michael Cavallero
Taylor, Michigan

Dear Michael:

Audio Analysts can be contacted at Box 713, Plattsburgh, NY 12901, (518) 561-5071.

Corrections:

Our Northwest Studio Update in January named Steve Fouce of Lakeside Associates as the designer of Cougar Run Studios. The design was actually done by Carl Yanchar of the same firm. Also the studio has added a Fairlight CMI, which was omitted.

Our studio listings section erroneously listed the 24 track Ocean Studio (Stinson Beach, CA) as Ocean Audio. We regret any confusion this may have caused.

Mix Magazine is published at 2608 Ninth St., Berkeley, CA 94710 and is ©1985, by Mix Publications, Inc. This is Volume Nine, Number Three, March, 1985. *Mix* (ISSN 0164-9957) is published monthly. Subscriptions are available for \$24.00 per year. Single or back issue price is \$4.00. Subscriptions outside U.S.A. are \$36.00. Please address all correspondence and changes of address to *Mix* Magazine, 2608 Ninth St., Berkeley, CA 94710, (415) 843-7901. Second Class postage paid at Berkeley, CA and additional mailing offices. *Mix* Magazine is distributed in recording studios, pro-audio stores, music stores and other related businesses. If you have a recording or music related business and would like to distribute *Mix*, please give us a call. Display advertising rates, specs and closing dates are available upon request. This publication may not be reproduced or quoted in whole or in part by mimeograph or any other printed means, without written permission of the publishers.

CONVENTIONS

77th AES CONVENTION

The 77th convention of the Audio Engineering Society will be held March 5 through 8, 1985 in Hamburg, West Germany. The city previously hosted successful AES meets in 1978 and 1981, and this year's event shows excellent prospects so far with the convention occupying the entire exhibit area of the Congress Center.

At press time, at least 42 technical papers were slated for presentation, along with eight sessions on the following topics: digital and analog recording; digital processing; room acoustics; loudspeakers; microphones; studio technology; measurements and instrumentation; and psychoacoustics. A special panel on the education of recording engineers will focus on the European parameters for preparing students for careers in the industry. Other events calendared include tours of Steinway & Sons, Studio Hamburg, the NDR studio, and other places of interest. Also not to be missed will be the AES Awards Banquet, to be held in the main ballroom of the Atlantic Hotel.

The next U.S. convention of the Society will take place May 3 through 6, 1985 at the Disneyland Hotel in Anaheim, California.

Record Attendance at Winter CES

The 1985 International Winter Consumer Electronics Show held this past January in Las Vegas attracted a record number of visitors and exhibitors, a sure sign that this year is going to be yet another banner year for the consumer electronics industry.

Compact Discs were still very much the rage, with more than 30 different manufacturers displaying CD hardware and all indicators pointing to continued enormous growth in that relatively new area of technology. Also shown was a combination digital video/audio disk system.

Stereo television continued to make significant inroads, with a score of

manufacturers displaying stereo TV hardware, and others showing new stereo VCRs, already threatening to make mono VCRs virtually obsolete. Also on the TV front was the introduction of flat screen television, the forerunner of the sort of "wall television" that futurists and science fiction writers have been predicting for years.

A new twist added to this year's show was the special "Live From Las Vegas" TV program, featuring highlights of the show, which was beamed by satellite to New York-area retailers unable to attend the show.

The summer CES will be held June 2 through 5 in Chicago.

Market Surveys Available

Quarry Hill, Inc. of Arlington, VA, is offering three extensively detailed

market surveys the company conducted on different areas of optical laser technology. The three surveys are: The Videodisk Market Survey and Report, which goes into the applications of videodisk technology and the potential of the videodisk market; The Optical Digital Data Disk Market Survey and Report, which identifies the storage technologies that are being used, attitudes and perceptions of users; and the CD-ROM (Compact Disc) Market Survey and Report, designed to identify the composition of a consumer trend-setting population and feelings about CD technology and its applications.

Each report is available separately for \$650, or all three can be purchased for \$1,450. For more information, write to Quarry Hill, Inc., P.O. Box 574, Arlington, VA 22216, or call (703) 237-0682.

notes

The architectural design, acoustics and engineering team of *Vin Gizzi* and *Francis Daniel* have formed *Benchmark Associates Inc.* to develop high tech facilities for the communications industry. They can be reached at 425 East 63rd St., New York, NY 10021, ph. 212/688-6262. *Soundcraft Electronics* has opened a new manufacturing facility in Borehamwood, just outside of London, to allow them to bring all stages of manufacturing under one roof. Nashville producer/studio executive *Norbert Putnam* has launched *Studio Standard Systems, Inc.*, a company to design and equip recording studios located at 2012 21st Ave. South in Nashville, TN 37212. *Shoreline Teleproduction Systems* has expanded its field sales force with the additions of *Larry Forbes*, *Alan Pecherer* and *Penny Russell*. *AKG Acoustics* have taken over distribution of their own products in the U.S., via their Stamford, CT facility, after twenty years with North American Philips Corporation. *Barcus-Berry Electronics* has established its national sales distribution program, with representatives including *Pro-Tech Marketing*, Norwalk, CA; *Audity 2001*, Denver, CO; *John B. Anthony Co.*, Stamford, CT; *Elrep Sales*, Tucker, GA; *New Horizons Electronics*, Bannockburn, IL; *Allen Cohen Sales Associates*, Ashuelot, NH; *Bernie Darmstedter Associates*, Baldwinsville, NY; *Bob White & Associates*,

Solon, OH; *Metro-Rep Sales*, Freehold, NJ; and *Northshore Marketing*, Seattle, WA. *Roland* will be holding seminars in electronic music during March and April in Los Angeles, San Francisco, Dallas, St. Louis, Washington, D.C., Philadelphia, New York City, Boston, Chicago, Minneapolis-St. Paul, Kansas City and Denver. For more info, call 800/352-7930 or 312/545-0460 collect in Illinois.

Bruel and Kjaer will be holding a seminar on "Sound Intensity—Theory and Measurement" March 6-8 in Anaheim, CA. Call 714/978-8066 for details. *Solid State Logic* has opened a sales, service and training facility headed by Andy Wild at 6255 Sunset Blvd., Suite 1026, Los Angeles 90028. The San Francisco Chapter of *NARAS*, in cooperation with Baldwin piano is hosting a seminar on piano acoustics and mixing techniques, April 3. Call 415/777-4633 for further info. Nashville's *Crescendo Productions* has moved to 630 Ninth Avenue, New York, NY 10036. *Ted Tedesco* has been promoted to the post of Operations Manager/Industrial of *VCA Duplicating Corporation/Midwest*. *Ron Colgan* has been named national sales manager for *Sharp Electronics Corporation's* Professional Products Division. *Bruce Poe* and *Bill Spence* have been promoted to Project Engineers and *Jeff Woodruff* to Electronics Group Technician 11, at *Electro-Voice*.



“WOW!”

When the boys from the engineering department walked in with their newest creation, we said: “Nice looking box. What is it?”

“This,” they said proudly, “is our new MSP-126 Multi-Tap Stereo Processor. It’s a stereo-tapped digital delay line with a 20kHz bandwidth, eight pre-programmed processing modes, and . . .”

“Hold the engineering jargon,” we said. “Just tell us what this gizmo does.”

“Oh, no problem,” they said. “Basically, the MSP-126 is a signal processor that creates a whole range of interesting effects. To begin with, it produces really great balanced stereo with flat response from any kind of program material. And it also creates other kinds of effects—some of which are subtle, dramatic, or even bizarre. It’s easy to fine-tune the effects you get, too. For each of the eight effects modes, there are 16 delay parameter setups and 16 amplitude variations. Okay?”

We tried to look enthusiastic. “Well, maybe it would help if you could just give us a few *examples* of these effects,” we said.

“Good idea,” they said. “One of the neat things the unit does is produce forward

and backward discrete repetitions. Then there’s a traditional ‘comb filter’ stereo synthesis. And delay-based panning. And binaural image processing for Walkman applications. And delay clusters. And concert hall early reflections.”

“That’s better,” we said. “We’ve probably got enough to do a pretty good ad for you. Before we go, though, you probably ought to run us through a quick demo. That might help if we get stuck for the right word to describe what the effects sound like.”

“Sure,” they said. “Hope you like what you hear.”

So we listened. Then we walked over to the typewriter, rolled in a blank sheet of paper, and typed a headline that seemed to say it all:

“WOW!”

If you’d like to see why we’re so excited about the MSP-126, ask your nearest Ursa Major dealer for a hands-on demonstration. It’s an astonishing experience.

MSP-126 STEREO PROCESSOR



URSA MAJOR, Inc.

Box 28, Boston, MA 02258 USA • Telephone (617) 924-7697
Telex: 921405 URSAMAJOR BELM

Circle #003 on Reader Service Card

SESSIONS

NORTHWEST

At the **Music Annex**, Menlo Park, CA, **Roger Wiersema** recorded two projects with **Ronnie Montrose** producing: **Lion**, for BGP Productions, and **Mae West**, a popular local act. Also Jim Dean worked on several sessions with **In-cense**, **The Press**, **The County Line Trio**, and **Los Romanticos**. . . At **Patchbay Studios** in San Rafael, **The Crew** has been working on several new songs with Patchbay engineer **Gordon Elliot**. . . At **Colorado Sound** in Westminster, CO jazz singer **Diane Reeves** recorded her new album on Palo Alto Records. . . **The Dynatones** were at San Rafael, CA's **Tres Virgos Studios** mixing their debut album for **Rounder Records**, **Tough to Shake**. The project was produced by **John Rewind** and engineered by **Joe Tarantino** and **Gordon Lyon**. Another independent album project at Tres Virgos was **Linda Tillery's Secrets** with **Ray Obiedo** producing with **Stacy Baird** and **Gordon Lyon** engineering. . . Action at **Color Zone Productions** in Novato, CA: **Johnny Colla** and **Bill Gibson** of Huey Lewis & The News were in doing demo work and putting the studio's Emulator II to good use; and songwriter **Annette Klyce** cut tracks with **Maurice Cridlin** producing and **Mikey Raskovsky** engineering. . . Long-time guitarist for **Graham Central Station**, **David Vega**, completed four new songs at **Freeway Recording Studios** in Oakland, CA. Engineer **Dave Humrick** was at the controls. . . At **Mushroom Studios** in Vancouver, **Keith Stein** was engineering an album for **Jim Foster** with L.A.'s **Walter Stewart** producing. **Alfie Zappacosta** also zipped in (between club dates and video taping) to lay down some tracks with Keith and Walter. . . Engineer/producer **Matt Wallace** was busy at **Starlight Sound** in Richmond, CA, working on releases from **My Sin**, **Don Jackovich** and **Monkey Rhythm**. Also at Starlight were the hard rocking **Michael Spears Band** with **Norman Kerner** behind the board. . .

SOUTHERN CALIFORNIA

At **Image Recording** in Hollywood **Dan Hartman** and **Jimmy Iovine** produced a project for Dan for MCA Records. **Shelly Yakus** engineered, with **Steve Krause** assisting. . . **Eddie Lee** and his 14-piece **Steady Money Band** finished their album at **Emerald City Recording**, Grover City, CA. Also at E.C.R., **Merrell Fankhauser** remixed some classic tapes of **Mu**, recorded on Maui in 1974. . . **Sound Image Studio**, North Hollywood, CA had **Demola Adi-**

poju from King Sunny Ade's band in working on a solo project for Moji Productions with **John Henning** at the board. . . Producer **Patrick Henderson** was in **Skip Saylor Recording** mixing tracks for a soon to be released LP by **Carl Anderson** for Epic Records. Skip Saylor was behind the board. Also in was Polygram act **Confunkshun**, tracking a single with producers **Billy Osborne** and **Zane Giles**. . . **Pakadern Studio** in Los Alamitos, CA played host to San Diego-based rock group, **Planet. Dino** and **John Elefante** were both in the studio with Planet producing the project. Dino also engineered with **Mike Mierau** assisting. . .

SOUTHWEST

William Walker Production Agency finished production on an album for **Inflight** at **Sumet Studios** in Dallas with **Stacy Brownrigg** engineering. **Bobby Dennis** mixed **Tribe's** two-song presentation for A&M Records. . . **Omega Audio** in Dallas was hired to provide 24 track recording services for a television music special starring **Red Steagall**. The show, titled "Red Steagall's Country Place" was shot at Studio "A" at the studios at Las Colinas in Dallas, Texas. . . **Luv Sound** in Dallas completed recording a new album, **I Am a Promise**, for Luv Records featuring **Joe Alan** with **Gary Scott** engineering. . . **Lonnie Mack** was overdubbing and mixing at **Austin Recording** recently. The producer was none other than **Stevie Ray Vaughn**. The album is going on Alligator records, the blues label from Chicago. . . Also in at Austin Recording was **Jerry Jeff Walker**, editing tracks he recorded there in September with engineer **Wink Tyler**. . . The ACTS Television Network used the facilities of **Sierra Recording** in Fort Worth, TX to mix live music segments of their **Country Crossroads** program, which featured **Bill Mack**, **Jerry Clower**, **David Houston**, **Christy Lane**, **Connie Smith**, **Jerry Van Dyke**, and the



Jerry Jeff Walker (L) and Bob Livingston at Austin Recording.

Sons of the Pioneers. Music director **Randy Brooks** supervised the mixing, with Sierra engineer **Randy Adams** at the board. . .

NORTH CENTRAL

Recent activity at **Ryansound Recording** in Detroit included **Somerset** cutting tracks for a single, produced by **Andre Jones**, **Dave Sanders** at the console; and **Film at Eleven** finishing up tracks for their demo produced by **Wayne**, **Raymond Wimbley** engineering. . . At **Sparrow Sound Design** in Chicago, the rock band **Foxfire** cut 16 track original songs for a new video pilot and pop/jingle singer **Ellen Germaine** completed four original songs for a West Coast demo. . . At **Sound Summit** in Lake Geneva, WI **Cheap Trick** put down tracks with producer **Jack Douglas** for their new LP on CBS/Epic. Engineering was **Paul Klingberg** with assistant engineer **John Patterson**. . . **Rock Corps**, produced by R.A. Sheffield, completed two single releases recorded at **A.R.S. Recording Studio** in Alsip, IL. Engineered by **Gary Cobb**. . .

SOUTHEAST

Reel Sound Studios is the name of a just-opened facility in Miami that offers multitrack audio for video services. Reel Sound features Tascam recorders, dbx noise reduction, Carvin console, Hafler DH-500s, Aphex Aural Exciters, Roland Digital Delays, dbx 160x compressors as well as an extensive selection of musical instruments and much more. . . Recording at **Island Records' Compass Point Studios** in Nassau, The Bahamas were CBS recording artists **Julio Iglesias** and **Stevie Ray Vaughn**. . . At **Music Mill** in Nashville, producer **Harold Shedd** finished mixing **Alabama's** new album, engineered by **Jim Cotton**, **Joe Scaife**, **Paul Goldberg** and **George Clinton**. And **John Anderson** was in working on his new album with **Jim Ed Norman** and **Lou Bradley** producing. . . London-based songwriter **Tony Hiller** teamed up at **Sound Emporium Recording Studios** in Nashville with writer/producer **Byron Hill** to demo songs the pair wrote together during Hiller's two-week visit. Hiller's credits include recordings by **Anne Murray**, **Olivia Newton-John**, **Crystal Gayle**, **Sonny & Cher** and many others. . . **Barbara Mandrell** layed new tracks for her next album at **Woodland Sound Studios** in Nashville. **Tom Collins** produced with independent engineer **Les Ladd** and **Tim Farmer** behind the con-



THE LEGEND CONTINUES

When you're in the studio, tape that's good enough is not enough. Which is why for ten years Ampex has continued pushing the potential of recorded sound. Through a decade of increased fidelity and reliability, Grand Master 456 remains an audio tape obsessed with performance. Which is why more top albums are recorded on Ampex tape than any other tape in the world. For Grand Master 456, the beat goes on.

AMPEX

Ampex Corporation, Magnetic Tape Division, 401 Broadway, Redwood City, CA 94063 415/367-3809 Ampex Corporation - One of The Signal Companies

AND THE BEAT GOES ON

World Radio History

Circle #004 on Reader Service Card

trols... Word Records recording artist **Dion** was in overdubbing and mixing his upcoming LP at **New River Studios** in Fort Lauderdale, FL. Sharing producing duties with Dion were **Eric Schilling** and **Paul Harris**, with Schilling engineering, assisted by New River's **Ted Stein**... At **Disc Mastering Inc.** in Nashville, producer **Brien Fisher** was in working on **The Kendalls'** new single and album for Polygram; and a new **Moe Bandy** album has been in the works for CBS, produced by **Blake Mevis**... **The Duchess** was at **Sandcastle Recording** in Greenville, SC, putting the finishing touches on her five-song debut entitled **Dangerous**, produced by **David Crossman**, and engineered by **Rick Sandidge**, part-owner of Sandcastle...

recording and mixing the new **Jeff Lorber Fusion** album; both projects produced by **The System** and engineered by **Mario Salvati**... **Fonda Rae** was in at **Power Play Studios** in L.I. City, New York cutting the followup to the Top 10 dance hit "Touch Me." It's called "Please Don't Make Me Wait," produced and engineered by **Patrick Adams**... **Phil Austin** of **Trutone Records**, Haworth, NJ completed mastering "Step Off," by **The Furious Five** on the Sugarhill label. **Shameek Gonsalves** was the engineer, **Sylvia Robinson** the producer... **Connie Francis** visited East Orange, NJ's **Eastern Artists Recording Studio (E.A.R.S.)** to record vocal overdubs. **John Lombardo** was at the board... Work has begun at **The Power House**, Camden, NJ, on the soundtrack for the

tion of a new dubbing/editing room... **Trod Nossel Recording** in Wallingford, CT now offers a fully automated 32-channel mixing service. Along with the installation of computerized mix-down, track capability has been increased to 24 via a Scully transport with customized electronics and expanded Automated Processes console... **Strawberry Jamm** in West Columbia, SC has upgraded to automated 24 track with the installation of a new MCI JH-636 automated plasma display console and a new MCI JH-24 multitrack recorder supplied by Studioworks of Charlotte, North Carolina. The new equipment has been integrated into a totally new control room designed by Tom Irby of Studio Supply Company, Nashville... **Glen Glenn Sound** in Hollywood, CA recently furthered its position as an innovator with the addition of the Sony PCM-3324 digital multitrack recorder. The purchase followed industry wide enthusiasm for Glenn's 30-minute experimental 70mm film **Digital Dream**, which features the first all-digitally-produced 6-channel soundtrack... **Trutone Records Disc Mastering Labs** of Haworth, New Jersey bought a Sony PCM-1610 digital processor, a Sony BVU-800AD 3/4" U-matic recorder, a Studer DAD-16 digital delay, and a Sony PCM-701 digital processor... **Soundcraft Electronics**, of Santa Monica, CA has announced the delivery of a TS 24 console to well known R&B producer, arranger and composer **Kashif**. The console has 40 channels and is fully fitted with Audio Kinetics MasterMix disk based automation... **New River Studios** of Fort Lauderdale, FL became the first studio in Florida to take delivery of an AMS RMX16 digital reverb. The unit was first used for Word Records artist **Dion** at the facility... Technological updates at **Greene Street Recording**, New York City, recently included a Roland Master Keyboard Controller with Roland modules Sync Box SBX-80, Super Jupiter MKS-80, Super Jupiter Programmer MPG-80, Planet P MKS-10 and Planet S MKS-30, as well as the Emulator II and the Bel BD 80 8 second sampling delay unit... **Hoyt & Walker Productions** of Little Rock has announced the opening of a new eight track facility designed specifically for broadcast production. The equipment list includes a custom Neotek Series I 16x8 console, Otari MX5050 8-track with dbx, autolocator and remote, and much more... **Kajem Recording** in Gladwyne, PA installed a Solid State Logic 4000E Computerized Console. **Kajem** is now the first and only studio in the Philadelphia region to offer the SSL System... **Nutmeg Recording** of New York City has finished its recent renovation and expansion. Studio A has been completely remodeled with the enlargement of the control room and the addition of a video interlock system. Along with the BTX Softouch/Cypher system, Nutmeg has added a new eight track for interlock, and a Lexicon digital reverb... **Classic Sound Studio**, in New York City, has added the Klark-Teknik DN780 digital reverberation system to its growing list of outboard equipment. **Classic** has expanded its mike collection and has recently purchased a Yamaha DX7 synth, Oberheim DX drum machine, and Sony PCM F-1 two track digital recording system...



At work on **J. Blackfoot's** new LP at **Ardent Recording** in Memphis are (L) engineer **Henry Bush** and writer/producer **Homer Banks**.

NORTHEAST

At **Secret Sound Studio** in New York City, **Ray Goodman & Brown** mixed a new album for **Panoramic Records**. **Al Goodman**, **Chuck Corrado**, **Kevin Owens** and **Walter Morris** all produced, with **Scott Noll** engineering and **Warren Bruleigh** assisting... At **Systems Two** in New York City, **George Logios** and **Willie Daniels** were in producing **Straffe's** follow-up to their most recent hit, "Set It Off." **Walter Gibbins** and **Audie Lebensfeld** engineered... **ServiSound** in New York City recorded singer and entertainer **Melba Moore**, mixer **Ralph Jones** handling all the audio engineering for the job... **Jim Pugh**, trombone player and recipient of the 1984 NARAS Most Valuable Player Award completed the cutting and production of his new digital album **Crystal Eyes** at **Trutone Records** in Haworth, New Jersey. **Carl Rowatti** was the mastering engineer transferring from the Mitsubishi MX-80 system with **Tom Jung** assisting... Recent projects at **Sorcerer Sound** in New York City included the **Angela Bofill** album for **Arista records**, including the hit single "Can't Slow Down," and

motion picture **Miracle in a Manger**, starring **Donald O'Connor** and **Morgana King**. The soundtrack album, showcasing the talents of tenors **Daniel Brewer** and **Hans Ashbaker**, is being produced by **MIAM Productions**, with arrangements by **Bill Grabowski**. **Power House** chief engineer **Mark Schultz** is at the board... At **Evergreen Recording** in New York City, **Stephen Miller** was in producing and engineering tracks for **Mitchell Forman's** new album for **Windham Hill Records'** new label, **Magenta Records**. **Hahn Rowe** was the assistant... At **Classic Sound Studio** in New York City, **Marian McPartland** recorded a solo piano album for **Concord Jazz**, **Frank Kulaga** engineering, **Carl Jefferson** producing; and **Bob Golden** produced saxophonist **Bud Shank** with **Kenny Barron**, **Al Foster**, and **Ron Carter** for **Muse Records**. **Jim Anderson** engineered with **Judy Elliot-Brown** assisting...

STUDIO NEWS

Celebration Recording purchased new Westlake studio monitors, a Studer half-inch two/four track mastering recorder, and installa-

First we proved it. Then we improved it.



Over the past four years we've installed over 500 Studer A800 multi-track recorders in studios all around the world. We've proven this machine on all counts—reliability, sonic performance, production versatility, and total client satisfaction. No other recorder has earned such widespread admiration among recording professionals.

And now, with the introduction of the A800 MKIII, we've improved on the proven standard. We've removed all transformers from the record and reproduce paths. We've added interfaces for Solid State Logic and

Neve/Necam automation, and for all SMPTE/EBU synchronizing and editing systems. We've also updated the software for the microprocessor controls to meet the most demanding industry requirements.

Improving the A800 was not an easy assignment, but at Studer the pursuit of perfection has become an ingrained habit. Discover the difference yourself. Call your Studer representative and ask for details on our new A800 MKIII...now, more than ever, the proven standard for impeccable performance.

STUDER REVOX

Studer Revox America, Inc. • 1425 Elm Hill Pike, Nashville, TN 37210 (615) 254-5651
Offices: Los Angeles (213) 780-4234 • New York (212) 255-4462 • Dallas (214) 760-8647 • Canada: Studer Revox Canada, Ltd.

Circle #005 on Reader Service Card

SOUND VISIONS

Some Thoughts on Speaker Technology

by Larry Oppenheimer

The *Hitchhiker's Guide to the Galaxy* is a truly remarkable book. The introduction starts like this: "Space," it says, "is big. Really big. You just won't believe how vastly, hugely, mind-bogglingly big it is!" The Guide's entry on the subject of loudspeakers contains an equally eloquent, if less loquacious comment. It says, "Ditto." This is a wily move on the part of the *Guide's* editors, for it is no more possible to comprehensively discuss any aspect of loudspeakers in a single book entry (or magazine article) than it is to transcribe the entire *Audio Cyclopaedia* on the back of a track sheet. Therefore, this is not the story of loudspeaker evolution or loudspeaker design. It's not an explanation of

Pioneers like Ed Long, Paul Klipsch, John Meyer, Amar Bose and others have changed the way you hear music.

some mysterious aspect of loudspeaker performance. It's not a story or explanation at all; it is simply a reflection on the perspectives and visions of a few of the preeminent names in loudspeakers. The idea is that it is helpful when trying to fully understand and use a tool such as a loudspeaker to know some of the thoughts that went into it. Herein are some of those thoughts. The people contacted for this article were chosen for their recognized accomplishments in the field and the distinctiveness of their contributions. There are a great many others who would have been equally appropriate.

What makes the subject of loudspeakers so vastly, hugely, mind-bogglingly big? After all, we're just trying to push air around. It seems that a coil of



The MDM-TA2 Time Align © Monitors

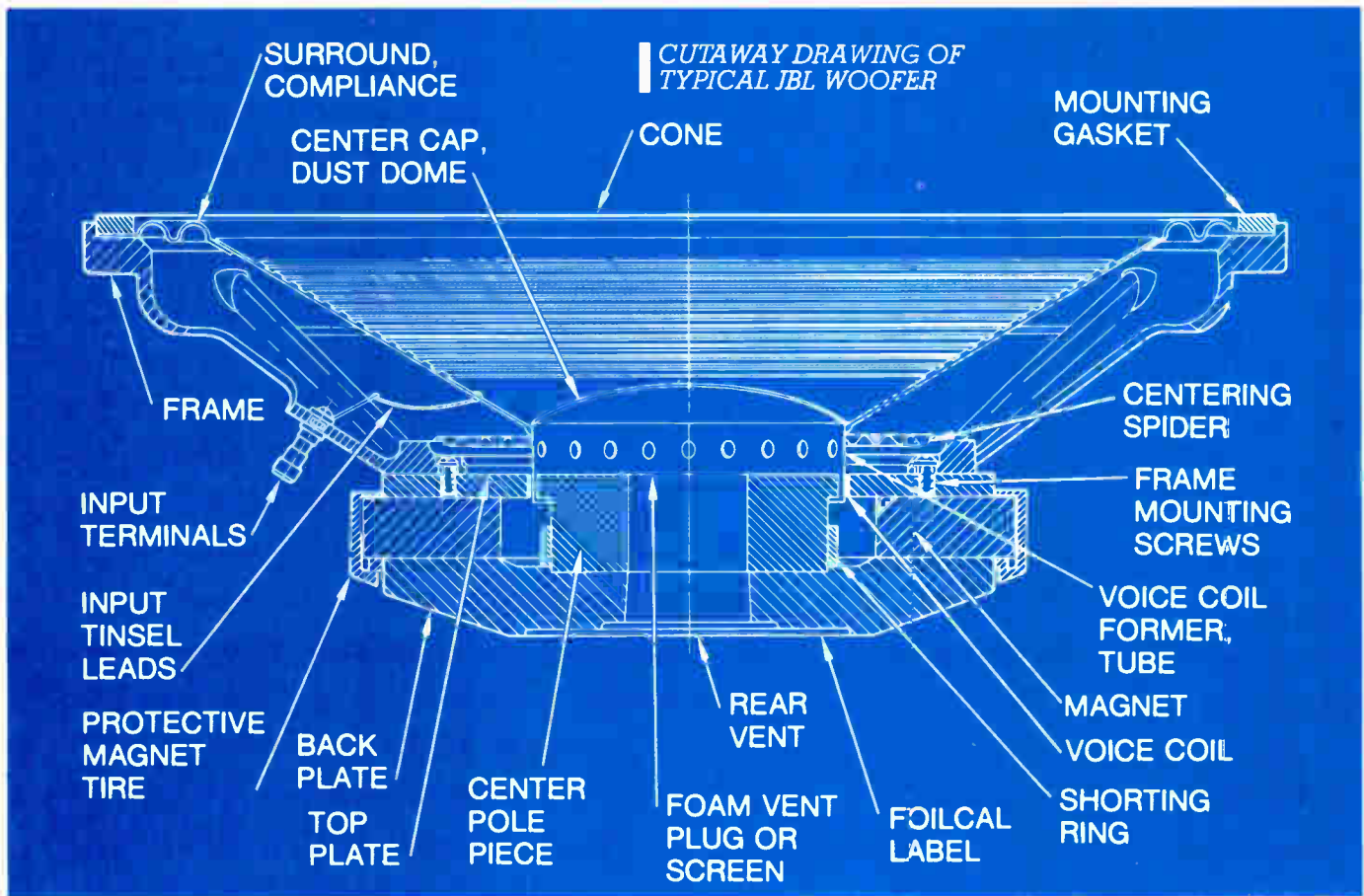

wire hung in the middle of some magnet and maybe glued to a cone of paper is all that's needed. Throw a few in a box and you're all set. Pump a little juice through and what do you get? Well, that depends on how you coiled the wire, how big the magnet is, what kind of paper and glue you used, and a zillion other factors ranging from the obvious to the arcane.

The formula described above does more or less accurately define the process of loudspeaker design, and many manufacturers do not extend this concept any further, yielding the audio equivalent of fast food. It's edible, but hardly gourmet fare. The good stuff comes from trained and practiced chefs skilled in the synthesis of fine recipes from available ingredients, the demands of the occasion, and an inspired palate. Like a good chef, a loudspeaker designer must have a thorough knowledge of the processes which are involved.

"You need a background which is not just in acoustics," points out Ed Long of E.M. Long Associates. "The background in chemistry, electronics and physics tie together in loudspeakers like they don't do in practically anything else."

Long has been designing loudspeakers and loudspeaker systems since the '60s, and is often noted for his work alone and with Ron Wickersham of Alembic, which produced the Time

Align[®] process, Near Field Monitoring[™], the Pressure Recording Process (which is the basis of PZM and other boundary-type microphones) and ELF[™] (Extended Low Frequency) technology. Long's statement underscores the feeling that the process of combining the scientific, the practical, and the subjective to produce a good loudspeaker is almost alchemical in

nature. It goes something like this: given a specified need or application, juggle a humongous number of contributing mechanical, electromagnetic, acoustic, and psychoacoustic factors and tradeoffs until the ones you feel are most important get taken care of, and end up with a result that sounds good, fits the need or application, can be produced well at a reasonable cost, and will sell in enough

The Compression Loudspeaker/Pattern Control Horn: An Encapsulated History

by Gregory A. DeTogne

Not that many people give it much thought, but horns have to a large degree shaped the daily interactions that have been vital to cultural development the world over. Witness the instrument personally chosen by Joshua to blow down the walls of Jericho, what is used each year to announce the running of the fabled Kentucky Derby, and which device best expresses our daily anger at other motorists (besides the ever-popular single-digit hand signal).

Once put into its proper perspec-

tive then, it's obvious to even the most casual observer that the horn is indeed more than just another contrivance. It's a socially significant tool man has relied upon for centuries to help him communicate beyond his normal verbal means.

With that in mind, it's hard to believe that horns in general really didn't evolve much from the time Neanderthal types carved the first prototypes out of animal horns and conch shells until early in this century, when pioneer sound tweaks added electrical energy to the concept and

—PAGE 108

numbers to make the whole affair worthwhile. (Although engineers design for the love of it, most want to get paid, too.)

This idea is more easily grasped with the help of the Great Pie-In-the-Ear Analogy. A chef is told that a pie (loudspeaker system) must be baked (designed) for dessert (a concert club). The most important question is: what kind of meal is to be served (what is the application)? If it is Thanksgiving dinner (a high level sound reinforcement situation), then something like a lemon meringue pie (home hi-fi direct radiator system) wouldn't be quite as appropriate as mincemeat (a high power, fully horn-loaded system) or pumpkin (horn-loaded

sound). Following a meal of fast food (an outdoor paging application), all of these pies would be too much trouble (cost, bulk, complexity of use) and couldn't satisfy the junk food junkie's hard core sugar craving (continual abuse by the elements), so it is perhaps best to serve a bag of jelly beans (an industrial paging horn and driver).

To sum up this half-baked analogy, what it boils down to is that improvements in speakers are usually the result of a good scientific understanding, much probing thought, and a lot of experiments. These things

with it; they were the first ones that actually perfected it, although there were similar cone-type speakers before that. Their basic speaker in 1926, a moving coil loudspeaker, was a coil of wire immersed in a magnetic structure moving a truncated cone to act as a piston to vibrate the air. Everything we've done since then looks and works just about the same way. We've used different magnets, we've got better materials, we've learned how to balance the suspension

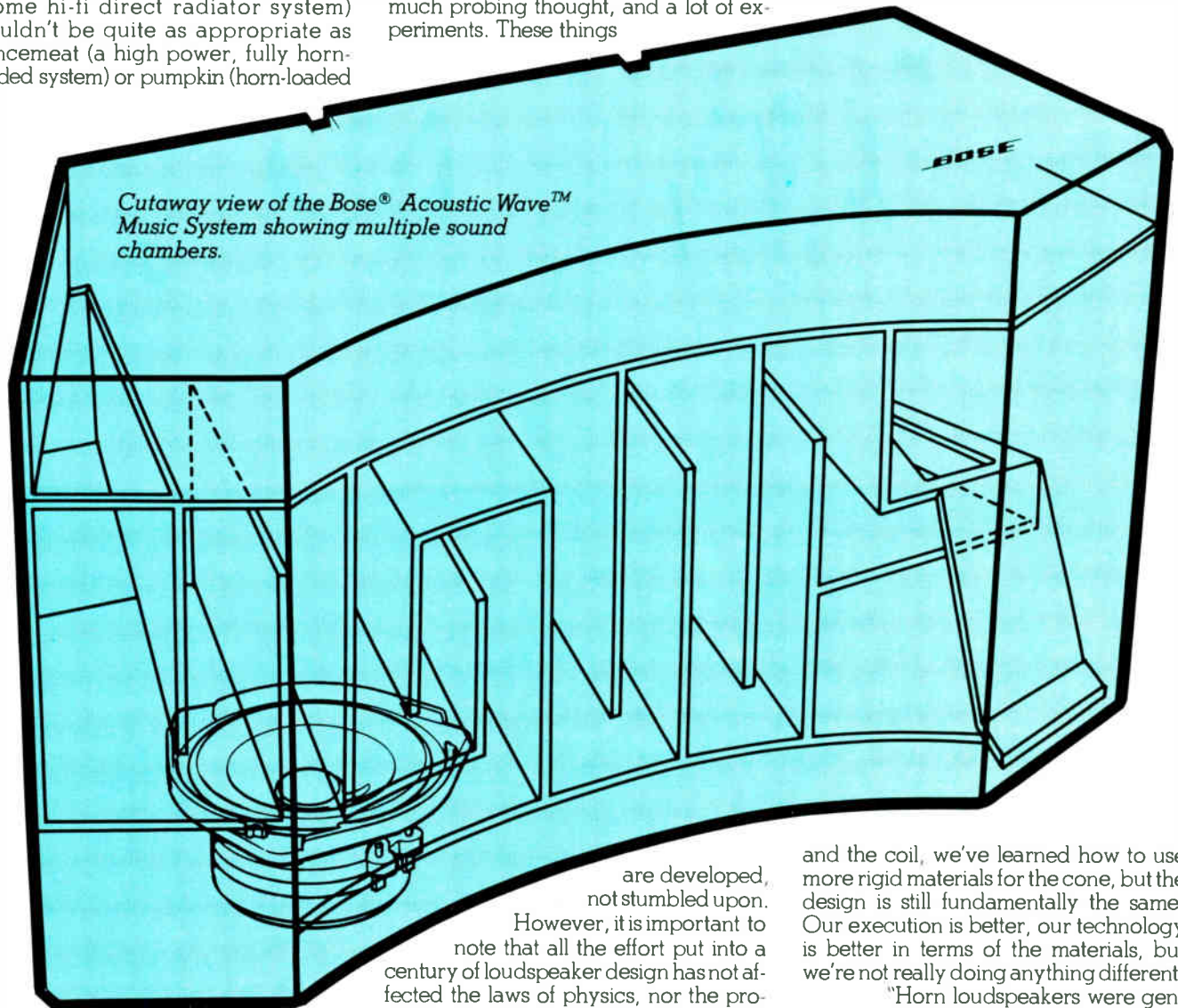

Cutaway view of the Bose® Acoustic Wave™ Music System showing multiple sound chambers.

high end, ported bass cabinets, also high power), largely because it would not be as traditional (efficient, roadworthy, controlled dispersion); although among an intimate gathering of a few friends for Thanksgiving (an acoustic performer in a tiny club or coffeehouse), lemon meringue might work OK. For an elegant tea party (living room listening), mincemeat would probably be too heavy and lemon meringue just right (wide dispersion, pleasant, if colored

are developed, not stumbled upon. However, it is important to note that all the effort put into a century of loudspeaker design has not affected the laws of physics, nor the process of alchemy. Loudspeaker designers are refining their craft with new materials and knowledge, but the craft is essentially the same as it ever was, in contrast to fields like signal processing, which has changed radically with the emergence of a whole new technology (microprocessors).

Mark Gander, Product Manager of the Professional Division at JBL, Inc. (long one of the speaker industry's giants), reflects on this: "The cone loudspeaker was invented around the turn of the century. Rice and Kellogg at General Electric in 1926 get credited

and the coil, we've learned how to use more rigid materials for the cone, but the design is still fundamentally the same. Our execution is better, our technology is better in terms of the materials, but we're not really doing anything different.

"Horn loudspeakers were generated about the same time; about the '20s and early '30s is when the compression driver was invented. The concept of the compression driver is making a very small piston and using an acoustical transformer, which is basically what a horn is—an air impedance matching device; using a real small driver to create high pressure at low volume velocity and transforming it to lower pressure and higher volume velocity out of the throat of the horn."

There are other ways of moving air that have been developed, notably

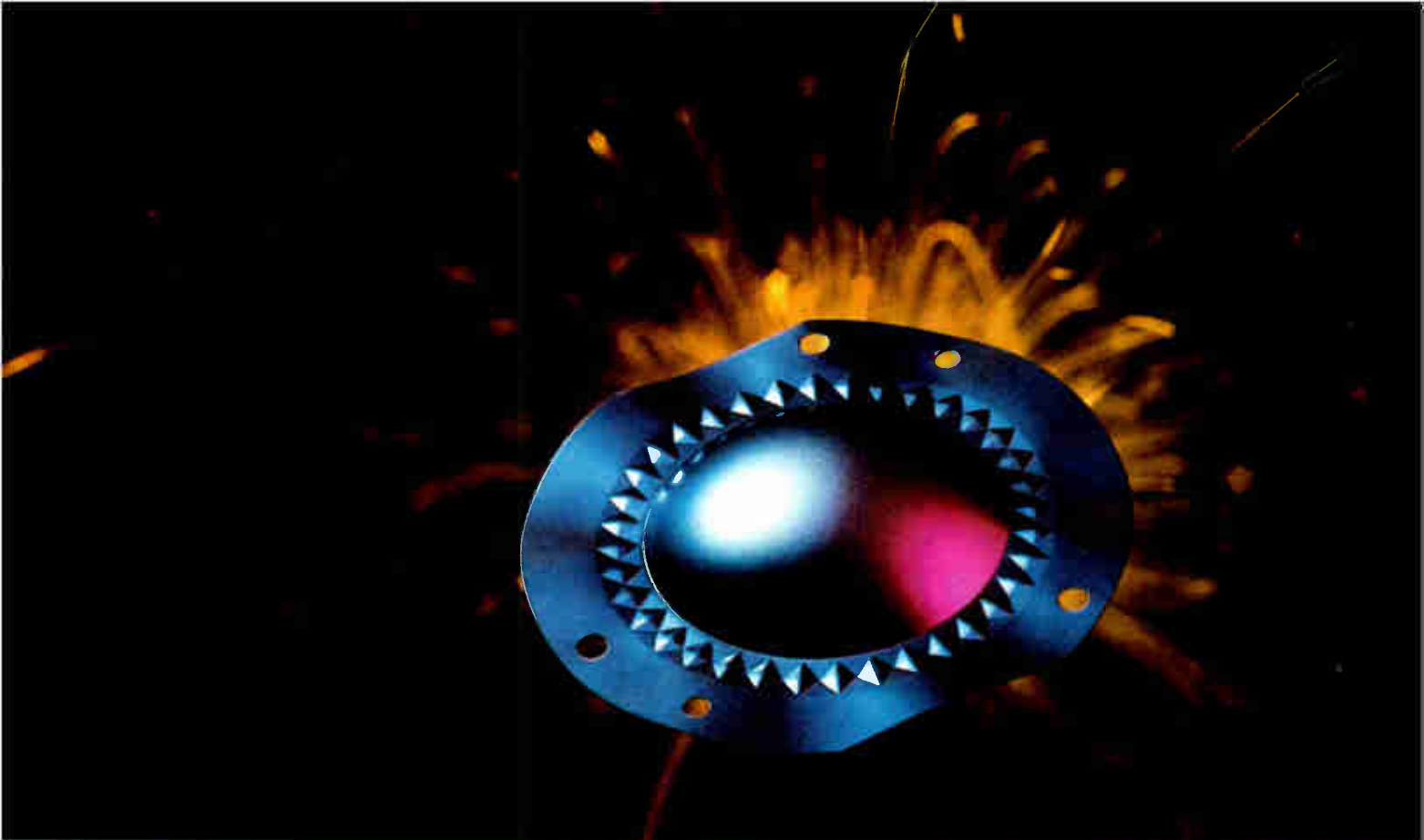

JBL's unique titanium diaphragm and "Diamond Surround" bring new purity and consistency to high frequency response.

IT TOOK JBL SCIENCE, A NITROGEN EXPLOSION, AND PURE TITANIUM TO GIVE YOU PERFECTED HIGH FREQUENCY SOUND.

High frequency sound has always fought with the technology that brings it to the ear. The driver diaphragm has been most vulnerable, pushed to the breaking point, unable to hold uniform frequency response.

JBL scientists decided to fight back. They exploded nitrogen into a remarkable metal, pure titanium, encircling their unique diaphragm with a vibration-absorbing "Diamond Surround," so revolutionary it warranted its own patent.

The result? A diaphragm that delivers and sustains a power and purity to high frequency response never before approached in the industry.

Perfecting titanium technology is just one of innumerable ways in which JBL science is re-shaping the quality of sound. From ultimate accuracy in laying down your initial tracks, to capturing the full power and subtlety of your final mix, JBL audio systems are focused on the most exacting demands of the recording studio professional. To find out which system is designed to meet your specific requirements, contact your authorized JBL professional products dealer today.



JBL Incorporated,
8500 Balboa Boulevard
P.O. Box 2200
Northridge, CA 91329
U.S.A.



JBL harman international JBL INCORPORATED 1984

Circle #006 on Reader Service Card

World Radio History

electrostatic and piezoelectric speakers, both of which have found their own niches—electrostatics primarily in home hi-fi, and piezoelectrics in high frequency sections of sound reinforcement systems, but the overwhelming number of loudspeakers in use are of the moving-coil, dynamic type.

Interest in loudspeaker technology picked up when sound for film began, which occurred at about the same time that Rice and Kellogg were putting the finishing touches on their design at GE. At this opportune time, in 1926, a young man named Paul Klipsch joined GE's testing department. Although he had just received his BSEE in New Mexico, Klipsch had already spent several years experimenting with speakers—the beginning of his life's work. The fundamentals of his design philosophy were formulated early, as he explains:

"Back in the early '20s, when I aspired to be a ham radio operator, I witnessed a demonstration of what we called 'wireless' in those days, wireless telephony. There was a little unlicensed 10 watt radio transmitter over in Juarez, Mexico, just across the river from El Paso (Texas), and they were transmitting the old scratchy shellac phonograph records. A radio receiver in El Paso which picked up the signal and broadcast it acoustically through a Magnavox horn-type loudspeaker. Having seen that speaker, I violated the Tenth Commandment: Thou Shalt Not Covet. Eventually, I got hold of one of those speakers . . . a terrible mechanism, very poor response, but at least it was loud. It was efficient over its narrow range, and that was something that appealed to me: efficiency. Years later, when I was in South America, I built a radio receiver to pick up WGY shortwave, Schenectady, New York. A friend of mine down there loaned me a cubical box, about a cubit in each dimension (a cubit is the distance

from your knuckle to your elbow). Inside this box was a horn that was curled up, and the thing that appealed to me about that was that it was efficient, and yet it was a horn.

"Some years later, in my graduate work at Stanford, one of my fellow graduate students remarked that any speaker would work better if it was placed in a corner, and I conceived of the corner as the final expansion of a horn. I built several experimental speakers that weren't worth a darn, but my first successful one was a corner horn loudspeaker which I evolved in 1942, when I actually got the thing to work the way I thought it ought to work. The period of gestation was about nine years. That, of course, resulted in a certain amount of

philosophy about horns: I thought efficiency was an important consideration because it takes less amplifier power, and back in those days of five and ten watt amplifiers, that was significant."

In 1943, Klipsch was granted a patent on his corner horn design, which he called the Klipschorn. In a few years, he started making his speakers in Hope, Arkansas, where he had served while in the Army. After designing horn-loaded mid- and high-frequency sections, the Klipschorn became the flagship of his line, which (with continual improvement along the way), it remains to this day. The Klipschorn's appearance marked the first time that consumers could have serious bass response in their living rooms. Klipsch published papers on his horn designs and continued to research the subject of loudspeakers, often going back to older work to gain new inspiration.

In the '60s, Klipsch expanded his line into the growing sound reinforcement market, and continued to probe classic papers for ideas. "In 1943, Beers and Belar of RCA wrote a paper on frequency modulation distortion in loudspeakers; that was about the middle of World War II; I was in active military duty at the time. I had read that paper, and I dug it up and reread it, tried to analyze it and think about it.

"It was 1967 when another period of gestation terminated. I tried to duplicate Beers' and Belar's work, but I was unsuccessful; however the audio spectrum analyzer became available and I got one of those darn things and, of course, the problem just fell apart in my hands. I wrote a paper in 1967 entitled, "Modulation Distortion in Loudspeakers"; I thought I was going to write about frequency modulation distortion, but I found out I was getting two kinds of distortion (frequency and amplitude). What makes an efficient speaker better is

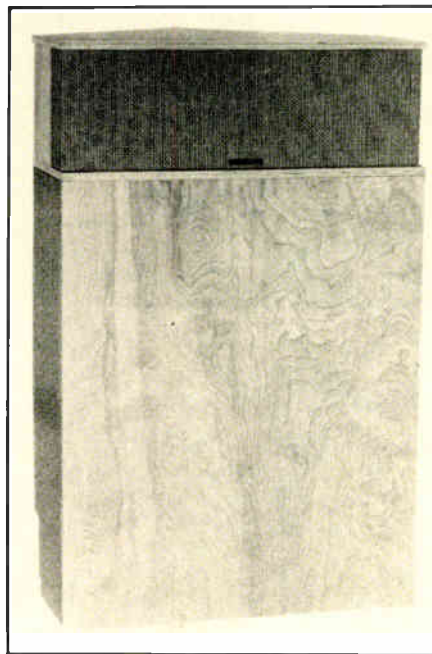

The Klipschorn—a folded corner-loaded horn.

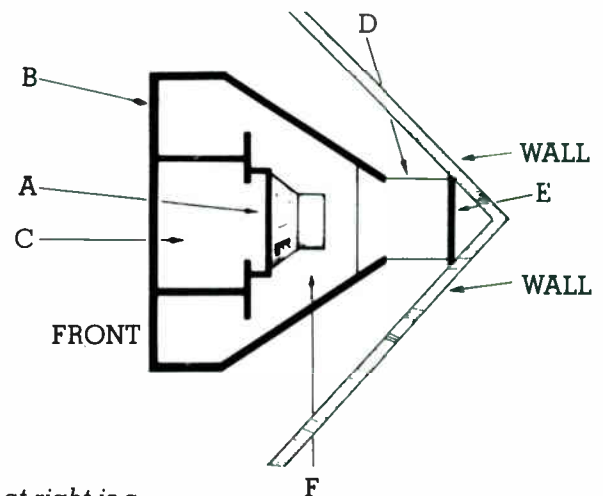
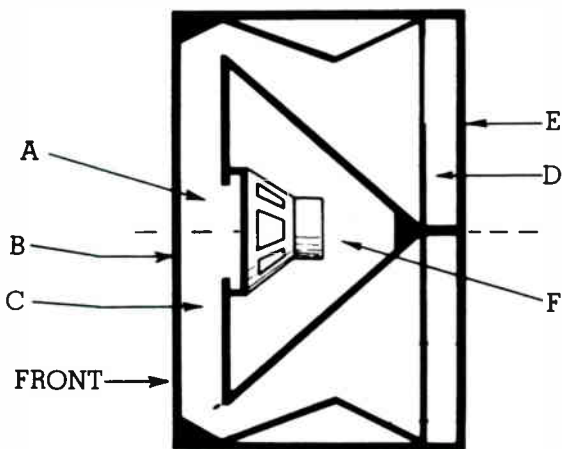

Klipschorn cross-sections: at left is a side view, at right is a top view looking downward. Letters indicate surfaces shown in both diagrams.

Satisfying, pure digital reverb at an affordable price.

Now with Version 1.3 Software.

The 200 is the first economical general-purpose digital reverberator designed for recording studios, musicians, film/video production houses, and broadcasters. Its versatility and high quality are matched only by its low price.

The 200's advanced technology brings you:

Hall, Plate, and Chamber programs — each with 10 preset variations — all in full stereo.

Size control — from a closet to the Taj Mahal — dramatically increasing the versatility of each program.

Adjustable pre-delay and attack time.

Programmable non-volatile memory for storing up to 30 user settings with instant recall.

Selectable diffusion, reverb time, contour, cutoff, and early echoes.

Affordable, natural-sounding digital reverb is not impossible — call your Lexicon dealer today.

Reverse control functions for stage performances.

Human-engineered panel controls for easy, intuitive operation.

On-board mixing.

Input level switch to accommodate a wide range of instruments and input sources.

Balanced input and output connections with a maximum signal level of +24 dBm.



lexicon

60 Turner Street
Waltham, MA 02154 USA
(617) 891-6790
Telex 923468

Export:
Gotham Export
Corporation,
New York, NY 10014

Circle #007 on Reader Service Card

World Radio History

not, per se, the efficiency, but the fact that as the efficiency goes up, the distortion goes down, almost inversely proportional. Let's take an ordinary direct radiator loudspeaker: a piston vibrating in a hole in a box.

Let's play like this cone is radiating two frequencies: 100 Hz and 1000 Hz. Now, as the 1000 Hz is being vibrated back and forth by the 100 Hz superimposed frequency, the cone is moving towards you and away from you, carrying this 1000 Hz with it. Well, the same thing happens with the Doppler effect: when you listen to a vehicle going by blowing the horn, the pitch decreases. If we could make this vehicle go back and forth, towards and away from us, the pitch would go up and down, it would flutter. It would be frequency modulated; that's a form of distortion that can be very irritating. Well, that's what happened in this loudspeaker. Now, if we can find out some way of making the diaphragm perform a smaller amount of excursion, suppose we load it in some manner, with a horn, so that the diaphragm has something to push against, and it doesn't have to move as far to give an amount of acoustical pressure, then you can see that the total motion is reduced, the Doppler effect would be reduced, and that particular form of distortion would be reduced.

"I'd been building horn loudspeakers since 1946, at least commercially since '47, and I was extolling the virtues simply because of its high efficiency, but as the philosophy developed in my little pea brain, I could tell them about the reduction in distortion. Now of course, some of the purveyors of less efficient speakers, direct radiator types, insisted that modulation distortion isn't important. I can demonstrate by mixing the two frequencies in a direct radiator that you can hear the side tone of distortion, the flutter, the tones that weren't supposed to be there."

In addition to the multitude of landmark papers that Klipsch has published on horn theory, stereophony, and distortion in loudspeakers, he has patents in several fields besides audio, including geophysics and firearms. In 1978, the Audio Engineering Society awarded Paul Klipsch its prestigious Silver Medal, affirming the audio world's respect for his pioneering work. Unanimous respect, however, is not necessarily unanimous agreement, and there have always been others, like Amar Bose, who chose to attack the problem differently.

In 1956 Amar Bose, then an assistant professor of electrical engineering at Massachusetts Institute of Technology, went shopping for hi-fi speakers armed with his considerable knowledge of electronics to help him plow through the plethora of specifications available

on these devices. He selected the best speaker and took it home. It sounded awful to him. How could this be? Obviously, what made a speaker sound "good" was more than a matter of "objective" specifications; it was also largely dependent on the way people perceived sound. His curiosity piqued, Bose began a research program in physical acoustics and psychoacoustics at MIT to investigate some of these questions. He filed a number of patents on devices he developed based on the information he



The Bose Professional System: 802-C control electronics (Top); two 802 Series II Articulated Array Loudspeakers; and the 302 bass system.

gathered, and in 1964 he formed Bose Corporation to develop his concepts into products.

As with Klipsch, Bose recognized the importance of ongoing research within the company, and the necessity of having very tight quality control over materials and processes (Klipsch has never published plans for his horn design because he believes that people would make them badly and then blame his design). Although much of Bose Corporation's early funding came

from defense-related contracts, in 1968 Bose kept his promise to the listening public by introducing the Bose 901, a speaker system that encompassed several radical approaches to loudspeaker design. The 901 was small, only about two cubic feet, and had an unusual pentagonal shape, with one 4½" speaker on the flat front face of the cabinet, and four of the same speakers on each of the two angled, rear faces. Furthermore, the 901 was accompanied by a small electronics unit. Bose's research had indicated that one of the reasons conventional speaker designs did not sound pleasing in the home was that the mid and high frequency portions of the sound were delivered directly from the speaker to the listener, whereas in a live music situation, most of that information was reflected off of walls and ceilings before reaching the listener, thus adding the natural ambience that makes live music warm and pleasant to listen to. Bose's speaker delivered almost all of its sound out of the rear faces, which were intended to be placed near one of these boundary surfaces, so that the sound would bounce around the room before reaching the listener. The speaker in the front of the cabinet delivered the all-important direct sound, essential to localization and intelligibility. This approach was termed Direct/Reflecting.

The 901 also introduced the concept of the full-range driver. Paul McKinley, of the Bose Corporation describes the philosophy: "In the course of designing any loudspeaker, the designer has a number of parameters that he has to deal with. They include such things as frequency response—you want a relatively flat spectrum—but they also include things like distortion, power handling, reliability, overall efficiency or total sound pressure capability. This is not to be confused with power handling because thermally you could design a loudspeaker that could take a thousand watts, but mechanically maybe it could only take a hundred watts, due to excursion limitations. You put all these into the pot and it becomes a tremendous orthogonal problem.

"What we found was that if you take the constraints of frequency response off the transducer designer, and let him maximize the other performance parameters, such as power handling, reliability and efficiency, there's a big win there. Instead of using conventional woofer/midrange/tweeter and crossover networks, we instead opted for letting the transducer designer optimize the loudspeaker itself to be a very, very reliable device, and correcting whatever frequency anomalies it may exhibit with an active electronic equalizer. This is a much more accurate and precise way to do it, not only immediately because you can electronic-

THE PRICE OF BEING A PERFECTIONIST IS HIGH.

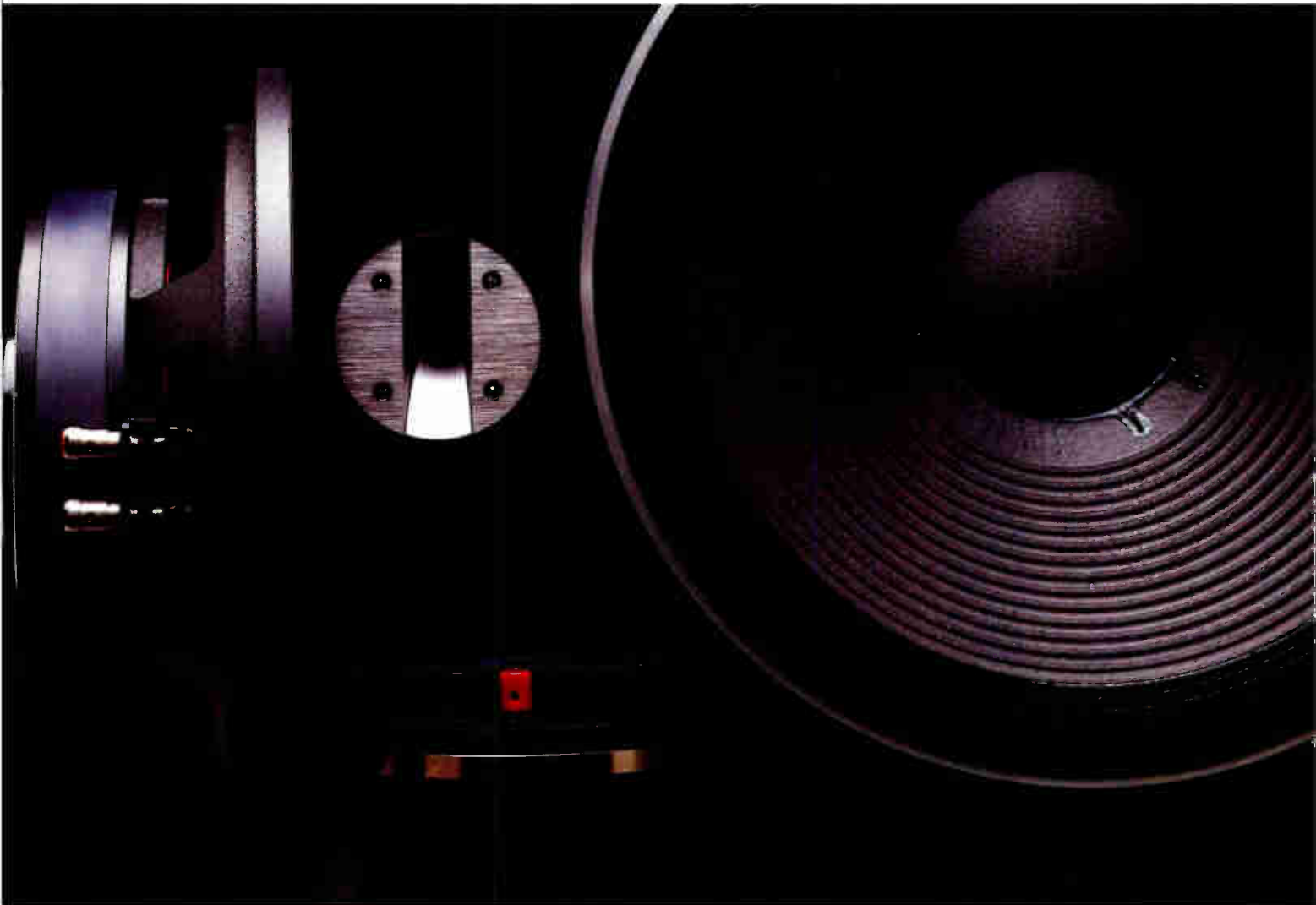

We're not out to sell TAD professional loudspeaker components to everyone.

Only those who can afford to eliminate the word "compromise" from their vocabulary.

Obviously, you won't hear that word bandied about amongst the engineers at TAD.

Because our entire existence is dedicated to the perfection of audio. To accomplish this you can't be willing to skimp, to cut corners, to make sacrifices, to settle for less than the best.

That's why every device we make is assembled entirely by hand. With the precision you'd expect of a watchmaker. Our diaphragm assembly, for instance, is mounted with a gap precision of ± 1 millionth inch to ensure high reliability.

We use tremendously expensive evaluation and testing techniques with the aid of computers and esoteric acoustical equipment like a Doppler Laser, a Laser Holograph, an Impulse Generator, and

an Anechoic Chamber, to mention just a few.

Finally, we feel to make first-rate products you can't settle for second-rate materials. So we use the finest money can buy. Such as Beryllium diaphragms and Alnico magnets.

Consequently, the sound we produce is totally uncolored, uncluttered, and unmatched.

Which is why our professional loudspeaker components are preferred by musicians, audio-system designers and recording engineers who are perfectionists when it comes to sound.

And who feel that the price of *not* being a perfectionist is high.

TAD Technical
Audio Devices

Professional Products Division of Pioneer Electronics (USA) Inc.
5000 Airport Plaza Dr., Long Beach, CA 90815. (213) 420-5700.

ly create an equalization curve which is very precise and very repeatable, but long term as well. Because, if you're dealing with, say, a woofer/tweeter combination with crossover components, you're typically dealing with large value capacitors, and they age with time. They have to handle high amounts of current because the load impedance of the drivers is fairly low, and it's just kind of a brutal environment for a capacitor. They also waste energy because some amount of energy has to be dissipated in the crossover, as opposed to directed to the drivers. That's the basic philosophy behind full-range drivers; we simply believe it's a better way to do things."

The concepts of Direct/Reflecting and full-range drivers are found throughout the Bose product line, although every product does not embrace both concepts. Because the full-range driver concept is almost unique to Bose, much work has gone into the design and construction of the drivers that are used. The choice of 4½" for the driver size is based on the tradeoff of the driver's ability to move quickly enough that it can be equalized for flat high frequency response, with the driver's surface area and excursion capability which determine its ability to reproduce low frequencies. Furthermore, the drivers are optimized for their particular function: the 4½" drivers used in Bose professional products employing the full-range driver idea is not at all the same as the driver in the 901, and neither is the same as the drivers originally used in those products, improvements having been made to accommodate research developments and new materials.

In fact, Bose professional products were created, in part, because the 901 had become so popular that they were commonly found being used in small and medium sized sound reinforcement systems with the rear faces aimed forward. If Bose speakers were going to be used in sound reinforcement situations, reasoned the Bose engineering team, then they should be designed for the job. After the requisite research, the result was the 802 Articulated Array loudspeaker system. Although the 802 (now 802 Series II) resembled a backwards 901, it was in fact a very different animal. The 802 uses eight full-range drivers on two angled faces, and has matched electronics—the 802-C System Controller—but it is not a Direct/Reflecting speaker because its job is not to create ambience as in a living room environment, but to reinforce a sound source in a space which will provide its own ambience. The cabinet is ported by two tuned air columns, and contains several chambers to load the drivers, in addition to being in a road-worthy package which allows stacking or hanging in virtually any way imaginable.

Further considerations given to the task of sound reinforcement include greater long-term power handling than the 901, and the Articulated Array, which McKinley explains: "The Articulated Array has to do with the acoustics of what happens when you put multiple identical drivers into an acoustic array. If you simply take a bunch of 4½" drivers and hold them to a flat plane, they interact in some very strange ways, and if you look at a polar plot you can get some very strange effects. What the Articulated Array does is angle the drivers away from each other slightly so that you get a very smooth polar plot with fairly broad, even dispersion."

In order to gain some of the power handling, a bit of the deep bass was sacrificed, and the bass is a bit limited in maximum output because of the limited number of small drivers in each cabinet. For many situations, the 802's bass response is quite adequate, but the rise of disco and synthesizers created demands for very deep bass at very high sound pressure levels. This prompted the creation of the 302 Tandem-Tuned bass system as an adjunct to the 802. To build the 302, Bose engineers had to look at the problems of high level, low frequency reinforcement and try to improve on current designs. Typically, one or more drivers are placed in a box, with either a horn loading scheme and/or some sort of port to provide loading to the rear of the speaker, while the front radiates more or less directly. At the port resonance, very little energy is needed from the speaker to excite the air in the cabinet, but above or below it, it is of little help. Going below the port resonance there is no loading on the rear of the speaker, and unfavorable conditions may force the speaker into excessive, possibly self-destructive excursion. Above, the speaker takes over the work, and less excursion is needed as the frequency increases, but there comes a point where the port is out of phase with the speaker, and the speaker must provide extra energy to overcome the port's effect.

Bose engineers once again found a unique answer to the problem. The 12" driver was rotated 90 degrees away from the front of the cabinet so that it faces the right side, and the rear of the speaker was loaded with a port tuned to 55 Hz. It was found that the out-of-phase point was about an octave above that, so rather than compensating the cabinet electronically and forcing the speaker to work harder, a second ported chamber was added in front of the speaker and tuned to 110 Hz, thus providing acoustic compensation. Each 302 cabinet contains two of these Tandem-Tuned systems, and the result is roof-raising levels of bass out of a cabinet which is only about seven cubic feet. The 802-C System Controller looks at how its out-

puts are connected (full-range 802s, passively crossed-over 802s and 302s, or bi-amplified) and automatically selects appropriate equalization and LED display.

John Meyer has been engaged, for the last fifteen years or so, in an ongoing quest to make "loud music" no longer a dirty expression by making the speaker system and the room cleaner. An early manifestation of Meyer's unconventional approach to speakers was a system employing a huge horn known as the Glyph, about which Stewart Brand wrote in the *Last Whole Earth Catalog*, "The first loud sound I've heard that didn't make me want to run." The first real step toward his present systems, however, came while he was working with San Francisco's Harry McCune Sound.

"In the early '70s, with the first systems I built at McCune's, we didn't know where the problem was," says Meyer. "We didn't know if it was the hall, or the variation in speakers, or just the different types of music that made it so difficult to have successful concerts from the artist's point of view. So the first project was to build a consistent system that we could put together and use night after night that was preset and pre-done. This was the beginning of a long experiment with fixed systems, which meant that you couldn't change the crossover; and all the EQ, or any change, had to be done from the mixing console or a change of microphone or something of that order."

This was the genesis of the JM3 system, which was a triamped, horn-loaded system with a fixed crossover; Meyer's first usage of electronics matched to the speaker, a concept that he, like Bose, embraces even more firmly now. But even once the JM3 was tested and found to be of the desired consistency, there were still problems, obviously from the room. Meyer continues: "We took data for about two years as we did various types of indoor and outdoor concerts, and came to the conclusion that the room was an independent factor; the speakers could be set the same and certain types of characteristics seemed to come up all the time. This obviously meant that we were going to have to develop a tool to look at what the room response was going to be with people actually in the room, because we could see that an empty room changed quite a bit sonically as it became a full room. There's very little data on full halls because it annoys the audience to try to run any test source." We tried different strategies: in 1973 we developed impulses and signal averaging, which means that you can put out a small click and look at it many times over using a computer.

Meyer left McCune with these questions in his mind, and spent a year in an acoustics laboratory in Switzerland

ONE BOX.

The MCX-106 Powered Recording Mixer gives you more functions than any other portable system.



WE STARTED WITH THE BASICS.

That means 6 input channels, each with trim control, LED peak indicator, and 3-band EQ. . . a stereo tape deck with dbx noise reduction. . . compression circuitry with an LED indicator. . . a full-octave graphic equalizer with a bypass switch. . .

...and so you can keep track of what's going on, there's a headphone monitoring system and fluorescent, assignable bargraph meters.

But that's just for starters.

MORE THAN A MIXER.

Four mixers, in fact. The MCX is an independent on-stage monitor mixer.

It's an effects mixer. Every channel has its own post reverb/effects send.

It's a main house mixer, with an extensive patch bay and an assignable auxiliary input.

And finally, it's a stereo recording mixer. A full-function, microprocessor-controlled cassette deck lets you record live performances, mixdown from multi-track, copy from masters, and do voice-over taping or sound-on-sound with the "pannable" aux input.

YOU CAN TAKE IT WITH YOU.

The MCX isn't another home-recording "ministudio." With its built-in, 300W power amp and tough road enclosure, it's a go-everywhere, do-

everything record/mix/playback system.

Take the MCX out on-the-road to record a live performance, then into the studio to create a demo tape. Or use it to *simultaneously* mix pre-recorded material with live singing tracks.

The MCX belongs wherever pro-quality audio is important.

FREEDOM OF CHOICE.

Employ the components of the MCX in one integrated system, or use them as separate and independent tools of production. Or put the MCX to work with other audio gear, using the patch bay for all your

re-routing techniques.

The MCX-106 provides a sound foundation for your musical recording project — your live

performance — your multimedia presentation — your A/V training film — or your video post-production strategy.

In just one easy-to-use, easy-to-move box.

Find out how much more the MCX-106 can do for you; call or write for our Applications Guide and complete technical data:



TOA Electronics, Inc., 480 Carlton Court
South San Francisco, California 94080
(415) 588-2538

In Canada: TOA Electronics, Inc.
10712-181 Street
Edmonton, Alberta T5S 1K8 (403) 489-5511

1984 TOA Electronics, Inc.
dbx is the registered trademark of dbx, Inc.

power

power

4 WAY/3 WAY STEREO ACTIVE CROSSOVER
FEP 204

DEALER INQUIRES WELCOME

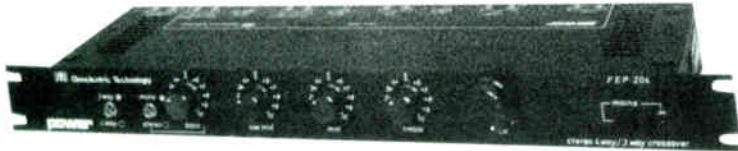

POWER FEP 204
COMELENTRIC CROSSOVER
4 CROSSOVER FREQUENCIES AT EACH POINT
FRONT PANEL BALANCE CONTROL
COMPATALAZATION OF SUB-BASS
3/4 WAY OPERATION
+20dbm OUTPUT

COMELENTRIC PROCESSING PRODUCES NO PHASE OR AMPLITUDE DISTORTION AT THE CROSSOVER POINTS. THE FEP 204 PROVIDES A STEREO SUMMED OUTPUT OF EACH OF THE 4 PASSBANDS. A SQUARE WAVE RECOMBINATION TEST QUICKLY PROVES THE FEP 204'S PRECISION FILTERING. LISTENING REVEALS SOUND OF STUNNING TRANSPARENCY !!!

power U.S.A.
ALAGATRONICS INC NYC

11 AVENUE OF THE AMERICAS
NEW YORK, NEW YORK 10013
(212) 219-0988

Circle #009 on Reader Service Card

rh SMART and SMART JR.

HI-TECH SOUND SYSTEMS pats. pend.

Microprocessor electronics control very compact R-H speaker systems to achieve studio monitor quality sound at very high sound pressure levels.



X-SERIES PROCESSORS



- Incredible 134 dB SPL, 40Hz-17KHz
- Fail-Safe System Overload Protection
- Time Coherent System Performance
- Compact Modular Array for Fast Set-up
- Optional Flying Hardware

NEW FOR 1985

SMART SUBWOOFER compact and fail-safe.

SMART JR. SYSTEMS with cost-effective single amplifier operation.

Designed for:
LIVE MUSIC CLUBS • DISCOS
THEATERS
CHURCHES
CONCERT RE-INFORCEMENT

WRITE OR CALL TODAY FOR FULL INFORMATION



RENKUS-HEINZ, INC. DRIVERS • HORNS • SPEAKER SYSTEMS
17851AB Sky Park Circle • Irvine CA 92714 • (714) 250-0166

Circle #010 on Reader Service Card

working with a computer analysis system and fabricating a better loudspeaker. He took this knowledge and produced the John Meyer ACD studio monitor, a quite expensive system which came complete with subwoofer, matched electronics, and a state-of-the-art power amplifier. One problem with the ACDs was that each speaker was so matched to its electronics that all repairs had to be sent back to Meyer (and still are) in order to maintain the matching of drivers and electronics. After returning to the U.S., Meyer Sound Laboratories, Inc. (MSLI) was formed to make sound reinforcement systems that were a logical evolution from the JM3. To avoid the trap of the ACDs, Meyer began to shift weight onto writing tight specifications for the drivers and finding manufacturers willing to try to work with him on them, and then enforcing them with rigorous 100% incoming materials testing.

"For the MSL3s [Meyer's large scale sound reinforcement speaker system] and the UPA1s [his smaller sound reinforcement system, current model is the UPA1a], a part had to meet a certain specification before it went into the product, and the electronics had to meet a certain specification so that you can change any electronics or any driver and keep the same characteristics," Meyer explains. "We do incoming testing on *everything*, any drivers we get we test to a very tight spec. Now the manufacturers are doing some of the pre-testing themselves; we're writing a minimum distortion spec because they're starting to get more interested in selection."

All of MSL's systems, including subwoofers and slant stage monitors, operate with an electronics unit which is matched to the design and provides not just frequency correction, but also crossover (except the 833 Studio Monitor which is passively crossed over), phase correction, and a speaker protection circuit which monitors the signal at the speaker terminals of the power amplifier for distortion and, if distortion is detected, reduces the input to the amplifier accordingly. Meyer's reasoning is similar to Bose's:

"It's really a very simple concept; instead of trying to make the woofer flat, we try to make the woofer consistent. We'll make it flat with electronics. What is the best way to make this woofer? We don't care if it has 20 dB up at 400 Hz, if it's that way every time. Artificially weighting the cone to make it have a flatter response just causes you to lose power. There are things that we can't control very well: polar patterns can be modified to some degree, but distortion you can't do anything about without getting into very complex servo systems, and even the best servo systems can only drop the distortion by ten times. You don't want to start with 10% to bring

it down to 1% when you could get it to 1% directly. It's a simpler system and, in PA, simplicity is important."

Meyer's speakers were intended to meet the needs of clients such as the Grateful Dead, Jefferson Starship, Journey, and Rush, who play huge spaces and feed the speakers equally huge amounts of amplifier power to get the very high sound pressure levels of a rock concert. As it is said around MSLI, "They can go balls to the wall 24 hours a day." In order to achieve these levels, speakers are typically stacked, but with box-like speakers a stack means that the drivers are physically separated from each other, leading to aberrations and less than maximal coupling. Meyer designed his speakers to fit into large arrays, with each speaker having a predictable effect on the dispersion of the system, and the drivers in close proximity to each other to insure proper coupling and to act like a single point source, thus maintaining time coherency.

The result is so clean and clear that Meyer speakers are being employed in many sound reinforcement situations that have nothing to do with rock and roll, such as the delicate task of reinforcing opera star Luciano Pavarotti, or the permanently installed system at the Oakland Coliseum. Meyer also produces stage monitor systems using the same principles, and these have provoked awestruck loyalty from almost everyone who has tried them. In 1983, Meyer's accumulated experience led to the introduction of the 833 Studio Monitor, a system which contains two speakers and, of course, matched electronics, but no power amp. Why? "People are in love with their power amps," laments Meyer, "it's impossible to break that." So instead, he published an article giving recommendations for selecting power amps.

Creating a consistent, flat system was only half the battle, however. The real difficulty still lay in trying to correct for the room's anomalies. In Meyer's case, most of the rooms involved were more likely designed for hockey than for music, and the elevated levels often provoked an unpleasant boominess which destroyed the speaker's clarity. Recently, Meyer achieved a breakthrough in understanding room phenomena. Using the latest in computer measurement equipment he has developed a technique which he calls Source Independent Measurement (SIM).

"Everybody's quest is to use music itself as the test source, but it has taken up to now to come up with the computer technology to use music itself as the reference signal, rather than any other other types of signals that have been used—impulses, noise, sine wave sweeps, or what have you—and to verify it in concert situations. Two groups have been very cooperative, Rush and the



The photo shows a 15 inch bass driver in a one cubic foot (28 liter) enclosure, a 6 inch bass driver in a one-quarter cubic foot (8 liter) enclosure tuned for use with the ELF™ System technology. Also shown are a professional version of the ELF electronics, and the ELF electronics in module and integrated circuit formats. The 15 inch system can produce 94 dB SPL at one meter from 16 to 150 Hz while the 6 inch system can produce the same frequency range at 82 dB SPL or 32 to 150 Hz at 92 dB SPL.

Grateful Dead, in letting us at times run some impulses right when the crowd was coming in, to verify the responses we were getting from the music, so we could run both types of tests in the room with people actually in it. This has been very helpful in verifying the results of SIM. Now we can actually establish characteristics in the occupied room to show evaluations and performances of systems."

Essentially, SIM works like this: a place in the signal chain, typically the output of the mixing console, is designated as the reference signal, and fed through a digital delay into the reference input of a dual-channel FFT (Fast Fourier Transform) analyzer. A calibrated laboratory microphone feeds the measurement input of the analyzer, and the delay is adjusted to compensate for the propagation delay from the speakers to the microphone. Music is put through the system and data are compared. With a little smoothing to compensate for spurious effects like long term reverb build-up, a good curve for the room response is yielded. But that's not all.

"One of the most exciting things that came out of this project, and we were wondering if it was possible, is to be able to correct for these room problems," Meyer says. "It's one thing to be able to measure them and say, 'Here they are,' but how could you correct for them? It always appeared to be one of these logic problems: how could you correct for something that appeared later in time? Your initial signal coming from the speaker hits the person, and the echo, obviously, takes longer and comes back and hits the person later. How can you put something in series with the speaker to get rid of this later phenomenon? It looked impossible, and the solution wasn't at all obvious. It took years of talking to people about it to realize that there are techniques called Echo Suppression that could work in this case. In other words, you could start another signal in the speaker that would meet the echo signal and cancel it. Obviously, a tricky type of maneuver here."

Indeed, Meyer had to carefully evaluate the technique to determine how effective it was, if it could be used at all. The idea that he operates on is to treat the room response, with all the ripples and anomalies created by reflections, as a complex filter, and to provide complementary correction signals for both frequency and phase. The technique works on frequencies up to a few kilohertz; Meyer recommends using absorptive materials to treat high frequency reflections because of the immense number of filters needed to correct the whole spectrum. Testing this technique with Rush and the Dead produced marked improvements in the clarity of the sound, even in venues renowned for their boominess or generally poor acoustics.

To implement this concept fully, a tool to provide the correction signals (inserted just after the reference point in the system) was needed. "We developed our own parametric equalizer, the CP10 especially for this purpose. If you take one and put it in the peak mode, and you take another and put it in the dip mode and the 'Q's and other settings the same, there will be no time delay through the unit other than the propagation delay of the op amps. It will be in the microseconds, no accumulated delay. I've shown this to some of the PhDs at Stanford and they go, 'That's impossible. That can't be because if filters create delay, that would imply that the next filter would create lead,' and we know that lead is going to be a real touchy issue. It was Dr. Julius Smith that came up with an explanation called 'deconvolution.' We realized that this thing was creating a complex conjugate in the time domain. In an acoustical situation the phase response doesn't just get better, it goes back to zero—the delay is being subtracted. There isn't any law of physics being broken here, it's just that it was something that wasn't obvious. No one suspected that you could deal with this in the time domain. We've been too long thinking of the frequency domain and the phase domain as separate entities and sometimes forget that they always coexist."

Now that Meyer has created a consistent, coherent speaker system, and a means of measuring and correcting for room problems, he is armed with the tools to redefine concert sound and let music fans really hear what the artist is creating.

Other environments in which a sound engineer is charged with making the sound good, such as in a studio, share the problems of room response and time smear, along with the need for a loudspeaker which will deliver the unvarnished truth. The consumer at home, on the other hand, does not need a truly accurate loudspeaker, since the objective is for the speaker to provide the consumer with enjoyable sound for source material over which (s)he has no control. This does not mean that it is easier designing consumer speakers, it just means that accuracy is not usually a primary, or even desirable design criterion. Price and size are typically higher priorities. This very real distinction in approaches is another illustration of the application defining the design, an illustration which Ed Long, with feet planted firmly in both the consumer and monitoring camps, paints vividly.

"I learned early on that there's a big difference between monitors and consumer loudspeakers," he says. The distinction seems to be lost on some people; some people seem to pick monitors which 'sound best'. A recording engineer or a broadcast engineer isn't sitting

there to be subjectively pleased. He'd like to be, but he's got control over whether he is or not. As a consequence, he needs to have everything under control; he needs to have his tape machines aligned, he needs to know that the console isn't messed up, that there aren't noisy ICs in it or that the EQ pots aren't all going haywire. If he's got control over it, he can do something, but if he's trying to put EQ on something and the equalizer isn't working, he's in big trouble. The same is true of the monitors. If the monitors are not precision calibrated acoustical transducers that are made to be as clear and precise as they can be, then he's got to fight that.

"I didn't start out to get into building monitors, and I still design consumer equipment. The difference, though, is that when you know how to design a successful consumer loudspeaker, what you do is make the loudspeaker reproduce the current type of program material—radio, records, tapes, and what have you—very pleasantly, and to try to have it reproduce the best of these kinds of program materials with pretty good sound and yet not allow the poorer quality ones to come through and show how really bad they are. And it's a trick. You try to make the thing come through with as much clarity as you can, but always guided by certain psychoacoustic knowledge that you use when you design loudspeakers which isn't really in books. It isn't published; it's in another area. I had the fortune to have some training in psychoacoustics, and look at it the way that a psychoacoustician looks at it, rather than just an engineer. I've always tried to apply that knowledge that I picked up then and it seems to work. When you're designing a monitor, you don't want any of that at all; you don't want any of the obscurity, you want to just bring that sound right through and let it be exactly the way it's supposed to be on tape."

Like Klipsch and Bose, Long speaks from . . . well, uh, Long experience, having produced award-winning speakers as far back as the early '60s, but, unlike Klipsch and Bose, rather than forming a company to mass produce and market his designs, he has chosen the route of independent consulting. What this has meant is that Long has designed speakers, audio, or RF products for (or in collaboration with) a wide variety of firms ranging from GTE/Sylvania and General Dynamics to Ampex and UREI. Long has synthesized the knowledge gained from this broad background into a perspective which is iconoclastic and fervently opinionated, but never solemn or contentious.

This is well illustrated by Long's development of Time Align® techniques in the mid-'70s, which made his

name a household word in recording studios. Although the importance of time delay between drivers in a multiple array loudspeaker system had been recognized since shortly after they were introduced, a technique for analyzing and correcting for this phenomenon had not been clearly set out before Long's 1976 paper on the Time Align® technique. Time Align is a registered service trademark which he licenses to various manufacturers. Many in the industry found a good deal of sense in the idea of aligning drivers in a multi-way system to eliminate time delay between them, thus preserving the coherence of transient waveforms, but others disagreed, often vehemently. Some still do: both Klipsch and McKinley expressed reservations about the validity and importance of this concept.

Long accepts this criticism with a shrug: "If people say, 'I don't hear anything,' I don't disbelieve them. I say, 'Fine, you probably don't.' I said at an Audio Engineering Society meeting one time, 'If you don't hear the effect of Time Align we aren't going to make you turn in your AES cards, snip the buttons off your shirt, and tear your epaulets off with the drums rolling in the background.' If you don't hear it, that's cool, but don't say that everybody else can't hear it. Give a break to the people who can hear it."

In 1976, Time Align® was a concept, a paper, and some prototype speaker designs, but it was an idea whose time soon came. Shortly after presenting his paper to the Spring 1976 AES convention, Long was approached by Jim Cunningham, an associate from earlier work in Chicago on four channel sound. Cunningham worked at UREI Electronics, which was headed by Bill Putnam, another transplanted Chicagoan, and he soon sparked Putnam's interest in the idea. Long entered into a collaboration with UREI on a design, and both contributed their ideas. The design was based around the industry's workhorse speaker, the Altec 604 coaxial. Putnam lengthened the horn, lowering its cutoff and thus creating greater latitude in the crossover design, which was fine with Long. But he accepted some of Long's ideas cautiously, being understandably nervous about a major new project based on a commercially unproven design.

"They weren't sure about some things," recalls Long. "For instance, I ran with a ported system on the 813 that was different than what anybody else also did at that time. Bill Putnam was against the port; he'd never heard a good one and he was pretty convinced. I considered it an achievement that I told him I could do it and he believed me. He was pretty adamant about stuff, not a push-around guy. He really had good, strong feelings

—PAGE 104



16-TRACK REALITY

Don't just dream about owning your own 16-track. Now you can get all that extra flexibility for a whole lot less than you might think.

With models starting as low as \$5900*, each Fostex B-16 1/2" 16-track recorder is complete with:

- Dolby + C noise reduction circuits (defeatable) on individual record/reproduce cards
- rock stable 3-motor transport mounted on a 1/4" machined alloy plate
- 15 ips with $\pm 15\%$ variable speed operation
- multi-pin connector for video interlock synchronizers
- Killer Sound

Why even consider a re-built old 2" machine? At two, three, even four times the price, it won't sound as good as the B-16. And it won't even perform as well as the B-16, configured with some of the options.

For example, the model with independent tape monitoring is really a whole package:

- direct drive capstan motor with phase locked loop speed control
- 7" rack mount unit with 16 independent channels of decode & reproduce (defeat switch)
- remote control unit with individual track select buttons, headphone jack and level control, line out jack and a VU meter for fast alignment

You'd have to pay almost ten times the price of a B-16 to get this kind of dedicated monitoring function. Tape reproduce is entirely separate from the record/sync electronics.

Which makes the compact B-16 perfect for live audio and video remotes. It even has handles.

And it's as easy to use as it is to own. You can expect nice user-friendly touches like:

- blinking track numbers for record ready status
- real time tape counter with search-to-zero from either direction
- servo control over reel rocking in edit mode
- spot erase capability
- coarse and fine pitch controls with blinking LED for ON status
- optional full function remote control and auto locator

Increase your audio production capability while decreasing your costs. You'll not only save on your initial investment, but operating costs as well — both tape and maintenance.

Right now, the B-16 is the smart move in 16-track hardware. Let your Fostex Professional Multitrack Dealer^o prove it. For real.

- * Suggested retail
- + Dolby is a registered trademark of Dolby Labs, Inc.
- ^o Just call us for the nearest one

Fostex[®]
PROFESSIONAL MULTITRACK

FOSTEX CORPORATION OF AMERICA 15431 Blackburn Avenue, Norwalk, CA 90650 (213) 921-1112

COTTON CLUB

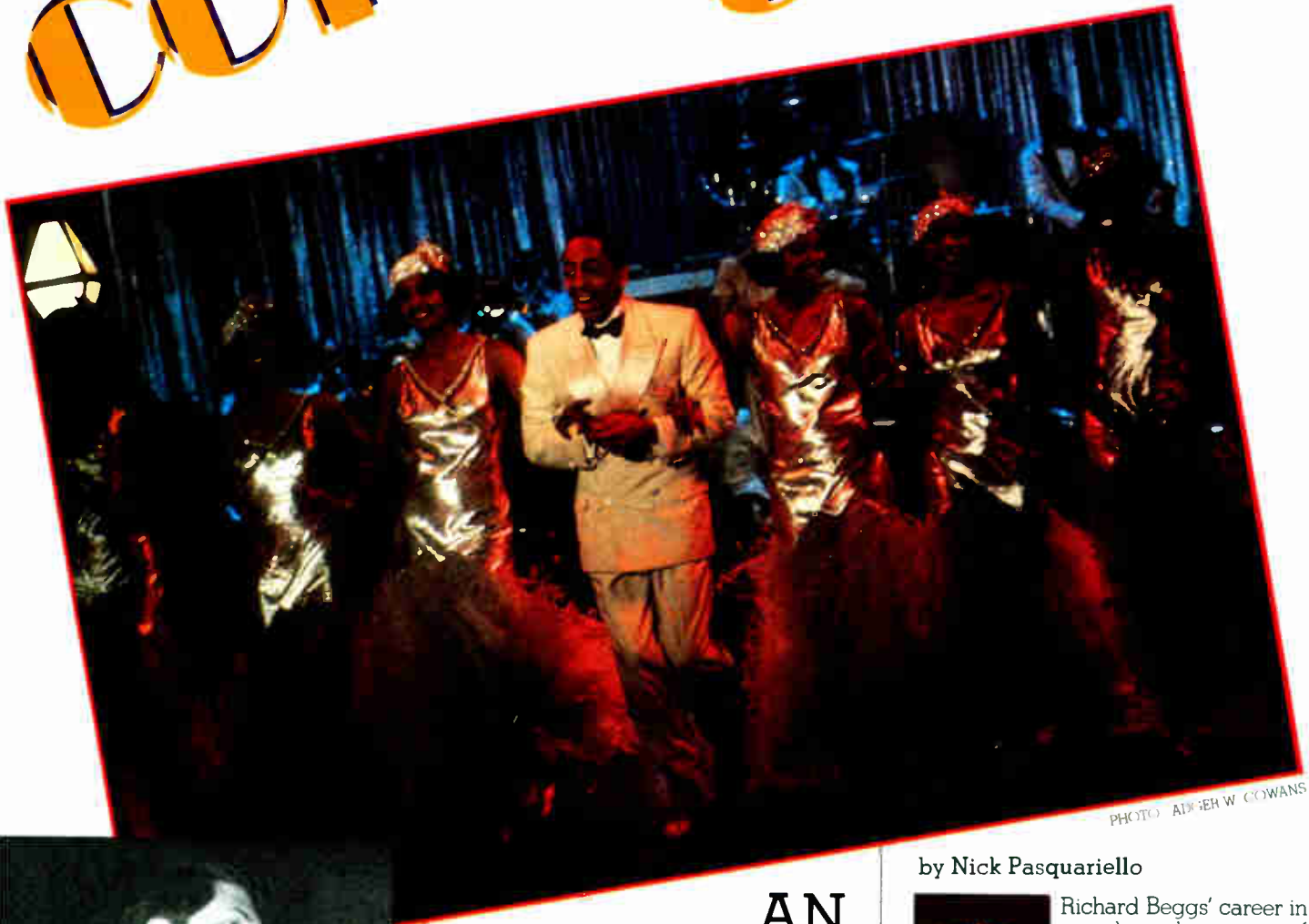

PHOTO: ALFRED W. COWANS

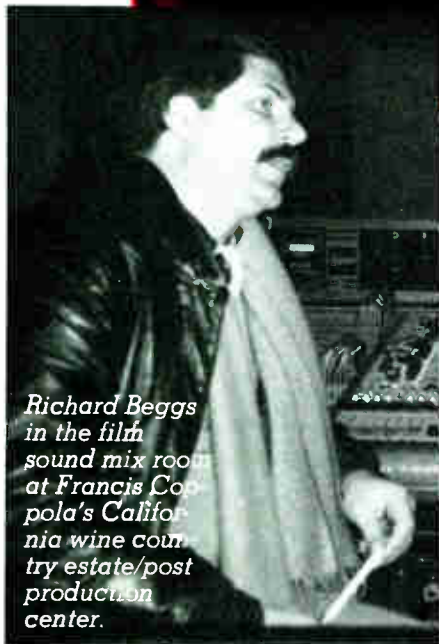

PHOTO: DAVID SCHWARTZ

Richard Beggs in the film sound mix room at Francis Coppola's California wine country estate/post production center.

AN INTERVIEW WITH FRANCIS COPPOLA'S SOUND DESIGNER RICHARD BEGGS

by Nick Pasquariello



Richard Beggs' career in sound is a classic story of being in the right place at the right time. During the 1960s, San Francisco was a mecca for nascent rock and roll musicians thirsty for stardom. Beggs saw an opportunity to develop an early fascination with sound into a potential business. And so, at virtually the amateur level he began recording demo reels for budding rock bands. This was a subsistence level occupation, but as Beggs' skills (and those of the bands he worked for) improved, his income increased. In the late '70s, Beggs' studio occupied space in Francis Coppola's post-production building. Picture editing and sound mixing on *Apocalypse Now* were commencing there, and Beggs was hired to work as part of this team.

Since the early 1980s, Richard Beggs has been Sound Designer on all of Francis Coppola's feature films, usually doubling as re-recording mixer. He also holds the distinction of having worked with Coppola longer than any current member of the Zoetrope filmmaking team. In addition, he has been re-recording mixer on seven other more conventional theatrical features with other directors (see list below). As this article goes to press, Beggs begins prepping the sound design and mixing of Coppola's first cable television show: *Rip Van Winkle* for HBO's *Faerie Tale Theater*. This marks Beggs' first assignment using only video (no film) sound materials; characteristic of a craftsman always open to exploring new technological territory.

As part of the Coppola/Zoetrope post-production team, Beggs helped implement a number of Coppola innovations in the use of feature film sound production. These include: use of two-inch 24 track audio technology in the sound mixing process and an automated sound mixing board. Both innovations were introduced in 1977 on *Apocalypse Now*.

The Coppola/Zoetrope team is known in the film industry for being in-



straight about the Coppola team's efforts to modernize an industry all too prone to technological lethargy.

What follows are Richard Beggs' film sound credits. Dates indicate the year the picture was released in the U.S.; asterisks (*) mark pictures directed by Francis Coppola.

*Apocalypse Now** (1979) (re-recording mixer and synthesist, Academy Award for the former credit); *No Nukes* (1979) (re-recording mixer); *Zulu Dawn* (1979) (re-recording mixer); *The Island* (1980) (re-recording mixer); *One from the Heart** (1981) (sound designer and supervising re-recording mixer); *The Outsiders** (1983) (sound designer and supervising re-recording mixer); *D.C. Cab* (1983) (re-recording mixer); *Mike's Murder* (1983) (re-recording mixer); *Rumblefish** (1983) (sound designer and re-recording mixer); *Repo Man* (1984) (re-recording mixer); *Ghostbusters* (1984) (sound designer); *Cotton Club** (1984) (sound designer and supervising re-recording mixer).

Mix: Why didn't the credit "sound designer" exist before (long time Coppola associate) Walter Murch virtually single handedly invented it?

Beggs: Movie making has always been compartmentalized. Movie making is divided into all these little fiefdoms or kingdoms: there's the camera department, there's the costume, there's the art department, there's the production recordist, there's the post-production mixer. And all of these people have their own area of expertise and their own order of importances and their own idea of how they relate to the picture. It's amazing that all the people get together and agree to get anything done. Even in the worst movies—the worst movie is a miracle.

Sound and picture and music have been traditionally very separate little

kingdoms, jealously guarded and somewhat autonomous, until they get to the mixing stage where, traditionally, the composer might show up, the picture editor shows up. All of these people don't necessarily have the same idea about what's going to happen.

Traditionally, music and sound effects have been a kind of loyal opposition. The composer frequently takes the position that: "My music is being buried in sound effects." The sound effects editor says: "In this scene the music is taking all of the action. What is the point of my cutting all of this stuff if nobody's going to hear it?" And the mixer is sitting there listening to these two people trying to mediate. The director, if he has the presence of mind, will say what he wants. Everybody has to go along with that.

Well, the sound design idea is that there is a person who, in addition to balancing the three aspects of the sound track—dialogue, music and effects—has an overall view and understanding of the picture and the director's intentions. And that person is a creative collaborator in the filmmaking process. The sound designer works to integrate these various

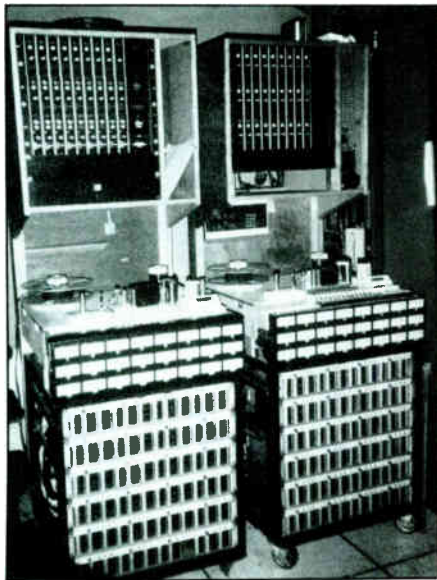

Coppola's studio boasts twin Ampex 1200 24 track recorders with dbx.

novative and for their willingness to take risks, but general recognition of their contributions to making the job of the filmmaker an easier, less costly one, has been slow to come. Indeed, a recent editorial piece in the industry bible, *Variety*, compared Coppola to Lee De Forest (inventor of television) who never received recognition for his contributions to communications technology nor society at large. It would be nice to think that this interview might help set the record

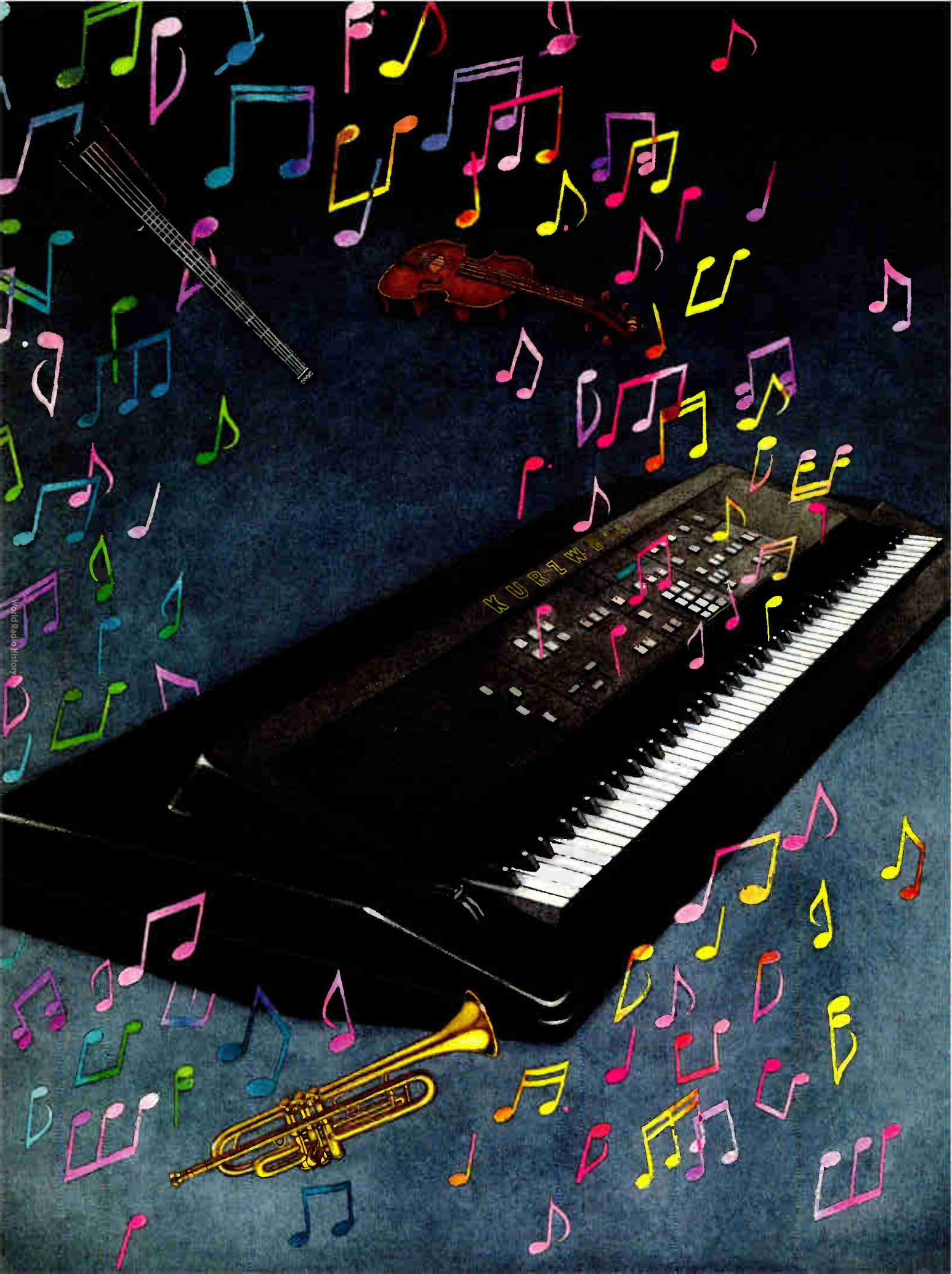

Just when you thought you'd heard everything. First the Kurzweil 250 sounded like an acoustic instrument. Now it can sound like anything.

USER SAMPLING: Now you can customize your Kurzweil 250 with our new Sound Modeling Program™. The Sound Modeling Program allows you to sample your own sounds and store them off-line on a hard-cased disk. You can play them back from the keyboard as is—or program them for bizarre new effects using the powerful sound editors contained in the instrument. The Sound Modeling Program offers from 20–100 seconds sampling time at a 5–25 kHz variable sampling rate. Also, trimming, looping, pitch and amplitude adjustment give you the flexibility you need to get the best sound possible.

PROGRAMMABILITY: The Kurzweil 250 is more than just a preset instrument. True, we give you 30 resident sounds including the grand piano sound we're known for. And with our optional Sound Block you can expand your resident instrument library to 45 total sounds and 124 keyboard setups. But the 250 is also a digital synthesizer, with the programmability you want in a performance keyboard. Continuously variable vibrato/tremolo/amplitude parameters. A 256-segment envelope generator. Five modes of transposition. Three modes of stereo chorusing. Variable brightness and pitch modulation. All of which you can assign to any instrument—even one you've sampled yourself. And when you have exactly the sound you're looking for, you can play it alone, or combine it with other sounds in up to 87 keyboard splits and up to 6 layers. Furthermore, you can store your most important programs in battery-packed memory—so they're at your fingertips for live performances.

EXPANDED SEQUENCER MEMORY: The Kurzweil 250 Sequencer can be expanded to an 8,000-note capacity spread over 12 polyphonic tracks. Full editing capabilities now include looping, quantization, individual track editing and volume control, and individual note editing. So you can make all your changes without going through the tedious process of re-recording over and over again.

MACATTACH™: MacAttach joins your Kurzweil 250 to an Apple Macintosh™ personal computer, and that opens up incredible possibilities. You can save your most complex sounds, sequences, and keyboard setups to build an infinite library of programs.

ONCE A KURZWEIL, ALWAYS A KURZWEIL. A year ago, Kurzweil astonished the musical world with the first keyboard that could compare itself convincingly to a \$35,000 concert grand. Hence, the Kurzweil legend. And in case you're wondering if we really live up to that legend, send for our demo cassette.

FOR YOUR DEMONSTRATION CASSETTE. Send \$6.95 (Mass. residents add 35¢ tax) to: Kurzweil Music Systems, Inc., P.O. Box 863, Providence, Rhode Island 02901.

Circle #012 on Reader Service Card



elements of the soundtrack before they get to the dubbing stage.

What frequently happens is that the composer never talks to the sound effects people, the effects people never ask the composer what he has in mind. There

beyond making sure that certain fundamental things sound right—whether the music and dialogue are at the right level in relation to each other and the effects don't hide the dialogue. Those are the basic considerations most directors have.

technical quality control on any picture?

Beggs: On any picture a mixer does that. A mixer can say, "This is distorted, I'd like another door slam." But when you get into the area of whether or not you even want a door slam... Or maybe instead of having a literal door you might want the door of a vault closing for artistic reasons because it might sound more interesting to you. Those are creative decisions and those aren't normally the mixer's purview. But under Francis, I can make those decisions and experiment with the track.

Usually on a picture you have the supervising sound effects editor; he more or less picks and supervises the effects. The editors cut them at his behest, the mixer mixes them, and the director

Also integral to the Coppola operation are the 6 track 35mm film dubbers, located one floor above many oak barrels of gently aging Cabernet (not pictured).

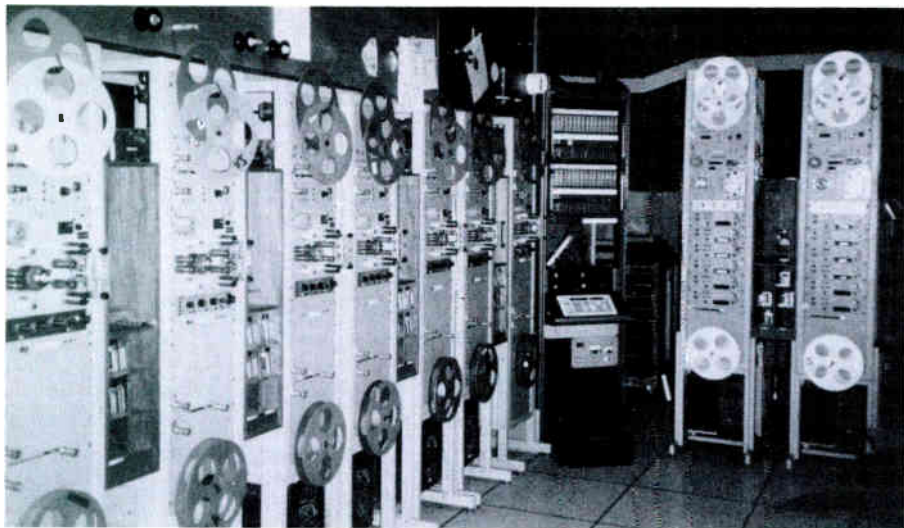

PHOTO: DAVID SCHWARTZ

are eight or nine people on a movie cutting a gigantic sound effects scene. The composer has scored a gigantic piece of music for 110 musicians. When you get on the sound mixing stage you discover you can't use both of them. What do you do? Theoretically, the sound designer is there to avoid or at least mitigate this situation by seeing ahead and working around it.

He knows by talking to the composer and the director that, for example, in this scene it makes more sense for the music to carry it. So, then he goes and talks to the sound effects editor and says: "In this scene we're going to play it like this. So, don't cut the sound so heavy, etc." He develops or controls the concept of the track and integrates it with the picture.

Mix: Can you give me some examples of creative interaction between you and Coppola on *Cotton Club*?

Beggs: He basically leaves me alone. I pretty much work by myself. We talk initially about some directions or concepts or feeling and then I come up with a group of ideas and rough them in. We'll have a screening, he'll make a few notes and say, "Yes, no, maybe." I will work on that information. Sometimes, we will disagree but we invariably resolve the problem by mutual agreement.

Mix: Has that been the way it's been on all of your collaborations?

Beggs: Basically, all of my pictures with him have been that way to one degree or another.

Other directors aren't accustomed to or don't want to relinquish that much control or don't have that much interest

Francis has a real interest in sound as a partner in the image and wants it to work on different levels and do things.

Mix: How does that difference in attitude on the part of Coppola influence the way you work? For example, are you less creative on a picture like *Repo Man*?

Beggs: Well, yes. On those kinds of pictures I function more as a craftsman and exercise taste but without the autonomy I'm given on Francis' pictures. On *D.C. Cab* there was a music cue that didn't work and I said, "Why don't we use part of that cue in the other reel, instead of using it here?" The director said, "OK." But this was definitely an exception.

Basically, you mix what's put in front of you. I don't control or choose the effects. I may make suggestions but that is the extent of my involvement. I don't say: "This is unacceptable, do it again." Basically, a mixer in Hollywood is like a service: you go to a dubbing stage, you bring all your material and these guys just do what you tell them to do.

Mix: You wouldn't send a sound effects editor down to re-record material?

Beggs: Well, you might ask him, "Could we get something better?" It would be a technical decision. Artistic decisions are usually the prerogative of the director or the editor in those situations.

Mix: But with Coppola, is it your capacity?

Beggs: Yes. With Francis I'm basically the sound director, sound designer. I'm more or less responsible for the soundtrack and everything you hear in it, subject to Francis' approval.

Mix: Don't you exercise a good deal of

oversees the whole proposition.

My concept of the sound designer—how I prefer to work—is that I work closely with or function as a supervising sound editor and as a mixer. I prepare and cut some of my own effects. I build my own materials for special sequences that I want to be directly responsible for creating. I work closely with the composer so our work is integrated. I make no distinction between effects and music. So what happens—and why Hollywood is so weird—is I will cross three or four union categories.

Mix: What was your greatest challenge while working on *Cotton Club*?

Beggs: The fundamental mixer problem on *Cotton Club* was the music/dialogue issue; how to play the club sequences successfully. We were faced with a difficult problem because the actors didn't loop their lines as if they were in a noisy environment.

Mix: Is that because of a mistake in shooting?

Beggs: No. It's because of extremely complicated production techniques. It's a trade off between artistic intent, technical requirements and limitations, and good craftsmanship.

When the lines were originally performed, the background sounds [band, crowds, etc.] were relatively low, not at all what you would expect in a loud night club so the actors tended not to project. The loops were performed similarly. Francis was also striving for a certain quality of performance. Performance is the primary goal. Technical or craft issues fall into place to support the performance.

The video revolution is making a dramatic impact on the way the music industry looks at its own product. Careers come to life overnight in the eye of a camera. Artists who've tried to get their tapes heard for years, are suddenly gaining long-deserved visibility.

If locking into video is your next step, TASCAM advanced audio systems can move your music right into the picture. Our recorder/reproducers give you the solid quality and innovative functions you demand as a professional, syncing you to the limitless possibilities of video. Our mixers put you in total control of the creative process, with engineering depth and operational ease.

For mixing, our M-520 places a full range of artistic choices at your command, with 20 balanced input channels, 8 print busses and 16 tape returns, effects busses, an independent 16-input monitoring section, and much more.

For recording/reproducing, our 58 is the industry's first 1/2" 8-track with all the technological sophistication of a 1" machine, but at far less cost. Its unique "Omega Drive" assures exacting tape to head contact and smooth tape handling – entirely eliminating tape stretch or bounce. And microprocessor 3-motor servo control significantly speeds up your recording and editing, taking you quickly and accurately to your mark without stalking and stuttering through time code. And if your budget is a bit more restrictive, take a close look at our hard-working 48, boasting most of the 58's comprehensive features.

When it's time to master your mix into mono plus code, our 42 delivers exceptional precision. And our 44B is the perfect stereo plus code post production tool.

In an industry where seeing has become believing, TASCAM lets you put your music's best image forward. See your TASCAM dealer for full details or write TASCAM, TEAC Professional Division, 7733 Telegraph Road, Montebello, CA 90640, (213)726-0303.

Copyright 1984 TEAC Corporation of America

Put your music in the video scene, with TASCAM's full line of SMPTE-compatible audio equipment.

In an Industry Where Out of Sight Can Put You Out of Mind, Tascam Gives Your Music Video Visibility.

Circle #013 on Reader Service Card





PHOTO: ALFRED W. COWANS

Gregory Hines as Sandman Williams in a cappella tap in the Cotton Club.

So, how can you have crowds and blaring music at peak level and still have this dialogue remain intelligible? It's very difficult. So, the actors act in an environment that will be quite different on the screen. You would have to say to them: "OK, you have to speak loudly because you're in a loud club." It's hard to get them to do it and be natural so it's let go to be solved later in post.

It's hard to explain. But when it's costing \$75,000 a day just in extras it's hard to ask somebody: "Could you do a take where it looks like you're talking a little louder." Nobody wants to hear about it. Ninety-nine percent of this movie is looped. Almost everything you hear with the exception of three or four scenes is looped.

Mix: Well, doesn't that solve the problem you were talking about the background sound in the nightclub scenes?

Beggs: No, it doesn't because actors duplicate their original performance unless Francis wants the performance to change. This was the big problem in

Rumblefish. Michael Rourke spoke in a virtual whisper, *soto voce*, almost all the time even if you were at the other end of the block.

Cotton Club's problems were similar, if not so severe. Whispers and *soto voce* are always a problem especially in loud environments. People speak in your ear or very close if they want to communicate this way. You can't do that in the theater. You have to lower the background or make the whisper very loud. Loudness doesn't help that much though. *Soto voce* and whispers are all bottom and top. There's no middle, no middle range to grab and punch through. The whisper can be at peak modulation, but imbedded in a loud background it cannot be heard. Whereas a normal voice at moderate level can be easily distinguished. Loudness does not equal intelligibility.

The looping on *Cotton Club* was pretty good. We didn't have the problems nearly that we had on *Rumblefish*, but the *soto voce* performance is still there and you can only distort the performance so far in terms of the audience's credibility. They have to hear the dialogue so loud and still have it be natural. Then you say: "Now we have to pull the music back. But where do we lose the feeling of the scene that they're in? How important is that compared to the strain the audience experiences attempting to follow the dialogue?"

Looping takes care of a lot of problems in terms of being able to control acoustical relationships. If you used production sound only, you wouldn't have any choice, you'd have to take what you've got. In a musical, that's next to impossible.

Mix: *Cotton Club* is a musical by the very fact that more than 50% of its screen time is dominated by musical action. Taking that as a given, do you know what was the conceptual framework which governed how *Cotton Club* was cut?

Beggs: There was much more music in it at one time; many more numbers. And one of the big problems editorially with the picture was balancing the desire to have as much music in these *Cotton Club* numbers as possible against the need to have a story line or a plot line that would keep the audience involved.

My feeling is that the problem of blending the music and the drama was very successfully solved: integrating the musical aspect into the story without having that "Here-is-a-number" feeling. The scene that comes closest to being a number is the hoofers club sequence with all the old guys. It's one of the favorite scenes and it's there because it's so lovable and it builds atmosphere. It's not necessary for the plot. It's not exposition.

All of the other numbers are rationalized by the plot.

Mix: I would like to get as clear a concept as possible of what you did on *Cotton Club*. For example, did this picture come to you with all the musical sequences already inserted in it?

Beggs: The picture was cut and locked to soundtrack in New York City. It was brought to Napa [Coppola's post production facility] for music pre-mix and final mix. Dialogue pre-mix was done at Lucasfilm. We screened and recut the picture four times as a result of exhibitor previews in Chicago, San Jose, Boston and Seattle.

On this picture I did less than on any other picture I've done, mainly because the picture was an East Coast picture. I wasn't even going to work on it. I was brought in very late. By comparison, on *Rumblefish* I worked very closely with Francis and the composer [Stewart Copeland] throughout the whole picture. In this case, the source music is a given—the stuff that's on screen, you're not going to move it, you can't change it, you can't take it out or move it unless the picture's lifted [read deleted] or moved.

The underscore worked by and large. It was done once and then was reorchestrated at Francis' request. I got in at that stage.

Once again by comparison, I worked a lot with the music editor on *Cotton Club* [Norman Hollyn]. Obviously, on a picture like this he's very important. There was an incredible amount of preparation and sheer physical effort spent to make sure that when it's all together the musicians we are seeing are playing in sync with the music we are hearing on the track. It sounds pretty basic but it's extremely difficult.

Mix: What was the time frame of the whole filmmaking process of *Cotton Club*?

Beggs: Pre-production began in July of 1983. Francis began working on the script when I was finishing *Rumblefish*. They began shooting in September [1983]. They broke for Christmas with some pick-up shooting in January. February, March, April, May were all editorial [picture cutting]. Sound editorial and all of that stuff began in June and July. I started working on this picture in July.

My work with the sound editors consisted of a trip to New York where I discussed what we were after in building the soundtrack. I listened to some premixes back there to make sure they were coming along all right. Usually, I prefer to hire all the sound editors myself and put together my own team. This being a New York production I had nothing to do with hiring them.

Mix: Francis is known as someone who has been endeavoring to bring new tech-

FOR THE NEXT STAGE IN YOUR CAREER.

The band has paid its dues. Played the garages, the dives, the schools. But now you're into some good-paying steady gigs. And ready to go for broke. Without going broke.

You're ready for a Yamaha MC mixing console. A full line of new consoles that have many legendary M-Series features and reliability. And are affordably priced.

There are three models in the line—the MC1204, MC1604 and MC2404.

Which one you choose depends on how many channels you need. The first two numbers after the MC tell you how many input channels that model has. The last, how many output channels.

Whichever MC mixer you choose, you get input channels that are modularly constructed in blocks of four for easy access.

Each channel has a pad switch and gain control with peak LED, three-band EQ with sweepable midrange, two pre-EQ and pre-fader

foldback sends, two post-EQ and post-fader echo sends, pan control, group 1-4 assignment switches, cue and channel on/off switches, and a 100-millimeter fader.

All are color-coded and logically grouped for easy operation.

With four group outputs that are assignable to the master stereo outputs. And two echo and two foldback sends.

There are even two MC monitor models, the MC1608M and MC2408M. They offer the additional capability of on-stage monitoring. So each member of the band can hear exactly what he or she needs to hear.

Now that we've set the stage, why not visit your Yamaha Combo dealer for a demo of the MC consoles. Or write: Yamaha International Corporation, Combo Products Division, P.O. Box 6600, Buena Park, CA 90622. In Canada, Yamaha Canada Music Ltd., 135 Milner Ave., Scarborough, Ont. M1S 3R1.

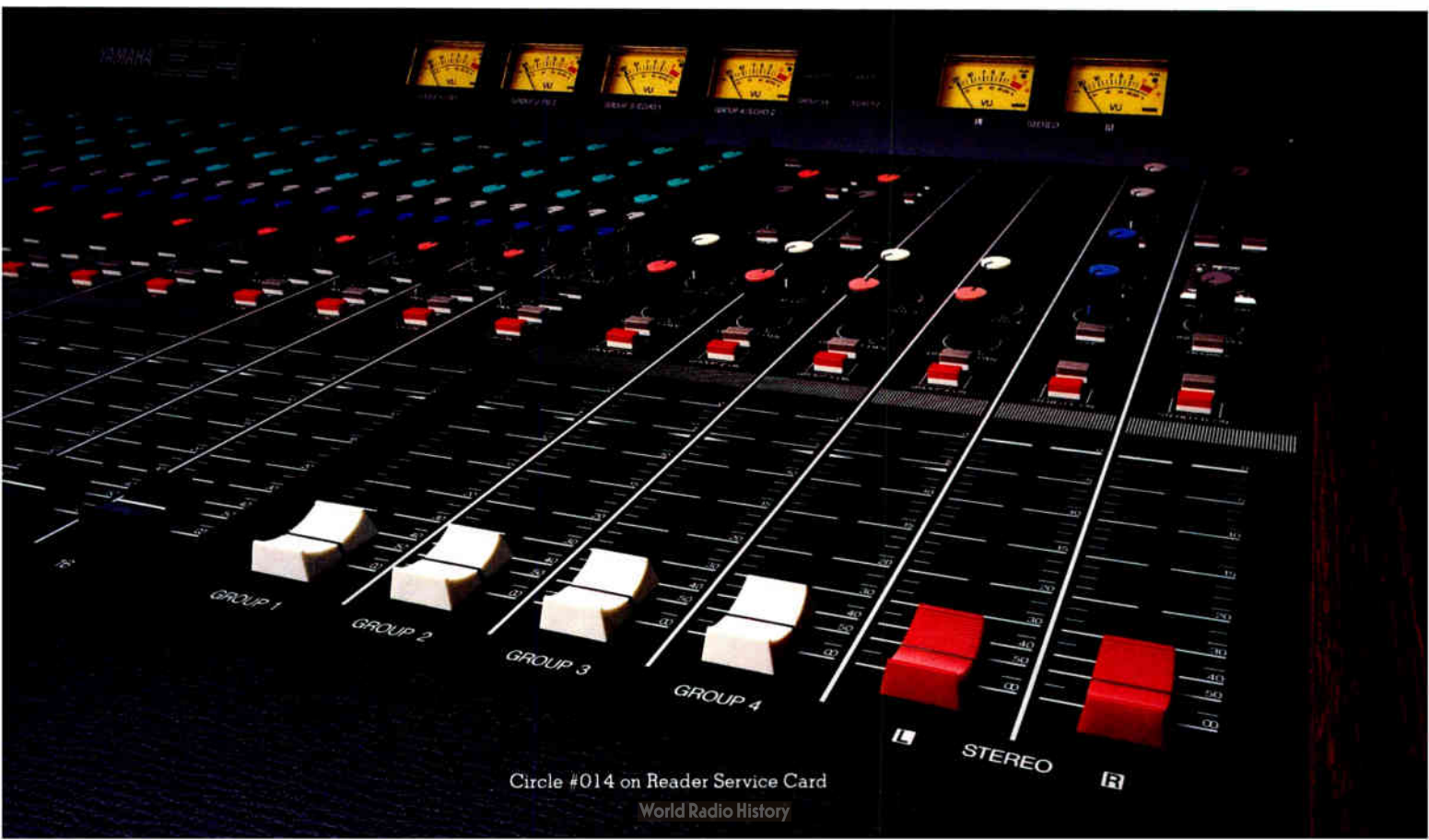

Circle #014 on Reader Service Card

World Radio History

IF YOU'RE IN THE STUDIO...

If you're in the studio, whether as an engineer, producer, artist, tech or manager, you know there are some things you can't do without—things like good clients, the best tape, efficient maintenance and organization . . .

There's something else you should never be without if you're in the studio, and that's MIX! Because MIX is the

publication that is most dedicated to keeping recording professionals informed about their industry. MIX keeps you up to date on the latest equipment and production techniques. It tells you what other studios, engineers and producers are doing. And MIX listings are the most complete guide available *anywhere* to studios and other production facilities . . .

If you're a recording professional, *you're in the MIX!* If you're not a subscriber, don't delay: use the coupon in this issue to subscribe to MIX today. Because in the studio, there are a few things you should never be without . . .

...**YOU'RE**
IN THE **Mix**
THE RECORDING INDUSTRY MAGAZINE



PHOTO: MICHAEL MENDELSON



PHOTO: MICHAEL MENDELSON

nologies into filmmaking. To what extent do you think that his innovations or drive to innovate filmmaking have influenced the way you work?

Beggs: Francis has given me carte blanche. His ideas are aesthetic and theoretical; they're not technical. When we first started working together in '79 he liked the way recording studios worked on 24 tracks and said, "Richard, can you work this way on a movie?" And I said, "Yeah, I don't know why not." And so we did it.

Mix: Coppola used a video system on *Cotton Club* to make pre-cuts of scenes at the end of shooting days. Did you see any of the video pre-cuts on *Cotton Club*, and did you use them in your work?

Beggs: Only in terms of looking at them and preparing myself for what was coming. This picture was very conventional and I really didn't do very much of that. For instance, on *Rumblefish* and *One from the Heart* I got a video cut of the picture at a very early stage and began building and manipulating sound on 24 track to those pictures well in advance of the final mix. And I would then take those elements on 24 track into the final mix locked to picture and use them. I'd work essentially in a recording studio building all this stuff. On *Cotton Club* there wasn't the necessity or the need to do it. The picture just wasn't structured that way. The track didn't have those requirements. It could have been done that way but it wasn't set up that way.

Mix: What has been the greatest single technological advance which has helped you in film sound since you started in '79?

Beggs: Automated mixing. I don't know any films other than Francis' films that I have worked on that have been mixed with automation.

Mix: What are benefits of this system?

Beggs: Repeatability. On a conventional mixing deck you have three mixers: dialogue, effects and music. Nowadays you record on three separate recorders so that if the dialogue guy gets his stuff right he can sort of stop and then the music guy can work until he's ready and so on. And you can see the advantage of that.

Well, a lot of times you can be mixing a sequence and you have 25 or 30 elements coming in and you can get it almost right. But there's something that isn't quite right; you've rehearsed it four or five times. You've got it just about how you want it. Do you try to do it again and possibly lose what you've got and get the thing that is outstanding? Or do you just say, "It's as good as we can get it for now, it's not worth trying to do it again because it will never be as good," and go on?

With automation you save everything you want and you can go in at any

one point and change any one aspect—when a reel goes down and then comes back up, and you have to punch in which frequently happens: a line has to change. Especially in a master where all the effects and everything are going. You have to match on a big board conceivably as many as 90 elements, that when you punch in, the join is imperceptible. And so every level has to be what it was maybe three weeks or a month ago. The automation will remember all of these things for you in terms of level. Equalization is something else. We don't have automated equalization. But theoretically that should be in your head and it shouldn't be that far off.

Another big advantage is that you

can do a lot of one man mixing, which I like to do. Everything is stored in data. You don't really record anything. It's all in memory. I can work on dialogue. Then I can go work on effects. Then I can rough in music. It's all in memory. Then I can work a little bit on music. And just jump back and forth constantly working and shaping the thing. Then you go back, push the button and record it.

The automated board doesn't really save that much more time. It theoretically can, but I find I use the time it saves to do more and do it better. There's a reluctance on the part of people in the business to confront a piece of new equipment. The new is always threatening. And it shouldn't be. ■



• **AHB**

Sets the Stage with the New SRM-186 Monitor Mixer. The Monitor System designed to incorporate Communication between Artist & Engineer.

The result . . . Tighter On Stage Mixes Tailored to the Artists needs. The SRM-186, represents the Leading Edge in Detail, Reliable Quality and Affordability.

On Stage and Studio Features: • 18 Microphone/Line Input Channels. • 2 Dedicated Line Input Channels. • All Inputs Fully Matrixed to 6 Separate Outputs. • Full Passive Microphone Splitter System. • Long Throw 100MM Glass Smooth Faders. • Road Tough Flight Case Installation.

For more detailed information on the ALLEN AND HEATH SRM-186 Monitor Call or Write Today. Give yourself "The Edge" with the monitor that achieves its recognition . . . through your results.

imagineering by

mbi / **AHB**

group

Allen & Heath Brenell Ltd.
69 Ship Street, Brighton, BN1 1AE
England

Allen & Heath Brenell (USA) Ltd.
5 Connair Road
Orange, Ct. 06477 / (203) 795-3594

Circle #015 on Reader Service Card

The **DIGITAL RENTAL** *Business*

by Robert Carr

THE AUDIO BUSINESS HAS ALWAYS BEEN KNOWN AS a haven for motivated mavericks. With the maturation of digital technology and the wider acceptance of digital products, almost every aspect of the recording/playback chain—from studio to consumer—will eventually be based on digital processing. That means a lot of new career opportunities opening up for some of these ambitious people, who are looking to expand their career horizons.

One company already capitalizing on the evolution from analog to digital is Nashville-based Digital Associates. Formed by independent recording engineers Rick Horton and Mike Poston, Digital Associates supplies recording studios and mastering facilities in the Nashville area with Mitsubishi digital recorders, such as the X-800 32 track and the X-80 two track mastering machine. Although they only started in May of 1984 with one X-80, they took delivery of an X-800 32 track two months later and recently picked up a second X-80 in response to the growing demand for digital mastering gear.

ASSESSING THE MARKET

Any savvy businessman or woman knows they must conduct a certain amount of research. Even if you have a strong feeling for the potential in a market, it never hurts to get some feedback on whether or not there is actually a need for that product or service before blindly committing to a long-term investment in time, money and effort. In the case of Digital Associates, owners Mike Poston and Rick Horton started with this premise: "Nashville is known for its cautious attitude. You have to keep in mind

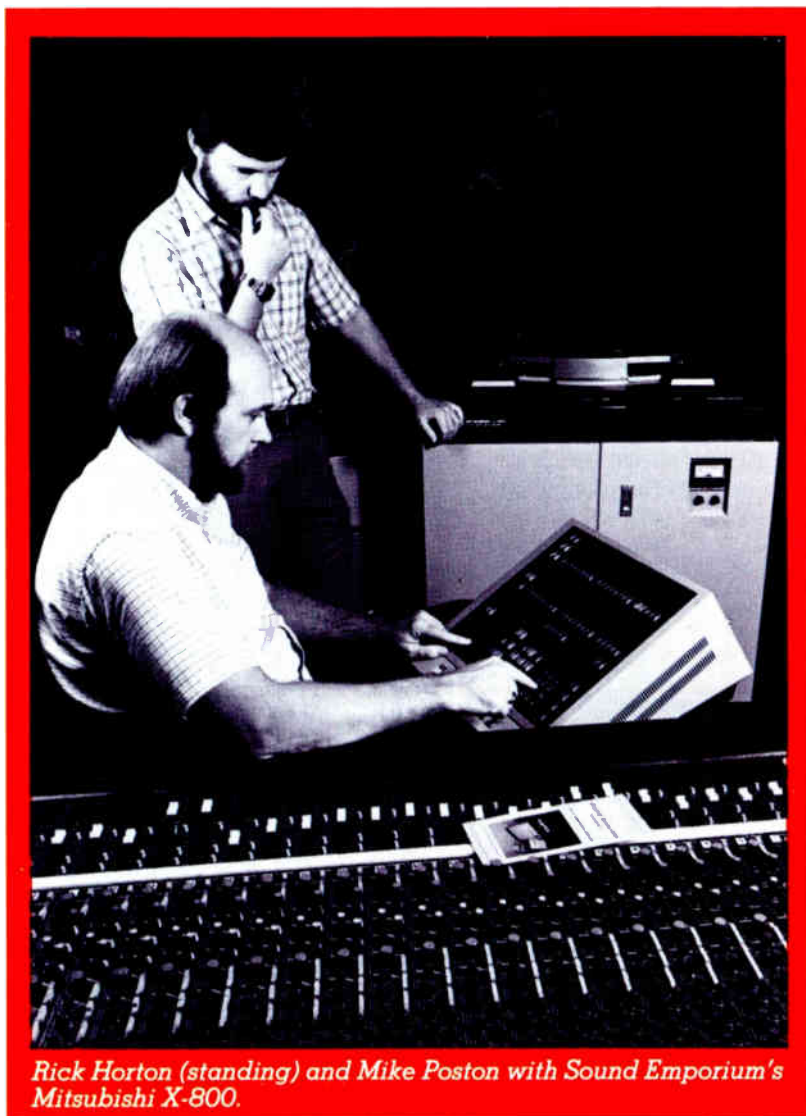

Rick Horton (standing) and Mike Poston with Sound Emporium's Mitsubishi X-800.

SOUND CHOICE.

Professionals around the world have chosen AKG microphones for their unique combination of performance, application oriented design and technical excellence.

Suitable for the most sophisticated recording techniques, whether in-studio or live performance, XY, MS single-point stereo or multi-track pick-up. AKG's large diaphragm and small diaphragm condenser microphone systems are proven representatives of excellence.

For every musical event from classical to rock, vocal and instrumental, the sound choice is AKG.



77 Selleck Street
Stamford, CT 06902
203/348-2121

Attention: Audio/Video/Music Schools

Your students deserve the most up-to-date information in the field of music and recording technology. They can get it each month in *MIX Magazine*, provided to you on a convenient basis through our special school distribution plan.

For more details on how you can provide *MIX* to your students, contact Allison Hershey at (415) 843-7901 or write to *MIX Magazine*, 2608 9th St., Berkeley, CA 94710.

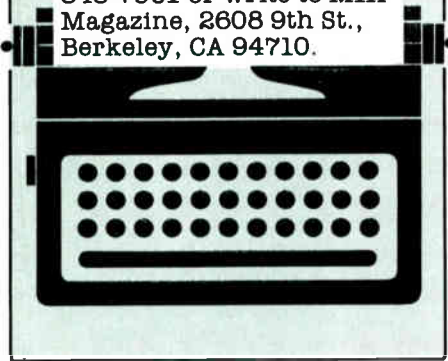

HAVE A RECORDING STUDIO PROBLEM?

Call **DataLine**
(213) 651-4944

The Society of Professional Audio Recording Studios, a non-profit organization, offers SPARS members, and non-members referred by a SPARS member, a national telephone 'hot-line.'

Questions regarding any area of recording studio operations including business practices, audio engineering, and technical maintenance will be answered by SPARS-approved sources at no charge.

Want a problem solved?
Call SPARS—
(213) 651-4944



SPARS Board of Directors and Consultants

Murray R. Allen
Universal Recording
Corporation, Chicago

Jerry Barnes
United Western Studios
Los Angeles

Charles Benary
Soundworks Digital
Audio/Video Studios
New York

Larry Boden
JVC Cutting Center
Los Angeles

Bruce Botnick
Digital Magnetics
Los Angeles

Nick Collieran
Alpha Audio
Richmond

Mick Emmerman
Criteria Recording
Miami

Bob Lifton
Regent Sound
New York

Lanard Peariman
Editti-Chicago

John Rosen
Kanga Professional
Services, Nashville

Christopher Stone
Record Plant, Inc.
Los Angeles

Joseph D. Tarala
Sigma Sound Studios
Philadelphia

David Teeg
New York

John Worum
Worum Audio Associates
New York

that even though there is a large record business here, the album budgets are significantly lower than what's allotted for pop albums cut in Los Angeles or New York. Generally speaking, those smaller recording budgets mean that the studios have not been as willing to spend the big bucks for expensive equipment."

With this in mind, Horton and Poston decided to contact some of their industry acquaintances in order to find out how many were actually mixing to digital, doing digital projects, or had interest in working that way. "I was really surprised to discover that so many records were being digitally mastered in Nashville," says Poston. "Jimmy Bowen Productions, for instance, have been doing all their artists that way for the last 18 months. But they've been using either the Sony or the JVC systems, because they were the only ones in town."

Why did Horton and Poston think they could get enough business with the Mitsubishi system, when the JVC and Sony units were already established in the area? The answer can be found in the first impression that the X-80 two track made on these guys back in April of 1984. "When Tom Behrens [the Nashville representative for Digital Entertainment Corporation, Mitsubishi's North American marketing company] loaned me an X-80 to use for a day, all he did was roll it into the studio, and check the level. There were none of the normal set-up procedures and adjustments that you usually do for other machines. Then he showed me how to do one razor-blade edit, and left saying, 'Use it just like a normal two track.' Well, I was astounded by the first playback—crisp, clean bass as well as highs, and no degeneration of sound quality over time. I called Rick right away and said, 'This is what we've been looking for in a two track as far as audio quality is concerned.' We really just wanted to have this technology available for ourselves."

Based on this and the results they got from their informal "market research," Digital Associates established a pricing structure accordingly. Horton and Poston knew that most studios wouldn't pay \$1,000 a day for a 32 track. So they worked out a rate of \$600 a day, and devised a scale that declined according to the longevity of the rental agreement. The same philosophy applied to the two track rates. "Rick and I spent about a week working out the rent structures, and in all honesty, we did them without knowing what the competition's rates were. We based our decisions on our conversations with people around town, and what they said they could afford. We wanted to charge fees that were fair to our customers, that paid for the machine and maintenance, and gave us a chance to use the machine ourselves."

Of course, prospective clients

didn't immediately beat a path to D.A.'s door. Rentals were slow the first month (May of 1984) for the X-80, with random single-day rentals comprising most of the work orders until summer. Likewise, when the X-800 arrived in July, it worked for a week, sat for two weeks, and went out for a couple of days the fourth week—typical usage patterns following the introduction of a new product or service. By October, however, the 32 track Mitsubishi machine was working by the week with negotiations going on for 60- and 90-day contracts. The two track was also going out for two and three weeks at a time. "Right now we're focusing just on the record people," says Poston. "But we plan to explore new possibilities soon, like video or film work, because the machine is designed specifically to work with SMPTE timecode. But mainly, in this type of business, word-of-mouth is the best advertising. The more the people use the machine, the more they realize how much they like it. Already (by the first of October 1984) we have our two X-80 two tracks booked for the whole month."

HIDDEN RESPONSIBILITIES

Creeping into the picture after the fact are all the auxiliary services a company like Digital Associates must provide in addition to their primary function of simply renting a piece of equipment. Questions like: How will the machine get to its destination? Who will set it up? How will it be interfaced with existing equipment applied in a variety of formats? Who will provide maintenance service? How about training clients to use the machine? Otherwise, any realistic thoughts of staying in business go right out the window.

Initially, Mike or Rick delivered the X-80 two track to clients themselves, but the arrival of the X-800 32 track made that procedure unfeasible. Digital Associates now contracts a professional delivery service to move all the machines and take the responsibility for setting them up, plugging them in, and having the second engineer pump 1k tones through the circuitry to ensure that nothing serious happened during transit. Then either Horton or Poston show up personally to provide a brief description of how the machine operates, to get the invoices signed, and answer any questions that might come up during the early part of the session.

Horton and Poston report that the maintenance aspect has been relatively light. And that's part of the reason they've been able to keep the rental rates so low. "We haven't encountered any major breakdowns since we took possession of these machines," says Poston. "And the couple of minor things that happened in transit with the two track were taken care of quickly. We do our own

service, because we each have a strong technical background. The manuals are really comprehensive, and Tom Behrens acts as our consultant, so we can get advice when we need it. In addition, Mitsubishi has guaranteed us parts delivery by the following morning. The two times we've wanted parts, they were here as promised. We've had no problems."

INTERFACE PROBLEMS

More serious, at least initially, was the question of being able to interface the 32 track with all the console configurations that currently exist in Nashville studios. Such issues as transformer vs. transformerless boards, various output-buss levels, and similar non-standard setups all had to be taken into consideration.

While the two track generally interfaces via the conventional two track cables, some clients wish to run analog and digital multi-tracks simultaneously. How do you connect the extra tracks to a 24 track board? Horton and Poston spent several days trying to determine the most practical and universal method that would be compatible with the majority of situations they might encounter. "We originally thought of building several different snake cables to accommodate all the possible types of bays," says Poston. "But we ruled that out, because of the strain-relief problem. Unless

you're dealing with molded cords, you can't guarantee that your patch cords are not going to get ripped out. If something goes wrong too often, that's a lot of time we have to spend doing repairs, and we ultimately have to raise the rates to compensate for our work."

They finally devised a patch panel that parallels both quarter-inch and TT connectors, and accommodates just about anything that a studio could want. If the client wants to do simultaneous analog and digital, then all 32 channels of the X-800 go through Digital Associate's patch bay to the studio console patch bay via 30-inch patch cords. "If the digital multi-track is the only machine to be used on the session," says Poston, "then 24 tracks go through the typical tape-machine snake, and the remaining eight audio tracks as well as the five data tracks interface through our patch panel." (Ed. note: In addition to the normal 32 audio tracks, the X-800 provides two channels for various sync data, a single track dedicated to SMPTE timecode, and two analog tracks so engineers can do normal analog functions like tape rocking to locate downbeats and cue points.)

EXTERNAL CONSIDERATIONS:

Even with all the best planning and preparation, great advertising, a strong product or service, and efficient

customer service, unforeseeable variables can always crop up to throw stumbling blocks in the path of your progress. For Digital Associates, it's the way the industry is handling the transition from analog to digital.

Compact digital discs are catching on fast, because the quality of material recorded from start to finish in the digital domain provides a clarity that is unsurpassed by any other medium. Unfortunately, many of the titles have been recorded or mastered analog and then released or re-released as a digital product. Of course, those CDs exhibit the noise and/or typical annoyances of analog releases, yet the consumer thinks they are true digital recordings.

"Consumers are paying top dollar for software that is not truly a digital recording," says Poston. "They notice that the quality is not that much better than the analog recordings they're already used to, and eventually they'll get turned off to digital products. Consumers need to be educated about what they're buying. If record companies realize that they can sell analog product at digital prices, artists will not get the budgets to do digital sessions. Not only will that put us out of business, but the potential of digital audio could be defeated before it really has a chance to get off the ground." ■

MX1688 Recording Mixer

6 x 8 x 2 with control room mixing

The Carvin MX1688 recording console offers the professional quality features and signal performance you've grown to expect from Carvin! Use of the best components and professional audio design enable the MX1688 to interface with any professional tape deck. For additional information on this console and Carvin's complete product line send \$1 to Carvin, Dept. MX62, 1155 Industrial Ave., Escondido, CA 92025. A similar 16 channel 4 x 2 MX1644 mixer is available for \$1995.

Recording Features

- Eight Track Studio Control Center
- Input/Output Channel Organization
- Independent 8 Into 2 Monitor Mixer
- Four Auxiliary Busses w/ Pre Post
- Three Band Parametric EQ w/ Delet Switch
- Mute and Solo on all Input and Output Channels
- Two Effects Returns w/ Pan and Solo
- Talkback w/ Built-in Mic and Monitor Dimming
- Peak Warning Indicators w/ Peak Stretching
- Patch Points on all Channels
- Microphone Phantom Power
- Cue and Effects Sends from Output Channels
- Alternate Metering of Cue and Two-Track
- Quick Tape Playback Through Monitors
- Independent Mic and Line Preamps
- Studio Feed w/ Source Selection
- Totally Modular Internal Construction
- Input Noise of -127 dBv, THD less than .05%
- 20 dB headroom at All Stages

P.A. Features

- Eight Sub-Groups w/ Solo and Mute
- Channels Assignable to L & R Stereo Output
- Four Independent Monitor Mixes Available
- Headphone Monitoring of Main or Monitor
- 11 Step Gain Controls for Easy Set-up
- Talkback to Monitors

MX1688

\$2995 + 49 Frt.

Product Information

Toll Free 800-854-2235

Calif 800-542-6070

Circle #016 on Reader Service Card

World Radio History

CARVIN CATALOG
 \$1 for Bulk Mail \$2 for Rush 1st Class Mail
 Name _____
 Street _____
 City _____ State _____ Zip _____ **MX62**

Is Nashville becoming

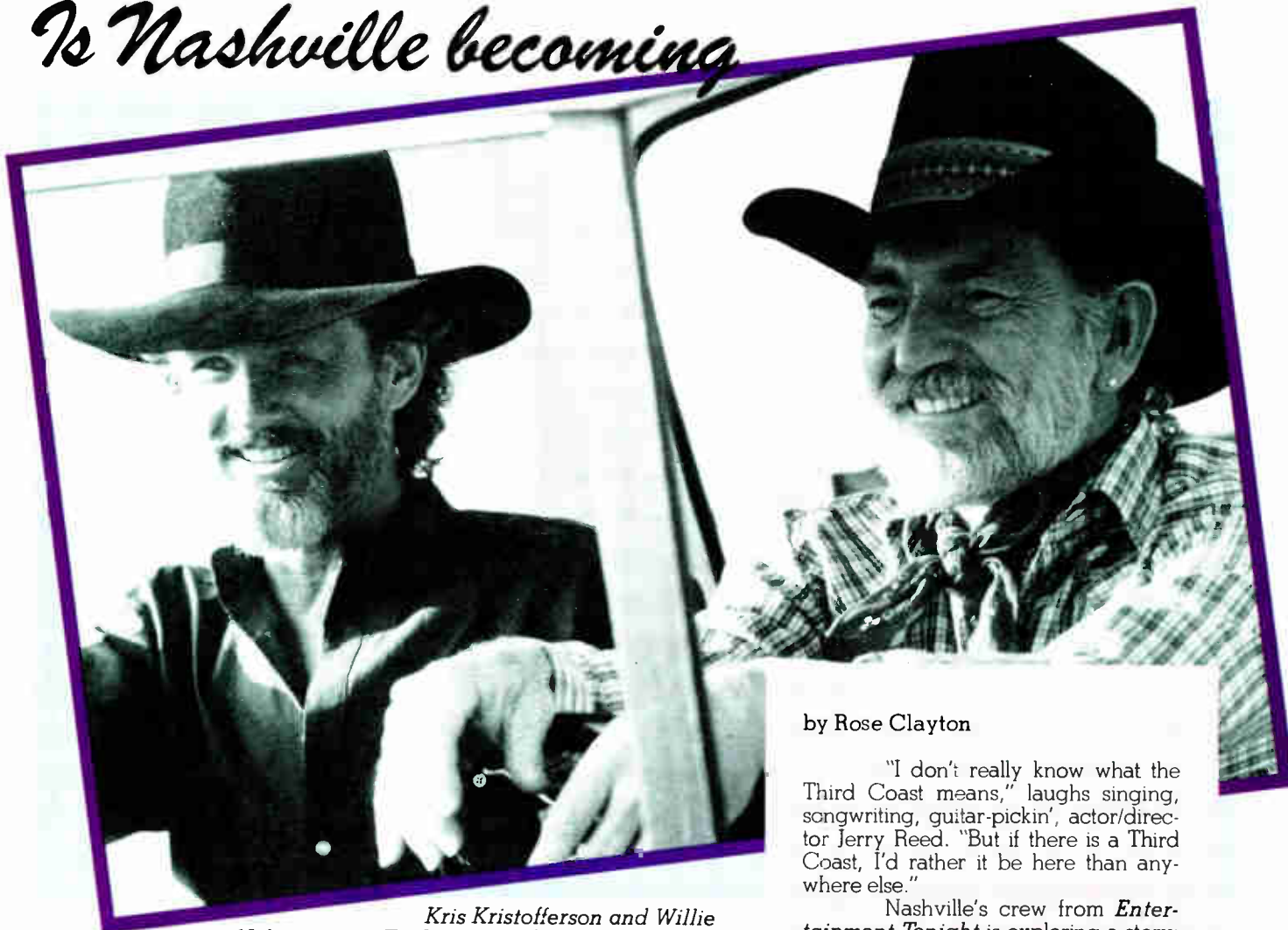

Kris Kristofferson and Willie Nelson star in Tri-Star's new film "Songwriter."

by Rose Clayton

"I don't really know what the Third Coast means," laughs singing, songwriting, guitar-pickin', actor/director Jerry Reed. "But if there is a Third Coast, I'd rather it be here than anywhere else."

Nashville's crew from *Entertainment Tonight* is exploring a story: Are references made in New York and Los Angeles to Nashville being Movie City a slip of the tongue, or is the country music capital, known around the world as Music City U.S.A. undergoing an evolution?

As "ET" is focusing on Reed between takes of his directing debut, *What Comes Around*, other cameras around the city are busy eyeballing four different feature-length motion pictures. That brings the total to nine films for 1984.

It's been a busy decade for Music City since the movie *Nashville* hit in 1974. Country-music entertainers have been featured in 58 films for TV or movies over that period.

When he stars in his self-directed effort, Reed will edge Kris Kristofferson as the country music recording artist making the most movies. (Kristofferson has seven films, but one's a TV feature.)

While Reed and Kristofferson lead the race, Willie Nelson finishes a close third with five movies and one TV film in five years. Nelson, (who also records for CBS, sings duets and collects Grammys in his spare time), teamed up with Kristofferson in '84 for *Songwriter*, which was, of course, also about country

MOVIE CITY?

Eventide SP2016 Generation II



1985



Does More for You Every Day, And Sounds Better Doing It.

Day after day, as the studio calendar shows, our incredibly versatile Generation II software package fulfills the promise of the Eventide SP2016 Effects Processor/Reverb. Each SP2016 is shipped with all of the effects shown, already installed and ready to use.* And Generation II software puts you in control of a wide variety of parameters for each program. What's more, there are even more programs to come.

Program software is supplied data compressed onto 11 ROM chips

But what the calendar photo can't convey is the noticeably superior audio quality of our effects. Especially on the most critical reverberation programs, our proprietary SP2016 hardware and advanced Generation II software designs make a difference you can readily hear. So let your ears decide. The SP2016 is available from a very select group of Eventide dealers. To arrange for a demo by an SP2016 dealer, just call Eventide at (201) 641-1200.

Eventide

the next step

One Alsan Way, Little Ferry, New Jersey 07643

World Radio History

Circle #017 on Reader Service Card

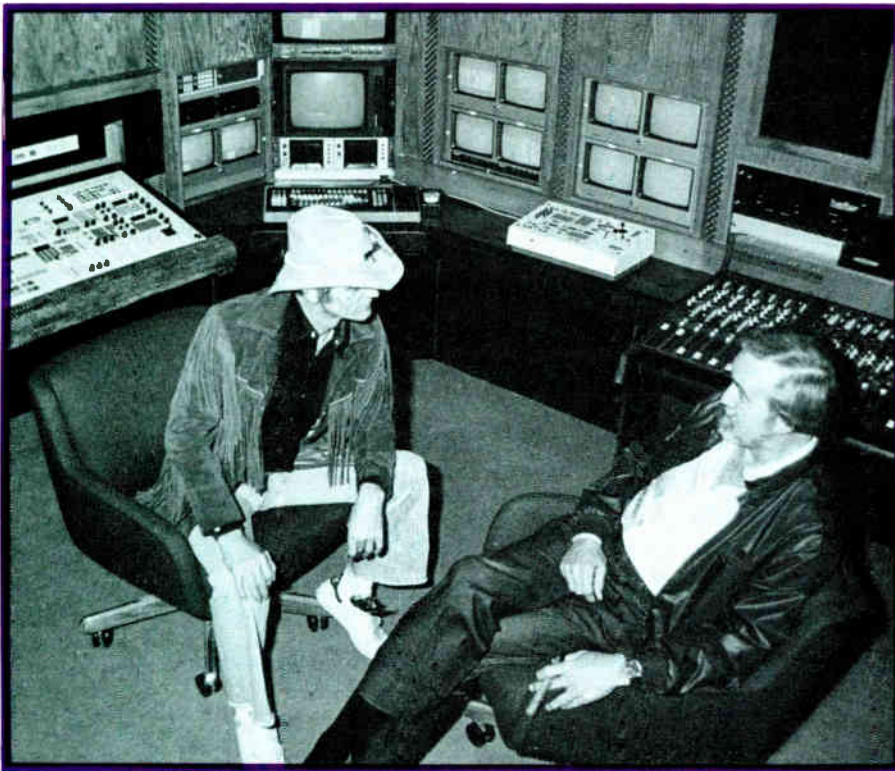

Jerry Reed, left, and "Nashville Now" host Ralph Emory in Reed's TSC Video Studio.

music, singers, records, etc.

What makes Nashville's posture so pleasing in the movie scene now is that films released in 1985 will bear the tag—filmed on location in Tennessee.

"In 1979, Tennessee's total production budget was \$14 million," reports Jane Word, director of the state's Film, Tape and Music Commission. "Preliminary year-end tallies for '84 indicate an overall budget of \$150 million with an estimated \$73 million left behind in the state." This figure will cap a record-breaking \$120 million for '83 with about \$53 million remaining.

The reason for the increase, says Word, is, "We are promoting with continuing success the idea that film companies can not only shoot movies here, but that they can have soundtracks recorded and films underscored here. This creates work, not only for musicians, but for producers and arrangers as well. It's a hand in hand business. The film industry already looks to Nashville for music."

Filmmakers questioned about Tennessee's on-location charm, as compared to sound stage productions, list its varied landscape, naturally beautiful seasons, geographic accessibility from other on-location shoots, genuine Southern hospitality, cooperation of state officials, along with its expanding pool of creative and technical talents as secrets of its lure.

Tennessee's movies are star quality both in front of and behind the

camera. Aces like Timothy Bottoms, Patricia Neal, and Ernest Borgnine opened the year's shooting season with the Disney Channel's acclaimed feature-film *Love Leads the Way*.

Jeff Bridges and Karen Allen spent 46 of *Star Man's* 86 total production days in the state with Columbia Pictures dumping \$4 to \$6 million of its \$21 million budget in the Volunteer State's treasury. These figures match dollars spent on filming segments of Sissy Spacek's film *The River* in East Tennessee.

Two academy-award winning actresses graced Nashville at the same time. Spacek (of *Coal Miner's Daughter*) starred in *Marie*, as the heroine of Peter Mass' book about Marie Ragghianti's role in revealing corruption in Tennessee's Board of Pardons and Paroles; and, Jessica Lange (from *Tootsie*) portrayed country-singing legend Patsy Cline in *Sweet Dreams*. Producing *Marie* for the Dino De Laurentis company, was Frank Capra, Jr., and behind *Sweet Dreams*, on a \$13 million budget, was Bernard Schwartz, whose *Coal Miner's Daughter* was the second largest-grossing movie of 1980 behind *The Empire Strikes Back*.

So where do Nashville and the movies go next? Reed has another vested interest in the success of his film *What Comes Around*. He is the owner of TSC Video on Nashville's Music Row where his movie is being edited in his high-tech editing suite from video tapes made from film shot only the day before. *What*

Comes Around will be the first movie made in Tennessee using this new technique and going from pre- to post-production without involving the Hollywood studios.

But, it is not only the motion picture industry that is giving the city's creative film and tape professionals a shot on both sides of the camera.

The advent of the Nashville Network in March, 1983, gave Music City its golden opportunity to become a major television center. By November of '84, TNN was recognized as the nation's fastest growing cable network entertainment service with access to 60 percent of all cable households in America.

With 60 million people identified as country music listeners in America, more than 500 million country albums sold, and 2,000 country radio stations in the marketplace, it is little wonder that the Nashville Network is the fourth largest producer of original programming (4,000 hours) for television in the U.S.

As part of the 480-acre Opryland entertainment and hotel complex, TNN, co-owned by Group W, is a \$100 million investment that employs more than 200 in its creative and technical services and a wealth of freelancers that use its in-house facilities to produce the segments that they contribute.

Jerry Bailey, manager of press information services for Group W, says that by the end of 1985, more than 27 million cable subscribers will have access to the Nashville Network, and its demand for programming will continue to accelerate.

Anticipating the growth of country music and the future of Nashville as a major news center, record producer Dick Heard switched to producing independent segments for television in 1979. He has since become the city's leading producer of celebrity-related television news and features covering the entire Midsouth for exposure on *Entertainment Tonight*, MTV, *Lifestyles of the Rich and Famous*, Turner Broadcasting, and Japan Television Network.

During the past year, Heard also produced the Nashville Hotline segments for the syndicated series, *On Stage America*, as well as a myriad of individual high-quality projects such as electronic press kits, music videos, promotional spots, and documentaries for his select clientele. Future plans include programs for the Hospital Satellite Network, two network specials and a 13-week syndicated series.

Heard's crews, like those of most of the city's other production companies are selected from the large pool of freelance talent now available in the Nashville area.

"Business is healthy, strong and consistent," reports Debbie Pfaelzer,

Eventide's Newest Harmonizer® Bursts Upon The Audio Scene



The H969 is coming through to deliver. . .

The Cleanest Audio

The H969's new ProPitch™ digital electronic-splicing algorithm gives you the cleanest, most glitch-free pitch change ever. Deglitching is active over a wider bandwidth, too — a full octave wider. And Eventide has employed 16 bit linear PCM circuitry in the H969 for the first time in a Harmonizer, for superb audio performance in all modes.

The Easiest To Use

We know that you don't always think in terms of "pitch ratios". Sometimes, you simply want to go up a major third, or down a fifth. So to make things easy, the H969 gives you twelve "instant" pitch change presets. Setting a precise major third, minor third, fifth, seventh or octave of pitch change is a cinch — just push one button. Each interval can be selected as a sharp (increase pitch) or flat (decrease pitch). There are also instant presets for sharp and flat micro-pitch change, for vocal doubling and effects.

You choose from two ways to select pitch ratios and delay times on the H969 — positional and auto incremental. Individual coarse and fine adjust controls make it a snap to get exactly the pitch ratio you want. And once you choose your settings, the digits are rock-stable. Unless of course, you ask the H969 to automatically vary the pitch ratio — up or down, at your choice of speed.

To make the H969 as easy to use in live performance as it is in the studio, we've included a front panel preamplified input, in addition to the usual XLR-type studio level input. Just plug in your instrument. There's a companion front panel output jack, too. The H969 also has remote line in/out switching capability, plus remote pitch ratio/delay time set provisions. A keyboard can also be accommodated.

The Widest Delay Range . . . And More

With the H969, you get much more delay than we've ever put into a Harmonizer before — 1.5 seconds at full bandwidth (40Hz - 15kHz \pm 1dB). Need even more? Just hit the "double mode" button and you can extend delay range to over 3 seconds, with 8kHz bandwidth. For added convenience, you can choose and save any five delay times for instant recall. Delay time and pitch ratio are each displayed on an independent readout.

The Broadest Array Of Effective Features

The H969's full 1.5 / 3 + second digital memory is available in Infinite Repeat as well as Reverse Audio modes, dramatically increasing the versatility and usefulness of these effects. You can also vary the length of the reversed or repeated audio segment after capture. Pitch change, Flange and Doppler effects can be used in tandem with Reverse and Repeat modes.

Flanging on the H969 Harmonizer offers unlimited options. Flange sweep rate can be varied over a very wide range, or you can sweep manually. You can freeze the flange sweep at any point you select, and you can preset the point at which the flange sweep begins. We've also added a new Doppler mode.

The Best Harmonizer Ever

The H969 is an addition to Eventide's full line of Harmonizer special effects units. Our industry standard H949 is still going strong. The H969 ProPitch Harmonizer maintains Eventide's leadership position. For your most demanding applications, the H969 represents the state-of-the-art in pitch change technology. Hear it at your Eventide dealer soon.

Eventide
the next step

One Alsan Way
Little Ferry, N.J. 07643
(201) 641-1200

Circle #018 on Reader Service Card

client services manager for Scene III that moved from Chicago to Nashville in 1975. Since then, Scene III has expanded into a full-service film, video, and audio production company complete with a computer editing suite with digital effects and a remote unit.

Widely known for its outstanding music videos, Scene III has produced for Music City's top country artists including: Janie Fricke, Ray Charles, Crystal Gayle, the Statler Brothers, and Larry Gatlin & the Gatlin Brothers Band, as well as for contemporary Christian music acts.

Although music videos comprise only 20 percent of Scene III's total business, Scene III also has combined its

efforts on two one-hour music specials for the 7-Up Company and co-produces the popular *Music City U.S.A.* with Multimedia Entertainment.

The largest syndicators of country music shows in the world, Multimedia Entertainment produces, not only *Music City U.S.A.*, but the long-running *Pop Goes the Country*. In addition, Multimedia has an *America Comes Alive* series which includes the annual "Music City Awards Show" and "Music City News Top Country Hits" show—the one awards show that solely honors the songwriters.

"Double Platinum," "The Charlie Daniels Volunteer Jam," "Hank Williams—The Man and the Music" "A Tribute to Chet Atkins," and "Ronnie Milsap

—A Celebration" are just a few of the numerous specials Multimedia produced during the past year. One long-awaited special currently in production is the star-studded "Winning Hand" TV special with Dolly Parton, Willie Nelson, Kris Kristofferson, Brenda Lee and others.

With a full-time staff of 15 and a freelance corp that numbers up to 30, Multimedia Entertainment also has co-produced projects, such as, *New Faces in Country Music* and *Behind the Scenes* with another active video company, Jim Owens Productions.

Publicist Bill Jones for Jim Owens Productions says, "We're real proud of the quality of the projects we've done. We won a silver medal from the International Film and TV Festival for Moe Bandy and Joe Stampley's music video "Where's the Dress?" and also a silver medal for *This Week in Country Music* for the best weekly music series behind *Entertainment Tonight* and we think that's a pretty good showing."

Jim Owens Productions, which is both a production and postproduction studio, relocated in Nashville from Atlanta in 1974. Its staff has grown from five members to 19, and its list of credits likewise continues to swell.

Music videos have been shot by JOP for Mel Tillis and Glen Campbell, Larry Gatlin and the Gatlin Brothers Band, and The Statler Brothers, among others. However, the highlight of its year was the spectacular two-hour special, "This Year in Country Music," which will now be an annual presentation.

Nashville is also the home of Film House, Inc., "probably the largest syndicator in the country for commercials for radio and TV stations," according to producer Anne Hahn. Seventy percent of Film Houses' productions are for commercials with the remainder of its work being industrial, educational and documentary films for major corporate clients. Film House, after more than nine years of growth in Nashville, recently moved into a stunning new partially solar two-story building on Music Row.

So . . . whether it's film or video, the Nashville scene provides a wide range of opportunities in all phases of the creative process. Dale Cornelius, executive director of the 1,100-member Nashville Music Association, says that its film and video category is the organization's largest.

Says Cornelius: "What's unique about Nashville is that while we promote our own personal projects, we promote Nashville at the same time. Word is getting out that we have talented people here and that this is a creative and productive place to work. There is a great deal of camaraderie, and business is done with a much more hospitable approach. I think that carries over to all areas of entertainment in Nashville." ■

REALTIME EQUALIZERS: SIMPLY PERFECT SOUND, EVERY TIME

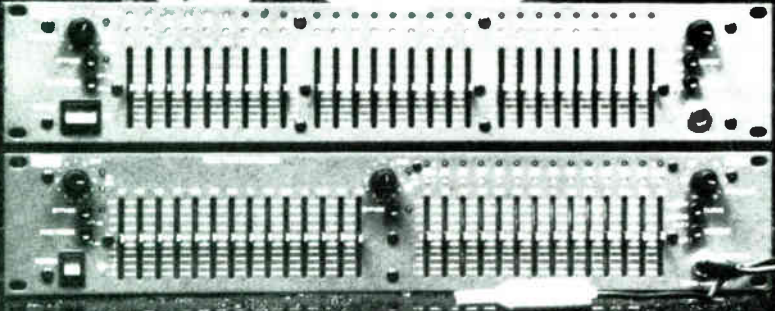

**RE 27 1/3-OCTAVE and RE 14 DUAL 1/3-OCTAVE
REALTIME EQUALIZERS**

We could write pages of claims on how the innovative three-color realtime analyzers built into the RE 27 and RE 14 will enable such a dramatic sonic improvement you'll think you have a whole new sound system. We could expound upon how quick and simple it is to adjust each slider until all the green LED's are on, yielding ±1 dB system accuracy that's practically impossible to achieve by ear. We could tell you how much better Rane's State Variable equalizers eliminate feedback without ruining the rest of the sound, and how these Constant-Q filters are more precise and independent, reducing the need to re-adjust adjacent sliders.

But don't take our word...believe your own ears. Test-drive an RE 27 or RE 14 at your nearest Rane dealer. Hear for yourself the kind of eye-opening effect they have on any speaker system. No sticker-shock, though: only \$849 for the RE 27 and \$749 for the RE 14, suggested list price.

Plain equalizers are becoming obsolete. Ask anyone who's used a Realtime Equalizer. They work wonders.



6510 216th SW, Mounlake Terrace, WA 98043 (206) 774-7309

Circle #019 on Reader Service Card

VANNELLI ON AMEK

“ Getting the sound you hear in your head takes time, patience and a little sweat. Having the *right* console at your fingertips makes life a little easier. ”
– Gino Vannelli

“ Clarity, depth, resonance and full spectrum of sound is what we strive for in our recordings. That's why Gino and I chose AMEK. ”
– Joe Vannelli

Joe and Gino Vannelli
at their 36X24 AMEK ANGELA

Hear it on Gino Vannelli's
upcoming album "Black Cars"

Call or write for more information about
AMEK's complete line of consoles.

In the US: **AMEK CONSOLES, INC.**
10815 Burbank Boulevard, North Hollywood, CA 91601
Phone (818) 508-9788 • Telex 662526

In Canada: **AUDIO CONCEPT**
4460 Thibault, St-Hubert, Qué., Canada J3Y 7T9
Phone (514) 445-2662 • Telex 05-268728

In the UK: **AMEK SYSTEMS & CONTROLS, LTD.**
Islington Mill, James Street, Salford M3 5HW, England
Phone (061) 834-6747 • Telex 668127

AMEK

His energy sapped, Fogerty says he lost his sense of what was good, of what his music should be. "I never doubted that I was going to record again. But I was going to stick it out until I was ready. The voice was still there, but the joy of singing wasn't there. I wanted it *all* back before I came back."

An Engineer Out of Left Field

Jim Gaines, general manager of The Plant in Sausalito, California has been helping engineer Jeffrey Norman along for about ten years, "Since I started as a gofer at Wally Heider's," (a now defunct 24 track San Francisco studio), Norman remembers. The two have worked together on some very successful albums, including Huey Lewis's *Sports* which Gaines engineered, assisted by Norman. Last year Norman decided to leave the staff of The Plant to work independently and with producer Ann Fry in a partnership dubbed Left Field Productions.

When Fogerty asked Gaines about recording at The Plant, the old pro recommended his protege. So Norman stepped out of Left Field into Centerfield for a while. Coincidentally, a heartfelt enthusiasm for baseball provided common ground for the two strangers as Fogerty began his walk through 1984 recording technology. "Working with John is great. I know I'll never miss a key game," says Norman with a laugh and a subtle appreciation for the professional absurdity of such a statement. When Mark Slagle signed on as assistant engineer, the team was complete.

Alone In The Pit

Completely complete. There were no other musicians, arrangers, producers, record company executives or nosey reporters cluttering the confines of Studio C (420 square feet with two isolation booths, a Trident series 80B console, Studer A-80 VU MKIII tape recorders). Fogerty acted as producer and arranger, and performed all vocals and instrumentation, as he has on three previous solo albums.

This smallest of The Plant's three studios got stuck with the nickname, "The Pit" in the late '60s when Sly Stone customized the room so that the musicians could play in a circle around a sunken console and tape recorders with no control room/studio separation. For years after that it was a rehearsal hall, until The Plant converted it and later upgraded just in time for the Fogerty project in the summer of '84. Norman describes "C" this way: "Essentially, it was developed for demos and overdubbing. It's the kind of room where the instrument sounds just like the instrument," perfect for the straightforward sound you'd expect

from the man who wrote "Proud Mary."

But Fogerty himself isn't big on acoustic pedantry. "I'm not one of those people who believes in 'studio and the sound' and all that. I really don't. I think it's who's on both sides of the glass. I think that's where it's at. The fact that it was just my size was kind of cool, though, because there's just one of me . . . and I would set up the equipment as if each guy was there."

Naturally, the tracks had to go down one at a time. To insure a more

hearsal studio for the last nine years, probably just figuring another anonymous Northern California band was making all that racket—practicing for their shot with a label. Fogerty has been diligently reporting for work every day, though for a while it was with no inspiration. "I tried everything—disco, lounge. When I first got the sequencer and my drum machine all hooked up and talking to each other I went off on a binge of a month of techno-pop baloney. You can do that.



Engineer Jeffrey Norman.

spontaneous sound, however, Fogerty used a stereo PA system (three 750 watt BGW amps—tramped—Gauss speakers, Forsythe bass speakers) so he could play off a speaker as if it were a real rhythm guitarist standing in the corner. "It has to be that way, otherwise you won't get any energy," he says. "I did earphone trips way back in the beginning when I started this [*The Blue Ridge Rangers*, Asylum Records, 1972]. Well, I tried actually at the end of the *soggy* album for Asylum [*Hoodoo*, 1975, never released] to have them play through the studio monitors to get some soul, to get some feeling. They were so wimpy. Every time that kick drum and the bass would hit, it would go [he lets out a slow, sputtering, spitting noise while smashing his hands down on the table]—it was terrible. I began to get the idea that I'd better get a PA." A scratch rhythm guitar track went down first using a click track. Next came the real drum track, which then became the rhythm track; then came the bass, followed by the rhythm guitar and the saxophone.

The kids from the nearby high school have been walking past Fogerty's modest suburban eight track re-

It all sounds wonderful, but it didn't mean anything."

When he finally did feel he had his sound and decided to take the big step to the outside world, he was meticulously prepared. Engineer Norman reports that Fogerty had everything written down: changes, amp settings, etc. After much deliberation about types of wood and tuners, and how much metal would be needed to give the bottom end the warmth he wanted, Fogerty commissioned Phil Kubicki in Santa Barbara to make a "swamp bass." Seymour Duncan made the pick ups. The drums were culled from all over.

Fogerty's philosophy is to spend the time outside the studio getting the exact instrument sound. "It was my theory to be as well prepared as I could be before I'd go in there. I've had several false starts over the last ten years, and I didn't want to humiliate myself again. I mean it really is—it's kind of like trying to be a high jumper and you've got 50,000 people watching and you're not ready when they put it up to six feet—and you go smack right into the bar [pounds his fist into his palm]. I did that several times and fell on my face. So I said, the next time I go, I got to be really ready and have it together because there's that grind-

PHOTO: REBECCA SWEARINGEN

STUDIO QUALITY BUILT IN

Pictured below is the Ibanez MSP1000, GE1502, and the GE3101



A Special
Thanks to
KAJEM STUDIOS
of Gladwyne, PA

Ibanez

For a full color catalog send \$2.00 to: Tama, dept. MIX • P.O. Box 886, Bensalem, PA 19020 • 17421 "B"
East Gale Ave., City of Industry, CA 91748 P.O. Box 2009, Idaho Falls, ID 83403 • In Canada: 6969
Trans Canada Highway, Suite 105, St.-Laurent, Quebec, Canada H4T1V8

Circle #021 on Reader Service Card

World Radio History

BE TRUE TO YOUR MASTER



AGFA magnetite 12



Agfa Magnetite 12 cassette duplicating tape delivers true master quality sound. Outstanding high and low output combines with the lowest noise floor available to provide unmatched versatility and tremendous enhancement capabilities. Magnetite 12 fulfills the needs of the most demanding master. You spend too much time perfecting your master recording to trust its sound to an unfaithful cassette duplicating tape.

Trust Agfa Magnetite 12.
It gives as good as it gets.

**AGFA
AUDIO**

ing down period at the end when you're running out of energy and you start having self doubts—which is exactly what happened. I had those six songs done and I could hear the thundering herd again. And I said, 'Oh God, here it comes again—that feeling—and I can't let it happen like it did before.'"

So when Norman got behind the board and started adjusting the sound, Fogerty admits he got a bit nervous. "He's only a mild knob twiddler, though. We laughed about that. That's a Pete Townshend expression. I would say, 'Wait a minute, wait a minute. I've been working on this a long time.' I would have him repeat to me what he was doing. This was the first day, which we ended up having to do over. Most of what he was doing was fine. I just didn't want him to get carried away because most engineers, just because it's there, say 'Well, I'm supposed to do something, I'll try this.' But I told him, 'Just listen to the bass the way it is.' I think that was the one that really startled him. It's just wonderful sounding. Real warm."

Swamp Rock: No Room for Slapback-Whiplash

If Fogerty introduced his engineer to some "old fashioned" tonal qualities, Norman turned one of his pop heroes of the early '70s onto some of the pleasures of 1980s technology. One example: the AMS digital reverb, which Fogerty learned to love immediately. He recently purchased one for his rehearsal studio.

Echo played an important role in Creedence's music. Hits such as "Green River" and "Run Through the Jungle" are perhaps best remembered for that steamy vocal quality. Fogerty calls echo an extra instrument that has to be tuned and troubled over in the same way one would treat a guitar. He objects to the slapback-as-whiplash effect. "There's a right way and a wrong way to do slapback," he says. "The Sun Records use of it was real warm. The vocal was the whole thing. There was a resurgence of using slapback in '78-'79. The use of it just didn't ring true to me in a lot of cases. It doesn't give you the same warm feeling. It's just there; it's an effect like so many effects that have come along in the last six years. Boxes everybody uses. It's something you really have to think about and be careful with."

As a case in point, much care went into the echo on the horn part in "Rock and Roll Girls." Norman wanted a punchier, modern rock decay, while Fogerty heard in his head a longer, smoother, less affected decay. Naturally, the boss won. "I got what I wanted, but it was like a trade a little later when

there was something he was going for. I listened and I listened and I couldn't see it. But then I said, 'Okay, you're right. Does that make up for the horn in 'Rock and Roll Girls?' We tried to keep it as light as we could always—so I would invent these characters that would be there with us. We had the producer and his girlfriend watching,

of about four years (1969-'72), and now a song sounds on the radio is still his yardstick while mixing, no matter what the studio monitors say. "I mixed this album in the front seat of a Toyota Landcruiser," he remarks. "We would put in our 10 or 11 hours in the studio, then we'd do a pass onto a cassette, and then I'd run with the cassette out



PHOTO: MICHAEL LUTTERBACK

because you know that goes on. And the producer's got to be showing his stuff, so he reaches over and touches a knob—doesn't *do anything*, and then he turns to the girlfriend, Becky, and says, 'See what I just did.' But I don't think there's anything on the record we tried for but didn't achieve."

A talk with a hit performer/producer from 15 years ago highlights many of the technical advances the re-cording industry has seen since then, and what audiences have grown to expect. Fogerty admits that mixing in 1984 was a completely different experience. After he'd mixed half the album, in fact, he had to go back and do it over again: "I went home and put on a Creedence record and said, 'Yeah, new stuff matches, sounds fine.' Then I put on a contemporary record and said, 'Whoa!' The contemporary record just jumped right out at me, and the Creedence just sort of laid there. So I went back to the drawing board. I had to work with the correct balances between higher and lower registers. Nowadays you can print a lot more on a record. It used to take me about an hour-and-a-half per tune. Now we averaged about 10 or 12 hours."

Radio listeners heard 20 singles from Fogerty and CCR over a period

into the truck and listen to it—get all the relationships from that."

Gremlins in the Computer

While automation enhances the mixing process, a computer can sometimes create special effects that nobody programmed. At home late at night Fogerty would be listening to a cassette of "Big Train (From Memphis)" when he'd swear he was hearing a second vocal track he'd never laid down. The song is about Elvis Presley's impact on his youth. "It sent a chill up my spine—like, 'Big E is here singing with me.' Then we found out one of the computer modules was defective, and it would intermittently play the main vocal when it wasn't supposed to. That's one thing I found out. These computers aren't always nice to me."

The Way of the Wah-Wah

For a musician who's been repeatedly using the word "warm" to describe the sound he's looking for, Fogerty interestingly enough, used a drum machine on the song, "Zanz Kant Danz." He calls this a deliberate stylistic device to characterize the content of the song (which he referred to as "the robot song" while in the studio). On the general subject of drum machines,

—PAGE 158

Sun and Fun Recording

This month's *Mix* is loaded with Southeastern listings, detailing all the recording opportunities south of the Mason-Dixon line, a part of the country enjoying unprecedented growth as population and commerce migrate from the Rust Belt to the Sun Belt. But rather than rely on facts, I decided to collect some estimations, opinions, and hearsay to find out the real state of affairs regarding recording on my home turf. Thus I left my South Miami home, but instead of letting my motorcycle take its instinctive easterly route to the beach, I headed north on I-95 to North Miami/Ft. Lauderdale, the mecca of South Florida recording. I turned on my tape recorder for a wide cross section of industry practitioners, talking to everyone from engineers to owners to reps, to find out whether business was good, bad, or Chapter 11.

My first stop was at A.R.T., an up-and-coming company specializing in live sound system installations for night clubs or small concert halls. In addition, A.R.T. sells designs and materials for new and renovation jobs,

and performs maintenance for all their customers. Paul Hugo, co-owner, pointed to club installations as the most rapidly developing aspect of the business. The last year has seen a steady pace of openings, or re-makes, with an average of one-and-a-half per month. In addition, there is a growing trend toward knowledgeability on the part of the owners, which results in demand for more sophisticated equipment, and better sound. In part, this has evolved a trend to purchase a smaller amount of equipment, but of higher quality.

Hugo noted that a number of their clients were dissatisfied former clients from another company noted for its poor design. The tide seems to be turning toward clients and companies interested in doing it right the first time. The bottom line is however, still a concern too. The South Florida economy is seasonal, and this is sometimes reflected in the audio industry. For example, Hugo noted that many club owners choose their slow summer months for new construction or elaborate renovation, and use the

busy winter for fine-tuning and particular changes aimed to re-awake the interest of steady customers. In addition, South Florida is the access point for the growing Caribbean market. Multi-lingualism and familiarity with island preferences are important considerations. A.R.T. has thus readily found its niche as a high-end design company, busy with the increasing number of clubs in the area.

Criteria Recording Studios in North Miami is the long-standing flagship of South Florida recording. Founded in 1955 by Mack Emerman, the facility now includes five recording studios, and a disk mastering suite. Emerman characterized the summer as unexpectedly bad, however more recently business has been unexpectedly good, particularly beginning in December, with bookings stretching through the spring. In part, this might be a result of a long-term shake-out in South Florida audio studios. There are now fewer comprehensive facilities than in the past, affording clients fewer choices.

Recent Criteria clients have included Bob Seger, Shytalk, Mountain, Robin Gibb, Julio Iglesias, and Candy. A new recording project, described as a video postcard, will result in half-hour video tapes of visits to cities around the U.S. This is an all-digital project with Mitsubishi X-800 and X-80, to be released on Beta and VHS Hi-Fi.

According to Mr. Emerman, future directions for Criteria include greater involvement in postproduction; for example, Studio A, with its 50 x 75 x 20 foot dimensions, could be redesigned as a sound stage or large mixing room; with projection, dubbars, and digital audio, all locked-up, it would provide a needed posting facility for South Florida.

Coconuts Recording Co., in North Miami Beach occupies a unique position in the South Florida recording scene. Under the ownership of Shirley Kaye, Coconuts is an "insiders" studio which, according to Kaye, is extremely successful precisely because of its anonymity. With jingle work during the day, and album work at night, business has been stable and busy, with no summer slump. Most of the album clients are from out-of-state, typically as a result of a producer's referral, and rarely miss meals, because according to Kaye, "I worry if they don't have lunch." Future endeavors will include expanded audio

—PAGE 145

ATTENTION MCI 500C/D OWNERS: Your mic-inputs will sound much better with the MPC-500C/MPC-500D mic-preamp cards!

- **990 OP-AMP** offers higher slew rate and output current, lower noise and distortion, and better sound than stock 5534.
- **JE-16B MIC-INPUT TRANSFORMER** provides one-third the distortion, 15 dB higher input levels and better sound than stock JE-115-KE.
- **SERVO/DC COUPLING** eliminates coupling and gain-pot capacitors resulting in much better sound without DC offset problems.
- **ON-CARD REGULATION** eliminates the need for the MCI "swinging transistors." Reduces crosstalk and improves sound quality. And more!

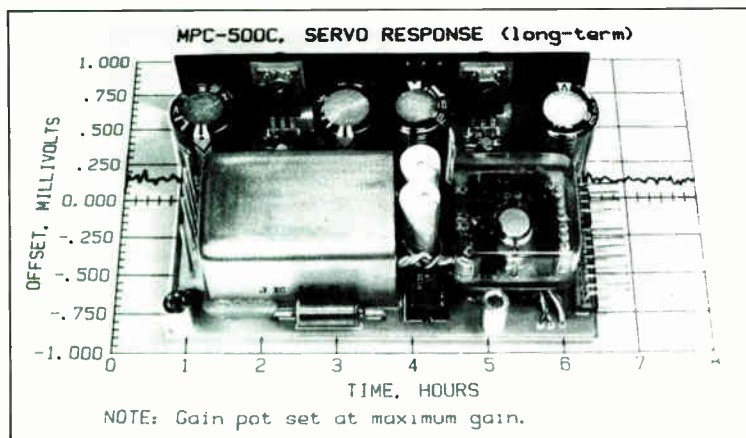

THE HARDY CO. BOX AA631 EVANSTON, IL 60204 (312) 864-8060

Circle #024 on Reader Service Card

—FROM PAGE 52, SOUTHEAST

Europe, with thousands of demos coming in over the past year. Norman adds that an R&B/soul version of the program is now in the works, as the show currently only plays rock and top-40 formats. The studio has also upgraded to 16 tracks and added more outboard gear to their arsenal.

Bill Allgood, president of New Age Sight and Sound, hopes his new three studio facility in Atlanta will be ready for a grand opening the first week in March. Under construction since December, the Jerry Milam-designed facility features a live end-dead end style control room with RPG diffusors fitted into the back wall of Control Room A, which is equipped with a 50 input South Workshop automated console, a Sony 3324 24 track digital recorder and Sony 1610 digital mastering system. All of the control rooms are built around a central 40x50 foot music room: control B offers 24 track analog recording; and a video control/editing suite allows live shoots as well as postproduction in either 3/4 or one-inch formats. The studio also expects to be providing digital rental services to their customers.

Crawford Post Production is another new addition to Atlanta's growing reputation as a major media production market. The company actually began five years ago as a small 3/4-inch off-line and audio house on Spring Street, and now occupies a three acre site with a 20,000 square foot building. On line since last October, the new facility boasts an enormous 34x27 control room which seats 30 (designed by Les Duncan of Trackside Engineering), equipped with dual 24 tracks and a 48 input Neve 8128 console with Necam II; a 32x25 foot recording room with a 14 foot lighting grid/ceiling; a small studio ("B") equipped for voiceovers and smaller projects; three video suites—two are one-inch, one is interformat (1", 3/4", VHS, M-format); three graphics suites; and a 35/16mm Rank MKIII film transfer room. One of Crawford's more popular bits of hardware is their Montage editing system, which is very popular with film editors according to studio marketing manager Kathy Kelly: "Film people love it," she explains, "It's fast and you can store your EDL (edit decision list) which is compatible with our Ampex Touch Screen editor. It's an easy machine to learn."

Kelly adds that Crawford is now in the process of purchasing three Earth stations and a mobile uplink truck which should be on line by press time. The firm already has received bookings from ABC, Turner Broadcasting, and regional television stations for their satellite uplink services. Also on the horizon is Crawford Communications, an in-house interactive videodisk

—PAGE 56

SUCKER.

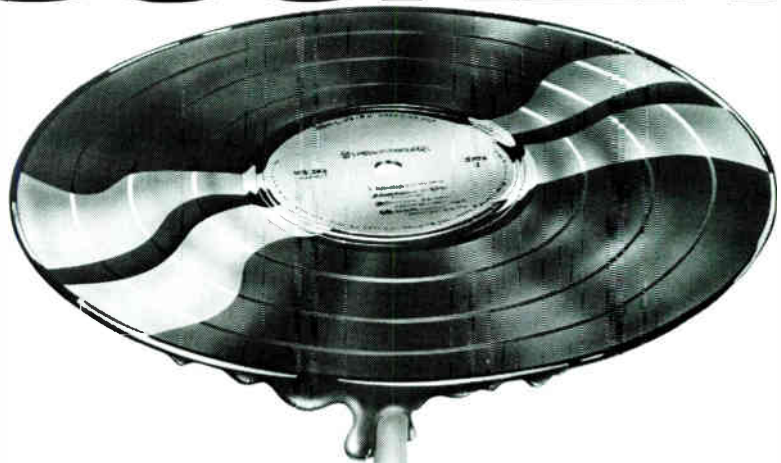

**They said they could handle it.
And you believed them.**
**Next time—before you find yourself
in a sticky situation—call Ardent.**
**Our professionals and state-of-the-
art equipment offer everything you'd
expect in recording, mastering
and video capabilities.**

ARDENT.
Ahh—the sweet taste of success.

**24 track & 46 track studios •
Automated mixing • Neumann
Mastering Equipment • One inch
video tape production and editing
• Ikegami EC 35 • Ultimatte 4 •
Chyron IV Graphics • NEC E-FLEX
digital effects • Steadicam**

ARDENT

2000 Madison Avenue • Memphis, TN 38104
901-725-0855 / 726-6553

Circle #025 on Reader Service Card

Your Recordings Can Only Sound as Good as the Cables Used to Record Them



**Introducing Prolink™ High Performance
Studio Cables by Monster Cable®**

Many people in the recording business used to think that cables were just cables. And in fact, many of us still do.

A Sound of their Own. Many engineers have found that the opposite is true. They are discovering that ordinary cables have "a sound of their own" and distort music recording and reproduction in ways that we were never even aware of. Critical areas such as clarity, depth of bass response, quickness

of transients, and the "naturalness" and "presence" of voices and instruments, are all lost through conventional cables.

A Monster New Technology in Cable Design. Monster Cable has shown music listeners worldwide that the sound of their playback systems could be significantly improved simply by changing their cables to the Monster. Now you can obtain an improvement in the sound of both recording and playback that will sur-

prise the most critical and skeptical of engineers, simply by switching from your current connecting cables to Prolink by Monster Cable.

Come Hear the Monster.

We invite you to hear our entire line of microphone, speaker, and studio hookup cables. Put them through your most critical listening and durability testing. You'll discover just how good your recordings can really sound.

Prolink™

For your free brochure please call or write Paul Stubblebine, Professional Products Division Manager.

Monster Cable® Products, Inc.
101 Townsend, San Francisco CA 94107
415 771-1355 Telex: 470584 MCSYU1

Circle #026 on Reader Service Card

Music Resources

The camera may never lie, as that old saying goes, but sound certainly can—and often does—quite effectively in fact.

With the advent of Music Resources, the Nashville area's first and only all-electronic music recording studio, musicians, producers and artists have an opportunity to learn the capabilities of computerized, synthesized, and electronically generated sounds.

Music Resources is the brainchild of Steve Schaffer, a 37-year-old musician who built his first recording studio in Nashville 15 years ago.

Schaffer confirms that there are some reservations and even some resistance from other musicians who do not understand the new technology. That is why he offers consultation, along with other services, at his studio.

"It [his Synclavier computer system] can bend notes and play them backwards," explains Schaffer. "If a singer can't sing on pitch but the phrasing and feeling's right, the machine can repair it. If they don't sing on beat, I can move it back. The machine actually eliminates the musician's need to keep going back over something until his performance begins to go down."

Another advantage of technology is being able to synch sound more precisely with film and video. Schaffer explains that on one commercial produced at Music Resources there were 86 visual images in 23 seconds that "had to be nailed to notes." Obviously a symphony can't do that.

"Live musicians will not be replaced by machines," according to Schaffer. "A solo instrument has an articulation that is too difficult or impossible to program." But, people with dualistic roles better start practicing!

Schaffer is now programming a "real sound" library that currently has a catalog of 40 instruments that musicians and producers can call up to repair, or embellish a track. The service is available for those working at other studios who just want to lease the musical passages.

Computerized music is here to stay. Schaffer's attitude is a good one—Don't fight it. Learn to use it to make you better at what you do.

—Rose Clayton



PHOTO: CHUCK SAGLE

Mesa Records recording artist Karen Taylor-Good recently recorded a series of children's songs at Music Resources, the Nashville area's newly-opened studio geared exclusively for the computerized and electronic production of music. Explaining the studio's Synclavier® computer system is studio president Steve Schaffer, who designed and built the studio and compiled its extensive digital library of real sounds.

—FROM PAGE 55, SOUTHEAST

manufacturing and design firm headed up by Jeff Kempf.

Studio A at Crescendo Records is currently undergoing a major remodeling, according to engineer Gary Ham. The re-design, being handled by Bill Morrison of Acoustic Physics Labs (Doraville, GA), should be completed by the end of this month. The control room is now fitted with a Morrison's custom four-way, all-cone, lead lined monitor system, which "sounds great" according to Ham. Recent session activity at Crescendo includes work by Candi Staton, Atlanta, Kevin Kendrick, Quincy Jones Productions, and Gears.

Jimmy Johnson, co-owner of Muscle Shoals Sound Studios in Sheffield, Alabama, says things have really picked up at his facility, located in a 31,000 square foot building formerly occupied by the U.S. Navy Reserve. The biggest news is the studio's acquisition of a Mitsubishi X-80 digital two track recorder. "I love it," Johnson exclaims proudly. "Everybody who comes in here loves it. Producers are really losing out if they don't try digital mixing. Once they try it, they don't go back to analog mix-downs. It gives you a mirror image of your multitrack tape. The X-80 is just fantastic. I'm a real believer in that fella." Among the groups to use the X-80 so far are the Oak Ridge Boys, who mixed part of their latest greatest hits album there. However the studio offers much more than mere hardware to attract clients. The relaxed country atmosphere and

riverside ambience, as well as the availability of legendary session players has attracted artists such as Julian Lennon (he cut basic tracks for his *Valotte* debut album there); Dealers, a group of Memphis-based dance-meisters; and Nashville's Golden Spear to the studio in recent months.

John Saviano, of Reliable Music, a Charlotte, North Carolina-based retailer, notes strong sales over the past year, especially to the musician and home studio market. Certain items, such as Soundcraft consoles; Tascam 500 series mixers and model 38 recorders; and digital reverbs like the Lexicon PCM60 and the Klark-Teknik DN-780 have sold particularly well over the past few months, and Saviano feels the Otari MX-70 one-inch 16 track machines will be another popular item once they are available. Recent studios he has equipped include Jay Howard Productions, a 16 track commercial audio production facility in Charlotte, and Silverstar Recording (McBee, SC) who upgraded with a Soundcraft 1600 console and additional outboard gear.

Also in Charlotte, Reflection Sound Studios have kept both of their 24 track rooms busy of late with a variety of projects, mostly of the new rock genre, according to studio manager Mark Williams. Don Dixon was recently in producing Marty Jones for A&M Records, Buzz of the Light for CBS, and The Graphic for a compilation LP on Dalton Records. Robert Kirkland produced local rockers The Other Mothers and

The Professional Cassette Decks



Tandberg's new Series TCD 900 is a superior and cost-efficient alternative to the (unprofessional) practice of using inferior home tape decks for Professional applications. These new Professional Cassette Decks offer unparalleled sound capability, advanced mechanical and electronic design, plus extraordinary control flexibility based on an 8-Bit microprocessor with 32K of EPROM memory. These are the type of quality products for which Tandberg is well known, and are designed and built in keeping with the company's more than 50-year reputation for quality, performance and long-term owner loyalty.

TCD 910 Master Cassette Recorder

TCD 910 is designed to replace both reel-to-reel and cartridge machines in many applications, and is capable of producing tapes at sound and silence levels beyond that required by broadcast and studio requirements. Combined with its extremely

accurate real time counter and sophisticated autolocator functions, this machine is truly a multipurpose cassette recorder.

Features include:

- High precision, rugged 4 motor tape transport with direct load, instant access cassette positioning.
- Discrete three head system with built-in record azimuth adjustment is combined with Tandberg's proprietary Active Phase Correction Circuitry, exclusive discrete, wide band electronics, plus the highly regarded Actilinear II and Dynec systems. In addition, the latest generation Dolby B and C noise reduction processors are utilized.
- All audio circuitry uses high spec polypropylene capacitors and metal film resistors.
- Built-in autolocator with 10 cue points in real time, auto cut search and cue/review.
- Auto stop and/or rewind after cut.
- Electronically balanced XLR input/output connectors.
- Front panel bias and record

current adjustment, with built-in oscillators.

- Optional RS 232 computer interface, infrared wireless and hard wire remote with fader start.
- Wide range of options and accessories.

TCD 911 Cassette Playback Deck

The TCD 911 offers the same quality of construction and design as the TCD 910. Its special features include:

- Playback pitch control.
- External playback azimuth control, for optimum performance from any pre-recorded cassette.

In a multi-deck studio situation, the TCD 910, combined with the TCD 911, makes for the ideal match of performance, reliability and price.

TANDBERG TCD 900 SERIES PROFESSIONAL CASSETTE DECKS

TANDBERG OF AMERICA

Professional Products Division • One Labriola Court • P.O. Box 58 • Armonk, NY 10504 • (914) 273-9150

Circle #027 on Reader Service Card

World Radio History

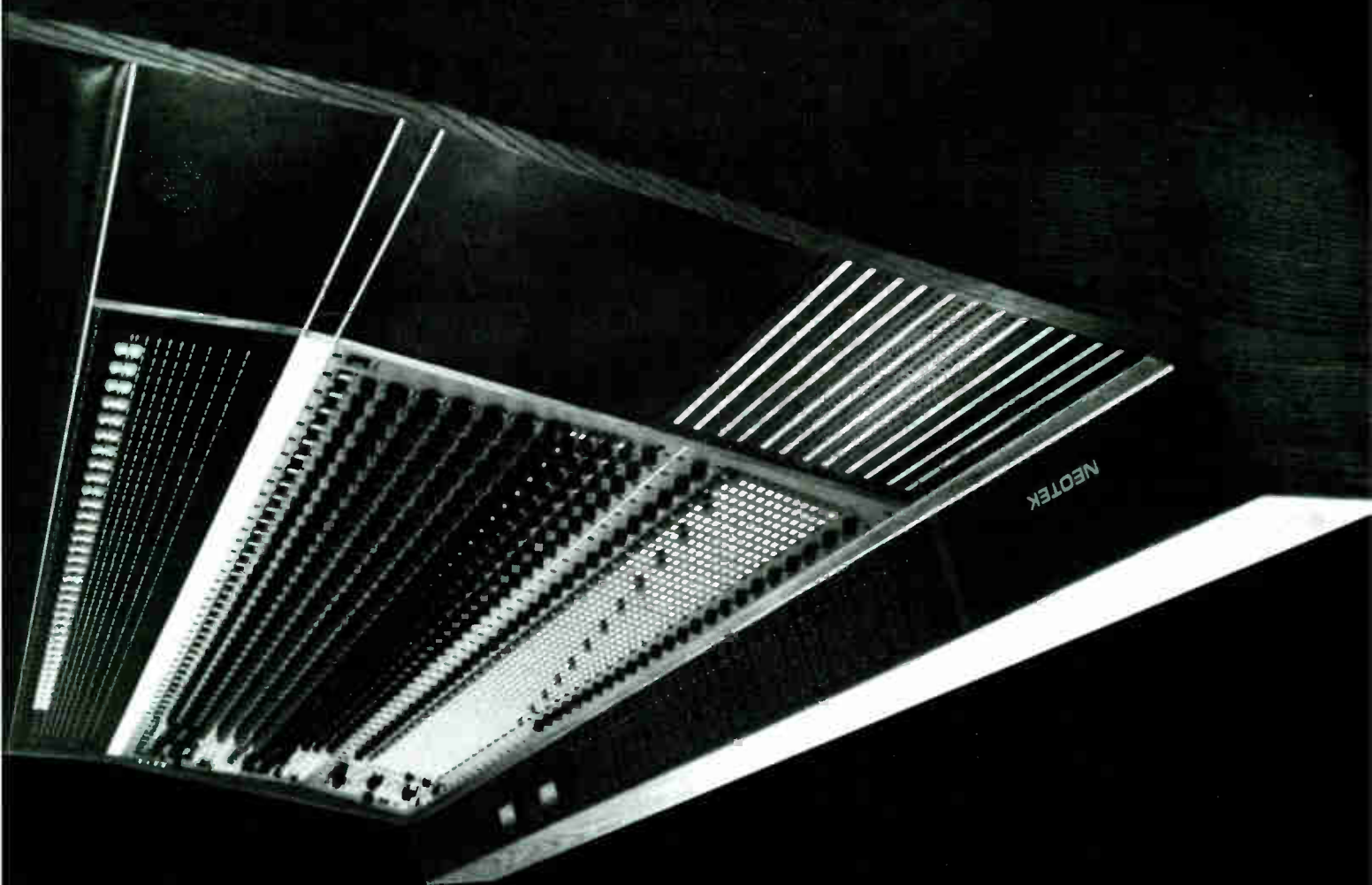

what we make,

It's not only
World Radio History

it's what we know.

The choice of a console is one of the most important you will ever make. You want more than just a pretty top plate and lots of knobs and switches. You know that the sonic performance of the console is absolutely critical to the quality of the product you produce, and to your own reputation for performance. NEOTEK consoles are the choice of studios who know that performance means value, and who demand the best of both.

Advanced technology NEOTEK consoles have always been at the cutting edge of analog design, with completely transformerless consoles and mic preamps five years ahead of any other manufacturer. NEOTEK offered the first, and still the best, state variable equalizers and the first consoles with three way solo systems. The latest NEOTEK consoles employ hybrid circuits and active compensation topologies that won't be seen on other consoles for years. When it comes to console design, NEOTEK is the definition of state of the art.

Sonic Performance The legendary sound quality of NEOTEK consoles is a major reason that they are owned by the greatest orchestras in the country: Chicago, Cleveland, St. Louis, Philadelphia. They are at the Lincoln Center, the Metropolitan Opera, the Julliard School of Music, the Berkeley Repertory Theater, the Rome Opera. They are used by audiophile labels like Delos and Varese Sarabande and exclusively for the superlative TELARC CDs. It is just as important to have this performance in your studio, because it is a superiority that everyone can hear and none can afford to ignore.

Technical specifications The measured performance of NEOTEK consoles is unsurpassed. In terms of noise, distortion, and signal bandwidth they exceed the specifications of 16-bit digital recorders. In a time when others are claiming to be 'ready for digital,' NEOTEK continues to improve designs that were ready for digital long before digital was ready for the best in analog. As the result of striving for the ultimate sonic performance, NEOTEKs produce the finest specifications ever measured on production consoles.

Essential intangibles If you can appreciate the driving quality of a Porsche, you can understand why engineers like working on NEOTEK consoles. The signal flow is easy to follow, controls do what you expect, and the equalizer is musical even when cranked to extremes. The construction quality of these consoles maintains their performance and resale value in the long run. You will find shielded cable wired to metal frame jacks instead of ribbon cable to plastic, and instrument grade components are used exclusively. Console frames are made of solid hardwood, with the feel of fine hand finished furniture.

Made to order NEOTEK manufactures a full range of consoles designed for specific applications. There are console series for multitrack recording, four and eight channel recording, broadcast production, theater effects and sound reinforcement, film and television post production, and sophisticated sound reinforcement. Each is built to individual order in the United States. Engineers at the factory are available to tailor each console to the most demanding installation.

If you are about to choose a console, choose NEOTEK.

Let others compromise.

NEOTEK CORPORATION

1154 West Belmont Avenue Chicago, Illinois 60657 U.S.A. 312-929-6699



Joe Cocker listens to tracks while cutting at Ardent Recording, Memphis, Tennessee. Pictured left to right: Tom Sullivan, Road Manager; Kim Jenkins, Assistant Engineer; Joe Cocker; Larry Marshall, Keyboardist; Carl Marsh, Fairlight Programmer; seated—Terry Manning, Engineer/Producer.

The Woodpeckers; and Reflection went on the road last fall to cut some REM live dates, although no release plans for these had been made public at press time.

Deborah Camp, editor of the *Memphis Star*, a local music monthly, sees a burgeoning and vibrant music scene in her town. "There has been a huge revival of blues and rockabilly music," Camp notes, "especially with younger audiences who are just discov-

ering these for the first time." She adds that Christian music is also very strong in Memphis, ranging from DeGarmo & Key's popular albums and videos, to an increasing number of choirs and a capella groups keeping the local studios busy. Memphis State University is also getting into the act, and their High Water label has just released its second LP, this one by local blues group The Fieldstones

After just one year in the business, Sounds Unreel of Memphis has been doing very well, according to owner Jon Hornyak, with a lot of three-session days booked over the past few months. The studio actually opened with just the control room and bathroom completed (the scaffolding was still up in the music room when Danny Tate christened the facility while mixing two sides from *Sex Will Sell* with producer Carl Marsh.) Since then, Sounds Unreel has hosted a large number of new and/or unsigned talent: Mississippi band Ssipp, produced by Ed Townsend; The Crime; and The Breaks (now signed to RCA).

It's not like it was few years ago, but business is steady; there's never a dull moment," comments Paula Crowe, of Ardent Studios in Memphis. Exciting things are underfoot at the facility, including a complete remodeling of studio B, which will be fitted with a Westar console, audio/video synchronization gear, and a Fairlight music system. The booking sheets have also been steadily filled with the likes of Joe Cocker, who was in working on his new LP due for release this spring; and the Bar-Kays and ZZ Top are due to be in the studio by summer.

Bob Todrank, of Valley Audio, a Nashville retailer, sees 1985 as a strong year for studio upgrades and construction. "Last summer was fairly slow, but things really picked up during the fall and winter, and this spring really looks good. It's mind boggling—we have six to ten new studio projects coming before June." The Otari MTR-90 recorders have been hot sellers at Valley Audio, with new decks recently going to Warner Bros. and the Pickin' Post. Valley's Micki Harrison adds that the Linn 9000 is another high interest item: "We've had a lot of orders for them. Everybody loves them."

At Nashville based Studer/Revox America, Joe Bean notes that sales of their A80 24 track machines have been particularly strong throughout the Southeast over the past few months, with recorders going to Alpha Recording, San Juan, Puerto Rico; Amphion Recording, Florida; Crawford Post Production, Atlanta; Soundscape, Atlanta; Steve Morse (of the Dregs), Atlanta; Perfect Pitch, Statesville, NC; Merit Music, Nashville; Florida Sound, Tampa; and Lake Bradford Recording in Tallahassee.

The Mobile Audio remote recording truck in Nashville has been busy of late with a variety of projects including the Alabama Music Hall of Fame Awards sponsored by the Muscle Shoals Music Assn., and a number of tour dates with Prince. The work with Prince entailed doing a live version of "Baby I'm a Star" for a single release and a 17 minute audio track for an MTV mini-video of "I Would Die for You" which segues into

Reliable Music

featuring
RECORDING STUDIO, BROADCAST AUDIO &
SOUND REINFORCEMENT EQUIPMENT.



HOW CAN WE HELP YOU?

- QUALITY AUDIO • GUARANTEED PERFORMANCE
- DEPENDABLE SERVICE • COMPETITIVE PRICES

704/375-8662

PRO AUDIO DIVISION 1001 S. INDEPENDENCE BLVD. CHARLOTTE, NC 28202

Circle #029 on Reader Service Card

"Baby I'm a Star." Mobile Audio also has offices in Atlanta.

Paul Goldberg, manager of producer Harold Shedd's Music Mill studio in Nashville reports a flurry of album activity, even over the Christmas and New Year holidays, a time when most studios are idle. A few of Shedd's recent projects include working with Alabama, Glen Campbell, and Mel Tillis. Other artists making use of the facility include John Anderson, produced by Lou Bradley and Jim Ed Norman; Vince Gill produced by Emory Gordy; Gus Harden produced by Mark Wright; and Karen Taylor produced by Barry Beckett. When clients require a digital mix, Music Mill provides a JVC system rented from Masterfonics.

Roy Clark's Sound Emporium is currently undergoing a total remodel of control room A which should be completed by the end of this month, according to engineer Gary Laney. The new room will feature a Neve 8128 console, Studer recorders, new monitors (brand undecided at press time) and an additional \$30,000 in outboard gear and microphones. Although the studio is best known for its country clientele, rock bookings are also on the upswing with local bands Civic Duty and Citizen Earth in cutting tracks in past months.

Master Mix, Nashville's com-



Audiovisions' Control Room A, Louisville, Kentucky

bined mastering room and remix facility has done quite well recently, says manager Hank Williams. "Business is really good," Williams explains. "The remix room is one year old now, and people really fall in love with the monitoring system, which is an all-cone, four-way system built by Claude Fortier. Since the room is large and open, it's also becoming very popular for synth and overdub business." A few clients who have used the room include Dolly Parton, Shelley West, Restless Heart (a new act on RCA), and the new MTM (Mary Tyler Moore)

label based in Nashville.

The purchase of a 3M digital system by Treasure Isle in Nashville has turned out to be a good move, according to Richard Stevens who says business has improved tremendously in spite of the fact that Castle Recording has another 3M system nearby. "Actually it helps us, because when their system is booked people can still come to us and vice-versa. Having a compatible machine in town is really helpful." Recent projects at the studio include Emmy Lou Harris tracking and overdubbing for her

STUDIOS OF THE SOUTHWEST

Listings of studios in the Southwestern U.S. will appear in the July issue of *Mix*. Don't miss this opportunity to let producers, musicians and other potential clients know about your facility and services. To receive a questionnaire, mail the coupon below today!

Name of Studio _____

of Tracks _____

Owner _____

Studio Manager _____

Address _____

City _____

State _____ Zip _____

Return Immediately to:
Mix Magazine, 2608 Ninth Street
Berkeley, CA 94710

**For Information, call Lauri Newman
at (415) 843-7901.**



RECORDING FACILITIES INCLUDE:

- SOUNDWORKSHOP
- AUTOMATED CONSOLE
- STUDER TAPE MACHINES
- LEXICON 224XL REVERB



VACATION WHILE YOU WORK

AT NORTHWEST FLORIDA'S FIRST 24 TRACK AUTOMATED STUDIO.

RECORD AT NIGHT AND RELAX DURING THE DAY AT PENSACOLA BEACH "KNOWN WORLD-WIDE FOR ITS SUGAR WHITE SAND BEACHES"

FOR ACCOMMODATIONS OR MORE INFORMATION
PLEASE CALL 904-434-0052

SOUNDTRAK
RECORDING STUDIO
P.O. BOX 12422 • PENSACOLA, FLORIDA 32582

Circle #030 on Reader Service Card



Castle Recording

In a city of more than 70 commercial recording studios, Nashville's The Castle is unquestionably unique. Some members of the music industry even refer to it as a utopia . . . a place where the best of both worlds meet—a picture of tranquility on the outside; a study of high technology within.

An authentic stone structure, The Castle stands majestically atop a knoll, surrounded by cedar trees on a six-acre tract, bordered by a river, off a rural road only 20 minutes outside Nashville.

Local legend has it that The Castle, built about 1930, was once a gambling casino that doubled as a hideout for gangsters such as Al Capone. Later it was converted into a well-known restaurant where its clientele was said to have included Betty Grable, Bob Hope, Spencer Tracy and other such guests.

A half century later, celebrities continue to come to The Castle, but for a much different type of experience. Now, the real beauty of the edifice is found in its sound.

When exposed, the old thick stone walls of the mansion are admired for their exceptional crisp tone, and the elegantly carpeted floors and heavy drapery for their effectiveness in deadening the main room as it traces tracks for master recordings.

The double glass windows and doors that span the space between the stone walls securely capture the rich sounds emanating from Music City's first completely digital multi-track recording studio.

"It's a link between the past and the future—a tension that is necessary in the creative process," says co-owner Ann Nuyens when describing The Castle's atmosphere. "What the musicians like here is that they feel free. They can see outside and be influenced by nature."

Nuyens, her husband Josef, Sr. and 24-year-old son Josef, Jr., own The Castle Recording Studio. Josef Jr. oversees the operation.

The Nuyens family, which also in-

cludes daughter Mimi, a guitar major at a local college, was the first European bluegrass act to tour the U.S. when they embarked from Belgium in 1970. They became so entranced by bluegrass music that they finally immigrated here and began to record.

"We were experienced in all kinds of studios and critical of sound because all our instruments were acoustic," explains Josef, Jr. "What we heard on tape was not what we were hearing ourselves playing." So came the inspiration for buying the family owned and operated recording studio.

Their dedication to purity of sound continued to increase the Nuyens' investment in The Castle, and before long it had expanded into a state-of-the-art 48 track recording facility featuring a synthesizer room (known as the future room) for its Fairlight CMI system. It was in the future room, "where expression comes to life," that the idea for a full production company was conceived.

"We have traveled a lot," Josef, Jr. relates. "We have connections in Los Angeles, England, and New York (where Josef, Sr. once worked on Wall Street), and we know what is happening electronically. The whole point of this business is staying ahead of, rather than keeping up with what's current."

And so, as the result of the Nuyens' philosophy, The Castle has produced Nashville's first fully-digital recording with Deborah Allen's current RCA LP, appropriately entitled "Let Me Be The First."

Others who have recorded at The Castle include: Emmylou Harris, John Schneider, Reba McEntire, Dolly Parton, Ricky Skaggs, The Whites, Earl Thomas Conley, members of Culture Club, Freeze (from England), Leon Russell, Elton John's band, and The Castle production company's New York-based band Film at Eleven. Also, the soundtrack from the Dolly Parton/Burt Reynolds' motion picture "The Best Little Whorehouse in Texas" came from The Castle.

—Rose Clayton

Ballad of Sally Rose LP, jingles for Budweiser and Ford trucks, and producer Terry Manning working with Jason & the Scorchers and Molly Hatchet.

The Benson Company's Great Circle Sound in Nashville has had nearly round the clock bookings reports spokesman Greg Fisher. One interesting session, of overdubs for Sambi Patti's *Song from the Heart* album on Impact Records required a 39 piece string session. Another noteworthy point is that the LP (which has been nominated for a Grammy Award) is quite possibly the first contemporary Christian album to be released on CD.

Sound Stage Recording Studios in Nashville has acquired two Mitsubishi X-800 32-track digital recorders, one of which will be kept at the studio full time, the other will float among MCA-Nashville president Jimmy Bowen's various projects around town. Bowen has worked at Sound Stage's second room—dubbed The Backstage—for several years now, and is a longtime advocate of digital recording.

Nashville-based producer/studio executive Norbert Putnam has formed Studio Standard Systems, a company to design and equip recording studios. The firm's first project is the design and development of Digital Recorders a \$2 million, 7200 square foot completely digital recording complex planned for Nashville's Melrose area. The facility, designed by Putnam and architect Robert Anderson, will feature two automated studios with digital multitracks, and should be on-line by this July.

DIY Recording, in nearby Hendersonville, Tennessee went 24 track last summer and has since picked up a lot of business, especially in the area of jingle and rock and roll recording. Recent projects include Eric Saxon cutting some tracks, and Ron Fairchild producing newcomers Williams & Ree. The studio was part of an historic session when they packed up one of their consoles and followed the Oak Ridge Boys to mix a live concert in Merrillville, Indiana, broadcast live (in AM stereo) by WMAQ radio in Chicago.

Also in Hendersonville, at Acorn Sound, the Oak Ridge Boys' studio, the Oaks completed their 12th album, tentatively titled *Step On Out* in January. Steve Cropper and Razy Bailey were in earlier cutting some song demos together. And last September the studio played host to an LEDE workshop/seminar sponsored by Valley Audio. The event was a resounding success and exposed a packed house of engineers, producers and studio owners to the design technology the studio showcases.

Audiovisions, in Louisville, Kentucky, opened about a year and a half ago, and has done quite well since.

—PAGE 145



It delivers the punch without the bruise.

When you want to increase sonic punch, compressor/limiters are indispensable. Orban's 412A (Mono)/414A (Dual-Channel/Stereo) Compressor/Limiter is uniquely versatile—it can serve as a gentle “soft-knee” compressor to smooth out level variations, or as a tight peak limiter to protect other equipment from overload distortion.

Most importantly, the 412A always delivers its punch with finesse. Instead of the usual pumping and squashing, what you get is amazingly natural sound: the dynamic “feel” of the program material is preserved even when substantial gain reduction occurs. Like a true champion, the 412A works hard but makes it look easy.

In the studio, use the 412A's INPUT ATTENUATOR control to adjust the amount of gain reduction without significantly changing the output level. Or, in sound reinforcement, adjust G/R with the THRESHOLD control to avoid feedback-producing below-threshold gain changes. The feature-packed 412A also has front-panel ATTACK and RELEASE controls, and an OUTPUT ATTENUATOR.

Instead of a handful of low-resolution flashing lights, it has an easily readable, illuminated gain reduction *meter*. Inside, intelligent circuitry automatically readjusts the threshold as you vary other controls to keep the peak output level constant—you don't have to keep fiddling with the OUTPUT ATTENUATOR to avoid overloading downstream equipment.

But the best news is that the most flexible and natural-sounding compressor/limiter is also one of the least expensive. Now you can afford fully professional level control with Orban quality, reliability, service, and documentation. Check it out today at your nearest Orban dealer.

orban Orban Associates Inc.
645 Bryant Street
San Francisco, CA 94107
(415) 957-1067 Telex: 17-1480

SOUTHEAST

STUDIO LOCATION INDEX

ALABAMA

- 8 **Anniston**
Leatherwood Sound 67
- 24 **Birmingham**
Polymusic Studios, Inc. 89
Prestige Productions, Inc. 74
Sound of Birmingham Studios 75
Spectrum Recording Services 92
- 8 **Decatur**
Birdland Studio 66
- 24 **Dothan**
Studio Four 93
- 8 **East Tuscaloosa**
Underground Sound 70
- 24 **Fort Payne**
Cook Sound Studios 78
- 8 **Huntsville**
Communication Enterprises 66
Sound Cell 75
- 8 **Lexington**
Woodrich Recording Studio 70
- 8 **Mobile**
Nomad Productions 68
Southern Sound Productions 75
- 16 **Montgomery**
Studio B 75
- 24 **Sheffield**
Broadway Sound Studio 77
Muscle Shoals Sound Studios 86
- 24 **Smith Station**
Studio "7" Recording Co 93
- 24 **South Birmingham**
Boutwell Recording Studios 77

FLORIDA

- 24 **Allamonte Springs**
Smith & Smith Sound Studios 90
- 24 **Clearwater**
Florida Sound Recording 81
Pink Pelican Music Co. 68
Sun Tracs Recording Studio 75
- 24 **Coral Gables**
O.L. Recording/Criteria's
Wheels 89
- 16 **Coral Spring**
Black Night Recording 72
- 16 **Davie**
Distant Thunder Recording 72
- 8 **Deerfield Beach**
L7 Studios 67
- 24 **FT. LAUDERDALE**
Spectrum Recording Studios 93
- 24 **FT. LAUDERDALE**
Artisan Recorders, Inc. 76
New River Studios, Inc. 88
Prisma Recording Studio 89
Soundshine Productions Rec 91
- 24 **FT. MEYERS**
Sound Check 91
- 16 **Gainesville**
Mirror Image Recording 74
- 16 **Hialeah**
Life Productions Audio 73
- 24 **Jacksonville**
August Recording Studio 77
Images Inc. 67
Key Recording Studio 73
Monolith Productions 68
Rick Painter Sound Studio 68
The Warehouse Rec. Studio 93
- 24 **Juno**
Silhouette Studios 69
- 8 **Lake Park**
T&S Studio 70
- 8 **Largo**
Classic Sound & Recordings 66
- 24 **Lauderhill**
Mystereo Audio 88
- 16 **Margate**
Dove Sound and Recording 72
- 8 **Melbourne**
Hummingbird Recordings 67
Topaz Recordings 70
- 24 **Miami**
Climax Recording Studios 78

- 24 **Criteria Recording Co., Inc.** 80
- 16 **Cross-over Recording Studio** 72
- 8 **Florida Music Sales, Inc.** 67
- 8 **Gopher Creek Audio** 67
- 24 **Miami Sound Studio** 86
- 24 **Pat Applerson Studios, Inc.** 76
- 8 **Soundtrack, Inc.** 69
- 8 **N. Miami**
Lunale Sound Studio 67
Quadradial Cinema Corp 89
South Coast Rec. Company 92
Studio Center Sound Rec 93
- 8 **N. Miami Beach**
Coconuts Recording Co., Inc 78
International Sound 84
John St. John 84
- 16 **Orlando**
American Recording Center 72
Bee Jay Recording Studios 77
- 4 **Ovideo**
Ron Sound Co 69
- 8 **Pace**
Campmeeting Productions 66
- 16 **Panama City Beach**
Ocean Opry Rec. Studios 74
- 24 **Pensacola**
Soundtrek Recording Studio 92
- 24 **Pensacola Beach**
Princess Brde Studio 68
- 16 **Pompano Beach**
Florida Vidcom 72
- 8 **Sarasota**
Shady Lady Rec. Studios 69
Telesat Recording 93
- 8 **Sunrise**
FXL Sound Studios 67
- 16 **Tallahassee**
Lake Bradford Studios 73
The Musical Moon 86
- 8 **Tampa**
Full Sky Recording 67
Hayes Recording Studio 82
Horizon Productions 67
Morrison Recording Inc 86
Progressive Music Studios 74
- 24 **Temple Terrace**
Island Recording Studio 84
- 16 **Valparaiso**
Playground Recording Studio 74
- 16 **West Palm Beach**
Jalex Recordings 73
Saturn Sound Studios Inc. 74
- 8 **Winter Haven**
Happy Faces Production 67

GEORGIA

- 8 **Albany**
Boone Studio 66
- 24 **Alpharetta**
Monarch Sound, Inc. 86
- 8 **Americus**
Paradigm Productions 68
- 24 **Atlanta**
Axis Sound Studio 77
Black & Silver Studio 66
Cheshire Sound Studios 78
Crawford Post Production 80
Crescendo Recorders 80
Doppler Studios, Inc 80
Jam Studios, Inc. 84
Master Sound Studios, Inc. 85
New Age Sight & Sound 88
Eddy Offord Studios 88
- 8 **Performance Productions** 68
- 4 **Project 70 Audio Services** 68
- 24 **RKM Sound Studios** 90
- 24 **Sam's Tape Truck** 90
- 24 **Songbird Studio** 90
- 24 **Southern Tracks Recording** 92
- 24 **Twelve Oaks Rec. Studio** 93
- 24 **WEB IV Studio** 93
- 4 **Wonderdog Studios** 70
- 24 **Augusta**
Studio South 93

- 8 **Avondale Estates**
J.B.S. Studio 67
- 16 **Canton**
Snapfinger Music 74
- 8 **Carrollton**
Coley Recording Studio 66
- 8 **Conyers**
Keynote Recording 67
- 8 **Covington**
Protracks 68
- 8 **Sound Investment Rec. Studio** 69
- 8 **Decatur**
Audio Craft 66
- 24 **Doraville**
Studio One, Inc 93
- 4 **Douglasville**
Bright Star Studio 66
- 16 **Fort Oglethorpe**
The Sound Room, Inc. 75
- 8 **Hapeville**
Music Workshop 84
- 24 **Lookout Mtn.**
Pyramid Recording 89
- 8 **Macon**
Amazing Music 66
- 24 **Capricorn Sound Studios** 77
- 8 **McDonald Sound** 68
- 8 **New Beginning Sound** 68
- 8 **Marietta**
Davroy Recording 66
- 8 **Rome**
Mobile Audio 86
- 16 **Willow Creek Rec. Studios** 75
- 8 **Savannah**
Reel Time Rec. Studios 74
- 4 **Smyrna**
Dragon Path 66
- 16 **Stockbridge**
Real to Reel 74
- 4 **Studio Seven** 70
- 16 **Warner Robins**
Hidden Meaning Rec. Studios 72

KENTUCKY

- 24 **Ashland**
Chandler Audio Inc. 78
- 8 **Barbourville**
Lundy Recording Studio 67
- 8 **Elizabethtown**
Alpha Recording 66
- 8 **Frankfort**
Kentucky Dept of the Arts 67
- 8 **Georgetown**
Mays Country Demos 68
- 8 **Lexington**
Sun-Ray Records 70
Track-16 Recording 75
- 24 **Louisville**
Allen-Martin Production Audio 76
Audiovisions 77
Derbytown Sound Studios 72
Falk Recording Service 72
Shinshine Sound Rec. Studio 70
- 24 **Paducah**
Audio Creations Rec. Studio 77
Lost River Recording Studio 67

LOUISIANA

- 8 **Arabi**
Celebrity Studios 66
- 24 **Baton Rouge**
River City Recorders 90
- 8 **Bogalusa**
Studio in the Country 93
- 24 **Church Point**
Sound Center Recorders 69
- 16 **Denham Springs**
Little Woods Recording 74
- 8 **Keithville**
Authorized Music Inc 66
- 8 **Lafayette**
La Louisiane 67
Matrix Studio Productions 74
PM Music Productions 68

- 8 **Lake Charles**
Goldband 67
- 24 **Metairie**
Knight Recording Studio, Inc 84
- 24 **New Orleans**
Pace Recording Service 89
Rosemont Studio 74
Sound Services 69
- 8 **St. Rose**
J.B.G. Audio Production 67
- 8 **Shreveport**
Reel Productions & Assoc. 68
- 16 **West Madrone**
JY Recording 73

MISSISSIPPI

- 8 **Corinth**
Jobe Sound Studio 67
- 24 **Forest**
Pinewood Studio 89
- 8 **Hattiesburg**
Mariah Recording 68
Paragon Recording 74
- 24 **Jackson**
Malaco Records 85
Master Track Studios 85
- 16 **The Mississippi Rec. Company** 74
- 8 **Laurel**
Studio 77 70
- 24 **Pearl**
International Rec. Studio, Inc. 84

NORTH CAROLINA

- 16 **Albemarle**
Studio Four Recording 75
- 24 **Asheville**
Dawn Records, Inc 80
- 24 **Bailey**
Mega Sound Studio 86
- 24 **Burlington**
American Multimedia, Inc. 76
- 24 **Cedar Mt.**
Flack Productions 81
- 16 **Charlotte**
Audio Inc 72
HMC Studios 82
Lamon Sound Studio 73
Reflection Sound Studios 89
Studio South 70
ZBOP/AV 70
- 8 **Greensboro**
Acoustic Creations 66
The Process Rec. Studios 74
Sound Labs 75
- 8 **Greenville**
Audio Arts Rec. Company 66
- 24 **Jacksonville**
Datatrak Recordings & Productions 80
- 24 **Mt. Airy**
Granite City Sound 82
- 24 **Raleigh**
Audiolomics, Inc 77
Sound Trax, Inc 92
- 8 **Rocky Point**
Twin Oaks Studio 70
- 4 **Salisbury**
Hoffman Music 67
- 16 **Sanford**
Beechtree Studio 72
- 8 **Statesville**
Carson Towne Recording 66
Perfect Pitch Recording 89

PUERTO RICO

- 24 **Puerto Nuevo**
Crescendo Audio Productions 80
- 24 **Rio Piedras**
Telectron Inc. 93
- 24 **San Juan**
Ochoa Recording 88

SOUTH CAROLINA

- 24 **Columbia**
G.E.M. Recordings 82
- 24 **Greenville**
Mark Five Studio 85
Sandcastle Recording Studio 74
Spectrum South Inc. 70
- 4 **John's Island**
Island Sounds Rec. Studio 67
- 16 **Mauldin**
Studio 105 75
- 24 **West Columbia**
Strawberry Jamm Rec. Studio 93

TENNESSEE

- 8 **Antioch**
Rocking Horse Studio 69
- 24 **Brentwood**
Gold Mine Studio 82
- 24 **Cleveland**
Faith Productions Studios 81
- 24 **Cleveland City**
Majestic Sound Studio 84
- 24 **Franklin**
The Bennett House 77
The Castle Rec. Studio 77
Music Resources 74
- 24 **Hendersonville**
Acorn Sound Recorders, Inc. 76
A.M.I. Studio 76
D.I.Y. Recording, Inc. 80
- 8 **Hermitage**
Jack O'Diamonds Rec. Studio 68
- 16 **Johnson City**
Mountain Aire Recording 74

- 24 **Knoxville**
Big Mama Recording Studio 7
- 16 **Lebanon**
Pickin' Post Sound Studios 7
- 24 **Madison**
Cinderella Sound Studio 7
- 24 **Hilltop Recording Studio, Inc.** 8
- 4 **Maryville**
Stonebridge Recording 70
- 16 **Memphis**
American Sound Studio 7
Arden Recordings, Inc. 7
Blackwood Sound Factory 7
Capulation 6
Commercial Music Recording Complex 7
Communion Communications 7
Cotton Row Recording 7
Galaxy Sound Rec. Studios 6
IDH Recording 6
Lyn-Lou Recording Studio 7
Mastercraft Recording Corp. 8
Mauw Boggs Recordings 6
Memphis Sound Productions 6
Sounds Unreel Studios 9
Studio K 9
USC Sound Enterprises 7
Wilkinson Sound Studios 7
- 4 **Nashville**
Archer Productions 6
Audio Media Recorders 7
Bonner Ingles 6
Broken Door Studio 7
Bullet Recording 7
Champ Sound 6
Creative Workshop I and II 8
Denny Music Group Studio 7
Emerald Sound Studio 8
Fanta Professional Services 8
Fat Tracks 7
Glaser Sound Studios, Inc 8
Great Circle Sound 8
Hearth Productions 6
Horizon Rec. Arts Studio 6
Hummingbird Studio 8
Al Jolson Enterprises, Inc 6
LSI Recording 8
Master Mix 8
Music City Music Hall 8
Music Mill 8
Oak Valley Sound 8
Pet's Place 88
Pollyfox 98
Pollyfox Grand 98
Reel Sounds 68
The Reflections 98
Roxy Recording Studio 98
Scene Three, Inc 98
Scroggs Sound Studio, Inc 98
Singleton Sound 7
Sound Emporium Studios, Inc 91
Sound Stage 91
Spotland Productions 70
Star Track 70
Stargem Recording Studio 91
Studio 80 70
Studio 19 91
Treasure Isle Rec. Studio 91
Wild Tracks Rec. Studio 91
Woodland Sound Studios 93
Young'un Sound, Inc. 93
- 8 **Summertown**
Village Media 70

VIRGINIA

- 8 **Eastville**
Oak Grove Studio 68
- 8 **Norton**
Homestead Recording Studio 68
- 24 **Richmond**
Alpha Audio 76
Audiomage Recording 66
Island Studios Inc. 73
- 8 **Vienna**
Gizmo Recording Inc. 67
- 16 **Virginia Beach**
Commercial Audio 72
Master Sound Rec. Studio 85
Supermusic & Video Prod. 70
- 8 **Winchester**
Sounds of Winchester 69
- 8 **Woodbridge**
Amberwood Recording Studio 68
- 24 **WEST VIRGINIA**
Albans 68
Accurate Recording 68
Clother 68
The Perfect Mix Gospel Studio 68
Mullens 68
Tri-Star Recording Studio 70
Parkersburg 70
SweetSong Productions/ The Music Factory 70
Wheeling 70
WJS Recording 93

All studio information listed has been supplied to the Mix by studios responding to questionnaires mailed in November, 1984. People, equipment and locations change, so please verify critical information with the studios directly. The Mix does not take responsibility for the accuracy of the information supplied to us by the studios.

BBE IF YOU HAVEN'T HEARD IT YET... WHY NOT?

BBE is engineered and market tested:
ten years in development.

BBE is patented technology: forty-two
claims applied for, forty-two claims granted.

BBE applications: dramatically improves
sound quality in recording studios, motion picture production,
live concerts, TV and radio broadcasting, motion picture
theatres... anywhere amplified sound is used commercially.
We said anywhere!

But don't take our word for it. Take theirs:

"I can't imagine working on another album without BBE. This is particularly true for digitally recorded masters where the use of equalizers tends to create more problems than they solve. BBE is the missing link."

*STEVE LEVINE, PRODUCER OF CULTURE CLUB, 1984 BPI PRODUCER OF THE YEAR,
PRODUCER OF THE NEW DIGITAL BEACH BOYS ALBUM*

"We find BBE to be an extremely useful tool in the handling of problem TV and film production soundtracks."

JOHN BONNER, CHIEF ENGINEER, GOLDWYN SOUND FACILITY

"Everyone in broadcasting looks for the ultimate in signal clarity with as much definition as possible. BBE accomplishes this without compromise."

PAUL SAKRISON, CHIEF ENGINEER, KIK-FM

"In my opinion, BBE is an indispensable tool in live sound reinforcement. Use of the device at the Pacific Amphitheatre and with tour groups proves that BBE really makes live amplified sound, sound live. That's what it's all about."

MICHAEL ADAMS, SOUND IMAGE (SOUND REINFORCEMENT CONTRACTORS)

"Our company, which deals in theater sound installations and service, was asked to evaluate the BBE 202R audio processor. We were very impressed. The need for this product in theaters can only increase due to the public's demand for better motion picture sound."

JAMES T. WARD, THEATER SOUND CONTRACTOR

"I'm a perfectionist not only when I play music but in the recording process as well. BBE makes the recording sound live and that's what I want. No more sessions without it."

BILL SHIELDS "ALL STAR BAND," PRODUCED BY STANLEY CLARKE

BBE TM All the sound you've never heard.

Barcus-Berry Electronics, Inc.
5381 Production Drive
Huntington Beach, CA 92649

PROVE IT TO YOURSELF.

Ask for a hands-on demonstration.
Call any authorized BBE dealer or
sales representative shown here.
Or call us direct.

SEAWIND SOUND CO.
2861 Saturn St., Suite A
Brea, CA 92621
714-961-8870

**TERRACE ENTERTAINMENT
SYSTEMS**
P.O. Box 264,
3328 Acapulco Dr.
Dana Point, CA 92629
714-496-1305

WESTLAKE AUDIO INC.
7265 Santa Monica Bl.
Los Angeles, CA 90046
213-851-9800

PRO-TECH MARKETING
13031 San Antonio Dr., #211
Norwalk, CA 90650
213-929-8868

**LEO'S AUDIO AND MUSIC
TECHNOLOGIES**
5447 Telegraph Ave.
Oakland, CA 94609
(415) 652-1553

SOUND IMAGE, INC.
1945 Diamond St., Suite A
San Marcos, CA 92069
619-744-8460

AUDITIES 2001
2377 E. Mississippi Ave.
Denver, CO 80210
303-777-4595

LISTENUP AUDIO/VIDEO
999 S. Logan St.
Denver, CO 80209
(303) 778-0780

JOHN B. ANTHONY CO.
992 High Ridge Rd.
Stamford, CT 06905
203-322-9202

ELREP SALES CO.
4508 Bibb Bl. B-4
Tucker, GA 30084
404-938-7108

**NEW HORIZONS ELECTRONICS
MARKETING INC.**
2211 Lakeside Dr.
Bannockburn, IL 60015
312-234-5911

YOPE COMPANY
3564 Rolling View Dr.
White Bear Lake, MN 55110
(612) 770-9760

ALLEN COHEN SALES ASSOC.
Old Hinsdale Rd.
Ashuelot, NH 03441
603-239-6284

METROREP SALES
57 South St.
Freehold, NJ 07728
201-462-1221

DARMSTEDTER ASSOC.
41 R. Oswego St.
Baldwinsville, NY 13027
315-638-1261

BOB WHITE & ASSOC.
34325 Lakeview
Solon, OH 44139
216-248-1317

SOUTHWEST PRO AUDIO, INC.
1500 Summit St.
Austin, TX 78741
512-443-4567

SOUTHWEST PRO AUDIO, INC.
3341 Towerwood, #205
Dallas, TX 75234
214-243-4477

NORTHSHORE MARKETING INC.
11000 Lake City Way N.E.
Seattle, WA 98125
206-364-5444

*Inquiries/orders will be
handled on a first come,
first served basis.*

**TOLL FREE NUMBER
1-800-854-6481**

*In California, Hawaii, and
Alaska, call (714) 898-9211*



•• ACCURATE RECORDING
952 Poplar Dr., St. Albans, WV 25177
(304) 727-4008
Owner: Bill Stevens
Studio Manager: Bill Stevens

•• ACOUSTIC CREATIONS
6307 Jasper Rd., Greensboro, NC 27409
(919) 294-1785
Owner: Kip Williams
Studio Manager: Kip Williams

•• ALPHA RECORDING
also REMOTE RECORDING
207 So. Mulberry, Elizabethtown, KY 42701
(502) 765-7899
Owner: Alpha Recording
Studio Manager: Jim Cottrell

•• AMAZING MUSIC
also REMOTE RECORDING
Macon Mall, Macon GA 31206
(912) 474-4700
Owner: Edward Vance
Studio Manager: Edward Vance

•• AMBERWOOD RECORDING STUDIO
12538 Cavalier Dr., Woodbridge, VA 22192
(703) 494-0234
Owner: Jim Williams
Studio Manager: Jim Williams

•• AMERICAN SOUND STUDIO
827 Thomas, Memphis, TN 38107
(901) 525-0540
Owner: Glolite Enterprises
Studio Manager: William E. Glorie

•• ARCHER PRODUCTIONS
24 Music Square West, Nashville, TN 37203
(615) 383-6306
Owner: Nick Archer

•• AUDIO ARTS RECORDING COMPANY
also REMOTE RECORDING
Rt. 1 Box 59, Hwy 43 North, Greenville NC 27834
Owner: Lewis Gidley, Sonny Johnson
Studio Manager: Sonny Johnson
Engineers: Lewis Gidley
Dimensions of Studios: Studio A: 24 x 16 x 10; Studio B: 11 x 12 x 7.
Dimensions of Control Rooms: 13 x 13 x 8.
Tape Recorders: TEAC/Tascam 80-8 w/dbx 8 track, TEAC/Tascam 22-2 w/dbx ½ track; TEAC 2300 SX ¼ track.
Mixing Consoles: TEAC/Tascam 5B 8 in/4 out.

Monitor Amplifiers: Ampzilla.
Monitor Speakers: JBL 4311, Auratone 5C
Echo, Reverb, and Delay Systems: Sound Workshop 211C, DeltaLab ADM 1024 Electron, DeltaLab Echotron 256-4096.
Other Outboard Equipment: Aphex Aural Exciter Type B, (2) dbx model 160x compressors; (2) dbx model 163 compressor, (2) dbx model 164 compressor 200 MXR dual 1.5 band EQ, Valley People HH 2x2 Interface; Symetrix SG-200 dual signal gate
Microphones: Shure SM58; Shure SM57; AKG D12E, AKG D200E, (2) Sennheiser MD 421, Sony ECM 23F; Electro-Voice PL76, others available on request.
Instruments Available: on request.
Rates: \$30.00/hr basic specialty rates for large or special projects. Please call for competitive prices

•• AUDIO CRAFT
1244 Clairmont Rd., Decatur, GA 30030
(404) 636-5051
Owner: Henry Howard
Studio Manager: Henry Howard

•• AUDIOIMAGE RECORDING
also REMOTE RECORDING
210 East Franklin St., Richmond, VA 23219
(804) 644-7700
Owner: AudioImage Productions Inc
Studio Manager: John Rountree, John Valentine

•• AUTHORIZED MUSIC INC.
RT. 1 Box 360A Lot 44C, Keithville, LA 71047
(318) 925-0466
Owner: Christy Fisher, Donald Jones, Micheal Jones
Studio Manager: Christy Fisher, Hank Wilson

•• BALL TELEVISION GROUP
1101 N. Fulton Avenue, Evansville, IN 47710
(812) 428-2300
Owner: Martin A. Ball, President
Studio Manager: Dan Wiesjahn

•• BIRDLAND STUDIO
3116 Sandlin Rd. S.W., Decatur, AL 35601
(205) 353-8324
Owner: Owen Brown, James Murphree
Studio Manager: Owen Brown

•• BLACK & SILVER STUDIO
3608 Hidden Acres Drive, Atlanta, GA 30340
(404) 934-3048
Owner: James L. Lanier
Studio Manager: James L. Lanier, Charles Nelson

•• BONNER JINGLES
1110 16th Ave., South, Nashville, TN 37212
(615) 256-0440
Owner: The Franklin Group
Studio Manager: Jerry Attip

•• BOONE STUDIO
313 Highland Ave., Albany GA 31701
(912) 436-6508
Owner: Jesse Boone
Studio Manager: Jesse Boone

•• BRIGHT STAR STUDIO
3117 Bright Star Road, Douglasville, GA 30135
(404) 949-6335
Owner: Theresa & Mick Butorac
Studio Manager: Mick Butorac

•• CAMPMEETING PRODUCTIONS
200 Hwy 90 East, Pace, FL 32570
(904) 994-7131
Owner: Pace Assembly Ministries, Inc.
Studio Manager: Greg Broxson

•• CAPULATION
2022 Colfax Ave., Memphis, TN 38116
(901) 396-9790
Owner: Brian Phillips
Studio Manager: Demnio Mondor, Jamie Doe, Cherr

•• CARSON TOWNE RECORDING
also REMOTE RECORDING
P.O. Box 5485, Old Wilkesboro Rd., Statesville, NC 28677
(704) 872-1619
Owner: Kent Wooten, Mike Daniels, Beth Warren
Studio Manager: Kent Wooten

•• CELEBRITY STUDIOS
1910 Karl St., Arabi, LA 70032
(504) 277-5687
Owner: Steve Esponge
Studio Manager: George Artiques

•• CHAMP SOUND
also REMOTE RECORDING
1705 Church St., Nashville, TN 37203
(615) 327-2979
Owner: Jim Stanton
Studio Manager: Jim Stanton

•• CLASSIC SOUND & RECORDINGS, INC.
14130 Coral Way, Largo, FL 33541
(813) 531-6356
Owner: Walter T. Priest
Studio Manager: Bobby Farrell

•• COLEY RECORDING STUDIO
P.O. Box 1529, Carrollton, GA 30117
(404) 832-0616
Owner: Phil Coley

•• COMMUNICATION ENTERPRISES, INC.
also REMOTE RECORDING
P.O. Box 4205, 2116 South Memorial Parkway
Huntsville, AL 35802
Owner: Tom Linscott, Charles Snoddy
Studio Manager: Charles Snoddy

•• COMMUNION COMMUNICATIONS
P.O. 11582, Memphis, TN 38111
(901) 683-1919
Owner: Rick Tarrant
Studio Manager: Rick Tarrant

•• DAVROY RECORDING
also REMOTE RECORDING
2427 Kingsley Dr. N.E., Marietta, GA 30062
(404) 973-9536
Owner: Roy Franco, David Hobbs
Studio Manager: Roy Franco, David Hobbs

•• DRAGON PATH
also REMOTE RECORDING
3594 Marion St., Smyrna, GA 30309
(404) 874-0903
Owner: Frank French

•• FLORIDA MUSIC SALES, INC.
8370 W. Flagler St., Suite 230, Miami, FL 33144
(305) 223-1205
Owner: Art Weissman

•• FULL SKY RECORDING
P.O. Box 261072, Tampa, FL 33685
(813) 886-1892
Owner: Michael A. Normandau
Studio Manager: Michael A. Normandau

•• FXL SOUND STUDIOS
7766 NW 44 St., Sunrise, FL 33321
(305) 741-7766
Owner: Frank X. Locoonto

•• GALAXY SOUND RECORDING STUDIOS
also REMOTE RECORDING
1508 Harlem, Memphis, TN 38114
(901) 274-2726
Owner: GCS Communications Inc
Studio Manager: Larry Henderson

•• GIZMO RECORDING INC.
308 Talahi Rd., Vienna, VA 22180
(703) 938-6692
Owner: Bob Dunbar

•• GOLDBAND
313 Church St., Lake Charles, LA 70601
(318) 439-8839
Owner: Eddie Shuler
Studio Manager: Jeff Le Jeune

•• GOPHER CREEK AUDIO
1331 NE 119 St., N. Miami, FL 33177
(305) 251-8231
Owner: Gary A. Schmitt, Bob Smith
Studio Manager: Gary A. Schmitt
Engineers: Gary A. Schmitt, Kathy Modlin, Ed Dukstein
Dimensions of Studios: 30 x 30
Dimensions of Control Rooms: 30 x 18
Tape Recorders: MCI/Ampex JH-5 8 1/2", Tascam Series 70 8H
8-1/2", MCI/Ampex JH-5 4-1/2", MCI/Ampex JH-5 2-1/4"
Mixing Consoles: (2) Tascam Model 5 16 x 8
Monitor Amplifiers: BGW 750 monitor, Yamaha P2050 cue
system
Monitor Speakers: JBL 4312, TOA cubes, Minimus 0 3's
Echo, Reverb, and Delay Systems: Lexicon PCM 60, Korg
digital delay, Roland tape delay, MXR flanger/doubler
Other Outboard Equipment: UREI 1176 limiter, dbx 160 &
160x UREI & Orban Para EQs, Aphex Aural Exciter
Microphones: Neumann U47 & 67 (tube), Sennheiser 421, Shure
SM57, PZM's, AKG D12E, Asst. Beyer, AKG, Audio-Technica
and Shure
Instruments Available: Harrington 5'8" grand, Rhodes, Linn
Drum, Gretsch studio drums
Rates: Our rates are what we feel are the best in Southern Florida
Call for special advertising and songwriter discounts

•• HAPPY FACES PRODUCTION
419 Lanier Lane, Winter Haven, FL 33880
(813) 324-3487
Owner: Charlie Massey

•• HEARTH PRODUCTIONS
3608 Woodmont Blvd., Nashville, TN 37215
(615) 297-6292
Owner: Dunkin Nelson
Studio Manager: Erik Thorsen

•• HOFFMAN MUSIC
also REMOTE RECORDING
1723 W. Innes St., Salisbury, NC 28144
(704) 636-5670
Owner: Sandy Hoffman
Studio Manager: Sandy Hoffman

•• HOMESTEAD RECORDING STUDIO
RT. 1 Box 1097, Norton VA 24273
(703) 679-4182
Owner: Ron Swindall
Studio Manager: Ron Swindall

•• HORIZON PRODUCTIONS
1010 West Platt St., Tampa, FL 33606
(813) 254-3399
Owner: Robert Stephenson
Studio Manager: Philip Schwarz

•• HORIZON RECORDING ARTS STUDIO
2607 Eastland Ave., Nashville, TN 37206
(615) 226-2227
Owner: Richard Owens

•• HUMMINGBIRD RECORDINGS
113-A Nelson Avenue, Melbourne, FL 32935
(305) 259-6576
Owner: John Foley
Studio Manager: John Foley

•• IDH RECORDING
also REMOTE RECORDING
6804 Starkenburg Lane, Memphis, TN 38115
(716) 795-5048
Owner: Israel Hill
Studio Manager: Israel Hill

•• IMAGES INC.
also REMOTE RECORDING
1662 Stockton St., Jacksonville, FL 32204
(904) 388-3300
Owner: John B. Reitzammer
Studio Manager: Mark Grandin

•• ISLAND SOUNDS RECORDING STUDIO
also REMOTE RECORDING
River Rd., John's Island, SC 29455
(803) 559-1177
Owner: Steve Green, Tim McKeivlin
Studio Manager: Steve Green

•• J.B.G. AUDIO PRODUCTION
425 St. Rose Ave., St. Rose, LA 70087
(504) 468-9200
Owner: Bob Hummaugh
Studio Manager: Glenn Hummaugh

•• J.B.S. STUDIO
106 N. Avondale Rd., Avondale Estates, GA 30002
(404) 296-0604
Owner: Brad Jones
Studio Manager: Ethelle Fitch

Engineers: Brad Jones, Dan Vaganek
Dimensions of Studios: 40 feet wide x 50 feet deep with 22
foot ceilings. Two isolation booths 5 x 12
Dimensions of Control Rooms: 21 feet deep x 25 feet wide
Tape Recorders: Otari MX 5050, MK-III 8-1/2", Otari MTR 12
2-1/4", Otari MX 5050 2-1/4", Revox A-700 2-1/4"
Mixing Consoles: Speck E 01 Speckmix 16 16 x 8
Monitor Amplifiers: Crest, Haller
Monitor Speakers: Custom designed. There is no room equaliza-
tion. The monitors are flat without EQ. We also have Auratones
Echo, Reverb, and Delay Systems: Lexicon 200 digital reverb,
Audio Digital TC 2 digital delay, DeltaLab ADM 1024, DeltaLab
ADM 64 digital delay
Other Outboard Equipment: Eventide 949 Harmonizer, Valley
People Kepex, Valley People Maxi-Q, DynaMite De-esser, dbx
165a Compressor/Limiter, 160X Compressor/Limiters, 163 Com-
pressor/Limiters, Aphex Aural Exciter Type B
Microphones: Neumann U87, KM84, AKG 414, 460, 452,
Sennheiser 421, 441, Electro-Voice Re-20, Crown PZM, Shure
SM-57, SM-58, Beyer MD-400, Sony ECM 50PS, Shure head-
phone mike, Sennheiser MKH-815 Shotgun
Instruments Available: Conover 1928 5' baby grand piano
complete drum kit, Music Man bass guitar
Video Equipment & Services: Sony 5850 1/4" video cassette
recorder, Sony 5800 3/4" video cassette player, Sony HM 440
Video editing controller, BTX shadow synchronization system. The
Otari MX-5050 8 track can be locked to follow the Sony 5850 1/4"
video cassette recorder, thereby allowing video sweetening.
Rates: 8-Track - \$35/hr, video sweetening - \$50/hr; video editing
\$30/hr

•• JOBE SOUND STUDIO
also REMOTE RECORDING
Rt. 8, Box 433, Corinth, MS 38834
(601) 287-9538
Owner: Joseph A. Jobe
Studio Manager: Joseph A. Jobe

•• AL JOLSON ENTERPRISES, INC.
MASTERLINK STUDIO
also REMOTE RECORDING
31 Music Sq. West, Nashville, TN 37203
(615) 242-1580
Owner: Albert Jolson
Studio Manager: Albert Jolson
Engineers: Charles Lyon
Dimensions of Studios: 15 x 18, drum booth 5 x 12
Dimensions of Control Rooms: 15 x 18
Tape Recorders: Studer B-67 2; Studer A-80 2&4; Otari MX 50
50 8, Nagra 4 S 2

Mixing Consoles: Studiomixer 16 x 8, Studer 169 8 x 4
Monitor Amplifiers: (2) Studer A-68 main monitors, (3) Yamaha
P 20-50 aux monitors & cue system
Monitor Speakers: Westlake BBSM 10, Yamaha NS-10 M
Echo, Reverb, and Delay Systems: Lexicon model 200 digital
reverb, Yamaha analog delay
Other Outboard Equipment: Symetrix Limiter/Compressor
150, 501, 522, Otari DP 40-50 high speed cassette dupe. Denon
real time dupe
Microphones: AKG 452, Neumann U87, K84, (3) Shure SM57;
Sennheiser 421, Countryman EM 101, (4) Audio Technica
various
Instruments Available: Yamaha Electric, Baby Grand; Slinger-
land drums
Video Equipment & Services: Minolta K 800 S AF
Rates: Studio \$25/hr with engineer. Duplication rates: high speed
- C 7 \$1.78 to C-90 \$2.13. Real Time - C 10 \$2.44 to C-120
\$7.55. Bulk rates available

•• KENTUCKY DEPT. OF THE ARTS
Berry Hill Mansion, Frankfort, KY 40601
(502) 564-8076
Owner: Kentucky Dept. of the Arts
Studio Manager: Fred Gooding

•• KEYNOTE RECORDING
1468 Old Salem Rd., Conyers, GA 30208
(404) 483-9508
Owner: Sam Trama
Studio Manager: Sam Trama

•• LA LOUISIANNE
also REMOTE RECORDING
711 Stevenson St., Lafayette, LA 70501
(318) 234-5577, 984-6924
Owner: Carol J. Hachou, Sr.
Studio Manager: Carol J. Hachou, Jr.

•• LEATHERWOOD SOUND
also REMOTE RECORDING
4107 Bynum-Leatherwood Rd., Anniston, AL 36206
(205) 238-1038
Owner: Kevin Freeman, Mike Callis
Studio Manager: Mike Callis, Kevin Freeman

•• L-7 STUDIOS
273 NW 1 St. #30, Deerfield Beach, FL 33441
(305) 427-1836
Owner: Bob & Jill Wlos
Studio Manager: Bob Hupe

•• LINALE SOUND STUDIO
1995 N.E. 150 St., N. Miami, FL 33181
(305) 944-1006
Owner: Frank Linale
Studio Manager: Randy Bird

•• LOST RIVER RECORDING STUDIO
631 N. 9th St., Paducah, KY 42001
(502) 444-7594
Owner: Clyde Wood
Studio Manager: Andy Wood
Engineers: Laddie Wood
Dimensions of Studios: Studio A 14 x 12, Studio B 12 x 7
Dimensions of Control Rooms: 9 x 12
Tape Recorders: TEAC 3340S 4 track, TEAC 3300S 2 track,
TEAC A-170 cassette, Technics M270X cassette, Panasonic
RS-808 8 track cartridge
Mixing Consoles: Tapco (4 mixers in 6' console) 6000H series,
24 in x 4 out, TEAC/Tascam Model 1, TEAC meter bridge MB20
Monitor Amplifiers: Crown D 60
Monitor Speakers: Custom built, also cubes
Other Outboard Equipment: dbx 155, (4 track), dbx 152 (2
track), Dolby, (8 track tapes), (6) AKG K-140 headphones
Microphones: Audio-Technica AT 813, Shure 585, E-V DS-35,
Barcus Berry 1355 guitar transducer
Instruments Available: Baldwin Acrosonic piano, Fender-
Rhodes piano-bass, synthesizer, electric piano, small organ, Leslie
tone cabinet, Fender Bandmaster amp, Fender Bassman amp, two
Sunn amps, 6 & 12 string Alvarez acoustic guitars, bass guitar,
Gibson classic guitar, steel guitar, violin, conga drums, percussion
(All instruments in studio)
Rates: Call or write for prices

•• LUNDY RECORDING STUDIO
P.O. Box 485, Barbourville, KY 40906
(606) 546-6650
Owner: David Duane, Wuran Lundy
Studio Manager: David Lundy
Engineers: W.D. Lundy, D.D. Lundy, D.A. Lundy
Dimensions of Studios: 24 x 30

—LISTING CONTINUED ON PAGE 68

—FROM PAGE 67

Dimensions of Control Rooms: 12 x 20.
Tape Recorders: Scully 284-B 8; Ampex AG-440-B 2; Ampex 351-2 2; Ampex AG-600-B 2.
Mixing Consoles: Interface 308-B 24 x 8; Sony MX-20 8 x 4.
Monitor Amplifiers: McIntosh, Southwest Tech.
Monitor Speakers: E.V. Altec, JBL 4311
Echo, Reverb, and Delay Systems: Mechanical Fairchild, Tapco.
Other Outboard Equipment: LA2-A's, LA3-A's; Ashly Audio SC-5; UREI Dual Graphic EQ 535; Sansui Cassette Deck.
Microphones: Neumann U47s, U48s; RCA 77DX, Electro-Voice; Beyers; AKG; Shure; Sony; 20 in all.
Instruments Available: 6'8" Chickering sound piano; Fender amps, Peavey amps, Korg Poly-800; Baldwin organ and one full drum set.
Video Equipment & Services: Tape duplication Ampex BLM 200 plus 5 slaves method of duplication; Bin Loop, tape used 3M/Ampex/Capitol tape Duplicating Speed: 32-1 King loader.
Rates: Upon request.

•• **MARIAH RECORDING**
also **REMOTE RECORDING**
Village Green Mall, Hattiesburg, MS 39401
(601) 545-1886
Owner: Vaughn Wilson
Studio Manager: Vaughn Wilson

•• **MAUW-BOGGS RECORDINGS**
667-669 Hawthorne, Memphis, TN 38107
(901) 278-5003
Owner: Bobby Davis, Vikki Davis, Tom Davis
Studio Manager: Bobby Davis

•• **MAYS COUNTRY DEMOS**
340 North Broadway, Georgetown, KY 40324
(502) 863-1533
Owner: Elmer L. Jones
Studio Manager: Norman L. Mays

•• **MCDONALD SOUND**
2808 Napier Ave., P.O. Box 2186, Macon, GA 31204
(912) 746-9308
Owner: Ray McDonald
Studio Manager: Ray McDonald

•• **MEMPHIS SOUND PRODUCTIONS**
also **REMOTE RECORDING**
2850 Lamb Place, Suite #5, Memphis, TN 38118
(901) 363-3856
Owner: John E. McDowell, Tim Goodwin, John L. Fleskes
Studio Manager: Tim Goodwin
Engineers: John McDowell, Tim Goodwin, John Fleskes
Dimensions of Studios: Main 24 x 24 x 12; Drum: 13 x 12 x 8, Isolation: 8 x 8 x 8.
Dimensions of Control Rooms: 14 x 13 x 9
Tape Recorders: Tascam 38 8, (2) Studer/Revox PR99 2; Tascam A3440 4; Recordex Cassette Duplicator Super Pro H ST 1 2.
Mixing Consoles: Tascam M-50 12 x 8 x 2; Tascam M-30 8 x 4 x 2, Soundcraft 4008 32 x 8 x 2.
Monitor Amplifiers: McIntosh MC2300, BGW 250; UREI 6250; Kenwood KA701.
Monitor Speakers: JBL 4430, Infinity RS10, B&O Ref.
Echo, Reverb, and Delay Systems: Ursa Major 8 x 32; Lexicon PCM60, Aphex Aural Extier; (2) DeltaLab Timelines; Effectron 1024; DOD Dual-Delay; Yamaha analog delay; dbx (4) 903 comp., (2) 904 gates, 8ch. 150 noise red., (2) 911; Orban Para-EQ.; JVC Analyzer; Hall Eng. test set.
Other Outboard Equipment: Huge PA to pull gear from.
Microphones: Neumann U47, U89; AKG C452E8, D12E; (7) Sennheiser MD421; EV RE20; (3) DS35, Shure (14) 57s, (8) 58s, SM5B, SM81, PZM, Stereo Hot-Plate; (2) Countryman.
Instruments Available: LinnDrum w/memory ext.; Korg Poly-61; Wurliizer studio grand; Wurliizer electric piano; Pearl drums w/Zildjans and Sonor pedal, Pre-CBS Fender Bassman.
Video Equipment & Services: 1/2" Stereo w/Dolby JVC; newvicon JVC camera; Tiling; PA 32 x 32 x 32 for crowds to 50,000; Staff writers, arrangers, production, musicians, singers.
Rates: \$40/hr including all gear, inst. Block rates available.

•• **MONOLITH PRODUCTIONS**
6541 Powers Ave., Jacksonville, FL 32217
(904) 246-7288
Owner: Jesus Cabarrus, Jr.
Studio Manager: Carlos Carreras Rodnruez

•• **NEW BEGINNING SOUND**
2847 Bob-O-Link Dr., Macon, GA 31206
(912) 788-3388
Owner: Harold E. Thomas
Studio Manager: Harold E. Thomas



NOMAD PRODUCTIONS
Mobile, Al

•• **NOMAD PRODUCTIONS**
also **REMOTE RECORDING**
P.O. Box 6868, Mobile, AL
(205) 479-2769
Owner: Nomad Productions, Inc
Studio Manager: Barry L. Little
Extras: We specialize in classical music recording. We have produced numerous radio programs including "Second Saturday Series," a live poetry, prose, short story reading plus jazz bands, "Music in Mobile", featuring the Mobile and Eastern Shore Chamber Music Seasons, and "Alabama Tale-Telling Festival", an annual event in Selma, Alabama featuring story tellers from across the nation

•• **OAK GROVE STUDIO**
Box 338, Eastville, VA. 23347
(804) 678-5300
Owner: Ed Johnston
Studio Manager: Ed Johnston
Engineers: Ed Johnston, independents welcome
Dimensions of Studios: 26 x 12
Dimensions of Control Rooms: 24 x 18
Tape Recorders: MCI 110C one inch 8, MCI 110B 1/2 inch 2; NAD 6050C cassette.
Mixing Consoles: Ramsa WR 8816
Monitor Amplifiers: Yamaha, NAD (cue system).
Monitor Speakers: JBL, AKG 240 headphones (6 pairs)
Echo, Reverb, and Delay Systems: Lexicon 224-X reverb, DeltaLab DL-2 stereo delay with flanging capabilities Tape echo.
Other Outboard Equipment: Valley People Kepex II (6) and Gain Brain II (3); MCI JH-22 phase meter, dbx 20-20 computerized equalizer analyzer with RTA display, Countryman direct boxes (3), 150' custom 27 input snake with gold-plated connections.
Microphones: Neumann, AKG, Sennheiser, Shure.
Instruments Available: Yamaha DX7, LinnDrum machine, Ludwig drums with Zildjian cymbals, modified Fender Stratocaster, Martin 12 string, Peavey TS-40 bass, Marshall and Vox Super Beatle guitar amps, Peterson Strobe Tuner, Morley Wah-Wah.
Rates: 8 Track — \$15/hour
Extras: We are located on a 170 acre farm in a relaxed country setting. The house is old colonial dating back to 1750 and overlooks a creek. Clients like to walk around the farm and look at and/or make friends with our foals and horses
Direction: Our direction is quality work at wholesale prices and repeat business because of same. Give us a call.

•• **JACK O'DIAMONDS RECORDING STUDIO**
4201 Central Pike, Hermitage, TN 37076
(615) 883-9600
Owner: Alex Zanets
Studio Manager: Jon "Mr. 813" D'Amelio

•• **RICK PAINTER SOUND STUDIO**
also **REMOTE RECORDING**
2826 Iroquois Avenue, Jacksonville, FL 32210
(904) 388-7649
Owner: Rick Painter
Studio Manager: Donna Painter

•• **PARADIGM PRODUCTIONS**
P.O. Box 1968 Americus, GA 31709
(912) 273-5646
Owner: John Waldron
Studio Manager: John Waldron

•• **THE PERFECT MIX GOSPEL STUDIO**
also **REMOTE RECORDING**
P.O. Box 18, Clothier, W.VA 25047
(304) 369-4394
Owner: Timothy Williams
Studio Manager: Timothy Williams

•• **PERFORMANCE PRODUCTIONS, INC.**
1303 Spring Street N.W., Atlanta, GA 30309
(404) 892-7536
Owner: Glenn Wisenbaker

•• **PINK PELICAN MUSIC CO.**
2908 Edenwood St., Clearwater, FL 33519
(813) 799-0661
Owner: Paula Sili
Studio Manager: Tom Klepacki

•• **PM MUSIC PRODUCTIONS**
268 John Wayne Dr., Lafayette, LA 70508
(318) 234-2490
Owner: Paul Mulioletto
Studio Manager: Paul Mulioletto

•• **PRINCESS BRIDE STUDIO**
also **REMOTE RECORDING**
1308 Via de Luna, Pensacola Beach, FL 32561
(904) 932-3221
Owner: Dave White
Studio Manager: Dave White

•• **PROJECT 70 AUDIO SERVICES, INC.**
also **REMOTE RECORDING**
777 Lambert Drive N.E., Atlanta, GA 30324
(404) 875-7000
Owner: Jerry L. Connell, John G. Harrill
Studio Manager: Jerry L. Connell

•• **PROTRACKS**
75 Steele Road, Covington, GA 30209
(404) 786-1397
Owner: Steve Jeffries
Studio Manager: Steve Jeffries



REEL PRODUCTIONS & ASSOCIATES, INC.
Shreveport, LA

•• **REEL PRODUCTIONS & ASSOCIATES, INC.**
also **REMOTE RECORDING**
701 Suite A Jordan St., Shreveport, LA 71101
(318) 227-1200
Owner: Robert C. Smith, Robert C. Green
Studio Manager: Rob Smith
Engineers: Total of 3 (Audio Production Studio) Rob Smith, Chief engineer

Dimensions of Studios: 12 x 17 M.C. Room, 10 x 9 Booths (3)

Dimensions of Control Rooms: 12 x 17, 10 x 15 sub-control
Tape Recorders: MCI JH-110-B's ¼" 2 track, 110-B-4 ½" 2 and 4 track, 110-B-8, 1" 8 track, Ampex AG series AG-350, 351 full and 2 track.

Mixing Consoles: Harris Corp. Executive 30'S, Yamaha M916 32/4.

Monitor Amplifiers: BGW-100-01-B x 2, ATI- Headphone amps x 2; McIntosh 2205 x 1.

Monitor Speakers: JBL 4311-BX x 4.

Echo, Reverb, and Delay Systems: Lexicon T93, Eventide FL-201; Orban 111B reverb.

Other Outboard Equipment: ADR vocal stressors, dbx 165's, 162's compressors/limiters, dbx noise reduction 180's (4); Compellor, Orban parametric EQ dual channel, ACG 411, Valley People 430 processor; UHEI equalization 537.

Microphones: U-87's, AKG 414 EB, AKG, 452-EB, Sennheiser 816, 416, 441, E-V RE20's, 635A, RCA BX77, Superscope EC-9P's, Beyer MCE-5's, Tram mic system, E V 655's, Crown PZM-61.P

Video Equipment & Services: On location sound, wireless system (Cetec Vega), Nagra 4 2 film sound, EFP sound capabilities within 500 miles of Shreveport, LA

Rates: Studio \$50/hr., on location \$50/hr., Talent \$35 to \$50/spot, per market

•• **REEL SOUNDS**

75 Parris Ave., Nashville, TN 37210
(615) 255-6347

Owner: Dana Clark

Studio Manager: Cindy Clark

•• **ROCKING HORSE STUDIO**

P.O. Box 751, Antioch, TN 37013-0751
(615) 832-2379

Owner: Michael Smith

Studio Manager: Michael Smith

Engineers: Michael Smith

Dimensions of Studios: 22 x 18

Dimensions of Control Rooms: 8 x 10

Tape Recorders: Otari Mark III-8 8 track, Revox PR 99 2 track

Mixing Consoles: Sound Workshop Logex 8 12 x 8 x 2

Monitor Amplifiers: Fostex 600 Watt (main), Yamaha P2050

(cue system).

Monitor Speakers: E-V Sentry 100 and Klipsch Heresy
Echo, Reverb, and Delay Systems: AKG BX-5. Tape delay & Ibanez analog delay.

Other Outboard Equipment: (2) dbx 160 comp/limiters, (8) Countryman direct boxes.

Microphones: Beyer M500, M400, (2) M69, (2) Audio Technica ATM 11, (2) Shure SM 85, Sennheiser 221, 441, E-V PL91, AKG D 707 M

Instruments Available: Fender Rhodes 73 (modified); Prophet 5; Korg Polysix; LinnDrum (on request); Evans FET 500 guitar/steel amp, Peavey LTD 400 amp, Fender Princeton reverb (1968), Peavey Vegas 400.

Rates: \$20/hr with special block rates available (8 track), \$15/hr recording and/or editing (2 track)

•• **RON SOUND CO.**

333 Butterfly Forest Rd., Ovide, FL 32765

(305) 349-5832

Owner: Ron Schrader

Studio Manager: Ron Schrader

•• **SHADY LADY RECORDING STUDIOS**

also **REMOTE RECORDING**

P.O. Box 156, Sarasota, FL 33578

(813) 758-9673

Owner: Joanne K McInnis

Studio Manager: James E "Sausa" McInnis

•• **SILHOUETTE STUDIOS**

11657 Ellison Willson Rd., Juno, FL 33408

(305) 627-4743

Owner: Mark Brown

Studio Manager: Cerenia Frazo

•• **SOUND CENTER RECORDERS**

329 N. Main, Church Point, LA 70525

(318) 684-2176

Owner: Lee Lavergne

Studio Manager: Lee Lavergne

•• **SOUND INVESTMENT RECORDING STUDIO**

also **REMOTE RECORDING**

Rt. 3 Box 702, Covington, GA 30209

(404) 267-8771

Owner: Steve Matcum, Linda Matcum

Studio Manager: Steve Matcum

•• **SOUND SERVICES**

also **REMOTE RECORDING**

5138 Lakeview Ct., New Orleans, LA 70126

(504) 241-2389

Owner: Marc T Hewitt

Studio Manager: Marc T Hewitt

•• **SOUNDS OF WINCHESTER**

P.O. Box 574, Winchester, VA 22601

(703) 667-9379

Owner: Jim McCoy

Studio Manager: Bertha McCoy

•• **SOUNDTRACK, INC.**

1975 N.E. 149 St., Miami, FL 33181

(305) 945-4449

Owner: George Blackwell

Studio Manager: Jenny Blackwell

Engineers: George Blackwell, Paul Kaminsky, Vince Oliveri

Dimensions of Studios: 14 x 10

Dimensions of Control Rooms: 17 x 11

Tape Recorders: Otari MX-7800 8 track, Mark III 4 track, Mark III 2 track, MCI JH110C 3 track (Vid Layback), Sony PCM10

digital 2 track, TEAC 4430 4 track, Otari 5050B (5) 2 track,

Technics RS1100 (2) cassette

Mixing Consoles: Sound Workshop Series 30 16 x 8

Monitor Amplifiers: Audio Effects Sansui

Monitor Speakers: JBL 4311, Yamaha NS10, Auratone, Visonik

Echo, Reverb, and Delay Systems: Eventide 949 Harmonizer,

Visonik, Lexicon PCM42, Lexicon PCM60, AKG BX10

Other Outboard Equipment: (2) UHEI 1176 Complimiters,

Shamp Noise Gates, Parametric EQ, Custom 2-way phone patch

Microphones: Neumann; AKG, Sennheiser, Beyer

Video Equipment Services: JVC ¾" video, Sony ¾" video,

Panasonic ½" video, BTX Shadow SMPTE Interlock

Rates: Dubbing/Editing: \$30/hr; Analog-Digital Audio: \$65/hr.

Only Swintek GIVES YOU A CHOICE in wireless microphone systems

- Choice of mics—Beyer M500, Shure SM57, SM58, SM78, SM85
- Choice of finishes—chrome, black chrome or gold
- Integral antenna or rubber duckie
- Systems for hand held mics, lavalier mics, electric instruments or ENG/EFP/LPTV

Unsurpassed field-proven reliability assures the high audio quality that professionals demand. VHF high band and narrow RF signal bandwidth permit numerous systems to be simultaneously used on nearby frequencies without interference or receiver desensitizing by local TV or radio broadcast signals. All metal construction assures durability and RF shielding. dB-S companders permit wide dynamic range without unnatural compression. Swintek—the proven performers.

alan gordon enterprises inc.



1430 Cahuenga Blvd.
Hollywood, Ca. 90078
(213) 466-3561



SMPT E Interlock \$100/hr
Extras: Complete interconnection with our sister studio South Coast Recording Company (24 Track) available upon request
Direction: We are THE place for commercial audio

•• SPECTRUM SOUTH INC.
 Suite 204 Morgan Manor, 730 S. Pleasantburg Drive
 Greenville, SC 29607
 (803) 232-7369
 Studio Manager: Van R. Cook

•• SPOTLAND PRODUCTIONS
 1443 12th Ave. South, Nashville, TN 37203
 (615) 385-2957
 Owner: Gene Clark
 Studio Manager: Deborah Trimble

•• STAR TRACK
 also REMOTE RECORDING
 5543 Old Hickory Blvd., Nashville, TN 37218
 (615) 244-3467
 Owner: Ida May Music Inc.
 Studio Manager: Dana C. Belser

•• STONEBRIDGE RECORDING
 Rt. 15, Box 54, Maryville, TN 37801
 (615) 983-7448
 Owner: Michael Ishibashi
 Studio Manager: Michael Ishibashi

•• STUDIO 80
 also REMOTE RECORDING
 311 Margo Lane, Nashville TN 37211
 (615) 834-4124
 Owner: Jake Brooks
 Studio Manager: Steve Brooks

•• STUDIO SEVEN
 6482 Hearn Rd., Stockbridge, GA 30281
 (404) 474-4102
 Owner: Scott Davis
 Studio Manager: Tim Schipper

•• STUDIO 77
 Rt. 12, Box 66, Laurel, MS 39440
 (601) 426-2619
 Owner: Bill J. Nichols
 Studio Manager: Bill J. Nichols
 Engineers: Bill J. Nichols
 Dimensions of Studios: 20 x 28 (8 x 10) (8 x 9) iso booths
 Dimensions of Control Rooms: 14 1/2 x 18
 Tape Recorders: Tascam 48 w/dbx 1/2" 8 track, Tascam Portastudio 144 4 track, Otari MX 5050 BII 2 track, Sansui DW 9 2 track cassette, Nakamichi DMP 100 2 track with NEC 840 video cassette
 Mixing Consoles: Amek-TAC Scorpion 24 x 8 x 2
 Monitor Amplifiers: Crown D 150A series II, D 75
 Monitor Speakers: Electro Voice Sentry 100's
 Echo, Reverb, and Delay Systems: Lexicon PCM 60 digital reverb, Acoustic chamber, Roland SDE 1000 digital delay, MXH Pitch Shift Doubler
 Other Outboard Equipment: Roland Jazz Chorus 120 amp, Garfield Mini Doc, dbx 160X compressor, Hockman X 100, dbx 163 compressor
 Microphones: AKG, Shure, Audio Technica, Sennheiser, Sony
 Instruments Available: 5' 10" Kawai grand piano, '73 Fender Rhodes, Sequential Circuits Pro I synth, Rhodes Chroma Poly synth w/computer interface (Apple II+), Oberheim DX, Yamaha RX 15, Dr. Rhythm Six Programma St 305, Lynx II synthesizer, Yamaha MR 10, Yamaha Acoustic Drums
 Rates: Please call

•• STUDIO SOUTH
 also REMOTE RECORDING
 3423 South Boulevard, Charlotte, N.C. 28209
 (704) 525-0296
 Owner: Bill Schirman

•• SUN-RAY RECORDS
 1662 Wyatt Parkway, Lexington, KY 40505
 (606) 254-7474
 Owner: James T. Price
 Studio Manager: Kathy Parvin, Charley Stephens A & R

•• SUNSHINE SOUND RECORDING STUDIO
 also REMOTE RECORDING
 2826 Whitlock St., Louisville, KY 40213
 (502) 968-8757
 Owner: Carl Sandler
 Studio Manager: Debbie Sandler



•• SUPERMUSIC & VIDEO PRODUCTIONS
 also REMOTE RECORDING
 5685 Weblin Dr., Virginia Beach, VA 23462
 (804) 499-6383 (evenings)
 Owner: Ron Wagener
 Studio Manager: Ron Wagener

•• SWEETSONG PRODUCTIONS/ THE MUSIC FACTORY
 also REMOTE RECORDING
 P.O. Box 2041, Parkersburg, WVA 26102
 (304) 489-2911
 Owner: Roger Hoover
 Studio Manager: Frank Limbacher

•• T&S STUDIO
 P.O. Box 12115, Lake Park, FL 33410
 (305) 622-5981
 Owner: Tom Green
 Studio Manager: Tom Green



TOPAZ RECORDINGS
 Melbourne, FL

•• TOPAZ RECORDINGS
 also REMOTE RECORDING
 7290 Waelti Dr. Melbourne, FL 32935
 (305) 636-4294
 Owner: Rick Waelti
 Studio Manager: Rick Waelti
 Engineers: Rick Waelti
 Dimensions of Studios: (2) 6 x 8 voc/studio/rit booths, 12 x 8 drum room, main studio area 15 x 24
 Dimensions of Control Rooms: 12 x 8
 Tape Recorders: Otari MX5050 MKIII 8 tracks, Otari 5050B II 2 track, TEAC VTRX stereo cassette, TEAC cassette duplicator
 Mixing Consoles: Soundcraft 400B 16 x 8
 Monitor Amplifiers: Yamaha P 2050 stereo, Prevey M 2000 Stereo
 Monitor Speakers: Pioneer, Otexia
 Echo, Reverb, and Delay Systems: Lexicon PCM 42 Digital Delay, Urban Stereo Reverb 111B
 Other Outboard Equipment: dbx 160X compressor, dbx noise reduction
 Microphones: Audio Technica AIM 31, Sennheiser MD421, Shure SM 58S, AKG 300 series
 Instruments Available: Ludwig drum set, Yamaha X 15 digital electric drum machine, Wurliatzer electric piano, Korg 800 organ, the user, ARP String Ensemble, alto sax, tenor sax, trumpet, sax extensions, etc.
 Rates: \$50/hr, black rates available
 Direction: We produce all our tapes in a warm, wet, tropical, and tropical, picturesque atmosphere. We have a relaxed atmosphere which lends itself to a high degree of creativity. Our goal is to give the best possible recording with state of the art 8 track equipment in a casual setting at an economical price.

•• TRI STAR RECORDING STUDIO
 1228 Guyandotte Ave., Mullens, WV 25882
 (304) 294-6724
 Owner: Gary Martin
 Studio Manager: Gary Martin

•• TURNKEY BREWSTER A-V Inc.
 also REMOTE RECORDING
 2532 Langhorne Rd., Lynchburg, VA 24501
 (804) 528-4448
 Owner: Brewster Sound & Video Inc.
 Studio Manager: Troy Jones

•• TWIN OAKS STUDIO
 P.O. Box 187, Rocky Point, NC 28457
 (919) 675-9226
 Owner: Tempo I, Inc.
 Studio Manager: Leo J. Touchut

•• UNDERGROUND SOUND
 3010 Skyland Blvd., East Tuscaloosa, AL 35405
 (205) 556-6489
 Owner: Andy Chappell
 Studio Manager: Andy Chappell

•• USC SOUND ENTERPRISES
 also REMOTE RECORDING
 190 Waynoka Lane, P.O. Box 11211, Memphis, TN 38111
 (901) 458-0275
 Owner: Rodney Peperthout

•• VILLAGE MEDIA
 P.O. Box 263 Drake Lane, The Farm, Summertown, TN 38483
 (615) 964-2441
 Owner: The Farm
 Studio Manager: Michael Luskier

•• WILKERSON SOUND STUDIOS
 3794 Park Avenue, Memphis, TN 38111
 (901) 458-1624
 Owner: Skip Wilkerson
 Studio Manager: Skip Wilkerson

•• WONDERDOG SOUNDS
 234 Peach Tree Way, N.E., Atlanta, GA 30305
 (404) 231-3408
 Owner: Mark Michaelson
 Studio Manager: Mark Michaelson

•• WOODRICH RECORDING STUDIO
 P.O. Box 38, Lexington, AL 35648
 (205) 247-3983
 Owner: Woody Richardson
 Studio Manager: Woody Richardson

•• ZBOP/AV
 1521 Nassau Blvd., Charlotte, NC 28205
 (704) 889-4508, 376-2864
 Owner: Cal Walker
 Studio Manager: Cal Walker

THE CONTRACTORS WORKSHOPS '85 EXHIBITS AND MORE
 March 9th, 10th, 11th, 1985 • Orlando, Florida
 Phone 312/577-8360 for free information.

If It's Worth Doing, It's Worth Doing Right!

FLANNER'S PRO AUDIO, INC.

Serving The Recording & Broadcast Industries

2323C Bluemound Rd
Waukesha, Wisconsin 53186

NOW 2 LOCATIONS

Milwaukee (414) 785-9166
Chicago (312) 451-1440
Order Desk (800) 558-0880

SALE • SERVICE • DESIGN • INSTALLATION

NEOTEK SERIES II

— LET OTHERS COMPROMISE —

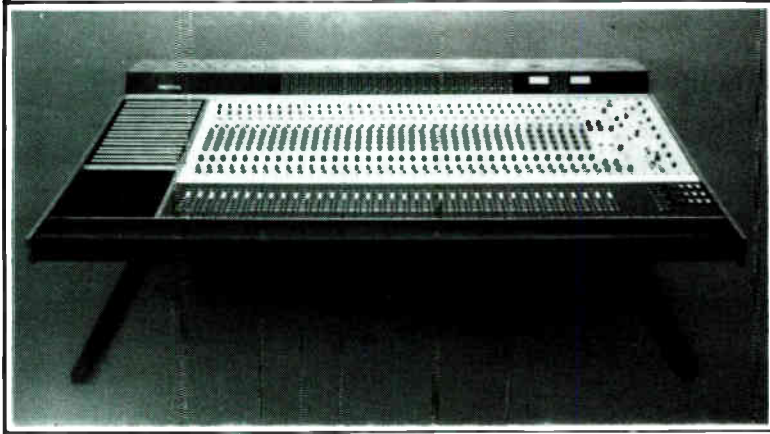

Series II 28x24

EXCLUSIVE NEOTEK DEALER IN:

- Wisconsin
- Illinois
- Minnesota
- Iowa
- Nebraska
- Kansas
- Missouri
- No. Dakota
- So. Dakota
- Texas
- Oklahoma

- S/N-96dbu
- Crosstalk >67db
- Freq. Response 20HZ to 20KHZ
- THD 0.05% from 20 to 20KHZ

Flanner's Pro-Audio has been representing Neotek recording and production consoles for 8 years. Neotek consoles are American made with features engineers want, and a price which owners like. Neotek consoles are available in many different configurations with a variety of options! Call Flanner's Pro-Audio today for complete information and pricing on Neotek recording consoles. NEOTEK— "Where quality and performance is their way of building consoles."

UNDER \$18,500

For 20x16

SONY/MCI — THE SOLUTION

FROM MICROPHONES TO MULTI-TRACK TAPE SYSTEMS SONY'S GOT IT!

Flanner's Pro-Audio sells Sony/MCI professional audio products in the midwest. Sony/MCI known for its quality, performance, and reliability. From microphones to multi-track recording systems Sony/MCI is the solution. Call Flanner's Pro-Audio today and let our sales staff assist you in whatever your audio requirements are. From simple microphones or complete multi-track systems!

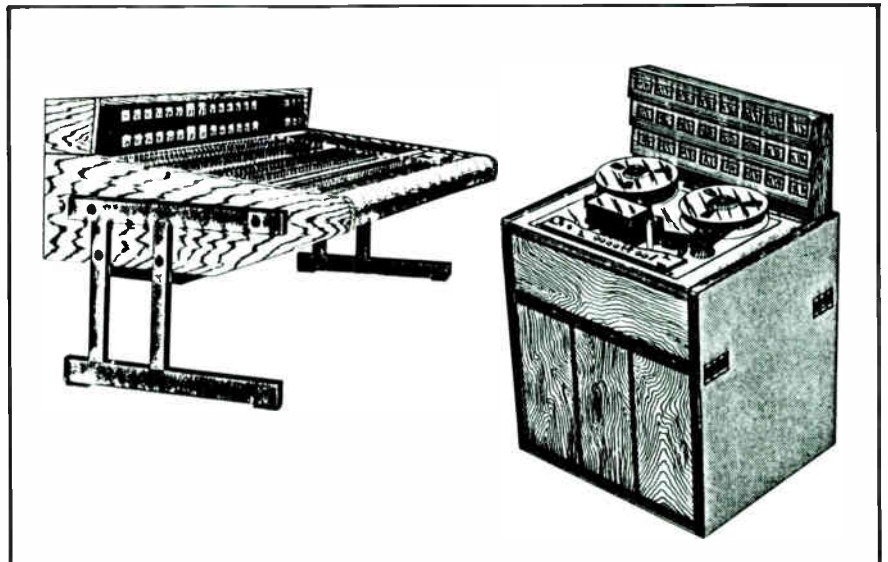

MIDWEST MASTER DISTRIBUTOR



••• **COMMERCIAL AUDIO**
also REMOTE RECORDING
 77-79 South Witchduck Rd., Virginia Beach, VA 23462
 (804) 497-6506
 Owner: Abbey Music and Recording, Inc.
 Studio Manager: Alan Sawyer
 Engineers: Marty Rogers, Alan Sawyer, Alan Waite, Eric Burgess
 Dimensions of Studios: 15 x 30.
 Dimensions of Control Rooms: 14 x 21.
 Tape Recorders: Tascam 85-16B 16 track, Fostex B-16 16 track, Otari 50-50 II 2 track
 Mixing Consoles: Allen and Heath Syncon 40/24
 Monitor Amplifiers: Yamaha P 2200, Crown D-150, AB Systems.
 Monitor Speakers: JBL 4311, Fostex RM 780, Auratone 5-C.
 Echo, Reverb, and Delay Systems: UREI Cooper Time Cube, 3 DeltaLab Ellectron 1024, AKG BX 10 EII, Lexicon Digital, MXR Digital Delay
 Other Outboard Equipment: Rebis rack with 2 stereo compressors, 2 parametric EQs, 2 VCA gates and 1 phono preamp. 2 dbx 161, dbx 162, EXR Exciter, Symetrix noise gates and stereo compressor/limiters, console automation w/level, mute, and 12 stereo subgroups
 Microphones: 12 Sennheiser 441 and 421s, 4 Shure SM 81s, 6 Shure SM 57s, Neumann U87, 3 Crown PZMs, E.V RE 20, DS 35, 2 Fostex M11 RP and other Sony, Shure, AKG and E-V mikes
 Instruments Available: Jupiter B, Prophet 5, Ludwig drums and tympani, Wuritzer electric piano, Baldwin acoustic piano
 Video Equipment & Services: ¼ and ½ inch sweetening with monitors in control room and studio ¼ and ½ inch video demos shot in studio or on location.
 Rates: \$55 per hour in studio. Location rates on a per job basis

••• **AMERICAN SOUND STUDIO**
 827 Thomas St., Memphis, TN 38107
 (901) 525-0540
 Owner: Glolite Enterprises
 Studio Manager: William E. (Bill) Glore

••• **AUDIO INC.**
 820 East Blvd., Charlotte, NC 28203
 (704) 376-3818
 Owner: Frank Rogers
 Studio Manager: Sandi Rogers

••• **ALIVE RECORDINGS**
 1251 Virginia Ave., Harrisonburg, VA 22801
 (703) 434-6703
 Owner: Mennonite Board of Missions
 Studio Manager: Abe Rittenhouse

••• **AMERICAN RECORDING CENTER**
also REMOTE RECORDING
 515 W. 18th St. Orlando, FL 32805
 (305) 425-1342
 Owner: Jeff Pratt
 Studio Manager: Jeff Pratt

Engineers: Jeff Pratt - Chief Engineer; Jeff Rayno - Assistant Engineer
 Dimensions of Studios: 10 x 13, 4 x 8 (2 vocal booths); 15 x 10 (keyboard room); 11 x 12 (drum booth); 12 x 20 (Studio A); 15 x 44 (Studio B).
 Dimensions of Control Rooms: 22 x 13.
 Tape Recorders: (2) TEAC 8516 (1 "A" and 1 "B") 16 track each; TEAC 58 8 track; TEAC 52 2 track; Technics 1520 2 track; (10) TEAC for real time copies 122 cassette; TEAC 25-2 2 track; (2) Nakamichi-cassette 582 2 track; Otari MX5050 2 track.
 Mixing Consoles: TEAC M16 24 x 16 with Roland automation system.
 Monitor Amplifiers: Crown 150, BGW 250, Yamaha 2100.
 Monitor Speakers: JBL 4315 B, Technics, Auratones.
 Echo, Reverb, and Delay Systems: Lexicon 200 digital reverb; Master-Round 305 reverb; MICMIX 404 Plate Synthesizer reverb; DeltaLab DL4 echo; Eventide H-910 Harmonizer; 4 channels - Aphex Exciters.
 Other Outboard Equipment: Aphex Compellor, Orban parametric EQ; (2) dbx 165 OverEasy limiters; (2) dbx 160 limiters; (2) UREI 1176 LN stereo limiters; UREI 964 digital metronome; GT4 noise gates; (2) White ½ octave EQ; custom 10 channel headphone mixer by Stevenson designed by American Recording Studio. BTX Softouch synchronization equipment.
 Microphones: Neumann U89, U87; (4) AKG 414, 452; (6) Sennheiser 441; (4) Crown PZMs (4) Sennheiser 421; (2) E.V RE 20; Countryman direct boxes; (5) Shure SM-81; AKG 900 shotgun.
 Instruments Available: Yamaha 7½' conservatory grand; 5' Chickering piano; Rhodes Stage piano; ARP-Omni 2 polyphonic synthesizer; C-3 Hammond Organ; full set of Slingerland drums; DMX drum synthesizer.
 Video Equipment & Services: 3 Camera 3 Tube ¾" Video Recorders; 28 ft. Mobile Unit; BTX Softouch for video to audio sweetening.
 Rates: 2 to 8 track \$35/hr; 16 track \$55/hr; video with 3 cameras \$200/hr; 30 track rate \$75/hr; video-audio sweetening \$125/hr. Call for block rates.

••• **AUDIO VISUAL IMAGING, INC.**
 7953 Twist Lane, Springdale, VA 22153
 (703) 569-7646
 Owner: Doug McCullough
 Studio Manager: Doug McCullough

••• **BEECHTREE STUDIO**
 2804 Beechtree Dr., Sanford, NC 27330
 (919) 947-5629
 Owner: Bill Trapp
 Studio Manager: John Edwards

••• **BLACK NIGHT RECORDING**
also REMOTE RECORDING
 8358 NW 14th St., Coral Spring, FL 33065
 (305) 752-7317
 Owner: Brian Austin, Austin Productions Inc.
 Studio Manager: Brian Austin

••• **WALLY CLEAVER'S RECORDING**
also REMOTE RECORDING
 1518 Princess Anne St., Fredericksburg, VA 22401
 (703) 373-6511
 Owner: Peter L. Bonta
 Studio Manager: Gerry Rothschild
 Engineers: Peter Bonta, Gerry Rothschild, Gary Herrewig
 Dimensions of Studios: Live room: 20 x 22; dead room: 9 x 13½; voc. booth: 6 x 7
 Dimensions of Control Rooms: Main room: 12 x 14, post prod. room: 10 x 10
 Tape Recorders: Tascam 85-16B 16 track; Otari 5050 II 2 track; Tascam 32-2 2 track; (3) TEAC V-35 cassette.
 Mixing Consoles: Allen & Heath 2416 24 x 16 x 8 x 2
 Monitor Amplifiers: Crown D-150A; (2) Dyna mono-60s; Dyna stereo-70; JVC 20 x 2.
 Monitor Speakers: JBL 4311s; Pioneer HPM-500s; Mimms-7s.
 Echo, Reverb, and Delay Systems: AKG BX-10 IIe, Intersound PRV-1, Lexicon PCM-41.
 Other Outboard Equipment: (2) Symetrix 522 stereo comp/lim/gate/duckers; (2) dbx-160s, (2) dbx-163s; DOD 15 x 2 EQ; Intersound para. EQ; dbx noise reduction on all channels; SMPTE ext. sync. lock on 16 trk; Ibanez analog delay; stereo chorus; Rat distortion; Boss comp.; Mutron & Morley phasers; MXR flanger; Koss & Audio-Technica headphones.
 Microphones: Neumann U-47; AKG 414, D-190s; Shure (3) SM-57, SM-53, SM-54; Electro-Voice (2) RE-20; Sennheiser (2) 441, 421, (2) 409, RCA BK-5B; Sony ECM-33; PZM; Stromberg-Carlson MC-41; (2) Adams transducers; Audio-Technica, ATM-13R, ATM-11R, ATM-10R, custom DI boxes.
 Instruments Available: Yamaha 6 ft. grand piano; Rhodes stereo piano; Roland Juno-60 synth; Helpinstill piano; MXR drum computer; Dr. Rhythm; 6 pc. Rogers drums; Roto-Toms; 1982 Fender Concert amp; Vox AC-15; Pre-CBS Champ; Ampeg VT-40; B-15; Roland PlayBus; Fender Strat, Tele, elec. 12 strng, 1957 Precision bass; Gretsch Nashville; 1952 Gibson acoustic guitar; congas and misc. percussion instruments.
 Video Equipment & Services: call for info.
 Rates: \$38.50/hr. call for block rates.

••• **CROSS-OVER RECORDING STUDIO, INC.**
 8060 W. 21st Ave., Miami, FL 33016
 (305) 822-9708
 Owner: Mr. Carlos Oliva
 Studio Manager: Raul Murciano

••• **DENNY MUSIC GROUP STUDIO**
 39 Music Square East, Nashville, TN 37203
 (615) 256-3558
 Owner: John E. Denny
 Studio Manager: Sonny Flaharty

••• **DERBYTOWN SOUND STUDIOS**
 5900 Outer Loop, Louisville, KY 40219
 (502) 968-2320
 Owner: John Wesley
 Studio Manager: John Wesley

••• **DISTANT THUNDER RECORDING**
 P.O. Box 290096, Davie, FL 23328
 (305) 474-3073
 Owner: Yarrow Ann Kearney
 Studio Manager: Yarrow Ann Kearney

••• **DOVE SOUND AND RECORDING**
also REMOTE RECORDING
 488 N.W. 69 Ave., Margate, FL 33063
 (305) 726-2194
 Owner: Tom Rabolli, John A. Nickerson
 Studio Manager: Beverly Nickerson

••• **FALK RECORDING SERVICE**
also REMOTE RECORDING
 7914 Fegenbush Lane, Louisville, KY 40228
 (502) 239-1010
 Owner: Gary Falk

••• **FAT TRACKS**
 1214 17th Ave. S., Nashville, TN 37212
 (615) 383-9602
 Owner: Robert Krusen

••• **FLORIDA VIDCOM**
 3685 N. Federal Highway, Pompano Beach, FL 33064
 (305) 943-5590
 Owner: Joseph Carey, Jerry Potts
 Studio Manager: Michael Hoffmann

••• **HIDDEN MEANING RECORDING STUDIOS**
also REMOTE RECORDING
 1134 Watson Blvd., Warner Robins, GA 31093
 (912) 923-5507
 Owner: David Norman
 Studio Manager: David Norman
 Engineers: David Norman, Maurice Owens, Wes Gee, Mike Fisher
 Dimensions of Studios: 22 x 24

Tape Recorders: Tascam Model 85-16B 16 track, Tascam Model 38 8 track; Tascam Model 32 2 track.
Mixing Consoles: Canary 32 x 8; Soundcraft 12 x 4; Yamaha PM-700 & Yamaha EM-300 12 x 4; Tascam M-520.
Monitor Amplifiers: Yamaha 2200, (2) BGW 750s, (6) Crown DC-300As & D-75s.
Monitor Speakers: JBL 4312; Custom MR. O 52T triamp.
Echo, Reverb, and Delay Systems: Eventide H-910 Harmonizer, Lexicon Super Prime Time 97, EXR Exciter, Sound Workshop vocal doubler, Yamaha digital reverb, (2) Eventide Harmonizers.
Other Outboard Equipment: dbx noise reduction (8-channels), (2) Soundcraftmen RP 2215 EQ, Furman, Crown VFX-2A Active Crossover, (2) Furman 3-way stereo 5-way mono active crossover, 16 channel remote, split/snakes, Yamaha active parametric preamp & crossover, Valley People compressor/limiters.
Microphones: Sennheiser MD 421s, Sennheiser MD 441s; Shure SM-57s, SM-58s, 565-De, 566s, 588s, 65s; Electro-Voice PL-95s; AKG 414.
Instruments Available: Arp Odyssey, Simmons drums, Hammond M-101 organ, 2 Minimoogs, Lab Senes, Ampeg V-4 and Acoustic 370 amps, Slingerland drums, Fender Strat, gong, congas, timbales, Korg Poly 61, Fender Rhodes 73, Ovation 6-string acoustic, Wurlitzer electronic piano, Wurlitzer acoustic piano, Octobans, windchimes, Conn Strobotuner, Leslie cabinet (RV-122), Rickenbacker 4001 bass, Oberheim DMX drum machine (extra), live sound reinforcement system.
Rates: Call for rates.



HIDDEN MEANING RECORDING STUDIOS
 Warner Robins, GA

••• ISLAND STUDIOS INC.
 9 West Grace St., Richmond, VA 23220
 (804) 643-2022
 Studio Manager: Wayne Moore

••• JALEX RECORDINGS
 also REMOTE RECORDING
 319 Clematis St., West Palm Beach, FL 33401
 (305) 832-1538
 Owner: Jon A. Lind
 Studio Manager: Susan Elliott
 Engineers: Bill Harriss, Jon A. Lind.
 Dimensions of Studios: 38 x 17 plus vocal booth
 Dimensions of Control Rooms: 17 x 14
Tape Recorders: Ampex MM1100 16 track; Ampex AG 440B 8 track, Ampex AG 440 4 track, Ampex AG440 2 track; MCI JH 110B 2 track, Ampex 351-2 2 track; Nagra SD 2 track, Nagra 4.2 mono, several other 1/4" machines.
Mixing Consoles: MCI 416 w/5534s, 24 in x 24 out
Monitor Amplifiers: AB Systems, Peavey, Crown
Monitor Speakers: JBL, Auratones
Echo, Reverb, & Delay Systems: MICMIX XL 305.
Other Outboard Equipment: Graphics, limiters, noise reduction, DDL, van-speed, etc.
Microphones: Neumann U-47s (tube), U-87s, KM-84s, Sony C-500, C-37Ps, ECM-22Ps, ECM 50P, Shure SM-57s, SM 76s; Sennheiser MKH-405, MD-421s, MD-21, AKG C-412, D 224E, D-E119ES; E-V 649B, 635A, RE-55; Beyers M-500, Crown PZMs; The Co. direct boxes
Instruments Available: Steinway grand, Hammond B-3, Rhodes piano, drums, congas, mammba.
Rates: \$20 to \$100 per hour. Block time available. Call (305) 832-1538

••• JY RECORDING
 201 Trenton, West Monroe, LA (mailing address)
 3706 Gouville, Monroe, LA 71201
 (318) 325-4413 or 323-0805
 Owner: James E. Young
 Studio Manager: James E. Young

••• KEY RECORDING STUDIO
 2969 Edison Ave., Jacksonville, FL 32205
 (904) 388-TAPE
 Owner: John L. Key II
 Studio Manager: David Pittman

••• LAKE BRADFORD STUDIOS
 also REMOTE RECORDING
 2195 Lake Bradford Rd., Tallahassee, FL 32304
 (904) 576-4741
 Owner: Charlie Roberts
 Studio Manager: Reg Furlough

••• LAMON SOUND STUDIO
 also REMOTE RECORDING
 6870 A Newell Hickory Grove Rd., Charlotte, NC 28212
 (704) 537-0133
 Owner: Dwight I. Moody Jr. & sons
 Studio Manager: David Moody
 Engineers: David Floyd, David Moody
 Dimensions of Studios: A- 20 x 30 (also a fully sealed, 10 x 12, comfortable isolation booth, and a special, very live, percussion annex), B: 10 x 8
 Dimensions of Control Rooms: 18 x 20.
Tape Recorders: MCI JH 100 w/Autolocator 16 track; Ampex AG 440B 2 track; Technics SL-1500LIS 2 track; TEAC X-7 2 track, Kenwood KX-1030 cassette
Mixing Consoles: MCI JH 400 (light meters), 24 in x 24 out, console has been extensively modified with reciprocal mid-band EQ, channel mutes, mike padding, individual buss/tape return solos, large producer's desk, stop clock
Monitor Amplifiers: Yamaha P-2201, Symetnx HA 10Bs
Monitor Speakers: Control Room E-V Sentry V, JBL 4401s, Auratone 5C, other JBLs available. Studio: E-V Sentry V, AKG, Koss, and Sennheiser headphones
Echo, Reverb, & Delay Systems: AKG BX10, H-910 Harmonizer
Other Outboard Equipment: (3) UREI 1176LN limiters, Orban 622B, H 910 keyboard for Harmonizer, Technics SL1200 turntables, Wollensak 2770 tape duplicator
Microphones: (4) AKG C-414, (2) C-451 w/accessories, (2) E-V RE-20s, (4) 635-As, (2) Shure SM-81s, AKG D1000, D750, Shure 545SD, Sescrom direct
Instruments Available: Yamaha 6' conservatory grand, Slingerland drums, conga and various percussion instruments, Fender bass and electric guitars, Martin acoustic, various Guild guitars, amps, and Oberheims (rental), many other instruments available on loan or rent from related company, Oberheim drum machine.
Rates: \$65/hr. base, with special record packages and block time packages always available. 2" tape may be rented or purchased. Write for a free brochure.

••• GERALD LEWIS RECORDING
 also REMOTE RECORDING
 216 South Pershing Drive, Arlington, VA 22204
 (703) 521-1871
 Owner: Gerald Lewis
 Studio Manager: Gerald Lewis

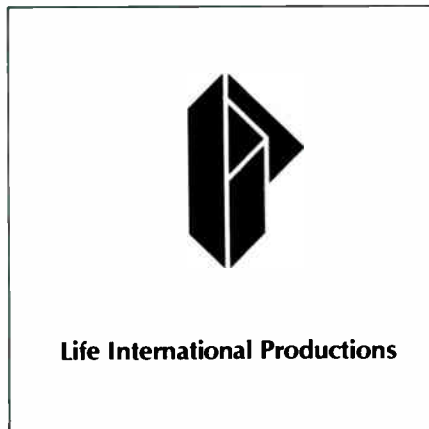

Life International Productions

LIFE PRODUCTIONS AUDIO
 Hiialeah, FL

••• LIFE PRODUCTIONS AUDIO
 750 E. 25th St., Hiialeah, FL (Miami) 33013
 (305) 940-9197
 Owner: A M I Corporation
 Studio Manager: Rodger Shrack
 Engineers: Theo French, Roger Shrack
 Dimensions of Studios: 25 x 22 x 12.
 Dimensions of Control Rooms: 19 x 12 x 7.5
Tape Recorders: MCI JH110 8 track, Otari 5050-B 2 track,

YOURS FREE!

The essential planning & price guide for all of your custom record and tape needs

It's quick • convenient
 • easy-to-use



Now available throughout the United States, **WORLD RECORDS** Canada's largest exclusive custom record and tape manufacturer and packager gives you the audiophile pressings, glossy board jackets, chromium cassettes and service you've been searching for.

And we can ship them all to you prepaid, to your door, in as few as 3 weeks! Hassle free!

WORLD RECORDS delivers .. each and every item, fully guaranteed to your original masters because we know how much you depend on them to promote your image. See what we've got to offer you. Then see just how fast we can deliver it.

STATE of the ART MASTERING
 Neumann VMS 80 Lathe/Digital, 1/2" & 1/2 Speed/Full metal protection

ULTRA GLOSS BOARD JACKETS
 Quantities as low as 500/
 true colour reproduction

CHROMIUM CASSETTES
 Full frequency response on CrO₂ tape/
 Non-abrasive head cleaning leader
VIRGIN VINYL PRESSING
 Audiophile grade/" Assured Excellence
 Guaranteed*

IN-HOUSE CREATIVE SERVICES
 Typesetting/Graphic artists/
 Colour scanner

AIR DELIVERY
 Prepaid air freight delivery to over 200 cities/
 No Customs hassles

call or write for our planning guide & price lists



WORLD RECORDS
 Baseline Rd. W.
BOWMANVILLE, ONTARIO
 L1C 3Z3
416-576-0250

Circle #034 on Reader Service Card

Technics 1506 US 2/4 track, Technics M260 cassette
Mixing Consoles: Sound Workshop 2012 12 x 18
Monitor Amplifiers: BGW 750 B (mains); BGW 100B (reference).
Monitor Speakers: UREI 811 A (mains), Auratone 5C (reference)
Echo, Reverb, & Delay Systems: AKG BX10E, Real Time delay
Other Outboard Equipment: dbx 160 X compressor, 162 compressor, Orban 622 B parametric, UREI 530 Graphic EQ
Microphones: (3) Neumann U-87, (4) Sony ECM 50 (4), AKG CK-9, E V 635A
Instruments Available: Acoustic guitars, acoustic bass viol
Video Equipment & Services: Complete 1" and 3/4" edit, field production, and creative direction MTV tapes a specialty. All state of the art
Rates: 8 track \$75/hr., 2 track \$50/hr

••• **LITTLE WOODS RECORDING**
 Rt. 2, Box 356, Denham Springs, LA 70726
 (504) 664-3746
 Owner: Lyle W. Simms
 Studio Manager: Will Simms

••• **LYN-LOU RECORDING STUDIO**
 1518 Chelsea Ave., Memphis, TN 38108
 (901) 725-1400
 Owner: Andy Graves
 Studio Manager: Leon Sides, I R Enoch, Jr., Larry Rogers

••• **MAGGARD SOUND STUDIO**
 220 Railroad Avenue Box 342, Big Stone Gap, VA 24219
 (703) 523-1373
 Owner: Charles Maggard, Alan Maggard
Studio Manager: Charles Maggard
Engineers: Alan Maggard, Charles Maggard and Dirk Johnson
Dimensions of Studios: 30 x 28
Dimensions of Control Rooms: 20 x 13
Tape Recorders: Tascam 85 16 16 track, Revox B 77 2 track, Crown 800 2 track
Mixing Consoles: TEAC Model 15 24 x 8
Monitor Amplifiers: Hafler 500, Crown DC 150, Sony, Pioneer, Kenwood
Monitor Speakers: E V Sentry 500, JBL 4311, Auratones
Echo, Reverb, and Delay Systems: Lexicon PCM60 MICMIX Master-Room, HOT Plate, DeltaLab ADM 256, Ibanez Z2 HD 1000, Vesta Fire Digital Delay
Other Outboard Equipment: Ashly limiter/compressors, Vesta Fire limiters, GateX noise gate expanders, Aphex Aural Exciter, Vesta Fire noise gate
Microphones: Shure, E V, Beyer, Sony, Sennheiser, Alter
Instruments Available: 6 ft Yamaha grand piano, stereo Fender Rhodes, Wurliizer electric piano, Crumar string machine, pre CBS Precision Bass, Fender Telecaster, Fender Stratocaster, '58 D-2R Martin guitar, A O Gibson mandolin, Tama drums, Pearl roto toms, 2 Peavey amps, bass monitor amp
Rates: Call or write for prices

••• **MAJOR RECORDING STUDIO**
 P.O. Box 2072, Waynesboro, VA 22980
 (703) 949-0106
 Owner: John H. Major
 Studio Manager: John H. Major

••• **MATRIX STUDIO PRODUCTIONS**
 also **REMOTE RECORDING**
 315 W. Convent, Lafayette, LA 70501
 (318) 234-3522
 Owner: Gregory Allain, Alan R. Nolan

••• **MIRROR IMAGE RECORDING**
 also **REMOTE RECORDING**
 619 S. Main St., Gainesville, FL 32601
 (904) 376-1688
 Owner: Bob McPeck
 Studio Manager: Bob McPeck

••• **THE MISSISSIPPI RECORDING COMPANY**
 107 N. State St., Jackson, MS 39201
 (601) 354-0857
 Owner: Jerry Puckett
 Studio Manager: Lane Dinkins

••• **MOUNTAIN AIRE RECORDING**
 501 South Roan St., Johnson City, TN 37601
 (615) 926-9491
 Owner: William R. Livesay, Jr.
 Studio Manager: Brian K. Moore

••• **MUSIC RESOURCES**
 805 Shady Glen Court, Franklin TN 37064
 (615) 794-3700
 Owner: Steve Schaffer
Dimensions of Studios: 25 x 20 x 9 1/2
Tape Recorders: Tascam 85-16B 16 track analog tape machine with dbx and remote control, Sony PCM F1 digital 2 track master



recorder; TEAC A-6100 analog 2 track master recorder.
Mixing Consoles: Tascam M-15-B recording console 32 x 32.
Monitor Amplifiers: Sony.
Monitor Speakers: JBL 4311 studio monitors.
Echo, Reverb, and Delay Systems: Lexicon Model 200 digital reverb, Loft 450 analog delay.
Other Outboard Equipment: Valley People Gain Brain II (2), Valley People Maxi-Q parametric equalizers (2), White 10 band graphic equalizer, Garfield Electronics "Mini-Doc" sequencer clock interface device, Sony cassette deck, turntable.
Microphones: (2) AKG C 414 EB, (2) Crown PZM GP, B&K P48.
Instruments Available: Music Resources' exclusive "Real Sounds" digital library contains 40 plus instruments, including all symphonic instruments; Synclavier digital music system by New England Digital, including: touch/velocity sensitive 76-note keyboard with memory extension; sample to disk system, Kennedy tape backup sub-system; terminal display system (DEC VT-100 Retro-Graphics 640); music printing option with IDS Pnsm 80 printer; 32-voice configuration; stereo option; SMPTE reader card; 10 megabyte Winchester hard disk; 5 1/4" Shugart floppy drive; LinnDrum machine; Sequential Circuits Prophet-10; Steinway grand piano.
Rates: Please call.

••• **OCEAN OPRY RECORDING STUDIOS**
 8400 W. Hwy. 98, Panama City Beach, FL 32407
 (904) 234-5464
 Owner: Wayne Rader
 Studio Manager: Dennis Rader

••• **PARAGON RECORDING**
 Rt. 13 West Hills #00, Hattiesburg, MS 39401
 Owner: Jeff Everett, Tom Carter
 Studio Manager: Jeff Everett

••• **PICKIN' POST SOUND STUDIOS**
 Watertown Highway, Lebanon, TN 37087
 (615) 449-1770
 Owner: Jewell W. Nave
 Studio Manager: Joe W. Nave

••• **PLAYGROUND RECORDING STUDIO**
 103 Westview Ave., Valparaiso, FL 32580
 (904) 678-7211
 Owner: Finley Duncan
 Studio Manager: Bruce Duncan

••• **PRESTIGE PRODUCTIONS, INC.**
 also **REMOTE RECORDING**
 2717 - 19th St. So., Birmingham, AL 35209
 (205) 871-7328
 Owner: Kenny Wallis, Rick Maze, Henry Strzelecki
 Studio Manager: Kenny Wallis

••• **THE PROCESS RECORDING STUDIOS**
 also **REMOTE RECORDING**
 3404-E West Wendover Ave., Greensboro, NC 27407
 (919) 855-1941
 Owner: The Process Inc
Studio Manager: Adrienne Hardy
Engineers: Ron Schrank, Chief Peter Deane, Adrienne Hardy
Editing & Duplication: Laird Landis Associate
Dimensions of Studios: A 30 x 40 x 16, isolation booth, 12 x 15 x 9, vocal booth, 10 x 9 x 9 B, 10 x 11 x 9
Dimensions of Control Rooms: A 22 x 22 x 14 B 16 x 14 x 9 C 14 x 12 x 9 D 10 x 9 x 9
Tape Recorders: 3M M79 16 track, Tascam 80-8 8 track, Otari MX 5050BQII 4 track, (2) MX 5050BII 2 track, MX 5050 mono track, TEAC A 3300SX 2 track, ITC PD II mono, Technics RS 1500US 2 track, Studer Revox PR-99 2 track, TEAC 122 2 track
Mixing Consoles: Sound Workshop Series 34 26 x 24 automated, Tangent 3216 18/16, TEAC 2B/MB-20 6/4, Tascam M 50 12 x 8
Monitor Amplifiers: UREI

Monitor Speakers: JBL 4430, 4311, Fostex RM 780, Auratone, TOA, Bose, Alterc
Echo, Reverb, & Delay Systems: MICMIX XL 305, DeltaLab ADM 1024, Loft 440, Lexicon PCM60
Other Outboard Equipment: (3) Technics SL 1800 MK2, (5) TEAC V-35, Orban 526A, (2) Ashly SC 50, (2) Roqer Mayer RM 68, Symetrix SQ-200, Audioarts 4100, Symetrix TI 101, Slantion model 310, Soundcraftsmen 20-12A, Fender SRA 200, Marantz 240, dbx type A on all recorders, Dynaco SE 10 (2) dbx 160X
Microphones: AKG, Sennheiser, Electro Voice, Crown PZM, Shure, Beyer
Instruments Available: 5' grand piano, Fender Rhodes Stage, Crumar Performer, Crumar DS 2, Rogers drums w/Tama hard ware, percussion kit, Fender twin reverb, Yamaha RX 11 drum computer
Rates: Call Adrienne for rates and studio availability

••• **PROGRESSIVE MUSIC STUDIOS**
 also **REMOTE RECORDING**
 2116 Southview Ave., Tampa, FL
 (813) 251-8093
 Owner: Ken Veenstra
 Studio Manager: Ken Veenstra

••• **REAL TO REEL**
 4911B N. Henry Blvd., Stockbridge (Atlanta), GA 30281
 (404) 474-4776
 Owner: Bill Turpin and Mrs. H R Turpin
 Studio Manager: Scott Long and Ed Roland

••• **REEL TIME RECORDING STUDIOS**
 205A Television Circle, Savannah, GA 31406
 (912) 927-1761
 Owner: Phil L. Hadaway III
Studio Manager: Phil L. Hadaway III
Engineers: Phil Hadaway, others available
Dimensions of Studios: A: 30 x 35, B: 15 x 15
Dimensions of Control Rooms: 23 x 21
Tape Recorders: Tascam 48 B track, Tascam 85-16B 16 track, Revox A700 2 track; TEAC A-3300 2 track
Mixing Consoles: Malcolm Hill J-3-24 24 x 8 x 16
Monitor Amplifiers: Hafler-DH500, Crown DC-300A Crown DC-150, Crown D-60
Monitor Speakers: Tannoy SRM-12B, Yamaha NS-10M, UREI 813B, Auratones.
Echo, Reverb, and Delay Systems: SMR-01 digital reverb, MXR-1500 digital delay, Orban reverb, tape delay
Other Outboard Equipment: dbx 160 compressors, Aphex Model B Aural Exciter Furman EQ, Soundcraftsmen EQ, Valley People Dyna-Mite, dbx noise reduction, Crown OC-150 Controller, LT Sound Vocal Eliminator
Microphones: Neumann, Sennheiser, AKG, Sony, Fender, Crown, Beyer, Shure.
Instruments Available: Yamaha G-3 grand piano, Yamaha drums, Simmons SDS-8 drums, LinnDrum computer, Korg Polysix, Yamaha GS-2, Yamaha DX7, Yamaha CS-50, Roland GR-700 guitar synth, Fender guitar amps, Gallien Kruger bass amp, guitars and basses
Video Equipment & Services: 1/2" Beta and VHS available
Rates: 8 track \$35/hr; 16 track \$60/hr

••• **ROSEMONT STUDIO**
 1938 Dumaine St., New Orleans, LA 70116
 (504) 821-8611
 Owner: Al Taylor
 Studio Manager: Al Taylor

••• **SANDCASTLE RECORDING STUDIO**
 also **REMOTE RECORDING**
 Wade Hampton Mall Suite 109, Greenville, SC 29609
 (803) 235-1111
 Owner: Chris Cassels, Rob Cassels, Rick Sandidge
 Studio Manager: Gloria Yvette Epley

••• **SATURN SOUND STUDIOS INC.**
 511 S. Olive Ave., W. Palm Beach, FL 33401
 (305) 832-2148
 Owner: Allen Peerson, Clinton Smith
 Studio Manager: James Crockett

••• **SINGLETON SOUND**
 3106 Belmont Blvd., Nashville, TN 37212
 (615) 385-1960
 Owner: The Shelby Singleton Corp
 Studio Manager: John A. Singleton

••• **SNAPPINGER MUSIC**
 Rt. 5 East Lake Circle, Canton, GA 30114
 (404) 442-3300
 Owner: Don R. Bryant
 Studio Manager: Don R. Bryant

•••SOUND CELL
also REMOTE RECORDING
 601 Meridian St., Huntsville, AL 35801
 (205) 539-1868
 Owner: Doug Jansen Smith
 Studio Manager: Doug Jansen Smith

•••SOUND OF BIRMINGHAM RECORDING STUDIOS
also REMOTE RECORDING
 3625 5th Ave. So., Birmingham, AL 35222
 (205) 595-8497
 Owner: Don H. Mosley
 Studio Manager: Charles F. Harnach

•••SOUND LABS
 2319 Fernwood Drive, Greensboro, NC 27408
 (919) 288-0185
 Owner: Sound Labs, Inc.
 Studio Manager: Tom Rowan

•••SOUND LABS, INC.
 5808 Columbia Pike, Falls Church, VA 22041
 (703) 820-2025
 Owner: Roy E. Blair
 Studio Manager: Steve Bramley

•••THE SOUND ROOM, INC.
also REMOTE RECORDING
 325 Patterson Ave., Fort Oglethorpe, GA 30742
 (404) 866-2432
 Owner: Steve Mullinex
 Studio Manager: Steve Mullinex

•••SOUND TRAX, INC. RECORDING STUDIOS AND
 PRODUCTION SERVICES
 1626 Glenwood Ave., Raleigh, NC 27608
 (919) 832-9953
 Owner: Sound Trax, Inc.
 Studio Manager: Don Stone

•••SOUTHERN SOUND PRODUCTIONS
also REMOTE RECORDING
 717 Dauphin Island Parkway, Mobile, AL 36606
 (205) 476-1171
 Owner: Jerry Powell
 Studio Manager: Jerry Powell

•••STUDIO B
 1119 Bell St., Montgomery, AL 36104
 (205) 834-6881
 Owner: Harold and Jayonn Bearden
 Studio Manager: Jayonn Bearden

•••STUDIO FOUR RECORDING
also REMOTE RECORDING
 P.O. Box 1686, Albemarle, NC 28001
 (704) 983-2277
 Owner: SFR Services
 Studio Manager: Paula F. Hearne
 Engineers: Gene Hearne
 Dimensions of Studios: 15 x 30 with two 3 x 3 vocal isolation
 booths, 15 x 6 drum booth
 Dimensions of Control Rooms: 10 x 10
 Tape Recorders: Fostex B-16 16 tracks, TEAC/Tascam 40-4 4
 tracks TEAC/Tascam 32-2B 2 tracks, TEAC/Tascam 122 2
 tracks
 Mixing Consoles: TEAC/Tascam 15 24 x 16 x 8
 Monitor Amplifiers: Crown D-150, Sherwood
 Monitor Speakers: Altec, Auratones, CDS customized cabinets
 Echo, Reverb, and Delay Systems: Ibanez DM 1000 Ibanez
 HM1000, Tapco 4400 reverb, Omni Craft noise gate
 Other Outboard Equipment: Complete dbx and Dolby B & C
 noise reduction, 163 dbx limiters, AKG K40 headphones
 Microphones: Beyer, AKG, Shure, Electro-Voice, Audio
 Technica
 Instruments available: Kohler & Campbell baby grand piano,
 other instruments available upon request
 Video Equipment & Services: 1/2" and 3/4" available upon re-
 quest
 Rates: 16 Track \$22/hr., 4 Track \$14 50/hr

•••STUDIO 105
 105 Miller Rd., Mauldin, SC 29662
 (803) 288-5908
 Owner: Phil Blackwell
 Studio Manager: Phil Blackwell

•••SUN TRACS RECORDING STUDIO
also REMOTE RECORDING
 1211-B Hamlet Ave., Clearwater FL 33516
 (813) 447-0238
 Owner: Partnership

•••THRESHOLD RECORDING
 410 Elm Ave. S.W., Roanoke, VA 24016
 (703) 345-2539
 Owner: F. Howard Beasley, J. Harold Thompson
 Studio Manager: F. Howard Beasley
 Engineers: J. Harold Thompson
 Dimensions of Studios: 30 x 25
 Dimensions of Control Rooms: 20 x 12
 Tape Recorders: Ampex MM1100R 16 track ATR 102 2 track
 440 R 2 track, Ampex 440 B 2 track, 440 B full track
 Mixing Consoles: Loft modular devices, model 440, 24 x 16
 Monitor Amplifiers: Ashly Audio FET, AB systems
 Monitor Speakers: E.V. Sentry III, Altec 9845, Auratones
 Echo, Reverb, & Delay Systems: (2) BAE I.P. 140 plate, AKG
 BX 20, (2) Loft 450X, Eventide 1745
 Other Outboard Equipment: Ashly SC 50 limiters/compressors,
 Symetrix 501 limiter/compressor, Allison Gain Brains & Kepex
 Ashly SC 66, parametrics, Ashly SC 33 noise gates
 Microphones: AKG 451, Neumann U87, Shure 57 58, E.V. 15,
 20, Studer 5U, Wahrenbrock PZMs, RCA 77BX, BK5
 Instruments Available: Steinway grand piano, Hammond B 3
 organ, Rhodes 88, Hohner D 6 clavinet, assorted guitars, Fender
 P bass
 Rates: Available on request

•••TRACK-16 RECORDING
also REMOTE RECORDING
 118 Constitution, Lexington, KY 40508
 (606) 253-0588
 Owner: Thomas D. Tandy
 Studio Manager: Thomas D. Tandy

•••WILLOW CREEK RECORDING STUDIOS
 2228 Redmond Circle, Rome, GA 30161
 (404) 232-6954
 Owner: Morqan Ayers
 Studio Manager: Morqan Ayers

CORRECTION

The following studio was inadvertently omitted from our Northwest Studio Directory. Our apologies.

•••BEAR CREEK RECORDING STUDIO
 20711 Bear Creek Rd., Los Gatos, CA 95030
 (408) 354-2351
 Owner: Justin Mayer
 Studio Manager: Justin Mayer
 Engineers: Justin Mayer
 Dimensions of Studios: 12 x 15
 Dimensions of Control Rooms: 10 x 15
 Tape Recorders: 3M M56 16/8 track, Tascam 80 8/8 track Otari
 MX 5050 BII 2 track, Teac C3X 2 cassette
 Mixing Consoles: TMS Studiomixer II 17 in 8 out, Tascam Model
 I 8 in 2 out
 Monitor Amplifiers: BGW
 Monitor Speakers: JBL 4311, Auratone
 Echo, Reverb, and Delay Systems: Ursula Major Stargate 32 i
 digital reverb, custom plate reverb, Ellectron II
 Other Outboard Equipment: (2) dbx 161 compressor limiters
 Tascam DX8 noise reduction, (4) GT4 noise gates, Furman
 parametric equalizer, MXR stereo 10 band equalizer
 Microphones: Neumann U87, Electro Voice PL20, (2) Senn
 heiser 421s, (2) Sony ECM 22ps, (2) Shure SM57s, AKG D1000
 E
 Instruments Available: Emulator II, Drumlator, baby grand
 piano, Prophet-5, Gibson Hummingbird 6 string acoustic guitar
 Rates: \$27/hr for 2" 16 track and 1" 8 track, \$17/hr for 1/2" 8
 track, block rates available

THE CONTRACTORS EXPO '85
 March 9th, 10th, 11th, 1985 • Orlando, Florida
 workshops exhibits
 contractors suppliers
 Phone 312/577-8360 for free information.

"You Supply the Recording" We'll Produce the Rest

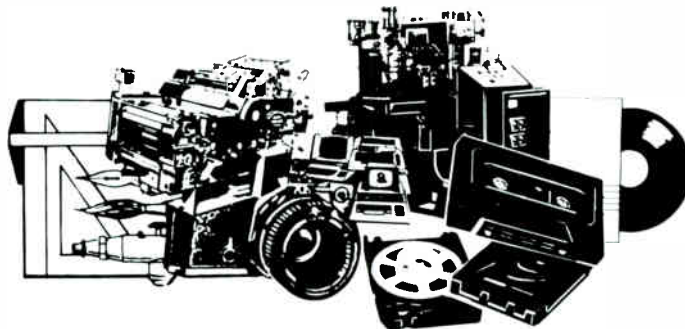

**LAYOUTS/AIRWORK/COMPUTER TYPESETTING/COLOR SEPARATION
 FINAL NEGATIVES/COLOR KEYS/4 COLORS PRINTING/POSTERS/RECORDS
 LABELS/JACKETS/COMPLETE CASSETTE & 8 TRACK LABELS/6 AUTOMATIC
 SMT RECORDS PRESSES/L.P. & 45/MASTERING/STAMPERS/COMPLETE
 CASSETTE & 8 TRACK/MANUFACTURING/HIGH SPEED DUPLICATION**

**PROSOUND INC.
 RECORD PRESSING
 DIVISION OF MIAMI TAPE
 (305) 558-0152**

**UNIVERSAL LITHO & ALBUM INC.
 (305) 557-2552 557-2562**

**MIAMI TAPE INC.
 (305) 558-9211 558-9212**

8180 N.W. 103 St. Hialeah Gardens, Florida. 33016

Circle #035 on Reader Service Card

24 TRACK STUDIOS

southeast

♦♦♦♦ PAT APPLESON STUDIOS, INC.
also REMOTE RECORDING
1000 NW 159 Drive, Miami, FL 33169
(305) 625-4435
Owner: Pat Appleson
Studio Manager: Rich Rudner



ARDENT RECORDINGS, INC.
Memphis, TN



ACORN SOUND RECORDERS, INC.
Hendersonville, TN

♦♦♦♦ ACORN SOUND RECORDERS, INC.
329 Rockland Rd., Hendersonville, TN 37075
(615) 824-4924
Owner: Oak Ridge Boys
Studio Manager: Jimmy Tarbutton
Engineers: Jimmy Tarbutton. Independents welcome.
Dimensions of Studios: 25 x 36 including booths; drum room 13 x 15.
Dimensions of Control Rooms: 22 x 24
Tape Recorders: Studer A-80, 24 track; Studer B-67, 2 track; Otari MTR-12, 2 track, Sony cassette.
Mixing Consoles: Harrison MR4, 32 x 24
Monitor Amplifiers: Haller D-500, Crown
Monitor Speakers: UREI B13B Time Aligned, JBL, Eastern Acoustic Works, Auratones
Echo, Reverb, & Delay Systems: Lexicon 224X w/Larc remote, Eventide SP-2016, Super Prime Time, Eventide 1745A DDL
Other Outboard Equipment: Kepex II, ADR Stereo Sweep EQ, (4) dbx 160 kmeters, UREI 1176 limiter, Eventide harmonizer, (2) White 1/2 octave graphic EQ, (2) Lang EQ
Microphones: Neumann U47s, U89s, U87s, U64s, KM86, KM88, Studer Stereo, Sennheiser 421s, E-V RE20s, AKG 451s, Sony C37s, AKG D12E, (4) Shure 546s, Shure SM57s
Instruments Available: Yamaha C7 grand piano, Wurlitzer electric piano, Rhodes electric piano, Hohner clavichord, Hammond B3 organ, ARP String Ensemble, Fender guitar amps, Pearl drums
Video Equipment & Services: Panasonic 3/4", Panasonic 1/2" VHS, Sony 1/2" Beta
Rates: Call for rates

♦♦♦♦ ALLEN-MARTIN PRODUCTION AUDIO
also REMOTE RECORDING
9701 Taylorsville Rd., Louisville, KY 40299
(502) 267-9658
Owner: Ray Allen, Hardy Martin
Studio Manager: Mike Gibson

♦♦♦♦ ALPHA AUDIO
2049 West Broad St., Richmond VA 23220
(804) 358-3852
Owner: Alpha Recording Corp.
Studio Manager: (Traffic) Mary Ann Turner, (Adm) Barbara Wright

♦♦♦♦ AMERICAN MULTIMEDIA, INC.
also REMOTE RECORDING
Route 8, Box 215A, Burlington, NC 27215
(919) 229-5554
Owner: Richard Clark
Studio Manager: Kent Smith
Engineers: Bob Kelly, Bob Gaude, Kent Smith, Ellen Threat
Dimensions of Studios: 25 x 33
Dimensions of Control Rooms: 25 x 14
Tape Recorders: Otari MTR 90 24 track; Otari MTR 10 2 track; Otari MTR 10-4 4 track; Otari MX 5050 2 track; Sony PCM 1610 2 track; JVC 2 track; Sony PCM-F1 2 track.
Mixing Consoles: Neve 8108 32 x 24
Monitor Amplifiers: UREI Model 6250/6500.
Monitor Speakers: UREI Time Align monitors, Auratones.
Echo, Reverb, and Delay Systems: Lexicon 224X, Lexicon 224, Lexicon Model 200, Lexicon Super Prime Time, Prime Time II, several PCM 42s.
Other Outboard Equipment: Aphex II Aural Exciter, EXR Exciter, Orban De-Esser 536-a, dbx-900 compressors, (24) dbx 165 compressors, (2) dbx 900 Noise Gates, Roland Vocoder SVC-350, Rockman X-100.
Microphones: AKG, Beyer, E-V, A.T., RCA, Crown, Sony.
Instruments Available: Yamaha DX7, Oberheim OB-8, Prophet-10, LinnDrum, Oberheim DSX sequencer, Simmons SDS-7 dig. drums, Rogers drums, Kawai electric grand, Hammond C-3 with 147 Leslie, Fender Rhodes, Moog Taurus.
Video Equipment & Services: Complete post-production facility 300 Grass Valley switcher (2 channels of DVE) CMX-340X editor, Ikegami HL79 and 356 cameras and monitors, Ampex VPR 2-b with TBC 1" recorders, VHS, Beta and 3/4" dubbing services Remote tele-production capabilities.
Rates: \$65/hr for audio studio. Video rates on request.

♦♦♦♦ A.M.I. STUDIO
111 Freehill Rd., Hendersonville, TN 37075
(615) 822-6790
Owner: Michael R. Radford, Kenneth Bridger
Studio Manager: Marty McReynolds

♦♦♦♦ ARDENT RECORDINGS, INC.
also REMOTE RECORDING
2000 Madison Ave., Memphis, TN 38104
(901) 725-0855
Owner: John Fry
Studio Manager: Trish Hardy
Engineers: Robert Jackson, John Hampton, Eddie Degarmo, Dana Key, Joe Hardy, Larry Nix, Henry Bush, Terry Manning, Al Smith
Dimensions of Studios: Studio A: 25 x 40 x 16; Studio B: 25 x 20 x 16; Studio C: 25 x 35 x 14; Mastenna 15 x 20 x 10. Each studio with two isolation booths.
Dimensions of Control Rooms: Studio A: 16 x 25 x 10, Studio B: 16 x 25 x 10; Studio C: 18 x 25 x 10.
Tape Recorders: (3) MCI JH 1624 24 track; (3) MCI JH-110 2 track; 3M M79 2 track; (2) 3M M64 2 track; (3) Scully 280 2 track; MCI JH-110B 1/2" 2 track, dbx digital 2 track.
Mixing Consoles: MCI 542, 42 in x 32 out. Spectra Sonics 24-16, 28 in x 24 out; 36 x 24 Westar with time code automation; Mastering room equipped with Neumann VMS-70 lathe with Zuma digital control.
Monitor Amplifiers: BGW, Crown.
Monitor Speakers: JBL 4350, Audicon, Yamaha, KEF, JBL 4340, Auratones, Advent.
Echo, Reverb, and Delay Systems: 3 EMT 140, 3 acoustic chamber, (2) H949 Harmonizer, Lexicon, Eventide, Marshall, ADR, Quantec room simulator, Effectron, BEL.
Other Outboard Equipment: Limiters and compressors: Neve, dbx, ADR, Fairchild, UA, EMT; EQs: Neve, Orban, ADR, Pultec. Noise gates: Kepex, ADR, Outer Ear. All multi-tracks and two tracks equipped with Dolby A; (dbx optional for two tracks). All rooms tuned with UREI filters and E&K spectrum analyzer. Studio equipped with MCI automation.
Microphones: Neumann U87, U67, U64, M249, KM86, KM84; AKG C414, C451, D224, D12, D290; Sennheiser MD421, MD441; E-V RE20, RE16; Shure SM53, Beyer M201; AKG C-422 stereo.
Instruments Available: Steinway grand, Yamaha grand, Chickering grand; Hohner clavinet; Hammond organ; Fender Rhodes 88; Gretsch drums; Fender, HiWatt, Acoustic, Ampeg amplifiers; Fairlight, MIDI piano interface, extra-BTX Softouch synchronizer, Fairlight sensus X with SMPTE MIDI, dbx digital 2 track.
Video Equipment & Services: Complete video production services and sweetening.
Extras: Cable television, kitchen, two lounge.
Rates: Upon request.
Direction: Clients: ZZ Top, Bar-Kays, Parliament/Funkadelic, Robin Trower, Led Zeppelin, Cor: Funk Shun, Emerson Lake & Palmer, Bootsy's Rubber Band, Cheap Trick, Memphis Horns, Commodores, Leon Russell, Isaac Hayes, Black Oak Ray, Roy Clark, Charlie Rich, Amazing Rhythm Aces, DeGarmo & Key, Too Tall Jones, Shaun Cassidy, Chocolate Milk, Kwark, Johnny Cash, Staple Singers, Bobby Blue Bland, Glad, Blackwood Brothers, Mylon LeFevre, Lou Rawls, Phil Driscoll, Ray Parker Jr., Xavon.

♦♦♦♦ ARTISAN RECORDERS, INC.
1755 Southwest 81st Lane, Ft. Lauderdale, FL 33324
(305) 474-3176
Owner: Peter J. Yanilos
Studio Manager: Michael Musick

**** AUDIO CREATIONS RECORDING STUDIO
also REMOTE RECORDING
 4815 Clarks River Rd., Paducah, KY 42001
 (502) 898-6746
 Owner: Ralph G. Rowton Jr., George Cumbee
 Studio Manager: George Cumbee

****AUDIOFONICS, INC.
 1101 Downtown Blvd., Raleigh, NC 27603
 (919) 821-5614
 Owner: Larry Gardner
 Studio Manager: Bill Blankshup

****AUDIO MEDIA RECORDERS
 808 19th Ave. South, Nashville, TN 37203
 (615) 320-5985
 Owner: C.E. Jackson
 Studio Manager: C.E. Jackson
 Dimensions of Studios: #1: 20 x 28, #2: 14 x 13.
 Dimensions of Control Rooms: #1: 22 x 16, #2: 13 x 16.
 Tape Recorders: #1: Studer A-800 24 track, Studer B-67 2 track; #2: Studer A-80 24 track, Studer B-67 2 track.
 Mixing Consoles: #1: Harrison 3232C, 28 in x 28 out; #2: Harrison MR-2-28.
 Monitor Amplifiers: BGW, Phase Linear, McIntosh.
 Monitor Speakers: Westlake TM1, JBL 4310, and Yamaha in both studios.
 Echo, Reverb, & Delay Systems: (3) EMT stereo units, Lexicon 102, Lexicon 224X, Super Prime Time.
 Other Outboard Equipment: Eventide Harmonizer; (6) dbx 160s, dbx 165; Dolby noise reduction; UREI 1176LNs (2), (2) LA-2As, LA-3As; stereo Orban EQ, Pultec EQ.
 Microphones: Shure SM57s; Sennheiser 421; Neumann 87 FET, 47 FET, 67s, 249s, 84s; AKG 414s, 451s, 202E, C-60; E-V RE20s, RE15s, 635s; Studer; Schoeps SKM5s.
 Instruments Available: Yamaha 9' grand, B-3 organ, Fender Rhodes, Hohner clavinet, Wurliizer electric piano, ARP Axxe and Omni, Pearl drum set, 50 percussion instruments.
 Rates: Supplied on request and based on volume.



AUDIOVISIONS
 Louisville, KY

**** AUDIOVISIONS
 710 Distillery Commons, Louisville, KY 40206
 (502) 587-6863
 Owner: J.R.E. Inc.
 Studio Manager: Bob Ernspeker
 Engineers: Bob Ernspeker, John Schroeder, Tim Creed
 Dimensions of Studios: A 30 x 60, B 10 X 10
 Dimensions of Control Rooms: A: 20 x 20, B: 10 x 15 (both LEDE)
 Tape Recorders: TEAC 80-8 8 track, Studer A-80 24 track; (3) Ampex ATR-70 2 track; Studer A-80 2 track; Studer B-67 2 track.
 Mixing Consoles: NEOTEK C 36 x 24, TEAC M-50 12 x 8
 Monitor Amplifiers: McIntosh, Yamaha
 Monitor Speakers: UREI-813, JBL-4411
 Echo, Reverb, and Delay Systems: EMT, Audicon, Lexicon, Eventide, Yamaha, MXR
 Other Outboard Equipment: Parametric EQ; all channels, White EQ; Pultec EQ; dbx 165 comp.; dbx noise reduction all channels, Roland phaser.
 Microphones: U87, U67, AKG C414EB, KM84, RE20, Sony C35, Senn. 421, Crown PZM, AKG 451
 Instruments Available: Prophet-5, Memorymoog, Yamaha grand Hohner Clavinet, stereo Rhodes, Wurliizer piano, MXR and Sequential Circuits digital drums, Yamaha drum set
 Video Equipment & Services: Adams-Smith SMPTE lock system for audio to video recording, Sony monitor, JVC time code with full stereo video recording via JVC 3-track x 3/4" recorder
 Rates: A: \$65-\$95/hr., B: \$55-\$65/hr., SMPTE lock \$15/hr extra

**** AUGUST RECORDING STUDIO
 2136 Kings Ave., Jacksonville, FL 32207
 (904) 399-8283
 Owner: Wayne Fanning
 Studio Manager: Wayne Fanning

**** AXIS SOUND STUDIO
 (Division of Spire Audio-Visual)
 1314 Ellsworth Ind. Dr., Atlanta, GA 30318
 (404) 355-8680
 Owner: Spire Audio-Visual, Miami, FL
 Studio Manager: Chuck Fedonczak
 Engineers: George Pappas, Chuck Fedonczak.
 Dimensions of Studios: 40 x 60 x 20.
 Tape Recorders: Studer A80 VU 24/16 track, A80 VU 1/2" 2 track also 1/4" 2 track, B67 1/4" 2 track; Ampex AG440 1/2" 4 track, AG440 1/4" 2 track, Sony TC 756 1/4" 1/4 track.
 Mixing Consoles: Neve 8068 32 x 16 with Necam Automation.
 Monitor Amplifiers: Crown PSA 2, McIntosh 2125, 2 Leach Superamps, Studer, White crossover & graphic EQ.
 Monitor Speakers: Main-custom JBL each w/2 2215 15" woofers, 2441 mid driver and 2405 H.F. drivers. Also 1 pair Ed Long MDM4, 1 pair JBL 4313B, 1 pair JBL 4311, 1 pair Auratones, Yamaha NS-10M.
 Echo, Reverb, & Delay Systems: 2 EMT stereo plates (tube type), AMS digital reverb, plus miscellaneous DDLs & echo units, Harmonizers, etc.
 Other Outboard Equipment: 4 Neve limiters, 1176 UREI, 162 dbx, 160 dbx, Allison Gain Brains & Kepex units, Sontec parametric EQ
 Microphones: AKG, Neumann, Shure, E-V, Studer, Schoeps, PZM, C-Ducers, Sennheiser.
 Instruments Available: Yamaha C-3 grand piano, Hammond B-3 organ, Hohner clavinet, Rhodes 73, Mini Moog, Rogers drum kit, assorted Fender and Marshall amps.
 Video Equipment & Services: 1/2" and 3/4" editing and production, 1" available on request. CMX/Sony 3/4" A-B Roll editing suite with digital effects.
 Rates: Call Chuck Fedonczak at (404) 355-8680.

**** BEE JAY RECORDING STUDIOS
 5000 Eggleston Ave., Orlando, FL 32804
 (305) 293-1781
 Owner: Eric T. Schabacker
 Studio Manager: Jim Katt

**** THE BENNETT HOUSE
 134 4th Ave. N., Franklin, TN 37065
 (615) 790-8696
 Owner: Bob Montgomery
 Studio Manager: Don Cobb
 Engineers: Chief Engineer: Gene Eichelberger; Engineers: Gene Eichelberger, Don Cobb, Clarke Schleicher, J.T. Cantwell
 Dimensions of Studios: Studio A: 44 x 18, two isolation booths. Studio B: 9 x 12, overdub booth
 Dimensions of Control Rooms: 20 x 26
 Tape Recorders: (2) MCI transformerless w/SMPTE lock-up, BTX sync 24/46 track; (2) Studer B62 2 tracks; Ampex ATR 100 1/2" 2 track; (4) Technics cassettes. (2) Studer 800s, Studer cassette
 Mixing Consoles: Studio A, 28 in x 24 out. Studio B, Bud Wyatt Trident Series 80
 Monitor Amplifiers: Yamahas
 Monitor Speakers: JBL 4411s, John Meyer monitors, Yamaha NS10s, Braun 3-way, Auratones.
 Echo, Reverb, & Delay Systems: EMT 250 Digital, Lawson Plate, AMS DDL, Eventide 949, Lexicon 224
 Other Outboard Equipment: Scamp Rack with 10 noise gates, (2) EQs, (2) limiter/compressors, time shape module, auto pan, vocal stressor and misc.
 Microphones: Tube M-249, 87s, 414, 421s, 224s, etc. AKG Tube.
 Instruments Available: Baldwin 7' and Eddie Reynolds Rhodes.
 Rates: Call for rates.

**** BIAS RECORDING COMPANY, INC.
also REMOTE RECORDING
 5400 Carolina Place, Springfield, VA 22151
 (703) 941-3333
 Owner: Bill McElroy, Bob Dawson
 Studio Manager: Gloria Daniels
 Engineers: Bob Dawson, Bill McElroy, Jim Robeson, Norm Rowland
 Dimensions of Studios: Studio A: one 16 x 25 room; one 20 x 30 room; Studio B: one 16 x 25 room.
 Dimensions of Control Rooms: Studio A: 12 x 16; Studio B: 12 x 16
 Tape Recorders: Ampex (Studio A) MM-1200 24 track; Ampex (Studio B) MM-110 16 track; Studer (7)B-67 2 track, A-67 2 track; Ampex 440-B 4 track; Technics (2)M-280 cassette.
 Mixing Consoles: API (Studio A) Modified 2488 w/Allison Fader 24/8; API (Studio B) Modified 1604 16/4
 Monitor Amplifiers: Studio A: Bryston, Studio B: Crown.
 Monitor Speakers: Studios A & B: Sierra/Hidley and Auratone.
 Echo, Reverb, & Delay Systems: (2) EMT 162; AKG BX20E; Eventide Harmonizer; Lexicon Prime Time.

Other Outboard Equipment: UREI 1176 LN; UREI LA-4; UREI 964 digital metronome; dbx 160; Teletronix LA-2A; Kepex, Dynamite, MXR studio phaser; MXR studio flanger.
 Microphones: Neumann, Sony, AKG, Shure.
 Instruments Available: Yamaha C-5 grand piano, Hammond C3 w/Leslie, Fender Rhodes, Hohner clavinet, Slingerland drums, Fibes drums, Fender Precision Bass, Fender Twin Reverb, blonde Fender Pro, tweed Fender Deluxe (2), tweed Fender Vibrolux.
 Rates: Studio A: 24 track, \$95/hr; 2/8/16 track, \$80/hr. Studio B: 8/16 track, \$60/hr.; 2 track, \$40/hr.

**** BIG MAMA RECORDING STUDIO
also REMOTE RECORDING
 400 Enaley Dr., Knoxville, TN 37920
 (615) 577-5597
 Owner: Norbert Stovall

**** BLACKWOOD SOUND FACTORY
also REMOTE RECORDING
 Box 17272, Memphis, TN 38187-0272
 (901) 365-6900
 Owner: Ron Blackwood
 Studio Manager: Dee Huffman

**** BOUTWELL RECORDING STUDIOS INC.
also REMOTE RECORDING
 720-726 23rd St., South Birmingham, AL 35233
 (205) 251-8889
 Owner: E. Boutwell, G. Bass, C. Haden, M. Harrellson, W. Thompson, N. Cotton
 Studio Manager: Nancy Cotton

**** BROADWAY SOUND STUDIO
 1307 Broadway St., Sheffield, AL 35660
 (205) 381-1833
 Owner: David Johnson
 Studio Manager: Cal Freeman

**** BROKEN DOOR STUDIO
 5405 Stanford Drive, Nashville, TN 37215
 (615) 269-0727
 Owner: Keebie Media Group
 Studio Manager: Peter Keebie

**** BULLET RECORDING
 49 Music Square West, Nashville, TN 37203
 (615) 327-4621
 Owner: Randy A. Holland
 Studio Manager: Danny Mundhenk

**** CAPRICORN SOUND STUDIOS
 536 Broadway, Macon GA 31201
 (912) 745-8518
 Owner: Phil Walden
 Studio Manager: Tad Bush

**** THE CASTLE RECORDING STUDIO, INC.
 Old Hillsboro Road, Rt. 11, Franklin, TN 37064
 (615) 791-0810
 Owner: Joseph Nuyens
 Studio Manager: Joseph Nuyens
 Engineers: Chuck Ainlay, Keith Odle, Giles Reaves
 Dimensions of Studios: size of castle
 Dimensions of Control Rooms: size of castle
 Tape Recorders: Studer A80 MKIII 24 track, Studer A80 MKII 24 track, Studer A80 2 track, (2) Studer B67 2 track, 3M DMS digital 32 track, (2) 3M DMS digital 4 track.
 Mixing Consoles: Solid State Logic 4000 E with Total Recall Computer 48/32, Yamaha 1608 16/8.
 Monitor Amplifiers: (3) 4B Bryston on main; Yamaha 2201 on alternates; BGW 250s on cue.
 Monitor Speakers: JBL 4430 Biradials, Yamaha NS-10s, JBL 4411; Auratones.
 Echo, Reverb, and Delay Systems: Lexicon 224x with Larc, Lexicon 224, AMS DMX 15-80 with 1.6 sec. delay on A side and 3.2 sec. delay on B side, Lexicon Super Prime Time 97, Lexicon Prime Time 93, (2) Large Ecoplate II.
 Other Outboard Equipment: AMS DMX 15-80s with deglitch card in both channels; Adam-Smith synchronizer system; Eventide H1910; (2) ADR Vocal Stressors, ADR 504; (4) Valley People Kepex II, (2) 504 Scamp parametric EQ; S 25 Scamp de-Esser, (1) Trident stereo limiter/compressor, (2) UREI 1176; SSL has built-in compressor/limiter, expander/gates on all 48 channels.
 Microphones: Complete assortment of Neumann, Neumann old tubes, Sennheiser, AKG, AKG tubes, Shure, Altec, PML, Sony.
 Instruments Available: Fairlight CMI system and printer, Yamaha DX11, Yamaha DX7, Bosendorfer 7'3" grand, Roland Jupiter 8; Oberheim DMX, Simmons 7-piece set, Simmons SD56, Roland TY 808, PRO I, Hammond B3 w/Leslie, Rhodes, tack piano, Martin guitars from private collection.
 Rates: Available upon request.



CHANDLER AUDIO INC.
Ashland, KY

•••• CHANDLER AUDIO INC.
1617 W. Midland Trail Road, Ashland, KY 41101
(606) 928-9507
Owner: Denny Chandler
Studio Manager: Denny Chandler
Engineers: Denny Chandler, Dirk Hawkins
Dimensions of Studios: 22 x 24, drum booth 9 x 8
Dimensions of Control Rooms: 19 x 16
Tape Recorders: Studer A80 24 track, Tascam 80 R R track, Ampex ATR 800 2 track, Tascam 122 cassette
Mixing Consoles: Harrison 3624 36 x 24 x 4 x 2
Monitor Amplifiers: Crown, UREI
Monitor Speakers: UREI 813B, IBL 4311, MDM-4, Auratones
Echo, Reverb, and Delay Systems: Yamaha Rev 1, custom stereo plate, Eventide Harmonizer 910, Eventide flanger/ phaser, ADA STD 1, Kora SDD 3000, MXR Digital Delay, Ursa Major Space Station
Other Outboard Equipment: DynaMites, UREI 1176, Ashby compressor/limiters, Gates noise gates, Aphex B, Boss Stereo Chorus, White equalizers
Microphones: Neumann UR7, AKG 414, The Tube, 451, Shure SM57, 58, 81, 54, SMS, SM7, 330, E.V. RE20, Sennheiser 421, 441, Crown PZM, Beyer M300
Instruments Available: Yamaha C7 grand piano, Hammond M3 w/Leslie, Yamaha DX 7, Oberheim ORR 360 Systems, Roland Vocoder, ARP Strna Ensemble, ARP 2600, Simmons SDS 7, LinnDrum, Rogers drum set, Musser vibes, LP congas, Musser bells, Ovation 6 & 12 string, Rhodes
Rates: \$50 per hour 24 track, \$25 per hour 8 track

•••• CHESHIRE SOUND STUDIOS
also REMOTE RECORDING
2093 Faulkner Rd. NE, Atlanta, GA 30324
(404) 321-3886
Owner: T.G. Wright, Jr.
Studio Manager: Karen Smith
Engineers: Director of Engineering Tom Race, Engineers Tom Wright, Lewis Padgett
Dimensions of Studios: A 32 x 44 x 16, B 18 x 15
Dimensions of Control Rooms: A 18 x 24, B 14 x 10
Tape Recorders: Ampex MM1100 24 track, Ampex (4) 440B 2/4 track, Ampex 1200 24 track
Mixing Consoles: MCI 428B automated, 28 in x 24 out, MCI 636C automated complete cassette production facility, 1/2 master ing 24 track to 24 track dubbing
Monitor Amplifiers: SAF, Yamaha, Crown
Monitor Speakers: JRL, Eastern Acoustic Works, Auratone, Yamaha, MDM-4s
Echo, Reverb, and Delay Systems: Live echo chambers, Lexicon 224, Lexicon 200, Model 93, Model 92, DeltaLab DL 1, DL 2, Eventide Harmonizer, MXR transposer
Other Outboard Equipment: Parametric equalizers, UREI 1176N, dbx 160, Orban 245F, 111B, 24 channels dbx and Dolby
Microphones: Wright microphones SB 1 and TSB-2, Neumann, AKG, Sony, etc
Instruments Available: Send for brochure
Rates: Send for brochure

•••• CINDERELLA SOUND STUDIO
1108 Cinderella St., Madison, TN 37115
(615) 865-0891
Owner: Wayne Moss
Studio Manager: Wayne Moss

•••• CLIMAX RECORDING STUDIOS, INC.
2994 North Miami Ave., Miami, FL 33127
(305) 576-6888
Owner: Pablo Cano, President
Studio Manager: Pablo Cano



Engineers: Armando Terron, Pablo Cano, Rudy Perez
Dimensions of Studios: 90 x 35 x 16
Dimensions of Control Rooms: 17 x 15
Tape Recorders: MCI JH 114 24 track, JH 110 2 track, Tascam 122 cassette
Mixing Consoles: MCI 428R 24 x 24
Monitor Amplifiers: Yamaha, McIntosh, IIREI
Monitor Speakers: Custom built bamped TADs, 4311 4312 Auratones
Echo, Reverb, & Delay Systems: Lexicon 224, AKG BX10, 949 & 910 Harmonizers
Other Outboard Equipment: ADC vocal stessor, UREI, OBX, Valley People limiters, Kexep II gates, Aphex, others upon request
Microphones: Neumann, AKG, Sennheiser, RCA, F.V., Sony, Shure
Instruments Available: 9' Steinway concert piano, Fender Rhodes, Yamaha electric pians, Prophet-5, clavinet, drums, others upon request. Also, alphaSyntrau Metatrak program with Apple II computer, Oberheim DX computer drums, and Fender twin amplifier
Rates: \$100/hr or bulk rates. We work 7 days a week and 24 hours a day. Free estimates on productions
Direction: Besides our studio facilities, among the finest in South Florida, our staff, number one in creativity and different musical and technical talents, is working together with Producer Orlando "Papito" Hernandez serving bulk rates, estimates on single writing, musical arrangements and compositions and other musical American and Latin services. Among them are Al Caiola, Emmanuel, Armando Manzanero, James Earl Jones, SIN TV Net works, WRHC radio station, and others

•••• COCONUTS RECORDING CO., INC.
1830 N.E. 153rd St., N. Miami Beach, FL 33162
(305) 940-4656
Owner: Shirley P. Kaye
Studio Manager: Shirley P. Kaye

•••• COMMERCIAL MUSIC RECORDING COMPLEX
Memphis State University
Dept. of Music, MSU, Memphis, TN 38152
(901) 454-2559
Owner: Memphis State University
Studio Manager: Larry Lipman
Engineers: Larry Lipman, advanced students in audio degree program
Dimensions of Studios: Studio A: 60 x 60 x 20, Studio B: 23 x 16 x 20
Dimensions of Control Rooms: 20 x 16 x 12
Tape Recorders: MCI JH24 24 track, MCI JH110B 2 track, others
Mixing Consoles: MCI JH636 24 x 24
Monitor Amplifiers: BGW, AR Systems
Monitor Speakers: UREI 813A, IBL 4401, Auratones
Echo, Reverb, and Delay Systems: Lexicon 224XL, Lexicon M97 Super Prime Time
Other Outboard Equipment: Harmonizer H949, dbx 160X, DynaMite, other Multitrack equipped with dbx. Monitors tuned with IIRFI filters and B&K spectrum analyzer, console equipped with MCI automation
Microphones: Neumann U47, U87, KM84, AKG C414, C452, Sennheiser MD421, Shure SM81, SM57, E.V. RE20, RE10, Crown PZM
Instruments: Steinway grand, Baldwin grand, Yamaha DX7, full complement of studio, orchestral and percussion instrumentation available
Video: Complete video production services available, seen to be interlaced with recording studios
Rates: The CMUS Complex is operated primarily as an instructional facility and was developed to handle the needs of the University's Commercial Music degree programs and Highwater record company. Although normally unavailable for commercial use, studio rental is authorized under special circumstances. Availability and rates upon request

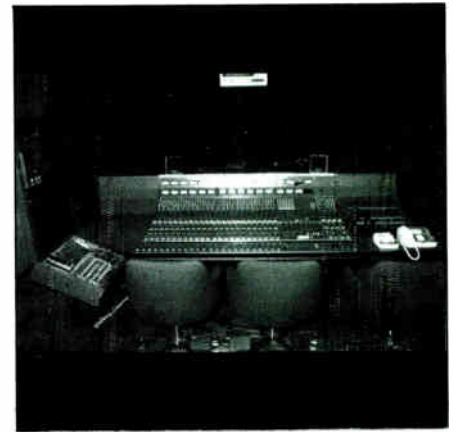

COOK SOUND STUDIOS
Fort Payne, AL

•••• COOK SOUND STUDIOS
1419 Scenic Rd., Fort Payne, AL 35967
(205) 845-2286
Owner: Jeff Cook
Studio Manager: John Estes
Engineers: John Estes, independents
Dimensions of Studios: 28 x 37
Dimensions of Control Rooms: 14 x 16
Tape Recorders: Studer A80 VU MK II 24 track, A80 VU MKII 1/2" 2 track, A710 cassette, Revox PR99 2 track
Mixing Consoles: Neve 805R 2R in x 24 out
Monitor Amplifiers: McIntosh 2300, McIntosh 2105, Yamaha 2200, Yamaha 2050
Monitor Speakers: UREI 813, Yamaha NS 10M, Auratones
Echo, Reverb, & Delay Systems: FMT plate, Lemcon Super Prime Time, Ursa Major R432
Other Outboard Equipment: Eventide Harmonizer; (3) dbx 160X compressors, FXR EXIV Exciter, Orban 622R parametric, UREI 1176LN compressors, SCAMP rack w/gates, compressors, de-essers, sweep EQ, Neve compressor/limiter, telephone distort module, notch and correction filters, and background noise suppressor
Microphones: Neumann M49, (2) U48, (2) U47, (3) UR7, AKG (4) 414, (4) 452, Shure (2) SM7, (3) SM81, (8) SM57, Electro Voice (2) RE-20; Audio-Technica (2) ATM31R, Sennheiser (4) 421, Studer SKM 5
Instruments Available: Yamaha acoustic piano, Oberheim OB-Xa w/DSX, Yamaha SK 15, Music Man, Fender and Carvin amps, Rhodes 73, Geesch drums
Rates: \$75/hr.

•••• COTTON ROW RECORDING
1503 Madison Ave., Memphis, TN 38104
(901) 276-8518, 276-8520
Owner: Ward Archer, Jr.
Studio Manager: Nikos Lyras
Engineers: Niko, Lyras, Danny Jones, Gerard Harris, Danny Green
Dimensions of Studios: 32 x 22 x 14, isolation booth (2) 5 x 12 x 12, 6 x 6 x 12
Dimensions of Control Rooms: 17 x 20 x 12
Tape Recorders: Otari MTR 90 24 track, Otari MTR-10 2 track, Otari 9505B 2 track, TEAC A 3300SX 2 track, Tascam 122 cassette, Techna: M-6R cassette
Mixing Consoles: Audiotronics 501 (modified) 26 x 15
Monitor Amplifiers: Yamaha P2201, BGW 250R, BGW 250C, BGW 100R, Crown D 150A
Monitor Speakers: E.V. Sentry III modified by Steven Durr, E.V. Sentry V, JRL 4311, JRL 4401, Auratones
Echo, Reverb, and Delay Systems: Lexicon 224, Lexicon PCM 60, 2 Lexicon PCM 41s, DeltaLab Eltron, DeltaLab Eltron and Eltron II
Other Outboard Equipment: dbx 160x compressors, UREI 530 and 527 A graphic EQs, White 4000 EQs, Valley People DynaMite gates/limiters/de-essers, Omm Craft GT-4 gates
Microphones: AKG 414, AKG 451, AKG 2000, AKG 1000, AKG D12 Neumann KM-84 Sennheiser MD421, Crown PZM 6 I.P.R., Shure SM 57
Instruments Available: Kawai 6 foot grand, Hammoir B-3 organ, Memory Moog, MiniMoog, Yamaha DX7, Yamaha "S80, Polysix, Roland GR 700 guitar synthesizer, Roland Jazz Chorus guitar set p. Roland Cube 100 guitar amp, Fender Twin and Pro Reverb amps, Gretsch drums (8 piece) Simmons SD-R electronic drum set, several percussion instruments, Fender Stratmaster guitar, Schecter Stratocaster guitar, Gibson 355 guitar, Takamine acoustic guitars (6 and 12 string), Schecter bass, Music Man bass
Rates: \$65-75 per hour

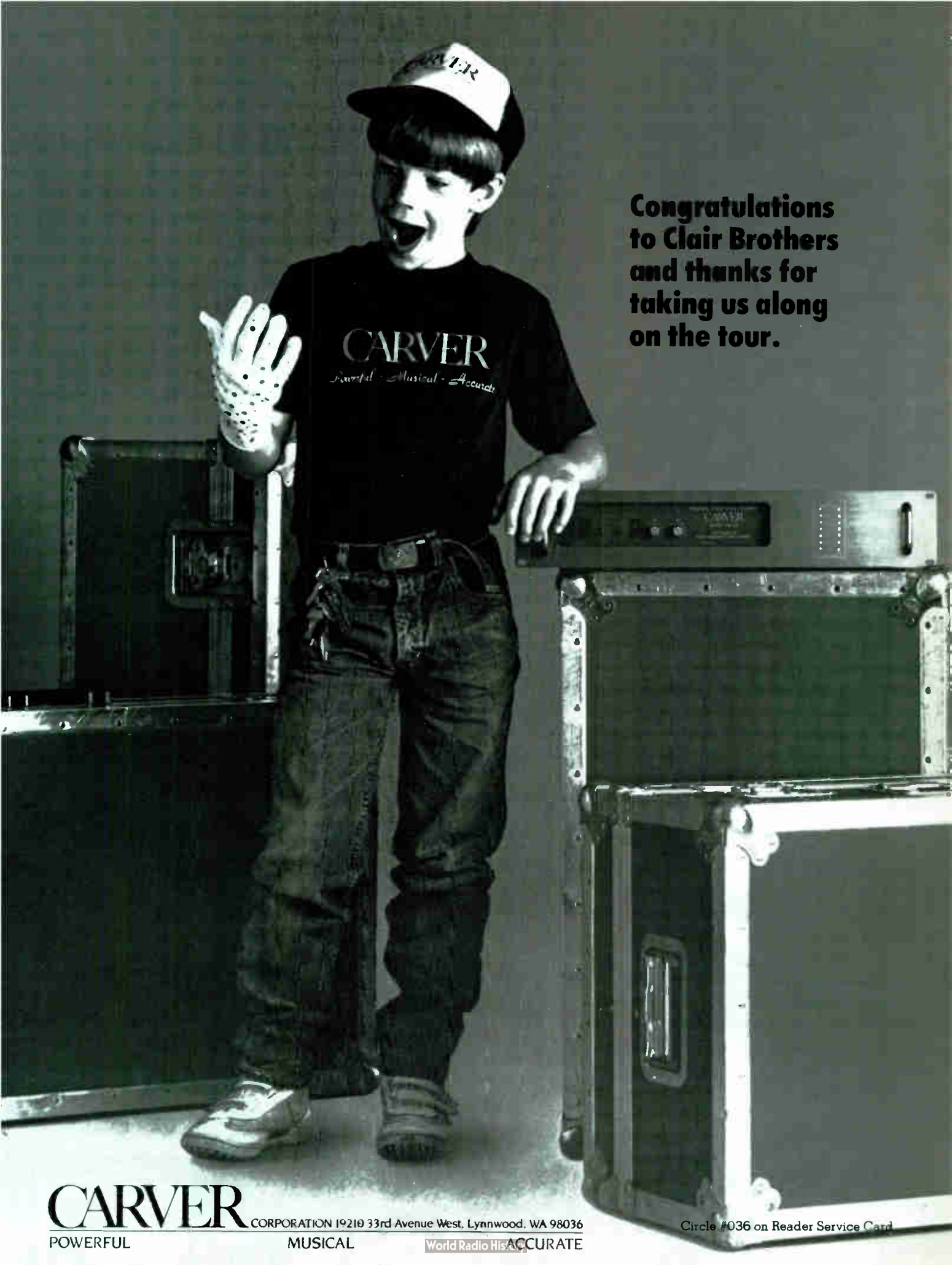

**Congratulations
to Clair Brothers
and thanks for
taking us along
on the tour.**

CARVER

CORPORATION 19210 33rd Avenue West, Lynnwood, WA 98036

POWERFUL

MUSICAL

World Radio His ACCURATE

Circle #036 on Reader Service Card



CRAWFORD POST PRODUCTION
Atlanta, GA

**** CRAWFORD POST PRODUCTION
535 Plasamour Dr. NE, Atlanta, GA 30324
(404) 876-7149

Owner: Jesse C. Crawford
Studio Manager: Steve Carlisle
Engineers: Kathy Gray, Todd Plewacki, independents
Dimensions of Studios: Studio A: 32 x 25 x 14, Studio B: 6 x 8.
Dimensions of Control Rooms: Studio A: 34 x 27 x 14, Studio B: 12 x 12.
Tape Recorders: Studio A: Ampex 124, 24 track, Studer A80, 24 track, Studer A8C, 1/2" 2 track, (2) Ampex 102 2 track. Studio B: Ampex mono, Ampex 102, 2 track.
Mixing Consoles: Studio A: Neve 8128, 48-channel w/Necam II automation. Studio B: Trident Series 70, 24 channel.
Monitor Amplifiers: Crown, Hafler, AB.
Echo, Reverb, and Delay Systems: Eventide Harmonizer, (2) Lexicon 224X dbx limiters, compressors, gates, para. EQ, dbx digital mastering system, Lexicon 200.
Other Outboard Equipment: BTX (3 mach.) Softouch Controllers.
Microphones: Neumann, AKG, Sennheiser, Beyer, Milab, Crown, Shure E-V, Schoeps.
Instruments Available: Yamaha C7 grand piano, LinnDrum, Tama drums, Simmons drums, Prophet-T8 Syn., and assorted percussion instruments.
Rates: Studio A: 24 track with picture and automation, \$165/hour; 4 or 2 track with picture, \$150/hour; 24 track without picture, \$135/hour; mono, 4 or 2 track without picture, \$80/hour; Lexicon time compression (1200B), add \$100/hour; dbx digital mastering add \$100/hour. Studio B: 2, 4, or 8 track with picture, \$150/hour; 1/2" 8 track without picture, \$90/hour; mono, 4 or 2 track without picture, \$80/hour; Lexicon time compression (1200B), add \$100/hour.
Extras: Crawford's Studio A was constructed from the ground up with optimum acoustics in mind, by Les Duncan of Trakside Engineering, who designed and oversaw the entire project. Superb isolation characteristics were achieved by employing decoupled slabs on discrete footings, exterior walls of sand filled block, multi-layered high density interior walls, and floated floors. The studio varies side to side from a very live to a dead environment, and the acoustic design of the control room is performance certified. A few client amenities include 5' x 6' large screen Thomson TVPI projection system visible from anywhere in the control room, and audio control from either control room for sync sound shoots in the Insert Stage which is positioned between the two audio studios.
Direction: Crawford Post Production is mainly a post house for film and video specializing in high-quality audio production for those two mediums. Currently in production, though, is an album project for Geffen Records.

**** CREATIVE WORKSHOP I and II
2804/06 Azalea Place, Nashville, TN 37204
(615) 385-0670
Owner: Buzz Cason
Studio Manager: Richard Carpenter

**** CRESCENDO AUDIO PRODUCTIONS, INC.
also REMOTE RECORDING
#707 Calle Constitucion, Puerto Nuevo, Puerto Rico 00920
(809) 792-1970
Owner: Brooke F. Cadwallader
Studio Manager: Maya Acciaro
Engineers: Chief: Alan Manger
Dimensions of Studios: Studio A: 50 x 40 x 20, Studio B: 29 x 23 x 20.
Dimensions of Control Rooms: 22 x 24 x 14.
Tape Recorders: MCI JH-24 track transformerless, MCI JH 110B



2 track, MCI JH 110B 4 track; Ampex 440 2 track; Scully 280B 4 track; Revox B77 2 track; Studer A80RC 1/4" 2 track.
Mixing Consoles: MCI 528B 28 in x 24 out; Spectra Sonics 1024 24 in x 24 out.
Monitor Amplifiers: Crown M-600, McIntosh MC2120.
Monitor Speakers: UREI 813, UREI 811, Big Reds, Auratone, Ed Long, Yamaha NS 10M.
Echo, Reverb, and Delay Systems: Ecoplates, AKG BX10, Lexicon 224XL.
Other Outboard Equipment: Eventide H-949; DeltaLab DL-2 Acousticcomputer; dbx 165 compressor/limiter; dbx 160 compressor/limiter; Valley People Gan Brain II; Valley People Kepex II; Valley People Dyamite 410; Ashly SC-68 parametric notch filter; Dolby B 24 trk; Dolby 2 trk; UREI 964 digital metronome; MCI time code.
Microphones: Neumann U67, U48, U47 FET, U89, Sennheiser 406; 416, 421, 441; AKG 414, C406, Beyer M-500; Shure SM-57; E-V RE20; RCA 77D, BK5, 44, AKG 451.
Instruments Available: 9' grand piano, marimba, vibes, Fender bass, Roland guitar synthesizer, Yamaha, Oberheim, Crumar synthesizers, Fender Twin Reverbs, Les Paul Gibson, Fender Bassman, Yamaha bass amp, Fender Rhodes 88 Electric piano.
Video Equipment & Services: Magna-Tech 16-35 mm Xenon lamp projector; Sony BVU-200 U-Matic videotape recorder; Advent large screen & Sony Trinitron monitors; Magna-Tech high speed film mixing system; Audio Kinetics Q-Lock 310-3 Time Code Computer; Off Line Editing.
Rates: Available upon request.



CRESCENDO AUDIO PRODUCTIONS, INC.
Puerto Nuevo, Puerto Rico

**** CRESCENDO RECORDERS
125 Simpson St., Atlanta, GA 30313
(404) 223-0108
Owner: William J. Ray
Studio Manager: Gary W. Ham
Engineers: Gary W. Ham, Senior Engineer; Thom Kidd, Engineer.
Dimensions of Studios: A: 41 x 28; B: 18 x 13.
Dimensions of Control Rooms: A: 22 x 18; B: 14 x 9.
Tape Recorders: Otari MTR-90 24 track, Studer A80VU Mark III 24 track, (2) Otari MTR-10 2 track, Otari MTR-10 4 track, dbx 700 Digital Audio 2 track.
Mixing Consoles: Harrison 3232 w/Automation 32/32, Soundcraft 2400 24/24 out, 40 input mixing.
Monitor Amplifiers: Crest 4001s, 3500s, 3000s, 2500s.
Monitor Speakers: JBL 4313B, 4411, Toa Cubes, Westlake TM-1, Yamaha NS-10.
Echo, Reverb, & Delay Systems: EMT 140, Lexicon 200, 2 live chambers, Master-Room Plate Synthesizer, DeltaLab 1024, 512, Compuelectron, Roland DDL, Lexicon Prime Time, Marshall Time Modulator.

Microphones: AKG, Neumann, Sennheiser, Shure, Sony, RCA, Beyer
Instruments Available: Bosendorfer grand piano, Gretsch drums, Hammond B-3 organ w/Leslie.
Rates: \$125.00 Studio A, \$90.00 Studio B.



CRESCENDO RECORDERS
Atlanta, GA

**** CRITERIA RECORDING CO., INC./
CRITERIA VIDEO SERVICES, INC.
also REMOTE RECORDING
1755 N.E. 149th St., Miami, FL 33181
(305) 947-5611
Owner: Mack Emerman
Studio Manager: Marjorie Curry

**** DATATRAK RECORDINGS & PRODUCTIONS
121 Brynn Marr Road, Jacksonville, NC 28540
(919) 353-7776
Owner: Fred C. Mosbey III
Studio Manager: Walter McCreary/Obryan Burnett

**** DAWN RECORDS, INC.
also REMOTE RECORDING
56 Ravenscroft Dr., Asheville, NC 28801
(704) 254-8000
Owner: Richard A. McBrayer
Studio Manager: Eric Wilson

**** D.I.Y. RECORDING, INC.
361 W. Main, Hendersonville, TN 37075
(615) 822-5648
Owner: DIY Recording Inc.
Studio Manager: Ted Wilson
Engineers: Ron Fairchild, Ted Wilson, John Stuecker.
Tape Recorders: MCI JH24 24 track, Revox PR99 2 track, TEAC A-3300 SX 1/4 track, Sony Laseramphous TC-FX5CS-F cassette, Sony PCM 70, ES digital 2 track, Sony Beta Hi-Fi digital 2 track.
Mixing Consoles: MCI JH 636-GO 28 x 24.
Monitor Amplifiers: Yamaha P2200, Crown DC-150 (2).
Monitor Speakers: Yamaha NS 1000, EAW MS-50, Yamaha NS10M.
Echo, Reverb, and Delay Systems: Lawson 8' plate w/remote, MXR 01 digital reverb, Yamaha R1000 digital reverb, Roland SDE-3000 delay, Super Prime Time, DeltaLab, DL4 Delay.
Other Outboard Equipment: Kepex, Audioarts parametric EQ, dbx 163 limiters, Altec tube limiters, MXR graphic EQ.
Microphones: Neumann U87; AKG 414s, 451, D1000Es; Sennheiser 441, 421s; PZMs, SM57s; Beyer M201.
Instruments Available: Kurzweil 250, Young Chang grand piano, Roland Jupiter 8, Prophet V, Minimoog, ARP 2600, ARP Odyssey, Oberheim DMX, Steinberger bass and guitar, Roland Super Jupiter, Yamaha DX7.
Rates: Upon request.

**** DOPPLER STUDIOS, INC.
1922 Piedmont Circle, N.E., Atlanta, GA 30324
(404) 873-6941
Owner: Pete Caldwell
Studio Manager: Pete Caldwell
Engineers: Bill Quinn, Chief Engineer; Joe Neil, Steve Davis, Jeff Brugger, Curt Bush, Granger Beem, Mitch Eaton.
Dimensions of Studios: A: 35 x 50 (with 2 isolation booths and live end-dead end), B: 25 x 35 (with 1 isolation booth and live end-dead end), C: 15 x 20, D: 12 x 15

Dimensions of Control Rooms: A: 15 x 25, B: 15 x 17, C: 10 x 15, D: 15 x 13.

Tape Recorders: Otari MTR-90-II 24 track; Otari MTR-10 2 track; 3M 79 24/16 track; Ampex ATR-100 2/mono; Scully 280 4/2/mono.

Mixing Consoles: Sphere Eclipse C, 40 in x 40 out; Sphere A, 28 in x 24 out; Audiotronics 110-A, 20 in x 4 out; custom, 8 in x 8 out.

Monitor Amplifiers: Crest, Yamaha.

Monitor Speakers: UREI 813, JBL 4311, Auratones.

Echo, Reverb, & Delay Systems: Lexicon 224, Lexicon Prime Time, EMT 140 plates, Eventide 1745M, Marshall Time Modulator.

Other Outboard Equipment: ADR Vocal Stressor, dbx 160, 163, 165 and UREI 1176 compressor/limiters, Kepex, Gain Brain, dbx noise reduction, Orban Parametric equalizers and de-essers.

Microphones: Neumann, AKG, Studer, Sennheiser, Shure, and E.V.

Instruments Available: Steinway grand and Baldwin baby grand pianos, Ludwig and Rogers drum sets, Hammond B-3 w/Leslie cabinet, Fender amps.

Video Equipment & Services: Video Sync with Sony 5850 3/4" VCR, BTX Shadow system, 35 mm stripe and 16 mm in 3 rooms. Layback to Sony 1" type C.

Rates: Upon request.

FANTA PROFESSIONAL SERVICES
Nashville, TN

**** **FANTA PROFESSIONAL SERVICES**
also **REMOTE RECORDING**
1213 16th Ave. S., Nashville, TN 37212
(615) 327-1731
Owner: Johnny Rosen

**** **FLACK PRODUCTIONS**
P.O. Box 100, Cedar Mt., NC, 28718
Owner: Tommy Flack
Studio Manager: Tommy Flack

**** **FLORIDA SOUND RECORDING**
3350 Ulmerton Rd., Clearwater, FL 33520
(813) 577-7113
Owner: Florida Sound Recording Inc.
Studio Manager: Paula DeStelano
Engineers: Gary Rivera & Ernie Sample

Dimensions of Studios: 18-x 22, 10 x 18 isolation room.
Dimensions of Control Rooms: A: 18 x 22, B: 18 x 12.
Tape Recorders: Studer A80 VU 24 track, Studer A80 RC 1/4"-1/2" 2 track, Studer A710 2 track, Otari MX5050 BII 2 track, Otari MX5050 4 track.
Mixing Consoles: Neve 8068 MKII 32 x 24
Monitor Amplifiers: Carver PMLS, AB-205C.
Monitor Speakers: UREI 813B, JBL 4313, Yamaha NS10M.
Echo, Reverb, and Delay Systems: Lexicon digital reverb, DeltaLab Super Time Lines.
Other Outboard Equipment: dbx 160x compressors, Neve 32264x compressors
Microphones: AKG, Shure, Sennheiser, E.V.
Instruments available: Kawai 6 ft. grand piano.
Rates: Call for rates.



FLORIDA SOUND RECORDING
Clearwater, FL

Atlanta's Heavyweight.

DOPPLER

DOPPLER STUDIOS, INC.
Atlanta, GA

**** **EMERALD SOUND STUDIO**
1033 16th Ave. So., Nashville, TN 37212
(615) 321-0511
Owner: David Malloy, Even Stevens
Studio Manager: Maggie McGuinness



FAITH PRODUCTIONS STUDIOS
Nashville, TN

**** **FAITH PRODUCTIONS STUDIOS**
1441 Guthrie Drive, Cleveland, TN 37311
(615) 472-3361 ext. 347
Owner: Church of God
Studio Manager: Mike Baker

S.S.I./TOTAL RECALL	3M DIGITAL	STUDER/ ANALOG
<p>ECHO SYSTEMS Lexicon 224-XL Digital reverb Lexicon 224 Digital reverb AMS RMX 16 Reverb System Echo plate II (2)</p> <p>DELAY SYSTEMS AMS DMX 15-80 w/3.2 sec. delay Lexicon Super Prime Time Lexicon Prime Time Lexicon PCM 42's (2) Yamaha D 1500 Dig. Delay w/MIDI</p>	<p>OTHER OUTBOARD GEAR AMS DMX Harmonizer ADR F 769 X-R Vocal Stressor (2) KEPEX II Gates (4) Scamp mini rack Scamp 526 Mini PSU Scamp 504 Para EQ (2) Scamp 525 Stereo Deesser Trident stereo limiter LA 1176 Limiters (2)</p> <p>MONITOR SYSTEM JBL 4430LR Birađial Yamaha NS10/JBL/ Auratone 4B Bryston/ Yamaha 2201-2100 & BGW Amps. White 4400 EQ</p>	<p>INSTRUMENTS FAIRLIGHT CMI II-X Yamaha DX-I & DX-7 Synth. Roland Jupiter 8 Simmons Drums (7 piece) SDS-6 Simmons Sequencer Oberheim DMX drummachine Roland TR 808 Pearl Drumset Sequential Circuits PRO-I Bösendorfer Grand Piano Hammond B3/Leslie organ Tack piano Fender Rhodes</p> <p>MICROPHONES Assortment of NEUMANN AKG, SHURE, Sennheiser NEUMANN TUBES Etc.</p>
<p>CASTLE RECORDING STUDIO INC.</p> <p>Old Hillsboro Road • Rt 11 • Franklin, TN 37064 - Tel. 615 791-0810 Telex 750471</p>		

—PAGE 82

Circle #037 on Reader Service Card

TASCAM SERIES

TEAC Professional Products Group

Factory authorized speaker
reconing and parts distributor

We are the
largest audio
and video tape
and accessory
warehouse in
Tennessee.



**Reel to reel
tape - 3M, Scotch**
all grades on
reels or hubs.

SCOTCH
RECORDING TAPE.

Cassettes, C-10 thru C-120

Leader & splicing tape

Empty reels & boxes

All widths and sizes - Competitive
prices - Bulk rates available



Home and professional sound systems.
205 Twenty-second Avenue North
Nashville, Tennessee 37203

Circle #038 on Reader Service Card

FOR JUST THE SOUND YOU WANT.

- MCI 24 Track
- SONY 701 DIGITAL
2 Track
- KURZWEIL
- YAMAHA DX-7
- ROLAND
Super Jupiter
Jupiter 8
- SEQUENTIAL CIRCUITS



THE PRODUCTION SPECIALIST

615/822-5648
361 West Main Street
Hendersonville, Tenn. 37075

Circle #039 on Reader Service Card



•••• G.E.M. Recordings
2825 Millwood Ave., Columbia, SC 29205
(803) 256-3413

Owner: Gordon R. Goodwin, Richard L. McMahan, John V. Epps
Studio Manager: John Epps

•••• GLASER SOUND STUDIOS, INC.
916 19th Ave. So., Nashville, TN 37212
(615) 327-0005
Owner: Glaser Bros.
Studio Manager: June Glaser

•••• GOLD MINE STUDIO
2020 Sunnyside Dr., Brentwood, TN 37027
(615) 373-8840
Owner: Chris Christian
Studio Manager: Richard Headen

•••• GRANITE CITY SOUND
137 Riverside Dr., Mt. Airy, NC 27030
(919) 789-9311
Owner: Roger Easter
Studio Manager: Russell Easter, Jr.

•••• GREAT CIRCLE SOUND
365 Great Circle Rd., Nashville, TN 37228
(615) 256-1763
Owner: The Benson Co.
Studio Manager: Bob Clark
Engineers: Bob Clark
Dimensions of Studios: 40 x 60
Dimensions of Control Rooms: 18 x 21
Tape Recorders: Studer A 800 24 track, MCI JH-110, Studer A710 cassette, Studer A-80 VU 1/2" 2 track Nakamichi RX-505 cassette
Mixing Consoles: MCI JH 528, 28 in x 28 out
Monitor Amplifiers: McIntosh 2300, Crown D 150, Yamaha P-2200
Monitor Speakers: UREI Time Aligned 813, Auratone SC, Technics SB-F2, Yamaha NS-10M
Echo, Reverb, & Delay Systems: Lexicon digital delay 102 Delta, EMT 240 Gold Foil, AKG BX 20, spring echo
Other Outboard Equipment: Eventide flanger, (4) UREI 1176 limiters, (2) UREI LA3A limiters, (2) dbx 160 limiters, Orban parametric EQ, Orban de-esser, Harmonizer, Kepex, Dolby, (2) ADH vocal stressors; Dimension D, SDE 3000 DDL, Korg SDD 3000 DDL
Microphones: Neumann U87, U47, KM84, Sennheiser 421, 441, AKG 414, 224E, D202, Shure SM56, 57, E-V RE16, Beyer 160
Instruments Available: Yamaha 7'4" grand piano, ARP String Ensemble, Hammond C3 organ & Leslie, Wuritzer electric piano, clavinet, Music Man bass & guitar amps, UREI bandpass filter
Rates: Available upon request

•••• HAYES RECORDING STUDIO
2406 So. MacDill Ave., Tampa, FL 33629-5999
(813) 837-6384
Owner: Paul Hayes
Studio Manager: John Uhrig
Engineers: John Uhrig, Ernie Sample
Dimensions of Studios: A 20 x 24 x 12, Isolation rooms 8 x 9 and 8 x 10
Dimensions of Control Rooms: A 20 x 15 x 9, B (production): 10 x 20
Tape Recorders: Ampex MM1200 24 track, (3) Ampex 440 B 2 track, Ampex 440 B 1 track, Ampex 440 B 8 track, Ampex ATR 700 2 track, TEAC 40-4 4 track; Studer A80HC 2 track 1/2" & 1/4", Tascam 122 cassette; Studer A710 cassette
Mixing Consoles: A Sphere A custom 24 in x 16 out, B OpAmp Labs 216 custom 12 in x 4 out
Monitor Amplifiers: Crest P3500, 2501S, Yamaha P2050, McIntosh 2105 (phones)
Monitor Speakers: E-V Sentry III, MDM4, Auratone 5C, E-V Sentry IA, JBL 4401

Echo, Reverb, & Delay Systems: BAE LP140 plate, MICMIX XL 305, Master Room III, DeltaLab DL2, Eventide H910, MXR 175, Digital time delay, MXR 174 pitch doubler DeltaLab Super Time Line ADM2048

Other Outboard Equipment: dbx 160 compressor/limiters, MXR 136 dual limiter, Orban 516EC de-esser, Audioarts 4200 parametric, ADR Vocal Stressor, 32 channels dbx NR EXR3 Exciter, UREI 539 Room EQ, Countryman direct boxes SMPTE time code available, Symetrix SG200 noise gates, Technics SP 25 turntables, Symetrix TI-101 Telephone Interface

Microphones: Neumann U87, U47 (tube), AKG 414/P48, 452EB, 451E, D202, Beyer M160N, E-V RE20, RE16, 666, Shure SM54, SM57, SM58, Sennheiser MD421, RCA 77DX, 44DX, Sony C37 (tube); Countryman 85; Wahrenbrock PZM 130

Instruments Available: Marshall & Wendall grand piano, Hammond organ w/Leslie, Deagan electric chimes, Ludwig drums w/Zildjian cymbals, Fender Champ and Twin amplifiers. Other instruments available on rental basis

Rates: Available on request. Producer packages available. Extras: Studio musicians available, full sound effects library, production music library, custom audio visual production, custom and stock jingle tracks. Ten minutes from Tampa International airport. Accommodations arranged on the Gulf of Mexico.

Direction: Established in 1959, we have become the fastest growing 24 track facility on the West Coast of Florida. We have a relaxed, hassle free atmosphere with the technical and creative support you want.



HAYES RECORDING STUDIO
Tampa, FL

•••• HILLTOP RECORDING STUDIO, INC.
902 New Due West Ave., Madison, TN 37115
(615) 865-5272

Owner: Billy Linneman, Jack & Betty Jo Linneman
Studio Manager: Betty Carpenter

•••• HMC STUDIOS
5457 Old Monroe Rd., Charlotte, NC 28212
(704) 536-0424
Owner: Nick Hice
Studio Manager: Nick Hice
Engineers: Hank Poole, Jim Brock, Doug Hawthorne
Dimensions of Studios: 50 x 50 x 23
Dimensions of Control Rooms: 13 x 28 x 10
Tape Recorders: MCI JH 114-24 w/Autolocator 24 track; Scully 280B 2 track; Aiwa cassette
Mixing Consoles: MCI 424 24/24
Monitor Amplifiers: Crown
Monitor Speakers: JBL
Echo, Reverb, and Delay Systems: EMT stereo, EMT mono, Eventide
Other Outboard Equipment: UREI and dbx limiters, Eventide phaser and flanger, Orban de-esser, Pultec EQ and filters, White 3rd octave EQ, Technics SMK10 turntable
Microphones: Neumann U87, U86, KM84, U47, Sennheiser 405, 421, Shure SM57, SM58, Electro Voice RE15, RE20, Sony ECM-50, PZM
Instruments Available: 7' Yamaha grand, Hammond B3 organ, Gretsch drums, ARP Odyssey, Axe, Hohner clavichord, Wuritzer, harpsichord, Fender Rhodes, Minimoog, Music Man, Fender amps
Rates: 24 track, \$125, 16 track, \$90, 2 track, \$55, mono, \$45. Block rates available. Please call.

•••• HUMMINGBIRD STUDIO
50 Music Sq. W., 8th Floor, Nashville, TN 37203
(615) 321-4789
Owner: Incorporated
Studio Manager: Lynn Fuston

NO DROPOUTS

Samson's "Phase-Reflex" technology solves wireless' biggest problem.



The total freedom of movement promised by wireless mic and instrument systems is a very attractive option for most modern musicians and singers. Unfortunately, the stratospheric prices of the more "professional" systems exceed their ability to eliminate problems like *drift*, *interference* and *dropouts*—so many of the most adventurous performers have gone back to messy cabling.

Samson's Broadcast Series "Phase-Reflex" Wireless System finally solves the big problem of dropouts, and other types of interference, by incorporating the most sophisticated wireless technology available into a versatile and surprisingly cost-effective package.

We've combined the most refined "true diversity" receiving system operating at a Hi-Band VHF/FM frequency range to insure full-fidelity wireless performance with no unexpected interruptions or surprises.

The system consists of a full-frequency response microphone (with a choice of the Shure SM58 Dynamic or SM85 Condenser capsule) or "belt pack" instrument/lavalier transmitter and Samson's PR-50 30 Channel FM Digital Receiver. These elements working together result in a frequency response of 20 Hz to 18 kHz, extremely low

harmonic distortion and excellent signal-to-noise specs for the strongest, most uncolored and "natural" sound possible. The system's range is a full 300 ft. under the most adverse conditions and 1500 ft. line of sight.

To offer greater performance, the Samson PR-50 receiver features an exclusive three parameter "Auto-Mute" (patent pending) function to mute off-station noise when the mic is off; a streamlined and compact 19" rack-mountable housing and balanced line outs and a line level out for recording and mixing. Samson's HT-20 microphone transmitter uses a standard 9V battery and has no protruding antenna to get in your way.

And when it comes to the *bottom line*, Samson's Broadcast Series System is priced at \$1,295 U.S. (w/Shure SM58 mic cartridge), \$2,000 less than our closest performing competitor. In fact, competitive units at twice the price don't offer all of these features. We've created the system that solves your biggest problems with wireless. The Samson Broadcast Series "Phase-Reflex" Wireless System is the first real step towards experiencing the ultimate freedom of wireless.

SAMSON®

WE TOOK THE WORRY OUT OF WIRELESS.

Samson Music Products,
124 Fulton Avenue, Hempstead, New York 11550
516 489-2203 Telex 510 222 1630

In Canada: Omnimedia Corporation Ltd.,
9653 Cote de Liesse, Dorval, Quebec H9P 1A3
514 636 9971

•••• INTERNATIONAL RECORDING STUDIO, INC.
 also REMOTE RECORDING
 McKay Circle, P.O. Box 6102, Pearl, MS 39208
 (601) 939-1111
 Owner: Jackie Thompson
 Studio Manager: Steve Stringer

•••• INTERNATIONAL SOUND
 80 NE 168 St., North Miami Beach, FL 33162
 (305) 652-0777
 Owner: Tom Pace, Jr.
 Studio Manager: Tom Pace, Jr.



ISLAND RECORDING STUDIO
 Temple Terrace, FL

•••• ISLAND RECORDING STUDIO
 6122 Liberty Ave., Temple Terrace, FL 33617
 (813) 985-1926
 Owner: Designed Computer Systems, Inc.



Studio Manager: David Artis
 Engineers: Doug Brewer, David Artis.
 Dimensions of Studios: 15 x 20 main room, drum booth 8 x 10.
 Dimensions of Control Rooms: 14 x 20.
 Tape Recorders: ACES TR-24 24 track, Otari 5050B 2 track, Scully 280 B-4 4 track, Magnecord 1024 2 track, Telex 230 Mono.
 Mixing Consoles: ACES ML32/24 28 x 24.
 Monitor Amplifiers: Crown DC-300.
 Monitor Speakers: E-V Sentry 500 in control room, E-V Sentry 1A in studio, Auratone 5C.
 Echo, Reverb, and Delay Systems: DeltaLab ADM-1024; DOD R880, Fairchild 658 Reverberation, Klark Teknik DN-780, etc.
 Other Outboard Equipment: EXR Exciter, Klark-Teknik DN 360, Furman PQ6 parametric EQ, dbx compressors, Valley People DynaMite comp/lim/noise gate etc
 Microphones: Electro-Voice, Shure, Sennheiser, AKG, RCA, Sony Electret condensers, Audio-Technica, Crown PZM, Neumann U87s
 Instruments Available: Knabe 6' grand piano, Mellotron, Electro-Pro, 9 piece Ludwig drum set, Roland Bolt 60 head, 2 Fender 2-12' cabinets with JBL, 1 Fender 2-15" with JBL, 1 Fender Bassman complete, timbales, various rhythm instruments, harmona-hose, etc.
 Video Equipment & Services: available on request.
 Rates: 24 track. \$45/hour.

•••• JAM STUDIOS, INC.
 also REMOTE RECORDING
 P.O. Box 490121, Atlanta, GA 30349
 (404) 458-6912
 Owner: John K. Adams
 Studio Manager: John K. Adams

•••• JOHN ST. JOHN AND HIS 27 TALENTED FRIENDS
 1830 NE 153rd St., N. Miami Beach, FL 33162
 (305) 945-6444
 Owner: John St. John
 Studio Manager: Lori Hope

•••• KNIGHT RECORDING STUDIO, INC.
 3116 Metairie Rd., Metairie, LA 70001
 (504) 834-5711
 Studio Manager: Traci Borges, President; Bob Lawrence, V.P.

•••• LIVE OAK SOUND RECORDERS
 808 Live Oak Dr., Chesapeake, VA 23320
 (804) 420-7442
 Owner: Live Oak Sound, Inc.
 Studio Manager: Jim Mikles
 Engineers: Jim Mikles, Steve Peppos, Mike Tremble.
 Dimensions of Studios: Main room 40 x 100 x 24(h), isolation room 10 x 20 x 12, isolation B 7 x 10 x 12.
 Dimensions of Control Rooms: 18 x 21 x 10.
 Tape Recorders: MCI JH 114 24 track, MCI JH110 2 track, Ampex/Inovonics 354/380 2 track, Sony 701ES digital 2 track.
 Mixing Consoles: Neotek 1E 36 x 24.
 Monitor Amplifiers: Hafler, BGW, Crest, Phase Linear.
 Monitor Speakers: Westlake TM 1, Altec 604, JBL 4311, Auratone.
 Echo, Reverb, and Delay Systems: Ecoplate II, MXR 01, AKG BX10, Prime Time, Electron, Ibanez.
 Other Outboard Equipment: Valley People Dyna-Mites, dbx compressors, MXR graphic EQs, Ashly parametric EQ.
 Microphones: Neuman U87s, KM84s, AKG 414s, 451; Sennheiser MD421s; Shure SM53s, SM57s, Beyer M88s, E-V 666.
 Instruments available: Yamaha C7 grand piano, Rhodes, Korg Poly-61, Simmons drums, Yamaha drums, various amps.
 Video equipment & services: Adams-Smith sync to any video format, 1", 3/4", Beta, VHS; full ADR and scoring services. Computer video editing for 1" and 3/4".
 Rates: \$85/hr block rates available. Call for details.

•••• LOFT PRODUCTIONS
 607 Chain Bridge Rd., McLean, VA 22101
 (703) 524-5631
 Owner: Charles Bogdonoff
 Studio Manager: Pam Fox

•••• LSI RECORDING
 1006-17th Ave. So., Nashville, TN 37212
 (615) 327-4565
 Owner: Pat Carter
 Studio Manager: Pat Carter
 Engineers: Danny Dunkleberger (chief engineer), Victor Caldwell, Al McGuire (independent).
 Dimensions of Studios: 29 x 20 with two isolation booths: 9 x 14 and 9 1/2 x 7 1/2.
 Dimensions of Control Rooms: 15 1/2 x 20
 Tape Recorders: MCI JH-24 24 track, Studer 1/2" & 1/4" (convertible) ABORC 2 track, Otari MTR-10 2 track, Technics (1/4 track) 1506 2 track, Nakamichi 582 cassette.
 Mixing Consoles: Harrison (modified) 4032C 32 x 32.
 Monitor Amplifiers: UREI, McIntosh, Crown, BGW.
 Monitor Speakers: UREI 813s, MDM-4s, Auratone 5-Cs, Klipsch Herseys.
 Echo, Reverb, and Delay Systems: Lexicon 224, 2 Lawson plates, Lexicon Prime-Time, DeltaLab DL-1 & DL-4, Eventide Harmonizer 910, Cooper Time Cube.
 Other Outboard Equipment: (2) dbx 160x, (2) UREI LA-3As, (2) Universal Audio 175s, ADR Vocal stessor, UREI 1176, 3 channel Orban De-Esser, UREI Digital Metronome, Pultec Tube equalizer, (2) UREI passive filters, EXR Exciter, Eventide Phaser, Harrison Autoset automation, 26 channels dbx noise reduction.
 Microphones: Neuman U87s, U47s, U67 tube, KM 84, KM 86; Sennheiser MD421s, MKH 405; AKG 414EB, D202s, D160Es, C-452EB, CK-9; Shure SM56, SM5B, 55S; Sony C500, C37P, ECM 22P, ECM 50, ECM 99, ECM 150; Electro-Voice RE15, RE 16, RE 20; Wahrenbrock PZMs; Studer SKM 5U
 Instruments available: Kawai 7'4" piano, Yamaha DX7, ARP 2600 synthesizer and keyboard, Hammond B-3 organ and Leslie cabinet, Rhodes 73 electric piano, Wurflitzer, Hohner electric clavinet D-6, Pearl drum set, Yamaha bass amp, Fender Super Reverb amp.
 Rates: call for rates.

•••• MAJESTIC SOUND STUDIO
 3800 Keith St., Cleveland City, TN 37311
 (615) 472-8200
 Owner: Church of God of Prophecy
 Studio Manager: Thomas Duncan

PLAN THE
 FUTURE SUCCESS
 OF YOUR STUDIO
 STARTING AT THE
 BOTTOM LINE.
 YOUR CONSOLE

Neve Custom 28/4/28, limiters, returns, class-A, more	\$25K
Neve 8058 Mk-I 28/16/28 many options, mint	74K
Neve 8088 Mk-II 40/32/40 Necam, custom, extras, WARRANTY	188K
Neve 8068 Mk-II 32/16/32 many options	80K
Neve Custom 30/16/24, 4-band, limiters, discreet	40K
Trident Series 80-B, 32/24/24, full patch, 1 month old	33K
Trident TSM, automated, 40/32/32, 3 years old	80K
Harrison MR-4, 36/36, 10 months old, automation, all options	63K
Harrison 4832-C, 48/32/48, autose, extras, immediate delivery	60K
BTX Softouch System, less than 1 year old	8K
2 24 Trk Dolby Systems, MH-16 & MH-8, mint	12K
MCI-428 28/24/28, automated, 5534's, gates on inputs, more	30K

Call for more: Mikes, Neve modules, Necam System, etc.



TOM SEMMES
 ASSOCIATES
 1035 Draughon Avenue • Box 40108
 Nashville, Tennessee 37204
 (615) 292-8130
 Telex 786569 TOM SEMMES NAS

Circle #041 on Reader Service Card

**** MALACO RECORDS
3023 W. Northside Dr., Jackson MS 39213
(601) 982-4522
Owner: Malaco, Inc.
Studio Manager: Wol Stephenson

**** MARK FIVE STUDIO
10 Michael Dr., Greenville, SC 29610
(803) 269-3961
Owner: Bill Huffman, Joe Huffman, Harold Huffman, Michael Burnette
Studio Manager: Eddie Howard

**** MASTERCRAFT RECORDING CORP.
437 N. Cleveland, Memphis, TN 38104
(901) 274-2100
Owner: Howard Craft
Studio Manager: James Craft



MASTER MIX
Nashville, TN

**** MASTER MIX
1808 Division St., Nashville, TN 37203
(615) 321-5970
Owner: Trio Ent. Co.
Studio Manager: Hank Williams
Engineers: Tom Brown, Chief Engineer
Dimensions of Studio: 625 square feet.
Tape Recorders: Otari MTR 90/24 tracks, MTR 10 1/2" and 1/4" machines.
Mixing Consoles: Neve/Necam II 38 & 24 x 24 early 1970's discrete with 4 band 1081 equalizers.
Monitor Amplifiers: Bryston, Halfer, Yamaha.
Monitor Speakers: 4-way, all-cone time coherent custom system by Dr. Claude Fortier with a proprietary 4 way active electronic Acoustic Align Crossover network by State of the Art Elektronik. Auratone, Rogers, Yamaha.
Echo, Reverb, and Delay Systems: EMT 250/251 - Lexicon 224XL with Larc, Super Prime Time, Eventide H-949.
Other Outboard Equipment: Compressors/limiters: ADR, dbx, Neve, Sontec, UREI, Valley People. Equalizers: ADR, Sontec, Trident.
Extras: Over-dub room, utilizing RPG Diffusion, Stereo Disk Mastening.
Direction: Master Mix features a dedicated remix room designed with a no compromise attitude. This offers the remix client the acoustic environment necessary to complete his project with less guesswork, and greater accuracy, in a pleasant environment.

**** MASTER SOUND RECORDING STUDIO
5249 Challedon Dr., Virginia Beach, VA 23462
(804) 499-0000, 496-0553
Owner: Robert Ullsh
Studio Manager: Robert Ullsh
Engineers: Robert Ullsh, Bruce Buehman, Steve Peppos.
Dimensions of Studio: 35 x 45 with two isolation rooms 10 x 12 and 10 x 8
Dimensions of Control Rooms: 20 x 22
Lounge area: 18 x 12 (approximately 2,400 total sq. ft.)
Tape Recorders: Sony/MCI JH24 24 track with auto-locator III, Tascam 85-16E, Otari MTR-12 C 1/2 track with SMPTE, 2 Tascam 52 1/2 tracks with SMPTE middle tracks, Tascam C-3RX cassette.
Mixing Consoles: Amek Angela 28 x 24 with a total of 62 returns.
Monitor Amplifiers: Acoustat Trans-Nova Twin 200 MOSFET, Kenwood Basic M-2 400 watt.
Monitor Speakers: JBL 4435s, JBL 4411s, Auratones.
Echo, Reverb, and Delay Systems: Lexicon 200 digital stereo reverb, EMT design plate reverb, Lexicon PCM-42 digital delay, Roland SDE-3000 digital delay.
Other Outboard Equipment: dbx 160x compressor-limiters,

Universal 175 tube limiter, Orban 424A stereo gated compressor/limiter, LT Sound CLX-2 stereo compressor/limiter/expander, MXR dual 2/3 octave E.Q. MXR 1/3 octave E.Q., Orni Craft GT-4 4 channel noise gate, 8 channels of 4-band sweepable parametric E.Q.
Microphones: AKG "The Tube", (5) C-414 P-48s, (3) C-451s, (2) C-452s, (1) D-12; Neumann U89; E-V RE20; (3) Sennheiser 421s, assortment of 17 dynamic mics.
Instruments Available: Yamaha 74" conservatory grand piano, 7 piece Ludwig drum set, Simmons drum set, Oberheim DMX drum synthesizer, Fender Rhodes piano, Korg Poly-6, Roland Jano-60, Prophet-5, Fender Stratocaster-Elite, Fender Precision Bass-Elite, Washburn & Tama acoustic guitars.
Video Equipment and Services: Sony U-matic 5850, Q-Lock 3.10 synchronizer, Sony 19" monitor, Q-Lock 3.1C synchronizer
Rates: 16 track \$60/hr, 24 track \$85/hr, 24 track audio/video: \$125/hr. Discounts available for block project rates.

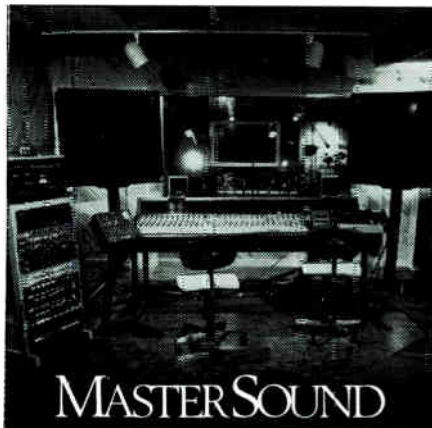

MASTER SOUND RECORDING STUDIO
Virginia Beach, VA

**** MASTER SOUND STUDIOS, INC.
also REMOTE RECORDING
1227 Spring St. N.W., Atlanta, GA 30309
(404) 873-6425
Owner: Bob Richardson
Studio Manager: Bob Richardson
Engineers: Bob Richardson, Ron Christopher, Buzz Richardson and Bret Richardson.
Dimensions of Studio: Music: 43 x 25; Production: 10 x 10.
Dimensions of Control Rooms: Music: 23 x 25; Production: 10 x 10.
Tape Recorders: (2) MCI JH-114 24 track, MCI JH-110 1/2" 2 track, (4) MCI JH-110 1/4" 2 tracks; (2) Ampex AG 440B 2 track, (2) Ampex AG 440B mono's; MCI JH-110B 1/2" 2 track mastering.
Mixing Consoles: SSL 4000E 40 in x 32 buss out - full automation plus total recall; Audiotronics 110B, 20 in x 4 out.
Monitor Amplifiers: BGW 250, 500; Crown D150, 300.
Monitor Speakers: Audicon-custom; JBL 4313, Auratones.
Echo, Reverb, & Delay Systems: EMT 140 mono and stereo, Lexicon 224, Lexicon 102; Marshall, Eventide, ADR.
Other Outboard Equipment: dbx 165, 160, UREI LA2, LA3, 1176; ADR limiters; Pultec; Orban EQ; ADR Vocal Stresser; Orban de-esser.
Microphones: Neumann U64, U68, U47, U47 FET, KM86, KM88, U86, U87, M49; AKG 414, C60, C61, 202; Shure (all types); E-V (all types); Schoeps (all types), Sony C37, ECM50; RCA 77DX; Sennheiser (all types); Altec; Telefunken; others.
Instruments Available: Baldwin 9' concert grand, Steinway 7' grand, Rhodes 7' stage, Hammond B-3 organ, Slingerland drums, Musser vibes, Ork bells, percussion kit, effects kit, Fender, Ampeg and Music Man amps.
Video Equipment & Services: MCI JH45 audio/video sync lock; Sony VP-1000 3/4" U-Matic; (2) Panasonic 19" color monitors. BTX Softouch Synchronizer, Sony BVU 8500 VCR.
Rates: On request.

**** MASTER TRACK STUDIOS
426 Bradford Dr., Jackson, MS 39208
(601) 956-8226
Owner: Rick Garner
Studio Manager: Randy Everett
Engineers: Rick Garner and Randy Everett
Dimensions of Studio: 34 x 24 x 17; 12 x 14 x 8 iso.; 8 x 12 iso.
Dimensions of Control Rooms: 22 x 22 x 12.
Tape Recorders: Stephens 821A-24 24 & 16 track, Scully 280B



Send For Your Free Copy Of This Brochure Before You Have Any More Cassettes Duplicated

You really owe it yourself and to your budget to find out how competitive Eva-Tone can be on your next audio cassette order.

We're the people who've been producing high quality, low cost Soundsheets for more than 20 years. Now we've added high speed, high quality audio cassette duplication to our line, along with custom printing, complete mailing services -- even computer list maintenance for qualified customers.

Your copy of "Cassette Talk" has everything you need to know to help you make an ordering decision. Information on tape, shells, labeling, shrink wrapping and pricing. And of course you can call or write your Eva-Tone representative for answers to any other question you may have.

If you want an answer faster than through the mail, call us toll-free at 1-800-EVA-TONE. (In Florida call 813-577-7000.) You're going to like what you hear.

TELL ME MORE ABOUT EVA-TONE:

Cassettes Soundsheets Printing Mailing

NAME: _____ TITLE: _____

ORGANIZATION: _____

ADDRESS: _____

CITY/STATE/ZIP: _____ PHONE: _____

MAIL TO:

EVA-TONE 4801 ULMERTON RD. / P.O. BOX 7020
CLEARWATER, FLORIDA 33518-7020

MIX - 3/85

Circle #042 on Reader Service Card

2 track, Nakamichi 550 cassette, Pioneer CT-F800 cassette
Mixing Consoles: Sphere Eclipse A 28 x 24
Monitor Amplifiers: BGW, Crown, Yamaha
Monitor Speakers: JBL 4320, 4311 and Auratones
Echo, Reverb, & Delay Systems: Ursa Major Space Station, Lexicon Delta T, Lexicon Prime Time, EMT 262 Plate, Eventide 1745 M DDL pitch transposer, Orban 111 B
Other Outboard Equipment: (2) UREI 1176LN, (2) LA 3A, (2) dbx 160 comp, (2) dbx 163, UREI digital metronome, EXH Exciter, 28 channels dbx noise reduction, MXR pitch transposer, MXH graphic EQ, Moog parametric EQ, Oberheim DX digital drummer
Microphones: (4) Neumann U87, (8) Senn 421, (2) Senn 441, E V RE20, AKG D12E, 452, 422, 414, D1000E, Shure SM57, 58 (all others available)
Instruments Available: Juno 60, Korg MS 20 Helpinstill piano, Rhodes elec, Gibson ES Artist Fender Strat Fender Precision Bass, Fender Jazznaster, Marshall 100W amp Fender Super Reverb, MXH effects rack Tomi Scholz Hockman amp, MXH Omni effects
Video Equipment & Services: available upon request
Rates: 24 track \$60/hr 16 track \$55/hr

**** MEGA SOUND STUDIO
 also REMOTE RECORDING
 P.O. Box 189, Main St., Bailey, NC 27807
 (919) 235-3362

Owner: Lam Recording Co., Inc
Studio Manager: Richard H. Royall, President
Engineers: Johnny Falcone, Richard H. Royall, Daniel H. Dixon
Dimensions of Studios: 18 x 30
Dimensions of Control Rooms: 12 x 18
Tape Recorders: MCI JH 114 24 Autolocator III 24 track, Scully 280B 2 track, Revox A 77 2 track, Revox A 77 1/2 track, Sony & Nakamichi cassettes
Mixing Consoles: MCI 400 Series, 24 in. x 24 out
Monitor Amplifiers: Crown, McIntosh, Phase Linear, Yamaha
Monitor Speakers: Bi-amplified JBL, and Auratone reference monitors
Echo, Reverb, & Delay Systems: AKG BX 20, DeltaLab DL2, Lexicon Prime Time, Eventide Harmonizer H910, Eventide Instant Flanger
Other Outboard Equipment: 24 channels of dbx noise reduction, dbx 187 noise reduction on mixdown, dbx & UREI compressor/limiters, Ashly parametric EQ, UREI 529 1/2 octave EQs, DI boxes with Jensen transformers, Eventide audio analyzer with Apple II 32K computer
Microphones: AKG, E V Neumann, HCA, Sennheiser, Shure, Sony
Instruments Available: Yamaha conservatory grand piano, Hammond B-3 organ, Fender Precision bass guitar, Fender Rhodes electric piano, Pearl drum kit with symbols by Paiste and Zildjian, Yamaha CS 60 B voice polyphonic synthesizer, Sequential Circuits Pro One monophonic synthesizer, Roland Juno 60 polyphonic synthesizer, Yamaha acoustic guitars
Video Equipment & Services: Full video production services in association with Diversified Media Equipment, JVC, Sony, Panasonic and Datamax computer animation
Rates: Write or call for rate card



MIAMI SOUND STUDIO
 Miami, FL

**** MIAMI SOUND STUDIO
 697 N.W. 28 St. Miami, FL 33127
 (305) 635-4890

Owner: Carlos and Arque Diaz Gratacos
Studio Manager: Arque Diaz Gratacos
Engineers: Carlos Diaz Gratacos, Jr., Paul Khoury
Dimensions of Studios: 17 1/2 x 13 1/4 x 28
Dimensions of Control Rooms: 17 x 10 x 15
Tape Recorders: Studer A-80 24 track, Ampex 440 B 2 track, Scully 2-80 24 track, Studer/Revox 77 2 track
Mixing Consoles: Neve 802B 24 x 16 24



Monitor Amplifiers: McIntosh 2300, 2105, 255
Monitor Speakers: JBL 4343 (Gauss) JBL 4311, Auratone, SC Tannoy, Fostex
Echo, Reverb, & Delay Systems: Echo delay tape, (2) EMT 140 echo chambers, Lexicon digital reverb 200, Lexicon prime time 93
Other Outboard Equipment: Eventide Harmonizer, Scamp Hack, UREI Teletronix LA2A limiters, LA3A limiters, Pultec equalizers/compressors, Neve limiters/vocal doubler, Electra digital delay, Roland phase shifter, Roland stereo flanger, Simmons Clap Trap, LinnDrum, Simmons electronic drums, Roland Dimension D
Microphones: Neumann U87s, U67s, KM84s, AKG 451, E V RE 20, Sennheiser, Shure 57, Sony C-37P, HCA 77-DX, RCA 44
Instruments Available: Yamaha grand piano, Fender Rhodes, Roland synthesizer, Rhythm Box harmonizer, Slingerland drums, Syriate, Hammond B3
Rates: Rates upon request
Direction: Studio philosophy: simply that our engineers strive to treat every recording as if it were their own aspiration, to be categorized as a hit making quality studio. Logo: "We've got the sound you want"

**** MOBILE AUDIO
 only REMOTE RECORDING
 P.O. Box 6115, Rome, GA 30161
 (404) 232-7844

Owner: Rick Norvell, burgett Mooney
Studio Manager: Rick Norvell
Engineers: Al Craig, Kevin Burgart, Client independents
 welcom.ed
Dimensions of Studios: 45' air ride trailer
Dimensions of Control Rooms: 20' x 8'3"
Tape Recorders: (2) Otari MTR-90 II 24 or 46 track, MTR 12 1/2" 2 track, MTR 10 4 track, Sony #1CFX 1010 cassette
Mixing Consoles: Sound Workshop Series 34 balanced and transformerless 36 in x 24 out audio console
Monitor Amplifiers: Haller DH500s, Haller DH220s
Monitor Speakers: (2) Fostex LS3Bs, (2) Electro-Voice 100As, Auratone 5Cs
Echo, Reverb, & Delay Systems: Lexicon 200 digital reverb unit
Other Outboard Equipment: Valley People 430 stereo Dyna Mite unit, Valley People HH 2x2 level matching interfaces units with rack mount, dbx 160 X limiters, Audioarts 4200A stereo parametric equalizers, any additional outboard gear patched in upon request
Microphones: Countryman FE1 direct boxes, AKG 414s/EB/P48 with combination shock mount, 460Bs combination, with capsule swivels, D12Es, 125Es, Beyer M260s, M201s, Sennheiser MD421s, MD431s, MD441Us, Shure SM81s, SM57s, Sony ECM 50PSWs, KM86Bs, KMS84Bs, and all necessary assorted beyer stands and heavy duty booms
Video Equipment & Services: Panasonic 3400 camera and power supply, (3) Panasonic, BTS 1900N color monitors, 300' video snake, (2) 150' cables, BTX Softouch System for two machines including Shadow synchronizer, Cypher SMPTE generator/reader plus front panel, video character inserter, patch bay for video interface
Rates: Quoted on a job to job basis. Please call for quote within your budget demands
Extras: Luxurious lounge for audio/video monitoring, overdubbing producer/directors' office, general clientele hang-out area. Lounge is prepared for unlimited equipment possibilities. Any and all required equipment available upon request
Direction: Mobile Audio's direction is to continue forward with excellent workmanship and new friendships based on our 1984 Client Credits consisting of Prince Revolution Tour 84/85, C B N Network Special, The Newport Jazz Festival, Kris Kristofferson, Jerry Jett Walker, Woody Herman PBS Special, B.B. King, Tony Carey, Dwight Twilley, The Judds, Earl Thomas Conley, DJH Broadway (King Biscuit Flower Hour), Auburn, University Album Project, Jerry Reed, and much much more upon request

**** MONARCH SOUND, INC.
 also REMOTE RECORDING
 7 Roswell St., P.O.B. 228, Alpharetta, GA 30201
 (404) 475-4533

Owner: Phil Benton, Paul Davis, Joel Katz
Studio Manager: David Pensado
Engineers: David Pensado
Tape Recorders: Otari MTR-90 24 track; Ampex MM1100 16 track, 440-B 4/2 track
Mixing Consoles: Electrodyne 16/8/2, Trackside Engr. 8/24/2
Monitor Amplifiers: AB, Crown, BGW
Monitor Speakers: Les Duncan, JBL 4333A, MDM 4, Eastern Acoustic, ROR, Auratone, Yamaha, Phase Linear
Echo, Reverb, & Delay Systems: Lexicon 224, Ursa Major, Lexicon PCM 42, live room
Other Outboard Equipment: Harmonizers H949 & 910, dbx limiters 165-160, noise reduction for all machines, Chorus Echo-2, B gates, Lacy Thompson CLX-2 ltn/compress/de-ess/duck/exp, Orban, Audioarts, Sphere, API, Orange County, UREI filters, Time Cube
Microphones: AKG, Neumann, Shure, E V, Sennheiser
Instruments Available: Synclavier II, Prophet 5, Linn, Simmons, Jupiter 8, Yamaha elec grand, Rhodes, Wuritzer, Ovalton, Tele, Martin, Les Paul Marshalls, Fender Twin & Super, Peavey artist
Video Equipment & Services: 1/2" record or monitor
Rates: Call for rates

**** MORRISOUND RECORDING INC.
 also REMOTE RECORDING
 5120 N. Florida Ave., Tampa, FL 33603
 (813) 238-0226

Owner: Morrisound Recording Inc
Studio Manager: Tom and Laurel Morris
Dimensions of Studios: A 22 x 24; B designed for voiceover and production
Dimensions of Control Rooms: A 22 x 18; B 13 x 6
Tape Recorders: Otari MTR-90 24 track, Otari 5050 1/2" 8 track, (2) Otari 5050B 2 tracks, Denon cassette decks (4), Otari MTR 12 1/2" 2 track
Mixing Consoles: Sound Workshop Series 34 w/automation 32 in x 24 out, Soundcraft 400B 16 x 8 x 4 x 2
Monitor Amplifiers: Haller
Monitor Speakers: UREI 811A, UREI 813B, JBL 4312s, EAW M550s, Auratones, E V Sentry 100s
Echo, Reverb, & Delay Systems: Lexicon 224 digital reverb, Master Room, Eventide Harmonizer, DeltaLab DL 4 digital delay and DL 5 Harmonocomputer, Loft analog delay/flanger
Other Outboard Equipment: dbx 165s, Valley People Dyna-mites, Omni Craft noise gates, EXH exciter, dbx noise reduction, Audioarts parametrics, LAU compressor/limiter, individual musician controlled 8 channel headphone mixers
Microphones: Neumann U87s, AKG 414, 45s, E V RE20s, Sennheiser 441s, 421s, Shure SM57s, Audio Technica ATM 10, 11, 31s 41s
Instruments Available: Yamaha grand piano, Fender, Rhodes, Hammond C3 w/Leslie, Gretsch drum kit, Fender, Lab and Roland guitar amps
Video Equipment & Services: BTX Shadow system for film and video scoring and sweetening
Rates: Please call for rates

**** MUSCLE SHOALS SOUND STUDIOS, INC.
 1000 Alabama Ave., Sheffield, AL 35660
 (205) 381-2060
Owner: Johnson Hawkins, Hood, Becking
Studio Manager: David Hood for bookings

**** THE MUSICAL MOON
 1105 E. Lafayette St., P.O. Box 1717
 Tallahassee, FL 32302
 (904) 681-0704
Owner: Scott S. Carswell
Studio Manager: Chris Pieser

**** MUSIC CITY MUSIC HALL
 30 Music Square West, Nashville, TN 37203
 (615) 255-9084 studio; 244-1060 office
Owner: Owen Bradley
Studio Manager: Cecile Light
Engineers: Bill Harris, Doug Crider
Dimensions of Studio: 50 x 80 x 30 with walls up, 50 x 40 x 30 with walls down
Dimensions of Control Rooms: 28 x 18 x 10
Tape Recorders: Studer A-80 24 track, Studer A-80 Master Recorder 2 track, Studer B67 2 track, Ampex AG-440 4 track, Studer B710 cassette recorder
Mixing Consoles: Neve 8038, 32 in x 24 out w/Allison Research Fader Automation
Monitor Amplifiers: McIntosh 2100s
Monitor Speakers: UREI 813s, JBL 4313s, Auratones
Echo, Reverb, & Delay Systems: Lexicon 224XL, (3) EMT plates, Gotham Audio digital delay, Eventide Harmonizer, Cooper Time Cube
Other Outboard Equipment: Two ADH Vocal Stressers; Scamp rack, Teletronix compressors, LA 2A, LA 3A limiters, BTX synchronizer & generator (32 tracks to 40 tracks possible), EXH Exciter, Dolby noise reduction, Eventide Phaser
Microphones: Neumann U87s, U67s, U47s, U48s, M49s, KM84s, KM56s, E V RE16s, RE20, Sony ECM50s, C500s, C55s; HCA 44s, 77s, ELA 251s, AKG 414, 105 mikes total

Instruments Available: Baldwin 9' grand, Hohner D-6 clavinet, stereo Fender Rhodes, Wurlitzer electric piano, Celeste, Zucker electric harpsichord, Deagan vibes, mamba, Hammond organ with B-3 Leslie, Yamaha PF15 Electronic piano.
Rates: Available upon request

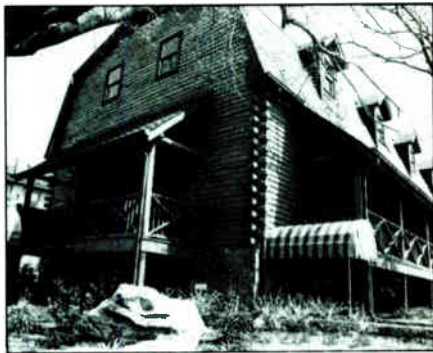

MUSIC MILL
Nashville, TN

♦♦♦♦ **MUSIC MILL**
 1710 Roy Acuff Pl., Nashville, TN 37203
 (615) 254-5925
Owner: Harold Shedd/Donny Canada
Studio Manager: Paul Goldberg
Engineers: Jim Cotten, Chief Engineer, Paul Goldberg, Joe Scaife, George Clinton
Dimensions of Studios: 27 x 30 (drum, piano, and vocal iso booths)
Dimensions of Control Rooms: 22 x 14 main, 22 x 14 mix room (vocal O.D. booth)
Tape Recorders: Studer (2) A-800 24 track, Studer (2) A-800RC 1/2" 2 track; Studer (3) B-67 1/4" 2 track; Studer A-710 cassette.
Mixing Consoles: Trident TSM Allison/Fadex automation 32 in x 24 out; Trident TSM Allison/Fadex automation 28 in x 24 out
Monitor Amplifiers: McIntosh 2300, BGW 750 C, BGW 500B, BGW 250.
Monitor Speakers: Auratone Super Reds w/Master Lab cross overs, JBL 4430, Auratone S.C., White 4320 EQ, Yamaha NS-10M.
Echo, Reverb, & Delay Systems: (2) EMT 140, (2) BAE 1-140, Lexicon PCM 41, Lexicon Prime Time, Eventide Harmonizer, Lexicon 224x with LARC
Other Outboard Equipment: Scamp F300 expander gates, Scamp de-essers, Eventide Harmonizer, dbx 160X compressor/limiter, ADR Vocal Stresser, UREI LA 3A, UREI LA 2A, Orban de-esser, Omni Craft GT 4 noise gates, Kepex II, Marshall Tape Eliminator, Aphex Aural Exciter Type B
Microphones: Neumann U67, U87, U47, KM84, KM88, E V RE16, RE15, RE20, Sennheiser MD421, Studer SKM5, Shure SM56, SM57, SM81, AKG 452ER, 414EB, C460B, RCA 77DX, Beyer M101; Sony ECM30, Lawson PZM, Sanken CU41
Instruments Available: Yamaha 57" grand piano, Fender Rhodes 88, Wurlitzer electric piano, guitar and bass amps, full Pearl drum kit, "Dync My Piano" custom built piano with Tri Stereo Chorus
Rates: Call

**Find
it
in
MIX
CLASSIFIEDS**
See Page 159...

Soundcraft

DeltaLab
CompuEFFECTRON

OTARI

BIG DISCOUNTS

150 PRODUCT LINES FOR THE PROFESSIONAL
 TAPE RECORDERS • MIXERS • AMPLIFIERS • TURNTABLES • SIGNAL PROCESSING
 MICS • TAPE • CASSETTES • TEST EQUIPMENT • SPEAKERS • HEADPHONES • INTERCOMS

FULL COMPASS SYSTEMS

6729 SEYBOLD RD., MADISON, WI 53719-1393

**TOLL FREE IN ALL
50 STATES**
1 (800) 356-5844
IN WISCONSIN
1 (800) 362-5445
LOCAL (608) 271-1100

Circle #043 on Reader Service Card

Optimize — don't compromise:

**If you demand optimum performance from
your tape recording equipment . . .
you need our services!**

JRF maintains a complete lab facility insuring precision relapping and optical alignment of all magnetic recording heads and assemblies. Worn unservicable heads can be restored to original performance specifications. 24-hour and special weekend service available.

- Broadcasting
 - Mastering
 - Recording Studios
 - Tape Duplicating

New and reconditioned replacement heads from mono to 24-track . . . Many in stock.

For repair or replacement, we're at your service!

Call or write.

JRF/Magnetic Sciences, Inc.
 101 LANDING ROAD, LANDING, NJ 07850 • 201/398-7426

Circle #044 on Reader Service Card



MUSIC WORKSHOP
Hapeville, GA

◆◆◆ **MUSIC WORKSHOP**
601 North Central Ave., Hapeville, GA 30354
(404) 761-6631
Owner: C A Venable, Jr
Studio Manager: C A. Venable, Jr.
Engineers: C A. Venable Jr., Rick Brown, Annette C. Venable, Alan Swain, Ted Stovall
Dimensions of Studios: 25 x 40
Dimensions of Control Rooms: 20 x 20
Tape Recorders: Ampex 1200 24 track, Ampex ATR 800 2 track, Scully 280 2 track, Studer cassette
Mixing Consoles: Flockinger Mod 24 24/24
Monitor Amplifiers: Crown, Yamaha, White EQ and crossovers.
Monitor Speakers: JBL 434.3, Auratones
Echo, Reverb, & Delay Systems: Live echo chamber, AKG B12E plate reverb, Lexicon 224X with LARC, Lexicon Super Prime Time, Lexicon Prime Time, Eventide Harmonizer, others available upon request.
Other Outboard Equipment: UREI 1176s, dbx 16Cs and 165s, Allson noise gates, Kepexes, Gain Brains.
Microphones: Neumann tube U48s and U47s, 87s, 89s; Telefunken tube U48; AKG tube C60, D12E, C414EB, Sennheiser, RCA; Milab, Sony; Beyer; Shure; Audio-Technica, PZM, E-V RE20.
Instruments Available: Knabe 9' concert grand piano, Linn-Drum (programmer available), guitar amplifiers: Mesa Boogie, Music Man, Fender, Ampex, Marshall; Roland guitar synthesizer, Hammond B3 with Leslie, Ludwig studio kit.
Rates: Call or write for brochure
Extras: Fresh orange juice and spring water.
Direction: Recent projects include Shirley Finney, Berte Higgins, The Visitors, Sentimental Journey Orchestra, Bobby Carmichael, Mose Davis, Kodac Harrison, Bobby Whitlock, Bernadine Mitchell and Chaunkee

◆◆◆ **MYSTERIOUS STUDIO**
2750 N.W. 56 Ave., Suite 404,
Lauderhill, FL 33313
(305) 486-9212
Owner: K&L Production
Studio Manager: Leonard Williams

◆◆◆ **NEW AGE SIGHT & SOUND**
Suite 164, 120 Interstate North Parkway East,
Atlanta, GA 30339
(404) 956-7956
Owner: Media Associates, Ltd., William Allgood, President.
Engineers: William Allgood, Dean Gleason, Greg Turner, Independent.
Dimensions of Studios: Studio A: 40 x 50; Studio B: 14 x 17; Video shares Studio A.
Dimensions of Control Rooms: Control Room A: 20 x 23 (LEDE type); Control Room B: 14 x 12; Video Control-Editing, 14 x 16.
Tape Recorders: MCI JH-24 w/Autolocator III 24 track, MCI IH-110 B 2 (1/4" 1/2" mastering), Sony 854-4 4 (1/4" track), Digital Sony 3324, w/Autolocator RM3300 24 track, Sony 1610 2-track processor, Sony F-1 2-track processor.
Mixing Consoles: Studio A - Sound Workshop Series 34 50 inputs, 48 automated 50 x 24 x 48, Studio B - Sound Workshop Series 34 28 inputs 28 x 24, Video - Sound Workshop Logex 8 12 x 8, Remote - Panasonic WR-500 10 x 2.
Monitor Amplifiers: (2) Hafler DH-220, (2) Hafler P 500, (3) Hafler P220.
Monitor Speakers: UREI 613B, JBL 4430, Tannoy SRM-15X, Electro-Voice Sentry 100, Auratone 5C, Magneplanar, JBL 4411.
Echo, Reverb, and Delay Systems: Lexicon 224x w/LARC, Klark Teknik DN 780 digital reverb, Orban 111 B, Lexicon Prime Time II.
Other Outboard Equipment: (2) dbx 165A comp. limiters; (4) Gain-Brain II; (6) Kepex II, Eventide 969 Harmonizer, White 4400 and Vector Research 100m EQ, BTX synchronizer system



Microphones: Neumann U87, KM84, SM2, AKG 414-EB, Crown 30GP PZM, Sennheiser 421U, Electro-Voice RE-20, Shure SM-57, Sony C35-P, ECM 22-P, ECM 30 (35 microphones, total)

Instruments Available: Steinway 9' Model D, Yamaha DX7, Minimoog, Oberheim X-pander, Rhodes electric piano, Sequential Circuits drum machine.

Video Equipment & Services: Ampex VPR 2 1" recorder, (2) JVC CR8250U 3/4" edit recorders, JVC CR 6650U 3/4" recorder, Sony BVU 800 DA 3/4" edit recorder, Panasonic NV8500 professional VHS 1/2" edit recorder, IVC 2650U 1/2" VHS recorder, Sony SL-2000 1/2" Beta recorder, (3) Sony M3 three-tube cameras, JVC KM-2000 3-buss switcher w/chroma-key, Convergence/JVC VE-92 editor w/time code, Symtec PGS III computer character/graphics generator; Sony, Panasonic, NEC monitors.

Rates: Please call or write for rates — variable with digital, analog, studio, etc



NEW RIVER STUDIOS, INC.
Fort Lauderdale, FL

◆◆◆ **NEW RIVER STUDIOS, INC.**
also REMOTE RECORDING
408 S. Andrews Ave., Fort Lauderdale, FL 33301
(305) 524-4000/Miami 947-9393
Owner: New River Productions, Inc
Studio Manager: Virginia Cayia
Engineers: Chief: Ted Stein. Maintenance: Dale Peterson. Independent: Steve Klein, Peter Yianilos, Dennis Hetzendorfer, Eric Schilling.
Dimensions of Studios: 36 x 22 w/ceilings of 18 & 13, Iso Booth: 9 x 12.
Dimensions of Control Rooms: 24 x 20
Tape Recorders: (2) Studer A800 Mark III 24 track; (2) Studer A80 1/2" & 1/4" 2 track; (2) Studer B710 cassettes; Studer/Revox B77 2 track.
Mixing Consoles: Neve 8108 w/Necam 96 56 in x 48 out.
Monitor Amplifiers: Acoustat TNT200
Monitor Speakers: UREI 813 B Main Monitors, JBL 4311s, JBL 4430s, Auratone 5Cs, Yamaha NS10s.
Echo, Reverb, & Delay Systems: EMT 251 digital reverb, EMT 140 Plate, (2) Lexicon 42 digital delays, AMS RMX-16 digital reverb
Other Outboard Equipment: (2) Eventide H949 Harmonizers, Eventide H910 Harmonizer, Dolby SP48 noise reductions, Dolby 361s, Lexicon Super Prime Time, (Scamp rack with Dynamic noise filters, Auto Panner, Time Shaper, De-esser, parametric equalizer, gates, scamp compressor/limiter) dbx 165 compressor/limiter, dbx 162 compressor/limiter, Teletronix LA2As, ADR Vocal Stressor, Neve compressor/limiter, Kepex II equalizers and Gain Brain.
Microphones: Neumann M49, U87, U89, U47, KM86, KM84; AKG 414, D12, D19; Beyer M88, M101; Schoeps CMTS 501, MK4; Sennheiser MD421U; Shure SM57, SM81; Sony C37P; Crown PZM30; Electro-Voice RE20, 666, Countryman Isomax Pro H.

Instruments Available: Yamaha C7D 7'4" grand piano, Dyno My, Fender Rhodes 73, Hammond B3 Organ & Leslie, Micro Moog & Arp 2600, Sonor Drum Kit, Music Man 112RD amp, Mesa Boogie amp, Ampeg B15 bass amp, Yamaha A4115 keyboard amp.

Video Equipment & Services: JVC 3/4" Umatc VCR, JVC 2082 monitors, w/O Lock 3.10 synchronizer

Rates: Available upon request Block bookings available All equipment included in rates.

Extras: Private lounge with kitchen, telephone room, conference & listening room Boat dockage outside studio, home cooking, Location recording available through our association with Artisan Recorders dual 24 track mobile truck

Direction: We are a full service facility, able to arrange discounted rates for housing, car & boat rentals, transportation, etc. Only minutes from beach, near 3 international airports, walking distance to fine restaurants, shops & hotels. The studio is located in historical Mediterranean style village in heart of Fort Lauderdale's yachting community. Credits include Cyndi Lauper, Ahmed Jamal, INXS, Bellamy Brothers, Dion, Miami Sound Machine, Rudy, Carnival Cruise Lines, Marc Araman Music, Norwegian Cruise Lines, Eastern Air Lines.

◆◆◆ **OAK VALLEY SOUND**
105 Oak Valley Dr., Nashville, TN 37207
(615) 227-9404

Owner: Henry Slaughter
Studio Manager: Fred Cameron

◆◆◆ **OCHOA RECORDING**
also REMOTE RECORDING
G.P.O. Box 3002, San Juan, Puerto Rico 00936
(809) 754-6363

Owner: Tony Ochoa, Jack Sherdell
Studio Manager: Tony Ochoa

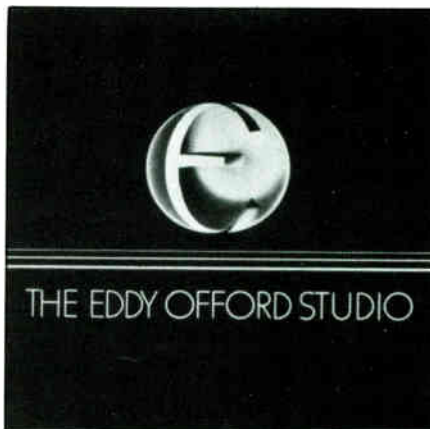

EDDY OFFORD STUDIOS
Atlanta, GA

◆◆◆ **EDDY OFFORD STUDIOS**
also REMOTE RECORDING
P.O. Box 90903 (1493 Jefferson St.),
Atlanta, GA 30364
(404) 766-5143

Owner: Eddy Offord
Studio Manager: Valma Valle
Engineers: Eddy Offord, Chuck Allen
Dimensions of Studios: 10,000 sq. ft.
Tape Recorders: MCI JH-100 24-track; MCI JH-110 2 track; Stellamaster 2 track; Studer A-800.
Mixing Consoles: Neotek Series III, 28 in x 24 out.
Monitor Amplifiers: Crown DC 300A, D-75s (phones).
Monitor Speakers: JBL 4350s, JBL 4311s; MDM TA3s.
Echo, Reverb, and Delay Systems: Lexicon 224 digital reverb; Klark-Teknik DN34; AKG BX 20 reverb
Other Outboard Equipment: Dolby noise reduction; NTP limiters; Barth EQ; UREI limiters and compressors; Eventide digital delay, flanger harmonizer and phaser, survival projects.
Microphones: Schoeps, Neumann, Shure, Beyer, E.V. Crown PZM, and transformerless active direct boxes. We also have a unique headphone system (patent pending) that allows each musician to mix his/her own phones.

Instruments Available: Steinway B piano, Moeller pipe organ, Simmons drums, Synclavier.

Rates: Available upon request.
Extras: Kitchen services available; game and video rooms planned; guest passes available for American Fitness Center. With 550 theater seats inside, studios are video and radio broadcast capable. Accommodations can be arranged for out of town visitors.

Direction: Eddy Offord produced 7 albums by Yes and engineered 4 albums by Emerson, Lake & Palmer, Melody Maker Top Ten Producers list ten years in a row. We are unlike any other

studio in the business in that there is no physical barrier separating the musicians and the board. Located in 40 year old East Point Theatre, Eddy Olford Studios has an ambience that must be seen to be appreciated. We are totally musician oriented and dedicated to technical and excellence and comfort.

•••• **PACE RECORDING SERVICE**
1431 N. Dorgenois St., New Orleans, LA 70119
(504) 949-2414
Owner: Glen Himmaugh, Peter Schulman
Studio Manager: Glen Himmaugh

•••• **PERFECT PITCH RECORDING & PRODUCTION CO.**
Rt. 8, Box 433-A, Statesville, NC 28677
(704) 872-2360

Owner: Marcus Kearns
Studio Manager: Marcus Kearns
Engineers: Marcus Kearns, Asst. David York (also independent)
Dimensions of Studios: 12 x 20; Iso booth 6 x 10.
Dimensions of Control Rooms: 20 x 24.
Tape Recorders: Studer A80 VU MK III 24 track; Studer A80 RC 2 track (1/2"), A810 (1/4") 2 track, A710 cassette.
Mixing Consoles: MCI JH 636 30 x 24 automated, fully loaded
Monitor Amplifiers: Banner 900 power amp, Banner 300 power amp, NAD 250.
Monitor Speakers: JBL 4430, 4401, 4311.
Echo, Reverb, & Delay Systems: Lexicon 224X with LARC digital reverb, Lexicon Super Prime Time, Eventide H949 Harmonizer.
Other Outboard Equipment: Scamp rack (dual de-esser, comp/lim., exp/gate, dual gate), White Equalizers.
Microphones: AKG, Sennheiser 421s, Neumann (87s & 89s), Electro-Voice, Shure.
Instruments Available: Bosendorfer 74" grand piano, Fairlight CMI (with A/C), Yamaha DX7, Oberheim OB-Xa, Oberheim DSX sequencer, ARP 2600, LinnDrum computer, Simmons drums, Sonor acoustic drums, Roland 350 Vocoder, Gibson Les Paul, Roland, Ampeg amps, Yamaha CP-70 electric grand, Fender Rhodes, Garfield Mini-Doc.
Rates: Upon request.

•••• **PETE'S PLACE**
809 18th Ave., South, Nashville, TN 37203
(615) 327-3211
Owner: Pete Drake
Studio Manager: Al Pachuki

•••• **PINEWOOD STUDIO**
Rt. 2 Box 122, Forest MS 39074
(601) 536-2255

•••• **POLLYFOX**
38 Music Square East # 212, Nashville, TN 37203
(615) 321-0088
Owner: Glen Fox
Studio Manager: Michael Davis

•••• **POLLYFOX GRAND**
920 19th Ave. So., (at Grand Ave.), Nashville, TN 37203
(615) 321-0088
Owner: Glen Fox
Studio Manager: Michael Davis

•••• **POLYMUSIC STUDIOS, INC.**
225 Oxmoor Cir. #812, Birmingham, AL 35209
(205) 942-3222
Owner: Daniel E. Whiteside
Studio Manager: Mike Panepento
Engineers: Mike Panepento, Andy Bray, Daniel Whiteside.
Dimensions of Studios: 25 x 23 main; 15 x 20 keyboard room; 12 x 8 iso.
Dimensions of Control Rooms: 25 x 23 main; 15 x 8 edit/copy room.
Tape Recorders: Ampex MM-1200 24 track, ATR-800 2 track, ATR-102 2 track, ATR-700 2 track; TEAC 3340 4 track; Technics and JVC cassettes.
Mixing Consoles: Trident Series 70 28 x 16; Quantum QM-128 20 x 8.
Monitor Amplifiers: BGW and Yamaha.
Monitor Speakers: JBL 4411, 4311B, 4401; Auratones
Echo, Reverb, & Delay Systems: Lexicon 224; Eventide Harmonizer & Flanger; MXR DDL, Yamaha REV-1 digital reverb, Roland Vocoder.
Other Outboard Equipment: Orban parametrics; UREI, Eventide and Ashly comp/limiters.
Microphones: Neumann, Shure, E.V., RCA, Sennheiser, AKG.
Instruments Available: Synclavier II w/16 voices, digital music printing, sample-to-disk, DEC VT-100 monitor, Prism 80 printer, LinnDrum; Yamaha G-2 piano; Hammond B-3 w/128 Leslie; Fender Rhodes; Prophet 5; Roland MC-8; ARP 2600, Odyssey, Omni; Poly and Micro Moog; full Yamaha and Pearl drum sets;

vibes and a complete array of Latin percussion; assorted guitars and amps.

Rates: \$50/hr. and \$1400/week.
Extras: Polymusic has a highly qualified, friendly staff of musicians, writers, lyricists, and arrangers to assist you. We also have an in-house jingle production company.
Direction: Our productions cover a broad range of musical styles, and our wide range of services is a definite plus. Polymusic has a growing list of loyal clients, and we invite you to become one of them.

•••• **PRISMA RECORDING STUDIO**
also **REMOTE RECORDING**
5208 N.E. 12th Ave., Ft. Lauderdale, FL 33334
(305) 491-8463
Owner: Michael Fourens, Arthur Gabe
Studio Manager: Arthur Gabe, Irene Ross

•••• **PYRAMID RECORDING**
1228 Lula Lake Road, P.O. Box 331,
Lookout Mtn., GA 37350
(404) 820-2356
Owner: R. H. MacLellan
Studio Manager: Jim Stable

•••• **QL RECORDING/CRITERIA'S WHEELS**
only **REMOTE RECORDING**
314 Romano Ave., Coral Gables, FL 33134
(305) 446-2477
Owner: Rent-A-Sound Inc.
Studio Manager: Chief Engineer: Rob Burr

•••• **QUADRADIAL CINEMA CORP.**
14203 N.E. 18th Ave., No. Miami, FL 33181
(305) 940-7971, 940-7972, 940-7978, 940-7994
Owner: Robert M. Ingria, Mary A. Shahan
Studio Manager: Mary A. Shahan
Extras: In-house award-winning record and film directors and producers. Special effects. Video/film shooting stage. Off-line editing suite, offices and conference room.
Direction: A creative force especially amplifying the magnitude of talent exhibited by our clientele in the musical and the visual arts.



REFLECTION SOUND STUDIOS
Charlotte, NC

•••• **REFLECTION SOUND STUDIOS**
also **REMOTE RECORDING**
1018 Central Ave., Charlotte, NC 28204
(704) 377-4596
Owner: Wayne Jernigan
Studio Manager: Mark Williams
Engineers: Steve Haigler, Mark Williams, Wayne Jernigan, Chip Garrett
Dimensions of Studios: Studio "A": 44 x 32 w/18' ceiling; Studio "B": tape duplicating; Studio "C": 28 x 24 w/12' ceiling; 18' remote recording truck.
Dimensions of Control Rooms: Studio "A": 18 x 16; Studio "C": 18 x 14 plus alcove for recorders.
Tape Recorders: Studio "A": MCI transformerless JH-24 w/JH-45 (SMPTE) 24 track, MCI transformerless JH-110B 1/2" 2 track, MCI transformerless JH-110B 1/4" 2 track, Ampex AG-440B servo w/VSO 2 track; Studio "C": MCI transformerless JH-24 track, Studer/Revov PR99 2 track; Ampex AG-440B full track, Otari MX 5050B 1/4 track.
Mixing Consoles: Studio "A": MCI transformerless/automated JH-636; 36 w/plasma meters 36 x 36; Studio "C": MCI transformerless JH-636-24 w/VCA grouping 24 x 24 (both boards purchased new, late '83).

—LISTING CONTINUED ON PAGE 90

8 SECONDS OF AUDIO SAMPLING

Bel

BD-80 Digital Delay Processor

- Store Up to 8 Seconds
- Trim and Edit the Memory
- Trigger Internally or Externally

All at a Very Affordable Price

Made in England. Distributed in U.S.A. by
Peter Tempel Audio
230 El Camino Del Mar, San Francisco, CA 94121
Phone: (415) 751-2355 Telex 184-967
Dealerships Available in Some Areas

Circle #045 on Reader Service Card

PERFECT PITCH

24 TRACK RECORDING
STUDIO/AUTOMATED
CONSOLE/STUDER

PRE/POST PRODUCTION
AND COMPOSITION
FACILITY

CMI FAIRLIGHT/
LINN DRUM

704-872-2360
RT 8, BOX 433-A
STATESVILLE, NC
28677

Circle #046 on Reader Service Card

The art of shaping sound.

SONEX is a high-performance acoustical foam that upgrades your studio inexpensively. Ideal for a temporary isolation booth, it can also eliminate slap echo and harsh resonances in the main room or silence noisy tape equipment in the control booth.

Write for our color brochure today.



Alpha Audio®

2049 West Broad St.
Richmond, VA 23220 (804) 358-3852

Circle #047 on Reader Service Card

SCMS

STUDIO CONSTRUCTION,
DESIGN & EQUIPMENT

REPRESENTING:

AKG	ORBAN
APHEX	OTARI
ATLAS	PROTON VIDEO
AUDIOTECHNICA	RTS
AURATONE	SENNHEISER
BEYER	SESCOM
CROWN	SHURE
DAVID HAFNER	SONY MICS
DBX	STUDER REVOX
ECHOPATE	SWITCHCRAFT
EDCOR	SYMETRIX
E-V	TENTEL
EVENTIDE	3-M TAPE
JBL	TASCAM 40 & 50
LOFT	UREI
MICMIX	VALLEY PEOPLE
NORTRONICS	VIKING CASES
	XEDIT/EDITALL
	AND MANY MORE

SONY
PROFESSIONAL AUDIO

CHARGE IT!



(704) 889-4508
(in N.C.)

(800) 438-6040

Circle #048 on Reader Service Card



FROM PAGE 89

Monitor Amplifiers: AR Systems, BGW, White room EQ, 1/6 octave A and 1/3 octave C.
Monitor Speakers: TAD, IRI, Big Bed, F.V. Sentry III, KFF, PCR, also two stereo systems in the room.
Echo, Reverb & Delay Systems: Lexicon 224X, IARC, EMT 140 (tube), more plate, AKG BX 20, Lexicon 200.
Other Outboard Equipment: Studio A, Delta lab digital and left analog filters, IREI, E-V, 1/3 octave level processors, White EQ, and EXR Exciter, Dolby noise reduction on request, Studio C, dbx and Orban level processors, A: ditronics EQ, EXR Exciter.
Microphones: Microphone collection includes a broad range of vintage and modern state-of-the-art Neumann, AKG, Sennheiser, Shure, F.V. Shure, and RCA.
Instruments Available: Stud. A: Yamaha 74' Conservatory grand piano, Hammond B3, stereo Fender Rhodes (RR), Farfisa organ, talk piano, and other electronic keyboards, Sonor drums, Gene Boppe percussion, Murray Gibson Fender bass, other guitars, and amp Stack, C: Kawai 74' grand piano, Sonor drums.
Video Equipment & Services: Inquire.
Rates: Reasonable hourly rates, excellent block rates are available for both studio. Please ask for latest rate card.

•••• THE REFLECTIONS

2741 Harmon Drive, Nashville, TN 37204
(615) 269 0828
Owner: Gene Lawson
Studio Manager: Gene Lawson

•••• (ROYAL SHIELD'S) RIVER CITY RECORDERS

1251 N. Acadian Thoroughway West,
Baton Rouge, LA 70802
(504) 383 8671
Owner: (Royal Shield, Inc.) Homer Sheeler, Sr. Pres.
Studio Manager: Paul Adams
Engineers: Cecil O. Duke, Chief Engineer, Derek Miller, Senior Engineer, Henderson Dennis, Technician, Joseph Arrington, Jr., Art Engineer.
Dimensions of Studios: 36 x 24
Dimensions of Control Rooms: 21 x 17
Tape Recorders: MCI IH 24 24/16 track, (2) MCI IH 10 2 track, TFA-C 3340 4 track, Sony TC 388-4 2 track.
Mixing Consoles: Harrison 28 x 24. Automated with Alltron 65k programmer.
Monitor Amplifiers: Melatosh, Crown, Yamaha, BGW.
Monitor Speakers: Altec, Big Bed, IRI, 4331A, IRI 4311, MDM 4, Auratone.
Echo, Reverb, and Delay Systems: EMT 140T, AKG BX 10/II, Lexicon Prime Time, Eventide Harmonizer.
Other Outboard Equipment: IREI 1176, IIREII A 4, Invoices 201, Eventide Omnigressor, ADR Vocal Stressor, F769X B ADR sweep equalizer, ADR noise gates, Orban de esser, Dolby noise reduction (4 channel).
Microphones: Neumann U97, Neumann U47, Neumann KM84, AKG 414, Sennheiser 421, Electro-Voice RE 20, Shure SM 57, Shure SM 58, Shure SM 61.
Instruments Available: Fender Precision bass guitar, Fender Bassman Ten amplifier, Fender Twin Reverb guitar amplifier, Hammond B3 organ w/ Leslie, Fender Rhodes RR' piano, Ludwig drums, set Yamaha organ.
Video Equipment & Services: Available on request.
Rates: \$100/hr. special rate for projects. Variable with volume/block time per week. Call for quote.

•••• RKM SOUND STUDIOS

1200 Spring St. N.W., Atlanta, GA 30309
(404) 874-3667
Owner: Kinder Music Corp.
Studio Manager: Jeff Kinder

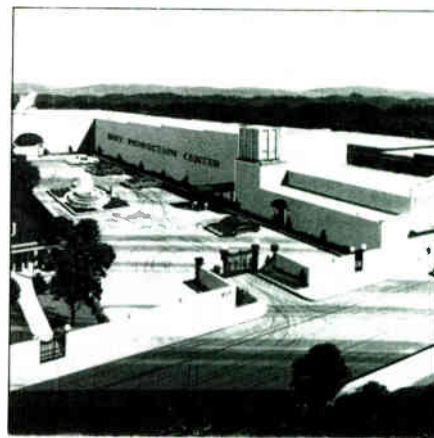

ROXY RECORDING STUDIO
Nashville, TN

•••• ROXY RECORDING STUDIO

827 Meridian St., Nashville, TN 37203
(615) 227-0920
Owner: BRT Incorporated
Studio Manager: Dan J. Herschfeld

•••• SAM'S TAPE TRUCK

ONLY REMOTE RECORDING
2785 Osborne Rd. N.E., Atlanta, GA 30319
(404) 237-9075
Owner: Larry Goode, Joe Neil
Studio Manager: Ruth Neil

•••• SCENE THREE, INC.

ONLY REMOTE RECORDING
1813 8th Ave. So., Nashville, TN 37203
(615) 385-2820
Owner: Mae Ball, Kitty Moon, President

•••• SCRUGGS SOUND STUDIO, INC.

2828 Azalea Place, Nashville, TN 37204
(615) 383-7994
Owner: Randy Scruggs and Steve Scruggs
Studio Manager: Dorothy Smith
Engineers: Call for information.
Dimensions of Studios: 26 x 35 w/cathedral ceiling.
Dimensions of Control Rooms: 12 x 16.
Tape Recorders: MCI IH 24 transformerless 24 track, MCI IH 110 1/2 transformerless 2 track, MCI IH 110 1/4 transformerless 2 track, Sony cassette deck.
Mixing Consoles: MCI IH 636 w/full automation & VCA group ing, 28 in x 24 cut.
Monitor Amplifiers: McIntosh 2300, Crown DC 300, Crown DC 150, BGW.
Monitor Speakers: Altec 604E, Big Beds w/Mastering Lab cross overs, IRI 4311s, MDM 4 mixdown monitors, Auratone, Beyer's Echo, Reverb, & Delay Systems; Lexicon digital reverb, custom plate reverb, Lexicon Prime Time.
Other Outboard Equipment: Vocal Stressor, Audiotics stereo parametrics, dbx compressor/limiters, MXR phaser, Eventide Harmonizer, API 550 A EQ, 24 tracks dbx noise reduction, Orban Silence Controller, noise gates, and EXR Exciter.
Microphones: Neumann U97, KM84, U47, AKG 414s, 451s, 452s; Sennheiser 431s; Sony condensers; Calrec condensers; Shure SM57s, SM58, E-V RE 20s, Beyer condenser.
Instruments Available: Yamaha 7 1/2 grand piano, stereo Rhodes RR electric piano, ARP synthesizer, Ludwig wood shell drums, various assortment of amplifiers, musical instruments, Hammond A 100 organ w/ Leslie, Oberheim drum machine, other equipment available on rental basis.
Rates: Call for rates.

•••• SMITH & SMITH SOUND STUDIOS

828 Orienta Avenue Box 12,
Altamonte Springs, FL 32701
(305) 425-9100
Owner: Mr. H. Tracy (Mel) Smith
Studio Manager: Mrs. Laura Smith

•••• SONGBIRD STUDIO

1715 DeFoor Ave., Atlanta, GA 30318
(404) 351-5955
Owner: Richard Heard
Studio Manager: Roger Wright



SOUND CHECK
Ft. Meyers, FL

•••• **SOUND CHECK**
1635 Jackson St., Ft. Myers, FL 33901
(813) 334-4994
Owner: Jim Becker
Studio Manager: Jim Becker

•••• **SOUND EMPORIUM STUDIOS, INC.**
3102 Belmont Blvd., Nashville, TN 37212
(615) 383-1982
Owner: CAC Investments: Roy Clark, Curly Corwin, Jim Abercrombie
Studio Manager: Rick Horton
Engineers: Rick Horton, Gary Laney (staff), Mike Poston, Charlie Tallent, Billy Sherrill, (independent)
Dimensions of Studios: A: 33 x 39 x 22 w/16 x 20 string alcove; B: 14 x 23 x 14 dog leg and 10 x 7 drum booth.
Dimensions of Control Rooms: A: 20 x 20; B: 15 x 17
Tape Recorders: Studer A-80 VU II 24 track, Studer A-80 VU MKIV 24 track, (2) Studer A-80 BC 2 track (1/4" & 1/2"), (4) Studer B-67 2 track, (3) Studer B-710 (cassette), Mitsubishi X800 32 track, digital Mitsubishi X-80 2 track.
Mixing Consoles: Studio A: Neve F128 w/Necam 96 automation 44 x 32, Studio B: Harrison 3232 w/automation 32 x 32.
Monitor Amplifiers: BGW, Halfer, Crown, Sony.
Monitor Speakers: Sierra (Gauss woofers, TAD drivers); Yamaha NS-10, Auratone 5c & T6.
Echo, Reverb, & Delay Systems: EMT 140 stereo plates, (2) acoustic echo chambers, AMS RMS-16, Quantec QRS Room Simulator (8 x 10 x 35)
Other Outboard Equipment: Dolby (2, 24), DDL, vocal stessor, Neve limiters, Priritime, phasers, flangers, various limiters/compressors, noise gates.
Microphones: AKG, Neumann, PZM, RCA, Sanken, Sennheiser, E-V, Studer, Superscope, Wright, Shure
Instruments Available: Fender Rhodes, Wuritzer, Hammond organs, clavinet, celeste, Chickering grand piano (Studio A), Steinway grand piano (Studio B), Jack piano, tympani, congas, vibes, marimba, orchestra bells, Minimoog, harpachord.
Video Equipment & Services: Video playback and syncing capabilities.
Rates: Upon request.

•••• **SOUND SHINE PRODUCTIONS RECORDING STUDIO**
723 W. Sunrise Blvd., Ft. Lauderdale, FL 33311
(305) 463-9882
Owner: Tom Graefe
Studio Manager: Paul Avakian

•••• **SOUND STAGE**
10 Music Circle South, Nashville, TN 37203
(615) 256-2676
Owner: 8 owners—Incorporated
Studio Manager: Pat Meyer
Engineers: Chief Engineer: Brent King Maintenance Supervisor: Mike Porter Engineers: Ron Treat, Steve Tillisch.
Dimensions of Studios: Studio A (front stage): 48 x 30; Studio B (back stage): 30 x 20
Dimensions of Control Rooms: Front stage: 15 x 30. Back stage: 24 x 24.
Tape Recorders: (2) Studer A-80 24/16 track Studer A-80 1/2"; Studer A-80 1/4" 2 track; Studer B-67 1/4" 2 track, upon request JVC Digital System 2 track
Mixing Consoles: Neve 8068 w/Necam, 32 in x 16 out, Trident w/65k automation TSM, 32 in x 24 out
Monitor Amplifiers: AB Systems, McIntosh, BGW, Crown.
Monitor Speakers: George Aurispurger custom monitors, JBL 1176s, Auratone, Bohvar, JBL 4311, Yamaha NS10.
Echo, Reverb, & Delay Systems: EMT 251 digital reverb, (4) EMTs, EMT Gcid Foil, Lexicon Delta T, Lexicon Prime Time,

Digital Multi-track Comes To Atlanta!

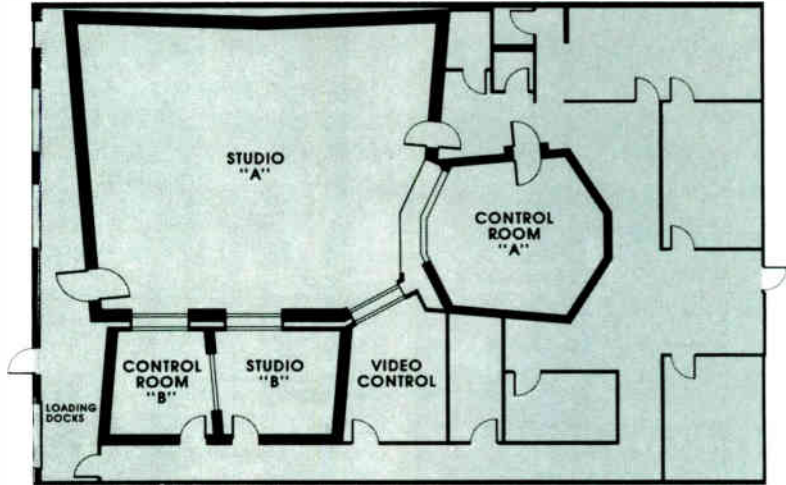

Suite 164
120 Interstate North
Parkway East
Atlanta, GA 30339
404/956-7956

First in Atlanta with Sony 24-track digital recording, New Age Sight & Sound offers you the many advantages of digital in our spacious new studios, equipped with top-of-the-line Sony 2-track and multi-track equipment. We feature the Sony PCM-3324 Digital Audio Recorder/DASH format, Sony 1610 2-track Digital Audio Processor, and the Sony BVU-800DB U-matic Video Recorder. This great three-unit combination provides the superior performance of digital audio in a complete system for remote or in-studio recording. We invite you to also check out our video studio, featuring the Symtec PGS III computer character/graphics generator. Our experienced professionals are fully qualified as recording engineers and consultants. Call today for fees and information – and ask about our digital trial offer!

NEW AGE SIGHT & SOUND

Circle #049 on Reader Service Card

THE MD 421. HASN'T OVERLOADED IN 20 YEARS. NEVER WILL.



Rock band, jet engine, pistol shot, fire engine. No sound on earth can overload our tough MD 421 cardioid dynamic. Yet it's sensitive enough for the softest whisper. Add the MD 421's excellent response and directional characteristics, and it's easy to see why it's so popular for so many different applications.

SENNHEISER®
Sennheiser Electronic Corporation (N.Y.)
48 West 38th Street · New York, NY 10018 · (212) 944-9440
Manufacturing Plant: D-3002 Wedemark, West Germany
©1985, Sennheiser Electronic Corporation (N.Y.)

NOW WITH 2-YEAR LIMITED WARRANTY

Circle #050 on Reader Service Card

Specializing in Magnetic Audio Head Services

Complete Precision Head
Relapping; Recontouring
and Optical Alignment

Free Evaluation

24 Hour Turnaround

New Replacement Heads
Available

AUTERI
Associates Inc.
(516) 331-5022

AUTERI ASSOCIATES, INC.
9 HENEARLY DRIVE,
MILLER PLACE, NEW YORK 11764

Circle #051 on Reader Service Card

Thoroughbred Music Studio Supplies at Competitive Prices

AKG	MXR
Aphex	Oberheim
Audio-	Otari
Technica	PPG
Countryman	QSC
Crest	Ramsa
Crown	Rane
dbx	Roland
DeltaLab	Scotch
Electro-Voice	Sennheiser
Emulator	Sequential
Fostex	Circuits
Hill	Simmons
JBL	Soundcraft
Klark-Teknik	Symetrix
Lexicon	Technics
Linn	Turbosound
	UREI

2204 E. Hillsborough Avenue
Tampa, Florida 33610
813-237-5597
Florida's Music Supermarket



American
Express



Circle #052 on Reader Service Card



Eventide digital delay, Cooper Time Cube.
Other Outboard Equipment: Eventide Harmonizer, UREI, Teletronix, dbx, Neve limiters; ADR Vocal Stressors; ADR Scamp Rack; Kepex; Gain Brain; Pultec tube EQ; Orban De-esser, UREI; Soundcraft parametrics, AMS delay, etc.
Microphones: Neumann, U47, U87, KM86, KM84, KM54; AKG 414, 451, 452, D12, D224; Sennheiser 421, 441; Sony 33P, 22; Beyers M69; Studer SKM5U, SK-S501; Crown PZM plates; E-V RE-16, RE-20.
Instruments Available: 9' C. Bechstein, 7' Steinway, Hammond B-3, Rhodes stereo 88, 73; Hohner clavinet; Wurflitzer Star Tack piano.
Rates: \$130/hr w/engineer, \$160/hr. mixdown w/Necam.

•••• SOUND TRAX, INC.
1626 Glenwood Ave., Raleigh, NC 27608
(919) 832-9953
Owner: Cheatham, Critz, Hancock, Irons, Stone
Studio Manager: Don Stone



SOUND TREK RECORDING STUDIO, INC.
Pensacola, FL

•••• SOUND TREK RECORDING STUDIO, INC.
P.O. Box 12422, Pensacola, FL 32582
(904) 434-0052
Owner: C.B. Fowler
Studio Manager: Glen S. Fowler
Engineers: Glen S. Fowler, Paul Garcia
Dimensions of Studios: 675 sq. ft. including drum booth & 2 vocal booths.
Dimensions of Control Rooms: 14 1/2 x 15 1/2
Tape Recorders: Studer A-80 MKIII 24 track, Studer B-67 2 track; Scully 280 4 track; Tascam 32-2B 2 track, Tascam 122 (cassette) 2 track; AKAI GX-77 2 track.
Mixing Consoles: Sound Workshop 3028 MB 28 w/parametric EQ automation & Super Group.
Monitor Amplifiers: (2) Crown PS 200, Crown D-75.
Monitor Speakers: JBLs 4411, 4311, Auratone 5C cubes.
Echo, Reverb, & Delay Systems: Ecoplate II, Lexicon 224X with LARC digital reverb; Eventide Harmonizer 949, Loft delay line.
Other Outboard Equipment: Orban 424 stereo compressor; 2 dbx 160X compressors; Omu Craft noise gates (4 channels), Valley People Dynamites, Aphex Aural Exciter, Countryman direct boxes.
Microphones: AKG 414-P48s, 451s, D-12E; Neumann U87; Sennheiser MD 421s; Crown PZMs; Calrec CM1051C, CC56; Countryman 250 Max's.
Instruments Available: Baldwin 6'3" grand piano, 7 piece drum kit, Fender and Yamaha amps, various types of synthesizers.
Rates: Please call for rates.

•••• SOUNDS UNREEL STUDIOS
also REMOTE RECORDING
1902 Nelson, Memphis, TN 38114
(901) 278-8346
Owner: Jon Hornyak and Don Smith
Studio Manager: Jon Hornyak
Engineers: Don Smith, Jack Holder, Jon Hornyak.
Dimensions of Studio: A: 44 x 19 x 12; B: 19 x 15'6" x 11'.
Dimensions of Control Rooms: A: 19 x 15 1/2 x 11 1/4.
Tape Recorders: Otari MTR 90-II 24 track; TEAC 6100 2 track; Otari MTR 10 2 track, MX 5050B 2 track.
Mixing Consoles: Soundcraft TS24 32/24.
Monitor Amplifiers: Yamaha, Crown, BGW, McIntosh.
Monitor Speakers: Steven Durr Custom Monitors (JBL, TAD), MDM TA-2, Yamaha NS10M, Auratones.
Echo, Reverb, & Delay Systems: Ursa Major 8X32 digital reverb, Korg programmable digital delay, Loft analog delay/flanger, Roland Chorus Echo, Eventide harmonizer.
Other Outboard Equipment: dbx 900 Mainframe w/limiters/compressors, noise gates, & de-esser, Symetrix 501 lim/comp, dbx 161 lim/comp, Roland Dimension D.
Microphones: AKG 414, 451, D 12E, 224, Neumann U87, KM84; Shure SM7, SM57, SM58; Sennheiser 421; E-V RE-20, RE-16; Crown PZM; Beyers M500.
Instruments Available: Hammond B-3, Yamaha CP-70B, Yamaha DX-7, Minimoog, Oberheim 4 voice, Oberheim DMX, Rhodes, Prophet 5, PPG 2.3 and Wavetern, Juno 60, Roland MSQ700 Sequencer, Strings & Thangs custom guitars & bass, Twin Reverb, Lab, Marshall amps
Rates: Upon request.

•••• SOUTH COAST RECORDING COMPANY
1975 NE 149th St., No. Miami, FL 33181
(305) 945-7272
Owner: Paul Kaminsky, George Blackwell
Studio Manager: Jenny Blackwell
Engineers: Paul Kaminsky, Vince Oliver, George Blackwell.
Dimensions of Studios: 27 x 16
Dimensions of Control Rooms: 14 x 11
Tape Recorders: MCI JH 116-24 24 track, JH 110-A 2 track, JH 110 2 track; Sony PCM 10 digital 2 track.
Mixing Consoles: Sound Workshop Series 1600 with automation 28/24.
Monitor Amplifiers: APT Model 1, Crown
Monitor Speakers: JBL 4430, 4311, Rogers Studio One, Auratone, Visonik/David 702, Yamaha NS-10
Echo, Reverb, & Delay Systems: AKG BX-10, Ecoplate III, Lexicon Prime Time, Eventide Harmonizer, Klark-Teknik Analogue Processor, Lexicon 200, (2) Lexicon PCM 42.
Other Outboard Equipment: UREI 1176N, dbx 165, ADR stereo complex limiter, (2) Allison Gain Brain II, (2) Kepex II, ADR Scamp rack incl. (4) F-300 gates, parametric EQ, Orban de-esser.
Microphones: AKG, Neumann, Sennheiser, Sony, Shure E-V, Beyers.
Instruments Available: Yamaha grand, Fibes drums, percussion.
Video Equipment & Services: BTX Shadow, BTX Reader/Generator, Sony VP Series 3/4" video, providing interlock with 24 track.
Rates: \$60/hr., blocks available, video interlock extra, PCM digital extra.

•••• SOUTHERN TRACKS RECORDING
3051 Clairmont Rd., Studio Complex, Atlanta, GA 30329
(404) 329-0147
Owner: Bill Lowery
Studio Manager: Mike Clark
Engineers: Doug Johnson, Mike Clark
Dimensions of Studios: George Augspurger designed — Main room 25 x 40, Iso Booth: 1-15 x 18, 2-16 x 20, Dead Alcove 12 x 12, Vocal Booth 8 x 10
Dimensions of Control Rooms: George Augspurger design — 22 x 26.
Tape Recorders: Ampex 1200 24 track, Studer A80 2 track, (2) Ampex 440 2 track.
Mixing Consoles: Harrison 2824 with automation.
Monitor Amplifiers: Crest, Hafler, BGW, Crown, AB.
Monitor Speakers: Custom George Augspurger System — JBL 4311, 4301, AR and Auratones.
Echo, Reverb, and Delay Systems: Lexicon 224, EMT, Super Prime Time, Eventide Harmonizer.
Other Outboard Equipment: Dolby, Orban parametric EQ, Vocal stresser, Kepex, Auto Flanger, dbx 165 and 160 limiters, UREI EQ, AudioTec Exciter.
Microphones: Neumann 87s, 47s; AKG 414s; Sennheiser 441s, 421s; EV RE20, Wright mikes
Instruments Available: Ludwig drums, Yamaha grand, Rhodes.
Rates: \$175/hr call for block rates

•••• SPECTRUM RECORDING SERVICES
also REMOTE RECORDING
536 Huffman Rd., Birmingham, AL 35215
(205) 833-6906
Owner: Huffman Assembly of God Church
Studio Manager: Randy Harper

**** SPECTRUM RECORDING STUDIOS
990 So. Federal Hwy., Deerfield Beach, FL 33441
(305) 428-0119
Owner: Jim Kalamasz
Studio Manager: Jim Kalamasz

**** STARGEM RECORDING STUDIO
43 Music Square East, Nashville, TN 37203
(615) 244-1025
Owner: Wayne Hodge
Studio Manager: Dan Hodge

**** STARTEC
1737 DeSales St., Northwest, Suite 400
Washington D.C., 20036
(202) 347-8864
Studio Manager: Nick Koumoutseas

**** STRAWBERRY JAMM RECORDING STUDIO
3964 Apian Way, West Columbia, SC 29169
(803) 356-4540
Owner: Bob and Mary Curlee
Studio Manager: Mary Curlee

**** STUDIO CENTER SOUND RECORDINGS, INC.
14875 NE 20th Ave., N. Miami, FL 33181
(305) 944-2911
Studio Manager: Craig Powell

**** STUDIO FOUR
1918 Wise Dr., Dothan, AL 36303
(205) 794-9067
Owner: Jerry Wise
Studio Manager: Steve Clayton

**** STUDIO IN THE COUNTRY
Box 490, Bogalusa, LA 70427
(504) 735-8224
Owner: Gene Foster
Studio Manager: Gene Foster

**** STUDIO K
904 Rayner, Memphis, TN 38114
(901) 726-9155
Owner: Allen A. Jones
Studio Manager: Ron Evans

**** STUDIO 19
821-19th Ave., So., Nashville, TN 37203
(615) 327-4927
Owner: Larry Rogers, Pat Brewer
Studio Manager: Sissie Brewer

**** STUDIO ONE, INC.
3864 Oakcliff Ind. Court, Doraville, GA 30340
(404) 449-5147
Owner: Buddy Bue
Studio Manager: Gloria Bue

**** STUDIO "7" RECORDING CO.
P.O. Box 57, Smith Station, AL 36877
Owner: Frank B. Gowan
Studio Manager: James Gregory Jenkins

**** STUDIO SOUTH
2510 Peach Orchard Road, Augusta, GA 30906
(404) 793-7800
Owner: Howard Lovett
Studio Manager: Howard Lovett

**** TELECENTRO INC.
Barboza 555 Ave., Rio Piedras, Puerto Rico 00923
(809) 764-0111
Owner: Mr. Ortiz
Studio Manager: Mr. Ortiz

**** TELESTAR RECORDING
also REMOTE RECORDING
2074 17th St., Sarasota, FL 33580
(813) 365-0337
Owner: Rick C. Moulton
Studio Manager: Lynn Nieder
Engineers: Rick Moulton, Rick Michael
Dimensions of Studio: 25 x 30.
Dimensions of Control Rooms: 20 x 16
Tape Recorders: MCI-Sony JH 24 24 and 16 tracks, (2) MCI JH-110 2 track; Otari-Tascam cassette duplication (8 cassettes); Sony (digital) F-1 2 track.

Mixing Consoles: MCI-Sony JH-636 30/24.
Monitor Amplifiers: BGW, JBL, Yamaha, SAE.
Monitor Speakers: JBL-4430, Yamaha-NS-10, Auratones.
Echo, Reverb, and Delay Systems: Lexicon 224X, Lexicon PCM-60, (2) Lexicon PCM 42, Eventide Harmonizer.
Other Outboard Equipment: UREI LA-3s, 1176s; dbx 160s, Allison Research Gain Brains and Kepexes, Orban De-Esser, Valley People Dyna-Mics, Valley People 610, Audioarts parametrics, EXR-EXIV, AXE direct boxes.
Microphones: U87s, 414s; PZMs; Shure SM-85s, 57s, 56s, 81s; Beyers 160s; etc.
Instruments Available: Kawai 6' grand, Hammond B-3, Linn-Drum computer, most any instrument available on rental basis.
Video Equipment & Services: Video productions available.
Rates: Upon request. Hourly and block rates are both available.

**** TREASURE ISLE RECORDING STUDIO
2808 Azalea Place, Nashville, TN 37204
(615) 327-2580
Owner: Mariner Trust
Studio Manager: Fred Vail
Engineers: Dave Shipley, Chief Engineer; Richard Stevens, Tom Harding
Dimensions of Studio: 42 x 30 plus vocal booth, 24' ceiling; 12 x 14 drum booth with 13' ceiling.
Dimensions of Control Rooms: 22 x 24.
Tape Recorders: 3M 32-track digital, Studer A80 24 track; Studer A80 1/2" 2 track; Studer B67 2 track; Scully 280 (3) IVC 2 track digital Ampex ATR 800 2 track.
Mixing Consoles: Trident Model 80 32 in 56 out, 12 Trident "A" range mike and EQ modules.
Monitor Amplifiers: Crown, BGW, Quad, McIntosh, UREI and Studer.
Monitor Speakers: Westlake Design, JBL 4320, 4311; "Little Red"; Tannoy SRM 10B.
Echo, Reverb, and Delay Systems: Live echo chamber, Echoplate, AKG BX20, (2) Prime Times, Sony digital reverb DRE-2000.
Other Outboard Equipment: ADR Scamp rack with 13 modules, ADR Vocal Stressor, (4) dbx limiters, (3) UREI limiters, Eventide Harmonizer, Eventide Flanger, de-essers, noise gates, (4) Kepex II noise gates.
Microphones: Neumann, U87, U67, U47, KM84; AKG 414, 452, D-100E; Shure SM77; E-V RE-15, RE-20; Crown PZM; Sony ECM-50; RCA 77, D-12, AKG C12A, The Tube, (2) Bruel and Kjaer.
Instruments Available: Baldwin grand, Fender Rhodes, Fender amps, Pearl drums w/extra toms, Hammond D-3 organ, Multimooog, Korg Polysix.
Video Equipment & Services: Available for video use, the studio has spacious rooms and high ceilings, and very impressive interior decor.
Rates: \$85 to \$125/hr; day and week block rates available on request.
Extras: Whirlpool, sundeck, sauna, 20 x 20 musicians' lounge with wet bar, fireplace, kitchen, conference room, writer's room, 14 ft. beamed ceiling, glass atrium, 5,000 sq. ft. complex structure is 12 inch block sand filled. Acoustical design by Richard Lee.
Direction: Treasure Isle is the largest new studio in Nashville to be built in the past five years. It brings to its new facility a great tradition in recording. Treasure Isle, in its original location at 49 Music Square West, was formerly Island Recorders, and before that, Richey House. Clients have included: Christy Lane, T. G. Shepard, Allman Brothers, Johnny Cash, Louise Mandrell, producer Rodney Crowell, producer Chet Atkins, producer Wes Farrell, The Beach Boys, Molly Hatchet, The Scorchers, producer Barry Beckett, Emmylou Harris, Linda Ronstadt, Dolly Parton, Budweiser, Ford, Turner Broadcasting System, Amy Sky, producer Paul Worley.

**** TWELVE OAKS RECORDING STUDIO
3830 South Cobb Dr., Ste. 100-A, Atlanta, GA 30080
(404) 435-2200, 435-2221
Owner: Sonny Lallerstedt, Randy Bugg
Studio Manager: R. Bugg

**** THE WAREHOUSE RECORDING STUDIO
also REMOTE RECORDING
2071 Emerson St. #20, Jacksonville, FL 32207
(904) 399-0424
Owner: Tom Markham, Skip Osmundsen
Studio Manager: Tom Markham

**** THE WAREHOUSE RECORDING STUDIO
also REMOTE RECORDING
2071 Emerson St. #20, Jacksonville, FL 32207
(904) 399-0424
Owner: Tom Markham, Skip Osmundsen
Studio Manager: Tom Markham

**** WEB IV STUDIO
2107 Faulkner Road N.E., Atlanta, GA 30324
(404) 321-5993
Owner: Ilene Berns
Studio Manager: Brendan O'Brien
Engineers: Tommy Cooper, Brendan O'Brien.
Dimensions of Studio: 70 x 35 (2,450 sq. ft.) (1,100 sq. ft. hardwood floors); 3 isolation booths.
Dimensions of Control Rooms: 21 x 20.
Tape Recorders: Studer A-80 24 track; Studer A-80 VU 2 track; Studer A-80 RC 2 track; Ampex 440B 2 track.
Mixing Consoles: Sphere Eclipse Type C 32 in x 24 out.

Monitor Amplifiers: Crest P-3500/AB 410; Yamaha P-2200; AB 105.

Monitor Speakers: JBL 4350; JBL 4313; ROR; Auratones.
Echo, Reverb, & Delay Systems: EMT 250 digital reverb, EMT 140 plate; Eventide Harmonizer (model H949); Lexicon PCM 41, Prime Time, Delta T; Marshall Time Modulator; MXR flanger/doubler; Roland RE-301 chorus/echo; two live echo chamber.
Other Outboard Equipment: UREI 1176, LA-3A 527 graphic EQ, 550 filters; dbx 165, 162, 160; ADR Vocal Stressor; Orange Country Vocal Stressor; Audio Arts 4200 EQ; Orban De-esser, Parasound EQ; Pultec EQP-1A3 EQ; Allison Gain Brain, Kepex; 24 track Dolby and dbx noise reduction; 2 track Dolby noise reduction.
Microphones: Neumann U87, U89, KM84, KM86, KM88, U47, FET; AKG 414, C24 (stereo tube), 451, 452, 224; Schoeps (Studer) SKH54U; Sennheiser 421, 441; Shure SM56, SM57, SM58; E-V RE-10, RE-15, RE-20, 635.

Instruments Available: Baldwin 9' grand piano (SD-10), Fender Rhodes, Wurliizer electric piano, Hammond B-3, Hohner D-6 clavinet, Oberheim OB-X polyphonic synthesizer, Yamaha electronic organ, xylophone, vibes, drums, assorted percussion; Fender, Marshall, acoustic, Ampeg amplifiers; Minimoog, ARP Odyssey, ARP Pro-Soloist, Univox Stringman, Prophet-5, Roland JP-8
Rates: Please call for rates.

**** WILD TRACKS RECORDING STUDIO
805 18th Avenue South, Nashville, TN 37203
(615) 327-3900
Owner: Stephen S. Singleton
Studio Manager: Stephen S. Singleton

**** WIS Recording
1320 National Rd., Wheeling, WV 26008
(304) 242-8601
Owner: Bill Shvlin
Studio Manager: Bill Shvlin

**** WOODLAND SOUND STUDIOS
1011 Woodland Street, Nashville, TN 37206
(615) 227-5027
Owner: Ernie's Record Mart, Nashville, TN
Studio Manager: Ema Jean Bean - Traffic Manager
Engineers: Ken Cribles, Tim Farmer, Denny Purcell.
Dimensions of Studio: A: 45 x 36 x 22. B: 41 x 30 x 15.
Dimensions of Control Rooms: Both A & B: 30 x 15.
Tape Recorders: Studer A80 MKIV 16 and 24 track; Studer A800 24 track; (2) Studer A80-R 2 track; (2) Studer A80-RC 2 track; Mitsubishi X80 2 track; Studer 1/2" analog Pre-Lusten 2 track; Mitsubishi digital delay 2 track; Sony-FI digital 2 track.
Mixing Consoles: Neve 8038, 24 in x 24 out; Neve 8078, 36 in x 24 out.
Monitor Amplifiers: AB systems 410; McIntosh MC2200, Times One.
Monitor Speakers: THE-1, MDM-4, Westlake TM1, Auratones, Altec 9845, MDM-4.
Echo, Reverb, & Delay Systems: EMT Plates, AKG, Prime Time, DDL.
Other Outboard Equipment: UREI digital metronome; Eventide Harmonizers; Pandora digital time line; UREI 1176s (5-A, 4-B), Eventide Clockworks Instant Phaser; Orban De-esser 1-50 or 60; crystal syn. pulse generator; 14KC signal generator sync. (for film use); Nakamichi 700 III cassette deck; Nakamichi 1000 II cassette decks; 66 channels Dolby; 56 channels dbx; (4) UREI LA-4As; ADR Vocal Stressor; (2) Lexicon Prime Times.
Microphones: AKG C414 EB, C452 EB, D224 E; Altec M49; E-V RE-11, RE-15, RE-16, RE-20, RE-50, 635A, 668, 1751 & 649; Neumann U87, U47, U67, KM86, M 249B, RM84; Sennheiser MD 421U; Shure SM56, SM53, SM54, SM7; Sony ECM50, ECM22P, C55; Studer SKM5-U, Sanken IMP-1600.

Instruments Available: Baldwin concert grand SD 9', Steinway model B, Hammond organs (B-3, C-3), Wurliizer electric pianos, Fender Rhodes (Dyn-o-my), Hohner clavinet, Allen electric harpsicord, celeste, electronic chime, vibes, tack piano, ARP String Ensemble, Fender guitar amps, studio, drums, congas, latin percussion.
Video Equipment & Services: 1/2" and 3/4" playback and monitor.
Rates: On request.

**** YOUNG'UN SOUND, INC.
114-17th Ave. So., Nashville, TN 37203
(615) 244-5656
Owner: Chip Young
Studio Manager: Chip Young, Jan Naylor

**Find it in
MIX Classifieds...
see page 159.**

JIM KELTNER

THE SUNNY SIDE OF THE BEAT

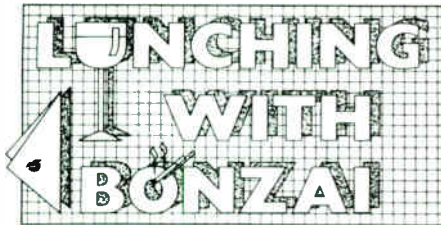

by Mr. Bonzai

Whether conscious or not, you've been rocked in Jim Keltner's rhythmic cradle. Perhaps it was a pop-doodle Gary Lewis Top 40 smash, a painful Lennon revelation, a Dylan revival meeting, or a playful Van Dyke Parks romp—but the chances are very good that your soul's foot has tapped in time to this man's heartbeat.

Our first lunching got cancelled because of a last minute call from Jackson Browne. To fit the Keltner schedule, I finagled a mobile lunching with Jim during a drive to Paiste in Orange County. He had to make a hurried visit to the cymbal manufacturer to test out some new splashes, high-hats and rides.

My arrival at Jim's home coincided with the departure of Ry Cooder. As we shook hands quickly, I glanced around a living room festooned with Germanic sideboards and massive carved furniture. We zipped out to the car and settled in for a freeway chat.

Bonzai: What do you think of the changes brought about by electronic drums?

Keltner: I used to be intimidated by all the new drum machines. When I realized how much fun it could be, I started getting into it. It's worth taking the time to learn. With that attitude alone, I got into it immediately—and I don't consider myself a guy with heavy duty brainpower like a lot of my friends. I just had the desire.

Bonzai: When did this start happening?

Keltner: In February, 1982, when I was getting ready to do a tour of Europe with Ry Cooder. This was my first tour with him and I wanted to have some special percussion—logs and bells and funny sounds rather than just the drums.

I soon realized that it was going to be very complicated. I would need a big



PHOTO MR BONZAI

Session drummer Jim Keltner in a familiar pose.

rack and I would have to find the right logs and carry them around. I wanted a big sound and you need big logs.

I met my buddy John Parker, who was then the manager of the drum section at the Guitar Center in Hollywood, and he showed me one of the first Simmons SDS-5s. It looked crazy at first but we tried it out and my mind was blown. They sounded big and tubby and punchy—just what I was looking for. From that point on I was hooked.

I don't play heavy, loud, crunch rock 'n' roll myself, but I like a lot of the drummers I hear playing that way. Some guys have problems with the idea of playing electronic drums and with some it's difficult to physically adjust, but to me they're just a logical extension of the drum kit. You hear the SDS-5 on every other record on the radio, so I try not to play them in the same conventional way. I still love the sound of real drums.

Bonzai: Do you blend the two?

Keltner: Yes, and for a while I've been using the Simmons SDS-7 unit, which is incredible because you can blow your own chips for it. I'm in the process of creating some new sounds of my own—not necessarily drum sounds. With these machines, you can improve on your real drum sounds with various triggering devices like the MX-1. We just did that

with the new Linn 9000 the other day and it was pretty amazing. The sensitivity isn't quite there yet, but the technology for it is. It just needs to be made more affordable. I love playing drums and I know there is no way they'll be totally replaced by machines.

Bonzai: Do you think that younger drummers are missing out on perfecting their organic chops?

Keltner: Sure, there's going to be a lot of that. There are some players who are becoming very good programmers. They are doing some really nice drum things and I don't see anything wrong with that, but I think that if really good drummers get into the machines it will be even better.

Bonzai: You have a remarkably open attitude . . .

Keltner: I don't see them as a threat—they're my friends, and they are obviously only as good as the hands that are on them. I want to learn. Doing patterns on a drum machine is not as easy as you would think. The better drummer you are, and the more technique you have, the more you may be inclined to overdo it.

Bonzai: Hal Blaine said that it was knowing when *not* to play.

Keltner: Hal used to tell me that all the

time. With the drum machines it's the same thing. I've really gotten crazy at times—I'd start doing something really nice and by the time I'd finished, I'd have too much garbage on it—just by getting too excited and letting my ears fool me. When you're playing drums or using a machine, it still comes down to musical sensibility, and sensitivity.

Bonzai: When did you play your first professional gig?

Keltner: It was at Jefferson Recreation Center in Pasadena—seven bucks for the night. I met my wife while I was in junior high in Pasadena.

Bonzai: Can you remember the first session or gig where you really felt like you were on your way?

Keltner: Well, I jumped quickly. Around '65 I joined up with Gary Lewis & the Playboys, and went directly from playing jazz on the Sunset Strip to playing pop-rock.

Bonzai: Didn't Leon Russell write one of their big hits?

Keltner: Right, in fact I met Leon at a studio a few nights after joining Gary. We found out that we had Tulsa in common, along with Carl Radle, the bass player and Tommy Triplehorn, the guitar play-

er. All these Tulsa people surfaced and it took my career into a whole new ballgame. I had been with Gary for just a couple of months before we went into the studio. Hal Blaine had played drums on all his stuff prior to that, but they decided to give me a shot. I hadn't really been in a studio before, other than doing a few demos, and I didn't know exactly what to do. I watched Hal on a few things and he gave me a few pointers. Suddenly after being proficient in playing jazz I found myself not knowing what to do with rock 'n' roll. I really wanted to make it good and authentic. To tell the truth, I wanted to sound like Hal, and I didn't. To me I sounded real clumsy and weird, too tight and a little too busy—like a little mouse.

Bonzai: Did you have a drum kit like his?

Keltner: I had a jazz kit, and I didn't know at the time that tuning was so important. Hal gave me some important tips, and by the time we cut "Just My Style", I had it together enough to sound convincing. It was a hit. Blam, the first thing I did in the studio was a big hit record. It was a thrill to hear it on the radio, and I was really hooked.

Then I was fired after seven months for a stupid reason. I brought it on myself, and there was a clash. It was about three years before I did any more

recording. You remember the "Gene Krupa Story", where he was busted for pot, and his reputation was ruined? They showed him playing dives and strip joints with his head hanging down. That's how I felt. I went from being a star and signing autographs in supermarkets to playing in terrible little clubs all around L.A. with an accordion player, a weird singer and no bass.

Finally, I got with a couple of nice little groups, like the Afro-Blues Quintet. We even played in Watts during the riots—it was a wild experience being the only white guy around.

Bonzai: Both you and Hal have been in that situation.

Keltner: White musicians love to talk about it—makes us sound soulful, but it really was a great experience. Around '68 I went into the studio with Gabor Szabo to do his first album. Then in '69 I joined Delaney & Bonnie & Friends, with Carl Radle.

Bonzai: Of all the people you've worked with, who are your favorites?

Keltner: It's impossible to say, when you've worked with people like Lennon and Dylan, and Randy Newman—some of the great songwriters of all time. It's very hard to say, but I guess Dylan is my

LESS THAN ONE PERCENT FAILURE!

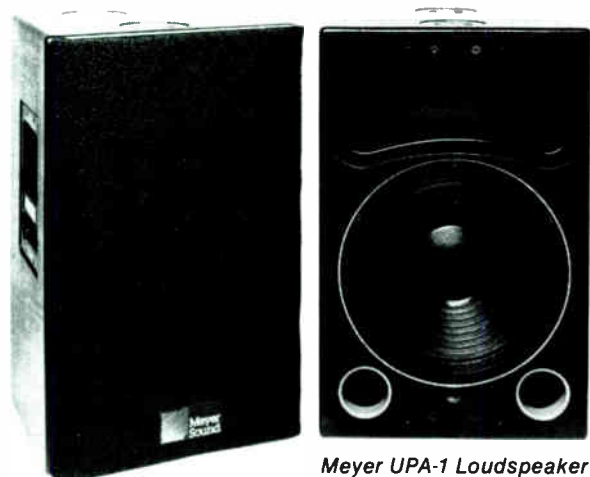

Meyer UPA-1 Loudspeaker System, U.S. Patent 271967

We were pleased, but not surprised, when our distributors and dealers told us that buyers of Meyer Sound equipment reported **less than a one percent failure rate** in the new gear they purchased.*

At Meyer Sound we take extraordinary precautions to ensure that **all** the components used in our systems are of the highest quality obtainable. All the parts in each piece of Meyer equipment are **100 percent tested** to guarantee reliability and consistent performance. Each assembled unit is thoroughly tested again before leaving our factory.

At Meyer Sound reliability isn't just a word to sell loudspeakers—it's the philosophy on which our reputation is built. If you've heard about Meyer, but you haven't *heard* Meyer, call or write us. We'll give you the name of a dealer who can arrange a demonstration.

*Figure includes warranty and non-warranty repairs on an annual basis.



**Meyer
Sound**

Meyer Sound Laboratories
2832 San Pablo Avenue
Berkeley, CA 94702

(415) 486-1166

Circle #053 on Reader Service Card



Keltner makes a big hit at the Paiste factory.

favorite. I loved working with John, too—I always felt like I was on a cloud when I was around him.

Bonzai: Which of his records did you play on?

Keltner: I drummed on two tunes on the *Imagine* album. I still get a lump in my throat when I hear "Jealous Guy." It reminds me so much of that time. He sang it so pretty and it's such a pretty little song. I also played on "I Don't Want to be a Soldier." After that I did all of his stuff until he took that long break, got back with Yoko, and was raising Sean.

Bonzai: So you were around John during those really tough times?

Keltner: I was. He was going through being away from Yoko. It didn't look like it was painful to a lot of folks, but to me and a few other people that were hanging with him all the time, believe me, it was a painful period for him. He loved Yoko so much. She was the true love of his life—period.

He loved Yoko for all the reasons that you love a woman. She was a really important part of his life, so when they separated he went a little crazy and drank rather heavily, but a lot of that has been exaggerated. I've talked with my wife Cynthia about the things that have been written about his "lost weekend" in Los Angeles—in all fairness he wasn't crazed *all* the time. We had some wonderful sane moments.

Bonzai: Can you describe working with him?

Keltner: Musically, the one thing that always stood out for me with John—the big difference between working with him and a lot of other people—was that his songs played themselves. They were just so complete when he came to us with them. He would bring a little chord chart and there was hardly ever any reworking. I never had to search for a drum part. Generally, it all just fell into place. It always amazed me.

Bonzai: How did you get introduced to Bob Dylan?

Keltner: I was in Leon's studio with Carl Radle and Jesse Ed Davis. Leon wanted to cut some of Dylan's songs to send to him as a Christmas present. We did "Hard Rain" and a couple of other tunes. After that I went off to England with my family and I got a call from Leon saying that we were going to do a session with Dylan. I went out of my mind. I returned to New York and we recorded "Watching the River Flow" and "When I Paint My Masterpiece." It was fantastic meeting Dylan and watching how he worked. He had a cold that day and you can hear it on those songs. He was completing the lyrics and I'd look over at him, standing up against the wall. I could see his lips moving and he was writing things on a little pad. He'd talk to Leon a little and make a few changes. We just did a couple of takes and that was it.

A while later we did the soundtrack for *Pat Garrett and Billy the Kid*. "Knockin' on Heaven's Door" turned out to be a single and I still love listening to that. I didn't hear from him again until he had recorded *Slow Train* and he called me to come and hear it and see if I wanted to go on tour with him. After I'd heard *Slow Train* I said I'd go—wherever you want to go, whatever you want to do.

I spent two years with him on tour and played on two albums: *Saved* and *Shot of Love*. Both of those albums were at the peak of his experience with Jesus, where he was really telling the world. Everybody comes to their own conclusions about that, but I definitely can tell you that it was a very powerful time in my life and I could see that it was an extremely powerful time in his life. I actually saw him change from being pretty hard to be around, to a guy that was incredibly open and wonderful to be around.

Everybody's got a story about Bob and a lot of them are about how cold he is. I've heard people say that they worked with Dylan for 12 hours and he never said a word. That always makes

me laugh, because I've been in that situation, too—but I know the other side of him as well.

Bonzai: What have you been up to for the past couple of years?

Keltner: I've been working a lot of Ry Cooder as a sort of band member and partner. I'm really enjoying that because Cooder is one of my very favorite musicians in the world. The guy plays guitar like nobody else. He's not an Eddie Van Halen—he's not a solo type of guy. He can't really play that type of guitar—I think he can, but he says he can't.

But what he does with the slide guitar—nobody else can touch him.

He's been doing a lot of film work—*Southern Comfort*, *The Long Riders*, *Streets of Fire*. I've played on a good bit of the film stuff—we did some wonderful things on *Streets of Fire* but a lot of it got covered up by loud sound effects. Ry did *Paris, Texas* with Jimmy Dickinson. It's Cooder at his best, with that real lonely sound of the slide guitar.

Bonzai: Do you compose?

Keltner: Not really. What I do is come up with sketches and grooves and little melody hooks and stuff that I work on at my house. Ry was here today to pick up a tape I worked on last night. He'll take that home and listen and get ideas and build around that, maybe write some words. I've put a few words throughout the tape. We just send our ideas back and forth.

Bonzai: You were both recently playing with Van Dyke Parks, weren't you?

Keltner: Yeah, we did McCabe's. We backed up Sir Lancelot—an 82-year old guy who was one of the inventors of Calypso music. It was a wild combination. The band was very sympathetic—we played with great dynamics, and we hit some mean grooves.

Bonzai: We're talking about a type of music that isn't going to soar up the *Billboard* charts . . .

Keltner: That's right.

Bonzai: How do you feel about that? Do you just go with your instincts?

Keltner: Absolutely. I've had the great pleasure and honor of playing with some great musicians and writers—great artists. Some records have become big hits and some will never be heard, but I wouldn't trade any of it. Van Dyke is working on a film score now with Lennie Nesihaus. It should be a lot of fun and a little challenging. His mind is so bizarre and then some poor sucker like me has to come along and play what he dreams up.

Bonzai: Who's your best musical friend?

Keltner: I would have to say Cooder,

WHEN YOU NEED FACTS ABOUT PROFESSIONAL AUDIO EQUIPMENT

There is hardly another business on earth where there is so much disagreement about the tools of the trade.

Competing manufacturers each argue the superiority of their products. Rumors fly about various pieces of equipment, spread most often by people who've never actually used them.

All this has very little to do with the facts.

At Everything Audio we talk facts. We get them from hands-on experience with the equipment we sell. We get them from what our customers tell us about their experiences. We get them from reading every brochure, manual, book, and magazine article published in the pro audio field.

And we give them to you.

Because we know that professional audio is a serious investment for you. The choices are too important to be made based on rumor or unproven claims.

When you need facts, call Everything Audio.

MORE PROFESSIONAL BRANDS

We sell more brands of professional consoles and tape machines than any other dealer in the western United States.

Call us for a list of the more than 200 brands of professional audio equipment we sell.

Equipment Sales
Factory-Trained Service Technicians
Studio Design

**EVERYTHING
AUDIO**

16055 Ventura Blvd., Suite 1001
Encino, California 91436
Phone (818) 995-4175 or (213) 276-1414



WHEN YOU NEED FACTS, CALL EVERYTHING AUDIO

Circle #054 on Reader Service Card

World Radio History

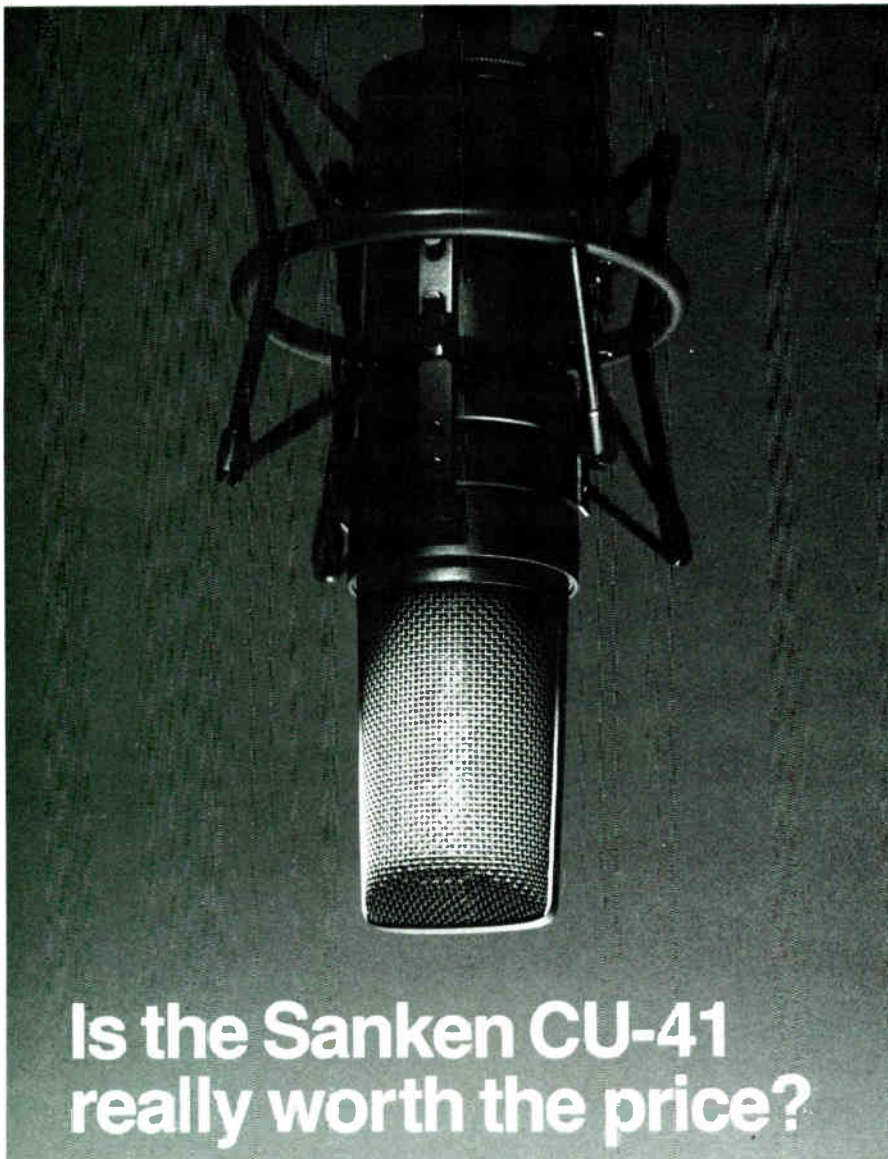

Is the Sanken CU-41 really worth the price?

The Sanken CU-41 is the most expensive microphone of its kind. Its breakthrough double-condenser design gives you textbook performance: a flat frequency response from 20Hz to 20kHz; an inherent noise level less than 15dB; and a dynamic range of 125dB.

But specs alone aren't reason enough to invest in the CU-41. Neither is the fact that leading sound engineers from LA to London, including Doug Perry, Eric Prestidge, Steve Levine and Tony Faulkner, are using the CU-41 to record the likes of Dolly Parton, Anne Murray, Culture Club, and the London Symphony Orchestra.

To really evaluate and appreciate one of the world's first microphones able to capture the full potential of digital recording, you must try the CU-41 yourself. **Call the Sanken dealer nearest you to arrange a free trial.**

The CU-41 by Sanken.
Discover the new standard.



Japan's most original microphone maker.

Exclusive CU-41 Dealers

Martin Audio Video Corp.

423 W. 55th St., New York, NY 10019 (212) 541-5900

Studio Supply Company, Inc.

1717 Elm Hill Pike, Suite B-9, Nashville, Tenn. 37210. (615) 366-1890

Audio Industries Corporation

1419 N. La Brea Ave., Hollywood, CA 90028 (213) 851-4111

Sole agent: Pan Communications, Inc. 5-72-6 Asakusa, Taito-ku, Tokyo 111 Japan Telex J27803 HiTech/Phone 03-871-1370

Circle #055 on Reader Service Card

but there are so many people that I love working with. I just did some experimenting with drum sounds at Jackson Browne's—I'm looking forward to doing some things with him and Russ Kunkel.

Bonzai: Have you ever witnessed a miracle?

Keltner: Yes, I've witnessed a lot. When I was ten years old, my mom was about to die. She had about a 20% chance of living through a spinal operation. I was at an Oral Roberts tent meeting that night with my family and we prayed along for those in the hospitals. The next morning she was fine. She came through in better shape than anyone had ever come through an operation like that. That was the first miracle I ever witnessed, and all of them have been performed by God.

Bonzai: Was there a period when people thought you were a crackpot?

Keltner: I don't know if crackpot is the word. My reputation for years was "that crazy Jim," "that crazy drummer," "that guy is so crazy." I wasn't too terribly responsible, but I wasn't the kind of guy you wouldn't invite over to your house.

Bonzai: What does your mother think of you?

Keltner: I am probably the single most important source of pride in her life. Of course, she's also very proud of my beautiful sis, Judy.

Bonzai: What would you have become if you hadn't become a drummer?

Keltner: I originally wanted to be a baseball player. I was a pretty good pitcher back home in Tulsa. But the music came so fast. I don't know if I could do anything else well, but I could be happy doing a lot of things—gardening, for instance.

Bonzai: There is a tremendous pressure on drummers, perhaps more than on other musicians. It's where everybody looks first if something is going wrong.

Keltner: Well, in a great many records that are made by hit artists, the drums play a hugely important part in whether they become a hit or not—the way it feels when it comes over that little speaker. Generally, the first thing that a person feels is that heartbeat—the way the drummer has constructed the heartbeat of that song.

Bonzai: Do you have any plans for a solo album?

Keltner: Yes, I definitely want to do that. I'm getting closer to it all the time. I've got a fair collection of interesting ideas on tape. In many ways I feel that I am a better player than ever before. I listen more than I used to. Listening is the biggest part of playing music, when you're working with others—even if you're playing by yourself. ■

PREVIEW



Yamaha CX5M Music Computer

Introduced at last month's NAMM show in Anaheim, CA, the Yamaha CX5M Music Computer combines a Z-80 based microprocessor with an FM voiced sound synthesis system. In addition to accepting all MSX tape and cartridge programs from Microsoft, Inc., the unit uses custom Yamaha software for a variety of musical applications. Built-in software accesses the synthesizer's 46 preprogrammed voices, which can be recorded and played back via internal memory (up to 2,000 notes). An auto-accompaniment section provides bass, rhythm and chord patterns. With the addition of an optional keyboard (either the full size YK-10 at \$200, or the mini YK-01 at \$100), the computer becomes a live performance synthesizer, equipped with MIDI and a programmable keyboard split.

Software programs available at present include: FM Music Composer, which visually displays the notes played on the keyboard and allows storage and printing of compositions via a standard dot matrix or ink jet printer; FM Voicing Program, for the manipulation of and creation of new sounds using the computer's FM synthesis system; DX7 Voicing Program displays the parameters of voices in a visual graph form when a Yamaha DX7 and video monitor are connected to the computer; and the FM Music Macro program facilitates the creation of FM synthesis sounds for games and video applications without the use of a music keyboard.

The CX5M Music Computer is priced at \$469, and the software described above are \$50 each. Optional accessories include plug-in data memory cartridges and an RF modulator to display the computer's output on a standard television set.

Circle #056 on Reader Service Card



Meyer Sound Ten Band Parametric

The CP-10 complementary phase parametric equalizer from Meyer Sound of Berkeley, CA, is a stereo unit with five bands of equalization per channel and additional high- and low-

cut shelving filters. Front panel controls include ± 15 dB cut/boost, center frequency selection (10:1 range), .1 to 1.1 octave bandwidth adjustment, individual bypass switches for each band, and the high/low cut filters.

The unit's front panel can be removed without disturbing equalization settings and each of the ten EQ circuits is mounted on its own removeable gold-socketed PC board, facilitating service. Rear panel connectors are XLR-type. The CP-10 is priced at \$2,500.

Circle #057 on Reader Service Card



Soundcraft Series 600 Consoles

Designed for cost-effective 8 and 16 track recording applications, the Soundcraft Series 600 are full-feature, eight buss consoles available in 16, 24, and 32 input versions. Standard features include: 8 group outputs paralleled for 16 track operation; a 16 track monitor section; direct channel outputs; LED bar graph metering; switchable -10 or $+4$ dB outputs; and six auxiliary sends on each input module which can be switched to affect the signal at either pre/post fader or pre/post EQ points.

The Soundcraft Series 600 consoles are now available and are priced as follows: 16 channel, \$6,950; 24 channel, \$8,750; and 32 channel, \$10,950. Stereo input modules for audio/video postproduction are optional.

Circle #58 on Reader Service Card

Tannoy NFM8 Minimonitor

The Tannoy NFM8 is a ducted port system employing an all new 8" dual concentric driver. The unit consists of a polyolefin copolymer woofer and a one-inch HF dome coupled to a compression horn lens. The concentrically mounted diaphragms are precisely time aligned, insuring total phase coherency at all angles.

The cabinet of the NFM8 is constructed from MDF (the same high impact material used in Tannoy's Wildcat series of live performance systems). The enclosures are finished in suede black epoxy, and two sides of each cabinet employ acoustic isolation pads, providing a non slip finish to all console surfaces while in the horizontal or vertical position. The pads isolate the monitor from the console surfaces while in the horizontal or vertical position to eliminate buzzing or rattling. The NFM8s are priced at \$748/pair.

Circle #059 on Reader Service Card



CFD 1-100 Horn from DDS

Design Direct Sound of Seattle, WA, has expanded its line of Continuous Frequency Distribution™ horns with the CFD 1-100. This compact horn exhibits smooth off-axis frequency response, with the virtual absence of on-axis beaming. Its short throat-to-flange dimension simplifies time alignment with low frequency direct radiators, making the CFD 1-100 a good choice for near-field applications and foreground installations.

CFD designs incorporate several flare rates into one horn, resulting in even frequency response across the sound field. Suggested list price for the DDS CFD 1-100 is \$71.

Circle #069 on Reader Service Card

Dynafex Chip from SSMT

Solid State Micro Technology of Santa Clara, CA, has introduced a new IC which contains the proprietary Dynafex single-ended noise reduction circuitry. The SSM 2200 chip is a single channel of Dynafex noise reduction with few external components required. SSMT plans to introduce other variations which include a battery powered device and stereo versions.

The SSM 2200/Dynafex device is available to qualified OEMs on a non-exclusive, royalty-free basis. The standard 16 pin DIP device (other packaging options available) is priced at \$6.00 (1000 piece orders) and is in stock for immediate delivery.

Circle #070 on Reader Service Card

Compact Seck Audio Mixers

The Seck 62 and Seck 122 offer six or twelve input channels with two outputs in a unique, ultra-portable package which is totally metal-encased and is only two inches deep. The rugged design is enhanced by a double-sided fiberglass printed circuit board and the elimination of all wired connections: all input and output connectors are mounted directly to the circuit board, resulting in high reliability.

Each one of the mixers' input channels feature: switchable line/mike inputs, three band equalization, two pre-fade sends, two post-fader sends, a pre-EQ patch point for the insertion of outboard devices on any individual input, a solo switch, and 100mm long throw faders are used throughout. The output section includes stereo LED meters, with a resettable peak-hold



switch; +4dBm balanced XLR outputs; and a 1700mw mono headphone amp with level control. The six input version can be rack mounted with optional adapters.

Seck products are distributed in the U.S. by Connectronics (Stamford, CT); by Bandive LTD. in the U.K.; and by Decidis in France.

Circle #071 on Reader Service Card



JVC VP-101 Digital Audio Processor

The VP-101 digital audio processor from JVC is designed for digital recording and playback with virtually any NTSC videocassette recorder with external sync capability, making it ideal for audio mastering in video post-production.

The processor employs EIAJ pulse code modulation (PCM) and 14-bit linear quantization. Sampling frequency measures 44.1 kHz (+0.01, -0.11%) and frequency response is virtually flat from 5Hz to 20kHz. Wow and flutter is negligible. VP-101 design features include a sync output for videocassette synchronization; two-color fluorescent peak meters (bar type); mode indicators for "at-a-glance" system status; and line/microphone mixing. The processor also has copy, emphasis and record selectors as well as a headphone jack with level control.

Circle #072 on Reader Service Card



Studer A820 Analog Recorder

The Studer A820 is a microprocessor-controlled two track mastering machine designed for demanding applications. The recorder features: 14-inch reel capacity (a 16-inch version is also available); simplified changing from 1/4" to 1/2" formats; LED real time (positive or negative) tape counter; five address memory locator; three DC motor drive; programmable operating and special function controls; varispeed with readout in percent, halftones, or inches per second; and balanced inputs/outputs available in either transformer or active electronic versions.

Options for the A810 include a time code channel, mono/stereo switch, signal generator, and an RS 232/422 interface (SMPTE/EBU format). The A820's transport is similar to that of the Studer D820 digital recorder, thus reducing the spare parts inventory required for studios equipped with both machines.

Circle #073 on Reader Service Card

SYSTEMS OF THE 80'S

Where do you go for all your audio and video needs?

Consider the advantages of coming to Professional Audio Services:

- ▶ We specialize in Recording and Sound Reinforcement system design
- ▶ Our staff ensures professional service on all equipment we sell
- ▶ We offer new state of the art equipment to service you better

Otari • ITAM • Lexicon • Audioarts
dbx • BGW • AKG
and many other fine products

Whether you're building a whole studio or buying piece by piece, at Professional Audio Services we'll give you master quality recording systems at competitive prices. A free "hands-on" demonstration from our qualified sales staff is also available.

For all your audio and video needs, come to Professional Audio Services for the Systems of the 80's.



99 East Magnolia / Suite 215 / Burbank, California 91502 / 818-843-6320

Circle #060 on Reader Service Card

World Radio History

FIELD TEST



FOSTEX B-16M 16 TRACK TAPE RECORDER

by Joe Van Witsen

The multitrack tape recorder has been the standard medium of recording music for the past 20 years. Recently, the multitrack recorder has worked its way into areas of the industry other than music mastering studios. The reasons for this are increasing demands for quality stereo sound in film, radio and video production, and a greater interest by musicians to create compositions on tape in a non-pressured environment. But perhaps the clearest explanation for the sudden proliferation of multitracks is the advancements made in recording technology: tape formulation, noise reduction, and tape head design have reached a price/performance ratio whereby it has become possible to record a high quality audio signal on an increasingly smaller tape format.

This Field Test examines the Fostex B-16M, Fostex's latest entry into the professional recorder marketplace. The B-16M is the three head version of the B-16 series. Fostex broke new ground with the B-16 by placing 16 tracks of audio onto half-inch tape. The advantages of half-inch over one or two-

inch tape are: lower tape cost and lighter weight which can be moved by smaller motors, (allowing the entire recorder to be scaled down in size and weight.) Weighing in at 67 pounds, with physical dimensions of 17.5"x17"x9.25", the B-16 can easily be lifted and carried by one person. Prior to the B-16, moving a 16 track recorder required three or four persons and a van. Its small size allows it to be mounted into a standard 19-inch rack, making it ideal for small broadcast and video vehicles and off-line video edit rooms which are notoriously cramped. A two-inch tape recorder generally takes up about 12 cubic feet, about the size of a washing machine, and spaces must be designed to accommodate them. With rack mounting, the B-16 can even be flush with the wall. For table top use, a one by two foot space is all that is required. An optional roll-around console allows the B-16 to operate at any angle.

The operational features of the B-16 are simple and straightforward. Located just below the tape path area is the track selection panel with 16 push-track track selectors and illuminated track number indicators. This panel also con-

tains the power switch, input monitor select, coarse and fine pitch adjustment and LED tape timer. A meter panel is located below track selection. This contains 16 twelve-segment LED level indicators with program level in green and peak level in red. To my knowledge, this is the first analog multitrack recorder to use an LED metering system. The advantages are: no calibration, no bulb replacement and visibility of all 16 tracks in one glance. Another advantage is the ability to see the levels on the machine from a greater distance than with needle meters.

The meter panel can be removed and placed on top of the machine or it can be placed in a remote location, say near a mixing console, or video monitor. Just to the right of the meter panel is the main control panel with push buttons for record, play, fast forward, rewind, return to zero, and stop. The stop button, when pressed twice, releases the reel brakes for manual editing.

Two remote control units are available. The model 8090 is a simple remote unit containing track select, transport controls, input monitor select,

LED tape timer, cue button and a repeat button which will repeatedly play the tape between the zero point and the cue point. The model AL-16 is a full function remote control that features transport controls, track select, LED tape timer, LED target time indicator, numeric keypad with nine position autolocator with trim function, find, cue and mode select keys as well as three user-definable soft-keys allowing a sequence of routines to be stored. The AL-16 is remarkably compact considering all its functions.

The rear of the deck contains the 16 inputs and outputs (RCA jacks), a remote punch-in, punch-out jack for a foot switch, remote control plug, meter remote jack, noise reduction internal/external select, and a port for a SMPTE synchronizer. The B-16 has been specifically designed for synchronizing work, the transport is prewired and the ballistics optimized for fast chase and lock with no overshoot.

The B-16M is a multitrack recording system consisting of the basic B-16D converted to a three head configuration, allowing simultaneous playback monitoring during recording and monitor signal mixing features. The system is composed of the B-16 multitrack recorder with three head assembly, the

model 8091 audio tape monitor unit containing playback amplifiers for 16 channels and a mixing amplifier housed in a 7 inch high rack mount chassis, and the 8090 remote control unit. This controls the monitor unit and can control signal mixing of any combination of the 16 tracks and also controls the input/sync select and playback monitor signals from the recorder. A headphone amplifier is also contained for monitoring convenience. 15 ips is the standard tape speed with a 30 ips option for critical mastering purposes.

The B-16M is rugged and very well built. Two deeply recessed hand slots on both sides allow for easy handling. The tape threading path is unconvoluted, allowing rapid spooling and near instantaneous speed stability. Two large idler wheels are at the left and right of the head block assembly. The supply idler serves to guide the tape through an optical tape presence sensor while the takeup idler generates the tach pulses which drive the LED tape timer. The head block contains erase, record and play heads, tape roller guides, manual tape lifter, and manual head gate.

The transport performance is impressive. Shuttling is smooth and quiet with even tape packing. When command-

ed from the AL-16 to find a cue, the machine races to its destination and coasts to park exactly at the desired location.

The sound quality of the B-16M is excellent. Transients are clean, with no harmonic distortion evident. The signal to noise ratio is also excellent with Dolby C delivering a S/N of 80dB weighted, 60dB unweighted referenced to 3% THD at 1kHz. This allowed track bouncing without noticeable quality loss. The sound quality I got from the B-16M is superior to some two inch machines I have used.

Final Evaluation: The B-16M is an extremely cost efficient production tool. Its size, weight and operational ease make it available to locations and projects where a remote recording truck would have been required before. The sound quality is comparable to larger format systems at a fraction of their price. The only possible disadvantage of the B-16 is that as of this writing it is the only 16 track half-inch recorder on the market, so tape recordings made on the B-16 must be copied to another format in order to work in another studio. But with so many features going for it, half-inch may soon become the new defacto 16 track analog standard. The Fostex engineers know what they are doing. ■

The missing links?

The visual side of your presentations may be superb; but is the audio side as good? The missing link could be the quality of your loudspeakers.

With the Tannoy Lynx, part of the Wildcats professional loudspeakers system, you can be sure of 'recording studio' sound quality for every presentation.

The Lynx uses 2 of the renowned 12" Tannoy Dual Concentric speakers in a double cabinet. You can split the Lynx and use both halves separately or for large presentations you simply strap the two halves together to give you a really powerful system. Whatever your presentation, or wherever your location...

...dare you turn your back on a Wildcat?

WILDCATS
LIVE PERFORMANCE LOUDSPEAKERS FROM **TANNOY**

Tannoy North America Inc., 97 Victoria Street North, Kitchener, Ontario, Canada, N2H 5C1. Telephone: (519) 745 1158

—FROM PAGE 24, **LOUDSPEAKERS**
about things, which is one reason why the crazy guy went with Time Align®. Can you imagine: you run a company that's making electronic stuff and you decide to make a loudspeaker and go up against Altec and JBL? That took guts to do; to actually back the project and go ahead and do it." Even Putnam was amazed at the reception which the UREI 813 Time Align® monitors received; they quickly attained the status of industry standard.

Calibration Standard Instruments was formed in the mid-'70s after word had spread about the small, incredibly accurate reference monitors that Long had built for his own work in recording and design, which were made to be used within three feet of the listener. In making field recordings to gather known source material for loudspeaker evaluations, Long often found himself attempting to monitor on location in difficult acoustic environments. Consumer bookshelf speakers were the right size, but they were too colored and their lack of time coherency became exaggerated when they were listened to very close up. He designed the MDM4 (for Mix Down Monitor 4-channel; many of the early pairs were used in four channel work) to deal with the problem. Then he went further, and made a qualified description of the proper environment for the use of this tool, calling it Near Field Monitoring™, and specifying allowable limits for distances between speakers and to the listener, time offset in the speaker, and effects of the first order reflection (typically off the mixing console). After giving his Time Align paper he began incorporating that into his Near Field Monitors™, resulting in the MDM-TA2 and MDM-TA3.

In essence, Long is dealing with the same problems of room acoustics that Meyer is, but he has the simpler option of eliminating room anomalies by moving the speakers closer to the listener until the contribution of the reverberant field is negligible in comparison to the direct field from the speakers.

If it appears that designing monitors is closer to Ed Long's heart than designing consumer loudspeakers, perhaps it is because he finds it disheartening to have to design a consumer loudspeaker with the thought in mind that it will have to cover up for a lot of awful source material. Badly recorded or mastered material vexes him, as does industry conservatism and obsolete concepts that won't die, like mono compatibility. "Even at this stage of the game, there's still a lot of material that would make people say, 'Wow, that's awful!' if they could only hear how bad it sounds over really good loudspeakers," Long complains. And on mono: "We should get away from mono compatibility now;

it's the thing that's ruined stereo since the beginning, and it's had everybody going crazy. Here we are, how many years after stereo came in?, and we're still mono compatible."

The frustrations of poor quality source material have not made Ed Long want to quit designing consumer loudspeakers, though they've made him want to improve the source material. This was part of the motivation which led him to collaborate with Ron Wickersham in the creation of the Pressure Recording Process (PRP)®. PRP® came about because most microphones exhibit large differences between their on-axis response (to the subject of the recording) and their random incidence response (to the reverberant field), typically yielding unnatural recordings. In the PRP, the transducer is placed in the pressure zone at a boundary (such as a floor or wall or table), where there is no distinction between direct and random incidence sound. Long and Wickersham have a very fruitful and unlikely collaboration. They met at an AES convention when Long struck up a conversation after being amused by Wickersham playing with his child. On occasions, the two have been spotted walking through the crowd at a Grateful Dead concert, Long in a two-piece suit and well-trimmed hair, and Wickersham in a tie-dyed t-shirt and large, bushy beard. But the two have a special chemistry that has led them to conceive and execute a number of crazy ideas, the latest being the ELF™ technology.

The ELF™ technology is a system employing unique acoustical design along with matched electronics which allows very significant amounts of very low bass to be reproduced by an extremely small package. A 15-inch driver in a one cubic foot enclosure develops a whopping 94 dB SPL at 1 meter from 16 to 150 Hz. (no, that's not a typo). Even more amazing is that a 6-inch driver in a half-cubic foot enclosure can reproduce the same frequency range at 82 dB SPL. By the time you read this, ELF speaker systems will probably be available from CSI, making an ideal match to the small TA2.

Long and Meyer, and to some extent Klipsch and Bose, all have companies of a size that allow them to make products following a very specific concept, or reflecting a particular point of view. The situation changes, however, at a company as large and varied as JBL, Inc. There is a good case to be made for the statement that there are more JBL speakers in use in the sound industry than any other brand.

"We service a lot of different markets," notes Mark Gander, "broadcast, recording, musical instrument, pro sound-type reinforcement, tour sound—large scale reinforcement, sound con-

tracting—engineered sound for stadiums and speech-type systems, industrial/commercial type sound—for paging systems, life safety warning systems, hi-fi, audio-visual. These are just some of the markets, I probably left some out.

"We try to address each market individually," Gander explains, "In a lot of cases we'll design one loudspeaker system that can do a lot of jobs, but in other cases we'll design a system that is for a certain application; if there is a big enough and specific enough need, that's the only way to do it—with a specialized product." An excellent example of this is the differentiation which JBL makes between speakers which are sound producers (such as musical instrument applications) and those which are reproducers (such as for studio monitoring). A reproducer of sound needs to be completely faithful to the source material, and hence must exhibit flat, linear frequency response with a smooth rolloff. However, to get that screaming guitar sound a speaker is needed which is not entirely faithful, but has certain desirable distortion characteristics.

JBL's awareness of these differences has led to a lot of research into transducer design. Research on low frequency transducers has identified the contributions of various aspects of the speaker's construction to the resulting sound. For example, the relationship between the height of the voice coil and the height of the magnetic gap in which it is suspended can indicate the speaker's peak displacement, and hence its third harmonic distortion characteristic. The shape and material used for the surround (the part of the speaker which connects the cone to the rim), the shape of the cone, the materials used for the former (which connects the voice coil to the cone), even the kind of wire used for the voice coil—all these things play a part in determining what the final result will sound like. Having identified these factors (and a number of others), JBL engineers are able to use this knowledge to tailor a speaker to a specific set of characteristics. One of the results of this research is JBL's Symmetrical Field Geometry (SFG) magnetic structure. The voice coil hangs in the gap between the pole piece, inside the coil, and the top plate which is mounted on top of the magnet outside the coil. Unfortunately, in many speakers the top plate is cantilevered over the magnet, while the pole piece is not cantilevered at all, but a solid slug of metal, which yields a non-symmetrical magnetic field for the voice coil to move in—in other words, a distortion mechanism. To counter this effect, JBL engineers designed an undercut pole piece with a cantilever equal to that of the top plate, making the magnetic field symmetrical, which is the essence of SFG.

Low frequency transducer

Some Things are Better Than Others...

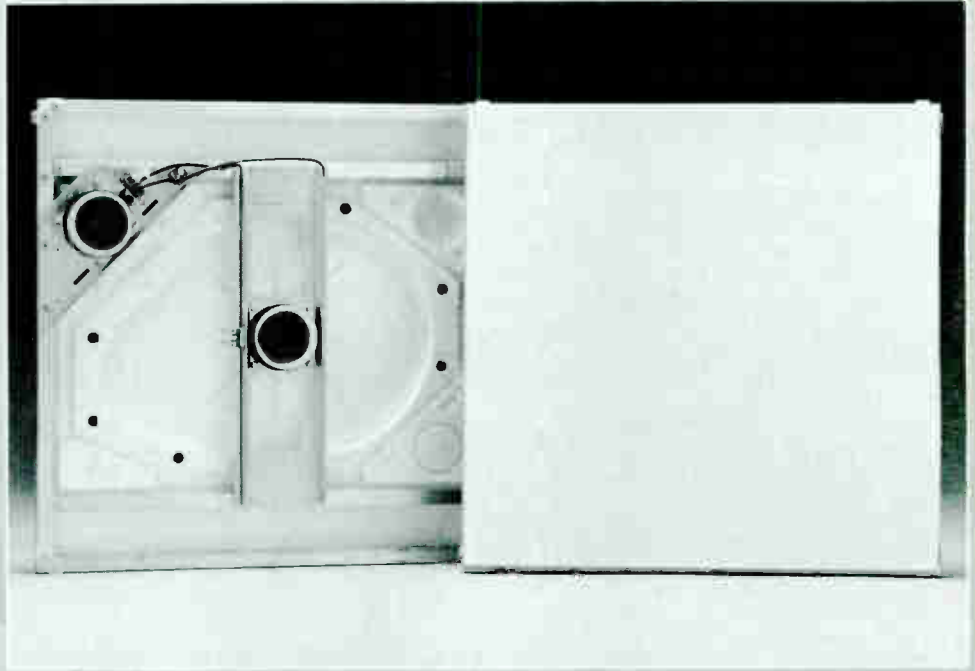
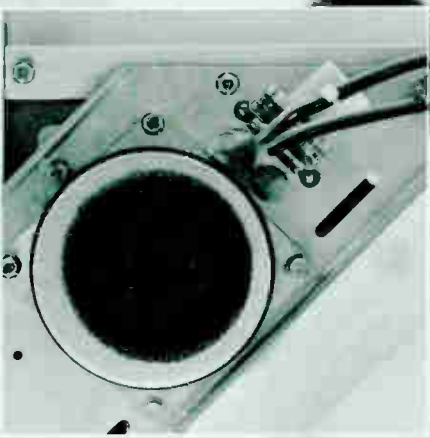

Introducing One of Those Things...

Consider a speaker which easily fits into a 2' x 2' drop ceiling, becoming an invisible part of it. With such wide dispersion that it can replace up to 12 ordinary speakers. With the dynamic range to provide foreground as well as background capability.

BES technology brings a whole new level of performance capability to the ceiling environment. For example our C70D specifications rival well known monitor systems of great bulk and expense—which *won't* fit in a ceiling. Frequency response ± 3 dB 40–19 kHz; distortion less than 1% above 400 Hz at 96 dB SPL.

What you hear is precisely etched high frequency response, along with solid impact response at low frequencies. Furthermore, 180° dispersion across the entire rated spectrum plus Phase Coherent radiation reduce the tendency to feedback.

Often you can install a BES High Performance Ceiling Speaker for far less than traditional ceiling speakers.

Some things really *are* better than others.

B.E.S.

345 Fischer Street, Costa Mesa, CA 92626
TELEX 67-3373 / 714-549-3833 / **800-592-4644**

- Please have a sales rep contact me
 Please send me the BES C70S, C70D ceiling speaker brochures.

NAME _____

FIRM _____

STREET _____

CITY _____

STATE _____ ZIP _____

TELEPHONE () _____

Circle #062 on Reader Service Card

technology is not the only thing that has been happening at JBL. Materials and construction research on compression drivers has brought advancements such as the use of materials such as titanium for diaphragms, and a three-dimensional diamond pattern suspension to hold them. But the greatest step in high frequency reproduction that has come from JBL has not been in this area. "Horns," muses Gander, "are one example of loudspeaker technology where there has recently been advances. Not really in terms of the transducer itself; again, there are newer things in materials and power handling, but there are still a diaphragm and a magnet coupled to the throat of a horn. The one thing we have seen recently is the constant directivity devices. All the horns previously were pretty much based on an exponential formula because the exponential mathe-

matical law, when applied to a three-dimensional flaring bell from throat to mouth of a horn, provides the best acoustic load to efficiently transform the sound over the widest frequency range. There were a few other flares used, but basically they were slight modifications of the exponential, and people said, 'Well, I've got to use the exponential formula or something very close to it.'

"Multicell horns were basically a bunch of exponential trumpets formed into a spherical segment based on the angle you wanted to cover. Those were the first horns to try to get some sort of consistency in coverage. The next step was radial or sectoral [horns]. They all used roughly the exponential flare, but those methods only approximated, over a limited bandwidth range, the coverage angles you wanted. Recent work by guys like Don Keele [who created the in-

dustry's first constant directivity horn, the Electro-Voice "white" horns] and Cliff Henriksen [who, along with Mark Ureda, created the Altec Manta Ray horns which followed Keele's] specifically, but loudspeaker designers in general have shown that by not restricting yourself purely to the exponential formula, and by making a compromise between the loading of the diaphragm and the coverage angle that you want to maintain, you can come up with 'trick' methods of putting horn sidewalls together to accurately cover segments of a space that you want and hold them over the full bandwidth of the horn, within restrictions of the mouth size. Most of these modern designs have three flare rates: one from the driver out to some sort of horizontal gap or aperture, then another one to cover the dimension perpendicular to that gap, and then a final one out to the bell to control diffraction effects out where the wavelength approaches the dimensions of the bell.

"JBL wanted to do a next generation [following the E-V and Altec devices] constant directivity-type of horn. The BiRadials [also designed by Don Keele, by then at JBL] have a more complex flare that smoothly combines the secondary flare from the gap out toward the mouth and the final mouth flare together into one complex equation." A number of different BiRadial horns were created for different applications: the full-blown version for sound reinforcement [the 2360, 2365, and 2366 which vary in coverage angles] called Constant Coverage, several flat front versions designed for portability and arrays [which sacrificed a little of the vertical coverage for a more compact size], a large Constant Coverage version for studio monitors [known as the "cheeks"], and a smaller version of the studio horn [known as the "baby cheeks"] which is built onto a very high frequency transducer. The BiRadials have had very good acceptance in the market, making a noticeable impression in theater sound. JBL components, including the large BiRadial horn, were selected by Lucas-Film for use in their THX theater sound system. But the BiRadial horn alone is not JBL's only contribution to theater sound, a field which has progressed much slower until recently than other areas of the audio industry.

"Our theater systems are a good example of us introducing a radically new concept," Gander points out. "Everybody thought for years that the only way to do a motion picture system was with those midrange horn-type loudspeakers, like the Altec A7 [Voice of the Theatre]. When you look back on the history of that stuff, the only reason they used that was that they only had ten or fifteen watt amplifiers. They didn't have power, so they had to squeeze the abso-

CREATIVITY
The creative process hasn't really changed since man first put pencil to paper. Continuing advancements in electronics technology have, however, changed the tools of creativity at an ever increasing rate. Since 1956, Leo's Audio, Music and Drums have been the leaders in supplying and supporting the needs of musicians and audio professionals. And we too have changed. Introducing our latest creation: Leo's Audio and Music Technologies. The equipment and service center for today's musician, recordist, broadcaster and post production facility. Incomparable equipment selection, knowledgeable sales consultants and systems interface experts and professional services including maintenance and customization...

leo's audio and music technologies
Anticipating the needs of musicians and audio professionals since 1956.

5447 TELEGRAPH AVE. • OAKLAND • CA • 94609 (415) 652-1553

Circle #063 on Reader Service Card

This is a Grammy.[®]

It's the most prestigious award in the field of recording, given for creative excellence —the only such award that covers all aspects of recording's arts and crafts.

AND WHO DECIDES THE ANNUAL GRAMMY WINNERS?

Only the voting members of the National Academy of Recording Arts & Sciences (NARAS)[®]

ARE YOU ONE OF THEM?

If not, we cordially invite you to join over 5,000 members of NARAS eligible to vote for the Grammys because they have themselves contributed creatively to commercially-released recordings. You will also receive invitations to your chapter's functions like seminars, panel discussions, and educational and social activities. And you will be entitled to receive invitations to the Grammy Awards at members' reduced rates, as well as reduced rates on current albums offered to voting members in our bi-monthly NARAS Awards Guide.

HOW CAN I JOIN?

Simply fill in and mail the form below. You will receive an application form from the NARAS chapter nearest you. The application describes membership eligibility requirements for producers, engineers, musicians, songwriters, singers, arrangers and others.



National Academy of Recording Arts & Sciences[®]

Membership Department
303 N. Glenoaks Boulevard, Suite 140M
Burbank, California 91502

Yes, I am very interested in knowing how to become a member of NARAS. Please send me an application form and other information as soon as possible.

Name _____ Company if applicable _____

Address _____

City _____ State _____ Zip Code _____



**DeCUIR
SAMPLE CASE
COMPANY**

LOS ANGELES, CALIFORNIA

"EXCELLENCE WITHOUT EQUAL"

Your only source for the finest in sound enclosures for P.A. systems, amp racks, monitors and speaker cabinets when quality and affordability counts. All solid core plywood construction with premium carpet covering for a rugged performance. Most models come complete with fiberglass, phonejacks and recessed handles. Completely constructed and assembled in the U.S.A. A complete line of guitar and band instrument cases are also available.



WHOLESALE & DEALERS ONLY

DeCuir Sample Case Company
4012 So. Broadway Pl.
Los Angeles, CA 90037
Tel. (213) 233-4184

Circle #065 on Reader Service Card

Pumping Ferrite

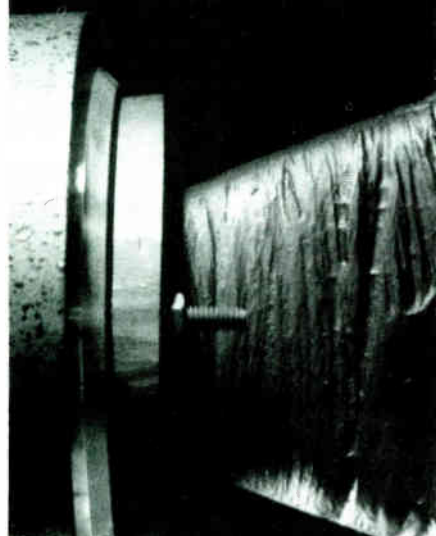

DDS horns are guaranteed to keep physically fit for FIVE YEARS.

DDS
DESIGN DIRECT SOUND
6850 35th NE Seattle WA 98115

Circle #066 on Reader Service Card

lute maximum efficiency out of the system: they couldn't afford to sacrifice any efficiency for smoother response down to the deep bass notes. Everybody now buys 60 or 100 watt amplifiers, so we pioneered the idea of using direct radiators that still give you real smooth response, flat down to very low frequencies, and then putting a constant directivity horn on top of it that matches the coverage angle that the woofer has narrowed to at the crossover point so that you get a coverage angle that is broad at the low end, then narrows at the crossover point, and then is held all the way through the horn's range. That was a radical design approach which came about because of rethinking the problem."

Computers are also aiding in the study of psychoacoustics, a field which is just now really budding, and, in the opinion of most loudspeaker designers, is the most important element of their craft. But other than the obvious fact of

computers being heavily involved, what might the future bring to sound reproduction (or production, with the massive use of electronic musical instruments)? Virtually no one was foolish enough to speculate on this. Except Gander:

"There may come at some time—maybe a year, or ten years, or maybe a long time—a way to magically excite the air molecules and do something incredibly radical. Maybe laser beams coming together in the room, not within some confined chamber, but just around you. I'm really in deep space, now; I'm talking extremely pie-in-the-sky." Maybe, but then again, who was foolish enough five or ten years ago to predict that you would be able to wear a TV on your wrist and carry a disk player in your coat pocket which would sound better than anything previously existing? Think about it. Then rethink it. ■

—FROM PAGE 13, COMPRESSION

created primitive PA systems. Once the latter occurred, the horn would never be the same again—man had stumbled upon the age of sound reinforcement.

In typical American fashion, the actual development of "loudspeaking" horns didn't really take off until the late 1920s when entrepreneurs discovered that there was a huge market for the devices ripe for the picking in the motion picture business. Although not the earliest, Al Jolson popularized the age of the talkies with *The Jazz Singer*, and movie houses everywhere were anxiously waiting to draw the huge crowds that wanted to see the silver screen speak. Before they could reap the new profits though, it was necessary to upgrade their theatres for sound . . .

To fill the needs of the movie houses, giant corporations like Western Electric/Bell Labs and RCA were more than happy to oblige, and in the process, they continued the horn's march along the evolutionary scale. Since a huge profit was clearly at stake, the corporate giants bought the brightest engineering minds available, and let them loose on the project. What followed could certainly be described as one of audio's "golden ages."

E.C. Wenthe and A.L. Thuras at Bell Labs produced one of the first high fidelity loudspeakers for the movie industry, which was a compression driver attached to a pattern control horn. They called it the 555-W, and it had a continuous 30-watt input capacity, which far ex-

ceeded any earlier design.

According to Bob Clement, an engineer with West Chester University and noted collector of old movie house equipment, the Western Electric 555 and its offspring the 594 were extremely efficient. "They had to be," he said, "because the tube amplifiers at the time were only capable of producing around 5 watts, and they had to fill huge auditoriums. With these early compression drivers, there was no back wave lost at all, everything was forced forward into a full-length exponential-type horn that coiled around and opened up into a six-foot wide mouth. At the time, large theaters would utilize two of these systems behind the screens, while smaller places could get away with using only one."

In 1935, as the general public sat in their mohair theater seats watching and listening to the early talkies, people like Harry Olson, James B. Lansing, Robert Stephens, and Harry Kimball worked in conjunction with John K. Hilliard of Metro-Goldwyn-Mayer Studios to take Wenthe and Thuras' work a step further by designing a theater loudspeaker system that could be mass-produced and adapted to virtually any movie house. Their design included a selection of multicellular horns, and low-frequency loudspeaker cones coupled to oversized horns usable to 50 Hz. To extend the baffle area of the low-frequency transducers, the enclosures were additionally equipped with Batman-like "wings" that simulated half-space conditions. Also of interest in this system was the Lansing 284E

THE SPEAKERS THAT SHOOK THE INDUSTRY

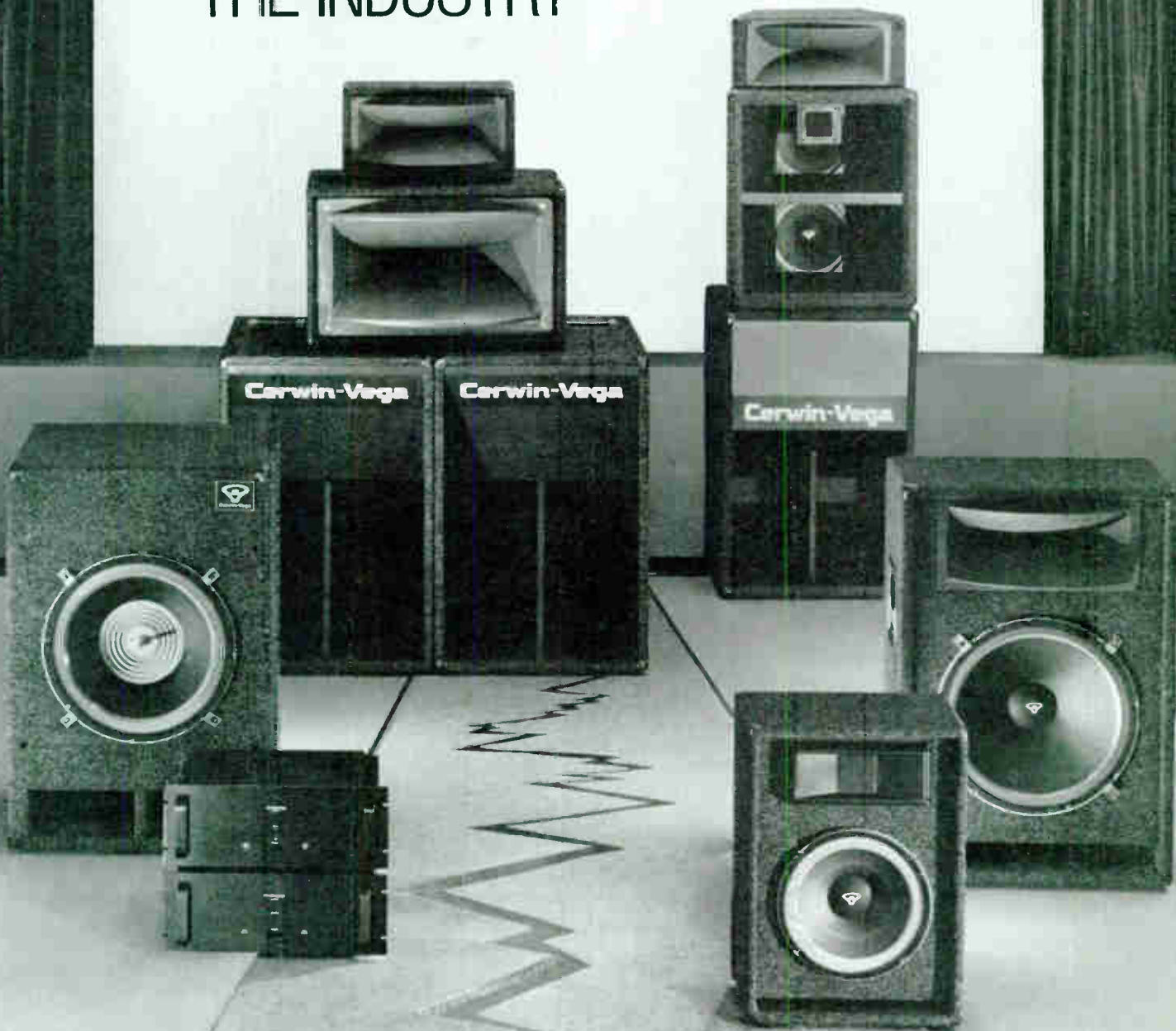

As an audio professional, you've probably already heard a lot of good things about Cerwin-Vega. That's because for the past thirty years we've been able to combine inspired engineering with real-world practicality to provide new standards in acoustic and electronics performance.

Our efforts have resulted in superior live music sound reproduction, (the Rolling Stones used our products for guitars and keyboards on their '81 U.S. tour), the Academy Award winning Sensurround® cinema special effects system, and the single-handed invention of high level dance music playback (or disco, as it came to be known).

With these credentials, it's no accident that we currently manufacture the most capable line of professional products for the wide, diversified world of commercial sound.

Our current product line is based on highly evolved performance principles of enormous power handling, excellent efficiency, clear, intelligible midrange and high frequency projection, and ultimate reliability.

The Cerwin-Vega V-100 system, for instance, is something of an engineering marvel. Its dual 18" horn loaded bass components are direct descendants of the speakers which reproduced an earthquake for Universal Studios, and the midrange and high frequency compression drivers use advanced diaphragm technology which reduces distortion ten fold over competitive designs. The V-100

is rated at 1000 watts power handling E.I.A., and can produce sound pressure levels approaching 130 dB.

That's a lot of system. But even the smallest Cerwin-Vega pro speaker, the 12" two-way V-19, delivers more performance value than anything else on the market. And between these two extremes, we've got enough speakers in enough configurations to cover any possible commercial sound application. They're even available in a variety of finishes, including a rugged carpet covering, and a textured epoxy paint for fixed installations.

And, of course, we offer a full line of compression drivers for jobs requiring custom installation.

If you're looking for a way to turn any pro sound job into something special, into a true audio experience, then you should consider the real movers and shakers in the industry—Cerwin-Vega Professional Audio Products.

Even if you don't have to recreate an earthquake.

 **Cerwin-Vega!**

12250 Montague St., Arleta, Ca. 91331
(213) 896-0777 Telex No. 662250

Altec Multicellular Horns.

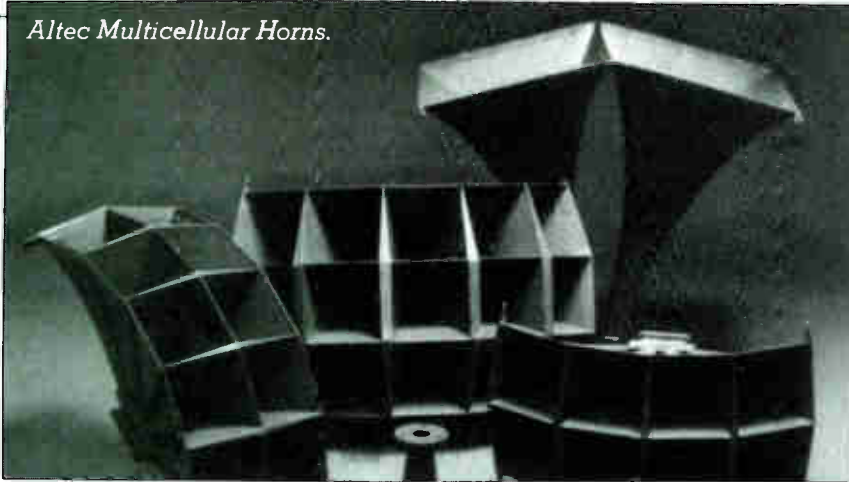

high-frequency driver, which is essentially the same as many drivers still being manufactured today.

The following year, Hilliard and crew won a technical award from the motion picture industry for their work. Subsequently, some of them went on to help develop the fledgling West Coast loudspeaker industry into what it is today. As the decade wore down and World War II began to loom upon the horizon, the market for theater sound showed signs of becoming saturated. The big money that was once there was gone, because just about every theater in the country was outfitted with one of the popular systems available. Along with the money, the best minds also left the research area of new loudspeaker technology for more exciting arenas like aerospace and computers. What followed could be described as the Dark Ages for fresh ideas in compression driver/horn theory.

In hindsight then, the cinema was responsible for bringing about modern-day sound technology and the compression driver/horn loudspeaker system. Once cinematic sound needs were fulfilled though, the times didn't warrant a need for change until audio entered another age—that of touring sound.

During the late '60s, an engineer named Bruce Howze and a few others began to realize that the loudspeaker systems in use by touring groups definitely needed a shot in the arm when it came to mid-range performance. At the time, Howze was working for a Philadelphia-based contractor called Festival Group, which among other distinctions, was supplying tour sound for Janis Joplin and the Jefferson Airplane. As was common practice then, most road shows relied upon the two-way systems that had been developed for cinema sound. In addition to the aforementioned defi-

ciency in mid-range performance necessary for live sound reinforcement, these loudspeakers were never intended for portable use because of their massive, awkward nature. Howze contemplated the problem, and began taking serious action upon starting his own sound manufacturing concern, Community Light & Sound.

Once established in their Philadelphia-based plant, Community began work on a variety of solutions to the problems posed by poor tour sound. "Our first horn/driver combinations were mid-range units that employed 10" and 12" cone-type loudspeakers as their driver mechanisms," Howze recalls. "These horns represented a definite improvement over existing equipment, and development continued for a number of years, yielding several successful products. The further we pushed this concept, the more we became aware of the basic limitations of cone loudspeakers for this application. Their power response band-width was too limited, and their cone and motor mechanisms too weak to provide



(Left) An internal glimpse of Community Light and Sound's M4, which reveals the unit's 6½ inch diaphragm. The diaphragm is made from aluminum skins bonded to a rigid foam core.

wide-range high SPL performance. To get beyond these limitations, it was obvious that a new type of driver was needed. What we envisioned was a very large compression driver with a tremendous power and pumping capacity."

While Howze and the rest of the engineering staff at Community continued their research, the folks at Electro-Voice and Altec began introducing their lines of constant-directivity horns, and JBL unveiled its line of Bi-Radial horns. Unlike the first radial horns, which could only hold accurate coverage in a horizontal fashion, the BiRadial line was able to obtain accurate coverage in both the horizontal and vertical dimensions. Driven by bolt-on compression drivers with one and two-inch throats, two types were produced: the constant-coverage BiRadials, and the flat-front BiRadials. The former (models 2360, 2365, and 2366) are large-mouthed devices (30" square) with coverage angles of 90 x 40, 60 x 40, and 40 x 20 respectively. The sheer size of these horns makes them extremely popular with contractors when it comes to filling sound needs for huge stadiums because of their ability to hold even coverage angles at 500 Hz and below. Conversely, the flat-front Bi-Radials (models 2380, 2385, and 2386) were primarily designed to be stuffed into enclosures or used in small clusters. Outwardly, these horns are built without flanges on the front edge, and are ideal under circumstances where vertical coverage isn't as critical. With the recent rise in the number of portable systems and multi-way touring systems, they have become increasingly visible on the audio scene.



(Right) Featuring a 4 inch diameter throat and a power output of 100 acoustic watts, the M4 compression loudspeaker measures 13 inches in diameter and weighs 38 pounds.

That British sound

▶ ITAM #1610: 1" 16 track
Recorder/Reproducer \$11,950.00

■ 1" 8trk., pre-wired \$9,950.00

BOTH TAPE MACHINES FEATURE:

- +4dBm IN/OUT ■ 15/30ips
- Full-function 9 cue position remote-autolocator ■ stand
- 50% range vari-speed

◀ ACES TR-24: 2" 24 track
Recorder/Reproducer

\$19,950.00

■ 2" 16trk., pre-wired 24 trk

\$14,950.00



▶ ACES ML24:

I/O console, 32 in x 24 buss,
Integrated wired patch bay

\$17,025.00

■ ACES SM16: Split console,
32 in x 16 buss \$15,665.00

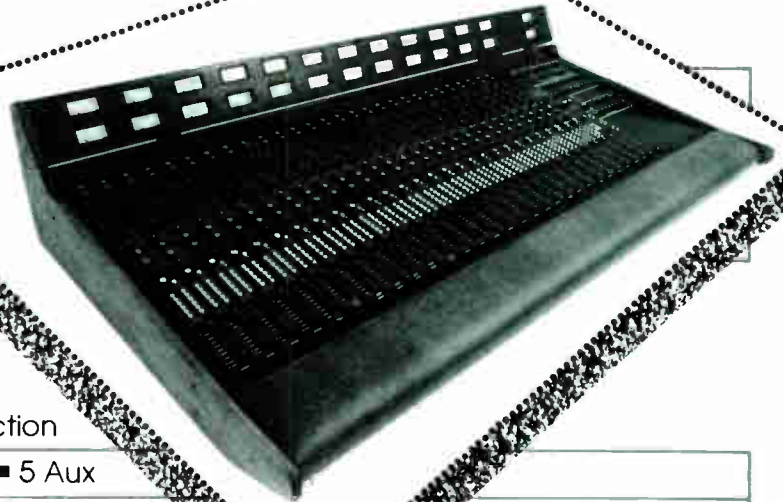

BOTH CONSOLES FEATURE: Fully modular construction

- Audiofad long-throw conductive plastic faders ■ 5 Aux sends
- 5 band switchable EQ ■ Input LED PPM's ■ Stand
- +48v phantom power ■ LED display (optional) ■ Two year parts warranty
- Other frame sizes available ■ Many options available



As the breakthroughs mentioned above caught the public's eye, the lights were still burning well into the night back at the homefront at Community Light and Sound. Finally, after well over a decade of research, Howze, John Wiggins, and Cliff Henriksen hit upon the ingredients that later blossomed into the M4 Series of compression loudspeakers and pattern control horns.

"The M4 Series represents an entirely new concept," Howze said while smoking an omnipresent Clint Eastwood-style cigar jammed into his favorite holder. "Compared to previous designs, the M4 has a lot more power, and is physically bigger. By itself it provides perfect voice rein-

forcement, and in a three-way system, it's the only way to do mid-range. It has versatility too: on one hand, it's a driver that can give you levels of pressure that provide intelligible sound at Grand Prix races, and on the other, it's a loudspeaker that's equally at home in opera houses, where there's a need for extremely low distortion and a high grade of sound.

Measuring 13 inches in diameter, the M4 weighs in at a hefty 38 lbs. (the unit's ceramic magnet alone weighs 11 lbs.) and is encapsulated in molded fiberglass before being attached to one of Community's pattern control horns. To meet their engineering goal of having 100 acoustic watts of power output while maintaining

low distortion levels, Howze and associates chose a 4.5-inch voice coil and a four-inch diameter throat. A six and a half-inch diaphragm coupled to this massive motor structure makes high sound pressure levels a reality. The latter is a composite of aluminum skins bonded to a rigid foam core, which provides the strength and stiffness required for such performance levels.

"The throat size of the M4 was one of the most important details we had to take into consideration," Howze said. "Other drivers of similar configuration have relied upon much smaller throats, so even though they are able to operate in the same range as the M4, the distortion levels are constantly higher."

To further increase efficiency and improve linearity, the M4 was constructed using a symmetrical gap geometry. A flux stabilizing ring was also added to keep the magnetic field from varying under high power inputs. For a phase plug, it was decided that one with no passband resonances would be the most appropriate. That way, the plug would remain completely "neutral", and the M4's sound would be unaffected by resonances or phase shifts.

From an historical perspective, the M4 is a vast departure from the early compression drivers/horns that were cranked out by Bell Labs, RCA, and General Electric. A few years after its introduction at the 1981 AES Show, other manufacturers began dabbling with ideas of how to draw upon compression driver theory to solve mid-range sound problems. Developed by Renkus-Heinz, the SSD-5600 is billed as a low/mid-range compression driver, and physically looks quite similar to the M4. It utilizes a large, unsupported aluminum diaphragm and a fairly powerful magnetic circuit routed through a low-compression, low flare-rate phase plug.

Emilar also joined the mid-range compression driver race recently with the development of its model EC-600. Like the M4 and the SSD-5600, it too resembles a giant land mine and has a larger-than-normal diaphragm and throat area (6" and 3.2" respectively).

It goes without saying that the advancements made in horn technology during the past ten years are sophisticated by modern standards. Yet what is modern now will eventually represent just another link in the evolution of sound projected from horns. Given the industry penchant these days for digitalizing things and sticking computers into them, the future will undoubtedly hold many more surprises for our ears. ■

Blow Their Socks Off With Gauss Efficiency

All Gauss loudspeakers are designed to give you high conversion efficiency. A fancy way of saying they give you more power per watt... so you get the sound pressure you want with a smaller number of cabinets and amplifiers. You don't have to lose your socks to pay for all that sound!

Gauss speakers are also built to be the world's most reliable loudspeakers. Our exclusive double spider construction and our ten minute torture test on every Gauss loudspeaker assure you of that. So, you know they will keep knocking your audiences' socks off for years after you buy them.

There's a Gauss loudspeaker to fit every professional need from 10" ...

to an 18" that handles 400 watts... to our 200 watt coaxial designed to knock the socks off recording engineers.

For more information on the entire Gauss line, see your authorized Gauss dealer or write Cetec Gauss, 9130 Glenoaks Blvd., Sun Valley, CA 91352, (213) 875-1900, Telex: 194 989 CETEC.

More Power Per Watt
gauss
by Cetec



© 1985 Cetec-Gauss

Circle #067 on Reader Service Card

"HERE'S THE BEEF!"



'000' Series power amplifiers



RMS (20Hz - 20kHz) both channels	bridged mono
DX 1000 375/8 600/4 800/2*	1200/8
DX 1000A 500/8 800/4 1000/2*	1600/8
DX 2000 400/8 600/4 1000/2 1500/1*	1200/8 2000/4
DX 3000 550/8 900/4 1500/2 2000/1.5* 1800/8 3000/4	

THD (20Hz - 20kHz) : 0.05% within rated power IMD SMPTE : 0.002% within rated power

Hill Audio, Inc. • 231 Marquis Court, Lilburn, GA 30247, U.S.A. • (404) 923-3198 • TLX 293827 HLAD
 Hill Audio, Ltd. • Hollingbourne House, Hollingbourne Kent, ME17 1QJ, England • (062 780) 555/6/7 • TLX 966641 HILL
 Headwater Industrie • 635 Caron Avenue, Windsor, Ontario, N9E 5B8, Canada • (519) 256-2454

by Carol Kaye

Last month we were speaking with former L.A. session great, now transplanted Tennessean, Billy Strange. We continue...

Mix: What prompted your move from Los Angeles to Tennessee?

Billy: I think the music scene got kind of tiring for me in Los Angeles, from the standpoint that motion pictures were not a big thrill at that time, television was not that healthy, it was no

longer fun for me. I was making good money doing commercials and all, but the record industry seemed to be moving elsewhere, and that's still the backbone for me. My most fun times have always been in the studio with musicians, whether I'm producing or arranging, or both. Actually I moved to Nashville to open up a publishing firm for Frank and Nancy Sinatra, and I spent the first three years here behind a desk...not in the studio.

Mix: Well what's going on here in Nashville, musically, in your estimation?

Billy: I think the majority of better music in the record industry is coming from Nashville now. I think the caliber of musicians has a lot to do with it. And, as you're aware, there are a lot of New York and L.A. musicians who have moved to Nashville. Singularly, each one of us has our own reasons why we get away from something we're doing and move somewhere else. But I think the basis of the major moves that have been made by the musicians and the entertainers to Nashville is because the music is a bit freer. You're not locked into a situation of having to back up a four-piece group that gets out on stage and plays heavy metal. Horn players have a terrible time working in the L.A. and New York areas, unless they are doing motion picture calls or jingles. But here in Nashville it's beginning to blossom for those players. People are utilizing players such as Dennis Soley and Jim Horn... saxes are a whole new thing in Nashville, not that Boots Randolph hasn't been here for 25 years, but there's a rejuvenation of musical freedom here.

Mix: Has country music blossomed into pop music and made it easier for non-traditional players to live here and to record?

Billy: It's a very comfortable place to live. There's probably less pressure here, both in and out of the studio, on players who are "in show business." I think there's less pressure on them to perform and to be on stage 24 hours a day, not just while they're working. But that pressure got to me in California. Whereas here, everybody is very laid back. It's a very easy place to work. The musicianship in Nashville is as good or better than any place I have ever heard in my life.

Mix: You played me a tape of a string section and it was fantastic.

Billy: The Nashville Symphony is probably one of the most respected symphonies in the country right now.

Mix: Has the capital of the recording

a chat with
BILLY STRANGE

PART 2



Billy Strange at 1977 Nashville recording session.

Composition without Compromise.

You need to finish the music today. You've got all those boxes spread out all over the studio. They're supposed to work together, but they don't . . . Why?

Because musical instrument manufacturers refuse to build one instrument that will do everything you need. Is this really the future?

Finally, the needs of composers, arrangers, performers, producers, songwriters and studios are being met head-on with a product that is expandable, interfaceable and presents a clear vision towards the future of music composition. The Linn 9000.

Linn 9000

Everything you've ever Dreamed of in a Drum Machine

All the sensitivity of a real drummer is here: velocity sensitive programming for dynamics, exacting hi-hat decay amounts for every note, programmable tempos, mix, and tuning for each of the 100 sequences. The 9000 also offers 18 of the longest and highest fidelity digitally recorded sounds yet to date. If you need alternate sounds, load them in from cassette, the optional 3.5" disk drive, or maybe you might want to sample your own sounds using our optional user sampling card. User sampling, the disk drive, and SMPTE interlock will be available Spring 1985.

Everything You'll ever Need in a MIDI keyboard controller

The ability to compose 32 different tracks on 16 assignable MIDI channels with all the expression and nuance of your performance is now possible. This MIDI sequencer integrates perfectly with the drum machine in the 9000 yet it's easier to use than a multi-track tape machine. The beauty is in the simplicity of the operating system; punch-in and out, auto-locate, fast forward, rewind, insert a part, copy another, merge them all. The 9000 operates the way you've always wanted to — simply, yet without compromise.



Linn

For detailed information and full color brochure please send \$1.00 to:
Linn Electronics, Inc. 18720 Oxnard St., Tarzana, CA 91356 (818) 708-8131 telex #704197 LINNELEC UD
"From the inventors of the Digital Drum Machine."

In A/B tests, this tiny condenser microphone equals any world-class professional microphone. Any size, any price.

Compare the Isomax II to any other microphone. Even though it measures only $5/15"$ x $5/8"$ and costs just \$189.95,* it equals any world-class microphone in signal purity.

And Isomax goes where other microphones cannot: Under guitar strings near the bridge, inside drums, inside pianos, clipped to horns and woodwinds, taped to amplifiers (up to 150 dB sound level!). Isomax opens up a whole new world of miking techniques — far too many to mention here. We've prepared information sheets on this subject which we will be happy to send to you free upon request. We'll also send an Isomax brochure with complete specifications.

Call or write today.

* Pro net price for Omnidirectional, Cardioid, Hypercardioid, and Bidirectional models.



COUNTRYMAN ASSOCIATES INC.
417 Stanford Ave., Redwood City, CA 94063 • (415) 364-9988



Circle #075 on Reader Service Card

The Department of Music Production and Engineering is now accepting applications for two positions in its department.

MUSIC PRODUCTION: Applicants must have professional experience in music production (film, TV, records, jingles, etc.) and the music business. Appropriate degrees or equivalent professional training required. Previous teaching experience is desirable but not required. Teaching responsibilities will include production courses in records, TV, film, jingles, etc. Salary and rank commensurate with qualifications.

RECORDING ENGINEER: Applicants must have extensive professional experience in the recording industry (film, records, TV, etc.), must be active recording engineers having recorded various musical styles and combinations (vocal, solo, orchestra,

etc.) Appropriate degrees, theoretical background or equivalent professional training required. Previous teaching experience is highly desirable. Teaching responsibilities will include courses in mix, multitrack recording, etc. Salary and rank commensurate with qualifications.

Berklee College of Music is a private four-year institution with an educational mission of practical career preparation in the various contemporary styles of today's professional music world. The 200 or more internationally respected faculty work with 2,500 students from over 75 countries and the U.S.

Please send resume, letters of reference, and supportive background materials to:

The MP&E Search Committee
Office of the Dean of Faculty
Berklee College of Music
Dept. MX
1140 Boylston Street
Boston, MA 02215



Berklee College of Music

An Equal Opportunity Employer.

Circle #076 on Reader Service Card

business shifted to Nashville in your opinion?

Billy: Well, they're calling Nashville the Third Coast. I recall the days when New York was the center, and then it shifted to L.A.

Mix: People like you made Los Angeles the recording capital. I remember that, but you've kind of kept a low profile since those days.

Billy: That's part and parcel of how I feel about the business. As I said earlier, the spotlight never thrilled me. I'd like to leave something that people will say "Yeah, that was very good" and I have some things that I've done that I'm proud of. I think I'm going to, if not this next six month period, this next year or two or three or five years from now, to be able to do something more in Nashville than I ever did in L.A. That does not mean a multitude of things, like scoring fifty films or doing a hundred television shows or cutting five thousand records. I think the quality of work here is more important than the quantity of work. And you know in L.A. how many sessions...we were doing three and four and five and six a day.

Mix: Music by the ton.

Billy: I remember the days when Glen Campbell and I were the only two "funky" guitar players in L.A. when we'd walk into a session where a fifty-piece orchestra was sitting there waiting for us to show up and play a sixteen bar solo, at double scale, and then go next door and do the same thing. We were being paid for ten or twelve sessions a day.

Mix: Well usually it was your solo that happened to be the catchy thing on the record.

Billy: Maybe so, but I'm not sure that we weren't taking advantage of an opportunity. But I find no fault with that.

Mix: You seem to have a natural ability around the TV cameras. It seems that being a director would be a natural thing for you.

Billy: Well that might be a natural progression of events. We all wear many hats throughout our lifetime... You've been a great jazz guitarist and are now one of the world's most renowned bass players...you're a publisher. I'm all of those things, also. Maybe not in the same respect, but having been a singer and a guitar player and a producer and an arranger and an actor, I think we progress through our lifetime doing different things that we consider a step up in our careers. ■



Sounds Interchange

Crescendo Audio Productions

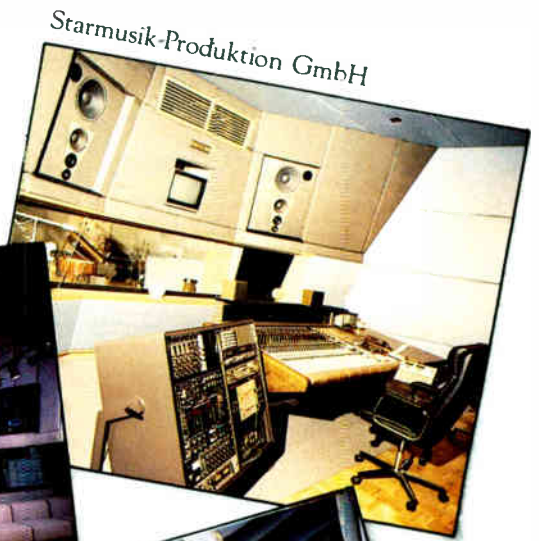

Starmusik-Produktion GmbH



NBC-TV Post Production #1



TresVirgos Studios

Ask the Owners

Salim Sachedina
Sounds Interchange
Toronto, Canada
(416) 364-3512

Alan Manger
Crescendo Audio Productions
San Juan, Puerto Rico
(809) 792-1970

Ralph and Jennie Arnie
Starstudio GmbH
Hamburg, West Germany
49-40/40-10-51

Craig Curtis
NBC-TV Post Production #1
Burbank, California
(213) 840-3260

Jerry Jacob
TresVirgos Studios
San Rafael, California
(415) 456-7666

The sound choice for the future
whether building or rebuilding.

Chips Davis
The LEDE Designer
(702) 731-1917

For your additional listening pleasure; McClear Place Mastering, Toronto Radio-TV Caracas, Caracas, Venezuela/Audio Archives, Syracuse Univ., Syracuse, N.Y...Coming soon: Grammy's House, Reno, Nevada, Satellite Television Corp. (Div. of Comsat) Las Vegas, Mennonite Brethren Communications, Winnepeg Alberta Canada. Additional Projects for NBC.



MARTIN RUSHENT: Synth-Pop Kingpin

by John Diliberto

Producer Martin Rushent calls his studio Genetic Sound. You can picture him sitting among the circuitry and screens of his computerized synthesizers, mutating the very DNA of music like some Doctor Doom of synth-pop.

Rushent was responsible for what he calls a "minor turning point in popular music": the Human League's *Dare* (1981), which included the hit "Don't You Want Me." Except for the voices of Phil Oakey and Company, there wasn't a single conventional instrument to be heard on the record; all the tracks were played by synthesizers and rhythm machines.

But Rushent isn't as evil and calculating as all that. He doesn't even wear a metal mask. In fact, the blond, bearded Briton has a fatherly demeanor and a decidedly upbeat approach to his work. As Human Leaguer Oakey said in a recent *Melody Maker*, "You can't just have a bit of Martin—it's all of him."

More than half of Rushent's 37 years have been spent in recording studios, from psychedelia to art rock to proto-punk. He had his own brief fling as an artist, in the days when everyone in England was in a band "or you didn't get a girl." He didn't have too much success on that side of the glass, but he did get a job as a tape operator at London's Advision Studios. "It's an obsolete job now," Rushent notes. "Computers do that now."

Rushent got into recording just as production techniques were going through the twisted roofs of psychedelia.

Multitrack recording and tape processing were just coming onto the scene, and Rushent learned first-hand as studios went from two track to four, eight, sixteen and beyond. He graduated from tape op to engineer, spun tapes for Julie Driscoll and Brian Auger's phase-shifted *Wheels of Fire*, assisted Eddie Offord in the halcyon days of Yes and ELP, and engineered Gentle Giant's *Three Friends* and Tony Visconti's production of T. Rex's *Electric Warrior*.

"I spent a couple of days working with Keith Emerson on that Moog he'd just gotten," Rushent recalls ruefully. "I remember telling him it was never going to work, because it took an hour to get it into tune and if the temperature changed you were back to where you started. If you listen to early ELP and other synthesizer records, you can hear the problems they had. It was all bleeps and bleeps and little solos—get it done quickly, because it'd go out of tune after four bars." Little did Rushent know that years later he'd be a champion of synthesized pop music.

Rushent got a taste for producing while he was engineering Gentle Giant's *Octopus*. Because the band was producing, Rushent wound up assuming many of the producer's responsibilities. He also learned a few techniques from Giant, who were no slouches when it came to pushing the parameters of the studio: "They were one of the first to pare things down and record instruments individually," Rushent recalls.

Rushent soon quit Advision and began looking for someone to hire him as a producer. After six months he got tired of waiting and built his own eight track studio and recorded a now forgotten band named Stretch. Their first single, "Why Did You Do It?" was enough of a hit in the UK to get him a job with United Artists in 1977, just as the punk boom was getting under way.

It's a long way from ELP and Gentle Giant to Generation X, The Buzzcocks and Dr. Feelgood, but all those groups' debut recordings were produced by this ex-hippie, the same Rushent who sat up nights nursing Keith Emerson's Moog. But it wasn't long before he would get bored with punk and make the moves that would establish him as a savant of synth-pop. "I joined the backlash," he laughs. "I was tired of wearing a leather jacket all the time and wanted to start wearing nice clothes."

—PAGE 120

Eight is not enough

As a pioneer in the world of multi-track, 4-track was fine in the beginning. When 8-track came along, it was great. Now, eight is not enough! Akai's revolutionary new MG-1212 is the answer! A 12-channel mixer combined with a 14-track recorder: twelve tracks for audio and TWO EXTRA tracks for internal control of built-in computerized auto punch in/punch out; and for external controls like click or SMPTE eliminate the need of using valuable audio tracks. Akai's new high-speed 1/2" cassette technology, combined with EE tape fidelity, offers mastering quality and ease of tape loading. Buy an Akai MG-1212. ... I did!

Jeff Baxter

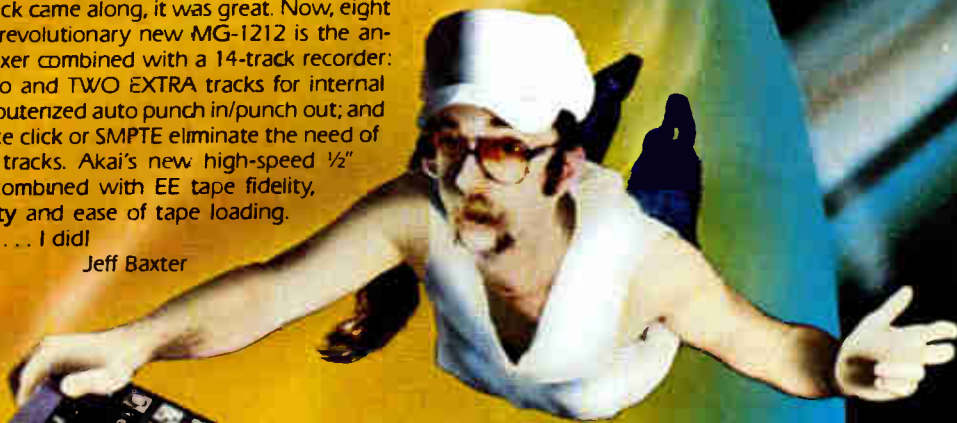

Test fly one today
at your nearest Akai
dealer or write to . . .

AKAI

P.O. Box 2344, Ft. Worth, TX 76113
817-336-5114

Circle #078 on Reader Service Card

By coincidence, Rushent's Genetic offices were right above The Blitz, a club where wearing nice clothes was what life was all about. Rushent recorded the first disk by Blitz house band Visage, replete with electronic drums and synthesizers, and went on to produce demos for Ultravox's *Vienna* as well as for Joy Division and Spandau Ballet.

At the same time, Rushent took the first steps into computer synthesis with the Roland MC-8 Microcomposer. Rushent looks back on it with a bit of self-deprecating humor. "I saw an advert that said 'for those who can't play, this is the answer.' That's for me! That's how I made the transformation from a sort of mad

punk producer into Dr. Click."

The MC-8 was cumbersome, but it had a vast potential that Rushent tapped when Pete Shelley left the Buzzcocks and needed a band for his new demos. Enter Martin Rushent and the MC-8, the band. They recorded a clever electro-pop ditty called "Homosapien," according to Rushent, "the only real things on it are guitar and synth." It was supposed to be a demo, but the record company loved it and the entire *Homosapien* LP was recorded the same way.

For Rushent, computer synthesis was a dream that unlocked his imagination and blurred the lines between artist and producer. "I fell in love with that way of doing things," he exudes. "Be-

cause as a producer it put you right in there with the artist." It was also more dependable than some of the musicians Rushent would work with. "Because of commercial pressures," he admits, "I use it a lot to make up for the shortcomings of the artists that I'm working with."

Take The Human League for instance. In their early days, The Human League were a competent pop distillation of Kraftwerk-style electronics with two LPs under their belts. But the musicians split to go into Heaven 17, leaving the singer and slide projectionist without a band. A re-formed Human League sought out Rushent and placed themselves at his mercy. Rushent explains: "They came to me and said, 'Look! None of us can play anything, but we heard this Pete Shelley album and we know you can't play, either. It's only you and Peter, and he just sings and plays guitar—so it must be something else. We heard it was a machine. That's what we want, because the only guy who can play in the band is a guitarist and we don't want any guitars.'"

The resulting collaboration between man and machine, *Dare*, marks the beginning of the dominant trend in the '80s, computerized dance music—or what had been known in the '70s as euro-disco. But wasn't that what punk had been reacting against? "I never felt that I was selling out the punk ethic or becoming a *poseur*," Rushent says. "It was just a natural transition."

In fact, Rushent's adherence to the tyranny of the beat became complete with the LinnDrum and computer synthesizers like the Fairlight CMI and the Synclavier II. Perfecting the groove is Rushent's mission. "You get tracks with that tremendous drive and perfection of beat, and it's got to come from somewhere," he explains. "Why do they have that? Because they're sitting right on the money, they're on time, they're not late."

It's a good thing Rushent doesn't produce any jazz artists. The shifting pulse of poly-rhythmic syncopation would drive him mad. "I've got to purge my system of this desire for absolute perfection," Rushent confesses. "We had a case recently where I said the snare drums were late and everyone said no. I was the only one who could hear that it was late. Well we measured it and it was 15 milliseconds late. Now 15 milliseconds isn't anything, and most people can't hear it, but it bothered the hell out of me."

However, Rushent does cut loose when he does his 12" remixes. Rushent's 12" remixes of his artists' songs have gotten more bizarre and complex due to his increased use of the digital sampling feature of the Synclavier II. The artists leave Rushent alone in his sound laboratory for these odd concoctions. "When the record's finished and

—PAGE 158



LaSalle Music is the exclusive East Coast Dealer for **Fairlight CMI**. We offer both sales and rentals. We also carry the most comprehensive line of Keyboards and Drum Machines in New England.

KURZWEIL	OBERHEIM	MOOG	YAMAHA
PPG	ROLAND	KORG	BIT ONE
EMULATOR	SEQUENTIAL CIRCUITS	LINN DRUM	ENSONIO

LaSalle Music
Professional Audio & Musical Instruments

75 North Beacon St., Watertown, MA 02172 (617) 923-4420
1116 Boylston St., Boston, MA 02115 (617) 536-0066
22 La Salle Rd., West Hartford, CT 06107 (203) 236-5401
outside MA (800) 533-3388

The greatest innovation in audio mixing has just gotten better: Necam 96.

Picture courtesy
Atlantic Studios, N.Y.



The challenge: Take a technological triumph, Necam II, a computer-assisted audio mixing system, and make it better by making it faster, more informative, more intelligent and loaded with exciting features.

The result: Necam-96

- **Incredible speed:** Feather-touch sensitive faders eliminate hundreds of intermediate steps for lightning-fast operation.
- **Total Information Color Video Display:** Our high-resolution display tells where you are at a glance, including time code, mix names, event times, scene changes and more: all labels, mutes, stores and events can be rapidly changed.

NECAM 96

- **Unique Intelligent Rollback:** With or without updates. The faders move to where they need to be automatically—no PEC/Direc: comparison needed. Sophisticated effects build up a snap.

- **Smart Keys:** Our human-engineered software is the fastest ever developed to eliminate repetitive keystrokes.

- **Technological Sophistication:** Necam 96 will interface with any synchronizer as master or slave; read SMPTE time code, foot/frame counts, or even tacho pulses.

Take the next step. For further information call Neve at (203) 744-6230 or write:

Demand Neve

RUPERT NEVE INCORPORATED: Berkshire Industrial Park, Bethel, CT 06801 (203) 744-6230 Telex 969638 • 7533 Sunset Blvd., Hollywood, CA 90046 (213) 874-8124 • RUPERT NEVE OF CANADA, LTD. represented by: Sonotechnique, 2585 Bates, Suite 304, Montreal, P.Q. H3S 1A9 Canada (514) 739-3368 Telex 055-62171 • NEVE ELECTRONICS INTERNATIONAL, LTD. Cambridge House, Melbourn, Royston, Hertfordshire, SG86AU England Phone (0763) 60776 • RUPERT NEVE GmbH: 6100 Darmstadt, Bismarckstrasse 114, West Germany Phone (06151) 81764.

BASIC Program for the Design of T, H, PI, and O Pads

by Ronald G. Ajemian

Pads are used for a variety of signal attenuation tasks. Most commonly, these passive signal reduction devices are placed between a microphone and a console preamplifier. While the basic design equations remain the same, the calculations change according to the impedances, and amount of attenuation involved. For example, since the output impedance of professional low impedance microphones range from 50 to 300 ohms, proper matching dictates designing a new pad for every application—a tedious and time-consuming task. Since many recording and broadcast studios now house microcomputers, a program to solve the necessary design equations could shift the burden from man to machine. Furthermore, since BASIC is widely used on many personal computers, it is the logical language for this program.

The design equations for symmetrical and non-symmetrical T, H, PI, and O pads are shown in figure one. Symmetrical means that the source and load impedances are equal whereas non-symmetrical refers to unequal values. The BASIC program computes the appropriate pad component values, as well as the minimum loss of the pad. Exact numerical values are output for the resistor values; a useful modification to the program would round-off these values to the nearest standard value.

—PAGE 124

The Design of Resistive Symmetrical and Non-Symmetrical T & H Pads

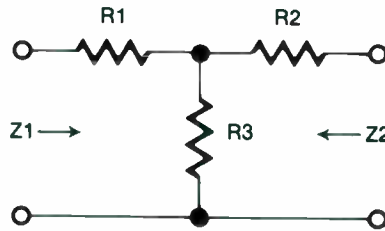

$$K_{min} = \left(\sqrt{Z1/Z2} + \sqrt{Z1/Z2-1} \right) \quad \left. \begin{array}{l} Z1 \geq Z2 \\ S \geq 1 \end{array} \right\}$$

$$S = \sqrt{Z1/Z2}$$

$$A_{min} = 20 \log K_{min}$$

$$K = \text{antilog}(A/20) \text{ or } K = (10)^{A/20}$$

$$R1 = (Z1(K^2 + 1) - 2KS) / K^2 - 1$$

$$R2 = (Z2(K^2 + 1) - 2KS) / K^2 - 1$$

$$R3 = 2KS / K^2 - 1$$

Diagram 1: T-PAD with associated design equations.

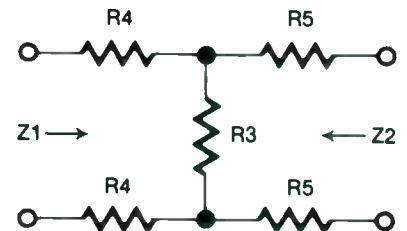

$$R3 = 2KS / K^2 - 1$$

$$R4 = R1/2$$

$$R5 = R2/2$$

Diagram 2: H-PAD design equations associated with Diagram 1.

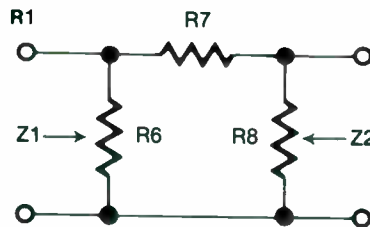

$$K_{min} = \left(\sqrt{Z1/Z2} + \sqrt{Z1/Z2-1} \right) \quad \left. \begin{array}{l} Z1 \geq Z2 \\ S \geq 1; \\ S1 \geq 1 \end{array} \right\}$$

$$S = \sqrt{Z1/Z2} ; S1 = \sqrt{Z1/Z2}$$

$$A_{min} = 20 \log K_{min}$$

$$K = \text{antilog}(A/20) \text{ or } K = (10)^{A/20}$$

$$R6 = Z1(K^2 - 1) / (K^2 - 2KS1 + 1)$$

$$R7 = S(K^2 - 1) / (2K)$$

$$R8 = Z2(K^2 - 1) / (K^2 - 2KS1 + 1)$$

Diagram 3: Pi-PAD with associated design equations

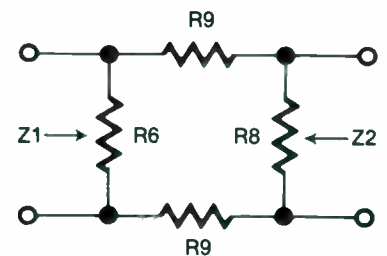

$$R6 = Z1(K^2 - 1) / (K^2 - 2KS1 + 1)$$

$$R8 = Z2(K^2 - 1) / (K^2 - 2KS1 + 1)$$

$$R9 = S(K^2 - 1) / (4K)$$

Diagram 4: O-PAD design equations associated with Diagram 3.

Drawn by Ronald Ajemian

Digital Services

48 Track Digital Recording — Nationwide
Rentals • Consulting • Engineering

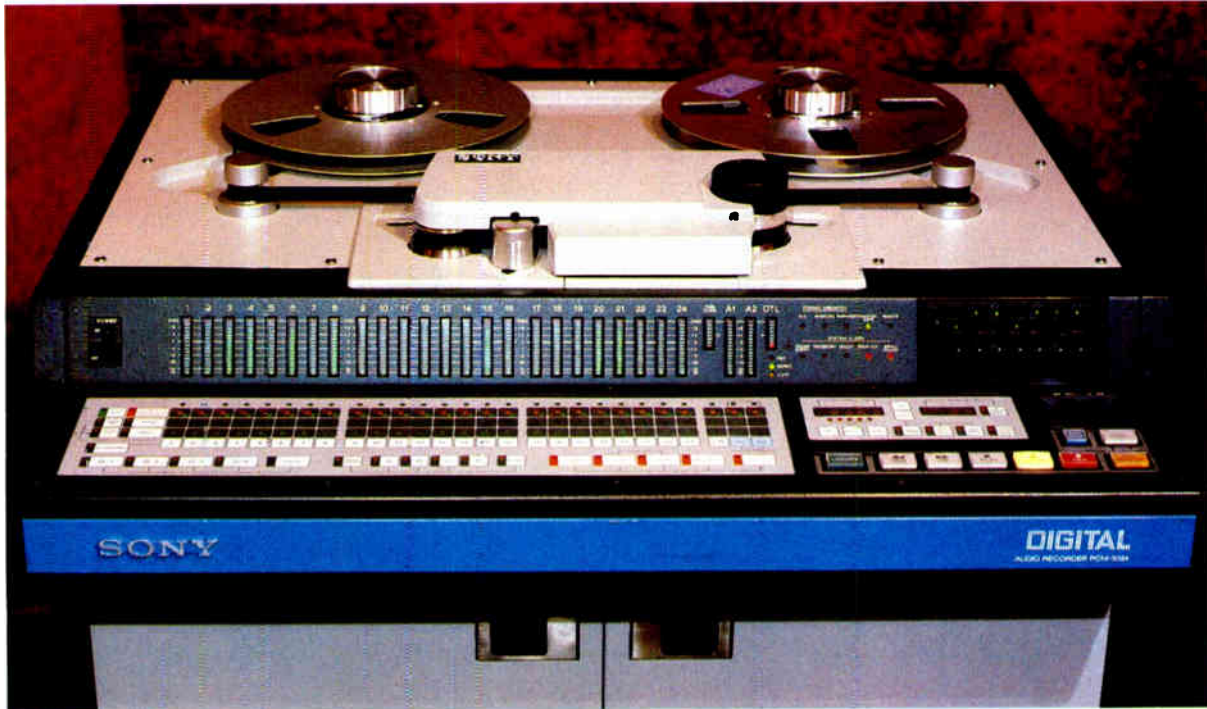

The Digitals: 4 Sony PCM 3324 Digital Multitracks • Complete PCM 1610/DAE 1100 Electronic Editing System • RTW/F1 Portable Digital Recorders and Format Transferring

The Facilities: Any studio, remote, or post production facility your project may use. Our Remote Truck and Studios offer complete Digital or Analog multitrack production with automated mixing and SMPTE interlock.

The Experience: First Sony multitrack owner/operator • First Digital Audio to Film Optical Transfer for Movie Sound • Our clients include Neil Young, Frank Zappa, Neil Diamond, Barbra Streisand, CBS Masterworks, Telarc Records, Talking Heads, Texas Chamber Orchestra, plus many others.

John Moran	(713) 520-0201	Houston, TX
David Hewitt	(914) 425-8569	New York, NY
Elliot Mazer	(415) 644-4321	San Francisco, CA
Mark Wolfson	(818) 506-5467	Los Angeles, CA

Digital Services

2001 Kirby Dr., Suite 1001, Houston, TX 77019 Telex 790202

Guitar Showcase
**PROFESSIONAL
 SOUND)))))))))**
 Division

We specialize in the sales and service of Professional Sound and Recording equipment.

We are now the exclusive South Bay Otari dealer.

Servicing Corporations, Churches and Institutional accounts

**Professional
 Recording
 Equipment**

- AKG • Ampex • Audiex
- DBX • JBL • Master Room • Onkyo • Tascam • Teac

**Sound
 Reinforcement**

- | | |
|----------------|----------|
| Atlas | Symetrix |
| Audio Technica | Tapco |
| BiAmp | TOA |
| Bose | Yamaha |
| Delta Lab | Peavey |
| Electro Voice | Fender |
| Goldline | EXR |
| Harbinger | Mike Mix |
| Hill Audio | MXR |
| Ramsa | Furman |
| Sennheiser | New Mark |
| Sescom | Shure |
| Sony | Sundholm |



3090 S. Bascom Ave.
 San Jose, CA
 (408) 377-5864

Open Mon-Thurs 11-9
 Fri 11-8, Sat 10-5
 Closed Sun

Financing Available
 All Major Cards Accepted

—FROM PAGE 122, BASIC

The BASIC program is shown in figure 2. In the program, lines 30, 50, and 110 prompt the operator to enter the appropriate values for Z1 and Z2 (source and load impedance), and attenuation (in dB) desired. Lines 70, 90, and 130 through 240 perform the necessary computation, and lines 260 through 440 output the values of the resistors. The program line 510 returns execution to line 10 and the program begins again. The program ends at line 520; the program can be saved by typing SAVE after line 520. The program could be optimized in several ways by efficient and inquisitive BASIC programmers. As always, it may be necessary to alter the programming of the design equations depending on the rendition of BASIC being used.

EXAMPLE:

Design non-symmetrical T, H, PI, and O pads with source impedance of 600 ohms and load impedance of 150 ohms. The desired attenuation is 20 dB.

NOTE: If your BASIC doesn't have SQR for square root, substitute $N \blacktriangle .5$. (eg. SQR (25) substitute $25 \blacktriangle .5$). Mathematically the square root of a number can be done exponentially:

$$\sqrt{N} = (N)^{1/2} = (N)^{\blacktriangle .5}$$

FIGURE ONE

T.H.PI AND O PAD DESIGN
 Z1 IS GREATER THAN OR EQUAL TO Z2
 ENTER SOURCE IMPEDANCE Z1 (OHMS)= ?600
 ENTER LOAD IMPEDANCE Z2 (OHMS)= ?150
 K= 3.73205
 MINIMUM PAD LOSS A= 11.439 dB
 ENTER ATTENUATION DESIRED IN (dB)= ?20

T PAD DESIGN
 R1= 551.515 OHMS
 R2= 92.4242 OHMS
 R3= 60.6061 OHMS

H PAD DESIGN
 R3= 60.6061 OHMS
 R4= 275.758 OHMS
 R5= 46.2121 OHMS

PI PAD DESIGN
 R6= 973.77 OHMS
 R7= 1485 OHMS
 R8= 163.187 OHMS

O PAD DESIGN
 R6= 973.77 OHMS
 R8= 163.187 OHMS
 R9= 742.5 OHMS

TYPE 1 TO CONTINUE. 0 TO STOP
 ?1

FIGURE TWO

BASIC PROGRAM FOR THE DESIGN OF SYMMETRICAL AND NON-SYMMETRICAL T, H, PI AND O PADS.

```
00010 PRINT "T, H, PI AND O PAD DESIGN"
00020 PRINT "Z1 IS GREATER THAN OR EQUAL TO Z2"
00030 PRINT "ENTER SOURCE IMPEDANCE Z1 (OHMS)=";
00040 INPUT Z1
00050 PRINT "ENTER LOAD IMPEDANCE Z2 (OHMS)=";
00060 INPUT Z2
00070 K=(SQR(Z1/Z2)+SQR(Z1/Z2-1))
00080 PRINT "K=";K
00090 A=20*CLG(K)
00100 PRINT "MINIMUM PAD LOSS A=";"A";"DB"
00110 PRINT "ENTER ATTENUATION DESIRED IN (DB)=";
00120 INPUT A
00130 K=10^(A/20)
00140 S=SQR(Z1*Z2)
00150 S1=SQR(Z1/Z2)
00160 R1=(Z1*(K^2+1)-2*K*S)/(K^2-1)
00170 R2=(Z2*(K^2+1)-2*K*S)/(K^2-1)
00180 R3=(2*K*S)/(K^2-1)
00190 R4=R1/2
00200 R5=R2/2
00210 R6=Z1*(K^2-1)/(K^2-(2*K*S1)+1)
00220 R7=S*(K^2-1)/(2*K)
00230 R8=Z2*(K^2-1)/(K^2-(2*K/S1)+1)
00240 R9=S*(K^2-1)/(4*K)
00250 PRINT
00260 PRINT "T PAD DESIGN"
00270 PRINT "R1=";R1;"OHMS"
00280 PRINT "R2=";R2;"OHMS"
00290 PRINT "R3=";R3;"OHMS"
00300 PRINT
00310 PRINT "H PAD DESIGN"
00320 PRINT "R3=";R3;"OHMS"
00330 PRINT "R4=";R4;"OHMS"
00340 PRINT "R5=";R5;"OHMS"
00350 PRINT
00360 PRINT "PI PAD DESIGN"
00370 PRINT "R6=";R6;"OHMS"
00380 PRINT "R7=";R7;"OHMS"
00390 PRINT "R8=";R8;"OHMS"
00400 PRINT
00410 PRINT "O PAD DESIGN"
00420 PRINT "R6=";R6;"OHMS"
00430 PRINT "R8=";R8;"OHMS"
00440 PRINT "R9=";R9;"OHMS"
00450 PRINT
00460 PRINT "TYPE 1 TO CONTINUE, 0 TO STOP"
00470 INPUT Q
00480 IF Q=1 THEN 500
00490 STOP
00500 PRINT
00510 GOTO 30
00520 END
SAVE
```

NOTEWORTHY

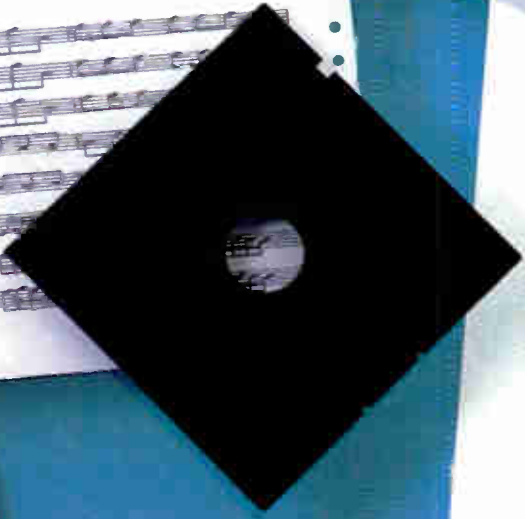
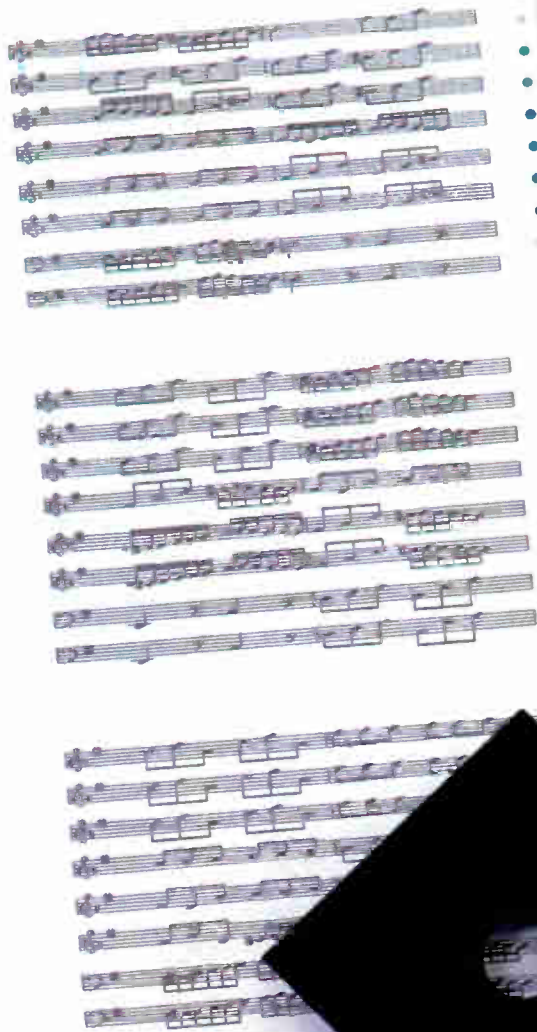

Collabtree

Music Printing Software for musicians who would rather create than copy. If you want to write music, take note!

POLYWRITER & POLYWRITER UTILITIES
Two new programs for MIDI that let you record, auto-correct, transcribe, edit, add lyrics, print out, and play back music from any MIDI synthesizer, sequencer or data source. Use from 1 to 28 instrument parts in eight different score formats to generate the finest sheet music available on an Apple II computer. With Polywriter Utilities, MIDI/4 and Polywriter become a fully integrated system. Combine step editing with real-time recording and print out the finished product.

Passport makes your music noteworthy with Polywriter and Polywriter Utilities, two more fine programs from the Passport Library of Music Software. Available for Apple II computers.

Passport products are available at fine music stores everywhere. For the one nearest you call (415) 726-0280.

Passport
625 Miramontes
Half Moon Bay, CA 94019

PASSPORT

Apple II and IIe are trademarks of Apple Computer, Inc. Passport, POLYWRITER, POLYWRITER UTILITIES, MIDI/4 plus, and D/V8 are trademarks of Passport Designs, Inc.

Circle #083 on Reader Service Card
World Radio History

VIDEO NEWS

by Mia Amato

BROADCAST: MUSIC— TV PROLIFERATES

The number of TV broadcasters programming multi-hour or 24-hour music video continues to grow. Unlike recent attempts at satellite-fed national networks—*VH-1*, *Discovery Network*, *Odyssey*—these efforts are being broadcast locally by low-power stations or small UHF stations, but reach out regionally through carriage on cable TV systems. Here's an update by region:

EASTERN U.S.

WXLI-TV 61

P.O. Box TV 61
Greensboro, NC 27420
Music Director: *Jeff Johnson* (919/855-5610). Primarily pop and Top 40.

TV-69

1001 Waldo Road
Gainesville, FL 32601
Program Director: *Thomas Zingale* (904/376-6969). Experimental; everything from *Molly Hatchet* to *Streisand*.

Homer & Associates' new clip for Steve Miller features "Bongo," a computer simulated 3-D animated character drawn on a Bosch FGS-4000 graphics unit. The Post Group supplied a tape transfer of 35mm live action and on-line editing to insert the animated character.



CENTRAL U.S.

"Music Video 60"

WPWR-TV
4255 Westbrook Drive
Aurora, IL 60507
Coordinator: *Judi Goode* (312/851-7515) Progressive.

"Teletunes"

KBDI-TV 12
P.O. Box 427
Broomfield, CO 30020
Producer: *Wick Frazier* (303/469-5234). A small public TV station; very progressive.

TV-61

7509 North 35th Avenue
Phoenix, AZ 85021
Producer: *Hope Smith* (602/841-2822). Pop, jazz, and some country.

WESTERN U.S.

"Good Night LA"

KABC-TV
5141 Prospect
Hollywood, CA 90027
Producer: *David Kellog* (213/557-

4448). Progressive post-Letterman hours on ABC-owned major station. Emphasis on New Music and animated videos; in a pop mix; kind to LA bands.

KRLR-TV 21

920 South Commerce
Las Vegas, NV 89106
Music Director: *Bob Bell* (702/382-2121). Progressive Pop.

"Magic Number Video"

KSTS-48
2349 Bering Drive
San Jose, CA 95131
Producers: *Isaac* and *Penny Stevenson* (408/946-3400). Weekend play. Mostly black artists' videos in a dance mix.

"Video 22"

KWHY-TV
5545 Sunset
Los Angeles, CA 90028
Producer: *Linda Rosenfield* (213/446-5441). Progressive pop and soul.

These stations will accept a 3/4-inch cassette of a music clip for preview and will be most responsive if it touts a record on a nationally or regionally distributed label. Most have no interest in unsigned local bands unless the video is *exceptional*, but are willing to be approached for promotions of tour dates, club schedules, local album releases, and the like.

PRODUCTIONS: Give My Regards to Hoboken

Dick Lynn writes from Hoboken (where I used to live, next door to Fiore's deli) that his *Blue Light Productions* has completed a "mini-documentary" to promote *Chris Spedding*, a British session guitarist who's worked with such rock luminaries as *Roger Daltrey*, the *Sex Pistols*, and *Bryan Ferry*. Spedding appears as lead guitarist in *Paul McCartney's* film, *Give My Regards to Broadstreet*, and is trying to crack the U.S. market via this video sampler following several solo LPs in England.

If you need a Betacam in Michigan . . . you can now call *Video Remote Services* in Bloomfield Hills . . . In Los Angeles, *Starfax Inc.* recently transferred 130,000 feet of film to video from a seven-camera *Yes* concert in Edmonton for client *Razor Productions*, using their new electronic image and audio transfer system they call "Starsync." *One Pass Video* (San Francisco) has opened a spanking new 60'x70'x20' soundstage, King Street Studios, around the block from its China Basin headquarters. In Orinda, CA, *Positive Video* continues to expand with the installation of a CMX-3400 edit system.

TRUE EQUALITY



In the past, low price has often been equated with low quality. No longer!

DOD's R-830B and R-831B EQ's feature computer aided design, low noise, high slew rate, low distortion, and extremely accurate controls. Add to this DOD's low prices, and the result is two of the most popular EQ's on the market today.

- Modular PC board construction
- Center detented, linear potentiometers
- All metal chassis
- Four-level LED output indicators
- Low cut filter
- Bypass switch
- 12 dB boost or cut
- Signal to noise greater than 95 dB
- IM distortion less than 0.01%
- One year warranty

If you haven't yet discovered the true equality, you owe yourself a visit to your nearest DOD dealer for a demonstration.

DOD

5639 South Riley Lane Salt Lake City, Utah 84107 Telephone (801) 268-8400

Circle #084 on Reader Service Card



JON ROSEMAN:

The Godfather of The Modern Music Video

by Lou CasaBlanca

When the definitive history of Video Music is written, Jon Roseman will emerge as one of the key movers and shakers involved in its conception. Without question there were music films and music videos before the formation of Jon Roseman Productions International LTD in 1976. However, it was Roseman, and a small team of die-hard filmmakers, who nearly single-handedly "institutionalized" the production of video clips as a business.

In 1976, in what feels like another lifetime, I went to England to co-produce a couple of albums for Island Records: **Automatic Man** (LPS9397) and **Go** (LPS 9387), with Stomu Yamashta, Steve Winwood and Michael Shrieve. While there I was exposed to music video on English television, particularly a weekly program called the **Top of the Pops**. Even then, in many European record and department stores, video was well integrated into point-of-sale merchandising. Island Records chairman Chris Blackwell, one of those people who is seemingly always ahead of the times, was setting up a demo video facility in Island's headquarters and studios at St. Peter's Square. The very first tape produced was sent to Warners' U.S. and was instrumental in the signing of The Babys to a deal with the label.

London was seething with record and concert activity. The punks on the Kings Road in Chelsea were the original **Rocky Horror Show**. The Roundhouse, the Fillmore of the London Music scene, the rock and reggae clubs, the pubs and discos were all going strong on a non-stop schedule. The music scene in London relied increasingly on music video for exposure. In fact television airplay on programs such as **Ready Steady Go** and **The Old Grey Whistle Test** was, and is today, critical to major success in the U.K. While working at Trident Studios, which was involved in television production and audio manufacturing as well as recording and mastering, I met some of the people working on a video for Queen's "Bohemian Rhapsody," one of the first concept and live concert music videos. Directed by Bruce Gowers and produced by Jon Roseman for Trillion Video, the producers were given very short notice but managed to put together one of the most enduring music videos ever produced.

Prior to setting up Jon Roseman Productions, Roseman was production manager with **London Weekend Television**. The company was formed as an agency representing directors, producers, and TV personalities. At the time, the company was managed by Lexi Godfrey, who was with Queen's management and Trillion Video. In addition



"Singing is what I do. The Peavey HD-40 allows our audiences to hear the vocals just as we originate them on stage . . . Also very little outboard equalization is needed with the HD-40."

Gary Morris

THE MICROPHONE. An instrument for the vocalist.

Any performer who is serious about delivering vocals to the audience must work his microphone just as a musician masters an instrument. The microphone should reproduce the vocals accurately and must have good "gain-before-feedback" for concert situations.

The Peavey Celebrity Series Microphones are designed to have everything . . . except competition. We invite comparison of our microphones with other cardioid microphones. You'll see why we feel that in terms of performance, features, and price, there is no competition. Just ask Gary Morris.

Gary will be playing the lead male role (opposite Linda Ronstadt) in the New York Shakespeare Festival production of "La Boheme". Catch him at this event or in concert in your area soon.

(Send \$1.00 for our Professional Audio Catalog featuring detailed information on all Peavey microphones and sound reinforcement systems to: Dept. Celebrity, Peavey Electronics Corporation, 711 A Street, Meridian, MS 39301.)



PEAVEY ELECTRONICS CORPORATION
711 A Street Meridian, MS 39301 U.S.A.
Telephone: (601) 483-5355 Telex: 504115

1984

to director Bruce Gowers, Simon Fields, a commercial producer, Russell Mulcahy, an Australian director/cameraman, TV director David Mallet, and writer Paul Flattery joined the company.

About the same time, Roseman decided to expand into the U.S. market and hired Carol Rosenstein, who had worked as an assistant to Martin Scorsese on **New York, New York** and other features, to coordinate the American operation. After meeting with Roseman in L.A., I joined to help launch the company and develop programming opportunities for the U.S. market.

The Roseman track record and demo reel were so impressive that many record labels who were still on the fence decided to go with the company and take the plunge into the infant medium. It was this initial wave of marketing and production activity that really stimulated the American record labels into regular video music clip production. In rapid-

fire succession videos were done for the Atlanta Rhythm Section, the Bee Gees, George Benson, Blondie, Alice Cooper, Neil Diamond, the Doobie Brothers, Michael Jackson, Al Jarreau, Journey, Chaka Khan & Rufus, Prince, Rod Stewart, Supertramp, Styx, The Tubes and Van Halen, among many others.

After almost two years of production and an almost inhuman burn-out schedule, the company went through a major upheaval resulting in the formation of several production companies which have gone on to become the major producers of video music on both sides of the Atlantic.

After recovering from this tumultuous period, Roseman formed Jon Roseman Television Limited, working with directors Mike Brady, Chris Ashbrook and doing some directing himself. JRTV has produced Eurythmics, Flock of Seagulls, the Thompson Twins, Wham, Musical Youth, ABC, Christine McVie,

and Scandal. Jon Roseman is probably the most outspoken producer/director in the video music business—sometimes to his own detriment—however, his equally outrageous sense of humor and keen ability to create consistently innovative programming is what has established him as a major force in the music video. JRTV will be opening a new office in L.A. and expanding into television specials and feature films production.

In the tradition of the great film producers, Jon Roseman has helped to create a legacy. His ability to find and attract talented filmmakers, and to present them with unique production opportunities has been directly responsible for the development of some of the most important music producers and directors in the industry. Beyond his own business and creative achievements, past, present and future, Roseman's place in the history of music video and pop culture is assured. ■

MVPA FILM PRODUCTION COST SUMMARY

Production Co.:		Bid Date	
Address:		Record Co.:	
Telephone No.:		Record Co. Representative	
Job #		Tel:	
Production Contacts:		Artist:	
		Artist Management:	
		Tel.:	
		Artist Production Contact:	
		Tel.:	
		Album Title:	
Director:		Song Title:	
Cameraman:		Length:	
Writer:			
Art Director:			
No. pre-prod. days		pre-light/rehearsal	
No. build/strike days		Hours:	
No. Studio shoot days		Hours:	
No. Location days		Hours:	
Location sites:			
Delivery Date:			

SUMMARY OF PRODUCTION COSTS		ESTIMATED	ACTUAL		
1	Pre-production and wrap costs	Totals A & C			
2	Shooting crew labor	Total B			
3	Location and travel expenses	Total D			
4	Props, wardrobe, animals	Total E			
5	Studio & Set Construction Costs	Totals F, G, and H			
6	Equipment costs	Total I			
7	Film stock develop and print	No. feet mm Total J			
8	Miscellaneous	Total K			
9		Sub-Total: A to K			
10	Editorial & Tape Finishing	Total O to U			
11	Director & Creative Fees	Total L			
12	Insurance				
		Sub-Total: Direct Costs			
13	Production Fee				
14	Talent costs and expenses	Totals M and N			
15					
16					
17		Grand Total (Including Director's Fee)			
18	Contingency				

Comments:

MUSIC VIDEO PRODUCERS ASSOCIATION

Recently, a new organization, the Music Video Producers Association was created to help consolidate the music video business. It was formed by producers and directors who feel that the industry needs a forum for the exchange of technical data, the study of industry-wide problems and to foster improved working relationships among record companies, management companies, production companies, artists, labor unions and government. The association has set up a series of guidelines relating to billing, payment cancellations and other nuts and bolts issues.

If you would like more information on membership eligibility and dues contact Michael Pillot c/o Picture Music International, 24 East 23rd Street, 5th floor, New York, NY 10010 (212-420-5900).

Music Video Producers Association standard bid form.

Everyone Says They're Better — We Prove It!



- Time Delay
- Reverberation
- Crossovers
- Tape Noise Reduction
- Compressor / Limiters
- Expanders
- Spectrum Analyzers
- Parametric EQ

With all the strong claims by advertisers, it's not easy to distinguish between the hot air and the hot products. That's exactly why we prepared this demonstration album. In it we show you what our products do and how they compare with the best of our competition under identical circumstances.

You will hear our phenomenal MICROPLATE[®] Reverb with over 18 KHz bandwidth in side by side reverb only comparisons with the EMT[®] Plate on percussion and vocals. No other spring reverb would dare attempt such a comparison! The cost is incredible too, under \$600 mono, \$1,200 in stereo!

We also show our CLX-2 Compressor/Limiter/Expander in side by side comparisons with the dbx[®] 165 and illustrate the CLX's audibly superior freedom from distortion as well as its other abilities of De-Essing, Expansion, Keyed Expansion, Push button Stereo Tracking, and Ducking.

Other demos feature our exceptionally versatile parametric equalizers, time delays and tape noise reduction. Examples are drawn from the master tapes of top 40 Hits and show some of the most sophisticated recording techniques ever devised. Let your ears decide who sounds best before you buy. Only direct sales allow us to offer a superior product at prices lower than the competition.

Write or call for a free 24 page brochure and demo album.

**LT Sound, Dept. MX-1, P.O. Box 338,
Stone Mountain, GA 30086 Phone (404) 493-1258**

LT Sound

We Make A Better Product

YOUR WORLD

For you, it's the sixth session of the day. For them, it's the biggest session of the year. So you push yourself and your board one more time. To find the perfect mix between four singers and 14 musicians. Between 24 tracks and at least as many opinions. To get all the music you heard—from the deepest drums to the highest horns—on to the one thing they'll keep. The tape.

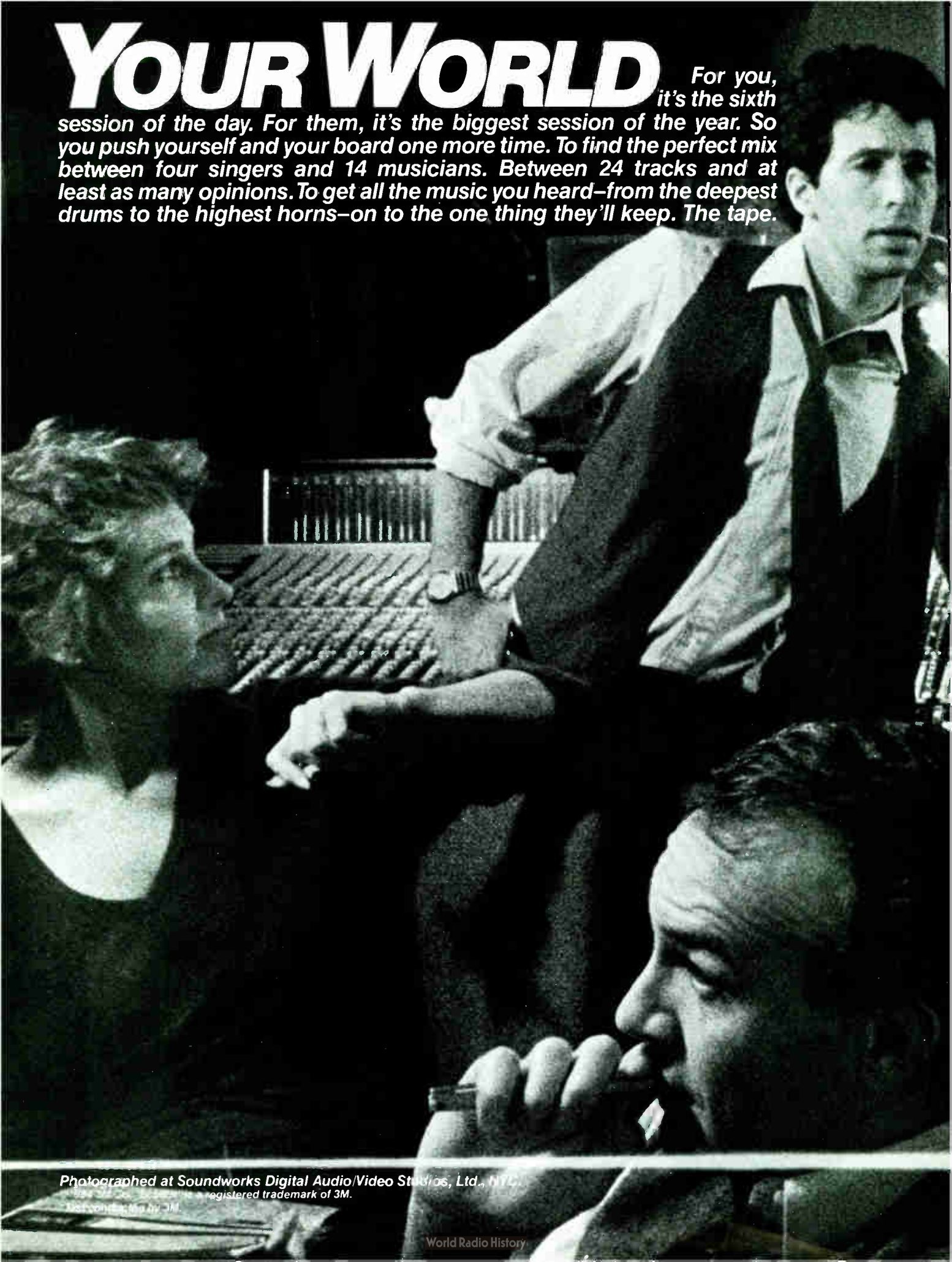

Photographed at Soundworks Digital Audio/Video Studios, Ltd., NYC.

© 1994 3M Corp. 3M and the 3M logo are registered trademarks of 3M.

Use only 3M tape.

World Radio History



OUR TAPE



We know that our tape is the one constant you have to be able to count on. So we make mastering tapes of truly world-class quality. Like Scotch® 226, a mix of Scotch virtuosity and the versatility to meet your many mastering needs—music, voices, effects. And Scotch 250—with the greatest dynamic range and lowest noise of any tape, it is simply the best music mastering tape in the world. Both tapes were preferred by Ampex and Agfa users at a listening test* conducted at the 1983 Audio Engineering Society

convention in New York. They are both backed by our own engineers a call away. They are just two of the tapes that make us...number one in the world of the pro.

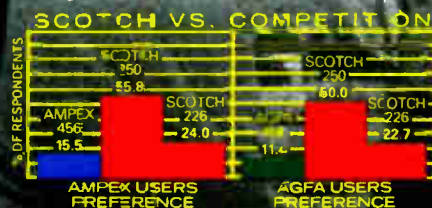

Scotch®
AUDIO & VIDEO TAPES

NUMBER ONE IN THE WORLD OF THE PRO

3M

Another Comeback for Gary U.S. Bonds

The 1981 "comeback" of Gary U.S. Bonds—precisely 20 years after he burst onto the music scene with back-to-back number one records ("New Orleans" and "Quarter to Three")—was the nicest surprise of the year. Dedication joined Bonds' gritty vocals with the songwriting and production talents of Bruce Springsteen and his E Street Band cohorts in a marriage made in rock and roll heaven. With the success of "Jole Blon" and "This Little Girl is Mine," EMI America Records surely patted itself on the collective back for such a clever signing.

But the 1982 followup, *On the Line*, faded into premature obscurity after one single, and the EMI America deal lapsed. Why did the label allow their find to recede into obscurity?

"Actually, it was mutual," says Bonds. "There were changes in the company, and the people I liked were gone. And the company started losing acts and making mistakes. Kim Carnes had the biggest record of the year, and they didn't want to deal with promoting her. 'This is stupid,' I said. 'If they don't want to promote a girl who has a double platinum record, what are they going to do with me?'"

"I'm not a demanding person," Bonds laughs, "but there are things you do require as an artist. These big companies, they don't care. They don't even know you. You walk in and they go, 'You come to clean up?' I say, 'Yeah, open up the safe!'"

So Bonds went with Phoenix Records, an aggressive if underdistrib-



1961: (L-R) Bonds' manager Frank Guida, Dick Clark, Gary U.S. Bonds.

uted independent label, with the self-produced album *Standing in the Line of Fire*. "I know it's rough with an indie label," he concedes, "but I had success with an indie—Legrand—way back when. I know the music business a little bit, and I'm not some kid that's going to get shoved in the corner with a lollipop."

"I don't want to hear, 'Every-

thing's okay—we'll buy you a Cadillac next week' any more. I know a lot of guys that the only thing they got was a Cadillac and a new suit."

Bonds, born Gary Anderson 45 years ago, came up in the heyday of fly-by-night record companies which plucked youngsters from obscurity and

—PAGE 136

THE FAR SIDE

By GARY LARSON

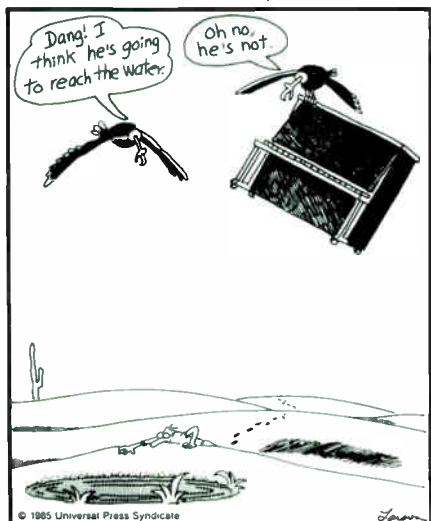

You Can't Keep the dB's Down

With all the gratuitous sex, ultra violence, and rampant misogyny that's depicted daily on rock video shows around the country, one would imagine there's just about anything your average rock video producer can stick on the screen and still pass the requisite board of censors.

Unless the video in question happens to feature suicide as its theme, like the dB's' "Amplifier." Produced by Walter Williams, creator of the hapless clay man Mr. Bill, the original video stuck pretty faithfully (and humorously) to the song lyrics: they tell the story of some poor schmuck named Danny who kills himself because his girlfriend moved out, cleaned out the apartment, and left

only his amplifier for spite. Some highlights included singer/songwriter/rhythm guitarist Peter Holsapple morosely eating a bowlful of brightly-hued and obviously lethal capsules with a spoon, and then hanging himself.

It's all actually very funny, if blackly so, with the implicit message that suicide is *not* painless, and certainly not the answer to life's problems. However, teen suicide being of the epidemic proportions it is, video network honchos (uncoubtedly fearing that "Amplifier's" subtleties would be lost on a volatile and highly suggestible age group) refused to air it. So Mr. Bill got in the act in version two, exhorting viewers to keep those

—PAGE 140

Bruce Lundvall Returns to His Roots

When Bruce Lundvall left Elektra/Musician last year to assume the helm of newly created Manhattan Records and a rejuvenated Blue Note Records, it was in a sense a return to his roots.

"It's kind of magical," says the personable record company executive who had previously put in 21 years at Columbia before his stint with E/M. "I grew up with the label. It was always my favorite. I began buying Blue Note records on 78s—Bud Powell's *Un Poco Loco*, Thelonious Monk's *Mysterioso*. My family lived in New Jersey, and I used to take the bus into Manhattan, go to Colony Records and buy everything I could, then go to the Royal Roost or Birdland, and catch the last bus back home. So I have a real special affection for the label."

During his formative years as an aspiring jazz saxophonist, Lundvall was nurtured on the sounds of Monk, Powell, Milt Jackson, Clifford Brown and Horace Silver, all Blue Note artists during the '40s and '50s. Now with an ambitious reissue policy as well as a number of exciting new recordings to be released in the coming months, Lundvall is carrying on in the great tradition of Blue Note founders Alfred Lion and Frank Wolff, two wily entrepreneurs who had uncanny ears for jazz.

Wolff died in 1971, Lion lives a reclusive existence somewhere in New Mexico. Lundvall never met either one but says he did talk on the phone to Lion recently, informing him of his plans to revitalize Blue Note.

"I sent him a Telex telling him about this gala concert we're going to have at Town Hall in late February to kick off the label. In it I explained how we're planning to have as many of the living players from the old Blue Note days on hand to perform in various all-star aggregations and jam sessions that we'll put together. So the next day the phone rings, I pick it up and it's Alfred Lion, wildly excited. 'I must come to the concert,' he says. 'I want to be there.' Then he says, 'Listen, I have a list of all these people I want to have play at this concert. First, bass players . . . ' and he goes on to list all these names. Then he says, 'Second, tenor players. Is Dexter going to be there?' Then he goes down this whole list of tenor players. So we talk and he calls me back a few minutes later: 'I forgot one thing. Rudy Van Gelder. You must have Rudy there.' Then he calls

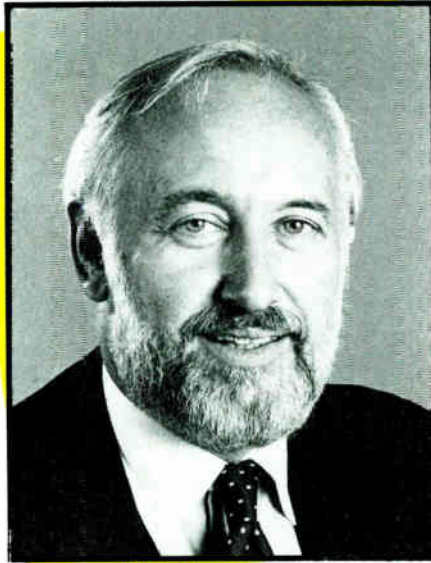

Blue Note's Bruce Lundvall.

back a third time: 'Listen, one more person who absolutely must be at this concert. . . Lee Miles, the artist. He had a very unique approach to all our covers. He must be there.' So as you can see, Alfred is very excited about the concert

and about what we're doing with Blue Note."

Alfred Lion left his native Berlin in 1938 to settle in the United States, escaping the right-wing Nazi domination of his homeland. On December 23rd of that year he attended the celebrated Spirituals To Swing concert at Carnegie Hall and was instantly swept up by the power and glory of boogie-woogie piano masters Albert Ammons and Meade Lux Lewis. Two weeks later he brought them into a New York studio to make some private recordings. This was the birth of Blue Note Records.

Those first records carried the same label design that Blue Note would use for the next 30 years. The label's first brochure in May of 1939 carried a statement of purpose that Lion rarely strayed from. It read: "Blue Note Records are designed simply to serve the uncompromising expressions of hot jazz or swing. Any particular style of playing which represents an authentic way of musical feeling is genuine expression. By virtue of its significance in place, time and circumstance, it possesses its own tradition, artistic standards and audience that

—PAGE 137

SMART MIDI CONNECTIONS™

Use our MIDI CONNECTIONS and turn a minimum of equipment into a complete, inexpensive and multifaceted recording, composing and arranging system.

All you need is a MIDI synthesizer, an APPLE II personal computer and, optionally, a drum machine and/or tape recorder plus

the ingredient that makes all the difference—the CONNECTIONS software and hardware interface that enables you to use the power of your computer to enhance the power of your music.

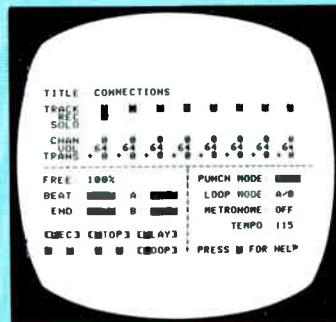

The true genius of CONNECTIONS is its tape recorder-like simplicity enabling you to:

- Use up to 8 polyphonic music tracks assignable to any of 16 MIDI channels
- Store up to 18,000 notes
- "punch in" and "punch out" as desired
- Auto correct your composition, adjusting from half notes to sixty fourth notes
- Transpose your music up and down

and... much much more.

All SMART-MIDI products from Cherry Lane Technologies unite computers and synthesizers to assist you, the musician, to be a more perfect composer and performer.

What could be more important?

SMART MIDI & CONNECTIONS are trademarks of Cherry Lane Music Co., Inc.



110 MIDLAND AVENUE • PORT CHESTER, NEW YORK 10573

Circle #086 on Reader Service Card

—FROM PAGE 134, BONDS

turned them into overnight stars, only to drop them back into oblivion with nothing but that Cadillac and an overdue tax obligation. Bonds was discovered on a streetcorner in his native Norfolk, Virginia, singing doo-wop. "I think everybody did that down south," he recalls, "just hang around and sing. My group was called the Turks, after my favorites the Turbans."

The 19-year-old was approached by Frank Guida, who had co-written a song called "New Orleans" with Joe Royster. It was a country-and-western sort of tune, and Guida wanted Bonds to give it a rock/R&B feel. The single was released in a sleeve with the eye-catching inscription "Buy U.S. Bonds," and a name and a career were born.

"I thought the song was pretty good, but for about a year it didn't get around, mainly because it was on a small, independent label. If it wasn't for Dick Clark I'd probably still be in Norfolk, twiddling my thumbs." Clark agreed to play "New Orleans" on *American Bandstand* to see whether the kids thought it had a good beat and could dance to it. Recalls Bonds, "He said, 'If it gets a response, okay. If not, go out and

get yourself a truck driving job.'"

Abysmal production notwithstanding, "New Orleans" became a smash. Bonds and his sax player, Gene "Daddy G" Barge, wrote and arranged the followup, "Quarter to Three," never really expecting the trick to work a second time. "It didn't sound that good," he says, "but it was a fun record. It was so badly produced that no one could understand the lyrics, so you could make up your own dirty words and sing along. I wrote those lyrics in ten minutes, anyway."

The biggest problem Bonds faced in launching his career was not so different from the one he has now: he is black, and he is a rock singer—not a crossover balladeer or an R&B torch crooner or any of the other things it's acceptable for a black artist to be.

"When 'New Orleans' came out we didn't send out promo pictures, for that one reason," says Bonds. "We didn't do any live shows for the first year, for that one reason. At the time if you were a black artist it didn't matter if you sounded like Elvis Presley, you didn't go on the white radio stations. 'New Orleans' wasn't an R&B record, but by the time

they found out I was black I had two hits out and it was too late."

Haven't things changed in twenty years? Are you kidding? "Bruce Springsteen writes a song and I sing it, it's R&B," muses Bonds. "He sings the song the same way and it's rock. There's something wrong with that method."

Bonds never did have to take that truck driving job, and he never stopped performing after his early-'60s career peak. He was playing in lounges and doing oldies shows—"kicking around, not doing venues as large and not making as much money, but having just as much fun"—when Springsteen joined him on a New Jersey stage and decided to stick around to help him launch his "comeback." Their professional relationship has since ended, but the two remain friends. "That boy's got a little soul in him," cracks Bonds. "He's had a neckbone once or twice in his life."

After a lengthy break due to a car crash involving two of his band members, Bonds is back on the road. And okay, he's doing the smaller halls again, with less money and maybe no Top 40 hits, but it's what he does and it's what he likes to do. "I'm just doing my

A WORLD CLASS SOURCE FOR PRESTIGE EQUIPMENT

Ocean Audio is a world class source for prestige used equipment. We carry an extensive inventory — from rare condenser microphones to top-of-the-line automated consoles. Because we buy our equipment from a worldwide network, our inventory consists of the most desirable equipment at the most competitive prices.

We are more than brokers who simply "list" availabilities; we purchase and stock much of the equipment we sell.

You owe it to yourself to check with us before you make that expensive equipment purchase. We can help you beat the high cost of high tech.

Contact us now for that specific piece you want to buy or sell.

Ocean Audio International
A World Class Source for Prestige Equipment

Tel: (213) 454-6043
Telex: 316706 OCEANAUDIO



thing, and I'm going to continue doing it for at least 50, 60 more years. It takes a long time to get it right."

—*Ethlie Ann Vare*

—FROM PAGE 135, LUNDVALL

keeps it alive. Hot jazz, therefore, is expression and communication, a musical and social manifestation, and Blue Note records are concerned with identifying its impulse, not its sensational and commercial adornments."

This spirit would be illustrated by Alfred Lion's handwritten notation on a session report for an unissued date: "This session would be okay for release, but it is just not up to Blue Note's standards." Lundvall hopes to continue in that same tradition.

"We'll keep it a very serious jazz label," he says. "We're not going to attempt any broadscale crossover records or any of that. We'll have those artists who are the acknowledged masters—McCoy Tyner, Dexter Gordon, Stan Getz with Jackie Maclean, Stanley Turrentine with George Benson and Jimmy Smith, George Russell. And we'll release some albums by exciting new artists like Stanley Jordan and Bennie Wallace."

He adds, with a tone of concern, "I hope we'll be able to make a small profit on this, but by not doing some of the things I did on Elektra/Musician, that may be a problem. The whole concept of that label was that it represented the musician's concept. Therefore, it allowed me to use a very broad palette. I could do all kinds of people. And, of course, people like Tom Scott and Lee Ritenour sold a lot of records, so they were able to generate a real nice profit and support some of the other people who weren't selling as well—those artists who were making more straight ahead music or were more experimental. But I think with Blue Note, the tradition of the label is so rich that I can't do those kinds of broad-based commercial kinds of projects. I'm going to have to do this with real serious music. I think that's what the label has to be. So we're going to keep it in the tradition, and I'm even going to try to use Alfred Lion as a consultant."

As the former president of CBS Records in the States and the senior vice president of Elektra/Asylum/Nonesuch Records, Lundvall exhibited an uncanny sixth sense when it came to signing new talent. Among the many artists he signed over the past 25 years are such stellar names as Herbie Hancock, Bob James, Phoebe Snow, Dexter Gordon and Return To Forever.

"Listening to people like Art Tatum and Bud Powell and Charlie

—PAGE 139

SHOW

SHOPPING LIST

1. Stop by **SPRAGUE MAGNETICS**.
 - A. **REPLACEMENT HEADS & RECORDER SPARE PARTS FOR:**
Ampex, MCI, 3M, Otari, Revox, Sony BVH, Teac and Studer.
 - B. **REPLACEMENT CART HEADS:**
Ampro, ATC, Pacific Recorders, ITC, Broadcast Electronics, etc...
 - C. **REPLACEMENT FILM HEADS:**
Magnasync, Magnatech, MTM, etc...
 - D. **DUPLICATOR HEADS:**
Cetec Guass, Electrosound, etc...
 - E. **REFURBISHMENT SERVICES:**
All types of heads, 24 Hour turn-around, FREE evaluation.
 - F. **ALIGNMENT TAPES:**
MRL, Nortronics and STL

**SPRAGUE
MAGNETICS
INC.**

15759 Strathern Street/Van Nuys, CA 91406
(818) 994-6602 TLX:754239 FAX:818-994-2153

800-553-8712 800-325-4243 N. CA

Circle #088 on Reader Service Card

SMART MIDI™ TEXTURE™

by Roger Powell

Roger Powell brings together over 12 years of experience as a synthesist, performer and computer specialist in TEXTURE, the most powerful music composition software available today.

TEXTURE™ is a unique 'Modular Recording' style program that offers easy, flexible editing and manipulation of musical material. Compositions may be recorded as a series of smaller pieces called 'PATTERNS' then linked together as 'PARTS' to form a whole song.



The true genius of TEXTURE™ is its support of the compositional process. TEXTURE™ enables you to:

- Have up to 64 PATTERNS/PARTS instantly accessible to be tied together to form a whole song (each PATTERN/PART consists of up to 8 polyphonic, individual phrases or tracks)
- Save and retrieve hundreds more PATTERNS/PARTS from a floppy disk
- Punch-in and punch-out
- Use simple 'MENU' style commands accessible from single key strokes
- Step edit your music
- Autocorrect your composition, adjustable from quarter notes to thirty-second notes and ... much much more



110 MIDLAND AVENUE • PORT CHESTER, NEW YORK 10573

SMART MIDI is a trademark of Cherry Lane Music Co., Inc.
TEXTURE © 1985 by Roger Powell

Circle #089 on Reader Service Card

quality price service

These are what set IAN apart from other duplicating companies.

From 100 to 100,000 copies you'll find the same consistent quality in each tape.

- Audio & Video Tape Duplication in all formats. AGFA, BASF, 3M
- In House Printing & Packaging
- Full Line of Studio Supplies

ian Communications Group
10 Upton Drive • Wilmington, MA 01887
(617) 658-3700

Circle #090 on Reader Service Card

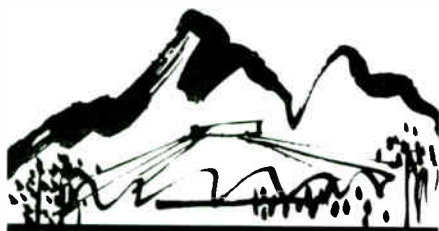

ASPEN MUSIC FESTIVAL
Gordon Hardy, President & Dean • Jorge Mester, Music Director

Aspen Audio Recording Institute
Aspen, Colorado

Summer 1985 • 4 Sessions

July 1-July 14
July 15-July 28
July 29-August 11
August 12-August 25

In the splendor of the Rocky Mountains, the Aspen Audio Recording Institute offers 4 intensive hands-on workshops in live recording techniques. Faculty is drawn from noted professionals of the recording industry. Using State-of-the-Art equipment, students record daily rehearsals and concerts of the Festival presenting a full range of recording experience from orchestra to opera, contemporary to jazz.

For further information write:
The Aspen Audio Recording Institute
The Aspen Music Festival
1860 Broadway Suite 401
New York, New York 10023

The Aspen Music School admits students of any race, color, national or ethnic origin

Circle #091 on Reader Service Card

MIX WORDS

© 1985 Armand E. St. Martin

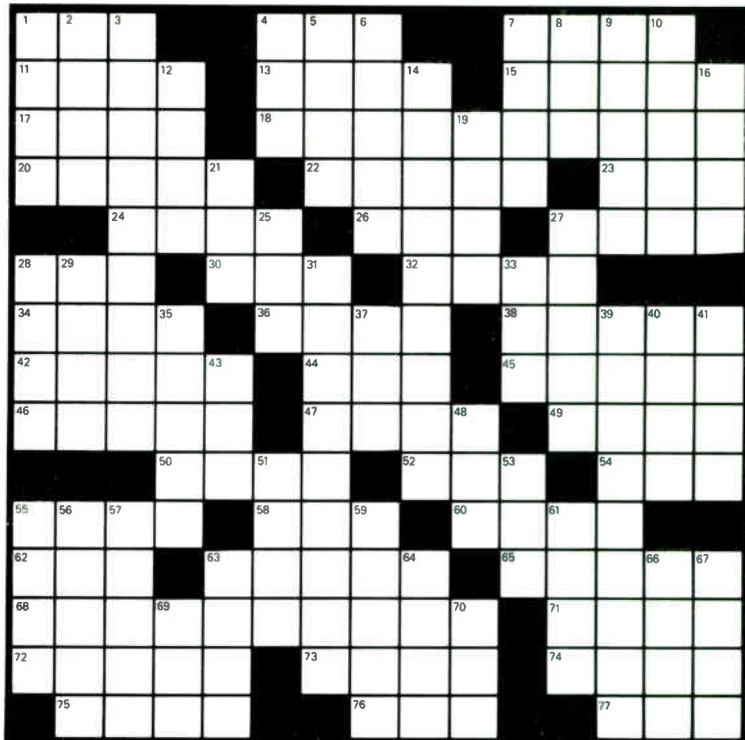

GRAND OL' WORDPLAY

ACROSS

- Fowl female
- Needlefish
- Tone_____
- Certain accts.
- On the peak
- Henley was one
- Latch part
- C&W mainstay
- Else
- Caravansary
- Gist
- Bridal_____
- Baseball's Mel
- Raison d'
- Stat for 26 Across
- Doc_____
- Mythological goddess
- Famed scat singer
- _____one
- Half of Peter & Gordon
- Southern_____
- Man's name
- Fishing gear
- Attest
- Atmosphere
- Ghetto
- "_____ Man"
- Siesta
- Synthesizer abbr.
- Fancy
- Tolkien's talking tree
- Attempt
- Name in the U.K.
- Winter constellation
- Nom de guerre
- Country guitarist
- St. _____'s Fire
- We too (L.)
- Aviation prefix
- Pass lightly
- Erotic
- One of a nursery-rhyme trio
- Affirmative

DOWN

- Dwarfs' syllables
- Latin lesson word
- "_____ Cats"
- Cumberland_____

- Chemical compounds (suffix)
- Cowboy's contest
- _____ Arnaz
- Dine
- Representative
- Flower (Fr.)
- Graf _____
- Acropolis sight
- River to North Sea
- Two a.m., e.g.
- Disencumber
- Singer Cole
- Lets up
- Confederates
- Played a horn
- Thielemans' axe
- _____ Safari
- Warning signal
- Randy Andy's old flame

- William of the mountain?
- Barney Google says this is sufficient
- San _____
- "Able was I _____, I saw Elba"
- "_____ Boot"
- Prefix with meter and scope
- School gp.
- Mate
- Ceases
- Silly
- Symbol
- Arabic letter
- Examination (comb. form)
- Roman fiddler
- Marie, to Pierre
- Barflies
- Poison; prefix
- Rocker Stewart

Solution to February Mix Words

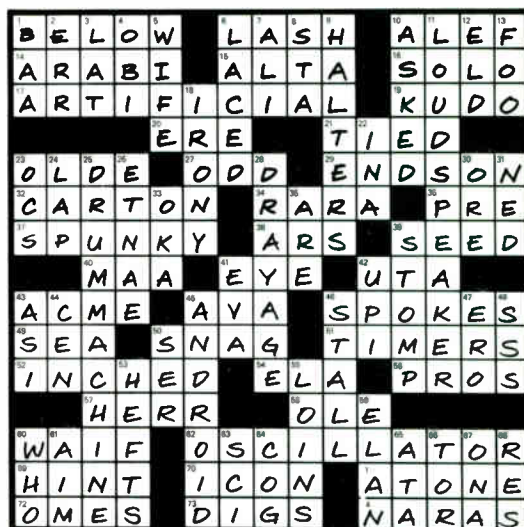

—FROM PAGE 137, LUNDVALL

Parker as a kid really gave me a certain kind of ear training in a way," he says. "And it wasn't only the records. I used to go and see these people play. I was really seeing genius firsthand, being exposed to these absolute giants who you well knew were beyond anything that you would ever hear. It all kind of ingrained in me that ability to identify those people who are really special as opposed to those people who are talented but not particularly magical."

One signing that Lundvall is particularly proud of was getting Willie Nelson under wraps for Columbia. "I signed him after everyone had passed on him. He was dropped by Atlantic and everyone else at CBS just passed on him, but I knew all about him because I was a big fan of his when I was a little kid. So I signed him for next to nothing and of course he's sold millions and millions of records for CBS. His very first record there, *Red Headed Stranger*, sold two million."

A Lundvall enterprise that was widely praised by industry heads and jazz fans alike was the signing of Dexter Gordon, who had been living as an expatriate in Denmark for years before Lundvall sought him out.

"He came to New York from Copenhagen for the first time in about 14 years and played at a place on 59th Street. I went there the first night and signed him on the spot. He was amazed. He thought that maybe he might get some kind of deal with a small jazz label. I had been a fan since I was 12 years old. I had 78s by Dexter Gordon. So I signed him."

Lundvall was also instrumental in coaxing the reclusive Miles Davis out of retirement in 1981. "I thought they were going to fire me when I signed Miles," he recalls. "He, of course, hadn't made a record for five years but when the first record came out, *The Man With The Horn*, it paid for the whole deal and then some. I got the company to give him a Steinway piano for his 50th birthday. Probably that as much as anything made him sign with us. He was so thrilled with that Steinway."

It's that kind of personal interest and commitment that distinguishes Bruce Lundvall in the industry. He's been an important factor in the business, a catalyst for the careers of many artists over the past 25 years. And now he stands to help advance the careers of many more young artists as the head of Blue Note Records. Carrying on the legacy of Alfred Lion is bound to be no small pleasure for this life-long jazz fan.

—Bill Milkowski

Synthesizer Video Instruction Tapes

At last month's NAMM show in Anaheim, CA, Ferro Productions of Belleville, NJ, introduced their SynthArts series of synthesizer instructional videotape courses. The titles include "Secrets of Analog & Digital Synthesizers" and "Making the Most of MIDI." Each course consists of two volumes, with each volume containing a two-hour video tape (VHS or Beta) recorded in stereo hi-fi, as well as a comprehensive workbook/manual. The courses feature demonstrations using the most popular equipment from leading synthesizer manufacturers, and are taught by Steve De Furia, synthesist/programmer with such recording artists as Frank Zappa, Stevie Wonder, John Farrar, David Paich, Steve Pocar, and Lee Ritenour, as well as former faculty member of the Electronic Music Department of Berklee College of Music.

"The Secrets of Analog and Digital Synthesis," is a comprehensive

and entertaining overview of all aspects of the creation and performance of synthesizer sounds. The course provides a straightforward guide to creating sounds on any synthesizer, as well as stage and studio performance techniques, including: "The Physics of Sound," "The Synthesist as Magician and Impersonator," "Programming the Yamaha DX7" "Programming the Oberheim Xpander," the basics of MIDI, using sequencers and drum machines, and the interfacing of different brands of gear.

"Making the Most of MIDI", available later this year, is a continuation of the previous course and explores all aspects of the Musical Instrument Digital Interface. The course is intended to demystify the sometimes bewildering information and choices facing the MIDI musician.

Among the manufacturers whose equipment is represented in the series are Roland, Oberheim, Sequential Circuits, Yamaha, Fender/Rhodes, Moog, Linn, E-mu, Apple, Commodore, and many more. "Secrets of Analog & Digital Synthesizers" is available in two volumes, each retailing at \$129.95.

SMART MIDI™ DX-HEAVEN

DX-HEAVEN is your window into the inner workings of the DX 7 and 9. DX-HEAVEN harnesses the powerful performance and synthesis features of the DX and for the first time all of its many variables are simultaneously available and at your fingertips.

All you need is a DX 7 synthesizer, an Apple II personal computer and a MIDI interface ...

plus the most important ingredient—the DX-HEAVEN software



The true genius of DX-HEAVEN is its incredible interactive screen displays and speed. DX-HEAVEN reacts QUICKLY and ACCURATELY to the users needs and demands enabling you to:

- Have a full screen display of ALL voice parameters
- Have the screen draw envelope changes as you make them
- Get instantaneous retrieval of 6 banks of 32 sounds each, (perfect for studio or performance applications)
- Have the DX Functions, displayed, stored, and linked to voices
- See an accurate graphic display of operator envelope vs. time and ...

much much more



110 MIDLAND AVENUE • PORT CHESTER, NEW YORK 10573

SMART MIDI is a trademark of Cherry Lane Music Co., Inc.
DX-HEAVEN © 1984 by R.J. Melvin

Circle #092 on Reader Service Card

SAVE BY BUILDING OUR RACK MOUNT STUDIO EQUIPMENT

QUADRAFUZZ — four separate frequency bands of distortion are mixed for the smoothest fuzz you've ever heard. no. 6720 \$ 39.88

HYPERFLANGE/CHORUS — the cleanest, widest range, most versatile flanger anywhere at any price. no. 6750 \$149.95

VOCODER — unmatched performance in a versatile, low cost rack package. no. 6710 \$99.95

HOT SPRINGS — user's agree, short of studio plate systems, you won't find a better reverb at any price. no. 6740 \$59.95

ADD \$3 SHIPPING
FOR EACH KIT ORDERED

Innovative, cost effective designs by Craig Anderton in easy to assemble kits from:

PAIA Electronics, Inc.

Direct mail orders and inquiries to: Dept. 11x
1020 W. Wilshire, Oklahoma City, OK 73116 • (405)843-9626

Ask for your free catalog.

CHARGE TO VISA OR MC TOLL-FREE
1-800-654-8657 9AM to 5PM CST MON-FRI

Circle #093 on Reader Service Card

SOUND SYSTEM

BUZZ

ITS TOO BAD YOU
CANT ALWAYS KEEP IT CLEAN

BUT NOW
ITS ONLY TEMPORARY
INTERFERENCE WITH
A

MODEL PS-1



In addition to reducing RFI the PS-1 can also protect your sound reinforcement equipment from:

- HIGH VOLTAGE TRANSIENTS
- UNEXPECTED POWER UP TRANSIENTS
- IMPROPER LINE POLARITY



**linear & digital
systems, inc.**

46 marco lane
centerville, oh.45459

Circle #094 on Reader Service Card

PHOTO: STEPHANIE CHEBNIKOWSKI



The dB's

—FROM PAGE 134, dB's

high-apple-pie-in-the-sky hopes and never to let life get them . . . *that* down.

"Anybody that would watch the video and think, 'hmm, the dB's want me to go out and kill myself,' would have to have a screw loose somewhere," protests Holsapple. "And when we did the song, suicide was not as rampant as it is now. The powers that be at the major video networks were having a bit of a problem with the scene where I'm shoveling the pills in my mouth, and where my feet drop in the very next frame.

"Obviously, the easiest thing to do would have been to edit those portions out, but then the song would make virtually no sense. So Mr. Bill comes on and does a little introduction about how bad things have been for him, but they never really got him down; and at the end he just advises them to bounce back from life's troubles."

Holsapple pauses. "The 'bounce back' stuff has been a parallel to the dB's situation. It's always been my policy that it pays to be optimistic, and that's not easy in Ronald Reagan America."

The dB's' career might best be described as frustrating. Although critically praised since the beginning, and despite creative associations with like-minded fellow Southerners such as R.E.M., Let's Active, and Jason & the

Scorchers, the four popsters from Winston-Salem, N.C. haven't risen significantly above cult-favorite status in their six year existence.

Call it the fickle finger of fate, call it the lack of any discernible taste in the American mass audience—the band's relative obscurity certainly isn't any fault of their own. Their jangly '60s-influenced pop, alternately tough, charming, quirky, haunting, and soulful, with hooks that fasten in your brain and words that aren't just put there to give Holsapple something to do with his mouth, is some of the best stuff this country has to offer.

Small wonder, then, that the group's first two albums were English imports, the Brits having a quicker ear than we do in determining what's worthwhile among our own countrymen's contributions. *Stands For decibels* and *Repercussion* on the Albion label both featured a healthy sampling of the dB's two songwriters and singers, lead guitarist Chris Stamey and rhythm guitarist Holsapple. (The latter's "Amplifier," in fact, first turned up on 1982's *Repercussion*.)

"We used to do in-store appearances at record stores who were kind enough to ask us, when all we had were imports," recalls Holsapple, "and they'd have maybe one or two copies of the album in stock. So they'd get sold, and we'd just be stuck sitting around with nothing to sign. Maybe somebody'd

—PAGE 144

BREAK INTO THE FUTURE OF ELECTRONIC MUSIC

THE ROLAND ELECTRONIC MUSIC SEMINAR

Do you have questions about MIDI, computer music software, computer interface, SMPTE time code and other audio/video applications for synthesizers, sequencers or drum machines? Now you can get the answers. Be a part of the future. Let the Roland Electronic Music Seminar bring you up to speed on today's tools of the trade. Whether you're a hobbyist, studio or performing musician, a songwriter or composer for film, TV audio/visual presentations, the Seminar is what you need to get the edge on the competition. Spend one whole day in an environment that will bring it all together for you—all the latest advances, explained by top players and some of the most authoritative clinicians in the field. RolandCorp US—the company behind some of the most exciting developments in synthesis and computer music technology—will be conducting Electronic Music Seminars all across the country. "A great overview!"... "Best investment of the year!"... "Lots of info!"... These are some of the reactions we've gotten from musicians who have already attended the seminar. Some of today's most respected synthesists—Michael Boddicker, Suzanne Ciani, Gary Wright—will lead a team of clinicians in presenting the applications, equipment, and special techniques that have placed them at the forefront of modern electronic music. The topics covered by the day-long seminar include system design, computer music software and computers, recording and educational applications and audio/video synchronization. You also get a volume of reference materials and a series of tapes that reinforce all the valuable information presented at the seminar. The Roland Electronic Music Seminar is a unique opportunity—your chance to learn today's music technology from the people who have made their names designing and playing it. Seminar dates are: Los Angeles, March 2; Washington DC, March 6; New York, March 9; Philadelphia, March 12; Boston, March 14; San Francisco, March 19; Dallas, March 23; St. Louis, March 26; Kansas City, March 28; Denver, March 31; Chicago, April 13; and Minneapolis, April 16, 1985. To book a reservation or to obtain more information, call toll free (800) 352-7930. In Illinois, call collect (312) 545-0460. Sponsored by: RolandCorp US, 7200 Dominion Circle, Los Angeles, CA 90040.



Grover Helsley Recording: A Blend of Old and New

On July 15, 1984, a long-cherished dream finally came true for Grover Helsley when his company, Grover Helsley Recording Inc., took over the lease of the historic old RCA studios on the corner of Sunset and Ivar in the heart of Hollywood. "I think many people dream of the day when they can become the boss of the place where they work—but for me, it actually happened," explains the veteran recording engineer, whose association with the studios goes back a long way, having been a mixer there in the days when it was still the RCA Records' studio, and then head mixer when the complex later became Filmways/Heider Scoring Services. "It just seems very appropriate that it should happen this way, after all the years I've spent in-

Grover Helsley



WE'RE EXPANDING!

That's right! We're Expanding and Compressing and Limiting and Gating and

Ducking and Reducing Noise. Listen closely and you'll hear that our line of dynamic range processors is the most versatile in the industry. Not only can we boast of unbeatable specs and competitive pricing, but most important, our processors sound great... which means

they make you sound great! If audio is a part of your life, then we can make life easier for you! Call or write for details.

Symetrix

109 Bell Street
Seattle, Washington 98121, USA
Telephone (206) 624-5012
Telex 703282

Circle #096 on Reader Service Card

MUSIC NOTES

side these walls," adds Helsley.

The happy and proud new owner was born in Los Angeles in 1941, and was always attracted to electronics and show business. His "Hollywood upbringing" included a fifth birthday party held over at Lucille Ball's house, and on graduating from high school he pursued his growing interest in electronics by joining Hollywood Radio and Electronics. It was while working there that Helsley met an enterprising young engineer named Walley Heider, and when one day Heider offered him a job with his new remote recording business, he eagerly jumped at the chance.

Between 1962 and 1967 he helped pioneer the field of mobile recording with Heider, working with such artists as Frank Sinatra, Barbra Streisand and Sammy Davis Jr., and at the Monterey Pop and Jazz Festivals. Then, in 1967, Helsley joined RCA Records as a maintenance technician and mixer, beginning his long association with the studios. Over the next decade he engineered classic sides by Harry Nilsson, Jose Feliciano and other artists, while simultaneously engineering for Pablo Records and cutting tracks with such jazz greats as Count Basie, Lionel Hampton, Ella Fitzgerald, Oscar Peterson and Cleo Laine.

In 1977 Helsley was reunited with Walley Heider when the latter took over the RCA facility, and appointed Helsley as head mixer of Heider/Filmways Scoring Services with a full round of administrative duties, in addition to his engineering work on feature films and television scoring dates. "We did a lot of big movie soundtracks and famous rock and roll albums during this period," points out Helsley. "The Rolling Stones recorded *Some Girls* here, and producer Jimmy Iovine worked out of here with such artists as Tom Petty, Stevie Nicks and Bob Seger. The studios had also hosted countless film and television scoring projects, including *Urban Cowboy*, *10*, *Smokey and The Bandit II*, *Sharkey's Machine*, *Falcon Crest*, *Remington Steele*, *Lou Grant* and *Dallas*, so it was really the end of an era when Filmways finally closed in 1982 on the tail of the recording industry slump," adds Helsley.

"In fact, the doors were closed for some two years after that period, and nothing happened," continues Helsley, who in the meantime created Grover Helsley Recording Inc. while continuing to work as an independent engineer. At the same time, he began negotiating to lease the recording complex, which was also attracting considerable attention from other industry people. After some

long and hard bargaining, he finally took over the studios in July of 1984.

Now fully operational again as Grover Helsley Recording, the refurbished studios are busier than ever, thanks to the perseverance of their new owner, who helped design the facility's custom-built Neve consoles and who is intimately familiar with each of the three rooms. "They're great rooms so, although we're doing a little remodeling and sprucing the place up, we're certainly not going to change the acoustics at all—there's simply no need," explains Helsley.

Helsley's plans for the future include taking full advantage of the facility's multi-purpose design, and apart from such record and television work, will also emphasize videotaping sessions for TV shows, as well as the production of music video projects. "We already do *The Bob Newhart Show* in Studio A, and we're picking up more and more shows all the time," he points out, "In fact, we're just about to start *The Lucy Arnaz Show*, and we've already done one show for *Ripley's Believe It Or Not* series, with plans for future shows. And, like I said, we definitely want to go after the video market, as we can easily accommodate any kind of production in Studio B."

Helsley is also helping to lease the nine floors of office space above the studio complex with the goal of developing the site into a complete entertainment center, and there are already many music-related companies in the building, including RCA Records and the JVC Cutting Center which is directly tied into Grover Helsley Recording via cables originally installed by RCA. "In fact, we just made an agreement with JVC enabling us to do direct-to-disk, as well as giving us the capability of the JVC digital recording system and the Sony digital recording system," he adds. "On top of that, we've also got various artists and music companies basing their activities out of here now. George Clinton has just moved his entire operation over here, and already has offices and all his Synclavier equipment set up. We also have two film music editing companies housed here—Damask, which is owned by Ken Johnson, and Musicue, which is owned by Steve Livingstone. These two work both separately and together. So really the future for the studios looks very bright indeed, because we have the space, the equipment, the personnel and the support of our neighbors in the building, and in terms of work, we can do film scoring, television scoring, commercials, records—everything."

—Iain Blair

The Affordable

Digital Real Time Third-Octave Spectrum Analyzer

- Full 30 Bands • Six Memories • Quartz Controlled "Switched Capacitive Filtering" to eliminate drift • Ruggedized for Road Use • Microprocessor Controlled • Built-in Pink Noise Source • "Flat," "A," or "User Defined" Weighted Curves may be employed
- ROM User Curves Available.



MODEL 30

Affordable at just \$1895.00

GOLD LINE

Box 115mx • West Redding, CT 06896

(203) 938-2588

SEND FOR COMPLETE LITERATURE:

NAME _____
 COMPANY _____
 STREET _____
 CITY _____
 STATE _____ ZIP _____

Circle #097 on Reader Service Card



Custom Length
 BASF
 Chrome
 Cassettes

AMPEX
 Blank Recording Tape

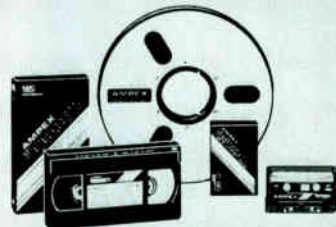





Authorized Distributor

**UNITED TAPE
 COMPANY**

10746 Magnolia
 N. Hollywood, CA
 (818) 980-6700
 Ask for Steve

Authorized Reseller
 Information Processing Media **BASF**

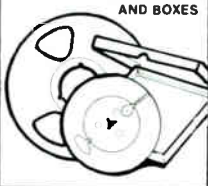
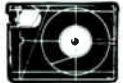
Circle #098 on Reader Service Card

 <p>CONNECTORS AND MICROPHONE CABLES</p>	 <p>BLANK-LOADED AUDIO CASSETTES</p>
 <p>TAPES & CASSETTES from AMPEX AGFA BASF MAXELL TDK 3M</p>	 <p>EMPTY REELS AND BOXES</p>
 <p>NAB BROADCAST CARTRIDGES</p>	 <p>CASSETTE BOXES, LABELS, ALBUMS</p>
 <p>ACCESSORIES</p>	

Ask for our
44 PAGE CATALOG
of
PROFESSIONAL SOUND RECORDING & DUPLICATING SUPPLIES

Recording Supply Div. of Polyline Corp
1233 Rand Road, Des Plaines IL 60016
(312) 298 - 5300

35

Circle #099 on Reader Service Card

L.D. Systems
is
professional
sound and lighting:

Sales
Rental
Installation
Production & Repair Services

**Other companies
may do it all.**

**Only L.D. Systems
does it all so well.**

 **L D SYSTEMS, INC.**
467 W. 38TH HOUSTON, TEXAS 77018 (713) 895-9400
professional sound and lighting sales, services and rentals

Circle #100 on Reader Service Card

—FROM PAGE 140, dB's

bring in a copy of *Planet Waves* and we'd sign that . . ."

Fortune smiled briefly on the lads when a U.S. label finally took an interest in them. A year and a half of negotiations later the dB's were signed to Warner Bros.—distributed Bearsville Records. But before recording got under way, a good-sized bomb dropped. Chris Stamey, the acknowledged leader of the band, wanted out.

"Chris wanted to work outside the two guitar-bass-drums framework," Holsapple says. "He'd offered to do the record with us, but time became a little oppressive, and he wanted to go off and do what he did. From knowing the guy for quite a while, I'd say he eschews the ordinary, and would rather go for something experimental. I think he's a whole lot happier.

"The parting was very friendly —I played on his new record. And we'll all still get together sometimes and . . . drink milk."

Stamey's departure left the dB's without a lead guitarist and with Holsapple holding the frontman's bag. "Chris and I had each sung lead on the songs we'd written," he relates, "which worked out about fifty-fifty. But now it was a real shock, coming to the conclusion that I was going to have to be standing up there alone . . . Of course, you're never really alone with a band."

Holsapple's confidence was further buoyed by the solo tour he'd done a couple of years before, just him and his guitar opening for R.E.M. "That really helped me focus things down to where I knew I had to become a singer, which I hadn't had to be before."

The lead guitar vacancy was filled by bassist Gene Holder, who'd been moonlighting as lead player with the Hoboken, N.J. pop band The Individuals while the dB's Bearsville contract was being sorted out. "Gene plays some really amazing stuff," Holsapple says admiringly.

Drummer Will Rigby stayed put on the traps, and the dB's recorded their first domestic album *Like This* as a three-piece. Recording was done at Bearsville Studios, with The Waitresses' Chris Butler producing. "He's a hard slave-driving man as far as working out bugs from the basic tracks," Holsapple says approvingly. "He also helped us rewrite and rearrange the basic structure of the songs.

"The band," he adds, "is 100 percent responsible for the arrangements. I come in with sort of folk songs—Woody Guthrie with a guitar on his shoulder—and they turn them into dB's songs somehow.

"I think our sound is a little more

accessible now," he muses. "We wanted *Like This* to have as much diversity as a dB's record should have, and I don't think we lost that quality when Chris left.

"We may have lost a little bit of the outward strangeness of the band. But part of the idea of pop music comes from the word 'popular,' and we certainly would not mind having a hit."

Like This sounded like it was chock full of 'em. The syncopated, jiving "Amplifier," the achingly tuneful "Love Is For Lovers," the wry, hook-laden "She Got Soul" all should have been played

"I think our sound is a little more accessible now...we may have lost a little bit of the outward strangeness of the band."

into the ground, but no such luck. Or rather, typical dB's luck. And they may have to wait awhile for another chance at that first hit, because the fickle finger has poked fate in the eye again. Bearsville Records folded in December, and so far Warner Bros. hasn't picked up the dB's option. Short-sighted of them, of course, but what can you do.

"It sounds very capitalistic," sighs Holsapple, "but we would like to move our standard of living up just one iota, so we could pay our rent and not have to worry about food for the table. We did choose this as a vocation, I realize that; it would've been just as easy to take up arc welding as a profession. But that doesn't seem to be too much to ask."

The dB's'll bounce back. They always do. If they don't, their loyal fans will destroy Winston-Salem. These guys have a new tradition to uphold—the continual creation of radical American pop from Dixie.

As to why this pop renaissance occurred in the South, Holsapple theorizes, "At the time when all of us were in our first bar bands, we couldn't escape playing the Allman Brothers/Marshall Tucker stuff, because that's what the bar patrons wanted to hear. You could stand up there and do songs by The Move, The Kinks, and Big Star, and they still wouldn't stand up until you played the first chords of 'Ramblin' Man.'

"We got tired of that, so I guess that's where our rebellious, renegade stance comes from. We're as proud of being from the South as Dicky and Duane, but we handle it in a different way."

—Moira McCormick

—FROM PAGE 62, SOUTHEAST

The studio, which specializes in recording for advertising and corporate communications clients, has added an Adams-Smith 2600 SMPTE synchronizer and 3/4" VTR and plans to complete building a third studio by May of this year. One recent project involved producing a 12 minute slideshow soundtrack for the Kentucky Derby Museum. This complex job involved conforming live sounds captured by 15 persons with Nagra recorders at the last derby, and transferring these sounds to two synchronized Ampex 24 track machines, which later received the narration and

music tracks. Once assembled, the entire system was brought into the museum itself for the final mix, so the sound would be custom optimized to the room. This setup precluded the use of automation, so a "lot of hands and a lot of takes were required to pull it off," according to engineer Tim Creed.

Chandler Audio is a "new" studio operated by Denny Chandler, who took over the badly managed and poorly maintained Riverside Studio in Ashland, Kentucky about a year ago. Chandler explains that one of his main obstacles is trying to overcome the former studio's bad reputation for shod-

dy maintenance. So after taking over, one of his first priorities was to put the equipment in shape. "The people at Harrison have been very helpful," says Chandler, who has now completed the revitalization of his Harrison 2436 console. "I had to completely re-wire the studio and then I brought in my collection of outboard gear. People were afraid to come here before, but now business is picking up." Another advantage the facility offers is its tri-state location, convenient to clients from Kentucky, West Virginia, and Southern Ohio, and Chandler is now drawing business from all three areas. ■

—FROM PAGE 54, SUN & FUN

for video work, however the press of the current work load has postponed that expansion. As a SPARS regional vice-president, Ms. Kaye plans to work toward further unification of the South Florida studios. She places great emphasis on mutual support, for example, loaning Criteria some microphones during some slightly too-busy days there in December.

New River Studios in Ft. Lauderdale is a relative newcomer to the area, and has the only 48 track room outside of Criteria. Studio manager Virginia Cayia described some of their recent activities which included vocal overdubs and mixing to video with Cyndi Lauper for her single "Money." Miami Sound Machine's album work at New River helps to extend their visibility to Central and South America. Until recent economic adversity reversed the trend, a growing number of Latin performers were traveling to South Florida to record; now that is limited to the wealthier clients. Jingle work continues to be the bread and butter for New River, and business is good, particularly because of the non-reliance on the ups and downs of booking album work. Cayia noted that future local rumor includes the construction of a Universal film studio in Ft. Lauderdale on State Road 84; the only tangible evidence is a large sign in the vacant lot proclaiming that fact. However she had higher hopes for the recent repeal of a state sales tax law; there is no longer a five percent levy on time, only a tax on materials. This affects both the recording and motion picture industry in Florida.

My next stop was at Video Tape Associates in Hollywood. According to chief audio engineer Joe Moore, 99 percent of his work is audio for video, primarily television commercials, and they are booked solid, five days a week. The bulk of the work is local and regional, with a fair sampling of

national clients, such as McDonalds, Goodyear, Norwegian Caribbean Lines, Lincoln-Mercury, Blue Cross-Blue Shield, and increasingly, South American accounts such as Colgate-Palmolive. Elements for the audio mix are supplied by the client, or VTA, then edited and placed on the video master, via automated 24 track audio.

Business at VTA can be described as fabulous; unlike the situation in some music-only studios, booking time for audio for television is continually increasing, to the extent that a computer system has been installed at VTA solely to handle booking. Every evening at 5:00 p.m., Moore is handed a computer print-out listing his appointments for the next day. Three on-line editing rooms are booked day and night, sometimes with 20 hour shifts. Moreover, according to Moore, that load appears to be typical in many Southeastern video studios. Although historically there has been a seasonal variation in the number of bookings, with September through February being peak months, summer work during the past two years has seen heavy booking. An area for potential growth is network television work in South Florida, with programs such as **Miami Vice**, possibly signaling a re-emergence of a local television industry, something not seen in Florida since the 1960s.

My final conversation was with Ron Warren, the regional 3M representative. As the man who sells the magnetic stuff, more than anyone he should know how South Florida's recordists are doing. He is enthusiastic about the state of affairs, and moreover sees momentum and anticipation on the part of his clients, indicating future uptrends, particularly in video, which currently accounts for 65 percent of his volume. However according to Warren, audio tape sales have been steady, and showing marked improvement since Novem-

ber. Echoing others' statements, he believes that the South Florida market is becoming less seasonal, particularly over the last two years. Although fluctuation does occur, the business cycle is beginning to flatten out. In general, from his standpoint, Mr. Warren has seen a 12 to 15 percent yearly growth in the regional market over the past five years, with increasing growth particularly in the last quarter of 1984. In conclusion, he summarized 1984 as an exceptional year, and is convinced that 1985 will be even better.

South Florida is thus a prospering yet unfulfilled market. While it will always find a fair share of regional work in audio, video, and film, and attract some national and international clients, there is no specific direction for growth. That will come only as a result of careful cultivation of industries such as television and film. The motion picture industry has long flirted with South Florida, with recently promising signs. In 1983, 27 feature films were shot on location here, along with 836 short subjects and TV commercials, for a total of \$147 million. While that is a little shy of the \$22.8 billion spent by tourists in 1983, Florida now ranks third in the film industry behind California and New York. With the growing decentralization of the film business, Florida stands to gain an increasing market share, and is currently actively selling the sunshine to attempt to lure the high-visibility, well-paying industry. The audio recording and postproduction business would incalculably benefit by sustained growth in the Florida film industry.

With the situation firmly in hand, secure in the belief that the art and science of audio was alive in South Florida, I took advantage of the only real reason for being here. I headed for the beach.

—Ken Pohlmann

The book the recording industry never knew it needed . . .

Now it knows better!

"This book could quickly become the New and Improved Testament for recording studios, the quintessential handbook for studio dwellers, a reference tome and tour book for what really goes on behind closed double doors...an upthrusting plea for insanity in a sane world."

—Ken Pohlmann

Music Engineering Department Head, University of Miami

"Mr. Bonzai has captured the true meaning of *Studio Life* in this incisive satire of what really happens in a recording studio. I could not stop laughing. All my friends will definitely get this book from me for Christmas."

—Chris Stone, President
Record Plant, Los Angeles

"Mr. Bonzai kamikazes into **Studio Life** with the fervor of a thousand engineers trying to splice together the Red Sea. If you're interested in life in the recording studio, I urge you to read this book. It's all here, the inner workings of Tapeland U.S.A."

—Stephen Bishop
Songwriter/Recording Artist

"I hope you enjoy your copy of *Studio Life* as much as I did mine. I boiled mine for dinner." —Stan Freberg, *Humorist/Recording Artist*

"...a must for anyone who is in the industry. It's comforting to know that all the insanities and extraterrestrial experiences affiliated with the record industry didn't just happen to me. *Studio Life* should be the new Bible for all studios."

—Michael Sembello
Recording Artist

"Mr. Bonzai is a one-man show and tell."

—Gerald Vincent Casale, *Devo*

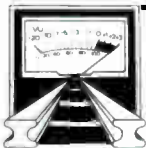

STUDIO LIFE: *The Other Side of the Tracks* by Mr. Bonzai

YES! Please send me _____
copies of STUDIO LIFE.

Name _____

Enclosed is my payment of \$7.95
per copy plus \$1.00 postage, or

Address _____

Bill to: VISA Mastercharge

City _____

Credit Card Number _____

State _____

Zip _____

Expiration Date _____

Signature _____

PAYMENT MUST ACCOMPANY ORDER
Quantity Discounts, Inquiries Welcome
Make checks payable to MIX Publications
Mail to: Studio Life, c/o MIX Magazine
2608 Ninth St., Berkeley, CA 94710
(415) 843-7901



JASON & THE SCORCHERS

Lost and Found

EMI America ST 17153

by Bruce Borgerson

Produced by Terry Manning with associate producers Warner Hodges and Jeff Johnson; engineered by Terry Manning; assistant engineers: Tom Harding; Recorded at Treasure Isle Recorders and Emerald Sound Studios, Nashville, TN; mixed at Alpha Sound, Memphis, TN; mastered at Masterdisk, New York, NY.

What if Hank Williams, Sr. had been given the opportunity to record a few tunes backed by The Ramones? What if Gram Parsons had joined the New York Dolls instead of the Flying Burrito Brothers? What if . . .

We'll never know the answers to these questions, but at least Jason & the Scorchers are leaving a trail of clues—a trail of shattered drumsticks, smoking amplifiers, sweating fans, and charmed critics. After forging their bashing blend of country and punk (punktry? punkabilly?) in the dank new wave dives of Nashville, the foursome soon attracted a sizeable following, released two discs on the independent Praxis label, landed

gigs at notable New York clubs, caught the jaded New York critics by surprise, and finally ended up last year with a signed contract from EMI America. *Fervor*, their second Praxis disc, was re-released by EMI after the original material was re-mixed and a torrid cover of Dylan's "Absolutely Sweet Marie" was added. Also released as a single, "Sweet Marie" had good video exposure on MTV but met with shrugs and head-shaking at most AOR radio stations. (What is this stuff anyway? A '60s folk-rock song with outlandish country rube vocals and hyperkinetic electric guitars? Do I dare program this between Journey and the Eurythmics?) Consequently, in their homeland, *Fervor* barely raised the band above cult status. They fared far better among more receptive European audiences. Their first tour captivated the London rock press, several singles were released, and sales of *Fervor* soon surpassed the U.S. totals. A hastily scheduled second European tour saw the Scorchers headlining concerts drawing upwards of 8,000. In the lands of cerebral synth-rock, the Scorchers' 100-proof blend of blood, sweat and angst has proven to be a welcome stimulant.

In *Lost and Found*, their first full-length LP (*Fervor* was a 7-song mini-LP), the Scorchers are roaring back with

the same thrashing energy, only this time with a more controlled, refined sound. The title is appropriate because some of the offhand, reckless charm of *Fervor* has been lost; at the same time, however, the group has found consistency, polish, and—they fervently hope—some music more accessible to a broad American rock audience.

Although the album as a whole has the momentum of a buffalo stampede, the band does provide breathing space with a couple of plaintive country ballads. Acknowledging a genuine debt to their country roots, the Scorchers recruited veteran sessionmen Kenny Lovelace (fiddle) and Earl Poole Ball (piano) to aid them on several tracks.

Of *Lost and Found's* 11 songs, five are written by lead vocalist Jason Ringenberg, whose yelping style has been tamed of its excesses but not of its enthusiasm. Bassist Jeff Johnson and drummer Perry Baggs (teamed with co-writer Larry Napier) contribute two tunes each, and two covers of 1950s country classics are also included—Hank Williams' "Lost Highway" and Eddy Arnold's "I Really Don't Want to Know." What the Scorchers do to these standards could bring Hank out of his grave and put Eddy into his.

Considerable credit for the

Scorchers' tighter recorded sound goes to producer/engineer Terry Manning, whose other recent credits include ZZ Top, George Thorogood, and Molly Hatchet. A former session guitarist and engineer at Stax/Volt in Memphis, Manning was initially recruited to re-mix *Fervor* and produce the added "Sweet Marie" sessions.

"Bringing in Terry was my idea," says guitarist and associate producer Warner Hodges. "I jokingly said one day that I'd like to work with ZZ Top's people because they were the only ones doing something remotely similar to what we were doing, and they were also getting great sounds. At first we just had a good laugh, and then I thought, 'Hell, we've got a deal and some money, let's

give him a call and give it a whirl.' It worked out very well. It takes a lot of talent and patience to take four young hellions and make something out of them. I also respect Terry enormously for listening to us. There are not too many people with that kind of track record who would take Jeff and me—the original gutter boys—and really listen to our ideas."

Manning's task was not an easy one: help take the Scorchers' rampaging, whirling-dervish stage show and translate it into grooves on vinyl. The job began with selecting and re-arranging the material in pre-production sessions.

"Some of the songs had to be changed," admits Hodges. "We added on to some songs—like 'White Lies' and

'Money Talks'—because they were too short. It's hard getting airplay with a 96-second song. But the biggest problem, especially for Jason and Perry, was adapting to the studio procedure—not playing everything live at the same time. A few cuts, like 'Lost Highway,' were done live in the studio, but mostly we built up the tracks separately."

The rhythm bottom tracks were laid down with bass and drums playing together or, in some cases, with drummer Baggs playing from memory to nothing but a click track. Then, for the hard-rockers, Hodges added two or three layers of electric guitar by interweaving his high-volume power chords with stuttering eighth notes, controlled feedback and stinging leads. Hodges' guitar parts have a dual, seemingly contradictory role: they kick in an afterburner of thrust, but they also hold the whole sound together. This importance is reflected in the time and effort put into the album's guitar overdubs.

Development of guitar sounds was a three-way collaboration involving Hodges, Manning, and guitar builder/techno-freak Dave Sutherland, who connected with Hodges shortly before recording began. Hodges and Sutherland would work on finding the right sound in the studio, with Manning then deftly tailoring it for the tape.

"Warner and Terry would tell me what kind of sound they wanted," says Sutherland, "and I would suggest a certain guitar and amp. We'd try that and, if it didn't work, we'd try something else. On any given day we'd have seven or eight guitars, plus three or four speaker cabinets. We'd mix and match until we got what we wanted." Guitars used on *Lost and Found*—most of them Sutherland's—include a stock 1951 Telecaster, a custom Telecaster, custom Stratocaster, stock Strat, re-worked Jazzmaster, and two exotic guitars hand built by Sutherland. Amps utilized included a Dean Markley, Mesa Boogie, early 1960s Fender Super Reverb, Spectra, Hiwatt head, and custom speaker cabinets made by Sutherland.

Although Sutherland had been building and modifying guitars and amps for years, the Scorchers' sessions were his first foray into a recording studio. "It was great working with Terry," says Sutherland. "After he saw what I could do, he gave me a free hand to try anything. For somebody with his track record to let somebody who had never been in a studio before just go out there and try things is pretty amazing. And he said some of the sounds we got were among the best he's recorded!"

All guitar overdubs were cut with Hodges romping about in Treasure Isle's roomy (fortunately!) control room. Usually, each part was recorded in stereo, with one amp positioned in the live

SPEND MORE TIME MAKING: MUSIC FOR AUDIO MUSIC FOR VIDEO MUSIC FOR FILM MUSIC FOR MONEY! it's **SMPL**™.

Get the most complete synchronizer system on the market today! You'll spend more time making music while the SMPL System's 10 point autolocator quickly locates audio, video and MIDI tracks and synchronizes audio/audio, audio/video, MIDI/time code.

SMPL supports all North American and European video and film formats.

Automatic punch in and punch out, time code metronome, recorder remote control and many more user friendly production tools are at your fingertips.

And, all this costs a lot less than you ever imagined.

See the

SMPL™ System

Now available with

SMPL™ Lock and MIDI instrument sync option...at your local music or pro audio dealer.

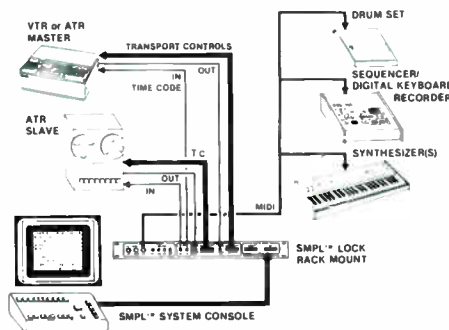

SYNCHRONOUS TECHNOLOGIES

P.O. Box 14467 • 1020 W. Wilshire Blvd. • Okla. City, OK 73113 • (405) 842-0680

Circle # 101 on Reader Service Card

end of the large (30'x40' with 25' ceiling) main studio and another amp in a hard-walled upstairs storage room. The split signal and long cables did cause some headaches. "We were losing a lot of guitar signal," says Sutherland. "On some cuts we were using the '51 Tele with the original pickups. Well, the magnets had deteriorated to where there wasn't much output, so we were fighting that signal loss constantly. I'm working on a rack of pre-amps and amps for the next album so we don't have to worry about it again."

Despite the problems, the trio concocted some remarkable guitar sonics. The sustained feedback "lead" on "Lost Highway" is a notable example: "At first I couldn't control the feedback at all," says Hodges. "I had to play it live, out in the room, and the three bottom strings were feeding back so bad that I just de-tuned them, loosened them until they were nothing. Then I hit that power chord and Dave was standing right in front of me, shaking the pickup to make the feedback come out right. At the end, when I heard the high feedback coming in, I grabbed the flatted strings and yanked on them."

"We were out there for about forty minutes working on that," adds Sutherland. "I was working the pedals and knobs while Warner was playing. It took us a long time to get the low, roaring feedback with the second order harmonic overtones but without the high-pitched squeal. When he yanks those strings it's a weird sci-fi kind of sound, like a spaceship in a movie. I'm sure Hank never heard it that way!"

For weight, thickness, and searing edge, the sounds on "White Lies" stand out. "We used Terry's 100 watt Hiwatt on that," says Sutherland, "with every knob at maximum. We ran it through my custom-built cabinet with a single Electro-Voice 12" speaker rated at 250 watts. We put it over in the live end of the big room and let it run wide open for a couple of hours while we worked on the tune."

"I was playing the '51 Tele on that," continues Hodges. "We had used that combination on a couple tunes before "White Lies," but after those tracks Terry's poor Hiwatt was never quite the same."

Once again, the Scorchers' rampaging sound has challenged the limits of mortal musical instruments. But the Hiwatt has not died (or gone comatose) in vain. Although some may say the Scorchers' brand of "punktry" represents a limited genre—and, granted, the mixture may be too volatile to endure over a stretch of five or six albums—none can deny that in *Lost and Found*, Jason & the Scorchers have welded together a vital new synthesis of country's romantic tradition and rock's explosive rebellion. ■

Brush reconditioning adds new life to your magnetic heads... at one-third the replacement cost!

Brush, the first name in new magnetic heads, is also the first name in reconditioned heads. Brush reconditioned heads typically double or even triple their original life, and the cost is only a fraction of the replacement cost. Brush reconditioning is fast, too, usually within 24 hours. Forty years experience in manufacturing and reconditioning heads assures you of quality that equals or exceeds original specifications, and we will evaluate your worn heads...at no charge. Call toll free for more details.

BRUSH
The First Name In
Magnetic Heads.

1-800-233-0362
717-286-5611
Third & Reagan Sts.
P.O. Box 638
Sunbury, PA 17801

Circle #102 on Reader Service Card

GRD
AMERICA'S MOST
EXPERIENCED
REAL TIME DUPLICATOR

The world's largest state-of-the-art cassette duplication facility continues to give you incredible sonic excellence. GRD was first to introduce Real-Time cassette duplication at a reasonable cost, and elevated the cassette to audiophile quality. This year GRD has taken the next step into the future with Digital Duplicating. AGFA's super-extended normal bias 612 tape and high bias 627 tape. GRD will faithfully reproduce your most demanding programs without compromise... in Real-Time at unreal prices.

HIGH QUALITY PRINTING
AND ASSEMBLY
CUSTOM LOADED BLANK
AGFA CASSETTES, CHROME, 612

(602) 252-0077
P.O. BOX 13054
PHX., AZ 85002

THE RECORDERS' Quartet Block Auto
Bias 30-2000 Hz 325% w/r m
Dolby B - more than 67 db
S/N ratio

Circle #103 on Reader Service Card

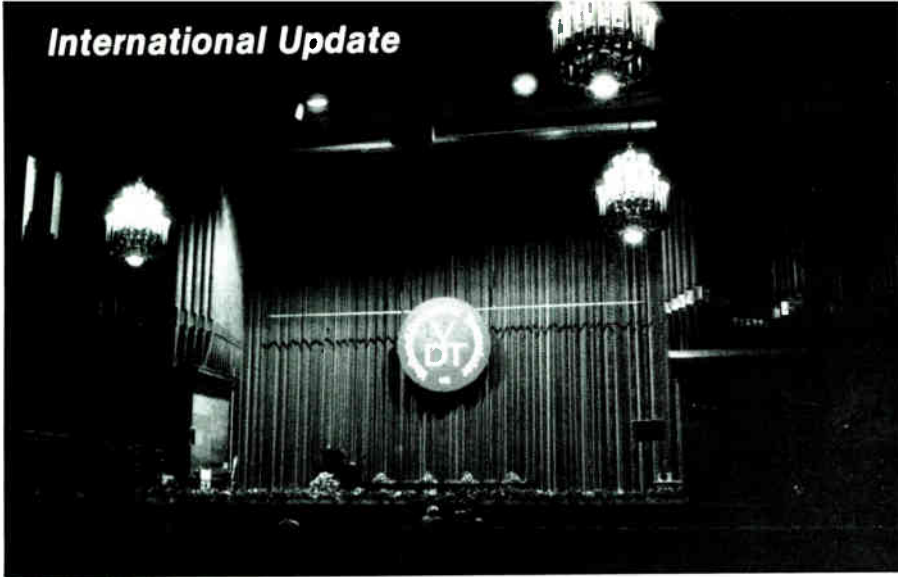

German Sound Engineers' Convention

by Marco Fratnik

The VDT (Verband Deutscher Tonmeister) is an organization gathering German sound engineers from the record industry, film, TV, radio and theater. The conventions aim to promote communications between sound engineers, manufacturers and researchers. Conferred for the first time this year, the "Golden Bobby" is an award sponsored by Agfa-Gevaert that honors the most outstanding recording.

The technical conferences and manufacturers' shows may remind you of an AES convention, yet the atmosphere was noticeably different and the welcome talks expressed it clearly: there is nothing wrong with putting the emphasis on technology, but many other qualities, such as knowing the repertoire, are required from a "Tonmeister". Further concern for the profession was shown during the roundtable ("The Situation of the Recording Engineer Toward Copyrights") while other speeches supported a more cost-oriented view ("The Practical Use of Music Computers in the Recording Studio"). This "fast-food-music" approach supposedly increases efficiency without degrading the quality. Of course, if you like fast-food you missed my point.

TECHNICAL SPEECHES

A central topic of discussion was the improvement of microphone quality. Philip White (Briel & Kjaer) explained the need of matching the characteristics of microphones with those of digital recorders. The main divergence seems to appear in the phase shift and/or the frequency response of most microphones at extreme frequencies (both high and low). While an amplitude fall can be boosted by an appropriate equalization, an altered time response cannot

be corrected as easily. Of course nobody would bother if this didn't have an audible adverse effect (a low-frequency signal loses clarity if its phase shift is too large). What makes it even more noticeable is the extended low frequency response of digital recorders. The advocated solution consists in lowering the corner frequency of the microphone down to a few Hertz, while carefully keeping the phase shift down to a minimum (the B&K series 4000 boasts a 3.5 Hz corner frequency with an 80 degree phase shift)

Other problems occur at high frequencies which is not surprising considering that this microphone is omnidirectional. Usually, omnidirectional microphones have a 6 dB peak around 7-8 kHz for a 0 degree incidence angle. At other angles, the diaphragm is not evenly displaced over all its surface because the wavelength of the signal is much shorter than its diameter. One of the countermeasures proposed is to reduce the diameter of the diaphragm. Further optimization is required to take into account the angle of incidence. The conclusion is nevertheless optimistic: it is possible to build microphones that do not degrade the specifications of digital equipment.

Jorg Wuttke (Schoeps) presented new orientations for developing omnidirectional capsules while Manfred Hibbing (Sennheiser, see under "products") proposed to lower the noise-floor. The latest trends are toward omnidirectional, symmetrical capsule microphones.

Roland Masslich explained the basis of a research project by ANT on the development of a digital mixer.

The first step is to develop a channel processor, similar in function to the analog I/O module, thus the unit contains at least an input gain control, an equalizer, a pan-pot and a channel gain

control. A new processing element is included: a time delay, which is simple to obtain with digital technology. This delay will allow, for example, the elimination of the time difference between the signals of two microphones placed in different locations.

Two master units are necessary: one of them to alter the settings of the board and the other to direct the operations as well as running control and test routines.

Each channel input accepts analog inputs (via an ADC) and digital ones (parallel and serial).

Of course, a very high clock rate is necessary to run this board in real time especially if all the channel signals

are multiplexed on a single data bus. A frequency of about 10 MHz—and up to 50 MHz for large boards—must be used.

All the filters are programmable and—due to their digital conception—permit new types of signal processing that were impossible with their analog counterparts. A further advantage is the easier control over the phase shift in digital filters. The gain control also assumes a new dimension: the same processing device can be a simple amplifier but also functions as a limiter, a compressor, an expander or a noise gate. It all depends on the programmed algorithm.

As with any other digital system, a simulation of the process is essential before a prototype can be assembled. The simulation permits derivation of the algorithms as well as testing the psychoacoustic qualities of the system. To run these tests, a set of analog signals are digitized and stored, in real time, in a mass storage medium. A computer will then apply the algorithms on this material and store the treated data in another memory. This method permits one to run reliable A-B tests.

Once these specifications and methods are developed, the components of the system can be defined. One can guess that a 16 bit microprocessor can not satisfactorily perform all these tasks. Double precision arithmetic is needed, which of course means 32 bits. But a 32 bit micro would require a much higher efficiency in the calculations. Another alternative is offered: cascaded and/or parallel 4 or 8 bit micros. It is then possible to run about one hundred operations every microsecond on 32 bits words (please notice that 32 bits correspond to more than 180 dB!)

The ANT project also includes the development of a microphone and a pre-amplifier (these two being still analog) that will match the specifications

PLAIN TALK by magnifax

Q: Aren't the Magnefax duplicators obsolete?

A. Magnefax is an "old" company which has been serving the needs of the duplicating community for the past 25 years. The design of the common mandrel capstan has been used since the beginning and still constitutes the backbone of all Magnefax machines. This design has been time-tested and is now proven, this is far to be the definition of obsolescence! Since 1959 the machine has been continuously refined in terms of design and production. Magnefax uses the most recent technology including digital metering, optocoupling and Large Scale Integration circuitry. State of the art equipment is used in all phases of the production and all components used in the machines are of the highest quality available.

Q. How does a Magnefax compare to the competition?

A. Although the duplicating ratio of a Magnefax is only of 16:1, the output in terms of tapes/hour is comparable to machines costing three to four times more. Because our machines come with a seven slaves configuration as standard, in term of cost/output the Magnefax are unbeatable. The main advantages of the "low" 16:1 duplicating ratio of a Magnefax system are found in the quality of the final product: The dynamic range in the high end of a Magnefax is unequalled and would be impossible to achieve at 64:1 or even 32:1, the slower speed resulting of the 16:1 ratio translates into reduced mechanical wear and the lowest maintenance of any machine on the market today.

Comparing a Magnefax duplicator to the competition is being unfair to the competition, a Magnefax duplicator is a standard by itself.

Q. Why does the machine look like that? I mean weird.

A. The common mandrel design dictates the overall look of the system and the advantages of such a design outweigh the machine's unusual appearance. While other manufacturers are using so called sophisticated techniques to achieve constant speed and minimum wow and flutter between master and slaves (PLL, feedback dc motors etc...) Magnefax uses the common mandrel design which solves all of these problems: The common capstan between master and slaves reduces relative speed variations to 0% with only one heavy duty motor driving the capstan thus leading to the lowest possible maintenance. A conventional duplicating machine with seven slaves will use at least eight motors to perform the same job than a Magnefax with its single, reliable motor...In addition, Magnefax has a lower floor space requirement than the conventional duplicating systems: a Magnefax duplicator is at home with only 20 square feet...most brands require this much for the master unit only. As to the vertical handling of the pancakes in the Magnefax vs. the horizontal positioning of the competition's units: we do not say that they are wrong but we do say that we are right to position the tape vertically in the machine when we see the end result: a perfectly packed pancake.

Who said that the machine looked weird anyway?

Q. How expandable is the Magnefax duplicating system?

A. A Magnefax system is not expandable because too many compromises would have to be made in terms of performance and reliability. The fact is that equal or superior output in terms of tapes/hour can be achieved with one Magnefax for up to 75% savings when compared to the competition. If you need more output, buy a second Magnefax machine. By doing so you are still ahead financially, you doubled your output, you can run two different jobs simultaneously and in the very improbable case that something goes wrong with one of your machines your business is not completely dead.

How is that for expandability?

Q. Is the Magnefax system upgradable or am I stuck with what I bought?

A. Good question, here is a good answer: First of all, when you buy a Magnefax duplicator you are not "stuck": you have purchased the best possible machine. Yes the system is upgradable. Although all Magnefax duplicators reflect the best available technology, we are continuously evaluating upgrades to our machines through active research and development. Our modular design for the electronics is a proof of our commitment. Some options will be provided soon for the 7.5 IPS machine but any existing 7.5 IPS Magnefax can be upgraded at any time.

Q. How much maintenance is required on a Magnefax machine?

A. Our favorite question. Near zero is the answer, a drop of oil once in a while for the bearings of the shaft, normal head maintenance (cleaning and lapping) and that is basically it. It is not uncommon to have customers say to us that in years of normal use all that they ever changed were the pinch rollers...Once a customer complained that one of the motor belts broke and he was wondering if it was a sign that things would be starting to go downhill for his machine. After we reassured him we asked how long he had been using the duplicator prior to this unfortunate accident, the answer was 17 years...

Q. Do we need specialized personnel to run a Magnefax duplicator?

A. No. After a normal training phase anyone can load and run the system.

Q. Most Magnefax machines are used for voice duplication and not for music. Why is that?

A. Until now Magnefax provided only a 3.75 IPS stereo machine for cassette tape duplication. This fact seriously limited the market to the voice business although spectacular results are obtained with music recorded at 3.75 IPS. The new machine answers the needs of companies using 7.5 IPS masters and teams unsurpassed quality of music duplication with the legendary Magnefax reliability.

Q. What about field support?

A. As previously mentioned, near zero maintenance is required. Every machine is thoroughly tested prior to shipment but in the unlikely event that something goes wrong we can provide technical support by phone (most of the problems can be field corrected after talking to one of our engineers) or have one of our representatives contact you for further action. In any case the problem will be corrected within a very short period of time.

Q. If the machine is this good how come I don't hear more about it?

A. In order to keep the quality of the production very high we have to work on a small scale. It takes a full two days for a skilled worker to finish by hand the shaft used for the common mandrel to our specifications (and this is the final phase for a piece which first has been hardened and rectified to very close tolerances on the finest machines available. Another fact is that you cannot find too many used Magnefax duplicators on the market since users tend to keep them forever (98% of the Magnefax systems ever built are still in operation). Finally the fact is that since the Magnefax duplicators are a standard by themselves we do not need to advertise the product aggressively. When all things are taken into account we really don't have any competition.

Q. Why should I buy a Magnefax duplicating system?

A. Did you listen to what I said?

magnifax

International, Inc.

Route 1, Rogers, AR 72756

(501) 925-1818 TELEX 53-6433 AIDC LRK



Schoeps showed new omnidirectional microphone capsule developments, while Studer demonstrated their approaches to digital recording.



Brüel and Kjaer demonstrated the need for matching the characteristics of microphones with those of digital recorders.

of the board.

Roger Lagadec from Studer summarized the basis from which their digital open-reel tape machine was developed. The DASH format is a set of rules that specify the manner of recording a digital signal on tape. Of course, these specifications impose mechanical and electrical constraints as well.

A DASH format tape recorder must have 2 to 48 channels, a clock rate of either 48 or 44.1 kHz (for a 16 bit

word). Three main "sub-formats" are defined by the tape speed and the number of tracks per channel: DASH-F (fast) is 30 ips with one track/channel, DASH-M (medium) is 15 ips with two tracks/channel. Four additional tracks are reserved for time code, a "help track" containing further information on the recorded material and labels, and one or two tracks permitting one to localize the digital signal (to help editing for example). Analog recorded "search tracks"

would require two more heads; to avoid this, Studer plans to record them in pulse-width modulation.

Digital data, of course, must be processed before it can be recorded on tape. The data stream is first divided in blocks to which synchronization words are added. Then an error detection code is added and interleaving is applied to reduce the adverse effects of drop-outs. Additional data will help error correction. Symmetrical processing is neces-

USED RECORDING EQUIPMENT FOR SALE

CONSOLES

Harrison 3232 B/C Automated Updated VCA	CALL FOR PRICE
MCI 636 28 I/O modules 14 Parametrics Automated	\$33,000
Neve 8058 MK 2 28 Inputs 4 Echo Ret. 8 Aux Send 8 Aux Ret.	\$76,000
Trident TSM 40 Inputs 6 Years Old	\$60,000
Helios 28 Inputs 3 Band Sweep EQ 4 Echo Ret 24 Monitors 1977 Straight Console	\$18,000
Trident A Range 28 Inputs 24 Group 48 Monitors	\$80,000
Aengus Wired for 16x8x16 Has 8x8x8 In Place 2 Phono Inputs With MAP EQ	\$2,750
With API 550 EQ	\$3,800
Neve 1977 Fully Discrete Custom 52 Input/24 Groups 32 Monitors With 4 Band EQ Mint Condition	CALL FOR PRICE
THE ULTIMATE CONSOLE	CALL FOR PRICE
API 2488 With 16 550 A EQ/8 550 EQ 24 Input 4 Echo Ret 24 Monitor Excellent Shape	CALL FOR PRICE
Neve 36x16x24 3 Band EQ 12 years old	\$60,000
MCI 556C Fully Loaded Automated (delivered)	\$80,000
Helios 16x8x16 Older Type	\$6,000
MCI 542 With 28 I/O Modules	\$58,000
Quad Eight Ventura	\$19,500
API 2C Input 8 Groups 16 Monitor 550 EQ	\$13,500
Trident Series 80 6 Years Old 32x24x24	\$30,000
Trident Series 80 B As New	\$36,000
Neotek 16x16 Series 3	\$14,000
Electrodyne 24 Input	\$4,500
Harrison 4032 C Automation Ready 3 Years Old	\$72,000
Trident B Range 30 Inputs 16 Groups 16 Monitors	\$16,000

TAPE RECORDERS

ATR 124 With Remote All Updates	\$42,500
Studer A800	CALL FOR PRICE
MCI 16 Trk JH 114 With AL3 4 Years Old	\$14,000
Otari MTR 90 MK 1 24 Trk With Auto Locator	\$21,000
Otari MTR 90 MK 2 24 Trk With Auto Locator	\$28,000
Studer A80 8 Trk	\$8,000
Studer A80 24 Trk	\$26,000
MCI JH110	\$3,250
3M M64 2 Trk	\$1,200
3M M64 4 Trk	\$1,700
3M M79 24 Trk With Auto Locate 2	\$16,000
3M M79 24 Trk With XP 14 Auto Locator	\$16,500
Lyrec MK 1 24 Trk 5 Years Old 4,000 Hrs Use	\$20,000

OUTBOARD GEAR

Lexicon 224 XL As New	\$9,600
EMT 251	\$15,000
EMT 250	\$16,000
EMT 140	CALL FOR OPTIONS
Eventide H910 Harmonizer	\$1,000
Eventide 1745 M	\$1,000
EXR 3	\$800
AMS DDL 1.6/0.4 Seconds 2 Pitch Change	\$6,600
Dynamite Stereo	\$475
Scamp Modules and Racks	CALL FOR PRICE
Neve 1064 Input Modules Mic/Line Inputs 3 Band EQ 24 Available	(each) \$600
Pultec Lang API UREI and Fairchild Equipment is Available	CALL FOR CURRENT LIST
Fostex Professional Products Are Available Headphones Microphones Etc.	
PYE Limiters	\$300

Decca Stereo Tube Limiter	\$.600
Marshall Time Modulator	\$.600
DeitaLab DL-1	\$.275
ITI Parametric EQ's	(per channel) \$.250
Mastering Lab Crossover As Is	(pair) \$.200
Dobby M16 Rack With 8 Channels	\$.5,000
EMT Amplifiers (plate reverb) Convert your Mono 140 to Stereo for Cheap	CALL FOR PRICE
BGW Crossover	\$.300
Melcore EQ's	\$.100

MISCELLANEOUS

UREI 815 Monitors	\$2,600
Altec 604 Speakers With Crossover (each)	\$300
Modules for MCI 428 A Console/Valley People Trans Amp All 5534's Beige	(each) \$1,000
Spectrosonics 101 Cards	(each) \$10

MICROPHONES

All Neumann and AKG Tube Type Microphones are available as complete working systems • Schoeps, Sony, RCA, Electro-Voice, Sennheiser and other mikes are also available . . . CALL FOR CURRENT LIST

WANTED

ANYTHING BY PULTEC, LANG, UREI, McINTOSH, ITI, SONTEC, TUBE FAIRCHILD LIMITERS, OLD MIKES OR PARTS, MARANTZ MODEL 2 OR 9, JBL 2231 SPEAKERS. WE BUY SELL AND TRADE.

**Dan Alexander Audio
Box 9830
Berkeley, CA 94709**

415/527-1411

Circle #105 on Reader Service Card

sary in the playback chain and supplementary circuitry must be inserted to handle error correction. The amount of error will be displayed on a scale of eight LEDs: the green ones will indicate that any error has been fully corrected, the yellow LEDs indicate that a small error occurred, while the reds will light up in case of muting or unreadable data.

In spite of these precautions some errors can still be too large to be corrected therefore stringent mechanical tolerances must be respected (especially in the head construction and alignment).

Top quality tapes must be used in order to accept the high data density.

Dieter Berger from Neumann explained the need for a new architecture of automated boards. Depending on whether a board is used for TV, recording or broadcasting the needs are different. Some applications may necessitate a recall-type automation while others require a fully dynamic automation. To achieve this great level of flexibility it is necessary to use a modular architecture. Moreover, the controls of the board are not centralized: there is one microprocessor-based controller for every four modules. The modules are standard in size (A1 racks and Europe-cards).

Flexibility is further increased by the buss system. Each module has two connectors in the back. One of them is used for audio signals and the other connects the module to the control buss. Because several modules are managed by a single controller it is necessary to address them. The address is provided by hardware bridges into the audio signal connector. The advantage of having an address that any two modules are interchangeable without adjustment.

Another buss connects the microcontrollers between them. Outputs to external microcontrollers and floppy disks are also provided.

Each microprocessor card contains the same hardware and its function depends exclusively on the content of the EPROM. This greatly simplifies maintenance. The micro is a 6809 addressing 64k of internal RAM.

The other main topics were acoustics, studies on recording and playback architectures, audio technology for TV and film.

PRODUCTS

The AES convention took place in New York only a few weeks earlier and, of course, not many products had been developed since. There is however a surprise: a prototype mixing board by SELÅ (Sweden). Maybe you remember that about two years ago this company commercialized the 2880-6F, a portable stereo audio mixer. The board was specifically designed for film use (in conjunction with two Nagra recorders). New solutions were then applied: con-

ductive plastic faders, switchable scales for the faders (log/expanded), a limiter with release time set by a circuit measuring the energy contained in the peaking signal and a Q control on each equalizer, making them fully parametric. The new mixer, the SELÅ 2880-RP6, is a similar model (six microphone inputs) offering a similar quality (the typical equivalent input noise is lower than 1 dB!)

CEGITES (France) simplifies audio-video synchronization and helps save a lot of time (they claim up to 50%) with the introduction of the VMP800S. This system, which tracks by displaying

the presence of a audio signals seven seconds before they occur, is available for 8 or 16 basic tracks but can be expanded thanks to its modular conception. It is easily installed on any system.

A new monitoring system from MB-Electronic (W. Germany): it not only looks but also sounds like a cross between loudspeakers and headphones. The resultant sound field is in front of the head (instead of inside it with traditional headphones). Bass frequencies are also transmitted to the body through the harness. All the electronics are located in the box behind the head. In spite of its bulky look

• PRODUCT DIVERSITY
• NO COMPROMISE QUALITY
• PRICE

audio digital

1000 S. BERTELSEN ROAD • SUITE 4
EUGENE, OR 97402 • (503) 687-8412

Circle #106 on Reader Service Card

the system can be carried for an extended period of time without causing fatigue.

Sennheiser (W. Germany) introduced a low-noise cardioid microphone, the MKH 40. Inherent noise level is rated at 10 dBA and the frequency response is rather linear from 40 Hz to 20 kHz thanks to the symmetrical assembly of the capsule. The microphone also has a roll-off filter (corner frequency is 250 Hz and an attenuation of 12 dB/octave) and a 10 dB attenuator. The cardioid characteristic is well conserved throughout the entire bandwidth.

Philips (Holland) presented a professional Compact Disc system (LHH 200) for broadcasting which permits control of up to three players. Any point of a disc can be cued in less than two seconds with frame accuracy. A dial knob permits rapid access of the desired frame. The time-code information contained in the P- and Q- subcode channels of each player can be displayed on the LED display of the control module.

RE Instruments (Denmark) showed an FFT audio analyzer—the RE201—that permits measurement of harmonic distortion, intermodulation, difference frequency distortion, transient intermodulation distortion, level peak and (real-) RMS, wow and flutter, crosstalk and phase. Every parameter is programmable through a very elaborate (but easy to use) software and several operations can be sequenced. The analyzer incorporates two 16 bit microprocessors. The RS232 port is standard while the IEEE488 is optional.

Another two-channel signal analyzer was presented by Bruel & Kjaer (Denmark also): the model 2032. It would be shorter to explain what it can not do, rather than the contrary. Of course, this one is also programmable and can be directly connected on an IEEE488 buss.

The AVP-500/AVS-500 Synchronizer is a synchronizer by Sony. The basic system permits the synchronization of one master and three slaves but several processing units could be cascaded to control up to 32 machines. Two hundred takes can be programmed (with punch in/out, offset of each slave machine from 1/80 of a frame up to 24 hours and 8 relay functions). The synchronizer works with SMPTE, EBU, drop frame and film time codes.

In order to write a reasonably short article I had to pick a few speeches and products out of a very large hat. Most of the events I discarded are not of inferior quality or interest but simply too complex to be summarized in a few words. ■



Virgin Records' Town House Three control room in Battersea, England.

Acoustics with Andy Munro and Town House Three

"We understand the artistic requirements of clients, as do a number of acousticians. But we are then able to apply a fair amount of scientific theory to the problems, which most are unable to do."

by Richard Dean

Acoustic consultant Andy Munro of Hendon-based Turnkey Two reclines in the re-furbished splendor of one of his latest projects in Battersea, London. The location is Town House Three, the old Rampart Studios bought from The Who last October by Richard Branson's Virgin Records label.

"The studio was run without any change for six months before we were brought in to do a re-fit," says Munro. After the initial design and planning stage, Turnkey started work on an enlarged control room, a studio with guitar booth, and a drum isolation room for the new owners at the end of April this year. The job was completed at the beginning of July.

"The premises used to be Methodist Hall," Munro continues, "and from what I can gather The Who initially bought it for equipment storage, and its studio role came almost as an afterthought. In any event, it was in a pretty awful state when we first moved in. A lot of the original parquet floor was all right, although it was all caked in filth and had to be re-laid. But the original dividing walls were made out of old breeze blocks, and the foundations were inadequate."

"In the first instance we had some opposition from the District Surveyor's office because it turned out that they weren't consulted for the original Rampart conversion." Munro managed to smooth oil on the troubled local authority waters by sinking a 7 ft. foundation beneath the isolation room cavity wall and substantially re-building the structure—at one point half the studio roof was supported by Acro jacks. "Once the DS realized that we were prepared to work professionally, we both got on all right," he adds.

Munro's career in acoustics now spans over 100 recording studios from scratch with many more "re-vamps" both at home and abroad, plus work for Elstree Studios and the National Theatre, and even the odd isolation room for banks and other bug-free zones. But it all started when he dropped out of a mechanical engineering degree course to work in the "much more interesting" field of acoustics with Shure in 1974.

THE MIX BOOKSHELF



The MIX BOOKSHELF Catalog is a selection of the best audio/video/music books and tape courses currently available from more than forty leading industry publishers.

Now it is simple and convenient to order these hard-to-find titles from a single source by phone or through the mail. Send for our free catalog.

104) RECORDING STUDIO HANDBOOK. John Woram A complete handbook dealing with every major aspect of recording technology, including transducers, compressors, tape recorder alignment, mike techniques, limiting and expanding, noise and noise reduction, signal processing, magnetic recording, and recording consoles and techniques. 481 pp (H) \$39.50

120) CRITICAL LISTENING COURSE. F. Alton Everest This invaluable course specifically addresses the important nuances of the audio world. The 106 page training manual with ten pre-recorded lessons on cassette tapes lead you from basic to advanced listening techniques in increasing progression. Topics include estimating frequency, frequency band limitations, sound level changes, components of sound quality, frequency response irregularities, various types of distortion, reverberation effects on speech and music, signal vs. noise, and voice colorations. \$129.95

130) BUILDING A RECORDING STUDIO. Jeff Cooper, M. Arch., S.M., S.B., B.S.A.D. A step by step guide to recording studio construction for small or large budgets. Thorough coverage of the principles of acoustics, how acoustics affect recording, soundproofing a room, plus chapters on the studio, the control room, and a glossary of the 100 most misunderstood terms in acoustics. 209 pp.(P) \$30.00

146) THE MICROPHONE HANDBOOK. John Eargle This up to date volume covers the practical aspects of microphone use and design with concise information for solving specific mike problems. Detailed chapters explain microphone patterns, mike sensitivity, condenser mikes, proximity and distance effects, interference problems, techniques and systems for stereo, and much more. 256 pp.(H) \$31.95

160) DICTIONARY OF CREATIVE AUDIO TERMS. CAMEO The first comprehensive dictionary of creative audio terminology containing over 1,000 definitions for those without much technical training. Focuses on creative audio/ musical equipment, techniques, systems, and practices. Illustrated to give a quick and comprehensive grasp of meanings. 100 pp.(P) \$4.95

217) VIDEO EDITING & POST-PRODUCTION: A PROFESSIONAL GUIDE. Gary H. Anderson A new "real world" guide to both technical and nontechnical factors of videotape post-production by a four-time Emmy Award winner. Complete and detailed info on time codes, formats, offline and online editing, digital effects, future trends, and more. Includes glossary and selected directory of equipment manufacturers. 165 pp.(H) \$34.95

241) REVOLUTIONARY TECHNOLOGY. AN INTRODUCTION TO THE VIDEO AND DIGITAL AUDIO DISC. David Matthewson This book covers the technicalities and special production problems of the three major videodisk systems, Laservision, Selectavision, and VHD. Applications are thoroughly compared; domestic, industrial, commercial, educational, etc. Includes section on compact digital audio disks which use a variation of Laservision technology. 120 pp.(P) \$11.95

307) MAKING MUSIC; THE GUIDE TO WRITING, PERFORMING, AND RECORDING. Ed. by George Martin This is both an authoritative guide for everyone who makes music and a unique source of insight into the genius and work habits of 65 of the world's leading music figures (e.g. contributors on songwriting include McCartney, Sting, Sondheim, Webb, and Simon, among others). There are sections on writing, arranging, performing, recording, and music business all written by experts. 352 pp.(H) \$17.95

310) HOW TO MAKE AND SELL YOUR OWN RECORD. Diane Sward Rapaport This brand new edition offers technical information, practical tips, and business guidance for self-production of record and cassette releases. Every aspect of a recording project is covered, from planning and budgeting through sales and promotion. Includes sample forms and worksheets as well as advice on raising money and negotiating contracts. 167 pp.(P) \$12.95

366) ELECTRONIC PROJECTS FOR MUSICIANS. Craig Anderton Shows how to inexpensively build your own preamp, compressor/limiter, ring modulator, phase shifter, noise gate, talk box, tuning standard, plus 20 other accessories. Written in clear, easy-to-follow language with a complete overview, hundreds of helpful diagrams, and step by step instructions. 220 pp.(P) \$14.95

THE RECORDING INDUSTRY RESOURCE CENTER • 2608 NINTH STREET • BERKELEY, CA 94710

MIX BOOKSHELF

PLEASE SEND BOOKS TO:

NAME _____

COMPANY NAME _____

ADDRESS _____

CITY _____

STATE _____

ZIP _____

Please send complete Bookshelf Catalog (FREE)

MIX Bookshelf, 2608 Ninth St., Berkeley, CA 94710

Allow 4-6 Weeks for Delivery

MARCH 1985

Book #

Qty.

Price

_____	_____	_____
_____	_____	_____
_____	_____	_____
_____	_____	_____
_____	_____	_____

SUBTOTAL _____

\$2.00 postage & handling per book (\$3.00 outside US) _____

CA residents add 6.5% tax _____

TOTAL _____

Check enclosed for total.

Bill to: VISA MC

Credit Card # _____

Exp. Date _____

Signature _____

Spectrum Magnetics is your Company for Audio Cassette duplication and Packaging!

As an Artist-Musician, you strive for the finest and most accurate reproduction of your musical material. At Spectrum Magnetics, we understand that desire . . . and we have made it our goal.

We have the people and the machines to realize that goal with your Audio Cassettes. Our bin-loop duplication process will give you what you want because our people know how, and we use quality components. Direct-to-cassette labeling, Norelco style boxes and shrink wrapping provide you with a complete, professional package. Insert (J card) printing is done by one of the premier printers in the trade.

For the ultimate in cassette reproduction, Spectrum Magnetics can duplicate your material on BASF Chrome tape (High bias, Normal or Chrome equalization) at a slight additional charge.

Our products are top quality, our delivery is fast and our prices are competitive. Call us today for a free demonstration cassette.

Call us today TOLL FREE and find out more. 800-441-8854 (in Pennsylvania call 717-295-9275)

Spectrum Magnetics, Inc.

1770 Lincoln Highway East
P.O. Box 218
Lancaster, PA 17603

Circle #107 on Reader Service Card

MOVING?

FOR UNINTERRUPTED SERVICE

MAIL TO:

**MIX PUBLICATIONS
2608 NINTH STREET
BERKELEY, CA 94706**

(PLEASE ATTACH OLD ADDRESS LABEL HERE)

(PLEASE PRINT NEW ADDRESS BELOW)

NAME _____
COMPANY _____
ADDRESS _____
CITY _____ STATE _____ ZIP _____

International Update

After five years with Shure, including some time spent in Chicago, Munro was getting more and more involved in studio design and approached Turnkey—the 4½ million pounds-turnover company founded by Andrew Stirling, Ivor Taylor and Andy Bereza from Allen & Heath/Brenell—to form a specialist acoustics consultancy. Hence Turnkey Two was born.

"We approach each room individually rather than use a uniform East-lake-style approach," says Munro, "I would say that building studios in this way requires about 30% acoustic and 70% architectural design, and you should mention our architect Roger D'Arcy, with Hugh Flinn as the design draftsman. A lot of our success is down to the efforts of this team," adds the ever-modest Munro. An associate company—Room Service—handles the construction side, under the watchful eye of Kevin Daisley. "We've deliberately kept the building side independent," adds Munro.

Back in the pink and grey opulence of Townhouse Three's reception area Munro explains the work done in this particular case in more detail. First the structure and acoustics. The obligatory lounge and kitchen have been incorporated above the reception and workshop, on the same level as a 7-8 ft. void above the studio and control room. This houses the unusual but apparently compatible combination of echo plates and air conditioning, while the ceilings suspended beneath all use resonated granite chippings sunk into an epoxy base.

Sliding double doors with enough space for a vocal dub separate the control room from the studio, with the guitar booth let into the control room on one side. On the other is a booth for amplifiers and power supplies, while the isolation room is opposite at the other end of the studio. Those doors are a particularly smooth-running Swedish design which lock anywhere along the track.

Most of the walls are finished in black fabric, with a matrix of wooden slatting on some panels in the isolation room and control rooms. But I was interested to note a low level of sound absorptive trapping, and the inclusion of both high-level windows and three or so full-length mirror sheets in the studio.

"Studios need an ambience these days," says Munro. "Things have changed since the old 'dead acoustic' days where bands were used to playing on the road above all, and expected to set up their equipment in the studio like a

gig. A number of things have helped this along—better use of recording techniques like multitrack and direct-injection, and more advanced foldback to musicians.

"Of course the studio-first-gig-later phenomenon of electronic pop started a shift in studio design, first demanding an increase in the overdub capacity of the control room. But now that guitar sounds are coming back, bands are discovering that if you're going to use a studio area it may as well contribute a natural acoustic, which you can't simulate electronically."

And so to the control room. "We began by knocking out an existing corridor, which gave us a room 10m wide with a 75m² total area," says Munro. "This meant that we could accommodate a full set of keyboards, but also that the acoustic had to be more absorptive than usual." Nevertheless, most of the trapping, especially the multi-element hanging systems, is restricted to the corners.

"Nobody is sure why the brain separates a mono two-tone of 4kHz and 40 Hz into left and right on headphones. In fact we don't even know how the brain manages to extract stereo from headphones."

"We stripped out the old six-channel monitoring system, which I think was installed for the 'Quintaphonic' dub of the Tommy movie, and replaced it with a tri-amp Yamaha-driven soft-dome arrangement." Why softdomes? Or put another way, why not horns? "Horns produce high levels, but they distort," claims Munro. "A softdome on the other hand has a cleaner sound, but until about two years ago couldn't deliver the necessary 130dB peak level for monitoring. To achieve this a massive magnet is required and there's only one firm which has managed to do it. That's ATC with its 'SuperDome.' Various people have tried to incorporate these into monitors—some of which have been an unmitigated disaster—but we're now satisfied with our own design which we used at the extensive re-fit by Windmill Lane, Dublin. But it so happens that we've used a design by Roger Quedsted for Townhouse Three."

The SuperDome is joined by two parallelled Gauss 15-inch bass drivers with an ATC lin tweeter and

House With Recording Studio

for sale West LA Area— Canyon view setting near Malibu beaches. Architect designed red-wood with decks, hot tub, tile, 3 bedroom, 220 sq. foot control room, 280 sq. foot studio with air cond. & elec. per Westlake Audio specs. \$279,000. Call Bernie (213) 455-3635.

24 Track Recording Studio for Sale. Located in Studio City, CA. Call Steve at (213) 850-1653 — \$275,000.

FOR SALE

Complete 24 track pro studio. Turn key. Includes grand piano. \$75,000. Free installation & training. Call 503-726-1378 after 6 pm or 503-998-2758.

Miscellaneous

Need a Hit?

The Song Brokers
3262 Central
Alameda, CA 94501
(415) 523-9876

**Stay in touch—
read Mix
every month.**

How to Place a Mix Classified

Please print or type in CAPITAL LETTERS and lower case. There are 8 lines to the inch and approximately 24 CAPITAL letters per line or 30 lower case letters. \$60 per inch — 1" minimum. Additional lines \$10 per line. **Bold type** \$10 per line. Black border or gray screen \$10 extra. Logos or display advertising up to 4" will be charged at \$75/inch. Multiple insertion rates at 10% discount. **Payment by check, money order or charge must accompany ad. DEADLINE is the 10th of the month, 1 ½ months prior to publication.**

Categories Available (check one)

- | | | |
|---|---|---|
| <input type="checkbox"/> Employment Wanted | <input type="checkbox"/> Equipment Rentals | <input type="checkbox"/> Equipment Wanted |
| <input type="checkbox"/> Instruction | <input type="checkbox"/> Recording Services | <input type="checkbox"/> Rehearsal Space |
| <input type="checkbox"/> Employment Offered | <input type="checkbox"/> Miscellaneous | <input type="checkbox"/> Equipment for Sale |
| <input type="checkbox"/> Record & Tape Supplies | <input type="checkbox"/> Maintenance Services | <input type="checkbox"/> Business Opportunities |

Name _____

Address _____

Phone _____

If paying by: VISA MASTERCARD

Card #: _____ Expiration Date: _____

Signature: _____

Mail to:
Mix Classified, 2608 9th St., Berkeley, CA 94710
(415) 843-7901

Attention:
Recording Schools & Programs

The July issue of *Mix* will include our annual *Directory of Recording Schools and Programs*. If your school was not listed in our 1984 Directory, you can ensure a listing by completing and returning the coupon below. A questionnaire will be mailed to you.

Name of School or Program _____

Chief Administrator _____

Address _____

City _____ State _____ Zip _____

Telephone (_____) _____ Best Time to Call _____

**Return coupon to: Mix Publications, 2608 Ninth Street, Berkeley, CA 94710
For more information, call Lauri Newman at (415) 843-7901.**

PULSAR LABORATORIES, INC. NOW AVAILABLE A MONTHLY LEASING PROGRAM

*100% Financing
*No Collateral Required

*100% Tax Write Off
*Investment Tax Credit

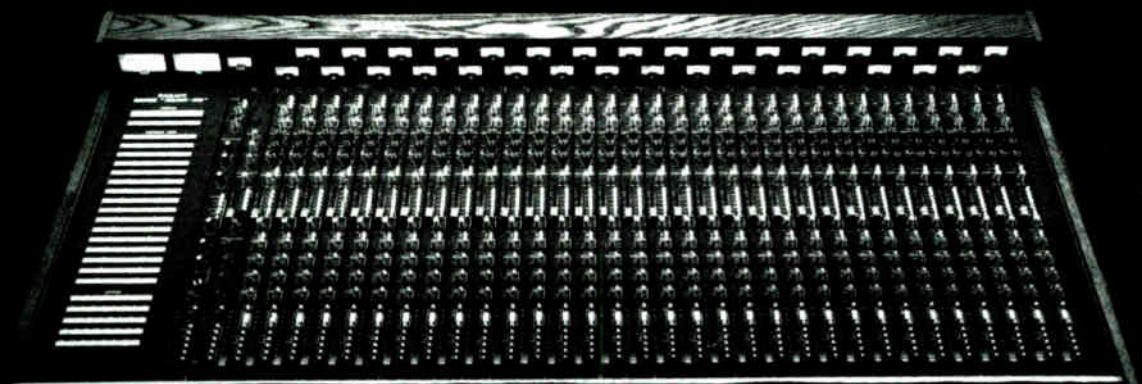

"ON TRACK" I/O recording consoles

24 channel @ \$475 a month
32 channel @ \$600 a month

SERIES 80 front consoles

32x8 @ \$250 a month
24x8 @ \$215 a month

M8 monitor consoles

32x8 @ \$250 a month
32x16 @ \$515 a month

Call for additional pricing and information 216-784-8022

Circle #110 on Reader Service Card

ADVERTISERS INDEX

PAGE ADVERTISER

157 Advanced Music Systems (AMS)
50 Agfa Audio
119 Akai/IMC
37 AKG Acoustics
152 Dan Alexander Audio
35 Allen & Heath Brenell
90 Alpha Audio
45 Amek Consoles
9 Ampex
55 Ardent
138 Aspen Music Festival
153 Audio Digital
82 Audio Systems
92 Auteri Associates
65 Barcus Berry Electronics
116 Berklee College of Music
105 B.E.S.
148 Brush Magnetics
79 Carver Corporation
39 Carvin
81 Castle Recording Studio
109 Cerwin Vega!
112 Cetec Gauss
135, 137, & 139 Cherry Lane Technologies
116 Countryman Associates
53 Crown International
117 Chips Davis Design
108 Design Direct Sound (DDS)
108 DeCuir Sample Case Company
4 Digital Entertainment Corporation
123 Digital Service
82 D.I.Y. Recording
127 DOD Electronics
85 Eva-Tone Soundsheets

PAGE ADVERTISER

41, 43 Eventide Clockworks
97 Everything Audio
71 Flanner's Pro Audio
25 Fostex Corporation of America
87 Full Compass Systems
143 Goldline
69 Alan Gordon Enterprises
148 G.R.D.
124 Guitar Showcase
54 Hardy Company
2 Harrison Systems
113 Hill Audio
138 IAN Communications
49 Ibanez
15 JBL
87 JRF Magnetic Sciences
28, 29 Kurzweil
120 LaSalle Music
144 LD Systems
106 Leo's Audio & Music Technologies
17 Lexicon
140 Linear & Digital Systems
115 Linn Electronics
131 LT Sound
151 Magnefax International
95 Meyer Sound
75 Miami Tape
55 Monster Cable
107 N.A.R.A.S.
58, 59 Neotek
121 Rupert Neve Inc.
91 New Age Sight & Sound
136 Ocean Audio
63 Orban Associates
140 PAIA Electronics
125 Passport Designs

PAGE ADVERTISER

129 Peavey Electronics
89 Perfect Pitch
144 Polyline
22 Power USA
101, 111 Professional Audio Services & Supply
162 Pulsar Laboratories
44 Rane Corporation
60 Reliable Music
22 Renkus-Heinz
141 RolandCorp US
83 Samson Music Products
98 Sanken Microphone Company
90 SCMS Pro Audio
84 Tom Seaman Associates
91 Sennheiser
163 Shure Brothers
164 Soundcraft Electronics
61 Soundtrek
156 Spectrum Magnetics
137 Sprague Magnetics
11 Studer Revox
69 Switek
142 Symetrix
149 Synchronous Technologies
57 Tandberg of America
103 Tannoy
31 Tascam
19 Technical Audio Devices (TAD)
89 Peter Tempel Audio
92 Thoroughbred Audio
132, 133 3M
21 TOA Electronics
143 United Tape
7 Ursa Major
73 World Records
33 Yamaha International

crossover in each of the Qusted cabinets, and Munro is a great believer in the tri-amping technique used in the system. "It's transformerless, which reduces signal delays and subsequent phase shifts. The Yamaha amp also has a very high slewing rate—the ability to switch large signals quickly—which is very important for high frequencies."

What about the suggestion that monitoring systems should be operated "flat," with colorations compensated by tuning of the room acoustics? "All monitor systems are EQ'ed," retorts Munro, rather dismissively. "Even Urei cabinets have corrections to the frequency response inside." Townhouse Three is among the majority of studios with graphics in the monitor chain, although very little correction is used in practice. "An EQ should be used to tune the electronics, not the room," he asserts.

In fact Munro is particularly proud of the control he has over the final sound in his work. He uses an Ivey IE30A analyzer which has the usual frequency spectrum facilities but also a computer-controlled snare pulse with a programmable time offset for the return sound analysis. This means you can look at snapshots of the room response throughout the reverb decay period, among other things. It's a system that hinges on theory first postulated in 1956 by Munro's mentor, the distinguished academic Richard Heyser.

"We understand the artistic requirements of clients, as do a number of acousticians. But we are then able to apply a fair amount of scientific theory to the problems, which most are unable to do," he claims. While some may have acquired the experience to know when a particular technique produces a certain result, they may not know why. This is fine, until something different is required or a non-standard environment is encountered, according to Munro. "Once again, we treat each room individually, as I believe you must do," he adds.

It seems more than likely that Turnkey Two will steam on into a commercially bright future—but what's in store for the rest of us in the field? "I think the next development will be in the understanding of psycho-acoustics," Munro reflects. "We know for instance that both two-channel stereo and especially surround-sound work well, and have theories about phase differences, first reflections, delays, and so on.

"But nobody is sure why the brain separates a mono two-tone of 4kHz and 40Hz into left and right on headphones. In fact we don't even know how the brain manages to extract stereo from headphones, whether it's bi-aurally recorded with a dummy head or worse still, a normal crossed-pair or multi-mike recording. Basically, we've still got a lot to learn."

it's about time...



If you are one of the increasing number of people who have used an A.M.S. digital processor in a professional studio you will probably understand why owning such a unit is rather special. Not only are you complimented on having made the best possible choice for sound quality, versatility and ease of use by your mix engineer or visiting producer – your service department will enthuse about the quality of design and ease of repair should ever the unit fail – even your accountant will have a smile on his face when he realises you could have spent twice as much and been less happy.

... it's a time when more people are realising you don't have to cut corners to own the very best.

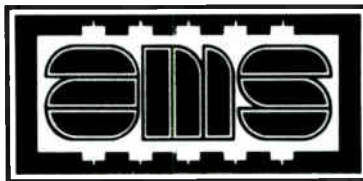

England

Advanced Music Systems

Tel: (0282) 57011 Telex: 63108 AMS G

U.S.A.

Harris Sound (Los Angeles)

For Nationwide Sales, Rental or Service Tel: (213) 469-3500

—FROM PAGE 51, FOGERTY

however, Fogerty says he thinks eventually people will get tired of hearing the exact same snare sound, for example, throughout an entire song—that drum machines may just go the way of the wah-wah of the late '60s.

When describing his own drumming ability, Fogerty freely admits with characteristic honesty that, "I'm only 60 percent there." This triggers his animated fondness for drummer idols Gene Krupa and Al Jackson. The plain round table in front of us becomes a circle of toms and snares as he patters away excitedly, eyes closed, a smile on his lips.

Inevitably, the question arises, "Why not just use a real drummer—or a real band for that matter? God knows, with synthesizers nipping at their heels, they could use the work." He nods that he just might use a combination of his own stuff and tracks from another drummer in the future. But while Fogerty is sincerely generous in recognizing and appreciating other musicians' styles, he is also an autocrat. It is clear from his precise methodology in constructing this album that he hears the song in his head and it's just plain easier for him to do it all himself, rather than try to explain it to other musicians

or producers. It is perhaps the flip-side of this absolutism that has prevented him from making records all these years. If he didn't hear it, he wasn't going to fake it.

Flash: Los Angeles Calling

Before he poses for some photographs, a quick phone call from Warner Bros. confirms that the single, "Old Man Down the Road" is charting in next week's *Radio and Records*. "Number 35. That's my number on the CHR charts," he reports two days after the album is released. Ten years ago he told *Melody Maker*, "When you narrow it down, it's the excitement of making a hit single. I think that's the center of the whole thing for me. . . . The album to me is just a place you put all your hit singles." Today he is excited but composed. "I just happen to have read that recently because for the first time in 12 years I've had the courage to drag out my old scrap book and look at it. I never really wanted to go into it before because I would just choke. 'Oh. . . what have you been *doing* for eight years?' But we pulled that out and read it and I still agree with it pretty much. To say it the same way, a hit single, that's the ultimate. I grew up weaned on hit singles. That's what we

heard; that's what we had. It was either rock and roll or rhythm and blues, and they were hits. Duane Eddy didn't get to make an *album*—he made six hit singles, then they made an album out of it. Now, I think three singles from a record is fine. I have a nagging suspicion about bleeding an album to death, and I'm not sure why. I think it's because by the time you've gotten to the fifth single, the album's been out more than a year. You may sell another million copies—that is 'profit,' but I think the feedback, or backlash is that you've been around with that same thing so long everybody's really sick of it."

Asked about his plans for releasing more records, Fogerty estimates he'll be putting out an album every year or so. "I may hit it a little faster than that. Creedence always did. I really believe in giving people music. If you've got it, give it to them." Fogerty's understandably happy about getting it back, and about getting it together at The Plant for this album. Meanwhile, Jeffrey Norman came away a little changed from the experience. Recently, he was spotted walking down the main street in Sausalito, California with three Duane Eddy albums under his arm. ■

—FROM PAGE 120, RUSHENT

we've mixed the 7", I sit there fiddling with delay lines, sampling bits of the record and spewing it back out, mixing ten or fifteen second segments as ad libs. I'll fill up two rolls of tape and piece them together. It's very much like a *musique concrete* sort of thing, or collages. I'll fly something in from one part of a song by sampling it and then dropping it into another part." Rushent also "flies" sounds, melodic fragments and entire rhythms from other artists' disks. "I've nicked the drum sound from David Bowie's *Let's Dance* on several occasions," he admits mischievously.

The *League Unlimited Orchestra* and the "Fascination" 12" disks by The Human League, and the 12" disks by Intaferon, are complete departures from acoustic reality, sounding something like Stockhausen with a beat. "I think if you took away the bass and drums you'd be left with some pretty weird stuff," Rushent agrees.

If there's one element of the punk ethos left in Rushent's work, it's the belief that anyone can do it—at least anyone with access to a \$50,000-plus computer music system. "The computer synthesizers are great levelers as far as technical ability," claims Rushent. "These machines give a good ideas-man a shot. I *don't* mean that any Herbert can walk up

to one of these synthesizers and make great sounds and music. But if you've got good ideas, you can make them sound good."

With all this technology, with this burning desire for perfecting the beat, one might wonder why Rushent produced a group as basic, non-technical and certainly non-computerized as The Go-Gos. It was obviously a chance to do something different, but it also proved a point: that there is no "Rushent Sound."

"A producer's work should be transparent," he professes. "I don't like the way some groups are used as puppets for producers." This seems contradictory to Rushent's pleasure in being asked by a group like The Human League to "please make our record for us and let us know when we can sing," but he sees both methods as collaborations. His presence on The Go-Gos *Talk Show* is subtle, supportive and non-intrusive—he didn't even use electronic drums. Well, almost! "As far as the drums went," says Rushent, "in order to keep us tight we programmed in the drums as a guide and played along with them."

You can still see Rushent's drive for perfection, the narcotic of the computer junkie. Rushent's new drug is the Synclavier II. His only regret is that he

doesn't have enough time to experiment and study its full potential, so he's hired someone full-time to do that for him at Genetic. In fact, Studio Two is built around his Synclavier, along with a Fairlight CMI, PPG Wave 2.2, Yamaha DX7, Jupiter 800, Jupiter 8, LinnDrums, Simmons drums, and various Korgs. They all go through an MCI 500 Series console "that we've hot-rodged through the roof" and into an MCI 24 track machine.

(For those who like their recordings more basic, Studio One contains two Otari 24 track decks, a 48 track Solid State Logic desk, MCI and Ampex ½" and ¼" machines, and "every signal processing device you can think of.")

Rushent is looking to the days when an entire studio can exist in a single Synclavier II. "You could have a backing track that consists of sampled sounds, re-synthesized sounds, and conventional digital synthesizer sounds, that has never been a piece of tape. You can put the vocals on directly into the machine, mix and edit." Eventually you'll just transmit the whole record down phone lines to the pressing plant.

But for the moment, Rushent is content with his current Genetic set-up. It's my Starship Enterprise," he says blissfully. "You get inside and time's gone." ■

Employment Offered

WANT TO WORK IN NASHVILLE? Need experienced mastering engineer, evenings and weekends, to handle brisk business in top-notch facility. Prefer someone with excellent credits and current following. Send letter and resume including mastering credits and salary requirements: Mix Classified, P.O. Box 2526, Berkeley, CA 94703.

DISK MASTERING ENGINEER Metro New York area disk mastering studio seeks top mastering engineer with following. The right individual can expect a substantial increase in salary. All members of our staff know about this ad. Reply in confidence to: Mix Classified, P.O. Box 2526, Berkeley, CA 94703.

Equipment For Sale

Looking for Eventide SP-2016 or H949? Space Station Banner RTA ADR Scanner. Need AKG, BGW, dbx, E/V, Neumann, Orban, Sennheiser, Shure, Technics, UREI or White products? Call UAR for the best quote: (512) 690-8888, 8536 Fairhaven, San Antonio, TX 78229.

Platesound Plate Reverb now available. The finest built units using today's technology. Adjustable decay. 1/2 second to 6 seconds. Frequency response: 80-20,000. One year full guarantee. \$995. Send or call for brochure and specs. 1-(813) 996-4707. Call collect. **PLATESOUND**, P.O. Box 1500, Land-O-Lakes, Florida 33539.

LOW OVERHEAD MEANS LOWEST PRICES. We carry most major lines of pro audio & recording equipment. **Get your best price, then call me.** 3M Tape and accessories at factory prices.

S.C.M.S.

East U.S. Toll free:

(800) 438-6040

West & N.C.: (704) 889-4509

Sam Ash Music Store Mail Order Service. Deal with the professionals. N.Y.C.'s largest inventory and best prices on musical instruments, sound and recording gear. 1-800-645-3518. N.Y. State 1-800-632-2322.

3M 16 Track Model 56 Excellent Condition with Selectake, Remote and Martin Vari-speed. \$10,500. (205) 595-8497.

SYNTHESIZER BLOWOUT!

Tired of impersonal service? You think you're getting your best deal? Try Starsound Audio for free! 1-800-354-7252. Fluid synthesis spoken here. Most major lines in stock. Roger, Tom, Scott or Bill.

NEW API PRODUCTS

Modules—Equalizers—Parts
Factory Warranty! Immediate delivery at CLOSEOUT PRICES! For further information call:

RAATA AUDIO SYSTEMS, INC.
1446 N. Cherokee Ave.,
Hollywood, California 90028
(213) 469-9593 Telex 910-321-4465

SIGMA SOUND STUDIOS GREAT EQUIPMENT BUYS:

24, 2 tr recorders, console automation, synchronizers, hi speed dupe equip plus lots of audio processing gear.

Call or Write:

212 N. 12th St., Phila., PA 19107
(215) 561-3660

THE AUDIO/VIDEO PROFESSIONALS FOR ANY PRODUCTIONS

Shop for Pro Audio and Video from America's oldest, most experienced Professional—no matter where you live. Expert advice, in-depth parts and a wide selection of Otari, Soundcraft, EECO, UREI, Ursa Major, BTX, Fostex, Tascam, Hafler Pro, Sony, JVC, Perreaux, Allen and Heath, Symetrix, White Instrument, Ampex, etc., and many more for Recording Studios and Audio/Video Post Production facilities.

Harvey Electronics Pro Division

25 West 45 Street
New York, New York 10036
(800) 223-2642
(212) 921-5920

GREAT PRICES EXCELLENT SERVICE ON NEW & USED EQUIPMENT

OTARI, SOUNDSCRAFT, TRIDENT, APHEX, LEXICON, VALLEY PEOPLE, NEUMANN, TASCAM, SONY.

E.A.R. PRO AUDIO

(602) 267-0600

API UPDATE

If you own an API console, or want to own, sell, repair, or modify one, you NEED to talk to us. WOLFF ASSOCIATES is an authorized dealer for all API products. We also correct in-house problems such as grounding/signal flow. New modules/parts. WOLFF ASSOCIATES, 1378 Northgate Sq., Reston, VA 22090 (703) 689-0448.

STUDIO LIQUIDATORS LOWEST PRICES. Soundcraft 3B mixer 32x24 w/patchbay \$17,900; Audiotronics mixer 26x24 w/patchbay \$14,000; Tascam Model 115 mixer, 16x8 \$4,500; Lexicon 224 digital reverb \$4,500; Ampex ATR-100 2 trk recorder \$4,500; Tascam 85-16 recorder 16 trk on 1" w/dbx \$8,000; AKG BX-10 reverb \$1,100; AKG BX-20 reverb \$2,000; Phone (902) 423-0233.

LIKE NEW: Ursa Space Station \$1,000; Aphex II \$2,000; Marshall Time Modulator \$900. Call (212) 226-4278. Ask for Robyn.

Highest-Tech lowest cost studio gear. Call Peakdesign for the best in every class. E.q. new: Engl. modlr. consoles, 4 EQ, 4 sends, 24x8x16 \$6,000 to 32/16/16 \$9,500. Excel-faders, sound features. 24/8/16 w/full disk based automat \$12,900. Latest Sony PCM digital 2 Trk mastering deck \$1,500. Fostex B16 16 Trk \$4,700, \$5,700 w/autoloc. SYNCMERGE \$289 puts/gets SMPTE and pulse sync on 1 Trk. Also call for QXL, TX 816, FX synths, SMPTE, Sync, custom computers, all the newest/imported/hard to find gear. (415) 524-7538.

NEOTEK SERIES III: 28x24 with 16 busses, 6 echo returns custom "pre-return" submaster fader, extra patch bay, producer's desk, leg set, patch cords, spare parts, exc. cond. White 32-band EQ's \$550 ea. 312-864-4460.

TANGENT 3216: 18x16 in 24 frame. Patch bay, pedestal base, sub-master solo, and lots of mods. Excellent condition. Extensive spares kit. Can send technician to assist installation. Price negotiable. Going automated. The Process Recording (919) 855-1941.

Used recording equipment for sale by major midwest studio. CALL Jim M. for prices at (614) 663-4030. Consoles: Sound Workshop Series 30 24x24, Sphere Eclipse 20x16, Allen and Heath 16x8, Logex-8 12x8, Interface 104 16x8 stage monitor mixer. Tape recorders: MCI JH-110 16 track, Otari MK III 1/2" 8 track, 3M M79 1/2 track, Otari 5050B 1/2 tracks, Tascam 122 cassettes. Other goodies: Yamaha digital reverb, amp racks with cases, Great British Spring reverb, Ashly SC-70 crossover, Tapco 4400 reverbs, Bose 802 PA speakers.

Soundcraft 800B 32x8 in heavy duty road case, new condition \$15,000. Soundcraft 200 24x4x2 in flight case \$3,000. (404) 261-4947.

AMPEX ATR 102 w/VSO \$6,000, UREI 811's \$1,400 pr. 30 channels,

Roland VCA's make offer, Altec 729 —Dual 1/2 octave Eq, Ampex/GRT 1/2" Bin loop cassette Duplicator 4 slaves all New Heads \$15,000, 4 RE-20's \$175 ea. David or Roger (415) 328-8338.

SUPER DEAL—16 TRACK PACKAGE

Tangent 3216 16x16 Transformerless Console and Tascam 85-16 16 Track w/dbx and auto-locator — both in excellent condition. \$13,500 Package. Call Charlie (904) 576-3147.

MCI JH 114 24 Trk w/auto-locator II, brand new heads in top shape \$20,000. Sound Workshop 1600 console 20x16x2 Full patch-bay & ARMS automation, w/optional custom expander board w/10 extra inputs \$9,500. Call Steve (213) 663-3223.

Equipment for complete 16 trk recording studio. Fair market value \$66,000. Equipment by MCI, Neumann, JBL, etc. Sold as package, offers requested. Located in Central Illinois, Tonika, IL. (815) 442-3452.

Complete 16 trk recording studio equipment package. New Audioarts 24x16x2 console, 3M Recorder w/auto-locator & remote, 288 pt. patchbay w/all necessary cables, Studer/Revox 1/2 track recorder w/remote, Lexicon Prime Time, MasterRoom Reverb, Harmonizer, para EQ, dbx limiters, Aural Exciter, Rhodes electric piano, Koss headphones. \$32,000 all. (818) 888-6126.

NEUMANN MASTERING ROOM

Including tap machine, SX68 Head, VG66 Amplifier Rack, Level sets, High Frequency limiters, Elliptical Equalizer and variable pitch and depth. Make offer. Please call Jim at (513) 681-8402.

USED EQUIPMENT SALE

All types of recording equipment. Consoles, recording machines needed and for sale, new listings available. Contact: Randy Blevins (615) 361-8429 or 361-6768.

DYNAMIX D3000 console 32 inputs, 16 buss, stereo buss, 16 tape returns, patch bay, desk & stand. \$12,000. MCI JH100 24 trk. 1979 cabinet 1979 electronics (xformerless) plus 16 trk head block plus spare parts. \$16,000. (818) 701-7802.

TRIDENT Trimix 32x16x24 console. 4 Sends, full patch-bay desk, 56 remix inputs, 4 band Eq., V.U. meters, many extras. Super well maintained, mint condition. 2 years old. Looks and sounds great. 24K. (212) 840-1350.

3M-79-24tk w/seltake 2 & BTX interface. cond. good 16K. AUDITRONICS 501 (26 in) w/producers desks. cond. fair 7K. PACKAGE PRICE 20K FIRM. SHEFFIELD AUDIO/VIDEO (301) 628-7260.

Otari 5050 BQ2 4 Trk, new in box \$1,850, dbx 155 mint cond. \$450, MICMIX MR III reverb \$590, dbx 208 8 channel, new in box, \$2,350, Biamp 2442 24 channel board, new \$3,000, Tascam 80-8 dx8, remote excellent \$3,500, DeltaLab DL2 \$850, Orban 621B Parametric \$475 w/power supply. Dan (215) 776-1455.

HARRISON 2824 CONSOLE ALL MODS. INC. ALLISON VCA'S 8 ADDITIONAL ECHO RETURNS EX. COND. PPM LED METERS 504 PATCH POINTS \$27,500 CALL KURT (215) 642-2346.

16 TRACK STUDIO FOR SALE Best name equipment, all almost new, available as a package or individually. Send for price list. TRANS-AUDIO, Box 237, Manville, N.J. 08835.

Neotek, Soundcraft, ADR, Otari, Clear-Com, Eventide, Crest, dbx. Best prices on all the best gear, new, used, and demo. Also, like new, Otari MX-7800 w/remote \$6,500. Soundcraft 800 18x8 \$8,995. Tascam 8516 w/dbx \$7,500. ADR Scamp rack system. Call **Pyramid Audio Inc.** (312) 339-8014. 450 W. Taft Drive, So. Holland, IL 60473. **Call us last!**

FRANKFORD/WAYNE DISC MASTERING EQUIP SALE We're Overstocked! with Lathes, Stereo Cutterheads - Complete Disk Mastering Systems... Cheap!!!!!! Frankford/Wayne Mastering Labs. 134 N. 12th St., Philadelphia, PA 19107, (215) 561-1794.

VINTAGE MIKES
Call Bill Bradley
(312) 751-1216

FOR SALE
24 TRACK AMPEX 1100 NEW HEADS REMOTE SEARCH TO CUE \$15,000. CALL TOM (615) 327-0519.

3M 79 Series 24 track, 5 years old, rebuilt transport, lots of spare parts, capstan and reel motor defeats. Includes Audio Kinetics loc, and Dolby trigger harness excellent condition, \$19,500 (215) 423-7300. Ask for Mal or Mark.

Model 4 Trk MCI JH 110, Ruslang cabinet, 2 Scully 280 2 Trk Ruslang cabinets, TEAC model 5 console, Ampex 351 mono w/Autotech C-7 electronics, Sound Workshop series 30 console 16x8. Make offer. SOUND-HOUND INC., 45 W. 45th St., NY, NY 10036 (212) 575-8664.

Instruction

BE A RECORDING ENGINEER!
New classes quarterly.
INSTITUTE OF AUDIO/VIDEO
ENGINEERING
1831 Hyperion, Dept. E

HOLLYWOOD, CA 90027
(213) 666-3003

LEARN FROM THE PROFESSIONALS ELECTRIC BASS

By Carol Kaye:
How to Play the Elec. Bass . . . \$4.95
Elec. Bass Lines #1 3.95
Elec. Bass Lines #2 3.95
Personally Yours 4.95
Elec. Bass Cassette Course . . 35.00
Elec. Bass Lines #3 3.95
Elec. Bass Lines #4 4.95
Elec. Bass Lines #5 3.95
Elec. Bass Lines #6 3.95
How to Play Elec.
Bass Chords 4.95
and:
Easy Elec. Bass (Carroll/
Kaye) 4.95
Jazz Improvisation - Bass Clef
(Most) 5.95

GUITAR

Joe Pass Guitar Style 6.95
J. Pass Guitar Style
Cassette 9.00
Jazz Guitar Solos (Pass) 4.95
J. Pass Guitar Chords 3.95
J. Pass Chord Solos 4.95
Jazz Duets (Pass/Ellis) 5.50
Jazz Duets Cassette 7.95
Laurindo Almeida Guitar 6.00

Foreign postage: \$2.00 1st book, \$1.00 ea. additional. \$1.50 for cassette. \$8.50 C.K. Bass Cassette Course - \$13.50 to Australia, N.Z. & Asia.

Sorry, no CODs. Colorado add 6% tax.
Good store discounts.

GWYN PUBLISHING CO.
5555 D.T.C. Parkway, Suite 1017
Englewood, Colorado 80111
(303) 699-7928

GOOD MUSIC MAKES
A HAPPY WORLD

Free Catalog

"Start Your Own Music School" with a complete "how-to" text containing over 70 tested forms.

Business of Education:

Three-ring binder with print ready forms \$60. Soft cover edition \$15. Send check or money order to NAIMM, 5140 Avenida Encinas, Carlsbad, CA 92008.

INSTRUCTORS-AUDIO TECHNOLOGY, VIDEO TECHNOLOGY, ELECTRONICS. Full-time and part-time faculty openings to teach basic and advanced technology at leading proprietary technical institute. Industry experience and/or teaching experience required. Professional, satisfying atmosphere. Dynamic Greenwich Village location. Send resume and salary history to Philip Stein, Director, INSTITUTE OF AUDIO RESEARCH, 64 University Place, New York, NY 10003.

I.C.A. INSTITUTE OF COMMUNICATION ARTS

2 year program or part time studies in audio eng/video production, ent. buss, synth/audio production, comm, music theory/arr., sound reinforcement. 700 hours of "in-studio." Write: I.C.A., 1730 Burrard St., Vancouver, BC, CANADA V6J 367. (604) 734-5474.

Maintenance Services & Repair

AMPEX

Parts - Tape - Recorders
Northwestern Inc.
1-800-547-2252

Record & Tape Services & Supplies

AUDIO CRAFT CO.
Audio Cassette Duplication
Real Time
Demo Cassettes Improved
Fr. Res. 20 to 20k Hz ± 2
"Satisfaction Guaranteed"
WHILE-U-WAIT SERVICE
AVAILABLE
2701 E. Sunrise Blvd.
Ft. Lauderdale, FL 33304
(305) 563-0553
Toll free: 1-800-432-0405 (FL.)

REAL-TIME

Cassette Duplication C45 as low as 98¢. 4-color printing, foil labels, shrink wrap. Send for complete price list & services inc. bulk price on Agfa & chrome tape. CAT, 3005 W. Glendale Ave., Phx, AZ 85021 (602) 246-4976

AUDIO DISC MASTERING

Midwest's newest Neumann transfer system is now open for your highly specialized needs. Call or write for details. Precision Disk Works, 932 W. 38th Place, Chicago, IL 60609, (312) 225-9117.

PROFESSIONAL RECORDING SUPPLIES

We are a major distributor of Ampex, Agfa & 3M bulk & reel master tape from ¼" to 2". We also stock empty reels, boxes, video cassettes, Norelco boxes & other recording supplies. We manufacture custom length bulk cassettes using top quality tapes. Cassette duplication service available. Please call or write for our FREE catalog.

Advance Recording Products

7190 Clairmont Mesa Blvd.,
San Diego, CA 92111
In Calif.: (800) 858-1061
CA Phone No: (619) 277-2540
Outside Calif.: (800) 854-1061

REAL-TIME CASSETTE DUPLICATION from analog or digital masters, we are the finest, most elaborate facility in the world. Complete packaging, price competitive. Call MIRROR IMAGE (303) 751-2268.

RECORD PRESSING

Midwest's newest & finest record plant specializing in custom pressing. 7", 9", 10", 12", colored vinyl, picture disks, custom packaging, premium work, competitive prices, fast turnaround. For more info: Contact Lenny

Eames, Precision Record Labs Ltd., 521 W. 26th, Chicago, IL 60616, (312) 225-9117.

CASSETTE DUPLICATION

Real time and high speed, excellent quality. Competitive rates. Call for information: (212) 473-1203, WK Studio, 611 Broadway, Suite 531, New York, NY 10012.

AUDIOPHILE CASSETTE DUPLICATION

from
DIGITAL or ANALOG MASTERS
including
PCM, dbx 700, and Nagramaster
½ trk or ¼ trk Stereo/Mono
Finest Chrome or Normal Bias
Cassettes. Call today!

ORPHARION RECORDINGS

P.O. Box 91209
Long Beach, CA 90809-1209
(213) 438-4271

REAL TIME

High quality cassette duplication. Full service mastering-sweetening printing. Dedicated to excellence Eastern Standard Productions 26 Baxter St., Buffalo, NY 14207 (716) 876-1454

DISC MASTERING - Cut from your tapes at low cost - Plating, Pressing, Labels & Jackets - LPs, EPs & 45s. Write for free information:

THE CUTTING EDGE
Box 217 M
Ferndale, NY 12734
(914) 292-5965.

REAL-TIME

Best Quality Cassettes using Nakamichi LX-5 decks only. Custom loaded Agfa or BASF Chrome. Label and insert printing, shrinkwrap, blank tapes. Competitive pricing.

YOU NEVER HEARD IT BETTER Uni-Sette, Inc. 5125 Marconi Ave., Carmichael, CA 95608. (916) 485-9534.

ROCK BOTTOM PRICES

(On Tape Brands)
AGFA, AMPEX, 3M-SCOTCH
AUDIO & VIDEO TAPE, ¼" 2".
Custom Agfa cassettes. Reels,
boxes, leaders, splicing tapes,
metal reels & CAPITOL Broad-
cast cartridges & specialty items.
Catalog upon request. BURLING-
TON AUDIO TAPES, 106 Mott St.,
Oceanside, NY 11572. 1-800-331-
3191, in N.Y. (516) 678-4414.

Studios For Sale

LARGE MIAMI STUDIO

Lease, rent, sale or merger with film, video or recording producer. 5 minutes to I-95. Great potential. Li'l Wally Studio (formerly Warren Sound). Call Mr. Jay (305) 758-0000.

House With Recording Studio for sale West LA Area—Canyon view setting near Malibu beaches. Architect designed red-wood with decks, hot tub, tile, 3 bedroom, 220 sq. foot control room, 280 sq. foot studio with air cond. & elec. per Westlake Audio specs. \$279,000. Call Bernie (213) 455-3635.

24 Track Recording Studio for Sale. Located in Studio City, CA. Call Steve at (213) 850-1653 — \$275,000.

FOR SALE

Complete 24 track pro studio. Turn key. Includes grand piano. \$75,000. Free installation & training. Call 503-726-1378 after 6 pm or 503-998-2758.

Miscellaneous

Need a Hit?

The Song Brokers
3262 Central
Alameda, CA 94501
(415) 523-9876

**Stay in touch—
read Mix
every month.**

How to Place a Mix Classified

Please print or type in CAPITAL LETTERS and lower case. There are 8 lines to the inch and approximately 24 CAPITAL letters per line or 30 lower case letters. \$60 per inch — 1" minimum. Additional lines \$10 per line. **Bold type** \$10 per line. Black border or gray screen \$10 extra. Logos or display advertising up to 4" will be charged at \$75/inch. Multiple insertion rates at 10% discount. **Payment by check, money order or charge must accompany ad. DEADLINE is the 10th of the month, 1 ½ months prior to publication.**

Categories Available (check one)

- | | | |
|---|---|---|
| <input type="checkbox"/> Employment Wanted | <input type="checkbox"/> Equipment Rentals | <input type="checkbox"/> Equipment Wanted |
| <input type="checkbox"/> Instruction | <input type="checkbox"/> Recording Services | <input type="checkbox"/> Rehearsal Space |
| <input type="checkbox"/> Employment Offered | <input type="checkbox"/> Miscellaneous | <input type="checkbox"/> Equipment for Sale |
| <input type="checkbox"/> Record & Tape Supplies | <input type="checkbox"/> Maintenance Services | <input type="checkbox"/> Business Opportunities |

Name _____

Address _____

Phone _____

If paying by: VISA MASTERCARD

Card #: _____ Expiration Date: _____

Signature: _____

Mail to:
Mix Classified, 2608 9th St., Berkeley, CA 94710
(415) 843-7901

Attention:
Recording Schools & Programs

The July issue of *Mix* will include our annual *Directory of Recording Schools and Programs*. If your school was not listed in our 1984 *Directory*, you can ensure a listing by completing and returning the coupon below. A questionnaire will be mailed to you.

Name of School or Program _____

Chief Administrator _____

Address _____

City _____ State _____ Zip _____

Telephone (_____) _____ Best Time to Call _____

Return coupon to: Mix Publications, 2608 Ninth Street, Berkeley, CA 94710
For more information, call Lauri Newman at (415) 843-7901.

PULSAR LABORATORIES, INC. NOW AVAILABLE A MONTHLY LEASING PROGRAM

* 100% Financing
* No Collateral Required

* 100% Tax Write Off
* Investment Tax Credit

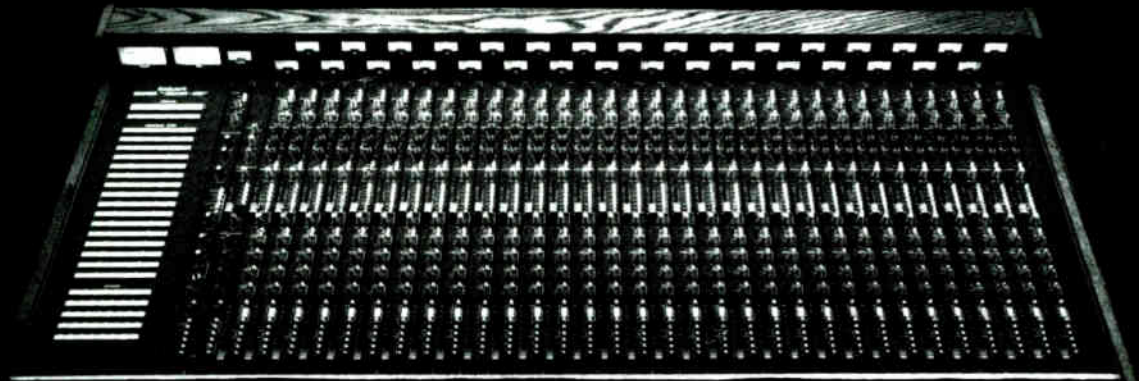

"ON TRACK" I/O recording consoles
24 channel @ \$475 a month
32 channel @ \$600 a month

SERIES 80 front consoles
32x8 @ \$250 a month
24x8 @ \$215 a month
M8 monitor consoles
32x8 @ \$250 a month
32x16 @ \$515 a month

* Call for additional pricing and information 216-784-8022 *

Circle #110 on Reader Service Card

ADVERTISERS INDEX

PAGE	ADVERTISER	PAGE	ADVERTISER	PAGE	ADVERTISER
157	Advanced Music Systems (AMS)	41, 43	Eventide Clockworks	129	Peavey Electronics
50	Agfa Audio	97	Everything Audio	89	Perfect Pitch
119	Akai/IMC	71	Flanner's Pro Audio	144	Polyline
37	AKG Acoustics	25	Fostex Corporation of America	22	Power USA
152	Dan Alexander Audio	87	Full Compass Systems	101, 111	Professional Audio Services & Supply
35	Allen & Heath Brenell	143	Goldline	162	Pulsar Laboratories
90	Alpha Audio	69	Alan Gordon Enterprises	44	Rane Corporation
45	Amek Consoles	148	G.R.D.	60	Reliable Music
9	Ampex	124	Guitar Showcase	22	Renkus-Heinz
55	Ardent	54	Hardy Company	14	RolandCorp US
138	Aspen Music Festival	2	Harrison Systems	83	Samson Music Products
153	Audio Digital	113	Hill Audio	98	Sanken Microphone Company
82	Audio Systems	138	IAN Communications	90	SCMS Pro Audio
92	Auteri Associates	49	Ibanez	84	Tean Seimmes Associates
65	Barcus Berry Electronics	15	JBL	91	Sennheiser
116	Berklee College of Music	87	JRF Magnetic Sciences	163	Shure Brothers
105	B.E.S.	28, 29	Kurzweil	164	Soundcraft Electronics
148	Brush Magnetics	120	LaSalle Music	61	Soundtrek
79	Carver Corporation	144	LD Systems	156	Spectrum Magnetics
39	Carvin	106	Leo's Audio & Music Technologies	137	Sprague Magnetics
81	Castle Recording Studio	17	Lexicon	11	Studer Revox
109	Cerwin Vega!	140	Linear & Digital Systems	69	Switek
112	Cetec Gauss	115	Linn Electronics	142	Symetrix
135, 137, & 139	Cherry Lane Technologies	131	LT Sound	149	Synchronous Technologies
116	Countryman Associates	151	Magnefax International	57	Tardberg of America
53	Crown International	95	Meyer Sound	103	Tannoy
117	Chips Davis Design	75	Miami Tape	31	Tascam
108	Design Direct Sound (DDS)	55	Monster Cable	19	Technical Audio Devices (TAD)
108	DeCuir Sample Case Company	107	N.A.R.A.S	89	Peter Tempel Audio
4	Digital Entertainment Corporation	58, 59	Neotek	92	Thoroughbred Audio
123	Digital Service	121	Rupert Neve Inc.	132, 133	3M
82	D.I.Y. Recording	91	New Age Sight & Sound	21	TOA Electronics
127	DOD Electronics	136	Ocean Audio	143	United Tape
85	Eva-Tone Soundsheets	63	Orban Associates	7	Ursa Major
		140	PAIA Electronics	73	World Records
		125	Passport Designs	33	Yamaha International



Great performers have one thing in common.

Mick Jagger, Pete Townshend, Tina Turner, Ronnie Milsap, Brian Wilson, Randy Owen—great performers know their legendary stature depends on the quality of their voices. That makes the purity of vocal reproduction critical. That makes rugged, reliable Shure mics essential.

Shure mics have been the number one choice of top professionals for many years from the legendary SM58 dynamic to Shure's newest trailblazer, the SM87 condenser.

Whether you're on your way up, or you've already made it, don't trust your great performances to anything less than the best—Shure mics.

SHURE®

THE SOUND OF THE PROFESSIONALS®...WORLDWIDE.

Circle #109 on Reader Service Card



The 2" multi-track for those with a 1 track mind. Value.

When selecting a multi-track, it's easy to get thrown off track. Why pay for technology, for technology's sake? It contributes most where you want it the least. Cost. But for professionals who value their music as much as their money, there's

stan motor delivers variable speeds in excess of 45 ips with heavy duty performance. And in video applications, external frequency or voltage controllers easily interface with the Mark III.

Versatile Value.

The headblock is a precision milled, flat wired, self contained unit which simply plugs into place. Therefore, upgrading from 16 to 24 track recording can be accomplished without disturbing any head alignments, saving expensive time.

configuration allowing timely and hassle-free maintenance. We've also added new audio channels with low frequency record and replay trim, adjustable phase compensation and available sync head transformer.

These features, coupled with our optional full function nine memory autolocator, makes the Mark III the ultimate in appropriate tape technology.

Soundcraft's 760 Mark III Series. It's everything the 2" professional needs to get back on the right track. At a price that really attracts attention. Under \$18,000*.

*Suggested retail SCM 762-16B. Other models up to \$24,950.

Appropriate Technology

Soundcraft

Soundcraft Electronics
1517 20th Street, Santa Monica, CA 90404
(213) 453-4591 Telex: 664-923
In Metropolitan N.Y. call (212) 315-0877

Soundcraft Electronics Canada, Inc.
1444 Hymus Blvd., Dorval, Quebec, H9P 1J6
(514) 685-1610 Telex: 05-822582

Soundcraft Electronics Limited
5-8 Great Sutton Street, London, EC1V0BX,
England Telephone: 01-251-3631 Telex: 21198



one recorder that's second to none. The new Mark III Series from Soundcraft.

Heavy Duty Value.

A newly developed German cap-

Extra Value For Nothing Extra.

Another valuable feature is its durable construction and modular

World Radio History