

Registered by Australia Post. Publication No. MBP0407.

# Electronics Today



OCTOBER 1986

\$2.95\*  
NZ \$3.95 incl. GST



**MIDI: REAL  
COMPUTER MUSIC**

**OPTICAL FIBRE  
TESTER**

**A CAREER IN  
ELECTRONICS**

**PROJECTS:  
COMMODORE  
TAPE COPIER  
END OF THE  
HEAVY BREATHERS  
DUALING  
JOYSTICKS**

Roland S-10

Roland



# SCOPE

# 60W SOLDERING SYSTEM

Illuminated Temp. readout monitors actual tip temperature.

Select the tip temp. required.

Zero Voltage switching for maximum component safety.

Ceramic encapsulated element for lowest earth leakage.

60 Watts of back-up power -30W Pencil optional.

Burnproof & flexible lead

Floating earth model available with plug-in lead and clip.

MODEL: ETC60LFE

CODE: ETC60L



## INFINITELY ADJUSTABLE 200°-470°C with zero voltage protection



Screw type connector prevents accidental plug removal.



30 Watt Soldering Pencil is an optional tool to replace 60W standard tool. Special miniature tips are available.

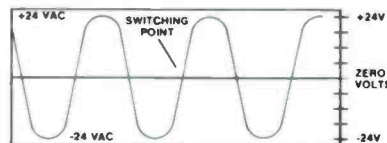

Damaging Spikes and induced tip voltages likely to damage MOS devices are virtually eliminated by Z.V.S.\* circuitry.

\* ZERO VOLTAGE SWITCHING OF HEATER

Anti Seize tip retention design - reduced risk of thread seizure by removing locking nut to cooler end of barrel.



### TIPS FOR 60 WATT IRONS

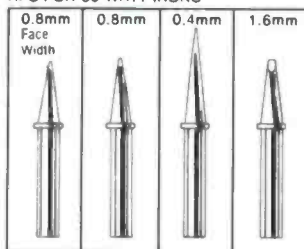

### REPLACEMENT TIPS \* FITTED AS STANDARD

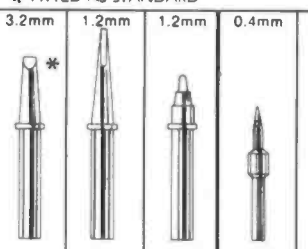

### TIPS FOR 30 WATT PENCIL

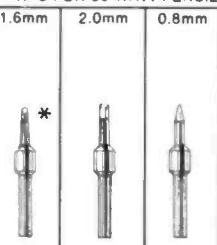

Code SF 0.8/21 DF 0.8/22 DF 0.4/23 DF 1.6/24 DF 3.2/25 DF 1.2/26 SF 1.2/27 ZF 0.4/51 SF 1.6/56 SF 2.0/57 ZF 0.8/59

### WANT MORE INFORMATION THEN CONTACT

#### VICTORIA

ELECTROTOOL (03) 848 1811  
 RADIO PARTS (03) 329 7888 (03) 211 8122 (060) 21 8177  
 TELEPARTS (052) 21 7085  
 SCHOOL OF ELECTRONICS (03) 288 7051  
 McGRATHS (03) 663 1122  
 ALL ELECTRONICS (03) 662 3506  
 ELLISTRONICS (03) 561 5844  
 BALLARAT ELECTRONICS (053) 311 947

#### S.A.

GERRAD & GOODMAN (08) 269 1811  
 BEEJAY (08) 277 8499  
 GRAPHIC ELECTRONICS (08) 363 0277

#### TAS.

QHE ELECTRONICS (003) 316533 (002) 34 2233  
 W.A.  
 ATKINS CARLYLE (09) 481 1233  
 COVENTRY MOTOR REPLACEMENTS (09) 276 0111

#### N.S.W.

C.L.C. AGENCIES (02) 750 4005  
 D. JH. COULTER (049) 671 455  
 EBSON PTY. LTD. (02) 707 2111  
 PROMARK ELECTRONICS (02) 439 6477  
 DAVID REID ELECTRONICS (02) 267 1385  
 SELECTRO PARTS (02) 708 3244  
 T.V. PARTS (02) 747 6707

#### QLD.

ST LUCIA (07) 52 7466  
 SOUTHPORT ELECTRONICS (075) 32 3632  
 BAS-AUDIOTRONICS (07) 44 7566  
 COLOURVIEW (07) 275 3188  
 DELBOUND (07) 839 6155  
 SOLEX ELECTRONICS (077) 72 2015  
 STEVENS ELECTRONICS (079) 51 1723  
 CAIRNS INSTRUMENTS (070) 51 1849  
 ROBCO EQUIPMENT (077) 72 2633  
 SELECTRO (07) 848 8197



# Electronics Today

INTERNATIONAL

## FEATURES

<b>MIDI: real computer music</b> What all the commotion's about	<b>18</b>
<b>Chip-8 interpreter for the VZ</b> Using the editor from August issue	<b>28</b>
<b>Interfacing sensors</b> New practices for interfacing transducers	<b>34</b>
<b>Reflectometers</b> The devices that test optical fibre	<b>38</b>
<b>TV power supplies</b> The how, where, why and fix it	<b>42</b>
<b>Creating with electronics</b> Towards a power supply	<b>64</b>
<b>Inside your computer</b> ASCII and keyboard	<b>68</b>
<b>Calculated fun</b> Try some problems on an old four function calculator	<b>70</b>
<b>Tantalizing tropics</b> What lures the SW monitor	<b>84</b>
<b>Radio in Macau</b> A European pocket in Asia	<b>86</b>
<b>A career in electronics</b> Things you should know before you choose	<b>95</b>
<b>Horizontal rockets</b> HOTOL is taking off	<b>104</b>

## REVIEWS

<b>Tasmanian PRO</b> Protel PCB CAD system	<b>72</b>
<b>A good track recorder</b> Four multitrack recorders reviewed	<b>88</b>

## PROJECTS

<b>ETI-282: Telephone screamer</b>	<b>50</b>
<b>ETI-1604: Dual Microbee joystick</b>	<b>54</b>
<b>ETI-1603: Commodore 64 tape pirate</b>	<b>60</b>

## OFFERS

<b>ETI-Freedman Electronics competition</b>	<b>85</b>
<b>Subscriptions offer</b>	<b>25</b>

## DEPARTMENTS

<b>News Digest</b>	<b>8</b>
<b>Feed Forward</b>	<b>46</b>
<b>New Products</b>	<b>76</b>
<b>Advertisers Index</b>	<b>67</b>
<b>Dregs</b>	<b>110</b>

**COVER:** Photography by Peter Beattie.

**EDITOR**

Jon Fairall B.A.

**EDITORIAL STAFF**

Mary Rennie B.A.

S. K. Hul B.Sc. (Hons), M.Eng.Sc. MIEEE, MIREE

Neale Hancock B.E.

**DRAUGHTING**

David Burrows

**DESIGNER**

Brian Jones

**ART STAFF**

Ray Eirth

**ADVERTISING MANAGER**

Peter Hayes B.Sc.

**ADVERTISING PRODUCTION**

Brett Baker

**READER SERVICES**

Carmel Trlutcio

**ACOUSTICAL CONSULTANTS**

Louis Challis and Associates

**RF CONSULTANTS**

Associated Calibration Laboratories

**PUBLISHER**

Michael Hannan

**MANAGING EDITOR**

Leo Simpson B.Bus.

**HEAD OFFICE**

180 Bourke Road, (PO Box 227, Waterloo, NSW 2017)

Alexandria, NSW 2015.

Phone: (02) 693-6666.

Telex: AA74488, FEDPUB.

Federal Facsimile: (02) 693-2842.

**ADVERTISING**

**New South Wales**

Mark Lewis (02) 693-6666

**Victoria and Tasmania**

Virginia Salmon (03) 662-1222

**Queensland**

Peter Hayes (02) 693-6666

**South Australia and Northern Territory**

Dane Hansen (08) 212-1212

**Western Australia**

Ashley Croft (09) 481-3171

**New Zealand**

John Easton, 79-6648 (Auckland)

**OFFICES**

**New South Wales:** The Federal Publishing Company, 180 Bourke Road, Alexandria, NSW 2015. Phone (02) 693-6666. Telex: AA74488 FEDPUB.

**Victoria and Tasmania:** The Federal Publishing Company, 23rd Floor, 150 Lonsdale Street, Melbourne, Vic. 3000. Phone: (03) 662-1222. Telex: AA34340, FEDPUB.

**South Australia and Northern Territory:** John Fairfax & Sons, 101-105 Waymouth Street, Adelaide. 5000. Phone (08) 212-1212. Telex: AA82930.

**Queensland:** The Federal Publishing Company, 26 Chermide Street, Newstead, Qld. 406. Phone: (07) 854-1119, Telex: AA145520.

**Western Australia:** Jim Wells, John Fairfax & Sons, 454 Murray Street, Perth, WA 6000. Phone: (09) 321-8217. Telex: AA92635.

**New Zealand:** 3rd Floor, Communications House, 12 Heather Street, Parnell, Auckland. PO Box 8770, Symonds St, 37-291. Telex NZ63122. Phone (09) 396-096.



**ELECTRONICS TODAY INTERNATIONAL** is published and distributed monthly by the Electronics Division of the Federal Publishing Company Pty Limited, 180 Bourke Road, Alexandria, NSW 2015 under licence from Double Bay Newspapers Pty Limited, General Newspapers Pty Limited and Suburban Publications Pty Limited. Printed by Hannanprint, Sydney. Distributed by Magazine Promotions. \*Maximum and recommended Australian retail price only. Registered by Australia Post, Publication No NBP0407. ISSN No 0013-5216.

**COPYRIGHT** 1985, Double Bay Newspapers Pty Limited, General Newspapers Pty Limited and Suburban Publications Pty Limited (trading as "Eastern Suburbs Newspapers").



# AutoCAD<sup>®</sup> is PCB

## The Auto-Board System

The Auto-Board System provides the designer with a powerful design tool with the capability of having a prototype on your desk by the end of the day.

**Schematic Capture:** Creates a schematic diagram to extract interconnection information (netlist) and symbols to Australian Standards.

**PCB Layout:** Provides the ability to position electronic packages on virtually any size or shape board.

**Auto-routing:** Automatically connects traces to components with a 70-90% success rate.

Used in conjunction with AutoCAD<sup>®</sup>, the Auto-Board System provides an extensive symbol and component library and complete editing facilities.

For Details contact Entercom Computer Co. (03) 429 9888

## SATCAM

SATCAM is a powerful design-assist tool for the professional electronics engineer. SATCAM incorporates many features not found in generic PCB-CAD packages, such as photoplotting, a comprehensive symbol/component library and CNC drill generation. Among its other features are:

- Fast Professional Schematic Designs
- Cost effective PCB designing
- Automatic netlists and costing
- Photo tooling and NC control drivers
- Total Bureau support
- Supported on 30 different microcomputers
- Library of 30,000 components.

For details contact International Systems Database. Sydney (02) 498 6522 Melbourne (03) 870 3830

The Auto-Board System and SATCAM are complete electronics/PCB CAD packages which fully integrate with AutoCAD<sup>®</sup>, the leading Computer-Aided Design solution. Whether you are a small or large company, AutoCAD<sup>®</sup> and SATCAM or Auto-Board System can increase your productivity and enhance your creativity.



The NCR PC8 Advanced Technology (AT) PC is an ideal CAD workstation with its 8 MHz 80286 processor and native 640 by 400 colour graphics capability.

Houston Instruments have defined the industry standard in low cost, high quality plotting with its best selling, A1 size, 16 ips DMP-52 plotter.



**AUTOCAD<sup>®</sup>**  
NUMBER ONE IN AUSTRALIA  
AND WORLDWIDE

For further information or demonstration contact your nearest "Authorized AutoCAD<sup>®</sup> Dealer" by contacting us at ...  
136 BRIDE RD., RICHMOND  
VICTORIA 3121 AUSTRALIA.  
PHONE: (03) 429 9888 TELEX: 30625 ME1400

**ENTERCOM**



# When mainframe power gets this small, Du Pont Electronics will have helped get it there.



Model of computer is an artist's conception.

Du Pont technology has been helping electronic companies worldwide to develop smaller, more reliable and less costly products for over 20 years.

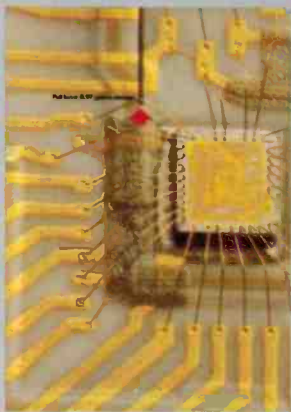

For example, in 1964 Du Pont's thick film technology helped computer companies develop a new, ceramic circuit which contributed significantly to the reduced size and enhanced performance of computers. Today, this technology permits instant

communication between the most complex semiconductor devices for even greater miniaturization.

Du Pont's photopolymer-based dry film technology enabled easier production of high-density, high-reliability printed wiring boards. More recently,

this technology led to improved solder masking which also increased circuit density and reliability.

The interconnection of smaller and smaller circuits is aided by Du Pont's connector technology. One result of this technology is the modular jack which links keyboards and personal computers to data transmission networks.



Du Pont's significant contributions often result from developmental "partnerships" in which customers draw on Du Pont's unmatched resources to solve problems faster and move into production quickly and reliably.

Whether you need materials or components for today's products or scientific resources to help create tomorrow's, DU PONT can help.

Write to:

Du Pont Electronics  
22-25 Paul Street North  
North Ryde NSW 2113

Phone:

887 1333 in Sydney, or  
from elsewhere in Australia  
(008) 22 6326 for the  
price of a local call.

ADMIN/DUP 278

**DU PONT**



# Do you look for a standard HCMOS supplier or for the one that sets the standard?

Right now, we have a complete range of high-speed CMOS (HCMOS) logic IC's. And we have them in both DIL and in our space-saving SO-package, now a JEDEC world standard. For your HCMOS needs come to us, Philips Elcoma, the Australian source.

Plug our pin and function-compatible 74HCT IC's straight into your LSTTL sockets - often without redesign! LSTTL level compatibility with dramatically reduced power consumption. Without sacrificing system speed, and at the right price.

Using MOS already? Then look at our 74HCT for TTL-level CMOS and NMOS systems, or our 74HC for all-CMOS systems.

Or, design-in HCMOS and enjoy all of its benefits. Like freedom from latch-up and high

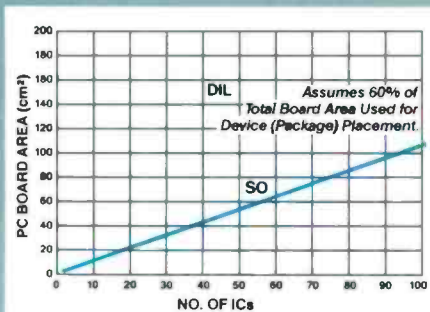
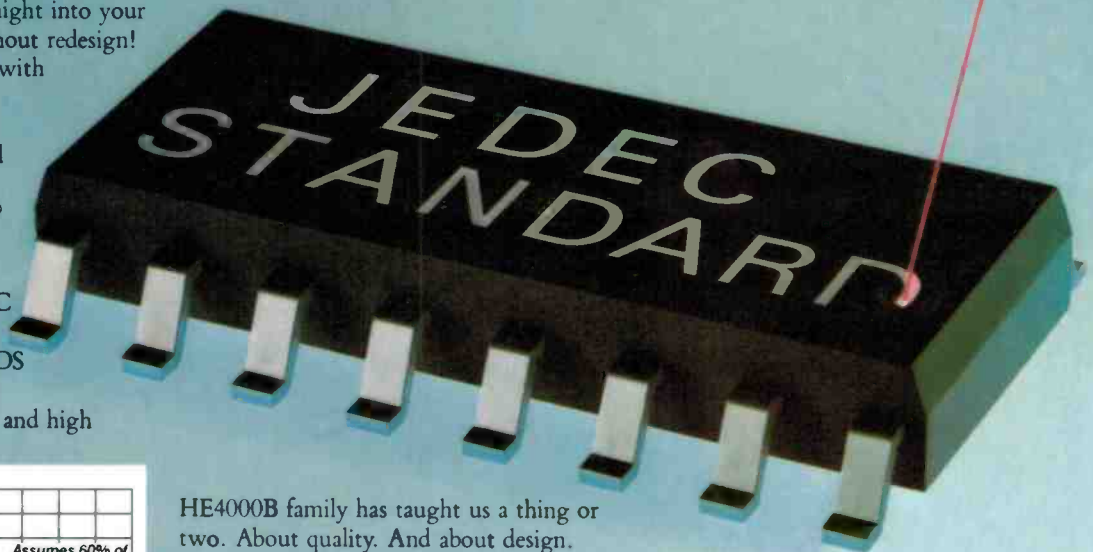

Save board space. Our SO-versions are up to 65% smaller than comparable DILs, and are up to 10 times lighter.

reliability (5 FITS). Noise immunity critical? Then think about 74HC.

Space and cost conscious? Then use SO-versions and benefit from Surface-Mounted Device (SMD) technology.

At Philips, we know about CMOS. Ten years as European leader with the

HE4000B family has taught us a thing or two. About quality. And about design. Our patented HCMOS input structure, for example, makes it possible for us to produce 74HC (CMOS input levels) or 74HCT (LSTTL input levels) with a single mask change. So the type range is available in both versions.

Need samples or data? Then call your nearest Philips Electronic Components and Materials office. We're ready with full technical support and documentation. Plus a User Guide, set to become the standard for designing with HCMOS.

**HCMOS** The name is Philips  
HIGH-SPEED LOGIC The product is HCMOS

Philips Electronic Components  
and Materials  
11 Waltham Street,  
Artarmon, N.S.W. 2064  
Telex AA20165 AUSLCEC+

Sydney (02) 439 3322  
Melbourne (03) 542 3333  
Adelaide (08) 243 0155  
Perth (09) 277 4199  
Brisbane (07) 44 0191

the UN 279



Electronic  
Components  
and Materials

# PHILIPS



# Fluke. First Family of DMMs.



When accuracy, performance and value are important, professionals the world over look to Fluke — the first family of DMMs.

Reliable Fluke-quality 3½- or 4½-digit DMMs fit every need — from design engineering to industrial troubleshooting.

There's the low-cost 70 Series — the most DMM you can get for the money. The tough 20 Series — totally sealed and built to survive the dirtiest, grimeiest, roughest jobs. The reliable 8020B Series — made to withstand the rigors of the field service environment. The precise 8060A Series — the most powerful and complete test and measurement system available in a hand-held package. And, of course, the versatile Bench/Portables that carry on the Fluke tradition for precision and durability in lab-quality bench instruments.

Fluke comes in first again with the world's largest selection of quality accessories to help extend the capabilities of your DMM even further.

There's no need to look anywhere else. Uncompromising Fluke design and leading edge technology are the reasons why attempts at imitation will never fool the millions of professionals that accept nothing less than a Fluke.

FROM THE WORLD LEADER  
IN DIGITAL MULTIMETERS.

**FLUKE**

## **ELMEASCO** **Instruments Pty. Ltd.**

**N.S.W.** 15 McDonald St, Mortlake. Tel: (02) 736 2888  
**VIC.** 12 Maroondah Hwy, Ringwood. Tel: (03) 879 2322  
**QLD.** 243 Milton Rd, Milton. Tel: (07) 369 8688  
**S.A.** 241 Churchill Rd, Prospect. Tel: (08) 344 9000  
**W.A.** 46-48 Kings Pk Rd, West Perth. Tel: (09) 481 1500

Talk to your local distributor about Fluke

• A.C.T. Actlec Pty Ltd (062) 80 6576 • George Brown 80 4355 • N.S.W. Ames Agency 699 4524 • George Brown (02) 519 5855 Newcastle 69 6399 • Bryan Catt Industries 526 2222 • D.G.E. Systems (049) 69 1625 • David Reid 267 1385 • W.F. Dixon (049) 61 5628 • Macelec (042) 29 1455 Ebon 707 2111 • Selectro Parts 708 3244 • Geoff Wood 427 1676 • N. TERRITORY Thew & McCann (089) 84 4999 • QUEENSLAND L. E. Boughen 369 1277 • Colourview Wholesale 275 3188 • Fred Hove & Sons 277 4311 • Nortek (077) 79 8500 • St Lucia Electronics 52 7466  
• Selectro Parts (Qld) 394 2422 • S. AUSTRALIA Protronics 212 3111 • Trio Electrix 212 6235 • A.W.M. Wholesale  
• TASMANIA George Harvey (003) 31 6533, (002) 34 2233 • VICTORIA A.W.M. Electrical Wholesale • Radio Parts 329 7886 • G.B. Telespares 328 3371 • Browntronics 419 3986 • R.K.B. Agency 82 7704 • A.J. Ferguson 347 6688  
• SIRS Sales (052) 78 1251 • Mektronics 690 4593 • W. AUSTRALIA Atkins Carlisle 321 0101 • Dobbie Instruments 276 8888 • Cairns Instrument Services 325 3144 • Willis Trading 470 1118



# Telecom — the new marketeer?

Telecom's Managing Director, Mel Ward, has been monumentally busy, recently. The consequence of his flurry of activity has been that Telecom has formed an overseas marketing arm, which is busy bidding on jobs in Indonesia, India and Saudi Arabia, and has secured a contract with China.

The opening shots to all this began when Communications Minister, Michael Duffy, announced that Telecom would set up a subsidiary company called Telecom Australia International (TAI) specifically to tout for international trade.

Duffy's plan was that TAI would offer both consultancy and sales to other countries. Telecom would supply consultancy services through its own employees and hardware from contracts let within Australia. Duffy, announcing the move, said that Telecom had expertise in long distance and rural communications that would be very interesting to many overseas countries.

At the same time he announced the appointment of Ward to the post of Chairman of Directors of TAI. One of his first public jobs was to welcome a delegation from China headed

by Zhu Gaofeng, Vice Minister of Posts and Telegraphs in China.

He was in Australia recently for a tour of country exchanges to see the Telecom designed Digital Radio Concentrator System (DCRS) in operation. Ward, at a ceremony during the tour, said that Chinese Telecom authorities had gone on a program to increase the number of telephone services from 6.2 million phones to 13 million by 1990, and 30 million by the turn of the century.

To do this, they would require a large trunk capacity and many switching systems.

Ward said he believed Telecom was well placed to make a substantial contribution to the evolving Chinese network. Currently, plans are in hand for Telecom to act as consultants on the Beijing to Shanghai digital microwave link.



Zhu Gaofeng and Mel Ward.

Meanwhile, on a less flamboyant note, the STD network has been falling apart under the strain of STD calls after 9 pm. Apparently, tens of thousands of people wait until nine o'clock each evening when the cheap STD rates come on, and then rush to use the lines. As a result, Telecom has put back the economy rate to 10 pm, presumably in the hope that people will not wait until 10 pm.

The situation points to a perennial communications problem of matching demand with supply. In the ideal situation, the number of calls would be spread evenly throughout each 24 hour period. Thus, the least number of paths through the network would need to be provided, for the greatest number of calls.

What really happens is that almost no calls are made late at night, there is a rush just after

9 am, and another just after lunch, and the call rate tapers off into the evening. The problem then is to either provide sufficient capacity in the network to handle the peak rate, or accept a large number of failed calls during those times.

Telecom attempts to fight the problems with a differential tariff. Make the calls cheaper when there is excess capacity in the network, and hope the punters will make calls in the slow periods. Sometimes it works too well.

The situation also points up another trend in the inverse distance/price relationship. The latest round of price hikes has seen rates drop by 17% for calls of more than 165 km, and 7% for calls between 85 and 165 km. However, short distance trunk calls will rise by 4%. Local calls are now 18c each.

## The cause of death

NASA has released a report by Dr Joseph Kerwin, himself a former astronaut, on the last few seconds of lives of the Challenger crew. Kerwin says: "It is possible, but not certain, that loss of consciousness did occur in the seconds following the orbiter break-up."

The US shuttle, Challenger, exploded on its way to Earth orbit on 28 January, killing the crew and passenger, first teacher in space, Christa McAuliffe.

The report by Kerwin was commissioned after press speculation that the astronauts had

survived the explosion and in fact were alive until their crew module hit the water, a minute or so after the explosion that ripped the spacecraft apart.

The voice transcripts analysed by Kerwin were the comments of Francis Scobee, Michael Smith, Ellison Onizuka and Judith Resnik for a period of two minutes five seconds prior to launch. Detailed analysis of tapes shows absolutely no alarm from the astronauts until fractionally after the first hints of an explosion are visible on film of the disaster. Then the com-



Challenger, pre explosion.



## CD-ROM spec

Philips and Sony have published the provisional compact disc interactive media system (CD-I) specifications, also known as the provisional *Green Book*. They provide a complete format for the interactive use of CD-ROM.

In June the two companies reviewed the CD-I specifications with their licensees in Tokyo and in New York. The final specification is expected by the end of the year.

In 1980 Philips and Sony jointly developed the compact disc digital audio system and in 1982 subsequently marketed compact disc digital audio products. Since that time consumer acceptance of compact audio discs and players has grown dramatically. The compact disc system features large information storage capacity on a small, sturdy easy-to-use disc. The two companies reached agreements for CD-ROM applications in 1983. In May 1985 they announced the *Yellow Book* or physical format specification for CD-ROM, which laid the groundwork for storing character and graphic information on optical discs.

With the *Yellow Book* specification, a CD-ROM drive can act as a computer peripheral for business use. Information stored on the CD-ROM disc can be retrieved with the use of a personal computer. The CD-I system does not require the support

of a floppy disk, and the CD-I player, which contains its own intelligence, will be a stand alone unit suitable for audio and video as well as text and data applications.

CD-I specifies how various types of information on a compact disc are identified, how each type of information is encoded, and how tracks, files and records are laid out on the disc.

The power of CD-ROM is already being demonstrated. Recently, the Netmap Corporation showed how 200,000 A4 pages of information can be stored on a single disc.

200,000 sheets of A4 paper would form a stack 20 metres high.

Netmap's laser information storage and retrieval system accepts information through a document scanner at the rate of one A4 page each 12 seconds. Any stored item can be located within 220 milliseconds and printed out in a further eight seconds.

Netmap has already installed such a unit at the Defence Research Centre, Salisbury, in South Australia. This is part of a three stage contract won against intense international competition from major manufacturers.

For further information, contact George Sprague of Philips on (02)925-3333, or John Brothers of Netmap on (062)81-1322.

mander depressed his mic switch to open the command voice communication channel. An intake of breath has been identified on computer enhanced versions of the voice tape, but Challenger was being ripped apart before he had a chance to say anything.

The prospect that the astronauts had not died instantly was first raised by reports that the crew compartment had been discovered, intact and relatively undamaged, on the ocean floor. However, this ghoulish prospect was diminished somewhat by further analysis of the destruction mechanism of the Challenger. The latest opinion is that the spaceship itself was ripped apart

by aerodynamic forces, ie, air pressure, as it cartwheeled away from the exploding fuel tank. If this scenario is correct, the astronauts would have been subjected to lethal gravitational forces.

Meanwhile Challenger's sister ship, the Atlantis, is sitting on Pad 39B at Kennedy. NASA has spent \$US3.3m on rotating service structure, the RSS, to enclose the shuttle. This has been done to reduce the risk of damage to the precious heat resistant tiles from hail and wind blown debris.

Informed sources are predicting that Atlantis will sit on 39B until at least mid-1988, before any possibility of another flight.

FGE 2500 Die Fairchild gate array.

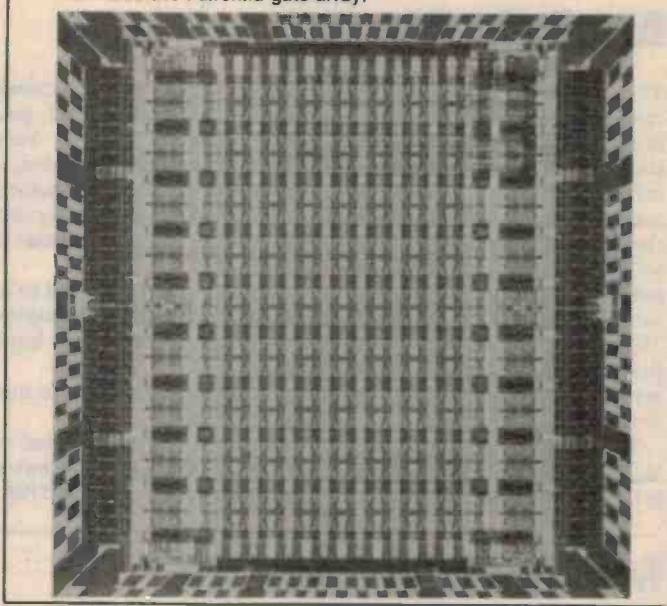

## Adelaide CAD centre

The Chairman of Integrated Silicon Design, Dr Peter Cole, recently announced the signing of an agreement between Fairchild Semiconductor Corporation, Protronics and Integrated Silicon Design to provide gate array design services for Australian industry. This will happen through the establishment of a Fairtech Design Centre using Fairchild software.

Integrated Silicon Design is well established as a custom and semi-custom design house for integrated circuits, but has sought for some time to expand its activities into other areas of the IC design market.

"The difficulty in obtaining custom or semi-custom integrated circuit designs is the large up-front cost," said Dr Cole. "Many companies simply cannot afford to outlay the amount of money required to take advantage of this technology over relatively low volume runs typical of manufacturing industry in this country. As a result of this joint venture all sectors of industry will have access to less complicated gate array technology at a very reasonable price. They can therefore plan strategically for product improvements and cost reductions which, in turn, will enable them to remain competitive in their chosen markets."

The marketing activity of the joint venture will be conducted

principally by Protronics, a member of the George Brown group of companies, and Fairchild Semiconductor, and the design simulation and testing of the end product will be conducted by Integrated Silicon Design. This facility adds to Integrated Silicon Design's existing technical capability in a way which will enable the company to offer its services at all levels in the IC design market.

Customers of the Fairtech Design Centre will receive a complete service from design of the original circuit right through fabrication and delivery of the finished product, thus making it not only economical but convenient compared with sourcing overseas from some semiconductor companies and the problems therewith.

South Australian based MIC, Samic Ltd, is the principal shareholder in Integrated Silicon Design and two of its staff, Ian Kowalick and Brian Baldwin, sit as Directors on the Board of the company. Dr Cole said that the initiative of Samic in structuring a joint venture was evidence of the active and constructive management role played by MICs in their investee companies.

For further information contact Mr A. Grasso of Integrated Silicon Design on (08)223-5802.



## New CAD

The Centre for Industrial Microelectronics Applications, a division of Technisearch Ltd, in cooperation with the Department of Industry, Technology and Commerce, has announced the development of a complete set of software tools for the computer aided design of electronic subsystems from pcb to VLSI. This comes as a result of a section 39 Public Interest Contract involving the University of New South Wales and RMIT.

The software is substantially technology independent and targeted at companies requiring the

capacity to design electronic subsystems in pcb, hybrid, gate array, standard cell or hand crafted full custom. Included, is highly sophisticated simulation, automatic routing and capabilities for user generated circuit libraries.

The software is designed to be run on a range of workstations, from micro to mini-based hardware.

Commercial vendors are now being selected.

Enquiries can be directed to Di Martin or Trevor Andrews at Technisearch on (03) 660-5100.

## Moves at HCJB

Clayton Howard, who recently left HCJB Quito, Ecuador, after 22 years has returned for a stint of seven months on his old "DX Party Line" to allow current compere, John Beck, to return to the US. While in the US, Beck attended the Convention of the Association of North American Radio Clubs in Montreal.

HCJB's "DX Party Line" is heard 0930 UTC Monday, Wednesday and Saturday on 6130 kHz, 9745 kHz and 11925 kHz. A transmission to Europe at 2130 UTC on the

same days is heard on 15270 kHz and 17790 kHz.

Radio HCJB has extended its service to the South Pacific by 30 minutes and the English broadcast can now be heard 0700-1130 UTC. Voice of the Andes has likewise extended its time by 30 minutes with English broadcasts 1100-1130 UTC daily. The extra time includes programs "Music in the Night" hosted by HCJB staff member Brian Seeley, "Focus on the Family" with Dr James Dobson and "Insight for Living" with Charles Swindoll.

— Arthur Cushen

## KILOHERTZ COMMENT

**AUSTRIA:** Vienna is well received on two transmissions in English; a broadcast 0430-0500 UTC is carried on 9755 kHz while later, 0630-0700 UTC, a similar transmission is received on 9735 kHz.

**BELIZE:** Radio Belize is shortly to be joined by some high powered Voice of America transmitters, but in the meantime the local station continues to be heard on 3285 kHz. Sign on is at 1100 UTC, and the station closes 0600 UTC; it has been heard during the Winter at the latter time.

**CANADA:** This month sees the introduction of an agreement signed between Radio Canada International and Radio Japan for the leasing one hour each day of an RCI transmitter at Sackville. This transmitter will be used to relay Radio Japan broadcasts of English and Japanese, in order to give better reception in North America than the direct transmissions from Tokyo. The agreement is with the Japanese Foundation, a quasi-governmental cultural organization and will cost the Foundation 48 million yen.

**DUBAI:** The Voice of UAE, Radio Dubai, is using 9640 kHz for an English broadcast 0330-0400 UTC. This frequency replaces 11730 kHz; an additional channel of 11940 kHz carries the same program.

**FRENCH GUIANA:** An agreement between Radio France International and Radio Beijing to relay one another's broadcasts, continues to operate with relays of Radio Beijing from the Montsinery transmitter in French Guiana. Broadcasts in English are 0200-0300 UTC on 6015, 9635 kHz; 0300-0400 UTC on 11970, 11980, 15280, 15445 kHz; 0400-0500 UTC on 11980, 15280; 0500-0600 UTC on 9565 kHz.

**KOREA:** Radio Korea, Seoul is received with an English broadcast 0900-1000 UTC on 7275 kHz, while a further transmission 2030-2130 UTC is on 15575 kHz. This is only two of many English transmissions carried by the Korean Broadcasting System on short-wave.

**LITHUANIA:** Broadcasts of Radio Vilnius include an English one daily 2200-

The Gamma on hold.



## Microswede

Owen Hill, who 10 years ago was selling kit computers in Sydney for a living, has recently announced the creation of Microbee (UK) and Microbee AB of Sweden, to help distribute his computers in these markets.

The 'Bee is already a raging success in Scandinavia. Five thousand have been sold, half of them to schools, which gives Microbee a 30 per cent share of the Swedish educational market. Owen Hill has also been successful in the other Scandinavian countries and in Russia.

One of the best sales was to the University of Stockholm's Linguistic Department, which

has resulted in the development of programs for the 'Bee in 25 languages. This is a source Microbee intends to use to its advantage in other market areas.

According to Owen Hill, Microbee has big plans for attacking the European market. So it's important to have control over marketing operations.

Meanwhile, the release of the Gamma, Microbee's much vaunted successor to its traditional range of computers is still on hold. According to Jamieson Rowe of Microbee, there are a couple of prototypes in existence, but they are in the possession of software houses. Microbee is delaying the launch of the new computer until it can offer some software to go with it.

2230 UTC according to announcements on frequencies of 6100, 9640, 9665, 11790, 11895 and 13605 kHz. Reception has been possible on 9640 kHz and the new 13605 kHz during the English broadcast.

**SOUTH AFRICA:** Radio South Africa, Johannesburg is using the new frequency of 15270 kHz for the English transmission 0630-0730 UTC. The announcement indicates 5980, 7275 and 11900 kHz are also used, but in the South Pacific the best reception is on 11900 kHz and 15270 kHz.

**SWITZERLAND:** Berne has introduced a new transmission in English 0630-0700 UTC on 9870, 12030, 15430 kHz. There have been some frequency changes, including a new frequency 9885 kHz used 1830-1900 UTC, and 2100-2130 UTC for English programs. Other new channels in use are 11925 kHz 0200-0230 UTC; 11745 and 11905 kHz 0830-0900 UTC, 1000-1030 UTC; 15585 and 17830 kHz 1100-1130 UTC, 1330-1400 UTC.

**TAIWAN:** The Voice of Asia, Taipei on

7445 kHz is observed opening in English at 1100 UTC. The broadcast continues to 1200 UTC; the station announces another transmission 1530-1630 UTC.

**USSR:** Radio Tashkent broadcasts in English 1200-1230 UTC and 1330-1400 UTC on several new channels; the frequencies now carrying the broadcast are 7325, 9600, 9715, 11785 and 15460 kHz.

**YUGOSLAVIA:** Radio Yugoslavia, Belgrade is received with an English broadcast 2115-2130 UTC on 7240 kHz. This frequency provides the best reception, though a further channel 6100 kHz has also been noted with the same program.

This item was contributed by Arthur Cushen, 212 Earn St, Invercargill, New Zealand who would be pleased to supply additional information on medium and shortwave listening. All times quoted are UTC (GMT) which is 10 hours behind Australian Eastern Standard Time.



# Rod Irving Electronics has the range and the low prices!

**NEW!**



**HIGH INTENSITY RED LED DISPLAYS**  
**Overall Dimensions:**  
 12.7mm across, 19mm high.  
 Cat. Z110190  
 1-9 10+ 100+  
**\$1.95 \$1.75 \$1.50**

**HIGH INTENSITY RED LED BAR GRAPH**  
**Dimensions:**  
 Overall: 63mm across, 5mm high.  
 LEDs: 10 x 5mm x 1mm  
 Cat. Z110180  
 1-9 10+ 100+  
**\$2.95 \$2.75 \$2.50**



**10 TURN WIRE WOUND POTENTIOMETER**  
**Spectrol Model 534**  
 1/4" shaft.  
 Equiv (Bourns 3540S, Beckman 7256)  
 Dials to suit 16-1-11, 18-1-11, 21-1-11.  
 R14050 50R R14100 5K  
 R14055 100R R14110 10K  
 R14060 200R R14120 20K  
 R14070 500R R14130 50K  
 R14080 1K R14140 100K  
 R14090 2K  
 1-9 10+  
**\$13.50 \$12.50**



**SPECTROL 43P**  
 Equiv (Bourns 3006)  
 Essential for precision work  
 R14200 10R R14290 10K  
 R14210 20R R14300 20K  
 R14220 50R R14310 50K  
 R14230 100R R14320 100K  
 R14240 200R R14330 200K  
 R14250 500R R14340 500K  
 R14260 1K R14350 1M  
 R14270 2K R14360 2M  
 R14280 5K  
 1-9 10+  
**\$1.95 \$1.75**



**RCA GOLD PLATED PLUGS AND SOCKETS**  
 For those who need the ultimate in connection. Essential for laser disc players to get that fantastic sound quality.  
 Plug Cat. P10151 \$3.75  
 Socket Cat. P10150 \$2.95



**CANON TYPE CONNECTORS**  

Cat. No.	Description	Price
P10960	3 pin line male	Was \$3.90 <b>NOW \$2.70</b>
P10962	3 pin chassis male	Was \$3.00 <b>NOW \$2.10</b>
P10964	3 pin line female	Was \$4.50 <b>NOW \$2.95</b>
P10966	3 pin chassis female	Was \$4.95 <b>NOW \$3.15</b>



**BRAND NEW FANS**  
 Not noisy pullout! Stacks of uses in power amps, computers, hotspot cooling etc. Anywhere you need plenty of air.  
 240V 4 5/8" Cat. T12461 \$12.95  
 115V 4 5/8" Cat. T12463 \$12.95  
 240V 3 1/2" Cat. T12465 \$12.95  
 115V 3 1/2" Cat. T12467 \$12.95  
 10+ fans (mixed) only \$10 each!



**NICADSI**  

Size	Desc.	1-9	10+
AA	1.2 A.H.	\$1.95	\$1.85
C	1.2 A.H.	\$7.95	\$6.50
D	1.2 A.H.	\$7.95	\$6.50



**UNIVERSAL BATTERY CHARGER AND TESTER**  
 Save money on expensive batteries with this universal battery charger. Features include meter tester, and provisions for D, C, AA, AAA, Ni button and cell batteries, 5V and 6V (square types). Comes complete with detailed instructions.  
 Cat. M23533 \$27.95



**S100 PROTOCARDS**  
 Horizontal Buss Cat. H19125 \$59.50  
 Vertical Buss Cat. H19130 \$59.50  
 Pad per Hole Cat. H19135 \$59.50



**ELECTRET MIC INSERTS**  
 With pins for easy board insertion.  
 Cat. C10170  
 1+ 10+ 100+  
**\$1.25 \$1.10 \$1.00**



**JOINABLE PCB MOUNTING SCREW TERMINALS**  

Way	1-9	10+
2 Way	P10520 \$0.60	\$0.55
3 Way	P10521 \$0.85	\$0.75



**METEX 3800 MULTIMETER**  
**Features...**  
 • Push-button ON/OFF power switch.  
 • Single 30 position easy to use rotary switch for FUNCTION and RANGE selection.  
 • 1/2" high contrast LCD.  
 • Automatic over-range indication with the "1" displayed.  
 • Automatic polarity indication on DC ranges.  
 • All ranges fully protected plus Automatic "ZERO" of all ranges without short circuit except 200 ohm Range which shows "000 or 001".  
 • High Surge Voltage protection 1.5 KV-3 KV.  
 • Diode testing with 1 mA fixed current.  
 • Audible Continuity Test.  
 • Transistor hFE Test.  
**SPECIFICATIONS**  
 Maximum Display: 1999 counts  
 3 1/2 digit type with automatic polarity indication.  
 Indication Method: LCD display.  
 Measuring Method: Dual-slope in A-D converter system.  
 Over-range Indication: "1" Figure only in the display.  
 Temperature Ranges: Operating 0°C to +40°C  
 Power Supply: one 9 volt battery (006P or FC-1 type of equivalent)  
 Cat. Q91530 Normally \$99.95  
**SPECIAL \$89.95**



**METEX 3530 MULTIMETER**  
**Features...**  
 • Push-button ON/OFF power switch.  
 • Single 30 position easy to use rotary switch for FUNCTION and RANGE selection.  
 • 1/2" high contrast LCD.  
 • Automatic over-range indication with the "1" displayed.  
 • Automatic polarity indication on DC ranges.  
 • All ranges fully protected plus Automatic "ZERO" of all ranges without short circuit except 200 ohm Range which shows "000 or 001".  
 • High Surge Voltage protection 1.5 KV-3 KV.  
 • Capacitance measurements to 1pF.  
 • Diode testing with 1 mA fixed current.  
 • Audible Continuity Test.  
 • Transistor hFE Test.  
**SPECIFICATIONS**  
 Maximum Display: 1999 counts  
 3 1/2 digit type with automatic polarity indication.  
 Indication Method: LCD display.  
 Measuring Method: Dual-slope in A-D converter system.  
 Over-range Indication: "1" Figure only in the display.  
 Temperature Ranges: Operating 0°C to +40°C  
 Power Supply: one 9 volt battery (006P or FC-1 type of equivalent)  
 Cat. Q91540 Normally \$129  
**SPECIAL \$119**



**POT CORES**  
 FX2242 Assembly, 2 halves, 36mm diameter L12100 \$6.95  
 Former to suit FX2242 L12101 \$0.95  
 FX2243 Assembly, 2 halves, 24mm diameter L12110 \$7.95  
 Former to suit FX2243 L12111 \$1.00  
 E Core 2 halves L12115 \$6.95  
 Former to suit E Core L12116 \$3.95  
 Complete E Core assembly, (including end plates and bolts) L12117 \$12.95



**SPECTROL MULTIDIALS**  
 Model 16-1-11 (.9")  
 Cat. R14400 \$21.95  
 Model 18-1-11 (1" x 1.75" Rect.)  
 Cat. R14405 \$38.50  
 Model 21-1-11 (1.82")  
 Cat. R14410 \$37.50

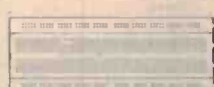

**BREADBOARDS**  

Cat. No.	Description	Price
P11000	100 Holes	\$ 2.75
P11005	640 Holes	\$10.75
P11007	640+100 Holes	\$14.95
P11009	640+200 Holes	\$17.50
P11010	1280+100 Holes	\$26.95
P11011	1280+300 Holes	\$32.50
P11012	1280+400 Holes	\$39.95
P11015	1920+500 Holes	\$59.95
P11018	2560+700 Holes	\$69.95



**RITRON 19" RACK CASE**  
 Tremendous Value Dimensions 48(W) x 134(H) x 250(D)mm  
 Cat. H10415 Normally \$47.95  
**SPECIAL, ONLY \$42.95**



**DIECAST BOXES**  
 Diecast boxes are excellent for RF shielding, and strength. Screws are provided with each box.  
 H11451 100 x 50 x 25mm \$ 5.95  
 H11452 110 x 60 x 30mm \$ 5.50  
 H11453 120 x 65 x 40mm \$ 6.95  
 H11461 120 x 94 x 53mm \$11.50  
 H11462 188 x 120 x 78mm \$13.50  
 H11464 188 x 188 x 64mm \$29.50



**SLOPING FRONT INSTRUMENT CASE**  
 Plastic with metal front panel, available in two sizes.  
 H10450 190 x 120mm \$12.95  
 H10455 265 x 185mm \$21.95  
 measurements are approximate only



**1uF 50V MONOLITHIC**  
 Cat. R16080  
 1-9 100+ 1000+  
**30c 25c 10c**

**XENON/STROBE TUBES**  
 As used in projects or as replacements  
 Cat. S14050 \$2.95



**SCOPE 60W SOLDERING SYSTEM**  
 • Infinitely adjustable temp. 200 C to 470 C. Sliding control selects desired tip temperature (LED readout monitors tip temp.)  
 • Safety holder features ceramic burn-proof bush and can be converted to left-hand-side.  
 • Soft and cool hand grip in pliable rubber.  
 • Screw type connector prevents accidental plug removal and guarantees solid contacts.  
 • Temperature lock allows production supervisors to control soldering temperatures.  
 • Anti setze tip retention design reduces risk of thread seizure by removing locking nut to cooler end of barrel.  
 • Optional 30W soldering pencil is available for finer work.  
 Cat. T12900 Normally \$159  
**NOW \$149**

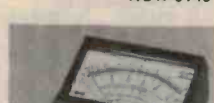

**ANALOGUE WORKHORSE KT370**  
**FEATURES:**  
 • Fuse and diode protection  
 • hFE measurements 0 - 1000 (by x 10 range)  
 • Mirror scale for more accurate reading  
**SPECIFICATIONS...**  
**RANGES:**  
 DC Voltage: 0 - 0.1, 0.5, 2.5, 10, 50, 250, 1000V (20k ohm/V)  
 AC Voltage: 0 - 10, 50, 250, 500V, 1000V (8k ohm/V)  
 DC Current: 0 - 0.05, (50uA), 2.5, 25, 250mA  
 Resistance: 0 - 2K, 20K, 2M, 20M ohm  
 Load Current: 0 - 150mA, 15mA, 150mA  
 Load Voltage: 0 - 3V  
 Volume Level: 10 - +22dB - +62dB  
 DC Current Amplification Factor (hFE) 0 - 1000  
**ACCURACY**  
 DC Voltage & Current: +/- 3% t.s.  
 AC Voltage: Within +/- 4% t.s.  
 Resistance: Within +/- 3% of arc.  
 Battery: 1.5V (um-3) 2pcs 9V (x250) tip.  
 Fuse: 0.5A, 50 x 20mm  
 Diode: 4148 x 2  
 C.C. .04uF 50V  
 Size: 147 x 99 x 57mm  
 "The same type as I have carried in my toolbox since I started in electronics 15 years ago." - Rod  
 Cat. Q11030 only \$34.95

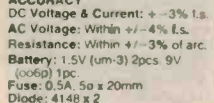

**10W HORN SPEAKERS**  
 White durable plastic, 8 ohms  
 Cat. C12010 Normally \$11.95  
**SPECIAL, ONLY \$9.95**



**10W HORN SPEAKERS**  
 White durable plastic, 8 ohms  
 Cat. C12010 Normally \$11.95  
**SPECIAL, ONLY \$9.95**

**XENON/STROBE TUBES**  
 As used in projects or as replacements  
 Cat. S14050 \$2.95



**DB CONNECTORS**  

Cat. No.	Description	Price
P10880	DE9P Male	\$1.95
P10881	DE9S Female	\$2.25
P10882	DE9C Cover	\$1.20
P10884	DE9P R.A. Plug	\$3.65
P10885	DE9S R.A. Skt	\$4.25
P10890	DA15P Male	\$2.10
P10891	DA15S Female	\$2.25
P10892	DA15C Cover	\$1.25
P10894	DA15P R.A. Plug	\$4.25
P10895	DA15S R.A. Skt	\$5.00
P10900	DB25P Male	\$2.75
P10901	DB25S Female	\$2.95
P10902	DB25C Cover	\$1.25
P10904	DB25P R.A. Plug	\$4.50
P10905	DB25S R.A. Skt	\$5.95



**EVERY DAY LOW PRICES!**  
**RELAYS**  

1-9	10+	100+
S.P.D.T. 3A connectors	\$1.30	\$1.10
D.P.D.T. 3A connectors	\$1.95	\$1.75
S.P.D.T. 12V Coil 10A 20V	\$14.14	\$14.14
	\$4.95	\$3.95

**TOGGLE SWITCHES**  

Cat.No.	Description	Price
S11010	SPDT econ mini	\$1.95
S11020	DPDT econ mini	\$1.95
S11025	C/OFF econ mini	\$2.25
S11030	DPDT C/OFF econ	\$2.50
S11034	4PDT mini	\$6.95
S11036	SPST std 125V 3A	\$1.75



**Rod Irving Electronics**  
 48 A Beckett St, MELBOURNE  
 Phone (03) 663 6151  
 425 High St, NORTHCOLE  
 Phone (03) 489 8866  
 Mail Order and Correspondence:  
 P.O. Box 620, CLAYTON 3168  
 Telex: AA 151938

**MAIL ORDER HOTLINE (03) 543 7877 (2 lines)**

**POSTAGE RATES:**  

\$1	\$8.99	\$2.00
\$10	\$24.99	\$3.00
\$25	\$49.99	\$4.00
\$50	\$99.99	\$5.00
\$100	\$199.99	\$7.50
\$200	\$499.99	\$10.00
\$500 plus		\$12.50

This is for basic postage only. Comet Road Freight, bulky and fragile items will be charged at different rates.  
 Certified Post for orders over \$100 included free!  
 Registered Post for orders over \$200 included free!

All sales tax exempt orders and wholesale inquiries to: RITRONICS WHOLESALE, 56 Renner Rd, Clayton, Ph. (03) 543 2166 (3 lines)

Errors and omissions excepted





# LATEST KITS!

## SOLDERING IRON TEMPERATURE CONTROL KIT

An important factor in good soldering technique is the correct choice of soldering temperature. If you have put off buying a temperature controlled soldering iron because they are so expensive, your problems are solved with this low cost soldering iron temperature controller kit. It provides fully regulated, adjustable temperature control over a reasonably wide range and will work with just about any conventional 240V soldering iron rated from 20W to 75W.

(ETI 1532, ETI Sept. '86)  
Cat. K55320 ..... \$24.95

## TELEPHONE APPLIANCE CONTROLLER

This clever project lets you dial your home number and switch a mains appliance on or off, without paying for the phone call. You can use it to turn on outside lights, a spa or an electric blanket.

(86i56, EA June '86)  
Cat. K86061 ..... \$54.95

## THE SCREACHER CAR BURGLAR ALARM

Here is a low cost car alarm designed with a new deterrent strategy. Instead of using the alarm to try to draw the attention of passers-by to the felony in progress, this alarm sounds inside the car, to deafen the thief and make it too uncomfortable to proceed with pinching the vehicle!

(86a19, EA August '86)  
Cat. K86081 ..... \$29.95

## FOUR CHANNEL MIXER

This four channel mixer project gives professional quality with impressive specifications.

**SPECIFICATIONS:**  
Max. input sensitivity - 50dB (2.5mV)  
Signal to noise ratio: -78dB relative to +4dB  
Distortion: 0.03% at +4dB, 2kHz  
Output impedance: 3k ohm nominal  
Output Impedance: 100 ohms  
Frequency Response: 10Hz to 30kHz (-1 dB)

(ETI1404, ETI July '85)  
Cat. K54040 ..... \$99

## RS232 FOR COMMODORE

A simple project to give your Commodore RS232 compatibility.

(ETI 1801, ETI July '86)  
Cat. K56010 ..... \$14.95

## LAMP SAVER

Does your house eat lamps? Does it seem that you are always having to replace expensive spotlights, ornamental lamps or bulbs in inaccessible places? The solution to these problems is the Lamp Saver which will greatly extend the life of any 240V AC incandescent lamp.

(86p5, EA June '86)  
Cat. K86062 ..... \$14.95

## PARAMETRIC EQUALISER

Does your music system want a few frequency response? Does your guitar or keyboard need some equalisation to brighten the sound? Well, here is a module which can be used by itself on individual instruments or ganged to equalise your music system.

(ETI 1406, ETI August '86)  
Cat. K54060 ..... \$16.50

## TURBO ENGINE COOL-DOWN TIMER KIT

Got one of those new turbocharged cars? If so, you need this project. When the ignition is switched off, it keeps the engine running for approximately 90 seconds to stop the turbocharger from over heating. A temperature sensor ensures that the circuit operates only when the engine reaches a preset temperature.

(86au7, EA September '86)  
Cat. K86091 ..... \$29.95

## RITRON MULTI PURPOSE MODEM KIT

The RITRON Multi Purpose Modem has all the features you require...

- CCITT V21 300 Baud Full duplex
- CCITT V23 1200/75
- Bell 103 300 Full duplex
- Bell 202 1200 Half duplex
- Auto answer, auto disconnect.

Telecom Approval No. C84/37/1134  
Cat. K90010 ..... only \$249

## DIGITAL SAMPLER KIT

Digital sampling is at the core of many of the special sound effects used by modern musicians. A trigger input (usually a construction drum pad) triggers a prerecorded sound from the digital sampler. This sound has been recorded into the 4k of onboard memory and can be digitally manipulated so that it sounds completely different on playback. The unit has controls for gain, regeneration and mixing. It also gives a choice of a number of different triggering methods.

(ETI 1402 May, June, July '86)  
Cat. K41420

Please phone for price and availability

## BIT PATTERN GENERATOR KIT

In applications where you are required to look for a particular byte of information in a serial or parallel data path, short of a logic analyser or a storage oscilloscope, there is not a lot to help you. However, this Bit Pattern Generator gives you a simple and economical way to detect and display specific bytes of data. It may be used on both parallel and serial data paths.

(ETI 172, May '86)  
Cat. K41720 (Serial/Parallel Kit)

Please phone for price



## FUNCTION GENERATOR

This Function Generator with digital readout produces Sine, Triangle and Square waves over a frequency range from below 20Hz to above 160kHz with low distortion and good envelope stability. It has an inbuilt four-digit frequency counter for ease and accuracy of frequency setting.

(EA April '82, 82A03A/B)  
Note: The RIE Function Generator has a high quality screen printed and prepunched front panel!  
Cat. K82040 ..... \$109



## RADIOTELETYPE CONVERTER FOR THE MICROBEE

Have your computer print the latest news from the international shortwave news service. Just hook up this project between your short wave receivers audio output and the MicroBee parallel port. A simple bit of software does the decoding. Can be hooked up to other computers too.

(ETI Apr. '83)  
Cat. K47330 ..... \$19.95



## ELECTRIC FENCE

Mains or battery powered, this electric fence controller is both inexpensive and versatile. Based on an automatic ignition coil, it should prove an adequate deterrent to all manner of livestock. Additionally, its operation conforms to the relevant clauses of Australian Std 3129.

(EA Sept. '82) 82EF9  
Cat. K82092 ..... Normally \$19.95  
SPECIAL, ONLY \$14.95



## TRANSISTOR TESTER

Have you ever desoldered a suspect transistor, only to find that it checks OK? Trouble-shooting exercises are often hindered by this type of false alarm, but many of them could be avoided with an "in-circuit" component tester, such as the EA Handy Tester.

(EA Sept. '83) 83TTR8  
Cat. K83080 ..... Normally \$18.95  
SPECIAL, ONLY \$14.95

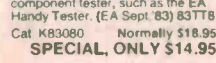

## PLAYMASTER 300 WATT AMPLIFIER

This module will deliver up to 200 watts into an 8 ohm load and up to 300 watts into a 4 ohm load. Comprehensive protection is included and a printer circuit board brings it all together in a rugged easy-to-build module. It can be built in either fully-complementary or quasi-complementary versions, so output transistor shortages should be no problem at all.

(80PA6) (EA July '80)  
Cat. K80060 ..... Normally \$109  
SPECIAL, ONLY \$99

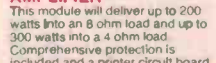

## PHONE MINDER

Dubbed the Phone Minder, this handy gadget functions as both a bell extender and paging unit, or it can perform either function separately.

(EA Feb. '84) 84TP2  
Cat. K84021 ..... \$27.50

## 15V DUAL POWER SUPPLY

This simple project is suitable for most projects requiring a dual voltage.

(ETI 581, June '76)  
Cat. K45810 ..... \$27.50



## HUMIDITY METER

This project can be built to give a readout of relative humidity either on a LED dot-mode display or a conventional meter. In addition it can be used with another project as a controller to turn on and off a water mist spray in a hothouse, for example.

(ETI May '81) ETI-258 (Includes humidity sensor \$19.50)  
Cat. K42560 ..... \$39.50



## MUSICOLOR IV

Add excitement to parties, card nights and discos with EAs Musicolor IV light show. This is the latest in the famous line of musicolors and it offers features such as four channel "color organ" plus four channel light chaser, front panel LED display, internal microphone, single sensitivity control plus opto-coupled switching for increased safety.

(EA Aug '81) 81MCS  
Cat. K81080 ..... \$99



## VIDEO FADER CIRCUIT

Add a touch of professionalism to your video movies with this simple Video Fader Circuit. It enables you to fade a scene to black (and back again) without loss of picture lock (sync) or colour.

(EA Jan '86, 85F10)  
Cat. K86010 ..... \$19.95



## AUDIO TEST UNIT

Just about everyone these days who has a stereo system also has a good cassette deck, but not many people are able to get the best performance from it. Our Audio Test Unit allows you to set your cassette recorder's bias for optimum frequency response for a given tape or alternatively, it allows you to find out which tape is best for your recorder.

(81A10) (EA Oct '81)  
Cat. K81101 ..... \$59.50

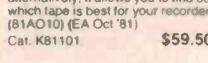

## FREQUENCY STANDARD

Get the equivalent of a rubidium frequency standard by draping a piece of wire over the back of your TV set! Believe it or not your humble television can provide an extremely stable and accurate reference frequency. The wire acts as a transducer to pick up electromagnetic radiation from the back of the set.

Normally you would need to spend thousands of dollars to achieve accuracy beyond the "parts per thousand" you expect from ordinary meters. With this simple project, an extremely accurate 1MHz signal can be derived for very little outlay.

(ETI 174, July '86)  
Cat. K41740 ..... \$24.95

## MULTI SECTOR ALARM STATION

Protect your home and possessions from burglars with this up to the minute burglar alarm system. It's easy to build, costs less than equivalent commercial units, and features eight separate inputs, individual sector control, battery back up and self-test facility.

**Specifications:**

- Eight sectors with LED status indication.
- Two delayed entry sectors.
- Variable exit, entry and alarm time settings: entry delay variable between 10 and 75 seconds; exit delay variable between 5 and 45 seconds; alarm time variable between 1 and 15 minutes.
- Resistive loop sensing: suits both normally open and normally closed alarm sensors.
- Battery back-up with in-built charge circuit.
- Built-in siren driver.

The RIE kit includes a superb printed and prepunched metal case and inside metal work, plus a gel battery! Unbeatable VALUE!

Cat. K85900 ..... Normally \$129  
SPECIAL, \$119

## LISTENING POST

This device attaches between the audio output of a shortwave receiver and the input port of a computer. It allows decoding and printing out of Morse code, radioteletype (RTTY) and facsimile (FAX) pictures using the computer. It has been designed from all readily available parts. Details for writing the software program are included.

(AEM 3500, July '85)  
Cat. K93015 ..... \$37.95

## AEM DUAL SPEED MODEM

The ultimate kit modem featuring 1200/300 baud, case etc. Exceptional value for money!

(AEM 4600 Dec '85)  
Cat. K46000 ..... \$169



## 30 V/1 A FULLY PROTECTED POWER SUPPLY

The last power supply we did was the phenomenally popular ETI-131. This low cost supply features full protection, output variation from 0V to 30V and selectable current limit. Both voltage and current metering is provided.

(ETI Dec. '83) ETI 162  
Cat. K41620 ..... Normally \$59.50  
SPECIAL, \$44.50

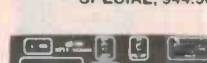

## COMPUTER DRIVEN RADIO-TELETYPE TRANSCIVER

Here's what you've been asking for, a full transmit-receive system for computer driven radio teletype station. The software provides all the latest "whizz-bangs" like split-screen operation, automatically repeating test message, printer output and more. The hardware uses tried and proven techniques. While designed to team with the popular Microbee, tips are available on interfacing the unit to other computers.

(ETI Nov. '84) ETI 755  
Cat. K47550 ..... \$139

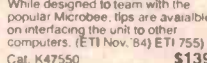

## CRYSTAL CONTROLLED TV PATTERN GENERATOR

Anyone wishing to obtain the maximum performance from colour TV receiver needs a pattern generator. Why not build this superb unit which provides five separate patterns: dot, crosshatch, checkerboard, grey scale and white raster?

Note: The RIE kit includes a large ABS type case!

(80pp6, EA June '80)  
Cat. K80033 ..... Normally \$67.50  
SPECIAL, \$62.50



## DIGITAL CAPACITANCE METER Mk.2

Updated from the EA March '80 issue, this Digital Capacitance Meter checks capacitor values from 1pF to 99.99uF over three ranges. Its main features include a nulling circuit and a bright 4 digit LED display.

\*Note: The RIE kit contains quality silk screen printed and prepunched front panel AND an exclusive High Intensity Display! (80cm3a, EA August '85)  
Cat. K80030 ..... \$69.50



## DELUXE CAR BURGLAR ALARM

Stop your car from being one of the 70,000 + stolen cars stolen each year with this "state of the art" car burglar alarm. Features include key switch operation, delayed entry and exit, automatic reset, and provision for an auxiliary battery. Further more, of the 10 most important features listed by NRMA, this EA Deluxe Car Alarm has 9 of them!

(84ba5, EA May '84)  
Cat. K84050 ..... \$79.50

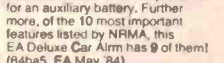

## SPEAKER PROTECTION UNIT

An expensive speaker system can be readily destroyed by a 20 watt amplifier. Carelessness with a high power amplifier can melt voice coils like cheese on toast. However, with this Speaker Protection Unit you can avoid risking the misery and expense.

(ETI455...)  
Cat. K44550 ..... \$44.95

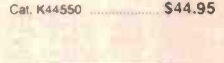

## PRINTED CIRCUIT BOARDS

ETI 044	\$2.95
ETI 163	\$7.95
ETI 164	\$2.95
ETI 183	\$6.95
ETI 256	\$2.95
ETI 268	\$1.95
ETI 278	\$3.95
ETI 324	\$4.95
ETI 412	\$3.95
ETI 449	\$2.00
ETI 453	\$2.95
ETI 455	\$3.95
ETI 458	\$6.95
ETI 464	\$3.95
ETI 466	\$9.95
ETI 477	\$9.95
ETI 4785A	\$2.95
ETI 4785B	\$1.95
ETI 4785C	\$1.95
ETI 4785D	\$1.95
ETI 480	\$2.95
ETI 494	\$3.95
ETI 496	\$5.95
ETI 499	\$7.95
ETI 581	\$3.95
ETI 666	\$3.95
ETI 668	\$4.95
ETI 672	\$2.95
ETI 688A	\$4.95
ETI 688B	\$2.95
ETI 699	\$8.95
ETI 724	\$2.95
ETI 733	\$5.95
ETI 736A	\$3.95
ETI 736B	\$3.95
ETI 755A	\$8.95
ETI 755B	\$2.95
ETI 755C	\$2.95
80pa8	\$15.95
80pp6	\$7.95
80bm10	\$3.95
82ps2	\$6.95
82eg2	\$2.95
82vc3	\$4.95
82pa7	\$11.95
82pc10	\$3.95
83ma11	\$5.95
84au1	\$2.95
84ma11	\$2.95
85ef11	\$7.95
AEM 4600	\$21.95



**12 months warranty!**

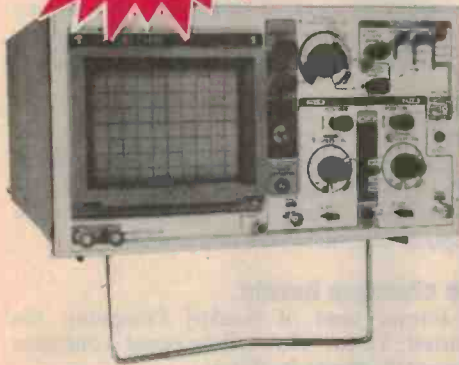

## HUNG CHANG (RITRON) 20 MHz DUAL TRACE OSCILLOSCOPE

- Wide bandwidth and high sensitivity
- Internal graticule rectangular bright CRT
- Built in component tester
- Front panel trace rotator
- TV video sync filter
- Z axis (Intensity modulation)
- High sensitivity X-Y mode
- Very low power consumption
- Regulated power supply circuit

COMPONENT TESTER is the special circuit with which a single component or components in circuit can be easily tested. The display shows faults of components, size of a component value, and characteristics of components. This feature is ideal to troubleshoot solid state circuits and components with no circuit power. Testing signal (AC Max 2 mA) is supplied from the COMPONENT TEST IN terminal and the result of the test is fed back to the scope through the same test lead wire at the same time.

### CRT

CRT: 6" (150mm) Flat-faced high brightness CRT with Internal Graticule.  
Effective display area: 8 x 10 div (1 div = 10 mm)  
Acceleration potential: 2KV

### VERTICAL

Operating Modes: CH-A, CH-B, DUAL, ADD (CH-B can be inverted.)  
Dual modes: Alter; 0.2u/s - 0.5ms/div. Chop; 1ms - 0.5s/div.  
CHOP frequency 200kHz approximately.  
Deflection factor: 5mV/div 20V/div +/- 3%, 12 ranges in 1-2-5 step with fine control.  
Bandwidth: DC; DC - 20MHz (-3dB), AC; 10Hz - 20MHz (-3dB).  
Rise Time: Less than 17ns  
Overshoot: Less than 3%  
Input Impedance: 1M ohm +/- 5%, 20pF +/- 3pF  
Maximum Input Voltages: 800Vp or 300V (DC+AC Peak)  
Channel Isolation: Better than 60 dB at 1kHz.

### HORIZONTAL

Sweep Modes: NORMAL and AUTO  
Time Base: 0.2u/s - 0.5s/div +/- 3%, 20 ranges in 1-2-5 step with fine control.  
Sweep Magnifier: 5 times (5X MAG).  
Linearity: 3%

### TRIGGERING

Sensitivity: INTERNAL 1 div or better for 20Hz - 20MHz (Triggerable to more than 30MHz); EXTERNAL: 1Vp-p or better for DC - 20MHz (Triggerable to more than 30MHz).  
Source: INT, CH-A, CH-B, LINE and EXT.  
Slope: Positive and Negative, continuously variable with level control PULL AUTO for free-run.  
Coupling: AC, HF, REJ and TV. TV SYNC Vertical and Horizontal Sync Separator Circuitry allows any portion of complex TV video waveform to be synchronized and expanded for viewing TV-H (Line) and TV-V (Frame) are switched automatically by SWEEP TIME/DIV switch.  
TV-V: 0.5s/div to 0.1ms/div. TV-H: 50u/s/div to 0.2u/s/div.

### X-Y OPERATIONS

X-Y Operations: CH-A; Y axis, CH-B; X axis Highest Sensitivity: 5mV/div.  
COMPONENT TESTER  
Component Tester: Max AC 9V at the terminal with no load. Max current 2mA when the terminal is shorted. (Internal resistance is 4.7k Ohm)

### OTHER SPECIFICATIONS

Intensity Modulation: TTL LEVEL (3Vp-p). Positive brighter  
BANDWIDTH: DC - 1MHz MAXIMUM INPUT VOLTAGE: 50V (DC+AC Peak)  
Calibration Voltage: 0.5Vp-p +/- 5%, 1kHz +/- 5%, Square wave.  
Trace Rotation: Electrically adjustable on the front panel.  
Power Requirements: AC; 100, 120, 220, 240V 20W  
Weight: 7kg approximately  
Size: 162(H) x 294(W) x 352(D)mm.

Cat. Q12105 ..... only \$849  
(tax exempt only \$695)

Bulk orders, schools, please phone (03) 543 2166 for special low pricing

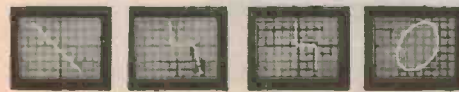

**SAVE \$10!**



### DIGITAL SPEEDO/DIGITAL TACHO/SPEED ALERT

- Digital readout (LED) for both tachometer and speed.
- Alarm with sound at variable preset speed.
- Audible beeper and visual indicator.
- In built light indicator for night illumination.
- Designed for 12 volt negative earth electrical systems.
- Speeds: 0 - 199kph
- Tachometer: 0 - 9900kph
- Speed alert: 40 - 120kph
- Complete with mounting hardware.

Cat. A15064 Normally \$69.50  
**SPECIAL ONLY \$59.50**



### CODE KEY PAD

- Telephone type digital keypad.
- Four digit, changeable code.
- Over 5000 possible combinations.
- Power consumption: 5mA standby, 50mA alarm.
- Two sector LED and 1 arm LED.
- Wrong number lockout.
- 12V DC operation.
- Relay output
- Panic button.
- Normally open tamper switch
- Dimensions: 145 x 100 x 37mm
- ACP3 compatible.

Cat. A113014 Normally \$69.50  
**SPECIAL ONLY \$55.60**

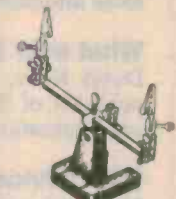

### PC BOARD HOLDER

Better than an extra pair of hands! A must for all PCB work.  
Cat. T12444 ..... \$9.95



### DPM-200 PANEL METER

- Ultra Low Power
  - Separately Addressable Annunciator
  - 15mm Digits
  - Bandgap Reference
- A low profile LCD DPM with a range of useful symbols as shown. The DPM 200 features 15mm 3 1/2 digit display, and ultra low current consumption and a bandgap reference for high stability. It also features Auto-zero, Auto-polarity, 200mV f.s.d. It may be used in single-ended, differential or ratiometric modes. The f.s.d can be easily changed by the user to indicate any other units. The decimal points and symbols can all be driven from an internal source. Wide supply and symbols can all be driven from an internal source. Wide supply rail (5-15V DC) with a variable threshold low battery warning indicator. Supplied with mounting clips and comprehensive data sheet.

**SPECIFICATIONS:**  
Accuracy: 0.1% +/- 1 digit  
Linearity: +/- 1 digit  
Samples/sec: 3  
Temp. Stability: 50 ppm typical  
Temp. Range: 0 - 50°C  
Supply Voltage: 5 - 15V DC  
Supply Current: 50uA typical  
Max DC Input Volts: +/- 20V  
Cat. Q15510 ..... \$99.95



**NEW!**

### ARGUS 726 ADJUSTABLE MAGNIFIER WITH LAMP

- Absolutely perfect for close up work! Intricate PCB's, projects, etc., will be a breeze under this superb, adjustable magnifying lamp.
- Magnifies 1.75 times
  - 40 watt incandescent lamp
  - 2 spring-balanced arms, extendable to 95cm
  - Adjustable head for optimum viewing angle.
  - Comes with desk clamp. (Interchangeable with base)
  - Fantastic Value!

Cat. ..... Our price \$89

### CRAZY SPECIAL!

### CRYSTALS SPECIALS

We simply have too many of these prime spec. crystals in stock!

Description	Cat.No.	1-9	10+
1MHz	Y11000	\$6.00	\$5.20
1.8432MHz	Y11003	\$6.00	\$5.20
4MHz	Y11020	\$2.00	\$1.60
4.194304MHz	Y11022	\$2.00	\$1.60
4.433618MHz	Y11023	\$2.00	\$1.60
4.75MHz	Y11025	\$2.00	\$1.60
4.915200MHz	Y11026	\$2.00	\$1.60
5MHz	Y11030	\$2.00	\$1.60
6MHz	Y11040	\$2.00	\$1.60
6.144MHz	Y11042	\$2.00	\$1.60
6.670MHz	Y11045	\$2.00	\$1.60
8MHz	Y11050	\$2.00	\$1.60
8.867238MHz	Y11055	\$2.00	\$1.60
10MHz	Y11060	\$2.00	\$1.60
12MHz	Y11070	\$2.00	\$1.60
14.31818MHz	Y11072	\$2.00	\$1.60
15MHz	Y11075	\$2.00	\$1.60
18MHz	Y11082	\$2.00	\$1.60
18.432MHz	Y11085	\$2.00	\$1.60
20MHz	Y11090	\$2.00	\$1.60



### ECONOMY TRANSFORMERS

2155 240V 6-15V 1A	1-9	10+
Cat. M12155	\$9.95	\$8.95
2156 240V 6-15V 2A		
Cat. M12156	\$14.95	\$13.95
2840 240V 9V CT		
Cat. M12840	\$6.95	\$5.95
2851 240V 12-6V CT 150mA		
Cat. M12851	\$5.95	\$5.50
2860 240V 15V CT 250mA		
Cat. M12860	\$5.95	\$4.95
6672 240V 15-30V 1A (tapped)		
Cat. M16672	\$14.95	\$13.95



### "SNAP TOGETHER" PLASTIC CABINET

Top and bottom simply snap together (no screws required), removable front and back panels. Dimensions 186(W) x 125(D) x 50(H)mm  
Cat. H10116 ..... \$6.95

### STANDARD DESOLDING PUMP

Light weight, powerful suction teflon tip. Replacement tips teflon and ceramic. Length 195mm.  
Cat. T11241 \$16.95, Now \$14.95

### MINI DESOLDERING PUMP

Light weight, powerful suction, teflon tip. Replacement tips teflon and ceramic. Length 165mm.  
Cat. T11251 \$15.95, Now \$13.95

### DELUXE DESOLDERING PUMP

Light weight, non conductive powerful suction, ceramic long life tip. One of the best in the business. Length 210mm, replacement tip HT3C ceramic.  
Cat. T11261 \$22.95, Now \$19.95



### PUSH BUTTON DIALLERS

Tired of old fashion dialling and re-dialling engaged numbers? These convenient push button diallers include last number redial (up to 16 digits) and instructions for an easy changeover.  
Cat. A12030 ..... NORMALLY \$19.95  
**SPECIAL, ONLY \$14.95**



**VALUE!**

### RECHARGEABLE 12V GELL BATTERIES

Leakproof and in 3 convenient sizes, these long service life batteries are ideal for burglar systems, emergency lighting or as a computer backup power supply. Ideal for many power needs.  
Cat. S15029 12V 1.2 AH \$17.50  
Cat. S15031 12V 2.6 AH \$32.50  
Cat. S15033 12V 4.5 AH \$39.50

### CORDLESS RECHARGEABLE SOLDERING IRON

- Built in solder point illumination
- Easy replacement of solder tip
- Protective stand which also functions as charging unit
- Sponge pad attach to stand
- Plug pack power adaptor
- Includes Nicad battery
- Instruction manual
- 12 months warranty

Cat. T12480 ..... Normally \$69.95  
**SPECIAL, \$59.95**



### ARLEC SUPER TOOL

- A versatile 12V electric tool for...
- Sanding
  - Engraving
  - Grinding
  - Polishing
  - Cutting
  - Drilling
  - Milling
  - Erasing, etc.

**Features:**  
Operates on safe, low 12 volts from mains electricity via AC adaptor (supplied). Light and easy to handle with touch switch and lock for continuous running. High torque motor, 10,000 R.P.M. Can drill 2mm holes in steel. 2 year guarantee.

**Contents:**  
● 12V Super Tool  
● Plugpack AC adaptor  
● 1 spherical milling cutter  
● 1 wire brush  
● 1 grinding wheel  
● 4 drill bits, 0.6, 0.8, 1.0, 1.2mm  
● Set of 5 chuck collets  
● 6 eraser sticks  
● Instruction sheets  
Cat. T12300 ..... \$49.95



### HOOK UP WIRE

Cat. No. Description  
W11251 13/12 TND BLK  
W11252 13/12 TLD BROWN  
W11253 13/12 TLD ORANGE  
W11254 13/12 TLD YELLOW  
W11255 13/12 TLD GREEN  
W11256 13/12 TLD BLUE  
W11257 13/12 TLD WHITE  
PRICES PER 100 METRE ROLL

1-9	10+
\$5.95	\$5.00

W11260 14/20 RED	1-9	10+
W11261 14/20 BLACK	\$12.00	\$10.00
W11265 14/20 BLUE		
W11268 14/20 WHITE		
PRICES PER 100 METRE ROLL		
1-9	10+	
\$12.00	\$10.00	

W11270 24/20 RED	1-9	10+
W11272 24/20 BLACK	\$14.00	\$12.00
W11274 24/20 GREEN		
PRICES PER 100 METRE ROLL		
1-9	10+	
\$14.00	\$12.00	

W11280 32/2 BROWN	1-9	10+
W11282 32/2 BLUE	\$20.00	\$18.00
PRICES PER 100 METRE ROLL		
1-9	10+	
\$20.00	\$18.00	



### FREE STANDING, FOLD UP MAGNIFIER

An economically priced "hands free" magnifier, lets you take care of all those tricky fine detailed jobs so often encountered in electronics, or any of many other practical uses such as home, work, hobbies etc.  
Cat. T12083 ..... \$14.95



### OMNI-DIRECTIONAL WIRELESS MICROPHONE

Tuneable: 92 - 104MHz  
Freq. Responses: 50 - 15kHz  
Range: Over 300 feet in open field.  
Modulation: FM  
Power Source: 9V Battery  
Type: Electrical Condenser.  
Dimensions: 185 x 27 x 38mm  
Weight: 160 grams  
Cat. A10450 ..... \$19.95

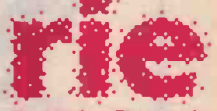

### Rod Irving Electronics

48 A Becken St, MELBOURNE  
Phone (03) 663 6151  
425 High St, NORTHCOLE  
Phone (03) 489 8866  
Mail Order and Correspondence:  
P.O. Box 620, CLAYTON 3168  
Telex: AA 151938



### MAIL ORDER HOTLINE (03) 543 7877 (2 lines)

**POSTAGE RATES:**

\$1 - \$9.99	\$2.00
\$10 - \$24.99	\$3.00
\$25 - \$49.99	\$4.00
\$50 - \$99.99	\$5.00
\$100 - \$199	\$7.50
\$200 - \$499	\$10.00
\$500 plus	\$12.50

This is for basic postage only. Comet Road Freight, bulky and fragile items will be charged at different rates.

Certified Post for orders over \$100 included free!  
Registered Post for orders over \$200 included free!

All sales tax exempt orders and wholesale inquiries to:  
RITRONICS WHOLESALER,  
56 Renver Rd, Clayton,  
Ph. (03) 543 2166 (3 lines)

Errors and omissions excepted

\*Apple and IBM are registered trade names





**PROLOGUE** Microphones From

**SHURE**®



Prologue 16L-LC



Prologue 14L-LC  
Prologue 14H-LC



Prologue 12L-LC  
Prologue 12H-LC



Prologue 10L-LC  
Prologue 10H-LC



Prologue 8L



Prologue 10L/LC  
R/R \$85

## MICROPHONE OF THE MONTH

**Inexpensive  
Quality Microphones  
From Shure Ideally Suited  
For The Home Recordist**

### PROLOGUE 10

The slim, probe shape of the Prologue 10 is intended to give the unit a low profile when hand-held or stand-mounted in both vocal and instrumental applications. It is an excellent choice for podium use also. It is available as either a high-impedance (10H-LC) or low-impedance (10L-LC) model. Frequency response is 80 to 10,000Hz.

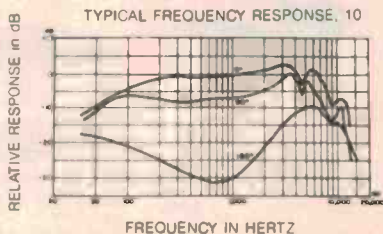

**SHURE**

**AUDIO ENGINEERS PTY LTD**  
342 Kent Street, Sydney, NSW 2000  
Ph: (02) 29-6731

**AUDIO ENGINEERS (QLD)**  
Cnr. Jane & Buchanan Streets,  
West End, Qld. 4101  
Ph: (07) 44-8947

**MARKETEC PTY. LTD.**  
51 Scarborough Beach Road,  
North Perth, WA. 6000  
Ph: (09) 042-1119

## BRIEFS

### Rod Irving CRO contest

The oscilloscope contest run in ETI by Rod Irving has been won by Robert Ayton of Keilor East in Victoria. The draw was made by David McDonald of RIE and Jon Fairall of ETI.

### Light highway

Route selection has begun for the fibre link between Perth and Adelaide. The link is scheduled for completion in 1992 at a cost of \$300 million. It will give Australia one of the most extensive optical fibre networks in the world.

### Amtron Tyree changes hands

Dieter Monch, former head of Nixdorf Computer, has bought out Amtron Tyree, the Sydney-based connector manufacturer previously owned by Tytel.

### Optical moves

Laserex has acquired Quentron, the Adelaide electro optical manufacturer. The move will make Laserex one of the most formidable electro optical companies in Australia.

### Scientific Devices

Castle Associates of the UK, which manufactures sound level and vibration meters has appointed Scientific Devices of Melbourne its Australasian agent. Call (03)579-3622 for more information.

### What ever happened to . . .

David Kelly, former editor of ETI, has been appointed publisher of the Technical and Industrial Group for Thomson Publications Australia.

### CAD advice

Marconi has appointed Christian Pior as Sales Engineer for its CAD systems, at the same time, appointing RCS design in Melbourne as a representative.

### Penn Central gets new distributorship

Vitronics' in-line reflow solder systems are now being represented in Australia and New Zealand by Penn Central. Penn Central is on (02)648-1661.

### Labtam on the move

Labtam Ltd has established a Victorian branch office at 46 Burwood Rd, Hawthorne in Melbourne, (03)819-4200. The Sydney office has also moved, to 31 Albert St, Chatswood, (02)411-2588.

### HP board test

Hewlett Packard has set up a board test facility in the Sydney suburb of Rosebery. It is designed for use by small companies that can't justify the expense of their own board test facility. The head of technical staff at the new plant is Heiko Weber. Manager is Greg Kershaw.

### Corvus Transporter drops in price

Horizon Technology has announced that the Corvus Network Transporter advertised in the July issue of ETI is now selling for less than \$600, down from \$900. This makes it one of the cheapest LAN packages around. Phone Horizon on (03)662-1611.

### NOTES & ERRATA

Project 687, VZ200 modification, July '86: Pin nos 4 and 5 of IC1 were transposed. They should be as outlined below.



## The research bounty

The inaugural members of the Federal Government's Industry Research and Development Board were announced recently. They will administer the new Grants for Industry Research and Development (GIRD) scheme.

The member's include Bill Krickler who was appointed Chairman, Elizabeth Bryan from the Australian Industry Development Corporation, John Eady from Comalco, Bruce Holloway from Monash University and David Solomon from the CSIRO.

GIRD replaces the Australian Industrial Research and Development Incentives Scheme (AIRDIS) and will operate for five years from 1 July 1986. It is designed to complement the 150% tax concession introduced last June as a support for local R&D but which the Government considered did not adequately cover "smaller, start-up, innovative companies without enough profits to take advantage of the tax concession".

The principal elements of the GIRD scheme are three: a grant of up to 50% of eligible R&D expenditure (between \$20,000 and \$50,000) conducted in-house; a generic technology grant to cover emerging technologies such as biotechnology, which are judged to have future significance for Australia's competitiveness; and national interest agreements for projects of significant interest (such as the bionic ear).

The 150% tax deduction, on the other hand, applies to companies which spend \$50,000 or more in the year of income claimed on R&D activities. The concessions do not apply to individuals, partnerships or trusts. (Deductions of 100% to 150% are available at a phased-in rate to companies whose expenditure on R&D lies between \$20,000 and \$50,000.)

Approved research and development for the purposes of the concession is that which would lead to normally commercial products, processes or services

in the areas of industrial design, engineering design, production engineering, operations research, mathematical modelling and analysis, psychological research and computer software development. The sorts of current expenses deductible are labour costs directly incurred in R&D activities as well as payments to contractors for facilities. Expenses ineligible for deduction include production and marketing costs. Capital expenditure on plant and equipment used exclusively for R&D (including up to \$10 million on a unit of pilot plant) is deductible at a rate of 150% over three years in three equal amounts. Extensions, alterations or new buildings with the same proviso of exclusive R&D use, are deductible at the rate of 100% over three years in equal amounts. The R&D work must be carried out in Australia.

Companies claiming the concession must register with the Industry Research and Development Board providing a descrip-

tion of past and present R&D activities, staffing, facilities, sources of funds. The IR&DB does a preliminary screening, basically to ensure registrations are formally in order and it is then up to the Taxation Office to interpret the legislation and decide on claims. The Taxation Office will refer to the IR&DB if unsure of the research nature of a company's claimed expenditure and is bound by the decision of the IR&DB.

Since the tax concession became law last June (retrospective to 30 June 1985) and as we go to press, only about 1200 registrations have been lodged with the board. But the annual cost to the government to promote private industry R&D through the GIRD scheme and the 150 tax deduction is projected at upwards of \$150m.

Enquiries about these incentive schemes should be directed to regional offices of The Department of Industry, Technology and Commerce or the Australian Taxation Office.

## Plastic gun detector

Things never stand still in the arcane world of terrorism and counter terror. Philips has just released news of an X-ray machine being installed in custom stands and airports around the country that will detect plastic.

The move has become necessary after customs officials began worrying about the inability of current X-ray equipment

to detect the new generation firearms, which often have plastic components. Since the X-ray only picks up the metal, the characteristic gun shape is lost, and consequently the terrorist is able to evade the security system.

According to Philips, the device will even show the outline of toy guns.



## Mica on a high

Mica Computers of Canberra is now making its way profitably, having ended a four-year development period, Managing Director Graham Cole announced recently.

The former software-development company was given seed funding by the Canberra Development Board in 1982 to estab-

lish a manufacturing and research facility for IBM-compatible computer terminals. Later, with further development funding from the Australian Industry Development Corporation, these were enhanced to become multi-function workstations.

Mica is now making local area network products and special

communications boards for IBM-PCs in addition to terminals.

According to Cole, recent big successes are subcontracting through Digital Equipment Corp in the Department of Aviation's multimillion dollar contract for its national network; delivery to Telecom of more than a dozen eight- and nine-workstation MicaLANs with cluster-controllers; and winning a place on the Govern-

ment Panel Period Contract for computing equipment.

"We have delivered 29 systems to Aviation on time and there are about another 30 systems to go. We now have our LANs installed for Telecom in NSW, Victoria, South Australia and Western Australia and we have another four to deliver over the next month or so." For more information contact Mica Components on (062)80-4509.



## COMING EVENTS

### OCTOBER

**Pacex**, an international process and control exhibition will be held 21-23 October in Melbourne. Contact Thomson Exhibitions, 47 Chippen St, Chippendale, NSW 2008. (02) 699-2411.

**Professional Engineers Week '86** will be held 4 to 12 October with variously located public meetings and displays. Contact Kelvin Lillingstone-Hall on (03) 606-7559.

Conventions on **Engineering Education** will be held 6 to 7 October nationally. Contact Barry Hewish on (062) 73-3633.

**Electronics 86, the Australian International Electronics and Computer Technology Exhibition and Conference**, opens from 7-9 October, 1986, at the Royal Showground in Adelaide.

**An International congress on technology and technology exchange** is to be held 6 to 8 October in Pittsburg, Pennsylvania. Contact US Embassy or Consulate.

**The International Fibre Optics Communications/Local Area Networks Exposition** is on 8 to 10 October in Orlando, Florida. Contact the US Embassy or Consulate.

**Interkama '86**, the tenth international congress and exhibition on measurement techniques and automation is on 6 to 11 October in Dusseldorf. Contact Dexpo (Australia) on (02) 918-9209.

A series of seminars on **OSI and network architecture, fibre optics, packet switching and office automation** will be held in Melbourne and Sydney throughout October. Contact Management Technology Education on (02) 290-3555 or (03) 67-7117.

**Electric-Asia '86**, SE Asia's sixth international exhibition of electrical engineering, etc, is on 21 to 25 October at the World Trade Centre, Singapore. Contact Interfama Pty Ltd, PO Box 533 Marine Pde, Singapore 1544. Telex RS 24980 INFAMA.

**Systec '86**, a trade fair for computer integration in logistics, development design manufacture and quality assurance is on 27 to 30 October in Munich. Contact the German-Australian Chamber of Industry and Commerce on (02) 29-3998.

### NOVEMBER

**Infotex 86**, a computer and electronics exhibition presented by the NSW Chamber of Manufacturers and the Australian Computer Society will be held 4-6 November in Canberra. For further details contact Atek Promotions, 131 City Walk, Canberra, ACT 2601. (062)49-7799.

Aussat will hold a conference for satellite users — **Aussat '86: New Horizons** on 5 and 6 November at the Hyatt Kingsgate Hotel in Sydney. Contact Aussat Public Affairs Dept. on (02) 238-7800.

**Computer Expo '86** will be held 5 to 8 November at the Mayfair Crest Hotel, Brisbane. Contact Robert Woodland on (07) 372-3233.

Seminars on understanding **data communications** will be held 10 to 11 November at the Ansett International, Perth; 17 to 18 November at the Grosvenor Hotel, Adelaide; 20 to 21 November, Sheraton Hotel, Melbourne; 27 to 28 November, Sheraton Hotel, Brisbane; 1 to 2 December, Gazebo Hotel, Sydney. Contact Management Technology Education on (02) 290-3555 or (03) 67-7117.

**The 1st Australian Artificial Intelligence Congress and Exhibition** will be held 18 to 20 November, Hyatt on Collins. Contact (02) 439-5133.

**Pronic '86** an international exhibition of products for electronics will be held in Paris 18 to 21 November. Contact French Chamber of Commerce and Industry on (02) 29-3320.

Munich will be host to **Electronica '86**, the 12th international trade fair for electronic components and assemblies. Set aside 11-15 November. More details are available from the German Australian Chamber of Industry and Commerce on (02)29-3999.

### DECEMBER

The third '**mathematics-in-industry**' study group will be held at Monash University, Melbourne, from 1 to 5 December, 1986. Further information is available from Dr F.R. de Hoog, CSIRO Division of Mathematics and Statistics, GPO Box 1965, Canberra, ACT 2601. (062) 82-2011.

The **11th Optical Fibre Technology Conference** will be held 1 to 4 December. Contact the Institute of Radio & Electronics Engineers on (03) 606-6581 for more information.

A seminar on **integrating voice and data** is on 3 to 5 December at the Gazebo, Sydney. Contact Management Technology Education on (02) 290-3555 or (03) 67-7117.

The **Pacific Region Conference on Electrical Engineering Education** is on 15 to 17 December at Vue Grand, Queenscliffe, Vic. Contact John Hulskame at RMIT on (03) 660-2453 for more information.

The **Intelligent Autonomous Systems Conference** is on 8 to 11 December in Amsterdam. Contact Secretariat, Conference IAS, C/- Congressbureau "Van Neutegen", PO Box 27783, 3003 MB Rotterdam. (010) 433-3179.

### JANUARY

**Information Online '87** will be held 27 to 29 January at the Hilton, Sydney. Contact Kay Paterson on (02) 332-4622.

### FEBRUARY

**Finance '87 Melbourne**, an exhibition of money-handling technology, will be held at the World Trade Centre, Melbourne, 10 to 13 February. For further information contact BPI Exhibitions on (02) 266-9799.

### MARCH

**An International CAD/CAM Congress** on current realities and future directions will be held 17 to 20 March in Melbourne. Contact ACADS/FACE Congress Secretariat, 576 St Kilda Rd, Melbourne, Vic 3004. (03) 51-9153.

The dates and venues for the two PC87s are as follows: **Eighth Australian Personal Computer Show**, Centrepoint, Sydney, 18-21 March, 1987; and **Ninth Australian PC Show 'Communications 87'**, 'Office Technology 87', Royal Exhibition Building, Melbourne, 1-4 June, 1987.

### APRIL

**ATUG '87 4th Australian Telecommunications Exhibition & Conference** will be held at the Hilton Hotel in Sydney 7 to 9 April. Contact Riddell Exhibitions on (03) 429-6088.

### MAY

**Photographics '87**, an exhibition of the equipment and technology of photographics will be held 23 to 26 May at the RAS Showgrounds in Sydney.

### JUNE

**Videotex '87 Exhibition & Conference** is on in Melbourne over three days in June. Contact Riddell Exhibitions on (03) 429-6088.



# Bargain Hunters Shop Here

**PREMIUM QUALITY 'ERNI' DIL SWITCHES**  
6 WAY PCB mfg.  
COLOUR-CODED  
\$2.00 ea  
10+ \$1.75 ea

**PCB DRILL**  
POWERFULL  
6,000 RPM  
MOTOR  
12V DC  
\$12  
Incl. 1.0mm drill bit

**12Vdc PIEZO SIRENS**  
2 TONE FLAT TIP  
\$24 VERY LOUD \$18

**12Vdc FLUORO CAMPING or WORK LIGHT**  
8 WATT  
\$17.50  
Incl. alligator clip + lighter plug!

**5 1/4" FLOPPY DISKS**  
DOUBLE SIDED \$24 per 10  
DOUBLE DENSITY \$200 per 100  
10 YEAR GUARANTEE Limited qty

**PUBLIC ADDRESS HORN**  
**SPEAKERS GALORE**  
6" 10W PLASTIC \$14  
8" x 5" 15W METAL \$32  
8" 15W + LINE TRANS. \$59  
12" 25W METAL \$89  
16" 35W DRIVER INCL. \$105  
16" 50W AND TRANS \$119

**PA AMPLIFIERS**  
FOR ALL OCCASIONS  
10W \$175 20W \$215  
30W \$230 40W \$276  
50W \$263 60W \$329  
All PA gear supplied!  
SEND S.A.E. FOR SPECS!

**IDC FLAT-RIBBON CONNECTORS**  
DB25 MALE \$10.50  
DB25 FEMALE \$10.50  
CENTRONICS MALE \$13.50  
CENTRONICS FEMALE \$13.90  
34 Pin Edge driver disk \$6.50  
10 PIN SOCKET-FOR PCB \$2.50 ea  
16 PIN SOCKET-FOR PCB \$3.30 ea  
24 PIN SOCKET-FOR PCB \$4.40 ea  
34 PIN SOCKET-FOR PCB \$6.50 ea  
40 PIN SOCKET-FOR PCB \$6.95 ea  
50 PIN SOCKET-FOR PCB \$7.50 ea

**ALL COMPUTER ACCESS!**  
COMPUTER TERMINAL WALL PLATES  
Wood-grain finish - suit standard electrical fittings  
High Quality!  
Tax-free prices on request.  
DB25 SOCKET x2 \$17.95  
DB25 SOCKET \$13.20  
DB25 PLUG \$13.20  
DB9 SOCKET \$9.90  
5 Pin DIN SOCKETS \$8.60  
Send S.A.E. for full details.

**IBM EXPANSION TYPE Registered CHASSIS**  
ADD HARD DISK, UP TO 3 x FLOPPY DISKS etc.  
5 x PC/XT/AT expan. slots  
60/100W power supply  
Cooling fan \$595 Tax free  
Connectors \$520  
plus computer interface.

**UHF CONVERTER** for SBS CHAN 28  
Tunable UHF 4/5 to VHF channel 1  
\$69

**PRINTER CABLES** for Apple IBM Centronics  
20 pin plug to Centronics \$21.50  
DB25 plug to Centronics \$24.00  
Standard length: 1.5 metres

**COMPUTER HI-QUALITY RIBBON CABLE** FOR I.D.C. CONNECTORS  
16 wire 2.20m 34 wire 3.90  
26 wire 2.95m 50 wire 6.95

**MAKE YOUR OWN SHIELDED COMPUTER CABLES**  
6 Conductor 1.50m \$97/100m  
9 " \$1.15/m \$77/100m  
12 " \$1.80/m \$177/100m  
16 " \$2.50/m \$163/100m  
25 " \$3.95/m \$260/100m

**SERIAL/PARALLEL CONVERTER** \$150  
Ideal for IBM's each

**TV SIGNAL AMPLIFIER**  
4 x 75 ohm Outputs  
12dB gain  
VARIABLE Reduced! FOR...  
was \$69.50 now \$49.50  
VHF UHF FM

## BE GENUINE FOR THE BEST OF THE BARGAINS...

6.5mm stereo panel mount sockets 2 for...\$1.00  
3PDT racker action switch, buy 4 for...\$1.00  
Assorted new watt resistors pack 100...\$1.50  
Hi-stab resistors 1% and 2% ass't pak 30/\$1.00  
1.2V 500mAh nicad batteries AA size ea...\$1.95  
Plastic/metal knobs assorted pak 40 for...\$1.50  
Ignition noise filter kit CB/car radio...\$2.50  
BOY3B (similar 2N3055) power trans 2 for...\$1.00  
Molex IC socket pins, handy to have 100/\$1.75  
30 metres insul hook-up wire, 5 colours \$1.95  
Flashing red LED's, 100% g'teed, 2 for...\$1.00  
NPN 40V unmarked T05 silicon trans 20/\$1.00  
600PIV 3 AMP avalanche rectifiers 4 for \$2.00  
VHF trans MRF-603 (similar 2N5590) 2 for \$9.95  
Electrolube spray-can (similar WD40) ea \$3.50  
2200uF 64Vw Philips can electrolytic ea...\$1.75  
SCR 100V 1A T0-5 TS1232 from STC, 4 for \$1.00  
SCR 200V 10A T066 TS1218 from STC 4 for \$2.00  
Mica washer + insulators T03, 20 for...\$1.00  
Mica washer + insulator T0220 tab 20for \$1.00  
PCB mount fuse-clip for 3AG fuse 12 for \$1.00  
2N3054 60V 4amp T0-66 transistor...3 for \$2.00  
B0237 tab transistor...5 for \$2.00  
Mini Philips screwdrivers set of 4...\$3.20  
Burglar alarm reed switch + magnet N.C. \$2.50  
Alarm module entry/exit N.O./N.C. 12V...\$15.00  
Vibration/glass break sensor N.O./N.C...\$5.00  
12V to 6.9, 12VDC 300mA car volt convert \$2.50  
Compression power mike for CB/Zway...\$15.00  
560uF + 47uF 160Vw dual electro caps...\$2.00  
NE-2 neon lamp 25e ea or 10/52 or 100/\$15.00  
12V 40mA pigtail lamps 25e ea or 10 for \$2.00  
3AG panel mount fuseholders 4 for...\$2.00  
DPDT slide switches, PCB mount 30e ea 4/\$1.00  
Hi-Fi moving coil magnetic cartridge...\$19.95  
12V car cassette tape head demagnetizer \$2.00  
240V AC tape head demagnetizer...\$5.00  
3 speakers ON-OFF stereo switch-box...\$9.50  
TV/aerial/computer switch-box TV-9...\$4.95  
TV aerial VHF/UHF masthead mixer...\$8.90  
5K log 45mm mono slider potentiometer...\$2.50  
Bourns 1K 10 turn cermet trimpot...\$1.95  
2" extra-stroke ferrite bar magnets...ea \$2.35  
12 way plastic elect. terminal block...\$1.00  
Crystal hi-impedance earphone...\$1.95  
Magnetic hi-impedance earphone...\$1.00  
24V DC relay DPDT 140 ohm coil 25A cont \$4.00  
220V AC DPDT miniature cradle relay...\$2.95  
Video to RF TV modulators VHF CH 1 out...\$3.95  
240V mains illuminated ON-OFF switch...\$2.00  
6V DC motors medium size 2400rpm...\$3.00  
Stereo speaker vol cont Bohm 100W L-pad \$15.50  
BZY93 24V 20 watt zener diode stud mtg...\$1.00  
BC238 30V 500mA T0-92 transistor 10 for \$1.00  
" cone tweeters 25w 8 ohm, were \$5 now \$2.50  
5" mid-range 25w 8 ohm, were \$10 now ea \$5.00  
Crossover capacitors suit above, ea set \$1.00  
Battery test meter all 1.5V + 9V batts...\$4.50  
3 pos 10amp rotary switch with knob...\$1.00  
Mini PVC tuning gang for trans radios...\$1.00  
58mm (2 1/2") 8 ohm mini speakers...\$1.80  
Co-ax cable wire stripping tool...\$2.00  
2 pin mains power lead and mini socket...\$1.95  
Elapsed time XXXX XXHRS meter 36-80Vdc \$14.95  
240V AC to 12V DC 100mA plug-pack...\$5.00  
240V AC to 9V DC 600mA Artec plug-pack \$10.00  
5"X3" 4 ohm Magnavox speaker...\$2.50  
200 ohm 25W WW ceramic pnt...ea \$2.00

**PREMIUM QUALITY 'FUJI' RELAYS**  
12V DC \$2.95 ea  
1% 3A 10+ CONTACTS \$2.50 ea  
330A COIL PCB MOUNTING

**NEW FANS**  
High quality from C.I.C. Co Taiwan Ltd  
\$20 ea  
10+ \$16 ea  
3" (80mm) 115v 3" (80mm) 240v  
5" (120mm) 240v  
• Super-quiet  
• Long life  
• Guaranteed

**BELT-DRIVE TURNTABLE!**  
SCOOP PURCHASE! BELOW NORMAL COST!  
As made for AWJ, 2 speed, 33/45 RPM, strobe, platter, magnetic cartridge, 12vdc 240v pack, add \$5 \$29 ea

**FANS**  
5" 220VAC  
All tested OK!  
\$10 each  
10+ \$8 each  
EX-COMPUTER

**MOTORIZED SLIDE-IN TURNTABLE DRAWER**  
240v \$60  
TO SUIT ABOVE BELT-DRIVE TURNTABLE - includes 12v supply

## AVAIL ONLY WHILE PRESENT STOCKS LAST!

**NEW! Electronic RHYTHM BOX** \$79  
• 4 selectable rhythms: Rock, Cha Cha, Rumba, Tra, Rock Disco, Bossanova  
• Waiz, Skw  
• Power 3V battery or AC adaptor  
• Volume control  
• Rhythm tempo control, 10 steps  
• Powers on LED  
• Footswitch facilities  
• Output level 150mV (max)  
• Dimensions 190 x 52 x 132mm

**Hitachi Handy Heatshrink**  
4 Sizes, 4 Colours  
1 Metre Lengths  
3.5mm diam \$1.90  
5 mm diam \$2.15  
7 mm diam \$2.40  
10 mm diam \$3.10

**MINIATURE 12V DC DIL RELAYS** \$3 ea  
Single pole, 1KA  
Electrothermal

**THERMALLOY HEATSINKS** for IC's  
Suit 14, 16 pins  
were 95c now 50c ea 45c

**NEW! DIGITAL ECHO CHAMBER** \$98  
Features 2 microphone inputs with 1 volume control  
1 aux input with 1 volume control, volume control  
for delay - more general and extra  
Outputs for footswitch, delay and mix  
• Delay time 180m seconds  
• Inputs like 1 and 2 - 40dB, Late - 20dB  
• Output level 30mV (max)  
• Frequency response 50 - 15kHz  
• Signal/noise ratio 40dB  
• Power 9V battery or AC adapter  
• Powers on LED

**NEW HANDY HEATSHRINK PAK** 14x100mm pcs.  
Just slip over solder joint and heat - plastic shrinks no to form a tight seal. Ass't sizes \$3.50

**DOOR MONITOR and INTERCOM**  
Peep-hole viewer with built-in 2way intercom for front door protection.  
was \$9.98 SAVE \$1.98 \$7.98

**JACKPOT**  
Box No 5  
Our biggest ham ever! Nearly 5Kg of parts for electronic hobbyist.  
A little bit of everything - VALUED AT \$70! \$15

**LGE DC MOTORS**  
POWERFULL 3,000 RPM  
6V-12V DC  
17mm diam 80mm long  
ONLY \$5 ea

**MINIATURE LAPEL MICROPHONES**  
CONDENSOR MIKE \$15.00 ea  
FM WIRELESS \$18.00 ea

**4049 HEX BUFFER I.C.** \$40 ea  
10 for \$3.00 or ea.  
PACK & 3 PLUS 5% OF ORDER VALUE!

**SOLAR CELL**  
Output: 0.4V  
\$4 ea 450mA  
**SOLAR BATTERY CHARGER** \$12 ea  
Charges AA ni-cads 240 hrs

**18V 7WATT SOLAR PANEL**  
Charge 12V batteries up to 380mA or 2AM per day  
SEND S.A.E. for SOLAR CATALOGUE! Qty 3 \$83.00



# MIDI: REAL COMPUTER MUSIC

Neale Hancock



When you've run out of things to do with your PC you might consider using it to write music via the Musical Instrument Digital Interface (MIDI).

WHILE MIDI has been around for a few years (the MIDI 1.0 standard specification was introduced in 1983), PC users have never been better catered for, with the plethora of MIDI hardware, MIDI software and MIDI interfaces around now. MIDI interfaces for PCs usually take the form of a card which fits directly into the expansion slots or user ports of a personal computer, much like an RS232 card.

There are MIDI interfaces available for a number of popular personal computers such as the Apple IIe, the IBM-PC, the Commodore 64 and the Apple Macintosh. MIDI interfaces and software for Apples and IBMs can usually be used with their compatibles as well. There are also some PCs which have their own on-board MIDI interface. Atari and Yamaha are currently selling such machines. The Yamaha music computer (the CX5M) not only has MIDI capability

but also an eight channel on-board FM sound generator. The music written on MIDI-fitted PCs can be edited, looped, rewritten and saved on mass storage such as disk or cassette tape.

### The being and doing of MIDI

MIDI is basically an asynchronous serial data link, not unlike RS232, which enables musical data to be transmitted from computer to instrument, or from instrument to instrument. Each instrument and computer is fitted with a MIDI IN for receiving data, and a MIDI OUT for transmitting data. Some instruments are fitted with a MIDI THRU port to allow chaining of instruments. The shortcoming of the MIDI THRU port was adequately covered in our March 1986 issue, so I will not go into it here.

A diagram of a MIDI system is shown in Figure 1. The musical data transmitted via MIDI can be roughly divided into four categories: playing data, control data, addressing data and synchronization data.

Playing data consists of the note played, the length of time it is played for and the velocity with which the key is struck. With a keyboard instrument such as a piano, striking the keys, with greater velocity, ie, faster, can increase the volume of the note and in some cases it can actually change the sound of the note (a harsher sound usually results when a key is struck in this way).

Since playing technique is largely reducible to the velocity and the length of the note, control over these parameters enables the MIDI user to write and play music more expressively. In conjunction with a synthesiser or sound module that responds to MIDI information, dynamic and expressive music can be written on and played from a PC — a far cry from pre-MIDI computer music, which sounded more like the robot's annual ball!!!

Control, information carried by the MIDI bus includes selection of voices, as



well as pitch bending and pitch modulation. Voice information allows different sounds to be selected within a piece of music. When used via MIDI, voices can be selected remotely from another synthesiser or a PC. Pitch bending and modulation give keyboard players direct control over pitch and filters. They are usually used in a live playing situation (often in solos), where they are implemented via two finger wheels or a joystick located at the extreme left of the keyboard used.

Each instrument in the MIDI system has its own address, numbered from one to 16. Data is sent to all the instruments on a common two-wire serial data link. To allow each instrument in the system to receive data individually, they are all set to different MIDI addresses. So with multi-part music, each instrument playing a different part (bass, melody, rhythm, etc) would be set to a different MIDI address. The data sent down the MIDI link by the system master (in this case a personal computer) has addresses for each instrument included in it. Only the instrument set to a particular MIDI address will receive data sent to that address. This is analogous to a postman with a sack full of letters to different addresses, where the postman is the MIDI data link, an addressed letter is MIDI information and the houses corresponding to the addresses on the letters are the instruments.

Drum machines are a special case. Referred to as rhythm composers by some manufacturers, they can run by themselves and, in most instances, do not have playing information sent to them.

But since it can run by itself at its own tempo, there needs to be a way of keeping it

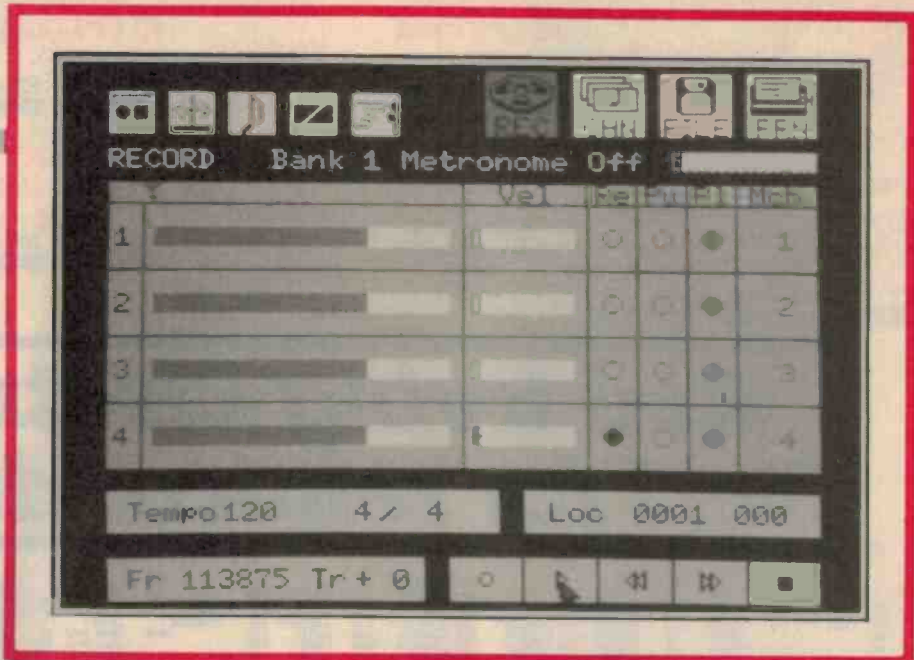

Screen display for step time software.

in time with the PC. The MIDI bus has a synchronization signal (called the MIDI clock) which allows the PC to set the tempo of the drum machine. In this situation the PC is referred to as the master and the drum machine is referred to as the slave.

Timing information also allows the computer to locate the song position pointer. The song position pointer is used in a similar way to a tape counter on a tape deck to keep track of where you are in a song. The position of the pointer is very accurate as it is measured by the number of MIDI clock pulses (the same ones used for synchronization). It's therefore more accurate and useful than its counterpart on a tape recorder. Besides giving a visible indication of your position within a song (either in bars or in minutes and seconds, depending on soft-

ware) the song position pointer can also be preset to allow immediate access to any point in the song.

Besides being a physical link for data, MIDI is also a data standard. The MIDI standard is adhered to by all companies which manufacture electronic musical instruments ensuring that equipment from different manufacturers is compatible. This is a great advantage to those who wish to buy equipment from different manufacturers.

### MIDI works

The MIDI OUT port on a PC converts parallel information from the computer's data bus to a serial form, as shown in Figure 2. This conversion is done via a UART (universal asynchronous receiver transmitter) or

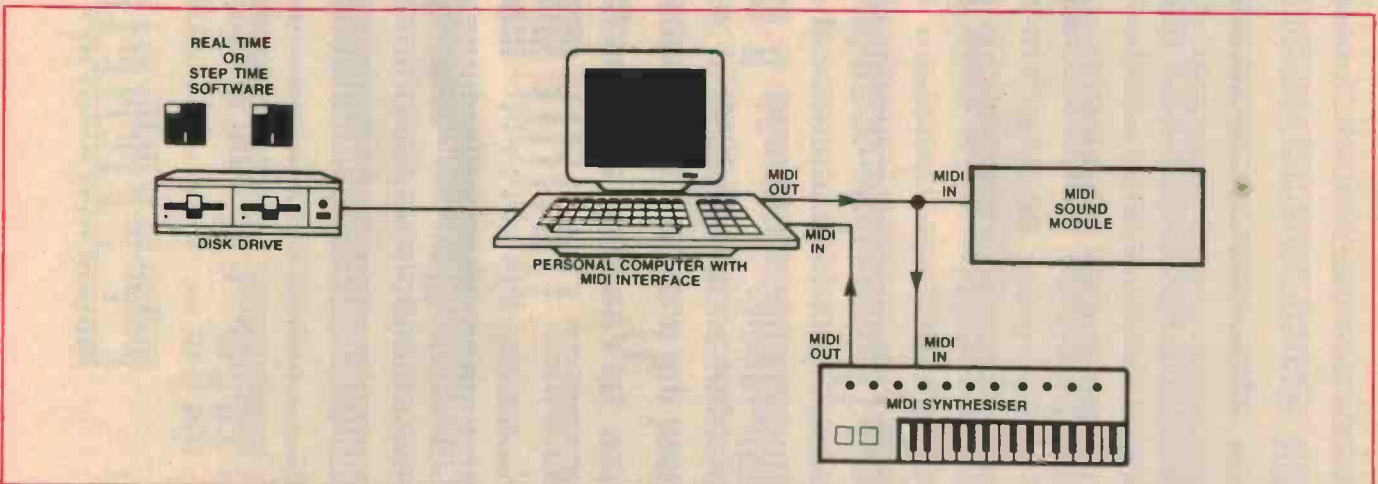

Figure 1. A basic MIDI system for step time and real time music composition.





**SUPER IC SPECIAL**  
**6264**  
 1-9 10-99 100+  
 \$6.50 \$5.50 \$5.25

**SUPER IC SPECIAL**  
**41256-15**  
 1-9 10-99 100+  
 \$5.95 \$5.50 \$4.95

**SUPER IC SPECIAL**  
**8087**  
**\$299**

**SUPER IC SPECIAL**  
**6802**  
 1-9 10-99 100+  
 \$5.00 \$4.75 \$4.50

**SUPER IC SPECIAL**  
**AM 7910**  
 WORLD MODEM CHIP  
 \$24.95

**SUPER IC SPECIAL**  
**ZN429**  
 1-9 10-99 100+  
 \$7.95 \$7.50 \$6.95

**SUPER IC SPECIAL**  
**ADC0820**  
 1-9 10+  
 \$24.95 \$22.95

**SUPER IC SPECIAL**  
**6116LP-3**  
 1-9 10-99 100+  
 \$3.95 \$3.75 \$3.50

**SUPER IC SPECIAL**  
**27128**  
 1-9 10-99 100+  
 \$7.00 \$6.50 \$6.25

**SUPER IC SPECIAL**  
**4164**  
 1-9 10-99 100+  
 \$2.95 \$2.75 \$2.50

**SUPER IC SPECIAL**  
**2732**  
 1-9 10-99 100+  
 \$6.25 \$5.95 \$5.50

**SUPER IC SPECIAL**  
**5mm LEDs**  
**PRIME SPEC.**  
 1-99 100+ 1,000+  
 \$0.15 \$0.11 \$0.10

**SUPER IC SPECIAL**  
**LM394CH**  
 1-9 10-99 100+  
 \$6.95 \$6.75 \$6.50

# No.1 for semiconductors!

4582	2.25	74LS32	70	74LS593	1.80	74C76	1.90	74S251	3.90	UA710CN	1.00	TR1853	8.90	HP5002-2811		BC640	1.00	MRF641	48.00	ZN5822	90	78L05	50
4583	1.85	74LS33	2.00	74LS594	2.00	74C73	2.30	74S252	4.90	LM711	1.20	COB8818	24.00	BCY70	1.90	MRF646	53.00	ZN5825	90	78L12	50		
4001	50	4584	8.5	74LS37	70	74LS596	2.50	74C85	2.30	74S257	3.00	LM723	7.50	BCY71	1.80	MRF901	2.80	ZN5826	90	78L15	75		
4002	50	4585	2.10	74LS38	80	74LS598	3.00	74C86	1.50	74S258	3.30	LM723CH	1.50	BD140	1.00	MPP131	90	ZN5827	90	78L18	75		
4006	1.90	4586	60	74LS39	80	74LS599	1.90	74C89	9.90	74S260	2.90	LM725	4.75	BD141	1.00	MPP132	90	ZN5828	90	78L24	75		
4007	40	4587	40	74LS40	80	74LS600	1.90	74C90	1.80	74S274	1.90	LM733	1.50	BD201	90	TIP31B	70	ZN5829	90	78L25	1.20		
4008	1.20	7400	35	74LS41	80	74LS601	1.90	74C91	1.80	74S275	1.90	LM733	1.50	BD202	90	TIP31C	75	ZN5830	90	78L26	1.20		
4010	80	7401	45	74LS42	80	74LS602	1.90	74C92	1.80	74S276	1.90	LM733	1.50	BD203	90	TIP31D	75	ZN5831	90	78L27	1.20		
4011	40	7402	45	74LS43	80	74LS603	1.90	74C93	1.80	74S277	1.90	LM733	1.50	BD204	90	TIP31E	75	ZN5832	90	78L28	1.20		
4012	40	7403	45	74LS44	80	74LS604	1.90	74C94	1.80	74S278	1.90	LM733	1.50	BD205	90	TIP31F	75	ZN5833	90	78L29	1.20		
4013	60	7404	60	74LS45	80	74LS605	1.90	74C95	1.80	74S279	1.90	LM733	1.50	BD206	90	TIP31G	75	ZN5834	90	78L30	1.20		
4014	1.90	7405	90	74LS46	80	74LS606	1.90	74C96	1.80	74S280	1.90	LM733	1.50	BD207	90	TIP31H	75	ZN5835	90	78L31	1.20		
4015	1.90	7406	80	74LS47	80	74LS607	1.90	74C97	1.80	74S281	1.90	LM733	1.50	BD208	90	TIP31I	75	ZN5836	90	78L32	1.20		
4016	75	7407	80	74LS48	80	74LS608	1.90	74C98	1.80	74S282	1.90	LM733	1.50	BD209	90	TIP31J	75	ZN5837	90	78L33	1.20		
4017	1.90	7408	60	74LS49	80	74LS609	1.90	74C99	1.80	74S283	1.90	LM733	1.50	BD210	90	TIP31K	75	ZN5838	90	78L34	1.20		
4018	1.90	7409	60	74LS50	80	74LS610	1.90	74C100	1.80	74S284	1.90	LM733	1.50	BD211	90	TIP31L	75	ZN5839	90	78L35	1.20		
4019	90	7410	90	74LS51	80	74LS611	1.90	74C101	1.80	74S285	1.90	LM733	1.50	BD212	90	TIP31M	75	ZN5840	90	78L36	1.20		
4020	1.50	7411	70	74LS52	80	74LS612	1.90	74C102	1.80	74S286	1.90	LM733	1.50	BD213	90	TIP31N	75	ZN5841	90	78L37	1.20		
4021	1.50	7412	70	74LS53	80	74LS613	1.90	74C103	1.80	74S287	1.90	LM733	1.50	BD214	90	TIP31O	75	ZN5842	90	78L38	1.20		
4022	1.50	7413	70	74LS54	80	74LS614	1.90	74C104	1.80	74S288	1.90	LM733	1.50	BD215	90	TIP31P	75	ZN5843	90	78L39	1.20		
4023	1.50	7414	80	74LS55	80	74LS615	1.90	74C105	1.80	74S289	1.90	LM733	1.50	BD216	90	TIP31Q	75	ZN5844	90	78L40	1.20		
4024	1.50	7415	80	74LS56	80	74LS616	1.90	74C106	1.80	74S290	1.90	LM733	1.50	BD217	90	TIP31R	75	ZN5845	90	78L41	1.20		
4025	1.50	7416	80	74LS57	80	74LS617	1.90	74C107	1.80	74S291	1.90	LM733	1.50	BD218	90	TIP31S	75	ZN5846	90	78L42	1.20		
4026	1.50	7417	80	74LS58	80	74LS618	1.90	74C108	1.80	74S292	1.90	LM733	1.50	BD219	90	TIP31T	75	ZN5847	90	78L43	1.20		
4027	1.50	7418	80	74LS59	80	74LS619	1.90	74C109	1.80	74S293	1.90	LM733	1.50	BD220	90	TIP31U	75	ZN5848	90	78L44	1.20		
4028	1.50	7419	80	74LS60	80	74LS620	1.90	74C110	1.80	74S294	1.90	LM733	1.50	BD221	90	TIP31V	75	ZN5849	90	78L45	1.20		
4029	1.50	7420	80	74LS61	80	74LS621	1.90	74C111	1.80	74S295	1.90	LM733	1.50	BD222	90	TIP31W	75	ZN5850	90	78L46	1.20		
4030	1.50	7421	80	74LS62	80	74LS622	1.90	74C112	1.80	74S296	1.90	LM733	1.50	BD223	90	TIP31X	75	ZN5851	90	78L47	1.20		
4031	2.95	7422	80	74LS63	80	74LS623	1.90	74C113	1.80	74S297	1.90	LM733	1.50	BD224	90	TIP31Y	75	ZN5852	90	78L48	1.20		
4032	2.75	7423	80	74LS64	80	74LS624	1.90	74C114	1.80	74S298	1.90	LM733	1.50	BD225	90	TIP31Z	75	ZN5853	90	78L49	1.20		
4033	2.75	7424	80	74LS65	80	74LS625	1.90	74C115	1.80	74S299	1.90	LM733	1.50	BD226	90	TIP31A	75	ZN5854	90	78L50	1.20		
4034	3.95	7425	80	74LS66	80	74LS626	1.90	74C116	1.80	74S300	1.90	LM733	1.50	BD227	90	TIP31B	75	ZN5855	90	78L51	1.20		
4035	1.95	7426	80	74LS67	80	74LS627	1.90	74C117	1.80	74S301	1.90	LM733	1.50	BD228	90	TIP31C	75	ZN5856	90	78L52	1.20		
4036	1.95	7427	80	74LS68	80	74LS628	1.90	74C118	1.80	74S302	1.90	LM733	1.50	BD229	90	TIP31D	75	ZN5857	90	78L53	1.20		
4037	1.95	7428	80	74LS69	80	74LS629	1.90	74C119	1.80	74S303	1.90	LM733	1.50	BD230	90	TIP31E	75	ZN5858	90	78L54	1.20		
4038	1.95	7429	80	74LS70	80	74LS630	1.90	74C120	1.80	74S304	1.90	LM733	1.50	BD231	90	TIP31F	75	ZN5859	90	78L55	1.20		
4039	1.95	7430	80	74LS71	80	74LS631	1.90	74C121	1.80	74S305	1.90	LM733	1.50	BD232	90	TIP31G	75	ZN5860	90	78L56	1.20		
4040	1.95	7431	80	74LS72	80	74LS632	1.90	74C122	1.80	74S306	1.90	LM733	1.50	BD233	90	TIP31H	75	ZN5861	90	78L57	1.20		
4041	1.95	7432	80	74LS73	80	74LS633	1.90	74C123	1.80	74S307	1.90	LM733	1.50	BD234	90	TIP31I	75	ZN5862	90	78L58	1.20		
4042	1.95	7433	80	74LS74	80	74LS634	1.90	74C124	1.80	74S308	1.90	LM733	1.50	BD235	90	TIP31J	75	ZN5863	90	78L59	1.20		
4043	1.95	7434	80	74LS75	80	74LS635	1.90	74C125	1.80	74S309	1.90	LM733	1.50	BD236	90	TIP31K	75	ZN5864	90	78L60	1.20		
4044	1.95	7435	80	74LS76	80	74LS636	1.90	74C126	1.80	74S310	1.90	LM733	1.50	BD237	90	TIP31L	75	ZN5865	90	78L61	1.20		
4045	1.95	7436	80	74LS77	80	74LS637	1.90	74C127	1.80	74S311	1.90	LM733	1.50	BD238	90	TIP31M	75	ZN5866	90	78L62	1.20		
4046	1.95	7437	80	74LS78	80	74LS638	1.90	74C128	1.80	74S312	1.90	LM733	1.50	BD239	90	TIP31N	75	ZN5867	90	78L63	1.20		
4047	1.95	7438	80	74LS79	80	74LS639	1.90	74C129	1.80	74S313	1.90	LM733	1.50	BD240	90	TIP31O	75	ZN5868	90	78L64	1.20		
4048	1.95	7439	80	74LS80	80	74LS640	1.90	74C130	1.80	74S314	1.90	LM733	1.50	BD241	90	TIP31P	75	ZN5869	90	78L65	1.20		
4049	1.95	7440	80	74LS81	80	74LS641	1.90	74C131	1.80	74S315	1.90	LM733	1.50	BD242	90	TIP31Q	75	ZN5870	90	78L66	1.20		
4050	1.95	7441	80	74LS82	80	74LS642	1.90	74C132	1.80	74S316	1.90	LM733	1.50	BD243	90	TIP31R	75	ZN5871	90	78L67	1.20		
4051	1.95	7442	80	74LS83	80	74LS643	1.90	74C133	1.80	74S317	1.90	LM733	1.50	BD244	90	TIP31S	75	ZN5872	90	78L68	1.20		
4052	1.95	7443	80	74LS84	80	74LS644	1.90	74C134	1.80	74S318	1.90	LM733	1.50	BD245	90	TIP31T	75	ZN5873	90	78L69	1.20		
4053	1.95	7444	80	74LS85	80	74LS645	1.90	74C135	1.80	74S319	1.90	LM733	1.50	BD246	90	TIP31U	75	ZN5874	90	78L70	1.20		
4054	1.95	7445	80	74LS86	80	74LS646	1.90	74C136	1.80	74S320	1.90	LM733	1.50	BD247	90	TIP31V	75	ZN5875	90	78L71	1.20		
4055	1.95	7446	80	74LS87	80	74LS647	1.90	74C137	1.80	74S321	1.90	LM733	1.50	BD248	90	TIP31W	75	ZN5876	90	78L72	1.20		
4056	1.95	7447	80	74LS88	80	74LS648	1.90	74C138	1.80	74S322	1.90	LM733	1.50	BD249	90	TIP31X	75	ZN5877	90	78L73	1.20		
4057	1.95	7448	80	74LS89	80	74LS649																	





**IBM\* COMPATIBLES**  
from \$995\*

**IBM\* COMPATIBLES**  
from \$995\*

Incredible deals to suit everyone including special package deals!  
256K RAM, single drive, graphics, disk controller and printer cards. \$995  
256K RAM: Colour Graphics, Disk Controller Card, 1 parallel port, 2 disk drives and 3 months warranty. only \$1,395

640K RAM: Colour graphics, Multifunction Card, Disk Controller Card, 2 serial and 1 parallel ports. A 120 C.P.S. printer and a monochrome monitor and 3 months warranty! only \$1,495

256K PACKAGE DEAL: Includes Colour Graphics Card, Multifunction Card, Disk Controller Card, 2 serial and 1 parallel ports. A 120 C.P.S. printer and a monochrome monitor and 3 months warranty! only \$1,995

640K PACKAGE DEAL: Includes Colour Graphics Card, Multifunction Card, Disk Controller Card, 2 serial and 1 parallel ports. A 120 C.P.S. printer, a monochrome monitor and 3 months warranty! only \$2,095  
IBM is a registered trademark.

**STOP PRESS!**  
**TURBO-286K CARD!**  
Make your XT work as fast as an AT! ie: up to 9 times faster!  
**\$995**



**IBM\* AT COMPATIBLE!**  
IBM\* AT COMPATIBLE!

- 6 MHz
- 80286 CPU
- 8 slots
- 1 MByte main board
- 1.2 MByte Floppy disk drive
- 20 MByte Hard disk
- Colour graphics display card
- Floppy and Hard disk controller card
- Printer card and RS232
- 200W Power supply
- Keyboard
- Manual

All this for just \$3,995  
(Monitor not included)

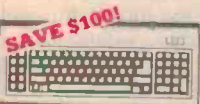

**"IBM\* AT TYPE" KEYBOARD**

- 100% IBM\* PC, XT compatible
- Low profile keyboard design
- Proper placement of shift keys with large key tops to suit professional typists
- 3 step height-angle adjustment
- Cherry brand TS-Moooc 19mm low profile switches, meet 30mm ergonomic requirement and provide high performance and maximum reliability.
- Curl lead plugs straight into PC/XT
- 3 Status displays
- Just like the "real McCoy" only at fraction of the price!

Cat. X12020 ..... Normally \$249  
**SPECIAL, ONLY \$149**



**NEW INTRA HIGH RESOLUTION RGB COLOUR MONITOR!**

Size: 14 inch  
Sync. Horiz. Scan Freq: 15.75 KHz  
Sync. Vert. Scan Freq: 50 Hz  
Band width: 18 MHz  
Dot Pitch: .31mm  
Resolution: 640 x 400 dots  
Display Format: 80 x 25 Characters  
Display Colours: 16 colours  
Input Connector: 9 pin D type  
Cat. X14520 ..... only \$695



**CANON A-40 PRINTER**

- Serial Impact Dot Matrix
- 140 C.P.S.
- Near Letter Quality Mode
- 1.4K Buffer

Cat. C20040 ..... \$525



**COMPUTER PAPER**

Quality paper at a low price! 2,500 sheets of 11 x 9 1/2", 60 gsm bond paper.  
Cat. C21001 ..... Normally \$44.95  
**SPECIAL, ONLY \$37.95**



**APPLE\* COMPATIBLE SLIMLINE DISK DRIVES**

Japanese Chinon mechanism.  
Cat. X19901 ..... Normally \$225  
**NOW \$195**  
(\*Apple is a registered trade mark.)



**TELEPHONE ADAPTOR**

• Australian plug to U.S. socket  
• Length 10cm  
• Cream colour cable  
Cat. Y16026 ..... \$6.95



**TTL MONITORS**

Fantastic resolution! Enjoy a crisp, sharp image with the latest Ritron TTL monitor! IBM\* compatible, green display, swivel and tilt base.  
Green Cat. X14510 ..... \$289  
Amber Cat. X14512 ..... \$289



**RITRON 2 MONITORS**

Stylish, swivel base monitor, available in amber or green.  
Green Cat. X14506 ..... \$235  
Amber Cat. X14508 ..... \$239



**ANTI GLARE SCREEN**

Half the price of other brands!! Relieve eye strain and headaches and increase productivity with these Anti Glare Screens. Suitable for 12" monochrome and colour monitors.  
Cat. X99995 ..... \$24.95



**5 1/4" FLOPPY DISK SPECIALS!**

All prices 10 disk boxes!

XIDEX 1-9 10+  
S/S D/D \$29.95 \$29.95  
Cat C12401  
D/S D/D \$38.95 \$36.95  
Cat C12410  
High Density \$125  
Cat C12520

**VERBATIM DATALIFE**  
S/S D/D \$27.95 \$26.95  
Cat. C12501  
D/S D/D \$34.95 \$32.95  
Cat. C12504

**VERBATIM VALULIFE**  
S/S D/D \$24.95 \$22.95  
Cat. C12421  
D/S D/D \$29.95 \$25.95  
Cat. C12425

**3 1/2" DISK SPECIALS**  
Verbatim S/S Cat. C12810 \$64.95  
Verbatim S/S Cat. C12612 \$69.95  
Xidex S/S Cat. C12600 \$65.95  
Xidex D/S Cat. C12602 \$69.95

**NEED HIGH DENSITY DISKS FOR YOUR IBM AT?**  
"Buy your High Density disks at below recommended retail prices from Rod Irving Electronics and SAVE!!"  
R.R.P. \$113 Our Price \$99.95



**TELECOMMUNICATION EXTENSION LEADS**

Cat. Y16010 ..... 5m \$12.50  
Cat. Y16012 ..... 10m \$14.95

**NEW! DIRECT IMPORT!**



**IBM\* COMPATIBLE DISK DRIVES**  
Tired of paying up to 100% more for Japanese Disk Drives? We now have "direct import" Taiwanese disk drives at much lower prices!

Cat.No.	Description	Price
C11801	500K	\$199
C11803	1 M/Byte	\$219
C11805	1.6 M/Byte	\$239

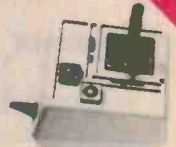

**JOYSTICK FOR IBM**  
Features Selectable "Spring centering" or "free floating". Electrical trim adjustments on both axis. 360 degree cursor control.  
Cat. C14205 ..... \$49.95



**APPLE JOYSTICKS**  
Ideal for games or word processing. Fits most 6502 "compatible" computers.  
Cat. C14200 ..... \$39.95

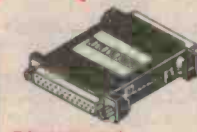

**RS232 INLINE SWITCHING BOX**

• 25 pin "D" plug to 25 pin "D" socket  
• DIP switches allow easy switching of internal wiring.  
Cat. X15662 ..... \$32.95



**IBM\* XT COMPATIBLE CARDS**

High Resolution Colour/Graphic/Mono/Printer  
Cat. X ..... \$395

640K Main Board  
Cat. X18020 ..... \$249

Turbo Mainboard  
Cat. X18030 ..... \$295

Mono Graphic Printer Card  
Cat. X ..... \$175

Mono Graphics Adaptor Card  
Cat. X ..... \$175

Monochrome Card  
Cat. X ..... \$119

Colour Graphic Display Card  
Cat. X ..... \$129

Colour Graphic/Printer Card  
Cat. X ..... \$169

384K Multifunction Card (includes cable, but not RAM)  
Cat. X ..... \$199

768K Multifunction Card (includes cable, but not 41256 RAM)  
Cat. X ..... \$199

768K Memory Expansion Card (41256 RAM not included)  
Cat. X ..... \$89

Multi I/O and Disk Controller Card (includes cable)  
Cat. X ..... \$199

I/O Plus II Card (includes cable)  
Cat. X ..... \$138

Floppy Disk Controller Card (2 drive capability)  
Cat. X18005 ..... \$79

Floppy Disk Controller Card (4 drive capability)  
Cat. X ..... \$99

Parallel Printer Card  
Cat. X18017 ..... \$37.50

RS232 Card  
Cat. X18026 ..... \$59.50

Clock Card  
Cat. X ..... \$59.50

Clock/RS232 Card  
Cat. X ..... \$99

Games Adaptor Card (2 joystick ports)  
Cat. X ..... \$39.50

Hard Disk Drive Card  
Cat. X ..... \$299

**IBM\* AT COMPATIBLE CARDS**

Main Board 6MHz (with Phoenix Bios)  
Cat. X ..... \$1,050

Enhanced Graphics Adaptor Card (Award Bios)  
Cat. X ..... \$495

PC/XT/AT Serial/Parallel Card  
Cat. X ..... \$149

Floppy & Hard Disk Controller Card  
Cat. X ..... \$699

1 M/Byte RAM Card (Without RAM)  
Cat. X ..... \$299

3 M/Byte RAM Card (Without RAM)  
Cat. X ..... \$299

2.5 M/Byte Multifunction Card (Without RAM, includes cable)  
Cat. X ..... \$449



**RITRON MULTI PURPOSE MODEM**  
The RITRON Multi Purpose Modem has all the features you require...  
• CCITT V21 300 Baud Full duplex  
• CCITT V23 1200/75  
• Bell 103 300 Full duplex  
• Bell 202 1200 Half duplex  
• Auto answer, auto disconnect  
• Telecom Approval No. C94/37/1134  
Cat. X19103 ..... only \$299

**WE HAVE A WIDE RANGE OF CABLE AND CONNECTORS!!**



**Rod Irving Electronics**  
48 A Beckett St, MELBOURNE  
Phone (03) 663 6151  
425 High St, NORTHCOTE  
Phone (03) 489 8666  
Mail Order and Correspondence:  
P.O. Box 620, CLAYTON 3158  
Telex: AA 151938



**MAIL ORDER HOTLINE (03) 543 7877 (2 lines)**

**POSTAGE RATES:**  
\$1 \$9.95 ..... \$2.00  
\$10 \$24.99 ..... \$3.00  
\$25 \$49.99 ..... \$4.00  
\$50 \$99.99 ..... \$5.00  
**FREE POSTAGE FOR ALL ORDERS OVER \$50!** \$12.50

This is for basic postage only. Comet Road Freight, bulky and fragile items will be charged at different rates.

Certified Post for orders over \$100 included free!  
Registered Post for orders over \$200 included free!

All sales tax exempt orders and wholesale enquiries to RITRONICS WHOLESALE, 56 Remver Rd, Clayton, Ph. (03) 543 2166 (3 lines)

Errors and omissions excepted

\*Apple and IBM are registered trade names



**MICRODOT DISKS**  
100% certified and error free guaranteed!  
Where else can you get 100% guaranteed disks at these prices?!

5 1/4" S/S (C12440) 1-9 boxes \$17.95 10+boxes \$16.95  
5 1/4" D/S (C12445) \$19.95 \$17.95  
Bulk and dealer inquiries welcome please phone (03) 543 2166



# MIDI

**TABLE 1a. MIDI CODES.**

PARAMETER TO BE CHANGED	STATUS BYTE		DATA BYTE 1		DATA BYTE 2		
	Binary Parameter Code	Value MIDI Address	Range of Decimal Values	Information Carried	Range of Decimal Values	Information Carried	Range of Decimal Values
note off	1000	0000-1111	128-143	key pressed*	0-127	release velocity †	0-127
note on	1001	0000-1111	144-159	key pressed*	0-127	attack velocity †	0-127
polyphonic key pressure	1010	0000-1111	160-175	key pressed*	0-127	pressure value	0-127
control change	1011	0000-1111	176-191	control no‡	0-127	value of change	0-127
voice change	1100	0000-1111	192-207	voice no	0-127		
channel key pressure	1101	0000-1111	208-223	pressure value	0-127		
pitch bend	1110	0000-1111	224-239	LSB of value	0-127	MSB of value	128-32647
SYSTEM MESSAGES	STATUS BYTE		DATA BYTE 1		DATE BYTE 2		
	Binary Value	Deciml Value					
bulk dump	1111	0000	240	manufacturer's ID	0-127	any number of bytes	1-a very large No
undefined	1111	0001	241				
song position pointer	1111	0010	242	position (LSB)	127	position (MSB)	128-32647
song select	1111	0011	243	selected song	0-127		
undefined	1111	0100	244				
undefined	1111	0101	245				
request tuning	1111	0110	246				
end of system exclusive	1111	0111	247				
timing clock	1111	1000	248				
undefined	1111	1001	249				
start	1111	1010	250				
continue	1111	1011	251				
stop	1111	1100	252				
undefined	1111	1101	253				
active sensing	1111	1110	254				
system reset	1111	1111	255				

\*See table 1b.  
 † See table 1c.  
 ‡ See table 1d.  
 NB: 0000 to 1111  
 in the MIDI  
 address column  
 accounts for MIDI  
 addresses 1 to 16.



**TABLE 1b. MIDI CODES FOR EACH NOTE**

Musical note	middle C...	C...	C...	C...	C...	C...	C	C#	D	D#	E	F	F#	G	G#	A	A#	B	C...	C...	C...	C...	
Decimal value	0	12	24	36	48	60	61	62	63	64	65	66	67	68	69	70	71	72	84	96	108	120	127

an ACIA (asynchronous communication interface adaptor). These elements also add start and stop bits to the serial data stream which is transmitted at 31.25 Kbaud via a 5 mA current loop. This is derived by dividing down a 2 MHz crystal. The serial data is then output to the MIDI cable via an opto-coupler.

Data received at a MIDI IN port passes through a high speed, high sensitivity opto-coupler which keeps everything in the MIDI system electrically isolated. The reason why electrical isolation is important is to remove any connection with electrical ground, and thus eliminate earth loops which would otherwise interfere with data.

A UART or ACIA removes the start and stop bits from the incoming serial data stream then converts the serial data into parallel data. The parallel output from the UART or ACIA is sent to the data input lines of a microprocessor. If the MIDI instrument receiving data is a synthesiser, it has an internal microprocessor controlling all of its functions which receives information via the MIDI interface. This information is used to control the synthesiser remotely.

### Data format of MIDI

Each byte of MIDI information has 10 bits. Eight of these are data bits, one is a start bit and one is a stop bit. Three MIDI bytes make up a MIDI word. The first byte in the word is a status byte and the next two bytes are data bytes. The first four bits of the status byte select the parameter to be changed in the MIDI instrument such as note on, note off, key pressure, voice selection, control change and pitch bend. The other four bits of the status byte select which MIDI address the data is to be sent to. Table 1 shows a list of the main MIDI codes and their use.

Once the MIDI channel and the parameter are selected by the status byte, the MIDI data carried by the next two bytes changes the selected parameter. When a note on message is sent in the first byte, the next byte carries the information saying which note is to be changed; the third byte carries the information about the velocity of the note played. For instance, if MIDI channel 1 is to receive a middle C note played very hard, the data in each byte would be as follows. The first byte would have a value of 144, the second byte would have a value of 60 and the final byte, signifying the playing velocity, would have a value of around 110. All of these values have been derived from Table 1.



**TABLE 1c. MIDI CODES FOR PLAYING VELOCITY**

Playing velocity	Off ... very soft (ppp) ... soft (pp) ... average (mf) ... hard (ff) ... very hard (fff)
Decimal value	0 ..... 1 ..... 64 ..... 127

**Firing up**

Music can be written into a personal computer in two main ways: in step time and in real time. Writing music in step time requires the notes, the rests and velocity data to be entered one by one from the computer keyboard. This method is much like writing a musical score onto manuscript, but instead of giving it to musicians to play, you give it to the personal computer to play. Music written with real time software is just like recording the music on a multi-track tape recorder, but with added facilities such as editing, looping and chaining. More about this later.

Software is available for both step time and real time music writing and is usually bought with the interface. It is up to the buyer to specify which software s/he wants. (You can read about the latest advances in MIDI hardware and software in our sister publication *Sonics* magazine.)

**Step time software**

Step time software (or music composition software as it is called by some manufacturers) is ideal for people whose music writing skills are greater than their playing skills. With this software, creative and complex musical ideas can be implemented without having to spend years developing the playing technique.

Writing music and getting a computer to play it with all the feel and dynamics of a musician might seem to be cheating to some people. However, to get music to sound good, time has to be spent composing it, and thus make it 'expressive' by good use of timing and velocity. Lack of playing skill on a particular instrument does not mean that one cannot write music for that instrument. I am sure that composers of a classical music are not virtuosos of each instrument for which they write.

Because using step time software is like writing music on manuscript paper, some very basic music theory (for instance knowing what the different musical symbols mean) will go a long way. Most step time software appears on the PC screen as a blank staff with a cursor. The notes and rests are written onto the staff from the computer keyboard or from a special music

**TABLE 1d. MIDI CONTROL CODES**

STATUS BYTE		DATA BYTE 1		DATA BYTE 2	
Binary Value	Decimal	Information	Decimal	Information	Decimal
Parameter	MIDI	Carried	Value	Carried	Value
Code	Address	Range			
1011	0000-1111	Keyboard controller 0	0	MSB	0-127
		modulation wheel	1	MSB	0-127
		keyboard controllers (2-31)	2-31	MSB	0-127
		keyboard controller 0	32	LSB	0-127
		modulation wheel	33	LSB	0-127
		keyboard controllers (2-31)	34-63	LSB	0-127
		switches (on/off)	64-95	on/off	off=0 on=127
		undefined	96-121		
		local control	122	on/off	off=0 On=127
		all notes off	123		0
		omni mode off	124		0
		omni mode on	125		0
		mono modo on	126	number of channels	1-16
		poly mode on	127		0

keyboard. With most step time software, notes can be tied, dotted and written as triplets; chords can be written as well.

Whilst the average computer user may not be conversant with music written on a staff one quickly discovers the meaning of all the musical marks. This is assisted by the music being displayed on the staff as it is being played by the computer. It is not difficult to associate what is seen with what is heard.

Playing information such as velocity, note duration, tempo and voice setting can be input along with the score and displayed at the top of the staff. MIDI messages such as stop, start, and continue which are used for controlling other MIDI instruments (such as drum machines) can also be displayed at the top of the staff. The playing information and MIDI messages can be changed at any time by inserting them at the relevant point in the score.

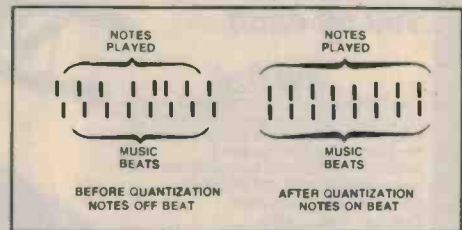

Figure 3. Quantization, showing how off-beat notes can be corrected.

There are a number of advantages to using step time software, apart from allowing music to be composed beyond playing skills. Using step time software one can edit, repeat and copy compositions and print them out as hard copy. These functions are implemented much in the same way as similar functions on a word processor.

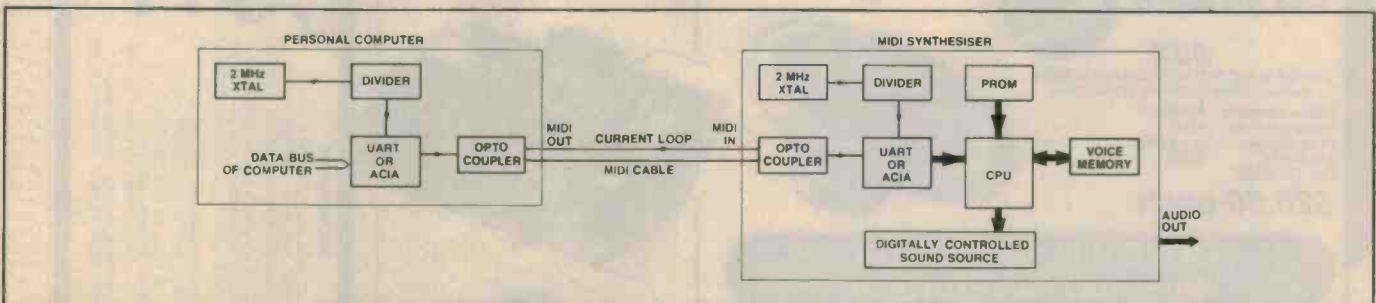

Figure 2. Block diagram of a MIDI system showing the relevant signal paths.











# MIDI

One major advantage of using step time software is that a MIDI-fitted synthesiser is not required to write the playing information. You might wonder how music is to be played back without a synthesiser or keyboard to create the sounds. The answer is to use a MIDI sound module (sometimes called a MIDI expander). A MIDI sound module is essentially a MIDI synthesiser without a keyboard. It is cheaper and occupies less space than a synthesiser. Some MIDI sound modules are made to fit the standard 19" rack which allows them to be stacked like a hi-fi system. One such unit currently available from Roland is the MKS7 Super Quartet. This unit has a bass section, a melody section, a chord section and a rhythm section (drums) all separately accessible via MIDI and contained in a two-rack unit case.

The main disadvantage of step time software is that it can be a bit tedious to compose music from a computer keyboard (even if you have a mouse) because of the number of keystrokes required to input each note and shift octaves. Yamaha gets around this problem by fitting its CX5M with a special music keyboard to allow notes to be written directly onto the musical stave on the screen.

## Real time software

As mentioned earlier, real time software

performs the same sort of task as a multi-track tape recorder. The real time software makes it possible for a MIDI-fitted personal computer to record playing information from a MIDI keyboard. It should be stressed that it is only the playing information which is recorded and not the actual sounds.

When hearing music played back from a real time recorder it is easy to think that the actual sound has been recorded. This is so because for each note pressed, the pitch, timing and velocity information from the keyboard are all stored in the personal computer as it happens. It also stores mistakes made when the music is played, so some playing skill is required. Along with playing information control information such as voice changes, key pressure as well as information from the pitch bend and modulation finger wheels are stored.

The real time software can make up for some of the shortcomings of the not so brilliant keyboard player. Unlike with a multi-track recorder, mistakes can be easily edited out. For instance, if you are recording a flashy keyboard solo and you strike a dud note mid-flight, real time software actually allows you to edit out just the single offending note and replace it with the correct one.

Other capabilities of the software are quantization and looping. The quantization facility allows notes which are off beat to be

put onto the nearest beat. Figure 3 shows this facility diagrammatically. Looping allows any bar of music to be repeated, so the bar in question need only be played once.

Real time software also permits overdubbing as with a multitrack recorder. The real time recorder designates different tracks with different MIDI addresses for the overdubs.

Recording keyboard sounds using real time software via MIDI has a multitude of advantages over using tape. But the greatest advantage of all is that no degradation of signal is experienced, which is not the case when multitrack recording is run on a tape deck.

The main disadvantage of MIDI real time recorders is that each track of the real time recorder (represented by a MIDI address) requires its own sound source, whereas with a multitrack recorder the same synthesiser can be overdubbed on each channel, using a different sound for each overdub. However, some MIDI sound modules and synthesisers can receive on more than one MIDI address at the same time, such as the Roland MKS7 Super Quartet.

As a conclusion, I hope that this explanation of MIDI has enlightened you on a creative and interesting application of the personal computer. With MIDI, creativity can be combined with a bit of technical competence to produce some expressive and 'feelingful' music. ●

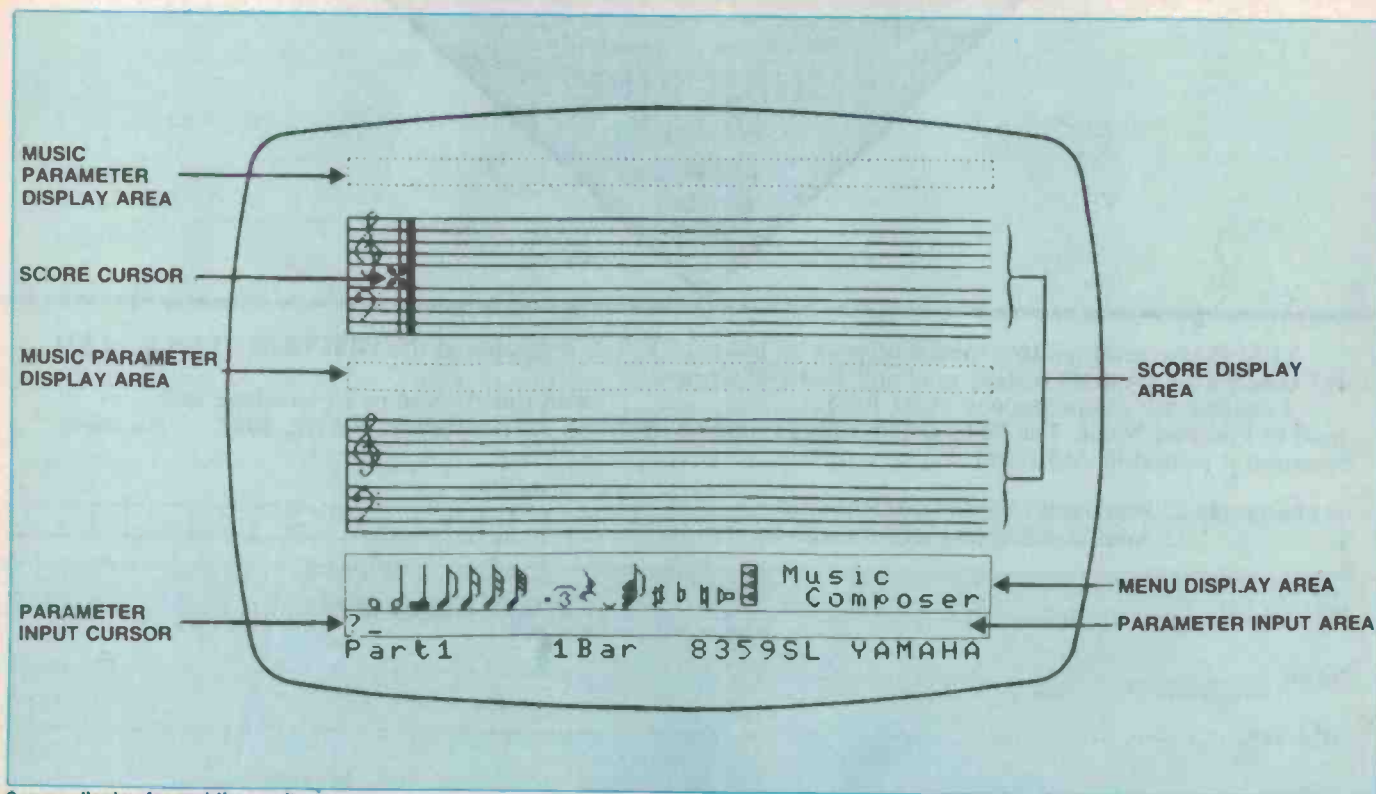

Screen display for real time software.



# Even our tiniest transformer has to earn its stripes.

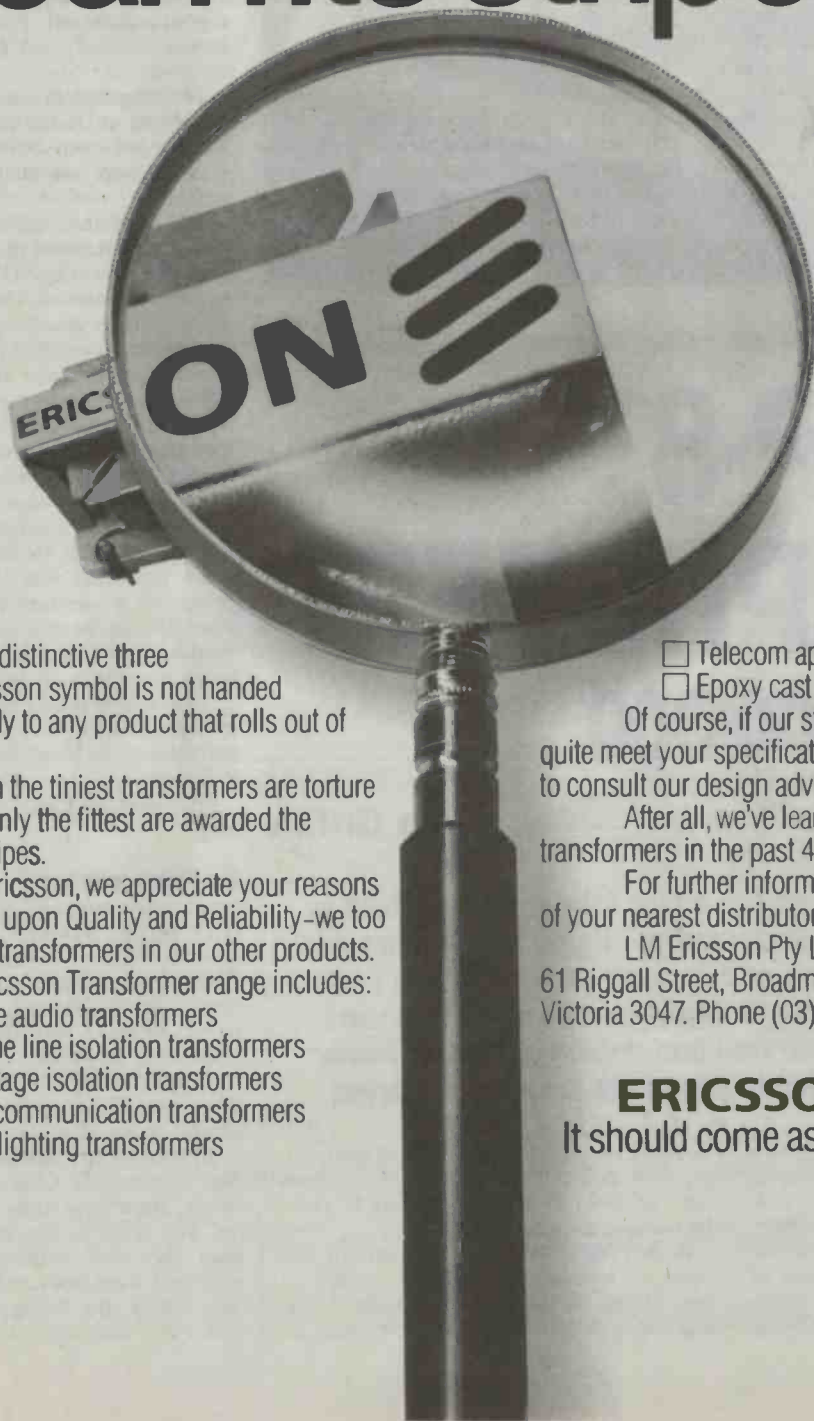

The distinctive three striped Ericsson symbol is not handed out willy-nilly to any product that rolls out of the factory.

Even the tiniest transformers are torture tested and only the fittest are awarded the Ericsson stripes.

At Ericsson, we appreciate your reasons for insisting upon Quality and Reliability—we too employ our transformers in our other products.

The Ericsson Transformer range includes:

- Miniature audio transformers
- Telephone line isolation transformers
- High voltage isolation transformers
- General communication transformers
- Runway lighting transformers

- Telecom approved transformers
- Epoxy cast transformers

Of course, if our standard range doesn't quite meet your specifications, please feel free to consult our design advisory service.

After all, we've learned a lot about transformers in the past 45 years.

For further information, or the address of your nearest distributor, please contact

LM Ericsson Pty Ltd,  
61 Riggall Street, Broadmeadows,  
Victoria 3047. Phone (03)3092244.

**ERICSSON**   
It should come as no surprise.



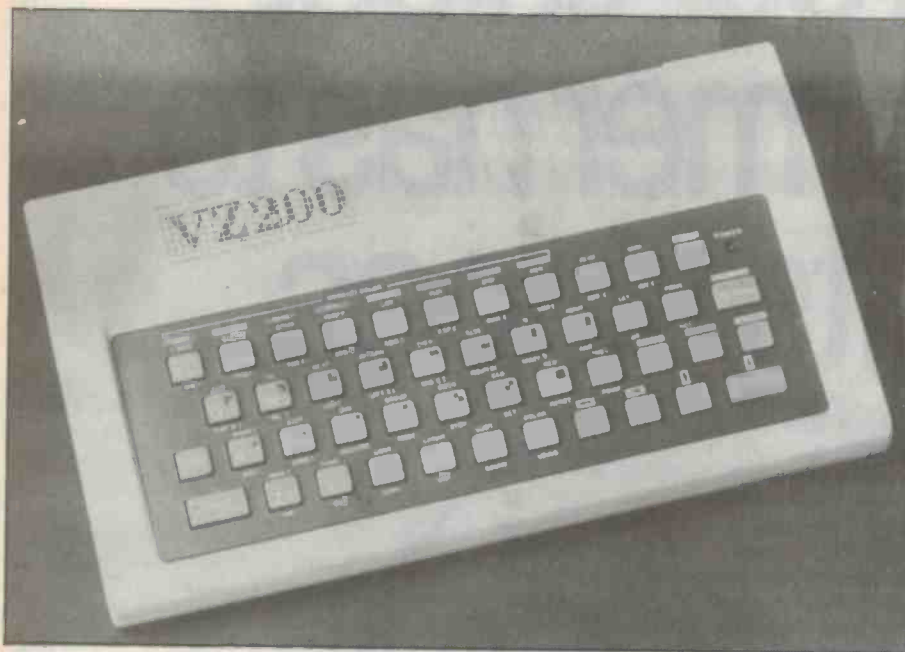

# A CHIP-8 INTERPRETER — for VZ200/300

Chris Griffin

How's it going? Did you get the editor from the last article in August '86, typed in, up, and running? If you had any trouble refer to the note at the end of the article. In this article I use the editor to set up the Chip-8 interpreter, to write and run Chip-8 programs. I will also mention details of this particular dialect and show a few simple programs to get you started.

THE CHIP-8 interpreter (Listing 1) is a machine language program which executes instructions beginning at location 8200 (this is in hex — remember!). The interpreter has an 'address space of 4K, meaning that it can only access 4096 bytes of memory. Therefore only three hex digits are required to specify an address. 8200 is

referred to as 200 by the Chip-8 interpreter, 54A refers to 854A, etc. So, if from time to time, I drop the leading 8, don't be too bothered about it!

Each Chip-8 instruction consists of two bytes of hexadecimal data — a total of four digits. Between 200 and AFC, the locations in which a program may be

stored, there is thus room for about 1150 instructions. You can also use locations (8)000 to (8)1FF to store parts of the program, but never forget that execution is from location 200, so you'll have to use this section of memory for subroutines or shape data.

Chip-8 is a 'what you write is what you get' sort of language in that there is no way to break out of a program that is running, unless you have allowed for this possibility. This is one aspect that could take a little getting used to, but don't worry, you will! The Chip-8 interpreter has in this regard a trade off. A little speed is gained in the sacrifice; and for me, the speed is worth it!

The language of Chip-8 supports only 16 variables, an index register, and a stack pointer (which is rarely used in programs — it is more useful to the interpreter itself!).

The variables, labelled by a 'V', followed by a number (0,1,2...D,E or F), are each one byte long. They can only be used to store numbers in the range 0 to 255, so all operations involving variables are limited in this way. If any extra space is required to store the answer to a calculation, VF is used for the extra piece. (It is called the carry, and is only relevant to a few arithmetic commands. Larger number manipulation is available to a limited degree, using the index register called 'I'. This is a 12-bit number (3 hex digits) and is used to point to memory locations in much the same way that the editor program has a memory pointer. When you store 6B0 in the index register, it points to location 86B0, as might be expected! The index register is an important part of the system as it is used extensively in graphics manipulation; it also allows more than 16 variables to be used by a single program, if desired.

OK, now let's get things up and running!

## Getting started

Load your copy of the editor program (ETI August 86 issue), and run it. Then, type in Listing 1 beginning at location 7AE9 (type M7AE9 (cr) P then the data shown in the listing). Check the things typed, to make sure they are correct and type in the following:

(i) M9BDF (cr) P0082 (cr)

This sets the memory pointer to 8200 whenever the editor is run.

(ii) M8EC7 (cr) PE97A (cr)

This connects the Chip-8 interpreter to the editor, allowing it to be activated by pressing XC. 8EC7 is the location which contains the start address for the routine which we want activated by XC — and we store 7AE9, the interpreter start address, here. By the way, locations 8EBF to



8ECD contain the start addresses for all of the X commands (XC through XF), so it's easy to add your own!

(iii) M8200 (cr) PF000 (cr)

A very short Chip-8 program, just to test things out.

Now, save everything. Use OVZCHIP8 (cr) 7AE9 (cr) 8F30 (cr) if you have a tape system, or use BBSAVE "VZCHIPS", 7AE9, 8F30 (cr) if disks are your forte (after saving to disk, you can restart the editor with ?USR(O)).

Let's run the Chip-8 program entered in (iii) above, by pressing XC. The screen should have flashed, and the editor restarted. If it has, so far so good. If not, check that the interpreter you typed in is the same as mine! Tape users will probably have to start all over again!! (This is because B: programs run automatically from tape, but not from disk.) When everything works thus far, read on...

### Chip-8 graphics

Graphics takes place on the VZ's mode 1 screen. The individual points are labelled with two coordinates in exactly the same manner as BASIC (except, everything is in hex). Chip-8 allows you to display points (like BASIC), entire shapes (of up to 8 x 16 dots) and line drawings in 256 sizes (although there are some restrictions!) in any combination of colours you care to imagine. (Of course, only four colours can be used at once in this mode — there is little that can be done about this.) An object can be positioned anywhere on the screen, even overlapping another object. Overlapping objects are stored on the screen in exclusive-or form. Table 1 shows the consequences of this in colour mode 0 (COLOR, 0), which is read as: 'if a red object is placed on a blue area of the screen, the overlap is displayed in yellow' etc. Funny idea? Not really! These conditions allow you to remove objects by simply re-displaying them. If we number the colours 0 for green, 1 for yellow, 2 for blue, 3 for red, and change to COLOR, 1 mode the same sort of ideas apply to buff, cyan, magenta and orange.

A collision occurs if the following pairs of colours overlap: 1&1, 2&2, 3&3, 3&1, 3&2. Collisions are registered through an object called 'HIT'. HIT equals 1 means that there has been a collision, HIT equals 0, otherwise. After a graphics command has been executed, HIT is stored in VF (variable F), to allow you to check for collision with Chip-8 instructions.

### Shape drawing

A 'SHAPE' is eight dots wide, and between 1 and 16 dots long, and is considered as residing in a grid (see Figure 1 for

TABLE 1. COLOUR OVERLAP

Overlapping colours	Green	Yellow	Blue	Red
Green	Green	Yellow	Blue	Red
Yellow	Yellow	Green	Red	Blue
Blue	Blue	Red	Green	Yellow
Red	Red	Blue	Yellow	Green

an example 8 x 9 shape in its grid). Each row of the shape is represented by two bytes of data, that is, four dots to each byte. The colour of each dot can be independently defined using the number of the colour that is required.

For the first row of the shape down, we have two green dots (which are in essence invisible) five blue dots, and one green dot. The colour codes are 0,0,2,2,2,2,2,0. Group this information into clusters of two digits: 00 22 22 20, then for each cluster, multiply the first digit by 4 and add the second to it, giving 0 A A 8 in our example. The two bytes used to describe this row are thus 0A and A8. Every other row is complete in exactly the same manner and the data stored in a segment of memory.

		B	B	B	B	B	
		B	Y	B	Y	B	
		B	B	B	B	B	
				R			
			R	R	R		
	R	R		R		R	R
			R				
			R		R		
		R				R	

Figure 1. Example of a nine row shape (a robot figure). Each square is filled with the colour that is desired. Those with no colour are green by default, as this behaves invisibly. Y — yellow colour value is 1  
B — blue colour value is 2  
R — red colour value is 3  
The last row, for example, is 00300030, which is 0C0C in hex.

To put this shape up onto the screen, we set the index register I to point to the first byte of the shape data, and use a SHOW command. From the table of Chip-8 commands (Table 2), it is obvious that the SHOW command is D<sub>x</sub>yn, but what does that mean? An example should make this clearer: D456 will show a shape, six rows long, with the top left

hand corner at (V4,V5). If we want to display the example shape at (V3,V4), then use the command D349 — the 9 means that our shape is nine rows long.

Let's write up a real Chip-8 program now.

### Writing Chip-8 programs

To write a Chip-8 program, simply put the instructions, one after another, in memory from location 200 onwards. Consider the short program that we typed in earlier; pressing XC did nothing much, so what was the Chip-8 program? Well, it consisted of the single instruction F000, which from Table 2, 'jumps back to the editor, or restarts the program if the editor is not found' — in other words: END! So, that's why nothing much happened! For a real program, see Listing 2a. Type this one in (from 8200), and run it XC. You should get the picture we designed earlier in the top left hand corner of the screen. Press a key, and the program ends. Do you understand what went on? The comments given may be of some help! Notice that we didn't need to switch on mode 1 graphics — it's automatic! (Chip-8 operates entirely in this mode.) For more examples, we need more concepts so read on.

### Colour registers

The colour register is another VZ/Chip-8 object — like HIT. This, however, is used to store colour data for some commands (F<sub>x</sub>29, 8<sub>x</sub>yD and 8<sub>x</sub>yE). The register takes on the following values for colours: 00 — invisible or colour 0, 55 — colour 1, AA — colour 2, FF — colour 3. All other values give combinations of these, and are best experimented with! To load the colour register with 55, we could use the following sequence of code. 6F55 FFCC, which says, load VF with 55, then load the colour register with VF. Once the colour is set, we can use 8<sub>x</sub>yD to plot a point, or F<sub>x</sub>29 to draw a number, in the colour that we have defined. Type in and run Listing 2b for an idea of colour register graphics operation.

### Joysticks and keyboard

The command ExB4, reads both joysticks at once, and assigns V<sub>x</sub> to one of the following values, depending on the joystick position: 00 — nothing, 2E — up, 20 — down, 4D — left, 2C — right, OD — fire. These codes were chosen as they correspond to the cursor control keys on the VZ keyboard. Using ExB3 instead of ExB4 reads the keyboard and allows the result of this command to be treated in an identical manner to the ExB4 command it replaces. The break key returns a value of 01 if it is pressed, so it too can be easily tested for.



# CHIP-8 INTERPRETER

## Printing out numbers

See Listing 2c for an example of number printing. The Chip-8 interpreter has shape data for the numbers 0,1,2,3...D,E,F automatically built in. All that is required is to retrieve them. The statement Fx29 does just that: retrieves the shape data for the last digit of Vx. If V8 is 7A, F829 retrieves data for the number A, and sets the index register to point to the place where the retrieve data is stored, so that the next display command will show the correct thing. (The data is stored in system memory and will never get in the way of one of your Chip-8 programs.) That's OK for single digit numbers. But what about bigger ones, like 8A, EB etc, or even decimal numbers (for game scores, for instance)?

The process of printing decimal numbers is easy, but fairly long, if you write in Chip-8. See Listing 2d, which repeatedly counts from 0 to 99, for an example. Some important commands are the following.

(i) Fx33, converts Vx to a three digit decimal number, and stores each digit in a different memory location, pointed to by the index register. The hundreds get stored at I, tens at I plus 1, and units at I plus 2, so that if we could load these values into variables, each digit could be displayed in the usual way.

(ii) F265 loads the memory from I, into variables V0, V1 and V2. V0 contains the hundreds, V1 the tens, V2 the units. We can now easily display each digit.

Notice also that the printing process is put in a subroutine at location 228, this saves me repeating the whole process in order to remove the numbers. (Recall: to remove things in Chip-8, simply re-display them.)

## How to draw large shapes

8xyE is a command designed to draw large shapes on the graphics screen. Often, the object to be drawn is simple in structure, yet too big for a single 8 x 16 dot shape so under these circumstances, this command is used. 8xyE uses data pointed to by the index register, and also a 'SIZE' value stored in VF, to draw the shape from the point (Vx, Vy). VF equals 1 allows the shape to be drawn exactly as defined. VF equals 2 draws the shape twice the size in both x and y directions, etc. Shape data is given by a series of bytes, from two to as many as required. (Shape data for this command has no maximum length.) The last byte is always 00, required to tell the interpreter when the end has been reached! Each byte, which is made up of eight bits, contains eight pieces of infor-

TABLE 2 — VZ/CHIP-8 COMMAND SUMMARY

0000	No operation. Does nothing.	Cxyy	Load Vx with a random number ANDed with yy.
00A0	Store I on the subroutine stack.	Dxyn	Show a pattern with data pointed to by I, consisting of n rows with the top left hand corner at (Vx,Vy).
00A8	Take I off the subroutine stack.	Ex9E	Skip the next instruction if Vx equals the key that is down.
00AE	Load I with the subroutine stack pointer.	ExA1	Skip the next instruction if Vx does not equal the key that is down.
00C0	Set colour to set 0 (green background).	ExB3	Load Vx with the key that is currently down.
00C1	Set colour to set 1 (buff background).	ExB4	Load Vx with the present joystick position.
00E0	Clear the screen.	F000	Jump back to the editor or restart the program if no editor is present.
00EE	Return from a subroutine.	Fx02	Set the sound pitch to Vx.
0nnn	For nnn larger than OFF, calls a machine code routine at location 8nnn. Allows user machine code subroutines.	Px0A	Wait for a key to be pressed and load Vx with that key.
1nnn	Go to 8nnn.	Fx18	Beep for Vx cycles.
2nnn	Go sub 8nnn.	Fx19	Produce white noise (hiss) for Vx cycles.
3xyy	Skip the next instruction if Vx equals yy.	Fx1E	Add Vx to I.
4xyy	Skip the next instruction if Vx does not equal yy.	Fx29	Produce a digit pattern for the last digit of Vx and point I at this pattern (colour is given by colour register).
5xy0	Skip the next instruction if Vx equals Vy.	Fx33	Convert Vx to a decimal number and store each digit in a different byte (100s, 10s, 1s in 3 bytes from 1).
6xyy	Load Vx with yy.	Fx55	Store V0 through Vx to memory pointed to by I (on completion, I is I plus x plus 1).
7xyy	Add yy to Vx.	Fx65	Load V0 through Vx from memory pointed to by I (on completion, I is I plus x plus 1). Opposite of Fx55.
8xy0	Load Vx with Vy.	FxCC	Load the colour register with Vx.
8xy1	Load Vx with Vx OR Vy.	Any other commands should be avoided — their functions are not defined, but in general, they do not represent no operation.	
8xy2	Load Vx with Vx AND Vy.		
8xy3	Load Vx with Vx XOR Vy (exclusive or).		
8xy4	Load Vx with Vx plus Vy (the carry is stored in VF).		
8xy5	Load Vx with Vx minus Vy (the carry is stored in VF).		
8xy6	Load Vx with Vx multiplied by Vy (carry is in VF).		
8xyD	Plot a point at coordinates (Vx,Vy) with colour as in the colour register.		
8xyE	Draw a shape with data pointed to by I, of size VF, beginning at the point (Vx,Vy).		
9xy0	Skip next instruction if Vx does not equal Vy.		
Annn	Load I with 8nnn.		
Bnnn	Go to 8nnn plus V0.		

TABLE 3. PITCH/DURATION VALUES FOR SOUND COMMANDS

Pitch	Duration 2	Duration 1	Duration 1/2	Duration 1/4
C 79	79	3C	1E	0F
Db 72	80	40	20	10
D 6C	88	44	22	11
Eb 66	90	48	24	12
E 60	98	4C	26	13
F 5B	A0	50	28	14
Gb 55	AB	55	2B	15
G 50	B5	5B	2D	17
Ab 4C	C0	60	30	18
A 48	CB	66	33	19
Bb 44	D7	6C	36	1B
B 40	E4	72	39	1C
C 3B	F2	79	3B	1E

(Other octaves can be approximated by halving and doubling the pitch and duration values.)

PLOT	LEFT	RIGHT	DOWN	UP	FOUR	TWO	ONE
------	------	-------	------	----	------	-----	-----

Figure 2. 8xyE allocation of bits. A '1' in the bit position activates the associated words, eg, PLOT UP and LEFT 5 is 11001101.

mation; Figure 2 gives the key to this. The process of drawing a shape involves directing an invisible cursor about the screen (in eight possible directions), leaving trails as we go if required! A typical instruction to the cursor might be: PLOT UP 2 DOTS, which is coded as 1 0 0 0 1 0 1 0 using 1s

and 0s. To get this in hexadecimal form, group data into groups of four: 1000 1010. For each group, convert the binary number into hexadecimal, in this example: 8A.

Example: A square. To draw a square, imagine the following cursor instructions: ▶





# MICRO-EDUCATIONAL PTY LTD

8/235 DARBY ST NEWCASTLE 2300 Ph (049) 26 4122

*Australia's Largest Computer Mail-Order Company*

# FREE SOFTWARE

for your IBM, APPLE or Macintosh (add \$5 for Mac disks)  
**HURRY! ORDER NOW!**

- **FREE** Winter Newsletter
- **FREE** Micro-Educational pen.
- **FREE** Library Disk for your Apple, IBM or MAC.

### BLANK DISKS

Top-quality, US-made:  
 5.25 SSDD **\$1.70!**  
 5.25 DSDD **\$1.90**  
 3.5 SS/DSDD **\$5!!!**  
 Lifetime Warranty.

We're up to Library Disk#5 on the Apple, #2 on the IBM and #1 on the Mac. These are our selection from the best public domain programs which we collect into our Disk Library. Previously available only to customers spending over \$50 with us, we have decided to give these away FREE in this magazine offer.

**TO ORDER** your FREE Library Disk send the Order Form below together with 6 x 36c stamps to cover postage. (Macintosh owners please add \$10 to cover cost of 3.5" disk.)

If you hurry, we'll even include a FREE Micro-Educational pen AND our FREE Winter Newsletter.

**WHY DO WE DO IT?** To introduce you to the cheapest and most convenient way ever devised to buy computer gear. Mail (and phone, AND VIATEL) Order. In the US 30% of all computer goods are purchased through direct mail-order.

**WHY?** Because it's cheap, reliable and incredibly convenient. In Australia, Micro-Educational is now the largest single retailer of computer diskettes, with mail-order retail sales this year exceeding one million disks.

### ARE YOU STILL PAYING THROUGH THE NOSE FOR COMPUTER EQUIPMENT?

If you're not buying direct from us chances are you are! If you think mail-order is risky or a little bit shonky, try us out. We've been around long enough to be proud of our reputation and service, and we feel we have the cheapest, most efficient service around.

**AND WE KNOW ABOUT COMPUTERS.** Our team are highly knowledgeable in the fields of Apple, IBM, Macintosh, Laser Typesetting, Modem and Viatel communications, applications software and hardware servicing. We are not just a retailer. We back everything we sell with in-house technical and workshop backing and provide extensive telephone support.



Mail to: P.O. 160 THE JUNCTION 2291

## ORDER FORM

**SPECIAL:** Full set of  
 Apple disks 1-5  
**\$20**

Dear George,

Please rush me the following: \_\_\_\_\_

for my Apple II+/IIc/IIc/IBM/Macintosh/ OTHER \_\_\_\_\_ computer by overnight courier.  
 Enclosed please find 6 x 36c stamps/cheque/purchase order/ Bankcard/Mastercard/VISA

# \_\_\_\_\_ for \$ \_\_\_\_\_ which includes \$6/\$12 courier (\$12>5Kg)

NAME: \_\_\_\_\_ ADDRESS: \_\_\_\_\_

P/CODE: \_\_\_\_\_





# CHIP-8 INTERPRETER

## LISTING 1.

```

7AE9 = F3 31 FF 8F 3E 09 32 3B   7C71 = 7F C9 21 20 7F 34 6E 26   7DF9 = 1A 2A 10 7F 06 64 CD 09
7AF1 = 78 CD 9C 7B 00 00 00 21   7C79 = 24 3A 21 7F 86 2B AE 32   7E01 = 7E 06 0A CD 09 7E 77 C9
7AF9 = FF 7F 22 1C 7F 21 00 82   7C81 = 21 7F A1 12 C9 79 E6 0F   7E09 = 0E 00 18 02 0C 90 B8 30
7B01 = 22 1E 7F 2A 1E 7F 46 23   7C89 = B7 20 02 3E 10 D9 47 D9   7E11 = FB 71 23 C9 1A 32 E5 7D
7B09 = 4E 23 22 1E 7F 78 E6 0F   7C91 = CD E5 7B 7E 26 00 87 87   7E19 = 32 5F 7E C9 1C 4B 06 00
7B11 = 5F 16 7F C6 80 08 78 1F   7C99 = 6F 29 29 29 44 4D 1A E6   7E21 = 58 2A 10 7F C3 F5 7E 1C
7B19 = 1F 1F E6 1E C6 2E 6F 26   7CA1 = 03 D9 CD 70 7E 5F 08 D9   7E29 = 4B 06 00 58 2A 10 7F EB
7B21 = 7B 08 47 7E 23 6E 67 CD   7CA9 = AF 32 0F 7F 2A 10 7F 56   7E31 = C3 28 7F 1A 4F 46 AF 32
7B29 = 2D 7B 18 D7 E9 78 4E 7B   7CB1 = 23 5E 23 E5 2E 00 79 87   7E39 = 0F 7F CB 79 C0 78 FE 40
7B31 = 61 7D C4 7B D4 7B E0 7B   7CB9 = 28 09 CB 3A CB 1B CB 1D   7E41 = D0 87 87 6F 26 00 29 29
7B39 = F0 7B FC 7B FF 7C 03 7B   7CC1 = 3D 20 F7 7A CD E4 7C 7B   7E49 = 29 79 51 00 1F 1F E6 1F
7B41 = F6 7C 63 7C 68 7C 73 7C   7CC9 = CD E4 7C 7D CD E4 7C D9   7E51 = 4F 06 70 09 7A E6 03 C6
7B49 = 86 7D 00 7D 3D 7B B7 20   7CD1 = 79 C6 20 4F 78 CE 00 E6   7E59 = 6C 5F 16 7E 1A E6 FF 57
7B51 = 70 79 FE EE 20 0F 2A 1C   7CD9 = 07 47 08 5F 08 D9 E1 10   7E61 = AE 77 A2 BA CB 3E 01 32
7B59 = 7F 23 46 23 4E 22 1C 7F   7CE1 = CE D9 C9 D9 B7 28 11 60   7E69 = 0F 7F C9 C0 30 0C 03 4F
7B61 = ED 43 1E 7F C9 FE AE 38   7CE9 = 69 16 70 19 57 AE 77 A2   7E71 = D9 1A 1F 1F E6 1F C9 1A
7B69 = 09 20 2C 2A 1C 7F 22 10   7CF1 = BA 28 05 3E 01 32 0F 7F   7E79 = 4F 46 3A 0F 7F 5F DD 2A
7B71 = 7F C9 FE A8 20 0F 2A 1C   7CF9 = 7B 3C E6 1F 5F D9 C9 79   7E81 = 10 7F AF 32 0F 7F 18 11
7B79 = 7F 23 46 23 4E ED 43 10   7D01 = FE B3 28 19 30 1E D9 CD   7E89 = D5 78 08 78 84 47 79 85
7B81 = 7F 22 1C 7F C9 FE A0 C0   7D09 = F4 2E D9 47 1A B8 79 28   7E91 = 4F 08 3D 20 F5 15 20 F1
7B89 = 2A 1C 7F ED 5B 10 7F 73   7D11 = 06 FE A1 C0 C3 D7 7B FE   7E99 = D1 CD CB 7E C8 CB 7F 28
7B91 = 2B 72 2B 22 1C 7F C9 FE   7D19 = 9E C0 C3 D7 7B D9 CD F4   7EA1 = E7 D5 7B 08 C5 D9 C1 CD
7B99 = E0 20 13 21 00 70 11 01   7D21 = 2E D9 12 C9 DB 20 06 05   7EA9 = 3B 7E D9 78 84 47 79 85
7BA1 = 70 75 01 FF 07 ED B0 3A   7D29 = 1F 30 02 10 FB 3E 37 80   7EB1 = 4F 08 3D 20 EE 15 20 EA
7BA9 = 3B 78 32 00 68 C9 E6 F0   7D31 = 6F 26 7D 7E 12 C9 00 0D   7EB9 = D1 CD CB 7E C8 CB 7F 20
7BB1 = FE C0 C0 79 17 17 17 17   7D39 = 2C 4D 20 2E 79 FE 29 28   7EC1 = E0 C5 D9 C1 CD 3B 7E D9
7BB9 = E6 10 C6 09 32 3B 78 18   7D41 = 48 30 44 FE 18 28 44 30   7EC9 = 18 BE 21 00 00 DD 7E 00
7BC1 = E6 C5 C9 2A 1C 7F ED 5B   7D49 = 51 FE 02 20 09 1A 6F 26   7ED1 = B7 C8 E6 07 20 02 3E 08
7BC9 = 1E 7F 73 2B 72 2B 22 1C   7D51 = 00 23 22 96 7D C9 FE 0A   7ED9 = 57 DD 7E 00 DD 23 CB 77
7BD1 = 7F 18 8D 1A B9 C0 2A 1E   7D59 = 20 1B D9 CD F4 2E B7 20   7EE1 = 28 01 2D CB 6F 28 01 2C
7BD9 = 7F 23 23 22 1E 7F C9 1A   7D61 = FA CD F4 2E B7 28 FA CD   7EE9 = CB 67 28 01 24 CB 5F 28
7BE1 = B9 C8 18 F2 79 1F 1F 1F   7D69 = F4 2E B7 28 F4 08 CD 50   7EF1 = 01 25 B7 C9 ED B0 22 10
7BE9 = 1F E6 0F 6F 26 7F C9 CD   7D71 = 34 08 D9 12 C9 21 FE 8A   7EF9 = 7F C9 00 00 00 00 00 11
7BF1 = E5 7B 4E 18 DE CD E5 7B   7D79 = 7E FE E5 20 04 23 7E FE   7F01 = 11 11 11 11 11 11 11 11
7BF9 = 4E 18 E4 79 12 C9 1A 81   7D81 = 8B C2 E9 7A C3 FD 8A 18   7F09 = 11 11 11 11 11 11 11 11
7C01 = 12 C9 CD E5 7B 79 E6 0F   7D89 = 65 18 42 1A 6F 26 00 29   7F11 = 11 11 11 11 11 11 11 11
7C09 = FE 06 28 2F 30 47 FE 03   7D91 = 29 23 4D 44 21 2D 00 C3   7F19 = 11 11 11 11 11 11 11 11
7C11 = 28 13 30 15 B7 20 03 7E   7D99 = 5C 34 FE 1E 20 0C 2A 10   7F21 = 11 00 00 00 00 00 00 ED
7C19 = 12 C9 3D 20 04 1A B6 12   7DA1 = 7F 1A 4F 06 00 09 22 10   7F29 = B0 EB 22 10 7F C9 00 FC
7C21 = C9 1A A6 12 C9 1A AE 12   7DA9 = 7F C9 1A 6F D9 16 21 5A   7F31 = CC CC CC FC 30 30 30 30
7C29 = C9 FE 04 20 0A 1A 86 12   7DB1 = 4A D9 3A 3B 78 57 0E 10   7F39 = 30 FC 0C FC C0 FC FC 0C
7C31 = 3E 00 8F 32 0F 7F C9 1A   7DB9 = D9 CD 73 7C D9 AA 57 32   7F41 = FC 0C FC C0 C0 CC FC 0C
7C39 = 96 18 F4 D5 4E 1A 5F 06   7DC1 = 00 68 06 70 10 FE 0D 20   7F49 = FC C0 FC 0C FC FC C0 FC
7C41 = 08 16 00 62 6A 29 CB 11   7DC9 = EF 2D 20 EA C9 1A E6 0F   7F51 = CC FC FC 0C 0C 0C 0C FC
7C49 = 30 01 19 10 F8 D1 7D 12   7DD1 = 47 87 87 80 C6 30 5F 16   7F59 = CC FC CC FC FC CC FC 0C
7C51 = 7C 32 0F 7F C9 FE 0D CA   7DD9 = 7F 0E 05 41 21 12 7F 22   7F61 = FC FC CC FC CC CC FC CC
7C59 = 34 7E FE 0E CA 78 7E C9   7DE1 = 10 7F 1A E6 FF 77 23 13   7F69 = FC CC F0 FC C0 C0 C0 FC
7C61 = 00 00 ED 43 10 7F C9 3A   7DES = 36 00 23 10 F5 C9 FE 65   7F71 = F0 CC CC CC F0 FC C0 FC
7C69 = 00 7F 6F 26 00 09 22 1E   7DF1 = 28 2A 30 20 FE 33 20 2F   7F79 = C0 FC FC C0 F0 C0 C0 00
7DF9 = 1A 2A 10 7F 06 64 CD 09
7E01 = 7E 06 0A CD 09 7E 77 C9
7E09 = 0E 00 18 02 0C 90 B8 30
7E11 = FB 71 23 C9 1A 32 E5 7D
7E19 = 32 5F 7E C9 1C 4B 06 00
7E21 = 58 2A 10 7F C3 F5 7E 1C
7E29 = 4B 06 00 58 2A 10 7F EB
7E31 = C3 28 7F 1A 4F 46 AF 32
7E39 = 0F 7F CB 79 C0 78 FE 40
7E41 = D0 87 87 6F 26 00 29 29
7E49 = 29 79 51 00 1F 1F E6 1F
7E51 = 4F 06 70 09 7A E6 03 C6
7E59 = 6C 5F 16 7E 1A E6 FF 57
7E61 = AE 77 A2 BA CB 3E 01 32
7E69 = 0F 7F C9 C0 30 0C 03 4F
7E71 = D9 1A 1F 1F E6 1F C9 1A
7E79 = 4F 46 3A 0F 7F 5F DD 2A
7E81 = 10 7F AF 32 0F 7F 18 11
7E89 = D5 78 08 78 84 47 79 85
7E91 = 4F 08 3D 20 F5 15 20 F1
7E99 = D1 CD CB 7E C8 CB 7F 28
7EA1 = E7 D5 7B 08 C5 D9 C1 CD
7EA9 = 3B 7E D9 78 84 47 79 85
7EB1 = 4F 08 3D 20 EE 15 20 EA
7EB9 = D1 CD CB 7E C8 CB 7F 20
7EC1 = E0 C5 D9 C1 CD 3B 7E D9
7EC9 = 18 BE 21 00 00 DD 7E 00
7ED1 = B7 C8 E6 07 20 02 3E 08
7ED9 = 57 DD 7E 00 DD 23 CB 77
7EE1 = 28 01 2D CB 6F 28 01 2C
7EE9 = CB 67 28 01 24 CB 5F 28
7EF1 = 01 25 B7 C9 ED B0 22 10
7EF9 = 7F C9 00 00 00 00 00 11
7F01 = 11 11 11 11 11 11 11 11
7F09 = 11 11 11 11 11 11 11 11
7F11 = 11 11 11 11 11 11 11 11
7F19 = 11 11 11 11 11 11 11 11
7F21 = 11 00 00 00 00 00 00 ED
7F29 = B0 EB 22 10 7F C9 00 FC
7F31 = CC CC CC FC 30 30 30 30
7F39 = 30 FC 0C FC C0 FC FC 0C
7F41 = FC 0C FC C0 C0 CC FC 0C
7F49 = FC C0 FC 0C FC FC C0 FC
7F51 = CC FC FC 0C 0C 0C 0C FC
7F59 = CC FC CC FC FC CC FC 0C
7F61 = FC FC CC FC CC CC FC CC
7F69 = FC CC F0 FC C0 C0 C0 FC
7F71 = F0 CC CC CC F0 FC C0 FC
7F79 = C0 FC FC C0 F0 C0 C0 00
7F81 = 00 0

```

PLOT RIGHT 1 DOT, PLOT DOWN 1 DOT, PLOT LEFT 1 DOT, PLOT UP 1 DOT, END. From Figure 2, the codes are: 10100001, 10010001, 11000001, 10001001, '00'. That is: A1 91 C1 89 00 in hex. The program shown in Listing 2e uses this data to draw squares

of random sizes all over the screen — try it!

### Using sound commands

Table 3 shows pitch and duration values used in VZ/Chip-8 sound commands. The values given here are not tuned to a stand-

ard pitch, but are chosen so that the scale sounds reasonably tuneful when played.

To play a note, of duration V1, at pitch V2, use a segment of code like: F292 F118. Be sure to use the correct duration for the pitch under consideration, otherwise your tunes will sound uneven! You



### LISTING 2a.

```
8200 — 6A 00 — put '00' to VA
      A2 0A — point I at 820A, the start of the shape data
      DA A9 — show a nine row shape at (VA,VA) ie (0,0)
      FB 0A — wait for a key to be pressed, store its value in VB
      F0 00 — end
820A — 0A A8
      09 98
      0A A8
      00 C0
      03 F0
      3C CF
      00 C0
      03 30
      0C 0C
```

} data for the shape in Figure 1.

### LISTING 2b. RANDOM DOTS

```
8200 — CA 7F — put a random number (less than 7F) to VA
      CB 3F — put a random number (less than 3F) to VB
      CC FF — put a random number in VC
      FC CC — load the colour register with VC (ie: random colours)
      8A BD — plot a point at (VA,VB), a random screen position
      EF B3 — scan the keyboard and load the key pressed into VF
      3F 01 — if that key is '01' (the BREAK key), skip the next instruction
      12 00 — otherwise, go back to the start (plot another point)
      F0 00 — end; if BREAK key is down, the program will end
```

### LISTING 2c. SCREEN FULL 0' NUMBERS

```
8200 — 6F AA
      FF CC — load colour register with blue
      6A 00 — '00' to VA
      6B 00 — '00' to VB
8208 — 6C 00 — '00' to VC
820A — FC 29 — prepare to show VC as a number
      DA B5 — show the number at (VA,VB)
      7A 08 — Increase VA by '08', the next number will be beside the one just shown
      7C 01 — increase VC by '01', the next number to display is one more than the last
      3C 10 — if the whole row has been shown, skip next instruction
      12 0A — otherwise, go back to 820A and show another number
      7B 08 — prepare to show on next row; increase VB by '08'
      3B 40 — if we have finished the last row, skip next instruction
      12 08 — otherwise, go back to 8208, begin a new row
      FF 0A — full screen; wait for a key to be pressed
      F0 00 — end
```

### LISTING 2d. COUNTING

```
8200 — 6F FF FF CC 6A 00 22 28 6B 00 6C 00 7C 01 3C 00
8210 — 12 0C 7B 01 3B 06 12 0A 22 28 7A 01 4A 64 6A 00
8220 — EF B3 3F 01 12 06 F0 00 A2 40 FA 33 A2 40 F2 65
8230 — 6B 00 6C 00 F1 29 DB C5 7B 04 F2 29 DB C5 00 EE
8240 — 00 00 00 00
```

### LISTING 2e. LOTS OF SQUARES

```
8200 — 65 FF F5 CC 6A 00 C6 7F C7 3F C5 1F 86 55 87 55
8210 — 85 54 75 01 8F 50 A2 24 86 7E 7A 01 3A 20 12 06
8220 — FF 0A F0 00 A1 91 C1 89 00 00
```

### LISTING 2f. CHIRP

```
8200 — CE 07 7E 02 CA 0F FA 02 FE 18 7A 01 3A 18 12 06
8210 — EF B3 3F 01 12 00 F0 00
```

don't have to stick to the pitch and duration values shown in Table 3, so other effects, such as sirens, can be created. A sample sound program is shown in Listing 2f.

### Saving completed programs

When you have written a program, and are satisfied that it does what you want, save it. There are two options here:

(i) Save the program *with* the editor. This is for programs which still have not been fully finished. Save all memory from 7AE9 to 8F30.

(ii) Save the program *without* the editor. This is for complete programs, only save memory from 7AE9 to the end of your Chip-8 program.

In either of the above cases, tape users will have to put up with the program running whenever it is loaded, so if the program is incomplete, make sure it ends otherwise you will never be able to edit it!

*NOTE: We have had complaints from readers who could not get the editor listed last month running. Printed below are corrections to lines 70 and 380, and two new lines 770, 780 to be added. As well as this, we understand that in some issues of the magazine, the figure 32 between 90 and D6 in line 510 was printed so indistinctly as to look like 37. So if you have any problems after amending the listing, check line 510.*

### CORRECTIONS TO THE 'EDITOR' LISTING.

THE FOLLOWING ARE THE CORRECTED LINES.

70 IFT = 118550, PRINTUSR (1)

380 DATA10,78,C9,DF,20,E9,F1,11,  
27,8E,C3,7B,8B,00,00,00

770 DATA8B,C3,EC,8B,2D,22,A0,78,  
C9,00,00,00  
780DATAZZ

NB. THE LAST TWO LINES NEED TO BE ADDED TO THE PROGRAM.

Those who couldn't be bothered typing in Listing 1 can get a copy (tape only) by writing to 'Chris Griffin, PO Box 233, Diamond Creek, Victoria 3089' and including \$5 with the letter (for postage, packing, tape, and my time!).



# INTERFACING SENSORS

A host of practical applications open up when you make your computer talk to the real world. But it's not as straightforward as it seems. For details of traps for new players read on.

WHEN ENGINEERS first started interfacing process transducers with digital computer systems, they ran into problems. They often wound up with a lot of signal noise and, hence, unreliable measurements. This was mainly caused by poor practices, including use of the wrong type of signal cable, poor grounding and cable routing, and poor layout of termination cabinets.

These early efforts, however, paved the way for today's greatly improved practices. For example, now high and low level signal cables are never run in the same cable tray. When shielded cable is used, the shield is grounded at one end only. Other modern improvements include the use of multiplexing to reduce transmission costs and new ways of interfacing pneumatic signals with digital devices.

The booming use of microprocessors in instrumentation has intensified interest in interfacing with digital devices. The microprocessor is being used in thousands of applications such as calculators, data loggers, data acquisition systems, computers, automobiles, and, of course, instrumentation. Today, most sensors send analogue signals to a microprocessor-based receiving device. Often the sensors themselves include microprocessors. This allows sensor measurements to be sent over a digital communications channel. And it's almost certain that every new plant will use microprocessor-based instrumentation.

Sensors and transducers, as well as alarms, final control elements and measurements devices, have different types of outputs that must be interfaced with a computer. These include:

- contact closure;
- high level analogue;
- low level analogue;
- pneumatic;
- digital.

## Contact closure

First, let's look at interfacing contact closures. In this article we will consider a

computer to be any digital device, microcomputer, data logger, programmable controller (PC), minicomputer, and so on which includes an analogue or digital multiplexer.

Contact closures are used to represent binary information, such as the on/off status of a motor, or the presence of an alarm. A contact should be isolated from ground and all other signals. The contact input, or digital input, is connected to a digital multiplexer within the computer system. Make certain that the contact is rated for the voltage and current of the computer sensing signal.

## Analogue signals

Analogue signals are divided into two categories, high level and low level. Not everyone agrees on the exact breakpoint for these two categories. However, signals below 200 millivolts are generally thought of as low level. Signals greater than 1 volt are classified as high level. For example, a 4-20 mA signal working across a 250 ohm impedance has a voltage drop of 1 to 5 volts and is considered to be a high level signal. Thermocouple signals, on the other hand, are classified as low level.

Low level analogue signals present more problems than high level signals because they are more susceptible to noise. This noise can be a combination of electrostatic coupling, inductive pickup, common mode noise.

Electrostatic coupling noise occurs with the coupling of the electric fields surrounding signal wires. This is due to the capacitance between the signal conductors and between the conductors and ground. The capacitance between the conductors increases as the cable length increases. Thus, electrostatic coupling is more of a problem in long cables.

To eliminate this noise, use shielded cable and ground one end to the shield. One fairly popular approach you can use is aluminium-polyester tape and a drain wire as the shield. For even better noise

M.G. Thor

*Merrill Thor is Senior Control Systems Engineer with Stone and Webster Engineering. This article is reprinted with kind permission of Hewlett Packard.*

rejection, use cable with a separate shield for each pair of wires and also an overall shield.

## Inductive pickup

Power lines, motors, transformers and so on, generate electromagnetic fields which can be picked up inductively. This is also called electromagnetic noise. Using twisted pairs greatly reduces inductive pickup and the more twists per metre, the greater the noise reduction. Eighteen twists per metre should be enough. Where a low level signal cable is close to high voltage cables, the low level cable can be run in conduit.

## Common mode noise

A common mode voltage is a signal that appears simultaneously at both input terminals with respect to a common reference point. This common reference point is usually ground. The common mode voltage contains no useful information. The useful signal is the voltage that is present across the input terminals — ie, the normal mode voltage.

The analogue input multiplexers used in computer systems reject common mode noise. Almost all common mode noise is at power line frequency, 60 Hz. Typically, these analogue 'front-ends' provide 120 dB attenuation of a 60 Hz common mode voltage.

Common mode noise can be caused by





inductive coupling, capacitive coupling, and by improper grounding procedures which result in ground loops.

### Ground loops

A signal circuit should be grounded in one place only. Figure 1 shows why this is true. Here, one signal lead is grounded at the analogue input multiplexer and also in the field at the thermocouple junction. Because these two grounds may be several hundred feet apart, there may be a large potential difference between the two grounds. This difference ( $E$  in the figure) causes a current  $I$  to circulate through both signal conductors. This combines with the signal current and creates a common mode voltage at the analogue input terminals.

### Cabling procedures

Wherever possible, run cables carrying different types of signals in separate trays. Use separate trays for power wiring. Where signal cables must cross power wiring, it should be done at right angles, with as much separation as is practical.

### Which end to ground?

We have shown that both the signal circuit and the cable shield should be grounded only in one place. However, there is some question as to whether this grounding should be done at the field end or at the computer end of the cable. For example,

thermocouples may be either grounded or ungrounded in the field. The grounded variety provides a connection between the tip of the sensor and the sheath. The contact with the sheath provides a quicker recognition of temperature changes at the measuring point. However, any accidental grounding of the signal cable will result in common mode noise. Therefore, there is no clear-cut answer as to whether grounded or ungrounded thermocouples are best. In cases where thermocouples are being used for control, the quicker response time is very important and the grounded type may be preferred. Often millivolt to current transmitters are installed in the field for temperature control loops. This allows the temperature measurement to be sent as a 4-20 mA high level signal and reduces the noise.

A convention should be established that grounds cable shields at the computer terminal boards or at the sensor in the field. Either practice must be strictly followed.

### Pneumatic

Today, there are still some new plants being built that are planning to use pneumatic instruments — though most are going electronic. And many older pneumatic plants are adding computer systems. Because of this need to interface pneumatic transducers with digital systems, let's see how it can be done.

The use of a pneumatic to current (P/I)

converter is one method. It takes a 3-15 psig pneumatic signal and converts it to a 4-20 mA signal which can then be connected to a digital device in the same manner as any other analogue input.

This method requires one P/I converter for each pneumatic signal. Where there are many pneumatic signals, this may be costly. Also, you should consider the maintenance work needed to keep a large number of converters in calibration. In existing plants, you may not have enough space to mount racks of P/I converters. All in all, this might be the best solution for interfacing a small number of signals with a computer.

A pneumatic multiplexer is often used when many pneumatic signals need to be interfaced. The device senses the pneumatic signals one at a time and converts each one to an electrical analogue signal. Some multiplexers provide digital output. The switching is slow (only a few points per second), but it costs much less than using individual P/I converters and the maintenance time is less. If speed is important, several units can be operated at once.

Another solution is to use pneumatic-to-digital (P/D) converters. One of these devices accepts a 3-15 psig pneumatic signal and converts it to digital signals. These can be sent over a communications channel. This method is particularly useful where the digital system won't accept ana-



logue signals. As with P/I converters, this solution becomes less practical as the number of signals increases.

### Digital transducers

Some transducers provide digital outputs. However, this doesn't necessarily make them easier to interface to a computer than an analogue output device. Communications between the transducers and computer may not be compatible. If that happens, special programs must be written for the computer. This could be complicated and expensive. However, if the development costs can be amortized over several applications, a digital interface will often cost less. Digital interfaces can be divided into two categories: parallel and serial.

The data to be transferred to the computer is held in a register. The 16-bits of data each have dedicated signal paths. During the period when the register is being updated, the data ready signal will be false. When the register contains valid data, the data ready signal will be true. The computer should be programmed to read the data when the data ready signal changes from false to true. This interrupts whatever the computer is doing and tells it

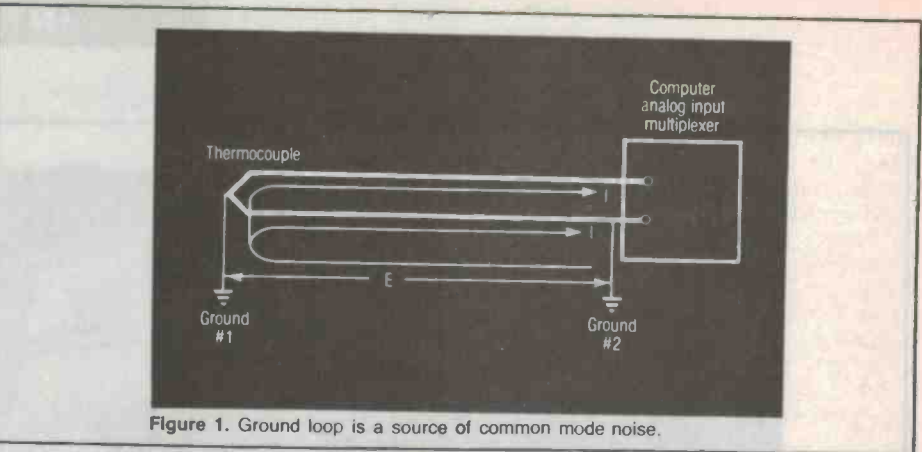

Figure 1. Ground loop is a source of common mode noise.

to read data that is now available. Also the computer is programmed to disregard any information read when the data ready signal is false.

Sometimes a parity check bit is included. A parity check is the simplest but least secure method of error checking. This involves adding an extra bit, called a parity bit, to the message. This bit is set or reset so the total number of binary 1s in the message is always odd. (This is referred to as 'odd parity'. Similarly, some systems use 'even parity', where the number of binary 1s in a message is always even.)

In a serial interface, the message is sent a bit at a time, with the bits following in order. The parallel interface is, of course,

much faster. An entire block of data can be sent in the same time as one bit can be sent over a serial interface.

The separate communications channel required for each bit makes the parallel interface expensive. For communications over long distances, the serial interface is the lower cost method. Parallel interfaces are used for short distances where high speed is essential.

Serial interfaces are gaining in popularity even for short distances, however, because data rates of 1 million bits per second can be achieved today. In addition, a serial interface allows the use of the same software to be used for interfacing with a digital transducer, regardless of the

## GW THE ALTERNATIVE 20 MHz OSCILLOSCOPE

While other 20MHz CRO's are content to be like the rest, GW offers you the real alternative. The GOS-522 is a 2 Channel, CRO with a unique 'ALTERNATIVE TRIGGERING' mode between Channels 1 and 2. This allows you to compare test points between good and bad boards simultaneously!

12 MONTH WARRANTY

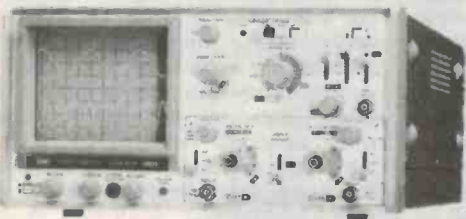

**GW Instrument's GOS-522 offers more 'real' facilities for your dollar:**

- Fast 20ns/DIV sweep speed – for high precision
- Large 6 inch rectangular, internal graticule CRT
- Trigger Level Lock and Variable Hold-off – for operating ease
- DC Trigger Coupling – for low frequency signals
- AUTO NORMAL and SINGLE SHOT sweep modes

### GW's "ALTERNATE TRIGGERING" MODE:

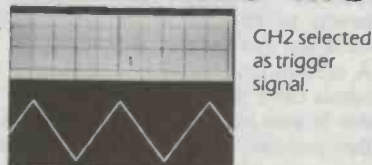
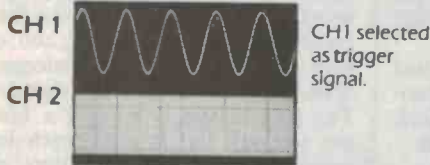

WITH PROBES:

\$733<sup>excl.</sup><sub>tax</sub>

\$855<sup>incl.</sup><sub>tax</sub>

WITHOUT PROBES:

\$698<sup>excl.</sup><sub>tax</sub>

\$815<sup>incl.</sup><sub>tax</sub>



**EMONA INSTRUMENTS**

A division of Emona Enterprises Pty Ltd

1st Floor,  
720 George Street, Sydney, 2000  
Phone: (02) 212-4599

ALSO AVAILABLE FROM:

NSW David Reid Electronics  
Geoff Wood Electronics  
QLD Baltec Systems Pty Ltd Brisbane  
Nortek Townsville  
VIC Radio Parts Group Melbourne

TAS George Harvey Electronics Hobart  
George Harvey Electronics Launceston  
WA Hinco Engineering Pty Ltd Perth  
SA Int'l Communication Systems Pty Ltd Port Adelaide



distance from the computer. This eliminates the need for two software programs — a parallel program for short distances and a serial program for long distances.

For long distances, greater than a couple of hundred metres, digital data is normally transmitted over the communications channel as modulated signals. At the receiving end, the signals are demodulated back into digital signals. The transformation of digital logic to modulated signals and the transformation from modulated signals to digital logic is performed by a modulator-demodulator (modem or data set). A modem is not required for short distances. In this case, the use of a current loop would be satisfactory.

The four standard digital interfaces used between transducers and sensors are:

IEEE-488;

EIA RS232c;

BCD;

CAMAC.

Hewlett Packard developed the IEEE-488 Interface and it is often referred to as the HP Interface Bus (HP-IB). It can be used to transmit data in either direction to

up to 15 instruments. The Bus consists of 16 parallel signal lines. Eight lines are used for data and eight lines carry data transfer control signals.

RS232c is a standard that defines the signals used in the interface to the modem, the voltage levels used for these signals, the cable connectors to be used, and the location of the signals on the pins in the connectors. It is popular for interfacing teletypes and terminals to a computer. Because of its limited range (up to 33 metres), it is often used with a modem. Some transducers provide an output which emulates the data format from a teletype and is compatible with RS232c. RS449 is slowly replacing RS232c because it provides higher transmission speeds over longer distances.

BCD (binary coded decimal) is another interface form. It is a very old and popular interface that separates decimal numbers into binary groups of 4 bits.

The communications, except for timing, in BCD is always from the instrument to the computer. There is no standard for BCD, again making it hard to interface several different instruments.

Each instrument again requires a separate computer I/O card. The language

spoken over this interface is, of course, BCD. Each decimal number (0-9) has an equivalent 4-bit code where the most significant bit has a weight of 8. BCD makes no allowances for letters or other characters.

The bit serial interface requires fewer lines than any other interface on our list, making it economical for long distances. Many instruments use the serial interface, and because of the serial standard, they will all interface with the same I/O card design. One I/O card, however, is still needed for each instrument.

The CAMAC interface includes a network or data highway that allows modules to communicate with each other. The highway may be a 66-line parallel path for short distances or a serial link for long distances. To be used with CAMAC, a transducer must be compatible with the highway and must plug into a CAMAC equipment rack, known as a 'crate'.

More sophisticated methods of error detection are used when a communications channel is used. This is because a communications channel, such as a telephone line, microwave link and so on is highly susceptible to errors due to noise on the signal. ●

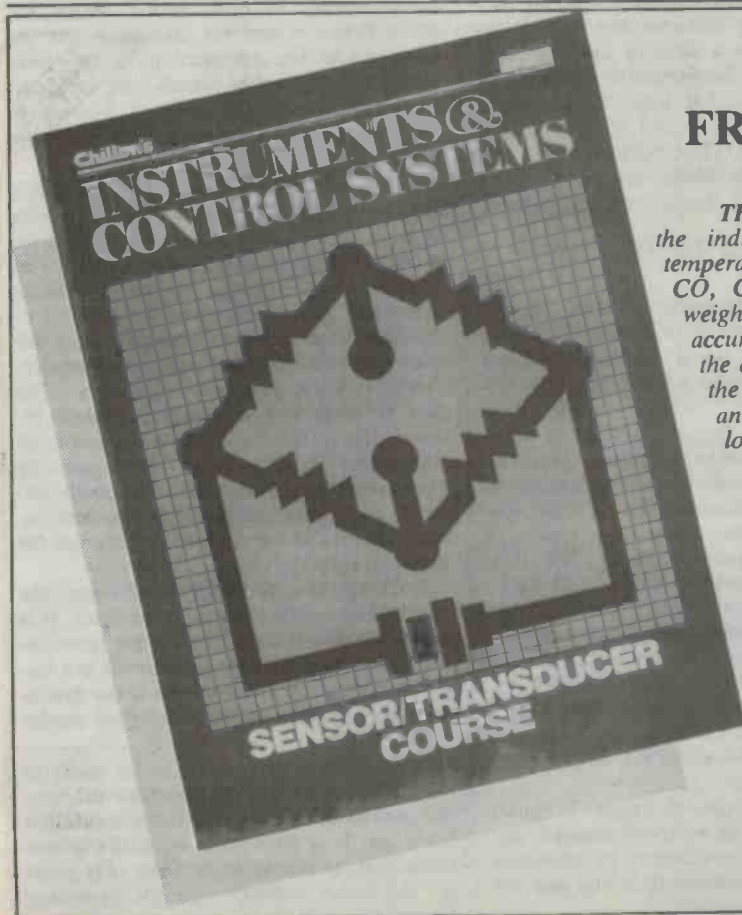

## FREE OFFER FROM HEWLETT PACKARD

*THIS BOOKLET will give you a clear understanding of the industrial sensors and transducers used to measure temperature, pressure, flow, level, pH, conductivity, oxygen, CO, CO<sub>2</sub>, vibration, acceleration, viscosity, moisture and weight. Topics include: basic operating principles, ranges, accuracy, type of output, advantages and disadvantages of the devices. Also, it will cover any electronics required for the various devices and discuss the interfacing of sensors and transducers with data acquisition systems, data loggers and computers.*

**LIMITED QUANTITY AVAILABLE**

**WRITE TO:**

Marketing Communications Dept.  
HEWLETT PACKARD AUSTRALIA,  
31-41 Joseph Street,  
Blackburn, Victoria 3130.



**HEWLETT  
PACKARD**



# REFLECTOMETERS

As optical fibres come into sight, the instruments to test them also become more visible. One of the most important is the optical time domain reflectometer.

OPTICAL TIME domain reflectometry is a widely used method of measuring the attenuation of light as it travels down an optical fibre. It is used to test the fibre, to measure the effectiveness of splices in the cable, and most importantly, to find cable faults in the field.

Optical time domain reflectometers are well on the way to becoming the standard piece of test gear for communications engineers, more fundamental than, say, a CRO. That they have been so widely adopted speaks volumes about the value of the reflectometry method. However, they have limitations. Some are set by the quality of the engineering in the box itself, others by the physics of the situation.

## How it works

The OTDR works by transmitting pulses of light into a fibre and measuring the reflections that occur, as illustrated in Figure 1. The time delay of reflections corresponds to distance along the fibre, allowing the OTDR to produce a *fibre signature*. Two types of reflections occur:

- *Pulse reflections* are generated at breaks or joints where the optical signal encounters something other than a continuous glass core.
- *Backscatter reflections* are generated uniformly along a fibre as the transmitted pulse travels through. The backscatter signal that returns to the OTDR is of constant amplitude except for the attenuation of the pulse travelling forward and the reflections travelling back through the fibre. Thus, the decay of the backscatter signal over time provides a measurement of fibre attenuation. An abrupt point of loss in a fibre reduces the amplitude of the backscatter signal from all subsequent points, resulting in a characteristic step in the fibre signature. This is the basis for measuring splice loss.

The principal attractions of optical time domain reflectometry are that it requires

access to only one end of the fibre under test, and that it provides a way of telling how attenuation takes place with distance. This is vital information if you are trying to find a break or fault in the cable.

Credit for the early development of optical time domain reflectometry goes to Dr Stuart Personick and Dr Michael Bar-noski, who first observed the backscatter signal and recognized its usefulness for loss measurements.

While OTDR is a simple and highly useful measurement concept, the OTDR instrument itself is a difficult item to engineer. There are fundamental problems of signal and noise that limit measurement range and resolution, and complicate the specification of OTDR performance. The arrival of single-mode technology has made the OTDR design task even more challenging.

## Single-mode

The basic single-mode OTDR design problem is illustrated in Figure 2, where four key optical signal levels are shown representing realistic values for 1300 nm single-mode fibre.

The uppermost line is a reference point indicating the power launched into the fibre under test, allowing for reasonable coupling losses through the OTDR system. The remaining three lines represent the signals received by the OTDR. The two types of reflections (pulse and backscatter) are shown relative to the peak power of the launch pulse. The bottom line labelled 'noise floor' indicates the receiver noise equivalent power (NEP) — essentially the minimum detectable signal, given the receiver's electronic noise and realistic coupling losses in the optical path into the instrument.

The horizontal axis of Figure 2 shows how these change as we try to increase the resolution of the instrument by changing pulse width and bandwidth. The shorter

the pulse the more accurately we can define a position in the fibre. Unfortunately, the amount of backscatter radiation reduces as the pulse gets shorter, making reception more difficult. Also, to generate and receive shorter pulses requires more bandwidth. However, noise increases with increasing bandwidth. Figure 2 puts numbers to these inescapable facts of life.

Note that for a moderate resolution capability of 20 metres, the backscatter signal comes in only 10 dB above the noise floor — and no allowance has yet been made for attenuation in the fibre under test. In other words, the reflected signal levels shown in Figure 2 apply to the near end of a fibre connected to the OTDR.

A second issue illustrated in Figure 2 is that pulse reflections are much stronger than the backscatter signal — nearly four orders of magnitude stronger at 20 metre resolution, for example. While this means that pulse reflections are relatively easy to detect and backscatter correspondingly difficult, it also implies stringent requirements on the receiver electronics. The task of designing a sensitive optical receiver that can accommodate time domain waveforms having such wide dynamic range without distortion is exceedingly difficult. As Figure 2 shows, this problem becomes worse if the OTDR is designed for higher resolution.

Looking at the margin between the backscatter signal and the noise floor, it is apparent that this signal-to-noise ratio deteriorates by 15 dB for a factor of ten improvement in resolution. This is the fundamental *range/resolution trade off* of single-mode OTDR.

One of the first choices to be made in the design of an OTDR is where to place the instrument along this range/resolution trade off. It is possible to make an instrument that works at more than one point on the curve through multiple operating



## Richard DuPuy

Richard Ellis DuPuy is with Photon Kinetics of the US. This is an edited version of a paper he gave at the international symposium on optical and electro optical engineering in 1985. Reprinted courtesy of the Society of Photo Optical Instrument Engineers.

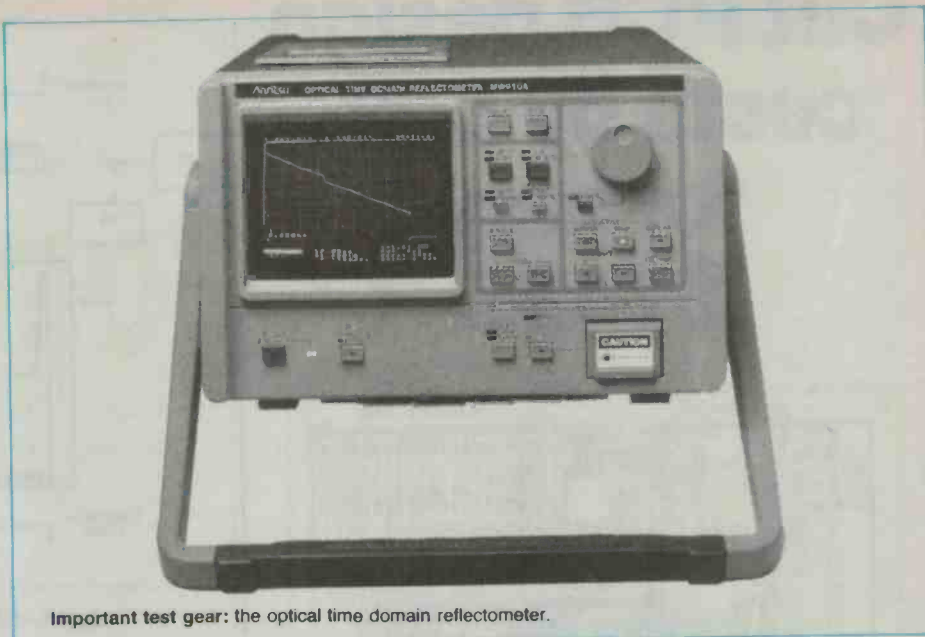

Important test gear: the optical time domain reflectometer.

modes; however, this tends to lead to compromises in design and complexity in operation. The more narrowly an OTDR is targeted, the simpler it can be made and the more effectively it can be optimized.

The problem of inadequate signal-to-noise ratio in OTDRs is addressed through signal averaging — a process in which repeated measurements of the fibre signature are combined, effectively reducing the receiver noise floor. Largely with respect to the way in which this signal processing is implemented, the design technology of OTDRs has progressed through three distinct generations of instruments. The second and third generations are pertinent to single-mode OTDR, differing in the way that the reflected signals are acquired and processed.

### Development

First generation OTDRs were the earliest multimode instruments, combining straightforward optical hardware with real-time oscilloscope displays.

Second generation technology, introduced in 1982, revolutionized multimode OTDRs through digital storage of the fibre signature and signal averaging. Second generation instruments utilize a sampling technique by which the fibre signature is pieced together from single-point measurements on a series of pulse repetitions.

Third generation OTDRs take the technology another step forward with high-speed waveform digitizing, enabling them to collect an entire fibre signature from a single launch pulse. The advantage of their efficient data acquisition can be seen in a comparison of signal averaging capability.

Table 1 shows the noise reduction that results from an increasing amount of averaging. The table also indicates the time re-

quired to complete the measurement, for representative second and third generation OTDR designs. Clearly, the efficiency of the third generation design gives it an advantage. In both cases, though, the increase in measurement time sets a practical limit to the amount of improvement available through the noise reduction process.

The third generation technology represents the state of the art in commercial single-mode OTDRs today, in the sense that it achieves superior signal-to-noise ratios and is the direction in which new product designs are tending. Nevertheless, second generation technology is still a viable choice for some applications. The simpler signal processing facilitates building more compact equipment with lower power consumption.

A limitation of third generation technology, arising from the speed and accuracy limits of analogue-to-digital converters, is that it cannot be applied directly to distance resolutions less than approximately 25 metres. In such cases a multi-step digitizing process must be used which reduces the efficiency of data acquisition. Therefore, for high resolution OTDR the measurement times will be greater than those listed in Table 1 (or, conversely, the noise reduction for a given measurement time will be less).

### Range and accuracy

Measurement range and the accuracy of loss measurements are tightly interrelated, and tied to the signal-to-noise (SNR) ratio.

The noise in an OTDR adds random errors to all points on the fibre signature. The amount of uncertainty that this causes is a direct function of the SNR. As the noise increases, both range and accuracy get worse. In fact, range and accuracy can

be accurately modelled in terms of the backscatter SNR and attenuation in the fibre under test.

The round-trip fibre attenuation between the OTDR and the point of measurement subtracts directly from the initial signal-to-noise ratio.

Specifications usually refer to the fibre loss that will reduce the backscatter or pulse signal just to the noise floor (SNR = 1).

A signal-to-noise ratio of 1 is seldom useful, so an OTDR cannot be expected to make measurements through the specified 'maximum fibre loss'. Only in certain fault location situations where the requirement is simply to discern the continuity of the fibre signature, is it practical to work close to the noise floor of an OTDR.

Loss measurements made by viewing the drop in the backscatter signal between the beginning and end of a cable are subject to increasing uncertainty, with the SNR of the backscatter reflections from the end of the cable the limiting factor.

It should be emphasized that the 'distance range' specifications often quoted for OTDRs are not identical to the 'measurement range' discussed above. *Distance range* is only a statement of the limit of the timing scale on an OTDR. It tells you how long the device will wait to receive the reflections from a pulse it has launched into the fibre.

Aside from noise-induced errors, the accuracy of an OTDR's logarithmic (dB) scale is a potential source of measurement error. The proper form for this specification is in terms of the maximum error per dB of indicated loss, or 'dB per dB'. It is a difficult characteristic to verify, requiring the generation of precision optical test signals. Luckily the 'dB scale resolution' of an OTDR is usually a very small number that is irrelevant to real measurement errors.



# Cut PCB design costs by 50% for only \$7495

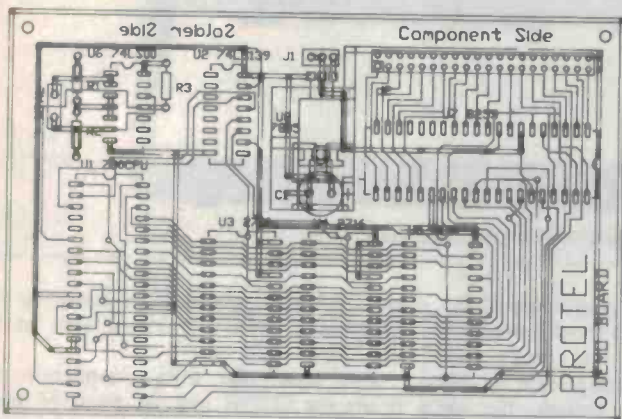

Now, every PCB designer can reduce costs by as much as 50% using technology as up to date as the designs. From concept to layout, to camera-ready art, and all with the aid and added speed of CAD.

This total package solution from **NEC** specialist, Sleebs, consists of:

- An APC III microcomputer with colour screen, colour graphics card, 384KB main memory, serial and parallel ports, MS-DOS.
- A serial Microsoft Mouse.
- A Roland DXY880 A3 size 8-pen plotter.
- Protel/PCB computer aided PCB design software.
- Full installation in metro Melbourne, Hobart or Launceston. Delivered freight-free to all other locations in Australia.

## sleebs

### COMPUTER INDUSTRIES

For detailed information about this special offer, send the coupon below to:

Sleebs Computer Industries

163 Eastern Road,  
South Melbourne. 3205  
Phone: 690 1333

73 Murray Street,  
Hobart. 7000  
Phone: 34 6477

Mk/Acd/301

Dear Sir,

Please send me more details about the PCD, CAD system.

Name: ..... Company: .....

Title: ..... Address: .....

P'code: ..... Phone: .....

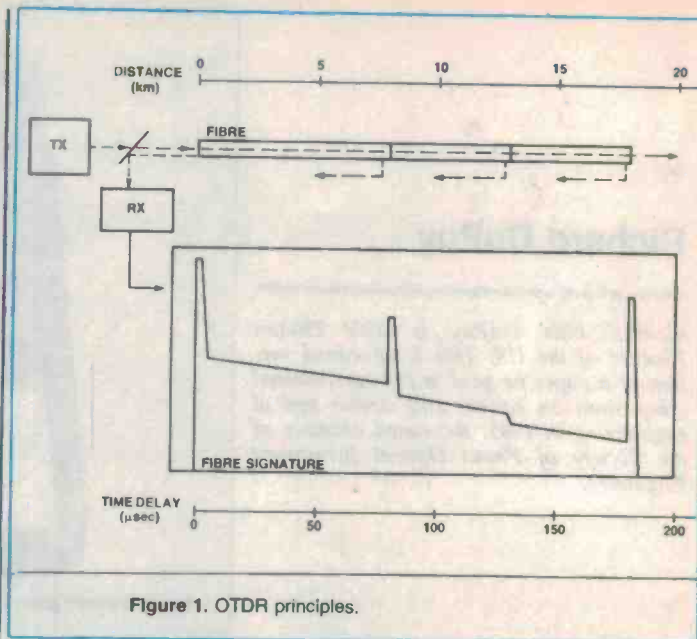

Figure 1. OTDR principles.

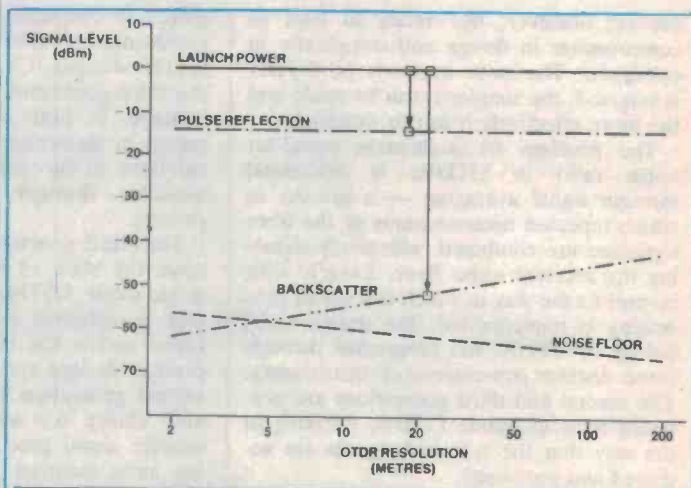

Figure 2. Signal and noise levels for 1300 nm single-mode OTDR.

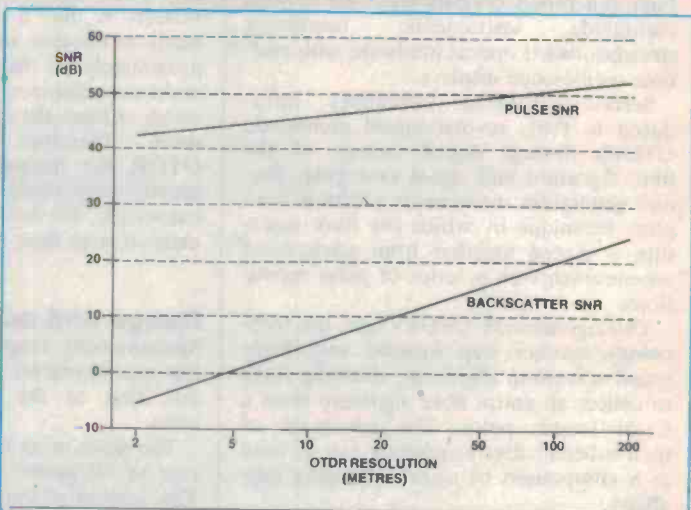

Figure 3. The single-mode OTDR range/resolution trade off.



**TABLE 1. SIGNAL AVERAGING.**

Number of averages	Noise reduction	Measurement time (2nd gen)	Measurement time (3rd gen)
1	0 dB	0.125 sec	0.0005 sec
10	5 dB	1.25 sec	0.005 sec
100	10 dB	12.5 sec	0.05 sec
1000	15 dB	2 min	5 sec
10 <sup>4</sup>	20 dB	20 min	50 sec
10 <sup>5</sup>	25 dB		7 min
10 <sup>6</sup>	30 dB		

## Future developments

Progress in optical time domain reflectometry can be expected to continue at a steady pace for the next several years. For the first time since the beginning of the fibre-optic revolution, it appears that the key features of the technology may remain stable long enough for measurement instruments to be refined through more than one design cycle. It is likely that OTDR improvements will be achieved through two routes: extensions of the existing technology, and pursuit of 'advanced' OTDR techniques.

The prospects for expanding the limits of today's third generation technology are reasonably encouraging. With improvements in semiconductor laser output power, receiver sensitivity, and high speed digitizing, an increase of 5 to 10 dB in signal-to-noise ratio across the resolution scale should be possible. Coupled with better design optimization, this will significantly increase the measurement range of OTDRs designed for relatively long-distance applications, as most existing instruments are.

This progress will also make it practical to move toward the high-resolution end of the scale. Sub-ten metre resolution single-mode OTDRs with useful measurement range and accuracy will be possible; the price will be in cost and power. As the spread of OTDRs along the range/resolution curve broadens, it is unlikely that a single versatile instrument will satisfy all applications.

'Advanced' OTDR techniques have been the subject of much R&D investigation over the years. These are substantial departures from conventional OTDR, either in the optical detection method or in the basic nature of the signals that are transmitted. Four specific techniques include:

- pulse compression OTDR ('correlation OTDR');
- swept frequency reflectometry;
- coherent detection OTDR;
- photon counting OTDR.

The third and fourth of these both represent attempts to improve the sensitivity of the OTDR receiver toward the fundamental quantum limit, which is roughly 10 dB below what is achieved in today's

instruments. Coherent detector technology looks promising for telecommunications in general. But the problems are difficult. However, if a lot of money is spent on R&D over the next few years, this may well be a front runner.

It is likely to take a number of years, though. The realization of true quantum-limited detection in OTDRs is probably not a realistic expectation; the practical limits that might be attained are not yet clear.

The centimetre-resolution single-mode OTDR will never be a reality; the physics of the OTDR process and the limits of opto-electronics will not support that concept. Nevertheless, as the long-wavelength single-mode fibre optics market stabilizes and OTDR designs evolve towards optimum performance, the breadth of applications addressable by this powerful measurement technique will continue to grow.

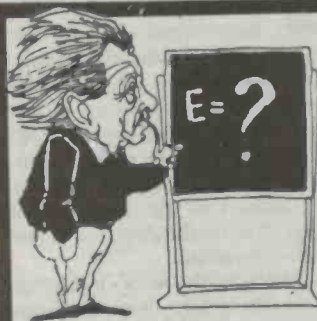

**Loss of memory can be disastrous especially in Computers. Install our**

## COMPUTER PROTECTOR

... protects your computer memory against spikes, glitches, lightning, on-off switches, electric motors etc. Max peak surge current up to 4500 amps; transient energy absorption up to 75 joules.



## Westinghouse Systems

80-86 Douglas Pde., Williamstown, Vic. 3016. Tel: (03) 397 1033. Tlx: 37477.

N.S.W.: Bryan Catt Industries P/L. Tel: (02) 526 2222.

QLD: Colourview Wholesale, Tel: (07) 275 3188. S.A.: F.R. Mayfield P/L. Tel: (08) 212 3161.

W.A.: Geo. Moss P/L. Tel: (09) 446 8844.



- PIF3-1A 1AMP 2 STAGE +E.L.C \$88
  - PIF3-3A 3AMPS 2 STAGE +E.L.C \$91
  - PIF3-6A 6AMPS 2 STAGE +E.L.C \$96
  - PIF3-10A 10AMPS 2 STAGE +E.L.C \$102
- Plus Sales Tax if applicable Add pack/post Bankcard and Visacard. Vic & NSW only.

WS25



# TV POWER SUPPLIES

Why they are like they are and how to do something about it. We even publish some practical tips on repairing one of the most common of them: the HMV C211 module.

Gerry Nicholson



COLOUR TELEVISION power supplies vary according to the design of the receiver and the preference of the designer. However, they all perform the same basic function and are subject to the same performance criteria, ie, they must regulate against mains input variations of at least plus or minus 10%, regulate against load variations, and they should fold back or cut off in case of short circuit or loaded output.

Three power supplies most commonly used are:

1. The series regulated type, employing a power transistor with a high current rating and a sufficient  $V_{CEBO}$  rating to withstand the full dc input voltage in case of short circuit output. This type of power supply is employed in the PYE T29-T30 chassis and others.
2. Thyristor supplies used in some of the early European sets sold in this country. These sets are mainly live chassis types. They were not very popular with the power supply authorities since many of them employed half-wave rectification, which the authorities claimed would cause oxidation of their mains conductors.
3. Switching or switched mode power supplies, as found in early Kreisler, Philips, HMV, some Japanese sets and the later European sets. These supplies full-wave rectify the mains. Then after filtering with a high voltage electrolytic (around  $0.3\mu/350V$ ) the 300 Vdc is chopped at a frequency of 15 kHz to 20 kHz using a high voltage

switching transistor driving the primary of the switch mode transformer. Regulation is achieved by varying the mark-space ratio of the drive waveshape in sympathy with the output from a separate control winding. The outputs are half-wave rectified from isolated secondary windings.

The advantages of this type of supply are the light weight isolating transformer, low power dissipation of the chopper transistor (since it is mainly either off or fully saturated) and the fact that output filtering is easily achieved with low value electrolytics at the high switching frequency.

The output requirements of all of these supplies also vary according to the design of the receiver. Some supply all of the high and low voltage dc outputs required, as well as the ac heater voltage for the tube. Others only supply 100 V to 230 Vdc to power the line output stage. The low voltage supplies are then rectified from the secondary windings on the line output transformer. In some cases the picture tube heater voltage is also derived from a winding on the line output transformer. In other cases the mains transformer has a 6.3 V heater winding. Figure 1 shows typical sources required to power a colour receiver. As indicated by the heading, the main purpose of this article is to describe repairing of one of these supplies: that employed in the HMV C211 chassis.

## HMV C211

The HMV C211 was the first colour chassis HMV produced at Homebush. Although some 10 years old these sets are still about,

and when in good repair give good service.

They are fully modular, which makes life easier when it comes to home service. One can simply exchange the faulty module, (or modules) and repair them later. The most common faults are in the power supply, the line scan module, the vertical module and the chrome module in that order. However, this article concentrates entirely on the switch-mode power supply module PCB1.

The method I describe here allows me to repair these units reasonably quickly without destroying any further parts. Before you start you will need a variac and a 240 V to 240 V isolating transformer. If you don't have a variac, another transformer with a 120 Vac output will suffice. You will also need a 60 watt incandescent lamp with fly leads you can solder to the power supply output, and a bridge rectifier made up on a piece of vero board. This should also have fly leads to connect to the input of the power supply. An oscilloscope and multimeter are also required.

I will come back to this later, but before we connect anything up, there are some components which need to be checked. Firstly check the chopper transistor TR102. This transistor is in a socket and can be easily recovered. If it is shorted TR103 (BR203) and TR101 (BC557) will probably also be destroyed. Replace all three. In some cases R110 1 ohm 2 W wirewound will be open and FS101 2 A will be blown. If the chopper is not blown, check all of the above components anyhow.

I also make a habit of checking R113 1



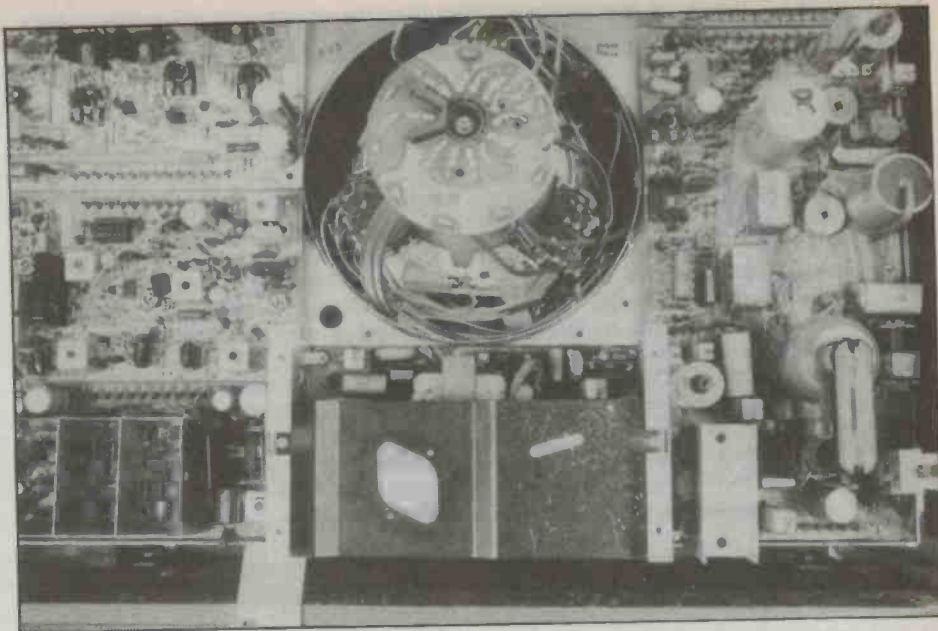

ohm, R112 33 ohm, and C109 390p (this capacitor often shorts and disables the power supply). C115 390p and C113 0.001 $\mu$  (both on the cold side of the transformer) also short and stop the supply.

There are three electros on the live side of the supply which often dry up causing a loud screech when the supply is operated. They are C101 10 $\mu$ , C102 47 $\mu$  and C104 also 47 $\mu$ , all 63 V types.

Finally check all the diodes on the live side while they are in circuit using the R x 1 scale on your multimeter. D107 will appear shorted as it has a choke across it, but it hardly ever is. Also D105 and 106 are reversed in parallel and will read half-scale either way.

By now you've almost checked every component in the power supply. However, there are some more which will show up under test if they are faulty. The large can electro C211 330 $\mu$ 350 V is one of them. It sometimes dries up causing the supply to hum. C108 0.0047 $\mu$  sometimes literally explodes and R108 100k 4 watt goes high or open so that the supply will not start. We have mentioned quite a few components but once you're familiar with this check list you will find you can complete it in about 10 minutes.

Once we have completed our checks and have replaced any faulty parts, we can connect the supply up and test it. Connect 120 - Vac to the input of the bridge. Connect the negative output to pin 101 of the supply and the positive output to pin 102. Connect the

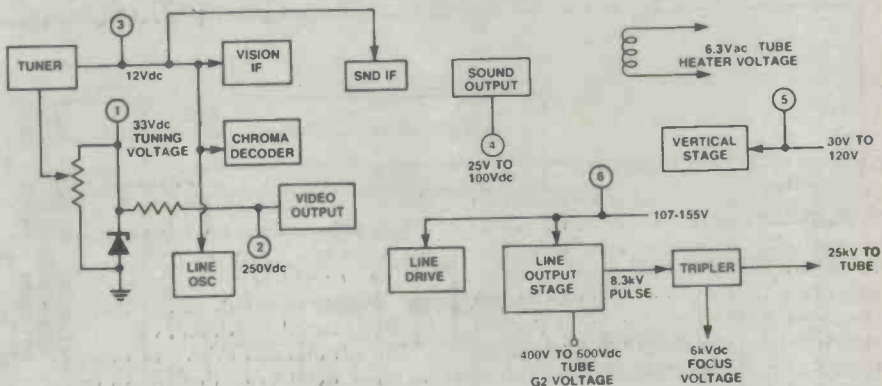

Figure 1. Typical sources required to power colour receiver.

lamp leads to pins 104 and 108, and before you switch on remove TR103 (BR203). Solder one end of a 56 ohm resistor to where TR103's cathode was located, and connect your oscilloscope to pin 12 of the transformer. Earth it at pin 101.

Using a 10/1 probe, set the sensitivity at 5V/cm and the sweep at 10 $\mu$  sec/division. Finally connect a diode between the gate connection and the cathode connection of TR103 and connect a multimeter (set on the 350 Vdc range) between pins 104 and 108. You can now switch on.

The supply should whistle for a moment then come on; the waveform at pin 12 should be as shown in Figure 2. The output across the lamp should read about 175 Vdc.

If the supply will not start there is obviously something damping the transformer or you missed something during the initial check. The circuit is self-oscillating, relying on feedback from pin 14 of the switch-mode transformer via R114 (10 ohm) to the base

of the chopper. If this resistor is open, the result is no oscillation. I have found one transformer with a cracked core causing damped oscillation but have never struck one which had shorted turns.

Once you have the unit operating and are satisfied with the waveshape and the output voltage, take a clip lead and short the end of the 56 ohm resistor you attached earlier to pin 13 on the transformer. The output across the lamp should drop to about 160 V and you can now check the regulating circuit. With the multimeter common lead connected to pin 101 the voltage at the D102 cathode should read around +27 V and the emitter of TR101 19 V. By varying RV101 you should be able to adjust the voltage at the collector of TR101 from -3 V pot clockwise, to between +6 and +8 V pot anticlockwise.

If you cannot obtain these results some obvious causes might be that R102 or R103 are high in value, C103 is shorted, D101,



# LAB NOTES

D102, D103 or D104 are leaky or open, R104 is open or high; it might lie with TR101 (which should have been checked).

Another resistor which goes high is R101. This eliminates the negative voltage at the D103 anode. Once you have this section working switch off, remove the 56 ohm resistor and the diode and replace the BR203 (TR103). Switch on again and you should be able to adjust the output using RV101 to between about 140 V and 175 V. Finally switch off, disconnect the 120 Vac from the bridge input, connect the 240 V isolated input and switch on. You should be

able to adjust the dc output (pin 108) to read the nominated 185 V by varying RV101. There may be a slight whistle from the supply as it is not fully loaded.

Before concluding, never apply the 240 V input while TR103 is out of the circuit or faulty. If you do, you will most certainly destroy another chopper transistor and a couple of other parts.

A further note: the BR203 (TR103) appears to be the only suitable device we have yet found as a regulating thyristor. We have tried other devices such as BRY55 and C103 but they were unsatisfactory.

We usually wash the printed circuitboard with metho using a toothbrush. This re-spreads the varnish, clears the board of flux and makes cracks easier to see. You can then put the power supply back into a set and adjust the voltages under normal load conditions. HMV recommends you adjust the 25 V rail using RV101. Remember, once the supply is back in a set the primary side of the transformer is LIVE so be careful. Use a plastic adjustor and plug the set into an isolating transformer while adjustments are being made. LIVE MAINS CAN KILL.

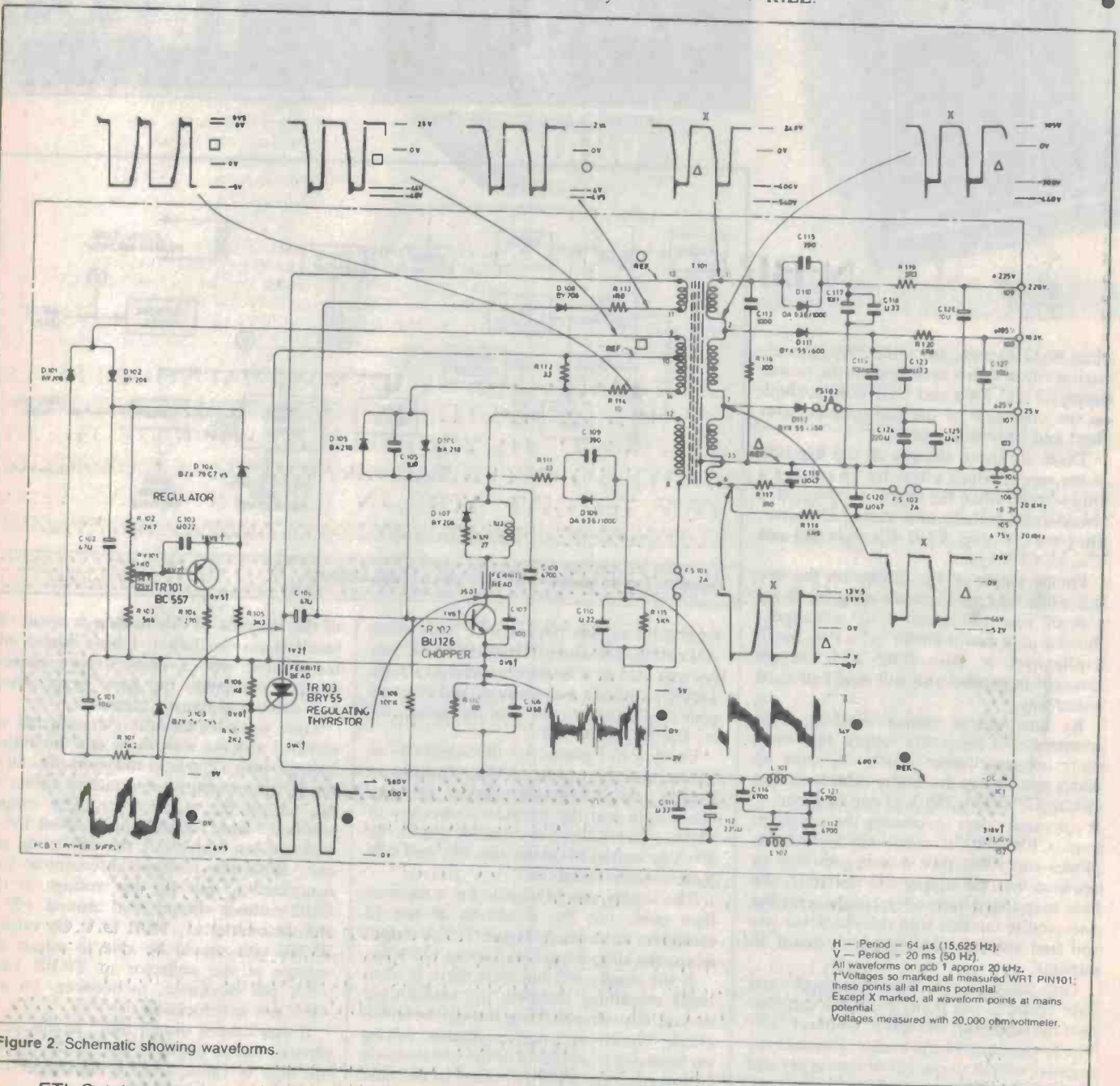

Figure 2. Schematic showing waveforms.



# Design excellence and quality in the best tradition.

## Allen-Bradley Components.

The vast experience Allen-Bradley has gained over the past 75 years of innovative electronic component manufacture, has produced a range of components that are world renowned for quality and performance reliability. Each product is specifically designed for its role in industry and is thoroughly tested to Allen-Bradley's stringent quality control standards before it is passed fit to wear the Allen-Bradley symbol.



For quality, performance and reliability, specify the best - Allen-Bradley. Contact our Electronic Components Sales Centre nearest you, we guarantee extra fast delivery on all standard products.

- Trimming Potentiometers.
- Adjustable Attenuators.
- Fixed and Programmable Attenuators.
- Surface Mount Components.
- Solid State Relays.
- Power Transistors.
- Fixed Resistors.
- Resistor Networks.
- Potentiometers.
- Diode Arrays.
- Custom Hybrid Circuits.



**ALLEN-BRADLEY**  
A ROCKWELL INTERNATIONAL COMPANY

See us at Stand 229 at Electronics '86.

VIC. 37 Chapman Street, Blackburn, 3130. Ph. 899 0335  
N.S.W. 22 Parramatta Road, Lidcombe, 2141. Ph. 648 2652  
QLD. 1925 Logan Road, Upper Mt. Gravatt, 4122. Ph. 343 7900  
W.A. P.O. Box 23, Subiaco, 6008. Ph. 387 1702  
S.A. K. D. Fisher, P.O. Box 170, St. Marys 5042. Ph. 277 3288

**IS YOUR TEST EQUIPMENT PAYING THE DIVIDENDS THAT YOU NEED TO KEEP THAT EDGE ON YOUR COMPETITION? IF IT ISN'T, THEN YOU OWE IT TO YOURSELF TO LOOK AT THE INSTRUMENTS THAT WE HAVE TO OFFER. HERE ARE JUST A FEW TO GIVE YOU AN IDEA OF WHAT IS AVAILABLE.**

### 5 MHz SWEEP/FUNCTION GENERATOR B+K Model 3030

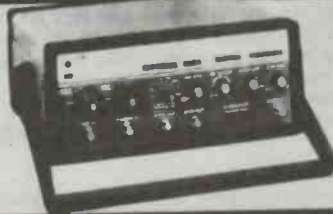

- 4 Decade, 10K: 1 log sweep
- 3 Decade, 1K: 1 linear sweep
- High accuracy sweep controls
- Variable symmetry controls
- Sine, Square, Triangle or Ramp
- Waveforms

### CRT RESTORER/ANALYZERS B+K Model 467D

- Emission, Leakage, Tracking & Focus continuity Tests
- Shorts removal, Gun cleaning & Balancing, cathode restoration
- 3 Meters for Indication
- Simultaneous 3 Gun Test
- Obsolescence proof updates



With the addition of a few more test instruments, you can have a highly effective test set up. Why don't you call us and let us show you how practical and cost efficient our Test and Measuring instruments really are. We'd be pleased to introduce you to our complete line of Test Tools. Just pick up your phone and dial us at:

#### SYDNEY:

Centrecourt, 25-27 Paul St. Nth., North Ryde, N.S.W.  
P.O. Box 261, North Ryde, N.S.W. 2113  
Phone: (02) 888 8777. Telex: AA25021

#### MELBOURNE:

1064 Centre Road, Oakleigh South, Vic.  
Private Bag No. 1, Oakleigh South, Vic. 3167  
Phone: (03) 575 0222. Telex: AA33012

**PARAMETERS LTD**  
PERFECTION IN MEASUREMENT  
SN BK1







## Quiz show simulation

This program simulates the answering mechanism used in quiz shows. A score of 20 is displayed for each of three players. Each player should be allocated a set of keys on the keyboard, eg,

Q W E  
A S

H J K  
N M

O P [  
L ;

If a player knows the answer he/she should press W/J/P. The computer signals the first pressed key and locks out the others. When a player answers correctly he/she should press the key to the right of the answer key, ie, E/K/. This will add 5 to their score. Similarly the key to the left, Q/H/O, will subtract 5. The key to the bottom right, S/M/;, will add 25.

Jason McCallum  
Perth, WA

XLIST

```
00100 REM *****
00105 REM *   SALE OF THE CENTURY SIMULATION   *
00110 REM *             by JASON McCALLUM             *
00115 REM *             PERTH, WESTERN AUSTRALIA       *
00120 REM *             completed 20-SEPT-1985       *
00125 REM *****
00126 POKE 140,1:POKE 162,30:POKE 163,128
00127 CLS
00130 REM MAIN LINE ROUTINE
00135 GOSUB 1000:REM READ IN USR DATA FOR GRAPHICS
00137 REM *****
00140 A=20:B=20:C=20
00150 CLS:CURS 1,8:PRINT A:CURS 31,8:PRINT B:CURS 61,8:PRINT C
00160 A1$=KEY$
00170 IF A1$="" THEN 160
00180 IF A1$="W" : P=1:Q=1:R=2:GOTO 2000
00190 IF A1$="J" : P=2:Q=3:R=4:GOTO 2000
00200 IF A1$="P" : P=3:Q=5:R=6:GOTO 2000
00210 IF A1$<"W" OR A1$>"N" OR A1$<"P" THEN 160
```

```
00290 REM *****
00400 REM PLAYER 1
00500 B1$=KEY$
00510 IF B1$="" THEN 500
00520 IF B1$="E" : A=A+5:GOTO 150
00522 IF B1$="D" : A=A-5:GOTO 150
00525 IF B1$="A" : GOTO 150
00528 IF B1$="S" : A=A+25:GOTO 150
00531 IF B1$<"E" OR B1$>"Q" OR B1$<"A" OR B1$>"S" THEN 500
00599 REM *****
00600 REM PLAYER 2
00610 C1$=KEY$:IF C1$="" THEN 610
00620 IF C1$="K" : B=B+5:GOTO 150
00630 IF C1$="H" : B=B-5:GOTO 150
00640 IF C1$="N" : GOTO 150
00650 IF C1$="M" : B=B+25:GOTO 150
00660 IF C1$<"M"ORC1$>"N"ORC1$<"H"ORC1$>"K" THEN 610
00799 REM *****
00800 REM PLAYER 3
00810 C1$=KEY$:IF C1$="" THEN 810
00820 IF C1$="I" : C=C+5:GOTO 150
00830 IF C1$="O" : C=C-5:GOTO 150
00840 IF C1$="L" : GOTO 150
00850 IF C1$=";" : C=C+25:GOTO 150
00999 REM *****
01000 REM *****GRAPHICS AND MUSIC
01010 FOR I=15000 TO 15024
01020 READ J:POKE I,J:NEXT I
01030 DATA 245,229,105,96,76,69,62,64,211,2,16,254,69,62,0
01040 DATA 211,2,16,254,13,32,239,225,241,201
01060 RETURN
02000 REM *****
02010 REM *** GRAPHICS SOUNDER ***
02012 CLS
02015 COLOURB D:COLOUR R
02020 FOR I=3925 TO 3900 STEP -1
02030 L=USR(15000,I)
02040 LORES
02050 X=INT(RND*960)+1
02060 CURS X:PRINT P
02065 NEXT I
02070 IF P=1 THEN 500
02080 IF P=2 THEN 600
02090 IF P=3 THEN 800
```

## Memory display utility II CHIP-8

This utility does exactly the same thing as the utility run in ETI July '83 with some advantages.

When the program is run, the computer will wait for you to enter the middle two digits of the

starting address of a 16-byte page that is to be displayed. After you've done that the screen will go blank for about two seconds then come back on with data.

Pushing 0 will get the computer back to the start of the program (enter two more digits); 5 goes

back a 16-byte page; D goes forward a 16-byte page; F goes back to the beginning of the current 256-byte page.

To run this program put 1F00 at 0600 or 0700 depending on which display you prefer.

Peter Ball  
Auckland, New Zealand

## MEMORY DISPLAY UTILITY MK2

```
F00 00FF 00FF 0000 0000 F000 0000 2F40 F100
F10 0010 2F40 0200 0700 00E0 00FC 2F24 F255
F20 0020 1F40 0002 0000 F00F 00F0 240F 001F
F30 000F 00FE 00FE 1FEF F10E 2F2F 005F 0400
F40 FB20 0005 7004 000E 0F24 0000 F000 0000
F50 0000 0000 2F40 0002 2F00 0000 0000 0000
F60 0000 0000 2F40 1F70 4000 0014 4201 001D
F70 2F40 20F0 000E 3201 1F00 0700 2000 00FF
F80 00FF 1F00 2701 2001 3210 1F10 0000 0000
F90 0000 0000 2F40 0000 2000 3030 1F94 0000
FA0 0010 0004 2F40 2000 3030 1FA2 0020 0000
FB0 0000 2F40 2000 2002 3010 1F00 0000 F300
FC0 300F 1F00 0100 0200 1FF0 3000 1FDC 0200
FD0 2101 3110 1FDA 0100 2001 1FF0 3305 1FEF
FE0 0200 211F 31FF 1F0C 010F 20FF 1FF6 3300
FF0 1F0E 0000 1F00 0000 0000 1F10
;F00 at 0000 or 0700, either display
```

```
00026 REM Dreamcards Chip-8 v2.2: 02000 to 225F (F7/C2)
00027 REM 02000 6200 433C F003 303C 432A F003 631E 6400
00028 REM 02010 6500 6600 6700 6800 6C00 2136 6000 8100
00029 REM 02020 A100 F01E F01E 71FF 31FF 1022 FC1E 2124
00030 REM 02030 300D 407C 1000 407E 1038 3023 1060 2124
00031 REM 02040 3000 104C 00E0 6900 6A00 102E 4001 1044
00032 REM 02050 3004 105A 3A00 7AFA 102E 4002 6900 4003
00033 REM 02060 212E 4005 2130 102E 3024 109C 2124 F045
00034 REM 02070 F000 6101 4002 0213 4004 0413 4003 611E
00035 REM 02080 4005 0613 4006 0713 3001 102E F003 611E
00036 REM 02090 431E 612A 432A 613C 0310 102E 3024 F045
00037 REM 020A0 2124 0100 2124 F025 2124 F035 2124 F045
00038 REM 020B0 F110 102E 3025 10C4 2124 F015 F007 3000
00039 REM 020C0 100C 102E 6E03 30A0 4057 4E05 0090 3700
00040 REM 020D0 7001 00E4 7001 613F 0105 3F01 212E 3A00
00041 REM 020E0 F001 A230 3E04 A25A 3500 D9A5 3A00 F001
00042 REM 020F0 3700 F001 A24B 3E04 A255 3400 D9A6 3700
00043 REM 02100 F001 4020 6050 4021 6026 70DA 3200 F001
00044 REM 02110 0004 0004 F01E 3200 F001 D9A5 00EE 6900
00045 REM 02120 09E4 101C F065 7001 4C00 7001 00EE 6900
00046 REM 02130 7A06 5A30 00EE 6A00 4003 00EE 4000 0000
00047 REM 02140 00EE 4040 4000 0040 4000 0000 4000 4000
00048 REM 02150 4040 2020 2040 0040 4040 0000 0000 4000
00049 REM 02160 0000 0040 4000 00E0 0000 0000 0000 4000
00050 REM 02170 2040 0000 00A0 00A0 E0A0 0040 4040 4040 E020
00051 REM 02180 E000 E0E0 20E0 20E0 2020 2020 E0A0 E0A0
00052 REM 02190 20C0 E000 E0A0 E0E0 0040 0040 0000 4000 4040
00053 REM 021A0 E0E0 A0E0 20E0 0040 0040 0040 2040 0040
00054 REM 021B0 2040 0040 2000 E000 E000 A0E0 A0A0 C0A0
00055 REM 021C0 2040 0040 0040 E040 C0A0 A0A0 C0E0 00C0
00056 REM 021D0 C0A0 C0E0 0000 00C0 00A0 A0E0 A0A0 A0A0 E0A0
00057 REM 021E0 00E0 E000 C000 00E0 00A0 A0E0 A0C0 A0A0
00058 REM 021F0 A0E0 4040 A0E0 2020 20A0 E0A0 A0C0 A0A0
00059 REM 02200 0000 0000 0000 00E0 00E0 A0E0 A0A0 E0A0
00060 REM 02210 A0A0 A0E0 E0A0 E0E0 00A0 A0E0 A0A0 A0A0
00061 REM 02220 E0C0 A0E0 00E0 20E0 E040 4040 40A0 A0A0
00062 REM 02230 A0E0 A0A0 A0A0 40A0 A0A0 A0E0 A0A0 40A0
00063 REM 02240 A0E0 A0E0 40A0 E020 4000 E000 0000 0000
00064 REM 02250 F0F0 F0F0 F000 0000 0000 FCFC FCFC FC00
00065 REM <<< SAMPLE TEXT >>>
00066 DATA * 305 CHIP-8 TEXT 33053TH15 IS HOW YOU
00067 DATA *PRINT%(100)2W2PRINT PRINT%23CHUNKY TEXT ON*
00068 DATA * YOUR MICROBEE. (140 & 120 44)(200)
00069 DATA *@1#3#9 IN ANY FORMAT!(200)@1#3#3UP TO 64*64(200)
00070 DATA *@1#0#3#3 OK%:(40 15 1 120)1*
```

## Home brew label maker

A program for programmers who like beer. By altering the strings in lines 190-240, the program can be customised for any user (and, indeed, for other labels besides home brew). Once you have set up your label, you need to remember to change the string B0\$ in line 240 to correspond with your date of bottling. Make sure that all of the strings have the same length to ensure a neat label.

The program should be easy to translate for other computers and printers. Line 180 activates double width print on my Olympia printer; line 380 deactivates it.

Adrian Gallagher  
Bendigo, Vic

## VZ200

```
100 REM * HOME BREW LABEL MAKER
110 REM * FOR VZ 200/300
120 REM * PRINTER: OLYMPIA HP
130 REM * (EPSON COMPATIBLE)
140 REM * BY A. GALLAGHER
150 REM * 14/5/86
160 REM * ALTER STRINGS TO SUIT
170 REM *****
180 LPRINT CHR$(27);"I";CHR$(132);"I" SELEC
T DOUBLE WIDTH PRINT
190 T$="*****"
200 S$=""
210 A$="" ADE'S * * ADE'S *
220 M$="" MEAN L * * MEAN L *
230 B$="" B I T T E R * * B I T T E R *
240 B0$="" B 17-5-86 * * B 17-5-86 *
250 CLS:INPUT "HOW MANY DOUBLE LABELS?";N
260 FOR I=1 TO N
270 PRINT T$
280 LPRINT S$;LPRINT S$
290 PRINT A$
300 PRINT M$
310 PRINT B$
320 LPRINT S$;LPRINT S$
330 LPRINT B0$
340 LPRINT S$
350 LPRINT T$
360 LPRINT:LPRINT:LPRINT
370 NEXT I
380 LPRINT CHR$(27);"I";CHR$(0);"I" DESELEC
T DOUBLE WIDTH PRINT
390 END
```



## Idea of the Month

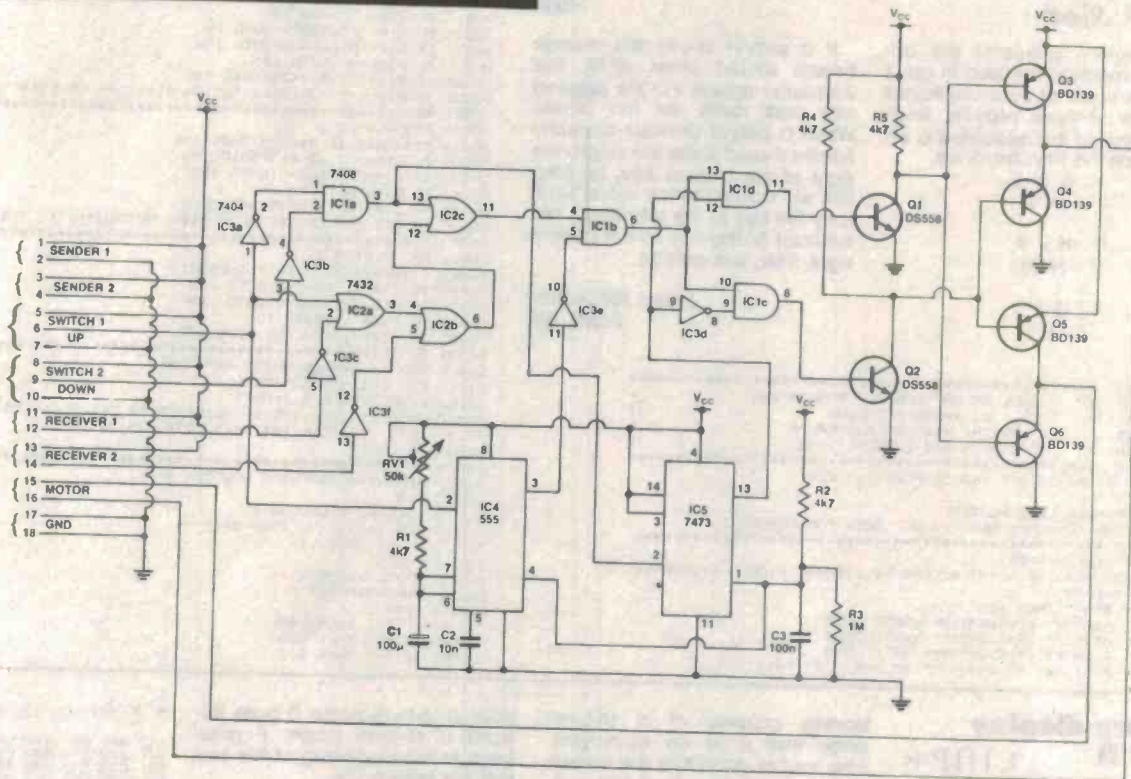

Feed Forward needs your minds. If you have ideas for circuits that you would like to enter in our idea of the month contest, programs for the computing columns or just want a word with the editor, send your thoughts to:

Feed Forward  
ETI, Federal Publishing,  
PO Box 227,  
Waterloo, NSW 2017

Contributors can look forward to \$20 for each published idea/program which should be submitted with the declaration coupon below.

Programs MUST be in the form of a listing from a printer. You should indicate which computer the program is for. Letters should be typewritten or from a printer, preferably with lines double spaced. Circuits can be drawn roughly, because we have a draughtsman who redraws them anyway, but make sure they are clear enough for us to understand.

### COUPON

Cut and send to: Scope-ETI 'Idea of the Month' Contest/  
Computing Column, ETI Magazine, PO Box 227,  
Waterloo NSW 2017.

"I agree to the above terms and grant *Electronics Today International* all rights to publish my idea/program in ETI Magazine or other publications produced by it. I declare that the attached idea/program is my own original material, that it has not previously been published and that its publication does not violate any other copyright."

\* Breach of copyright is now a criminal offence.

Title of idea/program .....

Signature ..... Date .....

Name .....

Address .....

Postcode .....

### 'Idea of the month' contest

Scope Laboratories, which manufactures and distributes soldering irons and accessory tools, is sponsoring this contest with a prize given away every month for the best item submitted for publication in the 'Ideas for Experimenters' column — one of the most consistently popular features in ETI Magazine. Each month, we will be giving away a 60 W portable cordless soldering iron, a 240 V charging adaptor together with a holder bracket. The prize is worth approximately \$100.

Selections will be made at the sole discretion of the editorial staff of ETI Magazine.



### RULES

The winning entry will be judged by the Editor of ETI Magazine, whose decision will be final. No correspondence can be entered into regarding the decision.

The winner will be advised by telegram. The name of the winner, together with the winning idea, will be published in the next possible issue of ETI Magazine.

Contestants must enter their names and addresses where indicated on each coupon. Photostats or clearly written copies will be accepted. You may send as many entries as your wish.

This contest is invalid in states where local laws prohibit entries. Entrants must sign the declaration on the coupon that they have read the above rules and agree to abide by their conditions.



## Electronic door controller

This circuit was initially designed as an electronic doggie door, but can be used in a variety of applications where automatic control is required.

The sender and receiver pair used in this case are a light source and a light dependent resistor (LDR). When the beam from the light source is broken, the circuit is tripped and the door opens with the aid of an ac

motor. When the door is fully open, switch 1 is tripped to switch off the motor. Then there is a delay created by IC4 (to allow Fido to toddle in). The time for this delay can be varied from between 0.5 and 5 seconds and is set by RV1. After this delay the motor is started again to close the door following the delay. When the door is fully closed, switch 2 is tripped to stop the motor running.

Ron Von Snarsky,  
Collaroy, NSW

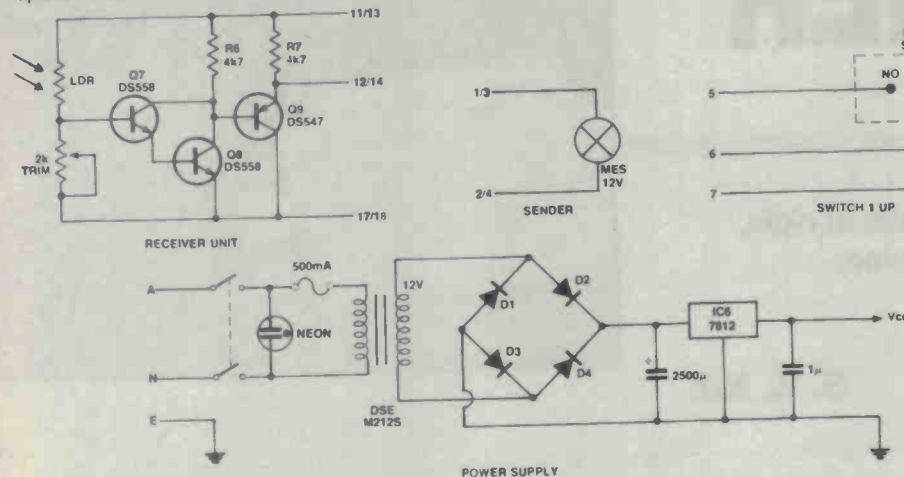

## Minimart

FOR SALE: 256K PARALLEL PRINTER BUFFER short form kit \$39, serial converter board to suit \$18, printer shaver board to suit \$12. For more info send SAE to Don McKenzie, 29 Ellesmere Cres, Tullamarine, Vic 3043.

FOR SALE: IBM-PC type printer cables, DB-25 to Centronics 36-way, 2 metres long, \$25 plus \$3 p&p. Don McKenzie, 29 Ellesmere Cres, Tullamarine, Vic 3043.

WANTED: BACK Issues of ETI, April '71 to December '83 inclusive. Phone (077)74-0300.

FOR SALE: ACT Vic-20 bi-monthly magazine. Many interesting articles and programs. August issue \$2; \$12 per year. Write to Chris Groenhout, 25 Kerford St, Watson, ACT 2602.

FOR SALE: MicroBee 16 Kbyte with monitor/TV, includes manual, power supply, \$200 software, battery backed memory and many extras. Sell \$250. Michael (053)34-1471, Vic.

FOR SALE: COMPLETE SET of ETI and EA back Issues 1974-84 in mint condition at \$10 per year. Mr Bailch (02)631-9202.

FOR SALE: VZ200/300 software. Back up your valuable tapes. Makes copy of any VZ200/300

tape. Send \$12 to E. Sundstrup, 29 Hunter St, Macedon, Vic 3440.

FOR SALE: VZ200/300 EXPANSION UNITS. 32K RAM for VZ200 only \$80 and 18K RAM for VZ300 only \$70. Ring David, on (07)209-8478 after hours.

FOR SALE: MICROBEE 32K with a 4 MHz modification. Comes with b/w monitor, cassette and heaps of programs. The lot for only \$300. No offers. Phone (02)625-6480.

FOR SALE: AVOMETER, mod 8 Mk C/W test leads, long reach safety prods, bulldog clips. \$75. McManamon, 103 Bungan Head Road, Newport, NSW 2106. (02)997-1693.

FOR SALE: EPROM 2732A, new, un-comp project, gtd. 100 at \$2.50 ono. (02)644-8825.

FOR SALE: AS NEW, VZ200 colour computer, transformer, TV cords, cassette cords, instruction manual. \$70 ono, phone Ben, (071)62-4478 after 5 pm.

FOR SALE: SUPER 80 Assembler/full screen editor \$15, disassembler \$9. Siemens M100 teleprinter (receive only) \$40. R. Vowels, 93 Park Drive, Parkville 3052.

FOR SALE: ULTRASONIC m'ment detector. Hyperware Mk III. Needs 12 volt ps \$60. Vemon van Duijnhouen (07)379-7354, 3 Elizabeth St, Sherwood, Qld 4075.

FOR SALE EXIDY Sorcerer computer MKII 56K with RAM pack, twin FDS drives, CP/M 2.2, word processing, voice recognition & synthesis, heaps of software and hardware, all manuals and circuits. \$1,200 ono Ph (047)21-2190 after 6.00 pm.

FOR SALE: 256K PARALLEL PRINTER buffer short form kit \$39, serial converter board to suit \$18, printer shaver board to suit \$12. For more info send SAE to Don McKenzie, 29 Ellesmere Cres, Tullamarine 3043.

FOR SALE: VIC-20 PROGRAM LIBRARY. High quality games, utilities, educational and misc programs available. Send SAE to Chris Groenhout, 25 Kerford St, Watson, ACT 2602 for list.

FOR SALE: DATA-100 line printer, parallel interface, VDUs and keyboards (2), manuals, cables, \$150 lot. Craig, 49 Forest Road, Heathcote. (02)520-2442.

FOR SALE: Complete set of ETI magazines from September '80. Current subscriptions to November '86 \$250. Jim Berry, 619 Burbridge Rd, West Beach, SA 5024.

FOR SALE: VIC-20 32K switchable RAM expansion boards. A&T \$80. Optional battery back-up available for \$20 extra. Inquiries to Andrew. (03)848-3524.

**READER SERVICES:** All enquiries regarding back issues, photocopies of articles, artwork or technical enquiries must be directed by mail to ETI Reader Services PO Box 227, Waterloo, NSW 2017. Enclose cheque or money order to the appropriate value with your request. Relevant charges including postage within Australia and New Zealand are: back issues \$4; photostat copies: \$4 per article or \$8 if project spreads over more than one issue; artwork: \$5 per board or panel up to 10 cm<sup>2</sup> or equivalent, \$10 for larger boards.

**TECHNICAL ENQUIRIES:** No enquiries by telephone will be accepted. Readers have two options: to submit a written enquiry with \$5 money order or cheque and receive a postal reply; this service is limited to projects published within the last five years; alternatively they may forward enquiry without money and expect a published reply in the Feed Forward columns at the editor's discretion.

**GENERAL INQUIRIES:** For all inquiries about back issues, subscriptions, photocopies of articles, artwork or submitting articles, call (02) 663-9999 or write to ETI Reader Services, 180 Bourke Rd, Alexandria, NSW 2015 (PO Box 227, Waterloo, NSW 2017).

**CONTRIBUTIONS:** Submissions must be accompanied by a stamped, self-addressed envelope. The publisher accepts no responsibility for unsolicited material.

**COPYRIGHT:** The contents of *Electronics Today International* and associated publications is fully protected by the Commonwealth Copyright Act (1968). Copyright extends to all written material, photographs, drawings, circuit diagrams and printed-circuit boards. Although any form of reproduction is a breach of copyright, we are not concerned about individuals constructing projects for their own private use, nor by bands (for example) constructing one or more items for use in connection with their performances. Commercial organisations should note that no project or part project described in *Electronics Today International* or associated publications may be offered for sale, or sold in substantially or fully assembled form, unless a licence has been specifically obtained so to do from the publisher, The Federal Publishing Company, or from the copyright holders.

**LIABILITY:** Comments and test results on equipment reviewed refer to the particular item submitted for review and may not necessarily pertain to other units of the same make or model number. Whilst every effort has been made to ensure that all constructional projects referred to in this edition will operate as indicated efficiently and properly and that all necessary components to manufacture the same will be available, no responsibility is accepted in respect of the failure for any reason at all of the project to operate effectively or at all whether due to any fault in design or otherwise and no responsibility is accepted for the failure to obtain any component parts in respect of any such project. Further, no responsibility is accepted in respect of any injury or damage caused by any fault in the design of any such project as aforesaid.



# TELEPHONE SCREAMER

If the creeps are keeping you awake at night, this little project might scare off some of the hazards of urban living.

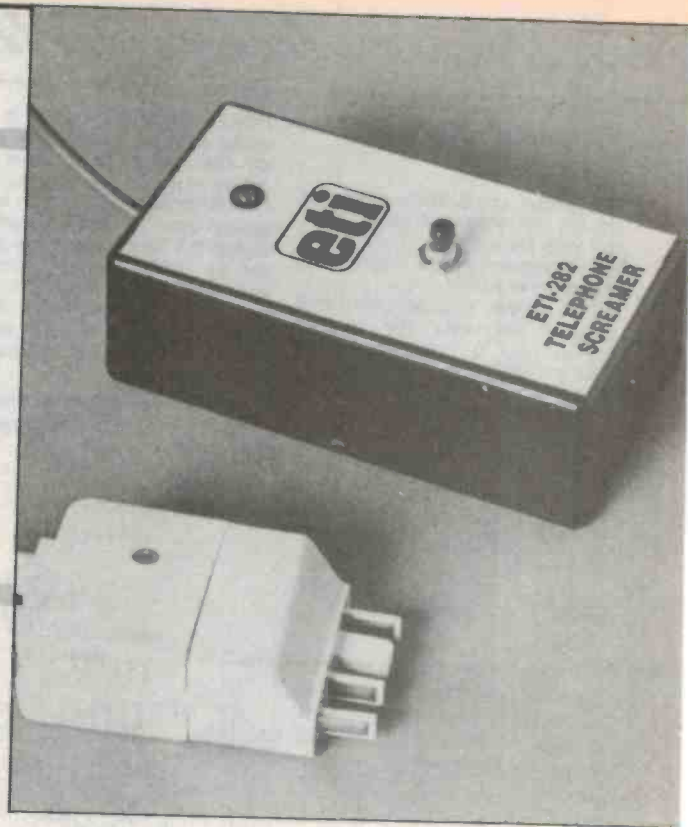

S. K. Hui

WE KNOW OF NO survey that has been conducted on the frequency of dirty phone calls. Nevertheless, a lot of you might have had the experience. Although the focus of much merriment for people who have never been the object of them, they are unpleasant, even frightening events for the victims. Unexpectedly wakened up in the middle of the night to the sound of heavy breathing, or even obscenity, is thoroughly nasty.

What to do about it? Wisdom is that you only excite the caller by yelling back. On the other hand it seems a bit too kind to let him off by simply hanging up the phone.

The best way to chastise such people is with this simple telephone screamer unit. It sends a loud tone down the line to the other end, insufficient to cause permanent ear damage, but strong enough to provide negative reinforcement for a dirty habit.

It will take no more than an afternoon to build, and gives you an effective means to fight back. The unit just plugs into the line socket in parallel with the phone via a double adaptor. The installation problem and the problem of having to modify your phone are eliminated. The unit can then be placed next to the phone ready for action! Simply depress a pushbutton to trigger the siren whenever you have to.

This simple circuit has been designed with considerable thought for safety. A totally insulated plastic case houses the completed circuit, which is powered by a harmless 9 Vdc battery. However, the law requires you to get approval from Telecom before connecting anything to the line.

## Design approach

To ensure simplicity in the project, both in construction and operation, the unit was designed to be connected in parallel with the phone. Normally, ie, with the pushbutton released, the battery is disconnected from the circuit, leaving the de-energized relay off. This disconnects the Telecom line from the rest of the circuitry, so that the phone and all associated pieces of equipment both at home and in the exchange act quite normally. However, when the pushbutton is depressed, the 9 V battery is connected to the circuit, energizing the relay and connecting the line to the circuit.

The circuit itself is just an oscillator which will start to oscillate when power is applied.

The circuit trades off simplicity against the cost of a battery. The cost of the battery could be saved if the dc from the line was tapped to power up the circuit. But there are a few problems. Firstly, Telecom would not be very happy about the general public tapping its exchange power (though the power required for the circuit is very small). Secondly, the line voltage seems to adjust its amplitude from time to time as the ac signal varies, so as to avoid clipping. To use this to supply power to the circuit some fairly heavy rectification circuitry would be needed.

The alternative is to use a battery. It

achieves our purpose with a much simpler circuit. It's even more attractive since a single battery should last a long time. It's completely disconnected from the circuit normally, so there is negligible current drain. And you would have to be very unlucky to use the screamer more than a few times in a year.

## Construction

Thanks to our kind editor, finally, after 15 months at ETI, I have my first simple project to build! I would be very surprised if anyone has trouble building this circuit or getting it to work. Unlike some of the complex projects we have done recently, you don't have to have a joint electronic and mechanical honours degree before you are qualified to build it!

To start, get hold of the pc board and a plastic box with dimensions 40 mm (d), 120 mm (l) and 65 mm (w). It should be readily available from electronics shops. The bottom lid of the box is removed by unscrewing four screws on the corners of the box.

Firstly, check the pc board for broken or bridged tracks, washing it carefully with water and steel wool. It is important to go through this ritual. If there is a board fault, finding it at this time will save you hours later. Notice that the board has four pre-drilled holes for mounting screws. Put the pc board flush against the lid of the



## ETI-282 — HOW IT WORKS

The heart of the circuit is an oscillator consisting of a 555 timer, R2, R3 and C3. The output signal of pin 3 of the 555 timer is a square wave with uneven mark/space ratio. The duration of the charging time (output high, mark) and discharging time (output low, space) of the 555 is given by the following formulae:

$$T_c = 0.693 (R_2 + R_3) C_3$$

$$T_d = 0.693 (R_3) C_3$$

Therefore, the period of the signal is:

$$T = T_c + T_d = 0.693 (R_2 + 2R_3) C_3$$

With the values chosen for R2, R3 and C3 (see the parts list), Tc and Td work out to be 0.21 ms and 0.153 ms respectively. This makes the total period T = 0.363 msec. The frequency of oscillation is:

$$F = 1/T = 2754.8 \text{ Hz}$$

This frequency is deliberately chosen to irritate the ears without violating the bandwidth (300-3.3 kHz) requirement of the network.

Although the fundamental frequency of the square wave is below 3000 Hz, Fourier tells us that the square wave has many harmonics with higher frequencies. They are of weaker strength than the fundamental and yet still fairly significant to Telecom. To remove them, a one pole first order low pass filter formed by R4 and C1 is used. The cutoff frequency of the filter is given by:

$$F_c = 1 / (C_1 \times R_4)$$

With the values chosen for C1 and R4, Fc is 3000 Hz. With the value for R4 (300R), a fair amount of signal from the oscillator is attenuated. If you want to increase the volume heard by your assailant, reduce the value of R4 and increase the value of C1 to balance, so that Fc is kept the same. Try a few different values for R4 until you find the most irritating one.

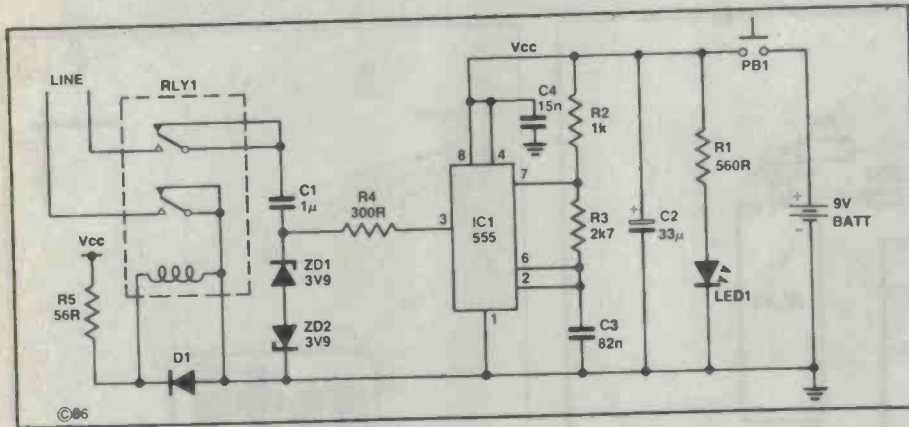

box and mark and drill out the centres of the holes.

Now mount the components. The board is single sided with less than 15 components, so it's not a big job. The circuit is so simple that it does not matter which component you put in first. The only points to watch are that the pc board holes carrying the relay are big enough, and the orientation of the polarised components. There are only five polarised components: three diodes, the integrated circuit and the electrolytic capacitor.

When you've mounted all the compo-

nents, don't screw the board down onto the lid. The pushbutton switch and the indicator LED should be mounted on the top of the box and connected to the pc board through a few hookup wires. Solder the hookup wire to the board and mount the pushbutton and the LED.

On the side panel of the box, drill another hole and mount a clamping grommet to clip the line cable tightly where it leaves the box. One end of the cable should be soldered to the board. The other end has a standard Telecom line plug for connection into the double adap-▶

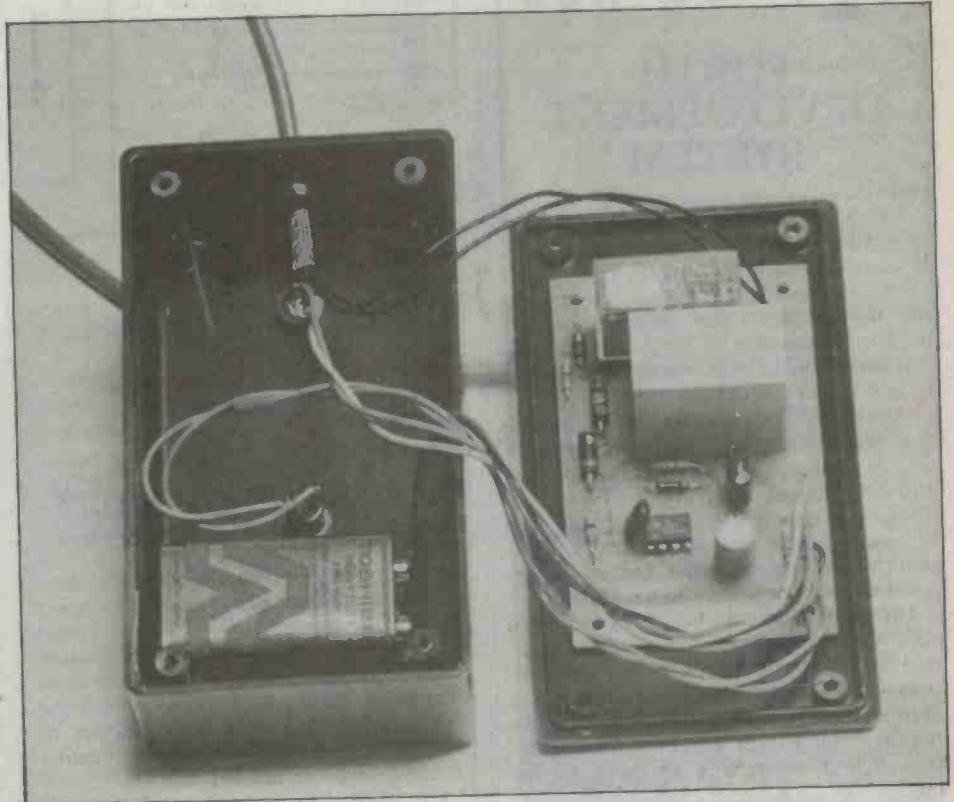
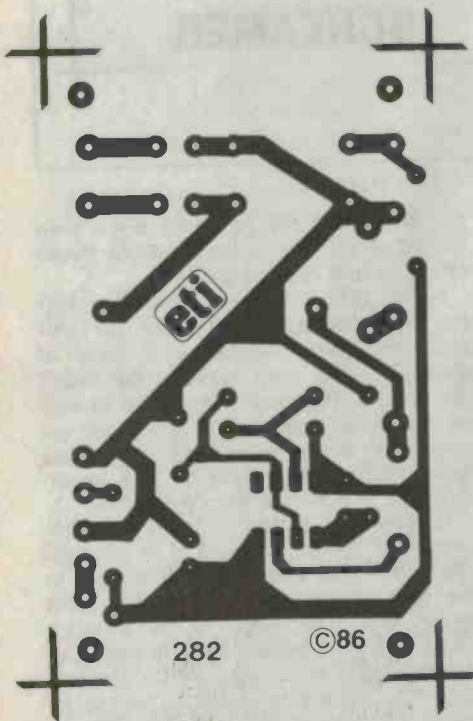



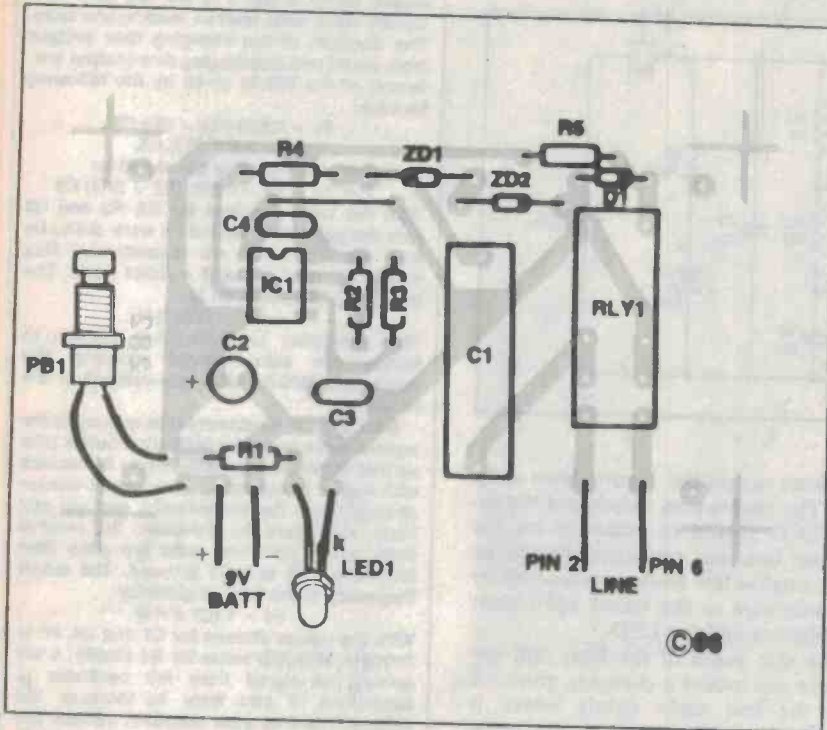

## ETI-282 TELEPHONE SCREAMER

### ETI-282 — PARTS LIST

Resistors.....	all 1/4W, 1% tol.
R1.....	560R
R2.....	1k
R3.....	2k7
R4.....	300R
R5.....	56R
Capacitors	
C1.....	1μ/250 V (Philips MKT-P 300 40)
C2.....	33μ/16 V elect
C3.....	82n greencap
C4.....	15n greencap
Semiconductors	
D1.....	1N4002
ZD1, ZD2.....	3V9 (1W or more)
LED1.....	standard 5 mm LED
IC1.....	555 timer
Relays	
RLY1.....	double pole 6 V coil (Fujitsu 621D006), Telecom App No RA80/157

**Miscellaneous**  
ETI-282 pc board, plastic box, a 9 V battery clip, LED holder, a pushbutton switch and a clamping grommet. One and a half metres of hookup wire and a section of Telecom cable with a line plug.

**Price estimate: \$21**  
(excluding battery and line double adaptor)



## Rockwell FORTH DEVELOPMENT SYSTEM

### STARTER KIT:

- (i) Mains D.S. Board, plated through holes and silkscreen.
- (ii) Complete RSC Forth Manual.
- (iii) R65FII Forth Kernel and microcomputer.
- (iv) R65FRI Development Rom.
- (v) Programmed Bipolar Prom.

**SPECIAL PRICE \$159.00**

P.O. Box 6502, Goodna, Qld. 4300  
PHONE: (07) 376-2955  
TELEX: AA43778 ENECON  
P.O. Box 12153, Wellington North,  
New Zealand.  
PHONE: 4 843-499  
TELEX: NZ30135 AUDITOR

**energy  
CONTROL**



# HI-COM UNITRONICS INT. PTY. LTD.

7 President Lane, Caringbah, NSW 2229. Phone (02) 524-7878

P.O. Box 626, Caringbah 2229. Bankcard or Mastercard Welcome

Mail order Postage  
 Less than \$50 ..... \$3.50  
 \$50-\$99 ..... \$4.50  
 \$100-\$250 ..... \$7.00  
 Above \$250 ..... \$10.00  
 Heavy item add extra

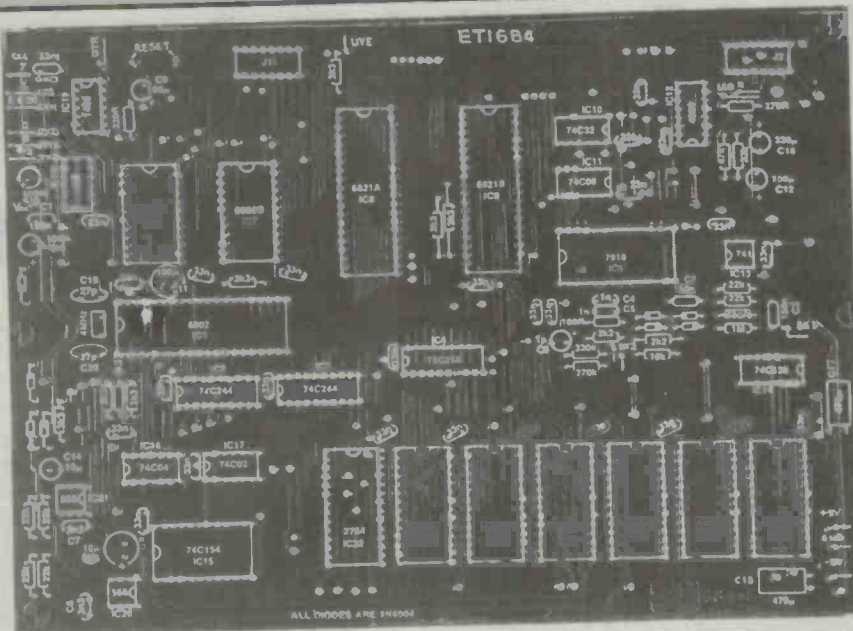

## ETI 684 INTELLIGENT MODEM KIT

**COMPLETE KIT AVAILABLE including power supply . . . \$420.00**

All PCBs are gold plated with components silk-screen printing and green solder mask (with plated through holes on the main PCB). This will save you hours of soldering! IC sockets are supplied for all ICs and only one side of the main board needs to be soldered. Apart from all components supplied as specified, all filter ceramic caps are replaced by the higher quality monolithic ceramic caps at no extra cost. Autobauding, Autodial, Auto-line Monitoring, Cassette-Recorder Interface, Answering Machine Capability, Hayes Command Compatible and many more!!! All specific components with 8K RAM as standard. Demonstration is available at the shop.



## IBM XT COMPATIBLE COMPUTER



High quality Japanese made multi-layer boards with 640K RAM, 2x360K Disk Drives, Colour Graphics Output, Parallel/Serial and Games Ports, Built-in Clock, Metal Case and Keyboard ..... **\$1750**  
 Optional enhanced Graphic and Super High Res. Colour Monitor extra ... **\$1850**  
 1M Byte UNFORMAT TEAC disk drive ..... **\$330**

**Z-NIX MOUSE FOR YOUR IBM PC/XT. \$16**  
 3 Button with int/F card, compatible with PC Paint, Paintbrush, Autocad, Lotus, etc.



## IBM XT COMPATIBLE COMPUTER

- 640K 8 slots NEC 8088 CPU ..... **\$450**
- MULTI I/O card (2 serial, 1 parallel, game port, floppy drive controller) ..... **\$288**
- Colour graphic card ..... **\$180**
- National disk drive 360K D/S ..... **\$275**
- IBM PC/XT keyboard ..... **\$160**
- IBM AT style keyboard for XT ..... **\$185**
- Metal computer case ..... **\$120**
- 135W switching power supply ..... **\$199**
- 20 MBYTES MINISCRIBE HARDDISK & CONTROLLER ..... **\$1299**
- JOYSTICK FOR IBM COMPUTER ..... **\$55**

Z-300 Mouse for your IBM PC/XT ... **\$160**

## DISK DRIVES FOR APPLE II + OR IIE..... \$275

- APPLE IIC ..... **\$350**
- TVM 14" COLOUR MONITOR 16 colours 640 x 400 interfaced ..... **\$750**
- TTL AMBER MONITOR FOR IBM PC/XT Computer ..... **\$249**
- 640 x 400 suit Hercules graphic card.

**SUPER 5 EN 1201 DOT MATRIX PRINTER ..... \$650**  
 120 CPS, NLQ, long life ribbon, IBM Graphics and 11 international characters built-in.

**SUPER 5 EN 1090 dot matrix printer ..... \$520**  
 100 CS, IBM Graphics and 11 international characters built-in.

**SUPER 5 1805 DOT MATRIX PRINTER ..... \$1150**  
 180 CPS, 15" paper, 3K buffer & all other extras as EP 1201.

**SERIAL PRINTER ADAPTOR FOR SUPER 5 PRINTER ..... \$150**

**RS232 SERIAL CABLE with RF Shielding 1.8M male to female, m/m or f/f ... \$25**

**TELEPHONE EXTENSION CORD**  
 5 Metres ..... **\$ 8.50**  
 10 Metres ..... **\$13.50**

**RS232 SWITCH for A Modem between 2 computers ..... \$139**

**CENTRONIC PRINTER SWITCH between 2 computers or a computer, between 2 printers ..... \$149**

## COMPONENTS

MODEM IC 7910 .....	\$28.00
6802 .....	\$ 9.00
6821 .....	\$ 5.00
6850 .....	\$ 4.00
SFH601 OPTOCOUPLER .....	\$ 5.50
1488 .....	\$ 1.30
1489 .....	\$ 1.30
2764 .....	\$ 7.80
6264 .....	\$13.50
4 Mhz CRYSTAL .....	\$ 5.90
2.4576 Mhz. ....	\$ 3.90

## CAPACITORS

2µF/440VAC SHIZUKI .....	\$10.50
1µF/250VAC PHILIPS .....	\$ 2.90
MKT 0.22/1000V .....	\$ 3.30
MKP 1µF/250V 10% .....	\$ 3.90
0.1µF/250VAC 50Hz .....	\$ 1.00
Polyester	
0.001 to 0.082 .....	\$ 0.25
0.1 to 0.22 .....	\$ 0.27
0.27 to 0.39 .....	\$ 0.35
0.47/250V .....	\$ 0.55
0.68/50V .....	\$ 1.00
1µF/50V .....	\$ 1.25

## ELECTROLYTIC CAPS SPECIAL

0.1µF to 0.47µF/50V .....	\$1.00/10 PCS
1µF to 22µF/16, 25, 50V .....	\$1.20/10 PCS
33µF to 100µF/16V, 25V .....	\$1.50/10 PCS
220µF to 470µF/50V .....	\$2.50/10 PCS
1000µF/50V .....	\$5.00/10 CS
2200µF/16, 1000µF/50V .....	\$12.50/10 PCS
3300µF/25V .....	\$13.50/10 PCS
3300µF/50V .....	\$2.50 EACH
4700µF/50V .....	\$3.00 EACH
100µF/100V .....	\$1.80 EACH
10000µF/100V/BRACKET .....	\$60.00 EACH

## ALL CERAMIC CAPS

1pF to 0.047 .....	\$0.95/10 PCS
Monolithic ceramic	
0.033, 0.1µF .....	\$0.35 EACH
600/600 ohm tel transformer .....	\$17.50



# DUAL MICROBEE JOYSTICK

Have you ever wanted to be able to use two joysticks with your Microbee? This circuit is the interface you have been waiting for, and as a bonus, it also provides a variable speed 'rapid fire' for both joysticks at the flick of a switch.

THIS PROJECT was developed as a result of a casual comment by a friend that the two player games require both players to share a keyboard — an awkward arrangement at best. A quick check of the Microbee technical literature revealed that bit 6 was unused in the standard joystick interface, and therefore could be used to select between two joysticks. To save firing finger strain (or to cheat in the eyes of some people!), an automatic 'rapid fire'

would be a bonus — simply hold the fire button and let the interface do the work of pressing the button!

Although this project was developed for the Microbee, it should be easily adaptable to other computers which provide an 8-bit parallel port capable of being programmed to have one output and seven inputs (such as the Microbee's Z80 P10 port). The only other requirement is a 5 V source to power the interface.

## The circuit

The circuit is based on the 4053 triple two-channel analogue multiplexer/demultiplexer (triple analogue change-over switch). The function of these switches in this circuit is to connect each joystick in turn to the computer's port. This time sharing of the two joysticks (only one joystick can be connected at a time) is controlled by the computer via bit 6 of the port. A high (logic 1, positive) on bit 6 selects joystick 1, while a low (logic 0, negative) will select joystick 2. This convention is used to ensure that most (all?) existing software uses joystick 1 and can be used without unplugging this interface. Most existing software simply programs the port for eight inputs, so bit 6 will be pulled high by the 10k pull-up resistor. Note that the 1.2k resistor between pins 8 and 15 of connector SK3 is to ensure compatibility with the Microbee joystick standard.

The rapid fire oscillator (IC4a, c, and d) can be adjusted over a range of about one to 10 hertz by means of potentiometer RV1, and is enabled by opening switch, SW1. If the switch is closed, the oscillator is halted and the fire button is locked through to bit 7 (via the joystick select switch, IC1b). When the oscillator is enabled (and the fire button is closed!), the fire button is open circuited and reclosed at the oscillator's frequency, and less importantly, its duty cycle. It therefore appears that the player is repeatedly pressing and releasing the button.

By now you'll be wondering what function is performed by IC5? It ensures that the rapid fire oscillator cannot override the fire button by ensuring that the fire button is through-connected until after it has been pressed. The fire signal is therefore presented to the computer port without delay, and is then synchronized to the rapid fire oscillator. Each fire button must be separately synchronized to ensure that the first button pressed fires the first shot.

Power for this interface circuit is obtained from the Microbee's parallel port. If your joysticks have two additional

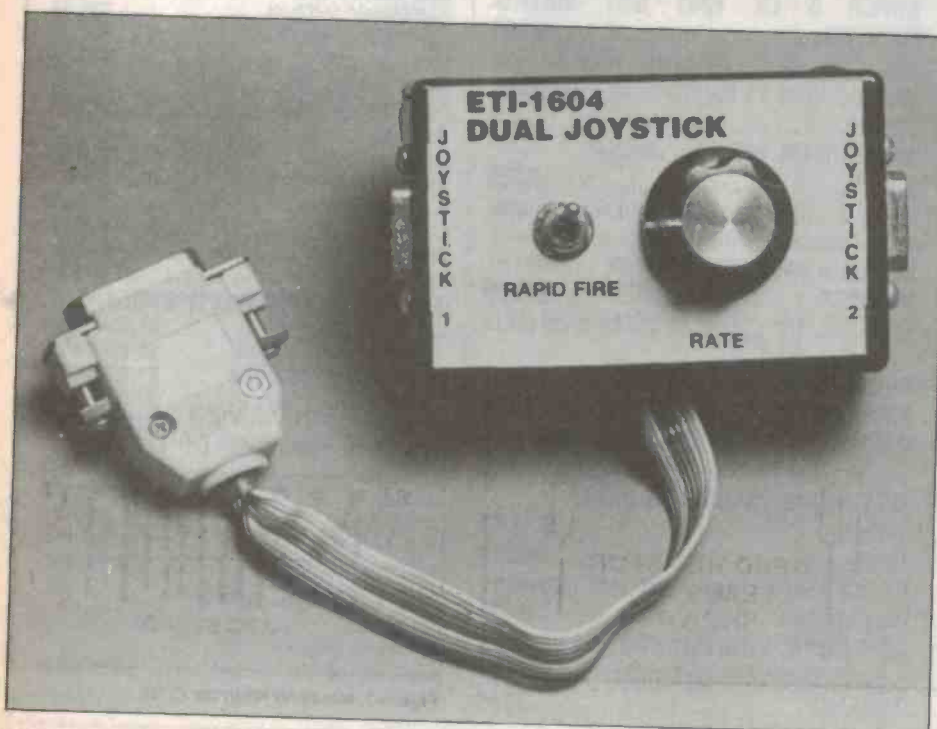



**Peter Jardine**

buttons (ie, 'select player 1', and 'select player 2'), they too can be used with this interface by adding a few insulated wire links on the underside of the circuit board (ie, link the pads from the select 1 and select 2 pins connector SK1 to IC2 pins 12 and 2 respectively, and of connector SK2 to IC2 pins 13 and 1 respectively). Note also that the rapid fire feature may be omitted if required by omitting R11-17, C7, D2-4, IC5, RV1, and SW1, and then inserting wire links in place of R14, R15, and SW1. This permanently links the fire buttons to the joystick select switch, IC1b.

**Construction**

The manner of construction of this circuit is not critical (the first prototype was assembled on two small pieces of vero-board and jammed into the same box), but using the printed circuit board is the recommended way to go. Start by checking the board for breaks in any of the tracks, or bridges of copper where there should not be any. Check that all the holes have been drilled and are clear (including the mounting holes). A good soldering iron (preferably temperature controlled) with a fine tip is required as the circuit board has quite a few fine (easily damaged) tracks.

Fit the two wire links first. The link running beside IC3 in particular, but preferably both, should be insulated tinned copper wire. Next mount the resistors (except R1-9), diodes, and capacitors, noting the correct polarities where appropriate. Try to mount the resistors so that, with the

board in a particular orientation, all the colour codes read from left to right, and top to bottom. Similar conventions should also be adopted for other non-polarized components wherever possible. This is a good construction habit to get into and

simplifies any later fault finding. Resistors R1-8 are mounted vertically to form a single-in-line (SIL) resistor group as shown in Figure 1. Note that you should be able to use a commercial 8 x 10k SIL resistor package if available. Resistor R9 is

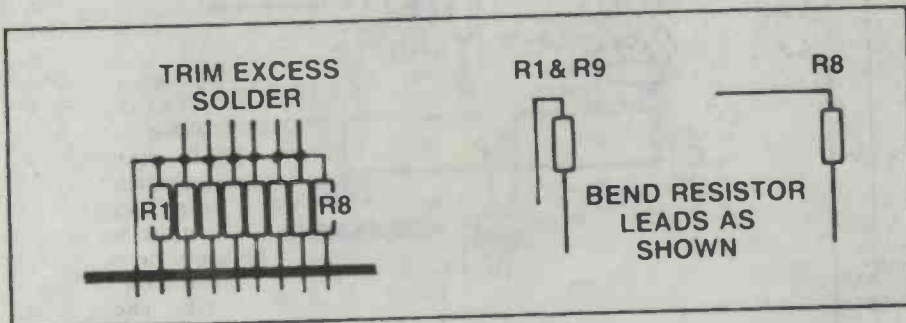
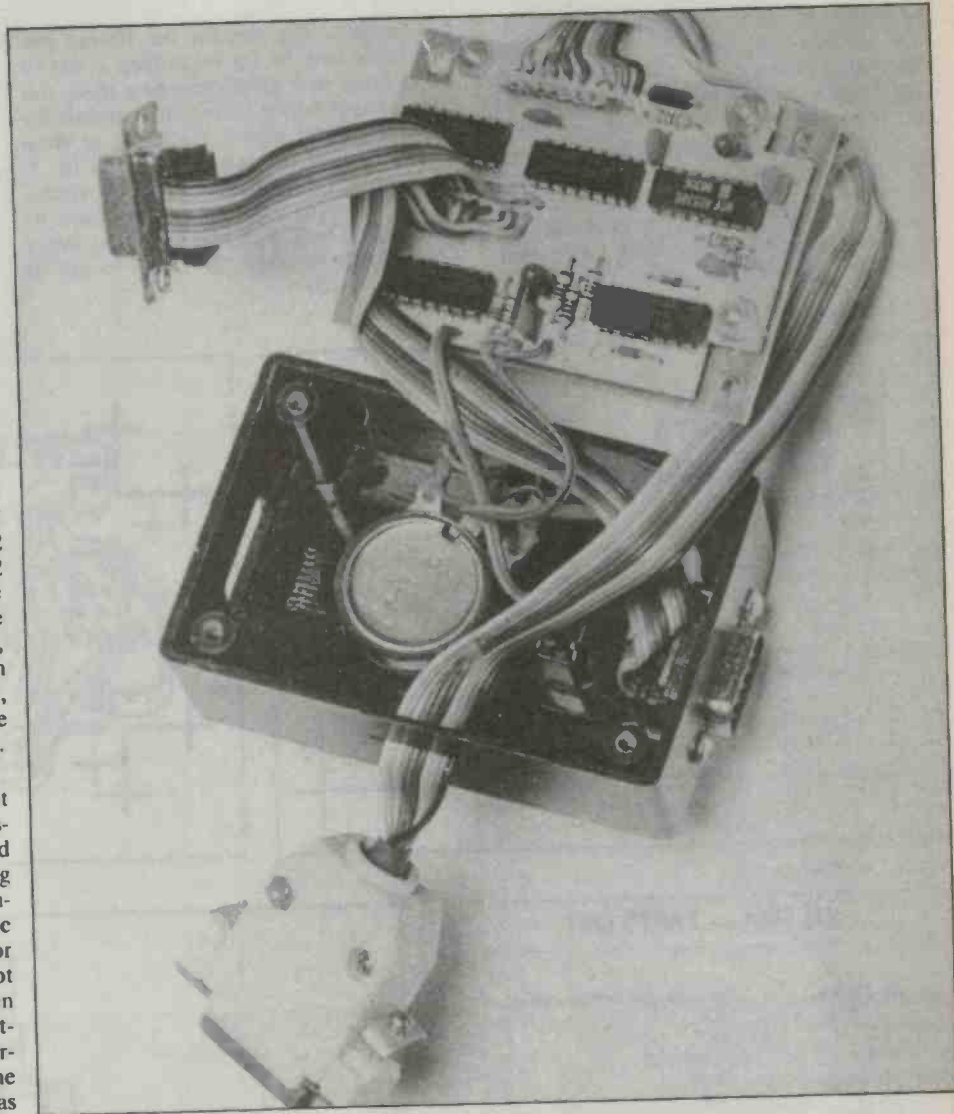

Figure 1. Mounting R1 to R8.

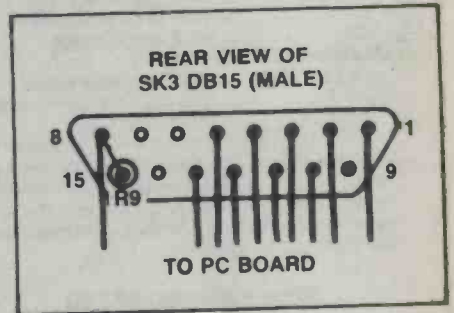

Figure 2. Mounting R9 in the DB15.



# Project 1604

mounted on back of connector SK3 inside the backshell (see Figure 2). The five integrated circuits, can now be mounted, again being careful to observe the correct orientations.

Before terminating connectors SK1-3, it is time to do the mechanical work and prepare the jiffy box to house the interface. Following the layout, you should obtain a compact interface unit. Note that the aluminium 'lid' is used as the base in

this project. The slot for the 10-way ribbon cable may be cut by drilling a line of small holes and joining/cleaning them out with a sharp hobby knife. The cut-outs for connectors SK1 and 2 are made as close to the 'top' of the box as they will fit. If you get a jiffy box with printed circuit board mounting ribs, these may have to be trimmed back with side cutters and/or a hobby knife to allow the circuit board to mount properly.

Connectors SK1 and 2 can now be terminated. This should be done in such a way that the ribbon cable emerges on the 'top' of the connector when it is mounted in the case. Use about 120 mm of 9-way ribbon cable for SK1, and 80mm for SK2. These connector cables can now be terminated on the circuit board.

A length (200-300 mm) of 10-way ribbon cable should be soldered to the correct pins of connector SK3, following the

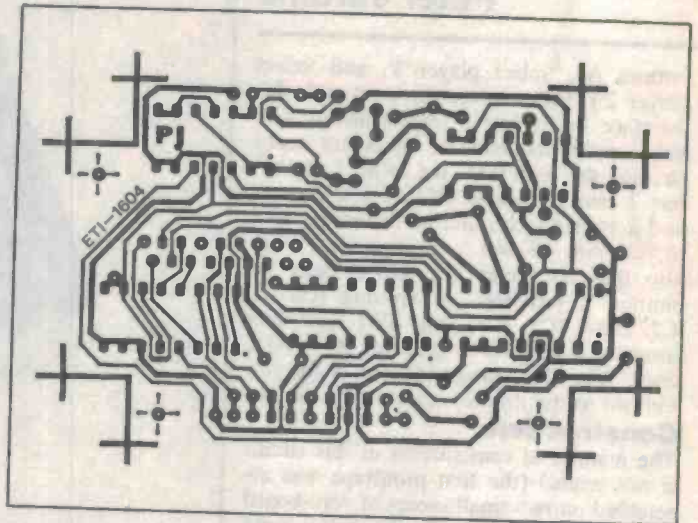

## ETI-1604 — PARTS LIST

**Resistors** .....all ¼W, 5% unless noted  
 R1-8, 11 .....10k  
 R9 .....1k2  
 R10 .....100R ½W  
 R12 .....270k  
 R13 .....1M  
 R14, 15 .....22k  
 R16, 17 .....100k  
 RV1 .....100k linear rotary pot

**Capacitors**  
 C1-5 .....10n ceramic  
 C6 .....10µ 25 VW tantalum  
 C7 .....6µ8 35 VW tantalum

**Semiconductors**  
 D1,2 .....1N4001, 1N4002 or similar  
 D3, 4 .....1N4148, 1N914 or similar  
 IC1-3 .....4053 triple analogue switch  
 IC4 .....4001 quad 2 input NOR  
 IC5 .....4013 dual D flipflop

**Miscellaneous**  
 SW1 .....SPDT miniature toggle  
 SK1, 2 .....DB9 male IDC connectors  
 SK3 .....DB15 male solder connector with backshell

ETI-1604 pc board; 80 x 50 x 25 mm jiffy box; 4 x rubber feet; 1 x knob; 1 x small tie cable; 10-way rainbow cable; insulated tin copper wire; 8 x ½" by ⅛" star washers; 12 x ⅛" Whitworth nuts (four are drilled out for spacers).

Price estimate: \$22.65

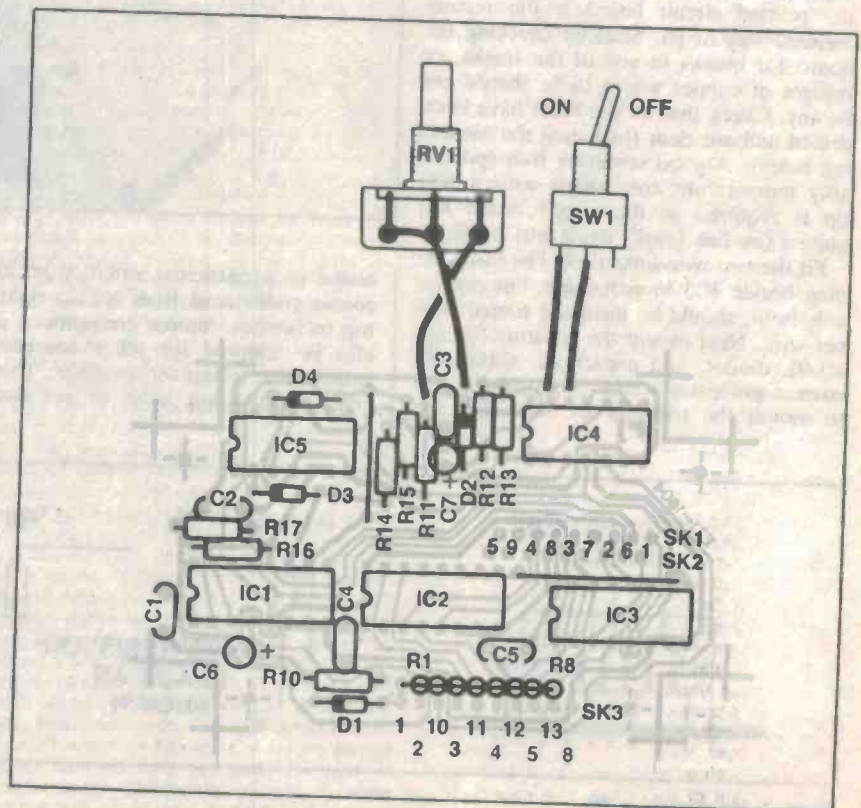



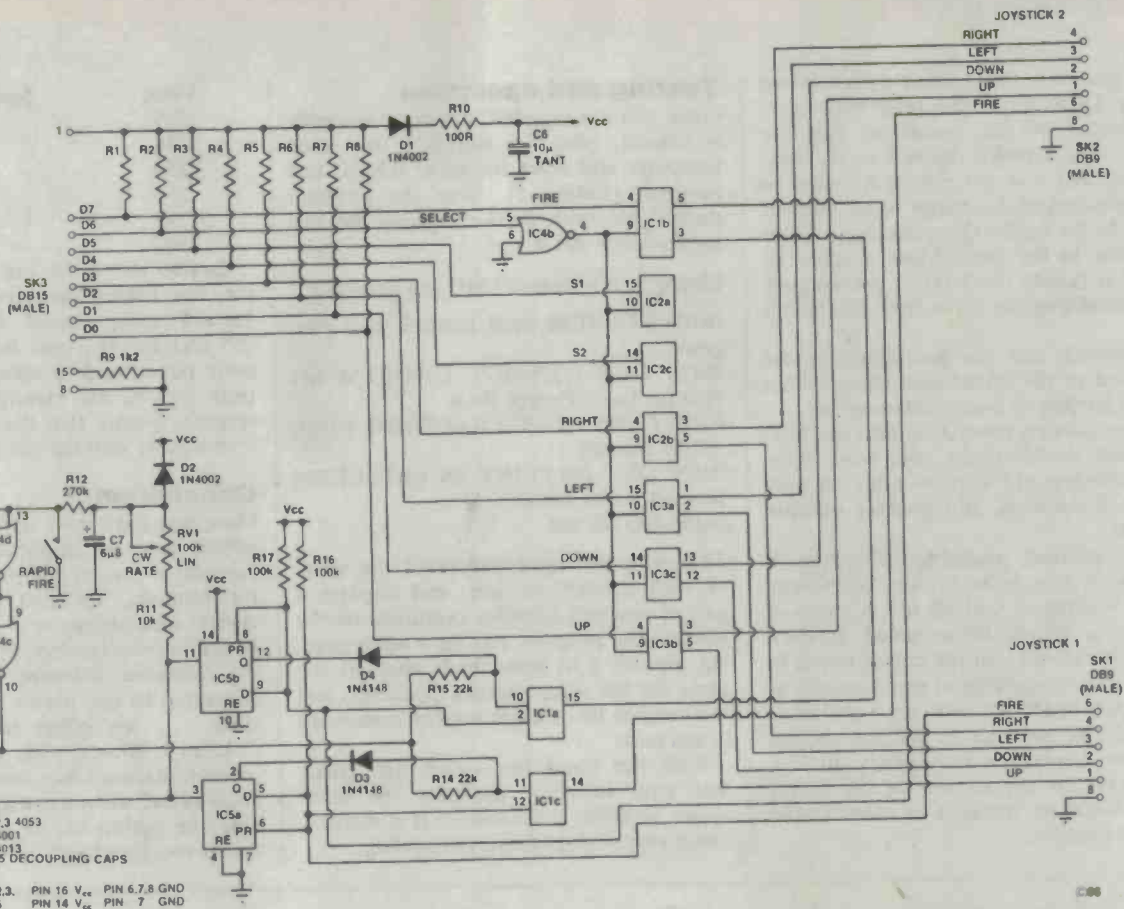

## ETI-1604 — HOW IT WORKS

The Microbee joystick standard does not specify a use for the 'data 6' bit, and it is this that allows us to use it as a control bit to select between the two joysticks. One gate of IC4 (gate b) is used to buffer and invert data line 6 from the Microbee and drive the analogue switches (4053s). A logic 1 on bit 6 selects joystick 1, and a logic 0 selects joystick 2, allowing most (all?) single joystick software to run without modification using joystick 1 (no need to unplug the interface).

The 'rapid fire' clock is formed by the slightly unusual arrangement of IC4 gates a, c, and d. The clock is enabled when the switch (SW1) is open, and its frequency is controlled by the 100k potentiometer RV1 (about a 10:1 range from 1 Hz to 10 Hz) in conjunction with the 10k resistor, R11, which limits the highest frequency of operation and the 6.8µ capacitor C7. The diode D2 ensures that the capacitor is discharged when the power is disconnected.

Gates c and d of IC4, together with the 270k (R12) and 1M (R13) resistors, form a non-inverting Schmitt trigger which senses the state of charge of the capacitor. Gate a of IC4 inverts the output of the Schmitt trigger to cycle the capacitor in addition to being used in the 'rapid fire' synchronization circuit. Assume that the capacitor voltage is zero initially, then the input to the Schmitt trigger will be below the lower threshold, forcing the output of IC4c low, and the output of IC4a high. The capacitor will now charge via the timing resistors

until the upper threshold of the Schmitt trigger is reached, at which time the output of IC4c will start to rise. The high open loop gain of the gates in a logic chip and the positive feedback provided by resistor R13 (1M), ensures that the output switches rapidly from low to high. The output of IC4a will now be low and the capacitor will discharge, again via the timing resistors.

When the lower threshold of the Schmitt trigger is reached, its output will again go low (aided by the positive feedback provided by resistor R13). This cycle will repeat itself whenever the clock is enabled. Note that if the switch is closed ('rapid fire' disabled), the output of IC4c will be low, and the 'fire buttons' will be permanently through connected to the joystick select switch (IC1b for the fire line).

While the 'rapid fire' clock is enabled, the synchronization circuits formed by IC5 function as follows. (Both halves function identically, so only one will be described.) While the 'fire button' is released, the D flip-flop is held in its preset state ( $\bar{Q}$  output = low) by the 100k resistor. This causes the associated electronic switch to connect the 'fire' line to the joystick select switch (IC1b).

The oscillator signal to the switch (via the 22k resistor) is overridden by the low  $\bar{Q}$  output of the flip-flop via the diode, and it therefore has no effect on the switch. When the 'fire' button is pressed, it is sensed via IC1b immediately by the computer, and the forced preset is removed from the flip-flop. Nothing else happens until the next rising edge of the complementary clock signal (from IC4a), at which time (if the 'fire' button

is still pressed) a logic 0 is clocked into the flip-flop. This sets the  $\bar{Q}$  output to a logic 1, which reverse biases the diode and allows the clock signal (from IC4c) to operate the electronic switch via the 22k resistor. This switch still does not change over, however, because the logic 0 (switch normal) on this clock line is what caused the rising edge on the complementary clock and enabled the switch to be controlled by this line. The electronic switch will now change over on every clock transition, allowing the 'fire' line to be pulled alternately high by the 10k pull-up resistor (connected to bit 7), and low by the closed 'fire' button. In this way, the synchronization circuit ensures that the 'fire' pulse to the computer is at least a half-cycle of the 'rapid fire' clock in width (unless the 'fire' button is released first!), no matter how close to the 'rapid fire' clock transitions the 'fire' button is pressed. The 'rapid fire' process is terminated immediately the 'fire' button is released (the flip-flop is forced back to its preset state by the 100k pull-up resistor).

The power supply is derived from the Microbee's parallel port and is filtered by a 10µF capacitor. The diode is to protect against reverse polarity (particularly if this interface is to be used with other machines), and the 100R resistor limits surge currents if the interface is plugged in while the computer is switched on (this is a BAD habit and should be avoided). The 1.2k resistor mounted on the backshell of connector SK3 ensures compatibility with the Microbee Joystick Standard, and therefore, compatibility with existing software.



order given on the printed circuit board overlay. Don't forget that resistor R9 must be mounted on this connector. Pass the ribbon cable through the slot in the box, checking that it is the right way round to be terminated on the circuit board without a twist in the cable. Once checked, solder this cable to the board. Use a cable tie around it (inside the box) to prevent any strain detaching the cable from the circuit board.

The switch and the potentiometer are connected to the board with short (about 60 mm) lengths of 2-way ribbon cable.

Before packing everything into the box, check and double check your work. Mistakes corrected at this point can save a lot of time, frustration, and possibly expense later on.

Once satisfied, assemble everything in the box. It is a tight fit, but with some careful fiddling, it will all fit. A sheet of thin plastic should be mounted between the aluminium lid and the circuit board to minimise the possibility of short-circuits as the circuit board spacers are very short (being drilled out nuts to suit the mounting screws used). For this reason, all protrusions on the copper side of the circuit board should be trimmed as close to the board as possible.

## Testing and operation

Once you are satisfied that your assembly is correct, plug the interface into your computer and enter the short BASIC test program (Listing 1). Save the program once it has been checked against the listing and then run it.

**Listing 1.** A simple BASIC test program.

```
00100 CLS:REM Dual Joystick Test Program.
00110 OUT 1,255:OUT 1,191:REM Set Port for Input Except Bit 6
00120 CURS 1,1:OUT 0,64:PRINT IN(0);:REM Joystick 1
00130 OUT 0,0:PRINT IN (0)+64:REM Joystick 2 (Set Bit 6)
00140 GOTO 120
```

This program alternately reads the value of each joystick in turn, and displays a pair of numbers (joystick positions) on the screen. The program sets bit 6 when reading joystick 2 to make both numbers the same for the same joystick positions, and the same as for a single joystick connected to the port.

With the rapid fire switch off, check that your interface produces the same values as those given below. If it doesn't, check your wiring before proceeding.

Value	Joystick Position
255	Neutral
254	Forward
253	Back
251	Left
247	Right
127	Fire

Enable the rapid fire circuit and hold the fire button operated. The displayed joystick value should alternate between 255 and 127 at a rate between about one cycle per second to about ten per second (too fast to be clearly legible on the screen). Ensure that the rapid fire rate is controllable with the potentiometer.

## Conclusion

Once you have your dual joysticks operational, potential applications (other than two player games) will present themselves, for example, for two joysticks tracked vehicle simulations, etc.

In the interim however, some of the existing Microbee software should be easily converted to two player dual joystick versions... any offers for the 'Microbee Column'? Who knows, now that a dual joystick standard has been defined, some commercial software may in future provide the option of, or even require, the use of two joysticks!



NEW SOUTH WALES GOVERNMENT

DEPARTMENT OF  
TECHNICAL AND FURTHER  
EDUCATION

## ELECTRONICS COURSES

NSW TAFE has courses in electronics technology for:

- electronics engineering technicians
- computer service technicians
- apprentices in electronics and telecommunications
- pre-apprentices
- tradespersons who want to update or extend their skills

**Enquiries:** TAFE Course Information Centre, 849 George Street, Railway Square, 2007. Phone (02) 212 4400.

*NSW Department of Technical & Further Education*

220808

## Try us for a SOFT TOUCH

in high quality membrane switches.

Now available at the touch of a finger, the highly responsive membrane switch, using state-of-the-art technology.

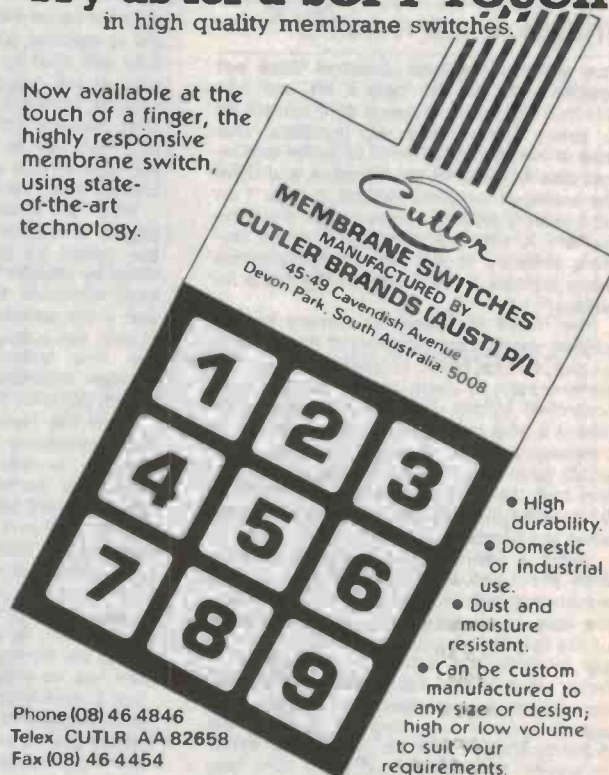

- High durability.
- Domestic or industrial use.
- Dust and moisture resistant.
- Can be custom manufactured to any size or design; high or low volume to suit your requirements.

Phone (08) 46 4846  
Telex CUTLR AA 82658  
Fax (08) 46 4454

Write or phone to discuss your requirements.







# COMMODORE 64 TAPE PIRATE

Need to copy tapes? Don't want to tie up the 64 while doing it? If so, this is for you. It allows you to copy from one datasette to the other under the control of the computer, but without hanging up the CPU in the process.

THIS PROJECT evolved out of the need to back up or duplicate existing data on cassette without having to load in the program, run it to check for errors, then save it onto a fresh blank tape. A most time consuming process you will agree.

The thought struck us to use two ordinary cassette players, taping from one and recording with the other. Well that was tried with no success, and lots of frustration.

It seems that the nice square pulses de-

Vickie and Jeff Rose

manded by the Commodore defeat most audio cassettes. The C2N-B has Schmitt triggers on both the input and output of its audio path to square up signals into and out of the tape.

Recording is thus a problem. A simple solution is to devise a black box providing a direct signal path between two data-sets. This is essentially what we have done, although the situation is complicated by the fact that we need an inverter in the signal path to get the right polarities, and we need to provide for various service signals and power paths.

Nevertheless, providing this is not difficult. We have kept the unit as simple as possible, with the parts count kept to a minimum and using only common or garden components.

## Construction

Construction should commence with careful inspection of both pcbs, going over each with a magnifying glass to see any hairline cracks in the copper foil or miniscule short circuits. Once you have satisfied yourself that all is well, carefully drill all holes to size. The two Miyama switches will need careful handling with the drilling, since they are not pcb-mount types. In fact they are square pegs in round holes so take your time in fitting them.

Next, mount and solder all resistors and link wires and the 1N4001 diode, paying attention to the diode's polarity. Follow this with the fitting of the OUD-M-DC 5 volt relay. Then solder in the two switches. Add the ceramic 0.1 $\mu$  capacitor, the BC548 transistor and lastly, the HEF4001BP CMOS IC, paying attention to normal CMOS handling procedures. Note that pin 1 is near the ceramic capacitors. Mount the two LEDs at a height of 13 mm from the board to the base of the LED so as to ensure correct height when assembled in the zippy box.

Next you will need 15 coloured wires





# Commodore tape pirate

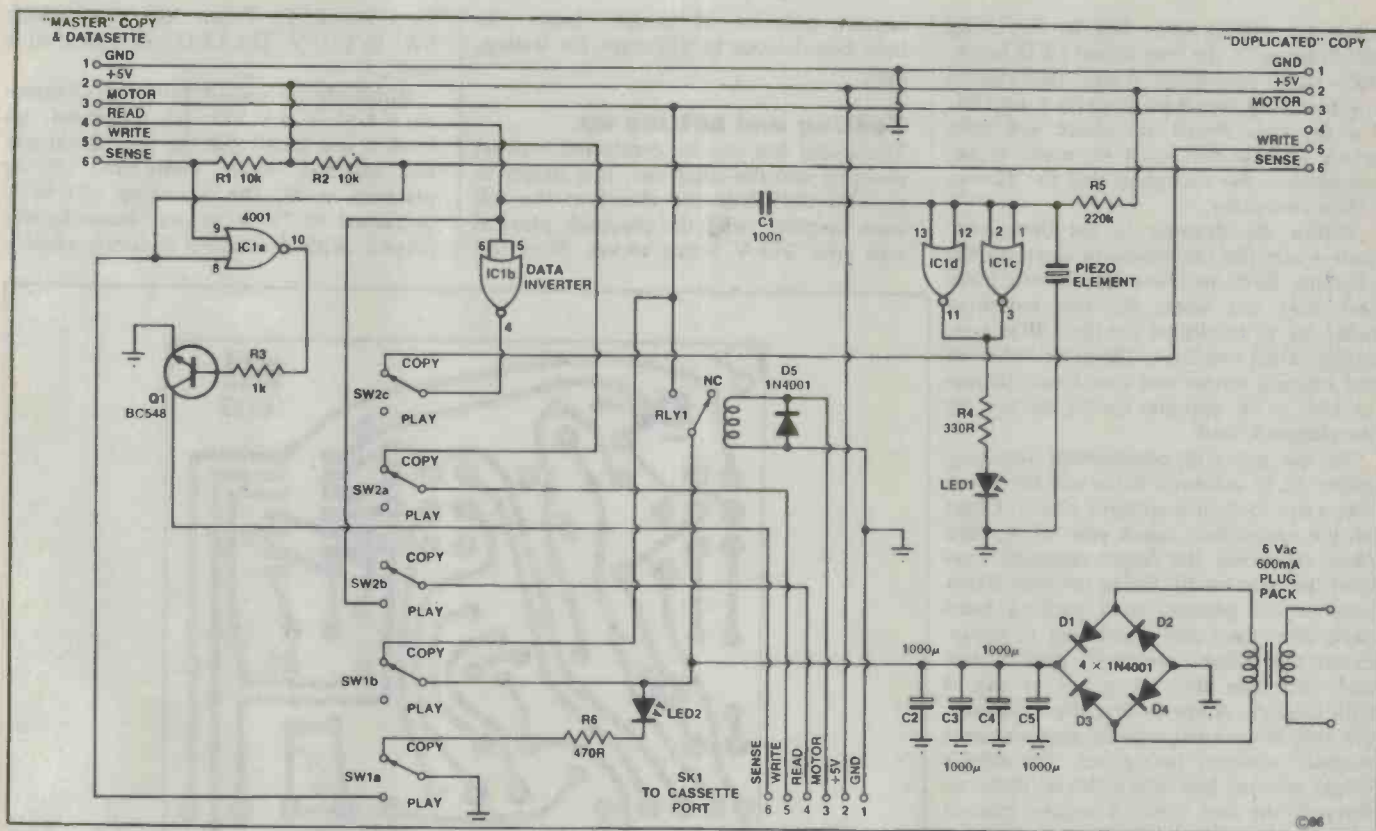

about 130 mm long. Following the component overlay carefully, insert and solder all 15 wires into their respective holes. Clean the base of the board with metho or thinner, whichever is handy, to remove all the excess flux from soldering.

Then comes the task of careful inspection for dry joints and short circuits.

Once you have satisfied yourself that all is well, you may coat the switching board with pc board lacquer. Notice that the piezo is left till later.

The next procedure is to cut out the slots between the finger contacts, then cut the larger slots for the C2N-B female plugs. This can be done with a hobby file with a safe edge. File only as much as required for a firm but not over-tight fit on both sides of the base pc board. The finger contacts and pads should be tinned, paying particular attention to the temperature you are applying. Don't overdo it!

Next mount all four 1N4001 diodes, observing the correct polarity. Bending their leads to suit the mounting pads, solder them carefully into place. Follow the same procedure and mount the four 1000µ electrolytic capacitors in their respective places.

Next bend the top six connectors on the 12-way Utilux plug to the downward position and solder them to the base pc board remembering there must be a 3 mm gap to

## ETI-1603 — HOW IT WORKS

Generally speaking, the unit is broken down into two distinct sections. Firstly, the power supply. For safety, a plugpack was used with an ac output of 6 to 7 volts at 600 mA minimum current. Four 1N4001 diodes form a bridge rectifier and 4 x 1000µ 16 V electrolytic capacitors give smooth operation of the cassette motors. The motors are supplied via the relay which is controlled in the play mode by the computer's motor output and diode-protected against back emf.

The relay switches the dc from the base board bridge rectifier/power supply, thus giving good mains isolation and letting the power supply do all the work to supply both datasets, something which the Commodore wasn't cut out to do.

The yellow LED lights when SW1 is put in the copy mode. This, in fact, overrides the relay contacts and in doing so supplies 8.8 volts to the motors directly.

### SWITCHING BOARD

In the play mode data is read via the fourth finger contact on the master datasette from the output of the 74LS14 Schmitt trigger. The data flows inside the datasette, through SW2 on the switching pc board, to the fourth finger contact in the cassette port, then to pin 24, the flag on the 6526 complex interface adaptor (CIA). Pin 6 on the master datasette also goes low in the play mode. This causes pin 9 of IC1a, a 4001 NOR gate,

to go low. The other input is pulled low by SW1a. When the output pin 10 of the 4001 goes high, this drives Q1 to pull pin 25 of the 6510 MPU low (cassette sense) via pin 6 on the port. The result is the computer going into the load mode. Pin 24 of the MPU goes low, thus enabling the supply of 6.8 Vdc to drive the relay which in turn supplies both datasette motors.

The 0.1µ capacitor, C1, decouples two inverter/LED drivers, IC1c and d, which are held high via R5. C1 also drives the piezo-ceramic device when a data signal is present at IC1b in either play or copy modes of operation. The piezo was chosen for its low power consumption characteristic and its ability to work on low voltage as well as very low current while still maintaining noise sufficient to be heard as far away as 10 metres (within the home).

The outputs from IC1c and d drive the red LED to give the visual indication of signal present.

In the copy mode the data is present at pins 5 and 6 of the 4001, and is inverted at the output pin 4, travelling via SW2c to the write input of the second unit, the fifth finger contact (on the right) copier datasette. This data inversion must take place to copy correctly since, when saving data, normally the MPU performs this function for you and comes out in the same inverted state.



# Project 1603

allow the plastic zippy box to fit. Using the drawing of the switch and LED holes, drill out all four holes to size, then mount the switching board in place as a trial fit. Put the base board into place and note where the cut-outs must be made to accommodate the two plugs and the 12-way Utilux connector.

Follow the drawing to cut these out, then gently file the plastic to clean up the cut-outs. Refit the base board into place and mark out where the two mounting holes are to be drilled for the Utilux connector. Drill two 2 mm diameter holes for self tapping screws and one 5 mm diameter hole at the opposite end of the box for the plugpack lead.

At this point in construction you may solder all 15 coloured wires and the two 6 Vac wires to their respective places. Clean off the excess flux, check your work, then place tape over the finger contacts. Lacquer the base board, lifting the four 1000µ caps in the process, then pushing them back into place and continuing to spray. Cover the Utilux connector's gold contact end with tape also, so as not to coat it with lacquer. Allow to dry, then assemble the switching board with its piezo-ceramic sounder soldered into place. The relay's height governs how much thread sticks up through the top since it makes contact with the top inside the box. Screw the shortest threaded switch into position first, then the other till finger tight. Now attach the piezo near the switching board with

contact adhesive or similar. Leave the base board loose at this stage for testing, etc.

## Testing and setting up

The initial test can be conducted without plugging into the computer. It is simply to test for 8.75 Vdc (or close) at the full wave rectifier, with the plugpack plugged into your 240 V mains socket. Next test

the yellow LED. This is done by switching SW1 to COPY. The LED will light if all is well.

Although the output from the Commodore C64 is 6.8 Vdc (as measured, no load) it was found that the tape speed was not affected when duplicating or in playback mode. The dc voltage of 8.98 V decreased to 7.4 V as one datasette was played. With the second datasette record-

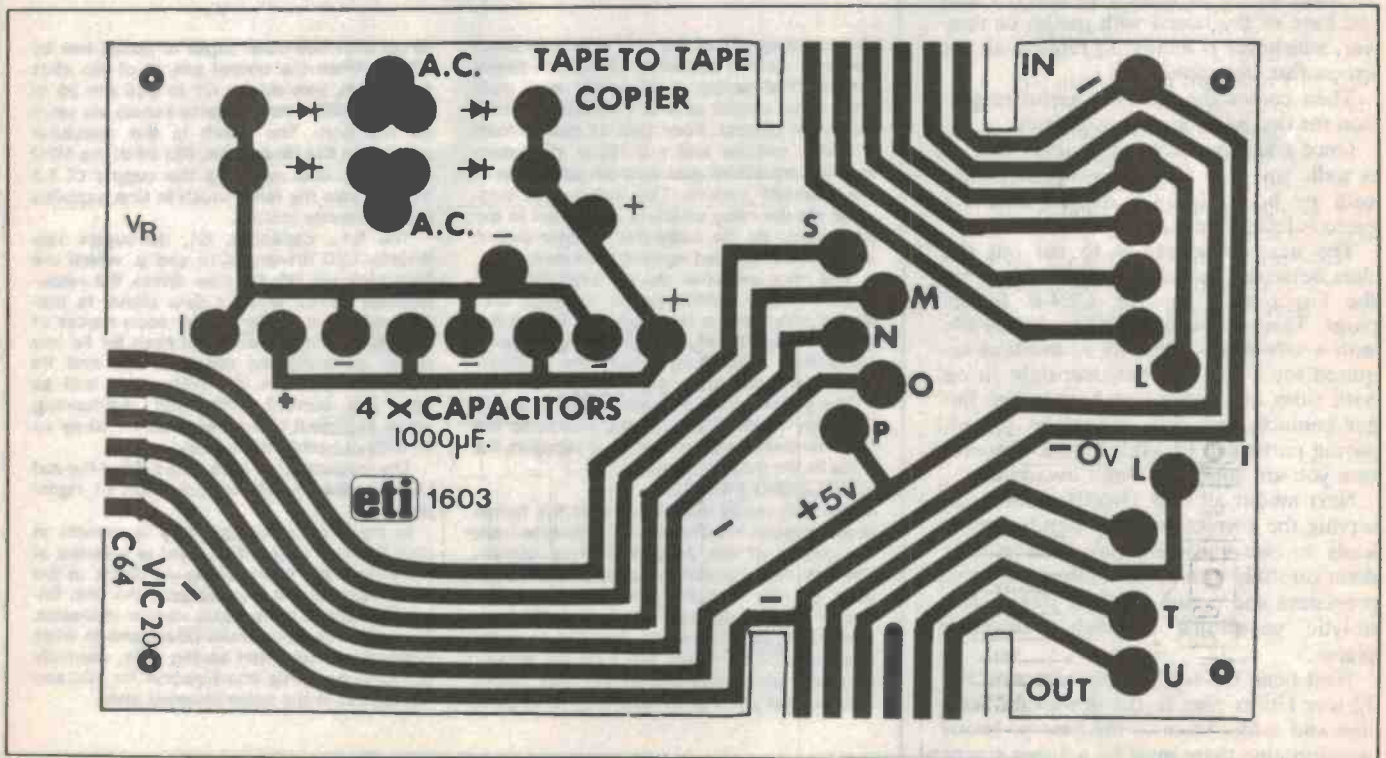
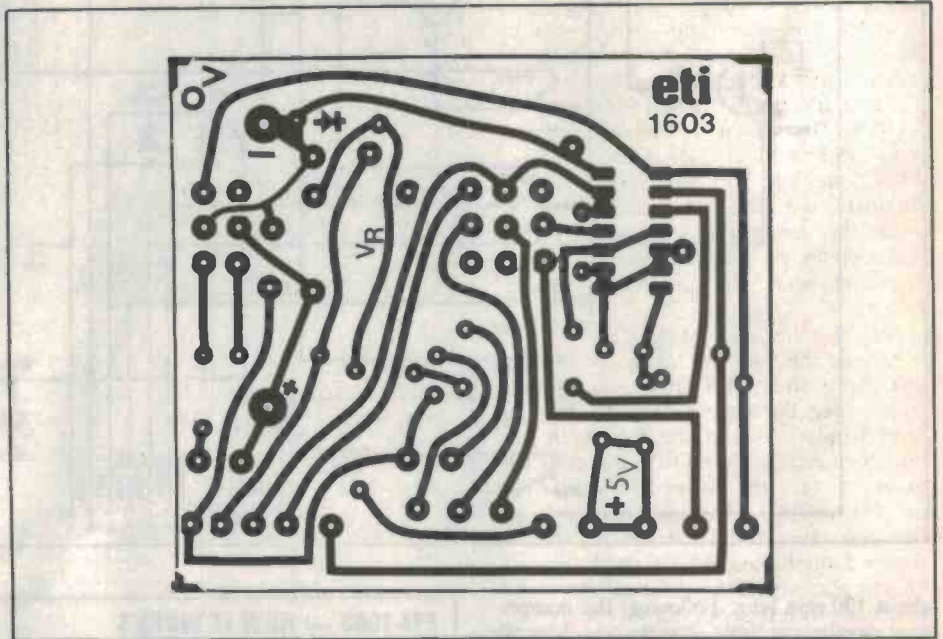



ing, the dc voltage dropped to 6.88 V. Any plugpack delivering around 6 to 7 Vac at 600 mA to 1 amp will do fine. I picked mine up at Prepak Electronics along with the 12-way Utilux connector.

The next test involves connecting the box to the cassette port and plugging one datasette into the left side (input master) and switching *both* switches to the play mode. Place a short program tape into the datasette as per normal loading, remembering that all equipment should be off prior to connecting up. Now, with the plugpack turned on and the computer monitor and screen showing READY, type in load [program name] and press RETURN. The screen will prompt with the usual PRESS PLAY ON TAPE, so press PLAY and you will see the red LED illuminate. As well, the piezo will sound while the program is loading. The LED will extinguish and the piezo will stop sounding when the program is loaded fully.

Now test that all went well.

Rewind the tape and set up for the next test. Turn off the ETI-1603 and the computer. Plug the second datasette into the right (copier) side of the box, then with both switches set to COPY and the computer on, turn the power to the plugpack on. The yellow LED should light as in the first test. Press RECORD/PLAY on the copier datasette and PLAY on the master. Shortly the red LED will illuminate simultaneously with the sound from the piezo.

Familiarize yourself with the signal sounds; the first sound is to initialize the computer, or to tell it that data is coming. Data loading is a collection of tones that vary in length and pitch depending on the data present. You will hear when the program is finished. Again, familiarize yourself with the selected tones that are present on all data on cassette. This will aid you in identifying when and where the program starts or stops.

Now, rewind the tape that you have just recorded, place it in the master datasette, turn both switches to PLAY and go

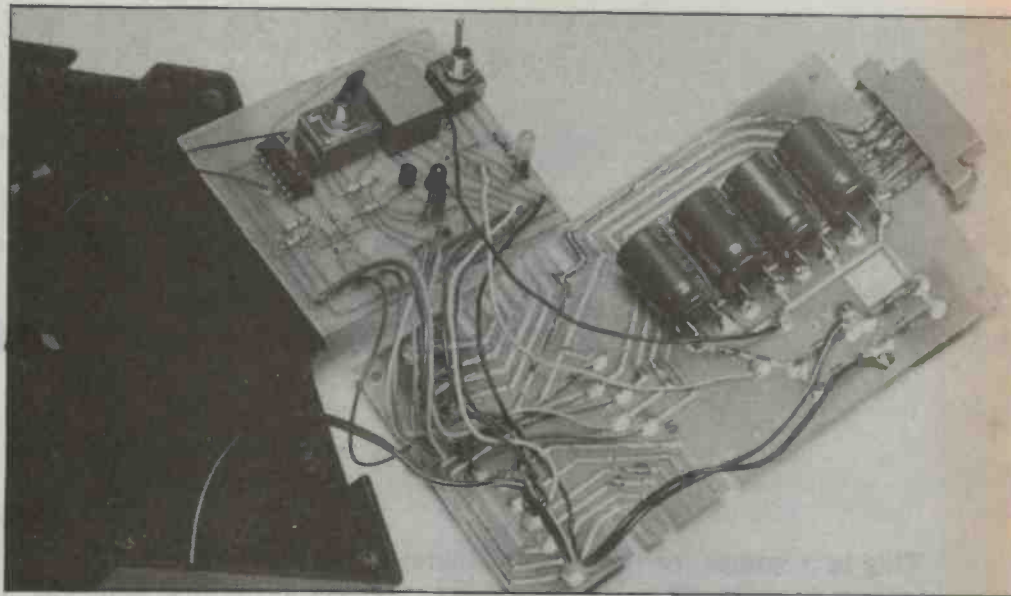

through the load routine as in the first test. Your program should load as if it was the original tape. If it does you are now

the proud owner of a datasette copier and you can practice on any tape in your collection.

### ETI-1603 — PARTS LIST

<b>Resistors</b> .....all ¼ W, 5%	
R1 .....	10k
R2 .....	10k
R3 .....	1k
R4 .....	330R
R5 .....	220k
R6 .....	470R
<b>Capacitors</b>	
C1 .....	0.1µ ceramic
C2-C5 .....	1000µ 16 V RB electro
<b>Semiconductors</b>	
D1-D5 .....	1N4001 or similar
LED 1 .....	5 mm red
LED 2 .....	5 mm yellow

Q1 .....	BC548/549/547, etc
IC1 .....	HEF4001B or similar
<b>Miscellaneous</b>	
SW1 .....	Miyama MS-500-F DPDT toggle
SW2 .....	Miyama MS-500-M 3PDT toggle
RLY .....	ODM-DC 5 V
Base pc board; switching pc board; front panel; 4 x rubber feet; 50 x 150 x 90 mm zippy box; plugpack transformer 6 Vac 600 mA or better; Utilux 12-way connector; black, red, white, brown, blue, violet, pink, orange, yellow, grey, green hookup wire.	

Price estimate: \$29

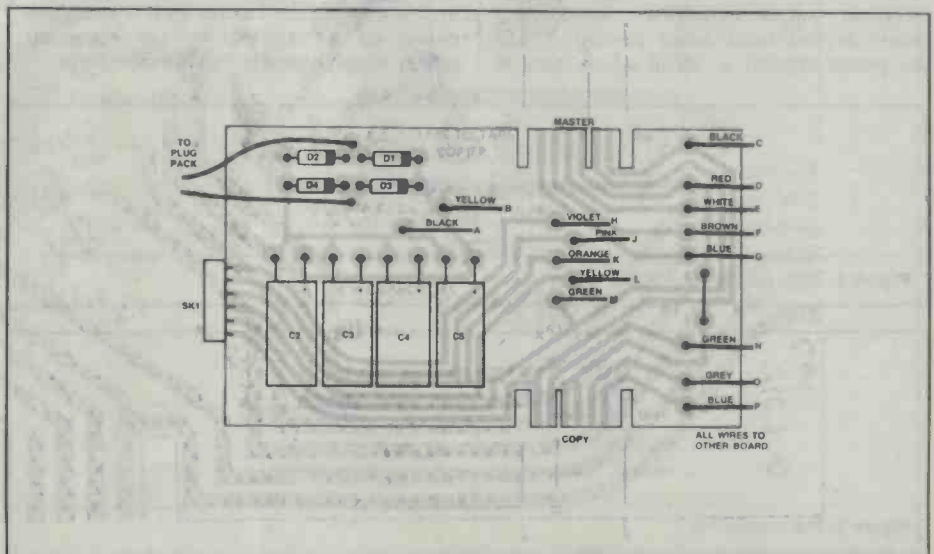
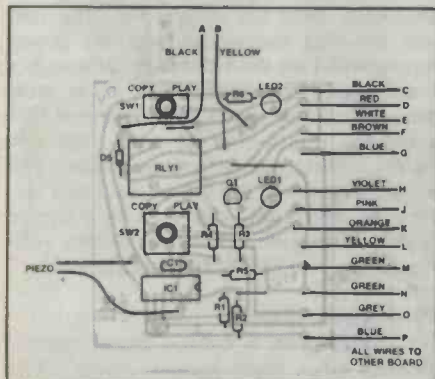



# POWER SUPPLIES

Peter Phillips

Part 1

This is a series for those with a limited background in practical electronics, but anxious to extend it. It starts with the design of a power supply and will work through most popular applications of electronics. Each section will end with a useful project. Thus the beginner should be able to build up a low cost range of simple test equipment.

WHEN NICOLA TESLA sold his patent detailing the now universal alternating current power distribution system to Westinghouse, he triumphed over Edison and the direct current technology then in vogue. A 'system in harmony with nature', the grid systems in all countries of the world now distribute electrical power using this scheme. The basic reason is the ease by which an alternating voltage can be transformed from one value to another. However, convenient as this method is for electrical supply authorities, most electronic devices need direct current. Enter the power supply: a circuit whose task is

to take the available ac voltage and convert it to the required dc voltage.

This article discusses power supplies and describes the basic design methods. Further research is advised if the requirements exceed a few amps or voltages higher than 40 volts. The three main elements of a power supply are a transformer, a rectifier circuit and a regulator, as shown in Figure 1. We commence by discussing the transformer and the rectifier. The subject of regulation will be presented in the next article, along with a complete circuit of a variable voltage regulated power supply suitable for workshop use.

## The transformer

Figure 2 shows the circuit symbol of a transformer, in turn illustrating the primary and secondary windings both wound on the same core. Transformer design is beyond the scope of this article, suffice it to say that the output voltage of a transformer is determined by a simple equation relating the number of turns of both windings and the input voltage. This, and other equations are listed in Figure 2.

Generally a 'step-down' transformer is used in electronics to obtain a voltage less than the 240 volts input. However, because the power in to a transformer roughly equals the power out, lowering the voltage at the secondary means that the ratio of secondary current to primary current is now *increased* by the same amount. Thus, a transformer connected to the 240 V mains having a turns ratio (primary to secondary) of 10:1 (or just plain 10) will produce 24 volts ac at the secondary. If 1 amp is taken from the secondary, then 0.1 amps will then flow in the primary. This gives 24 watts in (volts times current), and 24 watts out.

It is important to know the current and power rating of a transformer. Generally, the larger the transformer the more power it can handle; exceeding this rating will eventually burn the device out. The current handling requirements of the power supply will vary with the user, although a 1 amp rated transformer will cover most contingencies. It is not recommended that a smaller transformer be used, but one with a greater current rating is fine. The secondary voltage needed is again user dependent, and a transformer with a tapped secondary to give a range of output voltages up to 30 volts is usually sufficient.

## The sine wave

Tesla's dream of a 'natural power system' is truer than most people realise. The waveform that traces natural motion, such



Figure 1. Block diagram of a power supply.



Figure 2. The transformer.



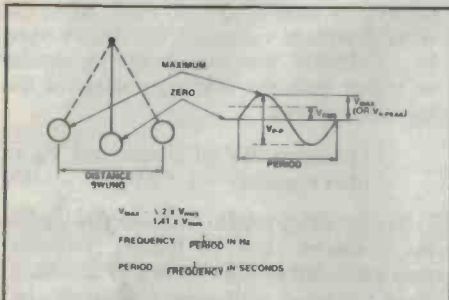

Figure 3. The sine wave. Top left traces the motion of a pendulum.

as a swinging pendulum, is the sine wave. The ac power distribution system operates with voltages that vary sinusoidally, and in order to select the right ratings for the components needed, it becomes necessary to delve a bit deeper into some ac theory concerning the sine wave.

Figure 3 illustrates the sine wave and the associated measurements. Notice how an alternating waveform changes direction and, eventually polarity, after reaching its peak values. In fact, the definition of an alternating voltage is one that 'periodically changes polarity'. The terms volts 'peak to peak' and volts '0 to peak' are used in reference to the sine wave, and bear greater explanation.

When an alternating voltage is read with an ac voltmeter, the reading shown is a value called the root mean square voltage. The standard abbreviation is volts rms, and usually any ac voltage not otherwise defined is an rms quantity. This voltage is a mathematical derivation from the maximum (or 0 to peak) value, and is the necessary value for calculating ac power. However, we need to work backwards. Because the meter provides the rms value, it becomes necessary to calculate the maximum voltage to ensure that component ratings are adequate. The relationship is simple; the maximum voltage of a sine wave is the rms value multiplied by the square root of 2 (or 1.41 x Vrms). Thus, a 240 volt rms voltage has a peak value of around 340 volts, and a peak-to-peak value of 680 volts.

Another aspect of the sine wave is its relationship to time. In order for the waveform to alternate between maximum positive and negative, some time must elapse. The number of alternations, or cycles that occur each second is a measure of the waveform's frequency. As is generally known, the frequency in Australia for mains power is 50 hertz. The 'hertz' (named after the German physicist) stands for cycles per second, so it is easily seen that one cycle takes 1/50 of a second to complete. This time interval is referred to

as the 'period' of the waveform, and for 50 Hz becomes 20 milliseconds. Knowing the foregoing allows proper selection of the components and establishes the relationship between the available ac voltage to the developed dc output voltage of the supply.

### Rectifier circuits

In order to convert a voltage (and current) that periodically changes polarity to one that has a constant polarity, a circuit known as a rectifier is required. The unidirectional characteristics of the diode make it the obvious choice, and various circuit configurations employing diodes are

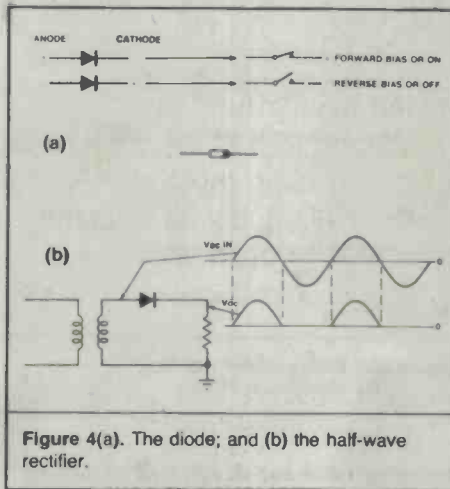

Figure 4(a). The diode; and (b) the half-wave rectifier.

used. A diode can be visualised as a switch, closed when the polarity is one way and open otherwise. Figure 4(a) shows a diode and how it behaves for the two possible polarities. Figure 4(b) illustrates the 'half-wave rectifier', showing a sine wave input and an output that can be considered dc, as the waveform produced never changes polarity.

However, this so-called dc output is still changing in value, even though the polarity is constant. Also, for half the time there is no output, making this circuit a rather poor choice if a steady dc is required. To obtain a smoother waveform, a capacitor can be placed across the output. When used this way, a capacitor acts as a reservoir, being topped up (or charged) when the voltage from the diode is high enough, and then discharged by the load between each charge, as shown in Figure 5. Thus, the capacitor has filtered out the large changes, and smoothed them to produce a more useful dc output. The amount of filtering depends on the size of the capacitor, although practical limits apply. The actual dc voltage that would be measured is a value approximately half way between the now much smaller variations.

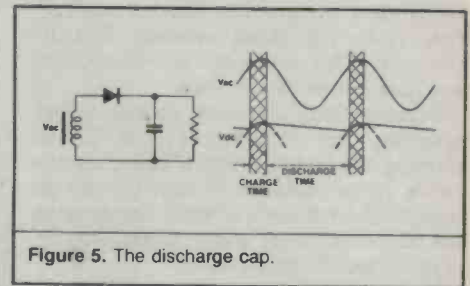

Figure 5. The discharge cap.

This variation is known as the ripple voltage, and should ideally be zero.

The next improvement that can be made is to arrange a number of diodes to make use of both halves of the input sine wave rather than only one. There are various circuits that do this, but the most common is one using four diodes arranged in what is known as a bridge configuration. Another circuit uses two diodes and a centre-tapped transformer. Figure 6(a) shows four diodes as a bridge circuit connected

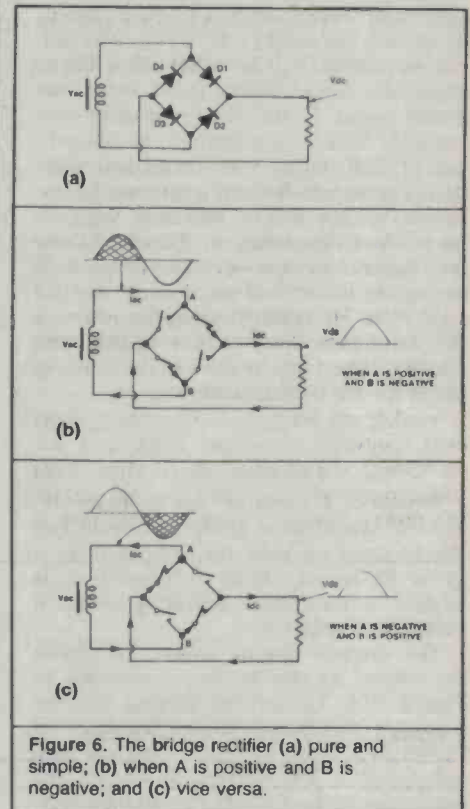

Figure 6. The bridge rectifier (a) pure and simple; (b) when A is positive and B is negative; and (c) vice versa.

to a transformer and the shape of the waveform across the load resistor. Figures 6(b) and 6(c) explain, using the switch analogy, how the circuit operates. Notice how two diodes are always on together, switching with each alternate half cycle. Unidirectional current (dc) flows through



the resistor while bidirectional current (ac) flows in the transformer winding. This circuit is popular as diodes are cheap, and any transformer can be used.

Because there are more positive pulses occurring each second (one each 10 ms), filtering the output with a capacitor becomes more practical. In fact, the advantages of the full-wave rectifier circuit make the half-wave circuit almost redundant, except for specific applications.

It now remains to analyse the output waveform to establish the relationship between the ac input and the dc output. This will also give insight to component ratings.

## Analysis of the circuit

Figure 7 shows how an analysis of the bridge rectifier circuit can be made. Figure 7(a) shows the circuit and the currents flowing. Notice that there are two currents: one labelled  $I_C$  and the  $I_{RL}$ . Also, the two relevant voltages  $V_{ac}$  and  $V_{dc}$  are shown. The waveforms shown in 7(b) illustrate all these quantities, the top waveform being the ac input to the bridge. The maximum voltage applied to the bridge is, as already discussed,  $1.41 \times V_{rms}$ . The output waveform ( $V_{dc}$ ) is shown below the ac input; the dotted outline is the shape that would occur if the filter capacitor was omitted. If losses are ignored, the dc voltage is nearly equal to the maximum value of the ac input. Because there are losses, the dc voltage will be less than  $V_{max}$ , by an amount depending on the transformer and the load current. Also, a voltage drop across the diodes will occur of around 1.5 to 2 volts. By approximating the losses, a rule of thumb equation relating the input and the output can be derived, resulting in the following basic equations:

$$V_{dc} = 1.2 V_{rms} \dots\dots\dots(1)$$

$$V_{rms} = 0.83 \times V_{dc} \dots\dots\dots(2)$$

Equations (1) and (2) are approximate, but are useful as a guide in establishing the ac input (in volts rms) required for a given dc output. Thus if 10 volts dc is needed, a transformer delivering around 8 volts rms is required.

The currents flowing around the circuit are shown as the bottom waveforms in Figure 7(b). The current flowing into the capacitor, and hence through the diodes is shown as a series of short, relatively high value pulses. The current flowing in the load resistor ( $I_{RL}$ ) is simply a straight line, exactly what is required. Again approximating, the height of the pulses is around 10 x the load current. The load current is actually the average value of the pulses. Thus, the diodes need to be able to handle short duration currents of 10 times the load current. As the diodes operate sequentially, one pair conducting while the others are off, and because power diodes

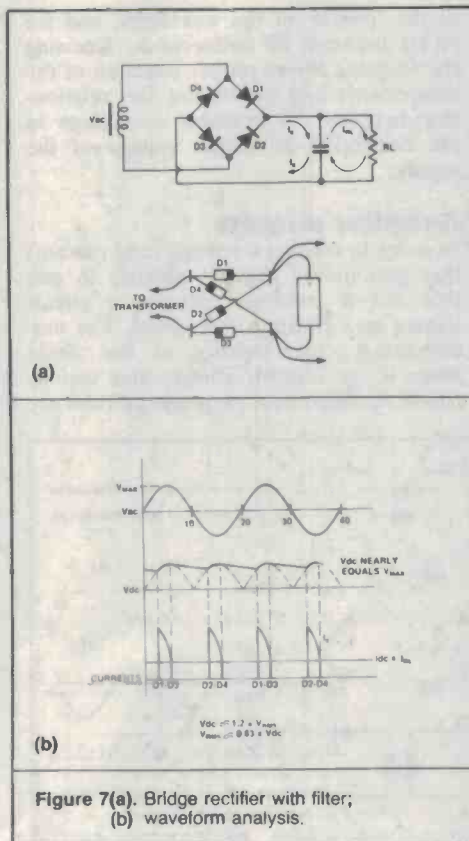

Figure 7(a). Bridge rectifier with filter; (b) waveform analysis.

are designed to handle this type of current waveform, equation (3) can be used to establish the current ratings of both the transformer and the diodes.

$$\text{Current rating of transformer secondary and diodes} = 1.25 \times \text{dc load current} \dots\dots\dots(3)$$

However, if the filter capacitor is made very large then the diode current might be excessive, as the pulses of current will be greater, even though the load current is still the same. So, choosing the size of the filter capacitor is important to avoid burning out the diodes and possibly the transformer, which has to deliver the high pulses of current. As a rough approximation, the filter capacitor size can be determined by the following empirical rule:

$$C = 2000 \mu F \times \text{the dc load current} \dots\dots\dots(4)$$

Thus, if a load current of 1 amp is required, a 2000  $\mu F$  filter capacitor may be sufficient. However, this equation is very approximate, and greater or smaller capacitance values may be appropriate depending on the presence of a regulator. The working voltage of the capacitor must at least equal the dc voltage, but good design would require this voltage to be in-

creased by around 25% to 50%. Also, the reverse voltage rating of the diodes must be considered, and this should be similar or higher than the working voltage of the capacitor. Hence:

$$\text{Minimum PIV of diodes and } V_w \text{ of filter capacitor} = 1.5 \times V_{dc} \dots\dots\dots(5)$$

So, by using simple approximations, all the unknowns can be found. Naturally, anticipate differences in actual results to those obtained with these equations, but they are suitable for many basic power supply circuits. By now, sufficient theory has been presented to enable a useful circuit to be developed. You may have a specific task in mind; a power supply for a portable tape-recorder or for any project previously operating from batteries. If the task is one that doesn't need a well regulated voltage, then a simple non-regulated power supply is possibly suitable.

## Calculating component sizes and ratings

The first item to consider is the transformer. Using equations (2) and (3), the voltage and current ratings required can be determined. A good general purpose, cheap, 1 amp transformer is the 2155, or for voltages higher than 15 volts rms, the 6672. Both these transformers are generally available at prices around \$6 and \$10 respectively. They both have a range of output voltages available by virtue of six tappings on the secondary.

For the bridge rectifier, two options are possible: either four individual diodes or a bridge assembly. The minimum power diode current rating is 1 amp, and most types have a PIV in excess of 100 volts. For load currents below 1 amp dc, either four 1 amp power diodes, (eg, type IN4002) or a WO-4 bridge will suit. A diode with a 3 amp rating is the IN5404, and a 6 amp bridge is provided by type PO-4.

The filter capacitor size can be determined from equation (4), and the working voltage from equation (5). The minimum value capacitance should be 1000  $\mu F$ , and for 1 amp circuits, a 2200  $\mu F$  is generally adequate. The addition of a regulator will allow the use of a 1000  $\mu F$  filter capacitor for currents up to 1 amp, as the regulator will reduce the ripple to virtually nothing. The remaining requirements are hook-up wire, a length of 240 V flex with a 3-pin plug, some terminal strips and either a case or some means of mounting everything. If the power supply is going to be used as an item of test equipment for general use, then a metal case large enough to include the regulator and a meter movement might be considered. Such a supply (the ETI-281) is the subject of the next article.



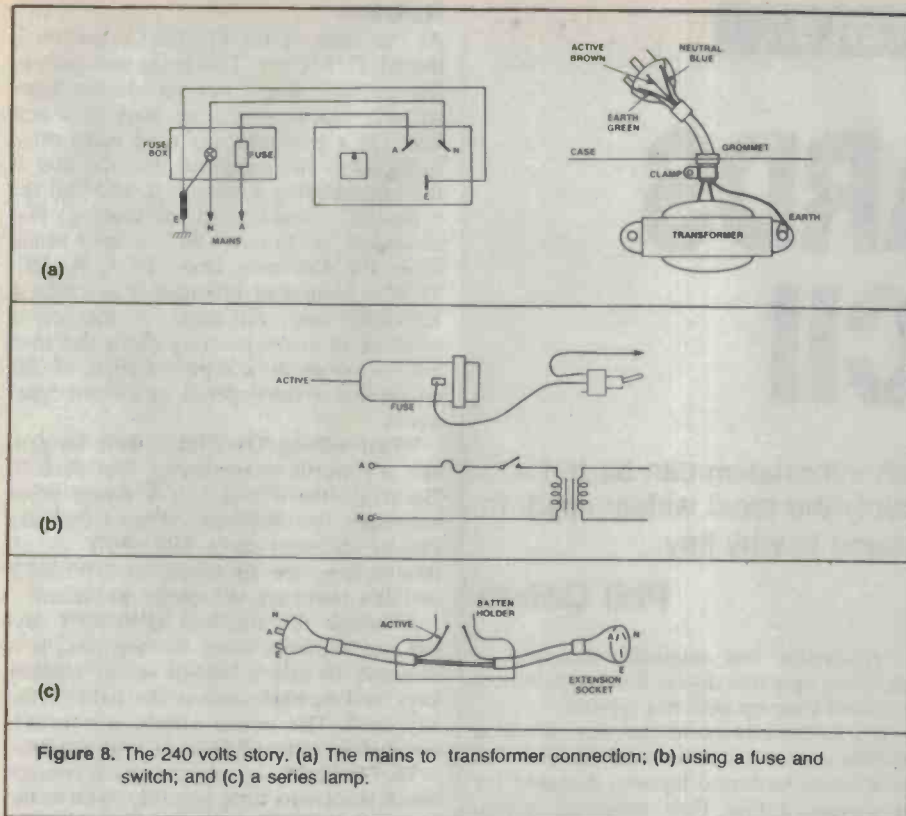

Figure 8. The 240 volts story. (a) The mains to transformer connection; (b) using a fuse and switch; and (c) a series lamp.

### THE 240 V MAINS

Although the construction and wiring of the basic circuit of Figure 7(a) is relatively simple, there are several points to note. Paramount is the 240 V connections, both at the transformer and the 3-pin plug.

The connections to a power point comprise an active, a neutral and an earth wire. In Australia the MEN (main, earth, neutral) system is standard, which means that the neutral wire is connected to the earth wire at the fuse box. The earth wire is then connected to a pipe driven into the ground at a point convenient to the fuse box. Providing all wires are properly connected, the only wire from a power point that 'hurts' when touched is the active wire. The path is then from the active, through you to earth, with disastrous results. To protect the innocent, all appliances connected to the mains are earthed, unless they conform to a standard, such as being encased in plastic, which makes it improbable that human contact with the active can occur.

The purpose of the earth is to provide a direct path, away from the user to ground, should a fault in the appliance occur. This will then blow the fuse and alert the consumer to the problem. Naturally, the earth wire must be intact, both at the appliance and through to the ground connection at the earth stake near the fuse box for this protection to be adequate. Figure 8, showing the correct way to connect the 240 volt mains, should be studied carefully. The physical layout is shown in (a) for a direct connection between the power outlet and the transformer.

Note particularly which pins of the power outlet are active, neutral and earth. Deaths have occurred because the active and neutral wires at the power point were reversed! Also, be sure you know which colour wire is which in the 3-core flex. The Australian standard has brown as the active and blue (the cold wire) the neutral. Always connect these wires in the manner shown for maximum protection.

At the appliance, the lead must always enter the case through a suitable grommet. The earth wire should be directly connected to the case, preferably near its point of entry. If a plastic case is used, the transformer core should be earthed by using a lug under the screw head fixing the transformer to the case. If no appliance fuse or switch is incorporated, the active and neutral wires should be soldered to the connection points on the transformer, with appropriate insulation. Make the earth wire longer than the others, to ensure it breaks last should tension on the flex cause it to pull through the grommet. If a fuse and an isolating switch are to be included, (always a good idea), they should be connected as shown in Figure 8(b). Note particularly which lug on the fuse holder and switch to use, and insulate all connections. Suitable insulation is provided with plastic tubing slid over the connection after soldering.

If the transformer has flying leads, connection using 240 volt rated connectors, adequately insulated is recommended. It is important to pay due respect to the mains connections, as 240 volts is lethal and a lot of power is available to create havoc should something go wrong. Many experimental workshops include an arrangement that places a light bulb in the active wire between the appliance and the mains. Figure 8(c) shows a simple means of implementing this handy protection device, by using a BC (bayonet cap) batten holder and a 3-pin extension lead socket. The size of the lamp depends on the power required by the device; usually either a 60 watt or a 100 watt lamp is suitable. Using this scheme, the worst that can happen if the appliance is faulty is to cause full brilliance of the lamp. Otherwise it will glow either dully or not at all. However, this idea offers no protection to the user against a lethal shock, but it prevents fuses blowing and the subsequent household mayhem. ●

## ADVERTISERS' INDEX

Allen Bradley .....	45
Amtex .....	85
Audio Engineers .....	14
Australian Maritime College .....	103
Australian School of Electronics .....	102
Bose .....	91
Capricorn Computers .....	83
Control Data .....	102
Convoy .....	94
Disco World .....	99
Domestic Electronics .....	58
Du Pont .....	5
Elmeasco .....	7
Emona .....	36
Energy Control .....	52
Entercom .....	4
ES Rubin .....	94
Foss Elect .....	25
Geoff Wood Electronics .....	59
Hewlett-Packard .....	37
Hi-com Unitronics .....	53
Icom .....	87
IEI .....	80
Jaycar .....	24
Jemal Products .....	83
LM Ericsson .....	27
Micro Educational .....	31
Mobex .....	100
Music Place .....	92
Parameters .....	45
Philips Elcoma .....	6
Prepak Electronics .....	17
Quantum .....	103
Rod Irving Electronics .....	11,12,13,20,21,79
Scan Audio .....	110,111
Scientific Devices .....	71
Scope .....	IFC
Sleebs .....	40
STC .....	107
Taytech .....	103
TAFE .....	51
Tektronix .....	OBC
Telecom Aust .....	101
Temple-Smith Aust .....	81
Texas Instruments .....	108,109
Truscotts .....	81
Westinghouse .....	41



# KEYBOARDS AND ASCII

Although not the only way in which information can be fed into a computer, the keyboard is certainly the most widely used. In this part of the series, we take it apart key by key.

Phil Cohen

A MODERN keyboard has around a hundred keys, and along with the screen, is the part of a computer that users complain about most often.

The basic layout of a comprehensive computer keyboard is split into a number of parts: the QWERTY section, the function keys, the control keys, the numeric pad and the cursor control pad.

The QWERTY section is the bit that deals with the letters of the alphabet and commonly-used symbols. It's called 'QWERTY' because that's the order of the keys along the first row — 'Q', then 'W', etc. This is the same layout that is used on the typewriter, and it's been around a long time.

Unfortunately, the layout of the keys on

a typewriter was originally designed to slow the operator down! Early typewriters couldn't keep up with fast typists!

It's an indictment of the way in which female operator's views were ignored that alternative keyboard layouts, designed for maximum, rather than minimum speed, have not been developed until recently, since males have begun using keyboards on a day to day basis. An example of this later layout is the 'Dvorjak' layout (named after its inventor, not the key sequence!). In this layout the most commonly-used keys such as the vowels are put near the strong first fingers, instead of being spread around — take a look at where the 'A' is on a QWERTY layout. Most typists have very strong left-hand little fingers!

## Return

At the right of the QWERTY section is the RETURN key. This is the successor of the carriage return key on electric typewriters, which caused the start of a new line. On a computer it's used more often to signal to the computer that the user is finished entering a command, and that the computer should start processing that command. So to enter dir, the user would press the following keys: D, I, R, RETURN. Note that although it is called a RETURN key, the label on the top is often of an arrow pointing down and then left — which is a representation of the movement of the paper in an electric typewriter.

When talking QWERTY with foreigners, it's worth remembering that French, German, Italian and half a dozen other languages use keyboard layouts that are slightly different from QWERTY — although they are all based on QWERTY and as a result are all equally inefficient!

Although the standard QWERTY layout has numbers along the top row, it is common to add a second set of number keys in a numeric pad at the right of the keyboard. This uses a calculator-style layout for fast entry of numeric information.

The 'cursor' is a commonly-used concept which involves a little pointer, often in the form of a block or line, which can be moved around the screen. In the Mackintosh operating system (see last month), it's a little arrow. A cursor control section of the keyboard usually includes keys with directional arrows on them (up, down, left and right) which are used for moving the cursor around the screen. On the IBM-PC the cursor control and numeric keypads use the same set of keys, and the user can switch between the two uses — the idea being that you would seldom use both at once.

Function keys are usually found in a block, and are traditionally labelled F1, F2, F3 . . . up to around F10 or F12, depending on the computer. These are keys whose function can be altered to suit the particular program that is being run. For example, when using WordStar, key F2 can be set to provide a particular sequence of characters that make the program indent the next paragraph. F3 is used to set the left margin, and so on. Often, the keyboard itself can be programmed by the computer to send a particular sequence for each of its function keys.

Computer keyboards are starting to sport more and more 'control keys'. This trend started with the SHIFT key on the standard typewriter keyboard, which when pressed causes capital letters to be typed.

When mainframe computers came along, the control or CTRL key was added — in essence, a different type of shift key, which sent special characters to the computer. CTRL-S (pressing the CTRL and S keys at the same time) was often used to stop the listing of a file on the screen. CTRL-C was used to cancel





**TABLE 1. THE ASCII CODES**

Code	Meaning	Code	Meaning
0 to 31	Various control codes	78	N
		79	O
		80	P
		81	Q
32	(space)	82	R
33	!	83	S
34	"	84	T
35	#	85	U
36	\$	86	V
37	%	87	W
38	&	88	X
39	'	89	Y
40	(	90	Z
41	)	91	[
42	.	92	\
43	+	93	]
44	,	94	^
45	-	95	_
46	.	96	~
47	/	97	a
48	0	98	b
49	1	99	c
50	2	100	d
51	3	101	e
52	4	102	f
53	5	103	g
54	6	104	h
55	7	105	i
56	8	106	j
57	9	107	k
58	:	108	l
59	;	109	m
60	<	110	n
61	=	111	o
62	>	112	p
63	?	113	q
64	@	114	r
65	A	115	s
66	B	116	t
67	C	117	u
68	D	118	v
69	E	119	w
70	F	120	x
71	G	121	y
72	H	122	z
73	I	123	{
74	J	124	
75	K	125	}
76	L	126	~
77	M	127	Control code

Readers with British interests note: There is no pound sterling sign in the ASCII standard! This has caused much confusion amongst manufacturers of printers destined for the British market.

the current program and return to DOS.

With the advent of more complex software, more control keys started to appear. The IBM-PC has, in addition to shift and control keys, an ALT key, which can be used to give characters from an extended character set (of which more later).

**Auto-repeat**

On later-model electric typewriters some keys are fitted with 'auto-repeat', which means that if you press the key down hard, or hold it down for half a second or so, the character that it represents will be typed again and again quickly. This sort of thing is very useful with characters like underline (   ) and minus ( - ) for forming

lines across the page.

On most computers, all keys have auto-repeat. This often causes beginners no end of problems, as they have a tendency to hold down the keys too long, and as a result get more than they bargained for. Software designers take note.

A feature found on computers and some typewriters is rollover. This is needed when you press one key — say the A — and then press the next — say B — while A is still being held down. On most computers, this will send AB to the computer.

The electronics in most keyboards is based around a custom chip, which figures out which keys are being pressed, and converts this to a code which it sends to the computer. Other functions provided by the chip may include programmable function keys, automatic repeat and rollover.

**ASCII**

In previous parts of this series, I said that in a computer's memory each byte was capable of holding one character. If you remember, a byte can be in one of 256 different states, which gives 256 possible characters.

In the early days of computing, different computers used different ways of deciding which state corresponded to which character. Now, this is all very well when the information is within the computer, but when you try to send information from one computer to another, or from a computer to a printer, you start to get problems.

Standardisation has not been very widespread in the computer industry, but at least there is one standard which (almost) every manufacturer agrees on, and that's the American Standard Code for Information Interchange (or ASCII). ASCII sets out which of the 256 possible patterns that can be held in a byte of memory represents which character (see Table 1).

Notice that only the first half of the possibilities are used — from 0 to 127. In more modern computers (such as the ubiquitous IBM-PC), the whole 256 possibilities are used, giving a much wider choice of characters, including foreign characters and mathematical symbols.

**ASCII and BASIC**

For those of you already familiar with the BASIC language, there are a couple of BASIC functions which convert from characters to their ASCII numbers and back.

ASC() gives the ASCII number which corresponds to a particular character — ASC(A) would give a result of 65. Similarly, CHR\$(66) gives B.

These functions are particularly useful in doing things like alphabetic sorting (converting the characters to their ASCII equivalents and then sorting by numbers), and conversion of numbers into character representations (CHR\$(48+N) gives a character from 0 to 9 which represents the value in N).

**Glossary**

- ASC()**: A BASIC function that returns the ASCII value of a character.
- ASCII**: American Standard Code for Information Interchange, which allocates each character and a particular value for storage in a computer.
- ALT**: a control key found on some computers which allows the entry of characters from an extended set.
- Auto-repeat**: what happens when you hold a key down for more than half a second — the keyboard assumes you want many entries of that key.
- BASIC**: a widely-used beginner's computer language.
- CHR\$( )**: a BASIC function which gives the character equivalent of an ASCII code.
- CTRL key**: a key which allows entry of special control codes at a keyboard.
- CTRL-C**: formed by pressing the CTRL and C keys down at the same time, this cancels the running of the current program.
- CTRL-S**: formed by pressing the CTRL and S keys down at the same time, this temporarily stops changes in the screen content.
- Carriage return**: an electric typewriter key which makes the carriage (the roller that carries the paper) move back to the left; also, a key on a computer which tells the machine you are finished entering a command.
- Control keys**: a phrase used to describe together the control, shift, return, ALT and other keys of similar function.
- Cursor**: a pointer which can be moved around the screen.
- Cursor control pad**: a number of keys used to control the position of the cursor.
- Dvorjak**: a keyboard layout more efficient than QWERTY.
- F1**: the designation of a function key.
- Function keys**: keys whose function is determined by the particular piece of software being run at the time.
- IBM-PC**: a personal computer developed by IBM Corporation, which has become a de facto industry standard.
- Numeric pad**: a grouping of number keys (1, 2, 3, ... 9, +, etc) for easy entry of numeric data.
- QWERTY**: the layout of a standard typewriter keyboard.
- Return key**: See Carriage return.
- Rollover**: the ability of the keyboard to determine that a key has been pressed even while another key is being held down.
- Shift key**: a typewriter or computer key which makes the entry of capital letters possible.
- Shift lock key**: a typewriter or computer key which locks on the function of the shift key.
- Underline character**: the character "   ".
- WordStar**: a commonly-used word processing program, which allows the creation, alteration and printing of documents.



# CALCULATED FUN

Got an old four function lying in the bottom drawer? This article shows how to use it to do some more complex operations and on the way have a bit of fun with maths.

Ian Compton

BY THE TIME the typical student leaves year 10, a whole swag of advanced mathematical operations have been learned: square roots, inverses and all the trig functions are just a small sample. However, all these are simply developments of the basic mathematical operations, a fact utilized in calculator architecture when manufacturers try to build scientific calculators.

Can a calculator without a square root key calculate square roots? The answer is yes. Even if it hasn't a memory or has only a single memory (these units are often sold as four-function-memory units).

The general structure of these following programs is iteration, ie, the operator has to run through a sequence of steps a number of times. Each time you go through the program the result is more accurate.

## Square root program

**Step 1:** Guess the square root. Write it down or put it into calculator memory.

**Step 2:** Multiply your guess by itself (square it).

**Step 3:** Subtract the number you want the square root of.

**Step 4:** Divide by 2.

**Step 5:** Divide by your current 'best guess'.

**Step 6:** Update your best guess by subtracting your answer from your original guess.

If your answer to Step 3 is negative, then your new best guess will be bigger than the old ones and vice versa.

Let's look at the square root of 45.

The square root of 49 is 7, so as the first guess of  $\sqrt{45}$  we'll put 7. Write it down.

	Display
Step 1: Enter 7	7
Step 2: $7^2$	49
Step 3: $-45 =$	4
Step 4: $\div 2$	2
Step 5: $\div$ by best guess =	0.28571429
Step 6a: CHS	-0.28571429
Step 6b: $+7$	6.71428571

If more accuracy is needed re-do Steps 2

to 6b to produce an updated best guess, which in this case will be 6.7082067. When squared this is 45.000037. Is this precision sufficiently accurate? If not, another pass may get there.

## Cubed roots

Taking cubed roots without the aid of the  $\sqrt[3]{x}$  key isn't simple, but it can be done using a series of estimates.

The process uses the relation:

$${}^3\sqrt{x} = \frac{x}{({}^3\sqrt{x})^2}$$

**Step 1:** Estimate the value.

**Step 2:** Square it.

**Step 3:** Divide Step 2 into the number you want the cube root of.

**Step 4:** Update the estimate by the formula:

$$E_{n+1} = \frac{2E_n + C}{3}$$

where E = your estimate;

C = the answer to Step 3.

If a crosscheck doesn't show your new estimate as accurate as you need, another

pass through the system will give a more precise value.

Example: What's the cube root of 30?  
 $\sqrt[3]{27} = 3$ , so first guess of  $\sqrt[3]{30}$  will be 3.1.

Enter first estimate in memory, or write it down.

	Display
Step 1: Estimate the value	3.1
Step 2: Square it	9.61
Step 3: Take reciprocal (divide equal on some calculators, 1/x on others)	0.10405827
Multiply by the value you want the cube root of: x 30 =	3.1217482
Step 4: Update the estimate x 2 = $\div$ 3 =	3.1072494

Another pass gives an updated estimate of 3.1072325 which gives 30 precisely on my calculator when multiplied out.

## Trigonometry

Next stage in developing 'scientific-type' functions with a 'simple' calculator involves generating Trig ratios.

From Year 12 Maths (well, that's where the author first heard of it when doing work on limits of series), there were some which had as limit a trigonometric function. If you chose the starting value suitably, you could calculate the sine, or the cosine of a given angle.

The value was the angle size measured in radians. Radians? Well, 2Pi radians (no, not even a whole number) make a full rotation, like 360° or 400 grads.

Some scientific calculators require angles for calculation of sine, cosine, or tangent, to be presented in radians.

Yes, there are conversion buttons: degrees to radians and radians to degrees without having to file in memory that 1 radian = 57.29578°. Or, in traditional language, 1 radian = 57° 17' 44.808".

Since angular measure in radians to sine or cosine becomes less precise as the angle gets larger, the relation  $\cos a = \sin(90 - a)$  will be needed. Calculating  $\sin a$  by the method explained later, the maximum error in the range 0° to 45° is  $5 \times 10^{-5}$ . Using the cosine formula, the maximum error in that range is  $3.6 \times 10^{-6}$ .

Other worthwhile formulae are:

$$\cos a = 1 - \sin^2 a$$

and:

$$\sin a = \cos(90 - a)$$

Using these it should always be possible to calculate a reasonably small angle.

## Calculating sine

Start with the angle measured in radians (1 radian = 57.29578°) and looking at sine 30° as an example:

	Display
Step 1: Enter angle size in degrees	30
Step 2: Convert to radians ( $\div 57.29578 =$ )	0.52359877
Step 3: Square this (times	





## USING THE CALCULATOR

equals on some calculators,  $x^2$  on others, just multiply together on others)

0.27415567  
**Step 4:** Write this down or store in calculator memory.  
**Step 5:**  $\div 20 = -1 =$  -0.98629222  
**Step 6:**  $x$  (value in Step 3)  $\div 6 =$  -0.04506627  
**Step 7:**  $+1 =$  0.95493373  
**Step 8:**  $x$  (root of value in Step 3) 0.50000213  
 Is this within your accuracy limits? The precise value is 0.50000000.

### Calculating cosine

Again, starting with an angle-size expressed in radians and looking at cosine  $30^\circ$  as an example:

	Display
<b>Step 1:</b> Enter angle size in degrees	30
<b>Step 2:</b> Convert to radians $\div 57.29578 =$	0.52359877
<b>Step 3:</b> Square it	0.27415567
<b>Step 4:</b> Write this down or store in calculator memory	
<b>Step 5:</b> $\div 30 = -1 =$ CHS	0.99086148
<b>Step 6:</b> $x$ (Step 3) $\div 12 =$	0.0226752
<b>Step 7:</b> $-1 =$	-0.97736248
<b>Step 8:</b> $x$ (Step 3) $\div 2 =$	-0.13397473

**Step 9:**  $+1 =$  0.86602527  
 Which is 0.00000014 low . . . Oh well, sometimes it isn't perfect if you do things the Hard Way!

### Tangents

There's a bit of work involved in calculating tangents! For angles between  $45^\circ$  and  $90^\circ$  the relationship  $\tan x = 1/\tan(90^\circ - x)$  is needed, too.

Between  $0^\circ$  and  $45^\circ$  the tangent can be calculated through the series

$$\tan x = \frac{x}{1 - \frac{x^2}{3} + \frac{x^4}{5} - \frac{x^6}{7} + \frac{x^8}{9} - \dots}$$

Interested people doing Year 11 or Year 12 (no time really!) Maths might like to simplify this expression into an "ordinary looking fraction" expression. It isn't easy!

Now into the program. If your calculator hasn't a memory (my abacus, a 12-digit one, hasn't), where the program shows M+, write the result down, and the many times the program shows MR, enter again what you wrote down!

Again taking  $45^\circ$  as a sample, the case where, in the range  $0^\circ$  to  $45^\circ$  the error is greatest . . .

	Display
Enter $45^\circ$	45
$\div 57.29578 =$	0.78539816
square	0.61685026
M+	
$\div 9 =$	0.06853892
CHS + 7 =	6.9314611
1/x	0.14426973
x MR =	0.08899282
CHS + 5 =	4.910072
1/x	0.20362422
x MR =	0.12560565
CHS + 3 =	2.8743943
Reciprocal	0.34789938
x MR =	0.21460182
CHS + 1 =	0.7853918
Reciprocal	1.2732395
x $\sqrt{\text{MR}} =$	

0.99999997 (multiply by x, not  $x^2$ )  
 Answer  $3 \times 10^{-8}$  low! Oh well, not enough steps!

People with an interest in this sort of thing might care to consult Jack Gilbert's *Advanced Applications for Pocket Calculators*, TAB books No 824. Not only does it detail interpolation methods for trig ratios, but also for logs and natural logs. ●

# LABORATORY POWER SUPPLIES

APLAB offer a complete range of regulated DC bench/rack power supplies combining high precision and regulation capabilities with continuously adjustable outputs.

Designed with single, dual and multiple outputs, these power supplies can be used in either constant voltage or constant current mode of operation.

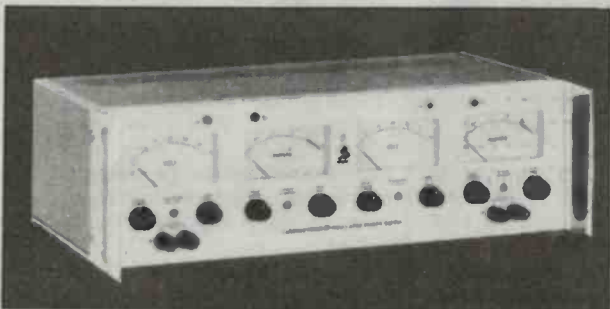

### Standard models include:

<b>SINGLE OUTPUT</b>	
OUTPUT: Output VOLTAGE: Current	
0-30V 0-1A to 30A	
0-70V 0-2A to 10A	
<b>DUAL OUTPUT</b>	<b>MULTIPLE OUTPUT</b>
0-30V 0-1A to 2A	0-30V 0-2A to 5A



**SCIENTIFIC DEVICES AUSTRALIA PTY. LTD.**

VIC. 2 JACKS RD., SOUTH OAKLEIGH, 3167  
 PHONE: (03) 579 3622 TELEX: AA32742  
 NSW. 559A WILLOUGHBY RD., WILLOUGHBY 2068  
 PHONE: (02) 95 2064 TELEX: AA22978  
 S.A. 31 HALSEY RD., ELIZABETH EAST 5112  
 PHONE: (08) 255 6575 TELEX: AA88125



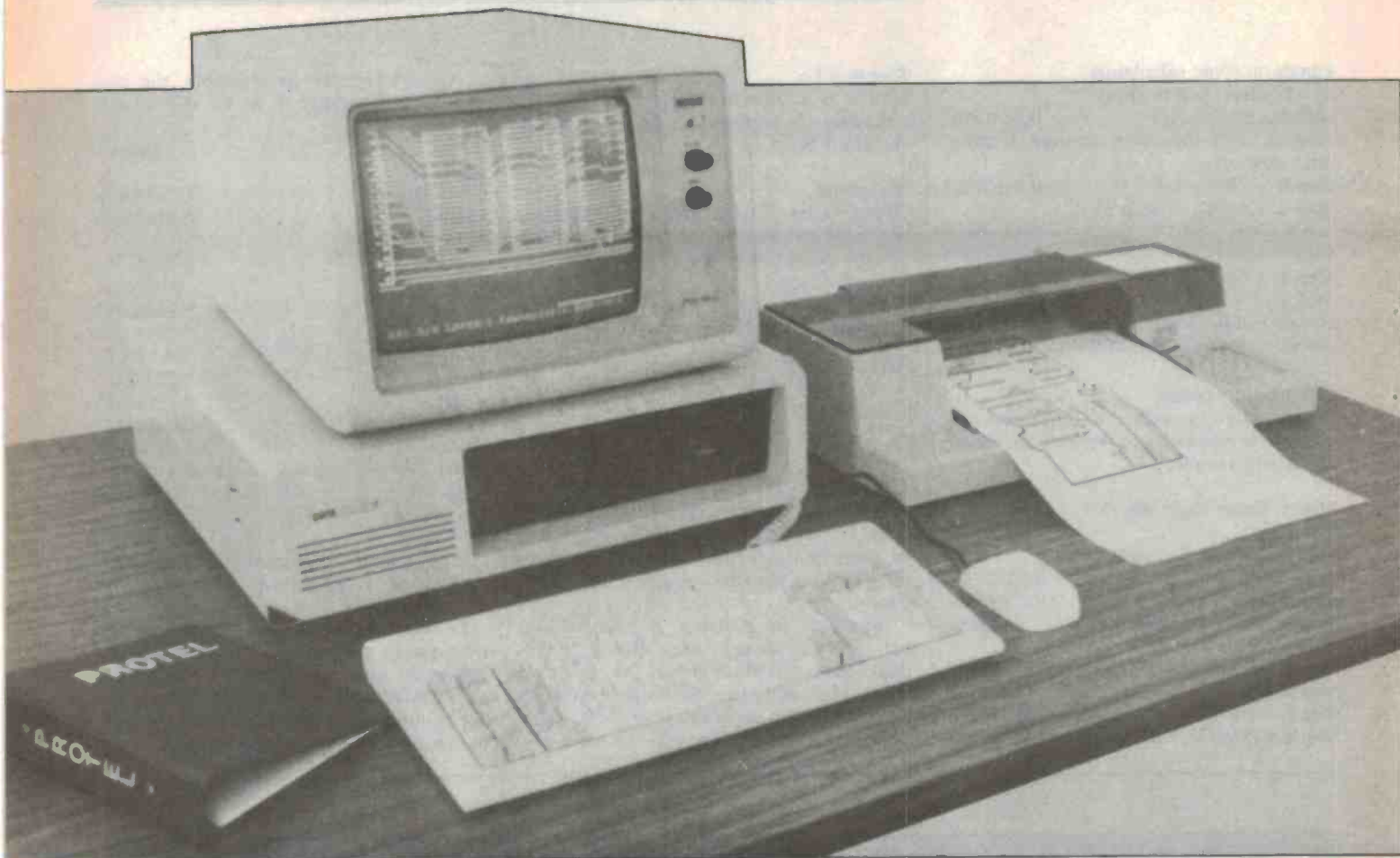

# TASMANIAN PRO

Tony Pugatschew

This is Part 2 of a close look at the two most popular CAD packages on the market. Last month it was smARTWORK, this month it's PROTEL's turn under the spotlight.

*Tony Pugatschew is lecturer in Physics at the South Australian Institute of Technology, The Levels, Adelaide.*

LAST MONTH I dealt with smARTWORK, a product from the Wintek Corporation in the US. This time around I want to look at PROTEL, a very similar sort of package produced by HST Industries down in Tasmania.

Like smARTWORK, PROTEL was designed because working engineers couldn't get a decent result from existing CAD packages. HST deals with scientific instrumentation, measurement systems and so on, and so it looked for a system that would be utilitarian above all else. PROTEL has no flashy bits and pieces, no auto route facility like smARTWORK for

instance, but it does do a number of things rather well. It operates much like a drafting tool, indeed, it is a drafting tool, albeit an extremely competent one.

For instance, it is the responsibility of the designer to make sure that tracks do not touch except where they should. PROTEL has no routine that would allow it to stop you making a fool of yourself! But it does do some of the things that a computer aided package is expected to be good at. It can store often used symbols in a library file. It can move or rotate them, indeed, it can move or rotate any part of the entire board. It can generate parts lists

and store complete pc boards for archiving. It can copy individual tracks over and over, or entire regions of the board as required.

In order to discuss PROTEL-PCB and lay a foundation for other comparisons, I have divided the package into main functional units, such as pad and component placement, track-laying, text insertion, block moving, changing the current layout and plotting the final artwork. PROTEL-PCB uses the function keys extensively in conjunction with the control and ALT key. I assume that readers are familiar with the placement of these keys.



## Library components

As seen from the summary, PROTEL-PCB offers a very wide variety of pad sizes and shapes. The pads can be round, or square. Furthermore, integrated circuit pads can be plotted as round or rectangular. This choice is made in the plotting program.

To select a specific pad the P command (CONTROL P) will present a pad selection menu that lists 22 pad sizes as well as the edge connector orientation. The edit screen is resumed after a pad selection is made and PgDn is typed. The selected pad is shown in the status line, for example, a round 50 mil pad is P:R50.

Once selected the pads may be placed on the board with the F1 key and removed by placing the cursor over the pad and pressing F2. Repetitive pad layouts such as dual-in-line integrated circuits can be drawn with consecutive pad insertions but PROTEL-PCB has a library file that contains often used, pre-designed library components. Accordingly the user can include a 14-pin DIP package by using the ALT F1 command which then prompts for a library component name and comments. For example the number can be given as U1 and the comment may be 74LS04 INVERTER. These comments and numbers are entered into a parts list that may be printed after the board is completed. An example display of the initial library components is shown in Figure 1. The library components can be rotated or moved after initial placement with the ALT F3 and ALT F4 options.

## Track laying

There are seven layers in PROTEL-PCB: the component side, the solder side, four middle layers and a component overlay. Pads appear on every layer whereas tracks and text are tied to a respective working layer. The layer is selected with the L command and the colours can be easily modified for personal preferences. The layers can be turned off if the detail becomes objectionable using the display options menu.

To lay tracks up, set the cursor on the centre of a pad and type F3 (or press the left button of the mouse). As the cursor is moved around the board the track pivots around the start point and only permits movement at 0, 45 or 90 degrees. The impression on the screen is similar to an expanding and contracting rubber band. F3 will place pivot points on the screen as the track is routed to its destination. F4 finally terminates the track.

In order to delete a track the cursor is placed over the section and the track disappears after F8 is typed. The track thickness is selected with the T command and

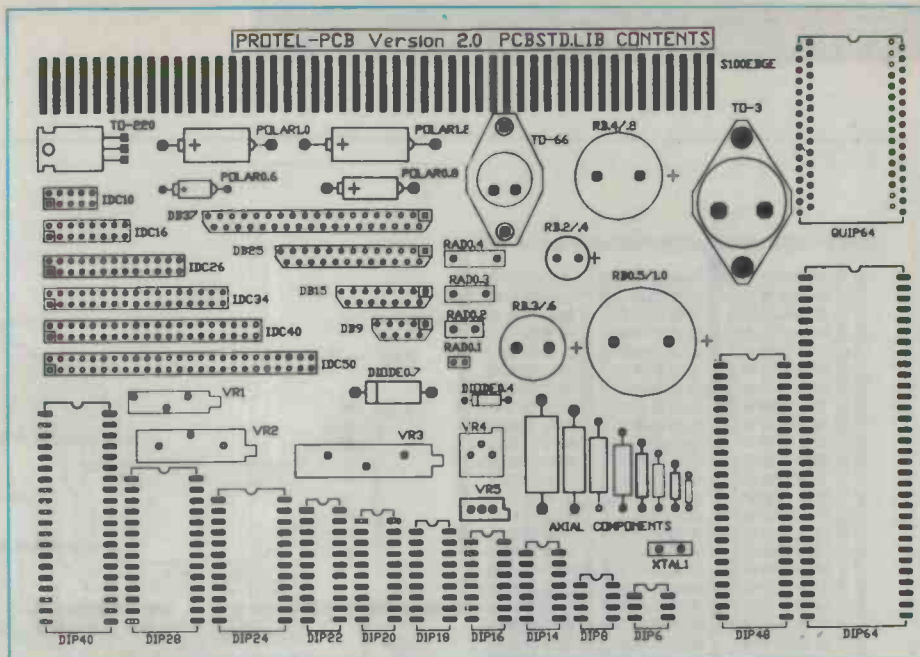

Figure 1. Initial library components.

## TABLE 1. SUMMARY TABLE OF PROTEL-PCB

Placement accuracy of components: 0.001 inches
Grid sizes: 1, 5, 10, 25, 50, 100, 125, 156, 200 mil
Maximum pcb size: 32 x 19 inches
Zoom window sizes: 32 x 19, 16 x 9.5, 6.4 x 3.8, 3.2 x 1.9 and 1.60 x 0.95 inches
Pad sizes: 50, 70, 100, 150, 200, 250 mil, round or square, 50 mil square with no hole
Library of common component outlines: user redefinable
DIP pad size: 50 x 130 and 80 x 130 mil rounded or sharp corners
Edge connector pad sizes: 50 x 250, 50 x 500, 80 x 500 and 120 x 1000 mil
Track sizes: 15, 30, 50, 100 mil
Text sizes: 80, 120, 160, 210, 280, 420, 560 mil with rotation and mirroring
Plot scales: 2:1, 1:1
Printer support: none
Plotter output types: final artwork, colour checkplot, padmaster, solder mask, silkscreen overlay
Printer: output of bill of components only
Multilayer boards of up to six layers
Plotters supported: HP series and Houston series
256K RAM
2 floppy disks or hard drive
Colour graphics adaptor
Colour monitor
Microsoft mouse (optional since screen cursor may be moved with the cursor keys)
NEC mouse
Photoplotters, Gerber series
Demonstration package available

### VERSION 2.0 EDITOR QUICK REFERENCES

F1	Place pad key
F2	Delete pad arc, copper
F3	Begin/continue track (or left side mouse button)
F4	End track laying (or right mouse button)
F5	Contract display
F6	Expand display
F7	Stretch tracks
F8	Delete track section
F9	Redraw screen
F10	Re-centre screen

### LIBRARY COMMANDS

ALT F1	Load component from the library
ALT F2	Delete component from board
ALT F3	Move/rotate a component
ALT F4	Move/rotate text
ALT F5	Find a component by specifying name
ALT F6	Identify component beneath cursor
ALT F7	Put component over cursor position
ALT F8	Relabel component over current cursor positions
ALT F9	List library components
ALT F10	List components on board

### BLOCK COMMANDS

KB	Mark a block
KV	Move a block
KH	Remove block markers
KY	Delete block
KR	Read in block

### OTHER COMMANDS

A	Place arc on overlay
B	Break track section
E	Erase track section
F	Fill area
G	Select grid size
I	Toggle cursor information
L	Select layer
O	Toggle ortho mode
P	Pad selection menu
Q	Quit editor
T	Select track size
W	Alter track width
X	Place text
Z	XZAP entire track
ALT C	Copy track stack
ALT E	Empty track stack
PgUp	Display options menu
PgDn	Return to editor



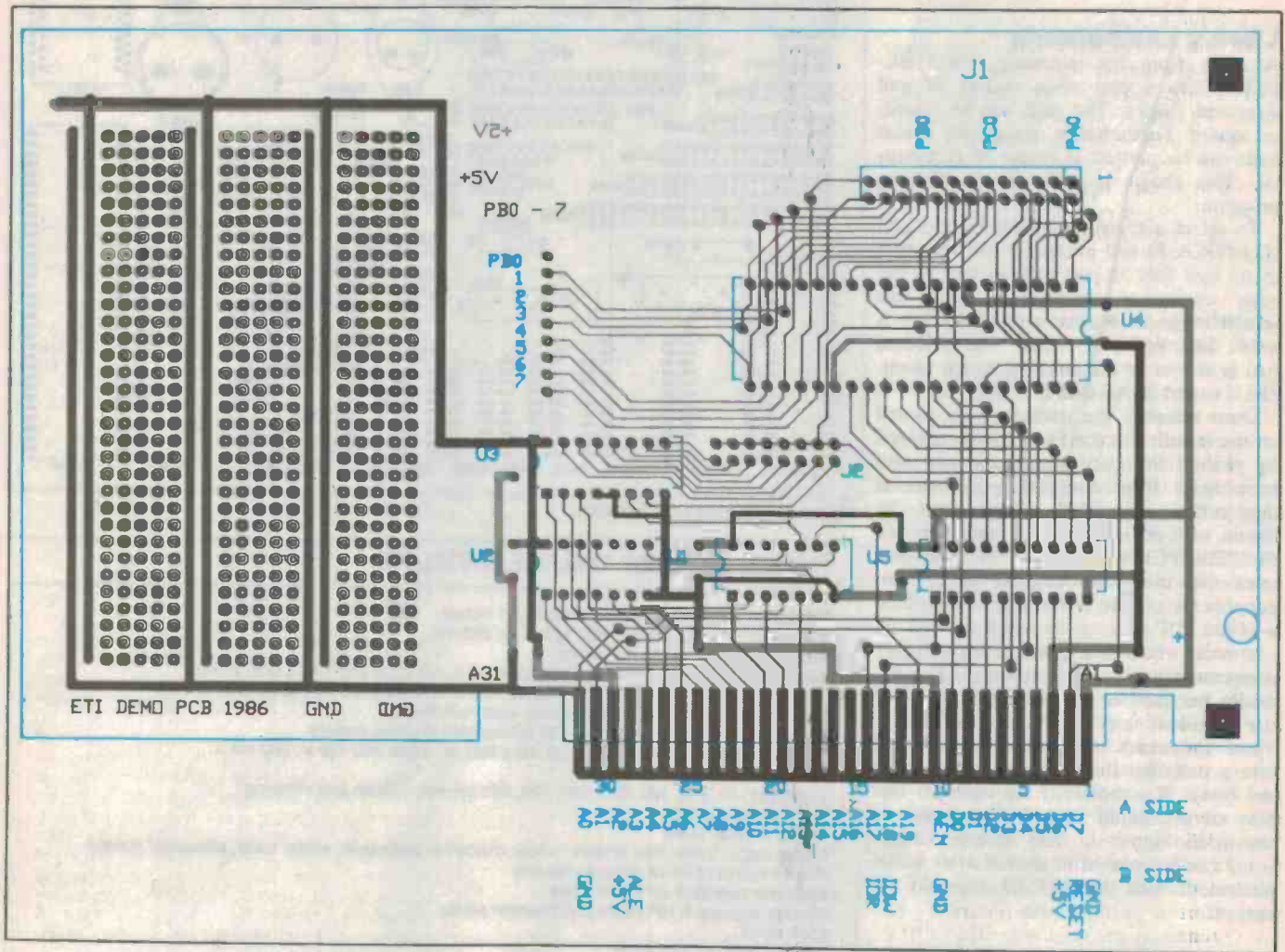

the width of an existing track can be changed with the W command.

One feature that is very useful in any computer based pc board package is a track repeat function. Its obvious use is in designing large memory blocks where the address and data lines are all bussed together. PROTEL-PCB uses a TRACK STACK function which permits a track pattern to be memorized and repeated. However, the TRACK STACK must be cleared prior to this with the ALT E command, otherwise every track drawn from the initial entry into the editor will be repeated. The new track section is drawn by placing the cursor at the end point. ALT C will then repeat the track from the end point to the track origin.

No drafting system would be useful if an ERASE function was not included. PROTEL-PCB permits the track section to be cleared with the F8 command or a complete track can be cleared with the CTRL-Z command (presumably this means ZAP a track!).

## Text placement

PROTEL offers full text capabilities, with seven sizes of text that can be rotated, moved and mirror imaged. This latter feature is important if text is to be placed on the solder or underside of the board. Since the board is designed by looking through the component side, the solder side text will only be readable on the solder side if it is mirrored.

The text sizes are obtained by typing Pg Up to obtain the display options menu and then using the X key. The text is placed with the X command and erased with the E command.

To move text, the cursor is placed on the string and ALT F4 is entered. The text string is then enclosed in a rectangular box and the cursor moved to the reference point at the lower left of the string. An option for moving the text, mirroring in the x and y axis direction and rotating in increments of 90 degrees is shown. The X, Y command will mirror the string in the x or y axis and the arrow or cursor keys will

then move the text in selected directions. Pressing the space bar will rotate the selected text string in successive increments of 90 degrees.

## AREA FILL commands

It is useful to create larger areas of copper on some pcbs for either ground planes or for heavy tracks. Rather than repetitively using thick tracks, an AREA FILL command is provided. By using F and selecting a first and second corner, an area is completely filled. Similarly, the area can be erased with the F2 command.

## BLOCK commands

The BLOCK commands permit the user to mark a rectangular block on the pcb layout and to move it to another position or to delete it completely. Furthermore, these blocks can be saved to the disk with a predefined and meaningful name such as ROM2764.pcb. However, PROTEL-PCB requires the file to be saved to disk before it can be copied. The insertion is per-



formed by reading in a block.

An interesting feature of these block move operations is that when a block is moved, the user is permitted to drag tracks with the component. The tracks are not set to orthogonal mode but just left as point to point connections. (commonly known as a 'rat's nest'). This is still useful because it becomes much faster to square up this layout rather than routing from scratch.

### Creating new components and libraries

As mentioned, the library function of PROTEL-PCB is a very useful feature. The insertion of predefined library units complete with detail means that the checking of the final board design can be easily performed. For example, it is possible to place text on the library unit so that pin details, etc, are also shown on the overlay. PROTEL-PCB permits the user to define specific libraries that can hold up to 200 components. The libraries can be switched.

In order to make a new component, the same commands are used to create a component but it is saved to a library rather than a disk file. After the unit has been drawn the cursor is positioned on the reference point (usually pin 1 for DIP packages). The user must return to the main menu and then the MAKE NEW library definition command is used. The ALT F9 command can then be used to check if the new unit is in the current library. Current entries in the library can be easily renamed or removed. The TIDY command can be used afterwards to put the library in alphabetical order and clean up the storage space if components have been removed.

### Preparing final artwork

PROTEL-PCB supports plotter output to both Hewlett-Packard plotters and the Houston instrument range. The system also supports the Gerber photoplotter systems which permit the final artwork to be plotted on photosensitive film directly.

To produce plot files the PLOT program is used. The user is presented with a menu which determines which file is plotted, the respective layers, reproduction ratio of plot (1:1, 2:1), the communication details with the plotter (baud rate, stop bits, data bits, etc,) and the x and y offsets. This permits the plot origin to be set at a different position from the plotter home position. This feature is very useful if preprinted media is used or the layout requires alignment marks or company details have to be added.

PLOT also allows choices concerning the DIP pad shape, pad shape, holes in

pads, and text in plot.

In order to produce high quality artwork some attention is required to the plotting media and pens. The paper or film must be dimensionally stable and must lie flat in the plotting system. This of course depends on the plotter used. The pens must draw even, opaque lines at a quite high writing speed. Common manual drafting pens are inadequate. Many suppliers have tungsten tipped pens designed exclusively for this application. The pens are expensive but are necessary to produce a high quality plot that will satisfy the board manufacturers. PROTEL-PCB includes a section on this point in the manual so the user has a good reference point.

The artwork has to be photographically reduced to produce same size masters, and, if plated through holes are used, then a drilling tape must also be produced. In this step, the absolute coordinates of each hole are produced on a drilling tape which controls the numerically controlled drill. This step is required in the plating technique.

PROTEL-PCB supports the Gerber photoplotters that produce the same size artwork directly and generate the drill tape. These devices are expensive and are available through pcb design bureaux. A separate program called GPLOT generates a disk file for the photoplotter. Since the photoplotter exposes film directly through variably shaped apertures a translation procedure must be used to define PROTEL plot details in relation to the photoplotter. The file called GPLOT.CFG contains details on the translation from PROTEL to the Gerber. The manual recommends close liaison with the commercial organization regarding this procedure.

### Manual

PROTEL-PCB is supplied with a comprehensive manual that is similar in packaging to the boxed IBM style manuals. Documentation includes a function key overlay, and a sample completed pcb to illustrate the final pad, track, edge connector arcs and text details. Two DIP pad sizes are also shown. This example board is a very useful feature because the user can plan the design with a firm picture of the important details. The manual is very comprehensive with a clear presentation of the main points and good discussion on problem areas such as the block moves. Apparently, due to the popularity of the program and export ventures, a typeset version will be produced in the future.

The three disks provide the EDITOR, PLOT and GPLOT files as well as a summary text file of the main commands. There is a demonstration pcb file that the new user can modify and plot.

### COMPARISON OF PROTEL AND SMARTWORK

Both these pcb design tools offer considerable sophistication and functionality. Virtually all the desired features are present in both but, as often happens, no one package combines all the wishes of the user.

smARTWORK is a very easy and reliable package to use. The text placement and auto routing functions assist in the rapid production of well-designed boards. The system provides the quickest introduction to pcb design. Since dot-matrix print output is possible, amateurs can use smARTWORK and still produce good prototype boards.

Advanced add-ons are available to convert smARTWORK files to Autocad or Cadplan. Wintek is working on Gerber Photoplotter utilities, which will be available shortly.

PROTEL-PCB offers nearly every feature that pc board designers require. The advanced drafting commands and the library and pad size options mean that high density boards with many layers are in the grasp of users.

However, the lack of a printer option, even for quick check plots, means that users must have access to plotters. The plot routines also need some attention, either in filleting or pad shaving, and definitely in plot file optimization. At the current time the plot files are on first-in first-plotted basis. This means that if a track is added at the end of the session then this track is drawn last. The pen movement back and forth takes time so plots can be sped up if tracks are drawn in some order. This may be difficult to implement.

A good feature of both of these packages is the documentation, which is excellent. There is also provision for user comments, and some evidence that these have influenced program revisions.

One thing is for sure, regardless of whether PROTEL-PCB or smARTWORK is chosen, you will never return to pads and tape for layouts. Furthermore, the discipline required to design pcb's using CAD, in terms of good design practice and documentation, may rub off on other aspects of the engineering workplace.

Since both packages are available as demonstration units I would advise prospective customers to avail themselves of this offer. A few hours trying each system is a very worthwhile exercise.

### Installation and protection

Version 2.0 of PROTEL-PCB is supplied with a keycard which plugs into one of the expansion slots of the PC. This keycard must be in place before the program will run. Too bad if you don't have a free slot on your PC! Its function is to limit the illegal use of the program. One advantage of this method of copy protection is that it means the actual disk can be copied with standard DOS commands and loaded onto hard drives.

The copyright question must be the most controversial one facing software developers. All agree that intellectual achievement and reward in the software industry must be maintained, but hardware protection is not the answer. Imagine the situation in the book industry if you had to use special glasses or a special light to read and use a certain book.

Reasonably priced software without the legal gibberish printed on the software packer would go a long way to providing a solution. ●



# Picosecond sampling

An innovative approach to capturing high speed signals has led to the development of the new Tektronix digitizing camera system (DCS).

Using CCD (charged-coupled device) technology and proprietary software algorithms, this new approach permits analogue oscilloscope users to add digitizing and signal processing capabilities to their scopes, while simultaneously improving the scope's measurement accuracy.

The CCD camera connects to the oscilloscope bezel like a conventional CRT camera. It reads the light given off by the CRT phosphor and transmits a video signal to a frame/store card for analogue-to-digital conversion and storage. The frame/store

card, which plugs into an IBM-PC, permits data manipulation and analysis by the PC.

Using this new approach, the DCS can capture repetitive signals at the bandwidth of any analogue oscilloscope, and captures transient events at up to two-thirds the analogue bandwidth. For analogue oscilloscopes with micro-channel plate (MCP) CRTs, the DCS acquires transient signals at full bandwidth. Utility software with the DCS includes menu-driven functions for setting up signal acquisition, parametric analysis and

signal processing.

This is the only storage system that can keep up with the very latest gigahertz bandwidth oscilloscopes. The DCS acquires and digitizes displayed transient waveforms at an effective sampling rate of four picoseconds, which equals 250 gigasamples per second.

Video information is stored and processed for the IBM-PC by a plug-in card containing video and A-D conversion circuits. The camera's NTSC standard RS170 video output allows for the transmission of the captured signal to the frame/store card. The NTSC RS170 output permits the use of video tape as a storage device,

large screen displays for classroom use, and television monitors for optimal real time viewing even at remote locations. The DCS employs full geometric correction, including correcting lens distortion and CRT electron optic distortion. Proprietary image processing allows trace centres to be extracted from one point in 4096 of the full oscilloscope screen.

As analogue oscilloscope performance and bandwidth increase, Tektronix says the DCS can adapt to these new performance levels. The digitizing camera's design has been optimised for finite conjugate imagery, which makes it ideal for high accuracy CRT imaging.

## Fibre relay

Siemens has developed an optical relay to meet the requirements of new communications technology using optical wave guides. Local area networks (LANs) in particular require switching elements by which data streams can be connected to optical fibres, or transferred or disconnected. This calls for a high degree of reliability over a long operating life. Network performance also depends on the switching element having a

low and repeatable insertion loss combined with a high switching speed.

An optical relay developed by Siemens fulfils these requirements through a temperature range of  $-20^{\circ}\text{C}$  to  $+70^{\circ}\text{C}$ . It is available for all conventional multimode fibres and guarantees an insertion loss of less than 1 dB. Repeatability is less than 0.2 dB for the duration of its life of more than 10 million operations. Connections can be set up or released in 20 ms. The optical relay comes in a hermetically-sealed plastic case and can also be mounted on circuit boards.

## Video DACs

Energy Control in Queensland has just released a new range of fast DACs. They have been developed by Brooktree Corporation in the US, and go under the names of Bt101, 2 and 3. There is also an evaluation kit, the Bt103 EVM.

The Bt101 is a CMOS 50 MHz DAC, essentially with three 8-bit DACs on one bit of silicon. These give RGB outputs. Other inputs are clock and reference white. Other outputs include a composite video and a sync.

The Bt102 goes a bit faster, 75 MHz, but is designed specifically for monochrome work. Applications include image processing and CAD workstations.

The Bt103, trades bits for speed. It has three 4-bit DACs, but runs at 75 MHz. The 103 EVM is an evaluation module for the Bt103. It is capable of driving the chip to create ramp and square waves at a full 75 MHz.

All three chips use CMOS logic, run off a single 5 V rail and are RS343 compatible. For more information contact Energy Control on (07)288-2455.

## VHS answers back

The latest blast in the long running battle between the VHS format and the eight mil lobby has been fired by JVC. The company's local agent, Hagemeyer, has released the GR-C7EA VHS camcorder in this country.

According to the company, it is the product of 10 years of research into optimizing the VHS format.

The camera is light and small, in fact, comparable to Sony's Video 8. It weighs in at just

1.4 kg, with dimensions 121 by 165 x 223 mm.

At centre stage is a half inch charged-couple device. This acts as the optical transducer, driving both the record heads inside the camera and the 0.6 inch viewfinder. The lens is reasonably fast at f1.6 and leads to a claimed sensitivity of 15 lux. Another big bonus is fully automatic white balance. Focus and exposure are fully automatic.

The biggest drawback is the price: \$3099.





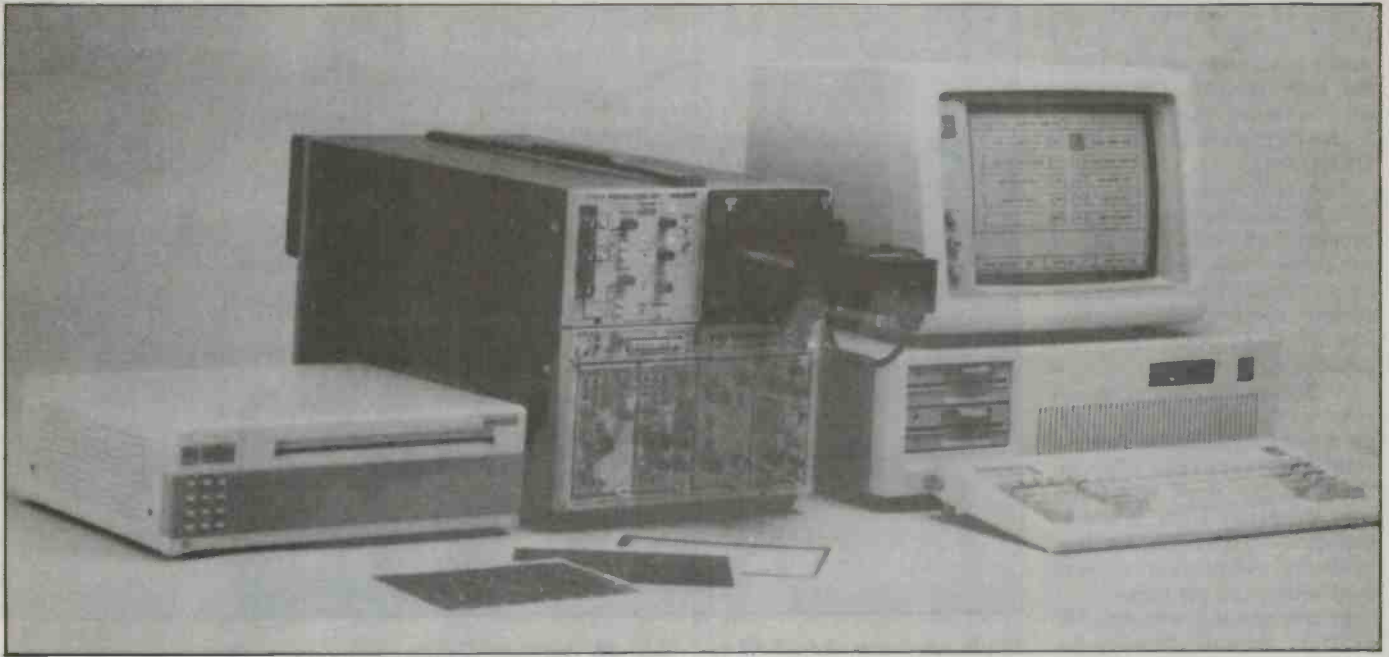

## Two languages from Microsoft

Microsoft Corporation has announced the release of its new C Compiler, Version 4.0, offering improved optimization. According to company publicity, it offers faster, more compact programs and a complete development tool kit. A key part of that tool kit is Microsoft Code View, a new window-oriented debugger that gives programmers complete control over their development environment.

Version 4.0 implements most of the Unix System VC Library and also supports the proposed ANSI standard.

According to Mike Olsson of Microsoft's Technical Department, "Microsoft understands the professional programmer's need for a C compiler that can generate truly high-performance

programs in the shortest time. In developing Version 4.0, we committed ourselves to meeting this goal".

Microsoft has a strategic interest in creating a high-performance C compiler, since C is the language used to develop most Microsoft products. The C language was used, for example, in developing products such as Xenix and Windows. Companies such as Lotus and Ashton-Tate have also used Microsoft C in developing their own products.

Included in Version 4.0 is a new window-oriented symbolic debugger, a new program maintenance utility and other tools.

A key advantage of the new debugger is that it lets the programmer see everything that is

going on — both in the program and inside the CPU — while the program is running. By opening windows as needed, the programmer can view source code, object code or both as the program is being executed.

The other release is QuickBASIC 2.0, a BASIC compiler. Microsoft says the new product offers high-speed, in-memory compilation and allows users to create structured and modular programs. In addition, its built-in editor and debugger shorten development time, letting programmers write, compile, and debug their programs without having to leave the programming environment.

The in-memory compilation feature of Microsoft QuickBASIC 2.0 lets it compile pro-

grams at speeds ranging from 6000 to 9000 lines per minute in an IBM-PC/AT or equivalent. Other compile options let the user create stand alone programs or BASIC libraries that can be reused in other programs. The user can also specify whether a program is to be optimized for speed or size during compilation.

Once compiled, programs will execute up to 10 times faster than programs developed with a BASIC interpreter. It's compatible with other BASIC interpreters that run under MS-DOS. Consequently, most programs developed with BASICA or GW BASIC can be re-compiled with QuickBASIC for faster execution.

For more information contact Microsoft's Customer Service Department on (02)452-5088.

## Better picture quality on VHS

Hagemeyer (Australasia) BV, marketer of JVC goods in Australia, has announced the release of the HR-D566EA VCR which incorporates the JVC developed HQ (high quality) picture improvement technology.

JVC Hagemeyer claims that the HR-D566EA combines sharper, clearer pictures with stereo hi-fi sound performance. JVC has also incorporated other features, such as an infrared remote control from which the user can program the timer up to one

year in advance.

The HR-D566EA also incorporates audio dub control, peak-hold level indicators, audio output selector, headphone level control, an audio limiter, shuttle search, instant recording and FM simulcast capability.

Also new from JVC is a range of hi-fi consisting of 28 new models. One of these is the compu-link control system,

which permits the user to have total remote control operation over all audio and video components. The 48-function remote control is computer linked via the SEA-RM20BK unit to all other JVC components. This allows the user to control volume, graphic equaliser settings, all audio components, the video recorder and the colour television.



## Light power

The new Hewlett-Packard 8152A optical average power meter is accurate up to 0.15 dB for both absolute (dBm) and relative power measurements. It is also programmable via HP-IB (IEEE-488).

Two optical inputs are available for individual power measurements on both channels, or for power-ratio measurements. This is useful for procedures that require checking the insertion loss or attenuation of optical connectors or cables.

A high-performance optical splitter, the HP 81000BS, supports these applications with a 1:10 power-split ratio. The instrument can work with fibre core diameters from 9 micrometres to 85 micrometres. It is mode and polarization independent within one per cent.

In combination with the HP 81521B optical head, the HP8152A covers the wavelength range from 850 to 1700 nm for multimode and single-mode applications. Power levels down to -70 dBm can be measured with

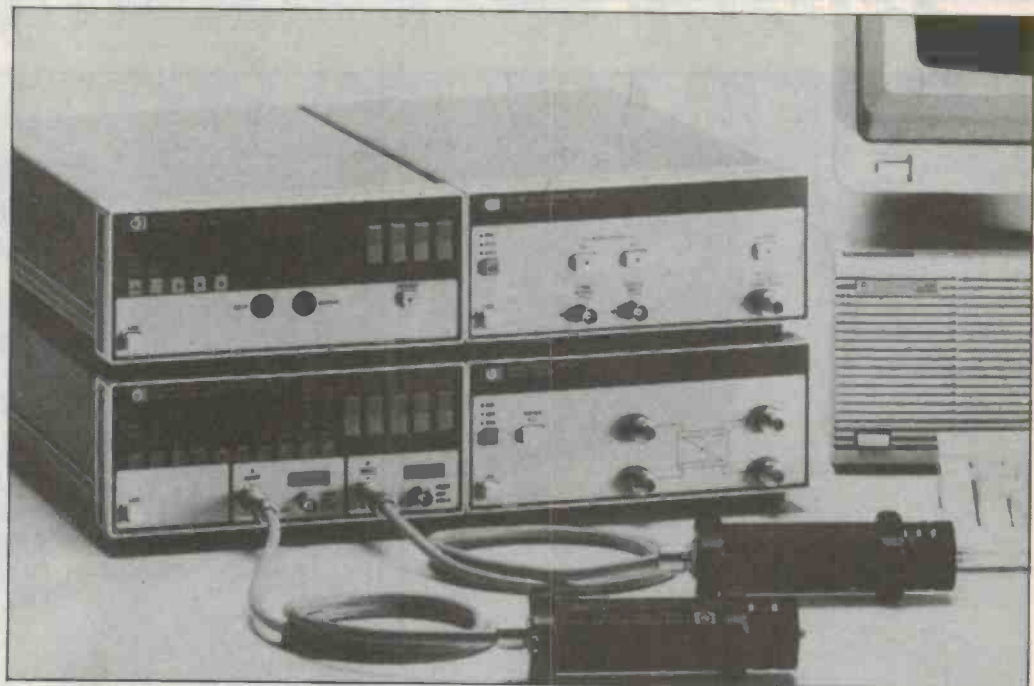

10 pW resolution. A 0.15 dB accuracy is achieved between 0 dBm and -50 dBm over the full specified temperature range of 0 to 55 degrees C. At  $25 \pm 5$  degrees C, the accuracy is

0.05 dB between 0 dBm and -60 dBm. All optical heads are calibrated individually over their entire specified wavelength range.

A flexible optical interface en-

sures easy and quick adaptation to all common optical connectors. To extend the measurement range beyond +3 dBm, additional attenuation filters may be inserted.

## Uninterruptible power

The Powerbank 500 is designed to minimise the problems created by mains power deviating from the nominal 240 volts. The mains power to the computer is supplied via the Powerbank 500, which also monitors the mains for low voltage or

power loss conditions. The Powerbank incorporates a three stage filter to quench harmful high energy interference as produced by a lightning strike.

If the sensing circuitry in the Powerbank detects unacceptable variations in the mains

power, it will switch over to its internal battery to provide 240 volts. The computer is also isolated from the source of the power problems. The switch over only takes 100 milliseconds.

After the computer has been isolated from the mains, the Powerbank's sensing circuitry

still monitors the mains power. When the mains power stabilizes again, the Powerbank automatically reconnects the computer to the mains. The internal battery is then automatically recharged for the next power failure.

For further information call Questek on (02) 808-3710.

## Fibre and CD

The elusive ideal in sound reproduction is to preserve and faithfully recreate the finely detailed presence of a live performance.

With this aim in mind, Onkyo Corporation has launched the Integra DX-320 Compact Disc Player with opto-coupling.

According to Onkyo, this is the first CD player to use optics to transfer information from the digital to analogue sections of the system. The heart of the system is the opto-coupling module, in which the optical signal transmitter and receiver are con-

nected by an 11 mm long optical fibre.

By circumventing transfer by electrical means this opto-coupling system keeps the digital and analogue circuitry isolated so as to prevent the introduction of spurious noise and electrical interference.

Other features of the Integra DX-320 include Onkyo's exclusive super servo/delta power supply, vibration damping, double oversampling and digital filter, 10-key, 16-step memory and 10-key infrared remote control.

For further information, please contact Margot Pickering of Lifner on (02)449-5666.

## Time delay

Alfratron has released news of a new CMOS time delay line from Dallas Semiconductor called the DS1000. It is claimed to be the most accurate time delay available due to laser trimming of on-board resistors. They have five equally spaced taps, offering delays from 20 ns to 500 ns with a tolerance of one nanosecond.

According to Dallas publicity supplied by Alfratron, the units can be dropped into the sockets of many popular types of delay lines manufactured using older technology. These delays would not have the same accuracy as

the new models.

Alfratron has also released news of the Dallas DS1216 'smartwatch', which adds time stamping and dating capability to a microcomputer without any sort of redesign. It comes with a bit of mated CMOS RAM, which is transformed into non-volatile read/write memory. The device is designed with an internal lithium source calculated to last at least 10 years.

The DS1000 comes in two versions, a 14-pin DIP or as an 8-pin surface mount package. The DS1216 is on a 28-pin JEDEC socket. They are available ex-catalogue, according to Alfratron. Ring (03)758-9000.



# "Don't buy until you've got a quote from us"!!



**MICRODOT  
5 1/4" FLOPPY DISKS**  
Have a look at these prices!  
These are 100% certified, prime spec.  
disks in labelled jackets.  
(not like our oppositions)

Description	1-9	10+	100+
Cat.No. boxes boxes boxes			
S/D D12440	\$14.50	\$13.90	\$13.00
D/S D12445	\$16.50	\$14.90	\$13.50

Plus 20% tax where applicable

Attention Schools, Government, Depts etc  
FREE sample disk available on request!  
(Please send \$2 to cover postage)

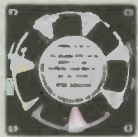

**FANS**

Cat.No. Description	1-9	10+	100+
T12451 240V 1/2"	10.50	10.00	8.00
T12465 240V 3/2"	10.50	10.00	9.00
T12463 115V 4 1/2"	10.50	10.00	9.00
T12467 115V 3 1/2"	10.50	10.00	9.00

(Fan guards to suit also available)  
Plus 20% tax where applicable

**ELECTROLYTIC  
SINGLE ENDED  
PCB MOUNT**

Cat.No. Description	10+	100+	1000+
R15405 0.47uF 63V	\$0.07	\$0.06	\$0.05
R15415 1uF 63V	\$0.07	\$0.06	\$0.05
R15422 2.2uF 25V	\$0.07	\$0.06	\$0.05
R15424 2.2uF 50V	\$0.06	\$0.05	\$0.04
R15425 2.2uF 63V	\$0.07	\$0.06	\$0.05
R15432 3.3uF 25V	\$0.07	\$0.06	\$0.05
R15435 3.3uF 63V	\$0.07	\$0.06	\$0.05
R15442 4.7uF 25V	\$0.07	\$0.06	\$0.05
R15443 4.7uF 35V	\$0.08	\$0.07	\$0.06
R15445 4.7uF 63V	\$0.07	\$0.06	\$0.05
R15461 10uF 16V	\$0.07	\$0.06	\$0.05
R15462 10uF 25V	\$0.07	\$0.06	\$0.05
R15463 10uF 35V	\$0.07	\$0.06	\$0.05
R15465 10uF 63V	\$0.07	\$0.06	\$0.05
R15481 22uF 16V	\$0.07	\$0.06	\$0.05
R15482 22uF 25V	\$0.08	\$0.07	\$0.06
R15483 22uF 35V	\$0.08	\$0.07	\$0.06
R15484 22uF 50V	\$0.09	\$0.08	\$0.07
R15502 25uF 25V	\$0.07	\$0.06	\$0.05
R15505 25uF 63V	\$0.10	\$0.08	\$0.07
R15512 33uF 25V	\$0.08	\$0.07	\$0.06
R15521 47uF 16V	\$0.09	\$0.08	\$0.07
R15522 47uF 25V	\$0.09	\$0.08	\$0.07
R15525 47uF 63V	\$0.10	\$0.09	\$0.08
R15531 100uF 16V	\$0.08	\$0.07	\$0.06
R15532 100uF 25V	\$0.08	\$0.07	\$0.06
R15533 100uF 35V	\$0.15	\$0.12	\$0.11
R15535 100uF 63V	\$0.24	\$0.22	\$0.20
R15541 220uF 16V	\$0.09	\$0.08	\$0.07
R15542 220uF 25V	\$0.14	\$0.12	\$0.11
R15543 220uF 35V	\$0.25	\$0.23	\$0.20
R15545 220uF 63V	\$0.26	\$0.24	\$0.22
R15552 330uF 25V	\$0.15	\$0.13	\$0.12
R15555 330uF 63V	\$0.34	\$0.30	\$0.28
R15561 470uF 16V	\$0.16	\$0.13	\$0.12
R15562 470uF 25V	\$0.23	\$0.20	\$0.18
R15563 470uF 35V	\$0.30	\$0.28	\$0.28
R15564 470uF 50V	\$0.40	\$0.30	\$0.30
R15565 470uF 63V	\$0.44	\$0.39	\$0.36
R15581 1000uF 16V	\$0.25	\$0.22	\$0.20
R15582 1000uF 25V	\$0.35	\$0.30	\$0.28
R15583 1000uF 35V	\$0.45	\$0.40	\$0.36
R15591 2200uF 16V	\$0.45	\$0.40	\$0.36
R15592 2200uF 25V	\$0.55	\$0.60	\$0.50
R15593 2200uF 35V	\$1.20	\$0.91	\$0.75
R15601 2500uF 16V	\$0.45	\$0.40	\$0.36
R15602 2500uF 25V	\$0.65	\$0.60	\$0.55

Plus 30% tax where applicable



**CRYSTALS**

Cat.No. Frequency	Can	100+	1,000+
Y11000 1MHz	HC33	4.75	4.00
Y11005 2MHz	HC33	1.95	1.70
Y11008 2.4578MHz	HC18	1.95	1.70
Y11015 3.57954MHz	HC18	90	60
Y11020 4.000MHz	HC18	90	60
Y11022 4.194304MHz	HC18	90	60
Y11025 4.75MHz	HC18	90	60
Y11026 4.9152MHz	HC18	90	60
Y11042 6.144MHz	HC18	90	60
Y11050 8.000MHz	HC18	90	60
Y11055 8.667236MHz	HC18	90	60
Y11072 12.00MHz	HC18	90	60
Y11072 14.318MHz	HC18	90	60
Y11060 16.00MHz	HC18	90	60
Y11065 18.432MHz	HC18	90	60
Y11090 20.00MHz	HC18	90	60

Full range of crystals available on indent.  
Plus 20% tax where applicable

**POLYESTER 100V  
"GREENCAP" TYPE**

Cat.No. Description	1-99	100+	1000+
R15131 001uF	0.06	0.04	0.03 1/2
R15137 0012uF	0.06	0.04	0.03 1/2
R15138 0015uF	0.06	0.04	0.03 1/2
R15140 0022uF	0.06	0.04	0.03 1/2
R15142 0033uF	0.06	0.04	0.03 1/2
R15143 0039uF	0.06	0.04	0.03 1/2
R15145 0047uF	0.06	0.04	0.03 1/2
R15146 0055uF	0.06	0.04	0.03 1/2
R15147 0082uF	0.06	0.04	0.03 1/2
R15148 011uF	0.07	0.05	0.04 1/2
R15150 015uF	0.07	0.05	0.04 1/2
R15152 022uF	0.07	0.05	0.04 1/2
R15154 033uF	0.07	0.05	0.04 1/2
R15155 039uF	0.07	0.05	0.04 1/2
R15156 047uF	0.08	0.06	0.05 1/2
R15157 056uF	0.08	0.06	0.05 1/2
R15158 068uF	0.08	0.06	0.05 1/2
R15159 082uF	0.08	0.07	0.05 1/2
R15160 1uF	0.09	0.08	0.07
R15162 15uF	0.11	0.10	0.09
R15164 22uF	0.15	0.14	.13
R15165 27uF	0.16	0.15	.14
R15172 1uF	0.70	0.55	0.50
R15178 2.2u	1.20	1.10	1.00
R15178 3.3uF	1.50	1.20	

Plus 30% tax where applicable



**SEALED LEAD ACID  
BATTERY 12V 1.2 AH**

Cat.No. Desc	1-9	10-99	100+
S15029	12.50	11.00	10.50

Plus 20% tax where applicable

**CARD EDGE CONNECTORS**

Cat.No. Description	10-24	25-99	100+
P12080 10 Way	2.95	2.50	2.10
P12082 20 Way	3.25	2.75	1.95
P12064 26 Way	3.55	2.95	2.20
P12066 34 Way	3.95	3.50	2.30
P12068 40 Way	4.50	3.90	3.50
P12070 50 Way	5.50	4.50	3.90

Plus 20% Sales Tax where applicable



**19" RACK MOUNT CASE**  
Tremendous value! Vented top panel!  
Dimensions: 480(W) x 134(H) x 250(D)mm.

1-9	10+
\$32.00	\$29.50

Plus 20% tax where applicable



**500K DISK DRIVE FOR IBM\***  
12 months warranty!  
1-9 10+ 100+  
\$165 \$135 \$125

Plus 20% tax where applicable  
(\*IBM is a registered trademark)

**MITSUBISHI DISK DRIVES**

Description	1-9	10+	25+
4851 5 1/4" 500K	\$195	\$185	\$175
4853 5 1/4" 1.1M/Byte	\$265	\$245	\$215
4854 5 1/4" 1.6M/Byte	\$295	\$260	\$235
2896 8" 1.6M/Byte	\$650	\$625	\$600

Plus 20% tax where applicable

**DISK DRIVE FOR APPLE\***  
(6502 SYSTEM)

1-9	10-24	25+
\$175	\$165	\$155

Plus 20% tax where applicable  
(\*Apple is a registered trademark)



**ECONOMY TOGGLE  
SWITCHES**  
Unbelievable Value!

Cat.No./Desc.	10-99	100+
S11010 (SPDT)	0.85	0.78
S11020 (DPDT)	0.95	0.88
S11034 (DPDT)	2.95	2.85

Plus 20% Sales Tax where applicable

**HORN SPEAKERS**

Cat.No.	1-9	10+
C12010 5" Plastic 10W Max	5.80	5.60
C12015 5" Metal 10W Max	5.75	5.50
C12012 12V Siren	9.90	9.60

Plus 20% tax where applicable

**ENCLOSED ROTARY  
SWITCHES**

Cat.No. Description	1-9	10+	100+
S13021 1 Pole 12 Position	1.00	.80	.70
S13022 2 Pole 6 Position	1.00	.80	.70
S13023 4 Pole 3 Position	1.00	.80	.70
S13025 3 Pole 4 Position	1.00	.80	.70

Plus 20% Sales Tax where applicable



**CANON TYPE AUDIO  
CONNECTORS**  
We've sold 1000+ because of their great value!

Cat.No. Desc.	1-9	10+
P109603 Pin Line Male	1.50	1.80
P109623 Pin Chassis Male	1.90	1.70
P109643 Pin Line Female	2.50	2.20
P109663 Pin Chassis Female	2.90	2.50

Plus 20% Sales Tax where applicable

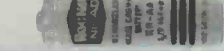

**NICADS**

Cat.No. Description	1-99	100+	250+
S15020 AA 1.2AH	\$1.80	\$1.70	\$1.50
S15021 C1.2AH	\$5.55	\$5.45	\$5.15
S15022 D1.2AH	\$5.75	\$5.50	\$5.25

Plus 20% tax where applicable



**RITRON II MONITORS**  
Swivel base monitor in stylish case.

Desc./Cat.No.	1-9	10+	50+
Green Cat. X14506	\$175	\$165	\$160
Amber Cat. X14508	\$175	\$165	\$160

Plus 20% tax where applicable

**FREE  
58 PAGE  
PRICE LIST!**  
Simply supply a  
Business Card!



**TRANSFORMERS**

Cat.No. & Desc.	1-99	100+	1000+
M12851 2851 240V 12-0V CT 150mA	3.00	2.75	2.50
M12155 2155 240V 6-15V 1A tapped	5.50	4.95	4.50
M12156 2156 240V 6-15V 2A tapped	8.50	8.25	7.90
M12840 2840 240V to 9V C.T. at 150mA	3.20	3.00	2.70
M12860 2860 240V to 15V C.T. at 250mA	3.50	3.00	2.80
M16672 6672 240V 15-30V 1A tapped	8.50	7.95	7.70

Plus 20% tax where applicable

**75 OHM COAX CABLE  
IN 100M ROLLS**

Cat.No. Description	1-4	5+	10+
W11222 3C2V 25.00	24.00	23.00	22.00
W11224 5C2V 30.00	29.00	28.00	27.00

LINE LOSS PER 100 FEET (33M 200MHZ)  
W11222 3C2V 6.2dB (Approx.)  
W11224 5C2V 3.5dB (Approx.)  
Plus 20% tax where applicable

**TELEPHONE CABLE  
(200 METRE ROLLS)**

Cat.No. Description	1-10	10+
W11302 2 Pair	\$34.00	\$28.00
W11303 3 Pair	\$42.00	\$39.00
W11310 10 Pair	\$120.00	\$115.00

Per 200m Roll  
Plus 20% Sales tax where applicable

**WE HAVE THE BEST  
MEMORY  
PRICES!**

"Check for the latest memory prices!"

	10-99	100+	1000+	10K+
4164-15P	\$ 2.00	\$ 1.70	\$ 1.65	\$ 1.50
41256	\$ 4.50	\$ 4.00	\$ 3.60	\$ 3.30
6116P-3	\$ 7.50	\$ 2.90	\$ 2.20	\$ 2.00
2716	\$ 5.00	\$ 7.00	\$ 6.50	\$ 6.00
2532	\$ 7.50	\$ 4.50	\$ 4.00	\$ 3.50
2732	\$ 6.50	\$ 6.50	\$ 6.40	\$ 6.30
27256	\$ 9.00	\$ 8.00	\$ 7.00	\$ 5.50
6264	\$ 5.50	\$ 5.00	\$ 4.50	\$ 4.00
2764	\$ 6.00	\$ 5.00	\$ 4.50	\$ 4.00

Plus 20% tax where applicable

# RITRONICS WHOLESALe Pty. Ltd.

56 Renver Road, CLAYTON, 3168, VICTORIA, AUSTRALIA. Phone (03) 543 2166 (4 lines). Telex AA151938  
N.S.W. DISTRIBUTOR: Bill Edge Electronics Pty. Ltd. 76 Porters Rd, KENTHURST 2156. Phone (02) 654 2046  
Minimum account order is \$50, minimum cash sale is \$25. Minimum post/pack \$3.00 Minimum account post/pack \$5.00. Comet Road Freight, bulky items and/or over 10kg is extra  
Bank Card, Visa and Master Card Welcome!



# HomeWatch

## PROFESSIONAL COMPUTERISED SECURITY KIT



Deluxe kit illustrated.

2 Kits available—Standard or Deluxe. 4 sector Control with switch selection of its many pre-programmed functions. Quality components for reliability. Comprehensive instructions included.

Literature, prices and further information available from:

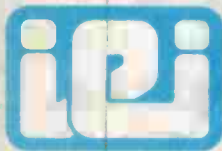

I.E.I. (Aust) Pty. Ltd.

15-17 Normanby Rd, Clayton, Vic, 3149  
Tel (03) 544 8411. Telex AA35780

248 Johnston St, Annandale, NSW, 2038  
Tel (02) 692 0999

31 Phillips St, Thebarton, SA, 5031  
Tel (08) 352 2066

## Portable multifunction instrument

Wavetek, San Diego, has released two data logging multimeters, the models 51 and 52. These units combine the functions of a digital multimeter, data logger/data acquisition system and a process controller. Both units can operate from an internal lead acid battery with a life of over 100 hours.

Both the models have a bit mapped liquid crystal display to show a series of menus. Selection from the menu is done via a row of soft keys on either side of the LCD screen.

The model 52 handles up to four plug-in modules, and can take four independent sets of measurements. Each plug-in can handle up to 60 sensors using an optional multiplex mode, thus enabling a total of 240 sensors to be monitored.

The model 52 has RS232 standard and GPIB optional for remote control and transfer of data. Measurement functions include temperature, volt-

amperes, dB, frequency, period, time interval, pulse width and continuity. The resolution of measurement is six digits, sensitivity is one microvolt, and accuracy is 0.04%.

This model also has an extended logging capability up to 776K of RAM, which corresponds to 97000 data points. The fastest data logging rate is 40 data points per second. The unit also has some special unit modifiers such as, delta, delta per cent, min/max, average, bar graphs and alarms.

The small size of the unit (89 mm (h) x 216 mm (w) x 307 mm (d)) is largely due to the use of custom gate array and surface mount components. Since the unit is software based it features closed box calibration.

For further information contact Scientific Devices, 2 Jacks Rd, South Oakleigh, Vic 3167. (03) 579-3622.

## TransZorb

General Semiconductor has released a series of voltage suppressors called TransZorb. The suppressors are the industry's first transient voltage suppressors available in low-profile surface-mountable packages. The new devices are designed for use in hybrid circuits on ceramic substrates or for direct mounting on printed circuit boards, and can be handled by most pick-and-place machines.

They are characterized by high surge capability, extremely fast response time, low on-state impedance, and can be used for both ac and dc applications, according to General Semi's publicity.

The SMB Series features 600 watts peak pulse power dissipation during a one millisecond pulse, a theoretical response time of  $1 \times 10^{-12}$  second, reverse current leakage of  $5 \mu\text{A}$ , and an operating and storage temperature of  $-65^\circ\text{C}$  to  $+150^\circ\text{C}$ . Available with breakdown voltages

ranging from 5 V to 220 V, these suppressors are particularly effective for protecting integrated circuits, MOS devices, hybrids, and other voltage-sensitive semiconductors and components from transients caused by induced lightning, electrostatic discharge, inductive switching, and nuclear EMP. If the suppressors themselves become overstressed, the failure mode is a short circuit.

These devices are designed specifically for transient suppression applications. Their wide flat leads are designed to provide a large contact area for good heat dissipation and a low resistance path for surge current flow to ground. The result is a low clamping factor (clamping voltage divided by breakdown voltage). The wide flat leads also assure mechanical stability during mounting operations.

For further information contact ESD on (03)338-8033.



## NEW PRODUCTS

Cooper Tools has released a portable 12 volt soldering iron, rated at 30 watts, and suitable for remote soldering.

The Weller SP30 is supplied with non-polar battery clips so there's no concern about positive or negative battery connections. With a long 4.5 metre lead, the SP30 is practical for use at some distance from the battery power source.

A range of four Weller tips are available for the SP30 iron. Each 4 mm wide tips is available in cone, screwdriver, chisel or space types. The Weller MT Series tips also suit the Weller SP250 iron.

Each iron is packaged on a card with hints on soldering, care and maintenance of Weller irons. A copy of the Weller Soldering Guide is also available.

For further information, contact Cooper Tools, PO Box 366, Albury, NSW 2640. (060)21-5511.

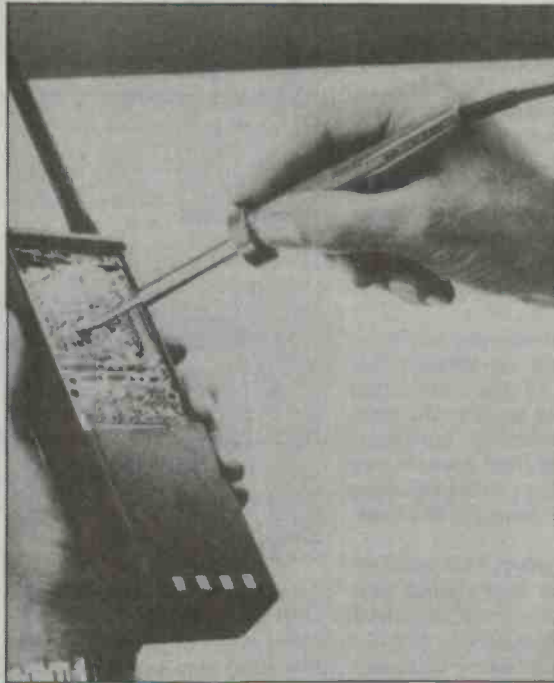

## Ian J. Truscotts ELECTRONIC WORLD

FOR ALL YOUR COMPONENTS! TEST GEAR, DATA BOOKS.

HUGE RANGE OF ACTIVE AND PASSIVE COMPONENTS.

### FLUKE MULTIMETERS

#### AMIDON FERRITE PRODUCTS

#### NEW!

10 mm LED's from \$1.30. Available in RED, GREEN & YELLOW.

CHROME BEZEL suit 5 mm LED \$1.20.

CHROME BEZEL suit 10 mm LED \$1.85.

### SPEECH CHIPS

SP0256-AL2: Speech Synthesiser \$13.95

CTS256-AL2: \$27.95

SET OF EACH ... \$39.50

30 Lacey St.,  
CROYDON, VIC. 3136.  
Ph: 723-3860/3094

Mail Orders Welcome

# WE ASKED THE WORLD WHAT THEY WANTED IN A SUB-RACK SYSTEM

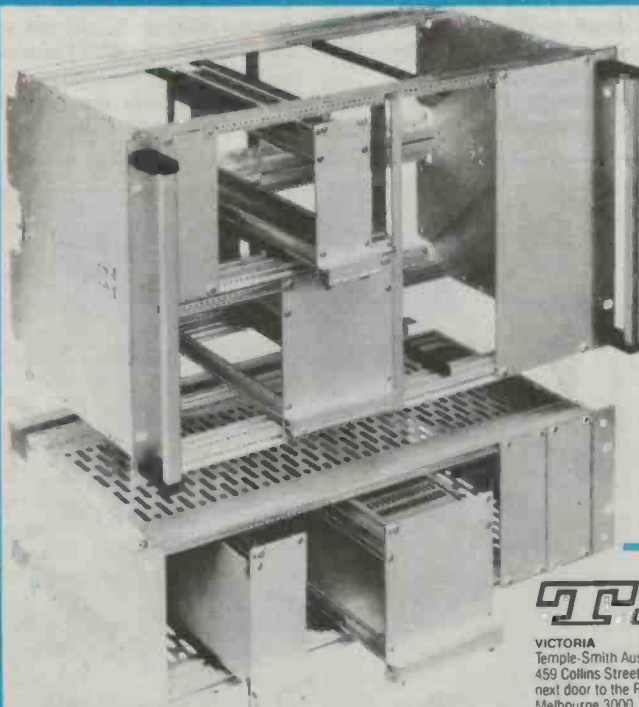

## THEN WE BUILT IT.

The BETACOM UNIRAC has been designed and developed after consultation with users of existing systems throughout the world.

Incorporating the widest range of options, allows the BETACOM UNIRAC sub-racks to be assembled to a customer's individual requirements as well as permit TSA to provide very prompt delivery.

Constructed of semi-sheared plate, cap screws and tapped extrusions give the BETACOM UNIRAC both positive assembly and rigid construction.

Also ask TSA about our custom sub-racks to suit your individual requirements.

## BETACOM UNIRAC

# TSA

TEMPLE-SMITH AUSTRALIA PTY. LTD.

2-12 Harp Street, Campsie. PO Box 196, NSW 2194  
Telephone (02) 78 3436 FAX (02) 7872529

VICTORIA  
Temple-Smith Australia Pty. Ltd.,  
459 Collins Street (moving  
next door to the Rialto in Jan 87)  
Melbourne 3000  
Telephone (03) 62 5971  
FAX: (03) 614 2293

SOUTH AUSTRALIA  
Graphic Electronic Industries  
Pty. Ltd.  
168 Payneham Road,  
Evanale 5069  
Telephone (08) 363 0277

WEST AUSTRALIA  
J. G. Thomas & Associates  
5 Durrham Road  
Bayswater 6053  
Telephone (09) 272 7122

QUEENSLAND  
Conwell Trading Company Pty. Ltd.  
52 Doggett Street  
Fortitude Valley 4006  
Telephone (07) 52 7850

H/TSA/093



## New rf products at GFS

GFS Electronics in Melbourne has released news of a number of new products. An antenna noise bridge, the MFJ202B, has just been imported from the US, and according to GFS, will measure resistance, reactance and impedance into the region of thousands of ohms.

Many noise bridges allow measurements in the tens or, at most, hundreds of ohms, which generally becomes inconvenient particularly when working with wire array type antennae. The 202B has a range expander facility which allows reading up to 3800 ohms.

GFS advises that a comprehensive manual comes with the 202, and demonstrates how to find antenna resonant frequency, determine tuned circuit fre-

quency and so on.

The MFJ1224 is a computer interface designed to make RTTY, CW, ASCII and AMTOR operations easier. It hooks between the receiver and the computer. According to GFS, it is sold with Commodore software, but can be used with almost any type of domestic computer. It sells for \$431.

Finally, there is an active antenna matcher, also from MFJ. It is numbered the 959 and aimed directly at shortwave listeners.

Many listeners are unable to accommodate an antenna that will cover all the bands they want to listen to. It's difficult to find a satisfactory broadband antenna, and local councils kick up a fuss when you start growing an antenna farm in the backyard.

The 959 solves this problem. The claim is that a single random piece of wire of any length will perform at least as well as a dipole over the entire shortwave



Model MFJ-959.



The MFJ-1224.

band. It does this by electrically matching the antenna to 50 ohms at the frequency of operation, and then providing 30 dB

of gain at 50 ohms to the receiver.

The price of the 959 is \$388. Phone GFS on (03)873-3777.

## Fast high voltage switcher

SGS has developed the Fast-switch range of ultra-fast high voltage transistors for switching power supply applications. Fast-switch transistors are produced in four package types including ISOWATT218 which is fully isolated and conforms to the creep-

age distance and isolation requirements of VDE, IEC, and UL specifications. The series of Fastswitch transistors ranges from 1 to 20 amps working current in five voltage bands 700 V, 850 V, 1000 V, 1200 V and 1300 V.

Fastswitch technology has been specifically optimized to produce devices with extremely short switching times with respect to their high voltage and current. They are suited for advanced switching power supply designs where fast switching is of prime importance.

Fastswitch transistors provide an economic solution to high

voltage switching in the frequency range 20 to 75 kHz. High efficiency and very fast switching result in smaller heat-sinks, lower cost and improved reliability for switching power supply designs. There are suitable types in the SGS Fastswitch series for switching power supplies with power output in the range 20 to 1800 watts.

## Programmable bar code readers

Two new bar code readers have been released by Melbourne based Intermec. The readers are known as the 9355 and 9356. The devices are known properly as on-line data collection devices, and can be used to read bar codes and send the information back to a host computer.

Both models are stand alone devices, consisting of a wand and a computer. There is no need for on-line reader and CRT terminal installations. This is a major advantage, especially on the shop floor, where a big VDU quickly becomes so much

of a nuisance that the advantages of the bar code are lost.

Applications envisaged by the company include work in progress tracking, production and inventory, shipping and receiving, time and attendance reporting and tool tracking.

One of the most interesting aspects of the Intermec product is the proprietary Interactive Reader Language (IRL). Using IRL, relatively unsophisticated operators can create quite sophisticated programs. Each reader contains 8K of CMOS RAM, which provides enough space for extensive IRL programs and sufficient data storage for normal functions.





## Magnet wire splicing

One of the problems of splicing magnet wires by brazing is the ever present reject rate caused by flux or heat damage. With a new splice design from Utilux, however, and the use of the Model M/8 splicing machine, splicing magnet wire can be virtually error-free.

The benefits of the device should be particularly felt in mass production methods in the white goods, automotive and electric motor industries.

The new splicer is designed specifically to crimp enamel coated magnet wire to another magnet wire or a combination of solid or stranded lead wires. As the splice is crimped, the magnet wire is automatically stripped of insulation and forced into direct and permanent contact with the brass electro tin, assuring the integrity of the finish.

A number of wires can be terminated within the one splice.

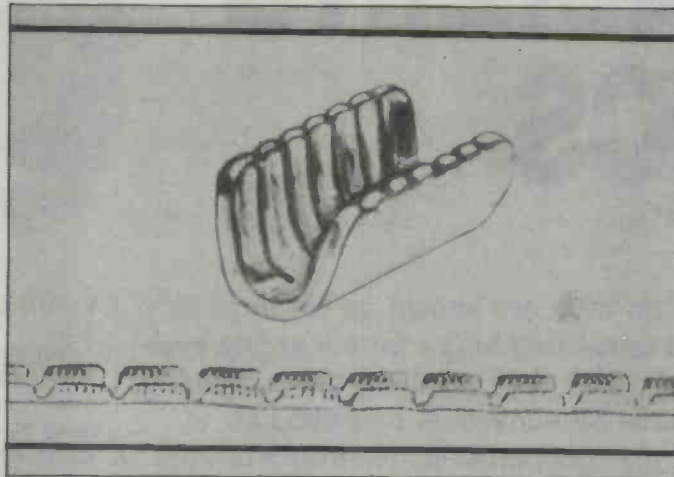

Utilux wire splice.

They can be copper, aluminium, or a combination of both and can be attached to flexible or solid pre-stripped conductors.

According to Utilux engineers, the new machine creates splices that are strong, resistant

to vibration and immune to contaminants such as stripped enamel residue and oxides.

For more information contact Utilux, 14 Commercial Rd, Kingsgrove, NSW 2208. (02)50-0155.

## Phase checker

The SCV PC80 is a French made absolute phase, engineering measuring tool that represents a highly portable, flexible way to measure the phase accuracy of electronic audio systems including microphones, passive or electronically crossed over loudspeakers, power amplifiers, and wiring phase in building and patch bays.

It measures either electronically or acoustically, by generating a one hertz special wideband pulse and receiving it with a built-in microphone or input. LEDs on the front panel indicate in-phase and reverse-phase signals. The transmitter also features an XLR output and level control for measuring wired systems.

Enquiries to AR Audio Engineering, Suite 204, 720 George St, NSW 2000. (02)211-3026.

## USED TEST EQUIPMENT

★  
WE BUY,  
WE SELL  
YOU WIN!

A NEW SERVICE TO THE AUSTRALIAN ELECTRONICS INDUSTRY!

Capricorn Computing Services Pty Ltd, a well established broker of computer equipment, offer for the first time in Australia.

### A TEST EQUIPMENT MATCHING SERVICE

**Selling** — the perfect way to dispose of your surplus equipment and get that extra cash when it's time to upgrade.

**Buying** — the price you pay is substantially lower than the new equipment price. A real alternative to the high cost of Test Equipment purchase and upgrade.

You tell us whether you are a buyer or seller (or both), what equipment you want to sell or purchase and if you have a specific model or your general requirements. We then match you up on our Database records with the equipment that you either want to buy or sell.

**We do all the matching — Buyer to Seller, Seller to Buyer.**

**You win the rewards in dollars saved!!!**

- |                     |                         |
|---------------------|-------------------------|
| ★ CRO'S             | ★ RADIO EQUIPMENT       |
| ★ SIGNAL GENERATORS | ★ DEVELOPMENT EQUIPMENT |
| ★ LOGIC ANALYSERS   | ★ POWER SUPPLIES        |
| ★ DATASCOPIES       |                         |

For further information, contact:

**CAPRICORN COMPUTING SERVICES PTY. LIMITED**

1st Floor, 1 Avon Rd, North Ryde 2113. (02) 888-3544

## PROTEL

AVAILABLE IN WEST AUSTRALIA

Low Cost, Professional Quality, Printed Circuit Board Design. \$890 (plus tax where applicable) per copy, plus \$10 pack and post within Australia.

- For IBM Systems
- 3 Track Widths
- 4 Pad Sizes
- Fast Check Plots
- Component Overlay
- Deliver your Disc, we will Quality Photo Plot Camera-Ready Artwork, and Manufacture your Boards.
- \$25 Demo Discs.

**JEMAL PRODUCTS PTY. LTD.**

**5 Forge Street, Welshpool**

**Tel. 350 5555 (3 lines) Telex 95494**

**Fax 458 6539**



# TANTALIZING TROPICS

Arthur Cushen

Transmissions broadcast on what are known as the tropical bands are an elusive and tantalizing target for the shortwave monitor. The stations from which they originate are something of an exception in shortwave broadcasting, operating in conditions geographically and economically different from the typical broadcaster.

IF YOU HAVE a general coverage shortwave receiver perhaps you have noticed an area along the frequency spectrum where there is little activity save for a few two-way transmissions and a lot of noise.

This part of the spectrum from 2300 kHz to 5060 kHz covers three bands, referred to as the tropical broadcast bands because they are commonly selected for domestic use by countries lying between the Tropics of Cancer and Capricorn.

The International Telecommunications Union (ITU) too assigns the bands to South Africa, Lesotho, Swaziland, Nepal, Pakistan, Afghanistan, Iraq and Iran. There are also occasional broadcasts on these bands from the USSR, Mongolia, People's Republic of China and North Korea.

The attraction of these bands for countries in the tropics is that shortwave broadcasts do not suffer from interference from high atmospheric static levels as do mediumwave broadcasts. On top of this, most of the countries using them are either sparsely populated or not economically able to support a large network of mediumwave stations. Power requirements are much less for shortwave than for mediumwave. In fact, one of the reasons that it is difficult to pick up tropical band broadcasts outside the tropics is that the stations are too low powered, operating at 10 kW or less in many cases.

## Frequencies

The tropical bands comprise the following frequencies: 2300 to 2495 kHz for the 120 metre band; 3200 to 3400 kHz for the 90 metre band; 4750 to 5060 kHz for the 60 metre band.

On the 60 metre band broadcasts from

the ABC which has at least four transmitters operating in the tropical zone can be heard. Broadcasts from Brisbane on 4920 kHz are received particularly well during the hours of darkness; the other broadcasts are from Alice Springs on 4835 kHz, Tennant Creek 4910 kHz and Katherine on 5025 kHz at 2130-0730 UTC.

Other signals heard over this band include those from the Solomon Islands on 5020 kHz in the evening, as well as signals from Indonesia, Malaysia and India. From around 0600 UTC to past 0800 and 1800

to 2000 UTC signals from Africa are evident.

During our winter, signals from Latin America become audible around the time 0400-1200 UTC. Regular signals include those from Sante Fe on 4945 kHz and Radio Reloj on 4832 kHz which both operate 24 hours a day. Lagos Nigeria on 4990 kHz and ELWA with news in English at 0600 UTC on 4760 kHz are also regular. Transmissions from Africa in African languages and broadcasts in French from former French colonies are also heard.

Moving down to the 75 metre band (3900-4000 kHz), which is not, incidentally, regarded as a tropical band, broadcasters include NSB Japan on 3925 and 3945 kHz, Vanuatu on 3900 kHz, and several Indonesian stations. BBC signals on 3955 kHz, Swiss Radio on 3985 kHz and VOA, Munich, on 3980 kHz can be heard during our evenings and mornings. The



Network of The National Broadcasting Commission, PNG.





BBC Singapore transmission on 3915 kHz and the Far East Network, Tokyo, on 3910 kHz can be heard around dawn.

The 90 metre band (3200-3400 kHz) contains almost all the regional stations in Papua New Guinea as well as carrying signals from Indonesia and many countries in Asia. During the evenings HCJB, Quito Ecuador, on 3220 kHz is heard at 0900 UTC, among many other Spanish speaking stations from Central and South America. At 0600 UTC the Liberian station, ELBC, on 3255 kHz has been noted in English. A signal close to Australia from Radio Noumea, New Caledonia, on 3355 kHz is received from 1900 UTC and during the evening.

Like the highest frequency band the lowest band, 120 metres (from 2300 to 2495 kHz) also carries signals from Australia: from Alice Springs on 2310 kHz, Tennant Creek on 2325 kHz and Katherine on 2485 kHz. All close at 1430 UTC. Signals from Africa and Latin America are less frequently heard on this band although a transmission from the Falkland Islands on 2380 kHz is often heard around 1000 UTC when reception is at best for long distance low frequency.

Between these bands there are also many other stations operating on out-of-band frequencies. Their signals originate from Indonesia, China, North Korea and the USSR and in all cases they use the local language.

### Monitoring the tropical band

It is a rare and satisfying contact which comes from the tropical band. Stations are generally low powered, carry transmissions in their own languages, with propagation aspects of the signals varying day to day, but they do not suffer from jamming.

The challenge is to identify these weak stations. The reward is appreciation from the stations — dispensed in the form of verification cards, letters or pennants.

Generally the best time to detect these signals is in the equinox period in March and September around dusk and dawn. A variety of signals from across the Pacific and Indian Oceans can be heard.

Rare stations which listeners should keep alert for include Bhutan on 3395 kHz, 1100-1400 UTC Monday to Saturday; Nepal on 5005 kHz in English at 1445 UTC; Sarawak on 4950 kHz in English at 1500 UTC; and the Cameroons on 4750 kHz in English on Sunday at 0615 UTC.

The 60 and 120 metre bands are easily located in relation to WWV which operates on 2500 and 5000 kHz, so dial calibration on your receiver can be made accurately. If your receiver has digital read-out, accuracy problems in locating these frequencies are overcome. ●

## WIN THIS QUALITY DIGITAL DELAY



### VALUED AT \$425 FROM FREEDMAN ELECTRONICS

Features include:

- 19" rackmount
- 16 kHz bandwidth
- up to 1 second delay time
- hold function
- modulation facilities
- high frequency boost

All you have to do is fill in the coupon, cut it out and send it to:

**ETI/Freedman Electronics  
Competition  
PO Box 227  
Waterloo, NSW 2017**

Entries close 31 November, 1986.

Name .....

Address .....

.....

..... Postcode .....

**UNINTERRUPTIBLE  
POWER SUPPLIES**

Electrical power protection for office and factory automation. Provides a stable output power irrespective of mains line condition such as brown-outs, mains failure, spikes, line noises, voltage dips, frequency variations, etc.

**DENSEI MINI U.P.S.**

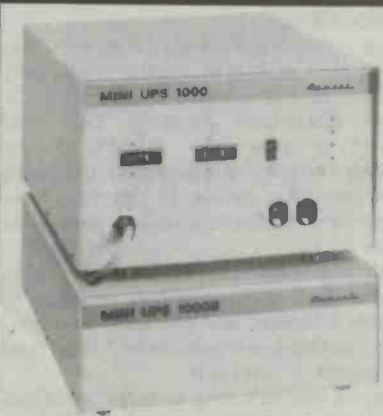

### FEATURES

- ★ Well regulated sine wave output
- ★ Compact space saving design
- ★ Maintenance free sealed batteries
- ★ Handles capacitive loads
- ★ True UPS operation, i.e. no changeover time
- ★ Approved by the Energy Authority
- ★ Available in 500VA, 1KVA, 3KVA
- ★ Application: Small business and personal computers; Data terminals; POS terminals; Communication equipment; Security systems; Medical equipment.

**AMTEX**  
ELECTRONICS

A DIVISION OF  
**TLE ELECTRICAL PTY LIMITED**  
(Incorporated in New South Wales)  
**36 LISBON STREET  
FAIRFIELD, NSW 2165, AUST**  
PHONE: (02) 728 2121, 727 5444  
TELEX: AA27922 ATTN AMTEX  
FACSIMILE: (02) 728 2837



An intrepid dxer's account of a world in the dragon's jaw.

# ON THE AIR IN MACAU

Thomas E. King VK2ATJ

OVER FOUR HUNDRED years ago the Spanish and Portuguese divided the then known world in half agreeing to only colonise their own acquisitions. Portugal's half included China!

As a result, the Portuguese established a trading post at Macau on the south coast of China in 1557, just 60 years after Columbus discovered America. This small enclave is now the world's longest standing territory administered by Portugal or any other nation. In this aspect and many others Macau is a unique part of the world.

Understandably the broadcasting industry in a 15.5 sq km territory which is 95 per cent Chinese, but governed by Portuguese speaking administrators, must also be unusual . . . and it is.

Despite Macau's long history, broadcasting history is relatively short. Radio Vila Verde, considered the territory's first station, only started transmissions in 1952. Funded by private money from Hong Kong and Macau, the appeal to local middle aged Chinese was made by a mix of music and racing information. (Macau is still noted for its liberal policy towards track racing: cars, horses and greyhounds. These played an important part in attracting 4.7 million visitors in 1985.) Apart from this fare the station provided frequent information on gold prices which was of interest to local businessmen as well as (it's commonly believed) smugglers!

Radio Vila Verde's broadcasting hours were short and the transmitter power was low. The broadcasting scene widened in the 1950s with the start of the Emissora Radio de Macau stations which provided dual service in Portuguese and Chinese for between four and six hours a day.

The broadcasting industry has undergone a major transformation since the beginning of this decade. In the six and a half years since 1 January 1980, FM and television services have been progressively introduced to the 450,000 people who live in the culturally blended territory.



Alberto Simao, Chief Engineer (1) and Jose Alberto Sousa, News Director were among those brought in from Portugal to establish a world-class broadcasting system for the territory of Macau.

FM broadcasting commenced in 1981 with stereo transmissions added in 1985. Today there is an AM Chinese service (250 watts on 980 kHz) running 24 hours a day. As well, the Chinese FM stereo service (2.5 kW on 101.7 MHz) is also operated around the clock. The FM stereo service in Portuguese (2.5 kW on 98 MHz

and an AM simulcast with 250 W on 900 kHz) is on the air from 6 am to midnight with entertainment and education oriented programs as well as considerable material shipped in from the Lisbon headquarters of Radio TV Portugal.

In contrast to the importing of Portuguese program material, only locally originated programs are aired on Macau's AM and FM stereo Chinese services. Program content (produced by 15 Chinese speaking radio journalists) is more entertainment oriented with some 'open line' talkback segments.

One of the most interesting aspects of Radio Macau's Chinese service is that there are far more listeners outside the territory than inside. Just 60 km away are the five and a half million people of Hong Kong. Many Hong Kong Chinese listen to selected programs from Macau despite heavy competition from broadcast stations in the British administered territory.

The biggest audience, however, begins at Macau's doorstep with an incalculable number of listeners (estimated in the millions) in Communist China able to receive the more lively broadcasts from the capitalist territory. Guangdong is well covered



The unique cultural blend of Macau is seen as pedicab drivers take tourists past the Lisboa Hotel, the territory's most sophisticated casino.





Despite the latest in equipment and program expertise the Portuguese service of Radio Macau has a very limited audience because of the language used in a basically Chinese speaking community.

by radio waves from its tiny neighbour yet programming is not specifically directed to the people in this, the most affluent province of China.

Although the FM signal of Radio Macau has an intended radius of some 80 km and it's 180 km to Canton, requests for record dedications frequently come from the provincial capital. (The AM signal coverage is even smaller yet reception reports for the 250 watt Portuguese and Chinese transmitters have come from Tibet, Japan and even Australia.)

Because of the attractiveness of the Chinese language AM and FM stations, Chinese advertisements began to be aired in 1985. The major advertisers to date have been supermarkets and hotels in Zuhai, a thriving business and tourist town just past the Macau/Chinese border post.

The Chinese ads have provided a good source of revenue to Radio TV Macau which by charter must be a self supporting operation. In part the Communist ads have helped support the capitalist Portuguese FM service which, understandably, has limited appeal because of the unfamiliar European language. (The Chinese Radio services in Macau do, however, try to help bridge the gap by providing language lessons in Portuguese, English and the official language of China, Mandarin.)

Portuguese is given a higher profile on the territory's sole television station. TDM, Teledifusao Macau, was created by the Government of Macau in cooperation with Radio TV Portugal on 1 January 1983. Its UHF channel 30 transmitter is on the air daily from 6 pm to midnight with extended hours on Saturday nights. As well, an educational TV service timed to the school session is also regularly televised.

While some programs are imported from Portugal and Brazil (another Portuguese speaking country) there is the locally produced "VIVA Musical", news broadcasts in several languages and the all important coverage of the Instant Lottery. A few English language movies are also shown that have been subtitled.

Because of the European fondness for sports, sports programming is an important part of the television day. During the recent World Cup the Macanese were given an extraordinarily good coverage through extensive use of the satellite for live and tape delayed TV and radio broadcasts.

Despite the professional efforts of TDM, many of the territory's TV antennae are pointed towards Hong Kong where four TV channels are available. Hours of transmission are longer in Hong Kong and two stations use the Cantonese language for much of their daily broadcast periods.

This may change, at least temporarily, later this year when the Miss World Beauty Contest is shown in Macau. The size of the local TV market will fall into obscurity, however, as estimated 700 million TV viewers in 50 countries watch the pageant.

Macau will be even more directly involved this year because the territory has been chosen as the venue for the swimwear competition. A taped 20 minute segment on Macau will be included in the live transmission via satellite from London. World viewers will get an excellent bird's eye view of unique Macau and its many attractions. For many, however, it will also be the first time they have an opportunity to see this little bit of Europe in Asia. ●

# "WHICH RADIO DO I NEED?"

...THE ANSWER IS  
IN THE PALM  
OF YOUR HAND

Whatever task you have to do the ICOM IC-40 is the one that can handle it.

It's ideally suited for farming, transport, sports, bushwalking & boating.

Whatever the communication problem you need to solve this is the radio that's being

proven every day in a million different uses.

Contact your local dealer for a demonstration of the most advanced CRS portable available in Australia.

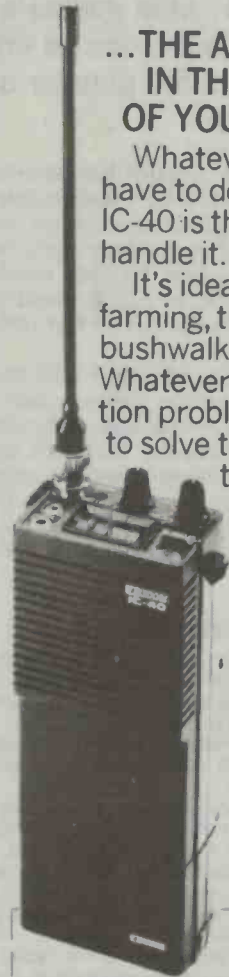

Please post to:

ICOM AUSTRALIA PTY. LTD.  
7 DUKE STREET WINDSOR 3182.  
VICTORIA.

Name \_\_\_\_\_

Address \_\_\_\_\_

City \_\_\_\_\_ Postcode \_\_\_\_\_

or phone ICOM on (03) 51 2284



The World System

IC0014



# A GOOD TRACK RECORDER . . .

For the user, what makes a good multitrack recorder has as much to do with price as ergonomics and specs. Here we review four of the popular units, as various in price as in performance.

WHEN PHILIPS' research laboratories at Eindhoven developed the compact cassette and the matching recorders in the early 50s, I doubt that researchers could have possibly foreseen how far that development would succeed or how it would supplant the conventional reel-to-reel recorder.

From an initial miserly 3 kHz bandwidth, the potential has grown so that 15, 20 or 25 kHz bandwidth easily falls within the scope of the cassette recorder's capabilities. Dynamic range (limited primarily by tape hiss), has inexorably grown from initially 40-45 dB to beyond 80 dB assisted by Dolby A, B, C and HX, and even more from dbx.

## How we tested them

It was interesting to note that for each recorder, the manufacturers recommended TDK SA-X type II recording tape, (with a 70 microsecond equalisation). For uniformity of testing and comparison conditions, I performed the objective testing on all machines with the same sample of TDK tape.

The various steps involved in the testing program included a record-to-replay frequency response on track 1 at four levels of +6, 0, -10 and -20 VU. The tape output level was set so that 0 VU corresponded to 100 millivolts. I also determined the record-to-replay frequency responses on tracks 2, 3 and 4 at 0 at -10 VU levels. These additional record-to-replay frequency responses were evaluated to identify potential differences between record/replay characteristics of each individual channel.

The next series of tests was to determine the record-to-replay frequency response for channel 1 with the input level at -20 VU and with the tone controls set at maximum and minimum boost and cut, as well as at the central indent position. The purpose of this test was to display the characteristics of the tone controls in terms of their full range impact on a recorded signal.

The next series of tests involved recording a swept sine wave signal on track 1, thence from track 1 to track 4 and finally replaying the same signal as a synchronized signal on the level recording.

This specific level recording displays two traces, the first (the upper of which) shows the

Advances such as these have come with improvements in recording tape, electronics and fundamental engineering including the rapid strides in micro-electronics and specialised integrated circuitry. And not all the moves have been in Japan. Some of the most notable developments, although not widely heralded, have continued to be produced by the Philips' Eindhoven laboratories.

The reel-to-reel recorder remains the mainstay in the commercial and professional recording industry. However, it exhibits far too many practical limitations for most amateur and many semi-professional applications. The obvious problems are cost, size and weight. But the most telling

characteristics of track 1, whilst the lower level recording displays the modification effects of recording from track 1 to track 4 as an overall transfer frequency response characteristic. The final set of level recordings separately show the third octave band signal-to-noise ratio achievable together with the weighted D, A, B, C noise threshold levels, both with and without the noise reduction system.

The speed accuracy of each of the recorders was determined with a TDK frequency reference tape, with the frequency controls set at their central indent positions. The maximum positive and negative range of speed adjustment was similarly determined. The wow together with the weighted and unweighted flutter were determined at three different points on the tape and averaged overall.

One of the most important parameters that the user would require is the distortion characteristics. They are obviously modified by multiple recording as the distortion characteristics increase with each subsequent 'ping pong' recording. I determined these at 0 VU and -6 VU signals for our standard frequencies of 100 Hz, 1 kHz and 6.3 kHz. The maximum input level at which the 3% third harmonic distortion at 333 Hz occurs was then determined. The dynamic range of the tape was determined with and without noise reduction (for Dolby B or dbx) relative to the 3% thd figure, using the data provided by the background noise level recordings. The erasure ratio was also determined relative to the 333 Hz signal recorded at 0 VU.

limitations, however, continue to be the messy problems of loading and unloading tape reels.

About eight years ago, the Japanese home recording market produced a new generation of four track compact cassette recorders specifically aimed at the amateur musician and it is four of these we review here.

The units under review are:

Fostex X-15 Series II Multitracker;  
Tascam Porta One Mini-studio;  
Vesta Fire MR-10 Personal  
Multi-track Recorder;  
Yamaha MT-1X Multi-tracker  
Cassette Recorder.

Each of these units exhibits differences in appearance, layout, features and size. As I subsequently discovered, they also have major ergonomic differences which affect their convenience when recording, dubbing and in general use.

## Objective results

The measured frequency response performance of the Fostex X-15 Series II Multitracker highlighted the need to stay well clear of peak signal levels above

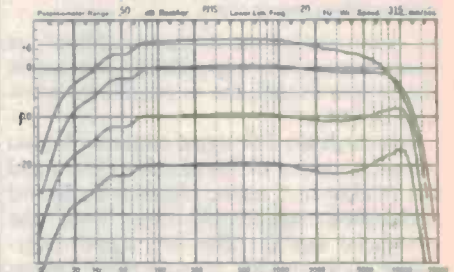

Figure 1. Fostex X-15. Record-to-replay frequency response at +6, 0, -10 and -20 VU line in.

0 VU when using this recorder (see Figure 1). At 0 VU the frequency response is  $\pm 1$  dB from 70 Hz to 8 kHz and is -3 dB at 36 Hz and 10 kHz. At -10 VU, the recorder displays a slight droop in the frequency response between 1 kHz and 5 kHz and a matching rise in the response from 5 kHz to 11 kHz. In practical terms, the frequency response adequately covers

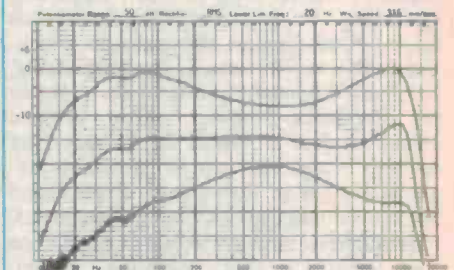
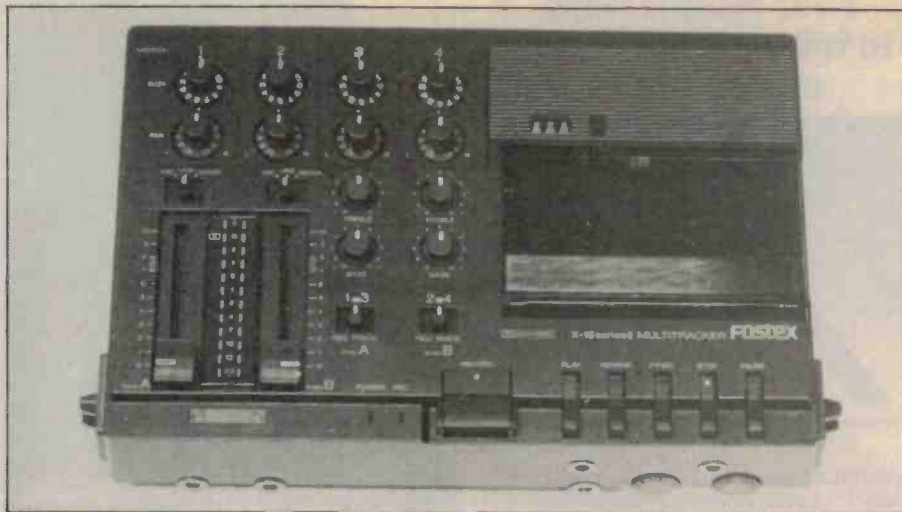

Figure 2. Fostex X-15. Record-to-replay frequency response with tone controls at max, mid and min.

the range from 35 kHz to 12 kHz. The frequency response characteristics of tracks 2, 3 and 4 are essentially the same as track 1 although track 3 exhibits a somewhat higher output (+5 dB at 10 kHz) than the other three channels,



The Fostex X-15. At top, four pairs of gain and pan controls. At left, next to the sliders, a pair of LED VU meters. All the knobs are colour coded. On the lower face of the unit are sockets for MIC IN on Ch A and Ch B, headphones, and PUNCH IN and OUT (remote). Out of sight to the left are RCA sockets for tape output. The cassette is covered by a red plastic lid.



which only typically exhibit a 2.5-3 dB rise in the response.

The range of boost and cut provided by the tone controls is  $\pm 10$  dB at both 100 Hz and 10 kHz (see Figure 2). The midband frequency deviation (rise or droop) with both controls set at MAXimum or MINimum is typically 6 dB which is a little more than I would want from a music recorder. When recording from track 1 to track 4 and back to track 1, the step in the frequency response, which is observable at 60 Hz, is effectively doubled so that the 2.5 dB step becomes a 5 dB step. Similarly, the high frequency response beyond 10 kHz drops much more sharply.

The dynamic range of the Fostex X-15 is only 66 dB A-weighted and 58 dB unweighted. This means that background hiss is audible and somewhat higher than most amateur musicians would want.

The wow and flutter figures are particularly good and amongst the best recorded. The distortion figures at 0 VU are also particularly good and at -6 VU are extremely good.

The speed accuracy was relatively poor with the unit running 5% high. The overall speed range provided was  $\pm 17.8\%$ .

#### Tascam Porta One

The Tascam Porta One provides very smooth frequency responses at all levels

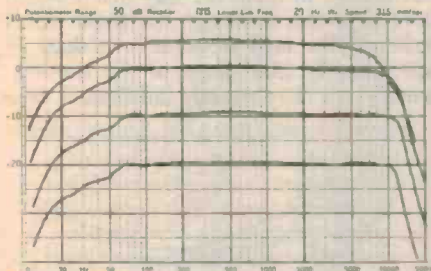

Figure 3. Tascam Porta One. Record-to-replay frequency response at +6, 0, -10 and -20 VU line in without dbx.

and on all four tracks (see Figure 3). At +6 VU there is obvious saturation at high frequencies but by the time the signal drops to 0 VU the response is only -1.5 dB at 10 kHz and -3 dB at 11.5 kHz. At -10 and -20 VU, the response is extremely smooth all the way from 60 Hz to 11 kHz being typically within  $\pm 0.5$  dB with dbx out. The change to dbx IN (see Figure 4) results in a noticeable increase in the non-linearity of the frequency response which gets bumpier,

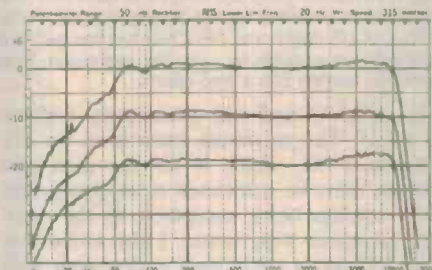

Figure 4. Tascam Porta One. Record-to-replay frequency response in line at 0, -20, -40 VU with dbx in.

although still generally good over the frequency range 50 Hz to 10 kHz.

It is evident from our measurements that dbx does have a potent dynamic effect on the record-to-replay signal process, which most listeners detect as a subtle change in the audible replay characteristics. The frequency response linearity for record-to-replay from track 1 to track 4 with Dolby out is exceptionally smooth. Significant non-linearities in record-to-replay only really start to show up when the dbx system is selected.

The boost and cut responses provided by the tone controls are particularly smooth and the extent of midband drift, when both high or low frequency boost or cut are simultaneously selected, is particularly well controlled, with the degree of offset amounting to only a 2 dB. The distortion characteristics of the unit are acceptable but not outstanding at 0 VU; fortunately they are much better at -6 VU. The high frequency distortion does exhibit a significant rise compared with the low and mid frequency ranges. The 3% third harmonic distortion of 333 Hz occurs at a +3 VU signal level.

The dynamic range with dbx out and in, is relatively good at 55 dB A-weighted and 74 dB A-weighted, respectively. The erasure ratio of 69.2 dB falls well short of the accepted norm, which I think should exceed 75 dB.

The measured wow figure was 0.1% peak-to-peak which is quite acceptable, and the weighted flutter figure of 0.06% is

also quite acceptable. The speed accuracy was 1.25% low with the range of speed settings being  $\pm 17\%$ .

#### Vesta Fire MR-10

The measured frequency response of the Vesta Fire MR-10 displays a particularly smooth response at -6 VU, although more than 1 dB of compression is evident at that recording level. The frequency response at 0 VU is particularly good and is within  $\pm 3$  dB from 50 Hz to 11 kHz. At lower recording levels, the selected bias and equalisation conditions result in a significant high frequency boost, which typically amounts to 3 dB or more over the frequency range 5 kHz to 10 kHz. The response on tracks 2, 3 and 4 is basically similar, rising to as much as 5 dB in the 5-10 kHz range. The result of recording from track 1 into track 4 is to produce a very substantial boost in high frequency response amounting to a peak in excess of 6 dB between 6 kHz and 10 kHz.

When the dbx noise reduction system is activated, we discerned a dramatic rise in the high frequency response between 2 kHz and 12 kHz (see Figure 5). The

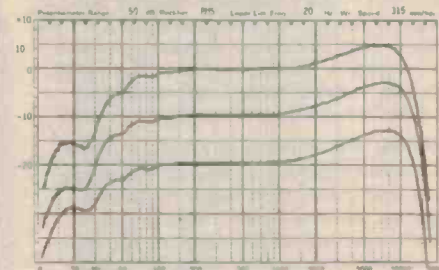

Figure 5. Vesta Fire MR-10. Record-to-replay frequency response at 0, -20 and -40 VU line in with dbx in.

peak level occurs in the 5-10 kHz range amounting to a 7 dB rise in the output signal's response.

The tone controls, when set to peak boost or cut, provide a useful 10 dB of boost and cut at 100 Hz and 10 kHz with a modest midband offset which is only  $\pm 2$  dB.

The distortion characteristics of the recorder are on the border of unacceptabil-



## Four Simple Ways to Improve the Sound of Your Music



Monster Cable's Interlink Reference A and Interlink Special  
Featuring "Bandwidth Balanced"™ Technology

### Interlink Reference A *Our Finest Cable Design lets you Re-discover your Favorite Music.*

Interlink Reference A is recognized worldwide as the best sounding interconnect available. Winner of International Audio Review's "Engineering Achievement Award" and flagship of the Interlink Series, Interlink Reference A sets a new standard for audio cable performance. The finest example of our "Bandwidth Balanced"™ design features 3 wire networks to provide ultra-wide bandwidth and absolute phase coherency over the entire audio spectrum. Audiophiles agree. The sonic improvements are worth every penny.

Standard Coaxial Construction



"Bandwidth Balanced" Construction  
Two "Balanced" Center Conductors  
Mid Frequencies  
Bass  
High Frequencies

### Interlink Special *High Technology Puts Big Performance into a Small Package.*

Based on the same "Bandwidth Balanced" technology incorporated in Interlink Reference A, Interlink Special is smaller and more flexible. Extended frequency extremes, superb transients, incredible instrument clarity, and an outstanding 3-dimensional image, make Interlink Special second only to one.

### Interlink 4

*A Price/Performance Breakthrough...*

Now Monster Cable's "Bandwidth Balanced" technology is yours in a very affordable, compact package. Using dual inner conductors, each with 2 wire networks, Interlink 4 delivers sound quality that other "audiophile cables" can't match at any price. We invite comparison with the competition.

### Interlink CD *Fulfilling the Promise of Digital*

Conventional cables run out of breath when trying to cope with today's digital sound. The detailed resolution, awesome dynamic range, and powerful bottom end available from digital are lost when you use ordinary interconnect cables. Interlink CD controls high frequency phase shifts to produce a richer musical sound while minimizing the harshness found in some CD program material. Connect yours with Interlink CD.

**interlink**

Write for a free brochure.

Convoy International Pty. Ltd.  
400 Botany Road,  
Alexandria. 2015  
Tel: (02) 698 7300

**MONSTER CABLE**®



The Tascam. The only true portable in our survey, with a ten C cell battery compartment. At top, four VU meters, with PAN, EQ HIGH and LOW and TRIM knobs in rows underneath. Level controls are in the form of sliders at bottom. Headphone volume is just to the right at top centre. Below is a monitor REMIX/CUE switch and RECORD function switch. Below these again is the master volume slider. At the top right are switches for light, dbx and power. Below these are the TAPE CUE and PITCH. Notice that the tape counter has a zero return.

ity at 0 VU and still moderately high at -6 VU. The maximum input level for 3% thd is 0 VU, which is far too high and which must be attributed to inappropriate VU settings being acceptable in the quality assurance department. I also noted that the VU meter calibration is very poor with the meters indicating -15 VU for a -10 VU input signal. The dynamic range with dbx OUT and IN, respectively, was a reasonable 52 dB (A) and 74.5 dB.

The erasure ratio, 81 dB, is the sort of performance that cassette recorders should be capable of providing. The wow figure is acceptable at 0.1% peak-to-peak, whilst the weighted flutter figure is 0.08%, which is moderately high. The speed accuracy is high at 2.5% and the range of adjustment is -23 to +21%.

### Yamaha MT-1X

The Yamaha MT-1X multitrack cassette recorder exhibits a significant level of saturation and droop at +6 VU and a slightly skew frequency response at 0 VU and lower. This characteristic does not significantly detract from its performance.

At -10 and -20 VU, the record-to-replay response is substantially broader than any of the other three recorders and is a little nearer to the normal requirement of 40 Hz to 16 kHz that most users would be seeking. The frequency responses on tracks 2 and 4 are generally comparable with the measured results on track 1, although track 3 exhibits a 2-3 dB boost in the 30-100 Hz region. When recording from track 1 to track 4, the extent of the frequency response rise in the 70 Hz to 300 Hz region becomes much more pronounced and, as I noted, a trifle irregular. By contrast, the high frequency droop in the 6-12 kHz region amounted to 2 dB. With the dbx noise reduction system activated, the frequency response seemed to become substantially smoother and generally better than that provided by the other three recorders (see Figure 6). Over

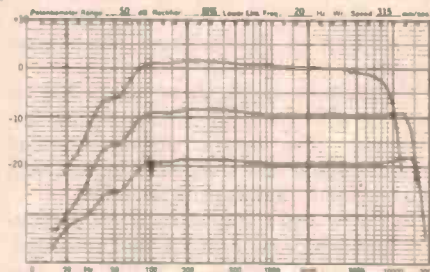

Figure 6. Yamaha MT-1X. Record-to-replay frequency response at 0, -20 and -40 VU line in with dbx in.

the frequency range 80 Hz to 13 kHz the frequency response is within 1 dB, but at both higher and lower frequencies the droop is quite pronounced.

When simultaneous boost or cut are applied to both sets of tone controls, they do not behave in quite the way that I would have expected. Although the boost works well and the high frequency cut does its job properly, the shape of the low frequency cut is obviously ineffectual (see

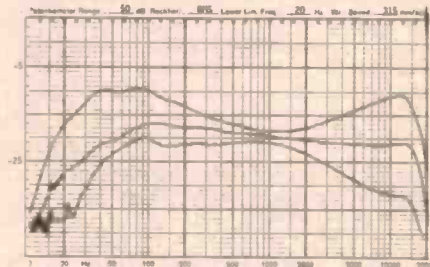

Figure 7. Yamaha MT-1X. Record-to-replay frequency response with tone controls at max, mid and min.

Figure 7). The measured distortion figures at 0 VU are quite good, as are the comparable figures at -6 VU. The maximum input level for 3% thd at 333 Hz is +5 VU which is exactly where it ought to be to correspond with the LED display on the front panel.

With dbx out, the noise figure is domi-



**STOP PRESS!**  
**Video  
RoomMate  
available  
now**

**Roommate**  
POWERED SPEAKER SYSTEM

# **CLOSE FIELD MONITORING**

**B**ring your personal electronics to life! Bose Corporation designed the RoomMate system to produce true high-fidelity sound from virtually any portable studio, personal stereo, or electric musical instrument. You see, there's more to the RoomMate system than meets the eye. Inside, it's packed with advanced electronic components. The result? A sophisticated system that works with ordinary audio sources to produce exceptionally good sound.

**Produces excellent sound quality.**

**Room filling sound.** Bose built a sophisticated amplification system into the powered speaker so that the RoomMate system can turn small sound into something a lot bigger.

**True high-fidelity sound with clear highs and strong, deep bass.** The RoomMate system has much of the same audio technology that made the Bose 901<sup>®</sup> speaker system an audio legend, such as helical voice coil drivers and active equalization. Specially-designed dual-tuned ports give the RoomMate system exceptionally deep, smooth bass.

**Balanced sound.** The built-in electronics balance the sound between both speakers, giving you true stereo when played with stereo sound sources and enhanced high fidelity when operating with mono sources.

**More signal and less noise.** The RoomMate system's on-board electronic amplifier and equalizer have been engineered for low distortion and reduced hiss.

**Fits almost anywhere — and complements any decor.**

**An audio studio system that requires very little space. The**

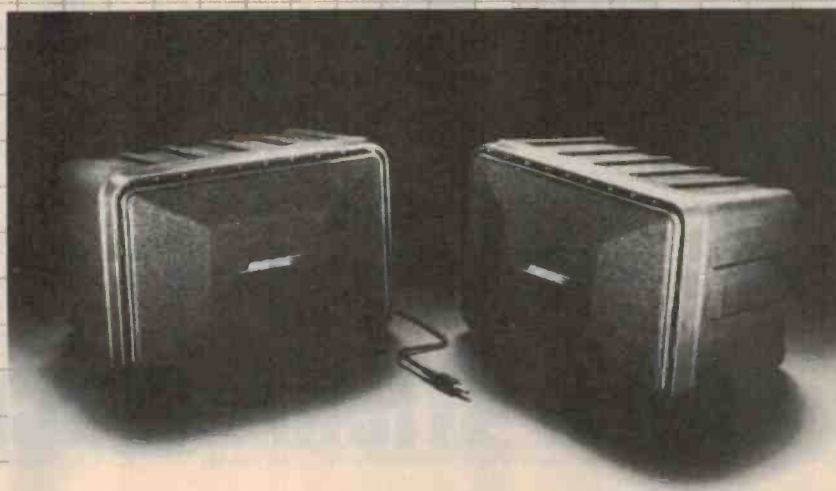

The Bose RoomMate system — high-fidelity powered speaker system in a very small package.

**RoomMate system fits almost anywhere,** because each cabinet measures only 6" x 9" x 6". When used with a portable studio, personal stereo or portable CD player, the RoomMate system becomes an ultracompact, complete audio system.

**Sophisticated, tasteful design.** The RoomMate system is available in black cabinets with matching grilles. The result is a piece of high technology that looks good in any setting.

**The RoomMate system is rugged and easy to use.**

**A quick plug brings better sound.** The RoomMate system is equipped with an audio input plug that will fit most portable studios or personal stereos. To operate the RoomMate system, all you do is plug it into your audio source's headphone or earphone jack.

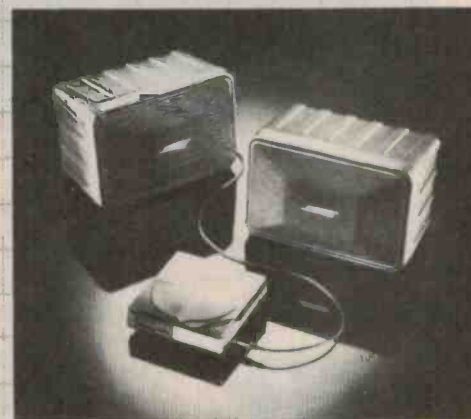

The RoomMate system combines with portable studios or personal stereos to become a compact full audio system.

**BOSE**  
BOSE AUSTRALIA Inc.  
11 Muriel Ave, Rydalmere  
Phone: 684-1255



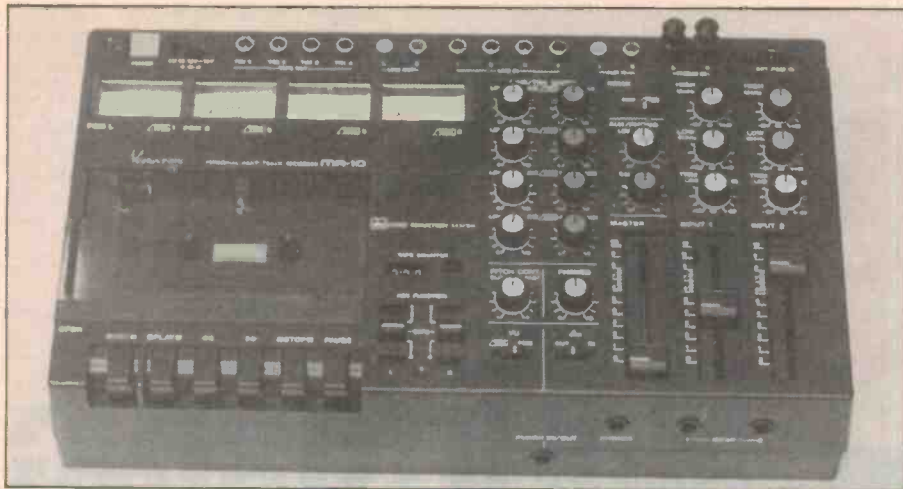

The Vesta Fire MR-10. In the centre of the unit is a rack of PAN and TRACK controls for all channels. To the right are level sliders and knobs for EQ and TRIM associated with each channel. In the centre is the master level slider. Notice that all the input and output sockets face upward at the back of the unit. The cassette well is covered by clear plastic.

nated by a 100 Hz hum component with a significant 50 Hz also being apparent. Notwithstanding, the noise figure is still excellent at 57.5 dB(A). With the dbx system activated, the noise figure is dramatically improved and the dynamic range achieves the remarkable figure of 91 dB(A) (although the 50 Hz and 100 Hz components are still quite pronounced in the one-third octave band analysis).

The erasure ratio is 73 dB, which almost conforms to my standard for this class of recording. The speed accuracy is -0.9% which is reasonably good, whilst the range of speed adjustment provided is -15.1 to +12.7%.

I was reasonably impressed by the objective test results provided by the Yamaha MT-1X. It is generally a credit to its designers.

#### How it felt

When it came to evaluating the subjective performance of each of these recorders, I was assisted by one of my associates, who is a skilled and experienced musician with extensive experience using portable multi-track recorders of the type under review. We proceeded to evaluate each of the recorders in turn, conducting similar recordings with similar instruments and multi-recording procedures.

#### Fostex X-15

The Fostex provided an interesting starting point and quickly displayed features both good and bad. The features that we did not like were the lack of a zero stop on the tape counter; the lack of a master fader; that the unit only plays back input signals in the recording mode so that you cannot rehearse overdubs; and the lack of adjustable gain control between mic and line inputs in order to provide coarse settings for some direct input instruments.

Significant difficulties were experienced as a result of this lack of appropriate latitude of adjustment between microphone and line levels. In practical use, when attempting to record an electronic drum unit we were forced to make the connection of the coaxial cables at the line input RCA socket, which proved to be a nuisance. When attempting to record an electronic guitar directly, we soon found that there was too much level on the mic input and this resulted in audible breakup on the A channel when recording at a level of "2".

## MIDI & 4TRACK SPECIALISTS



- Midi keyboards
- Midi peripherals
- Multi track
- Computer music making
- Music software
- Stockists of all major brands

- Friendly service
- Hands on demonstrations
- All major credit cards accepted
- Mail order — we send anywhere
- Over 50 years experience



**PARRAMATTA**  
11 Phillip Street  
Parramatta, NSW 2150  
☎ (02) 635-9563

**BLACKTOWN**  
Shop 5, 77 Main Street  
Blacktown, NSW 2148  
☎ (02) 622-2417



Mention this advert in your enquiry and receive a 10% discount. Offer expires November 1.



**Yamaha MT 10.** The artiest of the four recorders, the labelling is difficult to read and the tape is covered by an opaque door. From the left, each channel is laid out vertically. Top left is a slider for HIGH EQ, below it is LOW EQ. Next to the HIGH EQ is an LED VU meter, and below this is the AUX input control. Below this again is a rotary PAN control. At bottom is the level slider, with a mic/line PAN control and MIC/TAPE switch above. This pattern is repeated across the fascia four times. In the centre is the phone level on a rotary switch with the master below it. Pan and level monitor controls for each channel are on the rotary pots at top right.

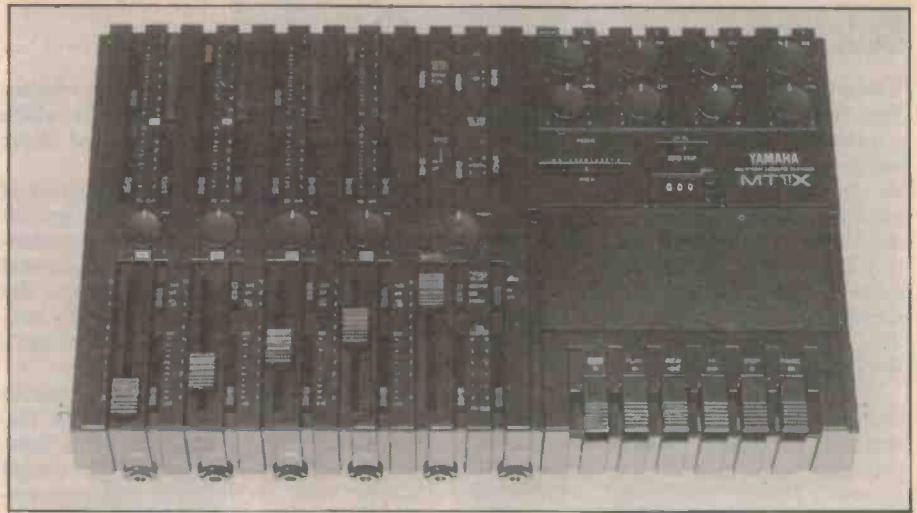

Conversely, with the guitar unit feeding into a line input, there was insufficient level and the quality suffered accordingly. The bass guitar could be recorded through a microphone input which confirmed that individual pieces of equipment have to have matched output signal levels conforming to the widely different characteristics of the line and mic input amplifiers.

In the 'ping pong' mode, we also experienced difficulty in mixing the three tracks using the monitor gain controls; these needed to be near the tops of their range in order to obtain sufficient signal to feed onto track 4. The 'ping pong' mix and the remix must unfortunately be done using the rotary line controls, instead of faders (which the Yamaha and the Tascam permit). The use of faders allows for a much more subtle mix than does the use of rotary pots.

There seemed to be much more audible tape noise as a result of 'ping pong' recording on this recorder than that produced by the other recorders. The Dolby B noise reduction system thus proved to be a real and practical limitation in terms of the achievable signal-to-noise ratio.

The most endearing feature was that the controls were easy to follow and the colour coded functional switches were easy to use.

As the Fostex X-15 Series II multitrack recorder is almost half the price of the most expensive recorder, any direct comparison really has to take this factor into account.

### Tascam Porta One

The Tascam Porta One Mini-studio is the most expensive of the four recorders and correspondingly has many attractive features.

In practical use, the provision of four faders, four VU meters and good colour coding of the functional controls were attractive. Added bonuses were 'zero stop' on the tape counter plus positive tape transport controls. The smoothness of the rotary controls, especially when adjustments were required during recording, also gained high marks for this recorder, and the connections and functional controls all proved to be above average. In terms of general convenience and usability this recorder is undoubtedly the best of the four reviewed.

MODEL	FOSTEX X-15	TASCAM PORTA ONE	VESTA 'FIRE' M-R-10	YAMAHA MT10
PARAMETER				
Price (RRP)	\$695	\$1,099	\$799	\$995
Dimensions (mm)	290 x 195 x 75	330 x 250 x 70	336 x 205 x 64	365 x 225 x 65
Weight (kg)	2.1	3.5	2	2.5
Battery Operation	NO	(internal battery compartment)	NO	NO
External Power Supply	supplied	optional extra	supplied	supplied
Basic Frequency Response @ -10VU ±3dB	35Hz - 12kHz	50Hz - 12.5kHz	40Hz - 13 kHz	35Hz - 15.5kHz
With Noise Reduction @ -10VU	40Hz - 12kHz	50Hz - 11kHz	40Hz - 15kHz	65Hz - 14kHz
Track 1 to Track 4	64Hz - 11.5kHz +4 -3dB	50Hz - 10.5kHz ±3dB	65Hz - 15kHz +7 -3dB	50Hz - 13kHz +3 -3dB
Signal to Noise dB(A) Straight	55dB	55dB	52dB	57.5dB
With Noise Reduction dB(A)	66dB	74dB	74.5dB	91dB
WOW % P to Peak	0.1	0.1	0.1	0.1
Weighted Flutter % RMS	0.04	0.06	0.08	0.08
Erasur Ratio dB	69.8	69.2	81.1	73.0
Distortion % 0VU 100-1k-6.3kHz	0.97 0.45 0.31	1.32 1.35 1.69	2.45 3.16 0.81	0.57 0.58 0.84
-10VU 100-1k-6.3kHz	0.20 0.12 0.15	0.47 0.68 0.90	0.72 1.71 0.54	0.32 0.21 0.53
Speed Accuracy %	+5.0	-1.25	+2.5	0.88
Ergonomic Design Features	* *	* * * *	* *	* * *
Electronic Performance	* *	* * * *	* * * *	* * * *

*It must be noted that the prices quoted are only recommended retail and are subject to much fluctuation. So sound out distributors and check any ads you come across.*

In the subjective assessment, the recordings of electronic drums sounded a trifle distorted at the bass end of spectrum, although the treble response was quite good. When 'ping pong' recording was conducted using tracks 1, 2 and 3 onto 4,

there was quite a perceptible 'wow' and 'tremolo' in the bass guitar sound which rather surprisingly was not evident when playing back the original on track 2. Overall, the Tascam Porta One Mini-studio performed reasonably well.



## SOUND REVIEW

### Vesta Fire MR-10

The Vesta Fire MR-10 recorder exhibited a number of good features during the subjective assessment. Having all the sockets on the top rear of the control panel is a good feature, and the multiplicity of low impedance, phono inputs and supplementary DIN socket work extremely well. The colour coding of knobs made it relatively simple to find the correct knob to adjust. The dbx noise reduction system also worked reasonably well.

The features we did not like were the lack of a zero stop on the tape counter, and that the control switches for record, play and pause proved to be rather cumbersome. During 'ping pong' recording or remixing the controls are easy to set but

you can only mix separate tracks by means of the rotary line level controls which proved to be rather tricky as noted above for the Fostex.

One disturbing feature was the extent of audible 'glitches' produced on the recording when the tape pause button is activated. When recording electronic drums and cymbals the quality of the recording did not prove to be particularly good. By contrast there was no noticeable loss of quality during the 'ping pong' recordings.

The overall impression of this recorder is that it displays a number of good features which are in part offset by its functional limitations. As this is the second cheapest unit, its features and performance must be assessed on that basis.

### Yamaha MT-1X

The Yamaha MT-1X recorder proved to be a generally well designed unit with ergonomic features that were matched by good electronic and functional performance.

The 'design feature' that we did not like was the use of one-colour silk screen printing in small letters on the panel which complicated the circuit and function identification. Yamaha would do well to address this problem, a very simple task. Also as mentioned the cassette cover is opaque, preventing the user from being able to see whether the tape is about to run out!

The zero stop on the tap counter was a good feature and the provision of a first class instruction manual in many languages was impressive.

There was no noticeable loss of quality when recording from separate tracks to the 'ping pong' tracks and the LED peak meter and MIC LINE controls positioned next to the faders also proved to be excellent features. The provision of AUXiliary and SEND/RETURN controls to add effects during mix down also proved handy. The position and performance of the pitch control was also sensibly conceived and convenient to use.

During the subjective appraisal some cross-talk was evident from the drums on channel 1 to channel 2 although not when channel 2 was replayed. The meter select switch has to be set in the stereo position to test levels then returned to the four track mode to record. This proved to be a trifle messy.

The electronic drums did not record as well as we expected and there was some discernible distortion of cymbal sounds which would have to be recorded at a lower level if a clean signal is to be produced. The quality of electronic guitar recordings exhibits some loss of treble response and during 'ping pong' recordings we found it essential to use the MONITOR LEVEL CONTROLS although faders would have been much more convenient or better.

Taken overall the Yamaha recorder offers acceptable performance matched by good ergonomic design features which could further be improved by appropriate colour coding and printing.

The electronic performance and price combine to make this recorder the pick of the bunch. ●

## Dust & Waterproof

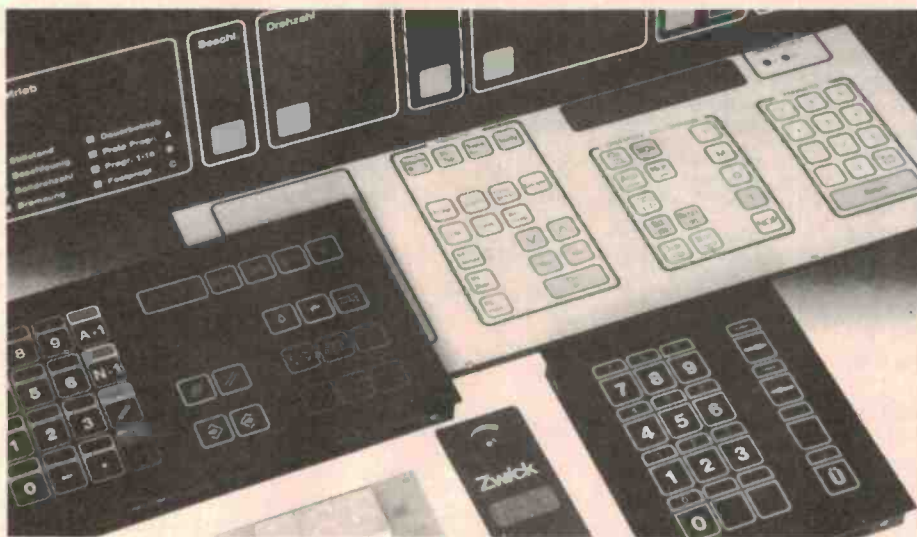

### Series RF15/RF19 Flat Panel Switches ...

Provide environmental protection, with a front overlay which seals off the mechanical key systems.

The switches have a very light finger-touch, but have a positive tactile feedback to the operator. The switch only travels approximately 0.5mm, yet there is a clear sense of operation.

Circuit pins use 15mm or 19mm grid references, enabling combined 7 segment displays and LED lighted panels.

Keys are available individually.



**E.S. RUBIN**  
ELECTRICAL

Head Office: 73-77 Whiting St. Artarmon NSW 2064.  
Phone 439 2333 Telex 121175 Fax 439 2278  
Vic. 138-140 Berkeley St. Carlton 3053. Phone 347 6588 Telex 30948  
SA: 49 Woodville Rd. Woodville 5011. Phone 268 1111 Telex 82529  
WA: 7 Rosslyn St. West Leederville 6007. Phone 382 2619 Telex 94623

Please send me information on Series RF15/RF19 Flat Panel Switches

Name \_\_\_\_\_  
Company \_\_\_\_\_  
Address \_\_\_\_\_  
Position \_\_\_\_\_

Send to: E.S. Rubin Pty Ltd  
P.O. BOX 92 Artarmon  
N.S.W. 2064



# A CAREER IN ELECTRONICS

At this time of the year thousands of young men and women are faced with deciding what they will do when they leave school. One of the options is electronics. In these pages we examine some of the issues: where to study, how to get a job, the different types of work you can do.

## A CAREER IN ELECTRONICS

It's difficult to write about careers in the electronics industry in Australia, if only because the number of different types of jobs available is now so vast that there are paths to suit almost anyone. The good news is that whatever the level of skill, the demand for the electronically trained far outweighs the supply. While that gives the politicians and the captains of industry grey hairs, it means increased salaries and improved conditions for people with appropriate skills. Anyone doubting this should take a cursory glance through a newspaper employment section. The jobs are everywhere.

One way to cut through the maze is to look at the different types of company one can join, and therefore on the job one can hold in that company. The electronics industry can be divided up into a number of different types of employer. Government departments, like OTC, Telecom, Aussat and Defence are in a group of their own with other government bodies and local councils. Then there are large private manufacturing companies. With the exception of AWA these are all foreign-owned and controlled. Of these, Philips, STC, IBM and Plessey are among the most important. Another group is the foreign-owned, non-manufacturer. Hewlett-Packard or Texas Instruments might be representative. Still another group is the small to medium sized locally owned operation. Typically, these have a staff between, say, 20 and several hundred. Famous names include Microbee or Labtam. Finally, there are the small companies, with less than 20 employees.

Telecommunications is the biggest employer in the industry, and government instrumentalities control most of the systems. These organizations offer a bigger range of career options than any other, and certainly a great variety of equipment, from the latest to the antedeluvian.

However, early on in a communica-

tions career you will be asked to specialise in one or other part of the business, and it becomes progressively harder to break out. For instance, Telecom trainees are asked to nominate which branch they want to enter in the second year of training, so the advantages of scale are a little illusory.

The type of work Telecom offers is a reflection of its charter: either designing large systems, building them or maintaining them. Numerically, most work is in maintenance, which explains Telecom's inexhaustible need for technicians.

A quite different sort of government department is the Defence Department. A career in the defence forces has idiosyncracies that derive from service traditions as much as from the nature of the work. For instance, you sign contracts that limit your freedom to leave the job at will, and you forgo many of the rights ordinary citizens take for granted.

On the other hand, the military offers, even in peace time, a job of unparalleled diversity, excitement and challenge. The people in the trade mention the diversity of the job as its biggest single advantage. In the words of one officer, "One year I was babysitting missile systems, the next running a dockyard maintenance depot and now I'm engaged in training".

The big trouble with the military is that it's a young man's game. In most organizations careers really start to take off in the early to middle 30s. In the military, this is the time most men are forced out. There is a requirement for officers beyond that age, but only for a very small number, and then not in technical fields.

The big advantage of working for the government is the same as it has always been: security of tenure, a strong union to look after your interests and not much pressure to work to deadlines.

Cynics would argue that the same

benefits apply to working in the big companies. These too, offer large bureaucracies, plenty of security and strong unions. In the nature of the case, however, the work is different, because it is always concerned with what is new.

Generally, the bread and butter work of actually putting the bits and pieces together is done by unskilled labour. The requirement for technicians comes in at the problem solving level, and for engineers at a design level. The amount of the latter depends on company policy. Some companies have established enviable reputations as designers of the highest order. In many, however, the role of the engineer is simply to implement the manufacturing process of an overseas designed product. This can be a surprisingly complex operation, but it often involves skills other than the purely electronic.

The group of non-manufacturing overseas companies offers employment of a totally different type. Their work is almost all related to their customer base, either in sales which really means tailoring systems for a customer's specific needs, or in maintenance. They almost always offer employees the opportunity to work on the very latest of products.

Probably the biggest challenges for the engineering graduate are in the largish local companies. This is where ground breaking research and development is going on in Australia. However, jobs in this field are few and far between and competition for them is fierce.

The little companies, at the bottom of the ladder in terms of economic importance, are numerically the biggest employer in the country, although not of technical staff. Generally, the owner also supplies all the needed engineering expertise. There will be space for a couple of technicians, maybe, but most of the employees will be unskilled.

They are most important, perhaps, because when you decide that working for someone else is a mug's game, this is where you wind up — trying to turn a small company into a bigger one.



# EDUCATION

Education for electronics can be achieved by a number of different paths. At the top of the tree of institutions: universities and institutes of technology. Below them: colleges of advanced education and finally colleges of technical and further education. This neat three tiered system is all government run, and qualifications are generally transportable across the country. Also available are private schools offering a wide variety of courses that vary from the exceptional to the downright fraudulent.

There are a number of different types of university courses. The mainstay, of course, is electrical engineering, which is a global course aiming to teach you how to make yourself proficient in any of the electrical arts, whether it be microelectronics or power reticulation. Usually students do a core of subjects during the first year, and then progressively more elective subjects in later years. It's not all open slather, however. Most universities constrain the mix of subjects so as to achieve a sufficiently broad education.

Some universities offer more selective courses. Communications is a favourite, or electronics. Many universities also offer courses in computers or computer systems, which can entail both hardware and software design. Newcastle University offers a Bachelor of Engineering (B. Eng.) in computers. The University of Tasmania offers a B. Eng. called Computer Systems. The Royal Melbourne Institute offers one called Digital Systems and Computer Engineering. These are usually less comprehensive than electrical engineering, but if you really know what you want to do, they have a great deal to recommend them.

Not all university courses are the same. Some schools have reputations in specific areas, depending on the interests of their staff; others have more general reputations as 'theoretical' or 'practical'. In Sydney, for instance, the Institute of Technology is considered practical while Sydney University considers itself theoretical. In Melbourne these roles are taken by RMIT and Melbourne University. On the other hand, if you want to study computer graphics you might like to try Newcastle University. Microelectronics is very strong at the University of New South Wales.

Whether or not any of this makes much difference to the education you get or your employability at the end is difficult to say. Employers will have their own prejudices, especially if they have been through a university somewhere. On the other hand, any univer-

NSW Dept of TAFE  
NSW Board of Adult Education  
(for evening courses in hobby  
electronics or computers)  
SA Education Department  
SA TAFE  
NT Education Department  
Vic Education Department  
Vic Technical Education  
Vic TAFE  
Old TAFE  
Qld Board of Adult Education  
WA Technical Education  
WA TAFE Information  
Tas Education Department  
Tas Board of Adult Education

323 Castlereagh St, Sydney, NSW 2000. (02) 212-4400.  
14/189 Kent St, Sydney, NSW 2000. (02) 237-6500.  
31 Flinders St, Adelaide, SA 5000. (08) 229-9911.  
31 Flinders St, Adelaide, SA 5000. (08) 227-4204.  
69 Smith St, Darwin, NT 5790. (089) 80-4211.  
2 Treasury Pl, Melbourne, Vic 3000. (03) 651-9111.  
Nauru House, 80 Collins St, Melbourne, Vic 3000. (03) 651-0000.  
42 Cardigan St, Carlton, Vic 3653. (03) 347-7611.  
Education Department Head Office. (07) 224-7966.  
157 Norris Rd, Bracken Ridge, Qld 4017. (07) 261-3133.  
151 Royal St, Perth, WA 6000. (09) 322-4434.  
184 St George Terrace, Perth, WA 6000. (09) 332-4434.  
116 Bathurst St, Hobart, Tas 7000. (002) 30-8022.  
Domain House, Aberdeen St, Giebe, Tas 7000. (09) 30-8022.

## DEPARTMENTAL ADDRESSES

sity course anywhere should, at an absolute minimum, teach you how to think for yourself, so perhaps the differences can be over emphasized, especially when you have a couple of years experience in the real world.

What's university like? First year is something of an ordeal, not only because the university itself is new, but because the subjects are often tedious in the extreme. Lecturers take the view that since high schools are unreliable, the university should re-teach the school syllabus. Old engineers around Australia flinch at the memory of hours spent in the back of Math 101, regurgitating year 12 subject matter and gaining experience in the aerodynamic properties of paper. The exams, however, tend to keep people on their toes, and indeed, can become a trap for the over confident. Most universities have now recognized the salutary effects of continuous assessment during the year in keeping students away from sedition, sex, drugs, rock and roll or any of the other pastimes that used to make university life attractive.

From second year, when you start getting into the nitty gritty of electronics, life becomes a lot more attractive, if ever more stressful. Most lecturers operate on the assumption that their subject is the only one you need spend any time on. The only consolation is that it is worth it in the end.

Colleges or institutes of advanced education offer diplomas in electrical engineering. In Queensland you can do the same thing at Townsville TAFE. These are short versions of the university courses, usually lasting two years full time or four years part time. In the nature of the case they can't cover the same ground, but they do offer a viable alternative for the person in a hurry.

The least difficult courses, (and some of the most useful) are offered by the various Departments of Technical and Further Education. They offer courses at a number of different levels: post certificate, certificate, trade or general interest. The glamour courses are the

certificates. You can do courses in Electrical Engineering, Electronic Engineering (which used to be known as Electronics and Communications), Data Processing, Computer Service Technology or Power Generation. Completion entitles one to associate membership of the Institute of Radio and Electronic Engineers. For really specialist knowledge there are a range of post certificate courses, usually one year long, that demand one of these certificates as a prerequisite.

One problem with the certificate course is that students come out of it thinking they know more than they do. Electronic employment specialists warn prospective graduates against looking for jobs as design engineers. Fully qualified professional engineers have problems landing these jobs. Certificate holders aren't even in the race.

For people interested in trade level study there is a whole swag of courses at pre-apprenticeship, trade or post trade level. These are designed to supplement on the job training, and in some circumstances lead to reduced apprenticeship times.

Of course, government bodies aren't the only ones who offer education. Private schools do so as well, and are definitely worth a second look if you are looking for anything less than a full university degree.

The Control Data Institute is fairly typical of private schools. Students study any of three courses in computer maintenance, programming or operations. Another school is the Australian School of Electronics, which offers two six month courses in 'Applied Electronic Fundamentals' or in 'Applied Microprocessor Fundamentals'. Rather more esoteric is the Australian Maritime College down in Launceston, which aims to fit young people up for a job in electronics at sea.

Since the reputation of the school stands or falls by the jobs its students get at the end of the course, the school orients its course strongly towards market requirements. In fact, one of the quickest ways to sort the wheat from



the chaff with any educational establishment is to approach prospective employers and ask them what courses they recommend.

Private schools face an inherent problem. The service they offer is available free, so why should anyone want to pay for their versions? The answer has to be that the school provides a better use of your time; so the cost of tuition plus salary forgone over a short period, is less than the cost of just salary foregone over a longer period.

Whether this is so or not depends on a number of imponderables that can really only be solved by each individual. It depends on the cost of the course, the time saving, the likely salary and so on.

Course costs are not cheap, generally in the order of several thousand dollars, but school owners do try to make them as time efficient as possible. This is unlike the technical colleges, which frequently appear to mark time for months on end.

It really comes down to attitude. Private schools, like universities expect students to work; in fact, to work extremely hard. Twelve hour days are not unusual by the time you sit in class and do homework. Technical colleges, on the other hand, are more like high schools in their attitudes to things. Teachers explain everything, and the class moves at the speed of the slowest.

Private schools would probably also make claims about the quality of the education they dispense. For instance, the Australian School of Electronics claims never to have more than 14 students in a class. Furthermore, instruction is in fully equipped workstations, unlike technical colleges, which are always short of space, teachers and equipment.

If none of this appeals to you, a further option is the correspondence course. It has the advantage of being something to do in your spare time. However, electronics is a difficult thing to study by mail, so courses are few and far between and generally involve a few weeks per year of practical demonstrations. Gippsland IAE offers an external Electrical Engineering Degree, the only one in the country. Other institutions, like Capricornia and Darling Downs as well as Gippsland IAE offer diplomas on the same basis. Murdoch University has a Graduate Diploma in Computing Studies.

In a new departure, New South Wales, Victorian and Queensland Departments of TAFE are also getting onto the correspondence bandwagon, offering electrical and electronic engineering by post. Also, some parts of electrical trades courses can be done on this basis.

## SURVIVING YOUR EDUCATION

Fascinating though you may find electronics, it doesn't put food in your stomach, a roof over your head or clothes on your back. At school these problems are taken care of; most readers will have an obliging Mummy and Daddy prepared to shoulder the burden. Come school leaving though, it's often time to fly the nest; Dad objects to someone making his razor blunt. Mum wants her lipstick for herself.

So you need money. The backstop is the government Tertiary Education Assistance Allowance, TEAS, pronounced 'tease' because it teases you with a suggestion of money. As we went to press it was valued at \$73.28 (cf: the dole at \$88.20 for an 18 year old). To add insult to injury, if you are, or could be, dependent on your parents TEAS reduces to \$47.50.

There are two ways to deal with the situation. Either pull your head in, study like a dog and spend nothing, or do a bit of part time work so you can live, if not like a civilised human being, then at least like a facsimile of one. Waitressing and taxi driving are the two internationally time honoured last resorts for students. They are both useful because when study gets you down, and you're wondering if it is all worth while, you can always consider a future that consists of nothing but restaurants or taxis. It soon gets you going again.

However, doing any form of engineering at almost any level puts you at a slight advantage with respect to other students. There are many different schemes available to support students through their studies.

For university students, there is little doubt that the best employer of all is the armed forces. Any of the armed services will take in young school leavers and put them through the Australian Defence Force Academy in Canberra, a college of the University of New South Wales. Academic entrance requirements are the same as for UNSW, although you have to go before a selection panel to ensure you are 'officer material'.

There is a catch, of course, and that is the study for service rule, which states that if the army trains you for a year, you must give them a year's service, plus one. So, to get a four year engineering degree, you sign up for 4+4+1=9 years.

Other opportunities exist for study support. Telecom offers a 'few' (read one or two), cadetships every year. Under this scheme, Telecom will pay you a wage to study full time. Generally, though, this option is available only to existing employees. The ABC also occasionally works on this basis, although at the moment there are no

ABC cadets.

Telecom's support for university students can be more subtle. Employees are entitled to up to five hours of study leave a week. This option, combined with flexitime and so on, can contrive to allow a day or more of attendance at university, plus a couple of night time lectures. This is enough to do more than a part time course (but slightly less than full time), and generally takes about five years. People who have been on this treadmill for a couple of years are clearly in prime positions for cadetships when they come up.

Cadetship schemes from private industry are few and far between, but some of the bigger companies may occasionally get involved. Generally, their support is limited to scholarships, often for post graduate students.

At a technician level, life can be a lot more comfortable than for university students. Most of the government instrumentalities have a huge demand for technicians and technical officers, and have training courses set up at TAFEs. Telecom trainee technical officers, for instance, comprise the biggest single group of students in electronics engineering at most TAFEs.

Telecom sends its trainees to school for six months, then to work for six months, on what is known as a sandwich course. Doing this, it takes four years to get a certificate. The ABC sends students to school full time. When they have obtained the certificate (after two and a half years) students are required to attend in-house modules totalling a further 25 weeks in which special TV training is given. After six years of this the trainee emerges as a broadcasting engineering officer.

The armed services will also train sub-professional staff on full pay. The navy and army both offer apprentice level entry only. The air force has a special entry for technical officer level candidates.

Recruiting into the navy at sub-professional levels is done via three separate entry mechanisms. Normal apprentice training consists of two years at HMAS Nirimba in Sydney, and then two years at sea. General entry training takes longer, but instruction is less intense. The navy also recruits people who already have trades for direct tradesman entry. In all cases full board and lodging is supplied during training, as well as standard rates of pay.

In addition, the navy offers on-going training as part of normal promotional procedure. This ensures a supply of people able to carry out technical officer type functions.



## SURVIVING THE INTERVIEW

So, education finished, you gird up your loins and step forward bravely into the fray. Onward to the university of hard knocks. Pssst! Wanna job, mate?

It can be an ordeal. Witness one young graduate who was wheeled in to see the selection committee of half a dozen of the firm's most senior men. As they shook hands the most senior of them said: "My, girlie, you've got sweaty palms. What are you nervous about?"

Fortunately, it's not always done like that. The function of an employment interview is to acquire an asset for the firm, not put you on the line. Still, however it's handled, it's still a nerve-racking experience. The problem is not helped by the fact that many job seekers have little or no idea what is expected of them, or how their suitability for the job will be judged.

What do they want? ETI went out to seek the men and woman who actually sit across the desk from the nervous job seeker.

Sell yourself. That's the word from both professional head hunters and employment managers who deal with this problem all the time. It matters not how good or bad your qualifications, the aim of the exercise will always be to convince the person on the other side of the desk that the company will benefit from your presence.

The process starts with the letter, either in response to an ad, or at your own instigation. Whether you get an invitation to attend an interview or not will depend on the impression it creates. Make it good. If English is not your forte, get someone to write it who can construct competent English sentences. However, remember the idea is not to write an essay. If the job is worth having, the employment officer will probably have a stack of letters to wade through. So keep it short, but make what you write telling.

A good idea is to use a number of sheets of paper. On one, compose a letter: I saw your ad; it sounds like the most fascinating thing since Shockley; I'd love to come and see you. On the next sheet write out your curriculum vitae, the facts of your life. This should include all your work experience and your educational qualifications. On a third sheet include as many personal details as an employer needs to know:

age, sex, nationality, hobbies and interests and so on.

Never submit something handwritten. Use a typewriter or printer. Remember the message is not only in what you say but in how you say it. A printer output says: "I'm interested in electronics, I run a PC, hire me". A high quality electric typewriter says: "I want your job so bad I went to the trouble of getting a good typing job done". A hand written note with coffee stains over the back says: "Frankly, sport, I don't give a damn". Who would you hire?

The letter, of course, is only the first hurdle. Next is the interview. It's possible to do a fair bit if preparation beforehand if you know what the person behind the desk is looking for. First off, in all probability, will be enthusiasm. No one ever lost a job interview by appearing keen. So take in a project you've built up and be prepared to discuss it. Show that you know something about the company, or at least about the industry it's in. Ask questions about your duties.

The second thing to watch is your dress. Never try for any job that's worth more than \$15,000 without a

shirt, tie and polished shoes. Of course, it pays to be sensible. If you are going for a technician's job, don't front up in a suit. On the other hand, don't be casual. Nobody ever lost a job by dressing conservatively.

Third thing: there are some stock questions almost all employers will fire at you: Why do you want this job? What do you want to be doing in five years? In 20 years? What are you really good at? Bad at? What can you contribute to the job? Be able to answer them.

Finally, the advice is to be aware that the interview is a two-way street. The company needs a body to make them money. You need a job. It's the basis of a good relationship. Be confident, be positive and ask questions. Above all don't just sit there and let the employer do all the talking. Believe in yourself.

### TYPICAL SALARIES 1986

Qualification	Years Experience	Salary Range \$000s
Certificate	0	19
Certificate	2	22
University	5	27
	0	22
	6	33
Project Engineer		40-50
Senior Project Engineer		100

### TERTIARY EDUCATION INSTITUTIONS

The 27 institutions at which professional degrees in electronics, communications or computing studies are offered in Australia:

Ballarat College of Advanced Education	(053) 30-1800
Bendigo College of Advanced Education	(054) 40-3222
Canberra College of Advanced Education	(062) 52-2225
Capricornia Institute of Advanced Education	(079) 36-1177
Chisholm Institute of Technology	(03) 573-2000
Darling Downs Institute of Advanced Education	(076) 20-4211
Footscray Institute of Technology	(03) 688-4200
Gippsland Institute of Advanced Education	(051) 22-0287
James Cook University	(077) 81-4745
Monash University	(03) 690-7977
Nepean College of Advanced Education	(047) 36-0222
Newcastle University	(049) 68-0401
New South Wales Institute of Technology	(02) 2-0930
Queensland Institute of Technology	(07) 223-2111
Queensland University	(07) 377-1111
Royal Melbourne Institute of Technology	(03) 662-0611
South Australia Institute of Technology	(08) 223-5114
Swinburne Institute of Technology	(03) 819-7977
Townsville College of TAFE	(077) 72-1400
University of Adelaide	(08) 228-5333
University of Melbourne	(03) 690-7977
University of New South Wales	(02) 697-2222
University of Sydney	(02) 692-2222
University of Tasmania	(002) 23-0561
University of Wollongong	(042) 27-0555
Western Australian Institute of Technology	(09) 350-7700



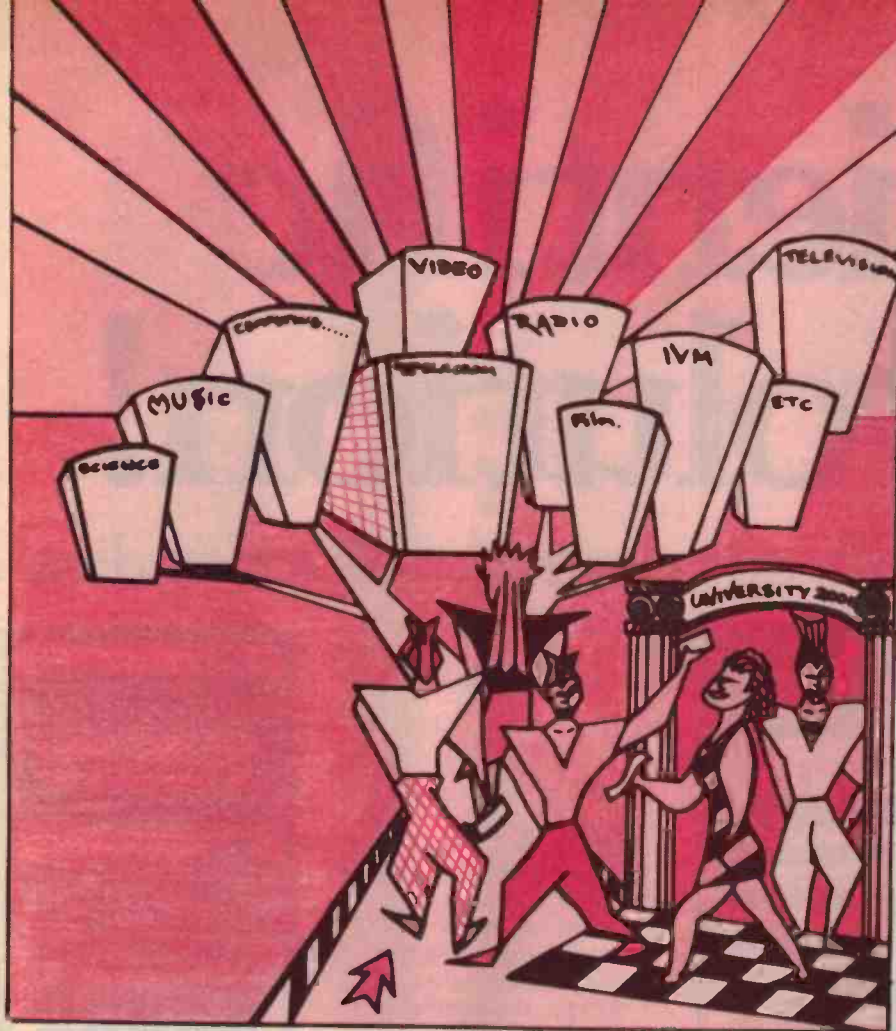

## A CAREER FOR GIRLS

A career in electronics is not only for men. An increasing number of women are realising that job opportunities in the traditional, untrained female fields are decreasing and the traditional, trained fields, such as secretarial, are less than satisfactory. They are moving into fields like electronics, where the money is better, and job prospects good.

At Sydney University, 9% of the first year electrical engineering students are female. Female enrolments in certificate courses at technical colleges are not as high — only 3% in electrical and electronic engineering in NSW in 1985. At the ABC, four out of 80 broadcast engineering trainees are women.

University staff blame the low numbers of girls in electrical engineering on the fact that they do not have the necessary levels of HSC mathematics and physics.

The armed forces is a major trainer of electronics engineers and technicians, although women are restricted to non-combat roles. Women entering the navy have the same career prospects as

men, with the exception that all their experience will be obtained on shore, or on training ships, not on warships. There are currently 15 women at the Navy's apprentice training school.

In most private and government organizations women entering electronics careers will have the same opportunities as men. There are two pieces of government legislation to enforce this equality of opportunity — the *NSW Anti-discrimination Act, 1977* and the *Commonwealth Sex Discrimination Act, 1984*. Both of these outlaw discrimination on the basis of sex, and provide avenues of appeal for those who think they have been victims of discrimination.

Large organizations are keen to be seen as 'equal opportunity employers' and girls applying for jobs or traineeships in electronics are likely to be greeted enthusiastically. Employers and educators are quick to point out that the low number of women training in electronics is not due to discrimination but to the small number of girls who apply for the jobs.

— Wendy Chapman

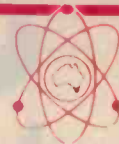

Disco World Pty. Ltd.

### Showrooms:

300 Main Street, Lilydale  
P.O. Box 509, Lilydale, 3140  
Melb. Vic. (03) 735-0588  
673 High Street, Preston  
(03) 470 5822

### AMPLIFIERS

ZPE Series II (600W) \$2500

### DISCO MIXERS

Citronic SM 350 \$997

Arista with equaliser \$380

**JUMBO STROBE** \$195

Scanner \$150

### HELICOPTER

2 ARM Spinner \$300

4 ARM Spinner \$498

6 ARM Spinner \$580



### PINSPOT

Par 36 \$59

Par 56 \$130



### MIRROR BALLS

MB 008-8" \$52

MB 012 \$85

MB 014 \$115

MB 018 \$160

MB 020 \$198

### SMOKE MACHINES

Great for Special Effects

Hand Held 240V \$360

**Dynamite 1200 Smoke Machine**

Has remote control lead to operate off-stage. We are so excited about this that full money back guarantee will be valid for 10 days from purchase date

Our own product \$1800

Fluid—1 litre \$15

### MIRROR BALL MOTORS

AC 240V \$39

Heavy Duty \$99

### ROLLING LIGHTS

8 x 4515 lamps \$1800

### AUDIO CHASER

(DW4LC4000) \$700

Musicolor and chaser all in one!

Our own product



### COSMO

24 lamps \$2600

Half Ball rotary light

6 lamps \$780

**LAMPS all colours, so cheap!**

**No Warranty on Breakages**

ES 240V 60W box of 25 \$100

BC 240V 40W box of 100 \$90

BC 240V 25W box of 100 \$85

Prices subject to change without notice. Items for hire or sale.

Power Cords not included. Send

S.A.E. with 60 cents postage for

free price list.

We have Plezo tweeters, Etone speakers,

Rope lights and many other products.

**Do You Want To Be An Agent?**



# Scientific Revolution!

Four new technically advanced models for students.

## FX100A

- 51 functions
- 10 digit mantissa
- 2 digit exponent
- True algebraic logic
- Fraction calculations
- 6 levels of parenthesis
- Standard deviation
- Permutations and combinations
- Percentage and random number
- Auto power off
- 8500 hours on penlight batteries

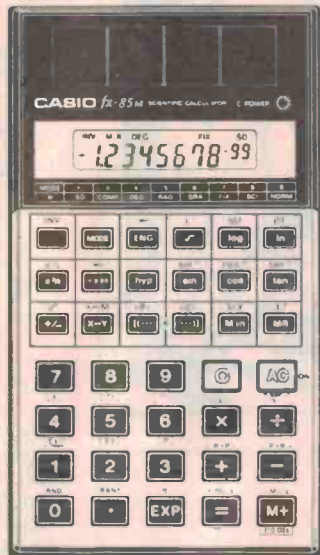
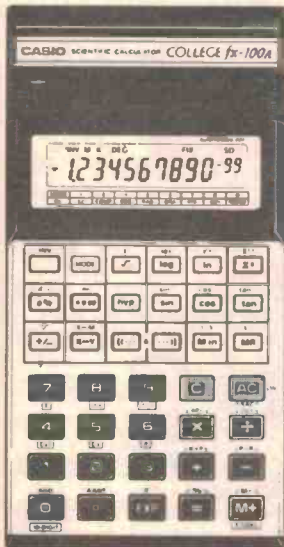

## FX85M

- 53 functions
- 8 digit mantissa
- 2 digit exponent
- Revolutionary new solar cell which recharges battery – works in any light and retains memory
- True algebraic logic
- Fraction calculations
- Permutations and combinations
- Standard deviation
- Percentage and random number
- 6 levels of parenthesis
- Indefinite battery life

## FX82A

- 38 functions
- 6 digit mantissa
- 2 digit exponent
- True algebraic logic
- Standard deviation
- 6 levels of parenthesis
- Auto power off
- 5500 hours on penlight batteries

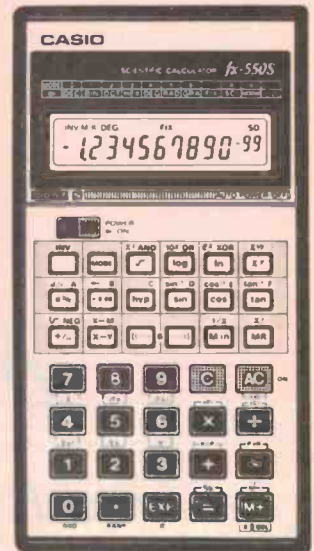
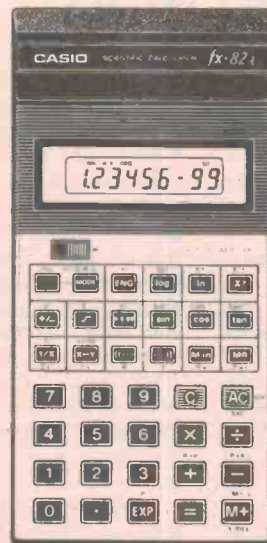

## FX550S

- 67 functions
- 10 digit mantissa
- 2 digit exponent
- True algebraic logic
- Fraction calculations
- Standard deviation
- Permutations and combinations
- 6 levels of parenthesis
- Binary/octal/hexadecimal operations
- 1800 hours on silver oxide battery



DISTRIBUTED AND WARRANTED BY MOBEX

**CASIO**

JAPANESE QUALITY, JAPANESE TECHNOLOGY

Available from Leading Department Stores, Calculator Shops and University Bookshops.



# ETI EMPLOYMENT

Electronics Today International introduces the most cost effective method of recruiting technical staff — the ETI employment pages.

The technically literate are scarcer than a laptop Cray, more valuable than gallium arsenide and about as hard to attract as deuterium to tritium nuclei!

**Reach them, talk to them, employ them through ETI.**

For as little as \$225\* you can reach 56,000 professionals, managers or skilled workers<sup>†</sup>, 29,000 technicians<sup>†</sup>, 7000 electronics engineers<sup>†</sup> and 5500 programmers/analysts<sup>†</sup>. Which makes us *the* national publication for electronics employment advertising.

For information and bookings call:

Mark Lewis, Sydney	(02) 693-6666
Virginia Salmon, Melbourne	(03) 662-1222
Dane Hansen, Adelaide	(08) 212-1212
Jim Wells, Perth	(09) 481-3171
John Easton, Auckland	79-6648

\* Sixth of a page

† Roy Morgan Research Centre Study

## T TELECOMMUNICATIONS T TECHNICIANS

keep  
Australia  
talking

Want a challenging career with real job security and continuous career development? It's yours with Telecom Australia, the organisation responsible for Australia's rapidly-developing telecommunications network.

We are looking for skilled, motivated men and women who can help us establish, maintain and operate the latest telecommunication technologies in the Sydney city region. In particular, we need specialists in the fields of:

- Digital/analogue data and voice transmission
- PABX installation and acceptance testing
- Installation or maintenance of subscriber equipment ranging from single service telephones to complex PABX switchboards and intercommunications systems.
- Installation or maintenance of switching equipment and transmission systems ranging from step by step and ARF Crossbar to processor controlled systems.

### Qualifications needed

You'll need to be an Australian citizen or a permanent resident of Australia, and possess one of the following qualifications:

- Tradesman's Certificate or Tradesman's Rights Certificate in the discipline of Telegraph

Mechanic or Radio Tradesman.

- Electronics and Communications Certificate or Electronic Engineering Certificate and four years' relevant experience.
- Trained as a Telecommunications Technician or Telecommunications Tradesman with Telecom Australia.
- Appropriate B or C level Certificate Examinations of the City and Guilds of London Institute.

### Promotion opportunities

Telecom Australia offers motivated people excellent opportunities to qualify for advancement to the Technical Officer structure and beyond by way of external Certificate studies or Telecom's training program.

### Salary and Benefits

We offer a negotiable salary range of \$18,276 to \$22,111 pa depending on your qualifications and experience. Benefits include security of employment, a career structure, superannuation after a qualifying period, generous leave entitlements including maternity leave and a nine-day working fortnight.

### Interested?

Call the Sydney Recruitment Officer, Telecom Australia, on (02) 266 9290 or call in person to the 15th Floor, 309 Kent St, Sydney.



**Telecom Australia**

An Equal Opportunity Employer

ARM20309



# If you're into computers you could have a job for life.

If you're interested in the finer points of digital electronics and computers, the computer industry needs you.

Enrol now into Control Data Institute's Computer Engineering course and you could be working in the ever-expanding computer industry in as little as 8 months.

Control Data Institute's flexible study programmes will allow you to study full-time or part-time in subjects such as **Electronics, Microprocessors, Mini Computers, Data Communication, Terminals, Disk Drives, Line Printers and Machine Language Programming.** Or if you choose, you can study individual subjects.

You can even get exemptions if you have some experience in the electronics field. And at the end of your



course of study, you qualify with a Diploma in Computer Engineering.

Control Data is accepting enrolments now for their Computer Engineering courses in Sydney and Melbourne. The demand for Control Data Engineering Graduates has never been higher.

For further information call Control Data Institute now. You can attend special monthly free engineering information seminars or phone Wendy Mason in Sydney on (02) 438 1300 or Sherrill Maconachie in Melbourne on (03) 268 9666 for a personal appointment.

**CD CONTROL DATA INSTITUTE**

**YOUR CAREER BEGINS HERE**

An education service of Control Data Australia Pty. Limited.

Burrows Doble Lawrence CDA 1640

## Master the Microprocessor

Learn how Microprocessors really work the practical way.

### The Purpose of this Course

There is a considerable expanding and world-wide demand for people with a real knowledge of microprocessors and general computer technology. Such people are needed to design and evaluate systems and to assess and develop the enormous range of possible applications, both present and future of microprocessors and to understand the installation and servicing of the main types of equipment of which they may form the most vital component.

(A microcomputer has already been produced to replace the mechanical programmer on a domestic washing machine for example.)

This Course provides the necessary basic information to enable a student to really understand the functioning of microprocessors and their supporting circuitry,

usually referred to as the "hardware". This is backed up by showing how to program a microcomputer (or produce its "software") in the most fundamental form of computer language called "machine code". No previous knowledge of computers is necessary, though a little basic knowledge of electronics plus digital and logic circuits will be found helpful.

A special introductory short course is available to provide this background information, if required by an individual student on the course without extra fee.

### Student — Tutor Contact

A qualified Tutor is available to every Student throughout this Course in order to deal with any queries which may arise and to assess certain questionnaires which are issued to Students throughout the period of training.

**Certificate**  
Issued to all Students completing the Course successfully. Course covers main requirement of the City and Guilds Certificates in Computers.

## Practical Self Study Course

### FREE COLOUR BROCHURE

Post coupon now The Australian School of Electronics Pty Ltd., P.O. Box 108, Glen Iris, Victoria, 3146.

Please send your brochure without any obligation to:

Name

Address

ETI 10/86

Postcode



### How the Course is organised

The basis for the practical work in the Course is the Microcomputer.

This is supplied completely assembled and ready to use.

The Course text is carefully arranged in sequence so that each new section follows logically from previous work. Hardware description and programming technique progress together, so that the Student is discouraged from treating them as distinctly separate subjects.

Following each section of descriptive text, detailed instructions are given in order to use the Microcomputer to provide a practical demonstration of each new function or technique. This provides a very powerful way of learning precisely how the system operates, and enables any possible ambiguities in the Student's mind to be quickly resolved.



# TAYTECH

## CUSTOMER ENGINEERING

Making the best of your career is a do-it-yourself project. Only you can take the credit – or the blame – for your performance. For Opportunity to knock on your door you need to make yourself available.

Taytech specialises in Technical Staff recruitment, and Max Taylor with twenty-five successful years in Field Service, has the personal experience and industry knowledge to advise you on your future success. We have positions in Education, Technical Support and Workshop. We also need:

### EXPERIENCED CUSTOMER ENGINEERS

(Opportunities for career advancement with job security.)

A no-obligation, no-cost, strictly confidential discussion with a genuine field service professional will gain you a very useful and objective career appraisal – at least!

Phone MAX TAYLOR on (02) 959 4423, or write:

Taytech, Suite 808, 275 Alfred St., North Sydney 2060.

ARM20279

## ELECTRONIC WIZARDRY PERFORMED DAILY.

The very best jobs for Electronic Engineers and Technicians can only be found with the very best recruitment consultancy – QANTUM.

Talk to Ron Crause on (02) 922 7900, for details of the most exciting career opportunities around.

LEVEL 4 90 MOUNT STREET NORTH SYDNEY NSW 2060

# QANTUM



## Australian Maritime College

### ASSOCIATE DIPLOMA IN MARITIME ELECTRONICS ASSOCIATE DIPLOMA IN MARINE RADIOCOMMUNICATION

Switch on to an interesting and challenging career. Successful graduates of the Associate Diploma courses qualify for a wide range of positions in the public and private sector – as engineering assistants, technical officers, design draftsmen and technicians, or as radio officers. Opportunities exist with several Government departments and with private industry in the marine electronics and communications fields.

**Entry Requirements:** HSC or equivalent level passes in Mathematics, a Science subject and preferably English.

**Course Duration:** two years full time.

There are no tuition fees for Australian residents. The courses are approved under TEAS. Both diplomas are recognised by the Australian Public Service Board and the Australian Institute of Engineering Associates.

Please send me more information on:

Associate Diploma in Maritime Electronics       Associate Diploma in Marine Radiocommunication

Name \_\_\_\_\_

Address \_\_\_\_\_

Send to: The Admissions Office,  
Australian Maritime College  
PO Box 986,  
Launceston, TAS. 7250  
Telephone: (003) 26 0731



# HORIZONTAL ROCKETS

The British are coming!!! Back in the space race, British Aerospace has announced plans for a horizontal take off and landing aerospace vehicle that will compete directly with US shuttle replacements, and may make the Europeans leaders in space travel early in the next century.

**Brian Dance**

IT IS NOW almost 30 years since the first man was rocketed into space. During that time space launching has been transformed into a major commercial enterprise with the European Space Agency (ESA) and Japan entering into competition with America's NASA. Military requirements initially dictated the major space efforts, but the rapidly growing need for economical intercontinental satellite communications has resulted in commer-

cialization of space launches. Unfortunately it took a space shuttle disaster to bring us down to Earth.

Rockets developed in the USSR, in the USA and in Europe are scrapped after being used for only one launch. This may be acceptable during the development of space launching techniques, but is not economical for the routine commercial launching of loads into Earth orbit or into outer space. Therefore much effort has

been spent on the development of re-useable space vehicles, culminating in the enormous success of the space shuttle before its last disastrous launch.

## European requirements

Europe's space program will remain viable only if a launch vehicle is developed which can compete with the space shuttle. The expendable Ariane European rocket can do so at present. However, European designers feel that it is unlikely that a launching system which operates by throwing away its components in flight will be able to offer much competition to a greatly improved second generation shuttle system.

The Space and Communications Division of British Aerospace has therefore undertaken far-reaching studies to identify and design the optimum commercial launch vehicle at its Stevenage headquarters in Hertfordshire, England. Such a vehicle must be re-usable for economy and, in order to meet the requirements of the vast majority of payload sponsors, must be able to place payloads of up to 7 tonnes (7000 kg) into low earth orbit cheaply and safely.

## HOTOL

The British Aerospace studies have led to the development of a concept known as HOTOL (horizontal take-off and landing launcher). HOTOL is an unmanned re-usable single-stage vehicle for placing spacecraft in low-earth orbits. It will employ a remarkable new propulsion technique which allows the use of atmospheric oxygen to minimise the mass of on-board propellant. Wings have been incorporated into the design to optimise the initial flight trajectory after take-off from a standard runway.

HOTOL is proposed as a more economical vehicle than the space shuttle for the task of launching spacecraft. It will be able to lift loads similar to those currently carried by Ariane and will provide Europe with the facility it needs both to remain competitive with future generations of the space shuttle and to retain its general capability in space.

The craft is essentially an unmanned air-

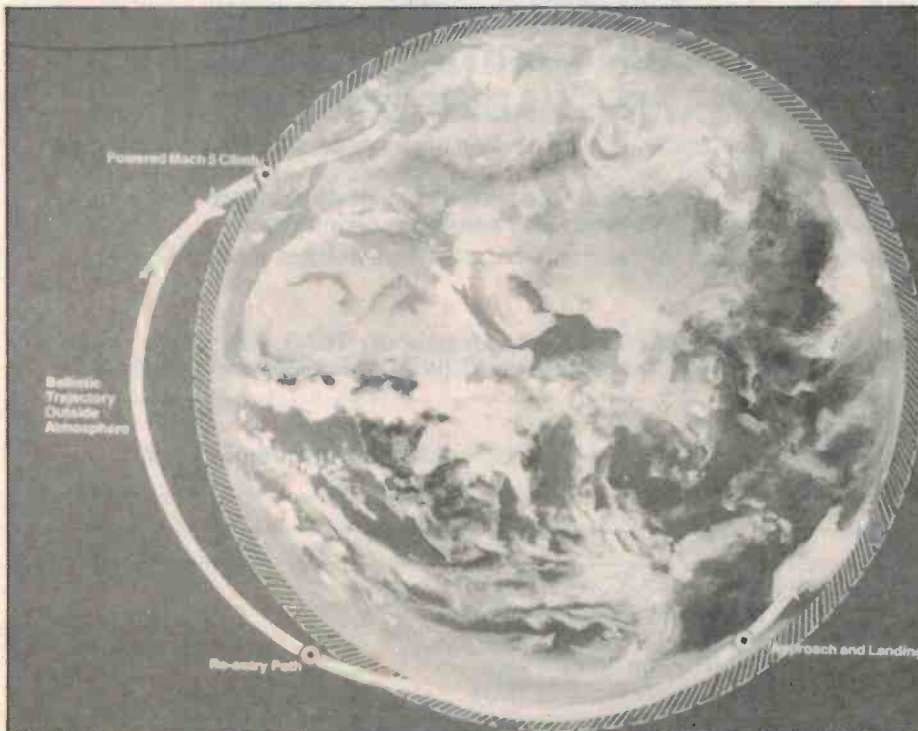

London to Sydney in 45 minutes.



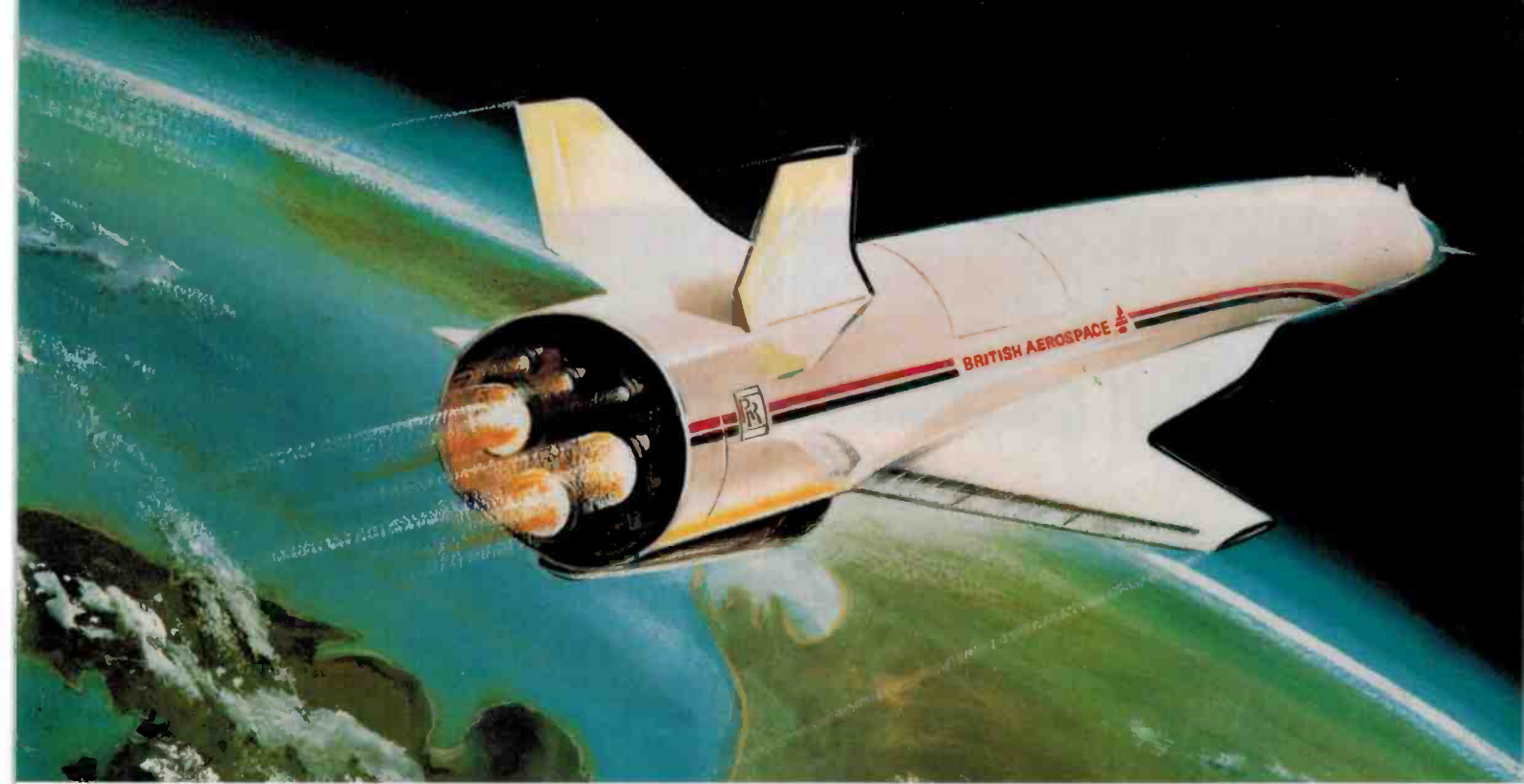

craft which will be powered by an air-breathing and rocket propulsion system. It will have the ability to take off and to land on runways from which Concorde could operate, and will be able to lift payloads of up to 7 tonnes placed in a cargo bay 4.5 m in diameter and 9 m in length. The propulsive and aerodynamic characteristics have produced a design for a vehicle which is fully recoverable and totally

and quickly re-usable with a minimum of refurbishment, preparation and expense. Importantly, it will have no expensive expendable parts, such as rocket boosters or external fuel tanks.

Most of the forward fuselage of HOTOL will be occupied by a large pressurized liquid hydrogen fuel tank, while at the rear a smaller liquid oxygen tank will be used to provide for flight outside the atmosphere where air breathing is impossible. The payload bay (of the same diameter as that of the shuttle) will be placed between the two tanks. This overall layout ensures minimum movement of the centre of gravity during flight.

The details of the engine are still security classified, but it will be conventionally mounted at the rear of the craft. Protection for the vehicle during re-entry, which generates much heat, will be concentrated mainly underneath the fuselage and underneath the wing. Small, forward-mounted canards provide positive aerodynamic control.

Because an undercarriage of adequate strength for take-off would be very heavy, HOTOL will be launched from a simple trolley. A lightweight undercarriage can be used for landing the vehicle, since the spacecraft will be much lighter when it returns after using its fuel; this obviates the carriage of much dead weight into orbit.

### Performance

HOTOL will take off at a speed of 290 knots (150 metres per second) with an acceleration of 0.56 g using a run of 2300 metres. Vertical acceleration at lift off is only 1.15 g and the climb attitude is about 24 degrees. The vehicle will go supersonic

after two minutes and will clear commercial air lanes at an altitude of 12 km (40,000 ft) after 4.5 minutes. It will reach an altitude of 26 km (85,000 ft) after nine minutes when its speed will be Mach 5. Various problems prevent air breathing after this point and dictate a ballistic trajectory on the main rocket engine.

When HOTOL achieves orbital velocity at an altitude of 90 km, the main engine will be cut off and the vehicle will coast to its operating altitude of about 300 km. A typical mission duration is expected to last about 50 hours, the position and altitude changes being produced by an orbital manoeuvring system (OMS). At the end of the mission, the OMS will slow the vehicle and bring the perigee down to about 70 km altitude ready for re-entry.

HOTOL will re-enter the atmosphere at a very high incidence angle of about 80 degrees, but this angle decreases as the speed falls. A hypersonic glide will commence at an altitude of about 25 km. The large wing structure and relatively low mass will result in the vehicle behaving much less like a projectile than is the case with the space shuttle. Re-entry temperatures are therefore lower and a high temperature metal alloy skin will suffice for the protection of the under-surface. Ordinary titanium will be employed on the upper surfaces. Thus the whole vehicle could be simply and economically constructed and maintained.

The high hypersonic lift-to-drag ratio of HOTOL during re-entry (more than double that of the space shuttle) gives it a high cross-range capability sufficient, say, for a landing in Europe from an equatorial orbit. Indeed, the ESA site at Kourou will

### US AEROSPACE PLANE

The US has also proposed a possible aerospace plane which could travel around the world in eight hours so as to enable intercontinental business trips to be completed in one day. The advantages of the proposed US aerospace plane over the space shuttle include the elimination of expensive launching sites and the choice of landing sites. If necessary an aerospace plane could abort a landing, go around the world and try again — an option not available to the shuttle. Turn-around time for an aerospace plane on the ground would be hours rather than weeks.

The proposed aerospace vehicle is very similar to today's passenger aircraft. Passengers would walk to their seats on a level floor and would not experience the extreme forces of acceleration of the present shuttle launches. Moderate acceleration over an appreciable time will take the plane to Mach 25. This aerospace plane will be able to fly high in the atmosphere or, when properly equipped, to climb from there into low earth orbit. From such an orbit the plane would provide a platform from which most of the shuttle achievements could be duplicated, but at much reduced costs.

The Americans state their proposed aerospace plane could be ready to fly in less than 10 years. The first contracts for the project have been signed recently with projected costs of some \$US400 million for the first steps.



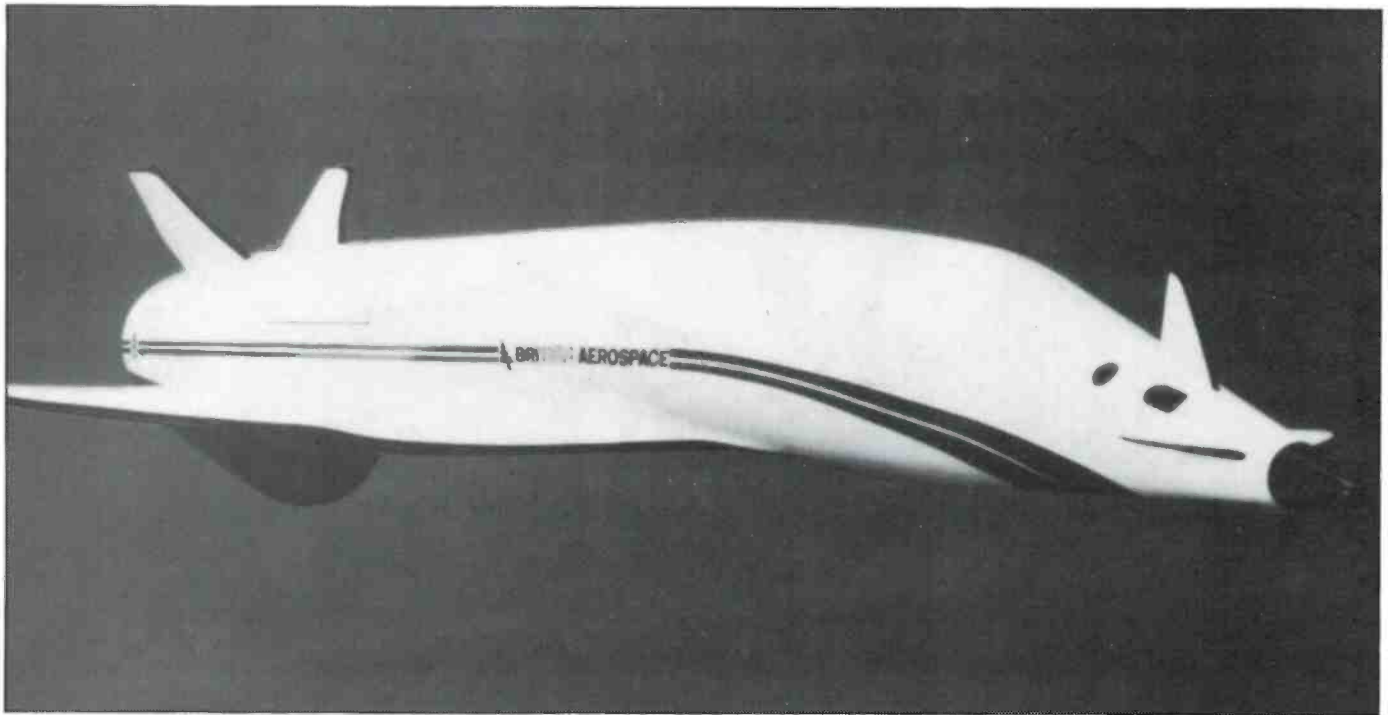

### DESIGN DATA FOR HOTOL

Mass at take-off	200 tonnes
Mass on landing	42 tonnes
Payload mass (for 300 km equatorial orbit)	7 tonnes
Length	63 metres
Wingspan	20 metres
Fuselage diameter	5.7 metres
Runway length	3000 metres
Take-off acceleration	0.56 g
Take-off speed	150 m/s (334 mph)
Landing speed	88 m/s (196 mph)
Lift-drag ratio	6.5:1 subsonic 4.5:1 supersonic
Propellants	liquid hydrogen liquid oxygen

be required only as a re-fuelling stop on the way from Europe to orbit.

#### The landing technique

HOTOL will use a similar final approach and landing technique to that used by the Space Shuttle, but it will be rather more gentle. The planned approach angle is 16 degrees and the touchdown speed 170 knots (88 metres per second), while the wet runway ground roll is 1800 metres.

Although the first operational flights of HOTOL will be remotely piloted by means of artificial intelligence and robotics systems to provide simplicity and economy, provision will be made from the outset for manned operation.

#### Economical operation

British Aerospace claims that HOTOL will reduce costs to low earth orbit by a

factor of five and, even with current perigee stages, will halve geosynchronous launch costs. This economy of operation, coupled with quick reaction and a rapid turn-around capability should enable HOTOL to compete realistically for about 75% of the commercial market from the beginning of the next century.

There are three main reasons why HOTOL will be able to compete at lower cost than the space shuttle or any other conventional launcher, namely:

- HOTOL uses atmospheric oxygen as fuel during the initial flight phase and this results in a great saving in the all-up weight of the vehicle at take-off. All current spacecraft are launched by rocket-powered vehicles using fuels in which the oxygen content can account for as much as 85% of the total fuel weight at take-off. Fuel weight at take-off can be greatly reduced by using a combination of air-

breathing and rocket propulsion to provide power. HOTOL's air breathing engines drive it to Mach 5 before rocket power is required.

- HOTOL will be developed initially as an unmanned orbital vehicle; from the engineering point of view, this enables it to be designed and built much more economically.

- HOTOL is completely re-usable with no expendable parts.

#### Conclusion

HOTOL could become operational by the early years of the next century. Later versions could carry men into orbit to service space platforms or other equipment in low-earth orbits. British Aerospace claims its major advantage is that it is forward-looking with ample potential for development beyond the cheap and effective spacecraft launcher which is presently planned.

The HOTOL designers state that a one hour passenger flight from Europe to Australia is a distinct possibility using HOTOL. Indeed, the flight time from over London to over Sydney could be only 45 minutes in such a trans-atmospheric skyliner, but normal air traffic procedures lead to an estimated 67 minutes flight time from take-off to landing.

A sum of £3 million (\$A6.6 million), contributed equally by the British Government and industry, has been allocated to fund a proof-of-concept study of HOTOL. This study will last up to two years. ●



# ANRITSU'S OTDR

Anritsu, the world leader in fiber optics measuring instruments, offers you its all-new, portable MW910A Optical Time Domain Reflectometer. This newest OTDR has the same pedigree as our popular MW98A, the best selling OTDR in the world. And Dual Band and portability make the MW910A no less special. Just take a look at the stats:

- Long range capability for faults up to 144 km away
- High resolution – within one meter
- Switchable wavelengths of 1.3 and 1.55 $\mu$ m in the same plug-in
- Optical masking for mechanical splices
- Compact and field-portable
- Simple, straightforward operation.

That's Anritsu's new OTDR in a nutshell: Proof positive that less is indeed more. Got just a little more time? Contact Anritsu for a demonstration or brochure.



**More Range: 144 km**  
**More Wavelengths: 1.3 and 1.55 $\mu$ m**  
**And Less Weight: Just 13 kg**

**Anritsu**  
WE'RE ON THE MOVE. WORLDWIDE.

**STC**

An Australian Company of **STC**

STANDARD TELEPHONES AND CABLES PTY. LIMITED  
(Incorporated in N.S.W.)

MELBOURNE – 58 QUEENSBIDGE STREET  
SOUTH MELBOURNE, VICTORIA 3205

TELEPHONE : (03) 615-6677

FAX : (03) 615-6667

TELEX : AA30878

SYDNEY – TELEPHONE : (02) 690-5276



# Design in TI's new

The new IBM® Token-Ring Network promises to become the industry standard. And if you are wondering about the best and quickest way to tie your product into this new 4-Mb/sec LAN, here's your solution: The TMS380 chip set from Texas Instruments.

TI's TMS380 is the *only* commercial chip set tested — and system-verified — by IBM. It's the silicon standard for this new high-speed office-system LAN.

And for a sure, fast entry into this exciting new market, you can begin with TI's TMS380 *Design-in Accelerator Kit*.

**Q. What kinds of products can communicate through the new LAN?**

**A. With the TMS380 chip set, almost any.**

TI's new TMS380 chip set was developed jointly with IBM. Its general-purpose system interface allows many kinds of equipment from various manufacturers to communicate through the IBM Token-Ring Network. And since this is an open network, any product in which you use the TMS380 can communicate with any other, when common languages are used.

**Q. Is expensive cabling required?**

**A. No.**

Your customers have the option of using telephone twisted pair or shielded twisted pair. And the point-to-point topology of the token ring makes it ideal for fiber optics, since the taps that are necessary with bus topologies are not required.

**Q. Where does TI's TMS380 chip set fit in?**

**A. It's the heart of your LAN adapter card or subsystem.**

The TMS380 chip set is a complete solution for the physical interface and media-access control. Its integrated LAN-adapter architecture provides for efficient, transparent handling of the IEEE 802.5 protocols. TI's TMS380 in your product will give your customers freedom to choose the cabling system that best suits their needs. And the flexibility to interface with any of the popular logical-link-control and higher-layer protocols.

◀ **Everything you need** to begin designing your own IBM Token-Ring Network LAN adapter is included in your TI *Design-in Accelerator Kit*: Three TMS380 chip sets, comprehensive literature, and debug software.

®Registered trademark of International Business Machines Corp.





# IBM compatibility with token-ring-LAN chip set.

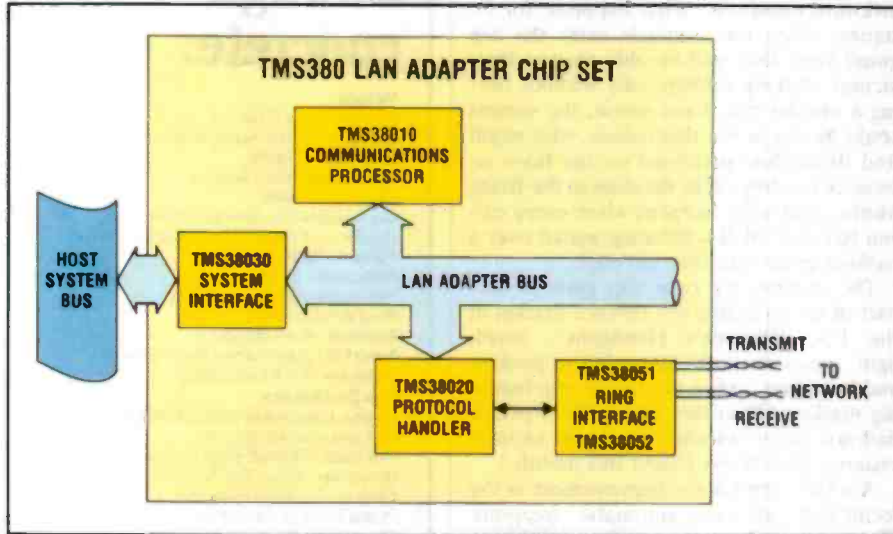

Five TMS380 chips form the heart of your LAN adapter. The TMS38030 automatically manages the interface between system memory and the adapter. The TMS38010 processes and buffers data. The TMS38020 contains RAS and LAN-management software and handles data in accordance with IEEE 802.5 protocols. And the TMS38051 and TMS38052 monitor cabling integrity, control network insertion, and perform clocking and signal conditioning.

**Q. What about network management?**

**A. Every service your system needs is built in.**

TI's new TMS380 chip set includes "self-healing" features that ensure the reliability, availability, and serviceability (RAS) of the network. And *only* the TMS380 chip set has them.

Among these special features are fault isolation of cable-system failures, error reporting, self-test diagnostics, and LAN-management services. So you're relieved of the risk, time, and expense of developing custom hardware and software for these essential functions.

**Q. Can it grow with my needs and my customers'?**

**A. Yes.**

On-chip RAS and LAN-management software make TI's TMS380 chip set completely compatible with the IBM Token-Ring LAN and give it a stable foundation to meet the need for future network expansion. As higher performance standards develop, the TMS380 chip set will accommodate them.

**Q. What's this about an Accelerator Kit?**

**A. It's your head start to IBM token-ring compatibility.**

TI's *Design-in Accelerator Kit* will give you a head start on designing IBM Token-

Ring Network compatibility into your products. It includes three chip sets, the *TMS380 User's Guide*, and the *Token Ring Adapter Bring-Up Guide* with debug software.

**TEXAS INSTRUMENTS**

Creating useful products and services for you.

## TEXAS INSTRUMENTS FIELD SALES OFFICES

Melbourne: (03) 267-4677  
Sydney: (02) 887-1122

## TEXAS INSTRUMENTS DISTRIBUTORS

### ADELAIDE:

EC & E: (08) 232-0001  
VSI: (08) 267-4848

### BRISBANE:

Rifa: (07) 832-3700  
VSI: (07) 52-5022

### MELBOURNE:

Rifa: (03) 480-1211  
VSI: (03) 543-6445

### PERTH:

VSI: (09) 328-8499

### SYDNEY:

Rifa: (02) 858-5966  
VSI: (02) 439-8622

To: Texas Instruments Australia  
6 Talavera Rd.,  
North Ryde 2113

- Please rush me a TMS380 Data Package.
- Place my name on the TMS380 Mail List.

Company .....

Name .....

Address .....

..... Suburb ..... State .....

Postcode ..... Ph: ( ) .....



LUDDITES ALL, we hate progress for the sake of progress, change for the sake of change. The Dregs Hack, however, not being narrow minded is prepared to accept that sometimes there are good reasons for change. Sometimes, however, change is more a monument to the stupidity and nastiness of man than his intellect, towering though it may be. Herewith a selection of new developments from the world of high tech, which prove that the naked ape is still as ape-like and well, naked, as he ever was:

**Copy boards**

Recently we came across what must be the world's best reason to invent a new technology. According to the delightful International Resource Development, a US-based marketing company, your good old photocopier is under threat.

It turns out that the copier is being used in a novel way by demented souls, one of whom, we are led to believe, is alive and well in every office. The new crime involves sitting on the copy machine, an example of quite shameless exhibitionism. The photocopies so produced are reported to be endlessly fascinating. The real excitement comes from trying to identify the streaker on the basis of the evidence left behind.

Anyway, IRD reports that the latest development is the copyboard designed for copying notes or graphics during meetings. The object to be copied must be passed between the scan head and the board, a very narrow space, effectively ruling out indecent practices. IRD reports that the same technology is used for fax machines, indeed, fax vendors are major manufacturers of the new devices.

**Zapguns**

The rest of the world has always had a morbid interest in the enthusiasm with which Americans shoot one another. It appears that every night the heros of the wild west ride again in subways and buses, terrorizing the like of you and I, who pass nervously to the security of our homes.

Now it's all about to change. Spurred on by vigilante movies from Hollywood, starring men with improbable chest development and even sillier names, America's gun pushers are ever keen to come out with new devices to thwart the baddies. The trouble is, the courts take a dim view of the citizenry killing each other. Indeed, in a famous vigilante incident last year, the victim of muggers found himself in court charged with murder.

Solution: stun guns. Stun guns are designed to immobilize but not to kill the person on the business end. According to the hype (and there's plenty of it) you can now defend yourself from the most determined attacker, without having to kill him and

thereby risk the wrath of the courts.

Superficially it's a great idea. But of late, police authorities have taken to asking some awkward questions. What happens, for instance, when the criminals carry the zap guns? Now they will be able to stun their victims, making robbery easy without risking a murder rap. Even worse, the victims could be the police themselves, who might find themselves paralysed on the floor instead of heading off to the clink in the Black Maria. And what happens when every citizen has one? Will a shouting match over a parking place turn into zap city?

The controversy over zap guns is only part of an exploding self defence market in the US. "Women's Handguns", small, light, weapons easily concealed in pockets and handbags, are in the centre of a booming market. Often they are made of plastic and not easily detected by airport security systems. (See News Digest this month.)

Another trend is the improvement in the technology of semi-automatic weapons. These are easily converted into full blown machine guns, easily accessible, cheap and easily concealed. Al Capone should have lived to see this.

**Mating**

Finding a mate is possibly the most important thing you will ever do in your life. It is an all consuming passion among the young, and old age is best defined as that time when the opposite sex stops being interesting. There are very good natural, evolutionary reasons for this, of course. To raise the young you must share your life with someone, so it helps if you like one another. It makes sense in evolutionary terms too. The continuation of the species depends on it.

The puzzling thing then is that the entire process is left almost entirely to chance. Mention sex and the brain switches off and the whole body goes into automatic. This is the stuff of true mystery. Art and literature centre almost exclusively on the multifarious ways in which people make complete idiots of themselves in the complex art of love.

Well, you will be pleased to know that intelligence is at long last being bought into play in the game of love. The new *objet d'amour* is an optical ROM card, similar to the credit card currently in use, but containing data in a much denser format. According to Matthijs Moes, who has just released a report on the subject, by 1990 singles bars will be equipped with card readers. When a customer places a card in the reader a host computer compares such attributes as age, height, interests and indicates the customer in the bar who might have similar interests. This indication will be visual, a picture being stored on the card.

The card will give a whole new meaning to the expression "personal computers".

**Where to hear superb musical reproduction through concrete:**

**Victoria**

- Ballarat - Sight & Sound
- Bendigo - Prouds Audio World
- Blackburn - Brashes
- Dandenong - Hi-Fi Sounds
- Geelong - Brashes
- Greensborough - Diamond Hi-Fi
- Hawthorn - Contemporary Sound Centre
- Malvern - Radio Parts Sales
- Melbourne - Brashes
- Melbourne - Radio Parts Sales
- Moorabbin - Brashes
- Rosebud - Rosebud Stereo
- Swan Hill - John Martins Music Studio
- Traralgon - A&P Electronics

**New South Wales**

- Albury - Haberechts World of Sound
- Bathurst - Selekt Sound
- Newcastle - Wardell Sight & Sound
- Byron Bay - Byron Bay Sound Centre
- Grafton - Buckleys Music House
- Maitland - High Street Hi-Fi
- Marrickville - Apollo Hi-Fi
- Nowra - Hi-Fi House
- Orange - Selekt Sound
- Port Macquarie - Hall of Electronics
- Roseville East - Hempel Sound
- Summer Hill - Apollo Hi-Fi
- Sydney - Sydney Hi-Fi Centre
- Tamworth - Sound Components
- Wagga Wagga - Pitmans Audio
- Wollongong - Hi-Fi House

**Queensland**

- Bowen - Plaza Sight & Sound
- Brisbane - Handos Sound Dimensions
- Cairns - Stereo World
- Ipswich - Ipswich Hi-Fi
- Kawana - Action Replay Video
- Mackay - Mackay Stereo Sales
- Maryborough - Keller Electronics
- Monto - Heilbron's Radio & TV
- Mount Isa - Hiway Sound Centre
- Nambour - Custom Sound Centre
- Southport - Gold Coast Hi-Fi & Video
- Toowoomba - Hunts Electronics & Hi-Fi

**South Australia**

- Adelaide - Blackwood Sound Centre
- Moonta - ABS Computers
- Mount Gambier - Elliotts Sound Equipment
- Whyalla - WTR Sight & Sound

**Western Australia**

- Fremantle - Alberts Hi-Fi
- Perth - Alberts Hi-Fi
- Victoria Park - Alberts Hi-Fi

**Northern Territory**

- Alice Springs - Aerial Installations
- Darwin - Sound Spectrum

**A.C.T.**

- Kingston - Kingston Hi-Fi
- Phillip - Brashes

**Tasmania**

- Devonport - Hi-Fi House
- Hobart - Quantum Electronics
- Launceston - Wills Hi-Fi

**Sole Australian Distributors:**  
**SCAN AUDIO Pty. Ltd.,**  
 52 Crown Street,  
 Richmond, Victoria 3121.  
 Telephone (03)4292199.  
 QLD. Office: (07)577433



# There are concrete reasons why these are the finest speakers ever!

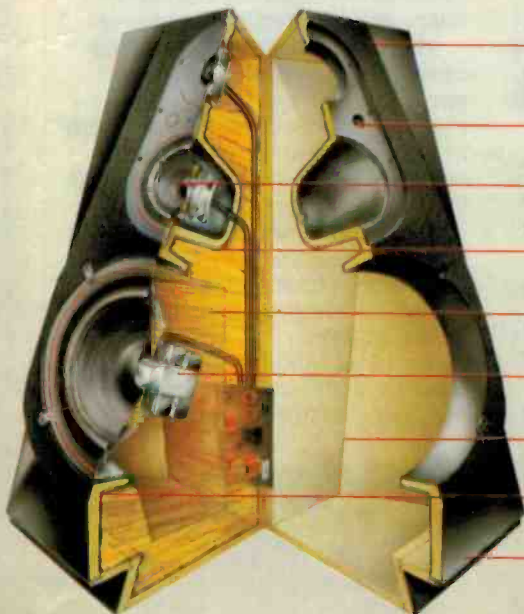
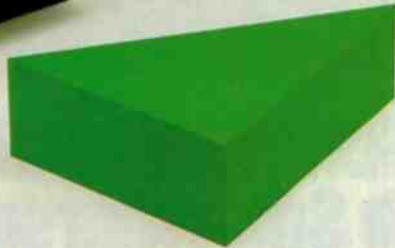

- Anti diffraction front
- Overload protection and attenuators
- 5" cone midrange
- Totally "dead" NCC concrete front
- Non-parallel cabinet
- 10" woofer with dbl. magnet
- High Performance x-over
- Centre-Bass-Reflex Phase linear front panel
- Solid built-in stand

From Jamo comes a range of loudspeakers based on the concept of an impossible-to-vibrate front baffle plate, coupled with a speaker enclosure in which no two sides are parallel.

The result is more costly to produce than conventional loudspeakers but in terms of result, the effect is literally incredible. The ability to cope with the often violent dynamics of compact disc recordings is also an outstanding feature of these speakers. You can see and hear the superlative Jamo Digital Monitor range at your nearest Jamo dealer today.

**Jamo** HI-FI

For a free, most comprehensive brochure, please contact your local Jamo dealer (he is listed on the opposite page), or contact Scan Audio direct on (03) 429 2199.



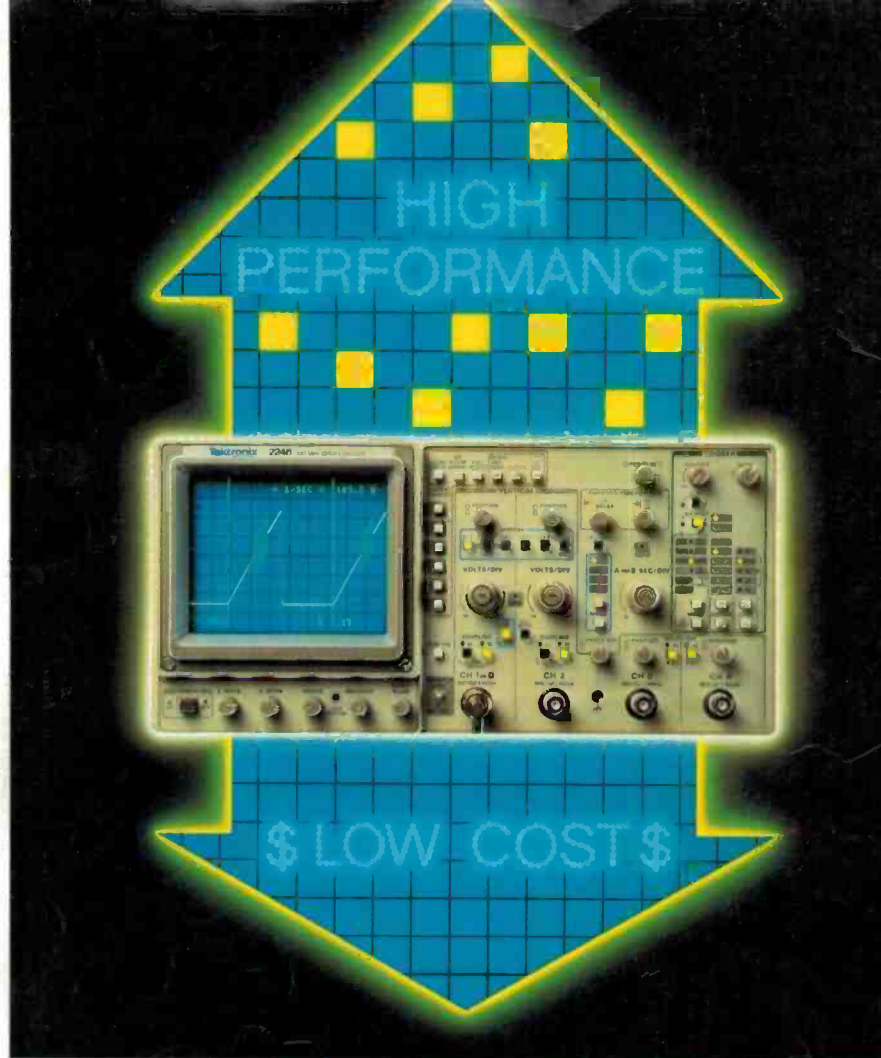

## New GPS Series: Tek sets the pace with SmartCursors™ and push-button ease.

Work faster, smarter, with two new general purpose scopes from Tektronix. The four-channel, 100 MHz 2246 and 2245 set the new, fast pace for measurements at the bench or in the field. They're easy to use and afford, by design.

**On top: the 2246 with exclusive integrated push-button measurements.** Measurements are accessed through easy, pop-up menus and implemented at the touch of a button. Measure peak volts, peak-to-peak,  $\pm$  peak, dc volts and gated volts with new hands-off convenience and on-screen readout of values.

SmartCursors™ track voltmeter measurements in the 2246 and visually indicate where ground and trigger levels are located. Or use cursors in the manual mode for immediate, effortless measurement of waveform parameters.

Both scopes build on performance you haven't seen at the bandwidth or prices. Lab grade features include sweep speeds to 2 ns/div. Vertical sensitivity of 2 mV/div at full bandwidth for low-level signal capture. Plus trigger sensitivity to 0.25 div at 50 MHz, to 0.5 div at 150 MHz.



Accuracy is excellent: 2% at vertical, 2% at horizontal. And four-channel capability includes two channels optimized for logic signals.

**Best of all, high performance comes with unmatched convenience.** You can see it and feel it – in the responsive controls and simple front-panel design, in extensive on-screen scale factor readouts, and in simplified trigger operation that includes Tek's Auto Level mode for automatic triggering on any signal.

**Push buttons now and call your Tek office for a hands-on demo of the GPS Series.**

Sydney 888 7066, Canberra 51 6111, Melbourne 813 1455, Brisbane 394 1155, Adelaide 223 2811, Perth 325 8433.

**Tektronix**  
COMMITTED TO EXCELLENCE