

# GEAR DRIVE CHAINS

PITCH	CIRCULAR PITCH	MATERIALS	BERG'S ® NAME	SPROCKET
<b>1/10</b>	<b>.1000</b>	Polyurethane (Green) .018 Dia. Stainless Steel Cable*	<b>Flex-E-Gear®</b>	Operates with 31A and 31B series.

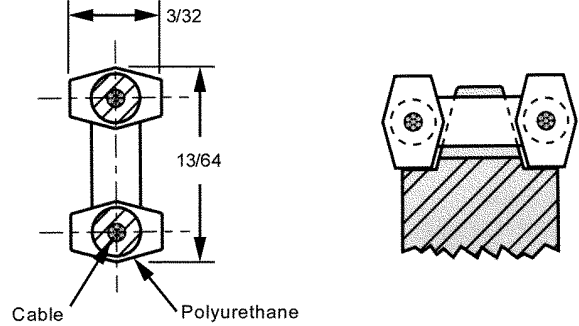
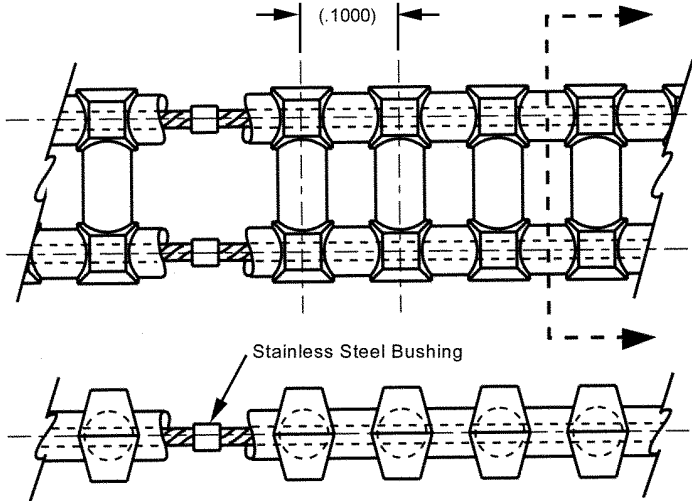

- For Field Splice Kit order 32GCF-7.
- \* Available with Aramid Core. See page VII for alternative belt construction or reverse bending applications.
- \*\*Reduce operating load rating by 50% for field splices.

STOCK NO.	NO. OF PITCHES	LENGTH (Ref.)
31GCF-45-E	45	4.50
31GCF-50-E	50	5.00
31GCF-55-E	55	5.50
31GCF-60-E	60	6.00
31GCF-65-E	65	6.50
31GCF-70-E	70	7.00
31GCF-75-E	75	7.50
31GCF-80-E	80	8.00
31GCF-85-E	85	8.50
31GCF-90-E	90	9.00
31GCF-95-E	95	9.50
31GCF-100-E	100	10.00
31GCF-105-E	105	10.50
31GCF-110-E	110	11.00
31GCF-115-E	115	11.50
31GCF-120-E	120	12.00
31GCF-125-E	125	12.50
31GCF-130-E	130	13.00
31GCF-135-E	135	13.50
31GCF-140-E	140	14.00
31GCF-150-E	150	15.00
31GCF-160-E	160	16.00
31GCF-170-E	170	17.00
31GCF-180-E	180	18.00
31GCF-190-E	190	19.00
31GCF-200-E	200	20.00
31GCF-210-E	210	21.00
31GCF-220-E	220	22.00
31GCF-230-E	230	23.00
31GCF-240-E	240	24.00
31GCF-250-E	250	25.00
31GCF-300-E	300	30.00
31GCF-360-E	360	36.00
31GCF-420-E	420	42.00
31GCF-480-E	480	48.00
31GCF-540-E	540	54.00
31GCF-600-E	600	60.00

BULK LENGTH - NOT SPLICED	
STOCK NO.	LENGTH
31GCF-5FT	5 FT
31GCF-10FT	10 FT
31GCF-25FT	25 FT
31GCF-50FT	50 FT
31GCF-100FT	100 FT

- Infinite Lengths
- Silent Drive
- Weight .13 oz./ft.
- Positive Drive
- Zero Backlash
- No Lubrication
- 90A Durometer
- Ultimate Tensile Strength 30 lbs. (4lbs./Pin)  
When belt is used in open loop configuration (without splice, no crimp bushing)
- Temperature Range +180°F to -15°F
- Recommended Operating Load 8 lbs.
- Recommended Max. Operating Speed 376 feet/min.

Other numbers of pitches available on request.

