

# 75" 4K Wireless Presentation Display (WPD)



**CDE7520**



- Easy cast function
- Wireless presentation across devices and rooms
- USB flash drive plug-and-play for photos, music & video
- Multitasking with powerful embedded player & OPS PC slot
- 4K slim bezel commercial display

The ViewSonic® CDE7520 is a 75" 4K wireless presentation display. The built-in screen sharing software\*, ViewBoard® Cast and Display, myViewBoard enable multiple users, whether on-site or on-line, to participate in conferences and share content with each other simultaneously, transforming the CDE7520 into a dynamic content hub. This reliable commercial display is equipped with a quad-core processor and internal memory, allowing constant multimedia play from internal storage or a USB flash drive. Supporting remote configuration and content management systems, the ViewSonic® CDE7520 is also suitable for diverse signage applications.

\*Chrome, Android, Windows, Mac OS, and iOS compliant

\*Miracast, Chromecast, and AirPlay support

# Start an Easy Group Presentation

## Instant Casting without Dongle or app Installation Any laptop with a browser

No setup required, just open a Chrome, Chromium, or Edge browser to share your content.

\*built-in myViewBoard Display app to support wireless casting



## All Content on One Screen Across devices with the app

From side-by-side to multiple screens overview, the display enables all mobile users to share their full HD content.



## Bring All Remote Participants Together

### 1080p 120° web camera

Built-in noise reduction, WDR, and backlight compensation make your meeting's audio-visual quality great in both bright and dark environments.

\*Optional VB-CAM-001



## **Conduct an Engaging Workshop**

### **Single Content to All Displays On-site or across rooms with the app**

Mirror your content to multiple displays for multi-group environments.



**Play Multimedia and Internet Resources**

**Friendly OS Environment Interface**  
**Embedded player with WiFi & OPS PC slots**

\*Optional WiFi module LB-WIFI-001 & OPS PC VPC12-WPO



## Integrated Multimedia Player

USB flash drive plug-and-play for photos, music, and video



## Link with Internet Resources

Web browser

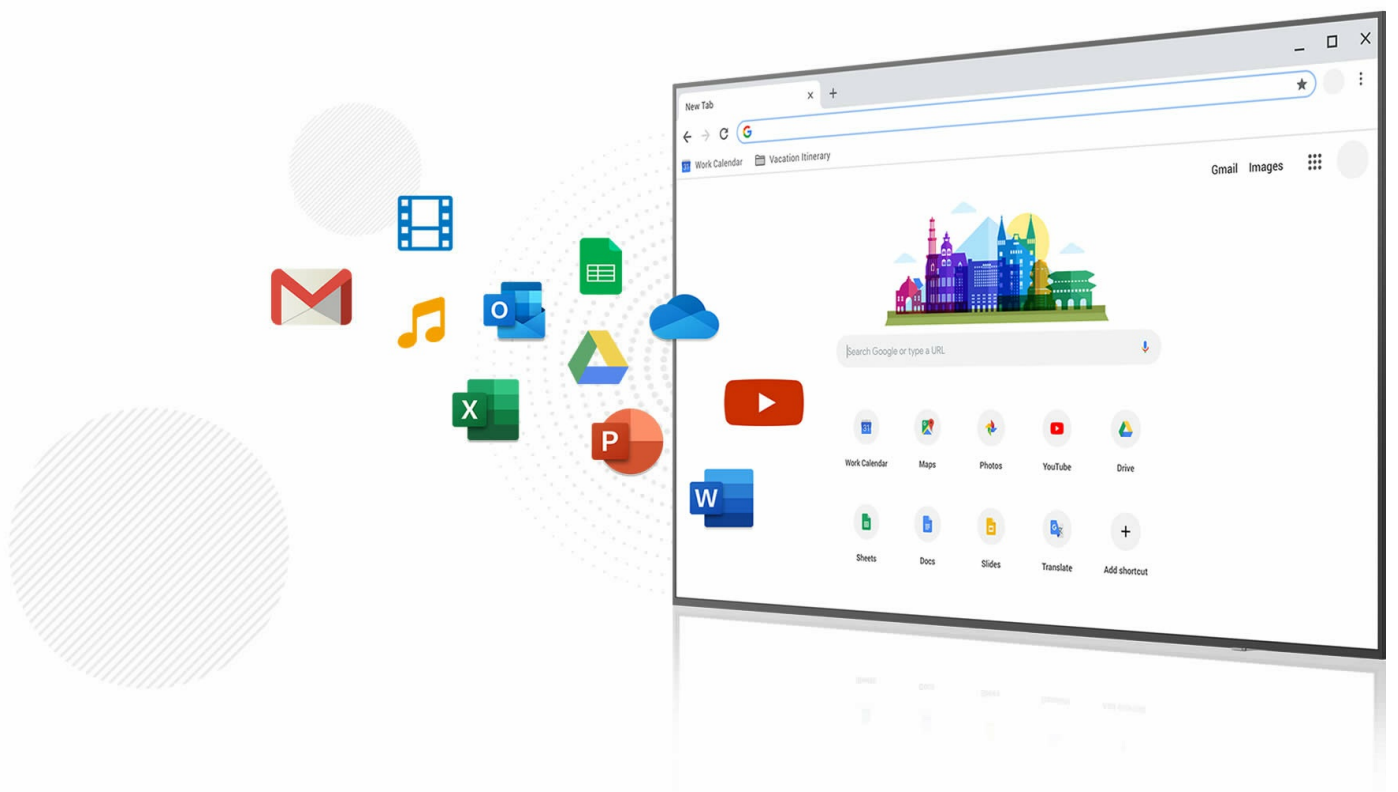

## Quality Image Display for a Modern Meeting

**4K**  
**High brightness with a slim bezel**



**Easy IT Remote Management**

**Remote Settings & Content Management**



# myViewBoard manager, SureMDM, Revel Digital and more

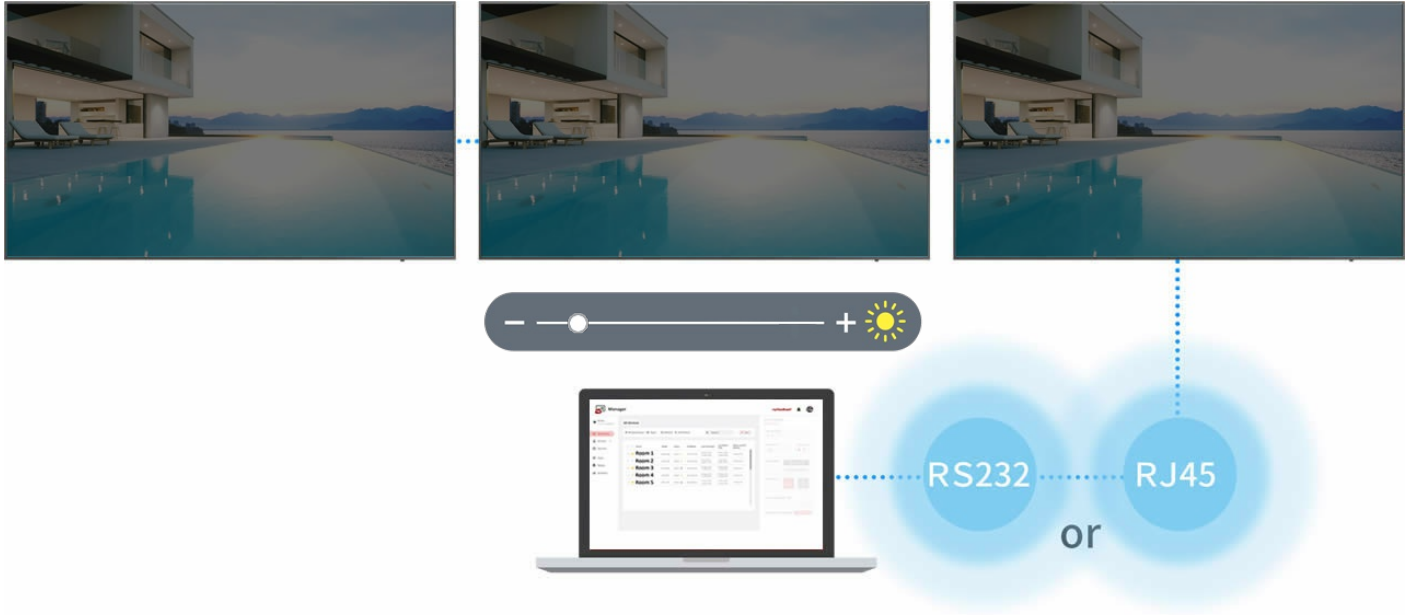

## Dimensions & I/O Ports

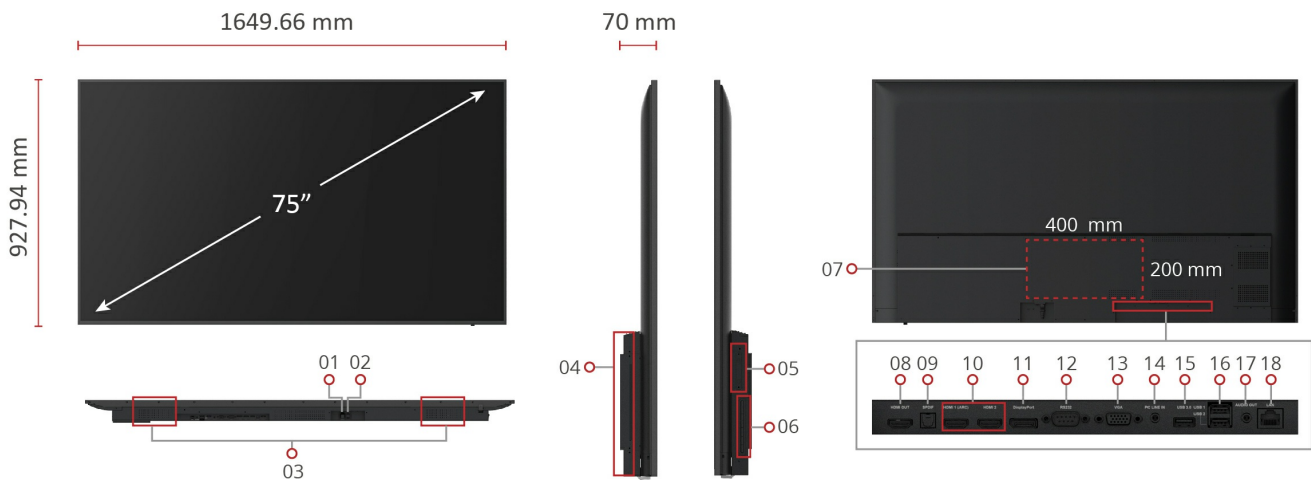

1. AC In
2. Power Switch
3. Internal Speakers
4. OPS Slot
5. WiFi Slot
6. Menu Controls
7. VESA® Wall Mount 400x200mm
8. HDMI Out
9. SPDIF
10. HDMI In x 2
11. DisplayPort
12. RS232
13. VGA

- 14. Audio In
- 15. USB 3.0 Type A (USB Playback)
- 16. USB 2.0 Type A x 2 (USB Playback)
- 17. Audio Out
- 18. LAN

## Technical Specifications

---

Display	Panel Size	75"
	Type/ Tech	TFT LCD Module. IPS type, DLED backlight
	Display Area (mm)	1649.664(H) × 927.936(V) (75" diagonal)
	Native Resolution	3840 x 2160
	Aspect Ratio	16:9
	Colors	1.07G colors
	Brightness	450 nits (typ.)
	Contrast Ratio	1200:1 Typ.
	Response Time	8 ms
	Viewing Angles	H = 178, V = 178 typ.
	Backlight Life	30,000 Hours (min)
	Surface Treatment	Anti-glare, 3H hardness, Haze 25%
	Bezel	Slim
	Orientation	Landscape
	INPUT	HDMI
RGB / VGA		x1
DisplayPort		x1
Audio		x1 (3.5mm)
RS-232		x1
OPS Slot		x1 (Optional Intel OPS VPC12-WPO)
WiFi Slot		x1 (Optional WiFi module LB-WIFI-001)
OUTPUT	HDMI	x1
	Audio	x1 (3.5mm)
	SPDIF	x1 (Fiber)
LAN	RJ45	x1
USB	Type A	2.0 Type A : x 2 (USB Playback), 3.0 Type A : x 1 (USB Playback)
SPEAKERS	SPEAKERS	Max. 16Wx2
COMPATIBILITY	RGB PC/HDMI PC	Up to 1920x1080@60Hz. Refer to timing table
	HDMI	480i, 480p, 720p, 1080i, 1080p, 4K2K@60Hz
	DisplayPort	480i, 480p, 720p, 1080i, 1080p, 4K2K@60Hz
	Android Version	Android 8.0
	POWER	Voltage
Consumption		Normal 240 W, Max 300 W
ERGONOMICS	Wall Mount (VESA® )	400x200 mm

OPERATING CONDITIONS	Temperature (° C)	0 to 40°C
	Humidity	20% ~ 80% non-condensing
DIMENSIONS (W x H x D)	Physical (inch / mm)	65.83 x 37.59 x 2.76 in/ 1672.0 x 955.0 x 70.0 mm
	Packaging (inch / mm)	71.97 x 43.23 x 8.66 in/1828 x 1098 x 220 mm
WEIGHT	Net (lb / kg)	29.30 kg / 64.60 lbs (w/o stand)
	Gross (lb / kg)	41.7 kg/91.93 lbs
REGULATIONS	REGULATIONS	cULus, FCC, Energy Star, EPEAT, MX-CoC, Mexico Energy, CE, CB, RoHS, ErP, REACH, WEEE, Custom Union, UkrSEPRO, RCM, MEPS
PACKAGE CONTENTS	PACKAGE CONTENTS	1. CDE7520 commercial display, 2. Remote control with batteries, 3. Quick start guide, 4. Power cables (1.5M), 5. HDMI-IN cable (3M) 6. HDMI-OUT cable (1.5M), 7. Wall mount screw, 8. RS232 adapter

## **ViewSonic® Limited Warranty**

---

ViewSonic provides customers with the security of a manufacturer's warranty against defected products. The type and duration of the applicable warranty service varies by product type, country of purchase and can also vary on an individual basis according to customer requirements agreed at time of purchase. The warranty will expire after the end of the warranty period.

---

For more product information, visit us at **[www.viewsoniceurope.com](http://www.viewsoniceurope.com)**

All rights reserved by ViewSonic Corporation. All other Corporate names and trademarks are the property of their respective companies. E&EO. All prices and specifications are subject to change without written notice. Images are for illustrative purpose only. Terms & Conditions Apply.