

# VacuSeal™ Fittings

January 2014

aerospace  
climate control  
electromechanical  
filtration  
**fluid & gas handling**  
hydraulics  
pneumatics  
**process control**  
sealing & shielding



ENGINEERING YOUR SUCCESS.

## Contents

### Introduction

Page 1

### Glands

Pages 2, 3, 4



### Bodies

Pages 4, 5, 6, 7

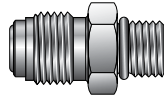

### Welded Assemblies

Page 8

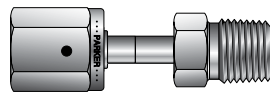

### Welded Modules

Page 9

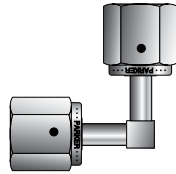

### Gaskets

Page 10



### Nuts, Caps, and Plugs

Page 11



### Hi-Flo Products

Page 12



### Featured Products

Page 13



### Make-Up Instructions

Page 14

### Ordering Instructions

Page 15

### Parker Veriflo Division



#### ⚠ WARNING – USER RESPONSIBILITY

**FAILURE OR IMPROPER SELECTION OR IMPROPER USE OF THE PRODUCTS DESCRIBED HEREIN OR RELATED ITEMS CAN CAUSE DEATH, PERSONAL INJURY AND PROPERTY DAMAGE.**

This document and other information from Parker-Hannifin Corporation, its subsidiaries and authorized distributors provide product or system options for further investigation by users having technical expertise.

The user, through its own analysis and testing, is solely responsible for making the final selection of the system and components and assuring that all performance, endurance, maintenance, safety and warning requirements of the application are met. The user must analyze all aspects of the application, follow applicable industry standards, and follow the information concerning the product in the current product catalog and in any other materials provided from Parker or its subsidiaries or authorized distributors.

To the extent that Parker or its subsidiaries or authorized distributors provide component or system options based upon data or specifications provided by the user, the user is responsible for determining that such data and specifications are suitable and sufficient for all applications and reasonably foreseeable uses of the components or systems.

Proposition 65 Warning: This product contains chemicals known to the state of California to cause cancer or birth defects or other reproductive harm.

#### Offer of Sale

The items described in this document are hereby offered for sale by Parker-Hannifin Corporation, its subsidiaries or its authorized distributors. This offer and its acceptance are governed by the provisions stated in the detailed "Offer of Sale" elsewhere in this document or available at [www.parker.com/veriflo](http://www.parker.com/veriflo).

© Copyright 2009 Parker Hannifin Corporation. All Rights Reserved.

## Introduction

Parker UHP fittings are designed as leak-free components for critical applications where ultra-high pure conditions are required. VacuSeal™ products, with their mating gasket and toroid design, provide a metal-to-metal seal with leak-free service from vacuum to positive pressure.

## Featured Products (see page 13)

- **TorqTite™** gasket to seal damaged toroids and virtually eliminate loosening of componentry due to thermocycling and vibration.
- **High-Purity Nickel and Hastelloy C-22®** glands for extremely corrosive applications.
- **Non-Rotational Female Nut** to prevent transmission of torque during make-up and therefore minimize twist of componentry which causes stress concentration.
- **Anti-Galling Female Nut** to ensure consistent make-up without plating or lubrication.

## Materials

### Typical Raw Material Specifications

FITTING MATERIAL	BAR STOCK	FORGINGS	RECOMMENDED TUBING SPECIFICATIONS
Stainless Steel 316	ASTM A276, ASME SA479	ASME SA182	ASME SA213, ASTM A213, ASTM A249
Stainless Steel 316L	ASTM A276, ASME SA479	ASME SA182	ASME SA213, ASTM A213, ASTM A249
Stainless Steel 316L VAR (Vacuum Arc Remelt)	ASTM A276, ASME SA479	ASME SA182	ASTM A269, MIL T8504, MIL T8506
Stainless Steel 316L VIM/VAR (Vacuum Induction Melt/Vacuum Arc Remelt)	ASTM A276, ASME SA479	ASME SA182	ASTM A269, MIL T8504, MIL T8506

Material is marked with heat code to ensure raw material traceability.

### Gaskets Typical Raw Material Specifications

MATERIAL SPECIFICATIONS	
Nickel	ASTM B162 (unplated)
Stainless Steel	ASTM A167 (Silver plated)

Hastelloy C-22® is a registered trademark of Haynes International, Inc.

## Specifications

- **Pressure Ratings** are based upon tests conducted on VacuSeal™ assemblies. All ratings comply with calculations per ANSI Code for Pressure Piping B31.3. **Working Pressures** are rated at ambient temperature and are based on a 4 to 1 design factor. To determine pressure ratings in accordance with ANSI B31.1, multiply **Working Pressure** by 0.94.
- **Temperature Ratings**  
Fittings:  
Stainless Steel 316, 316L, 316L VAR, 316L VIM/VAR 1000°F (537°C)  
Gaskets:  
High-Purity Nickel 600°F (315°C)  
Silver plated Stainless Steel 1000°F (537°C)
- **Dimensions** are for reference only and are subject to change. Tube ends conform to the dimensional requirements of ASTM A269.
- **Plating:** VacuSeal™ Female Nuts are Silver plated with an enhanced plating process. Avoid aggressive chemical processes used for cleaning, electropolishing and passivation that will remove plating. Removal or damage to plating will cause threads to gall, damaging fitting components and preventing a proper seal.
- **Testing:** VacuSeal™ products are rated to a Helium leak rate of  $1 \times 10^{-9}$  STD cc/sec.
- **Internal Surface Finishes:** VacuSeal™ components are available with controlled surface finishes to meet requirements of Ultra-High Purity systems.
- **Cleaning and Packaging:** Ultra-High Purity cleaning and packaging in a Class 100 Clean Room environment, is standard for all VacuSeal™ components.

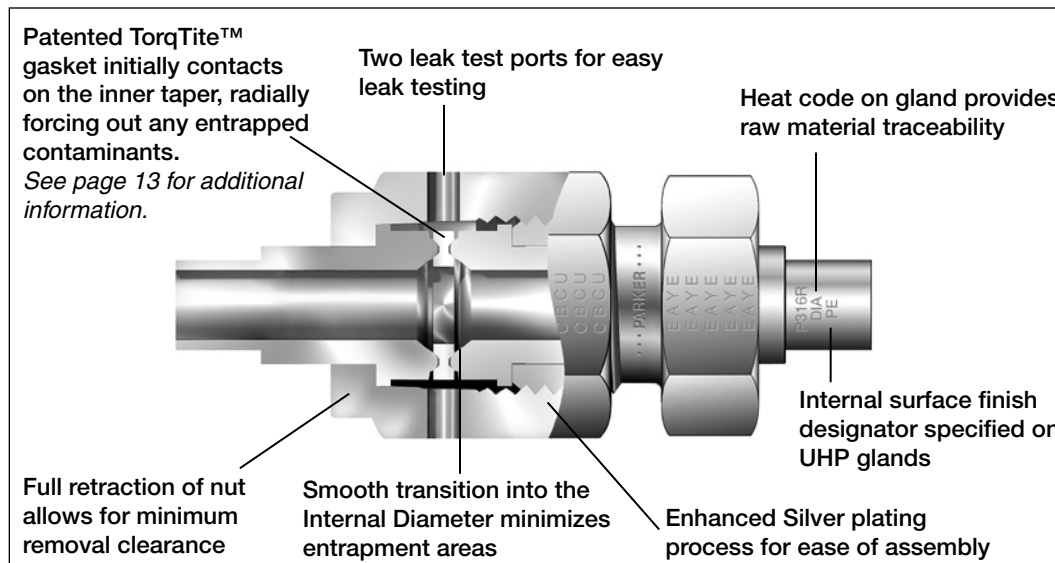

For Make-Up Instructions see page 14.

For Ordering Instructions see page 15.

## Glands

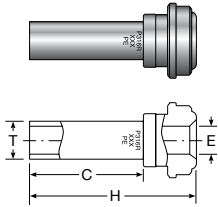

### Short Tube Butt Weld

T Tube O.D.	Ordering Number	C		E		H		Normal Wall Thickness	Working Pressure	
		in.	mm	in.	mm	in.	mm		psi	bar
<b>fractional</b>										
1/8	2-2 V1T3-* 1.08	0.75	19.0	0.07	1.8	1.08	27.4	0.028	8500	580
1/4	^4-4 V1M-* .60	0.25	6.3	0.18	4.6	0.60	15.2	0.035	5100	350
1/4	4-4 V1TW-* .72	0.38	9.7	0.18	4.6	0.72	18.3	0.035	5100	350
1/4	4-4 V1T3-* 1.10	0.75	19.0	0.18	4.6	1.10	27.9	0.035	5100	350
1/4	8-4 V1T3-* 1.12	0.75	19.0	0.18	4.6	1.12	28.4	0.035	3500	240
3/8	8-6 V1M-* .62	0.25	6.3	0.31	7.9	0.62	15.7	0.035	3300	220
3/8	8-6 V1T3-* 1.12	0.75	19.0	0.31	7.9	1.12	28.4	0.035	3300	220
1/2	^8-8 V1M-* .62	0.25	6.3	0.40	10.2	0.62	15.7	0.049	3500	240
1/2	8-8 V1TW-* .74	0.38	9.7	0.40	10.2	0.74	18.8	0.049	3500	240
1/2	8-8 V1T3-* 1.12	0.75	19.0	0.40	10.2	1.12	28.4	0.049	3500	240
<b>metric</b>										
6 mm	4-6M V1T3-* 1.16	0.75	19.0	0.16	4.1	1.16	29.5	1.0 mm	6800	460
8 mm	4-8M V1T3-* 1.16	0.75	19.0	0.24	6.1	1.16	29.5	1.0 mm	4900	330
10 mm	8-10M V1T3-* 1.16	0.75	19.0	0.31	7.9	1.16	29.5	1.0 mm	3500	240
12 mm	8-12M V1T3-* 1.16	0.75	19.0	0.39	9.9	1.16	29.5	1.0 mm	3100	210
18 mm	12-18M V1T3-* 1.22	0.75	19.0	0.59	15.0	1.22	31.0	1.5 mm	3000	200

^Old Part Number 4-4 V1M-\* .035

^^Old Part Number 8-8 V1M-\* .049

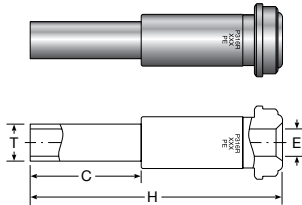

### Long Tube Butt Weld

T Tube O.D.	Ordering Number	C		E		H		Normal Wall Thickness	Working Pressure	
		in.	mm	in.	mm	in.	mm		psi	bar
<b>fractional</b>										
1/8	2-2 V1T3-* 1.42	0.75	19.0	0.07	1.8	1.42	36.1	0.028	8500	580
1/4	4-4 V1M-* 1.20	0.25	6.3	0.18	4.6	1.20	30.5	0.035	5100	350
1/4	4-4 V1T3-*	0.40	10.2	0.18	4.6	1.31	33.3	0.035	5100	350
1/4	4-4 V1TW-* 1.32	0.38	9.7	0.18	4.6	1.32	33.5	0.035	5100	350
1/4	4-4 V1T3-* 1.70	0.75	19.0	0.18	4.6	1.70	43.2	0.035	5100	350
1/4	8-4 V1T3-* 1.79	0.75	19.0	0.18	4.6	1.80	45.7	0.035	3500	240
3/8	8-6 V1M-* 1.29	0.25	6.3	0.31	7.9	1.29	32.8	0.035	3300	220
3/8	8-6 V1T3-* 1.79	0.75	19.0	0.31	7.9	1.79	45.5	0.035	3300	220
1/2	8-8 V1M-* 1.29	0.25	6.3	0.40	10.2	1.29	32.8	0.049	3500	240
1/2	8-8 V1TW-* 1.41	0.38	9.7	0.40	10.2	1.41	35.8	0.049	3500	240
1/2	8-8 V1T3-* 1.79	0.75	19.0	0.40	10.2	1.79	45.5	0.049	3500	240
3/4	12-12 V1T3-* 2.03	0.75	19.0	0.65	16.5	2.03	51.6	0.049	2400	160
1	16-16 V1T3-* 2.32	0.75	19.0	0.87	22.1	2.32	58.9	0.065	2400	160
<b>metric</b>										
6 mm	4-6M V1T3-* 1.70	0.75	19.0	0.16	4.1	1.70	43.2	1.0 mm	6800	460
8 mm	4-8M V1T3-* 1.70	0.75	19.0	0.24	6.1	1.70	43.2	1.0 mm	4900	330
10 mm	8-10M V1T3-* 1.79	0.75	19.0	0.31	7.9	1.79	45.5	1.0 mm	3500	240
12 mm	8-12M V1T3-* 1.79	0.75	19.0	0.39	9.9	1.79	45.5	1.0 mm	3100	210
18 mm	12-18M V1T3-* 2.03	0.75	19.0	0.59	15.0	2.03	51.6	1.5 mm	3000	200

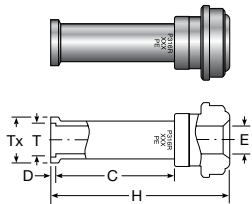

### Short Automatic Tube Butt Weld

T Tube Size	Ordering Number	C		D		E		H		Tx		Normal Wall Thickness	Working Pressure	
		in.	mm	in.	mm	in.	mm	in.	mm	in.	mm		psi	bar
<b>fractional</b>														
1/4	4-4 V1Y3-* 1.12	0.75	19.0	0.02	0.5	0.18	4.6	1.12	28.4	0.29	7.4	0.035	5100	250
1/2	8-8 V1Y3-* 1.16	0.75	19.0	0.04	1.0	0.40	10.2	1.16	29.5	0.55	14.0	0.049	3500	240
3/8	8-6 V1Y3-* 1.15	0.75	19.0	0.03	0.8	0.30	7.6	1.15	29.2	0.41	10.4	0.035	3300	220
<b>metric</b>														
6 mm	4-6M V1Y3-* 1.18	0.75	19.0	0.02	0.5	0.16	4.1	1.18	30.0	0.27	6.9	1.0 mm	6800	460
8 mm	4-8M V1Y3-* 1.19	0.75	19.0	0.03	0.8	0.24	6.1	1.19	30.2	0.35	8.9	1.0 mm	4900	330
10 mm	8-10M V1Y3-* 1.22	0.75	19.0	0.03	0.8	0.31	7.9	1.22	31.0	0.43	10.9	1.0 mm	3500	240
12 mm	8-12M V1Y3-* 1.20	0.75	19.0	0.04	1.0	0.39	9.9	1.20	30.5	0.52	13.2	1.0 mm	3100	210

## Glands (Continued)

### Long Automatic Tube Butt Weld

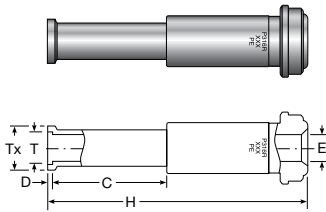

T Tube Size	Ordering Number	C		D		E		H		Tx		Normal Wall Thickness	Working Pressure	
		in.	mm	in.	mm	in.	mm	in.	mm	in.	mm		psig	bar
<b>fractional</b>														
1/4	4-4 V1Y3-* 1.72	0.75	19.0	0.02	0.5	0.18	4.6	1.72	43.7	0.29	7.4	0.035	5100	350
1/4	8-4 V1Y3-* 1.82	0.75	19.0	0.02	0.5	0.18	4.6	1.82	46.2	0.29	7.4	0.035	5100	350
3/8	8-6 V1Y3-* 1.82	0.75	19.0	0.03	0.8	0.31	7.9	1.82	46.2	0.41	10.4	0.035	3300	220
1/2	8-8 V1Y3-* 1.83	0.75	19.0	0.04	1.0	0.40	10.2	1.83	46.5	0.55	14.0	0.049	3500	240
3/4	12-12 V1Y3-* 2.07	0.75	19.0	0.04	1.0	0.65	16.5	2.07	52.6	0.80	20.3	0.049	2400	160
1	16-16 V1Y3-* 2.57	0.96	24.4	0.04	1.0	0.87	22.1	2.57	65.3	1.06	26.9	0.065	2400	160
<b>metric</b>														
6 mm	4-6M V1Y3-* 1.72	0.75	19.0	0.02	0.5	0.16	4.1	1.72	43.7	0.27	6.9	1.0 mm	6800	460
12 mm	8-12M V1Y3-* 1.83	0.75	19.0	0.04	1.0	0.39	9.9	1.83	46.5	0.52	13.2	1.0 mm	3100	210
18 mm	12-18M V1Y3-* 2.07	0.75	19.0	0.04	1.0	0.59	15.0	2.07	52.6	0.76	19.3	1.5 mm	3000	200

### Short Socket Weld

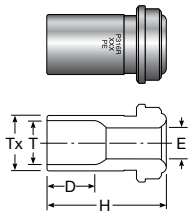

T Tube Socket	Ordering Number	D		E		H		Tx		Working Pressure	
		in.	mm	in.	mm	in.	mm	in.	mm	psig	bar
<b>fractional</b>											
1/4	4-4 V1W-* .50	0.28	7.1	0.19	4.8	0.50	12.7	0.35	8.9	5500	370
1/4	4-4 V1W-* .75	0.28	7.1	0.19	4.8	0.75	19.0	0.35	8.9	5500	370

### Socket Weld

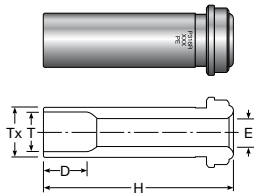

T Tube Socket	Ordering Number	D		E		H		Tx		Working Pressure	
		in.	mm	in.	mm	in.	mm	in.	mm	psig	bar
<b>fractional</b>											
1/16	1-1 V1W-* ①	0.10	2.5	0.05	1.3	0.70	17.8	0.13	3.3	9000	620
1/8	2-2 V1W-* .70	0.10	2.5	0.09	2.3	0.70	17.8	0.20	5.1	7100	480
1/4	4-4 V1W-*	0.28	7.1	0.19	4.6	1.31	33.3	0.35	8.9	5500	370
3/8	8-6 V1W-*	0.31	7.9	0.28	7.1	1.50	38.1	0.60	15.2	3500	240
1/2	8-8 V1W-*	0.38	9.7	0.40	10.2	1.50	38.1	0.60	15.2	3000	200
3/4	12-12 V1W-*	0.44	11.2	0.62	15.7	2.00	50.8	0.88	22.4	2800	190
1	16-16 V1W-*	0.62	15.7	0.87	22.1	2.22	56.4	1.19	30.2	2400	160

### Reducing Socket Weld

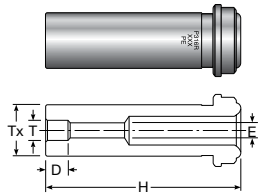

T Tube Socket	Ordering Number	D		E		H		Tx		Working Pressure	
		in.	mm	in.	mm	in.	mm	in.	mm	psig	bar
<b>fractional</b>											
1/8	4-2 V1W-* 1.31	0.16	4.1	0.09 ②	2.3	1.31	33.3	0.35	8.9	8000	550
1/4	8-4 V1W-*	0.25	6.3	0.19	4.8	1.50	38.1	0.60	15.2	3500	240

### Blind (undrilled) Gland

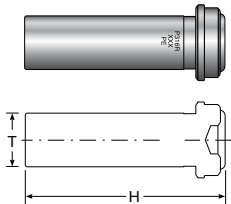

T Tube O.D.	Ordering Number	H	
		in.	mm
<b>fractional</b>			
1/8	2-2 V1W-* -BL	0.70	17.8
1/4	4-4 V1W-* -BL	1.31	33.3
1/2	8-8 V1W-* -BL	1.50	38.1
3/4	12-12 V1W-* -BL	2.00	50.8
1	16-16 V1W-* -BL	2.22	56.4

- ① Uses 2 BV-SS and 2 BVI-SS nuts
- ② May contain internal transitions
- ③ O-rings fluorocarbon is standard. Contact local Parker representative for other available materials

# VacuSeal™ Fittings

## Glands (Continued)

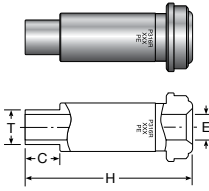

### Male Weld

T Tube O.D.	Ordering Number	C		E		H		Working Pressure		
		in.	mm	in.	mm	in.	mm	psig	bar	
<i>fractional</i>										
1/8	2-2 V1T3-* .70 .035	0.28	7.1	0.06	1.5	0.70	17.8	9000	620	
1/8	4-2 V1T3-* 1.31 .035	0.28	7.1	0.06	1.5	1.31	33.3	8000	550	
1/4	4-4 V1T3-* 1.31 .065	0.41	10.4	0.12	3.0	1.31	33.3	8000	550	
1/4	8-4 V1T3-* D970351	0.41	10.4	0.12	3.0	1.50	38.1	3500	240	
3/8	8-6 V1T3-* 1.50 .049	0.41	10.4	0.28	7.1	1.50	38.1	3500	240	
1/2	8-8 V1T3-*	0.50	12.7	0.40	10.2	1.50	38.1	3500	240	
3/4	12-12 V1T3-* 2.00 .109	0.62	15.7	0.53	13.5	2.00	50.8	3000	200	
1	16-16 V1T3-* 2.22 .120	0.81	20.6	0.75	19.0	2.22	56.4	2400	160	

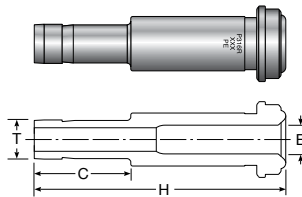

### Tube Adapter (A-LOK®)

T Tube O.D.	Ordering Number	C		E		H		Working Pressure		
		in.	mm	in.	mm	in.	mm	psig	bar	
<i>fractional</i>										
1/4	4-4 V1TU-*	0.62	15.7	0.16	4.1	1.62	41.1	8000	550	
3/8	8-6 V1TU-*	0.69	17.5	0.28	7.1	1.81	46.0	3500	240	
1/2	8-8 V1TU-*	0.91	23.1	0.39	9.9	1.78	45.2	3500	240	

Replace 'U' with a '2' to designate groove for CPI™ Fitting.

## Bodies

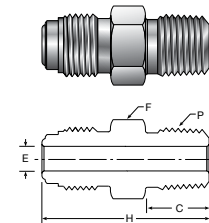

### Male NPT Connector

P Male NPT Size	Ordering Number	C		E		F Hex Flat	H		Working Pressure	
		in.	mm	in.	mm		in.	mm	psig	bar
<i>fractional</i>										
1/16	2-1 FV-SS	0.38	9.6	0.09	2.3	3/8	1.07	27.2	9000	620
1/8	2-2 FV-SS	0.38	9.6	0.09	2.3	7/16	1.07	27.2	9000	620
1/8	4-2 FV-SS	0.38	9.6	0.19	4.8	5/8	1.28	32.5	8000	550
1/4	4-4 FV-SS	0.57	14.5	0.25	6.4	5/8	1.49	37.8	8000	550
3/8	8-6 FV-SS	0.57	14.5	0.38	9.6	15/16	1.62	41.1	3500	240
1/2	8-8 FV-SS	0.76	19.3	0.41	10.4	15/16	1.81	46.0	3500	240
3/4	12-12 FV-SS	0.76	19.3	0.62	15.7	1 15/16	2.19	55.6	3000	200
1	16-16 FV-SS	0.95	24.1	0.87	22.1	1 15/16	2.47	62.7	2400	160

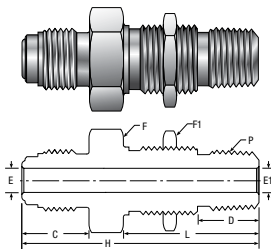

### Male Bulkhead Connector

P Male NPT Size	Ordering Number	C		D		E		E1		F Hex Flat	F1 Hex Flat	H		L		Panel Hole Size	Max. Panel Thick- ness	Working Pressure	
		in.	mm	in.	mm	in.	mm	in.	mm			in.	mm	in.	mm			psig	bar
<i>fractional</i>																			
1/4	4-4 VH2BF-SS	0.62	15.7	0.57	14.5	0.25	6.4	0.25	6.4	13/16	13/16	2.21	56.134	1.24	31.5	21/32	0.38	8000	550
1/4	8-4 VH2BF-SS	0.75	19.1	0.57	14.5	0.41	10.4	0.28	7.1	15/16	13/16	2.34	59.436	1.24	31.5	21/32	0.38	3500	240

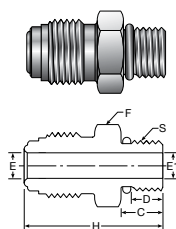

### Straight Thread O-Ring Seal Male Connector <sup>3</sup>

S Straight Thread Size	Ordering Number	C		D		E		E1		F Hex Flat	H		Uniform O-Ring Size	Working Pressure	
		in.	mm	in.	mm	in.	mm	in.	mm		in.	mm		psig	bar
<i>fractional</i>															
9/16-18	4-6 VHOA-SS	0.39	9.9	0.25	6.4	0.18	4.6	0.28	7.1	3/4	1.33	33.78	Fluorocarbon 906	4500	310
7/8-14	8-10 VHOA-SS	0.50	12.7	0.4	10.2	0.28	7.1	0.59	15.0	1	1.66	42.16	Fluorocarbon 910	3500	240
9/16-18	8-6 VHOA-SS	0.39	9.9	0.39	9.9	0.28	7.1	0.28	7.1	15/16	1.48	7.59	Fluorocarbon 906	3500	240

## Bodies (Continued)

### Female NPT Connector

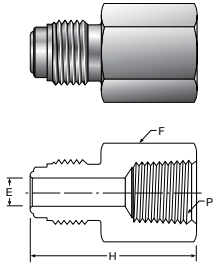

P Female NPT Size	Ordering Number	E		F Hex Flat	H		Working Pressure	
		in.	mm		in.	mm	psig	bar
<b>fractional</b>								
1/8	4-2 GV-SS	0.18	4.6	5/8	1.41	35.8	8000	550
1/4	4-4 GV-SS	0.25	6.4	3/4	1.44	36.6	6600	450
3/8	8-6 GV-SS	0.41	10.4	15/16	1.62	41.1	3500	240
1/2	8-8 GV-SS	0.41	10.4	1 1/16	1.91	48.5	3500	240
3/4	12-12 GV-SS	0.62	15.7	1 5/16	2.36	59.9	3000	200
1	16-16 GV-SS	0.87	22.1	1 5/8	2.51	63.8	2400	160

### Compression Tube Fitting Connector (A-LOK®)

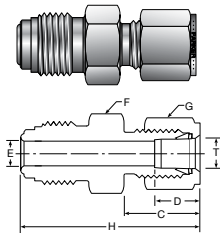

T Tube O.D.	Ordering Number	C		D		E		F Hex Flat	G Hex Flat	H		Working Pressure	
		in.	mm	in.	mm	in.	mm			in.	mm	psig	bar
<b>fractional</b>													
1/8	2-2 VHLZ-SS	0.60	15.2	0.50	12.7	0.09	2.3	5/8	7/16	1.53	38.86	8000	550
1/4	4-4 VHLZ-SS	0.70	17.8	0.60	15.2	0.19	4.8	5/8	9/16	1.62	41.15	8000	550
3/8	8-6 VHLZ-SS	0.76	19.3	0.66	16.8	0.28	7.1	15/16	11/16	1.84	46.74	3500	240
1/2	8-8 VHLZ-SS	0.87	22.1	0.90	22.9	0.41	10.4	15/16	7/8	1.95	49.53	3500	240

Dimensions - C, D, H are typical finger-tight.

Instrumentation Master Binder.

Change "L" to a "B" to select CPI™ one ferrule connector.

For maximum pressure ratings reference the Instrument Tubing Selection Guide, found in the Technical Section of your Parker

### Compression Tube Fitting Bulkhead Connector (A-LOK®)

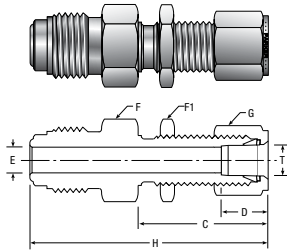

T Tube O.D.	Ordering Number	C		D		E		F Hex Flat	F1 Hex Flat	G Hex Flat	H		Panel Hole Size	Max. Panel Thick- ness	Working Pressure	
		in.	mm	in.	mm	in.	mm				in.	mm			psig	bar
<b>fractional</b>																
1/4	4-4 VH2LZ-SS	1.32	33.5	0.60	15.2	0.18	4.6	5/8	5/8	9/16	2.25	57.2	15/32	0.40	8000	550
1/4	4-4 VH2LZ-SS 1.88	1.05	26.7	0.60	15.2	0.18	4.6	5/8	5/8	9/16	1.88	47.8	15/32	0.13	8000	550
3/8	8-6 VH2LZ-SS	1.45	36.8	0.66	16.8	0.28	7.1	15/16	3/4	11/16	2.54	64.5	19/32	0.44	3500	240
1/2	8-8 VH2LZ-SS	1.65	41.9	0.90	22.9	0.41	10.4	15/16	15/16	7/8	2.74	69.6	25/32	0.50	3500	240

Dimensions - C, D, H are typical finger-tight.

Instrumentation Master Binder.

Change "L" to a "B" to select CPI™ one ferrule connector.

For maximum pressure ratings reference the Instrument Tubing Selection Guide, found in the Technical Section of your Parker

### Double Male Union

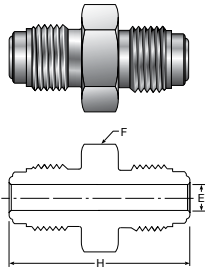

Size	Ordering Number	E		F Hex Flat	H		Working Pressure	
		in.	mm		in.	mm	psig	bar
1/8	2-2 HV-SS	0.09	2.3	3/8	1.13	28.7	9000	620
1/4	4-4 HV-SS	0.25	6.4	5/8	1.53	38.9	8000	550
1/2	8-8 HV-SS	0.41	10.4	15/16	1.84	46.7	3500	240
3/4	12-12 HV-SS	0.62	15.7	1 5/16	2.44	62.0	3000	200
1	16-16 HV-SS	0.87	22.1	1 5/8	2.59	65.8	2400	160

### Double Male Reducing Union

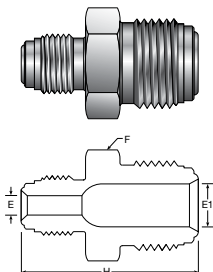

Size	Ordering Number	E		E1		F Hex Flat	H		Working Pressure	
		in.	mm	in.	mm		in.	mm	psig	bar
1/4x1/8	4-2 HV-SS	0.09	2.3	0.18	4.6	5/8	1.37	34.8	8000	550
1/2x1/4	8-4 HV-SS	0.18	4.6	0.41	10.4	15/16	1.71	43.4	3500	240

- ① Uses 2 BV-SS and 2 BVI-SS nuts
- ② May contain internal transitions
- ③ O-rings fluorocarbon is standard.  
Contact local Parker representative  
for other available materials

## Bodies (Continued)

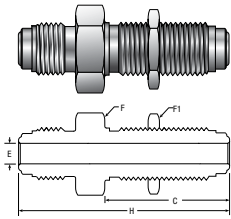

### Bulkhead Union

Size	Ordering Number	C		E		F Hex Flat	F1 Hex Flat	H		Panel Hole Size	Max. Panel Thickness	Working Pressure	
		in.	mm	in.	mm	in.	mm	in.	mm			psig	bar
1/4	4-4 WBV-SS 2.23	1.30	33.0	0.25	6.4	3/4	3/4	2.23	56.6	19/32	0.44	8000	550
1/4	4-4 WBV-SS 1.82	0.99	25.1	0.25	6.4	3/4	3/4	1.82	46.2	19/32	0.13	8000	550
1/2	8-8 WBV-SS 2.57	1.45	36.8	0.41	10.4	1 1/16	1 1/16	2.57	65.3	29/32	0.50	3500	240
1/2	8-8 WBV-SS 2.14	1.11	28.2	0.41	10.4	1 1/16	1 1/16	2.14	54.4	29/32	0.13	3500	240

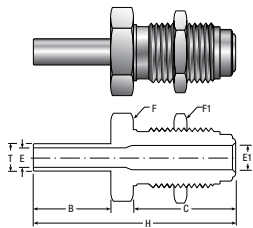

### Tube Butt Weld Bulkhead Connector

T Tube O.D. Size	Ordering Number	B		C		E		E1		F Hex Flat	F1 Hex Flat	H		Panel Hole Size	Max. Panel Thickness	Working Pressure	
		in.	mm	in.	mm	in.	mm	in.	mm	in.	mm	in.	mm			psig	bar
<i>fractional</i>																	
1/4	4-4 T3H2BV-* 2.36	0.75	19.1	1.30	33.0	0.18	4.6	0.22	5.6	3/4	3/4	2.36	59.9	19/32	0.44	5100	350
1/4	4-4 T3H2BV-* 1.95	0.75	19.1	0.99	25.1	0.18	4.6	0.22	5.6	3/4	3/4	1.95	49.5	19/32	0.13	5100	350

### Coupling

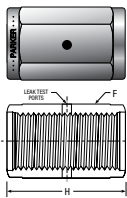

Size	Ordering Number	F Hex Flat	H	
			in.	mm
1/8	2 VHC-SS	7/16	0.66	16.8
1/4	4 VHC-SS	3/4	1.19	30.2
1/2	8 VHC-SS	1 1/16	1.31	33.3
3/4	12 VHC-SS	1 1/2	1.68	42.7
1	16 VHC-SS	1 3/4	2.04	51.8

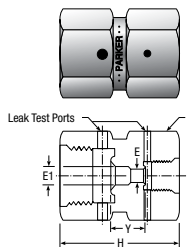

### Double Female Reducing Union

Size	Ordering Number	E		E1		F Hex Flat	H		Y		Working Pressure	
		in.	mm	in.	mm		in.	mm	in.	mm	psig	bar
1/4x1/8	4-2 HV7-SS	0.13	3.3	.25	6.4	3/4	1.16	29.5	0.36	9.1	8000	550
1/2x1/4	8-4 HV7-SS	0.25	6.4	.41	10.3	1 1/16	1.41	35.8	0.35	8.9	3500	240

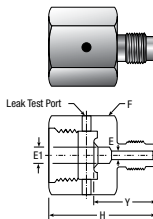

### Reducing Adapter

Size	Ordering Number	E		E1		F Hex Flat	H		Y		Working Pressure	
		in.	mm	in.	mm		in.	mm	in.	mm	psig	bar
1/8x1/4	4-2 V7HV-SS	0.09	2.3	.25	6.4	3/4	1.19	30.2	0.69	17.5	8000	550
1/4x1/2	8-4 V7HV-SS	0.18	4.6	.41	10.3	1 1/16	1.41	35.8	0.85	21.6	3500	240

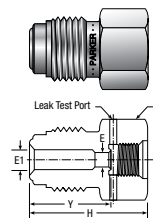

### Reducing Bushing

Size	Ordering Number	E		E1		F Hex Flat	H		Y		Working Pressure	
		in.	mm	in.	mm		in.	mm	in.	mm	psig	bar
1/4x1/8	4-2 VH7-SS	0.13	3.3	.18	4.6	5/8	1.06	26.9	0.76	19.3	8000	550
1/2x1/4	8-4 VH7-SS	0.25	6.4	.41	10.3	15/16	1.41	35.8	0.91	23.1	3500	240



## Bodies (Continued)

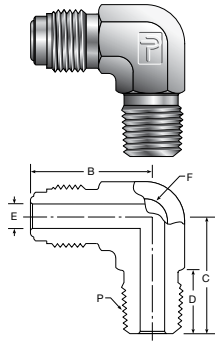

**VacuSeal™ To Male NPT Elbow**

P Male NPT Size	Ordering Number	B		C		D		E		F Hex Flat	Working Pressure	
		in.	mm	in.	mm	in.	mm	in.	mm		psig	bar
1/8	2-2 CV-SS	1.07	27.2	0.87	22.1	0.38	9.6	0.18	4.6	9/16	8000	550
1/4	4-4 CV-SS	1.13	28.7	1.06	26.9	0.57	14.5	0.25	6.4	9/16	8000	550
3/8	8-6 CV-SS	1.45	36.8	1.26	32.0	0.57	14.5	0.40	10.2	7/8	3500	240
1/2	8-8 CV-SS	1.31	33.3	1.31	33.3	0.76	19.3	0.41	10.4	7/8	3500	240

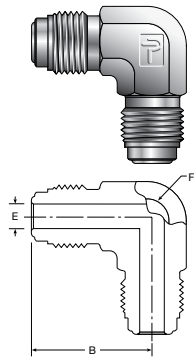

**Union Elbow**

Size	Ordering Number	B		E		F Wrench Flat	Working Pressure	
		in.	mm	in.	mm		psig	bar
1/8	2-2 EV-SS	0.89	22.6	0.09	2.3	7/16	9000	620
1/4	4-4 EV-SS	1.13	28.7	0.25	6.4	9/16	8000	550
1/2	8-8 EV-SS	1.31	33.3	0.41	10.4	7/8	3500	240
3/4	12-12 EV-SS	1.92	48.8	0.62	15.7	1 1/4	3000	200
1	16-16 EV-SS	2.00	50.8	0.87	22.1	1 5/8	2400	160

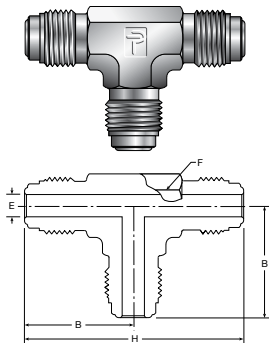

**Union Tee**

Size	Ordering Number	B		E		H		F Wrench Flat	Working Pressure	
		in.	mm	in.	mm	in.	mm		psig	bar
1/8	2-2-2 JV-SS	0.89	22.6	0.09	2.3	1.78	45.21	7/16	9000	620
1/4	4-4-4 JV-SS	1.13	28.7	0.25	6.4	2.25	57.15	9/16	8000	550
1/2	8-8-8 JV-SS	1.31	33.3	0.41	10.4	2.62	66.55	7/8	3500	240
3/4	12-12-12 JV-SS	1.92	48.8	0.62	15.7	3.84	97.54	1 1/4	3000	200
1	16-16-16 JV-SS	2.00	50.8	0.87	22.1	4.00	101.6	1 5/8	2400	160

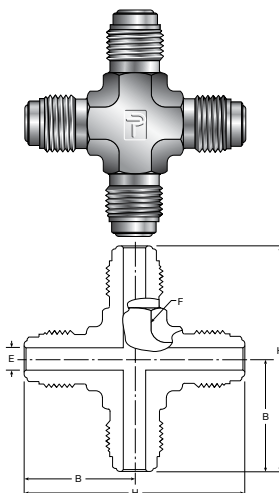

**Union Cross**

Size	Ordering Number	B		E		H		F Wrench Flat	Working Pressure	
		in.	mm	in.	mm	in.	mm		psig	bar
1/8	2 KV-SS	0.89	22.6	0.09	2.3	1.78	45.21	7/16	9000	620
1/4	4 KV-SS	1.13	28.7	0.25	6.4	2.25	57.15	9/16	8000	550
1/2	8 KV-SS	1.45	36.8	0.41	10.4	2.90	73.66	7/8	3500	240
3/4	12 KV-SS	1.92	48.8	0.62	15.7	3.84	97.54	1 1/4	3000	200
1	16 KV-SS	2.00	50.8	0.87	22.1	4.00	101.6	1 5/8	2400	160

- ① Uses 2 BV-SS and 2 BVI-SS nuts
- ② May contain internal transitions
- ③ O-rings fluorocarbon is standard.  
Contact local Parker representative  
for other available materials

## Welded Assemblies

### Male NPT Connector

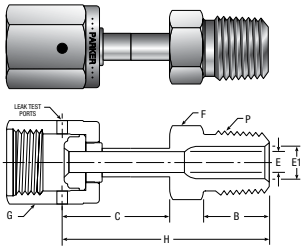

P Male NPT Size	Ordering Number	B		C		E		E1		F Hex Flat	G Hex Flat	H		Working Pressure	
		in.	mm	in.	mm	in.	mm	in.	mm			in.	mm	psig	bar
<b>fractional</b>															
1/8	2-2 V1HBF-*	.38	9.6	0.95	24.1	0.18	4.6	0.19	4.8	7/16	3/4	1.58	40.1	8000	550
1/4	4-4 V1HBF-*	.57	14.5	0.93	23.6	0.18	4.6	0.28	7.1	9/16	3/4	1.79	45.5	5100	350
3/8	8-6 V1HBF-*	.57	14.5	1.00	25.4	0.40	10.2	0.41	10.3	1 1/16	1 1/16	1.89	48.0	3500	240
1/2	8-8 V1HBF-*	.76	19.3	1.01	25.6	0.40	10.2	0.53	13.5	7/8	1 1/16	2.09	53.1	3500	240

### Female NPT Connector

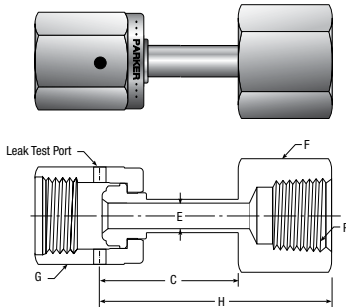

P Female NPT Size	Ordering Number	C		E		F Hex Flat	G Hex Flat	H		Working Pressure	
		in.	mm	in.	mm			in.	mm	psig	bar
<b>fractional</b>											
1/4	4-4 V1HBG-*	1.05	26.7	0.18	4.6	3/4	3/4	1.77	45.0	5100	350
3/8	8-6 V1HBG-*	1.06	26.9	0.40	10.2	7/8	1 1/16	1.95	49.5	3500	240
1/2	8-8 V1HBG-*	1.04	26.4	0.40	10.2	1 1/16	1 1/16	2.18	55.4	3500	240

### Compression Tube Fitting Connector (A-LOK)

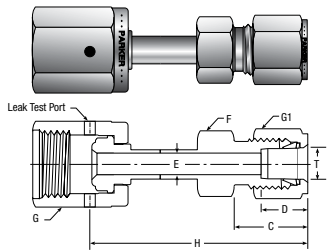

T Tube O.D.	Ordering Number	C		D		E		F Hex Flat	G Hex Flat	G1 Hex Flat	H		Working Pressure	
		in.	mm	in.	mm	in.	mm				in.	mm	psig	bar
<b>fractional</b>														
1/4	4-4 V1HLZ-*	0.70	17.8	0.60	15.2	0.18	4.6	1/2	3/4	9/16	1.94	49.3	5100	350
3/8	4-6 V1HLZ-*	0.76	19.3	0.67	17.0	0.18	4.6	5/8	3/4	11/16	1.97	50.0	5100	350
1/2	8-8 V1HLZ-*	0.87	22.1	0.90	22.9	0.40	10.2	13/16	1 1/16	1 7/8	2.23	56.6	3500	240

Dimensions - C, D, H are typical finger-tight.

Change "L" to a "B" to select CPI™ one ferrule connector.

Instrumentation Master Binder.

For maximum pressure ratings reference the Instrument Tubing Selection Guide, found in the Technical Section of your Parker

### Rotating Female Union

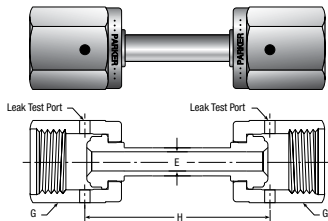

Size	Ordering Number	E		G Hex Flat	H		Working Pressure	
		in.	mm		in.	mm	psig	bar
1/4	4-4 V1HBV1-*	.18	4.6	3/4	1.35	34.3	5100	350
1/4	4-4 V1HBV1-* 1.70	.18	4.6	3/4	1.70	43.2	5100	350
1/2	8-8 V1HBV1-*	.40	10.2	1 1/16	1.25	31.8	3500	240
1/2	8-8 V1HBV1-* 1.84	.40	10.2	1 1/16	1.84	46.7	3500	240

### Female Elbow

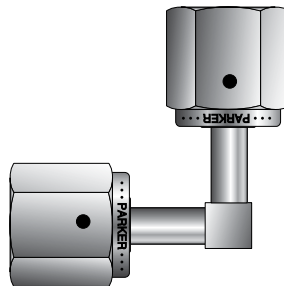

Ordering Number:  
MEM-44-\*VVFV

### Female Tee

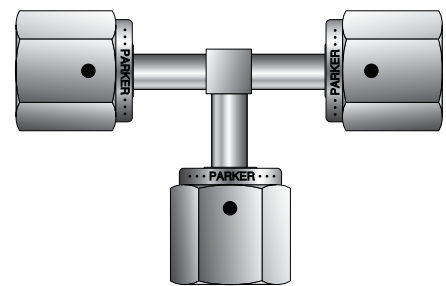

Ordering Number:  
MJM-444-\*VVFVVF

## Welded Modules

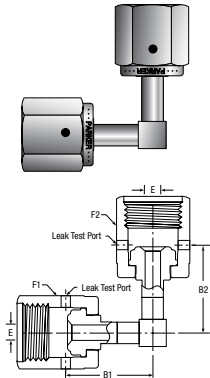

### Elbow Modules

Size	Ordering Number	B1		B2		E		F1 Hex Flat	F2 Hex Flat	Working Pressure	
		in.	mm	in.	mm	in.	mm			psig	bar
<b>fractional</b>											
1/4	MEM-44*VMSVF	1.60	40.6	1.00	25.4	0.18	4.6	5/8	3/4	5100	350
1/4	MEM-44*VMSVMS	1.60	40.6	1.60	40.6	0.18	4.6	5/8	5/8	5100	350
1/4	MEM-44*VFVF	1.00	25.4	1.00	25.4	0.18	4.6	3/4	3/4	5100	350
1/2	MEM-88*VFVF	1.17	29.7	1.17	29.7	0.18	4.6	1 1/16	1 1/16	3500	240

### Tee Modules

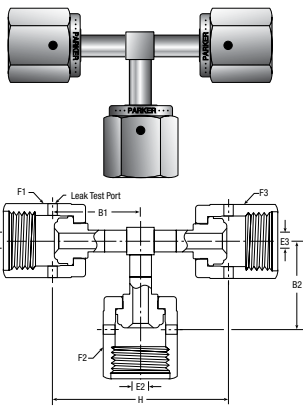

Size	Ordering Number	B1		B2		H		E1		E2		E3		F1 Hex Flat	F2 Hex Flat	F3 Hex Flat	Working Pressure	
		in.	mm	in.	mm	in.	mm	in.	mm	in.	mm	in.	mm				psig	bar
<b>fractional</b>																		
1/4	MJM-444*VFVFVMS	1.00	25.4	1.00	25.4	2.60	66.0	0.18	4.6	0.18	4.6	0.18	4.6	3/4	3/4	5/8	5100	350
1/4	MJM-444*VFVMSVMS	1.00	25.4	1.60	40.6	2.60	66.0	0.18	4.6	0.18	4.6	0.18	4.6	3/4	5/8	5/8	5100	350
1/4	MJM-444*VFVFVF	1.00	25.4	1.00	25.4	2.00	50.8	0.18	4.6	0.18	4.6	0.18	4.6	3/4	3/4	3/4	5100	350
1/4	MJM-444*VMSVMSVMS	1.60	40.6	1.60	40.6	3.20	81.3	0.18	4.6	0.18	4.6	0.18	4.6	5/8	5/8	5/8	5100	350
1/2x1/4	MJM-884*VFVMSVF	1.17	29.7	1.12	28.4	3.20	81.3	0.40	10.2	0.18	4.6	0.40	10.2	1 1/16	3/4	15/16	3500	240

### Cross Modules

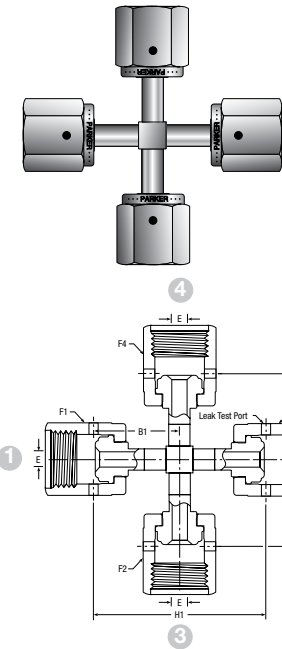

Size	Ordering Number	B1		B2		H1		H2		E		F1	F2	F3	F4	Working Pressure	
		in.	mm	in.	mm	in.	mm	in.	mm	in.	mm					psig	bar
<b>fractional</b>																	
1/4	MKM-4444*VMSVFVFVF	1.60	40.6	1.00	25.4	2.60	66.0	2.00	50.8	0.18	4.6	5/8	3/4	3/4	3/4	5100	350
1/4	MKM-4444*VFVFVFVF	1.00	25.4	1.00	25.4	2.00	50.8	2.00	50.8	0.18	4.6	3/4	3/4	3/4	3/4	5100	350

### Welded Module Ordering Information:

MKM - 4 4 4 4 2 VF VF VF VF  
 Type                                  Size                                  Stainless Steel 316L                                  End Connections

VF = Female VacuSeal™ Swivel  
VMS = Male VacuSeal™ Swivel  
Replace asterisk with 2 to specify Stainless Steel 316L.  
For additional configurations and sizes contact your local Parker Representative.

# VacuSeal™ Fittings

## Gaskets

VacuSeal™ gaskets are compatible with other high quality gasket face seal fittings.

### Non-Retained Flat Style

Size	Ordering Number	E		H		Tx	
		in.	mm	in.	mm	in.	mm
1/8	2 VG-*	0.09	2.3	0.02	0.5	0.26	6.6
1/4	4 VG-*	0.22	5.5	0.03	0.8	0.47	11.9
1/2	8 VG-*	0.44	11.1	0.03	0.8	0.78	19.9
3/4	12 VG-*	0.66	16.8	0.03	0.8	1.14	28.9
1	16 VG-*	0.89	22.7	0.03	0.8	1.41	35.7

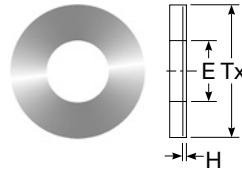

### Retained Flat Style

Retainer and gasket must be used as an assembly.

Note: Nickel Retained Flat Style Gaskets utilize a Stainless Steel Retainer

Size	Ordering Number	E		H		Tx	
		in.	mm	in.	mm	in.	mm
1/4	4 VGR-*	0.23	5.8	0.03	0.8	0.50	12.7
1/2	8 VGR-*	0.44	11.2	0.03	0.8	0.79	20.1

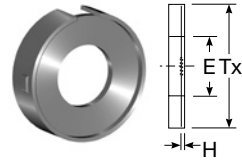

### Non-Retained Grooved Style (TorqTite™ Gasket)

Size	Ordering Number	E		H		Tx		T	
		in.	mm	in.	mm	in.	mm	in.	mm
1/4	4 GVGR-*	0.21	5.3	0.06	1.6	0.50	12.6	0.03	0.8
1/2	8 GVGR-*	0.43	10.9	0.06	1.6	0.78	19.8	0.03	0.8

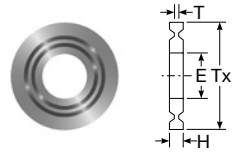

### Retained Grooved Style (Retained TorqTite™ Gasket)

Size	Ordering Number	E		H		Tx		T	
		in.	mm	in.	mm	in.	mm	in.	mm
1/4	4 GVGR-*	0.21	5.3	0.06	1.6	0.49	12.4	0.03	0.8
1/2	8 GVGR-*	0.43	10.9	0.06	1.6	0.79	20.1	0.03	0.8

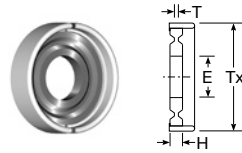

### Gasket Ordering Information

Specify gasket material by replacing asterisk with appropriate Ordering Number Designator.

MATERIAL	ORDERING NUMBER DESIGNATOR	EXAMPLE
High-Purity Nickel (electropolished)	N	4 VGR-N
Stainless Steel <sup>3</sup>	SS	4 VGR-SS
Teflon <sup>®</sup> 12	T	4 VG-T

Blind (undrilled) gaskets are available by adding a -BL suffix at the end of the part number.

Example: 4 VG-N-BL

- 1 Parker uses Teflon® or equal PTFE Polymer
- 2 Teflon® is only available for Non-Retained Flat Style gaskets
- 3 Stainless Steel gaskets are Silver plated

Teflon® is a registered trademark of Dupont Company

The retainer of Parker's patented Retained Flat Gasket helps to both locate the gasket over the toroid of the gland and hold the gasket in place during assembly, therefore minimizing radial damage to the toroids of the connection.

The unique design of the retainer minimizes potential scratches or nicks to the critical toroid surfaces during placement onto the gland.

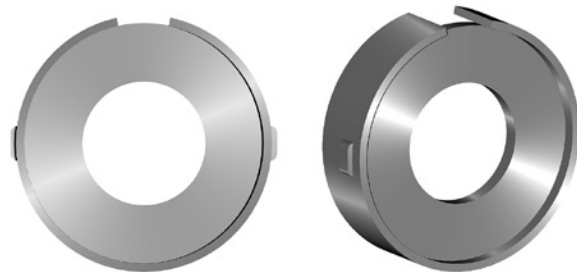

Note: All gaskets must be ordered in increments of 10

## Nuts, Caps, and Plugs

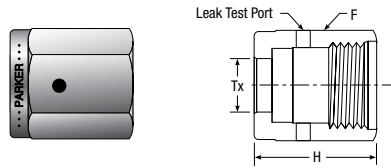

### Female Nut

Ordering Number	Size	F Hex Flat	H		Tx	
			in.	mm	in.	mm
2 BV-SS	1/8	7/16	0.53	13.5	0.21	5.3
4 BV-SS*	1/4	3/4	0.82	20.8	0.36	9.1
8 BV-SS	1/2	1 1/16	0.88	22.4	0.61	15.5
12 BV-SS	3/4	1 1/2	1.12	28.4	0.89	22.6
16 BV-SS	1	1 3/4	1.34	34.0	1.20	30.5

\*Previous Part Number 4 BV SS-D

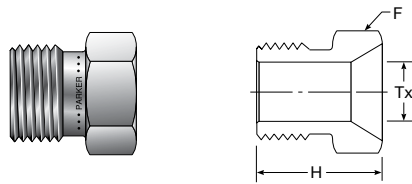

### Male Nut

Ordering Number	Size	F Hex Flat	H		Tx	
			in.	mm	in.	mm
2-BVI-SS	1/8	3/8	0.50	12.7	0.21	5.3
4 BVI-SS	1/4	5/8	0.72	18.3	0.36	9.1
8-BVI-SS	1/2	15/16	0.81	20.6	0.61	15.5
12-BVI-SS	3/4	1 5/16	1.00	25.4	0.89	22.6
16-BVI-SS	1	1 5/8	1.19	30.2	1.20	30.5

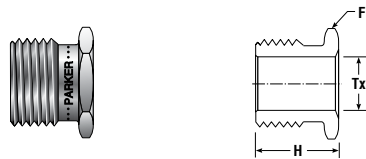

### Short Male Nut

Ordering Number	Size	F Hex Flat	H		Tx	
			in.	mm	in.	mm
4 BVI .54-SS	1/4	5/8	0.54	13.7	0.36	9.1
4 BVI .65-SS	1/4	5/8	0.65	16.5	0.36	9.1

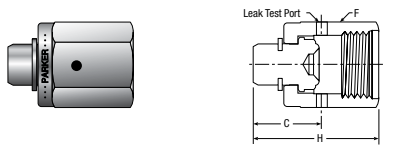

### Cap

Ordering Number	Size	C		F Hex Flat	H	
		in.	mm		in.	mm
4 FNV-SS	1/4	0.59	15.0	3/4	1.09	27.7
8 FNV-SS	1/2	0.59	15.0	1 1/16	1.16	29.5
12 FNV-SS	3/4	0.66	16.8	1 1/2	1.41	35.8
16 FNV-SS	1	0.63	16.0	1 3/4	1.55	39.4

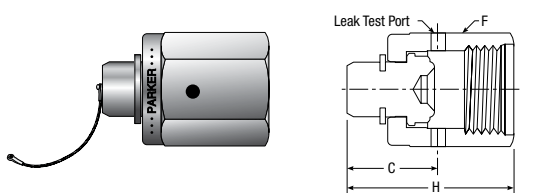

### Cap With Lanyard

Ordering Number	Size	C		F Hex Flat	H		Lanyard Length	
		in.	mm		in.	mm	in.	mm
4 FNV-SS-L	1/4	0.59	15.0	3/4	1.09	27.7	6	152.4
8 FNV-SS-L	1/2	0.59	15.0	1 1/16	1.16	29.5	6	152.4

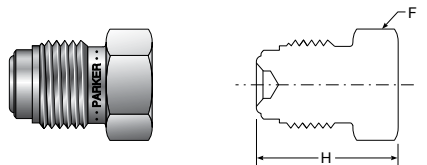

### Plug

Ordering Number	Size	F Hex Flat	H	
			in.	mm
2 PNV-SS	1/8	3/8	0.68	17.3
4 PNV-SS	1/4	5/8	0.91	23.1
8 PNV-SS	1/2	15/16	1.08	27.4
12 PNV-SS	3/4	1 5/16	1.43	36.3
16 PNV-SS	1	1 5/8	1.52	38.6

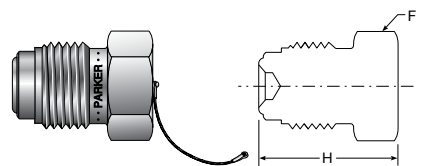

### Plug With Lanyard

Ordering Number	Size	F Hex Flat	H		Lanyard Length	
			in.	mm	in.	mm
4 PNV-SS-L	1/4	5/8	0.91	23.1	6	152.4
8 PNV-SS-L	1/2	15/16	1.08	27.4	6	152.4



### Protective Shipping Cap

Ordering Number	Size
C-VacuSeal	1/4

4 Taper in the back of nut allows mobility around 90° bends

## Hi-Flo Products

### Glands

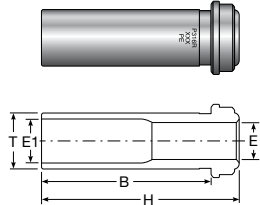

#### Tube Butt Weld

T Tube O.D.	Ordering Number	B		E		E1		H		Working Pressure	
		in.	mm	in.	mm	in.	mm	in.	mm	psig	bar
<i>fractional</i>											
3/8	4-6 VH1T3-*.60	0.41	10.4	0.25	6.4	0.30	7.6	0.60	15.2	3300	220
3/8	4-6 VH1T3-*	1.00	25.4	0.25	6.4	0.30	7.6	1.19	30.2	3300	220
3/8	4-6 VH1T3-*.1.31	1.12	28.4	0.25	6.4	0.30	7.6	1.31	33.3	3300	220

### Bodies

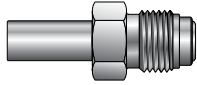

#### Tube Butt Weld

T Tube O.D.	Ordering Number	B		C		E		E1		F Hex Flat	H		Working Pressure	
		in.	mm	in.	mm	in.	mm	in.	mm	in.	mm	psig	bar	
<i>fractional</i>														
3/8	4-6 VHT3-*.1.68	0.75	19.1	0.62	15.7	0.25	6.4	0.30	7.6	5/8	1.68	42.7	3300	220

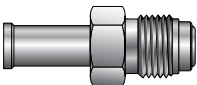
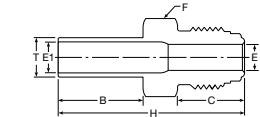

#### Automatic Tube Weld

T Tube O.D.	Ordering Number	B		C		D		E		E1		F Hex Flat	H		Tx	Working Pressure		
		in.	mm	in.	mm	in.	mm	in.	mm	in.	mm	in.	mm	in.	mm	psig	bar	
<i>fractional</i>																		
3/8	4-6 VHY3-*.1.71	0.75	19.1	0.62	15.7	0.03	0.8	0.25	6.4	0.30	7.6	5/8	1.71	43.4	0.41	10.4	3300	220

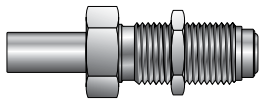
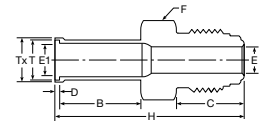

#### Bulkhead Connector

T Tube O.D.	Ordering Number	B		C		E		E1		F Hex Flat	F1 Hex Flat	H		Panel Hole Size	Max. Panel Thick- ness	Working Pressure	
		in.	mm	in.	mm	in.	mm	in.	mm	in.	mm	in.	mm	in.	mm	psig	bar
<i>fractional</i>																	
3/8	6-4 T3H2BV-*.2.36	0.75	19.1	1.30	33.0	0.23	5.8	0.30	7.6	3/4	3/4	2.36	60	19/32	0.44	3300	220

### Nuts

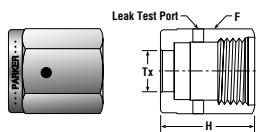

#### Female Nut

Size	Ordering Number	F Hex Flat	H		Tx	
			in.	mm	in.	mm
3/8	4 BVH-SS	3/4	0.82	20.8	0.39	9.9

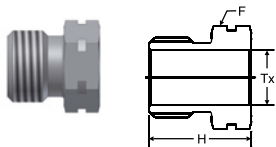

#### Male Nut

Size	Ordering Number	F Hex Flat	H		Tx	
			in.	mm	in.	mm
3/8	4 BVHI-SS	5/8	0.72	18.3	0.39	9.9

## Featured Products

### TorqTite™

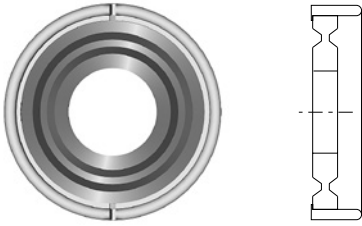

#### Check out the TorqTite™ Self-Aligning Face Seal Gasket

- Needs no installation tools
- Virtually eliminates loosening of components due to thermocycling and vibration (i.e. transportation)
- Seals even on damaged toroids
- Allows for higher torque without damaging sealing surfaces
- Easy open clean room bag requires no cutting
- Color coded retainers for material recognition
- Minimizes particle generation

## Make-Up Instructions

### Flat and Grooved Gasket Assembly

#### Step 1

Remove gasket from packaging.

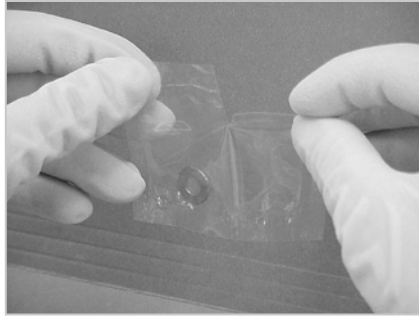

#### Step 2

Place gasket into female VacuSeal™ nut.

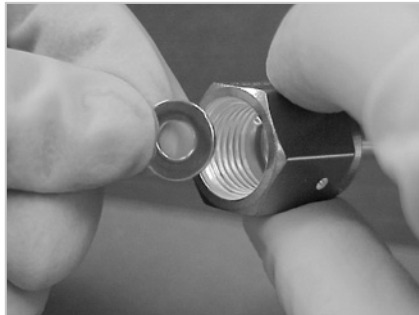

#### Step 3

Assemble components and snug to fingertight.

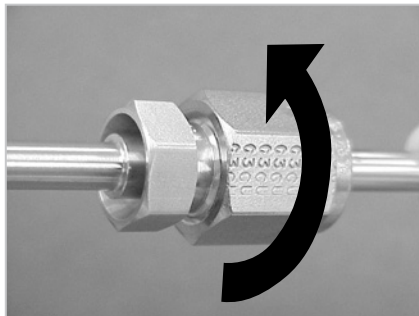

#### Step 4

Scribe the hex flat of both the male and female nuts.

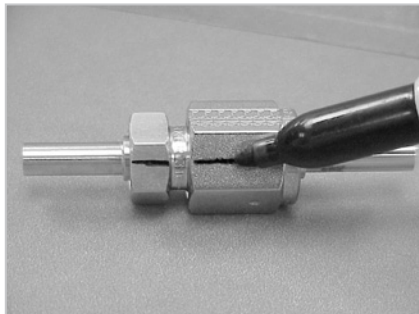

#### Step 5

Holding the backup wrench stationary, tighten the female nut 1/8 turn past fingertight.

**Warning:** Extreme over tightening will damage toroid surface and cause potential leakage.

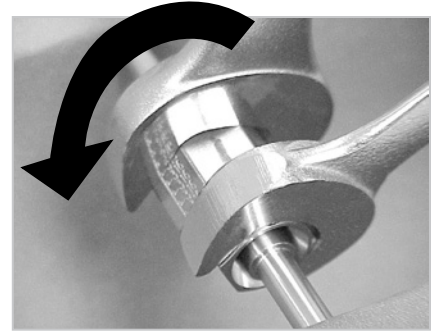

### Flat Gasket Remake

Upon remake of flat VacuSeal™ gasket, a new gasket must be installed for each remake, follow procedures for initial make-up.

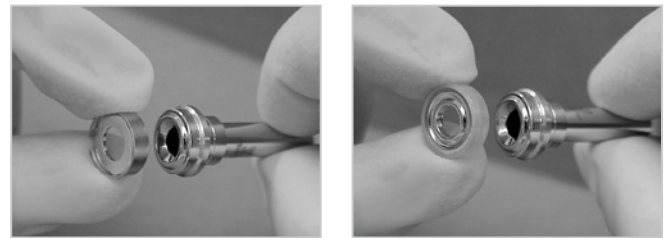

### Retained Gaskets Assembly

Guide retained gaskets over gland face, then continue step 3 of Flat and Grooved Gasket Assembly for completion of make-up.

### Protective Shipping Cap

Metallic protector caps are available to protect critical toroid surface from damage see page 11.

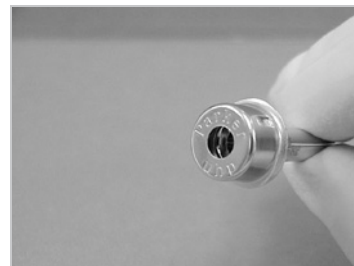



## Ordering Instructions

### How To Order

Parker VacuSeal™ components are ordered by Ordering Number, as listed in this catalog. Replace the asterisk within each Ordering Number with the corresponding material designator listed below.

### Assembly Example:

If your system requires a VacuSeal™ assembly connecting from 1/4" O.D. tubing to 1/4" O.D. tubing, you may order the following parts.



*Note: Each component must be ordered separately.*

### Nomenclature

Part numbers of Parker VacuSeal™ components are constructed from symbols that identify the size, configuration and material of each component.

### Component Example:

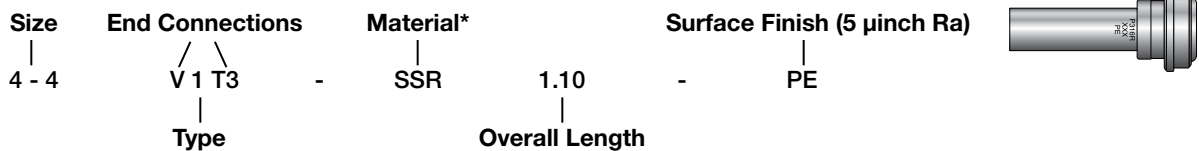

**Size:** Tube and Pipe are designated by the number of sixteenths of an inch. (i.e. 1/4" Pipe Thread = 4/16" = 4)  
Metric Tube O.D. is designated in millimeters with the suffix "M".  
(i.e. 4-6M V1T3-SSR 1.16)

**Type:** Designate shape of component.  
(i.e. 1=gland, E=elbow, J=tee, K=cross, etc.)

**\*Material:** Replace asterisks in Part Number to specify material:  
SS = Stainless Steel 316 (All non-welded bodies and components)  
SSR = Stainless Steel 316L VAR  
SSV = Stainless Steel 316L VIM/VAR  
Nickel and Hastelloy C-22® available upon request.

Forged product will be offered as a 15 RA or a standard.

**Size:** End Connections: Specify VacuSeal™ end first, followed by other corresponding ends:  
V = VacuSeal™  
M = Butt weld with .25" tube stub length  
T3 = Butt weld with .75" tube stub length  
TW = Butt weld with various tube stub length  
Y3 = Butt weld with End Collar  
W = Socket Weld

**Overall Length:** Specify length of component in inches.

*Note: Contact Parker representative for information on additional materials.*

### VacuSeal End Data Information

Size	VacuSeal Thread	*L	**C	H Hex	E
		in.	in.	in.	in.
4	9/16-18	.62	.97	5/8	.19
6	7/8-14	.75	1.10	15/16	.28
8	7/8-14	.75	1.10	15/16	.41
12	1-1/4-18	1.00	1.40	1-5/16	.53

\*Average Value

\*\*Dimension C is shown in the finger tight position

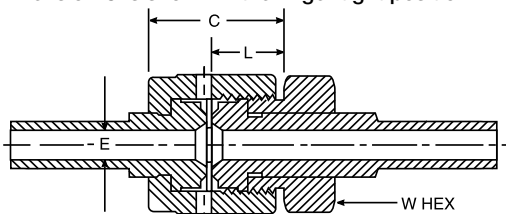

### Additional Products

#### MiniButtwelds™

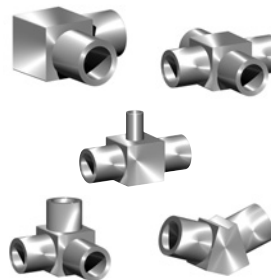

#### UltraSeal™ Fittings



Parker offers a full line of MiniButtweld™ products to complement the VacuSeal™ product line. Please refer to MiniButtweld™ (25000258) and UltraSeal™ (25000259) Fittings Catalogs for additional information.



# Parker's Motion & Control Technologies

At Parker, we're guided by a relentless drive to help our customers become more productive and achieve higher levels of profitability by engineering the best systems for their requirements. It means looking at customer applications from many angles to find new ways to create value. Whatever the motion and control technology need, Parker has the experience, breadth of product and global reach to consistently deliver. No company knows more about motion and control technology than Parker. For further info call 1-800-C-Parker.



## AEROSPACE

### Key Markets

- Aircraft engines
- Business & general aviation
- Commercial transports
- Land-based weapons systems
- Military aircraft
- Missiles & launch vehicles
- Regional transports
- Unmanned aerial vehicles

### Key Products

- Flight control systems & components
- Fluid conveyance systems
- Fluid metering delivery & atomization devices
- Fuel systems & components
- Hydraulic systems & components
- Inert nitrogen generating systems
- Pneumatic systems & components
- Wheels & brakes



## CLIMATE CONTROL

### Key Markets

- Agriculture
- Air conditioning
- Food, beverage & dairy
- Life sciences & medical
- Precision cooling
- Processing
- Transportation

### Key Products

- CO<sub>2</sub> controls
- Electronic controllers
- Filter driers
- Hand shut-off valves
- Hose & fittings
- Pressure regulating valves
- Refrigerant distributors
- Safety relief valves
- Solenoid valves
- Thermostatic expansion valves

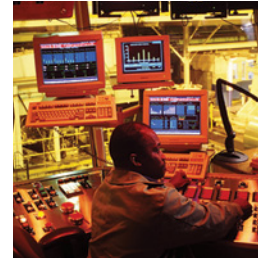

## ELECTROMECHANICAL

### Key Markets

- Aerospace
- Factory automation
- Life science & medical
- Machine tools
- Packaging machinery
- Paper machinery
- Plastics machinery & converting
- Primary metals
- Semiconductor & electronics
- Textile
- Wire & cable

### Key Products

- AC/DC drives & systems
- Electric actuators, gantry robots & slides
- Electrohydraulic actuation systems
- Electromechanical actuation systems
- Human machine interface
- Linear motors
- Stepper motors, servo motors, drives & controls
- Structural extrusions

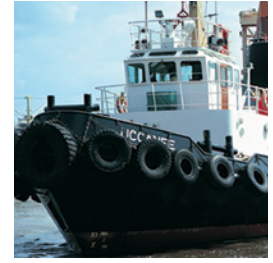

## FILTRATION

### Key Markets

- Food & beverage
- Industrial machinery
- Life sciences
- Marine
- Mobile equipment
- Oil & gas
- Power generation
- Process
- Transportation

### Key Products

- Analytical gas generators
- Compressed air & gas filters
- Condition monitoring
- Engine air, fuel & oil filtration & systems
- Hydraulic, lubrication & coolant filters
- Process, chemical, water & microfiltration filters
- Nitrogen, hydrogen & zero air generators



## FLUID & GAS HANDLING

### Key Markets

- Aerospace
- Agriculture
- Bulk chemical handling
- Construction machinery
- Food & beverage
- Fuel & gas delivery
- Industrial machinery
- Mobile
- Oil & gas
- Transportation
- Welding

### Key Products

- Brass fittings & valves
- Diagnostic equipment
- Fluid conveyance systems
- Industrial hose
- PTFE & PFA hose, tubing & plastic fittings
- Rubber & thermoplastic hose & couplings
- Tube fittings & adapters
- Quick disconnects



## HYDRAULICS

### Key Markets

- Aerospace
- Aerial lift
- Agriculture
- Construction machinery
- Forestry
- Industrial machinery
- Mining
- Oil & gas
- Power generation & energy
- Truck hydraulics

### Key Products

- Diagnostic equipment
- Hydraulic cylinders & accumulators
- Hydraulic motors & pumps
- Hydraulic systems
- Hydraulic valves & controls
- Power take-offs
- Rubber & thermoplastic hose & couplings
- Tube fittings & adapters
- Quick disconnects

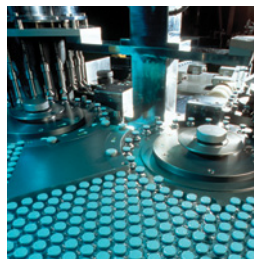

## PNEUMATICS

### Key Markets

- Aerospace
- Conveyor & material handling
- Factory automation
- Life science & medical
- Machine tools
- Packaging machinery
- Transportation & automotive

### Key Products

- Air preparation
- Brass fittings & valves
- Manifolds
- Pneumatic accessories
- Pneumatic actuators & grippers
- Pneumatic valves & controls
- Quick disconnects
- Rotary actuators
- Rubber & thermoplastic hose & couplings
- Structural extrusions
- Thermoplastic tubing & fittings
- Vacuum generators, cups & sensors



## PROCESS CONTROL

### Key Markets

- Chemical & refining
- Food, beverage & dairy
- Medical & dental
- Microelectronics
- Oil & gas
- Power generation

### Key Products

- Analytical sample conditioning products & systems
- Fluoropolymer chemical delivery fittings, valves & pumps
- High purity gas delivery fittings, valves & regulators
- Instrumentation fittings, valves & regulators
- Medium pressure fittings & valves
- Process control manifolds



## SEALING & SHIELDING

### Key Markets

- Aerospace
- Chemical processing
- Consumer
- Energy, oil & gas
- Fluid power
- General industrial
- Information technology
- Life sciences
- Military
- Semiconductor
- Telecommunications
- Transportation

### Key Products

- Dynamic seals
- Elastomeric o-rings
- EMI shielding
- Extruded & precision-cut, fabricated elastomeric seals
- Homogeneous & inserted elastomeric shapes
- High temperature metal seals
- Metal & plastic retained composite seals
- Thermal management



ENGINEERING YOUR SUCCESS.

Parker Hannifin Corporation  
**Veriflo Division**  
250 Canal Blvd  
Richmond, California 94804

phone 510 235 9590  
fax 510 232 7396  
veriflo.sales@parker.com

[www.parker.com/veriflo](http://www.parker.com/veriflo)

Parker Hannifin Corporation  
**Veriflo Division**  
**UHP Chemical Delivery**  
7075 East Southpoint Road  
Tucson, Arizona 85756

phone 520 574 2600  
fax 520 574 2700

