



Product Catalog

# Packaged Rooftop Air Conditioners Foundation™ Electric/Electric

3 to 5 Tons, 50Hz





# Introduction

## Packaged Rooftop Air Conditioners



Through the years, Trane has designed and developed the most complete line of Packaged Rooftop products available in the market today.

Trane customers demanded a product that provided exceptional reliability, was easy to install, and was competitively priced. Trane listened and is proud to introduce the new Trane Foundation™ Light Commercial rooftop unit.

With Foundation, Trane continues to provide the highest standards in quality and reliability, comfort, performance, and ease of installation.

## Copyright

This document and the information in it are the property of Trane, and may not be used or reproduced in whole or in part without written permission. Trane reserves the right to revise this publication at any time, and to make changes to its content without obligation to notify any person of such revision or change.

## Trademarks

Trane and the Trane logo, and Foundation are trademarks of Trane in the United States and other countries. All trademarks referenced in this document are the trademarks of their respective owners.

## Revision History

- Updated 2-inch MERV 13 throwaway filters information in Features and Benefits, Electrical Data and Mechanical Specifications chapters.
- Running edits.



# Table of Contents

Features and Benefits .....	4
Standard and Optional Features at a Glance .....	4
Outstanding Standard Features .....	5
Variety of Options .....	7
Other Benefits .....	8
Application Considerations .....	9
Selection Procedure .....	10
Cooling Capacity .....	10
Heating Capacity .....	11
Air Delivery Selection .....	11
Model Number Description .....	12
General Data .....	13
Performance Data .....	14
Controls .....	25
Thermostats .....	25
Electrical Data .....	26
Jobsite Connections .....	28
Dimensional Data .....	29
Weights .....	33
Mechanical Specifications .....	34



## Features and Benefits

Foundation™ has features and benefits that make it first class in the light commercial rooftop market. Designed with input from field contractors and technicians, its convertible airflow and ease of installation are outstanding.

### Standard and Optional Features at a Glance

#### Standard Features

- 2-inch throwaway filters
- 5kA SCCR (Short Circuit Current Rating)
- 5 year Limited Compressor Warranty
- 1 year Limited Parts Warranty
- Belt Drive Motors
- Cleanable Condensate Drain Pan
- Colored and Numbered Wiring
- Convertible Airflow
- Cooling to 45°F
- Discharge Line Thermostat
- Electromechanical Controls
- Easy Access Low Voltage Terminal Board (LTB)
- Foil-Faced and Edge Captured Insulation
- High Pressure Cutout
- Liquid Line Refrigerant Drier
- Locking Safety Device
- Locking Safety Device with Anti-Short Cycle Timer
- Microchannel Type Condenser and Evaporator Coils
- Operating Charge of R-410A
- Phase Monitor
- Provisions for Through-the-Base Electrical
- Quick Access Panels
- Quick Adjust Fan Motor Mounting Plate
- Single Point Power
- Single Side Service
- Standardized Components

#### Factory Installed Options

- Complete Coat™ Microchannel Condenser Coil

#### Factory or Field Installed Options

- Condensate Overflow Switch
- Electric Heaters
- Manual Outside Air Dampers
- Oversized Motor

#### Field Installed Options

- Crankcase Heater
- Low Ambient Kit
- Roof Curb
- Thermostat
- Tool-less Hail Guard
- 2-inch MERV 13 throwaway Filters

### Other Benefits

- Cabinet Design Ensures Water Integrity
- Convertible Airflow - Downflow to Horizontal Airflow Configuration
- Ease of Service, Installation and Maintenance
- Mixed Model Build Enables “Fastest in the Industry” Ship Cycle Times
- Rigorous Testing
- Unmatched Product Support

### Outstanding Standard Features

#### Colored and Numbered Wiring

Save time and money tracing wires and diagnosing the unit.

#### Compressor

Foundation™ contains the best compressor technology available to achieve the highest possible performance.

#### Controls—Electromechanical

This 24-volt control includes the control transformer and contactor pressure lugs for power wiring.

#### Convertible Units



Foundation 3-5 tons units ship in downflow configuration. Their convertible design makes it easy to convert them to a horizontal airflow configuration without any kit or tool.

#### Discharge Line Thermostat

A bi-metal element discharge line thermostats installed as a standard feature on the discharge line of each system. This standard feature provides extra protection to the compressors against high discharge temperatures in case of loss of charge, extremely high ambient and other conditions which could drive the discharge temperature higher.

#### Efficiency

Product efficiencies meet the requirements of ASHRAE 90.1 - 2016.

#### Easy Access Low Voltage Terminal Board

Foundation™ Low Voltage Terminal Board is mounted outside the main electrical control cabinet. It is extremely easy to locate and attach the thermostat control wiring and also test operation of all unit functions. This is another cost and time saving installation feature.

#### Foil Faced Insulation

All panels in the evaporator section of the unit have cleanable foil-faced insulation. All edges are either captured or sealed to ensure no insulation fibers get into the airstream.

## Features and Benefits

---

### Locking Safety Device with Anti-Short Cycle Timer

This device monitors compressor safety switch trips to prevent short cycling, protecting the compressor. A manual reset is required after a fourth safety switch trip within a 6 hour period.

### Low Ambient Cooling

All Foundation units have cooling capabilities down to 45°F as standard.

### Low Voltage Connections

The wiring of the low voltage connections to the unit and the thermostat is as simple as R-R, G-G, Y-Y, and W-W. This simplified system makes it easy for the installer to wire.

### Microchannel Coils

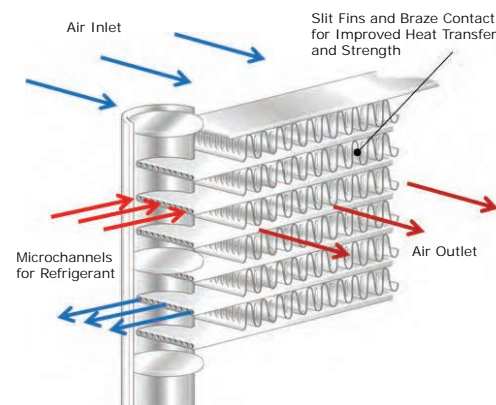

Microchannel coils are all-aluminum coils with fully-brazed construction. This design reduces risk of leaks and provides increased coil rigidity — making them more rugged on the jobsite. Their flat streamlined tubes with small ports and metallurgical tube-to-fin bond allow for exceptional heat transfer.

Microchannel all-aluminum construction provides several additional benefits:

- Light weight (simplifies coil handling)
- Easy to recycle
- Minimize galvanic corrosion

### Motors

All indoor fan motors are belt drive as standard.

### Pressure Cutouts

Low and high pressure cutouts are standard on all Foundation™ models.

### Phase Monitor

Foundation features a three-phase line monitor module that protects against phase loss, phase reversal and phase unbalance. It is intended to protect compressors from reverse rotation. It has an operating input voltage range of 190–600 Vac, and LED indicators for ON and FAULT. There are no field adjustments and the module will automatically reset from a fault condition.

### Quick-Access Panels

Remove four or less screws for access to the standardized internal components and wiring.

### Quick-Adjust Fan Motor Mounting Plate

With the quick-adjust slider plate, the belt and sheaves can be quickly adjusted without moving the mounted fan motor. This results in reduced time spent on routine maintenance.

### Single Point Power

A single electrical connection powers the unit and all on-board options.

### Single Side Service

Single side service is standard on all units.

### **Sloped Drain Pans**

Every Foundation™ unit has a non-corrosive, sloped drain pan made of rigid PVC - standard on all units - that is removable for easy cleaning.

### **Standardized Components**

Components are placed in the same location on all Foundation units. Familiarize yourself with one Foundation and you are familiar with every Foundation. Due to standardized components throughout the Foundation line, contractors/owners can stock fewer parts.

## **Variety of Options<sup>1</sup>**

### **Factory Installed Options**

#### **Complete Coat™ Condenser Coil**

The cathodic epoxy type electrodisposition coating is formulated for high edge build to a number of different types of heat exchangers. The coating is selected to provide excellent resistance and durability to corrosive effects of alkalies, acids, alcohols, petroleum, seawater, salt air, and corrosive environments.

### **Factory or Field Installed Options**

#### **Condensate Overflow Switch**

A condensate overflow switch is available to shut the unit down in the event that the condensate drain line becomes clogged. This option protects the unit from water overflowing from the drain pan and entering the base of the units.

#### **Electric Heat**

Electric heat is available as a factory or field installed option.

#### **Manual Outside Air Damper**

A 0–50 percent manual air damper is available.

#### **Oversized Motors**

Factory or field installed oversized motors are available for high static applications.

### **Field Installed Options**

#### **Crankcase Heaters**

These band heaters provide improved compressor reliability by warming the oil to prevent migration during off-cycles or low ambient conditions.

#### **Low Ambient Kit**

Allows system to operate in cooling below 45 degree by maintaining head pressure by cycling the outdoor fan motor allowing safe system operation without indoor coil icing.

#### **Roof Curbs**

Available for downflow units.

#### **Thermostats**

Available in programmable and non-programmable.

---

<sup>1</sup> Refer to "Model Number Description," p. 12 for option availability.



## Features and Benefits

---

### Tool-less Hail Guards

Tool-less, hail protection quality coil guards shall be field-installed for condenser coil protection. This option protects the condenser coil from vandalism and/or hail damage.

## Other Benefits

### Cabinet Integrity

For added water integrity, Foundation has a raised 1-1/8" lip around the supply and return of the downflow units to prevent water from blowing into the ductwork.

### Easy to Install, Service and Maintain

Because today's owners are very cost-conscious when it comes to service and maintenance, Foundation was designed with direct input from service contractors. This valuable information helped to design a product that would get the service technician off the job quicker and save the owner money. Foundation does this by offering outstanding standard features enhanced by a variety of factory and field installed options, multiple control options, rigorously tested proven designs and superior product and technical support.

### Outstanding Adaptability

The Foundation 3-5 Tons units match the footprint of specific Carrier WeatherMaker units.

### Rigorous Testing

All of Foundation's designs were rigorously rain tested at the factory to ensure water integrity. Foundation units incorporate either a one piece top or the Trane-Tite-Top (T3). Each part of the top overlaps in such a way that water cannot leak into the unit. These overlapped edges are gasketed and sealed to ensure superior water integrity.

Actual shipping tests were performed to determine packaging requirements. Units were test shipped around the country to determine the best packaging. Factory shake and drop tests were used as part of the package design process to help assure that the unit arrives at the job site in top condition.

Rigging tests include lifting a unit into the air and letting it drop one foot, assuring that the lifting lugs and rails hold up under stress. For the microchannel coils, the supplier will perform the leak check at 450 psig. The completely assembled refrigerant system is leak tested at a minimum of 225 psig with a refrigerant and nitrogen mixture.

All parts are inspected at the point of final assembly. Sub-standard parts are identified and rejected immediately. Every unit receives a 100% unit run test before leaving the production line to make sure it lives up to rigorous Trane requirements.

### Unmatched Support

Trane Sales Representatives are a Support Group that can assist you with:

- Product
- Application
- Service
- Training
- Special Applications
- Specifications
- Computer Programs and much more





# Application Considerations

Application of this product should be within the cataloged airflow and cooling considerations.

## **Clearance Requirements**

The recommended clearances identified with unit dimensions should be maintained to ensure adequate serviceability, maximum capacity and peak operating efficiency. Actual clearances which appear inadequate should be reviewed with local Trane sales personnel.

## **Complete Coat™ Microchannel Condenser Coil**

The cathodic epoxy type electrodisposition coating is formulated for high edge build to a number of different types of heat exchangers. The coating is selected to provide excellent resistance and durability to corrosive effects of alkalis, acids, alcohols, petroleum, seawater, salt air, and corrosive environments. This coating shall be available on microchannel condenser coils.

## **Condensate Trap**

The evaporator is a draw-through configuration. A trap must be field provided prior to start-up on the cooling cycle.

## **Low Ambient Cooling**

The Foundation line features low ambient cooling down to 45°F. The following options need to be included/considered when low ambient applications are required: continuous fan operation, crankcase heaters, or low pressure bypass timer. Contact your local Trane Representative for more assistance with low ambient cooling applications.

## **Unit Pitch**

These units have sloped condensate drain pans. Units must be installed level. Any unit slope must be toward access side of the unit.



# Selection Procedure

## Cooling Capacity

### Step 1

Calculate the building's total and sensible cooling loads at design conditions. Use the following calculation methods or any other standard accepted method. Factors used in unit selection:

- Total Cooling Load: 61MBh
- Sensible Cooling Load: 45 MBh
- Airflow: 2000 cfm
- Electrical Characteristics: 460/60/3
- Summer Design Conditions: Entering Evaporator Coil: 80 DB, 67 WB Outdoor Ambient: 95 DB
- External Static Pressure: 0.36 in. wg
- Rooftop: downflow configuration
- Accessories:
  - Roof curb
  - Electric Heat

### Step 2

As a starting point, a rough determination must be made of the size of the unit. The final selection will be made after examining the performance at the given conditions. Divide the total cooling load by nominal Btu/h per ton (12 MBh per ton); then round up to the nearest unit size.

$$61\text{MBh} / 12 \text{ MBh} = 5.0 \text{ tons}$$

### Step 3

Table 4, p. 16 shows that a EBC060A has a **gross** cooling capacity of 61.8 MBh and 48.9 MBh sensible capacity at 2000 cfm and 95 DB outdoor ambient with 80 DB, 67 WB air entering the evaporator.

#### To Find Capacity at Intermediate Conditions Not in the Table

When the design conditions are between values that are identified in the capacity table, interpolation is required to approximate the capacity.

**Note:** *Extrapolation outside of the table conditions is not recommended.*

### Step 4

In order to select the correct unit which meets the building's requirements, the fan motor heat must be deducted from the gross cooling capacity. The amount of heat that the fan motor generates is dependent on the effort by the motor—cfm and static pressure. To determine the total unit static pressure you add the external static pressure to the additional static related by the added features:

External Static Duct System: 0.36 in. wg

Standard Filter from Table 13, p. 23: 0.06 in. wg

Electric Heater Size kW from Table 13, p. 23: 0.07 in. wg

(Reference "Heating Capacity," p. 11 for determination of heater size).

Total Static Pressure: 0.49 in. wg

**Note:** *The Evaporator Fan Performance Table 9, p. 21 has already accounted for the pressure drop for standard filters and wet coils (see note below that table). Therefore, the actual total static pressure is 0.49 - 0.06 (from Table 13, p. 23) = 0.43 in. wg.*

With 2000 cfm and 0.43 wg.

[Table 9, p. 21](#) shows 0.77 bhp for this unit. Note below the table gives a formula to calculate Fan Motor Heat:  $2.8328 \times \text{Fan bhp} + 0.4714$ .

$$2.8328 \times 0.77 + 0.4714 = 2.65 \text{ MBh}$$

Now subtract the fan motor heat from the gross cooling capacity of the unit:

**Net** Total Cooling Capacity =  $61.8 \text{ MBh} - 2.65 = 59.15 \text{ MBh}$ .

**Net** Sensible Cooling Capacity =  $48.9 \text{ MBh} - 2.65 = 46.25 \text{ MBh}$ .

## Step 5

If the performance will not meet the required load of the building—total or sensible cooling load, try a selection at the next higher size unit.

## Heating Capacity

### Step 1

Calculate the building heating load.

### Step 2

Size the system heating capacity to match the calculated building heating load.

The electric heat accessory capacities are listed in [Table 14, p. 24](#). From the table, a 10 kW heater will deliver 34.14 MBh at 480 volts. In order to determine capacity at 380 volts, the heater voltage correction factor from [Table 15, p. 24](#) must be used. Therefore,  $34.14 \text{ MBh} \times 0.63$  (voltage correction factor) = 21.5 MBh.

## Air Delivery Selection

External static duct pressure drop through the air distribution system has been calculated to be 0.36 inches of water. From [Table 13, p. 23](#) static pressure drop across the filters is 0.06 and the 10kW heater is 0.07 inches of water.

Therefore the total static pressure is  $0.36 + 0.06 + 0.07 = 0.49$  inches.

Enter [Table 9, p. 21](#) for a EBC060A4 at 2000 cfm and 0.43 static pressure. The standard motor at 921 rpm will give the desired airflow at a rated bhp of 0.77.



# Model Number Description

<b>E</b>	<b>B</b>	<b>C</b>	<b>O</b>	<b>3</b>	<b>6</b>	<b>A</b>	<b>D</b>	<b>E</b>	<b>A</b>	<b>A</b>	<b>O</b>	<b>O</b>
1	2	3	4	5	6	7	8	9	10	11	12	13

## Digit 1 – Unit Type

E = Packaged Cooling, Electric Heat

## Digit 2 – Efficiency

B = ASHRAE 90.1 - 2016

## Digit 3 – Airflow Configuration

C = Convertible

## Digit 4, 5, 6 – Nominal Gross Cooling Capacity (MBh)

036 = 3 Tons

048 = 4 Tons

060 = 5 Tons

## Digit 7 – Major Design Sequence

A

## Digit 8 – Voltage Selection

D = 380-415/50/3

## Digit 9 – Unit Controls

E = Electromechanical

## Digit 10 – Heating Capacity

0 = No Heat

A = 4.7 kW Electric Heat

B = 6.3 kW Electric Heat

C = 9 kW Electric Heat

D = 12.5 kW Electric Heat

E = 15.7 kW Electric Heat

## Digit 11 – Minor Design Sequence

## Digit 12, 13 – Service Sequence

00 = None

## Digit 14 – Fresh Air Selection<sup>1</sup>

0 = No Fresh Air

A = Manual Outside Air Damper  
0-50%

## Digit 15 – Supply Fan/Drive Type/Motor

0 = Standard Motor

1 = Oversized Motor

## Digit 16 – Not Used

## Digit 17 – Condenser Coil Protection

0 = Standard Coil

4 = CompleteCoat™ Condenser Coil

## Digit 18 – Through The Base Provisions

0 = No Through The Base Provisions

## Digit 19 – Disconnect Switch

0 = No Disconnect

## Digit 20 – Not Used

## Digit 21 – Not Used

## Digit 22 – Not Used

## Digit 23 – Not Used

## Digit 24 – Not Used

## Digit 25 - System Monitoring Controls

0 = No Monitoring Controls

A = Condensate Drain Pan Overflow Switch

## Model Number Notes

1. All Factory Installed Options are Built-to-Order. Check order services for estimated production cycle.



# General Data

**Table 1. General data – 3-5 tons**

	<b>3 Tons</b>	<b>4 Tons</b>	<b>5 Tons</b>
	<b>EBC036</b>	<b>EBC048</b>	<b>EBC060</b>
<b>Cooling Performance<sup>(a)</sup></b>			
Gross Cooling Capacity	37,000	49,500	58,500
EER <sup>(b)</sup>	12	12	12
Nominal Airflow CFM / AHRI Rated CFM	1200 / 1200	1600 / 1600	2000 / 2000
AHRI Net Cooling Capacity	36,000	48,000	56,500
Seasonal Energy Efficiency Ratio (SEER) <sup>(c)</sup>	14	14	14
System Power (kW)	3.00	4.00	4.71
<b>Compressor</b>			
Number/Type	1 / Scroll	1 / Scroll	1 / Scroll
<b>Sound</b>			
Outdoor Sound Rating (BELS) <sup>(d)</sup>	80dBA	80dBA	78dBA
<b>Outdoor Coil</b>			
Type	Microchannel	Microchannel	Microchannel
Coil Width (in.)	0.63	0.81	1.0
Face Area (sq. ft.)	11.33	13.46	15.92
Rows/FPI	1 / 23	1 / 23	1 / 23
<b>Indoor Coil</b>			
Type	Microchannel	Microchannel	Microchannel
Coil Width (in.)	0.63	0.81	0.81
Face Area (sq. ft.)	6.44	6.44	6.44
Rows/FPI	2 / 16	2 / 16	2 / 16
Refrigerant Control	Thermal Expansion Valve	Thermal Expansion Valve	Thermal Expansion Valve
Drain Connection Number/Size (in.)	1 / 3/4-14 NPT female	1 / 3/4-14 NPT female	1 / 3/4-14 NPT female
<b>Outdoor Fan</b>			
Type	Propeller	Propeller	Propeller
Number Used/Diameter (in.)	1 / 23	1 / 23	1 / 23
Drive Type/No. Speeds	Direct / 1	Direct / 1	Direct / 1
cfm	4,000	4,000	4,000
Number Motors/hp	1 / 0.33	1 / 0.33	1 / 0.33
Motor rpm	950	950	950
<b>Indoor Fan</b>			
Type	FC Centrifugal	FC Centrifugal	FC Centrifugal
Number Used/Diameter (in.)	1 / 11x11	1 / 11x11	1 / 11x11
Drive Type/No. Speeds	Belt / 1	Belt / 1	Belt / 1
Number Motors	1	1	1
Motor hp (Standard/Oversized)	1.0 / 2.0	1.0 / 2.0	1.0 / 2.0
Motor rpm (Standard/Oversized)	1450 / 1450	1450 / 1450	1450 / 1450
Motor Frame Size (Standard/Oversized)	56 / 56	56 / 56	56 / 56
<b>Filters</b>			
Type Furnished	Throwaway	Throwaway	Throwaway
Number Size Recommended	(4) 16x16x2	(4) 16x16x2	(4) 16x16x2
<b>Refrigerant Charge (Pounds of R-410A)<sup>(e)</sup></b>			
Circuit 1	3.5	4.6	5.0

(a) Cooling Performance is rated at 95°F ambient, 80°F entering dry bulb, 67°F entering wet bulb. Gross capacity does not include the effect of fan motor heat. AHRI capacity is net and includes the effect of fan motor heat. Units are suitable for operation to ±20% of nominal cfm. Certified in accordance with the Unitary Air-Conditioner Equipment Certification Program, which is based on AHRI Standard 210/240.

(b) EER is rated at AHRI conditions and in accordance with AHRI Standard 210/240.

(c) Seasonal Energy Efficiency Ratio (SEER) is rated in accordance with AHRI standard 210/240.

(d) Outdoor Sound Rating shown is tested in accordance with AHRI Standard 270.

(e) Refrigerant charge is an approximate value. For a more precise value, see unit nameplate and service instructions.



# Performance Data

**Table 2. Gross cooling capacities 3 tons - EBC036AD**

		Ambient Temperature (°F)																	
		85						95						105					
Air	Ent	Entering Wet Bulb (°F)																	
Flow	DB	61		67		73		61		67		73		61		67		73	
cfm	(°F)	MBh	SHC	MBh	SHC	MBh	SHC	MBh	SHC	MBh	SHC	MBh	SHC	MBh	SHC	MBh	SHC	MBh	SHC
960	75	33.5	26.9	37.9	21.3	42.1	14.5	31.5	25.9	35.6	20.3	39.2	14.1	29.4	24.8	33.1	19.2	35.9	12.8
	80	33.6	31.2	37.9	26.2	42.1	20.2	31.6	29.6	35.6	25.2	39.2	19.0	29.7	29.3	33.2	24.0	36.0	17.7
	85	34.7	34.7	37.9	31.1	42.2	25.1	33.1	33.1	35.6	30.0	39.3	23.9	31.3	31.3	33.2	28.8	35.9	22.6
	90	36.9	36.9	38.0	35.5	42.2	30.0	35.0	35.0	35.8	34.2	39.3	28.8	33.1	33.1	33.4	33.2	36.0	27.5
1080	75	34.3	28.6	38.7	22.4	42.7	15.5	32.2	27.6	36.3	21.3	39.6	14.3	30.1	26.5	33.7	20.1	36.3	13.0
	80	34.5	32.5	38.7	27.8	42.8	21.0	32.5	32.2	36.3	26.7	39.6	19.8	30.6	30.6	33.7	25.5	36.4	18.5
	85	36.3	36.3	38.7	33.1	42.8	26.5	34.4	34.4	36.4	32.1	39.7	25.2	32.5	32.5	33.8	30.6	36.4	24.0
	90	38.3	38.3	38.9	38.0	42.8	31.9	36.5	36.5	36.7	36.7	39.7	30.7	34.2	34.2	34.3	34.3	36.5	29.4
1200	75	34.9	30.3	39.4	23.3	43.2	15.7	32.8	29.2	36.9	22.2	39.9	14.4	30.6	27.9	34.1	21.0	36.6	13.2
	80	35.3	35.3	39.4	29.3	43.2	21.8	33.5	33.5	36.9	28.2	40.0	20.5	31.5	31.5	34.2	27.0	36.7	19.2
	85	37.5	37.5	39.4	35.2	43.3	27.8	35.6	35.6	37.0	33.9	40.0	26.5	33.5	33.5	34.3	32.0	36.7	25.3
	90	39.7	39.7	39.8	39.8	43.3	33.8	37.6	37.6	37.7	37.7	41.0	32.9	35.2	35.2	35.2	35.2	36.8	31.2
1320	75	35.5	31.9	39.9	24.3	43.5	15.9	33.4	30.4	37.3	23.1	40.2	14.6	31.1	29.2	34.4	21.8	36.8	13.3
	80	36.4	36.4	40.0	30.8	43.5	22.5	34.4	34.4	37.4	29.6	40.3	21.3	32.3	32.3	34.5	28.3	36.9	19.9
	85	38.6	38.6	40.0	36.4	43.6	29.1	36.6	36.6	37.5	35.3	40.4	27.8	34.2	34.2	34.6	34.6	36.9	26.5
	90	40.8	40.8	40.9	40.9	43.7	35.6	38.5	38.5	38.6	38.6	40.4	34.3	35.7	35.7	35.7	35.7	37.0	32.9
1080	75	36.0	33.1	40.4	25.1	43.7	16.1	33.9	31.7	37.7	23.9	40.5	14.8	31.3	29.2	34.7	22.7	36.9	13.5
	80	37.2	37.2	40.4	32.2	43.8	23.2	35.2	35.2	37.7	30.9	40.6	22.0	33.0	33.0	34.7	29.6	37.0	20.6
	85	39.6	39.6	40.6	38.2	43.9	30.3	37.4	37.4	37.9	37.2	40.7	29.1	34.9	34.9	34.9	34.9	37.1	27.7
	90	41.6	41.6	41.8	41.8	43.9	37.2	39.2	39.2	39.3	39.3	40.7	35.9	36.2	36.2	36.3	36.3	37.2	33.5
		Ambient Temperature (°F)																	
		115						120						125					
Air	Ent	Entering Wet Bulb (°F)																	
Flow	DB	61		67		73		61		67		73		61		67		73	
cfm	(°F)	MBh	SHC	MBh	SHC	MBh	SHC	MBh	SHC	MBh	SHC	MBh	SHC	MBh	SHC	MBh	SHC	MBh	SHC
960	75	27.2	23.7	30.4	17.9	32.5	11.5	25.9	23.1	28.9	17.3	30.6	10.8	24.6	22.1	27.2	16.6	28.5	10.0
	80	27.6	27.6	30.5	22.9	32.6	16.4	26.5	26.5	28.9	22.2	32.0	16.2	25.4	25.4	27.3	21.5	28.5	14.9
	85	29.3	29.3	30.5	27.6	32.6	21.4	28.2	28.2	29.0	26.4	30.7	20.6	26.9	26.9	27.3	25.2	28.6	19.9
	90	30.8	30.8	30.9	30.9	32.7	26.0	29.5	29.5	29.5	29.5	31.7	25.8	27.9	27.9	27.9	27.9	30.6	24.4
1080	75	27.6	25.1	30.8	18.8	32.7	11.6	26.3	24.2	29.1	18.1	30.7	10.9	25.0	23.0	27.3	17.4	28.4	10.0
	80	28.5	28.5	30.8	24.3	32.8	17.1	27.4	27.4	29.2	23.9	32.6	17.0	26.2	26.2	27.4	22.7	28.5	15.5
	85	30.2	30.2	30.9	29.1	34.0	23.1	28.9	28.9	29.3	29.3	30.8	21.9	27.4	27.4	27.5	27.5	28.6	21.1
	90	31.6	31.6	31.6	31.6	32.9	27.8	30.1	30.1	30.1	30.1	32.6	25.8	28.4	28.4	28.4	28.4	28.6	22.9
1200	75	28.0	25.7	31.0	19.7	32.8	11.7	26.7	26.7	29.3	18.9	30.6	11.0	25.3	25.3	27.4	18.2	28.2	10.1
	80	29.3	29.3	31.1	25.6	32.9	17.8	28.1	28.1	29.4	24.7	30.7	17.0	26.7	26.7	27.5	23.3	28.4	16.2
	85	31.0	31.0	31.2	31.2	34.5	24.4	29.4	29.4	29.4	29.4	30.8	23.1	27.8	27.8	27.8	27.8	28.5	22.2
	90	32.2	32.2	32.2	32.2	33.0	29.5	30.5	30.5	30.5	30.5	30.9	28.5	28.5	28.5	30.2	30.2	28.5	28.5
1320	75	28.3	28.3	31.2	20.5	34.9	12.6	27.0	27.0	29.4	19.7	30.6	11.1	25.6	25.6	27.5	18.9	28.1	10.2
	80	29.9	29.9	31.3	26.9	32.9	18.5	28.6	28.6	29.4	25.8	30.7	17.7	27.1	27.1	27.6	24.1	32.0	18.0
	85	31.4	31.4	31.4	31.4	35.0	25.7	29.8	29.8	29.8	29.8	30.8	24.2	28.1	28.1	28.1	28.1	28.3	23.3
	90	32.6	32.6	33.4	33.4	33.1	30.8	30.7	30.7	32.1	32.1	33.6	30.8	28.3	28.3	31.2	31.2	28.2	28.2
1080	75	28.7	28.7	31.3	21.2	35.3	12.8	27.4	27.4	29.4	20.5	30.5	11.1	26.0	26.0	27.5	19.7	27.9	10.2
	80	30.4	30.4	31.4	28.0	32.9	19.1	29.0	29.0	29.5	27.1	30.6	18.3	27.2	27.2	27.6	25.3	32.3	18.7
	85	31.7	31.7	31.8	31.8	35.4	27.0	30.1	30.1	30.1	30.1	33.8	26.3	28.2	28.2	28.2	28.2	28.2	24.4
	90	32.9	32.9	32.9	32.9	33.0	33.0	33.1	33.1	33.2	33.2	33.9	33.9	31.9	31.9	32.0	32.0	32.5	31.9

**Notes:**

1. All capacities shown are gross and have not considered indoor fan heat. To obtain **NET** cooling capacity subtract indoor fan heat formula, refer to appropriate airflow table notes.
2. MBh = Total Gross Capacity
3. SHC = Sensible Heat Capacity

**Table 3. Gross cooling capacities 4 tons - EBC048AD**

		Ambient Temperature (°F)																	
		85						95						105					
Air	Ent	Entering Wet Bulb (°F)																	
Flow	DB	61		67		73		61		67		73		61		67		73	
cfm	(°F)	MBh	SHC	MBh	SHC	MBh	SHC	MBh	SHC	MBh	SHC	MBh	SHC	MBh	SHC	MBh	SHC	MBh	SHC
1280	75	45.5	36.8	51.1	28.8	56.8	19.4	42.7	35.2	47.8	27.2	52.9	18.8	39.6	33.6	44.3	25.6	48.8	17.0
	80	45.6	42.3	51.7	35.8	56.9	27.3	42.9	41.6	47.9	34.0	53.1	25.7	39.9	39.4	44.4	32.4	48.9	23.9
	85	47.3	47.3	51.7	42.5	57.0	34.1	45.0	45.0	47.9	40.7	53.2	32.5	42.4	42.4	44.5	39.1	49.0	30.8
	90	50.2	50.2	51.8	48.1	57.1	41.0	47.3	47.3	48.1	47.0	53.3	39.3	44.6	44.6	44.7	44.7	49.2	37.6
1440	75	46.5	39.1	52.2	30.2	57.8	20.8	43.6	37.6	48.7	28.6	53.7	19.0	40.4	35.8	45.0	26.9	49.2	17.2
	80	46.7	46.1	52.3	37.8	57.9	28.5	43.9	43.9	48.8	36.2	53.8	26.8	41.2	41.2	45.1	34.4	49.4	24.9
	85	49.4	49.4	52.3	45.3	58.0	36.2	46.8	46.8	48.9	43.5	53.9	34.4	43.6	43.6	45.2	41.0	49.5	32.6
	90	52.0	52.0	52.5	52.2	58.1	43.8	49.2	49.2	49.3	49.3	54.1	42.0	46.2	46.2	46.3	46.3	49.7	40.2
1600	75	47.4	41.4	53.1	31.6	58.6	21.1	44.4	39.7	49.4	29.9	54.2	19.3	40.9	36.8	45.5	28.1	49.5	17.4
	80	48.0	48.0	53.2	40.0	58.7	29.6	45.3	45.3	49.5	38.2	54.4	27.8	42.5	42.5	45.6	36.4	49.7	26.0
	85	51.2	51.2	53.2	47.6	58.8	38.1	47.9	47.9	49.6	44.5	54.5	36.3	44.8	44.8	45.7	44.2	49.9	34.4
	90	53.8	53.8	53.9	53.9	58.9	46.5	50.8	50.8	50.9	50.9	54.7	44.7	47.5	47.5	47.5	47.5	50.1	42.8
1760	75	48.0	43.0	53.8	32.9	59.2	21.4	44.9	41.2	49.9	31.1	54.6	19.5	41.3	39.7	45.8	29.3	49.7	17.6
	80	49.4	49.4	53.9	42.0	59.3	30.8	46.6	46.6	50.0	40.2	54.8	28.9	43.1	43.1	45.9	38.4	49.9	27.0
	85	52.3	52.3	53.9	50.6	59.5	40.0	49.2	49.2	50.1	48.6	55.0	38.1	45.9	45.9	46.1	46.1	50.1	36.2
	90	55.4	55.4	55.5	55.5	59.6	49.2	52.1	52.1	52.2	52.2	55.1	47.3	48.5	48.5	48.5	48.5	50.3	44.8
1920	75	48.9	43.9	54.4	34.2	59.6	21.7	45.4	43.5	50.3	32.3	54.9	19.8	41.2	41.2	46.1	30.4	49.8	17.8
	80	50.7	50.7	54.4	44.1	59.8	31.9	47.2	47.2	50.4	42.2	55.1	29.9	43.9	43.9	46.2	40.0	50.0	27.9
	85	53.6	53.6	54.5	53.1	60.0	41.9	50.3	50.3	50.5	50.5	55.3	39.9	46.7	46.7	46.8	46.8	50.3	37.9
	90	56.7	56.7	56.8	56.8	60.1	51.8	53.2	53.2	53.3	53.3	55.5	49.3	49.3	49.3	49.3	49.3	50.4	47.2
		Ambient Temperature (°F)																	
		115						120						125					
Air	Ent	Entering Wet Bulb (°F)																	
Flow	DB	61		67		73		61		67		73		61		67		73	
cfm	(°F)	MBh	SHC	MBh	SHC	MBh	SHC	MBh	SHC	MBh	SHC	MBh	SHC	MBh	SHC	MBh	SHC	MBh	SHC
1280	75	35.9	31.7	40.4	23.8	44.0	15.2	34.0	30.6	38.3	22.9	41.4	14.1	32.0	29.2	35.9	21.9	38.7	13.1
	80	36.6	36.6	40.5	30.6	44.2	22.1	35.0	35.0	38.4	29.6	41.5	21.0	33.3	33.3	36.0	28.6	38.8	20.0
	85	39.1	39.1	40.6	37.0	44.4	28.9	37.4	37.4	38.5	35.3	41.7	27.9	35.6	35.6	36.2	34.9	39.0	26.8
	90	41.4	41.4	41.5	41.5	44.5	35.7	39.6	39.6	39.7	39.7	41.9	34.6	37.5	37.5	37.6	37.6	39.1	33.6
1440	75	36.4	33.0	40.9	25.0	44.2	15.3	34.4	32.6	38.6	24.1	41.5	14.2	32.3	31.5	36.1	22.9	38.7	13.1
	80	37.8	37.8	41.0	32.5	44.4	23.0	36.1	36.1	38.7	31.5	41.7	22.0	34.2	34.2	36.3	30.5	38.9	20.9
	85	40.3	40.3	41.1	39.6	44.6	30.7	38.5	38.5	38.8	38.5	41.9	29.6	36.4	36.4	36.5	36.5	39.1	28.5
	90	42.7	42.7	42.7	42.7	44.8	38.2	40.6	40.6	40.6	40.6	42.0	37.0	38.2	38.2	38.2	38.2	39.2	35.2
1600	75	36.7	35.5	41.2	26.2	44.3	15.4	34.6	34.4	38.8	25.1	41.6	14.3	32.5	32.5	36.2	24.0	38.6	13.2
	80	38.8	38.8	41.3	34.5	44.5	23.9	37.0	37.0	38.9	33.4	41.8	22.9	34.9	34.9	36.3	31.8	38.9	21.8
	85	41.3	41.3	41.4	41.4	44.7	32.4	39.3	39.3	39.4	39.4	42.0	31.3	37.0	37.0	37.1	37.1	39.1	30.1
	90	43.5	43.5	43.6	43.6	44.9	40.1	41.2	41.2	41.2	41.2	42.1	39.2	38.7	38.7	38.7	38.7	39.1	38.0
1760	75	36.9	36.9	41.3	27.3	44.4	15.5	35.0	35.0	38.9	26.1	41.6	14.4	33.0	33.0	36.2	25.0	38.5	13.3
	80	39.6	39.6	41.5	36.1	44.5	24.9	37.6	37.6	39.0	34.1	41.8	23.8	35.4	35.4	36.3	33.7	38.8	22.6
	85	42.1	42.1	42.1	42.1	44.8	34.1	39.9	39.9	39.9	39.9	42.0	33.0	37.4	37.4	37.4	37.4	39.0	31.8
	90	44.1	44.1	44.2	44.2	44.9	42.6	41.7	41.7	41.7	41.7	42.1	41.4	39.9	39.9	40.0	40.0	40.2	40.2
1920	75	37.4	37.4	41.4	28.3	44.4	15.7	35.5	35.5	38.9	27.1	41.5	14.6	33.4	33.4	36.1	26.0	38.3	13.4
	80	40.2	40.2	41.6	36.3	44.6	25.8	38.1	38.1	39.0	36.5	41.7	24.7	35.8	35.8	36.2	35.2	38.7	23.5
	85	42.6	42.6	42.7	42.7	44.8	35.8	40.2	40.2	40.3	40.3	42.0	34.6	37.6	37.6	37.6	37.6	40.2	33.9
	90	44.5	44.5	44.6	44.6	44.9	44.8	42.0	42.0	42.1	42.1	42.1	42.1	40.8	40.8	40.9	40.9	40.9	40.9

**Notes:**

1. All capacities shown are gross and have not considered indoor fan heat. To obtain **NET** cooling capacity subtract indoor fan heat. For indoor fan heat formula, refer to appropriate airflow table notes.
2. MBh = Total Gross Capacity
3. SHC = Sensible Heat Capacity



## Performance Data

**Table 4. Gross cooling capacities 5 tons - EBC060AD**

		Ambient Temperature (°F)																	
		85						95						105					
Air	Ent	Entering Wet Bulb (°F)																	
Flow	DB	61		67		73		61		67		73		61		67		73	
cfm	(°F)	MBh	SHC	MBh	SHC	MBh	SHC	MBh	SHC	MBh	SHC	MBh	SHC	MBh	SHC	MBh	SHC	MBh	SHC
1600	75	54.3	44.9	60.5	34.9	66.6	24.2	50.9	43.2	56.8	33.3	62.2	22.5	47.4	41.5	52.9	31.5	57.4	20.6
	80	54.4	52.5	60.5	43.3	66.6	32.8	51.0	50.6	56.9	41.7	62.3	31.0	47.6	47.6	52.9	40.0	57.5	29.2
	85	56.5	56.5	60.4	51.5	66.7	41.3	53.5	53.5	56.8	49.9	62.4	39.6	50.5	50.5	52.9	47.3	57.5	37.7
	90	59.3	59.3	60.5	58.8	66.7	49.7	56.5	56.5	56.9	56.9	62.4	47.8	53.3	53.3	53.4	53.4	57.6	45.9
1800	75	55.5	47.8	61.6	36.6	67.6	24.7	51.9	46.0	57.8	34.9	63.0	22.9	48.2	43.4	53.6	33.1	58.1	21.0
	80	55.6	55.6	61.6	46.0	67.6	34.2	52.3	52.3	57.8	44.1	63.0	32.4	49.2	49.2	53.6	42.2	58.1	30.5
	85	58.3	58.3	61.5	54.5	67.7	43.7	55.3	55.3	57.8	51.8	63.1	41.8	52.1	52.1	53.6	50.7	58.2	39.8
	90	61.5	61.5	61.6	61.6	67.7	52.8	58.4	58.4	58.5	58.5	63.2	51.0	54.9	54.9	55.0	55.0	58.2	49.1
2000	75	56.5	50.4	62.6	38.3	68.3	25.1	52.6	47.3	58.6	36.5	63.5	23.2	48.8	46.0	54.2	34.6	58.5	21.3
	80	56.7	56.7	62.5	48.3	68.4	35.6	53.7	53.7	58.5	46.5	63.6	33.7	50.5	50.5	54.2	44.6	58.6	31.8
	85	60.0	60.0	62.5	57.3	68.5	46.0	56.9	56.9	58.5	55.7	63.7	43.9	53.5	53.5	54.1	53.6	58.7	41.9
	90	63.3	63.3	63.4	63.4	68.5	56.0	60.0	60.0	60.1	60.1	63.7	54.1	56.2	56.2	56.2	56.2	58.7	51.4
2200	75	56.9	51.1	63.3	39.8	68.9	25.4	53.2	50.3	59.2	38.0	64.0	23.6	49.2	48.2	54.6	36.1	58.9	21.6
	80	58.1	58.1	63.2	50.7	69.0	36.9	55.0	55.0	59.1	48.9	64.1	35.0	51.6	51.6	54.6	46.9	59.0	33.1
	85	61.5	61.5	63.1	60.5	69.2	47.9	58.3	58.3	59.0	58.5	64.2	46.0	54.5	54.5	54.6	54.6	59.1	44.0
	90	64.9	64.9	65.0	65.0	69.1	59.1	61.3	61.3	61.4	61.4	64.2	56.5	57.1	57.1	57.2	57.2	59.0	54.2
2400	75	57.4	54.4	63.9	41.2	69.4	25.8	53.6	52.4	59.6	39.4	64.4	23.9	49.5	49.5	54.9	37.1	59.1	21.9
	80	59.3	59.3	63.8	53.1	69.5	38.2	56.0	56.0	59.6	51.2	64.5	36.3	52.5	52.5	54.9	48.2	59.3	34.3
	85	62.8	62.8	63.6	63.3	69.6	50.0	59.4	59.4	59.4	59.4	64.5	48.1	55.4	55.4	55.4	55.4	59.3	46.0
	90	66.2	66.2	66.3	66.3	69.6	60.0	62.4	62.4	62.4	62.4	64.5	59.0	58.0	58.0	58.0	58.0	59.2	56.8
		Ambient Temperature (°F)																	
		115						120						125					
Air	Ent	Entering Wet Bulb (°F)																	
Flow	DB	61		67		73		61		67		73		61		67		73	
cfm	(°F)	MBh	SHC	MBh	SHC	MBh	SHC	MBh	SHC	MBh	SHC	MBh	SHC	MBh	SHC	MBh	SHC	MBh	SHC
1600	75	43.5	39.0	48.3	29.6	52.2	18.7	41.4	37.9	45.8	28.5	51.1	18.2	39.1	37.0	43.0	27.4	46.1	16.4
	80	44.4	44.4	48.4	37.8	52.3	27.2	42.6	42.6	45.8	36.7	49.4	26.2	40.6	40.6	43.1	35.5	46.2	25.0
	85	47.1	47.1	48.4	45.5	52.4	35.7	45.1	45.1	45.8	44.3	49.5	34.5	42.8	42.8	43.1	43.0	46.4	33.2
	90	49.5	49.5	49.5	49.5	52.5	43.9	47.2	47.2	47.3	47.3	51.0	43.3	45.5	45.5	45.6	45.6	48.8	42.4
1800	75	44.2	41.6	48.8	31.1	54.0	19.4	41.9	40.4	46.1	29.9	49.6	17.8	39.5	39.2	43.3	28.7	49.6	17.8
	80	45.8	45.8	48.9	40.2	52.7	28.5	43.8	43.8	46.2	39.1	49.7	27.4	41.5	41.5	43.4	37.9	46.4	26.2
	85	48.4	48.4	48.9	48.4	53.8	38.0	46.1	46.1	46.2	46.2	51.7	37.2	43.8	43.8	43.8	43.8	46.5	35.3
	90	50.7	50.7	50.7	50.7	53.8	46.9	48.4	48.4	48.4	48.4	51.8	45.5	47.2	47.2	47.2	47.2	49.6	44.2
2000	75	44.6	43.8	49.2	32.6	54.6	19.8	42.3	42.3	46.4	31.4	49.7	18.1	39.9	39.9	43.6	29.9	46.2	16.9
	80	46.8	46.8	49.2	42.5	54.6	30.2	44.7	44.7	46.5	40.8	49.9	28.6	42.2	42.2	43.7	38.9	46.5	27.4
	85	49.3	49.3	49.4	49.4	54.5	40.2	47.0	47.0	47.0	47.0	50.0	38.6	44.5	44.5	44.5	44.5	46.6	37.3
	90	51.7	51.7	51.8	51.8	54.4	49.7	50.3	50.3	50.4	50.4	52.3	48.8	48.6	48.6	48.7	48.7	50.0	47.8
2200	75	44.9	44.9	49.4	33.6	55.2	20.2	42.8	42.8	46.6	32.4	49.8	18.3	40.5	40.5	43.8	31.1	46.2	17.1
	80	47.6	47.6	49.5	43.4	55.0	31.5	45.3	45.3	46.6	42.8	50.0	29.6	42.8	42.8	43.7	41.5	50.4	29.8
	85	50.1	50.1	50.1	50.1	53.3	41.8	47.7	47.7	47.8	47.8	52.8	41.5	45.0	45.0	45.1	45.1	46.6	39.3
	90	53.3	53.3	53.4	53.4	54.9	52.4	51.6	51.6	51.7	51.7	52.8	51.5	49.8	49.8	49.9	49.9	50.5	50.5
2400	75	45.5	45.5	49.6	34.8	55.6	20.5	43.3	43.3	46.8	33.6	53.4	19.7	40.9	40.9	43.8	32.3	50.9	18.8
	80	48.3	48.3	49.6	46.0	55.4	32.8	45.9	45.9	46.7	44.7	53.1	32.0	43.3	43.3	43.8	43.3	50.6	30.6
	85	50.8	50.8	50.8	50.8	53.4	43.8	48.9	48.9	49.0	49.0	53.2	43.6	45.4	45.4	45.4	45.4	50.8	42.7
	90	54.5	54.5	54.6	54.6	55.3	55.1	52.8	52.8	52.8	52.8	53.1	53.1	50.9	50.9	50.9	50.9	51.0	51.0

**Notes:**

1. All capacities shown are gross and have not considered indoor fan heat. To obtain **NET** cooling capacity subtract indoor fan heat. For indoor fan heat formula, refer to appropriate airflow table notes.
2. MBh = Total Gross Capacity
3. SHC = Sensible Heat Capacity



**Table 5. Belt drive evaporator fan performance - 3 tons cooling only units - EBC036AD - downflow airflow**

External Static Pressure (Inches of Water)																					
		0.10		0.20		0.30		0.40		0.50		0.60		0.70		0.80		0.90		1.00	
cfm	rpm	bhp	rpm	bhp	rpm	bhp	rpm	bhp	rpm	bhp	rpm	bhp	rpm	bhp	rpm	bhp	rpm	bhp	rpm	bhp	
1-hp standard motor and pulley																					
960	---	---	---	---	587	0.17	645	0.21	698	0.25	746	0.29	792	0.34	834	0.38	875	0.43	913	0.48	
1080	---	---	550	0.17	612	0.21	668	0.25	720	0.30	768	0.34	813	0.39	855	0.44	895	0.49	933	0.54	
1200	---	---	578	0.20	638	0.25	693	0.30	743	0.34	790	0.39	834	0.44	876	0.50	915	0.55	953	0.60	
1320	---	---	608	0.25	666	0.30	718	0.35	767	0.40	813	0.45	856	0.51	897	0.56	936	0.62	973	0.68	
1440	578	0.24	639	0.29	694	0.35	745	0.41	793	0.46	838	0.52	880	0.58	920	0.64	958	0.70	995	0.76	
2-hp oversized motor and pulley																					

Continued

External Static Pressure (Inches of Water)											
		1.10		1.20		1.30		1.40		1.50	
cfm	rpm	bhp	rpm	bhp	rpm	bhp	rpm	bhp	rpm	bhp	
2-hp oversize motor and pulley											
960	949	0.53	984	0.58	1017	0.63	1050	0.68	1081	0.73	
1080	969	0.59	1004	0.64	1037	0.70	1070	0.75	1101	0.81	
1200	989	0.66	1024	0.72	1057	0.77	1089	0.83	1120	0.89	
1320	1009	0.74	1044	0.80	1077	0.86	1109	0.92	1140	0.98	
1440	1030	0.82	1064	0.88	1097	0.95	1129	1.01	1160	1.08	

**Notes:**

1. For Standard Evaporator Fan Speed (rpm), reference [Table 11, p. 23](#).
2. For Oversized Evaporator Fan Speed (rpm), reference [Table 12, p. 23](#).
3. 1-hp fan motor heat (MBh) = 2.8328 x Fan bhp. + 0.4714, 2-hp fan motor heat (MBh) = 2.7146 x Fan bhp. + 0.816.
4. Data includes pressure drop due to standard filters and wet coils. No accessories or options are included in pressure drop data.
5. Factory supplied motors, in commercial equipment, are definite purpose motors, specifically designed and tested to operate reliably and continuously at all cataloged conditions. Using the full horsepower range of our fan motors as shown in our tabular data will not result in nuisance tripping or premature motor failure. Our product's warranty will not be affected.



## Performance Data

**Table 6. Belt drive evaporator fan performance - 3 tons cooling only units - EBC036AD - horizontal airflow**

External Static Pressure (Inches of Water)																					
		0.10		0.20		0.30		0.40		0.50		0.60		0.70		0.80		0.90		1.00	
cfm	rpm	bhp	rpm	bhp	rpm	bhp	rpm	bhp	rpm	bhp	rpm	bhp	rpm	bhp	rpm	bhp	rpm	bhp	rpm	bhp	
1-hp standard motor and pulley																					
960	---	---	---	---	596	0.18	653	0.22	705	0.26	753	0.30	798	0.35	840	0.39	880	0.44	918	0.48	
1080	---	---	561	0.17	622	0.21	678	0.26	729	0.30	776	0.35	820	0.40	862	0.45	901	0.50	939	0.55	
1200	---	---	591	0.21	650	0.26	703	0.31	753	0.35	799	0.40	842	0.46	884	0.51	923	0.56	960	0.62	
1320	559	0.21	621	0.26	678	0.31	730	0.36	778	0.41	823	0.47	866	0.52	906	0.58	945	0.63	982	0.69	
1440	595	0.25	654	0.31	708	0.36	758	0.42	805	0.48	849	0.53	891	0.59	930	0.65	968	0.71	1005	0.77	
2-hp oversize motor and pulley																					

Continued

External Static Pressure (Inches of Water)											
		1.10		1.20		1.30		1.40		1.50	
cfm	rpm	bhp	rpm	bhp	rpm	bhp	rpm	bhp	rpm	bhp	
2-hp oversize motor and pulley											
960	954	0.53	989	0.58	1022	0.63	1054	0.69	1085	0.74	
1080	975	0.60	1010	0.65	1043	0.71	1075	0.76	1106	0.82	
1200	996	0.67	1030	0.73	1063	0.78	1095	0.84	1126	0.90	
1320	1017	0.75	1051	0.81	1084	0.87	1116	0.93	1147	0.99	
1440	1040	0.84	1073	0.90	1106	0.97	1137	1.03	1168	1.10	

**Notes:**

1. For Standard Evaporator Fan Speed (rpm), reference [Table 11, p. 23](#).
2. For Oversized Evaporator Fan Speed (rpm), reference [Table 12, p. 23](#).
3. 1-hp fan motor heat (MBh) = 2.8328 x Fan bhp. + 0.4714, 2-hp fan motor heat (MBh) = 2.7146 x Fan bhp. + 0.816.
4. Data includes pressure drop due to standard filters and wet coils. No accessories or options are included in pressure drop data.
5. Factory supplied motors, in commercial equipment, are definite purpose motors, specifically designed and tested to operate reliably and continuously at all cataloged conditions. Using the full horsepower range of our fan motors as shown in our tabular data will not result in nuisance tripping or premature motor failure. Our product's warranty will not be affected.

**Table 7. Belt drive evaporator fan performance - 4 tons cooling only units - EBC048AD - downflow airflow**

External Static Pressure (Inches of Water)																						
0.10		0.20		0.30		0.40		0.50		0.60		0.70		0.80		0.90		1.00				
cfm	rpm	bhp	rpm	bhp	rpm	bhp	rpm	bhp	rpm	bhp	rpm	bhp	rpm	bhp	rpm	bhp	rpm	bhp	rpm	bhp		
1-hp standard motor and pulley																						
1280	---	---	618	0.22	674	0.27	726	0.31	774	0.36	819	0.40	862	0.45	902	0.50	940	0.55	977	0.60		
1440	---	---	662	0.29	715	0.33	765	0.38	811	0.44	854	0.49	895	0.54	935	0.59	972	0.65	1008	0.70		
1600	653	0.31	708	0.36	758	0.42	805	0.47	849	0.53	891	0.58	931	0.64	969	0.70	1005	0.76	1041	0.82		
1760	695	0.38	746	0.44	794	0.49	840	0.55	882	0.61	923	0.68	961	0.74	999	0.80	1034	0.86	1069	0.93		
1920	752	0.49	800	0.55	845	0.62	888	0.68	929	0.75	968	0.82	1005	0.88	1041	0.95	2-hp oversized motor and pulley		1075	1.02	1108	1.09

Continued

External Static Pressure (Inches of Water)										
1.10		1.20		1.30		1.40		1.50		
cfm	rpm	bhp	rpm	bhp	rpm	bhp	rpm	bhp	rpm	bhp
2-hp oversize motor and pulley										
1280	1012	0.65	1046	0.71	1079	0.76	1110	0.81	1141	0.87
1440	1043	0.76	1076	0.82	1109	0.87	1140	0.93	1170	0.99
1600	1074	0.88	1107	0.94	1139	1.00	1170	1.06	1200	1.13
1760	1102	0.99	1134	1.05	1165	1.12	1196	1.19	1225	1.25
1920	1141	1.16	1172	1.23	1203	1.30	1232	1.37	1261	1.44

**Notes:**

1. For Standard Evaporator Fan Speed (rpm), reference [Table 11, p. 23](#).
2. For Oversized Evaporator Fan Speed (rpm), reference [Table 12, p. 23](#).
3. 1-hp fan motor heat (MBh) = 2.8328 x Fan bhp. + 0.4714, 2-hp fan motor heat (MBh) = 2.7146 x Fan bhp. + 0.816.
4. Data includes pressure drop due to standard filters and wet coils. No accessories or options are included in pressure drop data.
5. Factory supplied motors, in commercial equipment, are definite purpose motors, specifically designed and tested to operate reliably and continuously at all cataloged conditions. Using the full horsepower range of our fan motors as shown in our tabular data will not result in nuisance tripping or premature motor failure. Our product's warranty will not be affected.



## Performance Data

**Table 8. Belt drive evaporator fan performance - 4 tons cooling only units - EBC048AD - horizontal airflow**

External Static Pressure (Inches of Water)																					
		0.10		0.20		0.30		0.40		0.50		0.60		0.70		0.80		0.90		1.00	
cfm	rpm	bhp	rpm	bhp	rpm	bhp	rpm	bhp	rpm	bhp	rpm	bhp	rpm	bhp	rpm	bhp	rpm	bhp	rpm	bhp	
1-hp standard motor and pulley																					
1280	---	---	633	0.23	688	0.28	738	0.32	786	0.37	830	0.42	872	0.46	912	0.51	950	0.56	986	0.61	
1440	623	0.25	680	0.30	732	0.35	780	0.40	825	0.45	868	0.50	908	0.56	947	0.61	984	0.67	1019	0.72	
1600	675	0.33	728	0.38	777	0.44	823	0.49	866	0.55	907	0.61	946	0.66	984	0.72	1020	0.78	1054	0.84	
1760	718	0.40	768	0.46	815	0.52	859	0.58	901	0.64	940	0.70	978	0.76	1015	0.82	1050	0.89	1084	0.95	
1920	782	0.53	828	0.59	872	0.66	913	0.72	953	0.79	990	0.86	1027	0.93	1062	0.99	1096	1.06	1128	1.13	
2-hp oversized motor and pulley																					

Continued

External Static Pressure (Inches of Water)											
		1.10		1.20		1.30		1.40		1.50	
cfm	rpm	bhp	rpm	bhp	rpm	bhp	rpm	bhp	rpm	bhp	
2-hp oversized motor and pulley											
1280	1021	0.67	1055	0.72	1087	0.77	1118	0.83	1149	0.88	
1440	1054	0.78	1087	0.83	1119	0.89	1150	0.95	1180	1.01	
1600	1088	0.90	1120	0.96	1152	1.03	1182	1.09	1212	1.15	
1760	1117	1.02	1148	1.08	1179	1.15	1209	1.21	1238	1.28	
1920	1160	1.20	1191	1.27	1221	1.34	1250	1.42	1279	1.49	

**Notes:**

1. For Standard Evaporator Fan Speed (rpm), reference [Table 11, p. 23](#).
2. For Oversized Evaporator Fan Speed (rpm), reference [Table 12, p. 23](#).
3. 1-hp fan motor heat (MBh) = 2.8328 x Fan bhp. + 0.4714, 2-hp fan motor heat (MBh) = 2.7146 x Fan bhp. + 0.816.
4. Data includes pressure drop due to standard filters and wet coils. No accessories or options are included in pressure drop data.
5. Factory supplied motors, in commercial equipment, are definite purpose motors, specifically designed and tested to operate reliably and continuously at all cataloged conditions. Using the full horsepower range of our fan motors as shown in our tabular data will not result in nuisance tripping or premature motor failure. Our product's warranty will not be affected.

**Table 9. Belt drive evaporator fan performance - 5 tons cooling only units - EBC060AD - downflow airflow**

		External Static Pressure (Inches of Water)																				
		0.10		0.20		0.30		0.40		0.50		0.60		0.70		0.80		0.90		1.00		
cfm	rpm	bhp	rpm	bhp	rpm	bhp	rpm	bhp	rpm	bhp	rpm	bhp	rpm	bhp	rpm	bhp	rpm	bhp	rpm	bhp	rpm	bhp
1-hp standard motor and pulley																						
1600	695	0.35	746	0.40	794	0.46	839	0.51	881	0.57	921	0.63	959	0.68	996	0.74	1032	0.80	1066	0.86		
1800	766	0.48	813	0.54	857	0.60	899	0.66	938	0.72	977	0.79	1013	0.85	1048	0.91	1082	0.98	1115	1.05		
2000	838	0.63	881	0.70	922	0.77	962	0.84	999	0.91	1035	0.98	1070	1.05	1104	1.12	1136	1.19	1168	1.26		
2200	911	0.82	951	0.90	990	0.97	1027	1.05	1062	1.12	1096	1.20	1129	1.28	1161	1.35	1193	1.43	1223	1.51		
2400	985	1.05	1022	1.13	1058	1.21	1093	1.30	1126	1.38	1159	1.46	1190	1.54	1221	1.63	1251	1.71	1280	1.80		
2-hp oversized motor and pulley																						

Continued

		External Static Pressure (Inches of Water)										
		1.10		1.20		1.30		1.40		1.50		
cfm	rpm	bhp	rpm	bhp	rpm	bhp	rpm	bhp	rpm	bhp	rpm	bhp
2-hp oversize motor and pulley												
1600	1099	0.92	1131	0.99	1162	1.05	1192	1.11	1221	1.17		
1800	1147	1.11	1178	1.18	1208	1.25	1238	1.32	1266	1.39		
2000	1199	1.33	1229	1.41	1258	1.48	1286	1.56	1314	1.63		
2200	1252	1.59	1281	1.67	1309	1.75	---	---	---	---		
2400	1308	1.88	---	---	---	---	---	---	---	---		

**Notes:**

1. For Standard Evaporator Fan Speed (rpm), reference [Table 11, p. 23](#).
2. For Oversized Evaporator Fan Speed (rpm), reference [Table 12, p. 23](#).
3. 1-hp fan motor heat (MBh) = 2.8328 x Fan bhp. + 0.4714, 2-hp fan motor heat (MBh) = 2.7146 x Fan bhp. + 0.816.
4. Data includes pressure drop due to standard filters and wet coils. No accessories or options are included in pressure drop data.
5. Factory supplied motors, in commercial equipment, are definite purpose motors, specifically designed and tested to operate reliably and continuously at all cataloged conditions. Using the full horsepower range of our fan motors as shown in our tabular data will not result in nuisance tripping or premature motor failure. Our product's warranty will not be affected.



## Performance Data

**Table 10. Belt drive evaporator fan performance - 5 tons cooling only units - EBC060AD - horizontal airflow**

External Static Pressure (Inches of Water)																					
		0.10		0.20		0.30		0.40		0.50		0.60		0.70		0.80		0.90		1.00	
cfm	rpm	bhp	rpm	bhp	rpm	bhp	rpm	bhp	rpm	bhp	rpm	bhp	rpm	bhp	rpm	bhp	rpm	bhp	rpm	bhp	
1-hp standard motor and pulley																					
1600	682	0.34	734	0.39	782	0.44	828	0.50	871	0.56	911	0.61	950	0.67	988	0.73	1023	0.79	1058	0.85	
1800	750	0.46	798	0.52	843	0.58	885	0.64	926	0.70	965	0.77	1002	0.83	1037	0.89	1072	0.96	1105	1.02	
2000	819	0.60	864	0.67	906	0.74	945	0.81	984	0.88	1020	0.95	1056	1.02	1090	1.09	1123	1.16	1155	1.23	
2200	889	0.78	930	0.86	969	0.93	1007	1.01	1043	1.08	1078	1.16	1112	1.24	1144	1.31	1176	1.39	1207	1.47	
2400	959	0.99	997	1.08	1034	1.16	1070	1.24	1104	1.32	1137	1.40	1169	1.49	1200	1.57	1231	1.66	1260	1.74	
2-hp oversized motor and pulley																					

Continued

External Static Pressure (Inches of Water)											
		1.10		1.20		1.30		1.40		1.50	
cfm	rpm	bhp	rpm	bhp	rpm	bhp	rpm	bhp	rpm	bhp	
2-hp oversized motor and pulley											
1600	1091	0.91	1123	0.97	1154	1.03	1185	1.10	1214	1.16	
1800	1137	1.09	1168	1.16	1199	1.23	1228	1.30	1257	1.36	
2000	1186	1.30	1216	1.38	1246	1.45	1274	1.53	1302	1.60	
2200	1237	1.55	1266	1.63	1294	1.71	1322	1.79	---	---	
2400	1289	1.82	1317	1.91	---	---	---	---	---	---	

**Notes:**

1. For Standard Evaporator Fan Speed (rpm), reference [Table 11, p. 23](#).
2. For Oversized Evaporator Fan Speed (rpm), reference [Table 12, p. 23](#).
3. 1-hp fan motor heat (MBh) = 2.8328 x Fan bhp. + 0.4714, 2-hp fan motor heat (MBh) = 2.7146 x Fan bhp. + 0.816.
4. Data includes pressure drop due to standard filters and wet coils. No accessories or options are included in pressure drop data.
5. Factory supplied motors, in commercial equipment, are definite purpose motors, specifically designed and tested to operate reliably and continuously at all cataloged conditions. Using the full horsepower range of our fan motors as shown in our tabular data will not result in nuisance tripping or premature motor failure. Our product's warranty will not be affected.

**Table 11. Standard motor and drive/fan speed (rpm)**

Tons	Unit Model Number	Fan Sheave	6 Turns Open	5 Turns Open	4 Turns Open	3 Turns Open	2 Turns Open	1 Turn Open	Closed
3	EBC036AD	AK49X3/4"	544	608	672	736	800	864	928
4	EBC048AD	AK44X3/4"	612	684	756	828	900	972	1044
5	EBC060AD	AK41X3/4"	668	746	824	902	980	1058	1136

**Note:** Factory set at 3 turns open.

**Table 12. Oversized motor and drive/fan speed (rpm)**

Tons	Unit Model Number	Fan Sheave	6 Turns Open	5 Turns Open	4 Turns Open	3 Turns Open	2 Turns Open	1 Turn Open	Closed
3	EBC036AD	AK44X3/4"	N/A	864	956	1028	1100	1172	1224
4	EBC048AD	AK41X3/4"	N/A	934	1012	1090	1168	1246	1324
5	EBC060AD	AK41X3/4"	N/A	934	1012	1090	1168	1246	1324

**Note:** Factory set at 3 turns open.

**Table 13. Static pressure drop through accessories (inches water column) - 3 to 5 tons**

Tons	Unit Model Number	cfm	Standard Filters <sup>(a)</sup>	2-in. MERV 13 Filters <sup>(b)</sup>	Electric Heater Accessory (kW) <sup>(c)</sup>	
					5-15	20-25
3	EBC036A*	960	0.01	0.08	0.01	0.01
		1200	0.02	0.10	0.02	0.02
		1440	0.03	0.12	0.02	0.03
4	EBC048A*	1280	0.03	0.11	0.02	0.03
		1600	0.04	0.14	0.04	0.05
		1920	0.06	0.16	0.05	0.08
5	EBC060A*	1600	0.04	0.14	0.04	0.05
		2000	0.06	0.17	0.06	0.08
		2400	0.08	0.20	0.08	0.12

(a) Tested with 2-inch standard filters.

(b) Tested with 2-inch MERV 13 filters 3–5 tons.

(c) Nominal kW ratings at 380 volts.



## Performance Data

**Table 14. Auxiliary electric heat capacity**

Tons	Unit Model Number	Total <sup>(a)</sup>		No. of Stages	Stage1		Stage 2	
		kW Input <sup>(b)</sup>	MBh Output		kW Input	MBh Output	kW Input	MBh Output
3	EBC036AD	4.7	16.05	1	4.7	16.05	-	-
		6.3	21.51	1	6.3	21.51	-	-
		9	30.73	1	9	30.73	-	-
4	EBC048AD	4.7	16.05	1	4.7	16.05	-	-
		6.3	21.51	1	6.3	21.51	-	-
		9	30.73	1	9	30.73	-	-
		12.5	42.68	2	6.25	21.34	12.5	42.68
5	EBC060AD	4.7	16.05	1	4.7	16.05	-	-
		6.3	21.51	1	6.3	21.51	-	-
		9	30.73	1	9	30.73	-	-
		12.5	42.68	2	6.25	21.34	12.5	42.68
		15.7	53.6	2	7.85	26.8	15.7	53.6

(a) Heaters are rated at 415V. For other than rated voltage, CAP = (voltage/rated voltage)<sup>2</sup> x rated cap.

(b) For all input/output categories, does not include fan power or heat.

**Table 15. Electric heater voltage correction factors (applicable to auxiliary heat capacity)**

Nominal Voltage	Distribution Voltage	Capacity Multiplier
480	380	0.63
	400	0.69
	415	0.75
	440	0.84
	460	0.92
	480	1
	506	1.11

**Table 16. Air temperature rise across electric heaters (°F)**

kW	Stages	3 Tons 940 CFM EBC036A*	4 Tons 1280 CFM EBC048A*	5 Tons 1640 CFM EBC060A*
4.7	1	15.81	11.61	9.06
6.3	1	21.19	15.56	12.14
9	1	30.27	22.23	17.35
12.5	2	-	30.87	24.09
15.7	2	-	-	30.26

**Notes:**

1. For minimum design airflow, see airflow performance table for each unit.
2. To calculate temp rise at different airflow, use the following formula:  
Temp. rise across Electric Heater = kW x 3414/1.08 x cfm.





# Controls

## Thermostats

### Non-Programmable Thermostat

*TCONT402\*\*\* (3H/2C)*

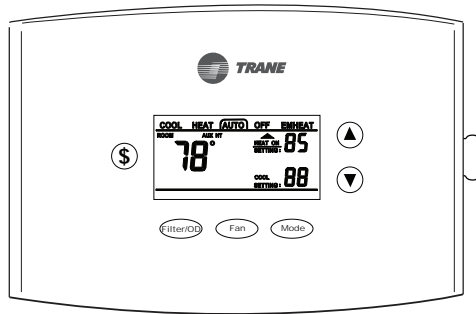

- Three heat/Two cool
- Auto-changeover
- Backlit Display & Keys
- Filter Reminder
- Keypad Lock
- Outdoor Temp Sensor Included

### Programmable Thermostat

*TCONT802\*\*\* (3H/2C)*

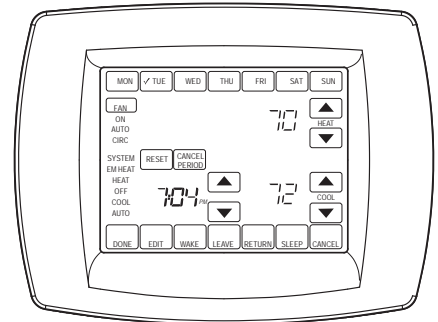

- Three heat/Two cool
- Interactive touchscreen
- Large display
- Real time clock



# Electrical Data

**Table 17. Unit wiring with cooling (no electric heat)**

Tons	Unit Model Number	Unit Operating Voltage Range	Standard Indoor Fan Motor		Oversized Indoor Fan Motor	
			Minimum Circuit Ampacity <sup>(a)</sup>	Maximum Fuse Size or Maximum Circuit Breaker	Minimum Circuit Ampacity	Maximum Fuse Size or Maximum Circuit Breaker
3	EBC036AD	380 <sup>(b)</sup>	11	15	12	15
4	EBC048AD	380 <sup>(b)</sup>	13	20	14	20
5	EBC060AD	380 <sup>(b)</sup>	14	20	15	20

(a) For Standard and Oversized Indoor Fan Motor, values do not include power exhaust accessory.  
 (b) Unit will operate reliably at 400Vac.

**Table 18. Unit wiring with electric heat (single point connection)**

Tons	Unit Model Number	Heater Model Number	Heater kW Rating <sup>(a)</sup>	Control Stages	Heater Amps	Standard Indoor Motor		Oversized Indoor Motor	
						Minimum Circuit Ampacity	Max Fuse Size or Max Circuit Breaker	Minimum Circuit Ampacity	Max Fuse Size or Max Circuit Breaker
<b>380 Volts Three Phase<sup>(b)</sup></b>									
3	EBC036AD	BAYHTFA407A	4.7	1	7.1	12	15	13	15
		BAYHTFA410A	6.3	1	9.6	15	15	16	20
		BAYHTFA415A	9.0	1	13.7	21	25	21	25
4	EBC048AD	BAYHTFA407A	4.7	1	7.1	13	20	14	20
		BAYHTFA410A	6.3	1	9.6	15	20	16	20
		BAYHTFA415A	9.0	1	13.7	21	25	21	25
		BAYHTFA420A	12.5	2	19.0	27	30	28	30
5	EBC060AD	BAYHTFA407A	4.7	1	7.1	14	20	15	20
		BAYHTFA410A	6.3	1	9.6	15	20	16	20
		BAYHTFA415A	9.0	1	13.7	21	25	21	25
		BAYHTFA420A	12.5	2	19.0	27	30	28	30
		BAYHTFA425A	15.7	2	23.9	33	35	34	35

(a) Heater kW ratings are at 480V for 380V units.  
 (b) Unit will operate reliably at 400Vac.

**Table 19. Electrical characteristics—compressor motor and condenser motor**

Tons	Unit Model No.	Volts	Compressor Motors						Condenser Fan Motors					
			No.	Phase	HP	RPM	Amps <sup>(a)</sup>		No.	Phase	HP	Amps <sup>(a)</sup>		
							FLA	LRA				FLA	LRA	
3	EBC036AD	380 <sup>(b)</sup>	1	3	4.2	3500	6.0	43.0	1	3	0.33	0.7	2.3	
4	EBC048AD	380 <sup>(b)</sup>	1	3	5.4	3500	7.8	52.0	1	3	0.33	0.7	2.3	
5	EBC060AD	380 <sup>(b)</sup>	1	3	5.9	3500	8.5	67.0	1	3	0.33	0.7	2.3	

(a) For Compressor Motors and Condenser Fan Motors: Amp draw for each motor; multiply value by number of motors to determine total amps.  
 (b) Unit will operate reliably at 400Vac.

**Table 20. Electrical characteristics—evaporator fan motor**

Tons	Unit Model Number	Standard Evaporator Fan Motor						Oversized Evaporator Fan Motor					
		No.	Volts	Phase	HP	Amps		No.	Volts	Phase	HP	Amps	
						FLA	LRA					FLA	LRA
3	EBC036AD	1	380 <sup>(a)</sup>	3	1	2	12.5	1	380 <sup>(a)</sup>	3	2	3	26.2
4	EBC048AD	1	380 <sup>(a)</sup>	3	1	2	12.5	1	380 <sup>(a)</sup>	3	2	3	26.2
5	EBC060AD	1	380 <sup>(a)</sup>	3	1	2	12.5	1	380 <sup>(a)</sup>	3	2	3	26.2

(a) Unit will operate reliably at 400Vac.

# Jobsite Connections

**Table 21. Typical number of wires**

Thermostats	
A	5 or 6 wires
B	3 Power Wires + 1 Ground Wire (three phase)

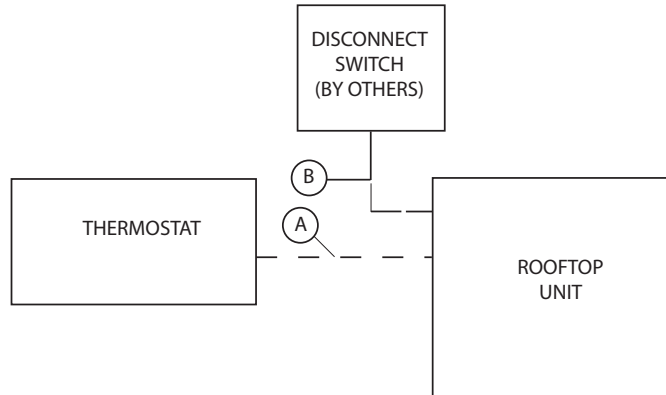

**Notes:**

- For specific wiring information, see the installation instructions.
- All wiring except power wire is low voltage.
- All customer supplied wiring to be copper and must conform to applicable electrical codes and local electric codes. Wiring shown dotted is to be furnished and installed by the customer.



# Dimensional Data

Figure 1. Cooling with optional electrical heat units — overview

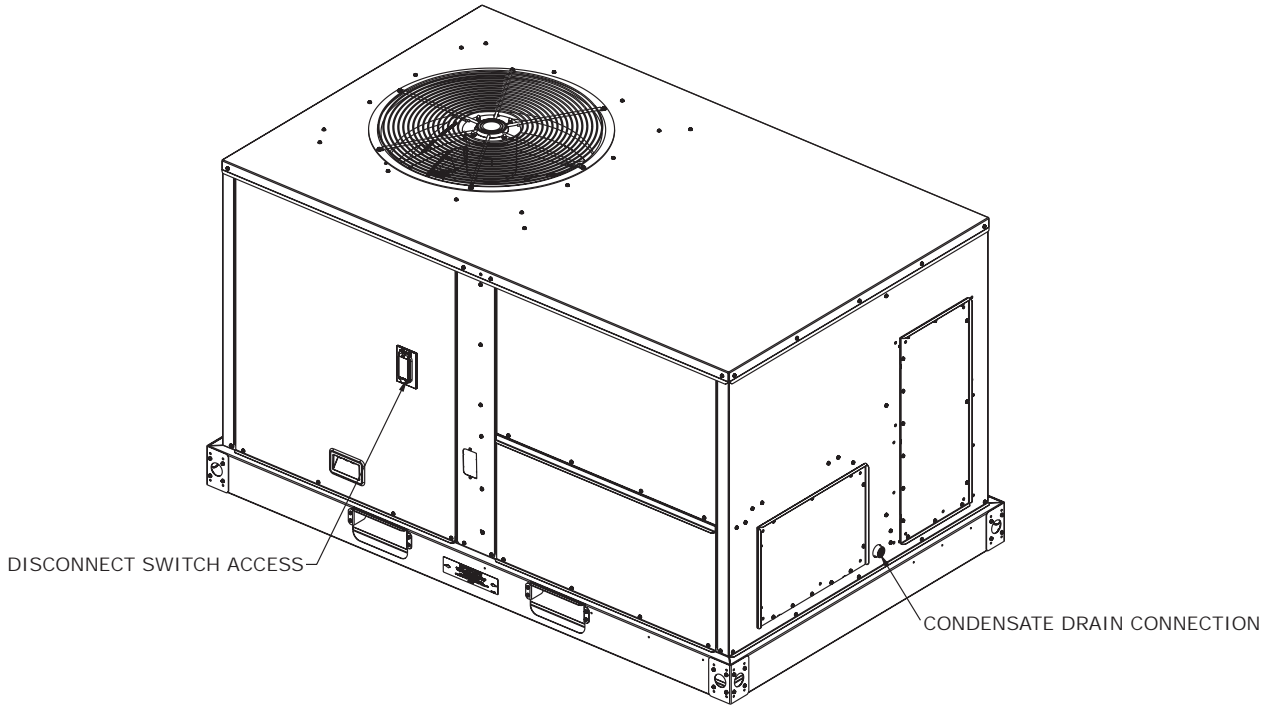
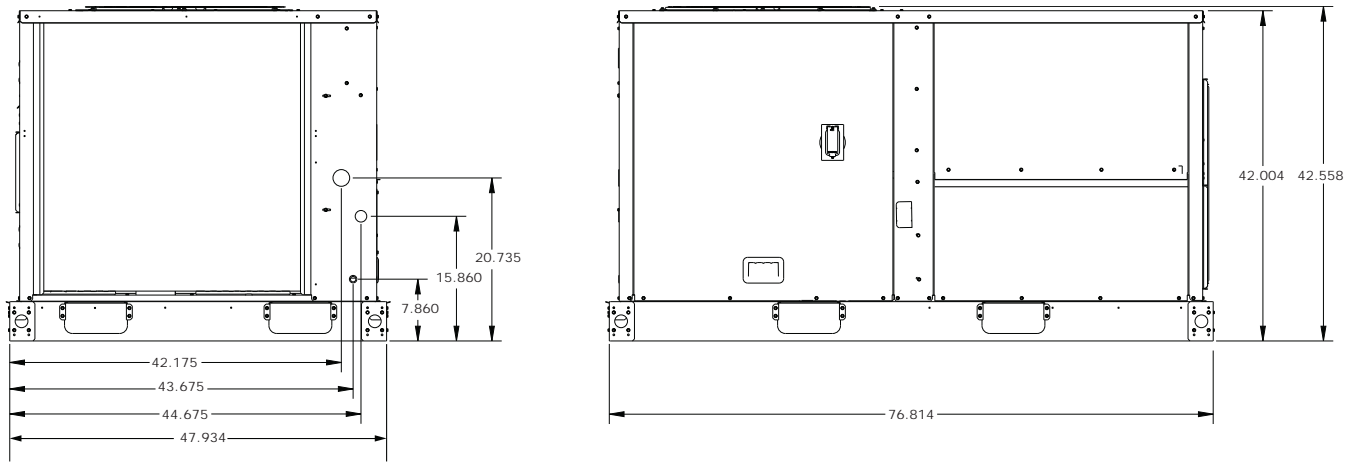

Figure 2. Cooling with optional electrical heat units — front & side views — 3-5 tons



NOTES:  
1. THRU-THE-BASE ELECTRICAL IS NOT STANDARD ON ALL UNITS.  
2. VERIFY WEIGHT, CONNECTION, AND ALL DIMENSION WITH INSTALLER DOCUMENTS BEFORE INSTALLATION

## Dimensional Data

Figure 3. Cooling with optional electrical heat — plan view — 3-5 tons

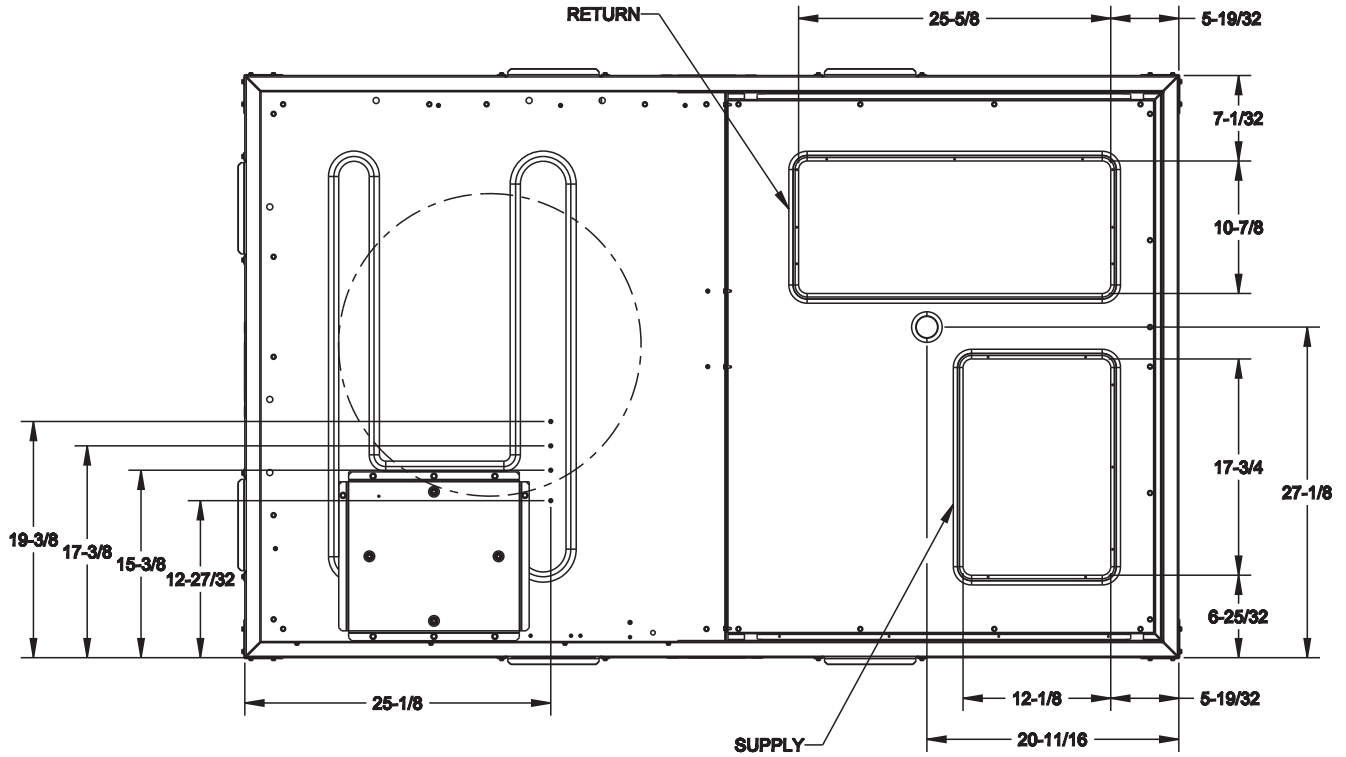

Figure 4. Cooling with optional electrical heat — back view (horizontal configuration) — 3-5 tons

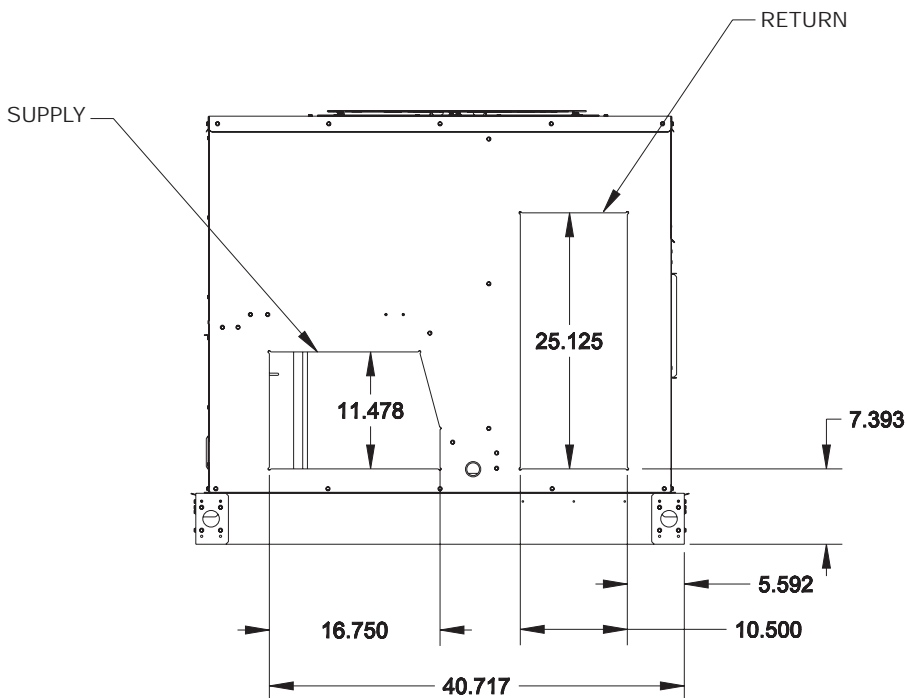

Figure 5. Cooling with optional electric heat — roof curb — 3-5 tons

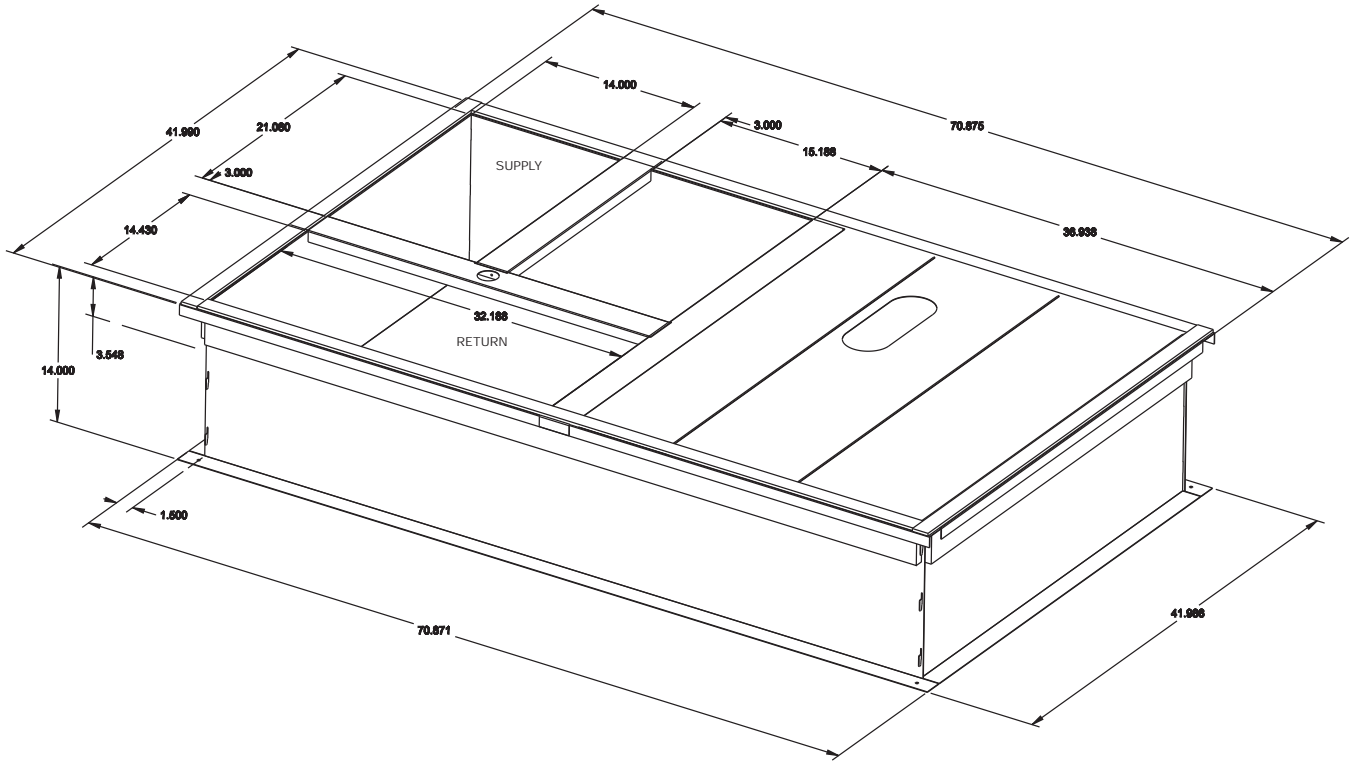
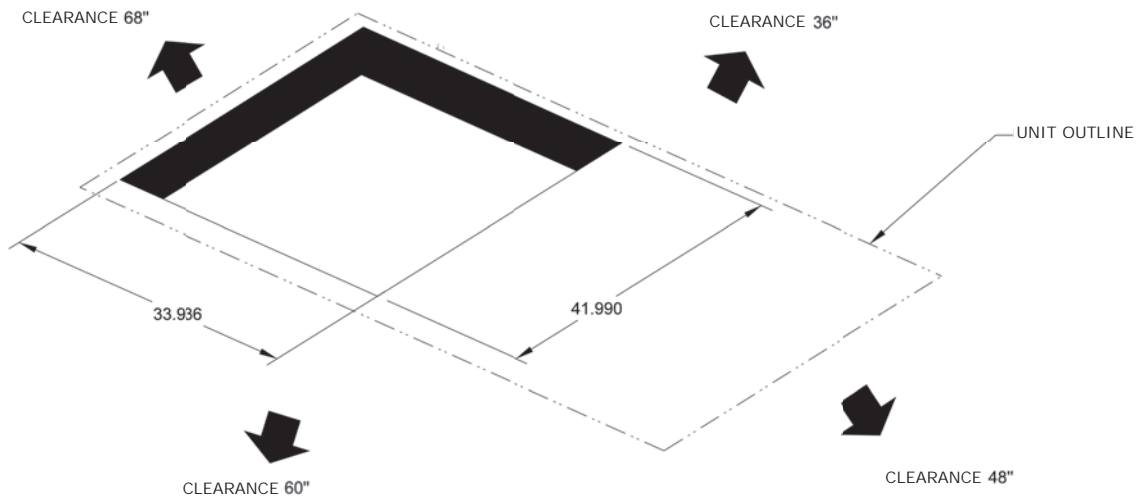
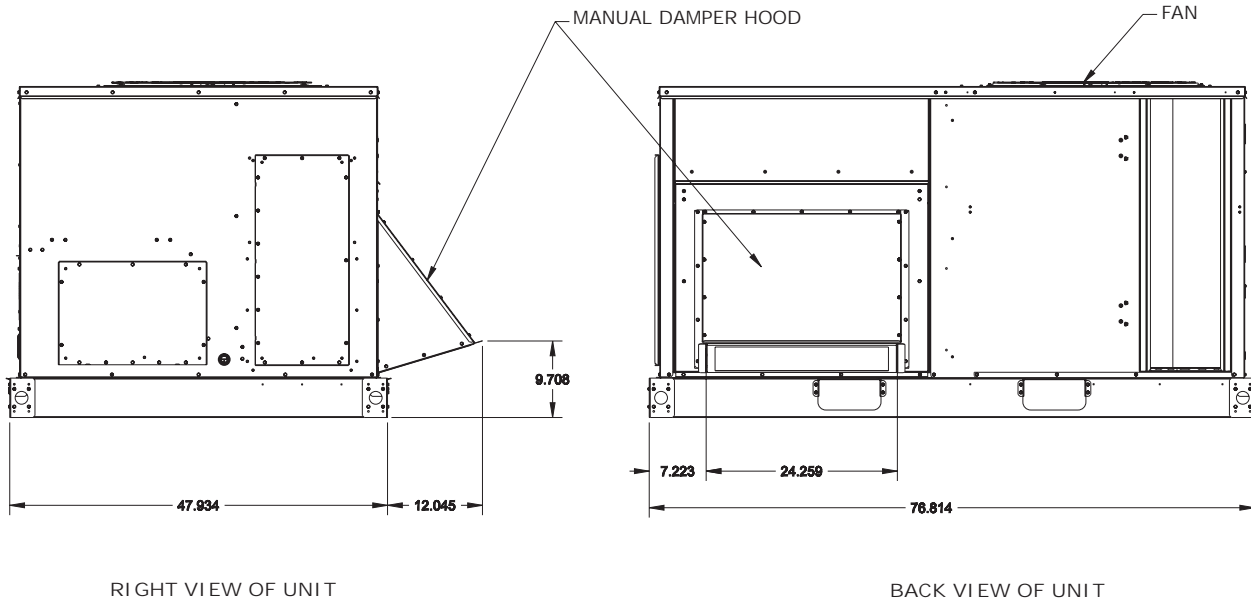

Figure 6. Cooling with optional electric heat — downflow unit clearance — 3-5 tons



## Dimensional Data

**Figure 7. Cooling with optional electric heat models — manual damper — 3-5 tons**



NOTE:  
 VERIFY WEIGHT, CONNECTION, AND ALL  
 DIMENSIONS WITH INSTALLER DOCUMENTS BEFORE  
 INSTALLATION.



# Weights

**Table 22. Maximum unit & corner weights (lb) and center of gravity dimensions (in.) cooling with optional electric heat units only**

Tons	Unit Model No.	Weights (lb) <sup>(a), (b)</sup>		Corner Weights <sup>(c)</sup>				Center of Gravity (in.)	
		Shipping	Net	A	B	C	D	Length	Width
3	EBC036*	542	492	90	102	159	141	41	29
4	EBC048*	570	520	104	108	157	152	39	28
5	EBC060*	590	540	113	112	157	158	38	28

(a) Weights are approximate.

(b) Weights do not include additional factory or field installed options/accessories. For option/accessory additional weights, reference [Table 23, p. 33](#) to be added to unit weights.

(c) Corner weights are given for information only.

**Figure 8. Center of gravity - 3-5 tons**

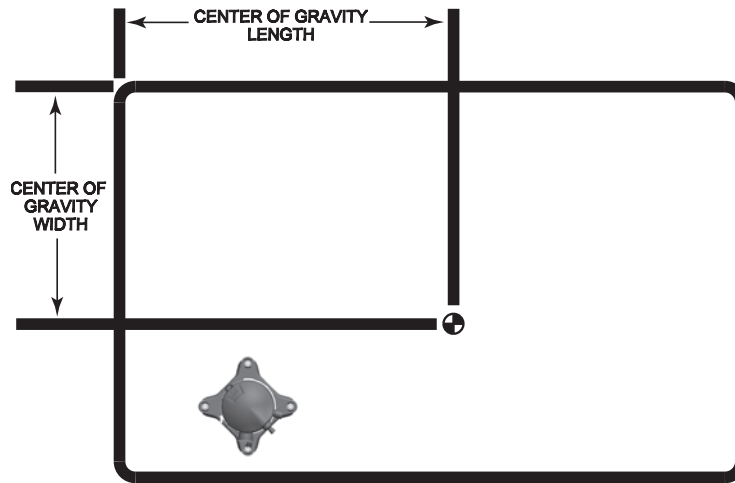

**Table 23. Accessory net weight (lb)<sup>(a), (b), (c)</sup>**

Accessories	EBC036-060
Manual Outside Air Damper	16
Roof Curb	61
Oversized Motor	5
Hail Guard	12
Electric Heaters	15

(a) Net weight should be added to unit weight when ordering factory-installed accessories.

(b) Weights for factory installed options and field installed accessories not listed are < 5 lb.

(c) To estimate shipping weight add 5 lb to net weight.



# Mechanical Specifications

## General

The units shall be dedicated downflow or horizontal airflow. The operating range shall be between 125°F and 45°F in cooling as standard from the factory for all units. Cooling performance shall be rated in accordance with ARI testing procedures. All units shall be factory assembled, internally wired, fully charged with R-410A, and 100 percent run tested to check cooling operation, fan and blower rotation and control sequence, before leaving the factory. Wiring internal to the unit shall be colored and numbered for simplified identification. Units shall be UL listed and labeled, classified in accordance to UL 1995/C 22.2, 236-15 5<sup>th</sup> Edition.

## Casing

Unit casing shall be constructed of zinc coated, heavy gauge, galvanized steel. Exterior surfaces shall be cleaned, phosphatized, and finished with a weather-resistant baked enamel finish. Unit's surface shall be tested 672 hours in a salt spray test in compliance with ASTM B117. Cabinet construction shall allow for all maintenance on one side of the unit. In order to ensure a water and air tight seal, service panels shall have lifting handles and no more than four screws to remove. All exposed vertical panels and top covers in the indoor air section shall be insulated with a 1/2-inch, 1-pound density foil-faced, fire-resistant, permanent, odorless, glass fiber material. The base of the downflow unit shall be insulated with 1/2-inch, 1-pound density foil-faced, closed-cell material. The downflow unit's base pan shall have no penetrations within the perimeter of the curb other than the raised 1 1/8-inch high supply/return openings to provide an added water integrity precaution, if the condensate drain backs up. The base of the unit shall have provisions for forklift and crane lifting.

## Compressors

All units shall have direct-drive, hermetic, scroll type compressors with centrifugal type oil pumps. Motor shall be suction gas-cooled and shall have a voltage utilization range of plus or minus 10 percent of nameplate voltage. Internal overloads shall be provided with the scroll compressors. All models shall have phase monitors, low and high pressure controls, and locking safety device as standard.

## Controls

Unit shall be completely factory wired with necessary controls and contactor pressure lugs or terminal block for power wiring. Unit shall provide an external location for mounting a fused disconnect device.

## Discharge Line Thermostat

A bi-metal element discharge line thermostat is installed as a standard option on the discharge line of each system. This standard option provides extra protection to the compressors against high discharge temperatures in case of loss of charge, extremely high ambient and other conditions which could drive the discharge temperature higher. Discharge line thermostat is wired in series with high pressure control. When the discharge temperature rises above the protection limit, the bi-metal disc in the thermostat switches to the off position, opening the 24 Vac circuit. When the temperature on the discharge line cools down, the bi-metal disc closes the contactor circuit, providing power to the compressor.

## Evaporator and Condenser Coils

Microchannel coils will be burst tested by the manufacturer. Microchannel condenser and evaporator coils shall be standard on all units. Coils shall be leak tested to ensure the pressure integrity. The evaporator coil and condenser coil shall be leak tested to 225 psig and pressure tested to 450 psig. Sloped condensate drain pans are standard.

## Filters

Two inch standard filters shall be factory supplied on all units.

**High Pressure Control**

All units include High Pressure Cutout as standard.

**Indoor Fan**

Units above shall have belt driven, FC centrifugal fans with adjustable motor sheaves. All motors shall be thermally protected. Oversized motors shall be available for high static application. All indoor fan motors meet the U.S. Energy Policy Act of 1992 (EPACT).

**Locking Safety Device**

Pressure switch monitoring allows for lockout in a situation where the switch is opened. By monitoring the Y input as well as the pressure switches, advanced decision making can be made to identify situations where faults/errors occur.

**Low Pressure Control**

All units include low pressure cutout as standard.

**Outdoor Fans**

The outdoor fan shall be direct-drive, statically and dynamically balanced, draw-through in the vertical discharge position. The fan motor(s) shall be permanently lubricated and shall have built-in thermal overload protection.

**Phase Monitor**

The Phase Monitor is a three-phase line monitor module that protects against phase loss, phase reversal and phase unbalance. It is intended to protect compressors from reverse rotation. It has an operating input voltage range of 190–600 Vac, and LED indicators for ON and FAULT. There are no field adjustments and the module will automatically reset from a fault condition.

**Refrigerant Circuits**

Each refrigerant circuit shall have independent thermal expansion valve, service pressure ports, and refrigerant line filter driers factory installed as standard. An area shall be provided for replacement suction line driers.

**Unit Top**

The top cover shall be double hemmed and gasket sealed to prevent water leakage.

**Factory Installed Options****Complete Coat™ Microchannel Condenser Coil**

The cathodic epoxy type electrodisposition coating is formulated for high edge build to a number of different types of heat exchangers. The coating is selected to provide excellent resistance and durability to corrosive effects of alkalis, acids, alcohols, petroleum, seawater, salty air, and other corrosive environments. This coating shall be available on microchannel condenser coils.

**Factory or Field Installed Options****Condensate Overflow Switch**

This option shall shut the unit down in the event that a clogged condensate drain line prevents proper condensate removal from the unit.

**Electric Heaters**

Electric heat modules shall be available for installation within the basic unit. Electric heater elements shall be constructed of heavy-duty nickel chromium elements internally delta connected for 240 volt, wye connected for 380, 480 and 600 volt. Each heater package shall have automatically reset high limit control operating as line break limits. Power assemblies shall provide single-point



## Mechanical Specifications

---

connection. Electric heat modules shall be UL listed or CSA certified. If ordering the Through the Base Electrical option with an Electric Heater, the heater must be factory installed.

### **Manual Outside Air Damper**

The rain hood and screen shall provide up to 50% outside air.

### **Oversized Motors**

Oversized motors shall be available for high static applications.

## **Field Installed Options**

### **Crankcase Heaters**

These band heaters provide improved compressor reliability by warming the oil to prevent migration during off-cycles or low ambient conditions.

### **Low Ambient Kit**

Allows system to operate in cooling below 45 degree by maintaining head pressure by cycling the outdoor fan motor allowing safe system operation without indoor coil icing.

### **Roof Curb—Downflow**

The roof curb shall be designed to mate with the downflow unit and provide support and a water tight installation when installed properly. The roof curb design shall allow field-fabricated rectangular supply/return ductwork to be connected directly to the curb. Curb shall be shipped knocked down for field assembly and shall include wood nailer strips.

### **Tool-less Hail Guards**

Tool-less, hail protection quality coil guards are available for condenser coil protection.

### **Two-Inch Pleated Filters**

Two-inch MERV 13 filters shall be available on all models.







Trane - by Trane Technologies (NYSE: TT), a global climate innovator - creates comfortable, energy efficient indoor environments for commercial and residential applications. For more information, please visit [trane.com](http://trane.com) or [tranetechnologies.com](http://tranetechnologies.com).

Trane has a policy of continuous product and product data improvement and reserves the right to change design and specifications without notice. We are committed to using environmentally conscious print practices.