

Williston Development Review Board (DRB) Staff Report	
<b>Application Stage:</b> Certificate of Appropriateness	<b>DRB Review Date:</b> May 11, 2021
<b>Application No:</b> HP 21-03	<b>Project Name:</b> Window Replacements & Fire Escape
<b>Property Address:</b> 38 Slate Barn Drive	<b>Zoning District:</b> Village Zoning District (VZD)
<b>Tax Parcel #:</b> 14:104:146.000	<b>Existing Lot Size:</b> 0.68 +/- acres

### Project Description

This is a request for a Certificate of Appropriateness to construct a stairwell and new doorway on the northeastern side of the house and replace 19 windows and add 3 windows where only storm windows currently exist. The property is located in the National Register Historic District of the Village Zoning District.

**Permit Review History:** This is the second time the DRB is reviewing this request.

- March 2, 2021 and March 16, 2021: HAAC review and recommendations
- April 27, 2021: DRB initial review & continuance. The DRB requested additional information on Pella window vendors and exterior muntins. The DRB was not in agreement that exterior storms would be approvable, citing Appendix H: “Do not alter the shape of original openings such as windows and doors.” The DRB also found it counterproductive to install storm windows over 1960s 1/1 replacement windows, which was the HAAC recommendation.
- May 11, 2021: tonight, DRB

**Fire Escape Recommendation:** Complies as proposed. HAAC recommendation, “Allow time for PT wood to season before painting fire escape.” The new door and wooden stairwell are proposed to the rear addition of the building, which was constructed in 1960s. The stairs will be offset from the side of the building. The stairs and new door will be minimally visible, if not entirely hidden, from view along Williston Road.

**Replacement Window Recommendation:** Complies as proposed. Pella Impervia Fiberglass windows with company-installed exterior muntins (2/2 pattern, 3M adhesive + prefabricated muntins) complies. This will retain and restore the 2/2 pattern throughout the building (some windows are 2/2, some are 1/1). The applicant has researched window patterns of the 1800s. “The beginning of the 1850’s was a swift transition from 6/6 divided light traditionally used during the Greek revival period (1830’s -> 1840’s) to 2/2 Italianate Style used in the 1860’s.” This house was constructed in the 1850s and the second story added in the 1880s. The back addition and conversion to a duplex took place in the 1960s. The only photo the town has is from 1977 and shows the 1/1 window pattern. The replacement windows were installed during 1960s renovations.

**Exterior Muntins:** Originally, the applicant proposed 1/1 replacement windows. The HAAC recommended a 2/2 window pattern to retain and restore the original character of the mid-1880s Greek Revival home. The applicant proposed installing exterior muntins on their own, however this option would have voided the manufacturer warranty on the windows. The applicant could not find a fiberglass replacement window with exterior muntins without significant expense. There are vinyl replacement windows with exterior muntins within budget, however the vinyl has a thicker 3” sash and chunkier appearance. The HAAC did not recommend a vinyl window. The HAAC and DRB agreed that a muntin pattern on the interior of window or between the glass panes would not suffice because the depth and shadow of exterior muntins would not be retained. The DRB continued their review on April 27<sup>th</sup> to get more information from the applicant on replacement window options.

**May 5<sup>th</sup> update from applicant:**

“I don't have an exact quote since they will be measuring on Friday and it will take time for them to get back to me, but their ballpark quote was \$1150 a window, which is not nearly as high as the Marvin option of \$1700 a window but obviously not quite as good as the other store at \$940 a window. That being said I still would like to do the work now rather than later.

The window is still the same, it's a Pella Impervia window, and the company would add the third-party kit using the 3M adhesive + pre fabbed Muntins for SDL look. This doesn't void the warranty because they are performing the work.

I did a little research about windows from the 1850s to late 1860s since we aren't exactly sure when the oldest part of the home was built. It appears that the beginning of the 1850's was a swift transition from 6/6 divided light traditionally used during the Greek revival period (1830's -> 1840's) to 2/2 Italianate Style used in the 1860's

Sources: <https://www.hpef.us/historic-windows/windows-through-time/19th-century> (See section on 1850s and 1860s)

<https://www.thisoldhouse.com/windows/21018270/victorian-era-windows>

So while I don't have a conclusive argument as to whether the windows were 6/6 as seen in the early 1800's or 2/2 as seen post 1850, I think either would be suitable to preserve the historic character of the building because those decades were a transition period for window styles. I can say from reading the New Hampshire Division of Historical Resources paper on Historic Wooden Window, the 2/2 windows were not built in the 1850's or 60's most likely they were built post 1880 based on the muntin size and shape. All muntins within the building appear to be like the one farthest to the right:

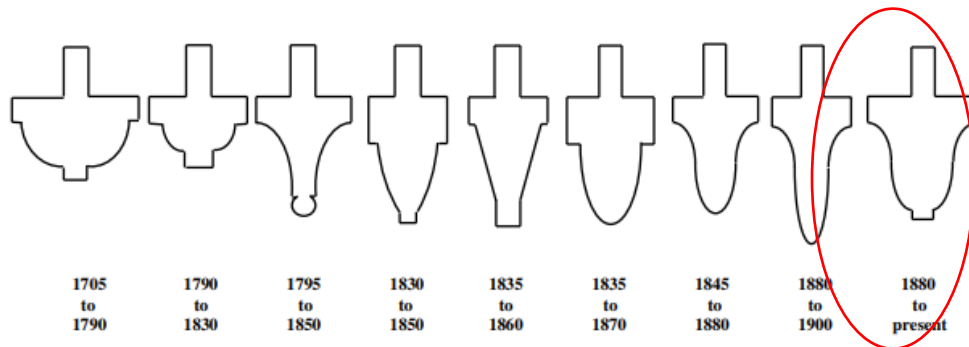

Link below to the paper.

[http://www.james-garvin.com/images/Window\\_Sashes2.pdf](http://www.james-garvin.com/images/Window_Sashes2.pdf)

## BYLAW EXCERPTS

### Appendix H: ALTERATIONS AND RENOVATIONS ADDITIONS

Incorporate elements of the original building, structure, or landmark into the renovation scheme.

- Do not obscure original materials.
- Do not alter the shape of original openings such as windows and doors.
- Do not obscure the facade or facade details by covering them with materials such as metal or plastic panels, signs, by painting them out, etc.
- Respect the original character and period of the building, structure or landmark.
- Do not try to make the building, structure or landmark look "historically" older than it really is. This devalues what is truly historic.
- Do not try to modernize the architectural features of a building, structure or landmark.

#### 42.8 Historic Design Review

**42.8.1 Must all development in the VZD be consistent with the Williston Village Historic District Design Review Guide?** Yes. Development in the VZD must be consistent with the *Williston Village Historic Design Review Guide (Guide)*, which is attached to this bylaw as Appendix H.

**42.8.2 If the Guide only says "should," do I really have to comply?** Yes, to the extent feasible. The use of 'should' and similar formulations of standards in this chapter does not exempt anyone from compliance. This language is, instead, an acknowledgement of the difficulties that are sometimes encountered in maintaining the historic appearance of existing buildings as they age, as well as of the fact that not all existing buildings in the VZD have historic character. 'Should' provides some flexibility for the Administrator or DRB to accept practical solutions that are in the spirit of the *Guide*. The designers of new buildings should read the *Guide* as mandatory.

**42.8.3 Does this bylaw add anything to the Guide?** Yes.

**42.8.3.1 Color.** The *Guide* does not make it clear that color is among the legitimate considerations in design review in the VZD. It is. The HAAC and DRB may consider the compatibility of proposed colors with those on surrounding buildings and the overall character of the Village.

**42.8.3.2 Fences.** The color and material of front yard fences in the VZD are subject to approval by the Administrator with the advice of the HAAC.

**42.8.3.3 Siding.** Vinyl siding is not permitted on historic structures. Cementitious fiberboard may be acceptable instead of clapboard outside the Williston Village National Register Historic District. Replacement siding must comply with this standard to the extent of the change being made.

**42.8.3.4 Signs.** Signs must comply with both the *Guide* and the standards adopted in Chapter 25 of this bylaw.

**42.8.3.5 Skylights.** Skylights are permitted, but they must not be visible from a public way.

#### HAAC Notes from March 16, 2021:

Aluminum storm windows: cheapest option, no exterior grille pattern, screen

Vinyl: 3" sash, chunkier, cheaper, has exterior muntin pattern, not best option environmentally

Fiberglass: 2" sash respect glass proportions, middle price point, interior muntin

Wood: most expensive, exterior grille.

#### HAAC Recommendations:

At their meeting on March 16, 2021 the HAAC made the following recommendations:

- Retain windows and replace exterior storms, except for the 3 small windows (2 bathroom and 1 laundry room as highlighted) which will be replaced with fiberglass awning windows
- Allow time for PT wood to season before painting fire escape



### **Proposed DRB Motion**

**As authorized by WDB 6.6.3, I \_\_\_\_\_, move that the Williston Development Review Board, having reviewed the application submitted and all accompanying materials, including the recommendations of the town's staff and the advisory boards required to comment on this application by the *Williston Development Bylaw*, and having heard and duly considered the testimony presented at the public meeting of May 11, 2021 accept the recommendations and approve HP 21-03.**

**This approval authorizes the applicant to seek an administrative permit for the proposed development, which must proceed in strict conformance with the certificate.**

# **Williston Village Historic District Certificate of Appropriateness**

**In accordance with WDB Chapter 42,  
the Historic and Architectural Advisory Committee  
recommends approval of a**

## **Certificate of Appropriateness**

**To: Nayo Ogilvie**

**Application number: HP 21-03**

**For: Fire Escape Stairwell and Window Replacement**

With the following recommendations:

- **Pella Impervia Fiberglass windows with company-installed exterior muntins (2/2 pattern, 3M adhesive + prefabricated muntins)**
- **The 3 small windows (2 bathroom and 1 laundry room as highlighted) may be replaced with fiberglass awning windows without muntins**
- Allow time for PT wood to season before painting fire escape

The property is located at:  
**38 Slate Barn Drive**

Dated: May 11, 2021

---

Chair, Development Review Board

**SECTION A – BUILDING AND PROPERTY DATA**

*The applicant may need to research landowner's personal records, permits on file in the Planning & Zoning Office, Land Records in the Town Clerk's Office, and/or the State of Vermont [Historic Sites and Structures Survey \(HSSS\)](#).*

**Date of Original Construction**

**Describe the architectural style and features.**

Architecture examples: Greek Revival, Colonial, Raised Ranch, etc.

Feature examples: the roof shape and material, siding, window pattern, chimneys, cornices, trim work, shutters, steps, porches, or other unique features of the structure.

**Describe previous additions, alterations, accessory structures, and/or demolitions. Include dates.**

*For example: window, roof or siding replacements, sheds or carriage houses, summer kitchens, etc.*

**Project Appropriateness**

How does the project preserve the character of the structure and property? Will original features will be removed or altered? Provide justification for this change. How does your project preserve the character of the National Register District and/or the Additional Review Area of the Village Zoning District?

**SECTION B – NEW STRUCTURE OR ADDITION**

Check here if a new structure or addition is not proposed

Existing structure height (ft)	
Existing structure size (SF of footprint)	
Proposed structure or addition size (SF of footprint)	
Height of proposed structure or addition (ft)	

**Describe the proposed building or addition.**  
*Include information about the architectural style, relationship to existing structure(s) on the parcel, and relationship to architecture in the district.*

**Building Materials**  
*Describe roof, siding, window, door, and foundation materials. If an addition is proposed, describe materials on existing structure.*

**SECTION C – ALTERATIONS**

Check here if section is not applicable

**Describe the proposed alterations.**

*Include information about the architectural style, relationship to existing structure(s) on the parcel and relationship to architecture in the district.*

Alteration is to:      Roof      Siding      Windows      Doors      Other (explain below)

**Existing Building Materials**

*Describe the existing building materials and color. Are these materials original to the structure? What materials will be replaced entirely? What materials will be refurbished?*

**Proposed Building Materials**

*Describe the proposed building materials and color.*



## Problems:

**Windows:** Windows are extremely drafty, and don't always stay open on their own which could create a fire hazard. Many of the storm windows are falling apart, currently 5 storms don't close.

**Fire Escape:** Currently there is no way to get a standard size couch or a queen size mattress and box spring into the second story apartment. Only a full size mattress will fit but you have to go through the second story window. There will be added egress capability for the building in the event of a fire.

## Project Description:

**Windows:** Replace 19 windows within the home and add 3 where only a window opening with a storm currently exists. The replacements are Pella Impervia fiberglass window inserts. Remove aluminum exterior storms.

The sash size of the replacement window is  $1 \frac{3}{4}$  inches, currently the windows have a sash size of  $1 \frac{7}{8}$  inches. Windows with dividers will be replaced with simulated divided light windows. The windows will be white interior and exterior to match the current windows. Exterior and interior trim should remain the same and be untouched.



New windows are double pane, argon filled with low E glass.









Replacement window

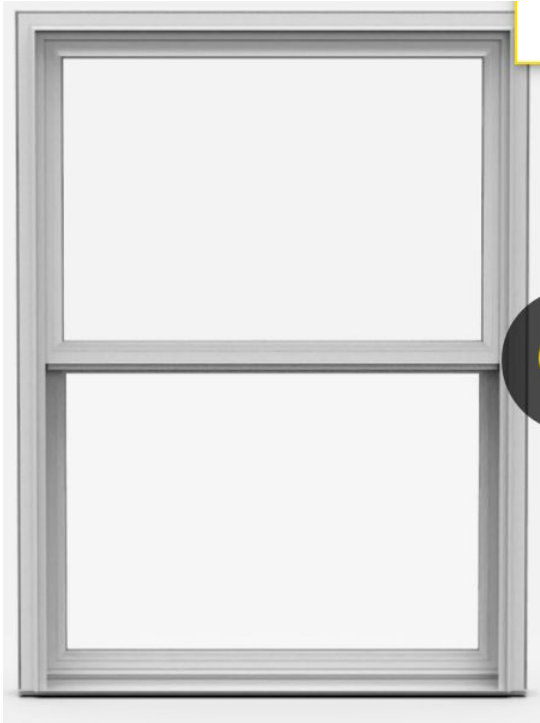

**Fire Escape:** Install stairs with landing on the back corner of the property. Using pressure treated lumber with sonotubes at the base of the posts. Remove two storm windows and frame in an exterior door. Add wood siding to the remaining space left on the door. Fire escape will be painted white

### Fire Escape Location

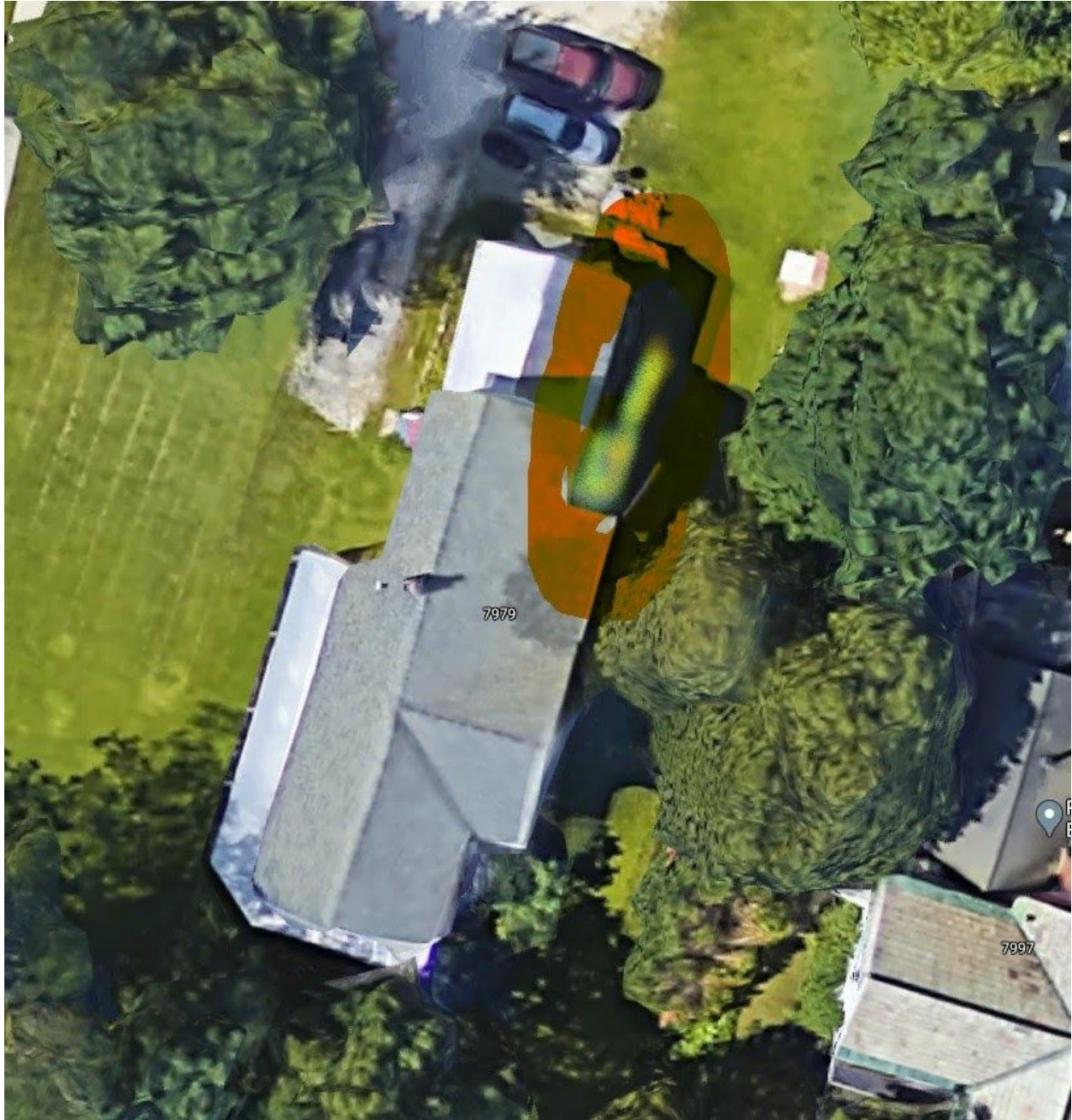









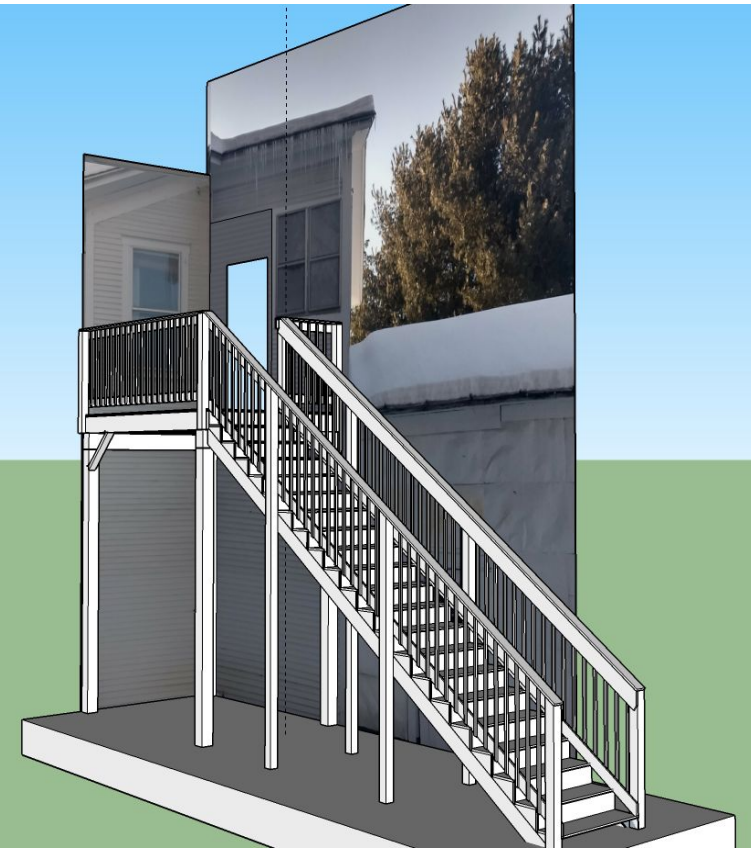
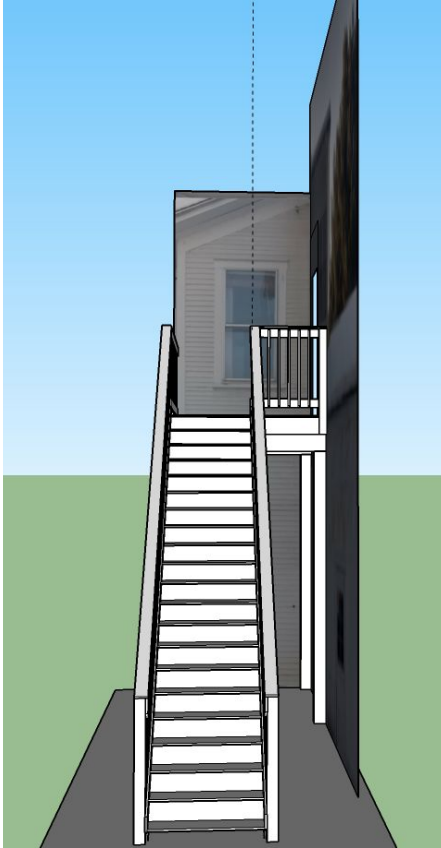



**Outcome:**

**Windows:** Provide safe efficient windows that accurately resemble the current windows installed. Match the divided panes for each window, as well as sash size of the current windows. Color of the windows will be white to match current paint color and trim will remain the same.

**Fire Escape:** Provide safe and easy access to move furniture in and out of the apartment for tenants. Extra egress method if a fire ever arises. Should not be overly visible from RT 2 or Slate Barn Drive.













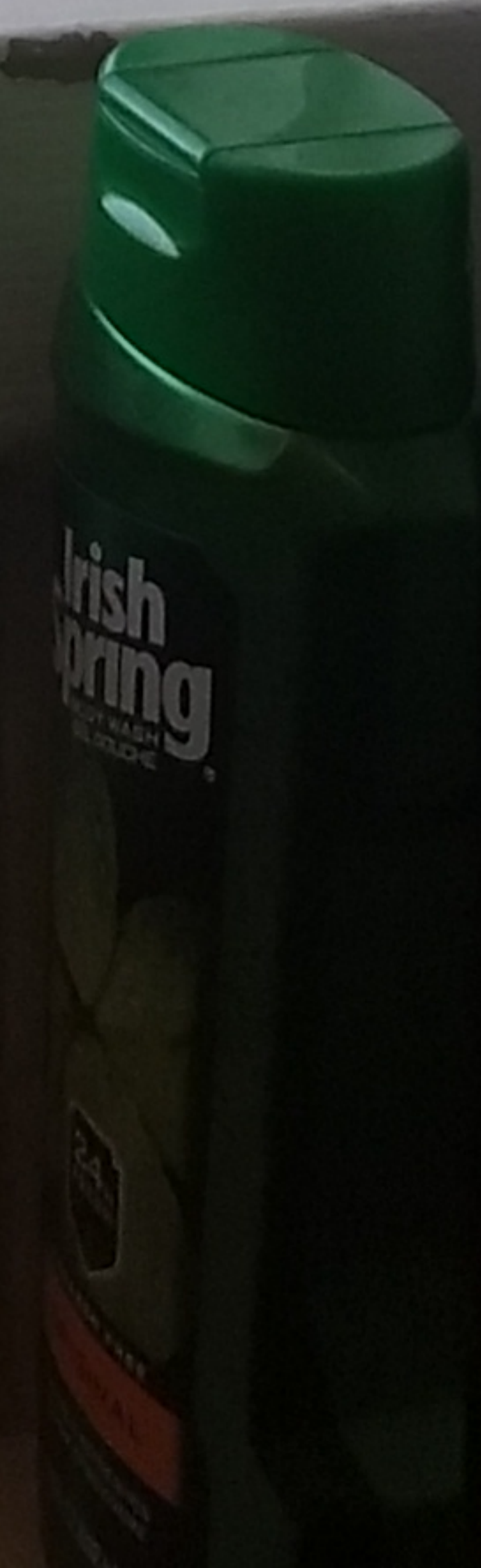
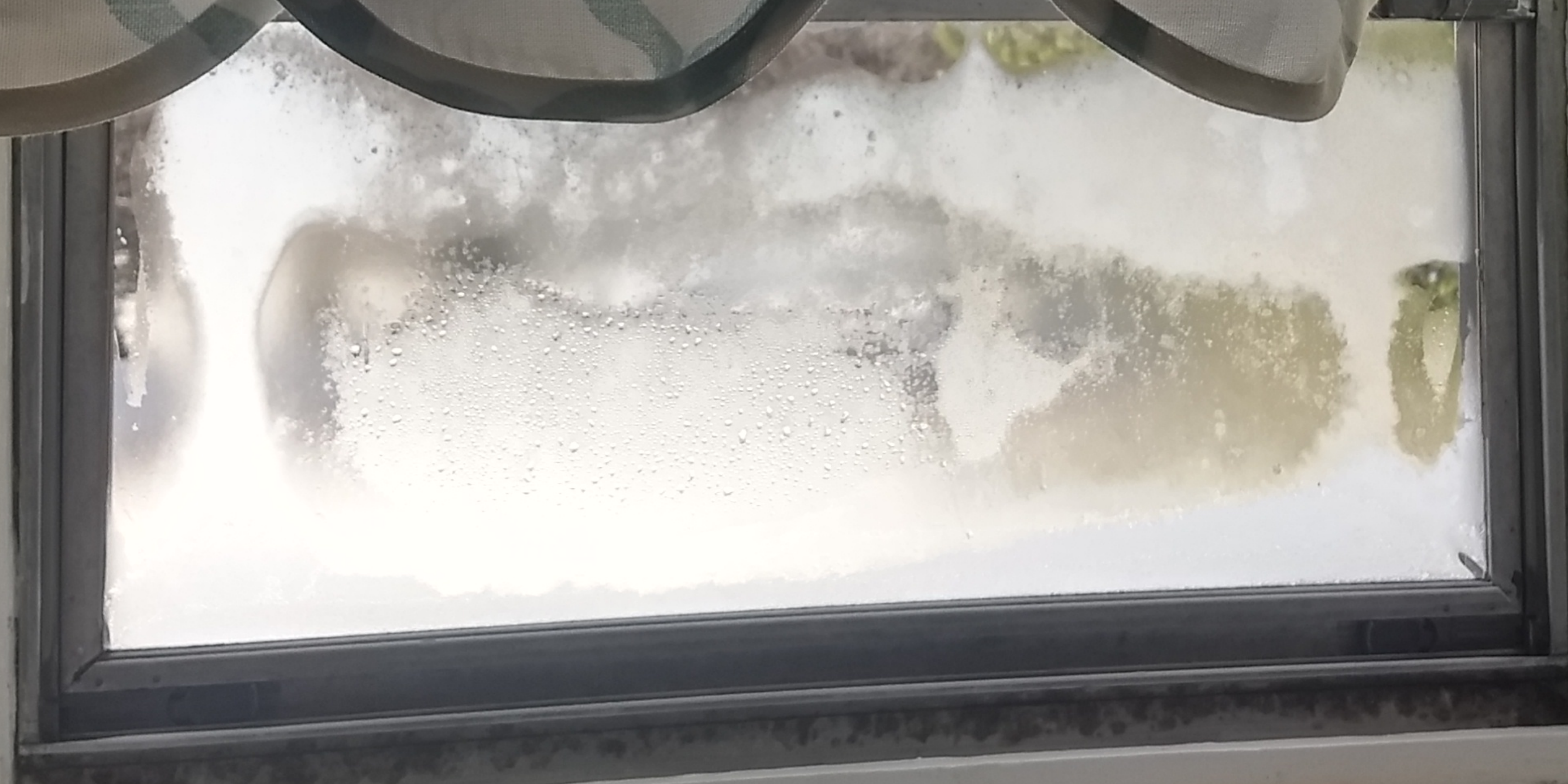











Product Selection Guide

Size and Performance Data ..... F-DH-2

Sound Transmission Class ..... F-DH-2

Features and Options..... F-DH-3

Glazing Performance..... F-DH-4

Grille Types..... F-DH-9

Size Tables ..... F-DH-10

Combination Assemblies..... F-DH-15

Design Data..... F-DH-17

Detailed Product Descriptions..... F-DH-23

Unit Sections

Block Frame ..... F-DH-25

Integral Nailing Fin..... F-DH-26

Document Navigation Tips:

Items listed in the table of contents above are active links that will take you to the corresponding page.  
 The Pella logo on each page is a link back to this table of contents.  
 Bookmarks are also included in this PDF document and are available as an additional navigation option.

Supporting documents for this product:

Test Reports:

[https://media.pella.com/professional/adm/CertificationReports/Test\\_Reports\\_IMP.pdf](https://media.pella.com/professional/adm/CertificationReports/Test_Reports_IMP.pdf)

CSI Specs (readable using Microsoft Word or other text editing application):

[https://media.pella.com/professional/adm/Fiberglass-CSI\\_Specs/08572\\_DH.rtf](https://media.pella.com/professional/adm/Fiberglass-CSI_Specs/08572_DH.rtf)

AIA Masterspec (readable using Microsoft Word or other text editing application):

[https://media.pella.com/professional/adm/Fiberglass-CSI\\_Specs/085413\\_fl.rtf](https://media.pella.com/professional/adm/Fiberglass-CSI_Specs/085413_fl.rtf)

Detailed Product Description (readable using Microsoft Word or other text editing application):

<https://media.pella.com/professional/adm/Fiberglass/F2-DH.rtf>

Size Tables (requires appropriate CAD software to read and use):

[https://media.pella.com/professional/adm/Fiberglass/IMP-DH-Elev\\_D.dwg](https://media.pella.com/professional/adm/Fiberglass/IMP-DH-Elev_D.dwg)

CAD cross sections (requires appropriate CAD software to read and use):

[https://media.pella.com/professional/adm/Fiberglass/IMP-DH-Detail\\_D.dwg](https://media.pella.com/professional/adm/Fiberglass/IMP-DH-Detail_D.dwg)

3D & BIM (requires appropriate software to read and use):

[https://media.pella.com/professional/adm/RevitFiles/Imp-Revit/Window-Double\\_Hung-Pella-Impervia.zip](https://media.pella.com/professional/adm/RevitFiles/Imp-Revit/Window-Double_Hung-Pella-Impervia.zip)

Sketchup (requires appropriate software to read and use):

[https://media.pella.com/professional/adm/Fiberglass/PellaSKP\\_Impervia\\_Double-Hung.zip](https://media.pella.com/professional/adm/Fiberglass/PellaSKP_Impervia_Double-Hung.zip)

Combination Recommendations:

[https://media.pella.com/professional/adm/Fiberglass/F2\\_Combinations.pdf](https://media.pella.com/professional/adm/Fiberglass/F2_Combinations.pdf)

Installation Details:

[https://media.pella.com/professional/adm/Fiberglass/Pella-Impervia\\_InstallationDetails.pdf](https://media.pella.com/professional/adm/Fiberglass/Pella-Impervia_InstallationDetails.pdf)

The information published in this document is believed to be accurate at the time of publication. However, because we are constantly working to improve our products, specifications are subject to change without notice. Consult your local Pella representative for up-to-date product information.

Microsoft and Microsoft Word are registered trademarks of Microsoft Corp.



# Impervia® Double-Hung Windows

## Size and Performance Data

	Block Frame	Precision Fit	Integral Nailing Fin
<b>Sizes</b>			
Standard Vent–Equal Sash, Cottage and Contemporary Sash	●	●	●
Special Fixed	●	●	●
Special Fixed Companion	●	●	●
Special Sizes Available	●	●	●
<b>Performance <sub>1</sub></b>			
Meets or Exceeds AAMA/WDMA Ratings	H-LC30-H-LC50 Hallmark Certified	H-LC30-H-LC50 Hallmark Certified	H-LC30-H-LC50 Hallmark Certified
Air Infiltration (cfm/ft <sup>2</sup> of frame @ 1.57 psf wind pressure)	0.3	0.3	0.3
Water Resistance	4.5 psf	4.5 psf	4.5 psf
Design Pressure	30–50 psf	30–50 psf	30–50 psf
<b>Other Performance Criteria</b>			
Forced Entry Resistance Level (Minimum Security Grade) <sub>2</sub>	10	10	10
Maximum Operating Force (lb) Initiate Motion/Maintain Motion	20/30 for units with sash ≤ 12 ft <sup>2</sup> 30/45 for units with sash > 12 ft <sup>2</sup>		
Maximum Locking Force (lb) Lock/Unlock	6/7	6/7	6/7

<b>Sound Transmission Class and Outdoor-Indoor Transmission Class</b>					
Frame Size Tested <sub>4</sub>	Glazing System			STC Rating	OITC Rating
	Overall Glazing Thickness	Exterior Glass Thickness	Interior Glass Thickness		
<b>Double-Hung - Dual pane insulating Glass</b>					
47-1/2" x 59-1/2"	11/16"	2.5mm	2.5mm	26	22
47-1/2" x 59-1/2"	11/16"	3mm	5mm	29	26
47-1/2" x 59-1/2"	11/16"	3mm	6mm Laminated	29	26

(1) See Design Data pages in this section for specific product performance class and grade values.

(2) The higher the level, the greater the product's ability to resist forced entry.

(3) Glazing configurations may result in higher operational forces

(4) ASTM E 1425 defines standard sizes for acoustical testing. Ratings achieved at that size are representative of all sizes of the same configuration.



# Impervia® Double-Hung Windows

## Features and Options

	Block Frame	Precision Fit	Integral Nailing Fin
<b>Glazing</b>			
<b>Glazing Type</b>			
Dual-pane Insulating Glass	S	S	S
<b>Insulated Glass Options / Low-E Types</b>			
Clear Insulating Glass (no Low-E coating)	S	S	S
Advanced Low-E Insulating Glass	O	O	O
SunDefense™ Low-E Insulating Glass	O	O	O
AdvancedComfort Low-E Insulating Glass	O	O	O
NaturalSun Low-E Insulating Glass	O	O	O
<b>Additional Glass Options</b>			
Annealed Glass	S	S	S
Tempered Glass	O	O	O
Noise reduction glass (3/5mm, 4/6mm combinations)	O	O	O
Noise reduction laminated glass (non-impact)	O	O	O
Tinted glass (Bronze, Gray, Green) Advanced Low-E	O	O	O
Obscure Glass <sub>1</sub>	O	O	O
<b>Gas Fill / High Altitude</b>			
Argon	S	S	S
High Altitude	O	O	O
High Altitude with argon	O	O	O
<b>Exterior</b>			
Powder-Coat White	S	S	S
Powder-Coat Tan, Brown, Black, or Morning Sky Gray	O	O	O
Dual-color (All exterior colors available with White interior)	O	O	–
<b>Hardware</b>			
Match interior finish	S	S	S
Satin Nickel, Bright Brass or Oil-Rubbed Bronze	O	O	O
<b>Sash Locks</b>			
Self-aligning sash lock	S	S	S
<b>Screens</b>			
Full or Half-Size Conventional Black Fiberglass	O	O	O
Full or Half-Size Inview™ screens	O	O	O
<b>Grilles</b>			
<b>Grilles-Between-the-Glass</b>			
3/4" Contoured White, Tan, Brown, Black, or Morning Sky Gray	O	O	O
<b>Patterns</b>			
Traditional	O	O	O
Prairie	O	O	O
Top Row	O	O	O
Special	O	O	O
<b>Tilt-Wash Cleaning</b>			
Both sashes tilt at bottom	S	S	S

S = Standard; O = Optional; (–) = Not available

(1) Contact your local Pella sales representative for current offering.





# Impervia® Double-Hung Windows

## Glazing Performance - Total Unit

Glazing Thickness	Type of Glazing	NFRC Certified Product #	Glass (mm)		Gap Fill	Performance Values <sub>1</sub>				Shaded Areas Meet ENERGY STAR® Performance Criteria in Zones Shown							
			Ext.	Int.		U-Factor	SHGC	VLT	CR	U. S.				Canada <sub>2</sub>			
										Zone				ER	Zone		
Vent										N	NC	SC	S	CA			
11/16"	Clear IG	PEL-N-126-00757-00001	2.5	2.5	air	0.48	0.58	0.61	43								
	with grilles-between-the-glass	PEL-N-126-00757-00002				0.48	0.52	0.54	43								
11/16"	Clear IG	PEL-N-126-00757-00003	3	3	air	0.48	0.58	0.61	43								
	with grilles-between-the-glass	PEL-N-126-00757-00004				0.48	0.52	0.54	43								
11/16"	Advanced Low-E IG	PEL-N-126-00788-00001	2.5	2.5	argon	0.31	0.28	0.52	57								
	with grilles-between-the-glass	PEL-N-126-00788-00002				0.31	0.25	0.46	57				S				
11/16"	Advanced Low-E IG	PEL-N-126-00788-00003	3	3	argon	0.31	0.28	0.52	57								
	with grilles-between-the-glass	PEL-N-126-00788-00004				0.31	0.25	0.46	57				S				
11/16"	SunDefense™ IG	PEL-N-126-00802-00001	2.5	2.5	argon	0.31	0.21	0.48	57								
	with grilles-between-the-glass	PEL-N-126-00802-00002				0.31	0.19	0.43	57				S				
11/16"	SunDefense™ IG	PEL-N-126-00802-00003	3	3	argon	0.31	0.21	0.48	57								
	with grilles-between-the-glass	PEL-N-126-00802-00004				0.31	0.19	0.43	57				S				
11/16"	AdvancedComfort Low-E IG	PEL-N-126-00814-00001	2.5	2.5	argon	0.27	0.27	0.51	45	N	NC						
	with grilles-between-the-glass	PEL-N-126-00814-00002				0.27	0.25	0.45	45	N	NC	SC	S				
11/16"	AdvancedComfort Low-E IG	PEL-N-126-00814-00003	3	3	argon	0.27	0.27	0.51	45	N	NC						
	with grilles-between-the-glass	PEL-N-126-00814-00004				0.27	0.25	0.45	45	N	NC	SC	S				
11/16"	NaturalSun Low-E IG	PEL-N-126-00776-00001	2.5	2.5	argon	0.32	0.51	0.59	56								
	with grilles-between-the-glass	PEL-N-126-00776-00002				0.32	0.46	0.52	56								
11/16"	NaturalSun Low-E IG	PEL-N-126-00776-00003	3	3	argon	0.32	0.51	0.59	56								
	with grilles-between-the-glass	PEL-N-126-00776-00004				0.32	0.46	0.52	56								
<b>Vent with Foam Insulation</b>																	
11/16"	Advanced Low-E IG	PEL-N-126-00862-00001	2.5	2.5	argon	0.29	0.28	0.52	58		NC						
	with grilles-between-the-glass	PEL-N-126-00862-00002				0.29	0.25	0.46	58		NC	SC	S				
11/16"	Advanced Low-E IG	PEL-N-126-00862-00003	3	3	argon	0.29	0.28	0.52	58		NC						
	with grilles-between-the-glass	PEL-N-126-00862-00004				0.29	0.25	0.46	58		NC	SC	S				
11/16"	SunDefense IG	PEL-N-126-00876-00001	2.5	2.5	argon	0.29	0.21	0.48	58		NC	SC	S				
	with grilles-between-the-glass	PEL-N-126-00876-00002				0.29	0.19	0.43	58		NC	SC	S				
11/16"	SunDefense IG	PEL-N-126-00876-00003	3	3	argon	0.29	0.21	0.48	58		NC	SC	S				
	with grilles-between-the-glass	PEL-N-126-00876-00004				0.29	0.19	0.43	58		NC	SC	S				
11/16"	AdvancedComfort Low-E IG	PEL-N-126-00888-00001	2.5	2.5	argon	0.25	0.27	0.51	46	N	NC						
	with grilles-between-the-glass	PEL-N-126-00888-00002				0.25	0.25	0.45	46	N	NC	SC	S				
11/16"	AdvancedComfort Low-E IG	PEL-N-126-00888-00003	3	3	argon	0.25	0.27	0.51	46	N	NC						
	with grilles-between-the-glass	PEL-N-126-00888-00004				0.25	0.25	0.45	46	N	NC	SC	S				
11/16"	NaturalSun Low-E IG	PEL-N-126-00850-00001	2.5	2.5	argon	0.30	0.51	0.59	57	N							
	with grilles-between-the-glass	PEL-N-126-00850-00002				0.30	0.46	0.52	57	N							
11/16"	NaturalSun Low-E IG	PEL-N-126-00850-00003	3	3	argon	0.30	0.51	0.59	57	N							
	with grilles-between-the-glass	PEL-N-126-00850-00004				0.30	0.46	0.52	57	N							

R-Value = 1/U-Factor  
 SHGC = Solar Heat Gain Coefficient  
 VLT % = Visible Light Transmission  
 CR = Condensation Resistance  
 ER = Canadian Energy Rating

(1) Glazing performance values are calculated based on NFRC 100, NFRC 200 and NFRC 500. ENERGY STAR® values are updated to 2016 (Version 6) criteria.

(2) The values shown are based on Canada's updated ENERGY STAR® 2020 initiative.

For center-glass values, see the Product Performance section.

See the Product Performance section for more detailed information or visit [www.energystar.gov](http://www.energystar.gov) for Energy Star guidelines.

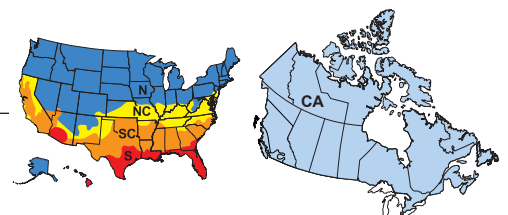



# Impervia® Double-Hung Windows

## Glazing Performance - Total Unit

Glazing Thickness	Type of Glazing	NFRC Certified Product #	Glass (mm)		Gap Fill	Performance Values <sub>1</sub>				Shaded Areas Meet ENERGY STAR® Performance Criteria in Zones Shown						
			Ext.	Int.		U-Factor	SHGC	VLT	CR	U. S.				Canada <sub>2</sub>		
										Zone				ER	Zone	
Vent with High Altitude Glazing										N	NC	SC	S	CA		
11/16"	(HA) Advanced Low-E IG	PEL-N-126-00781-00001	2.5	2.5	air	0.35	0.28	0.52	54							
	with grilles-between-the-glass	PEL-N-126-00781-00002				0.35	0.25	0.46	54				S			
11/16"	(HA) Advanced Low-E IG	PEL-N-126-00781-00003	3	3	air	0.35	0.28	0.52	54							
	with grilles-between-the-glass	PEL-N-126-00781-00004				0.35	0.25	0.46	54				S			
11/16"	(HA) SunDefense IG	PEL-N-126-00795-00001	2.5	2.5	air	0.34	0.21	0.48	54				S			
	with grilles-between-the-glass	PEL-N-126-00795-00002				0.34	0.19	0.43	54				S			
11/16"	(HA) SunDefense IG	PEL-N-126-00795-00003	3	3	air	0.34	0.21	0.48	54				S			
	with grilles-between-the-glass	PEL-N-126-00795-00004				0.34	0.19	0.43	54				S			
11/16"	(HA) AdvancedComfort Low-E IG	PEL-N-126-00809-00001	2.5	2.5	air	0.30	0.27	0.51	42	NC						
	with grilles-between-the-glass	PEL-N-126-00809-00002				0.30	0.25	0.45	42	NC	SC	S				
11/16"	(HA) AdvancedComfort Low-E IG	PEL-N-126-00809-00003	3	3	air	0.30	0.27	0.51	42	NC						
	with grilles-between-the-glass	PEL-N-126-00809-00004				0.30	0.25	0.45	42	NC	SC	S				
11/16"	(HA) NaturalSun Low-E IG	PEL-N-126-00771-00001	2.5	2.5	air	0.36	0.51	0.59	53							
	with grilles-between-the-glass	PEL-N-126-00771-00002				0.36	0.46	0.52	53							
11/16"	(HA) NaturalSun Low-E IG	PEL-N-126-00771-00003	3	3	air	0.36	0.51	0.59	53							
	with grilles-between-the-glass	PEL-N-126-00771-00004				0.36	0.46	0.52	53							
Vent High Altitude Glazing with Foam Insulation										N	NC	SC	S	CA		
11/16"	(HA) Advanced Low-E IG	PEL-N-126-00855-00001	2.5	2.5	air	0.33	0.28	0.52	54							
	with grilles-between-the-glass	PEL-N-126-00855-00002				0.33	0.25	0.46	54				S			
11/16"	(HA) Advanced Low-E IG	PEL-N-126-00855-00003	3	3	air	0.33	0.28	0.52	54							
	with grilles-between-the-glass	PEL-N-126-00855-00004				0.33	0.25	0.46	54				S			
11/16"	(HA) SunDefense IG	PEL-N-126-00869-00001	2.5	2.5	air	0.32	0.21	0.48	54				S			
	with grilles-between-the-glass	PEL-N-126-00869-00002				0.32	0.19	0.43	54				S			
11/16"	(HA) SunDefense IG	PEL-N-126-00869-00003	3	3	air	0.32	0.21	0.48	54				S			
	with grilles-between-the-glass	PEL-N-126-00869-00004				0.32	0.19	0.43	54				S			
11/16"	(HA) AdvancedComfort Low-E IG	PEL-N-126-00883-00001	2.5	2.5	air	0.28	0.27	0.51	42	NC						
	with grilles-between-the-glass	PEL-N-126-00883-00002				0.28	0.25	0.45	42	NC	SC	S				
11/16"	(HA) AdvancedComfort Low-E IG	PEL-N-126-00883-00003	3	3	air	0.28	0.27	0.51	42	NC						
	with grilles-between-the-glass	PEL-N-126-00883-00004				0.28	0.25	0.45	42	NC	SC	S				
11/16"	(HA) NaturalSun Low-E IG	PEL-N-126-00845-00001	2.5	2.5	air	0.34	0.51	0.59	54							
	with grilles-between-the-glass	PEL-N-126-00845-00002				0.34	0.46	0.52	54							
11/16"	(HA) NaturalSun Low-E IG	PEL-N-126-00845-00003	3	3	air	0.34	0.51	0.59	54							
	with grilles-between-the-glass	PEL-N-126-00845-00004				0.34	0.46	0.52	54							

R-Value = 1/U-Factor  
 SHGC = Solar Heat Gain Coefficient  
 VLT % = Visible Light Transmission  
 CR = Condensation Resistance  
 ER = Canadian Energy Rating

(1) Glazing performance values are calculated based on NFRC 100, NFRC 200 and NFRC 500. ENERGY STAR® values are updated to 2016 (Version 6) criteria.

(2) The values shown are based on Canada's updated ENERGY STAR® 2020 initiative.

For center-glass values, see the Product Performance section.

See the Product Performance section for more detailed information or visit [www.energystar.gov](http://www.energystar.gov) for Energy Star guidelines.

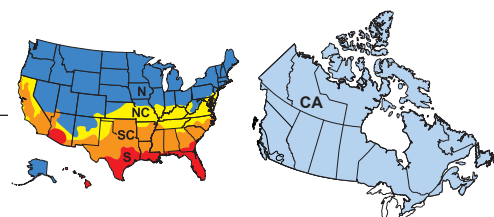



# Impervia® Double-Hung Windows

## Glazing Performance - Total Unit

Glazing Thickness	Type of Glazing	NFRC Certified Product #	Glass (mm)		Gap Fill	Performance Values <sup>1</sup>				Shaded Areas Meet ENERGY STAR® Performance Criteria in Zones Shown					
			Ext.	Int.		U-Factor	SHGC	VLT	CR	U. S.				Canada <sup>2</sup>	
										Zone	ER	Zone	Zone	Zone	
<b>Vent with 3mm / 5mm Glazing</b>										N	NC	SC	S	CA	
11/16"	Clear IG	PEL-N-126-00758-00001	3	5	air	0.49	0.57	0.61	42						
	with grilles-between-the-glass	PEL-N-126-00761-00001				0.49	0.51	0.54	42						
11/16"	Advanced Low-E IG	PEL-N-126-00789-00001	3	5	argon	0.32	0.28	0.52	55						
	with grilles-between-the-glass	PEL-N-126-00792-00001				0.33	0.25	0.46	55				S		
11/16"	SunDefense™ IG	PEL-N-126-00803-00001	3	5	argon	0.32	0.21	0.48	55				S		
	with grilles-between-the-glass	PEL-N-126-00806-00001				0.33	0.19	0.42	55				S		
11/16"	AdvancedComfort Low-E IG	PEL-N-126-00815-00001	3	5	argon	0.28	0.27	0.50	43	NC					
	with grilles-between-the-glass	PEL-N-126-00817-00001				0.29	0.25	0.45	43	NC	SC	S			
11/16"	NaturalSun Low-E IG	PEL-N-126-00777-00001	3	5	argon	0.33	0.51	0.58	55						
	with grilles-between-the-glass	PEL-N-126-00779-00001				0.34	0.46	0.52	54						
<b>Vent 3mm / 5mm Glazing with Foam Insulation</b>											NC				
11/16"	Advanced Low-E IG	PEL-N-126-00863-00001	3	5	argon	0.30	0.28	0.52	56		NC				
	with grilles-between-the-glass	PEL-N-126-00866-00001				0.31	0.25	0.46	56				S		
11/16"	SunDefense IG	PEL-N-126-00877-00001	3	5	argon	0.30	0.21	0.48	56		NC	SC	S		
	with grilles-between-the-glass	PEL-N-126-00880-00001				0.31	0.19	0.42	56				S		
11/16"	AdvancedComfort Low-E IG	PEL-N-126-00889-00001	3	5	argon	0.26	0.27	0.50	43	N	NC				
	with grilles-between-the-glass	PEL-N-126-00891-00001				0.27	0.25	0.45	43	N	NC	SC	S		
11/16"	NaturalSun Low-E IG	PEL-N-126-00851-00001	3	5	argon	0.31	0.51	0.58	55						
	with grilles-between-the-glass	PEL-N-126-00853-00001				0.32	0.46	0.52	55						
<b>Vent 3mm / 5mm High Altitude Glazing</b>															
11/16"	(HA) Advanced Low-E IG	PEL-N-126-00856-00001	3	5	air	0.34	0.28	0.52	52						
	with grilles-between-the-glass	PEL-N-126-00859-00001				0.35	0.25	0.46	52				S		
11/16"	(HA) SunDefense IG	PEL-N-126-00870-00001	3	5	air	0.34	0.21	0.48	52				S		
	with grilles-between-the-glass	PEL-N-126-00873-00001				0.35	0.19	0.42	52				S		
11/16"	(HA) AdvancedComfort Low-E IG	PEL-N-126-00884-00001	3	5	air	0.29	0.27	0.50	40		NC				
	with grilles-between-the-glass	PEL-N-126-00886-00001				0.30	0.25	0.45	40		NC	SC	S		
11/16"	(HA) NaturalSun Low-E IG	PEL-N-126-00846-00001	3	5	air	0.35	0.51	0.58	51						
	with grilles-between-the-glass	PEL-N-126-00848-00001				0.36	0.45	0.52	51						
<b>Vent 3mm / 5mm High Altitude Glazing with Foam Insulation</b>															
11/16"	(HA) Advanced Low-E IG	PEL-N-151-00816-00001	3	5	air	0.32	0.27	0.49	52						
	with grilles-between-the-glass	PEL-N-151-00821-00001				0.33	0.25	0.44	52				S		
11/16"	(HA) SunDefense IG	PEL-N-151-00838-00001	3	5	air	0.32	0.20	0.45	52				S		
	with grilles-between-the-glass	PEL-N-151-00843-00001				0.33	0.19	0.41	52				S		
11/16"	(HA) AdvancedComfort Low-E IG	PEL-N-151-00860-00001	3	5	air	0.28	0.26	0.47	39		NC				
	with grilles-between-the-glass	PEL-N-151-00863-00001				0.28	0.24	0.43	39		NC	SC	S		
11/16"	(HA) NaturalSun Low-E IG	PEL-N-151-00802-00001	3	5	air	0.33	0.48	0.55	51						
	with grilles-between-the-glass	PEL-N-151-00805-00001				0.34	0.44	0.50	51						

R-Value = 1/U-Factor  
 SHGC = Solar Heat Gain Coefficient  
 VLT % = Visible Light Transmission  
 CR = Condensation Resistance  
 ER = Canadian Energy Rating

(1) Glazing performance values are calculated based on NFRC 100, NFRC 200 and NFRC 500. ENERGY STAR® values are updated to 2016 (Version 6) criteria.

(2) The values shown are based on Canada's updated ENERGY STAR® 2020 initiative.

For center-glass values, see the Product Performance section.

See the Product Performance section for more detailed information or visit [www.energystar.gov](http://www.energystar.gov) for Energy Star guidelines.

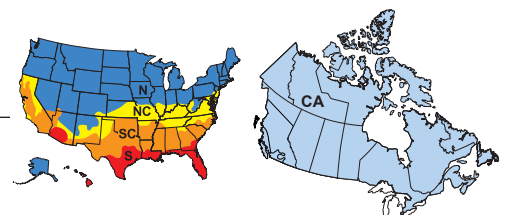



# Impervia® Double-Hung Windows

## Glazing Performance - Total Unit

Glazing Thickness	Type of Glazing	NFRC Certified Product #	Glass (mm)		Gap Fill	Performance Values <sub>1</sub>				Shaded Areas Meet ENERGY STAR® Performance Criteria in Zones Shown				
			Ext.	Int.		U-Factor	SHGC	VLT	CR	U. S.			Canada <sub>2</sub>	
										Zone	ER	Zone	ER	
<b>Vent with Tinted Glazing</b>										N	NC	SC	S	CA
11/16"	Bronze Advanced Low-E IG	PEL-N-126-00825-00001	5	3	argon	0.32	0.25	0.34	56				S	
	with grilles-between-the-glass	PEL-N-126-00826-00001				0.33	0.22	0.30	56				S	
11/16"	Gray Advanced Low-E IG	PEL-N-126-00827-00001	5	3	argon	0.32	0.23	0.29	56				S	
	with grilles-between-the-glass	PEL-N-126-00828-00001				0.33	0.21	0.26	56				S	
11/16"	Green Advanced Low-E IG	PEL-N-126-00829-00001	5	3	argon	0.32	0.28	0.46	56					
	with grilles-between-the-glass	PEL-N-126-00830-00001				0.33	0.25	0.40	56				S	
<b>Vent Tinted Glazing with Foam Insulation</b>											NC	SC	S	
11/16"	Bronze Advanced Low-E IG	PEL-N-126-00899-00001	5	3	argon	0.30	0.25	0.34	56				S	
	with grilles-between-the-glass	PEL-N-126-00900-00001				0.31	0.22	0.30	56				S	
11/16"	Gray Advanced Low-E IG	PEL-N-126-00901-00001	5	3	argon	0.30	0.23	0.29	56				S	
	with grilles-between-the-glass	PEL-N-126-00902-00001				0.31	0.21	0.26	56				S	
11/16"	Green Advanced Low-E IG	PEL-N-126-00903-00001	5	3	argon	0.30	0.28	0.46	56			NC		
	with grilles-between-the-glass	PEL-N-126-00904-00001				0.31	0.25	0.40	56				S	
<b>Vent Tinted High Altitude Glazing</b>													S	
11/16"	Bronze Advanced Low-E IG	PEL-N-126-00819-00001	5	3	air	0.36	0.25	0.34	52				S	
	with grilles-between-the-glass	PEL-N-126-00820-00001				0.37	0.23	0.30	52				S	
11/16"	Gray Advanced Low-E IG	PEL-N-126-00821-00001	5	3	air	0.36	0.23	0.29	52				S	
	with grilles-between-the-glass	PEL-N-126-00822-00001				0.37	0.21	0.26	52				S	
11/16"	Green Advanced Low-E IG	PEL-N-126-00823-00001	5	3	air	0.36	0.28	0.46	52					
	with grilles-between-the-glass	PEL-N-126-00824-00001				0.37	0.26	0.40	52					
<b>Vent Tinted High Altitude Glazing with Foam Insulation</b>													S	
11/16"	Bronze Advanced Low-E IG	PEL-N-126-00893-00001	5	3	air	0.34	0.25	0.34	53				S	
	with grilles-between-the-glass	PEL-N-126-00894-00001				0.35	0.23	0.30	52				S	
11/16"	Gray Advanced Low-E IG	PEL-N-126-00895-00001	5	3	air	0.34	0.23	0.29	53				S	
	with grilles-between-the-glass	PEL-N-126-00896-00001				0.35	0.21	0.26	52				S	
11/16"	Green Advanced Low-E IG	PEL-N-126-00897-00001	5	3	air	0.34	0.28	0.46	53					
	with grilles-between-the-glass	PEL-N-126-00898-00001				0.35	0.26	0.40	52					

R-Value = 1/U-Factor  
 SHGC = Solar Heat Gain Coefficient  
 VLT % = Visible Light Transmission  
 CR = Condensation Resistance  
 ER = Canadian Energy Rating

(1) Glazing performance values are calculated based on NFRC 100, NFRC 200 and NFRC 500. ENERGY STAR® values are updated to 2016 (Version 6) criteria.

(2) The values shown are based on Canada's updated ENERGY STAR® 2020 initiative.

For center-glass values, see the Product Performance section.

See the Product Performance section for more detailed information or visit [www.energystar.gov](http://www.energystar.gov) for Energy Star guidelines.

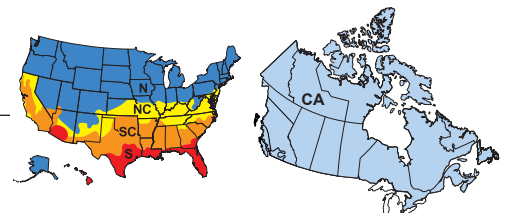



# Impervia® Double-Hung Windows

## Glazing Performance - Total Unit

Glazing Thickness	Type of Glazing	NFRC Certified Product #	Glass (mm)		Gap Fill	Performance Values <sub>1</sub>				Shaded Areas Meet ENERGY STAR® Performance Criteria in Zones Shown							
			Ext.	Int.		U-Factor	SHGC	VLT	CR	U. S.				Canada <sub>2</sub>			
										Zone				ER	Zone		
										N	NC	SC	S	CA			
<b>Vent with Laminated Glazing</b>																	
11/16"	Advanced Low-E IG	PEL-N-126-00790-00001	3	6	argon	0.34	0.28	0.51	54								
	with grilles-between-the-glass	PEL-N-126-00793-00001				0.35	0.25	0.45	54						S		
11/16"	SunDefense™ IG	PEL-N-126-00804-00001	3	6	argon	0.33	0.21	0.47	55						S		
	with grilles-between-the-glass	PEL-N-126-00807-00001				0.35	0.19	0.42	55						S		
<b>Vent Laminated Glazing with Foam Insulation</b>																	
11/16"	Advanced Low-E IG	PEL-N-126-00864-00001	3	6	argon	0.32	0.28	0.51	55								
	with grilles-between-the-glass	PEL-N-126-00867-00001				0.33	0.25	0.45	55						S		
11/16"	SunDefense™ IG	PEL-N-126-00878-00001	3	6	argon	0.31	0.21	0.47	55						S		
	with grilles-between-the-glass	PEL-N-126-00881-00001				0.33	0.19	0.42	55						S		
<b>Vent Laminated High Altitude Glazing</b>																	
11/16"	Advanced Low-E IG	PEL-N-126-00783-00001	3	6	air	0.39	0.28	0.51	50								
	with grilles-between-the-glass	PEL-N-126-00786-00001				0.40	0.25	0.45	50						S		
11/16"	SunDefense IG	PEL-N-126-00797-00001	3	6	air	0.38	0.21	0.47	51						S		
	with grilles-between-the-glass	PEL-N-126-00800-00001				0.40	0.19	0.42	51						S		
<b>Vent Laminated High Altitude Glazing with Foam Insulation</b>																	
11/16"	Advanced Low-E IG	PEL-N-126-00857-00001	3	6	air	0.37	0.28	0.51	51								
	with grilles-between-the-glass	PEL-N-126-00860-00001				0.38	0.25	0.45	51						S		
11/16"	SunDefense IG	PEL-N-126-00871-00001	3	6	air	0.36	0.21	0.47	51						S		
	with grilles-between-the-glass	PEL-N-126-00874-00001				0.38	0.19	0.42	51						S		

R-Value = 1/U-Factor  
 SHGC = Solar Heat Gain Coefficient  
 VLT % = Visible Light Transmission  
 CR = Condensation Resistance  
 ER = Canadian Energy Rating

(1) Glazing performance values are calculated based on NFRC 100, NFRC 200 and NFRC 500. ENERGY STAR® values are updated to 2016 (Version 6) criteria.

(2) The values shown are based on Canada's updated ENERGY STAR® 2020 initiative.

For center-glass values, see the Product Performance section.

See the Product Performance section for more detailed information or visit [www.energystar.gov](http://www.energystar.gov) for Energy Star guidelines.

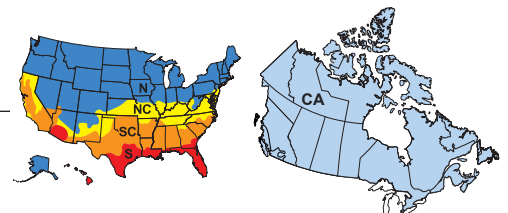



### Grille Profiles

#### Grilles-Between-the-Glass

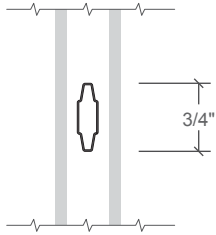

3/4" Contour

### Grille Patterns

#### Prairie Lite Patterns

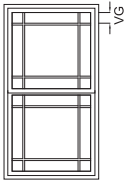

9-Lite Prairie

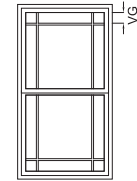
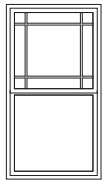

6-Lite Prairie

#### Prairie

- Standard corner lite dimension for Prairie patterns = 4" visible glass (VG).
- Pattern availability may vary depending on size of unit.

#### Other Patterns

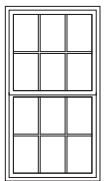

Traditional

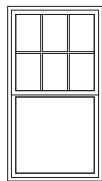

Special

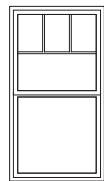

Top Row <sup>(1)</sup>

- Pattern availability may vary depending on size of unit.

(1) Standard visible glass to center line of separator bar = 14" or half of total visible glass height, whichever is smaller. Multiple rows are available up to 50% glass size.



# Impervia® Double-Hung Windows

## Size Tables

### Fixed Transoms

	(457) (445)	(610) (597)	(711) (699)	(762) (749)	(813) (800)	(914) (902)	(1 016) (1 003)	(1 067) (1 054)	(1 219) (1 207)
Opening	1' 6"	2' 0"	2' 4"	2' 6"	2' 8"	3' 0"	3' 4"	3' 6"	4' 0"
Frame	1' 5 1/2"	1' 11 1/2"	2' 3 1/2"	2' 5 1/2"	2' 7 1/2"	2' 11 1/2"	3' 3 1/2"	3' 5 1/2"	3' 11 1/2"
(356) (343)									
(457) (446)									
(610) (597)									

### Vent Units

(762) (749)									
(914) (902)									
(965) (953)									
(1 067) (1 054)									
(1 168) (1 156)									
(1 219) (1 207)									
(1 270) (1 257)									
(1 372) (1 359)									
(1 473) (1 461)									

#### Egress Notes:

Check all applicable local codes for emergency egress requirements.

E = Window meets minimum clear opening of 24" height, 20" width, and 5.7 ft<sup>2</sup>.

E1 = Window meets minimum clear opening of 24" height, 20" width, and 5.0 ft<sup>2</sup>.

See Design Data pages in this section for clear opening dimensions.

Not to scale.

Special size units are available in 1/8" increments.



# Impervia® Double-Hung Windows

## Size Tables

### Vent Units

	(457) (445)	(610) (597)	(711) (699)	(762) (749)	(813) (800)	(914) (902)	(1 016) (1 003)	(1 067) (1 054)	(1 219) (1 207)
Opening	1' 6"	2' 0"	2' 4"	2' 6"	2' 8"	3' 0"	3' 4"	3' 6"	4' 0"
Frame	1' 5 1/2"	1' 11 1/2"	2' 3 1/2"	2' 5 1/2"	2' 7 1/2"	2' 11 1/2"	3' 3 1/2"	3' 5 1/2"	3' 11 1/2"
(1 524) (1 511) 5' 0"	1-6/5-0	2-0/5-0	2-4/5-0	2-6/5-0	2-8/5-0	3-0/5-0 E <sub>1</sub>	3-4/5-0 E	3-6/5-0 E	4-0/5-0 E
(1 575) (1 562) 5' 2"	1-6/5-2	2-0/5-2	2-4/5-2	2-6/5-2	2-8/5-2 E <sub>1</sub> (2)	3-0/5-2 E (1)	3-4/5-2 E	3-6/5-2 E	4-0/5-2 E
(1 676) (1 664) 5' 6"	1-6/5-6	2-0/5-6	2-4/5-6	2-6/5-6 E <sub>1</sub> (2)	2-8/5-6 E <sub>1</sub>	3-0/5-6 E	3-4/5-6 E	3-6/5-6 E	4-0/5-6 E
(1 778) (1 765) 5' 10"	1-6/5-10	2-0/5-10	2-4/5-10 E <sub>1</sub> (2)	2-6/5-10 E <sub>1</sub>	2-8/5-10 E (1)	3-0/5-10 E	3-4/5-10 E	3-6/5-10 E	4-0/5-10 E
(1 829) (1 816) 6' 0"	1-6/6-0	2-0/6-0	2-4/6-0 E <sub>1</sub>	2-6/6-0 E <sub>1</sub>	2-8/6-0 E	3-0/6-0 E	3-4/6-0 E	3-6/6-0 E	4-0/6-0 E
(1 981) (1 969) 6' 6"	1-6/6-6	2-0/6-6	2-4/6-6 E <sub>1</sub>	2-6/6-6 E	2-8/6-6 E	3-0/6-6 E	3-4/6-6 E	3-6/6-6 E	4-0/6-6 E

#### Egress Notes:

Check all applicable local codes for emergency egress requirements.

E = Window meets minimum clear opening of 24" height, 20" width, and 5.7 ft<sup>2</sup>.

E<sub>1</sub> = Window meets minimum clear opening of 24" height, 20" width, and 5.0 ft<sup>2</sup>.

(1) Unit meets E<sub>1</sub> with High Performance sill adapter kit installed.

(2) Does not meet egress with High Performance sill adapter kit installed.

See Design Data pages in this section for clear opening dimensions

Not to scale.

Special size units are available in 1/8" increments.

Subtract 1/2" from opening height to calculate vent area for High Performance unit.





# Impervia® Double-Hung Windows

## Size Tables

### Vent Cottage Units

	(457) (445)	(610) (597)	(711) (699)	(762) (749)	(813) (800)	(914) (902)	(1 067) (1 054)	(1 219) (1 207)
Opening	1' 6"	2' 0"	2' 4"	2' 6"	2' 8"	3' 0"	3' 6"	4' 0"
Frame	1' 5 1/2"	1' 11 1/2"	2' 3 1/2"	2' 5 1/2"	2' 7 1/2"	2' 11 1/2"	3' 5 1/2"	3' 11 1/2"
(1 372) (1 359)								
(1 524) (1 511)								
(1 676) (1 664)								
(1 829) (1 816)								
(1 981) (1 969)								

#### Egress Notes:

Check all applicable local codes for emergency egress requirements.

E = Window meets minimum clear opening of 24" height, 20" width, and 5.7 ft<sup>2</sup>.

E1 = Window meets minimum clear opening of 24" height, 20" width, and 5.0 ft<sup>2</sup>.

See Design Data pages in this section for clear opening dimensions

Cottage units have unequal sash. Sash glass ratio is 40% upper sash to 60% lower sash.

Special size units are available in 1/8" increments.



# Impervia® Double-Hung Windows

## Size Tables

### Vent Contemporary Units

	(457) (445)	(610) (597)	(711) (699)	(762) (749)	(813) (800)	(914) (902)	(1 067) (1 054)	(1 219) (1 207)
Opening	1' 6"	2' 0"	2' 4"	2' 6"	2' 8"	3' 0"	3' 6"	4' 0"
Frame	1' 5 1/2"	1' 11 1/2"	2' 3 1/2"	2' 5 1/2"	2' 7 1/2"	2' 11 1/2"	3' 5 1/2"	3' 11 1/2"
(1 372) (1 359)								
(1 524) (1 511)								
(1 676) (1 664)								
(1 829) (1 816)								
(1 981) (1 969)								

#### Egress Notes:

Check all applicable local codes for emergency egress requirements.

E = Window meets minimum clear opening of 24" height, 20" width, and 5.7 ft<sup>2</sup>.

E1 = Window meets minimum clear opening of 24" height, 20" width, and 5.0 ft<sup>2</sup>.

See Design Data pages in this section for clear opening dimensions.

Contemporary units have unequal sash. Sash glass ratio is 60% upper sash to 40% lower sash.

Special size units are available in 1/8" increments.



# Impervia® Double-Hung Windows

## Size Tables

### Fixed Transoms

	(356) (343)		(914) (902)		(1 067) (1 054)		(1 219) (1 207)		(1 372) (1 359)		(1 524) (1 511)		(1 829) (1 816)		
	Opening	1' 2"	3' 0"	3' 6"	4' 0"	4' 6"	5' 0"	6' 0"	Frame	1' 1 1/2"	2' 11 1/2"	3' 5 1/2"	3' 11 1/2"	4' 5 1/2"	4' 11 1/2"
(356) (343)	1' 2"								1' 1 1/2"	2' 11 1/2"	3' 5 1/2"	3' 11 1/2"	4' 5 1/2"	4' 11 1/2"	5' 11 1/2"
(457) (446)	1' 6"								1' 1 1/2"	2' 11 1/2"	3' 5 1/2"	3' 11 1/2"	4' 5 1/2"	4' 11 1/2"	5' 11 1/2"
(610) (597)	2' 0"								1' 1 1/2"	2' 11 1/2"	3' 5 1/2"	3' 11 1/2"	4' 5 1/2"	4' 11 1/2"	5' 11 1/2"

### Fixed Units

	(762) (749)		(914) (902)		(1 067) (1 054)		(1 219) (1 207)		(1 372) (1 359)		(1 524) (1 511)		(1 676) (1 664)		(1 829) (1 816)	
	Opening	2' 6"	3' 0"	3' 6"	4' 0"	4' 6"	5' 0"	5' 6"	6' 0"	Frame	1' 2/2-6"	1' 2/3-0"	1' 2/3-6"	1' 2/4-0"	1' 2/4-6"	1' 2/5-0"
(762) (749)	2' 6"								2' 6"	3' 0"	3' 6"	4' 0"	4' 6"	5' 0"	5' 6"	
(914) (902)	3' 0"								3' 0"	3' 6"	4' 0"	4' 6"	5' 0"	5' 6"	6' 0"	
(1 067) (1 054)	3' 6"								3' 6"	4' 0"	4' 6"	5' 0"	5' 6"	6' 0"		
(1 219) (1 207)	4' 0"								4' 0"	4' 6"	5' 0"	5' 6"	6' 0"			
(1 372) (1 359)	4' 6"								4' 6"	5' 0"	5' 6"	6' 0"				
(1 524) (1 511)	5' 0"								5' 0"	5' 6"	6' 0"					
(1 676) (1 664)	5' 6"								5' 6"	6' 0"						
(1 829) (1 816)	6' 0"								6' 0"							

Not to scale.

Special size units are available in 1/8" increments.



# Impervia® Double-Hung Windows

## Special Sizes and Combinations

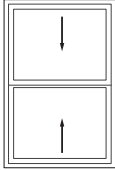
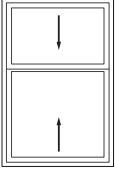
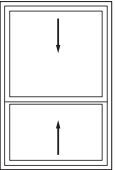
(Equal) Vent Unit	Cottage Vent Unit	Contemporary Vent Unit
 <p><b>MINIMUM</b> 1' 5-1/2" W x 2' 5-1/2" H (445 x 739)</p> <p><b>MAXIMUM</b> 3' 11-1/2" W x 6' 5-1/2" H (1 207 x 1 968)</p>	 <p><b>MINIMUM</b> 1' 5-1/2" W x 4' 5-1/2" H (445 x 1 359)</p> <p><b>MAXIMUM</b> 3' 11-1/2" W x 6' 5-1/2" H (1 207 x 1 968)</p>	 <p><b>MINIMUM</b> 1' 5-1/2" W x 4' 5-1/2" H (445 x 1 359)</p> <p><b>MAXIMUM</b> 3' 11-1/2" W x 6' 5-1/2" H (1 207 x 1 968)</p>

Below are available factory-assembled combination assemblies using joining mullions. See the Pella.com site, Installation Systems section for requirements and limitations related to mulling various combinations plus configurations size range information.

A combination is defined as an assembly formed by two or more separate windows or doors whose frames are mullioned together utilizing a combination mullion or reinforcing mullion.

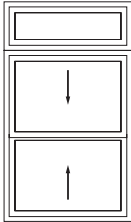
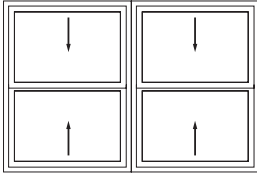
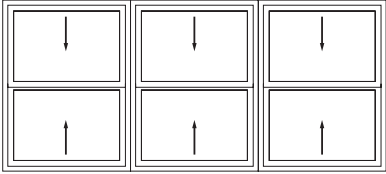
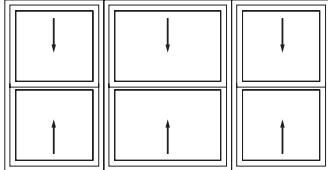
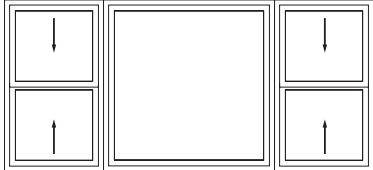
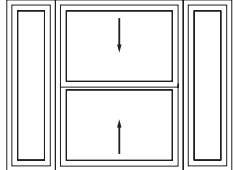
<p><b>Transom over Double-Hung</b></p>  <p><b>MINIMUM</b> 1' 5-1/2" W x 3' 7" H (445 x 1 092)</p> <p><b>MAXIMUM</b> 3' 11-1/2" W x 8' 5" H (1 219 x 2 565)</p>	<p><b>2-Wide</b></p>  <p><b>MINIMUM</b> 2' 11-1/2" W x 2' 5-1/2" H (914 x 762)</p> <p><b>MAXIMUM</b> 7' 11" W x 5' 5-1/2" H (2 413 x 1 676)</p>	<p><b>3-Wide</b></p>  <p><b>MINIMUM</b> 4' 4-1/2" W x 2' 5-1/2" H (1 346 x 762)</p> <p><b>MAXIMUM</b> 8' 10-1/2" W x 5' 5-1/2" H (2 718 x 1 676)</p>
<p><b>3-Wide with Unequal Center</b></p>  <p><b>MINIMUM</b> 4' 1/2" W x 2' 5-1/2" H (1 245 x 762)</p> <p><b>MAXIMUM</b> 8' 10-1/2" W x 5' 5-1/2" H (2 718 x 1 676)</p>	<p><b>3-Wide with Center Fixed</b></p>  <p><b>MINIMUM</b> 4' 1/2" W x 2' 11-1/2" H (1 245 x 914)</p> <p><b>MAXIMUM</b> 8' 11-1/2" W x 4' 11-1/2" H (2 743 x 1 524)</p> <p>Center Unit Width ≤ 4' 11-1/2"</p>	<p><b>3-Wide with Fixed Flankers</b></p>  <p><b>MINIMUM</b> 3' 8-1/2" W x 2' 11-1/2" H (1 143 x 914)</p> <p><b>MAXIMUM</b> 6' 2-1/2" W x 4' 11-1/2" H (1 905 x 1 524)</p>

### General Notes:

- To convert areas to square meters (m2), multiply square feet by 0.0929.
- Rough Opening = Frame Dimension + 1/2".
- Keep frame dimensions to the nearest 1/8" increment



**Fixed Special Sizes**

**MINIMUM**

1' 1-1/2" W x 2' 5-1/2" H  
 (13-1/2" x 29-1/2")  
 (343 x 739)

**MAXIMUM**

5' 11-1/2" W x 5' 11-1/2" H  
 (71-1/2" x 71-1/2")  
 (1 816 x 1 816)  
 Max frame area 33.51 sq ft.

**Clear Opening Formulas**

	Width	Height <sub>1</sub>
Equal Vent	FW - 4.125"	FH ÷ 2 - 3.75"
Cottage Vent	FW - 4.125"	(FH - ALGH) - 7"
Contemporary Vent	FW - 4.125"	(FH - AUGH) - 7"

**Miscellaneous Glass Formulas**

	Actual Glass Width (AGW)	Actual Glass Height (Lower Sash) (ALGH)	Actual Glass Height (Upper Sash) (AUGH)	Visible Glass Width (VGW)	Visible Glass Height (Lower Sash) (VLGH)	Visible Glass Height (Upper Sash) (VUGH)
Equal Vent	FW - 5.5"	FH ÷ 2 - 3.25"	FH ÷ 2 - 3.25"	FW - 6.438"	FH ÷ 2 - 4.188"	FH ÷ 2 - 4.188"
Cottage Vent	FW - 5.5"	(FH - 6.5") x 0.6	(FH - 6.5") x 0.4	FW - 6.4375"	(FH - 6.5") x 0.6 - 0.938	(FH - 6.5") x 0.4 - 0.938
Contemporary Vent	FW - 5.5"	(FH - 6.5") x 0.4	(FH - 6.5") x 0.6	FW - 6.4375"	(FH - 6.5") x 0.4 - 0.938	(FH - 6.5") x 0.6 - 0.938
Fixed	FW - 5.125"	FH - 5.125"		FW - 6.0625"	FH - 5.125"	

**KEY:**

FW = Frame Width  
 FH = Frame Height

(1) Subtract one Inch from opening height to calculate vent area for performance upgrade units.



# Impervia® Double-Hung Windows

## Design Data

Equal Vent									
Unit	Egress	Clear Opening <sup>3</sup> (Inches)		Vent Area Ft <sup>2</sup>	Visible Glass Ft <sup>2</sup>	Standard Glass Thickness (mm)		Performance Class & Grade <sup>4</sup>	
		Width	Height			Annealed	Tempered	Standard	Upgrade
1-6/2-6		13-3/8	11	1.0	1.6	3	3	LC30	LC50
1-6/3-0		13-3/8	14	1.3	2.1	2.5	3	LC30	LC50
1-6/3-2		13-3/8	15	1.4	2.2	2.5	3	LC30	LC50
1-6/3-6		13-3/8	17	1.6	2.5	2.5	3	LC30	LC50
1-6/3-10		13-3/8	19	1.8	2.9	2.5	3	LC30	LC50
1-6/4-0		13-3/8	20	1.9	3.0	2.5	3	LC30	LC50
1-6/4-2		13-3/8	21	2.0	3.2	2.5	3	LC30	LC50
1-6/4-6		13-3/8	23	2.1	3.5	2.5	3	LC30	LC50
1-6/4-10		13-3/8	26	2.3	3.8	2.5	3	LC30	LC50
1-6/5-0		13-3/8	26	2.4	3.9	2.5	3	LC30	LC50
1-6/5-2		13-3/8	27	2.5	4.1	2.5	3	LC30	LC50
1-6/5-6		13-3/8	29	2.7	4.4	2.5	3	LC30	LC50
1-6/5-10		13-3/8	31	2.9	4.7	2.5	3	LC30	LC50
1-6/6-0		13-3/8	32	3.0	4.8	2.5	3	LC30	LC50
1-6/6-6		13-3/8	35	3.3	5.3	2.5	3	LC30	–
2-0/2-6		19-3/8	11	1.5	2.5	3	3	LC30	LC50
2-0/3-0		19-3/8	14	1.9	3.2	2.5	3	LC30	LC50
2-0/3-2		19-3/8	15	2.0	3.5	2.5	3	LC30	LC50
2-0/3-6		19-3/8	17	2.3	3.9	2.5	3	LC30	LC50
2-0/3-10		19-3/8	19	2.6	4.4	2.5	3	LC30	LC50
2-0/4-0		19-3/8	20	2.7	4.6	2.5	3	LC30	LC50
2-0/4-2		19-3/8	21	2.8	4.9	2.5	3	LC30	LC50
2-0/4-6		19-3/8	23	3.1	5.3	2.5	3	LC30	LC50
2-0/4-10		19-3/8	25	3.4	5.8	2.5	3	LC30	LC50
2-0/5-0		19-3/8	26	3.5	6.1	2.5	3	LC30	LC50
2-0/5-2		19-3/8	27	3.6	6.3	2.5	3	LC30	LC50
2-0/5-6		19-3/8	29	3.9	6.8	2.5	3	LC30	LC50
2-0/5-10		19-3/8	31	4.2	7.2	2.5	3	LC30	LC50
2-0/6-0		19-3/8	32	4.3	7.5	2.5	3	LC30	LC50
2-0/6-6		19-3/8	35	4.7	8.2	2.5	3	LC30	–
2-4/2-6		23-3/8	11	1.8	3.1	3	3	LC30	LC50
2-4/3-0		23-3/8	14	2.3	4.0	2.5	3	LC30	LC50
2-4/3-2		23-3/8	15	2.4	4.3	2.5	3	LC30	LC50
2-4/3-6		23-3/8	17	2.8	4.8	2.5	3	LC30	LC50
2-4/3-10		23-3/8	19	3.1	5.4	2.5	3	LC30	LC50
2-4/4-0		23-3/8	20	3.2	5.7	2.5	3	LC30	LC50
2-4/4-2		23-3/8	21	3.4	6.0	2.5	3	LC30	LC50
2-4/4-6		23-3/8	23	3.7	6.6	2.5	3	LC30	LC50
2-4/4-10		23-3/8	25	4.1	7.2	2.5	3	LC30	LC50
2-4/5-0		23-3/8	26	4.2	7.5	2.5	3	LC30	LC50
2-4/5-2		23-3/8	27	4.4	7.8	2.5	3	LC30	LC50
2-4/5-6		23-3/8	29	4.7	8.4	2.5	3	LC30	LC50
2-4/5-10	E1 (2)	23-3/8	31	5.0	8.9	2.5	3	LC30	LC50
2-4/6-0	E1	23-3/8	32	5.2	9.2	2.5	3	LC30	LC50
2-4/6-6	E1	23-3/8	35	5.7	10.1	2.5	3	LC30	–

### Egress Notes:

Check all applicable local codes for emergency egress requirements.

E = Window meets minimum clear opening of 24" height, 20" width, and 5.7 ft<sup>2</sup>.

E1 = Window meets minimum clear opening of 24" height, 20" width, and 5.0 ft<sup>2</sup>.

(1) Unit meets E1 with High Performance sill adapter kit installed.

(2) Does not meet egress with High Performance sill adapter kit installed.

To convert areas to square meters (m<sup>2</sup>), multiply square feet (ft<sup>2</sup>) by 0.0929.

(3) Subtract one inch from opening height to calculate vent area for performance upgrade units.

(4) The upgrade value, where shown, is maximum performance with upgrade kit installed. Both values are based on maximum performance when glazed with the appropriate glass thickness.



# Impervia® Double-Hung Windows

## Design Data

Equal Vent									
Unit	Egress	Clear Opening <sup>3</sup> (Inches)		Vent Area Ft <sup>2</sup>	Visible Glass Ft <sup>2</sup>	Standard Glass Thickness (mm)		Performance Class & Grade <sup>4</sup>	
		Width	Height			Annealed	Tempered	Standard	Upgrade
2-6/2-6		25-3/8	10	1.9	3.4	3	3	LC30	LC50
2-6/3-0		25-3/8	14	2.5	4.3	2.5	3	LC30	LC50
2-6/3-2		25-3/8	15	2.6	4.7	2.5	3	LC30	LC50
2-6/3-6		25-3/8	17	3.0	5.3	2.5	3	LC30	LC50
2-6/3-10		25-3/8	19	3.3	5.9	2.5	3	LC30	LC50
2-6/4-0		25-3/8	20	3.5	6.3	2.5	3	LC30	LC50
2-6/4-2		25-3/8	21	3.7	6.6	2.5	3	LC30	LC50
2-6/4-6		25-3/8	23	4.1	7.2	2.5	3	LC30	LC50
2-6/4-10		25-3/8	25	4.4	7.9	2.5	3	LC30	LC50
2-6/5-0		25-3/8	26	4.6	8.2	2.5	3	LC30	LC50
2-6/5-2		25-3/8	27	4.8	8.5	2.5	3	LC30	LC50
2-6/5-6	E1 (2)	25-3/8	29	5.1	9.1	2.5	3	LC30	LC50
2-6/5-10	E1	25-3/8	31	5.5	9.8	2.5	3	LC30	LC50
2-6/6-0	E1	25-3/8	32	5.6	10.1	2.5	3	LC30	LC50
2-6/6-6	E	25-3/8	35	6.2	11.1	2.5	3	LC30	–
2-8/2-6		27-3/8	11	2.1	3.7	3	3	LC30	LC50
2-8/3-0		27-3/8	14	2.7	4.7	2.5	3	LC30	LC50
2-8/3-2		27-3/8	15	2.9	5.1	2.5	3	LC30	LC50
2-8/3-6		27-3/8	17	3.2	5.8	2.5	3	LC30	LC50
2-8/3-10		27-3/8	19	3.6	6.5	2.5	3	LC30	LC50
2-8/4-0		27-3/8	20	3.8	6.8	2.5	3	LC30	LC50
2-8/4-2		27-3/8	21	4.0	7.2	2.5	3	LC30	LC50
2-8/4-6		27-3/8	23	4.4	7.9	2.5	3	LC30	LC50
2-8/4-10		27-3/8	25	4.8	8.5	2.5	3	LC30	LC50
2-8/5-0		27-3/8	26	4.9	8.9	2.5	3	LC30	LC50
2-8/5-2	E1 (2)	27-3/8	27	5.1	9.2	2.5	3	LC30	LC50
2-8/5-6	E1	27-3/8	29	5.5	9.9	2.5	3	LC30	LC50
2-8/5-10	E (1)	27-3/8	31	5.9	10.6	2.5	3	LC30	LC50
2-8/6-0	E	27-3/8	32	6.1	11.0	2.5	3	LC30	LC50
2-8/6-6	E	27-3/8	35	6.7	12.0	2.5	3	LC30	–
3-0/2-6		31-3/8	11	2.4	4.3	3	3	LC30	LC50
3-0/3-0		31-3/8	14	3.1	5.5	2.5	3	LC30	LC50
3-0/3-2		31-3/8	15	3.3	5.9	2.5	3	LC30	LC50
3-0/3-6		31-3/8	17	3.7	6.7	2.5	3	LC30	LC50
3-0/3-10		31-3/8	19	4.1	7.5	2.5	3	LC30	LC50
3-0/4-0		31-3/8	20	4.4	7.9	2.5	3	LC30	LC50
3-0/4-2		31-3/8	21	4.6	8.3	2.5	3	LC30	LC50
3-0/4-6		31-3/8	23	5.0	9.1	2.5	3	LC30	LC50
3-0/4-10	E1	31-3/8	25	5.4	9.9	2.5	3	LC30	LC50
3-0/5-0	E1	31-3/8	26	5.7	10.3	2.5	3	LC30	LC50
3-0/5-2	E (1)	31-3/8	27	5.9	10.7	2.5	3	LC30	LC50
3-0/5-6	E	31-3/8	29	6.3	11.5	2.5	3	LC30	LC50
3-0/5-10	E	31-3/8	31	6.8	12.3	2.5	3	LC30	LC50
3-0/6-0	E	31-3/8	32	7.0	12.7	2.5	3	LC30	LC50
3-0/6-6	E	31-3/8	35	7.6	14.0	2.5	3	LC30	–

### Egress Notes:

Check all applicable local codes for emergency egress requirements.

E = Window meets minimum clear opening of 24" height, 20" width, and 5.7 ft<sup>2</sup>.

E1 = Window meets minimum clear opening of 24" height, 20" width, and 5.0 ft<sup>2</sup>.

(1) Unit meets E1 with High Performance sill adapter kit installed.

(2) Does not meet egress with High Performance sill adapter kit installed.

To convert areas to square meters (m<sup>2</sup>), multiply square feet (ft<sup>2</sup>) by 0.0929.

(3) Subtract one Inch from opening height to calculate vent area for performance upgrade units.

(4) The upgrade value, where shown, is maximum performance with upgrade kit installed. Both values are based on maximum performance when glazed with the appropriate glass thickness.



# Impervia® Double-Hung Windows

## Design Data

Equal Vent									
Unit	Egress	Clear Opening <sup>3</sup> (Inches)		Vent Area Ft <sup>2</sup>	Visible Glass Ft <sup>2</sup>	Standard Glass Thickness (mm)		Performance Class & Grade <sup>4</sup>	
		Width	Height			Annealed	Tempered	Standard	Upgrade
3-4/2-6		35-3/8	8	2.7	4.9	3	3	LC30	LC50
3-4/3-0		35-3/8	14	3.4	6.2	2.5	3	LC30	LC50
3-4/3-2		35-3/8	15	3.7	6.7	2.5	3	LC30	LC50
3-4/3-6		35-3/8	17	4.2	7.6	2.5	3	LC30	LC50
3-4/3-10		35-3/8	19	4.7	8.5	2.5	3	LC30	LC50
3-4/4-0		35-3/8	20	4.9	9.0	2.5	3	LC30	LC50
3-4/4-2		35-3/8	21	5.2	9.4	2.5	3	LC30	LC50
3-4/4-6		35-3/8	23	5.7	10.4	2.5	3	LC30	LC50
3-4/4-10	E	35-3/8	25	6.1	11.3	2.5	3	LC30	LC50
3-4/5-0	E	35-3/8	26	6.4	11.7	2.5	3	LC30	LC50
3-4/5-2	E	35-3/8	27	6.6	12.2	2.5	3	LC30	LC50
3-4/5-6	E	35-3/8	29	7.1	13.1	2.5	3	LC30	–
3-4/5-10	E	35-3/8	31	7.6	14.0	2.5	3	LC30	–
3-4/6-0	E	35-3/8	32	7.9	14.5	2.5	3	LC30	–
3-4/6-6	E	35-3/8	35	8.6	15.9	2.5	3	LC30	–
3-6/3-0		37-3/8	14	3.6	6.6	2.5	3	LC30	LC50
3-6/3-2		37-3/8	15	3.9	7.1	2.5	3	LC30	LC50
3-6/3-6		37-3/8	17	4.4	8.1	2.5	3	LC30	LC50
3-6/3-10		37-3/8	19	4.9	9.0	2.5	3	LC30	LC50
3-6/4-0		37-3/8	20	5.2	9.5	2.5	3	LC30	LC50
3-6/4-2		37-3/8	21	5.5	10.0	2.5	3	LC30	LC50
3-6/4-6		37-3/8	23	6.0	11.0	2.5	3	LC30	LC50
3-6/4-10	E	37-3/8	25	6.5	12.0	2.5	3	LC30	LC50
3-6/5-0	E	37-3/8	26	6.7	12.4	2.5	3	LC30	LC50
3-6/5-2	E	37-3/8	27	7.0	12.9	2.5	3	LC30	–
3-6/5-6	E	37-3/8	29	7.5	13.9	2.5	3	LC30	–
3-6/5-10	E	37-3/8	31	8.0	14.9	2.5	3	LC30	–
3-6/6-0	E	37-3/8	32	8.3	15.4	2.5	3	LC30	–
3-6/6-6	E	37-3/8	35	9.1	16.8	2.5	3	LC30	–
4-0/3-0		43-3/8	14	4.2	7.7	2.5	3	LC30	LC50
4-0/3-2		43-3/8	15	4.5	8.3	2.5	3	LC30	LC50
4-0/3-6		43-3/8	17	5.1	9.4	2.5	3	LC30	LC50
4-0/3-10		43-3/8	19	5.7	10.6	2.5	3	LC30	LC50
4-0/4-0		43-3/8	20	6.0	11.2	2.5	3	LC30	LC50
4-0/4-2		43-3/8	21	6.3	11.7	2.5	3	LC30	LC50
4-0/4-6		43-3/8	23	6.9	12.9	2.5	3	LC30	LC50
4-0/4-10	E	43-3/8	25	7.5	14.0	2.5	3	LC30	–
4-0/5-0	E	43-3/8	26	7.8	14.6	2.5	3	LC30	–
4-0/5-2	E	43-3/8	27	8.1	15.1	2.5	3	LC30	–
4-0/5-6	E	43-3/8	29	8.7	16.3	2.5	3	LC30	–
4-0/5-10	E	43-3/8	31	9.3	17.4	2.5	3	LC30	–
4-0/6-0	E	43-3/8	32	9.6	18.0	2.5	3	LC30	–
4-0/6-6	E	43-3/8	35	10.5	19.7	2.5	3	LC30	–

**Egress Notes:**  
 Check all applicable local codes for emergency egress requirements.

E = Window meets minimum clear opening of 24" height, 20" width, and 5.7 ft<sup>2</sup>.

E1 = Window meets minimum clear opening of 24" height, 20" width, and 5.0 ft<sup>2</sup>.

(1) Unit meets E1 with High Performance sill adapter kit installed.

(2) Does not meet egress with High Performance sill adapter kit installed.

To convert areas to square meters (m<sup>2</sup>), multiply square feet (ft<sup>2</sup>) by 0.0929.

(3) Subtract one Inch from opening height to calculate vent area for performance upgrade units.

(4) The upgrade value, where shown, is maximum performance with upgrade kit installed. Both values are based on maximum performance when glazed with the appropriate glass thickness.





# Impervia® Double-Hung Windows

## Design Data

Cottage Sash									
Unit	Egress	Clear Opening <sup>1</sup> (Inches)		Vent Area Ft <sup>2</sup>	Visible Glass Ft <sup>2</sup>	Standard Glass Thickness (mm)		Performance Class & Grade <sup>2</sup>	
		Width	Height			Annealed	Tempered	Standard	Upgrade
1-6/4-6		13-3/8	18-3/16	1.7	3.5	2.5	3	LC30	LC50
1-6/5-0		13-3/8	20-11/16	1.9	3.9	2.5	3	LC30	LC50
1-6/5-6		13-3/8	23-1/8	2.1	4.4	2.5	3	LC30	LC50
1-6/6-0		13-3/8	25-1/2	2.3	4.8	2.5	3	LC30	LC50
1-6/6-6		13-3/8	27-7/8	2.5	5.3	2.5	3	LC30	–
2-0/4-6		19-3/8	18-3/16	2.4	5.3	2.5	3	LC30	LC50
2-0/5-0		19-3/8	20-11/16	2.7	6.1	2.5	3	LC30	LC50
2-0/5-6		19-3/8	23-1/8	3.1	6.8	2.5	3	LC30	LC50
2-0/6-0		19-3/8	25-1/2	3.4	7.5	2.5	3	LC30	LC50
2-0/6-6		19-3/8	27-7/8	3.7	8.2	2.5	3	LC30	–
2-4/4-6		23-3/8	18-3/16	2.9	6.6	2.5	3	LC30	LC50
2-4/5-0		23-3/8	20-11/16	3.3	7.5	2.5	3	LC30	LC50
2-4/5-6		23-3/8	23-1/8	3.7	8.4	2.5	3	LC30	LC50
2-4/6-0		23-3/8	25-1/2	4.1	9.2	2.5	3	LC30	LC50
2-4/6-6		23-3/8	27-7/8	4.5	10.1	2.5	3	LC30	–
2-6/4-6		25-3/8	18-3/16	3.2	7.2	2.5	3	LC30	LC50
2-6/5-0		25-3/8	20-11/16	3.6	8.2	2.5	3	LC30	LC50
2-6/5-6		25-3/8	23-1/8	4.1	9.1	2.5	3	LC30	LC50
2-6/6-0		25-3/8	25-1/2	4.5	10.1	2.5	3	LC30	LC50
2-6/6-6		25-3/8	27-7/8	4.9	11.1	2.5	3	LC30	–
2-8/4-6		27-3/8	18-3/16	3.4	7.9	2.5	3	LC30	LC50
2-8/5-0		27-3/8	20-11/16	3.9	8.9	2.5	3	LC30	LC50
2-8/5-6		27-3/8	23-1/8	4.3	9.9	2.5	3	LC30	LC50
2-8/6-0		27-3/8	25-1/2	4.8	11.0	2.5	3	LC30	LC50
2-8/6-6	E1	27-3/8	27-7/8	5.3	12.0	2.5	3	LC30	–
3-0/4-6		31-3/8	18-3/16	3.9	9.1	2.5	3	LC30	LC50
3-0/5-0		31-3/8	20-11/16	4.5	10.3	2.5	3	LC30	LC50
3-0/5-6		31-3/8	23-1/8	5.0	11.5	2.5	3	LC30	LC50
3-0/6-0	E1	31-3/8	25-1/2	5.5	12.7	2.5	3	LC30	LC50
3-0/6-6	E	31-3/8	27-7/8	6.0	14.0	2.5	3	LC30	–
3-6/4-6		37-3/8	18-3/16	4.7	11.0	2.5	3	LC30	LC50
3-6/5-0		37-3/8	20-11/16	5.3	12.4	2.5	3	LC30	LC50
3-6/5-6		37-3/8	23-1/8	5.9	13.9	2.5	3	LC30	–
3-6/6-0	E	37-3/8	25-1/2	6.6	15.4	2.5	3	LC30	–
3-6/6-6	E	37-3/8	27-7/8	7.2	16.8	2.5	3	LC30	–
4-0/4-6		43-3/8	18-3/16	5.5	12.9	2.5	3	LC30	–
4-0/5-0		43-3/8	20-11/16	6.2	14.6	2.5	3	LC30	–
4-0/5-6		43-3/8	23-1/8	6.9	16.6	2.5	3	LC30	–
4-0/6-0	E	43-3/8	25-1/2	7.6	18.0	3	3	LC30	–
4-0/6-6	E	43-3/8	27-7/8	8.4	19.7	3	3	LC30	–

**Egress Notes:**  
 Check all applicable local codes for emergency egress requirements.  
 E = Window meets minimum clear opening of 24" height, 20" width, and 5.7 ft<sup>2</sup>.  
 E1 = Window meets minimum clear opening of 24" height, 20" width, and 5.0 ft<sup>2</sup>.  
 To convert areas to square meters (m<sup>2</sup>), multiply square feet (ft<sup>2</sup>) by 0.0929.

(1) Subtract one inch from opening height to calculate vent area for performance upgrade units.

(2) The upgrade value, where shown, is maximum performance with upgrade kit installed. Both values are based on maximum performance when glazed with the appropriate glass thickness.



# Impervia® Double-Hung Windows

## Design Data

Contemporary Sash									
Unit	Egress	Clear Opening <sub>1</sub> (Inches)		Vent Area Ft <sup>2</sup>	Visible Glass Ft <sup>2</sup>	Standard Glass Thickness (mm)		Performance Class & Grade <sub>2</sub>	
		Width	Height			Annealed	Tempered	Standard	Upgrade
1-6/4-6		13-3/8	18-3/16	1.7	3.5	2.5	3	LC30	LC50
1-6/5-0		13-3/8	20-11/16	1.9	3.9	2.5	3	LC30	LC50
1-6/5-6		13-3/8	23-1/8	2.1	4.4	2.5	3	LC30	LC50
1-6/6-0		13-3/8	25-1/2	2.3	4.8	2.5	3	LC30	LC50
1-6/6-6		13-3/8	27-7/8	2.5	5.3	2.5	3	LC30	–
2-0/4-6		19-3/8	18-3/16	2.4	5.3	2.5	3	LC30	LC50
2-0/5-0		19-3/8	20-11/16	2.7	6.1	2.5	3	LC30	LC50
2-0/5-6		19-3/8	23-1/8	3.1	6.8	2.5	3	LC30	LC50
2-0/6-0		19-3/8	25-1/2	3.4	7.5	2.5	3	LC30	LC50
2-0/6-6		19-3/8	27-7/8	3.7	8.2	2.5	3	LC30	–
2-4/4-6		23-3/8	18-3/16	2.9	6.6	2.5	3	LC30	LC50
2-4/5-0		23-3/8	20-11/16	3.3	7.5	2.5	3	LC30	LC50
2-4/5-6		23-3/8	23-1/8	3.7	8.4	2.5	3	LC30	LC50
2-4/6-0		23-3/8	25-1/2	4.1	9.2	2.5	3	LC30	LC50
2-4/6-6		23-3/8	27-7/8	4.5	10.1	2.5	3	LC30	–
2-6/4-6		25-3/8	18-3/16	3.2	7.2	2.5	3	LC30	LC50
2-6/5-0		25-3/8	20-11/16	3.6	8.2	2.5	3	LC30	LC50
2-6/5-6		25-3/8	23-1/8	4.1	9.1	2.5	3	LC30	LC50
2-6/6-0		25-3/8	25-1/2	4.5	10.1	2.5	3	LC30	LC50
2-6/6-6		25-3/8	27-7/8	4.9	11.1	2.5	3	LC30	–
2-8/4-6		27-3/8	18-3/16	3.4	7.9	2.5	3	LC30	LC50
2-8/5-0		27-3/8	20-11/16	3.9	8.9	2.5	3	LC30	LC50
2-8/5-6		27-3/8	23-1/8	4.3	9.9	2.5	3	LC30	LC50
2-8/6-0		27-3/8	25-1/2	4.8	11.0	2.5	3	LC30	LC50
2-8/6-6	E1	27-3/8	27-7/8	5.3	12.0	2.5	3	LC30	–
3-0/4-6		31-3/8	18-3/16	3.9	9.1	2.5	3	LC30	LC50
3-0/5-0		31-3/8	20-11/16	4.5	10.3	2.5	3	LC30	LC50
3-0/5-6		31-3/8	23-1/8	5.0	11.5	2.5	3	LC30	LC50
3-0/6-0	E1	31-3/8	25-1/2	5.5	12.7	2.5	3	LC30	LC50
3-0/6-6	E	31-3/8	27-7/8	6.0	14.0	2.5	3	LC30	–
3-6/4-6		37-3/8	18-3/16	4.7	11.0	2.5	3	LC30	LC50
3-6/5-0		37-3/8	20-11/16	5.3	12.4	2.5	3	LC30	LC50
3-6/5-6		37-3/8	23-1/8	5.9	13.9	2.5	3	LC30	LC50
3-6/6-0	E	37-3/8	25-1/2	6.6	15.4	2.5	3	LC30	–
3-6/6-6	E	37-3/8	27-7/8	7.2	16.8	2.5	3	LC30	–
4-0/4-6		43-3/8	18-3/16	5.5	12.9	2.5	3	LC30	–
4-0/5-0		43-3/8	20-11/16	6.2	14.6	2.5	3	LC30	–
4-0/5-6		43-3/8	23-1/8	6.9	16.6	2.5	3	LC30	–
4-0/6-0	E	43-3/8	25-1/2	7.6	18	3	3	LC30	–
4-0/6-6	E	43-3/8	27-7/8	8.4	19.7	3	3	LC30	–

### Egress Notes:

Check all applicable local codes for emergency egress requirements.

E = Window meets minimum clear opening of 24" height, 20" width, and 5.7 ft<sup>2</sup>.

E1 = Window meets minimum clear opening of 24" height, 20" width, and 5.0 ft<sup>2</sup>.

To convert areas to square meters (m<sup>2</sup>), multiply square feet (ft<sup>2</sup>) by 0.0929.

(1) Subtract one inch from opening height to calculate vent area for performance upgrade units.

(2) The upgrade value, where shown, is maximum performance with upgrade kit installed. Both values are based on maximum performance when glazed with the appropriate glass thickness.



# Impervia® Double-Hung Windows

## Design Data

Fixed Units				
Unit	Visible Glass Ft <sup>2</sup>	Standard Glass Thickness (mm)		Performance Class & Grade <sup>1</sup>
		Annealed	Tempered	
3-0/2-6	4.8	2.5	3	CW50
3-0/3-0	6.0	2.5	3	CW50
3-0/3-6	7.2	2.5	3	CW50
3-0/4-0	8.5	2.5	3	CW50
3-0/4-6	9.7	2.5	3	CW45
3-0/5-0	10.9	3	3	CW45
3-0/5-6	12.2	3	3	CW45
3-0/6-0	13.4	3	3	CW40
3-6/2-6	5.8	2.5	3	CW50
3-6/3-0	7.2	2.5	3	CW50
3-6/3-6	8.7	2.5	5	CW45
3-6/4-0	10.2	3	5	CW45
3-6/4-6	11.7	3	5	CW40
3-6/5-0	13.2	3	5	CW40
3-6/5-6	14.6	3	5	CW40
3-6/6-0	16.1	3	5	CW40
4-0/2-6	6.7	2.5	3	CW50
4-0/3-0	8.5	2.5	3	CW50
4-0/3-6	10.2	3	3	CW45
4-0/4-0	11.9	3	3	CW40
4-0/4-6	13.7	3	3	CW40
4-0/5-0	15.4	3	3	CW40
4-0/5-6	17.1	3	3	CW35
4-0/6-0	18.8	5	5	CW35
4-6/2-6	7.7	2.5	3	CW50
4-6/3-0	9.7	2.5	3	CW45
4-6/3-6	11.7	3	5	CW40
4-6/4-0	13.7	3	5	CW40
4-6/4-6	15.6	3	5	CW35
4-6/5-0	17.6	5	5	CW35
4-6/5-6	19.6	5	5	CW35
4-6/6-0	21.6	5	5	CW35
5-0/2-6	8.7	2.5	3	CW45/CW50
5-0/3-0	10.9	3	3	CW45
5-0/3-6	13.2	3	5	CW40
5-0/4-0	15.4	3	5	CW40
5-0/4-6	17.6	5	5	CW35
5-0/5-0	19.8	5	5	CW35
5-0/5-6	22.1	5	5	CW30
5-0/6-0	24.3	5	5	CW30
6-0/2-6	10.7	3	3	CW45/CW50
6-0/3-0	13.4	3	3	CW45
6-0/3-6	16.1	3	5	CW40
6-0/4-0	18.8	5	5	CW35
6-0/4-6	21.6	5	5	CW35
6-0/5-0	24.3	5	5	CW30
6-0/5-6	27.0	5	5	CW30
6-0/6-0	29.7	5	–	CW30

Fixed Units				
Unit	Visible Glass Ft <sup>2</sup>	Standard Glass Thickness (mm)		Performance Class & Grade <sup>1</sup>
		Annealed	Tempered	
<b>FLANKERS</b>				
1-2/3-0	1.5	2.5	3	CW50
1-2/3-6	1.8	2.5	3	CW50
1-2/4-0	2.1	–	3	CW50
1-2/4-6	2.5	–	3	CW50
1-2/5-0	2.8	–	3	CW50
<b>TRANSOM UNITS</b>				
1-6/1-2	0.6	3	3	CW50
1-6/1-6	0.9	2.5	3	CW50
1-6/2-0	1.2	2.5	3	CW50
2-0/1-2	0.9	3	3	CW50
2-0/1-6	1.4	2.5	3	CW50
2-0/2-0	1.9	2.5	3	CW50
2-4/1-2	1.1	3	3	CW50
2-4/1-6	1.7	2.5	3	CW50
2-4/2-0	2.3	2.5	3	CW50
2-6/1-2	1.2	3	3	CW50
2-6/1-6	1.9	2.5	3	CW50
2-6/2-0	2.5	2.5	3	CW50
2-8/1-2	1.3	3	3	CW50
2-8/1-6	2.0	2.5	3	CW50
2-8/2-0	2.7	2.5	3	CW50
3-0/1-2	1.5	3	3	CW50
3-0/1-6	2.3	2.5	3	CW50
3-0/2-0	3.2	2.5	3	CW50
3-4/1-2	1.7	3	3	CW50
3-4/1-6	2.7	2.5	3	CW50
3-4/2-0	3.6	2.5	3	CW50
3-6/1-2	1.8	3	3	CW50
3-6/1-6	2.8	2.5	3	CW50
3-6/2-0	3.8	2.5	3	CW50
4-0/1-2	2.1	–	3	CW50
4-0/1-6	3.3	2.5	3	CW50
4-0/2-0	4.4	2.5	3	CW50
4-6/1-2	2.5	–	3	CW50
4-6/1-6	3.8	2.5	3	CW50
4-6/2-0	5.1	2.5	3	CW50
5-0/1-2	2.8	–	3	CW50
5-0/1-6	4.2	2.5	3	CW50
5-0/2-0	5.7	2.5	3	CW50
6-0/1-2	3.4	–	3	CW50
6-0/1-6	5.2	–	3	CW50
6-0/2-0	7.0	–	3	CW50

(1) Maximum performance when glazed with the appropriate glass thickness. Second value, where shown, requires tempered glass.

To convert areas to square meters (m<sup>2</sup>), multiply square feet by 0.0929.



## Detailed Product Description

### Frame

- Frame is Duracast® fiberglass composite – five-layer pultruded fiberglass material [with optional foam insulation<sub>1</sub>] reinforced with a Pella patented interlocking mat.
- Nominal wall thickness of Duracast fiberglass composite members is .050" to .080" thick.
- [Overall frame depth is 3" for [Block Frame] [Integral Nailing Fin] [Overall frame depth is 3-1/4" for Precision Fit].
- Frame corners are mitered, joined and bonded with corner locks and mechanically fastened with injected polyurethane adhesive.
- Block frame jambs contain factory drilled (counter-bored) installation screw holes.
- Frame has 10° slope sill.

### Sash

- Sash is Duracast fiberglass composite–five-layer pultruded fiberglass material [with optional foam insulation<sub>1</sub>] reinforced with a Pella patented interlocking mat.
- All sash members have mitered corners bonded with corner locks and sealed with injected polyurethane adhesive.
- Both sashes tilt to interior for cleaning.

### Exterior / Interior

- Duracast fiberglass composite surfaces with powder-coat paint finish.
  - Color is [White] [Tan] [Brown] [Black] [Morning Sky Gray].
  - Dual-color option [Tan] [Brown] [Black] [Morning Sky Gray] exterior with White interior<sub>2</sub>.

### Glazing System

- Quality float glass complying with ASTM C 1036.
- 11/16" insulating glass [[annealed] [tempered]] [obscure<sub>3</sub>] [clear] [[Advanced] [SunDefense™] [AdvancedComfort] [NaturalSun] Low-E coated, [with argon]]] [[bronze] [gray] [green] Advanced Low-E [with Argon]] sealed and bonded to sash.
- High altitude glazing [with argon] available.

### Weatherstripping

- Fin-type pile on jambs, top rail and stile of upper sash.
- Vinyl-wrapped foam at sill on frame and bottom rail of lower sash.

### Hardware

- Galvanized block-and-tackle balances connected to sash with polyester cord and concealed within the frame.
- Upper and lower sash are fully operable for ventilation.
- All fasteners are corrosion-resistant material.
- Two locks are installed on units 37" wide or greater.
- Locks are zinc die-cast, self-aligning cam action factory-installed on the interlocker [powder-coat painted [White] [Tan] [Brown] [Matte Black] [Morning Sky Gray] to match finish] [Satin Nickel] [Bright Brass] [Oil-Rubbed Bronze].

### Optional Products

#### Screens

- Conventional Black Fiberglass
  - [Half-size] [Full-size] with black vinyl coated 18/16 mesh fiberglass screen cloth complying with ASTM D 3656 and SMA 1201.
  - Set in aluminum frame and fitted to outside of window.
  - Supplied complete with all necessary hardware.
  - Screen frame finish is baked enamel, color to match exterior.
- InView™ Screens
  - [Half-size] [Full-size] with black vinyl coated 18/18 mesh fiberglass screen cloth complying with SMA 1201.
  - Set in aluminum frame and fitted to outside of window.
  - Supplied complete with all necessary hardware.
  - Screen frame finish is baked enamel, color to match exterior.

#### Grilles

- Grilles-Between-the-Glass
  - Insulating glass contains 3/4" contoured aluminum grilles permanently installed between two panes of glass.
  - Grilles are factory prefinished [White] [Tan] [Brown] [Black] [Morning Sky Gray] to match interior and exterior finish.

#### Hardware

- Optional limited opening device available for field installation on vent units in [White] [Tan] [Brown] [Black] [Morning Sky Gray] foamed PVC to match interior of unit; nominal 3-3/4" opening.
- Optional window opening control device available for field installation. Device allows window to open less than 4" with normal operation, with a release mechanism that allows the sash to open completely. Complies with ASTM F2090-10.
- Optional field applied Duracast sash lift available for vent units in [White] [Tan] [Brown] [Black] [Morning Sky Gray].

### FOAM INSULATION INSERTS <sub>1</sub>

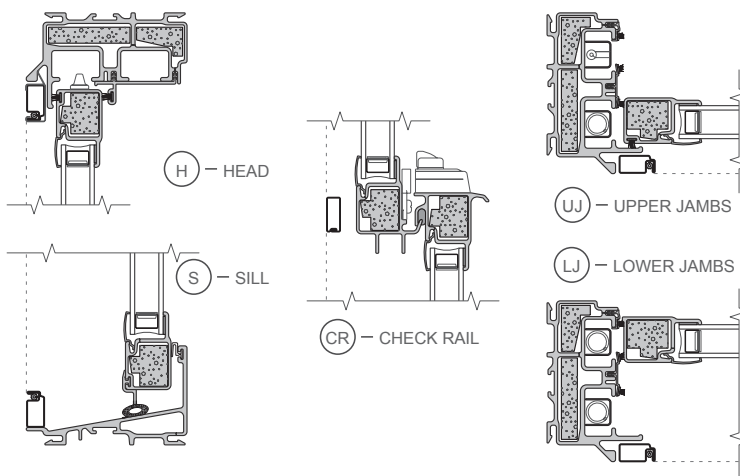

(1) Foam insulation inserts are not available with clear glazing.

(2) Dual-color finish is not available on products with integral nailing fin.

(3) Obscure glazing is not available when AdvancedComfort Low-E coated IG is specified.



# Impervia® Double-Hung Windows

## Frame Types

STANDARD  
BLOCK FRAME

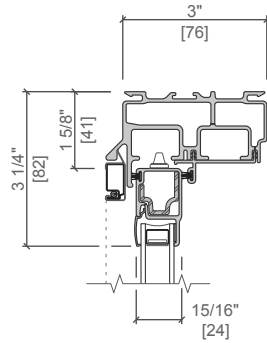

INTEGRAL  
NAILING FIN

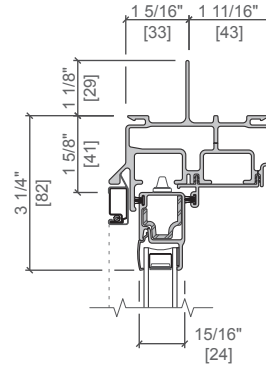

STANDARD  
BLOCK FRAME  
with STANDARD FIN

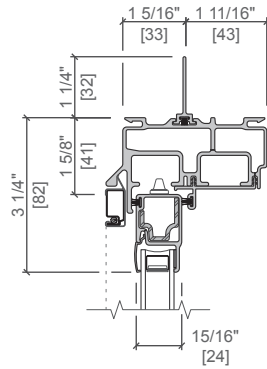

STANDARD  
BLOCK FRAME  
with OFF SET FIN

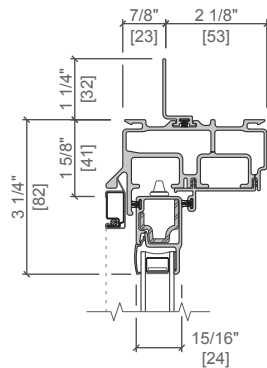

DP 50  
UPGRADE

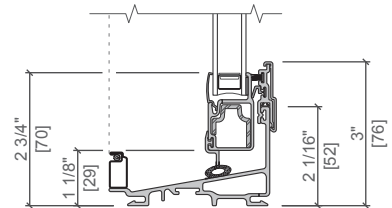

Scale 3" = 1' 0"  
All dimensions are approximate.



# Impervia® Double-Hung Windows

## Unit Sections

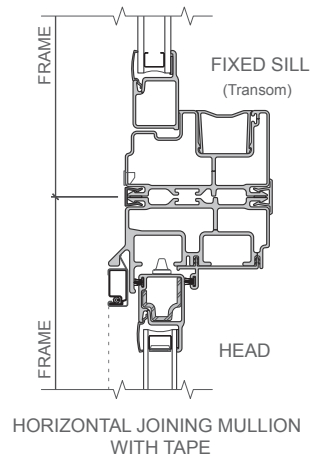
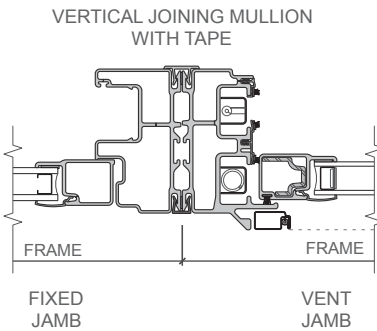
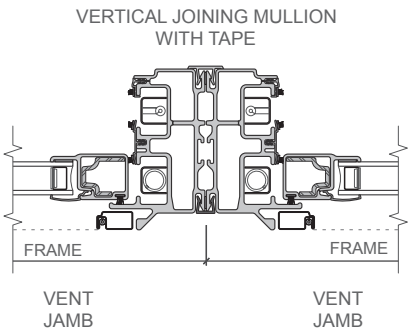
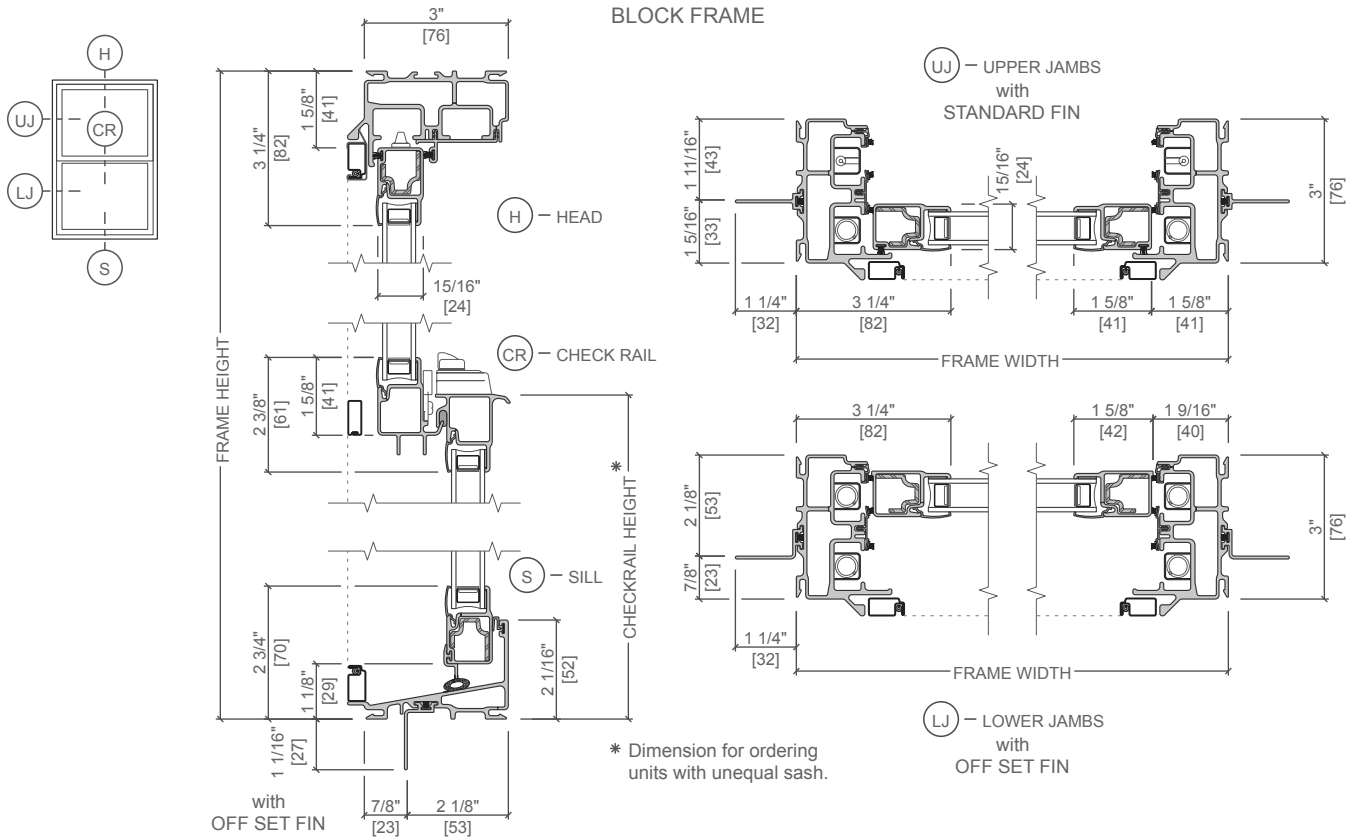

Scale 3" = 1' 0"  
All dimensions are approximate.



# Impervia® Double-Hung Windows

## Unit Sections

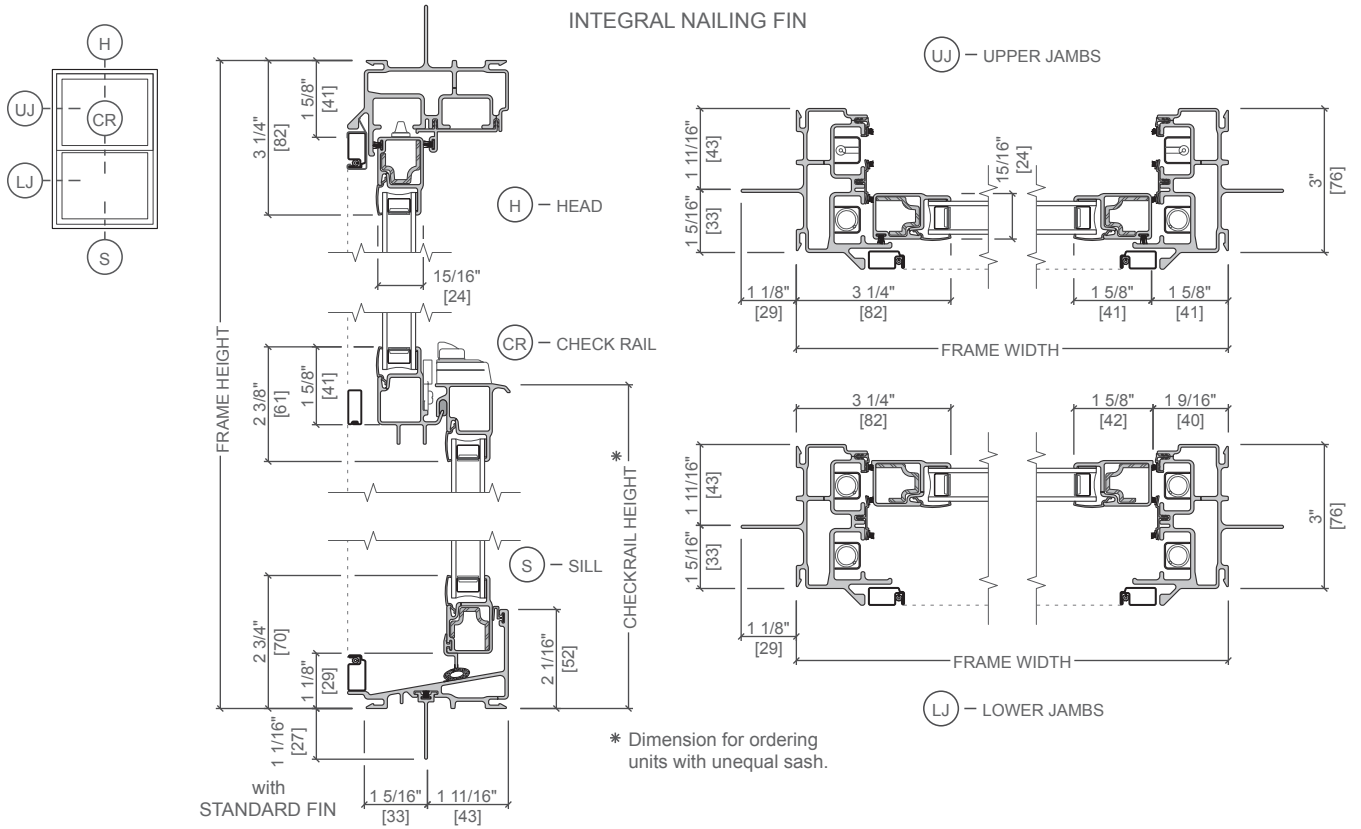

Scale 3" = 1' 0"  
All dimensions are approximate.