

SR555M



Display size  
**40"-55"**



Max load  
**75lb (34kg)**  
per display

**SMARTMOUNT.**

# Flat Panel Video Conferencing Cart

FOR TWO 40" TO 55" DISPLAYS

The SR555M SmartMount® Flat Panel Video Conferencing Cart has been designed to include all of the features you may need, making it perfect for any location. The mobility of the cart eliminates the need for multiple video conference systems, lowering your overall system cost. The structure is optimized to hold two 40"-55" displays, providing clear visibility for all participants. The camera locates anywhere above either display, for near perfect eye contact during your meetings. Additionally, the integrated cable management contains and conceals unsightly cables, helping you complete a clean and professional installation.

*The mobility of Peerless-AV's video conferencing carts allows mobile video collaboration in your desired location.*



## Additional Features

- ✓ Display can be located anywhere along the column for perfect viewing height (up to 60" at center)
- ✓ Integrated cable management protects, contains and conceals cables for a clean, professional installation
- ✓ Maneuvers easily on 4" (102mm) swivel casters, two locking
- ✓ Fully welded base structure provides rigidity, stability and quick assembly
- ✓ Textured black powder coat finish helps to hide finger prints and dust
- ✓ Open frame adaptor design to help prevent display component input interference
- ✓ Shelf can be positioned anywhere along the column by simply lifting and repositioning
- ✓ Camera mount can be located anywhere above either display
- ✓ Universal mount fits displays with mounting patterns from 200 x 200mm up to 400 x 400mm

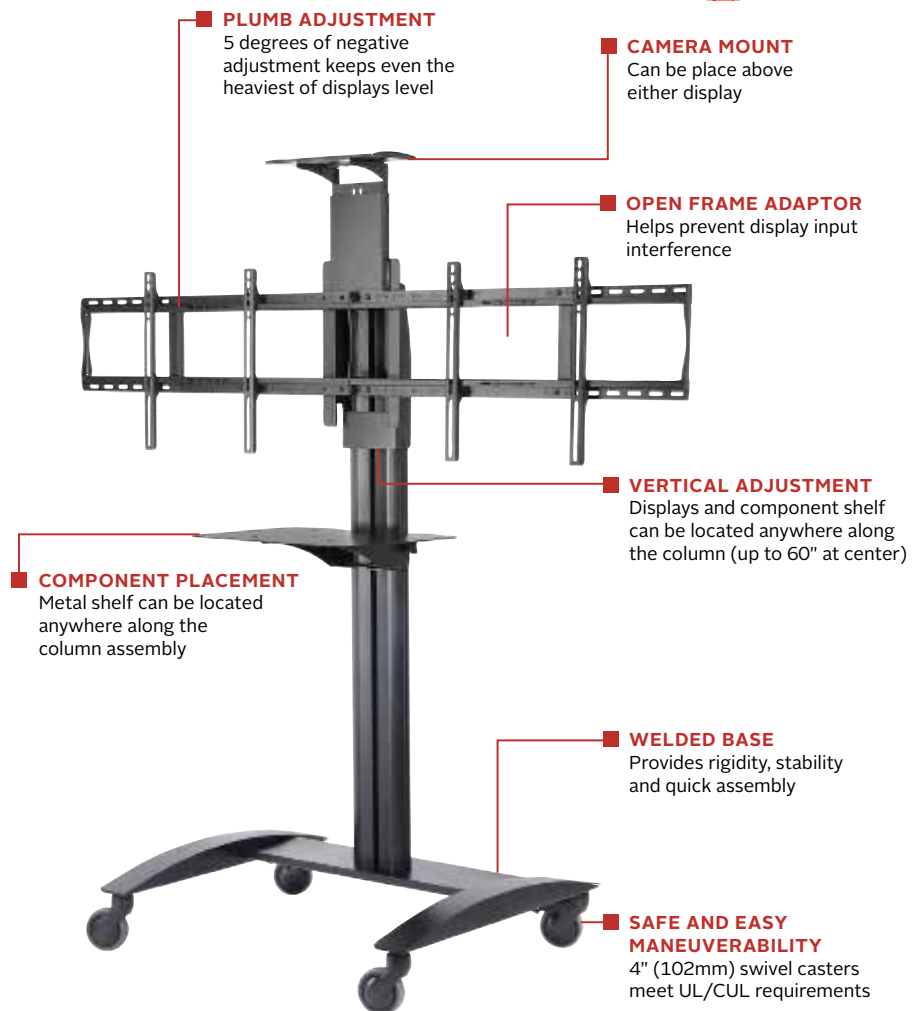

SR555M	SmartMount® Flat Panel Video Conferencing Cart for 40" to 55" Displays
--------	--

Product Specifications

	DIMENSIONS (W X H X D)	PRODUCT WEIGHT	LOAD CAPACITY	FINISH	AVAILABLE COLORS
SR555M	70.25" x 78.10" x 29.00" (1784 x 1983 x 737mm)	90lb (40.9kg)	75lb (34kg) per display	Textured Powder Coat	Black

Package Specifications

	PACKAGE SIZE (W x H x D)	PACKAGE SHIP WEIGHT	PACKAGE UPC CODE	PACKAGE CONTENTS	UNITS IN PACKAGE
SR555M	47.50" x 7.25" x 38.50" (1207 x 184 x 978mm)	98lb (44.5kg)	735029305057	Assembled base, aluminum column, dual screen universal display adaptor, metal component shelf, camera shelf, (2) swivel casters, (2) locking swivel casters, hardware & instructions	1

Accessories

- |   |                                      |
|---|--------------------------------------|
| <b>ACC310:</b> Feet Accessory                         | <b>ACC-GS1:</b> Tempered Glass Shelf |
| <b>ACC316:</b> Safety Belt                            | <b>ACC-LA:</b> Laptop Arm            |
| <b>ACC320:</b> Electrical Outlet Strip with Cord Wrap | <b>ACC-MS:</b> Metal Shelf           |
| <b>ACC-BPR:</b> Bumper Accessory for legs             |                                      |

All dimensions = inch (mm)

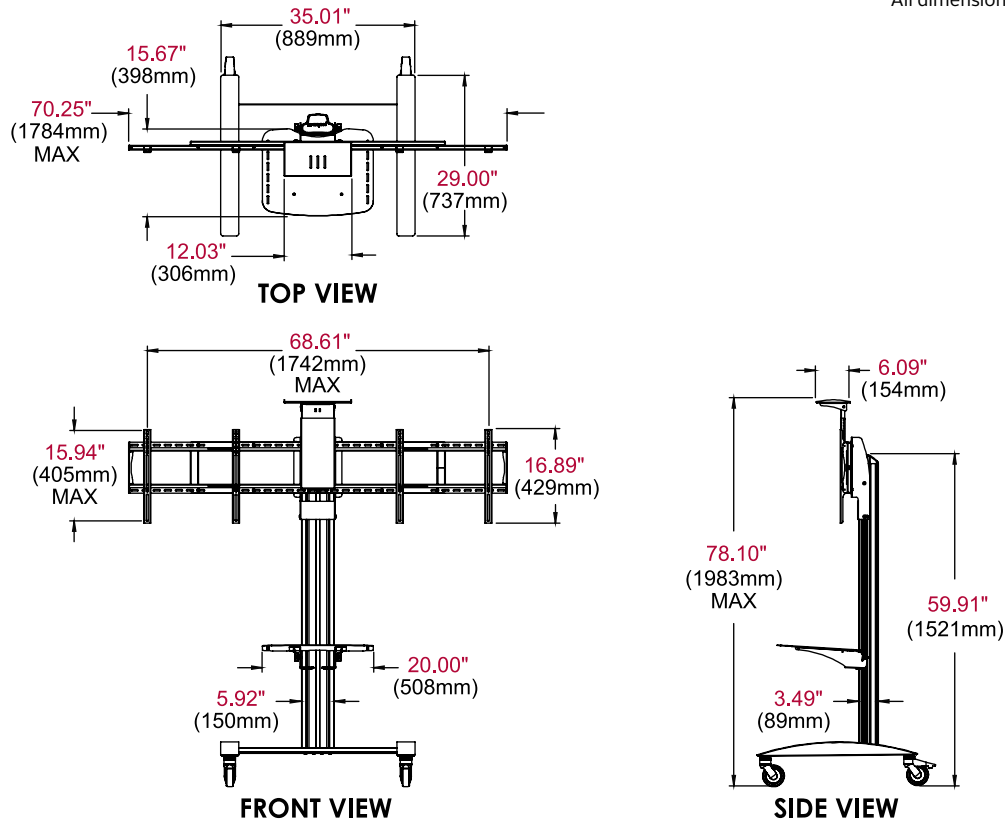

Architect Specifications

The SmartMount® Flat Panel Video Conferencing Cart shall be a Peerless-AV model SR555M and shall be located where indicated on the plans. Assembly and installation shall be done according to instructions provided by the manufacturer.

Visit [peerless-av.com](http://peerless-av.com) to see the complete line of AV solutions from Peerless-AV, including outdoor displays, wireless, kiosks, digital audio, display mounts, projector mounts, carts/stands, and a full assortment of accessories.

**Peerless-AV**  
 2300 White Oak Circle  
 Aurora, IL 60502 USA  
**(800) 865-2112**  
**(630) 375-5100**  
**Fax: (800) 359-6500**

**Peerless-AV Europe**  
 Unit 3 Watford Interchange  
 Colonial Way, Watford  
 Herts, WD24 4WP  
 United Kingdom  
**+44 (0) 1923 200100**  
**Fax: +44 (0) 1923 200101**

**Peerless-AV de México**  
 Ave de las Industrias 413  
 Parque Industrial Escobedo  
 Escobedo, N.L.,  
 Mexico 66050  
**+52 (81) 8384-8300**  
**Fax: +52 (81) 8384-8360**

