



# INSTRUCTION BULLETIN

No. 340266  
Machine: 6200  
Published: 6-99/00  
System: OPTIONS

**NOTE: DO NOT DISCARD the Parts List from the Instruction Bulletin. Place the Parts List in the appropriate place in your machine manual for future reference. Retaining the Parts List will make it easier to reorder individual parts and will save you the cost of ordering an entire kit.**

*NOTE: Numbers in parenthesis ( ) are reference numbers for parts listed in Bill of Materials.*

Installation instructions for kit number 384036

## **SYNOPSIS / PROBLEM:**

This kit contains the parts needed to install a seat belt kit on the model 6200 sweeper. Please follow step-by-step instructions.

## **SPECIAL TOOLS / CONSIDERATIONS: Hand drill,**

(Estimated time to complete: 1 hour)

## **PREPARATION:**

(Refer to FIG. 1)

**FOR SAFETY: Before leaving or servicing machine, stop on level surface and set parking brake. Then turn off machine and remove key.**

1. Disconnect battery cables from machine.



**WARNING: Always disconnect battery cables from machine before working on electrical components.**

## **INSTALLATION:**

(Refer to FIG. 1)

1. Open seat weldment. Remove operator seat from seat weldment.
2. Close seat weldment.
3. Drill two 1/2 in. (12.7 mm) seat belt mounting holes in seat weldment according to measurements given in figure one. (Refer to FIG. 1)
4. Mount seat belt (1), to seat weldment with hex screws (2), washers (3) and nuts (4).

*NOTE: Mount screws with one washer on each side of seat weldment*

5. Raise seat weldment, and remount operator seat to seat weldment.
6. Close seat weldment.

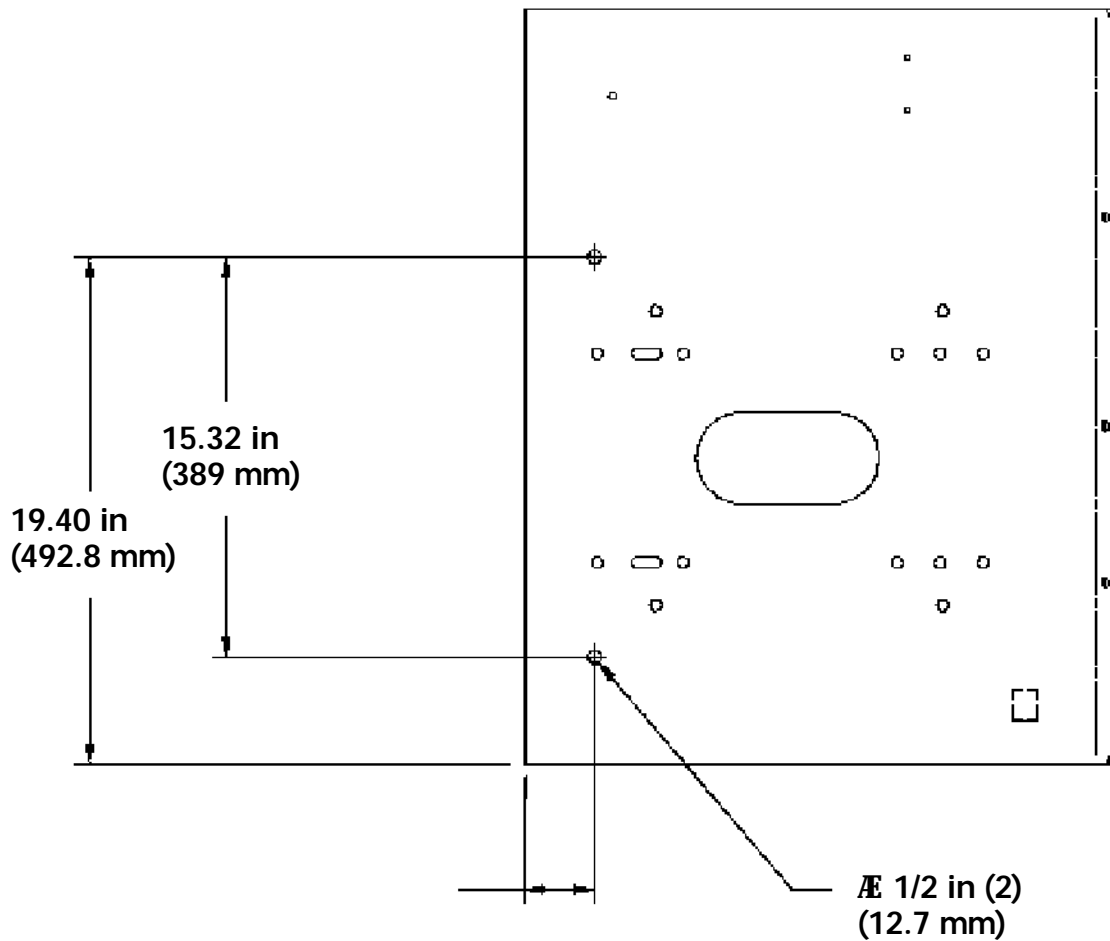

FIG. 1 - HOLE LOCATIONS FOR SEAT BELT INSTALLATION

BILL OF MATERIALS FOR 6200 SEAT BELT KIT 384036

Ref.	TENNANT Part No.	Description	Qty.
1	30533	Seat belt	1
2	41345	Screw, hex M12 X 1.75	2
3	32486	Washer, flt .50 SAE	4
4	08711	Nut, hxlocnyln M12 X 1.75	2

TENNANT COMPANY  
P. O. Box 1452  
Minneapolis, MN 55440-1452