



CC2541 Bluetooth Low Energy Slave Module and Protocol

Version: V2.31u

(Transparent Transmission & Direct-Driven)

Shenzhen RF-star Technology Co., Ltd.

Nov. 18th, 2019

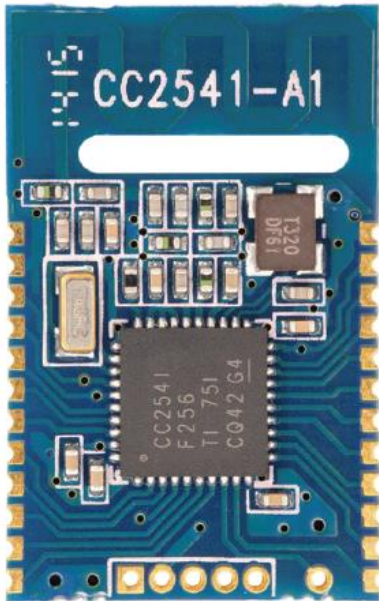

RF-CC2541A1



RF-BM-S01A

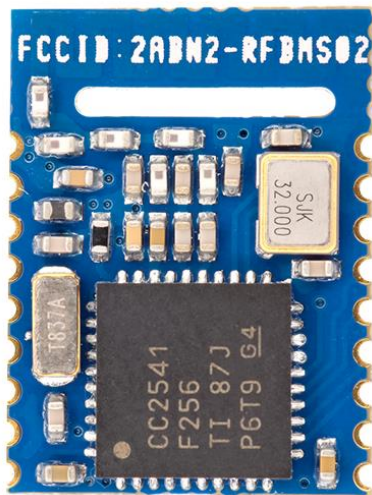

RF-BM-S02A

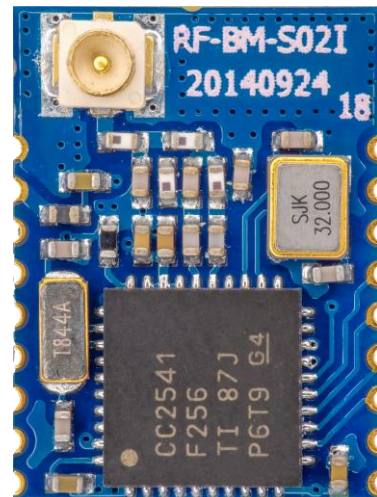

RF-BM-S02AI

Table of Contents

Table of Contents.....	2
Table of Figures.....	4
Table of Tables.....	5
1 Summary.....	6
2 Overview.....	7
3 Features.....	8
4 Schematic Diagram of Working Mode.....	11
5 Package and Pin Assignment.....	12
5.1 RF-CC2541A1 (Double Layer).....	12
5.2 RF-BM-S01A.....	15
5.3 RF-BM-S02A.....	18
5.4 RF-BM-S02AI.....	21
6 UART Transparent Transmission Protocol.....	24
7 AT Command.....	27
- AT Command List.....	27
- Connection Interval Configuration.....	30
- Acquire Module Name.....	30
- Module Rename.....	30
- Acquire Baud Rate.....	31
- Baud Rate Configuration.....	31
- Acquire MAC Address.....	31
- MAC Address Configuration.....	32
- Module Reset.....	32
- Module Reset - Light Recovery.....	32
- Module Reset - Deep Recovery.....	32
- Broadcast Cycle Configuration.....	33
- Add Customized Broadcast Packet.....	33
- Product ID Definition.....	33
- Transmit Power Configuration.....	34
- Internal Enable.....	34

- Output RSSI Signal Strength	34
- RTC Configuration and Acquisition	35
- Data Delay Configuration	35
- Connection Password Acquisition	36
- Connection Password Configuration	36
- Version Number Acquisition	36
8 BLE Protocol (APP Interface)	37
- Bluetooth Data Channel [Service UUID:0xFFE5]	37
- Serial Port Data Channel [Service UUID:0xFFE0]	38
- PWM Output (4 Channels) [Service UUID:0xFFB0]	39
- ADC Input (2 Channels) [Service UUID:0xFFD0]	42
- 8 Programmable I/Os [Service UUID:0xFFFF]	43
- Timed Reversal Output (2 Channels) [Service UUID:0xFFFF]	45
- Level Pulse Width Counter (2 Channels) [Service UUID:0xFFFF]	47
- Anti-Hijacking Password [Service UUID:0xFFC0]	48
- Battery Report [Service UUID:0x180F]	50
- RSSI Report [Service UUID:0xFFA0]	51
- Module Parameter Configuration [Service UUID:0xFF90]	52
- Device Information [Service UUID:0x180A]	58
- Port Timed Events Configuration [Service UUID:0xFE00]	59
9 Broadcast Data Configuration	68
- Default Broadcast Data	68
- Customized Broadcast Data	68
10 System Reset and Recovery	69
11 iOS APP Programming Reference	70
13 Application and Implementation	73
13.1 Basic Operation of Hardware Design	73
13.2 Trouble Shooting	75
13.2.1 Unsatisfactory Transmission Distance	75
13.2.2 Vulnerable Module	75
13.2.3 High Bit Error Rate	76
13.3 Electrostatics Discharge Warnings	76
13.4 Soldering and Reflow Condition	76

14 Revision History.....	77
15 Contact Us.....	80

Table of Figures

Figure 1. Schematic Diagram of Module (v2.31u) in Bridge Mode.....	11
Figure 2. Schematic Diagram of Module (v2.31u) in Direct-Driven Mode.....	11
Figure 3. PCB Footprint of RF-CC2541A1.....	12
Figure 4. Pin Assignments of RF-CC2541A1.....	12
Figure 5. PCB Footprint of RF-BM-S01A.....	15
Figure 6. Pin Assignments of RF-BM-S01A.....	15
Figure 7. PCB Footprint of RF-BM-S02A.....	18
Figure 8. Pin Assignments of RF-BM-S02A.....	18
Figure 9. PCB Footprint of RF-BM-S02AI.....	21
Figure 10. Pin Assignments of RF-BM-S02AI.....	21
Figure 11. Scheme of Data Delay Configuration.....	36
Figure 12. Diagram of Reversal Cycle (2 s).....	46
Figure 13. Diagram of Level Pulse Width Counting (IO4 as an Example, IO5 Being the Same)	47
Figure 14. Level Enabled Model & Pulse Enabled Model.....	56
Figure 15. Diagram of Timed Events, Timed Tasks & Timed Task Enabled Configuration.....	61
Figure 16. Recommendation of Antenna Layout.....	74
Figure 17. Specification of Antenna Seat.....	74
Figure 18. Specification of IPEX Wire.....	75
Figure 19. Recommended Reflow for Lead Free Solder.....	76

Table of Tables

Table 1. Power Consumption of CC2541	9
Table 2. Pin Functions of RF-CC2541A1	13
Table 3. Pin Functions of RF-BM-S01A.....	16
Table 4. Pin Functions of RF-BM-S02A.....	19
Table 5. Pin Functions of RF-BM-S02I.....	22
Table 6. Transmission Rate at Interval of 20 ms	25
Table 7. AT Command List.....	27
Table 8. Time Conversion to Hexadecimal.....	45
Table 9. Broadcast Status & IO6 Prompt Modes	57



1 Summary

RF-star's single-mode Bluetooth Smart® modules are high-performance and low-power Bluetooth 4.2 RF SoC modules that incorporate the Texas Instruments CC2541 transceiver chip among the industry's smallest packages.

These embedded Bluetooth 4.2 modules incorporate an LC balun, two crystals, the required RF matching filter for regulatory compliance, which makes the module filtering on select digital lines for better noise reduction and sensitivity.

RF-star can provide customers with the integration of the entire profiles, applications, radio and BLE protocol stack base on TI. With compliance to Bluetooth Low Energy standard, the RF-star's modules enable the creation of a new market for tiny, cost-effective and power-efficient wireless consumer products such as watches, medical sensors, mice, TV remote controls and fitness trainers.

- Bluetooth 4.2 single mode compliant ISM 2.4 GHz module
- Utilizes the TI CC2541 SoC with 256 KB Flash, 8 KB RAM
- Support slave mode
- Over 70 meter (230 ft) line of site (LOS) distance with integrated antenna
- Can be externally controlled via simple ASCII AT commands over the UART or programmed with custom applications embedded in the module
- RSSI monitoring for proximity applications
- 10-bit ADC
- Serial Interface (UART / SPI)
- Wake-up interrupt, watchdog timer
- AES Security Coprocessor
- CE, FCC, RoHS, and Bluetooth® certified

2 Overview

The Bluetooth LE modules which are mentioned in this document can work in bridge mode (transparent transmission mode) and direct-driven mode.

After powered-on, the module can broadcast automatically. Smart phone with specific APP running will scan and pair with it. When connection is successful, the smart phone can monitor and control the module through Bluetooth protocol.

In bridge mode, user CPU can communicate with the mobile device bi-directionally through the serial ports of modules. Users can also manage and control certain communication parameters through specific AT commands of serial ports. The detailed meaning of the user data is defined by the up-application. Mobile devices can write the module through the APP. And the data written will be sent to the user CPU through serial ports. Then the module will transmit the data packet from user CPU to the mobile devices automatically. Under the development in this mode, the user needs to undertake the code design for master CPU and the APP for mobile devices.

In direct-driven mode, users take simple peripheral expansion to the module. And APP drives the module directly through BLE protocol to implement the monitoring and control of the module by mobile devices. In this mode, users only need to do the code design for mobile devices.

3 Features

1. Easy to use, no need of any application experience of Bluetooth protocol stack.
2. UART design for user interface, full-duplex bi-directional communication, and support the minimum baud rate of 4800 bps.
3. Support bridge mode (serial port transparent transmission), and direct-driven mode (no additional MCU needed);
4. Default connection interval of 30 ms, which makes quick connection and enhance the compatible stability of Android phones.
5. Through AT command, support software reset and MAC address acquisition.
6. Through AT command, support the adjustment of Bluetooth connection interval and the control of different transmit rates (dynamic power consumption adjustment).
7. Through AT command, support the adjustment of the transmit power and broadcast interval, the customization of broadcast data and product ID, the configuration of data delay (receiving preparation time of user CPU serial port), the modification of the serial port baud rate and module names (all configurations can be saved after power-off).
8. The length of the UART data packet can be any value lower than 200-Byte (automatic sub-packet of large ones).
9. High-speed transparent transmission rate is maximum to 4 K/s and the stable rate is 2.5 K/s to 2.8 K/s.
10. Through APP, support the modification of module name, UART baud rate and product ID, support the customization of broadcast packet and cycle (all configurations can be saved after power-off).
11. Through APP, support the remote reset of module and the configuration of transmit power.
12. Through APP, support the adjustment of Bluetooth connection interval, but the configuration cannot be saved after power-off (dynamic power consumption adjustment).
13. All IOs are pulled out, including debug IO.
14. Support the prompt pin / general IO flexible configuration of connection status and broadcast status.
15. 6 bi-directional programmable IOs, input check triggered by external interrupt, and low power operation (applied in alarm triggering, lighting control, remote control toys, and various IO switches applications).
16. 2 programmable output ports of single timed / loop reversal (applied in smart appointment timed).
17. 2 ADC inputs (14 bit), enable / disable, free configuration of sampling cycle (applied in the collect of temperature, humidity, photometry and so on).
18. 4 programmable PWM outputs (120 Hz) (applied in lighting dimming and speed control).
19. Continuous RSSI acquisition of module, APP readable and auto-notifying, enable / disable, customized configuration of acquisition frequency (applied in lost, anti-lost and alarm).
20. Support the reading and prompt of module power, able to auto-report (applied in power notification).
21. Support the configuration, modification and recover of anti-hijacking password, and prevent from the malicious

connection of a third party, which can be ignored. The independent result notification of password operation to simplify the APP programming.

22. Support factory reset by single pin connected to the ground for 5 s long press, and remote factory reset by APP.
23. Support the customization of PWM initialization status (PWM status value before power-off: full-low, full-high).
24. Support the customization of PWM frequency ($61.036 \text{ Hz} < = f < = 8 \text{ kHz}$, 120 Hz by default).
25. Prompt of real-time system status in broadcast packet, including battery power, custom device ID, current value of 4 PWMs or collection value of 2 ADCs, current status of IO and so on (suitable for broadcast applications).
26. Pulse-width counting of 2 levels, $0 \sim 0 \times \text{FFFFFFFF ms}$ (about 49.7 days).
27. Support internal RTC, which can be synchronized check with APP in any time.
28. Support timed control of 6 IO and 4 PWM (OFF by default).
29. Support gradient mode of 4 PWM (applied in dimming up and down control).
30. Support the saving of IO configuration and output status, and the customization of the default initialization status.
31. Support the light recovery and deep recovery modes, which can recover user data flexibly while reserve the essential configurations.
32. Support string prompts of Bluetooth connection status (connection, normal disconnection and timeout disconnection) from TX serial port.
33. Support low-level-enabled mode and pulse-width-enabled mode, and support remote shutdown.
34. Support auto-shutdown after 30 s' non-connection in the pulse-width-enabled mode.
35. Support timeout (or disconnection) prompt by square wave alarm in the pulse-width-enabled mode.
36. Extremely low power in standby mode (current of $0.3 \mu\text{A}$ from TI official data for CC2541 SoC), and the measured power consumption data is as follows:

Table 1. Power Consumption of CC2541

Event	Average Current (Integral Measured ¹)	Average Current (Ammeter Measured ²)	Duration	Testing Conditions / Remark
Sleeping	0.3 μA	0.3 μA	–	EN disconnected
Broadcast	202 μA	0.25 mA	3.85 ms	Broadcast cycle: 250 ms
Connection	235 μA	0.35 mA	2.25 ms	Connection cycle: 100 ms
Single BLE Data Receiving	335 μA	0.61 mA	3.0 ms	20 Bytes, 10 times / second
Single BLE data transmitting	340 μA	0.6 mA	3.2 ms	20 Bytes, 10 times / second

Notes:

1. Official test method: Connect a 10 Ω resistor in series in the power circuit, and get the voltage drop waveform with

oscilloscope and conduct integrated computation.

2. Multi-meter test method: Connect a multi-meter (set at μA or mA level) in series between the battery and the module to check the value shown, with the test voltage of 3.07 V.

Above is the measured sampling data of module **RF-CC2541A1** and for reference only. If the lower power consumption is expected, connection interval or broadcast cycle can be appropriately increased, as shown in the chapters of [module parameter configuration](#) and [AT command](#).



4 Schematic Diagram of Working Mode

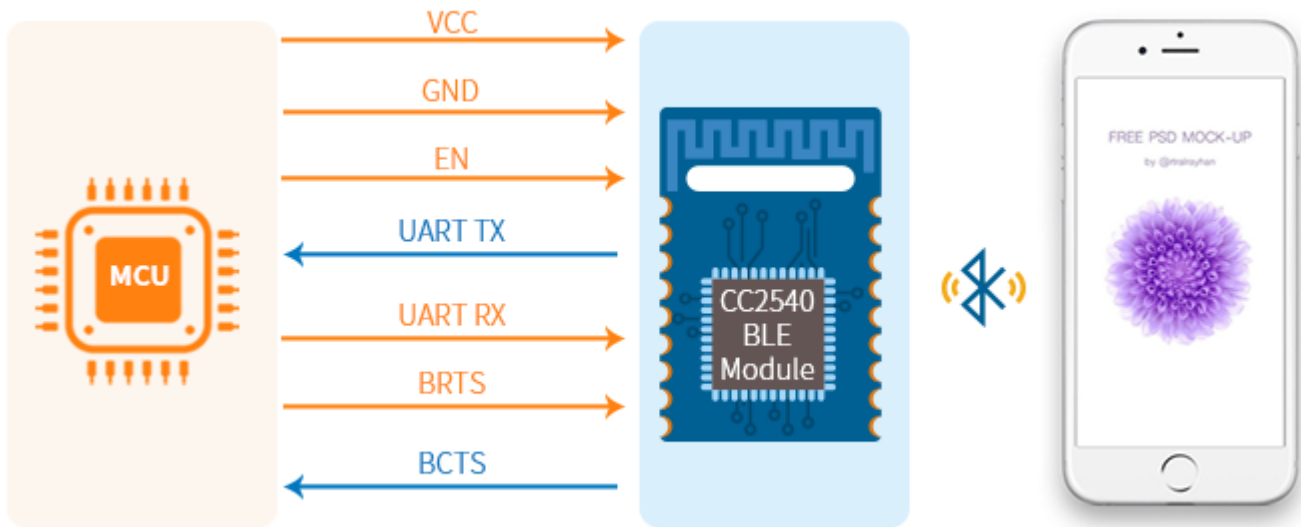

Figure 1. Schematic Diagram of Module (v2.31u) in Bridge Mode

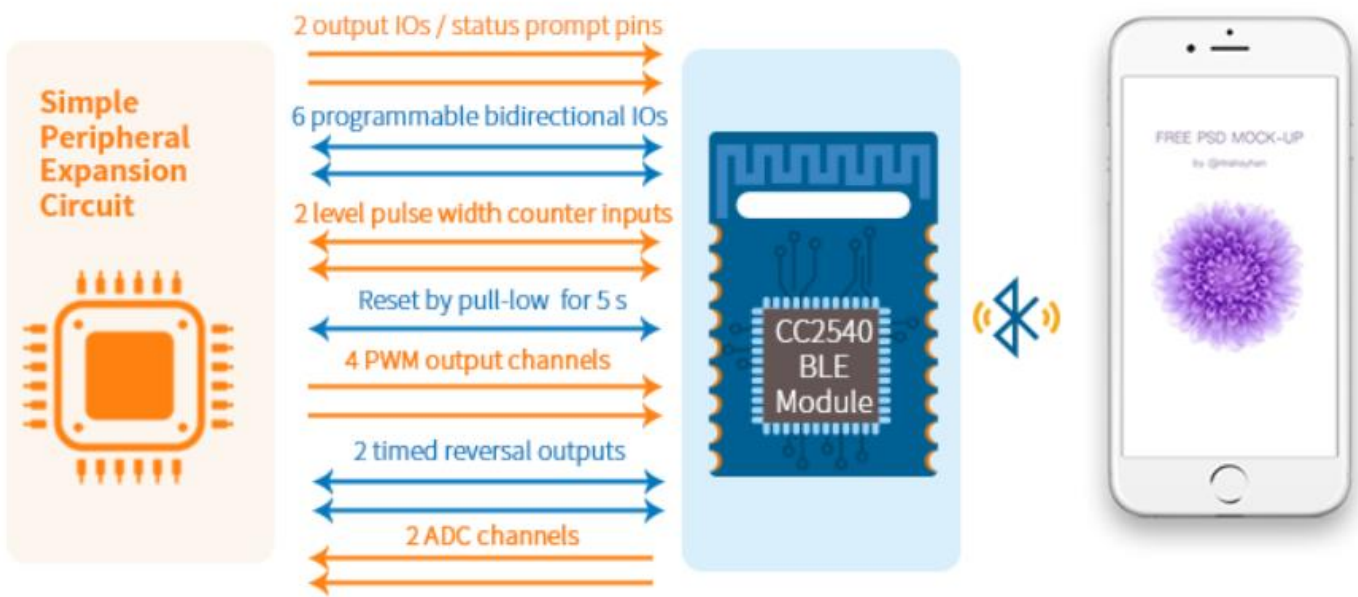

Figure 2. Schematic Diagram of Module (v2.31u) in Direct-Driven Mode

Note:

In order to avoid the high current caused by the output level difference between user CPU IO and module IO, a small isolation resistor is suggested to be connected in series in the output signal line TX, BCTS.

5 Package and Pin Assignment

5.1 RF-CC2541A1 (Double Layer)

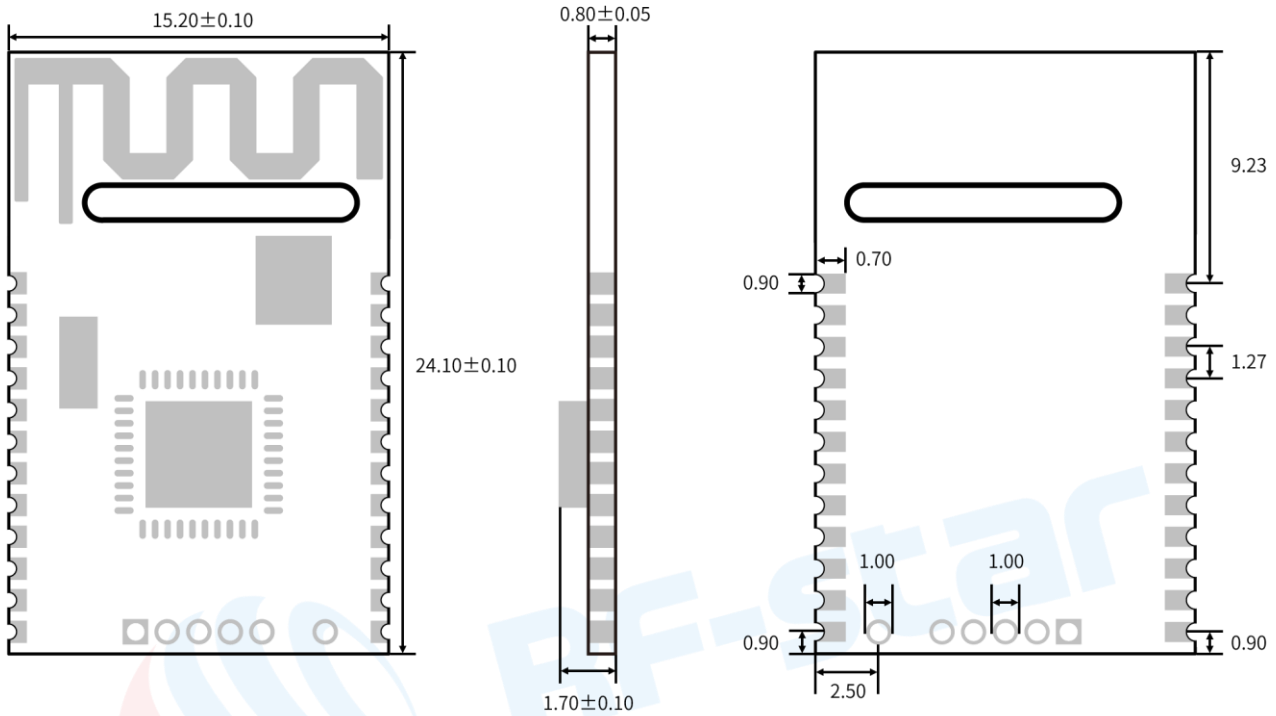

Figure 3. PCB Footprint of RF-CC2541A1

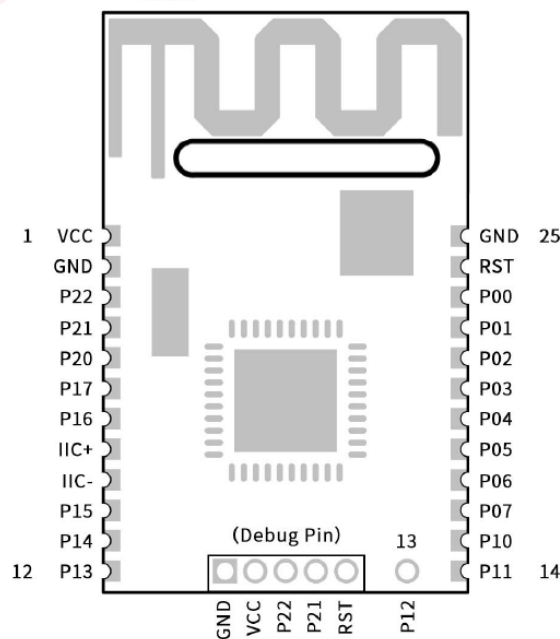

Figure 4. Pin Assignments of RF-CC2541A1

Table 2. Pin Functions of RF-CC2541A1

Pin	Name	Chip Pin	I/O	Description
1	VCC	-	-	Power supply 2.0 V ~ 3.6 V
2	GND	-	-	Ground
3	IO7	P2.2	O	Output port (able to timed reversal) / Sleep mode indicator
4	IO6	P2.1	O	Output port (able to timed reversal) / Connection status indicator (Prompt of low level or square wave, see details in "Module Parameter Configuration")
5	EN	P2.0		Module-enabled control circuit (level-enabled mode by default) <ul style="list-style-type: none"> Level-enabled mode - Active low, with internal pull-up. <p>0: Module starts to broadcast, until it connects to the mobile device.</p> <p>1: Enter sleep mode immediately (0.3 μA), regardless of the current status.</p> Pulse-enabled mode - Every pulse is received ($W > 200$ ms), the module will shift between boot-up (broadcast, allowed to be found and connected) and shutdown (complete sleep mode). (See details in "Module Parameter Configuration")
6	IO5	P1.7	I/O	<ul style="list-style-type: none"> Programmable bi-directional I/O, which can be set as input or output through BLE protocol. Input of level pulse-width counting when set as input.
7	IO4	P1.6	I/O	<ul style="list-style-type: none"> Programmable bi-directional I/O, which can be set as input or output through BLE protocol. Input of level pulse-width counting when set as input.
8	U+	USB+	I/O	I2C+ of CC2541, not used.
9	U-	USB-	I/O	I2C- of CC2541, not used.
10	IO3	P1.5	I/O	Programmable bi-directional I/O, which can be set as input or output through BLE protocol.
11	IO2	P1.4	I/O	Programmable bi-directional I/O, which can be set as input or output through BLE protocol.
12	IO1	P1.3	I/O	Programmable bi-directional I/O, which can be set as input or output through BLE protocol.
13	RESTORE	P1.2	I/O	Factory reset trigger or programmable bi-directional I/O

	/ IO0			<ul style="list-style-type: none"> • Within 30 seconds after power-on, keep this pin at low level for 5 s, the system can be partially reset (light recovery). If keep more than 20 s, the system can be completely reset (deep recovery). (See details in “System reset and recovery”) • 30 seconds after power-on, can be used as a common I/O and be set through BLE protocol (see details in 8 Programmable I/Os [service UUID: 0xFFFD]).
14	PWM1	P1.1	O	PWM output channel 1
15	PWM2	P1.0	O	PWM output channel 2
16	PWM3	P0.7	O	PWM output channel 3
17	PWM4	P0.6	O	PWM output channel 4
18	BRTS	P0.5	I	<p>As the request of data sending (for module wake-up)</p> <p>0: Master has data to send, and module will wait for data transmission from the master, so the module will not sleep.</p> <p>1. Master has no data to send, or data has been sent. So, the value of the signal line should be set at “1”.</p>
19	BCTS	P0.4	O	<p>Data input signal (for master wake-up, optional)</p> <p>0: Module has data to send, and the master will receive the data from the module.</p> <p>1: Module has no data to send, or data has been sent, and the value of the signal line should be set at “1”.</p>
20	TX	P0.3	O	Serial port TX
21	RX	P0.2	I	Serial port RX
22	ADC1	P0.1	I	Analog acquisition, Channel 1
23	ADC0	P0.0	I	Analog acquisition, Channel 0
24	RES	RST	I	Reset, active low
25	GND	-	-	Ground

Notes:

Since the corresponding function of RF-CC2541A1 pin 13 is only for internal test, the pad is designed as the via hole in the middle of PCB. Due to the software upgrade, a new function is given to pin 13 (factory reset). If the function is needed, a jumper can be used to enable it.

5.2 RF-BM-S01A

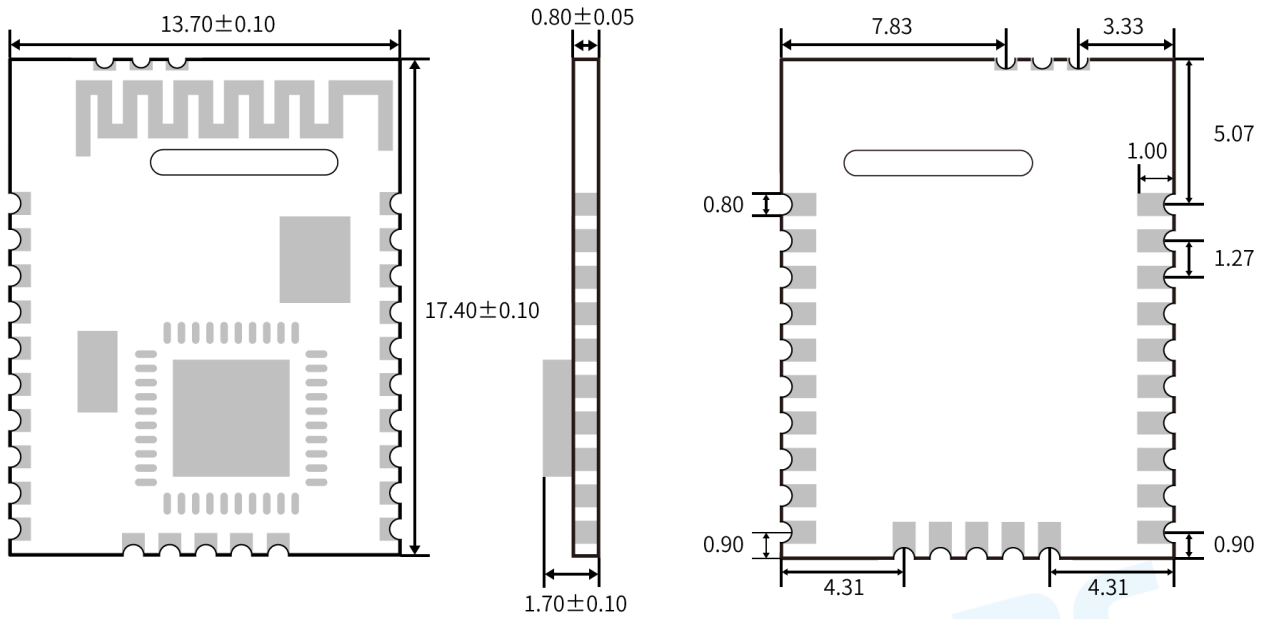

Figure 5. PCB Footprint of RF-BM-S01A

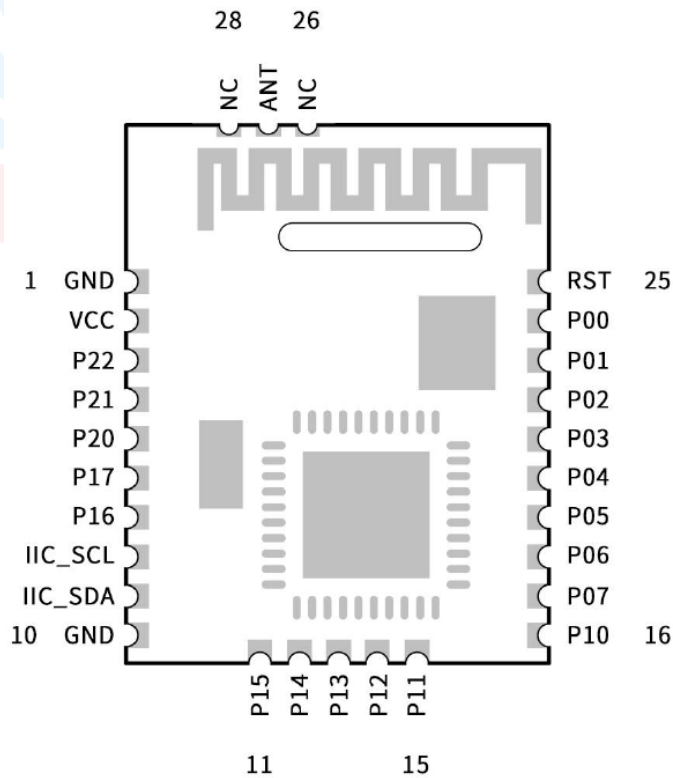

Figure 6. Pin Assignments of RF-BM-S01A

Table 3. Pin Functions of RF-BM-S01A

Pin	Name	Chip Pin	I/O	Description
1	GND	GND	-	Ground
2	VCC	VCC	-	Power supply: 2.0 V ~ 3.6 V
3	IO7	P2.2	O	Output port (able to timed reversal) / Sleep mode indicator
4	IO6	P2.1	O	Output port (able to timed reversal) / Connection status indicator (Prompt of low level or square wave, see details in " Module Parameter Configuration ")
5	EN	P2.0	I	Module-enabled control circuit (level-enabled mode by default) <ul style="list-style-type: none"> Level-enabled mode - Active low, with internal pull-up. <ul style="list-style-type: none"> 0: Module starts to broadcast, until it connects to the mobile device. 1: Enter sleep mode immediately (0.3 μA), regardless of the current status. Pulse-enabled mode - Every pulse is received ($W > 200$ ms), the module will shift between boot-up (broadcast, allowed to be found and connected) and shutdown (complete sleep mode). (See details in " Module Parameter Configuration ")
6	IO5	P1.7	I/O	<ul style="list-style-type: none"> Programmable bi-directional I/O, which can be set as input or output through BLE protocol. Input of level pulse-width counting when set as input.
7	IO4	P1.6	I/O	<ul style="list-style-type: none"> Programmable bi-directional I/O, which can be set as input or output through BLE protocol. Input of level pulse-width counting when set as input.
8	U+	USB+	I/O	I2C+ of CC2541, not used.
9	U-	USB-	I/O	I2C- of CC2541, not used.
10	GND	GND	-	Ground
11	IO3	P1.5	I/O	Programmable bi-directional I/O, which can be set as input or output through BLE protocol.
12	IO2	P1.4	I/O	Programmable bi-directional I/O, which can be set as input or output through BLE protocol.
13	IO1	P1.3	I/O	Programmable bi-directional I/O, which can be set as input or output

				through BLE protocol.
14	RESTORE / IO0	P1.2	I/O	<p>Factory reset trigger or programmable bi-directional I/O</p> <ul style="list-style-type: none"> • Within 30 seconds after power-on, keep this pin at low level for 5 s, the system can be partially reset (light recovery). If keep more than 20 s, the system can be completely reset (deep recovery). (See details in “System reset and recovery”) • 30 seconds after power-on, can be used as a common I/O and be set through BLE protocol (see details in 8 Programmable I/Os [service UUID: 0xFFFD]).
15	PWM1	P1.1	O	PWM output channel 1
16	PWM2	P1.0	O	PWM output channel 2
17	PWM3	P0.7	O	PWM output channel 3
18	PWM4	P0.6	O	PWM output channel 4
19	BRTS	P0.5	I	<p>As the request of data sending (for module wake-up)</p> <p>0: Master has data to send, and module will wait for data transmission from the master, so the module will not sleep.</p> <p>1: Master has no data to send, or data has been sent. So, the value of the signal line should be set at “1”.</p>
20	BCTS	P0.4	O	<p>Data input signal (for master wake-up, optional)</p> <p>0: Module has data to send, and the master will receive the data from the module.</p> <p>1: Module has no data to send, or data has been sent, and the value of the signal line should be set at “1”.</p>
21	TX	P0.3	O	Serial port TX
22	RX	P0.2	I	Serial port RX
23	ADC1	P0.1	I	Analog acquisition, Channel 1
24	ADC0	P0.0	I	Analog acquisition, Channel 0
25	RES	RST	I	Reset, active low

5.3 RF-BM-S02A

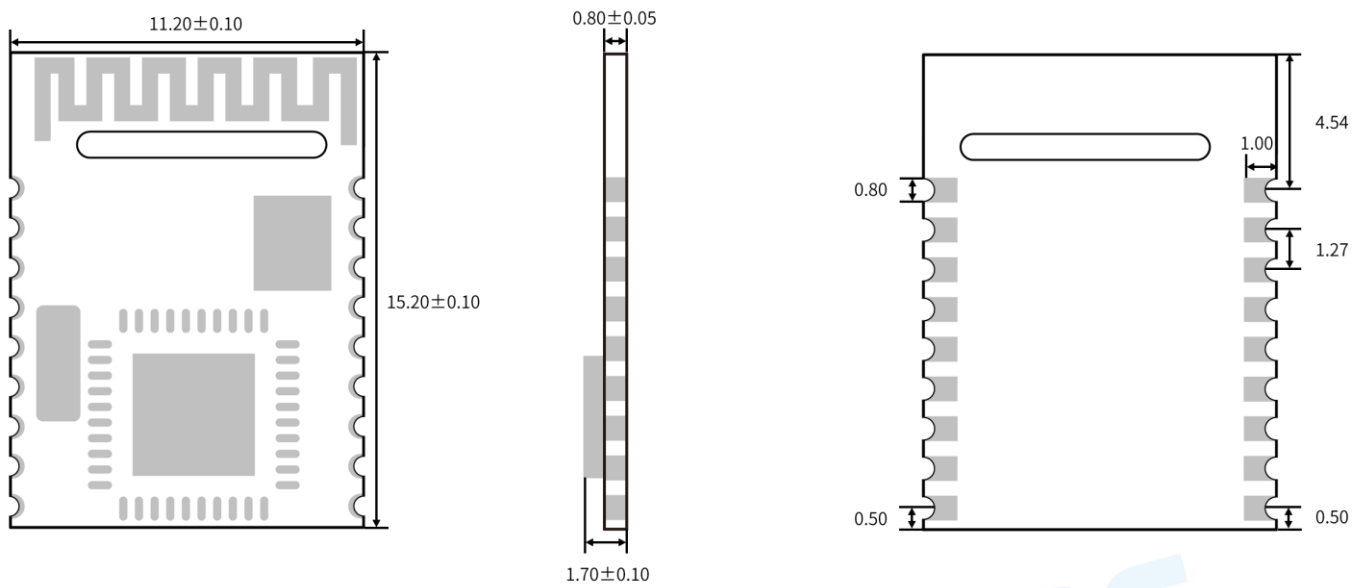

Figure 7. PCB Footprint of RF-BM-S02A

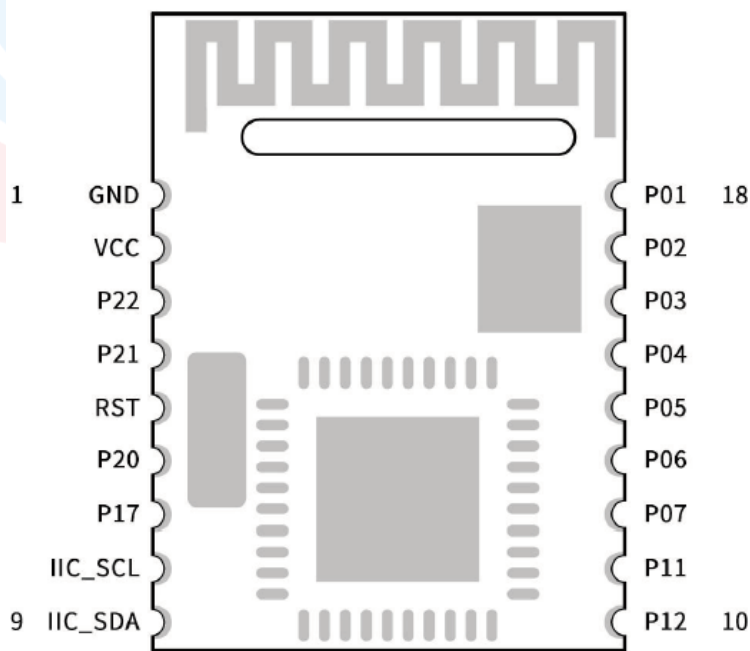

Figure 8. Pin Assignments of RF-BM-S02A

Table 4. Pin Functions of RF-BM-S02A

Pin	Name	Chip Pin	I/O	Description
1	GND	GND	Power	Ground
2	VCC	VCC	Power	Power supply: 2.0 V ~ 3.6 V
3	IO7	P2.2	O	Output port (able to timed reversal) / Sleep mode indicator
4	IO6	P2.1	O	Output port (able to timed reversal) / Connection status indicator (Prompt of low level or square wave, see details in " Module Parameter Configuration ")
5	RES	RST	I	Reset, active low
6	EN	P2.0		Module-enabled control circuit (level-enabled mode by default) <ul style="list-style-type: none"> Level-enabled mode - Active low, with internal pull-up. <ul style="list-style-type: none"> 0: Module starts to broadcast, until it connects to the mobile device. 1: Enter sleep mode immediately (0.3 μA), regardless of the current status. Pulse-enabled mode - Every pulse is received ($W > 200$ ms), the module will shift between boot-up (broadcast, allowed to be found and connected) and shutdown (complete sleep mode). (See details in "Module Parameter Configuration")
7	IO5	P1.7	I/O	<ul style="list-style-type: none"> Programmable bi-directional I/O, which can be set as input or output through BLE protocol. Input of level pulse-width counting when set as input.
8	U+	USB+	I/O	I2C+ of CC2541, not used.
9	U-	USB-	I/O	I2C- of CC2541, not used.
10	RESTORE / IO0	P1.2	I/O	Factory reset trigger or programmable bi-directional I/O <ul style="list-style-type: none"> Within 30 seconds after power-on, keep this pin at low level for 5 s, the system can be partially reset (light recovery). If keep more than 20 s, the system can be completely reset (deep recovery). (See details in "System reset and recovery") 30 seconds after power-on, can be used as a common I/O and be set through BLE protocol (see details in 8 Programmable I/Os [service UUID: 0xFFFD]).

11	PWM1	P1.1	O	PWM output channel 1
12	PWM3	P0.7	O	PWM output channel 3
13	PWM4	P06	O	PWM output channel 4
14	BRTS	P0.5	I	As the request of data sending (for module wake-up) 0: Master has data to send, and module will wait for data transmission from the master, so the module will not sleep. 1. Master has no data to send, or data has been sent. So, the value of the signal line should be set at "1".
15	BCTS	P0.4	O	Data input signal (for master wake-up, optional) 0: Module has data to send, and the master will receive the data from the module. 1: Module has no data to send, or data has been sent, and the value of the signal line should be set at "1".
16	TX	P0.3	O	Serial port TX
17	RX	P0.2	I	Serial port RX
18	ADC1	P0.1	I	Analog acquisition, Channel 1

Note:

RF-BM-S02A is of compact size. Some I/Os are not pulled out and the corresponding functions cannot be used.

5.4 RF-BM-S02AI

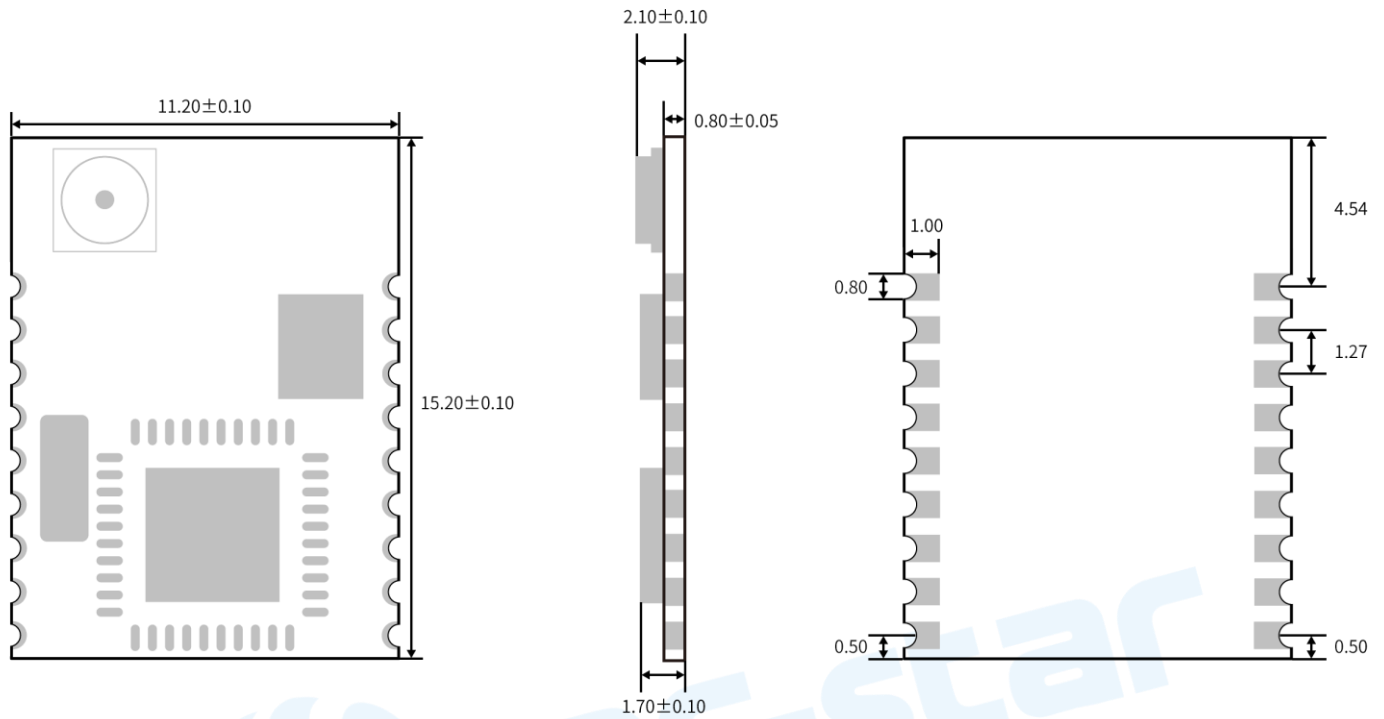

Figure 9. PCB Footprint of RF-BM-S02AI

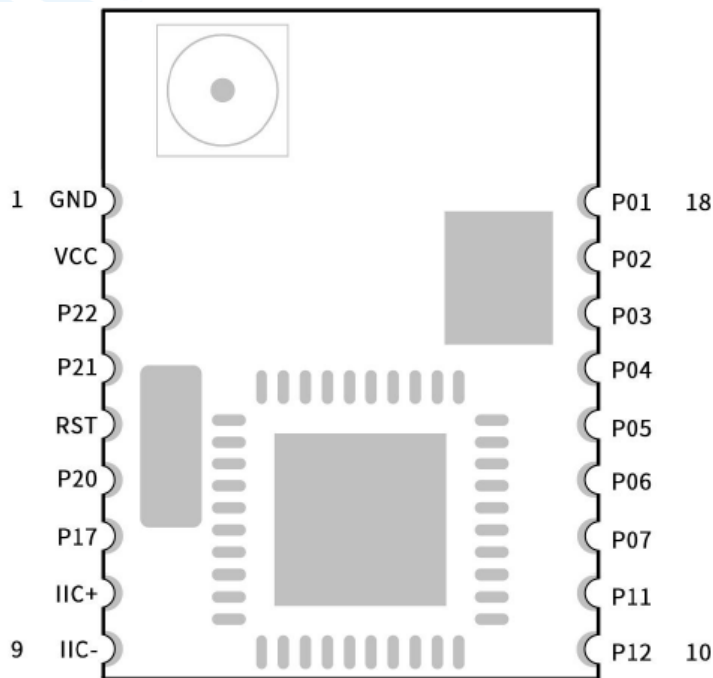

Figure 10. Pin Assignments of RF-BM-S02AI

Table 5. Pin Functions of RF-BM-S02I

Pin	Name	Chip Pin	I/O	Description
1	GND	GND	Power	Ground
2	VCC	VCC	Power	Power supply: 2.0 V ~ 3.6 V
3	IO7	P2.2	O	Output port (able to timed reversal) / Sleep mode indicator
4	IO6	P2.1	O	Output port (able to timed reversal) / Connection status indicator (Prompt of low level or square wave, see details in " Module Parameter Configuration ")
5	RES	RST	I	Reset, active low
6	EN	P2.0		Module-enabled control circuit (level-enabled mode by default) <ul style="list-style-type: none"> Level-enabled mode - Active low, with internal pull-up. <ul style="list-style-type: none"> 0: Module starts to broadcast, until it connects to the mobile device. 1: Enter sleep mode immediately (0.3 μA), regardless of the current status. Pulse-enabled mode - Every pulse is received ($W > 200$ ms), the module will shift between boot-up (broadcast, allowed to be found and connected) and shutdown (complete sleep mode). (See details in "Module Parameter Configuration")
7	IO5	P1.7	I/O	<ul style="list-style-type: none"> Programmable bi-directional I/O, which can be set as input or output through BLE protocol. Input of level pulse-width counting when set as input.
8	U+	USB+	I/O	I2C+ of CC2541, not used.
9	U-	USB-	I/O	I2C- of CC2541, not used.
10	RESTORE / IO0	P1.2	I/O	Factory reset trigger or programmable bi-directional I/O <ul style="list-style-type: none"> Within 30 seconds after power-on, keep this pin at low level for 5 s, the system can be partially reset (light recovery). If keep more than 20 s, the system can be completely reset (deep recovery). (See details in "System reset and recovery") 30 seconds after power-on, can be used as a common I/O and be set through BLE protocol (see details in 8 Programmable I/Os [service UUID: 0xFFFD]).

11	PWM1	P1.1	O	PWM output channel 1
12	PWM3	P0.7	O	PWM output channel 3
13	PWM4	P06	O	PWM output channel 4
14	BRTS	P0.5	I	As the request of data sending (for module wake-up) 0: Master has data to send, and module will wait for data transmission from the master, so the module will not sleep. 1. Master has no data to send, or data has been sent. So, the value of the signal line should be set at "1".
15	BCTS	P0.4	O	Data input signal (for master wake-up, optional) 0: Module has data to send, and the master will receive the data from the module. 1: Module has no data to send, or data has been sent, and the value of the signal line should be set at "1".
16	TX	P0.3	O	Serial port TX
17	RX	P0.2	I	Serial port RX
18	ADC1	P0.1	I	Analog acquisition, Channel 1

Note:

RF-BM-S02AI is of compact size. Some I/Os are not pulled out and the corresponding functions cannot be used.

6 UART Transparent Transmission Protocol

The bridge mode means to set up a bi-directional communication between user CPU and mobile devices by connecting the module with user CPU through serial port. Users can re-set serial port baud rate and BLE connection interval by the specified AT commands (see details in ["AT Command"](#)). The module will have different data TX & RX capability, as per different serial port baud rates and BLE connection intervals. Considering the use of low-speed CPU, the default baud rate is set at 9600 bps. In the application where there is a large amount of data transmission, or there is high real-time demand, it is suggested to set the serial port baud rate at the high speed of 115200 bps. Configuration can be saved after power-off.

When the BLE connection interval is 20 ms and the serial port baud rate is at 115200 bps, the module has the highest transmit ability in theory (4 K/s). Take the configuration in the level-enabled mode as an example, UART transparent transmission protocol will be introduced in detail as below.

The module can transmit a packet of the maximum 200-Byte through serial port at one time. According to the packet size, the packet will be sub-packed automatically and sent, with a maximum load of 20 Bytes for each wireless sub-packet. Data packets from mobile devices to the module must be sub-packed automatically (into 1 ~ 20 Bytes/packet) before sending. The module will transmit them to the master RXD in turn, when received the packets.

1. Hardware protocol of serial port: 9600 bps, 8, no parity, 1 stop bit.
2. When EN is set at high level, the Bluetooth module is in full sleep mode. When EN is set low, the module will start broadcast at the interval of 200 ms, until it pairs with mobile devices. When EN jumps from low to high, the module will enter sleep mode immediately, regardless of the current status.
3. After the module is connected, BRTS needs to be pulled low if the master (MCU) has data to send to the BLE module, and the data transmission can be started around 50 ms afterwards. BRTS should be pulled high by the master after transmission finished and make the module exit the serial RX mode. Pay attention to confirming that the data transmission has been completely finished before BRTS pulled-high. Otherwise there will be data truncation.
4. When there is data upload request, the module will set BCTS low, until data transmission finishes. The transmission can start at least 500 μ s afterwards. And this delay can be configured through the AT command (see details in ["AT command"](#)). BCTS will be set high by the module when data transmission is finished.
5. If the master BRTS is being kept at a low level, the Bluetooth module will always be in RX mode and the power consumption will be high.
6. After the module is connected, a string of `"TTM:CONNECT\r\n0"` will be printed from TX. The string could be used

to confirm whether the normal transmit operation is done. Of course, the connection status prompt pin can be used instead. Also, the connection can be checked by sending a specific confirmation string to the module from mobile devices. When APP automatically disconnects the module, there will be a string "TTM:DISCONNETH\r\n0" from TX. If the disconnection is abnormal, the string will be "TTM:DISCONNETH FOR TIMEOUT\r\n0".

7. **The default Bluetooth connection interval is 30 ms.** If low-speed TX mode is needed for saving power, connection interval must be adjusted by AT command (the maximum connection interval to be 2000 ms). 80-Bytes is maximum transmission length for each interval. Set the connection interval as T (unit: ms), and the highest transmit rate per second V (unit: Byte/s) is as follows:

$$V = 80 * 1000 / T \text{ (V is only relevant with T)}$$

If the Bluetooth connection interval of the module is 20 ms, and 80-Bytes is maximum transmission length for each interval, the theoretical maximum transmission capacity (transmit rate) will be $80 * 50 = 4K$ Byte/s. Tests have shown that the packet loss is very little when transmit rate under 2 K/s. **For safety's sake, it is suggested to do check-sum and re-transmission processing in the upper layer, no matter for high or low speed transmit applications.**

8. Here is an example of the communication with 20 ms connection interval in below. Configuration can be set by yourself. But the lower the transmit rate V_0 , the less packet leakage is.

Table 6. Transmission Rate at Interval of 20 ms

Communication Mode	BLE Connection Interval T (ms)	Highest Theoretical Transmit Rate V (Byte/s) $V = 80 * 1000 / T$	Serial Data Packet Length (Byte)	Serial Port Transmission Interval TS (ms) ¹	Actual Transmit Rate V_0 (Byte/s) $V_0 = L * 1000 / TS$	Remarks
1	20	4 K	80	TS >= T, If TS = 20 ms	$80 * 1000 / 20 = 4$ K	Too low TS, not recommended
2	20	4 K	200	TS >= T*3, If TS = 70 ms	$200 * 1000 / 70 = 2.8$ K	
3	20	4 K	200	TS >= T*3, If TS = 80 ms	$200 * 1000 / 80 = 2.5$ K	
4	20	4 K	80	TS >= T, If TS = 35 ms	$80 * 1000 / 30 = 2.6$ K	
5	20	4 K	70	TS >= T, i If TS = 30 ms	$70 * 1000 / 30 = 2.3$ K	
6	20	4 K	60	TS >= T, If TS = 30 ms	$60 * 1000 / 30 = 2$ K	

7	20	4 K	40	TS \geq T, If TS = 30 ms	$40 \times 1000 / 30 = 1.3 \text{ K}$
8	20	4 K	20	TS \geq T, If TS = 30 ms	$20 \times 1000 / 30 = 666$ Byte

Note:

- When $L < 80$, $TS \geq T$. When $80 < L < 160$, $TS \geq T \times 2$. When $160 < L < 200$, $TS \geq T \times 3$.
- Specific communication mode can be designed according to the practical application. Packet length of serial port can be designed between 80 Bytes and 200 Bytes (large packet transmission). According to BLE protocol, the formulas are as follows:

When $L < 80$, $TS \geq T$,

When $80 < L < 160$, $TS \geq T \times 2$,

When $160 < L < 500$, $TS \geq T \times 3$,

Transmission modes that comply with the above-said conditions are generally safe in operation. However, among them, when $TS = T$, $T \times TS = 2$ or $TS = T \times 3$, it is workable, but high package loss will be caused. It is recommended to add check-sum re-transmission mechanism. In other words, when a serial port data packet is as big as 80 Byte $< L < 200$ Bytes, the data can be sent to the module for one time, but certain time needs to be spared for module data transmission by Bluetooth. Otherwise there will be a rear-end data collision. For example, when the connection interval $T = 20$ ms, if the data packet length $L = 200$, the TS must larger than $T \times 3 = 60$ ms. So, setting $TS = 70$ ms is a logical choice.

- The size of the serial port data packets can be various and the length can be any value less than 200 Bytes, as long as the above conditions are met. But in order to utilize the communication payload in highest efficiency and to avoid communication running in full capacity, it is recommended to use data packets of 20 Bytes, 40 Bytes, or 60 Bytes in length.

Note:

Test shows that in iOS, calling the writing function to Characteristic with the parameter `CBCharacteristicWriteWithResponse` (writing mode with response) will reduce partially the transmit efficiency, but the correctness of a single packet will be ensured. While with the parameter `CBCharacteristicWriteWithoutResponse` (writing mode without response), the transmit efficiency will be increased, but the correctness of data packet needs to be checked by APP in upper layer.

7 AT Command

Strings starting with "TTM" will be regarded as AT commands to be parsed and executed, and will return exactly the same from the serial port. Afterwards the execution result will be output ("TTM:OK\r\n\r\n" or "TTM:ERP\r\n\r\n", etc.). **Data packets which do not start with "TTM" will be regarded as transparent transmission data.**

- AT Command List

Table 7. AT Command List

AT Command	Saved After Power-off	Parameter and Description	Possible Response	Remarks
TTM:CIT-Xms (Effective after successful connection)	No	Set BLE connection interval (in ms). X = "20", " 30 ", "50", "100", "200", "300", "400", "500", "1000", "1500", or "2000".	TTM:TIMEOUT\r\n\r\n TTM:OK\r\n\r\n TTM:ERP\r\n\r\n	Timeout configuration. Successful operation. Incorrect command format.
TTM:NAM-?	Yes	Acquire module name.	TTM:NAM- xxxxxxxxxxxxx, "xxxxxxxxxxxxx" is the module name.	Module name is returned.
TTM:REN-+ Name	Yes	Set module name. "Name" is the new module name with any string of no less than 16-bit length.	TTM:OK\r\n\r\n TTM:ERP\r\n\r\n	Successful operation. Incorrect command format.
TTM:BPS-?	-	Acquire baud rate.	TTM:BPS-X, "X" is the baud rate.	Baud rate is returned.
TTM:BPS-X	Yes	Set baud rate. X = "4800", " 9600 ", "19200", "38400", "57600", "115200".	TTM:BPS SET AFTER 2S ... \r\n\r\n TTM:ERP\r\n\r\n	Successful operation with new baud rate in 2 s. Incorrect command format.
TTM:MAC-?	-	Acquire MAC address.	TTM:MAC- xxxxxxxxxxxxx, "xxxxxxxxxxxxx" is	MAC address is returned.

			module address.	MAC	
TTM:MAC-X	Yes	Set MAC address. X is 1 12-bit MAC string, for example: 123456789ABC	TTM:OK\r\n\r\n0 TTM:ERP\r\n\r\n0		Successful operation. Incorrect command format.
TTM:RST-SYSTEMRESET	-	System reset.	Module is working!		Reset module.
TTM:RST-RSTPWD	-	Light recovery.	Module is working!		Recovery password.
TTM:RST-RESET	-	Deep recovery.	Module is working!		Recovery all parameters.
TTM:ADP-(X)	Yes	Set broadcast cycle. $T = X * 100$ ms. X = "2", "5", "10", "15", "20", "25", "30", "40" or "50". For example: X = 5, it means the cycle is 500 ms.	TTM:OK\r\n\r\n0 TTM:ERP\r\n\r\n0		Successful operation. Incorrect command format.
TTM:ADD-+Data	Yes	Set customized broadcast packet. Data is the customized broadcast packet. Data length ≤ 16 .	TTM:OK\r\n\r\n0 TTM:ERP\r\n\r\n0		Successful operation. Incorrect command format.
TTM:PID-+ Data	Yes	Set customized product ID. Data is the customized product ID. Data length = 2. 00 00 is by default.	TTM:OK\r\n\r\n0 TTM:ERP\r\n\r\n0		Successful operation. Incorrect command format.
TTM:TPL-(X)	Yes	Set transmit power (in dBm). X = "0", "-6", or "-23".	TTM:OK\r\n\r\n0 TTM:ERP\r\n\r\n0		Successful operation. Incorrect command format.
TTM:EUP-ON	-	Enable pull-up of EN pin.	TTM:OK\r\n\r\n0 TTM:ERP\r\n\r\n0		Successful operation. Incorrect command format.
TTM:EUP-OFF	-	Disable pull-up of EN pin.	TTM:OK\r\n\r\n0 TTM:ERP\r\n\r\n0		Successful operation. Incorrect command format.
TTM:RSI-ON	-	Enable timed output of RSSI signal strength every one second.	TTM:OK\r\n\r\n0 TTM:ERP\r\n\r\n0		Successful operation.

				Incorrect command format.
TTM:RSI-OFF	-	Disable timed output of RSSI signal strength.	TTM:OK\r\n\r\n0 TTM:ERP\r\n\r\n0	Successful operation. Incorrect command format.
TTM:RTC-?	-	Acquire RTC time.	TTM:RTC- xxxxxxxxxxxxxx, "xxxxxxxxxxxxxx" is the data.	Successful operation. Incorrect command format.
TTM:RTC-X	-	Set RTC time. X is the data: year, month, date, hour, minute and second.	TTM:OK\r\n\r\n0 TTM:ERP\r\n\r\n0	Successful operation. Incorrect command format.
TTM:CDL-Xms	Yes	Set the delay time between low level output of BCTS and TX data output (in ms). X = "0", "2", "5", "10", "15", "20", or "25". The actual delay (T) will be T = (X + Y) ms, if the minimum delay is no less than X, while 500 μs < Y < 1 ms.	TTM:OK\r\n\r\n0 TTM:ERP\r\n\r\n0	Successful operation. Incorrect command format.
TTM:PWD-?	-	Acquire connection password.	TTM:PWD- XXXXXX.	Connection password is returned.
TTM:PWD-xxxxxxx	Yes	X is 6 digital number. For example: 123456.	TTM:OK\r\n\r\n0 TTM:ERP\r\n\r\n0	Successful operation. Incorrect command format.
TTM:VER-?	-	Acquire version number.	TTM:VER-XXXXXX, "X" means the version number.	Version number is returned.

Note: Word in bold blue is by default. Row in yellow means not saved after power-off.

- Connection Interval Configuration

Input the following string `"TTM:CIT-Xms"` to RX to set the BLE connection interval, wherein X = "20", "30", "50", "100", "200", "300", "400", "500", "1000", "1500", or "2000" (in ms) (all data format is in ASCII code).

For example: `"TTM:CIT-30ms"` means the BLE connection interval is set as 30 ms.

After the command is executed, the following confirmation will be got from TX:

`"TTM:TIMEOUT\r\n\0"`: It means timeout and the failed modification.

`"TTM:OK\r\n\0"`: It means the operation is successful and the new connection interval is applied.

The success of connection interval configuration depends on the limit of connection intervals by mobile devices. The maximum connection intervals are varied in different version of iOS. Tests with iPhone 4s (iOS 5.1.1) show the fastest interval is 20 ms and the slowest is 2 s. On the other hand, due to the internal mechanism of BLE protocol, execution efficiency of this command will be different with different connection intervals. In iOS5.1.1, changing from the current connection interval of 2000 ms (max. 2000 ms) to other connection intervals, it takes around 100 s at least. While the execution will be fast when executing this AT command in other high-frequency connection intervals (for example: 100 ms).

The connection interval configuration cannot be saved after power-off. And the modification of AT command is only effective when the connection is successful.

- Acquire Module Name

Input the following string `"TTM:NAM-?"` to RX to acquire the module name.

After the command is executed, the following confirmation will be got from TX:

`"TTM:NAM-xxxxxxxxxxx\r\n\0"`, and "xxxxxxxxxxx" is the module name.

- Module Rename

Input the following string `"TTM:REN-" + Name` to RX to rename the module (length of name should not exceed 16 Bytes in ASCII code format).

For example: `"TTM:REN-ABC123"` means the module is renamed as "ABC123".

After the command is executed, the following confirmation will be got from TX:

"TTM:OK\r\n\r\n": It means the successful operation.

"TTM:ERP\r\n\r\n": It means the incorrect command format.

Test shows that the device name can be modified immediately in iOS6 and the above versions, but not in iOS5. The name can be saved after power-off.

- Acquire Baud Rate

Input the following string "TTM:BPS-?" to RX to acquire the baud rate.

After the command is executed, the following confirmation will be got from TX:

"TTM:BPS-X", and "X" is the baud rate. Wherein X = "4800", "9600", "19200", "38400", "57600", "115200" (all data format is in ASCII code).

- Baud Rate Configuration

Input the following string "TTM:BPS-X" to RX to set the baud rate. Wherein X = "4800", "9600", "19200", "38400", "57600", "115200" (all data format is in ASCII code).

For example: "TTM:BPS-115200" means the baud rate is 115200 bps.

After the command is executed, the following confirmation will be got from TX:

"TTM:BPS SET AFTER 2S...": It means the modification is successful.

"TTM:ERP\r\n\r\n": It means the incorrect command format.

Test shows that the baud rate can be modified immediately in iOS6 and above versions, but not in iOS5. Users can set through PC, or through the BLE APP interface of mobile devices. (See details in ["module parameter configuration \[service UUID: 0xFF90\]"](#))

- Acquire MAC Address

Input the following string "TTM:MAC-?" to RX.

After the command is executed, the following confirmation will be got from TX:

"TTM:MAC-xxxxxxxxxxx\r\n\r\n", and "xxxxxxxxxxx" is the Bluetooth module address in 6 Bytes.

- MAC Address Configuration

Input the following string "TTM:MAC-xxxxxxxxxx" to RX, wherein "xxxxxxxxxx" is the Bluetooth module address in 6 Bytes.

After the command is executed, the following confirmation will be got from TX:

"TTM:OK\r\n\r\n0": It means the successful operation.

"TTM:ERP\r\n\r\n0": It means the incorrect command format.

This command can be saved after power-off. when reset, the module will operate with the new MAC address.

- Module Reset

Input the following string "TTM:RST-SYSTEMRESET" to RX to force the module system reset once.

After the command is executed, the following confirmation will be got from TX:

"Module is working!": It means the successful operation.

- Module Reset - Light Recovery

Input the following string "TTM:RST-RSTPWD" to RX to force the module light reset once and recovery the password parameters.

After the command is executed, the following confirmation will be got from TX:

"Module is working!": It means the successful operation.

- Module Reset - Deep Recovery

Input the following string "TTM:RST-RESET" to RX to force the module deep reset once and recovery all the modified parameters, which means the module factory reset.

After the command is executed, the following confirmation will be got from TX:

"Module is working!": It means the successful operation.

- Broadcast Cycle Configuration

Input the following string **"TTM:ADP-(X)"** to RX to set the broadcast cycle of the module, $T = X * 100$ ms

Wherein X = **"2"**, "5", "10", "15", "20", "25", "30", "40" or "50" (all data format is in ASCII code).

For example: **"TTM:ADP-(2)"** means the broadcast cycle is 200 ms.

After the command is executed, the following confirmation will be got from TX:

"TTM:OK\r\n0": It means the successful operation.

"TTM:ERP\r\n0": It means the incorrect command format.

This command can be saved after power-off. when reset, the module will operate with new broadcast cycle.

- Add Customized Broadcast Packet

Input the following string **"TTM:ADD-"**+ Data to RX to customize broadcast packet. Wherein "Data" is the additional data ready to be broadcast ($0 < \text{Length} \leq 16$ Bytes) (all data format is in ASCII code).

After the command is executed, the following confirmation will be got from TX:

"TTM:OK\r\n0": It means the successful operation.

"TTM:ERP\r\n0": It means the incorrect command format.

This AT command is effective after configuration, and realize some customized broadcast packets. The data can be saved after power-off. If 16-bit data are set all set as 0, customized broadcast packets will not be used. Instead, the default broadcast packets are applied.

- Product ID Definition

Input the following string **"TTM:PID-"**+ Data to RX to define product ID, wherein "Data" is a 2-Byte product ID with the range from 0x0000 range to 0xFFFF ($L = 2$) (all data format is in ASCII code).

For example: **"TTM:PID-RS"** means the product ID is RS and RS is equal to 0x5253 in hexadecimal.

After the command is executed, the following confirmation will be got from TX:

"TTM:OK\r\n0": It means the successful operation.

"TTM:ERP\r\n0": It means the incorrect command format.

This product ID can be saved after power-off. ID will show in the broadcast packet and can be used to filter devices or to determine if it is a specific product.

- Transmit Power Configuration

Input the following string `"TTM:TPL-(X)"` to RX to set the corresponding transmit power (in dBm). Wherein X = `"0"`, `"-6"`, or `"-23"` (all data format is in ASCII code).

For example: `"TTM:TPL-(0)"` means the transmit power is set as 0 dBm.

After the command is executed, the following confirmation will be got from TX:

`"TTM:OK\r\n\r\n0"`: It means the successful operation.

`"TTM:ERP\r\n\r\n0"`: It means the incorrect command format.

Note: This configuration cannot be saved after power-off.

- Internal Enable

Input the following string `"TTM:EUP-ON\r\n\r\n0"` to RX to enable internal pull-up of EN pin which is the default configuration.

Input the following string `"TTM:EUP-OFF\r\n\r\n0"` to RX to disable internal pull-up of EN pin. When broadcast during disabled internal pull-up, more than 80 μ A current.

After the command is executed, the following confirmation will be got from TX:

`"TTM:OK\r\n\r\n0"`: It means the successful operation.

`"TTM:ERP\r\n\r\n0"`: It means the incorrect command format.

Note: This configuration cannot be saved after power-off. The default configuration is internal pull-up enabled.

- Output RSSI Signal Strength

Input the following string `"TTM:RSI-ON"` to RX to enable timed output of RSSI signal strength and the interval is 1 s.

Input the following string `"TTM:RSI-OFF"` to RX to disable timed output of RSSI signal strength.

After the command is executed, the following confirmation will be got from TX:

"TTM:OK\r\n\r\n": It means the successful operation.

"TTM:ERP\r\n\r\n": It means the incorrect command format.

If timed output RSSI signal strength is enabled, the string of RSSI signal strength will be output "TTM:RSI-xx\r\n\r\n" once every second.

For example: "TTM:RSI-63\r\n\r\n" means the RSSI signal strength is -63 dBm.

Note: This configuration cannot be saved after power-off. RSSI output will be disabled after re-power-on.

- RTC Configuration and Acquisition

Input the following string "TTM:RTC-xxxxxxxxxxxx" to RX to set RTC time. Year is with 4-bit, month, date, hour, minute and second are with 2-bit.

For example: "TTM:RTC-20170102030405" means the RTC time is 3:04:05, January 02, 2017.

After the command is executed, the following confirmation will be got from TX:

"TTM:OK\r\n\r\n": It means the successful operation.

"TTM:ERP\r\n\r\n": It means the incorrect command format.

Input the following string "TTM:RTC-?\r\n\r\n" to RX to acquire RTC time.

"TTM:RTC-xxxxxxxxxxxx\r\n\r\n": It means the successful operation.

"TTM:ERP\r\n\r\n": It means the incorrect command format.

Note: This configuration cannot be saved after power-off. RTC need to be re-configured after re-powered-on.

- Data Delay Configuration

Input the following string "TTM:CDL-Xms" to RX to set the delay time between low level output of BCTS and TX data output (in ms). Wherein X = "0", "2", "5", "10", "15", "20", or "25" (all data format is in ASCII code).

For example: "TTM:CDL-2ms" means the delay time is 2 ms.

After the command is executed, the following confirmation will be got from TX:

"TTM:OK\r\n\r\n": It means the successful operation.

"TTM:ERP\r\n\r\n": It means the incorrect command format.

To make the user CPU have enough time to wake-up from sleep mode and ready to receive data, the module is provided this delay (X) configuration. The BRTS will be set low before there is data to be sent through the serial port, while the delay time between low level output of BCTS and TX data output will be set by this parameter. The actual delay (T) will be $T = (X + Y)$ ms, if the minimum delay is no less than X, while $500 \mu s < Y < 1 \text{ ms}$.

This configuration can be saved after power-off. The scheme of data delay configuration is as follows:

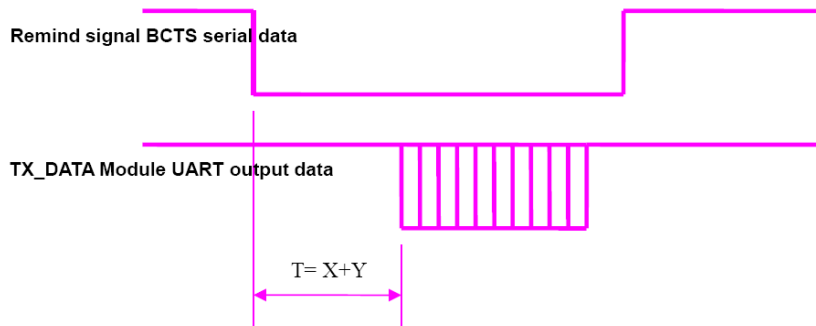

Figure 11. Scheme of Data Delay Configuration

- Connection Password Acquisition

Input the following string "TTM:PWD-?" to RX to acquire connection password.

"TTM:PWD-XXXXXX": It means the successful operation and XXXXXX is the password in 6-bit.

"TTM:ERP\r\n0": It means the incorrect command format.

- Connection Password Configuration

Input the following string "TTM:PWD-?" to RX to acquire connection password.

"TTM:PWD-XXXXXX": It means the successful operation and XXXXXX is the password in 6-bit.

"TTM:ERP\r\n0": It means the incorrect command format.

This configuration can be saved after power-off.

- Version Number Acquisition

Input the following string "TTM:VER-?" to RX to acquire module version number.

"TTM:VER-XXXXXX": It means the successful operation and XXXXXX is the module version number.

8 BLE Protocol (APP Interface)

- Bluetooth Data Channel [Service UUID:0xFFE5]

Characteristic UUID	Operation	Bytes	Default Value	Remarks
FFE9 (handle:0x0013)	Write	20	None	Written data will output from TX.

Remark: Bluetooth input data will be transmitted to serial output. APP operates write in this channel by BLE API, and the data will be output from TX. See details in ["UART Transparent Transmission Protocol"](#).



- Serial Port Data Channel [Service UUID:0xFFE0]

Characteristic UUID	Operation	Bytes	Default Value	Remarks
FFE4 (handle:0x000E)	Notify	20	None	Notification will be generated from the input data of RX in this channel and sent to smart devices.

Remark: Serial input data will be transmitted to BLE output. If notification switch of FFE4 channel is enabled, (01 00 is needed to be written in 0x000E+1 = 0x000F by BTool), a notify event will be generated in this channel when the master CPU transmits legal data to the module RX through serial port, and APP can directly process and use notify information in the callback function. See details in [“UART Transparent Transmission Protocol”](#).



- PWM Output (4 Channels) [Service UUID:0xFFB0]

Characteristic UUID	Operation	Bytes	Default Value	Example	Remarks	Module Pin
FFB1 (handle:0x004D)	Read / Write	1	0x01	0x00	Initialize 4 PWM with all-low pulse width	-
				0x01	Initialize 4 PWM with all-high pulse width	
				0x02	Initialize corresponding PWM with current pulse width	
FFB2 (handle:0x0050)	Read / Write	4	0xFFFFFFFF	0xFF000000	All-high pulse width in PWM1	P11
				0x00FF0000	All-high pulse width in PWM2	P10
				0x0000FF00	All-high pulse width in PWM3	P07
				0x000000FF	All-high pulse width in PWM4	P06
				0x20202020	32/256 Pulse width in PWM1 ~ PWM4	-
FFB3 (handle:0x0053)	Read / Write	2	0x8235	$500 \leq w \leq 65535$	Signal frequency configuration of 4 PWM is the same. 0x8235 (120 Hz) is by default.	-
FFB4 (handle:0x0056)	Read / Write	2	0x0000	$0 \leq t \leq 65535$	Time width of 4 PWM change is with the same range. 0x0000 is by default (sudden change).	-

Remark:

FFB1 is the configuration channel of 4-channel PWM initialization mode. Set 4-channel PWM initialization mode by write to FFB1 (1 Byte). The factory setting is 0x01 by default with all-high pulse width output. The setting can be saved after power-off.

0x00: Output 0% pulse width (all-low pulse width). Sleep mode is allowed in this mode.

0x01: Output 100% pulse width (all-high pulse width). Sleep mode is allowed in this mode.

0x02: Output current PWM. This value will be saved immediately after being configured and used as the initial value of 4-channel PWM in next power-on. Sleep mode is not allowed in this mode.

FFB2 is the configuration channel of 4-channel PWM duty-ratio. Adjust 4-channel PWM duty-ratio by write to FFB2 (4 Bytes). Each Byte is corresponded to one channel.

0xFF: Output 100% pulse width (all-high pulse width).

0x00: Output 0% pulse width (all-low pulse width).

If X is set, the duty ratio will be about $X / 0xFF$. And the latest configuration value can be got by read this channel.

After power on, the default value will be 0xFFFFFFFF (all-high pulse width output).

When this function is enabled, the module will not enter sleep mode, until it is set to 0xFFFFFFFF (all-high). It means PWM is disabled.

This channel is used for setting PWM duty-ratio with the range from 0x00 to 0xFF and the default signal frequency of 120 Hz. (See details in "FFB3 frequency control channel").

For example: 0xFF000000

1. Total of 4 PWM channels.
2. 0xFF000000, 4 Bytes are corresponded to 4 channels.
3. 0xFF means output all-high pulse width (100%), and 0x00 means output all-low pulse width (0%).
4. The pulse width frequency is 120 Hz by default.

FFB3 is the configuration channel of 4-channel PWM frequency control. Adjust 4-channel PWM frequency of square wave by write to FFB3 (2 Bytes). The width of the signal cycle W must meet: the condition $500 \leq w \leq 65535$ (a unit is equivalent to 0.00000025 s), and the corresponding square wave cycle: $0.000125 \text{ s} \leq T \leq 0.01638375 \text{ s}$. Therefore, the adjustable range of signal frequency of square wave is: $61.036 \text{ Hz} \leq f \leq 8 \text{ kHz}$, and 4 PWM frequencies of square wave are the same.

The latest configuration value can be got by read this channel. This configuration can be saved after power-off.

Factory setting of W is 0x8235 and the corresponding pulse-width frequency of is 120 Hz by default.

Example 1:

Output 120 Hz frequency of square wave: write 0x8235 (33333) to FFB3, and the corresponding square wave cycle will be $0x8235 * 0.00000025 \text{ s} = 0.00833325 \text{ s}$, then, get the frequency of 120 Hz.

Example 2:

Output 1 kHz frequency of square wave: write 0x0FA0 (4000) to FFB3 and the corresponding square wave cycle will be $0x0FA0 * 0.00000025 \text{ s} = 0.001 \text{ s}$, then, get the frequency of 1 kHz.

FFB4 is the configuration channel of control of 4-channel PWM time width change. Adjust 4-channel PWM change speed of square wave frequency by write to FFB4 (2 Bytes). This value t must meet: $0 \leq t \leq 65535$, (a unit is equivalent to 100

ms).

The longer t is, the slower the PWM change from the current value to the target is. While the smaller t is, the faster the change is. When t is zero, the target value will be reached immediately. The time width of change of 4-channel PWM shares the same value.

The latest configuration value can be got by read this channel. This configuration can be saved after power-off.

Factory setting of t is 0x0000 and the corresponding change mode is sudden change by default.



- ADC Input (2 Channels) [Service UUID:0xFFD0]

Characteristic UUID	Operation	Bytes	Default Value	Remarks
FFD1 (handle:0x0036)	Read / Write	1	0x00	Enable control 0x00: Close 2 ADC channels 0x01: Open ADC0 channel 0x02: Open the ADC1 channel 0x03: Open two ADC channels.
FFD2 (handle:0x0039)	Read / Write	2	0x01F4	Sampling cycle (ms) For example: 0x01F4 is corresponding to 500 ms.
FFD3 (handle:0x003C)	Read / Notify	2	0x0000	ADC0 sampling result: maximum to be 0x01FFF
FFD4 (handle:0x0040)	Read / Notify	2	0x0000	ADC1 sampling result: maximum to be 0x01FFF

Remark: 2-channel ADC input control. APP operates write in this channel FFD1 by BLE API to open two 13-bit ADC channels. Sampling cycle t (in ms, $t \geq 100$ ms) of two ADC channels is controlled by write in FFD2 channel. If notify of FFD3 and FFD4 is enabled (01 00 is needed to write to 0x003C+1 = 0x003D and 0x0040+1 = 0x0041 by BTool), a notify event with sampling results (0 ~ 0x1FFF, low Byte in front) will come in this channel after the sampling results are generated. Those sampling results can be processed and used by the APP in the callback function of notify. ADC reference power supply is the chip internal reference power supply of 1.25 V. So, the fluctuation of the voltage of power supply will not lead to any new measurement errors, but the sampling voltage measured must be controlled between 0 V ~ +1.25 V.

- 8 Programmable I/Os [Service UUID:0xFFF0]

Characteristic UUID	Operation	Bytes	Default Value	Remarks
FFF1 (handle:0x0017)	Read / Write	1	0b00000000	Configuration bit of IO7 ~ IO0 When the corresponding bit is set to 0: bit7 and bit6 indicate that IO7 and IO6 are signal prompt pin and active low. bit5 ~ bit0 indicate that IO5 ~ IO0 work as input ports. When the corresponding bit is set to 1: bit7 and bit6 indicate that IO7 and IO6 work as general output port. bit5 ~ bit0 indicate that IO5 ~ IO0 work as output ports.
FFF2 (handle:0x001A)	Write	1	--	IO7 ~ IO0 output status. It indicates the output level in IO7 ~ IO0. bit 7 and bit6 are only valid when IO7 and IO6 work as general output ports. When IO7 and IO6 work as signal prompt pin, bit7 and bit6 are invalid.
FFF3 (handle:0x001D)	Read / Notify	1	0x3F	IO5 ~ IO0 input status. Notifications can be read and received. When notify is enabled, the change of certain input level will be notified to APP. IO7 and IO6 can only work as output or signal prompt pin, and the corresponding pins are invalid.

Remark: Channel of I/O configuration and control.

FFF1 is the configuration channel for 8 I/Os. 8-bit control the configuration of IO7 ~ IO0 (8 I/Os) correspondingly. When the two high bits of BIT7 and BIT6 are 0, IO7 and IO6 work as signal prompt pin. IO7 prompts **sleep status**, wherein 0 stands for woken status and 1 for sleep status. IO6 prompts **connection status**, wherein 0 stands for connection status and 1 for disconnection status. When the two high bits of BIT7 and BIT6 are 1, IO7 and IO6 work as general output. The two pins cannot work as input ports.

When the 6 low bits of BIT5 ~ BIT0 are set to 1, IO5 ~ IO0 work as output ports. When those pins are set to 0, IO5 ~ IO0 are used as input ports.

FFF2 is the configuration channel of 8 I/Os output. 8-bit control the configuration of IO7 ~ IO0 (8 I/Os) correspondingly.

Only the corresponding bit is set as output, the pin is effective. When certain I/O is set as output, the corresponding bit in this channel can be written, so that the output control of the I/O is realized. The bit corresponding to the I/O that is set as input will be invalid.

Notes:

Configuration (FFF1) and output status control (FFF2) of IO are not saved after power-off by default.

But the configuration and output status of IO1 ~ IO7 (not including IO0) can be saved by writing **0x01** in the remote control expansion channel **FF99**. The module will use the last-time saved settings to initialize the 7 I/Os. That means the configuration and output status of IO0 cannot be saved after power-off. IO0 is always in input status after power-on by default. This pin is used to detect the function of factory reset (see details "Module Parameter Configuration").

FFF3 is the configuration channel of IO5 ~ IO0 input. The low 6-bit is corresponded to the input status of IO5 ~ IO0. Only the corresponding bit is set as input, the pin is effective. If notification switch of FFE3 channel is enabled, **(01 00 is needed to be written in 0x000F+1 = 0x000E by BTool)**, a notify event with a Byte (status of 6 I/Os) will come in this channel after the level status of the pin is changed, which is only effective to I/Os set as input. This status information can be processed and used by the APP in the callback function of notify. IO7 and IO6 can only work as output or signal prompt pin, so their corresponding bits are invalid.

- Timed Reversal Output (2 Channels) [Service UUID:0xFFF0]

Characteristic UUID	Operation	Bytes	Default Value	Remarks
FFF4 (handle:0x0021)	Read / Write	4	0x00000000	Configuration of the first time reversal delay of IO6 0: Enable the reversal of IO6 Non-0: In ms, delay before reversal
FFF5 (handle:0x0024)	Read / Write	4	0x00000000	Configuration of the second time reversal delay of IO6 0: Disable the second time reversal Non-0: In ms, delay before reversal
FFF6 (handle:0x0027)	Read / Write	4	0x00000000	Configuration of the first time reversal delay of IO7 0: Enable the reversal of IO7 Non-0: In ms, delay before reversal
FFF7 (handle:0x002A)	Read / Write	4	0x00000000	Configuration of the second time reversal delay of IO7 0: Disable the second time reversal Non-0: In ms, delay before reversal

Remark: This configuration channel is for timed reversal.

The module can be configured in timed reversal output mode, when IO6 and IO7 are set as general output. The next reversal time of IO6 and IO7 can be set by write in this channel. By setting the current status of IO output, 1 can jump to 0, or vice versa. Reversal will not be enabled if set to 0.

This function is effective only when the two high bits of BIT7 and BIT6 are set to 1 (as output) in FFF1.

Set the first time delay of reversal of IO6 in FFF4, and set the second time delay of reversal of IO6 in FFF5. If FFF4 is set to 0, reversal of IO6 will not be enabled. If FFF4 is set to a non-zero value, while FFF5 is set to 0, IO6 reversal is only enabled for once. FFF5 must be configured first and reversal is not enabled at this time. Then FFF4 can be set to non-zero values to enable the timed reversal of IO6. Similarly, [the timed reversal of IO6 can be disabled by write 0 to FFF4, and any value written before in FFF5 will be cleared](#). The timed range is from 0 to 0xFFFFFFFF ms (4294967295 ms, or around 1193 hours, or around 49.7 days). Time conversion to hexadecimal is as follows:

Table 8. Time Conversion to Hexadecimal

0.5 s	1 s	1.5 s	2 s	3 s	4 s	5 s
500 ms	1000 ms	1500 ms	2000 ms	3000 ms	4000 ms	5000 ms
0x01F4	0x03E8	0x05DC	0x07D0	0x0BB8	0x0FA0	0x1388

Take IO6 as an example, setting a periodic repeated reversal is as follows:

1. Set IO6 as general output by write 0bx1xxxxxx to FFF1.
2. Set IO6 at high level (1) by write 0bx1xxxxxx to FFF2.
3. Write 0x05DC (1.5 s) in FFF5 to set the second reversal delay, and 0 means reversal for only once.
4. Write 0x01F4 (0.5 s) in FFF4 to set the first reversal delay, and the reversal will be enabled immediately.

The steps of point 3 and 4 cannot be reversed. FFF5 must be configured before write non-zero value in FFF4 to enable reversal. Write 0 to FFF5 means reversal for only once. A square wave with the cycle of $1.5 + 0.5 = 2$ s will be generated after the operations mentioned above. During the period, high level (1) will last for 0.5 s and low level (0) will last for 1.5 s. Reversal can be disabled immediately by write 0 in FFF4 and IO6 will keep the current level.

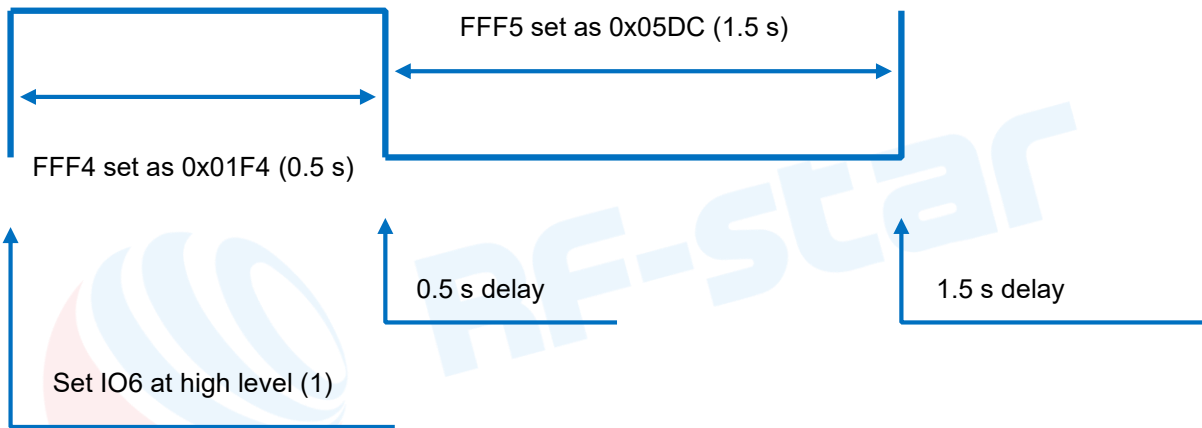

Figure 12. Diagram of Reversal Cycle (2 s)

FFF6 and FFF7 are the channels to configure the timed reversal delay for IO7 in the same way as for IO6.

Notes: If IO6 and IO7 are in the timed reversal cycle, write to the I/O output or re-configuration to signal prompt pin are invalid. Current timed reversal has to be disabled before the above operations are performed.

- Level Pulse Width Counter (2 Channels) [Service UUID:0xFFFF0]

Characteristic UUID	Operation	Bytes	Default Value	Remarks
FFF8 (handle:0x002D)	Read / Notify	4	0x00000000	IO4 level duration at last time (in ms).
FFF9 (handle:0x0031)	Read / Notify	4	0x00000000	IO5 level duration at last time (in ms).

Remark: This channel is for notification of counting I/O level duration.

Level pulse width counting mode can be enabled when IO4 and IO5 are set as general input.

This function is effective only when the two high bits of BIT5 and BIT4 are set to zero (as an input port) in FFF1.

FFF8 is the notification channel for IO4 (P1.6) level pulse width duration. If notification switch of FFE8 channel is enabled by APP through BLE API (01 00 is needed to be written in 0x2D+1 = 0x2E by BTool), a notify event with level duration [maximum value: 0xFFFFFFFF, in ms, range from 0 ~ 0xFFFFFFFF ms (4294967295 ms, or around 1193 hours, or around 49.7 days)] will generated in this channel after every reversal of IO4, which is only effective to I/Os set as input. This information can be processed and used by the APP in the callback function of notify.

FFF9 is the notification channel for IO5 (P1.7) level pulse width duration. If notification switch of FFE8 channel is enabled by APP through BLE API, (01 00 is needed to be written in 0x31+1 = 0x32 by BTool), a notify event with level duration [maximum value: 0xFFFFFFFF, in ms, range from 0 ~ 0xFFFFFFFF ms (4294967295 ms, or around 1193 hours, or around 49.7 days)] will generated in this channel after every reversal of IO5, which is only effective to I/Os set as input. This information can be processed and used by the APP in the callback function of notify.

Notes:

The level counted is not the current level but the last-time one). Current level can be got by read in FFF3. Due to the limitation of BLE protocol, delay of submission of sampling results will not be longer than the connection interval.

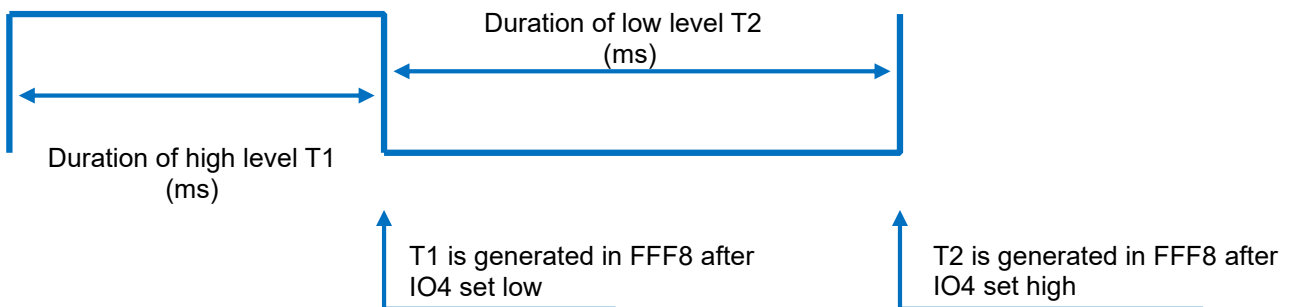

Figure 13. Diagram of Level Pulse Width Counting (IO4 as an Example, IO5 Being the Same)

- Anti-Hijacking Password [Service UUID:0xFFC0]

The module supports anti-hijacking password. Unauthorized mobile devices (or mobile phones) is prevent from being connected to the module effectively by this service. The initial password is 000000 (ASCII). In this case, APP does not need pairing with the module during connecting, so it is regarded as no use of password and any mobile device with specified APP can connect to the module.

The new password (not all zero) is set and saved by APP. If a new password (not all zero) is set, anti-hijacking is enabled. A password once configured requests will be submitted within **20 s** after APP connects to the module. Otherwise the connection is broken up. Any write operation except for password submission cannot be executed before APP submits the correct password.

If the password needs to be recovered, **the module must be reset first by pull-low RESTORE (IO0) pin for 5 s and the operation must be done within 30 s after connection set-up.** For safety, password read is not supported, and all passwords are kept by APP.

A password channel is provided to realize the submission, modification and cancellation of the password by protocol. Meanwhile, event notify service of password is also provided to inform APP of the results of password operations, including 4 events: right password, error password, successful password update and cancel password.

Characteristic UUID	Operation	Bytes	Default Value	Remarks
FFC1 (handle:0x0045)	Write (Saved after power-off)	12	"123456123456"(ASCII)	Submit current password of 123456, and the new password must be same as the previous one.
			"123456888888"(ASCII)	Change the previous password of 123456 into the new one of 888888, and the previous password must be correct.
			"888888000000"(ASCII)	Cancel password (by changing the password into the default value 000000, and the previous password must be correct.
FFC2 (handle:0x0048)	Notify	1	0(PWD_RIGHT_EVENT)	Right password.
			1(PWD_ERROR_EVENT)	Error password
			2(PWD_UPDATED_EVENT)	Successful password update.
			3(PWD_CANCEL_EVENT)	Cancel password.

Remark:

1. Password is all in 12-Byte ASCII, wherein the red part is the current password and the blue part is the new password.

2. Current password is "000000" by default before modified by APP.
3. The execution result of related password operations can be generated in this channel by enabling notification of FFC2(01 00 is needed to be written into 0x0048+1 = 0x0049 by BTool).
4. When APP submits "123456123456", it means the new password is the same with the current one. And APP will be notified in channel FFC2 of "notify:0(PWD_ RIGHT_EVENT)". It shows the password submission is correct.
5. When APP submits the password (red part) is different from the current one, such as: "123455xxxxxx", regardless of the value of "xxxxxx" part, APP will be notified in channel FFC2 of "notify: 1(PWD_ ERROR_EVENT)". It shows the password submission is wrong.
6. When APP submits "123456888888", it means the new password is "888888" and the current password is "123456". APP will be notified in channel FFC2 of "notify: 2(PWD_ UPDATED_EVENT)". It shows the password update is successful.
7. When APP submits "888888000000", it means the new password will be changed to an all-zero value. APP will be notified in channel FFC2 of "notify: 3(PWD_ CANCEL_EVENT)". It shows the password is cancelled.



- Battery Report [Service UUID:0x180F]

Characteristic UUID	Operation	Bytes	Default Value	Remarks
2A19 (handle:0x000A)	Read / Notify	1	Percentage of remaining capacity	Read the current percentage of battery remaining capacity, or create notification automatically.

Remark: The read and notify channel for battery power.

App can acquire the current percentage of battery remaining capacity by read 2A19 through BLE API. If notification switch of this channel is enabled (**01 00 is needed to be written in 0x000A+1 = 0x000B by BTool**), a notify event with percentage ([maximum: 100% (3 V), minimum: 0% (2 V)] will generated in this channel after percentage of battery remaining capacity is read. This information can be processed and used by the APP in the callback function of notify.



- RSSI Report [Service UUID:0xFFA0]

Characteristic UUID	Operation	Bytes	Default Value	Remarks
FFA1 (handle:0x005D)	Read / Notify	1	0x00	RSSI values can be read / notified automatically.
FFA2 (handle:0x005A)	Read / Write	2	0x0000	Configuration of RSSI cycle auto-read. 0x0000 is disabled auto-read.

Remark: The Channel is for RSSI read and return.

APP can acquire RSSI of mobile device by read FFA1 through BLE API. If notification switch of this channel is enabled (01 00 is needed to be written in 0x005D+1 = 0x005E by BTool), a notify event with RSSI will generated in this channel after RSSI is read. This information can be processed and used by the APP in the callback function of notify.

APP can acquire RSSI cycle (in ms) by read FFA2 through BLE API. RSSI cycle auto-read is disabled when cycle is set to 0x0000. But active read is still available at any time. The read RSSI value is of signed char type.

To disable RSSI return, RSSI notify of FFA1 need to be disabled and 0x0000 need to be written in FFA2 to disable RSSI read by module. Otherwise there will be unnecessary power consumption.

- Module Parameter Configuration [Service UUID:0xFF90]

Characteristic UUID	Operation	Saved or Not	Bytes	Default Value	Remarks
FF91 (handle:0x0062)	Read / Write	Yes	16	Tv231u-x xxxxxxx (ASCII string with terminator)	Device name, XXXXXXXXX for the last four Bytes of the MAC address.
FF92 (handle:0x0065)	Read / Write	No	1	1	Set Bluetooth connection interval: 0: 20 ms 1: 30 ms 2: 50 ms 3: 100ms 4: 200 ms 5: 300 ms 6: 400 ms 7: 500 ms 8: 1000 ms 9: 1500 ms 10: 2000 ms
FF93 (handle:0x0068)	Read / Write	Yes	1	1	Set baud rate of serial ports: 0: 4800 bps 1: 9600 bps 2: 19200 bps 3: 38400 bps 4: 57600 bps 5: 115200 bps
FF94 (handle:0x006B)	Write	-	1	None	Channel to control remote reset and recovery: - Remote reset control by writing 0x55 . - Remote light recovery control and reset by writing 0x35 (recover user data only). - Remote deep recovery control by writing 0x36

					(factory reset) and reset
FF95 (handle:0x006E)	Read / Write	Yes	1	0	Set broadcast cycle: 0: 200 ms 1: 500 ms 2: 1000 ms 3: 1500 ms 4: 2000 ms 5: 2500 ms 6: 3000 ms 7: 4000 ms 8: 5000 ms
FF96 (handle:0x0071)	Read / Write	Yes	2	0x0000	Set product ID
FF97 (handle:0x0074)	Read / Write	No	1	1	Set transmit power: 1: 0 dBm 2: -6 dBm 3: -23 dBm
FF98 (handle:0x0077)	Read / Write	Yes	16	Default broadcast packet.	Set customized broadcast data Customizing broadcast data: $0 < n \leq 16$. See details in " Broadcast Data Configuration ".
FF99 (handle:0x007A)	Write	-	1	None	Remote control extension channel: 0x01 : Saving-trigger control of I/O configuration output. Writing 0x01 will trigger the saving of current I/O configuration and output status. IO7 ~ IO1 will be initialized to use the saved configuration and output status when re-power on. But IO0 is always set as input by default when power on, which works as the test port of factory reset. 0x02 : Remote shutdown control. In pulse-enable mode, writing 0x02 to this channel can shut down the module remotely.
FF9A	Read /	Yes	1	0b00000000	System function EN switch:

(handle:0x007D)	Write				<p>BIT0: EN mode configuration.</p> <p>0 is by default and is corresponding to the low-level enabled.</p> <p>1 means pulse-enabled. The module will switch between boot-up (starting broadcast) and shutdown (stopping broadcast) in turn, once EN pin receives a pulse every time. Effective pulse width T must meet: $W > 200$ ms. When the broadcast time exceeds 30 s and the module is still not connected, it will shut down automatically.</p> <p>BIT1 ~ BIT7: Unused by now.</p>
------------------------	-------	--	--	--	--

Note: Command in Row in blue means this function cannot be saved after power-off.

Remark: The channel is for module parameter configuration.

FF91 is the channel for setting device name. Device name can be acquired and set by read and write to this channel accordingly. The length of device name set must meet the condition: $0 < L < 17$. And **the name is suggested to end with the terminator ('\0')**. The default name is "Tv2vvv- XXXXXXX\0" (16 Byte), wherein vvvv is the current firmware version number and XXXXXXX is the last four Bytes of MAC address.

FF92 is the channel to set the connection interval. Connection interval between mobile devices and the module can be set by write to this channel. Thus, the device power consumption and the data throughput can be controlled in a flexible way. In order to raise the connection speed, the setting of connection interval will not be saved. It will always work at the default value (30 ms) after power on. Test shows that it takes around 30 s to wait when the connection interval is changed from 500 ms to another interval by iPhone 4S (iOS 5.1.1). But it will be effectively very quickly if the connection interval is changed from a high frequency one (such as: 100 ms) which is affected by BLE protocols.

FF93 is the channel to set baud rate. Baud rate can be set by read and write to the channel. The new baud rate will be effective in two seconds after set and can be saved after power-off. 1 (9600 bps) is by default.

FF94 is the channel to control remote reset and recovery. Various controlling functions can be realized by writing different values to the channel.

1. Write **0x55** to this channel will **software-reset the module**.
2. Write **0x35** to the channel will **light-recovery the module**. All user settings will be recovered to the factory defaults,

including I/O output status, PWM initialization mode and user password. Afterwards, the module will be reset.

3. Write **0x36** to the channel will **deep-recovery the module**. All system settings will be recovered to the factory defaults and the module will be reset afterwards.

FF95 is the channel to set broadcast cycle. Broadcast cycle can be set by read and write to this channel. The setting can be saved after power-off. 0 (200 ms) is by default.

FF96 is the channel to set product ID by read and write to the channel. APP can filter and connect to the specific product through this code. The setting can be saved after power-off. 0x0000 is by default.

FF97 is the channel to set transmit power by write to this channel. **The setting cannot be saved after power-off. 1 (0 dBm) is by default.**

FF98 is the channel to set broadcast packets. Broadcast data can be customized by write to this channel. The setting can be saved after power-off. When the data is all 0 (16 Byte), it is regarded that default broadcast data is used instead of customized data. (See details in "[Broadcast Data Configuration](#)").

FF99 is the channel for remote control extension. By writing different values, the specific control functions can be realized. Writing **0x01** to this channel will trigger the module to save the current configuration and the output status of all I/Os (except IO0). When re-power on, the module will always initialize IO7 ~ IO1 with the saved settings and output status. While IO0 is always set to default input status to work as the triggering I/O of factory reset. But afterwards, IO0 can also be set as output, just as other I/Os. In the pulse-enabled mode, writing 0x02 to this channel will shut down the module remotely. But the function is invalid in level-enabled mode.

FF9A is the channel of system function enabled switch. Writing through BIT0 ~ BIT7 can be turned on or turn off specific functions of the system. 1 means on and 0 means off. All 0b00000000 is by default. **This setting can be saved after power-off.**

BIT0: 0 is default to level-enabled mode. In this mode, low-level is enabled to start broadcast and high-level is enabled to sleep (0.3 μ A). When the bit is set to 1, the module will be in pulse-enabled mode. The module will be switched between on (starting broadcast) and off (deep sleeping, 0.3 μ A) in turn, after get a legal pulse width ($W > 200$ ms). If the module is in the connection status, "off" takes no effect. While the module is in the broadcast status, "off" takes effect.

BIT1~BIT7: Reserved.

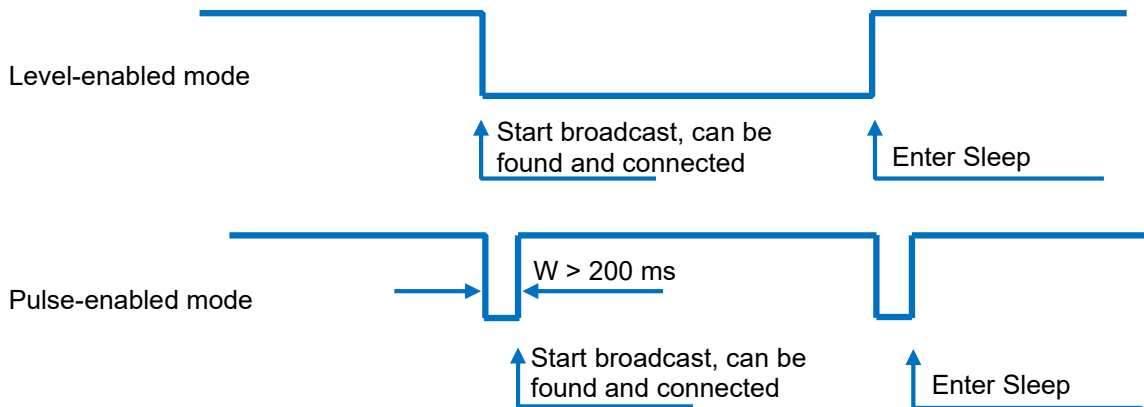

Figure 14. Level Enabled Model & Pulse Enabled Model

In level-enabled mode, broadcast (can be found and connected) has the following features:

1. If EN pin is enabled (set low), the module will keep broadcasting, until it is connected or EN is set high.
2. Regularly disconnected or timeout disconnected, as long as EN is set low, the module will always keep broadcasting, until it is connected again.

In pulse-enabled mode, broadcast (can be found and connected) has the following features:

1. If broadcasting last for 30 s after enabled, but still not connected, the module will stop broadcasting and shut down.
2. If regularly disconnected, the module will continue to broadcast for 30 s. If it is still not connected, the module will stop broadcasting and shut down.
3. If disconnected due to timeout, the module will keep broadcasting until it is connected again. And in this case, EN shutdown takes no effect.

In level-enabled mode, when IO6 works as signal prompt pin (prompt of Bluetooth connection status by default) and is connected at low level, it will output high level, if Bluetooth is disconnected (either timeout or active disconnecting) and not re-connected.

In pulse-enabled mode, when IO6 works as signal prompt pin (prompt of Bluetooth connection status by default), the output signal has the following features:

1. When connected, it will output low level pulse (1 s) for once.
2. When Bluetooth is regularly disconnected (active disconnecting by APP), it will output low level pulse (0.5 s) for once.
3. When Bluetooth is disconnected due to timeout, it will output the square wave of 2 Hz and last for 2 minutes. During this period, it will keep broadcasting and cannot be shut down, until the module re-connects with master device.

Broadcast status & IO6 prompt modes in different EN modes are summarized as follows:

Table 9. Broadcast Status & IO6 Prompt Modes

Module	Enabled but Not Connected		Connected		Actively Disconnected		Timeout Disconnected	
	IO6 Prompt	Broadcast Status	IO6 Prompt	Broadcast Status	IO6 Prompt	Broadcast Status	IO6 Prompt	Broadcast Status
Level Enabled Mode	High Level	Keep Broadcast	Low Level	Stop Broadcast	High Level	Keep Broadcast	High Level	Keep Broadcast
Pulse Enabled Mode	High Level	Broadcast for 30 s	Low Level Pulse W = 1 s	Stop Broadcast	Low Level Pulse W = 1 s	Broadcast for 30 s	2 Hz Square Wave for 2 min.	Keep Broadcast



- Device Information [Service UUID:0x180A]

Characteristic UUID	Operation	Bytes	Default Value	Remarks
2A23 (handle:0x0003)	Read	8	xxxxxx0000xxxxxx (Hex)	System ID, where xxxxxxxxxxxx is the MAC address of module, with low Byte in front.
2A26 (handle:0x0005)	Read	5	V2.31u (ASCII)	Firmware version number of the module.

Remark: This channel is for module information read.

Acquire module information by read this channel 2A23. For example: xxxxxx0000xxxxxx, wherein xx part is the MAC address of the module in six Bytes (low Byte in the front).

Acquire module version number by read this channel 2A26. For example: Vx.xx, wherein xx is firmware version number.



- Port Timed Events Configuration [Service UUID:0xFE00]

Port timed event configuration service is used to set the timed events of I/O or PWM. This service offers the function to set the timed task. That is, a certain master does certain actions at a certain time. The execution master can be any one among the 10 ports, including 6 sudden-change outputs and 4 gradually-changeable PWM. Action types can be sudden change or gradual change.

Timed event setting

This service provides up to 32 configurable timed events. Event refers to the specific action at a specific time.

Timed Event (EVT) = Execution Time + Action Type

Settings can be done through event read and write channel (UUID:0xFE03). Following parameters are included:

- Event index number, 1 Byte, used to indicate the index number of the event modified or set.
- Execution time (timed time), 7 Bytes, used to indicate the time of triggering an event.
- Action type, 1 Byte, used to indicate the action executed when the timed overflow, including high level output, low level output, level reversal, PWM sudden change, and PWM gradual change.
- Operating parameters, 3 Bytes, used to set target duty-ratio and gradual-change overhead time of PWM. The parameter has nothing to do with 6 sudden-change outputs, and is used specifically to define the gradual changes of 4 PWM channels.

Timed task configuration

Timed Task = A Certain Execution Body + A Certain Timed Event

The ports which can be set to execute timed events, or we say the execution bodies, include 6 I/Os and 4 PWM. When the timed events are started, timed tasks are formed. When the timed events are triggered, the body will execute as per the definition of events. Each port can be configured with up to 32 timed events, and has separate responding switches. There is no conflict among the settings of the ports. And the same timed events can be configured in different port at the same time. But if the action type of the event is invalid for certain ports, the action will be ignored. For example, IO0 port (no PWM function) is configured to start certain PWM gradual-change event, so IO0 will ignore it when the timed event is triggered. Settings can be done through the read and write channel (UUID:0xFE05), including the following parameters:

- Port index number, 1 Byte, used to indicate the port that is modified or configured;
- Event start bit, 4 Bytes, total of 32 bits, respectively control the responding switches of the 32 timed events.

Event read / write channel (UUID:0xFE03) and port event read / write channel (UUID:0xFE05) are multiplexing read / write interfaces. When writing each time, "event index number" or "port index number" of the first Byte is directed to the event or port that needs to be set (as an indicator). And other following Bytes are for details of settings.

If it is wanted to get the definition of certain event or the setting information of certain port, it is needed to write the index

number that is wished to be read, through event read indicator channel (UUID:0xFE02) or port event read channel port (UUID:0xFE04), before reading the event read / write channel (UUID:0xFE03) and port event read / write channel (UUID:0xFE05) to get the related information of specified index.

Timed task enabled configuration

Event port configuration channel (UUID:0xFE06) is used to control the enable switch of timed tasks (port timed events), including general enable bit (EA) of all the timed tasks, individual enable bit of timed events of 6 I/Os and 4 PWM, control bit of timed event clearance (CEVT), and control bit of port timed event clearance (CPORT). When control bits of timed event clearance and timed task clearance are set, the configuration information of all the 32 timedevents and 10 port timed events will be cleared.

UUID:0xFE03						
EVT0	EVT1	EVT2	EVT5 ... EVT28	EVT29	EVT30	EVT31
Timed Time	Timed Time	Timed Time	Timed Time	Timed Time	Timed Time
Action Type	Action Type	Action Type	Action Type	Action Type	Action Type
Operation Parameter	Operation Parameter	Operation Parameter	Operation Parameter	Operation Parameter	Operation Parameter

UUID:0xFE05									UUID:0xFE06	
	PORT0	bit0	bit1	bit2	bit29	bit30	bit31	IO0	EA
	PORT1	bit0	bit1	bit2	bit29	bit30	bit31	IO1	
	PORT2	bit0	bit1	bit2	bit29	bit30	bit31	IO2	
	PORT3	bit0	bit1	bit2	bit29	bit30	bit31	IO3	
	PORT4	bit0	bit1	bit2	bit29	bit30	bit31	IO4	
	PORT5	bit0	bit1	bit2	bit29	bit30	bit31	IO5	
	PORT6	bit0	bit1	bit2	bit29	bit30	bit31	PWM0	
	PORT7	bit0	bit1	bit2	bit29	bit30	bit31	PWM1	
	PORT8	bit0	bit1	bit2	bit29	bit30	bit31	PWM2	
	PORT9	bit0	bit1	bit2	bit29	bit30	bit31	PWM3	

CEVT	
CPORT	

Figure 15. Diagram of Timed Events, Timed Tasks & Timed Task Enabled Configuration

Response condition of timed event EVT

1. Timed time overflow triggering of timed event EVT.
2. Response port enables the response switch bit BIT pointed to the timed event EVT.
3. Enable individual enable bit of I/O / PWM pointed to the timed event of response port.
4. Enable general enable EA bit of timed events.

As the figure shown in the above, EVT2 is timed triggered. If PORT2 turns on the corresponding BIT2, while IO2 and EA bit are enabled at the same time, IO2 will trigger EVT2 to execute as per the action type.

About the priority

Low index event or action of port will be executed as priority. If the time of timed event 1 and timed event 2 are the same, and port 0 and port 1 both start these two timed events, and two timed events are triggered simultaneously, the priority of execution ports are like this:

1. Timed event 1 at port 0.
2. Timed event 1 at port 1.
3. Timed event 2 at port 0.
4. Timed event 2 at port 1.

Notes:

- If I/O need to be controlled regularly, the corresponding I/O need to be configured as output first. See details in “9 Programmable I/O”.
- Timed function is effective either when the module is connected or disconnected.
- The timed configuration cannot be saved after power-off. If the information is lost, it can be got back by synchronous refresh through APP.
- In order to avoid the error of RTC clock, it is suggested that RTC clock is synchronously refreshed before APP connected or disconnected.

Characteristic UUID	Operation	Bytes	Byte Number	Default Value	Definition	Remarks
FE01 (handle:0x0086)	Read / Write	7	BYTE7 ~ BYTE0	0x07D001010 00000	Second / minute /	RTC operation channel Current system clock can be

					hour / day / month / year (L) / year (H)	read and modified through this channel Value range: Sec.: 0~59 Min.: 0~59 Hour: 0~23 Day: 1~31 Month: 1~12 Year: More than 2000 1:0:0, January 1 st , 2000 is by default.
FE02 (handle:0x0089)	Read / Write	1	BYTE0	0x00	Event index number	Indicator of event read This indicator must be set before read certain event, which is pointed to the event that needs to be read, and read FE03 afterwards. Value range: 0 ~ 31, respectively for 32 timed events.
FE03 (handle:0x008C)	Read / Write	12	BYTE0	0x00	Event index number	Event read and write channel. Acquire and set the timed event by read and write to this channel.
			BYTE7 ~ BYTE1	0x000000 00000000	Second / minute / hour / day / month / year (L) / year (H)	Value range of event index number: 0 ~ 31, respectively for 32 timed events.
			BYTE8	0x00	Action type	
			BYTE9	0x00	PWM new duty value	
			BYTE10	0x00	Low Byte	Timed time (in second / minute / hour / day / month /

					of PWM gradual change	year) Value range is the same as with RTC clock. If one of the Bytes is invalid (FF), the effective Byte time at low level will be treated as loop timed. For example, the following timed time (Hex): 00 FF 01 01 D0 07 01 means the timed event will be triggered in the second of 0 at any minute.
			BYTE11	0x00	High Byte of PWM gradual change	Value range of action type: 0: No action; 1: I/O at low level 2: I/O at high level. 3: I/O at level reversal. 4: PWM sudden change. 5: PWM gradual change. New duty-radio of PWM: Action types are effective for 4 or 5, after the change of duty-radio. Value range: 0 ~ 255. When the value 0, the duty ratio is 0%, that is the all-low level. When the value is 255, the duty ratio is 100%, that is the all-high level. PWM sudden change time:

						<p>It is valid when the operation value is 5, and it takes from the current duty ratio changing to a new duty ratio. Greater value means slower changes, while smaller value means faster changes.</p> <p>Value range: 0 ~ 65535 (in 100 ms)</p>
FE04 (handle:0x008F)	Read / Write	1	BYTE0	0x00	Port index number	<p>Read indicator of port event</p> <p>Port index: The indicator must be set before read all the applicable events of certain port. Let the indicator is pointed to the port that will be read, followed by reading to FF05.</p> <p>Value range: 0 ~ 9: respectively for IO0 ~ IO5 and PWM0 ~ PWM3 timed ports.</p>
FE05 (handle:0x0092)	Read / Write	5	BYTE0 BYTE4 ~ BYTE1	0x00 0b0000000 000000000 000000000 00000000	Port index number Timed events enabled 0 ~ 31	<p>Port events readi and write channel</p> <p>Value Range: 0 ~ 9: respectively for IO0 ~ IO5 and PWM0 ~ PWM3 timed ports</p> <p>Enable switch of applicable events, with different bit corresponding to the 0 ~ 31 timed events respectively.</p> <p>Value range: 1: on</p>

						0: off.
FE06 (handle:0x0095)	Read / Write	2	BYTE0	0b00000000 0	Bit0: General Timed Enable	Event port configuration. Value range: 1: enabled 0: off BYTE0: BIT0, for general enabled of port events (EA). BYTE0: BIT1 ~ BIT7, BYTE1: BIT0 ~ BIT2, both for separate enabled of timed port events. BYTE1: BIT3 for clearance control of all timed event (CEVT) BYTE1: BIT4, empty for timed task control bit, remove the response configuration of all ports to any timed event (CPORT)
					Bit1: IO0 Enable	
					Bit2: IO1 Enable	
					Bit3: IO2 Enable	
					Bit4: IO3 Enable	
					Bit5: IO4 Enable	
					Bit6: IO5 Enable	
					Bit7: PWM0 Enable	
					Bit0: PWM1 Enable	
					Bit0: PWM1 Enable	
					Bit0: PWM1 Enable	
					Bit0: PWM1 Enable	
					Bit0: PWM1 Enable	
					Bit0: PWM1 Enable	

					PWM1	
					Enable	
					-	
					-	
					-	

Tips: How to fulfill a timed task in 4 steps:

1. Design one or more timed events (specify what to do at what time) (write 0xFE03).
2. Specify the I/O to execute this event (set up the relationship between the timed task and execution master) (write 0xFE05).
3. Turn on the response enabled switch of the I/O of the timed task (response allowed) (write 0xFE06).
4. Turn on the general enables switch of timed task (write 0xFE06).

For Example:

Example 1: See details in the diagram as follows, set IO2 reversal for once at 4:05:05, January 2nd, 2013.

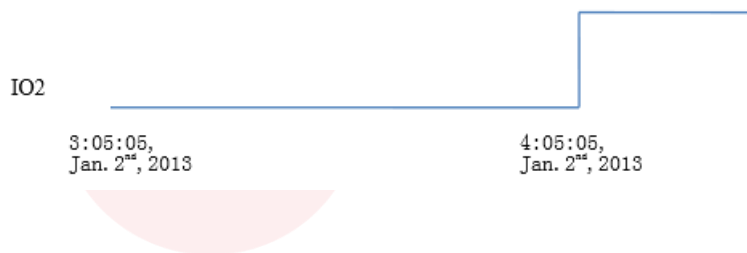

Steps of BLE master device operation to the slave module:

- Write 0x04 to the I/O in this channel (UUID:0xFFFF1) to set IO2 as output.
- Write the following data in the read / write channel (UUID:0x FE03) to set a timed task which will trigger I/O reversal at 4:05:05, January 2nd, 2013:
Hex (low Byte in the front): **00 05 05 04 02 01 DD07 03 00 00 00.**
- Write the following data in the read / write channel (UUID: FE05) to turn on the timed event 0 at the timed port of IO2:
Hex (low Byte in the front): **02 01 00 00 00.**
- Write the following data in this channel (UUID:0xFE06) to enable the general timed bit and enable bit IO2:
HEX (low Byte in the front): **09 00.**
- Write the following data to the RTC clock operation channel (UUID:0xFE01) to update the RTC of the module (such as: 3:05:05, January. 2nd, 2013):
Hex (low Bytes in the front): **05 05 03 02 01 DD 07.**

Till now, the timed configuration is completed. The timed event is waiting to be triggered.

Example 2: See details in the diagram as follows, set the duty ratio of PWM0 to change to 100% in a sudden at minute 30 of every hour, and then the duty ratio gradually changes to 0%. The overhead time is 1 s.

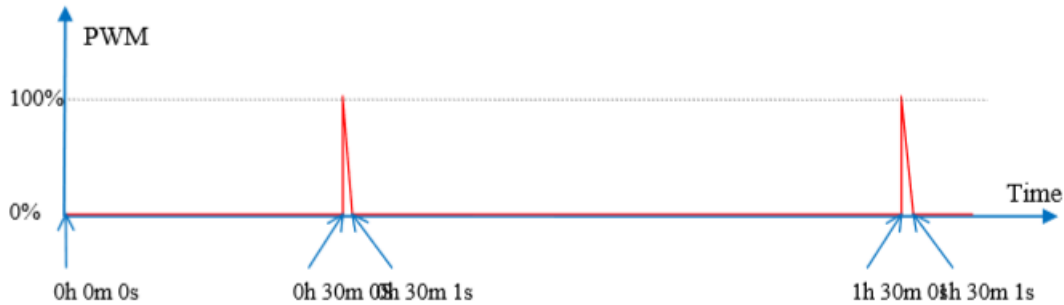

Steps of BLE master device operation to the slave module are as follows:

- Write the following data to the event read / write channel (UUID:0xFE03) to set timed event to trigger PWM sudden change at minute 30 of every hour, with duty ratio of 100%:
Hex (low to high Byte): **01 00 1E FF FF FF FF 04 FF 00 00.**
- Write the following data to the event read / write channel (UUID:0xFE03) to set timed event 2 to trigger PWM gradual change at minute 30 of every hour, with duty ratio of 0%. And the overhead time is 1 s:
Hex (low to high Byte): **02 00 1E FF FF FF FF 05 00 E8 03.**
- Write the following data to port event read / write channel (UUID:0xFE05) to start timed event 1 and timed event 2 at PWM0 timed port:
Hex (low to high Byte): **06 06 00 00 00.**
- Write the following data to this channel (UUID:0xFE06) to enable the general enable bit of timed port events and the PWM0 enabled bit:
Hex (low to high Bytes): **81 00.**
- Write the following data to RTC clock operation channel (UUID:0xFE01) to update the RTC clock of the module (such as: 3:04:05, January, 2nd, 2013):
Hex (low to high Byte): **05 04 03 02 DD 07 01.**

Till now, the timed functional setting has been completed. And the timed event is waiting to be triggered.

9 Broadcast Data Configuration

- Default Broadcast Data

When the module EN pin is set low, the module will broadcast at an interval of 200 ms. In the domain of the broadcast data GAP_ADTYPE_MANUFACTURER_SPECIFIC (iOS officially defined programming macro), the following packets are included (default of 9 Bytes):

```
{  
  0x00,0x00,           Customized device type code, 00 00 is by default, and can be set by AT command.  
  0x00, 0x00, 0x00, 0x00,   Current status of 4 PWM (by default), or 2 ADC acquisition values  
  0x00,                 Percentage of module power supply (2.0 V = 0%).  
  0x00, 0x00,           I/O configuration, I/O output / input status (real-time changing with I/O current status)  
}
```

Broadcast data will load automatically the current PWM status, or broadcast data is defined to be the acquisition value of 2 ADC, and data will be shown in the same position of 4-Byte. The module will always load automatically the data of the last-time operated channel. The current status of 4 PWM will be loaded when any value is written in PWM (FFB1). Or acquisition values of 2 ADC will be loaded when any nonzero value is written in ADC (FFD2).

- Customized Broadcast Data

Customizing the broadcast packet can be realized by AT command, and the maximum length is 16 Bytes (in blue). In the broadcast data GAP_ADTYPE_MANUFACTURER_SPECIFIC domain will contain the following packet, and the length is 2 + n Bytes:

```
{  
  0x00,0x00,           Customized device type code, 00 00 is by default, can be set by AT command;  
  Data [n],           Customized broadcast data, n <= 16;  
}
```

Note:

Customized broadcast data can be modified by AT command and saved after power-off. After re-power on, last-time customized broadcast data will be shown. If customized broadcast data is all 0 (16 Byte), the customized broadcast will not be used but the system default broadcast packets. To avoid the extra power consumption caused by too long broadcast data, customized broadcast data can be set to be any value in 1 Byte.

10 System Reset and Recovery

There are three methods of module reset, among which the third one can recovery system parameters:

1. Reset module by AT command (See details in [“AT Command”](#)).
2. Remote reset module by the service channel interface of APP [See details in [“BLE Protocol \(APP Interface\)”](#)].
3. Reset module by RESET pin of the module (See details in [“Module Parameter Configuration”](#)). **30 seconds after power-on**, set the pin low and hold **for 5 s**, the module will recover the parameters before user modified (light recovery, reset the module immediately after release press). 30 seconds after power-on, set the pin low and hold **for 20 s**, the module will be factory reset (deep recovery) immediately. This pin is with an internal pull-up, and the module will not enter recovery mode by default.

- **System parameters reset in light recovery including:**

- A. Anti-hijack password recovers to "000000". No password will be used by default.
- B. 4 PWM initialization mode recover to 0x01. 4 PWM output 100% high pulse width.
- C. I/O output status is 0. If I/O is set as output, low level output is by default.

- **System parameters reset in deep recovery including:**

- A. Anti-hijack password recovers to "000000". No password will be used by default.
- B. 4 PWM initialization mode recovers to 0x01. 4 PWM output 100% high pulse width.
- C. I/O output status is 0. If I/O is set as output, low level output is by default.
- D. Serial port baud rate recovers to 9600 bps.
- E. Device name recovers to "Tv231u-XXXXXXXX" and X is the last four Bytes of MAC address.
- F. Data delay recovers to 0 (500 μ s < Delay < 1ms).
- G. Output frequency of 4 PWM recovers to 0x8235 (120 Hz).
- H. Broadcast cycle recovers to 2 (200 ms).
- I. Connection interval recovers to 30 ms.
- J. Transmit power recovers to 0 dBm.
- K. Product ID recovers to 0x0000.
- L. I/O configuration Byte is 0x00. IO7 and IO6 are signal prompt pins, and IO5 ~ IO0 are output pins by default.
- M. Customized broadcast length recovers to 0.
- N. All customized broadcast data recovers to 0. Default broadcast data is used but customized broadcast data).
- O. EN mode recovers to 0. Level-enabled mode is by default.

Note: Due to the special use of RESTORE pin (IO0) in circuit design, continuous low level in 30 s before power-on should be avoided, otherwise the module will enter recovery mode.

11 iOS APP Programming Reference

The module is always to broadcast as slave, waiting for mobile phone to scan and connect as master. The scanning and connection are usually completed by APP. Due to the particularity of BLE protocol, there is no need to scan and connect Bluetooth LE devices in the system settings of the Smart phone. Smart devices are responsible for BLE connection, communication, disconnection, etc. And usually it is implemented by the APP.

Regarding BLE programming in iOS, the key point is the **read**, **write** and **enable notify switch** to **Characteristic (or called channel)** to. **To read and write in the channel can realize the direct control on the direct-drive mode functions of the module and no extra MCU is needed.** Typical functions that are involved are as follows:

```

/!*
 * @method writeValue:forCharacteristic:withResponse:
 * @param data The value to write.
 * @param characteristic The characteristic on which to perform the write operation.
 * @param type The type of write to be executed.
 * @discussion Write the value of a characteristic.
 * The passed data is copied and can be disposed of after the call finishes.
 * The relevant delegate callback will then be invoked with the status of the request.
 * @see peripheral:didWriteValueForCharacteristic:error:
 */
- (void)writeValue:(NSData *)data forCharacteristic:(CBCharacteristic *)characteristic
type:(CBCharacteristicWriteType)type;

```

Note: to write to a characteristic.

```
NSData *d = [[NSData alloc] initWithBytes:&data length:mdata.length];
```

```
[p writeValue:d
```

```
forCharacteristic:c
```

```
type:CBCharacteristicWriteWithoutResponse];
```

```

/!*
 * @method readValueForCharacteristic:
 * @param characteristic The characteristic for which the value needs to be read.
 * @discussion Fetch the value of a characteristic.
 * The relevant delegate callback will then be invoked with the status of the request.
 * @see peripheral:didUpdateValueForCharacteristic:error:

```

```

*/
- (void)readValueForCharacteristic:(CBCharacteristic *)characteristic;
Note: to read a characteristic

[p readValueForCharacteristic:c];

/*!
* @method setNotifyValue:forCharacteristic:
* @param notifyValue The value to set the client configuration descriptor to.
* @param characteristic The characteristic containing the client configuration.
* @discussion Ask to start/stop receiving notifications for a characteristic.
* The relevant delegate callback will then be invoked with the status of the request.
* @see peripheral:didUpdateNotificationStateForCharacteristic:error:
*/
- (void)setNotifyValue:(BOOL)notifyValue forCharacteristic:(CBCharacteristic *)characteristic;
Note: to open a characteristic notify enable switch.

[self setNotifyValue:YES forCharacteristic:c];//open notify enable switch.



[self setNotifyValue:NO forCharacteristic:c]; //close notify enable switch.

/*
* @method didUpdateValueForCharacteristic
* @param peripheral Pheripheral that got updated
* @param characteristic Characteristic that got updated
* @error error Error message if something went wrong
* @discussion didUpdateValueForCharacteristic is called when CoreBluetooth has updated a
* characteristic for a peripheral. All reads and notifications come here to be processed.
*
*/
-(void)peripheral:(CBPeripheral*)peripheral didUpdateValueForCharacteristic:(CBCharacteristic *)characteristic
error:(NSError *)error
Note: after each reading operation, this callback function will be performed. The application layer saves the data that is read in this function.

```

About the details of scanning, connecting, and other communication operations, please refer to the test APP source code (BLE Transmit Module v1.29) for transparent transmission in iOS, in which it realizes, for FFE9 and FFE4, the operations of data transmit from BLE to serial port and from serial port to BLE characteristics (notify and write). Other

controls on direct-drive functions are similar, all by reading or writing to certain characteristic. The only difference is the characteristic UUID and the Bytes of reading and writing operations.



13 Application and Implementation

13.1 Basic Operation of Hardware Design

1. It is recommended to offer the module with a DC stabilized power supply, a tiny power supply ripple coefficient and the reliable ground. Please pay attention to the correct connection between the positive and negative poles of the power supply. Otherwise, the reverse connection may cause permanent damage to the module;
2. Please ensure the supply voltage is between the recommended values. The module will be permanently damaged if the voltage exceeds the maximum value. Please ensure the stable power supply and no frequently fluctuated voltage.
3. When designing the power supply circuit for the module, it is recommended to reserve more than 30% of the margin, which is beneficial to the long-term stable operation of the whole machine. The module should be far away from the power electromagnetic, transformer, high-frequency wiring and other parts with large electromagnetic interference.
4. The bottom of module should avoid high-frequency digital routing, high-frequency analog routing and power routing. If it has to route the wire on the bottom of module, for example, it is assumed that the module is soldered to the Top Layer, the copper must be spread on the connection part of the top layer and the module, and be close to the digital part of module and routed in the Bottom Layer (all copper is well grounded).
5. Assuming that the module is soldered or placed in the Top Layer, it is also wrong to randomly route the Bottom Layer or other layers, which will affect the spurs and receiving sensitivity of the module to some degrees;
6. Assuming that there are devices with large electromagnetic interference around the module, which will greatly affect the module performance. It is recommended to stay away from the module according to the strength of the interference. If circumstances permit, appropriate isolation and shielding can be done.
7. Assuming that there are routings of large electromagnetic interference around the module (high-frequency digital, high-frequency analog, power routings), which will also greatly affect the module performance. It is recommended to stay away from the module according to the strength of the interference. If circumstances permit, appropriate isolation and shielding can be done.
8. It is recommended to stay away from the devices whose TTL protocol is the same 2.4 GHz physical layer, for example: USB 3.0.
9. The antenna installation structure has a great influence on the module performance. It is necessary to ensure the antenna is exposed and preferably vertically upward. When the module is installed inside of the case, a high-quality antenna extension wire can be used to extend the antenna to the outside of the case.
10. The antenna must not be installed inside the metal case, which will cause the transmission distance to be greatly weakened.
11. The recommendation of antenna layout.

The inverted-F antenna position on PCB is free space electromagnetic radiation. The location and layout of antenna is a key factor to increase the data rate and transmission range.

Therefore, the layout of the module antenna location and routing is recommended as follows:

 - (1) Place the antenna on the edge (corner) of the PCB.
 - (2) Make sure that there is no signal line or copper foil in each layer below the antenna.

(3) It is the best to hollow out the red part of the antenna position in the following figure ensure that S11 of the module is minimally affected.

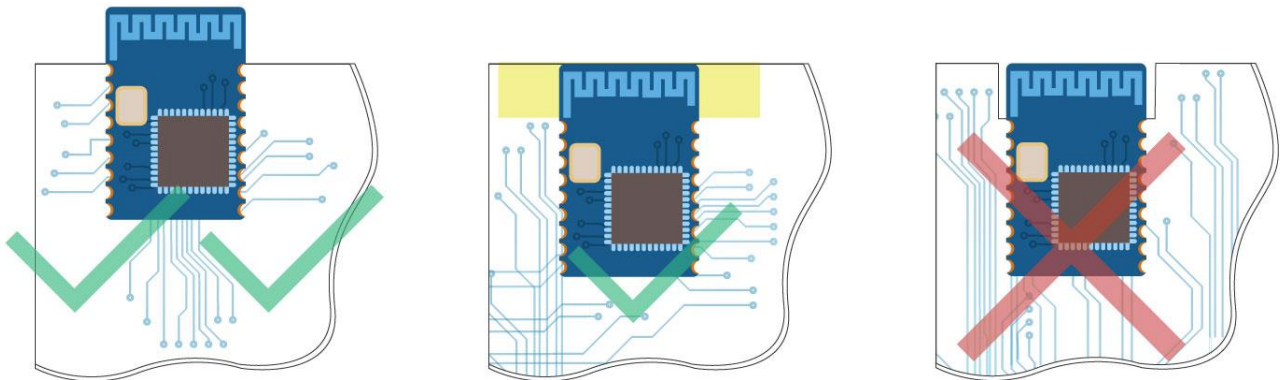

Figure 16. Recommendation of Antenna Layout

12. Antenna

RF-BM-S02A1 module is integrated the IPEX version 1 antenna seat, the specification of antenna seat is as follow:

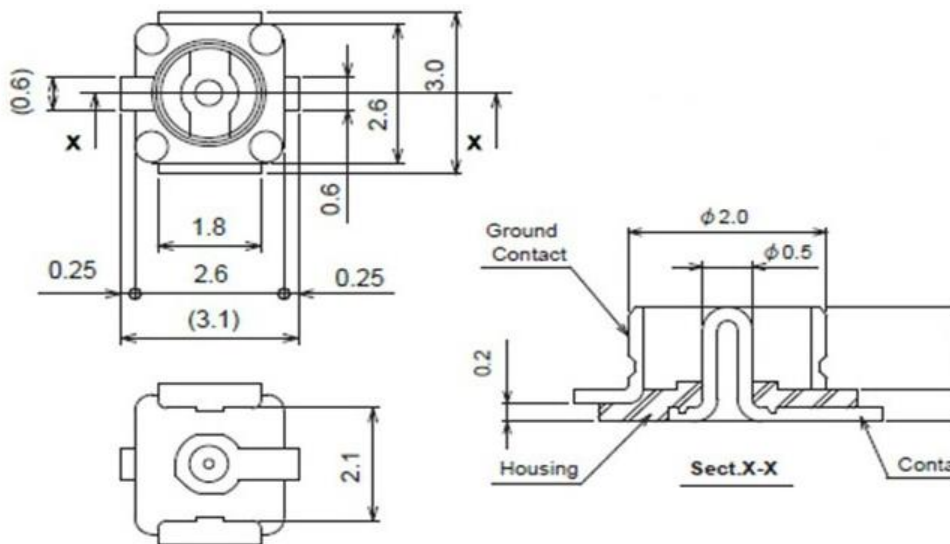

Figure 17. Specification of Antenna Seat

The specification of IPEX wire end is as follow:

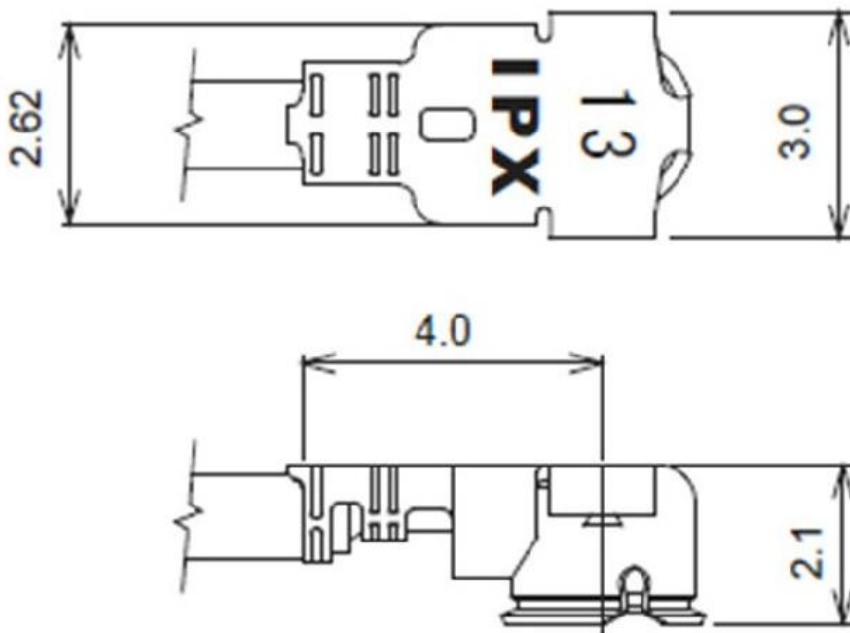

Figure 18. Specification of IPEX Wire

13.2 Trouble Shooting

13.2.1 Unsatisfactory Transmission Distance

1. When there is a linear communication obstacle, the communication distance will be correspondingly weakened. Temperature, humidity, and co-channel interference will lead to an increase in communication packet loss rate. The performances of ground absorption and reflection of radio waves will be poor, when the module is tested close to the ground.
2. Seawater has a strong ability to absorb radio waves, so the test results by seaside are poor.
3. The signal attenuation will be very obvious, if there is a metal near the antenna or the module is placed inside of the metal shell.
4. The incorrect power register set or the high data rate in an open air may shorten the communication distance. The higher the data rate, the closer the distance.
5. The low voltage of the power supply is lower than the recommended value at ambient temperature, and the lower the voltage, the smaller the power is.
6. The unmatchable antennas and module or the poor quality of antenna will affect the communication distance.

13.2.2 Vulnerable Module

1. Please ensure the supply voltage is between the recommended values. The module will be permanently damaged if the voltage exceeds the maximum value. Please ensure the stable power supply and no frequently fluctuated voltage.
2. Please ensure the anti-static installation and the electrostatic sensitivity of high-frequency devices.

- Due to some humidity sensitive components, please ensure the suitable humidity during installation and application. If there is no special demand, it is not recommended to use at too high or too low temperature.

13.2.3 High Bit Error Rate

- There are co-channel signal interferences nearby. It is recommended to be away from the interference sources or modify the frequency and channel to avoid interferences.
- The unsatisfactory power supply may also cause garbled. It is necessary to ensure the power supply reliability.
- If the extension wire or feeder wire is of poor quality or too long, the bit error rate will be high.

13.3 Electrostatics Discharge Warnings

The module will be damaged for the discharge of static. RF-star suggest that all modules should follow the 3 precautions below:

- According to the anti-static measures, bare hands are not allowed to touch modules.
- Modules must be placed in anti- static areas.
- Take the anti-static circuitry (when inputting HV or VHF) into consideration in product design.
Static may result in the degradation in performance of module, even causing the failure.

13.4 Soldering and Reflow Condition

- Heating method: Conventional Convection or IR/convection.
- Temperature measurement: Thermocouple $d = 0.1 \text{ mm}$ to 0.2 mm CA (K) or CC (T) at soldering portion or equivalent methods.
- Solder paste composition: Sn/3.0 Ag/0.5 Cu
- Allowable reflow soldering times: 2 times based on the following reflow soldering profile.
- Temperature profile: Reflow soldering shall be done according to the following temperature profile.
- Peak temperature: $245 \text{ }^{\circ}\text{C}$.

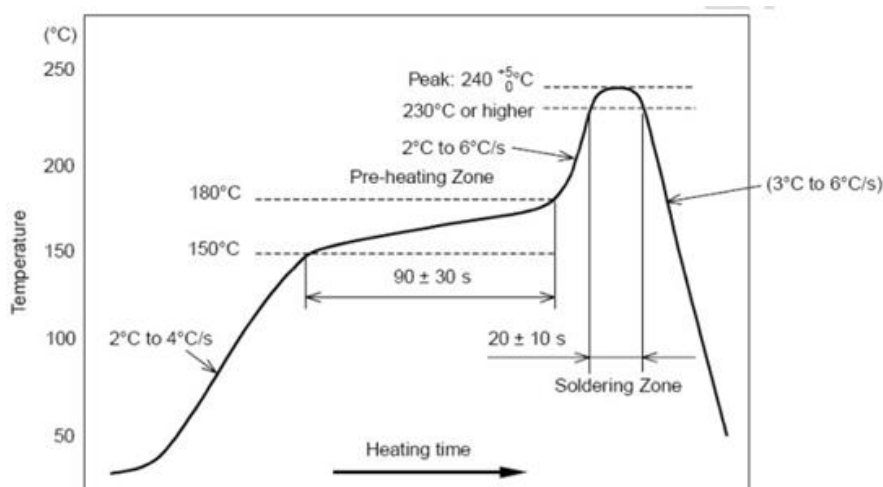

Figure 19. Recommended Reflow for Lead Free Solder

14 Revision History

Version No.	Issue Date	Description
V2.00	2013.04.27	The initial version is released.
V2.00	2013.05.14	Divide the pin attributes table of those modules in case misunderstandings. Modify the parameter errors.
V2.10	2013.07.19	<p>Correct the error of RSSI reading cycle configuration.</p> <p>Modify the bug of no permission fast write. Realize the function of prohibiting any write operation before the password is submitted successfully.</p> <p>Support the factory reset by I/O (P12) pull-low for 3 s, this function is only effective within 10 s after power-on.</p> <p>Test mode and recover mode are triggered respectively. No system parameters can be recovered in test mode.</p> <p>Support AT command to adjust baud rate.</p> <p>Support AT command to modify broadcast interval.</p> <p>Support AT command to add custom broadcast data.</p> <p>Support AT command to set data delay.</p> <p>Support AT command to customize device ID.</p> <p>Support customize PWM initialization rate.</p> <p>Support customize PWM frequency.</p> <p>Support broadcast data of system state, including battery power, custom device ID, 4 PWM values, I/O state and so on.</p> <p>Optimize flash erase and write function to lengthen the service life of flash.</p> <p>Optimize the processing logic of AT commands.</p> <p>Optimize serial port DMA RX and TX mechanism.</p>
V2.20u	2013.12.26	<p>Migrate the bottom layer of the latest TI official BLE protocol stack v1.3.2 to optimize the compatibility of IO7.</p> <p>The broadcast data automatically loads the ADC acquisition results or the PWM output status, which are four Bytes. Automatically load the channel data (ADC / PWM) of the last operation.</p> <p>Add two-way level pulse width counting function. Two IOs (IO4 and IO5) support level</p>

		<p>counting function.</p> <p>Add service channel settings of transmit power, device ID, custom broadcast packet, broadcast cycle which can be configured by APP.</p> <p>Correct the impact on IOs with timed reversal set during IO writing.</p> <p>Add RTC, and timed control for IO and PWM.</p> <p>Add the customization function of gradient change / sudden change of 4 PWM and the change duration.</p> <p>Modify the press duration for factory rest from 3 s to 5 s.</p> <p>Add IO configuration and output status saving function, and IO initialization status customization.</p> <p>Distinguish light recovery mode and deep recovery mode to flexibly recover user data.</p> <p>Add string prompt of Bluetooth normal disconnection and timeout disconnection.</p> <p>Add saving after power-off function of custom broadcast data.</p> <p>Add pulse-enabled mode to realize software boot-up and shut-down.</p> <p>Add remote shut-down function in pulse-enabled mode.</p> <p>Add "u" suffix of revision number to distinguish the UART version with SPI version.</p> <p>Add automatically enter sleep mode after 30 s non-connection in pulse-enabled mode.</p> <p>Optimize the prompt mode of IO6 in pulse-enabled mode.</p>
V2.21u	2014.03.11	<p>Cancel test mode.</p> <p>Optimize the configuration of connection interval.</p> <p>Optimize the matching between timeout disconnection and connection interval to increase the reconnection efficiency.</p> <p>Optimize the response mechanism of serial port event.</p> <p>Correct the error of abnormal IO6 after broadcast cycle modification.</p> <p>Delete the surplus power consumption in EN low period.</p> <p>Modify the revision number to v2.21u.</p>
V2.21u	2015.01.07	Add package information and pin attributes of RF-BM-S02I.
V2.21u	2016.05.16	Add BLE hardware part introduction.

V2.21u	2016.08.31	Modify the document error.
V2.21u	2017.06.17	The timeout time of anti-hijacking changes from 2 s to 20 s.
V2.21u	2017.07.04	Add the examples of AT command.
V2.21u	2017.07.07	Update the module pictures.
V2.21u	2017.09.01	Update the return information after baud rate modification.
V2.31u	2017.12.06	Update the compatibility of Android 8.0. Add connection interval of 30 ms and take 30 ms by default. Add AT command of MAC address configuration. Add AT command of read / write RTC. Add update function of enable and disable RSSI by serial port.
V2.31u	2018.01.25	Update the module pictures.
V2.31u	2018.02.26	Add AT command of module name acquisition. Add AT command of enable / disable EN internal pull-up. Update the feedback after successful connection from "TTM:OK" to "TTM:CONNECT" Modify the AT command of connection interval modification.
V2.31u	2018.03.13	Add AT command of baud rate acquisition.
V2.31u	2018.07.06	Modify the document errors.
V2.31u	2018.08.02	Update company address.
V2.31u	2019.10.18	Add AT command of revision number acquisition. Add AT command of password configuration. Add AT command of password acquisition.

Note: The protocol is updated from time to time. Before using this document, please make sure it is the latest version.

15 Contact Us

SHENZHEN RF-STAR TECHNOLOGY CO., LTD.

Shenzhen HQ:

Add.: Room 601, Block C, Skyworth Building, High-tech Park, Nanshan District, Shenzhen, Guangdong, China

Tel.: 86-755-8632 9687

Chengdu Branch:

Add.: No. B4-12, Building No.1, No. 1480 Tianfu Road North Section (Incubation Park), High-Tech Zone, Chengdu, China (Sichuan) Free Trade Zone, 610000

Tel.: 86-28-6577 5970

Email: sunny@szrfstar.com, sales@szrfstar.com

Web.: www.szrfstar.com

