

ACCESSORIES

CATEGORY

SPINDLE TEST BAR	X-3	ER POWER GOOD NUT	X-54~55
ER COLLET CHUCK TEST BAR	X-4	ER HIGH SPEED PRECISION NUT	X-56
SPINDLE MASTER BAR	X-5~8	HIGH SPEED POWER GOOD NUT	X-56~57
BMT TURRET MASTER BAR	X-9	ER POWER GOOD SEALED NUT	X-57
SOG SPINDLE ORIGIN GAUGE	X-10-11	ER WIND RESISTANCE NUT	X-58
ATC ALIGNMENT TOOL SET	X-12~16	SK3 WIND RESISTANCE NUT	X-58
ER COLLET	X-18~20	SKX SEALED NUT	X-59
ER-E COLLET	X-21	SKX SEALED CAP	X-60
ER-ES STEEL SEALED COLLET	X-22~23	EOC / TG CLAMPING NUT	X-61
ERS METALLIC SEALED COLLET	X-24~25	MLD SEALED CAP	X-62
ERS COOLANT COLLET [FID TYPE]	X-26~27	SR SEALED RING	X-63
ERS COOLANT COLLET [FOD TYPE]	X-28~29	BT PULL STUD	X-64~65
ER-EO SEALED COLLET	X-30	CAT PULL STUD	X-66
ER COOLANT COLLET [FID TYPE]	X-31	DAT PULL STUD	X-67
ER COOLANT COLLET [FOD TYPE]	X-32	ISO PULL STUD	X-68
ER-TC RIGID TAP COLLET	X-33~34	ONE PIECE PULL STUD	X-69
ER-TCO RIGID TAP SEALED COLLET	X-35~36	COOLANT SUPPLY UNIT & Key	X-70
ER-TC RIGID TAP COOLANT COLLET [FOD TYPE]	X-37	SQUARE SHANK ADAPTER	X-71
ER FLOATING TAP COLLET	X-38	PARTS FOR CSR COMBI SHELL	X-72
SKX COLLET	X-39~40	END MILL ARBOR	X-73
SKX - CO METALLIC SEALED COLLET	X-41	SPIGOT INTERCHANGEABLE	X-73
SLC COLLET / SLC SEALED COLLET	X-42~43	DIGITAL TORQUE WRENCH	X-74~76
EBL COLLET / EBL SEALED COLLET	X-44	NUT ADAPTERS FOR	X-74~76
SMG NON-PULLOUT COLLET	X-45	EXCHANGEABLE TORQUE WRENCH	X-74~76
HYC REDUCTION SLEEVE	X-45	TORQUE WRENCH ADAPTOR	X-77
HSC STRAIGHT COLLET	X-46	(FOR PULL STUD)	X-77
STRAIGHT COLLET	X-47	SPANNER FOR PULL STUD	X-78
STRAIGHT SEALED COLLET	X-48	ER SPANNER	X-79
EOC COLLET	X-49	SPANNER	X-80
TG COLLET	X-50~51	FIXED VALUE TORQUE WRENCH	X-81
TG SEALED COLLET	X-52	BEARING SPANNER	X-82
PRO-E POWER GOOD NUT	X-53	HLB / R FACE CONTACT TYPE BALL NOSE	X-83
UT CLAMPING NUT	X-53	FINISH END MILL CUTTER	X-83

HLB / FR FACE CONTACT TYPE BALL NOSE FINISH END MILL CUTTER	X-84	PSC INTERCHANGEABLE TYPE LIVE CENTER	X-107
		PSC TUNGSTEN SOLID CENTER	X-107
HLB / GR FACE CONTACT TYPE BALL NOSE FINISH END MILL CUTTER	X-85	MT INTERCHANGEABLE TYPE LIVE CENTER	X-108
		MT LIVE CENTER	X-108
HLB / IAP FACE CONTACT TYPE 90° END MILL CUTTER	X-86	OPTICAL EDGE FINDER	X-109
		E.S OPTICAL EDGE FINDER	X-109
HLB / CIAP FACE CONTACT TYPE 90° END MILL CUTTER	X-87	MECHANICAL EDGE FINDER	X-110
		SCREW	X-111
HLB / HF POWERLOC SQUARE SHANK HIGH-FEED END MILL	X-88	SHELL MILL SCREW	X-112
		SCREW WITH COOLANT FLUTE	X-113
HLB / SFC COLLET TYPE SHRINK FIT CHUCK	X-89~90	END MILL HOLDER REPLACEMENT LOCK SCREW	X-113
HLB / MAP FACE CONTACT TYPE 90° END MILL CUTTER	X-91	SCREW FOR SBL / SBLC COLLET CHUCK	X-114
		PARTS FOR SMG NON-PULLOUT MILLING CHUCK	X-115
HLB / CMAP FACE CONTACT TYPE 90° END MILL CUTTER	X-92	Z AXIAL PRESET GAUGE	X-116
		ZDI-100 / ZSW-100 Z AXIAL PRESET GAUGE	X-117
HLB / BFC FACE CONTACT TYPE BALL NOSE FINISH END MILL CUTTER	X-93~94	FIXED BLOCK FOR OIL HOLE HOLDER	X-118
		TOOL HOLDER LOCKING DEVICE	X-119
HLB / PMB FACE CONTACT TYPE FINISH BORING HEAD	X-95	ASSEMBLY DEVICE	X-120~122
		SPINDLE TAPER WIPER	X-123
HLB / PCK FACE CONTACT TYPE ROUGH BORING HEAD	X-96	ER COLLET WOODEN TRAY	X-124
		BOX	X-125
HLB / MCK FACE CONTACT TYPE BORING HEAD SHANK	X-97		
FLANGE FOR SAF	X-98~100		
TAP ADAPTER FOR STA	X-101		
DRILL SLEEVE	X-102		
DRILL CHUCK ARBOR	X-103		
TANG	X-104		
STRAIGHT SHANK MORSE TAPER ADAPER	X-105		
STRAIGHT SHANK DRILL SLEEVE	X-105		
STRALGHT SLEEVE FOR SIDE LOCK OIL HOLE HOLDER	X-106		

SPINDLE TEST BAR

主軸檢測棒

TAPER SHANK PRECISION	AT2
ROUNDNESS	1 μ m
SURFACE ROUGHNESS	Ra < 0.4 μ m
RUNOUT ACCURACY	5 μ m

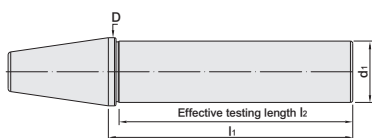
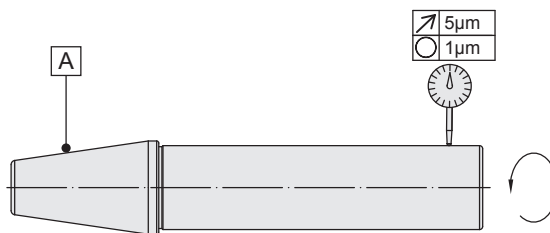

BT SERIES

MODEL NO.	TYPE	l ₁	l ₂	D	d ₁	WEIGHT (KGS)
5002-010-025-250	BT30 x 25 - 250	250	242	31.75	25	0.78
5002-010-032-235	BT30 x 32 - 235	235	200	31.75	32	1.46
5002-010-032-250	BT30 x 32 - 250	250	240	31.75	32	1.55
5002-010-032-300	BT30 x 32 - 300	300	295	31.75	32	1.83
5002-011-040-300	BT40 x 40 - 300	300	293	44.45	40	2.17
5002-011-040-335	BT40 x 40 - 335	335	300	44.45	40	2.38
5002-012-040-300	BT50 x 40 - 300	300	292	69.85	40	3.65
5002-012-063-335	BT50 x 63 - 335	335	300	69.85	63	8.52
5002-012-063-340	BT50 x 63 - 340	340	300	69.85	63	8.55

CAT SERIES

5002-031-040-300	CAT40 x 40 - 300	300	293	44.45	40	2.19
------------------	------------------	-----	-----	-------	----	------

DAT SERIES

5002-051-040-302	DAT40 x 40 - 302	302	293	44.45	40	2.17
------------------	------------------	-----	-----	-------	----	------

ISO SERIES

MODEL NO.	TYPE	l ₁	l ₂	D	d ₁	WEIGHT (KGS)
5002-111-020-100	ISO20 x 20 - 100	100	90	22.225	20	0.30
5002-111-022-152	ISO20 x 22 - 6"	152.4	140	23.911	22	0.52

HSK-A SERIES

MODEL NO.	TYPE	l ₁	l ₂	D	d ₁	WEIGHT (KGS)
5002-071-032-185	HSK40A x 32 - 185	185	150	40	32	1.13
5002-072-040-235	HSK50A x 40 - 235	235	200	50	40	1.85
5002-073-040-335	HSK63A x 40 - 335	335	300	63	40	2.78
5002-075-063-335	HSK100A x 63 - 335	335	300	100	63	8.03

MTB SERIES

MODEL NO.	TYPE	l ₁	l ₂	D	d ₁	T	WEIGHT (KGS)	
5002-179-251/5-307	MTB4 x 25 - 306.5	306.5	300	31.267	25	5/8"-11	M16x2.0P	1.6
5002-180-401/5-307	MTB5 x 40 - 306.5	306.5	300	44.399	40	1"-8	M24x3.0P	4.1

Features:

▶ MTB taper shank precision: AT3.

Benefits of using Spindle Test Bar?

- ▶ Maximizes tool holder performance, prolongs tool life and increases machining productivity.
- ▶ Helps to detect potential problems of spindle and saves downtime and costly repair cost.



Reminder:

- ▶ Spindle Test Bar is supplied with a wooden box for vertical storage.
- ▶ It's recommended to store in stock vertically to prevent deformation.

ER COLLET CHUCK TEST BAR

ER 筒夾式刀桿檢測棒

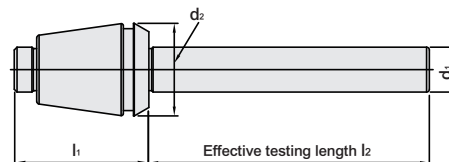

MODEL NO.	TYPE	l_1	l_2	d_1	d_2	WEIGHT (KGS)
5002-259-0805-080	ER8 - \varnothing 5 - 80	19.5	80	5	8.5	0.02
5002-259-1105-100	ER11 - \varnothing 5 - 100	26	100	5	11.5	0.03
5002-259-1607-100	ER16 - \varnothing 7 - 100	35.5	100	7	16.55	0.07
5002-259-2010-100	ER20 - \varnothing 10 - 100	39.5	100	10	20.55	0.14
5002-259-2513-100	ER25 - \varnothing 13 - 100	42	100	13	25.55	0.23
5002-259-3216-100	ER32 - \varnothing 16 - 100	48	100	16	32.55	0.38
5002-259-4020-100	ER40 - \varnothing 20 - 100	54	100	20	40.55	0.66
5002-259-5025-100	ER50 - \varnothing 25 - 100	68	100	25	51.85	1.22

Features:

- ▶ For the use to measure the runout accuracy of ER collet chuck and nut.

Benefits of using Spindle Test Bar?

- ▶ Maximizes tool holder performance, prolongs tool life and increases machining productivity.
- ▶ Helps to detect potential problems of spindle and saves downtime and costly repair cost.



Reminder:

- ▶ Spindle Test Bar is supplied with a wooden box for vertical storage.
- ▶ It's recommended to store in stock vertically to prevent deformation.



SPINDLE MASTER BAR

主軸精密標準棒

TAPER SHANK PRECISION	AT2
ROUNDNESS	1 μ m
SURFACE ROUGHNESS	Ra < 0.15 μ m
RUNOUT ACCURACY	3 μ m
CYLINDRICITY	5 μ m

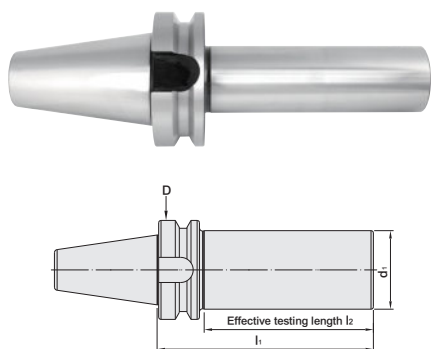
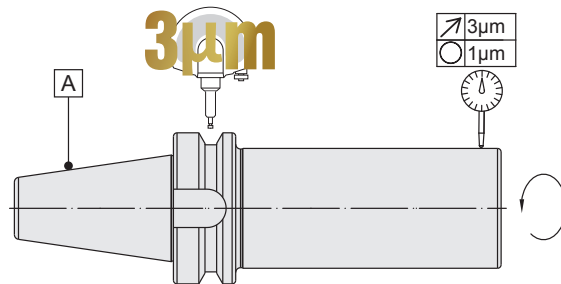

SBT SERIES

MODEL NO.	TYPE	l ₁	l ₂	D	d ₁	WEIGHT (KGS)
5002-025-025-250	SBT30 x 25 - 250	250	225	46	25	0.91
5002-025-032-150	SBT30 x 32 - 150	150	125	46	32	1.09
5002-025-032-235	SBT30 x 32 - 235	235	210	46	32	1.57
5002-025-032-300	SBT30 x 32 - 300	300	276	46	32	1.91
5002-026-040-300	SBT40 x 40 - 300	300	270	63	40	2.52
5002-026-050-200	SBT40 x 50 - 200	200	170	63	50	2.94
5002-026-050-350	SBT40 x 50 - 350	350	320	63	50	4.64
5002-027-050-200	SBT50 x 50 - 200	200	159	100	50	5.28
5002-027-050-360	SBT50 x 50 - 360	360	319	100	50	7.10

SCAT SERIES

5002-043-050-300	SCAT40 x 50 - 300	300	277.95	63.5	50	4.03
5002-044-050-300	SCAT50 x 50 - 300	300	280	98.425	50	6.88

SDAT SERIES

5002-066-050-200	SDAT40 x 50 - 200	200	170	63.55	50	2.98
5002-066-050-340	SDAT40 x 50 - 340	340	310	63.55	50	4.96
5002-067-050-200	SDAT50 x 50 - 200	200	178	97.5	50	4.67
5002-067-050-340	SDAT50 x 50 - 340	340	318	97.5	50	6.43

Benefits of using Spindle Master Bar?

- ▶ Maximizes tool holder performance, prolongs tool life and increases machining productivity.
- ▶ Helps to detect potential problems of spindle and saves downtime and costly repair cost.



Reminder:

- ▶ Spindle Master Bar is supplied with an aluminum box for vertical storage. ▶ It's recommended to store in stock vertically to prevent deformation.
- ▶ The runout precision 5 μ m is available upon request. Please inform the sales personnel when ordering. For the precision info., please refer to page X-3.

SPINDLE MASTER BAR

主軸精密標準棒

TAPER SHANK PRECISION	AT2
ROUNDNESS	1 μ m
SURFACE ROUGHNESS	Ra < 0.15 μ m
RUNOUT ACCURACY	3 μ m
CYLINDRICITY	5 μ m

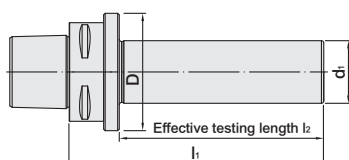
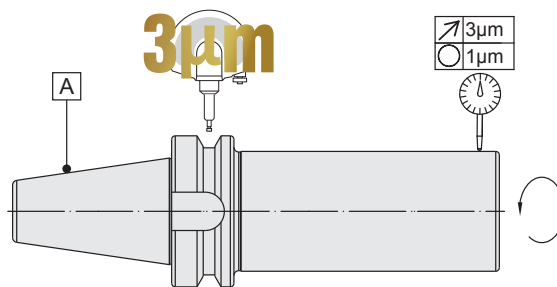

PSC SERIES

MODEL NO.	TYPE	l ₁	l ₂	D	d ₁	WEIGHT (KGS)
5002-140-020-180	PSC32 x 20 - 180	180	165	32	20	0.41
5002-141-032-180	PSC40 x 32 - 180	180	160	40	32	1.08
5002-142-032-180	PSC50 x 32 - 180	180	150	63	32	1.38
5002-142-032-245	PSC50 x 32 - 245	245	215	63	32	1.70
5002-142-040-280	PSC50 x 40 - 280	280	250	63	40	2.12
5002-143-040-182	PSC63 x 40 - 182	182	150	75	40	1.93
5002-143-040-232	PSC63 x 40 - 232	232	200	75	40	4.02
5002-143-040-352	PSC63 x 40 - 352	352	320	75	40	2.93
5002-144-040-240	PSC80 x 40 - 240	240	200	75	40	3.26
5002-144-040-320	PSC80 x 40 - 320	320	280	85	40	3.74
5002-144-040-360	PSC80 x 40 - 360	360	320	85	40	3.98
5002-146-060-480	PSC100 x 60 - 480	480	420	100	60	12.35

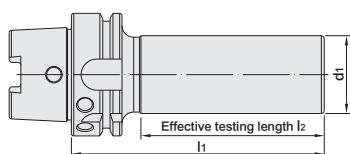

HSK-A SERIES

MODEL NO.	TYPE	l ₁	l ₂	d ₁	WEIGHT (KGS)
5002-069-020-150	HSK25A x 20 - 150	150	138	20	0.30
5002-070-024-180	HSK32A x 24 - 180	180	158	24	0.59
5002-070-025-150	HSK32A x 25 - 150	150	125	25	0.50
5002-071-032-180	HSK40A x 32 - 180	180	157	32	0.96
5002-071-032-200	HSK40A x 32 - 200	200	170	32	2.86
5002-071-032-300	HSK40A x 32 - 300	300	270	32	1.77
5002-072-032-150	HSK50A x 32 - 150	150	121	32	1.02
5002-072-032-240	HSK50A x 32 - 240	240	211	32	1.44
5002-072-032-300	HSK50A x 32 - 300	300	274	32	2.83
5002-073-040-200	HSK63A x 40 - 200	200	171	40	1.78
5002-073-040-346	HSK63A x 40 - 346	346	300	40	3.66
5002-073-050-200	HSK63A x 50 - 200	200	171	50	2.75
5002-073-050-350	HSK63A x 50 - 350	350	321	50	4.49
5002-074-040-346	HSK80A x 40 - 346	346	311	40	2.96
5002-074-050-200	HSK80A x 50 - 200	200	168	50	3.13
5002-074-050-350	HSK80A x 50 - 350	350	318	50	4.83
5002-075-040-349	HSK100A x 40 - 349	349	300	40	7.61
5002-075-050-200	HSK100A x 50 - 200	200	168	50	4.01
5002-075-050-329	HSK100A x 50 - 329	329	280	50	5.37
5002-075-050-350	HSK100A x 50 - 350	350	301	50	5.73
5002-076-050-349	HSK125A x 50 - 349	349	300	50	6.89
5002-076-063-361	HSK125A x 63 - 361	361	322	63	9.99



Reminder:

- ▶ Spindle Master Bar is supplied with an aluminum box for vertical storage. ▶ It's recommended to store in stock vertically to prevent deformation.
- ▶ The runout precision 5 μ m is available upon request. Please inform the sales personnel when ordering. For the precision info., please refer to page X-3.



SPINDLE MASTER BAR

主軸精密標準棒

TAPER SHANK PRECISION	AT2
ROUNDNESS	1 μ m
SURFACE ROUGHNESS	Ra < 0.15 μ m
RUNOUT ACCURACY	3 μ m
CYLINDRICITY	5 μ m

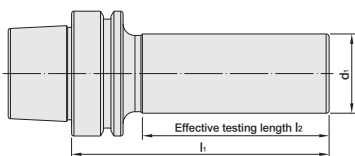
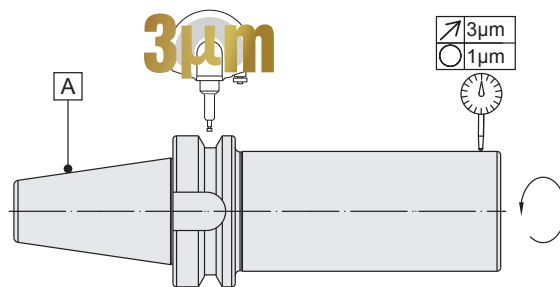

HSK-E SERIES

MODEL NO.	TYPE	l ₁	l ₂	d ₁	WEIGHT (KGS)
5002-097-020-175	HSK25E x 20 - 175	175	163	20	0.36
5002-097-025-175	HSK25E x 25 - 175	175	163	25	0.58
5002-098-020-180	HSK32E x 20 - 180	180	158	20	0.41
5002-099-032-180	HSK40E x 32 - 180	180	157	32	2.98
5002-100-032-180	HSK50E x 32 - 180	180	151	32	3.70
5002-100-032-240	HSK50E x 32 - 240	240	211	32	1.59
5002-101-040-335	HSK63E x 40 - 335	335	300	40	2.44
5002-101-050-200	HSK63E x 50 - 200	200	171	50	2.72
5002-101-050-350	HSK63E x 50 - 350	350	321	50	4.42
5002-107-050-200	HSK80E x 50 - 200	200	171	50	3.17
5002-107-050-350	HSK80E x 50 - 350	350	321	50	4.87

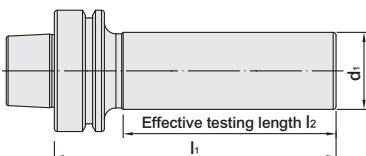

HSK-F SERIES

MODEL NO.	TYPE	l ₁	l ₂	d ₁	WEIGHT (KGS)
5002-106-032-180	HSK40F x 32 - 180	180	157	32	0.97
5002-102-032-240	HSK50F x 32 - 240	240	211	32	1.43
5002-103-040-346	HSK63F x 40 - 346	346	300	40	4.48
5002-103-040-335	HSK63F x 40 - 335	335	300	40	2.45
5002-103-050-200	HSK63F x 50 - 200	200	171	50	2.66
5002-103-050-350	HSK63F x 50 - 350	350	321	50	4.39
5002-104-050-200	HSK80F x 50 - 200	200	171	50	3.09
5002-104-050-350	HSK80F x 50 - 350	350	321	50	4.79

Benefits of using Spindle Master Bar?

- ▶ Maximizes tool holder performance, prolongs tool life and increases machining productivity.
- ▶ Helps to detect potential problems of spindle and saves downtime and costly repair cost.



Reminder:

- ▶ Spindle Master Bar is supplied with an aluminum box for vertical storage. ▶ It's recommended to store in stock vertically to prevent deformation.
- ▶ The runout precision 5 μ m is available upon request. Please inform the sales personnel when ordering. For the precision info., please refer to page X-3.

SPINDLE MASTER BAR

VDI 主軸精密標準棒

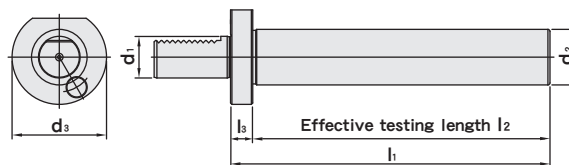

VDI SERIES

MODEL NO.	TYPE	d ₁	d ₂	d ₃	l ₁	l ₂	l ₃
5002-240-040-150	25 x 40 x 150	25	40	58	150	135	15
5002-241-040-230	30 x 40 x 230	30	40	68	230	214	16
5002-242-040-200	40 x 40 x 200	40	40	83	200	184	16
5002-243-040-200	50 x 40 x 200	50	40	98	200	185	15

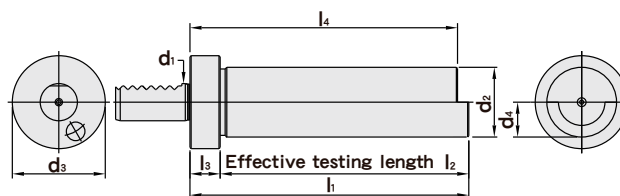

VDI SERIES

MODEL NO.	TYPE	d ₁	d ₂	d ₃	d ₄	l ₁	l ₂	l ₃	l ₄
5002-238-030-120	16 x 30 x 120	16	30	40	15	120	107	13	115.15
5002-239-040-150	20 x 40 x 150	20	40	50	20	150	131.9	18.1	145.2

Benefits of using Spindle Master Bar?

- ▶ Maximizes tool holder performance, prolongs tool life and increases machining productivity.
- ▶ Helps to detect potential problems of spindle and saves downtime and costly repair cost.



Reminder:

- ▶ Spindle Master Bar is supplied with an aluminum box for vertical storage. ▶ It's recommended to store in stock vertically to prevent deformation.
- ▶ The runout precision 5μm is available upon request. Please inform the sales personnel when ordering. For the precision info., please refer to page X-3.



BMT TURRET MASTER BAR

BMT 刀塔精密標準棒

ROUNDNESS	1 μ m
SURFACE ROUGHNESS	Ra < 0.15 μ m
RUNOUT ACCURACY	3 μ m
CYLINDRICITY	5 μ m

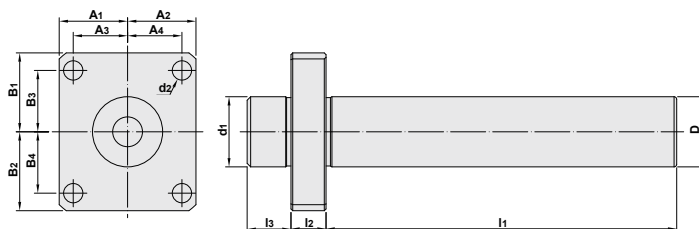
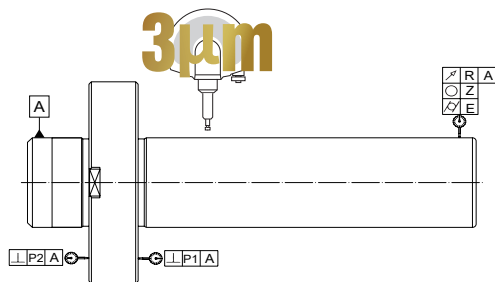

BMT SERIES

MODEL NO.	TYPE	l ₁	l ₂	l ₃	D	d ₁	d ₂	A ₁	A ₂	A ₃	A ₄	B ₁	B ₂	B ₃	B ₄	WEIGHT (KGS)
5002-370-040-200	BMT40 x 40 - 200	200	20	25	40	40	11	39	39	31	31	45	45	35	35	2.35
5002-371-040-200	BMT45 x 40 - 200	200	20	25	40	45	9	37.5	37.5	29	29	40	40	29	29	2.30
5002-372-040-200	BMT55 x 40 - 200	200	20	30	40	55	11	42.5	42.5	32	32	50	50	32	32	2.85
5002-373-050-275	BMT60 x 50 - 275	275	25	30	50	60	13	54	54	42	42	59	59	47	47	6.10
5002-374-050-275	BMT65 x 50 - 275	275	25	30	50	65	13	47.5	47.5	36.5	36.5	55	55	35	35	5.65
5002-375-050-275	BMT75 x 50 - 275	275	25	30	50	75	13	56	56	45	45	57.5	57.5	45	45	6.40

Benefits of using BMT Turret Master Bar?

- ▶ Prolongs tool life, maximizes machining performance and increases machining productivity.
- ▶ Helps to detect potential problems of turret and saves downtime and costly repair cost.



Reminder:

- ▶ BMT Turret Master Bar is supplied with an aluminum box for BMT vertical storage. It's recommended to store in stock vertically to prevent deformation.
- ▶ The runout precision 5 μ m is available upon request. Please inform the sales personnel when ordering.

SOG SPINDLE ORIGIN GAUGE

SOG 主軸原點規

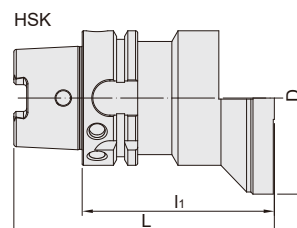
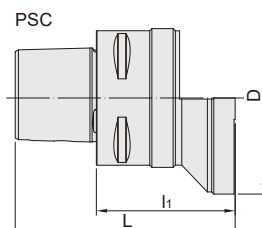

PSC SERIES

MODEL NO.	TYPE	L	l ₁	D	WEIGHT (KGS)
5140-S98-044-040	PSC32 x SOG44 - 40	59	40	44	0.26
5141-S98-054-050	PSC40 x SOG54 - 50	74	50	54	0.52
5142-S98-070-060	PSC50 x SOG70 - 60	90	60	70	0.99
5143-S98-090-065	PSC63 x SOG90 - 65	103	65	90	1.72
5144-S98-110-080	PSC80 x SOG110 - 80	128	80	110	3.46
5146-S98-130-100	PSC100 x SOG130 - 100	160	100	130	6.57

HSK SERIES

570T-S98-044-070	HSK32T x SOG44 - 70	89	70	44	0.36
571T-S98-054-070	HSK40T x SOG54 - 70	94	70	54	0.60
572T-S98-070-080	HSK50T x SOG70 - 80	110	80	70	1.06
573T-S98-090-090	HSK63T x SOG90 - 90	128	90	90	1.97
574T-S98-110-100	HSK80T x SOG110 - 100	148	100	110	3.51
575T-S98-100-130	HSK100T x SOG130 - 110	170	110	130	5.94

Features:

- ▶ Regular inspection and calibration of spindle origin achieves premium machining quality.
- ▶ SOG is an important gauge to calibrate axial and radial accuracy of CNC machines.
- ▶ Every SOG spindle origin gauge is inspected with high precision instrument and delivered with an inspection report. 100% quality guaranteed!

Application:

- ▶ Calibrating spindle accuracy of mill-turn machines.
- ▶ Calibrating tool post accuracy of CNC lathes.
- ▶ Setting rotary table machining origin of 5 axis machining centers



SOG SPINDLE ORIGIN GAUGE

SOG 主軸原點規

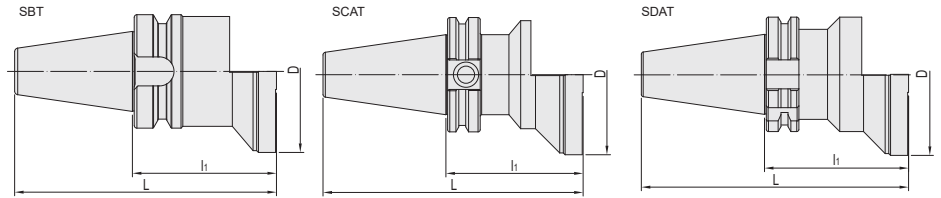

SBT SERIES

MODEL NO.	TYPE	L	l ₂	D	WEIGHT (KGS)
5025-S98-070-060	SBT30 x SOG70 - 60	108.4	60	70	0.83
5026-S98-090-080	SBT40 x SOG90 - 80	145.4	80	90	2.06
5027-S98-130-100	SBT50 x SOG130 - 100	201.8	100	130	6.48

SCAT SERIES

5043-S98-B12-300	SCAT40 x SOG3.5 - 3	5.687	3.000	3.500	2.06
5044-S98-B18-400	SCAT50 x SOG5 - 4	8.000	4.000	5.000	6.02

SDAT SERIES

5066-S98-090-080	SDAT40 x SOG90 - 80	148.4	80	90	1.98
5067-S98-130-110	SDAT50 x SOG130 - 110	201.75	100	130	6.72

Features:

- ▶ Regular inspection and calibration of spindle origin achieves premium machining quality.
- ▶ SOG is an important gauge to calibrate axial and radial accuracy of CNC machines.
- ▶ Every SOG spindle origin gauge is inspected with high precision instrument and delivered with an inspection report. 100% quality guaranteed!

Application:

- ▶ Calibrating spindle accuracy of mill-turn machines.
- ▶ Calibrating tool post accuracy of CNC lathes.
- ▶ Setting rotary table machining origin of 5 axis machining centers

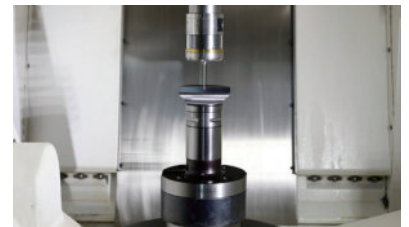
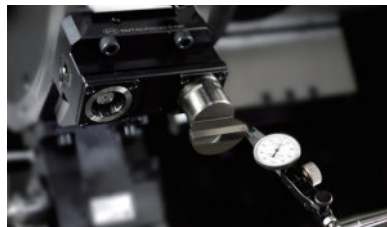

SBT / ATC ALIGNMENT TOOL SET

SBT / ATC 法蘭加厚型校刀三件組

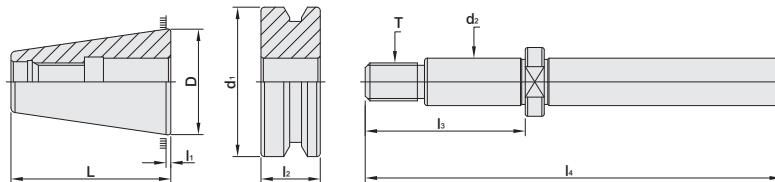





MODEL NO.	TYPE	L	l ₁	l ₂	l ₃	l ₄	D	d ₁	d ₂	T
5025-009-00	SBT30 - ATC	49.4	1	21	50.4	158.4	31.75	46	16	M12 x 1.75P
5026-009-00	SBT40 - ATC	66.4	1	26	67.5	175.5	44.45	63	20	M16 x 2.0P
5027-009-00	SBT50 - ATC	103.3	1.5	36.5	120	320	69.85	100	25	M24 x 3.0P

Features:

- ▶ For checking ATC positioning accuracy between ATC arm and machine spindle, and between ATC arm and tool magazine.

Advantages of using ATC Alignment Tool Set:

- ▶ Prevent tool holder tapers from abnormal wear.
- ▶ Detect the potential problems of machines and decrease the probability of machine breakdown.
- ▶ Prolong the use life of machine spindle.

Pull Stud	SPIGOT INTERCHANGEABLE DIGITAL TORQUE WRENCH	TORQUE WRENCH ADAPTOR (PULL STUD)	Spanner (Pull Stud)
			
X-64~65	X-73	X-77	X-78



SCAT / ATC ALIGNMENT TOOL SET

SCAT / ATC 法蘭加厚型校刀三件組

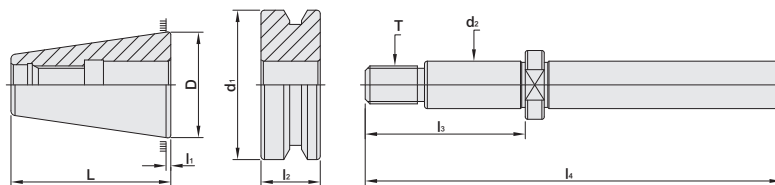

MODEL NO.	TYPE	L	l ₁	l ₂	l ₃	l ₄	D	d ₁	d ₂	T
5043-009-00	SCAT40 - ATC	69.199	0.95	18.1	67.5	175.5	44.45	63.5	20	5/8-11UNC
5044-009-00	SCAT50 - ATC	103.05	1.45	17.6	125	325	69.85	98.425	25.4	1-8 UNC

Features:

- ▶ For checking ATC positioning accuracy between ATC arm and machine spindle, and between ATC arm and tool magazine.

Advantages of using ATC Alignment Tool Set:

- ▶ Prevent tool holder tapers from abnormal wear.
- ▶ Detect the potential problems of machines and decrease the probability of machine breakdown.
- ▶ Prolong the use life of machine spindle.

Pull Stud	SPIGOT INTERCHANGEABLE DIGITAL TORQUE WRENCH	TORQUE WRENCH ADAPTOR (PULL STUD)	Spanner (Pull Stud)
X-66	X-73	X-77	X-78

SDAT / ATC ALIGNMENT TOOL SET

SDAT / ATC 法蘭加厚型校刀三件組

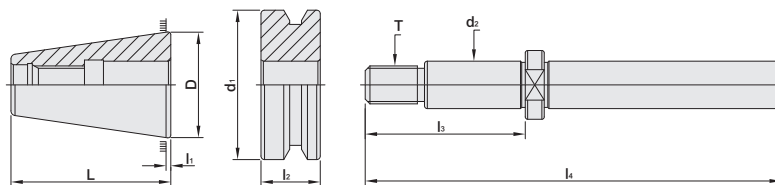
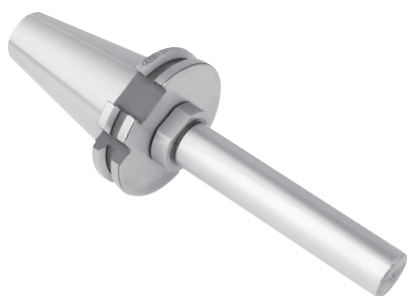





MODEL NO.	TYPE	L	l ₁	l ₂	l ₃	l ₄	D	d ₁	d ₂	T
5066-009-00	SDAT40 - ATC	69.4	1	18.1	67.5	175.5	44.45	63.55	20	M16 x 2.0P
5067-009-00	SDAT50 - ATC	103.25	1.5	17.6	120	320	69.85	97.5	25	M24 x 3.0P

Features:

- ▶ For checking ATC positioning accuracy between ATC arm and machine spindle, and between ATC arm and tool magazine.

Advantages of using ATC Alignment Tool Set:

- ▶ Prevent tool holder tapers from abnormal wear.
- ▶ Detect the potential problems of machines and decrease the probability of machine breakdown.
- ▶ Prolong the use life of machine spindle.

Pull Stud	SPIGOT INTERCHANGEABLE DIGITAL TORQUE WRENCH	TORQUE WRENCH ADAPTOR (PULL STUD)	Spanner (Pull Stud)
			
X-67	X-73	X-77	X-78



HSK / ATC ALIGNMENT TOOL SET

HSK / ATC 校刀三件組

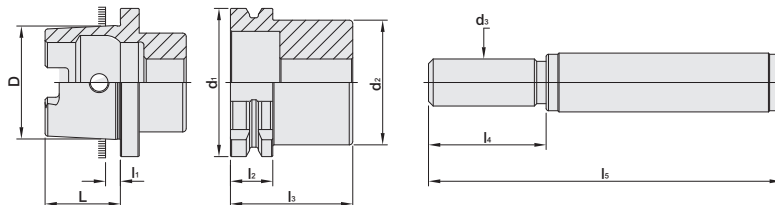

MODEL NO.	TYPE	L	l ₁	l ₂	l ₃	l ₄	l ₅	D	d ₁	d ₂	d ₃
5069-009-00	HSK25A - ATC	13	2.5	7	17	22	70	19.006	25	20	8
5070-009-00	HSK32A - ATC	16	3.2	14	30	50	100	24.007	32	26	8
5071-009-00	HSK40A - ATC	20	4	14	37	61	141	30.007	40	34	12
5072-009-00	HSK50A - ATC	25	5	18	43	74	174	38.009	50	42	15
5073-009-00	HSK63A - ATC	32	6.3	18	52	90	190	48.010	63	53	20
5074-009-00	HSK80A - ATC	40	8	18	54.5	100.5	200.5	60.012	80	68	20
5075-009-00	HSK100A - ATC	50	10	19	67	125	275	75.013	100	88	24
5076-009-00	HSK125A - ATC	63	12.5	19	74	145	295	95.016	125	111	30
5097-009-00	HSK25E - ATC	13	2.5	7	17	22	70	19.006	25	20	8
5098-009-00	HSK32E - ATC	16	3.2	14	30	50	100	24.007	32	26	8
5099-009-00	HSK40E - ATC	20	4	14	37	61	141	30.007	40	34	12
5100-009-00	HSK50E - ATC	25	5	18	43	74	174	38.009	50	42	15
5101-009-00	HSK63E - ATC	32	6.3	18	52	90	190	48.010	63	53	20
5102-009-00	HSK50F - ATC	20	4	18	43	61	141	30.007	50	42	12
5103-009-00	HSK63F - ATC	25	5	18	52	71	174	38.009	63	53	15
5105-009-00	HSK80F - ATC	32	6.3	18	54.5	90	190	48.010	80	68	20

Features:

- ▶ For checking ATC positioning accuracy between ATC arm and machine spindle, and between ATC arm and tool magazine.

Advantages of using ATC Alignment Tool Set:

- ▶ Prevent tool holder tapers from abnormal wear.
- ▶ Detect the potential problems of machines and decrease the probability of machine breakdown.
- ▶ Prolong the use life of machine spindle.

PSC / ATC ALIGNMENT TOOL SET

PSC / ATC 校刀三件組

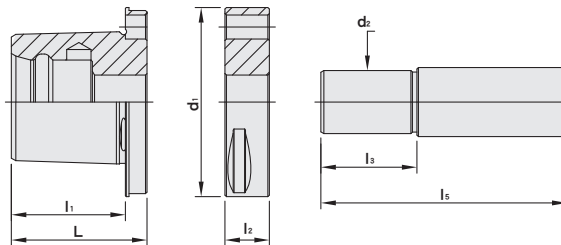

MODEL NO.	TYPE	L	l ₁	l ₂	l ₃	l ₅	d ₁	d ₂
5140-009-00	PSC32 - ATC	22	19	12	20	60	32	8
5141-009-00	PSC40 - ATC	28	24	16	28	78	40	12
5142-009-00	PSC50 - ATC	35	30	15	29	79	50	16
5143-009-00	PSC63 - ATC	45.2	38	14.8	32	82	63	21
5144-009-00	PSC80 - ATC	54.2	48	23.8	49	109	80	21
5146-009-00	PSC100 - ATC	66.2	60	29.8	56	115	100	24

Features:

- ▶ For checking ATC positioning accuracy between ATC arm and machine spindle, and between ATC arm and tool magazine.

Advantages of using ATC Alignment Tool Set:





- ▶ Prevent tool holder tapers from abnormal wear.
- ▶ Detect the potential problems of machines and decrease the probability of machine breakdown.
- ▶ Prolong the use life of machine spindle.





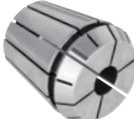



SYIC ER COLLET SERIES

SYIC ER 筒夾系列

[ISO 15488]

FEATURES	ER COLLET	ER-E COLLET	ER-ES STEEL SEALED COLLET	ERS METALLIC SEALED COLLET	ERS COOLANT COLLET (FID TYPE)	ERS COOLANT COLLET (FOD TYPE)
						
Runout accuracy	15μm	●	●	●	●	●
	10μm	●		●	●	●
	R 7μm		●	●	●	●
	UP 5μm	●	●	●	●	●
	P 3μm		●		●	●
Clamping range	0.5mm~2mm	N/A	N/A	N/A	N/A	N/A
Coolant pressure resistance	N/A	N/A	150 kgf/cm ²	150 kgf/cm ²	150 kgf/cm ²	150 kgf/cm ²
Coolant through	N/A	N/A	through tools	through tools	through collet flutes	through collet holes

FEATURES	ER-EO SEALED COLLET	ER COOLANT COLLET (FID TYPE)	ER COOLANT COLLET (FOD TYPE)	ER-TC RIGID TAP COLLET	ER-TC RIGID TAP COLLET SEALED COLLET	ER-TC RIGID TAP COLLET COOLANT COLLET (FOD TYPE)
						
Runout accuracy	15μm	●	●			
	10μm	●	●			
	R 7μm				-	-
	UP 5μm	●	●	●		
	P 3μm					
Clamping range	N/A	N/A	N/A	N/A	N/A	N/A
Coolant pressure resistance	50 kgf/cm ²	50 kgf/cm ²	50 kgf/cm ²	N/A	150 kgf/cm ²	150 kgf/cm ²
Coolant through	through tools	through collet flutes	through collet holes	N/A	through tools	through collet holes

FEATURES	ER FLOATING TAP COLLET	
		
Runout accuracy	15μm	
	10μm	
	R 7μm	-
	UP 5μm	
	P 3μm	
Clamping range	N/A	
Coolant pressure resistance	N/A	
Coolant through	N/A	

ER COLLET

ER 彈性筒夾

(ISO 15488)

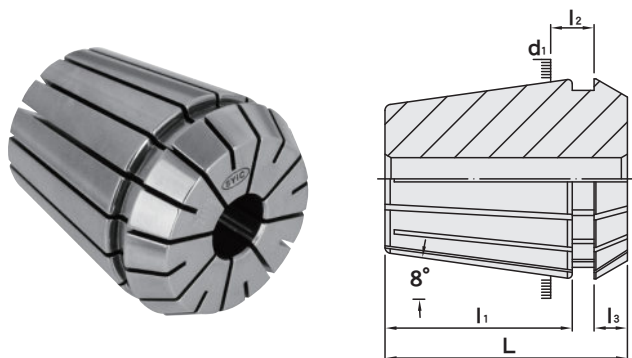

TYPE	d ₁	L	l ₁	l ₂	l ₃
ER8	8	13.5	10.8	2.98	1.5
ER11	11	18	13.5	3.8	2.5
ER16	16	27.5	20.8	6.26	4
ER20	20	31.5	23.9	6.36	4.8
ER25	25	34	25.9	6.66	5
ER32	32	40	30.9	7.16	5.5
ER40	40	46	34.9	7.66	7
ER50	50	60	46	12.6	8.5

ER8		ER11		ER16		ER20	
MODEL NO.	SIZE	MODEL NO.	SIZE	MODEL NO.	SIZE	MODEL NO.	SIZE
5250-122-008-001	1 - 0.5	5250-122-011-001	1 - 0.5	5250-122-016-001	1 - 0.5	5250-122-020-001	1 - 0.5
5250-122-008-001.5	1.5 - 1	5250-122-011-001.5	1.5 - 1	5250-122-016-001.5	1.5 - 1	5250-122-020-001.5	1.5 - 1
5250-122-008-002	2 - 1.5	5250-122-011-002	2 - 1.5	5250-122-016-002	2 - 1.5	5250-122-020-002	2 - 1.5
5250-122-008-002.5	2.5 - 2	5250-122-011-002.5	2.5 - 2	5250-122-016-002.5	2.5 - 2	5250-122-020-002.5	2.5 - 2
5250-122-008-003	3 - 2.5	5250-122-011-003	3 - 2.5	5250-122-016-003	3 - 2	5250-122-020-003	3 - 2
5250-122-008-003.5	3.5 - 3	5250-122-011-003.5	3.5 - 3	5250-122-016-003.5	3.5 - 2.5	5250-122-020-003.5	3.5 - 2.5
5250-122-008-004	4 - 3.5	5250-122-011-004	4 - 3.5	5250-122-016-004	4 - 3	5250-122-020-004	4 - 3
5250-122-008-004.5	4.5 - 4	5250-122-011-004.5	4.5 - 4	5250-122-016-004.5	4.5 - 3.5	5250-122-020-004.5	4.5 - 3.5
5250-122-008-005	5 - 4.5	5250-122-011-005	5 - 4.5	5250-122-016-005	5 - 4	5250-122-020-005	5 - 4
INCHES		5250-122-011-005.5	5.5 - 5	5250-122-016-005.5	5.5 - 4.5	5250-122-020-005.5	5.5 - 4.5
5250-122-008-A04	0.043 - 0.062	5250-122-011-006	6 - 5.5	5250-122-016-006	6 - 5	5250-122-020-006	6 - 5
5250-122-008-A08	0.086 - 0.125	5250-122-011-006.5	6.5 - 6	5250-122-016-006.5	6.5 - 5.5	5250-122-020-006.5	6.5 - 5.5
5250-122-008-A12	0.148 - 0.187	5250-122-011-007	7 - 6.5	5250-122-016-007	7 - 6	5250-122-020-007	7 - 6
INCHES		5250-122-011-A04	0.043 - 0.062	5250-122-016-007.5	7.5 - 6.5	5250-122-020-007.5	7.5 - 6.5
		5250-122-011-A06	0.054 - 0.093	5250-122-016-008	8 - 7	5250-122-020-008	8 - 7
		5250-122-011-A08	0.086 - 0.125	5250-122-016-008.5	8.5 - 7.5	5250-122-020-008.5	8.5 - 7.5
		5250-122-011-A10	0.117 - 0.156	5250-122-016-009	9 - 8	5250-122-020-009	9 - 8
		5250-122-011-A12	0.148 - 0.187	5250-122-016-009.5	9.5 - 8.5	5250-122-020-009.5	9.5 - 8.5
		5250-122-011-A14	0.179 - 0.218	5250-122-016-010	10 - 9	5250-122-020-010	10 - 9
		5250-122-011-A16	0.211 - 0.250	INCHES		5250-122-020-010.5	10.5 - 9.5
				5250-122-016-A04	0.043 - 0.062	5250-122-020-011	11 - 10
				5250-122-016-A06	0.054 - 0.093	5250-122-020-011.5	11.5 - 10.5
				5250-122-016-A08	0.086 - 0.125	5250-122-020-012	12 - 11
				5250-122-016-A10	0.117 - 0.156	5250-122-020-012.5	12.5 - 11.5
				5250-122-016-A12	0.148 - 0.187	5250-122-020-013	13 - 12
				5250-122-016-A14	0.179 - 0.218	INCHES	
				5250-122-016-A16	0.211 - 0.250	5250-122-020-A04	0.043 - 0.062
				5250-122-016-A18	0.242 - 0.281	5250-122-020-A06	0.054 - 0.093
				5250-122-016-A20	0.273 - 0.312	5250-122-020-A08	0.086 - 0.125
				5250-122-016-A22	0.304 - 0.343	5250-122-020-A10	0.117 - 0.156
				5250-122-016-A24	0.336 - 0.375	5250-122-020-A12	0.148 - 0.187
				5250-122-016-A26	0.367 - 0.406	5250-122-020-A14	0.179 - 0.218
						5250-122-020-A16	0.211 - 0.250
						5250-122-020-A18	0.242 - 0.281
						5250-122-020-A20	0.273 - 0.312
						5250-122-020-A22	0.304 - 0.343
						5250-122-020-A24	0.336 - 0.375
						5250-122-020-A26	0.367 - 0.406
						5250-122-020-A28	0.398 - 0.437
						5250-122-020-A30	0.429 - 0.468
						5250-122-020-A32	0.461 - 0.500

Features:

- ▶ Runout accuracy: 15µm, A class 10µm, UP class 5µm. Please indicate the runout accuracy needed when placing an order.
- ▶ Design: 8 slots in front and back, with good flexibility and convenient for clamping tools.
- ▶ Clamping range: ER8, ER11: 0.5mm; ER16,20,25,32,40: 1mm (ID ≥ 3mm), 0.5mm (ID < 3mm); ER50: 2mm (ID > 10mm), 1mm (ID ≤ 10mm).
- ▶ Surface roughness: Ra < 0.25µm, A class Ra < 0.15µm, UP class Ra < 0.1µm.
- ▶ Used for drills, taps, mills and reamers, etc.



ER COLLET

ER 彈性筒夾

(ISO 15488)

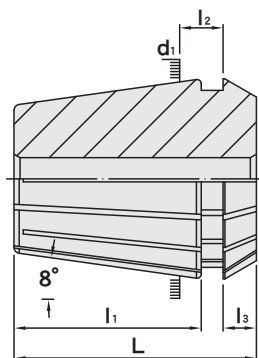

TYPE	d ₁	L	l ₁	l ₂	l ₃
ER8	8	13.5	10.8	2.98	1.5
ER11	11	18	13.5	3.8	2.5
ER16	16	27.5	20.8	6.26	4
ER20	20	31.5	23.9	6.36	4.8
ER25	25	34	25.9	6.66	5
ER32	32	40	30.9	7.16	5.5
ER40	40	46	34.9	7.66	7
ER50	50	60	46	12.6	8.5

ER25			
MODEL NO.	SIZE	MODEL NO.	SIZE
5250-122-025-001	1 - 0.5	5250-122-025-009	9 - 8
5250-122-025-001.5	1.5 - 1	5250-122-025-009.5	9.5 - 8.5
5250-122-025-002	2 - 1.5	5250-122-025-010	10 - 9
5250-122-025-002.5	2.5 - 2	5250-122-025-010.5	10.5 - 9.5
5250-122-025-003	3 - 2	5250-122-025-011	11 - 10
5250-122-025-003.5	3.5 - 2.5	5250-122-025-011.5	11.5 - 10.5
5250-122-025-004	4 - 3	5250-122-025-012	12 - 11
5250-122-025-004.5	4.5 - 3.5	5250-122-025-012.5	12.5 - 11.5
5250-122-025-005	5 - 4	5250-122-025-013	13 - 12
5250-122-025-005.5	5.5 - 4.5	5250-122-025-013.5	13.5 - 12.5
5250-122-025-006	6 - 5	5250-122-025-014	14 - 13
5250-122-025-006.5	6.5 - 5.5	5250-122-025-014.5	14.5 - 13.5
5250-122-025-007	7 - 6	5250-122-025-015	15 - 14
5250-122-025-007.5	7.5 - 6.5	5250-122-025-015.5	15.5 - 14.5
5250-122-025-008	8 - 7	5250-122-025-016	16 - 15
5250-122-025-008.5	8.5 - 7.5		

INCHES

5250-122-025-A06	0.054 - 0.093	5250-122-025-A24	0.336 - 0.375
5250-122-025-A08	0.086 - 0.125	5250-122-025-A26	0.367 - 0.406
5250-122-025-A10	0.117 - 0.156	5250-122-025-A28	0.398 - 0.437
5250-122-025-A12	0.148 - 0.187	5250-122-025-A30	0.429 - 0.468
5250-122-025-A14	0.179 - 0.218	5250-122-025-A32	0.461 - 0.500
5250-122-025-A16	0.211 - 0.250	5250-122-025-A34	0.492 - 0.531
5250-122-025-A18	0.242 - 0.281	5250-122-025-A36	0.523 - 0.562
5250-122-025-A20	0.273 - 0.312	5250-122-025-A38	0.554 - 0.593
5250-122-025-A22	0.304 - 0.343	5250-122-025-A40	0.586 - 0.625

ER32			
MODEL NO.	SIZE	MODEL NO.	SIZE
5250-122-032-002	2 - 1.5	5250-122-032-011.5	11.5 - 10.5
5250-122-032-002.5	2.5 - 2	5250-122-032-012	12 - 11
5250-122-032-003	3 - 2	5250-122-032-012.5	12.5 - 11.5
5250-122-032-003.5	3.5 - 2.5	5250-122-032-013	13 - 12
5250-122-032-004	4 - 3	5250-122-032-013.5	13.5 - 12.5
5250-122-032-004.5	4.5 - 3.5	5250-122-032-014	14 - 13
5250-122-032-005	5 - 4	5250-122-032-014.5	14.5 - 13.5
5250-122-032-005.5	5.5 - 4.5	5250-122-032-015	15 - 14
5250-122-032-006	6 - 5	5250-122-032-015.5	15.5 - 14.5
5250-122-032-006.5	6.5 - 5.5	5250-122-032-016	16 - 15
5250-122-032-007	7 - 6	5250-122-032-016.5	16.5 - 15.5
5250-122-032-007.5	7.5 - 6.5	5250-122-032-017	17 - 16
5250-122-032-008	8 - 7	5250-122-032-017.5	17.5 - 16.5
5250-122-032-008.5	8.5 - 7.5	5250-122-032-018	18 - 17
5250-122-032-009	9 - 8	5250-122-032-018.5	18.5 - 17.5
5250-122-032-009.5	9.5 - 8.5	5250-122-032-019	19 - 18
5250-122-032-010	10 - 9	5250-122-032-019.5	19.5 - 18.5
5250-122-032-010.5	10.5 - 9.5	5250-122-032-020	20 - 19
5250-122-032-011	11 - 10		

INCHES

5250-122-032-A04	0.043 - 0.062	5250-122-032-A28	0.398 - 0.437
5250-122-032-A06	0.054 - 0.093	5250-122-032-A30	0.429 - 0.468
5250-122-032-A08	0.086 - 0.125	5250-122-032-A32	0.461 - 0.500
5250-122-032-A10	0.117 - 0.156	5250-122-032-A34	0.492 - 0.531
5250-122-032-A12	0.148 - 0.187	5250-122-032-A36	0.523 - 0.562
5250-122-032-A14	0.179 - 0.218	5250-122-032-A38	0.554 - 0.593
5250-122-032-A16	0.211 - 0.250	5250-122-032-A40	0.586 - 0.625
5250-122-032-A18	0.242 - 0.281	5250-122-032-A42	0.617 - 0.656
5250-122-032-A20	0.273 - 0.312	5250-122-032-A44	0.648 - 0.687
5250-122-032-A22	0.304 - 0.343	5250-122-032-A46	0.679 - 0.718
5250-122-032-A24	0.336 - 0.375	5250-122-032-A48	0.711 - 0.750
5250-122-032-A26	0.367 - 0.406		

Features:

- ▶ Runout accuracy: 15µm, A class 10µm, UP class 5µm. Please indicate the runout accuracy needed when placing an order.
- ▶ Design: 8 slots in front and back, with good flexibility and convenient for clamping tools.
- ▶ Clamping range: ER8, ER11: 0.5mm; ER16,20,25,32,40: 1mm (ID ≥ 3mm), 0.5mm (ID < 3mm); ER50: 2mm (ID > 10mm), 1mm (ID ≤ 10mm).
- ▶ Surface roughness: Ra < 0.25µm, A class Ra < 0.15µm, UP class Ra < 0.1µm.
- ▶ Used for drills, taps, mills and reamers, etc.



ER COLLET

ER 彈性筒夾

(ISO 15488)

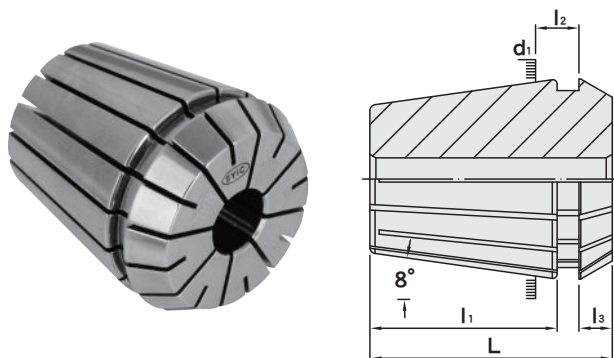

TYPE	d ₁	L	l ₁	l ₂	l ₃
ER8	8	13.5	10.8	2.98	1.5
ER11	11	18	13.5	3.8	2.5
ER16	16	27.5	20.8	6.26	4
ER20	20	31.5	23.9	6.36	4.8
ER25	25	34	25.9	6.66	5
ER32	32	40	30.9	7.16	5.5
ER40	40	46	34.9	7.66	7
ER50	50	60	46	12.6	8.5

ER40			
MODEL NO.	SIZE	MODEL NO.	SIZE
5250-122-040-003	3 - 2	5250-122-040-015	15 - 14
5250-122-040-003.5	3.5 - 2.5	5250-122-040-015.5	15.5 - 14.5
5250-122-040-004	4 - 3	5250-122-040-016	16 - 15
5250-122-040-004.5	4.5 - 3.5	5250-122-040-016.5	16.5 - 15.5
5250-122-040-005	5 - 4	5250-122-040-017	17 - 16
5250-122-040-005.5	5.5 - 4.5	5250-122-040-017.5	17.5 - 16.5
5250-122-040-006	6 - 5	5250-122-040-018	18 - 17
5250-122-040-006.5	6.5 - 5.5	5250-122-040-018.5	18.5 - 17.5
5250-122-040-007	7 - 6	5250-122-040-019	19 - 18
5250-122-040-007.5	7.5 - 6.5	5250-122-040-019.5	19.5 - 18.5
5250-122-040-008	8 - 7	5250-122-040-020	20 - 19
5250-122-040-008.5	8.5 - 7.5	5250-122-040-020.5	20.5 - 19.5
5250-122-040-009	9 - 8	5250-122-040-021	21 - 20
5250-122-040-009.5	9.5 - 8.5	5250-122-040-021.5	21.5 - 20.5
5250-122-040-010	10 - 9	5250-122-040-022	22 - 21
5250-122-040-010.5	10.5 - 9.5	5250-122-040-022.5	22.5 - 21.5
5250-122-040-011	11 - 10	5250-122-040-023	23 - 22
5250-122-040-011.5	11.5 - 10.5	5250-122-040-023.5	23.5 - 22.5
5250-122-040-012	12 - 11	5250-122-040-024	24 - 23
5250-122-040-012.5	12.5 - 11.5	5250-122-040-024.5	24.5 - 23.5
5250-122-040-013	13 - 12	5250-122-040-025	25 - 24
5250-122-040-013.5	13.5 - 12.5	5250-122-040-025.5	25.5 - 24.5
5250-122-040-014	14 - 13	5250-122-040-026	26 - 25
5250-122-040-014.5	14.5 - 13.5		

INCHES

5250-122-040-A08	0.086 - 0.125	5250-122-040-A32	0.461 - 0.500
5250-122-040-A10	0.117 - 0.156	5250-122-040-A34	0.492 - 0.531
5250-122-040-A12	0.148 - 0.187	5250-122-040-A36	0.523 - 0.562
5250-122-040-A14	0.179 - 0.218	5250-122-040-A38	0.554 - 0.593
5250-122-040-A16	0.211 - 0.250	5250-122-040-A40	0.586 - 0.625
5250-122-040-A18	0.242 - 0.281	5250-122-040-A42	0.617 - 0.656
5250-122-040-A20	0.273 - 0.312	5250-122-040-A44	0.648 - 0.687
5250-122-040-A22	0.304 - 0.343	5250-122-040-A46	0.679 - 0.718
5250-122-040-A24	0.336 - 0.375	5250-122-040-A48	0.711 - 0.750
5250-122-040-A26	0.367 - 0.406	5250-122-040-A56	0.836 - 0.875
5250-122-040-A28	0.398 - 0.437	5250-122-040-A64	0.961 - 1.000
5250-122-040-A30	0.429 - 0.468		

ER50			
MODEL NO.	SIZE	MODEL NO.	SIZE
5250-122-050-006	6 - 5	5250-122-050-021	21 - 19
5250-122-050-007	7 - 6	5250-122-050-022	22 - 20
5250-122-050-008	8 - 7	5250-122-050-023	23 - 21
5250-122-050-009	9 - 8	5250-122-050-024	24 - 22
5250-122-050-010	10 - 9	5250-122-050-025	25 - 23
5250-122-050-011	11 - 9	5250-122-050-026	26 - 24
5250-122-050-012	12 - 10	5250-122-050-027	27 - 25
5250-122-050-013	13 - 11	5250-122-050-028	28 - 26
5250-122-050-014	14 - 12	5250-122-050-029	29 - 27
5250-122-050-015	15 - 13	5250-122-050-030	30 - 28
5250-122-050-016	16 - 14	5250-122-050-031	31 - 29
5250-122-050-017	17 - 15	5250-122-050-032	32 - 30
5250-122-050-018	18 - 16	5250-122-050-033	33 - 31
5250-122-050-019	19 - 17	5250-122-050-034	34 - 32
5250-122-050-020	20 - 18		

INCHES

5250-122-050-A14	0.179 - 0.219	5250-122-050-A50	0.703 - 0.781
5250-122-050-A16	0.211 - 0.250	5250-122-050-A54	0.765 - 0.844
5250-122-050-A20	0.273 - 0.313	5250-122-050-A60	0.859 - 0.938
5250-122-050-A22	0.304 - 0.344	5250-122-050-A64	0.921 - 1.000
5250-122-050-A24	0.336 - 0.375	5250-122-050-A67	1.015 - 1.094
5250-122-050-A28	0.359 - 0.438	5250-122-050-A70	1.109 - 1.188
5250-122-050-A34	0.453 - 0.531	5250-122-050-A72	1.171 - 1.250
5250-122-050-A40	0.546 - 0.625	5250-122-050-A74	1.234 - 1.313
5250-122-050-A44	0.609 - 0.688		

Features:

- ▶ Runout accuracy: 15µm, A class 10µm, UP class 5µm. Please indicate the runout accuracy needed when placing an order.
- ▶ Design: 8 slots in front and back, with good flexibility and convenient for clamping tools.
- ▶ Clamping range: ER8, ER11: 0.5mm; ER16,20,25,32,40: 1mm (ID ≥ 3mm), 0.5mm (ID < 3mm); ER50: 2mm (ID > 10mm), 1mm (ID ≤ 10mm).
- ▶ Surface roughness: Ra < 0.25µm, A class Ra < 0.15µm, UP class Ra < 0.1µm.
- ▶ Used for drills, taps, mills and reamers, etc.



ER - E COLLET

ER - E 彈性筒夾

(ISO 15488)

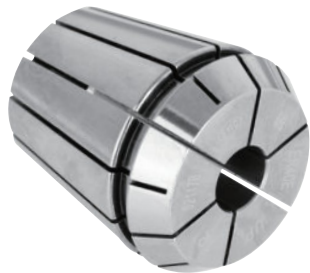

ER11E	
MODEL NO.	SIZE
5250-113-011-002	2
5250-113-011-003	3
5250-113-011-004	4
5250-113-011-005	5
5250-113-011-006	6
5250-113-011-007	7

INCHES

5250-113-011-A04	1/16
5250-113-011-A06	3/32
5250-113-011-A08	1/8
5250-113-011-A10	5/32
5250-113-011-A12	3/16
5250-113-011-A14	7/32
5250-113-011-A16	1/4
5250-113-011-A18	9/32

ER16E	
MODEL NO.	SIZE
5250-113-016-002	2
5250-113-016-003	3
5250-113-016-004	4
5250-113-016-005	5
5250-113-016-006	6
5250-113-016-007	7
5250-113-016-008	8
5250-113-016-009	9
5250-113-016-010	10

INCHES

5250-113-016-A04	1/16
5250-113-016-A06	3/32
5250-113-016-A08	1/8
5250-113-016-A10	5/32
5250-113-016-A12	3/16
5250-113-016-A14	7/32
5250-113-016-A16	1/4
5250-113-016-A18	9/32
5250-113-016-A20	5/16
5250-113-016-A22	11/32
5250-113-016-A24	3/8
5250-113-016-A26	13/32

Features:

- ▶ Runout accuracy: R class 7μm, UP class 5μm, P class 3μm.
- ▶ Design: 6 slots in front and back, increasing precision stability.
- ▶ Clamping one size tool is recommended.
- ▶ Surface roughness: Ra<0.12μm, UP/P class Ra <0.1μm.

ER20E	
MODEL NO.	SIZE
5250-113-020-002	2
5250-113-020-003	3
5250-113-020-004	4
5250-113-020-005	5
5250-113-020-006	6
5250-113-020-007	7
5250-113-020-008	8
5250-113-020-009	9
5250-113-020-010	10
5250-113-020-011	11
5250-113-020-012	12
5250-113-020-013	13

INCHES

5250-113-020-A04	1/16
5250-113-020-A06	3/32
5250-113-020-A08	1/8
5250-113-020-A10	5/32
5250-113-020-A12	3/16
5250-113-020-A14	7/32
5250-113-020-A16	1/4
5250-113-020-A18	9/32
5250-113-020-A20	5/16
5250-113-020-A22	11/32
5250-113-020-A24	3/8
5250-113-020-A26	13/32
5250-113-020-A28	7/16
5250-113-020-A30	15/32
5250-113-020-A32	1/2

5250-113-025-A06	3/32
5250-113-025-A08	1/8
5250-113-025-A10	5/32
5250-113-025-A12	3/16
5250-113-025-A14	7/32
5250-113-025-A16	1/4
5250-113-025-A18	9/32
5250-113-025-A20	5/16
5250-113-025-A22	11/32
5250-113-025-A24	3/8
5250-113-025-A26	13/32
5250-113-025-A28	7/16
5250-113-025-A30	15/32
5250-113-025-A32	1/2
5250-113-025-A34	17/32
5250-113-025-A36	9/16
5250-113-025-A38	19/32
5250-113-025-A40	5/8

ER25E	
MODEL NO.	SIZE
5250-113-025-002	2
5250-113-025-003	3
5250-113-025-004	4
5250-113-025-005	5
5250-113-025-006	6
5250-113-025-007	7
5250-113-025-008	8
5250-113-025-009	9
5250-113-025-010	10
5250-113-025-011	11
5250-113-025-012	12
5250-113-025-013	13
5250-113-025-014	14
5250-113-025-015	15
5250-113-025-016	16

INCHES

5250-113-032-003	3
5250-113-032-004	4
5250-113-032-005	5
5250-113-032-006	6
5250-113-032-007	7
5250-113-032-008	8
5250-113-032-009	9
5250-113-032-010	10
5250-113-032-011	11
5250-113-032-012	12
5250-113-032-013	13
5250-113-032-014	14
5250-113-032-015	15
5250-113-032-016	16
5250-113-032-017	17
5250-113-032-018	18
5250-113-032-019	19
5250-113-032-020	20

INCHES

5250-113-032-A08	1/8
5250-113-032-A10	5/32
5250-113-032-A12	3/16
5250-113-032-A14	7/32
5250-113-032-A16	1/4
5250-113-032-A18	9/32
5250-113-032-A20	5/16
5250-113-032-A22	11/32
5250-113-032-A24	3/8
5250-113-032-A26	13/32
5250-113-032-A28	7/16
5250-113-032-A30	15/32
5250-113-032-A32	1/2
5250-113-032-A34	17/32
5250-113-032-A36	9/16
5250-113-032-A38	19/32
5250-113-032-A40	5/8

ER32E	
MODEL NO.	SIZE
5250-113-032-003	3
5250-113-032-004	4
5250-113-032-005	5
5250-113-032-006	6
5250-113-032-007	7
5250-113-032-008	8
5250-113-032-009	9
5250-113-032-010	10
5250-113-032-011	11
5250-113-032-012	12
5250-113-032-013	13
5250-113-032-014	14
5250-113-032-015	15
5250-113-032-016	16
5250-113-032-017	17
5250-113-032-018	18
5250-113-032-019	19
5250-113-032-020	20

INCHES

5250-113-040-003	3
5250-113-040-004	4
5250-113-040-005	5
5250-113-040-006	6
5250-113-040-007	7
5250-113-040-008	8
5250-113-040-009	9
5250-113-040-010	10
5250-113-040-011	11
5250-113-040-012	12
5250-113-040-013	13
5250-113-040-014	14
5250-113-040-015	15
5250-113-040-016	16
5250-113-040-017	17
5250-113-040-018	18
5250-113-040-019	19
5250-113-040-020	20

INCHES

5250-113-040-A08	1/8
5250-113-040-A10	5/32
5250-113-040-A12	3/16
5250-113-040-A14	7/32
5250-113-040-A16	1/4
5250-113-040-A18	9/32
5250-113-040-A20	5/16
5250-113-040-A22	11/32
5250-113-040-A24	3/8
5250-113-040-A26	13/32
5250-113-040-A28	7/16
5250-113-040-A30	15/32
5250-113-040-A32	1/2
5250-113-040-A34	17/32
5250-113-040-A36	9/16
5250-113-040-A38	19/32
5250-113-040-A40	5/8
5250-113-040-A42	21/32
5250-113-040-A44	11/16
5250-113-040-A46	23/32
5250-113-040-A48	3/4

ER40E	
MODEL NO.	SIZE
5250-113-040-003	3
5250-113-040-004	4
5250-113-040-005	5
5250-113-040-006	6
5250-113-040-007	7
5250-113-040-008	8
5250-113-040-009	9
5250-113-040-010	10
5250-113-040-011	11
5250-113-040-012	12
5250-113-040-013	13
5250-113-040-014	14
5250-113-040-015	15
5250-113-040-016	16
5250-113-040-017	17
5250-113-040-018	18
5250-113-040-019	19
5250-113-040-020	20
5250-113-040-021	21
5250-113-040-022	22
5250-113-040-023	23
5250-113-040-024	24
5250-113-040-025	25
5250-113-040-026	26
5250-113-040-A08	1/8
5250-113-040-A10	5/32
5250-113-040-A12	3/16
5250-113-040-A14	7/32
5250-113-040-A16	1/4
5250-113-040-A18	9/32
5250-113-040-A20	5/16
5250-113-040-A22	11/32
5250-113-040-A24	3/8
5250-113-040-A26	13/32
5250-113-040-A28	7/16
5250-113-040-A30	15/32
5250-113-040-A32	1/2
5250-113-040-A34	17/32
5250-113-040-A36	9/16
5250-113-040-A38	19/32
5250-113-040-A40	5/8
5250-113-040-A42	21/32
5250-113-040-A44	11/16
5250-113-040-A46	23/32
5250-113-040-A48	3/4
5250-113-040-A56	7/8
5250-113-040-A64	1

ER - ES STEEL SEALED COLLET

ER - ES 斜槽止水筒夾

(ISO 15488)



ER11ES		ER16ES		ER20ES		ER25ES			
MODEL NO.	SIZE	MODEL NO.	SIZE	MODEL NO.	SIZE	MODEL NO.	SIZE	MODEL NO.	SIZE
5250-114-011-003	3	5250-114-016-003	3	5250-114-020-003	3	5250-114-025-003	3	5250-114-025-010	10
5250-114-011-003.5	3.5	5250-114-016-003.5	3.5	5250-114-020-003.5	3.5	5250-114-025-003.5	3.5	5250-114-025-010.5	10.5
5250-114-011-004	4	5250-114-016-004	4	5250-114-020-004	4	5250-114-025-004	4	5250-114-025-011	11
5250-114-011-004.5	4.5	5250-114-016-004.5	4.5	5250-114-020-004.5	4.5	5250-114-025-004.5	4.5	5250-114-025-011.5	11.5
5250-114-011-005	5	5250-114-016-005	5	5250-114-020-005	5	5250-114-025-005	5	5250-114-025-012	12
5250-114-011-005.5	5.5	5250-114-016-005.5	5.5	5250-114-020-005.5	5.5	5250-114-025-005.5	5.5	5250-114-025-012.5	12.5
5250-114-011-006	6	5250-114-016-006	6	5250-114-020-006	6	5250-114-025-006	6	5250-114-025-013	13
5250-114-011-006.5	6.5	5250-114-016-006.5	6.5	5250-114-020-006.5	6.5	5250-114-025-006.5	6.5	5250-114-025-013.5	13.5
5250-114-011-007	7	5250-114-016-007	7	5250-114-020-007	7	5250-114-025-007	7	5250-114-025-014	14
INCHES		5250-114-016-007.5	7.5	5250-114-020-007.5	7.5	5250-114-025-007.5	7.5	5250-114-025-014.5	14.5
5250-114-011-A06	3/32	5250-114-016-008	8	5250-114-020-008	8	5250-114-025-008	8	5250-114-025-015	15
5250-114-011-A08	1/8	5250-114-016-008.5	8.5	5250-114-020-008.5	8.5	5250-114-025-008.5	8.5	5250-114-025-015.5	15.5
5250-114-011-A10	5/32	5250-114-016-009	9	5250-114-020-009	9	5250-114-025-009	9	5250-114-025-016	16
5250-114-011-A12	3/16	5250-114-016-009.5	9.5	5250-114-020-009.5	9.5	5250-114-025-009.5	9.5		
5250-114-011-A14	7/32	5250-114-016-010	10	5250-114-020-010	10	INCHES			
5250-114-011-A16	1/4	INCHES		5250-114-020-010.5	10.5	5250-114-025-A14	7/32	5250-114-025-A28	7/16
		5250-114-016-A06	3/32	5250-114-020-011	11	5250-114-025-A16	1/4	5250-114-025-A30	15/32
		5250-114-016-A08	1/8	5250-114-020-011.5	11.5	5250-114-025-A18	9/32	5250-114-025-A32	1/2
		5250-114-016-A10	5/32	5250-114-020-012	12	5250-114-025-A20	5/16	5250-114-025-A34	17/32
		5250-114-016-A12	3/16	5250-114-020-012.5	12.5	5250-114-025-A22	11/32	5250-114-025-A36	9/16
		5250-114-016-A14	7/32	5250-114-020-013	13	5250-114-025-A24	3/8	5250-114-025-A38	19/32
		5250-114-016-A16	1/4	INCHES		5250-114-025-A26	13/32	5250-114-025-A40	5/8
		5250-114-016-A18	9/32	5250-114-020-A08	1/8				
		5250-114-016-A20	5/16	5250-114-020-A10	5/32				
		5250-114-016-A22	11/32	5250-114-020-A12	3/16				
		5250-114-016-A24	3/8	5250-114-020-A14	7/32				
		5250-114-016-A26	13/32	5250-114-020-A16	1/4				
				5250-114-020-A18	9/32				
				5250-114-020-A20	5/16				
				5250-114-020-A22	11/32				
				5250-114-020-A24	3/8				
				5250-114-020-A26	13/32				
				5250-114-020-A28	7/16				
				5250-114-020-A30	15/32				
				5250-114-020-A32	1/2				

Features:

- ▶ Runout accuracy: 15µm, A class 10µm, UP class 5µm.
- ▶ Surface roughness: Ra <0.25µm, A class Ra <0.15µm, UP class Ra <0.1µm.
- ▶ Used for coolant-through cutting tools.
- ▶ Water pressure up to 150 kgf/cm²(1400PSI).
- ▶ Only for tool shank with h6 tolerance and no flexible chucking range.



ER - ES STEEL SEALED COLLET

ER - ES 斜槽止水筒夾

(ISO 15488)



ER32ES			
MODEL NO.	SIZE	MODEL NO.	SIZE
5250-114-032-003	3	5250-114-032-012	12
5250-114-032-003.5	3.5	5250-114-032-012.5	12.5
5250-114-032-004	4	5250-114-032-013	13
5250-114-032-004.5	4.5	5250-114-032-013.5	13.5
5250-114-032-005	5	5250-114-032-014	14
5250-114-032-005.5	5.5	5250-114-032-014.5	14.5
5250-114-032-006	6	5250-114-032-015	15
5250-114-032-006.5	6.5	5250-114-032-015.5	15.5
5250-114-032-007	7	5250-114-032-016	16
5250-114-032-007.5	7.5	5250-114-032-016.5	16.5
5250-114-032-008	8	5250-114-032-017	17
5250-114-032-008.5	8.5	5250-114-032-017.5	17.5
5250-114-032-009	9	5250-114-032-018	18
5250-114-032-009.5	9.5	5250-114-032-018.5	18.5
5250-114-032-010	10	5250-114-032-019	19
5250-114-032-010.5	10.5	5250-114-032-019.5	19.5
5250-114-032-011	11	5250-114-032-020	20
5250-114-032-011.5	11.5		

INCHES

5250-114-032-A14	7/32	5250-114-032-A32	1/2
5250-114-032-A16	1/4	5250-114-032-A34	17/32
5250-114-032-A18	9/32	5250-114-032-A36	9/16
5250-114-032-A20	5/16	5250-114-032-A38	19/32
5250-114-032-A22	11/32	5250-114-032-A40	5/8
5250-114-032-A24	3/8	5250-114-032-A42	21/32
5250-114-032-A26	13/32	5250-114-032-A44	11/16
5250-114-032-A28	7/16	5250-114-032-A46	23/32
5250-114-032-A30	15/32	5250-114-032-A48	3/4

ER40ES			
MODEL NO.	SIZE	MODEL NO.	SIZE
5250-114-040-003	3	5250-114-040-015	15
5250-114-040-003.5	3.5	5250-114-040-015.5	15.5
5250-114-040-004	4	5250-114-040-016	16
5250-114-040-004.5	4.5	5250-114-040-016.5	16.5
5250-114-040-005	5	5250-114-040-017	17
5250-114-040-005.5	5.5	5250-114-040-017.5	17.5
5250-114-040-006	6	5250-114-040-018	18
5250-114-040-006.5	6.5	5250-114-040-018.5	18.5
5250-114-040-007	7	5250-114-040-019	19
5250-114-040-007.5	7.5	5250-114-040-019.5	19.5
5250-114-040-008	8	5250-114-040-020	20
5250-114-040-008.5	8.5	5250-114-040-020.5	20.5
5250-114-040-009	9	5250-114-040-021	21
5250-114-040-009.5	9.5	5250-114-040-021.5	21.5
5250-114-040-010	10	5250-114-040-022	22
5250-114-040-010.5	10.5	5250-114-040-022.5	22.5
5250-114-040-011	11	5250-114-040-023	23
5250-114-040-011.5	11.5	5250-114-040-023.5	23.5
5250-114-040-012	12	5250-114-040-024	24
5250-114-040-012.5	12.5	5250-114-040-024.5	24.5
5250-114-040-013	13	5250-114-040-025	25
5250-114-040-013.5	13.5	5250-114-040-025.5	25.5
5250-114-040-014	14	5250-114-040-026	26
5250-114-040-014.5	14.5		

INCHES

5250-114-040-A14	7/32	5250-114-040-A34	17/32
5250-114-040-A16	1/4	5250-114-040-A36	9/16
5250-114-040-A18	9/32	5250-114-040-A38	19/32
5250-114-040-A20	5/16	5250-114-040-A40	5/8
5250-114-040-A22	11/32	5250-114-040-A42	21/32
5250-114-040-A24	3/8	5250-114-040-A44	11/16
5250-114-040-A26	13/32	5250-114-040-A46	23/32
5250-114-040-A28	7/16	5250-114-040-A48	3/4
5250-114-040-A30	15/32	5250-114-040-A56	7/8
5250-114-040-A32	1/2	5250-114-040-A64	1

Features:

- ▶ Runout accuracy: 15 μ m, A class 10 μ m, UP class 5 μ m.
- ▶ Surface roughness: Ra <0.25 μ m, A class Ra <0.15 μ m, UP class Ra <0.1 μ m.
- ▶ Used for coolant-through cutting tools.
- ▶ Water pressure up to 150 kgf/cm²(1400PSI).
- ▶ Only for tool shank with h6 tolerance and no flexible chucking range.



ERS METALLIC SEALED COLLET

ERS 直溝止水筒夾

(ISO 15488)



ERS11		ERS16		ERS20		ERS25			
MODEL NO.	SIZE	MODEL NO.	SIZE	MODEL NO.	SIZE	MODEL NO.	SIZE	MODEL NO.	SIZE
5250-111-011-003	3	5250-111-016-003	3	5250-111-020-003	3	5250-111-025-003	3	5250-111-025-010	10
5250-111-011-003.5	3.5	5250-111-016-003.5	3.5	5250-111-020-003.5	3.5	5250-111-025-03.5	3.5	5250-111-025-010.5	10.5
5250-111-011-004	4	5250-111-016-004	4	5250-111-020-004	4	5250-111-025-004	4	5250-111-025-011	11
5250-111-011-004.5	4.5	5250-111-016-004.5	4.5	5250-111-020-004.5	4.5	5250-111-025-04.5	4.5	5250-111-025-011.5	11.5
5250-111-011-005	5	5250-111-016-005	5	5250-111-020-005	5	5250-111-025-005	5	5250-111-025-012	12
5250-111-011-005.5	5.5	5250-111-016-005.5	5.5	5250-111-020-005.5	5.5	5250-111-025-05.5	5.5	5250-111-025-012.5	12.5
5250-111-011-006	6	5250-111-016-006	6	5250-111-020-006	6	5250-111-025-006	6	5250-111-025-013	13
5250-111-011-006.5	6.5	5250-111-016-006.5	6.5	5250-111-020-006.5	6.5	5250-111-025-06.5	6.5	5250-111-025-013.5	13.5
5250-111-011-007	7	5250-111-016-007	7	5250-111-020-007	7	5250-111-025-007	7	5250-111-025-014	14
INCHES		5250-111-016-007.5	7.5	5250-111-020-007.5	7.5	5250-111-025-07.5	7.5	5250-111-025-014.5	14.5
5250-111-011-A06	3/32	5250-111-016-008	8	5250-111-020-008	8	5250-111-025-008	8	5250-111-025-015	15
5250-111-011-A08	1/8	5250-111-016-008.5	8.5	5250-111-020-008.5	8.5	5250-111-025-08.5	8.5	5250-111-025-015.5	15.5
5250-111-011-A10	5/32	5250-111-016-009	9	5250-111-020-009	9	5250-111-025-009	9	5250-111-025-016	16
5250-111-011-A12	3/16	5250-111-016-009.5	9.5	5250-111-020-09.5	9.5	5250-111-025-009.5	9.5		
5250-111-011-A14	7/32	5250-111-016-010	10	5250-111-020-010	10	INCHES			
5250-111-011-A16	1/4	INCHES		5250-111-020-010.5	10.5	5250-111-025-A14	7/32	5250-111-025-A28	7/16
		5250-111-016-A06	3/32	5250-111-020-011	11	5250-111-025-A16	1/4	5250-111-025-A30	15/32
		5250-111-016-A08	1/8	5250-111-020-011.5	11.5	5250-111-025-A18	9/32	5250-111-025-A32	1/2
		5250-111-016-A10	5/32	5250-111-020-012	12	5250-111-025-A20	5/16	5250-111-025-A34	17/32
		5250-111-016-A12	3/16	5250-111-020-012.5	12.5	5250-111-025-A22	11/32	5250-111-025-A36	9/16
		5250-111-016-A14	7/32	5250-111-020-013	13	5250-111-025-A24	3/8	5250-111-025-A38	19/32
		5250-111-016-A16	1/4	INCHES		5250-111-025-A26	13/32	5250-111-025-A40	5/8
		5250-111-016-A18	9/32	5250-111-020-A08	1/8				
		5250-111-016-A20	5/16	5250-111-020-A10	5/32				
		5250-111-016-A22	11/32	5250-111-020-A12	3/16				
		5250-111-016-A24	3/8	5250-111-020-A14	7/32				
		5250-111-016-A26	13/32	5250-111-020-A16	1/4				
				5250-111-020-A18	9/32				
				5250-111-020-A20	5/16				
				5250-111-020-A22	11/32				
				5250-111-020-A24	3/8				
				5250-111-020-A26	13/32				
				5250-111-020-A28	7/16				
				5250-111-020-A30	15/32				
				5250-111-020-A32	1/2				

Features:

- ▶ Runout accuracy: 10µm, R class 7µm, UP class 5µm, P class 3µm.
- ▶ Surface roughness: Ra<0.15µm, R class Ra <0.12µm, UP/P class Ra <0.1µm.
- ▶ Used for coolant-through cutting tools.
- ▶ Water pressure up to 150 kgf/cm²(1400PSI).
- ▶ Only for tool shank with h6 tolerance and no flexible chucking range.



ERS METALLIC SEALED COLLET

ERS 直溝止水筒夾

(ISO 15488)



ERS32			
MODEL NO.	SIZE	MODEL NO.	SIZE
5250-111-032-003	3	5250-111-032-012	12
5250-111-032-003.5	3.5	5250-111-032-012.5	12.5
5250-111-032-004	4	5250-111-032-013	13
5250-111-032-004.5	4.5	5250-111-032-013.5	13.5
5250-111-032-005	5	5250-111-032-014	14
5250-111-032-005.5	5.5	5250-111-032-014.5	14.5
5250-111-032-006	6	5250-111-032-015	15
5250-111-032-006.5	6.5	5250-111-032-015.5	15.5
5250-111-032-007	7	5250-111-032-016	16
5250-111-032-007.5	7.5	5250-111-032-016.5	16.5
5250-111-032-008	8	5250-111-032-017	17
5250-111-032-008.5	8.5	5250-111-032-017.5	17.5
5250-111-032-009	9	5250-111-032-018	18
5250-111-032-009.5	9.5	5250-111-032-018.5	18.5
5250-111-032-010	10	5250-111-032-019	19
5250-111-032-010.5	10.5	5250-111-032-019.5	19.5
5250-111-032-011	11	5250-111-032-020	20
5250-111-032-011.5	11.5		

INCHES

5250-111-032-A14	7/32	5250-111-032-A32	1/2
5250-111-032-A16	1/4	5250-111-032-A34	17/32
5250-111-032-A18	9/32	5250-111-032-A36	9/16
5250-111-032-A20	5/16	5250-111-032-A38	19/32
5250-111-032-A22	11/32	5250-111-032-A40	5/8
5250-111-032-A24	3/8	5250-111-032-A42	21/32
5250-111-032-A26	13/32	5250-111-032-A44	11/16
5250-111-032-A28	7/16	5250-111-032-A46	23/32
5250-111-032-A30	15/32	5250-111-032-A48	3/4

ERS40			
MODEL NO.	SIZE	MODEL NO.	SIZE
5250-111-040-003	3	5250-111-040-015	15
5250-111-040-003.5	3.5	5250-111-040-015.5	15.5
5250-111-040-004	4	5250-111-040-016	16
5250-111-040-004.5	4.5	5250-111-040-016.5	16.5
5250-111-040-005	5	5250-111-040-017	17
5250-111-040-005.5	5.5	5250-111-040-017.5	17.5
5250-111-040-006	6	5250-111-040-018	18
5250-111-040-006.5	6.5	5250-111-040-018.5	18.5
5250-111-040-007	7	5250-111-040-019	19
5250-111-040-007.5	7.5	5250-111-040-019.5	19.5
5250-111-040-008	8	5250-111-040-020	20
5250-111-040-008.5	8.5	5250-111-040-020.5	20.5
5250-111-040-009	9	5250-111-040-021	21
5250-111-040-009.5	9.5	5250-111-040-021.5	21.5
5250-111-040-010	10	5250-111-040-022	22
5250-111-040-010.5	10.5	5250-111-040-022.5	22.5
5250-111-040-011	11	5250-111-040-023	23
5250-111-040-011.5	11.5	5250-111-040-023.5	23.5
5250-111-040-012	12	5250-111-040-024	24
5250-111-040-012.5	12.5	5250-111-040-024.5	24.5
5250-111-040-013	13	5250-111-040-025	25
5250-111-040-013.5	13.5	5250-111-040-025.5	25.5
5250-111-040-014	14	5250-111-040-026	26
5250-111-040-014.5	14.5		

INCHES

5250-111-040-A14	7/32	5250-111-040-A34	17/32
5250-111-040-A16	1/4	5250-111-040-A36	9/16
5250-111-040-A18	9/32	5250-111-040-A38	19/32
5250-111-040-A20	5/16	5250-111-040-A40	5/8
5250-111-040-A22	11/32	5250-111-040-A42	21/32
5250-111-040-A24	3/8	5250-111-040-A44	11/16
5250-111-040-A26	13/32	5250-111-040-A46	23/32
5250-111-040-A28	7/16	5250-111-040-A48	3/4
5250-111-040-A30	15/32	5250-111-040-A56	7/8
5250-111-040-A32	1/2	5250-111-040-A64	1

Features:

- ▶ Runout accuracy: 10 μ m, R class 7 μ m, UP class 5 μ m, P class 3 μ m.
- ▶ Surface roughness: Ra<0.15 μ m, R class Ra <0.12 μ m, UP/P class Ra <0.1 μ m.
- ▶ Used for coolant-through cutting tools.
- ▶ Water pressure up to 150 kgf/cm²(1400PSI).
- ▶ Only for tool shank with h6 tolerance and no flexible chucking range.



ERS COOLANT COLLET FID TYPE

ERS 直溝出水筒夾 [FID型]

[ISO 15488]



ERS11 - FID		ERS16 - FID		ERS20 - FID		ERS25 - FID			
MODEL NO.	SIZE	MODEL NO.	SIZE	MODEL NO.	SIZE	MODEL NO.	SIZE	MODEL NO.	SIZE
5250-188-011-003	3	5250-188-016-003	3	5250-188-020-003	3	5250-188-025-003	3	5250-188-025-010	10
5250-188-011-003.5	3.5	5250-188-016-003.5	3.5	5250-188-020-003.5	3.5	5250-188-025-003.5	3.5	5250-188-025-010.5	10.5
5250-188-011-004	4	5250-188-016-004	4	5250-188-020-004	4	5250-188-025-004	4	5250-188-025-011	11
5250-188-011-004.5	4.5	5250-188-016-004.5	4.5	5250-188-020-004.5	4.5	5250-188-025-004.5	4.5	5250-188-025-011.5	11.5
5250-188-011-005	5	5250-188-016-005	5	5250-188-020-005	5	5250-188-025-005	5	5250-188-025-012	12
5250-188-011-005.5	5.5	5250-188-016-005.5	5.5	5250-188-020-005.5	5.5	5250-188-025-005.5	5.5	5250-188-025-012.5	12.5
5250-188-011-006	6	5250-188-016-006	6	5250-188-020-006	6	5250-188-025-006	6	5250-188-025-013	13
5250-188-011-006.5	6.5	5250-188-016-006.5	6.5	5250-188-020-006.5	6.5	5250-188-025-006.5	6.5	5250-188-025-013.5	13.5
5250-188-011-007	7	5250-188-016-007	7	5250-188-020-007	7	5250-188-025-007	7	5250-188-025-014	14
INCHES		5250-188-016-007.5	7.5	5250-188-020-007.5	7.5	5250-188-025-007.5	7.5	5250-188-025-014.5	14.5
5250-188-011-A06	3/32	5250-188-016-008	8	5250-188-020-008	8	5250-188-025-008	8	5250-188-025-015	15
5250-188-011-A08	1/8	5250-188-016-008.5	8.5	5250-188-020-008.5	8.5	5250-188-025-008.5	8.5	5250-188-025-015.5	15.5
5250-188-011-A10	5/32	5250-188-016-009	9	5250-188-020-009	9	5250-188-025-009	9	5250-188-025-016	16
5250-188-011-A12	3/16	5250-188-016-009.5	9.5	5250-188-020-009.5	9.5	5250-188-025-009.5	9.5		
5250-188-011-A14	7/32	5250-188-016-010	10	5250-188-020-010	10	INCHES			
5250-188-011-A16	1/4	INCHES		5250-188-020-010.5	10.5	5250-188-025-A14	7/32	5250-188-025-A28	7/16
		5250-188-016-A06	3/32	5250-188-020-011	11	5250-188-025-A16	1/4	5250-188-025-A30	15/32
		5250-188-016-A08	1/8	5250-188-020-011.5	11.5	5250-188-025-A18	9/32	5250-188-025-A32	1/2
		5250-188-016-A10	5/32	5250-188-020-012	12	5250-188-025-A20	5/16	5250-188-025-A34	17/32
		5250-188-016-A12	3/16	5250-188-020-012.5	12.5	5250-188-025-A22	11/32	5250-188-025-A36	9/16
		5250-188-016-A14	7/32	5250-188-020-013	13	5250-188-025-A24	3/8	5250-188-025-A38	19/32
		5250-188-016-A16	1/4	INCHES		5250-188-025-A26	13/32	5250-188-025-A40	5/8
		5250-188-016-A18	9/32	5250-188-020-A08	1/8				
		5250-188-016-A20	5/16	5250-188-020-A10	5/32				
		5250-188-016-A22	11/32	5250-188-020-A12	3/16				
		5250-188-016-A24	3/8	5250-188-020-A14	7/32				
		5250-188-016-A26	13/32	5250-188-020-A16	1/4				
				5250-188-020-A18	9/32				
				5250-188-020-A20	5/16				
				5250-188-020-A22	11/32				
				5250-188-020-A24	3/8				

Features:

- ▶ Runout accuracy: 10µm, R class 7µm, UP class 5µm, P class 3µm.
- ▶ Surface roughness: Ra<0.15µm, R class Ra <0.12µm, UP/P class Ra <0.1µm.
- ▶ Used for cutting tools without coolant holes.
- ▶ Water pressure up to 150 kgf/cm²(1400PSI).
- ▶ Only for tool shank with h6 tolerance and no flexible chucking range.



ERS COOLANT COLLET FID TYPE

ERS 直溝出水筒夾 [FID型]

[ISO 15488]



ERS32 - FID			
MODEL NO.	SIZE	MODEL NO.	SIZE
5250-188-032-003	3	5250-188-032-012	12
5250-188-032-003.5	3.5	5250-188-032-012.5	12.5
5250-188-032-004	4	5250-188-032-013	13
5250-188-032-004.5	4.5	5250-188-032-013.5	13.5
5250-188-032-005	5	5250-188-032-014	14
5250-188-032-005.5	5.5	5250-188-032-014.5	14.5
5250-188-032-006	6	5250-188-032-015	15
5250-188-032-006.5	6.5	5250-188-032-015.5	15.5
5250-188-032-007	7	5250-188-032-016	16
5250-188-032-007.5	7.5	5250-188-032-016.5	16.5
5250-188-032-008	8	5250-188-032-017	17
5250-188-032-008.5	8.5	5250-188-032-017.5	17.5
5250-188-032-009	9	5250-188-032-018	18
5250-188-032-009.5	9.5	5250-188-032-018.5	18.5
5250-188-032-010	10	5250-188-032-019	19
5250-188-032-010.5	10.5	5250-188-032-019.5	19.5
5250-188-032-011	11	5250-188-032-020	20
5250-188-032-011.5	11.5		

INCHES

5250-188-032-A14	7/32	5250-188-032-A32	1/2
5250-188-032-A16	1/4	5250-188-032-A34	17/32
5250-188-032-A18	9/32	5250-188-032-A36	9/16
5250-188-032-A20	5/16	5250-188-032-A38	19/32
5250-188-032-A22	11/32	5250-188-032-A40	5/8
5250-188-032-A24	3/8	5250-188-032-A42	21/32
5250-188-032-A26	13/32	5250-188-032-A44	11/16
5250-188-032-A28	7/16	5250-188-032-A46	23/32
5250-188-032-A30	15/32	5250-188-032-A48	3/4

ERS40 - FID			
MODEL NO.	SIZE	MODEL NO.	SIZE
5250-188-040-003	3	5250-188-040-015	15
5250-188-040-003.5	3.5	5250-188-040-015.5	15.5
5250-188-040-004	4	5250-188-040-016	16
5250-188-040-004.5	4.5	5250-188-040-016.5	16.5
5250-188-040-005	5	5250-188-040-017.5	17
5250-188-040-005.5	5.5	5250-188-040-017.5	17.5
5250-188-040-006	6	5250-188-040-018	18
5250-188-040-006.5	6.5	5250-188-040-018.5	18.5
5250-188-040-007	7	5250-188-040-019	19
5250-188-040-007.5	7.5	5250-188-040-019.5	19.5
5250-188-040-008	8	5250-188-040-020	20
5250-188-040-008.5	8.5	5250-188-040-020.5	20.5
5250-188-040-009	9	5250-188-040-021	21
5250-188-040-009.5	9.5	5250-188-040-021.5	21.5
5250-188-040-010	10	5250-188-040-022	22
5250-188-040-010.5	10.5	5250-188-040-022.5	22.5
5250-188-040-011	11	5250-188-040-023	23
5250-188-040-011.5	11.5	5250-188-040-023.5	23.5
5250-188-040-012	12	5250-188-040-024	24
5250-188-040-012.5	12.5	5250-188-040-024.5	24.5
5250-188-040-013	13	5250-188-040-025	25
5250-188-040-013.5	13.5	5250-188-040-025.5	25.5
5250-188-040-014	14	5250-188-040-026	26
5250-188-040-014.5	14.5		

INCHES

5250-188-040-A14	7/32	5250-188-040-A34	17/32
5250-188-040-A16	1/4	5250-188-040-A36	9/16
5250-188-040-A18	9/32	5250-188-040-A38	19/32
5250-188-040-A20	5/16	5250-188-040-A40	5/8
5250-188-040-A22	11/32	5250-188-040-A42	21/32
5250-188-040-A24	3/8	5250-188-040-A44	11/16
5250-188-040-A26	13/32	5250-188-040-A46	23/32
5250-188-040-A28	7/16	5250-188-040-A48	3/4
5250-188-040-A30	15/32	5250-188-040-A56	7/8
5250-188-040-A32	1/2	5250-188-040-A64	1

Features:

- ▶ Runout accuracy: 10 μ m, R class 7 μ m, UP class 5 μ m, P class 3 μ m.
- ▶ Surface roughness: Ra<0.15 μ m, R class Ra <0.12 μ m, UP/P class Ra <0.1 μ m.
- ▶ Used for cutting tools without coolant holes.
- ▶ Water pressure up to 150 kgf/cm²(1400PSI).
- ▶ Only for tool shank with h6 tolerance and no flexible chucking range.



ERS COOLANT COLLET FOD TYPE

ERS 直溝出水筒夾 [FOD型]

[ISO 15488]



ERS11 - FOD		ERS16 - FOD		ERS20 - FOD		ERS25 - FOD			
MODEL NO.	SIZE	MODEL NO.	SIZE	MODEL NO.	SIZE	MODEL NO.	SIZE	MODEL NO.	SIZE
5250-112-011-003	3	5250-112-016-003	3	5250-112-020-003	3	5250-112-025-003	3	5250-112-025-009	9
5250-112-011-003.5	3.5	5250-112-016-003.5	3.5	5250-112-020-003.5	3.5	5250-112-025-003.5	3.5	5250-112-025-009.5	9.5
5250-112-011-004	4	5250-112-016-004	4	5250-112-020-004	4	5250-112-025-004	4	5250-112-025-010	10
5250-112-011-004.5	4.5	5250-112-016-004.5	4.5	5250-112-020-004.5	4.5	5250-112-025-004.5	4.5	5250-112-025-010.5	10.5
5250-112-011-005	5	5250-112-016-005	5	5250-112-020-005	5	5250-112-025-005	5	5250-112-025-011	11
INCHES		5250-112-016-005.5	5.5	5250-112-020-005.5	5.5	5250-112-025-005.5	5.5	5250-112-025-011.5	11.5
5250-112-011-A06	3/32	5250-112-016-006	6	5250-112-020-006	6	5250-112-025-006	6	5250-112-025-012	12
5250-112-011-A08	1/8	5250-112-016-006.5	6.5	5250-112-020-006.5	6.5	5250-112-025-006.5	6.5	5250-112-025-012.5	12.5
5250-112-011-A10	5/32	5250-112-016-007	7	5250-112-020-007	7	5250-112-025-007	7	5250-112-025-013	13
5250-112-011-A12	3/16	INCHES		5250-112-020-007.5	7.5	5250-112-025-007.5	7.5	5250-112-025-013.5	13.5
5250-112-011-A14	7/32	5250-112-016-A06	3/32	5250-112-020-008	8	5250-112-025-008	8	5250-112-025-014	14
5250-112-011-A16	1/4	5250-112-016-A08	1/8	5250-112-020-008.5	8.5	5250-112-025-008.5	8.5		
		5250-112-016-A10	5/32	5250-112-020-009	9	INCHES			
		5250-112-016-A12	3/16	INCHES		5250-112-025-A14	7/32	5250-112-025-A26	13/32
		5250-112-016-A14	7/32	5250-112-020-A08	1/8	5250-112-025-A16	1/4	5250-112-025-A28	7/16
		5250-112-016-A16	1/4	5250-112-020-A10	5/32	5250-112-025-A18	9/32	5250-112-025-A30	15/32
		5250-112-016-A18	9/32	5250-112-020-A12	3/16	5250-112-025-A20	5/16	5250-112-025-A32	1/2
		5250-112-016-A20	5/16	5250-112-020-A14	7/32	5250-112-025-A22	11/32	5250-112-025-A34	17/32
				5250-112-020-A16	1/4	5250-112-025-A24	3/8	5250-112-025-A36	9/16
				5250-112-020-A18	9/32				
				5250-112-020-A20	5/16				
				5250-112-020-A22	11/32				
				5250-112-020-A24	3/8				

Features:

- ▶ Runout accuracy: 10µm, R class 7µm, UP class 5µm, P class 3µm.
- ▶ Surface roughness: Ra<0.15µm, R class Ra <0.12µm, UP/P class Ra <0.1µm.
- ▶ Used for cutting tools without coolant holes.
- ▶ Water pressure up to 150 kgf/cm²(1400PSI).
- ▶ Only for tool shank with h6 tolerance and no flexible chucking range.



ERS COOLANT COLLET FOD TYPE

ERS 直溝出水筒夾 [FOD型]

(ISO 15488)



ERS32 - FOD			
MODEL NO.	SIZE	MODEL NO.	SIZE
5250-112-032-003	3	5250-112-032-012	12
5250-112-032-003.5	3.5	5250-112-032-012.5	12.5
5250-112-032-004	4	5250-112-032-013	13
5250-112-032-004.5	4.5	5250-112-032-013.5	13.5
5250-112-032-005	5	5250-112-032-014	14
5250-112-032-005.5	5.5	5250-112-032-014.5	14.5
5250-112-032-006	6	5250-112-032-015	15
5250-112-032-006.5	6.5	5250-112-032-015.5	15.5
5250-112-032-007	7	5250-112-032-016	16
5250-112-032-007.5	7.5	5250-112-032-016.5	16.5
5250-112-032-008	8	5250-112-032-017	17
5250-112-032-008.5	8.5	5250-112-032-017.5	17.5
5250-112-032-009	9	5250-112-032-018	18
5250-112-032-009.5	9.5	5250-112-032-018.5	18.5
5250-112-032-010	10	5250-112-032-019	19
5250-112-032-010.5	10.5	5250-112-032-019.5	19.5
5250-112-032-011	11	5250-112-032-020	20
5250-112-032-011.5	11.5		

INCHES

5250-112-032-A14	7/32	5250-112-032-A32	1/2
5250-112-032-A16	1/4	5250-112-032-A34	17/32
5250-112-032-A18	9/32	5250-112-032-A36	9/16
5250-112-032-A20	5/16	5250-112-032-A38	19/32
5250-112-032-A22	11/32	5250-112-032-A40	5/8
5250-112-032-A24	3/8	5250-112-032-A42	21/32
5250-112-032-A26	13/32	5250-112-032-A44	11/16
5250-112-032-A28	7/16	5250-112-032-A46	23/32
5250-112-032-A30	15/32	5250-112-032-A48	3/4

ERS40 - FOD			
MODEL NO.	SIZE	MODEL NO.	SIZE
5250-112-040-003	3	5250-112-040-015	15
5250-112-040-003.5	3.5	5250-112-040-015.5	15.5
5250-112-040-004	4	5250-112-040-016	16
5250-112-040-004.5	4.5	5250-112-040-016.5	16.5
5250-112-040-005	5	5250-112-040-017	17
5250-112-040-005.5	5.5	5250-112-040-017.5	17.5
5250-112-040-006	6	5250-112-040-018	18
5250-112-040-006.5	6.5	5250-112-040-018.5	18.5
5250-112-040-007	7	5250-112-040-019	19
5250-112-040-007.5	7.5	5250-112-040-019.5	19.5
5250-112-040-008	8	5250-112-040-020	20
5250-112-040-008.5	8.5	5250-112-040-020.5	20.5
5250-112-040-009	9	5250-112-040-021	21
5250-112-040-009.5	9.5	5250-112-040-021.5	21.5
5250-112-040-010	10	5250-112-040-022	22
5250-112-040-010.5	10.5	5250-112-040-022.5	22.5
5250-112-040-011	11	5250-112-040-023	23
5250-112-040-011.5	11.5	5250-112-040-023.5	23.5
5250-112-040-012	12	5250-112-040-024	24
5250-112-040-012.5	12.5	5250-112-040-024.5	24.5
5250-112-040-013	13	5250-112-040-025	25
5250-112-040-013.5	13.5	5250-112-040-025.5	25.5
5250-112-040-014	14	5250-112-040-026	26
5250-112-040-014.5	14.5		

INCHES

5250-112-040-A14	7/32	5250-112-040-A34	17/32
5250-112-040-A16	1/4	5250-112-040-A36	9/16
5250-112-040-A18	9/32	5250-112-040-A38	19/32
5250-112-040-A20	5/16	5250-112-040-A40	5/8
5250-112-040-A22	11/32	5250-112-040-A42	21/32
5250-112-040-A24	3/8	5250-112-040-A44	11/16
5250-112-040-A26	13/32	5250-112-040-A46	23/32
5250-112-040-A28	7/16	5250-112-040-A48	3/4
5250-112-040-A30	15/32	5250-112-040-A56	7/8
5250-112-040-A32	1/2	5250-112-040-A64	1

Features:

- ▶ Runout accuracy: 10 μ m, R class 7 μ m, UP class 5 μ m, P class 3 μ m.
- ▶ Surface roughness: Ra<0.15 μ m, R class Ra <0.12 μ m, UP/P class Ra <0.1 μ m.
- ▶ Used for cutting tools without coolant holes.
- ▶ Water pressure up to 150 kgf/cm²(1400PSI).
- ▶ Only for tool shank with h6 tolerance and no flexible chucking range.



ER - EO SEALED COLLET

ER - EO 止水筒夾

[ISO 15488]

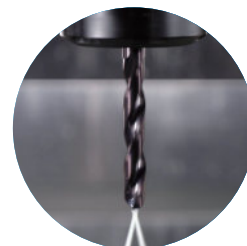

ER11EO		ER20EO		ER25EO		ER32EO		ER40EO			
MODEL NO.	SIZE	MODEL NO.	SIZE	MODEL NO.	SIZE	MODEL NO.	SIZE	MODEL NO.	SIZE	MODEL NO.	SIZE
5250-115-011-003	3	5250-115-020-003	3	5250-115-025-003	3	5250-115-032-003	3	5250-115-040-003	3	5250-115-040-015	15
5250-115-011-004	4	5250-115-020-004	4	5250-115-025-004	4	5250-115-032-004	4	5250-115-040-004	4	5250-115-040-016	16
5250-115-011-005	5	5250-115-020-005	5	5250-115-025-005	5	5250-115-032-005	5	5250-115-040-005	5	5250-115-040-017	17
5250-115-011-006	6	5250-115-020-006	6	5250-115-025-006	6	5250-115-032-006	6	5250-115-040-006	6	5250-115-040-018	18
5250-115-011-007	7	5250-115-020-007	7	5250-115-025-007	7	5250-115-032-007	7	5250-115-040-007	7	5250-115-040-019	19
INCHES		5250-115-020-008	8	5250-115-025-008	8	5250-115-032-008	8	5250-115-040-008	8	5250-115-040-020	20
5250-115-011-A08	1/8	5250-115-020-009	9	5250-115-025-009	9	5250-115-032-009	9	5250-115-040-009	9	5250-115-040-021	21
5250-115-011-A10	5/32	5250-115-020-010	10	5250-115-025-010	10	5250-115-032-010	10	5250-115-040-010	10	5250-115-040-022	22
5250-115-011-A12	3/16	5250-115-020-011	11	5250-115-025-011	11	5250-115-032-011	11	5250-115-040-011	11	5250-115-040-023	23
5250-115-011-A14	7/32	5250-115-020-012	12	5250-115-025-012	12	5250-115-032-012	12	5250-115-040-012	12	5250-115-040-024	24
5250-115-011-A16	1/4	5250-115-020-013	13	5250-115-025-013	13	5250-115-032-013	13	5250-115-040-013	13	5250-115-040-025	25
5250-115-011-A18	9/32	INCHES		5250-115-025-014	14	5250-115-032-014	14	5250-115-040-014	14	5250-115-040-026	26
ER16EO		5250-115-020-A08	1/8	5250-115-025-015	15	5250-115-032-015	15	INCHES		5250-115-040-A08	1/8
MODEL NO.	SIZE	5250-115-020-A10	5/32	5250-115-025-016	16	5250-115-032-016	16	5250-115-040-A10	5/32	5250-115-040-A32	1/2
5250-115-016-003	3	5250-115-020-A12	3/16	INCHES		5250-115-032-017	17	5250-115-040-A12	3/16	5250-115-040-A34	17/32
5250-115-016-004	4	5250-115-020-A14	7/32	5250-115-025-A08	1/8	5250-115-032-018	18	5250-115-040-A14	7/32	5250-115-040-A36	9/16
5250-115-016-005	5	5250-115-020-A16	1/4	5250-115-025-A10	5/32	5250-115-032-019	19	5250-115-040-A16	7/32	5250-115-040-A38	19/32
5250-115-016-006	6	5250-115-020-A18	9/32	5250-115-025-A12	3/16	5250-115-032-020	20	5250-115-040-A18	1/4	5250-115-040-A40	5/8
5250-115-016-007	7	5250-115-020-A20	5/16	5250-115-025-A14	7/32	INCHES		5250-115-040-A18	9/32	5250-115-040-A42	21/32
5250-115-016-008	8	5250-115-020-A22	11/32	5250-115-025-A16	1/4	5250-115-032-A08	1/8	5250-115-040-A20	5/16	5250-115-040-A44	11/16
5250-115-016-009	9	5250-115-020-A24	3/8	5250-115-025-A18	9/32	5250-115-032-A10	5/32	5250-115-040-A22	11/32	5250-115-040-A46	23/32
5250-115-016-010	10	5250-115-020-A26	13/32	5250-115-025-A20	5/16	5250-115-032-A12	3/16	5250-115-040-A24	3/8	5250-115-040-A48	3/4
INCHES		5250-115-020-A28	7/16	5250-115-025-A22	11/32	5250-115-032-A14	7/32	5250-115-040-A26	13/32	5250-115-040-A56	7/8
5250-115-016-A08	1/8	5250-115-020-A30	15/32	5250-115-025-A24	3/8	5250-115-032-A16	1/4	5250-115-040-A28	7/16	5250-115-040-A64	1
5250-115-016-A10	5/32	5250-115-020-A32	1/2	5250-115-025-A26	13/32	5250-115-032-A18	9/32	5250-115-040-A30	15/32		
5250-115-016-A12	3/16			5250-115-025-A28	7/16	5250-115-032-A20	5/16				
5250-115-016-A14	7/32			5250-115-025-A30	15/32	5250-115-032-A22	11/32				
5250-115-016-A16	1/4			5250-115-025-A32	1/2	5250-115-032-A24	3/8				
5250-115-016-A18	9/32			5250-115-025-A34	17/32	5250-115-032-A26	13/32				
5250-115-016-A20	5/16			5250-115-025-A36	9/16	5250-115-032-A28	7/16				
5250-115-016-A22	11/32			5250-115-025-A38	19/32	5250-115-032-A30	15/32				
5250-115-016-A24	3/8			5250-115-025-A40	5/8	5250-115-032-A32	1/2				
5250-115-016-A26	13/32					5250-115-032-A34	17/32				
						5250-115-032-A36	9/16				
						5250-115-032-A38	19/32				
						5250-115-032-A40	5/8				
						5250-115-032-A42	21/32				
						5250-115-032-A44	11/16				
						5250-115-032-A46	23/32				
						5250-115-032-A48	3/4				

Features:

- ▶ Runout accuracy: 15µm, A class 10µm, UP class 5µm.
- ▶ Used for coolant-through cutting tools.
- ▶ The design is to use O-rings to seal and achieve coolant through tools.
- ▶ Water pressure up to 50 kgf/cm².



ER COOLANT COLLET FID TYPE

ER - FID 出水筒夾

(ISO 15488)



TW PAT NO. M362073

ER16 - FID		ER25 - FID		ER32 - FID		ER40 - FID			
MODEL NO.	SIZE	MODEL NO.	SIZE	MODEL NO.	SIZE	MODEL NO.	SIZE	MODEL NO.	SIZE
5250-126-016-003	3	5250-126-025-003	3	5250-126-032-003	3	5250-126-040-004	4	5250-126-040-016	16
5250-126-016-004	4	5250-126-025-004	4	5250-126-032-004	4	5250-126-040-005	5	5250-126-040-017	17
5250-126-016-005	5	5250-126-025-005	5	5250-126-032-005	5	5250-126-040-006	6	5250-126-040-018	18
5250-126-016-006	6	5250-126-025-006	6	5250-126-032-006	6	5250-126-040-007	7	5250-126-040-019	19
5250-126-016-007	7	5250-126-025-007	7	5250-126-032-007	7	5250-126-040-008	8	5250-126-040-020	20
5250-126-016-008	8	5250-126-025-008	8	5250-126-032-008	8	5250-126-040-009	9	5250-126-040-021	21
5250-126-016-009	9	5250-126-025-009	9	5250-126-032-009	9	5250-126-040-010	10	5250-126-040-022	22
INCHES		5250-126-025-010	10	5250-126-032-010	10	5250-126-040-011	11	5250-126-040-023	23
5250-126-016-A08	1/8	5250-126-025-011	11	5250-126-032-011	11	5250-126-040-012	12	5250-126-040-024	24
5250-126-016-A10	5/32	5250-126-025-012	12	5250-126-032-012	12	5250-126-040-013	13	5250-126-040-025	25
5250-126-016-A12	3/16	5250-126-025-013	13	5250-126-032-013	13	5250-126-040-014	14	5250-126-040-026	26
5250-126-016-A14	7/32	5250-126-025-014	14	5250-126-032-014	14	5250-126-040-015	15		
5250-126-016-A16	1/4	5250-126-025-015	15	5250-126-032-015	15	INCHES			
5250-126-016-A18	9/32	5250-126-025-016	16	5250-126-032-016	16	5250-126-040-A10	5/32	5250-126-040-A32	1/2
5250-126-016-A20	5/16	INCHES		5250-126-032-017	17	5250-126-040-A12	3/16	5250-126-040-A34	17/32
		5250-126-025-A08	1/8	5250-126-032-018	18	5250-126-040-A14	7/32	5250-126-040-A36	9/16
		5250-126-025-A10	5/32	5250-126-032-019	19	5250-126-040-A16	1/4	5250-126-040-A38	19/32
		5250-126-025-A12	3/16	5250-126-032-020	20	5250-126-040-A18	9/32	5250-126-040-A40	5/8
		5250-126-025-A14	7/32	INCHES		5250-126-040-A20	5/16	5250-126-040-A42	21/32
		5250-126-025-A16	1/4	5250-126-032-A08	1/8	5250-126-040-A22	11/32	5250-126-040-A44	11/16
		5250-126-025-A18	9/32	5250-126-032-A10	5/32	5250-126-040-A24	3/8	5250-126-040-A46	23/32
		5250-126-025-A20	5/16	5250-126-032-A12	3/16	5250-126-040-A26	13/32	5250-126-040-A48	3/4
		5250-126-025-A22	11/32	5250-126-032-A14	7/32	5250-126-040-A28	7/16	5250-126-040-A56	7/8
		5250-126-025-A24	3/8	5250-126-032-A16	1/4	5250-126-040-A30	15/32	5250-126-040-A64	1
		5250-126-025-A26	13/32	5250-126-032-A18	9/32				
		5250-126-025-A28	7/16	5250-126-032-A20	5/16				
		5250-126-025-A30	15/32	5250-126-032-A22	11/32				
		5250-126-025-A32	1/2	5250-126-032-A24	3/8				
		5250-126-025-A34	17/32	5250-126-032-A26	13/32				
		5250-126-025-A36	9/16	5250-126-032-A28	7/16				
				5250-126-032-A30	15/32				
				5250-126-032-A32	1/2				
				5250-126-032-A34	17/32				
				5250-126-032-A36	9/16				
				5250-126-032-A38	19/32				
				5250-126-032-A40	5/8				
				5250-126-032-A42	21/32				
				5250-126-032-A44	11/16				
				5250-126-032-A46	23/32				
				5250-126-032-A48	3/4				

Features:

- ▶ Runout accuracy: 15μm, A class 10μm, UP class 5μm.
- ▶ The design of coolant grooves is good for cooling and metal chips removal, extending tool life.
- ▶ Water pressure up to 50kgf/cm².
- ▶ Used for cutting tools without coolant holes.



ER COOLANT COLLET FOD TYPE

ER - FOD 出水筒夾

(ISO 15488)



ER16 - FOD	
MODEL NO.	SIZE
5250-127-016-003	3
5250-127-016-004	4
5250-127-016-005	5
5250-127-016-006	6
5250-127-016-007	7

ER20 - FOD	
MODEL NO.	SIZE
5250-127-020-003	3
5250-127-020-004	4
5250-127-020-005	5
5250-127-020-006	6
5250-127-020-007	7
5250-127-020-008	8
5250-127-020-009	9

ER25 - FOD	
MODEL NO.	SIZE
5250-127-025-003	3
5250-127-025-004	4
5250-127-025-005	5
5250-127-025-006	6
5250-127-025-007	7
5250-127-025-008	8
5250-127-025-009	9
5250-127-025-010	10
5250-127-025-011	11
5250-127-025-012	12
5250-127-025-013	13
5250-127-025-014	14

ER30 - FOD	
MODEL NO.	SIZE
5250-127-030-003	3
5250-127-030-004	4
5250-127-030-005	5
5250-127-030-006	6
5250-127-030-007	7
5250-127-030-008	8
5250-127-030-009	9
5250-127-030-010	10
5250-127-030-011	11
5250-127-030-012	12
5250-127-030-013	13
5250-127-030-014	14
5250-127-030-015	15
5250-127-030-016	16
5250-127-030-017	17
5250-127-030-018	18
5250-127-030-019	19
5250-127-030-020	20

ER32 - FOD	
MODEL NO.	SIZE
5250-127-032-003	3
5250-127-032-004	4
5250-127-032-005	5
5250-127-032-006	6
5250-127-032-007	7
5250-127-032-008	8
5250-127-032-009	9
5250-127-032-010	10
5250-127-032-011	11
5250-127-032-012	12
5250-127-032-013	13
5250-127-032-014	14
5250-127-032-015	15
5250-127-032-016	16
5250-127-032-017	17
5250-127-032-018	18
5250-127-032-019	19
5250-127-032-020	20

ER40 - FOD	
MODEL NO.	SIZE
5250-127-040-004	4
5250-127-040-005	5
5250-127-040-006	6
5250-127-040-007	7
5250-127-040-008	8
5250-127-040-009	9
5250-127-040-010	10
5250-127-040-011	11
5250-127-040-012	12
5250-127-040-013	13
5250-127-040-014	14
5250-127-040-015	15

ER40 - FOD			
MODEL NO.	SIZE	MODEL NO.	SIZE
5250-127-040-016	16	5250-127-040-017	17
5250-127-040-018	18	5250-127-040-019	19
5250-127-040-020	20	5250-127-040-021	21
5250-127-040-022	22	5250-127-040-023	23
5250-127-040-024	24	5250-127-040-025	25
5250-127-040-026	26		

ER40 - FOD			
MODEL NO.	SIZE	MODEL NO.	SIZE
5250-127-040-A10	5/32	5250-127-040-A32	1/2
5250-127-040-A12	3/16	5250-127-040-A34	17/32
5250-127-040-A14	7/32	5250-127-040-A36	9/16
5250-127-040-A16	1/4	5250-127-040-A38	19/32
5250-127-040-A18	9/32	5250-127-040-A40	5/8
5250-127-040-A20	5/16	5250-127-040-A42	21/32
5250-127-040-A22	11/32	5250-127-040-A44	11/16
5250-127-040-A24	3/8	5250-127-040-A46	23/32
5250-127-040-A26	13/32	5250-127-040-A48	3/4
5250-127-040-A28	7/16	5250-127-040-A56	7/8
5250-127-040-A30	15/32	5250-127-040-A64	1

ER50 - FOD			
MODEL NO.	SIZE	MODEL NO.	SIZE
5250-127-050-006	6	5250-127-050-021	21
5250-127-050-007	7	5250-127-050-022	22
5250-127-050-008	8	5250-127-050-023	23
5250-127-050-009	9	5250-127-050-024	24
5250-127-050-010	10	5250-127-050-025	25
5250-127-050-011	11	5250-127-050-026	26
5250-127-050-012	12	5250-127-050-027	27
5250-127-050-013	13	5250-127-050-028	28
5250-127-050-014	14	5250-127-050-029	29
5250-127-050-015	15	5250-127-050-030	30
5250-127-050-016	16	5250-127-050-031	31
5250-127-050-017	17	5250-127-050-032	32
5250-127-050-018	18	5250-127-050-033	33
5250-127-050-019	19	5250-127-050-034	34
5250-127-050-020	20		

ER50 - FOD			
MODEL NO.	SIZE	MODEL NO.	SIZE
5250-127-050-A16	1/4	5250-127-050-A40	5/8
5250-127-050-A18	9/32	5250-127-050-A42	21/32
5250-127-050-A20	5/16	5250-127-050-A44	11/16
5250-127-050-A22	11/32	5250-127-050-A46	23/32
5250-127-050-A24	3/8	5250-127-050-A48	3/4
5250-127-050-A26	13/32	5250-127-050-A56	7/8
5250-127-050-A28	7/16	5250-127-050-A64	1
5250-127-050-A30	15/32	5250-127-050-A66	1-1/16
5250-127-050-A32	1/2	5250-127-050-A68	1-1/8
5250-127-050-A34	17/32	5250-127-050-A70	1-3/16
5250-127-050-A36	9/16	5250-127-050-A72	1-1/4
5250-127-050-A38	19/32	5250-127-050-A74	1-5/16

Features:

- ▶ Runout accuracy: 15µm, A class 10µm, UP class 5µm.
- ▶ The design of coolant holes is good for cooling and metal chips removal, extending tool life.
- ▶ Water pressure up to 50kgf/cm².
- ▶ Used for cutting tools without coolant holes.



ER - TC RIGID TAP COLLET

ER-TC 鋼性攻牙筒夾

(ISO 15488)

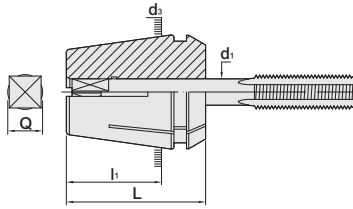

TYPE	d ₃	L	l ₁	CAPACITY
ER - TC16	16	27.5	17.5	M3 ~ M12
ER - TC20	20	31.5	20.7	M3 ~ M17
ER - TC25	25	34	23	M3 ~ M22
ER - TC32	32	40	27.34	M3 ~ M27
ER - TC40	40	46	31.34	M3 ~ M27
ER - TC50	50	60	38.9	M10 ~ M33

ER - TC16				ER - TC20				ER - TC25			
MODEL NO.	d ₁	Q	STANDARD	MODEL NO.	d ₁	Q	STANDARD	MODEL NO.	d ₁	Q	STANDARD
5250-116-016-11	2.24	2	ISO	5250-116-020-12	2.24	2	ISO	5250-116-025-17	2.24	1.8	ISO
5250-116-016-12	2.5	2.2	DIN/ISO	5250-116-020-13	2.5	2.2	DIN/ISO	5250-116-025-18	2.5	2.2	DIN/ISO
5250-116-016-13	2.8	2.6	DIN	5250-116-020-14	2.8	2.6	DIN	5250-116-025-19	2.8	2.6	DIN
5250-116-016-14	3.15	2.9	ISO	5250-116-020-15	3.15	2.9	ISO	5250-116-025-20	3.15	2.9	ISO
5250-116-016-15	3.5	3.3	DIN	5250-116-020-16	3.5	3.3	DIN	5250-116-025-21	3.5	3.3	DIN
5250-116-016-16	3.55	3.3	ISO	5250-116-020-17	3.55	3.3	ISO	5250-116-025-22	3.55	3.3	ISO
5250-116-016-17	4	3.8	JIS/DIN/ISO	5250-116-020-18	4	3.8	JIS/DIN/ISO	5250-116-025-23	4	3.8	JIS/DIN/ISO
5250-116-016-18	4.5	4.0	DIN/ISO	5250-116-020-19	4.5	4.0	DIN/ISO	5250-116-025-24	4.5	4.0	DIN/ISO
5250-116-016-20	5	4.7	JIS/ISO	5250-116-020-21	5	4.7	JIS/ISO	5250-116-025-26	5	4.7	JIS/ISO
5250-116-016-21	5.5	4.73	JIS	5250-116-020-22	5.5	4.73	JIS	5250-116-025-27	5.5	4.73	JIS
5250-116-016-22	6	5.09	DIN/JIS	5250-116-020-23	6	5.09	DIN/JIS	5250-116-025-28	6	5.09	DIN/JIS
5250-116-016-24	6.2	5.21	JIS	5250-116-020-24	6.2	5.21	JIS	5250-116-025-30	6.2	5.21	JIS
5250-116-016-25	6.3	5.21	ISO	5250-116-020-25	6.3	5.21	ISO	5250-116-025-31	6.3	5.21	ISO
5250-116-016-26	7	5.84	JIS/DIN	5250-116-020-26	7	5.84	JIS/DIN	5250-116-025-32	7	5.84	JIS/DIN
5250-116-016-27	8	6.88	DIN/ISO/JIS	5250-116-020-27	8	6.88	DIN/ISO/JIS	5250-116-025-33	8	6.88	DIN/ISO/JIS
5250-116-016-28	8.5	7.14	JIS	5250-116-020-28	8.5	7.14	JIS	5250-116-025-34	8.5	7.14	JIS
5250-116-016-29	9	7.95	DIN/ISO	5250-116-020-29	9	7.95	DIN/ISO	5250-116-025-35	9	7.95	DIN/ISO
5250-116-016-30	10	9.16	DIN/ISO	5250-116-020-30	10	9.16	DIN/ISO	5250-116-025-36	10	9.16	DIN/ISO
INCHES				5250-116-020-31	10.5	9.16	JIS	5250-116-025-37	10.5	9.16	JIS
5250-116-016-02	0.168	0.151	-	5250-116-020-32	11	10.53	DIN	5250-116-025-38	11	10.53	DIN
5250-116-016-03	0.194	0.180	-	5250-116-020-33	11.2	10.53	ISO	5250-116-025-39	11.2	10.53	ISO
5250-116-016-04	0.220	0.198	-	5250-116-020-34	12	10.53	DIN	5250-116-025-40	12	10.53	DIN
5250-116-016-05	0.255	0.198	-	5250-116-020-35	12.5	11.91	JIS/ISO	5250-116-025-41	12.5	11.91	JIS/ISO
				5250-116-020-36	13	11.91	JIS	5250-116-025-42	13	11.91	JIS
INCHES				INCHES							
				5250-116-020-02	0.168	0.151	-	5250-116-025-43	14	12.97	JIS/DIN/ISO
				5250-116-020-03	0.194	0.180	-	5250-116-025-44	15	14.06	JIS
				5250-116-020-04	0.220	0.198	-	5250-116-025-45	16	14.8	DIN/ISO
				5250-116-020-05	0.255	0.198	-	5250-116-025-02	0.168	0.151	-
				5250-116-020-06	0.318	0.258	-	5250-116-025-03	0.194	0.180	-
				5250-116-020-07	0.323	0.263	-	5250-116-025-04	0.220	0.198	-
				5250-116-020-08	0.367	0.307	-	5250-116-025-05	0.255	0.198	-
				5250-116-020-09	0.381	0.321	-	5250-116-025-07	0.318	0.258	-
				5250-116-020-10	0.429	0.37	-	5250-116-025-08	0.323	0.263	-
				5250-116-025-10							
				5250-116-025-11							
				5250-116-025-12							
				5250-116-025-13							
				5250-116-025-14							

Features:

- ▶ To clamp a tap by the slots size differential.
- ▶ This product is workable as long as d₁ size (shank dia. of tap) matches collet ID (patented design).
- ▶ When making an order, please inform collet type and the size of d₁ (shank dia. of tap).



ER - TC RIGID TAP COLLET

ER-TC 鋼性攻牙筒夾

(ISO 15488)

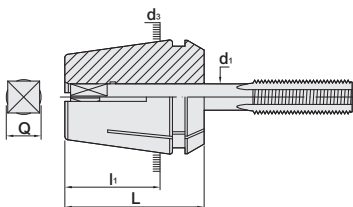

TYPE	d ₃	L	l ₁	CAPACITY
ER - TC16	16	27.5	17.5	M3 ~ M12
ER - TC20	20	31.5	20.7	M3 ~ M17
ER - TC25	25	34	23	M3 ~ M22
ER - TC32	32	40	27.34	M3 ~ M27
ER - TC40	40	46	31.34	M3 ~ M27
ER - TC50	50	60	38.9	M10 ~ M33

ER - TC32				ER - TC40				ER - TC50			
MODEL NO.	d ₁	Q	STANDARD	MODEL NO.	d ₁	Q	STANDARD	MODEL NO.	d ₁	Q	STANDARD
5250-116-032-23	2.24	2	ISO	5250-116-040-34	2.24	2	ISO	5250-116-050-01	7	5.84	JIS/DIN
5250-116-032-24	2.5	2.2	DIN/ISO	5250-116-040-35	2.5	2.2	DIN/ISO	5250-116-050-02	8	6.88	DIN/ISO/JIS
5250-116-032-25	2.8	2.6	DIN	5250-116-040-36	2.8	2.6	DIN	5250-116-050-03	8.5	7.14	JIS
5250-116-032-26	3.15	2.9	ISO	5250-116-040-37	3.15	2.9	ISO	5250-116-050-04	9	7.95	DIN/ISO
5250-116-032-27	3.5	3.3	DIN	5250-116-040-38	3.5	3.3	DIN	5250-116-050-05	10	9.16	DIN/ISO
5250-116-032-28	3.55	3.3	ISO	5250-116-040-39	3.55	3.3	ISO	5250-116-050-06	10.5	9.16	JIS
5250-116-032-29	4	3.8	JIS/DIN/ISO	5250-116-040-40	4	3.8	JIS/DIN/ISO	5250-116-050-07	11	10.53	DIN
5250-116-032-30	4.5	4.0	DIN/ISO	5250-116-040-41	4.5	4.0	DIN/ISO	5250-116-050-08	11.2	10.53	ISO
5250-116-032-32	5	4.7	JIS/ISO	5250-116-040-42	5	4.7	JIS/ISO	5250-116-050-09	12	10.53	DIN
5250-116-032-33	5.5	4.73	JIS	5250-116-040-43	5.5	4.73	JIS	5250-116-050-10	12.5	11.91	JIS/ISO
5250-116-032-34	6	5.09	DIN/JIS	5250-116-040-44	6	5.09	DIN/JIS	5250-116-050-11	13	11.91	JIS
5250-116-032-35	6.2	5.21	JIS	5250-116-040-45	6.2	5.21	JIS	5250-116-050-12	14	12.97	JIS/DIN/ISO
5250-116-032-36	6.3	5.21	ISO	5250-116-040-46	6.3	5.21	ISO	5250-116-050-13	15	14.06	JIS
5250-116-032-37	7	5.84	JIS/DIN	5250-116-040-47	7	5.84	JIS/DIN	5250-116-050-14	16	14.80	DIN/ISO
5250-116-032-38	8	6.88	DIN/ISO/JIS	5250-116-040-48	8	6.88	DIN/ISO/JIS	5250-116-050-15	17	15.44	JIS
5250-116-032-39	8.5	7.14	JIS	5250-116-040-49	8.5	7.14	JIS	5250-116-050-16	18	17.52	DIN/ISO
5250-116-032-40	9	7.95	DIN/ISO	5250-116-040-50	9	7.95	DIN/ISO	5250-116-050-17	19	18.22	JIS
5250-116-032-41	10	9.16	DIN/ISO	5250-116-040-51	10	9.16	DIN/ISO	5250-116-050-18	20	19.61	JIS
5250-116-032-42	10.5	9.16	JIS	5250-116-040-52	10.5	9.16	JIS	5250-116-050-19	21	20.5	JIS
5250-116-032-43	11	10.53	DIN	5250-116-040-53	11	10.53	DIN	5250-116-050-21	23	20.5	JIS
5250-116-032-44	11.2	10.53	ISO	5250-116-040-54	11.2	10.53	ISO	5250-116-050-22	24	23.4	JIS
5250-116-032-45	12	10.53	DIN	5250-116-040-55	12	10.53	DIN	5250-116-050-23	25	23.4	JIS/DIN
5250-116-032-46	12.5	11.91	JIS/ISO	5250-116-040-56	12.5	11.91	JIS/ISO				
5250-116-032-47	13	11.91	JIS	5250-116-040-57	13	11.91	JIS				
5250-116-032-48	14	12.97	JIS/DIN/ISO	5250-116-040-58	14	12.97	JIS/DIN/ISO				
5250-116-032-49	15	14.06	JIS	5250-116-040-59	15	14.06	JIS				
5250-116-032-50	16	14.8	DIN/ISO	5250-116-040-60	16	14.8	DIN/ISO				
5250-116-032-51	17	15.44	JIS	5250-116-040-61	17	15.44	JIS				
5250-116-032-52	18	17.52	DIN/ISO	5250-116-040-62	18	17.52	DIN/ISO				
5250-116-032-53	19	18.22	JIS	5250-116-040-63	19	18.22	JIS				
5250-116-032-54	20	19.61	JIS	5250-116-040-64	20	19.61	JIS				
INCHES				INCHES							
5250-116-032-03	0.168	0.151	-	5250-116-040-06	0.255	0.198	-				
5250-116-032-04	0.194	0.180	-	5250-116-040-07	0.318	0.258	-				
5250-116-032-05	0.220	0.198	-	5250-116-040-08	0.323	0.263	-				
5250-116-032-06	0.255	0.198	-	5250-116-040-09	0.367	0.307	-				
5250-116-032-09	0.318	0.258	-	5250-116-040-10	0.381	0.321	-				
5250-116-032-10	0.323	0.263	-	5250-116-040-11	0.429	0.370	-				
5250-116-032-11	0.367	0.307	-	5250-116-040-12	0.437	0.378	-				
5250-116-032-12	0.381	0.321	-	5250-116-040-14	0.480	0.422	-				
5250-116-032-13	0.429	0.370	-	5250-116-040-15	0.542	0.486	-				
5250-116-032-14	0.437	0.378	-	5250-116-040-16	0.562	0.483	-				
5250-116-032-15	0.480	0.422	-	5250-116-040-17	0.590	0.512	-				
5250-116-032-16	0.542	0.486	-	5250-116-040-20	0.652	0.576	-				
5250-116-032-17	0.562	0.483	-	5250-116-040-21	0.687	0.612	-				
5250-116-032-18	0.590	0.512	-	5250-116-040-22	0.697	0.623	-				
5250-116-032-20	0.652	0.576	-	5250-116-040-23	0.700	0.634	-				
				5250-116-040-25	0.760	0.689	-				
				5250-116-040-26	0.800	0.730	-				

Features:

- ▶ To clamp a tap by the slots size differential.
- ▶ This product is workable as long as d₁ size(shank dia. of tap) matches collet ID(patented design).
- ▶ When making an order, please inform collet type and the size of d₁(shank dia. of tap).



ER-TCO RIGID TAP SEALED COLLET

ER-TCO 鋼性攻牙止水筒夾

(ISO 15488)

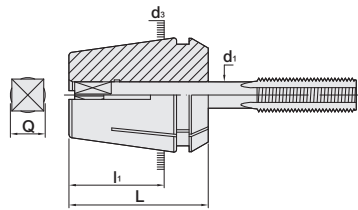

TYPE	d ₃	L	l ₁	CAPACITY
ER - TCO16	16	27.5	17.5	M3 ~ M12
ER - TCO20	20	31.5	20.7	M3 ~ M17
ER - TCO25	25	34	23	M3 ~ M22
ER - TCO32	32	40	27.34	M3 ~ M27
ER - TCO40	40	46	31.34	M3 ~ M27
ER - TCO50	50	60	38.9	M10 ~ M33

ER - TCO16			
MODEL NO.	d ₁	Q	STANDARD
5250-117-016-09	6	5.09	DIN / JIS
5250-117-016-10	6.1	5.2	JIS / ISO
5250-117-016-11	6.2	5.21	JIS / ISO
5250-117-016-13	7	5.84	DIN / JIS
5250-117-016-14	8	6.88	DIN / JIS
5250-117-016-15	8.5	7.14	JIS
5250-117-016-16	9	7.95	DIN / JIS
5250-117-016-00	10	9.16	DIN / JIS

INCHES

5250-117-016-01	0.168	0.151	-
5250-117-016-02	0.194	0.180	-
5250-117-016-03	0.220	0.198	-
5250-117-016-04	0.255	0.198	-
5250-117-016-05	0.318	0.258	-
5250-117-016-06	0.323	0.263	-
5250-117-016-07	0.367	0.307	-
5250-117-016-08	0.381	0.321	-

ER - TCO20			
MODEL NO.	d ₁	Q	STANDARD
5250-117-020-16	4.5	4	DIN / ISO
5250-117-020-18	6	5.09	DIN / JIS
5250-117-020-19	6.2	5.21	JIS
5250-117-020-20	6.3	5.21	ISO
5250-117-020-21	7	5.81	DIN / JIS
5250-117-020-22	8	6.88	DIN / JIS / ISO
5250-117-020-23	8.5	7.14	JIS
5250-117-020-24	9	7.95	DIN / JIS
5250-117-020-00	10	9.16	DIN / JIS
5250-117-020-01	10.5	9.16	JIS
5250-117-020-02	11	10.53	DIN
5250-117-020-03	11.2	10.53	ISO
5250-117-020-04	12	10.53	DIN
5250-117-020-05	12.5	11.91	JIS / ISO
5250-117-020-06	13	11.91	JIS

INCHES

5250-117-020-07	0.141	0.130	-
5250-117-020-08	0.168	0.151	-
5250-117-020-09	0.194	0.180	-
5250-117-020-10	0.220	0.198	-
5250-117-020-11	0.255	0.198	-
5250-117-020-12	0.318	0.258	-
5250-117-020-13	0.323	0.263	-
5250-117-020-14	0.367	0.307	-
5250-117-020-15	0.381	0.321	-
5250-117-020-17	0.429	0.370	-

ER - TCO25			
MODEL NO.	d ₁	Q	STANDARD
5250-117-025-19	4.5	4	DIN / ISO
5250-117-025-24	6	5.09	DIN / JIS
5250-117-025-25	6.1	5.2	JIS
5250-117-025-26	6.2	5.21	JIS
5250-117-025-27	6.3	5.21	ISO
5250-117-025-28	7	5.84	DIN / JIS
5250-117-025-29	8	6.88	DIN / JIS / ISO
5250-117-025-30	8.5	7.14	JIS
5250-117-025-31	9	7.95	DIN / JIS
5250-117-025-01	10	9.16	DIN / JIS
5250-117-025-02	10.5	9.16	JIS
5250-117-025-03	11	10.53	DIN
5250-117-025-04	11.2	10.53	ISO
5250-117-025-05	12	10.53	DIN
5250-117-025-06	12.5	11.91	JIS / ISO
5250-117-025-07	13	11.91	JIS
5250-117-025-08	14	12.97	DIN / JIS / ISO
5250-117-025-09	15	14.06	JIS
5250-117-025-10	16	14.8	DIN / ISO

INCHES

5250-117-025-11	0.168	0.151	-
5250-117-025-12	0.194	0.180	-
5250-117-025-13	0.220	0.198	-
5250-117-025-14	0.255	0.198	-
5250-117-025-15	0.318	0.258	-
5250-117-025-16	0.323	0.263	-
5250-117-025-17	0.367	0.307	-
5250-117-025-18	0.381	0.321	-
5250-117-025-20	0.429	0.370	-
5250-117-025-21	0.437	0.378	-
5250-117-025-22	0.480	0.422	-
5250-117-025-23	0.542	0.486	-



Features: ▶ Used for coolant-through taps. ▶ Water pressure up to 150kgf/cm²(1400PSI).
▶ When making an order, please inform collet type and d₁ size (shank dia. of tap).



ER-TCO RIGID TAP SEALED COLLET

ER-TCO 鋼性攻牙止水筒夾

(ISO 15488)

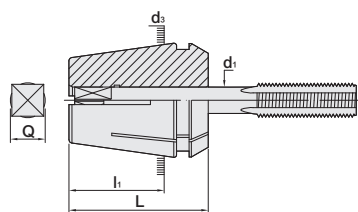

TYPE	d ₃	L	l ₁	CAPACITY
ER - TCO16	16	27.5	17.5	M3 ~ M12
ER - TCO20	20	31.5	20.7	M3 ~ M17
ER - TCO25	25	34	23	M3 ~ M22
ER - TCO32	32	40	27.34	M3 ~ M27
ER - TCO40	40	46	31.34	M3 ~ M27
ER - TCO50	50	60	38.9	M10 ~ M33

ER - TCO32			
MODEL NO.	d ₁	Q	STANDARD
5250-117-032-26	5.5	4.73	JIS
5250-117-032-30	6	5.09	DIN / JIS
5250-117-032-31	6.1	5.2	JIS
5250-117-032-32	6.2	5.2	JIS
5250-117-032-33	6.3	5.21	ISO
5250-117-032-35	7	5.84	DIN / JIS
5250-117-032-36	8	6.88	DIN / JIS / ISO
5250-117-032-37	8.5	7.14	JIS
5250-117-032-38	9	7.95	DIN / JIS
5250-117-032-01	10	9.16	DIN / JIS
5250-117-032-02	10.5	9.16	JIS
5250-117-032-03	11	10.53	DIN
5250-117-032-04	11.2	10.53	ISO
5250-117-032-05	12	10.53	DIN
5250-117-032-06	12.5	11.91	JIS / ISO
5250-117-032-07	13	11.91	JIS
5250-117-032-08	14	12.97	DIN / JIS / ISO
5250-117-032-09	15	14.06	JIS
5250-117-032-10	16	14.8	DIN / ISO
5250-117-032-12	17	15.44	JIS
5250-117-032-13	18	17.52	DIN / ISO
5250-117-032-14	19	18.22	JIS
5250-117-032-16	20	19.61	JIS

INCHES			
5250-117-032-11	0.168	0.151	-
5250-117-032-15	0.194	0.180	-
5250-117-032-17	0.220	0.198	-
5250-117-032-18	0.255	0.198	-
5250-117-032-19	0.318	0.258	-
5250-117-032-20	0.323	0.263	-
5250-117-032-21	0.367	0.307	-
5250-117-032-22	0.381	0.321	-
5250-117-032-23	0.429	0.370	-
5250-117-032-24	0.437	0.378	-
5250-117-032-25	0.480	0.422	-
5250-117-032-27	0.542	0.486	-
5250-117-032-28	0.562	0.483	-
5250-117-032-29	0.590	0.512	-
5250-117-032-34	0.652	0.576	-

ER - TCO40			
MODEL NO.	d ₁	Q	STANDARD
5250-117-040-30	6	5.09	DIN / JIS
5250-117-040-31	6.2	5.21	JIS
5250-117-040-32	6.3	5.21	ISO
5250-117-040-36	7	5.84	DIN / JIS
5250-117-040-39	8	6.88	DIN / JIS / ISO
5250-117-040-40	8.5	7.14	JIS
5250-117-040-42	9	7.95	DIN / JIS
5250-117-040-01	10	9.16	DIN / JIS
5250-117-040-02	10.5	9.16	JIS
5250-117-040-03	11	10.53	DIN
5250-117-040-04	11.2	10.53	ISO
5250-117-040-05	12	10.53	DIN
5250-117-040-06	12.5	11.91	JIS / ISO
5250-117-040-07	13	11.91	JIS
5250-117-040-08	14	12.97	DIN / JIS / ISO
5250-117-040-09	15	14.06	JIS
5250-117-040-10	16	14.8	DIN / ISO
5250-117-040-12	17	15.44	JIS
5250-117-040-13	18	17.52	DIN / ISO
5250-117-040-14	19	18.22	JIS
5250-117-040-16	20	19.61	JIS
5250-117-040-17	22	20.85	JIS

INCHES			
5250-117-040-11	0.168	0.151	-
5250-117-040-15	0.194	0.180	-
5250-117-040-18	0.220	0.198	-
5250-117-040-19	0.255	0.198	-
5250-117-040-20	0.318	0.258	-
5250-117-040-21	0.323	0.263	-
5250-117-040-22	0.367	0.307	-
5250-117-040-23	0.381	0.321	-
5250-117-040-24	0.429	0.370	-
5250-117-040-25	0.437	0.378	-
5250-117-040-26	0.480	0.422	-
5250-117-040-27	0.542	0.486	-
5250-117-040-28	0.562	0.483	-
5250-117-040-29	0.590	0.512	-
5250-117-040-33	0.652	0.576	-
5250-117-040-34	0.687	0.612	-
5250-117-040-35	0.697	0.623	-
5250-117-040-37	0.700	0.634	-
5250-117-040-38	0.760	0.689	-
5250-117-040-41	0.800	0.731	-

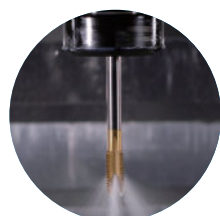

Features:

- ▶ Used for coolant-through taps. ▶ Water pressure up to 150kgf/cm²(1400PSI).
- ▶ When making an order, please inform collet type and d₁ size (shank dia. of tap).



ER-TC RIGID TAP COOLANT COLLET

FOD TYPE

ER 鋼性攻牙出水筒夾 [FOD型]

(ISO 15488)

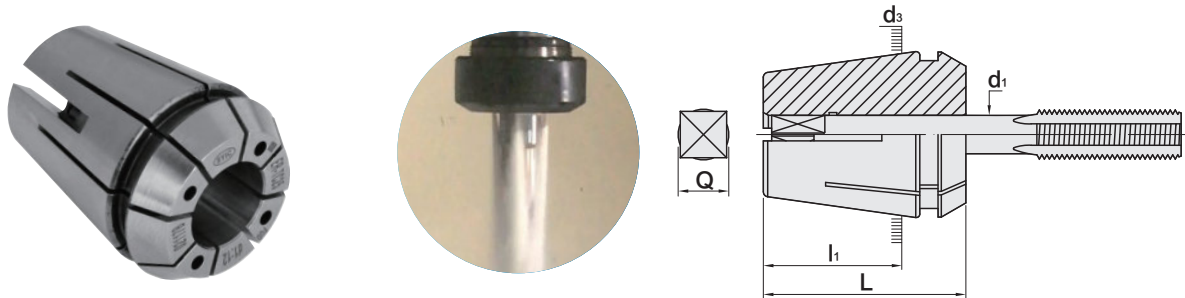

ER - TC16			
MODEL NO.	d ₁	Q	STANDARD
5250-118-016-01	3.5	3.3	DIN
5250-118-016-02	4	3.8	DIN/JIS/ISO
5250-118-016-03	4.5	4	DIN/ISO
5250-118-016-04	6	5.09	DIN/JIS
5250-118-016-05	7	5.84	DIN/JIS
5250-118-016-06	8	6.88	DIN/JIS
INCHES			
5250-118-016-07	0.323	0.263	-
5250-118-016-08	0.255	0.198	-

ER - TC20			
MODEL NO.	d ₁	Q	STANDARD
5250-118-020-00	3.5	3.3	DIN
5250-118-020-02	4.5	4	DIN/ISO
5250-118-020-03	6	5.09	DIN/JIS
5250-118-020-04	6.2	5.21	JIS
5250-118-020-05	7	5.84	JIS/DIN
5250-118-020-06	8	6.88	DIN/ISO/JIS
5250-118-020-07	8.5	7.14	JIS
5250-118-020-08	9	7.95	DIN/ISO
5250-118-020-09	10	9.16	DIN/ISO

ER - TC25			
MODEL NO.	d ₁	Q	STANDARD
5250-118-025-00	3.5	3.3	DIN
5250-118-025-01	4	3.8	JIS/DIN/ISO
5250-118-025-02	4.5	4	DIN/ISO
5250-118-025-03	6	5.09	DIN/JIS
5250-118-025-04	6.2	5.21	JIS
5250-118-025-05	7	5.84	JIS/DIN
5250-118-025-06	8	6.88	DIN/ISO/JIS
5250-118-025-07	8.5	7.14	JIS
5250-118-025-08	9	7.95	DIN/ISO
5250-118-025-09	10	9.16	DIN/ISO
5250-118-025-10	11	10.53	DIN
5250-118-025-11	12	10.53	DIN

ER - TC32			
MODEL NO.	d ₁	Q	STANDARD
5250-118-032-00	4.5	4	DIN/ISO
5250-118-032-01	6	5.09	DIN/JIS
5250-118-032-02	6.2	5.21	JIS
5250-118-032-03	7	5.84	JIS/DIN
5250-118-032-04	8	6.88	DIN/ISO/JIS
5250-118-032-05	8.5	7.14	JIS
5250-118-032-06	9	7.95	DIN/ISO
5250-118-032-07	10	9.16	DIN/ISO
5250-118-032-08	11	10.53	DIN
5250-118-032-09	12	10.53	DIN
5250-118-032-10	14	12.97	JIS/DIN/ISO
5250-118-032-11	16	14.8	DIN/ISO
5250-118-032-12	18	17.52	DIN/ISO

ER - TC40			
MODEL NO.	d ₁	Q	STANDARD
5250-118-040-00	6	5.09	DIN/JIS
5250-118-040-01	7	5.84	JIS/DIN
5250-118-040-02	8	6.88	DIN/ISO/JIS
5250-118-040-03	9	7.95	DIN/ISO
5250-118-040-04	10	9.16	DIN/ISO
5250-118-040-05	11	10.53	DIN
5250-118-040-06	12	10.53	DIN
5250-118-040-07	14	12.97	JIS/DIN/ISO
5250-118-040-08	16	14.8	DIN/ISO
5250-118-040-09	18	17.52	DIN/ISO
5250-118-040-10	20	19.61	JIS

Features: ▶ Used for taps without coolant hole. ▶ Water pressure up to 150kgf/cm²(1400PSI).
▶ When making an order, please inform collet type and d₁ size (shank dia. of tap).



ER FLOATING TAP COLLET

ER 伸縮攻牙筒夾

(ISO 15488)

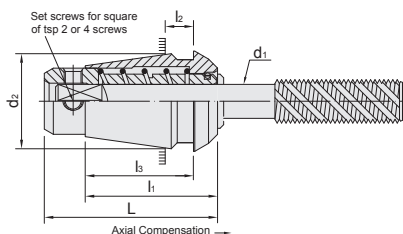

TYPE	L	l ₁	l ₂	l ₃	d ₂
FT 16	26.6	22	3	18	16
FT 20	31	22.6	4	17.9	20
FT 25	33.5	24.5	6	19.1	25
FT 32	43.3	30	7	24.5	32
FT 40	54	40	8	33	40

FT 16		FT 20		FT 25		FT 32		FT 40	
MODEL NO.	d ₁	MODEL NO.	d ₁	MODEL NO.	d ₁	MODEL NO.	d ₁	MODEL NO.	d ₁
5250-148-016-01	1.4	5250-148-020-01	2.24	5250-148-025-01	2.5	5250-148-032-02	4.5	5250-148-040-01	6
5250-148-016-02	1.6	5250-148-020-02	2.5	5250-148-025-02	2.8	5250-148-032-03	5	5250-148-040-02	6.2
5250-148-016-03	1.8	5250-148-020-03	2.8	5250-148-025-03	3	5250-148-032-04	5.5	5250-148-040-03	6.3
5250-148-016-04	2	5250-148-020-04	3	5250-148-025-04	3.15	5250-148-032-05	5.6	5250-148-040-04	7
5250-148-016-05	2.24	5250-148-020-05	3.15	5250-148-025-05	3.5	5250-148-032-06	6	5250-148-040-05	7.1
5250-148-016-06	2.5	5250-148-020-06	3.5	5250-148-025-06	3.55	5250-148-032-07	6.2	5250-148-040-06	8
5250-148-016-07	2.8	5250-148-020-07	3.55	5250-148-025-07	4	5250-148-032-08	6.3	5250-148-040-07	8.5
5250-148-016-08	3	5250-148-020-08	4	5250-148-025-08	4.5	5250-148-032-09	7	5250-148-040-08	9
5250-148-016-09	3.15	5250-148-020-09	4.5	5250-148-025-09	5	5250-148-032-10	7.1	5250-148-040-09	10
5250-148-016-10	3.5	5250-148-020-10	5	5250-148-025-10	5.5	5250-148-032-11	8	5250-148-040-10	10.5
5250-148-016-11	3.55	5250-148-020-11	5.5	5250-148-025-11	5.6	5250-148-032-12	8.5	5250-148-040-11	11
5250-148-016-12	4	5250-148-020-12	5.6	5250-148-025-12	6	5250-148-032-13	9	5250-148-040-12	11.2
5250-148-016-13	4.5	5250-148-020-13	6	5250-148-025-13	6.2	5250-148-032-14	10	5250-148-040-13	12
5250-148-016-14	5	5250-148-020-14	6.2	5250-148-025-17	7.1	5250-148-032-15	10.5	5250-148-040-14	12.5
5250-148-016-15	5.5	5250-148-020-15	6.3	5250-148-025-18	8	5250-148-032-16	11	5250-148-040-15	14
5250-148-016-23	5.6	5250-148-020-16	7	5250-148-025-19	8.5	5250-148-032-17	11.2	INCHES	
5250-148-016-16	6	INCHES		5250-148-025-20	9	5250-148-032-18	12	5250-148-040-30	0.255
INCHES		5250-148-020-19	0.141	5250-148-025-21	10	5250-148-032-19	12.5	5250-148-040-18	0.318
5250-148-016-18	0.141	5250-148-020-20	0.168	INCHES		INCHES		5250-148-040-19	0.323
5250-148-016-19	0.168	5250-148-020-21	0.194	5250-148-025-24	0.141	5250-148-032-24	0.168	5250-148-040-20	0.367
5250-148-016-21	0.220	5250-148-020-22	0.220	5250-148-025-25	0.168	5250-148-032-25	0.194	5250-148-040-21	0.381
		5250-148-020-23	0.255	5250-148-025-26	0.194	5250-148-032-26	0.220	5250-148-040-22	0.429
				5250-148-025-27	0.220	5250-148-032-27	0.255	5250-148-040-23	0.437
				5250-148-025-28	0.255	5250-148-032-28	0.318	5250-148-040-24	0.480
				5250-148-025-29	0.318	5250-148-032-29	0.323	5250-148-040-25	0.542
				5250-148-025-30	0.323	5250-148-032-30	0.367	5250-148-040-26	0.562
				5250-148-025-31	0.367	5250-148-032-31	0.381	5250-148-040-27	0.590
						5250-148-032-32	0.429	5250-148-040-28	0.652
						5250-148-032-33	0.437	5250-148-040-29	0.697
						5250-148-032-35	0.480		

Features:

- ▶ This product can avoid taps breaking when spindle reverses direction during tapping process.
- ▶ There are side lock screws at the bottom of collet, used for clamping a tap.
- ▶ Suitable for taps conforming to ISO-529, JIS, DIN-371, DIN-376 or DIN-352 standards.



SKX COLLET

SKX 高速機專用筒夾

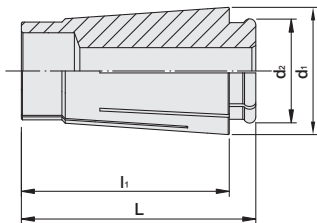

TYPE	L	l ₁	d ₁	d ₂
SKX - 6	25	21.4	10.2	8.8
SKX - 10	30.5	26.3	15.5	13.2
SKX - 13	39.05	34	20	17
SKX - 16	45.1	40	24.5	20.05
SKX - 20	54.2	48.95	29	24.85
SKX - 25	57.1	51.5	35.5	30

SKX - 6	
MODEL NO.	SIZE
5250-790-006-001	1
5250-790-006-002	2
5250-790-006-003	3
5250-790-006-004	4
5250-790-006-005	5
5250-790-006-006	6

INCHES

5250-790-006-A08	1/8
5250-790-006-A10	5/32
5250-790-006-A12	3/16
5250-790-006-A14	7/32
5250-790-006-A16	1/4

SKX - 10	
MODEL NO.	SIZE
5250-790-010-002	2
5250-790-010-003	3
5250-790-010-004	4
5250-790-010-005	5
5250-790-010-006	6
5250-790-010-007	7
5250-790-010-008	8
5250-790-010-009	9
5250-790-010-010	10

INCHES

5250-790-010-A08	1/8
5250-790-010-A10	5/32
5250-790-010-A12	3/16
5250-790-010-A14	7/32
5250-790-010-A16	1/4
5250-790-010-A18	9/32
5250-790-010-A20	5/16
5250-790-010-A22	11/32
5250-790-010-A24	3/8

SKX - 13	
MODEL NO.	SIZE
5250-790-013-002	2
5250-790-013-003	3
5250-790-013-004	4
5250-790-013-005	5
5250-790-013-006	6
5250-790-013-007	7
5250-790-013-008	8
5250-790-013-009	9
5250-790-013-010	10
5250-790-013-011	11
5250-790-013-012	12
5250-790-013-013	13

SKX - 16	
MODEL NO.	SIZE
5250-790-016-002	2
5250-790-016-003	3
5250-790-016-004	4
5250-790-016-005	5
5250-790-016-006	6
5250-790-016-007	7
5250-790-016-008	8
5250-790-016-009	9
5250-790-016-010	10
5250-790-016-011	11
5250-790-016-012	12
5250-790-016-013	13
5250-790-016-014	14
5250-790-016-015	15
5250-790-016-016	16

INCHES

5250-790-016-A08	1/8
5250-790-016-A10	5/32
5250-790-016-A12	3/16
5250-790-016-A14	7/32
5250-790-016-A16	1/4
5250-790-016-A18	9/32
5250-790-016-A20	5/16
5250-790-016-A22	11/32
5250-790-016-A24	3/8
5250-790-016-A26	13/32
5250-790-016-A28	7/16
5250-790-016-A30	15/32
5250-790-016-A32	1/2
5250-790-016-A34	17/32
5250-790-016-A36	9/16
5250-790-016-A38	19/32
5250-790-016-A40	5/8

SKX - 20	
MODEL NO.	SIZE
5250-790-020-003	3
5250-790-020-004	4
5250-790-020-005	5
5250-790-020-006	6
5250-790-020-007	7
5250-790-020-008	8
5250-790-020-009	9
5250-790-020-010	10
5250-790-020-011	11
5250-790-020-012	12
5250-790-020-013	13
5250-790-020-014	14
5250-790-020-015	15
5250-790-020-016	16
5250-790-020-017	17
5250-790-020-018	18
5250-790-020-019	19
5250-790-020-020	20

INCHES

5250-790-020-A08	1/8
5250-790-020-A10	5/32
5250-790-020-A12	3/16
5250-790-020-A14	7/32
5250-790-020-A16	1/4
5250-790-020-A18	9/32
5250-790-020-A20	5/16
5250-790-020-A22	11/32
5250-790-020-A24	3/8
5250-790-020-A26	13/32
5250-790-020-A28	7/16
5250-790-020-A30	15/32
5250-790-020-A32	1/2
5250-790-020-A34	17/32
5250-790-020-A36	9/16
5250-790-020-A38	19/32
5250-790-020-A40	5/8
5250-790-020-A42	21/32
5250-790-020-A44	11/16
5250-790-020-A46	23/32
5250-790-020-A48	3/4

Features:

- ▶ Runout accuracy: 5 μ m, R class 7 μ m, A class 10 μ m.
- ▶ One size clamping is recommended.
- ▶ Surface roughness: Ra <0.1 μ m, R class Ra <0.12 μ m, A class Ra <0.15 μ m.



SKX COLLET

SKX 高速機專用筒夾

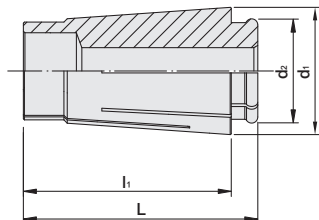

TYPE	L	l ₁	d ₁	d ₂
SKX - 6	25	21.4	10.2	8.8
SKX - 10	30.5	26.3	15.5	13.2
SKX - 13	39.05	34	20	17
SKX - 16	45.1	40	24.5	20.05
SKX - 20	54.2	48.95	29	24.85
SKX - 25	57.1	51.5	35.5	30

SKX - 25

MODEL NO.	SIZE	MODEL NO.	SIZE	MODEL NO.	SIZE
5250-790-025-003	3	5250-790-025-011	11	5250-790-025-019	19
5250-790-025-004	4	5250-790-025-012	12	5250-790-025-020	20
5250-790-025-005	5	5250-790-025-013	13	5250-790-025-021	21
5250-790-025-006	6	5250-790-025-014	14	5250-790-025-022	22
5250-790-025-007	7	5250-790-025-015	15	5250-790-025-023	23
5250-790-025-008	8	5250-790-025-016	16	5250-790-025-024	24
5250-790-025-009	9	5250-790-025-017	17	5250-790-025-025	25
5250-790-025-010	10	5250-790-025-018	18		

INCHES

5250-790-025-A08	1/8	5250-790-025-A24	3/8	5250-790-025-A40	5/8
5250-790-025-A10	5/32	5250-790-025-A26	13/32	5250-790-025-A42	21/32
5250-790-025-A12	3/16	5250-790-025-A28	7/16	5250-790-025-A44	11/16
5250-790-025-A14	7/32	5250-790-025-A30	15/32	5250-790-025-A46	23/32
5250-790-025-A16	1/4	5250-790-025-A32	1/2	5250-790-025-A48	3/4
5250-790-025-A18	9/32	5250-790-025-A34	17/32	5250-790-025-A56	7/8
5250-790-025-A20	5/16	5250-790-025-A36	9/16	5250-790-025-A64	1
5250-790-025-A22	11/32	5250-790-025-A38	19/32		

Features:

- ▶ Runout accuracy: 5 μ m, R class 7 μ m, A class 10 μ m.
- ▶ One size clamping is recommended.
- ▶ Surface roughness: Ra <0.1 μ m, R class Ra <0.12 μ m, A class Ra <0.15 μ m.



SKX - CO METALLIC SEALED COLLET

SKX 直溝止水筒夾

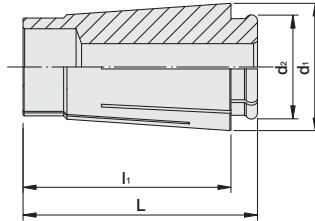
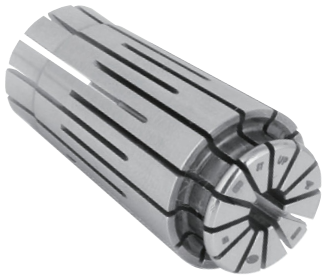

TYPE	L	l ₁	d ₁	d ₂
SKX10 - CO	30.5	26.3	15.28	12.7
SKX13 - CO	39.05	34	20	17
SKX16 - CO	45.1	40	24.5	20.05
SKX20 - CO	54.2	48.95	29	24.85
SKX25 - CO	57.1	51.5	35.5	30

SKX10 - CO	
MODEL NO.	SIZE
5250-774-010-003	3
5250-774-010-004	4
5250-774-010-005	5
5250-774-010-006	6
5250-774-010-007	7
5250-774-010-008	8
5250-774-010-009	9
5250-774-010-010	10

INCHES

5250-774-010-A10	5/32
5250-774-010-A12	3/16
5250-774-010-A14	7/32
5250-774-010-A16	1/4
5250-774-010-A18	9/32
5250-774-010-A20	5/16
5250-774-010-A22	11/32
5250-774-010-A24	3/8

SKX13 - CO	
MODEL NO.	SIZE
5250-774-013-004	4
5250-774-013-005	5
5250-774-013-006	6
5250-774-013-007	7
5250-774-013-008	8
5250-774-013-009	9
5250-774-013-010	10
5250-774-013-011	11
5250-774-013-012	12
5250-774-013-013	13

SKX16 - CO	
MODEL NO.	SIZE
5250-774-016-004	4
5250-774-016-005	5
5250-774-016-006	6
5250-774-016-007	7
5250-774-016-008	8
5250-774-016-009	9
5250-774-016-010	10
5250-774-016-011	11
5250-774-016-012	12
5250-774-016-013	13
5250-774-016-014	14
5250-774-016-015	15
5250-774-016-016	16

INCHES

5250-774-016-A12	3/16
5250-774-016-A14	7/32
5250-774-016-A16	1/4
5250-774-016-A18	9/32
5250-774-016-A20	5/16
5250-774-016-A22	11/32
5250-774-016-A24	3/8
5250-774-016-A26	13/32
5250-774-016-A28	7/16
5250-774-016-A30	15/32
5250-774-016-A32	1/2
5250-774-016-A34	17/32
5250-774-016-A36	9/16
5250-774-016-A38	19/32
5250-774-016-A40	5/8

SKX20 - CO	
MODEL NO.	SIZE
5250-774-020-006	6
5250-774-020-007	7
5250-774-020-008	8
5250-774-020-009	9
5250-774-020-010	10
5250-774-020-011	11
5250-774-020-012	12
5250-774-020-013	13
5250-774-020-014	14
5250-774-020-015	15
5250-774-020-016	16
5250-774-020-017	17
5250-774-020-018	18
5250-774-020-019	19
5250-774-020-020	20

SKX25 - CO	
MODEL NO.	SIZE
5250-774-025-006	6
5250-774-025-007	7
5250-774-025-008	8
5250-774-025-009	9
5250-774-025-010	10
5250-774-025-011	11
5250-774-025-012	12
5250-774-025-013	13
5250-774-025-014	14
5250-774-025-015	15
5250-774-025-016	16
5250-774-025-017	17
5250-774-025-018	18
5250-774-025-019	19
5250-774-025-020	20
5250-774-025-021	21
5250-774-025-022	22
5250-774-025-023	23
5250-774-025-024	24
5250-774-025-025	25

Features:

- ▶ Runout accuracy: 5µm, R class 7µm, A class 10µm.
- ▶ One size clamping is recommended.
- ▶ Surface roughness: Ra <0.1µm, R class Ra <0.12µm, A class Ra <0.15µm.

SLC COLLET

SLC 專用筒夾

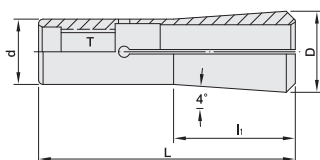

TYPE	D	d	L	l ₁	T
SLC - 6	10	8	36	24	M6
SLC - 8	15	12	51.5	22.2	M8
SLC - 12	18	14.5	57	25.45	M10
SLC - 20	27	21	70	35	M12
SLC - 25	32.4	25	80	43.5	M16

SLC - 6		SLC - 12		SLC - 20		SLC - 25	
MODEL NO.	SIZE	MODEL NO.	SIZE	MODEL NO.	SIZE	MODEL NO.	SIZE
5250-S37-006-003	3	5250-S37-012-003	3	5250-S37-020-003	3	5250-S37-025-006	6
5250-S37-006-004	4	5250-S37-012-004	4	5250-S37-020-004	4	5250-S37-025-008	8
5250-S37-006-005	5	5250-S37-012-005	5	5250-S37-020-005	5	5250-S37-025-010	10
5250-S37-006-006	6	5250-S37-012-006	6	5250-S37-020-006	6	5250-S37-025-012	12
INCHES		5250-S37-012-008	8	5250-S37-020-008	8	5250-S37-025-016	16
5250-S37-006-A08	1/8	5250-S37-012-010	10	5250-S37-020-010	10	5250-S37-025-018	18
5250-S37-006-A12	3/16	5250-S37-012-012	12	5250-S37-020-012	12	5250-S37-025-020	20
5250-S37-006-A16	1/4	INCHES		5250-S37-020-016	16	5250-S37-025-025	25
SLC - 8		5250-S37-012-A08	1/8	5250-S37-020-018	18	INCHES	
MODEL NO.	SIZE	5250-S37-012-A12	3/16	5250-S37-020-020	20	5250-S37-025-A16	1/4
5250-S37-008-003	3	5250-S37-012-A16	1/4	INCHES		5250-S37-025-A20	5/16
5250-S37-008-004	4	5250-S37-012-A20	5/16	5250-S37-020-A08	1/8	5250-S37-025-A24	3/8
5250-S37-008-005	5	5250-S37-012-A24	3/8	5250-S37-020-A12	3/16	5250-S37-025-A28	7/16
5250-S37-008-006	6	5250-S37-012-A28	7/16	5250-S37-020-A16	1/4	5250-S37-025-A32	1/2
5250-S37-008-008	8	5250-S37-012-A32	1/2	5250-S37-020-A20	5/16	5250-S37-025-A40	5/8
INCHES				5250-S37-020-A24	3/8	5250-S37-025-A48	3/4
5250-S37-008-A08	1/8			5250-S37-020-A28	7/16	5250-S37-025-A56	7/8
5250-S37-008-A12	3/16			5250-S37-020-A32	1/2	5250-S37-025-A64	1
5250-S37-008-A16	1/4			5250-S37-020-A40	5/8		
5250-S37-008-A20	5/16			5250-S37-020-A48	3/4		

Features:

- ▶ Runout accuracy: 5µm.
- ▶ Surface roughness: Ra < 0.1µm.
- ▶ Used for SBL collet chuck.



SLC SEALED COLLET

SLC 止水筒夾

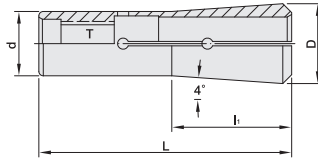

TYPE	D	d	L	l ₁	T
SLC6 - CO	10	8	36	24	M6
SLC8 - CO	15	12	51.5	22.2	M8
SLC12 - CO	18	14.5	57	25.45	M10
SLC20 - CO	27	21	70	35	M12
SLC25 - CO	32.4	25	80	43.5	M16

SLC6 - CO		SLC8 - CO		SLC12 - CO		SLC20 - CO		SLC25 - CO	
MODEL NO.	SIZE	MODEL NO.	SIZE	MODEL NO.	SIZE	MODEL NO.	SIZE	MODEL NO.	SIZE
5250-S38-006-003	3	5250-S38-008-003	3	5250-S38-012-003	3	5250-S38-020-003	3	5250-S38-025-006	6
5250-S38-006-004	4	5250-S38-008-004	4	5250-S38-012-004	4	5250-S38-020-004	4	5250-S38-025-008	8
5250-S38-006-005	5	5250-S38-008-005	5	5250-S38-012-005	5	5250-S38-020-005	5	5250-S38-025-010	10
5250-S38-006-006	6	5250-S38-008-006	6	5250-S38-012-006	6	5250-S38-020-006	6	5250-S38-025-012	12
INCHES		5250-S38-008-008	8	5250-S38-012-008	8	5250-S38-020-008	8	5250-S38-025-016	16
5250-S38-006-A08	1/8	INCHES		5250-S38-012-010	10	5250-S38-020-010	10	5250-S38-025-018	18
5250-S38-006-A12	3/16	5250-S38-008-A08	1/8	5250-S38-012-012	12	5250-S38-020-012	12	5250-S38-025-020	20
5250-S38-006-A16	1/4	5250-S38-008-A12	3/16	INCHES		5250-S38-020-016	16	5250-S38-025-025	25
		5250-S38-008-A16	1/4	5250-S38-012-A08	1/8	5250-S38-020-018	18	INCHES	
		5250-S38-008-A20	5/16	5250-S38-012-A12	3/16	5250-S38-020-020	20	5250-S38-025-A16	1/4
				5250-S38-012-A16	1/4	INCHES		5250-S38-025-A20	5/16
				5250-S38-012-A20	5/16	5250-S38-020-A08	1/8	5250-S38-025-A24	3/8
				5250-S38-012-A24	3/8	5250-S38-020-A12	3/16	5250-S38-025-A28	7/16
				5250-S38-012-A28	7/16	5250-S38-020-A16	1/4	5250-S38-025-A32	1/2
				5250-S38-012-A32	1/2	5250-S38-020-A20	5/16	5250-S38-025-A40	5/8
						5250-S38-020-A24	3/8	5250-S38-025-A48	3/4
						5250-S38-020-A28	7/16	5250-S38-025-A56	7/8
						5250-S38-020-A32	1/2	5250-S38-025-A64	1
						5250-S38-020-A40	5/8		
						5250-S38-020-A48	3/4		

Features:

- ▶ Runout accuracy: 5µm.
- ▶ Surface roughness: Ra < 0.1µm.
- ▶ Used for SBLC collet chuck.
- ▶ Water pressure: 21 bar.
- ▶ Used for coolant-through cutting tools.

EBL COLLET

EBL 筒夾

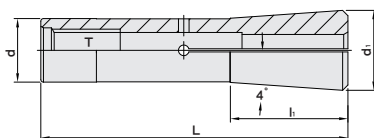

TYPE	L	l ₁	d	d ₁	T
EBL - 6	53	15	8.5	10.5	M6
EBL - 8	58	22.2	12	15.09	M8

EBL - 6		EBL - 8	
MODEL NO.	SIZE	MODEL NO.	SIZE
5250-277-006-003	3	5250-277-008-003	3
5250-277-006-004	4	5250-277-008-004	4
5250-277-006-005	5	5250-277-008-005	5
5250-277-006-006	6	5250-277-008-006	6
INCHES		INCHES	
5250-277-006-A08	1/8	5250-277-008-A08	1/8
5250-277-006-A12	3/16	5250-277-008-A12	3/16
5250-277-006-A16	1/4	5250-277-008-A16	1/4
		5250-277-008-A20	5/16

Features:

- ▶ Runout accuracy: 5µm.
- ▶ The extended length of EBL collet and special longer inner hole design of holder allow deeper tool insertion and shorter tool overhanging length, improving the machining stability.
- ▶ Used for tools without coolant holes. ▶ Surface roughness: Ra < 0.1µm.

EBL SEALED COLLET

EBL 止水筒夾

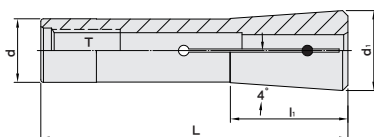

TYPE	L	l ₁	d	d ₁	T
EBL - 6 - CO	53	15	8.5	10.5	M6
EBL - 8 - CO	58	22.2	12	15.09	M8

EBL - 6 - CO		EBL - 8 - CO	
MODEL NO.	SIZE	MODEL NO.	SIZE
5250-278-006-003	3	5250-278-008-003	3
5250-278-006-004	4	5250-278-008-004	4
5250-278-006-005	5	5250-278-008-005	5
5250-278-006-006	6	5250-278-008-006	6
INCHES		INCHES	
5250-278-006-A08	1/8	5250-278-008-A08	1/8
5250-278-006-A12	3/16	5250-278-008-A12	3/16
5250-278-006-A16	1/4	5250-278-008-A16	1/4
		5250-278-008-A20	5/16

Features:

- ▶ Runout accuracy: 5µm.
- ▶ The extended length of EBL collet and special longer inner hole design of holder allow deeper tool insertion and shorter tool overhanging length, improving the machining stability.
- ▶ Used for coolant through tools.
- ▶ Capable of coolant pressure up to 25 bar.
- ▶ Surface roughness: Ra < 0.1µm.



SMG NON-PULLOUT COLLET



SMG防脫刀筒夾

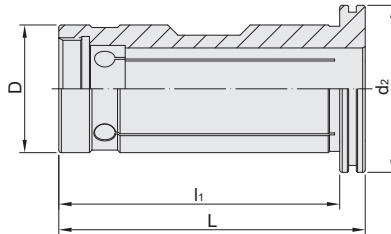

TYPE	D	d ₂	L	l ₁
SMG25	25	32.7	60	55
SMG32	32	42.7	64.6	59.6

SMG25		SMG32	
MODEL NO.	SIZE	MODEL NO.	SIZE
5253-626-025-012	12	5253-626-032-012	12
5253-626-025-016	16	5253-626-032-016	16
5253-626-025-020	20	5253-626-032-020	20
		5253-626-032-025	25

Features:

- ▶ Runout accuracy: 5μm.
- ▶ Used with SMG NON-PULL MILLING CHUCK.
- ▶ SMG collet can be used when tool shank is different from the inner hole of SMG NON-PULL MILLING CHUCK.
- ▶ Surface roughness: Ra < 0.1μm.

HYC REDUCTION SLEEVE

For hydraulic chuck

HYC 液壓套筒 [用於液壓刀桿]

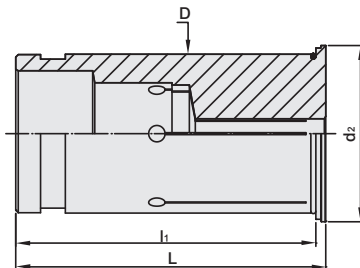

TYPE	D	d ₂	L	l ₁
HYC12	12	16.5	47	45
HYC20	20	24	52.5	50.5
HYC25	25	29	56.5	54.5
HYC32	32	35.5	62.5	60.5

HYC12		HYC20		HYC25		HYC32	
MODEL NO.	SIZE	MODEL NO.	SIZE	MODEL NO.	SIZE	MODEL NO.	SIZE
5253-266-012-003	3	5253-266-020-003	3	5253-266-025-006	6	5253-266-032-006	6
5253-266-012-004	4	5253-266-020-004	4	5253-266-025-008	8	5253-266-032-008	8
5253-266-012-005	5	5253-266-020-005	5	5253-266-025-010	10	5253-266-032-010	10
5253-266-012-006	6	5253-266-020-006	6	5253-266-025-012	12	5253-266-032-012	12
5253-266-012-008	8	5253-266-020-007	7	5253-266-025-014	14	5253-266-032-014	14
		5253-266-020-008	8	5253-266-025-016	16	5253-266-032-016	16
		5253-266-020-009	9	5253-266-025-018	18	5253-266-032-018	18
		5253-266-020-010	10	5253-266-025-020	20	5253-266-032-020	20
		5253-266-020-011	11			5253-266-032-025	25
		5253-266-020-012	12				
		5253-266-020-013	13				
		5253-266-020-014	14				
		5253-266-020-015	15				
		5253-266-020-016	16				

Features:

- ▶ Runout accuracy: 5μm. ▶ Surface roughness: Ra < 0.1μm.
- ▶ The slots of HYC collet are cut by using high-precision sawing technology, ensuring precise ID and strong clamping power.
- ▶ Please assemble the cutting tool into HYC reduction sleeve first, and then insert the sleeve with tool into a hydraulic chuck in order to avoid damage.

HSC STRAIGHT COLLET

For MLD Milling Chuck

HSC 高精度直式筒夾 [用於MLD直式筒夾銑床夾頭]

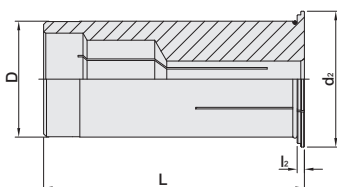

TYPE	D	d ₂	L	l ₂
HSC12	12	18.5	47	2
HSC20	20	26	54	2
HSC25	25	29	60	2
HSC32	32	37.5	72	2
HSC1/2"	12.7	18.5	47	2
HSC3/4"	19.05	26	54	2
HSC1"	25.4	29	60	2
HSC1-1/4"	31.75	37.5	72	2

HSC12		HSC20		HSC25		HSC32	
MODEL NO.	SIZE	MODEL NO.	SIZE	MODEL NO.	SIZE	MODEL NO.	SIZE
5253-269-012-003	3	5253-269-020-004	4	5253-269-025-004	4	5253-269-032-006	6
5253-269-012-004	4	5253-269-020-005	5	5253-269-025-005	5	5253-269-032-008	8
5253-269-012-005	5	5253-269-020-006	6	5253-269-025-006	6	5253-269-032-010	10
5253-269-012-006	6	5253-269-020-008	8	5253-269-025-008	8	5253-269-032-012	12
5253-269-012-008	8	5253-269-020-010	10	5253-269-025-010	10	5253-269-032-014	14
INCHES		5253-269-020-012	12	5253-269-025-012	12	5253-269-032-016	16
HSC1/2"		5253-269-020-016	16	5253-269-025-014	14	5253-269-032-018	18
MODEL NO.	SIZE	INCHES		5253-269-025-016	16	5253-269-032-020	20
5253-269-A32-A08	1/8	HSC3/4"		5253-269-025-020	20	5253-269-032-025	25
5253-269-A32-A12	3/16	MODEL NO.	SIZE	INCHES		INCHES	
5253-269-A32-A16	1/4	5253-269-A48-A16	1/4	HSC1"		HSC1-1/4"	
5253-269-A32-A20	5/16	5253-269-A48-A20	5/16	MODEL NO.	SIZE	MODEL NO.	SIZE
		5253-269-A48-A24	3/8	5253-269-A64-A08	1/8	5253-269-A72-A24	3/8
		5253-269-A48-A28	7/16	5253-269-A64-A12	3/16	5253-269-A72-A28	7/16
		5253-269-A48-A32	1/2	5253-269-A64-A16	1/4	5253-269-A72-A32	1/2
		5253-269-A48-A36	9/16	5253-269-A64-A20	5/16	5253-269-A72-A36	9/16
		5253-269-A48-A40	5/8	5253-269-A64-A24	3/8	5253-269-A72-A40	5/8
				5253-269-A64-A28	7/16	5253-269-A72-A48	3/4
				5253-269-A64-A32	1/2	5253-269-A72-A56	7/8
				5253-269-A64-A36	9/16	5253-269-A72-A64	1
				5253-269-A64-A40	5/8		
				5253-269-A64-A48	3/4		

Features:

- ▶ Runout accuracy: 5µm.
- ▶ Surface roughness: Ra < 0.1µm.



STRAIGHT COLLET

For MLD Milling Chuck

直式彈性筒夾 [用於MLD直式筒夾銑床夾頭]

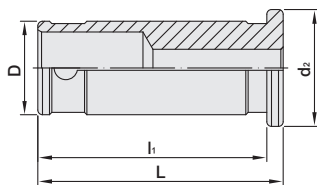

TYPE	D	d ₂	L	l _i
SSC12	12	19	44.5	42.5
SSC16	16	19	50	46
SSC20	20	25	52.5	49
SSC25	25	31	60	55
SSC32	32	37.5	64.6	59.6
SSC42	42	48	75	69
SSC3/4"	3/4"	25	52.5	49
SSC1"	1"	31	60	55
SSC1-1/4"	1-1/4"	37.5	64.6	59.6

SSC12	
MODEL NO.	SIZE
5253-618-012-0003	3
5253-618-012-0004	4
5253-618-012-0005	5
5253-618-012-0006	6
5253-618-012-0008	8

SSC20	
MODEL NO.	SIZE
5253-618-020-003	3
5253-618-020-004	4
5253-618-020-005	5
5253-618-020-006	6
5253-618-020-008	8
5253-618-020-010	10
5253-618-020-012	12
5253-618-020-016	16

SSC32	
MODEL NO.	SIZE
5253-618-032-003	3
5253-618-032-004	4
5253-618-032-005	5
5253-618-032-006	6
5253-618-032-008	8
5253-618-032-010	10
5253-618-032-012	12
5253-618-032-016	16
5253-618-032-020	20
5253-618-032-025	25

SSC42	
MODEL NO.	SIZE
5253-618-042-003	3
5253-618-042-004	4
5253-618-042-005	5
5253-618-042-006	6
5253-618-042-008	8
5253-618-042-010	10
5253-618-042-012	12
5253-618-042-016	16
5253-618-042-020	20
5253-618-042-025	25
5253-618-042-032	32

SSC16	
MODEL NO.	SIZE
5253-618-016-003	3
5253-618-016-004	4
5253-618-016-005	5
5253-618-016-006	6
5253-618-016-008	8
5253-618-016-010	10
5253-618-016-012	12

SSC25	
MODEL NO.	SIZE
5253-618-025-003	3
5253-618-025-004	4
5253-618-025-005	5
5253-618-025-006	6
5253-618-025-008	8
5253-618-025-010	10
5253-618-025-012	12
5253-618-025-016	16
5253-618-025-020	20

INCHES

SSC3/4"	
MODEL NO.	SIZE
5253-618-A48-A08	1/8
5253-618-A48-A12	3/16
5253-618-A48-A16	1/4
5253-618-A48-A20	5/16
5253-618-A48-A24	3/8
5253-618-A48-A28	7/16
5253-618-A48-A32	1/2
5253-618-A48-A36	9/16
5253-618-A48-A40	5/8

SSC1"	
MODEL NO.	SIZE
5253-618-A64-A08	1/8
5253-618-A64-A12	3/16
5253-618-A64-A16	1/4
5253-618-A64-A20	5/16
5253-618-A64-A24	3/8
5253-618-A64-A28	7/16
5253-618-A64-A32	1/2
5253-618-A64-A36	9/16
5253-618-A64-A40	5/8
5253-618-A64-A48	3/4

SSC1-1/4"	
MODEL NO.	SIZE
5253-618-A72-A08	1/8
5253-618-A72-A12	3/16
5253-618-A72-A16	1/4
5253-618-A72-A20	5/16
5253-618-A72-A24	3/8
5253-618-A72-A28	7/16
5253-618-A72-A32	1/2
5253-618-A72-A36	9/16
5253-618-A72-A40	5/8
5253-618-A72-A48	3/4
5253-618-A72-A56	7/8
5253-618-A72-A64	1

Features:

- ▶ Runout accuracy: 20µm, A class 10µm, UP class 5µm.

STRAIGHT SEALED COLLET

For hydraulic chuck

直式止水筒夾 [用於液壓刀桿]

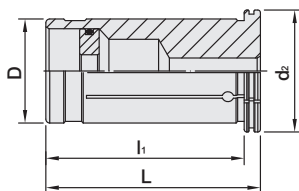

TYPE	D	d ₂	L	l _i
SSC12 - C	12	16	40	38
SSC20 - C	20	25	52.9	49.4
SSC25 - C	25	30.5	52.5	50.5
SSC32 - C	32	37.5	66	61
SSC42 - C	42	48	75	69
SSC1/2 - C	1/2"	16	46.5	44.5
SSC3/4 - C	3/4"	25	52.9	49.4
SSC1 - C	1"	30.5	52.5	50.5
SSC1-1/4 - C	1-1/4"	37.5	66	61

SSC12 - C	
MODEL NO.	SIZE
5253-S36-012-003	3
5253-S36-012-004	4
5253-S36-012-005	5
5253-S36-012-006	6
5253-S36-012-008	8

SSC25 - C	
MODEL NO.	SIZE
5253-S36-025-003	3
5253-S36-025-004	4
5253-S36-025-005	5
5253-S36-025-006	6
5253-S36-025-008	8

SSC32 - C	
MODEL NO.	SIZE
5253-S36-032-003	3
5253-S36-032-004	4
5253-S36-032-005	5
5253-S36-032-006	6
5253-S36-032-008	8

SSC42 - C	
MODEL NO.	SIZE
5253-S36-042-003	3
5253-S36-042-004	4
5253-S36-042-005	5
5253-S36-042-006	6
5253-S36-042-008	8

SSC20 - C	
MODEL NO.	SIZE
5253-S36-020-003	3
5253-S36-020-004	4
5253-S36-020-005	5
5253-S36-020-006	6
5253-S36-020-008	8
5253-S36-020-010	10
5253-S36-020-012	12
5253-S36-020-016	16

5253-S36-025-010	10
5253-S36-025-012	12
5253-S36-025-016	16
5253-S36-025-020	20

5253-S36-032-010	10
5253-S36-032-012	12
5253-S36-032-016	16
5253-S36-032-020	20
5253-S36-032-025	25

5253-S36-042-010	10
5253-S36-042-012	12
5253-S36-042-016	16
5253-S36-042-020	20
5253-S36-042-025	25
5253-S36-042-032	32

INCHES

SSC1/2" - C	
MODEL NO.	SIZE
5253-S36-A32-A08	1/8
5253-S36-A32-A12	3/16
5253-S36-A32-A16	1/4
5253-S36-A32-A20	5/16
5253-S36-A32-A24	3/8

SSC3/4" - C	
MODEL NO.	SIZE
5253-S36-A48-A08	1/8
5253-S36-A48-A12	3/16
5253-S36-A48-A16	1/4
5253-S36-A48-A20	5/16
5253-S36-A48-A24	3/8

SSC1" - C	
MODEL NO.	SIZE
5253-S36-A64-A08	1/8
5253-S36-A64-A12	3/16
5253-S36-A64-A16	1/4
5253-S36-A64-A20	5/16
5253-S36-A64-A24	3/8

SSC1-1/4" - C	
MODEL NO.	SIZE
5253-S36-A72-A08	1/8
5253-S36-A72-A12	3/16
5253-S36-A72-A16	1/4
5253-S36-A72-A20	5/16
5253-S36-A72-A24	3/8

5253-S36-A48-A28	7/16
5253-S36-A48-A32	1/2
5253-S36-A48-A36	9/16
5253-S36-A48-A40	5/8

5253-S36-A64-A28	7/16
5253-S36-A64-A32	1/2
5253-S36-A64-A36	9/16
5253-S36-A64-A40	5/8

5253-S36-A72-A28	7/16
5253-S36-A72-A32	1/2
5253-S36-A72-A36	9/16
5253-S36-A72-A40	5/8

5253-S36-A64-A48	3/4
------------------	-----

5253-S36-A72-A48	3/4
5253-S36-A72-A56	7/8
5253-S36-A72-A64	1

Features:

- ▶ Besides standard runout accuracy, UP class 5µm is also supplied.
- ▶ Used for coolant-through cutting tools.
- ▶ Coolant pressure: 7 bar.



EOC COLLET

FORM B

EOC B型 彈性筒夾

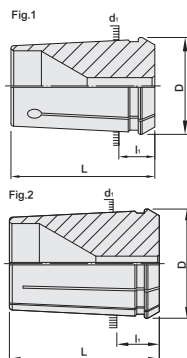

TYPE	L	l ₁	D	d ₁	Fig.
SYOZ - 25	52	13	35	32.9	1
EOC32 - B	60	17	43.7	41.3	2

SYOZ - 25				EOC 32 - B			
MODEL NO.	SIZE	MODEL NO.	SIZE	MODEL NO.	SIZE	MODEL NO.	SIZE
5250-689-025-003	3	5250-689-025-015	15	5250-119-032-004	4 - 3.5	5250-119-032-019	19 - 18.5
5250-689-025-004	4	5250-689-025-016	16	5250-119-032-005	5 - 4.5	5250-119-032-020	20 - 19.5
5250-689-025-005	5	5250-689-025-017	17	5250-119-032-006	6 - 5.5	5250-119-032-021	21 - 20.5
5250-689-025-006	6	5250-689-025-018	18	5250-119-032-007	7 - 6.5	5250-119-032-022	22 - 21.5
5250-689-025-007	7	5250-689-025-019	19	5250-119-032-008	8 - 7.5	5250-119-032-023	23 - 22.5
5250-689-025-008	8	5250-689-025-020	20	5250-119-032-009	9 - 8.5	5250-119-032-024	24 - 23.5
5250-689-025-009	9	5250-689-025-021	21	5250-119-032-010	10 - 9.5	5250-119-032-025	25 - 24.5
5250-689-025-010	10	5250-689-025-022	22	5250-119-032-011	11 - 10.5	5250-119-032-026	26 - 25.5
5250-689-025-011	11	5250-689-025-023	23	5250-119-032-012	12 - 11.5	5250-119-032-027	27 - 26.5
5250-689-025-012	12	5250-689-025-024	24	5250-119-032-013	13 - 12.5	5250-119-032-028	28 - 27.5
5250-689-025-013	13	5250-689-025-025	25	5250-119-032-014	14 - 13.5	5250-119-032-029	29 - 28.5
5250-689-025-014	14			5250-119-032-015	15 - 14.5	5250-119-032-030	30 - 29.5
INCHES				5250-119-032-016	16 - 15.5	5250-119-032-031	31 - 30.5
5250-689-025-A08	1/8	5250-689-025-A36	9/16	5250-119-032-017	17 - 16.5	5250-119-032-032	32 - 31.5
5250-689-025-A12	3/16	5250-689-025-A40	5/8	5250-119-032-018	18 - 17.5		
5250-689-025-A16	1/4	5250-689-025-A44	11/16	INCHES			
5250-689-025-A20	5/16	5250-689-025-A48	3/4	5250-119-032-A08	0.105 - 0.125	5250-119-032-A32	0.48 - 0.5
5250-689-025-A24	3/8	5250-689-025-A56	7/8	5250-119-032-A12	0.168 - 0.188	5250-119-032-A40	0.605 - 0.625
5250-689-025-A28	7/16	5250-689-025-A60	15/16	5250-119-032-A16	0.23 - 0.25	5250-119-032-A48	0.73 - 0.75
5250-689-025-A32	1/2	5250-689-025-A64	1	5250-119-032-A20	0.293 - 0.313	5250-119-032-A56	0.855 - 0.875
				5250-119-032-A24	0.355 - 0.375	5250-119-032-A64	0.98 - 1
				5250-119-032-A28	0.418 - 0.438	5250-119-032-A72	1.23 - 1.25

Features:

- EOC32-B collet has flexibility with clamping range 0.5mm.

TG COLLET

TG 彈性筒夾

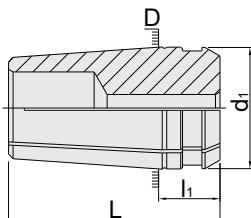

TYPE	L	l ₁	D	d ₁
TG 75	46.84	13.6	26.97	26.84
TG 100	60.32	16.32	35.02	32.5
TG 150	76.2	18	50.83	47.7

TG 75									
MODEL NO.	SIZE	MODEL NO.	SIZE	MODEL NO.	SIZE	MODEL NO.	SIZE	MODEL NO.	SIZE
5250-691-075-003	3	5250-691-075-006	6	5250-691-075-009	9	5250-691-075-012	12	5250-691-075-015	15
5250-691-075-004	4	5250-691-075-007	7	5250-691-075-010	10	5250-691-075-013	13	5250-691-075-016	16
5250-691-075-005	5	5250-691-075-008	8	5250-691-075-011	11	5250-691-075-014	14		

INCHES

5250-691-075-A06	3/32	5250-691-075-A15	15/64	5250-691-075-A24	3/8	5250-691-075-A33	33/64	5250-691-075-A42	21/32
5250-691-075-A07	7/64	5250-691-075-A16	1/4	5250-691-075-A25	25/64	5250-691-075-A34	17/32	5250-691-075-A43	43/64
5250-691-075-A08	1/8	5250-691-075-A17	17/64	5250-691-075-A26	13/32	5250-691-075-A35	35/64	5250-691-075-A44	11/16
5250-691-075-A09	9/64	5250-691-075-A18	9/32	5250-691-075-A27	27/64	5250-691-075-A36	9/16	5250-691-075-A45	45/64
5250-691-075-A10	5/32	5250-691-075-A19	19/64	5250-691-075-A28	7/16	5250-691-075-A37	37/64	5250-691-075-A46	23/32
5250-691-075-A11	11/64	5250-691-075-A20	5/16	5250-691-075-A29	29/64	5250-691-075-A38	19/32	5250-691-075-A47	47/64
5250-691-075-A12	3/16	5250-691-075-A21	21/64	5250-691-075-A30	15/32	5250-691-075-A39	39/64	5250-691-075-A48	3/4
5250-691-075-A13	13/64	5250-691-075-A22	11/32	5250-691-075-A31	31/64	5250-691-075-A40	5/8		
5250-691-075-A14	7/32	5250-691-075-A23	23/64	5250-691-075-A32	1/2	5250-691-075-A41	41/64		

TG 100									
MODEL NO.	SIZE	MODEL NO.	SIZE	MODEL NO.	SIZE	MODEL NO.	SIZE	MODEL NO.	SIZE
5250-691-100-003	3	5250-691-100-008	8	5250-691-100-013	13	5250-691-100-018	18	5250-691-100-023	23
5250-691-100-004	4	5250-691-100-009	9	5250-691-100-014	14	5250-691-100-019	19	5250-691-100-024	24
5250-691-100-005	5	5250-691-100-010	10	5250-691-100-015	15	5250-691-100-020	20	5250-691-100-025	25
5250-691-100-006	6	5250-691-100-011	11	5250-691-100-016	16	5250-691-100-021	21		
5250-691-100-007	7	5250-691-100-012	12	5250-691-100-017	17	5250-691-100-022	22		

INCHES

5250-691-100-A06	3/32	5250-691-100-A18	9/32	5250-691-100-A30	15/32	5250-691-100-A42	21/32	5250-691-100-A54	27/32
5250-691-100-A07	7/64	5250-691-100-A19	19/64	5250-691-100-A31	31/64	5250-691-100-A43	43/64	5250-691-100-A55	55/64
5250-691-100-A08	1/8	5250-691-100-A20	5/16	5250-691-100-A32	1/2	5250-691-100-A44	11/16	5250-691-100-A56	7/8
5250-691-100-A09	9/64	5250-691-100-A21	21/64	5250-691-100-A33	33/64	5250-691-100-A45	45/64	5250-691-100-A57	57/64
5250-691-100-A10	5/32	5250-691-100-A22	11/32	5250-691-100-A34	17/32	5250-691-100-A46	23/32	5250-691-100-A58	29/32
5250-691-100-A11	11/64	5250-691-100-A23	23/64	5250-691-100-A35	35/64	5250-691-100-A47	47/64	5250-691-100-A59	59/64
5250-691-100-A12	3/16	5250-691-100-A24	3/8	5250-691-100-A36	9/16	5250-691-100-A48	3/4	5250-691-100-A60	15/16
5250-691-100-A13	13/64	5250-691-100-A25	25/64	5250-691-100-A37	37/64	5250-691-100-A49	49/64	5250-691-100-A61	61/64
5250-691-100-A14	7/32	5250-691-100-A26	13/32	5250-691-100-A38	19/32	5250-691-100-A50	25/32	5250-691-100-A62	31/32
5250-691-100-A15	15/64	5250-691-100-A27	27/64	5250-691-100-A39	39/64	5250-691-100-A51	51/64	5250-691-100-A63	63/64
5250-691-100-A16	1/4	5250-691-100-A28	7/16	5250-691-100-A40	5/8	5250-691-100-A52	13/16	5250-691-100-A64	1
5250-691-100-A17	17/64	5250-691-100-A29	29/64	5250-691-100-A41	41/64	5250-691-100-A53	53/64		

Features:

- ▶ Increment by 1mm or 1/64".
- ▶ With 6 slots in front and back.



TG COLLET

TG 彈性筒夾

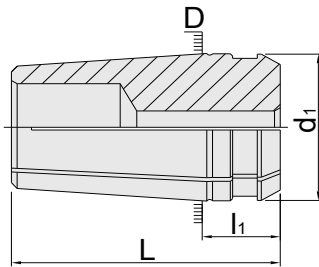

TYPE	L	l ₁	D	d ₁
TG 75	46.84	13.6	26.97	26.84
TG 100	60.32	16.32	35.02	32.5
TG 150	76.2	18	50.83	47.7

TG 150							
MODEL NO.	SIZE	MODEL NO.	SIZE	MODEL NO.	SIZE	MODEL NO.	SIZE
5250-691-150-004	4	5250-691-150-013	13	5250-691-150-022	22	5250-691-150-031	31
5250-691-150-005	5	5250-691-150-014	14	5250-691-150-023	23	5250-691-150-032	32
5250-691-150-006	6	5250-691-150-015	15	5250-691-150-024	24	5250-691-150-033	33
5250-691-150-007	7	5250-691-150-016	16	5250-691-150-025	25	5250-691-150-034	34
5250-691-150-008	8	5250-691-150-017	17	5250-691-150-026	26	5250-691-150-035	35
5250-691-150-009	9	5250-691-150-018	18	5250-691-150-027	27	5250-691-150-036	36
5250-691-150-010	10	5250-691-150-019	19	5250-691-150-028	28	5250-691-150-037	37
5250-691-150-011	11	5250-691-150-020	20	5250-691-150-029	29	5250-691-150-038	38
5250-691-150-012	12	5250-691-150-021	21	5250-691-150-030	30		

INCHES

5250-691-150-A10	5/32	5250-691-150-A32	1/2	5250-691-150-A54	27/32	5250-691-150-A70	1-3/16
5250-691-150-A11	11/64	5250-691-150-A33	33/64	5250-691-150-A55	55/64	5250-691-150-B46	1-13/64
5250-691-150-A12	3/16	5250-691-150-A34	17/32	5250-691-150-A56	7/8	5250-691-150-A71	1-7/32
5250-691-150-A13	13/64	5250-691-150-A35	35/64	5250-691-150-A57	57/64	5250-691-150-B47	1-15/64
5250-691-150-A14	7/32	5250-691-150-A36	9/16	5250-691-150-A58	29/32	5250-691-150-A72	1-1/4
5250-691-150-A15	15/64	5250-691-150-A37	37/64	5250-691-150-A59	59/64	5250-691-150-B48	1-17/64
5250-691-150-A16	1/4	5250-691-150-A38	19/32	5250-691-150-A60	15/16	5250-691-150-A73	1-9/32
5250-691-150-A17	17/64	5250-691-150-A39	39/64	5250-691-150-A61	61/64	5250-691-150-B49	1-19/64
5250-691-150-A18	9/32	5250-691-150-A40	5/8	5250-691-150-A62	31/32	5250-691-150-A74	1-5/16
5250-691-150-A19	19/64	5250-691-150-A41	41/64	5250-691-150-A63	63/64	5250-691-150-B50	1-21/64
5250-691-150-A20	5/16	5250-691-150-A42	21/32	5250-691-150-A64	1	5250-691-150-A75	1-11/32
5250-691-150-A21	21/64	5250-691-150-A43	43/64	5250-691-150-B40	1-1/64	5250-691-150-B51	1-23/64
5250-691-150-A22	11/32	5250-691-150-A44	11/16	5250-691-150-A65	1-1/32	5250-691-150-A76	1-3/8
5250-691-150-A23	23/64	5250-691-150-A45	45/64	5250-691-150-B41	1-3/64	5250-691-150-B52	1-25/64
5250-691-150-A24	3/8	5250-691-150-A46	23/32	5250-691-150-A66	1-1/16	5250-691-150-A77	1-13/32
5250-691-150-A25	25/64	5250-691-150-A47	47/64	5250-691-150-B42	1-5/64	5250-691-150-B53	1-27/64
5250-691-150-A26	13/32	5250-691-150-A48	3/4	5250-691-150-A67	1-3/32	5250-691-150-A78	1-7/16
5250-691-150-A27	27/64	5250-691-150-A49	49/64	5250-691-150-B43	1-7/64	5250-691-150-B54	1-29/64
5250-691-150-A28	7/16	5250-691-150-A50	25/32	5250-691-150-A68	1-1/8	5250-691-150-A79	1-15/32
5250-691-150-A29	29/64	5250-691-150-A51	51/64	5250-691-150-B44	1-9/64	5250-691-150-B55	1-31/64
5250-691-150-A30	15/32	5250-691-150-A52	13/16	5250-691-150-A69	1-5/32	5250-691-150-A80	1-1/2
5250-691-150-A31	31/64	5250-691-150-A53	53/64	5250-691-150-B45	1-11/64		

Features:

- ▶ Increment by 1mm or 1/64".
- ▶ With 6 slots in front and back.



TG SEALED COLLET

TG 止水筒夾

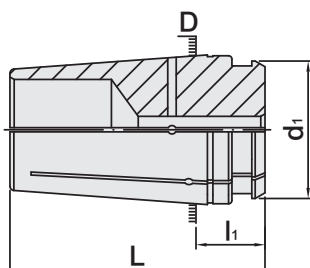

TYPE	L	l ₁	D	d ₁
TG 100	60.32	16.32	35.02	32.5
TG 150	76.2	18	50.83	47.7

TG 100

MODEL NO.	SIZE	MODEL NO.	SIZE	MODEL NO.	SIZE	MODEL NO.	SIZE	MODEL NO.	SIZE
5250-696-100-003	3	5250-696-100-008	8	5250-696-100-013	13	5250-696-100-018	18	5250-696-100-022	22
5250-696-100-004	4	5250-696-100-009	9	5250-696-100-014	14	5250-696-100-019	19	5250-696-100-023	23
5250-696-100-005	5	5250-696-100-010	10	5250-696-100-015	15	5250-696-100-020	20	5250-696-100-024	24
5250-696-100-006	6	5250-696-100-011	11	5250-696-100-016	16	5250-696-100-021	21	5250-696-100-025	25
5250-696-100-007	7	5250-696-100-012	12	5250-696-100-017	17				

INCHES

5250-696-100-A06	3/32	5250-696-100-A18	9/32	5250-696-100-A30	15/32	5250-696-100-A42	21/32	5250-696-100-A54	27/32
5250-696-100-A07	7/64	5250-696-100-A19	19/64	5250-696-100-A31	31/64	5250-696-100-A43	43/64	5250-696-100-A55	55/64
5250-696-100-A08	1/8	5250-696-100-A20	5/16	5250-696-100-A32	1/2	5250-696-100-A44	11/16	5250-696-100-A56	7/8
5250-696-100-A09	9/64	5250-696-100-A21	21/64	5250-696-100-A33	33/64	5250-696-100-A45	45/64	5250-696-100-A57	57/64
5250-696-100-A10	5/32	5250-696-100-A22	11/32	5250-696-100-A34	17/32	5250-696-100-A46	23/32	5250-696-100-A58	29/32
5250-696-100-A11	11/64	5250-696-100-A23	23/64	5250-696-100-A35	35/64	5250-696-100-A47	47/64	5250-696-100-A59	59/64
5250-696-100-A12	3/16	5250-696-100-A24	3/8	5250-696-100-A36	9/16	5250-696-100-A48	3/4	5250-696-100-A60	15/16
5250-696-100-A13	13/64	5250-696-100-A25	25/64	5250-696-100-A37	37/64	5250-696-100-A49	49/64	5250-696-100-A61	61/64
5250-696-100-A14	7/32	5250-696-100-A26	13/32	5250-696-100-A38	19/32	5250-696-100-A50	25/32	5250-696-100-A62	31/32
5250-696-100-A15	15/64	5250-696-100-A27	27/64	5250-696-100-A39	39/64	5250-696-100-A51	51/64	5250-696-100-A63	63/64
5250-696-100-A16	1/4	5250-696-100-A28	7/16	5250-696-100-A40	5/8	5250-696-100-A52	13/16	5250-696-100-A64	1
5250-696-100-A17	17/64	5250-696-100-A29	29/64	5250-696-100-A41	41/64	5250-696-100-A53	53/64		

TG 150

MODEL NO.	SIZE	MODEL NO.	SIZE	MODEL NO.	SIZE	MODEL NO.	SIZE	MODEL NO.	SIZE
5250-696-150-004	4	5250-696-150-011	11	5250-696-150-018	18	5250-696-150-025	25	5250-696-150-032	32
5250-696-150-005	5	5250-696-150-012	12	5250-696-150-019	19	5250-696-150-026	26	5250-696-150-033	33
5250-696-150-006	6	5250-696-150-013	13	5250-696-150-020	20	5250-696-150-027	27	5250-696-150-034	34
5250-696-150-007	7	5250-696-150-014	14	5250-696-150-021	21	5250-696-150-028	28	5250-696-150-035	35
5250-696-150-008	8	5250-696-150-015	15	5250-696-150-022	22	5250-696-150-029	29	5250-696-150-036	36
5250-696-150-009	9	5250-696-150-016	16	5250-696-150-023	23	5250-696-150-030	30	5250-696-150-037	37
5250-696-150-010	10	5250-696-150-017	17	5250-696-150-024	24	5250-696-150-031	31	5250-696-150-038	38

INCHES

5250-696-150-A10	5/32	5250-696-150-A28	7/16	5250-696-150-A46	23/32	5250-696-150-A64	1	5250-696-150-A73	1-9/32
5250-696-150-A11	11/64	5250-696-150-A29	29/64	5250-696-150-A47	47/64	5250-696-150-B40	1-1/64	5250-696-150-B49	1-19/64
5250-696-150-A12	3/16	5250-696-150-A30	15/32	5250-696-150-A48	3/4	5250-696-150-A65	1-1/32	5250-696-150-A74	1-5/16
5250-696-150-A13	13/64	5250-696-150-A31	31/64	5250-696-150-A49	49/64	5250-696-150-B41	1-3/64	5250-696-150-B50	1-21/64
5250-696-150-A14	7/32	5250-696-150-A32	1/2	5250-696-150-A50	25/32	5250-696-150-A66	1-1/16	5250-696-150-A75	1-11/32
5250-696-150-A15	15/64	5250-696-150-A33	33/64	5250-696-150-A51	51/64	5250-696-150-B42	1-5/64	5250-696-150-B51	1-23/64
5250-696-150-A16	1/4	5250-696-150-A34	17/32	5250-696-150-A52	13/16	5250-696-150-A67	1-3/32	5250-696-150-A76	1-3/8
5250-696-150-A17	17/64	5250-696-150-A35	35/64	5250-696-150-A53	53/64	5250-696-150-B43	1-7/64	5250-696-150-B52	1-25/64
5250-696-150-A18	9/32	5250-696-150-A36	9/16	5250-696-150-A54	27/32	5250-696-150-A68	1-1/8	5250-696-150-A77	1-13/32
5250-696-150-A19	19/64	5250-696-150-A37	37/64	5250-696-150-A55	55/64	5250-696-150-B44	1-9/64	5250-696-150-B53	1-27/64
5250-696-150-A20	5/16	5250-696-150-A38	19/32	5250-696-150-A56	7/8	5250-696-150-A69	1-5/32	5250-696-150-A78	1-7/16
5250-696-150-A21	21/64	5250-696-150-A39	39/64	5250-696-150-A57	57/64	5250-696-150-B45	1-11/64	5250-696-150-B54	1-29/64
5250-696-150-A22	11/32	5250-696-150-A40	5/8	5250-696-150-A58	29/32	5250-696-150-A70	1-3/16	5250-696-150-A79	1-15/32
5250-696-150-A23	23/64	5250-696-150-A41	41/64	5250-696-150-A59	59/64	5250-696-150-B46	1-13/64	5250-696-150-B55	1-31/64
5250-696-150-A24	3/8	5250-696-150-A42	21/32	5250-696-150-A60	15/16	5250-696-150-A71	1-7/32	5250-696-150-A80	1-1/2
5250-696-150-A25	25/64	5250-696-150-A43	43/64	5250-696-150-A61	61/64	5250-696-150-B47	1-15/64		
5250-696-150-A26	13/32	5250-696-150-A44	11/16	5250-696-150-A62	31/32	5250-696-150-A72	1-1/4		
5250-696-150-A27	27/64	5250-696-150-A45	45/64	5250-696-150-A63	63/64	5250-696-150-B48	1-17/64		

Features:

- ▶ Used for coolant-through cutting tools.



PRO - E POWER GOOD NUT



PRO - E 包固得威力鍍層螺帽

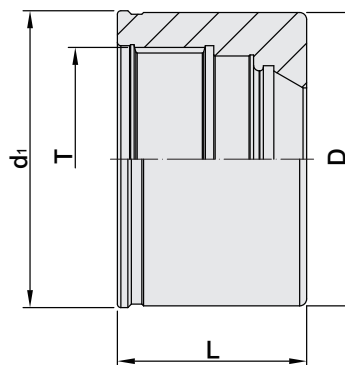

MODEL NO.	TYPE	L	D	d ₁	T	RECOMMENDED TIGHTENING TORQUE		WEIGHT (KGS)
5202-584-011	PRO - E11M	14.3	16	16.7	M14 x 0.7P	20 N-m	14 ft/lbs	0.08
5202-529-016	PRO - E16	22	30	30.3	M22 x 1.5P	40 N-m	30 ft/lbs	0.06
5202-529-020	PRO - E20	23.5	35	35.3	M27 x 1.5P	60 N-m	44 ft/lbs	0.09
5202-529-025	PRO - E25	24.6	42	42.7	M32 x 1.5P	80 N-m	59 ft/lbs	0.14
5202-529-032	PRO - E32	27	50	50.7	M40 x 1.5P	110 N-m	81 ft/lbs	0.19

Features:

- ▶ Its non-slot design decreases wind shear, and can be used for high speed application.

UT CLAMPING NUT



UT 螺帽

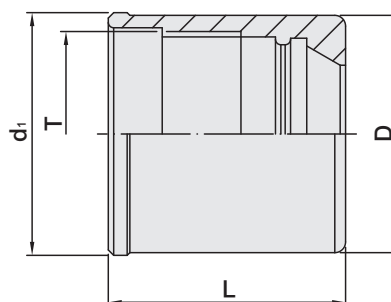

MODEL NO.	TYPE	L	D	d ₁	T	RECOMMENDED TIGHTENING TORQUE		WEIGHT (KGS)
5201-753-016	UT16	22	30	31	M22 x 1.5P	50 N-m	36 ft/lbs	0.064
5201-753-020	UT20	27.5	35	36	M27 x 1.5P	60 N-m	44 ft/lbs	0.098
5201-753-025	UT25	28.5	42	43	M32 x 1.5P	85 N-m	62 ft/lbs	0.150
5201-753-032	UT32	31	48	49	M40 x 1.5P	120 N-m	88 ft/lbs	0.166

ER POWER GOOD NUT



ER 包固得威力鍍層螺帽

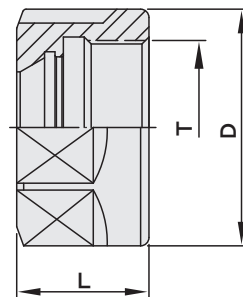
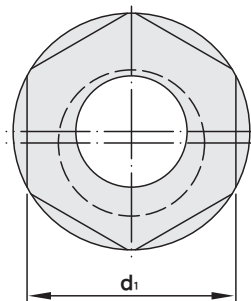

MODEL NO.	TYPE	D	d ₁	L	T	RECOMMENDED TIGHTENING TORQUE		WEIGHT (KGS)
5200-108-011	ER11 - A	19	17	11.3	M14 x 0.75P	30 N-m	22 ft/lbs	0.02
5200-108-016	ER16 - A	28	25	18.5	M22 x 1.5P	40 N-m	30 ft/lbs	0.05
5200-108-020	ER20 - A	34	30	20	M25 x 1.5P	60 N-m	44 ft/lbs	0.06

Features:

- ▶ Special surface treatment. Clamping power is increased twice.
- ▶ Pre-balance to G6.3 10,000rpm.

ER POWER GOOD NUT



ER 包固得威力鍍層螺帽

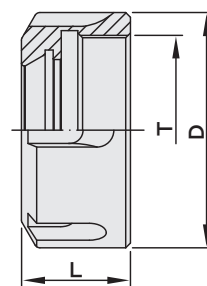
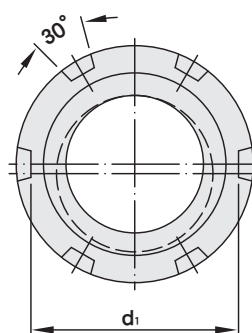

MODEL NO.	TYPE	D	d ₁	L	T	RECOMMENDED TIGHTENING TORQUE		WEIGHT (KGS)
5200-110-016	ER16 - UM-RD	31.7	26	18	M22 x 1.5P	40 N-m	30 ft/lbs	0.05
5200-110-020	ER20 - UM-RD	35	29	19.5	M25 x 1.5P	60 N-m	44 ft/lbs	0.10
5200-110-025	ER25 - UM-RD	42	36	21	M32 x 1.5P	80 N-m	59 ft/lbs	0.14
5200-110-032	ER32 - UM-RD	50	44	23.5	M40 x 1.5P	110 N-m	81 ft/lbs	0.20
5200-110-040	ER40 - UM-RD	63	57	26.5	M50 x 1.5P	130 N-m	95 ft/lbs	0.30
5200-110-050	ER50 - UM-RD	78	71	35.3	M64 x 2.0P	200 N-m	147 ft/lbs	0.50

Features:

- ▶ Special surface treatment. Clamping power is increased twice.
- ▶ Pre-balance to G6.3 10,000rpm.



ER POWER GOOD NUT

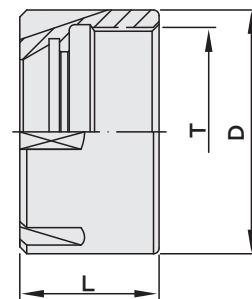
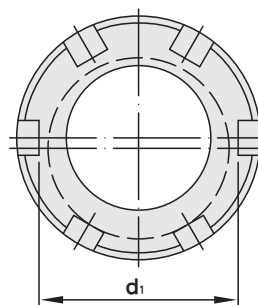

ER 包固得威力鍍層螺帽

台灣精品 2008
TAIWAN EXCELLENCE

MODEL NO.	TYPE	D	d ₁	L	T	RECOMMENDED TIGHTENING TORQUE		WEIGHT (KGS)
5200-123-008	ER8 - M	12	9.1	10.8	M10 x 0.75P	10 N-m	7 ft/lbs	0.01
5200-123-011	ER11 - M	16	12	11.3	M13 x 0.75P	20 N-m	14 ft/lbs	0.01
5200-123-016	ER16 - M	22	16.7	18	M19 x 1.0P	30 N-m	21 ft/lbs	0.05
5200-123-020	ER20 - M	28	21.85	19	M24 x 1.0P	40 N-m	24 ft/lbs	0.05
5200-123-025	ER25 - M	35	27.54	20	M30 x 1.0P	60 N-m	29 ft/lbs	0.08

Features:

- ▶ Special surface treatment. Clamping power is increased twice.
- ▶ Pre-balance to G6.3 10,000rpm.

ERS SHORT LENGTH CLAMPING NUT



ERS 短徑螺帽

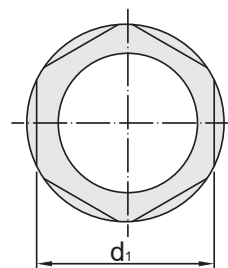
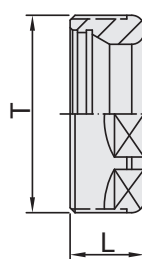

MODEL NO.	TYPE	L	d ₁	T	WEIGHT (KGS)
5204-125-016-01	ER16S	13.5	19	M24x1.0P	0.026
5204-125-020-01	ER20S	14	22	M28x1.5P	0.033
5204-125-025-01	ER25S	16.5	25	M32x1.5P	0.043
5204-125-032-01	ER32S	15	36	M40x1.5P	0.054

Features:

- ▶ Special surface treatment. Clamping power is increased twice.
- ▶ Pre-balance to G6.3 10,000rpm.



ER HIGH SPEED PRECISION NUT

BALL BEARING TYPE



ER 強力精密高速型螺帽

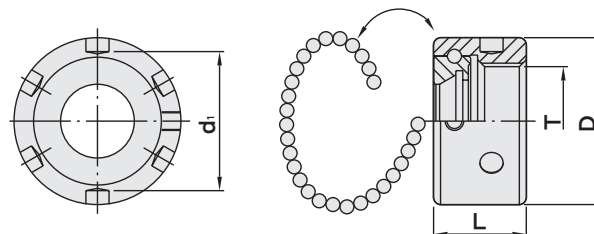

MODEL NO.	TYPE	D	d ₁	L	T	RECOMMENDED TIGHTENING TORQUE		WEIGHT (KGS)
5207-109-016	ER 16 - HSP	32	26	18	M22 x 1.5P	35 N-m	25 ft/lbs	0.01
5207-109-020	ER 20 - HSP	36	30	20	M25 x 1.5P	55 N-m	40 ft/lbs	0.10
5207-109-025	ER 25 - HSP	42	36	22.5	M32 x 1.5P	75 N-m	55 ft/lbs	0.10
5207-109-032	ER 32 - HSP	50	44	25	M40 x 1.5P	100 N-m	73 ft/lbs	0.15
5207-109-040	ER 40 - HSP	63	57	27.5	M50 x 1.5P	140 N-m	103 ft/lbs	0.27

Features:

- ▶ Applied for ER-HSP spanner [X-79]. ▶ The external diameter is ground precisely, decreasing unbalance. ▶ Can be ordered separately.
- ▶ According to ISO1941-1 standard, examined by a balancing machine. ▶ Higher precision and stability if matching ER Collet-UP class.

HIGH SPEED POWER GOOD NUT

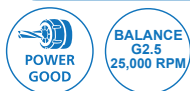

ER 高速型包固得威力鍍層螺帽



台灣精品 2008
TAIWAN EXCELLENCE

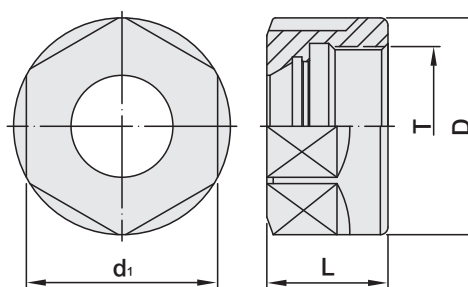

MODEL NO.	TYPE	D	d ₁	L	T	RECOMMENDED TIGHTENING TORQUE		WEIGHT (KGS)
5200-106-011	ER11A - HS	19	17	11.3	M14 x 0.75P	30 N-m	22 ft/lbs	0.02
5200-106-016	ER16A - HS	28	25	17.5	M22 x 1.5P	40 N-m	30 ft/lbs	0.05
5200-106-020	ER20A - HS	34	30	19	M25 x 1.5P	60 N-m	40 ft/lbs	0.10

Features:

- ▶ Special surface treatment. Clamping power is improved twice.



HIGH SPEED POWER GOOD NUT



ER 高速型包固得威力鍍層螺帽

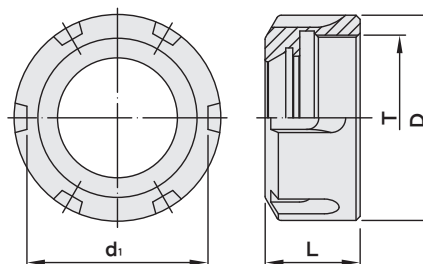

MODEL NO.	TYPE	D	d ₁	L	T	RECOMMENDED TIGHTENING TORQUE		WEIGHT (KGS)
5200-107-016	ER16 - HS	32	26	18	M22 x 1.5P	40 N-m	30 ft/lbs	0.06
5200-107-020	ER20 - HS	35	29.5	19.5	M25 x 1.5P	60 N-m	44 ft/lbs	0.11
5200-107-025	ER25 - HS	42	35.7	20.5	M32 x 1.5P	80 N-m	59 ft/lbs	0.14
5200-107-032	ER32 - HS	50	43.8	23	M40 x 1.5P	110 N-m	81 ft/lbs	0.20
5200-107-040	ER40 - HS	63	57	26	M50 x 1.5P	130 N-m	95 ft/lbs	0.30

Features:

- ▶ Special surface treatment. Clamping power is improved twice.

ER POWER GOOD SEALED NUT



ER 包固得威力鍍層止水螺帽

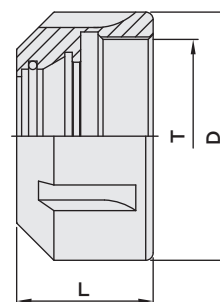

MODEL NO.	TYPE	D	L	T	SR SEALED RING	RECOMMENDED TIGHTENING TORQUE		WEIGHT (KGS)
5200-103-016	ER16 - CO	28	22.5	M22 x 1.5P	SR16	40 N-m	30 ft/lbs	0.05
5200-103-020	ER20 - CO	34	24	M25 x 1.5P	SR20	60 N-m	44 ft/lbs	0.07
5200-105-025	ER25 - CO	42	25	M32 x 1.5P	SR25	80 N-m	59 ft/lbs	0.10
5200-105-032	ER32 - CO	50	27.5	M40 x 1.5P	SR32	110 N-m	81 ft/lbs	0.15
5200-105-040	ER40 - CO	63	30.5	M50 x 1.5P	SR40	130 N-m	95 ft/lbs	0.27

Features:

- ▶ Use SR sealed ring [PX-63] to seal and achieve coolant through tools.
- ▶ Can bear the water pressure up to 21kgf/cm².

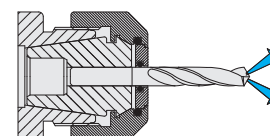

ER WIND RESISTANCE NUT



ER 無風阻螺帽

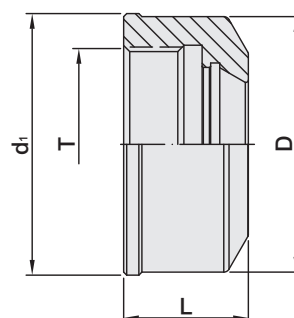

MODEL NO.	TYPE	L	D	d ₁	T	RECOMMENDED TIGHTENING TORQUE		WEIGHT (KGS)
5201-130-016	ER16	17.5	30	31	M22 × 1.5P	40 N-m	30 ft/lbs	0.05
5201-130-020	ER20	19	34	35	M25 × 1.5P	60 N-m	44 ft/lbs	0.10
5201-130-025	ER25	20.5	42	43	M32 × 1.5P	80 N-m	59 ft/lbs	0.14
5201-130-032	ER32	22.5	50	51	M40 × 1.5P	110 N-m	81 ft/lbs	0.23

Features:

- ▶ Its non-slot design decreases wind shear, and can be used for high speed application.

SK3 WIND RESISTANCE NUT

SK3 無風阻螺帽

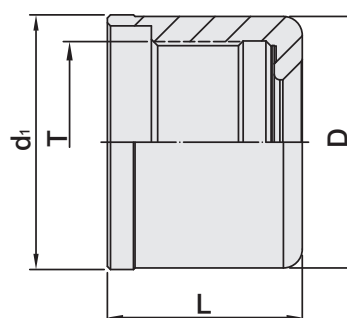

MODEL NO.	TYPE	L	D	d ₁	T	RECOMMENDED TIGHTENING TORQUE		WEIGHT (KGS)
5201-763-006	SK306	23	19.5	20	M14 × 1.0P	25 N-m	18 ft/lbs	0.03
5201-763-010	SK310	24	27.5	28	M21.5 × 1.0P	45 N-m	33 ft/lbs	0.04
5201-763-013	SK313	29.6	33	34.4	M27 × 1.0P	50 N-m	36 ft/lbs	0.06
5201-763-016	SK316	33	40	40.5	M32 × 1.5P	70 N-m	52 ft/lbs	0.10
5201-763-020	SK320	33	48	48.5	M40 × 1.0P	90 N-m	66 ft/lbs	0.14
5201-763-025	SK325	37	55	55.5	M45 × 1.5P	90 N-m	66 ft/lbs	0.25

Features:

- ▶ Its non-slot design decreases wind shear, and can be used for high speed application.



SKX SEALED NUT



SKX 止水螺帽

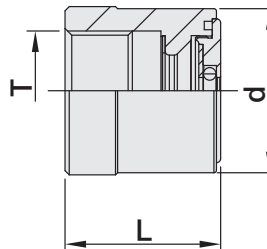

MODLE NO.	TYPE	L	d	T	RECOMMENDED TIGHTENING TORQUE		WEIGHT (KGS)
5203-774-006	SKX6 - CO	18.5	19.5	M14 x 1.0P	25 N-m	18 ft/lbs	0.04
5203-774-010	SKX10 - CO	21	30	M21.5 x 1.0P	45 N-m	33 ft/lbs	0.08
5203-774-013	SKX13 - CO	24.5	33	M27 x 1.0P	50 N-m	36 ft/lbs	0.06
5203-774-016	SKX16 - CO	28	40	M32 x 1.5P	70 N-m	51 ft/lbs	0.15
5203-774-020	SKX20 - CO	28	48	M40 x 1.0P	70 N-m	51 ft/lbs	0.19
5203-774-025	SKX25 - CO	30	55	M45 x 1.5P	100 N-m	73 ft/lbs	0.27



Features:

- ▶ SKX sealed nut is not included with SKX sealed cap. Please order the cap additionally.
- ▶ SKX sealed cap is designed with an o-ring. No need to use with SR sealed ring.
- ▶ For information of SKX sealed cap spanner, please refer to page X-80 (optional).

SKX SEALED CAP

SKX 止水墊片



SKX6 - CO		SKX13 - CO		SKX16 - CO		SKX20 - CO		SKX25 - CO	
MODEL NO.	SIZE	MODEL NO.	SIZE	MODEL NO.	SIZE	MODEL NO.	SIZE	MODEL NO.	SIZE
5297-1006 - 001	1	5297-1013 - 003	3	5297-1016 - 002	2	5297-1020 - 003	3	5297-1025 - 003	3
- 002	2	- 004	4	- 003	3	- 004	4	- 004	4
- 003	3	- 005	5	- 004	4	- 005	5	- 005	5
- 004	4	- 006	6	- 005	5	- 006	6	- 006	6
- 005	5	- 007	7	- 006	6	- 007	7	- 007	7
- 006	6	- 008	8	- 007	7	- 008	8	- 008	8
INCHES		- 009	9	- 008	8	- 009	9	- 009	9
5297-1006 - A08	1/8	- 010	10	- 009	9	- 010	10	- 010	10
- A10	5/32	- 011	11	- 010	10	- 011	11	- 011	11
- A12	3/16	- 012	12	- 011	11	- 012	12	- 012	12
- A14	7/32	- 013	13	- 012	12	- 013	13	- 013	13
- A16	1/4	INCHES		- 013	13	- 014	14	- 014	14
		5297-1013 - A08	1/8	- 014	14	- 015	15	- 015	15
		- A10	5/32	- 015	15	- 016	16	- 016	16
		- A12	3/16	- 016	16	- 017	17	- 017	17
		- A14	7/32	INCHES		- 018	18	- 018	18
		- A16	1/4	5297-1016 - A08	1/8	- 019	19	- 019	19
		- A18	9/32	- A10	5/32	- 020	20	- 020	20
		- A20	5/16	- A12	3/16	INCHES		- 021	21
		- A22	11/32	- A14	7/32	5297-1020 - A08	1/8	- 022	22
		- A24	3/8	- A16	1/4	- A10	5/32	- 023	23
		- A26	13/32	- A18	9/32	- A12	3/16	- 024	24
		- A28	7/16	- A20	5/16	- A14	7/32	- 025	25
		- A30	15/32	- A22	11/32	- A16	1/4	INCHES	
		- A32	1/2	- A24	3/8	- A18	9/32	5297-1025 - A08	1/8
INCHES				- A26	13/32	- A20	5/16	- A10	5/32
5297-1010 - A08	1/8			- A28	7/16	- A22	11/32	- A12	3/16
- A10	5/32			- A30	15/32	- A24	3/8	- A14	7/32
- A12	3/16			- A32	1/2	- A26	13/32	- A16	1/4
- A14	7/32			- A34	17/32	- A28	7/16	- A18	9/32
- A16	1/4			- A36	9/16	- A30	15/32	- A20	5/16
- A18	9/32			- A38	19/32	- A32	1/2	- A22	11/32
- A20	5/16			- A40	5/8	- A34	17/32	- A24	3/8
- A22	11/32					- A36	9/16	- A26	13/32
- A24	3/8					- A38	19/32	- A28	7/16
						- A40	5/8	- A30	15/32
						- A42	21/32	- A32	1/2
						- A44	11/16	- A34	17/32
						- A46	23/32	- A36	9/16
						- A48	3/4	- A38	19/32
								- A40	5/8
								- A42	21/32
								- A44	11/16
								- A46	23/32
								- A48	3/4
								- A56	7/8
								- A64	1

Features:

- ▶ SKX Sealed Nut is not included with SKX Sealed Cap. Please order the cap additionally.
- ▶ For information of SKX sealed cap spanner, please refer to page X-80 (optional).



EOC CLAMPING NUT



EOC 包固得栓緊螺帽

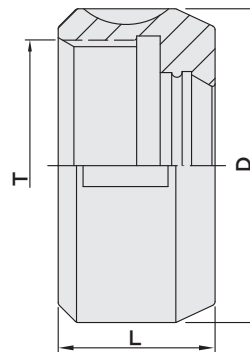

MODEL NO.	TYPE	D	L	T	RECOMMENDED TIGHTENING TORQUE		WEIGHT (KGS)
5200-121-025	EOC25	60	30	M48 x 2.0P	130 N-m	95 ft/lbs	0.30
5200-121-032	EOC32	72	33.5	M60 x 2.5P	220 N-m	162 ft/lbs	0.48

TG CLAMPING NUT



TG 包固得栓緊螺帽

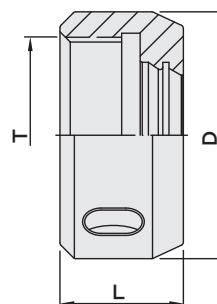

MODEL NO.	TYPE	D	L	T	RECOMMENDED TIGHTENING TORQUE		WEIGHT (KGS)
5200-691-075	TG75	50	25	TW 1-1/2" - 12	122 N-m	90 ft/lbs	0.52
5200-691-100	TG100	60	30	TW 1-7/8" - 12	130 N-m	95 ft/lbs	0.46
5200-691-150	TG150	82	35	TW 2-5/8" - 12	200 N-m	147 ft/lbs	0.50



MLD SEALED CAP

MLD 止水端蓋

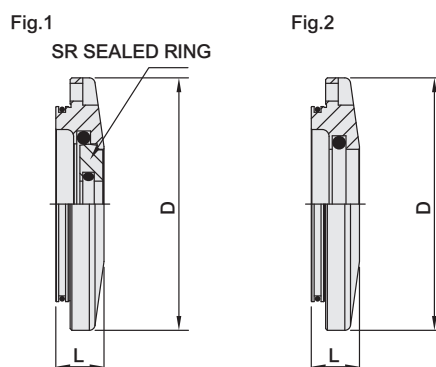
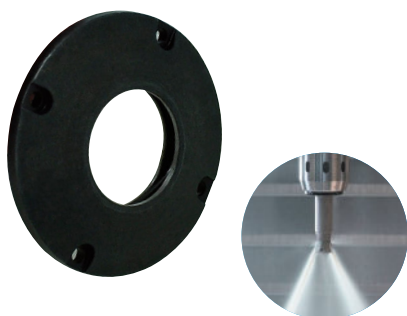

MODEL NO.	TYPE	L	D	RANGE	SR SEALED RING	Fig	WEIGHT (KGS)
5297-3012-003	MLD12	8.9	38.2	3 ~ 8	SR16	1	0.03
5297-3012-012	MLD12	8.9	38.2	12	-	2	0.03
5297-3016-003	MLD16	8.9	42.2	3 ~ 12	SR20	1	0.04
5297-3016-016	MLD16	8.9	42.2	16	-	2	0.04
5297-3020-003	MLD20	8.9	44	3 ~ 16	SR25	1	0.04
5297-3020-020	MLD20	8.9	44	20	-	2	0.04
5297-3025-003	MLD25	10.4	51	3 ~ 20	SR32	1	0.06
5297-3025-025	MLD25	10.4	51	25	-	2	0.06
5297-3032-003	MLD32	11.05	60	3 ~ 25	SR40	1	0.06
5297-3032-032	MLD32	11.05	60	32	-	2	0.06
5297-3042-003	MLD42	12.02	70	3 ~ 25	SR40	1	0.07
5297-3042-042	MLD42	12.02	70	42	-	2	0.07
5297-3A32-A08	MLD1/2"	8.9	38.2	1/8" ~ 3/8"	SR16	1	0.03
5297-3A32-A32	MLD1/2"	8.9	38.2	1/2"	-	2	0.03
5297-3A40-A08	MLD5/8"	8.9	42.2	1/8" ~ 1/2"	SR20	1	0.04
5297-3A40-A40	MLD5/8"	8.9	42.2	5/8"	-	2	0.04
5297-3A48-A08	MLD3/4"	8.9	44	1/8" ~ 5/8"	SR25	1	0.04
5297-3A48-A48	MLD3/4"	8.9	44	3/4"	-	2	0.04
5297-3A64-A08	MLD1"	10.4	51	1/8" ~ 3/4"	SR32	1	0.06
5297-3A64-A64	MLD1"	10.4	51	1"	-	2	0.06
5297-3A72-A08	MLD1-1/4"	11.05	60	1/8" ~ 1"	SR40	1	0.06
5297-3A72-A72	MLD1-1/4"	11.05	60	1-1/4"	-	2	0.06

Fig.1

Fig.2

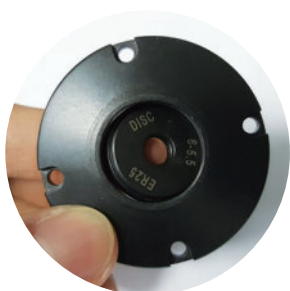

▶ Need to use with a sealed ring.

▶ The inner hole of MLD sealed cap same as tool shank. Do not need a sealed ring for use.

Features:

▶ Used for coolant-through cutting tools.



SR SEALED RING

SR 止水環



SR16		SR20		SR25		SR32		SR40	
MODEL NO.	SIZE	MODEL NO.	SIZE	MODEL NO.	SIZE	MODEL NO.	SIZE	MODEL NO.	SIZE
5297-2016-003.5	3.5 ~ 3.0	5297-2020-003.5	3.5 ~ 3.0	5297-2025-003.5	3.5 ~ 3.0	5297-2032-003.5	3.5 ~ 3.0	5297-2040-003.5	3.5 ~ 3.0
-004	4.0 ~ 3.5	-004	4.0 ~ 3.5	-004	4.0 ~ 3.5	-004	4.0 ~ 3.5	-004	4.0 ~ 3.5
-004.5	4.5 ~ 4.0	-004.5	4.5 ~ 4.0	-004.5	4.5 ~ 4.0	-004.5	4.5 ~ 4.0	-004.5	4.5 ~ 4.0
-005	5.0 ~ 4.5	-005	5.0 ~ 4.5	-005	5.0 ~ 4.5	-005	5.0 ~ 4.5	-005	5.0 ~ 4.5
-005.5	5.5 ~ 5.0	-005.5	5.5 ~ 5.0	-005.5	5.5 ~ 5.0	-005.5	5.5 ~ 5.0	-005.5	5.5 ~ 5.0
-006	6.0 ~ 5.5	-006	6.0 ~ 5.5	-006	6.0 ~ 5.5	-006	6.0 ~ 5.5	-006	6.0 ~ 5.5
-006.5	6.5 ~ 6.0	-006.5	6.5 ~ 6.0	-006.5	6.5 ~ 6.0	-006.5	6.5 ~ 6.0	-006.5	6.5 ~ 6.0
-008.5	8.5 ~ 8.0	-007	7.0 ~ 6.5	-007.5	7.5 ~ 7.0	-007	7.0 ~ 6.5	-007	7.0 ~ 6.5
-009	9.0 ~ 8.5	-007.5	7.5 ~ 7.0	-008	8.0 ~ 7.5	-007.5	7.5 ~ 7.0	-007.5	7.5 ~ 7.0
-009.5	9.5 ~ 9.0	-008	8.0 ~ 7.5	-008.5	8.5 ~ 8.0	-008	8.0 ~ 7.5	-008	8.0 ~ 7.5
-010	10.0 ~ 9.5	-008.5	8.5 ~ 8.0	-009	9.0 ~ 8.5	-008.5	8.5 ~ 8.0	-008.5	8.5 ~ 8.0
-010.5	10.5 ~ 10.0	-009	9.0 ~ 8.5	-009.5	9.5 ~ 9.0	-009	9.0 ~ 8.5	-009	9.0 ~ 8.5
-011	11.0 ~ 10.5	-009.5	9.5 ~ 9.0	-010	10.0 ~ 9.5	-009.5	9.5 ~ 9.0	-009.5	9.5 ~ 9.0
-011.5	11.5 ~ 11.0	-010	10.0 ~ 9.5	-010.5	10.5 ~ 10.0	-010	10.0 ~ 9.5	-010	10.0 ~ 9.5
WEIGHT (KGS)		-010.5	10.5 ~ 10.0	-011	11.0 ~ 10.5	-010.5	10.5 ~ 10.0	-010.5	10.5 ~ 10.0
0.01		-011	11.0 ~ 10.5	-011.5	11.5 ~ 11.0	-011	11.0 ~ 10.5	-011	11.0 ~ 10.5
		-011.5	11.5 ~ 11.0	-012	12.0 ~ 11.5	-011.5	11.5 ~ 11.0	-011.5	11.5 ~ 11.0
		-012	12.0 ~ 11.5	-012.5	12.5 ~ 12.0	-012	12.0 ~ 11.5	-012	12.0 ~ 11.5
		-012.5	12.5 ~ 12.0	-013	13.0 ~ 12.5	-012.5	12.5 ~ 12.0	-012.5	12.5 ~ 12.0
		-013	13.0 ~ 12.5	-013.5	13.5 ~ 13.0	-013	13.0 ~ 12.5	-013	13.0 ~ 12.5
		WEIGHT (KGS)		-014	14.0 ~ 13.5	-013.5	13.5 ~ 13.0	-013.5	13.5 ~ 13.0
		0.01		-014.5	14.5 ~ 14.0	-014	14.0 ~ 13.5	-014	14.0 ~ 13.5
				-015	15.0 ~ 14.5	-014.5	14.5 ~ 14.0	-014.5	14.5 ~ 14.0
				-015.5	15.5 ~ 15.0	-015	15.0 ~ 14.5	-015	15.0 ~ 14.5
				-016	16.0 ~ 15.5	-015.5	15.5 ~ 15.0	-015.5	15.5 ~ 15.0
				WEIGHT (KGS)		-016	16.0 ~ 15.5	-016	16.0 ~ 15.5
				0.01		-016.5	16.5 ~ 16.0	-016.5	16.5 ~ 16.0
						-017	17.0 ~ 16.5	-017	17.0 ~ 16.5
						-017.5	17.5 ~ 17.0	-017.5	17.5 ~ 17.0
						-018	18.0 ~ 17.5	-018	18.0 ~ 17.5
						-018.5	18.5 ~ 18.0	-018.5	18.5 ~ 18.0
						-019	19.0 ~ 18.5	-019	19.0 ~ 18.5
						-019.5	19.5 ~ 19.0	-019.5	19.5 ~ 19.0
						-020	20.0 ~ 19.5	-020	20.0 ~ 19.5
						-020.5	20.5 ~ 20.0	-020.5	20.5 ~ 20.0
						-021	21.0 ~ 20.5	-021	21.0 ~ 20.5
						-021.5	21.5 ~ 21.0	-021.5	21.5 ~ 21.0
						-022	22.0 ~ 21.5	-022	22.0 ~ 21.5
						WEIGHT (KGS)		-022.5	22.5 ~ 22.0
						0.01		-023	23.0 ~ 22.5
								-023.5	23.5 ~ 23.0
								-024	24.0 ~ 23.5
								-024.5	24.5 ~ 24.0
								-025	25.0 ~ 24.5
								-025.5	25.5 ~ 25.0
								-026	26.0 ~ 25.5
								WEIGHT (KGS)	
								0.02	

Features:

- ▶ One size clamping is recommended.
- ▶ Used for ER and MLD sealed nuts to seal and achieve coolant through tools.
- ▶ Can bear the water pressure up to 21 kgf/cm².



BT PULL STUD

BT 螺栓拉頭

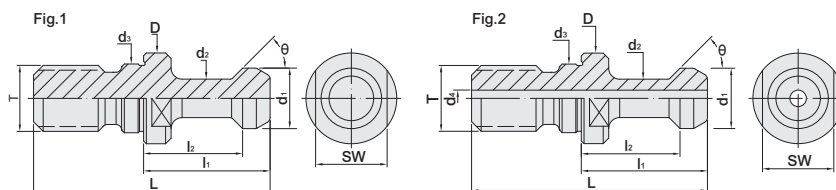

W/O Coolant

MODEL NO.	TYPE	L	l ₁	l ₂	D	d ₁	d ₂	d ₃	d ₄	θ	T	SW	Fig.	WEIGHT (KGS)
5230-010-45-00	BT30 - 45°	43	23	18	16.5	11	7	12.5	-	45°	M12	13	1	0.04
5230-011-45-00	BT40 - 45°	60	35	28	23	15	10	17	-	45°	M16	19	1	0.10
5230-012-45-00	BT50 - 45°	85	45	35	38	23	17	25	-	45°	M24	30	1	0.30
5230-010-60-00	BT30 - 60°	43	23	18	16.5	11	7	12.5	-	60°	M12	13	1	0.04
5230-011-60-00	BT40 - 60°	60	35	28	23	15	10	17	-	60°	M16	19	1	0.10
5230-012-60-00	BT50 - 60°	85	45	35	38	23	17	25	-	60°	M24	30	1	0.30
5230-010-90-00	BT30 - 90°	43	23	18	16.5	11	7	12.5	-	90°	M12	13	1	0.04
5230-011-90-00	BT40 - 90°	60	35	28	23	15	10	17	-	90°	M16	19	1	0.10
5230-012-90-00	BT50 - 90°	85	45	35	38	23	17	25	-	90°	M24	30	1	0.30

Coolant Thru

5231-010-45-00	BT30 - 45° - C	43	23	18	16.5	11	7	12.5	3	45°	M12	13	2	0.10
5231-011-15-00	BT40 - 15° - C	54	29	23	23	19	14	17	7	15°	M16	19	2	0.10
5231-011-45-00	BT40 - 45° - C	60	35	28	23	15	10	17	4	45°	M16	19	2	0.10
5231-011-45-01	BT40 - 45° - C - MAZAK	44.1	19.1	14.02	22	18.79	12.44	17	7	45°	M16	19	2	0.10
5231-012-45-00	BT50 - 45° - C	85	45	35	38	23	17	25	6	45°	M24	30	2	0.30
5231-012-45-01	BT50 - 45° - C - MAZAK	65.4	25.4	17.78	35.5	28.95	20.8	25	10	45°	M24	30	2	0.30
5231-011-60-00	BT40 - 60° - C	60	35	28	23	15	10	17	4	60°	M16	19	2	0.10
5231-012-60-00	BT50 - 60° - C	85	45	35	38	23	17	25	6	60°	M24	30	2	0.30
5231-011-90-00	BT40 - 90° - C	60	35	28	23	15	10	17	4	90°	M16	19	2	0.10
5231-012-90-00	BT50 - 90° - C	85	45	35	38	23	17	25	6	90°	M24	30	2	0.30

Features:

- ▶ Please make sure the pull stud conforms to the machine type.



BT PULL STUD

with ground thread

BT 研磨螺栓拉頭

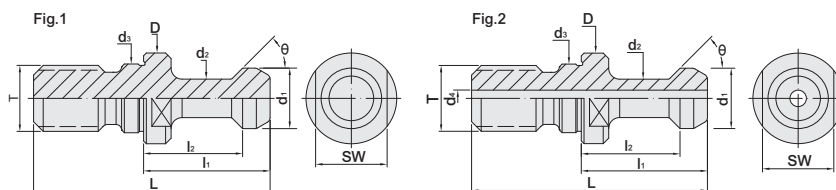

W/O Coolant

MODEL NO.	TYPE	L	l ₁	l ₂	D	d ₁	d ₂	d ₃	d ₄	θ	T	SW	Fig.	WEIGHT (KGS)
5232-010-45-00	BT30 - 45°G	43	23	18	16.5	11	7	12.5	-	45°	M12	13	1	0.04
5232-011-45-00	BT40 - 45°G	60	35	28	23	15	10	17	-	45°	M16	19	1	0.10
5232-012-45-00	BT50 - 45°G	85	45	35	38	23	17	25	-	45°	M24	30	1	0.30
5232-010-60-00	BT30 - 60°G	43	23	18	16.5	11	7	12.5	-	60°	M12	13	1	0.04
5232-011-60-00	BT40 - 60°G	60	35	28	23	15	10	17	-	60°	M16	19	1	0.10
5232-012-60-00	BT50 - 60°G	85	45	35	38	23	17	25	-	60°	M24	30	1	0.30
5232-010-90-00	BT30 - 90°G	43	23	18	16.5	11	7	12.5	-	90°	M12	13	1	0.04
5232-011-90-00	BT40 - 90°G	60	35	28	23	15	10	17	-	90°	M16	19	1	0.10
5232-012-90-00	BT50 - 90°G	85	45	35	38	23	17	25	-	90°	M24	30	1	0.30

Coolant Thru

5233-010-45-00	BT30 - 45°G - C	43	23	18	16.5	11	7	12.5	3	45°	M12	13	2	0.10
5233-011-45-00	BT40 - 45°G - C	60	35	28	23	15	10	17	4	45°	M16	19	2	0.10
5233-012-45-00	BT50 - 45°G - C	85	45	35	38	23	17	25	6	45°	M24	30	2	0.30
5233-011-60-00	BT40 - 60°G - C	60	35	28	23	15	10	17	4	60°	M16	19	2	0.10
5233-012-60-00	BT50 - 60°G - C	85	45	35	38	23	17	25	6	60°	M24	30	2	0.30
5233-011-90-00	BT40 - 90°G - C	60	35	28	23	15	10	17	4	90°	M16	19	2	0.10
5233-012-90-00	BT50 - 90°G - C	85	45	35	38	23	17	25	6	90°	M24	30	2	0.30

Features:

- ▶ Please make sure the pull stud conforms to the machine type.

CAT PULL STUD

CAT 螺栓拉頭

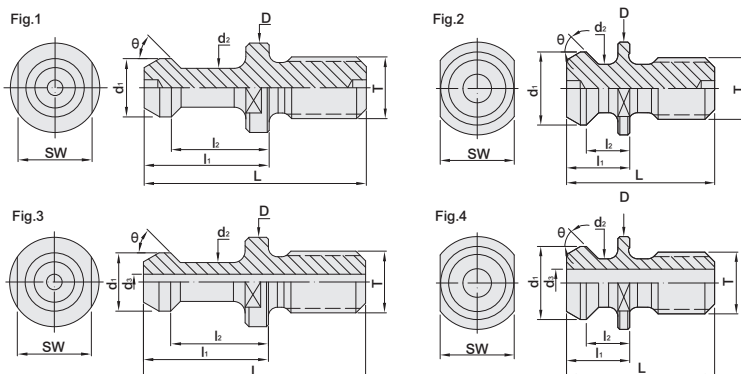

W/O Coolant

MODEL NO.	TYPE	L	l ₁	l ₂	D	d ₁	d ₂	d ₃	θ	SW	T-UNC	Fig.	WEIGHT (KGS)
5230-031-45-00	CAT40 - ANSI	1.5	0.64	0.44	0.94	0.74	0.49	-	45°	0.75	5/8" - 11	2	0.09
5230-032-45-00	CAT50 - ANSI	2.3	1	0.7	1.44	1.14	0.82	-	45°	1.25	1" - 8	2	0.25
5230-031-45-01	CAT40 - MAS - I	2.25	1.266	0.99	0.905	0.59	0.394	-	45°	0.748	5/8" - 11	1	0.09
5230-031-60-00	CAT40 - MAS - II	2.25	1.266	0.99	0.905	0.59	0.394	-	60°	0.748	5/8" - 11	1	0.09
5230-031-90-00	CAT40 - MAS - III	2.25	1.266	0.99	0.905	0.59	0.394	-	90°	0.748	5/8" - 11	1	0.09
5230-032-45-01	CAT50 - MAS - I	3.346	1.772	1.378	1.496	0.906	0.669	-	45°	1.181	1" - 8	1	0.25
5230-032-60-00	CAT50 - MAS - II	3.346	1.772	1.378	1.496	0.906	0.669	-	60°	1.181	1" - 8	1	0.25
5230-032-90-00	CAT50 - MAS - III	3.346	1.772	1.378	1.496	0.906	0.669	-	90°	1.181	1" - 8	1	0.25

Coolant Thru

5231-031-45-00	CAT40 - ANSI - C	1.5	0.64	0.44	0.94	0.74	0.49	0.281	45°	0.75	5/8" - 11	4	0.09
5231-032-45-00	CAT50 - ANSI - C	2.3	1	0.7	1.44	1.14	0.82	0.468	45°	1.25	1" - 8	4	0.25
5231-031-45-01	CAT40 - Coolant - I	2.25	1.266	0.99	0.905	0.59	0.394	0.157	45°	0.748	5/8" - 11	3	0.09
5231-031-60-00	CAT40 - Coolant - II	2.25	1.266	0.99	0.905	0.59	0.394	0.157	60°	0.748	5/8" - 11	3	0.09
5231-031-90-00	CAT40 - Coolant - III	2.25	1.266	0.99	0.905	0.59	0.394	0.157	90°	0.748	5/8" - 11	3	0.09
5231-032-45-01	CAT50 - Coolant - I	3.346	1.772	1.378	1.496	0.906	0.669	0.256	45°	1.181	1" - 8	3	0.25
5231-032-60-00	CAT50 - Coolant - II	3.346	1.772	1.378	1.496	0.906	0.669	0.256	60°	1.181	1" - 8	3	0.25
5231-032-90-00	CAT50 - Coolant - III	3.346	1.772	1.378	1.496	0.906	0.669	0.256	90°	1.181	1" - 8	3	0.25

Features:

- ▶ Please make sure the pull stud conforms to the machine type.



DAT PULL STUD

DAT 螺栓拉頭

(DIN 7388 - 3)

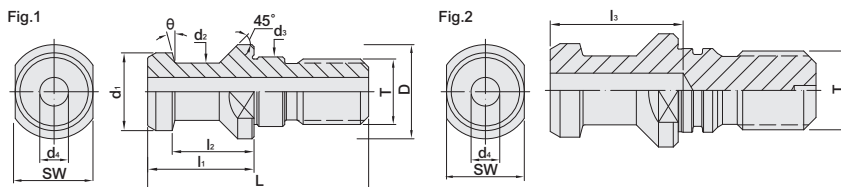

W/O Coolant

MODEL NO.	TYPE	L	l ₁	l ₂	l ₃	D	d ₁	d ₂	d ₃	d ₄	θ	SW	T	Fig.	WEIGHT (KGS)
5230-050-15-01	DAT30 - B	44	24	19	-	17	13	9	13	-	15°	14	M12	2	0.03
5230-051-15-01	DAT40 - B	54	26	20	27	23	19	14	17	7	15°	19	M16	2	0.09
5230-052-15-01	DAT50 - B	74	34	25	37	36	28	21	25	11.5	15°	30	M24	2	0.25
5230-050-15-02	DAT30 - A	44	24	19	-	17	13	9	13	-	15°	14	M12	1	0.03

Coolant Thru

5231-051-15-01	DAT40 - A - C	54	26	20	-	23	19	14	17	7	15°	19	M16	1	0.09
5231-052-15-01	DAT50 - A - C	74	34	25	-	36	28	21	25	11.5	15°	30	M24	1	0.25

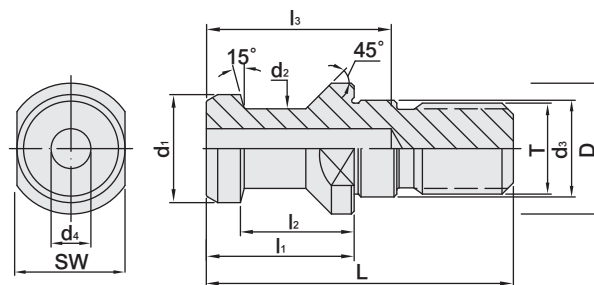

MODEL NO.	TYPE	L	l ₁	l ₂	l ₃	D	d ₁	d ₂	d ₃	d ₄	T	WEIGHT (KGS)
5230-051-15-02	DAT40	54	26	20	27	23	19	14	17	7	M16	0.09

(DIN ISO 7388 - UD)

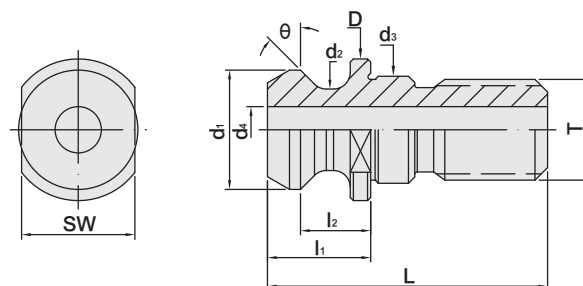

Coolant Thru

MODEL NO.	TYPE	L	l ₁	l ₂	D	d ₁	d ₂	d ₃	d ₄	θ	SW	T	WEIGHT (KGS)
5231-051-15-02	DAT40 - A - C	54	26	20	23	19	14	17	7	15°	19	M16	0.09
5231-052-15-02	DAT50 - A - C	74	34	25	36	28	21	25	11.5	15°	30	M24	0.25
5231-051-45-01	DAT40 - B - C	44.5	16.4	11.15	22.5	18.95	12.95	17	7.35	45°	18	M16	0.03
5231-052-45-01	DAT50 - B - C	65.5	25.55	17.95	37	29.1	19.6	25	11.55	45°	30	M24	0.10

Features: ▶ Please make sure the pull stud conforms to the machine type.



ISO PULL STUD

ISO 螺栓拉頭

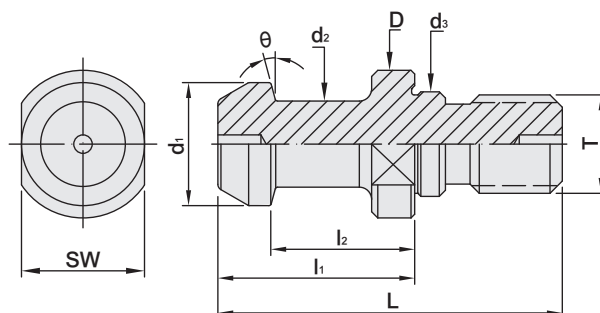

MODEL NO.	TYPE	D	d ₁	d ₂	d ₃	L	l ₁	l ₂	θ	SW	T	WEIGHT (KGS)
5230-111-15-01	ISO20 - 15°	12	9	6	8.5	26	12	9	15°	10	M8	0.01
5230-112-45-00	ISO25 - 45°	12	10	7	9	31	18	13.5	45°	10	M8	0.02
5230-112-15-01	ISO25 - 15°	12	10	7	8.5	28	16	11.7	15°	10	M8	0.02
5230-113-45-01	ISO30	17	12.8	9	13	45	24	19	45°	14	M12	0.03

Features:

- ▶ Please make sure the pull stud conforms to the machine type.



ONE PIECE PULL STUD WITH DRAW BOLT

一體式後拉螺絲拉頭

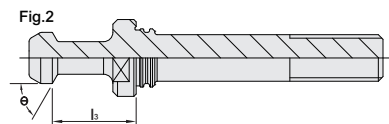
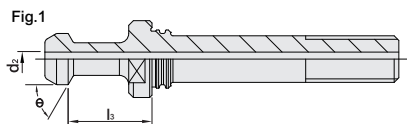

Coolant Thru

MODEL NO.	TYPE	l_3	d_2	θ	Fig.
5231-010-45-01	BT30 - 45° - C - MAS	18	3	45°	1
5231-010-60-01	BT30 - 60° - C - MAS	18	3	60°	1

W/O Coolant

5230-010-45-01	BT30 - 45° - MAS	18	-	45°	2
5230-010-60-01	BT30 - 60° - MAS	18	-	60°	2

Features:

- ▶ The pull stud of BT30 and SBT30 SFS slim-fit collet chuck is special one piece desing with draw bolt.
- ▶ There are two types of pull studs for BT30 and SBT30 SFS slim-fit collet chuck.
Please confirm the size of θ and l_3 before making an order.
- ▶ Custom-made order for pull studs of BT30 and SBT30 SFS slim-fit collet chuck is acceptable.

COOLANT SUPPLY UNIT & Key

HSK 給水管 / HSK COOLANT SUPPLY UNIT

[DIN 69895]

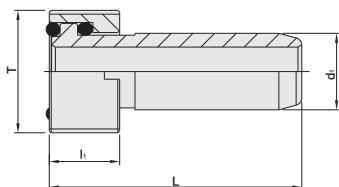

MODEL NO.	TYPE	L	li	d ₁	T	WEIGHT (KGS)
5316-2032	HSK32A - CP	26	5.5	6	M10 x 1.0P	0.01
5316-2040	HSK40A - CP	29.3	7.5	8	M12 x 1.0P	0.01
5316-2050	HSK50A - CP	33	9.5	10	M16 x 1.0P	0.02
5316-2063	HSK63A - CP	36.6	11.5	12	M18 x 1.0P	0.02
5316-2080	HSK80A - CP	40	13.5	14	M20 x 1.5P	0.04
5316-2100	HSK100A - CP	44	15.5	16	M24 x 1.5P	0.06

Features:

- ▶ Used with HSK-A, E and T type tool holders.

HSK 給水管扳手 / Key FOR HSK COOLANT SUPPLY UNIT

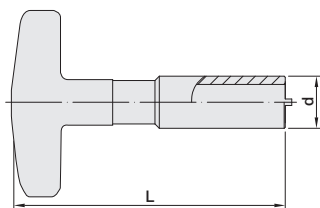

MODEL NO.	TYPE	L	d	WEIGHT (KGS)
5280-070-032	HSK32A - CPW	90	10.0	0.10
5280-071-040	HSK40A - CPW	90	13.5	0.12
5280-072-050	HSK50A - CPW	95	15.5	0.14
5280-073-063	HSK63A - CPW	100	17.5	0.16
5280-074-080	HSK80A - CPW	110	19.5	0.12
5280-075-100	HSK100A - CPW	125	23.5	0.32

Features:

- ▶ Used with HSK-A, E and T type tool holders.

PSC 給水管 / PSC COOLANT SUPPLY UNIT

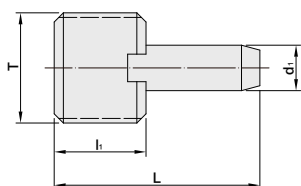

MODEL NO.	TYPE	L	li	d ₁	T	WEIGHT (KGS)
5316-1032	PSC32	22.4	10	4.95	M12 x 1.5P	0.01
5316-1040	PSC40	25.8	12	5.95	M14 x 1.5P	0.015
5316-1050	PSC50	28.35	14	7	M16 x 1.5P	0.026
5316-1063	PSC63	31	15	8	M20 x 2.0P	0.027
5316-1080	PSC80	31.3	15	10	M20 x 2.0P	0.07
5316-1100	PSC100	47	22	14	M24 x 2.0P	0.06

PSC 給水管扳手 / Key FOR PSC COOLANT SUPPLY UNIT

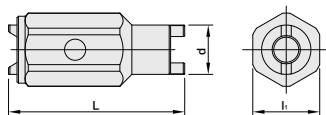

MODEL NO.	TYPE	L	li	d	WEIGHT (KGS)
5280-501-032	PSC32	40	14	10	0.03
5280-501-040	PSC40	45	17	12	0.051
5280-501-050	PSC50	50	19	14	0.071
5280-501-063	PSC63	60	25	17.5	0.16
5280-501-080	PSC80	60	29	17.5	0.22
5280-501-100	PSC100	75	30	21.5	0.25



SQUARE SHANK ADAPTER

COOLANT THRU

四角棒舌

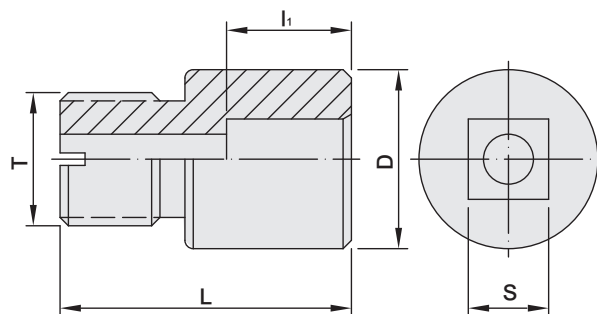

MODEL NO.	TYPE	L	li	D	S	T	WEIGHT (KGS)
5190-073	PLSS1/2" x M16	35	15	21.5	9.652	M16 x 2.0P	0.03
5190-083	PLSS3/4" x M16	35	15	21.5	14.288	M16 x 2.0P	0.04
5190-074	PLSS1/2" x M20	40	15	29	9.652	M20 x 2.0P	0.12
5190-084	PLSS3/4" x M20	40	15	29	14.288	M20 x 2.0P	0.12
5190-094	PLSS1" x M20	40	15	29	19.05	M20 x 2.0P	0.12
5190-105	PLSS1-1/4" x M24	40	15	34	19.38	M24 x 2.0P	0.18

We're Making a Better Connection Between the Cutting Tool and Spindle.

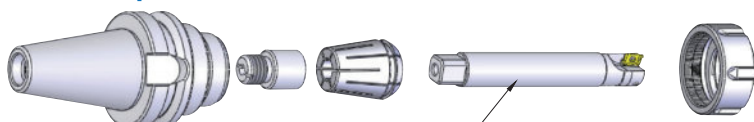

For the info. of PLIM, please refer to catalog NO.78.

Features:

- ▶ Adapts ER Chucks into PowerLOC Milling Holders: PowerLOC Square Shank Adapters turn our standard collet chucks into milling holders capable of performing heavier milling jobs than you ever thought possible.

PARTS

FOR CSR COMBI SHELL END MILL ARBOR

CSR 連結式銑刀柄零件

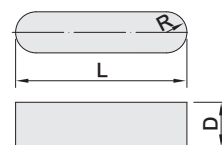

Key

MODEL NO.	TYPE	L	D	R	WEIGHT (KGS)
206-001-0040-001	Key - 16	22	4	2	0.002
206-001-0060-000	Key - 22	24	6	3	0.003
206-001-0070-000	Key - 27	24	7	3.5	0.004
206-001-0080-001	Key - 32	27	8	4	0.006
206-001-0100-000	Key - 40	31	10	5	0.008
206-001-0120-000	Key - 50	35	8	6	0.009

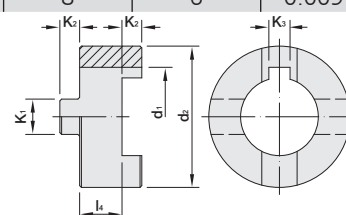

REMOVABLE RING



MODEL NO.	TYPE	d ₁	d ₂	k ₁	k ₂	k ₃	l ₄	WEIGHT (KGS)
5296-06-016-03-00	CORE - 16	16	32	8	5	4	10	0.009
5296-06-022-03-00	CORE - 22	22	40	10	5.6	6	12	0.01
5296-06-027-03-00	CORE - 27	27	48	12	6.3	7	12	0.02
5296-06-032-03-00	CORE - 32	32	58	14	7	8	14	0.03
5296-06-040-03-00	CORE - 40	40	70	16	8	10	14	0.04
5296-06-050-03-00	CORE - 50	50	90	18	9	12	16	0.05

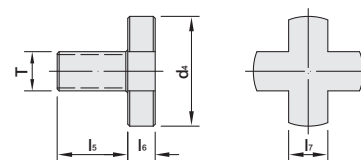

NUT



MODEL NO.	TYPE	d ₄	l ₅	l ₆	l ₇	T	WEIGHT (KGS)
5296-06-016-04-00	CONU - 16	20	16	6	8	M8	0.07
5296-06-022-04-00	CONU - 22	28	18	7	10	M10	0.08
5296-06-027-04-00	CONU - 27	35	22	8	12	M12	0.10
5296-06-032-04-00	CONU - 32	42	26	9	16	M16	0.20
5296-06-040-04-00	CONU - 40	52	30	10	20	M20	0.25
5296-06-050-04-00	CONU - 50	63	36	12	24	M24	0.30

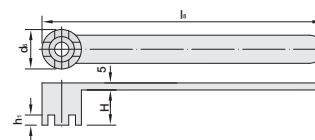

SPANNER



MODEL NO.	TYPE	d ₆	l ₈	H	h ₁	WEIGHT (KGS)
5280-059-016	COSP - 16	22	180	20	6.2	0.30
5280-059-022	COSP - 22	28	200	25	7.2	0.40
5280-059-027	COSP - 27	35	225	32	8.5	0.50
5280-059-032	COSP - 32	42	250	36	9.5	0.65
5280-059-040	COSP - 40	52	280	40	11	0.85
5280-059-050	COSP - 50	63	315	45	12	0.95

Features:

- Can purchase removable ring, nut and spanner separately.



SPIGOT INTERCHANGEABLE DIGITAL TORQUE WRENCH

數顯 LCD 扭力扳手



Two-color handle

MODEL NO.	TYPE	LENGTH	RANGE		WEIGHT (KGS)
408-006-000	DG - 135	365	10 - 135 N-m	7.4 - 99.6 ft/lbs	0.80
408-006-002	DG - 340	769	34 - 340 N-m	25 - 250.9 ft/lbs	1.40



Steel handle

MODEL NO.	TYPE	LENGTH	RANGE		WEIGHT (KGS)
408-006-003	DG - 252	373	10 - 135 N-m	7.4 - 99.6 ft/lbs	0.80
408-006-004	DG - 253	548	20 - 200 N-m	14.8 - 147 ft/lbs	1.05
408-006-005	DG - 254	748	34 - 340 N-m	25 - 250.9 ft/lbs	1.35



Two-color handle

MODEL NO.	TYPE	LENGTH	RANGE		WEIGHT (KGS)
408-006-006	DG - 264	373	10 - 135 N-m	7.4 - 99.6 ft/lbs	0.85
408-006-007	DG - 265	548	20 - 200 N-m	14.8 - 147 ft/lbs	1.10
408-006-008	DG - 266	748	34 - 340 N-m	25 - 250.9 ft/lbs	1.40



Steel handle

MODEL NO.	TYPE	LENGTH	RANGE		WEIGHT (KGS)
408-006-009	DG - 271	373	10 - 135 N-m	7.4 - 99.6 ft/lbs	0.65
408-006-010	DG - 272	548	20 - 200 N-m	14.8 - 147 ft/lbs	0.90
408-006-011	DG - 273	748	34 - 340 N-m	25 - 250.9 ft/lbs	1.20

NUT ADAPTERS FOR EXCHANGEABLE TORQUE WRENCH

螺帽轉接頭 [扭力扳手用]

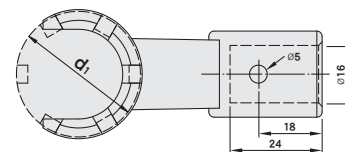

MODEL NO.	TYPE	d ₁	WEIGHT (KGS)
5281-123-011	ER11 - M	16	0.09
5281-123-016	ER16 - M	22	0.10
5281-123-020	ER20 - M	28	0.10
5281-123-025	ER25 - M	35	0.10

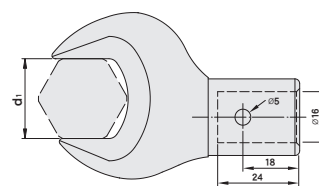

MODEL NO.	TYPE	d ₁	WEIGHT (KGS)
5281-108-016	ER16 - A, ER16A - HS, ER16 - CO	25	0.14
5281-108-020	ER20 - A, ER20A - HS, ER20 - CO	30	0.20

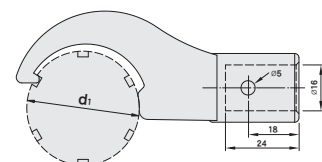

MODEL NO.	TYPE	d ₁	WEIGHT (KGS)
5281-121-025	EOC25	60	0.30

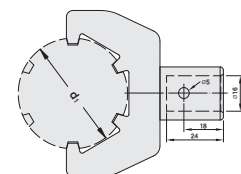

MODEL NO.	TYPE	d ₁	WEIGHT (KGS)
5281-110-016	ER16 UM/RD, ER16 - HS	31.7	0.18
5281-110-020	ER20 UM/RD, ER20 - HS	35	0.20
5281-110-025	ER25 UM/RD, ER25 - HS, ER25 - CO	42	0.25
5281-110-032	ER32 UM/RD, ER32 - HS, ER32 - CO	50	0.30
5281-110-040	ER40 UM/RD, ER40 - HS, ER40 - CO	63	0.40

Features:

- ▶ Used with spigot interchangeable digital torque wrench [PX-73].
- ▶ Set the torque according to recommended torque value to maintain the best cutting performance.



NUT ADAPTERS FOR EXCHANGEABLE TORQUE WRENCH

螺帽轉接頭 [扭力扳手用]

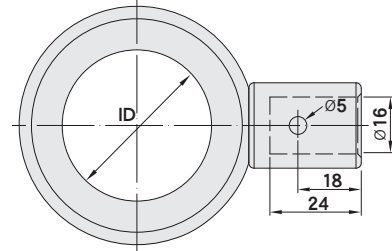

MODEL NO.	ID	SUITABLE NUT TYPE	WEIGHT (KGS)
5284-0180-00	18	ER11 W-TDQ	0.24
5284-0300-00	30	ER16 W-TDQ	0.28
5284-0340-00	34	ER20 W-TDQ	0.32
5284-0420-00	42	ER25 W-TDQ	0.35
5284-0500-00	50	ER32 W-TDQ	0.40
5284-0161-00	16	PTER11, PRO-E11M	0.42
5284-019.51-00	19.5	SK306, UT11, SKX6-CO, SCA13C, SCA12.7C	0.24
5284-027.51-00	27.5	SK310	0.25
5284-0301-00	30	ER16, PNER16, UT16, SKX10-CO, PRO-E16	0.25
5284-0331-00	33	SK313, SCA27C, SCA25.4C	0.25
5284-0341-00	34	ER20	0.33
5284-0351-00	35	UT20, PTER25, PRO-E20	0.40
5284-0401-00	40	PNER25, SK316, SKX16-CO, SCA32C, SCA31.75C	0.40
5284-0421-00	42	ER25 W-RDQ, UT25, PRO-E25	0.40
5284-0481-00	48	UT32, SKX20-CO, SK320	0.40
5284-0501-00	50	ER32, PNER32, PRO-E32	0.42
5284-0551-00	55	SKX25-CO, SK325	0.42
5284-0581-00	58	PRO25	0.42
5284-0631-00	63	PNER40, PRO32	0.58



No using adjustable spanner!



No using ER spanner with steel tube!



No using adjustable spanner with steel tube!

Features:

- ▶ Used with spigot interchangeable digital torque wrench [P.X-73].
- ▶ Set the torque according to recommended torque value to maintain the best cutting performance.

NUT ADAPTERS FOR EXCHANGEABLE TORQUE WRENCH

螺帽轉接頭 - 方型 [扭力扳手用]

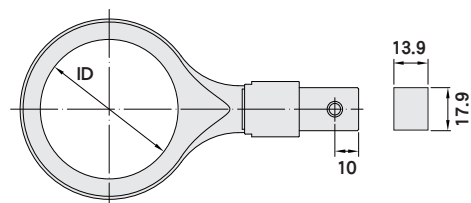

MODEL NO.	ID	SUITABLE NUT TYPE	WEIGHT (KGS)
5284-027.51-01	27.5	SK310	0.26
5284-0301-01	30	ER16, SKS10, PNER16, UT16, SKX10-CO, PRO-E16	0.26
5284-0331-01	33	SK313	0.26
5284-0341-01	34	ER20	0.34
5284-0351-01	35	PTER25, UT20, PRO-E20	0.41
5284-0401-01	40	PNER25, SK316, SKX16-CO	0.41
5284-0421-01	42	ER25, UT25, PRO-E25	0.41
5284-0481-01	48	UT32, SKX20-CO	0.41
5284-0501-01	50	ER32, PNER32, PRO-E32, SK320	0.43
5284-0551-01	55	SKX25-CO, SK325	0.43



No using adjustable spanner!



No using ER spanner with steel tube!



No using adjustable spanner with steel tube!

Features:

- ▶ Used with spigot interchangeable torque wrench.
- ▶ Set the torque according to recommended torque value to maintain the best cutting performance.



TORQUE WRENCH ADAPTOR (FOR PULL STUD)

拉頭轉接頭 [扭力扳手用]

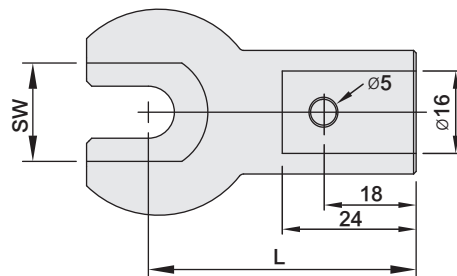

MODEL NO.	TYPE	SW	L	APPLICABLE PULL STUD	RECOMMENDED TIGHTENING TORQUE	WEIGHT (KGS)	
5281-541-301	PSTW - 30B	13	50	BT30 SBT30	45°, 60°, 90°	19 ~ 24 N-m 14 ~ 18 ft/lbs	0.22
5281-541-304	PSTW - 30D	14	50	DAT30	A, B	19 ~ 24 N-m 43 ~ 57 ft/lbs	0.23
5281-541-401	PSTW - 40B	19	50	BT40 SBT40 CAT40 SCAT40	45°, 60°, 90°, MAS- I MAS- II, MAS-III Coolant- I, Coolant - II Coolant -III	58 ~ 78 N-m 43 ~ 57 ft/lbs	0.23
5281-541-402	PSTW - 40BM	19	50	BT40	MAZAK	58 ~ 78 N-m 43 ~ 57 ft/lbs	0.2
5281-541-403	PSTW - 40C	19.05	50	CAT40	ANSI	58 ~ 78 N-m 43 ~ 57 ft/lbs	0.19
5281-541-404	PSTW - 40D	19	50	DAT40 SDAT40	A, B	58 ~ 78 N-m 43 ~ 57 ft/lbs	0.22
5281-541-405	PSTW - 40DB	18	50	DAT40 SDAT40	B(ISO7388/2)	58 ~ 78 N-m 43 ~ 57 ft/lbs	0.21
5281-541-501	PSTW - 50B	30	57	BT50 SBT50 CAT50 SCAT50	45°, 60°, 90° MAS- I, MAS- II MAS-III, Coolant- I Coolant - II, Coolant -III	196 ~ 245 N-m 144 ~ 180 ft/lbs	0.3
5281-541-502	PSTW - 50BM	30	57	BT50	MAZAK	196 ~ 245 N-m 144 ~ 180 ft/lbs	0.27
5281-541-503	PSTW - 50C	31.75	57	CAT50	ANSI	196 ~ 245 N-m 144 ~ 180 ft/lbs	0.26
5281-541-504	PSTW - 50D	30	57	DAT50 SDAT50	A, B	196 ~ 245 N-m 144 ~ 180 ft/lbs	0.29



No using adjustable spanner!



No using ER spanner with steel tube!



No using adjustable spanner with steel tube!

Features:

- ▶ Used with spigot interchangeable digital torque wrench [P.X-73].
- ▶ Set the torque according to recommended torque value to maintain the best cutting performance.

SPANNER FOR PULL STUD

拉頭扳手

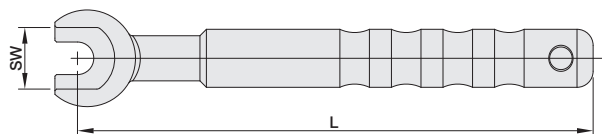

MODEL NO.	TYPE	SW	L	APPLICABLE PULL STUD		WEIGHT (KGS)
5287-540-301	PSW-30B	13	140	BT30, SBT30	45°, 60°, 90°	0.23
5287-540-304	PSW-30D	14	140	DAT30	A, B	0.22
5287-540-401	PSW-40B	19	160	BT40, SBT40 CAT40, SCAT40	45°, 60°, 90°, MAS-I, MAS-II, MAS-III, Coolant-I, Coolant - II, Coolant -III	0.31
5287-540-402	PSW-40BM	19	157	BT40	MAZAK	0.29
5287-540-403	PSW-40C	19.05	160	CAT40	ANSI	0.3
5287-540-404	PSW-40D	19	160	DAT40, SDAT40	A, B	0.3
5287-540-405	PSW-40DB	18	160	DAT40, SDAT40	B(ISO7388/2)	0.3
5287-540-501	PSW-50B	30	200	BT50, SBT50 CAT50, SCAT50	45°, 60°, 90°, MAS-I, MAS- II, MAS-III, Coolant-I, Coolant - II, Coolant -III	0.75
5287-540-502	PSW-50BM	30	200	BT50	MAZAK	0.72
5287-540-503	PSW-50C	31.75	200	CAT50	ANSI	0.72
5287-540-504	PSW-50D	30	200	DAT50, SDAT50	A, B	0.74

ER SPANNER

ER 扳手

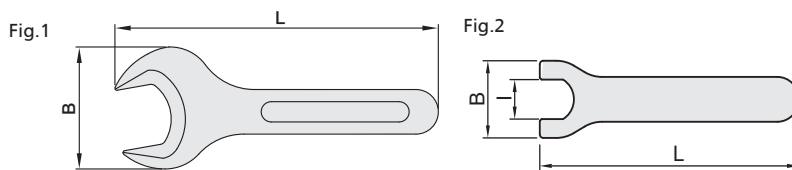

MODEL NO.	TYPE	NUT DIA	I	L	B	Fig	WEIGHT (KGS)
5280-108-011	ER11 - A, ER11A - HS	19	-	120	40	1	0.10
5280-108-016	ER16 - A, ER16A - HS, ER16 - CO	28	-	140	53	1	0.15
5280-108-020	ER20 - A, ER20A - HS, ER20 - CO	34	-	160	60	1	0.20
5282-125-019	ER16S	-	19	150	40	2	0.13
5282-125-022	ER20S	-	22	150	43	2	0.13
5282-125-025	ER25S	-	25	160	46	2	0.15
5282-125-036	ER32S	-	36	170	60	2	0.16

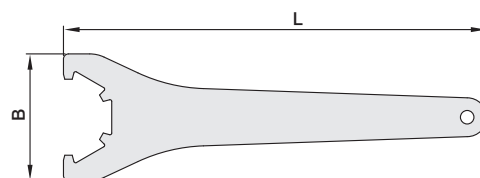

MODEL NO.	TYPE	NUT DIA	L	B	WEIGHT (KGS)
5280-110-016	ER16 UM/RD, ER16 - HS	31.7	162	54	0.18
5280-110-020	ER20 UM/RD, ER20 - HS	35	182	60	0.20
5280-110-025	ER25 UM/RD, ER25 - HS, ER25 - CO	42	206	65	0.22
5280-110-032	ER32 UM/RD, ER32 - HS, ER32 - CO	50	251	75	0.30
5280-110-040	ER40 UM/RD, ER40 - HSP, ER40 - HS, ER40 - CO	63	289	90	0.50
5280-110-050	ER50 UM/RD	78	351	107	0.90

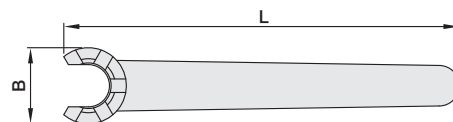

MODEL NO.	TYPE	NUT DIA	L	B	WEIGHT (KGS)
5280-123-008	ER8 - M	12	75	13	0.05
5280-123-011	ER11 - M	16	95	17	0.04
5280-123-016	ER16 - M	22	117	23	0.06
5280-123-020	ER20 - M	28	129	29	0.07
5280-123-025	ER25 - M	19	143	36	0.09

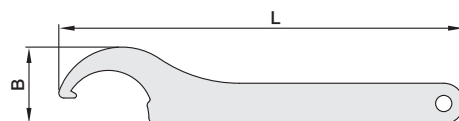

MODEL NO.	TYPE	NUT DIA	L	B	WEIGHT (KGS)
5280-109-016	ER16 - HSP	32	150	29	0.15
5280-109-020	ER20 - HSP	36	150	29	0.20
5280-109-025	ER25 - HSP, MLD12, MLD1/2"	42	200	38	0.22
5280-109-032	ER32 - HSP	50	200	38	0.30

Features:

- ▶ The spanner can be purchased separately.
- ▶ ER collet chuck doesn't include a spanner.

SPANNER

扳手

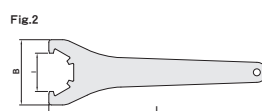
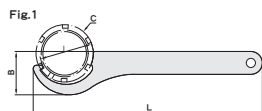

MODEL NO.	TYPE	L	B	C	I	Fig	WEIGHT (KGS)
5280-669-008	SPU8	155	26	36	31	1	0.06
5280-669-010	SPU10	155	27.5	43	35	1	0.06
5280-669-013	SPU13	170	37.5	48	46	1	0.08
5280-669-016	SPU16	170	40	54	49.5	1	0.08
5280-121-025	EOC25, MLD25, MLD1", TG100, SMG25	260	46	60	52	1	0.30
5280-463-042	MLD42	285	65	90	90	1	0.37
5280-121-032	EOC32	272	64	72	67	1	0.45
5280-460-020	MLD20, MLD3/4"	260	46	56.5	47.5	1	0.30
5280-460-032	MLD32, MLD1-1/4", SMG32	272	64	71	63	1	0.45
5280-658-020	MLD16, MLD5/8"	220	40	48	35.8	1	0.32
5280-691-150	TG150	272	64	82	67	1	0.50
5280-691-075	TG75	253	75	-	-	2	4.00

T型扳手 / Allen Wrench



Fig.1 Torx wrench

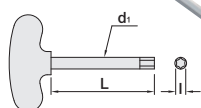
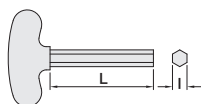
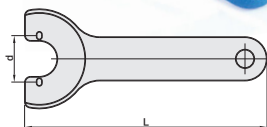
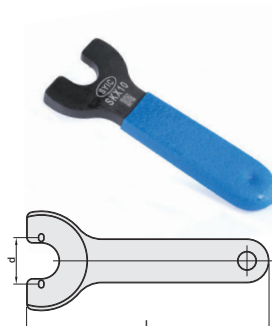

Fig.2 Allen wrench



MODEL NO.	TYPE	d ₁	L	I	Fig	WEIGHT (KGS)
5296-49-020-00	T20 - 100	3.9	100	T20	1	0.04
5296-49-020-01	T20 - 200	3.9	200	T20	1	0.04
210-003-200-001	T20 - 100	4	100	T20	1	0.04
210-003-200-003	T20 - 200	4	200	T20	1	0.04
210-003-200-004	T20 - 200	6	200	T20	1	0.04
210-003-050-005	T5 - 150	-	150	5	2	0.06
210-003-050-004	T5 - 200	-	200	5	2	0.06
210-003-060-003	T6 - 150	-	150	6	2	0.08
210-003-060-004	T6 - 200	-	200	6	2	0.10
210-003-080-002	T8 - 200	-	200	8	2	0.14
210-003-100-003	T10 - 200	-	200	10	2	0.16

SKX止水垫片扳手 SKX Sealed Cap Spanner



MODEL NO.	TYPE	L	d	WEIGHT (KGS)
5288-774-006	SKX06	82.5	10.5	0.06
5288-774-010	SKX10	82.5	15.8	0.05
5288-774-016	SKX16	92.5	24.8	0.07
5288-774-020	SKX20	92.5	28.8	0.07
5288-774-025	SKX25	95.0	34.8	0.09

SKX止水垫片握把式扳手 Easy Carry Spanner For SKX Sealed Cap



MODEL NO.	TYPE	L	d	WEIGHT (KGS)
5288-S03-106	SKX6 - CO	89	16	0.23
5288-S03-110	SKX10 - CO	89	25	0.27
5288-S03-116	SKX16 - CO	89	36	0.28
5288-S03-120	SKX20 - CO	89	42	0.29
5288-S03-125	SKX25 - CO	89	42	0.34



FIXED VALUE TORQUE WRENCH

定壓式扭力板手

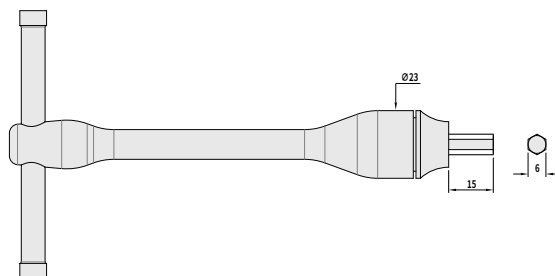

MODEL NO.	TYPE	RECOMMENDED TORQUE	WEIGHT (KGS)
5283-748-006	1-MT-TTDR-V104T12	10 N-m	0.19

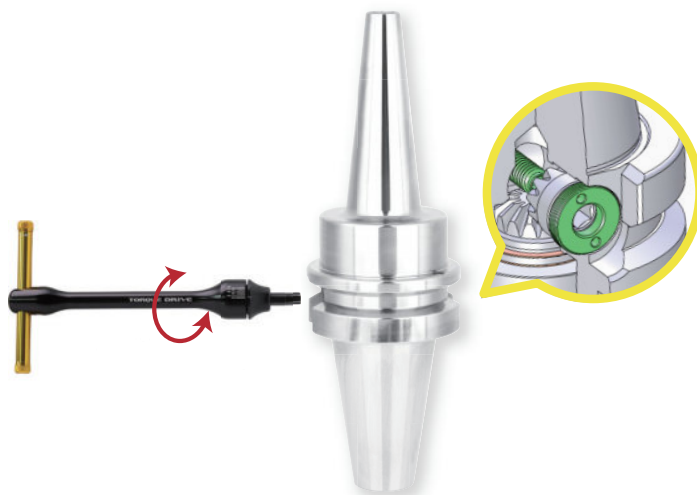

Features:

- ▶ USC Ultimate Side Clamping Chuck is delivered with a regular allen wrench. The fixed value torque wrench is optionally available.
- ▶ Using recommended torque to clamp the tool is helpful for USC chuck to maintain the best cutting performance.

BEARING SPANNER

軸承扳手

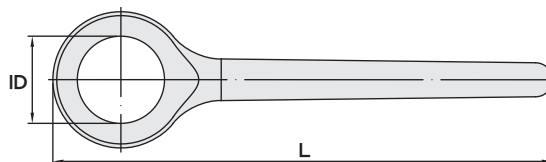

MODEL NO.	ID	SUITABLE NUT TYPE	NUT DIA	L	WEIGHT (KGS)
5285-0180-00	18	ER11 W-RDQ	18	120	0.33
5285-0300-00	30	ER16 W-RDQ	30	170	0.43
5285-0340-00	34	ER20 W-RDQ	34	172	0.43
5285-0420-00	42	ER25 W-RDQ	42	175	0.47
5285-0500-00	50	ER32 W-RDQ	50	180	0.50
5285-0121-00	12	PTER8, SP-ER8M	12	100	0.09
5285-0161-00	16	PTER11, PRO-E11M	16	195	0.38
5285-0181-00	18	ER11	18	195	0.38
5285-019.51-00	19.5	SK306, SKX6-CO, SCA13C, SCA12.7C	19.5	195	0.39
5285-0221-00	22	PTER16, SCA16C, SCA15.875C	22	195	0.40
5285-027.51-00	27.5	SK310	27.5	195	0.40
5285-0281-00	28	PTER20, , SCA22C, SCA22.225C	28	195	0.40
5285-0301-00	30	ER16, PNER16, UT16, PRO-E16	30	195	0.40
5285-0331-00	33	SK313, SCA27C, SCA25.4C	33	195	0.40
5285-0341-00	34	ER20	34	235	0.45
5285-0351-00	35	UT20, PTER25, PRO-E20	35	235	0.64
5285-0401-00	40	PNER25, SK316, SKX16-CO, SCA32C, SCA31.75C	40	235	0.64
5285-0421-00	42	ER25, UT25, PRO-E25	42	235	0.67
5285-0481-00	48	UT32, SKX20-CO, SK320	48	235	0.69
5285-0501-00	50	ER32, PNER32, PRO-E32	50	235	0.69
5285-0551-00	55	W-RDQ, SKX25-CO	55	235	0.91
5285-0631-00	63	PNER40, PRO32, SK325	63	250	0.70
5285-0581-00	58	PRO25	58	250	0.70
5285-0711-00	71	MLD32	71	270	1.24

Features:

- ▶ Used for all non wind resistance nuts.
- ▶ ◆ MLD32 bearing spanners need to be used with specially made MLD32 nuts.



No using adjustable spanner!



No using ER spanner with steel tube!



No using adjustable spanner with steel tube!



HLB / R FACE CONTACT TYPE BALL NOSE FINISH END MILL CUTTER

HLB / R 端面緊貼型圓刃刀具

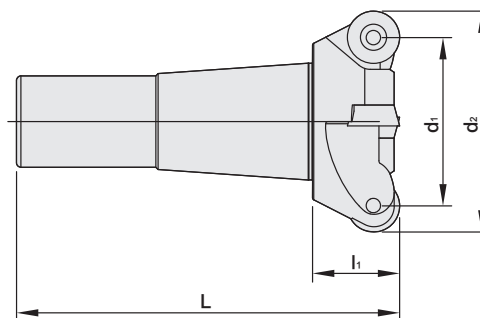

W/O Coolant

MODEL NO.	TYPE	L	l ₁	d ₁	d ₂	TEETH	INSERT	WEIGHT (KGS)
5262-608-012-051	HLB20 x R12 - 2"	88	20	38.8	50.8	4	RD..1204	0.33
5263-608-012-051	HLB25 x R12 - 2"	98	20	38.8	50.8	4	RD..1204	0.45

Coolant Thru

5262-609-012-051	HLB20 x RC12 - 2"	88	20	38.8	50.8	4	RD..1204	0.33
5263-609-012-051	HLB25 x RC12 - 2"	98	20	38.8	50.8	4	RD..1204	0.45

ACCESSORIES

INSERT	SCREW	WRENCH
RD..1204	M4-10-5.7-60	T15

Features:

- ▶ Two-face contact between collet taper, collet flange and the end of HBL tool holder, increases the rigidity of machining.
- ▶ Modular system, assembled with HBL collet chucks.
- ▶ HBL drawbar clamping design strengthens the axial clamping force.

Product information:

- ▶ Inserts are optional accessories. Need to be purchased additionally.

HLB / FR FACE CONTACT TYPE BALL NOSE FINISH END MILL CUTTER

HLB / FR 端面緊貼型圓刃刀具

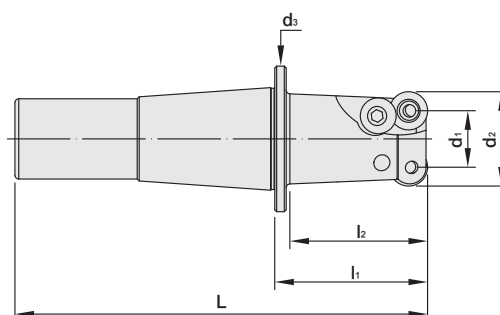

W/O Coolant

MODEL NO.	TYPE	L	l ₁	l ₂	d ₁	d ₂	d ₃	TEETH	INSERT	WEIGHT (KGS)
5262-158-025-040	HLB20 x FR25 - 40	108	40	36	15	25	38.1	2	RP..1003	0.28
5262-158-030-040	HLB20 x FR30 - 40	108	40	36	20	30	38.1	2	RP..1003	0.31
5262-158-032-040	HLB20 x FR32 - 40	108	40	36	22	32	38.1	3	RP..1003	0.33
5262-158-035-040	HLB20 x FR35 - 40	108	40	36	25	35	38.1	3	RP..1003	0.35
5263-158-025-040	HLB25 x FR25 - 40	108	40	36	15	25	44.45	2	RP..1003	0.36
5263-158-030-040	HLB25 x FR30 - 40	108	40	36	20	30	44.45	2	RP..1003	0.39
5263-158-032-040	HLB25 x FR32 - 40	108	40	36	22	32	44.45	3	RP..1003	0.41
5263-158-035-040	HLB25 x FR35 - 40	108	40	36	25	35	44.45	3	RP..1003	0.43

Coolant Thru

5262-162-025-040	HLB20 x FRC25 - 40	108	40	36	15	25	38.1	2	RP..1003	0.28
5262-162-030-040	HLB20 x FRC30 - 40	108	40	36	20	30	38.1	2	RP..1003	0.31
5262-162-032-040	HLB20 x FRC32 - 40	108	40	36	22	32	38.1	3	RP..1003	0.33
5262-162-035-040	HLB20 x FRC35 - 40	108	40	36	25	35	38.1	3	RP..1003	0.35
5263-162-025-040	HLB25 x FRC25 - 40	108	40	36	15	25	44.45	2	RP..1003	0.36
5263-162-030-040	HLB25 x FRC30 - 40	108	40	36	20	30	44.45	2	RP..1003	0.39
5263-162-032-040	HLB25 x FRC32 - 40	108	40	36	22	32	44.45	3	RP..1003	0.41
5263-162-035-040	HLB25 x FRC35 - 40	108	40	36	25	35	44.45	3	RP..1003	0.43

ACCESSORIES

INSERT	SCREW	CLAMP	CLAMP SCREW	WRENCH
RP..1003	M4 - 10 - 5.7 - 60	HR-5R	M5-0.8P	T15

Features:

- ▶ Two-face contact between collet taper, collet flange and the end of HBL tool holder, increases the rigidity of machining.
- ▶ Modular system, assembled with HBL collet chucks.
- ▶ HBL drawbar clamping design strengthens the axial clamping force.

Product information:

- ▶ Inserts are optional accessories. Need to be purchased additionally.



HLB / GR FACE CONTACT TYPE BALL NOSE FINISH END MILL CUTTER

HLB / GR 端面緊貼型圓刃刀具

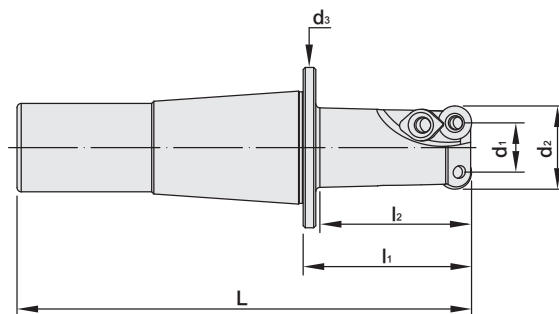

W/O Coolant

MODEL NO.	TYPE	L	l ₁	l ₂	d ₁	d ₂	d ₃	TEETH	INSERT	WEIGHT (KGS)
5262-263-025-040	HLB20 x GR25 - 40	108	40	36	15	25	38.1	2	RD..0802	0.28
5262-263-030-040	HLB20 x GR30 - 40	108	40	36	20	30	38.1	2	RD..10T3	0.31
5262-256-032-040	HLB20 x GR32 - 40	108	40	36	22	32	38.1	3	RD..10T3	0.33
5262-256-035-040	HLB20 x GR35 - 40	108	40	36	25	35	38.1	3	RD..10T3	0.35
5263-263-025-040	HLB25 x GR25 - 40	108	40	36	15	25	44.45	2	RD..0802	0.36
5263-263-030-040	HLB25 x GR30 - 40	108	40	36	20	30	44.45	2	RD..10T3	0.40
5263-256-032-040	HLB25 x GR32 - 40	108	40	36	22	32	44.45	3	RD..10T3	0.42
5263-256-035-040	HLB25 x GR35 - 40	108	40	36	25	35	44.45	3	RD..10T3	0.44

Coolant Thru

5262-262-025-040	HLB20 x GRC25 - 40	108	40	36	15	25	38.1	2	RD..0802	0.28
5262-262-030-040	HLB20 x GRC30 - 40	108	40	36	20	30	38.1	2	RD..10T3	0.31
5262-262-032-040	HLB20 x GRC32 - 40	108	40	36	22	32	38.1	3	RD..10T3	0.33
5262-262-035-040	HLB20 x GRC35 - 40	108	40	36	25	35	38.1	3	RD..10T3	0.35
5263-262-025-040	HLB25 x GRC25 - 40	108	40	36	15	25	44.45	2	RD..0802	0.36
5263-262-030-040	HLB25 x GRC30 - 40	108	40	36	20	30	44.45	2	RD..10T3	0.40
5263-262-032-040	HLB25 x GRC32 - 40	108	40	36	22	32	44.45	3	RD..10T3	0.42
5263-262-035-040	HLB25 x GRC35 - 40	108	40	36	25	35	44.45	3	RD..10T3	0.44

ACCESSORIES

INSERT	SCREW	CLAMP	CLAMP SCREW	WRENCH
RD..0802	M3-6.0-3.7-43	GR-5R	M3.5-8.0-5.5-60	T15
RD..10T3	M4-10-5.0-43	GR-5R	M3.5-8.0-5.5-60	T15

Features:

- ▶ Two-face contact between collet taper, collet flange and the end of HBL tool holder, increases the rigidity of machining.
- ▶ Modular system, assembled with HBL collet chucks.
- ▶ HBL drawbar clamping design strengthens the axial clamping force.

Product information:

- ▶ Inserts are optional accessories. Need to be purchased additionally.

HLB / IAP FACE CONTACT TYPE 90° END MILL CUTTER

HLB / IAP 端面緊貼型 90° 刀具

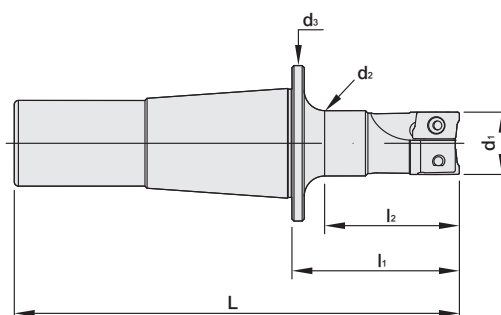

MODEL NO.	TYPE	L	l ₁	l ₂	d ₁	d ₂	d ₃	TEETH	INSERT	WEIGHT (KGS)
5261-243-010-040	HLB12xIAP10-40-1T	95	40	32	10	12	31.75	1	AP..1003	0.10
5261-243-012-040	HLB12xIAP12-40-1T	95	40	32	12	12	31.75	1	AP..1003	0.11
5261-244-016-040	HLB12xIAP16-40-2T	95	40	32	16	16	31.75	2	AP..1003	0.13
5262-243-010-040	HLB20xIAP10-40-1T	108	40	32	10	12	38.1	1	AP..1003	0.22
5262-243-012-040	HLB20xIAP12-40-1T	108	40	32	12	12	38.1	1	AP..1003	0.23
5262-244-016-040	HLB20xIAP16-40-2T	108	40	32	16	16	38.1	2	AP..1003	0.29
5262-244-020-040	HLB20xIAP20-40-2T	108	40	32	20	20	38.1	2	AP..1003	0.29
5262-245-020-040	HLB20xIAP20-40-3T	108	40	32	20	20	38.1	3	AP..1003	0.29
5262-244-025-040	HLB20xIAP25-40-2T	108	40	32	25	25	38.1	2	AP..1003	0.34
5262-245-025-040	HLB20xIAP25-40-3T	108	40	32	25	25	38.1	3	AP..1003	0.34
5262-246-025-040	HLB20xIAP25-40-4T	108	40	32	25	25	38.1	4	AP..1003	0.34
5262-244-032-040	HLB20xIAP32-40-2T	108	40	35	32	30.8	38.1	2	AP..1604	0.43
5262-245-032-040	HLB20xIAP32-40-3T	108	40	35	32	30.8	38.1	3	AP..1604	0.43
5263-243-010-040	HLB25xIAP10-40-1T	118	40	32	10	12	44.45	1	AP..1003	0.33
5263-243-012-040	HLB25xIAP12-40-1T	118	40	32	12	12	44.45	1	AP..1003	0.34
5263-244-016-040	HLB25xIAP16-40-2T	118	40	32	16	16	44.45	2	AP..1003	0.37
5263-244-020-040	HLB25xIAP20-40-2T	118	40	32	20	20	44.45	2	AP..1003	0.41
5263-245-020-040	HLB25xIAP20-40-3T	118	40	32	20	20	44.45	3	AP..1003	0.41
5263-244-025-040	HLB25xIAP25-40-2T	118	40	34	25	25	44.45	2	AP..1003	0.45
5263-245-025-040	HLB25xIAP25-40-3T	118	40	34	25	25	44.45	3	AP..1003	0.45
5263-246-025-040	HLB25xIAP25-40-4T	118	40	34	25	25	44.45	4	AP..1003	0.45
5263-244-032-040	HLB25xIAP32-40-2T	118	40	34	32	30.8	44.45	2	AP..1604	0.54
5263-245-032-040	HLB25xIAP32-40-3T	118	40	34	32	30.8	44.45	3	AP..1604	0.54

ACCESSORIES

INSERT	SCREW	WRENCH
AP..1003	M2.5-6.45-3.7-43	T8
AP..1604	M4-10-5.7-60	T15

Features:

- ▶ Two-face contact between collet taper, collet flange and the end of HBL tool holder, increases the rigidity of machining.
- ▶ Modular system, assembled with HBL collet chucks.
- ▶ HBL drawbar clamping design strengthens the axial clamping force.

Product information:

- ▶ Inserts are optional accessories. Need to be purchased additionally.



HLB / CIAP FACE CONTACT TYPE 90° END MILL CUTTER

HLB / CIAP 端面緊貼型 90° 刀具

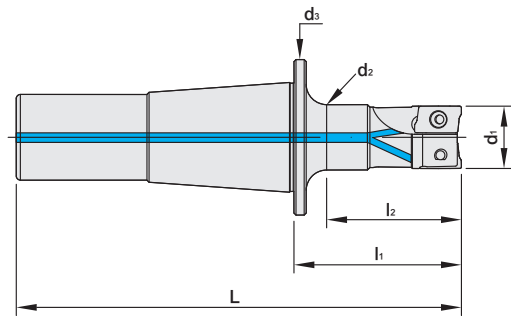

W/O Coolant

MODEL NO.	TYPE	L	l ₁	l ₂	d ₁	d ₂	d ₃	TEETH	INSERT	WEIGHT (KGS)
5261-051-010-040	HLB12xCIAP10-40-1T	95	40	32	10	12	31.75	1	AP..1003	0.10
5261-051-012-040	HLB12xCIAP12-40-1T	95	40	32	12	12	31.75	1	AP..1003	0.11
5261-052-016-040	HLB12xCIAP16-40-2T	95	40	32	16	16	31.75	2	AP..1003	0.13
5262-051-010-040	HLB20xCIAP10-40-1T	108	40	32	10	12	38.1	1	AP..1003	0.22
5262-051-012-040	HLB20xCIAP12-40-1T	108	40	32	12	12	38.1	1	AP..1003	0.23
5262-052-016-040	HLB20xCIAP16-40-2T	108	40	32	16	16	38.1	2	AP..1003	0.29
5262-052-020-040	HLB20xCIAP20-40-2T	108	40	32	20	20	38.1	2	AP..1003	0.29
5262-053-020-040	HLB20xCIAP20-40-3T	108	40	32	20	20	38.1	3	AP..1003	0.29
5262-052-025-040	HLB20xCIAP25-40-2T	108	40	32	25	25	38.1	2	AP..1003	0.34
5262-053-025-040	HLB20xCIAP25-40-3T	108	40	32	25	25	38.1	3	AP..1003	0.34
5262-054-025-040	HLB20xCIAP25-40-4T	108	40	32	25	25	38.1	4	AP..1003	0.34
5262-052-032-040	HLB20xCIAP32-40-2T	108	40	35	32	30.8	38.1	2	AP..1604	0.43
5262-053-032-040	HLB20xCIAP32-40-3T	108	40	35	32	30.8	38.1	3	AP..1604	0.43
5263-051-010-040	HLB25xCIAP10-40-1T	118	40	32	10	12	44.45	1	AP..1003	0.33
5263-051-012-040	HLB25xCIAP12-40-1T	118	40	32	12	12	44.45	1	AP..1003	0.34
5263-052-016-040	HLB25xCIAP16-40-2T	118	40	32	16	16	44.45	2	AP..1003	0.37
5263-052-020-040	HLB25xCIAP20-40-2T	118	40	32	20	20	44.45	2	AP..1003	0.41
5263-053-020-040	HLB25xCIAP20-40-3T	118	40	32	20	20	44.45	3	AP..1003	0.41
5263-052-025-040	HLB25xCIAP25-40-2T	118	40	34	25	25	44.45	2	AP..1003	0.45
5263-053-025-040	HLB25xCIAP25-40-3T	118	40	34	25	25	44.45	3	AP..1003	0.45
5263-054-025-040	HLB25xCIAP25-40-4T	118	40	34	25	25	44.45	4	AP..1003	0.45
5263-052-032-040	HLB25xCIAP32-40-2T	118	40	34	32	30.8	44.45	2	AP..1604	0.54
5263-053-032-040	HLB25xCIAP32-40-3T	118	40	34	32	30.8	44.45	3	AP..1604	0.54

ACCESSORIES

INSERT	SCREW	WRENCH
AP..1003	M2.5-6.45-3.7-43	T8
AP..1604	M4-10-5.7-60	T15

Features:

- ▶ Two-face contact between collet taper, collet flange and the end of HBL tool holder, increases the rigidity of machining.
- ▶ Modular system, assembled with HBL collet chucks.
- ▶ HBL drawbar clamping design strengthens the axial clamping force.

Product information:

- ▶ Inserts are optional accessories. Need to be purchased additionally.



HLB / HF POWERLOC SQUARE SHANK HIGH-FEED END MILL

HLB / HF 筒夾式大進給端銑刀

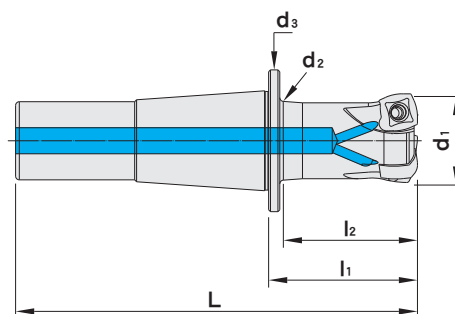

MODEL NO.	TYPE	d ₁	d ₂	d ₃	L	l ₁	l ₂	TEETH	INSERT	WEIGHT (KGS)
5262-265-025-040	HLB20 x HF25 - 40 - 3T	25	20.918	38.1	107.3	40	35.2	3	SNKX09T3	0.38
5262-265-032-040	HLB20 x HF32 - 40 - 3T	32	27.919	38.1	107.3	40	35.2	3	SNKX09T3	0.37
5262-270-032-040	HLB20 x HF32 - 40 - 4T	32	27.919	38.1	107.3	40	35.2	4	SNKX09T3	0.37
5263-265-025-040	HLB25 x HF25 - 40 - 3T	25	20.918	44.45	117.3	40	35.2	3	SNKX09T3	0.41
5263-265-032-040	HLB25 x HF32 - 40 - 3T	32	27.919	44.45	117.3	40	35.2	3	SNKX09T3	0.51
5263-270-032-040	HLB25 x HF32 - 40 - 4T	32	27.919	44.45	117.3	40	35.2	4	SNKX09T3	0.51

ACCESSORIES

INSERT	SCREW	WRENCH
SNKX09T3	M3.5-9.3-4.8-60	T5

Features:

- ▶ Two-face contact between collet taper, collet flange and the end of HBL tool holder, increases the rigidity of machining.
- ▶ Modular system, assembled with HBL collet chucks.
- ▶ HBL drawbar clamping design strengthens the axial clamping force.

Product information:

- ▶ Inserts are optional accessories. Need to be purchased additionally.



HLB / SFC COLLET TYPE SHRINK FIT CHUCK

HLB / SFC 筒夾式熱膨脹刀桿

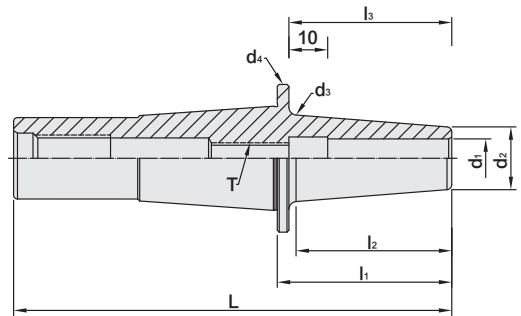

MODEL NO.	TYPE	L	l ₁	l ₂	l ₃	d ₁	d ₂	d ₃	d ₄	T
5261-651-003-045	HLB12 x SFC3 - 45	100	45	40.1	18	3	9	15.3	31.75	-
5261-651-003-080	HLB12 x SFC3 - 80	135	80	75.1	18	3	9	20.8	31.75	-
5261-651-003-110	HLB12 x SFC3 - 110	165	110	105.1	18	3	9	25.5	31.75	-
5261-651-004-045	HLB12 x SFC4 - 45	100	45	40.1	20	4	10	16.3	31.75	-
5261-651-004-080	HLB12 x SFC4 - 80	135	80	75.1	20	4	10	21.8	31.75	-
5261-651-004-110	HLB12 x SFC4 - 110	165	110	105.1	20	4	10	26.5	31.75	-
5261-651-005-045	HLB12 x SFC5 - 45	100	45	40.1	20	5	11	17.3	31.75	M4 x 0.7P
5261-651-005-080	HLB12 x SFC5 - 80	135	80	75.1	20	5	11	22.8	31.75	M4 x 0.7P
5261-651-005-110	HLB12 x SFC5 - 110	165	110	106	20	5	11	27.6	31.75	M4 x 0.7P
5261-651-006-045	HLB12 x SFC6 - 45	100	45	40.1	36	6	12	18.3	31.75	M5 x 0.8P
5261-651-006-080	HLB12 x SFC6 - 80	135	80	75.1	36	6	12	23.8	31.75	M5 x 0.8P
5261-651-006-110	HLB12 x SFC6 - 110	165	110	106	36	6	12	28.6	31.75	M5 x 0.8P
5261-651-008-045	HLB12 x SFC8 - 45	100	45	40.1	36	8	14	20.3	31.75	M6 x 1.0P
5261-651-008-080	HLB12 x SFC8 - 80	135	80	76	36	8	14	25.8	31.75	M6 x 1.0P
5261-651-008-110	HLB12 x SFC8 - 110	165	110	107	36	8	14	30.8	31.75	M6 x 1.0P
5261-651-010-045	HLB12 x SFC10 - 45	100	45	40.1	42	10	16	22.3	31.75	M8 x 1.25P
5261-651-010-080	HLB12 x SFC10 - 80	135	80	76	42	10	16	27.9	31.75	M8 x 1.25P
5261-651-010-110	HLB12 x SFC10 - 110	165	110	100	42	10	16	31.75	31.75	M8 x 1.25P
5262-651-003-045	HLB20 x SFC3 - 45	113	45	40.1	18	3	9	15.3	38.1	-
5262-651-003-080	HLB20 x SFC3 - 80	148	80	75.1	18	3	9	20.8	38.1	-
5262-651-003-110	HLB20 x SFC3 - 110	178	110	105.1	18	3	9	25.5	38.1	-
5262-651-004-045	HLB20 x SFC4 - 45	113	45	40.1	20	4	10	16.3	38.1	-
5262-651-004-080	HLB20 x SFC4 - 80	148	80	75.1	20	4	10	21.8	38.1	-
5262-651-004-110	HLB20 x SFC4 - 110	178	110	105.1	20	4	10	26.5	38.1	-
5262-651-005-045	HLB20 x SFC5 - 45	113	45	40.1	20	5	11	17.3	38.1	M4 x 0.7P
5262-651-005-080	HLB20 x SFC5 - 80	148	80	75.1	20	5	11	22.8	38.1	M4 x 0.7P
5262-651-005-110	HLB20 x SFC5 - 110	178	110	105.1	20	5	11	27.5	38.1	M4 x 0.7P
5262-651-006-045	HLB20 x SFC6 - 45	113	45	40.1	36	6	12	18.3	38.1	M5 x 0.8P
5262-651-006-080	HLB20 x SFC6 - 80	148	80	75.1	36	6	12	23.8	38.1	M5 x 0.8P
5262-651-006-110	HLB20 x SFC6 - 110	178	110	105.1	36	6	12	28.5	38.1	M5 x 0.8P
5262-651-008-045	HLB20 x SFC8 - 45	113	45	40.1	36	8	14	20.3	38.1	M6 x 1.0P
5262-651-008-080	HLB20 x SFC8 - 80	148	80	75.1	36	8	14	25.8	38.1	M6 x 1.0P
5262-651-008-110	HLB20 x SFC8 - 110	178	110	105.1	36	8	14	30.5	38.1	M6 x 1.0P
5262-651-010-045	HLB20 x SFC10 - 45	113	45	40.1	42	10	16	22.3	38.1	M8 x 1.25P
5262-651-010-080	HLB20 x SFC10 - 80	148	80	75.1	42	10	16	27.8	38.1	M8 x 1.25P
5262-651-010-110	HLB20 x SFC10 - 110	178	110	105.1	42	10	16	32.5	38.1	M8 x 1.25P
5262-651-012-045	HLB20 x SFC12 - 45	113	45	40.1	47	12	18	24.3	38.1	M10 x 1.5P
5262-651-012-080	HLB20 x SFC12 - 80	148	80	75.1	47	12	18	29.8	38.1	M10 x 1.5P
5262-651-012-110	HLB20 x SFC12 - 110	178	110	106	47	12	18	34.6	38.1	M10 x 1.5P

HLB / SFC COLLET TYPE SHRINK FIT CHUCK

HLB / SFC 筒夾式熱膨脹刀桿

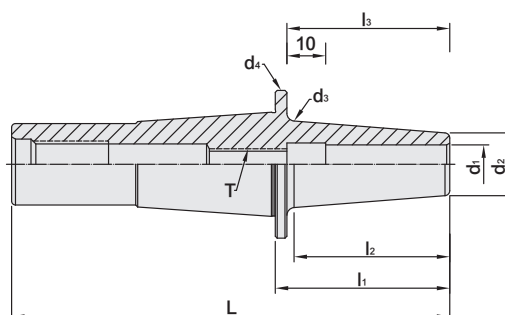

MODEL NO.	TYPE	L	l ₁	l ₂	l ₃	d ₁	d ₂	d ₃	d ₄	T
5263-651-003-045	HLB25 x SFC3 - 45	123	45	40.1	18	3	9	15.3	44.45	-
5263-651-003-080	HLB25 x SFC3 - 80	158	80	75.1	18	3	9	20.8	44.45	-
5263-651-003-110	HLB25 x SFC3 - 110	188	110	105.1	18	3	9	25.5	44.45	-
5263-651-004-045	HLB25 x SFC4 - 45	123	45	40.1	20	4	10	16.3	44.45	-
5263-651-004-080	HLB25 x SFC4 - 80	158	80	75.1	20	4	10	21.8	44.45	-
5263-651-004-110	HLB25 x SFC4 - 110	188	110	105.1	20	4	10	26.5	44.45	-
5263-651-005-045	HLB25 x SFC5 - 45	123	45	40.1	20	5	11	17.3	44.45	M4 x 0.7P
5263-651-005-080	HLB25 x SFC5 - 80	158	80	75.1	20	5	11	22.8	44.45	M4 x 0.7P
5263-651-005-110	HLB25 x SFC5 - 110	188	110	105.1	20	5	11	27.5	44.45	M4 x 0.7P
5263-651-006-045	HLB25 x SFC6 - 45	123	45	40.1	36	6	12	18.3	44.45	M5 x 0.8P
5263-651-006-080	HLB25 x SFC6 - 80	158	80	75.1	36	6	12	23.8	44.45	M5 x 0.8P
5263-651-006-110	HLB25 x SFC6 - 110	188	110	105.1	36	6	12	28.5	44.45	M5 x 0.8P
5263-651-008-045	HLB25 x SFC8 - 45	123	45	40.1	36	8	14	20.3	44.45	M6 x 1.0P
5263-651-008-080	HLB25 x SFC8 - 80	158	80	75.1	36	8	14	25.8	44.45	M6 x 1.0P
5263-651-008-110	HLB25 x SFC8 - 110	188	110	105.1	36	8	14	30.5	44.45	M6 x 1.0P
5263-651-010-045	HLB25 x SFC10 - 45	123	45	40.1	42	10	16	22.3	44.45	M8 x 1.25P
5263-651-010-080	HLB25 x SFC10 - 80	158	80	75.1	42	10	16	27.8	44.45	M8 x 1.25P
5263-651-010-110	HLB25 x SFC10 - 110	188	110	105.1	42	10	16	32.5	44.45	M8 x 1.25P
5263-651-012-045	HLB25 x SFC12 - 45	123	45	40.1	47	12	18	24.3	44.45	M10 x 1.5P
5263-651-012-080	HLB25 x SFC12 - 80	158	80	75.1	47	12	18	29.8	44.45	M10 x 1.5P
5263-651-012-110	HLB25 x SFC12 - 110	188	110	105.1	47	12	18	34.5	44.45	M10 x 1.5P
5263-651-014-045	HLB25 x SFC14 - 45	123	45	40.1	47	14	20	26.3	44.45	M10 x 1.5P
5263-651-014-080	HLB25 x SFC14 - 80	158	80	75.1	47	14	20	31.8	44.45	M10 x 1.5P
5263-651-014-110	HLB25 x SFC14 - 110	188	110	105.1	47	14	20	36.5	44.45	M10 x 1.5P
5263-651-016-050	HLB25 x SFC16 - 50	128	50	45.1	50	16	22	29.1	44.45	M12 x 1.75P
5263-651-016-080	HLB25 x SFC16 - 80	158	80	75.1	50	16	22	33.8	44.45	M12 x 1.75P
5263-651-016-110	HLB25 x SFC16 - 110	188	110	105.1	50	16	22	38.5	44.45	M12 x 1.75P
5263-651-018-050	HLB25 x SFC18 - 50	128	50	45.1	50	18	24	31.1	44.45	M12 x 1.75P
5263-651-018-080	HLB25 x SFC18 - 80	158	80	75.1	50	18	24	35.8	44.45	M12 x 1.75P
5263-651-018-110	HLB25 x SFC18 - 110	188	110	106	50	18	24	40.6	44.45	M12 x 1.75P
5263-651-020-050	HLB25 x SFC20 - 50	128	50	45.1	52	20	26	33.1	44.45	M16 x 2.0P
5263-651-020-080	HLB25 x SFC20 - 80	158	80	75.1	52	20	26	37.8	44.45	M16 x 2.0P
5263-651-020-110	HLB25 x SFC20 - 110	188	110	106.6	52	20	26	42.7	44.45	M16 x 2.0P

Features:

- ▶ Two-face contact between collet taper, collet flange and the end of HBL tool holder, increases the rigidity of machining.
- ▶ Modular system, assembled with HBL collet chucks.
- ▶ HBL drawbar clamping design strengthens the axial clamping force.



HLB / MAP FACE CONTACT TYPE 90° END MILL CUTTER

HLB / MAP 端面緊貼型 90° 刀具

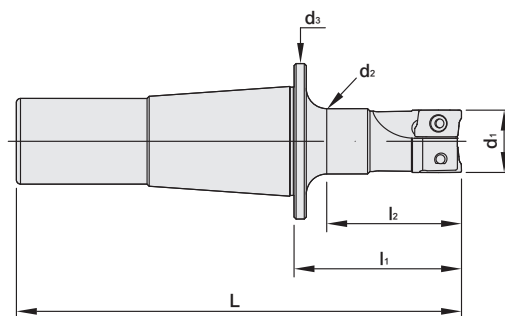

MODEL NO.	TYPE	L	l ₁	l ₂	d ₁	d ₂	d ₃	TEETH	INSERT	WEIGHT (KGS)
5261-467-010-040	HLB12 x MAP10 - 40 - 1T	95	40	32	10	12	31.75	1	AP..1135	0.10
5261-467-012-040	HLB12 x MAP12 - 40 - 1T	95	40	32	12	11	31.75	1	AP..1135	0.11
5261-468-016-040	HLB12 x MAP16 - 40 - 2T	95	40	34	16	16	31.75	2	AP..1135	0.13
5262-467-010-040	HLB20 x MAP10 - 40 - 1T	108	40	32	10	12	38.1	1	AP..1135	0.22
5262-467-012-040	HLB20 x MAP12 - 40 - 1T	108	40	32	12	11	38.1	1	AP..1135	0.23
5262-468-016-040	HLB20 x MAP16 - 40 - 2T	108	40	34	16	16	38.1	2	AP..1135	0.25
5262-468-020-040	HLB20 x MAP20 - 40 - 2T	108	40	34	20	16.8	38.1	2	AP..1135	0.28
5262-469-025-040	HLB20 x MAP25 - 40 - 3T	108	40	34	25	23.5	38.1	3	AP..1135	0.32
5262-471-025-040	HLB20 x MAP25 - 40 - 4T	108	40	34	25	23.5	38.1	4	AP..1135	0.32
5262-468-032-040	HLB20 x MAP32 - 40 - 2T	108	40	35	32	31.45	38.1	2	AP..1604	0.38
5262-469-032-040	HLB20 x MAP32 - 40 - 3T	108	40	35	32	31.45	38.1	3	AP..1604	0.41
5263-467-010-040	HLB25 x MAP10 - 40 - 1T	118	40	32	10	12	44.45	1	AP..1135	0.31
5263-467-012-040	HLB25 x MAP12 - 40 - 1T	118	40	32	12	11	44.45	1	AP..1135	0.31
5263-468-016-040	HLB25 x MAP16 - 40 - 2T	118	40	34	16	16	44.45	2	AP..1135	0.33
5263-468-020-040	HLB25 x MAP20 - 40 - 2T	118	40	34	20	16.8	44.45	2	AP..1135	0.36
5263-469-025-040	HLB25 x MAP25 - 40 - 3T	118	40	34	25	23.5	44.45	3	AP..1135	0.40
5263-471-025-040	HLB25 x MAP25 - 40 - 4T	118	40	34	25	23.5	44.45	4	AP..1135	0.40
5263-468-032-040	HLB25 x MAP32 - 40 - 2T	118	40	34	32	31.45	44.45	2	AP..1604	0.46
5263-469-032-040	HLB25 x MAP32 - 40 - 3T	118	40	34	32	31.45	44.45	3	AP..1604	0.49

ACCESSORIES

INSERT	SCREW	WRENCH
AP..1135	M2.5-6.45-3.7-60	T8
AP..1604	M4-10-5.7-60	T15

Features:

- ▶ Two-face contact between collet taper, collet flange and the end of HBL tool holder, increases the rigidity of machining.
- ▶ Modular system, assembled with HBL collet chucks.
- ▶ HBL drawbar clamping design strengthens the axial clamping force.

Product information:

- ▶ Inserts are optional accessories. Need to be purchased additionally.

HLB / CMAP FACE CONTACT TYPE 90° END MILL CUTTER

HLB / CMAP 端面緊貼型 90° 刀具

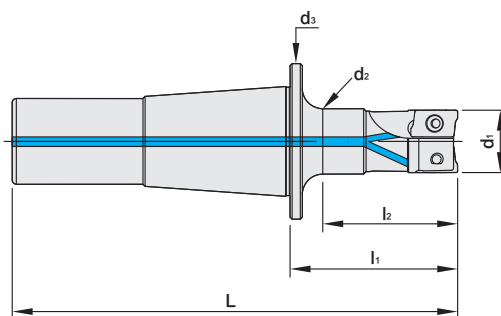

MODEL NO.	TYPE	L	l ₁	l ₂	d ₁	d ₂	d ₃	TEETH	INSERT	WEIGHT (KGS)
5261-041-010-040	HLB12 x CMAP10 - 40 - 1T	95	40	32	10	12	31.75	1	AP..1135	0.10
5261-041-012-040	HLB12 x CMAP12 - 40 - 1T	95	40	32	12	11	31.75	1	AP..1135	0.11
5261-042-016-040	HLB12 x CMAP16 - 40 - 2T	95	40	34	16	16	31.75	2	AP..1135	0.13
5262-041-010-040	HLB20 x CMAP10 - 40 - 1T	108	40	32	10	12	38.1	1	AP..1135	0.22
5262-041-012-040	HLB20 x CMAP12 - 40 - 1T	108	40	32	12	11	38.1	1	AP..1135	0.23
5262-042-016-040	HLB20 x CMAP16 - 40 - 2T	108	40	34	16	16	38.1	2	AP..1135	0.25
5262-042-020-040	HLB20 x CMAP20 - 40 - 2T	108	40	34	20	16.8	38.1	2	AP..1135	0.28
5262-043-025-040	HLB20 x CMAP25 - 40 - 3T	108	40	34	25	23.5	38.1	3	AP..1135	0.32
5262-044-025-040	HLB20 x CMAP25 - 40 - 4T	108	40	34	25	23.5	38.1	4	AP..1135	0.32
5262-042-032-040	HLB20 x CMAP32 - 40 - 2T	108	40	35	32	31.45	38.1	2	AP..1604	0.41
5262-043-032-040	HLB20 x CMAP32 - 40 - 3T	108	40	35	32	31.45	38.1	3	AP..1604	0.41
5263-041-010-040	HLB25 x CMAP10 - 40 - 1T	118	40	32	10	12	44.45	1	AP..1135	0.31
5263-041-012-040	HLB25 x CMAP12 - 40 - 1T	118	40	32	12	11	44.45	1	AP..1135	0.32
5263-042-016-040	HLB25 x CMAP16 - 40 - 2T	118	40	34	16	16	44.45	2	AP..1135	0.34
5263-042-020-040	HLB25 x CMAP20 - 40 - 2T	118	40	34	20	16.8	44.45	2	AP..1135	0.36
5263-043-025-040	HLB25 x CMAP25 - 40 - 3T	118	40	34	25	23.5	44.45	3	AP..1135	0.41
5263-044-025-040	HLB25 x CMAP25 - 40 - 4T	118	40	34	25	23.5	44.45	4	AP..1135	0.41
5263-042-032-040	HLB25 x CMAP32 - 40 - 2T	118	40	34	32	31.45	44.45	2	AP..1604	0.50
5263-043-032-040	HLB25 x CMAP32 - 40 - 3T	118	40	34	32	31.45	44.45	3	AP..1604	0.50

ACCESSORIES

INSERT	SCREW	WRENCH
AP..1135	M2.5-6.45-3.7-60	T8
AP..1604	M4-10-5.7-60	T15

Features:

- ▶ Two-face contact between collet taper, collet flange and the end of HBL tool holder, increases the rigidity of machining.
- ▶ Modular system, assembled with HBL collet chucks.
- ▶ HBL drawbar clamping design strengthens the axial clamping force.

Product information:

- ▶ Inserts are optional accessories. Need to be purchased additionally.



HLB / BFC FACE CONTACT TYPE BALL NOSE FINISH END MILL CUTTER

3°

HLB / BFC 端面緊貼型圓鼻刀具

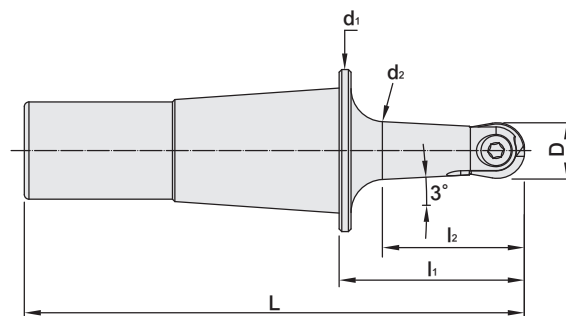

MODEL NO.	TYPE	L	l ₁	l ₂	D	d ₁	d ₂	INSERT	WEIGHT (KGS)
5261-035-004-040-0	HLB12 x BFC4 - 40	95	40	29.4	8	31.75	9.7	P3204-D08	0.10
5261-035-005-040-0	HLB12 x BFC5 - 40	95	40	29.4	10	31.75	11.6	P3204-D10	0.10
5261-035-006-040-0	HLB12 x BFC6 - 40	95	40	29.6	12	31.75	12.3	P3204-D12	0.11
5261-035-008-040-0	HLB12 x BFC8 - 40	95	40	29.4	16	31.75	16.4	P3204-D16	0.13
5261-035-010-040-0	HLB12 x BFC10 - 40	95	40	32.3	20	31.75	20.4	P3204-D20	0.15
5261-035-12.5-040-0	HLB12 x BFC12.5 - 40	95	40	36	25	31.75	25.6	P3204-D25	0.18
5262-035-004-040-0	HLB20 x BFC4 - 40	108	40	29.4	8	38.1	9.7	P3204-D08	0.22
5262-035-005-040-0	HLB20 x BFC5 - 40	108	40	29.4	10	38.1	11.6	P3204-D10	0.23
5262-035-006-040-0	HLB20 x BFC6 - 40	108	40	29.6	12	38.1	12.3	P3204-D12	0.24
5262-035-008-040-0	HLB20 x BFC8 - 40	108	40	29.4	16	38.1	16.4	P3204-D16	0.25
5262-035-010-040-0	HLB20 x BFC10 - 40	108	40	32.3	20	38.1	20.4	P3204-D20	0.27
5262-035-12.5-040-0	HLB20 x BFC12.5 - 40	108	40	32.3	25	38.1	25.2	P3204-D25	0.30
5263-035-004-040-0	HLB25 x BFC4 - 40	118	40	29.5	8	44.45	9.0	P3204-D08	0.31
5263-035-005-040-0	HLB25 x BFC5 - 40	118	40	29.5	10	44.45	10.7	P3204-D10	0.32
5263-035-006-040-0	HLB25 x BFC6 - 40	118	40	29	12	44.45	12.3	P3204-D12	0.33
5263-035-008-040-0	HLB25 x BFC8 - 40	118	40	29.5	16	44.45	15.3	P3204-D16	0.34
5263-035-010-040-0	HLB25 x BFC10 - 40	118	40	32.3	20	44.45	18.9	P3204-D20	0.36
5263-035-12.5-040-0	HLB25 x BFC12.5 - 40	118	40	32.3	25	44.45	23.5	P3204-D25	0.39

ACCESSORIES

INSERT	SCREW	WRENCH
P3204-D08	BFC-4R	T8
P3204-D10	BFC-5R	T15
P3204-D12	BFC-6R	T20
P3204-D16	BFC-8R	T20
P3204-D20	BFC-10R	T20
P3204-D25	BFC-12.5R	T30

Features:

- ▶ Two-face contact between collet taper, collet flange and the end of HBL tool holder, increases the rigidity of machining.
- ▶ Modular system, assembled with HBL collet chucks.
- ▶ HBL drawbar clamping design strengthens the axial clamping force.

Product information:

- ▶ Inserts are optional accessories. Need to be purchased additionally.

HLB / BFC FACE CONTACT TYPE BALL NOSE FINISH END MILL CUTTER

4.5°

HLB / BFC 端面緊貼型圓鼻刀具

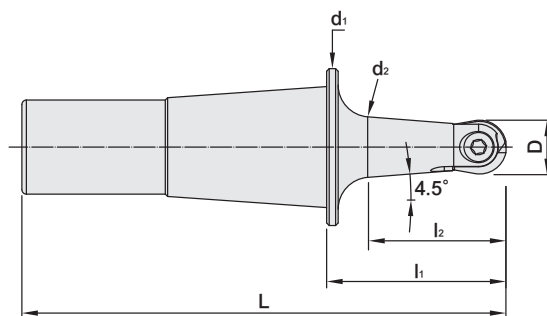

MODEL NO.	TYPE	L	l ₁	l ₂	D	d ₁	d ₂	INSERT	WEIGHT (KGS)
5261-035-004-040-3	HLB12 x BFC4 - 40D	95	40	29.4	8	31.75	11.1	P3204-D08	0.10
5261-035-005-040-3	HLB12 x BFC5 - 40D	95	40	29.6	10	31.75	12.9	P3204-D10	0.10
5261-035-006-040-3	HLB12 x BFC6 - 40D	95	40	29.6	12	31.75	13.3	P3204-D12	0.12
5261-035-008-040-3	HLB12 x BFC8 - 40D	95	40	29.6	16	31.75	17.5	P3204-D16	0.14
5261-035-010-040-3	HLB12 x BFC10 - 40D	95	40	32.4	20	31.75	21.7	P3204-D20	0.16
5261-035-12.5-040-3	HLB12 x BFC12.5 - 40D	95	40	36.8	25	31.75	26.9	P3204-D25	0.19
5262-035-004-040-3	HLB20 x BFC4 - 40D	108	40	29.4	8	38.1	11.1	P3204-D08	0.23
5262-035-005-040-3	HLB20 x BFC5 - 40D	108	40	29.6	10	38.1	12.9	P3204-D10	0.24
5262-035-006-040-3	HLB20 x BFC6 - 40D	108	40	29.6	12	38.1	13.3	P3204-D12	0.25
5262-035-008-040-3	HLB20 x BFC8 - 40D	108	40	29.6	16	38.1	17.5	P3204-D16	0.27
5262-035-010-040-3	HLB20 x BFC10 - 40D	108	40	32.4	20	38.1	21.7	P3204-D20	0.30
5262-035-12.5-040-3	HLB20 x BFC12.5 - 40D	108	40	32.4	25	38.1	26.3	P3204-D25	0.34
5263-035-004-040-3	HLB25 x BFC4 - 40D	118	40	29.5	8	44.45	10.0	P3204-D08	0.31
5263-035-005-040-3	HLB25 x BFC5 - 40D	118	40	29	10	44.45	11.8	P3204-D10	0.32
5263-035-006-040-3	HLB25 x BFC6 - 40D	118	40	29.6	12	44.45	13.3	P3204-D12	0.33
5263-035-008-040-3	HLB25 x BFC8 - 40D	118	40	29.6	16	44.45	16.1	P3204-D16	0.35
5263-035-010-040-3	HLB25 x BFC10 - 40D	118	40	32.4	20	44.45	19.5	P3204-D20	0.38
5263-035-12.5-040-3	HLB25 x BFC12.5 - 40D	118	40	32.4	25	44.45	23.9	P3204-D25	0.42

ACCESSORIES

INSERT	SCREW	WRENCH
P3204-D08	BFC-4R	T8
P3204-D10	BFC-5R	T15
P3204-D12	BFC-6R	T20
P3204-D16	BFC-8R	T20
P3204-D20	BFC-10R	T20
P3204-D25	BFC-12.5R	T30

Features:

- ▶ Two-face contact between collet taper, collet flange and the end of HBL tool holder, increases the rigidity of machining.
- ▶ Modular system, assembled with HBL collet chucks.
- ▶ HBL drawbar clamping design strengthens the axial clamping force.

Product information:

- ▶ Inserts are optional accessories. Need to be purchased additionally.



HLB / PMB FACE CONTACT TYPE FINISH BORING HEAD

HLB / PMB 端面緊貼型精搪頭

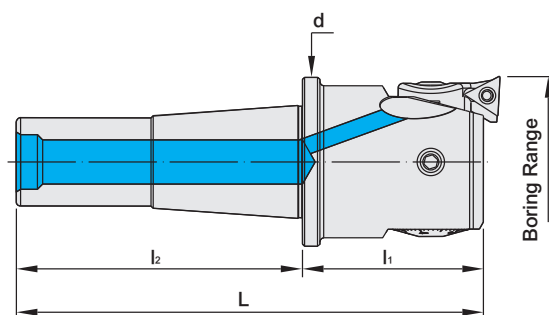

MODEL NO.	TYPE	INSERT SEAT	INSERT	BORING RANGE	L	l ₁	l ₂	d	WEIGHT (KGS)
5262-544-025-068	HLB20 x PMB25 - 68	SIC25 - 1	TB..06 TP..08	25 ~ 33	138	70	68	38.1	0.39
		SIC25 - 2	TB..06 TP..08	32 ~ 40	138	70	68	38.1	0.39
		SIC25 - 3	TB..06 TP..08	39 ~ 47	138	70	68	38.1	0.39
5262-544-032-084	HLB20 x PMB32 - 84	SIC32 - 1	TB..06 TP..08	32 ~ 42	151	83	84	38.1	0.59
		SIC32 - 2	TB..06 TP..08	41 ~ 51	151	83	84	38.1	0.59
		SIC32 - 3	TB..06 TP..08	50 ~ 60	151	83	84	38.1	0.59
5262-544-041-090	HLB20 x PMB41 - 90	SIC41 - 1	TP..09 TC..11	41 ~ 54	157	89	90	38.1	0.85
		SIC41 - 2	TP..09 TC..11	50 ~ 63	157	89	90	38.1	0.85
		SIC41 - 3	TP..09 TC..11	61 ~ 74	157	89	90	38.1	0.85
5263-544-025-068	HLB25 x PMB25 - 68	SIC25 - 1	TB..06 TP..08	25 ~ 33	148	70	68	44.45	0.48
		SIC25 - 2	TB..06 TP..08	32 ~ 40	148	70	68	44.45	0.48
		SIC25 - 3	TB..06 TP..08	39 ~ 47	148	70	68	44.45	0.48
5263-544-032-084	HLB25 x PMB32 - 84	SIC32 - 1	TB..06 TP..08	32 ~ 42	161	83	84	44.45	0.67
		SIC32 - 2	TB..06 TP..08	41 ~ 51	161	83	84	44.45	0.67
		SIC32 - 3	TB..06 TP..08	50 ~ 60	161	83	84	44.45	0.67
5263-544-041-090	HLB25 x PMB41 - 90	SIC41 - 1	TP..09 TC..11	41 ~ 54	168	90	90	44.45	0.93
		SIC41 - 2	TP..09 TC..11	50 ~ 63	168	90	90	44.45	0.93
		SIC41 - 3	TP..09 TC..11	61 ~ 74	168	90	90	44.45	0.93

TYPES FOR INSERT SEAT

TYPE	DRAWING	SUITABLE FINISH BORING HEAD	TYPE	DRAWING	SUITABLE FINISH BORING HEAD	STANDARD INSERT SEAT	OPTIONAL INSERT SEAT	
SIC32 - 1		PMB32	SIC32 - 1E		PMB32	SIC32 - 1	SIC32 - 2	SIC32 - 3
SIC32 - 2		PMB32	SIC32 - 2E		PMB32	Ø32 ~ Ø42	Ø41 ~ Ø51	Ø50 ~ Ø60
SIC32 - 3		PMB32	SIC32 - 3E		PMB32			
SIC41 - 1		PMB41	SIC41 - 1E		PMB41			
SIC41 - 2		PMB41	SIC41 - 2E		PMB41			
SIC41 - 3		PMB41	SIC41 - 3E		PMB41			
SIC53 - 1		PMB53	SIC53 - 1E		PMB53			
SIC53 - 2		PMB53	SIC53 - 2E		PMB53			
SIC53 - 3		PMB53	SIC53 - 3E		PMB53			
SIC68 - 1		PMB68	SIC68 - 1E		PMB68			
SIC68 - 2		PMB68	SIC68 - 2E		PMB68			
SIC68 - 3		PMB68	SIC68 - 3E		PMB68			

ACCESSORIES

INSERT	SCREW	WRENCH	INSERT	SCREW	WRENCH
TB..0601	M2-5.0-2.7-60	T6	TP..0902	M2.5-6.0-3.5-60	T8
TP..0802	M2-5.0-2.7-60	T6	TC..1102	M2.5-6.0-3.5-60	T8

Product information:

- ▶ The body of PMB Finish Boring Head is always designed to have coolant outlet.
- ▶ There are 3 types of insert seats and the boring range of insert seat can be enlarged by exchanging another insert seat.
- ▶ Inserts are optional accessories. Need to be purchased additionally.

HLB / PCK FACE CONTACT TYPE ROUGH BORING HEAD

HLB / PCK 端面緊貼型粗搪頭

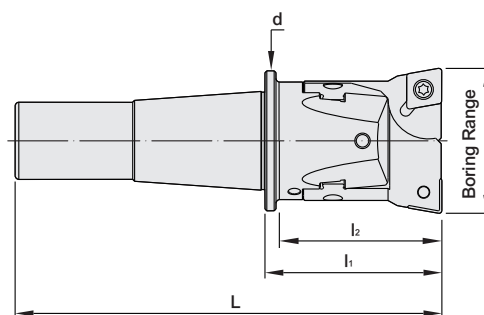

MODEL NO.	TYPE	BORING RANGE		L	l ₁	l ₂	d	INSERT	WEIGHT (KGS)
		MIN.	MAX.						
5262-543-024-068	HLB20 x PCK2430 - 68	24	30	141	73	68	38.1	CC..0602	0.34
5262-543-029-084	HLB20 x PCK2940 - 84	29	40	157	89	84	38.1	CC..09T3	0.47
5262-543-039-090	HLB20 x PCK3950 - 90	39	50	163	95	90	38.1	CC..09T3	0.51
5263-543-024-068	HLB25 x PCK2430 - 68	24	30	151	73	68	44.45	CC..0602	0.43
5263-543-029-084	HLB25 x PCK2940 - 84	29	40	167	89	84	44.45	CC..09T3	0.56
5263-543-039-090	HLB25 x PCK3950 - 90	39	50	173	95	90	44.45	CC..09T3	0.59
5263-543-049-090	HLB25 x PCK4965 - 90	49	65	171.5	93.5	90	44.45	CC..1204	0.62

ACCESSORIES

INSERT	SCREW	WRENCH
CC..0602	M2.5-6.45-3.7	T8
CC..09T3	M4-10-5.7-4.3	T15
CC..1204	M5-11-7.5-60	T20

Features:

- ▶ Two-face contact between collet taper, collet flange and the end of HBL tool holder, increases the rigidity of machining.
- ▶ Modular system, assembled with HBL collet chucks.
- ▶ HBL drawbar clamping design strengthens the axial clamping force.

Product information:

- ▶ Inserts are optional accessories. Need to be purchased additionally.



HLB / MCK FACE CONTACT TYPE BORING HEAD SHANK

HLB / MCK 端面緊貼型搪孔夾頭柄

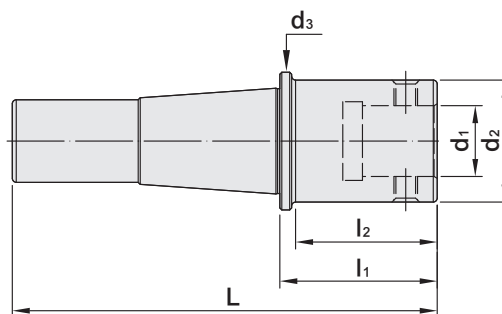

MODEL NO.	TYPE	L	l ₁	l ₂	d ₁	d ₂	d ₃	T	WEIGHT (KGS)
5262-487-001-040	HLB20 x MCK1 - 40	108	40	34	11	19	38.1	M4 x 0.5P	0.26
5262-487-002-040	HLB20 x MCK2 - 40	108	40	34	14	23.5	38.1	M5 x 0.5P	0.30
5262-487-003-040	HLB20 x MCK3 - 40	108	40	30	18	31	38.1	M6 x 0.75P	0.36
5263-487-001-040	HLB25 x MCK1 - 40	118	40	34	11	19	44.45	M4 x 0.5P	0.34
5263-487-002-040	HLB25 x MCK2 - 40	118	40	34	14	23.5	44.45	M5 x 0.5P	0.38
5263-487-003-040	HLB25 x MCK3 - 40	118	40	30	18	31	44.45	M6 x 0.75P	0.44

Features:

- ▶ Two-face contact between collet taper, collet flange and the end of HBL tool holder, increases the rigidity of machining.
- ▶ Modular system, assembled with HBL collet chucks.
- ▶ HBL drawbar clamping design strengthens the axial clamping force.

SHRINK FIT CHUCK FLANGE FOR SAF

4.5°

SAF 可調式刀桿法蘭盤 - SFC

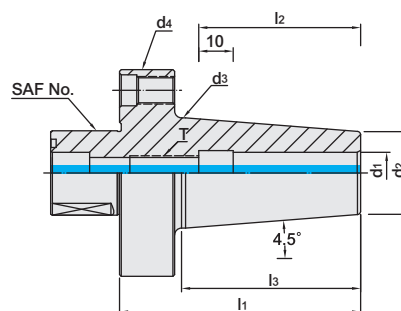

MODEL NO.	TYPE	l ₁	l ₂	l ₃	d ₁	d ₂	d ₃	d ₄	T	SAF NO.	WEIGHT (KGS)
5296-16-006-02-00	SFC6 - 70	70	36	52	6	21	27	60	M5 x 0.8P	1	0.52
5296-16-008-02-00	SFC8 - 70	70	36	52	8	21	27	60	M6 x 1.0P	1	0.51
5296-16-010-02-00	SFC10 - 70	70	42	52	10	24	32	60	M8 x 1.25P	1	0.56
5296-16-012-02-00	SFC12 - 70	70	47	52	12	24	32	60	M10 x 1.5P	1	0.54
5296-16-016-02-00	SFC16 - 75	75	50	57	16	27	34	60	M12 x 1.75P	1	0.59
5296-16-020-02-00	SFC20 - 80	80	52	60	20	33	42	80	M16 x 2.0P	2	1.19
5296-16-025-02-00	SFC25 - 100	100	58	81	25	44	52	80	M20 x 2.0P	2	1.72
5296-16-032-02-00	SFC32 - 100	100	58	81	32	44	52	80	M20 x 2.0P	2	1.58

SK3 COLLET CHUCK FLANGE FOR SAF

SAF 可調式刀桿法蘭盤 - SK3

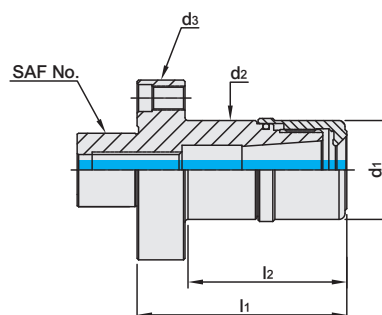

MODEL NO.	TYPE	l_1	l_2	d_1	d_2	d_3	SAF NO.	WEIGHT (KGS)
5296-17-006-02-00	SK306 - 50	50	29	19.5	19.5	60	1	0.39
5296-17-006-02-01	SK306 - 100	100	79	19.5	19.5	60	1	0.48
5296-17-010-02-00	SK310 - 50	50	32.5	27.5	27.5	60	1	0.42
5296-17-010-02-01	SK310 - 100	100	82.5	27.5	27.5	60	1	0.61
5296-17-013-02-00	SK313 - 70	70	53	33	33	60	1	0.55
5296-17-013-02-01	SK313 - 100	100	83	33	33	60	1	0.73
5296-17-016-02-00	SK316 - 70	70	49.9	40	40	80	2	1.08
5296-17-016-02-01	SK316 - 100	100	79.9	40	40	80	2	1.34

Standard Accessory: • NUT

Collet	Nut	SPIGOT INTERCHANGEABLE DIGITAL TORQUE WRENCH	NUT ADAPTERS FOR EXCHANGEABLE TORQUE WRENCH	Spanner
				
P.X-34~41	P.X-58	P.X-73	P.X-75	P.X-82

UT COLLET CHUCK FLANGE FOR SAF



SAF 可調式刀桿法蘭盤 - UT

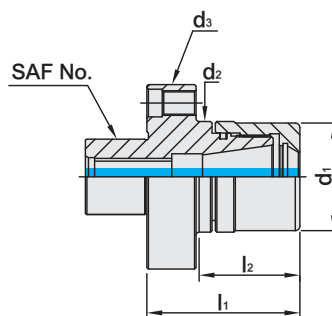

MODEL NO.	TYPE	l ₁	l ₂	d ₁	d ₂	d ₃	SAF NO.	WEIGHT (KGS)
5296-19-016-02-00	UT16 - 50	50	32	30	30	60	1	0.47
5296-19-020-02-00	UT20 - 50	50	33	35	36	60	1	0.49
5296-19-025-02-00	UT25 - 60	60	38.9	42	42	80	2	1.09
5296-19-032-02-00	UT32 - 60	60	40.9	48	48	80	2	1.12

Standard Accessory: • NUT

Collet	Nut	SPIGOT INTERCHANGEABLE DIGITAL TORQUE WRENCH	NUT ADAPTERS FOR EXCHANGEABLE TORQUE WRENCH	Spanner
				
P.X-18~21	P.X-54	P.X-73	P.X-75	P.X-82



TAP ADAPTER FOR STA



STA 同步補償攻牙刀桿心軸

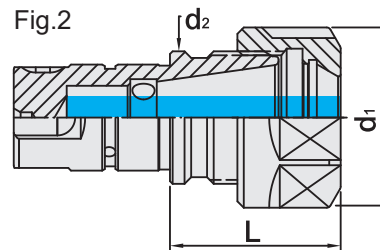
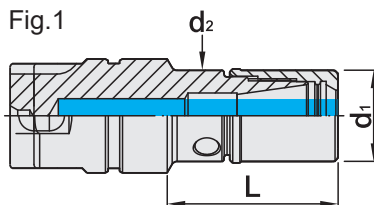

MODEL NO.	TYPE	L	d ₁	d ₂	CAPACITY	WEIGHT (KGS)	Fig
5296-23-S22-03-00	STA1 - ER11A - 70	70	19	19	M3 ~ M6	0.36	1
5296-23-S22-03-01	STA1 - ER16A - 25	25	28	20	M3 ~ M12	0.10	1
5296-23-S22-03-02	STA1 - ER16A - 70	70	28	22	M3 ~ M12	0.30	1
5296-23-S22-03-03	STA1 - ER16A - 150	150	28	28	M3 ~ M12	0.63	1
5296-23-S22-03-04	STA1 - ER20A - 34	34	34	25	M3 ~ M16	0.14	1
5296-23-S22-03-05	STA1 - ER20A - 70	70	34	25	M3 ~ M16	0.30	1
5296-23-S22-03-06	STA2 - ER32 - 40	40	50	40	M10 ~ M24	0.44	2
5296-23-S22-03-07	STA2 - ER32 - 70	70	50	40	M10 ~ M24	0.67	2

Standard Accessory: • NUT

Collet	Nut	Spanner
P.X-18~37	P.X-54~58	P.X-73~74、79

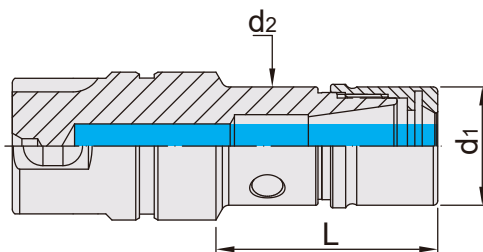

MODEL NO.	TYPE	L	d ₁	d ₂	CAPACITY	WEIGHT (KGS)
5296-23-S11-03-00	STA1-PRO-E11M-30	30	16	16	M3 ~ M6	0.10

Standard Accessory: • NUT

Collet	Nut	Spanner
PX-18、21~22、24、26、28、30	P.X-53	P.X-73、75、82



DRILL SLEEVE

鑽頭套筒

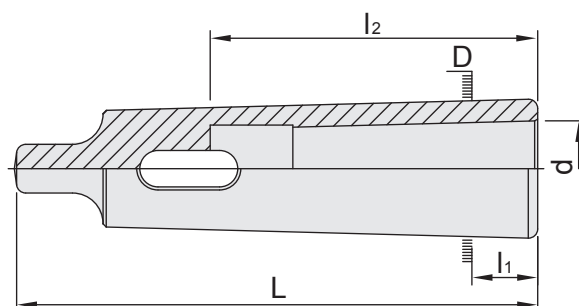

MODEL NO.	TYPE	D	d	L	l ₁	l ₂	WEIGHT (KGS)
5170-007-02	DS - MT1 x MT2	17.78	12.065	92	17	56	0.10
5171-007-03	DS - MT2 x MT3	23.825	17.78	112	18	67	0.19
5171-007-04	DS - MT2 x MT4	31.267	17.78	124	6.5	67	0.45
5172-007-04	DS - MT3 x MT4	31.267	23.825	140	22.5	84	0.40
5173-007-05	DS - MT4 x MT5	44.399	31.267	171	21.5	107	0.96
5174-007-06	DS - MT5 x MT6	63.348	44.399	218	8	135	2.80

DRILL CHUCK ARBOR

夾頭心軸

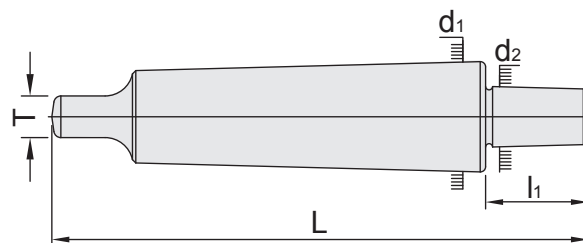

MODEL NO.	TYPE	d ₁	d ₂	L	l ₁	T	WEIGHT (KGS)
5171-255-06	MTA2 x JT6	17.78	17.17	109.4	29.4	6.3	0.19
5171-255-03	MTA2 x JT3	17.78	20.599	116	35	6.3	0.20
5172-255-06	MTA3 x JT6	23.825	17.17	128.4	29.4	7.9	0.30
5173-255-06	MTA4 x JT6	31.267	17.17	153.4	29.4	11.9	0.70
5183-030-16	MK2 x B16	17.78	15.733	112	29	6.3	0.18
5184-030-16	MK3 x B16	23.825	15.733	134	29	7.9	0.34
5185-030-16	MK4 x B16	31.267	15.733	159.5	29	11.9	0.65

Features:

- ▶ MTA=TANG TYPE ▶ Runout: 0.005mm ▶ Roundness: 0.005mm.



TANG

樁舌

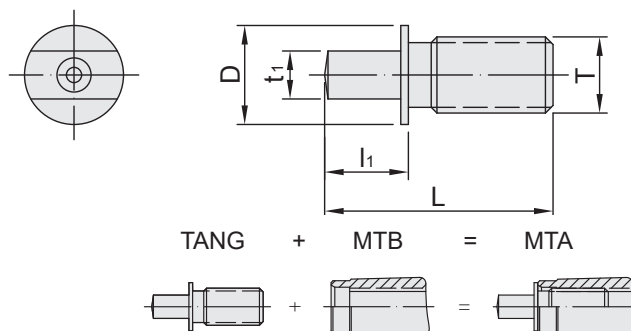

MODEL NO.	TYPE	D	L	l ₁	t ₁	T	WEIGHT (KGS)
5190-027	MT2	13	30	7	6.3	3/8" - 16	0.002
5190-021	MT2	13	30	7	6.3	M10 x 1.5P	0.002
5190-038	MT3	18	40	12	7.8	1/2" - 12	0.05
5190-032	MT3	18	40	12	7.8	M12 x 1.75P	0.04
5190-049	MT4	25	46	13	11.9	5/8" - 11	0.07
5190-043	MT4	25	46	13	11.9	M16 x 2.0P	0.07
5190-050	MT5	35	47	14	15.9	1" - 8	0.17
5190-056	MT5	35	47	14	15.9	M24 x 3.0P	0.17

Features:

- Tang is designed for MTB, used for MTA machine, such as drilling machine or Lathe.



STRAIGHT SHANK MORSE TAPER ADAPTER

直式鑽頭套筒

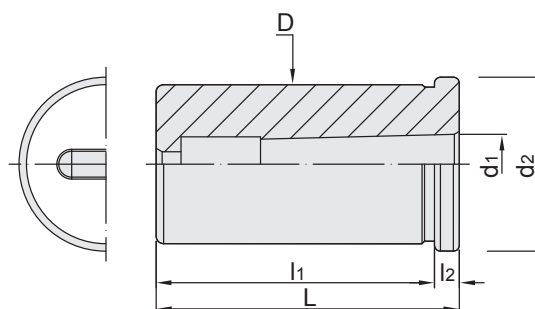

MODEL NO.	TYPE	L	l ₁	l ₂	D	d ₁	d ₂	WEIGHT (KGS)
5191-007-3201	SSC32 x MTA1	61	56	5	32	12.065	35	0.35
5191-007-3202	SSC32 x MTA2	73	65	8	32	17.78	37	0.35
5191-007-3203	SSC32 x MTA3	92	72	20	32	23.825	37	0.35
5191-007-4201	SSC42 x MTA1	61	56	5	42	12.065	47	0.62
5191-007-4202	SSC42 x MTA2	74	66	8	42	17.78	47	0.62
5191-007-4203	SSC42 x MTA3	92	75	17	42	23.825	47	0.62
5191-007-4204	SSC42 x MTA4	115	90	25	42	31.267	47	0.82

Features:

- ▶ MTA=TANG TYPE=DIN 228-B. ▶ SSC=Straight shank.

STRAIGHT SHANK DRILL SLEEVE

直式夾頭心軸

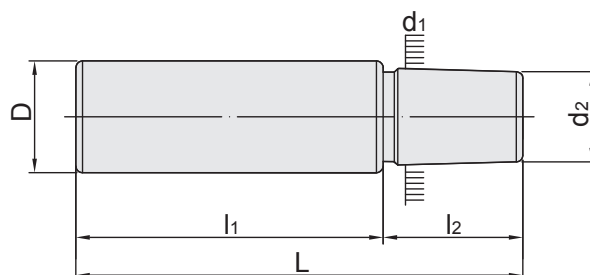

MODEL NO.	TYPE	D	d ₁	d ₂	L	l ₁	l ₂	WEIGHT (KGS)
5192-255-2006	SSC20 x JT6	20	17.17	15.851	84.4	55	29.4	0.20
5192-255-3206	SSC32 x JT6	32	17.17	15.851	99.4	70	29.4	0.50
5192-255-3203	SSC32 x JT3	32	20.599	18.951	105.95	70	35.95	0.60
5192-255-4206	SSC42 x JT6	42	17.17	15.825	99.4	70	29.4	1.15
5192-255-4203	SSC42 x JT3	42	20.599	18.951	135.95	100	35.95	1.20

Features:

- ▶ Suitable for any Milling Chuck or spring collet.



STRAIGHT SLEEVE

FOR SIDE LOCK OIL HOLE HOLDER

OSL 側固式油路刀把套筒

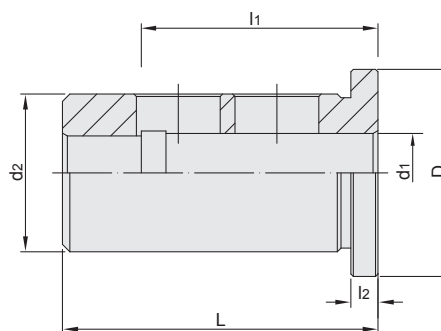

MODEL NO.	TYPE $d_2 - d_1$	D	L	l_1	l_2	WEIGHT (KGS)
5193-604-02016	OSL - 20 - 16	30	54	48	5.5	0.07
5193-604-02516	OSL - 25 - 16	35	60	48	5.5	0.19
5193-604-02520	OSL - 25 - 20	35	60	56	5.5	0.15
5193-604-03216	OSL - 32 - 16	42	64	48	5.5	0.35
5193-604-03220	OSL - 32 - 20	42	64	56	5.5	0.32
5193-604-03225	OSL - 32 - 25	42	64	56	5.5	0.22
5193-604-04016	OSL - 40 - 16	50	74	48	5.5	0.57
5193-604-04020	OSL - 40 - 20	50	74	60	5.5	0.54
5193-604-04025	OSL - 40 - 25	50	74	60	5.5	0.45
5193-604-04032	OSL - 40 - 32	50	74	60	5.5	0.30

PSC INTERCHANGEABLE TYPE LIVE CENTER

PSC 三角錐狀替換型活動頂心

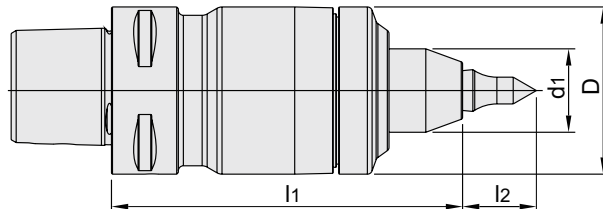

MODEL NO.	TYPE	l ₁	l ₂	D	d ₁	WEIGHT (KGS)
5142-229-050-105	PSC50 x LC50 - 105 (W/ Ø6, Ø8, Ø10, Ø12, Ø32 tips)	105	22	50	25	1.3
5142-229-050-120	PSC50 x LC50 - 120 (W/ Ø6, Ø8, Ø10, Ø12, Ø32 tips)	120	22	50	25	1.5
5143-229-068-145	PSC63 x LC68 - 145 (W/ Ø8, Ø10, Ø12, Ø26, Ø50 tips)	145	22	68	30	3.1

Product Information:

- ▶ PSC triple-contact face structure with the best bending strength and superior repeat positioning accuracy($\pm 2\mu\text{m}$).
- ▶ Bearing axial force(thrust force) is 2,100 KGS : bearing radial force(load capacity) 2,930 KGS.
- ▶ The special waterproof cap design can prevent the cutting fluid from penetrating the center to prolong the use life.
- ▶ Max. revolution: 4,500 RPM.
- ▶ With the design of tip exchangeable. The runout accuracy of the PSC Live Center used with the tip is within $5\mu\text{m}$.

PSC TUNGSTEN SOLID CENTER

PSC 三角錐狀鎢鋼固定型頂心

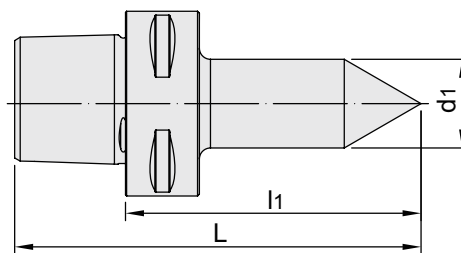

MODEL NO.	TYPE	L	l ₁	d ₁	WEIGHT (KGS)
5142-227-024-080	PSC50 x TC24 - 80	110	80	24	0.58
5143-227-032-100	PSC63 x TC32 - 100	130	100	32	0.80

MT INTERCHANGEABLE TYPE LIVE CENTER

MT 替換型活動頂心

Fig.1

Fig.2

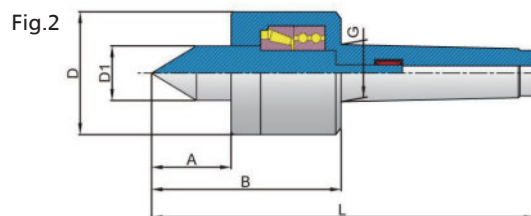
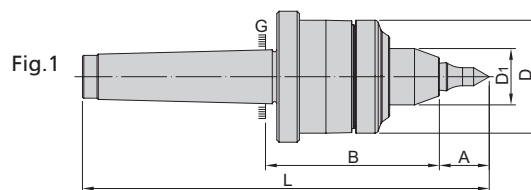

MODEL NO.	TYPE	A	B	D	D1	G	L	Fig.	Max. RPM	Bearing radial force (loading)	Bearing axial force (thrust)
408-002-001-008	MT3 - 003A (W/ Ø6, Ø8, Ø10, Ø12, Ø32 tips)	77.6	22	50	25	23.825 (MT3)	162.55	1	4200rpm	2,000kg	2,200kg
408-002-001-004	MT4 - 001A (W/ Ø8, Ø10, Ø12 tips)	31.5	96.5	67.5	30	31.65 (MT4)	208	2	4500rpm	2,930kg	2,100kg
408-002-001-006	MT5 - 002A (W/ Ø8, Ø10, Ø12 tips)	31.5	96.5	67.5	30	44.85 (MT5)	232	2	4500rpm	2,930kg	2,100kg

Product Information:

- ▶ Application: CNC lathe & high speed lathe.
- ▶ Usage: for the use of workpiece with length less than 500mm and for medium & heavy turning.
- ▶ Accuracy: 0.005mm.
- ▶ MT3-003A attached a spanner.

OPTIONAL TIPS: Ø50

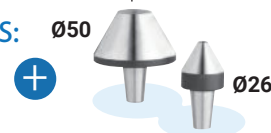

MT LIVE CENTER

MT 固定型活動頂心

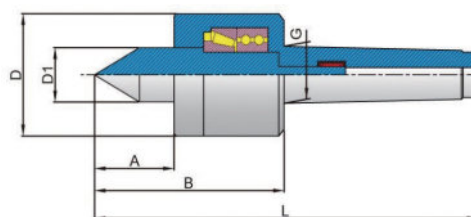

MODEL NO.	TYPE	A	B	D	D1	G	L	Max. RPM	Bearing radial force (loading)	Bearing axial force (thrust)
408-002-001-005	MT4 - 001B	49	113	67.5	30	31.65(MT4)	224	4500rpm	2,930kg	2,250kg
408-002-001-007	MT5 - 002B	49	113	67.5	30	44.85(MT5)	248	4500rpm	2,930kg	2,250kg

Product Information:

- ▶ Application: CNC lathe & high speed lathe.
- ▶ Usage: for the use of workpiece with length less than 500mm and for medium & heavy turning.
- ▶ Accuracy: 0.005mm.



OPTICAL EDGE FINDER

TOUCH POINT SENSOR

光電式尋邊器

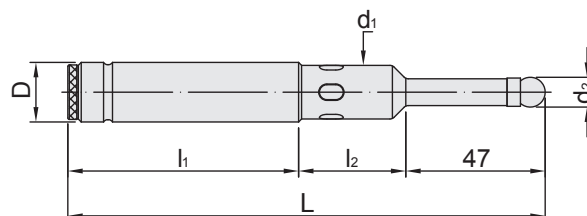

MODEL NO.	TYPE	D	d ₁	d ₂	L	l ₁	l ₂	BATTERY TYPE	WEIGHT (KGS)
5351-603-020	OP - 20	20	18	10	160	79	34	UM - 5(SP) 2P/R1/1.5V	0.3
5351-603-032	OP - 32	32	18	10	160	79	34	UM - 5(SP) 2P/R1/1.5V	0.6

Features:

- ▶ Quickly locate working edges.
- ▶ Save time to find positions, for Milling Machine, Jig borers, and other machine tools.
- ▶ Use dry batteries to light the red bulb.
- ▶ The scope of application includes edge surface, inside and outside diameters and high efficiency.
- ▶ There is a safety spring puller, which will put a ball precisely back to the position when ball breaks away from ball seat.

E.S. OPTICAL EDGE FINDER

警示鳴音 光電尋邊器

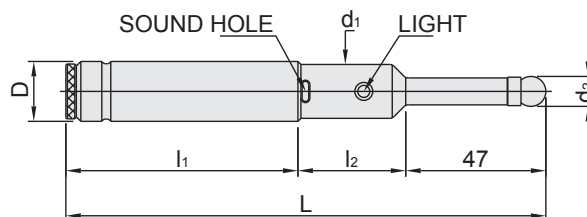

MODEL NO.	TYPE	D	d ₁	d ₂	L	l ₁	l ₂	BATTERY TYPE	WEIGHT (KGS)
5351-140-020	ES - 20	20	18	10	160	79	41	UM5 [#] x 2pcs	0.35
5351-140-032	ES - 32	32	18	10	160	79	41	UM5 [#] x 2pcs	0.60

Features:

- ▶ The red lamp can concentrate light and resist water.
- ▶ It will beep at the same time when the red lamp is on.
- ▶ When probe is in a deep hole you can't see the red light, but you can hear the sound.



MECHANICAL EDGE FINDER

偏心式尋邊器

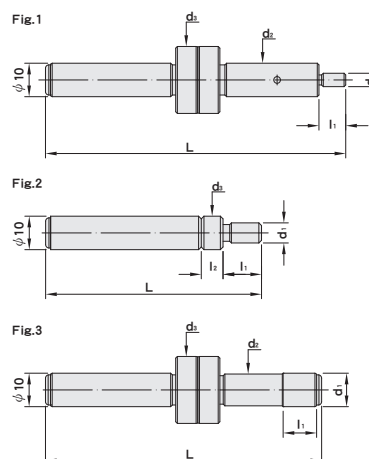

MODEL NO.	TYPE	L	l ₁	l ₂	d ₁	d ₂	d ₃	Fig	WEIGHT (KGS)
5351-458-0420	ME420	90	8	-	φ 4	φ 10	φ 20	1	0.06
5351-458-0610	ME610	65	11.5	6.5	φ 6	-	φ 10	2	0.03
5351-458-1020	ME1020	82.8	10	-	φ 10	φ 10	φ 20	3	0.06

Features:

- ▶ Accuracy of the point to point is within 0.002mm.
- ▶ Revolution within 400-600RPM.
- ▶ Max. flange is clear for our sight.
- ▶ 4mm is the min. hole that could be tested.
- ▶ Suitable for milling machine, drilling machine, and boring machine.

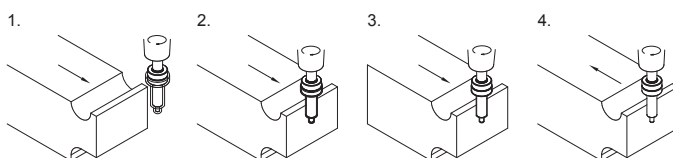

MECHANICAL EDGE FINDER

超硬膜偏心式尋邊器

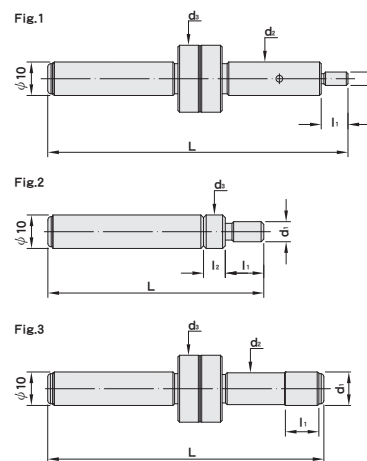

MODEL NO.	TYPE	L	l ₁	l ₂	d ₁	d ₂	d ₃	Fig	WEIGHT (KGS)
5351-276-0420	HME420	90	8	-	φ 4	φ 10	φ 20	1	0.06
5351-276-0610	HME610	65	11.5	6.5	φ 6	-	φ 10	2	0.03
5351-276-1020	HME1020	82.8	10	-	φ 10	φ 10	φ 20	3	0.06

Features:

- ▶ Hard anodic coating without magnetism.
- ▶ Accuracy of the point to point is within 0.002mm.
- ▶ Revolution within 400-600RPM.
- ▶ Max. flange is clear for our sight.
- ▶ 4mm is the min. hole that could be tested.
- ▶ Suitable for milling machine, drilling machine, and boring machine.

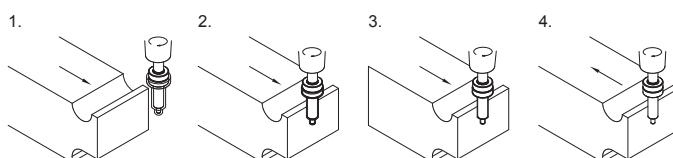

SCREW

給水型擋刀螺絲

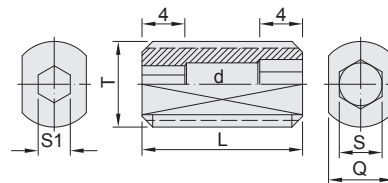

COOLANT PRESET SCREW



MODEL NO.	T	L	d	S	S1	Q	WEIGHT (KGS)
202-022-10050-000	M5 x 0.8P	15	2	2	2	3	0.003
202-022-10060-001	M6 x 1.0P	15	3	2.5	2.5	4	0.003
202-022-10080-002	M8 x 1.25P	15	4	4	3	6	0.005
202-022-10100-002	M10 x 1.5P	15	5	5	4	8	0.005
202-022-10120-002	M12 x 1.75P	15	6	6	5	10	0.01
202-022-10160-002	M16 x 2.0P	25	6	8	6	14	0.01
202-022-20200-003	M20 x 2.0P	25	6	10	8	18	0.03

給水型擋刀螺絲

COOLANT PRESET SCREW



MODEL NO.	TYPE	WEIGHT (KGS)	MODER NO.	TYPE	WEIGHT (KGS)
202-022-10050-001	M5 x 0.8P - 20	0.002	202-022-20180-001	M18 x 1.5P - 25	0.02
202-022-10060-000	M6 x 1.0P - 15	0.003	202-022-20200-000	M20 x 2.0P - 15	0.03
202-022-10080-000	M8 x 1.25P - 15	0.005	202-022-20220-001	M22 x 1.5P - 25	0.03
202-022-10100-000	M10 x 1.5P - 15	0.005	202-022-20240-000	M24 x 2.0P - 15	0.05
202-022-10120-000	M12 x 1.75P - 15	0.01	202-022-10280-000	M28 x 2.0P - 30	0.05
202-022-10116-000	M16 x 2.0P - 15	0.01			

擋刀螺絲

PRESET SCREW



MODEL NO.	TYPE	WEIGHT (KGS)	MODER NO.	TYPE	WEIGHT (KGS)
202-006-10060-000	M6 x 1.0P - 15	0.003	202-006-10160-000	M16 x 2.0P - 15	0.03
202-006-10080-000	M8 x 1.25P - 15	0.005	202-006-20200-000	M20 x 2.0P - 15	0.03
202-006-10100-000	M10 x 1.5P - 15	0.01	202-006-20240-000	M24 x 2.0P - 15	0.05
202-006-10120-000	M12 x 1.75P - 15	0.01			

MLD 設定螺絲

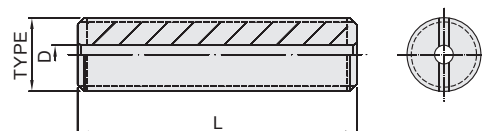

SET SCREW



MODEL NO.	TYPE	L	D	WEIGHT (KGS)
202-006-10120-002	M12 x 1.75P	40	φ4	0.03
202-006-10160-002	M16 x 2.0P	60	φ4	0.05
202-006-10160-001	M16 x 2.0P	35	φ4	0.05
202-006-20240-001	M24 x 3.0P	60	φ4	0.18
202-006-3A400-000	5/8" - 11UNC	60	φ4	0.07
202-006-3A400-001	5/8" - 11UNC	35	φ4	0.07
202-006-3A640-000	1" - 8UNC	60	φ4	0.20

► FOR Multi-lock collet chucks.



SHELL MILL SCREW

SPECIALLY USED FOR CAT INCH FINE THREAD

華司螺絲 [專用於CAT英制細牙平面銑刀柄]

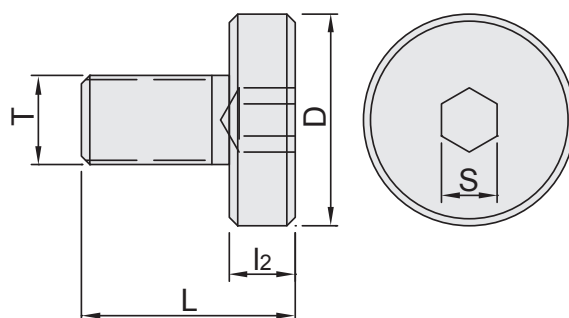

STANDARD TYPE

MODEL NO.	TYPE	D	L	l ₂	T	S	WEIGHT (KGS)
5299-035-A16-A32-00	FMA screw 1/2"	15.875	21.336	8.636	1/4" - 28UNF	3/16"	0.01
201-021-4A160-000	FMA screw 1/2"	15.875	46.736	8.636	1/4" - 28UNF	3/16"	0.04
201-021-4A240-002	FMA screw 3/4"	22.225	34.798	9.398	3/8" - 24UNF	1/4"	0.04
201-021-4A240-001	FMA screw 3/4"	22.225	47.498	9.398	3/8" - 24UNF	1/4"	0.06
201-021-4A320-000	FMA screw 1"	30.163	34.798	9.398	1/2" - 20UNF	5/16"	0.06
201-021-4A320-001	FMA screw 1"	30.163	53.848	9.398	1/2" - 20UNF	5/16"	0.08
201-021-4A400-000	FMA screw 1-1/4"	38.1	44.45	12.7	5/8" - 18UNF	5/16"	0.16
201-021-4A400-001	FMA screw 1-1/4"	38.1	57.15	12.7	5/8" - 18UNF	5/16"	0.20
201-021-4A480-000	FMA screw 1-1/2"	47.625	44.45	12.7	3/4" - 16UNF	3/8"	0.24
201-021-4A480-001	FMA screw 1-1/2"	47.625	57.15	12.7	3/4" - 16UNF	3/8"	0.27
201-021-4A640-000	FMA screw 2"	63.5	50.8	12.7	1" - 14UNF	1/2"	0.42
201-021-4A640-002	FMA screw 2"	63.5	63.5	12.7	1" - 14UNF	1/2"	0.60
201-021-4A640-001	FMA screw 2-1/2"	79.375	57.15	12.7	1" - 14UNF	1/2"	0.60

COOLANT TYPE

5299-045-A16-A32-00	FMA screw 1/2"	15.875	21.336	8.636	1/4" - 28UNF	3/16"	0.01
5299-045-A16-A80-00	FMA screw 1/2"	15.875	46.736	8.636	1/4" - 28UNF	3/16"	0.04
5299-045-A24-A64-00	FMA screw 3/4"	22.225	34.798	9.398	3/8" - 24UNF	1/4"	0.04
5299-045-A24-A80-00	FMA screw 3/4"	22.225	47.498	9.398	3/8" - 24UNF	1/4"	0.06
5299-045-A24-A64-00	FMA screw 1"	30.163	34.798	9.398	1/2" - 20UNF	5/16"	0.06
5299-045-A32-A88-00	FMA screw 1"	30.163	53.848	9.398	1/2" - 20UNF	5/16"	0.08
5299-045-A40-A72-00	FMA screw 1-1/4"	38.1	44.45	12.7	5/8" - 18UNF	5/16"	0.16
5299-045-A40-A88-00	FMA screw 1-1/4"	38.1	57.15	12.7	5/8" - 18UNF	5/16"	0.20
5299-045-A48-A72-00	FMA screw 1-1/2"	47.625	44.45	12.7	3/4" - 16UNF	3/8"	0.24
5299-045-A48-A88-00	FMA screw 1-1/2"	47.625	57.15	12.7	3/4" - 16UNF	3/8"	0.27
5299-045-A64-A80-00	FMA screw 2"	63.5	50.8	12.7	1" - 14UNF	1/2"	0.42
5299-045-A64-A96-00	FMA screw 2"	63.5	63.5	12.7	1" - 14UNF	1/2"	0.60
5299-045-A64-A88-00	FMA screw 2-1/2"	79.375	57.15	12.7	1" - 14UNF	1/2"	0.60

Features:

- For face mill arbors.



SCREW WITH COOLANT FLUTE

SPECIALLY USED FOR ALL TAPERS OF FACE MILL ARBORS EXCEPT CAT

給水槽螺絲 [專用於CAT以外所有錐度之平面銑刀柄]

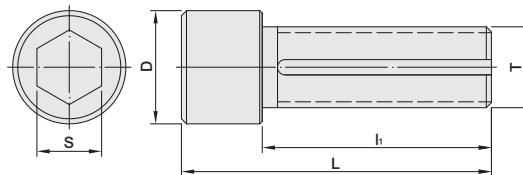
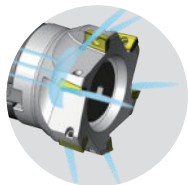

MODEL NO.	TYPE	L	l ₁	D	S	T	SUITABLE TOOL HOLDER	WEIGHT (KGS)
5299-045-M8-030-00	M8 x 1.25P - 30	38	30	13	6	M8 x 1.25P	FMB16	0.02
5299-045-M10-035-00	M10 x 1.5P - 35	45	35	16	8	M10 x 1.5P	FMB 22	0.02
5299-045-M12-030-00	M12 x 1.75P - 30	42	30	18	10	M12 x 1.75P	FMB 27 / 32	0.04
5299-045-M12-035-00	M12 x 1.75P - 35	47	35	18	10	M12 x 1.75P	FMB 27 / 32	0.04
5299-045-M16-050-00	M16 x 2.0P - 50	66	50	24	14	M16 x 2.0P	FMB 40	0.10
5299-045-A32-038-00	1/2" - 12W - 38.1	50.8	38.1	19.05	9.525	1/2" - 12W	FMA 25.4 / 31.75	0.04
5299-045-A40-038-00	5/8" - 11W - 38.1	53.975	38.1	22.225	14	5/8" - 11W	FMA 38.1	0.08
5299-045-A40-045-00	5/8" - 11W - 45	60.875	45	22.225	14	5/8" - 11W	FMA 50.8	0.10

Features:

- For face mill arbors to achieve coolant through cutters.

END MILL HOLDER REPLACEMENT LOCK SCREW

側固螺絲



MODEL NO.	TYPE	LENGTH	MODEL NO.	TYPE	LENGTH
202-021-10120-002	M12 x 1.75P	15	202-021-4A160-000	1/4-28UNF	5/16"
202-021-10140-001	M14 x 2.0P	16	202-021-4A200-000	5/16-24UNF	5/16"
202-021-10160-003	M16 x 2.0P	16	202-021-4A240-000	3/8-24UNF	3/8"
202-021-20180-001	M18 x 2.0P	20	202-021-4A280-000	7/16-20UNF	3/8"
202-021-20200-002	M20 x 2.0P	20	202-021-4A320-000	1/2-20UNF	7/16"
202-021-20240-000	M24 x 2.0P	25	202-021-4A400-000	5/8-18UNF	1/2"
202-021-3B320-002	6# - 32UNC	5/16"	202-021-4A480-000	3/4-16UNF	5/8"
202-021-3B320-001	8# - 32UNC	1/4"	202-021-4A640-000	1-14UNF	7/8"



SCREW FOR SBL & SBLC COLLET CHUCK

後拉螺絲

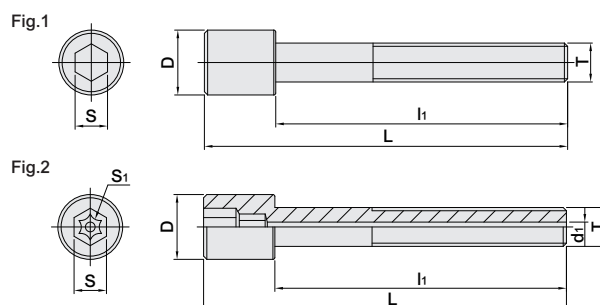

MODEL NO.	TYPE	L	l ₁	D	d ₁	S	S ₁	T	Fig
201-017-10060-000	M6 x 1.0P - 15	26	15	10	-	5	-	M6	1
201-017-10060-001	M6 x 1.0P - 20	31	20	10	-	5	-	M6	1
201-017-10060-002	M6 x 1.0P - 25	36	25	10	-	5	-	M6	1
201-017-10060-003	M6 x 1.0P - 30	41	30	10	-	5	-	M6	1
201-017-10060-004	M6 x 1.0P - 35	46	35	10	-	5	-	M6	1
201-017-10060-005	M6 x 1.0P - 40	51	40	10	-	5	-	M6	1
201-017-10060-007	M6 x 1.0P - 45	56	45	10	-	5	-	M6	1
201-017-10060-008	M6 x 1.0P - 50	61	50	10	-	5	-	M6	1
201-017-10060-009	M6 x 1.0P - 55	66	55	10	-	5	-	M6	1
201-017-10060-010	M6 x 1.0P - 60	71	60	10	-	5	-	M6	1
201-017-10060-011	M6 x 1.0P - 65	76	65	10	-	5	-	M6	1
201-017-10060-012	M6 x 1.0P - 70	81	70	10	-	5	-	M6	1
201-017-10060-013	M6 x 1.0P - 75	86	75	10	-	5	-	M6	1
5299-065-M6-100-00	M6 x 1.0P - 100	111	100	10	-	5	-	M6	1
5299-065-M6-130-00	M6 x 1.0P - 130	141	130	10	-	5	-	M6	1
5299-068-M6-015-00	M6 x 1.0P - 15	26	15	10	1.5	5	T20	M6	2
5299-068-M6-020-00	M6 x 1.0P - 20	31	20	10	1.5	5	T20	M6	2
5299-068-M6-025-00	M6 x 1.0P - 25	36	25	10	1.5	5	T20	M6	2
5299-068-M6-035-00	M6 x 1.0P - 35	46	35	10	1.5	5	T20	M6	2
5299-068-M6-040-00	M6 x 1.0P - 40	51	40	10	1.5	5	T20	M6	2
5299-068-M6-045-00	M6 x 1.0P - 45	56	45	10	1.5	5	T20	M6	2
5299-068-M6-050-00	M6 x 1.0P - 50	61	50	10	1.5	5	T20	M6	2
5299-068-M6-055-00	M6 x 1.0P - 55	66	55	10	1.5	5	T20	M6	2
5299-068-M6-060-00	M6 x 1.0P - 60	71	60	10	1.5	5	T20	M6	2
5299-068-M6-065-00	M6 x 1.0P - 65	76	65	10	1.5	5	T20	M6	2
5299-068-M6-070-00	M6 x 1.0P - 70	81	70	10	1.5	5	T20	M6	2
5299-068-M6-080-00	M6 x 1.0P - 80	91	80	10	1.5	5	T20	M6	2
5299-068-M6-085-00	M6 x 1.0P - 85	96	85	10	1.5	5	T20	M6	2
5299-068-M6-100-00	M6 x 1.0P - 100	111	100	10	1.5	5	T20	M6	2
5299-068-M6-130-00	M6 x 1.0P - 130	141	130	10	1.5	5	T20	M6	2
201-017-10100-000	M10 x 1.5P - 20	30	20	13.8	-	6	-	M10	1
201-017-10100-001	M10 x 1.5P - 25	35	25	13.8	-	6	-	M10	1
201-017-10100-002	M10 x 1.5P - 35	45	35	13.8	-	6	-	M10	1
201-017-10100-003	M10 x 1.5P - 55	65	55	13.8	-	6	-	M10	1
201-019-10100-000	M10 x 1.5P - 20	30	20	13.8	3	6	T20	M10	2
201-019-10100-005	M10 x 1.5P - 25	35	25	13.8	3	6	T20	M10	2
201-019-10100-002	M10 x 1.5P - 35	45	35	13.8	3	6	T20	M10	2
201-019-10100-003	M10 x 1.5P - 55	65	55	13.8	3	6	T20	M10	2
201-017-10120-003	M12 x 1.75P - 30	42	30	13.8	-	8	-	M12	1
201-017-10120-004	M12 x 1.75P - 52	64	52	13.8	-	8	-	M12	1
201-017-10120-005	M12 x 1.75P - 102	114	102	13.8	-	8	-	M12	1
201-017-10120-000	M12 x 1.75P - 30	42	30	13.8	-	6	-	M12	1
201-017-10120-001	M12 x 1.75P - 52	64	52	13.8	-	6	-	M12	1
201-017-10120-002	M12 x 1.75P - 102	114	102	13.8	-	6	-	M12	1
5299-068-M12-030-00	M12 x 1.75P - 30	42	30	13.8	2	8	T20	M12	2
5299-068-M12-052-00	M12 x 1.75P - 52	64	52	13.8	2	8	T20	M12	2
5299-068-M12-030-01	M12 x 1.75P - 30	42	30	13.8	2	6	T20	M12	2
5299-068-M12-052-01	M12 x 1.75P - 52	64	52	13.8	2	6	T20	M12	2

PARTS FOR SMG NON-PULLOUT MILLING CHUCK

背隙消除螺絲 / BACKLASH REMOVE SCREW



MODEL NO.	TYPE
5296-46-025-08-00	M16 x 1.5P - 25

定位片 / POSITIONING CHIP



MODEL NO.	TYPE
5296-46-025-07-00	EM - 25
5296-46-032-07-00	EM - 32

Features:

- ▶ Can purchase backlash remove screw and positioning chip separately.



Z AXIAL PRESET GAUGE

ZOP - 50 光電式 Z軸設定器

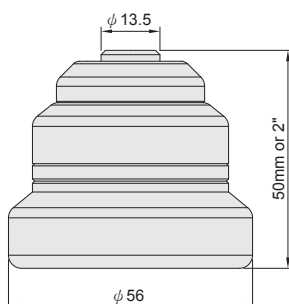

OPTICAL TYPE

MODEL NO.	TYPE	WEIGHT (KGS)
5352-870-050	ZOP - 50	0.5

Features:

- ▶ With magnetic base.
- ▶ The red lamp will be on when being touched.
- ▶ Accuracy 0.005mm.
- ▶ Used for vertical and horizontal machining centers.

ZSI - 50 Z軸設定器 無磁性 外插量錶式

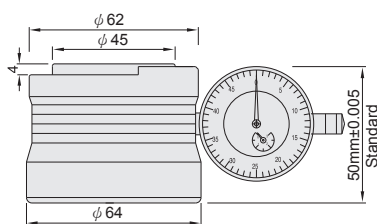

SIMPLE TYPE

MODEL NO.	TYPE	WEIGHT (KGS)
5352-871-050	ZSI - 50	1.35

Features:

- ▶ Without magnetic base.
- ▶ Accuracy 0.005mm.

ZDS - 50J Z軸設定器 有磁性 內藏量錶式

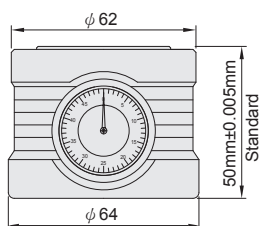

MAGNETIC TYPE

MODEL NO.	TYPE	WEIGHT (KGS)
5352-872-050	ZDS - 50J	1.35

Features:

- ▶ With magnetic base.
- ▶ Accuracy 0.005mm.

ZDI - 50 量錶式 Z軸設定器

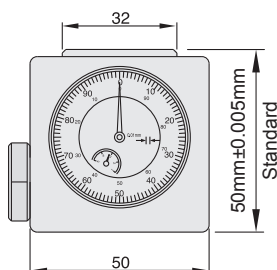

INDICATOR TYPE

MODEL NO.	TYPE	WEIGHT (KGS)
5352-873-050	ZDI - 50	1.01

Features:

- ▶ With magnetic base.
- ▶ Accuracy 0.005mm.



ZDI-100 Z AXIAL PRESET GAUGE

INDICATOR TYPE

ZDI - 100 量錶式 Z軸設定器

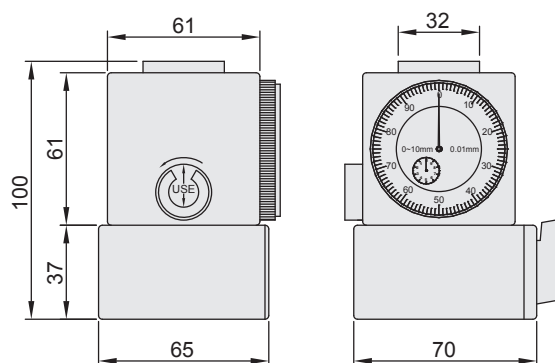

INDICATOR TYPE

MODEL NO.	TYPE	WEIGHT (KGS)
5352-873-100	ZDI - 100	2.24

Features:

- ▶ Height: 100mm.
- ▶ With magnetic design. The magnetism can be turned on or turned off by adjusting the switch.
- ▶ Adjust the dial indicator to "zero".
- ▶ Dial indicator for each increment: 0.01mm.
- ▶ Magnetic capacity: 80kg.

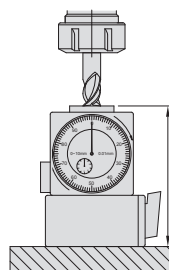

- ▶ When the tool touches the top of the gauge and both dial indicators read zero, the cutter distance is now 100mm above the workpiece.

ZSW-100 Z AXIAL PRESET GAUGE

MAGNETIC TYPE

ZSW - 100 Z軸設定器 有磁性內藏量錶式

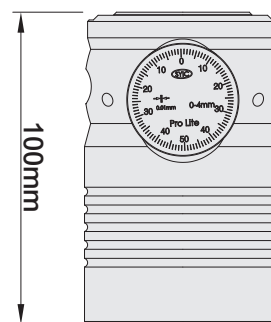

MAGNETIC TYPE

MODEL NO.	TYPE	WEIGHT (KGS)
5352-874-100	ZSW - 100	1.9

- ▶ Put the whole unit on the work piece. When cutter touched the probe face, please feed slowly until the needle shows "0." The cutter distance is now 100mm above the work piece.

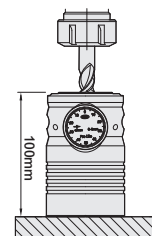

FIXED BLOCK

FOR OIL HOLE HOLDER

油路刀把用定位塊

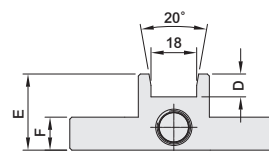
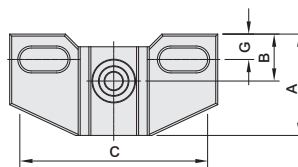
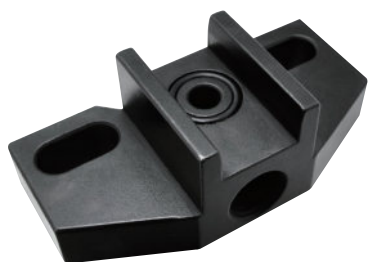

MODEL NO.	TYPE	A	B	C	D	E	F	G	WEIGHT (KGS)
5350-371-003	SFB - 3	40	18.5	45~65	9	30	13	10	0.30

TOOL HOLDER LOCKING DEVICE

FOR BT & HSK TOOL HOLDERS

鎖刀座



MODEL NO.	TYPE	02 FIXED BLOCK		08 ADAPTER		09 ADAPTER	
		MODEL NO.	TYPE	MODEL NO.	TYPE	MODEL NO.	TYPE
5301-021-010-00	BT30	301-021-011-02	BT40	301-021-010-08	AD50	301-021-010-09	BT30
5301-021-011-00	BT40	301-021-011-02	BT40	301-021-010-08	AD50	301-021-011-09	BT40
5301-021-012-00	BT50	301-021-012-02	BT50	301-021-012-08	BT50	-	-
5301-021-073-00	HSK63A	301-021-073-02	HSK63A	301-021-010-08	AD50	301-021-073-09	HSK63A
5301-021-075-00	HSK100A	301-021-075-02	HSK100A	301-021-075-08	HSK100A	-	-

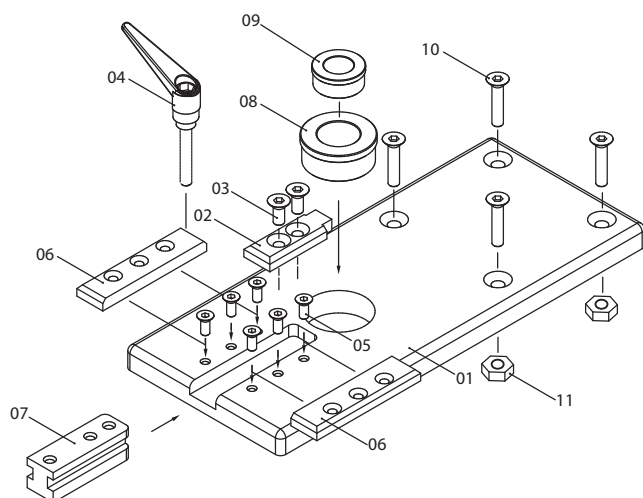

NO.	NAME OF EACH PART
01	FIXED PLATE
02	FIXED BLOCK
03	SCREW
04	FIXED HANDLE
05	SCREW
06	FIXED SPACER
07	SLIDING BLOCK
08	ADAPTER
09	ADAPTER
10	SCREW
11	NUT

Features:

- ▶ AD50 commonly-used 08 ADAPTER can be changed into BT30, BT40 and HSK63A all together by matching 09 ADAPTERS.



ASSEMBLY DEVICE

鎖刀座



TW PAT NO. M614470
 JP PAT NO. 3233841
 DE PAT NO. 202021103718
 CN PAT NO. ZL201922325128.6
 CN PAT NO. ZL202120822487.7
 US PAT NO. 11440150

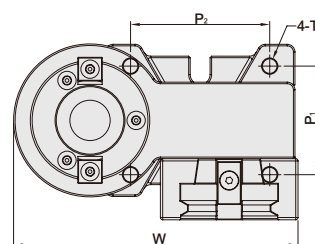
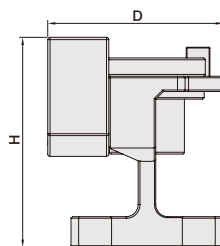

TWO - WAY TYPE OF 7/24 TAPER SERIES 立臥式

MODEL NO.	TYPE	COMPATIBLE TOOLING	D	H	W	P ₁	P ₂	T	WEIGHT (KGS)
5300-020-010-02	AD - BT30 - HV	BT / SBT30	110	137.5	186	71	91	M8	4.36
5300-020-011-02	AD - BT40 - HV	BT / SBT40	115	137.5	186	71	91	M8	4.38
5300-020-012-02	AD - BT50 - HV	BT / SBT50	152.5	192.5	242	112	116	M10	10.90
5300-020-031-02	AD - CAT . DAT40 - HV	CAT / SCAT / DAT / SDAT40	115	137.5	186	71	91	M8	4.39
5300-020-032-02	AD - CAT . DAT50 - HV	CAT / SCAT / DAT / SDAT50	152.5	192.5	242	112	116	M10	10.96



TW PAT NO. M614470
 TW PAT NO. M614781
 JP PAT NO. 3233841
 DE PAT NO. 202021103718
 CN PAT NO. ZL201922325128.6
 CN PAT NO. ZL202120822487.7
 CN PAT NO. ZL202120822431.1
 US PAT NO. 11440150

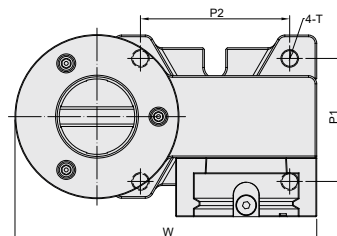
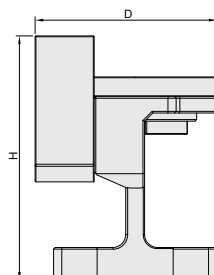

TWO - WAY TYPE OF HSK-A SERIES 立臥式

MODEL NO.	TYPE	COMPATIBLE TOOLING	D	H	W	P ₁	P ₂	T	WEIGHT (KGS)
5300-020-070-02	AD - HSK32A - HV	HSK32A	100	130.5	184	71	91	M8	4.82
5300-020-071-02	AD - HSK40A - HV	HSK40A	105	138.5	184	71	91	M8	5.25
5300-020-072-02	AD - HSK50A - HV	HSK50A	111	142.5	184	71	91	M8	5.47
5300-020-073-04	AD - HSK63A - HV	HSK63A / T	111	149	184	71	91	M8	5.54
5300-020-074-02	AD - HSK80A - HV	HSK80A	137.5	207	242	112	116	M10	12.5
5300-020-075-02	AD - HSK100A - HV	HSK100A	139.5	211.5	242	112	116	M10	12.3



Quick Positioning Design for HSK-A Assembly Device

- ▶ Because the sizes of two drive slots of HSK-A tool holders are unequal, this design facilitates end users to be able to quickly place HSK-A tool holders on HSK-A assembly device in a correct way.



ASSEMBLY DEVICE

鎖刀座

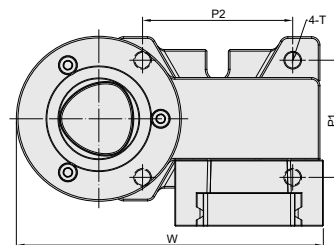
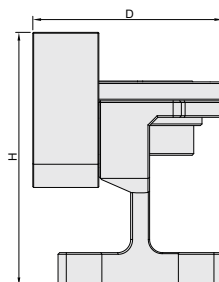

TW PAT NO. M638078
DE PAT NO. 202023100129

**TWO-WAY TYPE of PSC SERIES 立臥式**

MODEL NO.	TYPE	COMPATIBLE TOOLING	D	H	W	P1	P2	T	WEIGHT (KGS)
5300-020-140-02	AD-PSC32-HV	PSC32	105	134.5	186	71	91	M8	5.63
5300-020-141-02	AD-PSC40-HV	PSC40	110	140.5	186	71	91	M8	5.90
5300-020-142-02	AD-PSC50-HV	PSC50	110	144.5	186	71	91	M8	5.83
5300-020-143-02	AD-PSC63-HV	PSC63	115	153.5	186	71	91	M8	5.20
5300-020-144-02	AD-PSC80-HV	PSC80	139.5	201.5	242	112	116	M12	13.3
5300-020-146-02	AD-PSC100-HV	PSC100	146.5	227.5	242	112	116	M12	13.4

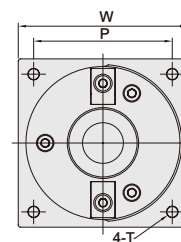
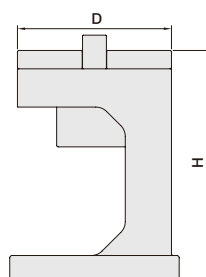

TW PAT NO. M614470
JP PAT NO. 3233841
DE PAT NO. 202021103718
CN PAT NO. ZL201922325128.6
CN PAT NO. ZL202120822487.7
US PAT NO. 11440150

VERTICAL TYPE 立式

MODEL NO.	TYPE	COMPATIBLE TOOLING	D	H	W	P	T	WEIGHT (KGS)
5300-021-010-02	AD - #30 - V	#30	100	150	110	90	M6	3.51
5300-021-011-02	AD - #40 - V	#40	100	150	110	90	M6	2.85
5300-021-012-02	AD - #50 - V	#50	115	190	157	130	M8	8.21

ASSEMBLY DEVICE

鎖刀座

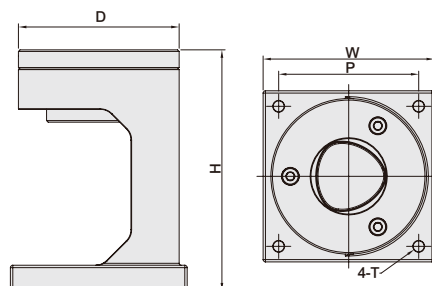

TW PAT NO. M614781
CN PAT NO. ZL202120822431.1

VERTICAL TYPE 立式

MODEL NO.	TYPE	COMPATIBLE TOOLING	D	H	W	P	T	WEIGHT (KGS)
5300-021-070-02	AD - HSK32A - V	HSK32A	100	150	110	90	M6	3.45
5300-021-071-02	AD - HSK40A - V	HSK40A	100	150	110	90	M6	3.59
5300-021-072-02	AD - HSK50A - V	HSK50A	100	150	110	90	M6	3.65
5300-021-073-02	AD - HSK63A - V	HSK63A / T	100	150	110	90	M6	3.29
5300-021-074-02	AD - HSK80A - V	HSK80A	128	191	160	130	M8	8.50
5300-021-075-02	AD - HSK100A - V	HSK100A	128	195	160	130	M8	7.53
5300-021-140-02	AD - PSC32 - V	PSC32	100	150	110	90	M6	4.01
5300-021-141-02	AD - PSC40 - V	PSC40	100	150	110	90	M6	3.85
5300-021-142-02	AD - PSC50 - V	PSC50	100	150	110	90	M6	3.81
5300-021-143-02	AD - PSC63 - V	PSC63	100	150	110	90	M6	3.32
5300-021-144-02	AD - PSC80 - V	PSC80	128	195	160	130	M8	9.05
5300-021-146-02	AD - PSC100 - V	PSC100	128	195	160	130	M8	8.51

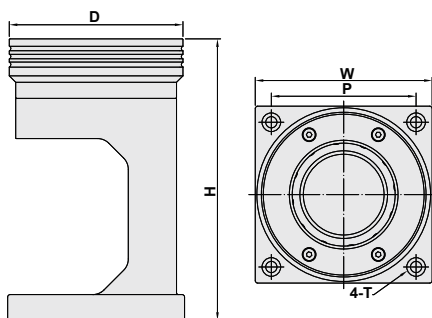

TW PAT NO. M621995
JP PAT NO. 3236278
DE PAT NO. 2021003893
CN PAT NO. ZL202122878903.8

ROLLER BEARING TYPE 軸承式

MODEL NO.	TYPE	COMPATIBLE TOOLING	D	H	W	P	T	WEIGHT (KGS)
5300-023-025-02	AD - Ø25 - B	HSK25A.E	100	164	110	90	M6	4.01
5300-023-032-02	AD - Ø32 - B	HSK32A.E / PSC32	100	175	110	90	M6	4.61
5300-023-040-02	AD - Ø40 - B	HSK40A.E.F / PSC40	100	175	110	90	M6	4.99
5300-023-050-02	AD - Ø50 - B	HSK50A.E.F / PSC50	108	175	110	90	M6	5.62
5300-023-063-02	AD - Ø63 - B	HSK63A.E.F / PSC63	108	175	110	90	M6	4.13
5300-023-080-02	AD - Ø80 - B	HSK80A.F / PSC80	150	230	160	130	M8	11.3
5300-023-100-02	AD - Ø100 - B	HSK100A / PSC100	150	230	160	130	M8	10.8



SPINDLE TAPER WIPER

主軸清潔棒



MODEL NO.	TYPE	WEIGHT (KGS)
408-005-000	#30	0.03
408-005-001	#40	0.04
408-005-002	#50	0.07

Features:

- ▶ For cleaning the oil or particles from machine spindle.
- ▶ Material: non-woven fabric.



MODEL NO.	TYPE	WEIGHT (KGS)
408-005-003	#30B	0.03
408-005-004	#40B	0.04
408-005-005	#50B	0.07

Features:

- ▶ For cleaning the oil or particles from machine spindle.
- ▶ Material: wool, which can prevent static electricity when cleaning the spindle taper and has better use life and cleaning effect.



MODEL NO.	TYPE	WEIGHT (KGS)
408-005-006	HSK40	0.08
408-005-007	HSK50A - 63F - 50E	0.06
408-005-008	HSK63A - 80F	0.08
408-005-009	HSK100	0.50

Features:

- ▶ For cleaning the oil or particles from machine spindle.
- ▶ Material: non-woven fabric.

ER COLLET WOODEN TRAY

ER筒夾木盤

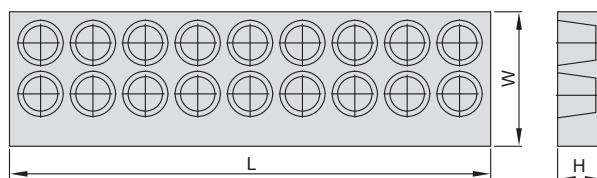
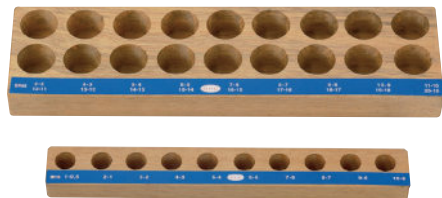

MODEL NO.	TYPE	L	W	H	Q'TY	WEIGHT (KGS)
211-010-000	ER 8	210	20	13	9	0.01
211-010-001	ER 11	210	20	13	13	0.01
211-010-002	ER 16	275	35	22	10	0.14
211-010-004	ER 20	275	35	22	12	0.12
211-010-005	ER 25	275	77	26	16	0.18
211-010-006	ER 32	340	90	30	18	0.48
211-010-008	ER 40	265	210	38	24	0.76
211-010-010	ER 50	235	210	37	12	0.64

BOX

包裝盒



MODEL NO.	TYPE	FULL PCS/SET	MATERIAL	SIZE	WEIGHT (KGS)
708-001-004-004	SLC6 / SLC12 / SLC20	6	Plastic	350 x 396 x 100	1.90
708-001-004-004	SKX6 / SKX10	6	Plastic	350 x 396 x 100	1.90
708-001-004-004	SKX13 / SKX16	6	Plastic	350 x 396 x 100	1.90
211-002-009	ER8 / ER 11	13	Wooden	223 x 75 x 95	0.20
211-002-010	ER16	10	Wooden	240 x 130 x 80	0.50
211-004-001	ER16 / ER20	10	Plastic	310 x 150 x 50	0.30
211-002-011	ER20	12	Wooden	290 x 140 x 80	0.50
211-002-012	ER25	15	Wooden	285 x 160 x 80	0.40
211-005-002	ER25	15	Plastic	320 x 240 x 100	0.90
211-002-014	ER32	18	Wooden	275 x 160 x 110	1.10
211-005-002	ER32	18	Plastic	320 x 240 x 100	0.90
211-002-017	ER40	23	Wooden	410 x 240 x 110	1.80
211-005-002	ER40	7	Plastic	320 x 240 x 100	0.90
211-002-018	ER50	17	Wooden	445 x 305 x 125	2.80
211-002-050	EOC 25	7	Wooden	300 x 165 x 90	1.00
211-002-051	EOC 25	15	Wooden	315 x 235 x 90	0.80
211-002-052	EOC 25	7 or 15	Wooden	305 x 280 x 110	1.80
211-004-005	EOC 25	7 or 15	Plastic	300 x 165 x 90	1.00
211-002-053	EOC 32	8	Wooden	305 x 240 x 110	1.90
211-002-054	EOC 32	16	Wooden	445 x 295 x 130	3.20
211-005-002	EOC 32	8 or 16	Plastic	320 x 240 x 100	0.90

Product information:

- ▶ Plastic boxes will not get broken easily and is easy to deliver.
- ▶ ISO#50 should be used with wooden box.
- ▶ The same type of box is suitable for the complete set or the required sizes of collets from customers.
- ▶ There is EVA inserted lining inside ER8 & ER11's wooden box.
- ▶ There's EVA inserted lining inside ER32 & ER40's plastic box.
- ▶ When ordering EOC25 wooden box, please indicate 7 pcs or 15 pcs needed.
- ▶ The plastic box for EOC25 7pcs and 5pcs is the same.
- ▶ EOC32 plastic case, empty inside but with a 16 hole of EVA insert lining, 8pcs or 16pcs are the same one.
- ▶ EOC25 NT50 or EOC32 NT50 must use wooden box.



MEMO

Blank lined area for writing a memo.



MEMO

15 horizontal grey bars for writing.

