

1-Needle,Overedging Industrial Sewing Machine

MO-3904-OE4

2-Needle,Overedging Industrial Sewing Machine

MO-3914-BE6

Safety Stitch Industrial Sewing Machine

MO-3916-DE4

PARTS LIST

29125408

No.0829-03

1. FRAME COMPONENTS(1)

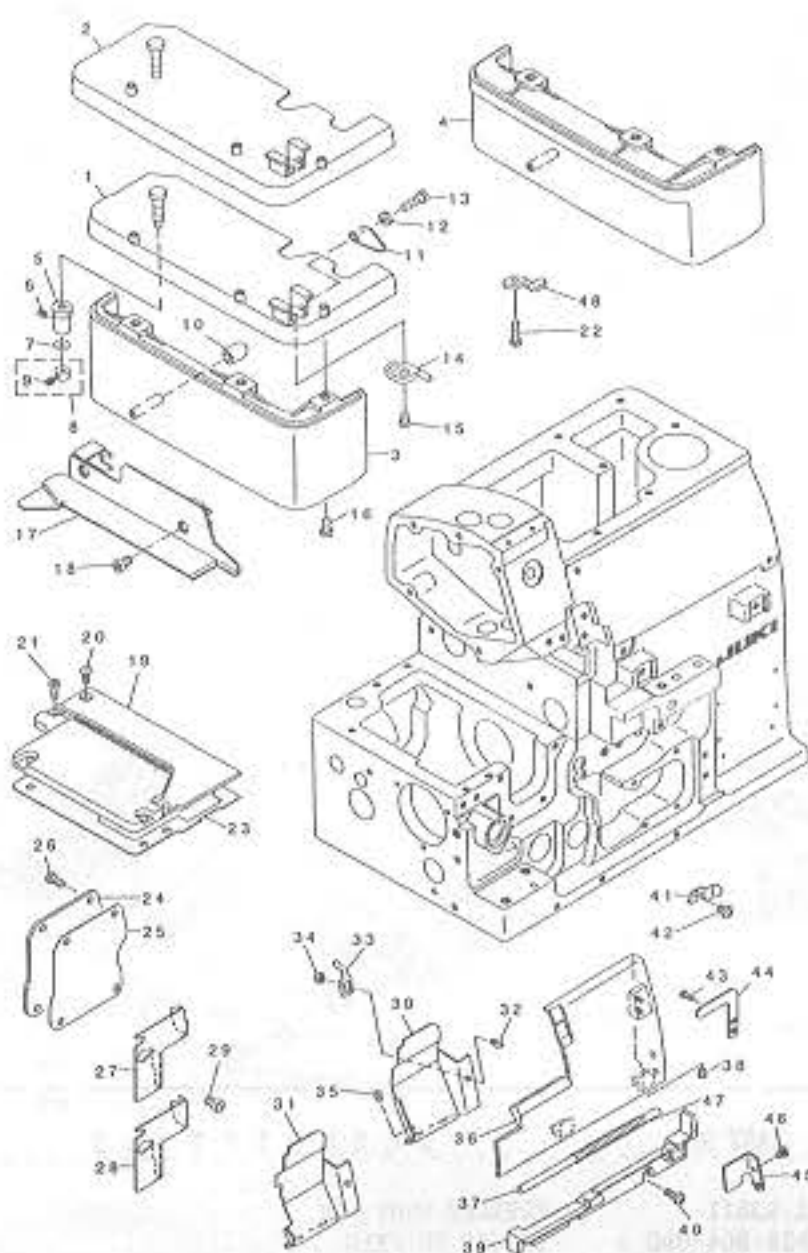

REF. NO	NOTE	PART NO.	DESCRIPTION	Qty
1		121-02752	CLOTH PLATE ASM.	1
2	#03	121-04550	CLOTH PLATE ASM.	1
3		119-49005	CLOTH BASE COVER	1
4	#03	119-49104	CLOTH BASE COVER	1
5		115-01301	ECCENTRIC BUSHING	1
6		SS-8110410-TP	SCREW 11/64-40 L= 3.5	1
7		WZ-0420350-KP	DISC SPRING	1
8		CS-040051A-SD	THRUST HOLDER D=4 W=5	1
9		SS-8080322-TP	SCREW 1/8-44 L=3.2	(1)
10		118-02204	RUBBER PLUG	1
11		118-02402	SPRING	1
12		NS-6110420-SP	NUT 11/64-40	1
13		SS-6111440-SP	SCREW 11/64-40 L=14.0	1
14		121-03305	STOPPER	1
15		SS-7110710-SP	SCREW 11/64-40 L=7	2
16		SS-4091015-SP	SCREW 9/64-40 L=10	2
17		121-01655	CLOTH PLATE SIDE COVER ASM.	1
18		SS-4120615-SP	SCREW 3/16-28 L=6	2
19		122-50510	FEED MECHANISM COVER	1
20		SM-1040801-SC	SCREW M4X0.7 L=8	1
21		SM-4040855-SP	SCREW	4
22		SS-7091410-SP	SCREW 9/64-40 L=13.5	1
23		122-50601	GASKET	1
24		119-51100	COVER	1
25		118-04309	GASKET	1
26		SM-4040855-SP	SCREW	4
27	#01	121-02307	CHIP GUARD COVER, LEFT	1
28	#02	121-02406	CHIP GUARD COVER, LEFT	1
29		SS-7110510-SP	SCREW 11/64-40 L=5	2
30	#01	121-47203	CLOTH WASTE COVER	1
31	#02	121-47807	CLOTH WASTE COVER	1
32		SS-2090520-SL	SCREW 9/64-40 L=5	1
33		121-01515	CLOTH WASTE COVER STOPPER	1
34		NS-6090310-SN	NUT 9/64-40	1
35		SS-3090610-SP	SCREW 9/64-40 L=6	2
36		121-01309	LOOPER COVER	1
37		118-03004	LOOPER COVER HINGE PIN	1
38		SS-8110410-TP	SCREW 11/64-40 L= 3.5	1
39		121-01200	LOOPER COVER BRACKET	1
40		SM-4041055-SP	SCREW M4 L=10	3
41		121-03404	LOOPER COVER PRESSER SPRING	1
42		SM-4040655-SP	SCREW	1
43		SS-7090530-SP	SCREW 9/64-40 L= 4.5	1
44		121-03206	LOOPER COVER PRESSER PLATE	1
45		121-01408	GUIDE PLATE	1
46		SS-7090610-SP	SCREW 9/64-40 L=6	1
47		B1140-716-000	SPRING	1
48		121-03511	CLOTH PLATE SUPPORTER	1

NOTE

#01... FOR MO-3904, MO-3914

#02... FOR MO-3916

#03... FOR JHK(MO-3916)

2. FRAME COMPONENTS(2)

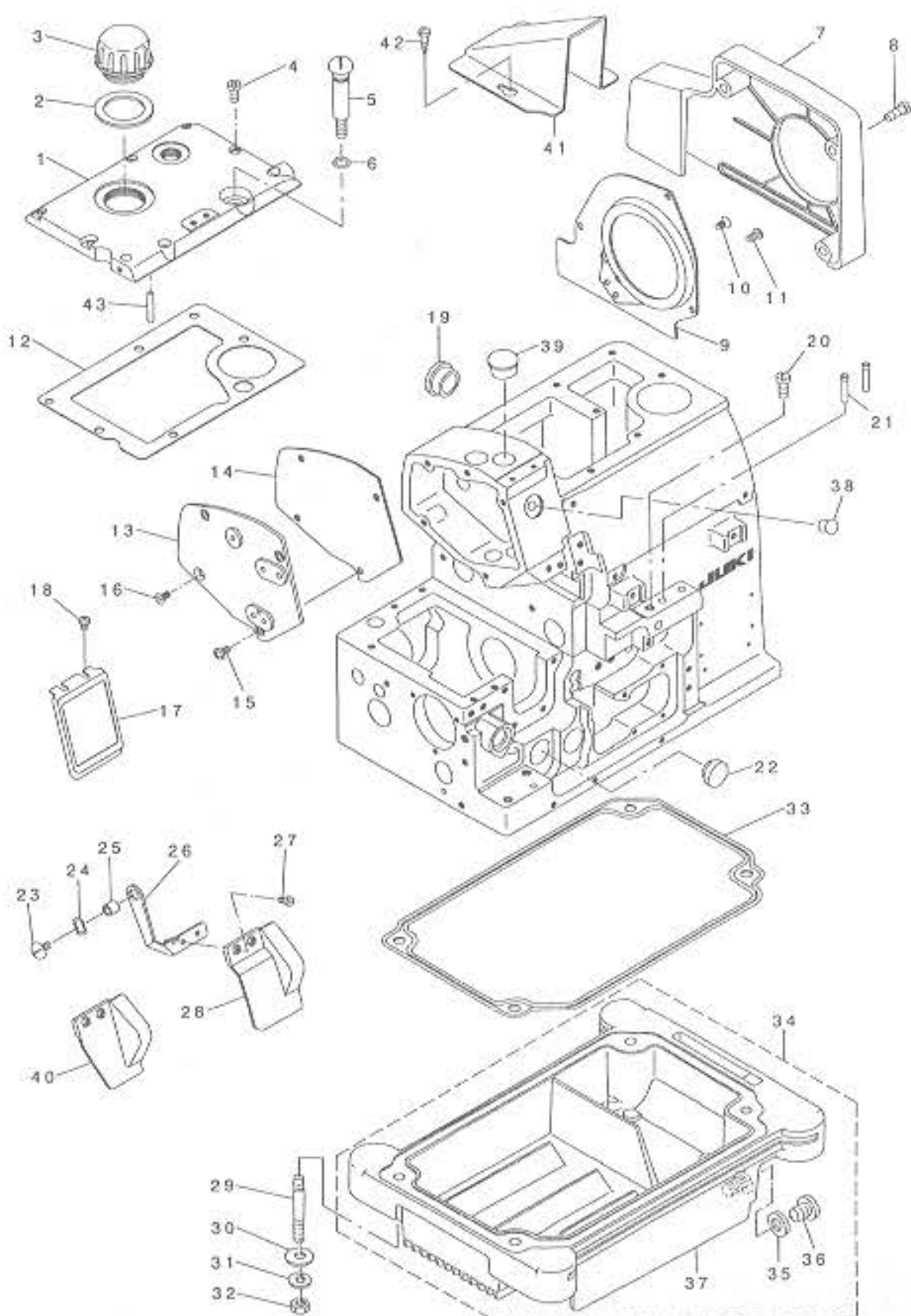

REF. NO	NOTE	PART NO.	DESCRIPTION	Qty
1		121-00400	UPPER COVER	1
2		115-00808	GASKET	1
3		121-00608	OIL CAP	1
4		SM-4051055-SP	SCREW	6
5		121-00806	OIL DRAIN SCREW	1
6		RO-0781901-00	RUBBER RING	1
7		121-01903	BELT COVER	1
8		SS-4151215-SP	SCREW 15/64-28 L=12	3
9		121-01804	COOLING FAN PLATE	1
10		SM-1040801-SC	SCREW M4X0.7 L=8	1
11		SM-4040855-SP	SCREW	2
12		121-00509	UPPER COVER GASKET	1
13		122-50205	SIDE COVER	1
14		121-00301	SIDE COVER GASKET	1
15		SM-4040855-SP	SCREW	3
16		SM-1040801-SC	SCREW M4X0.7 L=8	1
17		121-02661	BRAND LABEL ASM.	1
18		SM-4040601-SC	SCREW M4X0.7 L=6	2
19		TA-2050805-R0	RUBBER PLUG	1
20		SS-9151210-TP	SCREW 15/64-28 L=11.8	1
21		118-05207	THREAD GUIDE, LARGE	2
22	#01	TA-1871602-R0	RUBBER PLUG	1
23		SS-5110710-SP	SCREW 11/64-40 L=7	1
24		WZ-0850302-K0	WAVED WASHER 8.5X12.5X0.3	1
25		B3013-141-H0A	WASHER	1
26		121-02000	SAFETY PLATE BRACKET	1
27		SS-7090611-SL	SCREW 9/64-40 L=6.1	2
28	#02	121-02109	SAFETY PLATE	1
29		115-03703	SCREW STUD	4
30		WP-0751576-SD	WASHER 7.5X19X1.5	4
31		WS-0822010-KP	SPRING WASHER 8.2X15X2	4
32		NS-6680410-SP	NUT 9/32-28	4
33		115-03901	OIL RESERVOIR GASKET	1
34		115-03851	OIL RESERVOIR ASM.	1
35		RO-0742401-00	RUBBER RING	(1)
36		SM-0081001-SD	SCREW	(1)
37		115-03810	OIL RESERVOIR	1
38		TA-0750704-R0	RUBBER PLUG	1
39		TA-1701107-R0	RUBBER PLUG	1
40	#01	121-04907	SAFETY PLATE	1
41	#03	121-05201	BELT COVER B	1
42	#03	SK-3412000-SC	WOOD SCREW D=4.1 L=20	3
43		PS-0300132-KH	SPRING PIN 3X13	1

NOTE

#01...FOR M0-3904,M0-3914
 #02...FOR M0-3916
 #03...FOR JE

3. CRANKSHAFT COMPONENTS

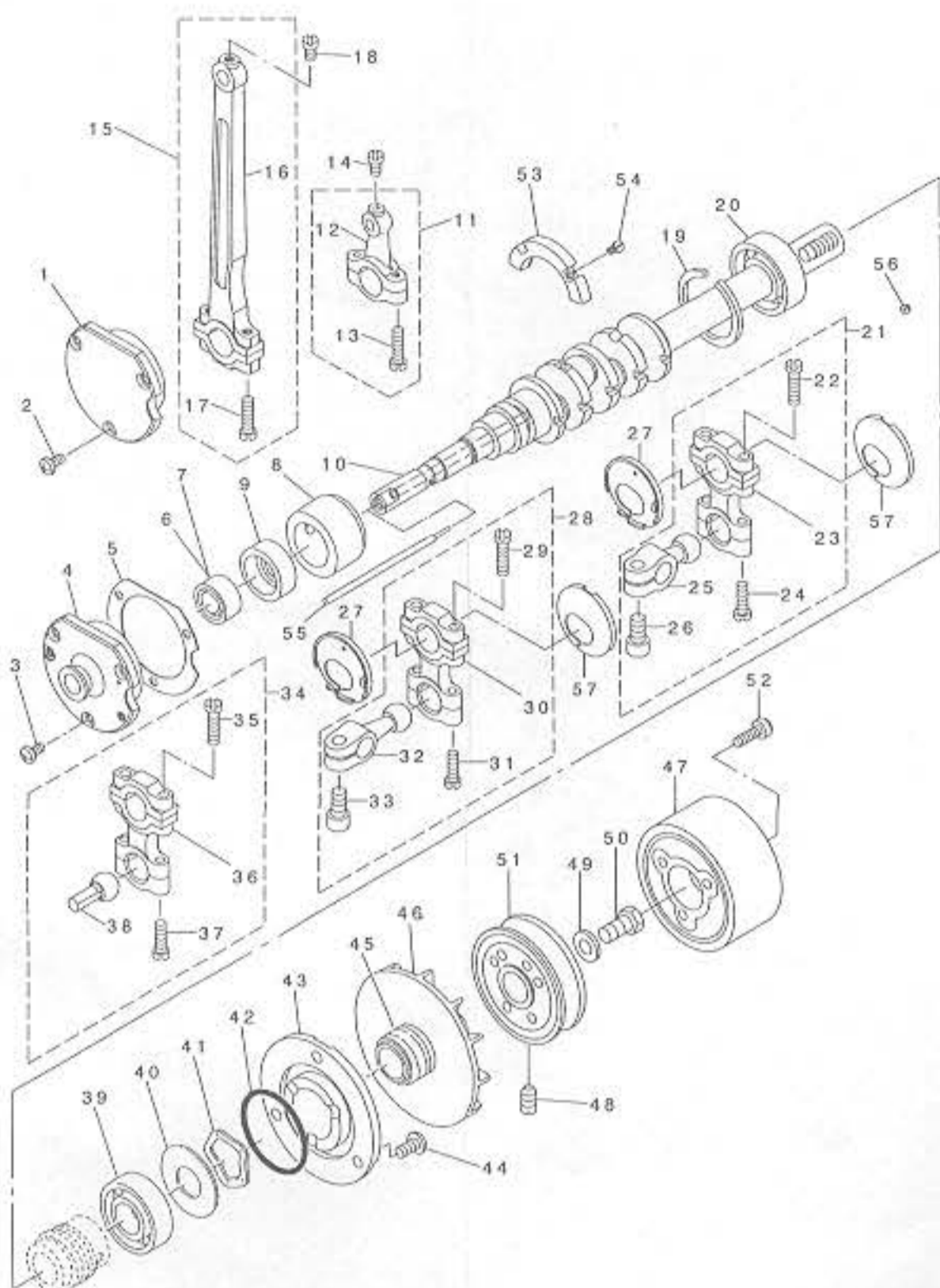

REF. NO	NOTE	PART NO.	DESCRIPTION	Qty
1	#01	121-08213	CRANKSHAFT BUSHING D	1
2	#01	SM-4040855-SP	SCREW	3
3	#02	SM-4040855-SP	SCREW	3
4	#02	121-08304	CRANKSHAFT BUSHING D	1
5		121-08403	GASKET	1
6	#01	B1215-804-000	BALL BEARING D	1
7	#02	SB-1100003-00	BALL BEARING	1
8		121-08007	CRANKSHAFT BUSHING C	1
9	#01	116-50900	RUBBER CAP	1
10		121-07108	CRANKSHAFT	1
11		121-32155	KNIFE DRIVING ROD ASM.	1
12		121-32106	KNIFE DRIVING ROD	(1)
13		SS-7111810-TP	SCREW 11/64-40 L=18	(2)
14		SS-7110840-SP	SCREW 11/64-40 L=7.8	1
15		121-09153	CONNECTING ROD ASM.	1
16		121-09104	CONNECTING ROD	(1)
17		SS-7111810-TP	SCREW 11/64-40 L=18	(2)
18		SS-7110840-SP	SCREW 11/64-40 L=7.8	1
19		B1212-704-000	BEARING RETAINER	1
20		B1211-804-000	BALL BEARING B	1
21		121-22362	UPPER LOOPER ROD ASM.	1
22		SS-7111810-TP	SCREW 11/64-40 L=18	(2)
23		121-22107	LOOPER DRIVING ROD	(1)
24		SS-7111410-TP	SCREW 11/64-40 L=14	(2)
25		121-22313	UPPER LOOPER ARM	(1)
26		SM-6061202-TP	SCREW M6 L=12	(1)
27		121-24400	STOPPER (L)	2
28	#01	121-23360	LOWER LOOPER ROD ASM., A	1
29		SM-6061202-TP	SCREW 11/64-40 L=18	(2)
30		121-22107	LOOPER DRIVING ROD	(1)
31		SS-7111410-TP	SCREW 11/64-40 L=14	(2)
32		121-23311	LOWER LOOPER ROD A	(1)
33		SM-6061202-TP	SCREW M6 L=12	(1)
34	#02	121-20150	LOWER LOOPER ROD ASM., B	1
35		SS-7111810-TP	SCREW 11/64-40 L=18	(2)
36		121-22107	LOOPER DRIVING ROD	(1)
37		SS-7111410-TP	SCREW 11/64-40 L=14	(2)
38		121-20101	LOWER LOOPER ARM B	(1)
39		B1211-804-000	BALL BEARING B	1
40		115-10609	WASHER	1
41		WZ-2640310-KII	WAVED WASHER 26.4X33.9X3.5	1
42		RO-3473501-00	RUBBER RING	1
43		121-07702	THRUST HOLDER	1
44		SM-4051055-SP	SCREW	3
45		121-07801	OIL SHIELD	1
46		118-11601	COOLING FAN	1
47		121-07611	FLYWHEEL A	1
48		SS-8151150-SP	SCREW 15/64-28 L=10.5	2
49		WP-0764016-SP	WASHER	1
50		SS-9681610-TP	SCREW 9/32-28 L=16	1
51		119-56505	HANDWHEEL C	1
52		SS-7111410-SP	SCREW 11/64-40 L=14	3
53		121-07900	BALANCER	1
54		SS-4080620-TP	SCREW 1/8-44 L=6	2
55		121-08106	OIL ADJUSTING BAR	1
56		SS-5080212-TP	SCREW 1/8-44 L=2	5
57		121-24509	STOPPER (R)	2

NOTE

#01... FOR NO-3904, MO-3914

4. NEEDLE DRIVING SHAFT COMPONENTS

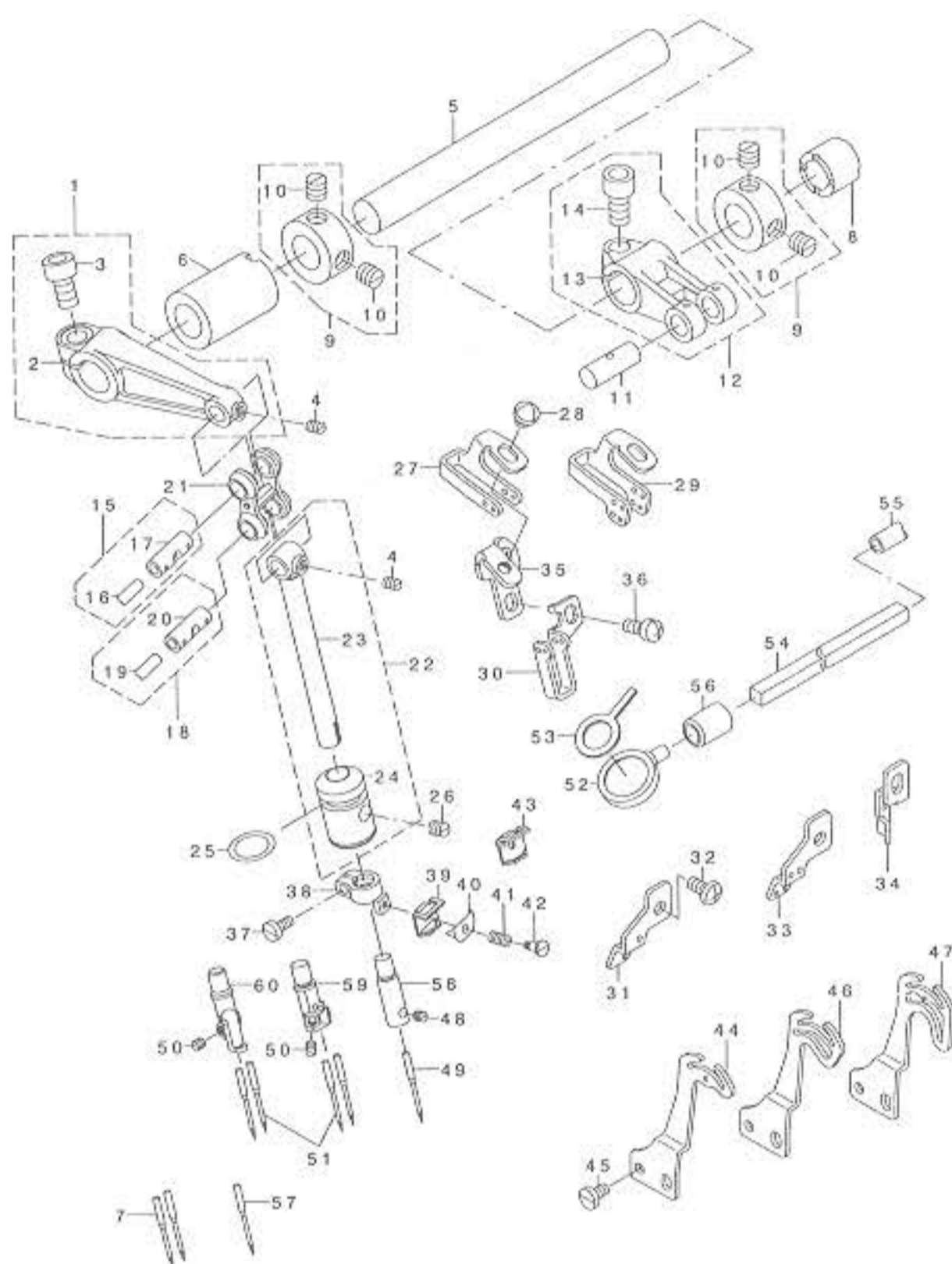

REF. NO.	NOTE	PART NO.	DESCRIPTION	Qty.
1		121-09666	NEEDLE DRIVING ARM ASM.	1
2		121-09617	NEEDLE DRIVING LEVER	(1)
3		SM-6061202-TP	SCREW M6 L=12	(1)
4		SS-8090530-TP	SCREW 9/64-40 L= 5.0	2
5		121-09302	NEEDLE DRIVING SHAFT	1
6		122-52805	BUSHING FRONT	1
7	#09	MC-0336007-50	NEEDLE B-27 NW75	2
8		121-09500	BUSHING, REAR	1
9		CS-1201010-SH	THRUST COLLAR ASM. D=12 W=10	2
10		SS-8660610-TP	SCREW 1/4-40 L=6	(4)
11	#01	118-23804	CRANK PIN C	1
12		121-09260	FEED FORKED CRANK ASM.	1
13		121-09211	NEEDLE DRIVING FORKED CRANK	(1)
14		SM-6061202-TP	SCREW M6 L=12	(1)
15	#01	121-09955	LINK PIN C ASM.	1
16		CQ-2520000-00	OIL WICK	(0.1)
17		121-09906	LINK PIN C	(1)
18	#01	121-09955	LINK PIN C ASM.	1
19		CQ-2520000-00	OIL WICK	(0.1)
20		121-09906	LINK PIN C	(1)
21		122-52904	NEEDLE DRIVING LINK	1
22		122-53050	NEEDLE HOLDER ASM.	1
23		121-10219	NEEDLE HOLDER	(1)
24		122-53100	NEEDLE HOLDER BUSHING	(1)
25		RO-1082401-00	RUBBER RING	1
26		SS-8110710-SP	SCREW 11/64-40 L=6.5	1
27	#05	121-11209	NEEDLE THREAD GUIDE	1
28		SS-4110515-SP	SCREW 11/64-40 L=5	1
29	#03	121-11308	THREAD GUIDE, 2-NEEDLE	1
30	#04	121-11407	THREAD GUIDE, CHAIN LOOPER	1
31	#05	121-11803	TAKE-UP LEVER GUIDE	1
32		SM-4040855-SP	SCREW	1
33	#03	121-11902	TAKE-UP LEVER GUIDE, 2-NEEDLE	1
34	#04	121-12009	TAKE-UP LEVER GUIDE, CHAIN LOOP	1
35		121-12108	NEEDLE THREAD GUIDE STAND	1
36		SM-4040855-SP	SCREW	2
37		SS-6080720-SP	SCREW	1
38		122-53209	NEEDLE CLAMP HOLDER	1
39	#06	121-10607	NEEDLE THREAD PRESSER GUIDE, A	1
40		121-10904	NEEDLE THREAD PRESSER PLATE	1
41		121-10805	NEEDLE THREAD PRESSER SPRING	2
42		SD-0280401-SL	HINGE SCREW D=2.8 H=4	1
43	#04	121-10706	NEEDLE THREAD PRESSER GUIDE, B	1
44	#02	121-11506	NEEDLE THREAD TAKE-UP LEVER	1
45		SS-6090670-TP	SCREW 9/64-40 L=6	2
46	#03	121-11605	TAKE-UP LEVER, 2-NEEDLE	1
47	#04	121-11704	TAKE-UP LEVER, CHAIN LOOPER	1
48	#02	SS-8080310-TP	SCREW 1/8-44 L=2.8	1
49	#02	MDC-27081100	NEEDLE DCX27 #11	1
50	#07	SS-8080310-TP	SCREW 1/8-44 L=2.8	2
51	#07	MDC-27081100	NEEDLE DCX27 #11	2
52		121-12207	COVER	1
53		121-12306	FELT A	1
54		121-12405	FELT B	1
55		BT-0600402-EA	OIL TUBE	0.2
56		TA-0951301-R0	RUBBER PLUG	1
57	#08	MC-0336007-50	NEEDLE B-27 NW75	1
58	#02	121-48607	NEEDLE CLAMP	1
59	#03	121-48706	NEEDLE CLAMP, 2-NEEDLE	1
60	#04	121-49803	NEEDLE CLAMP, CHAIN LOOPER	1

5. FEED MECHANISM COMPONENTS(1)

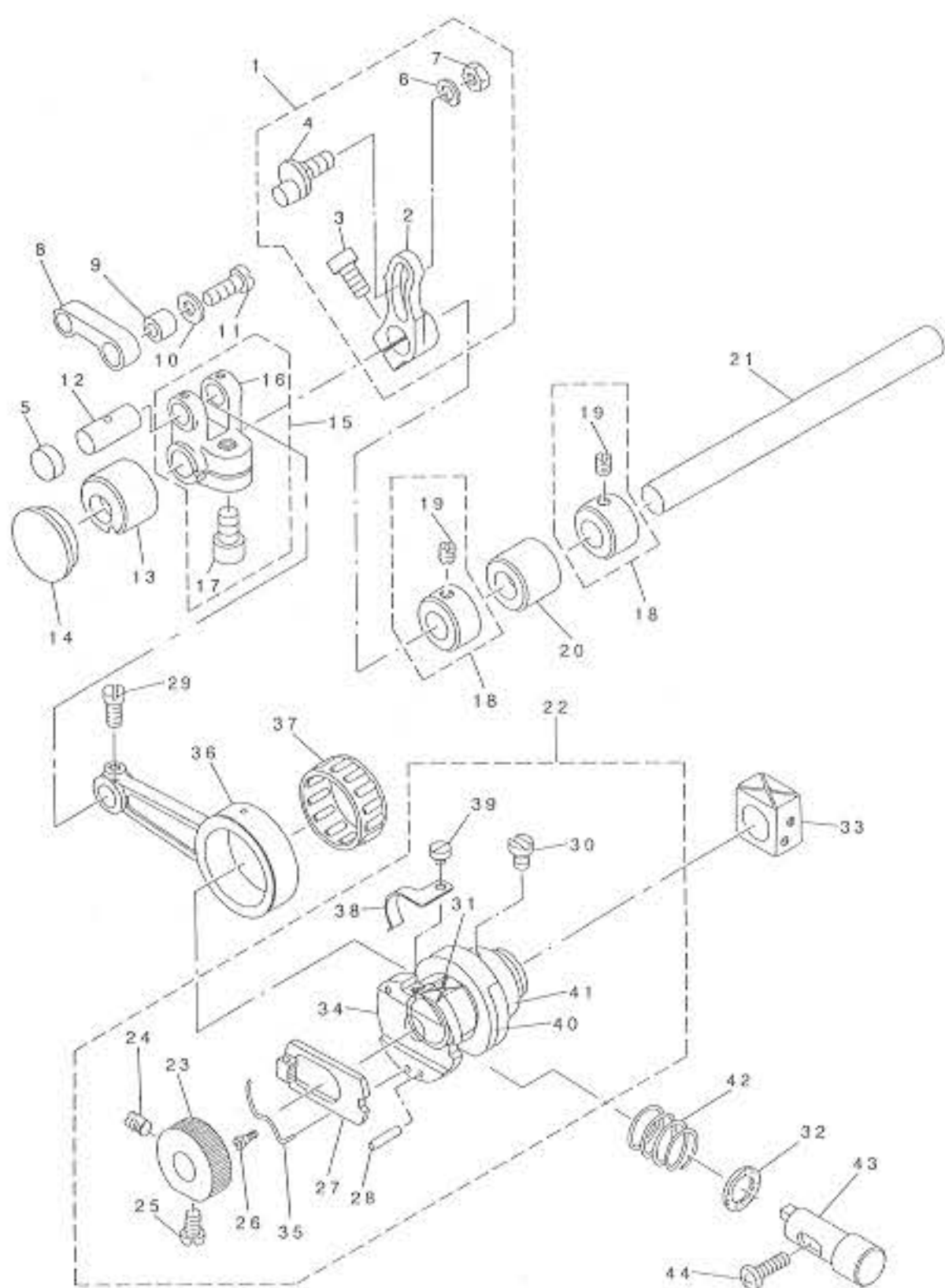

REF. NO	NOTE	PART NO.	DESCRIPTION	Qty
1		118-24067	MAIN FEED ROCKER ASM.	1
2		115-30110	MAIN FEED ROCKER	(1)
3		SM-6051202-TP	SCREW M5X0.8 L=12	(1)
4		118-24018	PIN	(1)
5		TA-1030402-R0	RUBBER PLUG D=10.3 L=4	1
6		119-48601	WASHER B	(1)
7		NS-6620320-SP	NUT 3/16-32	(1)
8		118-24109	MAIN FEED LINK	1
9		B1620-804-000	COLLAR	1
10		B2107-816-000	WASHER	1
11		SS-6121220-TP	SCREW 3/16-28 L=11.5	1
12	#01	118-23804	CRANK PIN C	1
13		121-17206	FEED ROCKER SHAFT BUSHING, FRO	1
14		TA-2050416-R0	RUBBER PLUG	1
15		B1611-804-0A0-A	FORKED LINK ASM.	1
16		B1611-804-000-A	FORKED CRANK	(1)
17		SM-6061002-TP	SCREW M6 L=10	(1)
18		CS-095081A-SH	THRUST COLLAR ASM, D=9.53 W=8	2
19		SS-8110410-TP	SCREW 11/64-40 L= 3.5	(4)
20		121-17305	FEED ROCKER SHAFT BUSHING, REA	1
21		121-18907	FEED SHAFT	1
22		121-16174	FEED ECCENTRIC BODY ASM.	1
23		121-18808	RATCHET GEAR	(1)
24		SS-8110750-SP	SCREW 11/64-40 L= 6.5	(1)
25		SS-6110710-TP	SCREW 11/64-40 L= 6.5	(1)
26		SD-0260271-SP	HINGE SCREW D= 2.60 H= 2.7	(1)
27		B1604-704-000	RATCHET PAWL	(1)
28		PS-0300132-KH	SPRING PIN 3X13	(2)
29		SS-7110910-TP	SCREW 11/64-40 L= 8.5	1
30		SS-7110810-SP	SCREW 11/64-40 L= 8.0	(2)
31		121-16307	FEED CAM BLOCK	(1)
32		121-18600	OIL SHEET	1
33		118-24406	SLIDE BLOCK	1
34		121-16406	FEED ADJUSTING CAM	(1)
35		B1606-704-000	RATCHET PAWL SPRING	(1)
36		121-16505	CRANK ROD	1
37	#01	121-16703	NEEDLE BEARING B	1
38		121-17107	RATCHET GEAR SPRING	(1)
39		SS-6080320-SP	SCREW 1/8-44 L= 2.5	(1)
40		121-16216	FEED CAM	(1)
41		121-16117	FEED ECCENTRIC BODY	(1)
42		B1652-704-000	SPRING	1
43		121-18501	PUSH BUTTON STUD	1
44		SM-4041401-SC	SCREW M4X0.7 L=14	1

NOTE

#01...SELECTING PART FOR FIT TOLERANCE

6. FEED MECHANISM COMPONENTS(2)

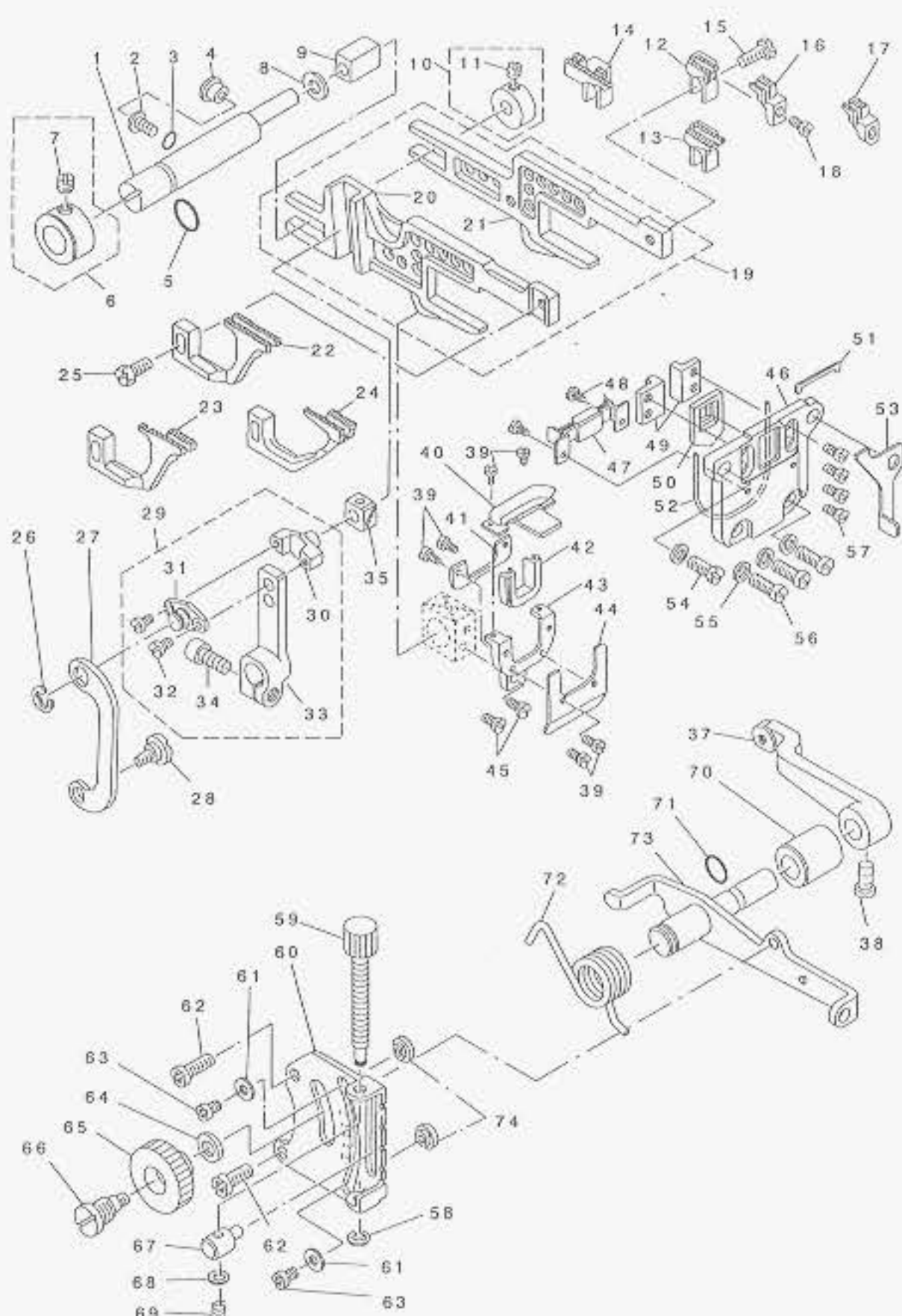

REF. NO	NOTE	PART NO.	DESCRIPTION	Qty
1		118-24505	FEED BAR SHAFT	1
2		SM-4040855-SP	SCREW	1
3		RO-0371801-00	RUBBER RING	1
4		TA-0800504-RO	PLUG D=8 L=4.5	1
5		RO-0781901-00	RUBBER RING	1
6		118-24653	THRUST COLLAR ASM.	1
7		SS-8660330-SP	SCREW 1/4-40 L= 3.0	(1)
8		115-29914	WASHER	1
9		B1624-704-000	SLIDE BLOCK	1
10		118-28050	COLLAR ASM.	1
11		SS-8110410-TP	SCREW 11/64-40 L= 3.5	(1)
12	#01	118-82107	MAIN FEED DOG	1
13	#02	119-49807	MAIN FEED DOG	1
14	#03	118-82800	MAIN FEED DOG	1
15		SS-9111050-SP	SCREW 11/64-40 L=9.5	1
16	#04	118-87106	AUXILIARY FEED DOG	1
17	#03	118-87403	AUXILIARY FEED DOG	1
18		SS-4080610-SP	SCREW 1/8-44 L=6.4	1
19		121-17461	MAIN FEED BAR ASM.	1
20		121-17511	DIFFERENTIAL FEED BAR	(1)
21		121-17412	MAIN FEED BAR	(1)
22	#01	B1657-804-00T	DIFFERENTIAL FEED DOG	1
23	#02	119-49906	DIFFERENTIAL FEED DOG	1
24	#03	121-72805	DIFFERENTIAL FEED DOG	1
25		SS-9111010-SP	SCREW 11/64-40 L=9.5	1
26		RE-0500000-K0	E-RING	1
27		118-26310	ADJUSTING LINK	1
28		SD-0720271-SP	HINGE SCREW D=7.2 H=2.7	1
29		118-28563	SUB-FEED ARM ASM.	1
30		118-25304	PIN	(1)
31		118-26401	PIN COVER	(1)
32		SS-6080410-SP	SCREW 1/8-44 L=4	(2)
33		118-28514	FEED ROCKER	(1)
34		SM-6051202-TP	SCREW M5X0.8 L=12	(1)
35		B1414-555-000	SLIDE BLOCK	1
36		SS-7060310-SP	SCREW 3/32-56 L=3	2
37		B1647-704-000-A	DIFFERENTIAL FEED LOCK NUT	1
38		B1646-704-000-A	DIFFERENTIAL FEED HINGE SCREW	1
39		SS-7060310-SP	SCREW 3/32-56 L=3	6
40		121-19756	RUBBER PRESSER PLATE ASM.	1
41		121-19806	RUBBER PRESSER PLATE	1
42		121-19608	OIL SHIELD RUBBER	1
43		121-19905	RUBBER COVER	1
44		121-20002	RUBBER BASE	1
45		SS-7090620-TP	SCREW 9/64-40 L=6.1	2
46		121-19400	RUBBER CASE	1
47		118-27607	OIL SHIELD RUBBER, LOWER	1
48		SS-7060510-SP	SCREW 3/32-56 L=4.8	2
49		118-24703	FEED BAR SUPPORT	2
50		121-19509	RUBBER	1
51		118-27904	RUBBER	1
52		RO-4801201-00	RUBBER RING	1
53		118-28308	SUPPORT THROAT PLATE	1
54		SM-6041002-TP	SCREW M4 L=10	1
55		WP-0480856-SP	WASHER 4.8X8.4X0.8	4
56		SN-4041055-SP	SCREW M4 L=10	3
57		SS-6090620-SP	SCREW 9/64-40 L=6	4
58		RE-0300000-K0	E-RING 3	1
59		118-26104	DIFFERENTIAL FEED SCREW	1
60		118-25908	DIFFERENTIAL FEED GRADUATION	1
61		WP-0371016-SD	WASHER 3.7X8X1	2
62		SL-4051231-SC	SCREW 3/16-28 L=12	2
63		SS-4090515-SP	SCREW 9/64-40 L=5	2
64		WP-0621016-SD	WASHER 6.2X13X1	1
65		B1647-704-000-A	DIFFERENTIAL FEED LOCK NUT	1
66		B1646-704-000-A	DIFFERENTIAL FEED HINGE SCREW	1
67		118-26005	DIFFERENTIAL FEED BLOCK	1
68		WP-0460556-SD	WASHER 4.6X7.5X0.5	1

7. CHAIN LOOPER COMPONENTS(FOR MO-3916)

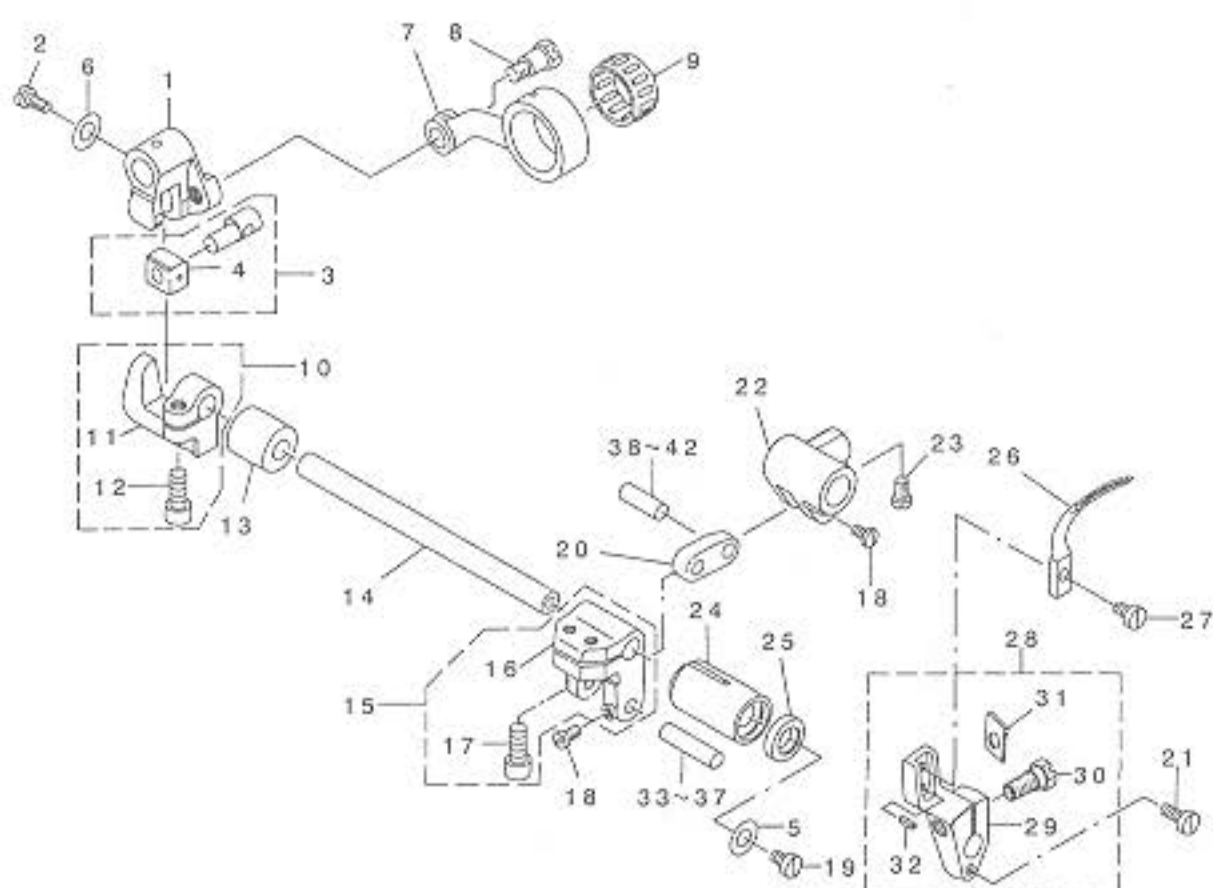

REF. NO	NOTE	PART NO.	DESCRIPTION	Qty
1		118-29900	CHAIN LOOPER SHAFT SLIDE ARM	1
2		SS-7111120-TP	SCREW	1
3		118-29751	PIN ASM.	1
4		B2105-816-000	CHAIN LOOPER SLIDE BLOCK	(1)
5		WP-0612066-SP	WASHER 6, 1X11X2	1
6		WP-0450846-SP	WASHER	1
7		B2102-816-000-A	CHAIN LOOPER ROD (22MM)	1
8		SD-0720803-TH	STEP-SCREW D=7.24 H=8	1
9	#01	B2119-816-800	BEARING B	1
10		121-20466	BRACKET ASM.	1
11		121-20476	BRACKET	(1)
12		SM-6051202-TP	SCREW M5X0.8 L=12	(1)
13		B2111-716-000	BUSHING, REAR	1
14		121-20507	CHAIN LOOPER SHAFT	1
15		115-39061	LOOPER SHAFT DRIVING ARM ASM.	1
16		115-39012	CHAIN LOOPER SHAFT DRIVING ARM	(1)
17		SM-6051202-TP	SCREW M5X0.8 L=12	(1)
18		SS-4080610-SP	SCREW 1/8-44 L=6.4	2
19		SD-0720332-SP	HINGE SCREW D= 7.24 H= 3.3	1
20		118-29801	CHAIN LOOPER SHAFT DRIV. LINK	1
21		SS-6090920-SP	SCREW	1
22		121-21612	DRIVING BALL ARM BRACKET	1
23		SS-6110710-TP	SCREW 11/64-40 L= 6,5	3
24		121-22008	BUSHING, FRONT	1
25		B2525-352-000	OIL SEAL RING	1
26		121-20705	CHAIN LOOPER	1
27		SS-6090620-TP	SCREW	1
28		121-21554	CHAIN LOOPER DRIVING ARM ASM.	1
29		121-21513	CHAIN LOOPER DRIVING ARM	(1)
30		SS-9151210-TP	SCREW 15/64-28 L=11,8	(1)
31		B2531-704-000	WASHER	(1)
32		PS-0250062-KH	SPRING PIN 2.5X6	(1)
33	#01	122-58208	PIN, LONG	1
34	#01	122-58307	PIN, LONG	1
35	#01	122-58406	PIN, LONG	1
36	#01	122-58505	PIN, LONG	1
37	#01	122-58604	PIN, LONG	1
38	#01	122-58703	PIN, SHORT	1
39	#01	122-58802	PIN, SHORT	1
40	#01	122-58901	PIN, SHORT	1
41	#01	122-59008	PIN, SHORT	1
42	#01	122-59107	PIN, SHORT	1

NOTE

#01, ... SELECTING PART FOR FIT TOLERANCE

8. UPPER & LOWER LOOPER COMPONENTS

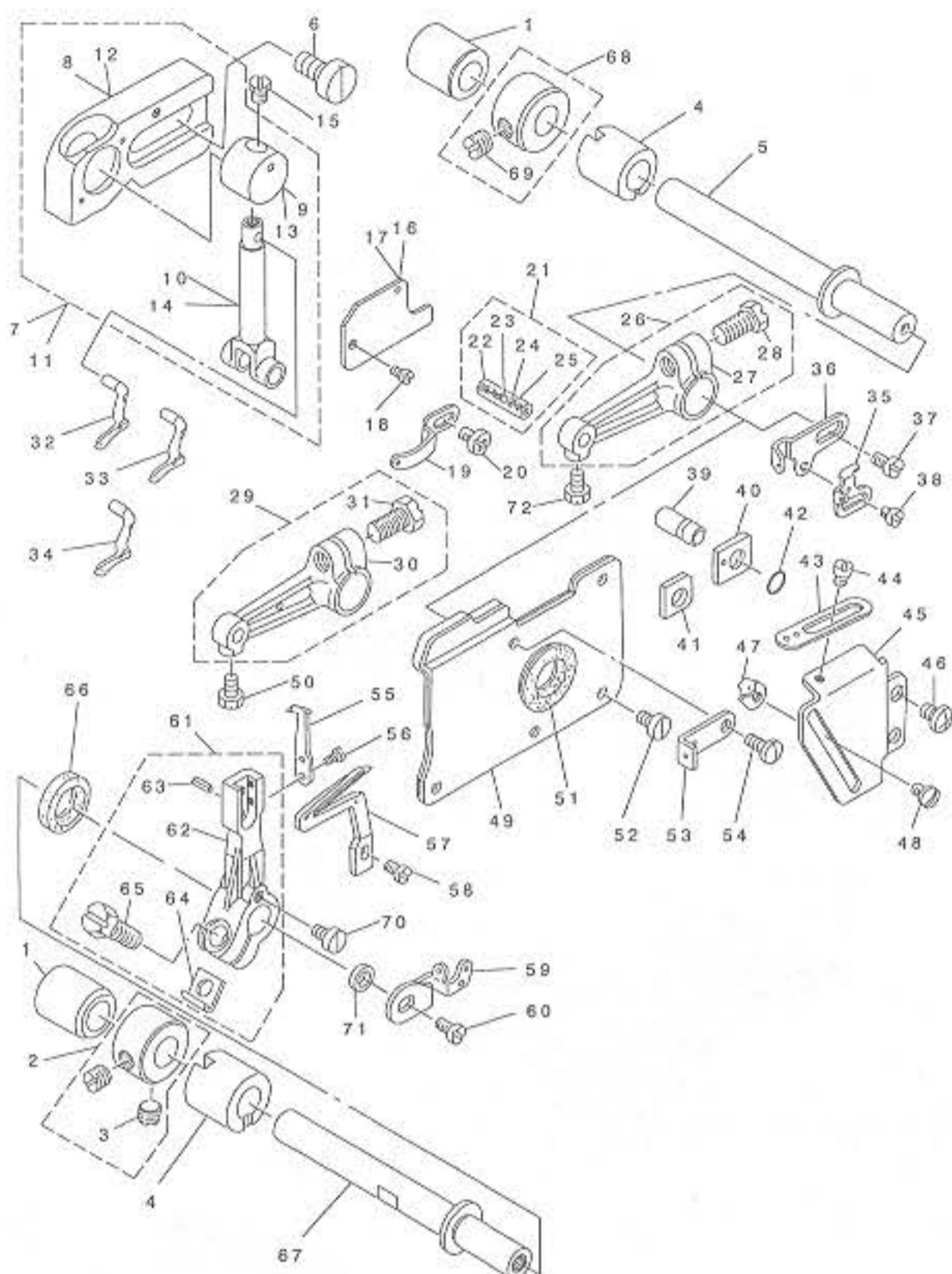

REF. NO	NOTE	PART NO.	DESCRIPTION	Qty.
1		121-22610	LOOPER SHAFT REAR METAL	2
2	#06	CS-1031210-SH	THRUST COLLAR ASM. D=10.32 W=1	2
3		SS-8660610-TP	SCREW 1/4-40 L=6	(4)
4		121-22511	LOOPER SHAFT FRONT METAL	2
5		121-22404	UPPER LOOPER SHAFT	1
6		SW-6061200-SP	SCREW	2
7	#01	121-23055	UPPER LOOPER GUIDE ASM.	1
8		121-23006	UPPER LOOPER GUIDE SUPPORT	(1)
9		121-23204	UPPER LOOPER GUIDE	(1)
10		121-22909	UPPER LOOPER HOLDER	(1)
11	#02	121-23154	UPPER LOOPER GUIDE ASM., B	1
12		121-23105	UPPER LOOPER GUIDE SUPPORT, B	(1)
13		121-23204	UPPER LOOPER GUIDE	(1)
14		121-22909	UPPER LOOPER HOLDER	(1)
15		SS-9090410-TP	SCREW	1
16	#01	118-33704	UPPER LOOPER GUIDE COVER	1
17	#02	B2515-704-00B	UPPER LOOPER GUIDE COVER B	1
18		SS-7060610-SP	SCREW 3/32-56 L= 5.5	2
19		118-33308	UPPER LOOPER THREAD GUIDE	1
20		SS-4090615-SP	SCREW 9/64-40 L=6	1
21	#03	118-31757	PIN ASM.	1
22		115-17000	PIN C	(1)
23		118-31708	OIL WICK STOPPER BALL	(1)
24		CQ-2020000-00	OIL WICK	(0.1)
25		CQ-2000000-00	OIL WICK	(0.1)
26	#01	121-22750	UPPER LOOPER ARM A ASM.	1
27		121-22701	UPPER LOOPER ARM A	(1)
28		SS-9151210-TP	SCREW 15/64-28 L=11.8	(1)
29	#02	121-22859	UPPER LOOPER ARM B ASM.	1
30		121-22800	UPPER LOOPER ARM B	(1)
31		SS-9151210-TP	SCREW 15/64-28 L=11.8	(1)
32	#02	121-76004	UPPER LOOPER	1
33	#04	118-88104	UPPER LOOPER	1
34	#05	119-99208	UPPER LOOPER	1
35		118-33506	LOWER LOOPER THREAD TAKE-UP	1
36		121-24004	THREAD TAKE-UP, RIGHT	1
37		SS-7110840-SP	SCREW 11/64-40 L=7.8	1
38		SS-6080410-SP	SCREW 1/8-44 L=4	1
39		118-31906	PIN	1
40	#06	118-31807	GAUGE	1
41	#07	119-91809	GAUGE	1
42		RO-0371801-00	RUBBER RING	1
43		121-23907	THREAD GUIDE, RIGHT	1
44		SS-3090610-SP	SCREW 9/64-40 L=6	1
45		121-23808	LOOPER THREAD TAKE-UP COVER	1
46		SW-4040655-SP	SCREW	2
47		118-33407	LOWER LOOPER THREAD GUIDE	1
48		SS-3090610-SP	SCREW 9/64-40 L=6	1
49		121-23667	OIL SHIELD ASM.	1
50		SS-9090610-TP	SCREW 9/64-40 L=5.5	1
51		B2530-704-000	UPPER LOOPER SHAFT RUBBER RING	1
52		SS-6090630-SP	SCREW 9/64-40 L=6	4
53		118-33100	LOOPER THREAD GUIDE	1
54		SS-7090850-SP	SCREW 9/64-40 L=8	1
55		118-90001	TRAVELING NEEDLE GUARD	1
56		SS-6060440-TP	SCREW 3/32-56 L=3.5	2
57		119-99307	LOWER LOOPER	1
58		SS-6090620-TP	SCREW	1
59		121-24103	LOOPER THREAD TAKE-UP, LEFT	1
60		SS-7110840-SP	SCREW 11/64-40 L=7.8	1
61		121-23550	LOWER LOOPER SUPPORT ARM ASM.	1
62		121-23501	LOWER LOOPER SUPPORT ARM	(1)
63		PS-0300062-KH	SPRING PIN 3X6	(1)
64		B2531-704-000	WASHER	(1)
65		SS-9151210-TP	SCREW 15/64-28 L=11.8	(1)
66		B2508-704-000	OIL SEAL	1
67		121-23410	LOWER LOOPER SHAFT	1
68	#07	CS-1031210-SH	THRUST COLLAR ASM. D=10.32 W=1	1
69		SS-8660610-TP	SCREW 1/4-40 L=6	(2)
70		SS-6090630-TP	SCREW 9/64-40 L=6	1
71		121-24608	COLLAR	1
72		SS-9090610-TP	SCREW 9/64-40 L=5.5	1

NOTE

- #01...FOR MO-3904,MO-3916
- #02...FOR MO-3914
- #03...SELECTING PART FOR FIT TOLERANCE
- #04...FOR MO-3904,MO-3916
(NEEDLE #9,#11,#14)
- #05...FOR MO-3904,MO-3916
(NEEDLE #14,#16,#18)
- #06...FOR MO-3916
- #07...FOR MO-3916

9. PRESSER FOOT COMPONENTS(1)

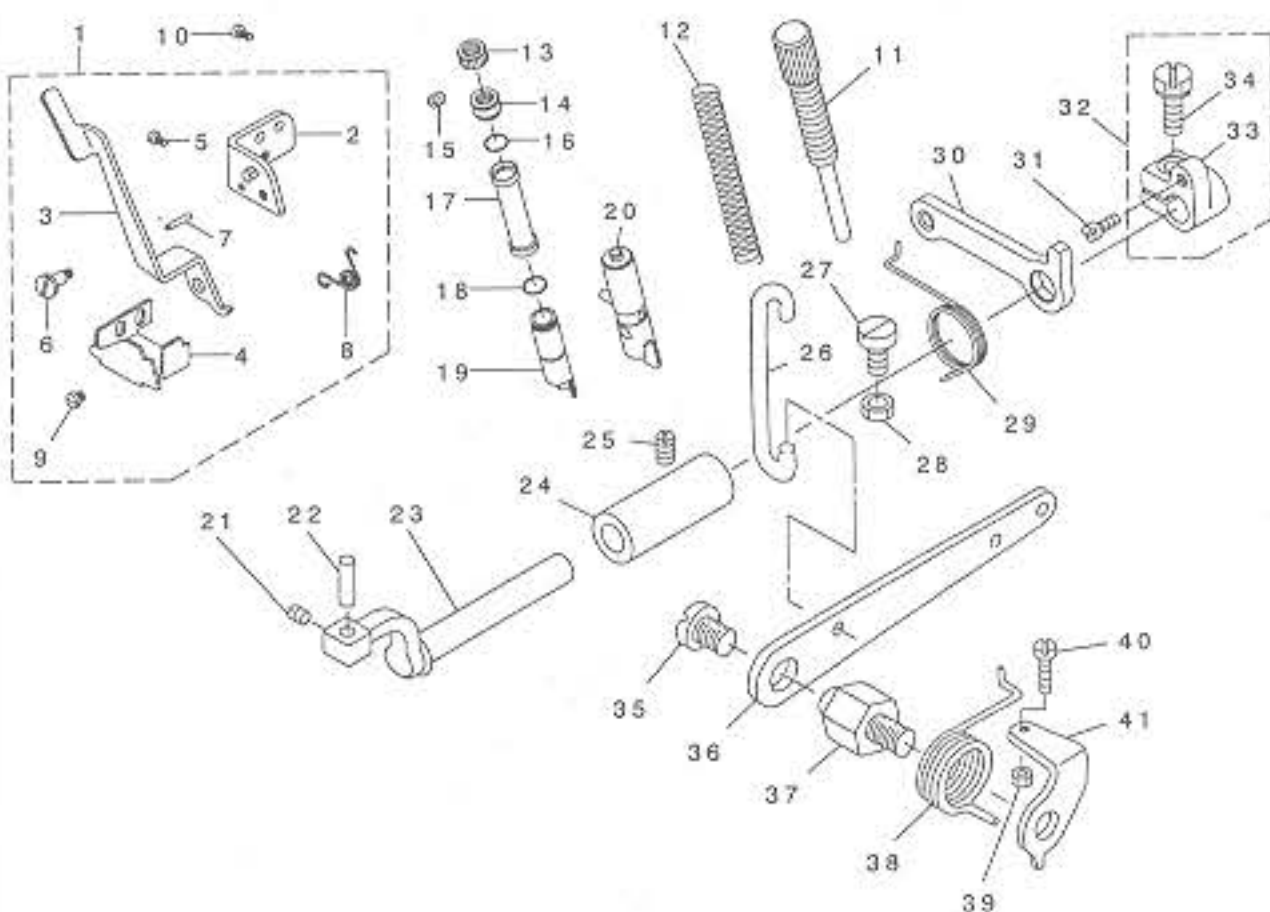

REF. NO	NOTE	PART NO.	DESCRIPTION	Qty
1		121-15069	FOOT LIFTING LEVER STAND ASM.	1
2		121-15002	FOOT LIFTING LEVER STAND	(1)
3		121-15119	PRESSER FOOT LIFTING LEVER	(1)
4		121-15200	STOPPER	(1)
5		SS-7110510-SP	SCREW 11/64-40 L=5	(2)
6		SD-0640241-SP	HINGE SCREW D= 6.35 H= 2.4	(1)
7		PS-0300142-KH	SPRING PIN 0.3 X 14	(1)
8		121-15309	SPRING	(1)
9		SS-6080340-SP	SCREW 1/8-44 L=2.9	(1)
10		SS-4110715-SP	SCREW 11/64-40 L=7	2
11		121-14716	PRESSER REGULATOR SCREW	1
12		121-15903	PRESSER SPRING	1
13		121-14807	PRESSER REGULATOR NUT	1
14		121-14609	PRESSER REGULATOR SCREW WASHER	1
15		SM-8040402-TP	SCREW M4X0.7 L=4	1
16		RO-1100901-00	RUBBER RING	1
17		121-14906	PRESSER BAR COVER	1
18		RO-1100901-00	RUBBER RING	2
19		121-14302	PRESSER BAR BUSHING	1
20		121-14468	PRESSER BAR ASM.	1
21		SS-8110520-TP	SCREW 11/64-40 L= 4.5	1
22		B1534-804-000	PRESSER FOOT ARM HINGE SHAFT	1
23		121-13205	PRESSER FOOT SHAFT	1
24		121-13304	BUSHING	1
25		SS-4121215-SP	SCREW 3/16-28 L=12	1
26		118-19414	LIFTING HOOK	1
27		SM-6061200-SP	SCREW M6 L=12	1
28		NM-6060003-SC	NUT M6	1
29		118-19703	PRESSER FOOT ARM SPRING	1
30		121-13502	LIFTING ARM	1
31		SS-6110710-TP	SCREW 11/64-40 L= 6.5	1
32		121-13858	PRESSER FOOT SHAFT THRUST ASM.	1
33		121-13403	PRESSER FOOT SHAFT THRUST	(1)
34		SS-9151210-TP	SCREW 15/64-28 L=11.8	(1)
35		SS-7161040-SP	SCREW 1/4-24 L= 9.5	1
36		118-19307	LIFTING LEVER	1
37		118-19109	LIFTING LEVER SCREW	1
38		118-19208	LIFTING LEVER SPRING	1
39		NS-6110420-SP	NUT 11/64-40	1
40		SS-7111410-SP	SCREW 11/64-40 L=14	1
41		B1529-804-000	PRESSER FOOT LIFTING LEVER STO	1

10. PRESSER FOOT COMPONENTS(2)

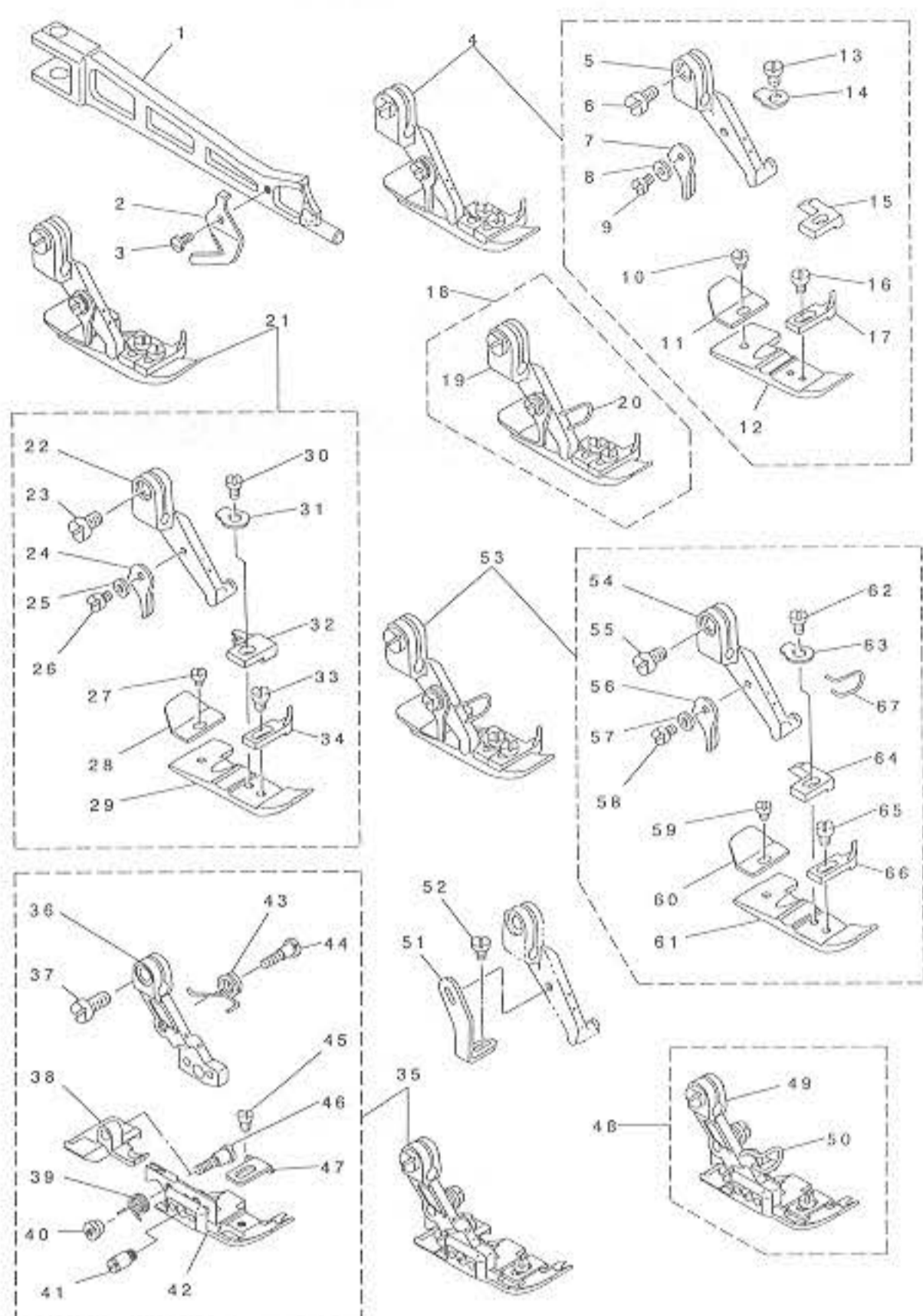

REF. NO	NOTE	PART NO.	DESCRIPTION	Qty
1		122-53811	PRESSER FOOT ARM	1
2		B1528-804-000-A	THREAD TRIMMER	1
3		SS-7060510-SP	SCREW 3/32-56 L=4.8	1
4	#01	118-76158	PRESSER FOOT ASM.	1
5		118-72009	PRESSER FOOT HINGE	(1)
6		SS-6090650-SP	SCREW 9/64-40 L=6	(1)
7		B1530-804-000	STOPPER	(1)
8		WP-0250516-SD	WASHER 2.5X6X0.5	(1)
9		SS-7060610-SP	SCREW 3/32-56 L= 5.5	(1)
10		SS-6060210-SP	SCREW 3/32-56 L= 1.9	(1)
11		B1511-814-000	REAR PRESSER FOOT	(1)
12		B1507-804-C00	PRESSER FOOT	(1)
13		SS-7080520-SP	SCREW 1/8-44 L=4.9	(1)
14		B1508-804-00B	SPRING	(1)
15		B1509-804-C00	STITCH TONGUE	(1)
16		SS-6060440-TP	SCREW 3/32-56 L=3.5	(1)
17		B1510-814-000	CURL GUARD	(1)
18	#02	118-76166	PRESSER FOOT ASM.	1
19		118-76158	PRESSER FOOT ASM.	(1)
20		118-20701	FINGER GUARD	(1)
21	#03	121-52450	PRESSER FOOT ASM.	1
22		118-72009	PRESSER FOOT HINGE	(1)
23		SS-6090650-SP	SCREW 9/64-40 L=6	(1)
24		B1530-804-000	STOPPER	(1)
25		WP-0250516-SD	WASHER 2.5X6X0.5	(1)
26		SS-7060610-SP	SCREW 3/32-56 L= 5.5	(1)
27		SS-6060210-SP	SCREW 3/32-56 L= 1.9	(1)
28		B1511-814-000	REAR PRESSER FOOT	(1)
29		B1507-814-00P	PRESSER FOOT	(1)
30		SS-7080520-SP	SCREW 1/8-44 L=4.9	(1)
31		B1508-804-00B	SPRING	(1)
32		121-60008	STITCH TONGUE	(1)
33		SS-6060440-TP	SCREW 3/32-56 L=3.5	(1)
34		B1510-814-000	CURL GUARD	(1)
35	#05	121-53755	PRESSER FOOT ASM.	1
36		121-56907	PRESSER FOOT HINGE	(1)
37		SS-6090650-SP	SCREW 9/64-40 L=6	(1)
38		121-64802	REAR PRESSER FOOT	(1)
39		121-67805	SPRING, FOR REAR PRESSER FOOT	(1)
40		B1513-816-000	NUT, FOR REAR PRESSER FOOT	(1)
41		121-67409	HINGE PIN	(1)
42		121-62202	PRESSER FOOT	(1)
43		121-67607	PRESSER FOOT ARM SPRING	(1)
44		121-67508	HINGE SCREW	(1)
45		SS-6060340-SP	SCREW 3/32-56 L= 2.5	(1)
46		B1514-816-000	SCREW	(1)
47		121-67706	PRESSER FOOT	(1)
48	#06	121-53763	PRESSER FOOT ASM.	1
49		121-53755	PRESSER FOOT ASM.	(1)
50		121-15408	FINGER GUARD	(1)
51	#07	B1539-804-000	PRESSER FOOT FIXING PLATE	1
52	#07	SS-6060410-TP	SCREW 3/32-56 L= 3.5	1
53	#04	118-76869	PRESSER FOOT ASM.	1
54		118-72009	PRESSER FOOT HINGE	(1)
55		SS-6090650-SP	SCREW 9/64-40 L=6	(1)
56		B1530-804-000	STOPPER	(1)
57		WP-0250516-SD	WASHER 2.5X6X0.5	(1)
58		SS-7060610-SP	SCREW 3/32-56 L= 5.5	(1)
59		SS-6060210-SP	SCREW 3/32-56 L= 1.9	(1)
60		B1511-814-000	REAR PRESSER FOOT	(1)
61		B1507-814-00P	PRESSER FOOT	(1)
62		SS-7080520-SP	SCREW 1/8-44 L=4.9	(1)
63		B1508-804-00B	SPRING	(1)
64		B1509-814-00P	STITCH TONGUE	(1)
65		SS-6060440-TP	SCREW 3/32-56 L=3.5	(1)
66		B1510-814-000	CURL GUARD	(1)
67		118-20701	FINGER GUARD	(1)

NOTE

#01... FOR MO-3904(FOR DOMESTIC USE)
 #02... FOR MO-3904(FOR EXPORT)
 #03... FOR MO-3914(FOR DOMESTIC USE)
 #04... FOR MO-3914(FOR EXPORT)
 #05... FOR MO-3916(FOR DOMESTIC USE)
 #06... FOR MO-3916(FOR EXPORT)
 #07... SPECIAL ORDER PART(FOR MO-3904,
 MO-3914)

11. THREAD TENSION COMPONENTS

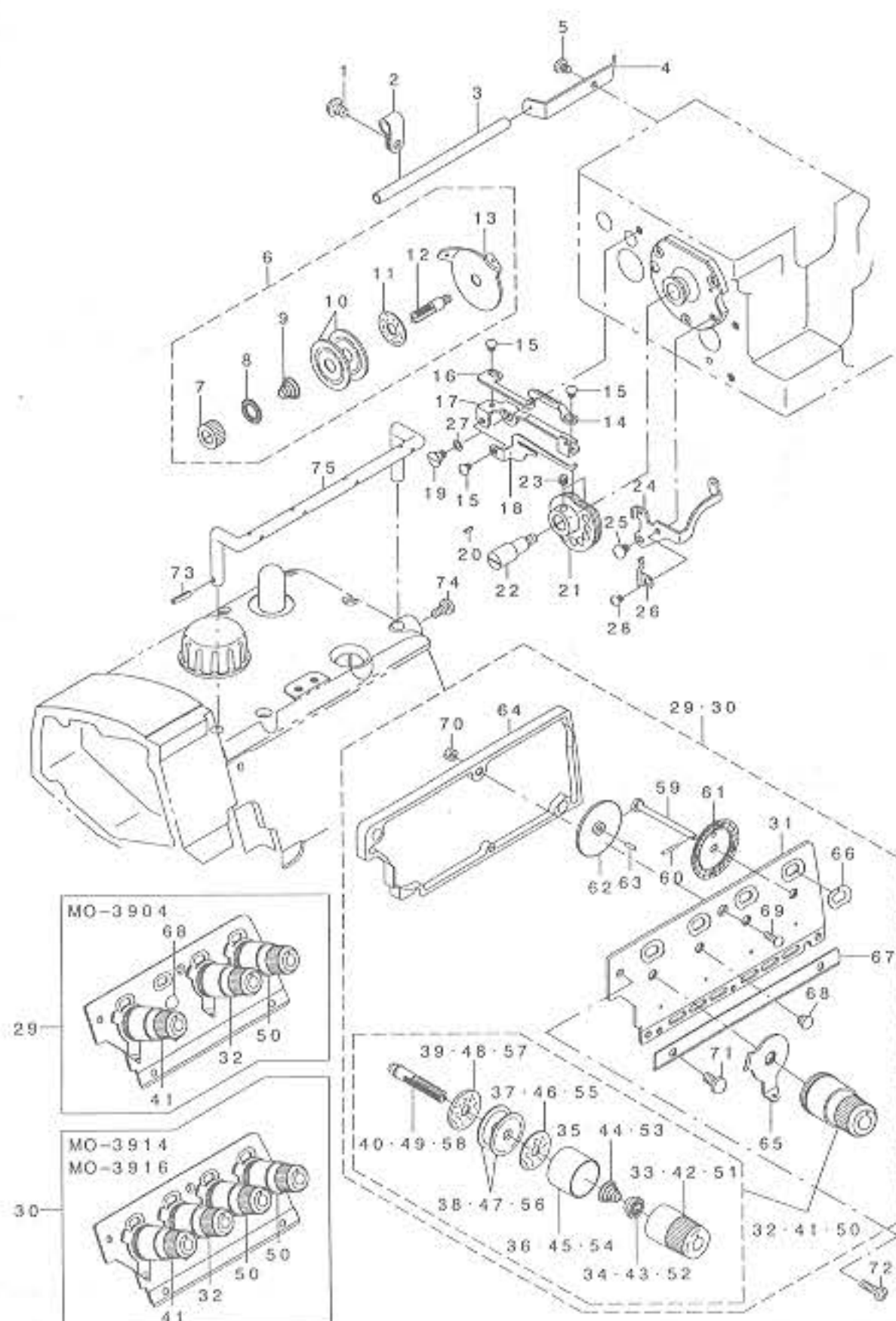

REF. NO	NOTE	PART NO.	DESCRIPTION	Qty
1	#01	SM-4050855-SP	SCREW M5 L=8	1
2	#01	B3113-352-000	MOUNTING BRACKET	1
3	#01	B2401-816-000	LOOPER THREAD GUIDE TUBE	1
4	#01	B2402-716-000	LOOPER THREAD GUIDE TUBE GUIDE	1
5	#01	SS-5150510-SP	SCREW 15/64-28 L=5	1
6	#01	115-50852	TENSION CONTROLLER ASM.	1
7		B2314-019-000	TENSION POST NUT	(1)
8		B3120-125-000	ROTATING STOPPER	(1)
9		B2017-372-000	TENSION SPRING NO.1	(1)
10		B3126-012-000	THREAD TENSION DISK	(2)
11		B3120-352-000	THREAD TENSION SPRING FELT	(1)
12		115-50803	THREAD TENSION POST	(1)
13		115-50308	THREAD GUIDE	(1)
14	#01	121-20903	THREAD GUIDE A	1
15	#01	SS-4090415-SP	SCREW 9/64-40 L=4	3
16	#01	121-21000	THREAD GUIDE B	1
17	#01	121-20804	THREAD GUIDE BASE	1
18	#01	121-21109	THREAD GUIDE HOOK	1
19	#01	SD-0600341-TP	HINGE SCREW D=6.0 H=3.4	1
20	#01	PS-0200052-KH	SPRING PIN 2.3X5	1
21	#01	B2201-816-000	THREAD CAM	1
22	#01	B2202-816-000	SHAFT	1
23	#01	SS-8110410-TP	SCREW 11/64-40 L= 3.5	2
24	#01	121-21208	THREAD GUIDE	1
25	#01	SS-4110515-SP	SCREW 11/64-40 L=5	1
26	#01	121-21307	THREAD GUIDE SPRING	1
27	#01	WZ-0640312-K0	WAVED WASHER	1
28	#01	SS-4090415-SP	SCREW 9/64-40 L=4	1
29	#02	121-80162	THREAD GUIDE PLATE ASM.	1
30	#03	121-80261	THREAD GUIDE PLATE ASM.	1
31		121-26207	THREAD GUIDE PLATE	(1)
32		121-26967	KNOB ASM., YELLOW	(2)
33		121-26918	KNOB, YELLOW	(1)
34		B3112-704-000	TENSION SPRING BUSHING	(1)
35		B3101-804-000	TENSION SPRING, RED	(1)
36		121-26702	TENSION DISK PRESSER	(1)
37		B3120-704-000	THREAD TENSION SPRING FELT	(1)
38		B3126-012-000	THREAD TENSION DISK	(2)
39		B3120-352-000	THREAD TENSION SPRING FELT	(1)
40		121-26405	THREAD TENSION BAR	(1)
41		121-26868	KNOB ASM., RED	(1)
42		121-26819	KNOB, RED	(1)
43		B3112-704-000	TENSION SPRING BUSHING	(1)
44		B3101-804-000	TENSION SPRING, RED	(1)
45		121-26702	TENSION DISK PRESSER	(1)
46		B3120-704-000	THREAD TENSION SPRING FELT	(1)
47		B3126-012-000	THREAD TENSION DISK	(2)
48		B3120-352-000	THREAD TENSION SPRING FELT	(1)
49		121-26405	THREAD TENSION BAR	(1)
50		121-27064	KNOB ASM., BLUE	(1)
51		121-27015	KNOB, BLUE	(1)
52		B3112-704-000	TENSION SPRING BUSHING	(1)
53		B3103-804-000	TENSION SPRING, BLUE	(1)
54		121-26702	TENSION DISK PRESSER	(1)
55		B3120-704-000	THREAD TENSION SPRING FELT	(1)
56		B3126-012-000	THREAD TENSION DISK	(2)
57		B3120-352-000	THREAD TENSION SPRING FELT	(1)
58		121-26405	THREAD TENSION BAR	(1)
59		121-27403	SCALE SHAFT	(1)
60		121-27502	SCALE SHAFT PIN	(1)
61		121-27601	SCALE GEAR	(1)
62		121-27700	GEAR	(1)
63		121-27809	GEAR SHAFT	(1)
64		121-27957	SCALE CASE ASM.	(1)
65		121-26504	NEEDLE THREAD GUIDE	(1)
66		121-28203	SCALE SIDE PLATE	(1)
67		121-28302	THREAD LOOPER GUIDE	(1)
68	#02	TA-0620504-R0	CAP	(1)
69		SS-2090830-SL	SCREW	(1)
70		NS-6090310-SP	NUT 9/64-40	(1)
71		SS-7110740-TL	SCREW 11/64-40 L= 7.0	(1)
72		SM-4041455-SN	SCREW M4 L=14	2
73		PS-0300132-KH	SPRING PIN 3X13	1
74		SS-7110910-TP	SCREW 11/64-40 L= 8.5	1
75		121-26108	CENTER THREAD GUIDE	1

NOTE

#01... FOR MO-3916
 #02... FOR MO-3904
 #03... FOR MO-3914, MO-3916

12. UPPER KNIFE COMPONENTS

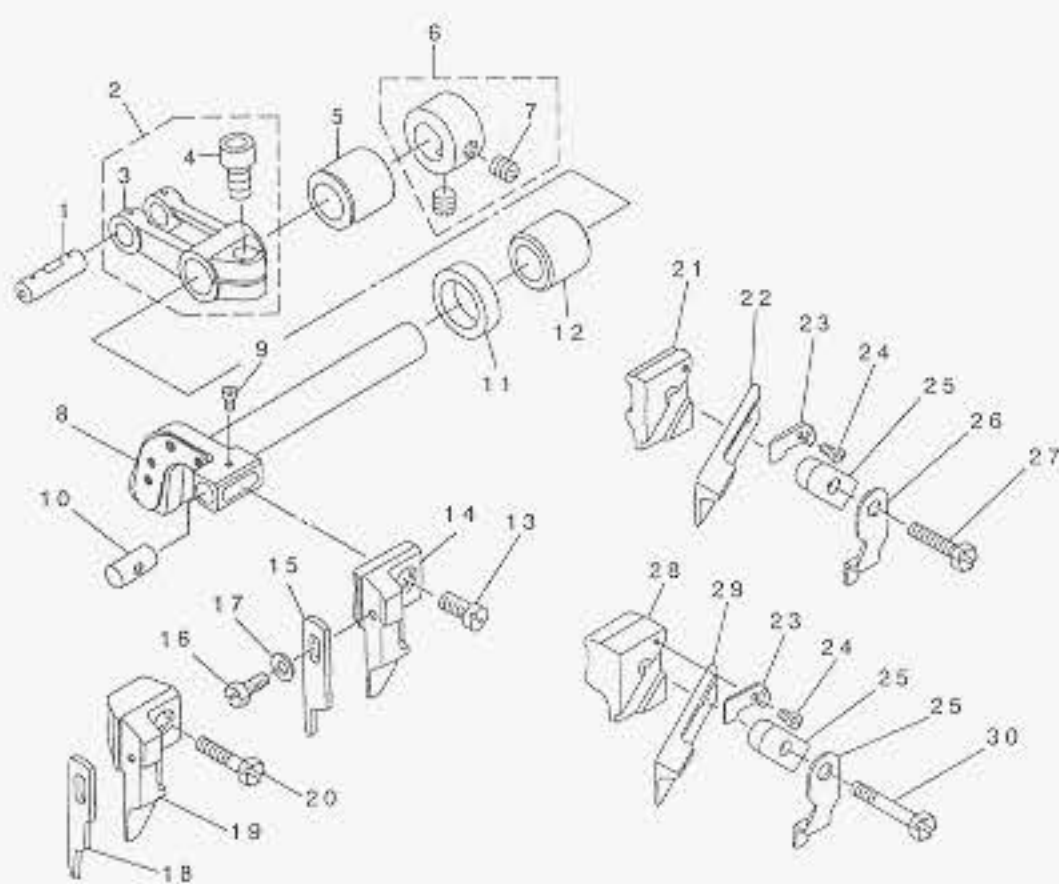

REF. NO	NOTE	PART NO.	DESCRIPTION	Qty
1	#01	118-23804	CRANK PIN C	1
2		121-32262	FEED FORKED ARM ASM.	1
3		121-32213	UPPER KNIFE DRIVING ARM	(1)
4		SM-6061202-TP	SCREW M6 L=12	(1)
5		121-32502	BUSHING, REAR	1
6		CS-111101E-SH	COLLAR ASM, D=11.11 W=10	1
7		SS-8660330-SP	SCREW 1/4-40 L= 3.0	(2)
8		121-32304	KNIFE DRIVING ARM SHAFT	1
9	#06	SS-4060310-SP	SCREW 3/32-56 L=2.5	1
10		115-65801	UPPER KNIFE GUIDE SHAFT	1
11		115-66809	OTL SEAL	1
12		121-32403	BUSHING, FRONT	1
13	#02	SS-6111040-SP	SCREW 11/64-40 L= 9.5	1
14	#02	121-33302	UPPER KNIFE SUPPORT A	1
15	#02	118-45609	KNIFE	1
16	#07	SS-9090813-TP	SCREW 9/64-40 L=8	1
17	#07	WP-0370316-S0	WASHER 3.7X8X0.3	1
18	#03	118-45708	KNIFE	1
19	#03	121-33401	UPPER KNIFE SUPPORT	1
20	#03	SS-6111610-SP	SCREW 11/64-40 L=16	1
21	#04	115-98000	UPPER KNIFE SUPPORT	1
22	#04	118-45807	UPPER KNIFE	1
23	#06	115-65702	WASHER	1
24	#06	SS-4060310-SP	SCREW 3/32-56 L=2.5	1
25	#06	115-65504	UPPER KNIFE PRESSER PLATE	1
26	#08	118-48405	UPPER KNIFE COVER	1
27	#04	SS-9111610-SP	SCREW 11/64-40 L=16	1
28	#05	118-45500	UPPER KNIFE SUPPORT	1
29	#05	118-45906	UPPER KNIFE	1
30	#05	SS-9112310-SP	SCREW 11/64-40 L=23	1

NOTE

#01... SELECTING PART FOR FIT TOLERANCE
 #02... MO-3904, MO-3914(FOR DOMESTIC USE)
 #03... MO-3916(FOR DOMESTIC USE)
 #04... MO-3904, MO-3914(FOR EXPORT)
 #05... MO-3916(FOR EXPORT)
 #06... FOR EXPORT
 #07... FOR DOMESTIC USE

13. LOWER KNIFE COMPONENTS

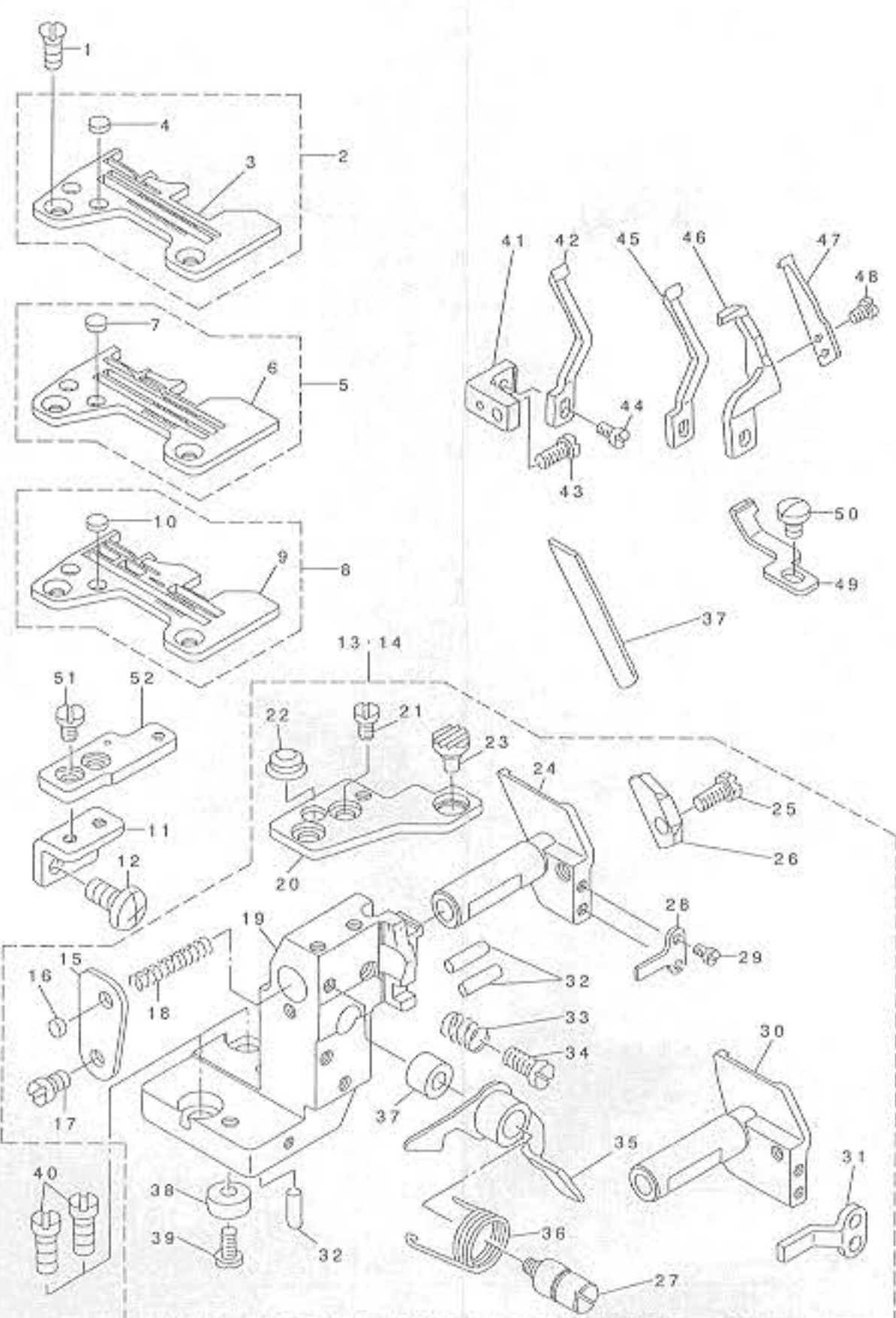

REF. NO	NOTE	PART NO.	DESCRIPTION	Qty
1		SS-2110910-SL	SCREW 11/64-40 L=9	2
2	#01	R4200-JOE-DAO	THROAT PLATE ASM.	1
3		R4200-JOE-D00	THROAT PLATE	(1)
4		118-06304	PLUG	(2)
5	#02	R4305-JOE-EAO	THROAT PLATE ASM.	1
6		R4305-JOE-E00	THROAT PLATE	(1)
7		118-06304	PLUG	(2)
8	#03	R4508-JOE-DAO	THROAT PLATE ASM.	1
9		R4508-JOE-D00	THROAT PLATE	(1)
10		118-06304	PLUG	(2)
11		118-04408	THROAT PLATE BASE B RETAINER	1
12		SM-4051055-SP	SCREW	2
13	#04	121-33658	LOWER KNIFE BRACKET ASM.	1
14	#03	121-33666	LOWER KNIFE BRACKET ASM.	1
15		121-33211	SPRING STOPPER	(1)
16		118-06304	PLUG	(1)
17		SS-7110720-SP	SCREW 11/64-40 L=7	(1)
18		118-46607	SPRING	(1)
19		121-32619	LOWER KNIFE BRACKET	(1)
20		121-02208	THROAT PLATE BASE A	(1)
21		SS-6110610-TP	SCREW 11/64-40 L=6	(2)
22		121-03701	RUBBER PLUG B	(1)
23		121-03602	RUBBER PLUG A	(1)
24	#04	121-32700	LOWER KNIFE SLIDE STUD	(1)
25		SS-9111010-SP	SCREW 11/64-40 L=9.5	(1)
26		121-33104	LOWER KNIFE PRESSER PLATE	(1)
27		121-02810	LEVER SHAFT	(1)
28	#04	121-32908	ROTATING STOPPER	(1)
29		SS-7090710-SP	SCREW 9/64-40 L= 6.8	(2)
30	#03	121-32809	LOWER KNIFE SLIDE STUD	(1)
31	#03	121-33005	ROTATING STOPPER	(1)
32		121-33708	HOLDER PIN	(3)
33		B4115-704-000	SPRING	(1)
34		SS-7151120-SP	SCREW 15/64-28 L=11	(1)
35		121-02950	LEVER ASM.	(1)
36		118-02006	LEVER SPRING	(1)
37		121-03107	RUBBER PLUG	(1)
38		B2739-761-000	WASHER	(1)
39		SS-7110840-SP	SCREW 11/64-40 L=7.8	(1)
40		SS-6151440-SP	SCREW 15/64-28 L=14	2
41		118-47100	NEEDLE GUARD HOLDER	1
42	#01	118-90100	NEEDLE GUARD	1
43		SS-7110840-SP	SCREW 11/64-40 L=7.8	1
44		SS-7090610-SP	SCREW 9/64-40 L=6	1
45	#02	118-90308	NEEDLE GUARD	1
46	#03	120-15301	NEEDLE HOLDER	1
47	#03	120-15400	NEEDLE HOLDER	1
48	#03	SS-7060510-SP	SCREW 3/32-56 L=4.8	2
49	#03	121-77903	NEEDLE HOLDER	1
50	#03	SS-7090510-SP	SCREW 9/64-40 L= 4.6	1
51		SS-6110610-TP	SCREW 11/64-40 L=6	2
52		118-47902	THROAT PLATE BASE B	1
53		118-46003	LOWER KNIFE	1

NOTE

#01... FOR MO-3904

#02... FOR MO-3914

#03... FOR MO-3916

#04... FOR MO-3904, MO-3914

14. NEEDLE COOLING MECHANISM COMPONENTS

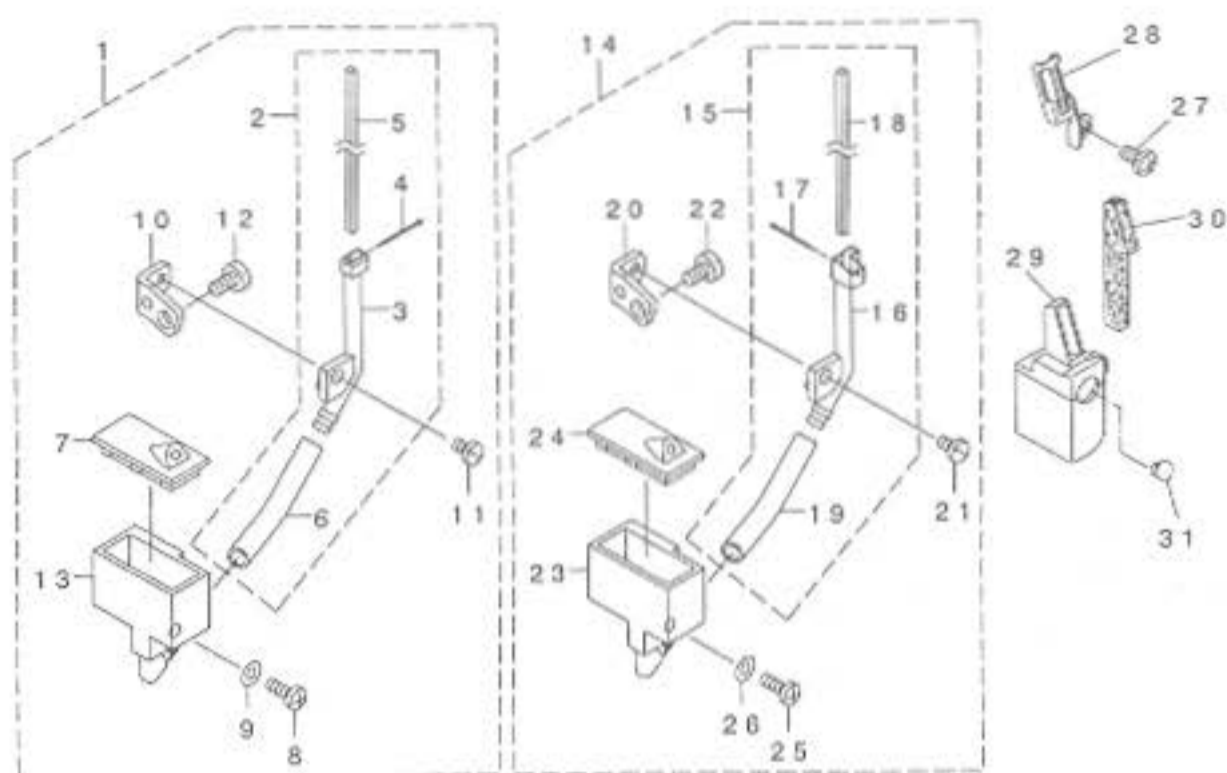

REF. NO	NOTE	PART NO.	DESCRIPTION	Qty
1	#01	118-55954	NEEDLE COOLER UNIT ASM. (OVER)	1
2		118-55970	NEEDLE COOLER ASM. (OVER)	(1)
3		118-55905	NEEDLE COOLER (OVER)	(1)
4		118-56101	NEEDLE COOLER PIN	(1)
5		118-56200	NEEDLE COOLER FELT	(1)
6		BT-0700500-EA	TUBE	(0.1)
7		118-56507	TANK COVER	(1)
8		SS-4091015-SP	SCREW 9/64-40 L=10	(1)
9		WP-0371026-SB	WASHER 3.7X7X1	(1)
10		118-56309	SUPPORT	(1)
11		SS-7090610-SP	SCREW 9/64-40 L=6	(1)
12		SS-7110840-SP	SCREW 11/64-40 L=7.8	(1)
13		118-56408	TANK	(1)
14	#02	118-56051	NEEDLE COOLER UNIT ASM. (INTER)	1
15		118-56077	NEEDLE COOLER ASM. (INTER)	(1)
16		118-56002	NEEDLE COOLER (INTER)	(1)
17		118-56101	NEEDLE COOLER PIN	(1)
18		118-56200	NEEDLE COOLER FELT	(1)
19		BT-0700500-EA	TUBE	(0.1)
20		118-56309	SUPPORT	(1)
21		SS-7090610-SP	SCREW 9/64-40 L=6	(1)
22		SS-7110840-SP	SCREW 11/64-40 L=7.8	(1)
23		118-56408	TANK	(1)
24		118-56507	TANK COVER	(1)
25		SS-4091015-SP	SCREW 9/64-40 L=10	(1)
26		WP-0371026-SB	WASHER 3.7X7X1	(1)
27		SM-4040855-SP	SCREW	1
28		121-38400	PRESSER	1
29		121-38152	SILICON TANK ASM.	1
30		121-38301	FELT	1
31		TA-0950806-R0	RUBBER PLUG	1

NOTE

#01... FOR NO-3904, MO-3914
#02... FOR NO-3916

15. LUBRICATION MECHANISM COMPONENTS

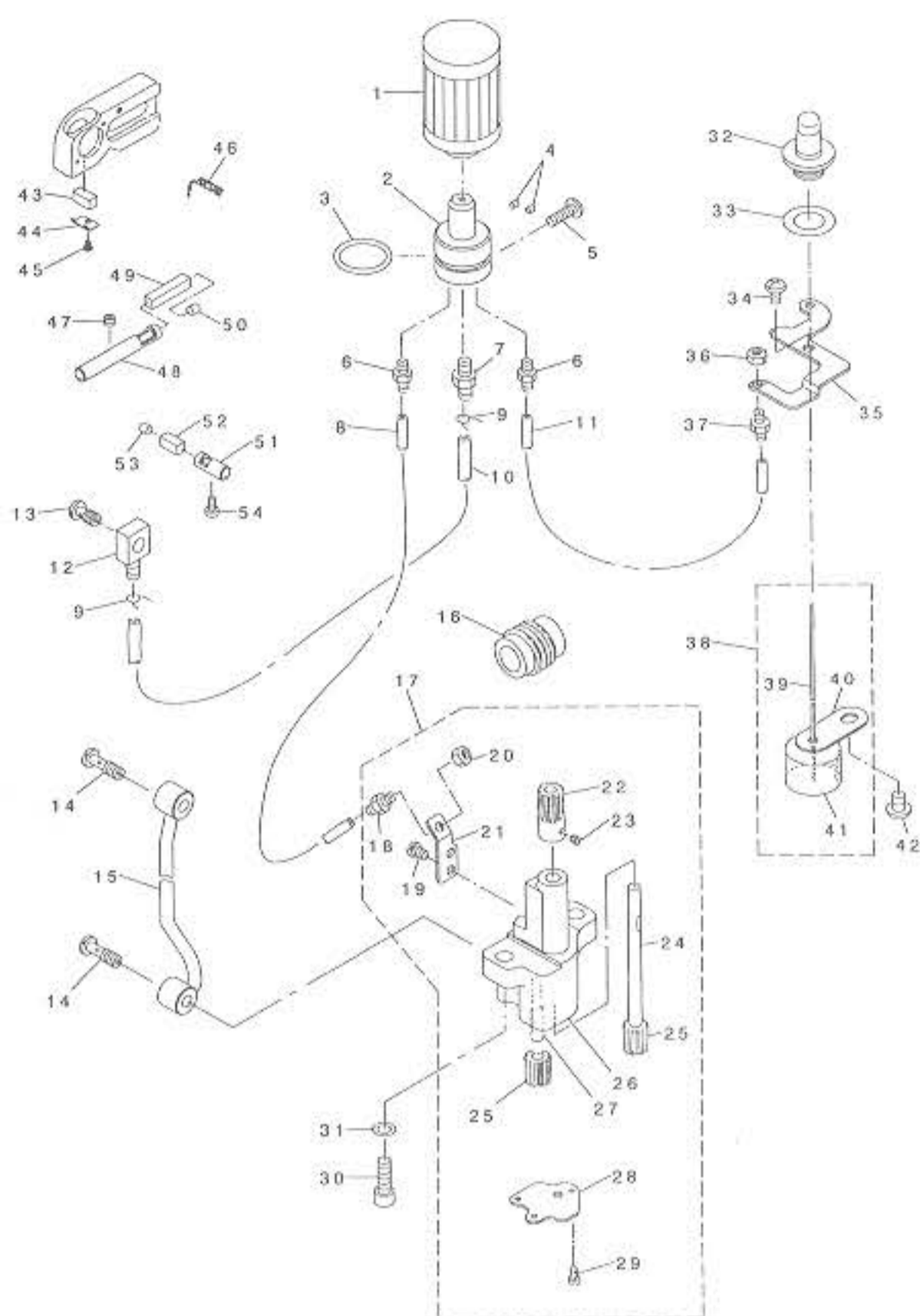

REF. NO.	NOTE	PART NO.	DESCRIPTION	Qty
1		118-43208	CARTRIDGE FILTER	1
2		121-29706	FILTER GUIDE	1
3		RO-2182401-00	RUBBER RING	1
4		TA-0290301-M0	PLUG 2.9X3.2X3	2
5		SM-4051601-SC	SCREW M5X0.8 L=16	1
6		SQ-1110451-MZ	CONNECTING SCREW	2
7		SQ-1150451-MZ	CONNECTING SCREW	1
8		BT-0500300-EG	OIL TUBE	0.2
9		101-26803	OIL TUBE HOLDER	2
10		BT-0500300-EA	OIL TUBE	0.3
11		BT-0500300-EA	OIL TUBE	0.16
12		SQ-0000451-MZ	CONNECTING SCREW	1
13		SQ-1150441-SD	CONNECTING SCREW	1
14		SQ-1150454-SD	CONNECTING SCREW	2
15		121-29458	OIL PIPE ASM.	1
16		121-29102	WORM	1
17		121-29250	OIL PUMP ASM.	1
18		SQ-1110451-MZ	CONNECTING SCREW	(1)
19		SS-4110615-SP	SCREW 11/64-40 L=6	(2)
20		NS-6110310-SP	NUT 11/64-40	(1)
21		121-29300	CONNECTING SCREW BRACKET	(1)
22		118-41707	WORM GEAR	(1)
23		SS-8110410-TP	SCREW 11/64-40 L= 3.5	(2)
24		118-41806	GEAR PUMP SHAFT, LARGE	(1)
25		118-40303	OIL PUMP PINION	(2)
26		118-40402	GEAR PUMP SHAFT	(1)
27		121-29201	OIL PUMP	(1)
28		118-43406	COVER	(1)
29		SS-6090650-SP	SCREW 9/64-40 L=6	(3)
30		SM-6061802-TP	SCREW M6 L=18	2
31		WP-0651056-SD	WASHER 6.5X11X1	2
32		121-30100	OIL GAUGE	1
33		121-30209	RUBBER PACKING	1
34		SM-4050855-SP	SCREW M5 L=8	1
35		122-55907	OILING EXIT SUPPORT	1
36		NS-6110310-SP	NUT 11/64-40	1
37		SQ-1110451-MZ	CONNECTING SCREW	1
38		121-29854	FLOAT ASM.	1
39		121-29904	OIL GAUGE BAR	(1)
40		121-30001	FLOAT SUPPORT	(1)
41		121-29805	FLOAT	(1)
42		SM-4060801-SE	SCREW	1
43		121-30803	OIL FELT	1
44		121-30704	FELT HOLDER	1
45		SS-7060310-SP	SCREW 3/32-56 L=3	1
46		CQ-2020000-00	OIL WICK	0.1
47		SM-8050402-TP	SCREW	1
48		121-30308	OILING PIN	1
49		121-30407	OIL FELT	1
50		TA-0400301-M0	PLUG D=4X4.5 L=3	1
51		121-30506	OILING PIN	1
52		121-30605	OIL FELT	1
53		TA-0400301-M0	PLUG D=4X4.5 L=3	1
54		SS-6121020-SP	SCREW 3/16-28 L= 9.5	1

16. SEMI-SUNKEN TYPE TABLE COMPONENTS

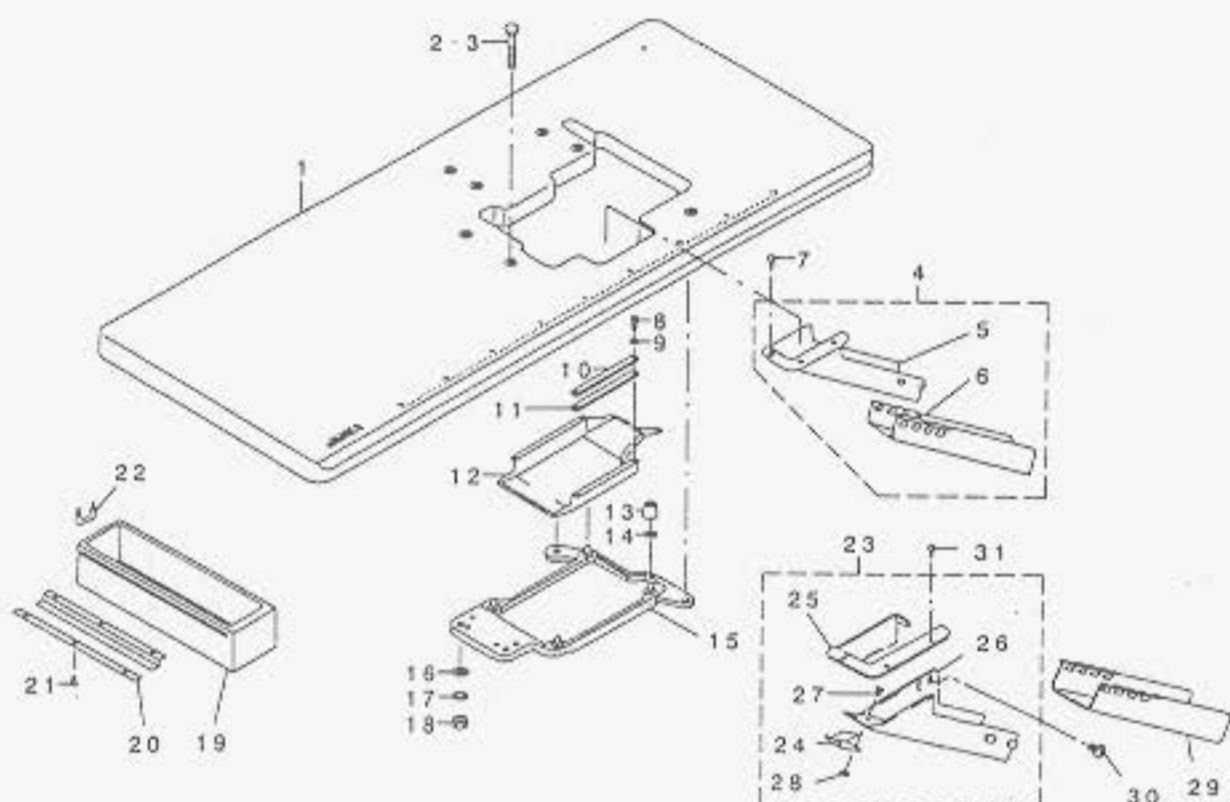

REF. NO	NOTE	PART NO.	DESCRIPTION	Qty
1		119-59400	TABLE (SEMI-SUNKEN)	1
2	#01	119-66702	BOLT A	4
3	#02	115-71601	BOLT A	4
4		119-60150	CLOTH WASTE CHUTE ASM. (BENCH)	1
5		119-60101	CLOTH WASTE CHUTE, UPPER(BENCH)	(1)
6		119-60002	CLOTH WASTE CHUTE, LOWER(BENCH)	(1)
7		SK-2351600-SC	WOOD SCREW D=3.5 L=16	3
8		SS-6090630-SP	SCREW 9/64-40 L=6	5
9		WP-0370316-SD	WASHER 3.7X8X0.3	3
10		118-50708	CASE PRESSER PLATE	1
11		118-50807	CASE SPONGE	1
12		118-49403	COOLING FAN CASE	1
13		115-71403	RUBBER CUSHION	4
14		118-49601	SPACER	4
15		118-49361	FRAME SUPPORT PLATE ASM.	1
16		WP-1102016-SC	WASHER 11X21X2	4
17		MS-1002560-KR	SPRING WASHER 10X18X2.5	4
18		NS-6240630-SN	NUT 3/8-18	4
19		111-55108	DRAWER	1
20		111-55207	DRAWER SUPPORT	2
21		SK-3311500-SC	WOOD SCREW D=3.1 L=15	6
22		D9204-555-DOO	DRAWER STOPPER	1
23	#03	121-35554	CLOTH WASTE CHUTE ASM.	1
24		121-35505	CLOTH WASTE CHUTE SUPPORT	(1)
25		119-62800	CLOTH WASTE CHUTE INLET	(1)
26		119-62909	CLOTH WASTE CHUTE, UPPER	(1)
27		SS-5090610-SP	SCREW 9/64-40 L=6	(3)
28		NS-6090310-SP	NUT 9/64-40	(3)
29	#03	119-60002	CLOTH WASTE CHUTE, LOWER(BENCH)	1
30	#03	SS-5110710-SP	SCREW 11/64-40 L=7	2
31	#03	SK-2351600-SC	WOOD SCREW D=3.5 L=16	3

NOTE #01...FOR DOMESTIC USE
#02...FOR EXPORT
#03...FOR JE

17. FULLY-SUNKEN TYPE TABLE COMPONENTS

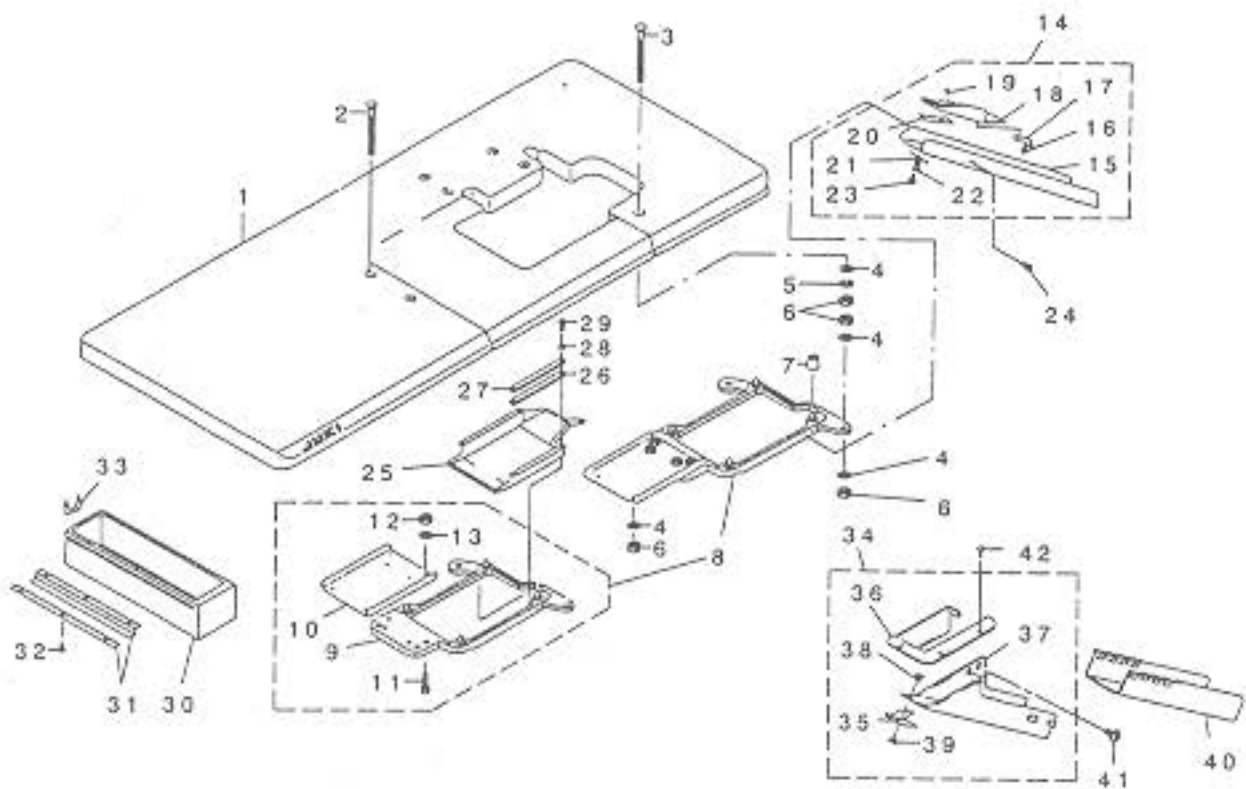

REF. NO	NOTE	PART NO.	DESCRIPTION	Qty
1		119-59558	TABLE ASM.	1
2		115-71809	BOLT C	2
3		115-71908	BOLT D	2
4		NP-1102016-SC	WASHER 11X21X2	12
5		NS-1002560-KR	SPRING WASHER 10X18X2.5	4
6		NS-6240630-SM	NUT 3/8-18	12
7		115-71403	RUBBER CUSHION	4
8		118-49379	FRAME SUPPORT PLATE ASM.	1
9		118-49361	FRAME SUPPORT PLATE ASM.	(1)
10		118-50906	FRAME SUPPORT AUXILIARY PLATE	(1)
11		SM-9082513-CF	SCREW WD L=25	(4)
12		NM-6080600-SM	NUT M8	(4)
13		NP-0850002-SC	WASHER 8.5X18X1.6	(4)
14		119-60259	CLOTH CHUTE ASM.	1
15		119-60200	CLOTH WASTE CHUTE	(1)
16		ST-6030821-UA	SCREW D=3-24 L=8	(2)
17		118-50401	CLOTH WASTE CHUTE INLET LEVER	(1)
18		119-60309	CLOTH WASTE CHUTE HOLE	(1)
19		SS-6090420-SP	SCREW 9/64-40 L=4.0	(2)
20		118-50609	RUBBER	(1)
21		118-50500	SPRING	(1)
22		NP-0370316-SD	WASHER 3.7X8X0.3	(1)
23		ST-6030821-UA	SCREW D=3-24 L=8	(1)
24		SS-5110710-SP	SCREW 11/64-40 L=7	2
25		118-49403	COOLING FAN CASE	1
26		118-50807	CASE SPONGE	1
27		118-50708	CASE PRESSER PLATE	1
28		NP-0370316-SD	WASHER 3.7X8X0.3	1
29		SS-6090630-SP	SCREW 9/64-40 L=6	5
30		111-55108	DRAWER	1
31		111-55207	DRAWER SUPPORT	2
32		SK-3311500-SC	WOOD SCREW D=3.1 L=15	6
33		08204-565-000	DRAWER STOPPER	1
34	201	121-35554	CLOTH WASTE CHUTE ASM.	1
35		121-35505	CLOTH WASTE CHUTE SUPPORT	(1)
36		119-62800	CLOTH WASTE CHUTE INLET	(1)
37		119-62909	CLOTH WASTE CHUTE, UPPER	(1)
38		SS-5090610-SP	SCREW 9/64-40 L=6	(3)
39		NS-6090310-SP	NUT 9/64-40	(3)
40	201	119-60002	CLOTH WASTE CHUTE, LOWER(BENCH)	1
41	201	SS-5110710-SP	SCREW 11/64-40 L=7	2
42	201	SK-2351600-SC	WOOD SCREW D=3.5 L=16	3

NOTE

201...FOR JE

18. THREAD STAND COMPONENTS(FOR MO-3904, MO-3914)

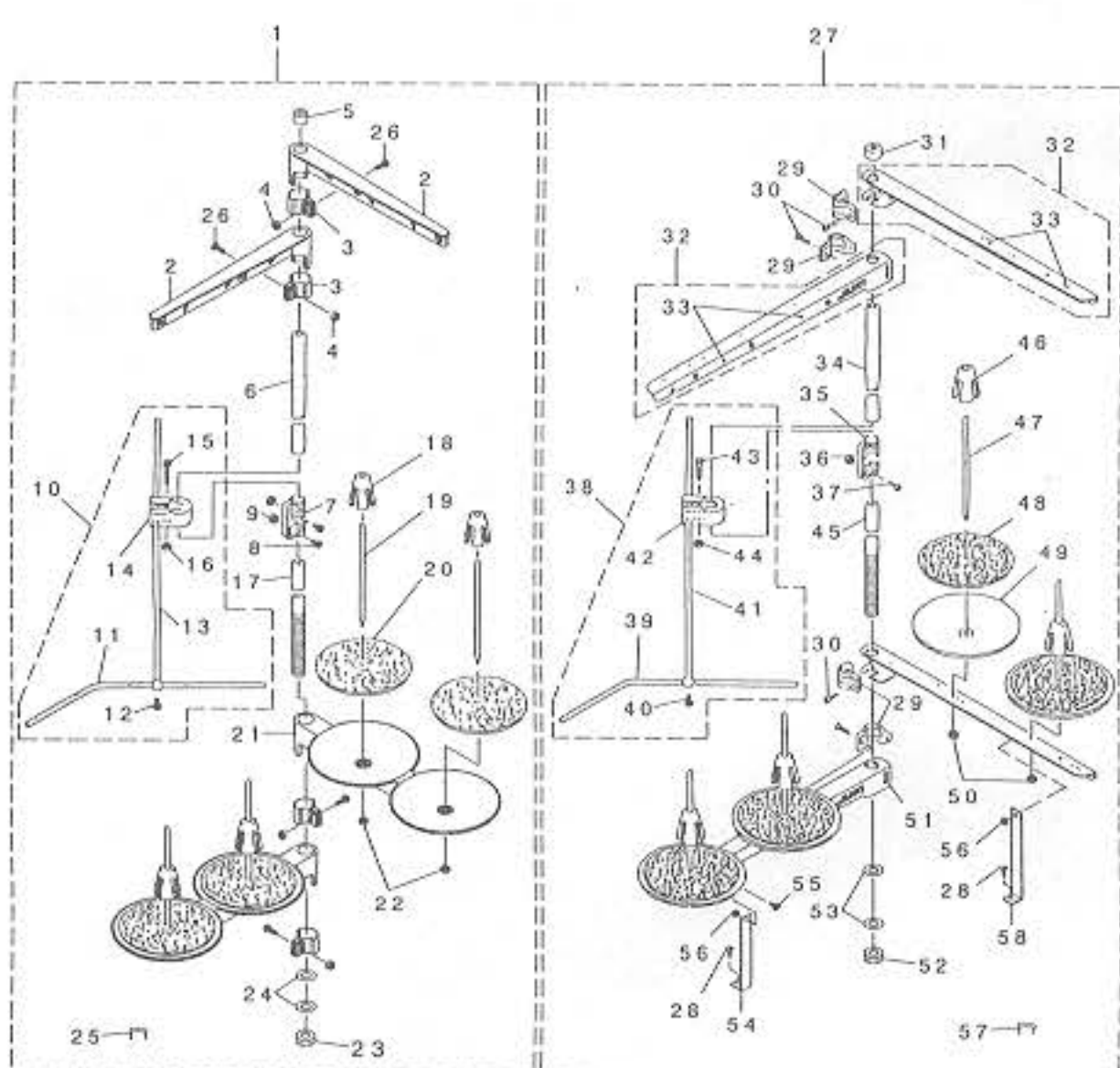

REF. NO.	NOTE	PART NO.	DESCRIPTION	Qty
1		119-69458	THREAD STANDING DEVICE ASM.	1
2		111-85352	THREAD GUIDE ASM.	(2)
3		111-85402	THREAD GUIDE ARM JOINT	(4)
4		NM-6050001-SE	NUT M5	(4)
5		B3311-704-000	SPOOL REST ROD CAP	(1)
6		111-85204	SPOOL REST ROD, UPPER	(1)
7		B3305-704-000-A	SPOOL REST ROD JOINT	(1)
8		SM-4051405-SE	SCREW M5 L=14	(2)
9		NM-6050001-SE	NUT M5	(2)
10		B3309-704-0A0	THREAD GUIDE ARM ASM.	(1)
11		B3311-804-000	LOWER THREAD GUIDE	(1)
12		SS-7110540-SP	SCREW 11/64-40 L=5	(1)
13		B3309-704-000	THREAD GUIDE ARM	(1)
14		B3304-704-000-A	THREAD GUIDE ARM HOLDER	(1)
15		SM-6053000-SE	SCREW M5X0.8 L=30	(1)
16		NM-6050001-SE	NUT M5	(1)
17		111-85105	SPOOL REST ROD, LOWER	(1)
18		111-85501	SPOOL RETAINER	(4)
19		B3320-704-L00-A	SPOOL PIN	(4)
20		B3311-012-000	SPOOL REST CUSHION	(4)
21		111-85006	SPOOL REST ARM	(2)
22		NM-6050001-SE	NUT M5	(4)
23		B3317-704-000	NUT	(1)
24		WP-1612616-SE	WASHER 16X30X2.6	(2)
25		MAO-11532000	CORD STAPLE	(3)
26		SM-4051405-SE	SCREW M5 L=14	(4)
27	#01	119-69953	THREAD STANDING DEVICE ASM.	1
28		SK-3382001-SE	SCREW D=3.8 L=20	(2)
29		B3318-704-L00-A	THREAD GUIDE ARM JOINT	(4)
30		SM-6061610-SC	SCREW M6 L=16	(4)
31		B3311-704-000	SPOOL REST ROD CAP	(1)
32		119-69573	SPOOL REST ARM A ASM.	(2)
33		B3319-704-L00	THREAD GUIDE	(4)
34		111-85204	SPOOL REST ROD, UPPER	(1)
35		B3305-704-000-A	SPOOL REST ROD JOINT	(1)
36		NM-6050001-SE	NUT M5	(2)
37		SM-4051405-SE	SCREW M5 L=14	(2)
38		B3309-704-0A0	THREAD GUIDE ARM ASM.	(2)
39		B3311-804-000	LOWER THREAD GUIDE	(1)
40		SS-7110540-SP	SCREW 11/64-40 L=5	(1)
41		B3309-704-000	THREAD GUIDE ARM	(1)
42		B3304-704-000-A	THREAD GUIDE ARM HOLDER	(1)
43		SM-6053000-SE	SCREW M5X0.8 L=30	(1)
44		NM-6050001-SE	NUT M5	(2)
45		111-85105	SPOOL REST ROD, LOWER	(1)
46		111-85501	SPOOL RETAINER	(4)
47		B3320-704-L00-A	SPOOL PIN	(4)
48		B3311-012-000	SPOOL REST CUSHION	(4)
49		119-66504	SPOOL REST	(4)
50		NM-6050001-SE	NUT M5	(4)
51		119-69508	SPOOL REST ARM A	(2)
52		B3317-704-000	NUT	(1)
53		WP-1612616-SE	WASHER 16X30X2.6	(2)
54		B3321-704-L00	SPOOL REST ARM SUPPORT, A	(1)
55		SM-4061201-SE	SCREW M6 L=12	(2)
56		NM-6060001-SE	NUT M6	(2)
57		MAO-11532000	CORD STAPLE	(3)
58		B3321-704-LOB	SPOOL REST ARM SUPPORT, B	(1)

NOTE

#01...SPECIAL ORDER PART FOR LARGE SPOOL THREAD STAND (FOR JE)

19. THREAD STAND COMPONENTS(FOR MO-3916)

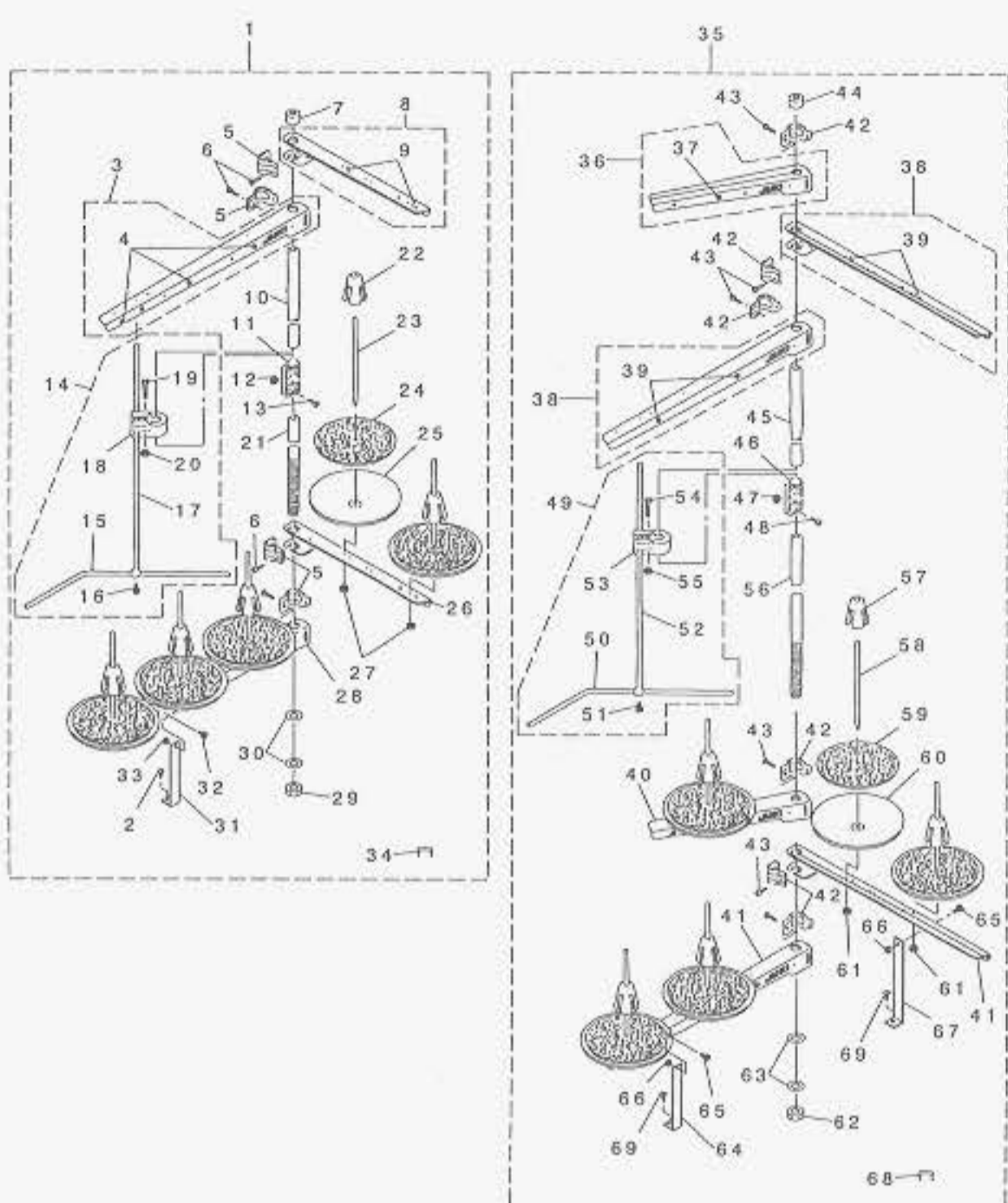

REF. NO	NOTE	PART NO.	DESCRIPTION	Qty
1		119-69557	THREAD STANDING DEVICE ASM.	1
2		SK-3382001-SE	SCREW D=3.8 L=20	(1)
3		119-69565	SPOOL REST ARM A ASM.	(1)
4		B3319-704-L00	THREAD GUIDE	(3)
5		B3318-704-L00-A	THREAD GUIDE ARM JOINT	(4)
6		SM-6061610-SC	SCREW M6 L=16	(4)
7		B3311-704-000	SPOOL REST ROD CAP	(1)
8		119-69466	THREAD GUIDE ARM B ASM.	(1)
9		B3319-704-L00	THREAD GUIDE	(2)
10		111-85204	SPOOL REST ROD,UPPER	(1)
11		B3305-704-000-A	SPOOL REST ROD JOINT	(1)
12		NM-6050001-SE	NUT M5	(2)
13		SM-4051405-SE	SCREW M5 L=14	(2)
14		B3309-704-0A0	THREAD GUIDE ARM ASM.	(1)
15		B3311-804-000	LOWER THREAD GUIDE	(1)
16		SS-7110540-SP	SCREW 11/64-40 L=5	(1)
17		B3309-704-000	THREAD GUIDE ARM	(1)
18		B3304-704-000-A	THREAD GUIDE ARM HOLDER	(1)
19		SM-6053000-SE	SCREW M5X0.8 L=30	(1)
20		NM-6050001-SE	NUT M5	(1)
21		111-85105	SPOOL REST ROD,LOWER	(1)
22		111-85501	SPOOL RETAINER	(5)
23		B3320-704-L00-A	SPOOL PIN	(5)
24		B3311-012-000	SPOOL REST CUSHION	(5)
25		119-66504	SPOOL REST	(5)
26		119-69409	THREAD GUIDE ARM B	(1)
27		NM-6050001-SE	NUT M5	(5)
28		119-69508	SPOOL REST ARM A	(1)
29		B3317-704-000	NUT	(1)
30		WP-1612616-SE	WASHER 16X30X2.6	(2)
31		B3321-704-L00	SPOOL REST ARM SUPPORT, A	(1)
32		SM-4061201-SE	SCREW M6 L=12	(1)
33		NM-6060001-SE	NUT M6	(1)
34		MAO-11532000	CORD STAPLE	(3)
35	#01	119-70050	THREAD STANDING DEVICE ASM.	1
36		119-69474	THREAD GUIDE ARM B ASM.	(1)
37		B3319-704-L00	THREAD GUIDE	(1)
38		119-69573	SPOOL REST ARM A ASM.	(2)
39		B3319-704-L00	THREAD GUIDE	(4)
40		119-69409	THREAD GUIDE ARM B	(1)
41		119-69508	SPOOL REST ARM A	(2)
42		B3318-704-L00-A	THREAD GUIDE ARM JOINT	(6)
43		SM-6061610-SC	SCREW M6 L=16	(6)
44		B3311-704-000	SPOOL REST ROD CAP	(1)
45		111-85204	SPOOL REST ROD,UPPER	(1)
46		B3305-704-000-A	SPOOL REST ROD JOINT	(1)
47		NM-6050001-SE	NUT M5	(2)
48		SM-4051405-SE	SCREW M5 L=14	(2)
49		B3309-704-0A0	THREAD GUIDE ARM ASM.	(1)
50		B3311-804-000	LOWER THREAD GUIDE	(1)
51		SS-7110540-SP	SCREW 11/64-40 L=5	(1)
52		B3309-704-000	THREAD GUIDE ARM	(1)
53		B3304-704-000-A	THREAD GUIDE ARM HOLDER	(1)
54		SM-6053000-SE	SCREW M5X0.8 L=30	(1)
55		NM-6050001-SE	NUT M5	(1)
56		111-85105	SPOOL REST ROD,LOWER	(1)
57		111-85501	SPOOL RETAINER	(5)
58		B3320-704-L00-A	SPOOL PIN	(5)
59		B3311-012-000	SPOOL REST CUSHION	(5)
60		119-66504	SPOOL REST	(5)
61		NM-6050001-SE	NUT M5	(5)
62		B3317-704-000	NUT	(1)
63		WP-1612616-SE	WASHER 16X30X2.6	(2)
64		B3321-704-L00	SPOOL REST ARM SUPPORT, A	(1)
65		SM-4061201-SE	SCREW M6 L=12	(2)
66		NM-6060001-SE	NUT M6	(2)
67		B3321-704-LOB	SPOOL REST ARM SUPPORT, B	(1)
68		MAO-11532000	CORD STAPLE	(3)
69		SK-3382001-SE	SCREW D=3.8 L=20	(2)

NOTE

#01...SPECIAL ORDER PART FOR LARGE SPOOL THREAD STAND (FOR JE)

20. SPECIAL ORDER PARTS COMPONENTS

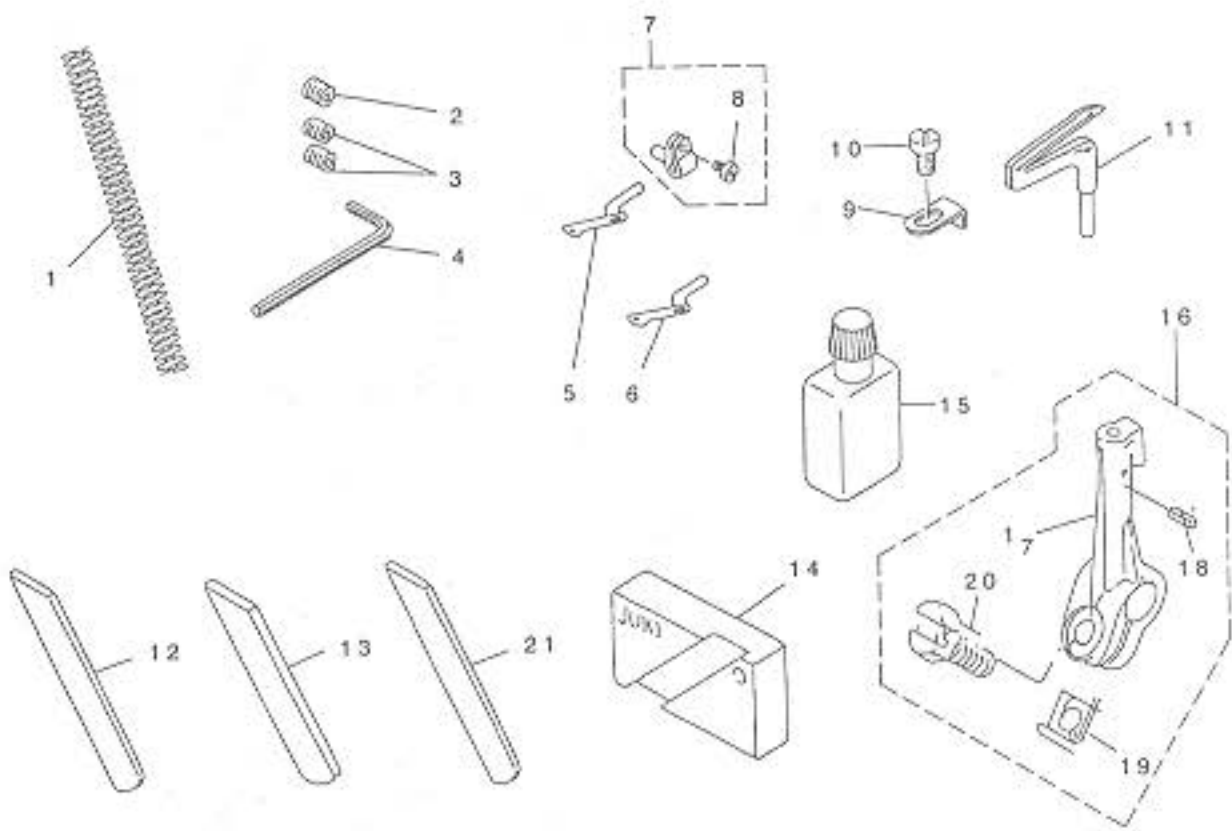

REF. NO	NOTE	PART NO.	DESCRIPTION	Qty
1		B1515-804-000-A	PRESSER SPRING	1
2	#01	SS-8080322-TP	SCREW 1/8-44 L=3.2	1
3	#04	SS-8080322-TP	SCREW 1/8-44 L=3.2	2
4		B9112-804-000	SPANNER	1
5	#05	B2519-804-000	UPPER LOOPER	1
6	#02	B2519-814-000	UPPER LOOPER	1
7		115-44756	UPPER LOOPER SUPPORT ARM ASM.	1
8		SS-6080410-SP	SCREW 1/8-44 L=4	(1)
9	#03	118-98103	PRESSER FOOT AUXILIARY PLATE	1
10	#03	SS-4080620-TP	SCREW 1/8-44 L=6	1
11		B2521-804-000	LOWER LOOPER	1
12		118-47605	LOWER KNIFE	1
13		119-92005	LOWER KNIFE	1
14		119-96907	LOWER KNIFE GAUGE	1
15		B9135-123-0B0	SILICON OIL LUBRICANT ASM. (30	1
16		121-23758	LOWER LOOPER SUPPORT ARM ASM.	1
17		121-23709	LOWER LOOPER SUPPORT ARM	(1)
18		PS-0300062-KH	SPRING PIN 3X6	(1)
19		B2531-704-000	WASHER	(1)
20		SS-9151210-TP	SCREW 15/64-28 L=11.8	(1)
21		119-64509	CERAMIC LOWER KNIFE	1

NOTE

#01... FOR NO-3904
 #02... FOR NO-3914
 #03... FOR NO-3904, NO-3914
 #04... FOR NO-3914, NO-3916
 #05... FOR NO-3904, NO-3916

Ref. no.	Usage	用途
1	For light-weight materials	薄物用
2~4	For needle set	針止め用
5~10, 12, 13	For adjustment type	調節式用
11, 21	For wide width	広幅用