

# SUPERMICR<sup>®</sup> A+ Server 2042G-6RF/TRF Quick Reference Guide

## Board Layout

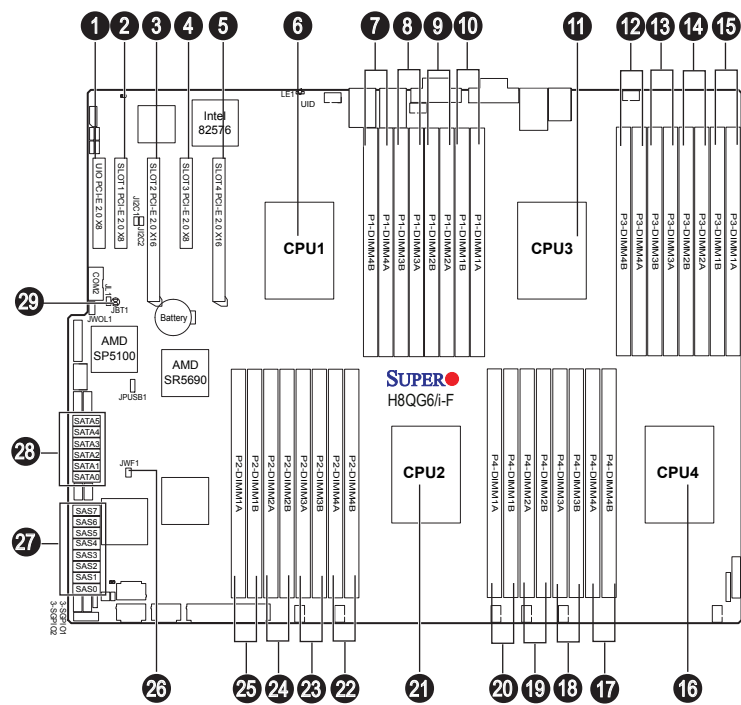

No.	Description	No.	Description
1	UIOP PCI-E 2.0 x8	16	CPU4
2	Slot1 PCI-E 2.0 x8	17	P4-DIMM4A/P4-DIMM4B
3	Slot2 PCI-E 2.0 x16	18	P4-DIMM3A/P4-DIMM3B
4	Slot3 PCI-E 2.0 x8	19	P4-DIMM2A/P4-DIMM2B
5	Slot4 PCI-E 2.0 x16	20	P4-DIMM1A/P4-DIMM1B
6	CPU1	21	CPU2
7	P1-DIMM4A/P1-DIMM4B	22	P2-DIMM4A/P2-DIMM4B
8	P1-DIMM3A/P1-DIMM3B	23	P2-DIMM3A/P2-DIMM3B
9	P1-DIMM2A/P1-DIMM2B	24	P2-DIMM2A/P2-DIMM2B
10	P1-DIMM1A/P1-DIMM1B	25	P2-DIMM1A/P2-DIMM1B
11	CPU3	26	JWF1 = Compact Flash Card Power Connector
12	P3-DIMM4A/P3-DIMM4B	27	SAS #0~SAS #3, SAS #4~ SAS #7 Ports (2042G-6RF only)
13	P3-DIMM3A/P3-DIMM3B	28	SATA0/SATA1/SATA2/SATA3/SATA4/SATA5 (2042G-TRF only)
14	P3-DIMM2A/P3-DIMM2B	29	JBT1 = CMOS Clear
15	P3-DIMM1A/P3-DIMM1B		

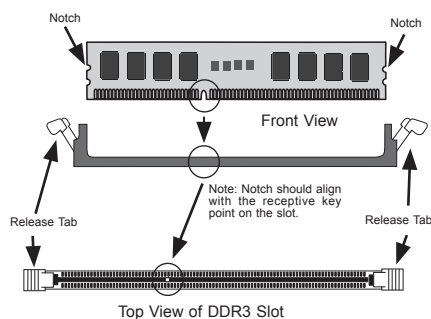

## MEMORY

### Memory Population for Optimal Performance -For a Motherboard with One CPU (CPU1) Installed

# DIMMS	CPU	Branch 0	Branch 1	Branch 2	Branch 3				
4 DIMMs	CPU1	P1-1A	P1-2A	P1-3A	P1-4A				
8 DIMMs	CPU1	P1-1A	P1-1B	P1-2A	P1-2B	P1-3A	P1-3B	P1-4A	P1-4B

### Memory Population for Optimal Performance -For a Motherboard with Two CPUs (CPU1 & CPU2) Installed

# DIMMS	CPU	Branch 0	Branch 1	Branch 2	Branch 3				
8 DIMMs	CPU1	P1-1A	P1-2A	P1-3A	P1-4A				
	CPU2	P2-1A	P2-2A	P2-3A	P2-4A				
16 DIMMs	CPU1	P1-1A	P1-1B	P1-2A	P1-2B	P1-3A	P1-3B	P1-4A	P1-4B
	CPU2	P2-1A	P2-1B	P2-2A	P2-2B	P2-3A	P2-3B	P2-4A	P2-4B

### Memory Population for Optimal Performance - For a Motherboard with Four CPUs (CPU1, CPU2, CPU3 & CPU4) Installed

# DIMMS	CPU	Channel 1	Channel 2	Channel 3	Channel 4				
16 DIMMs	CPU1	P1-1A	P1-2A	P1-3A	P1-4A				
	CPU2	P2-1A	P2-2A	P2-3A	P2-4A				
	CPU3	P3-1A	P3-2A	P3-3A	P3-4A				
	CPU4	P4-1A	P4-2A	P4-3A	P4-4A				
32 DIMMs	CPU1	P1-1A	P1-1B	P1-2A	P1-2B	P1-3A	P1-3B	P1-4A	P1-4B
	CPU2	P2-1A	P2-1B	P2-2A	P2-2B	P2-3A	P2-3B	P2-4A	P2-4B
	CPU3	P3-1A	P3-1B	P3-2A	P3-2B	P3-3A	P3-3B	P3-4A	P3-4B
	CPU4	P4-1A	P4-1B	P4-2A	P4-2B	P4-3A	P4-3B	P4-4A	P4-4B

### DIMM Module Population Configuration

For memory to work properly, follow the tables below for memory installation:

#### Per Channel DIMM Populations Options

DIMM Type	DIMM A	DIMM B	Max. MHz, 1.5V DIMMs	Max. MHz, 1.35V DIMMs	Max. GB/ Channel
Unbuffered DIMM	SR or DR	Empty	1600 MHz		8 GB
	SR	SR	1600 MHz	1333 MHz	8 GB
	DR	DR	1333 MHz		16 GB
Registered DIMM	SR or DR	Empty	1600 MHz		16 GB
	SR	SR	1600 MHz	1333 MHz	16 GB
	DR	DR	1600 MHz		32 GB
	QR	Empty	1333 MHz	1066 MHz	32 GB
Load Reduced DIMM	QR	QR	1066 MHz	800 MHz	64 GB
	QR	Empty		1333 MHz	32 GB
	QR	QR		1333 MHz	64 GB

**Note 1:** Due to OS limitations, some operating systems may not show more than 4 GB of memory.

**Note 2:** Due to memory allocation to system devices, the amount of memory that remains available for operational use will be reduced when 4 GB of RAM is used. The reduction in memory availability is disproportional.

## Front View & Interface

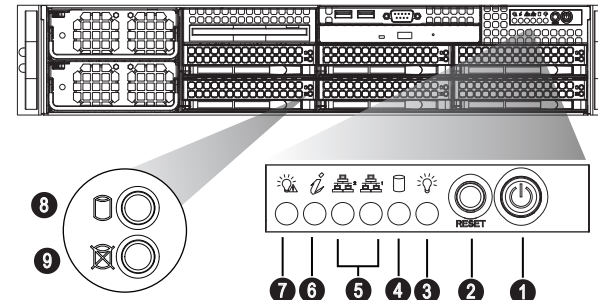

No.	Description
1	Power Button
2	Reset Button
3	Power LED
4	Device Activity LED
5	LAN1 LED & LAN2 LED
6	Information LED
7	Power Fail LED
8	Hard Drive Signal
9	Hard Drive Fail

## Rear View

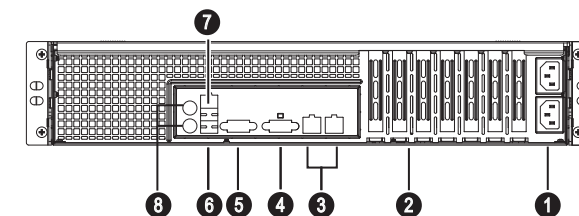

No.	Description
1	Power Supplies
2	4 Low Profile PCI Expansion Slot
3	LAN 1 & LAN 2 Ports
4	VGA Port
5	COM Port
6	USB Ports
7	Dedicate LAN for IPMI
8	PS2 Keyboard & Mouse Ports

## Beep Codes

BIOS Beep Codes		
Beep Code/LED	Message	Description
1 beep	Refresh	Circuits have been reset. (Ready to power up)
5 short beeps + 1 long beep	Memory	No memory detected
1 long beeps + 8 short beeps	Video	Video adapter disabled or missing

## CPU Installation

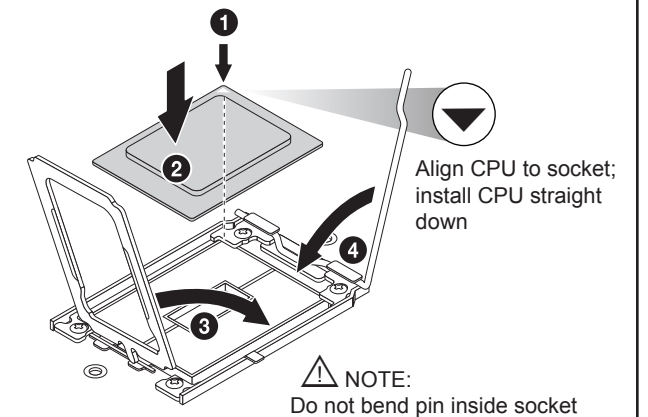

## Heatsink Installation

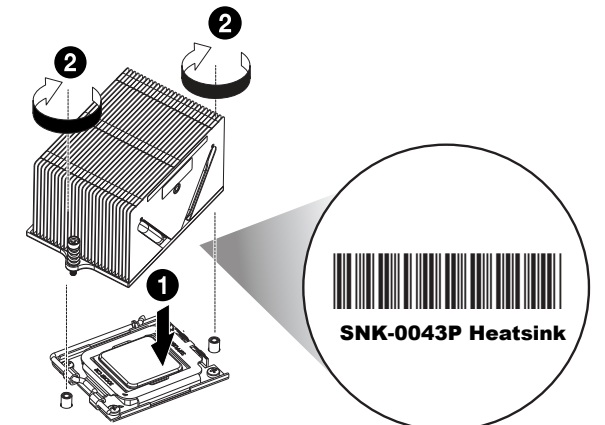

Attach the barcode label as illustrated

- Place heatsink on top of installed CPU
- Line up the two screws to socket
- Push down heatsink and screw down as shown
- NOTE: Only use 6-8 lb/ft of torque; otherwise, hand-tighten each screw, to avoid damaging the system

## Caution

**SAFETY INFORMATION**  
IMPORTANT: See installation instructions and safety warning before connecting system to power supply.  
[http://www.supermicro.com/about/policies/safety\\_information.cfm](http://www.supermicro.com/about/policies/safety_information.cfm)

**WARNING:**  
To reduce risk of electric shock/damage to equipment, disconnect power from server by disconnecting all power cords from electrical outlets.  
If any CPU socket empty, install protective plastic CPU cap

**CAUTION:**  
Always be sure all power supplies for this system have the same power output. If mixed power supplies are installed, the system will not operate.

For more information go to :  
<http://www.supermicro.com/support>

