

**STULZ**

CLIMATE. CUSTOMIZED.



# CyberOne EC DX

**Engineering Manual**

**Perimeter Mounted Precision Air Conditioners  
7 kW - 35 kW / 60 Hz**

## Notice

This document contains information protected by copyright. All rights are reserved. The owner of the equipment for which this manual is written may photocopy the contents of this manual for internal use only. No part of this document may be photocopied, reproduced, or translated into another language for use by anyone other than the owner of the equipment for which this manual is written without the prior written consent of STULZ Air Technology Systems, Inc. (STULZ).

This document contains confidential and proprietary information of STULZ Air Technology Systems, Inc. Distributing or photocopying this document for external distribution is in direct violation of United States copyright laws and is strictly prohibited without the express written consent of STULZ.

Unpublished rights reserved under the copyright laws of the United States and of other countries. Other brands and trade names are trademarks of their respective owners.

© 2020 STULZ Air Technology Systems, Inc. Printed in the United States of America. All rights reserved.

STULZ Air Technology Systems, Inc.  
1572 Tilco Drive  
Frederick, MD 21704 USA  
<https://www.stulz-usa.com>

## Table of Contents

Model Nomenclature Guide Specification.....	2
DX — Evaporator Sections.....	2
Air Cooled Remote Evaporator.....	2
DX — Water Cooled Systems.....	2
Integral Self-Contained.....	2
Water Regulating Valves.....	2
DX — Glycol Cooled Systems.....	2
Integral Self-Contained.....	2
Glycol Regulating Valves.....	2
DX Cooling with Assist Mode Free Cooling Systems.....	2
Water/Glycol Economizer Coil.....	2
Alternate Water Source.....	3
Chilled Water by Day and DX — Backup by Night.....	3
Selected Standard Features.....	4
Performance Data – Air Cooled.....	5
Performance Data – Water Cooled.....	6
Performance Data – Glycol Cooled.....	7
Performance Data – DX Water Cooled with Free Cooling.....	8
Performance Data –Glycol Cooled with Free Cooling.....	10
Performance Data – DX AR/W/G with FC/AWS.....	12
Electrical Data – DX AR/W/G with FC/AWS.....	13
Dimensional Data — COS-024/060-( )-U-EC.....	13
Up-Flow Vertical A/C.....	13
Ducted or Optional 2- or 3-way Plenum box.....	13
Dimensional Data — COS-024/060-( )-D-EC.....	14
Down-Flow Vertical A/C.....	14
Dimensional Data — COS-096/120-( )-U-EC.....	15
Upflow Vertical A/C.....	15
Ducted or Optional 2- or 3-Way Plenum Box.....	15
Dimensional Data— COS-096/120-( )-D-EC.....	16
Downflow Vertical A/C.....	16
CyberOne EC DX Series.....	17
Up-Flow/Down-Flow, Floor Mounted, Precision Air Conditioners.....	17
Summary.....	17
Design Requirements.....	17
Quality Assurance.....	17
Cabinet.....	17
Down-Flow.....	17
Up-Flow.....	17
Air Flow Patterns.....	18
Downflow.....	18
Upflow.....	18
Air Filtration.....	18
Mechanical Components.....	18

Backward Inclined, Plenum Style Fan, with an EC Motor.....	18
Floor Mounted Air Conditioners.....	18
Refrigeration System.....	18
Scroll Compressor.....	18
Evaporator Coils.....	19
Snap-Acting Hot Gas Bypass (Optional).....	19
Air Cooled Heat Rejection.....	19
-20°F, Variable Fan Speed Control.....	19
-30°F, Flooded Control.....	19
Water/Glycol Cooled Heat Rejection.....	19
Braze Plate Heat Exchanger.....	19
2-Way, 600 psig Regulating Valve (Standard).....	19
3-Way, 600 psig Regulating Valve (Optional).....	19
Free Cooling System (Optional).....	19
Alternate Water Source System (Optional).....	20
Steam Generating Humidifier (Standard).....	20
Dehumidification Cycle (Standard).....	20
Electric Reheat (Standard).....	20
Hot Gas Reheat (Optional).....	20
Hot Water Reheat (Optional).....	20
SCR Fired Reheat (Optional).....	21
Electrical System.....	21
Main Power Service Switch.....	21
Remote Start/Stop Contacts (Optional).....	21
Air Control.....	21
EC Fan Speed Control.....	21
E2 Series Controller.....	21
Field Configurable.....	22
Password Protection.....	22
Restorable Parameters/Factory Defaults.....	22
A/C Grouping pLAN Operation (Optional).....	22
Remote BMS Interface (Optional).....	23
Alarms.....	23
Large Bezel Display Panel — Touch Screen.....	23
Timer Feature.....	23
Optional Features.....	23
Adjustable Floor Stand.....	23
Enclosed Floor Stand.....	23
Seismic Rated Floor Stand.....	23
Condensate Pump.....	24
Smoke Detection.....	24
Firestat.....	24
Remote Water Detector — Spot Type.....	24
Remote Water Detector — Dual Spot Type.....	24

Remote Water Detector — Strip Type .....	24
Top Discharge Plenum Box.....	24
High Short Circuit Current Rating.....	24
Compressor Sound Jackets.....	25
Low Entering Condenser Water Kit.....	25
Air-Side Economizer Controls .....	25
Alternate Water Source .....	25
Primary Mode .....	25
Secondary/Backup Mode.....	25
Code Conformance.....	26

Nomenclature					
XXX-XXX-XXX-X-XX					
System	Capacity in 1,000s BTU/Hr	Model		Air Flow Pattern	Fan Cooling
COS = CyberOne MCS = Modular	024 042 060 096 120	AR = Remote (Split) Air Cooled W = Water Cooled G = Glycol Cooled	AWS = Alternate Water Source FC = Free Cooling	D = Down Flow U = Up Flow	EC = Direct Driven, single inlet, two-fold backward curved radial fan with electronically commutated (EC) motor
COS	042	G	F C	U	E C

Example: CyberOne, 42,000 BTU/Hr, Glycol Cooled, Free Cooling, Up Flow Air, Electronically Commutated Motor - COS-042-G-FC-U-EC.

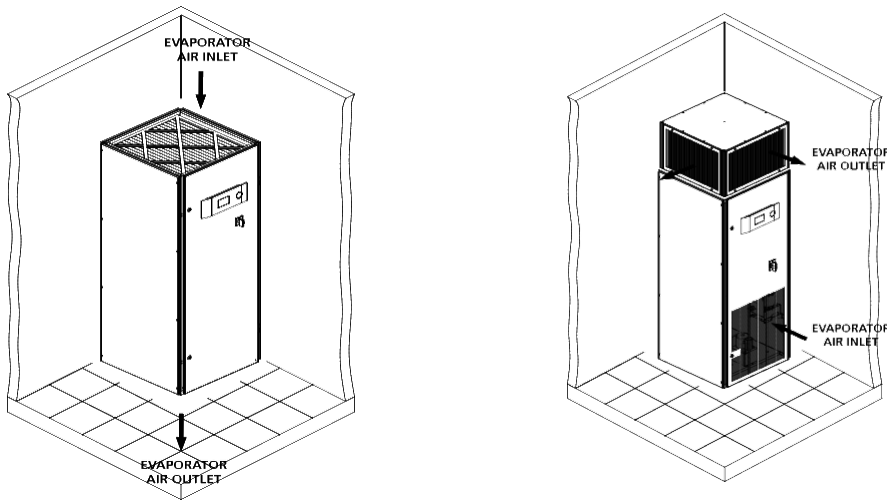

STULZ Condensers can be found in our Heat Rejection Engineering Manual.

STULZ Pump Packages and Drycoolers can be found in our Glycol Systems Engineering Manual.

## Model Nomenclature Guide Specification

### DX — Evaporator Sections

#### Air Cooled Remote Evaporator

(Models COS-( )-AR)

The system is a remote (split) air cooled, floor mounted precision air conditioner evaporator. The evaporator section houses, as a minimum, the evaporator coil, expansion valve, compressor, evaporator blower/motor and associated electrical and refrigeration components.

The COS-( )-AR evaporator section is located at some distance from its corresponding STULZ-ATS model HES-( )-CAA indoor or SCS-( )-( ) outdoor air-cooled condenser.

The evaporator system requires only a single point main power supply connection; and the system ships from the STULZ-ATS factory with a dry nitrogen holding charge ready for field refrigerant charging.

### DX — Water Cooled Systems

#### Integral Self-Contained

(Models COS-( )-W)

The system is a self-contained, floor mounted precision air conditioner to include integral water cooled, plate-fin condenser with factory installed head pressure water regulating control valve(s). Condenser (source) water is provided by a cooling tower or some other remote water source.

The system only requires single point supply power connection and ships from the factory with a full operating refrigerant charge.

#### Water Regulating Valves

Head pressure is automatically controlled by factory installed two- way water regulating valves rated for 600 psig w.w.p. As an option, 3-way valves are available.

### DX — Glycol Cooled Systems

#### Integral Self-Contained

(Models COS-( )-G)

The system is self-contained, floor mounted precision air conditioner to include integral glycol cooled, plate-fin condenser with factory installed head pressure glycol regulating control valve(s). Condenser (source) glycol solution is via a STULZ-ATS model GPS-( )-( )/F( )S-( ) remote glycol pump package and drycooler system.

The system only requires a single point supply power connection and ships from the STULZ-ATS factory with a full operating refrigerant charge.

#### Glycol Regulating Valves

Head pressure is automatically controlled by factory installed 2-way water regulating valves rated for 600 psig w.w.p. As an option, 3-way valves are available.

### DX Cooling with Assist Mode Free Cooling Systems

#### Water/Glycol Economizer Coil

(Models COS-( )-W/G-FC)

The system is a self-contained, floor mounted precision air conditioner to include:

- Combination integral compressor
- DX Water/Glycol Cooled refrigeration cycle
- Free-Cooling economizer cycle

The Free-Cooling cycle is provided to take advantage of low ambient air temperature

conditions to provide compressor-less cooling.

### **Alternate Water Source**

#### **Chilled Water by Day and DX — Backup by Night**

(Models COS-( )-AR, W, G-AWS)

The system uses a single compressor, floor mounted precision air conditioner that includes:

- Combination DX refrigeration cycle
- Alternate Water Source cooling cycle

The Alternate Water Source cooling cycle uses building chilled water supply as the primary cooling cycle with DX refrigerant cooling as a backup.



## Selected Standard Features

Model	COS-024/060-( )-EC	COS-096/120-( )-EC
<b>Selected Standard Features</b>		
<b>TEMPERATURE CONTROL</b>		
1-Stage Cooling Mode	Standard	Standard
1-Stage Electric Reheating	Standard	Standard
Cooling or Reheating Only (No Humidity Control)	Optional	Optional
<b>HUMIDITY CONTROL</b>		
Proportional Electrode Canister Steam Humidifier	Standard	Standard
Dehumidification Mode with 1-Stage Electric Reheat	Standard	Standard
<b>CONTROLS</b>		
Advanced Microprocessor w/ Alarms	Standard	Standard
<b>CABINET</b>		
Powder Coat Painted Galvanneal Steel	Standard	Standard
Insulated Stainless Steel Condensate Drain Pan	Standard	Standard
2 lb Density Thermal and Sound Insulation	Standard	Standard
Floor Stand (Adjustable)	Optional	Optional
<b>FILTERS/PLENUMS</b>		
2", 30% Dust Spot Eff. Pleated Filters	Standard	Standard
2 or 3-way Plenum Box (Up-Flow Units)	Optional	Optional
<b>DX-REFRIGERATION CIRCUIT</b>		
HCFC- R407C Refrigerant	Standard	Standard
Scroll Compressors	Standard	Standard
High Efficiency, Aluminum Fin/Copper Tube Coils	Standard	Standard
Thermal Expansion Valves	Standard	Standard
Refrigerant Sight Glasses and Filter/Drier Strainers	Standard	Standard
Refrigerant Service Valves	Standard	Standard
<b>BLOWERS MOTORS</b>		
Direct Drive Electrically Commutated (EC) Plug Fan	Standard	Standard
<b>ELECTRICAL</b>		
3-Phase Power Supply	See Electric Data Tables Below	
Multi-Voltage Control Transformer (24V Class 2)	Standard	Standard
Modular Motor Controllers with Integral Circuit Breakers	Standard	Standard
<b>SAFETY FEATURES</b>		
Audible/Visual Local and Remote Alarms	Standard	Standard
Main Power Non-Fused Disconnect, unit mounted	Standard	Standard
High / Low Refrigerant Pressure Switches (DX units)	Standard	Standard
Motor Overload Protection	Standard	Standard
<b>Specific Model Standard Features</b>		
<b>AIR COOLED</b>		
Low Ambient Head Pressure Control	Two types -20°F or -30°F	
Remote Air Cooled Condenser	Standard	Standard
<b>WATER/GLYCOL COOLED</b>		
2-way, 600 psig Water/Glycol Regulating Valves	Standard	Standard
3-way 400 psig Water/Glycol Regulating Valves	Optional	Optional
Stainless Steel Brazed Plate Heat Exchanger	Standard	Standard
<b>ALL SPLIT DX SYSTEMS</b>		
Liquid Line Solenoid Valve to Prevent Liquid Slugging	Standard	Standard
<b>CODE CONFORMANCE</b>		
CETL Conformance Compliance to UL 1995 Standard	Standard	Standard
CSA/C22.2 No. 236 (2011 Ed. 4)	Standard	Standard

# Performance Data – Air Cooled

Model	COS-024-AR-EC	COS-042-AR-EC	COS-060-AR-EC	COS-096-AR-EC	COS-120-AR-EC
<b>NET DX COOLING CAPACITY - kW(MBH), (includes standard DX evaporator motor heat @ std CFM and e.s.p. ratings)</b>					
<b>72°FDB/60.0°FWB, 50% RH</b>					
Total kW (MBH)	6.8 (23.5)	13.3 (45.3)	16.4 (55.9)	26.9 (91.9)	32.6 (111.4)
Sensible kW (MBH)	5.7 (19.6)	11.6 (39.6)	14.7 (50.1)	24.2 (82.7)	26.9 (92.0)
<b>80°FDB/62.9°FWB, 38% RH</b>					
Total kW (MBH)	7.4 (25.4)	14.3 (48.8)	17.7 (60.6)	29.4 (100.4)	35.1 (119.9)
Sensible kW (MBH)	7.2 (24.6)	14.3 (48.8)	17.7 (60.6)	29.4 (100.4)	33.8 (115.5)
<b>Reheat - Performance Capacities</b>					
<b>ELECTRIC REHEAT - Finned Reheat Coils, (Standard)</b>					
Hr. KwRating (No. of Stages)	6 Kw (1-tg)	9 Kw (1-stg)	9 Kw (1-stg)	9 Kw (1-stg)	9 Kw (1-stg)
<b>HOT GAS REHEAT - with 3-way Reheat Reclaim Valve, (Optional)</b>					
kW(MBH)	2.0 (7.0)	3.7 (12.7)	5.0 (17.2)	7.8 (26.6)	10.3 (35.1)
<b>HOT WATER REHEAT - Reheat rated @ 180°F Entering Water Temperature, EAT = 72°F DB, (Optional)</b>					
kW(MBH)	8.2 (27.8)	12.2 (41.6)	14.3 (48.8)	27.6 (94.3)	29.0 (98.8)
GPM	2.8	4.3	5.0	9.6	10.1
Pressure Drop, Coil ft. wg	0.5	1.0	1.4	5.3	5.8
Pressure Drop, Unit ft. wg	5.7	4.7	5.6	5.3	5.7
Valve Cv	2.2	4.0	4.0	8.0	8.0
Control Valve	2-way, 300 psig, Modulating (0-10 Vdc)				
<b>Humidification - Electrode Steam Canister Humidifier (Standard)</b>					
Steam Output, Lbs./Hour	2-5 lbs./hr.	4-10 lbs./hr.	4-10 lbs./hr.	4-15 lbs./hr.	4-15 lbs./hr.
Power Input	1.7 Kw	3.4 Kw	3.4 Kw	5.1 Kw	5.1 Kw
Std Control	Modulating	Modulating	Modulating	Modulating	Modulating
<b>Evaporator Blower / Motor - Backward Curved, Direct-Drive, EC Plug Fan</b>					
Horsepower	3.6 Hp	3.6 Hp	3.6 Hp	4.1 Hp	4.1 Hp
CFM @ ext. st. Pressure	1,000 @ 0.5	2,000 @ 0.5	2,700 @ 0.5	4,400 @ 0.5	4,800 @ 0.5
Drive Method	Direct Driven	Direct Driven	Direct Driven	Direct Driven	Direct Driven
Quantity of Fans	1	1	1	1	1
<b>Evaporator Coil - Aluminum Fin, Copper Tube</b>					
Rows/Face Area (ft <sup>2</sup> )	3/5.50	4/5.50	4/5.50	4/9.75	4/9.75
Face Velocity, fpm	182	364	491	451	492
<b>Compressors - Reheat pump duty rated Scroll - R-407C</b>					
Type, (Qty.)	Scroll, (1)	Scroll, (1)	Scroll, (1)	Scroll, (1)	Scroll, (1)
Watts Input	2,171	3,927	5,094	7,805	10,262
Tot. Reheat of Rej. kW(MBH)	10.1(34.5)	19.0(64.8)	23.8(81.4)	38.6(131.8)	48.2(164.5)
<b>Connection Sizes - Copper, (Refer to CyberONE IOM Manual for proper interconnecting refrigerant line sizing.)</b>					
Refrigerant					
Liquid Line, (Qty.)	1/2 OD, (1)	1/2 OD, (1)	1/2 OD, (1)	5/8 OD, (1)	5/8 OD (1)
Hot Gas Line, (Qty.)	5/8 OD, (1)	5/8 OD, (1)	5/8 OD, (1)	7/8 OD, (1)	7/8 OD (1)
Condensate Drain, (w/pump)	7/8 OD, (1/2OD)	7/8 OD, (1/2OD)	7/8 OD, (1/2OD)	7/8 OD, (1/2OD)	7/8 OD, (1/2OD)
Humidifier Inlet	1/4 OD	1/4 OD	1/4 OD	1/4 OD	1/4 OD
<b>Filters – 2" deep, 30% Dust-Spot Efficient Pleated Throwaway</b>					
Nom. Size (in.), (Qty.)	28.5 X 26 (1)	28.5 X 26 (1)	28.5 X 26 (1)	31.5 X 21.38 (2)	31.5 X 21.38 (2)
Approx. Weight	495 lbs	520 lbs	520 lbs	800 lbs	810 lbs

## Performance Data – Water Cooled

Model	COS-024-W-EC	COS-042-W-EC	COS-060-W-EC	COS-096-W-EC	COS-120-W-EC
<b>NET DX COOLING CAPACITY - kW(MBH), (includes standard DX evaporator motor heat @ std CFM and e.s.p. ratings)</b>					
<b>72°FDB/60.0°FWB, 50% RH</b>					
Total kW (MBH)	7.7 (26.4)	14.7 (50.2)	18.1 (61.8)	29.9 (102.0)	36.5 (124.8)
Sensible kW (MBH)	6.1 (20.8)	12.1 (41.3)	15.4 (52.5)	25.5 (87.0)	28.7 (97.9)
<b>80°FDB/62.9°FWB, 38% RH</b>					
Total kW (MBH)	8.2 (28.1)	15.8 (54.0)	19.6 (66.9)	32.1 (109.7)	39.2 (133.8)
Sensible kW (MBH)	7.5 (25.7)	15.1 (51.4)	19.3 (65.9)	31.8 (108.7)	35.5 (121.2)
<b>Reheat - Performance Capacities</b>					
ELECTRIC REHEAT - Finned Tubular Reheat Coils, (Standard)					
Htr Kw Rating (No. of Stages)	6 Kw (1-stg)	9 Kw (1-stg)	9 Kw (1-stg)	9 Kw (1-stg)	9 Kw (1-stg)
HOT GAS REHEAT - with 3-way Reheat Reclaim Valve, (Optional)					
kW(MBH)	1.6 (5.3)	2.8 (9.7)	3.8 (13.1)	6.2 (21.0)	8.1 (27.7)
HOT WATER REHEAT - Reheat rated @ 180°F Entering Water Temperature, EAT = 72°F DB, (Optional)					
kW(MBH)	8.2 (27.8)	12.2 (41.6)	14.3 (48.8)	27.6 (94.3)	29.0 (98.8)
GPM	2.8	4.3	5.0	9.6	10.1
Pressure Drop, Coil ft. wg	0.5	1.0	1.4	5.3	5.8
Pressure Drop, Unit ft. wg	5.7	4.7	5.6	5.3	5.7
Valve Cv	2.2	4.0	4.0	8.0	8.0
Control Valve	2-way, 300 psig, Modulating (0-10 Vdc)				
<b>Humidification - Electrode Steam Canister Humidifier, (Standard)</b>					
Steam Output, Lbs/Hour	2-5 lbs/hr	4-10 lbs/hr	4-10 lbs/hr	4-15 lbs/hr	4-15 lbs/hr
Power Input	1.7 Kw	3.4 Kw	3.4 Kw	5.1 Kw	5.1 Kw
Std Control	Modulating	Modulating	Modulating	Modulating	Modulating
<b>Evaporator Blower / Motor - Backward Curved, Direct-Drive, EC Plug Fan</b>					
Horsepower	3.6 Hp	3.6 Hp	3.6 Hp	4.1 Hp	4.1 Hp
CFM @ ext. st. press.	1,000 @ 0.5	2,000 @ 0.5	2,700 @ 0.5	4,400 @ 0.5	4,800 @ 0.5
Drive Method	Direct Driven	Direct Driven	Direct Driven	Direct Driven	Direct Driven
Qty. of Fans	1	1	1	1	1
<b>Evaporator Coil - Aluminum Fin, Copper Tube</b>					
Rows/Face Area (ft <sup>2</sup> )	3/5.5	4/5.5	4/5.5	4/9.75	4/9.75
Face Velocity, fpm	182	364	491	451	492
<b>Compressors - Scroll - R-407C</b>					
Type, (Qty.)	Scroll, (1)	Scroll, (1)	Scroll, (1)	Scroll, (1)	Scroll, (1)
Watts Input	1,641	3,011	3,873	6,129	8,141
<b>Water Cooled Condenser Data - Based on 0% Glycol Solution</b>					
Tot. reheat of Rej. kW(MBH)	10.4 (35.4)	19.6 (66.9)	24.4 (83.5)	39.7 (135.4)	50.1 (171.1)
GPM@85°F EWT/95°F LWT	7.1	13.4	16.7	27.1	34.2
Unit Press. Drop (ft. wg)	8.4	10.5	13.8	11.5	16.9
Condenser Type	Brazed-Plate	Brazed-Plate	Brazed-Plate	Brazed-Plate	Brazed-Plate
<b>Head Pressure Control</b>					
Standard Control	2-way, 600 psig Water Regulating Valves, (factory installed)				
Optional Control	3-way, 600 psig Water Regulating Valves, (factory installed)				
<b>Connection Sizes - Copper</b>					
Condensate Drain, (w/ pump)	7/8 OD, (1/2OD)	7/8 OD, (1/2OD)	7/8 OD, (1/2OD)	7/8 OD, (1/2OD)	7/8 OD, (1/2OD)
Humidifier Inlet	1/4 OD	1/4 OD	1/4 OD	1/4 OD	1/4 OD
Condenser In/Out	7/8 OD	1-1/8 OD	1-1/8 OD	1-3/8 OD	1-3/8 OD
<b>Filters – 2” deep, 30% Dust-Spot Efficient Pleated Throwaway</b>					
Nom. Size (in.), (Qty.)	28.5 × 26 (1)	28.5 × 26 (1)	28.5 × 26 (1)	31.5 × 21.38 (2)	31.5 × 21.38 (2)
Approx. Weight	465 lbs	490 lbs	490 lbs	720 lbs	730 lbs

## Performance Data – Glycol Cooled

Model	COS-024-G-EC	COS-042-G-EC	COS-060-G-EC	COS-096-G-EC	COS-120-G-EC
<b>NET DX COOLING CAPACITY - kW(MBH), (includes standard DX evaporator motor heat @ std CFM and e.s.p. ratings)</b>					
<b>72°FDB/60.0°FWB, 50% RH</b>					
Total kW (MBH)	6.7 (22.9)	12.9 (43.9)	15.9 (54.2)	26.1 (89.1)	31.8 (108.8)
Sensible kW (MBH)	5.7 (19.3)	11.3 (38.7)	14.5 (49.4)	23.9 (81.6)	26.6 (90.9)
<b>80°FDB/62.9°FWB, 38% RH</b>					
Total kW (MBH)	7.1 (24.3)	13.8 (47.3)	17.3 (59.1)	28.6 (97.5)	34.2 (116.9)
Sensible kW (MBH)	7.1 (24.3)	13.8 (47.3)	17.3 (59.1)	28.6 (97.5)	33.5 (114.3)
<b>Reheat - Performance Capacities</b>					
<b>ELECTRIC REHEAT - Finned Tubular Reheaters Coils (Standard)</b>					
Htr Kw Rating (No. of Stages)	6 Kw (1-stg)	9 Kw (1-stg)	9 Kw (1-stg)	9 Kw (1-stg)	9 Kw (1-stg)
<b>HOT GAS REHEAT - with 3-way Reheat Reclaim Valve, (Optional)</b>					
kW(MBH)	2.2 (7.5)	4.0 (13.6)	5.4 (18.4)	8.3 (28.3)	10.9 (37.3)
<b>HOT WATER REHEAT - Reheat rated @ 180°F Entering Water Temperature, EAT = 72°F DB, (Optional)</b>					
kW(MBH)	8.2 (27.8)	12.2 (41.6)	14.3 (48.8)	27.6 (94.3)	29 (98.8)
GPM	2.8	4.3	5.0	9.6	10.1
Pressure Drop, Coil f. wg	0.5	1.0	1.4	5.3	5.8
Pressure Drop, Unit ft. wg	5.7	4.7	5.6	5.3	5.7
Valve Cv	2.2	4.0	4.0	8.0	8.0
Control Valve	2-way, 300 psig, Modulating (0-10 Vdc)				
<b>Humidification - Electrode Steam Canister Humidifier, (Standard)</b>					
Steam Output, Lbs/Hour	2-5 lbs/hr	4-10 lbs/hr	4-10 lbs/hr	4-15 lbs/hr	4-15 lbs/hr
Power Input	1.7 Kw	3.4 Kw	3.4 Kw	5.1 Kw	5.1 Kw
Std Control	Modulating	Modulating	Modulating	Modulating	Modulating
<b>Evaporator Blower/Motor - Backward Curved, Direct-Drive, EC Plug Fan</b>					
Horsepower	3.6 Hp	3.6 Hp	3.6 Hp	4.1 Hp	4.1 Hp
CFM @ ext. st. press.	1,000 @ 0.5	2,000 @ 0.5	2,700 @ 0.5	4,400 @ 0.5	4,800 @ 0.5
Drive Method	Direct Driven	Direct Driven	Direct Driven	Direct Driven	Direct Driven
Qty. of Fans	1	1	1	1	1
<b>Evaporator Coil - Aluminum Fin, Copper Tube</b>					
Rows/Face Area (ft <sup>2</sup> )	3/5.5	4/5.5	4/5.5	4/9.75	4/9.75
Face Velocity, fpm	182	364	491	451	492
<b>Compressors - Scroll - R-407C</b>					
Type, (Qty.)	Scroll, (1)	Scroll, (1)	Scroll, (1)	Scroll, (1)	Scroll, (1)
Watts Input	2,329	4,201	5,449	8,305	10,883
<b>Water Cooled Condenser Data - Based on 40% Glycol Solution</b>					
Tot. reheat of Rej. kW(MBH)	9.9 (33.9)	18.8 (64.2)	23.8 (81.1)	38.3 (130.7)	47.9 (163.6)
GPM @ 110°F EGT	7.6	14.5	18.3	29.4	36.8
Unit Press. Drop (ft, wg)	9.7	12.1	16.3	13.4	19.7
Condenser Type	Brazed-Plate	Brazed-Plate	Brazed-Plate	Brazed-Plate	Brazed-Plate
<b>Head Pressure Control</b>					
Standard Control	2-way, 600 psig Water Regulating Valves, (factory installed)				
Optional Control	3-way, 600 psig Water Regulating Valves, (factory installed)				
<b>Connection Sizes - Copper</b>					
Condensate Drain, (w/ pump)	7/8 OD, (1/2OD)	7/8 OD, (1/2OD)	7/8 OD, (1/2OD)	7/8 OD, (1/2OD)	7/8 OD, (1/2OD)
Humidifier Inlet	1/4 OD	1/4 OD	1/4 OD	1/4 OD	1/4 OD
Condenser In/Out	7/8 OD	1-1/8 OD	1-1/8 OD	1-3/8 OD	1-3/8 OD
<b>Filters – 2" deep, 30% Dust-Spot Efficient Pleated Throwaway</b>					
Nom. Size (in.), (Qty.)	28.5 × 26 (1)	28.5 × 26 (1)	28.5 × 26 (1)	31.5 × 21.38 (2)	31.5 × 21.38 (2)
Approx. Weight	465 lbs	490 lbs	490 lbs	720 lbs	730 lbs

## Performance Data – DX Water Cooled with Free Cooling

Model	COS-024-W-FC-EC	COS-042-W-FC-EC	COS-060-W-FC-EC	COS-096-W-FC-EC	COS-120-W-FC-EC
<b>NET DX COOLING CAPACITY - kW(MBH), (includes standard DX evaporator motor heat @ std CFM and e.s.p. ratings)</b>					
<b>72°FDB/60.0°FWB, 50% RH</b>					
Total kW (MBH)	7.7 (26.4)	14.7 (50.2)	18.1 (61.8)	29.9 (102.0)	36.5 (124.8)
Sensible kW (MBH)	6.1 (20.8)	12.1 (41.3)	15.4 (52.5)	25.5 (87.0)	28.7 (97.9)
<b>80°FDB/62.9°FWB, 38% RH</b>					
Total kW (MBH)	8.2 (28.1)	15.8 (54.0)	19.6 (66.9)	32.1 (109.7)	39.2 (133.8)
Sensible kW (MBH)	7.5 (25.7)	15.1 (51.4)	19.3 (65.9)	31.8 (108.7)	35.5 (121.2)
<b>NET FC COOLING CAPACITY - kW (MBH), (includes standard DX evaporator motor heat @ std CFM and e.s.p. ratings)</b>					
<b>72°FDB/60.0°FWB, 50% RH</b>					
Total kW (MBH)	7.0 (23.9)	12.9 (44.0)	15.8 (53.8)	27.0 (92.2)	28.6 (97.7)
Sensible kW (MBH)	5.8 (19.9)	11.4 (38.9)	14.5 (49.5)	24.4 (83.3)	25.4 (86.7)
Flow Rate (GPM)	6.7	12.6	15.7	25.5	32.4
Coil Pressure Drop (ft. H <sub>2</sub> O)	11.2	6.9	10.1	12.0	18.4
Unit Pressure Drop (ft H <sub>2</sub> O)	21.1	18.0	25.3	24.0	35.5
<b>80°FDB/62.9°FWB, 38% RH</b>					
Total kW (MBH)	8.8 (30.0)	16.4 (55.9)	20.2 (69.0)	34.4 (117.4)	36.6 (124.9)
Sensible kW (MBH)	7.8 (26.6)	15.3 (52.4)	19.6 (67.1)	32.9 (112.3)	34.6 (118.1)
Flow Rate (GPM)	7.1	13.4	16.7	27.1	34.2
Coil Pressure Drop (ft H <sub>2</sub> O)	12.2	7.6	11.3	13.3	20.3
Unit Pressure Drop (ft H <sub>2</sub> O)	22.8	19.6	28.0	26.4	38.9

Model	COS-024-W-FC-EC	COS-042-W-FC-EC	COS-060-W-FC-EC	COS-096-W-FC-EC	COS-120-W-FC-EC
<b>Reheat - Performance Capacities</b>					
ELECTRIC REHEAT - Finned Tubular Heat, (Standard)					
Htr Kw Rating (No. of Stages)	6 Kw (1-stg)	9 Kw (1-stg)	9 Kw (1-stg)	9 Kw (1-stg)	9 Kw (1-stg)
HOT GAS REHEAT - with 3-way reheat Reclaim Valve, (Optional)					
kW(MBH)	1.6 (5.3)	2.8 (9.7)	3.8 (13.1)	6.2 (21)	8.1 (27.7)
HOT WATER REHEAT - Reheat rated @ 180°F Entering Water Temperature, EAT = 72°F DB, (Optional)					
kW(MBH)	8.2 (27.8)	12.2 (41.6)	14.3 (48.8)	27.6 (94.3)	29 (98.8)
GPM	2.8	4.3	5.0	9.6	10.1
Pressure Drop, Coil ft. wg	0.5	1.0	1.4	5.3	5.8
Pressure Drop, Unit ft. wg	5.7	4.7	5.6	5.3	5.7
Valve Cv	2.2	4.0	4.0	8.0	8.0
Control Valve	2-way, 300 psig, Modulating (0-10 Vdc)				
<b>Humidification - Electrode Steam Canister Humidifier with Adjustable Output, (Standard)</b>					
Steam Output, lbs/Hour	2-5 lbs/hr	4-10 lbs/hr	4-10 lbs/hr	4-15 lbs/hr	4-15 lbs/hr
Power Input	1.7 Kw	3.4 Kw	3.4 Kw	5.1 Kw	5.1 Kw
Std Control	Modulating	Modulating	Modulating	Modulating	Modulating
<b>Evaporator Blower / Motor - Backward Curved, Direct-Drive, EC Plug Fan</b>					
Horsepower	3.6 Hp	3.6 Hp	3.6 Hp	4.1 Hp	4.1 Hp
CFM @ ext. st. press.	1,000 @ 0.5	2,000 @ 0.5	2,700 @ 0.5	4,400 @ 0.5	4,800 @ 0.5
Drive Method	Direct Driven	Direct Driven	Direct Driven	Direct Driven	Direct Driven
Qty. of Fans	1	1	1	1	1
<b>Coil, (Both DX and Free-Cooling) - Aluminum Fin, Copper Tube</b>					
DX					
Rows/Face Area (ft <sup>2</sup> )	3/5.5	4/5.5	4/5.5	4/9.75	4/9.75
Face Velocity, fpm	182	364	491	451	492
Free Cooling					
Rows/Face Area (ft <sup>2</sup> )	3/5.5	4/5.5	4/5.5	4/9.75	4/9.75
Face Velocity, fpm	182	364	491	451	492
<b>Compressors - Scroll - R-407C</b>					
Type, (Qty.)	Scroll, (1)	Scroll, (1)	Scroll, (1)	Scroll, (1)	Scroll, (1)
Watts Input	1,641	3,011	3,873	6,129	8,141
<b>Water Cooled Condenser Data - Based on 0% Glycol Solution</b>					
Tot. Heat of Rej. W(MBH)	10.4 (35.4)	19.6 (66.9)	24.4 (83.5)	39.7 (135.4)	50.1 (171.1)
Condenser Type	Plate-Finned	Plate-Finned	Plate-Finned	Plate-Finned	Brazed Plate
<b>Head Pressure and Free Cooling Control</b>					
DX-Head Pressure Valve	3-way, 600 psig (factory installed)				
FC - Valve	3-way, 600 psig (factory installed)				
CV	5.0	8.0	8.0	16.0	16.0
<b>Connection Sizes - Copper</b>					
Condensate Drain, (w/ pump)	7/8 OD, (1/2OD)	7/8 OD, (1/2OD)	7/8 OD, (1/2OD)	7/8 OD, (1/2OD)	7/8 OD, (1/2OD)
Humidifier Inlet	1/4 OD	1/4 OD	1/4 OD	1/4 OD	1/4 OD
Source Water In/Out	7/8 OD	1-1/8 OD	1-1/8 OD	1-3/8 OD	1-3/8 OD
<b>Filters – 2" deep, 30% Dust-Spot Efficient Pleated Throwaway</b>					
Nom. Size (in.), (Qty.)	28.5 × 26 (1)	28.5 × 26 (1)	28.5 × 26 (1)	31.5 × 21.38 (2)	31.5 × 21.38 (2)
Approx. Weight	465 lbs	490 lbs	490 lbs	720 lbs	730 lbs

## Performance Data –Glycol Cooled with Free Cooling

Model	COS-024-G- FC-EC	COS-042-G-FC- EC	COS-060-G-FC-EC	COS-096-G-FC- EC	COS-120-G-FC- EC
<b>NET DX COOLING CAPACITY - kW(MBH), (includes standard DX evaporator motor heat @ std CFM and e.s.p. ratings)</b>					
<b>72°FDB/60.0°FWB, 50% RH</b>					
Total kW (MBH)	6.7 (22.9)	12.9 (43.9)	15.9 (54.2)	26.1 (89.1)	31.8 (108.8)
Sensible kW (MBH)	5.7 (19.3)	11.3 (38.7)	14.5 (49.4)	23.9 (81.6)	26.6 (90.9)
<b>80°FDB/62.9°FWB, 38% RH</b>					
Total kW (MBH)	7.1 (24.3)	13.8 (47.3)	17.3 (59.1)	28.6 (97.5)	34.2 (116.9)
Sensible kW (MBH)	7.1 (24.3)	13.8 (47.3)	17.3 (59.1)	28.6 (97.5)	33.5 (114.3)
<b>NET FC COOLING CAPACITY - kW (MBH), (includes standard DX evaporator motor heat @ std CFM and e.s.p. ratings)</b>					
<b>72°FDB/60.0°FWB, 50% RH</b>					
Total kW (MBH)	6.7 (22.9)	12.9 (43.9)	15.9 (54.2)	26.1 (89.1)	31.8 (108.8)
Sensible kW (MBH)	5.7 (19.3)	11.3 (38.7)	14.5 (49.4)	23.9 (81.6)	26.6 (90.9)
Flow Rate (GPM)	7.3	13.7	17.2	27.5	35.0
Coil Pressure Drop (ft H <sub>2</sub> O)	15.6	10.0	15.1	16.7	22.9
Unit Pressure Drop (ft H <sub>2</sub> O)	27.0	22.7	33.1	30.5	42.5
<b>80°FDB/62.9°FWB, 38% RH</b>					
Total kW (MBH)	7.1 (24.3)	13.8 (47.3)	17.3 (59.1)	28.6 (97.5)	34.2 (116.9)
Sensible kW (MBH)	7.1 (24.3)	13.8 (47.3)	17.3 (59.1)	28.6 (97.5)	33.5 (114.3)
Flow Rate (GPM)	7.6	14.5	18.3	29.4	36.8
Coil Pressure Drop (ft H <sub>2</sub> O)	15.9	12.0	16.0	17.9	24.2
Unit Pressure Drop (ft H <sub>2</sub> O)	27.4	25.0	34.1	31.9	44.0

Model	COS-024-G-FC-EC	COS-042-G-FC-EC	COS-060-G-FC-EC	COS-096-G-FC-EC	COS-120-G-FC-EC
<b>Reheat - Performance Capacities</b>					
ELECTRIC REHEAT - Finned Tubular Reheat Coils, (Standard)					
Htr Kw Rating (No. of Stages)	6 Kw (1-stg)	9 Kw (1-stg)	9 Kw(1-stg)	9 Kw (1-stg)	9 Kw (1-stg)
HOT GAS REHEAT - with 3-way reheat Reclaim Valve, (Optional)					
kW(MBH)	2.2 (7.5)	4.0 (13.6)	5.4 (18.4)	8.3 (28.3)	10.9 (37.3)
HOT WATER REHEAT - Reheat rated @ 180°F Entering Water Temperature, EAT = 72°F DB, (Optional)					
kW(MBH)	8.2 (27.8)	12.2 (41.6)	14.3 (48.8)	27.6 (94.3)	29 (98.8)
GPM	2.8	4.3	5.0	9.6	10.1
Pressure Drop, Coil ft. wg	0.5	1.0	1.4	5.3	5.8
Pressure Drop, Unit ft. wg	5.7	4.7	5.6	5.3	5.7
Valve Cv	2.2	4.0	4.0	8.0	8.0
Control Valve	2-way, 300 psig, Modulating (0-10 Vdc)				
<b>Humidification - Electrode Steam Canister Humidifier, (Standard)</b>					
Steam Output, Lbs/Hour	2-5 lbs/hr	4-10 lbs/hr	4-10 lbs/hr	4-15 lbs/hr	4-15 lbs/hr
Power Input	1.7 Kw	3.4 Kw	3.4 Kw	5.1 Kw	5.1 Kw
Std Control	Modulating	Modulating	Modulating	Modulating	Modulating
Optional Control	Modulating (0-10 Vdc)				
<b>Evaporator Blower / Motor - Backward Curved, Direct-Drive, EC Plug Fan</b>					
Horsepower	3.6 Hp	3.6 Hp	3.6 Hp	4.1 Hp	4.1 Hp
CFM @ ext. st. press.	1,000 @ 0.5	2,000 @ 0.5	2,700 @ 0.5	4,400 @ 0.5	4,800 @ 0.5
Drive Method	Direct Driven	Direct Driven	Direct Driven	Direct Driven	Direct Driven
Qty. of Fans	1	1	1	1	1
<b>Coil, (Both DX and Free-Cooling) - Aluminum Fin, Copper Tube</b>					
DX					
Rows/Face Area (ft <sup>2</sup> )	3/5.5	4/5.5	4/5.5	4/9.75	4/9.75
Face Velocity, fpm	182	364	491	451	492
Free Cooling					
Rows/Face Area (ft <sup>2</sup> )	3/5.5	4/5.5	4/5.5	4/9.75	4/9.75
Face Velocity, fpm	182	364	491	451	492
<b>Compressors - Scroll - R-407C</b>					
Type, (Qty.)	Scroll, (1)	Scroll, (1)	Scroll, (1)	Scroll, (1)	Scroll, (1)
Watts Input	2,329	4,201	5,449	8,305	10,883
<b>Glycol Cooled Condenser Data - Based on 40% Glycol Solution</b>					
Tot. Heat of Rej. kW(MBH)	9.9 (33.9)	18.8 (64.2)	23.8 (81.1)	38.3 (130.7)	47.9 (163.6)
Condenser Type	Plate-Finned	Plate-Finned	Plate-Finned	Plate-Finned	Plate-Finned
<b>Head Pressure and Free Cooling Control</b>					
DX-HeadPressure Valve	3-way, 600 psig (factory installed)				
FC - Valve	3-way, 600 psig (factory installed)				
Cv	5.0	8.0	8.0	16.0	16.0
<b>Connection Sizes - Copper</b>					
Condensate Drain, (w/pump)	7/8 OD, (1/2OD)	7/8 OD, (1/2OD)	7/8 OD, (1/2OD)	7/8 OD, (1/2OD)	7/8 OD, (1/2OD)
Humidifier Inlet	1/4 OD	1/4 OD	1/4 OD	1/4 OD	1/4 OD
Source Glycol In/Out	7/8 OD	1-1/8 OD	1-1/8 OD	1-3/8 OD	1-3/8 OD
<b>Filters – 2" deep, 30% Dust-Spot Efficient Pleated Thruway</b>					
Nom. Size (in.), (Qty.)	28.5 × 26 (1)	28.5 × 26 (1)	28.5 × 26 (1)	31.5 × 21.38 (2)	31.5 × 21.38 (2)
<b>Approx. Weight</b>	<b>465 lbs</b>	<b>490 lbs</b>	<b>490 lbs</b>	<b>720 lbs</b>	<b>730 lbs</b>



## Performance Data – DX AR/W/G with FC/AWS

Model	COS-024-( )- AWS- EC	COS-042-( )- AWS- EC	COS-060-( )- AWS- EC	COS-096-( )- AWS- EC	COS-120-( )-AWS- EC
<b>NET AWS COOLING CAPACITY – Based on 45°F EWT / 55°F LWT, 0% Glycol Solution (includes motor heat @ std CFM and e.s.p. ratings) - AWS Coil</b>					
AWS Coil Row/Face Area (ft <sup>2</sup> )	3/5.5	4/5.5	4/5.5	4/9.75	4/9.75
Face Velocity, fpm	182	364	491	451	492
AWS Valve	2-way, 600 psig (factory installed)				
<b>72°FDB/60.0°FWB, 50% RH</b>					
Total kW (MBH)	6.2 (21.2)	11.3 (38.6)	13.8 (47.3)	24.2 (82.5)	24.3 (83.0)
Sensible kW (MBH)	5.5 (18.7)	10.7 (36.7)	13.7 (46.8)	23.2 (79.3)	23.6 (80.7)
Flow Rate (GPM)	4.6	8.2	10.1	17.4	18.5
Unit Pressure Drop (ft H <sub>2</sub> O)	12.2	9.9	13.0	13.6	14.8
Valve Cv	5.0	8.0	8.0	16.0	16.0
<b>80°FDB/62.9°FWB, 38% RH</b>					
Total kW (MBH)	6.6 (22.6)	10.1 (34.6)	10.8 (36.8)	20.1 (68.4)	20.5 (69.8)
Sensible kW (MBH)	6.0 (20.5)	10.1 (34.6)	10.8 (36.8)	20.1 (68.4)	20.5 (69.8)
Flow Rate (GPM)	4.8	7.8	9.8	18.2	18.4
Unit Pressure Drop (ft H <sub>2</sub> O)	9.1	6.5	8.9	10.2	10.4
Valve Cv	5.0	8.0	8.0	16.0	16.0

## Electrical Data – DX AR/W/G with FC/AWS

Model	COS-024-AR, W, G-FC/AWS					COS-042-AR, W, G-FC/AWS					COS-060-AR, W, G-FC/AWS				
	FLA (OEM Rated)					FLA (OEM Rated)					FLA (OEM Rated)				
	AR	W	G	MCA	MFS	AR	W	G	MCA	MFS	AR	W	G	MCA	MFS
<b>Cooling and Electric Reheat and Humidifier</b>															
208/3/60	28.7	27.5	29.1	36.6	40.0	40.4	38.4	41.0	55.36	60.0	44.4	41.6	45.2	58.1	70.0
460/3/60	14.8	14.1	15.0	18.9	20.0	21.1	20.1	21.4	27.8	30.0	22.9	21.5	23.3	29.3	35.0
575/3/60	NA	NA	NA	NA	NA	16.9	16.1	17.2	21.6	25.0	18.1	17.0	18.5	24.2	30.0
<b>Cooling and Electric Reheat Only (No Humidifier)</b>															
208/3/60	28.7	27.5	29.1	36.6	40.0	40.8	38.4	41.0	55.3	60.0	44.4	41.6	45.2	58.1	70.0
460/3/60	14.8	14.1	15.0	18.9	20.0	21.1	20.1	21.4	27.8	30.0	22.9	21.5	23.3	29.3	35.0
575/3/60	N/A	N/A	N/A	N/A	N/A	16.9	16.1	17.2	21.6	25.0	18.1	17.0	18.5	24.2	30.0
<b>Cooling with Humidification (No Electric Reheat)</b>															
208/3/60	23.3	22.1	23.7	27.8	35.0	36.3	34.3	36.9	46.1	60.0	40.3	37.5	41.1	48.9	60.0
460/3/60	11.2	10.5	11.4	13.4	15.0	17.5	16.5	17.8	21.3	25.0	19.3	17.9	19.7	22.8	30.0
575/3/60	N/A	N/A	N/A	N/A	N/A	14.1	13.3	14.4	16.5	20.0	15.3	14.2	15.7	19.2	25.0
<b>Cooling Only, with or without Hot Gas, Hot Water or Steam Reheat</b>															
208/3/60	15.1	13.9	15.5	19.6	25.0	20.0	18.0	20.6	29.8	45.0	24.0	21.2	24.8	32.6	50.0
460/3/60	7.3	6.6	7.5	9.5	15.0	9.8	8.8	10.1	13.6	20.0	11.6	10.2	12.0	15.1	20.0
575/3/60	N/A	N/A	N/A	N/A	N/A	7.9	7.1	8.2	10.3	15.0	9.1	8.0	9.5	13.0	20.0

Model	COS-096-AR, W, G-FC/AWS					COS-0120-AR, W, G-FC/AWS				
	FLA (OEM Rated)					FLA (OEM Rated)				
	AR	W	G	MCA	MFS	AR	W	G	MCA	MFS
<b>Cooling and Electric Reheat and Humidifier</b>										
208/3/60	57.4	53.3	58.6	71.4	90.0	64.7	59.2	66.3	87.1	110.0
460/3/60	28.0	26.2	28.6	39.1	50.0	31.4	28.9	32.1	42.6	50.0
575/3/60	22.5	21.0	22.9	29.5	35.0	25.1	23.1	25.7	32.2	40.0
<b>Cooling and Electric Reheat Only (No Humidifier)</b>										
208/3/60	57.4	53.3	58.6	71.4	90.0	64.7	59.2	66.3	87.1	110.0
460/3/60	28.0	26.2	28.6	39.1	50.0	31.4	28.9	32.1	42.6	50.0
575/3/60	22.5	21.0	22.9	29.9	35.0	25.1	32.2	25.7	32.2	40.0
<b>Cooling with Humidification (No Electric Reheat)</b>										
208/3/60	51.2	47.1	52.4	60.1	80.0	58.5	53.0	60.1	75.8	110.0
460/3/60	23.4	21.6	24.0	31.7	45.0	26.8	24.3	27.5	35.2	50.0
575/3/60	18.8	17.3	19.2	24.1	35.0	21.4	19.4	22.0	26.2	40.0
<b>Cooling Only, with or without Hot Gas, Hot Water or Steam Reheat</b>										
208/3/60	37.6	32.9	38.2	45.9	70.0	44.3	38.8	45.9	61.5	100.0
460/3/60	16.7	14.9	25.0	40.0	20.1	17.6	20.8	20.8	28.5	45.0
575/3/60	13.5	12.0	13.9	18.7	30.0	16.1	14.1	16.7	20.9	30.0

Model	COS-096-AR, W, G-FC/AWS					COS-0120-AR, W, G-FC/AWS				
	FLA (OEM Rated)					FLA (OEM Rated)				
	AR	W	G	MCA	MFS	AR	W	G	MCA	MFS
<b>Cooling and Electric Reheat and Humidifier</b>										
208/3/60	57.4	53.3	58.6	71.4	90.0	64.7	59.2	66.3	87.1	110.0
460/3/60	28.0	26.2	28.6	39.1	50.0	31.4	28.9	32.1	42.6	50.0
575/3/60	22.5	21.0	22.9	29.5	35.0	25.1	23.1	25.7	32.2	40.0
<b>Cooling and Electric Reheat Only (No Humidifier)</b>										
208/3/60	57.4	53.3	58.6	71.4	90.0	64.7	59.2	66.3	87.1	110.0
460/3/60	28.0	26.2	28.6	39.1	50.0	31.4	28.9	32.1	42.6	50.0
575/3/60	22.5	21.0	22.9	29.9	35.0	25.1	32.2	25.7	32.2	40.0
<b>Cooling with Humidification (No Electric Reheat)</b>										
208/3/60	51.2	47.1	52.4	60.1	80.0	58.5	53.0	60.1	75.8	110.0
460/3/60	23.4	21.6	24.0	31.7	45.0	26.8	24.3	27.5	35.2	50.0
575/3/60	18.8	17.3	19.2	24.1	35.0	21.4	19.4	22.0	26.2	40.0
<b>Cooling Only, with or without Hot Gas, Hot Water or Steam Reheat</b>										
208/3/60	37.0	32.9	38.2	45.9	70.0	44.3	38.8	45.9	61.5	100.0
460/3/60	16.7	14.9	17.3	25.0	40.0	20.1	17.6	20.8	28.5	45.0
575/3/60	13.5	12.0	13.9	18.7	30.0	16.1	14.1	16.7	20.9	30.0

# Dimensional Data — COS-024/060-( )-U-EC

Up-Flow Vertical A/C  
Ducted or Optional 2- or 3-way Plenum box

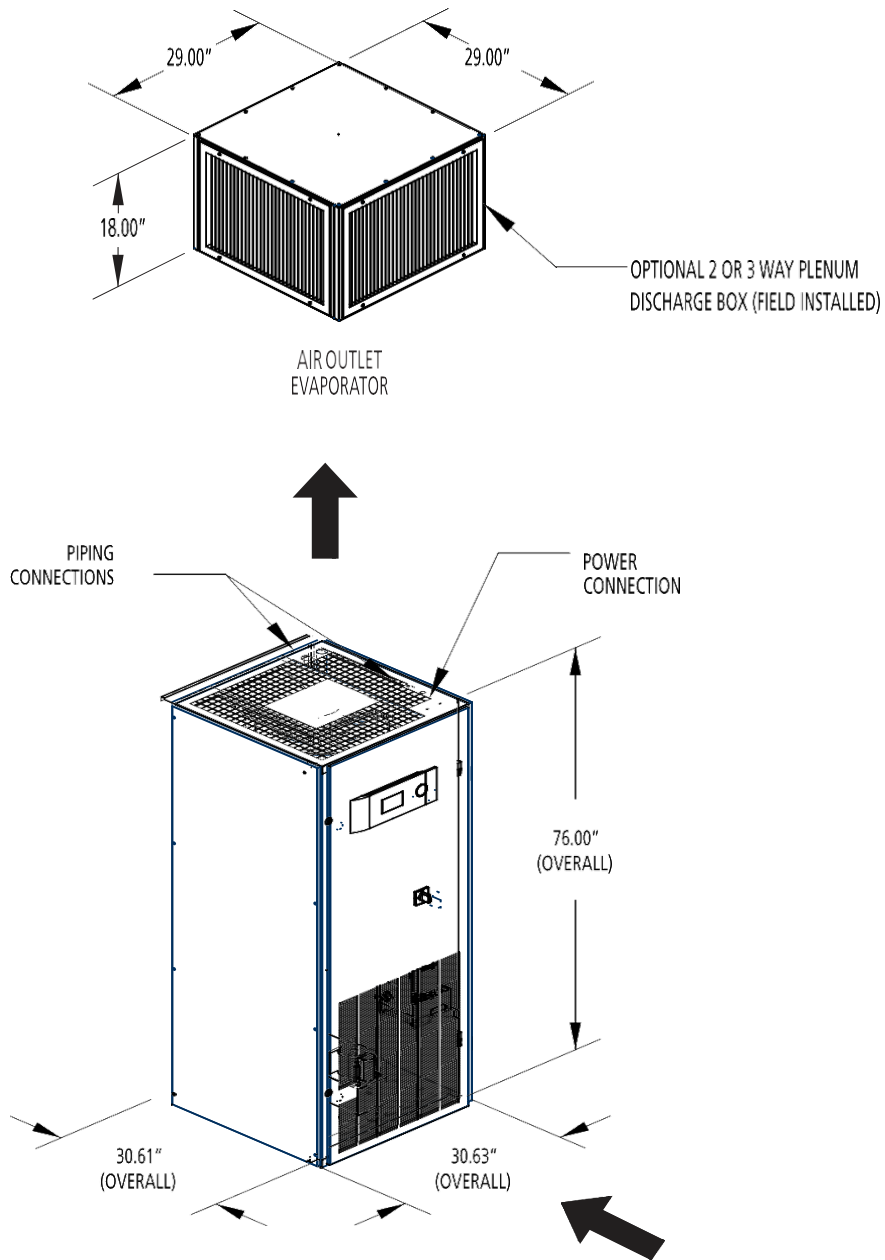

# Dimensional Data — COS-024/060-( )-D-EC

## Down-Flow Vertical A/C

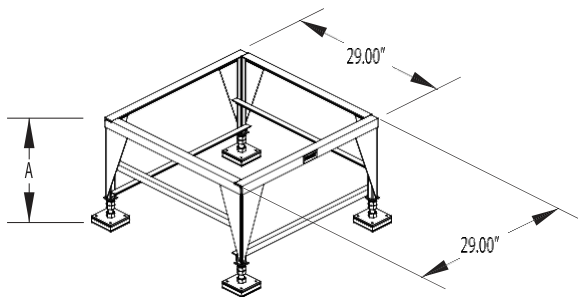
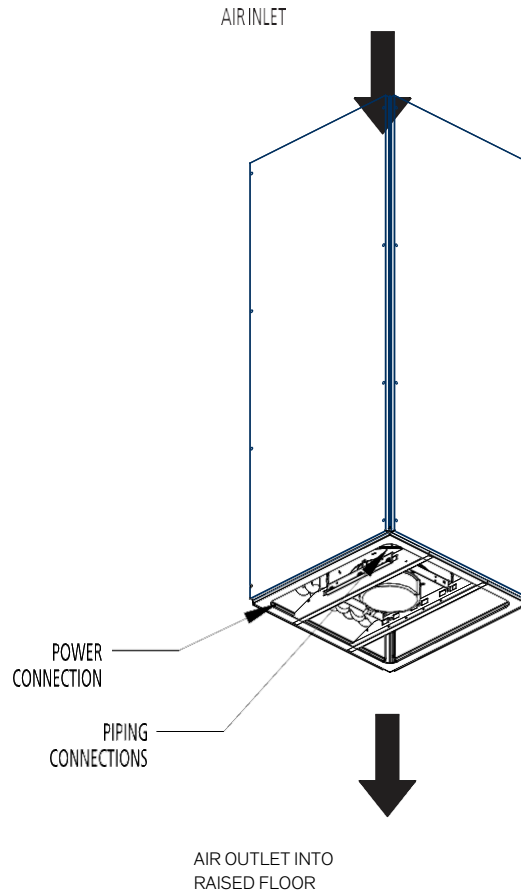
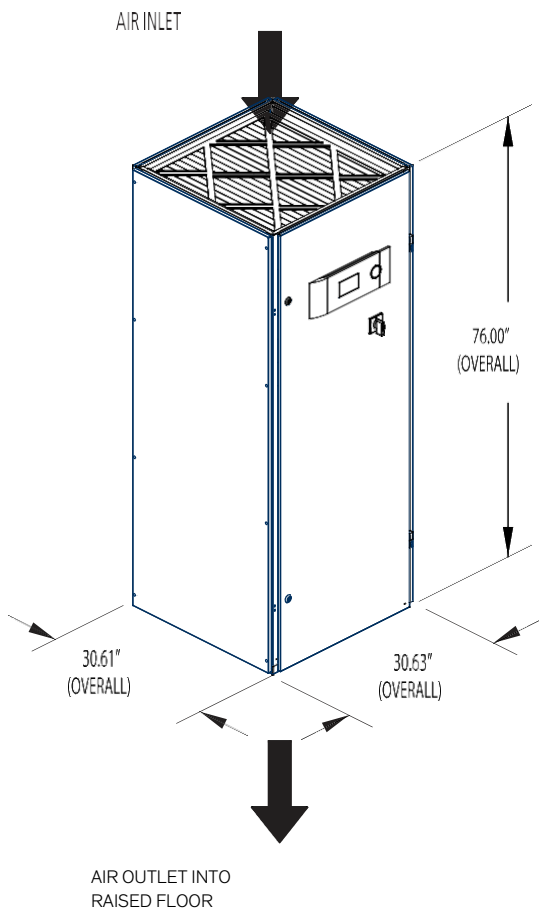

Dimensional Data Floor Stand Heights		
"A" Dimension		
Nominal Height	Adjustable Height	
	MIN	MAX
6	5.0	7.0
12	11.0	15.0
15	14.0	18.0
18	17.0	21.0
24	23.0	26.0

# Dimensional Data — COS-096/120-( )-U-EC

Upflow Vertical A/C  
Ducted or Optional 2- or 3-Way Plenum Box

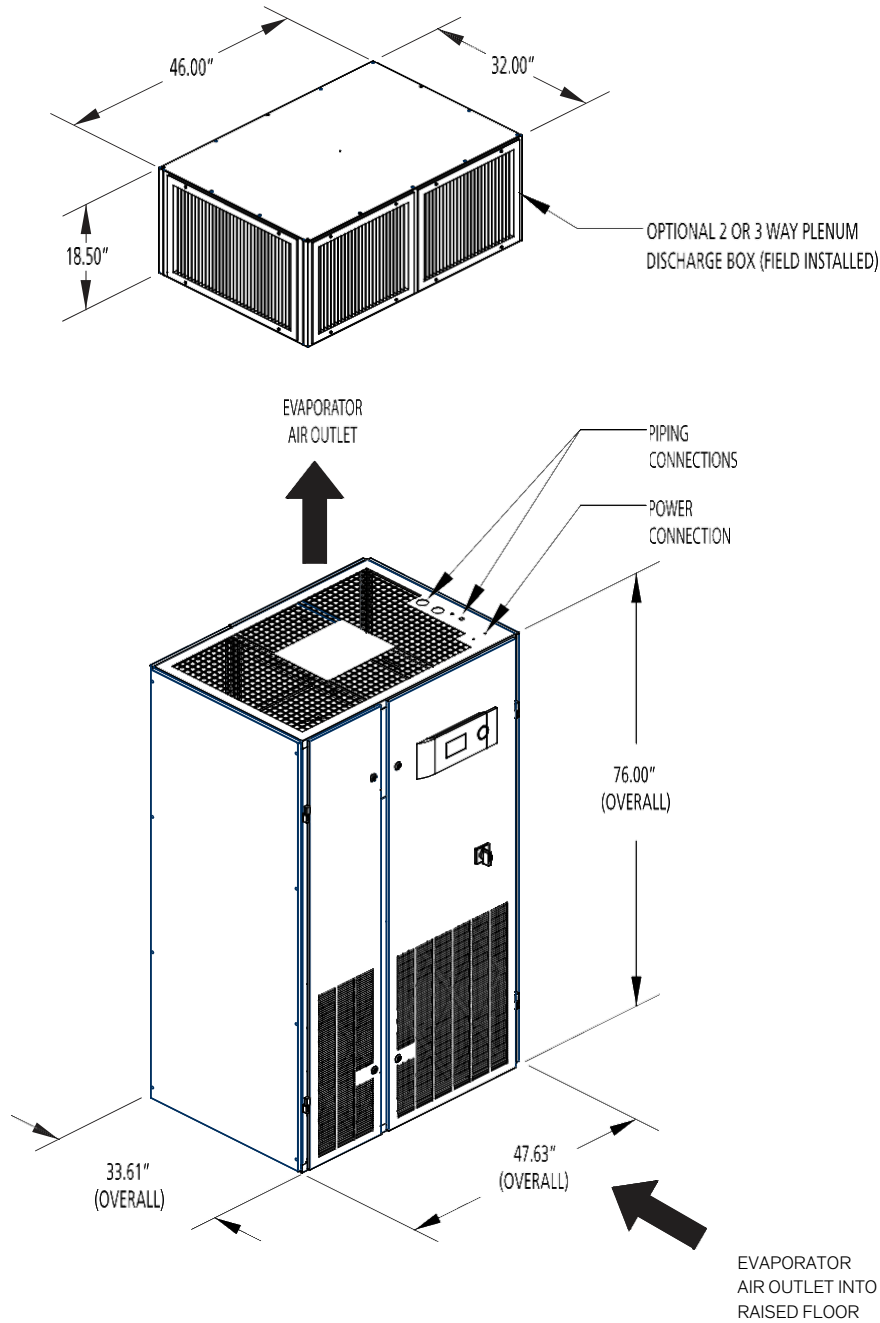

# Dimensional Data— COS-096/120-( )-D-EC Downflow Vertical A/C

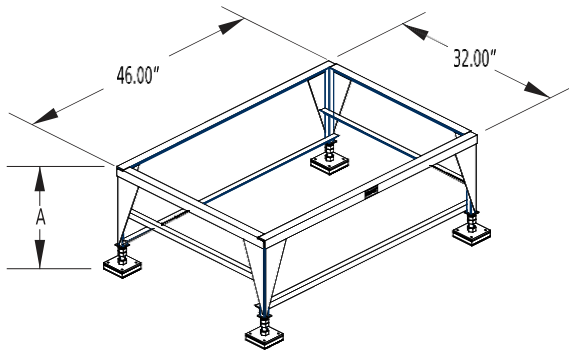
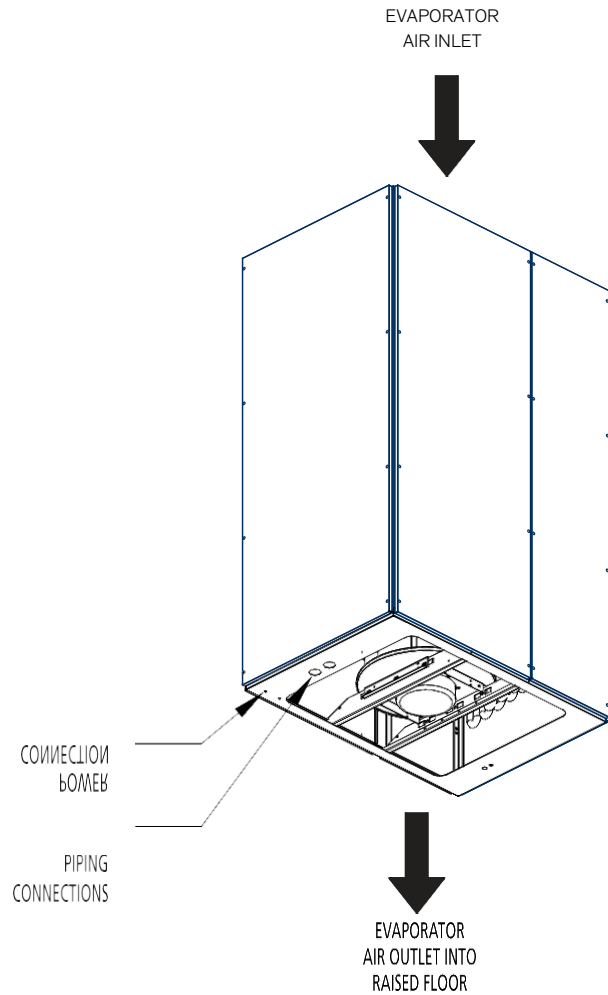
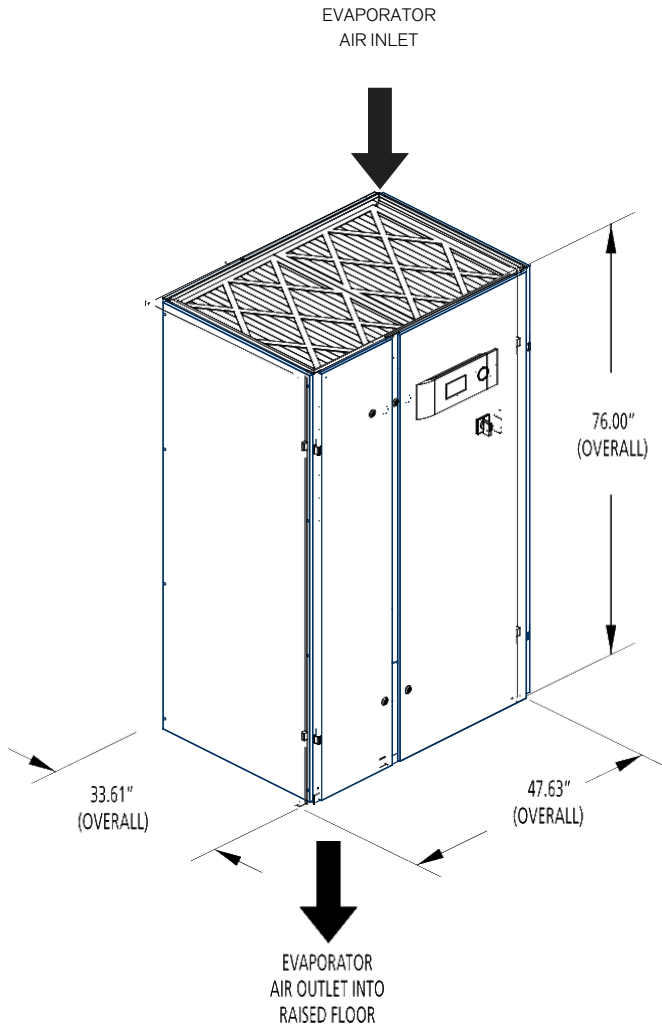

Dimensional Data Floor Stand Heights		
"A" Dimension		
Nominal Height	Adjustable Height	
	MIN	MAX
6	5.0	7.0
12	11.0	15.0
15	14.0	18.0
18	17.0	21.0
24	23.0	26.0

## **CyberOne EC DX Series Up-Flow/Down-Flow, Floor Mounted, Precision Air Conditioners**

### **Summary**

This specification describes requirements for a precision environmental control system. The CyberOne floor-mounted air conditioning system shall provide precision temperature and/or humidity control for computer rooms or rooms containing communications or other highly sensitive heat load equipment where continuous 24 hour a day, 365 days a year air conditioning is required.

Designed for front service access, CyberOne systems require minimum floor space. The units are designed with a wide range of options to handle all precision cooling applications.

### **Design Requirements**

The environmental control system shall be a CyberOne factory-assembled unit. The unit shall be designed for corner installation requiring front access through hinged and removable front access panels. No allowance for side service access shall be required.

CyberOne units are especially adapted for both raised and non-raised floors. The air handling system shall be specifically designed to provide a high sensible heat ratio.

### **Quality Assurance**

The manufacturer shall maintain a set of international standards of quality management to ensure product quality. Prior to shipment each system shall be subject to a complete operational and functional testing based on predefined procedures. The air conditioner manufacturer shall be ISO 9001:2015 certified.

### **Cabinet**

#### **Down-Flow**

Access panels shall be fabricated from 14 gauge galvanized steel. Door jambs and top cabinet frame shall be fabricated from 16 gauge galvanized steel. Bottom cabinet frame shall be fabricated from 10 gauge galvanized steel.

The panels shall be lined with 1/2" (13 mm), 2 lb (.90 kg), high-density sound and thermal insulation and sealed with a self-extinguishing gasket conforming to NFPA 90A and 90B. The main unit color shall be black, extra fine texture. A white finish shall optionally be provided.

#### **Up-Flow**

Access panels shall be fabricated from 14 gauge galvanized steel. Door jambs shall be fabricated from 16 gauge galvanized steel. Top and bottom cabinet frame shall be fabricated from 10 gauge galvanized steel.

The panels shall be lined with 1/2" (13 mm), 2 lb (.90 kg), high-density sound and thermal insulation and sealed with a self-extinguishing gasket conforming to NFPA 90A and 90B. The main unit color shall be black, extra fine texture. A white finish shall optionally be provided.



## **Air Flow Patterns**

### **Downflow**

The air conditioner shall be configured for a down-flow air pattern with top free return air and conditioned supply air discharge through bottom of the system.

### **Upflow**

The air conditioner shall be configured for an up-flow air pattern with free return air through front filtered grille or ducted rear return air and conditioned supply air discharge through the top of the unit.

### **Air Filtration**

All units shall be supplied with disposable air filters classified as UL 900 or UL 586. Filters shall be 2" deep (nominal). Filters shall be pleated with a Minimum Efficiency Reporting Value (MERV) of 8. Filters shall be installed in a front accessible, steel holding frame, and accessible through the front of the unit (except for the rear return configuration).

Optional: Filters rated up to MERV 11 shall be available.

## **Mechanical Components**

### **Backward Inclined, Plenum Style Fan, with an EC Motor**

The blower shall be direct driven, single inlet, backward curved centrifugal with an electronically commutated motor for maintenance free operation. The motor shall include:

- Integrated electronic control board and direct microprocessor control signaling for fan speed control
- Soft-starting capabilities
- RS-485 BUS connection
- Integrated current limitations

The fan shall be low noise, low vibration manufactured with an anti-corrosive aluminum impeller. Each fan impeller shall be dynamically and statically balanced in two planes to minimize vibration during operation.

## **Floor Mounted Air Conditioners**

### **Refrigeration System**

All piping and components contained within the refrigeration system shall be rated for use with R407C refrigerant. The refrigeration circuit shall include, as a minimum, a refrigerant dryer/strainer, sight glass with moisture detector, thermal expansion valve, evaporator coil, compressor, high-pressure switch with manual reset, and low-pressure switch with automatic reset.

### **Scroll Compressor**

The compressor shall be a high efficiency, high reliability, low noise scroll compressor. The compressor shall be complete with internal vibration isolation, internal thermal overloads, internal pressure relief valve, internal discharge gas vibration eliminator, and external vibration mounting isolation.

**Evaporator Coils**

The evaporator coil shall be constructed of seamless drawn copper tubes, mechanically bonded to tempered aluminum fins with enhanced design for maximum heat transfer and mounted in a sloped stainless-steel condensate drain pan. The coil shall be designed for a maximum of 500 ft/min face velocity.

**Snap-Acting Hot Gas Bypass (Optional)**

The CyberOne floor-mounted air conditioning system shall incorporate a snap acting hot gas bypass system to provide modulation of the unit's cooling capacity and evaporator coil freeze protection under low load conditions.

**Air Cooled Heat Rejection****-20°F, Variable Fan Speed Control**

The air-cooled system shall incorporate a low ambient, variable speed fan, head pressure control. The pressure control shall be for year-round air conditioning system operation down to -20°F DB minimum ambient air temperature.

**-30°F, Flooded Control**

The air-cooled system shall incorporate a low ambient flooded head pressure control. The pressure control shall be for year-round system operation down to -30°F DB minimum ambient air temperature. Liquid refrigerant receivers with receiver liquid sight glass and head pressure regulator valves (for flooded condenser operation) shall be included.

**Water/Glycol Cooled Heat Rejection****Braze Plate Heat Exchanger**

The refrigerant circuit shall be a factory installed single pass, counterflow configured, braze plate heat exchanger. It shall be constructed of type 316 stainless steel; designed and tested for a 650 psi WOG.

**2-Way, 600 psig Regulating Valve (Standard)**

The refrigerant circuit head pressure shall be controlled by a factory installed 2-way water/glycol regulating valve rated for 600 psig w.w.p. The 2-way condenser water modulating valve shall automatically meter the flow of water/glycol to the condenser. It shall do so in response to a proportional signal (0-10 VDC) provided to the valve by the microprocessor controller.

**3-Way, 600 psig Regulating Valve (Optional)**

The refrigerant circuit head pressure shall be controlled by a factory installed 3-way water/glycol regulating valve rated for 600 psig w.w.p. The 3-way condenser water modulating valve shall automatically meter the flow of water/glycol to the condenser. It shall do so in response to a proportional signal (0-10 VDC) provided to the valve by the microprocessor controller.

**Free Cooling System (Optional)**

DX Water/Glycol Cooled systems with Free-Cooling are provided with the following standard DX head pressure and Free-Cooling valve combination: 600 psig Rated System (standard):

- DX Valves = 3-way, 600 psig
- FC Valve = 3-way, 600 psig

### **Alternate Water Source System (Optional)**

The alternate water source cooling shall be controlled by the following standard and optional control valves:

- 2-way valve 600 psig
- 3-way valve (Optional) 600 psig

A 2/3-way modulating AWS cooling control valve shall be factory installed. Precision cooling control shall be accomplished via an analog control signal to the proportionally actuating control valve.

### **Steam Generating Humidifier (Standard)**

The humidifier shall be a self-contained atmospheric steam generator. The humidifier assembly shall include an integral fill cup, fill and drain valves, disposable steam cylinder and associated piping. The humidifier shall be equipped with an auto adaptive control system to optimize water conductivity, control automatic drain/flush cycles, minimize energy waste, and maximize cylinder life.

The humidifier shall have modulating output between 20% and 100% of rated capacity. The unit shall include draw in water tempering to ensure the drain water does not exceed 140°F during operation.

### **Dehumidification Cycle (Standard)**

The system shall be a refrigeration-based dehumidification mode. Moisture is condensed on the cooling coil and discharged through the condensate drain. Reheat (electric, hot gas, steam or hot water) shall be used to offset sensible cooling during the dehumidification cycle.

### **Electric Reheat (Standard)**

A factory mounted and wired low-watt density, plated finned-tubular design electric resistance heater shall be included to provide automatic sensible reheating during the dehumidification cycle and automatic heating mode. Electric heaters shall be provided with miniature thermal/magnetic circuit breakers that shall protect each ungrounded conductor. Also included will be one automatic reset and one manual reset over-temperature safety device (pilot duty).

### **Hot Gas Reheat (Optional)**

A factory-installed copper tube, aluminum-fin hot gas reheat coil and valve shall be provided for automatic sensible reheating mode during dehumidification cycle is provided. Hot compressor discharge gas shall be diverted from the condenser to the hot gas reheat coil providing energy-free sensible reheating.

### **Hot Water Reheat (Optional)**

A factory-installed, copper tube, aluminum-fin heat/ reheat coil and 2-way control valve shall be provided to control the flow of hot water for automatic sensible reheating mode during the dehumidification cycle and automatic heating mode as required.

**SCR Fired Reheat (Optional)**

The electric reheat shall be controlled through a “Zero Firing” Silicon Controlled Rectifier (SCR) with an extruded aluminum heat sink and solid-state logic system to provide close dry bulb temperature control.

**Electrical System**

The electrical system shall conform to National Electrical Code requirements. The control circuit shall be 24 volts AC, wire in accordance with NEC Class II requirements. The control circuit wire shall not be smaller than 18 AWG. All wiring shall be neatly wrapped and routed in bundles. Each wire shall end with a service loop and be securely fastened by an approved method. Each wire in the unit shall be numbered for ease of service tracing.

All electrically actuated components shall be easily accessible from the front of the unit without reaching over exposed high voltage components or rotating parts. Each high voltage circuit shall be individually protected by circuit breakers or manual motor starters on all three phases. The blower motor shall have thermal and short circuit protection. Line voltage and 24-volt control circuit wiring shall be routed in separate bundles.

The electric box shall be positioned for service convenience and shall include all the contactors, starters, fuses, circuit breakers, terminal boards and control transformer required for operation of the unit and shall allow for full service access.

**Main Power Service Switch**

The unit shall be provided with a unit mounted main power service non-fused disconnect switch.

**Remote Start/Stop Contacts (Optional)**

Included in the system’s electrical control circuit shall be a 2-pin terminal connection for remote start/stop of the CyberOne EC air conditioner by remote source.

**Air Control****EC Fan Speed Control**

The system shall include available fan speed control package. The unit’s controller shall permit control of the fan speed from 100% rated air volumetric flow rate to a user define minimum fan speed setting. Minimum and maximum fan speed settings shall be user adjustable. User configured control sequences shall be available for fan speed energy savings control.

**E2 Series Controller**

The advanced microprocessor-based E2 Series controller shall be equipped with flexible software capable of meeting the specific needs of the application. The setpoints shall be default and their ranges shall be easily viewed and adjusted from the user interface display. The program and operating parameters shall be permanently stored on a non-volatile system in the event of power failure.

The controller shall be designed to manage temperature and relative humidity (RH) levels to a user defined setpoint via control output signals to the system.

The controller shall receive inputs for measurable control conditions (temperature, relative humidity, and dew point) via return air or room mounted sensors. The internal logic will then determine if the conditions require cooling, humidification or

dehumidification. Control setpoints shall be established to maintain design conditions of the installation. The controller will respond accordingly to changes in these conditions and control the output/demand for the appropriate mode of operation until user defined conditions are achieved.

### **Field Configurable**

The program for the E<sup>2</sup> Series controller shall be field configurable, allowing the operator the capability of selecting control setpoints specific to the application. Operator interface for the E2 controller is provided via a door mounted user interface display panel. The display panel shall have a backlit LCD graphical display and function keys giving the user complete control and monitoring capability of the precision cooling system. The menu driven interface shall provide users the ability to scroll through and enter various menu screens.

### **Password Protection**

Access to the Info Menu, Alarms Log, and the ability to monitor room conditions shall be allowed without the use of a password. Modifications to the control setpoints shall require the use of a password. The controller shall be programmed to recognize predetermined security levels before allowing access to display screens containing critical variables. Three secured menu levels (Control, Service and Factory) will support unique passwords that must be entered to access the menu screens so only authorized personnel may perform modifications to the settings.

### **Restorable Parameters/Factory Defaults**

Upon initial start-up the system shall operate using the setpoints programmed by the factory. The customer may enter new operating parameters in the Control menu and the system will then operate accordingly. The new setpoints may be stored as, Customer Default Setpoints. The primary setpoints entered by the factory remain stored in the controllers' memory as, Factory Setpoints. The setpoints for the system may be re-adjusted in the Control menu at any time. If it becomes necessary, the customer may restore the setpoints back to the Customer Default setpoint values or to the original Factory (primary) setpoint values.

### **A/C Grouping pLAN Operation (Optional)**

Multiple CyberOne EC DX system controllers shall be able to be connected (grouped) to a pLAN local network, allowing the communication of data and information from each controller to a central control terminal or Lead controller. The Lead controller display screens can be used to monitor and adjust group control variables for the individual system controllers. Each E2 controller connected to the pLAN network shall be identified with its own unique address.

Multiple CyberOne EC DX systems consisting of up to eight precision air conditioners equipped with like controllers may be controlled and monitored via the E2 series controller. With multiple CyberOne EC DX systems each unit can selectively be configured as Active to operate as a primary A/C, Capacity Assist for staged operation, or as Standby to come online in case of a failed air conditioning unit to ensure continuous availability.

The controller may also be configured to rotate units with timed duty cycling to promote equal run-time and assure that each CyberOne EC DX system within the rotating group

is operationally exercised periodically.

### **Remote BMS Interface (Optional)**

The E2 series controller shall incorporate a communication interface port that can be field connected to a Building Management System via Modbus, BACnet MS/TP, SNMP, HTTP, or BACnet over ETHERNET/IP as configured by the factory. A controller interfaced to a network must be configured for BMS communication.

### **Alarms**

Alarm conditions shall activate a red LED indicator that backlights the alarm function key. As an option, an alarm condition may also be enunciated by an audible alarm signal. An alarm is acknowledged by pressing the alarm key. This calls up alarm display screens that provides a text message detailing the alarm conditions. After an alarm condition is corrected, the alarm can be cleared by pressing the alarm key.

### **Large Bezel Display Panel — Touch Screen**

The large bezel touch screen user interface display panel features a high-resolution backlit liquid-crystal graphical display equipped with contrast adjustment and LED illuminated function keys. The screens that appear on the user interface display panel present data that is from the controller.

The controller offers an alarm log plus four different interface menu levels to the operator: Information, Control, Service, and Factory. These menus permit the user to easily view, control, and configure operating parameters for the CyberOne system.

### **Timer Feature**

The timer shall enable set up of an operating schedule to automatically scale back or shut down the air conditioner during low demand or unoccupied periods. This is an energy saving feature offering the user the ability to create an operating schedule tailored to the needs of the building. An evening (night-setback) schedule may also be created, allowing the DX system to operate at night with relaxed temperature/humidity setpoints and offsets.

### **Optional Features**

CyberOne EC floor-mounted air conditioning system standard features can be deleted and/or substituted with optional features to allow you the flexibility to select the configuration best suited for your application.

### **Adjustable Floor Stand**

An adjustable floor stand shall be provided to allow for ease of installation of the CyberOne EC DX floor-mounted air conditioning system onto a raised floor environment. Floor stand height shall be adjustable and ship separately for field installation.

### **Enclosed Floor Stand**

A factory provided enclosed floor stand shall be factory constructed full cabinet length and pre-fabricated within the support structure for one-way front air discharge rated to the projects site seismic specifications.

### **Seismic Rated Floor Stand**

The unit floor stand shall be constructed and rated for use to the install site seismic performance requirements.

**Condensate Pump**

A condensate pump shall be factory installed within the CyberOne EC DX floor-mounted air conditioning system for automatic removal of condensate and humidifier flush water (if applicable). The condensate pump shall include an internal overflow safety float which, when wired to the remote start/stop terminals, shall open the unit's control circuit, thereby shutting the unit down in the event of a condensate overflow. The condensate pump shall be specifically designed to operate with the higher condensate temperatures caused by the flush and drain cycle of the electrode canister humidifiers.

**Smoke Detection**

A photo-electric smoke detector shall be factory installed and wired in the return air section of the CyberOne EC DX floor-mounted air conditioning system. The photo-electric detector shall include built-in circuitry that performs a functional test of all detection circuits at least once every 40 seconds without the need for generating smoke. The UL listed velocity range shall be 0-3000 fm. The air conditioner will shut down upon sensing smoke in the return air stream.

**Firestat**

The CyberOne EC DX floor-mounted air conditioning system shall be provided with a factory wired and mounted firestat. The firestat will shut down the air conditioner upon sensing a high return air temperature.

**Remote Water Detector — Spot Type**

A remote single point water/leak detector shall be factory supplied and shall ship separately for field installation. Upon sensing a water leak, the normally closed water detector control circuit shall open, thereby shutting down the STULZ CyberOne floor-mounted air conditioning unit's water producing components.

**Remote Water Detector — Dual Spot Type**

A dual remote single point water/leak detector shall be factory supplied and shall ship separately for field installation. Upon sensing a water leak, the normally closed water detector control circuit shall open, thereby shutting down the CyberOne floor-mounted air conditioning unit's water producing components.

**Remote Water Detector — Strip Type**

A 20 ft. remote strip/cable type water/leak detector shall be provided for remote field installation. In addition to the 20 ft. sensing cable, a 24-volt water detector power module shall require field mounting and wiring to the factory provided terminal connection. Upon sensing a water leak, the normally closed water detector control circuit shall open, thereby shutting down the CyberOne floor-mounted air conditioning unit's water producing components.

**Top Discharge Plenum Box**

A 2 or 3-way plenum discharge box shall be provided. The plenum box shall include double-deflecting, adjustable grilles. The plenum discharge box shall be selectable for upflow units only.

**High Short Circuit Current Rating**

The CyberOne floor-mounted air conditioning system shall be rated for a short circuit current rating for a minimum of 65k AIC. The higher short circuit current rating shall

include safe touch fusing upstream of the unit's main power disconnect switch.

### **Compressor Sound Jackets**

The compressor has a factory installed acoustical sound jacket. Each sound jacket has a snap closure system for ease of removing and reinstallation during maintenance. Each sound jacket has a Noise Reduction Coefficient NRC of 0.85 per ASTM C-423 and a Sound Transmission Loss STC of 11 per ASTM E-90.

### **Low Entering Condenser Water Kit**

For Water/Glycol systems that require entering condenser water temperatures from 45°F to 65°F, the system provides a factory installed in-line liquid refrigerant receiver to help reduce the negative effect the low condenser source can have on the evaporator. A compressor crankcase heater is standard with this option. (Compressor Sound Jackets are not available with this option due to the crankcase heater).

### **Air-Side Economizer Controls**

The CyberOne floor-mounted air conditioning system controller shall be equipped with a unique air-side economization mode for applications using outdoor air-side economizing.

The Air-Side economizer control package shall include an outdoor temperature and humidity sensor, remote space return air sensor, and supply air sensor for proper control during economizer operation.

Individual discrete analog output signals (0-10 VDC) are available to allow control of the external outdoor air intake damper and exhaust relief provisions. Control settings shall be included for both temperature and humidity properties of the outdoor air. A damper signal lockout shall be included if the outdoor air conditions reaches user adjustable limits.

The economizing damper signal shall allow a minimum output setting for minimum outside air control to meet ventilation requirements.

### **Alternate Water Source**

To use building chilled water supply when available as the primary cooling cycle, with compressor, cooling as a backup, an Alternate Water Source cooling cycle is provided. The air conditioner has two cooling modes of operation.

#### **Primary Mode**

The primary mode of cooling is a chilled water/glycol circuit with alternate water source cooling coil and 2- or 3-way modulating (0-10 Vdc) control valve rated for 600 psi WOG.

#### **Secondary/Backup Mode**

The controller microprocessor's Alternate Water Source program algorithm analyzes input data from factory provided water inlet temperature, and return room air temperature, and relative humidity sensors. Based on this data, the controller automatically controls the sequencing of the primary AWS chilled water to and from the secondary/ backup compressor DX mode of operation.

If chilled water is available, the system operates like a chilled water unit, without the compressor operating. When the water temperature is too high, or the water flow rate is not sufficient, the air conditioner automatically switches to the compressor, DX refrigerant cycle.



**Code Conformance**

The supplied system shall be with the following compliance approvals:

CETL US listed to UL 1995 (2011 Ed. 4)

CSA C22.2 No. 236 (2011 Ed. 4)



North American Headquarters

**STULZ Air Technology Systems, Inc.**

1572 Tilco Drive | Frederick, MD 21704

301.620.2033 | Fax: 301.662.5487 | [info@stulz-ats.com](mailto:info@stulz-ats.com)

Technical Support: 888.529.1266

[www.stulz-usa.com](http://www.stulz-usa.com)