

Installation, Operation and Maintenance Manual

Please read and save these instructions for future reference. Read carefully before attempting to assemble, install, operate or maintain the product described. Protect yourself and others by observing all safety information. Failure to comply with instructions could result in personal injury and/or property damage!

Type I



Type II



General Safety Information

Only qualified personnel should install this system. Personnel should have a clear understanding of these instructions and should be aware of general safety precautions. Improper installation can result in electric shock, possible injury due to coming in contact with moving parts, as well as other potential hazards. Other considerations may be required if high winds or seismic activity are present. If more information is needed, contact a licensed professional engineer before moving forward.

DANGER

Always disconnect power before working on or near a fan. Lock and tag the disconnect switch or breaker to prevent accidental power up.

CAUTION

When servicing the fan, motor may be hot enough to cause pain or injury. Allow motor to cool before servicing.

CAUTION

Precaution should be taken in explosive atmospheres.

1. Follow all local electrical and safety codes, as well as the National Electrical Code (NEC), the National Fire Protection Agency (NFPA), where applicable. Follow the Canadian Electrical Code (CEC) and ULC-S650 in Canada.
2. The rotation of the fan wheel is critical. It must be free to rotate without striking or rubbing any stationary objects.
3. Fan motor must be securely and adequately grounded.
4. Do not spin fan wheel faster than maximum cataloged fan rpm. Adjustments to fan speed significantly affects motor load. If the fan RPM is changed, the motor current should be checked to make sure it is not exceeding the motor nameplate amps.
5. Do not allow the power cable to kink or come in contact with oil, grease, hot surfaces or chemicals. Replace cord immediately if damaged.
6. Verify that the power source is compatible with the equipment.
7. Never open access doors to a duct while the fan is running.

Receiving

Upon receiving the product, check to make sure all items are accounted for by referencing the packing list and ensuring all items were received. Inspect each crate for shipping damage before accepting delivery. Notify the carrier if any damage is noticed. The carrier will make notification on the delivery receipt acknowledging any damage to the product. All damage should be noted on all the copies of the bill of lading which is countersigned by the delivering carrier. A Carrier Inspection Report should be filled out by the carrier upon arrival and filed with the Traffic Department. If damaged upon arrival, file claim with carrier. Any physical damage to the unit after acceptance is not the responsibility of Greenheck Fan Corporation.

Unpacking

Verify that all required parts and the correct quantity of each item have been received. If any items are missing, report shortages to your local representative to arrange for obtaining missing parts. Sometimes it is not possible that all items for the unit be shipped together due to availability of transportation and truck space. Confirmation of shipment(s) must be limited to only items on the bill of lading. Filters are shipped on a separate skid in their original packaging. Do not remove factory packaging or install filters until just prior to commissioning. Remove all other shipping/packing materials including fan tie down straps.

Handling

Units are to be rigged and moved by the lifting brackets provided or by the skid when a forklift is used. Location of brackets varies by model and size. Handle in such a manner as to keep from scratching or chipping the coating. Damaged finish may reduce ability of unit to resist corrosion.

Storage

Units are protected against damage during shipment. If the unit cannot be installed and operated immediately, precautions need to be taken to prevent deterioration of the unit during storage. The user assumes responsibility of the unit and accessories while in storage. The manufacturer will not be responsible for damage during storage. These suggestions are provided solely as a convenience to the user.

INDOOR - The ideal environment for the storage of units and accessories is indoors, above grade, in a low humidity atmosphere which is sealed to prevent the entry of blowing dust, rain, or snow. Temperatures should be evenly maintained between 30°F (-1°C) and 110°F (43°C). Wide temperature swings may cause condensation and “sweating” of metal parts. All accessories must be stored indoors in a clean, dry atmosphere.

Remove any accumulations of dirt, water, ice, or snow and wipe dry before moving to indoor storage. To avoid “sweating” of metal parts, allow cold parts to reach room temperature. To dry parts and packages, use a

portable electric heater to get rid of any moisture buildup. Leave coverings loose to permit air circulation and to allow for periodic inspection.

OUTDOOR - Units designed for outdoor applications may be stored outdoors, if absolutely necessary. Roads or aisles for portable cranes and hauling equipment are needed.

The unit should be placed on a level surface to prevent water from leaking into it. The unit should be elevated on an adequate number of wooden blocks so that it is above water and snow levels and has enough blocking to prevent it from settling into soft ground. Locate parts far enough apart to permit air circulation, sunlight, and space for periodic inspection. To minimize water accumulation, place all unit parts on blocking supports so that rain water will run off.

Do not cover parts with plastic film or tarps as these cause condensation of moisture from the air passing through heating and cooling cycles.

Inspection and Maintenance during Storage

While in storage, inspect fans once per month. Keep a record of inspection and maintenance performed.

If moisture or dirt accumulations are found on parts, the source should be located and eliminated. At each inspection, rotate the fan wheel by hand ten to fifteen revolutions to distribute lubricant on motor. Every three months, the fan motor should be energized. If paint deterioration begins, consideration should be given to touch-up or repainting. Fans with special coatings may require special techniques for touch-up or repair.

Machined parts coated with rust preventive should be restored to good condition promptly if signs of rust occur. Immediately remove the original rust preventive coating with petroleum solvent and clean with lint-free cloths. Polish any remaining rust from surface with crocus cloth or fine emery paper and oil. Do not destroy the continuity of the surfaces. Wipe thoroughly clean with Tectyl® 506 (Ashland Inc.) or the equivalent. For hard to reach internal surfaces or for occasional use, consider using Tectyl® 511M Rust Preventive or WD-40® or the equivalent.

Removing from Storage

As units are removed from storage to be installed in their final location, they should be protected and maintained in a similar fashion until the equipment goes into operation. Prior to installing the unit and system components, inspect the unit assembly to make sure it is in working order.

- Check all fasteners, set screws on the fan, wheel, bearings, drive, motor base, and accessories for tightness.
- Rotate the fan wheel(s), where applicable, by hand and assure no parts are rubbing.

Table of Contents

Receiving, Unpacking, Handling and Storage2	Installing Enclosure Panels9
Inspection and Maintenance during Storage2	Installing End Skirts9
Removing from Storage2	Installing Backsplash Panels	10
Hood Weight3	Installing Duct Collars	
Installation		Exhaust Duct Collars	11
Wall or Single Island Style Hoods4	Supply Duct Collars	11
Hood Installation Overview4	Exhaust Air Balancing Baffles	11-12
Hanging the Hood4	Balancing the Kitchen Exhaust System	12
Filler Panel Installation5	Testing Hood Air Volume - Procedures	
Installing Back Supply Plenum5	with Baffle Filters (GH Series)	12-15
Installing the Supply Duct Collar5	with High Velocity Cartridge Filters (GK Series)	16-17
Hanging the Back Supply Plenum5	with High Efficiency Filters (GX Series)	18-20
Hood Hanging Height5	Wiring	
Double Island Style Hoods6	Fire Suppression Wiring Diagrams	21-22
Installing U-Channel Strips6	Overall Wiring Plan View	23
Continuous Capture Plenum Hoods6	Wiring for Hood Switch Panels	24
Electrical Connections6	Circuit Diagrams	25
Ductwork6	Maintenance	26
Installing External Supply Plenums7	Hood Baffle and Air Diffusers	26
Supply Plenum Clip7	Grease Grabber™ Filters	26-27
Uni-strut7	Filter Cleaning and Maintenance	27
Hanger Brackets and Threaded Rod7	Filter Washing Frequency Guide	28
Installing the Supply Duct Collar to the Plenum7	Troubleshooting	29-30
External Supply Plenum		Replacement Parts	31
Weights and Dimensions8	Maintenance Log	32
Clearance Reduction Methods8	Our Commitment	32

Hood Model	Hood Depth (Multiply by Length) for Hood Weight*											
	2 ft .6096 m	2.5 ft .762 m	3 ft .914 m	3.5 ft 1.067 m	4 ft 1.219 m	4.5 ft 1.372 m	5 ft 1.524 m	5.5 ft 1.676 m	6 ft 1.829 m	6.5 ft 1.981 m	7 ft 2.134 m	7.5 ft 2.286 m
GH, GK, GXEW			30 lbs/ft 44.64 kg/m	32 lbs/ft 47.62 kg/m	35 lbs/ft 52.09 kg/m	38 lbs/ft 56.55 kg/m	40 lbs/ft 59.53 kg/m					
GH, GX, GXDW			36 lbs/ft 53.57 kg/m	38 lbs/ft 56.55 kg/m	41 lbs/ft 61.01 kg/m	44 lbs/ft 65.48 kg/m	46 lbs/ft 68.46 kg/m					
GH, GK, GXFW				40 lbs/ft 59.53 kg/m	44 lbs/ft 65.48 kg/m	48 lbs/ft 71.43 kg/m	52 lbs/ft 77.38 kg/m					
GH, GK, GXCW				48 lbs/ft 71.43 kg/m	51 lbs/ft 75.90 kg/m	54 lbs/ft 80.36 kg/m	57 lbs/ft 84.83 kg/m					
GH, GK, GXSW				44 lbs/ft 65.48 kg/m	48 lbs/ft 71.43 kg/m	52 lbs/ft 77.38 kg/m	56 lbs/ft 83.34 kg/m					
GGEW			39 lbs/ft 58.04 kg/m	41 lbs/ft 61.01 kg/m	44 lbs/ft 65.48 kg/m	47 lbs/ft 69.94 kg/m	49 lbs/ft 72.92 kg/m					
GGDW			45 lbs/ft 66.97 kg/m	47 lbs/ft 69.94 kg/m	50 lbs/ft 74.41 kg/m	53 lbs/ft 78.87 kg/m	55 lbs/ft 81.85 kg/m					
GGFW				49 lbs/ft 72.92 kg/m	53 lbs/ft 78.87 kg/m	57 lbs/ft 84.83 kg/m	61 lbs/ft 90.78 kg/m					
GGCW				57 lbs/ft 84.83 kg/m	60 lbs/ft 89.29 kg/m	63 lbs/ft 93.75 kg/m	66 lbs/ft 98.22 kg/m					
GGSW				53 lbs/ft 78.87 kg/m	57 lbs/ft 84.83 kg/m	61 lbs/ft 90.78 kg/m	65 lbs/ft 96.73 kg/m					
GH, GK, GXEV					52 lbs/ft 77.38 kg/m	54 lbs/ft 80.36 kg/m	56 lbs/ft 83.34 kg/m	58 lbs/ft 86.31 kg/m	61 lbs/ft 90.78 kg/m	63 lbs/ft 93.75 kg/m		
GH, GK, GXFV					61 lbs/ft 90.78 kg/m	66 lbs/ft 98.22 kg/m	68 lbs/ft 101.20 kg/m	72 lbs/ft 107.15 kg/m	75 lbs/ft 111.61 kg/m	79 lbs/ft 117.56 kg/m		
GH, GK, GXCV									81 lbs/ft 120.54 kg/m	84 lbs/ft 125.01 kg/m	87 lbs/ft 129.47 kg/m	90 lbs/ft 133.93 kg/m
GH, GK, GXSV						66 lbs/ft 98.22 kg/m	69 lbs/ft 102.68 kg/m	72 lbs/ft 107.15 kg/m	76 lbs/ft 113.10 kg/m	79 lbs/ft 117.56 kg/m		
GO/GD1	20 lbs/ft 29.76 kg/m	24 lbs/ft 35.72 kg/m	28 lbs/ft 41.67 kg/m	32 lbs/ft 47.62 kg/m	36 lbs/ft 53.57 kg/m	40 lbs/ft 59.52 kg/m	44 lbs/ft 65.48 kg/m	48 lbs/ft 71.43 kg/m	52 lbs/ft 77.38 kg/m			
GD2			43 lbs/ft 63.99 kg/m	48 lbs/ft 71.43 kg/m	53 lbs/ft 78.87 kg/m	58 lbs/ft 86.31 kg/m	63 lbs/ft 93.75 kg/m	68 lbs/ft 101.20 kg/m	73 lbs/ft 108.64 kg/m			
GD3			58 lbs/ft 86.31 kg/m	64 lbs/ft 95.24 kg/m	70 lbs/ft 104.17 kg/m	76 lbs/ft 113.10 kg/m	82 lbs/ft 122.03 kg/m	88 lbs/ft 130.96 kg/m	94 lbs/ft 139.89 kg/m			

*Hood weight calculations are based on standard selection. Hood height, accessories and material gauge affect overall hood weight.



Installation

Wall or Single Island Style Hoods

NOTE

If you have a back supply plenum (BSP), this must be installed before the hood. Please see page 5.

The installation of the canopy hoods shall be in accordance with NFPA 96 (latest edition) Standard for Ventilation Control and Fire Protection of Commercial Cooking Operations and ULC-S650 in Canada.

Greenheck does not recommend walking or standing on the hood top as damage can result and may void the warranty. If you must walk on the hood top, protect the hood with additional support and planks for flooring.

For wall/single island style hoods, prior to installation, check with local authorities having jurisdiction on clearances to combustible surfaces, etc.

With the hood still inside its packing crate, position the unit beneath its installation location. Carefully remove the packing crate. Place some protective material on the floor next to the crate to avoid damaging the hood as it is tipped on its side. Tip the hood carefully onto the protective material. If you have filler panels, install them now; refer to page 5, Filler Panel Installation. If you have integral filler panels, no additional installation is needed.

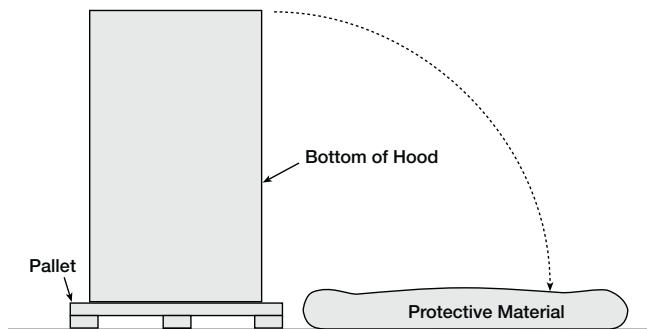

Hood Installation Overview

If a back supply plenum is provided, install it first. Before raising the hood, insert 1/2 in. (12.7 mm) diameter threaded rod (by others) into hanger brackets on hood top. Check the engineering drawings or UL label located on the inside of the hood for proper hood height above finished floor. Install filler panels if needed. Raise and hang the hood from adequate roof or ceiling supports. All hanger brackets must be used and the hood must be properly supported while lifting to prevent damage or distortion to the hood. The hood must be hung level to operate properly. After the hood is secured, make the exhaust duct connections. The fire system distributor must be contacted at this time. After the fire system has been installed, mount the enclosures, then the supply plenums. If a horizontal supply plenum is provided, it should be installed before the enclosures. Finally, make the electrical connections from the switches to the fans and complete the fire system circuits as required by the job specification.

Hanging the Hood

Before hanging the hood according to the hood installation instructions, please check the following if applicable:

1. Make sure the back supply plenum is properly secured, as described on page 5.
2. If the ductwork for the back supply will not interfere with the hood installation, it should be connected now.
3. Any filler panels should be attached to the hood before the hood installation. See page 5 for instructions.
4. Lift the hood, and position it so the filler panels are resting lightly on the top outside edges of the back supply. **The back supply is used to position the hood only, it is not intended to hold any hood weight.**

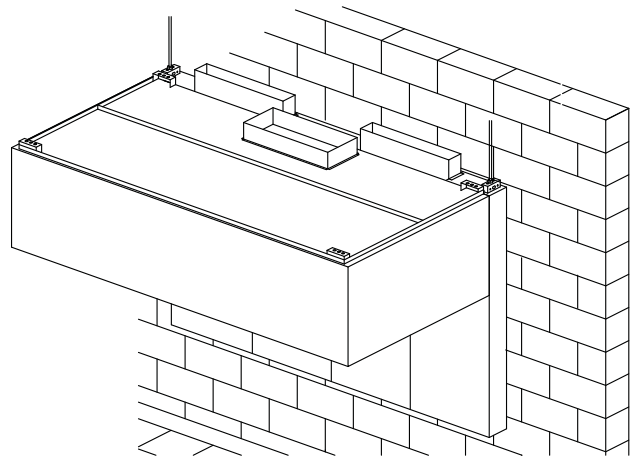

5. Connect the remaining ductwork for the back supply and the hood. It is recommended that caulk be applied at the mating seams and surfaces of the back supply, the hood, and the wall.
6. If the hood is equipped with clearance reduction methods, refer to page 8 for special considerations with hanging the hood.

Filler Panel Installation

1. Uncrate the hood and lay it on the floor with protective material between the hood and the floor.
2. Bolt the filler panels together with 5/16 in. bolts provided in the hardware package.
3. Position the filler panels to the hood back, and tack-weld them into place.

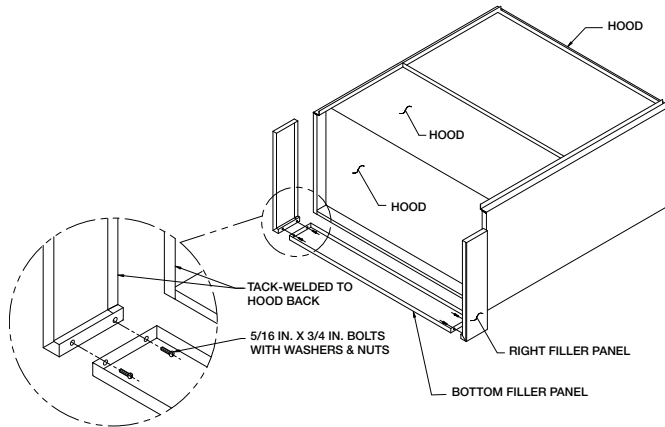

4. To allow for ease of cleaning, caulk the external seams with NSF Approved silicone caulk (GE SCS1009, or its equivalent). The caulk is not provided.

Installing the Back Supply Plenum

Installing the Supply Duct Collar

1. Find the center of the back supply plenum.
2. If the back supply plenum is to have one opening, cut the opening such that it is centered at $L/2$ from the plenum end. (Fig. 1)
3. If the back supply plenum is to have two openings, cut openings such that they are centered at $L/4$ from each end of the plenum. (Fig. 2)
4. Place the duct collar(s) over the opening(s), fastening with screws or tack-welds every 4 to 6 in. (10.16 to 15.24 cm). (Fig. 3)

Fig. 1

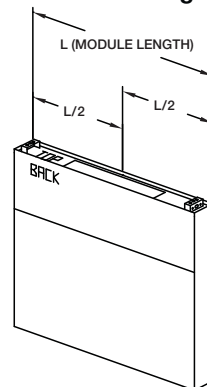

Fig. 2

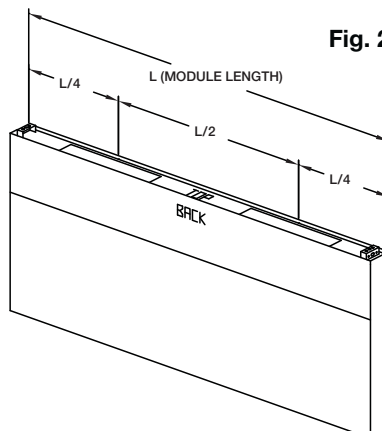
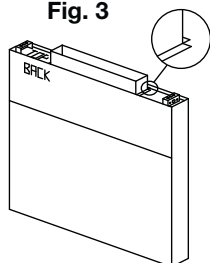
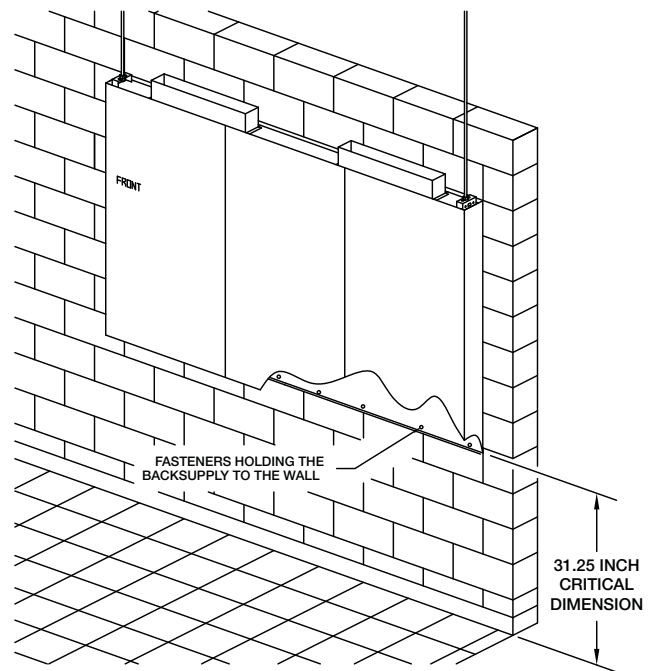

Fig. 3



Hanging the Back Supply Plenum

5. Hang the back supply plenum from the ceiling.
 - The back supply plenum needs to be mounted 31.25 in. (79.375 cm) above the finished floor. This is measured from the lowest rear edge of the back supply plenum to the finished floor.
 - Hang using threaded rod placed through the hanger brackets.
6. Fasten the back supply to the wall, going through the lower back supply wall.
 - These fasteners are to help maintain the location of the back supply, and are not intended to hold the weight of the back supply unit.
 - The fasteners should not interfere with the removable air diffusers



Hood Hanging Height

The hood hanging height is critical. Hanging the hood at the incorrect height may significantly reduce the ability of the hood to function properly and may be in violation of codes. The hood hanging height, typically 78 in. (198.12 cm) above the finished floor, is given on the UL label located on the end panel on the inside of the hood. The hood must be hung level to operate properly. The grease trough is pitched to drain into the grease container.

Double Island Style Hoods

NOTE

Before hanging the hoods, please verify the hood marks to make sure the correct hood is hung on the correct side.

A double island hood is created by installing two wall style hoods back to back. Use the installation procedure described on page 4 for single island hoods; install and level both hoods. After leveling, secure the hoods together by tack-welding and/or bolting the rear mounting brackets together.

Installing U-Channel Strip

1. After the hood is hung in position and leveled, apply caulk to the inside edge of the double island clip.
2. Position and install the clip by tapping into position along clip (friction fit).
3. Caulk edges to seal out grease and allow for ease of cleaning. Caulk with NSF Approved silicone caulk (GE SCS1009 or its equivalent). The caulk is not provided.

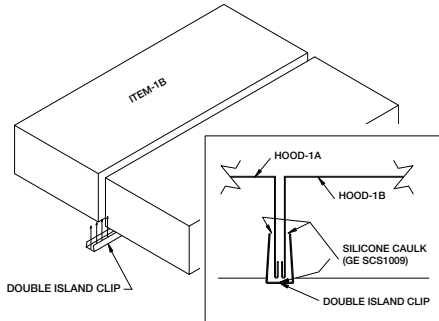

Continuous Capture Plenum Hoods

Remove the support angles provided for support during shipping on the open end panels. Use the installation procedure described on page 4 for single island hoods; install and level both hoods.

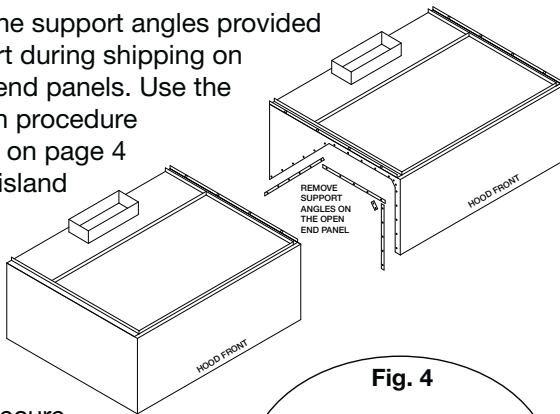

After leveling, secure the hoods together by tack-welding and/or bolting the angles that are located at the top of the hoods along its width (Fig. 4).

Next, fasten the hoods together at its inside plenum profile using u-clips and bolts (Fig. 5). Caulk this joint with NSF Approved silicone caulk (GE SCS1009 or its equivalent). The caulk is not provided.

After the hood is installed, remove all protective plastic.

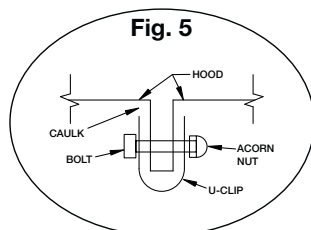
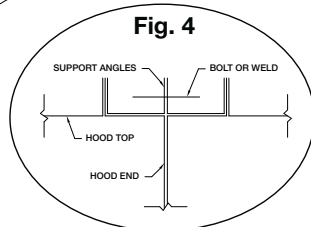

Electrical Connections

Access for wiring the hood control panel (when applicable) is provided by a junction box located on top of the hood when the control panel is mounted in the hood, or by the switch junction box when the control panel is mounted in the fire protection cabinet. The box is labeled "Control Voltage Wiring to Roof Top Fan Package". Use minimum 14 AWG copper wire. After all the wiring is completed, install the light bulbs (light bulbs not provided; standard light bulbs up to 100 watt may be used).

CAUTION

For multiple hood systems that have more than 14 lights total (incandescent or fluorescent), the hood lights must be wired to multiple circuits. Each circuit must have less than 14 lights total.

Standard Greenheck light switches shipped on hoods are rated for 15 amps and shall not have more than 14 lights connected to them. Higher amperage switches are available upon special request.

Ductwork

Exhaust

As specified in NFPA 96, Ch. 7.5 (latest edition), exhaust duct systems must be constructed in the following manner:

Materials: Ducts shall be constructed of and supported by carbon steel not less than 1.37 mm (0.054 in.) (No. 16 MSG) in thickness, or stainless steel not less than 1.09 mm (0.043 in.) (No. 18 MSG) in thickness.

Installation: All seams, joints, penetrations, and duct to hood collar connections shall have a liquid-tight external weld. If you have an automatic fire damper, please refer to that manual for installation instructions now.

Supply

Supply ductwork (where applicable) should be connected to the hood in a manner approved by the local code authorities.

NOTE

For hoods with fire dampers in the exhaust and supply duct collars, an access panel for cleaning and inspection shall be provided in the duct. This panel shall be as close to the hood as possible but should not exceed 18 in. (45.72 cm).

For proper installation of duct collars when they are shipped unattached, see page 11.

Installing External Supply Plenums

NOTE

The supply plenum is provided with plenum clips that assist in hanging the plenum. Do not hang plenums using only the clips. Threaded rod or uni-strut must also be used.

Using the Supply Plenum Clip

1. Fasten the hanging clip to the supply plenum. Two clips are needed for plenums less than 96 in. (243.84 cm) long and three for plenums greater than 96 in. (243.84 cm). The third clip is located in the center of the plenum length. If there is a cabinet, the clip should be 23.5 in. (59.69 cm) from the outside edge of the cabinet.

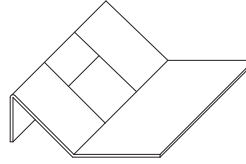

Supply Plenum Clip

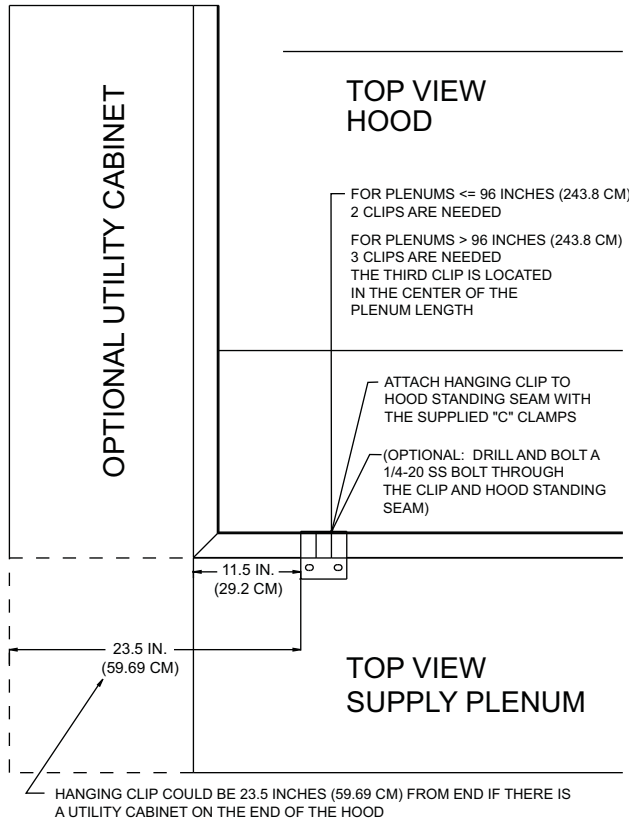

2. Using the c-clamps provided, clamp the supply plenum hanging clip to the hood standing seam. Option: Drill and bolt a 1/4-20 SS bolt through the clip and hood standing seam.

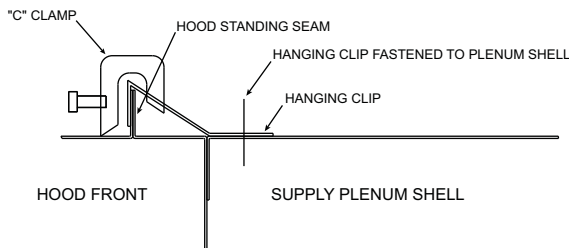

Using the Uni-strut

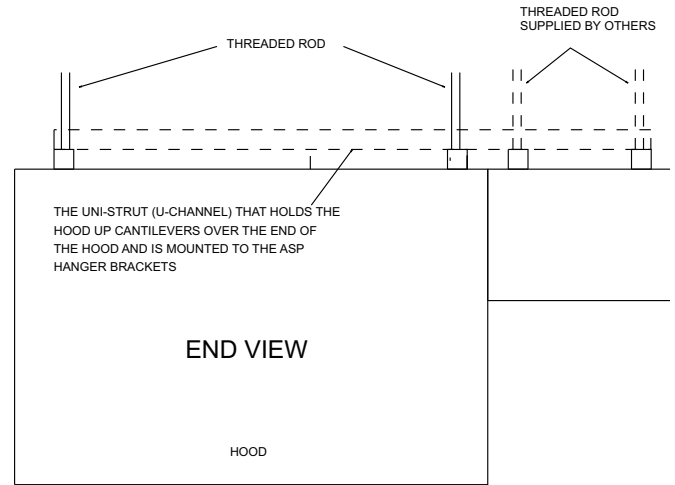

The uni-strut (supplied by others) supporting the hood, may be cantilevered over the end of the hood and used to mount to the hanger brackets on the supply plenums.

Using Hanger Brackets and Threaded Rod

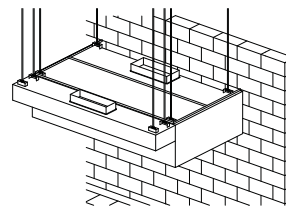

ASP
Air Curtain Supply Plenum

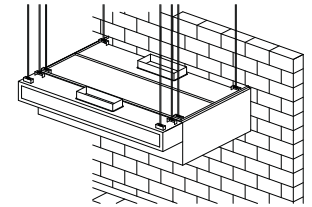

HSP or VSP
Variable Supply Plenum

1. Insert 1/2 in. (12.7 mm) diameter threaded rod (by others) into hanger brackets on the supply plenum top. Raise and hang the external supply plenum from adequate roof or ceiling supports.
2. The external supply plenum should be resting lightly against the hood. The hood is used to position the plenum only, it is not intended to support the plenum. All hanger brackets must be used and the plenum must be properly supported while lifting to prevent damage or distortion. The supply plenum must be hung level to operate properly.
3. It is recommended that caulk be applied at the mating seams and surfaces of the plenum, the hood, and the wall. If the supply plenum is next to a wall, you will also need to caulk around the surface next to the wall. Caulk the joints with NSF Approved silicone caulk (GE SCS1009, or its equivalent). The caulk is not provided.

Installing the Supply Duct Collar to the Plenum

Place the duct collar(s) over the opening, fastening with tack-welds at 1 to 2 in. (2.54 to 5.08 cm) intervals, or sheet metal screws at 3 to 6 in. (7.62 to 15.24 cm) intervals.

Weights and Dimensions

External Supply Plenum Type	Weight		Width		Height		Length per section	
	(lbs/ft)	(kg/m)	(in)	(mm)	(in)	(mm)	(ft)	(m)
Back Supply	35.0	52.09	6	152.4	Variable	Variable	3 to 16	.91 to 4.88
Air Curtain Supply • 14 inch	9.5	14.14	14	355.6	10	254	3 to 16	.91 to 4.88
Air Curtain Supply • 24 inch	12.5	18.60	24	609.6	10	254	3 to 16	.91 to 4.88
Variable Supply	16.0	23.81	12	304.8	18	457.20	3 to 16	.91 to 4.88
Horizontal Supply	14.0	20.83	12	304.8	18	457.20	3 to 16	.91 to 4.88

Clearance Reduction Methods

Clearance reduction methods have been evaluated and tested and are listed by UL (Underwriters Laboratory). The method of test was derived from the UL 710 test standard.

The hood may be installed with zero clearance to combustible materials if constructed in the following manner.

1. One inch (2.54 cm) thick layer of insulation of Owens Corning® Type 475, Johns Manville Type 475, IIG® MinWool-1200® Flexible Batt, or Knauf Insulation Type EI 475.
2. Insulation must be held securely in place. Pins that are welded or secured with an adhesive may be used.
3. A backsplash panel must be attached to the wall (insulated or uninsulated).

To comply with the UL listing, the cooking appliances must be as follows:

- Maximum surface temperature is 700°F (371°C)
- Appliances are located at least 3 in. (7.62 cm) from the rear wall
- Appliances are at least 40 in. (101.6 cm) below the bottom front edge of the hood

The hood may be installed with 3 in. (7.62 cm) clearance to limited combustible materials per NFPA 96 if constructed in one of the following methods:

- 3 in. (7.62 cm) rear uninsulated stand-off
- 3 in. (7.62 cm) top enclosure panel system
- 3 in. (7.62 cm) end uninsulated stand-off

Top Clearance Reduction Options

One inch (2.54 cm) layer of insulation installed on top of the hood (optional) meets zero inch requirements for clearance to combustible surfaces as outlined under the clearance reductions methods.

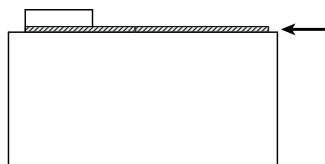

Three inches (7.62 cm) insulated airspace installed on top of hood (optional) meets NFPA 96 requirements for clearance to limited combustible surfaces.

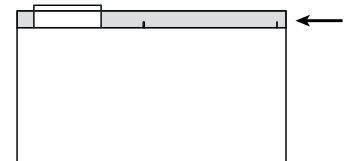

Back and Front Clearance Reduction Options

One inch (2.54 cm) layer of insulation in 3 in. (7.62 cm) back stand-off meets zero inch requirements for clearance to combustible surfaces as outlined under the clearance reduction methods.

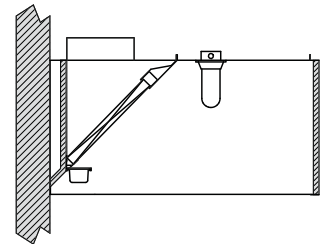

Three inches (7.62 cm) uninsulated back stand-off meets NFPA 96 requirements for clearance to limited combustible surfaces.

One inch (2.54 cm) layer of insulation factory-installed on the front of the hood (optional) meets zero inch requirements for clearance to combustible surfaces.

End Clearance Reduction Options

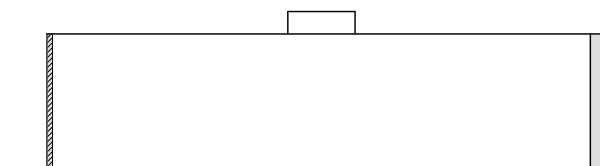

One inch (2.54 cm) layer of insulation factory-installed on the end of the hood (optional) meets zero inch requirements for clearance to combustible surfaces under the clearance reduction methods.

Three inches (7.62 cm) uninsulated airspace installed on end of hood (optional). Meets NFPA 96 requirements for clearance to limited combustible surfaces.

Installing Enclosure Panels

Before installing the enclosure panels, make sure the hood is hung in position with all the ductwork attached and electrical connections completed.

1. Position the end enclosure panels on the hood, and clamp into place with clamps provided or tack-weld the panels into place.
2. Fasten the end enclosure panels to the wall, method depends on wall construction. (Fasteners provided by others).

If the hood is a double island, bolt the end enclosure panels together. (Fasteners provided by others).

3. Position the front enclosure panel(s) on the hood, and bolt to the end enclosure panels with the 5/16 in. bolts provided in the hardware package.
4. Tack-weld or clamp the front enclosure panel(s) to the hood. If clamps are used, they must be positioned 4 in. (10.16 cm) from the ends and in the center of the front enclosure panel.
5. To allow for ease of cleaning, caulk the external seams with NSF Approved silicone caulk (GE SCS1009, or its equivalent). The caulk is not provided.
6. Installation instructions may not be applicable for concrete ceilings.

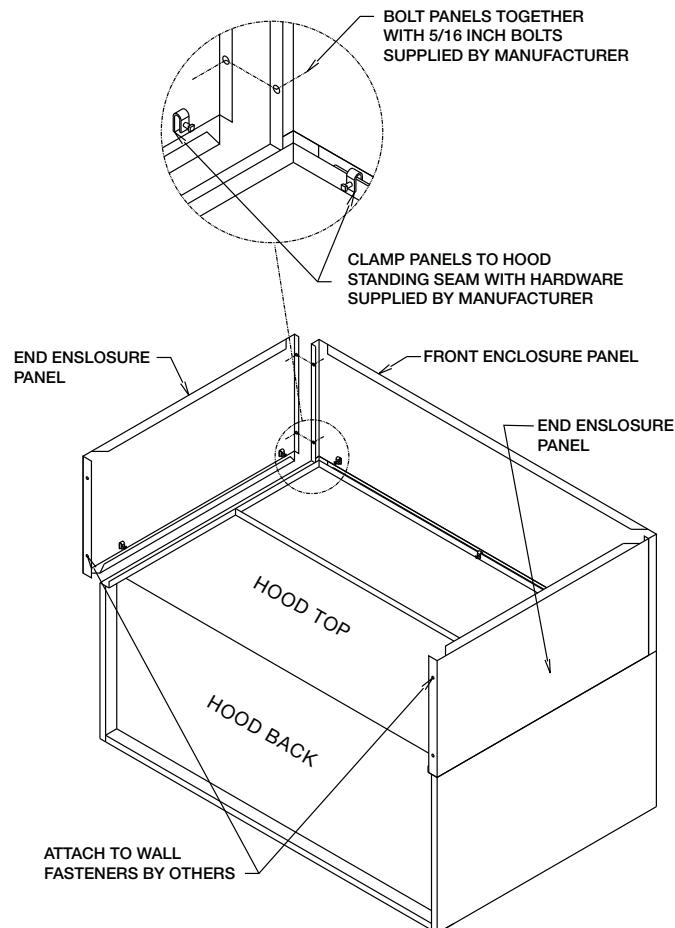

Installing End Skirts

1. After the hood is hung in position, line up the top of the end skirt with the end panels of the hood.
2. Drill a hole in the hood end panel to line up with the hole in the end skirt. Attach the end skirt with a 1/4 in. bolt and cap nut to the inside of the hood, or tack-weld the end skirt to the hood.
3. Position the end skirt against the wall and attach. The method depends on the wall construction. (Fasteners provided by others).
4. Caulk the internal joint formed by the end skirt and the hood end panel with NSF Approved silicone caulk (GE SCS1009 or its equivalent). The caulk is not provided.
5. To allow for ease in cleaning, also caulk all the external seams.

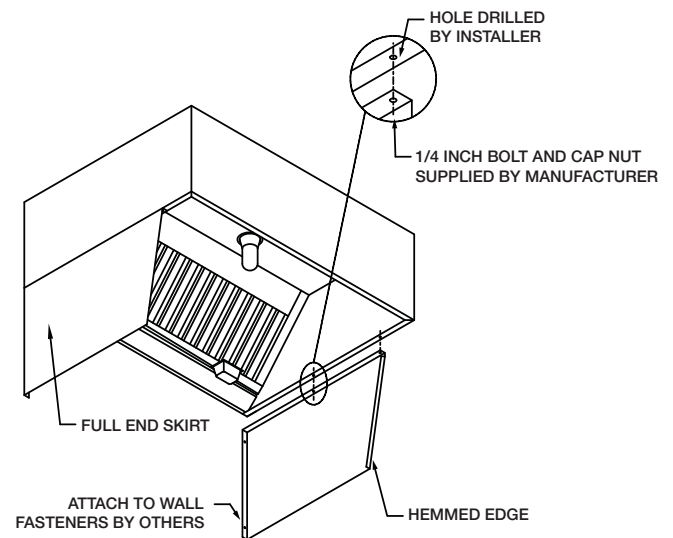

Installing Backsplash Panels

Flat Backsplash Panel

Material: Stainless

LENGTH		QTY
Inches	Millimeters	
<=47	<=1193.8	1
>47 <=93	>1193.8 <=2362.2	2
>93 <=138.8	>2362.2 <=3525.5	3
>138.8 <=185	>3525.5 <=4699	4
>185 <=231.3	>4699 <=5875.0	5

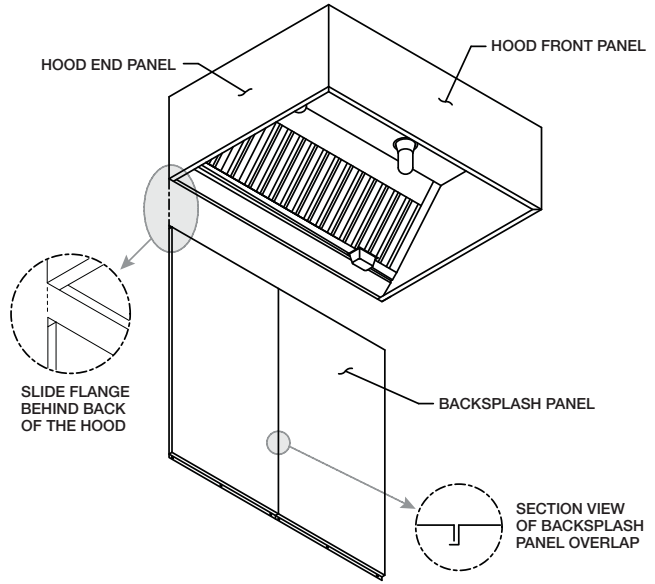
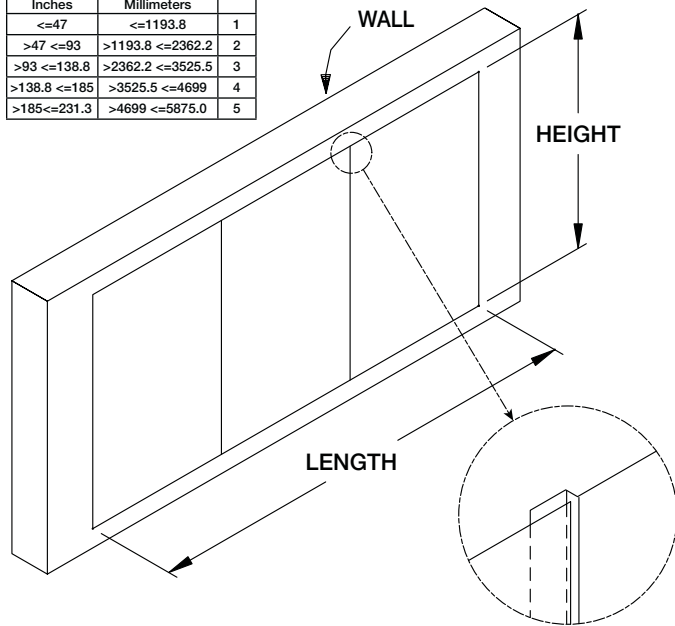

NOTE

Panels up to 47 in. (1193.8 mm) wide ship in one piece; over 47 in. (1193.8 mm) in multiple pieces.

Insulated Backsplash Panel

Material: Stainless

Insulation: 1 in. (25.4 mm)

LENGTH		QTY
Inches	Millimeters	
<=45	<=1143	1
>45 <=90	>1143 <=2286	2
>90 <=135	>2286 <=3429	3
>135 <=180	>3429 <=4572	4
>180 <=225	>4572 <=5715	5

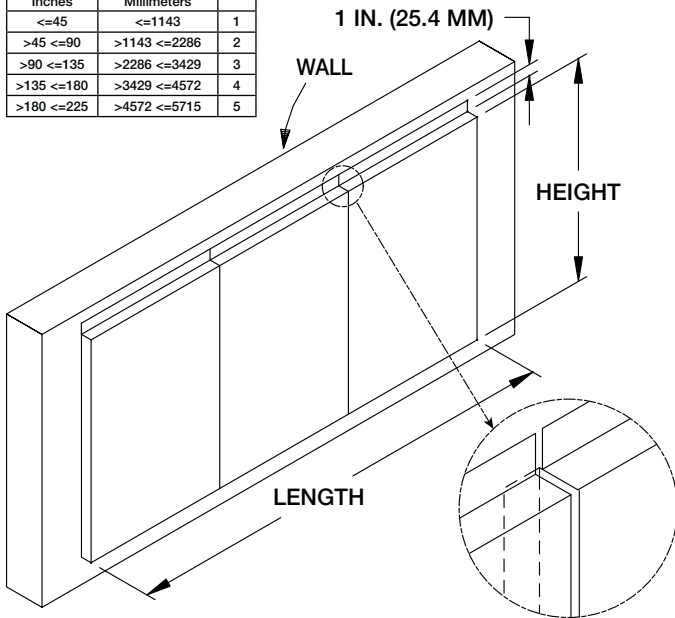

NOTE

Panels up to 45 in. (1143 mm) wide ship in one piece; over 45 in. (1143 mm) in multiple pieces.

1. After the hood is hung in position, slide the flat flange of the backsplash panel behind the back of the hood.

Note: If the backsplash panel length is greater than 45 in. (1143 mm), it will be shipped in multiple pieces.

2. After the backsplash panel has been positioned, drill holes in the panel and fasten to the wall. (Fasteners provided by others).

Note: The holes should be spaced to adequately secure the panel to the wall.

3. Caulk the joints between the hood and the backsplash panel with NSF Approved silicone caulk (GE SCS1009, or its equivalent). The caulk is not provided.
4. Caulk the joint between the backsplash panels when multiple panels are required, with NSF Approved silicone caulk (GE SCS1009, or its equivalent). The caulk is not provided.

Installing Duct Collars

Exhaust Collars

1. The exhaust duct connection needs to be located within 48 in. (121.92 cm) from the center of the hood length to the center of the duct connection and within shaded area as shown.

Top View of the Hood

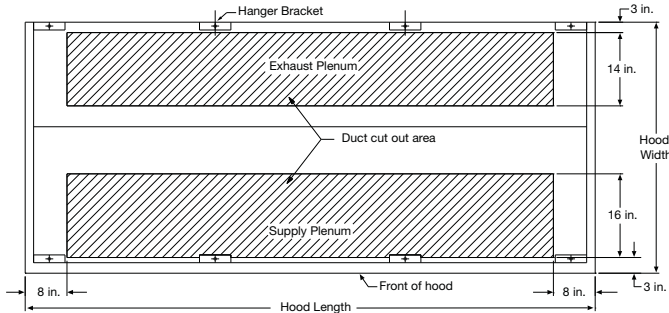

Back View of the Hood

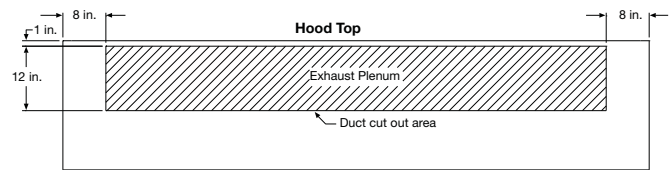

2. The exhaust duct connection is to be a continuous liquid-tight weld. Weld with a non-ferrous filler wire, such as silicon bronze or stainless steel filler wire. Protect all stainless steel areas from weld splatter.

Supply Collars

1. The supply duct connection needs to be located within the shaded Supply Plenum area as in the drawing above.
2. The supply duct connection is tack-welded at 1 to 2 inch (2.54 to 5.08 cm) intervals or sheet metal screws at 3 to 6 in. (7.62 to 15.24 cm) spacing to the hood.

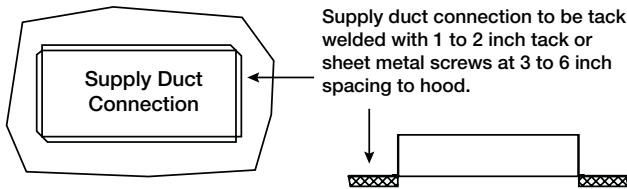

3. For hoods that are insulated, the edges of the insulation must be taped after the hole is cut. (The insulation tape is provided by others).

4. On combination hoods, make certain the fire damper is located over the internal supply chamber.

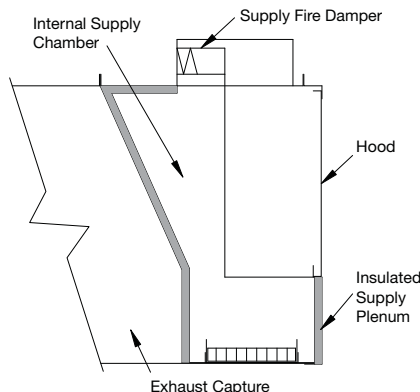

Exhaust Air Balancing Baffles (EABB)

This is a guide to assist in determining if multiple hoods on one fan can be balanced to have equal static pressure. For multiple hoods on one fan to achieve their designed exhaust flow, all of the hoods must have equal static pressure at their designed exhaust flow.

The laws of physics force the static pressure for each branch of a duct system on one fan to always be equal. This will happen by the flow rate increasing in low static branches and decreasing in high static branches until the static pressure is equal in all branches.

Checking for Balance

Every hood with exhaust air balancing baffles (EABB) has a range for its static pressure. The low static pressure number (when EABB is open) in this range is given by the standard calculation for hood static and is printed on the CAPS submittal page for that hood. The high static pressure number (when EABB is closed) in this range can be found by calculating the maximum potential increase of static and adding that value to the low static pressure number.

High static pressure number = low static pressure number + maximum increase

The maximum potential increase in static is given in the graph, or can be calculated from the following formula:

$$\text{Maximum Increase} = 0.0000036 \times (\text{Duct velocity})^2$$

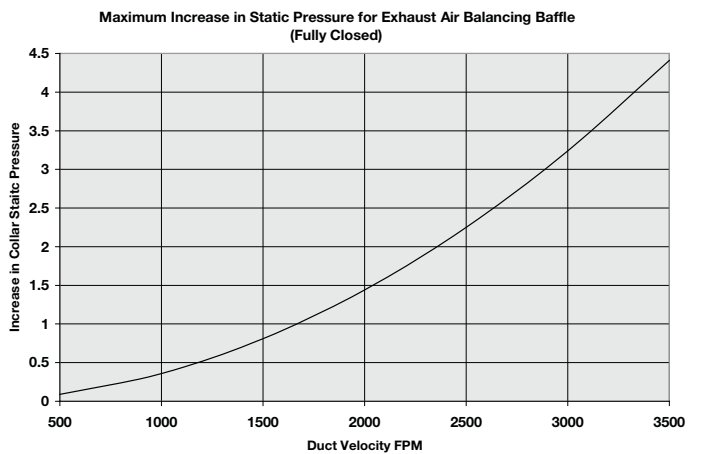

Step 1: Find the hood with the lowest static pressure as shown on the CAPS submittal pages.

Step 2: Calculate the high static pressure number for this hood as instructed above.

Step 3: Compare this high static pressure number to the low static pressure number of the remaining hoods. If the remaining hood's low static pressure number is lower than the high static pressure number calculated, then the system can be balanced; if the low static pressure number is higher than the calculated high static pressure number, then the system cannot be balanced. Refer to the examples.

Example 1:

Hood 1: Ps = 0.58 in. wg
Duct Velocity = 1900 ft/min.

Hood 2: Ps = 0.44 in. wg
Duct Velocity = 1800 ft/min.

Hood 2 has the lower Ps, at 1800 ft/min. the maximum increase in Ps is 1.17. The range for Hood 2 is 0.44 to 1.61. Hood 1 is less than 1.61 so these hoods can be balanced.

Example 2:

Hood 3: Ps = 2.00 in. wg
Duct Velocity = 2000 ft/min.

Hood 4: Ps = 0.44 in. wg
Duct Velocity = 1500 ft/min.

Hood 4 has the lower Ps, at 1500 ft/min. the maximum increase in Ps is .81. The range for Hood 4 is 0.44 to 1.25. Hood 3 is higher than 1.25, so these hoods cannot be balanced.

NOTE

For many systems, exhaust air balancing baffles may not be needed on the hood that has the highest static pressure. The exception to this is if the individual ductwork has uneven static pressures.

NOTE

When sizing the fan, use the static pressure from the highest hood and sum the CFM from all the hoods.

Balancing the Kitchen Exhaust System

A. To determine the proper dining room air balance:

1. Refer to engineering drawings to determine total exhaust CFM from dining areas. (exhaust fans, heating and air conditioning units, rest rooms, etc.)
2. Determine the total CFM of make-up air supplied to dining area.
3. Subtract #1 from #2 above. If the result is a negative number, a negative pressure is present in the dining area. In this case, kitchen exhaust odors could be drawn from the kitchen to the dining area. Therefore, exhaust or supply air should be adjusted to provide a slight positive pressure in the dining area.

B. To determine proper kitchen air balance:

1. Refer to engineering drawings to determine total exhaust from the kitchen area. (exhaust hoods, dishwasher hoods, etc.)
2. Determine total CFM of make-up air supplied to kitchen area. (make-up air hoods, heating and air conditioning units, etc.)
3. Subtract #1 from #2 above. The result should be a negative number. If the result is a positive number, a positive pressure is present in the kitchen area. Kitchen odors could be forced into the dining area. Also, a positively balanced kitchen area can adversely affect the performance of the exhaust hood.

CAUTION

According to NFPA 96, Ch. 8-3 Replacement Air: Replacement air quantity shall be adequate to prevent negative pressures in the commercial cooking area(s) from exceeding 4.98 kPa (0.02 in. wg).

NOTE

The airflow rates were established under controlled laboratory conditions.

NOTE

Greater exhaust and/or lesser supply air may be required for complete vapor and smoke control in specific installations.

Testing Hood Air Volume - Rotating Vane Method

Baffle Filter Style Hoods

A. Exhaust:

With all the filters in place, determine the total hood exhaust volume with a rotating vane anemometer as follows:

1. All cooking equipment should be on.
2. Measure the velocities. Velocity measurements should be taken at five locations per filter. These must be over a filter slot as in Fig. 6.

Fig. 6

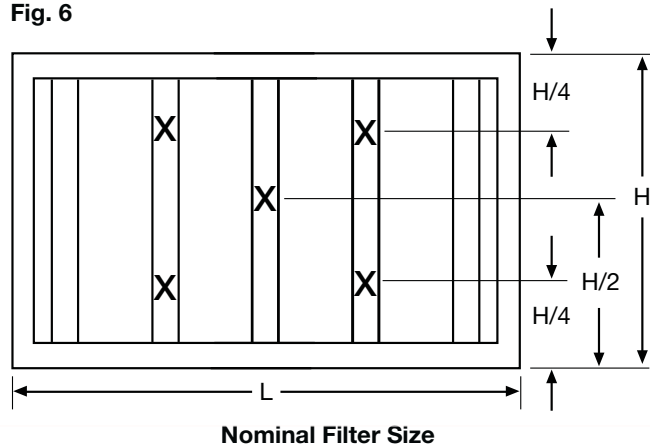

Measure and record the velocity of each location.

A digital 2.75 in. (69.85 mm) rotating vane anemometer or equivalent is suggested. The center of the anemometer should be held 2 in. (50.8 mm) from the face of the filters. It is helpful to make a bracket to keep the anemometer at the 2 in. (50.8 mm) distance and parallel to the filter. Both squareness and distance are very important for accuracy.

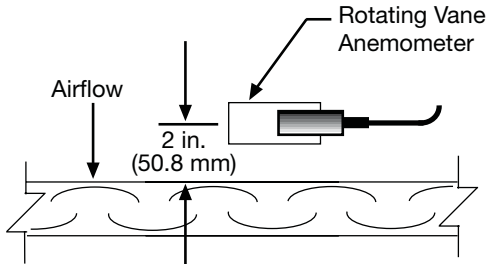

Calculate the average velocity for the filter.

- Determine the filter's conversion factor from the table.
- Calculate the filter's volume in CFM (m³/hr) by multiplying the average velocity by the conversion factor.
- Calculate the hood's volume by repeating the process for the remaining filters and summing the individual filter volumes.

Nominal Filter Size (H x L)		Imperial Conversion Factor	Metric Conversion Factor
Inches	Millimeters		
16 x 16	400 x 400	1.63	.157
16 x 20	500 x 400	2.13	.198
20 x 16	400 x 500	1.90	.177
20 x 20	500 x 500	2.48	.230

Example: Exhaust only hood with three 20 x 16 filters

Measured velocities in ft/min. for one 20 x 16 filter

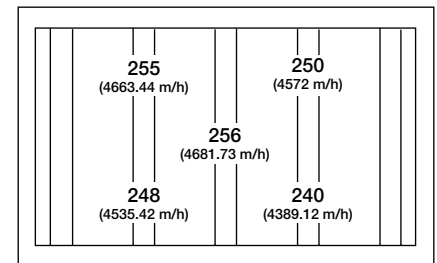

$$\text{Average Velocity} = \frac{\text{Sum of Velocity Readings}}{\text{Number of Readings}}$$

$$\text{(Imperial)} = \frac{255 + 250 + 256 + 248 + 240}{5} = \underline{249.8 \text{ ft/min.}}$$

$$\text{(Metric)} = \frac{4663 + 4572 + 4681 + 4535 + 4389}{5} = \underline{4568 \text{ m/hr}}$$

For a nominal filter size of 20 x 16, the conversion factor is 1.90 Imperial (.177 Metric)

$$\text{Volume for one filter} = \text{Conversion Factor} \times \text{Average Velocity}$$

$$\text{(Imperial)} = 1.90 \times 249.8 \text{ ft/min.} = \underline{474.6 \text{ cfm}}$$

$$\text{(Metric)} = .177 \times 4568 \text{ m/hr} = \underline{809 \text{ m}^3/\text{hr}}$$

$$\text{Total hood volume} = (\text{Filter 1 Volume}) + (\text{Filter 2 Volume}) + (\text{Filter 3 Volume})$$

$$\text{(Imperial)} = 474.6 + 455.4 + 470.1 = \underline{1400.1 \text{ cfm}}$$

$$\text{(Metric)} = 809 + 880 + 799 = \underline{2488 \text{ m}^3/\text{hr}}$$

B. Supply (if applicable):

Perforated Face Supply

1. Hood set up.

If the make-up air unit has a temperature control, it should be used to keep the supply air at the desired room discharge air temperature.

2. Measure velocities.

Divide the perforated face panel into a grid of equal areas, each approximately 4 in. (101.6 mm) square.

Measure the velocity at the center of each grid area. A digital 2.75 in. (69.85 mm) rotating vane anemometer or equivalent is suggested. The center of the anemometer should be held tight to the face of the panel and parallel to the filter. Both squareness and distance are important for accuracy. Calculate the average velocity of the panel.

3. Measure the length and height of the perforated face panel.

4. Calculate the perforated face panel volume using the following formula:

$$\text{CFM} = \text{avg. velocity} \times \text{length (in.)} \times \text{height (in.)} \times 0.005$$

$$\text{m/hr} = \text{avg. velocity} \times \text{length (m)} \times \text{height (m)} \times 0.72$$

5. Calculate the system's volume by repeating the process for the remaining panels and adding the individual panel volumes together.

Filter Readings (ft/min.)						
260	250	255	260	250	255	265
270	275	270	280	265	265	270
290	285	280	280	275	290	295
285	275	280	260	270	265	260

Filter Readings (m/hr)						
4755	4572	4663	4755	4572	4663	4846
4938	5029	4938	5121	4846	4846	4938
5304	5212	5121	5121	5029	5304	5395
5212	5029	5121	4755	4938	4846	4755

Example: Face supply hood with three 28 inch (.711 m) perforated panels

Measured velocities in ft/min. for one perforated panel

$$\text{Average Velocity} = \frac{\text{Sum of Velocity Readings}}{\text{Number of Readings}}$$

$$\text{(Imperial)} = \frac{260 + 250 + \dots + 265 + 260}{28} = \underline{270.7 \text{ ft/min.}}$$

$$\text{(Metric)} = \frac{4755 + 4572 + \dots + 4846 + 4755}{28} = \underline{4951 \text{ m/hr}}$$

Measure length and height. 28 inches (.711 m) long perforated panel by 16 inches (.406 m) high

$$\text{Volume for one panel} = \text{Conversion Factor} \times \text{Average Velocity} \times \text{Length} \times \text{Height}$$

$$\text{(Imperial)} = 0.005 \times 270.7 \text{ ft/min.} \times 28 \times 16 = \underline{606.4 \text{ cfm}}$$

$$\text{(Metric)} = 0.72 \times 4951 \text{ m/hr} \times .711 \times .406 = \underline{1029 \text{ m}^3/\text{hr}}$$

$$\text{Total system volume} = (\text{Panel 1 Volume}) + (\text{Panel 2 Volume}) + (\text{Panel 3 Volume})$$

$$\text{(Imperial)} = 606.4 + 614.3 + 593.8 = \underline{1814.5 \text{ cfm}}$$

$$\text{(Metric)} = 1029 + 1044 + 1009 = \underline{3082 \text{ m}^3/\text{hr}}$$



Testing Hood Air Volume - Shortridge Method

Baffle Filter Style Hoods

A. Exhaust:

With all the filters in place, determine the total hood exhaust volume with a Shortridge meter as follows:

1. All cooking equipment should be on. If the hood has internal short circuit make-up air, it should be turned off.
2. Measure velocities
 - Set up the Shortridge meter.
 - For 20 in. (500 mm) wide filters, position the grid as shown in Fig. 7 and 8. Average the two measurements.
 - For 16 in. (400 mm) wide filters position the grid as shown in Fig. 9.
 - Take velocity readings for each filter.
3. Calculate each filter's volumetric flow rate as follows:
Calculate each filter's average velocity by summing the velocity readings and dividing by the number of readings for each filter.
Multiply the average velocity by the conversion factor to obtain the volumetric flow rate for each filter.
4. Calculate the hood's total volumetric flow rate by summing the volumetric flow rate of each individual filter in the hood as calculated in Step 3.

NOTE

For best accuracy multiply the velocity of each filter by its conversion factor and sum the flow rates. Averaging the velocity measured for all filters may cause error.

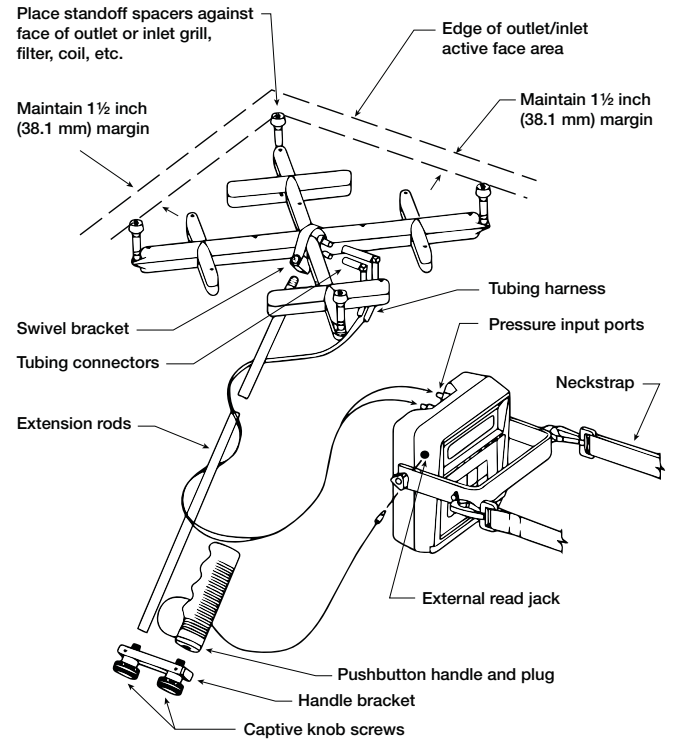

Nominal Filter Size (H x L)		Imperial Conversion Factor	Metric Conversion Factor
Inches	Millimeters		
16 x 16	400 x 400	1.66	.154
16 x 20	400 x 500	2.10	.195
20 x 16	500 x 400	1.96	.182
20 x 20	500 x 500	2.40	.223

Example: Measured velocities for a 20 x 20 filter = 185 and 189 ft/min.

$$\text{Average Velocity} = \frac{\text{Sum of Velocity Readings}}{\text{Number of Readings}}$$

$$\text{(Imperial)} = \frac{185 + 189}{2} = \underline{187.0 \text{ ft/min.}}$$

$$\text{(Metric)} = \frac{3383 + 3456}{2} = \underline{3420 \text{ m/hr}}$$

$$\begin{aligned} \text{Flow rate for one filter} &= \text{Conversion Factor} \times \text{Average Velocity} \\ \text{(Imperial)} &= 2.40 \times 187.0 \text{ ft/min.} = \underline{448.8 \text{ cfm}} \\ \text{(Metric)} &= .223 \times 3420 \text{ m/hr} = \underline{763 \text{ m}^3/\text{hr}} \end{aligned}$$

$$\begin{aligned} \text{Total hood flow rate} &= (\text{Filter 1 Flow Rate}) + \dots + (\text{Filter x Flow Rate}) \\ \text{(Imperial)} &= 448.8 + 457.8 + 437.5 + 444.8 = \underline{1788.9 \text{ cfm}} \\ \text{(Metric)} &= 763 + 778 + 743 + 756 = \underline{3040 \text{ m}^3/\text{hr}} \end{aligned}$$

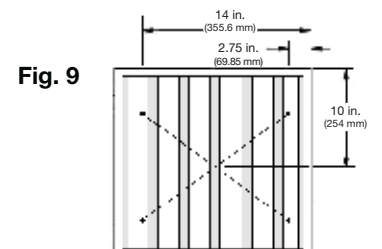
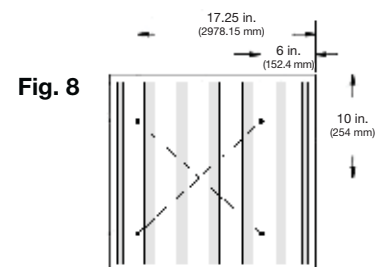
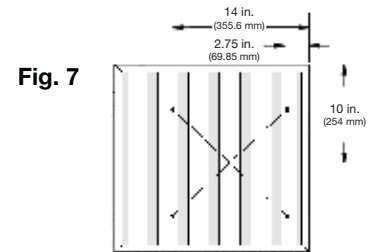

High Velocity Cartridge Filters - Rotating Vane Method

A. Exhaust

With all the filters in place, determine the total hood exhaust volume with a rotating vane anemometer as follows:

1. All cooking equipment should be on. If the hood has internal short circuit make-up air, it should be turned off.

2. Measure velocities.

Velocity measurements should be taken at three locations per filter. These must be over the inlet opening as shown in Fig. 10.

Measure the velocity of each location. A digital 2.75 in. (69.85 mm) rotating vane anemometer or its equivalent is suggested. The center of the anemometer should be held 2 in. (50.8 mm) from the face of the filters as in Fig. 11. It is helpful to make brackets to keep the anemometer at the 2 in. (50.8 mm) distance and parallel to the filter. Both squareness and distance are important for accuracy.

3. Calculate the average slot velocity.
4. Calculate the CFM per linear foot by dividing the average velocity by a conversion factor listed in the following table.
5. Calculate each filter's volumetric flow rate in CFM by multiplying the average velocity for each filter by the conversion factor.

Fig. 10

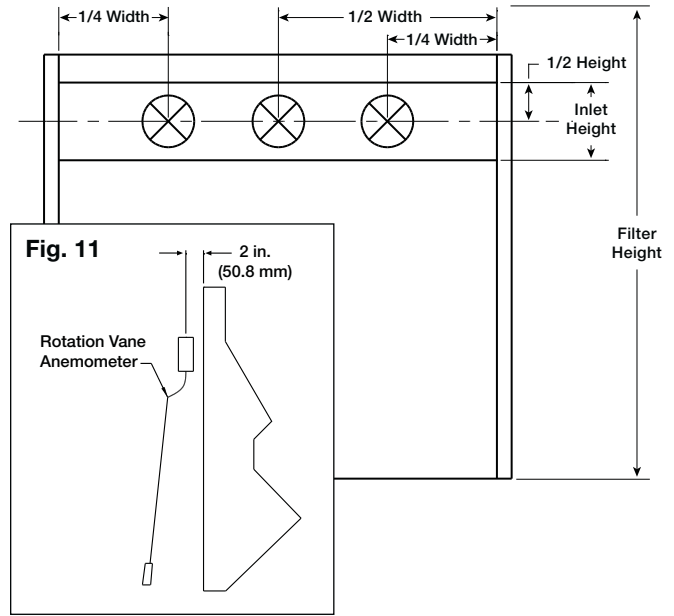

Cartridge Filter Size	Imperial Conversion Factor	Metric Conversion Factor
16 in. (400 mm) high with 4 in. (100 mm) high inlet	1.63 1/ft ³	5.35 1/m ³
20 in. (500 mm) high with 4 in. (100 mm) high inlet	2.15 1/ft ³	7.05 1/m ³
16 in. (400 mm) high with 7 in. (120 mm) high inlet	1.24 1/ft ³	4.07 1/m ³
20 in. (500 mm) high with 7 in. (120 mm) high inlet	1.58 1/ft ³	5.18 1/m ³

Example:

Measure the slot velocities in ft/min. for a 9 ft. (2.74 m) hood with four 20 x 20 in. (500 x 500 mm) filters with the standard 4 in. (101.6 mm) opening, three readings per filter.

$$\text{Average Velocity} = \frac{\text{Sum of Velocity Readings}}{\text{Number of Readings}}$$

$$\text{(Imperial)} = \frac{5330}{12} = \underline{444.2 \text{ ft/min.}}$$

$$\text{(Metric)} = \frac{97474}{12} = \underline{8123 \text{ m/hr}}$$

Filter Readings (ft/min.)		
470	440	425
482	430	453
455	431	441
399	439	465
Filter Readings (m/hr)		
8595	8047	7772
8815	7864	8284
8321	7882	8065
7297	8028	8504

$$\text{CFM per linear foot} = \frac{\text{Average Slot Velocity}}{\text{Conversion Factor}}$$

$$\text{(Imperial)} = \frac{444.2 \text{ ft/min.}}{2.15} = \underline{206.6 \text{ cfm/linear ft.}}$$

$$\text{(Metric)} = \frac{8123 \text{ m/hr}}{7.05} = \underline{1152 \text{ m}^3/\text{hr}}$$

$$\text{Hood exhaust volume} = \text{CFM/linear foot (m}^3/\text{hr / m)} \times \text{Hood Length}$$

$$\text{(Imperial)} = 206.6 \times 9 \text{ ft.} = \underline{1859.4 \text{ cfm}}$$

$$\text{(Metric)} = 1152 \times 2.74 \text{ m} = \underline{3156 \text{ m}^3/\text{hr}}$$

High Velocity Cartridge Filters - Shortridge Meter

A. Exhaust

With all the filters in place, determine the total hood exhaust volume with a Shortridge meter as follows:

1. All cooking equipment should be on. If the hood has internal short circuit make-up air, it should be turned off.
2. Measure velocities
 - Set up the Shortridge meter. Leave all holes of VelGrid open. Do NOT tape over holes that are not over openings. The conversion factor takes this into account.
 - Position the grid over each filter. Refer to Fig. 12
 - Take velocity readings for each filter.
3. Calculate each filter's volumetric flow rate as follows:
Calculate each filter's average velocity by summing the velocity readings and dividing by the number of readings for each filter.
Multiply the average velocity by the conversion factor to obtain the volumetric flow rate for each filter.
4. Calculate the hood's total volumetric flow rate by summing the volumetric flow rate of each individual filter in the hood as calculated in Step 3.

NOTE

For best accuracy multiply the velocity of each filter by its conversion factor and sum the flow rates. Averaging the velocity measured for all filters may cause error.

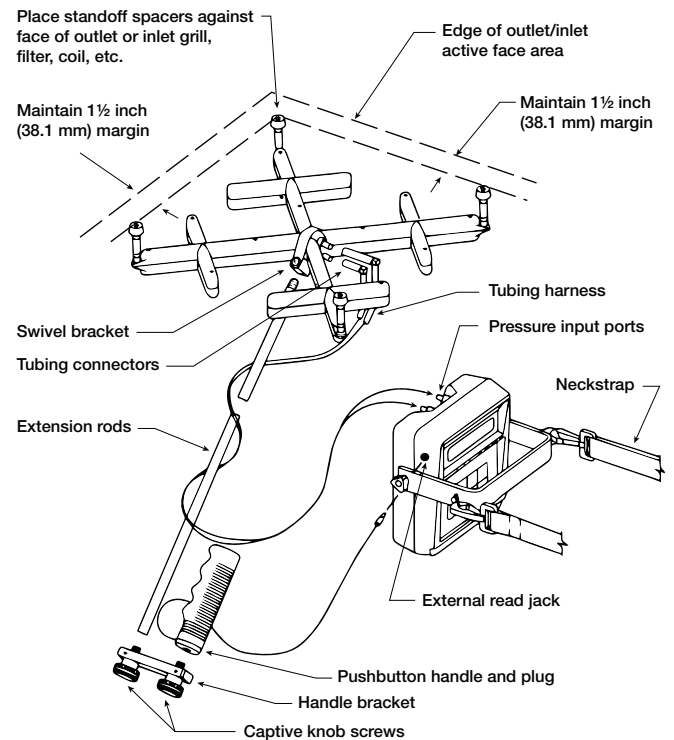

Nominal Filter Size (H x L)		Imperial Conversion Factor	Metric Conversion Factor
Inches	Millimeters		
16 x 16	400 x 400	1.22 ft ²	.113 m ²
16 x 20	400 x 500	1.67 ft ²	.155 m ²
20 x 16	500 x 400	1.21 ft ²	.112 m ²
20 x 20	500 x 500	1.50 ft ²	.139 m ²

Example:

Measured velocities for 20 x 20 filter = 282 ft/min. (5157 m/hr)

$$\begin{array}{rclclcl}
 \text{Flow rate for one filter} & = & \text{Conversion Factor} & \times & \text{Average Velocity} & & \\
 \text{(Imperial)} & = & 1.50 & \times & 282 \text{ ft/min.} & = & \underline{423.0 \text{ cfm}} \\
 \text{(Metric)} & = & .139 & \times & 5157 \text{ m/hr} & = & \underline{717 \text{ m}^3/\text{hr}}
 \end{array}$$

$$\begin{array}{rclclcl}
 \text{Total hood flow rate} & = & (\text{Filter 1 Flow Rate}) & + & \dots & + & (\text{Filter X Flow Rate}) \\
 \text{(Imperial)} & = & 423.0 & + & 421.8 & + & 420.7 & + & 418.2 & = & \underline{1683.7 \text{ cfm}} \\
 \text{(Metric)} & = & 717 & + & 717 & + & 715 & + & 711 & = & \underline{2860 \text{ m}^3/\text{hr}}
 \end{array}$$

Fig. 12

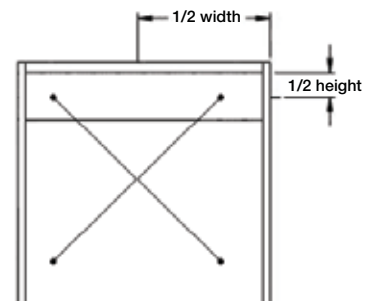

Grease-X-Tractor™ High Efficiency Filters or Grease Grabber™ Multi-Filtration System Rotating Vane Method

A. Exhaust

With all the filters in place, determine the total hood exhaust volume with a rotating vane anemometer as follows:

1. All cooking equipment should be off. If the hood has internal short circuit make-up air, it should be turned off.
2. Measure velocities

Measurement should be taken at six locations per filter. They must be over the inlet opening as shown in Fig. 13.

Measure the velocity of each location. A digital 2.75 in. (69.85 mm) rotating vane anemometer or its equivalent is suggested. The center of the anemometer should be held 2 in. (50.8 mm) from the face of the filters as in Fig. 14. It is helpful to make brackets to keep the anemometer at the 2 in. (50.8 mm) distance and parallel to the filter. Both squareness and distance are important for accuracy.

3. Calculate the average velocity for the filter.
4. Determine the filter's conversion factor from the table.
5. Calculate each filter's volumetric flow rate in CFM by multiplying the average velocity for each filter by the conversion factor.

Fig. 13

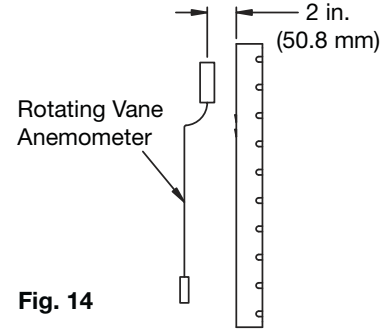
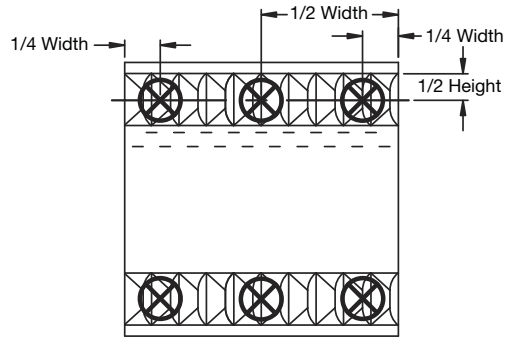

Fig. 14

Nominal Filter Size (H x L)		Imperial Conversion Factor	Metric Conversion Factor
Inches	Millimeters		
16 x 16	400 x 400	1.31 ft ²	.122 m ²
16 x 20	400 x 500	1.65 ft ²	.153 m ²
20 x 16	500 x 400	1.23 ft ²	.114 m ²
20 x 20	500 x 500	1.65 ft ²	.153 m ²

Example: (Imperial)

Hood Length: 7 feet 0 inches with four 20 x 20 filters.
Measure the velocities in ft/min. for each 20 x 20 filter (six readings per filter)

Filter 1	225	201	187
	210	238	197
Filter 2	228	222	226
	237	240	220
Filter 3	230	245	240
	250	223	219
Filter 4	225	265	219
	245	221	200

$$\begin{aligned} \text{Average slot velocity for Filter 1} &= \frac{\text{Sum of Velocity Readings}}{\text{Number of Readings}} \\ &= \frac{1258}{6} = 209.7 \text{ ft/min.} \\ &\text{(repeat for each filter)} \end{aligned}$$

For a nominal filter size of 20 x 20, the conversion factor is 1.65

$$\begin{aligned} \text{Volume for Filter 1} &= \text{Conversion Factor} \times \text{Average Velocity} \\ &= 1.65 \text{ ft}^2 \times 209.7 \text{ ft/min.} \\ &= 346.0 \text{ cfm (repeat for each filter)} \end{aligned}$$

Total hood volume

$$\begin{aligned} &= \text{Filter 1 Volume} + \text{Filter 2 Volume} + \text{Filter 3 Volume} + \text{Filter 4 Volume} \\ &= 346.0 + 377.6 + 386.9 + 378.1 = 1488.6 \text{ cfm} \end{aligned}$$

Example: (Metric)

Hood Length: 2.13 meters, with four 500 x 500 mm filters.
Measure the velocities in m/hr for each 500 x 500 mm filter (six readings per filter)

Filter 1	4114.80	3675.88	3419.86
	3840.48	4352.54	3602.74
Filter 2	4169.66	4059.94	4133.08
	4334.26	4389.21	4023.36
Filter 3	4420.12	4480.56	4389.12
	4572.00	4078.22	4005.07
Filter 4	4114.80	4846.52	4005.07
	4480.56	4041.65	3657.60

$$\begin{aligned} \text{Average slot velocity for Filter 1} &= \frac{\text{Sum of Velocity Readings}}{\text{Number of Readings}} \\ &= \frac{23006}{6} = 3834 \text{ m/hr} \\ &\text{(repeat for each filter)} \end{aligned}$$

For a nominal filter size of 500 x 500, the conversion factor is .153

$$\begin{aligned} \text{Volume for Filter 1} &= \text{Conversion Factor} \times \text{Average Velocity} \\ &= .153 \text{ m}^2 \times 3834 \text{ m/hr} \\ &= 586.7 \text{ m}^3/\text{hr (repeat for each filter)} \end{aligned}$$

Total hood volume

$$\begin{aligned} &= \text{Filter 1 Volume} + \text{Filter 2 Volume} + \text{Filter 3 Volume} + \text{Filter 4 Volume} \\ &= 587 + 642 + 657 + 642 = 2528 \text{ m}^3/\text{hr} \end{aligned}$$

Grease-X-Tractor™ High Efficiency Filters or Grease Grabber™ Multi-Filtration System Shortridge Method

A. Exhaust

With all the filters in place, determine the total hood exhaust volume with a Shortridge meter as follows:

1. All cooking equipment should be on. If the hood has internal short circuit make-up air, it should be turned off.
2. Measure velocities
 - Set up the Shortridge meter. Leave all holes of VelGrid open. Do NOT tape over holes that are not over openings. The conversion factor takes this into account.
 - For 20 in. (500 mm) high filters, position the grid as shown in Fig. 15 and 16. Average the two measurements.
 - For 16 in. (400 mm) high filters position the grid as shown in Fig. 17.
 - For 20 in. (500 mm) wide filters, position the grid over the left and right side of the filter. Average the two measurements.
 - Take velocity readings for each filter.

3. Calculate each filter's volumetric flow rate as follows:

Calculate each filter's average velocity by summing the velocity readings and dividing by the number of readings for each filter.

Multiply the average velocity by the conversion factor to obtain the volumetric flow rate for each filter.

4. Calculate the hood's total volumetric flow rate by summing the volumetric flow rate of each individual filter in the hood as calculated in Step 3.

Nominal Filter Size (H x L)		Imperial Conversion Factor	Metric Conversion Factor
Inches	Millimeters		
16 x 16	400 x 400	1.53 ft ²	.142 m ²
16 x 20	400 x 500	2.00 ft ²	.185 m ²
20 x 16	500 x 400	2.25 ft ²	.209 m ²
20 x 20	500 x 500	3.00 ft ²	.279 m ²

NOTE

For best accuracy multiply the velocity of each filter by its conversion factor and sum the flow rates. Averaging the velocity measured for all filters may cause error.

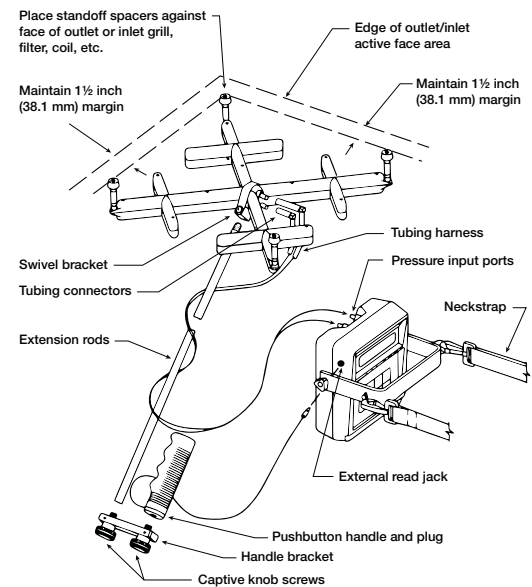

Example:

Measured velocities for 20 x 20 in. (500 x 500 mm) filter.

$$\text{Average Slot Velocity} = \frac{\text{Sum of Velocity Readings}}{\text{Number of Readings}}$$

$$\text{(Imperial)} = \frac{198 + 205}{2} = \underline{201.5 \text{ ft/min.}}$$

$$\text{(Metric)} = \frac{3021 + 3749}{2} = \underline{3385 \text{ m/hr}}$$

$$\text{Flow rate for one filter} = \text{Conversion Factor} \times \text{Average Velocity}$$

$$\text{(Imperial)} = 3.0 \times 201.5 \text{ ft/min.} = \underline{604.5 \text{ cfm}}$$

$$\text{(Metric)} = .279 \times 3385 \text{ m/hr} = \underline{944 \text{ m}^3/\text{hr}}$$

$$\text{Total hood flow rate} = (\text{Filter 1 Flow Rate}) + \dots + (\text{Filter x Flow Rate})$$

$$\text{(Imperial)} = 604.5 + 600.3 + 592.4 + 613.3 = \underline{2410.5 \text{ cfm}}$$

$$\text{(Metric)} = 944 + 1020 + 1006 + 1042 = \underline{4012 \text{ m}^3/\text{hr}}$$

Fig. 15

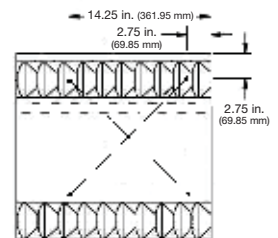

Fig. 16

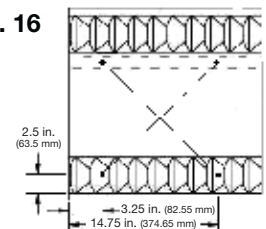
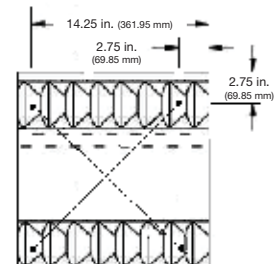

Fig. 17



Testing Hood Air Volume - Rotating Vane Method

Short Circuit Hoods

A. Supply

All cooking equipment should be off. The hood exhaust should also be off.

1. Measure Velocities

Velocity measurements should be made with a digital 2.75 in. (69.85 mm) rotating vane anemometer or its equivalent.

One velocity measurement should be taken for every 8 in. (203.2 mm) of short circuit opening length, starting tight against one edge of the opening, and finishing tight against the other edge. The anemometer should be placed at the bottom edge of the opening, flush with the bottom lip. Both squareness and placement are important for accuracy.

2. Calculate the average slot velocity.

3. Calculate the volumetric flow rate per linear foot by dividing the average velocity by a conversion factor of 5.52 per ft. If metric units are used, divide the average velocity by a conversion factor of 1.68 per meter.

4. Calculate the hoods supply volume by multiplying the CFM per linear foot by the total hood length.

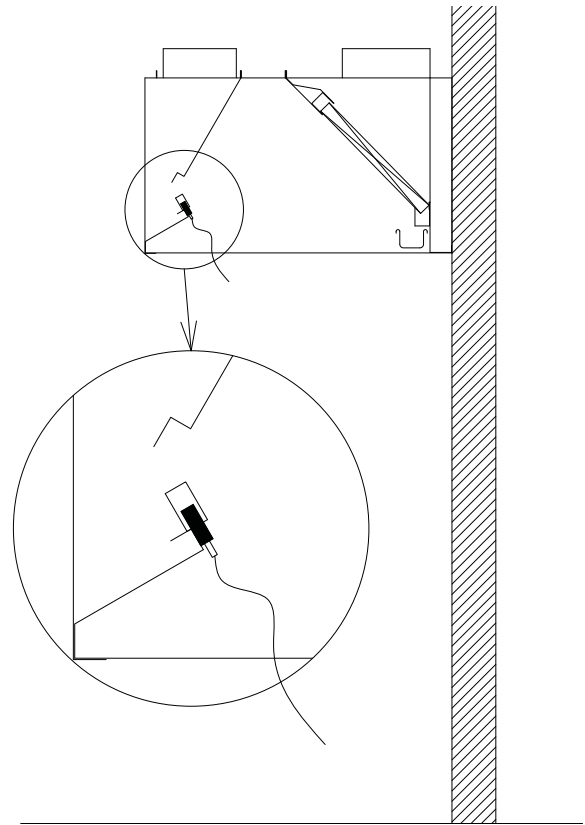

Example: 4 ft. (1.22 m) short circuit hood (36 inch (.914 m) short circuit opening)

Number of readings = 36 in. / 8 in. => 6 readings (.914 m / .2 m => 6 readings)

$$\begin{aligned} \text{Average Velocity} &= \frac{\text{Sum of Velocity Readings}}{\text{Number of Readings}} \\ \text{(Imperial)} &= \frac{786 + 900 + 1126 + 1048 + 1111 + 1115}{6} = \frac{6086}{6} = \underline{1014.3 \text{ ft/min.}} \\ \text{(Metric)} &= \frac{1335 + 1529 + 1913 + 1780 + 1888 + 1894}{6} = \frac{10339}{6} = \underline{1723 \text{ m/hr}} \end{aligned}$$

$$\begin{aligned} \text{CFM per linear foot} &= \frac{\text{Average Slot Velocity}}{\text{Conversion Factor}} \\ \text{(Imperial)} &= \frac{1014.3 \text{ ft/min.}}{5.52} = \underline{183.8 \text{ cfm/linear ft.}} \\ \text{(Metric)} &= \frac{1723 \text{ m/hr}}{1.68} = \underline{1026 \text{ m}^3/\text{hr}} \end{aligned}$$

$$\begin{aligned} \text{Hood supply volume} &= \text{CFM/linear foot (m}^3/\text{hr / m)} \quad \times \quad \text{Hood Length} \\ \text{(Imperial)} &= 183.8 \quad \times \quad 4 \text{ ft.} \quad = \underline{735.2 \text{ cfm}} \\ \text{(Metric)} &= 1026 \quad \times \quad 1.22 \text{ m} \quad = \underline{1252 \text{ m}^3/\text{hr}} \end{aligned}$$

Amerex Wiring Plan View

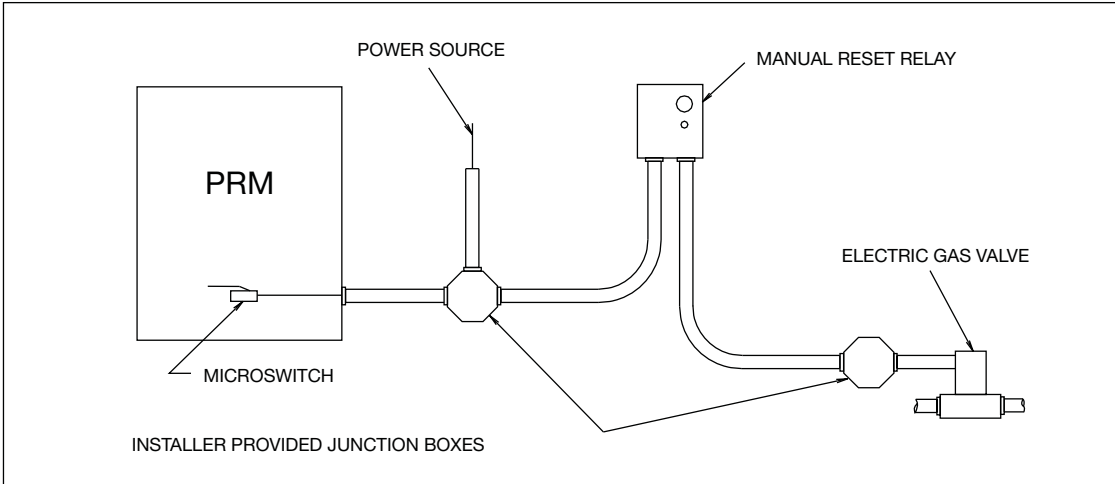

BASIC WIRING DIAGRAM

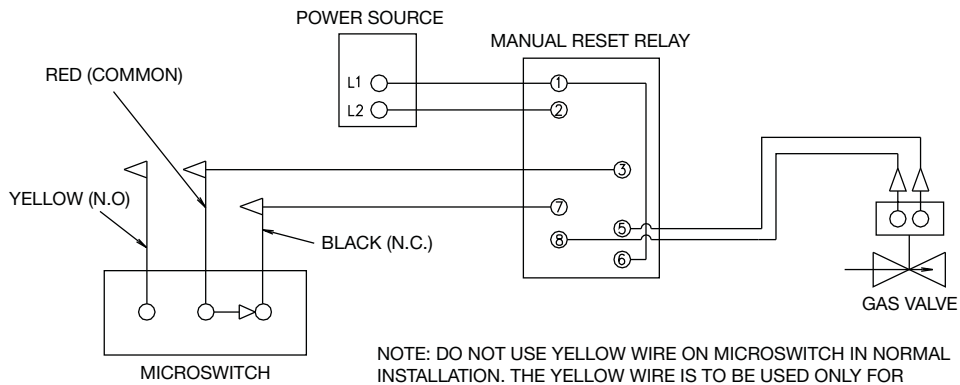

BASIC WIRING DIAGRAM

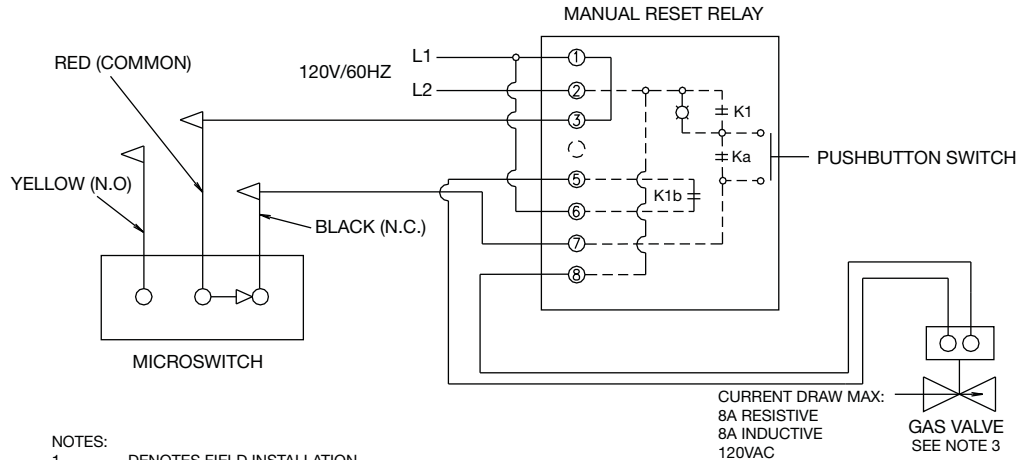

NOTES:

1. - - - - DENOTES FIELD INSTALLATION
2. - - - - DENOTES FACTORY INSTALLATION
3. GAS VALVE: UL LISTED ELECTRICALLY-OPERATED SAFETY VALVE FOR NATURAL OR LP GAS AS NEEDED OF APPROPRIATE PRESSURE AND TEMPERATURE RATING, 110V/60HZ OR AMEREX GAS VALVES, PN 12870, 12871, 12872, 12873, 12874, 12875 and 12876.
4. K1a and K1b ARE N.O. WHEN K1 IS DE-ENERGIZED.

Amerex Wiring Plan View

2 Snap-Action Switches provided by manufacturer may be wired as shown. Four typical examples shown

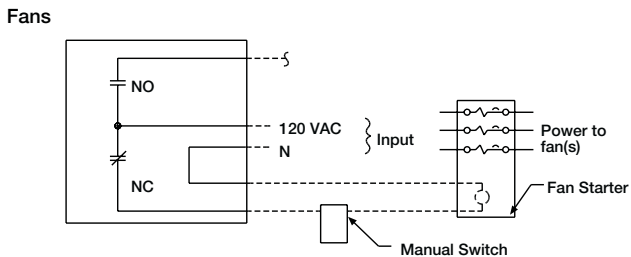
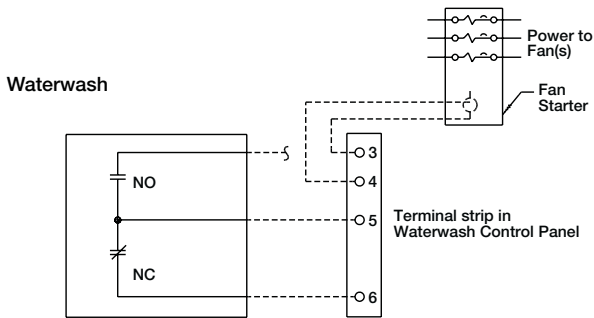
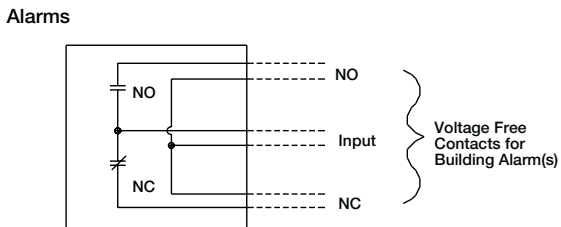
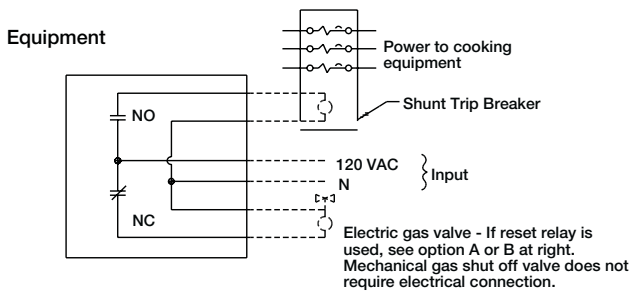

If prohibited by local codes, do not shut down exhaust fans with this method of wiring.

Option A Relay Part No. 14702

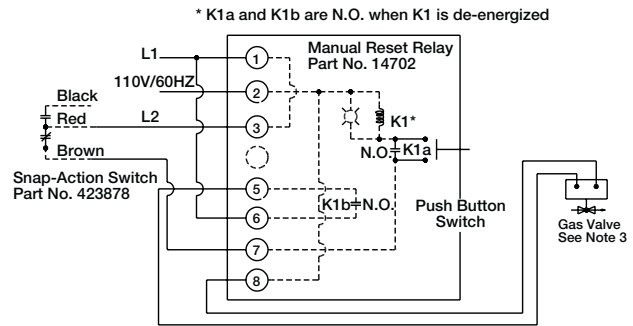

Option B Relay Part No. 426151

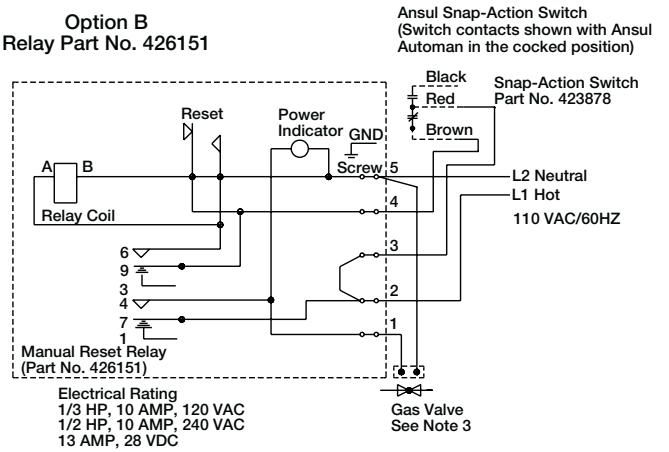

Note:

1. ——— Denotes field installation.
2. - - - - - Denotes factory installation.
3. Gas Valves: "UL Listed electrically-operated safety valve for natural or LP gas as needed of appropriate pressure and temperature rating, 110V/60HZ" or Ansul gas valves.
4. Do not use black wire on snap-action switch in normal installation. Black wire may only be used for extraneous alarm, light circuits, etc.

Overall Wiring Plan View for Kitchen Systems with Make-Up Air Control Centers

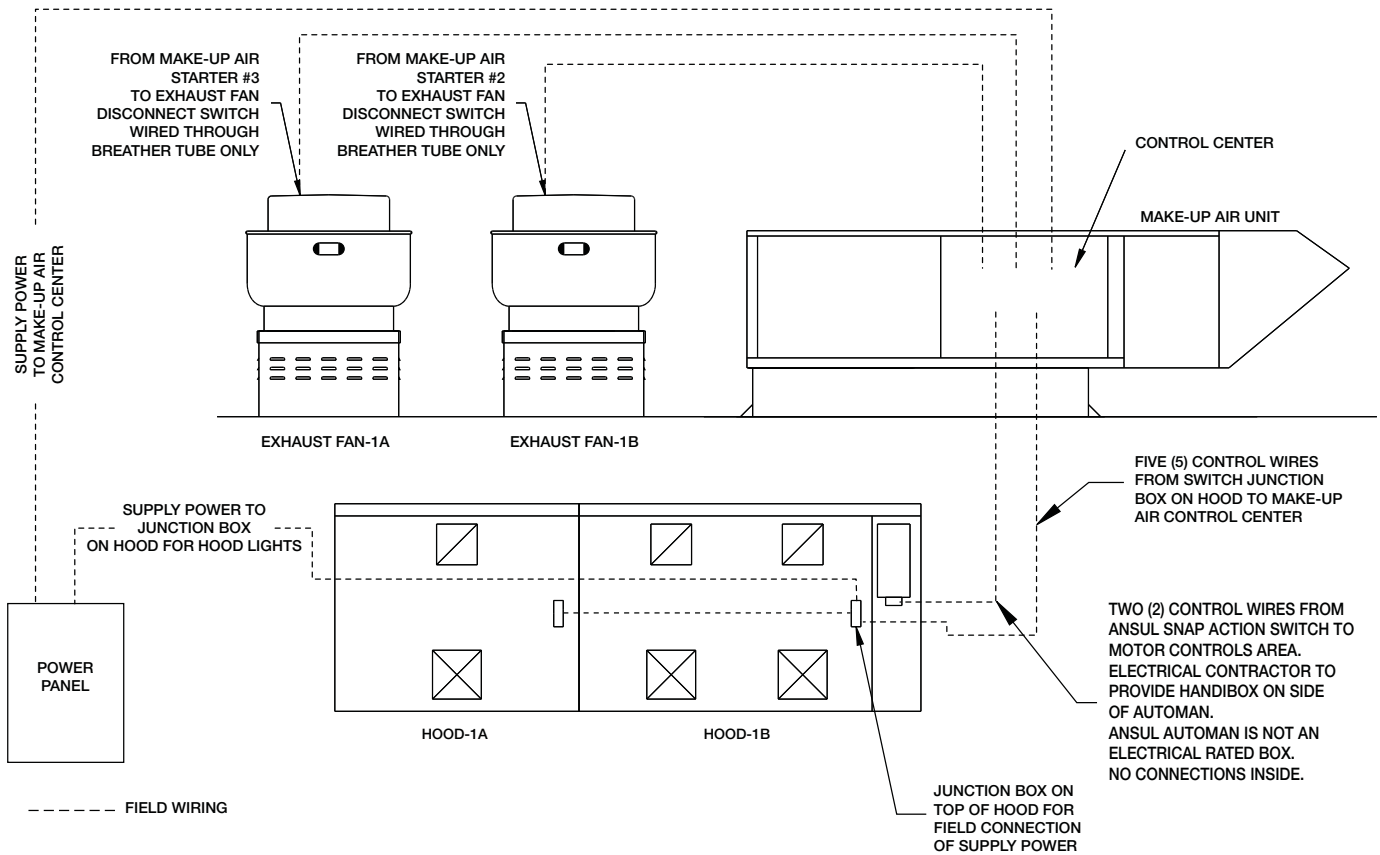

Overall Wiring Plan View for Kitchen Systems with Kitchen Fan Control Centers

This arrangement requires individual power connections for each supply and exhaust fan from remote circuit breakers thru the fans starter in the Kitchen Fan Control Center (KFCC). The make-up air fan will be wired directly from a remote breaker. It requires control wiring to be run to the KFCC.

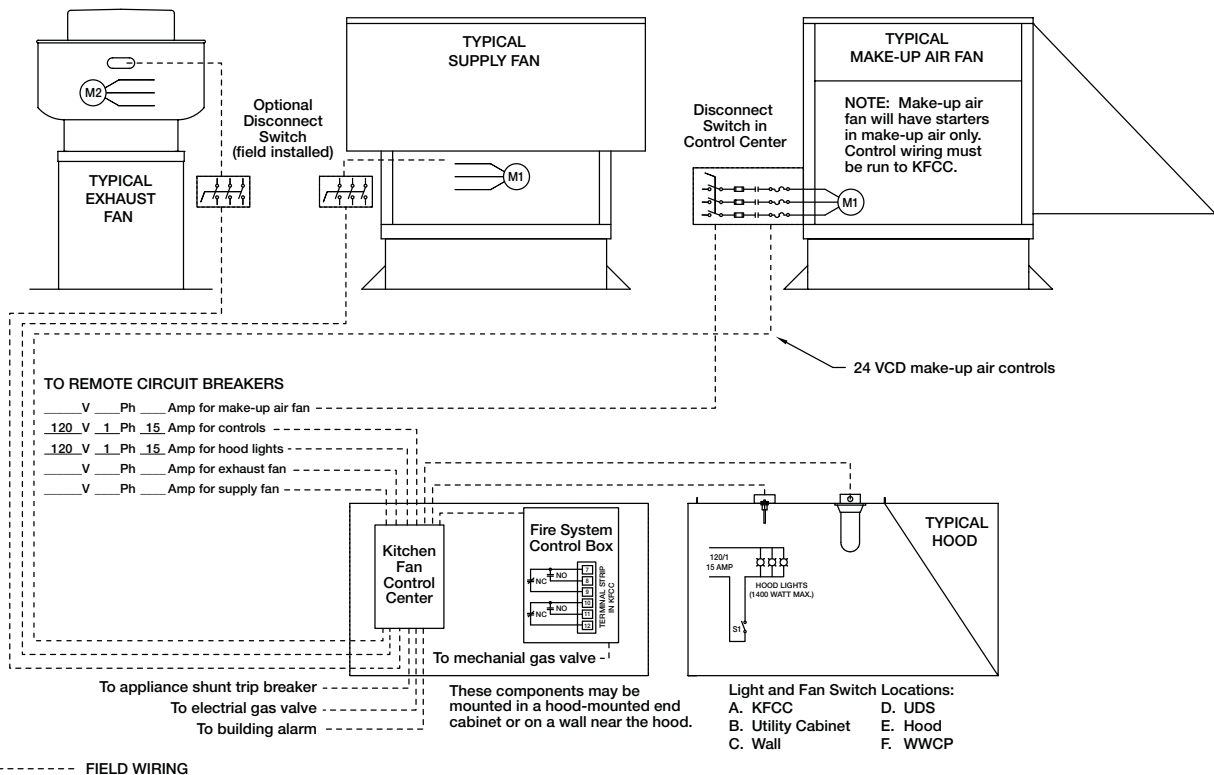

Wiring for Hood Switch Panels

The diagrams below show a typical hood switch panel remote mounted. For hood mounted switches refer to the wiring connection decal on the cover of the junction box on the hood top.

The diagram shows how to wire the exhaust and supply fans with a control panel to a fire suppression contact

(FSC1). When wired properly, the supply fan will be turned off if the fire system is activated and to allow the exhaust fan to continue to operate.

The fire suppression contact (FSC1) is provided as part of the fire suppression system and is normally mounted in the fire system control box.

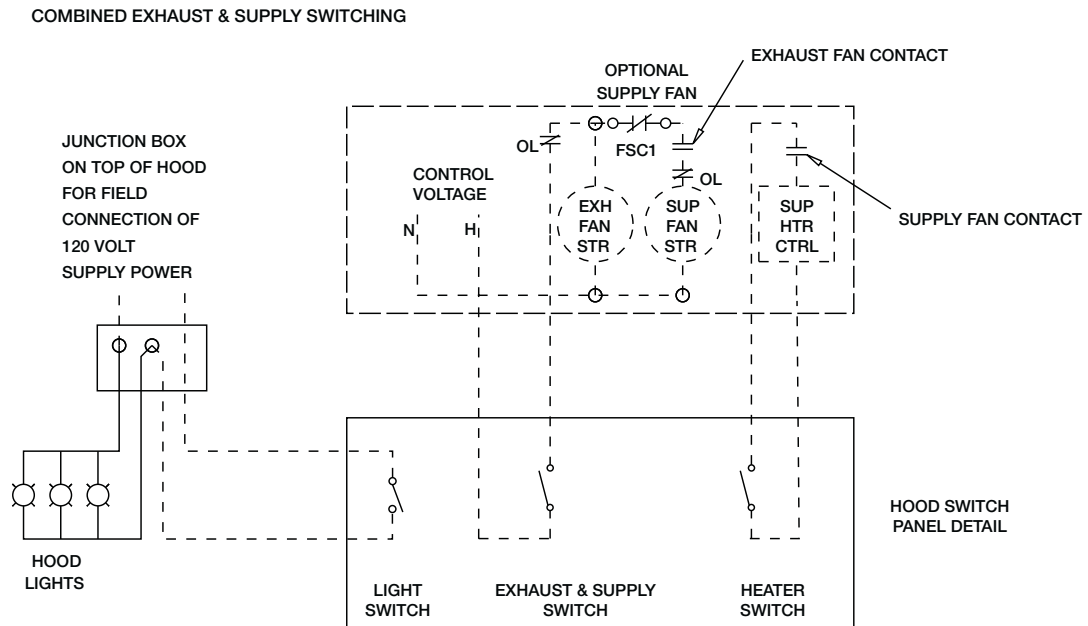

Circuit Diagrams

	Single Pole	Double Pole
Single Throw		
Double Throw		
Double Throw Center Off		

	Series Circuit	Parallel Circuit
Normally Open Contacts	<p>Off if both are not activated Off if either are not activated On if both are activated</p>	<p>Off if both are not activated On if either is activated On if both are activated</p>
Normally Closed Contacts	<p>On if both are not activated Off if either are not activated Off if both are activated</p>	<p>On if either is activated Off if either not activated Off if both are activated</p>

Maintenance

Daily Maintenance

1. Wipe grease from exposed metal surfaces on the hood interior using a clean, dry cloth.
2. Visually inspect the filters or cartridges for grease accumulation.
3. Remove grease cup, empty contents and replace cup.

Weekly Maintenance

1. Remove the grease filters or cartridges and wash in dishwasher or pot sink.

Note: Filters installed over heavy grease producing equipment may require more frequent cleaning. See Filter Washing Frequency Guide, page 28.

2. Before replacing filters, clean the interior plenum surfaces of any residual grease accumulations.

Periodic Maintenance

1. Painted hood exterior surfaces should be cleaned with a mild detergent solution.
2. Stainless steel hood exterior surfaces should be cleaned with a mild detergent and then polished with a good grade stainless steel polish to preserve the original luster.

Note: Never use abrasive cleaners or chemicals on hood surfaces. Never use chlorine based cleaners or iron wool pads to clean the hood. They may scratch or mar the material. Always rub with the grain of the stainless.

3. To maintain optimum performance of your hood and fan, duct cleaning should be performed as often as the application and code requires.
4. Recaulk the hoods with an NSF Approved silicone caulk, (GE SCS1009 or its equivalent) as needed.
5. Inspect the supply air discharge portion on external supply plenums to ensure the airstream is free from debris or other blockage.

Condensate Hood Baffle Installation, Fig. 18 and 19

1. Grasp the baffle with drain holes facing down and lift into the hood. For short hoods with only one baffle it may be necessary to turn the baffle slightly diagonally to fit past the drain channel.
2. After the baffle clears the drain channel of the hood, turn the baffle so it is lined up with the upper hanger in the hood.
3. Hook the upper channel of the baffle over the upper hanger of the hood and set the lower edge of the baffle into the condensate gutter. Repeat until all baffles are installed in the hood.
4. Center the baffle from side to side in the hood.

Fig. 18 - CORRECT

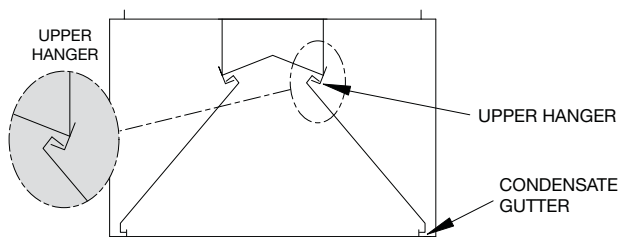
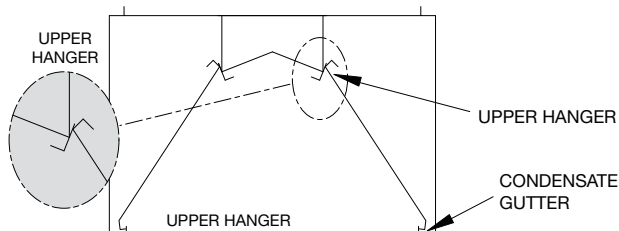
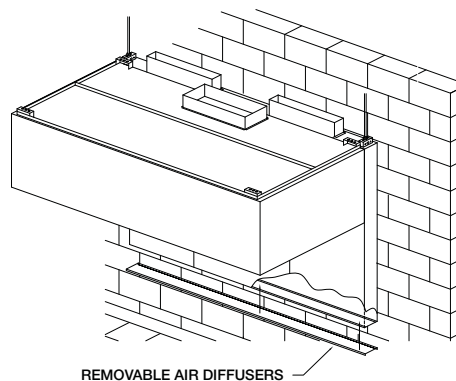

Fig. 19 - INCORRECT



Air Diffusers

The air diffusers, located at the bottom of the back supply will need to be cleaned as often as the application dictates. Inspect periodically to determine the cleaning schedule.



1. To clean the air diffusers, unfasten the screws. Remove the air diffusers from the back supply unit and wash in the sink or dishwasher.
2. Refasten with the stainless steel screws.

Grease Grabber™ Filter Installation

NOTE

Never install the second stage filter in the front filter channel. The second stage filter must be installed behind a UL Classified Grease-X-Tractor™ primary filter.

1. Slide the top edge of the second stage filter into the top rear filter channel; Fig. 20.

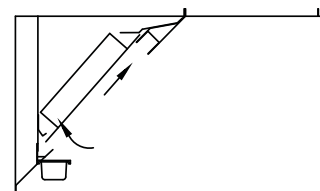

Fig. 20

2. Lifting the lower edge of the filter past the grease trough, continue to push the top of the filter into the channel.

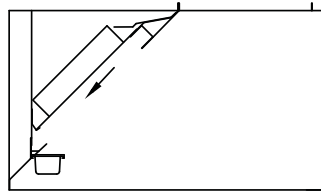

Fig. 21

3. When the filter is even with the bottom rear filter channel, set the filter into the channel; Fig. 21.

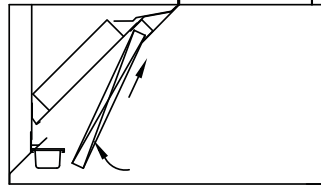

Fig. 22

4. Slide the filter to one end of the hood and repeat until all the filters are installed. Make sure the filters are placed tightly together with no visible gaps.

5. Install the Grease-X-Tractor™ primary filters in the same manner using the front filter channel. (Fig. 22)

Grease Grabber™ Filter Cleaning

Step 1 Remove the front row of Grease-X-Tractor™ filters shown in 1A. Begin by removing the middle filter(s) first (1B), then slide the outer filters toward the hood center and continue removing the filters.



Grease-X-Tractor™ filters, first row of filters

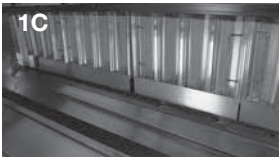

Grease Grabber™ filters, second row of filters

Step 2 Remove the Grease Grabber™ filters, starting in the middle of the hood: (2A) grab the handles on either side and lift the filter up, (2B) pull the bottom of the filter toward yourself, (2C) lower the filter out of the hood.

Repeat this process for each filter. The filters that are on the ends will have to be slid toward the middle and then lifted out.



Slide filter up



Pull bottom of filter towards yourself



Pull filter down

Step 3 Frequent Maintenance

NOTE

Required washing frequency is dependent on type of cooking and quantity of food cooked.

- Remove filters from hood and place each filter in a whirlpool sink or dishwasher.
- If using a whirlpool sink, cycle for 10 minutes. Use standard dish wash soap. (3A)
- If using a dishwasher, cycle it three times to ensure all grease is removed. (3B)
- If using standard sink, cover with hot water and degreaser and soak for two hours. Rinse after soaking.



Whirlpool sink method

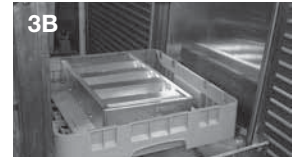

Dishwasher method

NOTE

For hoods with large quantities of filters, it is acceptable to wash three to four filters each day, cycling all of the filters in three days.

NOTE

The beads will discolor. Standard cooking will turn the beads yellow in color. Open flame cooking will cause the beads to blacken. Neither affects the performance of the filters.

Periodic Inspection

- Inspect filter fasteners. Verify they are not loose or missing.
- Each filter may be soaked in hot soapy water for two hours once a month prior to washing if grease build-up is found.
- Test for grease build-up by running water through the filter. If water runs freely and no air gaps are in the beaded pack, the filter is in working condition.
- Inspect the filters by holding it up to a light. Light shining through more than six holes in a group indicates filter damage.
- For filter replacement, call 1-800-355-5354

Step 4 Replace Grease Grabber™ filters in hood. Do Step 2 in reverse order (2C, then 2B, then 2A).

Step 5 Replace the front Grease-X-Tractor filters. Do Step 1 in reverse. Be sure to install filters in the ends of the hood first, then install the filters in the middle of the hood (1B, then 1A).

CAUTION

To prevent damage to filter media, do not wash second stage filters in detergents that contain hydroxides such as sodium hydroxide or potassium hydroxide.

Filter Washing Frequency Guide

NOTE

Standard cooking will turn the beads yellow in color. Open flame cooking will cause the beads to blacken. Neither affects the performance of the beads.

CAUTION

To prevent damage to filter media, do not wash second stage filters in detergents that contain hydroxides such as sodium hydroxide or potassium hydroxide.

Preference	Washing Equipment		Cooking Equipment	Chemical	Grease Grabber™ Filter		Baffle Filter or Grease-X-Tractor™ Wash Frequency
	Type	Temp.			Frequency Required	Time or Cycles	
1 Best	Commercial Grade Dish Washer	180° F Minimum	Griddle	Dish Washer Detergent	Every 3 days	2 cycles	Every 3 days, 2 cycles
			Fryer		Weekly	2 cycles	Twice a week, 1 cycle
			Charbroiler		Daily	2 cycles	Daily, 2 cycles
			Wok		Daily	2 cycles	Daily, 2 cycles
2	Low Temp. Dish Washer	140° F	Griddle	Dish Washer Detergent	Every 3 days	3 cycles	Every 3 days, 2 cycles
			Fryer		Weekly	3 cycles	Twice a week, 2 cycles
	Chemical Sanitizer		Charbroiler		Daily	4 cycles	Daily, 2 cycles
			Wok		Daily	4 cycles	Daily, 2 cycles
3	Power Wash Sink (Whirlpool) with Heater	180° F Minimum	Griddle	Pot & Pan Detergent	Every 3 days	10 minutes	Every 3 days, 5 minutes
			Fryer		Weekly	10 minutes	Twice a week, 5 minutes
			Charbroiler		Daily	15 minutes	Daily, 5 minutes
			Wok		Daily	15 minutes	Daily, 5 minutes
4	Power Wash Sink (Whirlpool) without Heater	140° F	Griddle	Pot & Pan Detergent	Every 3 days	15 minutes	Daily, 5 minutes
			Fryer		Weekly	15 minutes	Twice a week, 5 minutes
			Charbroiler		Daily	25 minutes	Daily, 10 minutes
			Wok		Daily	25 minutes	Daily, 10 minutes
5	Pot Sink with Heater	180° F	Griddle	Pot & Pan Detergent and/or Degreaser	Every 2 days	1 hour	Daily Soak 10 minutes, then scrub with scour pad and bottle brush.
	Rinse with sprayer after soaking.		Fryer		Every 2 days	1 hour	Daily Soak 5 minutes, then scrub with scour pad and bottle brush.
			Charbroiler		Daily	2 hours	Daily Soak 10 minutes, then scrub with scour pad and bottle brush.
			Wok		Daily	2 hours	
6 Worst	Pot Sink no Heater	140° F	Griddle	Commercial Grade Kitchen Degreaser	Daily	2 hours Change hot water every 30 minutes	Daily Soak 10 minutes then scrub with scour pad and bottle brush.
	Rinse with sprayer after soaking.		Fryer		Every 2 days	2 hours Change hot water every 30 minutes	
			Charbroiler		Not Recommended		
			Wok		Not Recommended		

Troubleshooting

Problem: Exhaust fan is not operating or is not operating at design levels.

Is the fan receiving power?	Replace fuses, reset circuit breakers, check disconnect.
Is the belt loose or broken?	Replace or tighten belt.
Is the fan rotating in correct direction?	Have the electrician correctly wire the fan.
Is the make-up air operating?	Problems with make-up air may interfere with the exhaust fan - check the manufacturer's installation manual.
Does the airflow need to be increased?	Adjust or replace pulleys to increase fan RPM, install a larger motor.
Does the fan vibrate?	Clean the fan wheel/blade, replace fan wheel if damaged, check for loose bolts, check for broken or damaged components, check for rags and other foreign objects.

Problem: Hood is full of smoke. There is smoke coming out of the edges of the hood.

Is the fan operating at design levels?	See exhaust fan troubleshooting section.
Is the fan correctly sized?	Refer to test and balance report, design specifications and fan curves; have an electrician check the motor amperage; try removing the filter temporarily to see if capture improves. (Make sure to replace filter to prevent risk of fire!); switch to different filters with lower static pressure.
Are the filters in good condition?	Clean filters, replace damaged filters, properly position filters.
Is there sufficient make-up air? <i>(Kitchen should be in a slight negative but not excessive. Check to see if there is a strong draft through an open door).</i>	Check make-up air unit, increase make-up air, make-up air should be evenly distributed throughout the kitchen.
Does the current cooking equipment match the original design?	Adjust or replace fan to match the cooking equipment load.
Are there multiple hoods on one fan?	One hood may be over exhausting and the other hood not drawing enough. Restrict second hood to help problem hood.
Are there closed dampers in the duct?	Open dampers.
Is the ductwork complex or too small?	Change to a higher static fan, modify the ductwork.
Is the ductwork obstructed?	Clear obstruction.
Is this a short circuit hood?	Turn off or reduce the amount of air supplied to short circuit.

Problem: Smoke blows away before reaching the bottom of the hood.

Are there cooling fans directed at the hood or cooking equipment?	Turn off or redirect fans.
Are there ceiling diffusers directing air at the hood?	Move diffusers to more neutral area or replace with a diffuser that directs air away from the hood.
Are there open windows or doors?	Close windows and doors.
Are there cross drafts or other drafts in the kitchen?	Find source of the draft and eliminate, add side skirts to hood (test with cardboard; use stainless for permanent side skirts); increase the amount of overhang on the spillage side; add a 6 in. (152.4 mm) lip around the base of the hood (test with cardboard; use stainless for permanent side skirts); make-up air should be spread out evenly through the kitchen.
Is the hood near a main walkway?	Add side skirts to hood (test with cardboard first); increase the amount of overhang on spillage side.
Are there pass-thru windows near the hood?	Adjust amount and locations of make-up air to eliminate drafts through the pass-thru windows.
Is this an air curtain hood?	Turn off or reduce the amount of make-up air.
Is the make-up air part of the hood or an attached plenum?	Try turning off or reducing the amount of make-up air; block off portions of the supply to direct air away from the problem area (test with cardboard).

Troubleshooting

Problem: Pilot lights are being blown out or cooking equipment is being cooled by make-up air.

Are there drafts from make-up air?	Try turning off or reducing the amount of make-up air; block off portions of the supply to direct air away from the problem area (test with cardboard first); remove any obstructions in front of supply that directs air toward cooking equipment.
------------------------------------	---

Problem: Cold air can be felt by the cook at the hood.

Is this a short circuit hood?	Turn off or reduce the amount of air supplied to short circuit.
Is this an air curtain hood?	Turn off or reduce the amount of air supplied to the air curtain; heat the supply air.
Is the make-up air part of the hood or an attached plenum?	Try turning off or reducing the amount of make-up air; heat the supply air.

Problem: The kitchen gets hot.

Is the hood capturing?	Hood is not drawing enough air, see sections above on fan performance and hood capture.
Is this an air curtain hood?	Turn off or reduce the amount of air supplied to the air curtain.
Is the make-up air part of the hood or an attached plenum?	Try turning off or reducing the amount of make-up air; cool the supply air.

Problem: Cooking odors in the dining area.

Is the hood capturing?	Hood is not drawing enough air, see sections above on fan performance and hood capture.
Is there a draft through doors between the kitchen and dining area?	Decrease make-up air in the kitchen; increase exhaust air through hood.

Problem: Grease is running off the hood.

Is there grease on top of the hood?	Exhaust duct is not correctly welded.
Is the caulk missing or damaged?	Clean problem area and recaulk.
Is the grease cup inserted properly?	Put grease cup back in place.

Problem: Hood is noisy.

Is the fan running in the correct direction?	See exhaust fan troubleshooting section.
Are the filters in place?	Replace missing filters.
Is the hood over exhausting?	Slow down fan (see exhaust fan troubleshooting section)

Before calling your manufacturer's representative to report a problem, have the following information available:

1. Review / summary of troubleshooting section in installation operation manual.
2. Hood model and serial number.
3. Current cooking equipment line-up.
4. Size of hood (length, width and height).
5. Island or wall configuration.
6. Multiple hoods on one fan.
7. Nature of spillage (one end; all around the edges).
8. Does the smoke make it to the hood?
9. Height hood is mounted above finished floor.
10. How make-up air is brought into the kitchen (hood, ceiling diffusers, separate plenum).
11. Is exhaust system controlled by a variable volume system?
12. Is the fan noisy?
13. Photos of the issue/problem may be helpful.

Replacement Parts

FILTERS	
Part Number	Filter Description (Height x Width x Depth)
457626	16 x 16 x 2 Aluminum Baffle Filter
457628	16 x 20 x 2 Aluminum Baffle Filter
457632	20 x 16 x 2 Aluminum Baffle Filter
457634	20 x 20 x 2 Aluminum Baffle Filter
457627	16 x 16 x 2 Stainless Steel Baffle Filter
457629	16 x 20 x 2 Stainless Steel Baffle Filter
457633	20 x 16 x 2 Stainless Steel Baffle Filter
457635	20 x 20 x 2 Stainless Steel Baffle Filter
851656	16 x 16 High Velocity Cartridge Filter
851657	16 x 20 High Velocity Cartridge Filter
851659	20 x 16 High Velocity Cartridge Filter
851660	20 x 20 High Velocity Cartridge Filter
851703	16 x 16 Grease-X-Tractor™ Aluminum Filter
851704	16 x 20 Grease-X-Tractor™ Aluminum Filter
851706	20 x 16 Grease-X-Tractor™ Aluminum Filter
851707	20 x 20 Grease-X-Tractor™ Aluminum Filter
851709	16 x 16 Grease-X-Tractor™ SS Filter
851710	16 x 20 Grease-X-Tractor™ SS Filter
851712	20 x 16 Grease-X-Tractor™ SS Filter
851713	20 x 20 Grease-X-Tractor™ SS Filter
458763	16 x 16 Flame Gard® 1 Baffle Filter
458764	16 x 20 Flame Gard® 1 Baffle Filter
454878	20 x 16 Flame Gard® 1 Baffle Filter
454879	20 x 20 Flame Gard® 1 Baffle Filter
852879	20 x 16 Grease Grabber™ Second Stage Filter
852878	20 x 20 Grease Grabber™ Second Stage Filter
852881	16 x 16 Grease Grabber™ Second Stage Filter
852880	16 x 20 Grease Grabber™ Second Stage Filter

REGISTERS	
Part Number	Description
452700	24 x 8 Aluminum Single Deflection H-OB
452701	36 x 8 Aluminum Single Deflection H-OB
452702	36 x 8 Aluminum Single Deflection H-OB
452703	44 x 8 Aluminum Single Deflection H-OB
453796	24 x 12 Aluminum Single Deflection H-OB
453797	36 x 12 Aluminum Single Deflection H-OB
453798	38 x 12 Aluminum Single Deflection H-OB
453799	44 x 12 Aluminum Single Deflection H-OB
452729	24 x 8 Aluminum 38° Fixed Blade RA-OB
452730	30 x 8 Aluminum 38° Fixed Blade RA-OB
452731	36 x 8 Aluminum 38° Fixed Blade RA-OB
452732	38 x 8 Aluminum 38° Fixed Blade RA-OB
452733	44 x 8 Aluminum 38° Fixed Blade RA-OB

SWITCHES	
Part Number	Description
850551	Light Switch Only
851776	Fan Switch Only
851777	Light Switch & Fan Switch (2 switches)
851778	Fan Switch & Heat Switch (2 switches)
851779	Exhaust, Fan & Supply Switch (2 switches)
851780	Light, Fan & Heat Switch (3 switches)
851781	Light, Exhaust, Supply Separate Switch (3 switches)
851782	Exhaust, Supply, Heat Separate Switch (3 switches)
851783	Light, Exhaust, Supply, Heat Separate Switch (4 switches)
851784	Fan Switch & Temper (3 position) (2 switches)
851510	Light, Fans, & Temper (3 position) (3 switches)
851511	Exhaust, Supply, & Temper (3 position) (3 switches)
851512	Light, Exhaust, Supply, & Temper (3 position) (4 switches)
851618	Automatic Fire Damper Test Switch

MISCELLANEOUS	
Part Number	Description
451131	Grease Cup
453498	Glass Globes for hood lights (clear)
851744	Grease Extractor Filter Removal Tool
851834	Baffle Filter Removal Tool
851747	High Velocity Cartridge Filter Removal Tool

Maintenance Log

Date _____ Time _____ AM/PM
Notes: _____

Date _____ Time _____ AM/PM
Notes: _____

Date _____ Time _____ AM/PM
Notes: _____

Date _____ Time _____ AM/PM
Notes: _____

Date _____ Time _____ AM/PM
Notes: _____

Date _____ Time _____ AM/PM
Notes: _____

Date _____ Time _____ AM/PM
Notes: _____

Date _____ Time _____ AM/PM
Notes: _____

Commitment

As a result of our commitment to continuous improvement, Greenheck reserves the right to change specifications without notice. Specific Greenheck product warranties are located on greenheck.com within the product area tabs and in the Library under Warranties.

Greenheck's Kitchen Ventilation Systems catalog provides additional information describing the equipment, fan performance, available accessories, and specification data.

AMCA Publication 410-96, Safety Practices for Users and Installers of Industrial and Commercial Fans, provides additional safety information. This publication can be obtained from AMCA International, Inc. at www.amca.org.

