

DEWALT®

POWER TOOLS, EQUIPMENT & ACCESSORIES CATALOG



GUARANTEED TOUGH.®

NEW POWER TOOLS

DC989KA
Page 10



DC988KA
Page 10



DC987KA
Page 10



DC985KA
Page 16



DC984KA
Page 16



DC983KA
Page 16



DC980KA
Page 20



DC011
Page 29



DC759KA
Page 10



DC728KA
Page 16



DC727KA
Page 20



DW059K-2
Page 12



DC385K
Page 14



DC390K
Page 13



DC490KA
Page 13



DC520KA
Page 12



DC550KA
Page 15



DW082K
Page 32



DW084K
Page 32



DW090PK
Page 35



DW092PK
Page 35



DW096PK
Page 35



D25101K/D25103K
Page 46



DW292/293
Page 53



NEW POWER TOOLS

DW294
Page 53



DC612KA
Page 17



DC614KA
Page 17



DC616KA
Page 11



DC618KA
Page 11



D51430
Page 58



D51431
Page 58



D51321
Page 59



DW828K
Page 95



DW304PK
Page 89



D28770/D28770K
Page 93



NEW ACCESSORIES

DW4747
Page 116



DW4770
Page 116



DW1787
Page 126



DW1969
Page 128



DW1770
Page 126



DW3993
Page 124



DW1582
Page 125



Since entering the NASCAR Nextel Cup series in 2000, DEWALT driver Matt Kenseth has made quite a name for himself in four short years. With a 1st place finish at the Coca-Cola 600 in May of 2000, Matt entered victory lane for the first time in the Nextel circuit and went on to win the Raybestos Rookie of the Year honors for 2000.

In 2001, although the checkered flag eluded the #17 DEWALT Ford Taurus, the year proved to be a great success for the pit crew. Led by crew chief Robbie Reiser, the DEWALT *Racing Team* captured the highly coveted Unocal 76 World Pit Crew Championship at Rockingham as they set a world-record pit stop time of 17.69 seconds!

In 2002, however, the checkered flag waived over the DEWALT car 5 times, more than any other driver that year. The DEWALT *Racing Team* also nailed down their second straight Unocal 76 World Pit Crew Championship by shattering their own old record with a 16.81 second stop. With wins at North Carolina, Texas, Michigan, Richmond and Phoenix, Matt and the entire DEWALT *Racing Team* secured an 8th place points finish for 2002.



In 2003, the DEWALT *Racing Team* proved they are victors by clinching the Nextel Cup Championship. While only winning in Las Vegas at the beginning of the season, Matt was able to capture 10 Top Five and 14 Top Ten finishes throughout the year. His hard work and consistency paid off, and he soon found himself making an acceptance speech at the Waldorf Astoria in New York City.

Matt Kenseth, Robbie Reiser and the entire DEWALT *Racing Crew* at Roush Racing have proved again and again that like DEWALT tools, they are GUARANTEED TOUGH.



For more information on DEWALT *Racing*, please visit www.DEWALT.com, www.mattkenseth.com or www.roushracing.com

DEWALT EVENTS



Champions at work - whether it's on the jobsite, at the race track or in the classroom, DEWALT knows what it means to be a champion. DEWALT also knows that the future builders of America need more than the best tools – they need the best training. This is why we are proud to be a leading supporter of SkillsUSA.

Today, SkillsUSA is leading the charge of American competitiveness by helping prepare highly-skilled craftsmen and tradesmen, and DEWALT is proud to be part of the team. We're involved on the state and national level as well, supplying the organization with tools and judging workmanship in competitions. It's an honor to be this closely tied to the hands that will be building America in the decades to come, and that's why our support of SkillsUSA will be important for generations to come.

ROLLING THUNDER

13 gears, 18 wheels, 107,000 miles, and 137 DEWALT tools. DEWALT's Rolling Thunder is the ultimate mobile tool and accessory experience. With an average of 3,000 visitors per show, Rolling Thunder draws people in to see power, speed and performance from innovative tools and world-class accessories. With hands-on demonstrations, new product showcases and DEWALT experts on hand, Rolling Thunder delivers both education and entertainment. 6,400 square feet of display area allows visitors to test everything from new cordless drills to portable planers. With 25 events each year, we look forward to seeing you at an upcoming show.



WARRANTY & SYMBOLS



We know how tough you can be on your tools, which is why every DeWALT tool is backed by a comprehensive service and warranty program that's just as tough. Because a tool is only as heavy duty as the company that stands behind it. DeWALT makes the highest quality products in the industry and we want to back them with the most comprehensive Warranty and Service Network in the business.

3-Year Limited Warranty

DeWALT will repair, without charge, any defects due to faulty materials or workmanship for three years from date of purchase.

1-Year Free Service Contract

DeWALT will maintain the tool and replace worn parts caused by normal use, for free, any time during the first year after purchase.

90-Day Money Back Guarantee

If you are not completely satisfied with the performance of your DeWALT Power Tool, Laser, or Nailer for any reason, you can return it within 90 days from the date of purchase with a receipt for a full refund—no questions asked.

Guaranteed Repair Cost Program

After the first year, we put a ceiling on the cost of each repair. That way, if a repair costs more than our guaranteed maximum rate, we absorb the excess cost. If it costs less, you pay less.

DeWALT Service Network

DeWALT High Performance Industrial Tools are backed by conveniently located, factory owned and authorized service centers which provide fast, "when you need it", repair service. For the center nearest you: see pages 150–156, call 1-800-4DEWALT, or visit www.DEWALT.com

Toll-Free Technical Assistance

Whenever you have a question about a DeWALT product, service, repair or replacement part, dial:

1-800-4 DEWALT
(1-800-433-9258)

The following are trademarks for one or more DeWALT Power Tools and Accessories: DeWALT®; the DeWALT® logo; GUARANTEED TOUGH®; VERSA-CLUTCH®; XRP™; XR PACK®; XR2®; XR+™; the yellow/black color scheme; the shape of the terminal block/tower configuration of the compact, XR PACK®, XR2® and XR+™ battery packs; the "D"-shaped air intake grill; the array of pyramids on the handgrip; the kit box configuration; and the array of lozenge-shaped humps on the surface of the tool; MULTI-CUTTER™; TUNE-UP®; RAPID LOAD®; ROCK CARBIDE®; EXTREME DURABILITY™; PILOT POINT®; MAGNETIC DRILL and DRIVE SYSTEM®; SERIES 20®; SERIES 40®; SERIES 60®; the black-colored rim on circular saw blades; the yellow-colored rim on circular saw blades; the boomerang-shaped heat vents in circular saw blades; the spiral-shaped heat vents in circular saw blades; the starburst-shaped heat vents in circular saw blades; TOUGH CASE™; TOUGH PACK™; GRC™; the GRC™ logo; GUARANTEED REPAIR COST™; DROP BOX EXPRESS™; DeWALT SERVICE NET™. Other trademarks may apply.
Copyright© 2004 DeWALT®













Approvals

DeWALT High Performance Industrial Tools bearing the monograms of an approval agency (Underwriter's Laboratories, Inc., CSA International, Norma Oficial Mexicana) have been evaluated and comply with the appropriate national standards. DeWALT 2-wire double insulated tools, DeWALT 3-wire grounded tools and DeWALT cordless tools are designed to comply with the OSHA requirements applicable to them. See **Symbols** below for explanation of tool markings.

OSHA requirements

Both 2-wire double insulated and 3-wire grounded tools are in compliance with OSHA requirements. The OSHA specification dealing with the grounding or double insulation of power tools is in Standard 1910.304. The basic electrical requirements for tools are in the National Electrical Code 1999-Paragraph 250-114. The exception to the grounding requirement in Paragraph 250-114 is given by the phrase: "Listed portable tools protected by an approved system of double insulation, or its equivalent, shall not be required to be grounded." DeWALT demonstrates compliance with this code requirement via approval by a Nationally Recognized Testing Laboratory. Other relevant OSHA specifications for power tools in industrial use are: 1910.213, 1910.243; in construction use are: 1926.302, 1926.304, 1926.404. Except as noted, stationary tools meet applicable OSHA regulations but may require the addition of a magnetic switch (no volt release) in the electrical supply circuit.

Symbols

-  or  or  Approved to US national standards
-  or  Approved to Canadian national standards
-  or  or  Approved to both US and Canadian national standards
-  or  Approved to Mexican national standards
-  Double Insulated  Grounded
-  Approved to ASME design guidelines

Trade Associations

DeWALT is an associated member of the following trade associations:



The descriptions, specifications and other claims made with respect to the products featured in this catalog are made as of the date of printing. DeWALT® retains the right to discontinue production of or make improvements or other changes to any of its products without notice. Product packaging and other product literature should be consulted for current descriptions, specifications and other claims relating to DeWALT® products. Improvements or other changes to products shall not obligate DeWALT® to make corresponding improvements or changes to products previously manufactured or sold.

TABLE OF CONTENTS

CORDLESS

24V	9
18V	10-15
14.4V	16-19
12V	20-22
9.6V	23-24
7.2V	24
Batteries	28
Chargers	29
Combo Kits	25-27

LASERS

Box Lasers	32
Cordless Rotary	31
Laser Accessories	33
Rotary	31-32

INSTRUMENTS

Optical Instruments	35
---------------------	----

DRILLS

1/4" Drills	38
1/2" Drills	39-42
3/4" Drill/Power Unit	43
3/8" Drills	37-38
Annular Cutters	43
Drill Presses	43
End Handle Drills	42
Right Angle Drills	42
Spade Handle Drills	41
Stud & Joist Drills	42

HAMMERS & HAMMERDRILLS

Compact SDS Hammers	46
Demolition Hammers	48-49
Hammerdrills	45
Large SDS Hammers	47
Spline Hammers	48
SDS Max Hammers	47

FASTENING

Cut-Out Tool	53
Drywall Screwdrivers	51
Deck Screwdrivers	51
Impact Wrenches	53
Metal Fastening	52

NAILERS

Brad Nailers	55
Coil Nailer	59
Finish Nailers	55
Framing Nailer	56-57
Staplers	58

COMPRESSORS

Hand Carry – Electric	61-62
Hand Carry – Gas	62
Wheeled Portable – Electric	64-65
Wheeled Portable – Gas	63

GENERATORS

Gas Generators	67-69
----------------	-------

MACHINERY

Compound Miter Saws	71-72
Miter Saw Stand	72
Miter Saw Accessories	73
Portable Table Saw/Accessories	74
Portable Thickness Planers/Accessories	74-75
Scroll Saw/Accessories	76
Woodworker's Table Saw	76
Woodworker's Table Saw/Accessories	77

WOODWORKING

Plate Joiner/Accessories	84
Planer/Accessories	84
Routers	79-81
Router Accessories	82
Sanders/Accessories	85-87
Trim Routers/Accessories	83

SAWS

7-1/4" Circular Saws	90
7-1/4" Framing Saw	91
8-1/4" Circular Saws	90
Jig Saws	91
Reciprocating Saws	89

METALWORKING

Band Saw/Accessories	93
Bench Grinders	100
Chop Saw	99
Cut-Off Machine	100
Multi-Cutter™ Saw	99
Nibblers	102
Polishers/Accessories	103
Sanders/Grinders:	
Small Angle (4-1/2", 5")	94-95
Medium Angle (5", 7")	95-96
Large Angle (7", 9")	96-97
Accessories	97
Shears	101
Straight/Die Grinders	98

ACCESSORIES

Abrasives	106-115
Bellhanger Bits	126
Circular Saw Blades	129-132
Diamond Blades	116
Drill Bits	128-129
Hand Hack Saw & Blades	124
Hole Saws	120-121
Jig Saw Blades	122-123
Masonry Drilling	133-140
Portable Band Saw Blades	121
PVC Saw & Blades	124
Quick Change	131-132
Reciprocating Saw Blades	117-119
Rough Wood Drilling	120
Saw Blades	141-147
Self Feed Bits	125
Screwdriving	130-132
Ship Auger Bits	126
Step Drill Bits	123
Tool Belts & Bags	127
Wood Boring Bits	125

SERVICE

Drop Box Express	148
Kit Boxes	148
Power Tool Repair	148
Service Centers	150-156
ServiceNET	149



"DeWALT Power Tools are designed and manufactured by facilities that operate under an ISO-registered quality system. Organizations that are successful in today's business environment are committed to meet or exceed customers' expectations and provide defect-free products and services. Many organizations have found that the ISO Series of Standards does provide a starting point and some important milestones toward that goal. The ISO 9000 series addresses those areas of quality management that are essential to winning (and keeping) customer's confidence in an organization's capability to consistently provide quality products and services. ISO, (International Organization for Standardization) is a worldwide federation of national standards that embodies more than 100 countries. Its scope is

standardization in the field of generic quality management, including quality systems, quality assurance and generic supporting technologies. It is important to remember that this is a quality system registration and not a product registration. It is also important to remember that any quality system requirements are complimentary to and not a replacement for technical specification for a product. To this point, the ISO series applies broadly to key organizations and to all product quality characteristics. Registration to an ISO standard is strictly voluntary and the only way to achieve registration is to be audited by an independent 3rd party to determine whether or not you comply to the intent of the standard. Once you achieve registration, your certificate is valid for 3 three years. However, every year during that 3 year period, you must go through an annual surveillance audit to determine whether or not you still comply."

NUMERIC INDEX

CAT. #	PAGE	CAT. #	PAGE	CAT. #	PAGE	CAT. #	PAGE
TOOLS		D55275	63	DC988CA	26	DW159	43
D21002	37	D55276	63	DC988KA	10	DW160	38
D21008K	37	D55390	64	DC988SA	26	DW217	38
D21009	37	D55395	65	DC988VA	10	DW222	38
D25101K	46	D55570	64	DC989KA	10	DW223G	38
D25103K	46	D55575	65	DC989VA	10	DW235G	39
D25201K	46	D55580	64	DG2900	67	DW236	39
D25203K	46	D55585	65	DG4300	67	DW236K	39
D25300D	46	DC011	29	DG6000	68	DW239	40
D25303K	46	DC385K	14	DG6000E	68	DW245	39
D25304K	46	DC390K	13	DG7000	68	DW246	40
D25404K	47	DC410KA	14	DG7000E	68	DW249	40
D25500K	47	DC490K	13	DW005K-2	9	DW252	51
D25550K	48	DC4KITA	26	DW006K-2	9	DW255	51
D25551K	48	DC4MEGA	26	DW007K-2	9	DW257	51
D25600K	47	DC500	15	DW008K-2	9	DW260K	52
D25650K	48	DC500K	15	DW0242	28	DW266	52
D25830K	49	DC520K	12	DW0246	29	DW267	52
D25850K	48	DC550K	15	DW0249	29	DW268	52
D25900K	49	DC5KITA	25	DW050K-2	23	DW269	52
D25940K	49	DC5KITVD	25	DW051K-2	21	DW272	51
D28474W	96	DC612KA	17	DW052K-2	21	DW272W	51
D28493N	96	DC612KN	17	DW053K-2	21	DW272WT	51
D28494N	96	DC614KA	17	DW054K-2	18	DW276	51
D28494S	97	DC614KN	17	DW055K-2	18	DW281	52
D28497	97	DC616KA	11	DW056K-2	12	DW284	52
D28499X	97	DC616KN	11	DW057K-2	12	DW297	53
D28754	100	DC618KA	11	DW059K-2	12	DW292	53
D28770	93	DC618KN	11	DW071K	31	DW292K	53
D28770K	93	DC6KITA	25	DW071KD	31	DW293	53
D51238K	55	DC6KTGA	25	DW071KI	31	DW294	53
D51256K	55	DC727KA	20	DW073K	31	DW304PK	89
D51275K	55	DC727VA	20	DW073KD	31	DW307MK	89
D51321	59	DC728KA	16	DW077KD	32	DW309K	89
D51430	58	DC728SA	27	DW077KI	32	DW313	91
D51431	58	DC759KA	10	DW082K	32	DW318K	91
D51822	57	DC9071	28	DW084K	32	DW321K	91
D51823	56	DC9091	28	DW090PK	35	DW364	90
D51844	57	DC9096	28	DW092PK	35	DW364K	90
D51845	56	DC980KA	20	DW096PK	35	DW368	90
D55150	62	DC983KV	16	DW120K	42	DW368K	90
D55151	61	DC983SA	27	DW124	42	DW369CSK	90
D55152	61	DC984KA	16	DW124K	42	DW378G	91
D55153	61	DC984VA	16	DW130	41	DW378GK	91
D55155	61	DC985KA	16	DW131	41	DW378GT	91
D55170	64	DC985VA	16	DW132	41	DW384	90
D55250	62	DC987CA	27	DW138	43	DW400	94
D55251	62	DC987KA	10	DW140	42	DW402	94
D55270	63	DC987SA	27	DW151	43	DW402K	94

Safety Facts

- Keep work area clean.** Cluttered areas and benches invite injury.
- Consider your work environment.** Don't expose power tools to rain. Don't use power tools in damp or wet locations. Keep work areas well lit.
- Guard against electric shock.** Prevent body contact with grounded surfaces.
- Keep visitors away.** All visitors should be kept away from the work area. Do not let visitors come in contact with tools or extension cords.
- Store idle tools.** When not in use, tools should be stored in a dry and high or locked-up place.
- Don't force tool.** It will do the job better and safer at the rate for which it was intended.
- Use the right tool.** Don't force small tools or attachments to do the job of a heavy-duty tool. Don't use tools for purpose not intended; for example, don't use a circular saw for cutting tree limbs or logs.
- Dress properly.** Do not wear loose clothing or jewelry. They can be caught in moving parts. Rubber gloves and non-skid footwear are recommended when working outdoors. Wear protective hair covering to contain long hair.
- Use safety glasses.** Also use the proper face or dust mask if cutting operation is dusty.
- Don't abuse cord.** Never carry a tool by cord or yank it to disconnect from receptacle. Keep cord from heat, oil, and sharp edges.
- Secure work.** Use clamps or a vise to hold work. It is safer than using your hand and it frees both hands to operate tool.

NUMERIC INDEX

CAT. #	PAGE	CAT. #	PAGE	CAT. #	PAGE	CAT. #	PAGE
DW411	85	DW756	100	DW918	19	DW3215-DW3232	141
DW411K	85	DW758	100	DW919	15	DW3310-DW3350	145
DW420	86	DW788	76	DW920K-2	24	DW3370-DW3372	144
DW421	85	DW802	94	DW9216	29	DW3508-DW3532	110
DW421K	85	DW802G	94	DW926K-2	23	DW3700-DW3778	122-123
DW423	85	DW818	94	DW933K	14	DW3970-DW3977	124
DW423K	85	DW821	94	DW934K-2	13	DW3981-DW3992	121
DW432	87	DW824	95	DW935K	19	DW3993-DW3996	124
DW433	87	DW827	95	DW936K	13	DW4418-DW4429	107
DW433K	87	DW828	95	DW937K	19	DW4432-DW4439	114
DW433KT	87	DW831	95	DW940K-2	22	DW4518-DW4554	107
DW443	86	DW840	96	DW941K-2	18	DW4532-DW4539	114
DW505	45	DW845	103	DW955K-2	23	DW4618-DW4629	107
DW505K	45	DW847	103	DW960K-2	11	DW4700-DW4773	116
DW511	45	DW849	103	DW965K-2	20	DW4719-DW4759	107
DW515K	45	DW870	99	DW966K-2	17	DW4801-DW4869	117-119
DW570K	47	DW871	99	DW968K-2	22	DW4900-DW4938	114
DW616	79	DW872	99	DW969K-2	17	DW4939-DW4990	115
DW616D	79	DW880	98	DW979K-2	22	DW4949-DW4999	107, 109
DW616K	79	DW882	98	DW999K-2	11	DW5204-DW5249	133
DW616M	79	DW887	98	ACCESSORIES		DW5348-DW5365	135
DW616PK	79	DW888	98	D18001-D180098	120-121	DW5400-DW5470	134-135
DW618	80	DW890	101	D5100-D5136	127	DW5700-DW5794	136
DW618B3	81	DW891	101	D6050	127	DW5740-DW5769	137
DW618D	80	DW892	101	D6100	127	DW5770-DW5786	140
DW618K	80	DW893	101	DW1169	128	DW5790-DW5794	136
DW618M	80	DW896	102	DW1204-DW1232	129	DW5801-DW5861	138
DW618PK	80	DW897	102	DW1263	129	DW5832-DW5847	140
DW621	81	DW898	102	DW1304-DW1332	129	DW5900-DW5945	139
DW621K	81	DW902	24	DW1363	129	DW5950-DW5967	140
DW625	81	DW904	22	DW1570-DW1595	125	DW7124-DW7296	141
DW660	53	DW9048	28	DW1602-DW1629	129	DW7605-DW7668	141-143
DW660K	53	DW9050	28	DW1630-DW1649	125	DW7737-DW7763	146
DW660SK	53	DW9057	28	DW1665-DW1692	126	DW8001-DW8016	110
DW670	83	DW906	19	DW1768-DW1782	126	DW8020-DW8039	112
DW673K	83	DW9061	28	DW1783-DW1796	123	DW8056-DW8059	110
DW680K	84	DW9062	28	DW1800-DW1808	121	DW8062-DW8086	111
DW682K	84	DW9071	28	DW1904-1932	128	DW8300-DW8330	113
DW703	71	DW9072	28	DW1956	128	DW8400-DW8486	108-109
DW705S	71	DW908	15	DW1969	128	DW8700-DW8725	111
DW706	71	DW9091	28	DW2001-DW2097	130-131	DW9052-DW9059	145
DW708	72	DW9094	28	DW2105-DW2163	130	DW9152-DW9158	145
DW712	72	DW9099	28	DW2190	129		
DW723	72	DW9107	29	DW2200-DW2263	130-131		
DW734	74	DW9109	29	DW2505-DW2574	132		
DW735	75	DW911	29	DW2602	130		
DW744S	74	DW9116	29	DW2700-DW2735	131		
DW746	76	DW9117	29	DW3103-DW3128	144		
DW746X	76	DW9118	29	DW3161-DW3193	145		

12. **Don't overreach.** Keep proper footing and balance at all times.
13. **Maintain tool with care.** Keep tools sharp and clean for better and safe performance. Follow instructions for lubricating and changing accessories. Inspect tool cords periodically and, if damaged, have repaired by an Authorized Service Center. Inspect extension cords periodically and replace if damaged. Keep handles dry, clean, and free from oil and grease.
14. **Disconnect tools** when not in use, before servicing, and when changing accessories, such as blades, bits, cutters.
15. **Remove adjusting keys and wrenches.** Form habit of checking to see that keys and adjusting wrenches are removed from tool before turning it on.
16. **Avoid unintentional starting.** Don't carry plugged-in tool with finger on switch. Be sure switch is off when plugged in.
17. **Outdoor use extension cords.** When tool is used outdoors, use only extension cords intended for use outdoors and so marked.
18. **Stay alert.** Watch what you are doing. Use common sense. Do not operate tool when tired.
19. **Check damaged parts.** Before further use of the tool, a guard or other part that is damaged should be carefully checked to determine that it will operate properly and perform its intended function. Check for alignment of moving parts, binding or moving parts, breakage of parts, mounting, and any other conditions that may affect its operation. A guard or other part that is damaged should be properly repaired or replaced by an Authorized Service Center unless otherwise indicated elsewhere in this catalog. Have defective switches replaced by Authorized Service Center. Do not use tool if switch does not turn it on and off.
20. **Do not operate portable electric tools near flammable liquids or in gaseous or explosive atmospheres.** Motors in these tools normally spark, and the spark might ignite fumes.

CORDLESS

CORDLESS

Patented 3-speed all metal transmission

max speed and greatest number of speed ranges for optimal performance

DEWALT built, high torque, high efficiency motor delivers maximum torque output without sacrificing run-time

1/2" metal ratcheting chuck with carbide jaws

helps to prevent bits from slipping and falling out

Superior ergonomics

optimal balance, control & weight

Maximum durability & reliability

built to withstand the job-site environment and the most demanding applications



XRP™ extended run time batteries

longer run-time and life



For Drill Bits

See page 128



For Screwdriver Bits

See page 130



DC988KA

HEAVY-DUTY XRP™ 1/2" (13mm) 18V CORDLESS HAMMERDRILL/DRILL/DRIVER



**DW005K-2
Heavy-Duty 24V SDS Rotary Hammer
with Chipping Function Kit**

- Variable speed, reversing switch delivers versatility in all applications
- Factory-set clutch reduces sudden, high torque reactions if bit jams
- Electro-pneumatic hammer mechanism for fast penetration and low vibration
- 360° side handle for better control and ease of use in tight spaces
- FAN COOLED battery and charger technology increases run-time and number of recharges

INCLUDES: 1 hour fan cooled charger, (2) 24V XR+™ PACK FAN COOLED batteries, 360° side handle, depth rod and heavy-duty kit box



**DW006K-2
Heavy-Duty 1/2" (13mm) 24V Cordless Hammerdrill/Drill Kit**

- Combines drill and hammerdrill into one tool providing versatility of applications in wood, metal and masonry
- 550 in-lbs of maximum torque provides a consistent supply of heavy-duty power
- All metal, ratcheting action, keyless chuck with carbide tipped jaws and spindle lock prevent bits from slipping in high-torque and hammerdrilling applications
- 360° side handle for increased versatility in all applications

INCLUDES: 1 hour fan cooled charger, (2) 24V XR+™ PACK FAN COOLED batteries, 360° side handle and heavy-duty kit box



**DW007K-2
Heavy-Duty 6-1/2" (165mm) 24V Cordless Circular Saw Kit**

- Weighs only 9.8 lbs. which reduces user fatigue
- Electric brake for increased productivity
- Durable and lightweight magnesium base
- 6-1/2" blade provides the capacity to cut 2X materials (ex. 2x4) at a 45° bevel
- FAN COOLED battery and charger technology increases run-time and number of recharges

INCLUDES: 1 hour fan cooled charger, (2) 24V XR+™ PACK FAN COOLED batteries, 16-tooth carbide tipped circular saw blade, blade wrench and heavy-duty kit box



**DW008K-2
Heavy-Duty 24V Cordless Reciprocating Saw Kit**

- Lever action keyless blade clamp for fast and easy blade changes
- Two speed control for metal and wood cutting
- Electric brake for greater control
- 3-Position adjustable shoe increases overall blade life
- On-board blade storage for convenience of carrying additional blades
- FAN COOLED battery and charger technology increases run-time and number of recharges

INCLUDES: 1 hour fan cooled charger, (2) 24V XR+™ PACK FAN COOLED batteries, 1 wood and 1 metal reciprocating saw blade and heavy-duty kit box



SPECIFICATIONS	DW005K-2	DW006K-2	DW007K-2	DW008K-2
Chuck/Arbor Size	SDS+	1/2"	15.88 mm	N/A
No Load Speed	0-1,150 rpm	0-450/0-2,000 rpm	4,000 rpm	0-2,400/0-2,900 spm
Blows/Min	0-4,200 bpm	0-7,650/0-34,000 bpm	N/A	N/A
Max. Torque	N/A	550 in-lbs	N/A	N/A
Blade Diameter	N/A	N/A	6-1/2"	N/A
Concrete Maximum	7/8"	1/2"	N/A	N/A
Concrete Optimum	5/32"-5/8"	N/A	N/A	N/A
Tool Length	13-1/2"	N/A	N/A	N/A
Stroke Length	N/A	N/A	N/A	1-1/8"
Tool Weight	9.3 lbs	8.7 lbs	9.8 lbs	8.4 lbs

18V CORDLESS

CORDLESS



DC989KA/DC989VA Heavy-Duty XRP™ 1/2" (13mm) 18V Cordless Hammerdrill/Drill/Driver Kit

- DeWALT built high torque motor delivers 500 in-lbs of maximum torque
 - XRP™ extended run-time batteries provide long run-time & battery life
 - Patented 3-speed transmission features a max 3rd speed at 2,000 rpm
 - Hammerdrill mode: 34,000 bpm drills faster holes in masonry applications
 - 1/2" metal ratcheting chuck with carbide jaws helps to prevent bits from slipping
- INCLUDES:** 1 hour charger, (2) 18V XRP™ batteries, 360° side handle, double-ended screwdriver bit and heavy-duty kit box
DC989VA Includes: same as DC989KA with 1 hour vehicle charger



DC988KA/DC988VA Heavy-Duty XRP™ 1/2" (13mm) 18V Cordless Hammerdrill/Drill/Driver Kit

- DeWALT built high torque motor delivers 500 in-lbs of maximum torque
 - XRP™ extended run-time batteries provide long run-time & battery life
 - Patented 3-speed transmission features a max 3rd speed at 2,000 rpm
 - Hammerdrill mode: 34,000 bpm drills faster holes in masonry applications
 - 1/2" metal ratcheting chuck with carbide jaws helps to prevent bits from slipping
- INCLUDES:** 1 hour charger, (2) 18V XRP™ batteries, 360° side handle, screwdriver bit and heavy-duty kit box
DC988VA Includes: same as DC988KA with 1 hour vehicle charger



DC987KA Heavy-Duty XRP™ 1/2" (13mm) 18V Cordless Drill/Driver Kit

- DeWALT built high torque motor delivers 500 in-lbs of maximum torque
 - XRP™ extended run-time batteries provide long run-time & battery life
 - Patented 3-speed transmission features a max 3rd speed at 2,000 rpm
 - 1/2" metal ratcheting chuck with carbide jaws helps to prevent bits from slipping
 - Superior ergonomics provides optimal balance, comfort and control
- INCLUDES:** 1 hour charger, (2) 18V XRP™ batteries, 360° side handle, double-ended screwdriver bit and heavy-duty kit box



DC759KA Heavy-Duty 1/2" (13mm) 18V Cordless Compact Drill/Driver Kit

- Compact size: fits into the tightest conditions
 - Lightweight design (5.2 lbs.) minimizes user fatigue
 - High performance motor delivers 450 in.-lbs. of maximum torque
 - Dual speed range: 0-400 / 0-1,500 rpm delivers optimal performance
 - 1/2" single sleeve keyless ratcheting chuck for tighter bit grip
 - Maximum durability and reliability withstands jobsite conditions
- INCLUDES:** 1 hour charger, (2) 18V batteries, double-ended screwdriver bit and heavy-duty kit box



SPECIFICATIONS	DC989KA/DC989VA	DC988KA/DC988VA	DC987KA	DC759KA
Chuck Size	1/2"	1/2"	1/2"	1/2"
Max. Torque	500 in-lbs	500 in-lbs	500 in-lbs	450 in-lbs
# of Speed Settings	3	3	3	2
No Load Speed	0-450/0-1,450/0-2,000 rpm	0-450/0-1,450/0-2,000 rpm	0-450/0-1,450/0-2,000	0-450/0-1,500
Blows/Min	0-7,650/0-24,650/0-34,000 bpm	0-7,650/0-24,650/0-34,000 bpm	N/A	N/A
Chuck	metal, single sleeve	metal, single sleeve	metal, single sleeve	plastic, single sleeve
# Clutch Settings	22	22	22	17
Tool Weight	5.95 lbs	5.95 lbs	5.9 lbs	5.2 lbs

18V CORDLESS



DW960K-2 Heavy-Duty 3/8" (10mm) 18V Cordless Right Angle Drill/Driver Kit

- 2 speed ranges 0-500/0-1,500 rpm for increased user flexibility providing a wide range of applications
- 310 in.-lbs. of maximum torque for increased applications such as turning large bits and fasteners
- Multi-grip trigger provides comfort and convenience by allowing the user to get into tighter spaces while still having access to the trigger

INCLUDES: (2) 18V batteries, 1 hour charger, screwdriver bit and heavy-duty kit box



DW999K-2 Heavy-Duty 7/8" (24mm) 18V Cordless SDS Rotary Hammer Kit

- Variable speed, reversing switch delivers versatility in all applications
- Factory-set clutch reduces sudden, high torque reactions if bit jams
- Electro-pneumatic hammer mechanism for fast penetration and low vibration
- 360° side handle for better control and ease of use in tight spaces

INCLUDES: 1 hour charger, (2) 18V XRP™ batteries, 360° side handle, depth rod and heavy-duty kit box



DC618KN/DC618KA Heavy-Duty XRP™ 1-1/4" - 2-1/2" 18V Cordless 16 Gauge 20° Angled Finish Nailer

- Works as fast as you do with consistent nail penetration into both soft and hard joints
- Sequential operating mode allows for precision placement and bump operating mode provides the user with production speed
- Headlights provide increased visibility in low-light conditions or confined areas without any light

INCLUDES: Reversible belt hook, no-mar tip, DeWALT safety glasses and heavy-duty kit box
DC618KA Includes: same DC618KN plus 1 hour charger and (2) 18V XRP™ batteries
DC619KA available with sequential only operating mode



DC616KN/DC616KA Heavy-Duty XRP™ 1-1/4" - 2-1/2" 18V Cordless 16 Gauge Straight Finish Nailer Kit

- Works as fast as you do with consistent nail penetration into both soft and hard joints
- Sequential operating mode allows for precision placement and bump operating mode provides the user with production speed
- Headlights provide increased visibility in low-light conditions or confined areas without any light

INCLUDES: Reversible belt hook, no-mar tip, DeWALT safety glasses and heavy-duty kit box
DC616KA Includes: same DC616KN plus 1 hour charger and (2) 18V XRP™ batteries
DC617KA available with sequential only operating mode



SPECIFICATIONS	DW960K-2	DW999K-2
Chuck Size	3/8"	N/A
Max. Torque	310 in.-lbs	N/A
# of Speed Settings	2	N/A
No Load Speed	0-500/0-1,500 rpm	0-1,100 rpm
Blows/Min	N/A	0-4,100 bpm
Chuck Type	plastic, 2-sleeve	SDS+
Tool Weight	4.7 lbs	7.85 lbs

SPECIFICATIONS	DC618KA	DC616KA
Nailer Operating Mode	selective	selective
Nail Diameter	16 gauge	16 gauge
Magazine Angle	20°	straight
Nail Length Capacity	1-1/4" - 2-1/2"	1-1/4" - 2-1/2"
Magazine Capacity	up to 120 nails	up to 110 nails
Magazine Loading	rear - load	rear - load
Tool Height	12.4"	12"
Tool Length	12.5"	12.75"
Tool Width	4.18"	4.18"
Tool Weight	8.5 lbs	8.5 lbs

18V CORDLESS

CORDLESS



DW059K-2 Heavy-Duty 1/2" (13mm) 18V Cordless High Torque Impact Wrench Kit

- 300 ft-lbs of maximum torque to perform a wide range of heavy-duty fastening applications
- 1,650 rpm/2,600 bpm for faster application speed
- Preferred rocker switch design for fast and easy fastening
- Comfort grip provides maximum comfort
- Durable magnesium gear case and all metal transmission for extended durability
- Heavy-duty impacting mechanism directs torque to fastener without kickback

INCLUDES: 1 hour charger, (2) 18V XRP™ batteries and heavy-duty kit box



DW057K-2 Heavy-Duty 1/2" (13mm) 18V Cordless Impact Wrench Kit

- Compact size & weight allows access into tighter areas and reduces user fatigue
- 1,650 in-lbs of max torque to perform a wide range of fastening applications
- 0-2,400 rpm/0-3,000 bpm for faster application speed
- Textured anti-slip comfort grip provides maximum comfort
- Durable magnesium gear case and all metal transmission for extended durability
- Heavy-duty impacting mechanism directs torque to fastener without kickback

INCLUDES: 1 hour charger, (2) 18V XRP™ batteries and heavy-duty kit box



DW056K-2 Heavy-Duty 18V Cordless Impact Driver Kit

- Compact size & weight allows access into tighter areas and reduces user fatigue
- 1,170 in-lbs of max torque to perform a wide range of fastening applications
- 0-2,400 rpm/0-3,000 bpm for faster application speed
- Textured anti-slip comfort grip provides maximum comfort
- Durable magnesium gear case and all metal transmission for extended durability
- Heavy-duty impacting mechanism directs torque to fastener without kickback

INCLUDES: 1 hour charger, (2) 18V XRP™ batteries and heavy-duty kit box



DC520KA Heavy-Duty 18V Cordless Drywall/Deck Screwdriver Kit

- Dual speed ranges (0-900/0-2,900 rpm); high speed for drywall, low speed for decking
- Depth sensitive "set and forget" nosepiece for consistent fastener depth
- DeWALT-built high-performance motor with fan cooling delivers maximum power and durability

INCLUDES: 1 hour charger, (2) 18V XRP™ batteries, bit tip/magnetic holder, drywall nosepiece, TEKS® nosepiece* and heavy-duty kit box



SPECIFICATIONS	DW059K-2	DW057K-2	DW056K-2
Drive	1/2" square with detent pin retention	1/2" square with detent pin retention	1/4" hex shank quick release
No Load Speed	1,650 rpm	0-2,400 rpm	0-2,400 rpm
Impacts/Min	2,600 bpm	0-3,000 bpm	0-3,000 bpm
Max. Torque	3,600 in-lbs	1,650 in-lbs	1,170 in-lbs
Max. Torque	300 ft-lbs	138 ft-lbs	98 ft-lbs
Tool Length	10-3/4"	6-1/2"	6-1/2"
Tool Weight	7.55 lbs	4.9 lbs	4.9 lbs

SPECIFICATIONS	DC520KA
Drive	1/4" Hex
No Load Speed	0-900/0-2,900 rpm
Max. Torque	180 in-lbs
Capacity (CRS)	12 ga.
Tool Weight	5.1 lbs



**DC390K
Heavy-Duty XRP™ 6-1/2" (165mm) 18V Cordless
Circular Saw Kit**

- 3,700 RPM for fast rip cuts and cross cuts
- 6-1/2" carbide tipped blade for 2x cutting capacity at 90° and 45°
- High strength magnesium shoe and upper guard provides increased durability
- 0 - 50° bevel capacity provides additional capacity for a multitude of applications
- Fan-cooled motor with replaceable brushes for maximum power and durability
- XRP™ extended run-time battery provides long run-time & battery life

INCLUDES: 1 hour charger, 18V XRP™ battery, 16-tooth carbide saw blade, blade wrench, rip fence and heavy-duty kit box



**DW936K
Heavy-Duty 5-3/8" (136mm) 18V Cordless Trim Saw Kit**

- Lightweight & compact design allows for use in tight work areas
- 5-3/8" (136mm) blade can cut a 2"x4" in one pass
- 50° bevel provides additional capacity for specialty applications
- DeWALT-built high-performance motor with fan cooling delivers maximum power and durability
- Rip fence adds accuracy and consistency to the cut line

INCLUDES: 1 hour charger, 18V battery, 16-tooth carbide saw blade rip fence, blade wrench and heavy-duty kit box



**DW934K-2
Heavy-Duty 6-3/4" (173mm) 18V Cordless
Metal Cutting Circular Saw Kit**

- 6-3/4" 40-tooth carbide tipped blade cuts up to 2" conduit and pipe in one pass
- All Metal Upper and Lower Guards are built to withstand drops to concrete
- Multi-Coated SIGHT-LINE™ Window stays clear up to 4Xs longer than plastic guards
- Stainless-steel shoe stays rust free while minimizing chip build-up which prevents marring of the cutting surface
- ULTRA SIGHT-LINE™ Scope allows maximum visibility to the cut line

INCLUDES: 1 hour charger, (2) 18V XRP™ batteries, 6-3/4" 40-tooth titanium carbide tipped blade, blade wrench and heavy-duty kit box



**DC490KA
Heavy-Duty 18 Gauge 18V Cordless Swivel Head and Shear Kit**

- Head swivels 360° which allows user to access tight quarters while maintaining comfort
- Cuts 7/32" strip which continuously curls out of the cutting area providing consistent and accurate cuts
- Cordless tool allows user to take the tool to the work piece

INCLUDES: 1 hour charger, (2) 18V XRP™ batteries, blade wrench and heavy-duty kit box



SPECIFICATIONS	DC390K	DW936K	DW934K-2
No Load Speed	3,700 rpm	3,500 rpm	3,200 rpm
Blade Diameter	6-1/2"	5-3/8"	6-3/4"
Arbor Size	16 mm	10mm	20 mm
Bevel Capacity	0-50°	0-50°	N/A
Depth Of Cut At 45°			
Depth Of Cut At 90°			
Tool Weight			

SPECIFICATIONS	DC490KA
Strokes/Min	0-2,300 spm
Ft./Charge	125 ft
Minimum Cutting Radius	5.5"
Capacity In Steel	18-28 ga.
Tool Weight	

18V CORDLESS

CORDLESS



DC385K Heavy-Duty XRP™ 18V Cordless Reciprocating Saw Kit

- 1" stroke length and 2,900 spm for fast cutting
- Keyless blade clamp allows quick blade change without touching blade or reciprocating shaft
- Electric brake minimizes blade breakage when exiting plunge cuts
- Compact and lightweight; 7.1 lbs.
- Pivoting shoe with open top for maximum visibility
- Blade can be reversed for flush and plunge cutting
- Variable speed with trigger lock for increased blade control

INCLUDES: 1 hour charger, 18V XRP™ battery, reciprocating saw blade and heavy-duty kit box



DW933K Heavy-Duty 18V Cordless Variable Speed Jig Saw Kit

- Keyless blade change system accepts universal and t-shank blades
- Tool free adjustable shoe slides forward, backward and bevels 45° in both directions
- 3-position orbital action
- Unique counter-balance mechanism
- Variable speed trigger 0-2,000 spm for more precise and faster cutting
- Dust blower keeps line of cut clear of chips

INCLUDES: 1 hour charger, 18V XRP™ battery, jig saw blades and heavy-duty kit box



DC410KA Heavy-Duty 4-1/2" 18V Cordless Cut-Off Tool

- 6,500 rpm provides high power for cutting and grinding applications
- Convenient trigger switch with lock-off button for easier gripping
- 3 Position side handle offers greater comfort and control
- Spindle lock allows users to change their wheels quick and easy
- Metal gear case dissipates heat for longer bearing, gear and motor life

INCLUDES: (2) 18V XRP™ batteries, 1 hour charger, Type 27 guard, Type 1 guard, wrench, backing flange, Type 1 wheel, Type 27 wheel, 3 position side handle and heavy-duty kit box



For Jig Saw Blades

See page 122



SPECIFICATIONS	DC385K	DW933K
Keyless Blade Clamp	Yes	Yes
Strokes/Min	0-2,900 spm	0-2,000 spm
Stroke Length	1"	1"
Ft/Min.	N/A	34 ft
Electric Brake	Yes	N/A
Tool Weight	7.1 lbs	5.5 lbs

SPECIFICATIONS	DC410KA
No Load Speed	6,500 rpm
Spindle Lock	Yes
Spindle Thread	5/8" -11
Tool Weight	7.0 lbs
Use Wheels RPM Above	10,000 rpm

18V CORDLESS



DC550KA Heavy-Duty 18V Cordless Cut-Out Tool

- Tool-free bit change for fast and easy bit changing without a wrench
- 26,000 rpm motor provides more cutting power
- Dust sealed switch provides durability and long switch life

INCLUDES: 1 hour charger, (2) 18V XRP™ batteries, 1 general purpose bit, 1 drywall cutting bit, 1/4", 1/8" collets and heavy-duty kit box



DC500/DC500K 2 Gallon Cordless or Corded Wet/Dry Vac

- Runs off of 12V-18V DeWALT battery packs or 120V AC
- Gore™ wet/dry filter traps 99.7% of drywall dust
- Wet/Dry filter eliminates change overs
- Washable filter- tap or water rinse to clean
- Heavy-duty rubber hose provides durability and flexibility
- Drain port on tank for easy emptying of liquids
- On-board hose, cord and accessory storage provides convenient transport and storage

INCLUDES: 5' heavy-duty rubber hose, crevice tool and wide nozzle
DC500K: same as DC500 plus 1 hour charger and 18V XRP™ battery



DW908 Heavy-Duty 18V Cordless Pivoting Head Flashlight

- Wide-angle beam maximizes light over a specific work area
- Pivoting head rotates 90° which allows light to be projected in any direction
- Extra-bright Xenon bulb maximizes brightness of the beam
- Battery sold separately
- Lightweight, compact design makes the flashlight durable and convenient
- Spare extra-bright Xenon bulb inside lens cover allows user to always have a working light

INCLUDES: extra Xenon bulb



DW919 Heavy-Duty 18V Cordless Flexible Floodlight

- Wide-angle beam is brighter than traditional flashlights
- Flexible neck allows for hands-free operation and light to be projected in any direction whether it is standing on its base, wrapped around a pipe, or hanging from rafters overhead
- Lockable head clip offers versatility and convenience of a lantern
- Spare extra-bright Xenon bulb inside lens cover allows user to always have a working light
- Battery sold separately

INCLUDES: extra Xenon bulb



SPECIFICATIONS	DC550KA
No Load Speed	26,000 rpm
Collet Diameter	1/4", 1/8"
Adjustable Guide	YES
Tool-Free Bit Change	YES
Tool Weight	4.5 lbs

SPECIFICATIONS	DC500/DC500K
Tank Size	2 gal
Hose Diameter	1-1/4"
Hose Length	5'
Voltage (DC Operation)	12V-18 V
Blower	YES
Tool Weight	7.2 lbs

SPECIFICATIONS	DW908	DW919
Bulb	Xenon	Xenon
Brightness	335 Lumens	325 Lumens
Bulb Life	110 hrs	110 hrs
Run-Time	3 hrs	3 hrs
Tool Weight	0.5 lbs	0.5 lbs

14.4V CORDLESS

CORDLESS



DC985KA/DC985VA Heavy-Duty XRP™ 1/2" (13mm) 14.4V Cordless Hammerdrill/Drill/Driver Kit

- DeWALT built high torque motor provides 450 in.-lbs of maximum torque
- XRP™ extended run-time batteries provide long run-time & battery life
- Patented 3-speed transmission features a maximum 3rd speed at 1,800 rpm
- Hammerdrill mode: 30,600 bpm drills faster holes in masonry applications
- 1/2" metal ratcheting chuck with carbide jaws helps to prevent bits from slipping

INCLUDES: 1 hour charger, (2) 14.4V XRP™ batteries, double-ended screwdriver bit and heavy-duty kit box
DC985VA Includes: same as DC985KA with 1 hour vehicle charger



DC984KA/DC984VA Heavy-Duty XRP™ 1/2" (13mm) 14.4V Cordless Hammerdrill/Drill/Driver Kit

- DeWALT built high torque motor provides 450 in.-lbs of maximum torque
- XRP™ extended run-time batteries provide long run-time & battery life
- Patented 3-speed transmission features a maximum 3rd speed at 1,800 rpm
- Hammerdrill mode: 30,600 bpm drills faster holes in masonry applications
- 1/2" metal ratcheting chuck with carbide jaws helps to prevent bits from slipping

INCLUDES: 1 hour charger, (2) 14.4V XRP™ batteries, double-ended screwdriver bit and heavy-duty kit box
DC984VA Includes: same as DC984KA with 1 hour vehicle charger



DC983KA Heavy-Duty XRP™ 1/2" (13mm) 14.4V Cordless Drill/Driver Kit

- DeWALT built high torque motor provides 450 in.-lbs of maximum torque
- XRP™ extended run-time batteries provide long run-time & battery life
- Patented 3-speed transmission features a maximum 3rd speed at 1,800 rpm
- 1/2" metal ratcheting chuck with carbide jaws helps to prevent bits from slipping
- Superior ergonomics provides optimal balance, comfort and control

INCLUDES: 1 hour charger, (2) 14.4V XRP™ batteries, double-ended screwdriver bit and heavy-duty kit box



DC728KA Heavy-Duty 1/2" (13mm) 14.4V Cordless Compact Drill/Driver Kit

- Compact size: fits into the tightest conditions
- Lightweight design (4.6 lbs.) minimizes user fatigue
- High performance motor delivers 400 in.-lbs. of maximum torque
- Dual speed range: 0-400 / 0-1,400 rpm delivers optimal performance
- 1/2" single sleeve keyless ratcheting chuck for tighter bit grip
- Maximum durability and reliability withstands jobsite conditions

INCLUDES: 1 hour charger, (2) 14.4V batteries, double-ended screwdriver bit and heavy-duty kit box



SPECIFICATIONS	DC985KA/DC985VA	DC984KA/DC984VA	DC983KA	DC728KA
Chuck Size	1/2"	1/2"	1/2"	1/2"
Max. Torque	450 in.-lbs	450 in.-lbs	450 in.-lbs	400 in.-lbs
# of Speed Settings	3	3	3	2
No Load Speed	0-450/0-1,400/0-1,800 rpm	0-450/0-1,400/0-1,800 rpm	0-450/0-1,400/0-1,800	0-400/0-1,400
Blows/Min	0-7,650/0-23,800/0-30,600 bpm	0-7,650/0-23,800/0-30,600 bpm	N/A	N/A
Chuck	metal, single sleeve	metal, single sleeve	metal, single sleeve	plastic, single sleeve
Clutch Settings	22	22	22	17
Tool Weight	5.25 lbs	5.25 lbs	5.2 lbs	4.6 lbs

14.4V CORDLESS



DW966K-2 Heavy-Duty 3/8" (10mm) 14.4V Cordless Right Angle Drill/Driver Kit

- 2 speed ranges 0-400/0-1,250 rpm for increased user flexibility providing a wide range of applications
- 210 in.-lbs. of maximum torque for increased applications such as turning large bits and fasteners
- Multi-grip trigger provides comfort and convenience by allowing the user to get into tighter spaces while still having access to the trigger

INCLUDES: 1 hour charger, (2) 14.4V batteries and heavy-duty kit box



DW969K-2 Heavy-Duty 14.4V Cordless Light Gauge Steel Framing Screwdriver Kit

- VERSA-CLUTCH® torque adjustment system to “dial” the proper torque needed to efficiently drive fasteners without stripping or breaking fastener
- 0-800/0-2,300 rpm for better fastener control in various material thickness
- First cordless tool designed for steel fastening applications that is ideal for use in 12-28 gauge CRS
- Not for use in “Red Iron” or structural steel

INCLUDES: 1 hour charger, (2) 14.4V batteries, #2 Phillips screwdriver bit, 5/16" nut runner and heavy-duty kit box



DC614KN/DC614KA Heavy-Duty XRP™ 1-1/4" - 2-1/2" 12V-14.4V Cordless 16 Gauge 20° Angled Finish Nailer

- Works as fast as you do with consistent nail penetration into both soft and hard joints
- Sequential operating mode allows for precision placement and bump operating mode provides the user with production speed
- Headlights provide increased visibility in low-light conditions or confined areas without any light

INCLUDES: reversible belt hook, no-mar tip, DeWALT safety glasses and heavy-duty kit box
DC614KA Includes: same as DC614KN plus 1 hour charger and (2) 14.4V XRP™ batteries
DC615KA available with sequential only operating mode



DC612KN/DC612KA Heavy-Duty XRP™ 1-1/4" - 2-1/2" 12V-14.4V Cordless 16 Gauge Straight Finish Nailer Kit

- Works as fast as you do with consistent nail penetration into both soft and hard joints
- Sequential operating mode allows for precision placement and bump operating mode provides the user with production speed
- Headlights provide increased visibility in low-light conditions or confined areas without any light

INCLUDES: reversible belt hook, no-mar tip, DeWALT safety glasses and heavy-duty kit box
DC612KA Includes: same as DC612KN plus 1 hour charger and (2) 14.4V XRP™ batteries
DC613KA available with sequential only operating mode



SPECIFICATIONS	DW966K-2	DW969K-2
Chuck Size	3/8"	N/A
Max. Torque	210 in.-lbs	210 in.-lbs
# of Speed Settings	2	2
No Load Speed	0-400/0-1,250	0-800/0-2,300 rpm
Chuck Type	plastic, 2-sleeve	N/A
Capacity (CRS)	N/A	12-28 ga.
Drive	N/A	1/4" Hex
Tool Weight	4.4 lbs	4.9 lbs

SPECIFICATIONS	DC614KA/DC614KN	DC612KA/DC612KN
Nailer Operating Mode	selective	selective
Nail Diameter	16 gauge	16 gauge
Magazine Angle	20°	straight
Nail Length Capacity	1-1/4" - 2-1/2"	1-1/4" - 2-1/2"
Magazine Capacity	up to 120 nails	up to 110 nails
Magazine Loading	rear - load	rear - load
Tool Height	12.4"	12"
Tool Length	12.5"	12.75"
Tool Width	4.18"	4.18"
Tool Weight	7.8 lbs	7.8 lbs

14.4V CORDLESS



**DW055K-2
Heavy-Duty 1/2" (13mm) 14.4V Cordless Impact Wrench Kit**

- Compact size & weight allows access into tighter areas and reduces user fatigue
- 1,550 in-lbs of max torque to perform a wide range of fastening applications
- 0-2,400 rpm/0-3,000 bpm for faster application speed
- Textured anti-slip comfort grip provides maximum comfort
- Durable magnesium gear case and all metal transmission for extended durability
- Heavy-duty impacting mechanism directs torque to fastener without kickback

INCLUDES: 1 hour charger, (2) 14.4V batteries and heavy-duty kit box



**DW054K-2
Heavy-Duty 14.4V Cordless Impact Driver Kit**

- Compact size & weight allows access into tighter areas and reduces user fatigue
- 1,150 in-lbs of max torque to perform a wide range of fastening applications
- 0-2,400 rpm/0-3,000 bpm for faster application speed
- Textured anti-slip comfort grip provides maximum comfort
- Durable magnesium gear case and all metal transmission for extended durability
- Heavy-duty impacting mechanism directs torque to fastener without kickback

INCLUDES: 1 hour charger, (2) 14.4V batteries and heavy-duty kit box



**DW941K-2
Heavy-Duty 18 Gauge 14.4V Cordless Swivel Head and Shear Kit**

- Head swivels 360° which allows user to access tight quarters while maintaining comfort
- Cuts 7/32" strip which continuously curls out of the cutting area providing consistent and accurate cuts
- Cordless tool allows user to take the tool to the work piece

INCLUDES: 1 hour charger, (2) 14.4V batteries, blade wrench and heavy-duty kit box



SPECIFICATIONS	DW055K-2	DW054K-2
Drive	1/2" square with detent pin retention	1/4" hex shank quick release
No Load Speed	0-2,400 rpm	0-2,400 rpm
Impacts/Min	0-3,000 bpm	0-3,000 bpm
Max. Torque	1,550 in-lbs	1,150 in-lbs
Max. Torque	129 ft-lbs	96 ft-lbs
Tool Weight	4.1 lbs	4.1 lbs
Tool Length	6-1/2"	6-1/2"

SPECIFICATIONS	DW941K-2
Strokes/Min	0-2,300 spm
Ft./Charge	125 ft
Minimum Cutting Radius	5.5"
Capacity In Steel	18-28 ga.
Tool Weight	5.8 lbs

14.4V CORDLESS



DW935K

Heavy-Duty 5-3/8" (136mm) 14.4V Cordless Trim Saw Kit

- 5-3/8" blade cuts 2X materials (ex. 2x4) on a 90° plane in a single pass
- Left side blade provides maximum visibility of cut line
- 50° bevel for added capacity
- DeWALT-built high-performance motor with fan cooling delivers maximum power and durability
- Spindle lock for easy blade changes

INCLUDES: 1 hour charger, 14.4V battery, 5-3/8" 16-tooth carbide circular saw blade, blade wrench and heavy-duty kit box



DW937K

Heavy-Duty 14.4V Cordless Reciprocating Saw Kit

- Keyless blade change allows quick blade change without touching blade or reciprocating shaft
- 7/8" stroke length and 0-2,700 spm for fast cutting
- Electric brake reduces coast time
- Compact and lightweight; 6.0 lbs.
- Pivoting shoe with open top for maximum visibility
- Blade reverses for upside down cutting

INCLUDES: 1 hour charger, 14.4V battery, reciprocating saw blade and heavy-duty kit box



DW906

Heavy-Duty 14.4V Cordless Pivoting Head Flashlight

- Pivoting head rotates 90° which allows light to be projected in any direction
- Wide-angle beam maximizes light over a specific work area
- Extra-bright Xenon bulb maximizes brightness of beam
- Battery sold separately
- Lightweight, compact design makes the flashlight durable and convenient
- Spare Extra-Bright Xenon bulb inside lens cover allows user to always have a working light

INCLUDES: extra Xenon bulb



DW918

Heavy-Duty 14.4V Cordless Flexible Floodlight

- Wide-angle beam is brighter than traditional flashlights
- Flexible neck allows for hands-free operation and light to be projected in any direction whether it is standing on its base, wrapped around a pipe, or hanging from rafters overhead
- Lockable head clip offers versatility and convenience of a lantern
- Battery sold separately
- Spare extra-bright Xenon bulb inside lens cover allows user to always have a working light

INCLUDES: extra Xenon bulb



SPECIFICATIONS	DW935K
No Load Speed	0-3,000 rpm
Blade Diameter	5-3/8"
Arbor Size	10 mm
Bevel Capacity	50°
Depth Of Cut At 45°	
Depth Of Cut At 90°	
Tool Weight	

SPECIFICATIONS	DW937K
Keyless Blade Clamp	Yes
Strokes/Min	0-2,700 spm
Stroke Length	7/8"
Electric Brake	Yes
Tool Weight	6 lbs

SPECIFICATIONS	DW906	DW918
Bulb	Xenon	Xenon
Brightness	300 Lumens	300 Lumens
Bulb Life	110 hrs	110 hrs
Run-Time	3 hrs	3 hrs
Tool Weight		

12V CORDLESS



**DC980KA
Heavy-Duty XRP™ 1/2" (13mm) 12V Cordless Drill/Driver Kit**

- DeWALT built high torque motor delivers 400 in.-lbs. of maximum torque
- XRP™ extended run-time batteries provide long run-time & battery life
- Patented 3-speed transmission features a max 3rd speed at 1,800 rpm
- 1/2" metal ratcheting chuck with carbide jaws helps to prevent bits from slipping
- Superior ergonomics provides optimal balance, control, and comfort

INCLUDES: 1 hour charger, (2) 12V XRP™ batteries, double-ended screwdriver bit and heavy-duty kit box



**DC727KA/DC727VA
Heavy-Duty 3/8" (10mm) 12V Cordless Compact Drill/Driver Kit**

- Compact Size: fits into the tightest conditions
- Lightweight design (3.9 lbs.) minimizes user fatigue
- High performance motor delivers 350 in.-lbs. of maximum torque
- Dual speed range: 0-400 / 0-1,400 rpm delivers optimal performance
- 3/8" single sleeve keyless ratcheting chuck for tighter bit grip
- Maximum Durability and reliability withstands job-site conditions

INCLUDES: 1 hour charger, (2) 12V batteries, double-ended screwdriver bit and heavy-duty kit box
DC727VA Includes: same as DC727KA with 1 hour vehicle charger



**DW965K-2
Heavy-Duty 3/8" (10mm) 12V Cordless
Right Angle Drill/Driver Kit**

- 2 speed ranges: 0-400/0-1,200 rpm allowing the user to get into tighter spaces while still having access to the trigger
- 180 in.-lbs. of maximum torque for increased applications such as turning large bits and fasteners
- Multi-grip trigger provides comfort and convenience allowing the user to get into tight spaces

INCLUDES: 1 hour charger, (2) 12V batteries and heavy-duty kit box



SPECIFICATIONS	DC980KA	DC727KA/DC727VA	DW965K-2
Chuck Size	1/2"	3/8"	3/8"
Max. Torque	400 in-lbs	350 in-lbs	180 in-lbs
# of Speed Settings	3	2	2
No Load Speed	0-450/0-1,400/0-1,800	0-400/0-1,400	0-400/0-1,200
Chuck Type	metal, single sleeve	plastic, single sleeve	plastic, 2-sleeve
Clutch Settings	22	17	N/A
Tool Weight	4.9 lbs	3.9 lbs	4.1 lbs

12V CORDLESS



DW053K-2 Heavy-Duty 1/2" (13mm) 12V Cordless Impact Wrench Kit

- Compact size & weight allows access into tighter areas and reduces user fatigue
- 1,400 in-lbs of max torque to perform a wide range of fastening applications
- 0-2,400 rpm/0-3,000 bpm for faster application speed
- Textured anti-slip comfort grip provides maximum comfort
- Durable magnesium gear case and all metal transmission for extended durability
- Heavy-duty impacting mechanism directs torque to fastener without kickback

INCLUDES: 1 hour charger, (2) 12V batteries and heavy-duty kit box



DW052K-2 Heavy-Duty 12V Cordless Impact Driver Kit

- Compact size & weight allows access into tighter areas and reduces user fatigue
- 1,000 in-lbs of max torque to perform a wide range of fastening applications
- 0-2,400 rpm/0-3,000 bpm for faster application speed
- Textured anti-slip comfort grip provides maximum comfort
- Durable magnesium gear case and all metal transmission for extended durability
- Heavy-duty impacting mechanism directs torque to fastener without kickback

INCLUDES: 1 hour charger, (2) 12V batteries and heavy-duty kit box



DW051K-2 Heavy-Duty 3/8" (9.5 mm) 12V Cordless Impact Wrench Kit

- Compact size & weight allows access into tighter areas and reduces user fatigue
- 1,200 in-lbs of max torque to perform a wide range of fastening applications
- 0-2,400 rpm/0-3,000 bpm for faster application speed
- Textured anti-slip comfort grip provides maximum comfort
- Durable magnesium gear case and all metal transmission for extended durability
- Heavy-duty impacting mechanism directs torque to fastener without kickback

INCLUDES: 1 hour charger, (2) 12V batteries and heavy-duty kit box



SPECIFICATIONS	DW053K-2	DW052K-2	DW051K-2
Drive	1/2" square with detent pin retention	1/4" hex shank quick release	3/8" square with hog ring retention
No Load Speed	0-2,400 rpm	0-2,400 rpm	0-2,400 rpm
Impacts/Min	0-3,000 bpm	0-3,000 bpm	0-3,000 bpm
Max. Torque	1,400 in-lbs	1,000 in-lbs	1,200 in-lbs
Max. Torque	117 ft-lbs	83 ft-lbs	100 ft-lbs
Tool Length	6-1/2"	6-1/2"	6-1/2"
Tool Weight	3.75 lbs	3.75 lbs	3.7 lbs

12V CORDLESS

CORDLESS



DW979K-2 Heavy-Duty 12V Cordless Drywall/Deck Screwdriver Kit

- Dual speed ranges (0-800/0-2,300 rpm); high speed for drywall, low speed for decking
- Depth sensitive “set and forget” nosepiece for consistent fastener depth
- DeWALT-built high-performance motor with fan cooling delivers maximum power and durability

INCLUDES: 1 hour charger, (2)12V batteries, bit tip/magnetic holder, drywall nosepiece, TEKS® nosepiece and heavy-duty kit box



DW968K-2 Heavy-Duty 12V Cordless Light Gauge Steel Framing Screwdriver Kit

- VERSA-CLUTCH® torque adjustment system to “dial” the proper torque needed to efficiently drive fasteners without stripping or breaking fastener
- First cordless tool designed for steel fastening applications making it ideal for use in 12-24 gauge CRS
- Not for use in “Red Iron” or structural steel

INCLUDES: 1 hour charger, (2) 12V batteries, #2 Phillips screwdriver bit, 5/16" nut runner and heavy-duty kit box



DW940K-2 Heavy-Duty 18 Gauge 12V Cordless Swivel Head and Shear Kit

- Head swivels 360° which allows user to access tight quarters while maintaining comfort
- Cuts 7/32" strip which continuously curls out of the cutting area providing consistent and accurate cuts
- Cordless tool allows user to take the tool to the work piece

INCLUDES: 1 hour charger, (2) 12V batteries, blade wrench and heavy-duty kit box



DW904 Heavy-Duty 12V Cordless Pivoting Head Flashlight

- Wide-angle beam maximizes light over a specific area of work
- Pivoting head rotates 90° which allows light to be projected in any direction
- Extra-bright Xenon bulb maximizes brightness of beam
- Battery sold separately
- Lightweight, compact design makes the flashlight durable and convenient
- Spare extra-bright Xenon bulb inside lens cover allows user to always have a working light

INCLUDES: extra Xenon bulb



SPECIFICATIONS	DW979K-2	DW968K-2
No Load Speed	0-800/ 0-2,300 rpm	0-750/ 0-2,300 rpm
Max. Torque	180 in-lbs	180 in-lbs
Capacity (CRS)	12 ga.	12-24 ga.
Drive	N/A	1/4" Hex
Tool Weight	4.2 lbs	4.2 lbs

SPECIFICATIONS	DW940K-2
Strokes/Min	0-2,300 spm
Ft./Charge	100 ft
Minimum Cutting Radius	5.5"
Capacity In Steel	28 ga.
Tool Weight	5.1 lbs

SPECIFICATIONS	DW904
Bulb	Xenon
Brightness	281 Lumens
Bulb Life	110 hrs
Run-Time	3 hrs
Tool Weight	0.5 lbs

9.6V CORDLESS



DW926K-2

Heavy-Duty 3/8" (10mm) 9.6V Cordless Compact Drill/Driver Kit

- Compact size and lightweight, weighs only 3.4 lbs
- 200 in-lbs of maximum torque output provides for a superior power to weight ratio in both fastening and drilling applications
- All metal planetary gears for increased durability and power
- Dual-speed range 0-300/0-1,100 rpm for a wide range of applications
- 15 position adjustable clutch offers maximum versatility and control
- Heavy-duty keyless chuck offers durability and convenience
- Professional grade variable speed trigger switch provides for maximum control and versatility in all applications

INCLUDES: 1 hour charger, (2) 9.6V batteries, double-ended screwdriver bit and heavy-duty kit box



DW955K-2

Heavy-Duty 3/8" (10mm) 9.6V Cordless Right Angle Drill/Driver Kit

- 2 speed ranges: 0-400/0-1,100 rpm for increased user flexibility for a wide range of applications
- 150 in-lbs. of maximum torque for increased applications such as turning large bits and fasteners
- Multi-grip trigger for increased comfort and convenience allowing the user to get into tight spaces
- Variable speed and reversing gives the user the ability to control speed for greater accuracy, and the convenience of reverse
- Durable, right-angle transmission with sealed ball bearing allows for longer tool life

INCLUDES: 1 hour charger, (2) 9.6V batteries and heavy-duty kit box



DW050K-2

Heavy-Duty 9.6V Cordless Impact Driver Kit

- Compact size & weight allows access into tighter areas and reduces user fatigue
- 900 in-lbs of max torque to perform a wide range of fastening applications
- 0-2,400 rpm/0-3,000 bpm for faster application speed
- Textured anti-slip comfort grip provides maximum comfort
- Durable magnesium gear case and all metal transmission for extended durability
- Heavy-duty impacting mechanism directs torque to fastener without kickback

INCLUDES: 1 hour charger, (2) 9.6V batteries and heavy-duty kit box



SPECIFICATIONS	DW926K-2	DW955K-2
Chuck Size	3/8"	3/8"
Max. Torque	200 in-lbs	150 in-lbs
# of Speed Settings	2	2
RPM	0-300/0-1,100 rpm	0-400/0-1,100 rpm
Chuck Type	plastic, 2-sleeve	plastic, 2-sleeve
Clutch Settings	15	N/A
Tool Weight	3.4 lbs	3.9 lbs

SPECIFICATIONS	DW050K-2
Drive	1/4" hex shank quick release
No Load Speed	0-2,400 rpm
Impacts/Min	0-3,000 bpm
Max. Torque	900 in-lbs
Max. Torque	75 ft-lbs
Tool Length	6-1/2"
Tool Weight	3.5 lbs

9.6V CORDLESS



**DW902
Heavy-Duty 9.6V Cordless Pivoting Head Flashlight**

- Wide-angle beam maximizes light over a specific area of work
- Pivoting head rotates 90° which allows light to be projected in any direction
- Extra-bright Xenon bulbs maximizes brightness of beam
- Batteries sold separately
- Lightweight, compact design make the flashlight durable and convenient
- Spare extra-bright Xenon bulb inside lens cover allows user to always have a working light

INCLUDES: extra Xenon bulb



7.2V CORDLESS



**DW920K-2
Heavy-Duty 1/4" (6mm) 7.2V Cordless Two-Position
Screwdriver Kit**

- 80 in-lbs of maximum torque output provides for a superior power to weight ratio in a variety of fastening applications
- Adjustable two-position handle allows for operation as both in-line and pistol-grip
- Variable speed and reversing trigger switch provides 0-500 rpm for fastening and pre-drilling into wood, plastic, and light-gauge metal
- Industrial quick-release hex-shank chuck allows for quick screwdriver bit change and prevents bit "run out"
- Electric brake provides increased productivity
- 7.2V battery pack allows for longer run-time and charges in one hour
- Heavy-duty metal hinge provides secure and sustained two-position lock.

INCLUDES: 1 hour charger, (2) 7.2V batteries, 2 screwdriver bits and heavy-duty kit box



Pistol-grip position provides control in driving and removing fasteners



In-line position allows for access into hard to reach areas

SPECIFICATIONS	DW902
Bulb	Xenon
Brightness	150 Lumens
Bulb Life	110 hrs
Run-Time	3 hrs
Tool Weight	0.5 lbs

SPECIFICATIONS	DW920K-2
No Load Speed	0-500 rpm
Max. Torque	80 in-lbs
Drive	1/4" Hex
Tool Weight	3.5 lbs



DC6KITA

Heavy-Duty XRP™ 18V Cordless Hammerdrill/Drill/Driver/Circular Saw/Reciprocating Saw/Right Angle Drill/Cut-Off Tool/Flexible Floodlight Combo Kit

DC988 XRP™ 1/2" hammerdrill/drill/driver, DC390 XRP™ circular saw, DC385 XRP™ reciprocating saw, DW960 right angle drill, DC410 cut-off tool, DW919 flexible floodlight, 1 hour charger, (2) 18V XRP™ batteries, (2) double-ended screwdriver bits, 360° side handle, 16-tooth carbide tipped circular saw blade, circular saw rip fence, reciprocating saw blade, type 1 and type 27 guards, wrench, backing flange, (1) type 1 and (1) type 27 wheel, 3-position side handle and contractor bag



DC6KTGA

Heavy-Duty XRP™ 18V Cordless Hammerdrill/Drill/Driver/Circular Saw/Reciprocating Saw/Impact Driver/Cut-Off Tool/Flexible Floodlight Combo Kit

DC988 XRP™ 1/2" hammerdrill/drill/driver, DC390 XRP™ circular saw, DC385 XRP™ reciprocating saw, DW056 impact driver, DC410 cut-off tool, DW919 flexible floodlight, 1 hour charger, (2) 18V XRP™ batteries, double-ended screwdriver bit, 360° side handle, 16-tooth carbide tipped circular saw blade, circular saw rip fence, reciprocating saw blade, type 1 and type 27 guards, wrench, backing flange, (1) type 1 and (1) type 27 wheel, 3-position side handle and contractor bag



DC5KITA

Heavy-Duty XRP™ 18V Cordless Hammerdrill/Drill/Driver/Circular Saw/Reciprocating Saw/Jig Saw/Flexible Floodlight Combo Kit

INCLUDES: DC988 XRP™ 1/2" hammerdrill/drill/driver, DC390 XRP™ circular saw, DC385 reciprocating saw, DW933 jig saw, DW919 flexible floodlight, 1 hour charger, (2) 18V XRP™ batteries, 360° side handle, double-ended screwdriver bit, 16-tooth carbide tipped circular saw blade, circular saw rip fence, reciprocating saw blade, jig saw blade and heavy-duty kit box



DC5KITVD

Heavy-Duty XRP™ 18V Cordless Hammerdrill/Drill/Driver/Circular Saw/Reciprocating Saw/Jig Saw/Flexible Floodlight/Vehicle Charger Combo Kit

INCLUDES: DC988 XRP™ 1/2" hammerdrill/drill/driver, DC390 XRP™ circular saw, DC385 reciprocating saw, DW933 jig saw, DW919 flexible floodlight, 1 hour charger, 1 hour vehicle charger, (3) 18V XRP™ batteries, 360° side handle, double-ended screwdriver bit, 16-tooth carbide tipped circular saw blade, circular saw rip fence, reciprocating saw blade, jig saw blade and heavy-duty kit box

CORDLESS COMBO KITS

CORDLESS



DC4KITA

Heavy-Duty XRP™ 18V Cordless Hammerdrill/Circular Saw/Reciprocating Saw/Flexible Floodlight Combo Kit

INCLUDES: DC988 XRP™ 1/2" hammerdrill/drill/driver, DC390 XRP™ circular saw, DC385 reciprocating saw, DW919 flexible floodlight, 1 hour charger, (2) 18V XRP™ batteries, 360° side handle, double-ended screwdriver bit, 16-tooth carbide tipped circular saw blade, circular saw rip fence, reciprocating saw blade and heavy-duty kit box



DC4MEGA

Heavy-Duty XRP™ 18V Cordless Hammerdrill/Drill/Driver/Reciprocating Saw/SDS Rotary Hammer/Flexible Floodlight Combo Kit

INCLUDES: DC988 XRP™ 1/2" hammerdrill/drill/driver, DC385 XRP™ reciprocating saw, DW999 7/8" SDS rotary hammer, DW919 flexible floodlight, 1 hour charger, (2) 18V XRP™ batteries, double-ended screwdriver bit, (2) 360° side handles and (1) depth rod, reciprocating saw blade and heavy-duty kit box



DC988CA

Heavy-Duty XRP™ 18V Cordless Hammerdrill/Reciprocating Saw Combo Kit

INCLUDES: DC988 XRP™ 1/2" hammerdrill/drill/driver, DC385 XRP™ reciprocating saw, 1 hour charger, (2) 18V XRP™ batteries, 360° side handle, double-ended screwdriver bit, reciprocating saw blade and heavy-duty kit box



DC988SA

Heavy-Duty XRP™ 18V Cordless Hammerdrill/Circular Saw Combo Kit

INCLUDES: DC988 XRP™ 1/2" hammerdrill/drill/driver, DC390 XRP™ circular saw, 1 hour charger, (2) 18V XRP™ batteries, 360° side handle, double-ended screwdriver bit, 16-tooth carbide tipped circular saw blade, circular saw rip fence and heavy-duty kit box

CORDLESS COMBO KITS



DC987CA **Heavy-Duty XRP™ 18V Cordless** **Drill/Driver/Reciprocating Saw Kit**

INCLUDES: DC987 XRP™ 1/2" drill/driver, DC385 XRP™ reciprocating saw, 1 hour charger, (2) 18V XRP™ batteries, 360° side handle, double-ended screwdriver bit, reciprocating saw blade and heavy-duty kit box



DC987SA **Heavy-Duty XRP™ 18V Cordless** **Drill/Driver/Circular Saw Combo Kit**

INCLUDES: DC987 XRP™ 1/2" drill/driver, DC390 XRP™ circular saw, 1 hour charger, (2) 18V XRP™ batteries, 360° side handle, double-ended screwdriving bit, 16-tooth carbide tipped circular saw blade, circular saw rip fence and heavy-duty kit box



DC983SA **Heavy-Duty XRP™ 14.4V Cordless** **Drill/Driver/Trim Saw Combo Kit**

INCLUDES: DC983 XRP™ 1/2" drill/driver, DW935 trim saw, 1 hour charger, (2) 14.4V XRP™ batteries, double-ended screwdriver bit, 5-3/8" carbide tipped trim saw blade and heavy-duty kit box



DC728SA **Heavy-Duty 14.4V Cordless Compact** **Drill/Driver/Trim Saw Combo Kit**

INCLUDES: DC728 1/2" drill/driver, DW935 trim saw, 1 hour charger, (2) 14.4V batteries, double-ended screwdriver bit, 5-3/8" carbide tipped trim saw blade and heavy-duty kit box







**For Related Power
Tool Accessories**

See pages 107-145



BATTERIES

CORDLESS

Voltage	Catalog Number	Type	Profile View
7.2V	DW9057*	Compact	
9.6V	DW9061*	Standard	
	DW9062	Compact	
	DW9048*	Univolt®	
12V	DC9071*	XRP™	
	DW9071	Standard	
	DW9072	Compact	
	DW9050*	Univolt®	
14.4V	DC9091*	XRP™	
	DW9091	Standard	
	DW9094	Compact	
18V	DC9096*	XRP™	
	DW9099	Standard	
24V	DW0242*	FAN COOLED XR+ PACK™	

* Available for purchase as an accessory

DeWALT BATTERY TYPES

XRP™ Extended Run-Time Battery Packs

- 40% more run-time than Standard batteries

Standard Battery Packs

- 25% more run-time than Compact batteries

Compact Battery Packs

- 15% smaller and 10% lighter than Standard batteries

Univolt® Battery Packs

- For use with Univolt® tools only

DeWALT'S Ground Breaking 3-Stage Charging Technology

1) 1 Hour Fast Charging

Provides the maximum charge of the battery within 1 hour

2) 1-3 Hour Equalization

Each individual cell is fully charged to maximize battery pack performance and life



3) Automatic Tune-Up

A trickle charge maintains the full charge of the battery pack when left on the charger after equalization stage

- DeWALT batteries will not develop a "memory". There is no need to drain the battery down before recharging. You should stop using a battery as soon as you feel a substantial decrease in power from the tool. Completely running down a battery may damage the battery. **Do not tape trigger to run down the battery.**
- To increase battery life, place the battery in the charger overnight after every 10th charge
- Recycle Power Tool Batteries. Visit www.rbrc.org or contact the toll free help line 1-800-8-BATTERY for recycling locations. **If it's rechargeable, it's recyclable.**



CHARGERS



The "X" indicates that the marked battery pack is compatible with that specific charger

BATTERY PACKS		CHARGERS									
Volts	Model #	DW9118 7.2V- 14.4V	DW9107 7.2V- 14.4V	DW9116 7.2V- 18V	DW9216 Dual Port 7.2V-18V	DW9117 15 Min. Charger 7.2V-18V	DC011 7.2V- 18V	DW911 7.2V- 18V	DW9109 Vehicle Charger 7.2V-18V	DW0246 FAN COOLED 24V	DW0249 FAN COOLED Vehicle Charger 24V
7.2V	DW9057	X	X	X	X	X	X	X	X		
9.6V	DW9061 DW9062	X	X	X	X	X	X	X	X		
12V	DC9071 DW9071 DW9072	X	X	X	X	X	X	X	X		
14.4V	DC9091 DW9091 DW9094	X	X	X	X	X	X	X	X		
18V	DC9096 DW9096 DW9098 DW9099			X	X	X	X	X	X		
24V	DW0242									X	X



SPECIALIZED CHARGERS

THIS CHARGER ROCKS



DC011 Heavy-Duty Worksite Radio/ Charger

- 1 hour charger for 7.2V to 18V DeWALT battery packs (except Univolt®)
- Heavy-duty AM/FM radio with auxiliary port allows user to listen to the radio or CD (when plugged into auxiliary port)
- Runs off of 9.6V to 18V DeWALT batteries making it a cordless radio

CHARGE FROM YOUR VEHICLE



DW9109
For 7.2V-18V
Batteries

DeWALT Vehicle Chargers

- Charge DeWALT batteries from your vehicle's power outlet (except Univolt®)
- Automatic shut-off protects excessive discharge of vehicle's battery
- Charges in 1 hour or less

QUICK CHARGER



DW9117 7.2V-18V 15 Minute Charger

- Charges in 15 minutes or less minimizing down time for charging
- Charges all DeWALT 7.2V-18V batteries (except Univolt® batteries) so users need only one charger for multiple cordless products
- DeWALT 3-stage charging system provides maximum run-time and extends overall life of the battery

DUAL PORT CHARGER



DW9216 7.2V-18V Dual Port 1 Hour Charger

- Charges two batteries in 1 hour or less, minimizing down time
- Charges all DeWALT 7.2V-18V batteries (except Univolt® batteries) so users need only one charger for multiple cordless products
- DeWALT 3-stage charging system provides maximum run-time and extends overall life of the battery

LASERS

OUTSHINES. OUTLASTS.

LASERS



Bright, sharp, high power beam
for increased visibility

Protected rotary head
for jobsite durability

Accurate to $\pm 1/8$ " per 100 feet
in both level & plumb modes

Out-of-level shut off
with HI alert to ensure accuracy

Scan mode with remote control
Remote works up to 200' from laser

Shock isolated leveling mechanism
for jobsite durability

Variable speed 0-800 RPM
for increased visibility

DeWALT Cordless System: 9.6V - 18V
no leaking batteries or dangling cords

DW077

HEAVY-DUTY 9.6V - 18V SELF-LEVELING ROTARY LASER

DANGER

LASER RADIATION
AVOID DIRECT EYE EXPOSURE.
MAXIMUM OUTPUT POWER
< 5mw@633nm-670nm
CLASS II LASER



**DW071K
Heavy-Duty Rotary Laser Kit**

- Manual leveling system is accurate to $\pm 1/4"$ per 100'
- Dual side-by-side laser diodes for an extremely bright, visible beam
- Variable speed, 0-600 RPM for increased visibility
- Protected rotary head & side impact roll cage for increased durability
- Built-in bump sensor alerts user if laser has been bumped after leveling
- Laser can be oriented level or plumb for all common applications

INCLUDES: rotary laser, laser target card and heavy-duty kit box



**DW071KI/DW071KD
Heavy-Duty Rotary Laser - Interior Kit**

- Manual leveling system is accurate to $\pm 1/4"$ per 100'
- Dual side-by-side laser diodes for an extremely bright, visible beam
- Variable speed, 0-600 RPM for increased visibility
- Protected rotary head & side impact roll cage for increased durability
- Built-in bump sensor alerts user if laser has been bumped after leveling
- Laser can be oriented level or plumb for all common applications
- Wall mount allows the laser to be attached to a wall for drop ceiling installation

INCLUDES: rotary laser, wall mount, laser target card, laser enhancement glasses and heavy-duty kit box

DW071KD Includes: same as DW071KI plus digital laser detector & clamp



**DW073K/DW073KD
Heavy-Duty 18V Cordless Rotary Laser Kit**

- Manual leveling system is accurate to $\pm 1/4"$ per 100'
- Multi-voltage adapter accepts all DeWalt batteries 9.6V - 18V
- Dual side-by-side laser diodes for an extremely bright, visible beam
- Protected rotary head & side impact roll cage for increased durability
- Built-in wall, floor and tripod mounts allow fast and easy setup for most common applications - eliminates need for separate tool mount accessories
- Variable speed, 0-600 RPM for increased visibility
- Two-position pivoting head for quick adjustment from level to plumb
- Built-in bump sensor alerts user if laser has been bumped after leveling

INCLUDES: rotary laser, 18V battery, 1 hour charger, laser target card, laser enhancement glasses and heavy-duty kit box

DW073KD Includes: same as DW073K plus digital laser detector & clamp



SPECIFICATIONS	DW071K	DW071KI/DW071KD	DW073K
Power Supply	3 D-Size Alkaline	3 D-Size Alkaline	9.6V - 18V DeWALT Batteries
Accuracy @ 100 ft.	$\pm 1/4$ in	$\pm 1/4$ in	$\pm 1/4$ in
Indoor Visibility Range	200 (dia) ft	200 (dia) ft	200 (dia) ft
Range with Detector	600 (dia) ft	600 (dia) ft	600 (dia) ft
Rotation Speed	0-600 rpm	0-600 rpm	0-600 rpm
Laser Class	IIla (<5mW) @ 635nm-650nm	IIla (<5mW) @ 635nm-650nm	IIla (<5mW) @ 635nm
Protected Head	Yes	Yes	Yes
Roll Bar	Yes	Yes	Yes
Bump Sensor	Yes	Yes	Yes
Tool Weight	6.6 lbs	6.6 lbs	8.9 lbs

LASERS

LASERS



DW077KI Self Leveling Rotary Laser - Interior Kit

- Fully automatic horizontal & vertical self leveling with out-of-level shutoff eliminates user error, ensures accuracy, and reduces set up time
- Multi-voltage adapter accepts all DeWALT batteries 9.6V - 18V
- Protected rotary head & weatherproof design deliver interior & exterior jobsite durability
- Bright, sharp, high power beam delivers maximum visibility, even over long distances

INCLUDES: self-leveling rotary laser, wall mount, wireless (IR) remote control, 18V battery, 1 hour charger, laser target card, laser enhancement glasses and heavy-duty kit box (w/ padded interior)



DW077KD Self Leveling Rotary Laser - Combo Kit (Int/Ext)

- Fully automatic horizontal & vertical self leveling with out-of-level shutoff eliminates user error, ensures accuracy, and reduces set up time
- Multi-voltage adapter accepts all DeWALT batteries 9.6V - 18V
- Protected rotary head & weatherproof design deliver interior & exterior jobsite durability
- Bright, sharp, high power beam delivers maximum visibility, even over long distances

INCLUDES: self-leveling rotary laser, digital laser detector, wall mount, wireless (IR) remote control, 18V battery, 1 hour charger, laser target card, laser enhancement glasses and heavy-duty kit box (w/ padded interior)



DW082K Laser Plumb Bob

- Self-leveling plumb bob is accurate to $\pm 1/8"$ @ 50'
- One button operation is fast & easy to use
- Overmolded housing helps maintain calibration under jobsite conditions
- Focused laser beam keeps dot small even over long distances for improved accuracy & visibility
- Locating magnets hold laser plumb bob to metal track for easy positioning
- Cross-hair beam pattern helps user find center of beam

INCLUDES: kit box



DW084K Self Leveling Level, Plumb, & Square, 4 Beam Laser

- Self-leveling 4 beam laser is accurate to $\pm 1/8"$ @ 70'
- One button operation is fast & easy to use
- Overmolded housing helps maintain calibration under jobsite conditions
- Focused laser beam keeps dots small even over long distances for improved accuracy & visibility
- Locating magnets hold Laser to metal track for easy positioning

INCLUDES: kit box



SPECIFICATIONS	DW077KI	DW077KD
Power Supply	9.6V-18V DeWALT Batteries	9.6V-18V DeWALT Batteries
Accuracy @ 100 ft.	1/8 in	1/8 in
Rotation Speed	0, 10, 60, 250 & 800 rpm	0, 10, 60, 250, & 800 rpm
Self-Leveling Range	$\pm 5^\circ$	$\pm 5^\circ$
Indoor Visibility Range	200 (dia) ft	200 (dia) ft
Range with Detector	(not included) 2000 (dia) ft	2000 (dia) ft
Laser Class	IIa (<5mW) @ 635nm	IIa (<5mW) @ 635nm
Tool Weight	5.5 lbs	5.5 lbs

SPECIFICATIONS	DW082K	DW084K
Power Supply	4 AA Alkaline	4 AA Alkaline
Plumb Up Accuracy	$\pm 1/8"$ @ 50'	$\pm 1/8"$ @ 70'
Level Accuracy	N/A	$\pm 1/8"$ @ 70'
Indoor Visibility Range	+/- 100 ft	+/- 100 ft
Laser Class	II (<1mW) @ 635nm	II (<1mW) @ 635nm
Dampening Type	magnetic	magnetic



**DW0714
Laser Enhancement Glasses**

- Laser enhancement glasses increase visibility of red beam lasers



**DW0732
Digital Laser Detector and Clamp**

- Detects rotary laser beam inside and outside over long distances or in bright light conditions
- Digital laser detector extends the interior & exterior range of the laser to 600'
- Front & Rear LCD displays for easy viewing
- Adjustable volume control: high, low, mute
- Automatic shutoff turns off detector if inactive for 5 minutes to conserve battery life
- Magnets located on top allow the detector to be attached to ceiling track or steel studs
- Quick release clamp for fast & easy setup
- 3-1/2" clamp capacity for mounting to dimensional 2x4s

**DW0736
Construction Tripod**

- Industry Standard 5/8"x11 mounting threads, flat head design
- Quick-Release legs for fast & easy setup
- Height 68" opened, 42" closed
- Lightweight, durable aluminum construction
- Pointed steel feet are stable on any terrain
- Built in strap for easy transport



**DW0730
Laser Target Card**

- Aids in locating the laser by enhancing the visibility of the beam
- Magnetic base for attaching to ceiling grid or steel studs



**DW0734
Construction Grade Rod**

- 13' length for most common applications
- Lightweight, durable aluminum construction
- 4 telescoping sections
- Markings in feet/inches/8ths
- Scale on back side for quick overall height measurements



**DW0772
Digital Laser Detector & Clamp**

- Consistent accuracy, near & far regardless of beam size
- Compatible with all rotary lasers (interior, exterior, visible, & invisible)
 - Extending the operating range of most lasers to over 1000'
- 100% waterproof design - when it's dropped in concrete, hose it off!
- Heavy-duty clamp for jobsite durability
- Durable windows help prevent nail & screw puncture
- Front & Rear LCD displays for easy viewing
- Adjustable volume control: high, low, & mute: 110dBA (High) can be heard on the noisiest jobsites
- Automatic shutoff turns off detector if inactive for 30 minutes to conserve battery life



INCLUDES: digital laser detector, one 9 volt battery and heavy-duty detector clamp

CONSTRUCTION INSTRUMENTS

INSTRUMENTS

Built-in sunshade
for reduced glare

Protected optics
for longer life

1:100 Stadia ratio
for easy distance
estimation

Soft eyecup
for comfort &
shade

Protected vial
mounted under the telescope
& protected on all sides

360° circle
for easy job layout

Vernier scale
(not shown)
measures angles to
within 5 arc-minutes

Built-in leveling base
three leveling knobs for
fast & easy setup

Continuous tangent drive
no locking knobs for faster &
easier sighting of targets

DW090

HEAVY-DUTY 20X BUILDERS LEVEL



**DW090PK
20x Builders Level Package**

- 20x magnification for 200'+ range
- $\pm 1/4"$ per 100' accuracy
- 360° horizontal circle with vernier scale for precise measuring of horizontal angles
- Heavy-duty leveling base is fast & easy to setup and level
- Protected leveling vial for jobsite durability

INCLUDES: heavy-duty aluminum tripod w/quick adjust legs and heavy-duty 8' aluminum grade rod (feet-inches-eighths)



**DW092PK
20x Transit Level Package**

- 20x magnification for 200'+ range
- $\pm 1/4"$ per 100' accuracy
- Transit capability allows user to determine vertical angles
- 360° horizontal circle with vernier scale for precise measuring of horizontal angles
- Protected leveling vial for jobsite durability
- Heavy-duty leveling base is fast & easy to setup and level

INCLUDES: heavy-duty aluminum tripod w/quick adjust legs and heavy-duty 8' aluminum grade rod (feet-inches-eighths)



**DW096PK
26x Auto Level Package**

- Magnetically dampened compensator for easy setup with optimum range and accuracy
- 26x magnification for 300'+ range
- $\pm 1/32"$ per 100' accuracy
- Heavy-duty leveling base is fast & easy to setup and level
- 360° horizontal circle for precise measuring of horizontal angles

INCLUDES: heavy-duty aluminum tripod w/quick adjust legs and heavy-duty 8' aluminum grade rod (feet-inches-eighths)

SPECIFICATIONS	DW090PK	DW092PK	DW096PK
Leveling Type	Manual	Manual	Auto
Accuracy @ 100 ft.	$\pm 1/4$ in	$\pm 1/4$ in	$\pm 1/32$ in
Magnification	20x	20x	26x
Range	200 ft	200 ft	300 ft
Stadia Ratio	1:100	1:100	1:100
Horizontal Circle Type	Continuous Drive	Continuous Drive	Continuous Drive

DRILLS

DRILLS



Anti-Lock Control (ALC) is designed to control the effects of drill kick-back in the event of bit lock-up.

This feature is available on the DW239 & DW249 1/2" corded drills.

For Self Feed Bits

See page 125

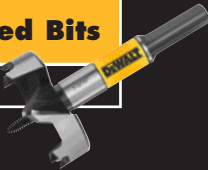

For Auger Bits

See page 126



DW239

**HEAVY-DUTY 1/2" (13MM) VSR DRILL
(0-850 RPM) WITH ANTI-LOCK CONTROL**



**D21002
Heavy-Duty 3/8" VSR Drill**

- All ball-bearing construction provides greater durability and longer tool life
- Contoured textured handle provides better gripping surface and reduces user fatigue
- Built-in two-way level for drilling accurate vertical and horizontal holes
- Glass-filled nylon housing is durable, impact resistant and provides lower maintenance cost
- Belt clip conveniently holds tool and frees user's hands for other work

INCLUDES: chuck key with holder



**D21008K
Heavy-Duty 3/8" VSR Drill Kit with Keyless Chuck**

- 6 Amp motor offers high performance and overload protection
- 3/8" Ratcheting Keyless Chuck offers greater bit retention
- All ball-bearing construction provides greater durability and longer tool life
- Contoured textured handle provides better gripping surface and reduces user fatigue
- Built-in two-way level for drilling accurate vertical and horizontal holes
- Glass-filled nylon housing is durable, impact resistant and provides lower maintenance cost

INCLUDES: heavy-duty kit box



**D21009
Heavy-Duty 3/8" VSR Drill with Metal Keyless Chuck**

- All-metal chuck offers greater durability
- The 6 Amp motor offers high performance and overload protection
- 3/8" Metal Keyless Chuck offers greater bit retention
- All ball-bearing construction provides greater durability and longer tool life
- Contoured textured handle provides better gripping surface and reduces user fatigue
- Built-in two-way level for drilling accurate vertical and horizontal holes
- Glass-filled nylon housing is durable, impact resistant and provides lower maintenance cost



SPECIFICATIONS	D21002	D21008K	D21009
Keyless Chuck	N/A	YES	YES
Chuck Size	3/8"	3/8"	3/8"
Amps	6.0 Amps	6.0 Amps	6.0 Amps
No Load Speed	0-2,500 rpm	0-2,500 rpm	0-2,500 rpm
Max Watts Out	480 W	480 W	480 W
Gear Reduction	Single	Single	Single
Capacity In Wood (Spade Bit)	1"	1"	1"
Capacity In Wood (Hole Saw)	1-1/8"	1-1/8"	1-1/8"
Capacity In Steel (Twist Bit)	3/8"	3/8"	3/8"
Tool Weight	3.2 lbs	3.5 lbs	3.5 lbs

DRILLS



DW217 Heavy-Duty 1/4" (6mm) VSR Drill (0-4,000 rpm)

- Helical-cut steel, heat-treated gears for increased durability and long gear life
- Metal gear housing for jobsite durability and increased reliability
- Rubber grip and two-finger trigger for increased comfort and greater control
- Designed for small diameter holes in light-gauge steel

INCLUDES: chuck key with holder



DW222 Heavy-Duty 3/8" (10mm) VSR Drill (0-1,200 rpm)

- Helical-cut steel, heat-treated gears for increased durability and long gear life
- Single-sleeve keyless chuck with spindle lock provides greater bit retention and tool-free convenience
- Two-finger trigger for increased comfort



DW223G Heavy-Duty 3/8" (10mm) VSR Drill (0-1,200 rpm)

- Helical-cut steel, heat-treated gears for increased durability and long gear life
- Metal gear housing for jobsite durability and increased reliability
- Two-finger rubber trigger for increased comfort
- DIN nose for side handle or rig mount
- 3-wire grounded plug/cord

INCLUDES: chuck key with holder



DW160 Heavy-Duty 3/8" (10mm) Right Angle Drill

- 100% ball-bearing construction provides durability and longer tool life
- Compact right-angle design for easy access in tight places
- Paddle switch is ideal for use in awkward positions and limited access areas
- Shielded chuck protects user and improves grip in confined areas
- Double gear reduction increases torque performance and decreases gear stress

INCLUDES: chuck key with holder



SPECIFICATIONS	DW217	DW222	DW223G	DW160
Chuck Size	1/4"	3/8"	3/8"	3/8"
Amps	6.7 Amps	6.7 Amps	7.0 Amps	3.2 Amps
No Load Speed	0-4,000 rpm	0-1,200 rpm	0-1,200 rpm	1,200 rpm
Max Watts Out	510 W	520 W	560 W	200 W
Gear Reduction	Single	Double	Double	Double
Capacity In Wood (Spade Bit)	3/4"	1-1/4"	1-1/4"	1-1/8"
Capacity In Wood (Hole Saw)	N/A	2-1/8"	2 1/8"	1-1/8"
Capacity In Steel (Twist Bit)	1/4"	3/8"	3/8"	3/8"
Capacity In Steel (Hole Saw)	N/A	1-1/4"	1-1/4"	3/4"
Tool Weight	3.2 lbs	3.3 lbs	3.6 lbs	3.75 lbs

DRILLS



DW235G Heavy-Duty 1/2" (13mm) VSR Drill (0-850 rpm)

- Helical-cut steel, heat-treated gears for increased durability and long gear life
- Metal gear housing for jobsite durability and increased reliability
- Two-finger trigger for increased comfort
- 360° side handle for greater control and versatility

INCLUDES: 360° side handle and chuck key with holder



DW236/DW236K Heavy-Duty 1/2" (13 mm) VSR Drill (0-850 rpm)

- All metal single-sleeve keyless chuck with spindle lock, carbide jaws and ratcheting action provides greater bit retention and tool-free convenience
- Helical-cut steel, heat-treated gears for increased durability and long gear life
- Metal gear housing for jobsite durability and increased reliability
- Rubber grip and two-finger trigger for increased comfort and greater control
- 360° side handle for greater control and versatility

INCLUDES: 360° side handle

DW236K Includes: 360° side handle and heavy-duty kit box



DW245 Heavy-Duty 1/2" (13mm) VSR Drill (0-600 rpm)

- Helical-cut steel, heat-treated gears for increased durability and long gear life
- Metal gear housing for jobsite durability and increased reliability
- Two-finger trigger for increased comfort
- Triple gear reduction provides increased torque and reduces gear stress
- 360° side handle for greater control and versatility

INCLUDES: 360° side handle and chuck key with holder



For Hole Saws

See page 120



SPECIFICATIONS	DW235G	DW236/DW236K	DW245
Chuck Size	1/2"	1/2"	1/2"
Amps	7.8 Amps	7.8 Amps	7.8 Amps
No Load Speed	0-850 rpm	0-850 rpm	0-600 rpm
Max Watts Out	600 W	600 W	600 W
Gear Reduction	Double	Double	Triple
Capacity In Wood (Self-Feed)	2-1/8"	2-1/8"	2-9/16"
Capacity In Wood (Hole Saw)	3-1/2"	3-1/2"	4"
Capacity In Wood (Auger Bit)	1-1/8"	1-1/8"	1-1/2"
Capacity In Steel (Twist Bit)	1/2"	1/2"	1/2"
Capacity In Steel (Hole Saw)	1-1/2"	1-1/2"	2-3/4"

DRILLS



DW246 Heavy-Duty 1/2" (13mm) VSR Drill (0-600 rpm)

- Single-sleeve keyless chuck with spindle lock provides greater bit retention and tool-free convenience
- Triple gear reduction provides increased torque and reduces gear stress
- Rubber grip and two-finger trigger for increased comfort and greater control
- Metal gear housing for jobsite durability and increased reliability
- Helical-cut steel, heat-treated gears for increased durability and long gear life
- 360° side handle for greater control and versatility

INCLUDES: 360° side handle



DW239 Heavy-Duty 1/2" (13mm) VSR Drill (0-850 rpm) with Anti-Lock Control

- Anti-Lock Control (ALC) monitors current to motor and shuts tool down in lock-up situations for improved tool control
- Helical-cut steel, heat-treated gears for increased durability and long gear life
- Metal gear housing for jobsite durability and increased reliability
- Rubber grip and two-finger trigger for increased comfort and greater control
- 360° side handle for greater control and versatility

INCLUDES: 360° side handle and chuck key with holder



DW249 Heavy-Duty 1/2" (13mm) VSR Drill (0-600 rpm) with Anti-Lock Control

- Anti-Lock Control (ALC) monitors current to motor and shuts tool down in lock-up situations for improved tool control
- Helical-cut steel, heat-treated gears for increased durability and long gear life
- Metal gear housing for jobsite durability and increased reliability
- Rubber grip and two-finger trigger for increased comfort and greater control
- Triple gear reduction provides increased torque and reduces gear stress
- 360° side handle for greater control and versatility

INCLUDES: 360° side handle and chuck key with holder



SPECIFICATIONS	DW246	DW239	DW249
Chuck Size	1/2"	1/2"	1/2"
Amps	7.8 Amps	7.8 Amps	7.8 Amps
No Load Speed	0-600 rpm	0-850 rpm	0-600 rpm
Max Watts Out	600 W	600 W	600 W
Gear Reduction	Triple	Double	Triple
Anti-Lock Control	No	Yes	Yes
Capacity In Wood (Self-Feed)	2-9/16"	2-1/8"	2-9/16"
Capacity In Wood (Auger Bit)	1-1/2"	1-1/8"	1-1/2"
Capacity In Steel (Twist Bit)	1/2"	1/2"	1/2"
Capacity In Steel (Hole Saw)	2-3/4"	1-1/2"	2-3/4"



DW130

Heavy-Duty 1/2" (13mm) Spade Handle Drill

- 5/8" spindle for increased durability in high torque applications
- 2-position rear spade handle and 3-position side handle gives greater control for all drilling and mixing applications
- Triple gear reduction provides increased torque and reduces gear stress
- Low 450 RPM provides increased torque for drilling large diameter holes in wood and metal
- AC/DC, forward/reverse rocker switch ideal for backing out jammed bits or mixing drywall mud

INCLUDES: 3-position side handle and chuck key with holder



DW131

Heavy-Duty 1/2" (13mm) Spade Handle Drill (450 rpm)

- AC/DC, reversing switch
- 5/8" spindle for increased durability in high torque applications
- Top handle and back handle for improved control for all drilling and mixing applications
- Triple gear reduction provides increased torque and reduces gear stress
- Trigger switch and toggle reversing lever provides easy forward/reverse action and assists in backing out jammed bits and or mixing drywall mud
- Low 450 RPM provides increased torque for drilling large diameter holes in wood and metal

INCLUDES: top handle and chuck key with holder



DW132

Heavy-Duty 1/2" (13mm) Spade Handle Drill (1,000 rpm)

- AC/DC, reversing switch
- 5/8" spindle for increased durability in high torque applications
- Top handle and back handle for improved control for all drilling applications
- Triple gear reduction provides increased torque and reduces gear stress
- Trigger switch and toggle reversing lever provides easy forward/reverse action and assists in backing out jammed bits
- 1,000 RPM speed is ideal for self-feed bits and small hole saw drilling applications

INCLUDES: top handle and chuck key with holder



SPECIFICATIONS	DW130	DW131	DW132
Chuck Size	1/2"	1/2"	1/2"
No Load Speed	450 rpm	450 rpm	1,000 rpm
Amps	7.0 Amps	7.0 Amps	7.0 Amps
Max Watts Out	580 W	715 W	715 W
Gear Reduction	Triple	Triple	Triple
Capacity In Wood (Spade Bit)	1-1/2"	1-1/2"	1-1/2"
Capacity In Wood (Self-Feed)	2-9/16"	2-9/16"	1-3/4"
Capacity In Wood (Hole Saw)	5"	5"	3"
Capacity In Wood (Auger Bit)	1-1/2"	1-1/2"	1-1/2"
Capacity In Steel (Hole Saw)	3"	4"	1-1/2"

DRILLS

DRILLS



DW140

Heavy-Duty 1/2" (13mm) End Handle Drill (600 rpm)

- 100% ball-bearing construction provides durability and longer tool life
- Die-cast metal gear housing for jobsite durability and tool reliability
- 3-position auxiliary side handle for greater control for all drilling applications
- Triple gear reduction provides increased torque and reduces gear stress
- D-handle design is ideal for drilling applications where added pressure is needed

INCLUDES: 3-position side handle and chuck key with holder



DW120K

Heavy-Duty 1/2" (13mm) Right Angle Drill Kit

- Three speed ranges offer versatility of matching the appropriate speed to the application. 400/900 rpm for right angle drilling and 600 rpm for straight drilling
- Die-cast metal gear housing for jobsite durability and tool reliability
- 5-position side handle offers improved control and versatility for all drilling applications
- 360° right angle attachment improves access to confined areas for increased productivity
- Triple gear reduction provides increased torque and reduces gear stress

INCLUDES: chuck key with holder, 5-position side handle, allen wrench and heavy-duty kit box



DW124/DW124K

Heavy-Duty 1/2" (13mm) Stud & Joist Drill

- 100% ball-bearing construction provides durability and longer tool life
- Mechanical-slip clutch in low gear to prevent bit lock-up and to provide control of reactionary torque
- Adjustable front handle and 2-position side handle provide maximum leverage and control
- Mechanically controlled 2-speed to match rpm/torque to application requirement
- Triple gear reduction provides increased torque and reduces gear stress
- 21" overall length provides greater control and leverage

INCLUDES: chuck key with holder, bail handle and 2-position side handle

DW124K Includes: chuck key with holder, 2-position side handle, bail handle and heavy-duty kit box



SPECIFICATIONS	DW140	DW120K	DW124/DW124K
Chuck Size	1/2"	1/2"	1/2"
No Load Speed	600 rpm	400/600/900 rpm	300/1,200 rpm
Amps	7.0 Amps	7.0 Amps	8.0 Amps
Max Watts Out	580 W	580 W	850 W
Gear Reduction	Triple	Triple	Triple
Capacity In Wood (Self-Feed)	2-1/8"	2-9/16"	4-5/8"
Capacity In Wood (Hole Saw)	4"	4"	6"
Capacity In Wood (Auger Bit)	1-1/2"	1-1/2"	1-1/2"
Capacity In Steel (Twist Bit)	1/2"	1/2"	1/2"
Capacity In Steel (Hole Saw)	1-1/2"	5"	5"

DRILLS



DW138

Heavy-Duty 3/4" (19mm) Drill/Power Unit (375 rpm)

- AC/DC switch
- 10 Amp motor provides power and overload capacity for higher torque applications
- Rotating brush ring for full power in forward and reverse
- No. 3 taper chuck mount with key drive for the highest reliability
- 375 RPM speed is ideal for driving speed reducers, light hoists and power heads
- Triple gear reduction provides increased torque and reduces gear stress
- Top handle and back handle for improved control for all high torque drilling applications

INCLUDES: top handle and chuck key with holder



DW151

Heavy-Duty 1/2" Magnetic Drill Press (450 rpm)

- Maximum capacity - 1 1/4" holes
- 1/2" chuck included
- Push button reversible feed handle offers tool-free handle set-up
- Smooth rack & Pinion drilling action
- Triple gear reduction provides increased torque and reduces gear stress
- Twin core magnet provides greater magnetic adhesion
- Easy access controls
- Unit ships with annular cutter adapter

INCLUDES: reversible side handle and 5ft. safety strap



DW159

Heavy-Duty 2" Magnetic Drill/Cutter Press (375 rpm)

- 2" Capacity in steel
- Arbor system provides auto-lubrication and slug ejection
- Push button reversible feed handle offers tool-free handle set-up
- Triple gear reduction provides increased torque and reduces gear stress
- Magnet rotates 120° to get into tight spaces
- 3/4" chuck and adapter available as accessory - DW1566

INCLUDES: 5 ft. safety strap and Reversible side handle



ANNULAR CUTTERS

Cat. #	Description	Cat. #	Description	Cat. #	Description	Cat. #	Description	Cat. #	Description
DW1500	7/16" X 1"	DW1513	1-1/4" X 1"	DW1529	7/16" X 2"	DW1542	1-1/4" X 2"	DW1528	Pilot for 1" Depth Cutters
DW1501	1/2" X 1"	DW1514	1-5/16" X 1"	DW1530	1/2" X 2"	DW1543	1-5/16" X 2"	DW1557	Pilot for 2" Depth Cutters
DW1502	9/16" X 1"	DW1515	1-3/8" X 1"	DW1531	9/16" X 2"	DW1544	1-3/8" X 2"	DW1563	Pilot for 1" Depth 7/16" & 1/2" Cutters
DW1503	5/8" X 1"	DW1516	1-7/16" X 1"	DW1532	5/8" X 2"	DW1545	1-7/16" X 2"	DW1564	Pilot for 2" Depth 7/16" & 1/2" Cutters
DW1504	11/16" X 1"	DW1517	1-1/2" X 1"	DW1533	11/16" X 2"	DW1546	1-1/2" X 2"		
DW1505	3/4" X 1"	DW1518	1-9/16" X 1"	DW1534	3/4" X 2"	DW1547	1-9/16" X 2"		
DW1506	13/16" X 1"	DW1519	1-5/8" X 1"	DW1535	13/16" X 2"	DW1548	1-5/8" X 2"		
DW1507	7/8" X 1"	DW1520	1-11/16" X 1"	DW1536	7/8" X 2"	DW1549	1-11/16" X 2"		
DW1508	15/16" X 1"	DW1521	1-3/4" X 1"	DW1537	15/16" X 2"	DW1550	1-3/4" X 2"		
DW1509	1" X 1"	DW1522	1-13/16" X 1"	DW1538	1" X 2"	DW1551	1-13/16" X 2"		
DW1510	1-1/16" X 1"	DW1523	1-7/8" X 1"	DW1539	1-1/16" X 2"	DW1552	1-7/8" X 2"		
DW1511	1-1/8" X 1"	DW1524	1-15/16" X 1"	DW1540	1-1/8" X 2"	DW1553	1-15/16" X 2"		
DW1512	1-3/16" X 1"	DW1525	2" X 1"	DW1541	1-3/16" X 2"	DW1554	2" X 2"		

SPECIFICATIONS	DW138
Chuck Size	3/4"
No Load Speed	375 rpm
Amps	10.0 Amps
Max Watts Out	1,100 W
Gear Reduction	Triple
Capacity In Steel (Twist Bit)	3/4"
Capacity In Steel (Hole Saw)	4"
Tool Weight	17.3 lbs

SPECIFICATIONS	DW151	DW159
Chuck Size	1/2"	1/2"
No Load Speed	450 rpm	375 rpm
Amps	6.0 Amps	10 Amps
Capacity In Steel (Twist Bit)	1/2"	1-1/4"
Capacity In Steel (Annular Cutter)	1 1/4"	2"
Watts	720 W	1,100 W
Gear Reduction	Triple	Triple
Reaming Capacity (in heavy gauge steel)	1/2"	1/2"
Length of Drill Stroke (less bits and adapters)	6.5"	4"
Magnetic Adhesion	1,350 lbs	2,800 lbs

HAMMERS & HAMMERDRILLS

HAMMERS



Quick change removable chuck
easily converts to keyless chuck
(D25304K only)

Three rubber-spring dust seals
Additional seals provide superior dust
protection leading to greater durability

Mode selector
for chiseling, hammer drilling & drilling only

Forward/Reverse
top mounted for
easy access

**Electronic
variable speed**
with copper heat sink
for superior switch life

**Rubber molded
soft grip handle**
reduces vibration/
increases comfort
& grip

**Heavy-duty 7.5
Amp motor**
for greater durability
& performance

Easy-grip SDS chuck
for fast & easy bit
changes

**Large hammer
mechanism**
2.33 ft/lbs. of impact
energy for increased
drilling speed & chipping
performance

Pop-off brushes
extend motor life by not damaging commutator
when brushes wear out

Dust-sealed ball bearings
for superior motor life

For SDS Drill Bits

See page 134



D25304K

**HEAVY-DUTY 1" L-SHAPED SDS ROTARY HAMMER WITH
QUICK CHANGE REMOVABLE CHUCK & 3-JAW KEYLESS CHUCK**

HAMMERDRILLS



DW511

Heavy-Duty 1/2" (13mm) VSR Single Speed Hammerdrill

- 6.7 Amp motor provides high performance and overload protection
- Dual mode: hammerdrill/drill for wood, steel or masonry applications
- 3.85 lbs. - lightweight design for extended use and less user fatigue
- Two-finger trigger for increased comfort
- 360° side handle with depth rod offers greater control, versatility, and increased depth accuracy
- Variable speed allows for precise hole placement on work surface

INCLUDES: 360° side handle, depth rod and chuck key with holder



DW505/DW505K

Heavy-Duty 1/2" (13mm) VSR Dual Range Hammerdrill

- 7.8 Amp motor provides high performance and overload protection
- High/low speed for high speed drilling or high torque applications
- Dual mode: hammerdrill/drill for wood, steel or masonry applications
- Lightweight design for less user fatigue
- Two-finger trigger for increased comfort
- 360° side handle with depth rod offers greater control, versatility, and increased depth accuracy
- Variable speed allows for precise hole placement on work surface

INCLUDES: 360° side handle, depth rod and chuck key
DW505K Includes: same as DW505 and heavy-duty kit box



DW515K

Heavy-Duty 1/2" (13mm) VSR Dual Range Hammerdrill Kit

- 8.2 Amp motor provides high performance and overload protection
- High/low gear for high speed drilling, or high torque applications
- Dual mode: hammerdrill/drill for wood, steel or masonry applications
- Rubber grip and two-finger trigger for increased comfort
- 360° side handle with depth rod offers greater control, versatility, and increased depth accuracy
- Lightweight design for less user fatigue
- Variable speed allows for precise hole placement on work surface

INCLUDES: 360° side handle, depth rod, chuck key with holder and heavy-duty kit box



**For Hammer
Drill Bits**

See page 133



SPECIFICATIONS	DW511	DW505/DW505K	DW515K
Amps	6.7 Amps	7.8 Amps	8.2 Amps
Max Watts Out	550 W	650 W	750 W
No Load Speed	0-2,700 rpm	0-1,100 / 0-2,700 rpm	0-1,050 / 0-2,400 rpm
Blows/Min	0-46,000 bpm	0-19,000 / 0-46,000 bpm	0-18,000 / 0-41,000 bpm
Capacity In Steel	1/2"	1/2"	1/2"
Capacity In Wood	1 1/4"	1-1/2"	1-1/2"
Concrete Optimum	3/16-3/8"	3/16 - 3/8"	3/16 - 7/16"
Concrete Maximum	1/2"	1/2"	1/2"
Tool Length	11 1/2"	13"	14"
Tool Weight	3.85 lbs	4.8 lbs	5.5 lbs

COMPACT SDS



D25101K/D25103K Heavy-Duty 1" Pistol Grip SDS Hammer

- 2.3 Ft Lbs of impact energy provide fast drilling and powerful chipping
- 7.5 Amp motor provides high performance and overload protection
- Reverse feature assists in the removal of fasteners
- Variable speed allows for precise hole placement on work surface
- Factory set clutch reduces sudden, high torque reactions if bit jams
- 360° side handle adjusts easily for preference or use in tight spaces

D25101K: Single mode designed specifically for concrete drilling only

D25103K: Three mode hammerdrill/drill for wood, steel or concrete drilling and chip mode



D25201K/D25203K Heavy-Duty 1" D-Handle SDS Hammer

- 2.3 Ft Lbs of impact energy provide fast drilling and powerful chipping
- 7.5 Amp motor provides high performance and overload protection
- Reverse feature assists in the removal of fasteners
- Variable speed allows for precise hole placement on work surface
- Factory set clutch reduces sudden, high torque reactions if bit jams
- 360° side handle adjusts easily for preference or use in tight spaces

D25201K: Single mode designed specifically for concrete drilling only

D25203K: Three mode hammerdrill/drill for wood, steel or concrete drilling and chip mode



D25303K/D25304K Heavy-Duty 1" L-Shape SDS Rotary Hammer

- L-Shape design offers superior balance and control
- 2.3 Ft Lbs of impact energy provide fast drilling and powerful chipping
- 7.5 Amp motor provides high performance and overload protection
- At only 11-1/2" this hammer is the most compact in the market allowing users to get into tight spaces
- Light weight design (6-1/2 lbs) provides comfort for extended use
- Dust extraction connection allows the use of the D25300D dust collection system
- Chipping (Hammer-Only) mode allows user to perform light chipping applications such as removal of mortar splatter

D25303K: Standard SDS chuck

D25304K: Quick change SDS chuck with 1/2" keyless chuck included



D25300D Heavy-Duty Rotary Hammer Dust Extraction

- For use with D25303 and D25304 hammers
- High efficiency filter delivers 99.95% efficiency at 5 microns
- Built-in motor keeps performance high while drilling
- 2-second power-off delay allows dust extraction to continue for 2 seconds after drill is switched off
- Lightweight at only 3.3 lbs



**For Cordless
SDS Hammers**

See pages 9 & 10

SPECIFICATIONS	D25101K	D25103K	D25201K	D25203K	D25303K	D25304K
Concrete Drilling	1"	1"	1"	1"	1"	1"
Impact Energy	2 ft/lbs	2.3 ft/lbs	2 ft/lbs	2.3 ft/lbs	2.3 ft/lbs	2.3 ft/lbs
Amps	7.5 Amps	7.5 Amps	7.5 Amps	7.5 Amps	7.5 Amps	7.5 Amps
Chipping	No	Yes	No	Yes	Yes	Yes
No Load Speed	0-1,100 rpm	0-1,100 rpm	0-1,100 rpm	0-1,100 rpm	0-1,100 rpm	0-1,100 rpm
Blows/Min	0-4,200 bpm	0-4,200 bpm	0-4,200 bpm	0-4,200 bpm	0-4,200 bpm	0-4,200 bpm
Switch	VSR	VSR	VSR	VSR	VSR	VSR
Clutch	Factory Set	Factory Set	Factory Set	Factory Set	Factory Set	Factory Set
Tool Length	14.2"	14.2"	16.6"	16.6"	11.5"	12.1"
Tool Weight	5.6 lbs	5.7 lbs	5.9 lbs	6.1 lbs	6.5 lbs	6.8 lbs

LARGE SDS



DW570K/D25404K Heavy-Duty 1-1/8" SDS Rotary Hammer Kit With Chipping Feature

- 8.3 Amp motor provides high performance and overload protection
- Hard-hitting hammer mechanism for fast and efficient penetration
- Fully sealed gearbox engineered for long life by keeping grease in and dust out
- Accepts SDS bits from 5/32" to 1-1/8"
- Higher drilling capacity than compact drilling hammers for increased productivity in 1/2" & larger applications
- Less weight than large drilling hammers reduces user fatigue in 5/8" & smaller applications
- Chipping (Hammer-Only) mode allows user to perform light chipping applications
- Rotation-only mode for wood and metal drilling (using SDS-to-Round Shank Adapter)

INCLUDES: 360° side handle, depth rod and heavy-duty kit box



SDS MAX



D25500K Heavy-Duty 1-9/16" SDS Max Rotary Hammer Kit

- 11.0 amp motor delivers high output and overload protection
- Electronic Variable Speed allows the user to control the speed of drilling and chipping
- 7.3 ft/lbs of impact energy provides fast drilling and powerful chipping
- SDS max toolholder is compatible with most bits the user has
- Rubber grip helps reduce the level of vibration felt by the user when operating the tool
- Rear handle mount means less bending over when using tool in down drilling applications

INCLUDES: 360° side handle, depth rod and heavy-duty kit box



D25600K Heavy-Duty 1.75" SDS Max Rotary Hammer

- 11.5 Amp motor delivers high output and overload protection
- Electronic Variable Speed allows the user to control the speed of drilling and chipping
- 7.3 ft/lbs of impact energy provides fast drilling and powerful chipping
- SDS max toolholder is compatible with most bits the user has
- Rear handle mount means less bending over when using tool in down drilling applications
- Factory clutch helps reduce the tools reaction to embedded steel when bits "lock-up" while in operation, preventing injury

INCLUDES: 360° side handle, depth rod and heavy-duty kit box



SPECIFICATIONS	DW570K/D25404K
Concrete Drilling	1-1/8"
Impact Energy	3.34 ft/lbs
Amps	8.3 Amps
Switch	VS
Chipping	Yes
No Load Speed	0-730 rpm
Blows/Min	0-4,100 bpm
Clutch	Yes
Tool Length	15.25"
Tool Weight	10.75 lbs

SPECIFICATIONS	D25500K	D25600K
Concrete Drilling	1-9/16"	1-3/4"
Impact Energy	7.3 ft/lbs	8 ft/lbs
Amps	11.0 Amps	11.5 Amps
Chipping	Yes	Yes
Wood/Steel Drilling	Yes with adaptor	Yes
No Load Speed	140-280 rpm	140-280 rpm
Loaded Speed (bpm)	1,330-2,660 bpm	1,330-2,660 bpm
Clutch	Yes	Yes
Tool Length	18.5"	18.5"
Tool Weight	13 lbs	13.4 lbs

SPLINE



**D25550K/D25551K
Heavy-Duty 1-9/16" Spline Rotary Hammer Kit**

- 11.0 amp motor delivers high output and overload protection
- Electronic Variable Speed allows the user to control the speed of drilling and chipping
- 7.3 ft/lbs of impact energy provides fast drilling and powerful chipping
- Rubber grip helps reduce the level of vibration felt by the user when operating the tool
- Rear handle mount means less bending over when using tool in down drilling applications
- Factory clutch helps reduce the tools reaction to embedded steel when bits "lock-up" while in operation, preventing injury
- Modular construction allows service technicians to repair tools quickly for less down time when you service tools
- Bit lock allows user to unwind jammed bits (D25551K only)

INCLUDES: 360° side handle, depth rod and heavy-duty kit box
D25551K Includes: same as D25550K and heavy-duty kit box



**D25650K
Heavy-Duty 1-3/4" Spline Rotary Hammer Kit**

- 11.5 amp motor delivers high output and overload protection
- Electronic Variable Speed allows the user to control the speed of drilling and chipping
- 8 ft/lbs of impact energy provides fast drilling and powerful chipping
- Spline toolholder is compatible with all spline drive bits
- Rubber grip helps reduce the level of vibration felt by the user when operating the tool
- Rear handle mount means less bending over when using tool in down drilling applications
- Bit Lock allows user to unwind jammed bits
- Factory clutch helps reduce the tools reaction to embedded steel when bits "lock-up" while in operation, preventing injury

INCLUDES: 360° side handle, depth rod and heavy-duty kit box



DEMOLITION



**D25850K
Heavy-Duty 12 lb. Spline Demolition Hammer**

- 11.5 Amp motor delivers high output and overload protection
- 8 ft/lbs of impact energy provides powerful chipping
- Rubber grip helps reduce the level of vibration felt by the user when operating the tool
- Rear handle mount means less bending over when using tool in down drilling applications
- Modular construction allows service technicians to repair tools quickly for less down time when you service tools
- Side handle allows for ease of use in chipping applications

INCLUDES: side handle, bit grease and heavy-duty kit box



SPECIFICATIONS	D25550K/D25551K	D25650K
Concrete Drilling	1-9/16"	1-3/4"
Impact Energy	7.3 ft/lbs	8 ft/lbs
Amps	11.0 Amps	11.5 Amps
Chipping	Yes	Yes
No Load Speed	140-280 rpm	140-280 rpm
Loaded Speed (bpm)	1,330-2,660 bpm	1,330-2,660 bpm
Clutch	Yes	Yes
Tool Length	18.5"	18.5"
Tool Weight	14.5 lbs. lbs	14.5 lbs

SPECIFICATIONS	D25850K
Bit Shank	Spline
Impact Energy	8 ft/lbs
Amps	11.5 Amps
Loaded Speed (bpm)	1,330-2,660 bpm
Variable Impact Control Dial	Yes - 7 Settings
Chisel Rotation	Yes - Manual
Tool Length	18.5"
Tool Weight	13.2 lbs



**D25830K
Heavy-Duty 12 lb. SDS Max Demolition Hammer**

- 11.5 amp motor delivers high output and overload protection
- 8 ft/lbs of impact energy provides powerful chipping
- Rubber grip helps reduce the level of vibration felt by the user when operating the tool
- Rear handle mount means less bending over when using tool in down drilling applications
- Modular construction allows service technicians to repair tools quickly for less down time when you service tools
- Side handle allows for ease of use in chipping applications

INCLUDES: side handle, heavy-duty kit box and bit grease



**D25900K
Heavy-Duty SDS Max Demolition Hammer Kit**

- 14 Amp motor provides high performance and overload protection
- Active Vibration Control (AVC) reduces vibration resulting in less user fatigue and more productivity
- Non-air pumping beatpiece eliminates masonry dust from entering the unit extending tool and seal life
- Spring-loaded dust seals ensure longer seal life
- Variable Impact Control Dial (19 settings) ensures accurate impact energy depending on the application
- Large on/off rocker switch allows for easy single finger operation
- One-step chisel rotation (12 positions) allows the user to quickly and accurately adjust the chisel, not the tool

INCLUDES: 360° adjustable side handle and heavy-duty kit box



**D25940K
Heavy-Duty 3/4" Hex Demolition Hammer**

- 15 Amp motor provides high performance and overload protection
- Active Vibration Control (AVC) reduces vibration resulting in less user fatigue and more productivity
- Non-air pumping beatpiece eliminates masonry dust from entering the unit extending tool and seal life
- Spring-loaded dust seals ensure longer seal life
- Large on/off rocker switch allows for easy single finger operation
- One-step chisel rotation (12 positions) allows the user to quickly and accurately adjust the chisel, not the tool
- Large rear rubber handle allows easy operation with 1 or 2 hands
- Variable position side handle allows 360° rotation and 150° adjustment for ease of use
- In-line design for easy operation of tool in horizontal or vertical applications

INCLUDES: 360° adjustable side handle, 16-inch Bull point chisel and heavy-duty kit box



SPECIFICATIONS	D25830K	D25900K	D25940K
Bit Shank	SDS Max	SDS Max	3/4" Hex
Impact Energy	8 ft/lbs	3.7-18.5 ft/lbs	22 ft/lbs
Amps	11.5 Amps	14 Amps	15 Amps
Loaded Speed (bpm)	1,330-2,660 bpm	1,020-2,040 bpm	1,620 bpm
Variable Impact Control Dial	Yes - 7 Settings	19 Settings	No Settings
Chisel Rotation	Yes - Manual	One-step, 12 Positions	One-step, 12 Positions
Tool Length	18.5"	25"	25"
Tool Weight	12.3 lbs	21.6 lbs	26.4 lbs

FASTENING

2,700 Impacts per minute
fast application speed
allows the user to increase
productivity

325 ft/lbs. of deliverable torque
enough torque for heavy-duty
industrial applications

Powerful 8.3 Amp motor
enough power for jobsite
applications

**Durable 1/2" anvil with
detent pin retainer**
provides the user with longer life
and superior socket retention

AC/DC rocker switch
forward/reverse rocker switch

Superior ergonomics
soft grip handle provides
greater user comfort

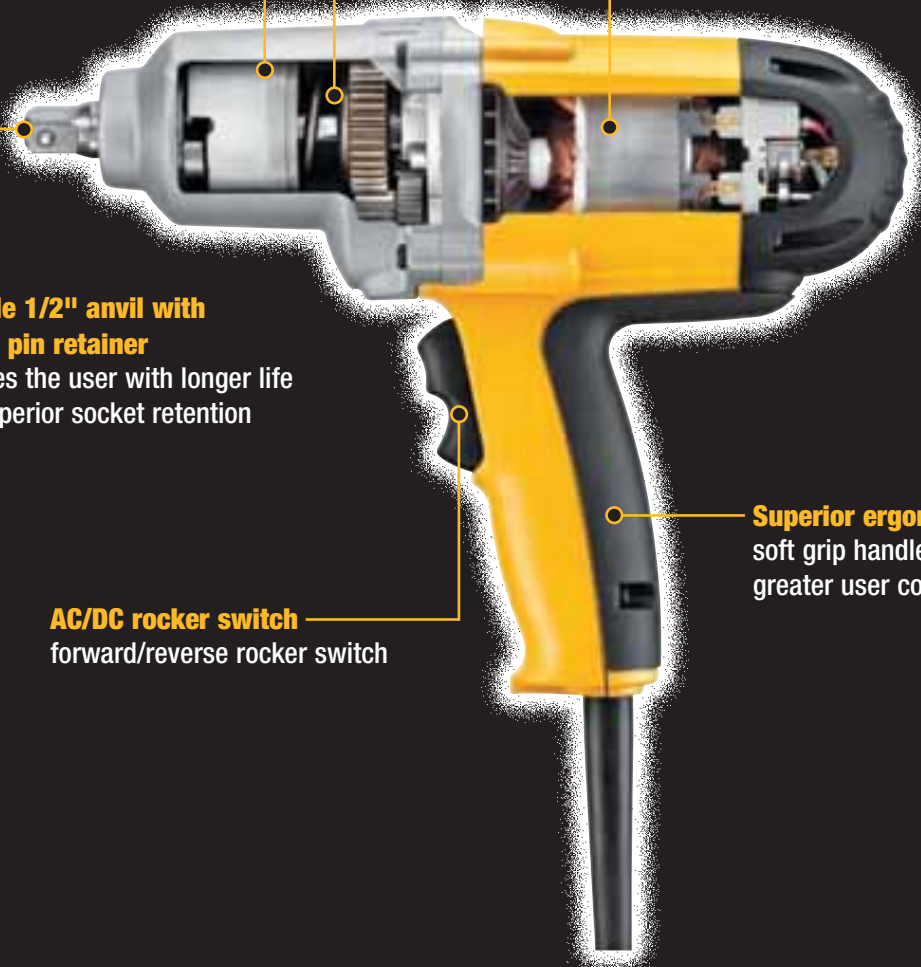

FASTENING

DW292

**HEAVY-DUTY 1/2" (13MM) IMPACT WRENCH WITH
DETENT PIN ANVIL**



**DW255/DW252
Heavy-Duty VSR Drywall Screwdriver**

- Depth-sensitive “set and forget” nosepiece for consistent fastener depth
- Two-finger trigger for increased comfort
- Hi-speed transmission for production drywall hanging
- Lightweight with excellent ergonomics
- Helical-cut, heat-treated gears for long life and durability



**DW272/DW272W/DW272WT
Heavy-Duty VSR Drywall Screwdriver**

- Metal gear housing for increased durability
- Depth sensitive “set and forget” nosepiece for consistent fastener depth
- Rubber grip and two-finger trigger for increased comfort
- Helical-cut steel, heat-treated steel gears for long life and durability
- Lightweight with excellent ergonomics

DW272W Includes: 50' two prong cordset
DW272WT Includes: 50' twist lock cordset



**DW257
Heavy-Duty VSR Deck/Drywall Screwdriver**

- Helical-cut steel, heat treated gears for long life and durability
- High torque for deck building, drywall and heavy gauge steel stud framing
- Depth-sensitive, “set and forget” nosepiece for consistent fastener depth
- Two-finger, rubber trigger for increased comfort
- Excellent ergonomics



**DW276
Heavy-Duty VSR Drywall/Framing Screwdriver**

- Helical-cut steel, heat-treated gears for long life and durability
- High torque for deck building and heavy gauge steel stud framing
- Metal gear housing for increased durability
- Depth sensitive, “set and forget” nosepiece for consistent fastener depth
- Rubber grip and two-finger trigger for increased comfort
- Excellent ergonomics



SPECIFICATIONS	DW252	DW255	DW272/DW272W/DW272WT	DW257	DW276
Amps	6.0 Amps	6.0 Amps	6.3 Amps	6.2 Amps	6.5 Amps
No Load Speed	0-4000 rpm	0-5300 rpm	0-4,000 rpm	0-2,500 rpm	0-2,500 rpm
Clutch	Standard	Standard	Standard	Standard	Standard
Torque	60 in-lbs	60 in-lbs	81 in-lbs	132 in-lbs	132 in-lbs
Max Fastener Size	#8	#8	#8	#12	#14
Tool Weight	2.8 lbs	2.9 lbs	3.1 lbs	3.5 lbs	3.6 lbs

FASTENING



DW266 Heavy-Duty VSR Depth-Sensitive Screwdriver

- Ideal for use with TEKS® screws*
- Helical-cut steel, heat-treated gears for long life and durability
- Metal gear housing for increased durability
- Depth-sensitive "set and forget" nosepiece for consistent fastener depth
- Rubber grip and two-finger, rubber trigger for increased comfort



DW260K Heavy-Duty VSR All-Purpose Screwdriver Kit

- High-power, multi-purpose kit for self-drilling fasteners in steel, deck/subfloor installation and drywall applications
- Depth sensitive, "set and forget" nosepiece for consistent fastener depth
- Two-finger trigger for increased comfort
- Helical-cut steel, heat-treated steel gears for long life and durability
- Excellent ergonomics

INCLUDES: 3 locators, 1/4", 5/16", & 3/8" & nutsetters, (5) #2 Phillips bit tips, bit tip holder and heavy-duty kit box



DW267/DW268/DW269 Heavy-Duty VSR VERSA-CLUTCH® Screwdriver

- Helical-cut steel, heat-treated gears for long life and durability
- High power motor for metal fastening applications
- VERSA-CLUTCH® torque adjustment system to "dial" the proper torque needed to efficiently drive fasteners without stripping or breaking fastener
- Rubber-grip and two-finger trigger for increased comfort
- Metal nose and gear case for durability on the job
- Excellent ergonomics offers less user fatigue



DW281/DW284 Heavy-Duty VSR Positive-Clutch Screwdriver

- DW281: 1/4" Quick-change bit holder
- DW284: Threaded clutch housing adaptor
- Metal gear case for increased durability
- Two-finger trigger for increased comfort
- Good product for production manufacturing environment
- Positive clutch for increased productivity
- Excellent ergonomics offers less user fatigue
- Helical-cut, heat-treated steel gears for long life and durability



SPECIFICATIONS	DW266	DW260K	DW267	DW268	DW269	DW281	DW284
Amps	6.5 Amps	6.2 Amps	6.5 Amps	6.5 Amps	6.5 Amps	6.5 Amps	6.5 Amps
No Load Speed	0-2,500 rpm	0-2,500 rpm	0-2,000 rpm	0-2,500 rpm	0-1,000 rpm	0-2,500 rpm	0-2,500 rpm
Clutch	Standard	Standard	VERSA-CLUTCH® System	VERSA-CLUTCH® System	VERSA-CLUTCH® System	Positive	Positive
Torque	132 in-lbs	132 in-lbs	164 in-lbs	132 in-lbs	344 in-lbs	132 in-lbs	132 in-lbs
Max Fastener Size	#14	#12	#14	#14	#14	#14	#14
Tool Weight	3.5 lbs	3.2 lbs	3.7 lbs	3.7 lbs	3.7 lbs	3.4 lbs	3.3 lbs



**DW292/DW292K/DW293
Heavy-Duty 1/2" (13mm) Impact Wrench**

- 325 ft-lbs of deliverable torque in forward and reverse
 - Detent pin anvil on DW292 and DW292K
 - Hog ring on DW293
 - AC/DC forward/reverse rocking switch
 - Soft grip handle for superior ergonomics
 - Ball bearing construction for increased durability
- DW292K Includes: heavy-duty kit box



**DW294
Heavy-Duty 3/4" Impact Wrench with Detent Pin Anvil**

- 325 ft-lbs of deliverable torque in forward and reverse
- Detent pin anvil
- AC/DC forward/reverse rocking switch
- Soft grip handle for superior ergonomics
- Ball bearing construction for increased durability



**DW297
Heavy-Duty 3/4" Impact Wrench**

- Easy forward or reverse, can run on AC or DC current
- Ball bearing construction for increased durability
- High torque level for heavy-duty fastening applications - 434 ft. lbs.
- Externally replaceable brushes for easy serviceability

INCLUDES: 360° side handle



**DW660/DW660K/DW660SK
Heavy-Duty Cut-Out Tool**

- Tool-free bit change for fast and easy bit changing without a wrench
- Turn-on/bump-off switch allows users to easily shut tool off
- 5 Amp, 30,000 rpm motor provides more cutting power
- Slim body design for less fatigue over prolonged use
- Dust-sealed switch provides durability and long switch life
- Jampot construction provides jobsite durability

INCLUDES: 1 general purpose bit, 1 drywall cutting bit and 1/4", 1/8" collets
 DW660K Includes: same as DW660 and heavy-duty kit box
 DW660SK Includes: same as DW660 with side handle, circle cutter and heavy-duty kit box



SPECIFICATIONS	DW292/DW292K/DW293	DW294	DW297
Amps	8.3 Amps	8.3 Amps	10 Amps
No Load Speed	2,100 rpm	2,100 rpm	1600 rpm
Torque	325 ft-lbs	325 ft-lbs	434 ft-lbs
Impacts/Min	2,700 bpm	2,700 bpm	1800 bpm
Tool Length	11-1/4"	11-1/4"	13"
Tool Weight	7 lbs	7 lbs	11 lbs

SPECIFICATIONS	DW660
Amps	5.0 Amps
No Load Speed	30,000 rpm
Collet Diameter	1/8, 1/4"
Adjustable Guide	Yes
Spindle Lock	Yes
Tool Length	10"
Tool Weight	3.2 lbs

NAILERS

NAILERS



Impact resistant exhaust cap
offers increased durability on the jobsite

Injection molded grip
durable & comfortable resists ripping or tearing

Adjustable hook
supports tool from rafters

Quick release jam clearing
for rapid removal of bent nails

Lightweight, compact & powerful
at 7.6 lbs., this 12-3/4" tool drives nails consistently into standard framing & engineered lumber

Tool-free adjustable depth setting
for quickly setting nail depth of drive

**For Nailer
Part Kits**

See page 59

D51845

HEAVY-DUTY 20° FULL ROUND HEAD FRAMING NAILER



**D51275K
Heavy-Duty 15 Gauge 1-1/4" - 2-1/2" Angled Finish Nailer Kit**

- Magnesium housing delivers a 3.85 lb. unit-among the lightest in the industry
- Tool-free indexed depth setting is lockable and repeatable
- Swept-back contact trip with a low profile no-mar pad allows better visibility and durability
- Tool-free jam clearing eliminates down-time from bent nails caught in the nosepiece
- Dual-load magazine can be loaded by either load & lock or lock & load for maximum convenience
- Tool-free 360° exhaust channels air and dust away
- Tool-free reversible belt hook allows user to place tool on belt when not in use
- Trigger lock-off allows trigger to be disabled when not in use

INCLUDES: DEWALT safety glasses, 2 allen wrenches, replacement bump trigger and heavy-duty kit box



**D51256K
Heavy-Duty 16 Gauge 1-1/4" - 2-1/2" Finish Nailer Kit**

- Lightweight aluminum housing delivers a 3.9 lb. unit-among the lightest in the industry
- Tool-free indexed depth setting is lockable and repeatable
- Dual-load magazine with 160 capacity can be loaded by either load & lock or lock & load for maximum convenience
- Swept-back contact trip with low profile no-mar pad allows for better visibility and durability
- Tool-free jam clearing feature eliminates down-time from bent nails caught in the nosepiece
- Tool-free 360° exhaust channels air and dust away from user
- Tool-free reversible belt hook allows user to place tool on belt when not in use
- Trigger lock-off allows trigger to be disabled when not in use

INCLUDES: DEWALT safety glasses, 2 allen wrenches, replacement bump trigger and heavy-duty kit box



**D51238K
Heavy-Duty 18 Gauge 2" Brad Nailer Kit**

- Tool-free indexed depth setting is lockable and repeatable
- Side low nail indicator window allows the user to quickly and easily see when it is time to reload
- Overmolded no-mar pad allows greater visibility and durability
- Tool-free jam clearing eliminates down-time from bent nails caught in the nosepiece
- Tool-free 360° exhaust channels air and dust away from user
- Trigger lock-off allows trigger to be disabled when not in use

INCLUDES: DEWALT safety glasses, allen wrench and heavy-duty kit box

SPECIFICATIONS	D51275K	D51256K	D51238K
Nail Diameter	15 gauge	16 gauge	18 gauge
Nail Length Capacity	1-1/4" - 2-1/2"	1-1/4" - 2-1/2"	5/8 - 2"
Magazine Angle	34°	Straight	Straight
Magazine Capacity	110 nails	160 nails	110 nails
Magazine Loading	Rear load, dual load	Rear load, dual load	Side load
Operating Pressure	70 - 120 psi	70 - 120 psi	70 - 120 psi
Depth Setting	Tool-free indexed	Tool-free indexed	Tool-free indexed
No Mar Pad	Low profile rubber	Low profile rubber	Low profile rubber
Integrated Belt Hook	Tool-free reversible	Tool-free reversible	None
Jam Clearing	Tool-free	Tool-free	Tool-free
Exhaust	360°	360°	360°
Padded Grips	Textured anti-slip	Textured anti-slip	Textured anti-slip
Trigger Lock Off	Yes	Yes	Yes
Firing Mode	Sequential trigger	Sequential trigger	Sequential trigger
Tool Height	11 1/2"	9.5"	8.75"
Tool Length	13"	12.5"	8.5"
Tool Width	3.5"	3.0"	2.3"
Tool Weight	3.85 lbs	3.9 lbs	2.8 lbs

FRAMING NAILERS



D51823 Heavy-Duty 31° Clipped Head Framing Nailer

- 7.5 lb. magnesium housing and aluminum magazine aid to provide one of the lightest nailers in the industry
- 12-3/4" height allows for toe-nailing in confined areas
- Unique engine design generates power to bury nails in both standard framing lumber and engineered lumber with minimal recoil
- Tool-free adjustable depth allows for quick and easy depth of drive setting
- Tool-free quick release jam clearing feature eliminates down-time removing bent nails caught in the nose piece
- Integrated rafter hook allows for increased versatility on the job-site
- Dry fire lockout extends bumper life by preventing tool from actuating when magazine is empty
- Impact resistant exhaust deflector protects tool from impacts to the cap
- Trigger lock-off allows trigger to be disabled when not in use

INCLUDES: DeWALT safety glasses and replacement bump trigger

NAILERS



D51845 Heavy-Duty 20° Full Round Head Framing Nailer

- 7.6 lb. magnesium housing and aluminum magazine aid to provide one of the lightest nailers in the industry
- 12-3/4" height allows for toe-nailing in confined areas
- Unique engine design generates power to bury nails in both standard framing lumber and engineered lumber with minimal recoil
- Tool-free adjustable depth allows for quick and easy depth of drive setting
- Tool-free quick release jam clearing feature eliminates down-time removing bent nails caught in the nose piece
- Integrated rafter hook allows for increased versatility on the job-site
- Dry fire lockout extends bumper life by preventing tool from actuating when magazine is empty
- Impact resistant exhaust deflector protects tool from impacts to the cap
- Trigger lock-off allows trigger to be disabled when not in use

INCLUDES: DeWALT safety glasses and replacement bump trigger

SPECIFICATIONS	D51823	D51845
Nail Style	Clipped Head	Full Round Head
Magazine Angle	31°	20°
Nail Length Capacity	2 - 3-1/2"	2 - 3-1/2"
Nail Diameter Range	.113-.131"	.113-.148"
Magazine Capacity	80 nails	65 nails
Engine Valve Type	Drop sleeve	Drop sleeve
Jam Clearing	Tool-free	Tool-free
Dry Fire Lockout	Yes	Yes
Integrated Rafter Hook	Tool-free	Tool-free
Depth Setting	Tool-free indexed	Tool-free indexed
Energy @ 100 psi	900 in/lbs	900 in/lbs
Tool Length	18.6"	20.74"
Tool Height	12.75"	12.75"
Tool Weight	7.5 lbs	7.6 lbs

FRAMING NAILERS



D51822

Heavy-Duty 31° Clipped Head Framing Nailer

- 7.5 lb. magnesium housing and aluminum magazine aid to provide one of the lightest nailers in the industry
- 12-3/4" height allows for toe-nailing in confined areas
- Unique engine design generates power to bury nails in both standard framing lumber and engineered lumber with minimal recoil
- Tool-free adjustable depth allows for quick and easy depth of drive setting
- Dry fire lockout extends bumper life by preventing tool from actuating when magazine is empty
- Impact resistant exhaust deflector protects tool from impacts to the cap
- Trigger lock-off allows trigger to be disabled when not in use

INCLUDES: DeWALT safety glasses and replacement bump trigger



D51844

Heavy-Duty 20° Full Round Head Framing Nailer

- 7.6 lb. magnesium housing and aluminum magazine aid to provide one of the lightest nailers in the industry
- 12-3/4" height allows for toe-nailing in confined areas
- Unique engine design generates power to bury nails in both standard framing lumber and engineered lumber with minimal recoil
- Tool-free adjustable depth allows for quick and easy depth of drive setting
- Dry fire lockout extends bumper life by preventing tool from actuating when magazine is empty
- Impact resistant exhaust deflector protects tool from impacts to the cap
- Trigger lock-off allows trigger to be disabled when not in use

INCLUDES: DeWALT safety glasses and replacement bump trigger



**For Cordless
Finish Nailers**

See pages 11 & 17

SPECIFICATIONS	D51822	D51844
Nail Style	Clipped Head	Full Round Head
Magazine Angle	31°	20°
Nail Length Capacity	2 - 3-1/2"	2 - 3-1/2"
Nail Diameter Range	.113-.131"	.113-.148"
Magazine Capacity	80 nails	65 nails
Engine Valve Type	Drop sleeve	Drop sleeve
Jam Clearing	5 mm or 3/16" Allen Key Required	Requires 5mm or 3/16" Allen Key
Dry Fire Lockout	Yes	Yes
Integrated Rafter Hook	No	No
Depth Setting	Tool-free indexed	Tool-free indexed
Energy @ 100 psi	900 in/lbs	900 in/lbs
Tool Length	18.6"	20.74"
Tool Height	12.75"	12.75"
Tool Weight	7.5 lbs	7.6 lbs

STAPLERS



D51430

Heavy-Duty 1" - 2" x 7/16" 16 Gauge Medium Crown Stapler

- Lightweight tool provides enhanced maneuverability and aids in minimizing user fatigue
- Cycle rate of 20 fasteners/second (@ 100 psi) provides a speed rating that works as fast as you do
- Low air consumption rating consumes less air per shot, allowing the tool to cycle faster and more consistently
- Clean nose area aids in more exact fastener placement
- Tool-free jam clear eliminates down-time from bent fasteners caught in the nose piece
- Tool-free indexed depth adjustment is lockable and repeatable, assisting in locating the perfect depth setting
- Tool-free 360° exhaust channels air and dust away
- Trigger lock-off allows trigger to be disabled when not in use

INCLUDES: DeWALT safety glasses, (2) Allen wrenches and replacement sequential trigger

NAILERS



D51431

Heavy-Duty 1" - 2" x 1/2" 16 Gauge Medium Crown Stapler

- Lightweight tool provides enhanced maneuverability and aids in minimizing user fatigue
- Cycle rate of 20 fasteners/second (@ 100 psi) provides a speed rating that works as fast as you do
- Low air consumption rating consumes less air per shot, allowing the tool to fire faster and more consistently
- Clean nose area aids in more exact fastener placement
- Tool-free jam clear eliminates down-time from bent fasteners caught in the nose piece
- Tool-free indexed depth adjustment is lockable and repeatable, assisting in locating the perfect depth setting
- Tool-free 360° exhaust channels air and dust away
- Trigger lock-off allows trigger to be disabled when not in use

INCLUDES: DeWALT safety glasses, (2) Allen wrenches and replacement sequential trigger

SPECIFICATIONS	D51430	D51431
Fastener Style	16 Gauge Staple	16 Gauge Staple
Crown Size	7/16"	1/2"
Fastener Length Capacity	1- 2"	1- 2"
Magazine capacity	160 Staples	160 Staples
Magazine Angle	Straight	Straight
Magazine Loading	Top Load	Top Load
Operating Pressure	70 - 120 psi	70 - 120 psi
Speed	20 Fasteners/Second @ 100psi	20 Fasteners/Second @ 100psi
Depth Setting	Tool-free indexed	Tool-free indexed
Jam Clearing	Tool-free	Tool-free
Padded Grips	Textured anti-slip	Textured anti-slip
Exhaust	360°	360°
Air Consumption	.039 scfm	.039 scfm
Firing Mode	Bump trigger installed	Bump trigger installed
Air Inlet	3/8"	3/8"
Trigger Lock Off	Yes	Yes
Tool Height	11"	11"
Tool Length	14.75"	14.75"
Tool Weight	4.5 lbs	4.5 lbs

COIL NAILER



D51321

Heavy-Duty 3/4" - 1-3/4" Coil Roofing Nailer

- Lightweight (4.9 lb) tool with a magnesium housing provides enhanced maneuverability and aids in minimizing user fatigue
- Produces a cycle rate that works as fast as you do
- Delivers the power to consistently drive nails in the toughest applications
- Tool-free depth adjustment assists in locating the perfect depth setting for precise nail penetration
- Convenient side-load canister design allows for quick and easy nail loading
- Carbide inserts in contact trip foot protect against premature wear
- Pneumatic-bias feed piston provides consistent nail feed as pressure fluctuates, minimizing skipping and jamming
- Integrated jam clearing nose door eliminates down-time from bent fasteners caught in the nose piece
- Double O-ring feed piston design provides protection against excessive feed piston wear
- Replaceable anti-skid pads aid in preventing the tool from sliding off the roof
- Nail height adjustment lever allows for quick and easy adjustments
- Hinged feed piston cover allows for quick and easy cleaning of feed piston area
- Trigger lock-off allows trigger to be disabled when not in use

INCLUDES: DeWALT safety glasses, (2) Allen wrenches and replacement sequential trigger

NAILER PARTS KITS

Finish Nailers

D512751	15 GA O-Ring Kit
D512752	15 GA Piston/Driver Assembly
D512753	15 GA Bumper Kit
D512561	16 GA O-Ring Kit
D512562	16 GA Piston/Driver Assembly
D512563	16 GA Bumper Kit
D512565	16 GA Piston/Driver Assembly
D512566	16 GA Bumper Kit
D512381	18 GA O-Ring Kit
D512382	18 GA Piston/Driver Kit
D512383	18 GA Bumper Kit
D512385	Finish Nailer Belt Hook Kit

Framing Nailers

D518004	Framing Nailer Pusher Spring Assembly
D518005	Framing Nailer O-ring Kit
D518006	Framing Nailer Bumper Kit
D518232	Clipped Head Piston/Driver assembly
D518452	Full Round Piston/Driver Assembly

Medium Crown Staplers

D514301	MC Stapler O-ring Kit
D514302	MC Stapler Piston/Driver Assembly
D514303	MC Stapler Bumper Kit
D514312	MC Stapler Piston/Driver Assembly

Coil Roofing Nailer

D513211	Coil Roofing Nailer O-ring Kit
D513212	Coil Roofing Nailer Piston/Driver Assembly
D513213	Coil Roofing Nailer Bumper Kit
D513214	Coil Roofing Nailer Anti-skid Pad Kit

OTHER

D500100	8oz. Pneumatic Nailer Oil
D500105	20oz. Pneumatic Nailer Oil
D510005	Pneumatic Nailer Trigger Valve
D510020	Pneumatic Nailer Bump Trigger
D510022	Finish Nailer Sequential Trigger
D510023	Framing Nailer Sequential Trigger
D512005	15G & 16G Overmolded No-mar pad

SPECIFICATIONS

D51321

Nail Style	Coil Roofing
Nail Diameter Range	.120"
Nail Length Capacity	3/4" - 1-3/4"
Canister Capacity	120
Operating Pressure	70-120 psi
Canister Loading	2-door side load
Nose Piece Carbide Inserts	Yes
Depth Setting	Tool-free thumb wheel
Jam Clearing	Integrated in nose door
Steel Wear Guards	Yes
Nail Platform Adjustment Lever	Yes
Hinged Feed Piston Cover	Yes
Shingle Guide	Yes
Padded Grips	Textured anti-slip
Firing Mode	Bump trigger installed
Trigger Lock Off	Yes
Tool Height	11.4"
Tool Length	10.6"
Tool Weight	4.9 lbs

COMPRESSORS

COMPRESSORS



D55155

**HEAVY-DUTY 2.75HP MAX, 1.2HP CONTINUOUS
4 GALLON ELECTRIC HAND CARRY COMPRESSOR**

HAND CARRY – ELECTRIC



D55155

Heavy-Duty 2.75 HP Max, 1.2 HP Continuous 4 Gallon Single Tank Electric Hand Carry Compressor

- 4.5 CFM delivered @ 100 PSI pump recovers in under 15 seconds
- New ergonomic design for easy portability
- Protected components for maximum durability
- Oil lubricated pump allows for increased life
- Ball valve drain allows for quick and thorough tank draining
- Convenient cord wrap for easy storage
- High-flow regulator for increased performance

INCLUDES: DEWALT compressor oil and 2 universal quick couplers



D55152

Heavy-Duty 2.7 HP Max, 1.1 HP Continuous 4 Gallon Electric Hand Carry Compressor with Control Panel

- 4.0 CFM delivered at 90 PSI pump provides rapid recovery
- Oil lubricated pump improves durability
- Cast iron cylinder enhances pump life
- High-flow regulator for increased performance
- Run multiple tools from dual universal quick couplers
- Ball valve drain allows for quick and thorough tank draining
- Convenient cord wrap for easy storage

INCLUDES: DEWALT compressor oil and control panel with two universal quick couplers



D55153

Heavy-Duty 2.75 HP Max, 1.2 HP Continuous 4 Gallon Electric Hand Carry Compressor

- 4.5 CFM delivered @ 100 PSI pump enables speedy recovery
- Oil lubricated pump improves durability
- Cast iron cylinder enhances pump life
- High-flow regulator for increased performance
- 4 gallon twin stack tank design with proven acceptance in the market
- Dual soft start valves assist in cold weather start up

INCLUDES: DEWALT compressor oil



D55151

Heavy-Duty 2.5 HP Max, 1.1 HP Continuous 4 Gallon Electric Hand Carry Compressor

- 3.2 CFM delivered @100 PSI pump enables quick recovery
- Oil lubricated pump improves durability
- Cast iron cylinder enhances pump life
- Lightweight design improves portability
- High-flow regulator for increased performance
- 4 gallon twin stack tank design proven acceptance in the market

INCLUDES: DEWALT compressor oil



SPECIFICATIONS	D55155	D55152	D55153	D55151
Drive	Direct drive	Direct	Direct drive	Direct drive
Horsepower (Max)	2.75 HP	2.7 HP	2.75 HP	2.5 HP
Horsepower (Continuous)	1.2 HP	1.1 HP	1.2 HP	1.1 HP
Tank Size	4 single ASME tank gal	4 gal	4 gal	4 gal
Power Supply	120V AC, 15 amps, 60 Hz, 2 pole induction motor	120V AC, 15 amps, 60 Hz, 2 pole induction motor	120V AC, 15 amps, 60 Hz, 2 pole induction motor	120V AC 14 amps, 60 Hz, 2 pole induction motor
CFM @100 PSI	4.5 CFM	3.8 CFM	4.5 CFM	3.2 CFM
Pump Speed	3,400 rpm	3,400 rpm	3,400 rpm	3,400 rpm
Tool Length	21.75"	18"	18"	18.5"
Tool Width	23"	18"	18.5"	15"
Tool Weight	61 lbs	65 lbs	56.5 lbs	53.32 lbs

HAND CARRY – ELECTRIC



D55150 Heavy-Duty 1.5 Max, 0.75 HP Continuous 4 Gallon Electric Hand Carry Compressor

- 2.6 CFM delivered @ 100 PSI
- Oil lubricated pump improves durability
- Cast iron cylinder enhances pump life
- 1750 RPM motor provides quiet, low vibration operation
- Low Amp draw (11 Amps) reduces risk of tripping breakers
- High-flow regulator for increased performance
- 4 Gallon twin stack tank design proven acceptance in the market
- Dual soft start valves assist in cold weather start up

INCLUDES: DeWALT compressor oil



HAND CARRY – GAS



D55250 Heavy-Duty 4 HP 4 Gallon Gas Hand Carry Compressor with Control Panel

- 4.5 CFM delivered @ 100 PSI enables speedy recovery
- 4 HP Honda OHV GX gas engine provides proven reliability and durability
- Oil lubricated pump improves durability
- Cast iron cylinder enhances pump life
- Protected components for maximum durability
- Convenient, portable compressed air - no electricity required
- High-flow regulator for increased performance
- Low oil shut off provides greater engine protection

INCLUDES: DeWALT compressor oil and 2 universal quick connect couplers



D55251 Heavy-Duty 4 HP 4 Gallon Gas Hand Carry Compressor

- 4.5 CFM delivered @ 100 PSI provides speedy recovery
- 4 HP Honda OHV GX gas engine provides proven reliability and durability
- Oil lubricated pump improves durability
- Cast iron cylinder enhances pump life
- Convenient, portable compressed air - no electricity required
- High-flow regulator for increased performance
- Low oil shut off provides greater engine protection
- Automatic idle control for reduced fuel consumption

INCLUDES: DeWALT compressor oil

SPECIFICATIONS	D55150	D55250	D55251
Drive	Direct drive	Direct drive	Direct drive
Horsepower (Max)	1.5 HP, 0.75 HP (Continuous)	4 HP	4 HP
Tank Size	4 gal	4 gal	4 gal
Power Supply	115V AC, 11 amps, 60 Hz, 4 pole induction motor	Honda gas OHV GX engine	Honda gas OHV GX engine
CFM @100 PSI	2.6 CFM	4.5 CFM	4.5 CFM
Pump Speed	1,700 rpm	3,450 rpm	3,450 rpm
Tool Length	18.5"	21.5"	18"
Tool Width	15"	18.5"	18.5"
Tool Height	16.75"	17"	17"
Tool Weight	57 lbs	68 lbs	68 lbs

WHEELED PORTABLE – GAS



D55270

Heavy-Duty 5.5 HP 8 Gallon Gas Wheeled Portable Compressor

- 8.9 CFM delivered @ 100 PSI for quick recovery
- Twin cylinder, cast iron, oil lubricated pump with Emglo's 50 years of proven durability and reliability
- 5.5 HP Honda OHV GX gas engine provides proven reliability and durability
- Low oil shut off provides greater engine protection
- Low profile design for easy maneuverability
- Ball valve drain allows for quick and thorough tank draining
- Semi-Pneumatic tire improves worksite mobility
- Automatic idle control for reduced fuel consumption

INCLUDES: DeWALT synthetic compressor oil and 3/8" NPT pressure regulator



D55271

Heavy-Duty 8 HP 8 Gallon Gas Wheeled Portable Compressor

- 16.2 CFM delivered @ 100 PSI for high volume applications
- Quad cylinder, cast iron, oil lubricated pump with Emglo's 50 years of proven durability and reliability
- 8 HP Honda OHV GX gas engine provides proven reliability and durability
- Low oil shut off provides greater engine protection
- Low profile design for easy maneuverability
- Ball valve drain allows for quick and thorough tank draining
- Semi-Pneumatic tire improves worksite mobility
- Automatic idle control for reduced fuel consumption

INCLUDES: DeWALT synthetic compressor oil and 3/8" NPT pressure regulator



D55275

Heavy-Duty 8 HP 17 Gallon Gas Wheeled Portable Compressor

- 16.2 CFM delivered @ 100 PSI for high volume usages
- Quad cylinder, cast iron, oil lubricated pump with Emglo's 50 years of proven durability and reliability
- 8 HP Honda OHV GX gas engine provides proven reliability and durability
- Low oil shut off provides greater engine protection
- Dual wheels make maneuvering easier on the worksite
- Ball valve drain allows for quick and thorough tank draining
- ASME coded 17 gallon OSHA recognized tank
- Automatic idle control for reduced fuel consumption

INCLUDES: DeWALT synthetic compressor oil and 3/8" NPT pressure regulator



D55276

Heavy-Duty 5.5 HP 17 Gallon Gas Wheeled Portable

- 8.9 CFM delivered @ 100 PSI for quick recovery
- Twin cylinder, cast iron, oil lubricated pump with Emglo's 50 years of proven durability and reliability
- 5.5 HP Honda OHV GX gas engine provides proven reliability and durability
- Low oil shut off provides greater engine protection
- Dual wheels make maneuvering easier on the worksite
- Ball valve drain allows for quick and thorough tank draining
- ASME coded 17 gallon OSHA recognized tank

INCLUDES: DeWALT synthetic compressor oil and 3/8" NPT pressure regulator



SPECIFICATIONS	D55270	D55271	D55275	D55276
Drive	Belt drive	Belt drive	Belt drive	Belt drive
Horsepower	5.5 HP	8 HP	8 HP	5.5 HP
Tank Size	8 gal	8 gal	17 gal	17 gal
Power Supply	Honda gas OHV GX engine	Honda gas OHV GX engine	Honda gas OHV GX engine	Honda gas OHV GX engine
CFM @100 PSI	8.9 CFM	16.2 CFM	16.2 CFM	8.9 CFM
Pump Speed	1,200 rpm	890 rpm	890 rpm	1,200 rpm
Tool Length	43"	43"	43"	43"
Tool Width	18.25"	18.25"	20.25"	20.25"
Tool Height	25"	27.75"	33.75"	31"
Tool Weight	160 lbs	213 lbs	238 lbs	185 lbs

WHEELED PORTABLE - ELECTRIC

D55170

Heavy-Duty 1.5 HP 8 Gallon Electric Wheeled Portable Compressor



- 6.5 CFM delivered @ 100 PSI enables quick recovery
- Twin cylinder, cast iron, oil lubricated pump with Emglo's 50 years of proven durability and reliability
- Low profile design for easy maneuverability
- On/Off constant run design for reduced breaker tripping
- Semi-Pneumatic tire improves worksite mobility
- Ball valve drain allows for quick and thorough tank draining

INCLUDES: DeWALT synthetic compressor oil and 3/8" NPT pressure regulator



D55570

Heavy-Duty 1.5 HP 8 Gallon Electric Wheeled Portable Compressor with Dual Voltage and Dual Control



- 6.5 CFM delivered @ 100 PSI for quick recovery
- Twin cylinder, cast iron, oil lubricated pump with Emglo's 50 years of proven durability and reliability
- Low profile design for easy maneuverability
- Dual control feature allows start/stop or constant run operation
- Dual voltage feature allows easy switching from 120 to 240 volt operation
- Semi-Pneumatic tire improves worksite mobility

INCLUDES: DeWALT synthetic compressor oil and 3/8" NPT pressure regulator



D55580

Heavy-Duty 2 HP 8 Gallon Electric Wheeled Portable Compressor with Dual Voltage and Dual Control



- 8.4 CFM delivered @ 100 PSI for quick recovery
- Twin cylinder, cast iron, oil lubricated pump with Emglo's 50 years of proven durability and reliability
- 2 HP motor provides increased performance
- Low profile design for easy maneuverability
- Dual control feature allows start/stop or constant run operation
- Dual voltage feature allows easy switching from 120 to 240 volt operation

INCLUDES: DeWALT synthetic compressor oil and 3/8" NPT pressure regulator



D55390

Heavy-Duty 3 HP 8 Gallon Electric Wheeled Portable Compressor with Dual Control



- 13.8 CFM delivered @ 100 PSI for high volume usage
- Quad cylinder, cast iron, oil lubricated pump with Emglo's 50 years of proven durability and reliability
- Low profile design for easy maneuverability
- Dual control feature allows start/stop or constant run operation
- Semi-Pneumatic tire improves worksite mobility
- Ball valve drain allows for quick and thorough tank draining

INCLUDES: DeWALT synthetic compressor oil and 3/8" NPT pressure regulator



COMPRESSORS

SPECIFICATIONS	D55170	D55570	D55580	D55390
Drive	Belt drive	Belt drive	Belt drive	Belt drive
Horsepower	1.5 HP	1.5 HP	2 HP	3 HP
Tank Size	8 gal	8 gal	8 gal	8 gal
Power Supply	2 pole induction motor	2 pole induction motor	2 pole induction motor	2 pole induction motor / 230 volt only
CFM @100 PSI	6.5 CFM	6.5 CFM	8.4 CFM	13.8 CFM
Pump Speed	900 rpm	900 rpm	1,070 rpm	800 rpm
Tool Length	43"	43"	43"	43"
Tool Width	18.25"	18.25"	18.25"	18.25"
Tool Height	23.5"	23.5"	23.5"	26.25"
Tool Weight	165 lbs	168 lbs	175 lbs	231 lbs



D55575

Heavy-Duty 1.5 HP 17 Gallon Electric Wheeled Portable Compressor with Dual Voltage and Dual Control

- 6.5 CFM delivered @ 100 PSI for quick recovery
- Twin cylinder, cast iron, oil lubricated pump with Emglo's 50 years of proven durability and reliability
- Dual wheels make maneuvering easier on the worksite
- Dual control feature allows start/stop or constant run operation
- Dual voltage feature allows easy switching from 120 to 240 volt operation
- Ball valve drain allows for quick and thorough tank draining
- ASME coded 17 gallon OSHA recognized tank

INCLUDES: DeWALT synthetic compressor oil and 3/8" NPT pressure regulator



D55585

Heavy-Duty 2 HP 17 Gallon Electric Wheeled Portable Compressor with Dual Voltage and Dual Control

- 8.4 CFM delivered @ 100 PSI for quick recovery
- Twin cylinder, cast iron, oil lubricated pump with Emglo's 50 years of proven durability and reliability
- 2 HP motor provides increased performance
- Dual wheels make maneuvering easier on the worksite
- Dual control feature allows start/stop or constant run operation
- Dual voltage feature allows easy switching from 120 to 240 volt operation
- Ball valve drain allows for quick and thorough tank draining
- ASME coded 17 gallon OSHA recognized tank

INCLUDES: DeWALT synthetic compressor oil and 3/8" NPT pressure regulator



D55395

Heavy-Duty 3 HP 17 Gallon Electric Wheeled Portable Compressor with Dual Control

- 13.8 CFM delivered @ 100 PSI for high volume usage
- Quad cylinder, cast iron, oil lubricated pump with Emglo's 50 years of proven durability and reliability
- 3 HP motor provides increased capacity
- Dual wheels make maneuvering easier on the worksite
- Dual control feature allows start/stop or constant run operation
- Ball valve drain allows for quick and thorough tank draining
- ASME coded 17 gallon OSHA recognized tank

INCLUDES: DeWALT synthetic compressor oil and 3/8" NPT pressure regulator



SPECIFICATIONS	D55575	D55585	D55395
Drive	Belt drive	Belt drive	Belt drive
Horsepower	1.5 HP	2 HP	3 HP
Tank Size	17 gal	17 gal	17 gal
Power Supply	2 pole induction motor	2 pole induction motor	2 pole induction motor / 230 volt only
CFM @100 PSI	6.5 CFM	8.4 CFM	13.8 CFM
Pump Speed	900 rpm	1,070 rpm	800 rpm
Tool Length	43"	43"	43"
Tool Width	20.25"	20.25"	20.25"
Tool Height	29.75"	29.75"	32"
Tool Weight	194 lbs	201 lbs	254 lbs

GENERATORS

GENERATORS

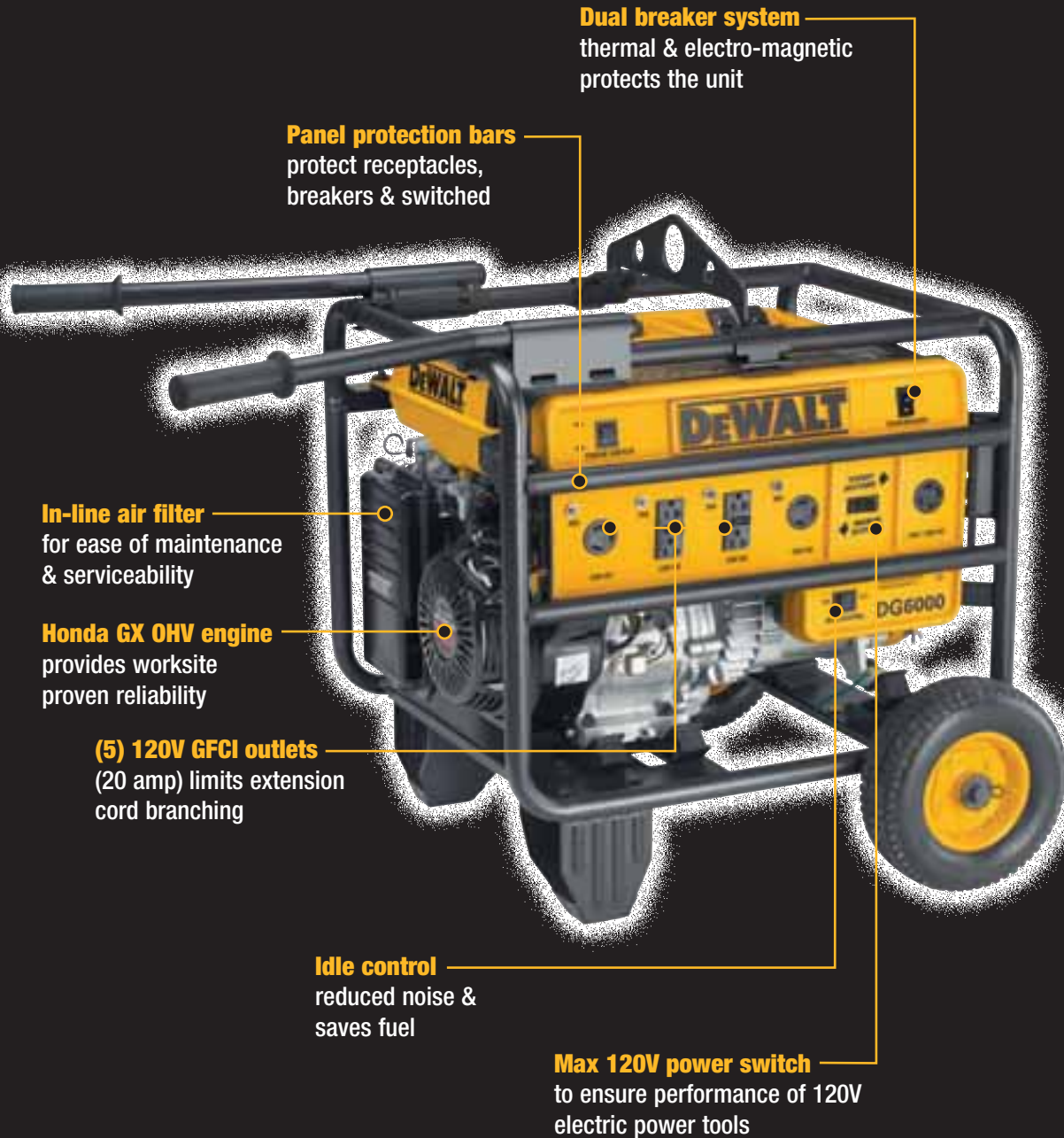

Dual breaker system

thermal & electro-magnetic
protects the unit

Panel protection bars

protect receptacles,
breakers & switched

In-line air filter

for ease of maintenance
& serviceability

Honda GX OHV engine

provides worksite
proven reliability

(5) 120V GFCI outlets

(20 amp) limits extension
cord branching

Idle control

reduced noise &
saves fuel

Max 120V power switch

to ensure performance of 120V
electric power tools

DG6000

HEAVY-DUTY 6000 WATT GAS GENERATOR



DG2900 Heavy-Duty 2900 Watt Gas Generator

- Honda 5.5 HP, OHV GX engine provide worksite reliability
- Maintenance free, brushless alternator for increased durability
- High amp surge capacity ideal for starting high amp tools
- Super quiet muffler reduces engine noise
- Low oil shut-off protects engine
- Dry Weight and dimensions do not include accessories

INCLUDES: spark plug wrench



DG4300 Heavy-Duty 4300 Watt Gas Generator

- Honda 8 HP, OHV GX engine provides jobsite reliability
- Maintenance free, brushless alternator for increased durability
- High amp surge capacity ideal for starting high amp tools including air compressors
- Maximum 120V power switch ensures peak performance of 120 and 240 volt tools
- Jobsite tested frame with panel protection bars for increased durability
- Super quiet muffler reduces engine noise
- Idle control saves fuel and reduces noise
- Low oil shut-off protects engine
- Dry Weight and dimensions do not include accessories

INCLUDES: wheel kit, handle kit, lifting hook and spark plug wrench



SPECIFICATIONS	DG2900	DG4300
Max AC Output	2900 watts	4300 watts
Rated AC Output	2400 watts	3800 watts
Max Current (120V/240V)	24.2/NA amps	35.8/17.9 amps
Alternator Type	Brushless	Brushless
Rated Current (120V/240V)	20/NA amps	31.7/15.9 amps
Honda GX Engine	5.5 HP	8 HP
Fuel Tank Capacity	3 gal	5 gal
120 Volt GFCI Receptacles (20 Amp)	2	4
120 Volt GFCI Twist Locking Receptacle (20 Amp)	1	1
120 Volt Twist Locking Receptacle (30 Amp)	0	0
120V/240V Twist Locking Receptacle (20 Amp)	0	1
120V/240V Twist Locking Receptacle (30 Amp)	0	0
Decibel, idle up (calculated 7 yards from unit)	72 dBA	70 dBA
Run-Time [@ 50% Maximum Output]	11.3 hrs	11.1 hrs
Tool Length	22.4"	24.4"
Tool Width	19.1"	21.7"
Tool Height	18.9"	20.1"
Dry Weight	99 lbs	159 lbs
Starting System	Recoil	Recoil

GAS GENERATORS



DG6000/DG6000E Heavy-Duty 6000 Watt Gas Generator

- Honda 11 HP, OHV GX engine provides worksite reliability
- Maintenance free, brushless alternator for increased durability
- High amp surge capacity ideal for starting high amp tools including air compressors
- Maximum 120V power switch ensures peak performance of 120 and 240 volt tools
- Worksite tested frame with panel protection bars for increased durability
- Super quiet muffler reduces engine noise
- Idle control saves fuel and reduces noise
- Low oil shut-off protects engine
- Dry Weight and dimensions do not include accessories

INCLUDES: wheel kit, handle kit, lifting hook and spark plug wrench
 DG6000E Includes: wheel kit, handle kit, lifting hook, spark plug wrench, housing for battery and battery not included



DG7000/DG7000E Heavy-Duty 7000 Watt Gas Generator

- Honda 13 HP, OHV GX engine provides worksite reliability
- Maintenance free, brushless alternator for increased durability
- High amp surge capacity ideal for starting high amp tools including air compressors
- Maximum 120V power switch ensures peak performance of 120 and 240 volt tools
- Worksite tested frame with panel protection bars for increased durability
- Super quiet muffler reduces engine noise
- Idle control saves fuel and reduces noise
- Low oil shut-off protects engine
- Dry Weight and dimensions do not include accessories

INCLUDES: wheel kit, handle kit, lifting hook and spark plug wrench
 DG7000E Includes: wheel kit, handle kit, lifting hook, spark plug wrench, housing for battery and battery not included



GENERATORS

SPECIFICATIONS	DG6000/DG6000E	DG7000/DG7000E
Max AC Output	6000 watts	7000 watts
Rated AC Output	5000 watts	6000 watts
Max Current (120V/240V)	50/25 amps	58.3/29.2 amps
Alternator Type	Brushless	Brushless
Rated Current (120V/240V)	41.7/20.8 amps	50/25 amps
Honda GX Engine	11 HP	13 HP
Fuel Tank Capacity	5 gal	5 gal
120 Volt GFCI Receptacles (20 Amp)	4	4
120 Volt GFCI Twist Locking Receptacle (20 Amp)	1	1
120 Volt Twist Locking Receptacle (30 Amp)	1	1
120V/240V Twist Locking Receptacle (20 Amp)	0	0
120V/240V Twist Locking Receptacle (30 Amp)	1	1
Decibel, idle up (calculated 7 yards from unit)	72 dBA	76 dBA
Run-Time [@ 50% Maximum Output]	8.2 hrs	8 hrs
Tool Length	26"	26"
Tool Width	21.7"	21.7"
Tool Height	20.5"	20.5"
Dry Weight	185 lbs	200 lbs
Starting System	Recoil	Recoil

GAS GENERATORS

RELIABILITY



The Honda GX series delivers jobsite reliability with a dependable easy-starting engine.



DeWALT's brushless alternator delivers increased reliability and durability due to less wearing between moving parts.

PERFORMANCE



The brushless alternator's high amp surge capacity drives more power especially during start up of larger pieces of equipment.



DeWALT's control panel contains a large number of outlets, intuitive max 120/240 volt which insures peak performance of your tool.



DeWALT's wheel kit comes standard with all DeWALT generators (except DG2900) for increased portability around jobsites.



Super quiet muffler reduces unwanted noise on jobsite.

DURABILITY



DeWALT generators feature a 1-1/8" frame, strong enough to withstand jobsite abuse by protecting against overhead and side impacts.



The DeWALT generator has an electromagnetic main breaker to protect the alternator and thermal breakers to protect the individual outlets.



The semi-pneumatic wheels, reinforced stands and 1-1/8" handles makes the DeWALT wheel kit the most durable on the market.

GENERATOR WATTS CALCULATOR

AMPS	COMMON POWER TOOLS	WATTS
15	Chop Saw	1800
15	Circular Saw	1800
19	Concrete Vibrators	2280
12	Recip. Saw	1440
5.5	3/8" Drill	660
7.9	1/2" Drill	950
15	Miter Saw	1800
7.5	Small Grinder	900
15	Large Grinder	1800
15	3 HP Compressor	1800
8	Stud & Joist Drill	960
9.5	1-1/2" Rotary Hammer	1140
6.0	Drywall Gun	720
7.5	1/2" Impact Driver	900

TOTAL AMPS	X 120 (Volts) =	TOTAL WATTS	(Watts needed from generator)
------------	-----------------	-------------	-------------------------------

Steps to purchasing the correct size generator

1. Add up the total number of amps required for all tools.
2. Multiply total number of amps required by volts. (120 volts are standard)
3. This will give you the total number of watts required to operate your tools.

NOTE: Most tools operate at 70% of the maximum power so the total number of watts may be overstated.

MACHINERY

MACHINERY

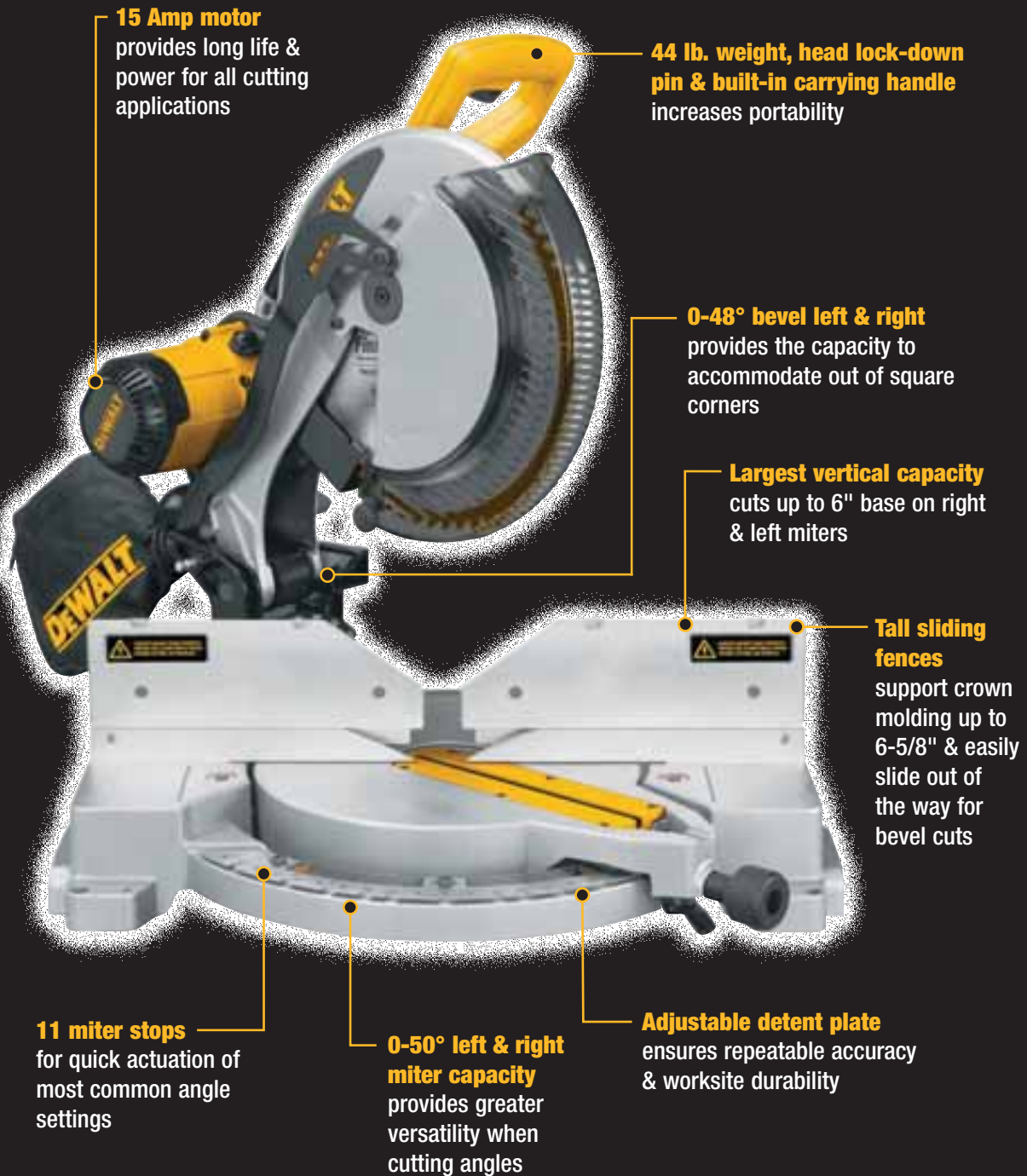

15 Amp motor
provides long life &
power for all cutting
applications

**44 lb. weight, head lock-down
pin & built-in carrying handle**
increases portability

0-48° bevel left & right
provides the capacity to
accommodate out of square
corners

Largest vertical capacity
cuts up to 6" base on right
& left miters

**Tall sliding
fences**
support crown
molding up to
6-5/8" & easily
slide out of
the way for
bevel cuts

11 miter stops
for quick actuation of
most common angle
settings

**0-50° left & right
miter capacity**
provides greater
versatility when
cutting angles

Adjustable detent plate
ensures repeatable accuracy
& worksite durability

For Saw Blades

See page 141



DW706

HEAVY-DUTY 12" DOUBLE BEVEL COMPOUND MITER SAW

MITER SAWS



DW703

Heavy-Duty 10" (254 mm) Compound Miter Saw

- Tall sliding fence supports crown molding vertically up to 4-1/2" and easily slides out of the way for bevel cuts
- 0-50° miter ability for greater capacity in all cutting applications
- 11 positive miter stops allow for quick settings and improved accuracy
- Steel-on-steel detent plate and pin offers repeatable accuracy and worksite durability
- 0-48° bevel delivers increased capacity for out-of-square corners
- 33 lb weight, head lock-down pin and built-in carrying handle for increased portability
- 15.0 Amp motor, 5,000 rpm provides enough power for all cutting applications
- Works great with the DW723 miter saw stand

INCLUDES: carbide blade, dust bag and blade wrench



DW705S

Heavy-Duty 12" (305mm) Compound Miter Saw

- Bevels 0-45° to the left with the ability to bevel to 48° for increased capacity
- 0-48° miter (left and right) for greater versatility cutting angles
- Extra-tall sliding fence allows 5-1/4" crown moldings to be cut standing vertically
- Easy-to-read stainless-steel miter scale with nine positive stops for ease and accuracy
- Lightweight (40 lbs.) with built-in carry handle for easy portability
- Electric brake
- Works great with the DW723 miter saw stand

INCLUDES: carbide blade, extension kit and dust bag



DW706

Heavy-Duty 12" (305mm) Double-Bevel Compound Miter Saw

- Gearbox and belt-drive design aid in delivering vertical capacity up to 6" base and 6-5/8" crown molding
- Double-bevel with positive bevel stops at crown molding settings, 0°, and 45° left and right - allows user to flip the saw not the material
- 0-50° left and right miter capacity for greater versatility cutting angles
- Quick bevel overrides provide capacity to bevel up to 48° both left and right to accommodate out of square corners
- Tall sliding fence supports crown molding up to 6-5/8" and easily slides out of the way for bevel cuts
- 44 lb weight, head lock-down pin, and built-in carrying handle increases portability
- 15.0 Amp, 4,000 rpm motor provides enough power for all cutting applications
- Works great with the DW723 miter saw stand

INCLUDES: carbide woodworking blade, dust bag and blade wrench



SPECIFICATIONS	DW703	DW705S	DW706
Amps	15.0 Amps	15.0 Amps	15.0 Amps
No Load Speed	5,000 rpm	4,000 rpm	4,000 rpm
Blade Diameter	10"	12"	12"
Arbor Size	5/8"	5/8" or 1"	5/8" or 1"
Vertical Capacity: Baseboard Against Fence	3-1/2"	4-1/4"	6"
Vertical Capacity: Crown Molding Vertically Nested	4-1/2"	5-1/4"	6-5/8"
Horizontal Capacity: Baseboard Lying Flat	6"	8"	8"
Horizontal Capacity: Crown Molding Lying Flat	5-1/4"	6-1/2"	6-1/2"
45° Bevel Cut Capacity (dimensional lumber)	2" x 6"	2" x 8"	2" x 8" left & right
90° Cross-Cut Capacity (dimensional lumber)	4" x 4"	4" x 6"	4" x 6"

MITER SAWS



DW712

Heavy-Duty 8-1/2" Single-Bevel Sliding Compound Miter Saw

- Cuts 3-1/2" crown nested vertically for increased vertical cutting capacity
- Cuts 3-1/4" base vertically for increased vertical cutting capacity
- Left miter capacity 50 and Right capacity 60 provides great versatility in miter cutting
- 11 positive miter stops provides improved accuracy
- Adjustable detent plate provides improved accuracy
- Easy to use bevel stops at 0, -2, 33.9, 45, 48
- Miter cam lock system provides increased comfort
- Horizontal main handle provides increased comfort during use
- Tall sliding fence provides increased cutting capacity

INCLUDES: carbide blade and blade wrench



DW708

Heavy-Duty 12" (305mm) Double-Bevel Sliding Compound Miter Saw

- Crosscut capacity of 12" at 90° and an extra-high fence to cut molding up to 5-1/4" standing vertically
- Tall sliding fence easily slides out of the way for bevel cuts
- Miters 50° to the left and 60° to the right for increased capacity for all worksite applications
- Bevels 45° left and right, with the ability to bevel to 48°, allowing the user to flip the saw, not the work, saving time and increasing productivity
- Easy-to-read stainless-steel miter scale has 11 positive stops for quick actuation of most common angle settings

INCLUDES: carbide blade and blade wrench



DW723

Heavy-Duty Miter Saw Stand

- Universal design works with all brands of miter saws
- Lightweight aluminum construction (35 lbs.) allows for easy transport to and from the jobsite
- 5-1/2' beam extends to support up to 16 ft. of material and up to 400 lbs.
- Legs provide superior support and fold for easy storage
- Work stops/supports can be repositioned quickly anywhere along the rail
- Non-marring feet on tool mount will not scratch material

INCLUDES: 2 convertible work supports/stops

For Saw Blades

See page 141



SPECIFICATIONS	DW712	DW708
Amps	15 Amps	15.0 Amps
No Load Speed	5400 rpm	4,000 rpm
Blade Diameter	8-1/2"	12"
Arbor Size	5/8"	5/8" or 1"
Vertical Capacity: Baseboard Against Fence	3-1/4"	4 1/4"
Vertical Capacity: Crown Molding Vertically Nested	3-1/2"	5 1/4"
Horizontal Capacity: Baseboard Lying Flat	11.8"	12"
Horizontal Capacity: Crown Molding Lying Flat	11.8"	9"
45° Bevel Cut Capacity (dimensional lumber)	2" x 12"	2" X 12"
90° Cross-Cut Capacity (dimensional lumber)	2" x 12"	4" X 12"

SPECIFICATIONS	DW723
Tool Width	10-1/4"
Tool Height	7-1/2"
Tool Weight	35.0 lbs

MITER SAWS ACCESSORIES



CLEANER WORK AREA

DW7053 Dustbag

SMOOTH CUTS

Carbide Tipped Saw Blades

EXACT CUTS

DW7054 Crown Stops

SECURE CLAMPING

DW7052 Material Clamp

REPETITIVE CUTS

DW7051 Length Stop

ADDED WORK SUPPORT

DW7050 Extension Kit

DW7050

Extension Kit (for DW705)

- Provides additional support for your material
- Stores by sliding under base
- Includes 1 pair of 20" rods, end plate and all mounting hardware



DW7051

Length Stop

(for all DeWALT Miter Saws)

- Makes repetitive cuts of the same length
- Adjusts 0-42" from the blade on one DW7050 or DW7080 extension support system



DW7052

Material Clamp (for DW705)

- Clamps the work piece against the fence



DW7053

Dust Bag

(for all DeWALT Miter Saws)

- Universal dust bag fits all DeWALT® miter saws



DW7054

Crown Stops (for DW705)

- Accurately positions crown molding vertically against the saw fence
- Includes 2 stops, one for each side of the blade

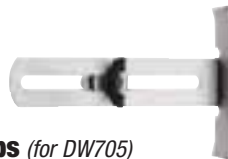

DW7055

Miter Saw Replacement Kerf Plate

(for DW703, DW705S and DW706)

- Durable plastic uncut plate for easy replacement
- Limits blade tear out



DW7080

Extension Kit

(for DW703, DW706, DW708)

- Provides additional support for your material
- Stores by sliding under base
- Includes 1 pair of 20" rods, end plate and all mounting hardware



DW7082

Vertical Clamp

(for DW703, DW706, DW708)

- Clamps the work piece against the fence



DW7084

Crown Stops

(for DW703, DW706, DW708)

- Accurately positions crown molding vertically against the saw fence
- Includes 2 stops, one for each side of the blade



	DW7050	DW7080	DW7051	DW7084	DW7052	DW7082	DW7053	DW7054	DW7055
DW705S	X		X		X		X	X	X
DW708		X	X	X		X	X		
DW706		X	X	X		X	X		X
DW703		X	X	X		X	X		X

MACHINERY

PORTABLE TABLE SAW



DW744S

Heavy-Duty 10" Portable Table Saw with Stand

- Exclusive, telescoping fence delivers 24-1/2" rip capacity without sacrificing portability
- Rack and pinion design makes fence adjustments fast, smooth and accurate ensuring that the fence is always parallel to the blade
- Telescoping rails retract within the saw top for easy portability
- Features a 15.0 Amp high-torque motor with the power to cut pressure-treated lumber and hardwoods
- Features heavy-duty internal motor mechanism which stabilizes the arbor, keeping vibration to a minimum
- Dust Collection Port easily connects to a vacuum for efficient dust extraction

INCLUDES: 10" 24-tooth carbide blade, portable table saw stand (DW7440) and miter gauge



DW7440 Portable Table Saw Stand

- All-metal construction
- Folds up for easy storage
- Lightweight and durable



DW7441 Out Feed and Side Support

- Provides added material support for large work pieces
- Sliding support rods store under table top
- All-metal construction
- Includes both out feed support and side support systems



DW7444 Dado Throat Plate

- Allows for use of stacked dado cutters



PORTABLE THICKNESS PLANER



DW734

Heavy-Duty 12-1/2" Thickness Planer with Three Knife Cutter-Head

- Powerful 15AMP, 10,000RPM motor handles larger, deeper cuts in hardwoods
- Three knife cutter-head provides 96 cuts per inch, one of the finest finishes of any portable planer
- Disposable, reversible knives deliver 30% more knife life and make knife change fast and easy
- Four-column carriage lock drastically reduces the movement that causes snipe
- Extra-long infeed and outfeed tables provide 33-1/2" of material support
- Material removal gauge and thickness scale deliver accurate cuts with every pass
- Turret depth stop allows users to return to their most frequently used depths with ease

INCLUDES: dust hood



DW7342 12-1/2" Disposable, Reversible Planer Knives

- M2 laminated tool steel stays sharper and lasts longer than conventional knife materials
- Machined locator pins make alignment of new knives fast and easy



DW7331 Dust Hood

(for use with the Dust Collection System)

- Includes adaptor for use with shop vacuum
- For use with DW733 & DW734



DW7332 Replacement Knives for DW734

- M2 laminated high speed tool steel keeps a sharp edge longer
- Knives can be resharpened multiple times saving on the cost of replacing knives
- Provides fast and easy knife change which saves time



SPECIFICATIONS

DW744S

Amps	15.0 Amps
No Load Speed	3,650 rpm
Blade Diameter	10"
Arbor Size	5/8"
Dust Port Diameter	2-1/4"
Depth Of Cut At 90°	3-1/8"
Depth Of Cut At 45°	2-1/4"
Max Rip To Right Of Blade	24-1/2"
Max Rip To Left Of Blade	15-1/2"
Max Width Of Dado	13/16"

SPECIFICATIONS

DW734

Amps	15 Amps
No Load Speed	10,000 rpm
Max. Depth of Cut	1/8"
Depth Capacity	6"
Width Capacity	12-1/2"
Tool Weight	80 lbs

PORTABLE THICKNESS PLANER



DW735

Heavy-Duty 13" Three Knife, Two Speed Thickness Planer

- Powerful 15MP, 10,000RPM motor handles larger cuts in wider materials with ease
- Three knife cutter-head delivers 30% longer knife life and makes knife change faster and easier
- Two speed gear box allows users to change feed speed to optimizing cuts per inch at 96 or 179 CPI
- Fan-assisted chip ejection vacuums chips off of the cutter-head and exhausts them out of the machine
- 19-3/4" cast aluminum base is 2X more rigid than a standard 10" base and folding tables
- Automatic carriage lock reduces the movement that causes snipe without the need for manual engagement by the user
- Material removal gauge and extra-large thickness scale deliver accurate cuts with every pass
- Extra-large turret depth stop allows users to return to most frequently used thicknesses with ease

INCLUDES: dust hose adapter and dust ejection chute



DW7350

Mobile Thickness Planer Stand

- Maximum versatility
- Durable and stable under heavy loads.
- Easy movement and storage of planer and stand

INCLUDES: mobile base, stand, hardware, MDF top and shelf



DW7351

13" Folding Tables

(for DW735 Planer)

- Productivity
- Performance

INCLUDES: two tables and hardware kit



DW7352

13" Disposable, Reversible Thickness Planer Knives

- M2 laminated tool steel stays sharper and lasts longer than conventional tool steel
- Machined locator holes help users align knives on cutter-head during knife change



DW7353

Chip Collector

(for DW735 Planer)

- Easy installation
- Inexpensive alternative to motorized dust collection system
- Versatility to work with most all trash cans
- Durable materials provide longer life

INCLUDES: chip collection bonnet with tube and hose clamp



SPECIFICATIONS

DW735

Amps	15 Amps
No Load Speed	10,000 rpm
Max. Depth of Cut	1/8"
Depth Capacity	6"
Width Capacity	13"
Tool Weight	92 lbs

SCROLL SAW



DW788 Heavy-Duty 20" Variable-Speed Scroll Saw

- Double parallel-link arm design dramatically reduces vibration and noise, for extremely accurate cuts
- Exclusive tool-free blade clamps allow blade changes in seconds
- On-off switch, electronic variable speed, flexible dust blower and blade-tensioning lever are all located on the front upper arm for added convenience
- Arm design pivots from the back of the saw to the front, shortening the arm movement for smoother, quieter operation
- Arm lifts so blade can be easily threaded through the material for inside cuts
- Unique arm design keeps the blade perpendicular to the work, dramatically reducing over or under cutting
- Oversized, cast-iron table provides excellent material support and bevels 45° left and right

INCLUDES: hex wrench and blades



DW7881 Worklight

- Flexible neck for easy positioning
- 25-watt bulb included



DW7880 Scroll Saw Stand

- All-metal construction
- Adjustable legs



WOODWORKERS TABLE SAW



DW746/DW746X Heavy-Duty 10" Woodworker's Table Saw

- Accurate, dependable fence. The DeWalt Precision Rip Fence delivers smooth action, solid locking and always travels parallel to the blade, making precise adjustments quickly and easily
- Massive cast iron trunnion provides solid arbor support delivering smooth, accurate cutting performance
- Blade elevation crank has plenty of hand clearance to make blade-height adjustments quick and easy. Accurate blade-angle adjustments are also easy thanks to the large, adjustable bevel scale and the graduated bevel crank (each revolution equals a 2° adjustment)
- The large, easy-access on/off switch eliminates fumbling around when you're ready to start or stop cutting operations
- Powerful and space efficient, the 1-3/4 HP TEFC induction motor provides the power you need to cut the toughest hardwoods. And unlike other saws in the category, the motor is located in board and out of your way, making it easy to store against the wall when not in use
- Easy dust collection, the DW746 is equipped with a dust collection port making it easy to connect your saw to your vacuum or dust-collection system
- DW746 does not include rail system

INCLUDES: 10" 30-tooth blade and miter gauge

DW746X Includes: 10" 30-tooth blade, miter gauge and 30" rails



SPECIFICATIONS	DW788
Amps	1.3 Amps
Strokes/Min	400-1,750 spm
Stroke Length	3/4"
Depth Of Cut (inches)	2"
Tool Weight	56 lbs

SPECIFICATIONS	DW746/DW746X
Horsepower	1-3/4 HP
No Load Speed	3,000 rpm
Blade Diameter	10"
Arbor Size	5/8"
Dust Port Diameter	2-1/2"
Depth Of Cut At 90°	3-1/8"
Depth Of Cut At 45°	2-1/8"
Max Rip To Right Of Blade	with DW7468: 30", Saw with DW7464: 52"
Max Rip To Left Of Blade	16"
Max Width Of Dado	13/16"

WOODWORKERS TABLE SAW ACCESSORIES



Sliding table accessory option. Unique, high-capacity/high-accuracy sliding table cross-cutting system delivers 30" of cross-cutting capacity at 90°, and makes large, angled cross-cuts quick and easy. When not in use, this unit stores away without leaving any cumbersome mounting hardware in your way. A solid ground, cast-iron table, industrial slides and a precision mitering guide delivers the quality and accuracy you demand.



DW7468 30" Precision Fence Rail System

- Precision ground fence rail
- Pre-applied precision rip scale



DW7466 Dado Throat Plate

- Allows for use of stacked dado cutters

DW7461 Heavy-Duty Sliding Table

- 30" cross-cut capacity at 90°
- Precision machined cast iron table, 16-3/8" x 27"
- Industrial self cleaning slides
- DeWALT® precision mitering guide 21" at 45°
- Quick action lock and release

DW7463 Heavy-Duty Out feed Table

- Provides additional material support
- Adjustable leveling feet
- Heavy-duty construction



DW7462 Heavy-Duty Cast Iron Extension Wing

- Precision machined cast iron
- 10" x 27"



DW7469 Low Profile Fence Face Attachment

- Low Face for cutting material with overhanging laminate

DW7460 Heavy-Duty Mobile Base

- Heavy-duty all metal construction
- Quick foot action lock and release
- Fits both 30" and 52" DeWALT® Fence Rail Systems

DW7464 52" Precision Fence Rail System

- Precision ground fence rail
- Pre-applied precision rip scale
- Table board included

WOODWORKING

2-1/4 HP (max motor HP)

EVS soft start motor

has power to rout smoothly through the toughest hardwoods

Dust-sealed switch

provides increased durability

Micro fine adjustment ring

for highly accurate adjustments in 1/64" increments

Spindle lock

allows for one-wrench bit change

Precision machined die-cast aluminum base & LEXAN® sub base

increases accuracy & extends durability

Detachable cord set

increases durability & no need for short cord motor

Through-the-column dust extraction

for a cleaner work environment

Tool-free adjustable motor cam lock with quick-release motor latches makes depth adjustment & base changes easy & provides solid locking

Micro-fine depth adjustment (5/128" per turn) for accurate depth setting

DW6183B

HEAVY-DUTY 2-1/4 HP (MAX MOTOR HP) EVS THREE BASE ROUTER KIT

LEXAN® is a registered trademark of General Electric Company

ROUTERS



DW616/DW616K/DW616M 1-3/4 HP (max. motor HP) Fixed Base Router

- 1-3/4 HP (maximum motor HP), 11 amp motor provides the power to rout smoothly through the toughest hardwoods
- Micro-fine depth adjustment ring provides precise depth adjustments in 1/64" increments and adjusts vertically for a constant switch/cordset location
- Adjustable, tool-free steel motor cam lock makes depth adjustment and base changes quick and solid-locking
- Quick release motor latches for fast and easy motor pack removal for bit and base changes

INCLUDES: DW616M Motor Pack, DW6184 Fixed Base, 1/4" and 1/2" collets, Sub-base concentricity gauge and 2 wrenches

DW616K Includes: same as DW616 and heavy-duty kit box

DW616M Includes: DW616M Motor Pack, 1/4" and 1/2" collets and 2 wrenches



DW616D 1-3/4 HP (max. motor HP) D-Handle Router

- 1-3/4 HP (maximum motor HP), 11 amp motor provides the power to rout smoothly through the toughest hardwoods
- Micro-fine depth adjustment ring provides precise depth adjustments in 1/64" increments and adjusts vertically for a constant switch/cordset location
- Adjustable, tool-free steel motor cam lock makes depth adjustment and base changes quick and solid-locking
- Quick release motor latches for fast and easy motor pack removal for bit and base changes
- Detachable cordset offers cordset serviceability and removes the need for a "shorty" cord motor pack

INCLUDES: DW616M Motor Pack, DW6183 D-Handle Base, 1/4" and 1/2" collets and 2 wrenches



DW616PK 1-3/4 HP (max. motor HP) Fixed Base / Plunge Router Combo Kit

- 1-3/4 HP (maximum motor HP), 11 amp motor provides the power to rout smoothly through the toughest hardwoods
- Micro-fine depth adjustment ring provides precise depth adjustments in 1/64" increments and adjusts vertically for a constant switch/cordset location
- Adjustable, tool-free steel motor cam lock makes depth adjustment and base changes quick and solid-locking
- Quick release motor latches for fast and easy motor pack removal for bit and base changes
- Integral, through-the-column dust collection collects 95% of the dust and provides superior bit visibility

INCLUDES: DW616M Motor Pack, DW6184 Fixed Base, DW6182 Plunge Base, 1/4" and 1/2" collets, 2 wrenches, sub-base concentricity gauge, vacuum adaptor and heavy-duty kit box



SPECIFICATIONS	DW616/DW616K	DW616M	DW616D	DW616PK
Amps	11 Amps	11 Amps	11 Amps	11 Amps
Horsepower	1-3/4 HP	1-3/4 HP	1-3/4 HP	1-3/4 HP
No Load Speed	24,500 rpm	24,500 rpm	24,500 rpm	24,500 rpm
Collet Diameter	1/2", 1/4"	1/2", 1/4"	1/2", 1/4"	1/2", 1/4"
Plunge Stroke	n/a	n/a	n/a	2 1/2"
Depth Stop	Micro-fine Ring	Micro-fine Ring	Micro-fine Ring	Micro-fine Ring
Base Dimension	6"	6"	6"	6"
Tool Weight	7.1 lbs	5.5 lbs	7.1 lbs	10.0 lbs

ROUTERS



DW618/DW618K/DW618M 2-1/4 HP (max. motor HP) EVS Fixed Base Router with Soft Start

- 2-1/4 HP (maximum motor HP), 12 amp electronic variable speed motor provides the power to rout smoothly through the toughest hardwoods
- Electronic variable speed with full feedback control for constant speed under load from 8,000-24,000 rpm and soft start to reduce start-up torque for enhanced control
- Micro-fine depth adjustment ring provides precise depth adjustments in 1/64" increments and adjusts vertically for a constant switch/cordset location
- Adjustable, tool-free steel motor cam lock makes depth adjustment and base changes quick and solid-locking
- Quick release motor latches for fast and easy motor pack removal for bit and base changes

INCLUDES: DW618M Motor Pack, DW6184 Fixed Base, 1/4" and 1/2" collets and wrench
 DW618K Includes: DW618M Motor Pack, DW6184 Fixed Base, 1/4" and 1/2" collets, wrench, sub-base concentricity gauge, large hole sub base and heavy-duty kit box
 DW618M Includes: DW618M Motor Pack, 1/4" and 1/2" collets and Wrench



DW618D 2-1/4 HP (max. motor HP) EVS D-Handle Router with Soft Start

- 2-1/4 HP (maximum motor HP), 12 amp electronic variable speed motor provides the power to rout smoothly through the toughest hardwoods
- Electronic variable speed with full feedback control for constant speed under load from 8,000-24,000 rpm and soft start to reduce start-up torque for enhanced control
- Micro-fine depth adjustment ring provides precise depth adjustments in 1/64" increments and adjusts vertically for a constant switch/cordset location
- Adjustable, tool-free steel motor cam lock makes depth adjustment and base changes quick and solid-locking
- Quick release motor latches for fast and easy motor pack removal for bit and base changes

INCLUDES: DW618M Motor Pack, DW6183 D-Handle Base, 1/4" and 1/2" collets and wrench



DW618PK 2-1/4 HP (max. motor HP) EVS Fixed Base / Plunge Router Combo Kit w/ Soft Start

- 2-1/4 HP (maximum motor HP), 12 amp electronic variable speed motor provides the power to rout smoothly through the toughest hardwoods
- Electronic variable speed with full feedback control for constant speed under load from 8,000-24,000 rpm and soft start to reduce start-up torque for enhanced control
- Micro-fine depth adjustment ring provides precise depth adjustments in 1/64" increments and adjusts vertically for a constant switch/cordset location
- Adjustable, tool-free steel motor cam lock makes depth adjustment and base changes quick and solid-locking
- Integral, through-the-column dust collection collects 95% of the dust and provides superior bit visibility

INCLUDES: DW618M Motor Pack, DW6184 Fixed Base, DW6182 Plunge Base, 1/4" and 1/2" collets, wrench, sub-base concentricity gauge, large hole sub-base, vacuum adaptor and heavy-duty kit box

SPECIFICATIONS	DW618/DW618K	DW618M	DW618D	DW618PK
Amps	12 Amps	12 Amps	12 Amps	12 Amps
Horsepower	2-1/4 HP	2-1/4 HP	2-1/4 HP	2-1/4 HP
No Load Speed	8,000-24,000 rpm	8-24,000 rpm	8,000-24,000 rpm	8,000-24,000 rpm
Collet Diameter	1/2", 1/4"	1/2", 1/4"	1/2", 1/4"	1/2", 1/4"
Plunge Stroke	n/a	n/a"	n/a	2 1/2"
Depth Stop	Micro-fine Ring	Micro-fine Ring	Micro-fine Ring	Micro-fine Ring
Base Dimension	6"	6"	6"	6"
Spindle Lock	Yes	Yes	Yes	Yes
Tool Weight	7.2 lbs	5.6 lbs	7.2 lbs	10.1 lbs



DW618B3

Heavy-Duty 2-1/4 HP (max. motor HP) Three Base Router Kit

- 2-1/4 HP (maximum motor HP), 12 amp electronic variable speed motor provides the power to rout smoothly through the toughest hardwoods
- Electronic variable speed with full feedback control for constant speed under load from 8,000-24,000 rpm and soft start to reduce start-up torque for enhanced control
- Micro-fine depth adjustment ring provides precise depth adjustments in 1/64" increments and adjusts vertically for a constant switch/cordset location
- Adjustable, tool-free steel motor cam lock makes depth adjustment and base changes quick and solid-locking
- Integral, through-the-column dust collection collects 95% of the dust and provides superior bit visibility

INCLUDES: DW618M Motor Pack, DW6184 Fixed Base, DW6182 Plunge Base, DW6183 D-Handle Base, 1/4" and 1/2" collets, wrench, sub-base concentricity gauge, large hole



DW621/DW621K

Heavy-Duty 2 HP (max. motor HP) EVS Plunge Router

- Full wave electronic variable speed motor with soft start runs at 8,000-24,000 rpm with constant speed under load to ensure a quality finish in all materials
- Rack and pinion depth adjuster, with micro-fine adjusting allows quick, accurate set ups
- Only plunge router with built-in dust extraction through the column, removes 95% of the dust
- Spindle lock button allows one-wrench bit changes
- Innovative rubber-coated knobs have plunge-lock and on/off built-in for maximum user control
- 1/4" - 1/2" collet capacity for greater versatility

INCLUDES: 1/4" and 1/2" collets, template guide bushing adapter and wrench
 DW621K Includes: edge guide w/dust collection, 1/4" and 1/2" collets, template guide bushing adapter, wrench and heavy-duty kit box



DW625

Heavy-Duty 3 HP (max. motor HP) VS Electronic Plunge Router

- 15.0 Amp motor uses state of the art circuitry for soft starts and smooth operation
- Full wave electronic variable speed motor runs at 8,000-22,000 rpm with constant speed under load to ensure a quality finish in all materials
- Rack and pinion depth adjuster, magnified scale and micro-fine bit depth adjuster provides fast and accurate depth settings
- Phosphorous bronze bushings provides a smooth and accurate plunge
- Spindle lock button allows one-wrench bit changes
- Dust extraction adapter for cleaner work sites
- 1/4" - 1/2" collet capacity for greater versatility
- Guide Bushing adapter plate accepts standard guide bushings for template work
- One piece motor shaft and spindle ensures perpendicularity and accuracy

INCLUDES: 1/4" collet, 1/2" collet, dust extraction adapter, template guide bushing adapter and wrench



SPECIFICATIONS	DW618B3	DW621/DW621K	DW625
Amps	12 Amps	10.0 Amps	15.0 Amps
Horsepower	2-1/4 HP	2 HP	3 HP
No Load Speed	8,000-24,000 rpm	8,000-24,000 rpm	8,000-22,000 rpm
Collet Diameter	1/2", 1/4"	1/4", 1/2"	1/4", 1/2"
Plunge Stroke	2 1/2"	2-1/8"	2-7/16"
Depth Stop	Micro-fine Ring	3 Stage Turret Stop	3 Stage Turret Stop
Base Dimension	6"	4-5/16 x 6-1/4"	5-5/8 x 6-11/16"
Spindle Lock	Yes	Yes	Yes
Tool Weight	10.1 lbs	9.0 lbs	11.2 lbs

ROUTER ACCESSORIES

FOR USE WITH DW616 AND DW618 ROUTERS

DW6182
Plunge Base



DW6183
D-Handle Base



DW6184
Fixed Base



DW6185
Detachable Cordset



DW6186
Spindle Lock



DW6187
Guide Bushing Base Plate



- Allows for one or two wrench bit changes
- Can be easily retrofitted to DW616 Routers

- For use on DW616/618 Fixed and D-Handle Bases

DW6189
Large Hole Base Plate



- For use on DW616/618 Fixed and D-Handle Bases

DW6190
Guide Bushing Single D Base Plate



- For use on DW616/618 Plunge Base

DW6191
Large Hole Single D Base Plate



FOR USE WITH DW616/618/621 ROUTERS



DW6212 – 1/2" Collet
DW6214 – 1/4" Collet
DW6238 – 3/8" Collet

- Longer length minimizes run out & reduces vibration
- Slotted on eight sides

FOR USE WITH DW621 ROUTER (ONLY)

DW6956
Fine Depth Adjuster



- Fine tunes the depth setting on router for precise cuts
- Ideal for use when router is mounted in a table

FOR USE WITH DW625 ROUTER (ONLY)



DW6902 – 1/4" Collet
DW6904 – 3/8" Collet
DW6905 – 1/2" Collet

- Longer length minimizes run out & reduces vibration
- Slotted on eight sides

DW6966
Fine Depth Adjuster



- Fine tunes the depth setting on router for precise cuts
- Ideal for use when router is mounted in a table

FOR USE WITH ALL DeWALT ROUTERS

DW6188
Template Guide Set



- Nine-piece, precision-machined steel template guide set
- Universal standard size for all DeWALT routers as well as any router that accepts a standard 1-3/16" outside diameter template guide
- Includes: (5/16" OD x 1/4" ID x 5/32" L), (3/8" OD x 9/32" ID x 5/16" L), (7/16" OD x 11/32" ID x 5/32" L), (1/2" OD x 13/32" ID x 5/32" L), (5/8" OD x 17/32" ID x 5/8" L), (3/4" OD x 21/32" ID x 9/16" L), (51/64" OD x 5/8" ID x 9/16" L) and 2 Lock Nuts

DW6913
Universal Edge Guide with Dust Collection



- For use with all DeWALT® routers
- Straight guide with fine fence adjuster for precision positioning of the parallel fence
- Attaches to standard shop vacuum cleaners (1-1/4", 1-3/8" and 1-1/2")

TRIM ROUTERS



DW673K Heavy-Duty Trim Router Kit

- Precision-machined, cast-aluminum bases for increased accuracy
- Tool-free base change, height and edge guide adjustment for quick changes without the need for a tool
- Adjustable ball-bearing and plate guide follower allow use with straight or template work
- Spindle lock button allows one-wrench bit changes
- Off-set base for tighter spaces for trimming backsplashes or scribing

INCLUDES: Standard Trim Base, 0-45° Tilt Base, Off-Set Base, 5" Round Base, Solid Surface Skis, ball-bearing guide, Plate Guide Follower, 1/4" collet, wrench and heavy-duty kit box



DW670 Heavy-Duty Fixed Base Trim Router

- Precision-machined, cast-aluminum fixed base for increased accuracy
- Adjustable ball-bearing and plate guide follower allow use with straight or template work
- Tool-free base change, height and edge guide adjustment for quick changes without the need for a tool
- Spindle lock button allows one-wrench bit changes

INCLUDES: 1/4" Collet and Wrench



DW6703 5" Round Base

- Use with DW670 base and DW6705 replacement base



DW6704 Solid Surface Skis

- Use with DW670 to level solid surface seam adhesive



DW6705 Standard Base

- Replacement base for DW670
- Ball-bearing guide
- Machined 360° tilt base
- Micro-fine depth adjustment



DW6706 Tilt Base

- Accessory base for DW670
- Machined 360° tilt base
- 45° tilt in either direction
- Micro-fine depth adjustment



DW6707 Offset Base

- Accessory base for DW670
- Machined 360° tilt base
- Plate guide follower
- Belt driven



DW6708 Seaming Base

- Accessory base for DW670
- Machined 360° tilt base
- Micro-fine depth adjustment
- 1/8", 1/4", 5/16", 3/8" bit scale

SPECIFICATIONS	DW673K	DW670
Amps	5.6 Amps	5.6 Amps
Horsepower	7/8 HP	7/8 HP
No Load Speed	30,000 rpm	30,000 rpm
Collet Diameter	1/4"	1/4"
Spindle Lock	Yes	Yes
Tool Weight	3.6 lbs	3.6 lbs

ROUTERS



DW682K Heavy-Duty Plate Joiner Kit

- 6.5 Amp, 10,000 rpm motor provides power for the hardest woods
- Dual rack and pinion fence ensures blade and fence are always parallel for accurate joints every time
- Integral one-piece fence is adjustable and tilts 0-90°
- Flush cuts can be made at 0° without removing fence
- 45° locating notch in fence allows indexing off the outside surface of a mitered joint
- Non-marring, heavy-duty aluminum shoe allows joiner to be clamped for stationary work

INCLUDES: carbide blade, dust bag, vacuum adapter, Torx® key, wrench and heavy-duty kit box



DW6805 Plate Joiner Carbide Blade

- 4" diameter, 6 tooth

PLANER



DW680K Heavy-Duty 3-1/4" Planer Kit with 3/32" (2.5mm) Depth of Cut

- Heavy-Duty 7.0 amp motor provides a smooth, even finish in the hardest of woods
- 3/32" (2.5 mm) maximum cut in one pass reduces the amount of passes on your material
- Accepts large resharpenable high speed steel blades for straight edging or framing applications
- Calibrated Depth Adjustment Knob for accurate depth setting and eliminating the need to re-zero your depth
- Also accepts reversible carbide blades for more detailed, accurate woodworking

INCLUDES: two reversible carbide blades, rabbeting fence and heavy-duty kit box



DW6654 Pair Of Carbide Planer Blades

- For use with DW677K, DW680K or DW678K
- Reversible carbide straight blades
- Sharpening on both sides allows reversal for longer life



DW6655 High Speed Steel Blades

- For use with DW680K
- Resharpenable



DW6658 Reversible Carbide Planer Blades

- For use with DW675K
- Reversible carbide straight blades

DW6659 Planer Bevel Gauge

- For use with DW675K
- Bevel gauge enables cuts of 0-45°

SPECIFICATIONS	DW682K
Amps	6.5 Amps
No Load Speed	10,000 rpm
Depth Of Cut (mm)	20 mm
Arbor Size	7/8"
Fence Type	Dual Rack and Pinion
Biscuits Accepted	0, 10, 20
Tool Weight	6.6 lbs

SPECIFICATIONS	DW680K
No Load Speed	15,000 rpm
Amps	7.0 Amps
Depth Of Cut (mm)	2.5 mm
Depth Of Cut (inches)	3/32"
Planing Width	3-1/4"
Rabbeting Depth	1/2"
Tool Weight	6.2 lbs

SANDERS



DW411/DW411K

Heavy-Duty 1/4 Sheet Palm Grip Sander

- 2.0 Amp motor moves at 13,500 opm, providing a superior finish
- Dual plane, counter-balanced low-vibration design reduces user fatigue
- Dust-sealed switch prevents contamination
- Sealed 100% ball-bearing construction

INCLUDES: dust bag and sandpaper punch

DW411K Includes: same as DW411 and heavy-duty kit box



DW4111

Dust Extraction Adapter

- Fits 1-1/4" (32mm), 1-3/8" (35mm) & 1-1/2" (38mm) standard vacuum hoses



DW421/DW421K

Heavy-Duty 5" Random Orbit Sander

- Provides maximum sanding speed for smooth finishes
- Controlled Finishing System® maintains pad speed and minimizes gouging during start up
- Dual-plane counter-balanced fan reduces user fatigue
- Dust-sealed switch prevents contamination
- Sealed 100% ball-bearing construction
- Accepts 5", 8-hole hook and loop™ paper
- Shop vacuum adapter for maximum dust collection

INCLUDES: dust bag and vacuum adapter

DW421K Includes: dust bag, vacuum adapter and heavy-duty kit box



DW423/DW423K

Heavy-Duty 5" Random Orbit Sander With Electronic Variable Speed

- Electronic variable speed from 7,000-12,000 opm provides greater control of material removal rate
- Controlled Finishing System™ maintains pad speed and minimizes gouging during start up
- Dual-plane counter-balanced fan reduces user fatigue
- Dust-sealed switch prevents contamination
- Sealed 100% ball-bearing construction
- Accepts 5", 8-hole hook and loop™ paper
- Shop vacuum adapter for maximum dust collection

INCLUDES: dust bag and vacuum adapter

DW423K Includes: dust bag, vacuum adapter and heavy-duty kit box



SPECIFICATIONS	DW411/DW411K	DW421/DW421K	DW423/DW423K
Amps	2.0 Amps	2.0 Amps	2.0 Amps
Orbits/Min	13,500 opm	12,000 opm	7,000-12,000 opm
Orbit Diameter	1/16"	3/32"	3/32"
Dust Collection	Yes	Yes	Yes
Paper Size/Type	1/4 Sheet	5", 8 Hole Hook & Loop™	5", 8 Hole Hook & Loop™
Dust Sealed Switch	Yes	Yes	Yes
Pad	N/A	DW4388	DW4388
Tool Weight	2.3 lbs	3.0 lbs	3.2 lbs

SANDERS



DW420 Heavy-Duty Random Orbit Palm Sander

- Controlled Finishing System™ maintains pad speed and minimizes gouging during start up
- Dual-plane counter-balanced fan reduces user fatigue
- 2.0 Amp motor operates at 12,000 opm, providing maximum sanding speed for smooth finishes
- Sealed 100% ball-bearing construction provides longer life
- Dust-sealed switch prevents contamination
- Uses 5" pressure sensitive adhesive paper



DW443 Heavy-Duty 6" Right Angle Random Orbit Sander With Electronic Variable Speed



- Electronic variable speed from 4,300-6,800 opm provides greater control of material removal rate
- Controlled Finishing System® maintains pad speed and minimizes gouging during start up
- Dual-plane counterbalanced fan reduces user fatigue
- Sealed 100% ball-bearing construction
- Accepts 6", 6-hole hook and loop paper
- Rubber-coated gear case for low vibration operation

INCLUDES: dust bag and side handle



DW4390 Dust Extraction Adapter

- Dust-free sanding
- Fits 1-1/4" (32mm), 1-3/8" (35mm) & 1-1/2" (38mm) standard vacuum hoses

DW4382–DW4395 Replacement Pads for Random Orbit Sanders

CAT#	DW420	DW421	DW422	DW423	DW443	DW444	SIZE/TYPE
	DW4382**	X					
DW4385**		X	X	X			5" PSA*, Medium, eight holes
DW4388**		X	X	X			5" Hook & Loop, Medium, eight holes
DW4389		X	X	X			5" Hook & Loop, Hard, eight holes
DW4392					X	X	6" PSA*, Medium, six holes
DW4395					X	X	6" Hook & Loop, Medium, six holes

* Pressure Sensitive Adhesive ** Includes CFS pad brake replacement disc

SPECIFICATIONS	DW420	DW443
Amps	2.0 Amps	4.3 Amps
Orbits/Min	12,000 opm	4,300-6,800 opm
Orbit Diameter	3/32"	3/16"
Dust Collection	No	Yes
Paper Size/Type	5" PSA™	6", 6 Hole Hook & Loop™
Dust Sealed Switch	Yes	Yes
Pad	DW4382	DW4395
Tool Weight	3.0 lbs	5.7 lbs

SANDERS



DW432 Heavy-Duty 3" X 21" Belt Sander

- Powerful 8AMP motor aggressively removes material in a variety of applications
- All-metal housing increases durability during a drop
- Three wheel design delivers lowest center of gravity and longest 3" X 21" platen available
- Innovative dust collection system is 20% more efficient than conventional dust bags
- Dust collection shut-off valve eliminates dust stream toward users when collector is not in use
- Two position front handle increases user comfort
- Top exit cord allows for easy use of overhead receptacles
- Rubber grips reduce vibration

INCLUDES: belt sander and sanding belt



DW433/DW433K Heavy-Duty 3" X 21" Variable Speed Belt Sander

- Powerful 8AMP motor aggressively removes material in a variety of applications
- All-metal housing increases durability during a drop
- Three wheel design delivers lowest center of gravity and longest 3" X 21" platen available
- Variable speed dial allows users to optimize belt speed for specific applications
- Innovative dust collection unit is 20% more efficient than conventional dust bags
- Dust collection shut-off valve eliminates dust stream toward users when collector is not in use
- Two position front handle increases user comfort
- Top exit cord allows for easy use of overhead receptacles

INCLUDES: belt sander and sanding belt
DW433K Includes: same as DW433 and heavy-duty kit box



DW433KT 3" x 21" VS Belt Sander with kit box and Inversion Stand/Frame

- Powerful 8AMP motor aggressively removes material in a variety of applications.
- All-metal housing increases durability during a drop.
- Three wheel design delivers lowest center of gravity and longest 3" X 21" platen available.
- Variable speed dial allows users to optimize belt speed for specific applications.
- Innovative dust collection unit is 20% more efficient than conventional dust bags.
- Dust collection shut-off valve eliminates dust stream toward users when collector is not in use.

INCLUDES: belt sander, sanding belt, DW4055 inversion stand & frame and heavy-duty kit box



DW4050 Vacuum Adapter



- Easy to install on either sander
- Minimizes dust allowed in shop environment
- For use with DW432 & DW433

DW4055 Sanding Frame & Inversion Stand

- Legs have machined holes for bench mounting
- Quick attach clip system
- Large depth adjustment knob
- Maximum versatility in the shop
- Includes: sanding frame, two legs and hardware



SPECIFICATIONS	DW432	DW433/DW433K	DW433KT
Amps	8.0 Amps	8.0 Amps	8.0 Amps
Dust Collection	Yes	Yes	Yes
Paper Size/Type	3" x 21"	3" x 21"	3" x 21"
SFPM	1,400	850 - 1,400	850 - 1,400
Dust Sealed Switch	No	No	No
Tool Weight	12.0 lbs	12.0 lbs	12.0 lbs

SAWS



Keyless blade change
allows for quick & easy
blade changing

Powerful 10.0 Amp motor
designed for heavy-duty
applications

4 Position Blade Clamp
allows for flush cutting
and increased versatility

2,800 SPM & 1-1/8"
stroke length
for fast cutting



Position 1



Position 2



Position 3



Position 4

**For Reciprocating
Saw Blades**

See page 117



DW304PK

HEAVY-DUTY RECIPROCATING SAW KIT

RECIPROCATING SAWS



DW309K Heavy-Duty Reciprocating Saw Kit

- Powerful 11.8 Amp motor designed for heavy-duty applications
- Lever-action keyless blade clamp allows for quick and easy blade changing
- Counter-balance mechanism minimizes vibration and reduces user fatigue
- 0-2,900 strokes per minute and 1-1/4" stroke length deliver fast cutting
- Variable speed dial and trigger provide efficient cutting speed with improved control
- Push-button adjustable shoe easily adjusts depth of cut and extends blade life

INCLUDES: metal cutting blade and heavy-duty kit box



DW307MK Heavy-Duty Reciprocating Saw Kit

- Powerful 10.5 Amp motor designed for heavy-duty applications
- Lever-action keyless blade clamp for quick and easy blade changing
- 0-2,800 strokes per minute and 1-1/4" stroke length deliver fast cutting
- Push-button adjustable shoe easily adjusts depth of cut and extends blade life
- Variable speed trigger provides improved control

INCLUDES: metal cutting blade and heavy-duty kit box



DW304PK Heavy-Duty Reciprocating Saw Kit

- 4 Position Blade Clamp allows for flush cutting and increased versatility
- Powerful 10.0 Amp motor designed for heavy-duty applications
- Lever-action keyless blade clamp for quick and easy blade changing
- 0-2,800 strokes per minute and 1-1/8" stroke length deliver fast cutting
- Variable speed trigger provides improved control

INCLUDES: metal cutting blade and heavy-duty kit box



SAWS

SPECIFICATIONS	DW309K	DW307MK	DW304PK
Amps	11.8 Amps	10.5 Amps	10.0 Amps
Strokes/Min	0-2,900 spm	0-2,800 spm	0-2,800 spm
Stroke Length	1-1/4"	1-1/4"	1-1/8"
Keyless Blade Clamp	Yes	Yes	Yes
4 Position Blade Clamp	N/A	N/A	Yes
Counter Balance	Yes	N/A	N/A
Adjustable Shoe	Yes	Yes	Fixed
Variable Speed Dial	Yes	N/A	N/A
Tool Length	17.5"	17.5"	17.5"
Tool Weight	8.4 lbs	7.7 lbs	7.0 lbs

CIRCULAR SAWS



DW368/DW368K Heavy-Duty 7-1/4" (184mm) Lightweight Circular Saw

- 9.5 lb. lightweight tool designed to reduce user fatigue and increase productivity
- 15 Amp, 2,200 MWO motor powerful enough for the toughest applications
- 56° beveling capacity with stops at 45° and 22.5° allows for aggressive bevel cuts while allowing user to locate common angles quickly
- Magnesium shoe designed for increased durability
- Clear line of sight aids in blade visibility from any angle
- Lower guard design improves performance when making bevel cuts and cutting shims

INCLUDES: carbide tipped blade and blade wrench
DW368K Includes: same as DW368 and heavy-duty kit box



DW369CSK Heavy-Duty 7-1/4" (184 mm) Lightweight Circular Saw Kit with High Strength Base and Electric Brake

- Innovative high strength base will withstand a 1 story drop
- 9.8 lbs lightweight tool designed to reduce user fatigue and increase productivity
- 15 Amp, 2,200 MWO motor powerful enough for the toughest applications
- 56° beveling capacity with stops at 45° and 22.5° allows for aggressive bevel cuts while allowing user to locate common angles quickly
- Clear line of sight aids in blade visibility from any angle
- Electric brake stops blade after use

INCLUDES: carbide tipped blade, blade wrench and heavy-duty kit box



DW364/DW364K Heavy-Duty 7-1/4" (184mm) Circular Saw with Rear Pivot Depth of Cut Adjustment and Electric Brake

- Rear pivot depth of cut adjustment allows your hand to remain behind the tool at all depth of cuts
- Powerful 15.0 Amp, 2,075 MWO motor made for long life and difficult applications
- Heavy-gauge, high-strength aluminum alloy base for increased durability on worksite
- 50° beveling capacity increases capacity in various applications
- Electric brake stops blade after use

INCLUDES: carbide tipped blade and blade wrench
DW364K Includes: same as DW364 and heavy-duty kit box



DW384 Heavy-Duty 8-1/4" (210mm) Circular Saw with Rear Pivot Depth of Cut Adjustment and Electric Brake

- Rear pivot depth of cut adjustment allows your hand to remain behind the tool at all depth of cuts
- 15.0 Amp, high-torque motor for increased productivity
- 50° bevel capacity increases range of applications
- Heavy-gauge, high-strength aluminum alloy base for increased durability on worksite
- Electric brake stops blade after use

INCLUDES: carbide tipped blade and blade wrench



SAWS

SPECIFICATIONS	DW368/DW368K	DW369CSK	DW364	DW384
Amps	15.0 Amps	15.0 Amps	15.0 Amps	15.0 Amps
Max Watts Out	2,200 W	2,200 W	2,075 W	2,075 W
No Load Speed	5,800 rpm	5,800 rpm	5,800 rpm	5,800 rpm
Bevel Capacity	56°	56°	50°	50°
Bevel Stops	45° / 22.5°	45° / 22.5°	N/A	N/A
Rear Pivot	N/A	N/A	Yes	Yes
Electric Brake	N/A	Yes	Yes	Yes
Blade Diameter	7-1/4"	7-1/4"	7-1/4"	8-1/4"
Depth Of Cut At 90°	2-3/8"	2-3/8"	2-7/16"	2-15/16"
Depth Of Cut At 45°	1-3/4"	1-3/4"	1-7/8"	2-1/4"



**DW378G/DW378GT/DW378GK
Heavy-Duty 7-1/4" (184mm) High-Torque Framing Saw**

- Lightweight - 13.0 lbs. for decreased user fatigue
- 15.0 Amp, high-torque motor for increased productivity
- 50° bevel capacity increases range of applications
- Integrated saw hook to hang tool on rafters/trusses
- High-strength cast aluminum base with integral stiffeners provides superior durability
- Lower guard design improves performance when making bevel cuts and cutting shims

INCLUDES: carbide tipped framing blade, grounded plug and blade wrench
 DW378GT Includes: same as DW378G and twist lock cordset
 DW378GK Includes: same as DW378G and heavy-duty kit box

UL I NOM-ANCE SPS OSHA DW378GT ☺



**DW321K
Heavy-Duty Top Handle Jig Saw Kit**

- 5.8 Amp motor moves blade at 500-3,100 spm providing power and speed control for the most demanding cutting applications
- Keyless blade change system accepts universal and t-shank blades
- Unique counter-balance mechanism and rubber grip provide smooth operation and reduce user fatigue
- Keyless adjustable shoe slides forward, backward and bevels 0-45° in both directions to allow cutting in tighter places, flush cuts and bevel cuts
- 4-position orbital action allows for cutting versatility in various materials

INCLUDES: 2 cobalt steel blades and heavy-duty kit box

UL □ NOM-ANCE SPS OSHA



**DW318K
Heavy-Duty Jig Saw**

- 4.5 Amp motor moves blade at 0-3,100 spm to provide the power and speed control for demanding cutting applications
- 4-position orbital action allows for cutting versatility in various materials
- 1" stroke provides greater cutting capacity
- Variable speed trigger allows user to match blade speed with the application
- 100% ball-bearing construction provides superior durability
- Shoe bevels 45° in both directions for beveled cuts

INCLUDES: Allen key, blade and heavy-duty kit box

UL SPS □ OSHA



**DW313
Heavy-Duty Jig Saw**

- 4.5 Amp motor moves blade at 0-3,100 spm providing power and speed control for demanding cutting applications
- 1" stroke provides greater cutting capacity
- Variable speed trigger allows the user to match the blade speed with the application
- 100% ball-bearing construction provides superior durability
- Shoe bevels 45° in both directions for beveled cuts

INCLUDES: Allen key and blade

UL SPS □ OSHA

SPECIFICATIONS	DW378G
Amps	15.0 Amps
Max Watts Out	2,000 W
No Load Speed	4,600 rpm
Bevel Capacity	50°
Blade Diameter	7-1/4"
Depth Of Cut At 90°	2-7/16"
Depth Of Cut At 45°	1-7/8"
Integrated Saw Hook	Yes
Tool Weight	13.0 lbs

SPECIFICATIONS	DW321K	DW318K	DW313
Amps	5.8 Amps	4.5 Amps	4.5 Amps
Strokes/Min	500-3,100 spm	0-3,100 spm	0-3,100 spm
Stroke Length	1"	1"	1"
Keyless Blade Clamp	Yes	N/A	N/A
Dust Blower	Yes	N/A	N/A
Orbital Action	4 position	4 position	N/A
Tool Weight	6.4 lbs	6.2 lbs	6.2 lbs

METALWORKING

Powerful 6 Amp motor
delivers enough power for
jobsite applications

Speed control knob
allows the user to tailor
the blade speed for the
application

Superior ergonomics
soft grip handle provides
greater user comfort &
allows the user to make
a more accurate cut



Innovative sight light
allows user to see the
cut line in dark jobsite
environments

4-3/4" cutting capacity
deep cut capacity allows
the user to cut 4-3/4"
round or rectangular stock

Rubber bumpers
allow aluminum castings
to withstand jobsite
abuse without damage

Lightweight at 15 lbs.
designed to reduce user fatigue

METALWORKING

D28770

HEAVY-DUTY DEEP CUT VSR BAND SAW

BAND SAWS



D28770/D28770K Heavy-Duty Deep Cut Variable Speed Band Saw

- Rubber bumpers protect casting from jobsite abuse
- Lightweight and well-balanced design allows for more accurate cuts
- Innovative sight light allows the user to see cut line in any jobsite environment
- Powerful 6 amp motor designed to withstand jobsite applications
- 4-3/4" deep cut capacity for round or rectangular stock
- Dual bearing blade guide rollers increase durability in the blade support system
- Durable and adjustable material guide allows the user to adjust for various jobsite materials
- Large front handle allows for more hand space and control
- Ergonomic soft grip handle provides comfort during use
- Externally replaceable brushes allow for quick repairs on the jobsite
- Speed control knob allows user to tailor the blade speed for various applications
- Integrated hang hook allows user to hang the saw without damaging front handle or castings

INCLUDES: hex wrench and standard 44-7/8"x1/2"x.020" blade
D28770K includes: same as D28770 and heavy-duty kit box



Sight Light



Integrated Hang Hook



Rubber Bumpers



Bi-Metal Portable Bandsaw Blades

- Matrix II High Speed Steel Edge For Heat & Wear Resistance
- 8% Cobalt Content For Added Durability & Wear
- Rc 65-67 Tooth Hardness For Increased Wear Resistance
- Alloy Steel Backer For Fatigue Resistance

PORTABLE BAND SAW BLADES

DW3981*	10 TPI Portable Band Saw Blade (.020" 3 pack)
DW3982*	14 TPI Portable Band Saw Blade (.020" 3 pack)
DW3983*	18 TPI Portable Band Saw Blade (.020" 3 pack)
DW3984*	24 TPI Portable Band Saw Blade (.020" 3 pack)
DW3985*	10/14 TPI Portable Band Saw Blade (.020" 3 pack)
DW3986*	14/18 TPI Portable Band Saw Blade (.020" 3 pack)
DW3987	10 TPI Portable Band Saw Blade (.025" 3 pack)
DW3988	14 TPI Portable Band Saw Blade (.025" 3 pack)
DW3989	18 TPI Portable Band Saw Blade (.025" 3 pack)
DW3991	10/14 TPI Portable Band Saw Blade (.025" 3 pack)
DW3992	14/18 TPI Portable Band Saw Blade (.025" 3 pack)

*Also available in quantities of 100

SPECIFICATIONS	D28770
Amps	6.0 Amps
Ft./Min.	82 - 280'
Max Capacity (Rectangular)	4-3/4"
Max Capacity (Round)	4-3/4"
Tool Length	21"
Tool Weight	15.0 lbs

SMALL ANGLE GRINDERS



DW400

Heavy-Duty 4-1/2" (115mm) Small Angle Grinder

- 5.0 Amp AC, 10,000 rpm motor provides power and speed for 4-1/2" grinding applications
- 2 position removable side handle for greater comfort and control
- Spindle lock for quick and easy wheel changes
- 5/8"-11 spindle thread accepts a wide range of 4-1/2" accessories

INCLUDES: grinding wheel, wrench, backing flange, clamp nut, guard and 2 position side handle



DW402/DW402K

Heavy-Duty 4-1/2" (115mm) Small Angle Grinder

- 7.5 Amp AC/DC, 10,000 rpm motor provides high power, overload protection and speed for 4-1/2" grinding applications
- Metal gear case dissipates heat for longer bearing, gear and motor life
- Convenient paddle switch with lock-on button for easier gripping
- 3 position removable side handle for greater comfort and control

INCLUDES: grinding wheel, wrench, matched flanges, guard and 3 position side handle
DW402K Includes: same as DW402 and heavy-duty kit box



DW802/DW802G

Heavy-Duty 4-1/2" (115 mm) Small Angle Grinder

- 9.0 Amp AC/DC, 10,000 rpm motor designed for faster material removal and higher overload protection
- Keyless adjustable guard can be adjusted without the use of tools
- Side positioned spindle lock button for easier wheel changing and protection from top hits to tool
- Low profile, air-cooled gearcase allows tool to get into tighter spaces
- Automatic turn-off brushes shut down the tool when brushes need to be changed to avoid tool damage
- Dust sealed switch for longer switch life against dust ingestion

INCLUDES: grinding wheel, wrench, matched flanges, keyless adjustable guard and 2 position side handle

DW802G Includes: same as DW802 and grounded plug & no lock-on



DW818/DW821

Heavy-Duty 4-1/2" (115mm) Small Angle Grinder

- 9.0 Amp AC/DC, 11,000 rpm motor for higher power in all 4-1/2" grinding applications
- Keyless adjustable guard can be adjusted without the use of tools
- Rubber grip side handle provides increased comfort and reduced user felt vibration
- Automatic turn-off brushes shut down the tool when brushes need to be changed to avoid tool damage
- Dust sealed sliding switch provides long life in high dust ingestion applications

DW818: 4-1/2" small angle grinder

DW821: 5" small angle grinder

INCLUDES: grinding wheel, wrench, matched flanges, keyless adjustable guard and 2 position rubber grip side handle



SPECIFICATIONS	DW400	DW402/DW402K	DW802/DW802G	DW818/DW821
Amps	5.0 AC Amps	7.5 AC/DC Amps	9.0 AC/DC Amps	9.0 AC/DC Amps
Max Watts Out	650 W	820 W	1000 W	995 W
No Load Speed	10,000 rpm	10,000 rpm	10,000 rpm	11,000 rpm
Use Wheels RPM Above	11,000 rpm	11,000 rpm	11,000 rpm	12,100 rpm
Spindle Lock	Yes	Yes	Yes	Yes
Spindle Thread	5/8"-11	5/8"- 11	5/8"-11	5/8"-11
Tool Length	10.25"	10.33"	11.5"	11.4"
Tool Weight	4.5 lbs	4.5 lbs	5.1 lbs	4.8 lbs

SMALL ANGLE GRINDERS

DW824

Heavy-Duty 5" (125mm) High Power Small Angle Grinder



- 12.0 Amp AC/DC, 11,000 rpm motor provides higher power and speed for 5" grinding applications
- Keyless adjustable guard can be adjusted without the use of tools
- Rubber grip side handle provides increased comfort and reduced user felt vibration
- Automatic turn-off brushes shut down the tool when brushes need to be changed to avoid tool damage
- Dust sealed sliding switch provides long life in high dust ingestion applications

INCLUDES: grinding wheel, wrench, matched flanges, keyless adjustable guard and 2 position rubber grip side handle



DW827

Heavy-Duty 6" (150mm) Cut-Off Tool / Small Angle Grinder



- 12.0 Amp AC/DC, 9,000 rpm motor provides high power and speed for 6" grinding and cutting applications
- Keyless adjustable guards can be adjusted without the use of tools
- Rubber grip side handle provides increased comfort and reduced user felt vibration
- Automatic turn-off brushes shut down the tool when brushes need to be changed to avoid tool damage
- Dust sealed sliding switch provides long life in high dust ingestion applications

INCLUDES: grinding wheel, cutting wheel, wrench, matched flanges, keyless adjustable type 27 guard, keyless adjustable type 1 guard and 2 position rubber grip side handle



DW828

Heavy-Duty 6" (150mm) Cut-Off Tool w/ Paddle Switch



- 9.0 Amp AC/DC, 9,000 rpm motor provides power and speed for 6" cutting applications
- Paddle switch with safety lock-off cannot be locked on
- Keyless adjustable guard can be adjusted without the use of tools
- Anti-lockup flanges eliminate wheel lock-up and allows user to change wheel without tools
- Side positioned spindle lock button for easier wheel changing and protection from top hits to tool
- Low profile, air-cooled gearcase allows tool to get into tighter spaces

INCLUDES: cutting wheel, wrench, anti-lockup flanges, keyless adjustable guard and 2 position rubber grip side handle



MEDIUM ANGLE GRINDERS

DW831

Heavy-Duty 5" (125mm) Medium Angle Grinder



- 12.0 Amp AC/DC, 10,000 rpm motor provides high speed for fast material removal
- High power-to-weight ratio for greater efficiency and reduced user fatigue
- Keyless adjustable guard can be adjusted without the use of tools
- Rear handle design for greater comfort and control
- External brush doors for easy servicing
- Sealed ball and roller bearings for extended motor life

INCLUDES: grinding wheel, wrench, backing flange, clamp nut, keyless adjustable guard and 2 position side handle



SPECIFICATIONS	DW824	DW827	DW828	DW831
Amps	12.0 AC/DC Amps	12.0 AC/DC Amps	9.0 AC/DC Amps	12.0 AC/DC Amps
Max Watts Out	1,300 W	1,300 W	1000 W	1,837 W
No Load Speed	11,000 rpm	9,000 rpm	9,000 rpm	10,000 rpm
Use Wheels RPM Above	12,100 rpm	9,900 rpm	9,900 rpm	11,000 rpm
Spindle Lock	Yes	Yes	Yes	Yes
Spindle Thread	5/8"-11	5/8"-11	5/8"-11	5/8"-11
Tool Length	11.75"	11.75"	11.5"	14.33"
Tool Weight	4.9 lbs	4.9 lbs	6.0 lbs	7.4 lbs

MEDIUM ANGLE GRINDERS



DW840

Heavy-Duty 7" (180mm) Medium Angle Grinder

- 13.0 Amp AC/DC, 8,000 rpm motor provides high power and speed for 7" grinding applications
- High power-to-weight ratio for greater efficiency and reduced user fatigue
- Keyless adjustable guard can be adjusted without the use of tools
- Rear handle design for greater comfort and control
- External brush doors for easy servicing
- Sealed ball and roller bearing for extended motor life

INCLUDES: grinding wheel, wrench, backing flange, clamp nut, keyless adjustable guard and 2 position side handle



LARGE ANGLE GRINDERS



D28474W

Heavy-Duty 7" (180mm) Large Angle Grinder

- High power 4 HP (maximum motor HP) 8,000 rpm motor with overload protection provides higher operating speeds under load
- Epoxy coated field and armature provide long service life against abrasion from airborne debris
- Keyless adjustable guard allows for guard adjustments to be made without tools
- Low profile gearcase allows for work in tight areas
- Automatic turn-off brushes shut down the tool when brushes need to be changed to avoid tool damage

INCLUDES: 7" guard, 5 position side handle and 7" grinding wheel



D28493N

Heavy-Duty 9" (230mm) Large Angle Grinder

- High power 4 HP (maximum motor HP) 5,000 rpm motor with overload protection provides higher operating speeds under load
- Epoxy coated field and armature provide long service life against abrasion from airborne debris
- Keyless adjustable guard allows for guard adjustments to be made without tools
- Low profile gearcase allows for work in tight areas
- Automatic turn-off brushes shut down the tool when brushes need to be changed to avoid tool damage

INCLUDES: 9" guard and 5 position side handle



D28494N

Heavy-Duty 9" (230mm) Large Angle Grinder

- High power 4 HP (maximum motor HP) 6,000 rpm motor with overload protection provides higher operating speeds under load
- Epoxy coated field and armature provide long service life against abrasion from airborne debris
- Keyless adjustable guard allows for guard adjustments to be made without tools
- Low profile gearcase allows for work in tight areas
- Automatic turn-off brushes shut down the tool when brushes need to be changed to avoid tool damage
- 5 position side handle provides improved ergonomics for specific applications

INCLUDES: 9" guard and 5 position side handle



SPECIFICATIONS	DW840	D28474W	D28493N	D28494N
Amps	13.0 AC/DC Amps	15.0 AC/DC Amps	15.0 AC/DC Amps	15.0 AC/DC Amps
Max Watts Out	2,250 W	3,084 W	3,084 W	3,084 W
No Load Speed	8,000 rpm	8,000 rpm	5,000 rpm	6,000 rpm
Use Wheels RPM Above	8,500 rpm	8,500 rpm	5,500 rpm	6,600 rpm
Spindle Lock	Yes	Yes	Yes	Yes
Spindle Thread	5/8"-11	5/8"-11	5/8"-11	5/8"-11
Tool Length	16.1"	19.2"	19.2"	19.2"
Tool Weight	8.0 lbs	13.15 lbs	13.6 lbs	13.6 lbs

LARGE ANGLE GRINDERS

D28494S

Heavy-Duty 7" (180mm) Large Angle Grinder



- High power 4 HP (maximum motor HP) 6,000 rpm motor with overload protection provides higher operating speeds under load
- Epoxy coated field and armature provide long service life against abrasion from airborne debris
- Keyless adjustable guard allows for guard adjustments to be made without tools
- Low profile gearcase allows for work in tight areas
- Automatic turn-off brushes shut down the tool when brushes need to be changed to avoid tool damage
- 5 position side handle provides improved ergonomics for specific applications

INCLUDES: 7" guard and 5 position side handle



D28497

Heavy-Duty 7" / 9" Large Angle Sander



- High power 4 HP (maximum motor HP) 6,000 rpm motor with overload protection provides higher operating speeds under load
- Epoxy coated field and armature provide long service life against abrasion from airborne debris
- Durable magnesium gearcase is easy to control
- Automatic turn-off brushes shut down the tool when brushes need to be changed to avoid tool damage
- 3 position side handle provides improved ergonomics for specific applications

INCLUDES: 3 position side handle



D28499X

Heavy-Duty 7" & 9" 5.3 HP Large Angle Grinder



- High power 5.3 HP (maximum motor HP) 6,000 rpm motor with overload protection provides higher operating speeds under load
- Epoxy coated field and armature provide long service life against abrasion from airborne debris
- Keyless adjustable guards allow for guard adjustments to be made without tools
- Rotating rear handle provides improved ergonomics in cutting and grinding applications
- Automatic turn-off brushes shut down the tool when brushes need to be changed to avoid tool damage

INCLUDES: 7" & 9" guards and 5 position side handle



ACCESSORY APPLICATION INFORMATION	7" Type 27 Grinding Wheel	9" Type 27 Grinding Wheel	6" Abrasive Cup Stone	4" Abrasive Cup Stone	6" Wire Wheel	4" Wire Cup Brush	6" Wire Cup Brush	7" Diamond Cup Wheel	7" Sanding Flap Disc	7" Sanding Disc	9" Sanding Disc	7" Type 1 Diamond or Abrasive Wheel
D28493N 5,000 RPM												
D28494S 6,000 RPM												
D28494N 6,000 RPM												
D28474W 8,000 RPM												
D28499X 6,000 RPM												
D28497 6,000 RPM												
NOTE:	Must be used with D284937 guard	Must be used with D284939 guard	Must be used with D284936 guard	Must be used with D284934 guard	Must be used with D284937/ D284939 guard	Must be used with D284837/ D284934 guard	Must be used with D284937/ D284936 guard	Must be used with D284937 guard	Must be used with D284937 guard	Must be used with D284937 guard		Must be used with D284931 guard
	<input checked="" type="checkbox"/> Optimal		<input type="checkbox"/> Capable				<input type="checkbox"/> Can Not Be Used					

SPECIFICATIONS	D28494S	D28497	D28499X
Amps	15.0 AC/DC Amps	15.0 AC/DC Amps	15.0 AC/DC Amps
Max Watts Out	3,084 W	3,084 W	3,950 W
No Load Speed	6,000 rpm	6,000 rpm	6,000 rpm
Use Wheels RPM Above	6,600 rpm	6,600 rpm	6,600 rpm
Spindle Lock	Yes	Yes	Yes
Spindle Thread	5/8"-11	5/8"-11	5/8"-11
Tool Length	19.2"	19.2"	20.7"
Tool Weight	13.15 lbs	12.9 lbs	14.5 lbs

DIE GRINDERS

DW887

Heavy-Duty 1-1/2" (40mm) Die Grinder

- 3.0 Amp, 25,000 rpm motor provides high power and speed for all 1-1/2" grinding applications
- AC/DC capacity works off welding machines and generators for increased productivity and versatility
- Convenient paddle switch with lock-on button for easy gripping
- Precision 1/4" collet with 1/8" reducing sleeve securely holds all proper accessories

INCLUDES: 2 wrenches, 1/4" collet and 1/8" reducing sleeve



DW888

Heavy-Duty 2" (50mm) Die Grinder

- 5.0 Amp, 19,000 rpm motor provides high power and speed for all 2" grinding applications
- AC/DC capacity works off welding machines and generators for increased productivity and versatility
- External brush caps for easy servicing
- Precision 1/4" collet with 1/8" reducing sleeve for maximum gripping strength - allows user to operate both 1/4" and 1/8" shaft accessories

INCLUDES: 2 wrenches, 1/4" collet and 1/8" reducing sleeve



DW880

Heavy-Duty 2-1/2" (65mm) Straight Grinder

- 5.0 Amp, 19,000 rpm motor provides high power and speed for all 2-1/2" grinding applications
- AC/DC capacity works off welding machines and generators for increased productivity and versatility
- Rotating adjustable guard for greater visibility
- External brush caps for easy servicing

INCLUDES: 2 wrenches, arbor nuts and flanges



DW882

Heavy-Duty 6" (150mm) Straight Grinder

- 13.0 Amp, 5,700 rpm motor provides high power and speed for 6" grinding applications
- AC/DC capacity works off welding machines and generators for increased productivity and versatility
- Rotating adjustable guard for greater visibility
- External brush doors for easy servicing

INCLUDES: wrench, arbor nuts and flanges



SPECIFICATIONS	DW887	DW888	DW880	DW882
Amps	3.0 AC/DC Amps	5.0 AC/DC Amps	5.0 AC/DC Amps	13.0 AC/DC Amps
Max Watts Out	350 W	485 W	485 W	2,250 W
No Load Speed	25,000 rpm	19,000 rpm	19,000 rpm	5,700 rpm
Spindle Thread	1/4" collet & 1/8" sleeve	1/4" collet & 1/8" sleeve	3/8"-24	5/8"-11
Tool Length	13.0"	19.2"	18.5"	24.4"
Tool Weight	3.25 lbs	6.0 lbs	6.8 lbs	14.8 lbs

CHOP SAWS



DW872

Heavy-Duty 14" (355mm) Multi-Cutter Saw

- Multi-Cutter offers versatility by cutting a wide variety of materials including ferrous and non-ferrous metals
- Utilizing a carbide tipped blade, the depth of cut remains constant throughout blade life
- Multi-Cutter cuts 4 times faster than chop saws and 8 times faster than portable band saws in 2" x 2" x 1/4" angle iron
- 14" 70-tooth carbide tipped blade delivers a lower cost-per-cut compared to cutting with abrasive wheels
- Specially designed carbide teeth deliver fast, precise, virtually burr-free cuts reducing the need for preparation grinding, and finished cuts that are cool to the touch
- Largest capacity in its class with even more capacity than a deep-cut portable band saw (5-3/16" round & 4-1/2" x 6-1/2" rectangular) allowing user to cut a wider variety of different size materials for more applications

INCLUDES: 14" carbide tipped blade, wrench and vertical clamp



DW871

Heavy-Duty 14" (355mm) Chop Saw

- Powerful 15.0 Amp/5.3 HP (maximum motor HP) motor provides more overload capacity, increasing performance and durability
- Patented tool-free, 45° adjustable fence allows for fast and accurate angle cuts without the hassle of using a wrench
- Ergonomically designed "D" handle provides a more comfortable hand position reducing user fatigue and increase productivity
- Quick-lock vise allows for fast clamping on different size materials to increase productivity
- Extra wide solid steel base provides increased stability when cutting longer material.
- Heavy-duty lock down pin allows head of the saw to be locked in the carrying position without the use of a chain
- The solid steel base also allows users to weld jigs or stops directly to the base
- On-board wheel change wrench allows for convenient storage greatly reducing the risk of lost wrenches

INCLUDES: 14" abrasive wheel and wrench



DW870

Heavy-Duty 14" (355mm) Chop Saw

- 15.0 Amp/3.2 HP (maximum motor HP) motor provides overload capacity, increasing performance and durability
- Ergonomically designed "D" handle provides a more comfortable hand position reducing fatigue and increasing productivity
- Quick-lock vise allows for fast clamping on different size materials to increase productivity
- 45° pivoting fence allows for fast and accurate angle cuts
- Steel base allows users to weld jigs or stops directly onto the base
- Spindle lock allows users to make wheel changes fast and easy saving time and money

INCLUDES: 14" abrasive wheel and wrench



SPECIFICATIONS	DW872	DW871	DW870
Amps	15.0 AC/DC Amps	15.0 AC/DC Amps	15.0 AC/DC Amps
Horsepower (max. motor output)	4.0 HP	5.3 HP	3.2 HP
No Load Speed	1,300 rpm	3,800 rpm	3,800 rpm
Spindle Lock	Yes	Yes	Yes
Quick Lock Vise	Yes	Yes	Yes
Wheel Arbor	1"	1"	1"
Wheel Diameter	14"	14"	14"
Max Capacity (Round)	5-3/16"	5"	4"
Max Capacity (Rectangular)	6-1/2" x 4-1/2"	4-1/2" x 6-1/2"	4" x 7-3/4"
Tool Length	21"	21"	23"
Tool Weight	47.0 lbs	40.0 lbs	36.3 lbs

BENCH GRINDERS



DW756 Heavy-Duty 6" (150mm) Bench Grinder

- Powerful 5/8 HP induction motor for heavy-duty grinding operations
- Industrial cast iron base and motor housing provide durability and prolong life
- Motor runs at 3,450 rpm for high speed material removal
- Precision-machined aluminum tool rests allow the user to accurately position work
- Rear exhaust ports in wheel guards for smoother operation
- 12-1/2" distance between wheels for longer and larger grinding applications

INCLUDES: 36 grit wheel, 60 grit wheel, eye shields, spark deflectors, tool rests and adjusting wrench



DW758 Heavy-Duty 8" (205mm) Bench Grinder

- 3/4 HP induction motor provides superior power for industrial grinding applications
- Rugged cast iron base and motor housing provide durability and prolonged life
- Motor runs at 3,600 rpm for high speed material removal
- Precision-machined aluminum tool rests allow the user to accurately position work
- Rear exhaust ports in wheel guards for a smoother operation
- 12-1/2" distance between wheels for larger and longer grinding applications

INCLUDES: 36 grit wheel, 60 grit wheel, eye shields, spark deflectors, tool rests and adjusting wrench



CUT-OFF MACHINE



D28754 Heavy-Duty 12" Cut-Off Machine

- 15.0 Amp/5.3 HP (maximum motor HP) motor provides high power and speed for metal and concrete cutting
- Epoxy coated field and armature provide long service life against abrasion from debris
- Adjustable guard for different cutting depths mounted at two points to maintain proper alignment
- Rotation directs sparks & debris towards front of the tool and helps prevent climbing in the cut
- Blade can be rotated to left side of saw changing rotation towards back of tool
- Dust sealed switch protects against dust ingestion for longer switch life
- Automatic turn-off brushes shut down the tool when brushes need to be changed to avoid tool damage

INCLUDES: wrench, masonry wheel and metal cutting wheel



SPECIFICATIONS	DW756	DW758
Amps	4.0 AC Amps	4.2 AC Amps
Horsepower	5/8 HP	3/4 HP
No Load Speed	3,450 rpm	3,600 rpm
Wheel Diameter	6"	8"
Spindle Diameter	1/2"	5/8"
Adjustable Tool Resets	Yes	Yes
Tool Length	15"	16"
Tool Weight	28.5 lbs	39.5 lbs

SPECIFICATIONS	D28754
Amps	15 AC/DC Amps
Horsepower (max motor output)	5.3 HP
Max Watts Out	3,950 W
No Load Speed	5,000 rpm
Wheel Diameter	12"
Depth of Cut	3-7/8"
Tool Length	23.9"
Tool Weight	24.7 lbs

SHEARS



DW890/DW891 Heavy-Duty 18 Gauge Swivel Head Shear

- Powerful, 5.0 Amp, all ball-bearing motor for long life
 - Head swivels 360° for cutting convenience
 - Cuts 7/32" strip which continuously curls out of cutting area for clear line of sight
 - Variable speed permits cutting of a wide variety of thickness
 - Cuts radius of 5-1/2" and larger
- DW890: 18 Gauge Swivel Head Shear
DW891: 14 Gauge Swivel Head Shear



DW8999 Left blade



Center Blades



DW8900 Right blade



DW8901 for use with DW890
DW8902 for use with DW891



DW892 Heavy-Duty 14 Gauge Shear

- Dependable, 3.0 Amp, all ball-bearing motor for long life
- Rugged aluminum alloy gear case for maximum durability
- Paddle switch for convenient one-handed operation
- Blades are easy to adjust and replace
- Cuts radius as small as 1"

INCLUDES: blade kit (upper and lower blades, screws, nuts and wrenches)



DW8920 Blade kit



INCLUDES: upper and lower blades, screws, nuts and wrenches



DW893 Heavy-Duty 12 Gauge Shear

- Powerful, 6.5 Amp, all ball-bearing motor for long life
- Rugged aluminum alloy gear case for maximum durability
- Paddle switch for convenient one-handed operation
- Four-edge blade design provides four times the life of standard blades
- Cuts radius as small as 1" for various applications



DW8930 Blade



Four edge blade same for top and bottom

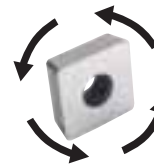

This unit has a 4 edge blade which can be rotated to give you four times the life of standard blades.

SPECIFICATIONS

	DW890	DW891	DW892	DW893
Amps	5.0 Amps	5.0 AC Amps	3.0 AC/DC Amps	6.5 AC/DC Amps
Max Watts Out	470 W	470 W	384 W	225 W
Strokes/Min	0-2,500 spm	0-2,500 spm	2,700 spm	1,950 spm
Capacity (Mild Steel)	18 ga.	14 ga.	14 ga.	12 ga.
Capacity (Stainless Steel)	20 ga.	16 ga.	16 ga.	14 ga.
Tool Length	9.1"	9.1"	9.5"	10.5"
Tool Weight	5.0 lbs	5.0 lbs	5.5 lbs	4.5 lbs

NIBBLERS



DW896 Heavy-Duty 16 Gauge Nibbler

- Dependable, 3.0 Amp, all ball-bearing motor for long life
- Round punch allows 360° pivot while cutting
- Rotating head allows changing cutting directions as desired
- Easy to change punch and die which saves time and money
- No distortion to material being cut
- Paddle switch for convenient one-handed operation
- Gear case constructed of strong aluminum alloy for maximum durability



DW8967 Replacement Punches

- set of five



DW8966 Punch and Die Set

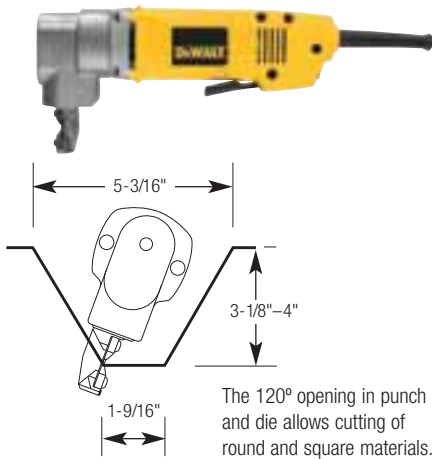

DW897 Heavy-Duty 16 Gauge Profile Nibbler

- Powerful, 6.5 Amp, motor for long life in continuous-duty applications
- 120° opening for cutting square and round corrugation
- Rotating head allows changing cutting directions as desired
- Cuts radius as small as 2"
- Easy to change punch and die saves time and money
- No distortion to material being cut
- Paddle switch for convenient one-handed operation
- Available in 220V



DW8972 Punch and wear plate



DW8973 Die



DW8974 Punch guide



DW898 Heavy-Duty 14 Gauge Nibbler

- Powerful, 6.5 Amp, motor for long life in continuous-duty applications
- Round punch allows 360° pivot while cutting
- Rotating head allows changing cutting directions as desired
- No distortion to material being cut
- Paddle switch for convenient one-handed operation
- Easy to change punch and die saving time and money
- Gear case constructed of strong aluminum alloy for maximum durability
- Available in 220V



The round punch design allows pivot turning of up to 360° for efficient cutting of almost any pattern

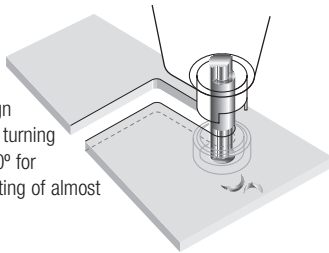

DW8985 Punch



DW8986 Die kit

Includes die, pin and retainer ring



METALWORKING

SPECIFICATIONS	DW896	DW897	DW898
Amps	3.0 AC/DC Amps	6.5 AC/DC Amps	6.5 AC/DC Amps
Max Watts Out	385 W	225 W	225 W
Strokes/Min	2,100 spm	1,950 spm	1,950 spm
Capacity (Mild Steel)	16 ga.	16 ga.	14 ga.
Capacity (Stainless Steel)	18 ga.	18 ga.	16 ga.
Starting Hole	1"	1"	5/8"
Tool Length	9.75"	10.5"	10.5"
Tool Weight	4.5 lbs	4.5 lbs	4.5 lbs

DW845

Heavy-Duty 7"/9" Single Speed Polisher

- Powerful, 7.0 Amp, all ball-bearing construction for long life
- Heat-treated, precision-cut gears for smooth operation
- External brush caps for ease of service
- Spindle lock for easy pad changing

INCLUDES: 2 position side handle, rubber backing pad and clamp nut



DW847

Heavy-Duty 7"/9" Variable Speed Polisher

- Powerful, 7.0 Amp, all ball-bearing construction for long life
- Variable speed lets you adjust the speed for different materials and applications
- Heat-treated, precision-cut gears for smooth operation
- External brush caps for easy servicing
- Spindle lock for easy pad changing

INCLUDES: 2 position side handle, rubber backing pad and clamp nut



DW849

Heavy-Duty 7"/9" Electronic Variable Speed Polisher

- Powerful, 8.0 Amp, all ball-bearing construction for long life
- Electronic module maintains specified speed even under load
- Conveniently-located variable speed dial lets user set maximum speed from 1,000 to 3,000 for different materials and applications
- Variable speed trigger allows user to instantly control speed from 0 to dialed setting
- Heat-treated, precision-cut gears for smooth operation
- External brush caps for easy servicing
- Spindle lock for easy pad changing

INCLUDES: 2 position side handle, rubber backing pad and clamp nut



DW4990

7" Flexible rubber backing pad with clamp nut

(Maximum rpm 5,000)



DW4988/DW4989

7-1/2" Polishing pad with 1-1/2" pile

- DW4988: 100% wool
- DW4989: Wool/poly blend



SPECIFICATIONS

	DW845	DW847	DW849
Amps	7.0 AC Amps	7.0 AC Amps	8.0 AC Amps
Max Watts Out	700 W	700 W	1,400 W
No Load Speed	2,300 rpm	0-1,750 rpm	0-1,000/0-3,000 rpm
Spindle Thread	5/8"-11	5/8"-11	5/8"-11
Spindle Lock	Yes	Yes	Yes
Tool Length	15.9"	15.9"	17.3"
Tool Weight	7.8 lbs	7.8 lbs	8.25 lbs

ACCESSORIES



ACCESSORIES

WHY DEWALT?

Power tools are only as effective as the accessories that go on them. At DEWALT, we are prime manufacturers of professional grade power tool accessories. The majority of our products are designed and manufactured in our own facilities where we use state-of-the-art processes and equipment to make the highest quality bits, blades, discs, wheels and more. Like everything from DEWALT, our accessories are designed to meet the uncompromising needs of the professional.

WORLD-CLASS PRODUCT DEVELOPMENT



DEWALT is committed to offering high quality products that exceed customers' expectations. The product design process is guided by three principles: end-user input; data collected from field-testing and laboratory work; and the Critical-to-Quality (CTQ) design process.

Extensive research and testing assures absolute product reliability and freedom from defects. At DEWALT, only proven designs make it to market. And with hundreds of active patents, DEWALT is widely recognized as the most innovative power tool accessory company in the business.

MANUFACTURING EXCELLENCE

Producing the best accessories in the business is about combining world-class materials with high-tech production facilities. Seven global DEWALT design and manufacturing facilities support a full and deep range of accessory products. These locations are staffed with highly experienced engineers, designers, technicians and production personnel who are dedicated to perfection. The raw materials that go into each product are selected specifically for the



applications and conditions in which they will be used. These materials are purchased from suppliers around the world who have met the stringent criteria of DEWALT's Qualified Supplier Program to ensure a continuous flow of only the highest quality materials.

At each location, quality metrics, premium materials and attention to detail have earned DEWALT manufacturing facilities the distinction of ISO 9001 certification. And our use of the Six Sigma process improvement system further ensures consistent quality.

PREMIUM SERVICE LEVEL

The best product in the world is useless if it is not available when the professional needs it. That's why DEWALT's distribution and transportation strategy is built around the demands of



our customers. Regardless of where you are or what you need, DEWALT assures timely and complete order fulfillment backed up by customer service and sales personnel who are equipped to offer assistance with

any questions. So when the job calls for the best product in the market, **DEWALT delivers.**



HOW ABRASIVES WORK.

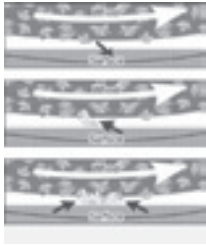

- Abrasive wheels are actually thousands of abrasive grains bonded together to form a single cutting tool. As the wheel contacts the material, the exposed grains begin to cut and grind material away.
- As the wheel grinds, the material fractures the surface of the grains, exposing new cutting points. It also wears away the bond between the grains exposing fresh grain.
- Eventually the surface grains are used up. The old grains are released as the bond wears away, and new grains are exposed. This process continues until the wheel is completely consumed.

THREE KEY COMPONENTS OF BONDED ABRASIVES.

- **Abrasive Grains** – Particles which provide shape, sharpness, hardness and friability
 - A - Aluminum Oxide** is used for cutting and grinding metal.
 - C - Silicon Carbide** is very hard and for use in concrete.
 - Z - Aluminum Zirconia** is a very fine dense grain used for rugged stock removal and long life.
- **Bonds** – The bonding agents hold the grains together and determine the resistance and hardness of the wheel. Hardness refers to how tightly the bonding agent resin material holds on to the grain particles.
 - Hard Wheels: Last longer, but may not cut as fast or as clean. Generally they are used on soft materials.
 - Soft Wheels: Cut fast and smooth, but do not last as long. Generally they are used on hard materials.
- **Fiberglass Reinforcements** – Reinforcement material provides extra strength so the wheel can be used at maximum Revolutions Per Minute (RPM) and still withstand the lateral pressure applied during use.

DEWALT ABRASIVE PRODUCT IDENTIFICATION.

- DEWALT utilizes an industry recognized color coding and identification system to help users identify the right bonded abrasive wheel for their application. There are also several other key identifiers to look for on a wheel; RPM's, wheel size, thickness and arbor size to ensure the correct product is used.



A	24	R	BF
Primary grain used to make the wheel	Size of the abrasive grain		Hardness of the bond
A - Aluminum Oxide	Coarse 16	Medium 30	Soft
C - Silicon Carbide	20	Fine 100	Medium
Z - Aluminum Zirconia	24	Very Fine 220	Hard
	46	120	
	60	240	
		280	
			Type of bond used
			B - Resinoid
			BF - Resinoid Reinforced
			RF - Rubber Reinforced
			S - Silicate
			V - Vitrified

ACCESSORIES

TYPE 27 - GRINDING WHEELS

All DeWALT Type 27 Depressed Center Grinding Wheels offer the best performance for almost any application through:

- 3 full sheets of fiberglass for added durability and safety in grinding
- 100% virgin grains, not inexpensive filler grains for enhanced removal and life
- A proprietary material mix to ensure premium performance
- Premium resin bonds that are 100% inspected before use for product consistency and quality

GENERAL PURPOSE

Aluminum oxide formulation for General Purpose heavy-duty cutting and grinding of ferrous metals (steel, iron welds, edge grinding, etc.). This formulation provides aggressive material removal and long wheel life.

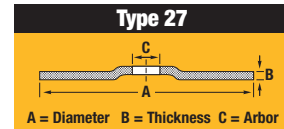

Cat #	Dia	Thickness	Arbor	Specs	Application	Max RPM	PKS
Metal Cutting / Light Grinding							
DW4418	4"	1/8"	5/8"	A24R	Metal Cutting	15,200	25
DW4518	4-1/2"	1/8"	7/8"	A24R	Metal Cutting	13,300	25
DW4522	4-1/2"	1/8"	5/8"-11	A24R	Metal Cutting	13,300	10
DW4618	5"	1/8"	7/8"	A24R	Metal Cutting	12,200	25
DW4750	7"	1/8"	7/8"	A24R	Metal Cutting	8,700	10
DW4751	7"	1/8"	5/8"-11	A24R	Metal Cutting	8,700	10
DW4752	9"	1/8"	7/8"	A24R	Metal Cutting	6,600	10
DW4753	9"	1/8"	5/8"-11	A24R	Metal Cutting	6,600	10
Metal Grinding							
DW4419	4"	1/4"	5/8"	A24R	Metal Grinding	15,200	25
DW4514	4-1/2"	1/4"	7/8"	A24R	Metal Grinding	13,300	25
DW4523	4-1/2"	1/4"	5/8"-11	A24R	Metal Grinding	13,300	10
DW4619	5"	1/4"	7/8"	A24R	Metal Grinding	12,200	25
DW4623	5"	1/4"	5/8"-11	A24R	Metal Grinding	12,200	10
DW4624	6"	1/4"	7/8"	A24R	Metal Grinding	10,100	10
DW4719	7"	1/4"	7/8"	A24R	Metal Grinding	8,700	10
DW4999	7"	1/4"	5/8"-11	A24R	Metal Grinding	8,700	10
DW4949	9"	1/4"	7/8"	A24R	Metal Grinding	6,600	10
DW4954	9"	1/4"	5/8"-11	A24R	Metal Grinding	6,600	10

CONCRETE/MASONRY

Silicon carbide formulation for grinding and cutting concrete, masonry, cast iron, ductile iron, and other masonry materials. This formulation provides aggressive material removal and long wheel life.



Cat #	Dia	Thickness	Arbor	Specs	Application	Max RPM	PKS
Concrete/Masonry Cutting							
DW4428	4"	1/8"	5/8"	C24R	Concrete Cutting	15,200	25
DW4528	4-1/2"	1/8"	7/8"	C24R	Concrete Cutting	13,300	25
DW4552	4-1/2"	1/8"	5/8"-11	C24R	Concrete Cutting	13,300	10
DW4628	5"	1/8"	7/8"	C24R	Concrete Cutting	12,200	25
Concrete/Masonry Grinding							
DW4429	4"	1/4"	5/8"	C24R	Concrete Grinding	15,200	25
DW4524	4-1/2"	1/4"	7/8"	C24R	Concrete Grinding	13,300	25
DW4551	4-1/2"	1/4"	5/8"-11	C24R	Concrete Grinding	13,300	10
DW4553	5"	1/4"	5/8"-11	C24R	Concrete Grinding	12,200	10
DW4629	5"	1/4"	7/8"	C24R	Concrete Grinding	12,200	25
DW4554	7"	1/4"	7/8"	C24R	Concrete Grinding	8,700	10
DW4759	7"	1/4"	5/8"-11	C24R	Concrete Grinding	8,700	10
DW4959	9"	1/4"	5/8"-11	C24R	Concrete Grinding	6,600	10

ACCESSORIES

TYPE 27 - GRINDING WHEELS (continued)

STAINLESS STEEL

Aluminum Oxide formulation for grinding harder metals such as steel, super alloys, and other high tensile alloys. This formulation provides aggressive removal and long life on ferrous metals (steel, iron welds, edge grinding).



Cat #	Dia	Thickness	Arbor	Specs	Application	Max RPM	PKS
Stainless Steel Cutting							
DW8452	4-1/2"	1/8"	7/8"	A30S	Stainless Cutting	13,300	25
DW8454	5"	1/8"	7/8"	A30S	Stainless Cutting	12,200	25
DW8456	7"	1/8"	7/8"	A30S	Stainless Cutting	8,700	10
DW8458	9"	1/8"	7/8"	A30S	Stainless Cutting	6,600	10
Stainless Steel Grinding							
DW8410	4"	1/4"	5/8"	A30S	Stainless Grinding	15,200	25
DW8414	4-1/2"	1/4"	7/8"	A30S	Stainless Grinding	13,300	25
DW8415	4-1/2"	1/4"	5/8"-11	A30S	Stainless Grinding	13,300	10
DW8464	5"	1/4"	7/8"	A30S	Stainless Grinding	12,200	25
DW8416	5"	1/4"	5/8"-11	A30S	Stainless Grinding	12,200	10
DW8466	7"	1/4"	7/8"	A30S	Stainless Grinding	8,700	10
DW8417	7"	1/4"	5/8"-11	A30S	Stainless Grinding	8,700	10
DW8468	9"	1/4"	7/8"	A30S	Stainless Grinding	6,600	10
DW8419	9"	1/4"	5/8"-11	A30S	Stainless Grinding	6,600	10

ALUMINUM

Aluminum Oxide formulation for grinding aluminum and other non-ferrous material without loading. This formulation provides fast removal and good wheel life.



Cat #	Dia	Thickness	Arbor	Specs	Application	Max RPM	PKS
DW8400	4"	1/4"	5/8"	A30N	Aluminum Grinding	15,200	25
DW8404	4-1/2"	1/4"	7/8"	A30N	Aluminum Grinding	13,300	25
DW8405	4-1/2"	1/4"	5/8"-11	A30N	Aluminum Grinding	13,300	10
DW8474	5"	1/4"	7/8"	A30N	Aluminum Grinding	12,200	25
DW8406	5"	1/4"	5/8"-11	A30N	Aluminum Grinding	12,200	10
DW8476	7"	1/4"	7/8"	A30N	Aluminum Grinding	8,700	10
DW8407	7"	1/4"	5/8"-11	A30N	Aluminum Grinding	8,700	10
DW8409	9"	1/4"	5/8"-11	A30N	Aluminum Grinding	6,600	10

PIPELINE CUTTING

Special Aluminum Oxide formulation designed for both cutting and light grinding in the pipeline industry on steel, cast iron and welds. This formulation provides optimum performance and long life. Three full sheets of fiberglass for added durability and safety.



Cat #	Dia	Thickness	Arbor	Specs	Application	Max RPM	PKS
DW8434	4-1/2"	1/8"	7/8"	A24R	Pipeline Cutting	13,300	25
DW8435	4-1/2"	1/8"	5/8"-11	A24R	Pipeline Cutting	13,300	10
DW8484	5"	1/8"	7/8"	A24R	Pipeline Cutting	12,200	25
DW8436	5"	1/8"	5/8"-11	A24R	Pipeline Cutting	12,200	10
DW8486	7"	1/8"	7/8"	A24R	Pipeline Cutting	8,700	10
DW8437	7"	1/8"	5/8"-11	A24R	Pipeline Cutting	8,700	10
DW8439	9"	1/8"	5/8"-11	A24R	Pipeline Cutting	6,600	10

ACCESSORIES

TYPE 27 - GRINDING WHEELS (continued)

METAL THIN CUTTING

Special Aluminum Oxide formulation designed for fast cutting and long life in all types of ferrous metals and stainless steels.



Cat #	Dia	Thickness	Arbor	Specs	Application	Max RPM	PKS
DW8420	4"	.045"	5/8"	A60T	Metal Cutting	15,200	25
DW8424	4-1/2"	.045"	7/8"	A60T	Metal Cutting	13,300	25
DW8425	5"	.045"	7/8"	A60T	Metal Cutting	12,200	25
DW8426	6"	1/16"	7/8"	A60T	Metal Cutting	10,100	25
DW8427	7"	1/16"	7/8"	A60T	Metal Cutting	8,700	25

TYPE 28 - GENERAL PURPOSE GRINDING

DeWALT Type 28 General Grinding Wheels for:

- Greater surface grinding coverage
- Horizontal metal grinding application

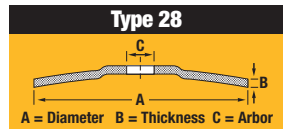

GENERAL PURPOSE

Cat #	Dia	Thickness	Arbor	Specs	Application	Max RPM	PKS
Metal Grinding							
DW8445	7"	1/4"	7/8"	A24R	Metal Grinding	8,700	10
DW8446	7"	1/4"	5/8"-11	A24R	Metal Grinding	8,700	10
DW8447	9"	1/4"	7/8"	A24R	Metal Grinding	6,600	10
DW8448	9"	1/4"	5/8"-11	A24R	Metal Grinding	6,600	10

TYPE 11 - CUP WHEELS

DeWALT Type 11 General Grinding Wheels for:

- Maximum surface grinding coverage
- Metal backing for greater durability
- Designed for aggressive grinding

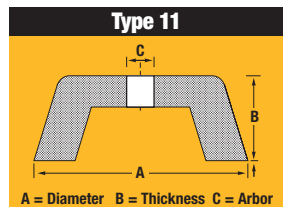

GENERAL PURPOSE

Cat #	Dia	Thickness	Arbor	Specs	Application	Max RPM	PKS
Metal Grinding							
DW4960	4"	2"	5/8"-11	A16R	Metal Grinding	9,000	4
DW4964	6"	2"	5/8"-11	A16R	Metal Grinding	6,000	4

CONCRETE/MASONRY GRINDING

Cat #	Dia	Thickness	Arbor	Specs	Application	Max RPM	PKS
Concrete/Masonry Grinding							
DW4961	4"	2"	5/8"-11	C16R	Concrete Grinding	9,000	4
DW4965	6"	2"	5/8"-11	C16R	Concrete Grinding	6,000	4

ACCESSORIES

TYPE 1 - CUTTING WHEELS

DeWALT offers a full range of Type 1 cutting wheels for low power chop saws, high power stationary machines, high speed portable saws, grinders and circular saws. These wheels are designed to offer a long service life and fast cutting.

- 10", 12", 14" and 16" diameters
- Double reinforcement of fiberglass provides user safety and up to 2X THE LIFE of single reinforced wheels
- Strict manufacturing controls to provide consistently high quality chop saw wheels
- Industrial formulations designed for specific user applications
- Premium grade abrasive grain provides fast cutting and long life
- These wheels provide a better value per cut with optimal formulations that provide fast cutting and long life
- Cut-off wheels are used on steel, bar stock, tubing, concrete blocks and bricks.



Type 1

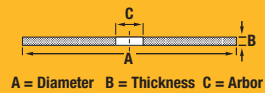

GENERAL PURPOSE HIGH PERFORMANCE INDUSTRIAL CHOP SAW WHEELS & STATIONARY MACHINE CUT-OFF WHEELS

Cat #	Dia	Thickness	Arbor	Specs	Application	Max RPM	PKS
DW8005	10"	7/64"	5/8"	A24R	Metal Cutting	6,100	10
DW8004	12"	7/64"	1"	A24R	Metal Cutting	5,000	10
DW8001	14"	7/64"	1"	A24R	General Purpose	4,300	10
DW8002	14"	7/64"	1"	A24R	Bar Cutter	4,300	10
DW8003	14"	7/64"	1"	A24R	Stud Cutting	4,300	10
DW8010	16"	7/64"	1"	A36S	Metal Cutting	3,800	10

XP EXTENDED Performance

Premium ceramic coated grain for faster cutting and longer life.

DW8057	12"	7/64"	1"	A24R	Metal Cutting	5,000	10
DW8059	14"	7/64"	1"	A24R	Light Gauge Stud	4,300	10

CONCRETE/MASONRY CUTTING STATIONARY MACHINE CUT-OFF WHEELS

Cat #	Dia	Thickness	Arbor	Specs	Application	Max RPM	PKS
DW8009	10"	1/8"	5/8"	C24R	Concrete Cutting	6,100	10
DW8008	12"	1/8"	1"	C24R	Concrete Cutting	5,000	10
DW8007	14"	1/8"	1"	C24R	Concrete Cutting	4,300	10
DW8011	16"	1/8"	1"	C30N	Concrete Cutting	3,800	10

STAINLESS STEEL CUTTING STATIONARY MACHINE CUT-OFF WHEELS

Cat #	Dia	Thickness	Arbor	Specs	Application	Max RPM	PKS
DW8015	12"	3/32"	1"	A30S	Stainless Steel	5,000	10
DW8016	14"	3/32"	1"	A30S	Stainless Steel	4,300	10

ABRASIVE SAW BLADES

Abrasive saw blades are designed for cutting all types of ferrous metal and concrete/masonry products. Constructed with two pieces of extra-strength fiberglass, premium grains, and high quality bonds, DeWALT abrasive blades are built to withstand the most demanding applications. This formulation provides fast cutting action with long service life.



METAL CUTTING

Cat #	Dia	Thickness	Arbor	Specs	Application	Max RPM	PKS
DW3508	6-1/2"	1/8"	5/8" - ◆	A24R	Metal Cutting	9,400	25
DW3511	7"	1/8"	5/8" - ◆	A24R	Metal Cutting	8,700	25
DW3531	8"	1/8"	5/8" - ◆	A24R	Metal Cutting	7,600	25

XP EXTENDED Performance

DW8056	7"	1/8"	5/8" - ◆	A24R	Metal Cutting	8,700	25
--------	----	------	----------	------	---------------	-------	----

CONCRETE/MASONRY CUTTING

Cat #	Dia	Thickness	Arbor	Specs	Application	Max RPM	PKS
DW3509	6-1/2"	1/8"	5/8" - ◆	C24R	Concrete/Masonry	9,400	25
DW3521	7"	1/8"	5/8" - ◆	C24R	Concrete/Masonry	8,700	25
DW3532	8"	1/8"	5/8" - ◆	C24R	Concrete/Masonry	7,600	25

ACCESSORIES

THIN CUTTING

Specially formulated for heavy-duty, fast cutting of all types of ferrous metals and stainless steels (INOX). Special double reinforced fiberglass provides increased durability and long life in most applications.



METAL CUTTING

Cat #	Dia	Thickness	Arbor	Specs	Application	Max RPM	PKS
DW8700	2-1/2"	.035"	3/8"	A60T	Metal Cutting	30,500	50
DW8701	2-1/2"	.035"	1/4"	A60T	Metal Cutting	30,500	50
DW8702	2-1/2"	.035"	3/8"	A36T	Metal Cutting	30,500	50
DW8703	2 1/2"	.035"	1/4"	A36T	Metal Cutting	30,500	50
DW8704	3"	1/16"	1/4"	A36T	Metal Cutting	24,400	50
DW8705	3"	1/16"	3/8"	A36T	Metal Cutting	24,400	50
DW8706	3"	.035"	3/8"	A36T	Metal Cutting	24,400	50
DW8708	3"	.035"	1/4"	A36T	Metal Cutting	24,400	50
DW8709	3"	1/8"	3/8"	A24R	Metal Cutting	24,400	50
DW8710	3"	1/8"	1/4"	A24R	Metal Cutting	24,400	50
DW8711	3"	1/16"	3/8"	A60T	Metal Cutting	24,400	50
DW8712	3"	.035"	3/8"	A60T	Metal Cutting	24,400	50
DW8061	4"	.045"	5/8"	A60T	Metal Cutting	19,000	25
DW8713	4"	1/16"	1/4"	A36T	Metal Cutting	19,000	25
DW8715	4"	1/16"	1/4"	A60T	Metal Cutting	19,000	25
DW8716	4"	1/16"	3/8"	A36T	Metal Cutting	19,000	25
DW8717	4"	.035"	3/8"	A36T	Metal Cutting	19,000	25
DW8718	4"	1/8"	3/8"	A24R	Metal Cutting	19,000	25
DW8719	4"	1/16"	3/8"	A60T	Metal Cutting	19,000	25
DW8720	4"	.035"	3/8"	A60T	Metal Cutting	19,000	25
DW8722	4"	1/16"	5/8"	A36T	Metal Cutting	19,000	25
DW8723	4"	1/16"	5/8"	A60T	Metal Cutting	19,000	25
DW8724	4"	.035"	5/8"	A60T	Metal Cutting	19,000	25
DW8062	4-1/2"	.045"	7/8"	A60T	Metal Cutting	13,300	25
DW8063	5"	.045"	7/8"	A60T	Metal Cutting	12,200	25
DW8064	6"	.055"	7/8"	A60T	Metal Cutting	10,100	25
DW8725	6"	.040"	7/8"	A60T	Metal Cutting	12,200	25
DW8065	7"	.055"	7/8"	A60T	Metal Cutting	8,700	25



CONCRETE CUTTING

Cat #	Dia	Thickness	Arbor	Specs	Application	Max RPM	PKS
DW8071	4"	.045"	5/8"	C46S	Concrete Cutting	15,200	10
DW8072	4-1/2"	.045"	7/8"	C46S	Concrete Cutting	13,300	10



STAINLESS STEEL CUTTING

Cat #	Dia	Thickness	Arbor	Specs	Application	Max RPM	PKS
DW8080	4-1/2"	1/8"	7/8"	A30S	Stainless Steel	13,300	25
DW8084	7"	1/8"	7/8"	A30S	Stainless Steel	8,700	25
DW8086	9"	1/8"	7/8"	A30S	Stainless Steel	6,600	25

ACCESSORIES

HIGH SPEED WHEELS

Designed to be durable, hard working blades for a variety of cutting applications in metal, concrete, ductile pipe and asphalt. Thicker fiberglass is utilized to withstand extreme applications and hold up to high speeds. Specially formulated to provide fast, free cutting and good life.

GENERAL PURPOSE

Cuts rebar, steel pipe, sheet metal, structural steel and stainless.



Cat #	Dia	Thickness	Arbor	Specs	Application	Max RPM	PKS
DW8020	14"	1/8"	1"	A24R	Metal Cutting	5,500	10
DW8021	14"	1/8"	20mm	A24R	Metal Cutting	5,500	10
DW8022	12"	1/8"	1"	A24R	Metal Cutting	6,400	10
DW8023	12"	1/8"	20mm	A24R	Metal Cutting	6,400	10

CONCRETE/MASONRY CUTTING

Cuts cured concrete and masonry products, including brick, block and pipe.



Cat #	Dia	Thickness	Arbor	Specs	Application	Max RPM	PKS
DW8024	14"	1/8"	1"	C24P	Concrete Cutting	5,500	10
DW8025	14"	1/8"	20mm	C24P	Concrete Cutting	5,500	10
DW8026	12"	1/8"	1"	C24P	Concrete Cutting	6,400	10
DW8027	12"	1/8"	20mm	C24P	Concrete Cutting	6,400	10
DW8038	14"	3/16"	1" - pin hole	C24P	Cured Concrete	4,300	10
DW8039	14"	3/16"	1" - pin hole	C24N	Green Concrete/Asphalt	4,300	10

DUCTILE PIPE CUTTING

Cuts sewer and water construction pipes, ductile iron, cast iron and concrete lined pipe.



Cat #	Dia	Thickness	Arbor	Specs	Application	Max RPM	PKS
DW8030	14"	1/8"	1"	A24/C24P	Ductile Cutting	5,500	10
DW8031	14"	1/8"	20mm	A24/C24P	Ductile Cutting	5,500	10
DW8032	12"	1/8"	1"	A24/C24P	Ductile Cutting	6,400	10
DW8033	12"	1/8"	20mm	A24/C24P	Ductile Cutting	6,400	10

ASPHALT CUTTING

Cuts soft aggregate.



Cat #	Dia	Thickness	Arbor	Specs	Application	Max RPM	PKS
DW8034	14"	1/8"	1"	C24N	Asphalt Cutting	5,500	10
DW8035	14"	1/8"	20mm	C24N	Asphalt Cutting	5,500	10
DW8036	12"	1/8"	1"	C24N	Asphalt Cutting	6,400	10
DW8037	12"	1/8"	20mm	C24N	Asphalt Cutting	6,400	10

TYPE 29 - ZIRCONIA FLAP DISCS

A flap disc is made of a series of overlapping cloth-backed sandpaper segments that have been designed to wear away, constantly exposing fresh new abrasive grains. The flap disc removes material quickly and leaves a high quality finish. This ability to aggressively remove material and leaves a clean finish in one step is the advantage over conventional fiber resin discs.

- Premium abrasive cloth provides up to 15X LONGER LIFE than fiber resin discs
- Zirconia grit 3X FASTER than fiber resin discs
- Type 29 fiberglass backing provides optimum (10°-25°) grinding angle, allows full use of the disc and won't mar
- Hubbed and non-hubbed product offering

DeWALT offers a high quality line of Zirconia Abrasive Flap Discs that provide exceptional performance, longer life, superior finish and greater value versus fiber resin discs.

Cat #	Dia	Arbor	Grit Specs	Max RPM	PKS
DW8300	4"	5/8"	Z36	15,200	10
DW8302	4"	5/8"	Z60	15,200	10
DW8303	4"	5/8"	Z80	15,200	10
DW8306	4-1/2"	7/8"	Z36	13,300	10
DW8308	4-1/2"	7/8"	Z60	13,300	10
DW8309	4-1/2"	7/8"	Z80	13,300	10
DW8310	4-1/2"	7/8"	Z120	13,300	10
DW8311	4-1/2"	5/8"-11	Z36	13,300	5
DW8312	4-1/2"	5/8"-11	Z60	13,300	5
DW8313	4-1/2"	5/8"-11	Z80	13,300	5
DW8315	5"	7/8"	Z36	12,200	10
DW8317	5"	7/8"	Z60	12,200	10
DW8318	5"	7/8"	Z80	12,200	10
DW8321	7"	7/8"	Z36	8,700	10
DW8323	7"	7/8"	Z60	8,700	10
DW8324	7"	7/8"	Z80	8,700	10
DW8325	7"	7/8"	Z120	8,700	10
DW8327	7"	5/8"-11	Z36	8,700	5
DW8329	7"	5/8"-11	Z60	8,700	5
DW8330	7"	5/8"-11	Z80	8,700	5

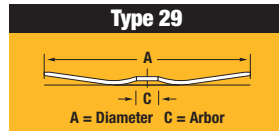

Welders use flap discs for weld blending, removing weld slag, deburring surface finishing and chamfering.



Metal fabricators use flap disks for all types of metal finishing, deburring, edge blending, chamfering and surface preparation.

GRINDS & FINISHES
3X
FASTER THAN
FIBER RESIN DISCS

15X
THE LIFE OF
FIBER RESIN DISCS

Materials	Applications	Grit			
		36	60	80	120
STEELS		36	60	80	120
carbon, high speed alloyed, unalloyed	Weld Bead Blending				
	Deburring/Edge Grinding				
	Surface Grinding/Prep				
STAINLESS STEELS		36	60	80	120
high alloy heat treated	Weld Bead Blending				
	Deburring/Edge Grinding				
	Surface Grinding/Prep				
SHEET METAL		36	60	80	120
carbon, high speed alloyed, unalloyed	Weld Bead Blending				
	Deburring/Edge Grinding				
	Surface Grinding/Prep				
ALUMINUM / NON-FERROUS		36	60	80	120
brass, bronze	Weld Bead Blending				
	Deburring/Edge Grinding				
	Surface Grinding/Prep				
CAST IRON		36	60	80	120
	Weld Bead Blending				
	Deburring/Edge Grinding				
	Surface Grinding/Prep				

Best Performance Could also be used if a finer or more coarse finish is desired

ACCESSORIES

WIRE BRUSHES

DEWALT offers an expanded range of high performance industrial wire brush products. These brushes are manufactured using highly specified wire grades and are constructed for perfect balance. These specifications provide a consistent level of industrial performance. Every wheel is inspected to ensure that each meets the demanding quality and one of the highest wire content counts in the industry.

There are three main wire types DEWALT offers.

- **WHEEL BRUSHES** are available in both knotted form for aggressive removal, and crimped wire for light duty applications. They are used on large and small angle grinders as well as bench grinders for deburring, weld cleaning, edge blending, rust removal.
- **CUP BRUSHES** are available in both knotted and crimped wire. They are used on large and small angle grinders for weld cleaning, rust removal, surface preparation.
- **END BRUSHES** are available in both knotted and crimped wire. They are used on both electric and portable air tools for light and heavy-duty work where space is limited. Applications include cleaning and finishing recessed areas and interior diameters of pipes, deburring, weld cleaning, spot facing.



Cat #	Description	Face Width	Trim Length	Max RPM	PKS
End Brushes					
DW4900	Spindle Adapter M10 x 1.25 to 5/8-11	–	–	–	1
DW4901	1" Crimped End Brush/Carbon Steel 1/4" Stem .012"	–	1"	20,000	1
DW4902	1" Knot End Brush/Carbon Steel 1/4" Stem .020"	–	1"	20,000	1
DW4903	3" Crimped Flat Faced End Brush/Carbon Steel 1/4" Stem .012"	1/2"	5/8"	20,000	1
Bench Grinder Brushes					
DW4904	6" Crimped Bench Wire Wheel, 5/8"-1/2" Arbor, Medium Face .014"	3/4"	1-1/8"	6,000	1
DW4905	6" Crimped Bench Wire Wheel, 5/8"-1/2" Arbor, Wide Face .014"	1"	1-1/8"	6,000	1
DW4906	8" Crimped Bench Wire Wheel, 5/8" Arbor, Medium Face .014"	3/4"	1-9/16"	4,000	1
DW4907	8" Crimped Bench Wire Wheel, 5/8" Arbor, Wide Face .014"	1"	1-9/16"	4,000	1
DW4908	10" Crimped Bench Wire Wheel, 3/4" Arbor, Wide Face .014"	1-9/16"	2-1/2"	3,600	1
Cup Brushes					
DW4910	3" Knotted Cup Brush/Carbon Steel 5/8"-11 Arbor .020"	–	7/8"	14,000	1
DW4915	3" Knotted Cup Brush/Carbon Steel 10mm x 1.25 Arbor .020"	–	7/8"	14,000	1
DW4916	4" Knotted Cup Brush/Carbon Steel 5/8"-11 Arbor .020"	–	1-1/8"	9,000	1
DW4917	6" Knotted Cup Brush/Carbon Steel 5/8"-11 Arbor .020"	–	1-3/8"	6,600	1
DW4920	3" Crimped Cup Brush/Carbon Steel 5/8"-11 Arbor .014"	–	13/16"	14,000	1
DW4922	5" Crimped Cup Brush/Carbon Steel 5/8"-11 Arbor .014"	–	1-3/8"	8,000	1
Stringer Beads/Cable Twists					
DW4925	4" Stringer Bead Wire Wheel/Carbon Steel 5/8"-11 Arbor .020"	1/4"	3/4"	20,000	1
DW4926	4" Stringer Bead Wire Wheel (Bulk)/Carbon Steel 5/8"-11 Arbor .020"	1/4"	3/4"	20,000	1
DW4927 *	4" Stringer Bead Wire Wheel (Bulk)/Stainless Steel 5/8"-11 Arbor .020"	1/4"	3/4"	20,000	1
DW4930	4" Full Cable Twist Wire Wheel/Carbon Steel 5/8"-11 Arbor .020"	1/4"	1"	20,000	1
DW4935	4" Full Cable Twist Wire Wheel/Carbon Steel 10mm x 1.25 Arbor .020"	1/4"	1"	20,000	1
DW4936	6" Stringer Bead Wire Wheel (Bulk)/Carbon Steel 5/8"-11 Arbor .020"	1/4"	1-5/16"	12,500	1
DW4937	6" Full Cable Twist Wire Wheel/Carbon Steel 5/8"-11 Arbor .020"	15/32"	1-3/8"	12,500	1
DW4938	6" Full Cable Twist Wire Wheel (Bulk)/Carbon Steel 5/8"-11 Arbor .020"	15/32"	1-3/8"	12,500	1

* For use on stainless steel or aluminum Grinding

FIBER RESIN DISCS

- Industrial stearate coating to prevent clogging.
- Thick backing paper for added durability.
- Superior friability allows the wheel to break down quickly, consistently exposing new grain for longer life.
- Applications: Metal surface finishing, edge and weld blending, surface preparation.



FIBER RESIN DISCS

Cat #	Dia	Thickness	Grit	Max. Speed	Qty	Cat #	Dia	Thickness	Grit	Max. Speed	Qty
DW4432	4"	5/8"	36	15,200rpm	25	DW4534	4-1/2"	7/8"	24	13,300rpm	5
DW4433	4"	5/8"	60	15,200rpm	25	DW4535	4-1/2"	7/8"	36	13,300rpm	5
DW4436	4"	5/8"	80	15,200rpm	25	DW4536	4-1/2"	7/8"	60	13,300rpm	25
DW4439	4"	5/8"	80	15,200rpm	5	DW4537	4-1/2"	7/8"	60	13,300rpm	5
DW4532	4-1/2"	7/8"	24	13,300rpm	25	DW4538	4-1/2"	7/8"	80	13,300rpm	25
DW4533	4-1/2"	7/8"	36	13,300rpm	25	DW4539	4-1/2"	7/8"	80	13,300rpm	5

ACCESSORIES

SANDER/POLISHER ACCESSORIES

- High quality raw materials for consistent performance.
- Applications: sanding and polishing wood and metal.

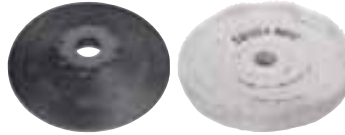

BACKING PADS

Cat #	Description	Dia	Max Speed
DW4939	4-1/2" Paper Board Backing Pad Only	4-1/2"	16,000
DW4940	4" Rubber Backing Pad with M10" x 1.25" Locking Nut	4"	12,000
DW4942	4-1/2" x 7/8" Backing Pad with 5/8"-11" Locking Nut	4-1/2"	16,000
DW4945	4-1/2" Rubber Backing Pad with 5/8"-11" Locking Nut	4-1/2"	12,000
DW4947	6-1/2" Quick Change Flex Backing Pad	6-1/2"	8,500
DW4950	5" Phenolic Disc	5"	6,000
DW4951	7" Phenolic Disc	7"	6,000
DW4952	9" Phenolic Disc	9"	6,000
DW4955	6-3/4" "Kool Flex" Backing Pad	6-3/4"	6,000
DW4956	8-7/8" "Kool Flex" Backing Pad	8-7/8"	6,000
DW4990	7" Super Flex Quick Change Rubber Backing Pad	7"	5,000

POLISHING

Cat #	Description	Dia
DW4980	5/8" x 1-1/2" Cotton Polishing Buff	6"
DW4988	Wool Polishing Pad 1-1/2" Pile	7-1/2"
DW4989	Blend Cutting Pad 1-1/2" Pile	7-1/2"

ABRASIVES APPLICATION CHART

How to select a wheel

1. Select the material you will be using based upon the choices on the left side of the chart.
2. Determine what you want to do to this material.
 - Cutting
 - Grinding
 - Cutting and Grinding
 - Finishing

ABRASIVE CATEGORY	Type 27			Type 29	Type 1							Type 28	Type 11
	Grinding	Cutting	Cutting & Light Grinding	Flap Discs	Wheels	High Speed Cut-Off Wheels for Portable Saws	Wheels for Stationary Cut-Off Saws	Abrasive Saw Blades	Grinding	Grinding	Grinding	Grinding	
	A24R General Purpose C24R Concrete/Masonry A30N Aluminum A30S Stainless Steel	A60T	Pipeliner	Flap Discs	General Purpose Bar Cutter Stud Cutter	A24R C24N Ductile Asphalt	A24R C24R	A24R C24R	General Purpose	Cup Wheels			
FERROUS METALS													
Angle Iron	•	•	•	•	•	•	•	•	•	•	•	•	
Bar Stock	•	•	•	•	•	•	•	•	•	•	•	•	
Cast Iron / Ductile Pipe	•					•	•		•				
Carbon Steel	•	•	•	•	•	•	•	•	•	•	•	•	
Channel Iron	•	•	•	•	•	•	•	•	•	•	•	•	
Decking	•	•	•	•	•	•	•	•	•	•	•	•	
Heavy Rebar	•	•	•	•	•	•	•	•	•	•	•	•	
High Tensile Steel		•	•	•	•								
Iron Pipes	•	•	•	•	•	•	•	•	•	•	•	•	
I-Beams / Rail Steel	•		•	•	•	•	•	•	•	•	•	•	
Light Gauge Metals		•	•	•	•	•	•	•	•	•	•	•	
Metal Studs		•	•	•	•	•	•	•	•	•	•	•	
Metal Tubing		•	•	•	•	•	•	•	•	•	•	•	
Stainless Steel		•	•	•	•	•	•	•	•	•	•	•	
Steel	•	•	•	•	•	•	•	•	•	•	•	•	
Thin Rebar		•	•	•	•	•	•	•	•	•	•	•	
Welds	•	•	•	•	•	•	•	•	•	•	•	•	
NON-FERROUS METALS													
Aluminum		•				•		•					
Brass		•				•		•					
Bronze		•				•		•					
Copper		•				•		•					
STONE													
Asphalt						•							
Brick	•					•		•	•			•	
Ceramic	•							•	•			•	
Concrete	•					•		•	•			•	
Green Concrete	•							•	•			•	
Masonry	•					•	•	•	•			•	

ACCESSORIES

DIAMOND BLADES

Extended Performance™ Premium Dry Cutting Continuous Rim Turbo Blades

Best for fast shallow cutting in brick, block and tile. Matrix design minimizes chipping. Steel body delivers constant depth of cut.



Cat #	Dia	Thickness	Arbor	Application	Max RPM
DW4700	4"	.080"	5/8", 7/8", 20mm	General Purpose	15,200
DW4701	4-1/2"	.080"	5/8", 7/8"	General Purpose	13,300
DW4702	7"	.090"	5/8", 7/8"◆	General Purpose	8,700
DW4703	8"	.090"	5/8", 7/8"◆	General Purpose	7,600
DW4704	12"	.110"	1", 20mm	General Purpose	6,300

High Performance™ Masonry Blades

Dry cutting continuous rim blades best for cutting brick and masonry material. Faster cut rate at a constant depth.



Cat #	Dia	Thickness	Arbor	Application	Max RPM
DW4724	4"	.060"	5/8", 7/8", 20mm	General Purpose	15,200
DW4725	4-1/2"	.080"	5/8", 7/8"	General Purpose	13,300
DW4712	7"	.090"	5/8", 7/8"◆	General Purpose	8,700

Extended Performance™ Premium Dry Cutting Segmented Rim Blades

Best for fast rough cutting in concrete, stone and block. Laser welded diamond segments increase durability.



Cat #	Dia	Thickness	Arbor	Application	Max RPM
DW4710	4"	0.250"	5/8", 7/8", 20mm	Mortar-Dry Tuck Pointing	15,200
DW4711	4"	0.080"	5/8", 7/8", 20mm	General Purpose	15,200
DW4713	4-1/2"	0.080"	5/8", 7/8"	General Purpose	13,300
DW4714	7"	0.080"	5/8", 7/8"◆	General Purpose	8,700
DW4716	12"	0.125"	1", 20mm	General Purpose	6,300
DW4747	12"	0.125"	1", 20mm	General Purpose Fast Cutting	6,300
DW4743	12"	0.125"	1", 20mm	Cured Concrete	6,300
DW4745	12"	0.125"	1", 20mm	Asphalt/Green Concrete	6,300
DW4742	14"	0.125"	1", 20mm	General Purpose	5,400
DW4748	14"	0.125"	1", 20mm	General Purpose Fast Cutting	5,400
DW4744	14"	0.125"	1", 20mm	Cured Concrete	5,400
DW4746	14"	0.125"	1", 20mm	Asphalt/Green Concrete	5,400

Extended Performance™ Premium Dry Cutting Tile Blades

Best for cutting tile, marble and granite. Provides a smooth finish and minimizes chipping. Blade can be used wet or dry.



Cat #	Dia	Thickness	Arbor	Application	Max RPM	Wet or Dry
DW4729	4"	.060"	5/8", 7/8", 20mm	Ceramic Tile	15,200	Both
DW4760	7"	.060"	5/8"	Ceramic Tile	8,700	Wet
DW4761	10"	.080"	5/8"	Ceramic Tile	6,000	Wet
DW4762	10"	.060"	5/8"	Porcelain Tile	6,000	Wet

Cup Grinders

Best for rough grinding, deburring & fast material removal of concrete, masonry and stone. Double rim provides longer life and more aggressive material removal.



Cat #	Dia	Thickness	Arbor	Application	Max RPM
DW4770	4"	5/8"-11	Single	General Purpose	15,000
DW4771	7"	5/8"-11	Single	General Purpose	8,600
DW4772	4"	5/8"-11	Double	Heavy Material Removal	15,000
DW4773	7"	5/8"-11	Double	Heavy Material Removal	8,600

ACCESSORIES

WOOD CUTTING RECIPROCATING SAW BLADES

- Raker tooth pattern keeps blade in the cut, minimizing vibration
- +6° hook angle for fast cuts through the toughest material
- Specially formulated anti-stick coating minimizes friction for faster, smoother cuts
- Reinforced shoulder of tooth provides increased durability when cutting through nails and other foreign objects



BLADE SPECS	
Height	3/4"
Thickness	.050"
Matrix	II Bi-Metal
Back	Taper
Wire	.040" HSS
Teeth	Reinforced

Cat #	Length	TPI	Body Type	Milwaukee*	Lenox**	Starrett***	Morse****
Wood Cutting 5 Packs							
DW4801	6"	3	Taper	-	20575-634R	-	-
DW4802	6"	6	Taper	48-00-5035	20572-656R	BT66-5	RB65006P
DW4803	9"	6	Taper	48-00-5036	20582-956R	BT96-5	RB95006P
DW4804	12"	6	Taper	48-00-5037	20585-156R	BT126-5	RB125006P
DW4847	6"	5/8	Taper	48-00-5031	-	-	-
DW4848	9"	5/8	Taper	-	-	-	-
DW4849	12"	5/8	Taper	-	-	-	-
Wood Cutting 25 Packs							
DW4802B25	6"	6	Taper	-	20530-B656R	-	-
DW4803B25	9"	6	Taper	48-00-8036	20558-B956R	-	-
DW4804B25	12"	6	Taper	-	20495-B156R	-	-
DW4847B25	6"	5/8	Taper	48-00-8031	-	-	-
Wood Cutting 100 Packs							
DW4802B	6"	6	Taper	48-01-6035	-	BT66-50	RB65006B
DW4803B	9"	6	Taper	48-01-6036	-	BT96-50	RB95006B
DW4804B	12"	6	Taper	48-01-6037	-	BT126-50	RB125006B
Multi-Material 5 Packs							
DW4850	6"	6	Straight	48-00-5012	20560-606R	B66-5	RB606STP
DW4805	4"	10	Straight	48-00-5090	-	B410-5	RB41014P
DW4806	6"	10	Straight	48-00-5092	20562-610R	B610-5	RB610P
DW4845	6"	10/14	Straight	-	-	B61014-5	RB61014P
DW4846	8"	10/14	Straight	48-00-5193	20580-810R	B81014-5	RB81014P
Multi-Material 25 Packs							
DW4806B25	6"	10	Straight	-	20493-B610R	-	-
DW4845B25	6"	10/14	Straight	-	-	-	-
DW4846B25	8"	10/14	Straight	-	20590-B810R	-	-
Multi-Material 100 Packs							
DW4806B	6"	10	Straight	48-01-6092	-	B610-50	RB610B
DW4845B	6"	10/14	Straight	-	-	B61014-50	RB61014B
DW4846B	8"	10/14	Straight	48-01-6193	-	B81014-50	RB81014B



BLADE	TPI	SELECTION
WOOD	3	Faster Cut Rougher Finish
	5/8	
	6	Slower Cut Smoother Finish
	10	



DW4802B Bulk Pack



DW4806
5 Pack

* Milwaukee is a trademark of Milwaukee Electric Tool Corporation
 ** Lenox is a trademark of Irwin Industrial Tool Company
 *** Starrett is a trademark of L.S. Starrett Company
 **** Morse is a trademark of M.K. Morse Company

ACCESSORIES

METAL CUTTING RECIPROCATING SAW BLADES

- Optimal tooth pattern helps increase speed and reduce vibration
- Tooth geometry is designed to wear more consistently
- Specially formulated anti-stick coating minimizes friction for faster, smoother cuts



SPEED
DURABILITY
CONSISTENCY

BLADE SPECS	
Height	3/4"
Thickness	.035"
Matrix	II Bi-Metal
Back Style	Straight Back
Wire	.040" HSS Wire

Cat #	Length	TPI	Body Type	Milwaukee	Lenox	Starrett	Morse
5 Packs							
DW4807	4"	14	Straight	48-00-5181	20550-414R	B414-5	RB414P
DW4808	6"	14	Straight	48-00-5182	20564-614R	B614-5	RB614P
DW4809	8"	14	Straight	48-00-5187	-	B81014-5	RB814P
DW4838	12"	14	Straight	-	20583-110R	B121014-5	RB1214P
DW4810	4"	18	Straight	48-00-5183	20552-418R	B418-5	RB418P
DW4811	6"	18	Straight	48-00-5184	20566-618R	B618-5	RB618P
DW4821	8"	18	Straight	48-00-5188	20578-818R	B818-5	RB818P
DW4812	4"	24	Straight	48-00-5185	20554-424R	B424-5	RB424P
DW4813	6"	24	Straight	48-00-5186	20568-624R	B624-5	RB624P
25 Packs							
DW4807B25	4"	14	Straight	-	20488-B414R	-	-
DW4808B25	6"	14	Straight	48-00-8182	20494-B614R	-	-
DW4809B25	8"	14	Straight	-	-	-	-
DW4839B25	12"	10/14	Straight	-	20491-B110R	-	RB12501014T25
DW4810B25	4"	18	Straight	-	20489-B418R	-	RB418T25
DW4811B25	6"	18	Straight	48-00-8184	20529-B618R	-	-
DW4821B25	8"	18	Straight	-	20487-B818R	-	RB818T25
DW4822B25	12"	18	Straight	-	21511-B118R	-	RB1218T25
DW4812B25	4"	24	Straight	-	20490-B424R	-	-
DW4813B25	6"	24	Straight	48-00-8186	20496-B624R	-	-
100 Packs							
DW4807B	4"	14	Straight	48-01-6181	-	B414-50	RB414B
DW4808B	6"	14	Straight	48-01-6182	-	B614-50	RB614B
DW4809B	8"	14	Straight	48-01-6187	-	B81014-50	RB814B
DW4839B	12"	10/14	Straight	48-01-6194	-	-	RB12501014T50
DW4811B	6"	18	Straight	48-01-6184	-	B618-50	RB618B
DW4821B	8"	18	Straight	48-01-6188	-	B818-50	RB818B

SETS & MERCHANDISING OPTIONS



DW4856 6 Pc. Set



DW4853 3 Pc. Set



DW4857 5 Pc. Set



DW4890 15 Pc. Set with Case

BLADE	TPI	SELECTION
METAL	10/14	Thicker Material
	14	↕
	18	
	24	



ACCESSORIES

DEMOLITION RECIPROCATING SAW BLADES

- Optimal blade height and blade thickness provides extreme durability
- Wider high speed steel strip for stronger teeth and longer wear
- Specially formulated anti-stick coating helps to minimize friction



BLADE SPECS
Height 1"
Thickness .050"/.062"
Matrix II Bi-Metal
.080" HSS Wire
Reinforced Teeth

Cat #	Length	TPI	Body Type	Milwaukee	Lenox	Starrett	Morse
5 Packs							
DW4862	6"	6	Taper	48-00-5021	20512-6066R	-	-
DW4863	9"	6	Taper	48-00-5026	20598-966R	-	-
DW4860	12"	6	Taper	48-00-5027	20500-106R	-	-
DW4864	6"	10	Straight	48-00-5712	20592-650R	-	RB6501014P
DW4865	9"	10	Straight	48-00-5713	-	-	RB8501014P
DW4866	6"	14	Straight	48-00-5782	20593-6514R	-	-
DW4868	9"	14	Straight	48-00-5787	20511-9514R	-	-
DW4867	6"	18	Straight	48-00-5784	20594-6518R	-	-
DW4869	9"	18	Straight	48-00-5788	-	-	-
25 Packs							
DW4863B25	9"	6	Taper	48-00-8026	20523-B966R	-	-
DW4865B25	9"	10	Straight	48-00-8713	-	-	-
100 Packs							
DW4863B	9"	6	Taper	-	-	-	-
DW4864B	6"	10	Straight	-	-	-	RB6501014B
DW4865B	9"	10	Straight	-	-	-	RB8501014B
DW4866B	6"	14	Straight	-	-	-	-
DW4868B	9"	14	Straight	-	-	-	-

MISCELLANEOUS RECIPROCATING SAW BLADES

Cat #	Length	TPI	Body Type	Milwaukee	Lenox	Starrett	Morse
5 Packs							
DW4814	3-1/2"	14	Scrolling	48-00-5162	20520-314RC	-	-
DW4815	3-1/2"	18	Scrolling	48-00-5163	20521-318RC	SB418-5	RB318SP
DW4816	6"	6	Scrolling	-	20521-676RC	-	RB65006CP
DW4851	6"	6	Drywall	48-00-5052	20570-636RP	VB66-5	RB606PP
DW4843	8"	Coarse	Carbide Grit	48-02-1430	-	-	-
DW4844	6"	Coarse	Carbide Grit	48-02-1420	-	-	-



DW4862
5 Pack



DW4814
5 Pack

ACCESSORIES

BI-METAL HOLE SAWS

- Increased durability unique tooth design/set pattern for improved metal cutting performance
- Wider high speed steel strip for increased tooth durability
- Longer life – M3 steel provides increased wear resistance
- Improved backing plate prevents warping at holes and increases cycles
- Pro's choice all hole saws are deep cut style for added versatility



Cat # Box	Cat # Skin Card	Size Imperial	Size Metric	Speed In steel (Recommended)	Pipe Entrance*		Pipe Tap*		Lenox	Morse	Starrett	Milwaukee
					Inches	mm	Inches	mm				
D180009	-	9/16"	14	550	-	-	-	-	30009-9L	AV09	VH0096	49-56-0006
D180010	-	5/8"	16	530	-	-	-	-	30010-10L	AV10	VH0058	49-56-0011
D180011	-	11/16"	17	500	-	-	-	-	30011-11L	AV11	VH1016	49-56-0016
D180012	D186012	3/4"	19	460	3/8	10	1/2	13	30012-12L	AV12	VH0034	49-56-0021
D180098	-		20	425	-	-	-	-	30098-20MMHS	-	-	-
D180013	-	13/16"	21	425	-	-	-	-	30013-13L	AV13	VH1036	49-56-0026
D180014	D186014	7/8"	22	390	1/2	13	3/4	19	30014-14L	AV14	VH0078	49-56-0031
D180015	-	15/16"	24	370	-	-	-	-	30015-15L	AV15	VH1056	49-56-0036
D180016	D186016	1"	25	350	-	-	-	-	30016-16L	AV16	VH0100	49-56-0041
D180017	-	1-1/16"	27	325	-	-	-	-	30017-17L	AV17	VH0116	49-56-0046
D180018	D186018	1-1/8"	29	300	3/4	19	1	25	30018-18L	AV18	VH0118	49-56-0051
D180019	-	1-3/16"	30	285	-	-	-	-	30019-19L	AV19	VH0136	49-56-0056
D180020	D186020	1-1/4"	32	275	-	-	-	-	30020-20L	AV20	VH0114	49-56-0061
D180021	-	1-5/16"	33	260	-	-	-	-	30021-21L	AV21	VH0156	49-56-0066
D180022	D186022	1-3/8"	35	250	1	25	-	-	30022-22L	AV22	VH0138	49-56-0071
D180023	-	1-7/16"	37	240	-	-	-	-	30023-23L	AV23	VH0176	49-56-0076
D180024	D186024	1-1/2"	38	230	-	-	1-1/4	32	30024-24L	AV24	VH0112	49-56-0081
D180025	-	1-9/16"	40	220	-	-	-	-	30025-25L	AV25	VH0196	49-56-0086
D180026	D186026	1-5/8"	41	210	-	-	-	-	30026-26L	AV26	VH0158	49-56-0091
D180027	-	1-11/16"	43	205	-	-	-	-	30027-27L	AV27	VH1116	49-56-0096
D180028	D186028	1-3/4"	44	195	1-1/4	32	1-1/2	38	30028-28L	AV28	VH0134	49-56-0101
D180029	-	1-13/16"	46	190	-	-	-	-	30029-29L	AV29	VH1136	49-56-0106
D180030	D186030	1-7/8"	48	180	-	-	-	-	30030-30L	AV30	VH0178	49-56-0111
D180032	D186032	2"	51	170	1-1/2	38	-	-	30032-32L	AV32	VH0200	49-56-0116
D180033	-	2-1/16"	52	165	-	-	-	-	30033-33L	AV33	VH0216	49-56-0121
D180034	D186034	2-1/8"	54	160	-	-	-	-	30034-34L	AV34	VH0218	49-56-0131
D180036	D186036	2-1/4"	57	150	-	-	2	51	30036-36L	AV36	VH0214	49-56-0136
D180038	D186038	2-3/8"	60	140	-	-	-	-	30038-38L	AV38	VH0238	49-56-0141
D180040	D186040	2-1/2"	64	135	2	51	-	-	30040-40L	AV40	VH0212	49-56-0146
D180041	-	2-9/16"	65	130	-	-	-	-	30041-41L	AV41	VH0296	49-56-0150
D180042	-	2-5/8"	67	130	-	-	2-1/2	64	30042-42L	AV42	VH0258	49-56-0155
D180043	-		68	125	-	-	-	-	30043-43L	-	-	-
D180044	D186044	2-3/4"	70	125	-	-	-	-	30044-44L	AV44	VH0234	49-56-0160
D180046	-	2-7/8"	73	120	-	-	-	-	30046-46L	AV46	VH0278	49-56-0165
D180048	D186048	3"	76	115	2-1/2	64	-	-	30048-48L	AV48	VH0300	49-56-0170
D180050	-	3-1/8"	79	110	-	-	-	-	30050-50L	AV50	VH0318	49-56-0175
D180052	D186052	3-1/4"	83	105	-	-	3	76	30052-52L	AV52	VH0314	49-56-0180
D180054	-	3-3/8"	86	100	-	-	-	-	30054-54L	AV54	VH0338	49-56-0185
D180056	D186056	3-1/2"	89	95	-	-	-	-	30056-56L	AV56	VH0312	49-56-0190
D180058	D186058	3-5/8"	92	95	3	76	-	-	30058-58L	AV58	VH0358	49-56-0195
D180060	-	3-3/4"	94	90	-	-	3-1/2	89	30060-60L	AV60	VH0334	49-56-0200
-	D186062	3-7/8"	98	85	-	-	-	-	30062-62L	AV62	VH0378	49-56-0205
D180064	D186064	4"	102	85	-	-	-	-	30064-64L	AV64	VH0400	49-56-0210
D180066	D186066	4-1/8"	105	85	3-1/2	89	-	-	30066-66L	AV66	VH0418	49-56-0215
D180068	D186068	4-1/4"	108	80	-	-	4	102	30068-68L	AV68	VH0414	49-56-0220
D180072	D186072	4-1/2"	114	75	-	-	-	-	30072-72L	AV72	VH0412	49-56-0230
D180076	-	4-3/4"	121	70	-	-	4-1/2	114	30076-76L	AV76	VH0434	49-56-0235
D180080	-	5"	127	65	-	-	-	-	30080-80L	AV80	VH0500	49-56-0240
D180088	-	5-1/2"	140	60	-	-	-	-	30088-88L	AV88	VH0512	49-56-0245
D180096	-	6"	152	55	-	-	-	-	30096-96L	AV96	VH0600	49-56-0250

*Values refer to nominal pipe size

ACCESSORIES

HOLE SAW MANDRELS

Cat #	Shank	Type	Fits Sizes	Lenox	Morse	Starrett	Milwaukee
DW1800	1/4" shank	Standard	9/16"- 1-3/16"	30004-4L	M24K	A4	49-56-6950
DW1801	3/8" shank	Standard	9/16"- 1-3/16"	30005-5L	M34	A1	49-56-7010
DW1802	7/16" shank	Standard	1-1/4"- 6"	-	M44	-	49-56-7000
DW1803	7/16" shank	Quick Change	1-1/4"- 6"	30002-2L	M45P	A2	49-56-7055
DW1804	1/2" shank	Quick Change	1-1/4"- 6"	30003-3L	M55P	-	49-56-7130
DW1818	3/8" shank	Standard	1-1/4"- 3"	-	-	-	-
DW1808	Pilot Bit			30853-B4321	MPD4S	A014D	49-56-8000

HOLE SAW SETS

Cat #	Description	Lenox	Morse	Starrett	Milwaukee
D180001	Plumber's set 3/4, 7/8, 1-1/8, 1-1/2, 1-3/4, 2-1/4	30808-600P	AV04P	KV1091	-
D180002	Electrician's set 7/8, 1-1/8, 1-3/8, 1-3/4, 2, 2-1/2	30821-600L	AV02E	KV1094	49-22-4050
D180003	Bi-Metal Door Lock Installation Kit	34085-200AL1	TACLKIT1	KS288	49-22-4063

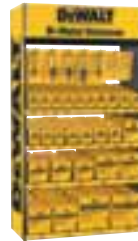

DSM920-M
25 SKU Merchandiser
Also available:
DM9180-M 15 SKU Rack

PORTABLE BANDSAW BLADES

- Matrix II high speed steel edge for heat and wear resistance
- 8% cobalt content for added durability and wear
- Rc 65-67 tooth hardness for increased wear resistance
- Alloy steel backer for fatigue resistance



BLADE SPECS

Height 1/2"
Thickness .020/.025"
Matrix II Bi-Metal
.029" HSS Wire

Cat #	Length	Height	Thickness*	TPI	Lenox	Milwaukee	Morse	Starrett
3 Packs								
DW3981	44-7/8"	1/2"	.020"	10	-	48-39-0501	ZWEP4410R	-
DW3982	44-7/8"	1/2"	.020"	14	80115-38-EW-14	48-39-0511	ZWEP4414W	BM14
DW3983	44-7/8"	1/2"	.020"	18	80116-38-EW-18	48-39-0521	ZWEP4418W	BM18
DW3984	44-7/8"	1/2"	.020"	24	80117-38-EW-24	48-39-0531	ZWEP4424W	BM24
DW3985	44-7/8"	1/2"	.020"	10/14	80114-38-EW-10/14	48-39-0551	ZWEP441014MC	BM1014
DW3986	44-7/8"	1/2"	.020"	14/18	80112-38-EW-14/18	48-39-0561	ZWEP441418MC	BM1418
DW3987	44-7/8"	1/2"	.025"	10	NA	-	-	-
DW3988	44-7/8"	1/2"	.025"	14	80145-385-EW-14	-	-	-
DW3989	44-7/8"	1/2"	.025"	18	82310-385-EW-18	-	-	-
DW3991	44-7/8"	1/2"	.025"	10/14	80144-385-EW-10/14	-	-	-
DW3992	44-7/8"	1/2"	.025"	14/18	80142-385-EW-14/18	-	-	-
100 Packs								
DW3981B	44-7/8"	1/2"	.020"	10	-	48-39-0502	ZWEP4410RB	-
DW3982B	44-7/8"	1/2"	.020"	14	-	48-39-0512	ZWEP4414WB	-
DW3983B	44-7/8"	1/2"	.020"	18	-	48-39-0522	ZWEP4418WB	-
DW3984B	44-7/8"	1/2"	.020"	24	-	48-39-0532	ZWEP4424WB	-
DW3985B	44-7/8"	1/2"	.020"	10/14	-	48-39-0552	ZWEP441014MCB	-
DW3986B	44-7/8"	1/2"	.020"	14/18	-	48-39-0562	ZWEP441418MCB	-

*Lenox blades are .023"

ACCESSORIES

JIG SAW BLADES

Wood Cutting:

- High carbon steel for optimal flexibility
- Optimized tooth form for speed and precision
- T shank and U shank designs available to fit all saws



BLADE SPECS

Height 5/16"
T & U Shank
High Carbon Steel
Taper Ground/Set

Metal Cutting:

- Bi-metal material for optimal flexibility and durability
- Optimized tooth form for speed and precision
- T shank and U shank designs available to fit all saws



BLADE SPECS

Height 5/16"
T & U Shank
Bi-Metal Material
Wavy Tooth Set

Cat #	Lgth	TPI	Application	Shank	Lenox*	Morse	Milwaukee	Bosch**
2 Packs								
DW3700H2	4"	6	Fast Wood Cutting HCS	U	20625-US486J	-	-	U144D2
DW3703H2	4"	6	Fast, Clean Wood Cutting HCS	U	20627-US456J	-	-	U201D2
DW3705H2	4"	8	Aluminum/Fiberglass HCS	U	-	-	-	-
DW3710H2	4"	10	Fine Finish Wood Cutting HCS	U	20632-US450J	-	-	U101B2
DW3712H2	4"	10	Downcutting HCS	U	20633-US450JR	-	-	-
DW3715H2	3"	12	Scrolling HCS	U	-	-	-	-
DW3750H2	4"	6	Fast Wood Cutting HCS	T	-	-	-	T144D2
DW3753H2	4"	6	Fast, Clean Wood Cutting HCS	T	-	-	-	-
DW3755H2	4"	8	Aluminum/Fiberglass HCS	T	-	-	-	T111C2
DW3760H2	4"	10	Fine Finish Wood Cutting HCS	T	-	-	-	T101B2
DW3762H2	4"	10	Downcutting HCS	T	-	-	-	-
DW3765H2	3"	12	Scrolling HCS	T	-	-	-	T119B02
5 Packs								
DW3700H	4"	6	Fast Wood Cutting HCS	U	20620-486J	SC416P	48-42-0200	U144D
DW3703H	4"	6	Fast, Clean Wood Cutting HCS	U	20608-456J	SC406P	48-42-0500	U201D
DW3705H	4"	8	Aluminum/Fiberglass HCS	U	-	-	48-42-0850	U111C
DW3710H	4"	10	Fine Finish Wood Cutting HCS	U	20614-450J	SC410P	48-42-0540	U101B
DW3712H	4"	10	Downcutting HCS	U	20615-450JR	SC410RP	48-42-0640	-
DW3715H	3"	12	Scrolling HCS	U	-	SC2712P	48-42-0650	-
DW3720-5	3"	14	Thick Metal Cutting BiMetal	U	20610-314J	SH2712P	48-42-2192	U118BF
DW3724-5	3"	18	Medium Metal Cutting BiMetal	U	20611-318J	SH2718P	48-42-2120	U118EF
DW3726-5	3"	24	Thin Metal Cutting BiMetal	U	20612-324J	SH2724P	48-42-2160	U118AF
DW3728-5	3"	36	Sheet Metal Cutting BiMetal	U	-	SH2732P	-	-
DW3750H	4"	6	Fast Wood Cutting HCS	T	20802-406S	SC0416P	48-42-5200	T144D
DW3753H	4"	6	Fast, Clean Wood Cutting HCS	T	20809-416SC	SC0406P	48-42-5500	T101D
DW3755H	4"	8	Aluminum/Fiberglass HCS	T	-	-	48-42-5850	T111C
DW3760H	4"	10	Fine Finish Wood Cutting HCS	T	20810-450S	SC0410P	48-42-5240	T101B
DW3762H	4"	10	Downcutting HCS	T	20811-450SR	SC0410RP	48-42-5540	T101BR
DW3765H	3"	12	Scrolling HCS	T	-	-	48-42-5640	T119B0
DW3770-5	3"	14	Thick Metal Cutting BiMetal	T	20805-314S	SB0314P	48-42-5192	T118BF
DW3774-5	3"	18	Medium Metal Cutting BiMetal	T	20806-318S	SB0318P	48-42-5121	T118EF
DW3776-5	3"	24	Thin Metal Cutting BiMetal	T	20807-324S	SB0324P	48-42-5161	T118AF
DW3778-5	3"	36	Sheet Metal Cutting BiMetal	T	-	-	-	-
50 Packs								
DW3700H50	4"	6	Fast Wood Cutting HCS	U	20700-B486J	SC416B	-	-
DW3703H50	4"	6	Fast, Clean Wood Cutting HCS	U	-	SC406B	-	-
DW3710H50	4"	10	Fine Finish Wood Cutting HCS	U	20702-B450J	SC410B	-	-
DW3712H50	4"	10	Downcutting HCS	U	-	SC410RB	-	-
DW3715H50	3"	12	Scrolling HCS	U	-	SC2712B	-	-
DW3720B50	3"	14	Thick Metal Cutting BiMetal	U	20705-B314J	SH2712B	-	-
DW3724B50	3"	18	Medium Metal Cutting BiMetal	U	20706-B318J	SH2718B	-	U118EF100
DW3726B50	3"	24	Thin Metal Cutting BiMetal	U	20707-B324J	SH2724B	-	U118AF100
DW3728B50	3"	36	Sheet Metal Cutting BiMetal	U	-	SH2732B	-	-
DW3750H50	4"	6	Fast Wood Cutting HCS	T	20812-B406S	SC0416B	-	T144D100
DW3753H50	4"	6	Fast, Clean Wood Cutting HCS	T	-	SC0406B	-	T101D100
DW3755H50	4"	8	Aluminum/Fiberglass HCS	T	-	-	-	T111C100
DW3760H50	4"	10	Fine Finish Wood Cutting HCS	T	20814-B450S	SC0410B	-	T101B100

*All Lenox Blades are Bi-Metal

**Bosch is a trademark of Robert Bosch GmbH

ACCESSORIES

Cat #	Lgth	TPI	Application	Shank	Lenox*	Morse	Milwaukee	Bosch
50 Packs (continued)								
DW3762H50	4"	10	Downcutting HCS	T	-	SC0410RB	-	T101BR100
DW3765H50	3"	12	Scrolling HCS	T	-	-	-	-
DW3770B50	3"	14	Thick Metal Cutting BiMetal	T	20815-B314S	SB0314B	-	-
DW3774B50	3"	18	Medium Metal Cutting BiMetal	T	20816-B318S	SB0318B	-	T118EF100
DW3776B50	3"	24	Thin Metal Cutting BiMetal	T	20817-B324S	SB0324B	-	T118AF100
DW3778B50	3"	36	Sheet Metal Cutting BiMetal	T	-	-	-	-

*All Lenox Blades are Bi-Metal

SETS & MERCHANDISING OPTIONS



DW3790 8 Pc. U Shank Set



DW3799 25 Pc. U Shank Set



DW3795H 5 Pc. T Shank Set



DW3791 8Pc. T Shank Set



DM9371-M
18 SKU
Combination Rack

Also Available:
DM9360-M
7 SKU Rack and
DM9361-M
7 SKU Rack

STEP DRILL BITS

- Full range of self starting, hole enlarging, multiple hole, single hole, metric & standard bits
- Multiple steps eliminate need for many special size drill bits
- Double fluted design for optimum speed & accuracy
- Size marking(s) for easier hole identification
- Most commonly used steps highlighted for quick recognition
- Flats on shank prevent bit slipping in chuck

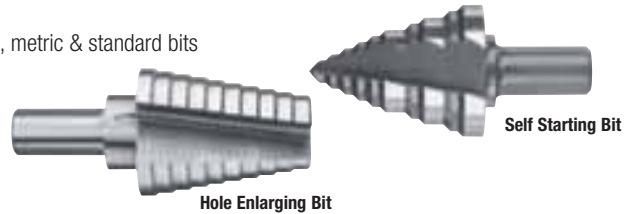

Hole Enlarging Bit

Self Starting Bit

Cat #	Description	# of Holes	Increments	Shank Size	Max. Mat. Thickness	Drill Size
Self Starting						
DW1783	1/8" – 1/2" by 1/32"	13	1/32"	1/4"	1/8"	1/4" & larger
DW1784	3/16" – 1/2" by 1/16"	6	1/16"	1/4"	3/8"	1/4" & larger
DW1785	1/4" – 3/4" by 1/16"	9	1/16"	3/8"	1/8"	3/8" & larger
DW1786	3/16" – 7/8" by 1/16"	12	1/16"	3/8"	1/8"	3/8" & larger
DW1787	7/8", 1-1/8", 1-3/8"	3	1/4"	1/2"	3/16"	1/2" & larger
DW1788	3/8", 1/2"	2	-	1/4"	3/16"	1/4" & larger
DW1789	7/8", 1-1/8"	2	-	1/2"	1/8"	1/2" & larger
DW1790	7/8"	1	-	3/8"	-	3/8" & larger
DW1793	4, 5, 6, 7, 8, 9, 10, 11, 12	9	1mm	1/4"	5mm	1/4" & larger
DW1795	6, 8, 10, 12, 14, 16, 18	7	2mm	3/8"	5mm	3/8" & larger
Hole Enlarging						
DW1791	9/16" – 1" by 1/16"	8	1/16"	1/2"	1/8"	1/2" & larger
DW1792	13/16" – 1-3/8" by 1/16"	10	1/16"	1/2"	1/8"	1/2" & larger
DW1794	14, 16, 18, 20, 22, 24, 25	7	2mm	1/2"	5mm	1/2" & larger
DW1796	20, 22, 24, 26, 28, 30, 32, 34	8	2mm	1/2"	5mm	1/2" & larger

Cat #	Description	Lenox	Morse	Milwaukee	Unibit*	Greenlee**
Competitive Listings						
DW1783	1/8" – 1/2" by 1/32"	30881-VB1	ESD01	48-89-9100	10231	34401
DW1784	3/16" – 1/2" by 1/16"	30884-VB4	ESD02	-	10232	36402
DW1785	1/4" – 3/4" by 1/16"	30883-VB3	ESD04	48-89-9105	10233	-
DW1786	3/16" – 7/8" by 1/16"	30908-VB8	ESD03	48-89-9130	10234	34403
DW1787	7/8", 1-1/8", 1-3/8"	-	ESD11	-	10235	-
DW1788	3/8", 1/2"	30886-VB6	-	-	-	-
DW1789	7/8", 1-1/8"	30888-VB11	ESD05	48-89-9135	10239	36413
DW1790	7/8"	30887-VB7	ESD10	48-89-9115	10311	34411
DW1791	9/16" – 1" by 1/16"	-	ESD08	48-89-9110	10220	-
DW1792	13/16" – 1-3/8" by 1/16"	-	ESD09	-	10221	34414
DW1793	4, 5, 6, 7, 8, 9, 10, 11, 12	30960-MVB412	-	-	11101	00470
DW1794	14, 16, 18, 20, 22, 24, 25	30961-MVB1424	-	-	11580	-
DW1795	6, 8, 10, 12, 14, 16, 18	30962-MVB618	-	-	11103	00471
DW1796	20, 22, 24, 26, 28, 30, 32, 34	30963-MVB2034	-	-	11581	-

*Unibit is a trademark of Irwin Industrial Tool Company ** Greenlee is a trademark of Greenlee Textron Inc.

ACCESSORIES

HACKSAW FRAME & BLADES

Frame:

- Quick change for easy blade change
- Removable hand guard for added protection
- Soft feel grips for added comfort
- High tension knob for tight fit
- Jab saw capability
- Easy blade storage
- 45° & 90° cutting capability

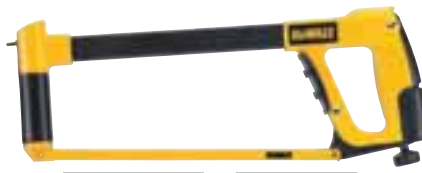

MATERIALS USED
Die Cast Aluminum
Rubber Overmolds
Steel Tubing
Glass Filled Nylon

BLADE SPECS
Height 1/2"
Thickness .025"
M2 Bi-Metal
.040" HSS Wire
D6A Backer

Blades:

- High Speed Steel Teeth for extra durability
- High Carbon Steel Backer for extra flexibility
- Specially Formulated Coating minimizes friction
- Rc 64-66 Tooth Hardness for increased wear resistance
- Tooth Designs (Raker & Wavy) optimized for application

Cat #	Description	Lenox	Milwaukee	Morse	Starrett	
Frame						
DW3970	12" High Tension Frame	20919-2012	48-08-0320	HHBF02	K153	
Cat #	Length	TPI	Lenox	Milwaukee	Morse	Starrett
Blades						
DW3971	10"	18	20150-S018HE	-	HHCB1018	-
DW3972	10"	24	20151-S024HE	-	HHCB1024	-
DW3973	10"	32	20152-S032HE	-	HHCB1032	-
DW3974	12"	14	-	-	HHCB1214	-
DW3975	12"	18	20154-S218HE	-	HHCB1218	-
DW3976	12"	24	20155-S224HE	-	HHCB1224	-
DW3977	12"	32	20156-S232HE	-	HHCB1232	-
10 Packs					(100 Packs)	
DW3971-10	10"	18	20140-V018HE	-	HHB1018P	BS1018
DW3972-10	10"	24	20141-V024HE	-	HHB1024P	BS1024
DW3973-10	10"	32	20142-V032HE	-	HHB1032P	-
DW3974-10	12"	14	20143-V214HE	48-43-0600	HHB1214P	-
DW3975-10	12"	18	20144-V218HE	48-43-0610	HHB1218P	-
DW3976-10	12"	24	20145-V224HE	48-43-0620	HHB1224P	-
DW3977-10	12"	32	20146-V232HE	48-43-0630	HHB1232P	-
100 Packs						
DW3974B	12"	14	-	-	HHB1214	BS1214
DW3975B	12"	18	20116-218HE	-	HHB1218	BS1218
DW3976B	12"	24	20117-224HE	-	HHB1224	BS1224
DW3977B	12"	32	20118-232HE	-	HHB1232	BS1232

PVC SAW & BLADES

- Ergonomic design for added comfort
- Belt/ladder hook for extra convenience
- Tool free blade changes for quick blade replacement
- Includes flush cutting capability without need for adapter
- 12" and 18" lengths available



Cat #	Description	Lenox	Greenlee	Starrett	Morse
DW3993	18" Blade & Handle	20980-HSF-180	00114	148-18	HS1801
DW3994	12" Blade & Handle	20985-HSF-120	00113	148-12	HS1201
DW3995	18" Replacement Blade	20981-HSB-18	00116	PVC-18	HSB18
DW3996	12" Replacement Blade	20982-HSB-12	00115	PVC-12	HSB12



Ergonomic Design



Flush Cutting Capability



ACCESSORIES

HEAVY-DUTY SELF FEED BITS

- 2 cutter design helps finish hole completely to reduce binding and stalling
- Self feed spur aggressively moves bit through material
- Shank flats ensure bit doesn't slip in chuck



Cat #	Description	Milwaukee	Lenox	Irwin*	Greenlee
DW1630	1"	48-25-1001	33100-LL100	43016	149G-1
DW1631	1-1/8"	48-25-1121	33112-LL112	43018	149G-1-1/8
DW1632	1-1/4"	48-25-1251	33125-LL125	43020	149G-1-1/4
DW1633	1-3/8"	48-25-1371	33137-LL137	43022	149G-1-3/8
DW1634	1-1/2"	48-25-1501	33150-LL150	43024	149G-1-1/2
DW1635	1-3/4"	48-25-1751	33175-LL175	43028	149G-1-3/4
DW1636	2"	48-25-2001	33200-LL200	43032	149G-2
DW1637	2-1/8"	48-25-2121	33212-LL212	43034	149G-2-1/8
DW1638	2-1/4"	48-25-2251	33225-LL225	43036	149G-2-1/4
DW1639	2-9/16"	48-25-2561	33256-LL256	43041	149G-2-9/16
DW1640	3"	48-25-3001	33300-LL300	43047	149G-3
DW1641	3-5/8"	48-25-3621	33362-LL362	43058	149G-3-5/8
DW1642	4-5/8"	48-25-4621	33462-LL462	43074	149G-4-5/8
DW1643	Replacement Parts (DW1630-DW1633)				
DW1644	Replacement Parts (DW1634-DW1638)				
DW1645	Replacement Parts (DW1639-DW1642)				
DW1646	5-1/2" Extension	48-28-4001	30846-55X	-	-
DW1647	12" Extension	48-28-4006	30847-12X	-	-
DW1648	5-Pc. Kit (1-3/8", 1-1/2", 2-1/8", 2-9/16", 5-1/2" Extension)				
DW1649	8-Pc. Kit (1", 1-1/8", 1-1/4", 1-1/2", 1-3/4", 2-1/8", 2-9/16", 5-1/2" Extension)				

WOOD BORING BITS

- Cutting spurs for optimum hole finish
- Hang hole for bit storage & wire pulling
- Full length heat treat for longer life
- Flats on shank prevent bit slipping in chuck
- 1/4" shank fits all drills & 1/4" quick change holders
- 6" & 16" lengths available



Cat #	Description	Irwin*	Milwaukee	Morse	Greenlee
DW1570	1/4" x 6"	88804	48-27-0251	WSB250	33A-1/4
DW1571	5/16" x 6"	88805	48-27-0311	WSB312	-
DW1572	3/8" x 6"	88806	48-27-0371	WSB375	33A-3/8
DW1573	7/16" x 6"	88807	48-27-0441	WSB437	-
DW1574	1/2" x 6"	88808	48-27-0501	WSB500	33A-1/2
DW1575	9/16" x 6"	88809	48-27-0561	WSB562	-
DW1576	5/8" x 6"	88810	48-27-0621	WSB625	33A-5/8
DW1577	11/16" x 6"	88811	48-27-0681	WSB687	-
DW1578	3/4" x 6"	88812	48-27-0751	WSB750	33A-3/4
DW1579	13/16" x 6"	88813	48-27-0811	WSB812	-
DW1580	7/8" x 6"	88814	48-27-0871	WSB875	33A-7/8
DW1581	15/16" x 6"	88815	48-27-0941	WSB937	-
DW1582	1" x 6"	88816	48-27-1001	WSB1000	33A-1
DW1583	1-1/8" x 6"	88818	48-27-1121	WSB1125	33A-1 1/8
DW1584	1-1/4" x 6"	88820	48-27-1251	WSB1250	33A-1 1/4
DW1585	1-3/8" x 6"	88822	48-27-1371	WSB1375	33A-1 3/8
DW1586	1-1/2" x 6"	88824	48-27-1501	WSB1500	33A-1 1/2
DW1587	6-Pc. Set	88899	49-22-0071	-	33AR-6
DW1588	6" Extension	90106	-	-	-
DW1589	12" Extension	90112	48-28-3350	-	901-12
DW1590	3/8" x 16"	88706	-	-	33L-3/8
DW1591	1/2" x 16"	88708	-	-	33L-1/2
DW1592	5/8" x 16"	88710	-	-	33L-5/8
DW1593	3/4" x 16"	88712	-	-	33L-3/4
DW1594	7/8" x 16"	88714	-	-	33L-7/8
DW1595	1" x 16"	88716	-	-	33L-1

* Irwin is a trademark of Irwin Industrial Tool Company

ACCESSORIES

POWER SHIP AUGER BITS

- Self feeding screw for fast material penetration
- Resharpenable edge for longer life
- Dual cutting lip for maximum durability (nails)
- Hollow center flute for aggressive chip extraction
- Heat treated for durability and life



Cat #	Diameter	Overall Length	Flute Length	Shank	Milwaukee	Lenox	Irwin	Greenlee
Short								
DW1665	5/8"	6"	4"	1/2"	-	31030-07A-1016	42410	30419
DW1666	11/16"	6"	4"	1/2"	48-13-0683	31031-07A-1116	42411	30421
DW1667	3/4"	6"	4"	1/2"	48-13-0753	31032-07A-1216	42412	30423
DW1668	13/16"	6"	4"	1/2"	48-13-0813	31033-07A-1316	42413	30425
DW1669	7/8"	6"	4"	1/2"	48-13-0873	31034-07A-1416	42414	30427
DW1670	15/16"	6"	4"	1/2"	48-13-0933	31035-07A-1516	-	-
DW1671	1"	6"	4"	1/2"	48-13-1003	31036-07A-1616	42416	30429
DW1672	1-1/16"	6"	4"	1/2"	48-13-1063	31037-07A-1716	-	-
DW1673	1-1/8"	6"	4"	1/2"	48-13-1123	31038-07A-1816	42418	30431
DW1674	1-1/4"	6"	4"	1/2"	48-13-1253	31040-07A-2016	42420	30433
DW1675	1-3/8"	6"	4"	1/2"	48-13-1373	31042-07A-2216	-	-
DW1676	1-1/2"	6"	4"	1/2"	48-13-1503	31044-07A-2416	-	-
Long								
DW1680	9/16"	17"	12"	7/16" Hex	48-13-5560	31009-008-0916	47409	-
DW1681	5/8"	17"	12"	7/16" Hex	48-13-5620	31010-008-1016	47410	30919
DW1682	11/16"	17"	12"	7/16" Hex	48-13-5680	31011-008-1116	47411	30921
DW1683	3/4"	17"	12"	7/16" Hex	48-13-5750	31012-008-1216	47412	30923
DW1684	13/16"	17"	12"	7/16" Hex	48-13-5810	31013-008-1316	47413	30925
DW1685	7/8"	17"	12"	7/16" Hex	48-13-5870	31014-008-1416	47414	30927
DW1686	15/16"	17"	12"	7/16" Hex	48-13-5930	31015-008-1516	47415	30929
DW1687	1"	17"	12"	7/16" Hex	48-13-6000	31016-008-1616	47416	30931
DW1688	1-1/16"	17"	12"	7/16" Hex	48-13-6010	31017-008-1716	47417	-
DW1689	1-1/8"	17"	12"	7/16" Hex	48-13-6120	31018-008-1816	47418	30935
DW1690	1-1/4"	17"	12"	7/16" Hex	48-13-6250	31020-008-2016	47420	30937
DW1691	1-3/8"	17"	12"	7/16" Hex	48-13-6370	31022-008-2216	47422	-
DW1692	1-1/2"	17"	12"	7/16" Hex	48-13-6500	31024-008-2416	47424	-

BELLHANGER BITS

- For installation of small wire systems computer, security, phone cable, etc.
- Pull wire back through hole by attaching a line or wire to bit
- One piece steel construction for added durability
- Full length heat treat for longer life
- 12", 18" & 24" lengths available



Cat #	Diameter	Length	Milwaukee	Irwin
DW1768	1/4"	12"	48-13-7125	38904
DW1769	5/16"	12"	48-13-7131	38905
DW1770	3/8"	12"	48-13-7137	38906
DW1771	7/16"	12"	-	38907
DW1772	1/2"	12"	-	38908
DW1773	1/4"	18"	48-13-7225	39004
DW1774	5/16"	18"	48-13-7231	39005
DW1775	3/8"	18"	48-13-7237	39006
DW1776	7/16"	18"	48-13-7243	39007
DW1777	1/2"	18"	-	39008
DW1778	1/4"	24"	48-13-7325	39404
DW1779	5/16"	24"	-	39405
DW1780	3/8"	24"	48-13-7337	39406
DW1781	7/16"	24"	-	-
DW1782	1/2"	24"	-	39408



FULL TOOL BELT SETS

All DeWALT Tool Belts and Bags share these quality features:

- Heavy-duty ballistic nylon or top grain leather provides maximum durability
- Reinforced solid steel rivets prevent pull through
- Double stitching for longer life
- Reinforced belt tunnel is 2X more durable
- Heat formed pockets for easy access



D5100SM / D5100LG Ballistic Nylon



D5101SM / D5101LG Top Grain Leather

POUCHES

D5104 Heavy-Duty Tool Pouch

- Ballistic Nylon
- Dedicated tool storage provides organization



D5110 Fastener Pouch

- Ballistic Nylon
- Large main pocket for bulk storage
- 4 heat formed pockets
- Size: 8.9"W x 12"H



D5126 Telecommunication's Pouch

- Ballistic Nylon
- Large main pocket with 2 compartments for organization
- 2 interior hand tool loops
- 3 heat formed pockets for hand tools
- Electrical tape holder
- Size: 8.2"W x 8.8"H



D5106 Heavy-Duty Nail Pouch

- Ballistic Nylon
- Dedicated nail storage provides organization



D5112 Technician's Pouch

- Ballistic Nylon
- Large single pocket
- 3 inner slots for tool storage
- Size: 4.8"W x 8.7"H



D5109 Electrician's Pouch

- Top Grain Leather
- Large 4 compartment pocket
- 5 heat formed pockets
- 6 interior tool loops for retention
- Tape measure clip
- Electrical tape holder
- Size: 9"W x 11.75"H



D5136 Trim Carpenter's Pouch

- Ballistic Nylon
- 2 large pockets
- 4 additional pockets for dedicated storage
- Lightweight hammer holder
- Size: 8.2"W x 8.8"H



D5122 Drywall Pouch

- Ballistic Nylon
- Large main pocket for greater capacity
- Keyhole saw loop
- Tape measure holder
- Size: 7"W x 8.3"H



TOOL BAGS

- Ballistic Nylon
- Reinforced bottom and side panel protects all contents
- Double stitching and steel rivets for maximum durability
- Interior/exterior pockets



D6050 Heavy-Duty 17" Tool Bag

- Size: 17"L x 11"W x 8.5"H

D6100 Heavy-Duty 21" Tool Bag

- Size: 21"L x 11"W x 11.5"H

ACCESSORIES

D5120 Universal Drill Holder

- Ballistic Nylon
- Designed for both left- and right-handed users
- Accepts mid-handle or pistol grip drills
- Nylon strap and buckle keeps drill in place when not in use
- Size: 6"W x 14"H



D5130 Tape Measure Holder

- Ballistic Nylon
- Holds up to 35' tape
- Size: 4.5"W x 6"H



D5128 Pliers/Tin Snip Pouch

- Ballistic Nylon
- Single tool storage
- Size: 2.7"W x 8"H



D5124 Hammer Holder

- Ballistic Nylon



D5118 Electrical Test Kit Pouch

- Ballistic Nylon
- Single pocket fits most test kits
- Retention strap keeps test kit in place
- Size: 4.4"W x 8.1"H



D5115SM/D5115LG Heavy Duty Work Belt

- Thick padding for greater comfort
- Works in conjunction with D5117 Comfort Belt



ACCESSORIES

PILOT POINT® GOLD FERROUS OXIDE DRILL BITS

- PILOT POINT® tip starts on contact, drills clean, accurate holes and reduces burrs that cause lock-up on breakthrough
- Tapered web provides greater durability to reduce breakage
- Size markings located above the shank to prevent wearing away
- No-spin shank eliminates #1 user complaint – bit spinning in the chuck



Cat #	Qty/Card	Bulk Cat#	Bulk Qty	Dia Inches	Dia Decimal	Drilling Depth	Overall Length
DW1904	2	DW1904B	12	1/16"	.0625	.88	1.88
DW1905	2	DW1905B	12	5/64"	.0781	1.00	2.00
DW1906	2	DW1906B	12	3/32"	.0938	1.25	2.25
DW1907	2	DW1907B	12	7/64"	.1094	1.50	2.62
DW1908	2	DW1908B	12	1/8"	.1250	1.62	2.75
DW1909	1	DW1909B	12	9/64"	.1406	1.75	2.88
DW1910	1	DW1910B	12	5/32"	.1562	2.00	3.12
DW1911	1	DW1911B	12	11/64"	.1719	2.12	3.25
DW1912	1	DW1912B	12	3/16"	.1875	2.31	3.50
DW1913	1	DW1913B	12	13/64"	.2031	2.44	3.62
DW1914	1	DW1914B	12	7/32"	.2188	2.50	3.75
DW1915	1	DW1915B	12	15/64"	.2344	2.62	3.88
DW1916	1	DW1916B	12	1/4"	.2500	2.75	4.00
DW1917	1	DW1917B	12	17/64"	.2656	2.88	4.12
DW1918	1	DW1918B	12	9/32"	.2812	2.94	4.25
DW1919	1	DW1919B	12	19/64"	.2969	3.06	4.38
DW1920	1	DW1920B	6	5/16"	.3125	3.19	4.50
DW1921	1	DW1921B	6	21/64"	.3281	3.31	4.62
DW1922	1	DW1922B	6	11/32"	.3438	3.44	4.75
DW1923	1	DW1923B	6	23/64"	.3594	3.50	4.88
DW1924	1	DW1924B	6	3/8"	.3750	3.62	5.00
DW1925*	1	DW1925B*	6	25/64"	.3906	3.75	5.12
DW1926*	1	DW1926B*	6	13/32"	.4062	3.88	5.25
DW1927*	1	DW1927B*	6	27/64"	.4219	3.94	5.38
DW1928*	1	DW1928B*	6	7/16"	.4375	4.06	5.50
DW1929*	1	DW1929B*	6	29/64"	.4531	4.19	5.62
DW1930*	1	DW1930B*	6	15/32"	.4688	4.31	5.75
DW1931*	1	DW1931B*	6	31/64"	.4844	4.38	5.88
DW1932*	1	DW1932B*	6	1/2"	.5000	4.50	6.00

Sets Description

DW1169 14-Pc. Set with TOUGH CASE™ container Contains: (2) 1/16", 5/64", 3/32", 7/64", (2) 1/8", 9/64", 5/32", 3/16", 7/32", 1/4", 5/16", 3/8"

DW1956 16-Pc. Set with TOUGH CASE™ container Contains: (2) 1/16", 5/64", 3/32", 7/64", 1/8", 9/64", 5/32", 11/64", 3/16", 13/64", 7/32", 1/4", 5/16", 3/8", 1/2"

DW1969 29-Pc. Set with TOUGH CASE™ container Contains: 1/16", 5/64", 3/32", 7/64", 1/8", 9/64", 5/32", 11/64", 3/16", 13/64", 7/32", 15/64", 1/4", 17/64", 9/32", 19/64", 5/16", 21/64", 11/32", 23/64", 3/8", 25/64", 13/32", 27/64", 7/16", 29/64", 15/32", 31/64", 1/2" *3/8" reduced shank

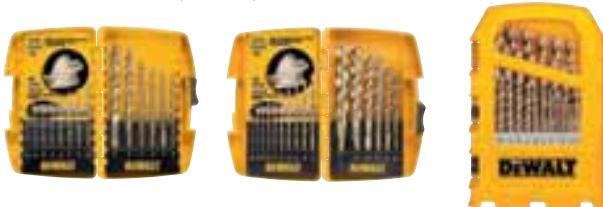

TOUGH CASE™ DRILLING CASES

- Industrial grade ABS material for maximum durability
- Interlocking hinge for longer life
- Sliding rubber lock keeps case closed
- Bit holder system keeps bits in place and identifies sizes



ACCESSORIES

TITANIUM SPLIT POINT DRILL BITS

- Extra hard titanium coating for maximum life
- Industrial grade steel
- Ideal for drilling in light gauge metals

Cat #	Qty/ Card	Dia Inches	Dia Decimal	Drilling Depth	Overall Length
DW1304	1	1/16"	.0625	.88	1.88
DW1305	1	5/64"	.0781	1.00	2.00
DW1306	1	3/32"	.0938	1.25	2.25
DW1307	1	7/64"	.1094	1.50	2.62
DW1308	1	1/8"	.1250	1.62	2.75
DW1309	1	9/64"	.1406	1.75	2.88
DW1310	1	5/32"	.1562	2.00	3.12
DW1311	1	11/64"	.1719	2.12	3.25
DW1312	1	3/16"	.1875	2.31	3.50
DW1313	1	13/64"	.2031	2.44	3.62
DW1314	1	7/32"	.2188	2.50	3.75



Cat #	Qty/ Card	Dia Inches	Dia Decimal	Drilling Depth	Overall Length
DW1315	1	15/64"	.2344	2.62	3.88
DW1316	1	1/4"	.2500	2.75	4.00
DW1320	1	5/16"	.3125	3.19	4.50
DW1324	1	3/8"	.3750	3.62	5.00
DW1328*	1	7/16"	.4375	4.06	5.50
DW1332*	1	1/2"	.5000	4.50	6.00

Set	Description
DW1363	13-Pc. Set with TOUGH CASE™ container Contains: (2) 1/16", 5/64", (2) 3/32", 7/64", (2) 1/8", 9/64", 5/32", 3/16", 7/32", 1/4"



COBALT SPLIT POINT DRILL BITS

- Industrial grade cobalt steel
- Ideal for drilling in stainless steel, abrasive metal and other hard to drill alloys

Cat #	Qty/ Card	Dia Inches	Dia Decimal	Drilling Depth	Overall Length
DW1204	1	1/16"	.0625	.88	1.88
DW1205	1	5/64"	.0781	1.00	2.00
DW1206	1	3/32"	.0938	1.25	2.25
DW1207	1	7/64"	.1094	1.50	2.62
DW1208	1	1/8"	.1250	1.62	2.75
DW1209	1	9/64"	.1406	1.75	2.88
DW1210	1	5/32"	.1562	2.00	3.12
DW1211	1	11/64"	.1719	2.12	3.25
DW1212	1	3/16"	.1875	2.31	3.50
DW1213	1	13/64"	.2031	2.44	3.62
DW1214	1	7/32"	.2188	2.50	3.75



Cat #	Qty/ Card	Dia Inches	Dia Decimal	Drilling Depth	Overall Length
DW1215	1	15/64"	.2344	2.62	3.88
DW1216	1	1/4"	.2500	2.75	4.00
DW1220	1	5/16"	.3125	3.19	4.50
DW1224	1	3/8"	.3750	3.62	5.00
DW1228*	1	7/16"	.4375	4.06	5.50
DW1232*	1	1/2"	.5000	4.50	6.00

Set	Description
DW1263	13-Pc. Set with TOUGH CASE™ container Contains: (2) 1/16", 5/64", (2) 3/32", 7/64", (2) 1/8", 9/64", 5/32", 3/16", 7/32", 1/4"



REDUCED SHANK DRILL BITS



Cat #	Qty/ Card	Dia Inches	Shank	Flute Length	Overall Length
DW1620	1	9/16"	3/8"	3"	6"
DW1622	1	5/8"	3/8"	3"	6"
DW1623	1	11/16"	3/8"	3"	6"
DW1625	1	3/4"	3/8"	3"	6"
DW1627	1	7/8"	1/2"	3"	6"
DW1629	1	1"	1/2"	3"	6"

12" DRILL BITS



Cat #	Qty/ Card	Dia Inches	Shank Inches	Flute Length
DW1602	1	1/8"	1/8"	1-5/8"
DW1604	1	3/16"	3/16"	2-5/16"
DW1606	1	1/4"	1/4"	2-3/4"
DW1608	1	5/16"	5/16"	3-3/16"
DW1610	1	3/8"	3/8"	3-5/8"
DW1612	1	7/16"	3/8"	4-1/16"
DW1614	1	1/2"	3/8"	4-1/2"

*3/8" reduced shank

TOUGH CASE™ STORAGE CONTAINER

- Industrial ABS case and steel hinge for maximum durability
- Adjustable storage compartments
- Sliding rubber latch keeps case closed
- Locking interior lids keep components secure

DW2190

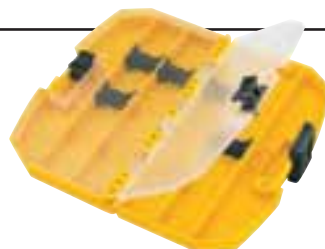

ACCESSORIES

SCREWDRIVER BITS



Cat #	Qty	Bulk	Bulk Cat #	Size Qty	Length
⊕ Phillips Bit Tips					
DW2001	2	DW2001BL	100	#1	1"
DW2002	2	DW2002BL	100	#2	1"
		DW2002B10	10	#2	1"
		DW2002B25	25	#2	1"
DW2003	2	DW2003BL	100	#3	1"
DW2125	25	-	-	#2	1"
⊕ Drywall Bit Tips					
DW2105	5	DW2004BL	100	#2	1"
⊕ Deck Bit Tips					
DW2025	3	-	-	#2	1"
DW2026	3	-	-	#2	2"
⊕ Phillips Power Bits					
DW2021	1	-	-	#1	2"
DW2022	1	DW2022B	100	#2	2"
		DW2022B6	6	#2	2"
DW2115	5	-	-	#2	2"
DW2023	1	DW2023B	100	#3	2"
DW2031	1	-	-	#1	3-1/2"
DW2032	1	-	-	#2	3-1/2"
DW2033	1	-	-	#3	3-1/2"
DW2061	1	-	-	#1	6"
DW2062	1	-	-	#2	6"
DW2063	1	-	-	#3	6"
⊖ Slotted Bit Tips					
DW2006	2	-	-	#6	1"
DW2008	2	-	-	#8	1"
DW2010	2	DW2010B	100	#10	1"
DW2012	2	-	-	#12	1"
⊖ Slotted Power Bits					
DW2015	1	-	-	#6	2"
DW2016	1	-	-	#8	2"
DW2017	1	-	-	#10	2"
DW2036	1	-	-	#6	3-1/2"
DW2038	1	-	-	#8	3-1/2"
DW2040	1	-	-	#10	3-1/2"
DW2042	1	-	-	#12	3-1/2"
DW2064	1	-	-	#6	6"
DW2065	1	-	-	#8	6"
DW2066	1	-	-	#10	6"

Cat #	Qty	Bulk	Bulk Cat #	Size Qty	Length
⊖ Square Recess Bit Tips					
DW2200	25	-	-	#2	1"
DW2201	2	DW2201BL	100	#1	1"
DW2202	2	DW2202BL	100	#2	1"
		DW2202B10	10	#2	1"
DW2203	2	DW2203BL	100	#3	1"
DW2204	2	-	-	#0	1"
DW2210	1	-	-	#0	2"
⊖ Square Recess Power Bits					
DW2211	1	-	-	#1	2"
DW2212	1	DW2212B	100	#2	2"
DW2213	1	-	-	#3	2"
DW2231	1	-	-	#1	3-1/2"
DW2232	1	-	-	#2	3-1/2"
DW2233	1	-	-	#3	3-1/2"
DW2261	1	-	-	#1	6"
DW2262	1	-	-	#2	6"
DW2263	1	-	-	#3	6"
Double-Ended Bits					
DW2024	1	DW2024B	100	P#2/S#8	⊕⊖
		DW2024B6	6	P#2/S#8	⊕⊖
DW2028	1	DW2028B	100	P#2/P#2	⊕⊕
		DW2028B6	6	P#2/P#2	⊕⊕
DW2029	5	-	-	-	-
DW2215	3	-	-	P#2/Sq#2	⊕⊖
		DW2214B	100	P#2/S#2	⊕⊖
⊕ Bits for Pozi Fasteners Set					
DW2069	3 Piece Set #1, #2, #3	-	-	-	1"
⊕ Star Bit Set					
DW2067	7 Piece Set	-	-	-	1"
⊖ Hex Bits					
DW2068	9 Piece Set	-	-	-	1"
⊕ Phillips Square Drive					
DW2602	3	-	-	#2	1"

Screwdriving
Bit Box
DW2002B25



TOUGH CASE™ SCREWDRIVING SETS

- Industrial grade ABS material for maximum durability
- Interlocking hinge for longer life
- Sliding rubber lock keeps case closed
- Bit holder system keeps bits in place and identifies sizes

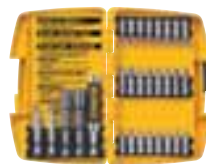

DW2160 13 Piece Screwdriving Set

Contains:

- Phillips bit tips: (1) #1, (2) #2, (1) #3
- Slotted bit tips: (2) #8
- Square Recess bit tips: (2) #2
- 2" Phillips power bit: (1) #2
- 2" Square Recess power bit: (1) #2
- Compact magnetic drive guide (1)
- 3-1/2" Phillips power bit: (1) #2
- 3-1/2" Square Recess power bit: (1) #2

DW2162 29 Piece Screwdriving Set

Contains:

- 1" Phillips bit tips: (1) #1, (10) #2, (1) #3
- 1" Slotted bit tips: (1) #6, (2) #8, (1) #10
- 1" Square Recess bit tips: (1) #1, (6) #2, (1) #3
- 2" Phillips power bit: (1) #2
- 2" Square Recess power bit: (1) #2
- Nutdrivers: (1) 1/4", (1) 5/16", (1) 3/8"
- Compact magnetic drive guide (1)

DW2161 21 Piece Screwdriving Set

Contains:

- 1" Phillips bit tips: (1) #1, (6) #2, (1) #3
- 1" Slotted bit tips: (1) #6, (1) #8, (1) #10
- 1" Square Recess bit tips: (1) #1, (3) #2, (1) #3
- 2" Phillips power bit: (1)
- 2" Square Recess power bit: (1) #2
- Nutdrivers: (1) 1/4", (1) 5/16"
- 2" Magnetic bit tip holder: (1)

DW2163 37 Piece Screwdriving Set

Contains:

- 1" Phillips bit tips: (1) #1, (10) #2, (1) #3
- 1" Slotted bit tips: (1) #6, (2) #8, (1) #10
- 1" Square Recess bit tips: (1) #1, (6) #2, (1) #3
- 2" Double-ended bits: (1) P#1/S#6, (3) P#2/S#8, (3) P#2/S#2, (1) P#3/S#10
- Magnetic nutsetters: (1) 1/4", (1) 5/16"
- Compact magnetic drive guide: (1)
- 3-1/2" Phillips power bit: (1) #2
- 3-1/2" Square Recess power bit: (1) #2

ACCESSORIES

DRILL FLIP DRIVE

- Black oxide split point drill bits start on contact
- Multi-cutter countersinks for superior finish
- Quick-change mechanism for easy one-step loading
- Contoured finger grip for easy one-handed release
- 5/16" shank for added durability



Screw Size Unit	Cat # Drill/Drive Insert	Cat # Drill/Countersink Drill Bits	Cat # Replacement
#6	DW2700	DW2710	DW2720
#8	DW2701	DW2711	DW2721
#10	DW2702	DW2712	DW2722
Sets	Description		
DW2730	8 Piece Drill Drive Set Contains: Drill Drive holder, Drill Drive connector, #6 & #8 Drill bits with countersinks, #8 Replacement drill bit, 3 Screwdriver bit tips, Heavy-duty container		
DW2735	12 Piece Drill Drive Set Contains: Drill Drive holder, Drill Drive connector, #6, #8 & #10 Drill bits with countersinks, #6 (2), #8 & #10 Replacement drill bits, 3 Screwdriver bit tips, Heavy-duty container		



QUICK CHANGE ACCESSORIES



Cat #	Qty	Bulk Cat #	Bulk Qty	Description
Bit Tip Holders				
DW2045	1	DW2045B	50	3" Magnetic holder
DW2046	1	-	-	2" Magnetic holder
DW2050	1	-	-	Quick change magnetic holder
Magnetic Drive Guides				
DW2054	1	-	-	Compact magnetic drive guide
DW2055	1	DW2055B	25	Magnetic drive guide
DW2056	1	-	-	Clear magnetic drive guide
DW2053	-	-	-	16 piece drive guide set
DW2095	-	-	-	7 piece drive guide set
DW2097	-	-	-	14 piece drive guide set
Nut Drivers				
DW2218	1	DW2218B	50	Nutdriver 1/4" 1-7/8"
		DW2218B2	2	Nutdriver 1/4" 1-7/8"
DW2219	1	DW2219B	50	Nutdriver 5/16" 1-7/8"
		DW2219B2	2	Nutdriver 5/16" 1-7/8"
DW2220	1	DW2220B	50	Nutdriver 3/8" 1-7/8"
DW2224	-	-	-	3 piece set 1/4", 5/16", 3/8" 1-7/8"
DW2221	1	DW2221B	50	Nutdriver 1/4" 2-9/16"
DW2222	1	DW2222B	50	Nutdriver 5/16" 2-9/16"
DW2223	1	DW2223B	50	Nutdriver 3/8" 2-9/16"
DW2225	1	DW2225B	50	Eyelag socket driver
Screwdriving Accessories				
DW2043	1	-	-	Adjustable screw depth setter
DW2014	1	DW2014B	50	#2 Drywall Dimpler
		DW2014B3	3	#2 Drywall Dimpler

ACCESSORIES

QUICK CHANGE ACCESSORIES

- Allows for quick and easy accessory changes
- Auto release for one handed operation
- Stainless steel interior parts for greater durability
- Compact industrial design for tight, hard to reach applications
- The RAPID LOAD® holder fits all brands of 3/8" and 1/2" cordless and corded drills



DW2505 RAPID LOAD Hex Holder



Cat #	Description
-------	-------------

Hex Shank Drill Bits

- Split-point tip prevents walking
- Black oxide coating provides longer life

DW2551	6 Piece Hex shank drill bit set
DW2552	1/16" Hex shank drill bit
DW2553	3/32" Hex shank drill bit
DW2554	1/8" Hex shank drill bit
DW2555	5/32" Hex shank drill bit
DW2556	3/16" Hex shank drill bit
DW2557	1/4" Hex shank drill bit

Rotary Masonry Drill Bits

- For drilling in brick, block, concrete
- Carbide tip aggressively penetrates surfaces

DW2571	3 Piece Rotary masonry bit set
DW2572	5/32" Rotary masonry bit
DW2573	3/16" Rotary masonry bit
DW2574	1/4" Rotary masonry bit



Cat #	Description
-------	-------------

Countersinks

- Four cutter countersink and tapered drill bit provide superior speed and finish

DW2535	3 Piece Countersink set
DW2512	6 Piece Countersink set
DW2537	#6 Countersink replacement drill bit 9/64"
DW2538	#8 Countersink replacement drill bit 11/64"
DW2539	#10 Countersink replacement drill bit 3/16"
DW2540	#12 Countersink replacement drill bit 7/32"
DW2567	#6 Countersink with 9/64" drill bit
DW2568	#8 Countersink with 11/64" drill bit
DW2569	#10 Countersink with 3/16" drill bit
DW2570	#12 Countersink with 7/32" drill bit

Socket Adapters

- Hardened steel for maximum durability
- Adapts sockets for use in drills

DW2541	1/4" Socket adapter
DW2542	3/8" Socket adapter

RAPID LOAD® SETS



DW2506 6 Piece Set

Contains:

- RAPID LOAD® Holder
- (1) #1 Phillips 2" Power Bit
- (1) #2 Phillips 2" Power Bit
- (1) #2 Square Recess 2" Power Bit
- (1) #8 Slotted 2" Power Bit
- (1) #10 Slotted 2" Power Bit

DW2518 30 Piece Set

Contains:

- RAPID LOAD® Holder
- (1) Compact Magnetic Drive Guide
- (1) 1/4" x 1-7/8" Magnetic Nutdriver
- (1) 5/16" x 1-7/8" Magnetic Nutdriver
- (1) 1/4" Socket Adapter
- (1) 3/8" Socket Adapter
- (1) 1/16" Hex Shank Drill Bit
- (1) 3/32" Hex Shank Drill Bit
- (2) 1/8" Hex Shank Drill Bits
- (1) 5/32" Hex Shank Drill Bit
- (1) 3/16" Hex Shank Drill Bit
- (1) #1 Phillips 2" Power Bit
- (1) #2 Phillips 2" Power Bit
- (1) #2 Square Recess 2" Power Bit
- (1) #8 Slotted 2" Power Bit
- (1) #10 Slotted 2" Power Bit
- (1) #1 Phillips 1" Insert Bit Tip
- (9) #2 Phillips 1" Insert Bit Tip
- (1) #1 Square Recess 1" Bit Tip
- (1) #2 Square Recess 1" Bit Tip
- (1) #8 Slotted 1" Insert Bit Tip

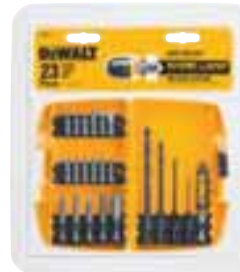

DW2523 23 Piece Set

Contains:

- RAPID LOAD® Holder
- (1) Compact Magnetic Drive Guide
- (1) 1/4" x 1-7/8" Magnetic Nutdriver
- (1) 1/4" Socket Adapter
- (1) 1/16" Hex Shank Drill Bit
- (1) 1/8" Hex Shank Drill Bit
- (1) 3/16" Hex Shank Drill Bit
- (1) 1/4" Hex Shank Drill Bit
- (1) #2 Phillips 2" Power Bit
- (1) #8 Slotted 2" Power Bit
- (1) #2 Square Recess 2" Power Bit
- (1) #1 Phillips 1" Insert Bit Tip
- (5) #2 Phillips 1" Insert Bit Tips
- (1) #3 Phillips Insert Bit Tip
- (1) #1 Square Recess 1" Bit Tip
- (2) #2 Square Recess 1" Bit Tips
- (1) #8 Slotted 1" Insert Bit Tip
- (1) #10 Slotted 1" Insert Bit Tip



DW2513 15 Piece Set

Contains:

- RAPID LOAD® Holder
- (1) Compact Magnetic Drive Guide,
- (1) 1/8" Hex Shank Drill Bit
- (1) 1/4" Hex Shank Drill Bit
- (1) #2 Phillips 2" Power Bit
- (1) #2 Square Recess 2" Power Bit
- (1) #1 Phillips 1" Insert Bit Tip
- (4) #2 Phillips 1" Insert Bit Tips
- (1) #1 Square Recess 1" Bit Tip
- (2) #2 Square Recess 1" Bit Tips
- (1) #8 Slotted 1" Insert Bit Tip
- (1) #8 Slotted 1" Insert Bit Tip

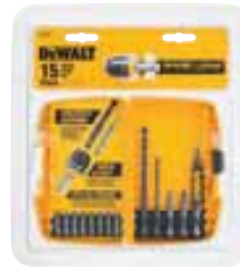

ACCESSORIES

HAMMER DRILL BITS

- ROCK CARBIDE® tip maximizes carbide surface contact for longer life bit
- Four flute design enlarged flutes clean debris out for fast, efficient drilling
- No spin shank eliminates bit slipping



**ROCK
CARBIDE®**



Cat #	Dia.	Usable Length	Overall Length	Bosch	Hawera*	Hilti**	Powers***	Relton****
DW5221	1/8"	2"	3"	HCBG01	70001	-	0501	RT-1-3
DW5209	5/32"	2"	3"	-	-	-	-	-
DW5227	5/32"	3"	6"	HCBG02	-	-	0503	-
DW5222	3/16"	2"	3"	HCBG03	70004	61465	0504	-
DW5223	3/16"	4"	6"	HCBG04	70007	61466	0505	RT-3-7
DW5224	1/4"	2"	4"	-	70010	61469	0512	RT-4-4
DW5225	1/4"	4"	6"	HCBG06	70013	61470	0513	RT-4-6
DW5226	1/4"	7"	12"	HCBG08	70016	-	0514	RT-4-12
DW5228	5/16"	4"	6"	HCBG09	70022	61474	0519	RT-5-6
DW5229	5/16"	7"	12"	HCBG11	70025	-	-	RT-5-12
DW5230	3/8"	4"	6"	HCBG12	70028	61477	0522	RT-6-6
DW5231	3/8"	7"	12"	HCBG14	70031	-	0523	RT-6-12
DW5234	7/16"	4"	6"	HCBG15	70037	-	0526	RT-7-6
DW5235	1/2"	4"	6"	HCBG16	70040	61483	0531	RT-8-6
DW5236	1/2"	7"	12"	HCBG18	70043	-	0532	RT-8-14
DW5241	5/8"	4"	6"	HCBG20	70052	62898	0538	RT-10-6
DW5242	9/16"	4"	6"	HCBG19	-	00061485	0535	RT-9-6
DW5217	5/8"	7"	12"	HCBG21	70055	-	0540	RT-10-14
DW5244	3/4"	4"	6"	HCBG22	70058	-	0545	RT-12-6
DW5245	3/4"	7"	12"	HCBG23	70061	-	0547	RT-12-14
DW5219	7/8"	7"	12"	HCBG25	-	-	0550	-
DW5249	1"	7"	12"	HCBG27	70073	-	0554	-
Bulk Packs								
DW5221B25	1/8"	2"	3"	HCBG01B25	70001B	-	-	BRT-1-3
DW5222B25	3/16"	2"	3"	HCBG03B25	70004B	409	0591	BRT-3-3
DW5223B25	3/16"	4"	6"	HCBG04B25	70007B	410	0592	BRT-3-7
DW5224B25	1/4"	2"	4"	-	70010B	411	0593	BRT-4-4
DW5225B25	1/4"	4"	6"	HCBG06B25	70013B	412	0594	BRT-4-6
DW5227B25	5/32"	3"	6"	HCBG02B25	-	-	-	-
DW5228B25	5/16"	4"	6"	HCBG09B25	70022B	-	-	BRT-5-6
DW5230B25	3/8"	4"	6"	HCBG12B25	70028B	414	0595	BRT-6-6
DW5235B25	1/2"	4"	6"	HCBG16B25	70040B	415	0596	BRT-8-6
Sets	Description							
DW5204	4-Pc. Set Contains: 3/16" x 3"; 1/4" x 4"; 5/16" x 6"; 3/8" x 6"							
DW5207	7-Pc. Set Contains: 3/16" x 3"; 1/4" x 4"; (2) 1/4" x 6"; 5/16" x 6"; 3/8" x 6"; 1/2" x 6"							

Fits all brands of Hammerdrills including:

DeWALT

DW505K
DW511K
DW515K
DW006K-2
DC989KA
DC988KA

Hilti

TM 7SII

Bosch

1194



* Hawera is a trademark of Hawera Probst GmbH & Company
** Hilti is a trademark of Hilti Aktiengesellschaft
*** Powers is a trademark of Powers Fasteners Inc.
**** Relton is a trademark of Relton Corporation

ACCESSORIES

ROCK CARBIDE® SDS+ BITS

- ROCK CARBIDE® tip maximizes carbide surface contact for longer life
- Titanium carbide for superior durability
- Four flute design cleans debris out for fast, efficient drilling
- Optimized core diameter maximizes hammer energy for greater impact power

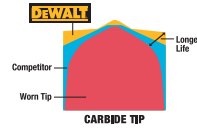

Cat #	Dia.	Usable Length	Overall Length	Bosch	Hawera	Hilti	Powers	Relton
DW5400	5/32"	2"	4"	HC2000	90001	-	-	207-1-4
DW5401	5/32"	4-1/2"	6-1/2"	HC2001	90002	-	0302	207-1-6
DW5402	3/16"	2"	4"	HC2010	90005	256099	0304	207-3-4
DW5403	3/16"	4-1/2"	6-1/2"	HC2011	90006	205299	0306	207-3-6
DW5404	3/16"	6-1/2"	8-1/2"	HC2012	90007	256100	0308	207-3-8
DW5405	3/16"	8"	10"	HC2013	90004	-	0310	207-3-10
DW5406	3/16"	10"	12"	HC2014	90008	256101	0312	-
DW5407	3/16"	12"	14"	HC2015	90009	-	0314	207-3-14
DW5408	3/16"	14"	16"	-	90909	256102	-	-
DW5410	7/32"	4"	6"	HC2031	90099	-	0315	207-2-6
DW5412	7/32"	8"	10"	-	90102	-	0317	207-2-10
DW5416	1/4"	2"	4"	HC2040	90010	205309	0320	207-4-4
DW5417	1/4"	4"	6"	HC2041	90013	205310	0321	207-4-6
DW5418	1/4"	6-1/2"	8-1/2"	HC2042	90014	205311	0322	207-4-8
DW5420	1/4"	10"	12"	-	90017	256106	-	207-4-10
DW5421	1/4"	12"	14"	HC2045	90015	-	0324	207-4-14
DW5424	5/16"	4"	6"	HC2051	90022	205316	0329	207-5-6
DW5426	5/16"	10"	12"	HC2054	90025	205320	0331	207-5-10
DW5427	3/8"	4"	6"	HC2061	90028	205324	0333	207-6-6
DW5429	3/8"	8"	10"	-	90029	-	-	207-6-10
DW5430	3/8"	10"	12"	HC2064	90031	205326	0336	-
DW5431	3/8"	16"	18"	HC2067	90032	205327	0338	207-6-18
DW5432	3/8"	22"	24"	HC2068	90033	205328	0339	207-6-25
DW5433	7/16"	4"	6"	HC2071	90037	205339	0341	207-7-6
DW5435	7/16"	10"	12"	HC2074	90038	-	0343	207-7-12
DW5436	7/16"	16"	18"	-	90039	205340	-	-
DW5437	1/2"	4"	6"	HC2081	90040	205352	0346	207-8-6
DW5438	1/2"	8"	10"	-	90041	-	0348	207-8-10
DW5439	1/2"	10"	12"	HC2084	90043	205354	0349	-
DW5440	1/2"	16"	18"	HC2087	90045	205355	0351	207-8-18
DW5441	1/2"	22"	24"	HC2088	90046	-	0352	207-8-25
DW5442	9/16"	4"	6"	HC2091	90048	28040	0354	207-9-6
DW5443	9/16"	10"	12"	HC2094	90050	28041	-	207-9-12
DW5444	9/16"	16"	18"	HC2097	90051	28042	-	207-9-18
DW5445	9/16"	22"	24"	-	-	28042	-	207-9-25
DW5446	5/8"	6"	8"	HC2102	90053	28043	0359	207-10-8
DW5447	5/8"	10"	12"	HC2104	90055	28044	0361	207-10-14
DW5448	5/8"	16"	8"	HC2107	90056	28045	0362	207-10-18
DW5449	5/8"	22"	24"	HC2108	90054	-	-	207-10-25
DW5450	11/16"	6"	8"	HC2112	90057	-	0364	207-11-10
DW5453	3/4"	6"	8"	HC2122	90059	28618	0368	207-12-8
DW5455	3/4"	10"	12"	HC2124	90061	28619	0370	207-12-14
DW5456	3/4"	16"	18"	HC2127	90063	28620	0371	207-12-18
DW5457	3/4"	22"	24"	HC2128	90064	-	-	207-12-25
DW5458	27/32"	6"	8"	HC2137	90263	28622	0373	207-13-18
DW5460	7/8"	6"	8"	HC2142	90065	-	0375	207-14-8
DW5461	7/8"	10"	12"	HC2144	90067	-	0376	207-14-14
DW5462	7/8"	16"	18"	HC2147	90069	28625	0377	207-14-18
DW5464	1"	8"	10"	HC2163	90071	28626	0380	207-16-8
DW5466	1"	16"	18"	HC2167	90076	28627	0382	207-16-18
DW5468	1-1/8"	8"	10"	HC2283	-	-	-	-
DW5469	1-1/8"	16"	18"	HC2287	-	-	-	-

ACCESSORIES

ROCK CARBIDE® SDS+ BITS (continued)

Cat #	Dia.	Usable Length	Overall Length	Bosch	Hawera	Hilti	Powers	Relton
Bulk Packs								
DW5401B25	5/32"	4-1/2"	6-1/2"	-	90002B	-	-	B207-1-6
DW5402B25	3/16"	2"	4" 0	HC2010B25	90005B	332315	0664	B207-3-4
DW5403B25	3/16"	4-1/2"	6-1/2"	HC2011B25	90006B	315225	0666	B207-3-6
DW5404B25	3/16"	6-1/2"	8-1/2"	HC2012B25	90007B	332318	0668	B207-3-8
DW5405B25	3/16"	8"	10"	HC2013B25	90004B	-	0670	B207-3-10
DW5406B25	3/16"	10"	12"	HC2014B25	90008B	332321	-	B207-3-14
DW5410B25	7/32"	4"	6"	HC2031B25	90099B	-	0675	B207-2-6
DW5416B25	1/4"	2"	4"	HC2040B25	90010B	315228	0680	B207-4-4
DW5417B25	1/4"	4"	6"	HC2041B25	90013B	315392	0681	B207-4-6
DW5418B25	1/4"	6-1/2"	8-1/2"	HC2042B25	90014B	-	0682	B207-4-8
DW5424B25	5/16"	4"	6"	HC2051B25	90022B	315232	0689	B207-5-6
DW5427B25	3/8"	4"	6"	HC2061B25	90028B	315234	0693	B207-6-6
DW5437B25	1/2"	4"	6"	HC2081B25	90040B	332353	0696	B207-8-6
DW5446B25	5/8"	6"	8"	HC2102B25	90053B	28858	0697	B207-10-8

Set	Description	Bosch	Hawera	Hilti	Powers	Relton
DW5470	5-Piece Set Contains: 3/16" x 4-1/2" x 6-1/2", 1/4" x 2" x 4", 1/4" x 4" x 6", 3/8" x 4" x 6", 1/2" x 4" x 6"	-	-	-	-	-

Fits all SDS Plus Hammers



DeWALT	Hilti	Bosch
D25101K	TE2	11250
D25103K	TE5	11228
D25201K	TE6	11224
D25203K	TE25	11239
D25303K		11222
D25304K		11236
DW570K		
DW999K-2		
DW005K-2		

SDS+ CHIPPING AND CHISELING ACCESSORIES

Cat #	Description	Bosch	Hawera
DW5348	10" Bull Point Chisel	1618600009	79500
DW5349	1-1/2" x 8" Scaling Chisel	1618601002	79510
DW5350	3/4" x 10" Cold Chisel	1618600610	79505

SDS+ CHIPPING AND CHISELING ACCESSORIES

Cat #	Description	Bosch	Hawera
DW5351	1/2" Chuck Adapter	1618571014	-
DW5352	A Taper	-	-
DW5353	1/2" Chuck and Key	1618571014	-

SDS+ HEX SHANK HAMMER BITS

- 1/4" hex shank for use with most concrete anchor systems



Cat #	Dia.	Usable Length	Overall Length	Bosch	Hawera
DW5359	5/32"	2"	5"	-	90120
DW5360	5/32"	3"	6"	HC2301	90122
DW5361	5/32"	4"	7"	HC2302	90124
DW5362	3/16"	2"	5"	HC2310	90110
DW5363	3/16"	3"	6"	HC2311	90112
DW5364	3/16"	4"	7"	HC2312	90114
DW5365 Drill Sleeve				-	-

ACCESSORIES

SPLINE SHANK HAMMER BITS

- ROCK CARBIDE® tip maximizes carbide surface contact for longer bit life
- Open head design channels more dust out
- U-flute design maximizes bit strength



Cat #	Dia.	Usable	Overall Length	Bosch Length	Hawera	Powers	Relton
2 Cutter Spine Shank							
DW5700	3/8"	5"	10"	HC4501	93304	1401	202-6-10
DW5701	3/8"	8"	13"	-	93306	1402	202-6-14
DW5702	7/16"	5"	10"	-	93310	1405	202-7-14
DW5703	1/2"	5"	10"	HC4510	93312	1407	202-8-14
DW5704	1/2"	11"	16"	HC4511	93316	1409	202-8-18
DW5705	1/2"	17"	22"	HC4512	93318	1410	202-8-22
DW5706	1/2"	22"	27"	HC4513	93320	1412	202-8-28
DW5707	1/2"	31"	36"	HC4514	93322	1413	202-8-42
DW5708	9/16"	5"	10"	HC4516	93324	1415	202-9-14
DW5735	9/16"	17"	22"	-	-	-	202-9-22
DW5709	5/8"	5"	10"	HC4520	93330	1418	202-10-14
DW5710	5/8"	11"	16"	HC4521	93334	1420	202-10-18
DW5711	5/8"	17"	22"	HC4522	93336	1421	202-10-22
DW5712	5/8"	22"	27"	-	93338	1423	202-10-28
DW5713	11/16"	5"	10"	-	93342	1427	202-11-14
DW5714	3/4"	5"	10"	HC4530	93346	1431	202-12-14
DW5715	3/4"	11"	16"	HC4531	93350	1413	202-12-18
DW5716	3/4"	17"	22"	HC4532	93352	1434	202-12-22
DW5717	3/4"	22"	27"	-	93354	1436	202-12-28
DW5719	7/8"	11"	16"	HC4540	93360	1443	202-14-18
DW5720	7/8"	17"	22"	HC4541	93362	1444	202-14-22
DW5721	1"	11"	16"	HC4550	93366	1449	202-16-18
DW5722	1"	17"	22"	HC4551	93368	1450	202-16-22
DW5723	1"	31"	36"	-	93370	1453	202-16-42
DW5724	1-1/8"	5"	10"	-	-	-	-
DW5725	1-1/8"	11"	16"	-	93372	1457	202-18-14
DW5726	1-1/8"	17"	22"	HC4561	93374	1474	202-18-22
DW5727	1-1/4"	11"	16"	-	93376	1464	202-20-14
DW5728	1-1/4"	17"	22"	HC4571	93378	1465	202-20-22
DW5729	1-3/8"	11"	16"	-	93382	1470	-
DW5730	1-3/8"	17"	22"	-	93384	1471	202-22-22
DW5731	1-1/2"	11"	16"	-	-	-	202-24-14
DW5732	1-1/2"	17"	22"	HC4591	93388	1477	202-24-22
DW5733	1-3/4"	17"	22"	-	93390	1486	-
DW5734	2"	17"	22"	-	93392	1490	-

ACCESSORIES



Fits all Spline Hammers:

DeWALT

D25650K
D25550K
D25551K

Bosch

11247



SPLINE ADAPTERS

Cat #	Converts to	Bosch	Hawera
DW5791	SDS	HA1020	75550
DW5792	A Taper	T1830	61001
DW5793	B Taper	T1831	69001
DW5794	Ejector Key	1601030009	75110
DW5790	1/2" Chuck	T1835	-

ACCESSORIES

SPLINE SHANK HAMMER BITS

- ROCK CARBIDE® tip maximizes carbide surface contact for longer bit life
- Open head design channels more dust out
- Longer helix increased flute travel expedites dust removal
- Four flute design additional flutes clean more debris out



Cat #	Dia.	Usable	Overall Length	Bosch Length	Hawera	Powers	Relton
4 Cutter Spline Shank							
DW5740	5/8"	5"	10"	HC4020	93021	7017	-
DW5741	5/8"	11"	16"	HC4021	93024	7020	-
DW5742	5/8"	17"	22"	HC4022	93025	7021	-
DW5743	5/8"	22"	27"	HC4023	93027	7023	-
DW5744	5/8"	31"	36"	HC4024	93028	-	-
DW5745	11/16"	11"	16"	HC4026	93026	-	-
DW5746	3/4"	5"	10"	HC4030	93031	7031	-
DW5747	3/4"	11"	16"	HC4031	93030	7033	-
DW5748	3/4"	17"	22"	HC4032	93033	7035	-
DW5749	3/4"	22"	27"	HC4033	93036	7036	-
DW5750	3/4"	31"	36"	HC4034	93037	-	-
DW5751	27/32"	11"	16"	HC4039	93038	-	-
DW5752	7/8"	11"	16"	HC4040	93039	7043	-
DW5753	7/8"	17"	22"	HC4041	93042	7045	-
DW5755	1"	11"	16"	HC4050	93045	7049	-
DW5756	1"	17"	22"	HC4051	93048	7051	-
DW5757	1"	31"	36"	HC4053	93049	-	-
DW5758	1-1/8"	11"	16"	HC4060	93051	7057	-
DW5759	1-1/8"	17"	22"	HC4061	93054	7059	-
DW5760	1-1/4"	11"	16"	HC4070	93057	7064	-
DW5761	1-1/4"	17"	22"	HC4071	93060	7066	-
DW5762	1-1/4"	31"	36"	HC4073	93061	-	-
DW5763	1-3/8"	11"	16"	-	-	7072	-
DW5765	1-3/8"	17"	22"	HC4081	93066	-	-
DW5764	1-1/2"	17"	22"	HC4091	93069	7017	-
DW5768	1-3/4"	17"	22"	-	93072	-	-
DW5769	2"	17"	22"	-	93075	-	-



Fits all Spline Hammers:

DeWALT

D25650K

D25550K

D25551K

Bosch

11247



ACCESSORIES

SDS MAX SHANK HAMMER BITS

- ROCK CARBIDE® tip maximizes carbide surface contact for longer bit life
- Open head design channels more dust out
- Longer helix increased flute travel expedites dust removal
- Four flute design additional flutes clean more debris out



Cat #	Diameter	Usable Length	Overall Length	Bosch	Hawera	Hilti	Powers	Relton
2 Cutter SDS Max Shank								
DW5803	1/2"	8"	13-1/2"	HC5010	95205	220632	8801	MX-8-14
DW5804	1/2"	16"	21-1/2"	HC5011	95210	220633	8802	MX-8-22
DW5801	9/16"	8"	13-1/2"	HC5015	95215	-	-	MX-9-18
DW5802	9/16"	16"	21-1/2"	HC5016	95220	-	-	MX-9-28
4 Cutter SDS Max Shank								
DW5806	5/8"	16"	13-1/2"	HC5020	95225	220636	8809	MX-10-14
DW5809	5/8"	16"	21-1/2"	HC5021	95230	220638	8810	MX-10-22
DW5807	5/8"	31"	36"	HC5023	95232	220636	8815	MX-10-42
DW5808	11/16"	16"	21-1/2"	HC5026	95233	220639	8815	-
DW5810	3/4"	8"	13-1/2"	HC5030	95235	220640	8817	MX-12-14
DW5812	3/4"	16"	21-1/2"	HC5031	95240	220641	8818	MX-12-22
DW5813	3/4"	31"	36"	HC5033	95245	220642	8820	MX-12-42
DW5814	13/16"	16"	21-1/2"	HC5036	95247	220643	-	-
DW5817	27/32"	16"	21-1/2"	HC5039	95251	220645	-	-
DW5815	7/8"	8"	13-1/2"	HC5040	95255	220646	8829	MX-14-14
DW5816	7/8"	16"	21-1/2"	HC5041	95260	220647	8830	MX-14-22
DW5818	1"	8"	13-1/2"	HC5050	95265	220649	8833	MX-16-14
DW5819	1"	16"	21-1/2"	HC5051	95270	220650	8834	MX-16-22
DW5820	1"	31"	36"	HC5053	95275	220651	8836	MX-16-42
DW5823	1-1/16"	18"	22-1/2"	HC5056	95277	220664	-	-
DW5821	1-1/8"	10"	15"	HC5060	95279	220653	8843	MX-18-14
DW5822	1-1/8"	18"	21-1/2"	HC5061	95285	220654	8844	MX-18-22
DW5824	1-1/4"	10"	15"	HC5071	95290	220655	8846	MX-20-14
DW5825	1-1/4"	18"	22-1/2"	HC5071	95295	220656	8847	MX-20-22
DW5826	1-1/4"	31"	36"	HC5073	95300	220657	8843	MX-20-42
DW5860	1-5/16"	18"	22-1/2"	HC5076	-	-	-	-
DW5827	1-3/8"	18"	22-1/2"	HC5081	95310	220659	8853	MX-22-22
DW5829	1-7/16"	18"	22-1/2"	HC5086	95317	-	-	-
DW5828	1-1/2"	18"	22-1/2"	HC5091	95320	220662	8859	MX-24-22
DW5861	1-9/16"	18"	22-1/2"	HC5096	95323	-	-	-
DW5830	1-3/4"	18"	22-1/2"	HC5098	95328	-	-	-
DW5831	2"	18"	22-1/2"	HC5099	95333	-	-	-

Fits all S
Max
Hammers:

DEWALT	Bosch
D25600K	11240
D25500K	11248EVS

Hilti
TE55
TE56
TE76



ACCESSORIES

1 PIECE CORE BITS

- Tool-free centering bit threaded design for easy removal
- Low friction core body 10% faster drilling
- Alternating tooth design increased durability & quicker centering



Cat #	Description	Bosch	Hawera	Hilti	Powers
SDS Max Shank					
DW5914	1-3/4" x 12" Core Bit	HC8501	97805	00307053	0270
DW5915	1-3/4" x 22" Core Bit	HC8506	97810	00307054	0271
DW5916	2" x 12" Core Bit	HC8510	97815	00307055	0281
DW5917	2" x 22" Core Bit	HC8515	97820	00307056	0282
DW5918	2-3/4" x 12" Core Bit	HC8521	97825	00307059	0283
DW5919	2-3/4" x 22" Core Bit	HC8526	97830	00307060	0284
DW5920	3-1/4" x 12" Core Bit	HC8531	97835	00307061	0285
DW5921	3-1/4" x 22" Core Bit	HC8536	97840	00307062	0286
DW5922	3-1/2" x 12" Core Bit	HC8540	97845	00307063	0287
DW5923	3-1/2" x 22" Core Bit	HC8545	97850	00307064	0288
DW5924	4" x 12" Core Bit	HC8550	97855	-	0290
DW5925	4" x 22" Core Bit	HC8555	97860	00307065	-
DW5926	5" x 22" Core Bit	HC8575	97865	00307066	-
DW5927	6" x 22" Core Bit	HC8595	97870	00307067	-
DW5945	Centering Bit	-	-	-	-
Spline Shank					
DW5930	1-3/4" x 12" Core Bit	HC8000	97505	-	0250
DW5931	1-3/4" x 22" Core Bit	HC8005	97510	-	0252
DW5932	2" x 12" Core Bit	HC8010	97515	-	0254
DW5933	2" x 22" Core Bit	HC8015	97520	-	0256
DW5934	2-3/4" x 12" Core Bit	HC8021	97525	-	0258
DW5935	2-3/4" x 22" Core Bit	HC8025	97530	-	0260
DW5936	3-1/4" x 12" Core Bit	HC8030	97535	-	0261
DW5937	3-1/4" x 22" Core Bit	HC8035	97540	-	0262
DW5938	3-1/2" x 12" Core Bit	HC8040	97545	-	0263
DW5939	3-1/2" x 22" Core Bit	HC8045	97550	-	0264
DW5940	4" x 12" Core Bit	HC8050	97555	-	0265
DW5941	4" x 22" Core Bit	HC8055	97560	-	0266
DW5942	5" x 22" Core Bit	HC8070	97565	-	0268
DW5943	6" x 22" Core Bit	HC8075	97570	-	-
DW5945	Centering Bit	-	-	-	-

2 PIECE CORE BITS

Cat #	Description	Hawera	Powers	Galaxy*	Relton	DrilTech**
DW5900	1-1/2" x 4" Core Bit Body	97005	0220	PCG1500	-	RK150
DW5901	2" x 4" Core Bit Body	97010	0222	PCG2000	CBT-32	RK200
DW5902	2-1/2" x 4" Core Bit Body	97015	0223	PCG2500	CBT-40	RK250
DW5903	3" x 4" Core Bit Body	97020	0224	PCG3000	CBT-48	RK300
DW5904	3-1/2" x 4" Core Bit Body	97025	0225	PCG3500	CBT-56	RK350
DW5905	4" x 4" Core Bit Body	97030	0226	PCG4000	CBT-64	RK400
DW5906	5" x 4" Core Bit Body	97035	0227	-	CBT-80	RK500
DW5907	Centering Core Bit Body	97040	0295	-	-	RK255
DW5908	Thread Adaptor	-	-	-	-	-
DW5909	7" Spline Core Bit Shank	97105	0228	-	S02TL-10	RA020
DW5910	16" Spline Core Bit Shank	97110	0229	PCGSPL18	S02TL-18	-
DW5911	7" SDS Max Core Bit Shank	97255	0230	PCGMAX12	SMXTL-10	RA030
DW5912	16" SDS Max Core Bit Shank	-	-	-	-	-

*Galaxy is a trademark of Saturne S.A.R.L.

**DRILTECH is a trademark of Driltech Mission, LLC.

ACCESSORIES

CHISELS & STEEL



Fits all Spline Hammers:
DeWALT
 D25650K
BOSCH
 11387



Fits all SDS Max Hammers:
DeWALT
 D25900K
 D25830K
HILTI
 705
 TE805
BOSCH
 11318
 11316



Fits all 3/4" Hex Hammers:
DeWALT
 D25940K
BOSCH
 11317



Fits all 1-1/8" Hex Hammers including:
BOSCH
 11304

Cat #	Description	Bosch	Hawera	Hilti	Powers
Spline - 3/4" Hex x 21/32" Round Spline Shank					
DW5770**	12" Bull Point Spline Shank	HS1813	79300	-	0950
DW5771**	18" Bull Point Spline Shank	HS1814	79310	-	0951
DW5779**	1" x 12" Cold Chisel Spline Shank	HS1811	79320	-	0952
DW5780**	1" x 18" Cold Chisel Spline Shank	HS1812	79330	-	0953
DW5773	1-1/4" x 12" Scaling Chisel Spline Shank	HS1816	79360	-	0954
DW5774	2" x 12" Scaling Chisel Spline Shank	HS1817	79370	-	0955
DW5775*	3" x 12" Scaling Chisel Spline Shank	-	-	-	-
DW5786B	4" Clay Spade Spline Shank	HS1822	-	-	-
DW5783*	9-1/2" Bushing Tool Spline Shank	HS1809	-	-	0960
DW5781	16" Asphalt Cutter Spline Shank	-	-	-	-
DW5785	3/4" Ground Rod Driver Spline Shank	HS1824	79380	-	0959
DW5772	12" Slotting Tool Spline Shank	HS1821	79340	-	0956
SDS Max					
DW5832**	12" Bull Point SDS Max Shank	HS1913	79810	02708	0965
DW5833**	18" Bull Point SDS Max Shank	HS1914	79815	204334	0966
DW5834**	1" x 12" Cold Chisel SDS Max Shank	HS1911	79800	0279	0967
DW5835**	1" x 18" Cold Chisel SDS Max Shank	HS1912	79805	204337	0968
DW5837	2" x 15" Scaling Chisel SDS Max Shank	HS1917	79825	259558	0970
DW5838*	3" x 12" Scaling Chisel SDS Max Shank	HS1910	79829	-	-
DW5848B	4" Clay Spade SDS Max Shank	HS1922	79850	-	-
DW5843*	12" Bushing Tool SDS Max Shank	HS1909	79860	62893	0975
DW5846	16" Asphalt Cutter SDS Max Shank	HS1906	-	-	-
DW5847	3/4" Ground Rod Driver SDS Max Shank	HS1924	79845	220701	0974
DW5842	12" Slotting Tool SDS Max Shank	HS1921	79835	01929	0971
3/4" Hex					
DW5950**	12" Bull Point 3/4" Hex Shank	HS1515	79400	-	0980
DW5951**	18" Bull Point 3/4" Hex Shank	HS1516	79410	-	0981
DW5953**	1" x 18" Cold Chisel 3/4" Hex Shank	HS1517	79420	-	0982
DW5954**	1" x 18" Cold Chisel 3/4" Hex Shank	HS1518	79430	-	0983
DW5952*	3" x 12" Scaling Chisel 3/4" Hex Shank	HS1503	79460	-	-
DW5959B	4" Clay Spade 3/4" Hex Shank	HS1504	-	-	-
DW5949*	9-1/2" Bushing Tool 3/4" Hex Shank	HS1520	-	-	-
DW5957	16" Asphalt Cutter 3/4" Hex Shank	HS1506	-	-	-
DW5958	3/4" Ground Rod Driver 3/4" Hex Shank	HS1524	79440	-	0984
1-1/8" Hex					
DW5960	20" Bull Point 1-1/8" Hex Shank	HS2161	79043	-	-
DW5962	20" Cold Chisel 1-1/8" Hex Shank	HS2163	79042	-	-
DW5961	3" x 20" Wide Chisel 1-1/8" Hex Shank	HS2164	79041	-	-
DW5965	5-1/2" Clay Spade 1-1/8" Hex Shank	HS2169	-	-	-
DW5963	17-1/2" Asphalt Cutter 1-1/8" Hex Shank	HS2167	-	-	-
DW5964	1" Ground Rod Driver 1-1/8" Hex Shank	HS2172	-	-	-
DW5966	6" x 6" Tamper Plate 1-1/8" Hex Shank	HS2124	-	-	-
DW5967	15" Tamper Shank 1-1/8" Hex Shank	HS2173	-	-	-

*Available in bulk packs of 10 (B10)

**Available in bulk packs of 15 (B15)

THIN KERF COATED WOODWORKING SAW BLADES

These thin-kerf coated blades feature large carbide tips for more resharpenings, balanced and tensioned laser cut plates for extreme accuracy and exclusive expansion slots to reduce vibration and noise for excellent surface finish.

- Anti-stick coating reduces friction for extended blade life, reduces pitch build-up, prevents rust, makes cleaning the blade easier
- Thin kerf provides a clean, smooth finish while minimizing material waste and motor load
- Large, micrograin carbide teeth for more resharpenings



Cat #	Diameter Inches	Arbor Inches	Teeth	Grind	Hook Angle	Plate Inches	mm	Kerf Inches	mm
Ideal for ripping, general purpose use and fine crosscutting in natural wood, plywood, particle board and MDF.									
10" Blades									
DW7124TK	10"	5/8"	24	FTG	Pos 20°	.071	1.8	.098	2.5
DW7150TK	10"	5/8"	50	ATB+R	Pos 15°	.071	1.8	.098	2.5
DW3215TK	10"	5/8"	60	ATB	Pos 10°	.071	1.8	.098	2.5
DW3218TK	10"	5/8"	80	ATB	Pos 10°	.071	1.8	.098	2.5
12" Blades									
DW3232TK	12"	1"	80	ATB	Neg 5°	.079	2.0	.102	2.6
DW7296TK	12"	1"	96	ATB	Neg 5°	.079	2.0	.102	2.6

SAW BLADE STABILIZERS



Cat #	Description	Diameter Inches	Arbor Inches	Plate Inches
Use on stationary saws against one side of a saw blade to minimize vibration and improve cut quality.				
DW7605	Saw Blade Stabilizer	5"	5/8"	.165
DW7606	Saw Blade Stabilizer	5"	1"	.165



WOODWORKING SAW BLADES

The choice for the finest results. DEWALT Woodworking Saw Blades are designed and manufactured to exacting tolerances for the quality-conscious user who expects accurate cuts, smooth surface finish and minimal splintering.

- Large, C4 micrograin carbide teeth are precision-ground with fine-grit diamond wheels so each tooth planes the wood for an exceptionally smooth finish.
- Ultra sharp cutting edges dramatically reduce splintering.
- Laser-cut expansion slots minimize noise and edge vibration for excellent surface finish.
- Heavy-gauge, laser-cut, hardened and tempered, steel plate is precision-balanced for accurate cuts producing tight joints.



Ripping



Cat #	Diameter Inches	Arbor Inches	Teeth	Grind	Hook Angle	Plate Inches mm	Kerf Inches mm
Fast Ripping							
For fast rip cuts in natural wood. Suitable for gang rip operation. Ideal for pre-sizing applications. <i>Recommended for use with table saws only.</i>							
DW7642	10"	5/8"	24	FTG	Pos 20°	.087 2.2	.118 3.0
DW7643	12"	1"	30	FTG	Pos 20°	.087 2.2	.118 3.0



Finish Ripping							
For rip cuts in natural wood where a smooth finish is required. Recommend higher tooth-count blades for cutting plywood, veneer and laminates. <i>Recommended for use with table saws only.</i>							
DW7654	10"	5/8"	40	TCG	Pos 10°	.087 2.2	.118 3.0
DW7655	12"	1"	40	TCG	Pos 10°	.087 2.2	.118 3.0

General Purpose



Combination							
For all-purpose ripping and crosscuts in natural wood, plywood, particleboard and MDF. <i>Recommended for use with table saws.</i>							
DW7640	10"	5/8"	50	ATB+R	Pos 15°	.098 2.5	.118 3.0
DW7641	12"	1"	60	ATB+R	Pos 15°	.098 2.5	.118 3.0



General Purpose							
For rip cuts in natural wood where a smooth finish is required. Recommend higher tooth-count blades for cutting plywood, veneer and laminates. <i>Recommended for use with table saws and miter saws.</i>							
DW7656	9"	5/8"	40	ATB	Pos 20°	.098 2.5	.118 3.0
DW7653	10"	5/8"	30	ATB	Pos 10°	.098 2.5	.118 3.0
DW7657	10"	5/8"	40	ATB	Pos 20°	.098 2.5	.118 3.0
DW7658	12"	1"	48	ATB	Pos 10°	.098 2.5	.118 3.0
DW7659	14"	1"	48	ATB	Pos 10°	.098 2.5	.118 3.0



WOODWORKING SAW BLADES (continued)

Crosscuts



Cat #	Diameter Inches	Arbor Inches	Teeth	Grind	Hook Angle	Plate Inches mm	Kerf Inches mm
Fine Crosscuts							
For very smooth crosscuts in plywood, veneer laminates, softwood and decorative hardwood. <i>Recommended for use with table saws and miter saws.</i>							
DW7644	8-1/2"	5/8"	60	ATB	Neg 5°	.063 1.6	.094 2.3
DW7645	10"	5/8"	60	ATB	Neg 5°	.098 2.5	.118 3.0
DW7646	10"	5/8"	60	ATB	Pos 10°	.098 2.5	.118 3.0
DW7647	10"	5/8"	80	ATB	Neg 5°	.098 2.5	.118 3.0
DW7648	12"	1"	60	ATB	Neg 5°	.098 2.5	.118 3.0
DW7649	12"	1"	80	ATB	Neg 5°	.098 2.5	.118 3.0
DW7650	12"	1"	96	ATB	Neg 5°	.098 2.5	.118 3.0
DW7651	14"	1"	100	ATB	Neg 5°	.098 2.5	.118 3.0
DW7652	15"	1"	100	ATB	Pos 10°	.098 2.5	.118 3.0

Specialty Applications



Cat #	Diameter Inches	Arbor Inches	Teeth	Grind	Hook Angle	Plate Inches mm	Kerf Inches mm
Melamines and Veneers							
For virtually chip-free cutting on both top and bottom surfaces of paper-based laminated cores (Melamine) and other veneer laminates. <i>Recommended for use with table saws, miter saws and slide miter saws.</i>							
DW7662	10"	5/8"	80	ATB	0°	.087 2.2	.118 3.0
DW7663	12"	1"	80	ATB	0°	.098 2.5	.118 3.0
Laminates							
For long-cutting life in laminates, particleboard and MDF. <i>Recommended for use with table saws and miter saws.</i>							
DW7660	10"	5/8"	80	TCG	0°	.087 2.2	.118 3.0
DW7661	12"	1"	80	TCG	0°	.098 2.5	.118 3.0
Solid Surface and Plastics							
Specialty blade for plastics, Corian, Nevamar and other solid surface materials. <i>Recommended for use with table saws, miter saws and slide miter saws.</i>							
DW7667	10"	5/8"	80	Mod TCG	0°	.087 2.2	.118 3.0
DW7668	12"	1"	80	Mod TCG	0°	.098 2.5	.118 3.0
Non-Ferrous Metals							
For cutting aluminum, brass, copper and all other non-ferrous metals. The use of lubricants is recommended for this application. <i>Recommended for use with miter saws only.</i>							
DW7665	10"	5/8"	80	TCG	Neg 5°	.098 2.5	.118 3.0
DW7666	12"	1"	80	TCG	Neg 5°	.098 2.5	.118 3.0



CONSTRUCTION SAW BLADES

Built for the Job Site. The DEWALT Construction saw blade line includes a full range of thin-kerf blades for long life on the job. Built for durability in the toughest job site applications.

- Thin kerf for fast, smooth cuts
- Exclusive wedge shoulder design puts more steel behind each tip for increased durability and accuracy
- Anti-stick coating reduces friction and gum-up
- Ribbed heat vents reduce flexing and binding



Miter/Table Saw Blades



Cat #	Diameter Inches	Arbor Inches	Teeth	Grind	Hook Angle	Plate Inches	Kerf Inches
Fast Ripping							
For fast rip cuts in natural wood, plywood and wood composites.							
DW3112	10"	5/8"	24	ATB	Pos 15°	.071	.097
General Purpose							
For all-purpose cutting in natural wood, plywood and wood composites.							
DW3103	10"	5/8"	32	ATB	Pos 5°	.071	.097
DW3114	10"	5/8"	40	ATB	Pos 15°	.071	.097
DW3123	12"	1"	32	ATB	Neg 5°	.071	.097
Fine Crosscuts							
For fine crosscuts in natural wood, plywood and wood composites.							
DW3106	10"	5/8"	60	ATB	Pos 5°	.071	.097
DW3126	12"	1"	60	ATB	0°	.071	.097
DW3128	12"	1"	80	ATB	Pos 5°	.071	.097
Combination Packs							
Packs include a general purpose blade and a fine crosscut blade.							
DW3106P5	10"	5/8"	32/60	ATB	Pos 5°	.071	.097
DW3128P5	12"	1"	32/80	ATB	Neg 5° / Pos 5°	.071	.097
Steel Circular Saw Blades							
Description							
Precision sharpened teeth for fast, smooth cuts and longer life.							
Fully hardened steel body prevents blade warping and binding.							
DW3370	10"	5/8"	30	Fast Cut		.069	.089
DW3372	10"	5/8"	80	Hollow Ground Planer		.086	.075

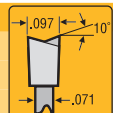
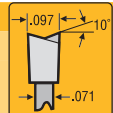
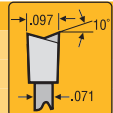
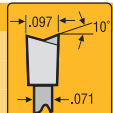

CONSTRUCTION SAW BLADES (continued)

Portable Construction Saw Blades



Cat #	Bulk #	Diameter Inches	Arbor Inches	Teeth	Grind	Hook Angle	Plate Inches	Kerf Inches	
Combination Framing									
For all-purpose cuts in natural wood, plywood and wood composites.									
DW3161	-	6-1/2"	5/8"	18	ATB	Pos 25°	.045	.071	
DW3171	DW3571	7-1/4"	5/8"	16	ATB	Pos 25°	.045	.071	
DW3192	DW3592B10	7-1/4"	5/8"	18	ATB	Pos 15°	.045	.071	
DW3178	DW3578B10	7-1/4"	5/8"	24	ATB	Pos 18°	.045	.071	
DW3176	DW3576B10	7-1/4"	5/8"	36	ATB	Pos 15°	.045	.071	
DW3182	DW3582	8-1/4"	5/8"	24	ATB	Pos 20°	.050	.076	
DW3184	-	8-1/4"	5/8"	40	ATB	Pos 15°	.050	.076	
Nail Cutting									
Specially formulated teeth provide maximum impact resistance to nails, truss plates, screws, staples, shingles, etc. Ideal blade for extreme applications such as remodeling, demolition and roofing.									
DW3191	DW3591B10	7-1/4"	5/8"	18	ATB	Pos 18°	.045	.071	
Pressure Treated/Wet Lumber									
Anti-stick coating reduces buildup on the blade when cutting pressure treated or wet lumber.									
DW3174	DW3574	7-1/4"	5/8"	20	ATB	Pos 25°	.045	.071	
HardiPlank® Fiber Cement							Specially designed for cutting fiber cement products. Polycrystalline Diamond Teeth (PCD) provide maximum life and durability and lasts 50X longer than carbide.		
DW3193	-	7-1/4"	5/8"	6 PCD	FTG	Neg 5°	.063	.090	
Steel Circular Saw Blades				Description		Plate Inches	Kerf Inches		
Precision sharpened teeth for fast, smooth cuts and longer life. Fully hardened steel body prevents blade warping and binding.									
DW3310	-	6-1/2"	5/8"	18	Fast Cut	.050	.090		
DW3330	-	7-1/4"	5/8"	16 slots	Iron/Steel	.050	.050		
DW3323	DW3523	7-1/4"	5/8"	20	Fast Cut	.050	.090		
DW3325	-	7-1/4"	5/8"	40	Combination	.050	.090		
DW3327	-	7-1/4"	5/8"	60	Hollow Ground Planer	.075	.065		
DW3332	-	7-1/4"	5/8"	60	Master Combination	.050	.086		
DW3329	-	7-1/4"	5/8"	68	Metal Cut	.050	.086		
DW3524	-	7-1/4"	5/8"	100	Crosscut	.050	.086		
DW3326	DW3526	7-1/4"	5/8"	140	Hollow Ground Plywood	.075	.065		
DW3350	-	8-1/4"	5/8"	40	Combination	.050	.084		

*HardiPlank® is a registered trademark of the James Hardie Corporation

Cordless Saw Blades



Cat #	Description	Diameter Inches	Arbor Inches	Teeth	Grind	Hook Angle	Plate Inches	Kerf Inches
5-3/8" Diameter Blades								
Ultra-thin kerf yields more cuts per charge by minimizing battery drain.								
DW9055	Fast Cutting	5-3/8"	10mm	16	ATB	Pos 20°	.039	.059
DW9054	Smooth Cutting	5-3/8"	10mm	24	ATB	Pos 20°	.039	.059
DW9052	Alu/Nonferrous Metals	5-3/8"	10mm	30	FTG	Pos 3°	.039	.059
DW9053	Vinyl/Paneling	5-3/8"	5/8"	78	Alt. Set	Neg 10/45°	.039	.059
DW9058	Combo (DW9052, DW9055)	5-3/8"	10mm	16/30	ATB/FTG	+20/+3°	.039	.059
DW9059	Combo (DW9052, DW9053, DW9055)	5-3/8"	10mm	30/78/24	ATB/Alt. Set	+18/-45/+20°	.039	.059
6-1/2" Diameter Blades								
DW9155	Fast Cutting	6-1/2"	5/8"	16	ATB	Pos 20°	.039	.059
DW9154	Framing	6-1/2"	5/8"	24	ATB	Pos 20°	.039	.059
DW9152	Aluminum	6-1/2"	5/8"	36	FTG	Pos 3°	.039	.059
DW9158	Combo (DW9155, DW9154)	6-1/2"	5/8"	16/24	ATB	Pos 20°	.039	.059
DW9153	Vinyl/Paneling	6-1/2"	5/8"	90	Alt. Set	0/35°	.039	.059

ACCESSORIES

FERROUS METAL CUTTING

Fast clean cuts in metal. DEWALT Metal Cutting Blades provide clean, fast cuts in a variety of ferrous, non-ferrous and stainless steel materials. Specially designed carbide teeth deliver precise, virtually burr-free cuts and produce cut material that is cool to the touch.

- 12% titanium carbide provides long life in metal cutting
- Modified ATB tooth geometry provides clean, virtually burr-free cuts
- Tri-fold braze absorbs stress making the tip stronger
- Expansion slots dissipate heat which extends blade life

SHARPEN
BLADE
AFTER EVERY
300
CUTS

LASTS
UP TO
40X
LONGER
THAN
ABRASIVE BLADES



Cat #	Dia Inches	Application	Arbor Inches	Teeth	Grind	Hook Angle	Plate Inches mm	Kerf Inches mm	Max RPM
<i>For use with metal cutting "dry cut" miter saws only.</i>									
14" Blades									
DW7747	14"	Heavy Gauge Metal	1"	70	M-ATB	0°	.071 1.8	.087 2.2	1,800
DW7745	14"	Thin Gauge Metal	1"	90	M-ATB	0°	.071 1.8	.087 2.2	1,800
DW7749	14"	Stainless Steel	1"	90	M-ATB	10°	.071 1.8	.087 2.2	1,800
12" Blades									
DW7737	12"	Heavy Gauge Metal	1"	60	M-ATB	0°	.071 1.8	.087 2.2	1,800
DW7739	12"	Stainless Steel	1"	80	M-ATB	10°	.071 1.8	.087 2.2	1,800



Cordless Metal Cutting

Cat #	Dia Inches	Application	Arbor Inches	Teeth	Grind	Hook Angle	Plate Inches mm	Kerf Inches mm	Max RPM
<i>For use with DEWALT DW934 18 Volt Cordless Metal Cutting Saw.</i>									
DW7763	6-3/4"	Mild Steel	20mm	40	M-ATB	0°	.055 1.4	.069 1.75	3,500



Let the blade do the work; do not force blade through the material.

RE-SHARPENING SERVICE

DEWALT's woodworking saw blade manufacturing plant in England produces premium saw blades to meet the exacting requirements of woodworkers around the world. Manufactured to precise tolerances for consistent, reliable performance, DEWALT Woodworking Saw Blades are engineered to provide world class cutting accuracy and smoothness.

Because of the exact manufacturing process, DEWALT recommends your DEWALT woodworking saw blades be re-sharpened by the DEWALT re-sharpening service.

All saw blades will be re-sharpened to original factory specifications to ensure that a re-sharpened blade will perform similar to a new, out of the box saw blade. Proper care and re-sharpening will ensure long life and high quality cuts.

Send Saw Blades to:

DEWALT Re-Sharpener Services
1180 Wernsing Road
Jasper, IN 47546

1-800-4 DEWALT

Visit www.DEWALT.com for more details.



GLOSSARY OF SAW BLADE TERMS

Positive Hook Angle

The slope of the tooth along the face is slanted forward. The higher the hook angle, the faster the cut, but the rougher the finish. Primarily used for ripping and crosscutting wood.

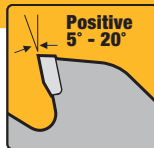

Recommendation

- ▶ Slight positive angles (5° - 10°) for crosscutting
- ▶ Aggressive positive angles (10° - 20°) for ripping

Negative Hook Angle

The slope of the tooth along the face is slanted backwards. The lower the hook angle, the slower the cut, but the finer the finish. Primarily used for cutting plastics, laminates and non-ferrous metals.

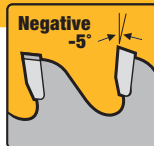

Recommendation

- ▶ Ideal for slide miter and radial arm saws

Plate

The thickness of the saw blade body.

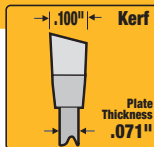

Kerf

The thickness of the carbide tooth. Thin-kerf blades produce less material waste and cut faster. They are a good choice for under-powered saws. Thick-kerf blades provide more stability and greater cutting accuracy.

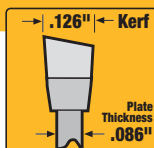

SAW BLADE TOOTH GEOMETRIES

Flat Top

Used on saw blades designed for fast ripping, or cutting of the wood along the grain line.



Alternate Top Bevel

Provides the shearing action required for good crosscutting and ripping. Used on saw blades for general purpose and crosscutting applications.



High Alternate Top Bevel

Minimizes grain tear-out and produces mirror-smooth finishes. Used in fine crosscutting blades and in blades designed for cutting melamines and veneers. In these applications, the H-ATB grind produces chip-free cuts on both top and bottom surfaces.



Modified Alternate Top Bevel

Used on blades for cutting ferrous metals. Produces smooth, burr-free edges.



Alternate Top Bevel with Raker Tooth

Provides both the shearing action needed for crosscuts and the flat-top raker tooth for rip cutting. Used in combination-style general purpose blades.



Triple Chip

Provides the shearing action required for good crosscutting and ripping. Used on saw blades for general purpose and crosscutting applications.



Modified Triple Chip

Reduces edge wear for longer tip life. Provides straight and chatter-free cuts in hard materials. Used on blades for cutting solid surface materials and plastics.



SERVICE

DeWALT factory service will provide superior professional tool repair with 89 factory owned and over 1000 authorized repair locations.

REPAIR

Our factory owned DeWALT Service Centers use the Guaranteed Repair Cost (GRC)[™] program to take the guesswork out of the repair process, saving you money and downtime! We guarantee the price of a repair will not exceed the published price. And since DeWALT repairs most major brands of power tools, you can count on us to get your tools back on the job site, Guaranteed.



THE COST... NEVER MORE, OFTEN LESS!

GRC REPAIRS INCLUDE:

- Complete teardown inspection
- Thorough cleaning & lubrication
- Replacement of worn and damaged parts
- Full performance and safety test



DROP BOX EXPRESS[™]

The Drop Box Express program is the solution for contractors and companies who are often in need of power tool repair and maintenance, but are unable to visit one of our factory owned locations. To learn more about this repair program and to sign up today, please contact a local DeWALT factory owned Service Center.



NEED REPAIR? SEND US YOUR TOOLS FROM ANYWHERE, ANYTIME!

ALL DROP BOX EXPRESS ACCOUNTS RECEIVE:

- Durable shipping container
- Shipping materials
- Tool tags
- Guaranteed customer satisfaction



KIT BOXES

DeWALT makes heavy-duty kit boxes for storing and carrying your DeWALT tools. Every kit box:

- Is produced using high strength quality materials for maximum durability
- Has additional space for accessories

To purchase a kit box contact your nearest DeWALT Service Center or call Parts Central toll free at **888-678-7278**.



NEED PARTS?



OTHER GREAT FEATURES INCLUDE:

- Printer-friendly parts lists
- Service bulletins and instruction manuals
- Current inventory status and pricing
- On-line order status and tracking

INTERACTIVE EXPLODED VIEWS



"HOW-TO" REPAIR VIDEOS



WIRING SCHEMATICS



24/7 ON-LINE PARTS ORDERING



Visit us today at: www.DEWALTservicenet.com

DeWALT Factory Owned Service Centers

City/State/Zip	Name/Address	Area Code	Phone Number	City/State/Zip	Name/Address	Area Code	Phone Number
Alabama				New York			
Birmingham, 35209	2412 Green Springs Hwy	205	942-0538	Buffalo, 14209	881 W Delavan Ave	716	884-6220
Mobile, 36608	3831 Airport Blvd	251	343-6624	DeWitt, 13214	3485 Erie Blvd E	315	446-3086
Alaska				Hicksville, 11801	259 South Broadway	516	938-8180
Anchorage, 99503	4831 Old Seward Hwy, Unit 103	907	561-7181	Latham, 12110	836 Troy-Schenectady Rd	518	785-1867
Arizona				Rochester, 14623	2969 W. Henrietta Rd	585	424-1310
Phoenix, 85013	4501 N 7th Avenue	602	279-6414	Woodside, 11377	56-15 Queens Blvd	718	335-1042
Tucson, 85714	3820 S Palo Verde Blvd, Suite 109	520	746-4090	North Carolina			
Arkansas				Charlotte, 28205	3007 E. Independence Blvd	704	374-1779
Little Rock, 72201	519 West 7th St	501	372-3040	Greensboro, 27407	4621 High Point Rd	336	852-1300
California				Raleigh, 27604	2930 Capital Blvd	919	878-0357
Anaheim, 92806	540 S. State College Blvd	714	772-4050	Ohio			
Fresno, 93726	4645 North Blackstone Ave	559	435-0810	Cincinnati, 45241	2310 E Sharon Rd	513	772-3111
Hayward, 94545	2512 Tripaldi Way	510	783-3959	Columbus, 43229	1948 Schrock Road	614	895-3112
Los Angeles (BF), 90706	9020 Alondra Blvd	562	925-7551	Dayton, 45409	2898 South Dixie Dr	937	298-1951
North Highlands, 95660	4968 Watt Ave, Suite B	916	344-3520	Parma Heights, 44130	6485 Pearl Rd	440	842-9100
Riverside, 92506	6215 Magnolia Ave, Suite B	909	787-9700	Toledo, 43615	522 South Reynolds Rd, Suite H	419	531-8921
San Diego, 92111	7290 Clairmont Mesa Blvd	858	279-2011	Oklahoma			
Woodland Hills, 91367	20940 Victory Blvd	818	884-6024	Oklahoma City, 73139	8507 South Western	405	634-8403
Colorado				Tulsa, 74146	11414 East 51st St, Unit C	918	249-8641
Denver, 80223	700 West Mississippi Ave, Unit B1	303	922-8325	Oregon			
Connecticut				Portland, 97230	14811 N E Airport Way, Suite 600	503	255-6556
Wethersfield, 6109	662 Silas Deane Hwy	860	563-5800	Pennsylvania			
Florida				Harrisburg, 17112	6080 Allentown Blvd	717	545-0651
Cooper City, 33330	12349 Southwest 53rd St, Suite 202C	954	434-1458	Langhorne, 19047	1234 East Lincoln Hwy	215	702-3875
Jacksonville, 32205	920 Cassat Ave	904	781-2253	Philadelphia, 19148	2715 South Front St	215	271-5500
Orlando, 32803	3218-G E. Colonial Dr	407	894-7011	Pittsburgh, 15201	3234 Penn Ave,	412	642-0204
Palm Harbor, 34684	35927 Us Highway 19 North	727	784-9105	Pittsburgh, 15237	4700 McKnight Rd	412	635-9440
Tampa, 33634	4909 West Waters Ave	813	884-0434	Whitehall, 18052	2242 MacArthur Rd	610	435-9544
West Palm Beach, 33415	310 S. Military Trail	561	689-3247	York, 17402	2201 Industrial Hwy	717	755-3441
Georgia				South Carolina			
Norcross, 30071	6115-C Jimmy Carter Blvd	770	246-1710	Greenville, 29605	1259 South Pleasantburg Dr, Unit C	864	299-8662
Illinois				North Charleston, 29405	4365 Dorchester Rd, Suite 104	843	745-9197
Villa Park, 60181	137 East North Ave, Unit B	630	834-0803	Tennessee			
Indiana				Knoxville, 37917	4118 North Broadway	865	688-0921
Hammond, 46323	7103 Kennedy Ave	219	845-5100	Memphis, 38133	2686 Kirby-Whitten Rd, Suite 102	901	384-8100
Indianapolis, 46224	5999 Crawfordsville Rd	317	243-8308	Nashville, 37210	746 Fesslers Lane	615	242-1633
Iowa				Texas			
Des Moines, 50310	3408 Merle Hay Road, Suite A	515	270-1340	Austin, 78757	911 West Anderson Lane	512	459-1133
Kansas				El Paso, 79915	6822 Gateway East	915	778-9769
Overland Park, 66214	9201 Quivira Rd	913	495-4330	Farmers Branch, 75234	1881 Valley View Ln, Suite 200	972	620-8655
Wichita, 62713	155 S. West St	316	943-1271	Fort Worth, 76111	721 North Beach St	817	831-3828
Kentucky				Garland, 75041	718 West Centerville Rd	972	686-9302
Louisville, 40213	5211 Preston Highway	502	968-7100	Houston, 77022	536 East Tidwell Rd	713	692-7111
Louisiana				McAllen, 78501	200 North McColl Rd	956	661-1122
Metairie, 70002	3504 North Causeway Blvd	504	837-2550	San Antonio, 78201	500 Culebra Ave	210	732-1221
Shreveport, 71108	7714 Jewella Rd	318	688-1553	Utah			
Maryland				Salt Lake City, 84115	1541 S 3rd St	801	486-5828
Baltimore, 21236	7830 Rossville Blvd	410	665-7400	Virginia			
Capitol Heights, 20743	7957-63 Central Ave	301	333-0865	Richmond, 23222	1424 Chamberlayne Ave	804	649-9245
Massachusetts				Virginia Beach, 23455	5760 Northampton Blvd, Suite 110	757	363-0091
Brighton, 2135	12 Market St	617	782-6264	Washington			
Michigan				Seattle, 98134	2100 Airport Way South	206	763-2010
Grandville, 49418	2982 28th St SW	616	261-0425	Spokane, 99212	5308 East Sprague Ave	509	535-9252
Warren, 48093	27035 Van Dyke Blvd	586	756-6711	Tacoma, 98409	3630 S Cedar St, Suite C	253	473-6040
Westland, 48185	8067 North Wayne Rd	734	427-1520	West Virginia			
Minnesota				Charleston, 25312	1638 Sixth Ave	304	343-0289
Eden Prairie, 55344	9709 Valley View RD, Suite 9709	952	884-9191	Wisconsin			
Missouri				West Milwaukee, 53214	1650 Miller Parkway	414	645-4285
St Louis, 63146	11477 Page Service Drive	314	997-9100	CANADA			
Nebraska				Vancouver, BC, V5M 3Y7	1735 Boundry Road	604	291-9942
Omaha, 68127	4229 S. 84th St	402	592-5666	Winnipeg, MB, R3H 0K3	934 St. James Street	204	783-7294
Nevada				Mississauga, ON, L4X 1L3	1480 Dundas Street East	905	277-0011
Las Vegas, 89118	5565 South Decatur Blvd, Ste 103	702	889-6025	Montreal, PQ, H1Y 1B4	3061 Belanger	514	722-1021
New Jersey				Dartmouth, NS, B3B 1L3	100 Iisley Ave. Unit G	902	453-5090
Elmwood Park, 7407	213 Route 46 West, Suite 4	201	475-3524	Pickering, ON, L1N 3X4	1050 Brock Road, 1 & 2	905	421-9784
Scotch Plains, 7076	2520 Rt 22 E	908	233-5665	Edmonton, AB, T6E 6H6	3751 99th Street	780	462-5005
New Mexico				London, ON, N5Z 3K7	257 Adelaide Street South	519	649-2407
Albuquerque, 87110	5617 Menaul Blvd. N.E.	505	884-1002	Ottawa, ON, K1Z 5A6	915 Clyde Avenue N., Unit B	613	724-7724
				Quebec, PQ, G2E 5H5	4975 Rideau Street, Unit 130	418	864-4300
				Calgary, AB, T2G 5N6	21 Highfield Circle, Bay 6	403	243-2066

for additional DeWALT Authorized Warranty Repair Centers see pages 151-156

DeWALT Authorized Warranty Repair Centers

City/State/Zip	Name/Address	Area Code	Phone Number	City/State/Zip	Name/Address	Area Code	Phone Number
Alabama				California (continued)			
Ashville, 35953	Walker Marine, 9700 County Rd 33	205	594-4800	Montclair, 91763	Tools-R-Us, 5461 Holt Blvd	909	988-5858
• Birmingham, 35210	B & G Equipment & Supply, 2748 Mary Taylor Rd	205	833-3033	Montebello, 90640	Acoustical Material Services, 1620 S Maple Ave	323	721-9011
Calera, 35040	Quality Tool Repair, 6180 Hwy 31	205	668-3131	Moreno Valley, 92553	Empire Mower, 22410 Alessandro Blvd	909	697-6688
Decatur, 35602	Power Tool Supply & Repair, 1713 Creighton Ave SE	256	350-0079	Morgan Hill, 95037	The Tool Store, 305 Vineyard Town Ctr 273	408	778-3252
• Huntsville, 35806	Engineered Maintenance Service, 7234 Governors West	256	837-2950	• N Hollywood, 91605	Bucknall Power Tool, 11910 Vose St	818	765-0228
Montgomery, 36117	Triangle Fastener Corp, 508 Hackel Drive	334	270-8800	N Hollywood, 91605	Airdraulics, 13261 Saticoy St	818	982-1400
Pelham, 35124	Tool Specialty Inc, 141 Commerce Court	205	733-9292	Newbury Park, 91320	Action Supply & Service, 3490 Lesser Drive	805	498-1137
Theodore, 36582	Mobile Mechanical Service, 5787 I-10 Industrial Pkwy	251	653-6948	Ontario, 91761	Combee Electric, 1619 E Holt Blvd	909	983-2238
Winfield, 35594	McCaleb Tool Supply, 710 Hwy 43 South	205	487-2222	★ Ontario, 91761	Dave's Tool Service & Supply, 780 South Milliken Ave	909	605-6558
Alaska				Oxnard, 93030	Electric Motor Service, 200 E 5th St	805	483-4233
• Fairbanks, 99701	Independent Rental, Inc, 2020 S Cushman St	907	456-6595	Oxnard, 93030	Junior's Tools, 2001 Eastman Ave	805	981-9100
★ Fairbanks, 99709	Fairbanks Aero Service, 1915 ADA St.	907	479-6666	Paramount, 90723	J & D Tool Repair, Inc, 14050 Orange Avenue Unit B	562	630-1644
Arizona				Pittsburg, 94565	Bay Saw & Tool Repair, 498 East 10th Street	925	432-6291
• Flagstaff, 86004	The Cutting Edge, 1620 N First St	928	773-8503	Rancho Cordova, 95742	All Trade Tool & Repair, 3515 Sunrise Blvd 23	916	631-3550
• Gilbert, 85234	Carlson Construction Supply, 75 W Baseline	480	962-6245	Rancho Cucamonga, 91730	HCS-Cutter Inc, 10411 26th St	909	987-0094
• Glendale, 85301	Banner Tool Service, 6741 N 57th Avenue	623	842-0800	Redding, 96002	Hydraulic Controls, 845 Industrial St	530	221-6500
★ Kingman, 86401	Kingman True Value, 3633 Stockton Hill Rd	928	757-4018	Richmond, 94805	Bay Air Service, 12640 San Pablo Ave	510	215-1170
Lake Havasu City, 86406	Southwest Service, 1421 Carlsbad Ct	520	453-2695	Riverside, 92507	Ken's Tool & Supply, 1651 Iowa Ave	909	686-2542
Phoenix, 85019	Jims Air Compressor/Road Runner Power, 3815 N 38th Ave	602	278-6451	Sacramento, 95826	Valley Tool Repair, 4131 Power Inn Rd	916	737-6300
Phoenix, 85020	The Shop, 8350 N 7th St	602	997-9531	Sacramento, 95834	Contractors Tool Repair, 4237 S Market Ct	916	922-6007
Phoenix, 85021	Pro-Tech Small Engine & Equip Repair, 2319 W Glendale Ave	602	347-0713	San Diego, 92110	Tool Depot, 3799 Gaines St	619	220-7111
Phoenix, 85022	Arizona Power Tool Svc, 13439 N Cave Creek Rd, Ste 5	602	485-4067	San Francisco, 94103	West Coast Construction, 28 13th St	415	861-6124
• Prescott, 86301	Prescott Power Tool, 1050 Willow Creek #1	928	445-2628	San Francisco, 94107	White Cap Tool Repair, 1225 6th St	415	626-3750
Tempe, 85283	APD Power Center, 412 West Gemini Dr	480	838-7472	San Francisco, 94124	Craig & Green, 1680 Evans Ave	415	642-8698
Tucson, 85713	GW Enterprises, 2830 S Alvernon Way	520	571-8998	San Jacinto, 92583	Hemet Valley Tool & Supply, 385 W Esplanade	909	654-1034
Tucson, 85714	Mechanics Tool Service Inc, 1301 E Apache Park Place	520	889-8484	San Jose, 95112	D & D Compressor Inc, 258 Kinney Dr	408	947-0491
Yuma, 85365	Yuma Farm Supply, 2222 East 16th St	520	329-9113	San Jose, 95112	T Precision Mechanic, 696 Kings Row, Suite 35	408	436-1420
Arkansas				San Luis Obispo, 93401	J P Tool Repair, 3440A Sacramento Dr	805	544-7152
Benton, 72015	Arkansas Onsite Service Inc, 624 S Third Street	501	860-6329	★ San Marcos, 92069	Protek / Toolmart Tool Repair, 1355 Grand Ave #108	760	471-4800
Eldorado, 71730	The Tool Room Inc, 508 Marsh Avenue	870	863-3036	Santa Ana, 92705	Orco Construction Supply, 2210 S Ritchey	714	641-1777
• Fort Smith, 72901	Tool Service Company, 5732 Wheeler Avenue	479	648-3125	• Santa Barbara, 93101	Jim Klippel Tool Repair, 424 Laguna St	805	963-0020
Fort Smith, 72904	Air Compressor Equipment, 3401 Kelley Highway	501	783 6181	Santa Cruz, 95060	Johns Electric Motor Svc, 457 May Ave	831	426-2900
Harrison, 72601	Harrison Tool Room, 1306 North Hwy 62 #65	870	365-0406	Santa Fe Springs, 90670	Action Tool/Southwest, 10125 Freeman Ave	562	944-7906
• Hot Springs, 71901	Tool Supply, 815 E Grand Avenue	501	623-8665	Santa Monica, 90404	Lehne & Son Spray Equipment, 1625-17th St	310	394-6463
★ Hot Springs, 71901	Arkansas Tool Service, 230 Valley Street	501	321-9851	• Santa Rosa, 95403	H & V Tool Repair, 1808 Empire Industrial	707	528-1111
Pine Bluff, 71601	Lawson Welding, 610 E 5th Street	870	534-2053	Simi Valley, 93063	Simi Tool Repair, 2512 Tapo St	805	584-8138
Pocahontas, 72455	The Tool Doctor, 2010 Industrial Drive	870	892-8665	Simi Valley, 93063	A Compressor Service, 2512 Tapo St	805	583-3276
Russellville, 72801	C & C Machine Company, 2120 E 2nd Street	501	968-7144	Stockton, 95208	United Rentals, 2911 E Fremont St	209	948-9500
Springdale, 72762	The Tool Hospital, 3670 Elm Springs Road	479	927-0400	Suisun, 94585	Fairfield Construction Supply, 405-A Railroad Ave	707	421-8008
Springdale, 72764	Air Compressor SVC, 801 Dyer	501	756-5938	Sun Valley, 91352	Orco Construction Supply, 8847 Lankershim Blvd	818	504-3170
Springdale, 72765	Tri-Bar Tool & Supply, 4315 N Thompson	479	751-3502	Tahoe City, 96145	Alpine Power Equipment, 2907 Lake Forest Rd	530	583-0159
California				Torrance, 90502	Universal Tool Service, 21804 S Vermont Ave	310	328-2121
Anaheim, 92805	Westside Building Mtls Co, 1111 E Howell Ave Box 711	714	385-1646	Victorville, 92392	Western Outdoor Power, 15582 7th St	760	245-2861
Apple Valley, 92307	Standard Elec Works, 22000 Hwy 18 / Box 1343	760	247-8909	Visalia, 93292	California Tool Warranty, 200 South Cotta Ct	888	330-9301
Aracataca, 95521	Humboldt Fasteners, 5100 Valley East Blvd	707	822-0209	Woodland, 95695	Elfrinks Inc, 446 5th St	530	662-7103
Bakersfield, 93307	NB Sales & Service, 1610 S Union	661	397-1950	Colorado			
Bakersfield, 93308	Electropower Inc, 3736 Gilmore Ave	661	322-1586	Boulder, 80301	Boulder Electric Motor, 3865 Walnut Street	303	443-1331
• Bakersfield, 93313	All Tool Repair, 6201 Schirra Court #12	661	396-8803	• Carbondale, 81623	Tools For Living, 0560 Highway 133	970	963-8776
Berkeley, 94710	Truitt & White Lumber, 642 Hearst Avenue	510	949-2600	Colorado Springs, 80904	Remco Equipment, 2210 Bott St	719	632-4621
Campbell, 95008	Railway Distributors, 264 Railway Avenue	408	866-9266	Colorado Springs, 80907	Tool Hospital, 4127 N Sinton Road	719	260-0619
• Canoga Park, 91304	Spark Tools, 7841 Alabama Avenue Unit 17	818	884-6821	Denver, 80204	A Pro Tool Service, 1950 W 13th Avenue #2	303	623-3743
Chico, 95928	MJB Welding, 357 East Park Ave	530	342-3589	Denver, 80223	Circle Service, Inc, 2089 S Zuni St	303	966-8036
Compton, 90221	Lee's Tools, 1924 North Long Beach Blvd	310	639-1900	Durango, 81303	Red Mtn Contractor Supply LLC, 29420 Hwy 160, Unit B	970	259-7943
Concord, 94520	The Compressor Shop, 3873 Joan Ave	925	676-7487	Eagle, 81631	Tool Clinic Inc, 725 Chambers Avenue	970	328-6282
Costa Mesa, 92626	Barton Industrial, 2980 McClintock (J)	714	546-8145	Fort Collins, 80524	Larimer Electric Motor Repair, 1808 East Lincoln Ave	970	484-8411
Escodido, 92025	Marts Appliance Service, 743 E Valley Pkwy	760	745-7711	Grand Junction, 81501	Air Compressor SVC, 386 27 1/2 Rd	970	245-1320
Fairfield, 94533	S & S Unlimited, 2352 N Texas St	707	429-3622	Grand Junction, 81501	Professional Tool Service, 2420 I-70 Business Loop	970	242-1224
• Fallsbrook, 92028	Mack's Tool Repair, 341 Industrial Way, Ste A	760	451-1078	Grand Junction, 81502	Energy Equipment & Supply Inc, 2467 Commerce Blvd	970	245-7269
Fontana, 92335	Allens Compressors, 16762 Springs St	909	823-3522	Greeley, 80631	Greeley Electric Repair, 2509 8th Avenue	970	352-1961
Fresno, 93703	All Tool Service, 1571 N Maple	559	252-2879	Longmont, 80501	A A A Electric, 24 S Main Street	303	776-6031
• Fresno, 93706	Associated Compressor & Equip., Inc, 2708 E Jensen Ave	559	485-3184	Loveland, 80538	Connective Systems & Supply, 5718 Wright Drive	970	663-2616
Garden Grove, 92643	J & M Service Inc, 11532 Anabel	714	530-3325	Northglenn, 80234	The Otten Group, Inc, 11450 North Cherokee St	303	450-2833
Gilroy, 95020	Abbotts Pro-Power, 110 Luchessa Ave 4B	408	847-0472	• Pueblo West, 81007	Pueblo West Rental Center, 579 E Enterprise Drive	719	647-2071
Glendale, 91205	Glendale Power Tool, 921 S Verdugo Rd	818	244-9277	Connecticut			
Glendora, 91740	Lans Elec Motor Repair, 438 West Carter Dr	626	963-9457	• Bethel, 06801	Tibby's Electric Motor Service, 40 Taylor Avenue	203	748-4694
• Grass Valley, 95945	Freddy's & Sons Pro Service, 540 E Main Street	530	273-6321	Branchford, 06405	The Tool Crib, 3 Research Dr	203	488-6200
Hesperia, 92345	Williams Tool Repair, 10182 I Avenue Unit E	760	949-3310	Hamden, 06514	Baltimore Electronic, 5 Manilla Ave	203	248-7553
Indio, 92201	Inland Power Equipment, 81405 Us Highway III	766	347-3155	Jewett City, 06351	Quality Tool Repair, 39 Wedgewood Dr, Suite K	860	376-5634
La Habra, 90631	Responsive Tech, 722 S Beach Blvd	877	737-7667	Manchester, 06040	Blish Equipment, 472 Center St	860	649-4323
Lancaster, 93534	Valley Cosntruction, 45346 N Trevor	661	948-5074	New Britain, 06051	Comp Rebuilders, 321 Ellis St	860	224-3737
• Livermore, 94550	Tool Tech Construction Supply, Inc, 4647-A las Positas Road	925	443-7922	New Haven, 06512	Colony Hardware & Supply, 15 Stiles Street	203	469-0000
Livermore, 94550	California Nail & Supply, 415 Mountain Vista Pkwy	925	443-7239	Oakville, 06779	Watertown Tool Repair, 28 Maine St	860	596-1344
Los Angeles, 90023	Minit Tool Co, 4170 E Washington Blvd	323	264-7006	Oakville, 06779	Kirco Appliance Service Center, 208 Main Street	860	274-7889
• Madera, 93637	United Rentals #568, 750 Madera Ave	559	673-2343	Plantville, 06479	R & D Services, 790 S Main St	860	628-5205
Martinez, 94553	Furber Saw, 895 Howe Rd	925	229-3774	Tolland, 06084	Gottier Small Engine Repair, 427 Tolland Stage Rd	860	875-2802
Modesto, 95351	Rayco Industrial Supply, 512 River Rd	209	529-8984	Unionville, 06085	Air Tool Sales & Service, 1 Burnham Avenue	860	673-2714
Modesto, 95351	Stanislaus Electric, 504 River Road	209	523-8269	W Hartford, 06110	Pneumatic Systems Co, 64 Cody St	860	953-1275
Modesto, 95354	United Rentals, 2443 Yosemite Blvd	209	531-2800	<ul style="list-style-type: none"> • Repairs Compressors & Generators ★ Repairs All DeWALT Products ◆ Repairs Lasers 			

SERVICE CENTERS

City/State/Zip	Name/Address	Area Code	Phone Number	City/State/Zip	Name/Address	Area Code	Phone Number
Delaware				Georgia (continued)			
Harrington, 19952	Weeks Services, 6045 Milford Harrington Hwy	302	398-3558	★ Stockbridge, 30281	Advanced Power Tool Repair, Inc, 118 Rock Quarry Rd, Ste B	770	389-5260
Hartly, 19953	T & T Small Engine, 2845 Hourglass Rd	302	492-8677	Tifton, 31794	Tifton Electric Motors, 1265 Hwy 82 East	229	382-4040
• New Castle, 19720	Eagle Nail & Tool Supply Inc, 325 S DuPont Highway	302	328-4888	Valdosta, 31601	Whitehead Hardware Co, 104 S Lee	229	242-3910
New Castle, 19720	Kompressed Air of Delaware, Inc, 144 Quigley Blvd, Ste 100	302	322-4900	• Valdosta, 31602	General Rental, 2717 Bemiss Rd	229	247-5797
Rehoboth Beach, 19971	Grand Rental Station, 803 G Rehoboth Ave	302	227-3151	Marietta, 30060	Roper Laser Co, 1171 South Marietta Parkway	770	422-1717
Wilmington, 19808	Appliance Service Center Corp, 3317B Old Capitol Trail	302	994-6259	Guam			
Florida				Tamuning, 96911	Fastening Specialty Guam Inc, 321 E Harmon Ind Park	671	646-4026
Atlantic Beach, 32233	Specialty Marine, 1420 Mayport Rd	904	247-3303	Hawaii			
• Belleview, 34420	B & M Equip Rental & Sales, Inc, 7722 SE 126th Place	352	245-9800	• Aiea, 96701	Small Engine Clinic, 98-019 Kamehameha Hwy	808	488-0711
• Clearwater, 33762	Atlas Const Equip Services LLC, 4193 114th Terrace North	727	299-0700	Aiea, 96701	Wiki Wiki Power Tool Repair, 99-1265 Hawawa Valley Street #B	808	486-1955
Crystal River, 34429	Taylor Rental, 8081 West Gulf to Lake Highway	352	795-5600	Hilo, 96720	J & J Lucas Repair Shop, 1682 Kilauea Avenue	808	935-4751
Davie, 33331	Sy's Supplies, 15751 SW 41st Street	954	389-5611	• Honolulu, 96819	F K S Rentals & Sales, 663 Kakoi Street	808	836-2961
• Daytona Beach, 32114	Contractor's Services, 145 Orange Ave	386	258-4161	Honolulu, 96819	Mercury Electric, 2290 Alahao Place Unite #20A	808	841-5711
Daytona Beach, 32117	C & C Power Tools, 856 Mason Avenue	386	253-5815	Honolulu, 96819	Slim's Power Tool, 1626 Republican	808	841-0902
Fort Lauderdale, 33334	American Air Compressor, 4051 NE 6th Ave	954	565-0808	• Kahului, 96732	F K S Rentals & Sales, 349 Hanakai Street	808	871-7171
Fl Walton Beach, 32548	Gatlin Lumber, 57 Beal Parkway	850	243-9102	Kailua-Kona, 96740	All Trade Industrial Supply, 73-5563 Maiau Street	808	329-0516
Fl. Lauderdale, 33314	Tool Repair Depot, 5416 South State Road 7	954	797-8998	★ Kailua-Kona, 96740	Kona Rent All, 74-5603 Pawai Place	808	329-1644
Gainesville, 32608	Authorized Appliance Service Co, 2614 SW 34th Street	352	375-3886	Lihue, 96766	Toolmaster Hawaii, 3061 Aukele Street	808	246-1000
Hialeah, 33010	United Tool Corporation, 501 East 9th St	305	884-3068	Idaho			
• Hudson, 34667	Suncoast Tool Repair, 14606 Marina Dr	727	697-0134	Boise, 83705	Air Equipment Company, 2350 S Orchard St	208	342-2464
Hudson, 34669	Pasco Preventive Mtc, Inc, 9731 Jim St	727	863-9499	★ Boise, 83706	KC Tool Supply Company, 5103 Irving Street	208	375-1313
Key West, 33040	Key West Electrical Repair & Supply, 311 Margaret St	305	296-8548	Boise, 83714	Gem State Electric, 112 W 32nd Street	208	344-5461
Lake Worth, 33461	John's Saw Service, Inc, 3277 Lake Worth Rd / Suite A	561	965-0477	• Coeur D'Alene, 83815	Coeur D'Alene Power Tool, 451 Cherry Lane	208	667-1158
• Lakeland, 33801	B & G Compressor Service, Inc, 4355 Hwy 92 East	863	666-8500	• Idaho Falls, 83402	Service Center Plus, 480 N Utah	208	524-7362
Lecanto, 34461	Citrus Power Equipment, 1919 West Gulf to Lake Highway	352	527-2015	★ Idaho Falls, 83402	Rossiter Electric, 1501 South Capital Ave	208	529-3665
• LeHigh Acres, 33971	Thadd's On The Spot Repair, 5320 Bywood St	239	850-2656	• Lewiston, 83501	Hahn Supply, 2121 Main Street	208	743-1577
• Longwood, 32750	Boynton Lawn & Garden Equip, 315 N County Road 427	407	831-3447	Nampa, 83651	Idaho Tool & Equipment, 452 Caldwell Blvd	208	465-7533
• Lutz, 33549	Hughes Tool Supply Inc, 1208 Us Highway 41 N	813	949-0441	Old Town, 83822	Albeni Falls Building Supply, 520 Highway 2	208	437-3153
Melbourne, 32901	Stebbins Hardware Inc, 405A E New Haven Ave	321	723-6434	Weiser, 83672	Whitman Truss & Lumber Inc, 315 West 2nd	208	414-0206
• Melbourne, 32935	Atlantic Mowers, 4660 N Highway 1	321	259-0095	Illinois			
★ Merritt Island, 32953	All Tools, Inc, 22 Lura Lane	321	452-6501	• Addison, 60101	Hugos Equipment Repair Inc, 415 W Belden Ave, Unit R	630	628-7977
Miami, 33155	AAA Equipment & Service, 2721 SW 69th Court	305	261-6920	• Batavia, 60510	Romic Industrial, 847 E Wilson St	630	879-1051
Middleburg, 32068	A-1 Tool Repair, 1851 Blanding Blvd	904	282-3707	Bensenville, 60106	General Air Compressor, Inc, 1078 Fairway Dr	630	860-1717
Naples, 34104	Naples Electric Tool Repair, 3427 Exchange Avenue Unit D	941	352-6331	Berwyn, 60402	Jack's Inc, 6642 W 26th St	714	530-3325
• Naples, 34104	The Equipment Bookie, 3727 Prospect Ave	239	403-8300	Bloomington, 61701	Struck Tool & Supply Co, 1106 E Bell Street	309	827-4691
North Fort Myers, 33903	Presher's Servicenter, 1349 Old Pondella Rd	941	574-2540	Bridgeview, 60455	Schaaf Equipment, 8657 Beloit Ave	708	598-9099
★ Ocala, 34475	Tool Doctor, 1825 N Magnolia Ave	352	622-5655	Chicago, 60625	Waring Industrial Tool, 4524 N Lincoln Avenue	773	728-1100
★ Orange City, 32763	DeBary Mower & Repair Inc, 1104 Shadick Dr	386	775-7505	Chicago, 60641	Dependable Tool Service, 2857 N Cicero Avenue	773	777-3480
Orlando, 32857	E & M Hydraulic, 6636 Old Cheney Hwy	407	277-2299	Chicago, 60661	West Loop Tool Rental Inc, 775 W Jackson	312	474-1155
Panama City, 32405	Bay Bolt & Industrial Supplies, 2013 N East Ave	850	784-4442	Decatur, 62521	Decatur Custom Tool, Inc, 410 N Jasper St	217	423-3639
Pembroke Park, 33009	441 Tool Repair, 1975-A South Park Road	305	681-3289	• East Peoria, 61611	Central Tool & Equipment, 900 South Main Street	309	694-9100
Pensacola, 32505	Gober's L C Electric Motor Service, 117 Industrial Blvd	850	476-7655	Effingham, 62401	Hoelscher Sales & Service, 700 N Henrietta St	217	342-2821
Pompano Beach, 33060	A1A Small Engine Repair, 420 S Dixie Hwy East	954	946-5044	Elburn, 60119	Tri City Maintenance, 40 West 165 Fabyan Pkwy	630	377-1581
Port Charlotte, 33954	Tropical Const. Supply Inc, 18412 Paulson Dr	941	743-5863	★ Elgin, 60123	A-1 Repair, 45 S Maple Street	847	695-8899
• Riverview, 33569	A to Z Enterprises, Inc, 6412 US Hwy 301 South	813	677-1797	Elk Grove Village, 60007	Instrument Repair Svc Inc, 1541 Elmhurst Road	847	439-0141
Riviera Beach, 33404	Air Compressor Works, Inc, 1956 West 9th St	561	844-4559	Elmhurst, 61529	H & H Industrial Tool & Repair, 102 N Magnolia Street	309	742-8006
Royal Palm Bch, 33411	Total Tool Service, 460 Bus Parkway, Suite F	561	795-0505	★ Homer Glen, 60491	Superior Small Engine Repair, Inc, 15806 Annico Drive Unit 8	708	645-0127
Sanford, 32773	The Utter Guys, 10 Keyes Ct	407	834-2106	Kankakee, 60901	General Oil Equipment, 1285 N Schuyler Ave	815	933-1013
• Sarasota, 34232	Assoc. Air & Pump Service, Inc, 2001 Cattlemen Road, Unit A	941	377-4373	Lombard, 60148	Berlands House of Tools, 600 Oak Creek Dr	630	200-0026
★ Sarasota, 34243	Sunray Repair Center, 8371 N Tamiami Trail	941	358-9999	McCook, 60525	Recco Tool & Supply, 8805 Joliet Road	708	442-7850
• St Augustine, 32084	Ernie's Tools, 20 South Dixie Hwy	904	829-5712	McHenry, 60050	Novotny Sales, 5615 North Wilmot Rd	815	385-7675
St Cloud, 34769	Heritage Paint, 1410 10th Street	407	892-7700	New Lenox, 60451	Evergreen Tool & Equipment, 21964 Howell Rd	815	462-7787
Stuart, 34997	Action Mower, 3566 SE Dixie Hwy	772	286-2480	Niles, 60714	Household Appliance Sales & Service, 7411 N Milwaukee	847	647-8250
Stuart, 34997	Appliance Doctors, 3166 SE Dixie Hwy	561	287-6437	Palatine, 60074	Berlands House of Tools, 20254 N Rand Dr	847	540-9200
Tallahassee, 32301	Southside Mower, 1885 S Monroe Street	850	224-5613	Peoria, 61602	C & H Repair & Supply Co, 2313-15 SW Adams St	309	676-3333
Tampa, 33603	A A Casey Company, 5124 Nebraska Ave	813	234-8831	Rockford, 61109	Bob's Hardware Inc, 2710-20th Street	815	398-0111
Tampa, 33610	Florida Tool Wty, 4509 B Orient Rd	813	246-5375	Schaumburg, 60193	All Power Tool Inc, 921 Estes Ct	847	891-3375
Vero Beach, 32960	Hoppes Authorized Vacuum & Appliance, 1872 Commerce Ave	772	562-4466	• Springfield, 62702	James Machinery, 223 N Mac Arthur	217	522-9115
West Palm Beach, 33405	Dixie Power Equipment, 1401 Allendale Road/ Ste C	561	689-4468	Woodale, 60191	Industrial Tool Products, 919 N Central Ave	630	766-4040
West Palm Beach, 33411	Florida Lawn & Garden, 9005 Southern Blvd	561	793-6530	Indiana			
Georgia				Elkhart, 46516	Alco Tool Supply, 54847 County Rd 17	574	295-5535
Alpharetta, 30004	Contractor Sales Inc, 1290 McFarland 400 Drive	678	366-1197	★ Evansville, 47715	Bailey Tools & Supply Inc, 5716 E Morgan Ave	812	475-1618
Atlanta, 30318	Power Tool Service, 1939 Hills Avenue NW	404	605-0101	Fort Wayne, 46802	Wayne Vaughn Equipment, 716 E Wayne St	219	424-4044
Augusta, 30901	Tool Service Center, 302 Walton Way	706	724-4803	Fort Wayne, 46805	Wagner Electric, 3610 N Clinton St	219	484-5532
★ Brunswick, 31525	Emery Rental Service, 4402 Highway 17 North	912	265-2190	★ Fort Wayne, 46825	Mill Supplies Inc, 5105 Industrial Rd	260	484-8566
Bryon, 31008	A.T.I. Sales Company, Inc, 18 Valley Road	478	956-3860	• Granger, 46530	Granger Lawnmower Service, 51105 Birch Road	574	272-0325
Columbus, 31904	Phoenix Saw Works, 5101 14th Avenue	706	327-5671	Indianapolis, 46202	Eskew Enterprises, 1447 North Harding St	317	264-9028
Comelia, 30531	Lanier Air Products, 101 Camp Creek	706	778-3939	Indianapolis, 46203	Anderson Brothers Tool Repair, 3531 Southeastern Avenue	317	356-6381
Dalton, 30719	F&D Tool Service, 132A Richardson Drive	706	277-6100	Indianapolis, 46203	Almac Air Tools, Inc, 6011 East Hanna Ave, Ste B	317	786-1355
Decatur, 30035	Ready Rent-all, 4400 Snapfinger Woods Dr	770	987-5500	Indianapolis, 46221	Macco Equipment Company, 3129 Kentucky Avenue	317	248-1444
Dublin, 31021	Mosley & Mosley Ent Inc, 208 W Madison St	478	272-5454	Indianapolis, 46254	Fastool Service Center, 5851 Guion Rd Bldg B	317	280-2502
Loganville, 30052	Atlanta Nail & Tool, 4450 Tuck Rd	770	466-5676	Jasper, 47546	Fisher Home Appliance, 8297 N Porterville Rd	812	695-5241
• Marietta, 30060	Roper Laser Co, 1171 South Marietta Parkway	770	422-1717	Jasper, 47546	Industrial Tools Sales & Service, 712 W 6th St	812	482-7895
Marietta, 30067	Precision Tool Repair Inc, 1726B Hazel Wood Dr	770	560-6811	Lafayette, 47905	Lawrence Bowers Electric, 729 Navco Drive	765	446-7171
Norcross, 30093	Stovall Turf & Industrial, 4385 International Blvd	678	921-4044	• Martinsville, 46151	Spina's Motor Sports, 390 State Road 37 North	765	342-6335
Savannah, 31406	Maycrest Hardware, 1609 Montgomery Crossroads	912	354-2045	Middlebury, 46540	Compress Air Inc, 112 Industrial Pkwy East	219	825-2121
Savannah, 31408	Georgia Fastener, 3201 W Bay Street	912	966-8000	Muncie, 47305	Peter Austin Company, 900 West 1st Street	765	288-6397
Savannah, 31415	The Tool Box Inc, 439 A Telfair Rd	912	238-5512	New Haven, 46774	Schmucker Motor Repair, 11524 Doty Rd	219	705-4173
				Terre Haute, 47807	Pro Trade Tool & Supply, 1209 E Poplar St	812	235-8665

- Repairs Compressors & Generators
- ★ Repairs All DeWALT Products
- ◆ Repairs Lasers

SERVICE CENTERS

City/State/Zip	Name/Address	Area Code	Phone Number	City/State/Zip	Name/Address	Area Code	Phone Number
Iowa				Maryland (continued)			
Burlington, 52601	Industrial Electric Motors, 1511 Mt Pleasant St	319	752-4917	Ellicott City, 21042	FJ Giltay & Assoc, 9460 Frederick Rd	410	465-0339
Cedar Rapids, 52402	Campbell Supply Company, 2127 N Towne Lane NE	319	395-0991	Gaithersburg, 20877	Standard Supplies Inc, 4 Meem Ave	301	948-2690
• Cedar Rapids, 52404	The Tool Hospital, 830 33rd Avenue SW	319	366-0731	Gaithersburg, 20877	Waters Appliance Service, 216 East Diamond Ave	301	258-7500
• Cedar Rapids, 52405	Puckett Tools & Fasteners, 410 1st Avenue NW	319	363-2211	Germantown, 20874	N & S Rentals, 19600 Frederick Road	301	428-3200
Davenport, 52802	Alter & Sons Inc., 514 S Howell Street	563	323-3601	Hagerstown, 21742	Small Appliance Repair, 13146 Pennsylvania Avenue	301	733-0183
Davenport, 52802	Tool Hospital, 724 W 2nd Street	563	386-1533	Huntingtown, 20639	Calvert Auto, 3970 Old Town Rd	301	855-9636
Des Moines, 50309	Puckett Tools & Fasteners, 841 11th Street	515	244-4189	Prince Frederick, 20678	Jims Air Tools, 470 Solomons Island	301	855-6000
Des Moines, 50314	Tool Hospital, 1523 Second Avenue	515	282-3323	Silver Spring, 20901	ATMS Inc., 8907 Garland Ave	202	636-8670
• Dubuque, 52003	Roeder Outdoor power, 2580 Rockdale Road	563	556-2071	Tuxedo, 20781	Jim's Air Compressor Inc, 5815 Arbor St	301	322-9050
Iowa City, 52240	Tool Hospital, 2003 S Gilbert Street	319	339-4737	Upper Marlboro, 20772	Diamond Tool Company, 8051 Penn Randall Place	301	967-2844
• Iowa City, 52240	Contractors Tool & Supply, 1423 Waterfront Drive	319	338-1121	Westminster, 21157	Swain Portable Power Tool Rep, 1280 Landing Lane	410	751-6802
• Johnston, 50131	Bradley Tools & Fasteners, 6250 NW Beaver Drive	515	331-0878	Massachusetts			
Lemars, 51031	Nelson Electric & Equipment Inc, 1400 Prospect Street, SW	712	546-9292	• Billerica, 01862	B&G Small Engine Repair, 265A Boston Rd	978	667-0290
★ Marshalls town, 50158	Blink Electric Motors, Inc, 116 North 1st Avenue	641	752-3036	Brockton, 02301	Isam Mitchell, 362 Montello St	508	586-1271
Pella, 50219	Gritters Electric, 210 SE 14th Street	641	628-3816	Fall River, 02721	Burns, Inc, 350 Mariano S Bishop Blvd	508	675-0381
• Sheldon, 51201	Glenn's Sport Center, Inc, 208 16th Street, Hwy 60 South	712	324-4387	Gloucester, 01930	Camco Industries, 2 Eastern Ave	978	281-3660
Sioux City, 51101	The Tool Doktor, 1510 Dace	712	293-0274	Holyoke, 01040	Reliance Electric Service, 573 S Canal Street	413	353-3557
• Waterloo, 50701	United Rentals #431, 3565 University Ave	319	234-5796	Hyannis, 02601	Northeast Tool Supply, 157 E Thornton Drive	508	778-4552
Waterloo, 50702	Campbell Supply Company, 911 Commercial St	319	234-6613	Lawrence, 01843	United Compressor & Pump Service, 34 Portland St	978	685-0808
Kansas				• Plymouth, 02360	C T Repair, 5 Robert Jay Way, Carmelot Park	508	976-2219
Coffeyville, 67337	Thompson Bros Supplies, 2319 W 8th	620	251-1740	Somerville, 02145	Robi Tool Sales, Inc, 168 Broadway	617	776-1234
• Dodge City, 67801	Southwind Supply, 309 N 14th Street	620	225-4384	• Springfield, 01105	Saw Center Inc, 472 Main Street	413	734-2045
Edwardsville, 66111	Fast Tool Service Center, 9911 Woodend Rd	913	422-8221	Stoughton, 02072	Kalman Electric Motors, 471 Page Street	781	341-4900
Emporia, 66801	Mid-America Electric, 315 Mechanic	620	342-2965	Michigan			
Garden City, 67846	NAAB Electric, 2013 West Jones St	620	276-8101	• Allegan, 49010	Joels Lawn & Garden, 1141 26th Street	269	673-8736
★ Lawrence, 66044	Fleetwood Mower & Rental, 710 West 6th Street	785	841-3112	Almont, 48003	Almont Do It Center, 4545 Van Dyke	810	798-3540
Salina, 67401	Mid-Kansas Tool Works, 314 W Cloud	785	825-6287	Alpena, 49707	ABC Ace Hardware, 1201 North Bagley	989	358-7378
Topeka, 66603	Salisbury Supply, 114 S E Quincy Street	785	233-7411	Ann Arbor, 48104	McCall Tool Supply, 2445 South Industrial Trail	734	747-8332
Topeka, 66608	White Star Machine, 121 N E Gordon	785	232-7731	Brighton, 48114	R & A tool Repair, 7777 Collingwood Dr	810	229-7495
Kentucky				Byron Center, 49315	Baker Fastening System, 870 74th Street Southwest	616	878-7105
• Elizabethtown, 42701	Hall's Supply & Tool Repair, 215 S Main Street	270	769-6698	Clarkston, 48346	Michigan Rental & Sales, 4906 White Lake Rd	248	625-1515
• Florence, 41042	B & W Supply, 6702 Dixie Highway	859	525-8715	Croswell, 48422	Moore & Carter Lumber Co, 5220 E Peck St	810	679-3494
Lexington, 40505	Kwik Set Fasteners, 1151 Commercial Drive	859	252-7518	Detroit, 48234	Electric Tool Service, 19442 Conant Ave	313	366-3830
Lexington, 40509	United Rentals Inc, 2150 Trade Center Dr	859	233-2163	Escanaba, 49829	Total Tool & Equipment, 200 N 12th Street	906	786-7242
Lexington, 40509	Jiffy Tool Repair/ Bluegrass tool, 1175 Brock McVey Drive	859	252-1849	Femdale, 48220	Detroit Air & Electric Tool Service, 3275 Hilton Road	248	548-2260
Lexington, 40511	City Electric Motor Co, 631 Kennedy Road	859	254-5581	• Haslett, 48840	Contractor Repair, 13612 Woodbury Rd	517	339-5709
Louisville, 40213	Smileys Air Tool Inc, 4552 Poplar Level Rd	502	966-3433	Holland, 49424	Holland Electric Motor & Supply, 11598 E Lakewood Blvd	616	392-1115
Owensboro, 42303	Electrical Equipment Repair, 1330 E 2nd Street	270	684-5357	• Hudsonville, 49426	Sawyer Engine & Repair, 4090 Chicago Drive	616	669-6040
Paducah, 42002	Warden Electric Co, 604 N 7th Street	270	443-4622	Kalamazoo, 49001	Kalamazoo Electric Motor, 658 E Vine Street	269	345-7802
Louisiana				Kalamazoo, 49009	General Rental, 6831 West Main St	269	375-8600
• Baton Rouge, 70814	Southern Fastener & Tool Co, 9440 Mammoth Drive	225	927-3333	Kingsford, 49802	IDG - Kingsford, 1021 Pyle Drive	906	774-3991
Broussard, 70518	Shannon Hardware, 101 Nolan Road	337	837-3131	Lansing, 48910	Denstaedt's Service Center, 3715 S Cedar Street	517	882-6211
Eunice, 70535	G & C Electric, 335 E Laurel	337	457-1300	Lansing, 48912	Rapid ApplianceService Inc, 1606 E Michigan Ave	517	485-1320
Geismar, 70734	Braud & Company, 9436 Highway 75	225	673-2012	Livonia, 48150	Daves Compressor Repair, 9980 Seltzer	734	525-5173
Harvey, 70058	Industrial Welding Supply, 1452 Fourth Street	504	362-9395	Livonia, 48152	Marsh Power Tools, 20579 Middlebelt Rd	248	476-7744
Houma, 70364	Roberts Repair, 4919 Highway 182	985	872-0896	★ Midland, 48640	Mid-Michigan Repair, 680 Poseyville Road	989	835-6014
Kenner, 70062	Automatic Fasteners, 101 27th St	504	466-4960	Petoskey, 49770	Ed's Electrical, 3916 Charlevoix Road	231	347-9599
Lafayette, 70503	Builders Tools & Fasteners, 4947 Johnston St	337	981-8759	Redford, 48239	Aircentric Corp, 12250 Inkerster Rd	313	937-2131
Lawtell, 70550	Thibodeaux Electric, 10107 Prejean Hwy	337	543-2382	Riverside, 49084	Riverside Electric Service, 3864 Riverside Road	269	849-1222
Metairie, 70002	R J Marchand Contractors, 3515 Division St	504	888-2922	Rockford, 49341	Air Supply Company, 7459 9 Mile Rd	616	874-7751
New Iberia, 70560	Voorhies Supply, 401 W St Peter	337	364-2431	Shelby Twp, 48316	Robinsons Saw Service, 52221 Van Dyke	810	731-7175
New Iberia, 70562	Templeton N Templeton, Hwy 90 & Curtis Lane	318	364-5747	Vicksburg, 49097	Michigan Tool Repair, 4796 East TU Ave	269	649-3455
New Orleans, 70125	Beerman Precision, 4206 Howard Avenue	504	486-9391	Minnesota			
Scott, 70583	Hi TECH Tools & Fasteners, Inc, 204 West Saul Dr	337	232-3795	Bloomington, 55420	Bloomington Rental, 9349 Bryand Ave South	953	881-5144
• Shreveport, 71101	McClamroch Machine, 939 Louisiana Avenue	318	222-9249	Burnsville, 55337	Thomas Tool & Supply, 3401 W Highway 13	952	895-5613
Sulphur, 70663	Joels Electric Power Tools, 808 E Carlton Street	337	527-3020	Crystal, 55429	Thomas Tool & Supply, 4901 West Broadway	763	533-2499
West Monroe, 71291	Tool Town, 504 North 7th Street	318	329-2929	Mankato, 56001	Northern States dba:Kato Tool Division, 212 Madison Avenue	507	388-4060
Maine				Maple Grove, 55369	G T Tool, 11071 93rd Ave North	763	424-4019
Augusta, 04330	Poulin's Electric Motors, 195 Church Hill Rd	207	622-1689	• Minneapolis, 55406	Honda Town, 4215 E Lake Street	612	722-1110
Bangor, 04401	John's Electric Motor Service, 499 Hammond St	207	947-7771	• Rochester, 55901	Thomas Tool & Supply, 945 37th Ave NW	507	281-3786
Bangor, 04402	N H Bragg, 92 Perry Rd	207	947-8611	Roseville, 55113	United Rentals, 1380 County Road C West	651	633-8171
Houlton, 04730	Hogan Tire, 135 Bangor St	207	532-2211	• St Cloud, 56302	Thomas Tool & Supply, 1201 Lincoln Avenue	320	253-4526
Old Orchard Beach, 04064	East Coast Tool Service, 17 Mc Arthur Ave	207	934-5216	St Cloud, 56303	Mathew Hall Lumber Company, 127 6th Avenue North	320	252-1920
Westbrook, 04092	Maine Tool Service & Supply, 422 Brook St	207	874-2420	• St Paul, 55104	Total Tool Repair, 315 N Pierce Street	651	646-4055
Maryland				Waite Park, 56387	Northern States Supply, 903 2nd Street S	320	253-3340
Aberdeen, 21001	Aberdeen Outdoor Power Equip, 1514A Philadelphia Blvd	410	272-2990	Willmar, 56201	Northern States Supply, 600 Industrial Drive	320	235-0555
• Arbutus, 21229	WTS Inc, 4000 Coolidge Ave, Suite C	443	543-0100	Willmar, 56201	Thomas Tool & Supply, 2987 W Highway 12	320	231-1009
Baltimore, 21214	Howard Lynch Associates, 6077 Hartford Road	410	426-7783	Winona, 55987	Fast Tool, 4730 N Service Drive	507	454-5374
Baltimore, 21224	Air Compressor SVC, 2510-A Bruening Hwy	410	633-0900	Winona, 55987	Lackore Electric Motor, 108 W 2nd Street	507	452-3103
Baltimore, 21237	Brock Tool & Supply, 1200 66th Street	410	483-4300	Mississippi			
Berlin, 21811	Myers Properties, Inc, 10714 Oceangate Way	410	641-3497	Gulfport, 39503	Beerman Precision, 10031 Lorraine Road	228	896-1146
• Burtonsville, 20866	Pat's Lawnmower, 15408 Old Columbia	301	421-1288	Hattiesburg, 39401	Mitchell Tool Sales & Service, 1000 Broadway drive	601	582-3308
• Cumberland, 21501	American Rent All, 219 North Mechanic Street	301	777-5000	Jackson, 39201	Flannigan Electric Co, 1820 So West Street	601	354-2756
Cumberland, 21502	Allegany Motor & Pump, 150 Wineow St	301	777-0340	★ Jackson, 39203	May & Co, 838 West Capital Street	601	354-5781
• Easton, 21601	Bayco Inc, 29448 Dover Rd	410	822-7722	Natchez, 39120	Home Hardware Center, 187 Sgt Prentiss Drive	601	445-5352
				Ocean Springs, 39564	Power Tool Source, 6820 Washington Avenue	228	872-8511
				• Pearl, 39208	Louie's Small Engine Repair, 5003 Hwy 80 E	601	939-1152
				Ridgeland, 39157	Appliance Parts Warehouse, 626 Ridgewood Rd	601	605-6386

- Repairs Compressors & Generators
- ★ Repairs All DeWALT Products
- Repairs Lasers

1-800-4 DEWALT

www.DEWALT.com

SERVICE CENTERS

City/State/Zip	Name/Address	Area Code	Phone Number	City/State/Zip	Name/Address	Area Code	Phone Number
Missouri							
Columbia, 65202	Automatic Tool & Fastener, 1809 Santa Fe Place	573	886-9777	Alamogordo, 88310	The Tool Store, Inc, 2419 D N White Sands Blvd	505	437-3131
Independence, 64055	CAS Equipment, 1026-b West 23rd St	816	254-2470	Albuquerque, 87107	Martin Saw & Tool, 3310 Stanford Drive NE	505	888-1675
Jefferson City, 65109	J C Industrial Supply, 706 Virginia Street	573	636-4171	Albuquerque, 87112	Aragons Lawn & Wood, 9402 Indian School Rd	505	299-0222
Joplin, 64804	Electric Motor Supply, 2301 W 20th	417	623-4544	Clovis, 88101	M & M Motor Repair, 213 Georgia	505	763-3088
Joplin, 64804	AI's Tool Repair, 1623 South Main Street	417	781-5030	• Farmington, 87401	Franks Supply, 2655 E Bloomfield Hwy	505	327-9831
Kansas City, 64108	Heath Sales & Service, 518 East 16th St	816	421-3330	★ Gallup, 87301	Wilson Rental & Repair, 600 E Highway 66	505	722-7886
Kansas City, 64129	Darco Equipment, 6519 Stadium Dr	816	924-1245	Las Cruces, 88001	Aire-Hydraulics, 900 South Solano	505	523-5636
Moscow Mills, 63362	JC Inc, 1300 Blackburn Court	636	366-9859	Raton, 87740	Records Rental & Shop, 1222 South Second	505	445-5688
• O'Fallon, 63366	Custom Pump Repair, 1277 West Terra Lane	636	978-8942	Roswell, 88201	Airgas Southwest, Inc, 1103 E Second St	505	622-1950
Saint Charles, 63301	Tool Service Center, 2431 Raymond Dr	636	940-2525	New York			
Springfield, 65802	The Tool Hospital, 423 N Belcrest	417	831-0954	Amherst, 14226	Philipps Bros Supply, 2525 Kensington Avenue	716	839-4800
Springfield, 65806	H K & W Supply, 610 W Chestnut Street	417	869-4527	Binghamton, 13901	Gleason Electric Motor Service, 330 Water Street	607	722-3312
W Plains, 65775	Johns Air Comp Sales & Service, 3634 County Rd 6300	417	256-5362	Binghamton, 13904	Hulbert Electrical Inc, 78 Travis Avenue	607	724-3968
Montana							
Billings, 59101	Tom's Service & Repair, 1111 6th Ave North	406	259-6179	• Bohemia, 11716	Dynamite Tool Company, 1551 Smithtown Avenue	631	563-8181
Billings, 59102	Teds Electric Service, 102 11th Street West	406	259-6418	Bronx, 10457	Kass Industrial Supply, 1715 Washington Ave	718	299-6060
• Black Eagle, 59414	Mosch Electric Motors, 2513 17th St NE	406	453-2481	• Brooklyn, 11204	J & A Repair Shop, 6206 20th Avenue	718	232-5746
Bozeman, 59715	Owenhouse Ace Hardware, 36 E Main	406	587-5401	★ Brooklyn, 11208	White Tool Supply Inc, 3047-51 Atlantic Avenue	718	277-8844
• Great Falls, 59404	Big Sky Power Equipment, 1301 3rd Street NW	406	761-6688	• Brooklyn, 11235	The Tool House Inc, 3000 Coney Island Avenue	718	743-6336
Kalispell, 59901	Toole Tyme Repair, 2593 Us Highway 2 East	406	756-0758	• Chadwicks, 13319	Mohawk LTD, One Newell Lane	800	225-6642
• Kalispell, 59901	Terrys Small Engine Repair, 217 E Evergreen Dr	406	752-1016	Cheektowaga, 14225	Air Tool Repair, 160 Holtz Drive	716	631-9010
Missoula, 59801	Hellgate Tool Repair, 2006 North Avenue West	406	549-3067	Cooperstown, 13326	Bruce Hall Corp, 206 Main Street	607	547-9961
★ Whitefish, 59937	Northwest Tool Repair, 1000 Baker Ave	406	862-6275	Corfu, 14036	Bailey Electric, 644 Main Road	585	599-6487
Nebraska							
Columbus, 68601	Tool Shed Of Columbus, 3121 13th Street	402	562-7606	• Eldred, 12732	Eldred Power & Auto, 550 Route 55	845	557-6168
Grand Island, 68803	Centaur Enterprises Inc, 214 N Arthur St	308	384-8087	• Fort Edeard, 12828	Wallace Supply Co, Inc, 1434 Route 9	518	793-5131
Grand Island, 68803	Construction Rental, 3505 W Old Potash Rd	308	384-9077	Garden City Park, 11040	Eastern Industrial Equipment, 2231 Jericho Turnpike	516	741-3198
Hastings, 68901	Hattens Electric Service, 130 S Hastings	402	463-4596	• Huntington Station, 11746	A & T Power Tools, 515 E Jericho Turnpike	631	271-2141
Kearney, 68847	Tool Doctor, 607 Avenue D	308	237-0802	Ithaca, 14850	Seneca Supply & Equipment, 7 Hall Rd	607	347-4455
Lincoln, 68508	The Tool House Inc, 800 Q Street	402	476-6673	★ Jamestown, 14701	Blose Tool Repair, 1487 Fote Avenue	716	487-1922
Lincoln, 68521	Tool Hospital, 1720 Adams Street	402	435-2996	Kings Park, 11754	The Warranty Center, 16 Church St	631	269-5054
Omaha, 68127	Tool Hospital, 9447 J Street	800	591-3388	Long Island City, 11101	Extech Industries, 43-87 Vernon Blvd	718	786-2288
Omaha, 68127	Flohr Electric & Gas Svc, 4356 S 90th St	402	331-6863	• Long Island City, 11101	Allied Building Products, 42-16 11 st	718	231-2220
Nevada							
Las Vegas, 89101	Carlson El Motor Service, 709 N Main St	702	384-8246	• Lynbrook, 11563	Merit Power Equipment Inc, 137 Lakeview Avenue	516	593-6116
★ Las Vegas, 89109	Tool Service, 3239 Industrial Road	702	734-9161	Monsey, 10952	On Time Supply, 20-E Robert Pitt Dr	845	352-8600
• Sparks, 89431	Industrial Equipment Repair, 310 Kresge Lane	775	331-1032	Montgomery, 12549	Air Power House Inc., 116 Neelytown Rd	854	457-3113
Sparks, 89431	Nevada Air & Industrial, 1001 Greg St	775	355-1600	New York, 10019	T P Rental Services Inc, 417 W 50th Street	212	713-1999
Sparks, 89434	White Cap Tool Repair, 1830 East Lincoln Way	775	353-3333	New York, 10021	Lexington Hardware & Electric, 797 Lexington Ave	212	838-5386
New Hampshire				★ Newburgh, 12550	Precision Propeller Repair, 135 S William Street	845	562-3880
Amherst, 03031	Power Tool & Fastener, 65 Rt 101A	603	673-2724	North Syracuse, 13212	Northeast Compressor Division, 7340 Thompson Rd	315	458-4115
Belmont, 03220	Contractor & Municipal, 170 Daniel Webster Hwy	603	524-2308	Olean, 14760	D & D Distributing Co, 2440 Constitution Avenue	716	373-2316
Brentwood, 03833	Brentwood Machine, Bldg 313 route 125	603	679-8452	• Ontario, 14519	Altra Rental & Supply, 2127 Route 104	315	524-9649
★ Exeter, 03833	Minuteman Tool Repair, 96 Epping Road	603	778-7776	Patchoque, 11772	Loper Equipment & Tool, 129 Medford Ave	631	475-2044
Hooksett, 03106	Air Service Of NH, 65 Londonderry Turnpike	603	668-7900	Port Chester, 10573	Empire Tools, LLC, 21 Abenroth Ave	914	937-1771
Manchester, 03103	ADM Tool Service Co Inc, 91 Maple Street	603	623-8724	Poughkeepsie, 12601	S & S Vacuum Cleaner, 420 Violet Avenue	845	452-6122
Nashua, 03060	Able Air Equip & Service, 50 Bridge St	603	424-6115	• Poughkeepsie, 12603	Dutchess Recreational Vehicles, 737 Freedom Plains Rd	845	454-2810
• Newport, 03773	New England Laser & Equip, 8 Reeds Mill Rd	603	863-1000	Rhinebeck, 12572	Williams Lumber, 6760 Route 9 North	845	876-9663
New Jersey				Rochester, 14617	R W Lindsay, Inc, 581 Rock Beach Rd	845	544-7310
Bellmawr, 08031	Tool Doctor Enterprise, 315 3rd Ave	856	933-1194	• Schenectady, 12305	Stewart Electric, 412 Broadway	518	393-5837
Branchville, 07826	Montage Tool & Supply Co, 42 Broad St	973	948-6400	• Southampton, 11968	One Source Tool, 341 County Road 39A Suite 1	631	283-8700
Brick, 08723	5 Star Sharpening, 198 Chambers Bridge Rd	732	920-2022	• Spencertown, 12165	Air Compressor Plus, 214 Reed St	518	392-4080
Clifton, 07011	The Tool Box, 119 Lakeview Ave	973	340-7652	• Staten Island, 10306	Tool Depot Div of A.H. Harris & Sons, 2041 Hylan Blvd	718	980-2400
East Orange, 07019	Von Rohr Equipment, 2 New Main Street	973	748-9111	Staten Island, 10309	H & E Tool Rental Corp, 6451 Amboy Road	718	948-0505
Fairfield, 07004	Raw Power Tool Repair, 66 Clinton Rd	973	244-1014	Tappan, 10983	Numax, 117 Route 303	914	365-2400
Fairlawn, 07410	American Nursery, 5-16 Saddle River Rd	201	794-0550	• Utica, 13502	McQuade & Bannigan, 1300 Stark Street	315	724-7119
Goucester City, 08030	Industrial Service & Supply, 502 South Broadway	856	456-0336	W Islip, 11795	Sunrise Tool Service, 124 Sunrise Hwy	631	661-5548
Kenilworth, 07033	Air Center Inc, 270 Monroe Ave	908	276-1992	Wantagh, 11793	Ace Tool Repair, 2201 Wantagh Ave	613	783-8899
• Keyport, 07735	Semcor Equipment Co, 18 Madison Street	732	264-6080	• Wappinger Falls, 12590	The B C Electric & Air, 885 Rt 376	845	227-8289
Lebanon, 08833	Hunterdon Mill & Machine Supplies, 289 Rte 22 East	908	534-2221	• Watertown, 13601	McQuade & Bannigan, 22696 Murrock Circle	315	788-2612
• Long Branch, 07740	Cougar Electronics, 622 Broadway	732	870-3302	West Islip, 11795	R & D Mover, 1632 Empier Blvd	716	671-9409
Midland Park, 07432	Godwin Tool, 189 Greenwood Avenue	201	445-4431	North Carolina			
Morrisstown, 07960	Cedar Knolls Outdoor Power, 26 Emmett Ave	973	292-3430	Asheville, 28801	B & K Tools & Supply, Inc, 268 Biltmore Avenue	828	254-5763
Neptune, 07753	Power Tool Co, 609 Memorial Drive	732	776-8282	Burlington, 27215	Payne's Tool & Supply Inc, 3325 S Church Street	336	227-1031
• Newark, 07105	D & R Industrial Saw Co, 306 Ferry Street	973	589-0077	Charlotte, 28209	Pattons Inc, 3201 South Blvd	704	523-4122
Northfield, 08225	Richards Sharpening, 824 Mill Rd	609	641-9481	Conover, 28613	Air Systems & Equip Co, 1550 Deborah Herman Rd	828	328-2256
Oaklyn, 08107	Liberty Power Tool Repair, LLC, 101-D Newton Ave	856	854-4384	Elizabeth City, 27909	Miles Jennings Inc, 1111 Halstead Blvd	252	335-0861
• Pennington, 08534	Auxiliary Svc & Hdwe Supply, 1590 Reed Rd	609	737-0986	Fayetteville, 28301	Hurst Annao Supply Co, 133 Grove Street	910	483-7104
Pleasantville, 08232	Shore Fasteners, 500 N Main St	609	646-6245	Franklin, 28734	The Tool Zone, 583 Depot Street	828	369-2520
Rockaway, 07866	Power Place, Inc, 344 Rte 46	973	627-8005	Greensboro, 27407	Lewis Systems, 3702 Boren Dr	336	299-0564
Saddle Brook, 07663	Riverdale/Hillside Tool, 280 Midland Avenue	201	791-6112	Hickory, 28602	Power Tool & Electric Equipment, 442 Highland Ave SE	828	327-8400
• Seaville, 08230	Advantage Rental & Sales, 100 Rte 50	609	390-2345	Hildebran, 28637	T & E Repairs, 374 I-40 Access Rd Southeast	828	397-6222
Trenton, 08619	Sinclair Industrial Supply, 93 Second Avenue	609	586-3300	Kinston, 28501	A & L Rental & Repair Inc, 1505 Greenville Hwy	252	523-8848
Trenton, 08619	Creston Inc, 109 Flock Rd	609	587-3334	• Manteo, 27954	Ace Rental & Repair, 308 N Hwy 64	252	475-3535
Union, 07083	Force Machinery Company, 2271 Route 22	908	688-8270	• Raleigh, 27603	Chris Supply Company, 1640 South Saunders St	919	833-4499
Vineland, 08360	Swanson Hardware, 533 North East Avenue	856	692-1950	Wilmington, 28403	American Tool & Tractor, Inc, 1950 Dawson St	910	251-0259
Vineland, 08360	Rental Country, 1044 West Landis Ave	856	692-7510	Wilmington, 28403	Honest Injun Equipment, 939 S Kerr Ave	910	791-9340
Vineland, 08360	La Torre Hardware, 1607 S Delsea Drive	856	691-9468	Winston Salem, 27105	Fastenal Company, 301 Perimeter Point Blvd	336	767-1176
				• Winston Salem, 27106	Piedmont Power Machine, 4994-C Indiana Ave	336	759-2022

- Repairs Compressors & Generators
- ★ Repairs All DeWALT Products
- ◆ Repairs Lasers

SERVICE CENTERS

City/State/Zip	Name/Address	Area Code	Phone Number	City/State/Zip	Name/Address	Area Code	Phone Number
North Dakota				Oregon (continued)			
• Bismarck, 58504	Acme Electric Motor Co., 1009 Basin Ave	701	258-1267	Mercer, 16137	Suhrie Industrial Supply, 627 Wilson Ave	724	662-1279
• Dickinson, 58601	Fix-It Shop, 316 21st Street East	701	225-0766	Moscow, 18444	Bill's Ace Hdwe, RD #6 Route 502	570	842-7645
Fargo, 58102	Northern States Supply, 1226 38th Street North	701	282-2088	Mountain Top, 18707	A & R Building Supply, 201 Church Road	570	474-6561
• Fargo, 58103	Acme Electric Motor Co, 920 36th Street SW	701	476-4620	• Myerstown, 17067	Keystone Air Power LLC, 1234 S College St	717	866-9224
• Grand Forks, 58203	Acme Electric Motor Co, 1705 13th Avenue North	701	746-6481	Newburg, 17240	Blue Mt Small Engine, 1490 S Square Hollow	717	423-5358
• Minot, 58701	Acme Electric, 700 20th Avenue SE	701	839-2263	Philadelphia, 19127	Regent Hydraulics, 4051 Cresson St	215	482-2050
West Fargo, 58076	Max Air, 1805 East Main Ave	701	282-2190	Pittsburgh, 15201	Kruman Equipment, 3000 Penn Ave	412	261-4847
Ohio				Port Royal, 17082	Doms Air Tool Repair, RD 1 Box 98	717	527-4877
Archbold, 43502	Wholesale Welding & Const, 700 E Lugbill Rd	419	445-2045	Reading, 19604	Electric Repair Co, 502 N Ninth Street	610	376-5444
• Beaver Creek, 45434	Authorized Tool Service, 2210 Heller Drive	937	429-5593	Roaring Spring, 16673	Central Hydraulics, Route 164 East	814	224-2535
• Cleveland, 44114	Kay Dee Air & Electric, 5466 Lake Court	216	881-2565	Roslyn, 19001	Thompkins Electric, 1081 Easton Road	215	884-3576
• Coldwater, 45828	Lefeld Welding Supplies & Rental, 600 North Second Street	419	678-2397	Saint Marys, 15857	Burkes Home Center, 1077 Million Dollar Hwy	814	781-1519
Freemont, 43420	Contractors Equip Rental, 201 S Stone St	419	334-3505	Scranton, 18505	Scranton Grinder & Hardware, 1020 Hemlock St	570	344-2520
Galion, 44833	Allied Electrical Repair, 1404 Harding Way E	419	468-4962	Shippensburg, 17254	Charles Tool & Supply, Inc, 18783 Paint Blvd	814	228-9420
★ Hartsville, 44632	Hartville Hardware, Inc, 940 W Maple Street	330	877-3631	Shippensburg, 17257	Martin's Electric Sales & Service, 573 Britton Road	717	530-8450
Holland, 43528	Power Tool Sales & Service, 6713 Angola Rd	419	868-8665	Slatington, 18080	Donward Electric, 450 West Church St	610	767-8148
• Lancaster, 43130	P & L, 1306 Collins Rd	740	687-4996	Stevens, 17578	Eagle Rental Center, 1327 N Reading Rd	717	336-3007
★ Leipsic, 45856	Village Hardware & Commercial Supply, 855 West Main Street	419	943-2501	• Stockertown, 18083	People's Building Supply Co, 201 E Center St	610	759-3710
Lima, 45801	The Lima Armature Works, 142 E Pearl Street	419	222-4010	Stroudsburg, 18360	Stroudsburg Electric Motor Service, 756 Phillips Street	570	421-8909
Marietta, 45750	American Producers Supply Co Inc, 119 2nd St	740	373-5050	Wilkers-Barre, 18702	Team Supply Inc, 1548 Hwy 315	800	924-8326
Minster, 45865	Western Ohio Hardware, 04405 State Route 66	419	628-3804	York, 17402	General Tool & Repair Inc, 2449 S Queen St	717	741-9592
• Mt. Vernon, 43050	Wiford Rental & Sales, 9105 Columbus Road	740	397-7368	Rhode Island			
North Canton, 44720	North Canton Repair Shop, 1555 N Main Street	330	499-3529	North Kingstown, 02852	Quaker Lane Tool Inc, 3520 Quaker Lane	401	294-9084
Oakwood Village, 44146	Knight Ergonomics & Assm Systems, 7690 First Place Suite D	440	439-3000	Warwick, 02888	Dajo Sales Company, 66 Illinois Ave	401	732-4940
Pemberville, 43450	Pemtronics Inc, 222 E Front	419	287-4428	South Carolina			
Salem, 44460	Ohio Tool Systems, 789 S Ellsworth Ave	330	337-3388	• Bluffton, 29910	Anchor Hardware Inc, # 9 Kitties Landing	843	815-9264
Sandusky, 44870	Sandusky Electric Inc, 1516 Milan Road	419	625-4915	Charleston, 29405	Tri County Tool Repair Inc, 1900 Doscher Ave	843	554-9005
Sandusky, 44870	Universal Equipment, 210 W Perkins Ave	419	625-2914	Columbia, 29201	Richland Industrial, 919 Catawba Street	803	252-3360
Staubenville, 43952	General Rental, Inc, 1606 Sunset Blvd	740	282-9588	Columbia, 29201	The MacMaster Co, Inc, 1047 Berea Rd	803	252-0799
★ Strongsville, 44149	Mek-Elek Company, 19097 Drake Road	440	238-1919	• Conway, 29526	Shell Small Engines Inc, 523 Highway 66	843	365-5042
Toledo, 43612	J & G Sales, 324 W Laskey Rd	419	476-7771	★ Conway, 29526	Conway Electric Motor Service, 402 Lewis Street	843	248-5302
Van Wert, 45891	Lees Ace Hardware, 674 W Erwin Rd	419	238-1546	• Florence, 29501	Florence Electric & Rewinding, Inc, 209 DeJongh Street	843	669-6654
Vandalia, 45377	Vandalia Rental, 950 Engle Rd	937	898-5061	Greenville, 29611	Carolina Rental, 707 S Washington Ave	864	269-8140
Wellington, 44090	Lemke Sales Company, 22672 Pitts Rd	440	647-2293	Mt Pleasant, 29464	Royal Ace Hardware, 883 Ben Sawyer Blvd	843	884-2551
West Carrollton, 45449	Mats Equipment Co Inc, 51 Pierce Ave	937	859-8057	• Myrtle Beach, 29577	Coastal Electric & Rewinding, 928 Ocoola Street	843	448-3586
• Willoughby, 44094	The Tool Shop, 38130 Airport Pkwy Unit 4	440	946-9950	• Seneca, 29672	Western Auto, 1293 Blue Ridge Blvd	864	882-5848
• Youngstown, 44507	O'Connors, 3230 Market Street	330	782-4705	• Summerville, 29483	BACS, Inc., 2153 N Main Street	843	821-3487
• Youngstown, 44512	Penn Tool Sales & Service, 625 Bev Road	330	758-0845	South Dakota			
• Youngstown, 44515	Power Tool & Supply Co Inc, 3699 LeHarp's Road	330	792-1487	Rapid City, 57701	Newkirk's Ace Hardware Inc, 320 West Blvd	605	342-4840
Oklahoma				Rapid City, 57701	United Building Centers, 666 Howard Street	605	343-1115
Altus, 73521	Kay Electric, 1101 W Broadway	580	482-1757	• Rapid City, 57702	Stan Houston Equipment Company, 1210 Deadwood Avenue	605	348-1155
Enid, 73701	Enid Electric Motor, 1406 N 4th Street	580	234-8622	Sioux Falls, 57104	Northern States Supply, 520 Benson Road	605	334-5695
• Oklahoma City, 73106	Whitton Supply, 1419 West Reno	405	236-5561	• Sioux Falls, 57106	Stan Houston, 501 S Marion Road	605	336-3727
Oklahoma City, 73109	Steves Wholesale Dist, 2423 S Walker	405	631-0352	Tennessee			
• Oklahoma City, 73127	Spectra Laser Products, Inc, 100 N Rockwell Ave., Bldg 96	405	495-8523	Athens, 37303	Electric Motor Service, 700 Decatur Pike	423	745-4182
Oklahoma City, 73129	Air Compressor Supply, 3916 South I 35 Service Rd	405	672-0382	Chattanooga, 37404	Dixie Industrial Service, 2108 East Main Street	423	698-8063
Oklahoma City, 73149	Mid-State Ind Supply Inc, 8320 S. Sheilds	405	632-1434	Chattanooga, 37407	The Walter A Wood Supply, 4509 Rossville Blvd	423	867-1033
Stillwater, 74074	Ewing Electric Motor, 1023 S Perkins Road	405	372-2078	Jackson, 38301	Smith Tool Service, 908 S Highland Ave	731	427-4012
Woodward, 73802	Kay Electric Motors, 810 48th Street	580	256-3254	Memphis, 38111	Appliance Service Center, 3560 Park Avenue	901	324-5898
Oregon				Memphis, 38112	Gordon Air Compressor Equip Co, Inc, 706 Scott St	901	327-1327
• Eugene, 97402	Jim's Tool Service, 515 Wilson Street	541	344-1243	Memphis, 38112	Power Equipment, 3050 Broad Avenue	901	327-8261
Klamath Falls, 97601	Quality Tool Repair, 836 Richmond	541	883-5870	Nashville, 37210	Reeves Power Tool Repair, 180 Lafayette Street	615	256-8817
• Medford, 97501	Precision Power Tool Repair, 2941 N Pacific Highway	541	770-5541	• Nashville, 37211	L & S Unlimited, 2308 Cruzen St	615	248-5006
Portland, 37214	Portland Compressor, 310 SE 12th Ave	503	235-0200	Texas			
• Redmond, 97756	Trade-N-Tools, 2392 South Hwy 97	541	548-0510	Abilene, 79605	Professional Hardware, 2442 Industrial Blvd	915	692-5881
Troutdale, 97060	Pacific Sales, 935 NW Corporate Dr	503	674-2744	Amarillo, 79102	Reids Appliance Service, 906 S Georgia	806	373-8812
Tualatin, 97062	Northwest Spray and Compressor, 19390 SW Mohave Ct	503	692-7266	Amarillo, 79107	Tascosa Tool Service, 306 N Fillmore	806	373-3434
Pennsylvania				• Austin, 78735	Earl's Repair Center, 7900 West Hwy 71	512	288-1334
Abington, 19001	Repair Unlimited Inc, 1730 Rockwell Rd	215	657-3335	• Baytown, 77520	C & M Equipment, 508 Cedar Bayou Rd	281	428-7045
• Allentown, 18104	Action Rentals, 4535 Broadway	610	395-3500	Beaumont, 77701	Newton Tool & Hardware, 620 Martin Luther King Pkwy	409	835-3979
Allentown, 18109	Eastern Rental & Equip, 1520 E Penn St	610	435-4769	Beaumont, 77720	Lone Star Air Compressor, 1680 Spindle Top Rd	409	832-4600
• Beaver Falls, 15010	D & G Rent-Alls, 2551 17th Ave	724	843-5500	Brownsville, 78520	Imperial Electric Motor Service, 905 E Tyler Street	956	546-4523
Bechtelsville, 19505	Passmore, 1108 Route 100	610	367-9087	Carrollton, 75006	Waggoner Air Compressor, 1510 Randolph # 501	972	242-1463
• Bellefonte, 16823	Triangle Building Supply & Service, 1076 E Bishop Street	814	355-7368	Carrollton, 75007	Fast Tool, 1432 MacArthur Drive	972	446-4389
Bensalem, 19020	Fast Tech Corporation, 1327-D Adams Rd	215	245-1717	College Station, 77845	Spayberry Tool Company, 2902 Cain Rd	979	693-2671
Butler, 16001	Montgomery Grand Rental, 271 New Castle Road	724	282-7368	Conroe, 77304	Brannen's Inc, 101 Amanda Street	409	756-5299
Carbondale, 18407	Holt Lumber Company, 231 Belmont Street	570	282-4400	• Corpus Christi, 78405	Corpus Christi Power Tool, 3701 Agnes St	361	883-1117
Carlisle, 17013	Turner Hydraulics, 1605 Industrial Dr	717	243-3329	Dallas, 75215	H & K Pump Sales & Service, 1910 S Lamar St	214	428-2868
Christiana, 17509	Beiler Pneumatics, 718 Vintage Rd	610	583-7064	Deer Park, 77536	Hurricane Tool & Supply, 4330 Center St	281	476-5530
• Doylestown, 18901	Paul B Moyer & Sons, 190 S Clinton Street	215	348-1270	El Paso, 79901	Kessels Pump Service, 1806 Magoffin	915	533-5421
• Ephrata, 17522	322 Electric Motor & Tools, 2352 Division Highway	717	354-6141	Fort Worth, 76112	Pneu-Precision Service, 6941C E Lancaster	817	429-6381
• Erie, 16501	Perry Mill Supply, 1115 W 12th Street	814	453-5641	Fort Worth, 76140	Joe Williams Air Comp, 6807 Anglin Dr	817	478-0601
• Frazer, 19355	Contractors Choice, 600 Lancaster Ave	610	408-0195	• Frisco, 75034	Frisco Lawn & Power Equip, 8722 Main St	972	335-0995
Gap, 17527	Gap Power Rentals Plus, 5399 Lincoln Highway East	717	442-8970	Garland, 75040	Garland Air Comp Repair, 634 N 5th Street Ste F	972	487-1939
Gordonville, 17529	Cross Keys Rental & Repair, 52 Queen Rd	717	768-8788	Greenville, 75402	Lektrotech, Inc, 6800 Highway 66	903	454-7146
Greensburg, 15601	Thomas Pneumatics HY, 2424 Keystone Ave	724	832-1110	Houston, 77020	Tricon Tool & Supply, 5809 Clinton Drive	713	678-7444
Hanover, 17331	C & E Pneumatic, 301 Poplar Street	717	632-5200	Houston, 77092	Empire Tool Traders, 11616 Hempstead Hwy	713	957-8665
Jessup, 18434	Fastenal, 1225 Mid Valley Drive	570	307-0992	Keller, 76244	Green Valley Compressor, 429 Main St	817	431-3330
Lansdale, 19446	West Side Lawn Mower Inc, 1122 N Broad St	215	855-5627	Kernville, 78028	Air Supply & Fastener, 91 Coronado Dr	830	896-3922
Latrobe, 15650	Latrobe Tool Service, 214 Route 30 East	724	532-1411	• Killeen, 76541	B C Repair Center, 112 N 4th Street	254	634-2960
Lewis Run, 16738	Lineman Electric Motors, 99 Lineman Road	814	362-8831	Laredo, 78040	Rubio Electric Co, 1719 San Bernardo Avenue	956	722-3908
• Mechanicsburg, 17055	DriveKore Inc, 101 Wesley Drive	717	697-8233	Longview, 75601	Air Power Sales & Service, 823 West Marshall	903	236-4311

- Repairs Compressors & Generators
- ★ Repairs All DeWALT Products
- ◆ Repairs Lasers

1-800-4 DEWALT

www.DEWALT.com

SERVICE CENTERS

City/State/Zip	Name/Address	Area Code	Phone Number	City/State/Zip	Name/Address	Area Code	Phone Number
Texas (continued)							
Longview, 75604	ToolCare, 301A Enterprise Street	903	295-9966	Anacortes, 98221	Ace Hardware of Anacortes, 1720 Q Avenue	360	293-3535
Lubbock, 79405	Lubbock Electric Company, 1108 34th St	806	744-2336	★ Bellevue, 98005	Power Tool Service, 12121 Northup Way 108	425	453-8015
Lubbock, 79412	Caprock Equipment Service, 2112 50th	806	747-9177	Bellingham, 98225	Pro-Tool Of Bellingham, 2238 James Street	360	733-7343
Lufkin, 75902	Maddux Building Materials, 1603 Atkinson Drive	936	634-3369	Centralia, 98531	Rentals Etc, Inc, 700 S Tower Street	360	736-8257
Mabank, 75147	Groom & Son Hardware & Lumber, 1310 South 3rd St	903	887-7581	Fife, 98424	Tap Tool Repair Inc, 1401 52nd Avenue East	253	922-5787
Mathis, 78368	Dinero Compressors & Equip, 623 N Front St	361	547-3992	Kennewick, 99336	Seco Equipment Inc, 110 North Washington	509	586-0551
McAllen, 78502	Rio Grande Plumbing Supply, 1010 East Pecan	956	686-9557	Kent, 98032	Glenco Supply Company, 1621 S Central # 46	253	852-1141
Midland, 79701	Midland Tool Specialty, 918 South Main	915	682-4647	Lakewood, 98498	Fastenal Tool Repair, 9725 47th Ave SW #20A	253	983-1561
• Nederland, 77627	Wayne Cureton, Inc, 106 18th Street	409	722-5354	★ Longview, 98632	C & H Industrial Tool & Supply, 1160 3rd Avenue	360	423-6496
Odessa, 79764	McCord Pump, 3711 Brazos Ave	915	362-4611	Lynnwood, 98037	Compressors NW Airware, Inc, 5800 188th Southwest	425	771-8055
Pharr, 78577	Valley Outdoor Power Equip, Inc, 1012 East 495	956	787-0469	Marysville, 98270	United Rentals #327, 3919 88th St NE	360	653-5552
Plano, 75074	American Tool & Fastener, 1331 E Plano Parkway, Suite B	972	801-9909	• Pasco, 99301	J & L Hydraulics, 1120 West Lewis St	509	545-9032
Pottsboro, 75076	NT CustomBilt Air Compressors, Inc, 96 Park	903	786-7177	Port Angeles, 98362	Janssen Tool Repair, 33 Cherry Tree Lane	360	452-1158
Prosper, 75078	Tex Air, 117 W Broadway, Suite B	972	346-3656	Port Angeles, 98362	L & L Tool Specialties, 1927 E 1st Street	360	457-1116
★ San Angelo, 76904	J & T's Welding, 5294 Old Christoval Road	915	651-1408	Seattle, 98107	Sunset Power Equipment, 6429 32nd N W	206	789-2180
San Antonio, 78201	Industrial Equipment Co., 637 East Crockett St	210	225-1312	Seattle, 98108	Sharp Shop, 128 South Lucille St	206	762-6480
San Antonio, 78215	Sankey Equipment Co, Inc, 925 Avenue B	210	227-4178	Snohomish, 98296	Shane Equipment Co, 18208 67th Ave SE	253	668-7272
San Antonio, 78216	E.A.H. San Antonio Inc, 136 El Mio	210	822-9393	• Spokane, 99202	Safway Supply Inc, East 1503 Riverside Ave	509	535-9841
Sherman, 75090	Texoma Tool Repair Co, 308 E Houston	903	892-1510	Spokane, 99212	Air Electric Tools, 5603 E 3rd Ave	509	534-3698
Victoria, 77904	Duffy's Lawn & Garden Equipment, 3508 Sam Houston	361	927-3135	Tacoma, 98409	Don Golden Company, 4704 S Washington	253	474-0148
Waco, 76707	Power Tool Repair, 6819 S 3rd Street Rd	254	662-5969	★ Tumwater, 98501	Coastal Nail & Staple, Inc, 715 C - 78th Ave SW	360	956-1973
★ Waco, 76707	Ludwig Saw & Tool Sharpening, 1701 Maple Avenue	254	754-6951	Union Gap, 98903	Yakima Air Compressor, 2526 Main St	509	453-5059
Whitehouse, 75791	Roquemore's Hardware Inc, 300 Hwy 110 N	903	839-6606	Vancouver, 98682	Cascade Compressor, 12216 NE 119th St	360	944-1189
Wichita Falls, 76305	Frank's Repair, 523 Homestead Lane	940	766-0342	★ Wenatchee, 98801	Tool Mart, 154 Marr	509	664-6606
Lufkin, 75901	Thompson Air Compressor, 2900 Atkinson Dr	936	634-8505	Yakima, 98902	AMB Tool & Equipment, 608 West Knob Hill Blvd	509	452-7123
Utah							
• Logan, 83421	Industrial Tool & Supply, 839 N Main Street	435	753-4256	Yakima, 98902	Cooper Electric Motor Service, 205 South Fourth Ave	509	452-9550
Logan, 84321	Glenn's Electric Motor & Supply, 501 N Main	435	752-4178	West Virginia			
Ogden, 84401	Northern Utah Tool Service, 2930 Pennsylvania Ave Unit 84	801	612-1192	Beckley, 25802	Air-Tech Tool Service, 325 City Avenue	304	253-6799
Orem, 84097	The Mending Shed, 1735 S State Street	801	225-8012	Huntington, 25701	Lawter Elect Motor Co, 202 Adams Avenue	304	522-8297
Provo, 84604	Electric Motor Company, 633 West 1720 North	801	373-0270	Martinsburgh, 25401	Biedler Electric Motor Repair, 194 Hacklison Way	304	263-9995
Salt Lake City, 84104	AAIRCO, 935 West 1860 South	801	972-3186	Wheeling, 26003	Fast Service Center, 1058 Main Street	304	232-5561
Salt Lake City, 84115	Arnold Compressor, 3596 S 300 W #8	801	269-8040	Wisconsin			
• St George, 84790	Dixie Fastening, 291 E 1400 South / Suite 3	435	673-5337	Antigo, 54409	DeWan Sewing Inc, 1809 Neva Rd	715	623-6800
St. George, 84770	Colorland Sales & Service, 550 N Bluff	435	673-4824	Chippewa Falls, 54729	Brock Enterprises, 304 Summit Avenue	715	726-8966
★ St. George, 84770	Quality Power Equipment, 130 N 800 E	435	627-0362	★ Green Bay, 54301	Power Tool Service, 300 N Webster Ave	920	437-2594
Vermont							
• Essex Junction, 05452	Burlington Tool Repair, 3 Kellogg Road	802	872-0051	• Green Bay, 54304	Woodworker's Depot Inc, 3001 Ramada Way	920	336-6900
Fairlee, 05045	Tool Barn Inc, RT 5 North	802	333-9311	• Green Bay, 54304	Allied Equipment Inc, 851 Potts Ave	920	499-2992
• South Barre, 05670	Reynolds & Son Inc, 47 Bridge Street	802	479-0101	Green Bay, 54304	Bay Verte Machinery, 975 Parkview Rd	920	336-7440
Virginia							
Chantilly, 20151	Scotts Turf Equipment, 14003 Lee Jackson Memorial	703	502-0567	La Crosse, 54601	Lackore Electric Motor, 4102 Mormon Coulee Ct	608	782-7635
• Charlottesville, 22901	Piedmont Tool Repair, 2811-D Hydraulic Road	434	817-3090	Madison, 53713	Jet Power Tool Repair Inc, 970 Jonathon Dr	608	271-2311
Chesapeake, 23320	Master Tool Repair, 119 Tilden Ave Suite E	757	547-8665	Oshkosh, 54901	Kitz & Pfeil, 427 N Main St	920	236-3340
Collinsville, 24078	Piedmont Specialty Co, 3135 Virginia Ave	276	647-7877	• Peaukee, 53072	Jensen Equipment Co, Inc, N27 W23015 Roundy Dr	262	547-5548
Dublin, 24084	Berkley Tool, 101 Town Center Drive	540	674-5784	Platteville, 53818	A-C Service of Platteville Inc, 150 N 2nd St	608	348-6487
• Fredericksburg, 22401	Fredericksburg Auto Parts, 400 Amaret St	540	373-2323	Rice Lake, 54868	Moberg Electric Inc, 1763 20 1/2 St	715	234-7961
Fredericksburg, 22408	Fredericksburg Supplies & Rental, 10708 Stoner Drive	540	891-8244	• Sheboygan, 53081	Willard Quasius Company, 1938 Union Ave	920	452-7368
Fredericksburg, 22408	Big Als Supply, 10825 E Houser Dr	540	891-2755	• Stanley, 54768	Ericksen's True Value, 207 N Broadway	715	644-3375
Hampton, 23661	ARCET, 3 Lockwood Drive	757	728-9353	★ Watertown, 53094	Watertown Ace Hardware, 401 Bernard St	920	261-3022
Harrisonburg, 22801	G L S Tool Clinic, 3075 Old Thirty Three Rd	540	434-6151	• Wauwatosa, 53213	Speedway Sales & Svc, 6600 W North Ave	414	453-5887
★ Leesburg, 20175	B & B Appliance & Lawn Equipment, 71 Lawson Rd	703	777-1093	Wisconsin Rapids, 54495	Wisconsin Valley Concrete Prod, 610 McKinley	715	423-7500
Lynchburg, 24506	Pearson Equipment, 3900 Harris Lane	434	845-5981	Wyoming			
• Manassas, 20109	Becker Small Engine, 7220 Gary Road	703	392-8588	Casper, 82601	Casper Saw Shop, 710 E Collins Dr	307	237-3279
Martinsville, 24112	The Electric Co, 934 N Memorial Blvd	276	656-3838	Rock Springs, 82901	Industrial Hoist and Crane, 590 Signal Drive	307	382-0089
• Midlothian, 23113	All - 4 - Rent, LLC, 14440 Sommerville Ct	804	897-4033				
Norfolk, 23517	Bryan Electric Company, 424 West 25th St	757	625-2525				
Richmond, 23225	Dominion Supply Inc, 1414 Semmes Ave	804	232-1085				
Roanoke, 24012	Marco Supply, 812 Pocahontas Avenue NE	540	344-6211				
Roanoke, 24014	Stultz Mach Tool & Eq, 1546 Brownlee Ave SE	540	981-9359				
Roanoke, 24017	Rent-Alls of Roanoke, Inc, 604 11th Street NW	540	345-0184				
• Sterling, 20164	Sterling Mower Repair, 45565 W Church Road	703	430-3989				
Virginia Beach, 23464	Mills Lawn & Garden, 928 Commonwealth Place	757	361-9293				
Woodbridge, 22191	JR Equipment Sales & Svc, 1635-5 Woodside Dr	703	491-1096				

- Repairs Compressors & Generators
- ★ Repairs All DeWALT Products
- Repairs Lasers

DEWALT®

INDUSTRIAL FOOTWEAR

**INTRODUCING THE
WORLD'S FIRST CORDLESS
NON-BATTERY OPERATED
POWER TOOL.**



MAXIMUM COMFORT • EXTREME DURABILITY

MASTER	2 X 6 STEEL & SOFT	2 X 8 TREATED	HEADER	JOIST
				
APPRENTICE	FOUNDATION	FOUNDATION	FOUNDATION	BEVEL STEEL & SOFT
				
DADO	2X4	TRUSS	PLUNGE	CROSS CUT
				



Visit www.DEWALT.com to see
our entire line of
high performance protective gear.



WWW.DEWALT.COM



THE MOST POWERFUL TOOL ON THE WEB



PRODUCTS:

Compare, review and research every DEWALT® tool and accessory including our latest innovations.



RETAILERS:

Locate all DEWALT retail partners.



SERVICE:

Order service parts on-line or find your closest service center.



EVENTS:

Get the latest information on DEWALT Racing and other local events in your area.



SUPPORT:

Search our database for answers to your product or service questions.

Sign up for e-mail updates... win tools...
be the first to know about anything DEWALT.

MEMBERSHIP IS FREE!

1-800-4 DEWALT