



TOOLING SYSTEM



C1~C26	ER SERIES COLLET CHUCK SYSTEM	C73~C81	KEYLESS DRILL CHUCK / 3D-TASTER
C27~C34	OZ SERIES COLLET CHUCK SYSTEM	C82~C90	BORING HEAD SERIES
C35~C36	MULTI-LOCK MILLING CHUCK	C91~C102	PRECISION FINISH BORING HEAD SETS
C37	C TYPE COLLET CHUCK SYSTEM	C103~C113	TOUCH POINT / PRESETTER SERIES
C38~C39	QUICK-CHANGE TOLLING / TG 100 COLLET SYSTEM	C114~C129	TAPPING SYSTEM
C40~C41	COLLETS (5C,R8,MT3,U2)	C130~C134	AIR TAPPING UNIT
C42~C43	TAPER SLEEVE / DRILL CHUCK ARBOR	C135~C137	TOOL STAND / LOCKING DEVICE
C44~C53	TOOL HOLDER (DIN2080 / 69871A ISO / NT / BT) / NC RIGHT ANGLE HEAD	C138~C142	SHEATH RACK TOOL CARTS SPINDLE TAPER WIRE
C54~C57	PULL STUDS	C143~C144	TOOL CABINET / WORK BENCH
C58~C60	COMPLETE NC TOOLING SET	C145	PARTS CABINET / TOOL BOX
C61~C64	TOOL HOLDER	C146	ECONOMICAL PALLET / HEAVY DUTY PALLET
C65~C66	HSK-A63 / HIGH SPEED TOOLING SYSTEM		
C67~C72	SK SPRING COLLET SYSTEM		



ER Spring Collet Chuck System

ER collet system of VERTEX is made of special elastic steel material under excellent heat treatment and precise grinding process, so it has precise accuracy, powerful clamping ability, and is durable. This collet can clamp for a specific standard size and its next size, (Refer to the data sheet on page 2). It can be widely used for boring, milling, drilling and tapping as well as for grinding operation, and is available for all sizes.

ER COLLET DIMENSIONS

TYPE	A	B	CLAMPING & RANGE $\varnothing D$
ER-8	8.5	13.5	$\varnothing 0.5\sim 5$
ER-11	11.5	18	$\varnothing 0.5\sim 7$
ER-16	17	27	$\varnothing 0.5\sim 10$
ER-20	21	31	$\varnothing 1\sim 13$
ER-25	26	35	$\varnothing 1\sim 16$
ER-32	33	40	$\varnothing 2\sim 20$
ER-40	41	46	$\varnothing 3\sim 26$
ER-50	52	60	$\varnothing 10\sim 34$

ACCURACY

L mm	D mm	DIN6499 Standard precision	VERTEX Standard precision	A Grade Optional
$\varnothing D \times 4$	1.0-1.4	0.02	0.015	0.01
	1.5-2.9	0.02	0.015	0.01
	3.0-5.9	0.02	0.015	0.01
	6.0-9.9	0.02	0.015	0.01
	10.0-17.9	0.03	0.02	0.01
	18.0-26.9	0.03	0.02	0.01
	27.0-34.9	0.03	0.02	0.01

THE HIGH PRECISION OF A GRADE IS AVAILABLE

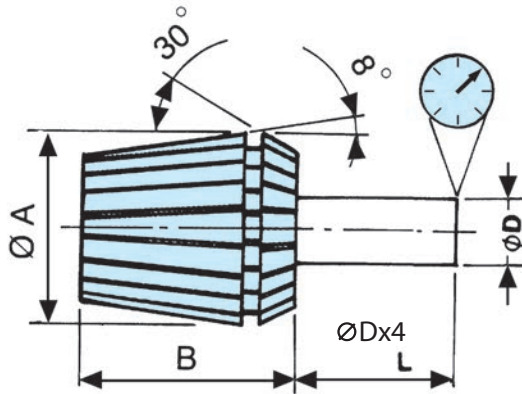

double-taper chuck

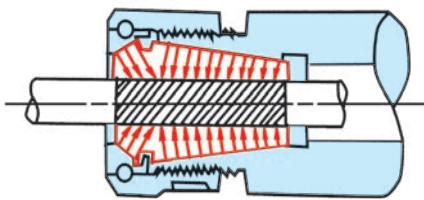

single-taper chuck

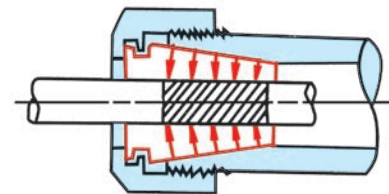

POWERFUL CLAMPING STRENGTH

The handle of the drill with double-taper chuck is longer than that with single-taper (grinding spring) collet. The clamping strength will be more powerful, if a screw-driver fastened by steel ball is adopted.

NOTE:

Mounting instructions for ER collets DIN 6499-A and DIN 6499-B

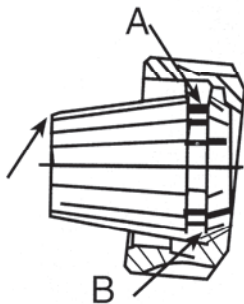

A - Place collet inside nut and rotate the nut to engage with the extractor spiral in collet groove.

B - Only then mount nut and collet together into the collet holder or machine spindle.

Note: Never use a 12-11mm collet to clamp a 12.2mm diameter, but rather use a 13-12mm collet.

Shank For Machining Center

BT

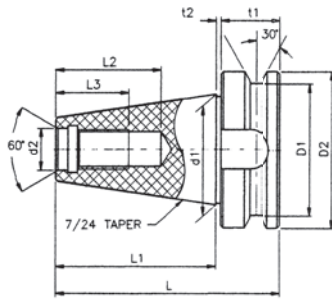

MAS BT SHANK

SPECIFICATION	D1	D2	t1	t2	L1	L2	L3	L	d1	d2	G
BT30	46	38	20	2	48.4	34	24	70.4	31.75	12.5	M12
BT40**	63	53	25	2	65.4	70	30	92.4	44.45	17	M16
BT50**	100	85	35	3	101.8	90	45	139.8	69.85	25	M24

SK

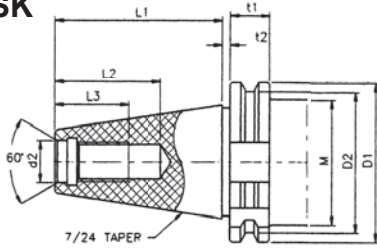

DIN 69871A SHANK

SPECIFICATION	D1	D2	t1	t2	L1	L2	L3	d1	d2	M	P	G
SK40	63.55	56.25	15.9	3.2	68.4	42.5	32	44.45	17	44.7	35	M16
SK50	97.5	91.25			101.75	61.5	47	69.85	25			70.1

*DRAW BAR DIN 69872 A TYPE

NT

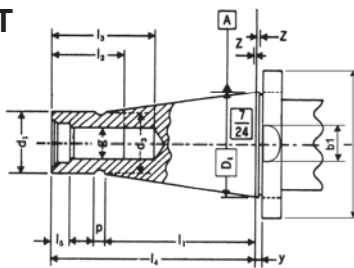

JIS B6101

TYPE	D1	Z	d1	d3	l	l1	p	y	g	i5	b1
NT30	31.750	0.4	17.4	16.5	68.4	48.4	3	1.6	M12, 1/2-12NC	6	16.1
NT40	44.450	0.4	25.3	24	93.4	65.4	5	1.6	M16, 5/8-11NC	8	16.1
NT50	69.850	0.4	39.6	38	126.8	101.8	8	3.2	M24, 1"-8NC	11.5	25.7

Drill Chuck Taper

JT

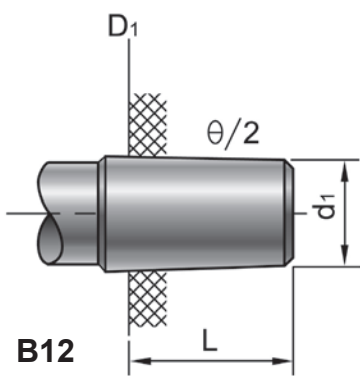

**B12
B16
B18**

JACOBS TAPER

TYPE	θ /2 TAPER	D1	d1	L
JT0		6.35	5.802	11.12
JT1		9.754	8.469	16.669
JT2	2° 19'52"	14.199	12.386	22.225
JT33	1° 49'01"	15.850	14.237	25.400
JT6	1° 29'88"	17.170	15.852	25.400
JT3	1° 31'26"	20.599	18.951	30.956
JT4	1° 29'59"	28.550	26.346	42.069
JT5	1° 29'05"	35.890	33.422	47.625

DIN 238

TYPE	θ /2 TAPER	D1	d1	L
B12	1° 25'43"	12.065	11.1	18.5
B16	1° 25'50"	15.733	14.5	24.0
B18	1° 25'50"	17.780	16.2	32.0

Morse Taper Shank MT

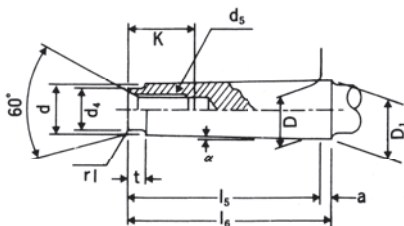

TYPE	D	a	D1	d	l5	l6	d4	d5
MT.0	9.045	3	9.2	6.4	50	53	6	-
MT.1	12.065	3.5	12.2	9.4	53.5	57	9	M6, 1/4-20NC
MT.2	17.780	5	18.0	14.6	64	69	14	M10, 3/8-16NC
MT.3	23.825	5	24.1	19.8	81	86	19	M12, 1/2-12NC
MT.4	31.267	6.5	31.6	25.9	102.5	109	25	M16, 5/8-11NC
MT.5	44.399	6.5	44.7	37.6	129.5	136	35.7	M20, 3/4-10NC
MT.6	63.348	8	63.8	53.9	182	190	51	M24, 1"-8NC

ER COLLET



ER Spring Collet Chuck System



STANDARD PRECISION TYPE

DIN 6499

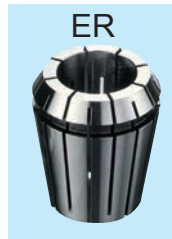
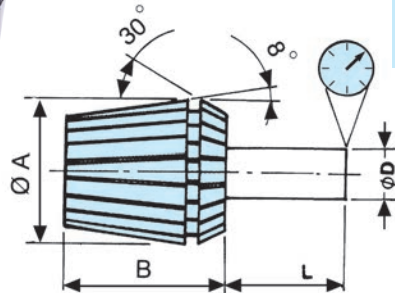

L mm	D mm	DIN6343 Standard precision	VERTEX Standard precision
6	1.0-1.4	0.02	0.015
10	1.5-2.9	0.02	0.015
16	3.0-5.9	0.02	0.015
25	6.0-9.9	0.02	0.015
40	10.0-17.9	0.03	0.02
50	18.0-26.9	0.03	0.02
60	27.0-34.9	0.03	0.02



ER COLLET

ER COLLET SET WITH CLAMPING RANGE

ER-25			ER-32			ER-40			ER-50		
15PCS/SET			18PCS/SET			23PCS/SET			12PCS/SET		
ORDER NO.	CAP. mm Ø	CODE NO.	ORDER NO.	CAP. mm Ø	CODE NO.	ORDER NO.	CAP. mm Ø	CODE NO.	ORDER NO.	CAP. mm Ø	CODE NO.
V25000	1-16	3005-101	V32000	2-20	3006-101	V40000	3-26	3007-101	V50000	10-34	3008-101
V25020	2-1	3005-001	V32030	3-2	3006-001	V40040	4-3	3007-001	V50120	12-10	3008-001
V25030	3-2	3005-002	V32040	4-3	3006-002	V40050	5-4	3007-002	V50140	14-12	3008-002
V25040	4-3	3005-003	V32050	5-4	3006-003	V40060	6-5	3007-003	V50160	16-14	3008-003
V25050	5-4	3005-004	V32060	6-5	3006-004	V40070	7-6	3007-004	V50180	18-16	3008-004
V25060	6-5	3005-005	V32070	7-6	3006-005	V40080	8-7	3007-005	V50200	20-18	3008-005
V25070	7-6	3005-006	V32080	8-7	3006-006	V40090	9-8	3007-006	V50220	22-20	3008-006
V25080	8-7	3005-007	V32090	9-8	3006-007	V40100	10-9	3007-007	V50240	24-22	3008-007
V25090	9-8	3005-008	V32100	10-9	3006-008	V40110	11-10	3007-008	V50260	26-24	3008-008
V25100	10-9	3005-009	V32110	11-10	3006-009	V40120	12-11	3007-009	V50280	28-26	3008-009
V25110	11-10	3005-010	V32120	12-11	3006-010	V40130	13-12	3007-010	V50300	30-28	3008-010
V25120	12-11	3005-011	V32130	13-12	3006-011	V40140	14-13	3007-011	V50320	32-30	3008-011
V25130	13-12	3005-012	V32140	14-13	3006-012	V40150	15-14	3007-012	V50340	34-32	3008-012
V25140	14-13	3005-013	V32150	15-14	3006-013	V40160	16-15	3007-013			
V25150	15-14	3005-014	V32160	16-15	3006-014	V40170	17-16	3007-014			
V25160	16-15	3005-015	V32170	17-16	3006-015	V40180	18-17	3007-015			
V25015	1.5	3005-016	V32180	18-17	3006-016	V40190	19-18	3007-016			
V25025	2.5	3005-017	V32190	19-18	3006-017	V40200	20-19	3007-017			
V25035	3.5	3005-018	V32200	20-19	3006-018	V40210	21-20	3007-018			
V25045	4.5	3005-019	V32025	2.5	3006-019	V40220	22-21	3007-019			
V25055	5.5	3005-020	V32035	3.5	3006-020	V40230	23-22	3007-020			
V25065	6.5	3005-021	V32045	4.5	3006-021	V40240	24-23	3007-021			
V25075	7.5	3005-022	V32055	5.5	3006-022	V40250	25-24	3007-022			
V25085	8.5	3005-023	V32065	6.5	3006-023	V40260	26-25	3007-023			
V25095	9.5	3005-024	V32075	7.5	3006-024	V40115	11.5	3007-024			
V25105	10.5	3005-025	V32085	8.5	3006-025	V40125	12.5	3007-025			
V25115	11.5	3005-026	V32095	9.5	3006-026	V40135	13.5	3007-026			
V25125	12.5	3005-027	V320105	10.5	3006-027	V40145	14.5	3007-027			
V25135	13.5	3005-028	V320115	11.5	3006-028	V40155	15.5	3007-028			
V25145	14.5	3005-029	V320125	12.5	3006-029	V40165	16.5	3007-029			
V25155	15.5	3005-030	V320135	13.5	3006-030	V40175	17.5	3007-030			
			V320145	14.5	3006-031	V40185	18.5	3007-031			
			V320155	15.5	3006-032	V40195	19.5	3007-032			
			V320165	16.5	3006-033	V40205	20.5	3007-033			
			V320175	17.5	3006-034	V40215	21.5	3007-034			
			V320185	18.5	3006-035	V40225	22.5	3007-035			
			V320195	19.5	3006-036	V40235	23.5	3007-036			
						V40245	24.5	3007-037			
						V40255	25.5	3007-038			
						V40265	26.5	3007-039			



ER Spring Collet Chuck System



**SUPER ULTRA PRECISION TYPE
A GRADE**



TYPE	ER-8			ER-11			ER-16			ER-20		
COMPLET SET	9PCS/SET			7PCS/SET			10PCS/SET			12PCS/SET		
FULL SET	ORDER NO.	CAP. mm Ø	CODE NO.	ORDER NO.	CAP. mm Ø	CODE NO.	ORDER NO.	CAP. mm Ø	CODE NO.	ORDER NO.	CAP. mm Ø	CODE NO.
	V08000S	0.5-5.0	3000-001	V11000S	0.5-7.0	3000-002	V16000S	0.5-10.0	3000-003	V20000S	1-13	3000-004
INDIVIDUAL UNIT	V08010S	1.0-0.5	3000-010	V11010S	1.0-0.5	3000-020	V16010S	1.0-0.5	3000-040	V20020S	2-1	3000-060
	V08015S	1.5-1.0	3000-011	V11020S	2.0-1.5	3000-021	V16020S	2.0-1.0	3000-041	V20030S	3-2	3000-061
	V08020S	2.0-1.5	3000-012	V11030S	3.0-2.5	3000-022	V16030S	3.0-2.0	3000-042	V20040S	4-3	3000-062
	V08025S	2.5-2.0	3000-013	V11040S	4.0-3.5	3000-023	V16040S	4.0-3.0	3000-043	V20050S	5-4	3000-063
	V08030S	3.0-2.5	3000-014	V11050S	5.0-4.5	3000-024	V16050S	5.0-4.0	3000-044	V20060S	6-5	3000-064
	V08035S	3.5-3.0	3000-015	V11060S	6.0-5.5	3000-025	V16060S	6.0-5.0	3000-045	V20070S	7-6	3000-065
	V08040S	4.0-3.5	3000-016	V11070S	7.0-6.5	3000-026	V16070S	7.0-6.0	3000-046	V20080S	8-7	3000-066
	V08045S	4.5-4.0	3000-017	V11015S	1.5	3000-027	V16080S	8.0-7.0	3000-047	V20090S	9-8	3000-067
	V08050S	5.0-4.5	3000-018	V11025S	2.5	3000-028	V16090S	9.0-8.0	3000-048	V20100S	10-9	3000-068
				V11035S	3.5	3000-029	V16100S	10.0-9.0	3000-049	V20110S	11-10	3000-069
				V11045S	4.5	3000-030	V16015S	1.5	3000-050	V20120S	12-11	3000-070
				V11055S	5.5	3000-031	V16025S	2.5	3000-051	V20130S	13-12	3000-071
				V11065S	6.5	3000-032	V16035S	3.5	3000-052	V20010S	1.0	3000-072
							V16045S	4.5	3000-053	V20025S	2.5	3000-073
							V16055S	5.5	3000-054	V20035S	3.5	3000-074
							V16065S	6.5	3000-055	V20045S	4.5	3000-075
							V16075S	7.5	3000-056	V20055S	5.5	3000-076
							V16085S	8.5	3000-057	V20065S	6.5	3000-077
							V16095S	9.5	3000-058	V20075S	7.5	3000-078
									V20085S	8.5	3000-079	
									V20095S	9.5	3000-080	
									V20105S	10.5	3000-081	
									V20115S	11.5	3000-082	
									V20125S	12.5	3000-083	



ER Spring Collet Chuck System



SUPER ULTRA PRECISION TYPE

DIMENSIONS

S GRADE / A GRADE Accuracy

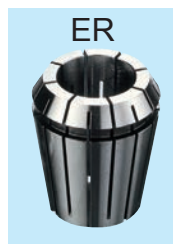
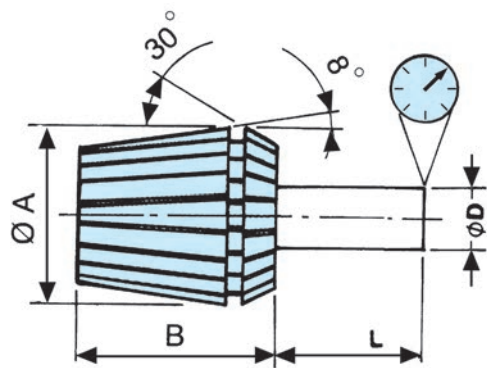

TYPE	A	B
ER08	8.5	13.5
ER11	11.5	18
ER16	17	27
ER20	21	31
ER25	26	35
ER32	33	40
ER40	41	46
ER50	52	60

L(mm)	øD(mm)	Ultra Precision(MM)
6	1.0-1.4	0.01
10	1.5-2.9	0.01
16	3.0-5.9	0.01
25	6.0-9.9	0.01
40	10.0-17.9	0.01
50	18.0-26.9	0.01
60	27.0-34.9	0.01



ER COLLET

ER-25			ER-32			ER-40			ER-50		
15PCS/SET			18PCS/SET			23PCS/SET			12PCS/SET		
ORDER NO.	CAP. mm Ø	CODE NO.	ORDER NO.	CAP. mm Ø	CODE NO.	ORDER NO.	CAP. mm Ø	CODE NO.	ORDER NO.	CAP. mm Ø	CODE NO.
V25000S	1-16	3000-005	V32000S	2-20	3000-006	V40000S	3-26	3000-007	V50000S	10-34	3000-008
V25020S	2-1	3000-090	V32030S	3-2	3000-110	V40040S	4-3	3000-130	V50120S	12-10	3000-160
V25030S	3-2	3000-091	V32040S	4-3	3000-111	V40050S	5-4	3000-131	V50140S	14-12	3000-161
V25040S	4-3	3000-092	V32050S	5-4	3000-112	V40060S	6-5	3000-132	V50160S	16-14	3000-162
V25050S	5-4	3000-093	V32060S	6-5	3000-113	V40070S	7-6	3000-133	V50180S	18-16	3000-163
V25060S	6-5	3000-094	V32070S	7-6	3000-114	V40080S	8-7	3000-134	V50200S	20-18	3000-164
V25070S	7-6	3000-095	V32080S	8-7	3000-115	V40090S	9-8	3000-135	V50220S	22-20	3000-165
V25080S	8-7	3000-096	V32090S	9-8	3000-116	V40100S	10-9	3000-136	V50240S	24-22	3000-166
V25090S	9-8	3000-097	V32100S	10-9	3000-117	V40110S	11-10	3000-137	V50260S	26-24	3000-167
V25100S	10-9	3000-098	V32110S	11-10	3000-118	V40120S	12-11	3000-138	V50280S	28-26	3000-168
V25110S	11-10	3000-099	V32120S	12-11	3000-119	V40130S	13-12	3000-139	V50300S	30-28	3000-169
V25120S	12-11	3000-100	V32130S	13-12	3000-120	V40140S	14-13	3000-140	V50320S	32-30	3000-170
V25130S	13-12	3000-101	V32140S	14-13	3000-121	V40150S	15-14	3000-141	V50340S	34-32	3000-171
V25140S	14-13	3000-102	V32150S	15-14	3000-122	V40160S	16-15	3000-142			
V25150S	15-14	3000-103	V32160S	16-15	3000-123	V40170S	17-16	3000-143			
V25160S	16-15	3000-104	V32170S	17-16	3000-124	V40180S	18-17	3000-144			
			V32180S	18-17	3000-125	V40190S	19-18	3000-145			
			V32190S	19-18	3000-126	V40200S	20-19	3000-146			
			V32200S	20-19	3000-127	V40210S	21-20	3000-147			
						V40220S	22-21	3000-148			
						V40230S	23-22	3000-149			
						V40240S	24-23	3000-150			
						V40250S	25-24	3000-151			
						V40260S	26-25	3000-152			



ER Spring Collet Chuck System



ER COLLET SET STANDARD PRECISION TYPE

DIN 6499



COLLET KITS STANDARD TYPE

ORDER NO.	TYPE	COLLET SIZE INSIDE DIA.	PCS/SET	KGS/PACKING	CODE NO.
V-08000	ER-8	1+0.5-5mm(1,1.5,2,2.5,3,3.5,4,4.5,5mm)	9PCS	1.065(C)	3001-101
V-11000	ER-11	1-7mm(1,2,3,4,5,6,7mm)	7PCS	1.075(C)	3002-101
V-11013		1+0.5-7mm(1,1.5,2,2.5,3,3.5,4,4.5,5,5.5,6,6.5,7mm)	13PCS	0.3(C)	3002-102
V-16000	ER-16	1-10mm(1,2,3,4,5,6,7,8,9,10mm)	10PCS	0.7(C)	3003-101
V-16008		3-10mm(3,4,5,6,7,8,9,10mm)	8PCS	0.6(C)	3003-102
V-20000	ER-20	2-13mm(2,3,4,5,6,7,8,9,10,11,12,13mm)	12PCS	0.9(C)	3004-101
V-20008		4-13mm(4,5,6,7,8,9,10,11,12,13mm)	10PCS	0.8(C)	3004-102
V-25000	ER-25	2-16mm(2,3,4,5,6,7,8,9,10,11,12,13,14,15,16mm)	15PCS	1.3(W)	3005-101
V-25008		4-16mm(4,5,6,7,8,9,10,11,12,13,14,15,16mm)	13PCS	1.0(W)	3005-102
V-25009		6,8,10,12,16mm	5PCS	1.325(C)	3005-103
V-25010		4,6,8,10,12,14,16mm	7PCS	0.35(C)	3005-104
V-32000	ER-32	3-20mm(3,4,5,6,7,8,9,10,11,12,13,14,15,16,17,18,19,20mm)	18PCS	3.3(P)	3006-101
V-32008		4,5,6,8,10,12,13,15,16,18,20mm	11PCS	2.8(C)	3006-102
V-32009		6,8,10,12,16,20mm	6PCS	0.9(C)	3006-103
V-40000	ER-40	4-26mm(4,5,6,7,8,9,10,11,12,13,14,15,16,17,18,19,20,21,22,23,24,25,26mm)	23PCS	6.5(P)	3007-101
V-40008		4,5,6,8,10,12,13,15,16,18,20,21,22,25,26mm	15PCS	4.2(P)	3007-102
V-40009		6,8,10,12,16,20,25mm	7PCS	2.0(P)	3007-103
V-50000	ER-50	12,14,16,18,20,22,24,26,28,30,32,34mm	12PCS	6.5(P)	3008-101

ER-Type Coolant Collet



● Collets to DIN6499B

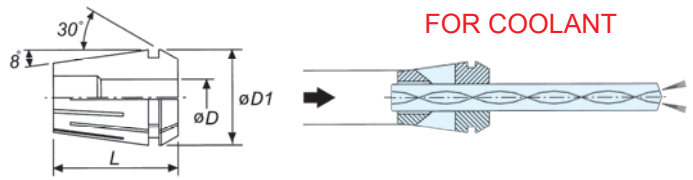

COOLANT COLLETS HAS ROUND SMALL THROUGH HOLE ON THE SLOTS, ONLY WHEN THE DIAMETER IS SMALL. THE REST IS SAME AS NORMAL ER COLLET.

- ER20 Ø4,5 MM
- ER25 Ø4,5,6,7 MM
- ER32 Ø4,5,6,7,8,9 MM
- ER40 Ø4,5,6,7,8,9 MM



ER-16			ER-20			ER-25			ER-32			ER-40		
PCS/SET			PCS/SET			PCS/SET			PCS/SET			PCS/SET		
ORDER NO.	CAP. mm Ø	CODE NO.	ORDER NO.	CAP. mm Ø	CODE NO.	ORDER NO.	CAP. mm Ø	CODE NO.	ORDER NO.	CAP. mm Ø	CODE NO.	ORDER NO.	CAP. mm Ø	CODE NO.
V16040L	4	3000-200	V20040L	4	3000-210	V25040L	4	3000-221	V32040L	4	3000-240	V40040L	4	3000-260
V16050L	5	3000-201	V20050L	5	3000-211	V25050L	5	3000-222	V32050L	5	3000-241	V40050L	5	3000-261
V16060L	6	3000-202	V20060L	6	3000-212	V25060L	6	3000-223	V32060L	6	3000-242	V40060L	6	3000-262
V16070L	7	3000-203	V20070L	7	3000-213	V25070L	7	3000-224	V32070L	7	3000-243	V40070L	7	3000-263
V16080L	8	3000-204	V20080L	8	3000-214	V25080L	8	3000-225	V32080L	8	3000-244	V40080L	8	3000-264
V16090L	9	3000-205	V20090L	9	3000-215	V25090L	9	3000-226	V32090L	9	3000-245	V40090L	9	3000-265
V16100L	10	3000-206	V20100L	10	3000-216	V25100L	10	3000-227	V32100L	10	3000-246	V40100L	10	3000-266
			V20110L	11	3000-217	V25110L	11	3000-228	V32110L	11	3000-247	V40110L	11	3000-267
			V20120L	12	3000-218	V25120L	12	3000-229	V32120L	12	3000-248	V40120L	12	3000-268
			V20130L	13	3000-219	V25130L	13	3000-230	V32130L	13	3000-249	V40130L	13	3000-269
						V25140L	14	3000-231	V32140L	14	3000-250	V40140L	14	3000-270
						V25150L	15	3000-232	V32150L	15	3000-251	V40150L	15	3000-271
						V25160L	16	3000-233	V32160L	16	3000-252	V40160L	16	3000-272
									V32170L	17	3000-253	V40170L	17	3000-273
									V32180L	18	3000-254	V40180L	18	3000-274
									V32190L	19	3000-255	V40190L	19	3000-275
									V32200L	20	3000-256	V40200L	20	3000-276
												V40210L	21	3000-277
												V40220L	22	3000-278
												V40230L	23	3000-279
ER COLLET ØD CLAMPING RANGE												V40240L	24	3000-280
ER-8	Ø0.5~5											V40250L	25	3000-281
ER-11	Ø0.5~7											V40260L	26	3000-282
ER-16	Ø0.5~10													
ER-20	Ø1~13													
ER-25	Ø1~16													
ER-32	Ø2~20													
ER-40	Ø3~26													
ER-50	Ø10~34													

ER TYPE COLLANT COLLET

ER-GB Tap Collets



NEW

ER-TAP

- Collets to DIN6499B
- Interchangeable with ER-collets
- For synchronized tapping

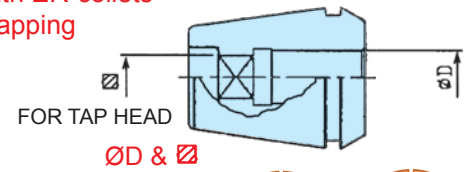

DIN/JIS STANDARD TAP SIZE

TYPE	ER-16GB					ER-20GB						
	ORDER NO.	øD mm	□ mm	TAP SIZE		CODE NO.	ORDER NO.	øD mm	□ mm	TAP SIZE		CODE NO.
FULL SET				DIN	JIS				DIN	JIS		
INDIVIDUAL UNIT	GB160450	4.5	3.4	M6		3000-400	GB200450	4.5	3.4	M6		3000-420
	GB160500	5	4		M4	3000-401	GB200500	5	4		M4	3000-421
	GB160550	5.5	4.5		M5	3000-402	GB200550	5.5	4.5		M5	3000-422
	GB160600	6	4.5		M6 1/4U	3000-403	GB200600	6	4.5		M6 1/4U	3000-423
	GB160601	6	4.9	M8		3000-404	GB200601	6	4.9	M8		3000-424
	GB160610	6.1	5		5/16U	3000-405	GB200610	6.1	5		5/16U	3000-425
	GB160620	6.2	5		M8	3000-406	GB200620	6.2	5		M8	3000-426
	GB160700	7	5.5	M10	M10 3/8U	3000-407	GB200700	7	5.5	M10	M10 3/8U	3000-427
	GB160800	8	6.2		7/16U	3000-408	GB200800	8	6.2		7/16U	3000-428
							GB200850	8.5	6.5		M12	3000-429
							GB200900	9	7.1	M12	1/2U	3000-430
							GB201000	10	8			3000-431

ISO 529 UNC AMERICA INCH TAP SIZE

TYPE	ER-16GB					ER-20GB				
	ORDER NO.	øD mm	□ mm	ISO529 UNC	CODE NO.	ORDER NO.	øD mm	□ mm	ISO529 UNC	CODE NO.
INDIVIDUAL UNIT	GB160451	4.5	3.55	1/4"-20	3000-411	GB200451	4.5	3.55	1/4"-20	3000-435
	GB160630	6.3	5	5/16"-18	3000-412	GB200630	6.3	5	5/16"-18	3000-436
	GB160710	7.1	5.6	3/8"-16	3000-413	GB200710	7.1	5.6	3/8"-16	3000-437
						GB200863	8	6.3	7/16"-14	3000-438
						GB200901	9	7.1	1/2"-13	3000-439

ER-25GB					ER-32GB					ER-40GB				
ORDER NO.	øD mm	□ mm	ISO529 UNC	CODE NO.	ORDER NO.	øD mm	□ mm	ISO529 UNC	CODE NO.	ORDER NO.	øD mm	□ mm	ISO529 UNC	CODE NO.
GB250451	4.5	3.55	1/4"-20	3000-521	GB320451	4.5	3.55	1/4"-20	3000-481					
GB250630	6.3	5	5/16"-18	3000-522	GB320630	6.3	5	5/16"-18	3000-482					
GB250710	7.1	5.6	3/8"-16	3000-523	GB320710	7.1	5.6	3/8"-16	3000-483	GB400710	7.1	5.6	3/8"-16	3000-531
GB250863	8	6.3	7/16"-14	3000-524	GB320863	8	6.3	7/16"-14	3000-484	GB400863	8	6.3	7/16"-14	3000-532
GB250901	9	7.1	1/2"-13	3000-525	GB320901	9	7.1	1/2"-13	3000-485	GB400901	9	7.1	1/2"-13	3000-533
GB251120	11.2	9	9/16"-12	3000-526	GB321120	11.2	9	9/16"-12	3000-486	GB401120	11.2	9	9/16"-12	3000-534
GB251251	12.5	10	5/8"-11	3000-527	GB321251	12.5	10	5/8"-11	3000-487	GB401251	12.5	10	5/8"-11	3000-535

ER-GB Tap Collets



NEW

ER-TAP

- Collets to DIN6499B
- Interchangeable with ER-collets
- For synchronized tapping

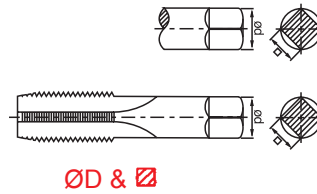

DIN/JIS STANDARD TAP SIZE

ER-25GB					ER-32GB					ER-40GB							
ORDER NO.	øD mm	□ mm	TAP SIZE		CODE NO.	ORDER NO.	øD mm	□ mm	TAP SIZE		CODE NO.	ORDER NO.	øD mm	□ mm	TAP SIZE		CODE NO.
			DIN	JIS					DIN	JIS					DIN	JIS	
GB250450	4.5	3.4	M6		3000-440	GB320450	4.5	3.4	M6		3000-460						
GB250500	5	4		M4	3000-441	GB320500	5	4		M4	3000-461						
GB250550	5.5	4.5		M5	3000-442	GB320550	5.5	4.5		M5	3000-462						
GB250600	6	4.5		M6 1/4U	3000-443	GB320600	6	4.5		M6 1/4U	3000-463	GB400600	6	4.5		M6 1/4U	3000-490
GB250601	6	4.9	M8		3000-444	GB320601	6	4.9	M8		3000-464	GB400601	6	4.9	M8		3000-491
GB250610	6.1	5		5/16U	3000-445	GB320610	6.1	5		5/16U	3000-465	GB400610	6.1	5		5/16U	3000-492
GB250620	6.2	5		M8	3000-446	GB320620	6.2	5		M8	3000-466	GB400620	6.2	5		M8	3000-493
GB250700	7	5.5	M10	M10 3/8U	3000-447	GB320700	7	5.5	M10	M10 3/8U	3000-467	GB400700	7	5.5	M10	M10 3/8U	3000-494
GB250800	8	6.2		7/16U	3000-448	GB320800	8	6.2		7/16U	3000-468	GB400800	8	6.2		7/16U	3000-495
GB250850	8.5	6.5		M12	3000-449	GB320850	8.5	6.5		M12	3000-469	GB400850	8.5	6.5		M12	3000-496
GB250900	9	7.1	M12	1/2U	3000-450	GB320900	9	7.1	M12	1/2U	3000-470	GB400900	9	7.1	M12	1/2U	3000-497
GB251000	10	8			3000-451	GB321000	10	8			3000-471	GB401000	10	8			3000-498
GB251050	10.5	8		M14 9/16U	3000-452	GB321050	10.5	8		M14 9/16U	3000-472	GB401050	10.5	8		M14 9/16U	3000-499
GB251100	11	9	M14		3000-453	GB321100	11	9	M14		3000-473	GB401100	11	9	M14		3000-500
GB251200	12	9	M16	5/8U	3000-454	GB321200	12	9	M16	5/8U	3000-474	GB401200	12	9	M16	5/8U	3000-501
GB251250	12.5	10		M16	3000-455	GB321250	12.5	10		M16	3000-475	GB401250	12.5	10		M16	3000-502
						GB321400	14	11	M18	M18 3/4U	3000-476	GB401400	14	11	M18	M18 3/4U	3000-503
						GB321500	15	12		M20	3000-477	GB401500	15	12		M20	3000-504
						GB321600	16	12	M20		3000-478	GB401600	16	12	M20		3000-505
						GB321700	17	13		M22 7/8U	3000-479	GB401700	17	13		M22 7/8U	3000-506
												GB401800	18	14.5	M22		3000-507
												GB401900	19	15		M24	3000-508
												GB402000	20	15		M27 1"U	3000-509
												GB402001	20	16	M27		3000-510
												GB402200	22	18	M30		3000-511

ER GB TAP COLLET



ER Spring Collet Chuck System **VERTEX**

Collet Chuck Kit With ISO Taper Shank DIN 2080/ISO SHANK

DIN 6499



NT-40
WITH MAHO GROOVE

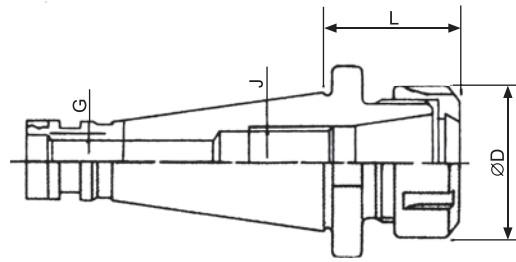

ER COLLET ØD CLAMPING RANGE	
ER-8	Ø0.5~5
ER-11	Ø0.5~7
ER-16	Ø0.5~10
ER-20	Ø1~13
ER-25	Ø1~16
ER-32	Ø2~20
ER-40	Ø3~26
ER-50	Ø10~34

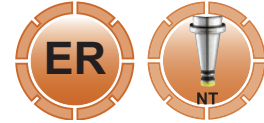

ORDER NO.	TAPER	COLLET TYPE	L	D	G	WEIGHT KGS	CODE NO.
V-101	NT-30	ER-32	55	50	1/2"-12W, M12X1.75P (USA 1/2"-UNC13)	0.7	3020-301
V-102		ER-40	70	63		1.1	3020-302
V-103	NT-40	ER-32	50	60	5/8"-11W or M16X2.0P	1.1	3021-301
V-104		ER-40	60	63		1.3	3021-302
V-105		ER-50	80	78		2	3021-303
V-106	NT-50	ER-32	60	50	1"-8W or M24X3.0P	3.1	3022-301
V-107		ER-40	65	63		3.4	3022-302
V-108		ER-50	80	78		4	3022-303
※ V-109	NT-30	ER-25	55	42	1/2"-12W, M12X1.75P	0.7	3020-303
※ V-110	NT-40	ER-25	50	42	5/8"-11W, M16X2.0P	1.1	3021-304

Collet Chuck kit With ISO Taper Shank

Including shank, full set of collets, wrench and case.

Caution:

Please notify the taper size, collet type, set range, and set numbers when ordering.

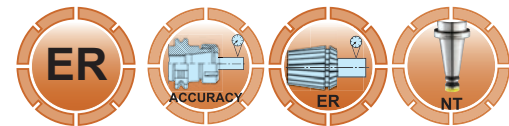

ORDER NO.	TAPER	COLLET TYPE	SET RANGE	SET PCS	WEIGHT KGS	CODE NO.
V-201	NT-30	ER-32	3-20	18	4.2	3020-401
V-202			4-20	11	3.2	3020-402
V-203			6-20	6	2.8	3020-403
V-204	NT-30	ER-40	4-26	23	7.3	3020-404
V-205			4-26	15	6	3020-405
V-206			6-25	7	4.6	3020-406
V-207	NT-40	ER-32	3-20	18	4.8	3021-401
V-208			4-20	11	3.8	3021-402
V-209			6-20	6	3.4	3021-403
V-210	NT-40	ER-40	4-26	23	8.2	3021-404
V-211			4-26	15	6.9	3021-405
V-212			6-25	7	5.2	3021-406
V-213	NT-40	ER-50	12-34	12	10	3021-407
V-214	NT-50	ER-32	3-20	18	6.4	3022-401
V-215			4-20	11	5.4	3022-402
V-216			6-20	6	5.5	3022-403
V-217	NT-50	ER-40	4-26	23	9.8	3022-404
V-218			4-26	15	8.5	3022-405
V-219			6-25	7	7	3022-406
V-220	NT-50	ER-50	12-34	12	11	3022-407
※ V-223	NT-30	ER-25	2-16	7	2.8	3020-407
※ V-224			4-16	15	2.4	3020-408
※ V-225	NT-40	ER-25	2-16	7	3.3	3021-409
※ V-226			4-16	15	3.0	3021-410



ER Spring Collet Chuck System



Extended Collet Holder With ISO Shank
DIN 2080/ISO SHANK EXTENDED CHUCK

DIN 6499

ER COLLET ØD CLAMPING RANGE	
ER-8	Ø0.5~5
ER-11	Ø0.5~7
ER-16	Ø0.5~10
ER-20	Ø1~13
ER-25	Ø1~16
ER-32	Ø2~20
ER-40	Ø3~26
ER-50	Ø10~34

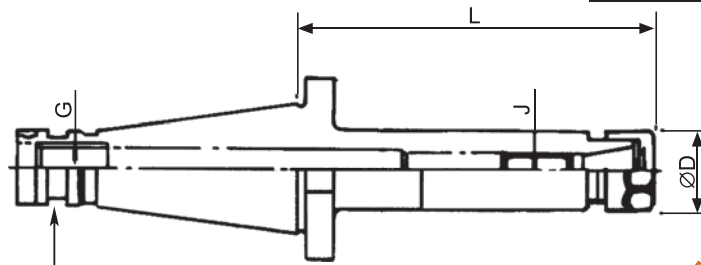

NT40 WITH MAHO GROOVE

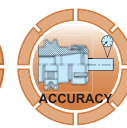

ER SYSTEM

ORDER NO.	TAPER	COLLET TYPE	L	D	G	WEIGHT KG	CODE NO.
V-231	NT-30	ER-16	76	28	1/2"-12W, M12X1.75P (USA 1/2"-UNC13)	0.6	3020-304
V-232	NT-40	ER-16	76	28	5/8"-11W or M16X2.0P	1.1	3021-314
V-233		ER-16	100	28		1.2	3021-305
V-234	NT-40	ER-20	76	34	5/8"-11W or M16X2.0P	1.2	3021-306
V-235		ER-20	100	34		1.4	3021-307



Extended Collet Chuck Kit With ISO Shank

Including shank, full set of collets, wrench and case

Caution:

Please notify the taper size, collet type, set range, and set numbers when ordering.



ORDER NO.	TAPER	COLLET TYPE	RANGE	PCS/SET	L	WEIGHT KGS	CODE NO.
V-241	NT-30	ER-16	1-10	10	76	1.9	3020-409
V-242			3-10	8		1.8	3020-410
V-243	NT-40	ER-16	1-10	10	76	2.2	3021-411
V-244			3-10	8		2.1	3021-412
V-245		ER-16	1-10	10	100	2.4	3021-413
V-246			3-10	8		2.3	3021-414
V-247	NT-40	ER-20	2-13	12	76	2.3	3021-415
V-248			4-13	10		2.2	3021-416
V-249		ER-20	2-13	12	100	2.6	3021-417
V-250			4-13	10		2.5	3021-418



ER Spring Collet Chuck System



Collet Holders With R-8 shank

R-8 SHANK

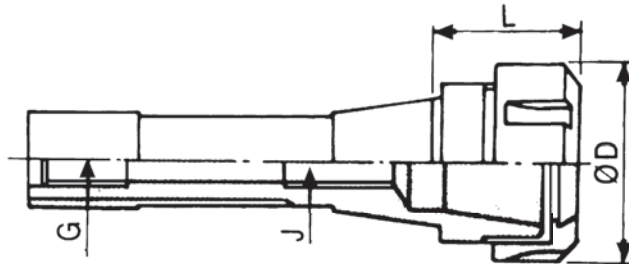

ER COLLET ØD CLAMPING RANGE	
ER-8	Ø0.5~5
ER-11	Ø0.5~7
ER-16	Ø0.5~10
ER-20	Ø1~13
ER-25	Ø1~16
ER-32	Ø2~20
ER-40	Ø3~26
ER-50	Ø10~34



ORDER NO.	TAPER	COLLET TYPE	L	D	G	WEIGHT KG	CODE NO.
V-301	R8	ER-16	38	28	7/16"X20 UNF	0.5	3027-301
V-302		ER-32	40	50	7/16"X20 UNF	0.8	3027-302
V-303		ER-40	70	63	7/16"X20 UNF	1.3	3027-303

Collet Chuck Kit With R-8 Shank

Including shank, full set of collets, wrench and case. (ER16 no Wrench)



Caution:

Please notify the taper size, collet type, set range, and set numbers when ordering.

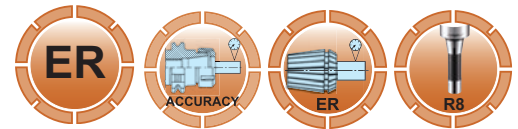

ORDER NO.	TAPER	COLLET TYPE	SET RANGE	SET PCS	WEIGHT KGS	CODE NO.
V-311	R8	ER16	1-10	10	1.5(W)	3027-401
V-312			3-10	8	1.45(P)	3027-402
V-313		ER32	3-20	18	4.3(P)	3027-403
V-314			4-20	11	3.2(P)	3027-404
V-315			6-20	6	2.9(P)	3027-405
V-316		ER40	4-26	23	7.3(P)	3027-406
V-317			4-26	15	6.1(P)	3027-407
V-318			6-25	7	4.6(P)	3027-408

ER Spring Collet Chuck System

Collet Holders With Morse Taper Shank DIN 6499 DIN 228

MT-SHANK
(MT / MK)

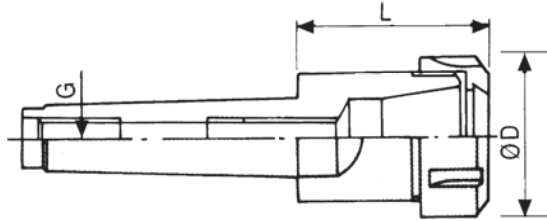

ER COLLET ØD CLAMPING RANGE	
ER-8	Ø0.5~5
ER-11	Ø0.5~7
ER-16	Ø0.5~10
ER-20	Ø1~13
ER-25	Ø1~16
ER-32	Ø2~20
ER-40	Ø3~26
ER-50	Ø10~34



ORDER NO.	TAPER	COLLET TYPE	L	D	G	WEIGHT KGS	CODE NO.
V-401	MT2	ER16	40	28	3/8"-16W or M10X1.5P	0.2	3023-301
V-402		ER20	43	34		0.3	3023-302
V-403		ER25	47	42		0.4	3023-303
V-404	MT3	ER16	40	28	3/8"-16W or 1/2"-12W M10X1.5P, M12X1.75P USA 1/2"-UNC13	0.3	3024-301
V-405		ER32	70	50		0.8	3024-302
V-406		ER40	80	63		1.1	3024-303
V-451	MT3	ER20	43	34	1/2"-12NC or M12X1.75P	0.3	3024-304
V-452		ER25	47	42		0.5	3024-305
V-407	MT4	ER32	60	50	5/8"-11W or M16X2.0P	1	3025-301
V-408		ER40	82	63		1.4	3025-302
V-409		ER50	85	78		2.2	3025-303
V-410	MT5	ER40	82	63	1"-8W or M24X3.0P	2.1	3026-301
V-411		ER50	85	78		2.9	3026-302

NEW



Collet Chuck Kit With Morse Taper Shank

Including shank, full set of collets, wrench and case.

(ER16, ER20 no Wrench)

1. ER16,20,25 Packed in Wooden Box(W)
2. ER32,40,50, Packed in Plastic Box(P)

Caution:

Please notify the taper size, collet type, set range, and set numbers when ordering.

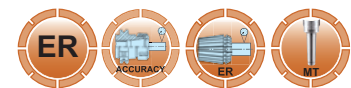

ER SYSTEM

NEW

ORDER NO.	TAPER	COLLET TYPE	SET RANGE	SET PCS	WEIGHT KGS.	CODE NO.
V-412	MT2	ER16	1-10	10	1.05	3023-401
V-413			3-10	8	1	3023-402
V-414	MT2	ER20	2-13	12	1.3	3023-403
V-415			4-13	10	1.2	3023-404
V-416	MT2	ER25	2-16	15	2.4	3023-405
V-418			4-16	7	1.3	3023-407
V-419	MT3	ER16	1-10	10	1.5	3024-401
V-420			3-10	8	1.1	3024-402
V-441	MT3	ER20	2-13	12	1.35	3023-408
V-442			4-13	10	1.3	3023-409
V-443	MT3	ER25	2-16	15	2.5	3023-410
V-444			4-16	7	2.1	3023-411
V-421	MT3	ER32	3-20	18	4.1	3024-403
V-422			4-20	11	3	3024-404
V-423			6-20	6	2.7	3024-405
V-424	MT3	ER40	4-26	23	7.2	3024-406
V-425			4-26	15	6	3024-407
V-426			6-25	7	4.5	3024-408
V-427	MT4	ER32	3-20	18	4.3	3025-401
V-428			4-20	11	3.2	3025-402
V-429			6-20	6	2.9	3025-403
V-430	MT4	ER40	4-26	23	7.3	3025-404
V-431			4-26	15	6.1	3025-405
V-432			6-25	7	4.6	3025-406
V-433	MT4	ER50	12-34	12	9	3025-407
V-434	MT5	ER40	4-26	23	8.2	3026-401
V-435			4-26	15	6.9	3026-402
V-436			6-25	7	5.4	3026-403
V-437	MT5	ER50	12-34	12	9.5	3026-404



ER Spring Collet Chuck System VERTEX®

Collet Holders With Straight Shank

DIN6499 STRAIGHT SHANK



ER COLLET ØD CLAMPING RANGE	
ER-8	Ø0.5~5
ER-11	Ø0.5~7
ER-16	Ø0.5~10
ER-20	Ø1~13
ER-25	Ø1~16
ER-32	Ø2~20
ER-40	Ø3~26
ER-50	Ø10~34



METRIC SIZE

ORDER NO.	COLLET TYPE	SHANK D1XL1	L	D	J	KGS	CODE NO.
V-530	ER11	Ø16X50	21	19	M6	0.1	3007-300
V-531		Ø16X100	21	19	M6	0.2	3007-311
V-532		Ø16X150	21	19	M6	0.3	3007-312
V-501A	ER16	Ø16X100	21	28	M10	0.3	3003-301A
V-501	ER16	Ø20X50	30	28	M10	0.2	3003-301
V-502		Ø20X100	30	28	M10	0.3	3003-302
V-503		Ø20X150	30	28	M10	0.4	3003-303
V-504	ER16	Ø25X100	30	28	M10	0.5	3003-304
V-504A		Ø25X50	30	28	M10	0.3	3003-306
V-505		Ø25X150	30	28	M10	0.7	3003-305
V-505A		Ø25X200	30	28	M10	0.5	3003-307
V-506	ER20	Ø20X50	36	34	M12	0.3	3004-301
V-507		Ø20X100	36	34	M12	0.3	3004-302
V-508		Ø20X150	36	34	M10	0.5	3004-303
V-509	ER20	Ø25X150	36	34	M10	0.7	3004-304
V-509A		Ø25X100	36	34	M12	0.5	3004-305
V-509B		Ø25X50	36	34	M12	0.3	3004-306
V-510	ER25	Ø20X50	46	42	M12	0.4	3005-301
V-511		Ø20X100	46	42	M12	0.5	3005-302
V-512		Ø20X150	46	42	M12	0.6	3005-303
V-513	ER25	Ø25X100	46	42	M12	0.6	3005-304
V-514		Ø25X150	46	42	M12	0.7	3005-305
V-515		Ø32X60	46	42	M12	0.6	3005-306
V-516	ER32	Ø25X80	54	50	M12	0.8	3006-301
V-517		Ø32X100	54	50	M12	1.1	3006-302
V-517A		Ø32X150	54	50	M12	1.5	3006-305
V-518		Ø40X100	54	50	M12	1.4	3006-303
V-523	ER40	Ø32X100	55	63	M16	1.5	3007-302
V-524		Ø40X100	55	63	M16	1.8	3007-303

With Flat Shank

NEW

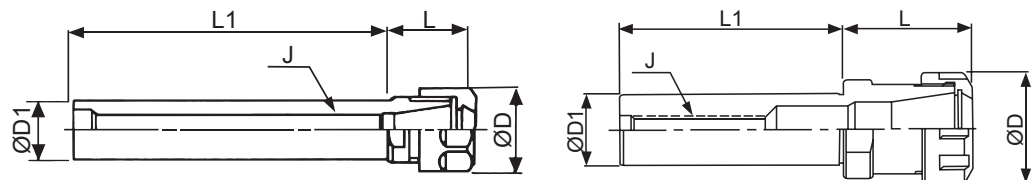

INCH SIZE

ORDER NO.	COLLET TYPE	SHANK D1XL1	L	D	J	KGS	CODE NO.
V-571	ER16	ST 5/8" X 4"	36	28	3/8"-16	0.2	3003-320
V-572		ST 3/4" X 4"	32			0.24	3003-321
V-573		ST 3/4" X 6"	32			0.32	3003-322
V-574		ST 1" X 4"	32			0.35	3003-323
V-575	ER20	ST 3/4" X 4"	34	34	3/8"-16	0.25	3004-320
V-576		ST 3/4" X 6"	34			0.33	3004-321
V-577		ST 1" X 4"	34			M12	0.36
V-578	ER32	ST 1" X 3"	58	50	M12	0.5	3006-320
V-579		ST 1-1/4" X 4"	58			0.6	3006-321



ER Spring Collet Chuck System



DIN 6499 STRAIGHT SHANK



Collet Chuck Kit With Straight Shank

Including shank, full set of collets, wrench and case.

ER COLLET ØD CLAMPING RANGE	
ER-8	Ø0.5~5
ER-11	Ø0.5~7
ER-16	Ø0.5~10
ER-20	Ø1~13
ER-25	Ø1~16
ER-32	Ø2~20
ER-40	Ø3~26
ER-50	Ø10~34

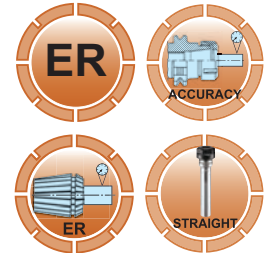

COLLET CHUCK SETS

ORDER NO.	SHANK D1XL1	COLLET TYPE	SET RANGE	SET PCS	KGS	CODE NO.
V-601	Ø20X50L	ER16	1-10	10	0.9	3003-401
V-602	Ø20X50L		3-10	8	0.8	3003-402
V-603	Ø20X100L		1-10	10	1	3003-403
V-604	Ø20X100L		3-10	8	0.9	3003-404
V-605	Ø20X150L		1-10	10	1.1	3003-405
V-606	Ø20X150L		3-10	8	0.5	3003-406
V-607	Ø25X100L	ER16	1-10	10	1.1	3003-407
V-607A	Ø25X50L		1-10	10	1.1	3003-411
V-608	Ø25X100L		3-10	8	1.1	3003-408
V-608A	Ø25X50L		3-10	8	1.1	3003-412
V-609	Ø25X150L		1-10	10	1.3	3003-409
V-610	Ø25X150L		3-10	8	1.3	3003-410
V-611	Ø20X50L	ER20	2-13	12	1.2	3004-401
V-612	Ø20X50L		4-13	10	1.2	3004-402
V-613	Ø20X100L		2-13	12	1.2	3004-403
V-614	Ø20X100L		4-13	10	1.2	3004-404
V-615	Ø20X150L		2-13	12	1.4	3004-405
V-616	Ø20X50L		4-13	10	1.3	3004-406
V-615A	Ø25X50L	ER20	2-13	12	1.3	3004-409
V-616A	Ø25X50L		4-13	10	1.3	3004-410
V-617	Ø25X100L		2-13	12	1.4	3004-407
V-617A	Ø25X150L		2-13	12	1.5	3004-411
V-618	Ø25X100L		4-13	10	1.4	3004-408
V-618A	Ø25X150L		4-13	10	1.5	3004-412
V-619	Ø20X50L	ER25	2-16	15	2.2	3005-401
V-621	Ø20X50L		4-16	7	1.7	3005-403
V-622	Ø20X100L		2-16	15	2.3	3005-404
V-624	Ø20X100L		4-16	7	1.8	3005-406
V-625	Ø20X150L		2-16	15	2.4	3005-407
V-627	Ø20X150L		4-16	7	2	3005-409
V-628	Ø25X100L	ER25	2-16	15	2.3	3005-410

ORDER NO.	SHANK D1XL1	COLLET TYPE	SET RANGE	SET PCS	KGS	CODE NO.
V-681	Ø16X50L	ER11	1-7	13	0.5	3002-401
V-682	Ø16X50L		1-7	7	0.5	3002-402
V-683	Ø16X100L	ER11	1-7	13	0.6	3002-403
V-684	Ø16X100L		1-7	7	0.5	3002-404

ORDER NO.	SHANK D1XL1	COLLET TYPE	SET RANGE	SET PCS	KGS	CODE NO.
V-630	Ø25X100L	ER25	6-16	7	2	3005-412
V-631	Ø25X150L		2-16	15	2.6	3005-413
V-633	Ø25X150L		6-16	7	1.9	3005-415
V-634	Ø32X60L	ER25	2-16	15	2.5	3005-416
V-636	Ø32X60L		6-16	7	1.9	3005-418
V-637	Ø25X80L	ER32	3-20	18	4.1	3006-401
V-638	Ø25X80L		4-20	11	3	3006-402
V-639	Ø25X80L		3-20	6	2.7	3006-403
V-640	Ø32X100L	ER32	4-20	18	4.3	3006-404
V-641	Ø32X100L		6-20	11	3.2	3006-405
V-642	Ø32X100L		6-20	6	2.9	3006-406
V-643	Ø40X100L	ER32	3-20	18	4.6	3006-407
V-644	Ø40X100L		4-20	11	3.5	3006-408
V-645	Ø40X100L		6-20	6	3.2	3006-409
V-646	Ø1"X3L	ER32	3-20	18	4.1	3006-410
V-647	Ø1"X3L		4-20	11	3	3006-411
V-648	Ø1"X3L		6-20	6	2.9	3006-412
V-658	Ø32X100L	ER40	4-26	23	7.3	3007-404
V-659	Ø32X100L		4-26	15	6.1	3007-405
V-660	Ø32X100L		6-25	7	4.6	3007-406
V-661	Ø40X100L	ER40	4-26	23	7.6	3007-407
V-662	Ø40X100L		4-26	15	6.5	3007-408
V-663	Ø40X100L		6-25	7	5	3007-409

- V-603, V-604 are the most popular item.
- THE ER-20/25/32/40 ARE TO BE CONTINUED
- V-613, V-614 are the most popular item.

ER SYSTEM

ER Spring Collet Chuck System

MINI TYPE STRAIGHT SHANK HOLDER

DIN 6499 MINI STRAIGHT SHANK

NEW

ER COLLET ØD CLAMPING RANGE	
ER-8	Ø0.5~5
ER-11	Ø0.5~7
ER-16	Ø0.5~10
ER-20	Ø1~13
ER-25	Ø1~16
ER-32	Ø2~20
ER-40	Ø3~26
ER-50	Ø10~34

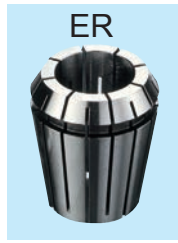
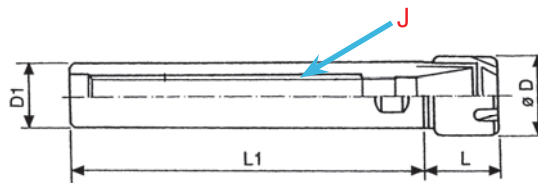

COLLET HOLDER (MINI TYPE)

ORDER NO.	COLLET TYPE	SHANK D1XL1	D	L	J	KGS	CODE NO.
V-541	ER8M	ST08X50L	12	24		0.04	3001-290
V-542		ST10X50L		19		0.05	3001-291
V-543		ST10X80L		19		0.07	3001-292
V-544	ER8M	ST12X50L	12	14		0.05	3001-293
V-545		ST12X100L		14		0.09	3001-294
V-546		ST12X150L		14		0.12	3001-295
V-551	ER11M	ST16X50L	16	22	M6	0.1	3011-301
V-552		ST16X100L	16			0.2	3011-302
V-552A		ST16X150L	16			0.3	3011-303
V-553	ER16M	ST20X50L	22	32	M10	0.2	3012-301
V-554		ST20X100L	22			0.3	3012-302
V-555		ST20X150L	22			0.4	3012-303
V-555A		ST20X200L	22			0.4	3012-307
V-556	ER20M	ST20X50L	28	33	M12	0.2	3013-301
V-557		ST20X100L	28			0.3	3013-302
V-558		ST20X150L	28			0.4	3013-303
V-559	ER20M	ST25X100L	28	33	M12	0.4	3013-304
V-560		ST25X150L	28			0.6	3013-305
V-561	ER16M	ST16X100L	22	22	M10	0.2	3012-304
V-562	ER16M	ST25X100L	22	22	M10	0.4	3012-305
V-563		ST25X150L	22			0.6	3012-306
V-563A		ST25X200L	22			32	0.5
V-557A	ER20M	ST20X200L	28	35	M12	0.4	3013-306
V-560A		ST25X200L	28			0.5	3013-307

※ For the 50L A side of the shank is milled has flate surface.

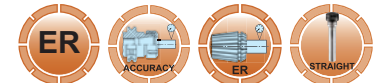

MINI TYPE NUT Collet Chuck Kit With Straight Shank

Including shank,
full set of collets,
wrench and case.

MINI TYPE

ORDER NO.	SHANK D1XL1	COLLET TYPE	SET RANGE	SET PCS	KGS	CODE NO.
V-691A	ST16X50L	ER11M	1-7	7	0.5	3011-401
V-691B	ST16X50L		1-7	13	0.5	3011-402
V-692A	ST16X100L	ER11M	1-7	7	0.6	3011-403
V-692B	ST16X100L		1-7	13	0.6	3011-404
V-693A	ST20X50L	ER16M	1-10	10	0.7	3012-401
V-693B	ST20X50L		3-10	8	1.0	3012-402
V-693C	ST16X100L	ER16M	1-10	10	0.6	3012-407
V-694A	ST20X100L	ER16M	1-10	10	0.9	3012-403
V-694B	ST20X100L		3-10	8	1.1	3012-404
V-695A	ST20X150L		1-10	10	1.3	3012-405
V-695B	ST20X150L		3-10	8	1.2	3012-406
V-695C	ST25X100L	ER16M	1-10	10	1.2	3012-408
V-695D	ST25X150L		1-10	10	1.4	3012-409
V-696A	ST20X50L	ER20M	2-13	12	1.3	3013-401
V-696B	ST20X50L		4-13	10	1.2	3013-402
V-697A	ST20X100L		2-13	12	1.1	3013-403
V-697B	ST20X100L		4-13	10	1.1	3013-404
V-698A	ST20X150L	ER20M	2-13	12	1.2	3013-405
V-698B	ST20X150L		4-13	10	1.2	3013-406
V-698C	ST25X100L		2-13	12	1.4	3013-407
V-698D	ST25X150L		2-13	12	1.5	3013-408



MINI TYPE NUT



Clamping Nuts For Collets



ER CLAMPING NUT SYSTEM

DIN 6499

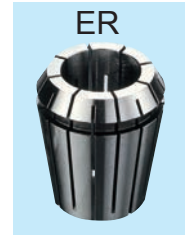

ER20M



ER16M



ER11MS



ER40KM
WITH A BEARING



ER40UM



ER16UM

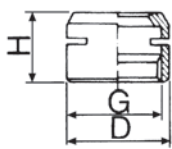

FIG.1 ER11,16,20MS

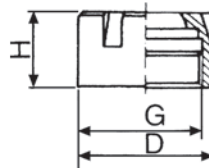

FIG.2 ER11,16,20M
ER8M, 25M

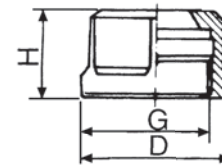

FIG.3 ER11,16,20UM

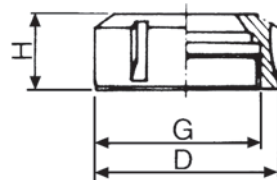

FIG.4 ER25,32,40,50UM

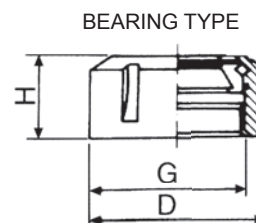

FIG.5 ER40,50KM



ER NUT SYSTEM

CLAMPING NUTS

ORDER NO.	Fig.	COLLET TYPE	D	H	G	WEIGHT KG.	CODE NO.
V-800	3	ER11UM	19	11.5	M14X0.75P	0.04	3015-001
V-801	3	ER16UM	28	17	M22X1.5P	0.05	3015-002
V-802	3	ER20UM	34	19	M25X1.5P	0.09	3015-003
V-803	4	ER25UM	42	20	M32X1.5P	0.13	3015-004
V-804	4	ER32UM	50	23	M40X1.5P	0.14	3015-005
V-805	4	ER40UM	63	25	M50X1.5P	0.25	3015-006
V-806	4	ER50UM	78	35	M64X2.0P	0.5	3015-007
V-807	1	ER11MS	16	12	M13X0.75P	0.008	3015-008
V-808	2	ER16M	22	18	M19X1.0P	0.03	3015-009
V-809	2	ER20M	28	19	M24X1.0P	0.045	3015-010
V-810A	5	ER40KM	63	29	M50X1.5P	0.3	3015-011
V-810B	5	ER50KM	78	40	M64X2.0P	0.58	3015-012
V-810C	2	ER11M	16	12	M13X0.75P	0.02	3015-013
V-810D	2	ER8M	12	10.8	M10X0.75P	0.05	3015-014
V-810E	2	ER25M	35	20	M30X1.0P	0.05	3015-015
V-811A		ER16MS	22	18	M19X1.0P	0.02	3015-016
V-811B		ER20MS	28	19	M24X1.0P	0.035	3015-017



Clamping Wrench For Collets



VERTEX®

ER WRENCH SYSTEM

DIN6499



ERMS

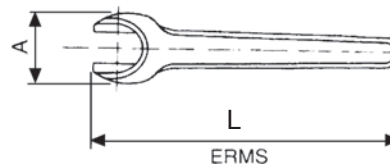

ERM

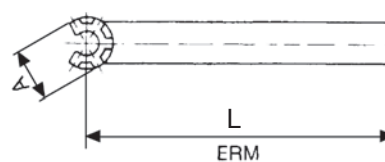

ERUM11, 16, 20

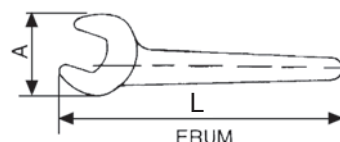

ERUM25, 32, 40, 50

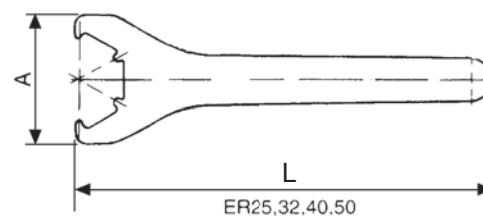

ORDER NO.	TYPE	A	L	KGS	CODE NO.
V-820	ER11UM	35	135	0.07	3015-100
V-821	ER11MS	22	100	0.07	3015-101
V-822	ER11M	17	95	0.05	3015-102
V-823	ER16M	22.5	118	0.06	3015-103
V-815	ER16UM	44	140	0.08	3015-104
V-824	ER20M	28	130	0.08	3015-105
V-816	ER20UM	53	170	0.1	3015-106
V-811	ER25UM	65	210	0.2	3015-107
V-812	ER32UM	75	250	0.4	3015-108
V-813	ER40UM	90	290	0.5	3015-109
V-814	ER50UM	110	350	0.9	3015-110
V-817	ER8M	13	75	0.04	3015-111
V-818	ER25M	36.5	135	0.1	3015-112
V-825	ER40KM	90	290	0.5	3015-113
V-826	ER50KM	110	350	0.9	3015-114
V-827	ER16MS	32	120	0.12	3015-115
V-828	ER20MS	38	150	0.15	3015-116



ER Spring Collet Chuck System



Collet Holders With BT Taper Shank
(For CNC Machine Center)
ER-32 ER-40

MAS403 BT-SHANK

ER COLLET ØD CLAMPING RANGE	
ER-8	Ø0.5~5
ER-11	Ø0.5~7
ER-16	Ø0.5~10
ER-20	Ø1~13
ER-25	Ø1~16
ER-32	Ø2~20
ER-40	Ø3~26
ER-50	Ø10~34



ACCURACY
RUNOUT 0.005mm
TAPER SHANK AT-3
R.P.M. 7000

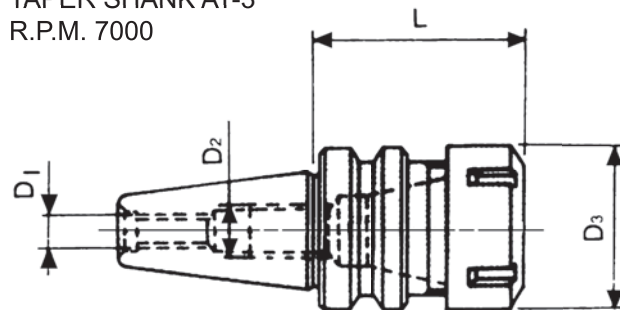

ER SYSTEM

ORDER NO.	TAPER	COLLET TYPE	D1	D2	D3	L	KGS	CODE NO.
V-700	BT30	ER32	M12	M12X1.75P	50	60	0.7	3031-303
V-703A	BT40	ER32	M16X2.0P	M22X1.5P	50	70	1.4	3032-305
V-703B		ER32	M16X2.0P	M22X1.5P	50	100	1.7	3032-306
V-704		ER40	M16X2.0P	M22X1.5P	63	80	1.7	3032-307
V-704B		ER40	M16X2.0P	M22X1.5P	63	100	2	3032-421
V-705		BT50	ER32	M24X3.0P	M28X1.5P	50	100	4.5
V-706	ER40		M24X3.0P	M28X1.5P	63	100	4.6	3033-306
V-706B	ER40		M24X3.0P	M28X1.5P	63	150	5.7	3033-307
V-707	ER50		M24X3.0P	M36X1.5P	78	100	5.1	3033-308
V-710	BT30	ER11	M12	M12X1.75P	19	60	0.5	3033-311
V-711		ER11	M12	M12X1.75P	19	100	0.6	3033-312
V-712		ER11M	M12	M12X1.75P	16	100	0.9	3033-313
V-713		ER16	M12	M12X1.75P	28	100	0.8	3033-314
V-714		ER16M	M12	M12X1.75P	22	100	0.7	3033-315
V-715		ER20	M12	M12X1.75P	34	60	0.6	3033-316
V-716		ER20	M12	M12X1.75P	34	100	0.9	3033-317
V-717		ER20M	M12	M12X1.75P	28	100	0.9	3033-318
V-718		ER25	M12	M12X1.75P	42	60	0.7	3033-319
V-719		ER40	M12	M12X1.75P	63	70	1	3033-320
V-720	BT40	ER11	M16	M22X1.5P	19	70	1.2	3033-321
V-721		ER11	M16	M22X1.5P	19	100	1.5	3033-322
V-722A		ER11M	M16	M22X1.5P	16	100	1.05	3033-323
V-722B		ER11M	M16	M22X1.5P	16	150	1.3	3033-323A
V-723A		ER16M	M16	M22X1.5P	22	100	1.3	3033-324
V-723B		ER16M	M16	M22X1.5P	22	150	1.5	3033-330
V-724A		ER20M	M16	M22X1.5P	28	100	1.6	3033-325
V-724B		ER20M	M16	M22X1.5P	28	150	1.6	3033-331
V-725		ER25	M16	M22X1.5P	42	70	1.3	3033-326
V-726		ER25	M16	M22X1.5P	42	100	1.6	3033-327
V-727		ER50	M16	M22X1.5P	78	90	2.2	3033-328



ER Spring Collet Chuck System VERTEX®

Collet Holders With Extension Type BT Taper Shank
ER-16, ER-20

ER COLLET ØD CLAMPING RANGE	
ER-8	Ø0.5~5
ER-11	Ø0.5~7
ER-16	Ø0.5~10
ER-20	Ø1~13
ER-25	Ø1~16
ER-32	Ø2~20
ER-40	Ø3~26
ER-50	Ø10~34

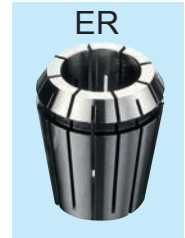

BT-40-ER20

ACCURACY
RUNOUT 0.005mm
TAPER SHANK AT-3
R.P.M. 7000

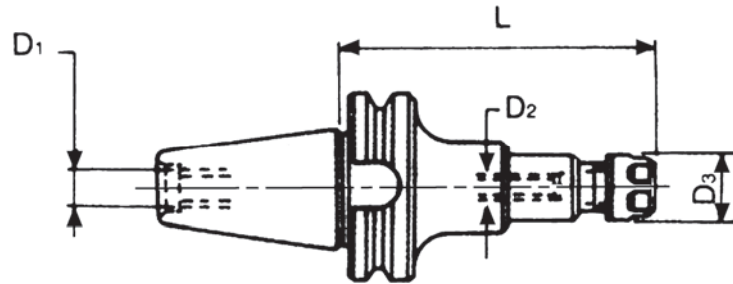

ORDER NO.	TAPER	COLLET TYPE	D3	L	D1	WEIGHT KGS	CODE NO.
V-770	BT30	ER16	28	60	M12	0.6	3031-301
V-772	BT40	ER16	28	70	M16	1.2	3032-301
V-773			28	100	M16	1.4	3032-302
V-774A			28	150	M16	1.7	3032-308
V-774			34	70	M16	1.3	3032-303
V-775	BT40	ER20	34	100	M16	1.5	3032-304
V-775A			34	135	M16	1.6	3032-309
V-775B			34	150	M16	1.9	3032-310
V-775C			BT40	ER25	42	150	M16
V-733	BT40	ER32	50	150	M16	2	3033-354
V-776	BT50	ER16	28	100	M24	2.3	3033-301
V-777			28	150	M24	4.3	3033-302
V-743A			28	200	M24	7.5	3033-364
V-778	BT50	ER20	34	100	M24	4.1	3033-303
V-779			34	150	M24	4.8	3033-304
V-735			34	200	M24	5	3033-356
V-736	BT50	ER25	42	100	M24	4.3	3033-357
V-737A			42	150	M24	4.8	3033-358
V-744A			42	200	M24	8	3033-365
V-738A	BT50	ER32	50	150	M24	5.5	3033-359
V-739A			50	200	M24	6.5	3033-360
V-741A	BT50	ER40	63	200	M24	7.5	3033-362
V-742A	BT50	ER50	78	150	M24	6.7	3033-363



ER Spring Collet Chuck System



MAS403 BT-SHANK DIN 6499

ER COLLET ØD CLAMPING RANGE

ER-8	Ø0.5~5
ER-11	Ø0.5~7
ER-16	Ø0.5~10
ER-20	Ø1~13
ER-25	Ø1~16
ER-32	Ø2~20
ER-40	Ø3~26
ER-50	Ø10~34



Collet Chuck Kit With BT Taper Shank

Including shank, full set of collets, wrench and case.

- 1.ER16, ER20 PACKED IN WOODEN BOX
- 2.ER32, ER40, ER50, PACKED IN PLASTIC BOX
- 3.PACKAGE INCLUDING : CHUCK, COLLET, WRENCH, BOX

Caution:

Please notify the taper size, collet type, set range, and set numbers when ordering.

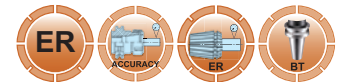

ER SYSTEM

ORDER NO.	BT TAPER	COLLET TYPE	SET RANGE	COLLET PCS	WEIGHT KGS	CODE NO.
V-780	BT30-60L	ER16	1-10	10	1.9	3031-401
V-780A	BT30-100L	ER16	1-10	10	2	3031-406
V-781	BT40-70L	ER16	1-10	10	2.3	3032-401
V-782	BT40-100L	ER16	1-10	10	2.7	3032-402
V-783	BT30-60L	ER20	2-13	12	2.5	3031-402
V-783A	BT30-100L	ER20	2-13	12	2.6	3032-413
V-783B	BT30-60L	ER25	2-16	15	2.5	3032-414
V-783C	BT30-60L	ER25	4-16	7	2.8	3032-415
V-784	BT40-100L	ER20	2-13	12	3	3032-403
V-784A	BT40-70L	ER20	2-13	12	2.8	3032-416
V-784B	BT40-70L	ER25	2-16	15	3.2	3032-417
V-784C	BT40-100L	ER25	4-16	7	3	3032-418
V-785	BT30-60L	ER32	3-20	18	4.4	3031-403
V-786	BT30-60L	ER32	4-20	11	3.8	3031-404
V-787	BT30-60L	ER32	6-20	6	3.4	3031-405
V-788	BT40-70L	ER32	3-20	18	5.2	3032-404
V-789	BT40-70L	ER32	4-20	11	4.2	3032-405
V-790	BT40-70L	ER32	6-20	6	3.8	3032-406
V-791	BT40-100L	ER32	3-20	18	5.7	3032-407
V-792	BT40-100L	ER32	4-20	11	4.7	3032-408
V-793	BT40-100L	ER32	6-20	6	4.3	3032-409
V-794	BT40-80L	ER40	4-26	23	8.9	3032-410
V-795	BT40-80L	ER40	4-26	15	7.6	3032-411
V-796	BT40-80L	ER40	6-25	7	6	3032-412
V-797	BT50-100L	ER40	4-26	23	11.3	3033-401
V-798	BT50-100L	ER40	4-26	15	10	3033-402
V-799	BT50-100L	ER40	6-26	7	8.5	3033-403
V-737	BT50-150L	ER40	4-26	23	12.2	3033-404
V-738	BT50-150L	ER40	4-26	15	11	3033-405
V-739	BT50-150L	ER40	6-26	7	9.5	3033-406
V-740	BT50-100L	ER50	12-34	12	12	3033-407
V-740C	BT40-90L	ER50	12-34	12	9	3033-408
V-740B	BT50-100L	ER32	3-20	18	7.5	3033-409



ST/ER Straight Shank With Double Head Spindle



M TYPE DOUBLE HEAD

FOR CNC LATHE ONLY

UM TYPE



M TYPE

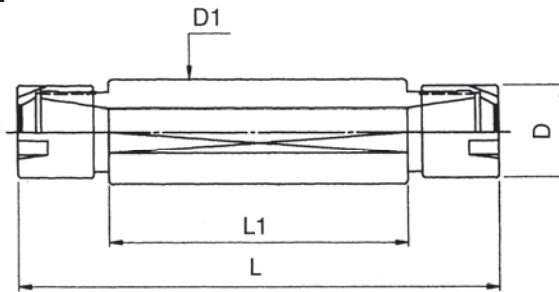

ER COLLET ØD CLAMPING RANGE	
ER-8	Ø0.5~5
ER-11	Ø0.5~7
ER-16	Ø0.5~10
ER-20	Ø1~13
ER-25	Ø1~16
ER-32	Ø2~20
ER-40	Ø3~26
ER-50	Ø10~34

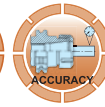

M TYPE

ORDER NO.	COLLET TYPE	SHANK (ØD1-ER-L1)	L	L1	D	WEIGHT (KGS)	CODE NO.
V-830	ER11	Ø20-ER11M2-50	70	50	16	0.2	3032-430
V-831		Ø20-ER11M2-78	108	78	16	0.3	3032-431
V-832	ER16	Ø20-ER16M2-50	82	50	22	0.2	3032-432
V-833		Ø20-ER16M2-70	112	70	22	0.32	3032-433
V-834	ER16	Ø25-ER16M2-50	92	50	22	0.25	3032-434
V-835		Ø25-ER16M2-80	122	80	22	0.35	3032-435
V-836	ER20	Ø25-ER20M2-50	92	50	28	0.3	3032-436
V-837		Ø25-ER20 M2-80	122	80	28	0.35	3032-437

UM TYPE

ORDER NO.	COLLET TYPE	SHANK (ØD1-ER-L1)	L	L1	D	WEIGHT (KGS)	CODE NO.
V-855	ER11	Ø20-ER11 UM2-50	80	50	19	0.15	3032-428
V-856		Ø20-ER11 UM2-70	100	70	19	0.19	3032-429
V-859	ER16	Ø25-ER16 UM2-80	124	80	28	0.35	3032-439
V-862	ER20	Ø25-ER20 UM2-80	134	80	34	0.38	3032-438



ST/ER Straight Shank With Single Head Spindle

FOR CNC LATHE ONLY

M TYPE SINGLE HEAD



UM TYPE

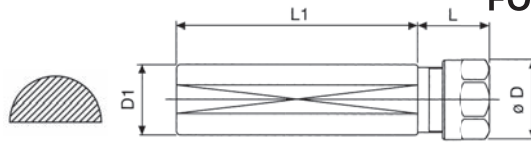

M TYPE SINGLE HEAD

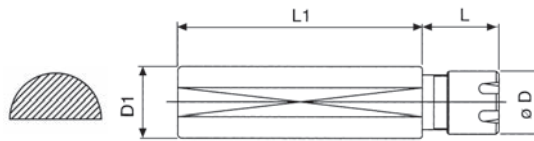

UM TYPE



ORDER NO.	COLLET TYPE	SHANK (ØD1-ER-L1)	L	L1	D	WEIGHT (KGS)	CODE NO.
V-841	ER16	Ø20-ER16M-70	21	70	22	0.2	3032-441
V-842		Ø25-ER16M-70	21	70	22	0.25	3032-442
V-843		Ø3/4"-ER16M-70	21	70	22	0.2	3032-443
V-844	ER16	Ø20-ER16UM-70	21	70	28	0.2	3032-444
V-845		Ø25-ER16UM-70	21	70	28	0.25	3032-445
V-846		Ø3/4"-ER16UM-70	21	70	28	0.2	3032-446
V-847	ER20	Ø22-ER20UM-70	23	70	34	0.25	3032-447
V-848		Ø25-ER20UM-70	23	70	34	0.3	3032-448



ER Collet Chuck System



MAS403 BT30/40/50 SHANK

ULTRA PRECISION TYPE
MAX. SPEED: 15,000RPM; G2.5
DYNAMIC BALANCE TESTED

ER COLLET ØD CLAMPING RANGE	
ER-8	Ø0.5~5
ER-11	Ø0.5~7
ER-16	Ø0.5~10
ER-20	Ø1~13
ER-25	Ø1~16
ER-32	Ø2~20
ER-40	Ø3~26
ER-50	Ø10~34

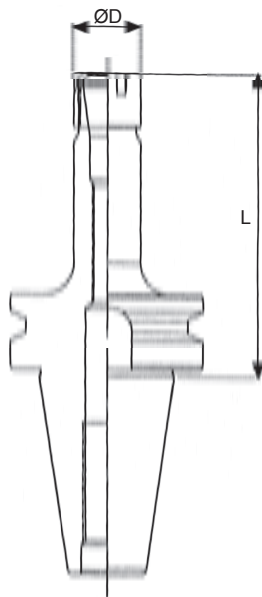
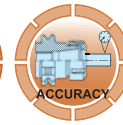

ORDER NO.	L	ØD	COLLET	WEIGHT (kg)	CODE NO.
BT30-ER11-60-B	60	19	ER11	0.5	3033-500
BT30-ER11-100-B	100	19	ER11	0.55	3033-501
BT30-ER16-60-B	60	28	ER16	0.5	3033-502
BT30-ER16-100-B	100	28	ER16	0.7	3033-503
BT30-ER20-60-B	60	34	ER20	0.55	3033-504
BT30-ER20-100-B	100	34	ER20	0.8	3033-505
BT30-ER25-60-B	60	42	ER25	0.6	3033-506
BT30-ER32-60-B	60	50	ER32	0.65	3033-507
BT40-ER11-70-B	70	19	ER11	1	3033-509
BT40-ER11-100-B	100	19	ER11	1.1	3033-510
BT40-ER16-70-B	70	28	ER16	1.1	3033-511
BT40-ER16-100-B	100	28	ER16	1.2	3033-512
BT40-ER20-70-B	70	34	ER20	1.2	3033-514
BT40-ER20-100-B	100	34	ER20	1.4	3033-515
BT40-ER25-70-B	70	42	ER25	1.2	3033-518
BT40-ER25-100-B	100	42	ER25	1.45	3033-519
BT40-ER32-70-B	70	50	ER32	1.3	3033-521
BT40-ER32-100-B	100	50	ER32	1.5	3033-522
BT30-ER11M-100-B	100	16	ER11	0.5	3033-523
BT30-ER16M-100-B	100	22	ER16	0.55	3033-524
BT30-ER20M-100-B	100	28	ER20	0.65	3033-525
BT40-ER11M-100-B	100	16	ER11	1.05	3033-526
BT40-ER16M-100-B	100	22	ER16	1.1	3033-527
BT40-ER20M-100-B	100	28	ER20	1.2	3033-528

ER SYSTEM



ER-SK Taper Shank



COLLET HOLDER WITH SK-SHANK
DIN 69871

& COLLET CHUCK SET DIN 69871

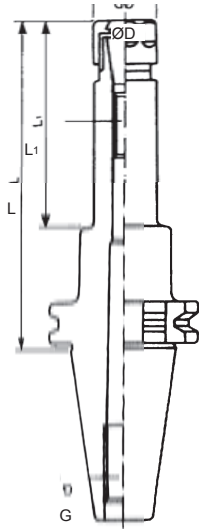

ER COLLET ØD CLAMPING RANGE	
ER-8	Ø0.5~5
ER-11	Ø0.5~7
ER-16	Ø0.5~10
ER-20	Ø1~13
ER-25	Ø1~16
ER-32	Ø2~20
ER-40	Ø3~26
ER-50	Ø10~34



ORDER NO.	COLLET TYPE	TAPER	D	L	G	WEIGHT KGS	CODE NO.
V-741	ER16	SK40	28	100	M16	1.5	3029-301
V-741K	ER16	SK30	28	60	M12	0.45	3029-311
V-741B	ER16	SK50	28	100	M24	3.5	3029-317
V-742	ER20	SK40	34	100	M16	1.5	3029-302
V-742C	ER16	SK40	28	70	M16	1.1	3029-315
V-742D	ER20	SK40	34	70	M16	1.2	3029-316
V-742E	ER20	SK50	34	100	M24	3.5	3029-318
V-744	ER20	SK50	34	150	M24	4.8	3030-302

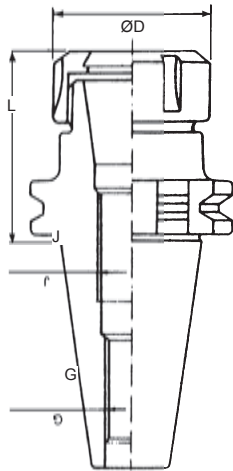

ORDER NO.	COLLET TYPE	TAPER	D	L	G	WEIGHT KGS	CODE NO.
V-745	ER32	SK40	50	70	M16	1.2	3029-303
V-745A	ER32	SK30	50	60	M12	0.8	3029-314
V-745B	ER32	SK50	50	100	M24	3.7	3029-320
V-746	ER40	SK40	63	80	M16	1.6	3029-304
V-747	ER40	SK50	63	100	M24	4.2	3030-303
V-749	ER25	SK40	42	70	M16	1.1	3030-304
V-749A	ER25	SK50	42	100	M24	3.4	3029-319

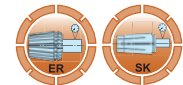

COLLET CHUCK KIT WITH SK-SHANK DIN 69871

INCLUDING SHANK, FULL SET OF COLLETS, WRENCH AND CASE.



ORDER NO.	ER TYPE	SK TAPER	SET RANGE	SET PCS	WEIGHT KGS	CODE NO.
V-751	ER16	SK40-70L	1-10	10PCS	2.3	3029-401
V-751A	ER16	SK30-60L	1-10	10PCS	1.8	3029-420
V-752	ER20	SK40-70L	2-13	12PCS	3	3029-402
V-753	ER32	SK40-70L	3-20	18PCS	5.2	3029-403
V-754	ER32	SK40-70L	4-20	11PCS	4.2	3029-404
V-754A	ER32	SK30-60L	3-20	18PCS	4.2	3029-423
V-754B	ER32	SK50-100L	3-20	18PCS	7	3029-424
V-755	ER32	SK40-70L	6-20	6PCS	3.8	3029-405
V-756	ER40	SK40-80L	4-26	23PCS	8.9	3029-406
V-757	ER40	SK40-80L	4-26	15PCS	7.6	3029-407
V-758	ER40	SK40-80L	6-25	7PCS	6	3029-408
V-759	ER40	SK50-100L	4-26	23PCS	11.3	3030-401
V-760	ER40	SK50-100L	4-26	15PCS	10	3030-402
V-761	ER40	SK50-100L	6-26	7PCS	8.5	3030-403
V-762	ER25	SK40-70L	2-16	15PCS	3.5	3029-409
V-763	ER25	SK40-70L	4-26	7PCS	3.2	3029-410

ER16, ER20 PACKED IN WOODEN CASE
ER32, ER40 PACKED IN PLASTIC CASE



ER Spring Collet Chuck System



COLLET HOLDER WITH CAT-SHANK

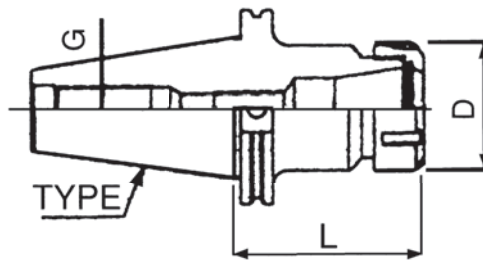

ER COLLET ØD CLAMPING RANGE	
ER-8	Ø0.5~5
ER-11	Ø0.5~7
ER-16	Ø0.5~10
ER-20	Ø1~13
ER-25	Ø1~16
ER-32	Ø2~20
ER-40	Ø3~26
ER-50	Ø10~34

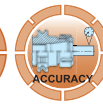
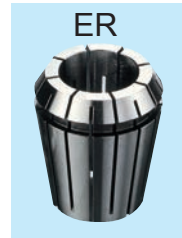

ORDER NO.	COLLET TYPE	TAPER	D	L	G	WEIGHT KGS	CODE NO.
V-870	ER16	CAT30	28	2"	1/2"-13	0.8	3034-301
V-871	ER16	CAT40	28	3"	5/8"-11	1.1	3035-301
V-872	ER20		34	3"		1.2	3035-302
V-873	ER25		42	2-1/2"		1.2	3035-303
V-874	ER32		50	2-1/2"		1.2	3035-304
V-875	ER40		63	3"		1.5	3035-305
V-876	ER40		CAT50	63		3-1/2"	1/8"

COLLET CHUCK KIT WITH CAT-SHANK

INCLUDING SHANK, FULL SET OF COLLET, WRENCH AND CASE.

1. ER16, ER20, ER25 PACKED IN WOODEN BOX.
2. ER32, ER40, PACKED IN PLASTIC BOX.
3. PACKAGE INCLUDING: CHUCK, COLLET, WRENCH, BOX.



ORDER NO.	COLLET TYPE	CAT TAPER	SET RANGE	SET PCS	WEIGHT KGS	CODE NO.
V-878	ER16	CAT40-3"L	1.0-10	10	2.3	3035-401
V-879	ER20	CAT40-3"L	2.0-13	12	2.5	3035-402
V-880	ER25	CAT40-2 1/2"L	2.0-16	15	3	3035-403
V-881		CAT40-2 1/2"L	4.0-16	7	2.8	3035-404
V-882	ER32	CAT40-2 1/2"L	3.0-20	18	5.2	3035-405
V-883		CAT40-2 1/2"L	4.0-20	11	4.2	3035-406
V-884		CAT40-2 1/2"L	6.0-20	6	3.8	3035-407
V-885	ER40	CAT40-3"L	4.0-26	23	8.9	3035-408
V-886		CAT40-3"L	4.0-26	15	7.6	3035-409
V-887		CAT40-3"L	6.0-25	7	6	3035-410
V-888	ER40	CAT50-3 1/2"L	4.0-26	23	11.2	3036-401
V-889		CAT50-3 1/2"L	4.0-26	15	9.8	3036-402
V-890		CAT50-3 1/2"L	6.0-25	7	8.3	3036-403

ER SYSTEM



Milling Chuck



COLLET HOLDER WITH #25
COLLET CHUCK DIN 6388 TYPE A
OZ-25

DIN 6388 # 25 SERIES
DIN 2080 NT-SHANK



VB-NT40
WITH MAHO GROOVE



VB-MT3



VB-R8



OZ-25 SERIES

1. Best selected quality tool steel hardened & Precision ground.
2. Accuracy of concentric to within 0.008" per inch. (0.02mm per 25 mm)
3. High rigidity & Clamping force.
4. 1 set including : 1 chuck shank holder
1 wrench ; 1 case.
7 or 15 pcs of collet.

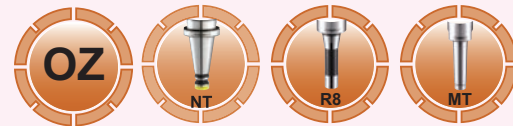

CHUCK SHANK ONLY

ORDER NO.	CHUCK SHANK	DRAW BAR THREADS		WEIGHT(kg)		MEAS. CFT	CODE NO.
		SAE	METRIC	SAE	METRIC		
VB-MT-2	MT2		M10X1.5P	1	1	0.3	3101-001
VB-MT-3	MT3	3/8"-16	M10X1.5P	1.1	1	0.3	3101-002
		1/2"-12	M12X1.75P				
		1/2"-13	M12X1.75P				
VB-MT-4	MT4	5/8"-11	M16X2.0P		1.4	0.3	3101-003
VB-MT-5	MT5	1"-8	M24X3.0P		2	0.5	3101-004
VB-R8	R-8	7/16"-20		1.3		0.3	3101-005
VB-NT30	NT30	1/2"-12	M12X1.75P	1.1	1.1	0.3	3101-006
		1/2"-13					
VB-NT40	NT40	5/8"-11	M16X2.0P	1.5	1.5	0.3	3101-007
VB-NT50	NT50	1"-8	M24X3.0P	3.4	3.4	0.5	3101-008

Please Notify the Draw Bar Thread Size When ordering.



Milling Collet Chuck Kit



INCLUDING SHANK, FULL SET OF COLLETS, WRENCH AND CASE, COLLET CHUCK KIT

DIN 6388 OZ-25 TYPE



NT40 WITH MAHO GROOVE



VB-MT3



VB-R8



OZ-25



DIFFERENT SHANK STYLE

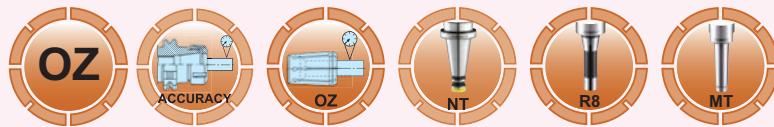

OZ SYSTEM

FULL SET

ORDER NO.	COLLETS SIZE OZ-25		PCS	WEIGHT (KGS)	CODE NO.
	TAPER	COLLETS			
VB-101	NT30	Inch 1/8"-1" 15PCS 1/4"-1" 7PCS Metric 3mm-25mm 15pcs 6mm-25mm 7pcs	7	3.7	3101-101
VB-102			15	5.2	3101-102
VB-103	NT40		7	4	3101-103
VB-104			15	5.5	3101-104
VB-105	NT50		7	6.5	3101-105
VB-106			15	8.5	3101-106
VB-107	MT3		7	3.3	3101-107
VB-108			15	5.2	3101-108
VB-109	MT4		7	3.9	3101-109
VB-110			15	5.4	3101-110
VB-111	MT5		7	4.7	3101-111
VB-112			15	6.2	3101-112
VB-113	R8		7	3.7	3101-113
VB-114			15	5.2	3101-114
VB-115	MT2		7	3.6	3101-115
VB-116		15	5.1	3101-116	

NEW

Please Notify the Type Size, Collet Type, Set Range, and Set Numbers When Ordering.

CONTENT COLLET SET SIZE

7 PCS/SET	MM	6, 8, 10, 12, 16, 20, 25MM
	INCH	1/4", 5/16", 3/8", 1/2", 5/8", 3/4", 1"
15 PCS/SET	MM	3, 4, 5, 6, 7, 8, 9, 10, 11, 12, 13, 16, 18, 20, 25MM
	INCH	1/8", 3/16", 1/4", 5/16", 3/8", 7/16", 1/2", 9/16", 5/8", 11/16", 3/4", 13/16", 7/8", 15/16", 1"



DIN 6388 Collet For Milling Chuck

COLLET DIN 6388, TYPE A

DIN 6388 #16,#25,#32 SERIES

COLLET MUST BE ASSEMBLED INTO THE CLAMPING NUT BEFORE INSERTING INTO THE CHUCK

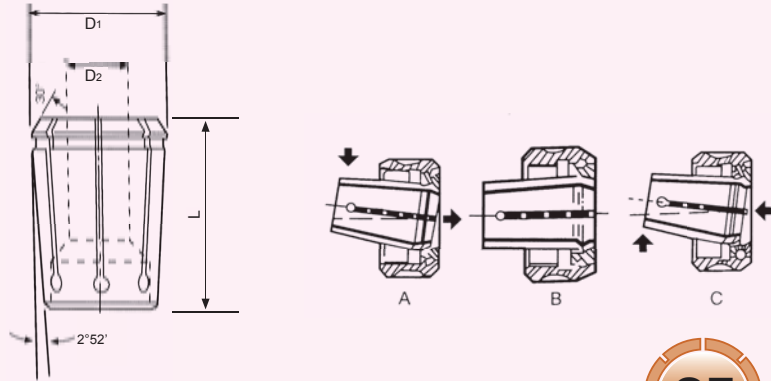

METRIC

ORDER NO.	D1	L	D2(MM)
OZ-25-□	35.05	52	3, 4, 5, 6, 7, 8, 9, 10, 11, 12, 13, 14, 15, 16, 18, 20, 25
OZ-32-□	44	60	6, 8, 10, 12, 16, 20, 25, 32

INCH

ORDER NO.	D1	L	D2(INCH)
OZ-25-□	35.05	52	1/8", 3/16", 1/4", 5/16", 3/8", 7/16", 1/2", 9/16", 5/8", 11/16", 3/4", 13/16", 7/8", 15/16", 1"
OZ-32-□	43.7	60	1/4", 5/16", 3/8", 7/16", 1/2", 9/16", 5/8", 11/16", 3/4", 13/16", 7/8", 15/16", 1", 1 1/8", 1 1/4"

■ RANGE SIZE:3-25(1/8"-1")

OZ-25 ■ D:35.05 ■ L:52 ■ TAPER:1:10 ■ WEIGHT:0.18KGS

ORDER NO.	MM SIZE	CODE NO.
OZ-2503	3.0	3100-101
OZ-2504	4.0	3100-102
OZ-2505	5.0	3100-103
OZ-2506	6.0	3100-104
OZ-2507	7.0	3100-105
OZ-2508	8.0	3100-106
OZ-2509	9.0	3100-107
OZ-2510	10	3100-108
OZ-2511	11	3100-109
OZ-2512	12	3100-110
OZ-2513	13	3100-111
OZ-2514	14	3100-112
OZ-2515	15	3100-113
OZ-2516	16	3100-114
OZ-2517	17	3100-115
OZ-2518	18	3100-116
OZ-2519	19	3100-117
OZ-2520	20	3100-118
OZ-2521	21	3100-119
OZ-2522	22	3100-120
OZ-2523	23	3100-121
OZ-2524	24	3100-122
OZ-2525	25	3100-123

ORDER NO.	INCH SIZE	CODE NO.
OZ-2526	1/8"	3100-124
OZ-2527	3/16"	3100-125
OZ-2528	1/4"	3100-126
OZ-2529	5/16"	3100-127
OZ-2530	3/8"	3100-128
OZ-2531	7/16"	3100-129
OZ-2532	1/2"	3100-130
OZ-2533	9/16"	3100-131
OZ-2534	5/8"	3100-132
OZ-2535	11/16"	3100-133
OZ-2536	3/4"	3100-134
OZ-2537	13/16"	3100-135
OZ-2538	7/8"	3100-136
OZ-2539	15/16"	3100-137
OZ-2540	1"	3100-138



DIN 6388 Collet For Milling Chuck VERTEX®

COLLET DIN 6388, TYPE A

DIN 6388 #16,#25,#32 SERIES

COLLET MUST BE ASSEMBLED INTO THE CLAMPING NUT BEFORE INSERTING INTO THE CHUCK

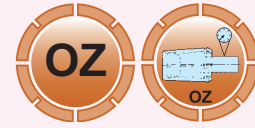

DIN6388 32#
OZ-32

- RANGE SIZE:6-32(1/4"-1 1/4")
- D:43.7 ■ L:60 ■ TAPER:1:10
- WEIGHT:0.25KGS

OZ-32

ORDER NO.	MM SIZE	CODE NO.
OZ-3206	6.0	3100-201
OZ-3207	7.0	3100-202
OZ-3208	8.0	3100-203
OZ-3209	9.0	3100-204
OZ-3210	10	3100-205
OZ-3211	11	3100-206
OZ-3212	12	3100-207
OZ-3213	13	3100-208
OZ-3214	14	3100-209
OZ-3215	15	3100-210
OZ-3216	16	3100-211
OZ-3217	17	3100-212
OZ-3218	18	3100-213
OZ-3219	19	3100-214
OZ-3220	20	3100-215
OZ-3221	21	3100-216
OZ-3222	22	3100-217
OZ-3223	23	3100-218
OZ-3224	24	3100-219
OZ-3225	25	3100-220
OZ-3226	26	3100-221

ORDER NO.	MM SIZE	CODE NO.
OZ-3227	27	3100-222
OZ-3228	28	3100-223
OZ-3229	29	3100-224
OZ-3230	30	3100-225
OZ-3231	31	3100-226
OZ-3232	32	3100-227

ORDER NO.	INCH SIZE	CODE NO.
OZ-3233	1/4"	3100-228
OZ-3234	5/16"	3100-229
OZ-3235	3/8"	3100-230
OZ-3236	7/16"	3100-231
OZ-3237	1/2"	3100-232
OZ-3238	9/16"	3100-233
OZ-3239	5/8"	3100-234
OZ-3240	11/16"	3100-235
OZ-3241	3/4"	3100-236
OZ-3242	13/16"	3100-237
OZ-3243	7/8"	3100-238
OZ-3244	15/16"	3100-239
OZ-3245	1"	3100-240
OZ-3246	1-1/8"	3100-241
OZ-3247	1-1/4"	3100-242

OZ SYSTEM



DIN 6388 Nuts & Wrench

BALL BEARING, NUTS FOR COLLETS DIN6388, TYPE A

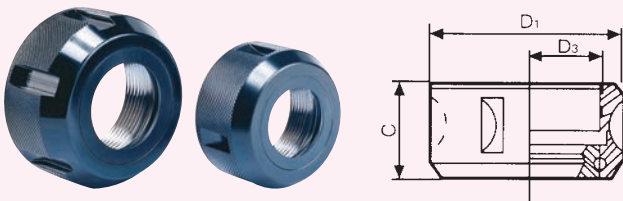

Unit:mm

ORDER NO.	C	D1	D3	COLLETS	WEIGHT kgs	CODE NO.
OZ-25N	33	60	M48X2	OZ-25	0.3	3100-301
OZ-32N	40	72	M60X2.5	OZ-32	0.7	3100-302

WRENCH FOR COLLETS DIN6388 TYPE A



Unit:mm

ORDER NO.	D1	COLLETS	WEIGHT kgs	CODE NO.
OZ-25W	60	OZ-25	0.35	3100-310
OZ-32W	72	OZ-32	0.4	3100-311



Milling Collet Chuck



OZ-25
COLLET HOLDER WITH BT-SHANK

DIN 6388 # 25 SERIES MAS 403
BT-SHANK



ORDER NO.	TAPER	DIN 6388	L	DRAW BAR	WEIGHT KGS	CODE NO.
VB-BT40	BT40	#25	80	M16X2.0P	1.7	3101-009
VB-BT50	BT50	#25	100	M24X3.0P	4.6	3101-010

Milling Collet Chuck Kit

Including Shank, full set of collets, wrench and case.



METRIC COLLET SYSTEM

ORDER NO.	TAPER	PCS/SET	WEIGHT KGS	CODE NO.
VB-241	BT40	7	4.4	3101-117
VB-242		15	5.9	3101-118
VB-251	BT50	7	7.5	3101-119
VB-252		15	9.5	3101-120

CONTENT COLLET SET SIZE

METRIC RANGE SET SIZE

7PCS: 6, 8, 10, 12, 16, 20, 25mm

15PCS: 3, 4, 5, 6, 7, 8, 9, 10, 11, 12, 13, 16, 18, 20, 25mm

INCH COLLET SET SIZE

ORDER NO.	TAPER	PCS/SET	WEIGHT KGS	CODE NO.
VB-231	BT40	7	4.4	3101-121
VB-232		15	5.9	3101-122
VB-233	BT50	7	7.5	3101-123
VB-234		15	9.5	3101-124

INCH RANGE SET SIZE

7PCS: 1/4", 5/16", 3/8", 1/2", 5/8", 3/4", 1"

15PCS: 1/8", 3/16", 1/4", 5/16", 3/8", 7/16", 1/2", 9/16", 5/8",

11/16", 3/4", 13/16", 7/8", 15/16", 1"



Milling Collet Chuck

COLLET HOLDER WITH BT-SHANK
OZ-32 MAS 403



DIN 6388 # 32 SERIES



ORDER NO.	TAPER	DIN 6388	L	DRAW BAR	WEIGHT KGS	CODE NO.
VB-226	BT40-OZ-32	#32	90	M16X2.0P	2.3	3102-003
VB-227	BT50-OZ-32	#32	100	M24X3.0P	5.1	3102-004
VB-228			150	M24X3.0P	6.8	3102-005

OZ SYSTEM

Milling Collet Chuck Kit

Including Shank, full set of collets, wrench and case.

**#32 SERIES BT-TYPE
MAS 403 BT-SHANK**

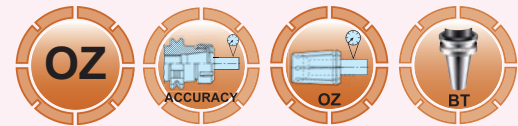

METRIC COLLET SYSTEM SET

ORDER NO.	TAPER	PCS/SET	WEIGHT KGS	CODE NO.
VB-243	BT40	8	7.4	3102-109
VB-244		15	9.4	3102-110
VB-253	BT50	8	10	3102-111
VB-254		15	12	3102-112

CONTENT COLLET SET SIZE

METRIC RANGE SET SIZE
8PCS: 6, 8, 10, 12, 16, 20, 25, 32mm
15PCS: 6, 8, 9, 10, 12, 13, 14, 15, 16, 18, 20, 22, 25, 26, 30, 32mm

INCH COLLET SYSTEM SET

ORDER NO.	TAPER	PCS/SET	WEIGHT KGS	CODE NO.
VB-256	BT40	10	7.4	3102-113
VB-257		15	9.4	3102-114
VB-258	BT50	10	10	3102-115
VB-259		15	12	3102-116

INCH RANGE SET SIZE
10PCS: 1/4", 5/16", 3/8", 1/2", 5/8", 3/4", 7/8", 1", 1-1/8", 1-1/4"
15PCS: 1/4", 5/16", 3/8", 7/16", 1/2", 9/16", 5/8", 11/16", 3/4", 13/16", 7/8", 15/16", 1", 1-1/8", 1-1/4"



Milling Collet Chuck

COLLET HOLDER WITH ISO-SHANK
OZ-32



DIN 6388 # 32 SERIES
DIN 2080 NT-SHANK

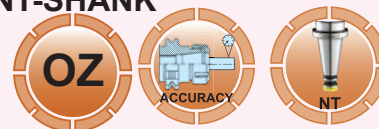

NT40
WITH MAHO GROOVE



OZ

ORDER NO.	TAPER	DIN 6388	DRAW BAR	WEIGHT KGS	CODE NO.
VB-130	NT30	#32	1.M12X1.75P	2	3102-006
VB-131	NT40	#32	1.M16X2.0P 2.5/8"-11W	2.2	3102-001
VB-132	NT50	#32	1.M24X3.0P 2.1"-8W	3.9	3102-002

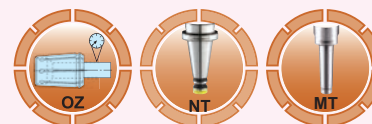

METRIC COLLET SYSTEM

ORDER NO.	TAPER	PCS/SET	WEIGHT KGS	CODE NO.
VB-121	NT40	8	7.5	3102-101
VB-121B	NT40	15	9.2	3102-102
VB-122	NT50	8	9.8	3102-103
VB-122B	NT50	15	11.8	3102-104
VB-123	NT30	8	7	3102-090
VB-123B	NT30	15	9	3102-091
VB-124	MTB5	8	8	3102-092
VB-124B	MTB5	15	10	3102-093



Milling Collet Chuck Kit

Including Shank, full set of collets, wrench and case.

OZ-32 DIN 6388



CONTENT COLLET SET SIZE

METRIC RANGE SET SIZE
8PCS:6, 8, 10, 12, 16, 20, 25, 32mm
15PCS:6, 7, 8, 9, 10, 11, 12, 13, 16, 18, 20, 25, 26,30, 32mm

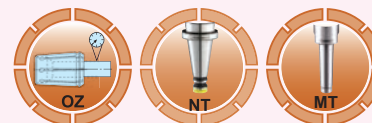

INCH COLLET SYSTEM

ORDER NO.	TAPER	PCS/SET	WEIGHT KGS	CODE NO.
VB-162	NT30	10	7	3102-094
VB-162B	NT30	15	9	3102-095
VB-163	NT40	10	7.2	3102-105
VB-164	NT40	15	9.2	3102-106
VB-165	NT50	10	9.8	3102-107
VB-166	NT50	15	11.8	3102-108
VB-167	MTB5	10	8	3102-096
VB-167B	MTB5	15	10	3102-097



INCH RANGE SET SIZE
10PCS:1/4", 5/16", 3/8", 1/2", 5/8", 3/4", 7/8", 1", 1-1/8", 1-1/4"
15PCS:1/4", 5/16", 3/8", 7/16", 1/2", 9/16", 5/8", 11/16", 3/4", 13/16", 7/8", 15/16", 1", 1-1/8", 1-1/4"



Milling Collet Chuck



COLLET HOLDER WITH
DIN 69871 & CAT TPE

DIN 6388 # 25, #32 SERIES

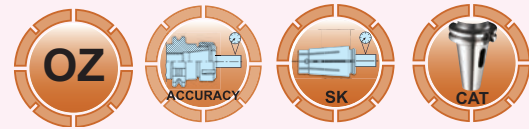

DIN 69871A & CAT SHANK

ORDER NO.	TAPER	DIN 6388	DRAW BAR	WEIGHT KGS	CODE NO.
VB-261	SK40-OZ25-80L	#25	M16X2.0P	1.6	3101-011
VB-262	SK50-OZ25-100L		M24X3.0P	4.2	3101-012
VB-263	CAT40-OZ25-3"L		5/8"-11W	1.9	3101-013
VB-264	CAT50-OZ25-3 1/2"L		1"-8W	4	3101-014
VB-265	SK40-OZ32-80L	#32	M16X2.0P	2.3	3102-011
VB-266	SK50-OZ32-100L		M24X3.0P	5	3102-012

OZ



OZ SYSTEM

Milling Collet Chuck Kit

Including Shank, full set of collets, wrench and case.

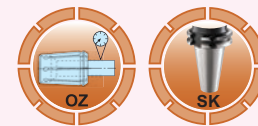

METRIC COLLET SYSTEM SET DIN69871A SK-TYPE WITH #25,#32

ORDER NO.	COLLET HOLDER	TYPE	DIN 6388	RANGE	SET PCS	KGS	CODE NO.
VB-271	SK40-OZ25-80L	SK40	#25	3.0-25	15PCS	5.7	3101-125
VB-272	SK40-OZ25-80L		#25	6.0-25	7PCS	4.2	3101-126
VB-273	SK40-OZ32-80L	SK40	#32	6.0-32	15PCS	9.2	3101-127
VB-274	SK40-OZ32-80L		#32	6.0-32	8PCS	7.2	3101-128
VB-275	SK50-OZ25-100L	SK50	#25	3.0-25	15PCS	9.3	3101-129
VB-276	SK50-OZ25-100L		#25	6.0-25	7PCS	7.3	3101-130
VB-277	SK50-OZ32-100L	SK50	#32	6.0-32	15PCS	11.8	3102-117
VB-278	SK50-OZ32-100L		#32	6.0-32	8PCS	9.8	3102-118

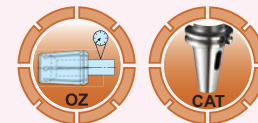

INCH COLLET SYSTEM SET CAT-TYPE WITH #25,#32

ORDER NO.	COLLET HOLDER	TYPE	DIN 6388	RANGE	SET PCS	KGS	CODE NO.
VB-281	CAT40-OZ25-3"L	CAT40	#25	1/8"-1"	15PCS	5.7	3101-131
VB-282	CAT40-OZ25-3"L		#25	1/4"-1"	7PCS	4.2	3101-132
VB-286	CAT40-OZ32-3"L	CAT40	#32	1/4"-1 1/4"	15PCS	9.2	3102-119
VB-287	CAT40-OZ32-3"L		#32	1/4"-1 1/4"	10PCS	7.2	3102-120
VB-288	CAT50-OZ25-3 1/2"L	CAT50	#25	1/8"-1"	15PCS	9.3	3101-133
VB-289	CAT50-OZ25-3 1/2"L		#25	1/4"-1"	7PCS	7.3	3101-134
VB-290	CAT50-OZ32-3 1/2"L	CAT50	#32	1/4"-1 1/4"	15PCS	11.8	3102-121
VB-291	CAT50-OZ32-3 1/2"L		#32	1/4"-1 1/4"	10PCS	10	3102-122



Multi-Lock Milling Chuck



COLLET HOLDER WITH ISO, BT & SK TAPER SHANK

STRAIGHT COLLET TYPE

C-32 C-42

DIN 2080, MAS 403 DIN 69871A

C-20,25,32,42 TYPE



C TYPE

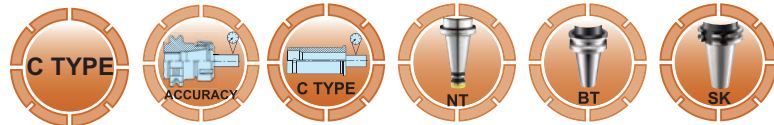
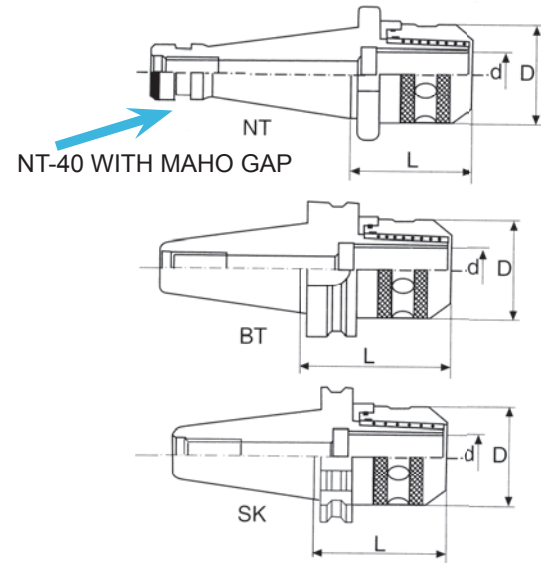

ORDER NO.	TAPER	CHUCK	d	D	L	DRAW BAR	KGS	CODE NO.
VB-431	NT40	NT40-MC32-95L	32	75	95	5/8"-11	3	3202-001
VB-432		NT40-MC32-95L	32	75	95	M16x2.0P	3.1	3202-002
VB-433	NT50	NT50-MC32-100L	32	75	100	1"-8	4.8	3202-003
VB-434		NT50-MC32-100L	32	75	100	M24x3.0P	5.1	3202-004
VB-435A	BT40	BT40-MC32-105L	32	75	105	M16x2.0P	3.2	3202-005
VB-435B		BT40-MC32-150L	32	75	150	M16x2.0P	3.5	3202-020
VB-436	BT50	BT50-MC32-110L	32	75	110	M24x3.0P	5.2	3202-006
VB-437		BT50-MC32-150L	32	75	135	M24x3.0P	7	3202-007
VB-438	NT50	NT50-MC42-110L	42	87	110	1"-8	6	3202-008
VB-439		NT50-MC42-110L	42	87	110	M24x3.0P	6.1	3202-009
VB-440	BT50	BT50-MC42-115L	42	87	115	M24x3.0P	6.1	3202-010
VB-441		BT50-MC42-150L	42	87	140	M24x3.0P	7.8	3202-011
VB-442	SK40	SK40-MC32-100L	32	75	100	M16x2.0P	3.1	3202-012
VB-443	SK50	SK50-MC32-105L	32	75	105	M24x3.0P	5.3	3202-013
VB-444A	BT30	BT30-MC20-95	20	52	95	M12x1.75P	1.3	3202-014
VB-446A	BT40	BT40-MC20-80	20	52	80	M16x2.0P	3	3202-016
VB-446B		BT40-MC20-120	20	52	120	M16x2.0P	2.7	3202-017
VB-447A		BT40-MC25-90	25	58	90	M16x2.0P	4.5	3202-018
VB-447B		BT40-MC25-135	25	58	135	M16x2.0P	3.2	3202-019
VB-448A	NT30	NT30-MC20-80	20	52	80	1. M12X1.75P 2. 1/2"-12	1.5	3202-030
VB-448B		NT30-MC25-85	25	58	85	1. M12X1.75P 2. 1/2"-12	1.5	3202-031
VB-451A	SK40	SK40-MC20-80	20	52	80	M16X2.0P	2	3202-035
VB-451B		SK40-MC25-90	25	58	90	M16X2.0P	2	3202-036
VB-452	SK50	SK50-MC42-110	42	87	110	M24X3.0P	5.7	3202-037



Multi-Lock Milling Chuck



MULTI-LOCK MILLING CHUCK KIT

Including shank, full set of collets,
wrench and case.

DIN 2080 NT-SHANK
MAS 403 BT-SHANK
DIN 69871A SK-SHANK



MILLING CHUCK

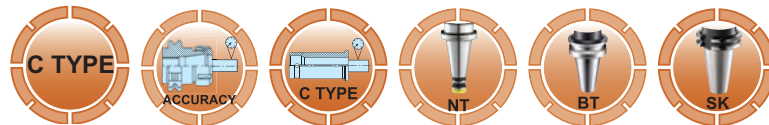

ORDER NO.	TAPER	CHUCK	COLLET	DRAW BAR	KGS	CODE NO.
VB-444I	NT40	NT40-MC32-95L	7PCS	5/8"-11	7	3202-101
VB-444		NT40-MC32-95L	7PCS	M16x2.0P	7	3202-102
VB-454I	NT50	NT50-MC32-100L	7PCS	1"-8	9	3202-103
VB-454		NT50-MC32-100L	7PCS	M24x3.0P	9	3202-104
VB-344A	BT40	BT40-MC32-105L	7PCS	M16x2.0P	7	3202-105
VB-344B		BT40-MC32-150L	7PCS	M16x2.0P	11.5	3202-118
VB-354A	BT50	BT50-MC32-110L	7PCS	M24x3.0P	9.5	3202-106
VB-354B		BT50-MC32-150L	7PCS	M24x3.0P	13	3202-119
VB-554	NT50	NT50-MC42-110L	8PCS	M24x3.0P	12	3202-107
VB-554I		NT50-MC42-110L	8PCS	1"-8	12	3202-108
VB-564A	BT50	BT50-MC42-115L	8PCS	M24x3.0P	12	3202-109
VB-564B		BT50-MC42-150L	8PCS	M24x3.0P	14	3202-109B
VB-565	SK-40	SK40-MC32-100L	7PCS	M16x2.0P	7	3202-110
VB-566	SK-50	SK50-MC32-105L	7PCS	M24x3.0P	9.5	3202-111
VB-567	BT-30	BT30-MC20-95	6PCS	M12x1.75P	6	3202-112
VB-569A	BT-40	BT40-MC20-80	6PCS	M16x2.0P	7	3202-114
VB-569B		BT40-MC20-120	6PCS	M16x2.0P	8	3202-115
VB-570A		BT40-MC25-90	7PCS	M16x2.0P	9.5	3202-116
VB-570B		BT40-MC25-135	7PCS	M16x2.0P	10.5	3202-117
VB-571	NT30	NT30-MC20-80L	6PCS	1. M12X1.75P 2. 1/2"-12	4	3202-120
VB-572		NT30-MC25-85L	7PCS	1. M12X1.75P 2. 1/2"-12	4	3202-121
VB-574	NT40	NT40-MC25-85L	7PCS	1. M16X2.0P 2. 5/8"-11	4.5	3202-123
VB-576	SK40	SK40-MC20-80L	6PCS	M16X2.0P	4.5	3202-125
VB-577		SK40-MC25-90L	7PCS	M16X2.0P	4.8	3202-126
VB-578	SK50	SK50-MC42-110L	8PCS	M24X3.0P	12	3202-127



C-20,25,32,42 Collet



C-TYPE COLLET

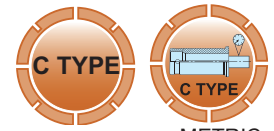

C TYPE

20, 25, 32, 42 STRAIGHT COLLET

ORDER NO.	COLLET	COLLETS SIZE d INSIDE DIAMETER	D1 O.D.	D2	L	PCS/SET	CODE NO.
C-20-6P	C-20	4, 6, 8, 10, 12, 16	20	25	52	6	3202-180
C-25-7P	C-25	4, 6, 8, 10, 12, 16, 20	25	31	60	7	3202-181
C-32-7P	C-32	6, 8, 10, 12, 16, 20, 25	32	37	73	7	3202-182
C-42-8P	C-42	6, 8, 10, 12, 16, 20, 25, 32	42	48	80	8	3202-183

METRIC

20, 25, 32, 42 STRAIGHT COLLET

INCH

ORDER NO.	COLLET	COLLETS SIZE d INSIDE DIAMETER	D1 O.D.	D2	L	PCS/SET	CODE NO.
C-20-6I	C-20	1/4", 5/16", 3/8", 1/2", 5/8", 3/16"	20	25	52	6	3202-184
C-25-6I	C-25	1/4", 5/16", 3/8", 1/2", 5/8", 3/4"	25	31	60	7	3202-185
C-32-7I	C-32	1/4", 5/16", 3/8", 1/2", 5/8", 3/4", 1"	32	37	73	7	3202-186
C-42-8I	C-42	1/4", 5/16", 3/8", 1/2", 5/8", 3/4", 1", 1 1/4"	42	48	80	8	3202-187

METRIC

ORDER NO.	d	CODE NO.
C-20-4	4	3202-200
C-20-6	6	3202-201
C-20-8	8	3202-202
C-20-10	10	3202-203
C-20-12	12	3202-204
C-20-16	16	3202-205
C-25-4	4	3202-229
C-25-6	6	3202-230
C-25-8	8	3202-231
C-25-10	10	3202-232
C-25-12	12	3202-233
C-25-16	16	3202-234
C-25-20	20	3202-235
C-32-6	6	3202-250
C-32-8	8	3202-251
C-32-10	10	3202-252
C-32-12	12	3202-253
C-32-16	16	3202-254
C-32-20	20	3202-255
C-32-25	25	3202-256
C-42-6	6	3202-280
C-42-8	8	3202-281
C-42-10	10	3202-282
C-42-12	12	3202-283
C-42-16	16	3202-284
C-42-20	20	3202-285
C-42-25	25	3202-286
C-42-32	32	3202-287

INCH

ORDER NO.	d	CODE NO.
C-20-3/16"	3/16"	3202-210
C-20-1/4"	1/4"	3202-211
C-20-5/16"	5/16"	3202-212
C-20-3/8"	3/8"	3202-213
C-20-1/2"	1/2"	3202-214
C-20-5/8"	5/8"	3202-215
C-25-1/4"	1/4"	3202-241
C-25-5/16"	5/16"	3202-242
C-25-3/8"	3/8"	3202-243
C-25-1/2"	1/2"	3202-244
C-25-5/8"	5/8"	3202-245
C-25-3/4"	3/4"	3202-246
C-32-3/16"	3/16"	3202-260
C-32-1/4"	1/4"	3202-261
C-32-5/16"	5/16"	3202-262
C-32-3/8"	3/8"	3202-263
C-32-1/2"	1/2"	3202-264
C-32-5/8"	5/8"	3202-265
C-32-3/4"	3/4"	3202-266
C-32-7/8"	7/8"	3202-267
C-32-1"	1"	3202-268
C-42-1/4"	1/4"	3202-290
C-42-5/16"	5/16"	3202-291
C-42-3/8"	3/8"	3202-292
C-42-1/2"	1/2"	3202-293
C-42-5/8"	5/8"	3202-294
C-42-3/4"	3/4"	3202-295
C-42-7/8"	7/8"	3202-296
C-42-1"	1"	3202-297
C-42-1 1/4"	1 1/4"	3202-298

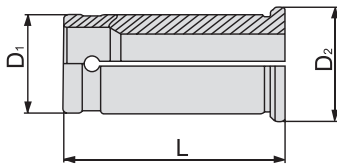

ORDER NO.	WEIGHT
C-20	0.1
C-25	0.18
C-32	0.22
C-42	0.35



C-20,25,32,42 Wrenches



ORDER NO.	L	D	WEIGHT KGS	COLLETS	CODE NO.
C-20W	227	52	0.22	C-20	3202-311
C-25W	227	58	0.22	C-25	3202-312
C-32W	260	75	0.33	C-32	3202-313
C-42W	270	87	0.35	C42	3202-314



Quick-Change Tooling System VERTEX®

MILLING-QUICK CHANGE HOLDER

OZ DIN 6388

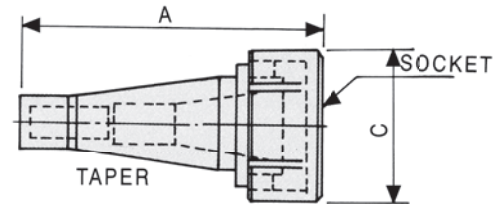

- QUICK-CHANGE CHUCK TAPER ACCORDING TO DIN 2080 SPECIFICATION.
- EASY AND FAST CHANGING MILLING CHUCK(HOLDER).
- CHUCK TAPER PRECISELY MACHINED SUITABLE FOR HEAVY CUTTING.
- ALL THE HOLDER SIZE ARE SPECIAL FOR THIS QUICK-CHANGE TOOLING SYSTEM ONLY.

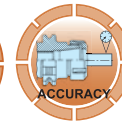

QUICK-CHANGE TOOLING

ORDER NO.	TAPER	SOCKET	A	C	WEIGHT KGS	CODE NO.
VD-103	NT40	NT40	181	89	2.4	3201-003
VD-105	NT50	NT40	175	89	3.8	3201-004

MILLING-QUICK CHANGE SYSTEM KIT

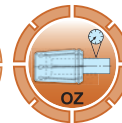

ORDER NO.	TAPER	SOCKET	FULL SET	WEIGHT KGS	CODE NO.
VD-113	NT40	NT40	1. MILLING QUICK-CHANGE HOLDER 2. DRILL CHUCK HOLDER 3. MORSE TAPER HOLDER 4. FACE MILL HOLDER	14	3201-008
VD-115	NT50	NT40	5. DIN6388 #25 COLLET CHUCK HOLDER 6. DIN6388 #25 15PCS COLLET 7. WRENCH 8. WOODEN BOX	16	3201-009

TG 100 Collet System



DIN 464E

● PRECISION TG10 COLLET WITHIN 20 MICRON

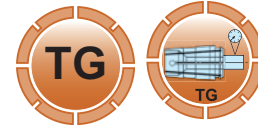
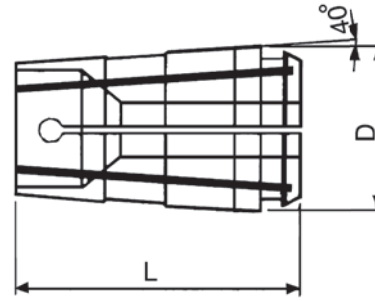

■ RANGE SIZE: 1/8" - 63/64"

TG-100 ■ D:35 ■ L:61 ■ TAPER:4 ■ WEIGHT:0.2KGS ■ HRC:47°

ORDER NO.	INCH	CODE NO.
TG10-01	1/8"	3204-001
TG10-02	3/16"	3204-002
TG10-03	1/4"	3204-003
TG10-04	5/16"	3204-004
TG10-05	3/8"	3204-005
TG10-06	7/16"	3204-006
TG10-07	1/2"	3204-007
TG10-08	9/16"	3204-008
TG10-09	5/8"	3204-009
TG10-10	11/16"	3204-010
TG10-11	3/4"	3204-011
TG10-12	13/16"	3204-012
TG10-13	7/8"	3204-013
TG10-14	15/16"	3204-014
TG10-15	1"	3204-015
TG10-16	5/32"	3204-016
TG10-17	7/32"	3204-017
TG10-18	9/32"	3204-018
TG10-19	11/32"	3204-019
TG10-20	13/32"	3204-020
TG10-21	15/32"	3204-021
TG10-22	17/32"	3204-022
TG10-23	19/32"	3204-023
TG10-24	21/32"	3204-024
TG10-25	23/32"	3204-025
TG10-26	25/32"	3204-026
TG10-27	27/32"	3204-027
TG10-28	29/32"	3204-028
TG10-29	31/32"	3204-029

ORDER NO.	INCH	CODE NO.
TG10-30	9/64"	3204-030
TG10-31	11/64"	3204-031
TG10-32	13/64"	3204-032
TG10-33	15/64"	3204-033
TG10-34	17/64"	3204-034
TG10-35	19/64"	3204-035
TG10-36	21/64"	3204-036
TG10-37	23/64"	3204-037
TG10-38	25/64"	3204-038
TG10-39	27/64"	3204-039
TG10-40	29/64"	3204-040
TG10-41	31/64"	3204-041
TG10-42	33/64"	3204-042
TG10-43	35/64"	3204-043
TG10-44	37/64"	3204-044
TG10-45	39/64"	3204-045
TG10-46	41/64"	3204-046
TG10-47	43/64"	3204-047
TG10-48	45/64"	3204-048
TG10-49	47/64"	3204-049
TG10-50	49/64"	3204-050
TG10-51	51/64"	3204-051
TG10-52	53/64"	3204-052
TG10-53	55/64"	3204-053
TG10-54	57/64"	3204-054
TG10-55	59/64"	3204-055
TG10-56	61/64"	3204-056
TG10-57	63/64"	3204-057



5C Collet System

5C RANGE



mm



5C Collet

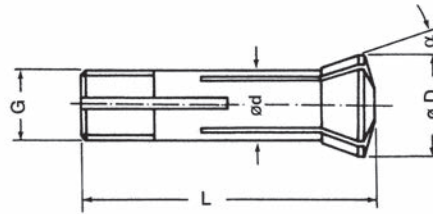

- L:87 ■ D:37.5 ■ G:31.75 ■ Accuracy: ±0.02mm
- α:10° ■ WEIGHT:0.21KGS ■ Hardness: HRC47°

ORDER NO.	Q'TY	RANGE SIZE
5C-□	1 PC	∅ 3, 4, 5, 6, 7, 8, 9, 10, 11, 12, 13, 14, 15, 16, 17, 18, 19, 20, 21, 22, 23, 24, 25MM
5C-□	1 PC	∅ 1/8", 3/16", 1/4", 5/16", 3/8", 7/16", 1/2", 9/16", 5/8", 11/16", 3/4", 13/16", 7/8", 15/16", 1"

COMPLETE SET AVAILABLE SIZE

ORDER NO.	Q'TY	RANGE SIZE	PACKING	WEIGHT KGS	CODE NO.
VE-102	7PCS	6, 8, 10, 12, 16, 20, 25	CARTON	1.5	3205-100
VE-102I	7PCS	1/4", 5/16", 3/8", 1/2", 5/8", 3/4", 1"	CARTON	1.5	3205-101



EMERGENCY TYPE SOFT COLLET

ORDER NO.	MATERIAL	kgs	CODE NO.
VE-5CN	NYLON		3205-203

- CAN BE MACHINED FOR INSIDE HOLE

ORDER NO.	∅ d	CODE NO.
5C-3	3	3205-001
5C-4	4	3205-002
5C-5	5	3205-003
5C-6	6	3205-004
5C-7	7	3205-005
5C-8	8	3205-006
5C-9	9	3205-007
5C-10	10	3205-008
5C-11	11	3205-009
5C-12	12	3205-010
5C-13	13	3205-011
5C-14	14	3205-012
5C-15	15	3205-013
5C-16	16	3205-014
5C-17	17	3205-015
5C-18	18	3205-016
5C-19	19	3205-017
5C-20	20	3205-018
5C-21	21	3205-019
5C-22	22	3205-020
5C-23	23	3205-021
5C-24	24	3205-022
5C-25	25	3205-023

inch

ORDER NO.	∅ d	CODE NO.
5C-1/8	1/8"	3205-024
5C-3/16	3/16"	3205-025
5C-1/4	1/4"	3205-026
5C-5/16	5/16"	3205-027
5C-3/8	3/8"	3205-028
5C-7/16	7/16"	3205-029
5C-1/2	1/2"	3205-030
5C-9/16	9/16"	3205-031
5C-5/8	5/8"	3205-032
5C-11/16	11/16"	3205-033
5C-3/4	3/4"	3205-034
5C-13/16	13/16"	3205-035
5C-7/8	7/8"	3205-036
5C-15/16	15/16"	3205-037
5C-1	1"	3205-038

COLLET SYSTEM



R8 Collet System



R8 Collet

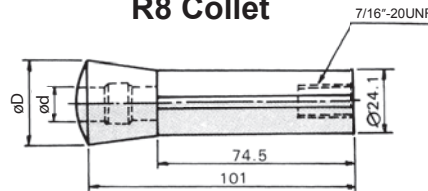

- L:101 ■ D:31.75 ■ Accuracy: ±0.02mm
- G:7/16"-20UNF ■ α:8°30' ■ WEIGHT:0.21KGS ■ Hardness: HRC47°

ORDER NO.	Q'TY	RANGE SIZE
R8-□	1 PC	∅ 3, 4, 5, 6, 7, 8, 9, 10, 11, 12, 13, 14, 15, 16, 17, 18, 19, 20 MM
R8-□	1 PC	∅ 1/8", 3/16", 1/4", 5/16", 3/8", 7/16", 1/2", 9/16", 5/8", 11/16", 3/4"

COMPLETE SET AVAILABLE SIZE

ORDER NO.	Q'TY	RANGE SIZE	WEIGHT KGS	CODE NO.
VE-110	6PCS	6, 8, 10, 12, 16, 20 MM	1.5	3206-100
VE-114	7PCS	6, 8, 10, 12, 14, 16, 20 MM	1.5	3206-101

EMERGENCY TYPE SOFT COLLET

ORDER NO.	Q'TY	RANGE SIZE	WEIGHT KGS	CODE NO.
VE-109I	5PCS	1/4", 3/8", 1/2", 5/8", 3/4"	1.1	3206-102
VE-110I	6PCS	1/4", 5/16", 3/8", 1/2", 5/8", 3/4"	1.5	3206-103
VE-114I	7PCS	3/16", 1/4", 5/16", 3/8", 1/2", 5/8", 3/4"	1.5	3206-104

ORDER NO.	∅ d	CODE NO.
R8-3	3	3206-001
R8-4	4	3206-002
R8-5	5	3206-003
R8-6	6	3206-004
R8-7	7	3206-005
R8-8	8	3206-006
R8-9	9	3206-007
R8-10	10	3206-008
R8-11	11	3206-009
R8-12	12	3206-010
R8-13	13	3206-011
R8-14	14	3206-012
R8-15	15	3206-013
R8-16	16	3206-014
R8-17	17	3206-015
R8-18	18	3206-016
R8-19	19	3206-017
R8-20	20	3206-018

inch

ORDER NO.	∅ d	CODE NO.
R8-1/8	1/8"	3206-019
R8-3/16	3/16"	3206-020
R8-1/4	1/4"	3206-021
R8-5/16	5/16"	3206-022
R8-3/8	3/8"	3206-023
R8-7/16	7/16"	3206-024
R8-1/2	1/2"	3206-025
R8-9/16	9/16"	3206-026
R8-5/8	5/8"	3206-027
R8-11/16	11/16"	3206-028
R8-3/4	3/4"	3206-029



U2 Collet System



NO.1 U2 COLLET RANGE SIZE 3~16mm

NO.2 U2 COLLET RANGE SIZE 18~25mm

NO.1



NO.2

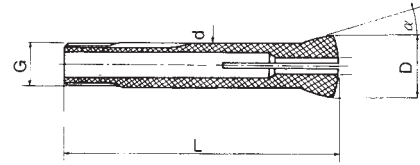

- L:120 ■ D:28 ■ d:20 ■ G:2.0P ■ Accuracy: ±0.02mm
- α:17°30' ■ WEIGHT:0.18KGS ■ Hardness: HRC47°



ORDER NO.	Q'TY	RANGE SIZE
VE-U2-□	1 PC	NO.1 Ø 1.5, 2, 3, 4, 5, 6, 7, 8, 9, 10, 11, 12, 13, 14, 15, 16 NO.2 Ø 18, 20, 25MM
VE-U2-□	1 PC	Ø 1/8", 3/16", 1/4", 5/16", 3/8", 1/2", 5/8"

ORDER NO.	d	CODE NO.
VE-U2-1.5	1.5	3207-026
VE-U2-2	2	3207-027
VE-U2-3	3	3207-001
VE-U2-4	4	3207-002
VE-U2-5	5	3207-003
VE-U2-6	6	3207-004
VE-U2-7	7	3207-005
VE-U2-8	8	3207-006
VE-U2-9	9	3207-007

ORDER NO.	d	CODE NO.
VE-U2-10	10	3207-008
VE-U2-11	11	3207-009
VE-U2-12	12	3207-010
VE-U2-13	13	3207-011
VE-U2-14	14	3207-012
VE-U2-15	15	3207-013
VE-U2-16	16	3207-014
VE-U2-18	18	3207-015
VE-U2-20	20	3207-016
VE-U2-25	25	3207-017

ORDER NO.	d	CODE NO.
VE-U2-1/8	1/8"	3207-018
VE-U2-3/16	3/16"	3207-019
VE-U2-1/4	1/4"	3207-020
VE-U2-5/16	5/16"	3207-021
VE-U2-3/8	3/8"	3207-022
VE-U2-1/2	1/2"	3207-023
VE-U2-5/8	5/8"	3207-024



MT3 Collet System

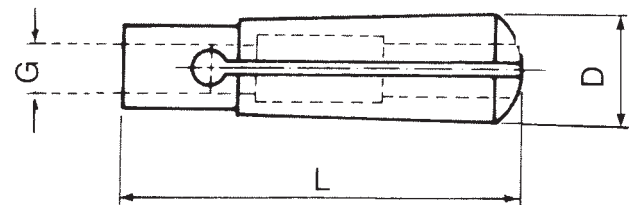

- D:24.1 ■ L:87 ■ WEIGHT:0.18KGS
- DRAW BAR SIZE: G1.M12X1.75P

ORDER NO.	Q'TY	RANGE SIZE	DRAW BAR SIZE
MT3-□	1 PC	Ø 4, 6, 8, 10, 12, 16, 20MM	G1

ORDER NO.	d	CODE NO.
MT3-4	4	3208-100
MT3-6	6	3208-101
MT3-8	8	3208-102
MT3-10	10	3208-103
MT3-12	12	3208-104
MT3-16	16	3208-105
MT3-20	20	3208-106

R8

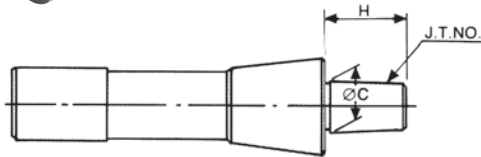

ORDER NO.	TAPER	JT NO.	C	H	WEIGHT (kg)	CODE NO.
VJ-120	R8	JT3	20.60	34	0.5	3209-000
VJ-121		JT1	9.754	18	0.5	3209-001
VJ-122		JT2	13.94	20	0.5	3209-002
VJ-123		JT6	17.17	26	0.5	3209-003
VJ-124		B16	15.733	24	0.5	3209-004

MT3.4.5

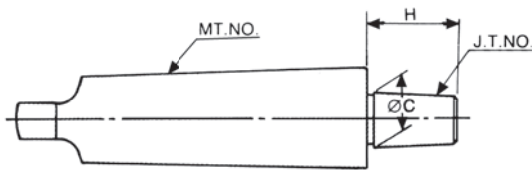

ORDER NO.	TAPER	JT NO.	C	H	WEIGHT (kg)	CODE NO.
VJ-126	MT2	JT3	20.6	34	0.24	3209-006
VJ-126-1		B16	15.733	29	0.2	3209-006A
VJ-126-3		B18	17.78	37	0.21	3209-006B
VJ-130		JT6	17.17	28	0.22	3209-029
VJ-130-2		JT5	35.89	50	0.5	3209-029A
VJ-130-4		JT4	28.55	45	0.4	3209-029B
VJ-137		JT2	14.2	25	0.2	3209-056
VJ-131	MT3	JT6	17.17	26	0.4	3209-030
VJ-131-2		JT5	35.89	50	0.7	3209-030A
VJ-131-4		JT33	15.85	28	0.3	3209-030B
VJ-134		B16	15.733	24	0.3	3209-033
VJ-134-2		B18	17.78	37	0.4	3209-033A
VJ-138		JT2	14.20	25	0.3	3209-034A
VJ-138-1	JT3	20.60	34	0.35	3209-034	
VJ-138-2	JT4	28.55	45	0.5	3209-035	
VJ-132	MT4	JT6	17.17	26	0.7	3209-031
VJ-132-1		JT3	20.60	34	0.7	3209-031A
VJ-132-7		JT4	28.55	45	0.85	3209-031B
VJ-132-4		JT5	35.89	50	1	3209-031C
VJ-132-5		JT2	14.2	25	0.64	3209-031D
VJ-132-6		JT33	15.85	28	0.65	3209-031E
VJ-132-8		B18	17.78	37	0.7	3209-031F
VJ-135		B16	15.733	29	0.7	3209-036
VJ-133	MT5	JT6	17.17	26	1.6	3209-032
VJ-133-1		JT3	20.60	35	1.6	3209-032A
VJ-133-2		JT4	28.55	46	1.8	3209-032B
VJ-133-3		JT5	35.89	51	2	3209-032C
VJ-133-4		JT2	14.2	26	1.6	3209-032D
VJ-133-5		JT33	15.85	29	1.6	3209-032E

COLLET SYSTEM

C12.16.20.25.32

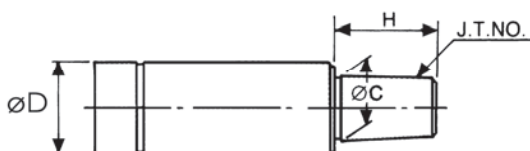

ORDER NO.	SHANK ØD	JT NO.	C	H	WEIGHT (kg)	CODE NO.
VJ-139	C20	JT1	9.754	19	0.2	3209-058
VJ-139-1		JT0	6.35	9	0.2	3209-058A
VJ-140		JT2	14.20	25	0.2	3209-059
VJ-140-1		JT3	20.60	35	0.2	3209-059A
VJ-140-2		B10	10.25	21	0.15	3209-059B
VJ-141		JT6	17.17	26	0.2	3209-060
VJ-140-3		B12	12.1	22.5	0.2	3209-060A
VJ-140-4		B16	15.733	26	0.2	3209-060B
VJ-140-5		B18	17.780	32	0.2	3209-060C
VJ-142		C25	JT6	17.17	26	0.3
VJ-143	C32	JT6	17.17	26	0.5	3209-062
VJ-147-1	C12	B12	12.1	22.5	0.1	3209-063
VJ-147-2	C12	B16	15.733	26	0.2	3209-064
VJ-147-3	C16	B12	12.1	22.5	0.2	3209-065
VJ-147-4	C16	B16	15.733	26	0.2	3209-066

Morse Taper Sleeve

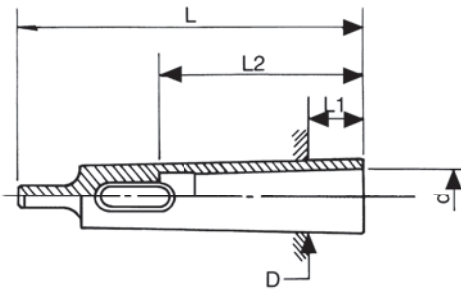

ORDER NO.	I.D.xO.D.	D	d	L	I1	I2	WEIGHT (kg)	CODE NO.
VQ-101	MT2xMT3	23.825	17.780	112	18	67	0.2	3210-001
VQ-102	MT2xMT4	31.267	17.780	124	6.5	67	0.5	3210-002
VQ-103	MT2xMT5	44.399	17.780	156	6.5	67	1.4	3210-003
VQ-104	MT2xMT6						4.13	3210-004
VQ-105	MT3xMT4	31.267	23.825	140	22.5	84	0.4	3210-005
VQ-106	MT3xMT5	44.399	23.825	156	6.5	84	1.3	3210-006
VQ-107	MT3xMT6	63.348	23.825	218	8	84	4	3210-007
VQ-108	MT4xMT5	44.399	31.267	171	21.5	107	1	3210-008
VQ-109	MT4xMT6	63.348	31.267	218	8	107	3.7	3210-009
VQ-110	MT5xMT6	63.348	44.399	218	8	133	2.9	3210-010
VQ-100	MT1xMT3	23.825	12.065	100	6	55	0.2	3210-011
VQ-100-1	MT1xMT2	17.780	12.065	89	14	55	0.22	3210-012
VQ-100-2	MT1xMT4	31.267	12.065	124	6.5	55	0.89	3210-013
VQ-100-3	MT1xMT5	44.399	12.065	156	7	55	1.33	3210-014



Morse Taper Extension Sockets

MORSE TAPER EXTENSION SOCKETS

- For adapting tools with morse taper shanks to machine having smaller morse taper spindle or for adapting tools with morse taper shanks to machine having the same or larger morse taper spindle.
- Hardened and ground throughout.

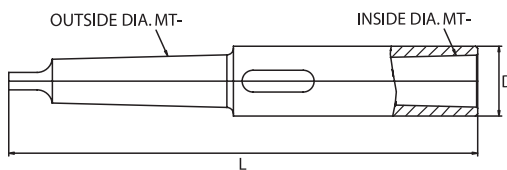

ORDER NO.	I.D.xO.D.	D	L	WEIGHT (kg)	CODE NO.
VQ-111-3	MT1xMT2	18.2	160	0.28	3210-018
VQ-111-1	MT1xMT3	20.2	175	0.4	3210-019
VQ-111-2	MT1xMT4	20.2	204	0.35	3210-020
VQ-112	MT2xMT2	24.2	175	0.35	3210-021
VQ-112-1	MT2xMT3	24.2	194	0.5	3210-022
VQ-112-2	MT2xMT4	24.2	219	0.9	3210-022A
VQ-112-3	MT2xMT5	24.2	254	1.85	3210-022B
VQ-113	MT3xMT2	32.2	196	0.56	3210-023
VQ-114	MT3xMT3	32.2	215	0.7	3210-024
VQ-115	MT3xMT4	32.2	240	1.1	3210-025
VQ-115-1	MT3xMT5	32.2	275	2.1	3210-025A
VQ-115-2	MT4xMT2	45.2	221	1.25	3210-026A
VQ-116	MT4xMT3	45.2	240	1.4	3210-026
VQ-117	MT4xMT4	45.2	265	1.7	3210-027
VQ-118	MT4xMT5	45.2	300	2.7	3210-028
VQ-119-1	MT5xMT3	63.2	275	3	3210-029A
VQ-119	MT5xMT4	63.2	300	3.25	3210-029
VQ-120	MT5xMT5	63.2	335	4.2	3210-030

R8 With Morse Taper Sleeve



R8 STANDARD

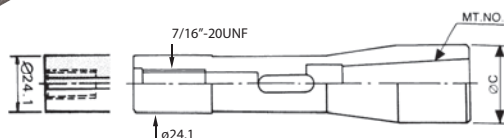

ORDER NO.	SHANK	SIZE	MT NO.	WEIGHT (kg)	CODE NO.
VQ-121	R8	R8-MT1	MT1	0.36	3211-003
VQ-122	R8	R8-MT2	MT2	0.4	3211-001
VQ-123	R8	R8-MT3	MT3	0.5	3211-002



Face Mill Arbor



NT30, 40, 50, R8, MT3, 4

DIN 2080/ISO SHANK



NT40 WITH MAHO GAP



NT30

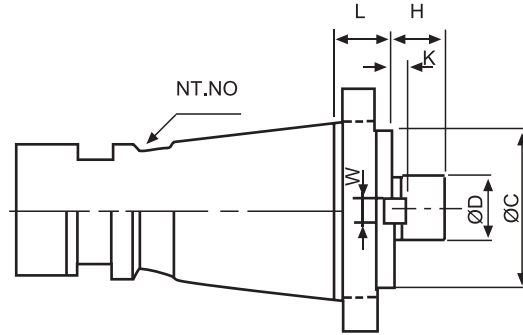
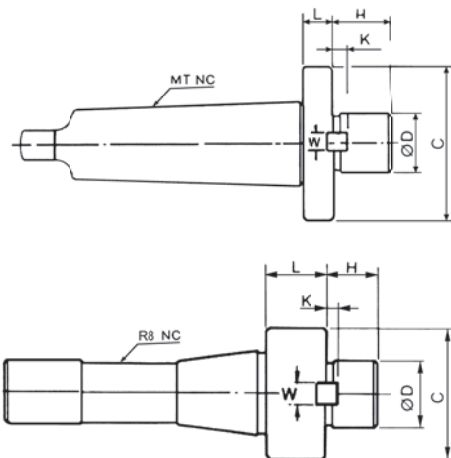

MATERIAL:SCM-21 HARDNESS:HRC 50°-55°

Squareness of mounting surface:Less than 0.0002"(0.005mm)

Deflection in shaft and taper:Less than 0.0002"(0.005mm)



INCH THREAD

INCH FMA TYPE

ORDER NO.	TAPER	SHAFT SIZE				MOUNTING SIZE		WEIGHT (kg)	CODE NO.
		D	H	W	K	C	L		
VF-101	NT30	25.4	20	9.57	5	65	20	0.7	3212-001
VF-102		31.75	23	12.75	7	73	20	1	3212-002
VF-103		38.1	22	15.90	9	82	20	1.1	3212-003
VF-104	NT40	25.4	20	9.57	5	65	20	1.2	3212-004
VF-105		31.75	22	12.75	7	73	20	1.5	3212-005
VF-106		38.1	23	15.90	9	82	20	1.8	3212-006
VF-109	NT50	25.4	20	9.57	5	65	20	3.2	3212-009
VF-110		31.75	22	12.75	7	73	20	3.3	3212-010
VF-111		38.1	23	15.90	9	82	20	3.6	3212-011
VF-112		50.8	24	19.05	10	95	20	4	3212-012
VF-114	R8	25.4	20	9.57	5	40	20	0.9	3212-014
VF-115		31.75	22	12.75	7	53	20	1.2	3212-015
VF-116	MT-3	25.4	20	9.57	5	40	20	0.7	3212-016
VF-117	MT-4	25.4	20	9.57	5	40	20	1	3212-017

METRIC FMB TYPE MM THREAD

ORDER NO.	TAPER	SHAFT SIZE				MOUNTING SIZE		WEIGHT (kg)	CODE NO.
		D	H	W	K	C	L		
VF-120	NT30	22	18	9.57	5	40	20	0.7	3212-100
VF-121		27	20	12.75	7	53	20	0.8	3212-101
VF-122		32	23	15.90	7	63	20	1.1	3212-102
VF-123	NT40	22	18	9.57	5	40	20	1.2	3212-103
VF-124		27	20	12.75	7	53	20	1.3	3212-104
VF-125		32	23	15.90	7	63	20	1.4	3212-105
VF-126		40	26	19.05	8	85	20	1.9	3212-106
VF-127		60	32	25.40	5	128	24	4	3212-107
VF-128	NT50	22	18	9.57	5	40	20	3.1	3212-108
VF-129		27	20	12.75	7	53	20	3.3	3212-109
VF-130		32	23	15.90	7	63	20	3.5	3212-110
VF-131		40	26	19.05	8	85	20	3.7	3212-111
VF-132	R8	60	32	25.40	5	128.57	24	5.4	3212-112
VF-134		22	18	9.57	5	40	20	0.9	3212-113
VF-135		27	20	12.75	7	53	20	1	3212-114
VF-136	MT-3	27	20	9.57	7	53	20	0.7	3212-115
VF-136-1		22	16	9.57	7	46	13.5	0.7	3212-115A
VF-137	MT4	27	20	9.57	7	53	20	1.1	3212-116

FACE MILL ARBOR



Morse Taper Adapter



NT-30, 40, 50, R8, MT3, 4

DIN 2080/ISO SHANK



MORSE TAPER ADAPTER WITH STRAIGHT SHANK

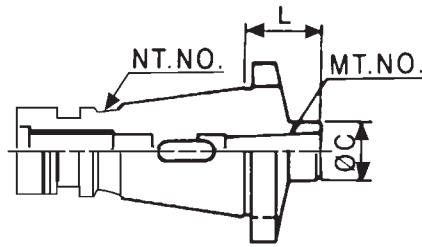

SIDE CUTTER ARBOR

ORDER NO.	CODE NO.
R8-SCA1	3211-080
NT30-SCA1	3211-081
ST40-SCA1	3211-082

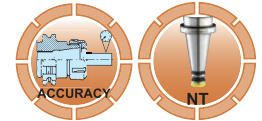

STANDARD TYPE

ORDER NO.	TAPER	TYPE	C	L	WEIGHT (kgs)	CODE NO.
VI-102	NT30	MT2	32	50	0.6	3211-031
VI-103		MT3	35	65	0.7	3211-032
VI-104		MT1	25	30	0.9	3211-033
VI-105	NT40	MT2	32	30	1	3211-034
VI-106		MT3	40	70	1.2	3211-035
VI-107		MT4	50	90	1.5	3211-036
VI-108	NT50	MT2	32	30	2.8	3211-037
VI-109		MT3	40	30	2.7	3211-038
VI-110		MT4	50	45	3.2	3211-039
VI-111		MT5	65	105	3.7	3211-040

PLEASE NOTIFY THE DRAW BAR THREAD SIZE IS MM SIZE OR INCH SIZE WHEN ORDERING.

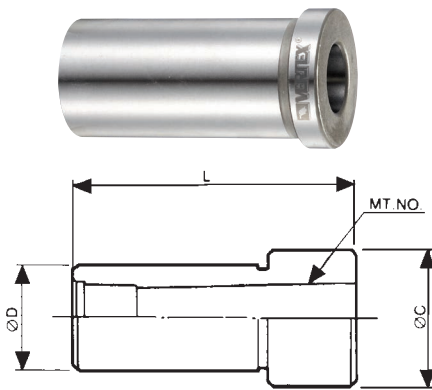

STANDARD TYPE

ORDER NO.	TAPER	SIZE	D	MT NO	C	L	WEIGHT (kg)	CODE NO.
VI-131	C20	C20-MT1	20	MT1	27	60	0.2	3211-060
VI-132		C20-MT2	20	MT2	27	70	0.2	3211-061
VI-133	C25	C25-MT1	25	MT1	33	60	0.3	3211-062
VI-134		C25-MT2	25	MT2	33	70	0.2	3211-063
VI-135		C25-MT3	25	MT3	33	90	0.2	3211-064
VI-136	C32	C32-MT1	32	MT1	37	60	0.36	3211-065
VI-137		C32-MT2	32	MT2	37	70	0.37	3211-066
VI-138		C32-MT3	32	MT3	37	90	0.35	3211-067
VI-138-4		C32-MT4	32	MT4	37	112	0.3	3211-068



Side Cutter Arbor

VRA-NT40

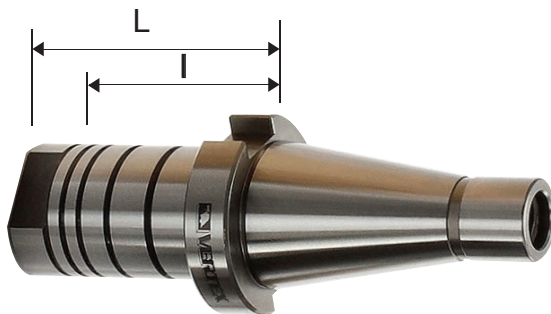

VRA-R8

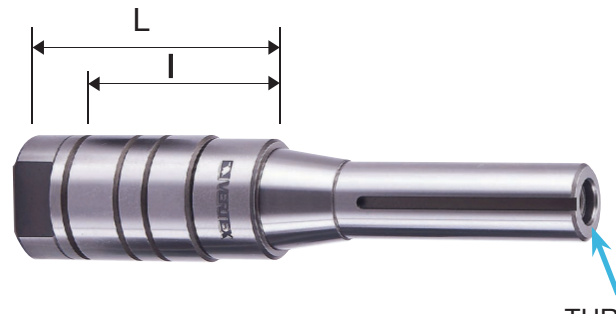

INCH

ORDER NO.	THREAD	L	I	CODE NO.
R8-SCA1"	7/16-20 UNF	86	62	3211-080
NT30-SCA1"	1/2-12 NC	84	60	3211-081
NT40-SCA1"	5/8-11 NC	88	65	3211-082

METRIC

ORDER NO.	THREAD	L	I	CODE NO.
R8-SCB22	7/16-20 UNF	86	62	3211-086
NT30-SCB27	M12 x 1.75P	84	60	3211-087
NT40-SCB27	M16 x 2.0P	88	65	3211-088



Jacobs Taper Drill Chuck Arbor



NT30, 40, 50-JT & B

DIN 2080/ISO SHANK

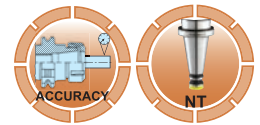
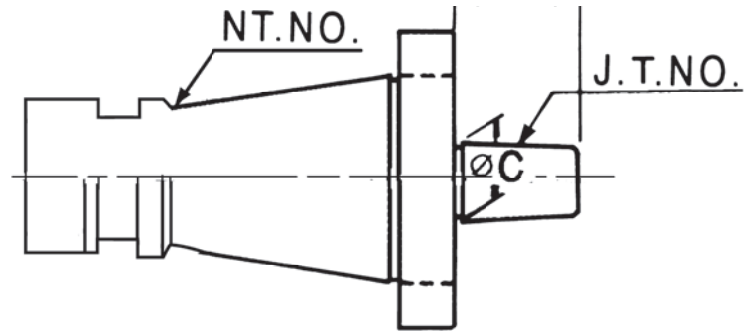

MORSE TAPER ADAPTER

ORDER NO.	TAPER	JT NO	C	H	WEIGHT (kgs)	CODE NO.
VJ-103	NT30	JT6	17.17	26	0.6	3209-092
VJ-106	NT40	JT6	17.17	26	1	3209-095
VJ-109	NT50	JT6	17.17	26	3.2	3209-098
VJ-111	NT30	B16	15.733	24	0.5	3209-099
VJ-112	NT40	B16	15.733	24	1	3209-100

PLEASE NOTIFY THE DRAW BAR THREAD SIZE IS MM SIZE OR INCH SIZE WHEN ORDERING.



Tang For Morse Taper Shank

SURFACE TREATMENT: BLACKENING

HRC 45°

NEW



Tang for draw bar thread type to tang type

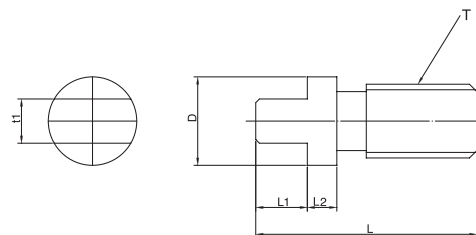

ORDER NO.	Morse	D	L	L1	L2	T	t1	WEIGHT	CODE NO.
VMTS-2	2	12	30	7	4	M10X1.5	6	0.02	3209-201
VMTS-3	3	17	40	12	4	M12X1.75	7.5	0.04	3209-202
VMTS-4	4	24	46	13	5	M16X2	11.5	0.09	3209-203
VMTS-5	5	34	47	14	5	M24X3	15.5	0.18	3029-204



NC Right Angle Head



High Precision

NEW

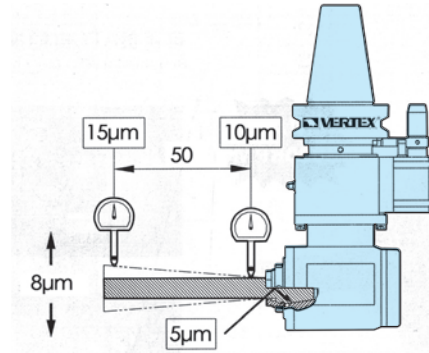
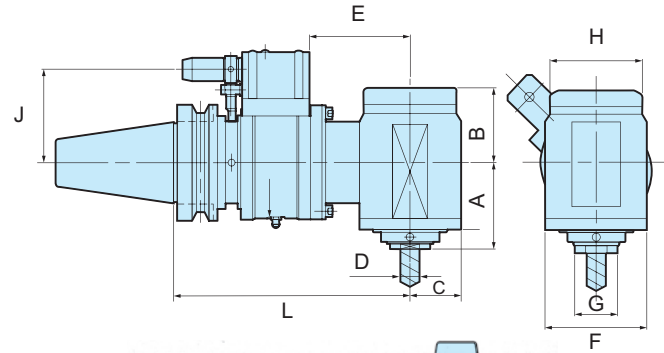

Minimum interference

ORDER NO.	A	B	C	ØD	E	F	ØG	H	L	J	WEIGHT	CODE NO.
BT40-RAER32-185	78.2	63.8	44	2-20	113	88	36	80	185	65	9	3214-201
BT50-RAER32-195					113				195	80	14	3214-202
SK40-RAER32-176					113				176	65	8.8	3214-203
SK50-RAER32-173					113				173	80	13	3214-204

VERTEX ANGLE HEAD MORE SMALLER Interference size contrast

	A	B	C
Other angle head Max. clamping diameter Ø20	Ø171	88	160
VERTEX = Angle head Max. clamping diameter Ø20	Ø156	88	140

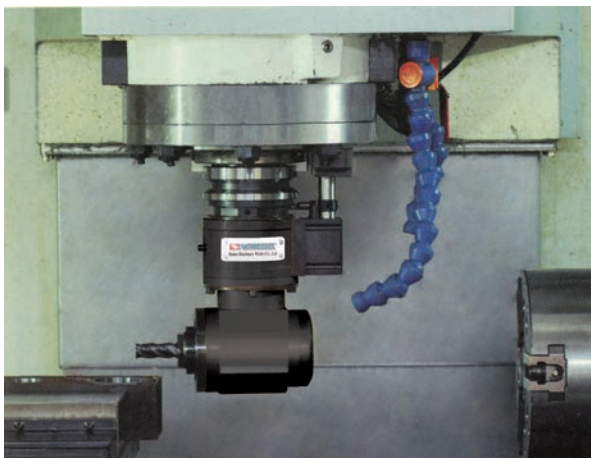
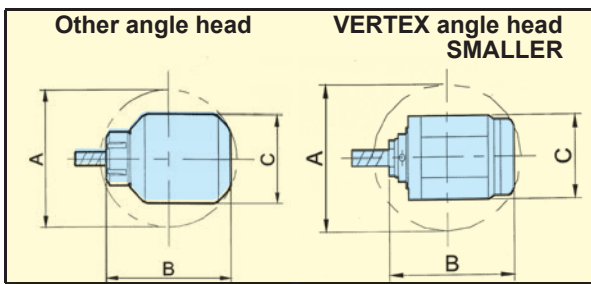

- Turn Vertical Machine To Horizontal
- Clamping range Ø 2- 20
- Max. speed : 3000 P. P. M.
Drive ratio 1:1
- For Light Cutting-facing, Drilling, Tapping & Internal Surface Machining
- Suitable For ATC
- Use Standard BT Shank & ER32 Collets
- Built Internal Collet Chuck System Assure The High Accuracy
- High Precision & Rigid-Made Body
- Free Adjustment OF The Driving Key & Location PIN
- For Special Angle Cutting (NC Universal Angular Head)
- Compact Design : Low Ineterference
- With Special Wrench
- Cautions : Check With VERTEX & Machine Tool Manufacturer First For The Machine Mounting Specification & Pull Stud.

CAUTION

The machine tool's spindle and angle head should Rotate in opposite direction, when use, please make sure machine tool's spindle is Rotating in Reverse direction.



NC Universal Angular Head



NEW



- Angular Head can be ROTATE 360°
- Angular adjust angle = 0° ~ 90°, 2° graduation.

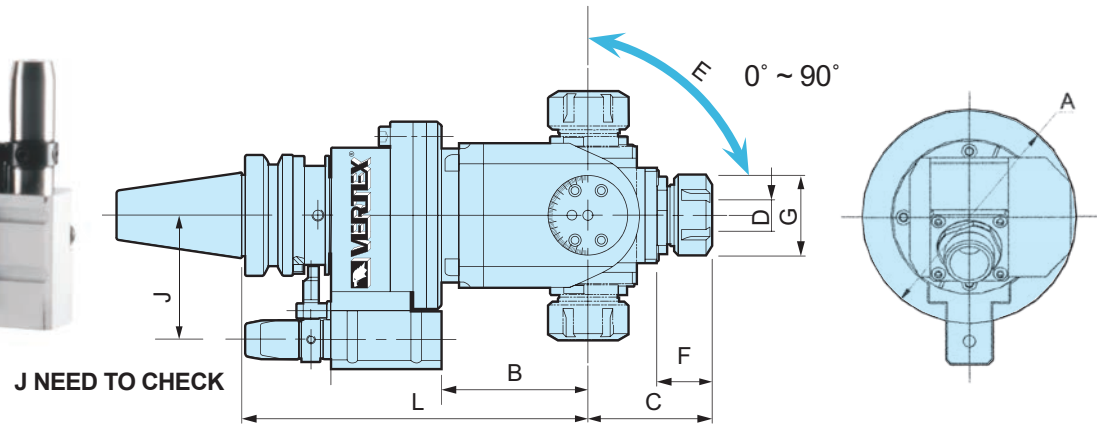

- Clamping Range $\varnothing 2 - \varnothing 16$
- Max. speed : 3000 P. P. M.
Drive ratio 1:1

ANGULAR HEAD

ORDER NO.	A	B	C	$\varnothing D$	E	F	$\varnothing G$	L	J	WEIGHT	CODE NO.
BT40-UAER25-182	138	80	65	2-16	$\pm 90^\circ$	29	42	182	65	9.2	3214-221
BT50-UAER25-200								200	80	13.6	3214-222
SK40-UAER25-173								173	65	9	3214-223
SK50-UAER25-178								178	80	12.6	3214-224

- For Light Cutting-facing, Drilling, Tapping & Internal Surface Machining
- Suitable For ATC
- Use Standard BT Shank & ER32 Collets
- Built Internal Collet Chuck System Assure The High Accuracy
- No Need To Hire Special Engineers
- Easy To Achieve High Precision
- Turn Vertical Machine To Horizontal

- High Precision & Rigid-Made Body
- Free Adjustment Of The Driving Key & Location PIN
- For Special Angle Cutting (NC Universal Angular Head)
- Compact Design : Low Ineterference
- With Special Wrench
- Cautions : J Check With VERTEX & Machine Tool Manufacturer First For The Machine Mounting Specification & Pull Stud.

CAUTION

The machine tool's spindle and angle head should Rotate in opposite direction, when use, please make sure machine tool's spindle is Rotating in Reverse direction.

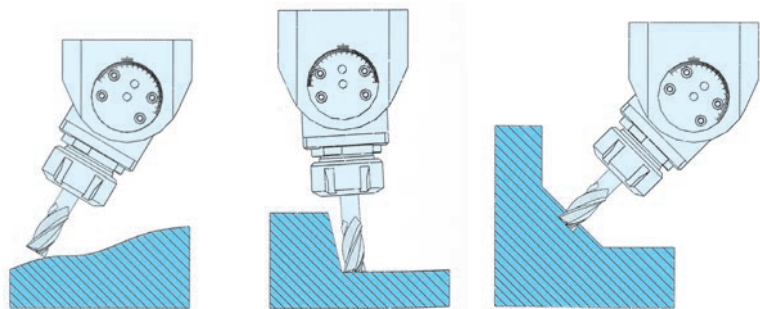

Profile machining

Pattern taper machining

Oblique surface machining



Oli-Feed Holder / Slo



Coolant hole holder for straight shank
BT40,BT50



Dimension

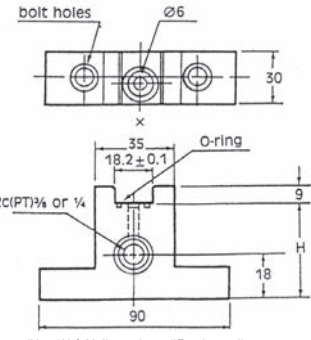
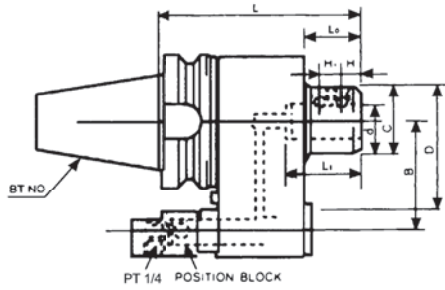

(Note)H & X dimensions differ depending on machines employed.

POSITIONING BLOCK

In using, OIL-FEED holder, positioning block illustrated here is necessary. The positioning block can be mounted to the spindle guide but it shall be mounted so as not to interfere with ATC arm, etc. of machine. it is necessary to consult the machine manufacturer about the proper mounting.

Unit:mm

ORDER NO.	d	L	B	C	D	L0	L1	H	H1	WEIGHT(kgs)	CODE NO.
BT40SLO32-165	32	165	65	53	90	52	60	15	15	4KGS	3214-001
BT50SLO32-165	32	165	80	54	100	42	60	15	15	7.1KGS	3214-003
BT50SLO40-170	40	170	80	64	100	52	70	19	18	7.8KGS	3214-004



Reducing sleeve for oil feed holder.

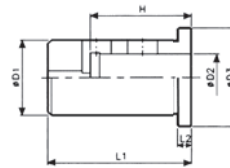

ORDER NO.	D1	D2	D3	L1	L2	H	WEIGHT(kg)	CODE NO.
OC32-20	32	20	42	63	6	48	0.4	3214-103
OC32-25		25				54	0.3	3214-104
OC40-25	40	25	50	63	6	54	0.6	3214-105
OC40-32		32				58	0.5	3214-106



Sidelock END Mill Holder

NT30, 40, 50, R8-SLA

DIN 2080
ISO SHANK

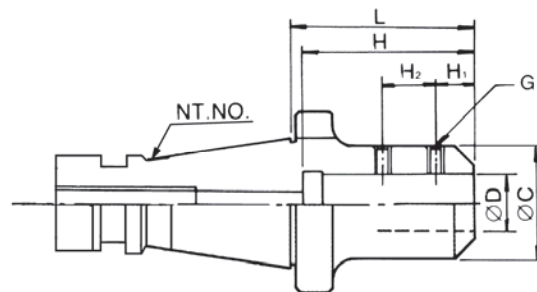

Unit:mm

ORDER NO.	TAPER	D	C	H	L	H1	H2	G	WEIGHT(kgs)	CODE NO.
VN-102	NT30	16	45	50	60	22	18	M10	0.7	3213-002
VN-103	NT30	20	50	60	65	25	20	M12	0.8	3213-003
VN-105	NT40	12	40	45	55	20	16	M10	1.0	3213-005
VN-106	NT40	16	45	50	60	22	18	M10	1.2	3213-006
VN-107	NT40	20	50	60	65	25	20	M12	1.3	3213-007
VN-108	NT40	25	50	65	75	25	22	M12	1.5	3213-008
VN-109	NT40	32	60	70	90	30	22	M16	1.7	3213-009
VN-112	NT50	16	45	50	60	22	18	M10	3.1	3213-012
VN-120	R8	20	50	60	65	25	20	M12	1.0	3213-020
VN-122	NT40	6	25	48	50	9	9.5	M6	0.9	3213-022
VN-123	NT40	8	28	54	56	14	15.5	M8	0.92	3213-023
VN-124	NT40	10	35	52	54	15	13.5	M10	1.03	3213-024

Face Mill Arbor

BT30,40,50



BT-SHANK MAS 403

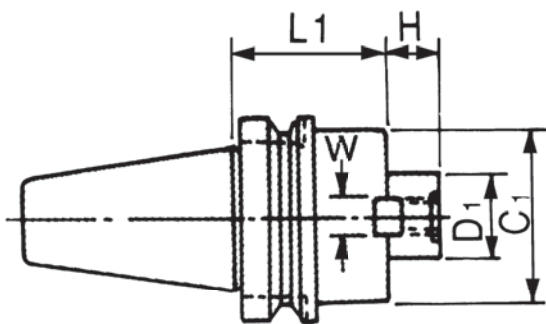

BT-121 ONLY

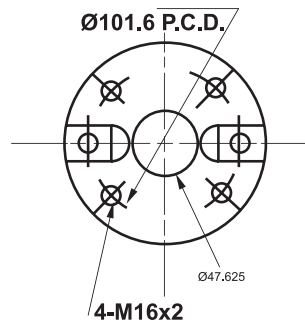

INCH FMA TYPE

ORDER NO.	TAPER	D1	L1	H	C1	W	C4	N.W. (KG)	CODE NO.
BT-101	BT30	25.4	45	22	45	9.5	33	1.0	3212-201
BT-103	BT40	25.4	45	22	50	9.5	33	1.6	3212-203
BT-105		25.4	90	22	50	9.5	33	1.6	3212-205
BT-106		31.75	45	30	60	12.7	40	1.8	3212-206
BT-108	BT50	31.75	90	30	60	12.7	40	2.8	3212-208
BT-109		38.1	60	34	74	15.9	50	2.5	3212-209
BT-111		25.4	45	22	60	9.5	33	4.2	3212-211
BT-112	BT50	25.4	105	22	50	9.5	33	4.9	3212-212
BT-113		25.4	150	22	50	9.5	33	6.2	3212-213
BT-114		31.75	45	30	70	12.7	40	4.0	3212-214
BT-115		31.75	75	30	60	12.7	40	4.8	3212-215
BT-116		31.75	105	30	60	12.7	40	5.6	3212-216
BT-117		38.1	45	34	85	15.9	50	4.6	3212-217
BT-118		38.1	75	34	85	15.9	50	5.6	3212-218
BT-119		50.8	45	36	95	19.05	65	4.8	3212-219
BT-121		-	47.625	75	38	128.57	25.4	-	7.9

METRIC FMB TYPE

ORDER NO.	TAPER	D1	L1	H	C1	W	C4	N.W. (KG)	CODE NO.
BT-150	BT30	22	45	18	48	10	33	2.0	3212-267
BT-151		27	45	20	60	12	33	2.2	3212-268
BT-152	BT40	22	45	18	48	10	50	1.5	3212-269
BT-153		22	90	18	48	10	33	2.2	3212-270
BT-154		27	45	20	60	12	33	1.7	3212-271
BT-155		27	90	20	60	12	33	2.7	3212-272
BT-156		32	45	22	62	14	50	1.8	3212-273
BT-157	BT50	40	60	26	85	16	50	2.7	3212-274
BT-158		22	45	18	60	10	33	4.2	3212-275
BT-159		22	75	18	60	10	33	4.6	3212-276
BT-160		27	45	20	70	12	33	4.3	3212-277
BT-161		27	75	20	60	12	33	4.9	3212-278
BT-162		27	105	20	60	12	33	5.7	3212-279
BT-163		32	75	22	75	14	50	5.5	3212-280
BT-164		32	105	22	80	14	33	6.5	3212-281
BT-165		32	150	22	80	14	33	8.7	3212-282
BT-166	40	75	26	85	16	50	6	3212-283	



FACE MILL ARBOE



Drill Chuck Holder / APU



Details on page C75, C76

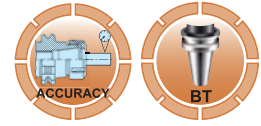
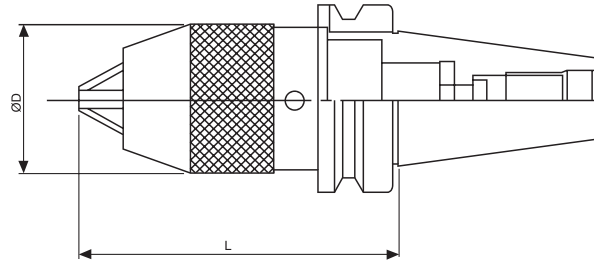

ORDER NO.	TAPER	ØD	KGS	CODE NO.
BT-180	BT30-APU08	37	1	3212-301
BT-181	BT30-APU13	50	1.4	3212-302
BT-182	BT40-APU08	37	1.5	3212-303
BT-183	BT40-APU13	50	2	3212-304
BT-184	BT40-APU16	58	2.5	3212-305
BT-186	BT50-APU13	50	4.7	3212-307
BT-188	BT50-APU16	58	4.8	3212-309



Morse Taper Adaptor

BT30,40,50-MTA,MTB

MAS 403 BT-SHANK

Pull Stud For MTB Adaptor

Pull Stud For MTA Adaptor

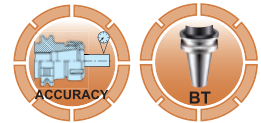
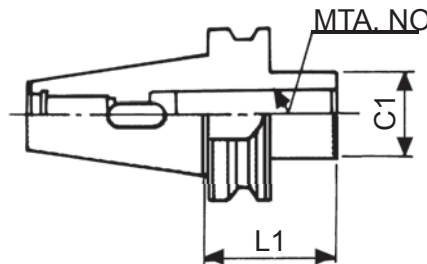
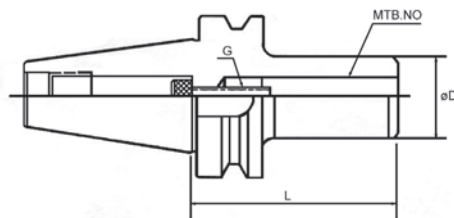

MTA TYPE (STANDARD TYPE)

ORDER NO.	TAPER	MT.NO.	L1	C1	WEIGHT(KG)	CODE NO.
BT-204	BT30	MT-2	60	32	0.6	3211-091
BT-207		MT-3	80	40	1.2	3211-092
BT-209		MT-1	50	25	1.1	3211-094
BT-212	BT40	MT-2	50	32	1.1	3211-095
BT-215		MT-3	75	40	1.3	3211-096
BT-216		MT-3	135	40	1.7	3211-096A
BT-218		MT-4	95	48	1.5	3211-097
BT-219		MT-4	165	48	2.3	3211-097A
BT-220	BT50	MT-1	45	25	3.5	3211-098
BT-223		MT-2	50	32	3.5	3211-099
BT-224		MT-2	135	32	4	3211-099A
BT-226		MT-3	65	40	3.6	3211-100
BT-227		MT-3	150	40	4.4	3211-100A
BT-229		MT-4	75	48	3.6	3211-101
BT-230		MT-4	180	48	4.9	3211-101A
BT-231		MT-5	105	65	4.2	3211-102

Morse Taper Adaptor



MTB TYPE (STANDARD TYPE)

ORDER NO.	TAPER	MT.NO.	L	ØD	G	WEIGHT(KG)	CODE NO.
BT-236	BT40	MTB1	45	25	M16	1	3211-105
BT-237		MTB2	45	32	M10	1	3211-106
BT-238		MTB3	75	40	M12	1.2	3211-107
BT-239		MTB4	75	48	M16	1.3	3211-108
BT-241	BT50	MTB2	45	32	M10	3.6	3211-110
BT-242		MTB3	60	40	M12	3.7	3211-111
BT-243		MTB4	75	48	M16	3.7	3211-112
BT-244		MTB5	120	65	M20	5.2	3211-113



Jacobs Taper Arbor



MAS 403 BT-SHANK

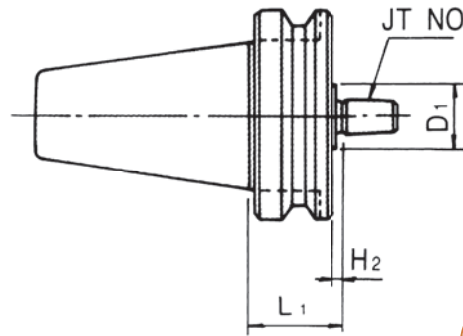

ORDER NO.	TAPER	JT.NO.	L1	D1	H2	WEIGHT (KG)	CODE NO.
BT-315	BT40	JT-6	45	30	4	1.2	3209-147
BT-316		JT-6	90	30	4	1.4	3209-148
BT-325	BT50	JT-6	45	30	4	4.2	3209-151
BT-332	BT40	B16*	45	30	4	1.45	3209-155
BT-332-1		B18*	45				3209-155A
BT-333	BT50	B16*	45	30	4	5.1	3209-156
BT-333-1		B18*	45				3209-156A

JACOBS TAPER ARBOR



Lever Checking Holders



M8 THREAD FOR CHECKING ARM

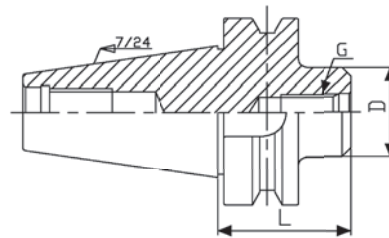

ORDER NO.	L	ØD	G	kgs	CODE NO.
BT40-M8	47	30	M8	1.3	3029-160
BT50-M8	58	30	M8		3029-161



Test Arbor



ORDER NO.	TAPER	G CAN FOR PULL STUD	A	L	KGS	CODE NO.
A50	BT-50	M24xP3.0	40	250	5.3	3405-412
A40	BT-40	M16xP2.0	40		3.9	3405-413
A30	BT-30	M12xP1.75	30		2.4	3405-414
AMT2	MT-2		18	200	1	3405-416
AMT3	MT-3		24	250	2	3405-417
AMT4	MT-4		32	250	3	3405-418



Sidelock End Mill Holder

BT 30, 40, 50-SLA



MAS 403



WELDON TYPE

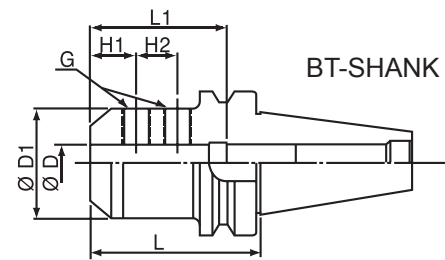
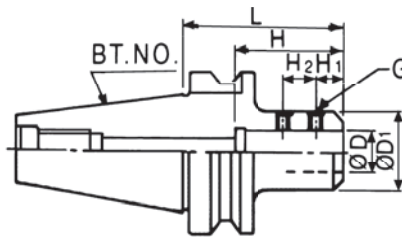

Unit:mm

ORDER NO.	SIZE	ØD	ØD1	L	L1	H1	H2	G	WEIGHT (kgs)	CODE NO.
BT-436	BT30-SLA6-60	6	25	60	30	12	10	M6x1.0	0.7	3213-126
BT-437	BT30-SLA8-60	8	28	60	35	14	12	M8x1.25	0.7	3213-127
BT-438	BT30-SLA10-60	10	35	60	40	15	14	M8x1.25	0.7	3213-128
BT-439	BT30-SLA12-60	12	42	60	50	20	16	M12x1.5	0.8	3213-129
BT-440	BT30-SLA16-75	16	48	75	60	20	18	M12x1.5	0.9	3213-130
BT-441	BT30-SLA20-75	20	52	75	70	23	19	M12x1.5	1.2	3213-131
BT-442	BT40-SLA6-75	6	25	75	30	12	10	M6x1.0	1.2	3213-132
BT-443	BT40-SLA8-75	8	28	75	35	14	12	M8x1.25	1.3	3213-133
BT-444	BT40-SLA10-75	10	35	75	40	15	14	M8x1.25	1.4	3213-134
BT-445	BT40-SLA12-75	12	42	75	50	20	16	M12x1.5	1.5	3213-135
BT-446	BT40-SLA14-75	14	44	75	50	20	16	M12x1.5	1.5	3213-136
BT-447	BT40-SLA16-75	16	48	75	60	20	18	M12x1.5	1.6	3213-137
BT-448	BT40-SLA18-75	18	50	75	60	20	18	M12x1.5	1.6	3213-138
BT-449	BT40-SLA20-90	20	52	90	70	23	19	M12x1.5	1.9	3213-139
BT-450	BT40-SLA25-90	25	62	90	80	24	25	M18x1.5	2.2	3213-140
BT-451	BT40-SLA32-90	32	63	90	80	24	28	M20x1.5	2	3213-141
BT-451-1	BT40-SLA32-100	32						M20x1.5		3213-141A
BT-452	BT40-SLA40-105	40	79	105	80	24	28	M20x1.5	3.2	3213-142
BT-453	BT40-SLA42-105	42	79	105	80	24	28	M20x1.5	3.1	3213-143
BT-454	BT50-SLA6-90	6	25	90	30	12	10	M6x1.0	3.9	3213-144
BT-455	BT50-SLA6-150	6	25	150	30	12	10	M6x1.0	4	3213-145
BT-456	BT50-SLA8-90	8	28	90	35	14	12	M8x1.25	3.7	3213-146
BT-457	BT50-SLA8-150	8	28	150	35	14	12	M8x1.25	4.2	3213-147
BT-458	BT50-SLA10-90	10	35	90	40	15	14	M8x1.25	4.2	3213-148
BT-459	BT50-SLA10-150	10	35	150	40	15	14	M8x1.25	4.3	3213-149
BT-460	BT50-SLA12-90	12	42	90	50	20	16	M12x1.5	4.2	3213-150
BT-461	BT50-SLA12-150	12	42	150	50	20	16	M12x1.5	4.9	3213-151
BT-462	BT50-SLA14-90	14	44	90	55	20	16	M12x1.5	4.2	3213-152
BT-463	BT50-SLA16-90	16	48	90	60	20	18	M12x1.5	4.3	3213-153
BT-464	BT50-SLA16-150	16	48	150	60	20	18	M12x1.5	5	3213-154
BT-465	BT50-SLA18-90	18	50	90	60	20	18	M12x1.5	4.3	3213-155
BT-466	BT50-SLA20-105	20	52	105	70	23	19	M12x1.5P	4.5	3213-156
BT-467	BT50-SLA20-150	20	52	150	70	23	19	M12x1.5	4.5	3213-157
BT-468	BT50-SLA20-200	20	52	200	70	23	19	M12x1.5	6.4	3213-158
BT-470	BT50-SLA25-105	25	65	105	80	24	25	M18x1.5	5	3213-160
BT-471	BT50-SLA25-150	25	65	150	80	24	25	M18x1.5P	6.3	3213-161
BT-472	BT50-SLA25-200	25	65	200	80	24	25	M18x1.5P	7.6	3213-162
BT-474	BT50-SLA32-105	32	72	105	80	24	28	M20x1.5	5.3	3213-164
BT-477	BT50-SLA32-250	32	72	250	80	24	28	M20x1.5	9.8	3213-167
BT-478	BT50-SLA40-120	40	90	120	90	30	32	M20x1.5	6.5	3213-168
BT-479	BT50-SLA42-120	42	90	120	90	30	32	M20x1.5	6.7	3213-169



Pull Studs

BT 30, 40, 50



FOR MAS 403

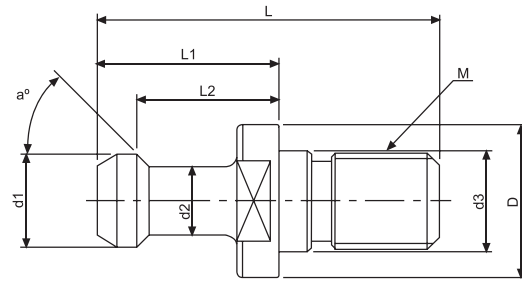

THREAD GROUND

- MATERIAL: SNCM 21
- HARDNESS: HRC 54°±2°
- SHANK BT-30(P 30T)/P30T-1-MAS/P30T-2-MAS
- SHANK BT-40(P 40T)
- SHANK BT-50(P 50T)
- P30T-1-MAS
- P30T-2-MAS

Unit:mm

ORDER NO.	TAPER NO.	a°	L	L1	L2	D	d1	d2	d3	M	NOTE	CODE NO.
BT-510	BT30X90°	90	43	23	18	16.5	11	7	12.5	M12	P30T-3(90°)	3215-007
BT-501	BT30X45°	45	43	23	18	16.5	11	7	12.5	M12	P30T-1(45°)	3215-008
BT-502	BT30X60°	60	43	23	18	16.5	11	7	12.5	M12	P30T-2(60°)	3215-009
BT-511	BT40X90°	90	60	35	28	23	15	10	17	M16	P40T-3(90°)	3215-010
BT-503	BT40X45°	45	60	35	28	23	15	10	17	M16	P40T-1(45°)	3215-011
BT-504	BT40X60°	60	60	35	28	23	15	10	17	M16	P40T-2(60°)	3215-012
BT-512	BT50X90°	90	85	45	35	38	23	17	25	M24	P50T-3(90°)	3215-013
BT-505	BT50X45°	45	85	45	35	38	23	17	25	M24	P50T-1(45°)	3215-014
BT-506	BT50X60°	60	85	45	35	38	23	17	25	M24	P50T-2(60°)	3215-015

PULL STUDS

Pull Studs

MAS 403
BT-40,50

JIS B6339-1986

• With through hole for internal coolant

FOR MAS 403

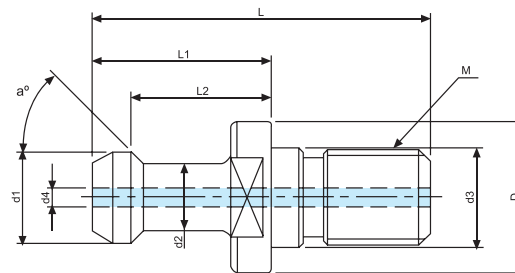

Unit:mm

ORDER NO.	TAPER NO.	a°	L	L1	L2	D	d1	d2	d3	d4	M	CODE NO.
BT-516	BT40X45°W	45	60	35	28	23	15	10	17	4	M16	3215-060
BT-517	BT40X60°W	60	60	35	28	23	15	10	17	4	M16	3215-061
BT-518	BT40X90°W	90	60	35	28	23	15	10	17	4	M16	3215-062
BT-519	BT50X45°W	45	85	45	35	38	23	17	25	7	M24	3215-063
BT-520	BT50X60°W	60	85	45	35	38	23	17	25	7	M24	3215-064
BT-521	BT50X90°W	90	85	45	35	38	23	17	25	7	M24	3215-065

FOR DIN 69872-1988

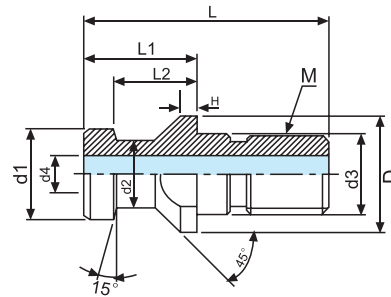

With Collant Hole

DIN 69872, (WITH THROUGH HOLE)-A TYPE

Unit:mm

ORDER NO.	TAPER NO.	L	L1	L2	D	d1	d2	d3	d4	M	H	CODE NO.
BT-522	DIN30-A	44	24	19	17	13	9	13	3	M12		3215-066
BT-523	DIN40-A	54	26	20	23	19	14	17	7	M16	4	3215-067
BT-524	DIN40-A-L	54	29	23	23	19	14	17	7	M16		3215-068
BT-525	DIN50-A	74	34	25	36	28	21	25	11.5	M24		3215-069

WITHOUT O-RING DIN69872-B TYPE

Unit:mm

ORDER NO.	TAPER NO.	L	L1	L2	I3	I4	D	d1	d2	d3	d4	M	CODE NO.
BT-526	DIN30-B	44	24	19	1.4		17	13	9	13		M12	3215-070
BT-527	DIN40-B	54	26	20	1.9	27	23	19	14	17	7	M16	3215-071
BT-528	DIN50-B	74	34	25	3	37	36	28	21	25	11.5	M24	3215-072

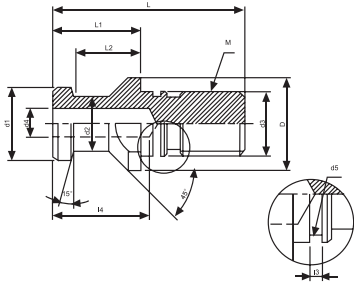

ISO-A TYPE

FOR ISO/JIS 7388/2/A-1984A

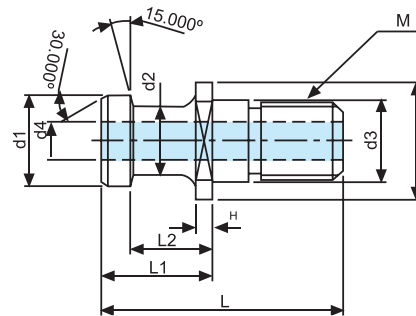

With Collant Hole

Unit:mm

ORDER NO.	TAPER NO.	L	L1	L2	D	d1	d2	d3	d4	M	H	CODE NO.
BT-529	ISO40-A	54	26	20	23	29	24	27	7	M16	3	3215-073
BT-530	ISO50-A	74	34	25	36	28	21	25	11.5	M24		3215-074

ISO-B TYPE

FOR ISO/JIS 7388/2/B-1984B

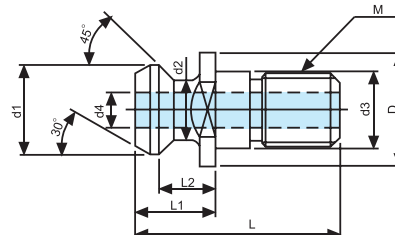

With Collant Hole

Unit:mm

ORDER NO.	TAPER NO.	L	L1	L2	D	d1	d2	d3	d4	M	CODE NO.
BT-531	ISO40-B	44.5	16.4	11.15	22.5	18.95	12.95	17	7.35	M16	3215-075
BT-532	ISO50-B	65.5	25.5	17.95	37	29.1	19.6	25	11.55	M24	3215-076

MAZAK FOR MAZAK MACHINE

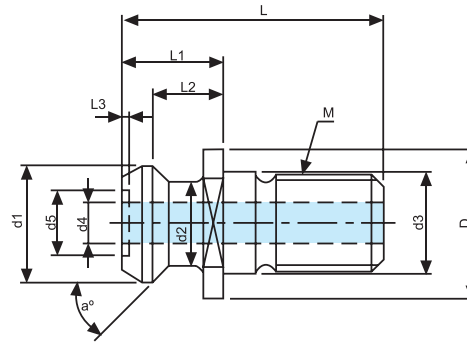

Unit:mm

ORDER NO.	TAPER NO.	a°	L	L1	L2	L3	D	d1	d2	d3	d4	d5	M	CODE NO.
BT-533	MAZAK BT50	45	65.2	25.2	17.58	1.8	37	28.95	20.83	25	10	16	M24	3215-077
BT-534	MAZAK BT40	45	44.1	19.1	14		22	18.8	12.45	17	7		M16	3215-078
BT-535	MAZAK CAT40	45	44.1	16.1	11		22	18.8	12.45	17	7		M16	3215-079

MITSUI FOR MITSUI MACHINE

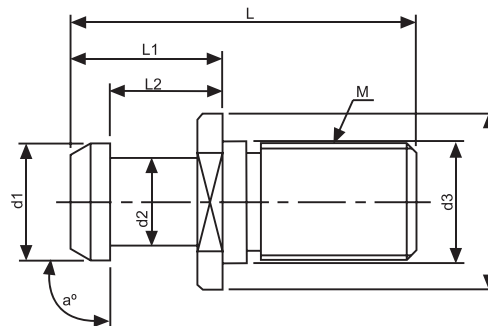

Unit:mm

ORDER NO.	TAPER NO.	a°	L	L1	L2	D	d1	d2	d3	M	CODE NO.
BT-536	MITSUI BT40	90	50	25	18	23	15	10	17	M16	3215-080
BT-537	MITSUI BT50	90	71	31	23	36	24	18	25	M24	3215-081

CAT FOR ANSI B5-50

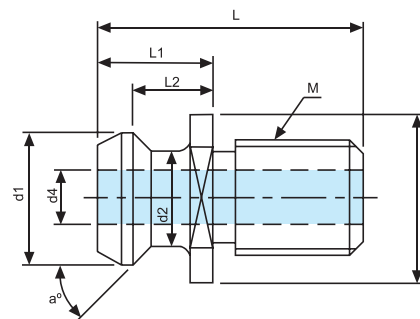

Unit:mm

ORDER NO.	TAPER NO.	a°	L	L1	L2	D	d1	d2	d4	M	CODE NO.
BT-538	CAT40	45	38.1	16.2	11.2	23.8	18.8	12.4	7.1	5/8"	3215-082
BT-539	CAT50	45	58.4	25.4	17.8	36	28.9	20.8	11.8	1"	3215-083

PULL STUDS

CAT-BT FOR BT MACHINE

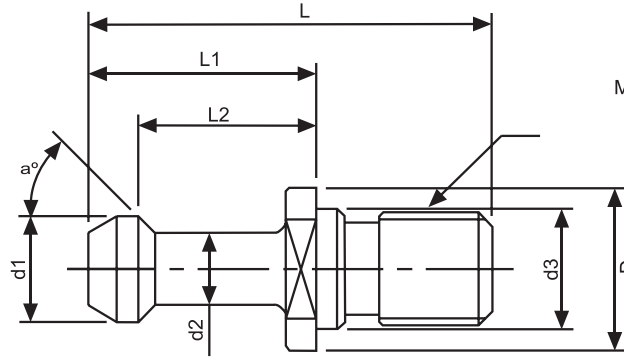

Unit:mm

ORDER NO.	TAPER NO.	a°	L	L1	L2	D	d1	d2	d3	M	CODE NO.
BT-540	CAT40X45°	45	57	32	25	23	15	10		5/8"	3215-084
BT-541	CAT40X60°	60	57	32	25	23	15	10		5/8"	3215-085
BT-542	CAT40X90°	90	57	32	25	23	15	10		5/8"	3215-086
BT-543	CAT50X45°	45	78.6	45	35.2	38	23	17		1"	3215-087
BT-544	CAT50X60°	60	78.6	45	35.2	38	23	17		1"	3215-088
BT-545	CAT50X90°	90	78.6	45	35.2	38	23	17		1"	3215-089
BT-546	CAT40X45°M	45	57	32	25	23	15	10	17	M16	3215-090
BT-547	CAT40X60°M	60	57	32	25	23	15	10	17	M16	3215-091
BT-548	CAT40X90°M	90	57	32	25	23	15	10	17	M16	3215-092

FOR JIS 6339B-40P

With Collant Hole
OKUNMA JIS #40

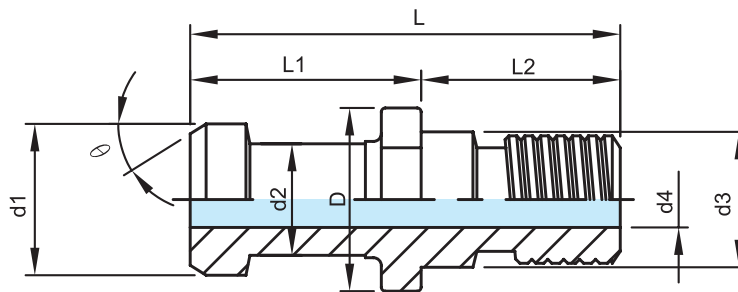

Unit:mm

ORDER NO.	TAPER NO.	a°	L	L1	L2	D	d1	d2	d3	d4	M	CODE NO.
BT-556	JIS	30	54	29	23	23	19	14	17	7	M16	3215-111

STEEL: SNCM-21



Complete NC Tooling Set



We recommend a complete set which is included tool holder, collet chuck, collet set, pull stud, tooling locking stand, edge finder for NC machining center. it is popular and suitable sale-mix in the market.



TOOLING SET

ORDER NO. VBT-30-0720 CODE NO. 3216-001 BT-30 WITH 7PCS. HOLDER & ER-20 COLLET

ITEM NO.	Descriptions	Figures	Quantity	Explanation
1	ER20 COLLET CHUCK BT30-ER20-60		3pcs.	For small Dia. End mill and Drills
2	MORSE TAPER ADAPTOR BT30-MTA1-50		1pc.	For drills with Morse taper Shank No.1.
3	MORSE TAPER ADAPTOR BT30-MTA2-60		1pc.	For drills with Morse taper Shank No.2.
4	END MILL HOLDER BT-30-SL12-60		1pc.	For straight shank end mill with Sidelock edge Dia. 12mm(WELDON Type)
5	END MILL HOLDER BT30-SL16-75		1pc.	For straight shank end mill with Sidelock edge Dia. 16mm(WELDON Type)
6	ER20 SPRING COLLET ER20-dØ		11pcs.	For item 1. Including 11 collets as below: Ø3,4,5,6,7,8,9,10,11,12,13mm
7	PULL STUD BT-501, BT-502		7pcs.	BT-501 $\theta = 45^\circ$ BT-502 $\theta = 60^\circ$
8	TOOL HOLDER LOCKING STAND VTS-BT-30		1pc.	For locking the pull studs or preparing Cutting tools of tool holders.
9	ELECTRONIC EDGE FINDER VPS-20B		1pc.	For setting work coordinate on Machine Centers.

ORDER NO. VBT-30-1520 CODE NO. 3216-011 BT-30 WITH 15PCS. HOLDER & ER-20 COLLET

ITEM NO.	Descriptions	Figures	Quantity	Explanation
1	ER20 COLLET CHUCK BT30-ER20-60		6pcs.	For small Dia. End mill and Drills
2	MORSE TAPER ADAPTOR BT30-MTA1-50		1pc.	For drills with Morse taper Shank No.1.
3	MORSE TAPER ADAPTOR BT30-MTA2-60		1pc.	For drills with Morse taper Shank No.2.
4	FACE MILL ARBOR BT30-FMB22-45		1pc.	For Holding the face milling Cutter Dia.50, 63mm
5	END MILL HOLDER BT-30-SL12-60		2pcs.	For straight shank end mill with Sidelock edge Dia. 12mm(WELDON Type)
6	END MILL HOLDER BT30-SL16-60		2pcs.	For straight shank end mill with Sidelock edge Dia. 16mm(WELDON Type)
7	END MILL HOLDER BT30-SL20-75		2pcs.	For straight shank end mill with Sidelock edge Dia. 20mm(WELDON Type)
8	ER20 SPRING COLLET ER20-dØ		11pcs.	For item 1. Including 11 collets as below: Ø3,4,5,6,7,8,9,10,11,12,13mm
9	PULL STUD BT-501, BT-502		15pcs.	BT-501 $\theta = 45^\circ$ BT-502 $\theta = 60^\circ$
10	TOOL HOLDER LOCKING STAND VTS-BT-30		1pc.	For locking the pull studs or preparing Cutting tools of tool holders.
11	ELECTRONIC EDGE FINDER VPS-20B		1pc.	For setting work coordinate on Machine Centers.



Complete NC Tooling Set



We recommend a complete set which is included tool holder, collet chuck, collet set, pull stud, tooling locking stand, edge finder for NC machining center. it is popular and suitable sale-mix in the market.



G.W.:39.6 kgs

ORDER NO. VBT-40-1532 CODE NO. 3216-002 BT-40 WITH 15PCS. HOLDER & ER-32 COLLET

ITEM NO.	Descriptions	Figures	Quantity	Explanation
1	ER32 COLLET CHUCK V-703A BT40-ER32-70		3pcs.	For small Dia. End mill and Drills
2	ER32 COLLET CHUCK V-703B BT40-ER32-100		3pcs.	For small Dia. End mill and Drills
3	MORSE TAPER ADAPTOR BT-209 BT40-MTA1-50		1pc.	For drills with Morse taper Shank No.1.
4	MORSE TAPER ADAPTOR BT-212 BT40-MTA2-50		1pc.	For drills with Morse taper Shank No.2.
5	MORSE TAPER ADAPTOR BT-215 BT40-MTA3-75		1pc.	For drills with Morse taper Shank No.3.
6	FACE MILL ARBOR BT-152 BT40-FMB22-45		1pc.	For holding the face milling Cutter Dia.50, 63mm
7	FACE MILL ARBOR BT-154 BT40-FMB27-45		1pc.	For holding the face milling Cutter Dia.80mm
8	END MILL HOLDER BT-447 BT40-SLA16-75		1pc.	For straight shank end mill with Sidelock edge Dia. 16mm(WELDON Type)
9	END MILL HOLDER BT-449 BT40-SLA20-90		1pc.	For straight shank end mill with Sidelock edge Dia. 20mm(WELDON Type)
10	END MILL HOLDER BT-450 BT40-SLA25-90		1pc.	For straight shank end mill with Sidelock edge Dia. 25mm(WELDON Type)
11	END MILL HOLDER BT-451 BT40-SLA32-90		1pc.	For straight shank end mill with Sidelock edge Dia. 32mm(WELDON Type)
12	ER32 SPRING COLLET V-32008 ER32-dØ		11pcs./set	For item 1.2. Including 11 collets as below: Ø4,5,6,8,10,12,13,15,16,18,20mm
13	PULL STUD BT-503 OR BT-504		15pcs./set	BT-503 $\theta = 45^\circ$ BT-504 $\theta = 60^\circ$
14	TOOL HOLDER LOCKING STAND VTS-BT-40		1pc.	For locking the pull studs or preparing Cutting tools of tool holders.
15	ELECTRONIC EDGE FINDER VPS-20B		1pc.	For setting work coordinate on Machine Centers.





Complete NC Tooling Set



We recommend a complete set which is included tool holder, collet chuck, collet set, pull stud, tooling locking stand, edge finder for NC machining center. it is popular and suitable sale-mix in the market.



ORDER NO. VBT-40-2432 CODE NO. 3216-003 BT-40 WITH 23PCS. HOLDER & ER-32 COLLET

ITEM NO.	Descriptions	Figures	Quantity	Explanation
1	ER32 COLLET CHUCK BT40-ER32-70		4pcs.	For small Dia. End mill and Drills
2	ER32 COLLET CHUCK BT40-ER32-100		4pcs.	For small Dia. End mill and Drills
3	MORSE TAPER ADAPTOR BT40-MTA1-50		1pc.	For drills with Morse taper Shank No.1.
4	MORSE TAPER ADAPTOR BT40-MTA2-50		2pc.	For drills with Morse taper Shank No.2.
5	MORSE TAPER ADAPTOR BT40-MTA3-75		2pc.	For drills with Morse taper Shank No.3.
6	FACE MILL ARBOR BT40-FMB22-45		1pc.	For holding the face milling Cutter Dia.50, 63mm
7	FACE MILL ARBOR BT40-FMB27-45		1pc.	For holding the face milling Cutter Dia.80mm
8	END MILL ARBOR BT40-SLA16-75		2pc.	For straight shank end mill with Sidelock edge Dia. 16mm(WELDON Type)
9	END MILL ARBOR BT40-SLA20-90		2pc.	For straight shank end mill with Sidelock edge Dia. 20mm(WELDON Type)
10	END MILL ARBOR BT40-SLA25-90		2pc.	For straight shank end mill with Sidelock edge Dia. 25mm(WELDON Type)
11	END MILL ARBOR BT40-SLA32-90		2pc.	For straight shank end mill with Sidelock edge Dia. 32mm(WELDON Type)
12	ER32 SPRING COLLET ER32-dØ		11pcs./set	For item 1.2. Including 11 collets as below: Ø4,5,6,8,10,12,13,15,16,18,20mm
13	PULL STUD BT-503 OR BT-504		23pcs./set	BT-503 $\theta = 45^\circ$ BT-504 $\theta = 60^\circ$
14	TOOL HOLDER LOCKING STAND VTS-BT-40		1pc.	For locking the pull studs or preparing Cutting tools of tool holders.
15	ELECTRONIC EDGE FINDER VPS-20B		1pc.	For setting work coordinate on Machine Centers.

TOOLING SET



Face Mill Holder



Holder For Face Mill Cutter.
DIN69871 A

DIN 69871A

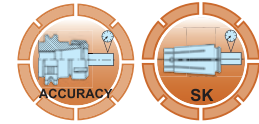
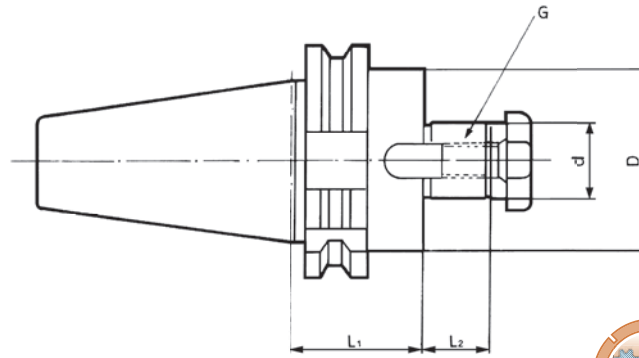

Unit:mm

ORDER NO.	SIZE	d	D	L1	L2	G	WEIGHT (kg)	CODE NO.
SK-112	SK40-FMB22-50	22	48	50	18	M10	1.5	3211-202
SK-113	SK40-FMB27-50	27	60	50	20	M12	1.6	3211-203
SK-114	SK40-FMB32-50	32	62	50	22	M16	2.1	3211-204
SK-117	SK50-FMB22-50	22	60	50	18	M10	3.5	3211-205
SK-118	SK50-FMB27-50	27	70	50	20	M12	3.5	3211-206
SK-119	SK50-FMB32-60	32	75	60	22	M16	3.7	3211-207
SK-120	SK50-FMB40-60	40	85	60	26	M20	4.7	3211-208



Morse Taper Holder-DIN 6383

Holder For Morse Taper Shank With Tang.
DIN69871 A

DIN 69871A

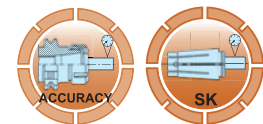
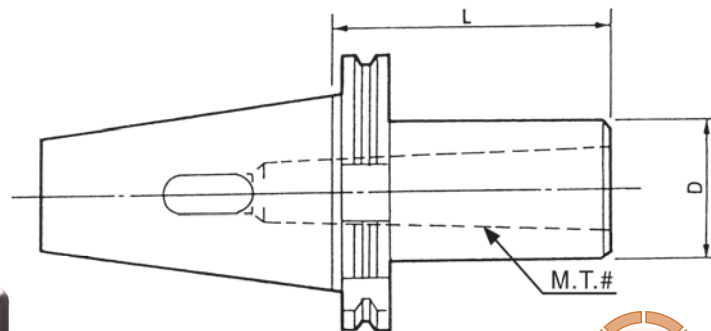

Unit:mm

ORDER NO.	SIZE	M.T.#	L	D	WEIGHT (kg)	CODE NO.
SK-214	SK40-MT1-45	1	45	25	1	3211-133
SK-215	SK40-MT2-50	2	50	32	1	3211-134
SK-216	SK40-MT3-70	3	70	40	1.2	3211-135
SK-217	SK40-MT4-95	4	95	48	1.3	3211-136
SK-218	SK50-MT1-45	1	45	25	3	3211-137
SK-219	SK50-MT2-60	2	60	32	2.9	3211-138
SK-220	SK50-MT3-65	3	65	40	3	3211-139



Sidelock End Mill Holder



DIN69871 A

WELDON TYPE

DIN 69871A

■ Dimensions:

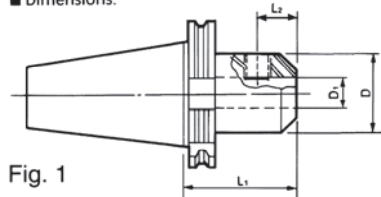

Fig. 1

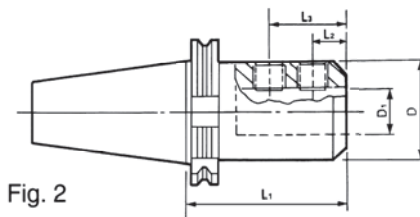
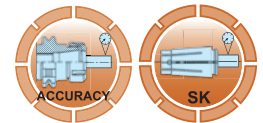

Fig. 2



Unit:mm

ORDER NO.	SIZE	Fig.	D1	D	L1	L2	L3	WEIGHT (kg)	CODE NO.
SK-417	SK40-EM6-50	1	6	25	50	18	-	1	3213-207
SK-418	SK40-EM8-50	1	8	28	50	18	-	1.1	3213-208
SK-419	SK40-EM10-50	1	10	35	50	20	-	1.1	3213-209
SK-420	SK40-EM12-50	1	12	42	50	22.5	-	1.2	3213-210
SK-421	SK40-EM16-63	1	16	48	63	24	-	1.5	3213-211
SK-422	SK40-EM20-63	1	20	52	63	25	-	1.4	3213-212
SK-423	SK40-EM25-100	2	25	65	100	24	49	2.4	3213-213
SK-427	SK50-EM10-63	1	10	35	63	20	-	3.4	3213-217
SK-428	SK50-EM12-63	1	12	42	63	22.5	-	3.4	3213-218
SK-429	SK50-EM16-63	1	16	48	63	24	-	3.5	3213-219
SK-430	SK50-EM20-63	1	20	52	63	25	-	3.5	3213-220
SK-431	SK50-EM25-80	2	25	65	80	24	49	3.8	3213-221

MILL HOLDER



Drill Chuck Holder / APU

DIN 69871A

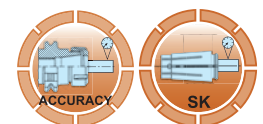
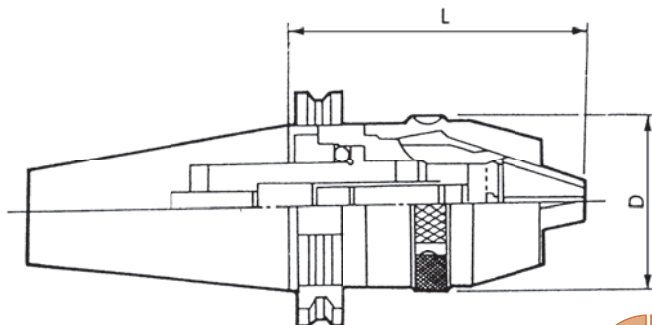

Unit:mm

ORDER NO.	SIZE DIN 69871A	SAME SIZE	Clamping range (Ømm)	D	L		WEIGHT (kg)	CODE NO.
					Minimum	Maximum		
SK-511	SK40-APU08	INT-8-SK40	0.5-8	35.6	81	90	1.4	3301-001
SK-512	SK40-APU13	INT-13-SK40	1-13	52	99	111	1.9	3301-002
SK-514	SK50-APU13	INT-13-SK50	1-13	52	93	106	3.9	3301-004
SK-509	SK30-APU08	INT-8-SK30	0.5-8	35.6	80	88	0.7	3301-005
SK-510	SK30-APU13	INT-13-SK30	1-13	52	98	104	1.34	3301-006
SK-515	SK40-APU16	INT-16-SK40	3-16	56.8	127	140	2.4	3301-007
SK-516	SK50-APU16	INT-16-SK50	3-16	56.8	98	111	3.9	3301-008

Face Mill Holder



CAT-FMA

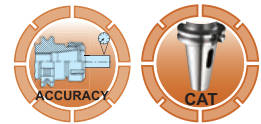
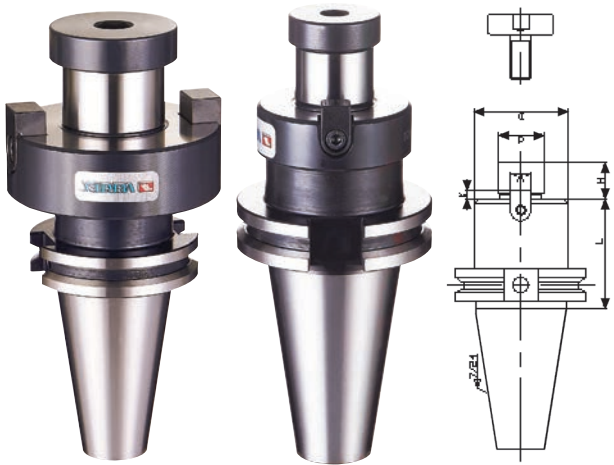

ORDER NO.	L	Ød(h6)	ØD	H	K	W	CODE NO.
CAT40-FMA25.4-2.0"	2.0"	25.4	50	20	5	9.5	3213-230
CAT40-FMA31.75-2.25"	2.25"	31.75	60	22	7	12.7	3213-231
CAT40-FMA38.1-2.4"	2.4"	38.1	80	25	9	15.9	3213-232
CAT50-FMA25.4-2.0"	2.0"	25.4	50	20	5	9.5	3213-233
CAT50-FMA31.75-1.5"	1.5"	31.75	60	22	7	12.7	3213-234
CAT50-FMA38.1-2.4"	2.4"	38.1	80	25	9	15.9	3213-235
CAT50-FMA50.8-2.4"	2.4"	50.8	100	28	12	15.9	3213-236



Side Lock Holders

CAT-SL

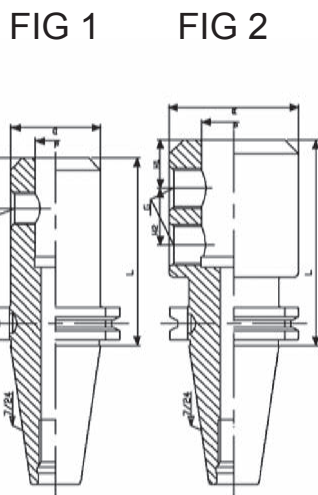
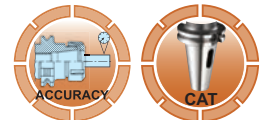

ORDER NO.	FIG	L	Ød	ØD	H1	H2	G	CODE NO.
CAT40-SL08-2.50"	1	2.5"	8	28	18	-	M8	3213-240
CAT40-SL10-2.50"			10	35	20		M10	3213-241
CAT40-SL12-2.62"		2.62"	12	42	22.5		M12	3213-242
CAT40-SL16-2.75"		2.75"	16	48	24		M14	3213-243
CAT40-SL20-3.50"		3.5"	20	48	25		M16	3213-244
CAT40-SL25-4.00"	2	4.0"	25	62	24	25	M18	3213-245
CAT40-SL32-4.00"			32	72		28	M20	3213-246
CAT50-SL08-2.50"	1	2.5"	8	28	18	-	M8	3213-247
CAT50-SL10-2.50"			10	35	20		M10	3213-248
CAT50-SL12-2.62"		2.62"	12	42	22.5		M12	3213-249
CAT50-SL16-2.75"		2.75"	16	48	24		M14	3213-250
CAT50-SL20-3.50"		3.5"	20	52	25		M16	3213-251
CAT50-SL25-4.00"	2	4.0"	25	65	24	25	M18	3213-252
CAT50-SL32-4.00"			32	72		28	M20	3213-253
CAT50-SL40-4.70"			4.7"	40				90

Morse Taper Holders

CAT-MTA

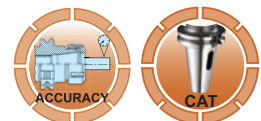
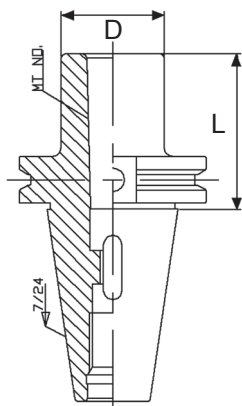

ORDER NO.	MT NO.	L	ØD	CODE NO.
CAT40-MTA2-60	2	60	32	3213-262
CAT40-MTA3-75	3	75	40	3213-263
CAT40-MTA4-90	4	90	50	3213-264
CAT50-MTA2-45	2	45	32	3213-265
CAT50-MTA3-45	3	45	40	3213-266
CAT50-MTA4-75	4	75	50	3213-267
CAT50-MTA5-105	5	105	65	3213-268



DC High Speed Slim Chuck System

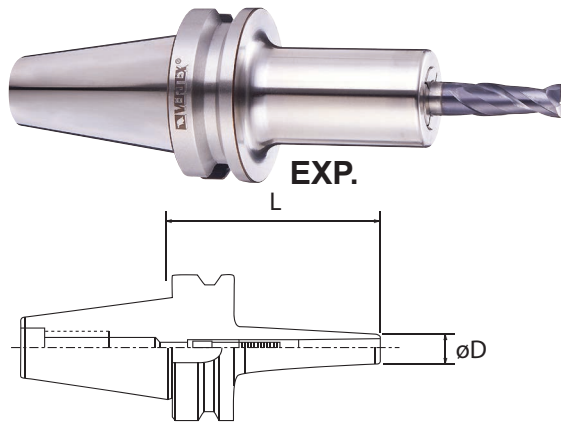

DC Collet System

- Back pulling lock design.
- High clamping force.
- Rigid & high stability.
- For high precision cutting.
- Collets with different sizes can be used on all kind of end mills, reamers, drills and tapping.
- Runout: below 0.005mm.
- Smallest outer diameter.
- Max speed :30.000rpm;G2.5.



ORDER NO.	COLLET TYPE	L	ØD	CLAMPING RANGE	WRENCH	BACK SCREW	WEIGHT (kg)	CODE NO.
BT40-DC6-60	DC6	60	15	2~6	4mm	M5	1.1	3218-046
BT40-DC6-90	DC6	90	15	2~6			1.2	3218-047
BT40-DC8-90	DC8	90	22	3~8	5mm	M6	1.2	3218-100
BT40-DC8-120	DC8	120	22	3~8			1.4	3218-101
BT40-DC10-90	DC10	90	28	3~10	6mm	M8	1.3	3218-102
BT40-DC10-120	DC10	120	28	3~10			1.5	3218-103
BT40-DC12-90	DC12	90	35	3~12	8mm	M10	1.35	3218-104
BT40-DC12-120	DC12	120	35	3~12			1.6	3218-105



Small Collet Of Slim Collet Chuck

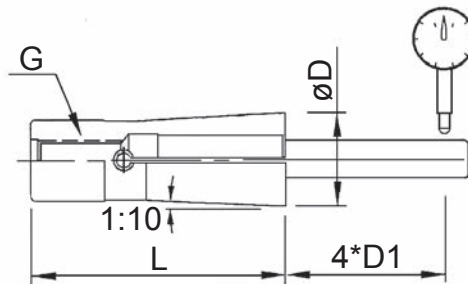
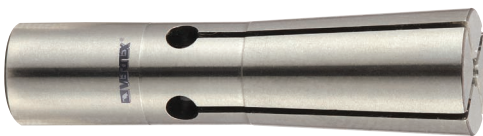

DC Collet System

- DC6 Series : For Clamping End Mills Drills, Reamers And Taps.
- Max. Clamping Diameter
- Runout : Below 0.005 mm

Dimension

TYPE	ØD	L	G
DC6	9.5	36	M5*0.8P
DC8	15	45	M6*1.0P
DC10	19	52	M8-1.25P
DC12	22	60	M10*1.5P

Precision DC Collet within 5 micron

ORDER NO.	ØD	L	CLAMPING CAPACITY FOR END MILL DLA.	CLAMPING CAPACITY FOR DRILL REAMER. TAP	WEIGHT(kg)	CODE NO.
DC6-2	9.5	36	2	2.00-1.75	0.02	3218-056
DC6-2.5	9.5	36	2.5	2.50-2.25	0.02	3218-058
DC6-3	9.5	36	3	3.00-2.75	0.02	3218-065
DC6-3.5	9.5	36	3.5	3.50-3.25	0.02	3218-067
DC6-3.175	9.5	36	3.175	3.50-3.175	0.02	3218-068
DC6-4	9.5	36	4	4.00-3.75	0.02	3218-069
DC6-4.5	9.5	36	4.5	4.50-4.25	0.02	3218-071
DC6-5	9.5	36	5	5.00-4.75	0.02	3218-073
DC6-5.5	9.5	36	5.5	5.50-5.25	0.02	3218-075
DC6-6	9.5	36	6	6.00-5.75	0.02	3218-077
DC8-3	15	45	3	3.00-2.75	0.037	3218-120
DC8-3.175	15	45	3.175	3.175-2.92	0.037	3218-121
DC8-4	15	45	4	4.00-3.75	0.036	3218-122
DC8-5	15	45	5	5.00-4.75	0.035	3218-123
DC8-6	15	45	6	6.00-5.75	0.034	3218-124
DC8-7	15	45	8	8.00-7.75	0.03	3218-125
DC10-3	19	52	3	3.00-2.75	0.074	3218-140
DC10-4	19	52	4	4.00-3.75	0.074	3218-141
DC10-5	19	52	5	5.00-4.75	0.074	3218-142
DC10-6	19	52	6	6.00-5.75	0.072	3218-143
DC10-8	19	52	8	8.00-7.75	0.068	3218-144
DC10-10	19	52	10	10.00-9.75	0.062	3218-145
DC12-3	22	60	3	3.00-2.75	0.11	3218-160
DC12-4	22	60	4	4.00-3.75	0.11	3218-161
DC12-5	22	60	5	5.00-4.75	0.108	3218-162
DC12-6	22	60	6	6.00-5.75	0.108	3218-163
DC12-8	22	60	8	8.00-7.75	0.104	3218-164
DC12-10	22	60	10	10.00-9.75	0.096	3218-165
DC12-12	22	60	12	12.00-11.75	0.084	3218-166

DC SLIM CHUCK



HSK-A63,A100(DIN-69893) Tool Holder

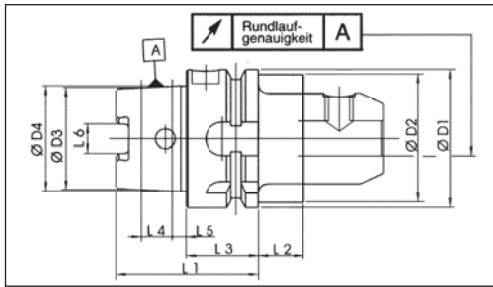

Form A

Compared to the steep taper the HSK has the following advantages

- High repetition accuracy when clamping tools into spindle
- Fix axial positioning by flat contact surface
- Suitable for high speed cutting
- No pull stud necessary

Material

- Special Cast-hardening steel for highly stressed parts
- Surface hardness 58-2 HRC

Tensile strength in core min.1000 N / mm²

DIN 69893

SIZE	ØD1	ØD2	ØD3	ØD4	L1	L2	L3	L4	L5	L6
HSK 63	63	53	46.53	48	58	16	26	14.7	6.3	12.54



HSK-A63,A100(DIN69893A) ER Collet Chucks

DIN69893 A

10000 R.P.M. G6.3

Caution: Excessive torque will damage the chuck, nut or collet.

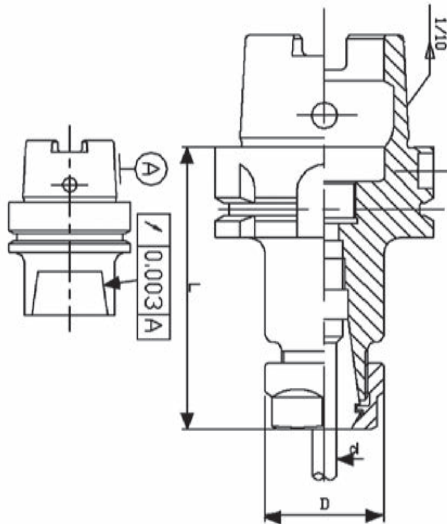

ORDER NO.	L	ØD	Ød RANGE	WEIGHT (kgs)	CODE NO.
HSK-A63-ER16-100	100	30	0.5-10	1.07	3217-100
HSK-A63-ER16-150	150	30	0.5-10	1.33	3217-101
HSK-A63-ER20-100	100	35	1.0-13	1.07	3217-102
HSK-A63-ER20-150	150	35	1.0-13	1.47	3217-103
HSK-A63-ER25-100	100	42	1.0-16	1.29	3217-104
HSK-A63-ER25-150	150	42	1.0-16	1.80	3217-105
HSK-A63-ER32-100	100	50	2.0-20	1.48	3217-106
HSK-A63-ER32-150	150	50	2.0-20	2.16	3217-107
HSK-A63-ER40-100	100	63	3.0-26	1.56	3217-108
HSK-A63-ER40-150	150	63	3.0-26	2.27	3217-109
HSK-A100-ER16-100	100	30	0.5-10	2.3	3217-110
HSK-A100-ER16-150	150	30	0.5-10	2.5	3217-111
HSK-A100-ER20-100	100	35	1.0-13	2.4	3217-112
HSK-A100-ER20-150	150	35	1.0-13	2.7	3217-113
HSK-A100-ER25-100	100	42	1.0-16	2.64	3217-114
HSK-A100-ER25-150	150	42	1.0-16	3.2	3217-115
HSK-A100-ER32-100	100	50	2.0-20	2.8	3217-116
HSK-A100-ER32-150	150	50	2.0-20	3.67	3217-117
HSK-A100-ER40-100	100	63	3.0-26	3.1	3217-118
HSK-A100-ER40-150	150	63	3.0-26	4.2	3217-119



HSK-A63,A100(DIN69893A) OZ Collet Chucks

DIN69893 A

10000 R.P.M. G6.3

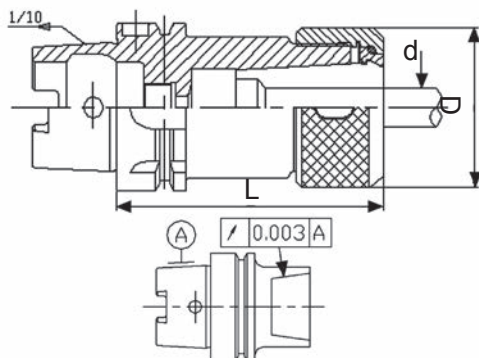

ORDER NO.	L	ØD	Ød RANGE	WEIGHT (kgs)	CODE NO.
HSK-A63-OZ25-100	100	60	2-25	1.6	3217-121
HSK-A63-OZ32-120	120	78	4-32	2.3	3217-122
HSK-A100-OZ25-100	100	60	2-25	2.9	3217-123
HSK-A100-OZ32-120	120	78	4-32	3.6	3217-124



HSK-A63,A100 Morse Taper Holders

DIN69892 A

DIN 69892A

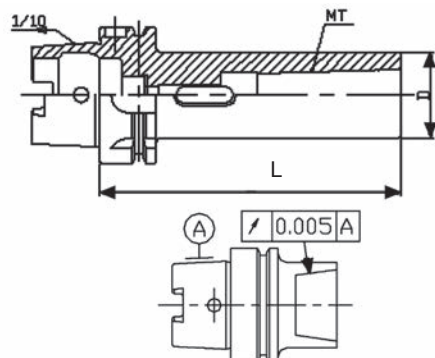

10000 R.P.M. G6.3

ORDER NO.	MT NO.	L	ØD	kgs	CODE NO.
HSK-A63-MTA1-100	1	100	25	1	3217-130
HSK-A63-MTA2-120	2	120	35	1.3	3217-131
HSK-A63-MTA3-140	3	140	40	1.6	3217-132
HSK-A63-MTA4-160	4	160	50	2.2	3217-133
HSK-A100-MTA1-110	1	100	25	2.2	3217-134
HSK-A100-MTA2-120	2	120	35	2.5	3217-135
HSK-A100-MTA3-150	3	140	40	2.9	3217-136
HSK-A100-MTA4-170	4	160	50	3.5	3217-137
HSK-A100-MTA5-200	5	200	65	5.3	3217-138



HSK-A63,A100 Face Mill Holders



DIN69893 A

DIN 69893A

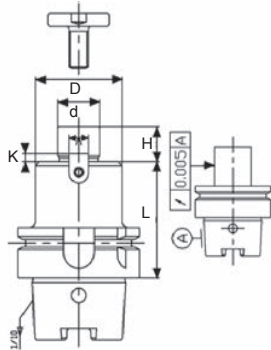

10000 R.P.M. G6.3

ORDER NO.	L	Ød(h6)	ØD	H	K	W	kgs	CODE NO.
HSK-A63-FMA25.4-60	60	25.4	50	20	5	9.5	1.4	3217-140
HSK-A63-FMA25.4-120	120						2.4	3217-141
HSK-A63-FMA31.75-60	60	31.75	60	22	7	12.7	1.6	3217-142
HSK-A63-FMA31.75-120	120						2.6	3217-143
HSK-A63-FMA38.1-60	60	38.1	80	25	9	15.9	2.0	3217-144
HSK-A63-FMA38.1-120	120						3.0	3217-145
HSK-A100-FMA25.4-60	60	25.4	50	20	5	9.5	2.7	3217-146
HSK-A100-FMA25.4-120	120						3.7	3217-147
HSK-A100-FMA31.75-60	60	31.75	60	22	7	12.7	2.9	3217-148
HSK-A100-FMA31.75-120	120						3.9	3217-149
HSK-A100-FMA38.1-60	60	38.1	80	25	9	15.9	3.3	3217-150
HSK-A100-FMA38.1-120	120						4.3	3217-151
HSK-A100-FMA50.8-60	60	50.8	100	28	12	15.9	4.1	3217-152
HSK-A100-FMA50.8-120	120						5.6	3217-153



HSK-A63,A100 Face Mill Holders

DIN69893 A

DIN 69893A

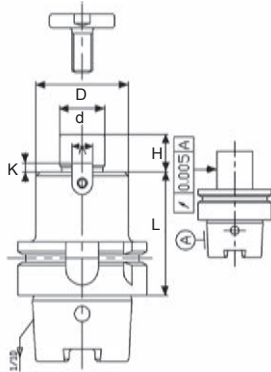

10000 R.P.M. G6.3

ORDER NO.	L	Ød(h6)	ØD	H	K	W	kgs	CODE NO.
HSK-A63-FMB22-50	50	22	48	18	5	10	1.1	3217-156
HSK-A63-FMB22-120	120						2.1	3217-157
HSK-A63-FMB27-60	60	27	60	20	6	12	1.5	3217-158
HSK-A63-FMB27-120	120						2.8	3217-159
HSK-A63-FMB32-60	60	32	72	22	7	14	1.8	3217-160
HSK-A63-FMB32-120	120						3.8	3217-161
HSK-A63-FMB40-60	60	40	80	25	8	16	2.1	3217-162
HSK-A63-FMB40-120	120						3.2	3217-163
HSK-A100-FMB22-50	50	22	48	18	5	10	2.5	3217-164
HSK-A100-FMB22-120	120						3.4	3217-165
HSK-A100-FMB27-60	60	27	60	20	6	12	2.9	3217-166
HSK-A100-FMB27-120	120						4.3	3217-167
HSK-A100-FMB32-60	60	32	72	22	7	14	3.4	3217-168
HSK-A100-FMB32-120	120						5.3	3217-169
HSK-A100-FMB40-60	60	40	80	25	8	16	3.6	3217-170
HSK-A100-FMB40-120	120						6.0	3217-171



HSK-A63,A100 Sidelock End Mill Holder

DIN69893 A

DIN 69893A

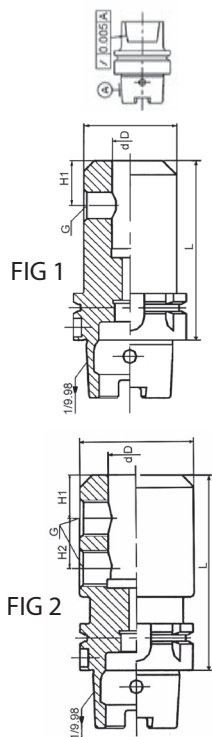

ORDER NO.	L	Ød	ØD	H1	H2	G	FIG	WEIGHT kg	CODE NO.		
HSK-A63-SLA6-80	80	6	25	18	24	M6x0.75	1	0.8	3217-180		
HSK-A63-SLA8-80	80	8	28	18		M8x1.0		0.9	3217-181		
HSK-A63-SLA10-80	80	10	35	20		M10x1.0		1.0	3217-182		
HSK-A63-SLA12-90	90	12	42	22.5		M12x1.5		1.2	3217-183		
HSK-A63-SLA14-90	90	14	45	23		M14x1.5		1.3	3217-184		
HSK-A63-SLA16-100	100	16	48	24				1.5	3217-185		
HSK-A63-SLA18-100	100	18	50	24				1.6	3217-186		
HSK-A63-SLA20-100	100	20	52	25				M16x1.5	1.7	3217-187	
HSK-A63-SLA25-110	110	25	62	24		25		M18x2.0	2	2.2	3217-188
HSK-A63-SLA32-110	110	32	63	24		28		M20x2.0		2.1	3217-189
HSK-A100-SLA10-80	80	10	35	20	24	M10x1.0	1	2.4	3217-190		
HSK-A100-SLA12-90	90	12	42	22.5		M12x1.5		2.6	3217-191		
HSK-A100-SLA16-100	100	16	48	24		M14x1.5		2.9	3217-192		
HSK-A100-SLA20-100	100	20	52	25		M16x1.5		3.0	3217-193		
HSK-A100-SLA25-110	110	25	64	24	25	M18x2.0	2	3.6	3217-194		
HSK-A100-SLA32-110	110	32	72	24	28	M20x2.0		4.1	3217-195		
HSK-A100-SLA40-120	120	40	80	30	32		M20x2.0	4.7	3217-196		

MORSE TAPER HOLDERS



SK Spring Collet System



HRC:47° 10µm JIS STD. 15000 R.P.M.



A GRADE

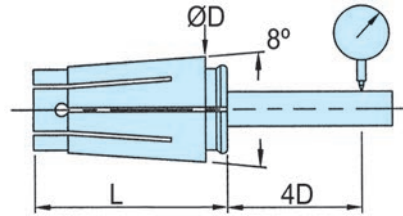

SCM 440

THE RUNOUT OF A COLLET IS 10µ.

THE GRIPPING RANGE OF DIA. OVER 3MM IS 0.5MM

THE GRIPPING RANGE OF DIA. BELOW 3MM IS 0.25MM



TYPE	SK-6A				SK-10A				SK-13A			
	0.005				0.02				0.048			
WEIGHT (KGS)	ORDER NO.	ØD	CAP. mm Ø	CODE NO.	ORDER NO.	ØD	CAP. mm Ø	CODE NO.	ORDER NO.	ØD	CAP. mm Ø	CODE NO.
INDIVIDUAL UNIT	SK0601A	2	2-1.75	3218-400	SK1001A	2	2-1.75	3218-411	SK1301A	3	3-2.75	3218-700
	SK0602A	2.5	2.5-2.25	3218-401	SK1002A	2.5	2.5-2.25	3218-412	SK1302A	3.5	3.5-3	3218-701
	SK0603A	3	3-2.75	3218-402	SK1003A	3	3-2.75	3218-413	SK1303A	4	4-3.5	3218-702
	SK0604A	3.5	3.5-3	3218-403	SK1004A	3.175	3.175-2.7	3218-414	SK1304A	4.5	4.5-4	3218-703
	SK0605A	4	4-3.5	3218-404	SK1005A	3.5	3.5-3	3218-415	SK1305A	5	5-4.5	3218-704
	SK0606A	4.5	4.5-4	3218-405	SK1006A	4	4-3.5	3218-416	SK1306A	5.5	5.5-5	3218-705
	SK0607A	5	5-4.5	3218-406	SK1007A	4.5	4.5-4	3218-417	SK1307A	6	6-5.5	3218-706
	SK0608A	5.5	5.5-5	3218-407	SK1008A	5	5-4.5	3218-418	SK1308A	6.5	6.5-6	3218-707
	SK0609A	6	6-5.5	3218-408	SK1009A	5.5	5.5-5	3218-419	SK1309A	7	7-6.5	3218-708
					SK1010A	6	6-5.5	3218-420	SK13010A	7.5	7.5-7	3218-709
					SK1011A	6.5	6.5-6	3218-421	SK13011A	8	8-7.5	3218-710
					SK1012A	7	7-6.5	3218-422	SK13012A	8.5	8.5-8	3218-711
					SK1013A	7.5	7.5-7	3218-423	SK13013A	9	9-8.5	3218-712
					SK1014A	8	8-7.5	3218-424	SK13014A	9.5	9.5-9	3218-713
					SK1015A	8.5	8.5-8	3218-425	SK13015A	10	10-9.5	3218-714
					SK1016A	9	9-8.5	3218-426	SK13016A	10.5	10.5-10	3218-715
					SK1017A	9.5	9.5-9	3218-427	SK13017A	11	11-10.5	3218-716
					SK1018A	10	10-9.5	3218-428	SK13018A	11.5	11.5-11	3218-717
								SK13019A	12	12-11.5	3218-718	
								SK13020A	12.5	12.5-12	3218-719	
								SK13021A	13	13-12.5	3218-720	
	TYPE	D	L	WEIGHT (kgs)								
	SK6	10.5	25	0.005								
	SK10	15.5	30.5	0.02								
	SK13	20	39	0.048								
	SK16	24.5	45	0.08								
	SK20	28.5	54	0.135								
	SK25	35.5	57	0.205								



SK Spring Collet System



HRC:47° 10µm JIS STD. 15000 R.P.M.



A GRADE

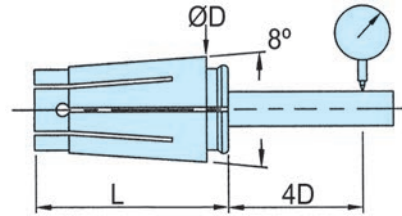

SCM 440

THE RUNOUT OF A COLLET IS 10µ.

THE GRIPPING RANGE OF DIA. OVER 3MM IS 0.5MM

THE GRIPPING RANGE OF DIA. BELOW 3MM IS 0.25MM

TYPE	SK-16A				SK-20A				SK-25A			
WEIGHT (KGS)	0.08				0.135				0.205			
	ORDER NO.	ØD	CAP. mm Ø	CODE NO.	ORDER NO.	ØD	CAP. mm Ø	CODE NO.	ORDER NO.	ØD	CAP. mm Ø	CODE NO.
INDIVIDUAL UNIT	SK1601A	3	3-2.75	3218-430	SK2001A	3	3-2.75	3218-460	SK2501A	6	6-5.5	3218-470
	SK1602A	3.175	3.175-2.7	3218-431	SK2002A	4	4-3.5	3218-461	SK2502A	8	8-7.5	3218-471
	SK1603A	3.5	3.5-3	3218-432	SK2003A	6	6-5.5	3218-462	SK2503A	10	10-9.5	3218-472
	SK1604A	4	4-3.5	3218-433	SK2004A	8	8-7.5	3218-463	SK2504A	12	12-11.5	3218-473
	SK1605A	4.5	4.5-4	3218-434	SK2005A	10	10-9.5	3218-464	SK2505A	14	14-13.5	3218-474
	SK1606A	5	5-4.5	3218-435	SK2006A	12	12-11.5	3218-465	SK2506A	16	16-15.5	3218-475
	SK1607A	5.5	5.5-5	3218-436	SK2007A	16	16-15.5	3218-466	SK2507A	18	18-17.5	3218-476
	SK1608A	6	6-5.5	3218-437	SK2008A	20	20-19.5	3218-467	SK2508A	20	20-19.5	3218-477
	SK1609A	6.5	6.5-6	3218-438					SK2509A	22	22-21.5	3218-478
	SK1610A	7	7-6.5	3218-439					SK2510A	24	24-23.5	3218-479
	SK1611A	7.5	7.5-7	3218-440					SK2511A	25	25-24.5	3218-480
	SK1612A	8	8-7.5	3218-441					SK2512A	25.4	25.4-25	3218-481
	SK1613A	8.5	8.5-8	3218-442								
	SK1614A	9	9-8.5	3218-443								
	SK1615A	9.5	9.5-9	3218-444								
	SK1616A	10	10-9.5	3218-445								
	SK1617A	10.5	10.5-10	3218-446								
	SK1618A	11	11-10.5	3218-447								
	SK1619A	11.5	11.5-11	3218-448								
	SK1620A	12	12-11.5	3218-449								
	SK1621A	12.5	12.5-12	3218-450								
	SK1622A	13	13-12.5	3218-451								
	SK1623A	13.5	13.5-13	3218-452								
	SK1624A	14	14-13.5	3218-453								
	SK1625A	14.5	14.5-14	3218-454								
	SK1626A	15	15-14.5	3218-455								
	SK1627A	15.5	15.5-15	3218-456								
	SK1628A	16	16-15.5	3218-457								

SK CILLET



SK Spring Collet System



HRC:47° 5µm JIS STD. 15000 R.P.M.



AA GRADE

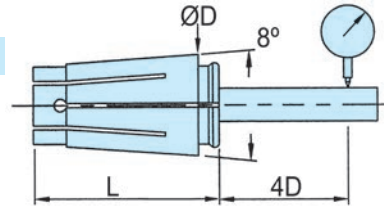

SCM 440
 THE RUNOUT OF AA COLLET IS 5µ.
 THE GRIPPING RANGE OF DIA. OVER 3MM IS 0.5MM
 THE GRIPPING RANGE OF DIA. BELOW 3MM IS 0.25MM



TYPE	SK-6AA				SK-10AA				SK-13AA			
WEIGHT (KGS)	0.005				0.02				0.048			
	ORDER NO.	ØD	CAP. mm Ø	CODE NO.	ORDER NO.	ØD	CAP. mm Ø	CODE NO.	ORDER NO.	ØD	CAP. mm Ø	CODE NO.
INDIVIDUAL UNIT	SK0601AA	2	2-1.75	3218-500	SK1001AA	2	2-1.75	3218-511	SK1301AA	3	3-2.75	3218-730
	SK0602AA	2.5	2.5-2.25	3218-501	SK1002AA	2.5	2.5-2.25	3218-512	SK1302AA	3.5	3.5-3	3218-731
	SK0603AA	3	3-2.75	3218-502	SK1003AA	3	3-2.75	3218-513	SK1303AA	4	4-3.5	3218-732
	SK0604AA	3.5	3.5-3	3218-503	SK1004AA	3.175	3.175-2.7	3218-514	SK1304AA	4.5	4.5-4	3218-733
	SK0605AA	4	4-3.5	3218-504	SK1005AA	3.5	3.5-3	3218-515	SK1305AA	5	5-4.5	3218-734
	SK0606AA	4.5	4.5-4	3218-505	SK1006AA	4	4-3.5	3218-516	SK1306AA	5.5	5.5-5	3218-735
	SK0607AA	5	5-4.5	3218-506	SK1007AA	4.5	4.5-4	3218-517	SK1307AA	6	6-5.5	3218-736
	SK0608AA	5.5	5.5-5	3218-507	SK1008AA	5	5-4.5	3218-518	SK1308AA	6.5	6.5-6	3218-737
	SK0609AA	6	6-5.5	3218-508	SK1009AA	5.5	5.5-5	3218-519	SK1309AA	7	7-6.5	3218-738
					SK1010AA	6	6-5.5	3218-520	SK13010AA	7.5	7.5-7	3218-739
					SK1011AA	6.5	6.5-6	3218-521	SK13011AA	8	8-7.5	3218-740
					SK1012AA	7	7-6.5	3218-522	SK13012AA	8.5	8.5-8	3218-741
					SK1013AA	7.5	7.5-7	3218-523	SK13013AA	9	9-8.5	3218-742
					SK1014AA	8	8-7.5	3218-524	SK13014AA	9.5	9.5-9	3218-743
					SK1015AA	8.5	8.5-8	3218-525	SK13015AA	10	10-9.5	3218-744
					SK1016AA	9	9-8.5	3218-526	SK13016AA	10.5	10.5-10	3218-745
					SK1017AA	9.5	9.5-9	3218-527	SK13017AA	11	11-10.5	3218-746
					SK1018AA	10	10-9.5	3218-528	SK13018AA	11.5	11.5-11	3218-747
									SK13019AA	12	12-11.5	3218-748
									SK13020AA	12.5	12.5-12	3218-749
								SK13021AA	13	13-12.5	3218-750	



SK Spring Collet System



HRC:47° 5µm JIS STD. 15000 R.P.M.



AA GRADE

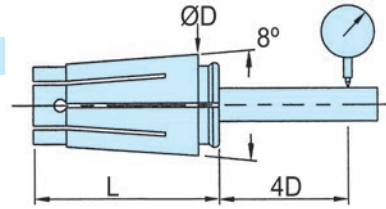

SCM 440

THE RUNOUT OF AA COLLET IS 5µ.

THE GRIPPING RANGE OF DIA. OVER 3MM IS 0.5MM

THE GRIPPING RANGE OF DIA. BELOW 3MM IS 0.25MM

SK COLLET

TYPE	SK-16AA				SK-20AA				SK-25AA			
WEIGHT (KGS)	0.08				0.135				0.205			
	ORDER NO.	ØD	CAP. mm Ø	CODE NO.	ORDER NO.	ØD	CAP. mm Ø	CODE NO.	ORDER NO.	ØD	CAP. mm Ø	CODE NO.
INDIVIDUAL UNIT	SK1601AA	3	3-2.75	3218-530	SK2001AA	3	3-2.75	3218-560	SK2501AA	6	6-5.5	3218-570
	SK1602AA	3.175	3.175-2.7	3218-531	SK2002AA	4	4-3.5	3218-561	SK2502AA	8	8-7.5	3218-571
	SK1603AA	3.5	3.5-3	3218-532	SK2003AA	6	6-5.5	3218-562	SK2503AA	10	10-9.5	3218-572
	SK1604AA	4	4-3.5	3218-533	SK2004AA	8	8-7.5	3218-563	SK2504AA	12	12-11.5	3218-573
	SK1605AA	4.5	4.5-4	3218-534	SK2005AA	10	10-9.5	3218-564	SK2505AA	14	14-13.5	3218-574
	SK1606AA	5	5-4.5	3218-535	SK2006AA	12	12-11.5	3218-565	SK2506AA	16	16-15.5	3218-575
	SK1607AA	5.5	5.5-5	3218-536	SK2007AA	16	16-15.5	3218-566	SK2507AA	18	18-17.5	3218-576
	SK1608AA	6	6-5.5	3218-537	SK2008AA	20	20-19.5	3218-567	SK2508AA	20	20-19.5	3218-577
	SK1609AA	6.5	6.5-6	3218-538					SK2509AA	22	22-21.5	3218-578
	SK1610AA	7	7-6.5	3218-539					SK2510AA	24	24-23.5	3218-579
	SK1611AA	7.5	7.5-7	3218-540					SK2511AA	25	25-24.5	3218-580
	SK1612AA	8	8-7.5	3218-541					SK2512AA	25.4	25.4-25	3218-581
	SK1613AA	8.5	8.5-8	3218-542								
	SK1614AA	9	9-8.5	3218-543								
	SK1615AA	9.5	9.5-9	3218-544								
	SK1616AA	10	10-9.5	3218-545								
	SK1617AA	10.5	10.5-10	3218-546								
	SK1618AA	11	11-10.5	3218-547								
	SK1619AA	11.5	11.5-11	3218-548								
	SK1620AA	12	12-11.5	3218-549								
	SK1621AA	12.5	12.5-12	3218-550								
	SK1622AA	13	13-12.5	3218-551								
	SK1623AA	13.5	13.5-13	3218-552								
	SK1624AA	14	14-13.5	3218-553								
	SK1625AA	14.5	14.5-14	3218-554								
	SK1626AA	15	15-14.5	3218-555								
	SK1627AA	15.5	15.5-15	3218-556								
	SK1628AA	16	16-15.5	3218-557								



BT-SK Collet Chuck System



JIS STD. 15000 R.P.M. 2.5G

AA

● THE SK CHUCK IS ACCORDING TO THE DESIGN OF ANGEL 8 WITH HIGH ACCURACY AND HIGH GRIPPING RANGE. THE GRIPPING TORQUE IS HIGHER THAN STANDARD ER CHUCK.

● THE DYNAMIC BALANCE OF SK CHUCK CAN BE REACHED 15000RPM X 2.5G.

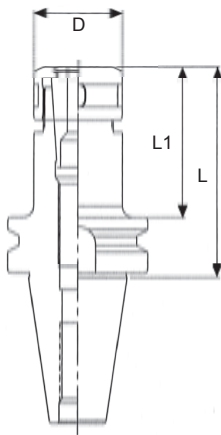
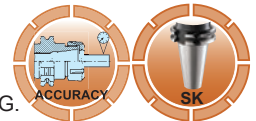

ORDER NO.	BT TYPE	COLLET TYPE	COLLET SIZE	D	L	L1	WEIGHT (kgs)	CODE NO.
SKB-201	BT-30-SK6-60	SK6	2-6	20	60	38	0.5	3218-600
SKB-202	BT-30-SK6-90	SK6	2-6	20	90	68	0.55	3218-601
SKB-203	BT-30-SK10-60	SK10	2-10	28	60	38	0.5	3218-602
SKB-204	BT-30-SK10-90	SK10	2-10	28	90	68	0.7	3218-603
SKB-205	BT-30-SK16-60	SK16	3-16	40	60	38	0.6	3218-604
SKB-206	BT-30-SK16-90	SK16	3-16	40	90	68	0.7	3218-605
SKB-207	BT-40-SK6-60	SK6	2-6	20	60	33	0.9	3218-606
SKB-208	BT-40-SK6-90	SK6	2-6	20	90	63	1	3218-607
SKB-209	BT-40-SK6-120	SK6	2-6	20	120	93	1.2	3218-608
SKB-210	BT-40-SK10-60	SK10	2-10	28	60	33	1	3218-609
SKB-211	BT-40-SK10-90	SK10	2-10	28	90	63	1.1	3218-610
SKB-212	BT-40-SK10-120	SK10	2-10	28	120	93	1.2	3218-611
SKB-213	BT-40-SK10-150	SK10	2-10	28	150	123	1.3	3218-612
SKB-214	BT-40-SK16-60	SK16	3-16	40	60	33	1.2	3218-613
SKB-215	BT-40-SK16-90	SK16	3-16	40	90	63	1.3	3218-614
SKB-216	BT-40-SK16-120	SK16	3-16	40	120	93	1.4	3218-615
SKB-217	BT-40-SK16-150	SK16	3-16	40	150	123	1.5	3218-616
SKB-218	BT-40-SK20-60	SK20	3-20	50	60	33	1.2	3218-617
SKB-219	BT-40-SK20-90	SK20	3-20	50	90	63	1.3	3218-618
SKB-221	BT-40-SK20-150	SK20	3-20	50	150	123	1.5	3218-620
SKB-222	BT-40-SK25-80	SK25	6-25	55	80	53	1.5	3218-621
SKB-223	BT-40-SK25-100	SK25	6-25	55	100	73	1.65	3218-622
SKB-224	BT-50-SK6-100	SK6	2-6	20	100	62	3.6	3218-623
SKB-225	BT-50-SK6-150	SK6	2-6	20	150	112	4	3218-624
SKB-226	BT-50-SK10-100	SK10	2-10	28	100	62	3.6	3218-625
SKB-227	BT-50-SK10-150	SK10	2-10	28	150	112	4	3218-626
SKB-228	BT-50-SK16-100	SK16	3-16	40	100	62	4	3218-627
SKB-229	BT-50-SK16-150	SK16	3-16	40	150	112	4.5	3218-628
SKB-230	BT-50-SK20-100	SK20	3-20	50	100	62	4.3	3218-629
SKB-231	BT-50-SK20-150	SK20	3-20	50	150	112	5.3	3218-630
SKB-232	BT-50-SK25-100	SK25	6-25	55	100	62	4.5	3218-631
SKB-233	BT-50-SK25-150	SK25	6-25	55	150	112	5.5	3218-632
SKB-234	BT-40-SK13-60L	SK13	3-13	33	60	33	1.1	3218-633
SKB-235	BT-40-SK13-90L	SK13	3-13	33	90	63	1.2	3218-634
SKB-236	BT-40-SK13-120L	SK13	3-13	33	120	93	1.3	3218-635
SKB-237	BT-40-SK13-150L	SK13	3-13	33	150	123	1.4	3218-636



Set Of SK Collet And MAS BT Chuck

DYNAMIC BALANCE TESTED

JIS STD.

15000 R.P.M.

AA



SK COLLET SET

METRIC RANGE SET SIZE
SK06/5pcs : Ø2, 3, 4, 5, 6
SK10/8pcs : Ø3, 4, 5, 6, 7, 8, 9, 10
SK16/8pcs : Ø3, 4, 6, 8, 10, 12, 14, 16
SK20/8pcs : Ø3, 4, 6, 8, 10, 12, 16, 20
SK25/7pcs : Ø6, 8, 10, 12, 16, 20, 25

ORDER NO.	BT TYPE	COLLET TYPE	SET RANGE	COLLET PCS	WEIGHT (kg)	CODE NO.
SKB-301	BT-30-SK6-60L	SK6	2-6	5	1.3	3218-640
SKB-302	BT-30-SK6-90L	SK6	2-6	5	1.45	3218-641
SKB-303	BT-30-SK10-60L	SK10	3-10	8	1.7	3218-642
SKB-304	BT-30-SK10-90L	SK10	3-10	8	1.9	3218-643
SKB-305	BT-30-SK16-60L	SK16	3-16	8	2.5	3218-644
SKB-306	BT-30-SK16-90L	SK16	3-16	8	2.8	3218-645
SKB-307	BT-40-SK6-60L	SK6	2-6	5	2.1	3218-646
SKB-308	BT-40-SK6-90L	SK6	2-6	5	2.3	3218-647
SKB-309	BT-40-SK10-60L	SK10	3-10	8	2.6	3218-648
SKB-310	BT-40-SK10-90L	SK10	3-10	8	2.8	3218-649
SKB-311	BT-40-SK16-60L	SK16	3-16	8	3	3218-650
SKB-312	BT-40-SK16-90L	SK16	3-16	8	3.3	3218-651
SKB-313	BT-40-SK20-60L	SK20	4-20	8	3.8	3218-652
SKB-314	BT-40-SK20-90L	SK20	4-20	8	4.1	3218-653
SKB-315	BT-40-SK25-80L	SK25	6-25	7	4.5	3218-654

ST-SK Straight Chuck



JIS STD. 15000 R.P.M.

AA

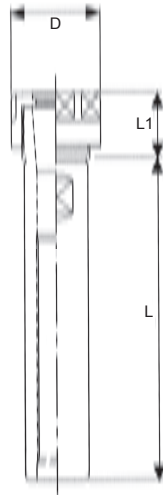

ORDER NO.	TYPE	COLLET	D	L	L1	WEIGHT(kg)	CODE NO.
SKS-210	ST-20-SK6-100	SK6	20	100	20	0.25	3218-660
SKS-211	ST-20-SK6-150	SK6	20	150	20	0.3	3218-661
SKS-212	ST-20-SK10-100	SK10	28	100	20	0.3	3218-662
SKS-213	ST-20-SK10-150	SK10	28	150	20	0.45	3218-663
SKS-214	ST-20-SK10-200	SK10	28	200	20	0.55	3218-664

Set Of SK Collet And Straight Chuck

JIS STD.

15000 R.P.M.

AA

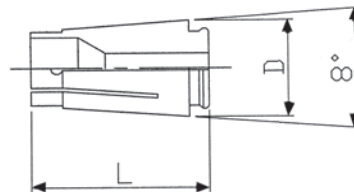

SK COLLET SET

METRIC RANGE SET SIZE

SK06/5pcs : Ø2, 3, 4, 5, 6

SK10/8pcs : Ø3, 4, 5, 6, 7, 8, 9, 10



ORDER NO.	ST TYPE	COLLET	SET RANGE	COLLET SET	WEIGHT (kg)	CODE NO.
SKS-231	ST-20-SK6-100	SK6	2-6	5	0.7	3218-670
SKS-232	ST-20-SK6-150	SK6	2-6	5	0.8	3218-671
SKS-233	ST-20-SK10-100	SK10	3-10	8	1.1	3218-672
SKS-234	ST-20-SK10-150	SK10	3-10	8	1.3	3218-673

SK Nut And Wrench

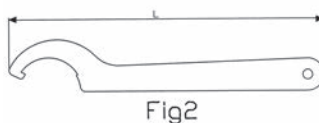
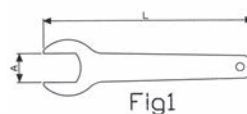
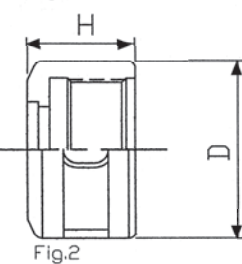
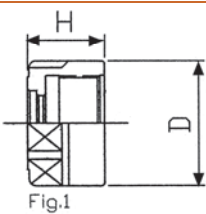
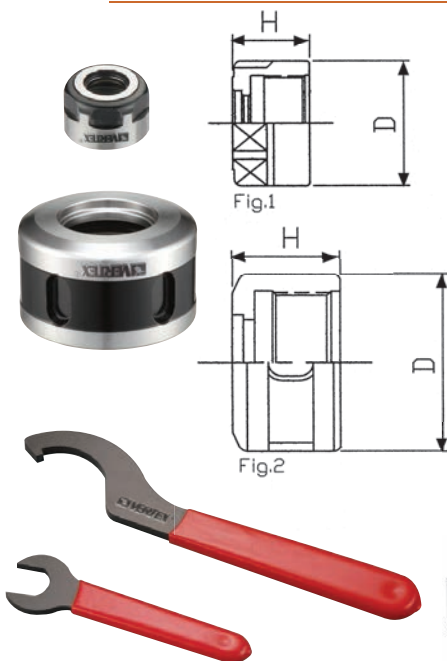

SK NUT

ORDER NO.	FIG	COLLET TYPE	D	H	WEIGHT (kg)	CODE NO.
SKN-601	1	SK06	19.5	15	0.05	3218-680
SKN-101	1	SK10	28	17	0.05	3218-681
SKN-161	2	SK16	40	24	0.08	3218-682
SKN-201	2	SK20	50	25	0.1	3218-683
SKN-251	2	SK25	55	30	0.12	3218-684

SK WRENCH

ORDER NO.	FIG	COLLET TYPE	A	L	WEIGHT (kg)	CODE NO.
SKW-601	1	SK06	18	130	0.08	3218-690
SKW-101	1	SK10	25	140	0.08	3218-691
SKW-161	2	SK16	X	195	0.2	3218-692
SKW-201	2	SK20	X	228	0.22	3218-693
SKW-251	2	SK25	X	228	0.22	3218-694



Find your exact zero points in all three axes in seconds with the new distance measuring scale (graduated and analogue).

- Black scale for radial deflection.
- Red scale for axial deflection
- Precise and effortless calipering of fixtures and workpiece edges.
- Setting of NC-programme zero points in seconds.
- Measuring of clamped workpieces.
- Generous overrun allowances prevent damage to Taster stylus.
- Easy and precise change of stylus.
- Weight: 0.93 KGS

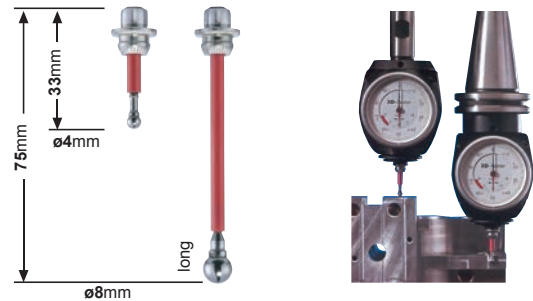
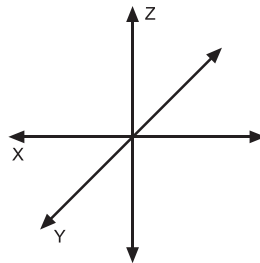

STYLUS

Change stylus in seconds

No screws or special tools required

Easy precision plug-in mechanism

ORDER NO.	TYPE	WEIGHT	CODE NO.
V-3D-05	ø4x33 standard stylus	10g	3219-005
V-3D-06	ø8x75 long stylus	15g	3219-006

TYPE	ACCURACY
3D-Taster	0.01mm



KNT Type Keyless Drill Chucks

FOR DRILL ONLY , NOT FOR END MILL OR TAP



This chuck for CNC keyless drill chuck holders, built by the highest engineering standard.

- Integrated drill chuck and holder once lock with a pull stud, the chuck will never come off.
- Special design ensures high rigidity.
- High service reliability.
- Easy to operate, long service life.
- 100% test and strict quality control assure the highest accuracy.
- 2500R.P.M.

ACCURACY

ITEM NO.	Ød mm	L mm	Max Run-out mm	Torque kgf-cm
KNT-8	3	35	0.05	160
	6			
	8	50		
KNT-13	5	55	0.05	320
	10			
	13	75		
KNT-16	5	55	0.05	480
	10			
	16	80		

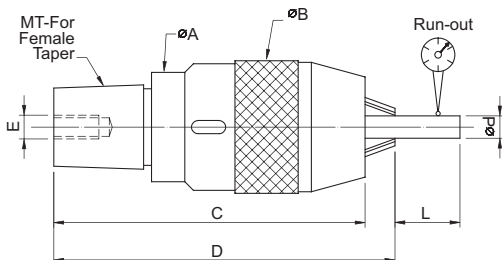

ORDER NO.	Clamping Capacity	For Female Taper	ØA	ØB	C	D	E	kg	QTY Pcs/ Cu-Ft	NW/ GW Kgs	CODE NO.
KNT-8	0.5-8	MT2	30	35	82.5	90	M6x1.0	0.3	40/0.6	15/16	3033-600
KNT-13	0.5-13	MT2	30	56	76	101	M8x1.25	1	30/0.6	30/31	3033-601
		MT3	38		106	118					3033-601A
KNT-16	3-16	MT3	43	56	115	128	M8x1.25	1.3	18/0.6	24/25	3033-602



Integrated Type Keyless Drill Chucks



FOR DRILL ONLY , NOT FOR END MILL OR TAP

CAT-TYPE

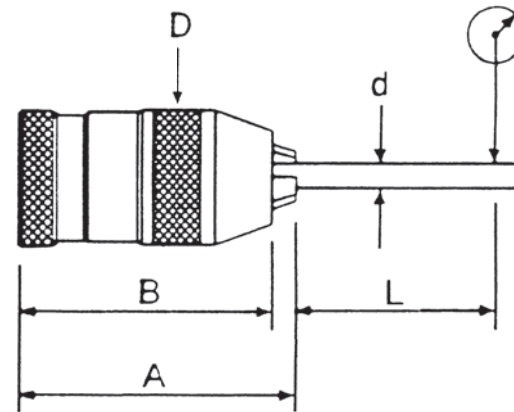

KEYLESS DRILL CHUCK

ACCURACY

ORDER NO.	Clamping Capacity		Taper	OUTER Ø / mm	WEIGHT (kgs)	CODE NO.	ITEM NO.	d mm	L mm	Max Tolerance mm	Torque kgf-cm
	mm	inch									
INT-8-CAT30	0.5-8	1/64"-1/8"	CAT30	Ø35	0.8	3301-073	INT-8	3	25	0.05	160
INT-13-CAT30	0.5-13	1/64"-1/2"		Ø51.5	1	3301-074		6			
						8		30			
INT-8-CAT40	0.5-8	1/64"-1/8"	CAT40	Ø35	1.32	3301-075	INT-10	3	25	0.05	260
INT-13-CAT40	0.5-13	1/64"-1/2"		Ø51.5	2.1	3301-076		6			
								10	30		
INT-16-CAT40	3-16	1/8"-5/8"	CAT50	Ø58	2.26	3301-077	INT-13	5	30	0.05	400
INT-13-CAT50	0.5-13	1/64"-1/2"		Ø51.5	3.95	3301-078		10			
INT-16-CAT50	3-16	1/8"-5/8"		Ø58	4.2	3301-079		13	25		
							INT-16	5	25	0.05	480
								10			
								16	30		



Integrated Type Keyless Drill Chucks

CAN FOR TAP

RL type keyless drill chuck with BT SHANK

SK SHANK
NT SHANK



FOR WRENCH

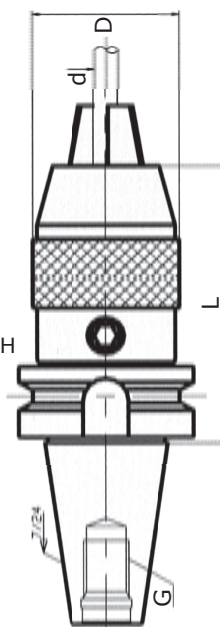

- RL type drill has reinforce torque design to increase more clamping capacity.
- Right turn and left turn allowable.
- No sudden drop when stop or suddenly shift to different direction.
- Highest speed 6000rpm.
- Shorten the shank length which is stronger than traditional design improves the total rigidity.

ORDER NO.	Clamping Capacity mm / d	L	D	G	CODE NO.
BT40-VRL13	0.5-13	95	50	M16	3301-090
BT40-VRL16	3-16	113	57	M16	3301-091
SK40-VRL13	0.5-13	85	50	M16	3301-092
SK40-VRL16	3-16	95	57	M16	3301-093
NT40-VRL13	0.5-13	112	50	M16	3301-094
NT40-VRL16	3-16	120	57	M16	3301-095



Integrated Type Keyless Drill Chucks



FOR DRILL ONLY , NOT FOR END MILL OR TAP



FOR SPECIFICATION PLEASE SEE P.C76

ACCURACY

ITEM NO.	d mm	L mm	Max Tolerance mm	Torque kgf-cm
INT-8	3	25	0.05	160
	6	30		
INT-10	3	25	0.05	260
	6	30		
INT-13	5	30	0.05	400
	10	25		
INT-16	5	25	0.05	480
	10			
	16	30		

The main-shafts is of integrated type, which is much more superior than the traditional design. The major features are as follows:

- Extremely rigid construction. Accuracy is same as page C66
- The accumulative tolerances can be reduced to a minimum, since the traditional mechanism requiring an ARBOR to connect the Drill Chucks which will generate the accumulative tolerances. The Integrated type Keyless Drill Chuck is designed to solve this problem totally.
- Prevent the Drill Chucks from falling out.
- Extremely safe in operation.
- 2500 R.P.M.

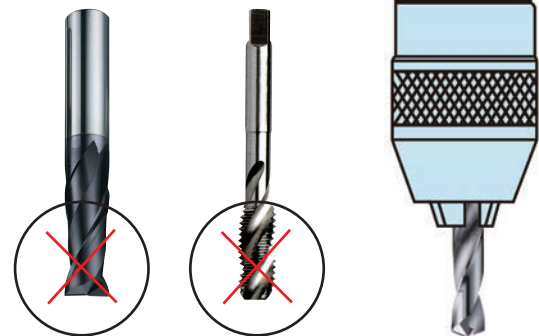
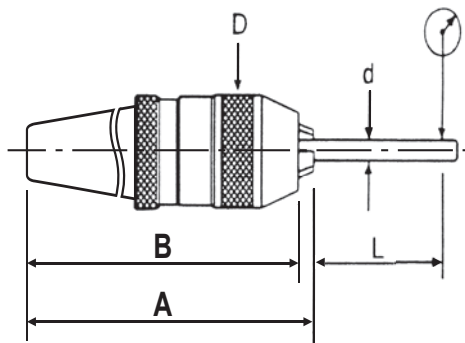

- CAUTIONS:
- ※ DO NOT USE END MILL AND TAP WITH DRILL CHUCK DRILL
 - CHUCK ONLY CAN PROCESS VERTICAL JOB.
 - ADD COOLANT WHILE HEAVY CUTTING.
- ※ WHILE PROCESSING:
- DO NOT MAKE HORIZONTAL MOVEMENT OR ELSE, IT WILL CAUSE 3 JAWS' DEFORMATION.
 - NOT FOR END MILL.



Integrated Type Keyless Drill Chucks



KEYLESS DRILL CHUCK

ORDER NO.	Clamping Capacity		Female Taper DIN or Jacobs	OUTER Ø / mm	Length		WEIGHT (kgs)	CODE NO.
	Ø mm	Ø inch			Open B mm	Closed A mm		
INT-8-MT-2	0.5-8	0-5/16"	MT-2	36	150	157	0.8	3301-030
INT-8-JC-20	0.5-8	0-5/16"	JC-20	36	133	141	0.8	3301-031
INT-8-BT30	0.5-8	1/64"-1/8"	BT30	36	126	132	1	3301-070
INT-8-BT40	0.5-8	1/64"-1/8"	BT40	36	142	150	1.5	3301-072
INT-8-NT30	0.5-8	1/64"-1/8"	NT30	36	136	142	0.8	3301-080
INT-8-NT40	0.5-8	1/64"-1/8"	NT40	36	159	166	1.3	3301-081
INT-8-SK40	0.5-8		SK-40	36	149	157	1.4	3301-083
INT-13-R8	1-13	1/64"-1/2"	R8	50	196	205	1.5	3301-032
INT-13-MT2	1-13	0-1/2"	MT-2	50	172	184	1.3	3301-082
INT-13-MT3	1-13	0-1/2"	MT-3	50	190	201	1.4	3301-033
INT-13-MT4	1-13	0-1/2"	MT-4	50	216	227	1.8	3301-034
INT-13-JC-20	1-13	0-1/2"	JC-20	50	153	164	1.4	3301-035
INT-13-JC-25	1-13	0-1/2"	JC-25	50	163	174	1.6	3301-036
INT-13-JC-32	1-13	0-1/2"	JC-32	50	173	185	1.8	3301-037
INT-13-NT30	1-13	0-1/2"	NT-30	50	86	99	1.4	3301-038
INT-13-NT40	1-13	0-1/2"	NT-40	50	85	96	1.8	3301-039
INT-13-BT30	1-13	1/64"-1/2"	BT30	50	96	108	1.4	3301-071
INT-13-BT40	1-13	0-1/2"	BT-40	50	100	111	2	3301-040
INT-13-BT50	1-13	0-1/2"	BT-50	50	106	117	4.7	3301-041
INT-13-NT50	1-13	0-1/2"	NT-50	50	100	112	4.3	3301-059
INT-13-SK30	1-13		SK-30	50	99	111	1.34	3301-084
INT-13-SK40	1-13		SK-40	50	100	113	1.9	3301-085
INT-13-SK50	1-13		SK-50	50	93	106	3.9	3301-087
INT-16-R8	3-16	1/8"-5/8"	R8	57	198	211	1.9	3301-042
INT-16-MT3	3-16	1/8"-5/8"	MT3	57	194	207	1.9	3301-043
INT-16-MT4	3-16	1/8"-5/8"	MT4	57	219	232	2	3301-044
INT-16-JC-20	3-16	1/8"-5/8"	JC-20	57	152	165	1.8	3301-045
INT-16-JC-25	3-16	1/8"-5/8"	JC-25	57	162	178	1.7	3301-046
INT-16-JC-32	3-16	1/8"-5/8"	JC-32	57	184	179	2.2	3301-047
INT-16-NT40	3-16	1/8"-5/8"	NT-40	57	113	126	2.6	3301-049
INT-16-BT40	3-16	1/8"-5/8"	BT-40	57	113	127	2.5	3301-050
INT-16-BT50	3-16	1/8"-5/8"	BT-50	57	111	124	5	3301-051
INT-16-NT50	3-16	1/8"-5/8"	NT-50	57	104	117	4.5	3301-056
INT-16-SK40	3-16	1/8"-5/8"	SK-40	57	127	141	2.4	3301-057
INT-16-SK50	3-16	1/8"-5/8"	SK-50	57	97	110	3.9	3301-058

ORDER NO.	SIZE DIN 69871A	Clamping range (Ømm)	D	L		WEIGHT (kg)	CODE NO.
				Minimum	Maximum		
INT-8-SK40	SK40-APU08	0.5-8	35.6	149	157	1.4	3301-001
INT-13-SK40	SK40-APU13	1-13	52	100	113	1.9	3301-002
INT-13-SK50	SK50-APU13	1-13	52	93	106	3.9	3301-004
INT-13-SK30	SK30-APU13	1-13	52	99	111	1.34	3301-006
INT-16-SK40	SK40-APU16	3-16	56.8	127	140	2.4	3301-007
INT-16-SK50	SK50-APU16	3-16	56.8	97	110	3.9	3301-008

ORDER NO.	Clamping Capacity		Taper	OUTER Ø / mm	WEIGHT (kgs)	CODE NO.
	mm	inch				
INT-8-CAT30	0.5-8	1/64"-1/8"	CAT30	Ø36	0.8	3301-073
INT-13-CAT30	0.5-13	1/64"-1/2"		Ø50	1	3301-074
INT-8-CAT40	0.5-8	1/64"-1/8"	CAT40	Ø36	1.32	3301-075
INT-13-CAT40	0.5-13	1/64"-1/2"		Ø50	2.1	3301-076
INT-16-CAT40	3-16	1/8"-5/8"	CAT50	Ø57	2.26	3301-077
INT-13-CAT50	0.5-13	1/64"-1/2"		Ø50	3.95	3301-078
INT-16-CAT50	3-16	1/8"-5/8"		Ø57	4.2	3301-079

Keyless Drill Chucks



TYPE: XHSP

SPECIAL HEAVY DUTY TYPE

FOR DRILL ONLY , NOT FOR END MILL OR TAP

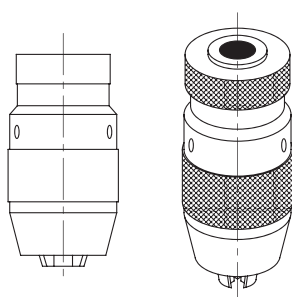

- Special design & manufacture against for super heavy torque(Clamping capacity) use.
- Owing to inspecting strictly & with excellent RUNOUT Accuracy and quality guaranteed the gripping power is double than the general brand.
- Avoid the drill dropped when used in instantaneous change of direction and equipped with spanner hole for tightening perfect safety.
- Especially suitable for CNC machining center & milling machine use.
- Accuracy: 50 mm length within 0.05 mm
- The key is optional

OPTIONAL ACCES.

Unit:mm



ORDER NO.	TYPE	Clamping Capacity		Female Taper DIN or Jacobs	OUTER Ø / mm	Length		Wt g	QTY Pcs./ Cu-Ft	N.W/G.W kgs	CODE NO.
		Ø mm	Ø inch			Open B mm	Closed A mm				
11015	8XHSP	0.5-8	0-5 / 16"	B10	34.3	64.8	72.7	320	40/0.6	13/14	3302-002
11016				J1	34.3	64.8	72.7	320	40/0.6	13/14	3302-003
11017				B12	34.3	64.8	72.7	320	40/0.6	13/14	3302-004
11018	10XHSP	1-10	0-3 / 8"	J33	42.4	80.8	91.1	700	40/0.6	28/29	3302-005
11019				J2S	42.4	80.8	91.1	700	40/0.6	28/29	3302-006
11020				B12	42.4	80.8	91.1	700	40/0.6	28/29	3302-007
11021				B16	42.4	80.8	91.1	700	40/0.6	28/29	3302-008
11025	13XHSP	1-13	0-1 / 2"	J6	50.3	93.7	105.3	1030	30/0.6	31/32	3302-009
11026				J33	50.3	93.7	105.3	1035	30/0.6	31/32	3302-010
11027				B16	50.3	93.7	105.3	1030	30/0.6	31/32	3302-011
11028	16XHSP	3-16	1/8 - 5/8"	J6	52	97	110.3	1450	24/0.6	35/36	3302-012
11029				B16	52	96.1	110.3	1450	24/0.6	35/36	3302-013
11030				B18	52	97	110.4	1450	24/0.6	35/36	3302-014
11035				J3	52	100.5	105.3	1450	24/0.6	35/36	3302-015
17000	6XHSP	0.5-6.5	1/64"- 1/4"	B12	34	64.8	72.7	320	40/0.6	13/14	3304-010
17002				J1	34	64.8	72.7	320	40/0.6	13/14	3304-011
17004				B10	34	64.8	72.7	320	40/0.6	13/14	3304-012
11031	Key	13XHSP		OPTIONAL ACCES. 							3304-001
11032		16XHSP									3304-002
11033		8XHSP									3304-003
11034		10XHSP									3304-004

Keyless Drill Chucks

TYPE: H

FOR DRILL ONLY , NOT FOR END MILL OR TAP

STANDARD TYPE



Unit:mm

- Industrial design especially for life and safety while in operation.
- All hardened parts ensure long term for milling machines and drilling.
- Accuracy: 35 m/m length within 0.08 m/m

ORDER NO.	TYPE	Clamping Capacity		Female Taper DIN or Jacobs	OUTER Ø mm	Length		Wt g	CODE NO.
		Ø mm	Ø inch			Open B mm	Closed A mm		
11061	6HE	0-6.5	0-1 / 4"	J1	34	64.8	72.7	410	3302-030
11062				B10	34	64.8	72.7	400	3302-031
11063	8HE	0.5-8	0-5 / 16"	J1	34	64.8	72.7	400	3302-032
11064				B10	34	64.8	72.7	400	3302-033
11065	10HE	1-10	0-3 / 8"	J2S	42.5	80.8	91.1	720	3302-034
11066				J33	42.5	80.8	91.1	700	3302-035
11067				B12	42.5	80.8	91.1	720	3302-036
11068				B16	42.5	80.8	91.1	700	3302-037
11070	13HE	1-13	0-1 / 2"	J6	50.5	93.7	105.3	1070	3302-039
11071				J33	50.5	93.7	105.3	1035	3302-040
11072				B16	50.5	93.7	105.3	1080	3302-041
11073	16HE	3-16	1/8 - 5/8"	J6	50.5	93.7	105.8	1070	3302-042
11074				B16	50.5	93.8	105.9	1080	3302-043
11075				B18	50.5	97.7	110	1090	3302-044



Keyless Drill Chucks



TYPE:S

FOR DRILL ONLY , NOT FOR END MILL OR TAP

HEAVY DUTY TYPE S



high accuracy and precision design, suitable for CNC machines and machine center. All parts are ground,heat treated,surface treated and under specific QC condition.

ORDER NO.	Size	Capacity		Taper Mount No DIN or Jacobs	Length(m/m)		Outer Dia (m/m)	Weight (g)	CODE NO.
		mm	inch		Open	Closed			
12201-1	8S	0.5-8	0-5/16	JT1	68	76	38	460	3302-060
12201-2				JT2S	68	76	38	450	3302-061
12201-3				B10	68	76	38	420	3302-062
12201-4				B12	68	76	38	450	3302-063
12202-1	10S	1-10	0-3/8	JT2	80	92	43	660	3302-064
12202-2				JT33	80	92	43	630	3302-065
12202-3				B10	80	92	43	640	3302-066
12202-4				B12	80	92	43	670	3302-067
12203-1	13S	1-13	0-1/2	JT33	90	102	49	970	3302-068
12203-2				JT6	90	102	49	1020	3302-069
12203-3				B12	90	102	49	1040	3302-070
12203-4				B16	90	102	49	1030	3302-071
12205-1	16S	3-16	1/8-5/8	JT6	97	110	55	1330	3302-073
12205-2				JT3	97	110	55	1330	3302-074
12205-3				B16	97	110	55	1340	3302-075
12205-4				B18	97	110	55	1360	3302-076

KEYLESS DRILL CHUCK



Keys Steel

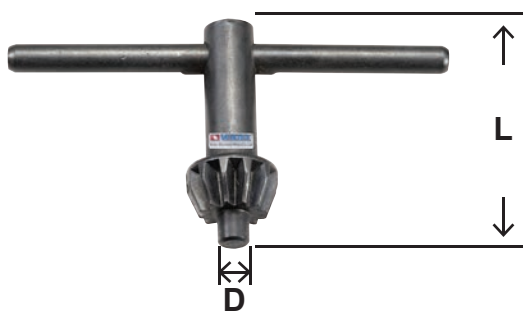

ORDER NO.	Type	Dmm	Lmm	Weight(g)	Packing	CODE NO.
14001	T1	3.2	35	20	Plastic Bag	3304-100
14002	T2	4	42	40		3304-101
14003	T3	5.5	44	45		3304-102
14004	T4	6	45	55		3304-103
14005	T5	6.5	45	50		3304-104
14007	T7	8	50	80		3304-106
14008	T8	9.5	65	150		3304-107



Note

CAUTIONS



CAUTIONS

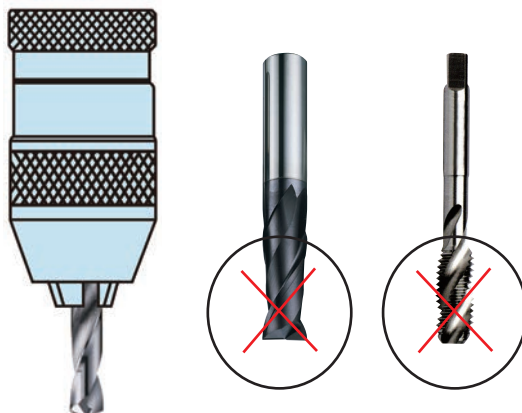

- CAUTIONS:
- ✘ DO NOT USE END MILL AND TAP WITH DRILL CHUCK
 - DRILL CHUCK ONLY CAN PROCESS VERTICAL JOB.
 - ADD COOLANT WHILE HEAVY CUTTING.
 - ✘ WHILE PROCESSING: DO NOT MAKE HORIZONTAL MOVEMENT OR ELSE, IT WILL CAUSE 3 JAWS' DEFORMATION. NOT FOR END MILL.



Key Type Drill Chucks



TYPE: G

HIGH PRECISION



- Remarkable products, super precision durable & rigity
- Big outside diameter suit for heavy duty
- The nut and jaws adopt AISI-52100 (bearing steel) and heat-treated,durability
- Precision can be assured.
- The taper is precision ground.
- Accuracy: 90mm length within 0.08 mm
- With keys



ORDER NO.	TYPE	Clamping Capacity		Female Taper DIN or Jacobs	OUTER Ø / mm	Length		Wt g	Key Size	QTY Pcs./ Cu-Ft	N.W/G.W kgs	CODE NO.
		mm	inch			Open B mm	Closed A mm					
10006	G-6H	0.5-6.5	1/64"-1/4"	J1	32	41	50	200	T2	100/0.82	20/21	3303-001
10050	G-13XH	0.5-13	1/64"-1/2"	J6	56	70.5	88	800	P6	36/0.83	30/31	3303-006
10051				B16	56	70.5	88	800	P6	36/0.83	30/31	3303-007
10052				J33	56	70.5	88	800	P6	36/0.83	30/31	3303-008
10068	G-16XH	1-16	1/32"-5/8"	J3	65	81	101	1000	P7	24/0.84	24/25	3303-009
10070				B18	65	81	101	1000	P7	24/0.84	24/25	3303-010
10074	G-19XH	3-19	1/8"-3/4"	J4	70	99.5	126	2150	P7	18/0.83	39/40	3303-011

Key Type Drill Chucks



- Suitable for heavy duty & extra heavy duty.
- For milling machine, lathe, drill machine & wood working machine.
- With keys

DRILL CHUCK

ORDER NO.	TYPE	Clamping Capacity		Female Taper DIN or Jacobs	Female Thread Inch or metric	OUTER Ø / mm	Length		Wt g	Key Size	CODE NO.
		mm	inch				Open B mm	Closed A mm			
10001	4H	0.5-4	1/64"-5/32"	JO		22	29	35	120	T1	3303-060
10003	6H	0.5-6.5	1/64"-1/4"	J1		32	40	50	230	T2	3303-062
10004				B10		32	40	50	190	T2	3303-063
10010	10H	1-10	1/32"-3/8"	J2		38	50.5	64	320	T3	3303-065
10011				J2S		38	50.5	64	320	T3	3303-066
10012				B12		38	50.5	64	330	T3	3303-067
10038	13H	1-13	1/32"-1/2"	J2S		47	65	81	520	T5	3303-071
10038-2					3/8-24	47	65	81	520	T5	3303-071-2
10038-3					1/2-20	47	65	81	330	T5	3303-071-3
10039				J6		47	65	81	570	T5	3303-072
10040				B16		47	65	81	580	T5	3303-073
10041				J33		47	65	81	580	T5	3303-074
10061	16H	1-16	1/32"-5/8"	J6		56	78	96	990	T7	3303-077
10062				J3		56	78	96	960	T7	3303-078
10063				B16		56	78	96	990	T7	3303-079
10064				B18		56	78	96	970	T7	3303-080
10072	19H	3-19	1/8"-3/4"	B22		67.5	89	126	1660	T8	3303-083
10073				J3		67.5	89	126	1680	T8	3303-084
10046	13XH	1-13	1/32"-1/2"	J6	1/2-20	52	69	82	770	T7	3303-086
10079	19XH	1-19		J4		69	94	132	1720	T8	3303-089

Material Analysis Table

PART NO.	PART NAME	MATERIAL	HEAT TREATED
1	Body	JIS-4051 SAE 1045	HRC45-48
2	Case	JIS-4018 SAE 1018	HRC38-40
3	Jaw	JIS-4051 SAE 1045	HRC52±2
4	Nut	JIS-4051 SAE 1045	HRC61±2

Run-out Accuracy & Torque Inspection Table

Type	4H	5H	6.5H	10H	13H	16H	19H	13XH	19XH
Ødmm	3.5	4.5	6	9	12	15	18	12	18
L1mm	25								
Max Run-out	0.15								
Torque kg-m	18	20	45	75	85	250	300	190	300



Key Type Drill Chucks Stainless



TAPER & THREAD MOUNT

NEW

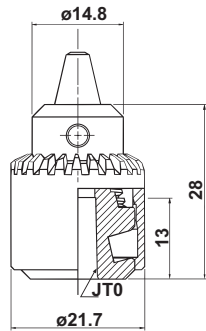

ORDER NO. 10090

Enlarged photo

FEATURES:

- Stainless - Anti - Rust
- Good Resistance - Acid Resistance
- Smooth operation
- Suit for EDM, Food, marine industry.



ORDER NO.	TYPE	Clamping Capacity		Female Taper DIN or Jacobs	OUTER Ø / mm	Length		Pitch	Wt g	Key Size	CODE NO.
		mm	inch			Open B mm	Closed A mm				
10090	4KST	0.3-4	1/64-5/32	JT0	22	28	35	5/16"-24	50	T0-3S	3303-100
10091	6KST	0.3-6.5	1/64-1/4	JT1	28.5	40.5	49	3/8"-24	125	T1-3S	3303-101
10092-2	10KST	0.3-10	1/64-3/8	ØD13	37	57	69	3/8"-24	250	T2-3S	3303-103
10092-3				ØD15	37	57	69		250		3303-104
10093	6KST	0.5-6.5	1/64-1/4	3/8	29.4	40.5	49	3/8"-24	130	T1-3S	3303-105
10094	10KST	0.5-10	1/64-3/8	3/8	39	51	63	3/8"-24	250	T2-3S	3303-106
10095	8KST	0.5-8	1/64-5/16	3/8	28.4	40.5	51	3/8"-20		T1-04	3303-107



Keyless Drill Chucks Stainless

KEYLESS TAPER & THREAD MOUNT

NEW

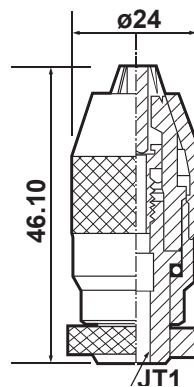

ORDER NO. 16001-31

FEATURES:

- Stainless - Anti - Rust
- Good Resistance - Acid Resistance
- Smooth operation
- Suit for EDM, Food, marine industry.

Enlarged photo

ORDER NO.	Size	Capacity		Taper Mount No DIN or Jacobs	Length(m/m)		Outer Dia (m/m)	Weight (g)	CODE NO.
		mm	inch		Open	Closed			
16001-30	3ST	0.3-3	1/64-1/8	JT0	44	50	30	110	3303-111
16001-31				JT1	44	48.5	24	110	3303-112
16001-61	6ST	0.3-6.5	1/64-1/4	JT1	62	68	33	300	3303-113



Keys For Stainless Key Type Drill Chuck

NEW



← 3/8"

ORDER NO.	Type	Dmm	Lmm	Weight(g)	Packing	CODE NO.
15001	T0-3S	3.2	60	16		3303-121
15002	T1-3S	4.0	65	40		3303-122
15003	T2-3S	5.5	71	45		3303-123



Modular Boring Systems

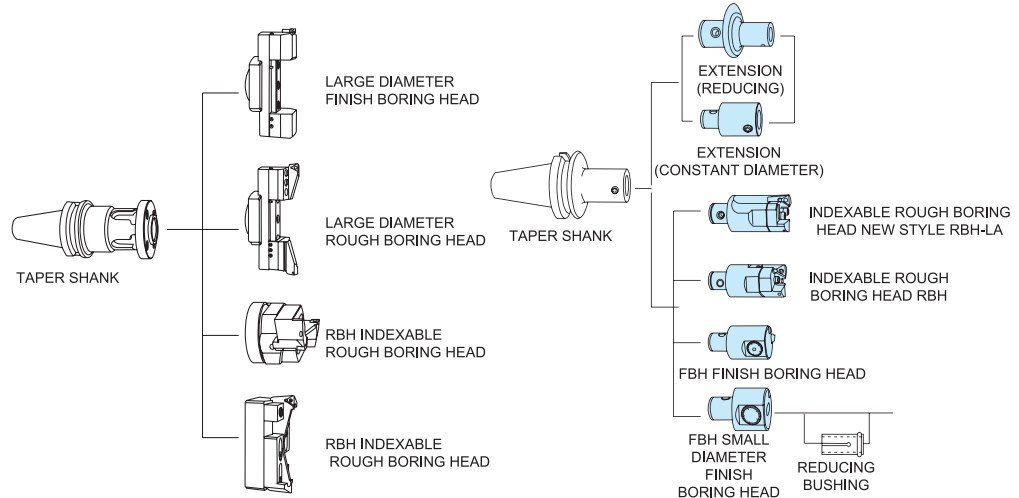

Taper Shank For Boring Heads Series BS70,100,200,300,400 Taper Shank For Boring Heads Series B1070~B6230

BORING SYSTEM

BS70~400 SERIES



B1070~6230 SERIES

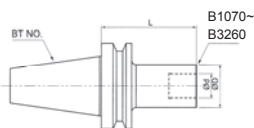
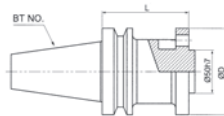

ORDER NO.	Length (L)	External Diameter (D)	Applicable Boring Heads	Weight (kgs)	CODE NO.
VT-BT30-B1070	70	19	FBB20	0.5	3320-214
VT-BT30-B2080	80	24	VRB25 ; FBB25	0.6	3320-215
VT-BT30-B3080	80	31	VRB32 ; FBB32	0.7	3320-216
VT-BT30-B4070	70	39	VRB40 ; FBB40 ; FBB44	0.8	3320-217
VT-BT30-B5060	60	50	VRB52 ; FBB52 ; FBB55	0.8	3320-218
VT-BT30-B6060	60	64	VRB68 ; VRB90 ; FBB68 FBB100 ; FBB150 ; FBB66	1.0	3320-219
VT-BT40-B1075	75	19	FBB20	1.2	3320-220
VT-BT40-B2085	85	23	VRB25 ; FBB25	1.2	3320-221
VT-BT40-B3095	95	30	VRB32 ; FBB32	1.45	3320-222
VT-BT40-B4085	85	38	VRB40 ; FBB40 ; FBB44	1.5	3320-223
VT-BT40-B5075	75	50	VRB52 ; FBB52 ; FBB55	1.8	3320-225
VT-BT40-B6065	65	64	VRB68 ; VRB90 ; FBB68 FBB100 ; FBB150 ; FBB66	2.15	3320-227
VT-BT40-BS70	70	95	VRB120 ; FBB200 VRB120 and above; FBB200 and above	3.2	3320-228
VT-BT50-B1115	115	19	FBB20	3.5	3320-229
VT-BT50-B2110	110	23	VRB25 ; FBB25	4	3320-230
VT-BT50-B3125	125	30	VRB32; FBB32	4.4	3320-232
VT-BT50-B4115	115	38	VRB40; FBB40; FBB44	4.8	3320-234
VT-BT50-B4175	175			5.2	3320-235
VT-BT50-B5105	105	50	VRB52; FBB52; FBB55	5.4	3320-236
VT-BT50-B5180	180			6.2	3320-237
VT-BT50-B5240	240			6.4	3320-238
VT-BT50-B6095	95	64	VRB68 ; VRB90 ; FBB68 FBB100 ; FBB150 ; FBB66	5.9	3320-239
VT-BT50-B6170	170			6.5	3320-240
VT-BT50-B6230	230			6.9	3320-241
VT-BT50-BS100	100	95	VRB120 VRB120 and above; VRB200 - 500; large diameter boring heads series FBB200-500	5.71	3320-242
VT-BT50-BS200	200			8.79	3320-244
VT-BT50-BS300	300			11.25	3320-246
VT-BT50-BS400	400			19.3	3320-247









Large Diameter 2 Inserts Rough Boring VERTEX®

Modular Style For Diameter Over 200 mm
Boring ϕD range from $\phi 200$ - $\phi 1,250$ mm



- ✘ Insert Not Included
- ✘ RB200C12 / RB200T16 / RB200T22 / RB200S12
ARE FOR VRB200 ~ VRB900
- ✘ Arbor is not included

Boring Head Type	ORDER NO.	VRB200	VRB300	VRB400	VRB500	VRB600	VRB900	
	Length	130	130	130	130	150	150	
	(kgs) Total Weight Steel/Alloy	9.5	11.5	13.5	15.5	33	43	
	D(mm) Boring Diameter Range	200-310	300-410	400-510	500-610	600-900	900-1200	
Module	Taper Shank		BT50-BS				BT50-FMA-47.625	
	Flange (kgs)Weight Steel/Alloy		BR200 2.7				BR600 8.8kg	BR900 13.5kg
	Extension Slide (kg)Weight Steel/Alloy		RST200 3.4 kg	RST300 5.4 kg	RST400 7.4 kg	RST500 9.4 kg	RST300 x2pcs 10.8 kg	RST400 x2pcs 14.8 kg
	Clamp Base (kg)Weight		RS200 0.98 kg					
	Height Setting Shim (kg)Weight		RS201 0.05 kg					
	Insert Holder		RB200C12	RB200T16	RB200T22	RB200S12		
	Applicable Insert		CCMT120404	TCMT16T304	TCMT220404	SCMT120404		
	(kg)Weight		0.68 kg					
	CODE NO.		3320-250	3320-251	3320-252	3320-253	3320-254	3320-255





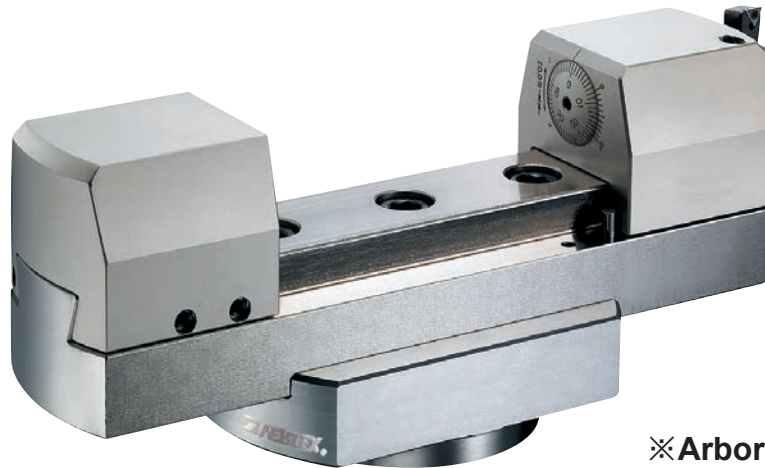

Enlargeable Finish Boring Head VERTEX®

Modular Style For Diameter Over 200 mm
Boring ϕD from $\phi 200$ - $\phi 1,250$ mm



※ Arbor is not included

BORING SYSTEM

Boring Head Type	ORDER NO.	VFB200	VFB300	VFB400	VFB500	VFB600	VFB900	
	Length	130	130	130	130	150	150	
	(kgs) Total Weight Steel/Alloy	7	7.8	8.6	9.4	15.8	22.1	
	D(mm) Boring Diameter	200-310	300-410	400-510	500-610	600-900	900-1200	
Module	Taper Shank		BT50-BS				BT50-FMA-47.625	
	Flange (kg)Weight Steel/Alloy		BR200 2.7 kg				BR600 8.8kg	BR900 13.5kg
	Extension Slide		RST200	RST300	RST400	RST500	RST300 x2pcs	RST400 x2pcs
	(kgs)Weight		1.1 kg	1.9 kg	2.7 kg	3.5 kg	3.8 kg	5.4 kg
	Balance Weight (kg)Weight		RBN200 1.6 kg					
	Finish Head (kgs)Weight		CB200 1.6 kg					
	Applicable Insert		TP08/ $\phi 3.2 \times M2/T6$, TP09/ $M2.5/T8$, TC11/ $M2.5/T8$					
	CODE NO.		3320-260	3320-261	3320-262	3320-263	3320-264	3320-265



Insert Type Boring Bar



ORDER NO. BBAR-D16 CODE NO.6004-071

※All inserts are floating price.
Contact us before ordering from F1~F49

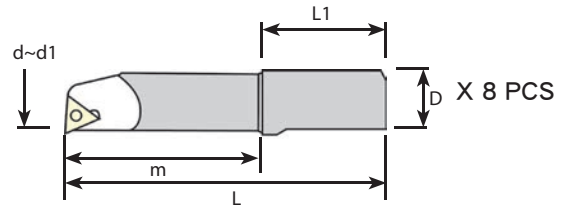

BORING BAR FOR BORING HEAD

8 PCS/SET

BORING BAR	SHANK D.	RANGE d~d1	DEPTH m	L1	SHANK L. L	INSERT	FIXING UNIT	WRENCH	WEIGHT (kg)
BRB1608-32	16	8-11	32	32	80	TBGT060102L	TS2001	T6	2
BRB1610-40	16	10-13	40	32	80	TPGH090204L	TS2504	T8	
BRB1612-53	16	12-15	53	32	85				
BRB1616-68	16	16-21	68	32	100	TPGH110304L	TS3005	T10	
BRB1620-83	16	20-26	83	32	115				
BRB1625-90	16	25-31	90	32	122				
BRB1630-90	16	30-36	90	32	122				
BRB1640-90	16	40-46	90	32	122				



Insert Type Boring Bar

ORDER NO. BBAR-D18A CODE NO.6004-072A

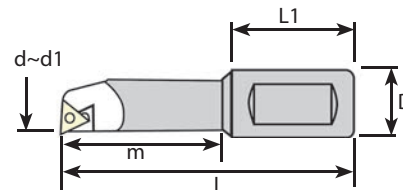

X 4 PCS

BORING BAR FOR BORING HEAD

4 PCS/SET

BORING BAR	SHANK D.	RANGE d~d1	DEPTH m	L1	SHANK L. L	INSERT	FIXING UNIT	WRENCH	WEIGHT (kg)
BRB1810-40	18	10-13	40	32	80	TBGT060102L	TS2001	T6	1.0
BRB1812-53	18	12-17	53	32	88	TPGH090204L	TS2504	T8	
BRB1816-68	18	16-21	68	32	104				
BRB1820-83	18	20-130	83	32	118	TPGH110304L	TS3005	T10	



Insert Type Boring Bar

ORDER NO. BBAR-D20 CODE NO.6004-073

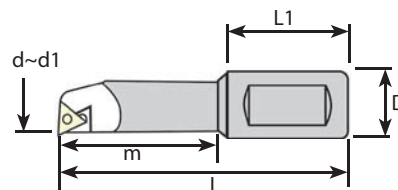

X 7 PCS

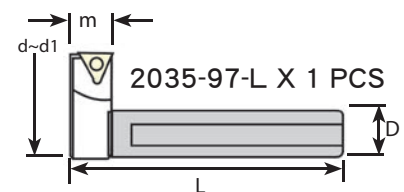

2035-97-L X 1 PCS

BORING BAR FOR BORING HEAD

8 PCS/SET

BORING BAR	SHANK D.	RANGE d~d1	DEPTH m	L1	SHANK L. L	INSERT	FIXING UNIT	WRENCH	WEIGHT (kg)
BRB2008-32	20	8-11	23	32	80	TBGT060102L	TS2001	T6	2.65
BRB2010-40	20	10-13	40	32	80	TPGH090204L	TS2504	T8	
BRB2012-53	20	12-17	53	32	85				
BRB2016-68	20	16-21	68	32	100	TPGH110304L	TS3005	T10	
BRB2020-83	20	20-130	83	32	115				
BRB2025-96	20	25-135	96	32	135				
BRB2030-115	20	30-140	115	32	154				
BRB2035-97-L	20	120-280	14		99				



Changeable 2 Inserts Rough Boring Head VRB



VMH-SYSTEM

Boring diameter from $\varnothing 25$ - $\varnothing 350$ mm

※Adjustable

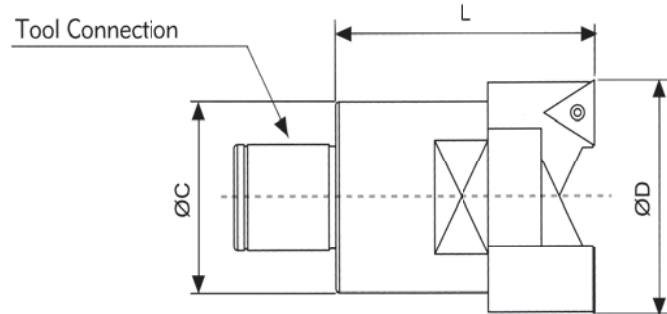

- INSERT STYLE
- C ◆
- T ▲
- S ■

BORING SYSTEM

	ORDER NO.	Tool connection	D(mm) Boring Range		L (mm)	C (mm)	Insert	Weight (g)	CODE NO.
		VRB25-33C	B2080	25	33	45	24	CCMT060204	0.15
VRB32-42C		B3080	32	42	55	31	CCMT060204	0.3	3320-271
VRB32-42T							TCMT110204		3320-272
VRB40-55C		B4070	40	55	65	39	CCMT09T304	0.5	3320-273
VRB40-55T							TCMT16T304		3320-274
VRB40-55S							SCMT09T304		3320-275
VRB52-70C		B5060	52	70	75	50	CCMT09T304	1	3320-276
VRB52-70T							TCMT16T304		3320-277
VRB52-70S							SCMT09T304		3320-278
VRB68-92C		B6065	68	92	85	64	CCMT120408	2	3320-279
VRB68-92T							TCMT16T304		3320-280
VRB68-92S							SCMT120404		3320-281
VRB90-122C		B6065	90	122	100	80	CCMT120408	2.9	3320-282
VRB90-122T	TCMT220408						3320-283		
VRB90-122S	SCMT120404						3320-284		
	VRB120-164C	VT-BT40-BS70 VT-BT50-BS100 VT-BT50-BS200 VT-BT50-BS300 VT-BT50-BS400	120	164	95	100	CCMT120408	3.8	3320-285
	VRB120-164T						TCMT220408		3320-286
	VRB120-164S						SCMT120404		3320-287
	VRB160-204C		160	204	130	CCMT120408	4.8	3320-288	
	VRB160-204T					TCMT220408		3320-289	
	VRB160-204S					SCMT120404		3320-290	
	VRB200-300C	VT-BT40-BS70 VT-BT50-BS100 VT-BT50-BS200 VT-BT50-BS300 VT-BT50-BS400	200	300	95	170	CCMT120408	6.5	3320-291A
	VRB200-300T						TCMT220408		3320-292A
	VRB200-300S						SCMT120404		3320-293A
	VRB300-400C		300	400	260	CCMT120408	10	3320-297A	
	VRB300-400T					TCMT220408		3320-298A	
	VRB300-400S					SCMT120404		3320-299A	



Taper Shank For Boring Heads Series



Modular Boring Systems

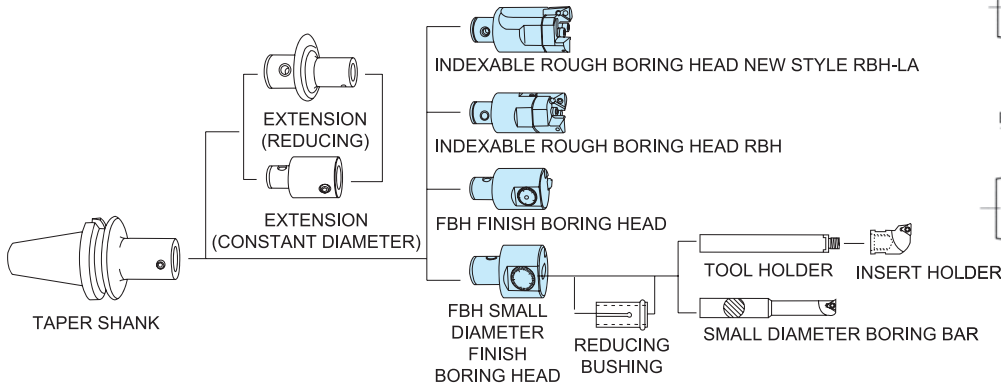
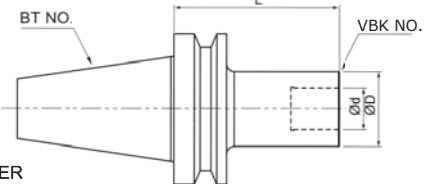
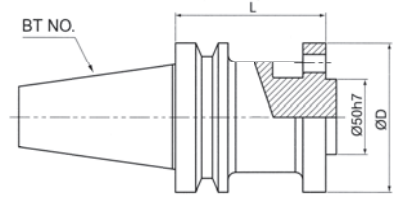

Extension (Reduced)

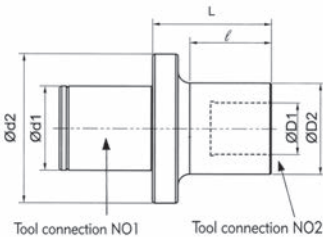

ORDER NO.	d1	d2	D1	D2	L	ℓ	Applicable Boring Heads	Weight (kg)	CODE NO.
VBQ2-1-36	14	24	11	19	36	30	FBB20	0.1	3320-301
VBQ3-1-41	18	31	14	24	41	30	FBB20	0.15	3320-302
VBQ3-2-37			14	24	37	25	VRB25 ; FBB25	0.15	3320-303
VBQ4-1-58	22	39	11	19	58	40	FBB20	0.3	3320-304
VBQ4-2-50			14	24	50	36	VRB25 ; FBB25	0.3	3320-305
VBQ4-3-50			18	31	50	37	VRB32 ; FBB32	0.35	3320-306
VBQ5-1-60	28	50	11	19	60	40	FBB20	0.45	3320-307
VBQ5-2-54			14	24	54	35	VRB25 ; FBB25	0.45	3320-308
VBQ5-2-74					74	55	VRB25 ; FBB25	0.5	3320-309
VBQ5-3-47			18	31	47	29	VRB32 ; FBB32	0.5	3320-310
VBQ5-3-72					72	54	VRB32 ; FBB32	0.6	3320-311
VBQ5-4-42					22	39	42	25	VRB40 ; FBB40
VBQ5-4-67	67	50	VRB40 ; FBB40	0.7			3320-313		
VBQ6-1-70	36	64	11	19	70	40	FBB20	0.9	3320-314
VBQ6-2-63			14	24	63	45	VRB25 ; FBB25	0.7	3320-315
VBQ6-2-93					93	75	VRB25 ; FBB25	0.8	3320-316
VBQ6-3-56			18	31	56	39	VRB32 ; FBB32	0.75	3320-317
VBQ6-3-96					96	79	VRB32 ; FBB32	0.95	3320-318
VBQ6-4-51					22	39	51	35	VRB40 ; FBB40
VBQ6-4-101			101	85			VRB40 ; FBB40	1.3	3320-320
VBQ6-5-41			28	50			41	25	VRB52 ; FBB52
VBQ6-5-91					91	75	VRB52 ; FBB52	1.45	3320-322



Extension (Constant Diameter)

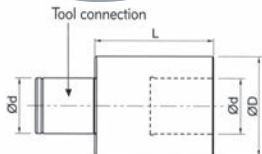

ORDER NO.	d	D	L	Applicable Boring Heads	Weight (kg)	CODE NO.
VBQ1-1-30	11	19	30	FBB20	0.07	3320-323
VBQ2-2-30	14	24	30	VRB25 ; FBB25	0.1	3320-324
VBQ3-3-30	18	31	30	VRB32 ; FBB32	0.15	3320-325
VBQ4-4-45	22	39	45	VRB40 ; FBB40 ; FBB44	0.4	3320-326
VBQ5-5-60	28	50	60	VRB52 ; FBB52 ; FBB55	0.8	3320-327
VBQ6-6-60	36	64	60	VRB68/VRB90 ; FBB68, 100, 150 ; FBB66	1.4	3320-328



Changeable 2 Inserts Rough Boring Head VRB-L VERTEX®

※Adjustable

Boring range from $\varnothing 25\text{mm}$ to $\varnothing 1250\text{mm}$;
a variety of tool holders and boring heads are for your selection.

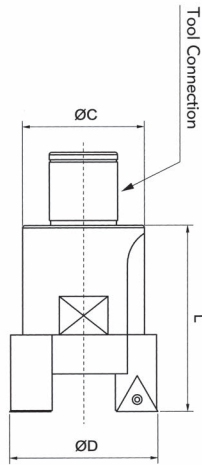
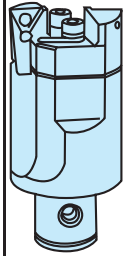

	ORDER NO.	Tool connection	D(mm) Boring Range	L (mm)	C (mm)	Insert	Weight (g)	CODE NO.	
	VRB25-35LC	B2080	25~35	50	24	CCMT060204	0.15	3320-340	
	VRB32-45LC	B3080	32~45	60	31	CCMT060204	0.3	3320-341	
	VRB32-45LT					TCMT110204		3320-342	
		VRB40-55LC	B4070	40~55	74	39	CCMT09T304	0.6	3320-343
		VRB40-55LT					TCMT16T304		3320-344
		VRB40-55LS					SCMT09T304		3320-345
		VRB52-75LC	B5060	52~75	80	50	CCMT09T304	1	3320-346
		VRB52-75LT					TCMT16T304		3320-347
		VRB52-75LS					SCMT09T304		3320-348
		VRB68-100LC	B6065	68~100	90	66	CCMT120408	2.5	3320-349
		VRB68-100LT					TCMT16T304		3320-350
		VRB68-100LS					SCMT120404		3320-351
	VRB90-130LC	B6065	90~130	100	88	CCMT120408	3.1	3320-352	
	VRB90-130LT					TCMT16T304		3320-353	
	VRB90-130LS					SCMT120404		3320-354	
	VRB120-164LC	VT-BT40-BS70 VT-BT50-BS100 VT-BT50-BS200 VT-BT50-BS300 VT-BT50-BS400	120~164	95	100	CCMT120408	3.8	3320-355	
	VRB120-164LT					TCMT220408		3320-356	
	VRB120-164LS					SCMT120404		3320-357	
	VRB160-204LC		160~204			130	CCMT120408	4.8	3320-358
	VRB160-204LT						TCMT220408		3320-359
	VRB160-204LS						SCMT120404		3320-360
	VRB200-310L	FMA-47.625	200~310	130	180	Optional Inserts CCMT120408 TCMT16T304 TCMT220408 SCMT120404	9.5	3320-361	
	VRB300-410L		300~410				11.5	3320-362	
	VRB400-510L		400~510				13.5	3320-363	
	VRB500-610L		500~610				15.5	3320-364	
	VRB600-900L		600~900				23	3320-365	
	VRB900-1200L		900~1200				32	3320-366	

BORING SYSTEM



FBB Finish Boring Head

Boring diameter from $\varnothing 20$ - $\varnothing 1250\text{mm}$

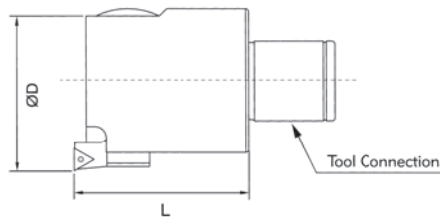

Ordering Example

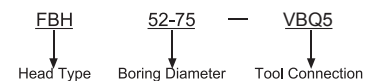

FEATURES:

- FBB finish boring head is suitable for finish boring with working ranges from $\varnothing 20\text{mm}$ to $\varnothing 1250\text{mm}$ on diameter.
- The dial has been graduated into 50 divisions, each of which is 0.01mm on diameter. Available is a sub-dial for finer adjustment.
- High precision internal lead screw with inner lubrication is free from the effects of chip, featuring high durability.
- Coolant nozzle easily cools the insert and prolongs insert's working life.
- Cartridge unit is housed in a square structure with two face support, proving high stability and rigidity.

ORDER NO.	Tool Connection	ØD Boring Range	length	Weight (kg)	Insert/Clamping/Screw	CODE NO.
FBB20	B1070	20-26	35	0.1	TPGH080204/Ø2.7xM2/T6	3320-370
FBB25	B2080	25-33	40	0.2		3320-371
FBB32	B3080	32-42		0.3		3320-372
FBB40	B4070	40-55	50	0.5	TPGH080204/Ø3.2xM2/T6	3320-373
FBB52	B5075	52-75	60	1		3320-374
FBB68	B6065	68-102	70	2		3320-375
FBB100	B6065	100-152		2.9		3320-376
FBB150	B6065	150-202		4.2		3320-377

FBB Finish Boring Head



Boring diameter from Ø3 - Ø40 mm



BORING CAPACITY
 FBB44 Ø8 - Ø20 m/m
 FBB55 Ø12 - Ø40 m/m
 FBB66 Ø8 - Ø40 m/m

FEATURES:

- Available are three different styles enabling small diameter boring from Ø8mm to Ø40mm. Boring range can be within Ø3mm to Ø10mm if small diameter solid carbide boring bar has been employed.
- The dial has been graduated into 50 divisions, each of which is 0.01mm on diameter. Available is a subdial for finer adjustment.
- High precision internal lead screw with inner lubrication is free from the effects of chip, featuring high durability.
- Cartridge unit is housed in a square structure with two face support, proving high stability and rigidity.

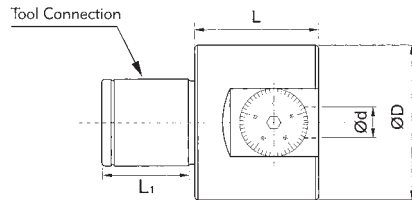

ORDER NO. Boring Head Type	Tool Connection	Ød Internal Diameter	ØD External Diameter	L length	L1	mm feed	Weight (kg)	CODE NO.
FBB44	B4070	10	39	32	Ø22x24L	0-2	0.4	3320-390
FBB55	B5060	12	50	40	Ø28x30L	0-3.5	0.8	3320-391
FBB66	B6065	16	64	50	Ø36x40L	0-5	1.4	3320-392

BORING BAR SLEEVE FOR FBB66

ORDER NO.	D mm	D1 mm	Applicable Carbide Tool Holder	CODE NO.
EC1608	16	8	ST08-5M	3320-393
EC1610	16	10	ST10-6M	3320-394
EC1612	16	12	ST12-6M	3320-395

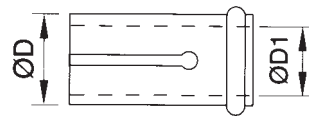

Small Diameter Boring Head FBB44

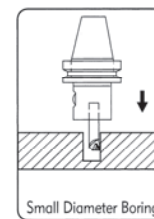
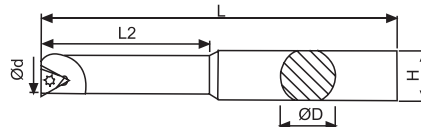

FOR FBB44 BORING CAPACITY FROM Ø8 - Ø20 MM

ORDER NO.	ØD mm	Ød mm	L mm	L2 mm	H mm	Insert	Clamp Screw	Wrench	CODE NO.	
BRB1008-32	10	8	64	32	9	TBGT060104 KYOCERA	M2	T6	3320-400	
BRB1010-40		10	72	40					3320-401	
BRB1012-45		12	77	27		TPGB090204 KYOCERA	M2.5	T8	3320-402	
BRB1016-45		16	77	27					3320-403	
BRB1020-45		20	77	27		TPGB090204 KYOCERA	M2.5	T8	3320-404	
BRB10-5PCS/SET	BRB1008-32 BRB1010-40 BRB1012-45 BRB1016-45 BRB1020-45									3320-405

FOR FBB66 BORING CAPACITY FROM Ø8 - Ø40 MM

ORDER NO.	ØD mm	Ød mm	L mm	L2 mm	H mm	Insert	Clamp Screw	Wrench	CODE NO.	
BRB1608-32	16	8	74	32	15	TBGT060104 KYOCERA	M2	T6	3320-406	
BRB1610-40		10	75	40					3320-407	
BRB1612-53		12	85	53		TPGB090204 KYOCERA	M2.5	T8	3320-408	
BRB1616-68		16	100	68					3320-409	
BRB1620-83		20	115	83		TPGB090204 KYOCERA	M2.5	T8	3320-410	
BRB1625-90		25	122	90					3320-411	
BRB1630-90		30	122	90					3320-412	
BRB1640-90		40	122	90					3320-413	
BRB16-8PCS/SET	BRB1608-32 BRB1610-40 BRB1612-53 BRB1616-68 BRB1620-83 BRB1625-90 BRB1630-90 BRB1640-90									3320-414



Carbide Shank Holder



Small Diameter Modular Boring Bar

Boring diameter from
Ø8 - Ø16 mm

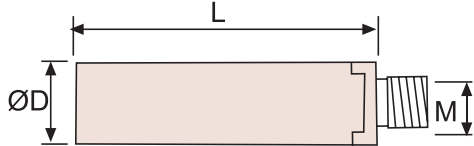

ORDER NO.	L mm	D mm	M mm	Applicable Insert Holder	Applicable Bushing	CODE NO.
ST08-5M-100	100	8	M5	IH09, IH10.5	EC1608	3320-420
ST10-6M-110	110	10	M6	IH12	EC1610	3320-421
ST12-6M-120	120	12		IH14, IH16	EC1612	3320-424
ST16-10M-160	160	16	M10x1.25P	IH18, IH20, IH22, IH24 IH26, IH28, IH30, IH32 IH34, IH36, IH38, IH40	---	3320-426



Insert Holder For Carbide Shank Holder

Boring diameter from Ø9 - Ø40 mm

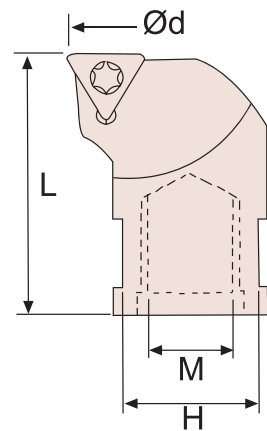

ORDER NO.	d(mm)	H(mm)	L(mm)	M(mm)	Insert	Clamping Screw	Wrench	CODE NO.
IH09	9	7	18	M5	TPGT080204L SUMITOMO	Ø3.2xM2	T6	3320-430
IH10.5	10.5	7	23	M6				3320-431
IH12	12	8						3320-432
IH14	14	10						3320-433
IH16	16	10						3320-434
IH18	18	14	27	M10x1.25P				3320-435
IH20	20	14						3320-436
IH22	22	14						3320-437
IH24	24	14						3320-438
IH26	26	14						3320-439
IH28	28	14						3320-440
IH30	30	14						3320-441
IH32	32	14						3320-442
IH34	34	14						3320-443
IH36	36	14						3320-444
IH38	38	14						3320-445
IH40	40	14			3320-446			

BORING SYSTEM



VRB Changeable 2 Inserts Rough Boring Head

Boring diameter from Ø25 - Ø500 mm



- The head is suitable for single bit boring, twin-bit boring and step boring with working diameter from Ø25 mm to Ø350 mm on diameter.
- New cartridge style with built-up rib. The pressure imposed on both cartridges counteracts producing highest rigidity and cutting efficiency, most suitable for a variety of borings.
- Boring head can be easily adjusted to different boring needs for machining on demand. Boring depth can be extended by tool connection.
- Clear side division provides a convenient adjustment without using a tool pre-setter.
- Most suitable for boring on various machine centers or boring mills. Universal design accepts inserts of any brands, which will reduce tool grinding and greatly improve boring performance.
- Patented step boring design; suitable for both level boring and step boring.



Changeable 2 Inserts Rough Boring Head VRB 200~900

Boring diameter from Ø25 - Ø204 mm



- Thickened cartridge with higher rigidity.
- Coolant nozzle easily cools the insert elongating its working life.
- Completed with chip pocket, improving chip flow of deep boring.
- Clamp plate solidifies cartridges and head, upgrading cutting rigidity.
- Patented step boring design; suitable for both level boring and step boring.



Enlargeable Modular Rough Boring Head With Diameter Over Ø200mm

Boring diameter from Ø200 - Ø2,000 mm



- This type is suitable for large diameter boring with ranges from 200 mm to 810 mm.
- The structure includes common flange and extension slide for both rough and finish boring heads. Adjustment range is within 110 mm on diameter.
- Options of various inserts for rough boring of different materials and boring styles.
- Available is the horizontal slide made of Aluminum alloy to reduce total weight.
- Options of external boring kit with boring range from Ø20mm to Ø300mm.



Precision Finish Boring Head Sets



Boring diameter Ø 6-90 mm

NEW

• Boring Bar
PAGE C85

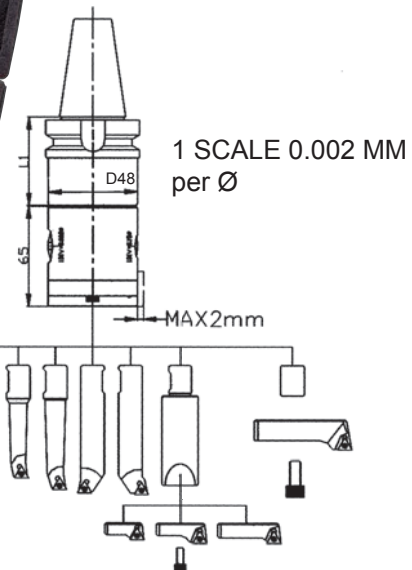

- Processing range Ød 6-90 mm.
- This slim set allows customer to process boring work in the narrow space with high precision.
- Precisely ground and hardened shank integrating with boring head for routing and smooth operation.
- Please keep boring head clean and lubricate constantly.



SET TYPE

ORDER NO.	Boring Range Ø	Shank	L1	Head Dia. ØD	PCS/SET	CODE NO.
VBHD-BT-30	6-90	BT30-VCK4-45	45	48	14 PCS/SET	3320-450
VBHD-BT-40		BT40-VCK4-60	60			3320-451
VBHD-BT-50		BT50-VCK4-75	75			3320-452
VBHD-SK-40		SK40-VCK4-65	65			3320-453
VBHD-SK-50		SK50-VCK4-75	75			3320-454
VBHD-NT-40		NT40-40-VCK4-60	60			3320-455
VBHD-NT-50		NT50-50-VCK4-60	60			3320-456
VBHD-HSK63A		HSK63A-VCK4-75	75			3320-457
VBHD-HSK100A		HSK100A-VCK4-75	75			3320-458

VBHD SHANK

ORDER NO.	L	WEIGHT	CODE NO.
BT30-VCK4-45	45		3320-450S
BT40-VCK4-60	60		3320-451S
BT50-VCK4-75	75		3320-452S
SK40-VCK4-65	65		3320-453S
SK50-VCK4-75	75		3320-454S
NT40-40-VCK4-60	60		3320-455S
NT50-50-VCK4-60	60		3320-456S
HSK63A-VCK4-75	75		3320-457S
HSK100A-VCK4-75	75		3320-458S

ACCESSORIES: BORING BAR SIZE FOR SET TYPE

Boring Bar	Range d	Depth m	Insert	Screw	Wrench	Feed mm/REV.
BR-1606-20	6-9	20	WBGT060102L	TS2	T6	0.05-0.1
BR-1608-28	8-11	28	TBGT060102L			0.05-0.1
BR-1610-36	10-13	36	TBGT060104L			0.07-0.15
BR-1612-42	12-15	42	TPGT090202L	TS25	T8	0.05-0.1
BR-1614-50	14-17	50				
BR-1616-60	16-20	60				
BR-1620-63	20-24	63	TPGT090204L			0.07-0.15
BR-1624-64	24-28	64				
BM5		60+SRTP2838/SRTP3652/SRTP4470		M5 X15 CAP	4	0.05-0.1
SRTP2838	28-38	+10	TPGT090202L	TS25	T8	
SRTP3652	36-52	+12				
SRTP4470	44-70	+12				TPGT090204L
BM8				M8 X 15 CAP	6	0.07-0.15
SRTP58-90	58-90	+20	TPGT090204L	TS25	T8	



Precision Finish Boring Head Sets



Boring diameter Ø 6-150 mm

NEW



● Boring Bar
PAGE C85

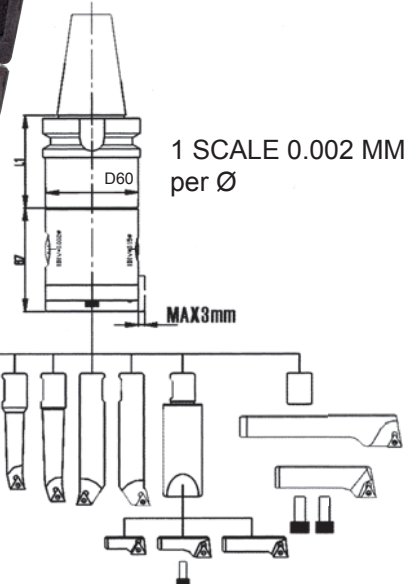

- Processing range Ød 6-150 mm.
- This slim set allows customer to process boring work in the narrow space with high precision.
- Please keep boring head clean and lubricate constantly.
- Precisely ground and hardened shank integrating with boring head for routing and smooth operation.



BORING HEAD SETS

SET TYPE

ORDER NO.	Boring Range Ø	Shank	L1	Head Dia. ØD	PCS/SET	CODE NO.
VBHE-BT-40	6-150	BT40-VCK5-60	60	60	15 PCS/SET	3320-460
VBHE-BT-50		BT50-VCK5-75	75			3320-461
VBHE-SK-40		SK40-VCK5-65	65			3320-462
VBHE-SK-50		SK50-VCK5-75	75			3320-463
VBHE-NT-40		NT40-40-VCK5-60	60			3320-464
VBHE-NT-50		NT50-50-VCK5-75	75			3320-465
VBHE-HSK63A		HSK63A-VCK5-75	75			3320-466
VBHE-HSK100A		HSK100A-VCK5-75	75			3320-467

VBHE SHANK

ORDER NO.	L	WEIGHT	CODE NO.
BT40-VCK5-60	60		3320-460S
BT50-VCK5-75	75		3320-461S
SK40-VCK5-65	95		3320-462S
SK50-VCK5-75	75		3320-463S
NT40-40-VCK5-60	60		3320-464S
NT50-50-VCK5-75	75		3320-465S
HSK63A-VCK5-75	75		3320-466S
HSK100A-VCK5-75	75		3320-467S

ACCESSORIES: BORING BAR SIZE FOR SET TYPE

Boring Bar	Range d	Depth m	Insert	Screw	Wrench	Feed mm/REV.
BR-1606-20	6-9	20	WBGT060102L	TS2	T6	0.05-0.1
BR-1608-28	8-11	28	TBGT060102L			0.05-0.1
BR-1610-36	10-13	36	TBGT060104L			0.07-0.15
BR-1612-42	12-15	42	TPGT090202L	TS25	T8	0.05-0.1
BR-1614-50	14-17	50				
BR-1616-60	16-20	60				
BR-1620-63	20-24	63	TPGT090204L			0.07-0.15
BR-1624-64	24-28	64				
BM5		60+SRTP2838/SRTP3652/SRTP4470		M5 X15 CAP	4	
SRTP2838	28-38	+10	TPGT090202L	TS25	T8	0.05-0.1
SRTP3652	36-52	+12				
SRTP4470	44-70	+12				
BM8				M8 X 15 CAP	6	
SRTP70110	70-110	+20	TPGT090202L	TS25	T8	0.05-0.1
SRTP110150	110-150	+20	TPGT090204L			0.07-0.15



Micro Boring Head Set



I Scale 0.002 mm Boring diameter from Ø6 - Ø154mm

NEW

• Boring Bar
PAGE C85



- Processing range Ø6-154 mm.
- Precisely ground and hardened shank integrating with boring head for routing and smooth operation.
- Please keep boring head clean and lubricated constantly.
- Easy & Simple operation.
- Complete set.
- Fine adjustment.
- Luxury box.
- Material : tool steel



SET TYPE

ORDER NO.	Boring Range Ø	Shank	L	Pcs/SET	Weight (kgs)	CODE NO.
VBH55-BT40	6-154	BT40-VBK5-75	75	18		3320-470
VBH55-BT50		BT50-VBK5-105	105	18		3320-471

INCLUDING ACCESSORIES : BORING BAR SIZE FOR SET TYPE

Boring Bar		Range	Insert	Screw	Wrench
BR1606A-21		Ø6 - Ø9	WBG060102	Ø3 x M2	T6
BR1608A-28		Ø8 - Ø11	TBGT060102	Ø2.7 x M2	T6
BR1610A-35		Ø10 - Ø13			
BR1612A-42		Ø12 - Ø15	TPGT090204	M2.5	T8
BR1614A-50		Ø14 - Ø17			
BR1616A-60		Ø16 - Ø20			
BR1620A-65		Ø20 - Ø24			
BR1624A-68		Ø24 - Ø28			
C16-BRM-SP27		Ø27 - Ø40			
C16-BRM-SP35		Ø35 - Ø50			
C16-BRM-SP45		Ø45 - Ø68			
CB-M10-SP55		Ø55 - Ø80			
CB-M10-SP68		Ø68 - Ø104			
CB-M10-SP100		Ø100 - Ø154			



Micro Boring Head Set



I Scale 0.002 mm Boring diameter from Ø6 - Ø204mm

NEW

● Boring Bar
PAGE C85



- Processing range Ø6-204 mm.
- Precisely ground and hardened shank integrating with boring head for routing and smooth operation.
- Please keep boring head clean and lubricated constantly.
- Easy & Simple operation.
- Complete set.
- Fine adjustment.
- Luxury box.
- Material : tool steel



BORING HEAD SETS

SET TYPE

ORDER NO.	Boring Range Ø	Shank	L	Pcs/SET	Weight (kgs)	CODE NO.
VBH68-BT40	6-204	BT40-VBK6-65	65	19		3320-476
VBH68-BT50		BT50-VBK6-95	95	19		3320-477

INCLUDING ACCESSORIES : BORING BAR SIZE FOR SET TYPE

Boring Bar		Range	Insert	Screw	Wrench
BR1606A-21		Ø6 - Ø9	WBGT060102	Ø3 x M2	T6
BR1608A-28		Ø8 - Ø11	TBGT060102	Ø2.7 x M2	T6
BR1610A-35		Ø10 - Ø13			
BR1612A-42		Ø12 - Ø15	TPGT090204	M2.5	T8
BR1614A-50		Ø14 - Ø17			
BR1616A-60		Ø16 - Ø20			
BR1620A-65		Ø20 - Ø24			
BR1624A-68		Ø24 - Ø28			
C16-BRM-SP27		Ø27 - Ø40			
C16-BRM-SP35		Ø35 - Ø50			
C16-BRM-SP45		Ø45 - Ø68			
CB-M10-SP68		Ø68 - Ø104			
CB-M10-SP100		Ø100 - Ø154			
CB150-RCM100-SP100		Ø150 - Ø204			



High Precision Boring Head Set



NEW

1 SCALE 0.005 mm
0.01 mm per Ø
BORING CAPACITY Ø8-Ø46

• Boring Bar
PAGE C85



Clamping Screw For Boring Bar

VBH 620

- Good for high speed, high precision boring work.
- Made of tool steel, high rigidity, no deformation.
- Each dividing scale is 0.005 mm, total stroke: 6 mm. For Ø diameter is 0.01 mm
- Can choose any taper (BT40, BT50, SK40, SK50) shank.
- Include 8 boring bars, range Ø8 ~ Ø46 mm.
- Boring bar size = Ø16 x 8 pcs
- Insert locking screw 8 x 3 = 24 pcs
- Wrench x 6 pcs
- 4 mm T wrench x 1 pcs



SET TYPE

ORDER NO.	SHANK TYPE	DRAWBAR	THREAD	Weight (kgs)	CODE NO.
		S.A.E	METRIC		
VBH620-NT40	NT-40	5/8"-11W	M16X2.0P	6.5	3320-480
VBH620-NT50	NT-50	1"-8W	M24X3.0P	7.8	3320-481
VBH620-BT40	BT-40		M16X2.0P	6.5	3320-482
VBH620-BT50	BT-50		M24X3.0P	8	3320-483
VBH620-SK40	SK-40		M16X2.0P	6.5	3320-484
VBH620-SK50	SK-50		M24X3.0P	7.8	3320-485

BORING BAR FOR BORING HEAD

BORING BAR	RANGE d	DEPTH m	SHANK L	INSERT	SCREW	WRENCH
BRB1608-32	8-11	32	80	TBGT060102L	TS2001	T6
BRB1610-40	10-13	40	80			
BRB1612-53	12-15	53	85	TPGH090204L	TS2504	T8
BRB1616-68	16-21	68	100			
BRB1620-83	20-26	83	115	TPGH110304L	TS3005	T10
BRB1625-90	25-31	90	122			
BRB1630-90	30-36	90	122			
BRB1640-90	40-46	90	122			



High Precision Boring Head Set



NEW

1 SCALE 0.005 mm
0.01 mm per Ø
BORING CAPACITY Ø8-Ø280

● Boring Bar
PAGE C85



Clampinf Screw For
Boring Head

Clamping Screw For
Boring Bar

VBH 2084

- Good for high speed, high precision boring work.
- Made of tool steel, high rigidity, no deformation.
- Each dividing scale is 0.005 mm, total stroke: 27 mm. For Ø diameter is 0.01 mm
- Can choose any taper (BT40, BT50, SK40, SK50) shank.
- Include 8 boring bars, range Ø8 ~ Ø280 mm.
- Boring bar size = Ø20 x 8 pcs
- Insert locking screw 8 x 3 = 24 pcs
- Wrench x 6 pcs
- Hexa 6 wrench x 1 pcs



SET TYPE

ORDER NO.	SHANK TYPE	DRAWBAR	THREAD	Weight (kgs)	CODE NO.
		S.A.E	METRIC		
VBH2084-R8	R-8	7/16"-20UNF	n/a	6.6	3320-491
VBH2084-NT30	NT-30	1/2"-12W	M12X1.75P	6.6	3320-492
VBH2084-NT40	NT-40	5/8"-11W	M16X2.0P	7	3320-493
VBH2084-NT50	NT-50	1"-8W	M24X3.0P	9	3320-494
VBH2084-BT40	BT-40		M16X2.0P	8	3320-495
VBH2084-BT50	BT-50		M24X3.0P	10.4	3320-496
VBH2084-SK40	SK-40		M16X2.0P	8	3320-497
VBH2084-SK50	SK-50		M24X3.0P	10.5	3320-501
VBH2084-MT3	MT-3		M12X1.5P	6.6	3320-498
VBH2084-MT4	MT-4		M16X2.0P	7	3320-499
VBH2084-MT5	MT-5		M24X3.0P	8	3320-500
VBH2084-C25	C25			7	3320-502
VBH2084-C32	C32			8	3320-503

BORING BAR FOR BORING HEAD

BORING BAR	RANGE d	DEPTH m	SHANK L	INSERT	SCREW	WRENCH
BRB2008-32	8-11	32	80	TBGT060102L SUMITOMO	TS2001	T6
BRB2010-40	10-13	40	80			
BRB2012-53	12-17	53	85	TPGH090204L MITSUBISHI	TS2504	T8
BRB2016-68	16-21	68	100			
BRB2020-83	20-130	83	115	TPGH110304L MITSUBISHI	TS3005	T10
BRB2025-96	25-135	96	135			
BRB2030-115	30-140	115	154			
BRB2035-97-L	120-280	14	99			

BORING HEAD SETS



Universal Boring And Facing Master Head **VERTEX**

**BORING CAPACITY Ø5-Ø250
FOR VERTICAL HOLE BORING IS Ø110**

1 SCALE 0.01 mm per Ø



• Boring Bar
PAGE C85

ORDER NO.	SHANK TYPE	DRAWBAR THREAD		Weight (kg)	CODE NO.
		S.A.E	METRIC		
VBHU-202	MT-3	1/2"-12W	M12X1.5P	6	3401-001
VBHU-203	MT-4	5/8"-11W	M16X2.0P	6.3	3401-002
VBHU-204	MT-5	1"-8W	M24X3.0P	7	3401-003
VBHU-205	R-8	7/16"-20UNF	n/a	6.2	3401-004
VBHU-206	NT-30	1/2"-12W	M12X1.75P	6	3401-005
VBHU-207	NT-40	5/8"-11W	M16X2.0P	6.2	3401-006
VBHU-208	NT-50	1"-8W	M24X3.0P	8.5	3401-007
VBHU-209	BT-40		M16X2.0P	6.9	3401-008
VBHU-210	C-25			4.5	3401-009
VBHU-211	SK-40		M16X2.0P	5.6	3401-010
VBHU-212	SK-50		M24X3.0P	8.3	3401-011
VBHU-213	BT-50		M24X3.0P	9.7	3401-012
VBHU-214	C-20			6	3401-013

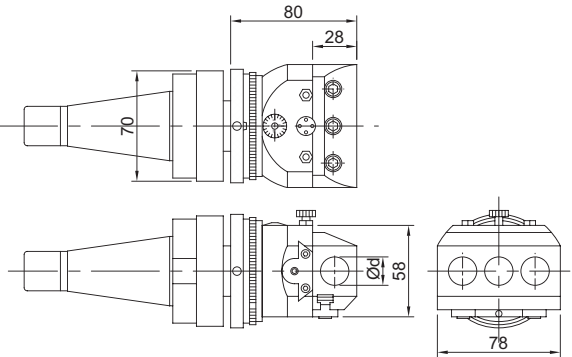

SPECIFICATION VBHU

Unit:mm

ACTUAL SIZE	OVERING BAR HOLE SIZE	BORING BAR HOLE SIZE	CENTER DIST BETWEEN HOLES.	CROSS HOLE DIA	OFFSET
78	100	18	23	18	15

It is construction with precision parts, freedom of selection feeding quantity, auto feed and stop. Processing range from 5mm to 250mm.

<p>Stop Rod BP-17</p>	<p>Square Bit(HSS) BP-18</p>	<table border="1"> <thead> <tr> <th colspan="2">Clamping Sleeve</th> </tr> <tr> <th>metric</th> <th>D</th> </tr> </thead> <tbody> <tr> <td>BP-7</td> <td>Ø10</td> </tr> <tr> <td>BP-8</td> <td>Ø12</td> </tr> </tbody> </table>	Clamping Sleeve		metric	D	BP-7	Ø10	BP-8	Ø12																
Clamping Sleeve																										
metric	D																									
BP-7	Ø10																									
BP-8	Ø12																									
<table border="1"> <thead> <tr> <th colspan="2">Allen Key</th> </tr> <tr> <th></th> <th>A</th> </tr> </thead> <tbody> <tr> <td>BP-14</td> <td>4</td> </tr> <tr> <td>BP-15</td> <td>5</td> </tr> <tr> <td>BP-16</td> <td>6</td> </tr> </tbody> </table>	Allen Key			A	BP-14	4	BP-15	5	BP-16	6	<table border="1"> <thead> <tr> <th colspan="2">Boring Bar</th> </tr> <tr> <th>metric</th> <th>L</th> </tr> </thead> <tbody> <tr> <td>BP-21</td> <td>104</td> </tr> </tbody> </table>	Boring Bar		metric	L	BP-21	104	<table border="1"> <thead> <tr> <th colspan="2">Boring Bar</th> </tr> <tr> <th>metric</th> <th>L</th> </tr> </thead> <tbody> <tr> <td>BP-1</td> <td>90</td> </tr> <tr> <td>BP-2</td> <td>120</td> </tr> </tbody> </table>	Boring Bar		metric	L	BP-1	90	BP-2	120
Allen Key																										
	A																									
BP-14	4																									
BP-15	5																									
BP-16	6																									
Boring Bar																										
metric	L																									
BP-21	104																									
Boring Bar																										
metric	L																									
BP-1	90																									
BP-2	120																									
<table border="1"> <thead> <tr> <th colspan="2">Boring Bar</th> </tr> <tr> <th>metric</th> <th>ØxL</th> </tr> </thead> <tbody> <tr> <td>BP-9</td> <td>Ø18x90</td> </tr> <tr> <td>BP-10</td> <td>Ø10x80</td> </tr> <tr> <td>BP-11</td> <td>Ø10x70</td> </tr> <tr> <td>BP-12</td> <td>Ø10x60</td> </tr> </tbody> </table>	Boring Bar		metric	ØxL	BP-9	Ø18x90	BP-10	Ø10x80	BP-11	Ø10x70	BP-12	Ø10x60														
Boring Bar																										
metric	ØxL																									
BP-9	Ø18x90																									
BP-10	Ø10x80																									
BP-11	Ø10x70																									
BP-12	Ø10x60																									



Interchangeable Shanks

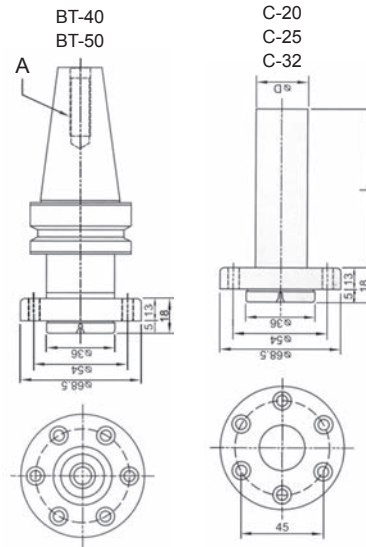
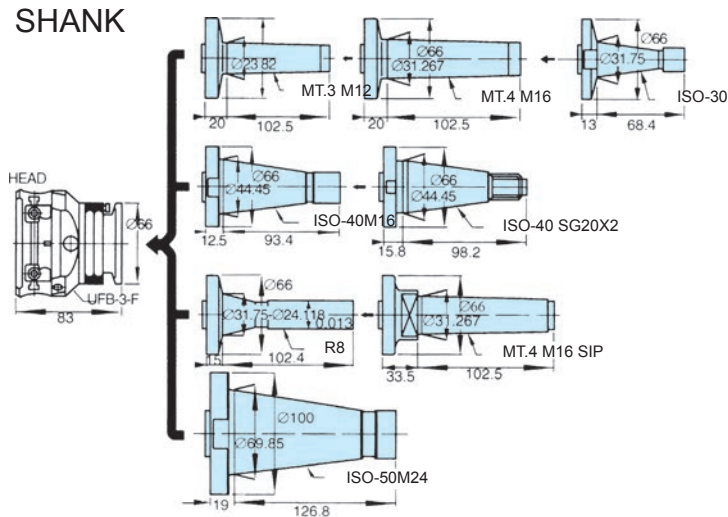

SHANK CHANGEABLE

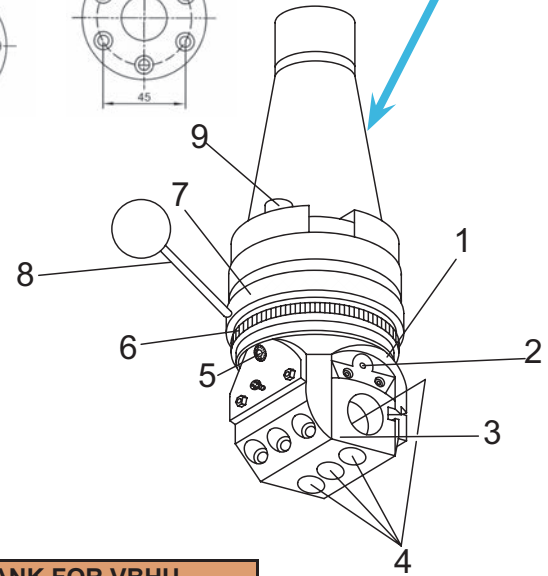

BORING HEAD SETS

Main part of the universal boring heads is the body(1), in which the tool slide (3) moves on dovetail guideways. The tool slide is provided with holes for accommodation of tools and tool holders(4). In boring holes or turning external cylindrical surfaces, the tool is adjusted with the aid of the graduated dial for fine setting of tool slide(5), one division of which means a change in diameter of bored hole by .0005".

On the types rapid adjustment of the tool slide(3) can be produced by rotating the graduated dial for quick adjustment of the tool slide(2).

During recessing, turning of front or rear facings or similar jobs calling for automatic transverse feed movement to the tool slide, the preselected feed movement to the tool slide is engaged with the aid of the engagement ring (6). After setting of tool, the automatic transverse feed movement to the tool slide is started by braking of the brake ring(7), by means of the handle(8).

The clutch(9) provides for tripping of the automatic feed movement when cutting resistance increases or when the trip dog is approached.

Mechanism of the boring heads has a lubrication circuit delivering oil from two lubricators to all friction surfaces.

All parts are hardened and working surfaces are ground.

SHANK FOR VBHU-		
MT-3	MT-4	MT-5
NT-30	NT-40	NT-50
R-8		
C-20	C25	C-32
BT-40		BT-50
	SK-40	SK-50

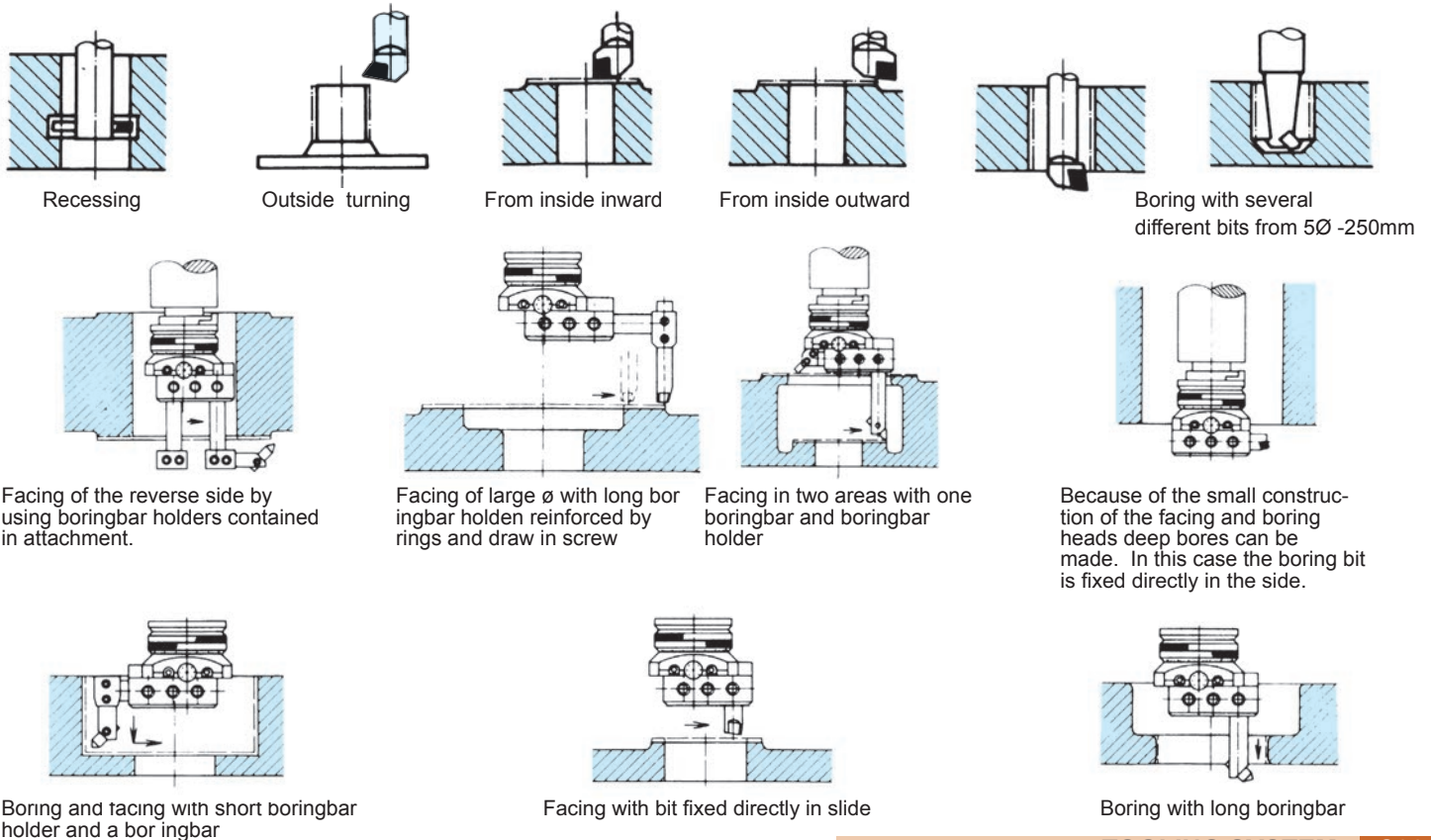



Boring Head Set C-Type



1 SCALE 0.01 mm
0.02 mm per Ø

● Boring Bar
PAGE C85



VBHC-BC2 SET TYPE



MAX. BORING DEPTH 50 mm

Here is a sturdy unit of extended boring range, capable of peeling off heavy roughing cuts as well as a tool of extreme sensitivity.

The use of a wide base bar holder, resting securely on the body, eliminates the need for a separate side plate. You will note this has now become an integral part of the body.

The direct reading adjusting screw is ground after hardening and a plainly marked dial face in nonreflecting satin chrome allows easy reading and adjustments of 0.01 or less.

All Criterion Boring Heads have threaded backs for use with a variety of shanks. This model takes a 1-1/2"-18 threaded shank.

SHANK SIZE: NT-30,40,50, MT-3,4,5,R8



VBHC-BC3 SET TYPE

BORING HEAD SETS

BORING CAPACITY Ø10~Ø110



ORDER NO.	WEIGHT (kgs)	CODE NO.
VBHC-R-8-BC-2	2	3401-150
VBHC-MT-2-BC-2	1.66	3401-149
VBHC-MT-3-BC-2	1.9	3401-151
VBHC-MT-4-BC-2	2.1	3401-152
VBHC-NT-30-BC-2	2.2	3401-153
VBHC-NT-40-BC-2	2.8	3401-154
VBHC-BT-30-BC-2	2.65	3401-155
VBHC-BT-40-BC-2	2.65	3401-156
VBHC-BT-50-BC-2	5.65	3401-157
VBHC-C-20-BC-2	1.75	3401-158
VBHC-SK-40-BC-2		3401-174
VBHC-SK-50-BC-2		3401-176

BORING CAPACITY Ø10~Ø220



ORDER NO.	WEIGHT (kgs)	CODE NO.
VBHC-R-8-BC-3	4.2	3401-160
VBHC-MT-2-BC-3	4	3401-148
VBHC-MT-3-BC-3	4	3401-161
VBHC-MT-4-BC-3	4.3	3401-162
VBHC-NT-30-BC-3	4.1	3401-163
VBHC-NT-40-BC-3	4.7	3401-164
VBHC-NT-50-BC-3	6.9	3401-165
VBHC-BT-30-BC-3	4.34	3401-166
VBHC-BT-40-BC-3	4.7	3401-167
VBHC-BT-50-BC-3	7.7	3401-168
VBHC-C-20-BC-3	4	3401-169
VBHC-SK-40-BC-3		3401-175
VBHC-SK-50-BC-3		3401-177



Boring Head Shank C-Type



FOR VBHC-TYPE
AND BC-2, BC-3, BC-4
BORING HEAD



D: 1 1/2"-18UNC

The shanks are made for C-type boring head use.
Also it can be replaced from time to time.

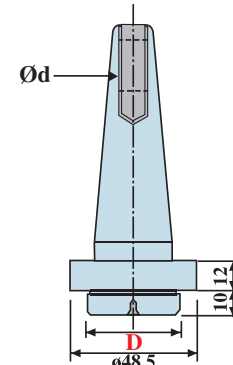
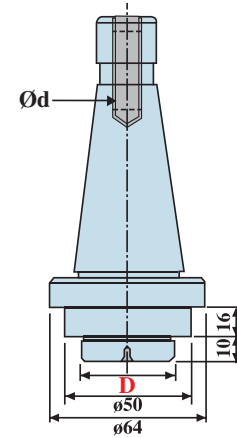
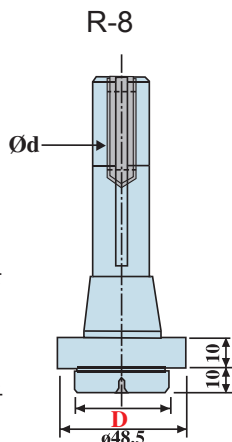
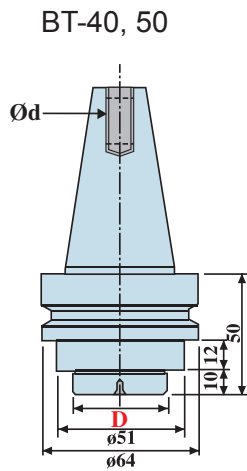

	Ød	
NT-30	M12x1.75P 1/2"-12UNC	MT-2 M10x1.5P 3/8-16NC
NT-40	M16x2.0P 5/8"-11UNC	MT-3 M12x1.75P 3/8"-16UNC
NT-50	M24x3.0P 1"-8UNC	MT-4 M16x2.0P 5/8"-11UNC
		MT-5 M24x3.0P 1"-8UNC

ORDER NO.	VBC-R8	VBC-NT30	VBC-NT40	VBC-MT2	VBC-MT3	VBC-MT4	VBC-MT5
WEIGHT (KG)	0.4	0.7	1.3	0.39	0.6	0.9	1.6
CODE NO.	3401-210	3401-211	340-212	3401-209	3401-213	3401-214	3401-215

ORDER NO.	VBC-BT40	VBC-BT50	VBC-C20	VBC-SK40	VBC-BT30	VBC-SK50
WEIGHT (KG)	1.4	3.97	0.4	1.28	1.1	1.3
CODE NO.	3401-216	3401-217	3401-219	3401-222	3401-223	3401-224

C-Type Boring Head



ORDER NO. VBC-2

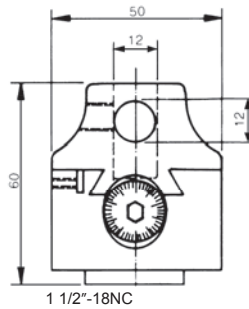

1 SCALE 0.01 mm
0.02 mm per Ø

Here is a small head that will be in constant demand in any shop.

Note the wide base bearing surface that assures maximum rigidity even when the bar holder is in an off-set position. This wide base design is a recent Criterion innovation that increases bearing surfaces by 50% over the older models.

A 1/2" double hole bar holder with a 1/2" cross hole is available.

The unit has a 1 1/2"-18NC threaded back and also features a direct reading dial screw.

SPECIFICATION

BORING CAPACITY Ø10-Ø100

ORDER NO.	ACTUAL SIZE	OVERALL LENGTH	BORING BAR HOLE SIZE	CENTER DIST BETWEEN HOLES.	CROSS HOLE DIA	OFFSET	WEIGHT (kg)	CODE NO.
VBC-2(l)	2"Dia.	2-7/16"	1/2"	5/8"	1/2"	5/8"	0.7	3401-301
VBC-2(m)	50	62	12	15	12	15	0.8	3401-302



ORDER NO. VBC-3

• Boring Bar
PAGE C85

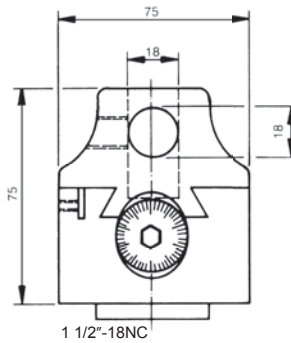

1 SCALE 0.01 mm
0.02 mm per Ø

Here is a sturdy unit of extended boring range, capable of peeling off heavy roughing cuts as well tool of extreme sensitivity. The use of a wide-base bar-holder resting securely on the body, eliminates the need for a separate side plate. You will notice it has now become an integral part of the body.

The direct reading adjusting screw is ground after hardening and a plainly marked dial face in non-reflecting satin chrome allows easy reading and adjustments of .0005 or less.

All Criterion Boring Heads have threaded backs for use with a variety of shanks. This model takes a 1-1/2"-18NC threaded shank.

SPECIFICATION

BORING CAPACITY Ø10-Ø220

ORDER NO.	ACTUAL SIZE	OVERALL LENGTH	BORING BAR HOLE SIZE	CENTER DIST BETWEEN HOLES.	CROSS HOLE DIA	OFFSET	WEIGHT (kg)	CODE NO.
VBC-3(l)	3"Dia.	3.5/32"	3/4"	15/16"	3/4"	1"	2	3401-303
VBC-3(m)	75	80	18	23	18	25	2	3401-304

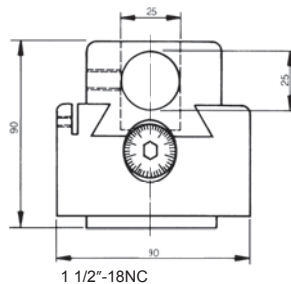

1 SCALE 0.01 mm
0.02 mm per Ø

This is a bigger boring head which can be put on large machine to process more as you want. The radius of boring hole can reach on about Ø 400mm long by a boring bar of 160mm.

All Criterion Boring Heads have threaded backs for use with a variety of shanks. This model takes a 1-1/2"-18NC threaded shank.

SPECIFICATION

BORING CAPACITY Ø10-Ø250

ORDER NO.	ACTUAL SIZE	OVERALL LENGTH	BORING BAR HOLE SIZE	CENTER DIST BETWEEN HOLES.	CROSS HOLE DIA	OFFSET	WEIGHT (kg)	CODE NO.
VBC-4(l)	4"Dia.	3-1/2"	1"	1-1/4"	1"	1"	4	3401-305
VBC-4(m)	100	90	25	32	25	25	4	3401-306

BORING HEAD



Touch Point Sensor



Edge Finder with Beeper & Optical

- No need to rotate while measuring.
- The red light was sealed with setting red-gel; it can concentrate the light and resist water.
- The sensor beeps while the red light is on.
- The sensor will beep when the user couldn't see the reverse side or get a clear sight.
- Example. If sensor's light is working, visually you couldn't see inside of the inner hole, while probing the user can be warned by the beeper.
- When probe the deep hole, you can't see the red light, but you can hear the sound from beeper.
- Accuracy: within $\pm 0.005\text{mm}$.
- ※ No need to rotate.

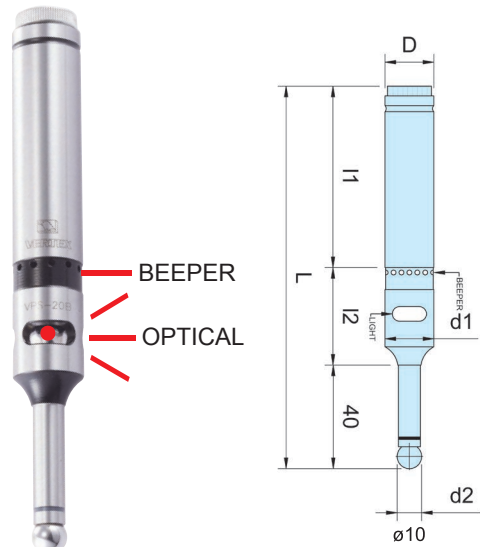

OPTICAL TYPE WITH BEEPER

Unit:mm

ORDER NO.	D	d1	d2	L	I1	I2	BATTERY TYPE	WEIGHT (kg)	CODE NO.
VPS-20B	Ø20	18	10	157	77	41	UM-5#(SP) x1PCS/12V	0.4	3402-001
VPS-32B	Ø32	18	10	157	74	41		0.7	3402-002
VPS-3/4B	Ø3/4	18	10	157	74	41		0.7	3402-012

Batteries used:UM5#,12V*1PCS

SCREW COVER



Touch Point Sensor

Optical Type

Without Beeper

- High sensitivity position sensor.
- Red pilot can be seen clearly.
- Whole travel of red pilot is sparkling, detecting also can be done during turning while spindle stops.
- Location of end surface, outer circle dia., inner circle dia. of the workpiece for processing can be detected with full effect.
- Devised with safety line excess, ball supported by spring, so even line excess, it will be separated easily from the base shown as the fig.
- The precision will reach up to micrometer while the ball returns to center position.
- Edge Finder
- Accuracy: Within $\pm 0.005\text{mm}$



VPS-20

VPS-32

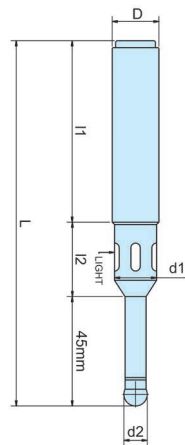

OPTICAL TYPE

Unit:mm

ORDER NO.	D	d1	d2	L	I1	I2	BATTERY TYPE	WEIGHT (kg)	CODE NO.
VPS-20	20	18	10	157	76	33	UM-5#(SP) x2P/R1.1.5V	0.4	3402-003
VPS-32	32	18	10	157	74	41		0.7	3402-004

After Reading the Following instruction, please use touch point sensor correctly due to it's a highly sensitive position detector. Don't Rotate the touch point sensor while using it.

1. Install BATTERY

Take off the screw cover and insert batteries correctly. Do not insert batteries upside down.

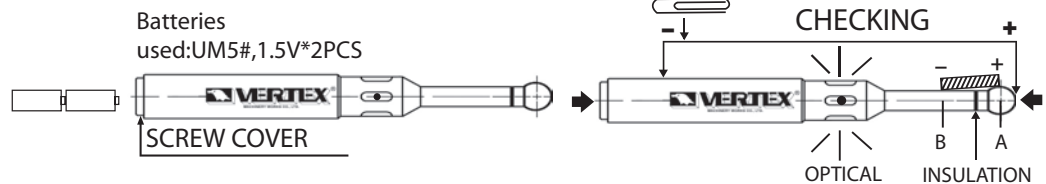

Batteries used:UM5#,1.5V*2PCS

SCREW COVER

2. CONFIRMATION OF LIGHTING

CHECK the lighting of red lamp by touching A-B part with a metal (clip, L-PLATE etc.)

3. MEASURING METHOD

As soon as the ball (outside dia. 10mm) touches the work piece with the main spindle stopped, The red lamp lights on.

※ No need to rotate.

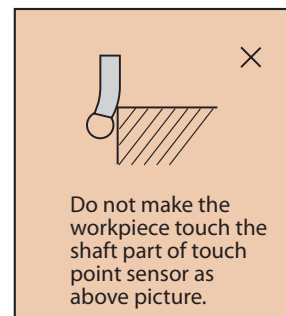
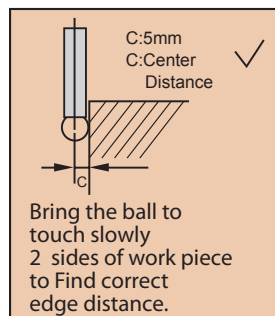

請注意 / 光電式尋邊器不適合迴轉使用
Notice: optical edge finder is not suited FOR Rotation.



Touch Point Sensor



Edge Finder



VPS-201

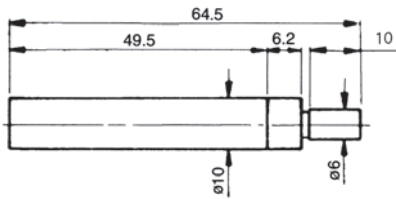

This series is a high precision setting device for positioning the accurate center between tool spindle of machine and reference surface of working at low-cost and saving time.
Accuracy : within ± 0.005 mm
Made of tool steel, hardened and ground.
Suitable rotation speed : VPS-201 500 to 700rpm.



CREAMIC TYPE VPS-201C

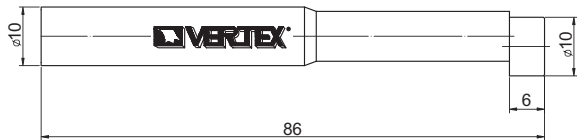

MECHANICAL TYPE

ORDER NO.	VPS-201	VPS-201C
WEIGHT (KG)	0.03	0.06
CODE NO.	3402-005	3402-007

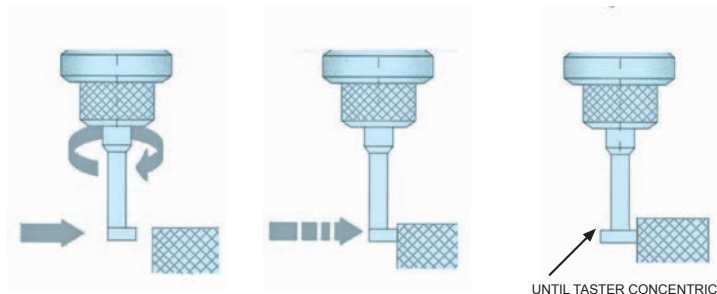

TOUCH POINT SENSOR



Touch Point Sensor

Deluxe Type



VPS-401



VPS-401C

CERAMIC

FEATURES:

- Material: high-carbon steel.
- Accuracy: within ± 0.003 mm
- Hardness: HRC $58^{\circ} \pm 1^{\circ}$
- R.P.M. Within 600-900
- Suitable for milling machine. Drill machine and boring machine.
- Edge Finder

VPS-401 (2 PCS/SET)
VPS-402A(LONG) SINGLE
VPS-402B(SHORT) SINGLE

ORDER NO.	VPS-401	VPS-401C
PCS/SET	2PCS/SET	2PCS/SET
MATERIAL	STEEL	CERAMIC
WEIGHT (KG)	0.26	0.26
CODE NO.	3402-006	3402-008

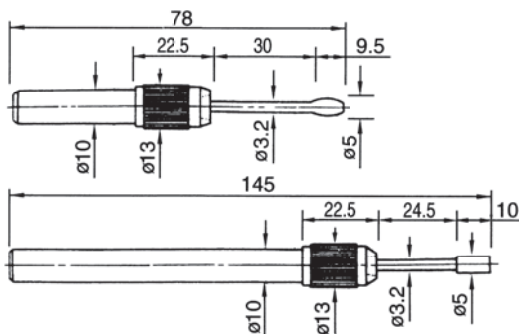

EXAMPLES-APPLICATION

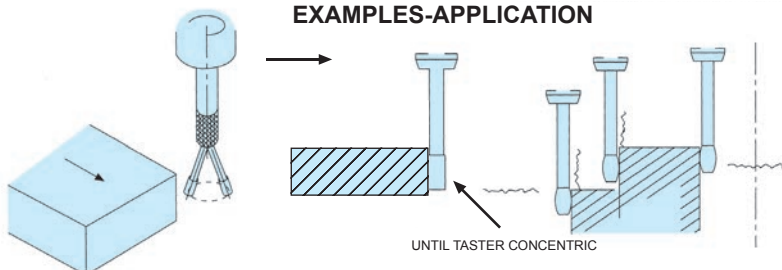



Touch Point Sensor



MECHANICAL TYPE



VPS-301 STEEL

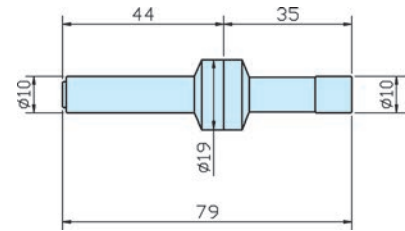

VPS-301S STAINLESS



VPS-302 STEEL

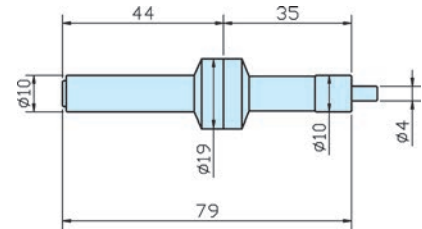

VPS-302S STAINLESS



VPS-301C CERAMIC TYPE

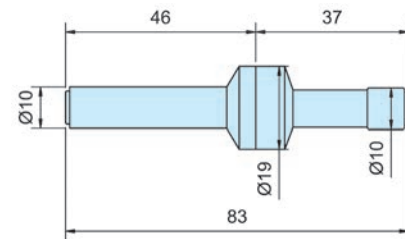

NEW



VPS-302C CERAMIC TYPE

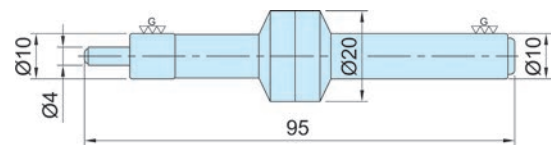

NEW



VPS-303
NON-MAGNETIC COATING

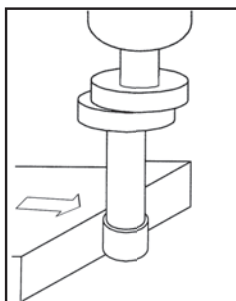
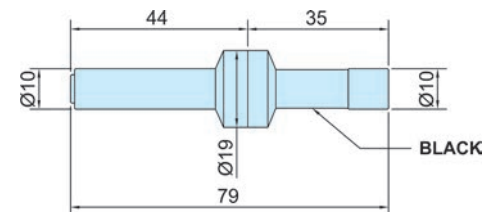

Spindle runs about 500rpm. move spindle closed to measuring surface.

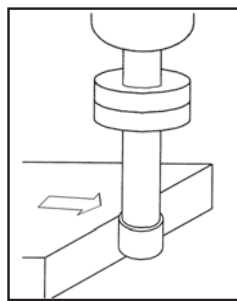

When measuring probe touches workpiece, it looks in one part.

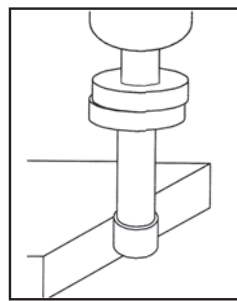

When the probe and shank are in alignment, probe will slide out of rotating center. Now, the center spindle is located 5mm away from measuring surface

- Accuracy of zero point to point is within $\pm 0.003\text{mm}$
- R.P.M. within 500-700.
- Max. flange can be clear your sight sense.
- MIN.(4mm) can be test mini hole for your workpiece.

ORDER NO.	MATERIAL	HARDNESS	WEIGHT (kg)	CODE NO.
VPS-301	ALLOY STEEL	HRC 56°	0.06	3402-100
VPS-302			0.05	3402-101
VPS-301S	STAINLESS	HRC 60°	0.06	3402-102
VPS-302S			0.06	3402-103
VPS-301C	CERAMIC	HRC 60°	0.06	3402-104
VPS-302C	CERAMIC	HRC 60°	0.06	3402-105
VPS-303	NON-Magnetic Coating	HRC 56°	0.06	3402-106

HP-50Z

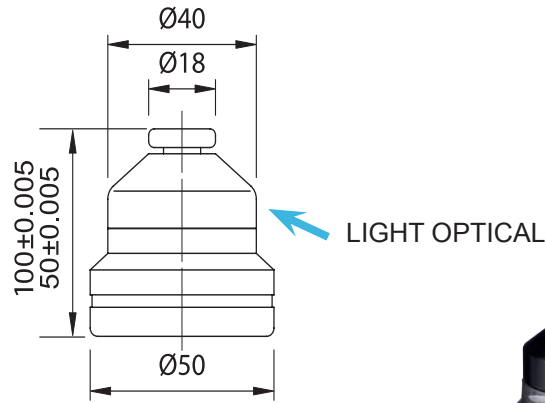

HP-50Z BATTERY
LR4476AG13
1SET/2PCS
HP-50ZM
LR44
1SET/2PCS

MODEL For NEXT

- Height 50 mm and 100 mm.
- With Magnetic base.
- The red lamp will be lighted up when touched.
- Accuracy 0.005 mm.
- Combined vertical and horizontal in a unit.
- Weight:0.7 kgs



HEIGHT PRESETTER

- A. HP-50 / 100 / ZM / EM SERIES BUILT-IN MEGNETS FOR EASIER SETUP. VERTICAL & HORIZONTAL !
- B. STANDARD HEIGHT : 50 OR 100 MM
- C. WEIGHT ABOUT 0.7-1.2 KGS
- D. WHEN TOUCHED, THE RED LAMP LIGHTS ON.
- E. ACCURACY : WITHIN 0.005 MM
- F. BATTERY TYPE : LR44 / A76 / G13 X 2 PCS

MANUAL:

1. THERE IS A MECHNISM BELOW THE TOUCH PLATE CAN BE ADJUSTED BY GAUGE BLOCK.
 2. WHEN MACHINE SPEED IS HIGH, PLEASE REDUCE THE SPEED & GO UP /DOWNWARD UNTIL THE RED LIGHT IS OFF.
 3. PROCEED AGAIN IN LOWER SPEED.
 4. HORIZONTAL POSITION (HPXXX-XXEM/ZM SERIES-MAGNETIC FUNC.ONLY)
PLEASE USE THE TOP TIP OF THE CUTTER TO TOUCH THE TOUCH PLATE.
- ※ CAN NOT USE VERNIER TO CHECK / RE-SET

EXAMPLE

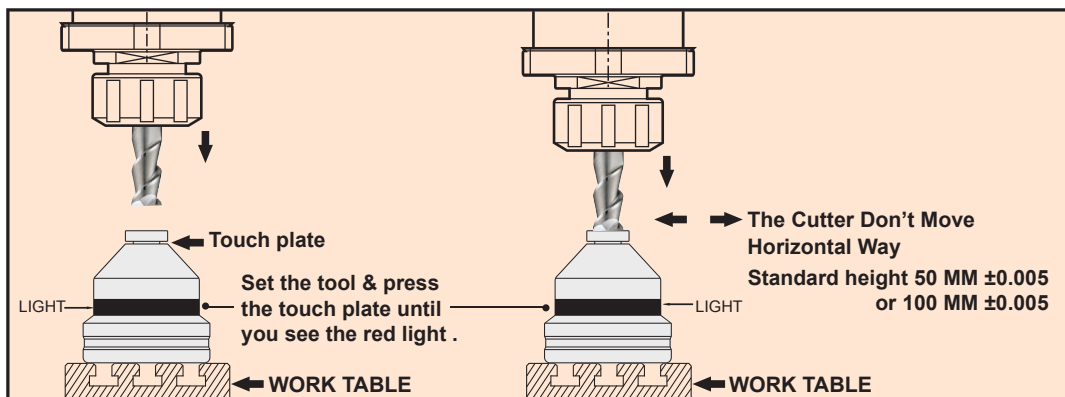

ORDER NO.	H	STYLE	WEIGHT (kg)		CODE NO.
			N.W.	G.W.	
HP-50Z	50mm	STANDARD TYPE	0.32	0.7	3403-001
HP-50ZM	50mm	WITH MAGNETIC BASE	0.32	0.6	3403-002
HP-100Z	100mm	STANDARD TYPE	1.0	1.25	3403-003
HP-100ZM	100mm	WITH MAGNETIC BASE	1.0	1.23	3403-004

NEW



Electronic Tool Length Setter



STAINLESS STEEL BASE WITH MAGNET

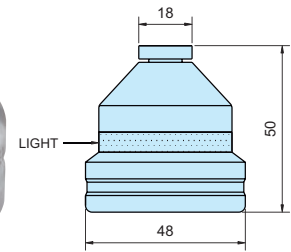
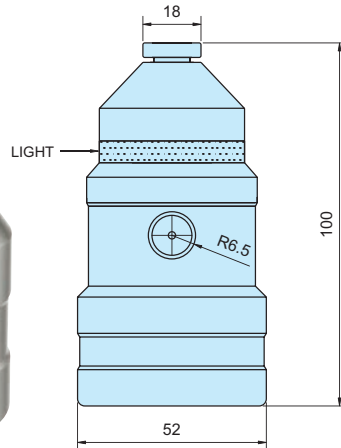

EXAMPLE

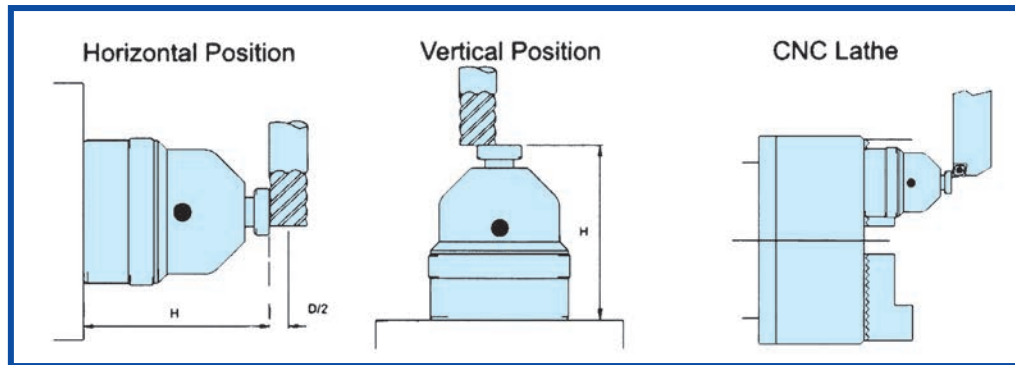

● HIGH ACCURACY

● EASY OPERATION

- Be sure to remove all chips and all from the sensor plate and the base of the HP-50E as well as from the workpiece and tool.
- To move the tool approaching the sensor plate slowly.
- When touching, the "LED" turns on immediately and "H" is just 50.00 mm.(or2")
- LED will not function if batteries are not set in correctly.
- Designed to be used on ferrous.

ORDER NO.	H	STYLE	WEIGHT(kg) N.W.	CODE NO.
HP-50EM	50mm	WITH MAGNETIC BASE	0.6	3403-032
HP-100EM	100mm		1.25	3403-033

Stainless Steel Base With Magnet

TOOL PRE-SETTER FOR MACHINING CENTERS.
CNC & STANDARD MILLING MACHINES AND
CNC & STANDARD LATHES



HP-50A



HP-100AM

COMPENSATION
PLAIN SURFACE

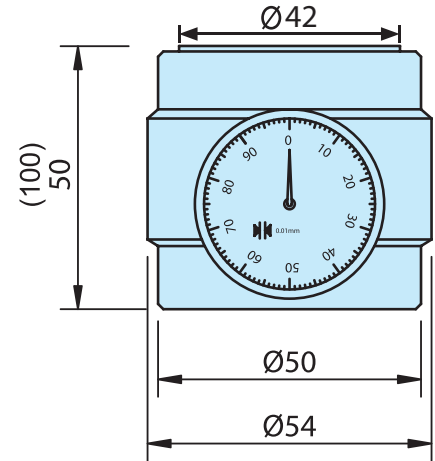

CHECKING BAR FOR
50 OR 100 MM POSITION
AT ZERO POINT

CHECKING BAR

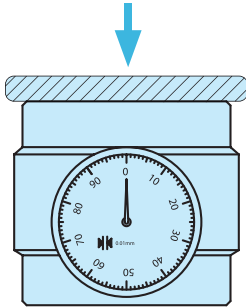

HP-50B

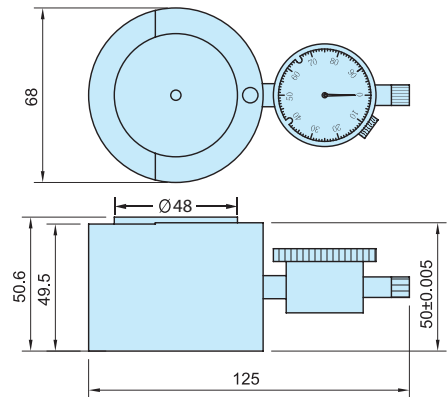

CHECKING BAR FOR
50 OR 100 MM POSITION
AT ZERO POINT

- Have the central measuring part of the zero setter presetter against a plain surface and aligned if with the outer reference surface. Turn the dial gauge for zero setting. Have the cutter touched against the z zero setter.
- Once the indicator position at zero, the distance between the tool tip to workpiece is 50mm, ± 0.005 , 100 mm, ± 0.005 .

EXAMPLE

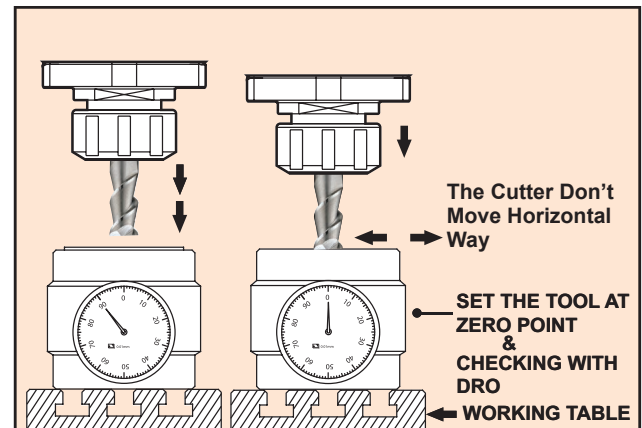

ORDER NO.	H	STYLE	WEIGHT (kg)	CODE NO.
HP-50A	50mm	STANDARD TYPE	1.1	3403-020
HP-50B			1.7	3403-021
HP-50AM		WITH MAGNETIC BASE	1.2	3403-022
HP-50BM			1.7	3403-023
HP-100A	100mm	STANDARD TYPE	1.78	3403-024
HP-100AM		WITH MAGNETIC BASE	1.77	3403-025

NEW



Height Presetter (For Machining Center)



ORDER NO.HP-100 CODE NO.3403-010

Height from reference surface	WEIGHT(kgs)
100mm	2.6

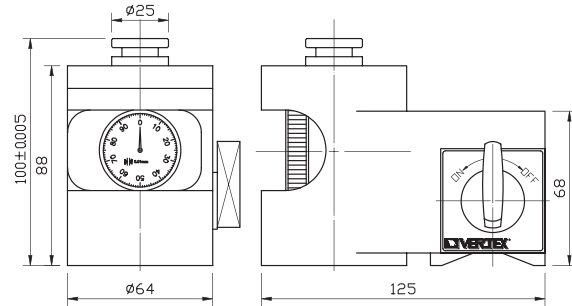

WITH CHECKING GAUGE

- Locate the height presetter on a place suitable for a reference surface of work piece.
- Apply the cutter on the measuring surface and slowly lower the Z-axis. Then, cutter gets near to the measuring position.
- A distance from the reference surface to the tool tip can be measured easily and precisely so that this presetter is most suitable not only for machineing centers but for NC lathes and NC milling machines.

* Magnetic base function can be used in vertical position & horizontal position.

* HEIGHT:100mm±0.005 , 1 scale 0.01mm



Centering Indicator

ORDER NO.VCI-170 CODE NO.3402-130



- RPM Within 800.
- Use for Internal or External.
- Use for Vertical or Horizontal.
- While Spindle Rotates, With Stop bar for Fixing The Head The Centering Indicator Always faces the operator.
- Centering finder by indicator

SHANK	ø10	mm
LENGTH	170	mm
INTERNAL	ø4~ø108	mm
EXTERNAL	ø0~ø108	mm
MIN. INDICATOR	0.01	mm
INDICATOR RANGE	0~6	mm
WEIGHT	0.8	kgs



Reversible Tapping Attachment for Drilling & Milling Machine

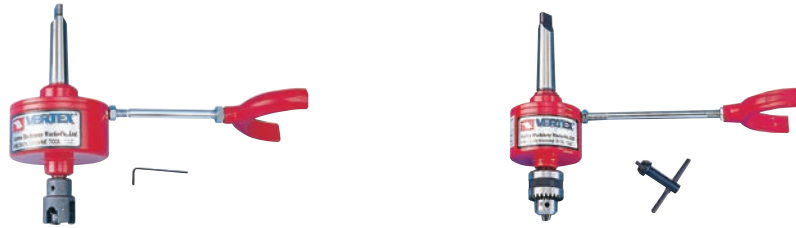

ORDER NO.	TAPPING CAPACITY	SHANK	TO WORK WITH DRILLING MACHINE	WEIGHT (KG)	PACKING mm	SPEED	CODE NO.
K1-1/2	Ø3-8mm	1/2"	DRILLING MACHINE MUST EQUIPPED WITH DRILL CHUCK CAPACITY 13M/M	0.8	90X90X190	1 : 1	3404-001
K1-MT-2	Ø3-8mm	MT-2	DRILLING MACHINE MUST EQUIPPED WITH MT-2 HOLE	1	90X90X240	1 : 1	3404-002
K2-1/2	Ø5-10mm	1/2"	DRILLING MACHINE MUST EQUIPPED WITH DRILL CHUCK CAPACITY 13M/M	1.5	100X100X210	1 : 1	3404-003
K2-MT-2	Ø5-10mm	MT-2	DRILLING MACHINE MUST EQUIPPED WITH MT2 HOLE	1.6	100X100X260	1 : 1	3404-004
K3-MT-3	Ø6-14mm	MT-3	OTHERS LIKE MT-3 SHANK BORING HOLE DRILLING MACHINE N.T. AVAILABLE	3.1	125X125X300	1 : 1	3404-005
K4-MT-3	Ø12-25mm	MT-3	OTHERS LIKE MT-3 SHANK BORING HOLE DRILLING MACHINE N.T. AVAILABLE	5.4	160X160X360	1 : 1	3404-006

K1 TYPE USED CHUCK TO FIX THE TAP

K2, K3, K4 TYPE USED THE SLIDING PLATE OF THE SQUARE SHARP HOLE TO FIX THE TAP.



Tap Chuck Series

VTA13

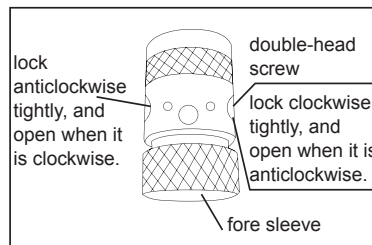
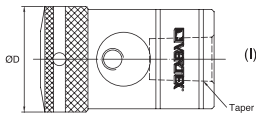

- THE DESIGN CAN PREVENT THE TAPS CHUCK FROM LOOSENING AFTER TAPPING.
- SUIT FOR VARIOUS TAPS. LARGE TAPPING CAPACITY. HIGH POWER TORSION.

VTA16-3
MT2

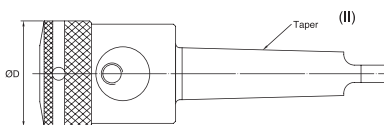

ORDER NO.		TAPPING CAPABILITY		D	Taper	N.W (kg)	CODE NO.
		mm	inch				
VTA13-1	I			43	J6	0.65	3404-000
VTA13-2	I	M3-M12	W1/8"~W1/2"	43	B16	0.65	3404-007
VTA13-3	II			43	MT2	0.6	3404-008
VTA16-2	I			48.5	B18	0.9	3404-017
VTA16-3	II	M3-M16	W1/8"~W5/8"	48.5	MT2	0.75	3404-018
VTA16-4	II			48.5	MT3	0.9	3404-019
VTA18-2	II	M9-M18	W3/8"~W3/4"	51	MT2	0.9	3404-019A
VTA18-3	III			51	MT3	1.06	3404-019B



Drill Tapper

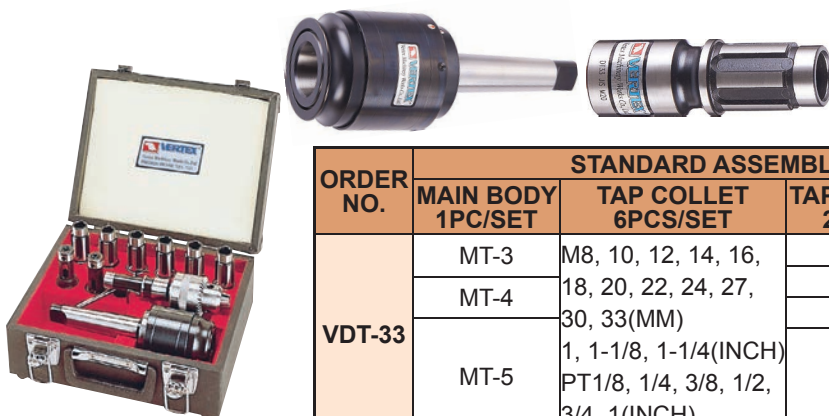

Including shank, full set of collets, wrench and case. (Used for radial drilling, lathe and tapping machines. 1 Main body, 6 JIS STD Tap Collet, 1 Drill Chuck Holder Optional in Collets & Tapper Sleeves.)0.6CUFT.

Unit:mm

ORDER NO.	STANDARD ASSEMBLY SPECIFICATION				G.W. kg	MEAS. CFT	CODE NO.
	MAIN BODY 1PC/SET	TAP COLLET 6PCS/SET	TAPER SLEEVE 2PCS/SET	DRILL CHUCK HOLDER 1PC/SET			
VDT-33	MT-3	M8, 10, 12, 14, 16, 18, 20, 22, 24, 27, 30, 33(MM)	33-MT1	33-JT6 With 1/2" Drill Chuck	11.9	0.6	3404-010
	MT-4	1, 1-1/8, 1-1/4(INCH)	33-MT2		12		3404-011
	MT-5	PT1/8, 1/4, 3/8, 1/2, 3/4, 1(INCH)	33-MT3		12.8		3404-012



Reversible Tapping Attachments

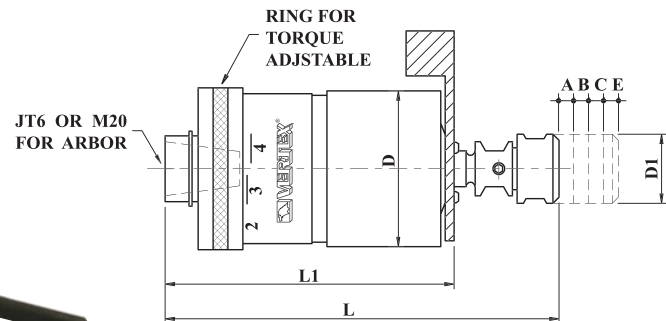

- Radial Float is SELF-CENTERING to compensate for hole center misalignment.
- Unique Double Spring Mechanism produces Automatic Feed and Cushion Drive. There are two springs for the feed and two springs for the reversal. Each set gives you double smoothness for ULTRA accurate tapping applications (not possible with this type of tapping head in the past).
- Pre-set Torque Control Permits easy operation of tap brake torque control
- JACOBS RUBBER FLEX COLLETS are standard accessory.

Reversing Type

ATTACHMENT DESIGNATIONS ORDER NO.	FOR TAPS	SUITABLE ADAPTERS SIZE	REC. MAX SPEED	LENGTH COMPENSATION				D DIA	D1 DIA	L	L1	WEIGHT (kgs)	CODE NO.
				COMP A	EXP. B	EXP. C	EXP. E						
VTA7-JT6	M2-M7	FC-10/FC-11	1500RPM	5	3.5	1.5	7.0	52	23	125.5	94.5	1.3	3404-020
VTA12-JT6	M3-M12	FC-20/FC-21	1000RPM	5	4.5	1.5	8.5	73.5	28	169	122	3.1	3404-021
VTA20-M20	M8-M20	FC-30/FC-31	600RPM	5.5	5	2.0	9.0	91	38	190	128	5.7	3404-022

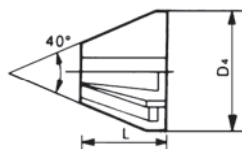

Rubber Flex Collet For VTA Tapper

ORDER NO.	COLLETS CAPACITY	D4	L	CODE NO.
FC-10	Ø 2.5 - Ø 4.5	16	11	3404-030
FC-11	Ø 4.5 - Ø 6.5	16	11	3404-031
FC-20	Ø 4 - Ø 7	21.5	13	3404-032
FC-21	Ø 7 - Ø 10	21.5	13	3404-033
FC-30	Ø 5.36 - Ø 9	26.5	15	3404-034
FC-31	Ø 10.38 - Ø 14	26.5	15	3404-035

CONNECTING ARBOR FOR VTA20-M20	
MT3-M20	3404-036A
MT4-M20	3404-037A

ARBOR EXAMPLE :



please see page C46





Expansible Tapping Holder

Compression Distance 6mm



ER20

ER32

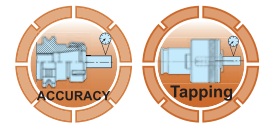
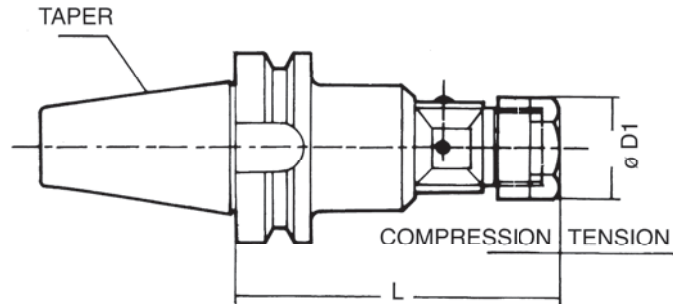

TAPPING HOLDER

HOLDER-BT-TYPE

Unit:mm

ORDER NO.	COLLET	HOLDER (DXL)	L	D ₁	TAPPING RANGE	WEIGHT (KGS)	CODE NO.
VET-271	ER20	BT40 20X100	100	34	M2-M16	2.2	3404-026
VET-272	ER20	BT50 20X95	95	34		4	3404-027
VET-273	ER32	BT40 32X110	110	50	M3-M25	2.4	3404-028
VET-274	ER32	BT50 32X110	110	50		4.5	3404-029



WITH SPANNER

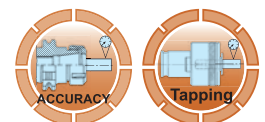
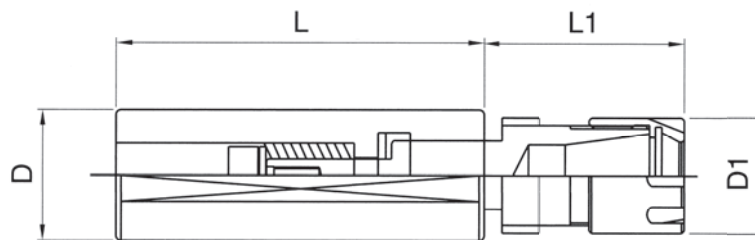

HOLDER-MINI TYPE

Unit:mm

ORDER NO.	COLLET	HOLDER (DXL)	L ₁	D ₁	TAPPING RANGE	WEIGHT (KG)	CODE NO.
VET-260	ER16	ER16M 20X70	35	22	M3-M10 1/8"-3/8"	0.2	3404-036
VET-261	ER16	ER16M 25X70	35	22		0.2	3404-037



Expansible Tapping Holder



- Floating and expansion design will reduce the differential of motor rotary speed and feeding speed so will extend the life of tap.
- Use ER High Spring Collet, you don't need to worry the few size will delay working, so their value is more than any other tapping system.
- Strong Vise clamping function which is controlled by one screw will keep the outlet which have been controlled by ER collet, so it can auto-center and you own the double lock and save in clamping.
- The series. can be fitted with ER20 collet as optional accessory.

STRAIGHT SHANK

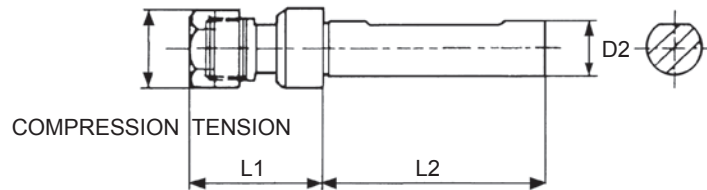

Compression Distance 6mm

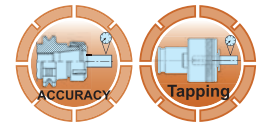

Unit:mm

SINGLE HOLDER

ORDER NO.	COLLET	HOLDER (D ₂ XL ₂)	L ₁	D ₁	TAPPING RANGE	WEIGHT (KG)	CODE NO.
VET-102	ER16	20X80	47	28	M3-M10 (1/8"-3/8")	0.4	3404-041

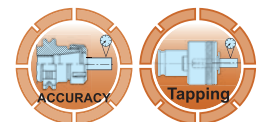
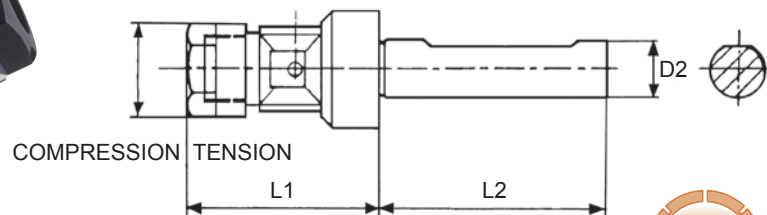

Unit:mm

SINGLE HOLDER

ORDER NO.	COLLET	HOLDER (D ₂ XL ₂)	L ₁	D ₁	TAPPING RANGE	WEIGHT (KG)	CODE NO.
VET-202	ER20	20X80	70	34	M3-M16 (1/8"-5/8")	1	3404-043
VET-252	ER20	25X80	70	34		1.2	3404-044
VET-303	ER32	32X100	90	50	(M3-M25) (1/8"-1")	2	3404-045

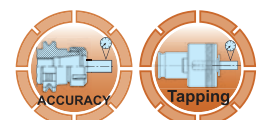

Unit:mm

SETS TYPE

ORDER NO.	COLLET	HOLDER (D ₂ XL ₂)	SET/PCS	WEIGHT (KG)	CODE NO.
VET-105	ER16	20X80	8	1	3404-046
VET-106	ER16	20X80	10	1.1	3404-047
VET-253	ER20	20X80	10	1.6	3404-048
VET-254	ER20	20X80	12	1.7	3404-049



Quick Change Tapping Chuck



European Type

SPECIAL!

**SAFETY !
QUICK !**



TAPPING CHUCKS

QUICK CHANGE TAPPING CHUCKS (with length compensation)

MAS-BT-30, 40, 50 Shank / DIN69871A SK-40, 50 / ST-20, 32 / MT-2, 3, 4

- Tension and compression feature allows taps to follow their own thread lead.
- With extreme light compression compression and tension operated by ball cage.

Quick Change Tapping Chucks

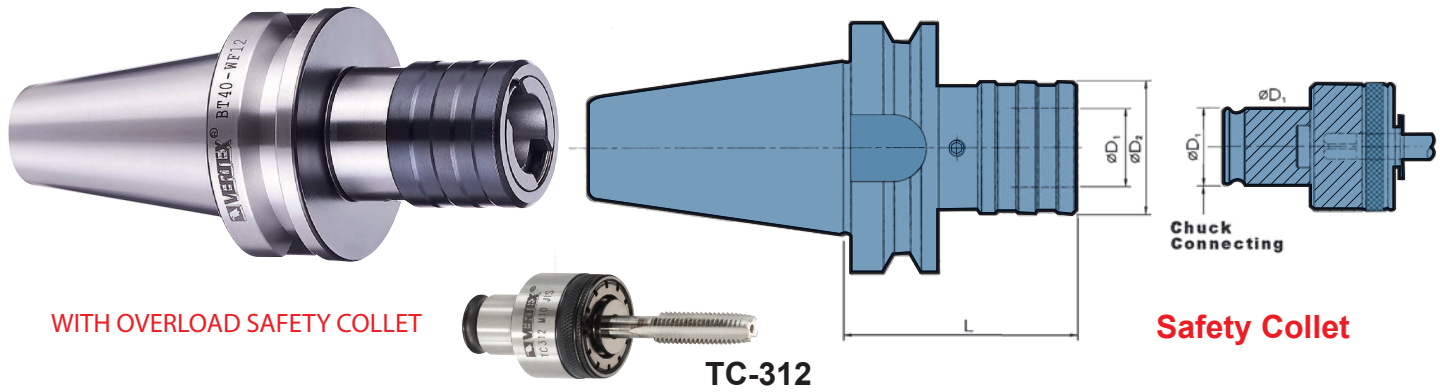

WITH OVERLOAD SAFETY COLLET

TC-312

Safety Collet

- Tension and compression feature allows taps to follow their own thread lead.
- With extreme light compensation compression and tension operated by ball cage.

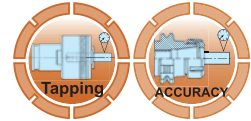

WF-BT30/BT40/SK30/SK40 LENGTH COMPENSATION TYPE

ORDER NO.	Thread Size	L	ØD1 Chuck Connecting DIA.	ØD2	Length Compensation		Tapping Collets	WEIGHT (kg)	CODE NO.
					Compression	Tension			
BT30-WF12	M2-M14	70	Ø19	36	7.5	7.5	TC-312	0.8	3404-050A
BT40-WF12	M2-M14	75	Ø19	36	7.5	7.5	TC-312	1.3	3404-050
SK40-WF12								1.3	3404-051
BT30-WF20	M5-M24	94	Ø31	53	12.5	12.5	TC-820	1.3	3404-052A
BT40-WF20	M5-M24	95	Ø31	53	12.5	12.5	TC-820	1.8	3404-052
SK40-WF20	M5-M24	95	Ø32	53	12.5	12.5	TC-820	1.8	3404-053

※Tapping Collet Reducer Adapter : TC820 / TC312-AD

Quick Change Tapping Chucks

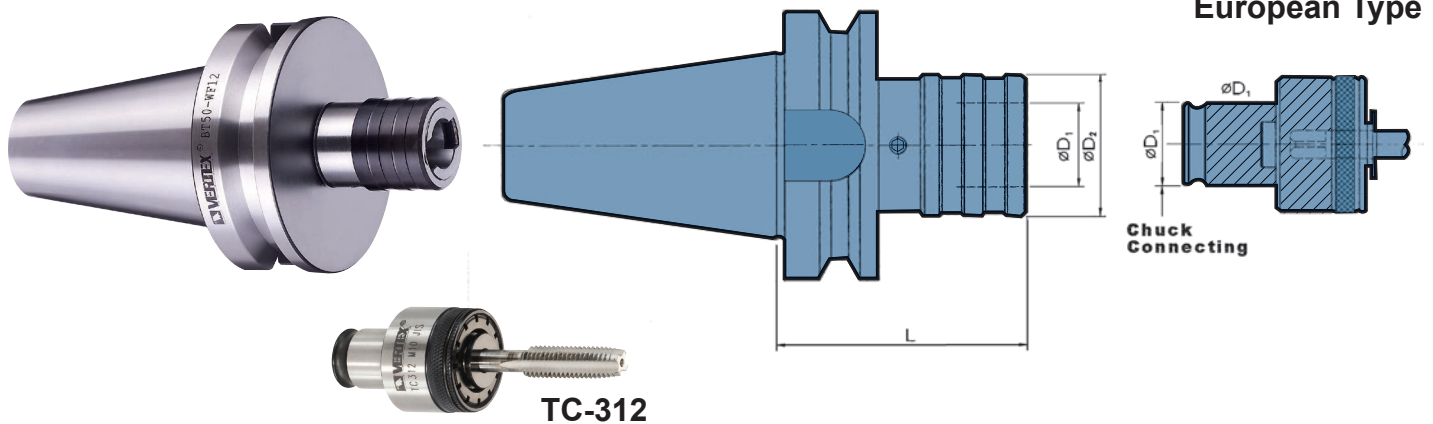

European Type

TC-312

WITH OVERLOAD SAFETY COLLET

- Tension and compression feature allows taps to follow their own thread lead.
- With extreme light compensation compression and tension operated by ball cage.

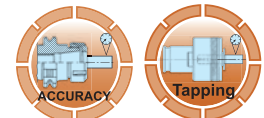

WF-BT50/SK50 LENGTH COMPENSATION TYPE

ORDER NO.	Thread Size	L	ØD1 Chuck Connecting DIA.	ØD2	Length Compensation		Collets	WEIGHT (kg)	CODE NO.
					Compression	Tension			
BT50-WF12	M2-M14	85	Ø19	36	7.5	7.5	TC-312	4	3404-060
SK50-WF12								4	3404-061
BT50-WF20	M5-M24	85	Ø31	53	12.5	12.5	TC-820	4.1	3404-062
SK50-WF20								4.1	3404-063
BT50-WF33	M14-M36	142	Ø48	78	20	20	TC-1433	5.8	3404-064

※Tapping Collet Reducer Adapter : TC820 / TC312-AD TC1433 / TC820-AD



Quick Change Tapping Chucks



QUICK CHANGE TAPPING CHUCKS (with length compensation)

STRAIGHT SHANK

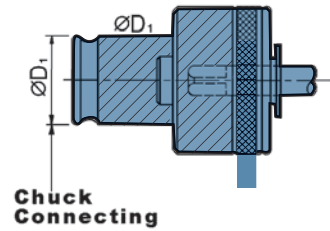
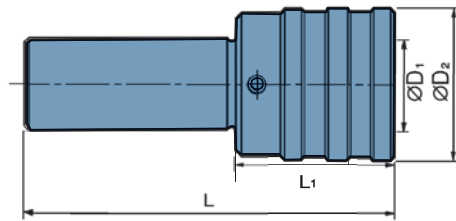

WITH OVERLOAD SAFETY COLLET



TC-312

- Tension and compression feature allows taps to follow their own thread lead.
- With extreme light compensation compression and tension operated by ball cage.

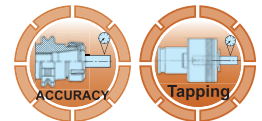

TAPPING CHUCKS

WF-ST LENGTH COMPENSATION TYPE

ORDER NO.	Thread Size	L	L ₁	ØD ₁ Chuck Connecting DIA.	ØD ₂	Length Compensation		Collets	WEIGHT (kg)	CODE NO.
						Compression	Tension			
ST20-WF12	M2-M14	105	40	Ø19	36	7.5	7.5	TC-312	0.4	3404-087
ST32-WF12									0.6	3404-088
ST20-WF20	M5-M24	120	65	Ø31	53	12.5	12.5	TC-820	1	3404-089

※Tapping Collet Reducer Adapter : TC820 / TC312-AD TC1433 / TC820-AD



Quick Change Tapping Chucks

Solid Type

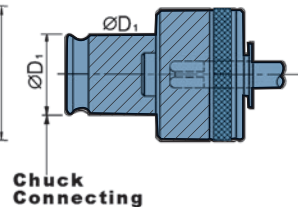
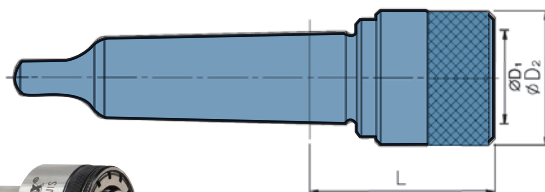

WITH OVERLOAD SAFETY COLLET



TC-312

- Tension and compression feature allows taps to follow their own thread lead.
- With extreme light compensation compression and tension operated by ball cage.

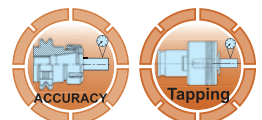

WF-MT LENGTH COMPENSATION TYPE

ORDER NO.	Thread Size	Morse Taper MT	L	ØD ₁ Chuck Connecting DIA.	ØD ₂	Length Compensation		Collets	WEIGHT (kg)	CODE NO.
						Compression	Tension			
MT2-WF12	M2-M14	MT2	47.5	Ø19	36	7.5	7.5	TC-312	0.4	3404-123
MT3-WF12		MT3							0.56	3404-123A
MT4-WF12		MT4	49						0.86	3404-123B
MT2-WF20	M5-M24	MT2	70	Ø31	53	12.5	12.5	TC-820	0.8	3404-124
MT3-WF20		MT3							0.96	3404-124A
MT4-WF20		MT4							1.5	3404-124B
MT4-WF33	M14-M36	MT4	103	Ø48	78	20	15	TC-1433	2.76	3404-125

※Tapping Collet Reducer Adapter : TC820 / TC312-AD TC1433 / TC820-AD



Quick Change Tapping Chucks



QUICK CHANGE TAPPING CHUCKS (with length compensation)

MAS-BT SHANK / DIN69871A SHANK

- Tension and compression feature allows taps to follow their own thread lead.

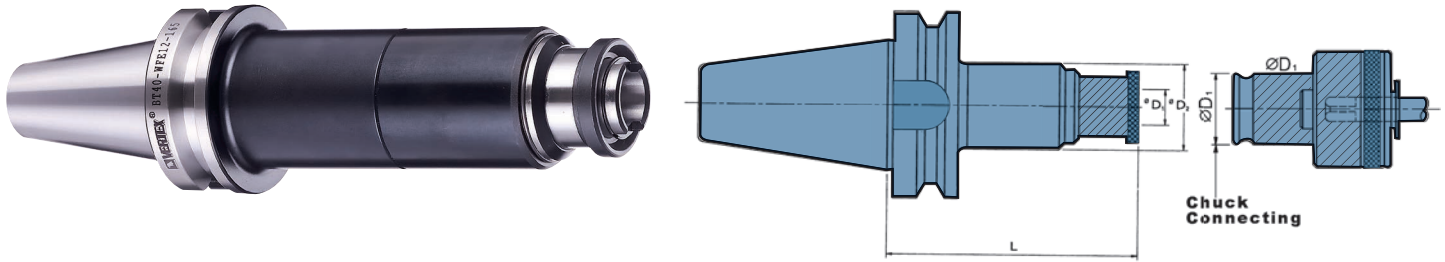

WITH OVERLOAD SAFETY COLLET



TC-312

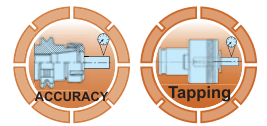

WFE-BT40 LENGTH COMPENSATION TYPE

ORDER NO.	Thread Size	L	ØD ₁ Chuck Connecting DIA.	ØD ₂	Length Compensation		Collets	WEIGHT (kg)	CODE NO.
					Compression	Tension			
BT40-WFE12-135	M2-M14	135	Ø19	46	15	20	TC-312	1.5	3404-070
BT40-WFE12-165		165							

※Tapping Collet Reducer Adapter : TC820 / TC312-AD TC1433 / TC820-AD



Quick Change Tapping Chucks

QUICK CHANGE TAPPING CHUCKS (with length compensation)

MAS-BT SHANK / DIN69871A SHANK

- Tension and compression feature allows taps to follow their own thread lead.

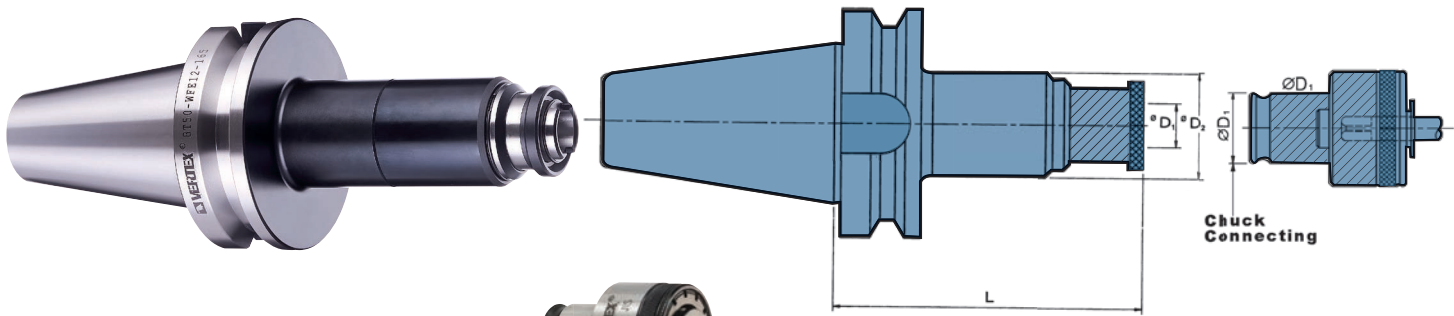

WITH OVERLOAD SAFETY COLLET



TC-312

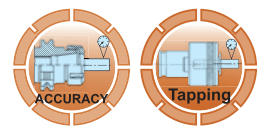

WFE-BT50 LENGTH COMPENSATION TYPE

ORDER NO.	Thread Size	L	ØD ₁ Chuck Connecting DIA.	ØD ₂	Length Compensation		Collets	WEIGHT (kg)	CODE NO.
					Compression	Tension			
BT50-WFE12-135	M2-M14	135	Ø19	46	15	20	TC-312	4.54	3404-080
BT50-WFE12-165		165							
BT50-WFE20-165	M5-M24	165	Ø31	58	15	15	TC-820	7	3404-084

※Tapping Collet Reducer Adapter : TC820 / TC312-AD TC1433 / TC820-AD



Quick Change Tapping Chucks



MSA-BT SHANK & DIN 69871A SHANK

Solid Type

- No tension or compensation stroke for use in synchronous tapping(rigid tapping) cycle.

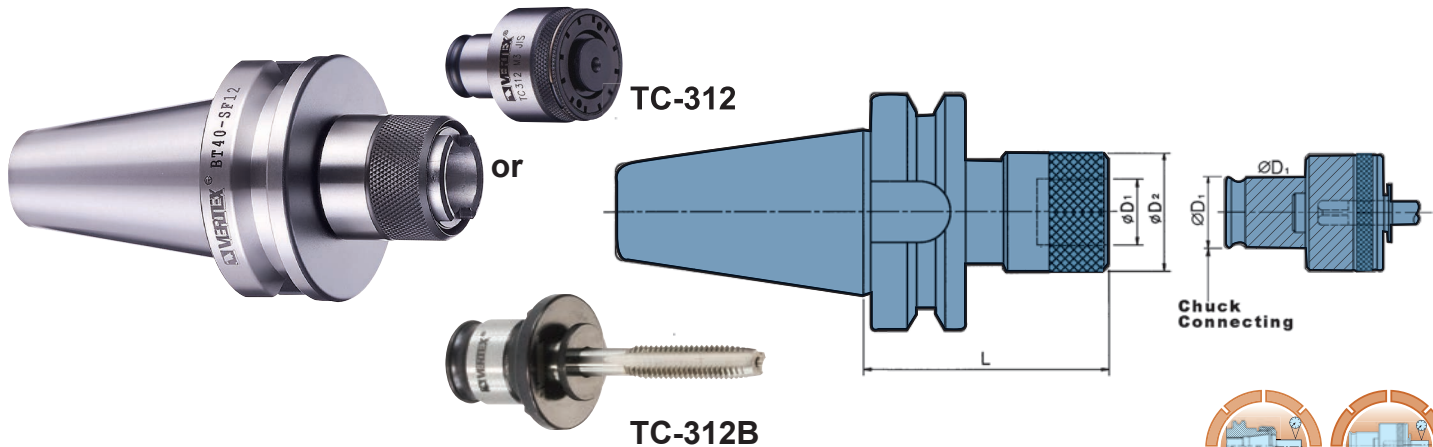

TAPPING CHUCKS

BT40-SF- RIGID TAPPING TYPE , NO LENGTH COMPENSATION

ORDER NO.	Thread Size	L	ØD ₁ Chuck Connecting DIA.	ØD ₂	Collets	WEIGHT (kg)	CODE NO.
BT40-SF12	M2-M14	72	Ø19	34	TC-312 TC-312B	1	3404-100
BT40-SF20	M5-M24	91	Ø31	50	TC-820 TC-820B	1.4	3404-102
BT40-SF33	M14-M36	130	Ø48	74	TC-1433 TC-1433B	3.5	3404-104

※Tapping Collet Reducer Adapter : TC820 / TC312-AD TC1433 / TC820-AD



Quick Change Tapping Chucks

MSA-BT SHANK & DIN 69871A SHANK

Solid Type

- No tension or compensation stroke for use in synchronous tapping(rigid tapping) cycle.

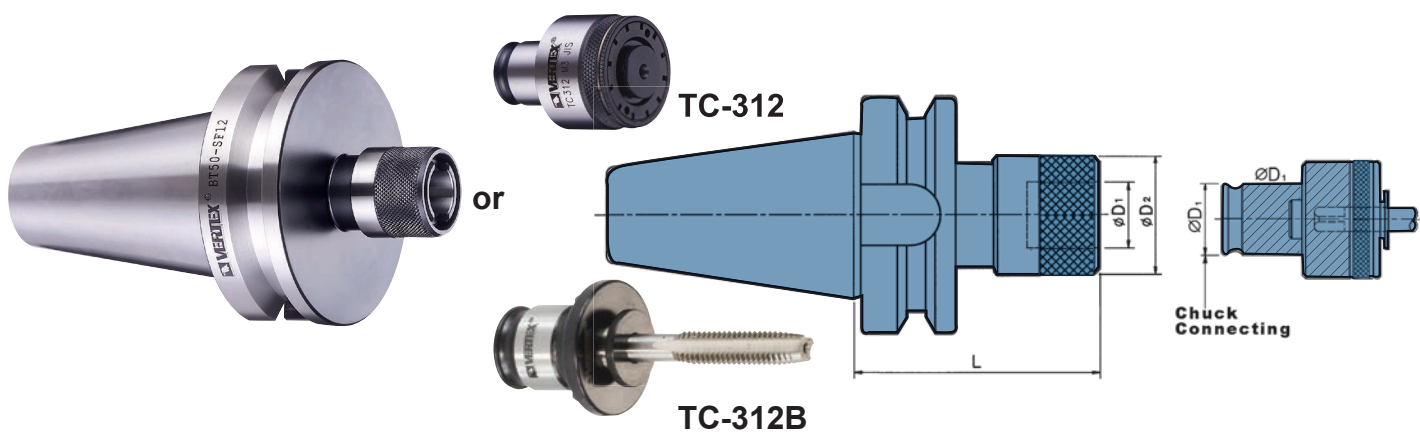

BT50-SF- RIGID TAPPING TYPE, NO LENGTH COMPENSATION

ORDER NO.	Thread Size	L	ØD ₁ Chuck Connecting DIA.	ØD ₂	Collets	WEIGHT (kg)	CODE NO.
BT50-SF12	M2-M14	78	Ø19	34	TC-312 TC-312B	3.6	3404-110
BT50-SF20	M5-M24	95	Ø31	50	TC-820 TC-820B	4	3404-112
BT50-SF33	M14-M36	142	Ø48	74	TC-1433 TC-1433B	5.6	3404-116

※Tapping Collet Reducer Adapter : TC820 / TC312-AD TC1433 / TC820-AD



Quick Change Tapping Chucks



QUICK CHANGE TAPPING CHUCKS

Solid Type

MORSE TAPER SHANK

- Tension and compression feature allows taps to follow their own thread lead.
- With extreme light compensation compression and tension operated by ball cage.

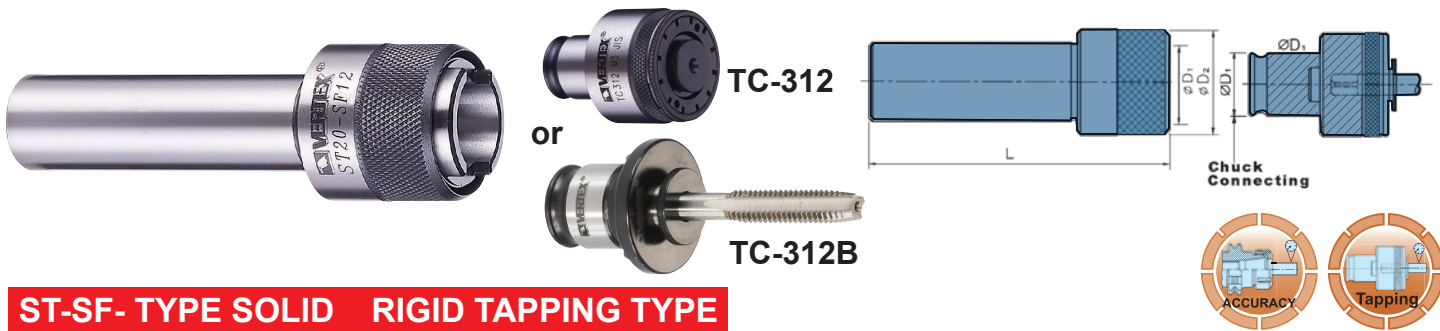

ST-SF- TYPE SOLID RIGID TAPPING TYPE

ORDER NO.	Thread Size	L	L ₁	ØD ₁ Chuck Connecting DIA.	ØD ₂	Collets	WEIGHT (kg)	CODE NO.
ST20-SF12	M2-M14	104	70	Ø19	34	TC-312	0.3	3404-140
ST32-SF12		106		Ø19		TC-312B	0.66	3404-140A
ST20-SF20	M5-M24	105		Ø31	50	TC-820 TC-820B	0.74	3404-141
ST32-SF33	M14-M36	169		Ø48	76	TC-1433 TC-1433B	2.86	3404-142A

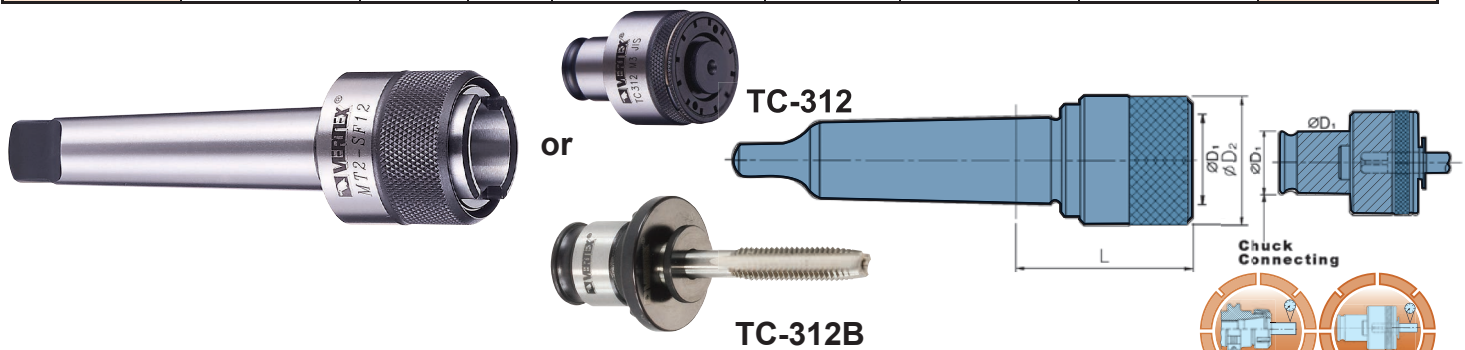

MT-SF- TYPE SOLID RIGID TAPPING TYPE, NO LENGTH COMPENSATION

ORDER NO.	Thread Size	Morse Taper MT	L	ØD ₁ Chuck Connecting DIA.	ØD ₂	Collets	WEIGHT (kg)	CODE NO.
MT2-SF12	M2-M14	MT2	45	Ø19	34	TC-312 TC-312B	0.3	3404-120
MT3-SF12		MT3					0.8	3404-120A
MT4-SF12		MT4					0.8	3404-120B
MT2-SF20	M5-M24	MT2	70	Ø31	50	TC-820 TC-820B	0.6	3404-121A
MT3-SF20		MT3					0.8	3404-121
MT4-SF20		MT4					1.18	3404-121B
MT3-SF33	M14-M36	MT3	99	Ø48	74	TC-1433 TC-1433B	0.84	3404-122A
MT4-SF33		MT4	99				2.2	3404-122

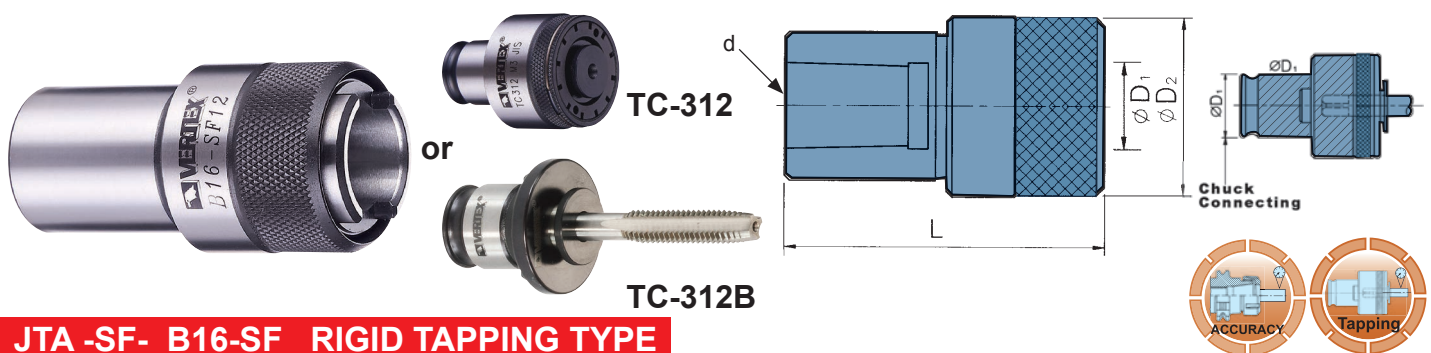

JTA -SF- B16-SF RIGID TAPPING TYPE

ORDER NO.	Thread Size	L	ØD ₁ Chuck Connecting DIA.	ØD ₂	d	Collets	WEIGHT (kg)	CODE NO.
JTA6-SF12	M2-M14	66	Ø19	32	JT6	TC-312 TC-312B	0.3	3404-130
B16-SF12					B16		0.22	3404-130A
B12-SF12					B12		0.2	3404-130B

※Tapping Collet Reducer Adapter : TC820 / TC312-AD TC1433 / TC820-AD



Quick Change Tapping Chucks Set



Shank with length compensation

European Type

NEW



SET TYPE BT-WF
SHANK WITH 7 PCS/SET OVERLOAD CLUTCH
TAPPING COLLET DIN, ISO & JIS SYSTEMS:
PLEASE SEE PAGE 121.

- Tension and compression feature allows taps to follow their own thread lead.
- With extreme light compensation compression and tension operated by ball cage.



Collets Size	
TC-312	M3, M4, M5, M6, M8, M10, M12
TC-820	M8, M10, M12, M14, M16, M18, M20

Please inform the collet size when ordering.
Please use following page as reference for collet size.

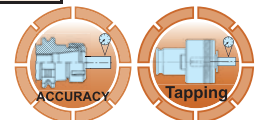

TAPPING CHUCKS

SETS

ORDER NO.	Shank Size	Thread Size	L	ØD1	ØD2	Length Compensation		Collets	PCS/SET	CODE NO.
						Compression	Tension			
VQT-312	BT-30-WF12	M3-M12	70	19	36	7.5	7.5	TC-312	7PCS	3404-190
VQT-320	BT-30-WF20	M8-M20	105	31	53	12.5	12.5	TC-820	7PCS	3404-191
VQT-412	BT-40-WF12	M3-M12	75	19	36	7.5	7.5	TC-312	7PCS	3404-192
VQT-420	BT-40-WF20	M8-M20	95	31	53	12.5	12.5	TC-820	7PCS	3404-193
VQT-512	BT-50-WF12	M3-M12	85	19	36	7.5	7.5	TC-312	7PCS	3404-194
VQT-520	BT-50-WF20	M8-M20	105	31	53	12.5	12.5	TC-820	7PCS	3404-195



Quick Change MT Tapping Chuck Set

With Overload Clutch

NEW



- Tension and compression feature allows taps to follow their own thread lead.
- With extreme light compensation compression and tension operated by ball cage.

SET TYPE MT-SF
SHANK WITH 7 PCS/SET OVERLOAD CLUTCH
TAPPING COLLET DIN, ISO & JIS SYSTEMS:
PLEASE SEE PAGE 121.

Collets Size	
TC-312	M3, M4, M5, M6, M8, M10, M12
TC-820	M8, M10, M12, M14, M16, M18, M20

Please inform the collet size when ordering.
Please use following page as reference for collet size.

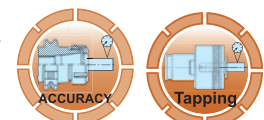

SETS

ORDER NO.	Shank Size	Thread Size	L	ØD2	Collets	PCS/SET	CODE NO.
VQT-712	MT3-SF12	M3-M12	39	32	TC-312	7PCS	3404-196
VQT-812	MT4-SF12	M3-M12	34	32	TC-312	7PCS	3404-197
VQT-720	MT3-SF20	M8-M20	59	50	TC-820	7PCS	3404-198
VQT-820	MT4-SF20	M8-M20	55	50	TC-820	7PCS	3404-199



Tapping Collet Reducer Adapter



This adapter is for transforming
This adapter allows the tapping chuck to use smaller size.
Transforming the big tapping size to smaller one.
large range type for tap M3~M24, TC312, TC820, TC1433
COST SAVING!

SIZE CONVERTER

ORDER NO.	TRANSFORMING SIZE	WIGHT	CODE NO.
TC820/TC312-AD	TC820 TO TC312	0.2	3404-461
TC1433/TC820-AD	TC1433 TO TC820	0.6	3404-462

※ Every tap needs a match size tapping collet.



Adjustable Wrenches

For Tapping Collet's Torque Force Adjustment

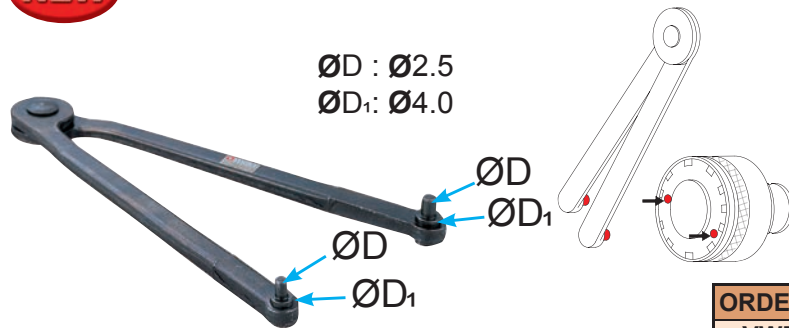

- Tool for Setting
- Time Saving

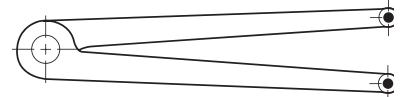

EXAMPLE



ORDER NO.	SIZE	ØD	COLLETS	WEIGHT	CODE NO.
VWR-40	7-40	2.5	TC-820	0.15 kgs	3404-150
VWR-60	11-60	4	TC-1433	0.15 kgs	3404-151



Quick Change Tapping Collet TC312 8PCS/SET

ORDER NO. TC-312-DIN371-A

CODE NO. 3404-175



QUICK CHANGE TAP COLLETS
(with overload safety collet)

TC-312 DIN371 8PCS/SET
(M1, M2, M3, M3.5, M4, M4.5, M8, M10)

NO.	ØD X □ SIZE SAME AS DIN371 TC312
1	M1, M1.1~M1.8
2	M2, M2.5, M2~M2.5
3	M3
4	M3.5
5	M4
6	M4.5, M5, M6
7	M8
8	M10



Quick Change Tapping Collet TC312 8PCS/SET

ORDER NO. TC-312-DIN376-B

CODE NO. 3404-176



QUICK CHANGE TAP COLLETS
(with overload safety collet)

TC-312 DIN376 8PCS/SET
(M4, M5, M6, M7, M8, M10, M12 M14)

NO.	ØD X □ SIZE SAME AS DIN376 TC312
1	M4
2	M5, M4.5
3	M6
4	M7
5	M8
6	M10
7	M12
8	M14



Quick Change Tapping Collet TC820 8PCS/SET



ORDER NO. TC820-DIN 376-C

CODE NO. 3404-177

NEW

**QUICK CHANGE TAP COLLETS
(with overload safety collet)**



**TC-820 DIN376 8PCS/SET
(M8, M10, M12, M14, M16, M18, M20, M22)**

NO.	ØD X □ SIZE SAME AS DIN376 TC820
1	M8
2	M10
3	M12
4	M14
5	M16
6	M18
7	M20
8	M22, M24

TAPPING CHUCKS



Quick Change Tapping Collet TC820 4PCS/SET

ORDER NO. TC820-DIN 371-D

CODE NO. 3404-178

NEW

**QUICK CHANGE TAP COLLETS
(with overload safety collet)**



**TC-820 DIN371 4PCS/SET
(M5, M6, M8, M10)**

NO.	ØD X □ SIZE SAME AS DIN371 TC820
1	M5, M6
2	M6, M5
3	M8
4	M10



Quick Change Tapping Collet TC820 8PCS/SET

ORDER NO. TC820-ISO2283-E

CODE NO. 3404-179

NEW

**QUICK CHANGE TAP COLLETS
(with overload safety collet)**



**TC-820 ISO2283 8PCS/SET
(M8, M10, M12, M14, M16, M18, M22, M24)**

NO.	ØD X □ SIZE SAME AS ISO2283 TC820
1	M8
2	M10
3	M12
4	M14
5	M16
6	M18, M20
7	M22
8	M24



Quick Change Tapping Collet



QUICK CHANGE TAP COLLETS
(with overload safety collet)

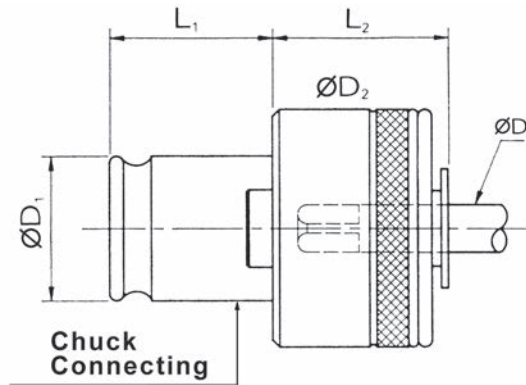

CHUCK SUIT FOR DIA. ØD1
 TC-312,312B IS Ø19 MM
 TC-820,820B IS Ø31 MM
 TC-1433,1433B IS Ø48 MM

- Torque is factory-set to protect the tap. Small adjustments can be made by a trained user to accommodate tap strength and material variations.
- Collet stops driving when set torque is exceeded.
- Every tap needs a match size tapping collet.
- ØD1 is chuck suit for dia.

Tapping Collet Reducer / Adapter

This adapter is for transforming
 This adapter allows the VAT-tapping spindle to use smaller size.
 Transforming the big tapping size to smaller one.

Large range type for tap M3~M24,
 TC312, TC820, TC1433
COST SAVING!
 Please see the page C121



Connecting Size List

QUICK CHANGE TAP COLLETS
(with overload safety collet)

JIS SYSTEM SIZE ※ORDER NO. SAME COLOR ARE INTER-CHANGEABLE



1PC ≒ 0.18kg

Size	Thread	Tap Shank		Ø D1	L1	L2	ORDER NO.	CODE NO.	ØD x □ Size same as JIS inch or mm
		ØD	□						
TC 312 (#1)	M2	3	2.5	Suit for DIA. 19	22	25	312-00	3404-200A	
	M3	4	3.2				312-01	3404-200	W1/8"
	M4	5	4				312-02	3404-201	M4.5
	M5	5.5	4.5				312-03	3404-202	M5.5, W3/16"
	M6	6	4.5				312-04	3404-203	W1/4", UNC1/4"
	M7	6.2	5				312-05	3404-204	M8
	M8	6.2	5				312-06	3404-205	M7
	M9	7	5.5				312-07	3404-206	M10, W3/8", UNC3/8"
	M10	7	5.5				312-08	3404-207	M9, W3/8", UNC3/8"
	M11	8	6				312-09	3404-208	W7/16", PT1/8", PS1/8", PF1/8", UNC7/16"
	M12	8.5	6.5				312-10	3404-209	
	•M14	10.5	8				•312-11	3404-210	M15, W9/16", UNC9/16"
	•M15	10.5	8				•312-12	3404-211	M14, W9/16", UNC9/16"
	UNC 1/4	6	4.5				312-13	3404-212	M6, W1/4"
	UNC 5/16	6.1	5				312-14	3404-213	
	UNC 3/8	7	5.5				312-15	3404-214	M9, M10, W3/8"
	UNC 7/16	8	6				312-16	3404-215	M11, W7/16", PT1/8", PS1/8", PF1/8"
	UNC 1/2	9	7				312-17	3404-216	W1/2"
	•UNC 9/16	10.5	8				•312-18	3404-217	M14, M15, W9/16"
	PT 1/8	8	6				312-19	3404-218	M11, W7/16, PS1/8", PF1/8", UNC7/16"
PT 1/4	11	9	312-20	3404-219	PS1/4, PF1/4				

Matching Size List



JIS SYSTEM SIZE

• TORQUE LIMIT TC-820 100 kgf
 ※ORDER NO. SAME COLOR ARE INTER-CHANGEABLE

1PC ≒ 0.6kg

Size	Thread	Tap Shank		ØD1	L1	L2	ORDER NO.	CODE NO.	ØD x □ Size same as JIS inch or mm
		ØD	□						
TC820 (#2)	M6	6	4.5	Suit for DIA. 31	36	30.5	820-00A	3404-228	W1/4", UNC1/4"
	M7	6.2	5				820-01	3404-230	M8
	M8	6.2	5				820-02	3404-231	M7
	M9	7	5.5				820-03	3404-232	M10, W3/8", UNC3/8"
	M10	7	5.5				820-04	3404-233	M9, W3/8", UNC3/8"
	M11	8	6				820-05	3404-234	W7/16", UNC7/16", PT1/8", PS1/8", PF1/8"
	M12	8.5	6.5				820-06	3404-235	
	M14	10.5	8				820-07	3404-226	M15, W9/16", UNC9/16"
	M15	10.5	8				820-08	3404-237	M14, W9/16", UNC9/16"
	M16	12.5	10				820-09	3404-238	
	M18	14	11				820-11	3404-240	W3/4", PT3/8", PS3/8", PF3/8", UNC3/4"
	M20	15	12				820-12	3404-241	
	M22	17	13				820-13	3404-242	W7/8", UNC7/8"
	UNC 3/8	7	5.5				820-14	3404-243	M9, M10, W3/8"
	UNC 7/16	8	6				820-15	3404-244	M11, W7/16", PT1/8", PS1/8", PF1/8"
	UNC 1/2	9	7				820-16	3404-245	W1/2"
	UNC 9/16	10.5	8				820-17	3404-246	M14, M15, W9/16"
	UNC 5/8	12	9				820-18	3404-247	W5/8"
	UNC 3/4	14	11				820-19	3404-248	M18, W3/4", PT3/8", PS3/8", PF3/8"
	UNC 7/8	17	13				820-20	3404-249	M22, W7/8"
	PT 1/8	8	6				820-21	3404-250	M11, W7/16", UNC7/16", PS1/8", PF1/8"
	PT 1/4	11	9				820-22	3404-251	PS1/4", PF1/4"
	PT 3/8	14	11				820-23	3404-252	M18, W3/4", PS3/8", PF3/8", UNC3/4"
	PT 1/2	18	14				820-24	3404-253	PS1/2", PF1/2"
	M24	19	15				820-25	3404-254	M25, PF5/8"

TAPPING CHUCKS

JIS SYSTEM SIZE

※ORDER NO. SAME COLOR ARE INTER-CHANGEABLE
 • TORQUE LIMIT TC-1433 700 kgf

1PC ≒ 1.8kg

Size	Thread	Tap Shank		ØD1	L1	L2	ORDER NO.	CODE NO.	ØD x □ Size same as JIS inch or mm
		ØD	□						
TC1433 (#3)	M15	10.5	8	Suit for DIA. 48	56	45	1433-02	3404-261	M14, W9/16", UNC9/16"
	M16	12.5	10				1433-03	3404-262	
	M20	15	12				1433-06	3404-265	
	M24	19	15				1433-08	3404-267	M25, PF5/8"
	M26	20	15				1433-10	3404-269	M27, W1", UNC1"
	M33	25	19				1433-15	3404-274	



Quick Change Tapping Collet



※ORDER NO. SAME COLOR ARE INTER-CHANGEABLE

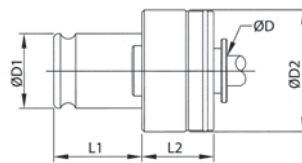

- Torque is factory-set to protect the tap for which a particular collet is designed. Small adjustments can be made by a trained user to accommodate tap strength and material variations.
- Collet stops driving when set torque is exceeded.
- Every tap needs a match size tapping collet.
- ØD1 is chuck suit for dia.

With Overload Safety Collet (With Clutch)



DIN 371 Type

ORDER NO.	Size	TC312 DIN 371 Tap	Tap Shank		Capacity	L1 (m/m)	L2 (m/m)	ØD1 (m/m)	ØD2 (m/m)	CODE NO.	ØD x □ Size same as DIN 371
			ØD	□							
312-01D	TC 312 DIN 371	M1~M1.8	2.5	2.1	M1~M14	22.5	25	Suit for DIA. 19	32	3404-501	
312-02D		M2~M2.5	2.8	2.1						3404-502	M2,M2.5
312-02DA		M2	2.8	2.1						3404-502A	M2~M2.5,M2.5
312-02DB		M2.5	2.8	2.1						3404-502B	M2,M2~M2.5
312-03D		M3	3.5	2.7						3404-503	
312-04D		M3.5	4.0	3.0						3404-504	
312-05D		M4	4.5	3.4						3404-505	
312-06D		M4.5	6.0	4.9						3404-506	M5,M6
312-07D		M5	6.0	4.9						3404-507	M4.5,M6
312-08D		M6	6.0	4.9						3404-508	M4.5,M5
312-09D	M8	8.0	6.2	3404-509							
312-10D	M10	10.0	8.0	3404-510							
ORDER NO.	Size	TC820 DIN 371 Tap	Tap Shank		Capacity	L1 (m/m)	L2 (m/m)	ØD1 (m/m)	ØD2 (m/m)	CODE NO.	ØD x □ Size same as DIN 371
			ØD	□							
820-01D	TC 820 DIN 371	M5	6.0	4.9	M5~M24	35	30.5	Suit for DIA. 31	50	3404-521	M6
820-02D		M6	6.0	4.9						3404-522	M5
820-03D		M8	8.0	6.2						3404-523	
820-04D		M10	10.0	8.0						3404-524	

DIN 376 Type

*Custom-build products are available on request.

ORDER NO.	Size	TC312 DIN 376 Tap	Tap Shank		Capacity	L1 (m/m)	L2 (m/m)	ØD1 (m/m)	ØD2 (m/m)	CODE NO.	ØD x □ Size same as DIN 376
			ØD	□							
312-21D	TC 312 DIN 376	M3.5	2.5	2.1	M3~M14	22.5	25	Suit for DIA. 19	32	3404-531	
312-22D		M4	2.8	2.1						3404-532	
312-23D		M4.5	3.5	2.7						3404-533	M5
312-24D		M5	3.5	2.7						3404-534	M4.5
312-25D		M6	4.5	3.4						3404-535	
312-26D		M7	5.5	4.3						3404-536	
312-27D		M8	6.0	4.9						3404-537	
312-28D		M10	7.0	5.5						3404-538	
312-29D		M12	9.0	7.0						3404-539	
312-30D		M14	11.0	9.0						3404-540	
ORDER NO.	Size	TC820 DIN 376 Tap	Tap Shank		Capacity	L1 (m/m)	L2 (m/m)	ØD1 (m/m)	ØD2 (m/m)	CODE NO.	ØD x □ Size same as DIN 376
			ØD	□							
820-21D	TC 820 DIN 376	M8	6.0	4.9	M8~M24	35	30.5	Suit for DIA. 31	50	3404-551	
820-22D		M10	7.0	5.5						3404-552	
820-23D		M12	9.0	7.0						3404-553	
820-24D		M14	11.0	9.0						3404-554	
820-25D		M16	12.0	9.0						3404-555	
820-26D		M18	14.0	11.0						3404-556	
820-27D		M20	16.0	12.0						3404-557	
820-28D		M22	18.0	14.5						3404-558	M24
820-29D		M24	18.0	14.5						3404-559	M22
ORDER NO.		Size	TC1433 DIN 376 Tap	Tap Shank						Capacity	L1 (m/m)
			ØD	□							
1433-01D	TC 1433 DIN 376	M14	11.0	9.0	M14~M36	55.5	45	Suit for DIA. 48	72	3404-571	
1433-02D		M16	12.0	9.0						3404-572	
1433-03D		M18	14.0	11.0						3404-573	
1433-04D		M20	16.0	12.0						3404-574	
1433-05D		M22	18.0	14.5						3404-575	M24
1433-06D		M24	18.0	14.5						3404-576	M22
1433-07D		M27	20.0	16.0						3404-577	
1433-08D		M30	22.0	18.0						3404-578	
1433-09D		M33	25.0	20.0						3404-579	
1433-10D		M36	28.0	22.0						3404-580	



Quick Change Tapping Collet



※ORDER NO. SAME COLOR ARE INTER-CHANGEABLE

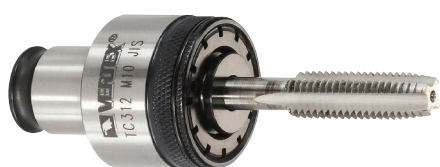

TC-312

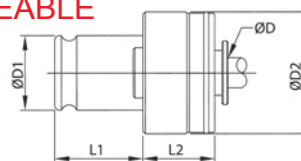

With Overload Safety Collet



ISO 529/2283 Type

*Custom-build products are available on request.

ORDER NO.	Size	TC312 ISO 529/2283 Tap	Tap Shank		Capacity	L1 (m/m)	L2 (m/m)	ØD1 (m/m)	ØD2 (m/m)	CODE NO.	ØD x □ Size same as ISO 529
			ØD	□							
312-21I	TC 312 ISO 529/2283	M3	2.24	1.8	M3~M14	22.5	25	Suit for DIA. 19	32	3404-631	
312-22I		M3.5	2.5	2.0						3404-632	M1~M2,M2
312-23I		M4	3.15	2.5						3404-633	M3
312-24I		M4.5	3.55	2.8						3404-634	M3.5
312-25I		M5	4.0	3.15						3404-635	M4
312-26I		M6	4.5	3.55						3404-636	M4.5
312-27I		M7	5.6	4.5						3404-637	
312-28I		M8	6.3	5.0						3404-638	M6
312-29I		M9	7.1	5.6						3404-639	M7
312-30I		M10	8.0	6.3						3404-640	M8
312-31I		M12	9.0	7.1						3404-641	M9
312-32I		M14	11.2	9.0						3404-642	

ORDER NO.	Size	TC820 ISO 529/2283 Tap	Tap Shank		Capacity	L1 (m/m)	L2 (m/m)	ØD1 (m/m)	ØD2 (m/m)	CODE NO.	ØD x □ Size same as ISO 529 / 2283	ØD x □ Size same as ISO 529
			ØD	□								
820-21I	TC 820 ISO 529/2283	M8	6.3	5.0	M8~M24	35	30.5	Suit for DIA. 31	50	3404-651		M6
820-22I		M9	7.1	5.6						3404-652	M7	
820-23I		M10	8.0	6.3						3404-653	M8	
820-24I		M12	9.0	7.1						3404-654	M9	
820-25I		M14	11.2	9.0						3404-655		
820-26I		M16	12.5	10.0						3404-656		
820-27I		M18	14.0	11.2						3404-657	M20	
820-29I		M20	14.0	11.2						3404-658	M18	
820-30I		M22	16.0	12.5						3404-659		
820-31I		M24	18.0	14.0						3404-660		

ISO 529 Type

ORDER NO.	Size	TC312 IOS 529 Tap	Tap Shank		Capacity	L1 (m/m)	L2 (m/m)	ØD1 (m/m)	ØD2 (m/m)	CODE NO.	ØD x □ Size same as ISO 529 / 2283	ØD x □ Size same as ISO 529
			ØD	□								
312-01I	TC 312 ISO 529	M1~M2	2.5	2.0	M1~M14	22.5	25	Suit for DIA. 19	32	3404-601	M3.5	M2
312-01IA		M2	2.5	2.0						3404-601A	M3.5	M1~M2
312-02I		M2.2~M2.5	2.8	2.24						3404-602		M2.5
312-02IA		M2.5	2.8	2.24						3404-602A		M2.2~M2.5
312-03I		M3	3.15	2.5						3404-603	M4	
312-04I		M3.5	3.55	2.8						3404-604	M4.5	
312-05I		M4	4.0	3.15						3404-605	M5	
312-06I		M4.5	4.5	3.55						3404-606	M6	
312-07I		M5	5.0	4.0						3404-607		
312-08I		M6	6.3	5.0						3404-608	M8	
312-09I		M7	7.1	5.6						3404-609	M9	
312-10I		M8	8.0	6.3						3404-610	M10	
312-11I		M9	9.0	7.1						3404-611	M12	
312-12I	M10	10.0	8.0	3404-612								

ORDER NO.	Size	TC820 ISO 529 Tap	Tap Shank		Capacity	L1 (m/m)	L2 (m/m)	ØD1 (m/m)	ØD2 (m/m)	CODE NO.	ØD x □ Size same as ISO 529 / 2283
			ØD	□							
820-01I	TC 820 ISO 529	M6	6.3	5.0	M6~M24	35	30.5	Suit for DIA. 31	50	3404-621	M8
820-02I		M7	7.1	5.6						3404-622	M9
820-03I		M8	8.0	6.3						3404-623	M10
820-04I		M9	9.0	7.1						3404-624	M12
820-05I		M10	10.0	8.0						3404-625	

TAPPING CHUCKS



Quick Change Tapping Collet



QUICK CHANGE TAP COLLETS

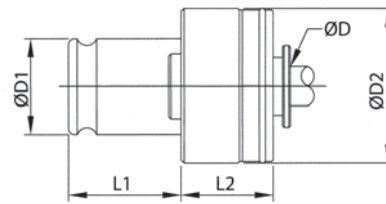
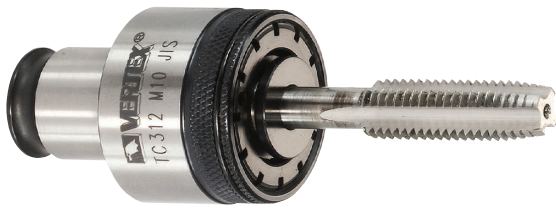

With Overload Safety Collet
(With Clutch)

ANSI TYPE



ORDER NO.	Size	TC312 ANSI Tap	Tap Shank				Capacity	L1 L2 (mm)	ØD1 ØD2 (mm)	CODE NO.	ØD x □ Size same as ANSI			
			ØD		□									
			inch	mm	inch	mm								
TC312-#5-ANSI	TC312 ANSI	#5	0.141	3.581	0.11	2.794	#5~#14	21.5	Suit for DIA. 19.0	3404-701	UNC1/8", M3, M3.15			
TC312-#6-ANSI		#6	0.141	3.581	0.11	2.794				3404-702	M3.5			
TC312-#8-ANSI		#8	0.168	4.267	0.131	3.327				3404-703	UNC5/32", M4			
TC312-#10-ANSI		#10	0.194	4.928	0.152	3.861				3404-704	UNC3/16", M4.5, M5			
TC312-#12-ANSI		#12	0.220	5.588	0.165	4.191				3404-705				
TC312-#14-ANSI		#14	0.255	6.477	0.191	4.851				3404-706	UNC1/4", M6, M6.3			
TC312-M3-ANSI		M3	0.141	3.581	0.11	2.794				M3~M14	25.0	32.0	3404-707	#5, UNC1/8", M3, M3.15
TC312-M4-ANSI		M4	0.168	4.267	0.131	3.327							3404-708	#8, UNC5/32"
TC312-M5-ANSI		M5	0.194	4.928	0.52	3.861							3404-709	#10, UNC3/16", M4.5
TC312-M6-ANSI		M6	0.255	6.477	0.191	4.851							3404-710	#14, UNC1/4", M6.3
TC312-M8-ANSI		M8	0.318	8.077	0.238	6.045	3404-711	UNC5/16", M7						
TC312-M10-ANSI		M10	0.323	8.204	0.242	6.147	3404-712	UNC7/16"						
TC312-M12-ANSI		M12	0.367	9.322	0.275	6.985	3404-713	UNC1/2", M12.5						
TC312-M14-ANSI		M14	0.429	10.897	0.322	8.179	3404-714	UNC9/16"						
TC312-UNC1/8-ANSI		UNC1/8	0.141	3.581	0.11	2.794	UNC1/8 ~ UNC3/8	25.0	32.0				3404-715	#5, M3, M3.15
TC312-UNC3/16-ANSI		UNC3/16	0.194	4.928	0.152	3.861							3404-716	#10, M4.5, M5
TC312-UNC1/4-ANSI		UNC1/4	0.255	6.477	0.191	4.851				3404-717	#14, M6, M6.3			
TC312-UNC5/16-ANSI		UNC5/16	0.318	8.077	0.238	6.045				3404-718	M7, M8			
TC312-UNC7/16-ANSI		UNC7/16	0.323	8.204	0.242	6.147				3404-719	M10			
TC312-UNC1/2-ANSI		UNC1/2	0.367	9.322	0.275	6.985				3404-720	M12, M12.5			
TC312-UNC3/8-ANSI	UNC3/8	0.381	9.677	0.286	7.264			3404-721						

ANSI TYPE

ORDER NO.	Size	TC820 ANSI Tap	Tap Shank				Capacity	L1 L2 (mm)	ØD1 ØD2 (mm)	CODE NO.	ØD x □ Size same as ANSI
			ØD		□						
			inch	mm	inch	mm					
TC820-UNC7/16-ANSI	TC820 ANSI	UNC7/16	0.323	8.204	0.242	6.147	UNC7/16 ~ UNC13/16	Suit for DIA. 31.0	3404-731	M10	
TC820-UNC1/2-ANSI		UNC1/2	0.367	9.322	0.275	6.985			3404-732	M12, M12.5	
TC820-UNC9/16-ANSI		UNC9/16	0.429	10.897	0.322	8.179			3404-734	M14	
TC820-UNC5/8-ANSI		UNC5/8	0.480	12.192	0.36	9.144			3404-735	M16	
TC820-UNC11/16-ANSI		UNC11/16	0.542	13.767	0.406	10.312			3404-736	M18	
TC820-UNC13/16-ANSI		UNC13/16	0.652	16.561	0.489	12.421			3404-738	M20	

ISO 529 UNC TYPE

ORDER NO.	Size	TC312 ISO Tap	Tap Shank		Capacity	L1 L2 (mm)	ØD1 ØD2 (mm)	CODE NO.	ØD x □ Size same as
			ØD	□					
			mm	mm					
TC312-UNC1/4-ISO	TC312 ISO529	UNC1/4	4.5	3.55	UNC1/4 ~ UNC1/2	21.5	Suit for DIA. 19.0	3404-751	
TC312-UNC5/16-ISO		UNC5/16	6.3	5				3404-752	
TC312-UNC3/8-ISO		UNC3/8	7.1	5.6				3404-753	
TC312-UNC7/16-ISO		UNC7/16	8	6.3				3404-754	
TC312-UNC1/2-ISO		UNC1/2	9	7.1				3404-755	



Quick Change Tapping Collet



**QUICK CHANGE TAP COLLETS
WITHOUT CLUTCH**

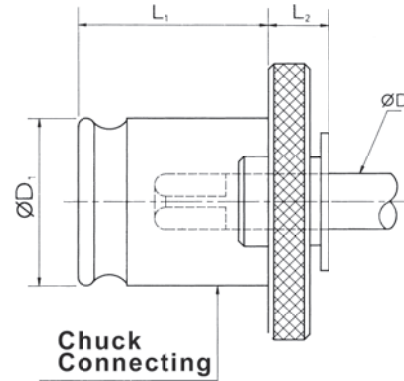

TAPPING CHUCKS

JIS SYSTEM SIZE

1PC ≒ 0.08kg

Size	Thread	Tap Shank		ØD1	L1	L2	ORDER NO.	CODE NO.	ØD x □ Same JIS inch or mm
		ØD	□						
TC312B (#1)	M3	4	3.2	Suit for DIA. 19	21.5	7	312B-01	3404-300	W1/8"
	M4	5	4				312B-02	3404-301	M4.5
	M5	5.5	4.5				312B-03	3404-302	M5.5, W3/16"
	M6	6	4.5				312B-04	3404-303	W1/4", UNC1/4"
	UNC 5/16	6.1	5				312B-05	3404-304	
	M7/M8	6.2	5				312B-06	3404-305	
	M9/M10	7	5.5				312B-07	3404-306	W3/8", UNC3/8"
	M11	8	6				312B-08	3404-307	W7/16", PT1/8", PS1/8", PF1/8", UNC7/16"
	M12	8.5	6.5				312B-09	3404-308	
	UNC 1/2	9	7				312B-10	3404-309	W1/2"
	M14	10.5	8				312B-11	3404-310	M15, W9/16"
	PT 1/4	11	9				312B-12	3404-311	PS1/4", PF1/4"

1PC ≒ 0.28kg

Size	Thread	Tap Shank		ØD1	L1	L2	ORDER NO.	CODE NO.	ØD x □ Same JIS inch or mm
		ØD	□						
TC820B (#2)	M7/M8	6.2	5	Suit for DIA. 31	35	11	820B-01	3404-330	
	M9/M10	7	5.5				820B-02	3404-331	W3/8", UNC3/8"
	M11	8	6				820B-03	3404-332	W7/16", UNC7/16", PT1/8", PS1/8", PF1/8"
	M12	8.5	6.5				820B-04	3404-333	
	UNC 1/2	9	7				820B-05	3404-334	W1/2"
	M14	10.5	8				820B-06	3404-335	M15, W9/16", UNC9/16"
	PT 1/4	11	9				820B-07	3404-336	PS1/4", PF1/4"
	UNC 5/8	12	9				820B-08	3404-337	W5/8"
	M16	12.5	10				820B-09	3404-338	
	M18	14	11				820B-11	3404-340	W3/4", PT3/8", PS3/8", PF3/8", UNC3/4"
	M20	15	12				820B-12	3404-341	
	M22	17	13				820B-13	3404-342	W7/8", UNC7/8"
	PT 1/2	18	14				820B-14	3404-343	PS1/2", PF1/2"



Tap Shank Dimensions INT. STD

For Tapping Chuck



JIS STANDARD

METRIC THREAD	INCH THREAD	Ød	□
M3	W 1/8	4	3.2
M4 M4.5		5	4
M5 M5.5		5.5	4.5
M6	W 1/4	6	4.5
	W 5/16	6.1	5
M8 M7		6.2	5
M10 M9	W 3/8	7	5.5
M11	W 7/16	8	6
M12		8.5	6.5
	W 1/2	9	7
M14 M15	W 9/16	10.5	8
	W 5/8	12	9
M16		12.5	10
M17		13	10
M18	W 3/4	14	11
M20		15	12
M22	W 7/8	17	13
M24 M25		19	15
M27 M26	W1	20	15
M28		21	17
	W 1-1/8	22	17
M30		23	17
M32	W1-1/4	24	19
M33		25	19
M35 M34	W1-3/8	26	21
M36 M38		28	21
M39 M40	W1-1/2	30	23
M42	W1-5/8	32	26
M45	W1-3/4	35	26
M48	W1-7/8	38	29

FOR TAP Thread	JIS		ISO		DIN 371		DIN 376	
	Ød	□	Ød	□	Ød	□	Ød	□
M3	4	3.2	3.15	2.5	3.5	2.7	2.2	-
M4	5	4	4	3.15	4.5	3.4	2.8	2.1
M5	5.5	4.5	5	4	6	4.9	3.5	2.7
M6	6	4.5	6.3	5	6	4.9	4.5	3.4
M8	6.2	5	8	6.3	8	6.2	6	4.9
M10	7	5.5	10	8	10	8	7	5.5
M12	8.5	6.5	9	7.1			9	7
M14	10.5	8	11.2	9			11	9
M16	12.5	10	12.5	10			12	9
M18	14	11	14	11.2			14	11
M20	15	12	14	11.2			16	12
M22	17	13	16	12.5			18	14.5
M24	19	15	18	14			18	14.5
M27	20	15	20	16			20	16
M30	23	17	20	16			22	18
PT 1/8	8	6						
PT 1/4	11	9						
PT 3/8	14	11						
PT 1/2	18	14						
PT 5/8	19	15						
PT 3/4	23	17						

DIN STANDARD

FOR TAP Thread	DIN 371		DIN 352		DIN 376	
	Ød	□	Ød	□	Ød	□
M1,M1.1,M1.2,M1.4,M1.6,M1.8	2.5	2.1	2.5	2.1		
M2,M2.2,M2.5	2.8	2.1	2.8	2.1		
M3	3.5	2.7	3.5	2.7	2.2	-
M3.5	4	3	4	3		
M4	4.5	3.4	4.5	3.4	2.8	2.1
M5,M6	6	4.9	6	4.9		
M8	8	6.2			6	4.9
M8			6	4.9	6	4.9
M10	10	8			7	5.5
M10			7	5.5	7	5.5
M12			9	7	9	7
M14			11	9	11	9
M16			12	9	12	9
M18			14	11	14	11
M20			16	12	16	12
M22,M24			18	14.5	18	14.5
M27			20	16	20	16
M30			22	18	22	18

DRILL HOLE SIZE FOR TAP THREAD

TAP THREAD	PITCH(P)	DRILL HOLE (d mm)
M1	0.25	0.75
M1.1	0.25	0.85
M1.2	0.25	0.95
M1.4	0.3	1.1
M1.6	0.35	1.25
M1.8	0.35	1.45
M2	0.4	1.6
M2.2	0.45	1.75
M2.5	0.45	2.05
M3	0.5	2.5
M3.5	0.6	2.9
M4	0.7	3.3
M4.5	0.75	3.75
M5	0.8	4.2
M6	1	5
M7	1	6
M8	1.25	6.75
M9	1.25	7.75
M10	1.5	8.5
M11	1.5	9.5
M12	1.75	10.2
M14	2	12
M16	2	14
M18	2.5	15.5
M20	2.5	17.5
M22	2.5	19.5
M24	3	21
M27	3	24
M30	3.5	26.5
M33	3.5	29.5
M36	4	32

FOR TAP Thread	JIS Ød	JIS □	ISO Ød	ISO □	DIN 371 Ød	DIN 371 □	DIN 376 Ød	DIN 376 □
W 1/8"	4	3.2						
W 3/16"	5.5	4.5						
W 1/4"	6	4.5						
W 5/16"	6.1	5						
W 3/8"	7	5.5						
W 7/16"	8	6						
W 1/2"	9	7						
W 5/8"	12	9						
W 3/4"	14	11						
W 7/8"	17	13						
W 1"	20	15						

JIS STANDARD PIPE THREAD

For Tap Style			Tapping Chuck Tap Size	
PT	PS	PF	Ød	□
1/8	1/8	1/8	8	6
1/4	1/4	1/4	11	9
3/8	3/8	3/8	14	11
1/2	1/2	1/2	18	14
		5/8	19	15
3/4	3/4	3/4	23	17
		7/8	24	19
1	1	1	26	21
	1 - 1/8	1 - 1/8	28	21
1 - 1/4	1 - 1/4	1 - 1/4	32	26
1 - 3/8	1 - 3/8	1 - 3/8	35	26
1 - 1/2	1 - 1/2	1 - 1/2	38	29



Mini Type Arm Type Air Tapping Unit

HIGH TORQUE HIGH EFFICIENCY EASY OPERATION



※Base not included

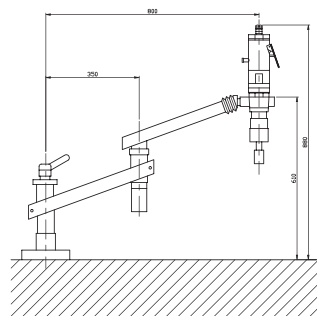

ACCESSORIES

- Air tapping spindle
- Parallel arm & Air combination
- Table mounting column
- Choose any six safety clutch tapping adapters
- Radial jib
- Air pressure: 6~8 kgs/cm²
- VAT-08/12 series require: 5HP compressor
- VAT-16/20 series require: 10HP compressor

※ GUARANTEED FOR 3 MONTHS.

※ MUST INSTALL ON A STABLE / HARD SURFACE FOR PARALLEL WORK.

ORDER NO.	VAT-708	VAT-712	VAT-716	VAT-720	VAT-722	VAT-724
For Tap	M3~M8	M5~M12	M8~M16	M10~M20	M12~M22	M14~M24
	TC-312	TC-312	TC-820	TC-820	TC-820	TC-820
Speed (rpm)	630/700	350/400	250	200	200	100
Weight (kgs)	13.2	13.1	17.3	20.6	20.6	22.1
Work Range	Rmax 700mm					
CODE NO.	3404-410	3404-411	3404-412	3404-413	3404-413A	3404-413B

AIR TAPPING UNIT



Small Arm Type Air Tapping Unit

HIGH TORQUE HIGH EFFICIENCY EASY OPERATION



※Base not included

ACCESSORIES

- Air tapping spindle
- Parallel arm & Air combination
- Table mounting column
- Choose any six safety clutch tapping adapters
- Radial jib, increases arm reach by 500 mm

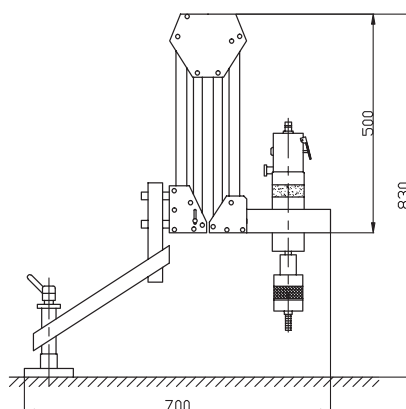

- Without stand plate
- Air pressure: 6~8 kgs / cm²
- VAT-08/12 series require: 5HP compressor
- VAT-16/20 series require: 10HP compressor

※ GUARANTEED FOR 3 MONTHS.

※ MUST INSTALL ON A STABLE / HARD SURFACE FOR PARALLEL WORK.



ORDER NO.	VAT-1408	VAT-1412	VAT-1416	VAT-1420	VAT-1422	VAT-1424
For Tap	M3~M8	M5~M12	M8~M16	M10~M20	M12~M22	M14~M24
	TC-312	TC-312	TC-820	TC-820	TC-820	TC-820
Speed (rpm)	700	400	250	200	200	100
Weight (kgs)	18.2	18.2	24.6	25.6	25.6	27.1
Work Range	Rmax 1400mm					
	Rmin 200mm					
CODE NO.	3404-415	3404-416	3404-417	3404-418	3404-418A	3404-418B

※VAT-1424 can be replaced by VAT-1624



Arm Type Air Tapping Unit



HIGH TORQUE HIGH EFFICIENCY EASY OPERATION

WORK RANGE
1600X500m/m
RMAX. X MIN.

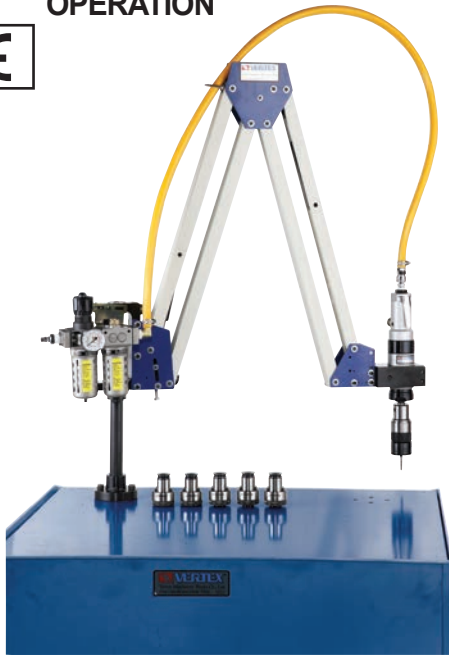

※Base not included

VAT-1608/1612/1616

VAT-1620/1622/1624

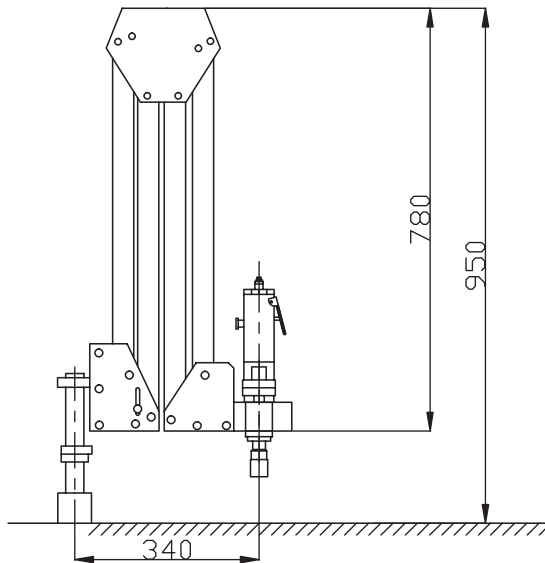

To solve all tapping problems

- Rapid positioning and high machining speed increase productivity.
- Lower tap damage rate, high thread accuracy.
- Tap shall never break for tapping through-hole or blind-hole.
- Tapping for heavier workpiece requires neither positioning equipments nor movement or large work area. Lower machining cost than that by CNC machine, drilling machine or manual tapping operation. Drilling to max: 6mm diameter
- Easy operation, no experience or strength required.
- Without stand plate.
- Air pressure: 6~8 kgs/cm²
- VAT-08/12 series require: 5HP compressor
- VAT-16/20 series require: 10HP compressor
- ※ GUARANTEED FOR 3 MONTHS.
- ※ MUST INSTALL ON A STABLE / HARD SURFACE FOR PARALLEL WORK.

Suggest collet size for standard acces



VAT-□□**08** COLLET SIZE TC312-M3,M4,M5,M6*2,M8

VAT-□□**12** COLLET SIZE TC312-M5,M6,M8*2,M10,M12

VAT-□□**16** COLLET SIZE TC312/TC820
TC312-M8,M10
TC820-M10,M12,M14,M16

VAT-□□**20** COLLET SIZE TC820-M10,M12,M14,M16,M18,M20

VAT-□□**22** COLLET SIZE TC820-M12,M14,M16,M18,M20,M22

VAT-□□**24** COLLET SIZE TC820-M14,M16,M18,M20,M22,M24

JIS & DIN376 Most Populared

ORDER NO.	VAT-1608	VAT-1612	VAT-1616	VAT-1620	VAT-1622	VAT-1624
For Tap	M3~M8	M5~M12	M8~M16	M10~M20	M12~M22	M14~M24
	TC-312	TC-312	TC-820	TC-820	TC-820	TC-820
Speed (rpm)	700	400	250	200	200	100
Weight (kgs)	16.9	17	21.1	24.6	24.6	26.10
Work Range	Rmax 1600mm					
	Rmin 500mm					
CODE NO.	3404-420	3404-421	3404-422	3404-428	3404-428A	3404-428B

VAT-1608, 1612, 1616, 1620, 1622, 1624 STANDARD ACCESSORIES

- Air tapping spindle
- Parallel arm
- Table mounting column
- Air combination
- Choose any six safety clutch tapping adapters

Air Tapping Unit

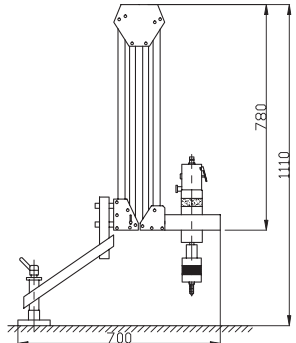

STANDARD ACCESSORIES:

- Air tapping spindle
- Parallel arm & Air combination
- Table mounting column
- Choose any six safety clutch tapping adapters
- Radial jib, increases arm reach by 500 mm
- Air pressure: 6~8 kgs / cm²
- VAT-08/12 series require: 5HP compressor
- VAT-16/20 series require: 10HP compressor

ORDER NO.	VAT-1908	VAT-1912	VAT-1916	VAT-1920	VAT-1922	VAT-1924
For Tap	M3~M8 TC-312	M5~M12 TC-312	M8~M16 TC-820	M10~M20 TC-820	M12~M22 TC-820	M14~M24 TC-820
Speed (rpm)	700	400	250	180/200	185/205	90/100
Weight (kgs)	19.7	23.9	23.5	26	28	28
Work Range	Rmax 1900mm Rmin 200mm					
CODE NO.	3404-425	3404-426	3404-427	3404-430	3404-431	3404-431A

※Base not included

※VAT-1924 can be replaced by VAT-1624
 ※GUARANTEED FOR 3 MONTHS.

Air Tapping Spindle



High torque, high efficiency for machining all tapping requirement. Light and handy main shaft design, easy operation.

The required pressure is 6.3kg/cm²=90 PSI.

- SP08 & SP12 Required 5 HP compressor and more.
- SP16 & SP20 Required 10 HP compressor and more.
- (must keep the air pressure at 6.3kg/cm²)
- ※GUARANTEED FOR 3 MONTHS.

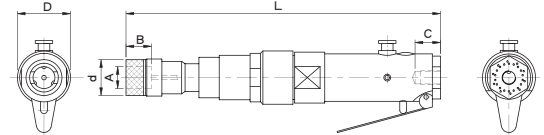

ORDER NO.	TAPPING CAPACITY	SPEED (rpm)	MOUNTING DIA.	A	B	C	D	d	L	WEIGHT (kgs)	CODE NO.
VAT-SP08	M3-M8	630/700	ø38.5 (1 1/2")	19	30	22	46	32	263	1.5	3404-432
VAT-SP12	M5-M12	350/400	ø38.5 (1 1/2")	19	30	22	46	32	263	1.5	3404-433
VAT-SP16	M8-M16	230/250	ø61.3 (2 13/32")	31	48	27	65	50	360	3.9	3404-434
VAT-SP20	M10-M20	180/200	ø61.3 (2 13/32")	31	48	27	65	50	360	3.9	3404-435
VAT-SP22	M12-M22	185/205	ø61.3 (2 13/32")	31	48	27	65	50	360	3.9	3404-435A
VAT-SP24	M14-M24	90/100	ø61.3 (2 13/32")	31	48	27	65	50	395	4.3	3404-435B

Parallel Arm For Air Tapping Unit

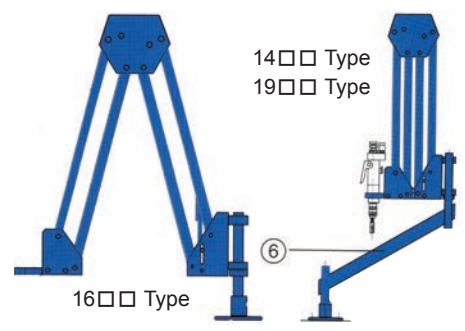

PARALLEL ARM

FOR THE AIR TAPPING UNIT

ORDER NO.	WEIGHT SP-08	WEIGHT SP-12	WEIGHT SP-16	WEIGHT SP-20	WEIGHT SP-22	WEIGHT SP-24	CODE NO.
VAT-ARM700-SP [08, 12, 16, 20, 22, 24]	12kgs	12kgs	14kgs	12kgs	12kgs	12.2kgs	3404-436
VAT-ARM1400x200-SP [08, 12, 16, 20, 22, 24]	17kgs	17kgs	18kgs	17kgs	17kgs	19.7kgs	3404-437
VAT-ARM1600x500-SP [08, 12, 16, 20, 22, 24]	17kgs	17kgs	18kgs	17kgs	17kgs	19.7kgs	3404-438
VAT-ARM1900x200-SP [08, 12, 16, 20, 22, 24]	19kgs	19kgs	20kgs	19kgs	19kgs	21.8kgs	3404-439

※ MUST INSTALL ON A STABLE / HARD SURFACE FOR PARALLE WORK.

AIR TAPPING UNIT



Adjustable Angle Head For Air Tapping Unit

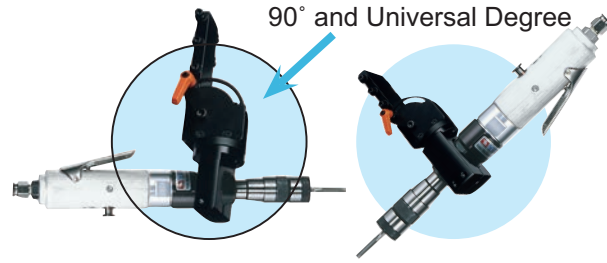
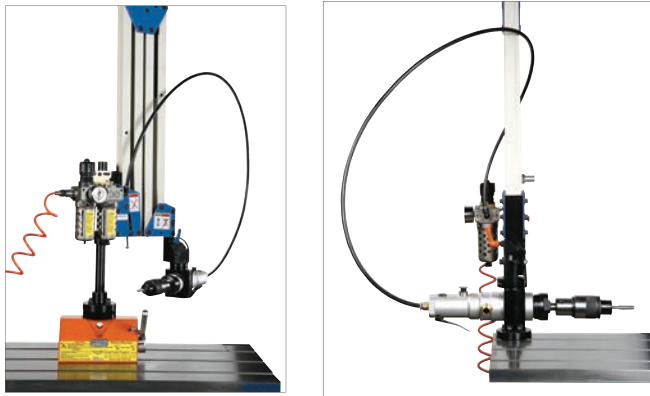

ORDER NO.	FOR VAT-TYPE	WEIGHT (kg)	CODE NO.
AT08-90°	VAT-1408 VAT-1908 VAT-1608	1.1	3404-440
AT12-90°	VAT-1412 VAT-1912 VAT-1612	1.1	3404-441

ORDER NO.	FOR VAT-TYPE	WEIGHT (kg)	CODE NO.
AT16-90°	VAT-1416 VAT-1916 VAT-1616	1.5	3404-442
AT20-90°	VAT-1920	1.5	3404-443
AT22-90°	VAT-1922	1.5	3404-444
AT24-90°	VAT-1924	1.5	3404-446



Magnetic Base For Air Tapping Unit

PORTABLE & MOVEABLE AIR TAPPING ARM



MAGNETIC BASE

EXAMPLE

● Special Accessory for VAT-Series

※ MUST INSTALL ON A STABLE / HARD SURFACE FOR PARALLEL WORK.



ORDER NO.	Magnetic Base		suit For VAT-Type	Weight (kgs)	CODE NO.
	Holding Power	Dimension LXWXH(mm)			
VLM-300A	300kg	155x90x93	VAT-708, 712, 716 VAT-1408, 1412, 1416 VAT-1608, 1612, 1616 VAT-1908, 1912, 1916	9.4	3404-450
VLM-600A	600kg	224x115x120	VAT-720, 722, 724 VAT-1420, 1422, 1424 VAT-1620, 1622, 1624 VAT-1920, 1922, 1924	21.9	3404-451



Mist Coolant System For Air Tapping Unit

ORDER NO. VAC-08 CODE NO. 3404-452
Without Oil

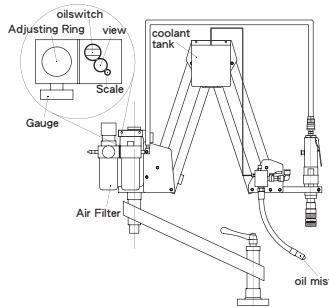
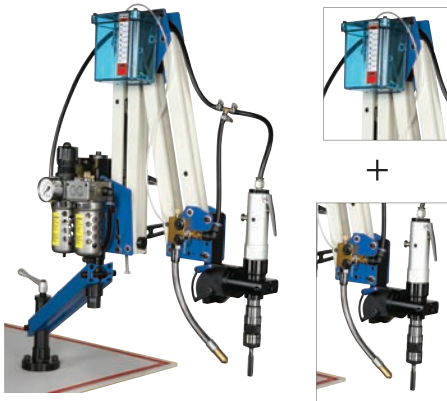

ENLARGE THE TAPPER LIFE 50%



Collet Rack For Air Tapping Unit

ORDER NO. VCR-08 CODE NO. 3404-453

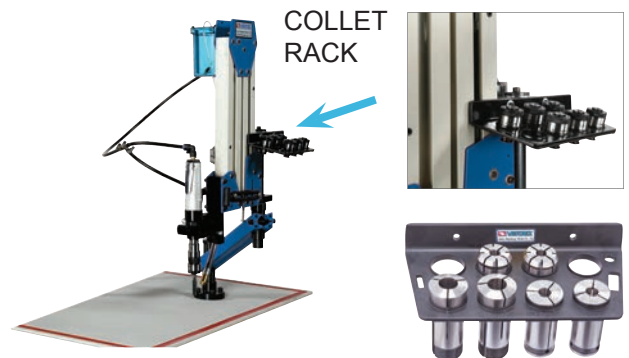

Portable Air Tapper



NEW

JIS STANDARD TAP

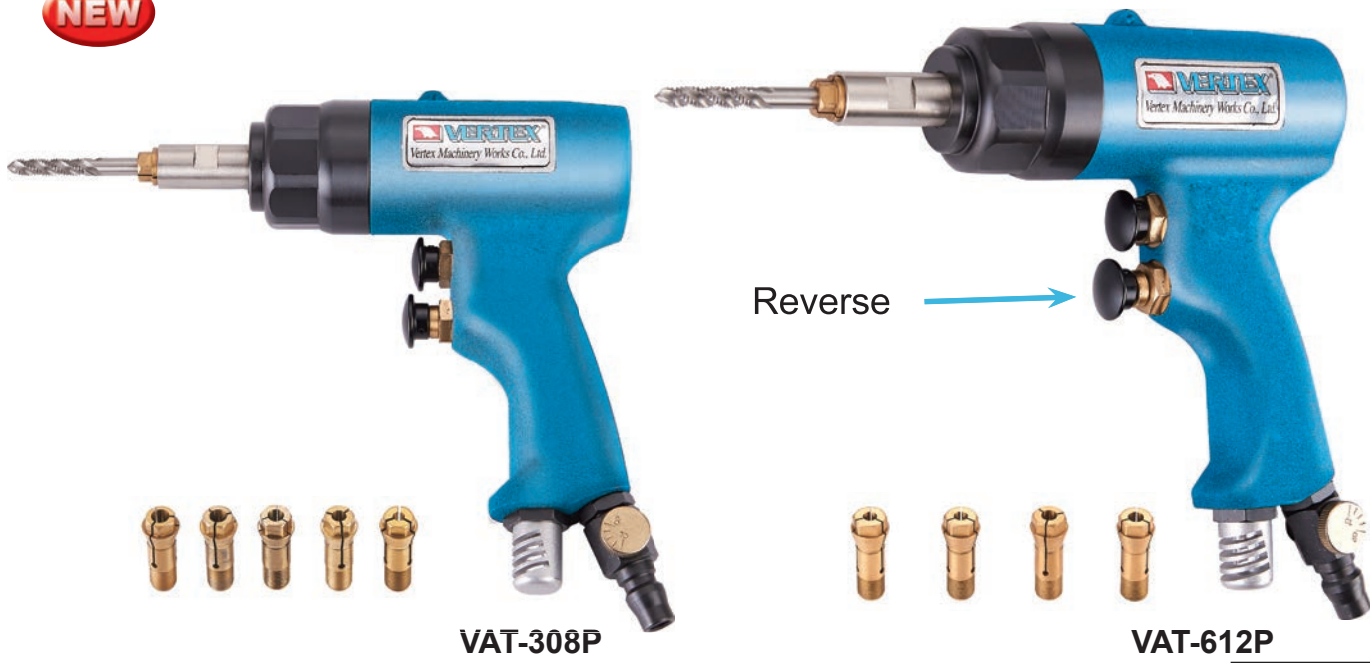

- Light weight.
- Suitable for big workpiece.
- Powerful.
- Easy operation.
- Required air pressure 6kg/cm²

- Air consumption is 0.25 ℓ/min.
- Required install air combination.
- Lubricate air inlet connector with 3 c.c. oil. Always before and after using.



AIR TAPPING UNIT

SET TYPE

ORDER NO.	TAPPING CAPACITY	COLLET SET (pcs/set)	WORKING SPEED (Y.P.M.)	SPINDLE SPEED (R.P.M.)	HOSE CONNECT SIZE	OVERALL LENGTH (mm)	N.W. (kgs)	CUFT	CODE NO.
VAT-308P	M3~M8	5 pcs	350	8500	PT 1/4"	158 mm	0.9	0.13	3404-471
VAT-612P	M6~M12	4 pcs	280	8000	PT 1/4"	168 mm	1.1	0.13	3404-472

ACCESSORIES COLLET SIZE pcs / set

ORDER NO.	∅D x ▨ JIS STD. FOR TAP SIZE	pcs/ set	N.W. (kgs)	CODE NO.
VAT-308PC	M3 (∅ 4 x 3.2) x 1pcs M4 (∅ 5 x 4) x 1pcs M5 (∅ 5.5 x 4.5) x 1pcs M6 (∅ 6 x 4.5) x 1pcs M8 (∅ 6.2 x 5) x 1pcs	5 pcs/set	0.2	3404-481
VAT-612PC	M6 (∅ 6 x 4.5) x 1pcs M8 (∅ 6.2 x 5) x 1pcs M10 (∅ 7 x 5.5) x 1pcs M12 (∅ 8.5 x 6.5) x 1pcs	4 pcs/set	0.3	3404-482

Note For VAT-Series / VAG-Series

CAUTIONS

CAUTION:

1. AIR COMPRESSOR PRESSURE 6~8 kg / cm², DRY AIR.
2. Always check oil level of the 3 in 1 air combination.
3. Tapping ARM has to be mounted on the same hardened work plate.
4. SET THE WORKPIECE SURFACE TO BE PARALLELED WITH TAPPING ARM STAND.
5. Always supply cutting oil while tapping.
6. Work every 1 hour rest 10 to 15 minutes, 8 hours per day. Every 3 months need service.
7. After use, drop some #60 oil / lubrication into air inlet. Air hose & connector must be cleaned before use!





Deluxe Type Tool Setting Stand

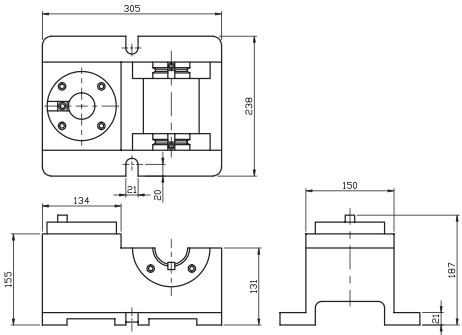

- This tool setting stand is one kind of subsidize tool for helping machine center to work efficiently. To be used fixing the tools on tool holder. It could avoid the method of using draw bar to fix (on machine center). It is safe, and doesn't effect the precision of machine's spindle.
- It's best for using on horizontal or vertical lines, simple & quick operations.
- A multi-function tool, it is changeable, has two kinds of specifications can be used. That is to say, one machine could be used as two sets machines.
- Additional special accessories to make your operating more convenient.
- CAT & SK share same model.

ORDER NO.	SHANK TAPERS		WEIGHT (kgs)	CODE NO.
	TOOL POST	ADAPTER HOLDING		
VTD-1	BT-#40x1	BT-#40x2	22.4	3405-001
VTD-2	BT-#50x1	BT-#50x2	22	3405-002
VTD-3	BT-#50x1	BT-#50x1 BT-#40x1	24	3405-003
VTD-4	BT-#40x1	BT-#50x1 BT-#40x1	24	3405-004
VTD-5	SK-40x1	SK-40x2	26	3405-005
VTD-6	SK-50x1	SK-50x2	24	3405-006
VTD-7	SK-50x1	SK-50x1 SK-40x1	25	3405-007
VTD-8	SK-40x1	SK-50x1 SK-40x1	25	3405-008
VTD-9	BT-30x1	BT-30x2	23	3405-009
VTD-10	SK-30x1	SK-30x2	23	3405-009A



Simple Type Tool Setting Stand

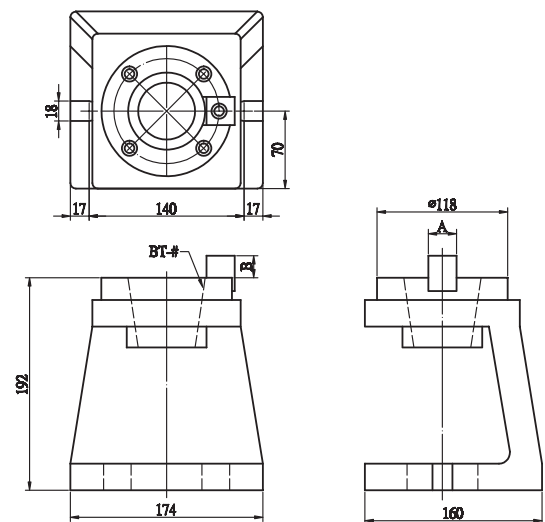

- This tool setting stand is one kind of subsidize tool for helping machine center to work efficiently. To be used fixing the tools on tool holder. It could avoid the method of using draw bar to fix (on machine center). It is safe, and doesn't effect the precision of machine's spindle.
- It is simple structive type. And could fix tooling on the above and hold the pull studs on the below of it. This is the excellent helping tools for simple, rapid and safe.

ORDER NO.	SHANK TAPERS	STD	WEIGHT (kg)	CODE NO.
VTS-BT-30	30	BT ISO NT	11.9	3405-010
VTS-BT-40	40		12.4	3405-011
VTS-BT-50	50		11.9	3405-012
VTS-SK-30	30	CAT DIN 69871A	11.9	3405-013
VTS-SK-40	40		12.4	3405-014
VTS-SK-50	50		11.9	3405-015

Tool Holder Locking Device

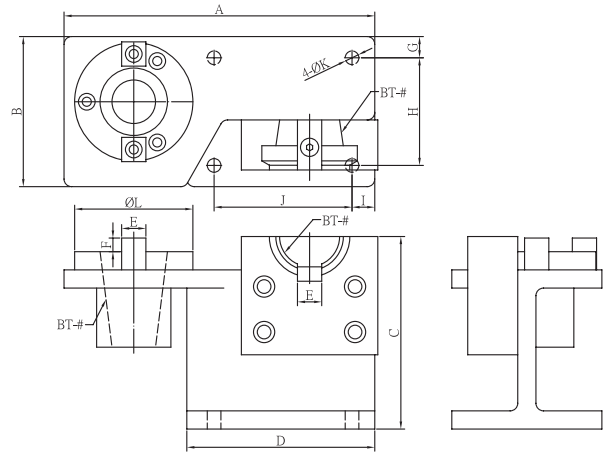

TOOL HOLDER LOCKING

ORDER NO.	A	B	C	D	E	F	G	H	I	J	K	L	CODE NO.
VTG-BT30	205	99	127	124	15	10	16	71	15	91	9	78	3405-020
VTG-BT40	205	99	127	124	16	9	14	71	15	91	9	78	3405-021
VTG-BT50	282	152	203	162	25	16	22	108	25	115	9	115	3405-022

ORDER NO.	STD	WEIGHT (KGS)	CODE NO.
VTG-BT30	ISO BT	4.1	3405-020
VTG-BT40		4.2	3405-021
VTG-BT50		11.8	3405-022
VTG-SK40	CAT SK DIN69871A	4	3405-024
VTG-SK50		12.3	3405-025

Tool Holder Locking Device

TILTING TYPE

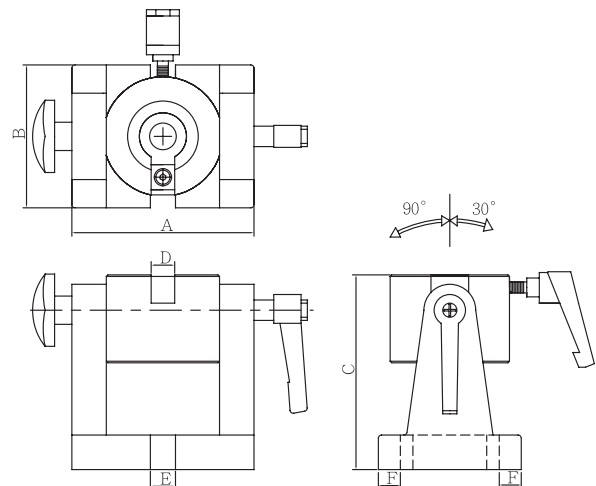

Example Shank Not Included

ORDER NO.	STD	WEIGHT (KGS)	CODE NO.
VTL-BT30	ISO BT	4.2	3405-030
VTL-BT40		4.3	3405-031
VTL-BT50		9.8	3405-032
VTL-SK30	DIN69871A	4	3405-033
VTL-SK40		4	3405-034
VTL-SK50		8	3405-035
VTL-NT30	NT	4.2	3405-036
VTL-NT40		4.3	3405-037
VTL-NT50		9.8	3405-038

ORDER NO.	A	B	C	D	E	F	CODE NO.
VTL-BT30	116	91	126	16	15	14	3405-030
VTL-BT40	117	91	136	16	15	14	3405-031
VTL-BT50	149	121	189	25	15	15	3405-032



Tool Holder Locking Fixtures



HSK TYPE

NEW

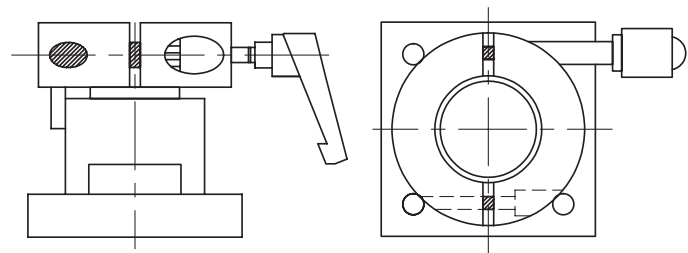

ORDER NO.	STD	WEIGHT (KGS)	CODE NO.
VTL-HSK40	DIN69893 HSK	2.5	3405-046
VTL-HSK50		3.5	3405-047
VTL-HSK63		4.5	3405-048



Round Tool Locking Device

NEW



Example

Feature:

- Light weight & compact design
- Quick setup time
- For tool holder locking
- Space saving

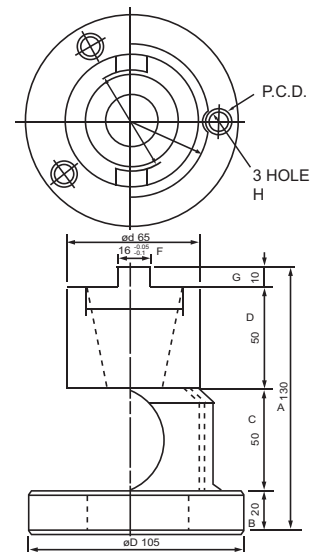

ORDER NO.	SHANK TAPER	ØD	Ød	3HOLE P.C.D.	H	A	B	C	D	E	F	WEIGHT (kg)	CODE NO.
VTO-BT30	30	90	50	70	ø14x9xø9	108	20	48	30	10	16	1.2	3405-190
VTO-BT40	40	105	65	85	ø14x9xø9	130	20	50	50	10	16	2.2	3405-191
VTO-BT50	50	135	95	115	ø14x9xø9	188	24	82	70	12	25.4	5	3405-192



Fast Tool Setting Stand

NEW

HSK TYPE



Example

LEVER FOR CLAMPING & UNCLAMPING

SETTING INSIDE FOR CLAMPING

※MOVEABLE KEY FOR FLEXIBLE PURPOSE FLEXIBLE

ORDER NO.	STD	WEIGHT (kg)	CODE NO.
VTS-HSK63	DIN69893HSK	10.5	3405-193
VTS-HSK100		11.5	3405-194

Spindle Taper Wiper



- Easily and quickly for cleaning spindle hole.
- Plastic body, the taper wiper is made of special cotton material, will not damage the spindle.
- The BT & DIN of taper are same

ORDER NO.	TAPER NO.	TOTAL LENGTH	WEIGHT (kg)	CODE NO.
VTW-30	#30	169mm	0.07	3405-060
VTW-40	#40	187mm	0.08	3405-061
VTW-50	#50	241mm	0.02	3405-062

TOOLING CART

Spindle Taper Wiper

NEW



WITH REPLACE WIPER



- Easily and quickly for cleaning spindle hole.
- Plastic body, the taper wiper is made of special cotton material, will not damage the spindle.
- The BT & DIN of taper are same
- Replaceable Wiper.
- Easy to replace new wipers.
- Included 2 sets x disposable wipers
- ECO Friendly

ORDER NO.	TAPER NO.	TOTAL LENGTH	WEIGHT (kg)	CODE NO.
VTW-30R	#30	162mm	0.08	3405-065
VTW-40R	#40	180mm	0.09	3405-066
VTW-50R	#50	230mm	0.18	3405-067

ORDER NO.	CONTAINS SPARE	WEIGHT (kg)	CODE NO.
VTW-30R-WIPER	20pcs / box	0.01	3405-530
VTW-40R-WIPER	20pcs / box	0.02	3405-531
VTW-50R-WIPER	25pcs / box	0.04	3405-532

Spindle Taper Wiper



H Type

ORDER NO.	TAPER NO.	TOTAL LENGTH	WEIGHT (kg)	CODE NO.
VTW-40H	HSK40	147mm		3405-073
VTW-50H	HSK50	159mm	0.1	3405-071
VTW-63H	HSK63	167mm	0.12	3405-072
VTW-100H	HSK100	191mm		3405-074



Tooling Rack Stand



NEW

VTT-30



VTT-31



- Compact design
- Clear Storage
- Easy to clean
- Portable design
- Large tooling storage
- VTT-30 with Rubber mat
- Big size variety

VTT-30
FLAT TABLE RUBBER

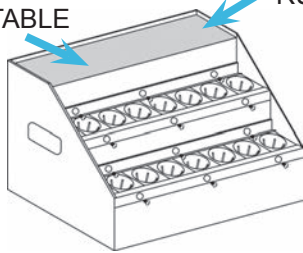

LxWxH : 550x430x360 mm
CAPACITY VTT-30 WITH

BT-30 16 SHEATH, 1FLAT TABLE
BT-40 14 SHEATH, 1FLAT TABLE
BT-50 10 SHEATH, 1FLAT TABLE
HSK63 12 SHEATH, 1FLAT TABLE

LxWxH : 550x430x360 mm
VTT-31 WITH

BT-30 24 SHEATH
BT-40 21 SHEATH
BT-50 15 SHEATH
HSK63 18 SHEATH

ORDER NO.	STD	TOOLING SHEATH CAPACITY	CODE NO.
VTT-30-30	BT-30, DIN69871A	16 pcs/set	3405-211
VTT-30-40	BT-40, DIN69871A	14 pcs/set	3405-212
VTT-30-50	BT-50, DIN69871A	10 pcs/set	3405-213
VTT-30-HSK63	HSK63	12 pcs/set	3405-214
VTT-31-30	BT-30, DIN69871A	24 pcs/set	3405-215
VTT-31-40	BT-40, DIN69871A	21 pcs/set	3405-216
VTT-31-50	BT-50, DIN69871A	15 pcs/set	3405-217
VTT-31-HSK63	HSK63	18 pcs/set	3405-218



Tooling Cart

FOR BT30,40,50 / SK30,40,50 / CAT30,40,50 / ISO30,40,50

NEW



TOOL LOCKING DEVICE

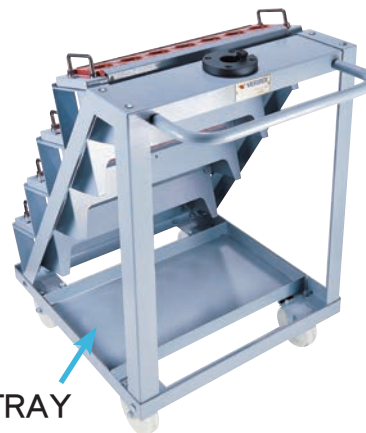

TOOL TRAY



WITH VTTR-FOLDING HANDLE
TOOLING SHEATH RACK

VTT-21

OVERALL SIZE:626 X 655X 980 mm WEIGHT:43KGS

- LARGE CAPACITY,CAN PUT MORE SHANK TOOLING TROLLEY.
- TAPER ANGLE RACK STAND DESIGN,ERGONOMIC DESIGN,USER FRIENDLY SAVE YOU ENERGY & EASY TO TAKE OUT YOUR TOOL HOLDER.
- CAN TAKE OUT/PUT IN WHOLE SET OF THE NEW TOOLING SHEATH RACK (VTTR-30/40/50 TR SERIES).CAN FOR SEPARATE USING.
- WITH FOLDING HANDLE CAN SAVE SPACE AND BETTER FREE ACTION MOVEMENT.
- CONVENIENT & SPEED INSTALLATION.
- STABLE & HEAVY DUTY.

ORDER NO.	FOR STD	TOOL LOCKING DEVICE	TOOLING SHEATH CAPACITY	CODE NO.
VTT-21-30	BT-30 DIN 69871A SK30, CAT30, ISO30	BT-30 DIN 69871A SK30, CAT30, ISO30	32PCS/SET	3405-080
VTT-21-40	BT-40 DIN 69871A SK40, CAT40, ISO40	BT-40 DIN 69871A SK40, CAT40, ISO40	28PCS/SET	3405-081
VTT-21-50	BT-50 DIN 69871A SK50, CAT50, ISO50	BT-50 DIN 69871A SK50, CAT50, ISO50	20PCS/SET	3405-082
VTT-21-HSK63	HSK63	HSK63	24PCS/SET	3405-083

FOR BT30,40,50 / SK30,40,50
CAT30,40,50 / ISO30,40,50

2 TIMES CAPACITY COMPARE WITH
For VTT-2 BT-40 IS 28 PCS
For VTT-11-40 IS 56 PCS

NEW

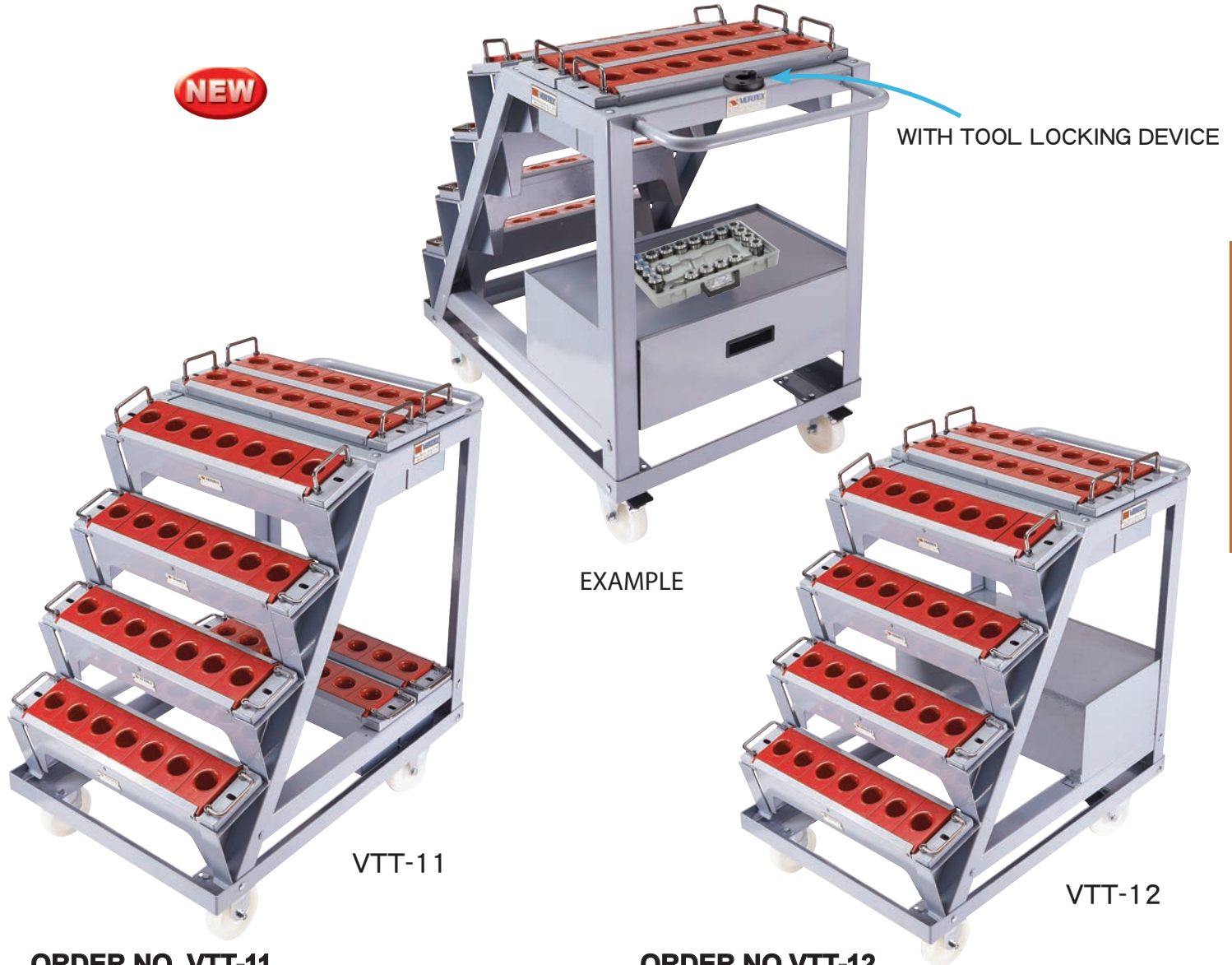

TOOLING CART

ORDER NO. VTT-11

TOOLING SHEATH TYPE

ORDER NO.	FOR STD	TOOLING SHEATH CAPACITY	CODE NO.
VTT-11-30	BT-30,SK30,CAT30, ISO30 DIN 69871A	64 PCS/SET	3405-230
VTT-11-40	BT-40,SK40,CAT40, ISO40 DIN 69871A	56 PCS/SET	3405-231
VTT-11-50	BT-50,SK50,CAT50, ISO50 DIN 69871A	40 PCS/SET	3405-232
VTT-11-HSK63	HSK63	48 PCS/SET	3405-233

OVERALL SIZE:626 X 960 X 1000MM,WEIGHT:63KGS

ORDER NO.VTT-12

TOOLING SHEATH WITH 1 DRAWERS

ORDER NO.	FOR STD	TOOLING SHEATH CAPACITY	CODE NO.
VTT-12-30	BT-30,SK30,CAT30, ISO30 DIN 69871A	48 PCS/SET	3405-240
VTT-12-40	BT-40,SK40,CAT40, ISO40 DIN 69871A	42 PCS/SET	3405-241
VTT-12-50	BT-50,SK50,CAT50, ISO50 DIN 69871A	30 PCS/SET	3405-242
VTT-12-HSK63	HSK63	36 PCS/SET	3405-243

OVERALL SIZE:626 X 960 X 1000MM,WEIGHT:65KGS

- LARGE CAPACITY,CAN PUT MORE SHANK TOOLING TROLLEY.
- TAPER ANGLE RACK STAND DESIGN,ERGONOMIC DESIGN,USER FRIENDLY
- SAVE YOU ENERGY & EASY TO TAKE OUT YOUR TOOL HOLDER.
- CAN TAKE OUT/PUT IN WHOLE SET OF THE NEW TOOLING SHEATH RACK (VTTR-30/40/50 TR SERIES).CAN FOR SEPARATE USING.
- WITH FOLDING HANDLE CAN SAVE SPACE AND BETTER FREE ACTION MOVEMENT. CONVENIENT & SPEED INSTALLATION.
- STABLE & HEAVY DUTY.

DRAWER:LxWxH: 610x360x215 mm



Tooling Trolleys

※ COLOR MAY VARY



VTT-2 PACKING
SET / 1 PAPER BOX

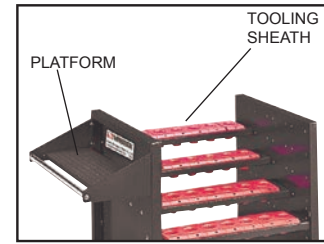

ORDER NO.:VTT-2
WEIGHT:51kgs

ORDER NO.	STD	TOOLING SHEATH CAPACITY	CODE NO.
VTT-2-30	BT-30,CAT30 DIN 69871A, ISO30,SK30	32 PCS/SET	3405-100
VTT-2-40	BT-40,CAT40 DIN 69871A, ISO40,SK40	28 PCS/SET	3405-101
VTT-2-50	BT-50,CAT50 DIN 69871A, ISO50,SK50	20 PCS/SET	3405-102
VTT-2-HSK63	HSK63	24 PCS/SET	3405-103

Overall Size : 1002x650x810 mm
Gray color



VTT-5 PACKING
SET / 3 PAPER BOXES
(2 DRAWERS/BOXES)



ORDER NO.:VTT-5
WEIGHT:64kgs
WITH 2 DRAWERS

ORDER NO.	STD	TOOLING SHEATH CAPACITY	CODE NO.
VTT-5-30	BT-30,CAT30 DIN 69871A, ISO30,SK30	32 PCS/SET	3405-110
VTT-5-40	BT-40,CAT40 DIN 69871A, ISO40,SK40	28 PCS/SET	3405-111
VTT-5-50	BT-50,CAT50 DIN 69871A, ISO50,SK50	20 PCS/SET	3405-112
VTT-5-HSK63	HSK63	24 PCS/SET	3405-113

Overall Size : 1002x650x810 mm
Gray color

VTT-6 PACKING
SET / 2 PAPER BOXES



ORDER NO.:VTT-6
WEIGHT:53kgs
WITH 1 DRAWERS

ORDER NO.	STD	TOOLING SHEATH CAPACITY	CODE NO.
VTT-6-30	BT-30,CAT30 DIN 69871A, ISO30,SK30	32 PCS/SET	3405-105
VTT-6-40	BT-40,CAT40 DIN 69871A, ISO40,SK40	28 PCS/SET	3405-106
VTT-6-50	BT-50,CAT50 DIN 69871A, ISO50,SK50	20 PCS/SET	3405-107
VTT-6-HSK63	HSK63	24 PCS/SET	3405-108

Overall Size : 1002x650x810 mm
Gray color



Tooling Rack

NEW

FOR BT30,40,50 / SK30,40,50
CAT30,40,50 / ISO30,40,50 / DIN 69871A

WITH FOLDING HANDLE

※SHOWS VTTR-40TR

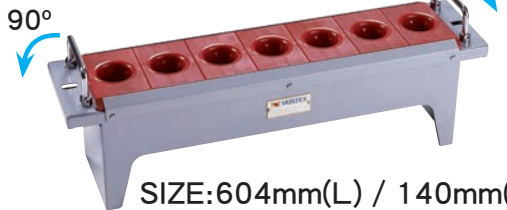

SIZE:604mm(L) / 140mm(W) / 160mm(H)

ORDER NO.	FOR STD	TOOLING SHEATH CAPACITY	WEIGHT (kgs)	CODE NO.
VTTR-30TR	BT30,SK30, CAT30,ISO30	8 PCS	4.0	3405-250
VTTR-40TR	BT40,SK40, CAT40,ISO40	7 PCS	4.0	3405-251
VTTR-50TR	BT50,SK50, CAT50,ISO50	5 PCS	4.0	3405-252



Tooling Sheath

※COLOR MAY VARY

THE BT & DIN OF TAPER ARE SAME.

ORDER NO.: VTTS-BT-30

WEIGHT:0.077kg

CODE NO. 3405-130

SIZE: 48 X 138 X 65mm

ORDER NO.: VTTS-BT-40

WEIGHT:0.085kg

CODE NO. 3405-131

SIZE: 63 X 138 X 74mm

ORDER NO.: VTTS-BT-50

WEIGHT:0.123kg

CODE NO. 3405-132

SIZE: 93 X 138 X 104mm

ORDER NO.: VTTS-HSK63

WEIGHT:0.08kg

CODE NO. 3405-133

SIZE: 50 X 140 X 85mm



TOOLING TROLLEYS



End Mill Sheath Rack

ORDER NO.VMS-2 CODE NO.3405-050



Material:ABS with 62 sheaths.

※End mills not included

Unit:mm

CAPACITY RANGE	SIZE	WEIGHT (kg)
Ø6~Ø42	205x205x80	0.4



Cutting Tool Sheath Rack

ORDER NO.VMS-3 CODE NO.3405-051



● For Drill & End Mill Use

● Ø1.0~Ø10.0(Ø1.0,1.1~9.9,10.0)EACH0.1^{mm}

ONE POSITION

Ø10.5, 10.9, 11.0, 11.5, 11.9, 12.0, 12.5, 12.9,

13.0 TOTAL 100 POSITION FOR DRILL &

END MILL

● 360° ROTATION

Unit:mm

CAPACITY RANGE	SIZE	WEIGHT (kg)
Ø1.0~Ø13.0	Ø174x90 ^{m/m}	0.21



Tooling Rack Stand

ORDER NO.VTC-20 CODE NO. 3405-221

NEW



● Suit for different kind small machine

● Powerful desing

● Compact & with big capacity

● With rubber mate

● 3 size drawer could store

● Different size tools

LxWxH : 460x370x860 mm

VTC-20 3 DRAWERS

1 FLAT TABLE CAN

USING FOR VDG-, VEG, U2, VCF-500 ETC.

STRONG TYPE

WEIGHT: 30.25 KGS

→ **DRAWER:**

□ W x L x H: 330 x 315 x 130 mm

□ W x L x H: 330 x 315 x 280 mm

Example



Tool Cabinet



ALL THE OVERALL SIZE IS WITH WHEELS HEIGHT.
* COLOR MAY VARY



5 Drawers Roll Cabinet
Cuft: 6.9'
Net Weight: 31.3 kgs
Gross Weight: 34 kgs

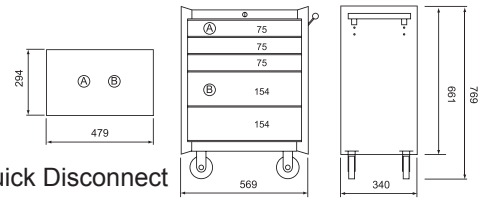

- Ball bearing slide with Quick Disconnect
- Heavy Duty 4"x1" Caster
- Double wall construction
- Electro - Powder Coating to Resist Scratch & solvent markings
- 10mm Top Mat
- All drawers appended to Drawer Liners
- Red color

* COLOR MAY VARY

ORDER NO.	CODE NO.
VTC-23	3405-144

	mm		
	W	D	H
DRAWERS	480	292	75
DRAWERS	480	292	154

570WX345DX769Hmm



7 Drawers Roll Cabinet
Cuft: 13'
Net Weight: 67.9 kgs
Gross Weight: 77.5 kgs

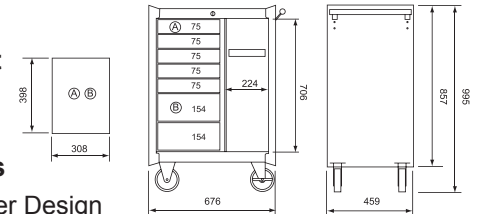

- Ergonomic Large Drawer Design
- Ball bearing slide with Quick Disconnect
- Heavy Duty 5"x2" Caster
- Double wall construction
- Electro - Powder Coating to Resist Scratch & solvent markings
- 10mm Top Mat
- All drawers appended to Drawer Liners
- Gray color

* COLOR MAY VARY

ORDER NO.	CODE NO.
VTC-25	3405-149

	mm		
	W	D	H
DRAWERS	308	395	75
DRAWERS	308	395	154

680WX460DX995Hmm



Tooling Trolleys

ORDER NO.VTC-100 CODE NO.3405-154
* COLOR MAY VARY

NEW



WxDxH	873x500x880 mm
Package	1PC/1CTN/2.73CUFT
N.W.	23.91KGS
G.W.	25.90KGS

- Grey color



Workbench

ORDER NO.VWB-1580 CODE NO.3405-158



NEW



SIZE : 1500W x 750D x 800H mm
* COLOR MAY VARY

DESCRIPTION	W	D	H	N.W.	G.W.	CUFT
OVERALL	1500	750	800	69.7	74.04	4.68



Hydro Lift Table

NEW



* COLOR MAY VARY
PACKING WITHOUT WOODEN CASE

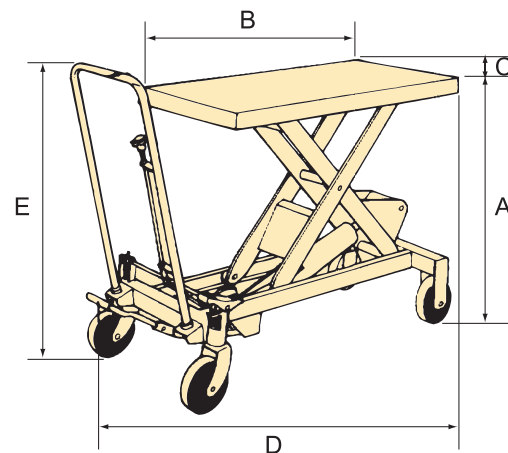

TOOL CABINET

ORDER NO.	A		B	C	D	E		Wheel	Brake Wheel	Load Capacity kgs	Weight	CODE NO.
	MAX. High From The Floor	MIN. Low From The Floor	Worktable Length	Worktable Width	Overall Length	Handle Bar High From The Floor	Overall Width					
VLT-300	900	270	815	500	1020	960	500	127 x 38	1	300	72	3405-170



Hydro Pallet Trolleys

NEW



* COLOR MAY VARY
PACKING WITHOUT WOODEN CASE

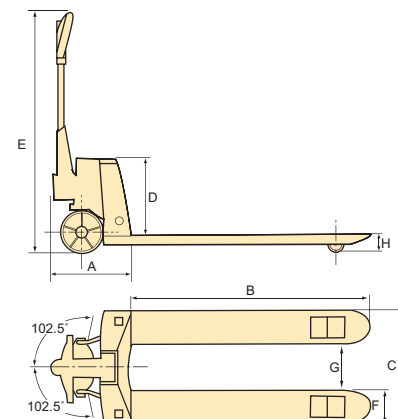

ORDER NO.	Overall Length	Overall Height	Body(Not Include Fork) A	The Fork Surface width F	Fork width C	Fork Length B	Fork Wide G	MAX. Fork Height	MIN. Fork High From The Floor H	Load Capacity kgs	Weight Kgs	CODE NO.
	A+B	E	A	F	C	B	G		H			
HPT-20NS	1300	1200	390	160	520	910	200	200	85	2000		3405-181
HPT-20NM	1460	1200	390	160	520	1070	200	200	85	2000		3405-182
HPT-20WL	1610	1200	390	160	685	1220	365	200	85	2000		3405-183



Parts Cabinet



※ COLOR MAY VARY

GRAY COLOR

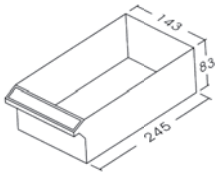

THE SIZE OF DRAWER
245D x 143W x 83H (m/m)

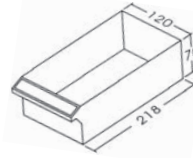

THE SIZE OF DRAWER
218D x 120W x 70H (m/m)



ORDER NO. VA6-212H

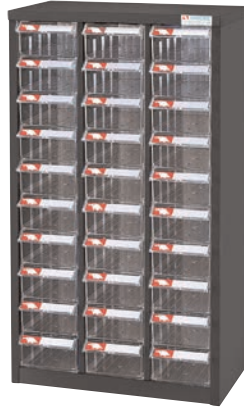

ORDER NO. VA6-330H



ORDER NO. VA7-324P



ORDER NO. VA7-448P



ORDER NO.	SIZE (mm)	DRAWER SIZE(mm)	METAL	DRAWER NUMBERS	WEIGHT(kgs)	CODE NO.
	W x D x H					
VA6-212H	362 x 265 x 571	245 x 143 x 83	STEEL PLATE COVER WITH ZINC. Drawer material: GPS	12PCS	10.8	3405-200
VA6-330H	533 x 264 x 937	245 x 143 x 83		30PCS	25.3	3405-201
VA7-324P	440 x 222 x 642	218 x 120 x 70		24PCS	15.5	3405-202
VA7-448P	586 x 222 x 937	218 x 120 x 70		48PCS	27.5	3405-203
VA1-525	586 x 222 x 350	218 x 90 x 55		25PCS	10	3405-204
VA1-575	586 x 222 x 937	218 x 90 x 55		75PCS	32.3	3405-205



Tool Box

※ COLOR MAY VARY

● COMES IN DIFFERENT COLOR



ORDER NO. VTB-102



ORDER NO. VTB-901



ORDER NO.	SIZE (mm)	MATERIAL	WEIGHT(kg)	CODE NO.
	W x D x H			
VTB-102	420 x 235 x 180	ABS	1.9	3405-300
VTB-901	378 x 182 x 144		0.9	3405-301



Parts Storage

COLOR: RED, BLUE, YELLOW



- Easy parts storage
- Organize

ORDER NO.	SIZE	PACKED	EACH WEIGHT (kg)	CODE NO.
VHB-1218	120Wx180Dx80H mm	60 PCS/CASE	8.6	1021-100
VHB-1525	150Wx250Dx120H mm	36 PCS/CASE	9.6	1021-101
VHB-2035	200Wx350Dx150H mm	18 PCS/CASE	0.585	1021-102
VHB-2045	200Wx450Dx177H mm	12 PCS/CASE	0.8	1021-103
VHB-3045	300Wx450Dx177H mm	8 PCS/CASE	1.8825	1021-104



Economical Pallet



PACKAGE 5PCS / SET

NEW



- Zinc Coating
- For Transport
- Light Weight Duty
- Recyclable
- Disposable: 1 Time Use
- Load: 500 Kgs

PARTS CABINET

ORDER NO.	SIZE	WEIGHT (kgs / 5 sets)	CODE NO.
VEPT-01	1100 x 1400 x 120 mm	85 kgs	3405-601
VEPT-02	1000 x 1100 x 120 mm	55 kgs	3405-602



Heavy Duty Pallet

PACKAGE 5PCS / SET

NEW

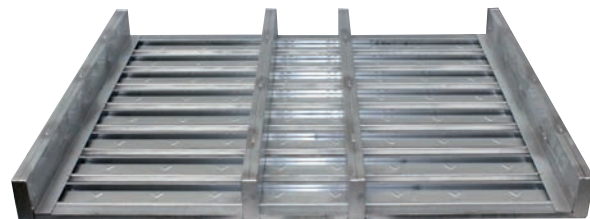

- Heavy Duty
- Zinc Coating
- Material: Steel
- For Transport
- Multiple Use
- Load: 1800 Kgs

ORDER NO.	SIZE	WEIGHT (kgs / 5 sets)	CODE NO.
VHPT-H01	1100 x 1400 x 120 mm	215 kgs	3405-611