

Eastman®

THE EASTMAN®
Eagle
Automatic Cutting System
Model: Eagle S3
Service Manual

Technical Support:
1-800-872-5595

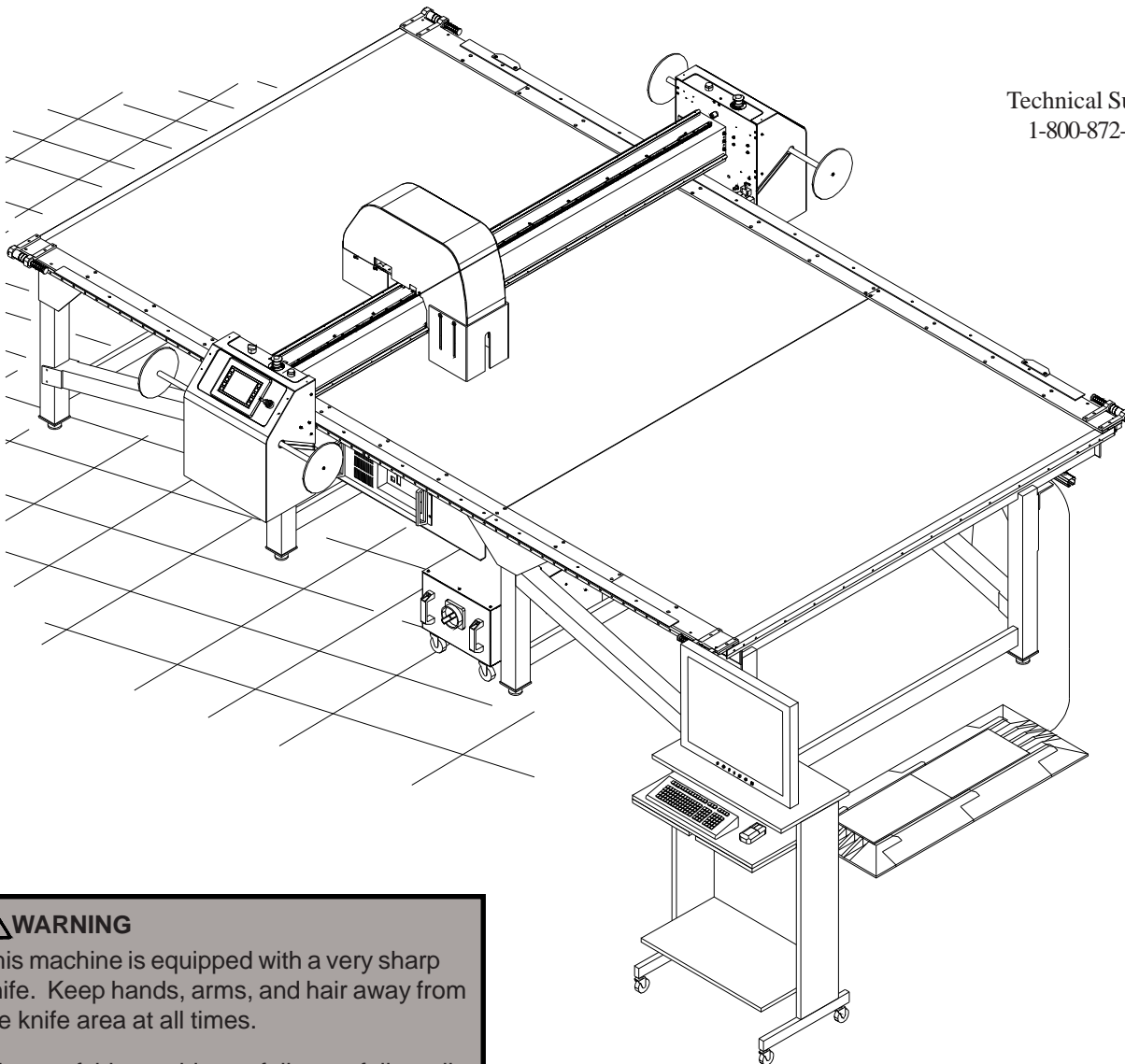

⚠ WARNING

This machine is equipped with a very sharp knife. Keep hands, arms, and hair away from the knife area at all times.

Misuse of this machine or failure to follow all safety instructions on this machine and in the instruction manual may result in serious personal injuries.

Eastman®

Over a Century of Cutting Expertise

779 Washington St., Buffalo, N.Y. 14203-1396 U.S.A. • (716)856-2200 • Fax (716)856-1140 or (716)856-2068
Manufacturers of Eastman Cloth Cutting and Cloth Spreading Machines
Website: www.EastmanCuts.com

Congratulations

Congratulations in selecting an Eagle S3 Static Cutter. With over 100 years of experience in the cutting room, Eastman is a world leader in cutting equipment. Every Eastman employee takes pride in each machine we build and back it with unprecedented support. Our Technical Service department is made up of a dedicated staff of professionals with years of experience installing, troubleshooting and servicing the Eagle S3 Static Cutter. Each technician is familiar with all aspects of the machine including mechanical, electrical and software.

Eastman Machine Company provides technical support and on-site service as required. We offer several affordable Extended Warranty plans that allow you to continue the superior technical support well after the machine is past our standard warranty. If you require on-site technical support or would like to schedule a preventive maintenance visit or need additional training, please call our headquarters in Buffalo, NY to arrange for a technician.

Technical Support

Eastman Machine Company
779 Washington Street
Buffalo, NY 14203
Phone: 716-856-2200
Fax: 716-856-2068

Limited Warranty. Eastman warrants to the buyer that the equipment shall be free from defects in materials or workmanship for a period of 180 days commencing on the date of invoice. Any goods or parts claimed by the buyer to be defective must be returned to Eastman, freight charges prepaid, within the 180 day warranty period. If Eastman determines that the goods or parts are defective in materials or workmanship, Eastman's sole obligation under this warranty shall be, at Eastman's sole option, to repair or replace the defective goods or parts or to provide the buyer credit equal to the portion of the purchase price allocable to the defective goods or parts. This warranty should not apply if defects are caused by product misuse or neglect, if the machine has been altered or modified by the buyer or if other than genuine Eastman parts are used in the machine. THIS WARRANTY IS APPLICABLE TO THIS PURCHASE ONLY. SELLER DISCLAIMS ALL OTHER WARRANTIES, EXPRESSED OR IMPLIED, INCLUDING, BUT NOT LIMITED TO, THE IMPLIED WARRANTIES OF MERCHANTABILITY AND FITNESS FOR A PARTICULAR PURPOSE.

Limitation of Liability. Eastman's liability to the buyer, and the buyer's remedies from Eastman whether in contract, negligence, under any warranty or otherwise, shall be limited to the remedies provided in the foregoing Limited Warranty. In no event shall Eastman have any responsibility or liability to the buyer for (a) any special, indirect, incidental, or consequential damages, including, but not limited to, loss of use, revenue, or profit even if Eastman has been advised of the possibility of such damages, or (b) any claim against the buyer by any third party. The price stated for the product sold is a consideration for limiting Eastman's liability.

IMPORTANT

The purchaser must instruct all operators on the proper use of this equipment. All standard industrial safety measures and equipment should be provided to protect the operator. Operators must be cautioned that improper or careless use of this equipment may cause personal injury. If you do not have qualified operators to instruct new persons, contact your EASTMAN sales representative or EASTMAN factory direct.

Electrical connections and servicing to this equipment should be made by a qualified electrician who is familiar with applicable codes and regulations. Disconnect this equipment from electrical power source before proceeding with any disassembly for adjustment or repair.

Your Eastman **Eagle Static Cutter** is designed to operate at a high rate speed. All personnel should be instructed to wear safety glasses and stand well clear of the **Eagle Static Cutter** when in operation.

Table of Contents

Instruction for Aligning, Cleaning and Replacing Consumable Parts	4
Round Knife Assembly	4
Drag Knife Assembly	5
Punch Assembly	7
Round Knife	9
Drag Knife	12
Punch	15
Removal of Plotter Pen to replace Pen refill	16
Airbrush Ink refill	18
Cleaning of Airbrush	18
Porex Plastic Table Surface	21
Replacing the XMP Controller Card and Loading Configuration Files	23
Pressure Transducer Calibration	23
Disassembly and Assembly Instructions for Parts requiring Service	24
Replacement of X Motor Belts	24
Replacement of Y Motor Belt	28
Replacement of Theta Motor Belt	34
Replacing the X-axis Linear Bearings	35
Replacing the Y-axis Top Linear Bearings	38
Replacing the Y-axis Front Linear Bearings	41
Replacing the XMP Controller Card and Loading Configuration Files	45
Pressure Transducer Calibration	45
Adjustment Procedures and Specifications for parts requiring Service	46
Checking and Adjusting Gantry Backlash	46
Checking and Adjusting Y-car Backlash	49
Checking and Adjusting Stop Discs	52
Scheduled Maintenance Procedure	54
Lubrication Chart	57
Yearly Maintenance Checklist for Eagle Static Cutter	58
Trouble Shooting Guides and Aides	65
UIT Error Messages	65
Additional Trouble Shooting	66
RF/EMI Interference	73
Electrical Schematics & Pneumatic Diagrams	73

Instruction for Aligning, Cleaning and Replacing Consumable Parts

Round Knife Assembly

- Turn the power off to the gantry, use lock out / tag out if required.
- Loosen the two allen head screws on the tool holder.

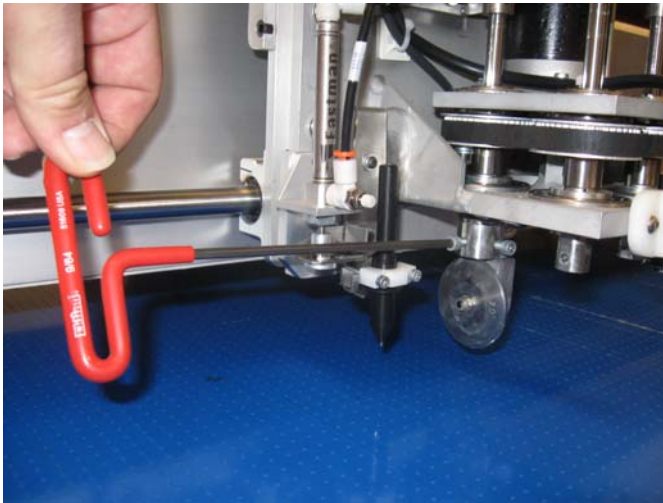

- Carefully slide the round knife assembly off the tool head spindle.
- Ensure that the removed round knife assembly is placed in a safe area because it contains sharp objects that pose hazards.
- Install new knife assembly on the desired tool head spindle ensuring that the alignment tang is engaged on the spindle.

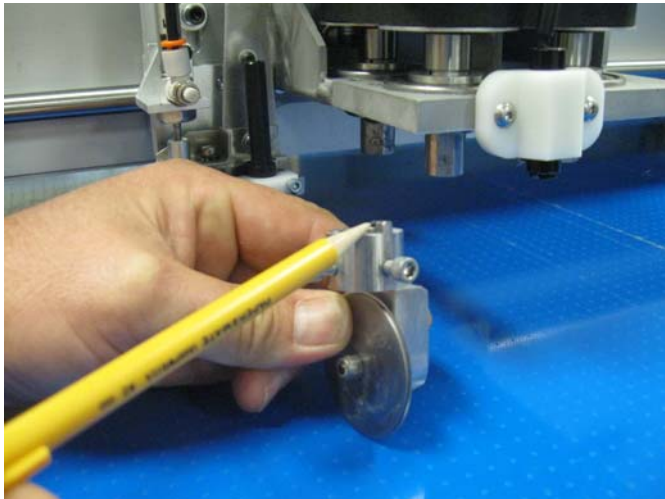

- Tighten the two allen head screws on the tool holder to secure it to the tool head spindle.
- If the tool type that is installed on the tool head spindle is different from the one removed than it is important to re-map or change the tool type that is represented in the software to match the one which is installed.

-
- Power on gantry

Note: Tools do not need to be recalibrated unless cut accuracy is critical to 0.010" or less. If calibration is needed refer to operator's manual.

Caution: Failing to re-map a tool after changing tool types can result in damage to the cutting table surface, tool and or tool spindle. (Example: changing a punch to a drag knife).

Drag Knife Assembly

- Turn the power off to the gantry, use lock out / tag out if required.
- Loosen the two allen head screws on the tool holder.

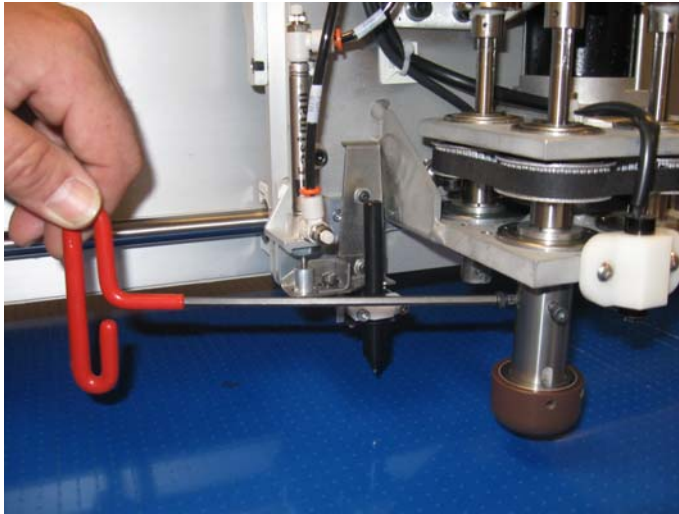

- Carefully slide the drag knife assembly off the tool head spindle.
- Ensure that the removed drag knife assembly is placed in a safe area because it contains sharp edges that pose hazards.

- Install new knife assembly on the desired tool head spindle ensuring that the alignment tang is engaged on the spindle.

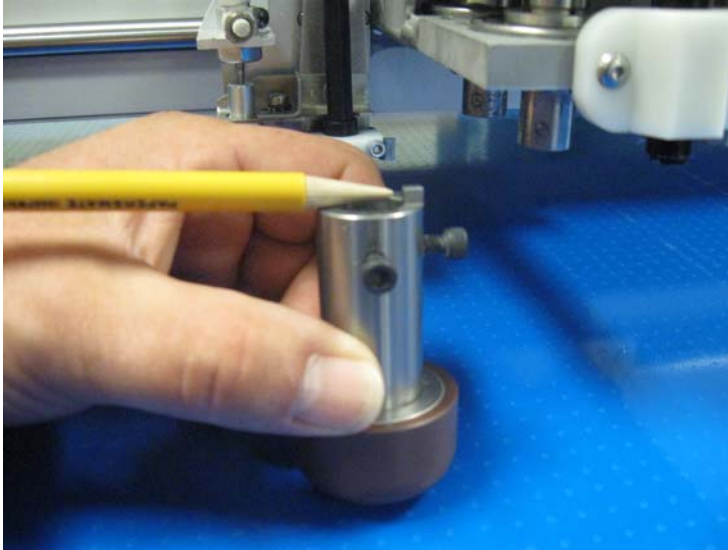

- Tighten the two allen head screws on the tool holder to secure it to the tool head spindle.
- If the tool type that is installed on the tool head spindle is different from the one removed than it is important to re-map or change the tool type that is represented in the software to match the one which is installed.
- Power on gantry.

Note: Tools do not need to be recalibrated unless cut accuracy is critical to 0.010" or less. If calibration is needed refer to operator's manual.

Caution: Failing to re-map a tool after changing tool types can result in damage to the table cutting surface, tool and or tool spindle. (Example: changing a punch to a drag knife).

Punch Assembly

- Turn the power off to the gantry, use lock out / tag out if required.
- Loosen the allen head screw on the tool holder.

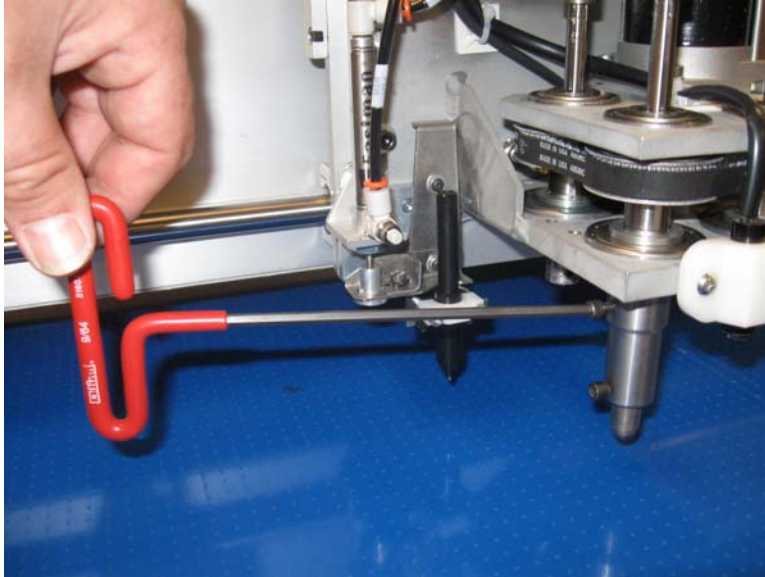

- Carefully slide the punch assembly off the tool head spindle.
- Ensure that the removed punch assembly is placed in a safe area because it contains sharp edges that pose hazards.
- Install new punch assembly on the desired tool head spindle ensuring that the alignment tang is engaged on the spindle.

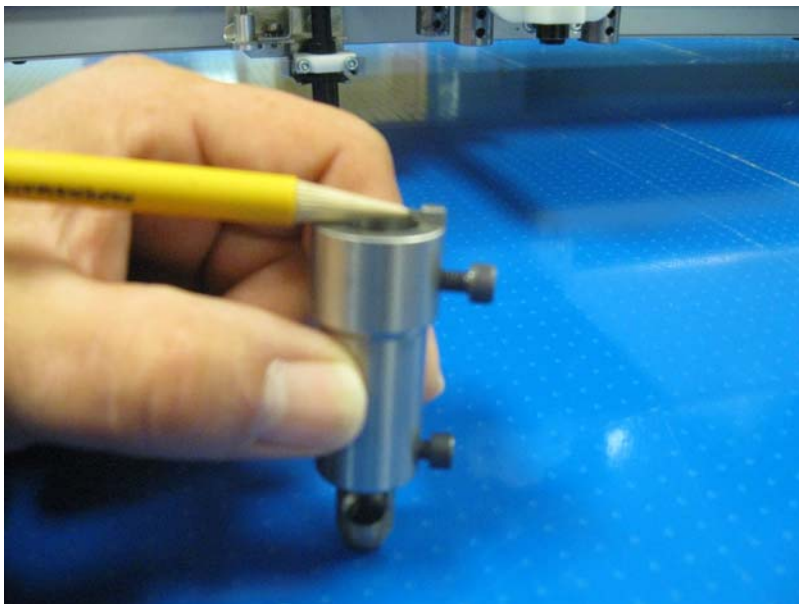

- Tighten the allen head screw on the tool holder to secure it to the tool head spindle.

Eastman®

Over a Century of Cutting Expertise

- If the tool type that is installed on the tool head spindle is different from the one removed than it is important to re-map or change the tool type that is represented in the software to match the one which is installed.
- Power on gantry.

Note: Tools do not need to be recalibrated unless cut accuracy is critical to 0.010" or less. If calibration is needed refer to operator's manual.

Caution: Failing to re-map a tool after changing tool types can result in damage to the table cutting surface, tool and or tool spindle. (Example: changing a punch to a drag knife).

Round Knife

- Place the tool holder assembly with the worn round knife to be replaced on the bench mount holder supplied by Eastman.
- The tool holder assembly should be secured on the bench mount holder with the alignment tang engaged to prevent movement.



- Using nut drivers supplied by Eastman loosen the bolt which secures the knife and depth limiters to the holder.

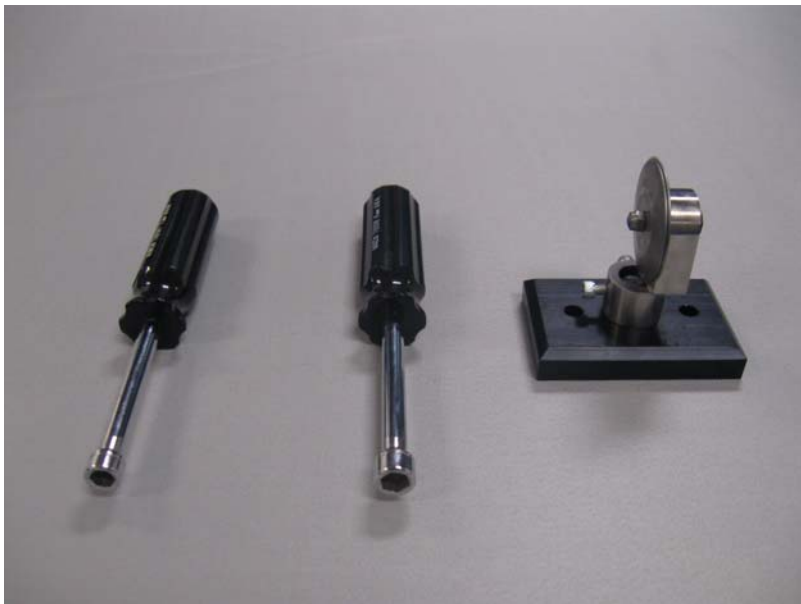



- Carefully remove the worn knife and replace with a new knife which is supplied by Eastman. Ensure that the depth limiters and new knife are installed in the same sequence as removed. Properly dispose the used / worn knife.

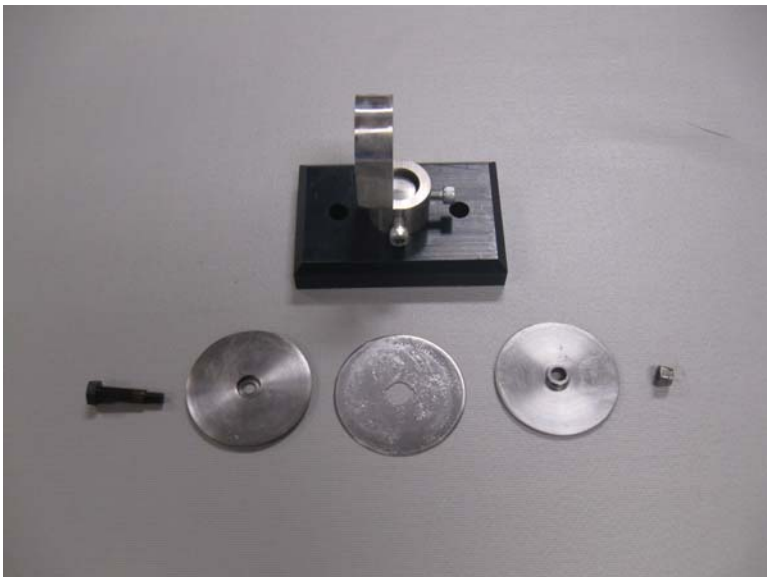



Drag Knife

- Place the tool holder assembly with the worn drag knife to be replaced on the bench mount holder supplied by Eastman.
- The tool holder assembly should be secured on the bench mount holder with the alignment tang engaged to prevent movement.



- Using allen wrench loosen the two screws found on the depth limiting plastic crown and the remove the depth limiting plastic crown from the tool holder assembly.

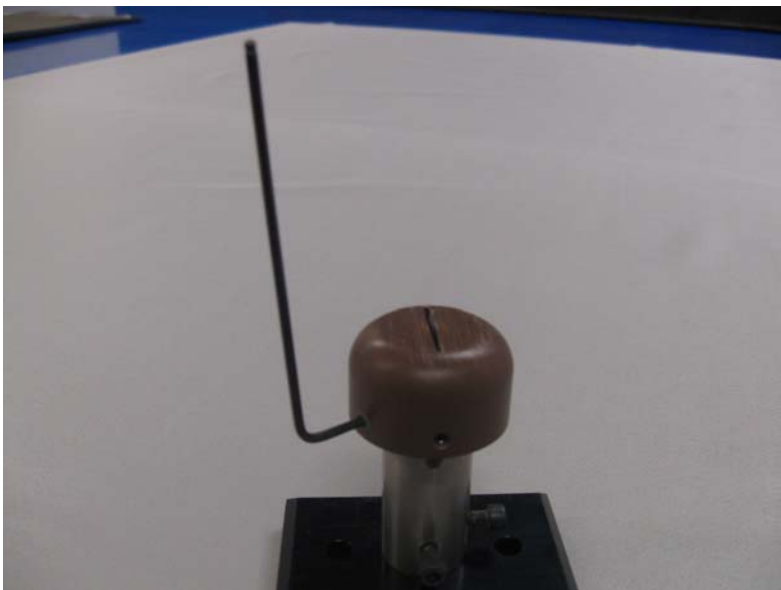

-
- Loosen the set screw that retains the knife in the holder.



- Carefully remove the worn knife and replace with a new drag knife. Ensure that the knife is replaced with the sharp edge pointing to alignment tang. Properly dispose the used / worn knife.



Eastman®

- If a change in depth of penetration is required for the knife, remove the assembly from bench mount holder, adjust the depth of set screw found inside the tool holder bore using allen key.
- Tightening the screw will result in less blade exposure, loosening the screw results in more blade exposure. It is advised the blade be exposed only enough to cut the material as required else may lead to damages to the cutting surface.

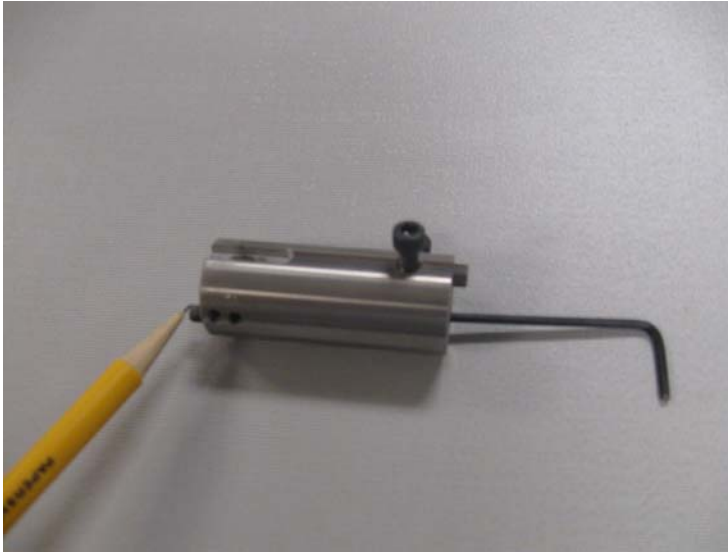

- Return the depth limiting plastic crown back on to the tool holder assembly and tighten both screws.

Punch

- Place the tool holder assembly with the worn punch to be replaced on the bench mount holder supplied by Eastman.
- The tool holder assembly should be secured on the bench mount holder with the alignment tang engaged to prevent movement.



- Using allen wrench loosen the allen head screw which holds the punch to the tool holder.
- Remove the worn punch and replace with new punch.



- Using allen wrench tighten the allen head screw which holds the punch to the tool holder.

Removal of Plotter Pen to replace Pen refill

- Using allen wrench remove the screws which holds the white plastic saddle.

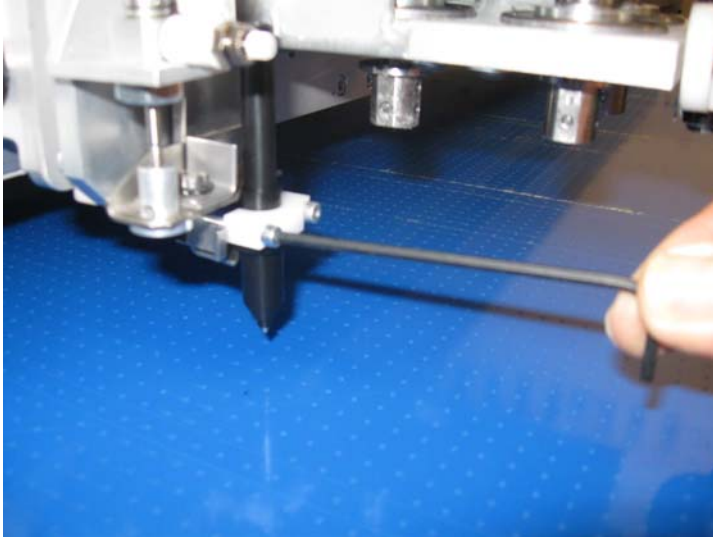

- Remove the plotter pen.

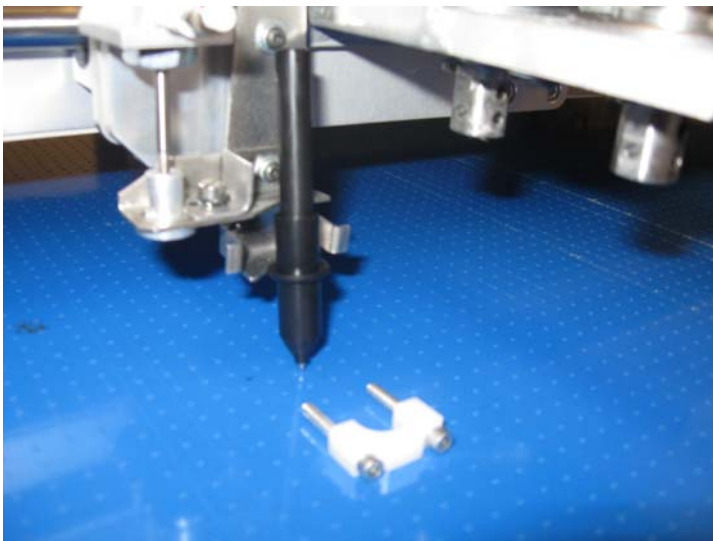

-
- Unscrew the plotter pen exposing the pen refill.

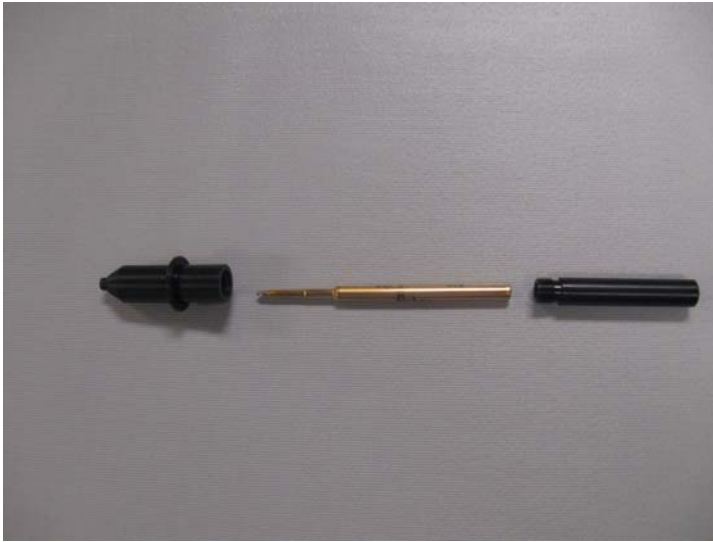

- Replace with new refill.
- Reassemble the plotter pen.
- Return plotter pen and white plastic saddle by mounting and tightening the screws with the allen wrench.

Airbrush Ink refill

- When the ink supply runs low, replace the 1/2 pint ink bottle with a fresh bottle of ink. This will eliminate impurities clogging the air brush.
- If refilling the ink reservoir from gallon containers, the ink reservoir should be drained and cleaned periodically depending on the ink usage. This will help avoid thick sediment from forming at the bottom of the ink reservoir.
- Ink should always be shaken before refilling or installing a new ink reservoir.
- The vent hole in the ink reservoir should be closed with the sealing pin when not in use. If the vent hole is not sealed, the ink will thicken and may cause airbrush clogging.

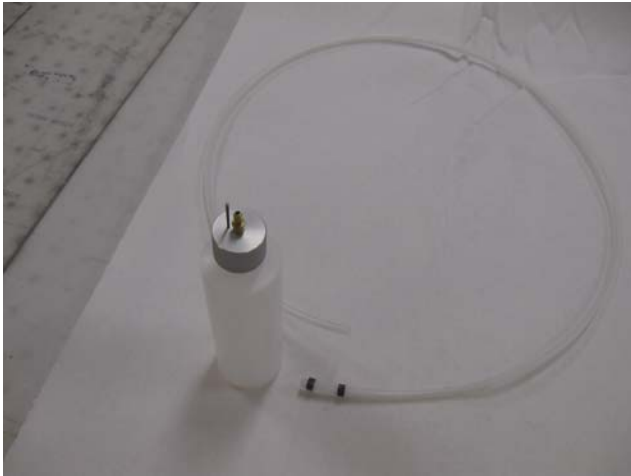

- It is recommended to activate the airbrush at the beginning and end of each shift since the ink is self cleaning ink it will clean the air brush as and when it is activated.
- If the ink is washable then 6 months shelf period is very important.

Note: washable ink has a 6 month expiration period. After expiration period the ink can potentially damage the air brush.

Cleaning of Airbrush

The air brush stylus has been designed for minimum maintenance. The leather packing washers should be lubricated once a month with light oil. Old packing washers cause leakage of air or fluid.

Flush clean solvent through the fluid passage of the stylus and wipe off the outside with clean solvent. Never leave the entire stylus immersed in solvent. Dirty spray caps and tips should be cleaned by soaking in solvent and blow clean with air.

Please note: Never use wire or sharp instruments to clean ports as permanent damage may occur.

Spray Tip and Cap Replacement

1. Remove the Airbrush stylus from tool head.
2. Release needle pressure from the seat of tip, by backing off the fluid adjusting nut.
3. Loosen spray cap nut and remove spray cap and spray tip. Leave needle in place.
4. Check cap and tip size. Install new cap and tip. Note: use only matching size cap and tip.
5. Secure spray cap nut.

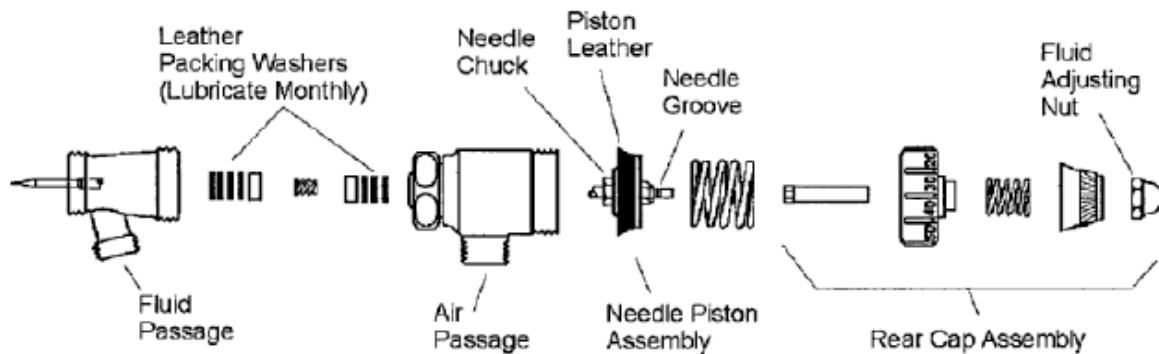

Needle Removal

1. Remove the Airbrush stylus from tool head.
2. Release needle pressure from the seat of tip, by backing off the fluid adjusting nut.
3. Remove the rear cap assembly.
4. Using a pair of pliers, grip the needle piston assembly nut and pull the assembly out.
5. Loosen the needle chuck and slide needle out.
6. Replace needle to desired position and secure needle chuck.
7. Reassemble in reverse order.

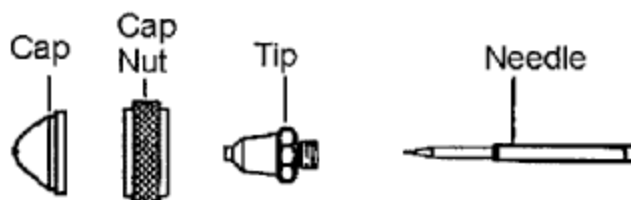

Needle Setting

Ink should be mixed thoroughly and always strained through a lint free cloth or fine mesh strainer before using.

The needle-piston assembly has a needle chuck which locks the needle in position. The single groove on the shank of the needle indicates location at which to lock the piston. Lock piston slightly below mark for use with very heavy fluids and slightly above mark (nearer blunt end) for light fluids.

Ex: Eastman MP style ink requires the groove to be completely covered.

Porex Plastic Table Surface

This procedure outlines the proper operation for changing the Porex table surface on the Eagle Static cutting system. Adhering to the following steps will reduce costly down time and ensure that the machine will operate properly when the procedure is complete. A clean and true cutting surface will guarantee that the machine can perform to its optimum level and that the cut parts will come out clean and precise.

Note: Always consult a trained Eastman Technician for the required size and the number of Porex table surfaces that are needed for your individual application.

Removing the Porex Surface

1. Remove the aluminum table end covers from both ends of the machine. If the machine is equipped with a Blue Jay End cutter it must also be removed.
2. Starting from one end of the machine begin scraping the Porex surface from the wooden tabletop using a flat wide putty knife. Be careful not to damage the wood surface underneath.
3. Remove all pieces of the Porex material until only the wooden tabletop remains.
4. Scrape the remaining glue from the wooden tabletops. A solvent may be required in areas where glue is built-up and difficult to remove.

Replacing the Porex

1. Mask off the table rack and rail using plastic drop cloths and masking tape. This is important to keep glue over spray off of the precision ground rails. The cutting gantry should also be covered using additional plastic drop cloths.
2. Carefully remove the Porex sheets from the shipping container, use caution in material handling as the sheets can easily be cracked and broken through careless handling.
3. Stack the Porex sheets onto the table at the end where gluing will start.
4. Test fit the first piece onto the table by lining the sheet up with the table edge. Using a pencil mark the edge of the sheet on the table.
5. Flip the sheet upside down with rough side up and place it on the far side of the mark you just made.
6. Using Spray Adhesive (67-26036) apply a medium coat of glue on the table surface, holding the can about 12"-14" away. Spray the glue in an even pattern back and forth the width of the sheet marked on the table. This coat should be even, not too wet and have a frosted appearance. Repeat the process by going back and forth across the table surface in a slow sweeping motion to ensure the entire table surface is coated. (This coat should also have a frosted appearance.) An entire can of spray adhesive is required to ensure enough glue is on the table surface.

WARNING

When applying the spray adhesive it should be done in a well ventilated area. Anyone working in the area is required to wear a respiratory to prevent inhalation of glue. Follow all safety instruction and cautions on spray can.

Caution

If the area the machine is located has a high humidity (above 40%) use a fan over the prepared table surface to prevent moisture from setting on and reacting with the adhesive applied to table and Porex surfaces. Allow enough room between sheets for Porex to expand and contract based on the high and low seasonal temperatures of the factory.

7. Using about half a can of glue per sheet, spray a light dusting of glue onto the rough side of the Porex sheet. This will provide a tacky surface for the glue already applied to the table to adhere too.
8. With the assistance of another person carefully line up the Porex sheet with the end of the tabletop. Leave equal distance between the rack plate and the Porex sheet on either side of the machine. Once the sheet is lined up it can be set in place. Using a tile roller, roll the entire surface of the Porex sheet making sure that the sheet is completely bonded to the table surface.
9. Utilizing another drop cloth, cover the surface that was just laid down and prepare the next sheet of Porex for application. Leave about a 1/8" between the first and second sheet of Porex. Mark the edge of the second sheet.
10. Remove the sheet and prepare the surface for gluing.
11. Follow the procedure outlined above for all additional Porex sheets.
12. Any Porex overhanging at the end of the table can be trimmed off using a sharp knife.
13. Any additional accessories that were removed from the machine (Blue Jay End Cutter) can now be reinstalled.

Seam Gluing Procedure

1. Once all the panels are glued in place, the drop cloths and masking tape can be removed from the machine.
2. Using a hot glue gun (67-26035) and Eastman Special Porous Plastic Glue Sticks (67-26034), fill in the seams left between panels. Make sure that the glue penetrates the entire seam from the table surface to the top of the Porex sheet. Fill in all of the seams between sheets but leave the gaps between both the rack plates and the Porex sheet empty.
3. Using a sharp putty knife or straight knife, scrape the excess glue from the top of the seam.
4. Continue this procedure until all seams are filled and scraped.

Replacing the XMP Controller Card and Loading Configuration Files

The Eagle Static cutter uses one XMP Controller card located inside the Computer. The XMP controller card communicates over the purple network cables with all of the Motor Amplifiers and the Slice Input/Output (IO) cards. This communication results in coordinated motion between the Gantry Cutting Tools and ensuring the most accurate cutting possible. The Configuration Files contain parameters for each node on the network (Controller Card, Amp, Slice IO, etc.).

In the rare case that a Controller Card needs replacement, the loading of the proper Configuration Files should be done with the help of Eastman's Technical Service Department. If the Eagle Machine's Computer is hooked up to the internet, Eastman's Technical Service Department has the capability of remotely accessing your machine through the internet and loading the proper files for you. If not, technical service can be provided over the phone.

Do not attempt to load the files yourself. Improper parameters can result in unpredictable machine operation. This may cause damage to your machine or injury to an operator.

Pressure Transducer Calibration

This topic is on hold for now as software team has to work on the same.

Disassembly and Assembly Instructions for Parts requiring Service

Replacement of X Motor Belts

Removing the X Motor Belts

1. Power down the machine using proper shut down / lock out procedures.
2. Remove the (6) screws using hexagonal wrench found on the left and right side of covers from both the operator and non-operator side of the gantry.



3. Remove the (6) screws using hexagonal wrench found on the control panel from both the operator and non-operator side of the gantry and place the control panel upwards.



-
4. Remove the (4) screws found on either side of the electronics tray and swing the electronics tray outwards.



5. Loosen the (4) screws of the motor and now the motor will drop down to loosen the tension on the belt.

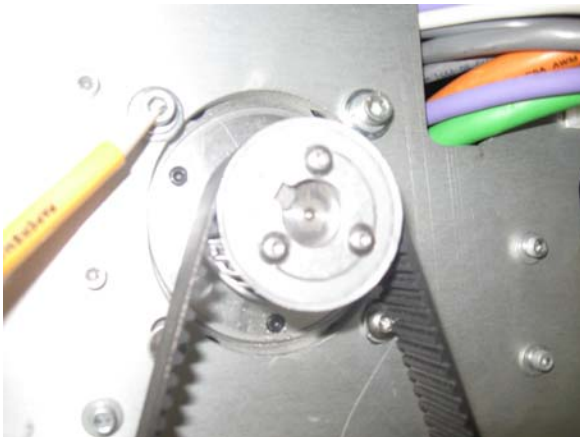

6. Cut the (2) zip ties found on the shaft support plate.



7. Remove the (6) screws found on the shaft support plate.

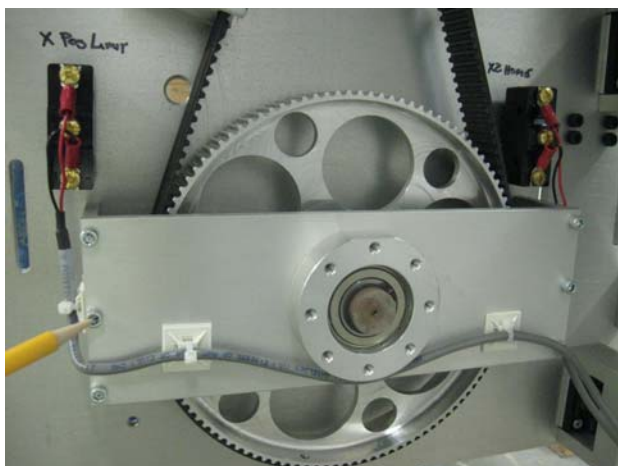

8. Rotate the shaft support plate to convenient orientation to get access to the belt.

-
9. Loosen the belt guide and push it outwards so that so that it will help relieve the tension on belt.

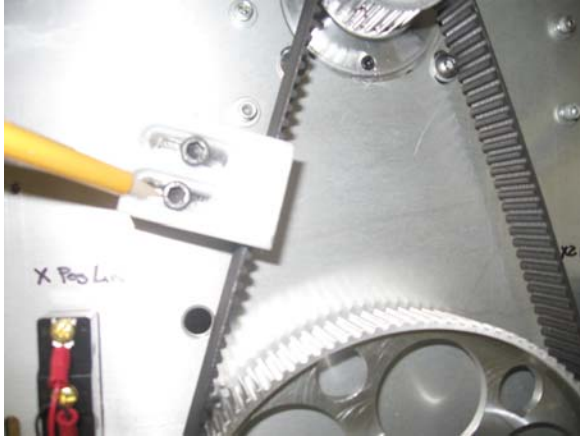

10. Remove the worn out belt.



Replacing the X Motor Belts

1. Take a new belt.
2. Put it on the big pulley and roll it on the motor pulley a couple of times until it seats itself.
3. Pick up the motor and put a screw driver under the motor housing and pick up the screw driver to get tension to the belt.



4. Tighten the (4) screws of the motor to get the tension on the belt.
5. Return the (6) screws back on the shaft support plate.
6. Return the (2) zip ties found back on the shaft support plate.
7. Return the control panel and secure it back with the screws.
8. Return the covers of the gantry and secure it back with the screws.

Replacement of Y Motor Belt

Removing the Y Motor Belts

1. Power down the machine using proper shut down / lock out procedures.
2. Using hexagonal wrench remove the (2) screws found on the left and right side of tool head cover which secure the tool head cover to the Y-car.



-
3. Remove the (4) screws found on the upper hinge which secure the top tool head cover.



4. Remove the (4) screws found on the left and right side of tool head bottom cover and remove the bottom cover.



5. Remove the two control I/O cables from the I/O block.
Note: the Y amp control I/O cable plugs into J1 and the theta amp control I/O cable plugs into J2.



6. Remove the (3) screws on the operator side of the Y car and slowly open the electronics tray and ensure that no wires interfere.

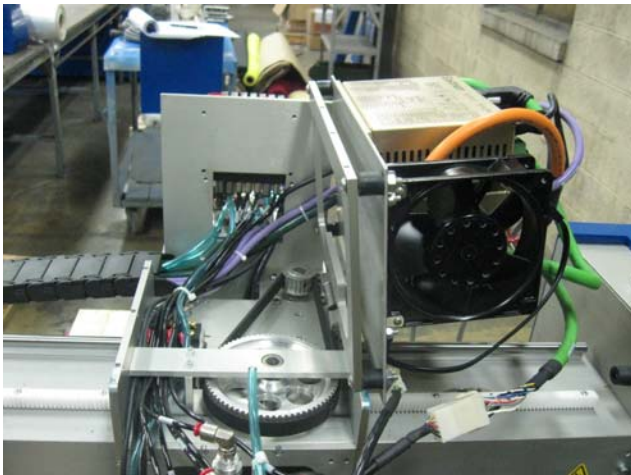
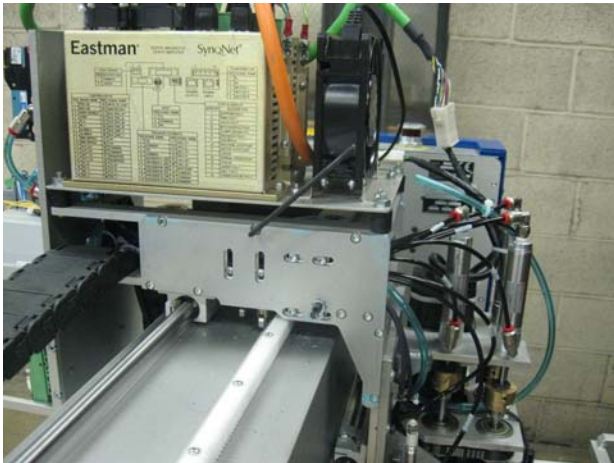

-
7. Remove the (2) screws found on the operator side on the Y pulley plate.

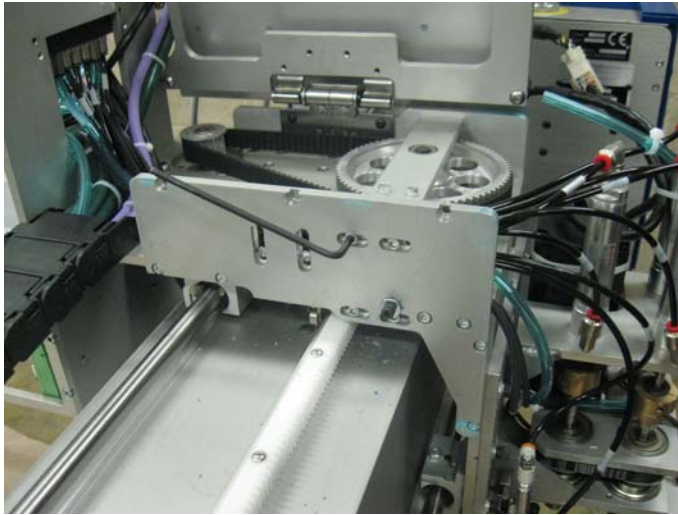

8. Remove the (2) screws found on the T of the Y pulley plate.

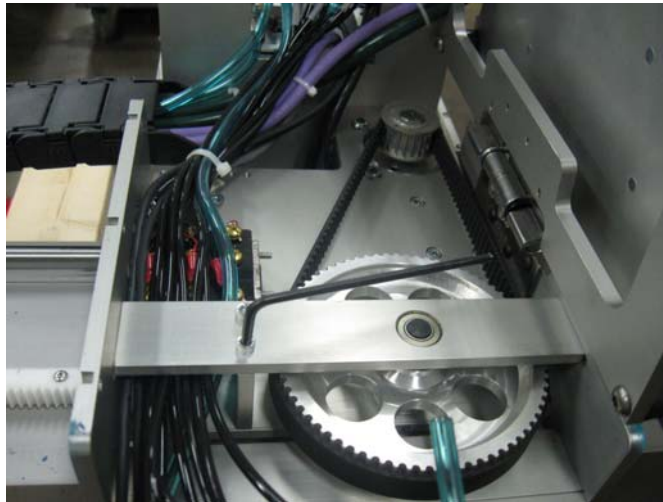

9. Remove the screws found on the non-operator side of Y pulley plate.

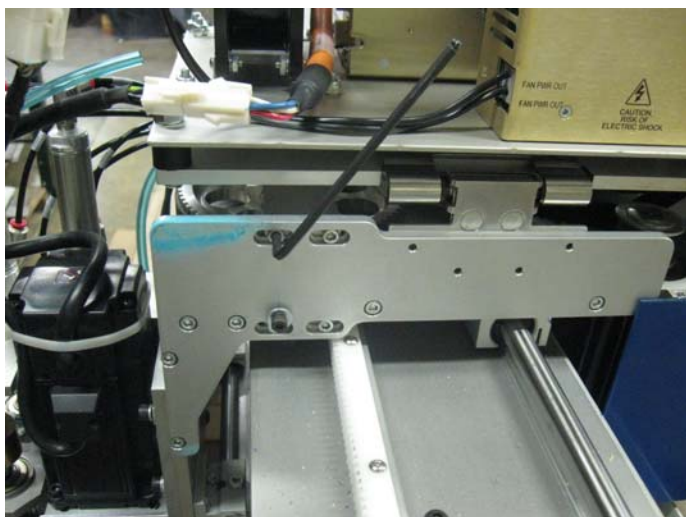

10. Remove the pulley plate.

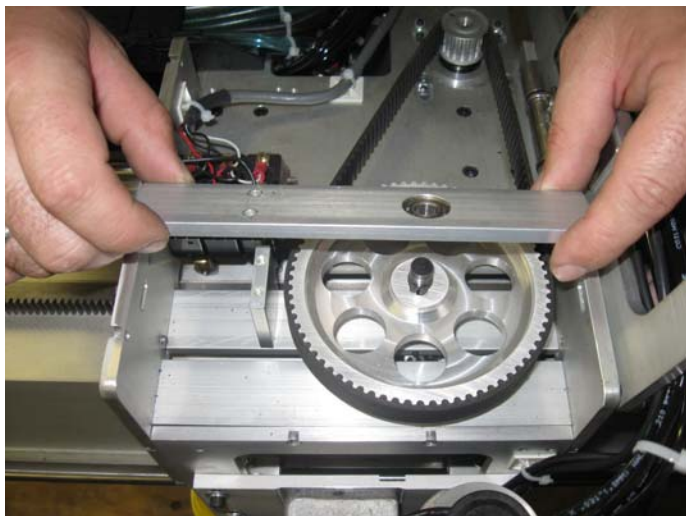

-
11. Loosen the (4) screws which hold the Y-motor mounting screws to take off the tension.

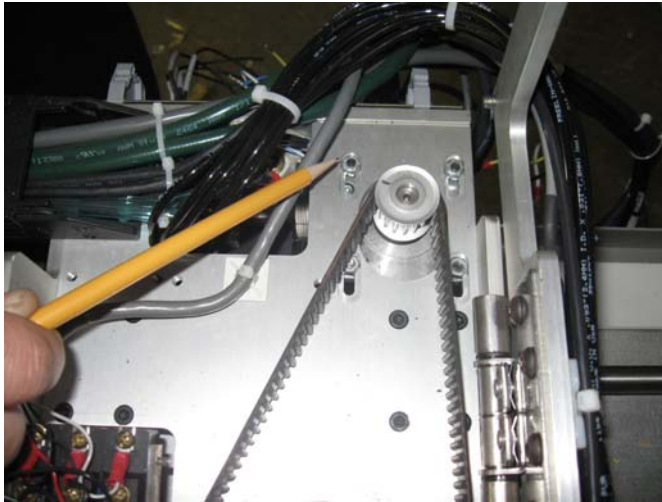

12. Loosen the belt and remove the worn out belt.



Replacing the Y Motor Belt

1. Take a new belt.
2. Put it on the big pulley and roll it on the motor pulley a couple of times until it seats itself.
3. Pick up the motor and put a screw driver under the motor housing and pick up the screw driver to get tension to the belt.
4. Tighten the (4) screws of the motor to get the tension on the belt.
5. Return the pulley plate.
6. Return the screws found on the non-operator side of Y pulley plate.

7. Return the (2) screws found on the T of the Y pulley plate.
8. Return the (2) screws found on the operator side on the Y pulley plate.
9. Return the (3) screws on the operator side of the Y car and slowly close the electronics tray and ensure that no wires interfere.
10. Return the two control I/O cables from the I/O block.
11. Secure the tool head top and bottom covers.

Replacement of Theta Motor Belt

On hold for now.

Replacing the X-axis Linear Bearings

It is important to regularly inspect and replace the linear bearings on the Eastman Eagle static machine. Properly maintaining your linear bearings with grease and regular replacement will prevent damage to the linear rails, increase life of spur gears, increase cutting performance and accuracy.

 **NOTE**

All work should be performed by a qualified technician with power turned off to the machine in accordance with company lock out procedures.

Removing Linear Bearings:

1. Power down the machine using the proper shut down/lock out procedures.
2. Remove the covers from both the operator and non-operator side of the gantry.
3. Remove the end stops from all four corners of table.

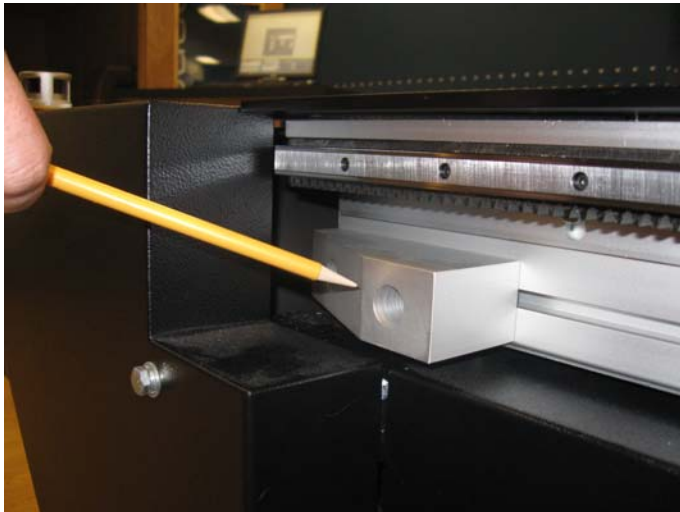

4. Place 2" x 4" wooden blocks under both the operator and non-operator side of gantry.

5. Remove the (4) screws which hold the linear bearing block to the side plate. Repeat this step for all the (4) bearing blocks.



- 6.. Unscrew the backlash adjusting screw from the backlash adjusting block until the gantry is resting on the 2" x 4" wooden blocks.



7. Remove the (4) screws from the bearing block which hold the bearing. Repeat this step for all the (4) bearing blocks.

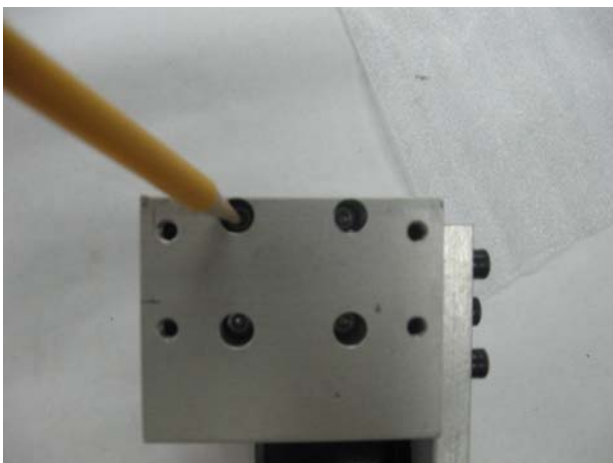

Installing New Bearings:

1. Remove new bearings from package and press the Zerk grease fitting provided into the bearings. Using a grease gun and the grease gun adapter provided with machine, fill the bearings with white or clear lithium grease.
2. Mount the bearing to the bearing block by securing it with (4) screws. Ensure the grease fitting is pointing to the outside of gantry for easy access.
3. Slide the bearing and bearing block unto the linear rail. Be careful not to damage the bearing seals when mounting on rail.
4. Position the bearing and bearing block directly under each of backlash adjusting screws and replace the screws through the side plate and into the bearing blocks. Do not fully tighten screws until the backlash is adjusted.
5. Begin adjusting the backlash adjusting screws to raise the gantry. Use a level to make sure that both blocks on each side plate are adjusted level to each other.
6. Adjust the backlash adjusting screws until the X-axis spur gear is fully engaged into the gear rack. Pull back and forth on the X-axis belt and ensure that there is no backlash between the gear and gear rack. (The gantry should move immediately when changing belt direction. The gantry should move easily without a dead spot).
7. Tighten the screws which hold the bearing block to the side plate and recheck the backlash. Re-adjust the backlash if necessary.

Replacing the Y-axis Top Linear Bearings

It is important to regularly inspect and replace the linear bearings on the Eastman Eagle static machine. Properly maintaining your linear bearings with grease and regular replacement will prevent damage to the linear rails, increase life of spur gears, increase cutting performance and accuracy.

 **NOTE**

All work should be performed by a qualified technician with power turned off to the machine in accordance with company lock out procedures.

Removing Linear Bearings:

1. Power down the machine using the proper shut down/lock out procedures.
2. Remove the top and bottom covers of the tool head found on the Y car of the gantry.
3. Remove the (8) screws found on the Y car which secure the linear bearings to the Y-car.

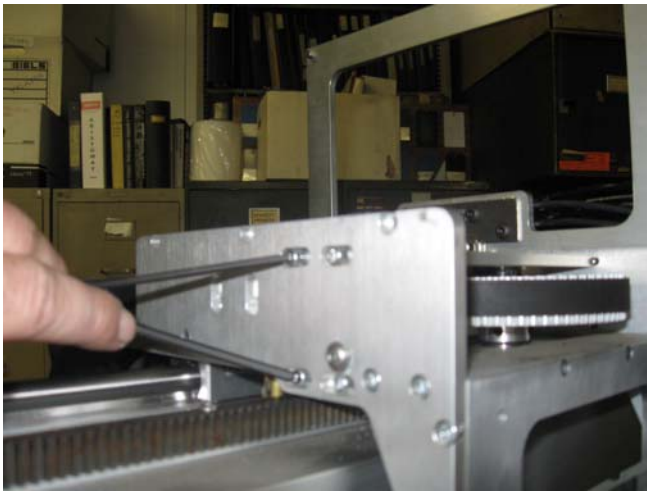

4. Lift the Y car slightly.

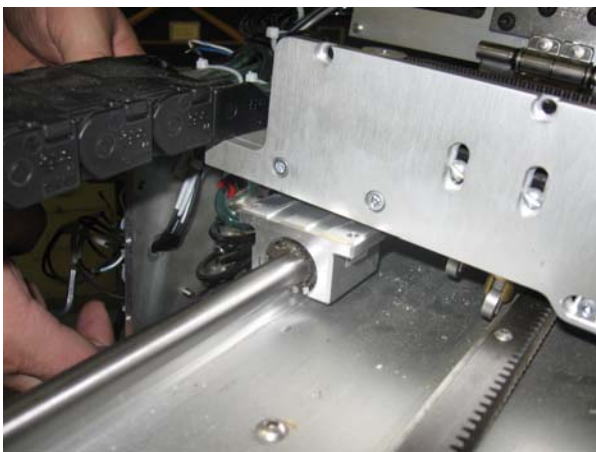

-
5. Slide the (2) bearings out towards the operator side.



6. Slide the (2) bearings out towards the operator side plate and remove them through the access relief / cutout.



Installing New Bearings:

1. Remove new bearings from package and press the Zerk grease fitting provided into the bearings. Using a grease gun and the grease gun adapter provided with machine, fill the bearings with white or clear lithium grease.
2. Slide the new bearings onto the linear rail and ensure that bearing adjustment screws are accessible from the back of gantry.



3. Be careful not to damage the bearing seals while mounting on the linear rail.
4. Slide the bearings under the Y-car and align with the mounting holes and secure back the (8) screws.
5. After the replacement of new bearings check for the Y car backlash and adjust as required.
6. Please note: bearing replacement may effect Y-car cutting calibration.

Replacing the Y-axis Front Linear Bearings

It is important to regularly inspect and replace the linear bearings on the Eastman Eagle static machine. Properly maintaining your linear bearings with grease and regular replacement will prevent damage to the linear rails, increase life of spur gears, increase cutting performance and accuracy.

 **NOTE**

All work should be performed by a qualified technician with power turned off to the machine in accordance with company lock out procedures.

Removing Linear Bearings:

1. Power down the machine using the proper shut down/lock out procedures.
2. Remove the top and bottom covers of the tool head found on the Y car of the gantry.
3. Identify all air lines marking them for spindle location and function if not already marked.



4. Disconnect all air lines by depressing the red color buttons and slightly pulling on the air lines.



5. Disconnect the theta motor cable and theta feedback cable.

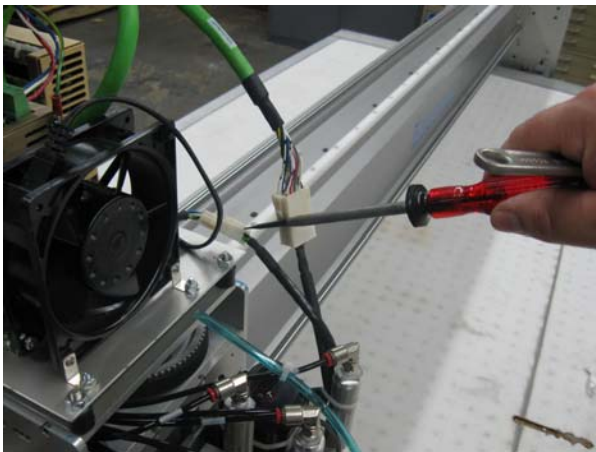

6. Remove the (6) screws which secure the tool head to the Y-car assembly.



-
7. Disconnect the laser pointer wiring from the back of Y-car assembly.
 8. Disconnect the positional sensor from the back of Y-car assembly.
 9. Remove the (8) screws which secure the linear bearings to the tool head interface plate.



10. Lift the Y car slightly.
11. Slide the (2) bearings out towards the operator side.

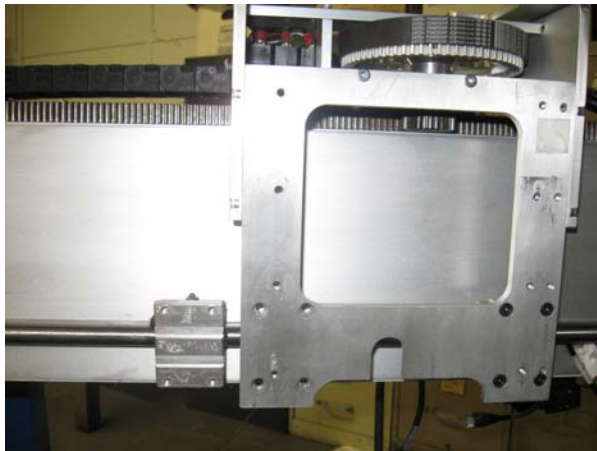

12. Slide the (2) bearings out towards the operator side plate and remove them through the access relief / cutout.



Installing New Bearings:

1. Remove new bearings from package and press the Zerk grease fitting provided into the bearings. Using a grease gun and the grease gun adapter provided with machine, fill the bearings with white or clear lithium grease.
2. Slide the new bearings onto the linear rail and ensure that bearing adjustment screws are accessible from the top of gantry.
3. Be careful not to damage the bearing seals while mounting on the linear rail.
4. Slide the bearings under the Y-car and align with the mounting holes and secure back the (8) screws.
5. After the replacement of new bearings check for the Y car backlash and adjust as required.
6. Please note: bearing replacement may effect Y-car cutting calibration.

Replacing the XMP Controller Card and Loading Configuration Files

The Eagle static machine uses one XMP Controller card located inside the Computer. The XMP controller card communicates over the purple network cables with all of the Motor Amplifiers and the Slice Input/Output (IO) cards. This communication results in coordinated motion between the Gantry Cutting Tools by insuring the most accurate cutting possible. The Configuration Files contain parameters for each node on the network (Controller Card, Amp, Slice IO, etc.).

In the rare case that a Controller Card needs replacement, the loading of the proper Configuration Files should be done with the help of Eastman's Technical Service Department. If the Eagle Machine's Computer is hooked up to the internet, Eastman's Technical Service Department has the capability of remotely accessing your machine through the internet and loading the proper files for you. If not, technical service can be provided over the phone.

Do not attempt to load the files yourself. Improper parameters can result in unpredictable machine operation. This may cause damage to your machine or injury to an operator.

Pressure Transducer Calibration

This topic is on hold for now as software team has to work on the same.

Adjustment Procedures and Specifications for parts requiring Service

Checking and Adjusting Gantry Backlash

This procedure ensures that the gantry drive gears are properly engaged to the gear racks so that pieces are accurately processed on the automated cutting machine. Performing this procedure also helps to minimize wear, repair, and replacement of gantry drive components. Any excessive backlash will result in accuracy issues observed in the cut piece.

Checking Gantry Backlash

1. Power-up automated cutting machine, zero the table, & move gantry to center of table.
2. Stand in front of operator side of gantry & alternately push from left to right against rear top corners of cover assembly – enabled gantry drive motors will resist movement.



3. If there is any free side-to-side movement there exist a backlash.
4. Repeat steps 1 thru 3 for non-operator side of gantry.
5. If free side-to-side movement is detected (backlash)
 - a) Turn off main power switch on the control cabinet.
 - b) Remove cover to access drive belt.
 - c) Pinch gantry drive belt & lightly pull it up & down, but not enough to move gantry.



- d) If no free movement in drive belt is found then backlash is okay. Replace cover assembly, ensure cable is reconnected.
- e) If free movement in drive belt is found then adjust the gantry backlash.

Adjusting Gantry Backlash

1. Remove all screws from gantry E-chain cover allen wrench & remove cover. (Although this step is not required, it allows for easier access & adjustment).
2. Slightly loosen eight (8) screws holding two (2) rail car connectors to gantry side plates using an allen wrench.

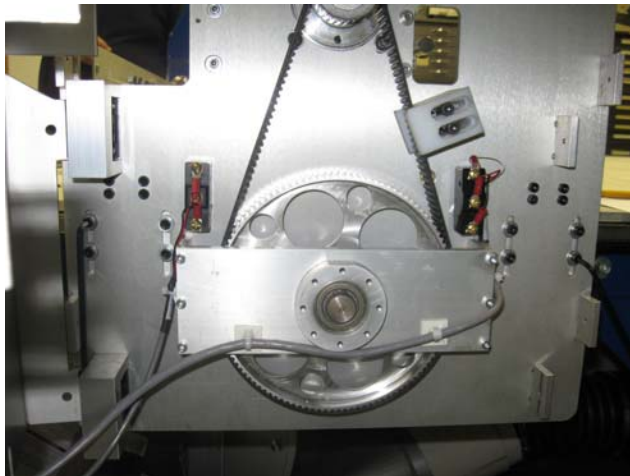

3. Place a level across top edge of the gantry side plate.

4. Using an allen wrench, turn each of two (2) backlash adjusting screws $\frac{1}{4}$ -turn clockwise into backlash adjuster block, raising gantry side plate, & raising gantry drive gear tighter into gear rack. Adjust screws so that gantry side plate remains level.

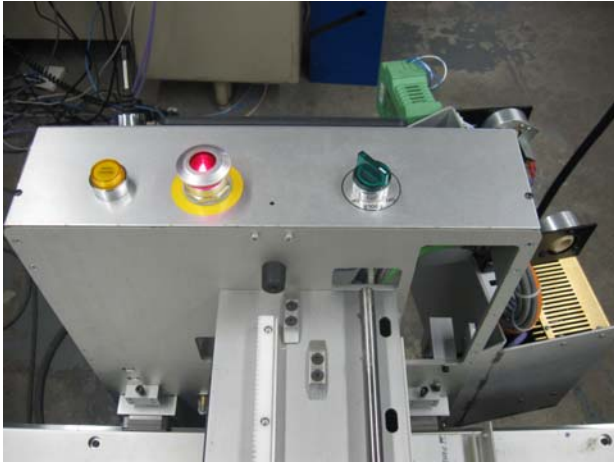

5. Recheck gantry drive belt backlash. Repeat adjustment until free movement in drive is eliminated. Do not over-tighten backlash else gantry movement will be restricted, causing amp faults & excessive drive component wear.
6. Retighten eight (8) screws holding two (2) rail car connectors to gantry side plates.
7. Recheck drive belt backlash again & readjust if necessary.
8. Replace gantry cover.
9. Perform the same procedure for non-operator side of gantry.
10. Replace E-chain cover.

Checking and Adjusting Y-car Backlash

Checking Y-car Backlash

1. Power down the machine using proper shut down / lock out procedures.
2. Hold the pulley and move the Y-car back and forth in Y direction and observe if there is any audible click or movement.

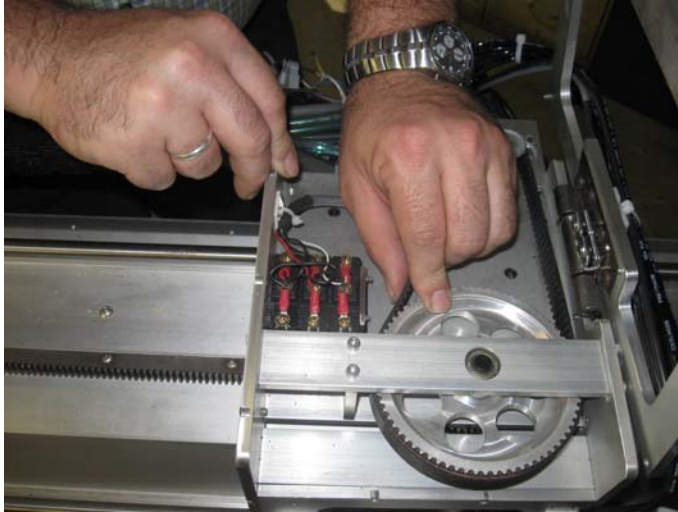

3. If there is any free side-to-side movement their exist backlash.
4. If free movement in drive belt is found then adjust the Y-car backlash.

Adjusting Y-car Backlash

1. Loosen motor mount bolts to relieve tension on drive belt.

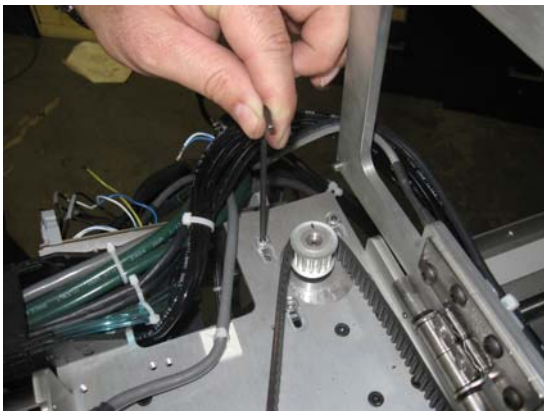

2. Loosen the (4) screws of the pulley plate on either side of the Y-car.

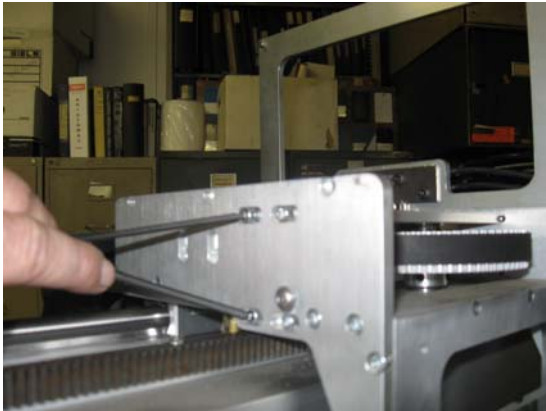

3. Tighten the (4) screws of the pulley plates on the non-operator side of Y-car.
4. Pull the pulley plate towards the linear rack and tighten the (4) screws of the pulley plates found on the operator side.



5. Ensure that all the (10) screws of the pulley plates are secured.

-
6. Using a screw driver or pry-bar apply pressure to motor belt to displace motor belt. Tighten the motor until there is no belt deflection.

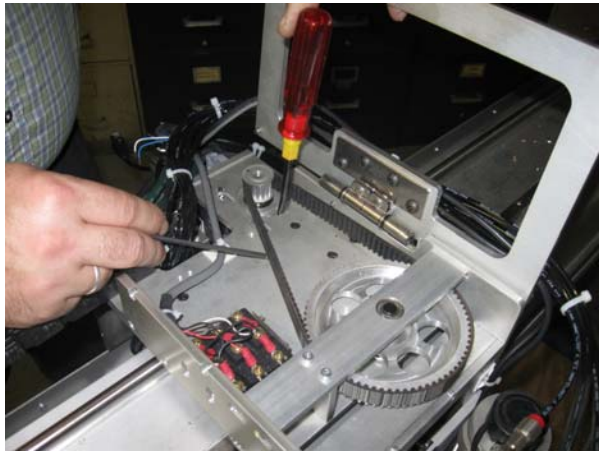

7. Tighten the motor mounting screws.
8. Please note when ever the belt is replaced the backlash adjustment should follow.

Checking and Adjusting Stop Discs

Checking Stop Discs

1. Power up the machine.
2. Move the stop discs to see if they are activated by a slight touch or vibration.
3. If the stop discs are not activated by slight touch or movement are then adjust the stop discs.

Adjusting Stop Discs

1. Remove the operator side cover which will expose the stop disc mechanism.
2. Check the plunger by the pause switch on the stop disc.
3. Loosen the nut while holding the set screw with allen key.

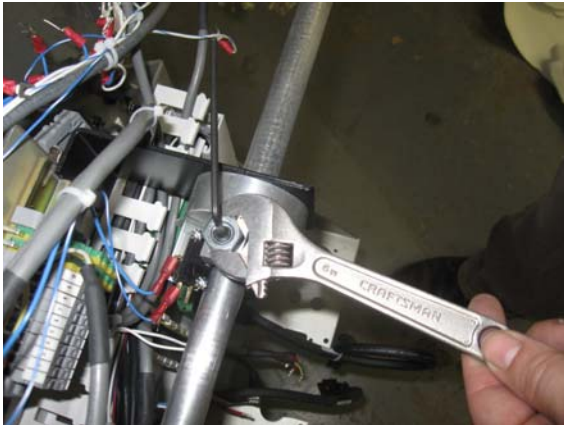

-
4. Tighten the set screw which in turn increases the force on the detent ball until sufficient tension is applied to the stop disc rod.

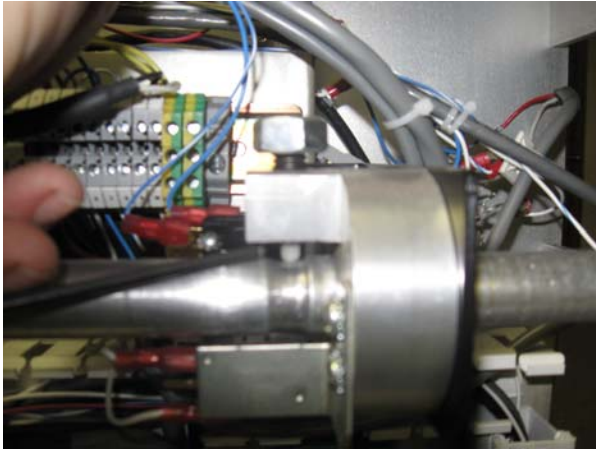

5. Tighten the nut while holding the set screw in position.
6. Return the cover.
7. Check the operation of stop disc.
8. Do the same check on non-operator side.

Scheduled Maintenance Procedure

CAUTION

It is important to perform regular maintenance on the equipment. A daily, weekly and monthly schedule should be maintained. Failure to do so can result in more frequent breakdowns damage to equipment and/or injury.

Proper Maintenance will help to ensure the reliable operation of your Eagle Static cutting system. You should allow 5 to 10 minutes for daily inspection, 30 minute weekly inspection and one hour monthly inspection. Time invested on these tasks will minimize downtime. Eastman Machine Company is not liable for damage as a result of poor maintenance and any resulting damage would be repaired at user's expense. All maintenance should be performed by qualified personnel, following all safety procedures.

The following is the recommended maintenance schedule:

Daily (Start of each shift)

1. Carefully inspect the machine and cutting table area. Look for any debris, loose cables or other obstructions that may interfere with the machine movement and cutting.
2. After switching on the computer and plotter carriage, start the plotter program. Check the X and Y-axis for motor torque and backlash. If backlash is excessive on either axis, adjust as required.
3. Check the pen lift. Pen should move smoothly up and down. Ensure pen is seated properly in mount, and that retaining strap is tight.
4. **Warning: Activate machine pause before performing this procedure. Failure to do so can result in damage to the equipment and/or serious personal injury.**
Check tool head. Check that tools are securely fastened to tool shaft. If the round knife blade is installed check that the blade mount rotates freely. Check the blade mounts for excessive side to side play. Check blade edge for nicks and replace as necessary. Check limiting disks relative to material thickness and requirements. If a drag knife is installed check cutting depth relative to material thickness and requirements. Adjust drag knife foot as necessary.
5. At the end of each work session make sure to turn both the computer and plotter carriage off. Remove any CD's or floppy disks from disk drives and clean up scrap materials from the cutting table.

Weekly or every 40 hours

Warning: Before performing any of the weekly tasks make sure the gantry and computer are turned off at the disconnect and locked out. Failure to do so can result in damage to the equipment and/or serious personal injury.

1. Turn off gantry and computer at the disconnect and lock out power to the machine per your lock out/tag out procedures.
2. Using a clean dry rag wipe and clean the table rail linear bearings and lubricate with Eastman lubricant 67-26324.
3. Lubricate air reciprocating cylinder couplings using Eastman lubricant 67-26009. (Refer to lubrication chart).
4. Lubricate reciprocating tool head shafts using Eastman lubricant 67-26009. (Refer to lubrication chart).
5. Using compressed air, clean dust and debris from inside the carriage.
6. Use a clean cloth to wipe down the Y-axis rails and lubricate. (Refer to lubrication chart).
7. Tighten any loose fasteners on the Y-car.
8. Remove the cover from the Y-car. Inspect the cutting head assembly for dust and debris, worn belt, damaged shaft, worn bearings, etc.
9. Rotate the tool holders by hand. They should rotate freely without any play relative to each holder and the drive motor. If they don't rotate freely examine the bearings for wear, examine shafts for damage and or bent condition and check belt for wear and proper tension.

Monthly or every 200 hours

Warning: Before performing any of the monthly tasks make sure the gantry and computer are turned off at the disconnect and locked out. Failure to do so can result in damage to the equipment and/or serious personal injury.

1. Turn off gantry and computer at the disconnect and lock out power to the machine per your lock out/tag out procedures.
2. Remove X-axis gantry covers.
3. Use compressed air to remove any dust and debris from the gantry end plate assembly.
4. Lubricate air cylinder couplings found on tool head shaft using Eastman lubricant 67-26009. (Refer to lubrication chart).
5. Lubricate tool head shafts using Eastman lubricant 67-26009. (Refer to lubrication chart).
6. Check X, Y and theta drive belts for signs of wear such as cuts, frays, or missing teeth. Replace if required.

Eastman®

Over a Century of Cutting Expertise

7. Check belt tension. Belts should be tight enough to eliminate excessive backlash between the driving and driven pulley. Overly tight belts will wear faster and place excessive loads on bearings. Adjust at motor mount by loosening the screws and slide the motor pulley assembly to increase distance between the drive and driven pulley and tightening motor mount screws while ensuring proper tension in the belt is maintained.
8. Check all shafts and pulleys. The pulleys should be seated tightly on the shafts. Check pulleys set screws and tighten.
9. Move plotter manually by pushing on the Y-carriage. X-axis drives require two people. Carriage and drives should move with continuous smooth force. Listen and feel for "hard" spots that will indicate a failed linear bearing.
10. Check the Y-axis backlash (gear play). The Y-axis gear should be snug against the y-axis rack. To adjust backlash, loosen the (8) rail y-car backlash plate screws. Push the small y-car gear toward the y-car rack. Be careful not to bind the y-car gear with the y-car rack. When proper adjustment is reached tighten the backlash plate screws.
11. Check the X-axis backlash (gear play). The X-axis drive gear should be snug against the X-axis rack. To adjust backlash, loosen the (8) rail x-car connector screws enough to allow X-carriage to move. Turn the (2) backlash adjuster screws until there is no backlash (play) between carriage and table. Be careful not to bind the x-axis carriage with the x-axis rail. When proper adjustment is reached, tighten the (8) rail car connector screws to specified torque. Note that it is important to keep the carriage level. It is a good idea to place a bubble level on the carriage to ensure the carriage remains level as the carriage is raised and lowered. Perform this adjustment to both front and back x-cars.
12. Inspect carriage wheels for any material threads or debris wound up around the wheel shafts. Check wheels for debris and remove as needed.
13. Check all electrical plug connections to ensure they are securely fastened.
14. Inspect the x-festoon wire or e-chain (if so equipped) for wear and movement.
15. Check for unusual noises coming from blower assembly. If clicking or grinding noises heard then call Eastman service technician.

Lubrication Chart

Below are the lubrication points for the Eagle Static Cutter

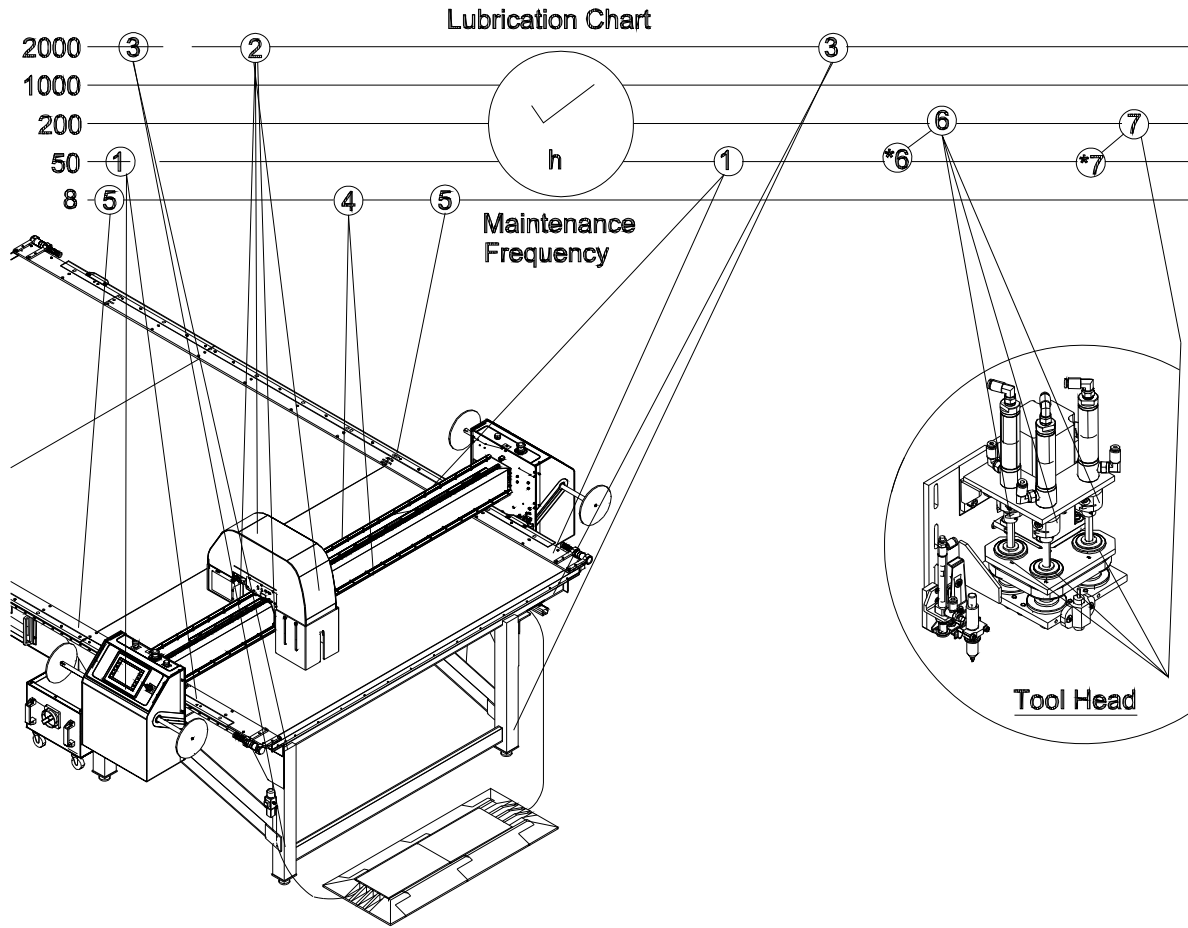

Gantry & Static Table

Machine Component	Gantry	Y-Car	Table Base	Gantry	Table Rail	Standard Tool Head		Reciprocating Tool Head	
Nature of Action / Action Point	1	2	3	4	5	6	7	*6	*7
Clean & Lube				8	8	200	200	*50	*50
Replenish	50	2000	2000						
Libricant Designation	Mobil: NLG1 Grade 2 Moblith AW-2			Mobil: SAE 10 Non-detergent Vactra No. 1		Loctite: Krytox PFPE Lubricant mfg# 29711			
Eastman No.	67-26324			67-26325		67-26009			

* Reciprocating tool head option only.

Eastman®

Over a Century of Cutting Expertise

Yearly Maintenance Checklist for Eagle Static Cutter

Below is the recommended maintenance checklist for the Eagle Static Cutter. It provides a good guideline for yearly maintenance and can be copied and kept as a maintenance log

Festoon & Cable Assembly	Comments	Signoff
Check & Secure festoon mounting track		
Check & Secure festoon roller track		
Check festoon end stop		
Check festoon end stop		
Check festoon trolley with webbing strap		
Check X-Axis cable festoon assembly (Loose connections or wear in cables)		
a) SynqNet In		
b) SynqNet Out		
c) UIT		
d) Gantry I/O		
e) Gantry Power		
f) Air Hose		

Front Cover Assembly	Comments	Signoff
Verify Stop Discs are operational		
Check Emergency Stop switch, wiring & light bulb		
Check Pause switch, wiring & light bulb		
Check limit switch & switch bracket		

Back Cover Assembly	Comments	Signoff
Verify Stop Discs are operational		
Check Emergency Stop switch, wiring & light bulb		
Check Pause switch, wiring & light bulb		
Check limit switch & switch bracket		

Control Panel Assembly	Comments	Signoff
Check U.I.T. control assembly & cables		
Check the joy stick for proper operation		
Check tools on/off switch, wiring & light bulb		
Check & Secure all screws		

Front End Plate Assembly	Comments	Signoff
Inspect drive belt (cracks, thread separation)		
Check & oil large pulley bearings		
Check X1 home switch & wiring		
Check X-ve limit switch & wiring		
Check wiring for 24V DC power supplies (Verify 24V DC power)		
Check & Secure all set screws		
a) Large Pulley		
b) X1 Motor drive pulley		
c) Spur gear		
Remove & inspect THK linear bearings(2)		
Check that the electronics tray is securely fastened to front end plate on both sides		
Check wiring and cables for any wear, cracks or loose connections		
Check all screw terminals to ensure that wiring is secure		
Check & adjust backlash for X1 motor assembly		
Check & Secure all screws		

Back End Plate Assembly	Comments	Signoff
Inspect drive belt (cracks, thread separation)		
Check & oil large pulley bearings		
Check X2 home switch & wiring		
Check X +ve Limit switch & wiring		
Check & Secure all set screws		
a) Large Pulley		
b) X2 Motor drive pulley		
c) Spur gear		
Remove & inspect THK linear bearings(2)		
Inspect all cable connections into gantry from X-axis E-chain		
a) SynqNet In		
b) SynqNet Out		
c) UIT		
d) Gantry I/O		
e) Gantry Power		
f) Air Hose		
Check that the electronics tray is securely fastened to front end plate on both sides		
Check wiring and cables for any wear, cracks or loose connections		
Check all screw terminals to ensure that wiring is secure		
Check cable mount & E-chain mount		
Check & adjust backlash for X2 motor assembly		
Check and secure all screws		
Check pressure regulator for calibrated output pressure		

Main Tube Assembly	Comments	Signoff
Check Y-Home switch and cam for proper operation		
Check Y +ve and Y -ve limit switch & cam for proper operation		
Check Y E-chain cables		
a) Y-car power cable filtered		
b) SynqNet In		
c) SynqNet out		
d) UIT		
e) Y-car power cable unswitched		
f) Y-car I/O cable		
g) Airline tubing		
Check that the electronics tray is securely fastened to front end plate on both sides		
Check wiring and cables for any wear, cracks or loose connections		
Check all screw terminals to ensure that wiring is secure		
Check & Secure linear Thompson Rail & oil or grease rail as required		
Check & Secure gear rack		
Check & Secure all screws		

Y-Carriage Assembly	Comments	Signoff
Inspect Y motor drive belt (cracks, thread separation)		
Check that the electronics tray is securely fastened to front end plate on both sides		
Check all screw terminals to ensure that wiring is secure		
Check Y Motor disconnect plug		
Examine Solenoid Block		
a) Use manual trigger to fire each solenoid		
b) Check for air leaks		
Check & Secure all set screws		
a) Large Pulley		
b) Y Motor drive pulley		
c) Spur gear		
Inspect Thompson Linear bearings		
Adjust Y-motor assembly backlash		
Check & Secure all screws		
Check Y Home switch		
Check Y +ve and Y -ve limit switches		
Check amplifier connections		
Inspect electrical components for any damage and ensure they are securely fastened to the Y-car		
Inspect & oil pen lift bearing assembly		

Tool Head Assembly	Comments	Signoff
Inspect theta motor drive belt (cracks, thread separation)		
Grease 16mm bearings(3) for air cylinders - Use Loctite High performance grease		
Test theta Home proximity sensor		
Secure theta Motor drive pulley set screws		
Examine cylinder motion - Fire cylinders manually via solenoid block		
Inspect the sharpening housing		
Inspect the knife intellicut system for any loose parts or wiring		

Rack & Rail Assembly	Comments	Signoff
Clean & oil THK rails		
Check Rack & Rail gap(s)		
Check Rack & Rail for wear		
Secure all screws		
a) Tighten ¼-20 2" Rack button screws		
b) Tighten #10-32 1/2" Rack button screws		
c) Tighten M3x16 Rail screws		
d) Tighten ¼-20 3/8" Dust cover screws		
e) Tighten #8-32 3/8" Cam (limit) screws		
f) Tighten ¼-20 3" shock mount screws		

Static Table Assembly	Comments	Signoff
Secure 3/8-16 1" Frame screws		
Secure angle brace(s)		
Examine Porex and/or Lexan surface		
Check table square and level		

Vacuum Components	Comments	Signoff
Examine PVC vacuum plumbing		
a) Check Silicon seals		
b) Vacuum leaks		
Examine 7.5HP blowers		
If using a VFD inspect & clean the cooling fan		
Inspect all power cables for any cracks or visible wear		
Inspect blower motor for any damage & clean any dust or debris found on the motor		

E-box Assembly	Comments	Signoff
Clean fan filter		
Use dry air to clean inside		
Tighten all screw terminals		
Secure all plugs and connections		
Check wiring for 24 VDC power supply & transformer		

Additional Comments:

Inspectors Signature:

Date:

Trouble Shooting Guides and Aides

UIT Error Messages

This has to be developed by software hence it is on hold as of now.

Additional Trouble Shooting

Any troubleshooting or maintenance performed on the machine should be done by a qualified technician. Before performing any work follow proper electric lockout procedures at your facility. All power to the machine should be off and proper care taken to prevent damage to the machine and/or injury.



WARNING

Failure to remove power and take proper safety precautions when performing maintenance and/or trouble shooting can result in injury or death. All work should be performed by a qualified technician.

The following trouble shooting covers machine problems that are not associated with software and/or does not generate an error message.

Problem: UIT Does Not Power Up

Description of Problem:

The UIT does not power. Screen is blank and not lit up.

Troubleshooting:

1. Touch the screen to see if it turns on. If the machine sits for a long period of time the touch screen goes into a sleep mode to protect the screen.
2. Check the power switch on the electronics drawer is in the on position.
3. Make sure that eSuite is running on the cutting machine PC.
4. Find the power over Ethernet injector (PoE) located behind the electronics drawer and check the green LED on the PoE injector. The LED on the front face is illuminated
5. If there is no green LED lit, check the AC input on the PoE injector. If the AC power is gone then check back through the AC power cable. Also check the fuse F4 which is the 115 VAC fuse in electronics drawer that protects the PoE injector.

Problem: Machine Stop during Cut due to unintentional pause

Description of Problem:

The machine stops in middle of cut and displays message “Machine Paused, Press Zero, Next or Abort” on Touch Screen. When pressing NEXT on the keypad, the machine will continue to cut where it left off. This is typically caused by an intermittent pause circuit, usually in the stop discs.

Troubleshooting:

1. Move the stop discs to see if they are activated by a slight touch or vibration.
 - a) Remove Operator side cover of gantry.
 - b) Check the plunger by the pause switch on the stop discs. If the plunger is too loose, tighten it to prevent the pause switch from activating.
 - c) Do the same check on the non-operator side.

Problem: The buttons on the Touch Screen are out of alignment

Description of Problem:

The buttons on the touch screen do not line up with the where the screen needs to be touched to activate the command. Operator needs to push above, below, right or left of the button for the command to take effect.

Troubleshooting:

The following procedure outlines the steps required to calibrate a touch screen on the Eastman Eagle static gantry. If you notice buttons are not lined up while you are pressing them a Touch Screen calibration may be needed.

Procedure:

1. Power down system including gantry power at the Diagnostic box.
2. Place finger on upper left corner of the touch screen while power is turned off.



3. With finger is still on touch screen have a co-worker turn gantry power on at the Diagnostic Box.

Eastman®

Over a Century of Cutting Expertise

4. After the "Power On Setup" screen appears, remove your finger from the corner of touch screen.



5. After the Power On Setup screen appears, use the left and right arrows to navigate, and select to enter a sub-menu. Toggle to page 2 until you see the calibration screen, and select to enter the sub-menu. Toggle down until Touch Screen is highlighted and select it to activate it.



6. Using a very small screw driver, paperclip or a fine tip object, press the center of the cross that is located at the top left corner of the screen.



-
7. Follow the same procedure for the bottom right cross.



8. Navigate to page 3 and toggle down to Save and Exit and select it.



9. Your Touch Screen will restart in normal mode. It is ok to run the machine after all proper startup procedures are followed.

Problem: Gantry goes past limit and hits End Stops

Description of Problem:

While cutting certain files, the gantry runs to end of table and hits end stops.

Troubleshooting:

1. Check the table limits to make sure that each tool can reach to the laser position without hitting a table limit.
 - a) Click on “eCut” then click on “Check Reference” in the main eSuite menu
 - b) After the table finishes zeroing, press “Yes” on the check table limits pop up box
 - c) On the Touch Screen Keypad press the “Y” then the “ENTER” key (ENTER key on keyboard)
 - d) The table will check the table limits to make sure each tool can reach within the set limits.

If the Y-car or Gantry hit a limit switch, reset the table limits in eSuite by clicking on eCut then “Machine Settings” and finally the “Size” tab. Adjust “Table Top”, “Table Bottom”, “Table Right” or “Table Left” limits as required.

Problem: The Cutting Tool or Pen does not come down.

Description of Problem:

A tool or Pen does not come down when cutting a file or they are delayed coming down at the beginning of a cut. This can be caused by an electrical short, tool mapping in software or a problem with the power supply.

Troubleshooting:

1. Make sure that Tool power on gantry is turned on. This can be verified by making sure the laser pointer is on.
2. Check the mapping of your tools and the layers are mapped properly under each tool.
 - a) The quick way to verify tool and layer mapping is to look at the tool bar at the bottom of the eCut window. If there is no Tool Bar then click on “View” then click on “Layers” and “Tools” in the main eSuite menu.
 - b) If the layer is not mapped to a tool or the tool is not on the tool holder then just click and drag the tool to the spindle or the layer to the tool before sending the file to the cutter.

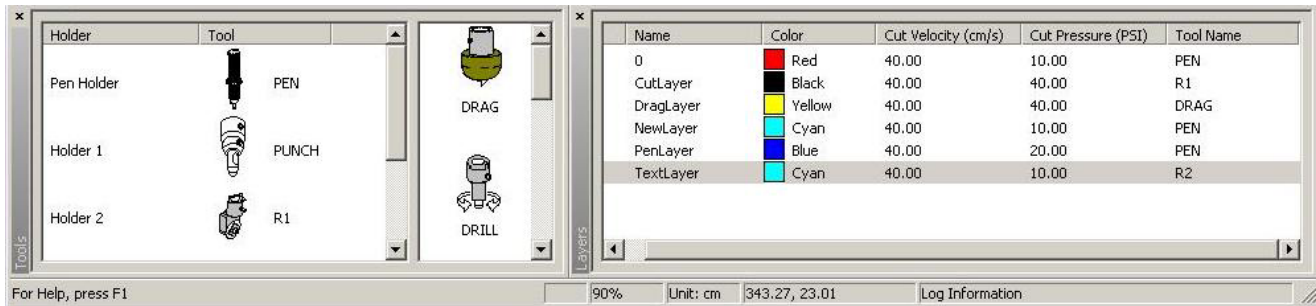

3. With eSuite closed, check tool holder to see if it moves freely and is not bent.
4. Make sure you have pressure at the tools. Try pulling tool holder down by hand to see if it has pressure.
5. Check the tool connections on the Y-axis Board on Y-car.
 - a) Hit the Cut Down button on the UIT and verify the corresponding LED lights for desired tool.
 - b) Try firing the tool manually by pressing red button under solenoid block. Each solenoid can be manually fired by pressing the individual button.
 - c) Try swapping the (4) pin MTE connector with the connector for another tool to see if tool fires.
6. The Pen or Tool delays coming down and misses beginning of marking or cut.
 - a) Check the voltage on the 12 VDC power supply. Make sure it is a minimum of 12 VDC.
 - b) Check solenoid connectors at Y-axis Board. Make sure you have good connection.
 - c) Bend pins on 12 VDC power supply out to get a better connection.
 - d) Try replacing 12 VDC power Supply. The supply may be going bad and can not deliver enough current.

Problem: Slivers in Y Direction

Troubleshooting:

1. Check backlash in the Y axis by physically trying to move the Y-car with gantry powered. If there is backlash power down the gantry and remove tool cover.
 - Inspect all pulleys for signs of slippage on the shaft.
 - Tighten the Y-axes motor belt by loosening motor mounting screws and sliding motor until the belt is tight.
 - With the power to the gantry off move the Y-car along the Delron rack. Make sure that the spur gear makes good contact with the rack from one side of the gantry to the other. If the spur gear does not make full contact loosen the screws holding down the Y-axis rack. Position the Y-car on one side of the table. As the Y-car passes each screw make sure that the rack makes full contact with the spur gear before tightening down the screw. Push the Y-car across the entire width of the table until all screws are tightened.
2. Inspect all pulleys on the Y-car for any indication it is slipping on the shaft. Mark the pulley and shaft with a marker and cut a file. When the machine stops, check the mark to verify pulley did not slip.

Problem: As the table cuts the Y-axes Home position begins to move to one side

Troubleshooting:

1. Inspect all pulleys on the Y-car for any indication it is slipping on the shaft. Mark the pulley and shaft with a marker and cut a file. When the machine stops, check the mark to verify pulley did not slip.
2. Verify there is no RF interference which may be causing the encoder signal to be off.
3. The Y-axes motor may have a bad encoder and needs to be replaced.

Problem: Motors Do Not Power-up

Troubleshooting:

1. Verify Gantry is powered.
 2. Verify that no E-stop is depressed.
 3. Try closing and restarting eSuite software.
 4. For further trouble shooting contact Eastman technical support.
-

RF/EMI Interference

Some factory environments may have equipment that generates Radio Frequency (RF) or Electro-Magnetic Interference (EMI). These signals in close proximity to the Eastman Eagle-S3 static machine can generate electrical noise and cause problems for the machine and computer. (Eastman does offer a shielded mouse.) It is recommended that any RF Welders or other equipment generating RF or EMI noise be a minimum of 75 feet (23 meter) from the static cutter.

Problems of this nature are typically difficult to resolve and must be approached in a systematic manner. To reduce the effects of electrical noise generated by RF, Eastman Machine Company has the following recommendations:

- Install an earth ground as close as possible to the transformer feeding AC power to the cutting machine and power feed unit.
- Enclose all AC power cables in rigid conduit and ground securely to the earth ground, Route the four power cables for the computer controls around the end of the table instead of under the unit, and
- Ground conduits to the frames of the power feed unit and the static cutter assemblies as well as to the individual chassis of the computer control assembly.
- Implementation of the foregoing should at least reduce the level of interference to a workable level but in the event that it does not, you should be prepared to provide RF and/or install power line filters as needed.

Electrical Schematics & Pneumatic Diagrams

The following electrical and pneumatic drawings are for reference only. Eastman maintains the right to change electrical and pneumatic specifications without notice. Any modifications to machine wiring without written permission from Eastman Machine Company shall void all warranties.

These drawings and specifications are the property of Eastman and shall not be reproduced, copied, used or disclosed to any third party without prior written consent of Eastman.

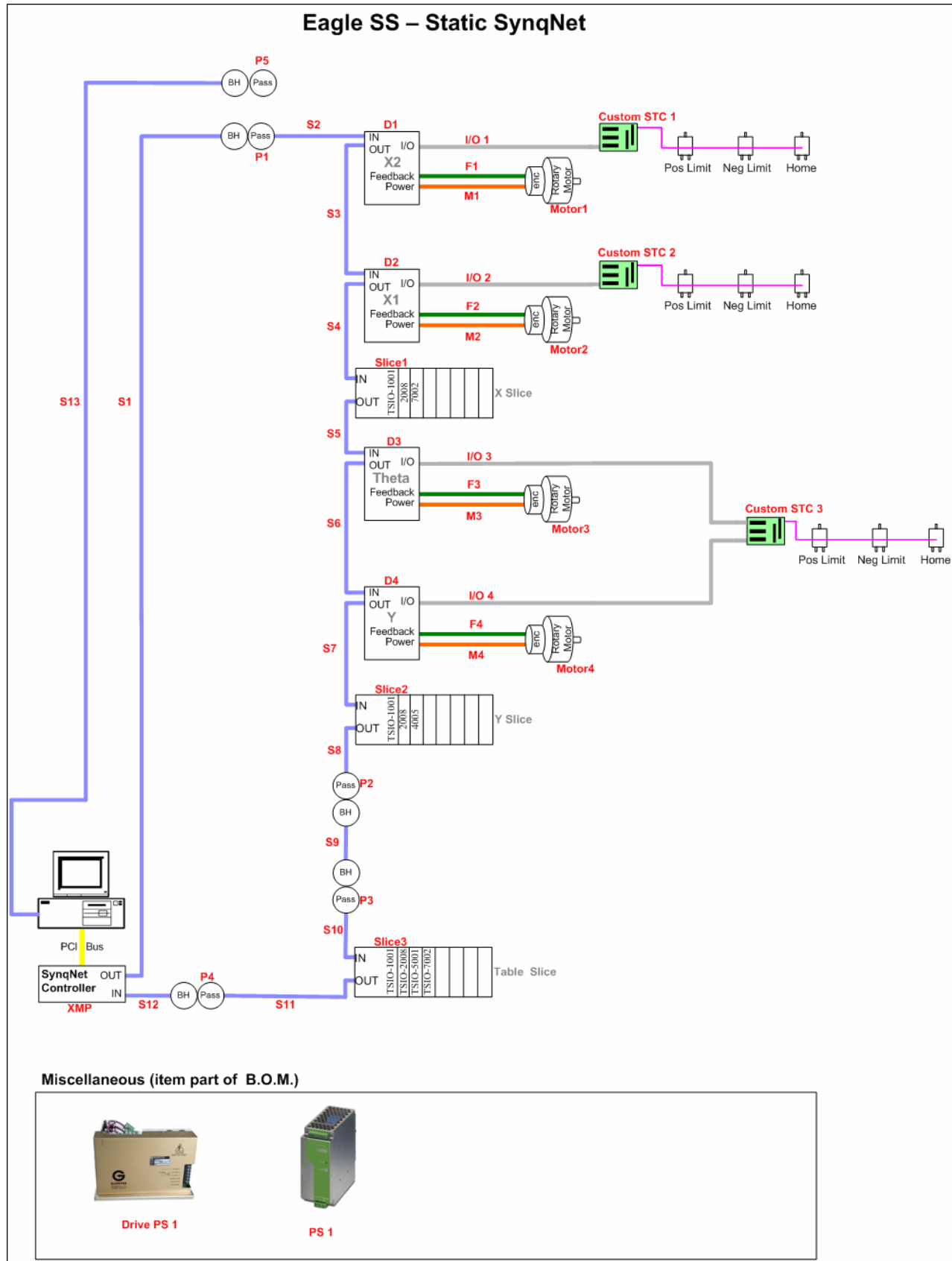

				MATERIAL SEE LIST OF MATERIALS		Eastman Machine Company 779 Washington Street, Buffalo, NY 14203-1396	
				HEAT TREAT -		EAGLE SS/ROUTER	
				FINISH -		BLOCK DIAGRAM	
				TOLERANCES UNLESS OTHERWISE SPECIFIED: XX ± .01 FRACTIONAL: ± 1/64 XXX ± .005 ANGULAR: ± 1° SURFACE FINISH PER ANSI B46.1 125 RMS SURFACE PROFILE		SCALE: NONE SIZE: C	
				15396 NEW RELEASE 9/12/07 SGJ		DRAWN BY: SGJ DATE: 9/12/07	
				EON REV CHANGES DATE BY		31-9000-35	

These drawings and specifications are the property of Eastman and shall not be reproduced, copied, used or disclosed to any third party without prior written consent of Eastman.

Primary wiring shown for 230 VAC Input Power - (Non-Router) Configuration

Static Table - Non Router Configuration

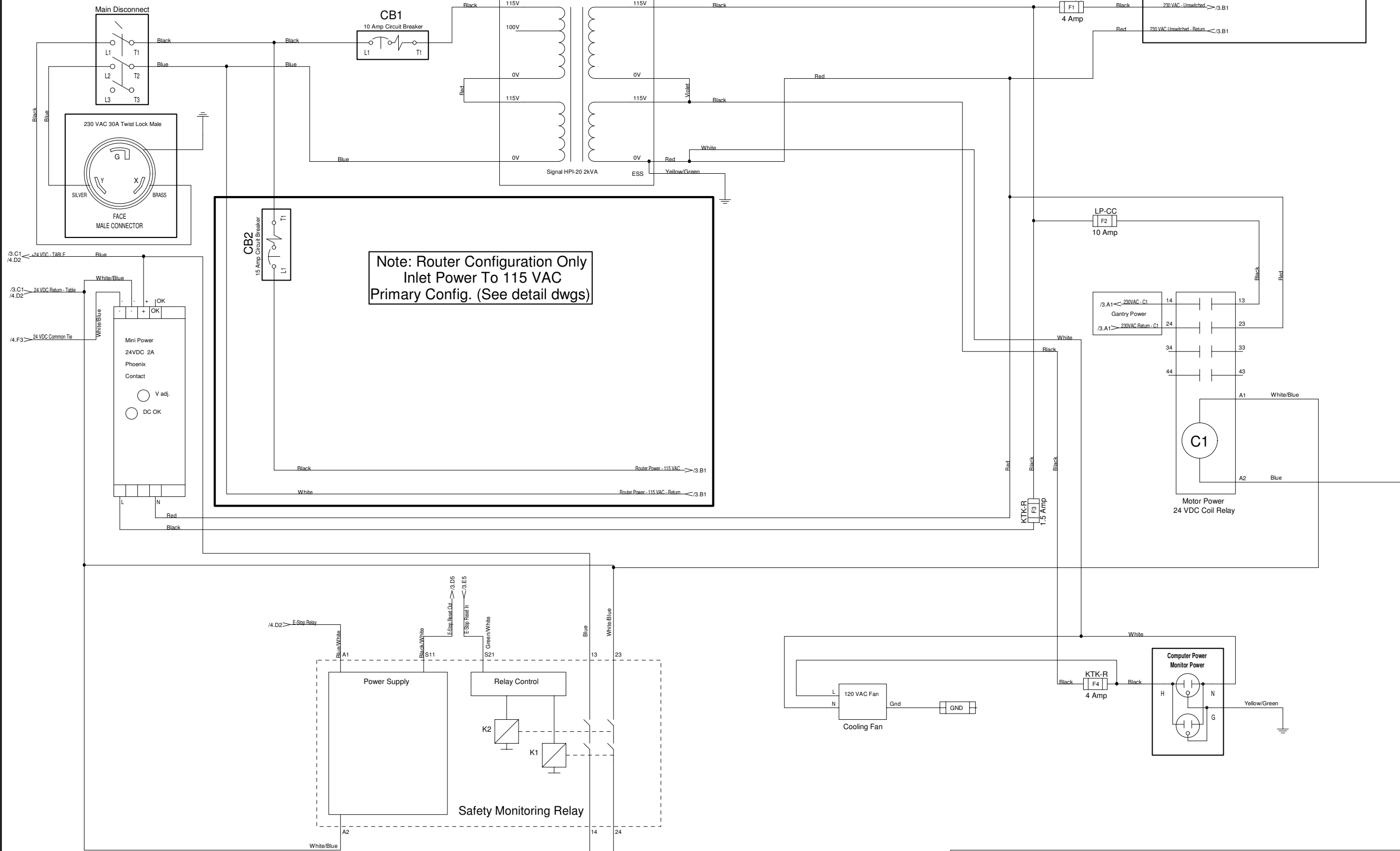

Note: Router Configuration Only
Inlet Power To 115 VAC
Primary Config. (See detail dwgs)

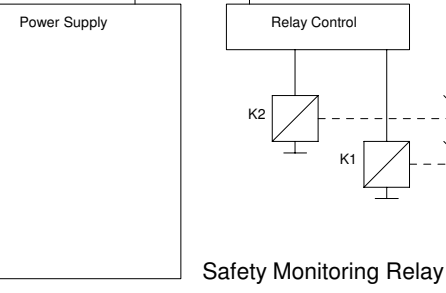

15396	NEW RELEASE	9/12/07	SQJ																	
REV	CHANGES	DATE	BY	DO NOT SCALE DRAWING																

Eastman Machine Company		779 Washington Street, Buffalo, NY 14203-1396	
EAGLE ROUTER			
POWER DISTRIBUTION / E-STOP LOOP			
SCALE	DATE	DATE	DATE
3/12/07	9/12/07		

31-9000-35
2 of 12

These drawings and specifications are the property of Eastman and shall not be reproduced, copied, used or disclosed to any third party without prior written consent of Eastman.

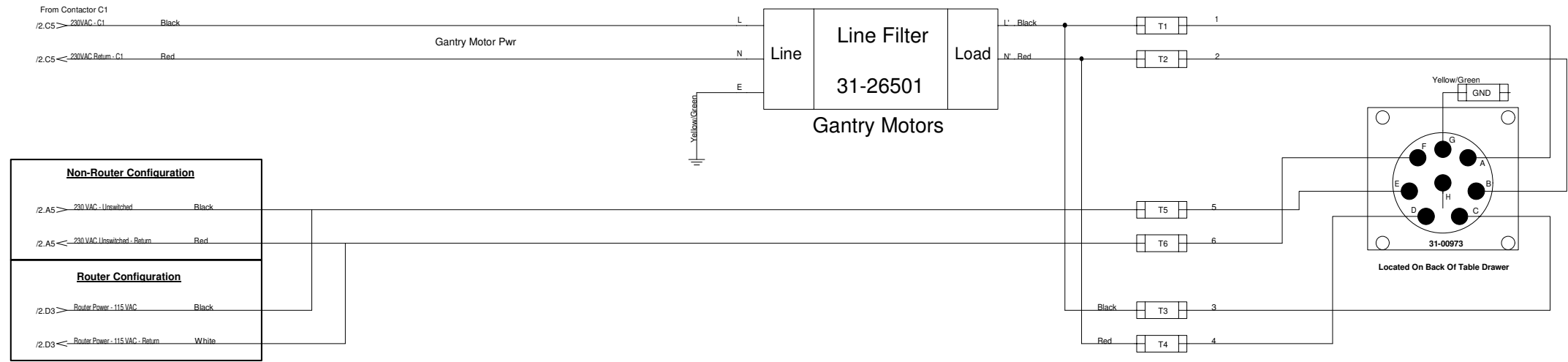

Non-Router Configuration		
/2.A5 >	230VAC - Unswitched	Black
/2.A5 <	230VAC Unswitched - Return	Red
Router Configuration		
/2.D3 >	Router Power - 115VAC	Black
/2.D3 <	Router Power - 115VAC - Return	White

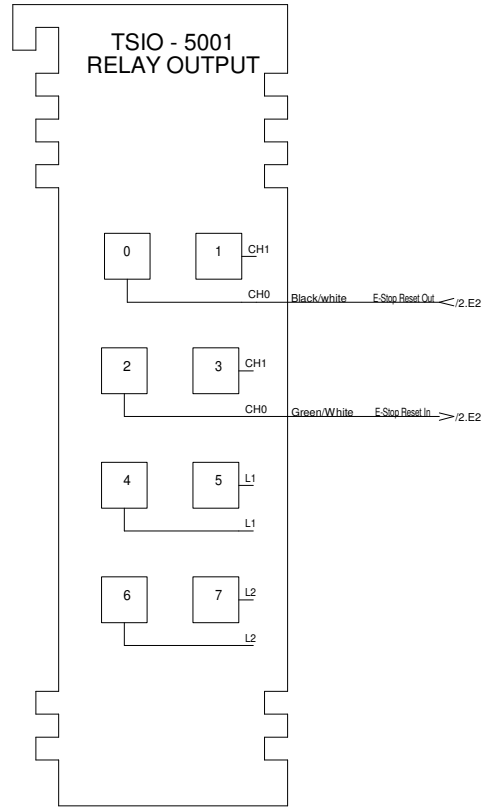
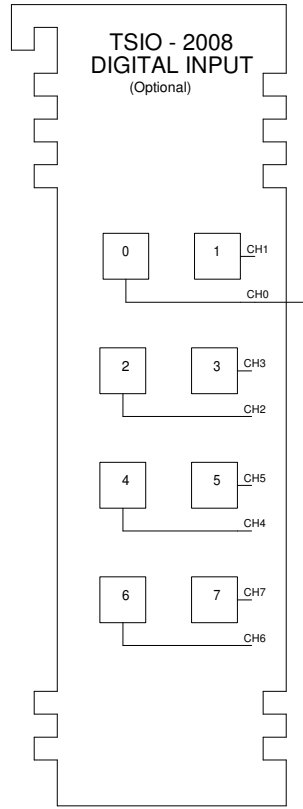
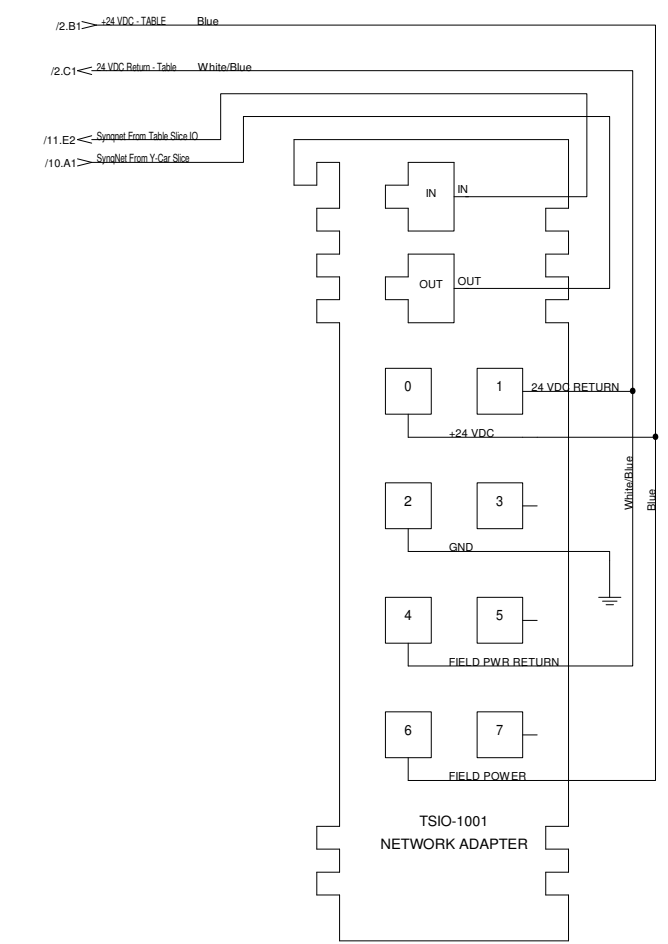
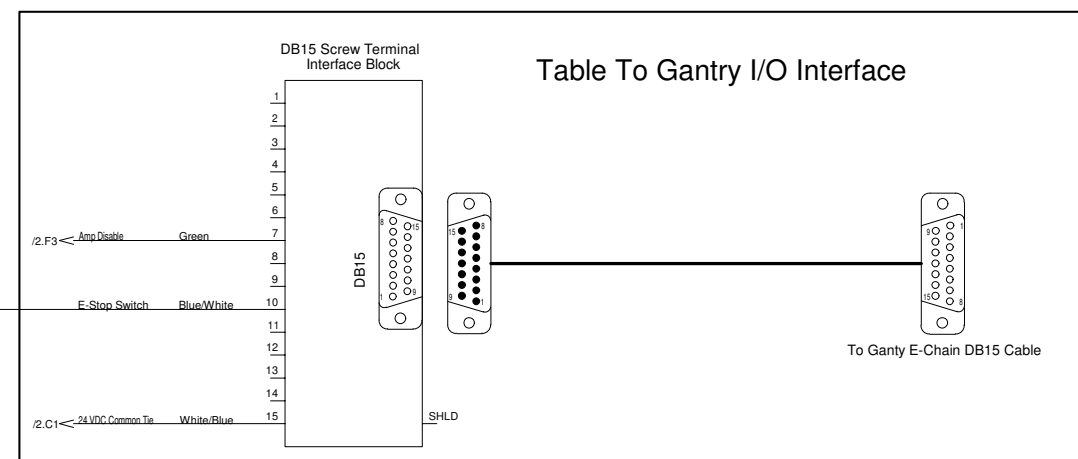
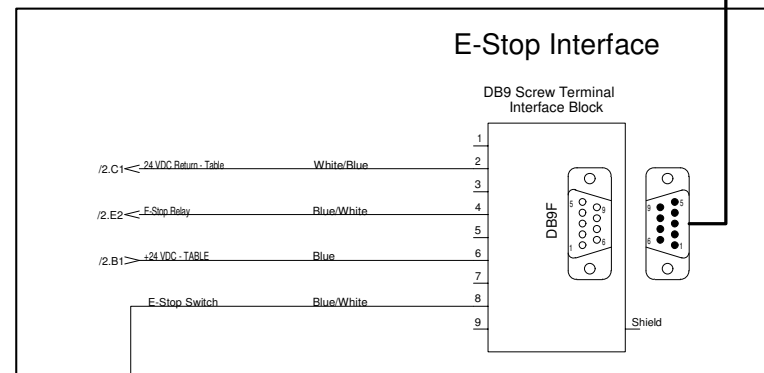
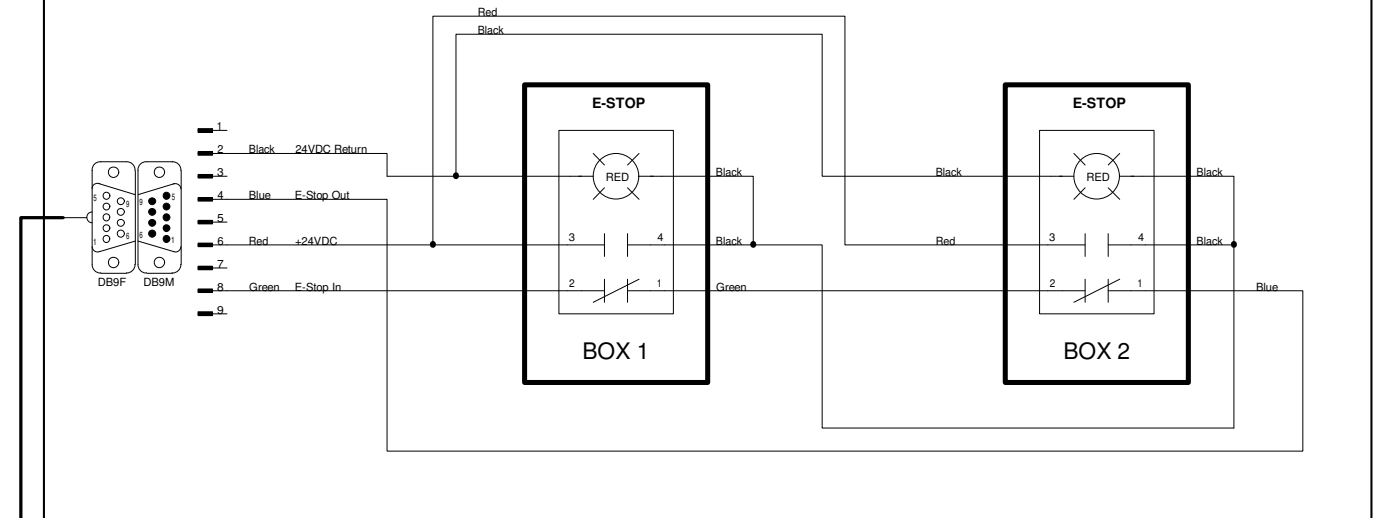

Table I/O

MATERIAL				-			
HEAT TREAT				-			
FINISH				-			
15396	NEW RELEASE	9/12/07	SGJ				
DRNBY	DATE	CHANGES	DATE	BY	DO NOT SCALE DRAWING		
Eastman Machine Company				779 Washington Street, Buffalo, NY 14203-1396			
EAGLE ROUTER				TABLE SLICE I/O			
SCALE	None	SIZE	D	31-9000-35			
DRNBY	DATE					3 of 12	
SGJ	9/12/07						

These drawings and specifications are the property of Eastman and shall not be reproduced, copied, used or disclosed to any third party without prior written consent of Eastman.

Table Remote E-Stop Boxes



				MATERIAL		-		Eastman Machine Company	
				HEAT TREAT		-		779 Washington Street, Buffalo, NY 14203-1395	
				FINISH		-		EAGLE ROUTER	
				15396		NEW RELEASE		REMOTE E-STOPS	
				DATE		9/12/07		SCALE None	
				BY		SGJ		DATE	
				CHANGES				31-9000-35	
				DATE				9/12/07	
				BY				4 of 12	

These drawings and specifications are the property of Eastman and shall not be reproduced, copied, used or disclosed to any third party without prior written consent of Eastman.

Gantry Power Cable (Table Drawer To Gantry)

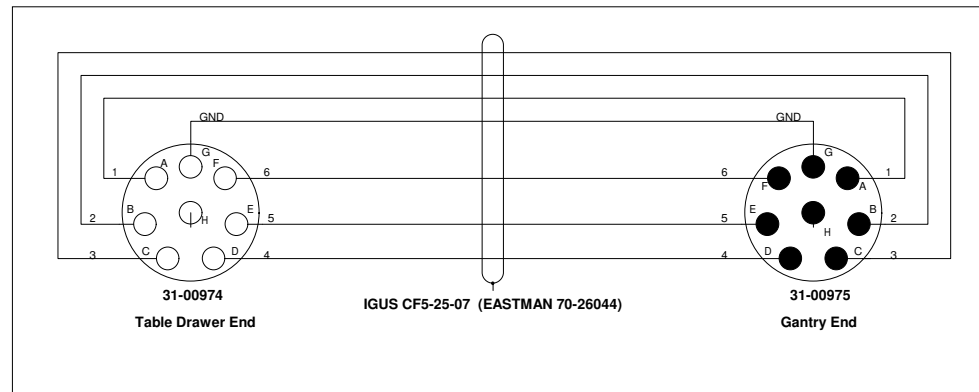

Gantry Bulkhead Power Connection

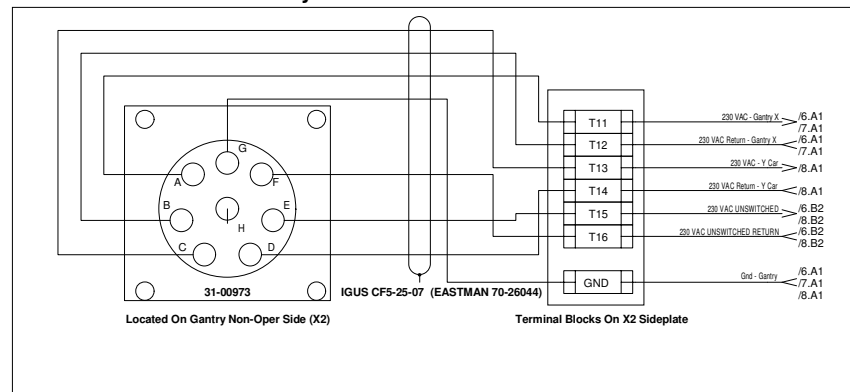

Gantry Bulkhead Power Connection - Router Configuration

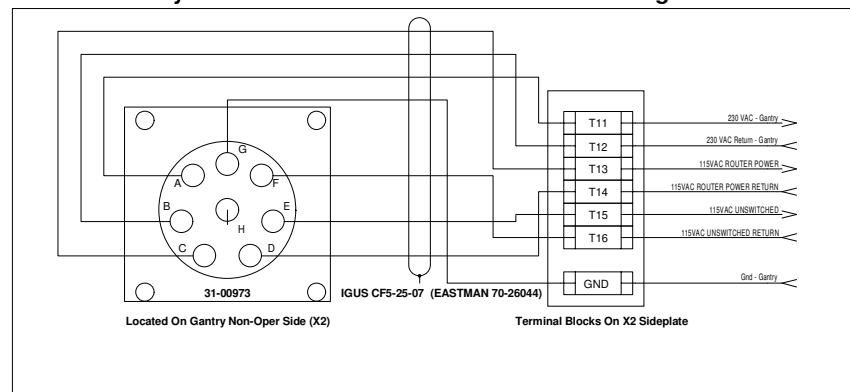

				MATERIAL		-		Eastman Machine Company 779 Washington Street, Buffalo, NY 14203-1396	
				HEAT TREAT		-		EAGLE ROUTER	
				FINISH		-		PERIPHERALS	
15396	NEW RELEASE	9/12/07	SGJ					31-9000-35	
EN	REV	CHANGES	DATE	BY	DO NOT SCALE DRAWING		SCALE: None SIZE: D DATE: 9/12/07		3 of 12

These drawings and specifications are the property of Eastman and shall not be reproduced, copied, used or disclosed to any third party without prior written consent of Eastman.

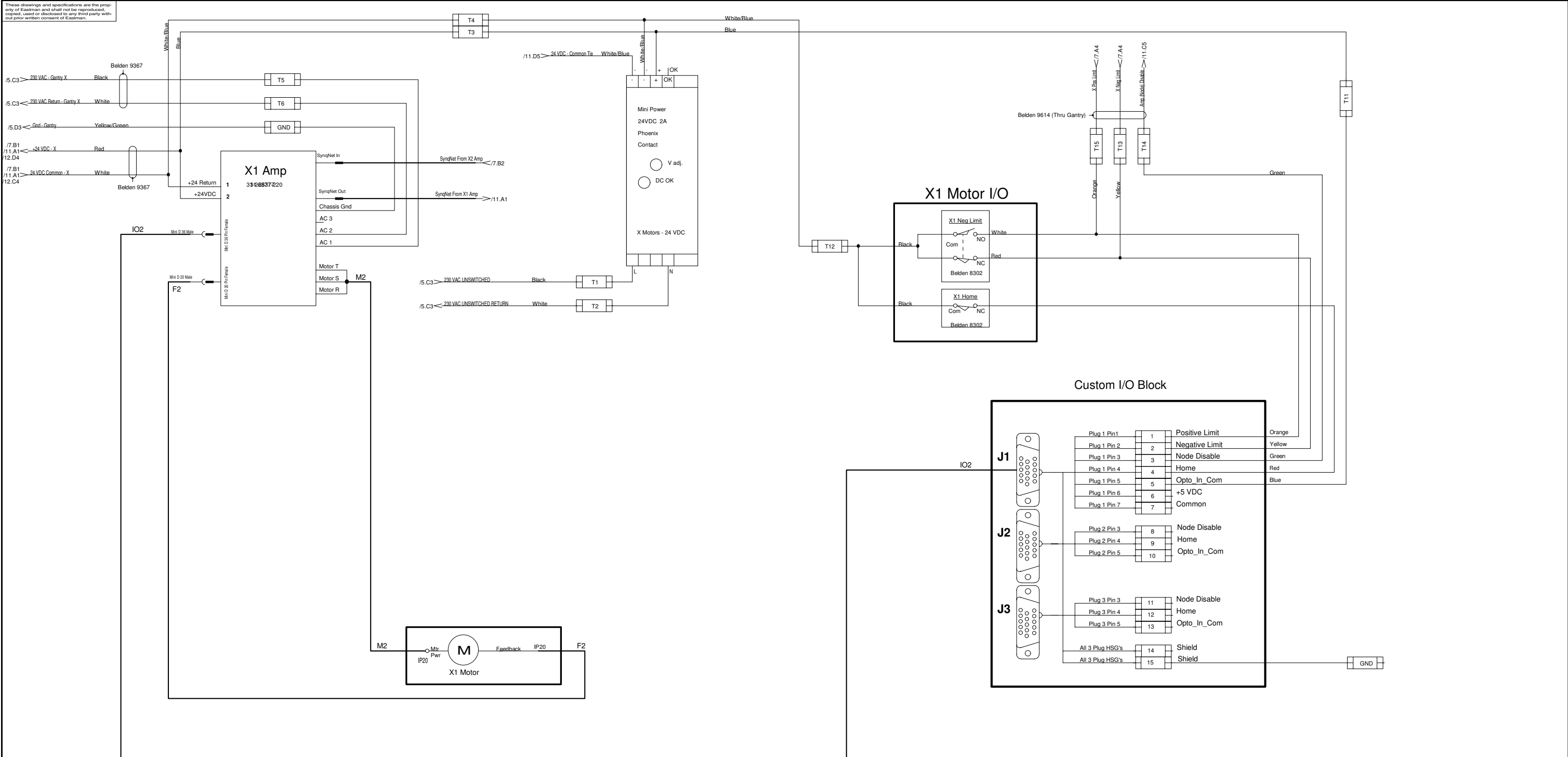

				MATERIAL		-		Eastman Machine Company	
				HEAT TREAT		-		779 Washington Street, Buffalo, NY 14203-1396	
				FINISH		-		EAGLE ROUTER	
				NEW RELEASE		9/12/07 SGJ		X1 MOTOR CONTROLS	
15396								SCALE: None	SIZE: D
DRN BY	REV	CHANGES	DATE	BY	DO NOT SCALE DRAWING			DATE	31-9000-35
								9/12/07	6 of 12

These drawings and specifications are the property of Eastman and shall not be reproduced, copied, used or disclosed to any third party without prior written consent of Eastman.

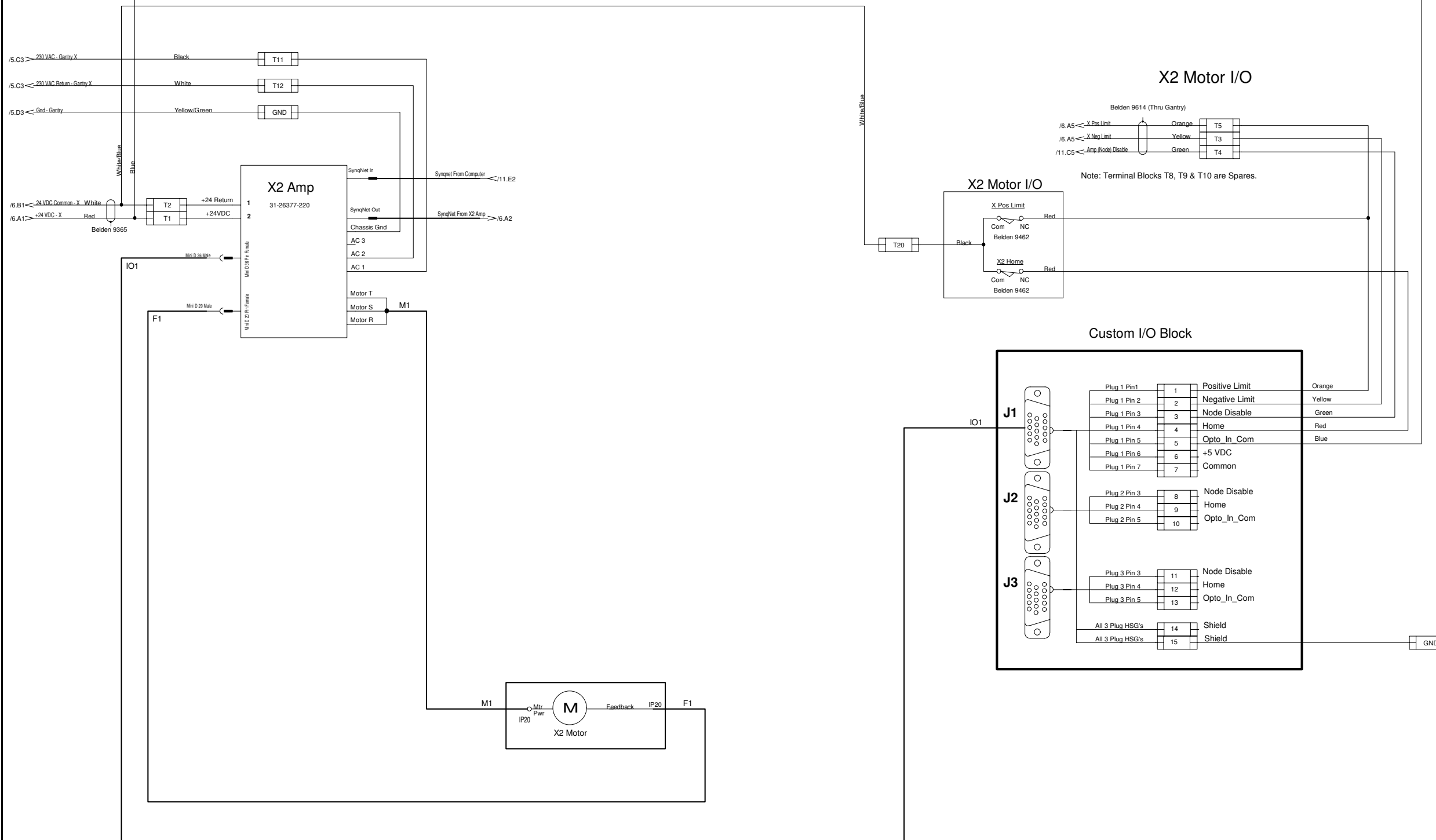

X2 Motor I/O

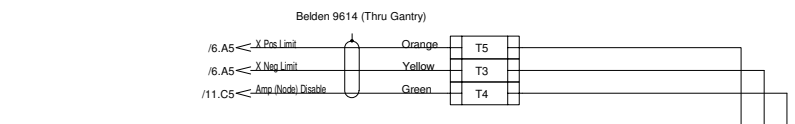

Note: Terminal Blocks T8, T9 & T10 are Spares.

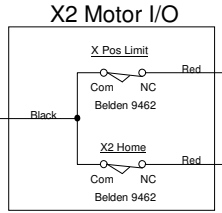

Custom I/O Block

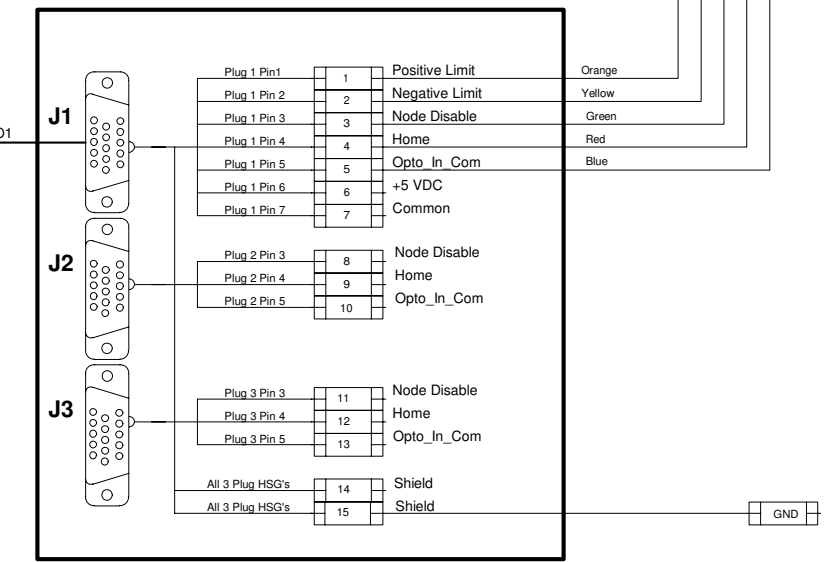

MATERIAL				-	
HEAT TREAT				-	
FINISH				-	
15396	NEW RELEASE	9/12/07	SGJ		
EN	REV	CHANGES	DATE	BY	DO NOT SCALE DRAWING
Eastman Machine Company 779 Washington Street, Buffalo, NY 14203-1396				EAGLE ROUTER	
X2 MOTOR CONTROLS				31-9000-35	
SCALE	None	SIZE	D	1 of 12	
DRAWN BY	SGJ	DATE	9/12/07		

These drawings and specifications are the property of Eastman and shall not be reproduced, copied, used or disclosed to any third party without prior written consent of Eastman.

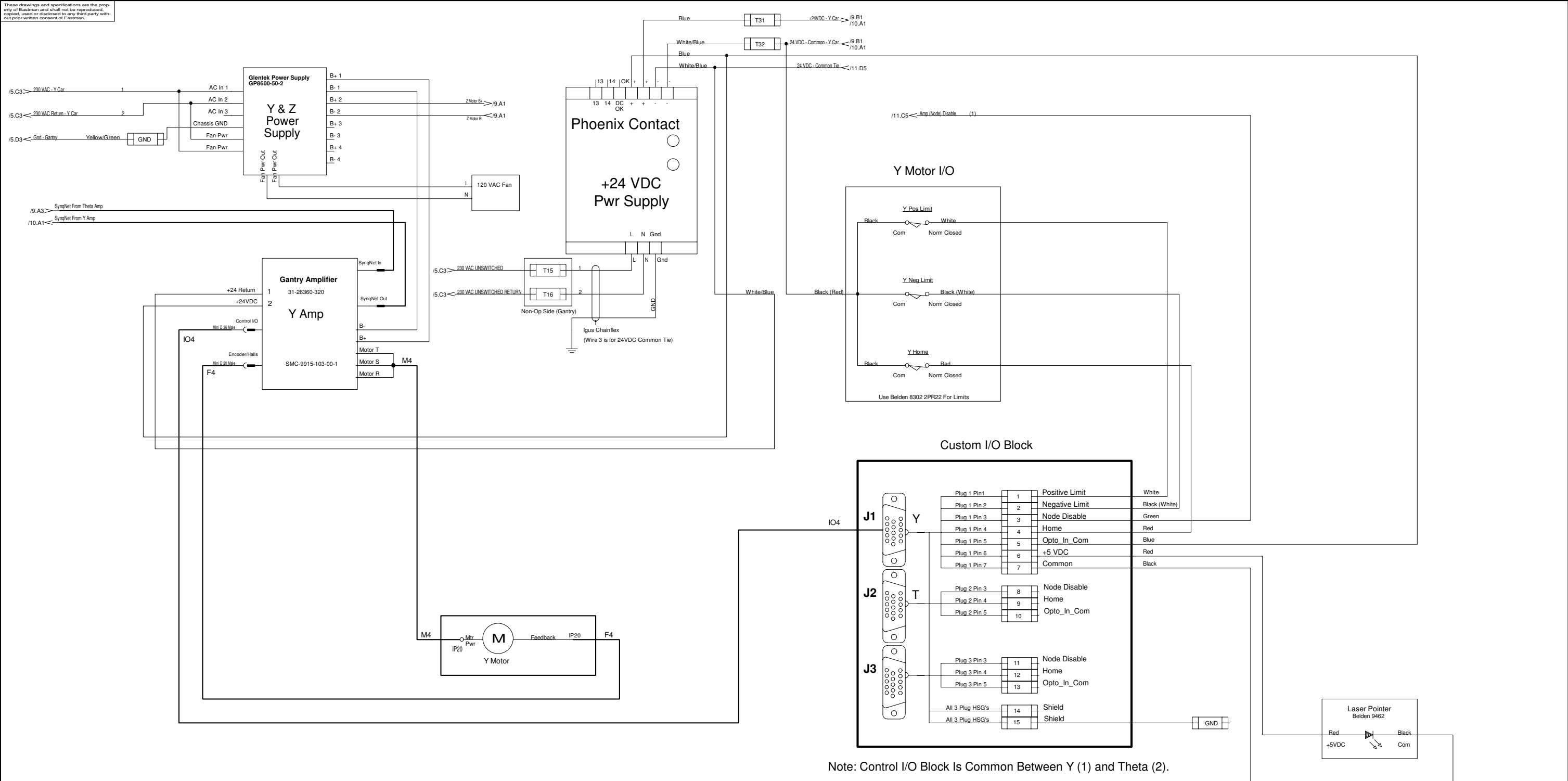

Note: Control I/O Block Is Common Between Y (1) and Theta (2).

MATERIAL				-			
HEAT TREAT				-			
FINISH				-			
15396	NEW RELEASE	9/12/07	SGJ	-			
EN	REV	CHANGES	DATE	BY	DO NOT SCALE DRAWING		
Eastman Machine Company				779 Washington Street, Buffalo, NY 14203-1396			
EAGLE ROUTER				Y MOTOR CONTROLS			
SCALE	None	SIZE	D	31-9000-35			
DRAWN BY	SGJ	DATE	9/12/07	8 of 12			

These drawings and specifications are the property of Eastman and shall not be reproduced, copied, used or disclosed to any third party without prior written consent of Eastman.

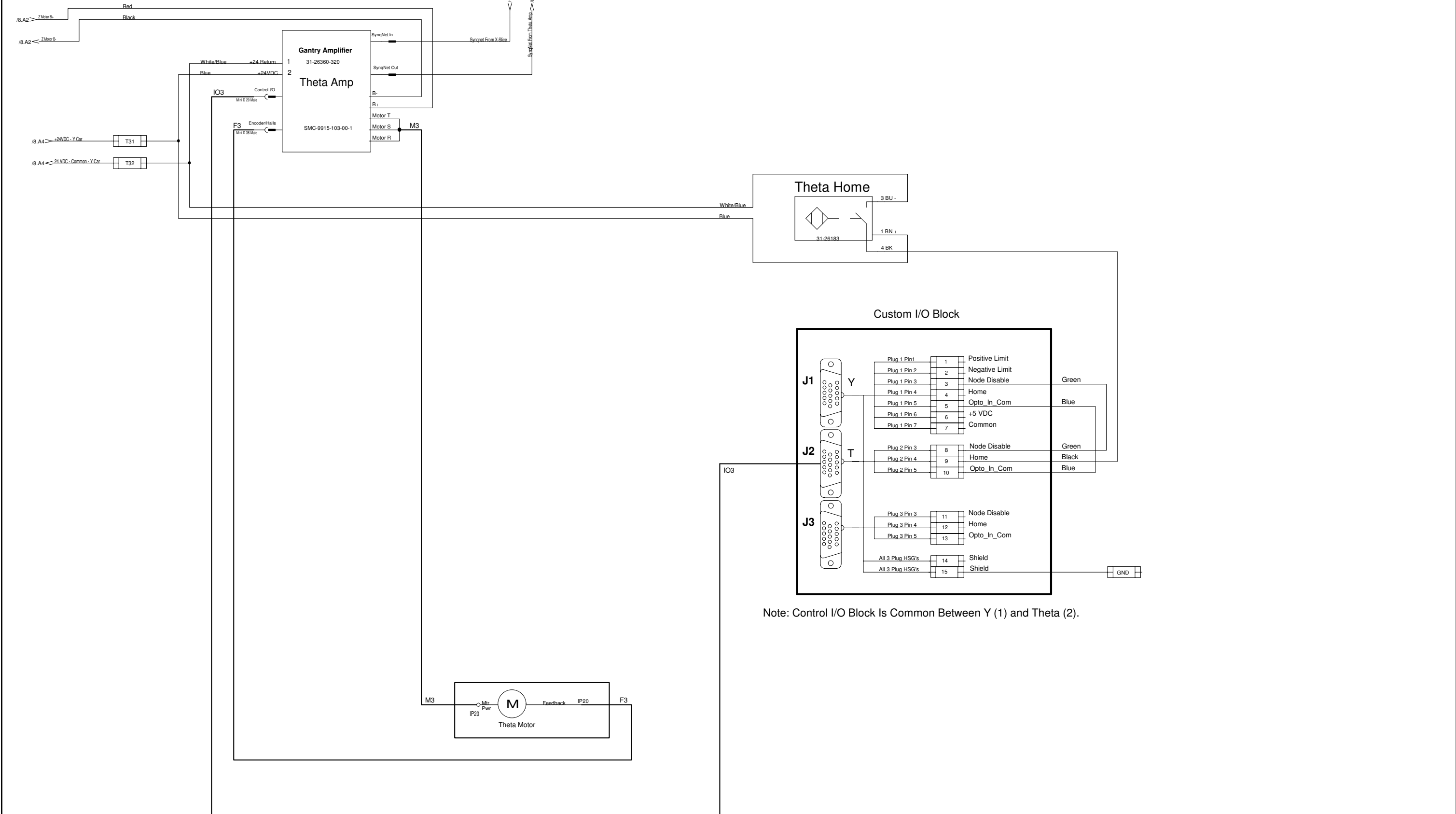

Note: Control I/O Block Is Common Between Y (1) and Theta (2).

				MATERIAL		-		Eastman Machine Company	
				HEAT TREAT		-		779 Washington Street, Buffalo, NY 14203-1396	
				FINISH		-		EAGLE ROUTER	
				DO NOT SCALE DRAWING				THETA MOTOR CONTROLS	
15396	NEW RELEASE	9/12/07	SGJ	SCALE		None		31-9000-35	
EN	REV	CHANGES	DATE	BY	DATE	DATE	DATE	9 of 12	

These drawings and specifications are the property of Eastman and shall not be reproduced, copied, used or disclosed to any third party without prior written consent of Eastman.

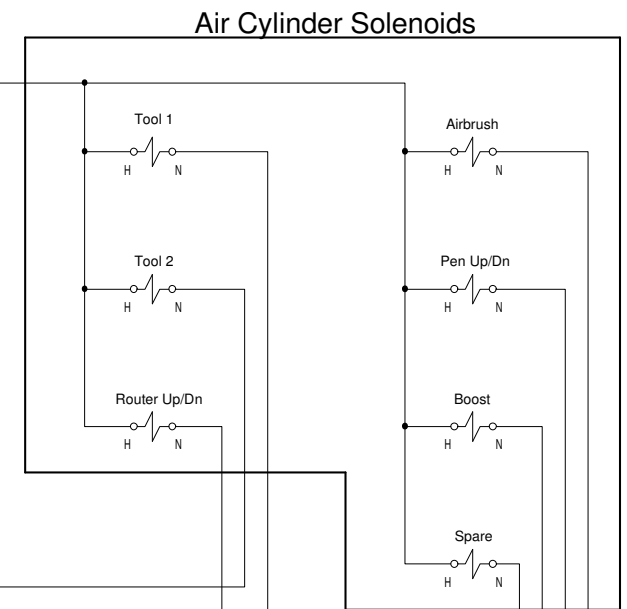
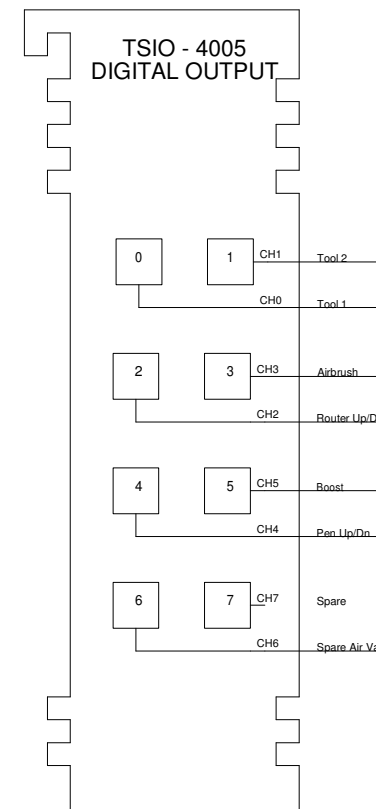
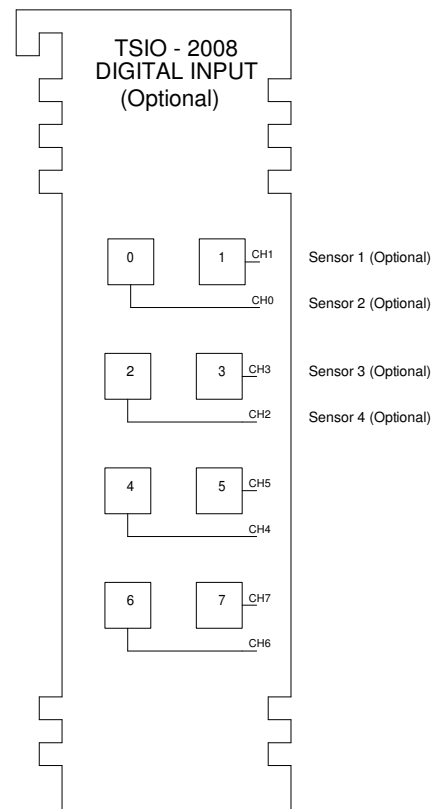
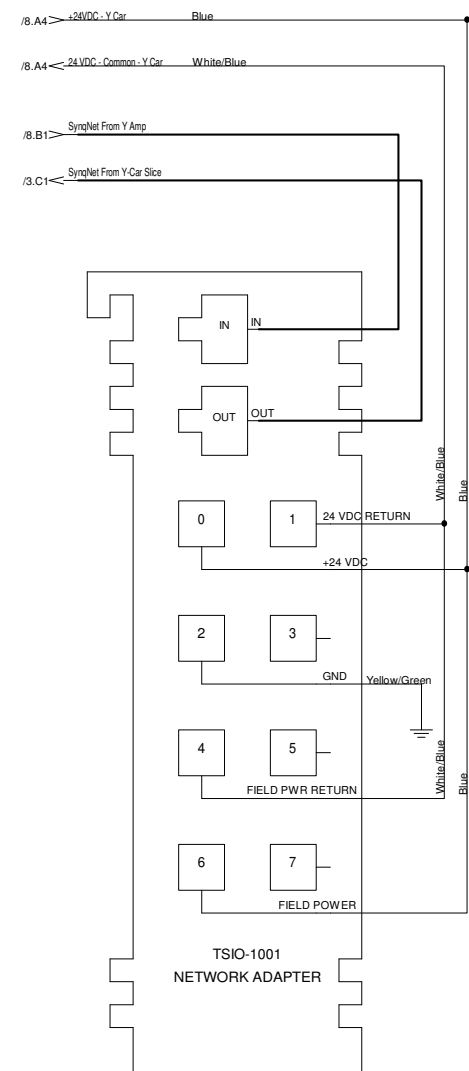

Y-Car I/O

				MATERIAL		-		Eastman Machine Company	
				HEAT TREAT		-		779 Washington Street, Buffalo, NY 14203-1396	
				FINISH		-		EAGLE ROUTER	
				NEW RELEASE		9/12/07		Y-CAR I/O	
15396				SGJ				SCALE	None
DRN BY	REV	CHANGES	DATE	BY	DO NOT SCALE DIMENSIONS			SIZE	D
								DATE	9/12/07
								31-9000-35	10 of 12

These drawings and specifications are the property of Eastman and shall not be reproduced, copied, used or disclosed to any third party without prior written consent of Eastman.

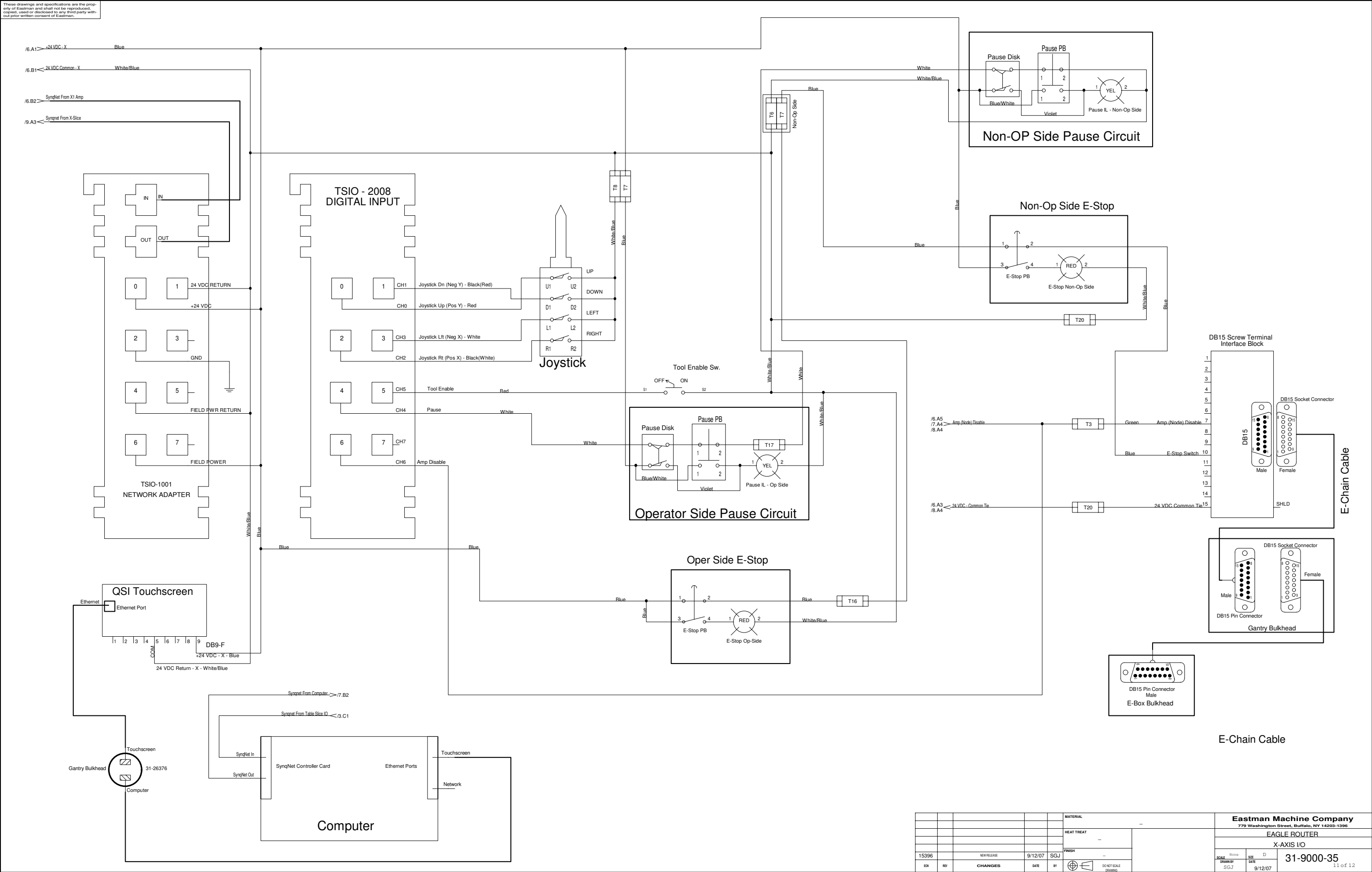

15396				NEW RELEASE				9/12/07				SGJ				FINISH				-											
EN				REV				CHANGES				DATE				BY				DO NOT SCALE DIMENSIONS											
MATERIAL																-															
HEAT TREAT																-															
EASTMAN MACHINE COMPANY																779 Washington Street, Buffalo, NY 14203-1396															
EAGLE ROUTER																X-AXIS I/O															
31-9000-35																11 of 12															

These drawings and specifications are the property of Eastman and shall not be reproduced, copied, used or disclosed to any third party without prior written consent of Eastman.

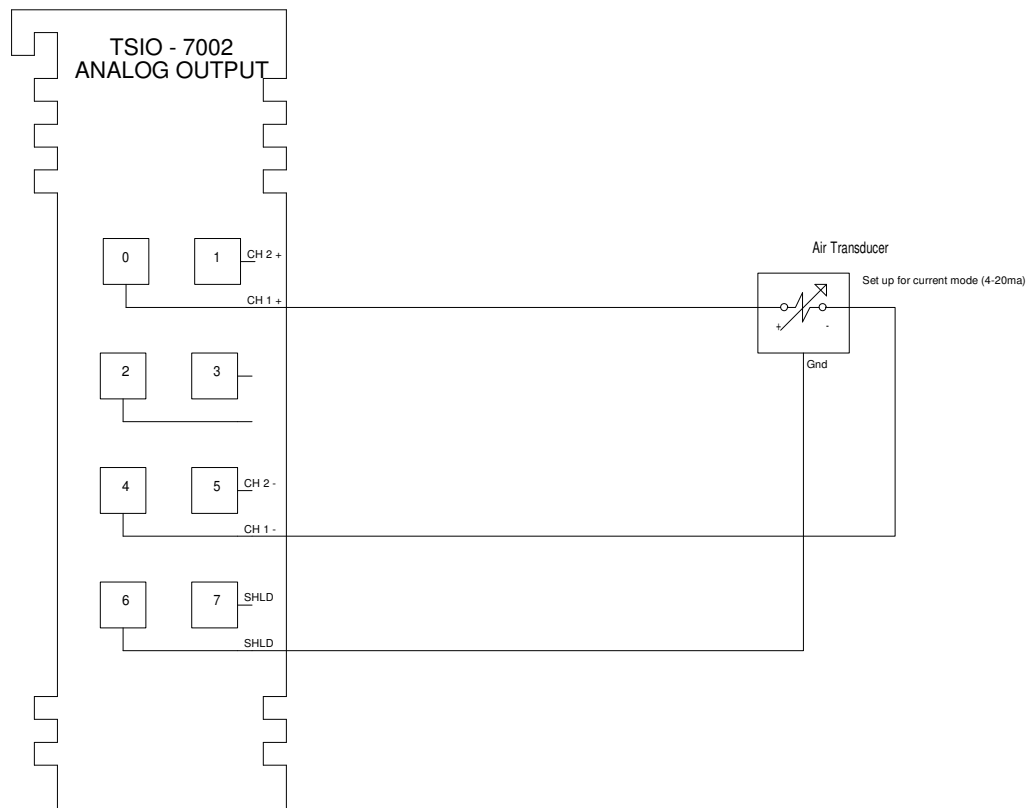

Part of X-Axis Slice I/O Assembly

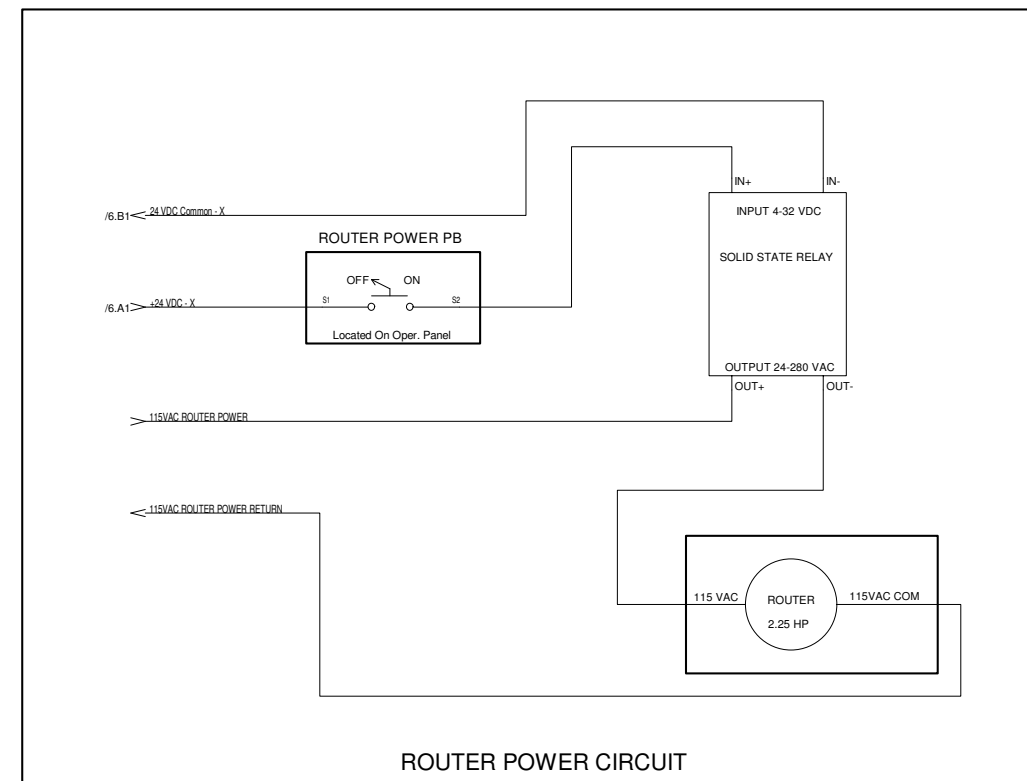

ROUTER POWER CIRCUIT

				MATERIAL		-	
				HEAT TREAT		-	
				FINISH		-	
15396		NEW RELEASE	9/12/07	SGJ		Eastman Machine Company 779 Washington Street, Buffalo, NY 14203-1396	
							EAGLE ROUTER
							X-AXIS I/O - #2
SCALE	None	SIZE	D			31-9000-35	
DRAWN BY	BSC	DATE	9/12/07			12 of 12	
EN	REV	CHANGES	DATE	BY	DO NOT SCALE DRAWING		

These drawings and specifications are the property of Eastman and shall not be reproduced, copied, used or disclosed to any third party without prior written consent of Eastman.

VALVE MANIFOLD
27-26050

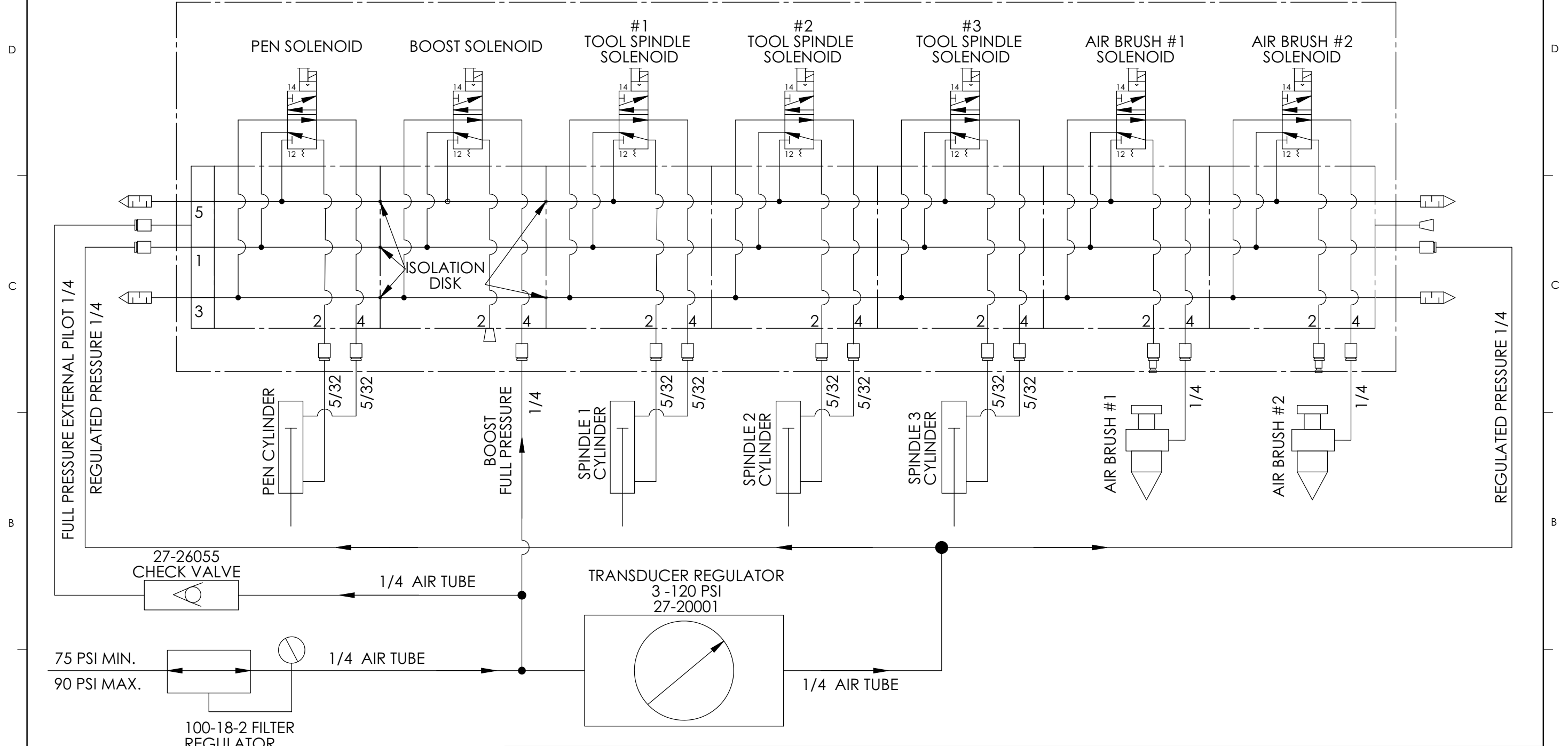

ECN	REV	CHANGES	DATE	BY
16146	A	ADD MORE DIAGRAMS	09/05/08	JWR
14900	-	NEW RELEASE	03/04/08	JWR

MATERIAL -
FINISH -
HEAT TREAT -
DIMENSIONS ARE IN INCHES
TOLERANCES UNLESS OTHERWISE SPECIFIED:
XX ± .01 FRACTIONAL: ± 1/64
XXX ± .005 ANGULAR: ± 1°
SURFACE FINISH PER ANSI 846.1 125 RMS
SURFACE PROFILE () .01
BREAK SHARP CORNERS MAXIMUM
ALL WELDS TO BE CLEAN AND FREE OF SPATTER
ALL SURFACES TO BE FREE AND CLEAR OF
SCRATCHES, RUST AND STAIN
INTERPRET DIMENSIONS AND TOLERANCING PER
ASME Y14.5M-1994

DO NOT SCALE DRAWING

Eastman Machine Co.
779 Washington Street, Buffalo, NY 14203-1396

TOOL HEAD PNEUMATICS, EAGLE C3 S3
STANDARD TOOL PNEUMATIC DIAGRAM

SCALE - SIZE B
DRAWN BY J.ROGACKI DATE 03/04/08

31-26611
SHEET 1 OF 6

These drawings and specifications are the property of Eastman and shall not be reproduced, copied, used or disclosed to any third party without prior written consent of Eastman.

VALVE MANIFOLD
27-26050

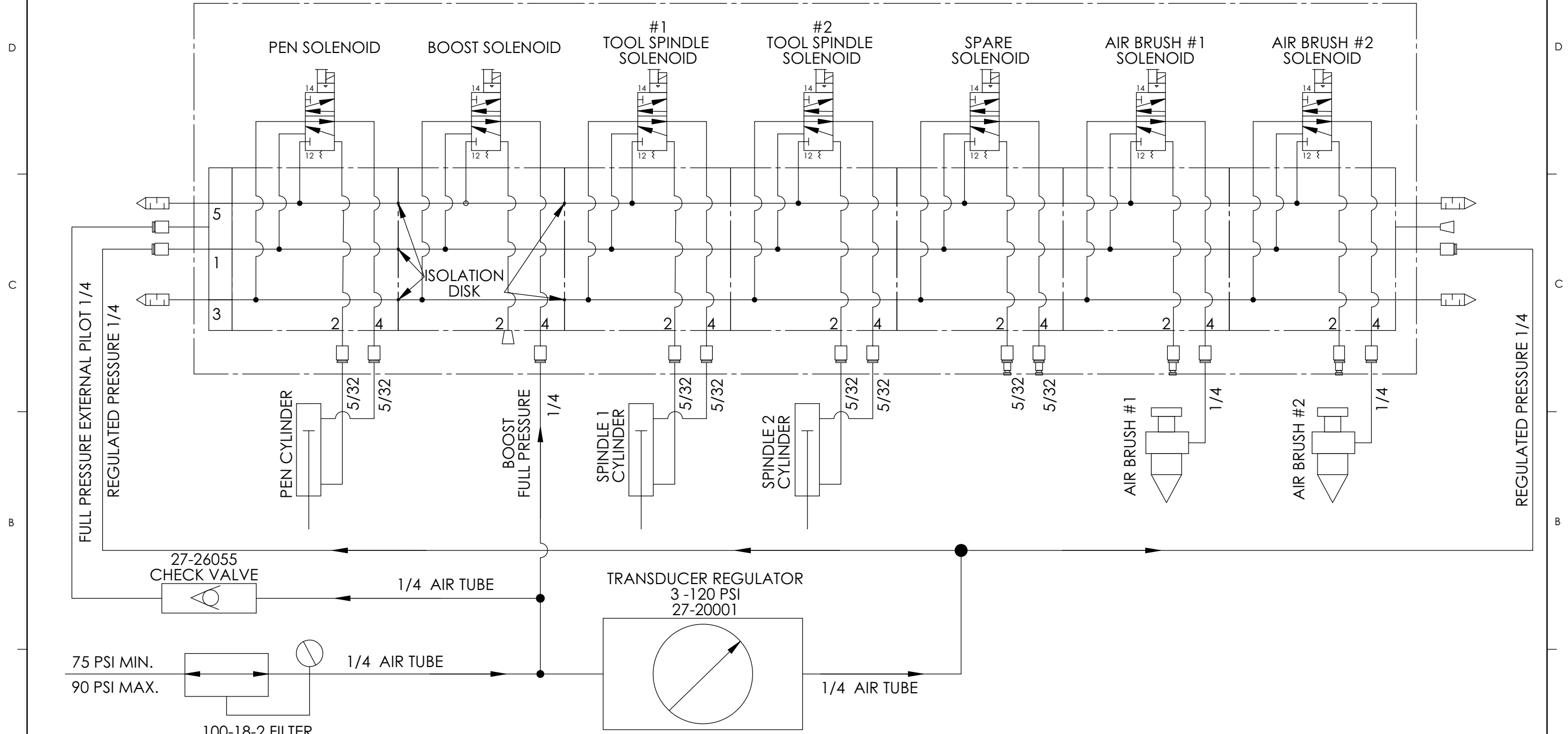

ECN	REV	CHANGES	DATE	BY	MATERIAL	FINISH
16146	A	ADD MORE DIAGRAMS	09/05/08	JWR		
14900	-	NEW RELEASE	03/04/08	JWR		

DIMENSIONS ARE IN INCHES
 TOLERANCES UNLESS OTHERWISE SPECIFIED:
 XX ± .01 FRACTIONAL: ± 1/64
 XXX ± .005 ANGULAR: ± 1°
 SURFACE FINISH PER ANSI 846.1 125 RMS
 SURFACE PROFILE () .01
 BREAK SHARP CORNERS MAXIMUM
 ALL WELDS TO BE CLEAN AND FREE OF SPATTER
 ALL SURFACES TO BE FREE AND CLEAR OF
 SCRATCHES, RUST AND STAIN
 INTERPRET DIMENSIONS AND TOLERANCING PER
 ASME Y14.5M-1994

HEAT TREAT
 DO NOT SCALE DRAWING

Eastman Machine Co.
779 Washington Street, Buffalo, NY 14203-1396

TOOL HEAD PNEUMATICS, EAGLE C3 S3

HEAVY DUTY PNEUMATIC DIAGRAM

SCALE: - SIZE: B
DRAWN BY: J.ROGACKI DATE: 03/04/08

31-26611
SHEET 2 OF 6

These drawings and specifications are the property of Eastman and shall not be reproduced, copied, used or disclosed to any third party without prior written consent of Eastman.

VALVE MANIFOLD
27-26050

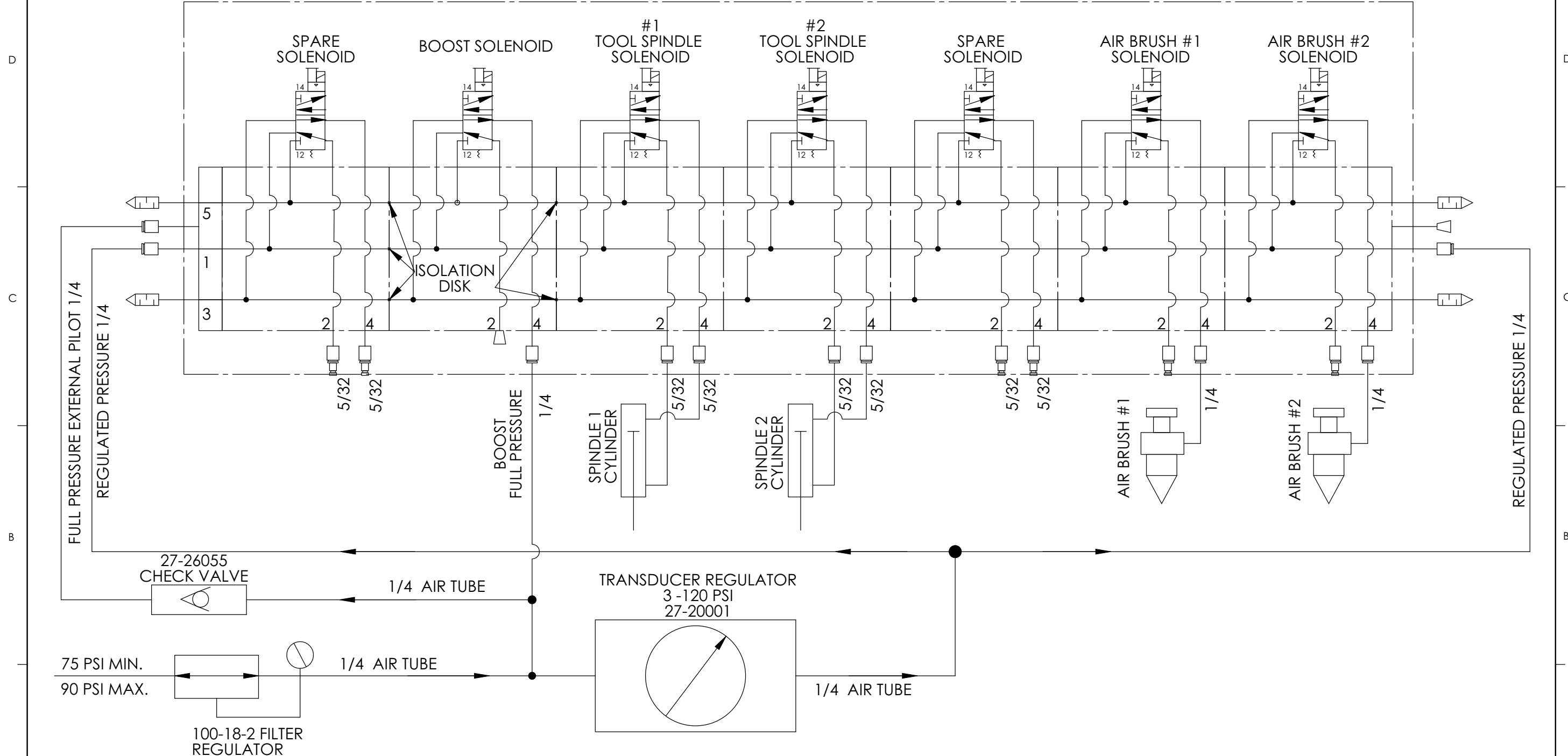

ECN	REV	CHANGES	DATE	BY	MATERIAL	FINISH
16146	A	ADD MORE DIAGRAMS	09/05/08	JWR		
14900	-	NEW RELEASE	03/04/08	JWR		

DIMENSIONS ARE IN INCHES
 TOLERANCES UNLESS OTHERWISE SPECIFIED:
 XX ± .01 FRACTIONAL: ± 1/64
 XXX ± .005 ANGULAR: ± 1°
 SURFACE FINISH PER ANSI 846.1 125 RMS
 SURFACE PROFILE () .01
 BREAK SHARP CORNERS MAXIMUM .010
 ALL WELDS TO BE CLEAN AND FREE OF SPATTER
 ALL SURFACES TO BE FREE AND CLEAR OF SCRATCHES, RUST AND STAIN
 INTERPRET DIMENSIONS AND TOLERANCING PER ASME Y14.5M-1994

HEAT TREAT

DO NOT SCALE DRAWING

Eastman Machine Co.
779 Washington Street, Buffalo, NY 14203-1396

TOOL HEAD PNEUMATICS, EAGLE C3 S3

HIGH FIBER PNEUMATIC DIAGRAM

SCALE: - SIZE: B

DRAWN BY: J.ROGACKI DATE: 03/04/08

31-26611

SHEET 3 OF 6

These drawings and specifications are the property of Eastman and shall not be reproduced, copied, used or disclosed to any third party without prior written consent of Eastman.

VALVE MANIFOLD
27-26050

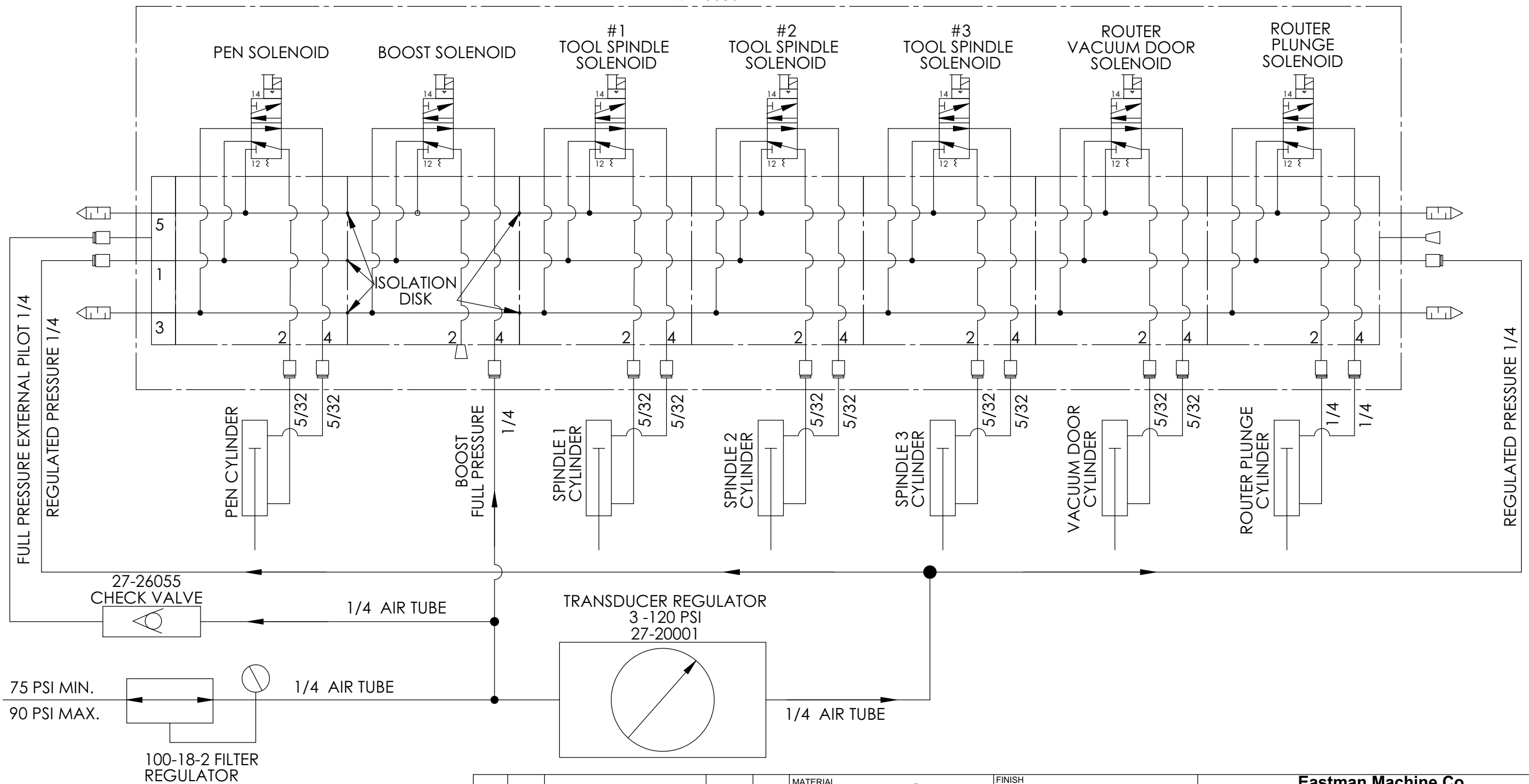

ECN	REV	CHANGES	DATE	BY
16146	A	ADD MORE DIAGRAMS	09/05/08	JWR
14900	-	NEW RELEASE	03/04/08	JWR

MATERIAL -
FINISH -
HEAT TREAT -
DIMENSIONS ARE IN INCHES
TOLERANCES UNLESS OTHERWISE SPECIFIED:
.XX ± .01 FRACTIONAL: ± 1/64
.XXX ± .005 ANGULAR: ± 1°
SURFACE FINISH PER ANSI 846.1 125 RMS
SURFACE PROFILE (A) .01
BREAK SHARP CORNERS MAXIMUM .010
ALL WELDS TO BE CLEAN AND FREE OF SPATTER
ALL SURFACES TO BE FREE AND CLEAR OF SCRATCHES, RUST AND STAIN.
INTERPRET DIMENSIONS AND TOLERANCING PER ASME Y14.5M-1994

DO NOT SCALE DRAWING

Eastman Machine Co.
779 Washington Street, Buffalo, NY 14203-1396

TOOL HEAD PNEUMATICS, EAGLE C3 S3

ROUTER/STANDARD PNEUMATIC DIAGRAM

SCALE - SIZE B
DRAWN BY J.ROGACKI DATE 03/04/08

31-26611
SHEET 4 OF 6

These drawings and specifications are the property of Eastman and shall not be reproduced, copied, used or disclosed to any third party without prior written consent of Eastman.

VALVE MANIFOLD
27-26050

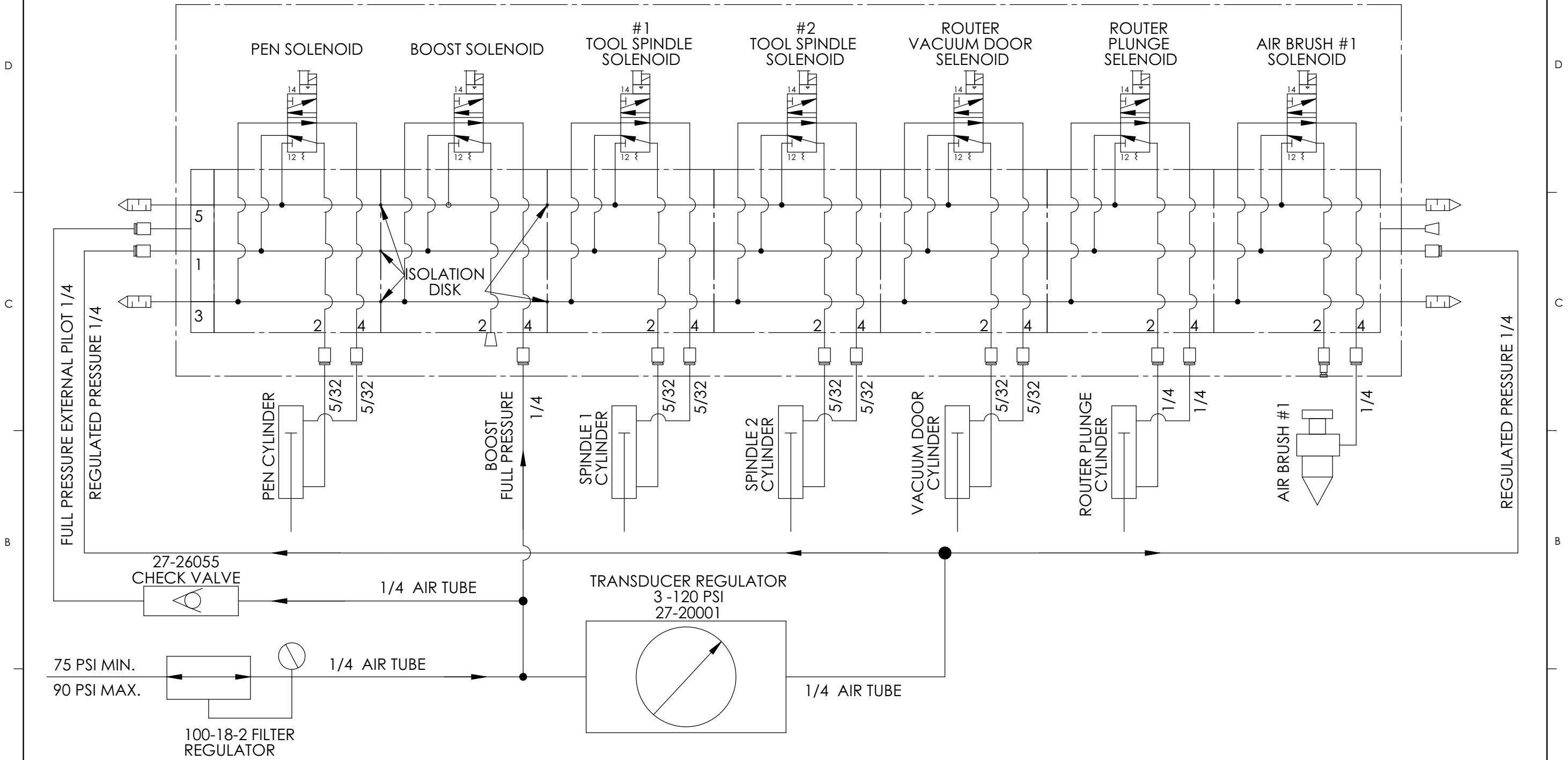

ECN	REV	CHANGES	DATE	BY
16146	A	ADD MORE DIAGRAMS	09/05/08	JWR
14900	-	NEW RELEASE	03/04/08	JWR

MATERIAL -
FINISH -
HEAT TREAT -
DIMENSIONS ARE IN INCHES
TOLERANCES UNLESS OTHERWISE SPECIFIED:
XX ± .01 FRACTIONAL: ± 1/64
XXX ± .005 ANGULAR: ± 1°
SURFACE FINISH PER ANSI 846.1 125 RMS
SURFACE PROFILE (A) .01
BREAK SHARP CORNERS MAXIMUM .010
ALL WELDS TO BE CLEAN AND FREE OF SPATTER
ALL SURFACES TO BE FREE AND CLEAR OF SCRATCHES, RUST AND STAIN.
INTERPRET DIMENSIONS AND TOLERANCING PER ASME Y14.5M-1994

DO NOT SCALE DRAWING

Eastman Machine Co.
779 Washington Street, Buffalo, NY 14203-1396

TOOL HEAD PNEUMATICS, EAGLE C3 S3

ROUTER/ HEAVY DUTY PNEUMATIC DIAGRAM

SCALE - SIZE B
DRAWN BY J.ROGACKI DATE 03/04/08

31-26611

SHEET 5 OF 6

These drawings and specifications are the property of Eastman and shall not be reproduced, copied, used or disclosed to any third party without prior written consent of Eastman.

VALVE MANIFOLD
27-26050

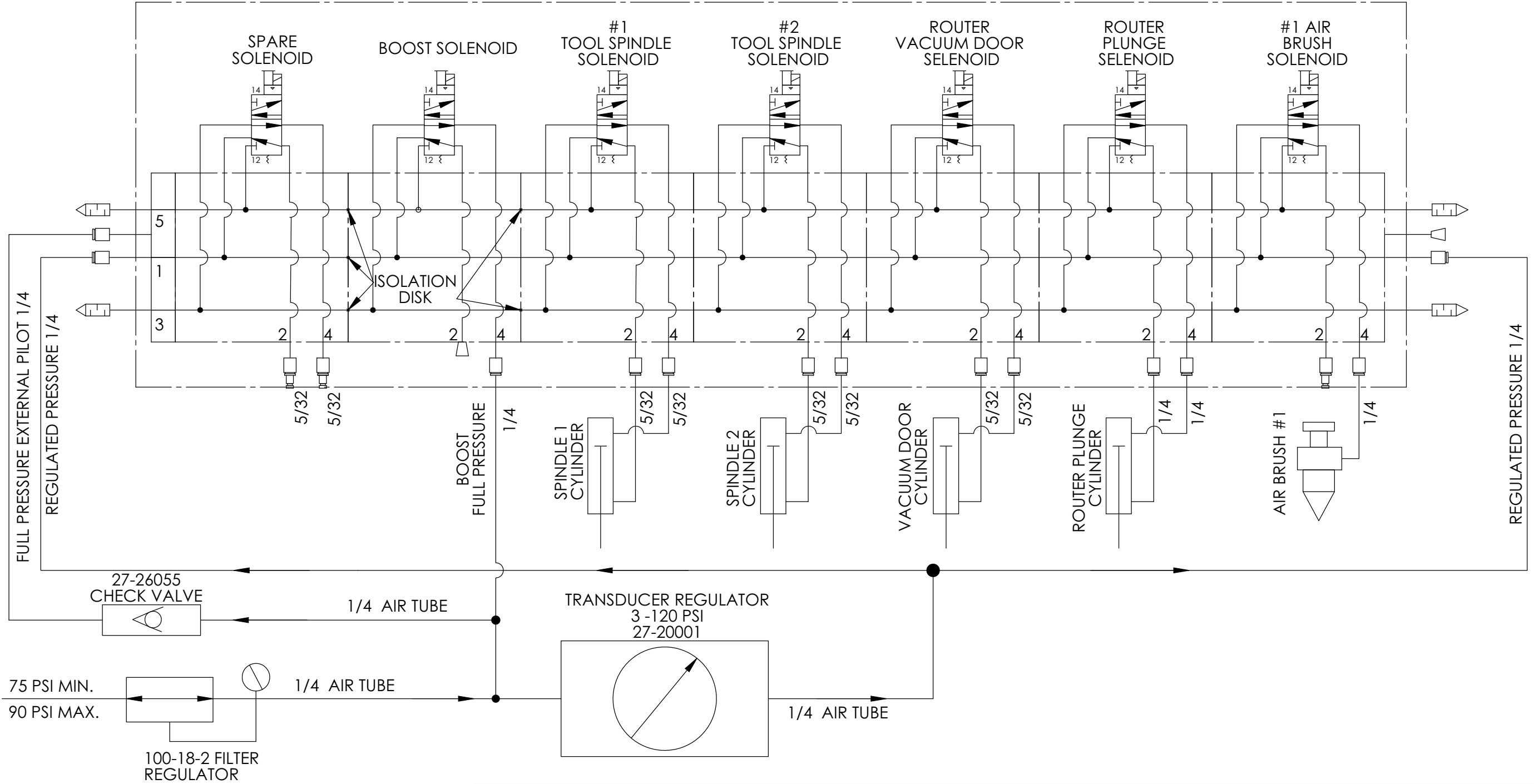

ECN	REV	CHANGES	DATE	BY	MATERIAL	FINISH
16146	A	ADD MORE DIAGRAMS	09/05/08	JWR		
14900	-	NEW RELEASE	03/04/08	JWR		

DIMENSIONS ARE IN INCHES
 TOLERANCES UNLESS OTHERWISE SPECIFIED:
 XX ± .01 FRACTIONAL: ± 1/64
 XXX ± .005 ANGULAR: ± 1°
 SURFACE FINISH PER ANSI 846.1 125 RMS
 SURFACE PROFILE () .01
 BREAK SHARP CORNERS MAXIMUM .010
 ALL WELDS TO BE CLEAN AND FREE OF SPATTER
 ALL SURFACES TO BE FREE AND CLEAR OF SCRATCHES, RUST AND STAIN
 INTERPRET DIMENSIONS AND TOLERANCING PER ASME Y14.5M-1994

HEAT TREAT	
DO NOT SCALE DRAWING	

Eastman Machine Co.
779 Washington Street, Buffalo, NY 14203-1396

TOOL HEAD PNEUMATICS, EAGLE C3 S3
ROUTER/ FIBER PNEUMATIC DIAGRAM

SCALE: - SIZE: B
DRAWN BY: J.ROGACKI DATE: 03/04/08

31-26611
SHEET 6 OF 6

Technical Data EASTMAN® Eagle S3

Eagle S3

Maximum Gantry Speed*	60 in/sec. (152 cm/sec.)
Cut Accuracy *	+/- 0.015" (+/- 0.4 mm)
Gantry Weight	230 lbs (105 kg)
Machine Operating Voltage	110 V/220 V VAC, Single Phase 50/60 Hz
Blower Operating Voltage	220V; 50/60 Hz
Minimum Operating Pressure	75 psi
Volume of Air Service	5 SCFM (15 SCFM w/Airbrush)

Information based on standard 78" wide machine size

* Relative to type and quality of fabric, cutting speed, pulling mode operational settings.etc.

Machine Size	Working Width	Table Width (including Rack and Rail)	Overall Machine Width
60" (153 cm)	58.6" (148 cm)	72" (183 cm)	93" (236 cm)
66" (168 cm)	64.6" (164 cm)	78" (198 cm)	99" (252 cm)
72" (183 cm)	70.6" (179 cm)	84" (213 cm)	105" (267 cm)
78" (198 cm)	76.6" (194 cm)	90" (229 cm)	111" (267 cm)

Please allow 3 ft working clearance on all sides.
For all other sizes consult factory.