

HYUNDAI

Molded Case Circuit Breaker



Hi Series Molded Case Circuit Breaker

Contents

Overview	04
Ratings	
Quick Selection Table	06
Fixed Thermal Type	08
Adjustable Thermal Type	12
Electronic Type	15
Features	
Overview	18
Thermal Type up to 250AF	20
Current Limiting Type up to 225AF	22
Electronic Type up to 1200AF	24
Accessories	26
Accessories	
Signal Accessories	32
Operating Accessories	35
Terminal Accessories	42
Plug-In Accessories	44
Spare Parts	48
Technical Information	
Trip Unit Configuration of Adjustable MCCBs	49
Capacity and Characteristic	53
Application	55
Insulating Distance from Line End	59
Characteristic Curves & Dimensions	
Fixed & Adjustable Thermal Type	60
Electronic Type	74
Order Information	86
Operation Environment	95

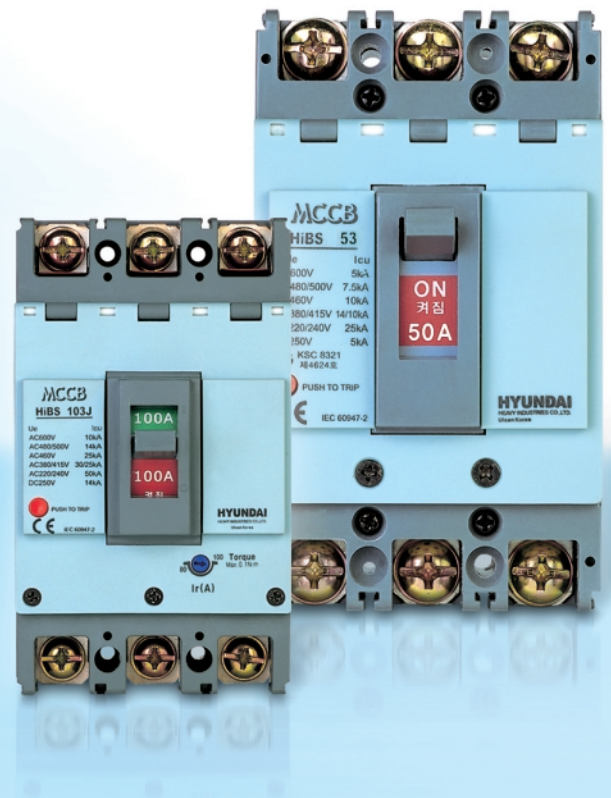



Hi Series Molded Case Circuit Breaker

Hyundai Hi Series Molded Case Circuit Breaker, which is reliable products, realizes the optimum design through electric and kinetic analysis.

Hi Series MCCB provides easy-to-use customer installation, while offering versatility and high performance to match today's demand for a reliable and cost-effective product, which is easy to maintain.

Electronic type

※ Icu at AC415V



800AF Icu 65/85/130kA
1000AF Icu 100/130kA
1250AF Icu 100/130kA



400AF Icu 50/85/130kA
600AF Icu 65/85/130kA



50AF Icu 85kA
100AF Icu 85kA
225AF Icu 85kA

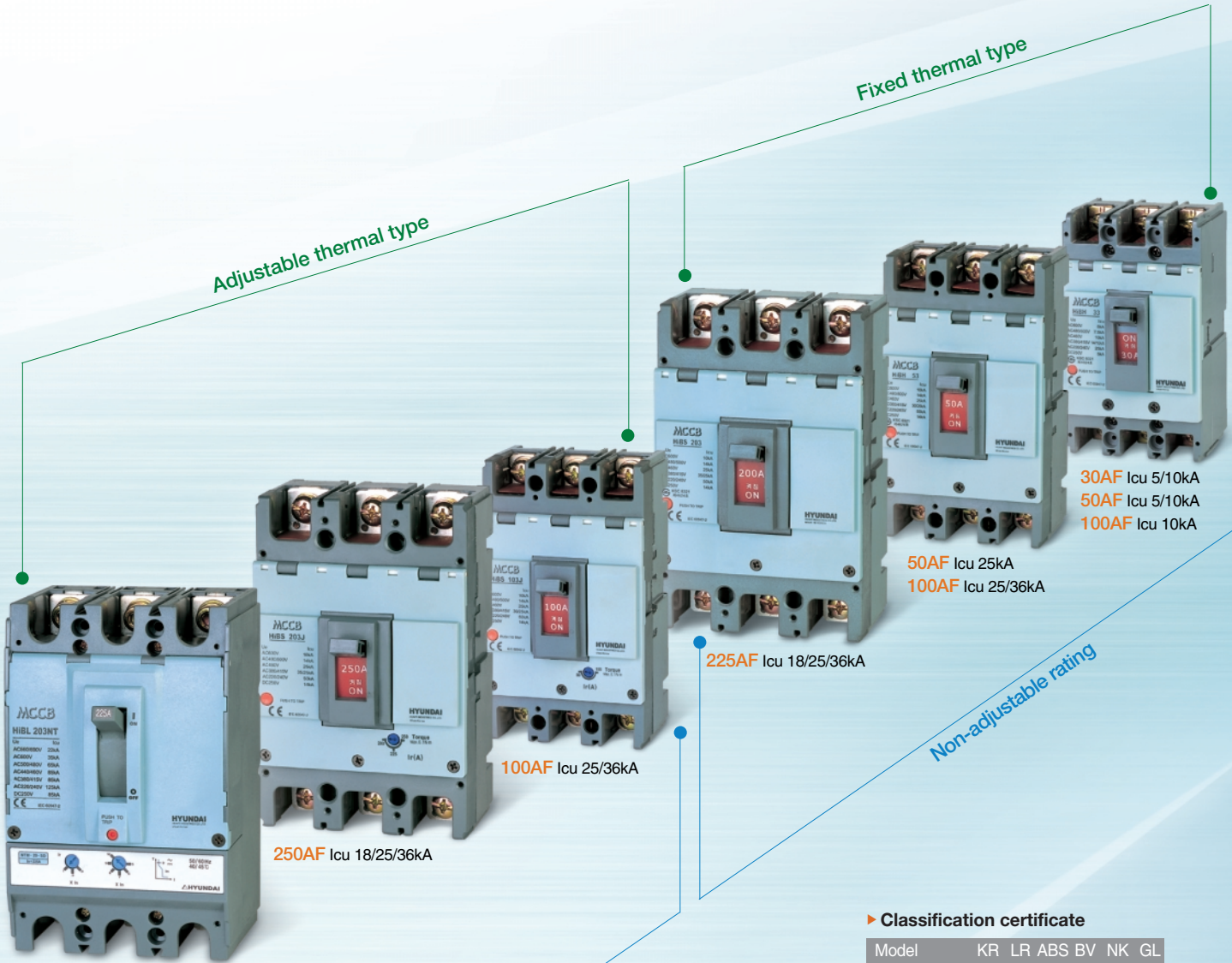

Adjustable thermal type

Fixed thermal type

Adjustable rating

Non-adjustable rating

50AF Icu 85/130kA
100AF Icu 85/130kA
225AF Icu 85/130kA

250AF Icu 18/25/36kA

100AF Icu 25/36kA

225AF Icu 18/25/36kA

50AF Icu 25kA
100AF Icu 25/36kA

30AF Icu 5/10kA
50AF Icu 5/10kA
100AF Icu 10kA

Qualified Standard & Approval

- ▶ **Standard**
 - KS C8321
 - IEC 60947-2
 - NEMA AB-1
- ▶ **Approval**
 - ISO 18001, 14001, 9001
 - CE (Community European / TÜV Rheinland)
 - TSE
 - GOST-R
 - CCC

► **Classification certificate**

Model	KR	LR	ABS	BV	NK	GL
HiBS53	●	●	●	●	●	●
HiBS63	●	●	●	●	●	●
HiBE103	●	●	●	●	●	●
HiBS103	●	●	●	●	●	●
HiBH103	●	●	●	●	●	●
HiBS203	●	●	●	●	●	●
HiBH203	●	●	●	●	●	●
HiBE403	●	●	●	●	●	●
HiBS403	●	●	●	●	●	●
HiBH403	●	●	●	●	●	●
HiBL403	●	●	●	●	●	●
HiBE603	●	●	●	●	●	●
HiBS603	●	●	●	●	●	●
HiBH603	●	●	●	●	●	●
HiBL603	●	●	●	●	●	●
HiBE803	●	●	●	●	●	●
HiBS803	●	●	●	●	●	●
HiBH803	●	●	●	●	●	●
HiBL803	●	●	●	●	●	●
HiBL53NT	●	●	●	●	●	●
HiBL103NT	●	●	●	●	●	●
HiBX103NT	●	●	●	●	●	●
HiBL203NT	●	●	●	●	●	●
HiBX203NT	●	●	●	●	●	●
HiBL403NE	●	●	●	●	●	●
HiBX403NE	●	●	●	●	●	●
HiBL603NE	●	●	●	●	●	●
HiBX603NE	●	●	●	●	●	●
HiBH803NE	●	●	●	●	●	●
HiBL1003NE	●	●	●	●	●	●
HiBL1203NE	●	●	●	●	●	●

Quick Selection Table

Molded case circuit breaker

	Frame	Model	Number of poles	Rated current (A)	Breaking capacity [Icu] (kA rms)		
					220/240V	380/415V	600V
■ Fixed thermal type	30	HiBS30 ¹⁾	2, 3	3, 5, 10, 15, 20, 30	10	7.5/5	2.5
		HiBH30 ¹⁾	2, 3	5, 10, 15, 20, 30	25	14/10	5
	50	HiBE50 ¹⁾	2, 3, 4	5, 10, 15, 20, 30, 40, 50	10	7.5/5	2.5
		HiBS50 ¹⁾	2, 3, 4	5, 10, 15, 20, 30, 40, 50	25	14/10	5
		HiBH50 ¹⁾	2, 3, 4	15, 20, 30, 40, 50	50	30/25	10
	60	HiBE60 ¹⁾	2, 3, 4	5, 10, 15, 20, 30, 40, 50, 60	10	7.5/5	2.5
		HiBS60 ¹⁾	2, 3, 4	5, 10, 15, 20, 30, 40, 50, 60	25	14/10	5
	100	HiBE100 ¹⁾	2, 3, 4	5, 10, 15, 20, 30, 40, 50, 60, 75, 100	25	14/10	5
		HiBS100 ¹⁾	2, 3, 4	15, 20, 30, 40, 50, 60, 75, 100	50	30/25	10
		HiBH100 ¹⁾	2, 3, 4	15, 20, 30, 40, 50, 60, 75, 100	65	42/36	18
	225	HiBE225 ¹⁾	2 ²⁾ , 3, 4	125, 150, 175, 200, 225	35	25/18	7.5
		HiBS225 ¹⁾	2 ²⁾ , 3, 4	125, 150, 175, 200, 225	50	35/25	10
		HiBH225 ¹⁾	2 ²⁾ , 3, 4	125, 150, 175, 200, 225	65	42/36	18
	400	HiBE400 ¹⁾	2 ²⁾ , 3, 4	250, 300, 350, 400	35	30	18
		HiBS400 ¹⁾	2 ²⁾ , 3, 4	250, 300, 350, 400	50	42	22
		HiBH400 ¹⁾	2 ²⁾ , 3, 4	250, 300, 350, 400	85	65	25
		HiBL400 ¹⁾	2 ²⁾ , 3, 4	250, 300, 350, 400	125	100	30
	600	HiBE600 ¹⁾	2 ²⁾ , 3, 4	500, 600	50	45	22
		HiBS600 ¹⁾	2 ²⁾ , 3, 4	500, 600	100	65	25
		HiBH600 ¹⁾	2 ²⁾ , 3, 4	500, 600	100	85	35
HiBL600 ¹⁾		2 ²⁾ , 3, 4	500, 600	125	100	35	
800	HiBE800 ¹⁾	2 ²⁾ , 3, 4	700, 800	50	45	25	
	HiBS800 ¹⁾	2 ²⁾ , 3, 4	700, 800	100	65	25	
	HiBH800 ¹⁾	2 ²⁾ , 3, 4	700, 800	100	85	35	
	HiBL800 ¹⁾	2 ²⁾ , 3, 4	700, 800	125	100	35	
■ Adjustable thermal type	50	HiBL50NT	3, 4	15, 20, 30, 40, 50	125	85	35
		HiBX50NT	3, 4	15, 20, 30, 40, 50	150	130	65
	100	HiBS100J ¹⁾	2, 3, 4	12.5-16, 16-20, 20-25, 25-32, 32-40, 40-50, 50-63, 63-80, 80-100	50	30/25	10
		HiBH100J ¹⁾			65	42/36	18
		HiBL100NT	3, 4	15, 20, 30, 40, 50, 60, 75, 100	125	85	35
		HiBX100NT	3, 4	15, 20, 30, 40, 50, 60, 75, 100	150	130	65
	225	HiBL225NT	3, 4	125, 150, 175, 200, 225 (250) ³⁾	125	85	35
		HiBX225NT	3, 4	125, 150, 175, 200, 225	150	130	65
		HiBE250J ¹⁾	2 ²⁾ , 3, 4	100-125, 125-160, 160-200, 200-250	35	25/18	7.5
		HiBS250J ¹⁾			50	35/25	10
		HiBH250J ¹⁾			65	42/36	18

※ 1) Ics=50% Icu

2) 2 pole has same dimension with 3 pole, but middle pole is removed.

3) 250A for HiBL225NT and HiBL225NE is non-standard and available on special request.





4) 630A for HiBS600NE, HiBL600NE and HiBX600NE is non-standard and available on special request.

	Frame	Model	Number of poles	Rated current (A)	Breaking capacity [Icu] (kA rms)		
					220/240V	380/415V	600V
Electronic type	50	HiBL50NE	3, 4	20-50	125	85	35
	100	HiBL100NE	3, 4	40-100	125	85	35
	225	HiBL225NE	3, 4	90-225 (250) ³⁾	125	85	35
	400	HiBS400NE	3, 4	200-400	85	50	30
		HiBL400NE	3, 4	200-400	125	85	35
		HiBX400NE	3, 4	200-400	150	130	65
	600	HiBS600NE	3, 4	302-600 (630) ⁴⁾	100	65	35
		HiBL600NE	3, 4	302-600 (630) ⁴⁾	125	85	42
		HiBX600NE	3, 4	302-600 (630) ⁴⁾	150	130	65
	800	HiBS800NE ¹⁾	3, 4	405-800	100	65	35
		HiBL800NE ¹⁾	3, 4	405-800	125	85	42
		HiBX800NE ¹⁾	3, 4	405-800	150	130	65
	1000	HiBS1000NE ¹⁾	3, 4	505-1000	100	100	50
		HiBL1000NE ¹⁾	3, 4	505-1000	150	130	65
	1200	HiBS1200NE ¹⁾	3, 4	605-1200	100	100	50
		HiBL1200NE ¹⁾	3, 4	605-1200	150	130	65

Switch disconnecter

Frame	Model	Number of poles	Dimension
50	HiSD53	3	Same dimension with HiBS53
100	HiSD103	3	Same dimension with HiBS103
225	HiSD203	3	Same dimension with HiBS203
400	HiSD403	3	Same dimension with HiBS403
600	HiSD603	3	Same dimension with HiBS603
800	HiSD803	3	Same dimension with HiBS803
400	HiSD403NE	3	Same dimension with HiBS403NE
600	HiSD603NE	3	Same dimension with HiBS603NE
800	HiSD803NE	3	Same dimension with HiBS803NE
1000	HiSD1003NE	3	Same dimension with HiBS1003NE
1200	HiSD1203NE	3	Same dimension with HiBS1203NE

Fixed Thermal Type

Ampere frame (AF)		30						50							
Model		HiBS30		HiBH30		HiBE50			HiBS50			HiBH50			
Number of poles		2	3	2	3	2	3	4	2	3	4	2	3	4	
Outside view															
IP degree		IP20													
Category		A													
Life time	Number of operating cycles	Per hour		240											
		Mechanical		30,000											
		Electrical at AC415V		9,500											
Rated current (A)		3, 5, 10, 15, 20, 30		5, 10, 15, 20, 30		5, 10, 15, 20, 30, 40, 50			15, 20, 30, 40, 50						
Rated insulation voltage (V) Ui		750													
Rated operational voltage (V) Ue		690													
Rated impulse withstand voltage (kV) Uimp		6													
Ultimate breaking capacity Icu (kA rms) KS C 8321 IEC 60947-2 NEMA AB-1	Ics=(% Icu)	50		50		50			50			50			
	AC660V	2.5		5.0		2.5			5.0			10			
	AC600V	2.5		5.0		2.5			5.0			10			
	AC480/500V	2.5		7.5		2.5			7.5			14			
	AC440/460V	5.0		10		5.0			10			25			
	AC380/415V	7.5/5.0		14/10		7.5/5.0			14/10			30/25			
	AC220/240V	10		25		10			25			50			
	DC250V	-		-		-			-			14			
	DC125V	-		-		-			-			20			
Standard features	Hydraulic-magnetic trip	☉		☉		☉			☉			-			
	Fixed thermal & fixed magnetic trip	-		-		-			-			☉			
	Thermal & adjustable magnetic trip	-		-		-			-			-			
Connection & mounting	Connection	Terminal screw	☉		☉		☉			☉			☉		
		Terminal bus bar	-		-		-			-			-		
	Plug-in mounting	Both line & load side	-	○	-	○	-	○	-	-	○	-	-	○	-
		Line side only	-	○	-	○	-	○	-	-	○	-	-	○	-
Accessories ¹⁾	Shunt trip SHT	○		○		○			○			-			
	Under voltage trip UVT	○		○		○			○			-			
	Auxiliary switch AUX	○		○		○			○			○			
	Trip alarm switch ALT	○		○		○			○			○			
	Operating handle	Surface type (TFG)	-	○	-	○	-	○	-	-	○	-	-	○	
		Extended type (TFH)	-	○	-	○	-	○	-	-	○	-	-	○	
	Interpole barrier (TQQ)	☉		☉		☉			☉			☉			
	Terminal cover (TCF)	○		○		○			○			○			
	Terminal bus bar (TBB)	-		-		-			-			-			
Dimensions (mm)	a	50	75	50	75	50	75	100	50	75	100	60	90	120	
	b	130		130		130			130			155			
	c	60		60		60			60			60			
	d	82		82		82			82			84.5			
Weights (kg) (Standard type)		0.57	0.8	0.57	0.8	0.57	0.8	1.0	0.57	0.8	1.0	0.75	1.07	1.3	
Page for characteristic & dimensions		Page 60		Page 60		Page 60			Page 60			Page 62			

※ - ☉: Standard, this configuration used unless otherwise specified ○: Optional standard, specify when ordering -: Stands for "No" or "Not available"

- The *2 pole are the same as 3 pole except that the middle pole materials are removed.
- 2 pole has same dimension with 3 pole, but middle pole is removed.
- 1) For the detail and not mentioned accessories, please refer to page no. 32-48.

60			100									225											
HiBE60			HiBS60			HiBE100			HiBS100			HiBH100			HiBE225			HiBS225			HiBH225		
2	3	4	2	3	4	2	3	4	2	3	4	2	3	4	*2	3	4	*2	3	4	*2	3	4



IP20

A

240									120								
30,000									25,000								
9,500									8,000								
5, 10, 15, 20, 30, 40, 50, 60			5, 10, 15, 20, 30, 40, 50, 60, 75, 100			15, 20, 30, 40, 50, 60, 75, 100						125, 150, 175, 200, 225					





750

690

6

50	50	50	50	50	50	50	50	50	50	50	50	50	50	50	50	50	50	50	50	50	50	50							
2.5	5.0	5.0	5.0	10	18	7.5	10	18	7.5	10	18	7.5	10	18	7.5	10	18	7.5	10	18	7.5	10	18						
2.5	5.0	5.0	5.0	10	18	7.5	10	18	7.5	10	18	7.5	10	18	7.5	10	18	7.5	10	18	7.5	10	18						
2.5	7.5	7.5	7.5	14	25	10	14	25	10	14	25	10	14	25	10	14	25	10	14	25	10	14	25						
5.0	10	10	10	25	35	18	25	35	18	25	35	18	25	35	18	25	35	18	25	35	18	25	35						
7.5/5.0	14/10	14/10	14/10	30/25	42/36	25/18	35/25	42/36	25/18	35/25	42/36	25/18	35/25	42/36	25/18	35/25	42/36	25/18	35/25	42/36	25/18	35/25	42/36						
10	25	25	25	50	65	35	50	65	35	50	65	35	50	65	35	50	65	35	50	65	35	50	65						
-	-	-	-	14	18	10	14	18	10	14	18	10	14	18	10	14	18	10	14	18	10	14	18						
-	-	-	-	20	25	15	20	25	15	20	25	15	20	25	15	20	25	15	20	25	15	20	25						
⊙	⊙	⊙	⊙	-	-	-	-	-	-	-	-	-	-	-	-	-	-	-	-	-	-	-	-						
-	-	-	-	⊙	⊙	⊙	⊙	⊙	⊙	⊙	⊙	⊙	⊙	⊙	⊙	⊙	⊙	⊙	⊙	⊙	⊙	⊙	⊙						
-	-	-	-	-	-	-	-	-	-	-	-	-	-	-	-	-	-	-	-	-	-	-	-						
⊙	⊙	⊙	⊙	⊙	⊙	⊙	⊙	⊙	⊙	⊙	⊙	⊙	⊙	⊙	⊙	⊙	⊙	⊙	⊙	⊙	⊙	⊙	⊙						
-	-	-	-	-	-	-	-	-	-	-	-	-	-	-	-	-	-	-	-	-	-	-	-						
-	○	-	-	○	-	-	○	-	-	○	-	-	○	-	-	○	-	-	○	-	-	○	-						
-	○	-	-	○	-	-	○	-	-	○	-	-	○	-	-	○	-	-	○	-	-	○	-						
○	○	○	○	○	○	○	○	○	○	○	○	○	○	○	○	○	○	○	○	○	○	○	○						
○	○	○	○	○	○	○	○	○	○	○	○	○	○	○	○	○	○	○	○	○	○	○	○						
○	○	○	○	○	○	○	○	○	○	○	○	○	○	○	○	○	○	○	○	○	○	○	○						
-	○	-	-	○	-	-	○	-	-	○	-	-	○	-	-	○	-	-	○	-	-	○	-						
-	○	-	-	○	-	-	○	-	-	○	-	-	○	-	-	○	-	-	○	-	-	○	-						
⊙	⊙	⊙	⊙	⊙	⊙	⊙	⊙	⊙	⊙	⊙	⊙	⊙	⊙	⊙	⊙	⊙	⊙	⊙	⊙	⊙	⊙	⊙	⊙						
○	○	○	○	○	○	○	○	○	○	○	○	○	○	○	○	○	○	○	○	○	○	○	○						
-	-	-	-	-	-	-	-	-	-	-	-	-	-	-	-	-	-	-	-	-	-	-	-						
50	75	100	50	75	100	50	75	100	60	90	120	60	90	120	105	140	105	140	105	140	105	140	105	140					
130	130	130	130	130	130	130	130	130	155	155	155	155	155	155	164	164	164	164	164	164	164	164	164	164					
60	60	60	60	60	60	60	60	60	60	60	60	60	60	60	60	60	60	60	60	60	60	60	60	60					
82	82	82	82	82	82	82	82	82	84.5	84.5	84.5	84.5	84.5	84.5	84	84	84	84	84	84	84	84	84	84					
0.57	0.8	1.0	0.57	0.8	1.0	0.57	0.8	1.0	0.75	1.07	1.3	0.75	1.07	1.3	1.25	1.38	1.69	1.25	1.38	1.69	1.25	1.38	1.69	1.25	1.38	1.69			
Page 60			Page 60			Page 60			Page 62			Page 62			Page 64			Page 64			Page 64			Page 64			Page 64		

Fixed Thermal Type

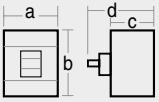
Ampere frame (AF)		400													
Model		HiBE400			HiBS400			HiBH400			HiBL400				
Number of poles		*2	3	4	*2	3	4	*2	3	4	*2	3	4		
Outside view															
IP degree		IP20													
Category		A													
Life time	Number of operating cycles	Per hour		120											
		Mechanical		20,000											
		Electrical at AC415V		8,000											
Rated current (A)		250, 300, 350, 400													
Rated insulation voltage (V) Ui		750													
Rated operational voltage (V) Ue		690													
Rated impulse withstand voltage (kV) Uimp		6													
Ultimate breaking capacity Icu (kA rms) KS C 8321 IEC 60947-2 NEMA AB-1	Ics=(% Icu)	50			50			50			50				
	AC660V	18			22			25			30				
	AC600V	18			22			25			30				
	AC480/500V	18			25			35			65				
	AC440/460V	25			35			50			85				
	AC380/415V	30			42			65			100				
	AC220/240V	35			50			85			125				
	DC250V	14			25			40			40				
	DC125V	20			30			50			60				
Standard features	Hydraulic-magnetic trip	-													
	Fixed thermal & fixed magnetic trip	⊙													
	Thermal & adjustable magnetic trip	-													
Connection & mounting	Connection	Terminal screw	⊙			⊙			⊙			⊙			
		Terminal bus bar	○			○			○			○			
	Plug-in mounting	Both line & load side	○	-	○	-	○	-	○	-	○	-			
		Line side only	-			-			-			-			
Accessories ¹⁾	Shunt trip SHT	○			○			○			○				
	Under voltage trip UVT	○			○			○			○				
	Auxiliary switch AUX	○			○			○			○				
	Trip alarm switch ALT	○			○			○			○				
	Operating handle	Surface type (TFG)	○			○			○			○			
		Extended type (TFH)	○			○			○			○			
	Extension handle (THA)	⊙			⊙			⊙			⊙				
	Interpole barrier (TQQ)	⊙			⊙			⊙			⊙				
	Terminal cover (TCF)	-													
	Terminal bus bar (TBB)	○													
Dimensions (mm)		a	140		185		140		185		140		185		
		b	257			257			257			257			
		c	110			110			110			110			
		d	145			145			145			145			
Weights (kg) (Standard type)		5.2	5.7	7.25	5.2	5.7	7.25	5.2	5.7	7.25	5.2	5.7	7.25		
Page for characteristic & dimensions		Page 66			Page 66			Page 66			Page 66				

※ - ⊙: Standard, this configuration used unless otherwise specified ○: Optional standard, specify when ordering -: Stands for "No" or "Not available"

- The *2 pole are the same as 3 pole except that the middle pole materials are removed.

- 2 pole has same dimension with 3 pole, but middle pole is removed.

- 1) For the detail and not mentioned accessories, please refer to page no. 32-48.

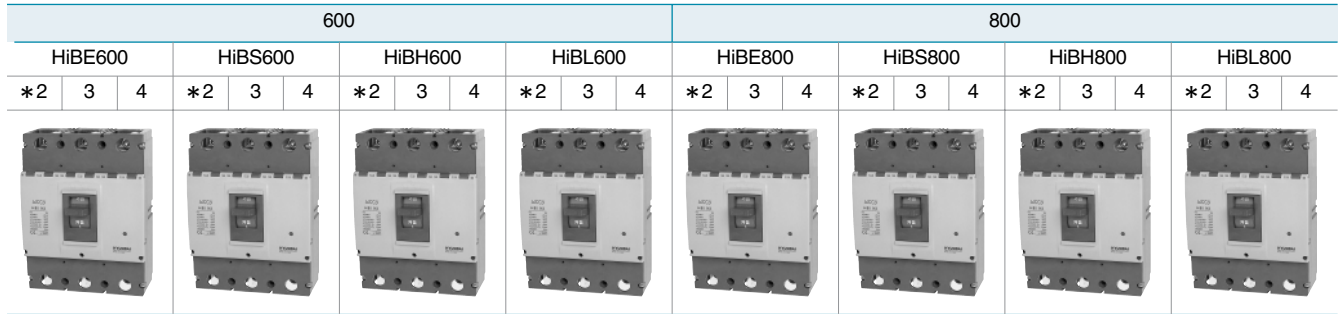

IP20

A





120

20,000

5,000

500, 600												700, 800																	
750												750																	
690												690																	
6												6																	
50			50			50			50			50			50			50			50			50					
22			25			35			35			25			25			35			35			35					
22			25			35			35			25			25			35			35			35					
25			45			50			65			35			45			50			65			65					
35			50			65			85			35			50			65			85			85					
45			65			85			100			45			65			85			100			100					
50			100			100			125			50			100			100			125			125					
20			40			40			40			20			40			40			40			40					
30			50			50			60			30			50			50			60			60					
-			-			-			-			-			-			-			-			-					
⊙			⊙			⊙			⊙			⊙			⊙			⊙			⊙			⊙					
-			-			-			-			-			-			-			-			-					
⊙			⊙			⊙			⊙			⊙			⊙			⊙			⊙			⊙					
○			○			○			○			○			○			○			○			○					
○	-		○	-		○	-		○	-		○	-		○	-		○	-		○	-		○					
-			-			-			-			-			-			-			-			-					
○			○			○			○			○			○			○			○			○					
○			○			○			○			○			○			○			○			○					
○			○			○			○			○			○			○			○			○					
○			○			○			○			○			○			○			○			○					
○			○			○			○			○			○			○			○			○					
○			○			○			○			○			○			○			○			○					
⊙			⊙			⊙			⊙			⊙			⊙			⊙			⊙			⊙					
⊙			⊙			⊙			⊙			⊙			⊙			⊙			⊙			⊙					
-			-			-			-			-			-			-			-			-					
○			○			○			○			○			○			○			○			○					
210	280		210	280		210	280		210	280		210	280		210	280		210	280		210	280		210	280				
280			280			280			280			280			280			280			280			280					
110			110			110			110			110			110			110			110			110					
145			145			145			145			145			145			145			145			145					
9.5	10.3	13.3	9.5	9.5	13.3	10.2	11.1	14.5	9.5	10.3	13.3	10.2	11.1	14.5	10.2	11.1	14.5	10.2	11.1	14.5	10.2	11.1	14.5	10.2	11.1	14.5			
Page 68			Page 68			Page 68			Page 68			Page 70			Page 70			Page 70			Page 70			Page 70			Page 70		



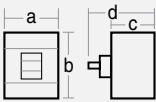

Adjustable Thermal Type

Ampere frame (AF)		50				100									
Model		HiBL50NT		HiBX50NT		HiBS100J		HiBH100J							
Number of poles		3	4	3	4	2	3	4	2	3	4				
Outside view															
IP degree		IP20													
Category		A													
Life time	Number of Operating Cycles	Per hour		240											
		Mechanical		30,000											
		Electrical at AC415V		9,500											
Rated current (A)		15, 20, 30, 40, 50				12.5-16, 16-20, 20-25, 25-32, 32-40, 40-50, 50-63, 63-80, 80-100 Adjustable									
Rated insulation voltage (V) U_i		750				750									
Rated operational voltage (V) U_e		690				690									
Rated impulse withstand voltage (kV) U_{imp}		8				6									
Ultimate breaking capacity Icu (kA rms) KS C 8321 IEC 60947-2 NEMA AB-1	Ics=(%Icu)		100		100		50		50						
	AC660V		22		60		10		18						
	AC600V		35		65		10		18						
	AC480/500V		65		100		14		25						
	AC440/460V		85		100		25		35						
	AC380/415V		85		130		30/25		42/36						
	AC220/240V		125		150		50		65						
	DC250V		85		85		14		18						
DC125V		-		-		20		25							
Protection characteristics	Long time delay	Adjustable	$(0.8 \times 0.9 \times 1.0) \times I_n$		$(0.8 \times 0.9 \times 1.0) \times I_n$		$(0.8-1.0) \times I_n$		$(0.8-1.0) \times I_n$						
	Short time delay	Adjustable	-		-		-		-						
	Instantaneous	Fixed	$10 \times I_n$		$10 \times I_n$		$15 \times I_n$		$15 \times I_n$						
		Adjustable	-		-		-		-						
	Ground fault trip	-		-		-		-							
	I ² T ramp	-		-		-		-							
	Pre-trip alarm LED	-		-		-		-							
Mechanism	Thermal magnetic		☉		☉		☉		☉						
	Electronic		-		-		-		-						
Connection & mounting	Connection	Terminal screw	☉		☉		☉		☉						
		Terminal bus bar	○		○		-		-						
	Plug-in mounting	Both line & load side	○	-	○	-	-	○	-	○	-				
		Line side only	○	-	○	-	-	○	-	○	-				
Accessories ¹⁾	Shunt trip SHT		○		○		-		○						
	Under voltage trip UVT		○		○		-		○						
	Auxiliary switch AUX		○		○		○		○						
	Trip alarm switch ALT		○		○		○		○						
	Operating handle	Surface type (TFG)	○		○		-		○						
		Extended type (TFH)	○		○		-		○						
	Extension handle (THA)		☉		☉		-		-						
	Interpole barrier (TQQ)		☉		☉		☉		☉						
	Terminal cover (TCF)		-		-		○		○						
	Terminal bus bar (TBB)		○		○		-		-						
Dimensions (mm)			a	105	140	105	140	60	90	120	60	90	120		
			b	165		165		155		155					
			c	87.5		87.5		60		60					
			d	105		105		84.5		84.5					
Weights (kg) (Standard type)		2.13		2.67		2.13		2.67		0.75	1.07	1.3	0.75	1.07	1.3
Page for characteristic & dimensions		Page 72		Page 72		Page 72		Page 72		Page 72					

※ - The *2 pole are the same as 3 pole except that the middle pole materials are removed.



- Our products are designed for 50/60Hz common use. However, for the electronic MCCB they can be adapted according to the regions or countries where it is to be used.

- 1) For the detail and not mentioned accessories, please refer to page no. 32-48.

100				225			
HiBL100NT		HiBX100NT		HiBL225NT		HiBX225NT	
3	4	3	4	3	4	3	4
							
IP20		IP20		IP20		IP20	
A		A		A		A	
240		240		240		240	
30,000		30,000		25,000		25,000	
9,500		9,500		8,000		8,000	
15, 20, 30, 40, 50, 60, 75, 100		15, 20, 30, 40, 50, 60, 75, 100		125, 150, 175, 200, 225 (250) ²⁾		125, 150, 175, 200, 225 (250) ²⁾	
750		750		750		750	
690		690		690		690	
8		8		8		8	
100		100		100		100	
22		60		22		60	
35		65		35		65	
65		100		65		100	
85		100		85		100	
85		130		85		130	
125		150		125		150	
85		85		85		85	
-		-		-		-	
$(0.8 \times 0.9 \times 1.0) \times I_n$		$(0.8 \times 0.9 \times 1.0) \times I_n$		$(0.8 \times 0.9 \times 1.0) \times I_n$		$(0.8 \times 0.9 \times 1.0) \times I_n$	
-		-		-		-	
10 × I _n		10 × I _n		10 × I _n (Upto 150A)		10 × I _n (Upto 175A)	
-		-		5-6-7-8-9-10 × I _n (From 175A)		5-6-7-8-9-10 × I _n (From 200A)	
-		-		-		-	
-		-		-		-	
-		-		-		-	
⊙		⊙		⊙		⊙	
-		-		-		-	
⊙		⊙		⊙		⊙	
○		○		○		○	
○	-	○	-	○	-	○	-
○	-	○	-	○	-	○	-
○		○		○		○	
○		○		○		○	
○		○		○		○	
○		○		○		○	
○		○		○		○	
○		○		○		○	
⊙		⊙		⊙		⊙	
⊙		⊙		⊙		⊙	
-		-		-		-	
○		○		○		○	
105	140	105	140	105	140	105	140
165		165		165		165	
87.5		87.5		87.5		87.5	
105		105		105		105	
2.13	2.67	2.13	2.67	2.13	2.67	2.13	2.67
Page 72		Page 72		Page 72		Page 72	

- For the thermal magnetic MCCB, AC/DC is common use. However, the electronic MCCB can not be used with DC.
- ⊙: Standard, this configuration used unless otherwise specified ○: Optional standard, specify when ordering -: Stands for "No" or "Not available"
- 2) 250A for HiBL225NT is non-standard and available on special request.

Adjustable Thermal Type

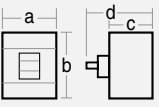
Ampere frame (AF)			250								
Model			HiBE250J			HiBS250J			HiBH250J		
Number of poles			*2	3	4	*2	3	4	*2	3	4
Outside view											
IP degree			IP20								
Category			A								
Life time	Number of operating cycles	Per hour	120								
		Mechanical	25,000								
		Electrical at AC415V	8,000								
Rated current (A)			100-125, 125-160, 160-200, 200-250 Adjustable								
Rated insulation voltage (V) U_i			750								
Rated operational voltage (V) U_e			690								
Rated impulse withstand voltage (kV) U_{imp}			6								
Ultimate breaking capacity Icu (kA rms) KS C 8321 IEC 60947-2 NEMA AB-1	Ics=(%Icu)		50			50			50		
	AC660V		7.5			10			18		
	AC600V		7.5			10			18		
	AC480/500V		10			14			25		
	AC440/460V		18			25			35		
	AC380/415V		25/18			35/25			42/36		
	AC220/240V		35			50			65		
	DC250V		10			14			18		
DC125V		15			20			25			
Protection characteristics	Long time delay	Adjustable	$(0.8-1.0) \times I_n$			$(0.8-1.0) \times I_n$			$(0.8-1.0) \times I_n$		
	Short time delay	Adjustable	-			-			-		
	Instantaneous	Fixed	$15 \times I_n$			$15 \times I_n$			$15 \times I_n$		
		Adjustable	-			-			-		
	Ground fault trip	-			-			-			
	I ² T ramp	-			-			-			
	Pre-trip alarm LED	-			-			-			
Mechanism	Thermal magnetic		☉			☉			☉		
	Electronic		-			-			-		
Connection & mounting	Connection	Terminal screw	☉			☉			☉		
		Terminal bus bar	○			○			○		
	Plug-in mounting	Both line & load side	○	-	-	○	-	-	○	-	-
		Line side only	○	-	-	○	-	-	○	-	-
Accessories ¹⁾	Shunt trip SHT		○			○			○		
	Under voltage trip UVT		○			○			○		
	Auxiliary switch AUX		○			○			○		
	Trip alarm switch ALT		○			○			○		
	Operating handle	Surface type (TFG)	○			○			○		
		Extended type (TFH)	○			○			○		
	Extension handle (THA)		-			-			-		
	Interpole barrier (TQQ)		☉			☉			☉		
	Terminal cover (TCF)		○			○			○		
	Terminal bus bar (TBB)		○			○			○		
Dimensions (mm)			a	105		140		105		140	
			b	164		164		164		164	
			c	60		60		60		60	
			d	84		84		84		84	
Weights (kg) (Standard type)			1.25	1.38	1.69	1.25	1.38	1.69	1.25	1.38	1.69
Page for characteristic & dimensions			Page 64			Page 64			Page 64		

※ - The *2 pole are the same as 3 pole except that the middle pole materials are removed.

- Our products are designed for 50/60Hz common use. However, for the electronic MCCB they can be adapted according to the regions or countries where it is to be used.



- 1) For the detail and not mentioned accessories, please refer to page no. 32-48.

Electronic Type

50		100		225		400					
HiBL50NE		HiBL100NE		HiBL225NE		HiBS400NE		HiBL400NE		HiBX400NE	
3	4	3	4	3	4	3	4	3	4	3	4
IP20											
A											
240		240		120				120			
30,000		30,000		25,000				20,000			
9,500		9,500		8,000				8,000			
20 - 50		40 - 100		90-225 (250) ²⁾				200 - 400			
750		750		750				750			
690		690		690				690			
8		8		8				8			
100		100		100		100		100		100	
22		22		22		22		22		60	
35		35		35		30		35		65	
65		65		65		35		50		100	
85		85		85		50		85		100	
85		85		85		50		85		130	
125		125		125		85		125		150	
-		-		-		-		-		-	
-		-		-		-		-		-	
9 Setting		9 Setting		9 Setting		15 Setting		15 Setting		15 Setting	
2-3-4-5-6-7-8-9-10×Ir		2-3-4-5-6-7-8-9-10×Ir		2-3-4-5-6-7-8-9-10×Ir		2-4-6-8-10×I ₁		2-4-6-8-10×I ₁		2-4-6-8-10×I ₁	
11×In		11×In		11×In		-		-		-	
-		-		-		3-6-8-10-11×I _{CT}		3-6-8-10-11×I _{CT}		3-6-8-10-11×I _{CT}	
-		-		-		○		○		○	
-		-		-		◎		◎		◎	
◎		◎		◎		◎		◎		◎	
-		-		-		-		-		-	
◎		◎		◎		◎		◎		◎	
◎		◎		◎		◎		◎		◎	
○		○		○		○		○		○	
○		○		○		○		○		○	
○		○		○		○		○		○	
○		○		○		○		○		○	
○		○		○		○		○		○	
○		○		○		○		○		○	
◎		◎		◎		◎		◎		◎	
◎		◎		◎		◎		◎		◎	
-		-		-		○		○		○	
○		○		○		○		○		○	
105		140		105		140		140		210	
165		165		165		255		255		255	
87.5		87.5		87.5		122		122		122	
105		105		105		159		159		159	
2.13		2.67		2.13		2.67		6.95		8.88	
2.13		2.67		2.13		2.67		6.95		8.88	
8.1		10.3		8.1		10.3		8.1		10.3	
Page 74		Page 74		Page 74		Page 76		Page 76		Page 76	

- For the thermal magnetic MCCB, AC/DC is common use. However, the electronic MCCB can not be used with DC.
 - ◎: Standard, this configuration used unless otherwise specified ○: Optional standard, specify when ordering -: Stands for "No" or "Not available"
 - ²⁾ 250A for HiBL225NE is non-standard and available on special request.

Electronic Type

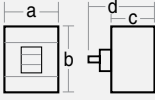
Ampere frame (AF)		600							
Model		HiBS600NE		HiBL600NE		HiBX600NE			
Number of poles		3	4	3	4	3	4		
Outside view									
IP degree		IP20							
Category		A							
Life time	Number of operating cycles	Per hour		120					
		Mechanical		20,000					
		Electrical at AC415V		5,000					
Rated current (A)		302 - 600 (630) ²⁾		302 - 600 (630) ²⁾		302 - 600 (630) ²⁾			
Rated insulation voltage (V) Ui		750							
Rated operational voltage (V) Ue		690							
Rated impulse withstand voltage (kV) Uimp		8							
Ultimate breaking capacity Icu (kA rms) KS C 8321 IEC 60947-2 NEMA AB-1	Ics=(% Icu)		100		100		100		
	AC660V		22		35		60		
	AC600V		35		42		65		
	AC480/500V		50		50		100		
	AC440/460V		65		85		100		
	AC380/415V		65		85		130		
	AC220/240V		100		125		150		
	DC250V		-		-		-		
DC125V		-		-		-			
Protection characteristics	Long time delay	Adjustable	15 Setting		15 Setting		15 Setting		
	Short time delay	Adjustable	2-4-6-8-10 × I ₁		2-4-6-8-10 × I ₁		2-4-6-8-10 × I ₁		
	Instantaneous	Fixed	-		-		-		
		Adjustable	3-6-8-10-11 × I _{CT}		3-6-8-10-11 × I _{CT}		3-6-8-10-11 × I _{CT}		
	Ground fault trip		○		○		○		
	I ² T ramp		◎		◎		◎		
Pre-trip alarm LED		◎		◎		◎			
Mechanism	Thermal magnetic		-		-		-		
	Electronic		◎		◎		◎		
Connection & mounting	Connection	Terminal screw	◎		◎		◎		
		Terminal bus bar	○		○		○		
	Plug-in mounting	Both line & load side	○	-	○	-	○	-	
		Line side only	○	-	○	-	○	-	
Accessories ¹⁾	Shunt trip SHT		○		○		○		
	Under voltage trip UVT		○		○		○		
	Auxiliary switch AUX		○		○		○		
	Trip alarm switch ALT		○		○		○		
	Operating handle	Surface type (TFG)	○		○		○		
		Extended type (TFH)	○		○		○		
	Extension handle (THA)		◎		◎		◎		
	Interpole barrier (TQQ)		◎		◎		◎		
	Terminal cover (TCF)		○		○		○		
Terminal bus bar (TBB)		○		○		○			
Dimensions (mm)			a	140	210	140	210	140	210
			b	255		255		255	
			c	122		122		122	
			d	159		159		159	
Weights (kg) (Standard type)		8.1		10.3		8.1		10.3	
Page for characteristic & dimensions		Page 78		Page 78		Page 78		Page 78	

※ - The *2 pole are the same as 3 pole except that the middle pole materials are removed.

- Our products are designed for 50/60Hz common use. However, for the electronic MCCB they can be adapted according to the regions or countries where it is to be used.

- 1) For the detail and not mentioned accessories, please refer to page no. 32-48.

- 2) 630A for HiBS600NE, HiBL600NE and HiBX600NE is non-standard and available on special request.

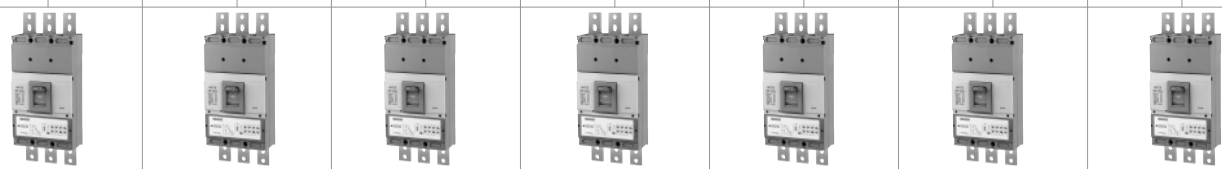
800			1000			1200							
HiBS800NE		HiBL800NE		HiBX800NE		HiBS1000NE		HiBL1000NE		HiBS1200NE		HiBL1200NE	
3	4	3	4	3	4	3	4	3	4	3	4	3	4
													
IP20													
A													
120						120							
20,000						10,000							
5,000						5,000							
405 - 800		405 - 800		405 - 800		505 - 1000		505 - 1000		605 - 1200		605 - 1200	
750													
690													
8													
50	50	50	50	50	50	50	50	50	50	50	50	50	50
22	35	50	40	60	40	60	40	60	40	60	40	60	60
35	42	65	50	65	50	65	50	65	50	65	50	65	65
50	50	100	75	100	75	100	75	100	75	100	75	100	100
65	85	100	75	100	75	100	75	100	75	100	75	100	100
65	85	130	100	130	100	130	100	130	100	130	100	130	130
100	125	150	100	150	100	150	100	150	100	150	100	150	150
-	-	-	-	-	-	-	-	-	-	-	-	-	-
-	-	-	-	-	-	-	-	-	-	-	-	-	-
15 Setting		15 Setting		15 Setting		15 Setting		15 Setting		15 Setting		15 Setting	
2-4-6-8-10×I ₁		2-4-6-8-10×I ₁		2-4-6-8-10×I ₁		2-4-6-8-10×I ₁		2-4-6-8-10×I ₁		2-4-6-8-10×I ₁		2-4-6-8-10×I ₁	
-	-	-	-	-	-	-	-	-	-	-	-	-	-
3-6-8-10-11×I _{CT}		3-6-8-10-11×I _{CT}		3-6-8-10-11×I _{CT}		3-6-8-10-11×I _{CT}		3-6-8-10-11×I _{CT}		3-6-8-10-11×I _{CT}		3-6-8-10-11×I _{CT}	
○	○	○	○	○	○	○	○	○	○	○	○	○	○
◎	◎	◎	◎	◎	◎	◎	◎	◎	◎	◎	◎	◎	◎
◎	◎	◎	◎	◎	◎	◎	◎	◎	◎	◎	◎	◎	◎
-	-	-	-	-	-	-	-	-	-	-	-	-	-
◎	◎	◎	◎	◎	◎	◎	◎	◎	◎	◎	◎	◎	◎
-	-	-	-	-	-	-	-	-	-	-	-	-	-
◎	◎	◎	◎	◎	◎	◎	◎	◎	◎	◎	◎	◎	◎
-	-	-	-	-	-	-	-	-	-	-	-	-	-
-	-	-	-	-	-	-	-	-	-	-	-	-	-
○	○	○	○	○	○	○	○	○	○	○	○	○	○
○	○	○	○	○	○	○	○	○	○	○	○	○	○
○	○	○	○	○	○	○	○	○	○	○	○	○	○
○	○	○	○	○	○	○	○	○	○	○	○	○	○
-	-	-	-	-	-	-	-	-	-	-	-	-	-
-	-	-	-	-	-	-	-	-	-	-	-	-	-
◎	◎	◎	◎	◎	◎	◎	◎	◎	◎	◎	◎	◎	◎
-	-	-	-	-	-	-	-	-	-	-	-	-	-
-	-	-	-	-	-	-	-	-	-	-	-	-	-
◎	◎	◎	◎	◎	◎	◎	◎	◎	◎	◎	◎	◎	◎
210	280	210	280	210	280	210	280	210	280	210	280	210	280
370	370	370	370	370	370	370	370	370	370	370	370	370	370
110	200	200	110	200	110	200	110	200	110	200	110	200	200
159	249	249	159	249	159	249	159	249	159	249	159	249	249
17.3	22	17.3	22	29.3	38	17.3	22	29.3	38	17.3	22	29.8	38
Page 80		Page 80		Page 80		Page 82		Page 82		Page 84		Page 84	

- For the thermal magnetic MCCB, AC/DC is common use. However, the electronic MCCB can not be used with DC.

- ◎: Standard, this configuration used unless otherwise specified ○: Optional standard, specify when ordering -: Stands for "No" or "Not available"

Hi Series Molded Case Circuit Breaker

Fixed & adjustable thermal type MCCBs

- Rated current from 3 to 800A
- Breaking capacity from 5 to 130kA

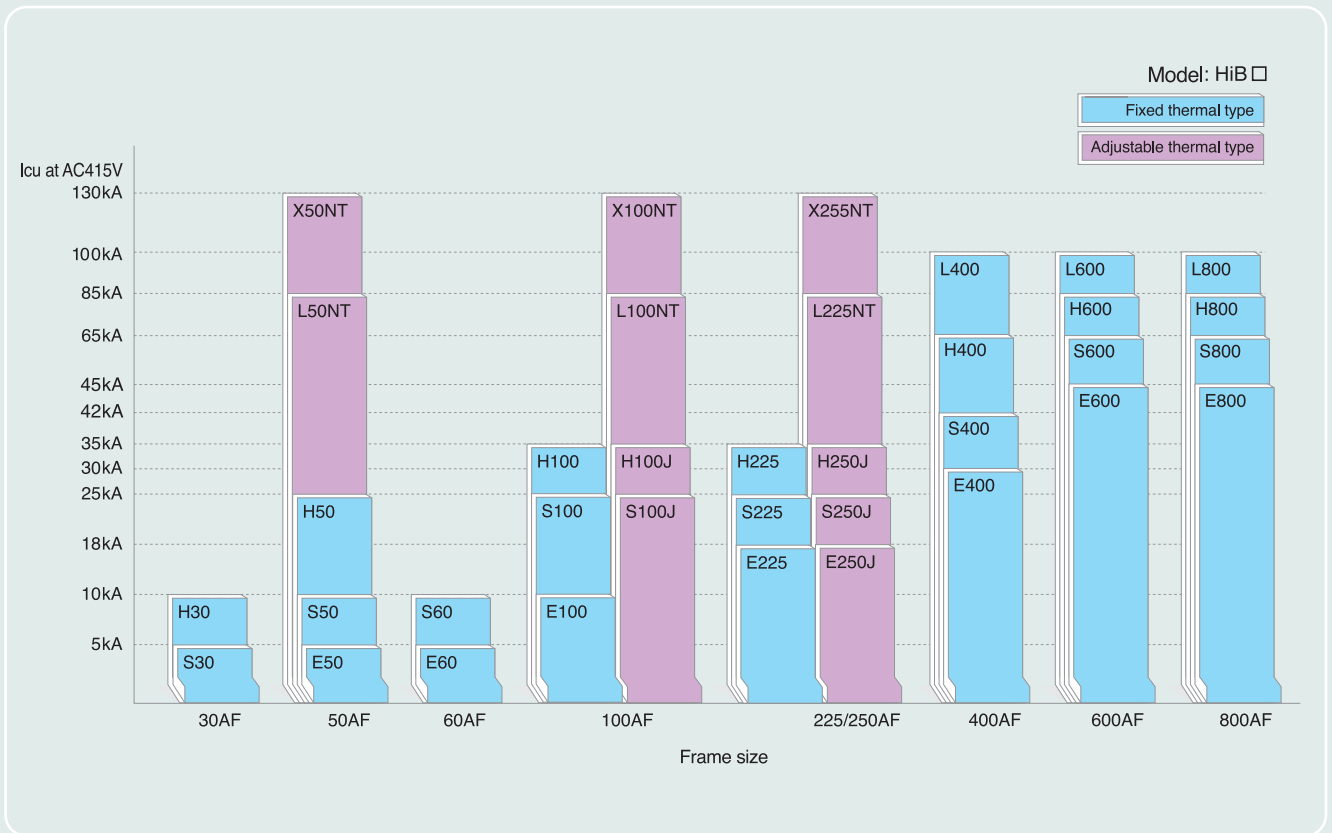

Electronic type MCCBs

- Rated current from 20 to 1200A
- Breaking capacity from 50 to 130kA
- Adjustable current-time rating
- LSIA characteristic curve

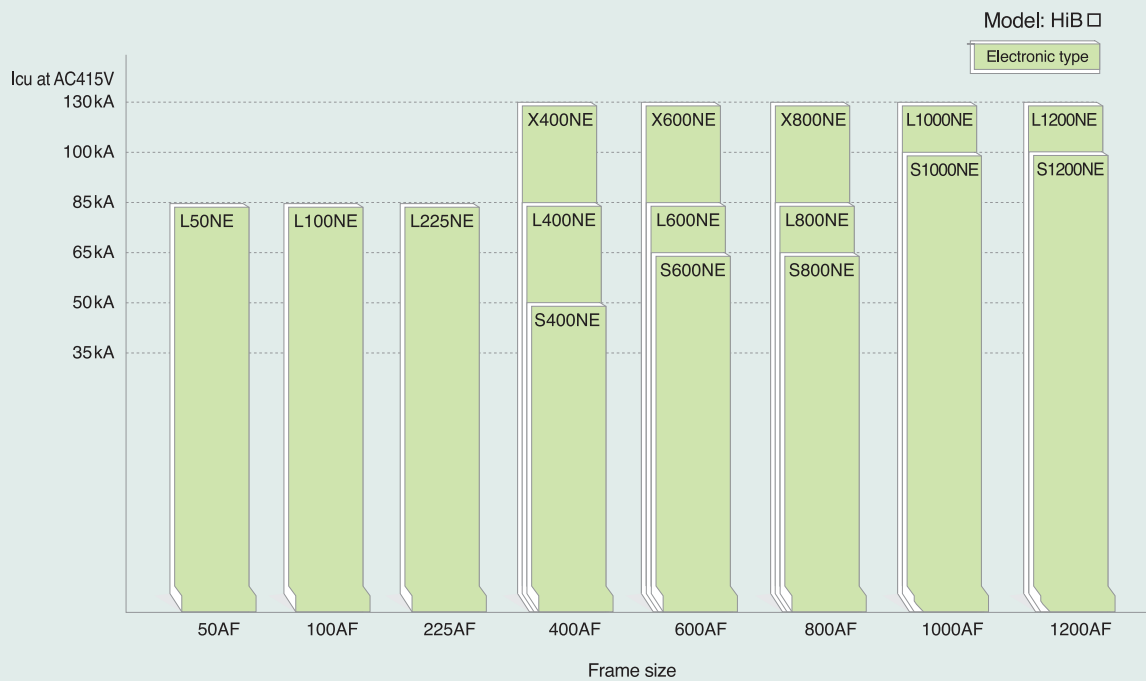

Thermal Type Hi Series Offering Reliability and Cost-effectiveness !

- Icu 5 to 35kA at 415V
- 30, 50, 60 , 225 & 250AF
- Adjustable or fixed thermal current
- 60mm depth and 50mm panel cutout
- Compact and light weight

Hi Series MCCB provides easy-to-use features while offering versatility and high performance to meet the requirements for space-saving and easy maintenance.

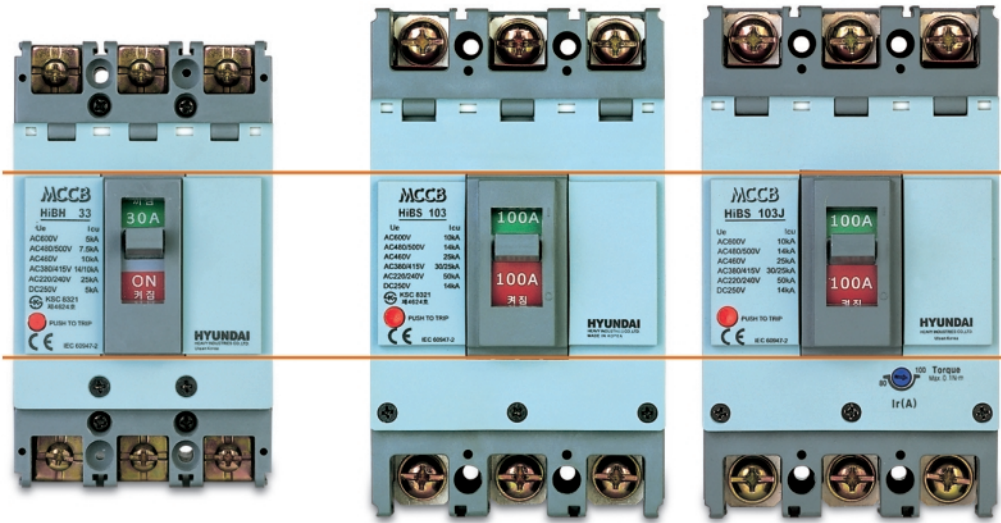

30, 50, 60 & 100AF
Fixed thermal
In from 3 to 100A
Icu = 5 / 10kA at 415V
2, 3, 4 pole
Hydraulic-magnetic trip unit

50 & 100AF
Fixed thermal
In from 15 to 100A
Icu = 25 / 35kA at 415V
2, 3, 4 pole
Fixed-thermal and
fixed-magnetic trip unit

100AF
Adjustable thermal
In from 12.5 to 100A
Icu = 25 / 35kA at 415V
2, 3, 4 pole
Adjustable-thermal and
fixed-magnetic trip unit

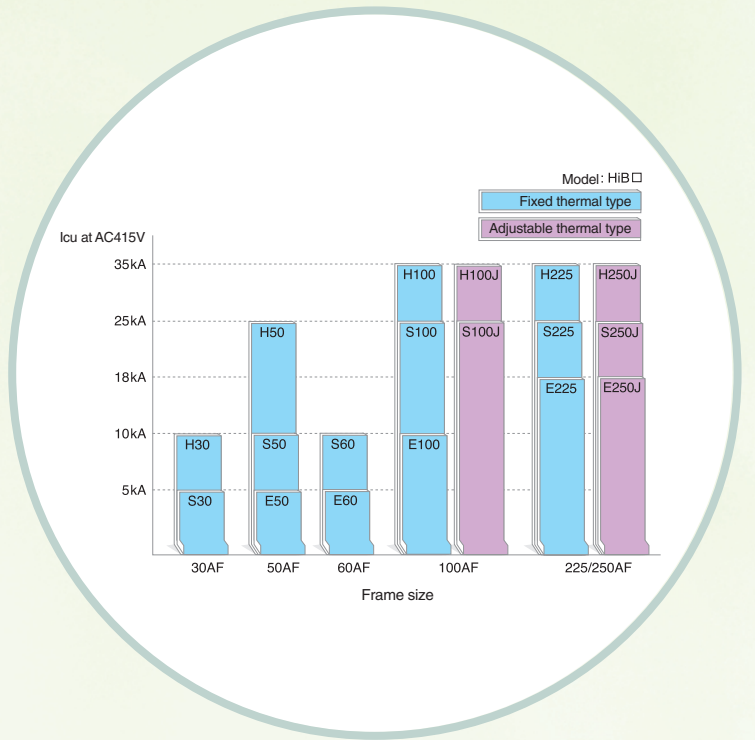

225AF
Fixed thermal
 In from 125 to 225A
 Icu = 18 / 25 / 35kA at 415V
 2, 3, 4 pole
 Fixed-thermal and
 fixed-magnetic trip unit



250AF
Adjustable thermal
 In from 100 to 250A
 Icu = 18 / 25 / 35kA at 415V
 2, 3, 4 pole
 Adjustable-thermal and
 fixed-magnetic trip unit

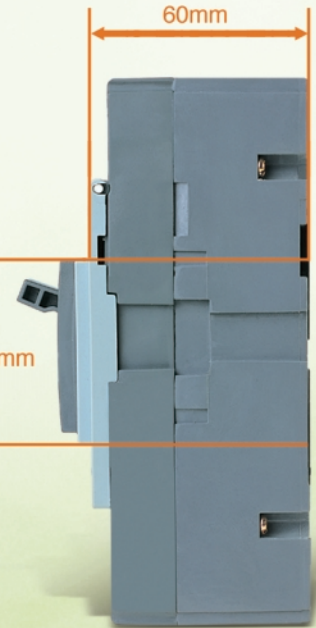

Side view

Current Limiting Type MCCB with High Breaking Capacity

- $I_{cu} = I_{cs}$ 85 & 130kA at 415V
- 50, 100 & 225AF
- Thermal-magnetic and electronic trip unit
- Field interchangeable trip unit

Thermal-magnetic trip unit

3-step adjustable current
(0.8-0.9-1.0)xIn

Electronic trip unit

- 9-step adjustable currents
- Overload indication via LED
- Frequency change-over switch (50-60Hz)
- Test in terminal for field test and monitoring

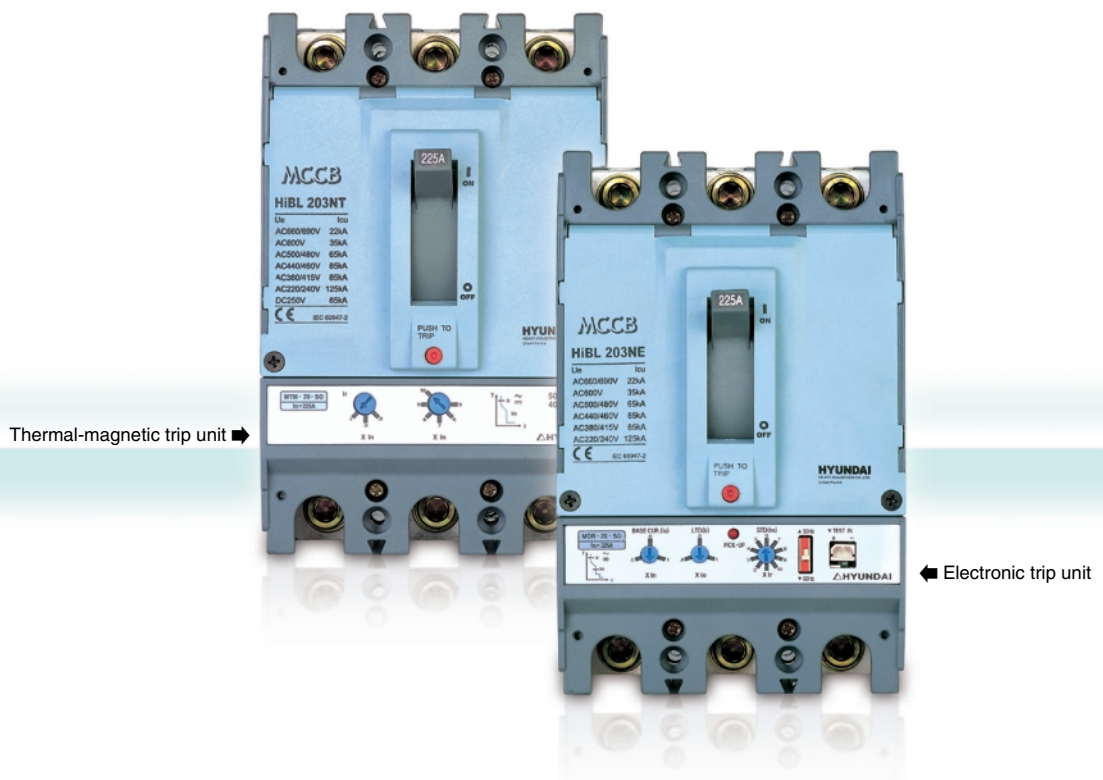
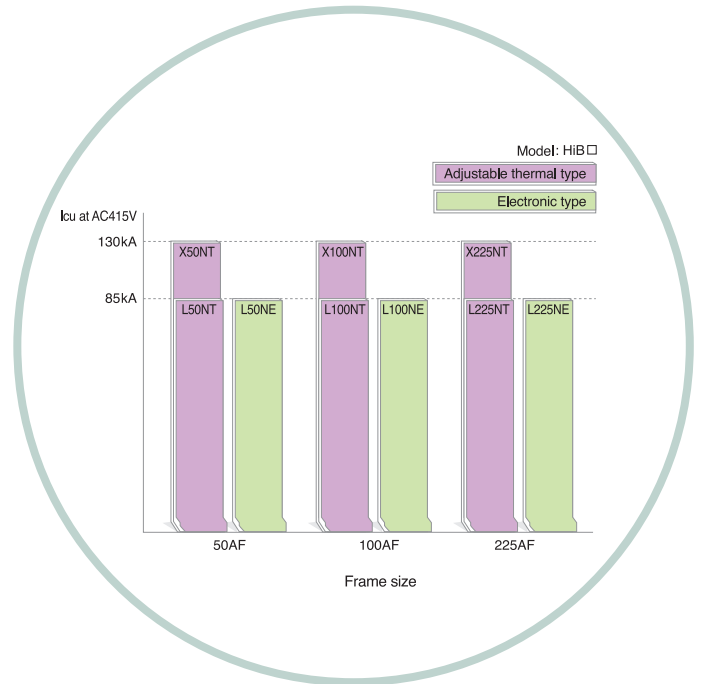

New cassette modular design

HYUNDAI's new cassette MCCB is one of the most sophisticated breakers in the world, which demonstrates HYUNDAI's superiority in product development and performance.

Optimized design provides easy-to-use customer installation while offering versatility and high performance to match today's demand for reliable, cost-effective and easy maintenance.

Field interchangeable trip unit !

Replacement for repair or exchange for another rating

HiB□50NT
Trip unit MTM-05-SO
(15, 20, 30, 40, 50A)



HiB□100NT
Trip unit MTM-10-SO
(15, 20, 30, 40, 50, 60, 75, 100A)

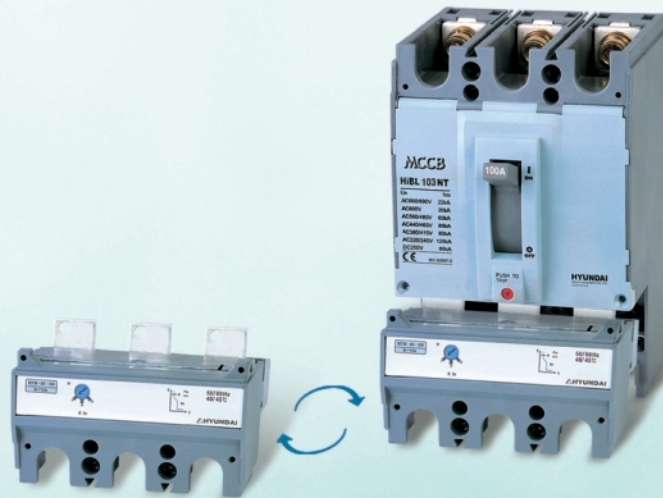

HiB□225NT
Trip unit MTM-20-SO
(125, 150, 175 and 200, 225A)

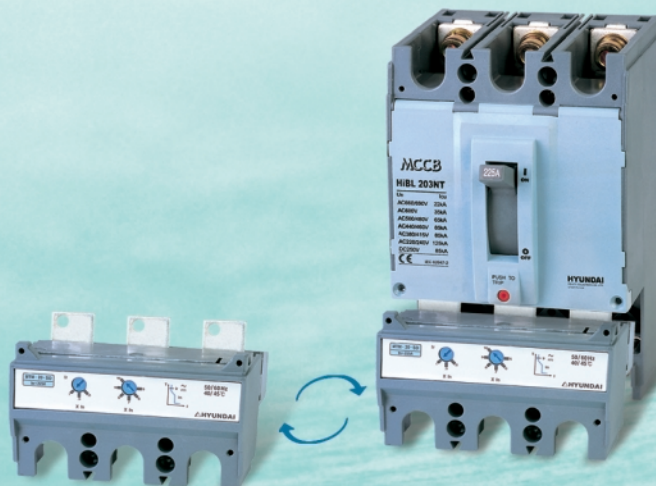

Electronic Type MCCB from 400 to 1200A

- $I_{cu} = I_{cs}$ upto 130kA at 415V
- 400, 600, 800, 1000 & 1200AF
- Fully adjustable LSIGA(LTD, STD, INST, GFT, Pre-trip Alarm) electronic trip unit
- Providing ground fault protection

Trip unit configuration

Overcurrent protection by LSI(LTD, STD, INST) curve I^2t characteristic available for short time curve

- **LTD**: Long Time Delay Trip
- **STD**: Short Time Delay Trip
- **INST**: Instantaneous Trip
- **GFT**: Ground Fault Trip
- **PRE-TRIP**: Pre-trip Alarm

Test in terminal for field test and monitoring
Frequency change-over switch (50 ↔ 60Hz)

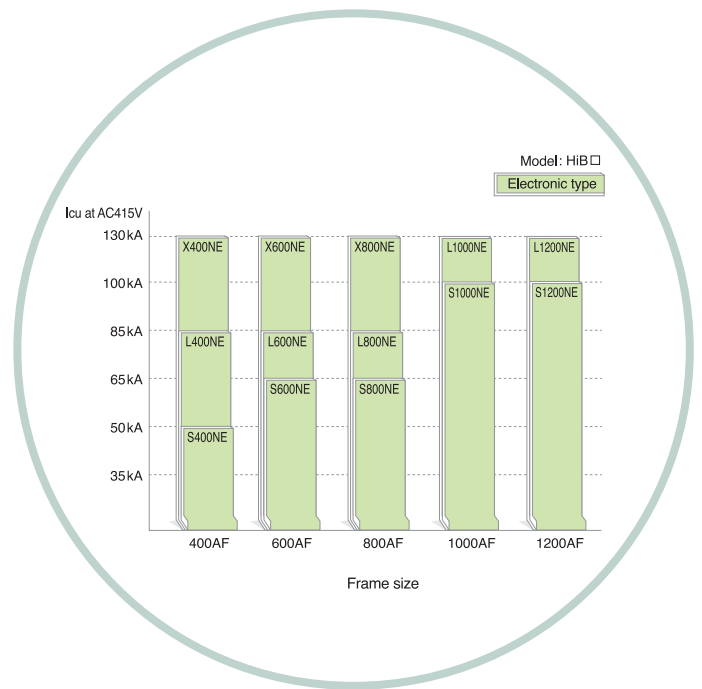

MOR-120-SG

CT RATING I_{CT} : 1200 A
RATED FREQ. 50 / 60 Hz

RATED FREQ. 50/60 Hz

PRE-TRIP $I_p = 0.9 \times I_n$
 $T_p = 40 \text{ SEC}$

TEST IN

LTD

$I_1: 0.9$

$T_1: 0.05$

SEC at $6 \times I_1$

STD

$I_2: 6$

$T_2: 0.3$

SEC at $6 \times I_2$

INST

$I_3: 10$

$T_3: 0.1$

BASE CUR.

GFT

$I_G: 0.3$

$T_G: 0.3$

BASE CUR.

HYUNDAI

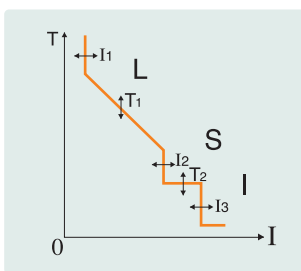

Curve for overcurrent protection

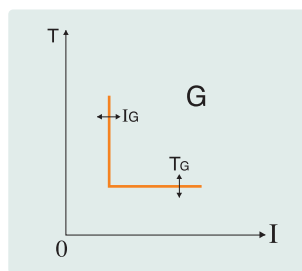

Curve for ground fault protection

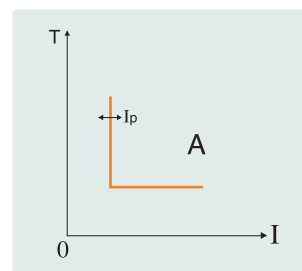

Curve for pre-trip alarm



MCCB
HIBS 603NE
 UN Rm
 AC690/690V 23A
 AC690V 23A
 AC690/690V 39A
 AC690/690V 49A
 AC690/690V 59A
 AC690/690V 69A
 CE IEC 60898-2

600A

PUSH TO TRIP

HYUNDAI

MCCB
HIBS 803NE
 UN Rm
 AC690/690V 23A
 AC690V 23A
 AC690/690V 39A
 AC690/690V 49A
 AC690/690V 59A
 AC690/690V 69A
 CE IEC 60898-2

800A

ON

HYUNDAI

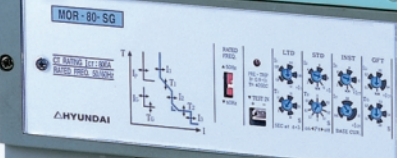

- ◆ For Fixed Thermal Type MCCB from 30 to 800AF
- ◆ For Adjustable Thermal Type MCCB from 100 to 250AF (J Type)

Internal and external accessories layout

Internally mounted accessories

- Cassette type accessories can be easily installed and removed.
- The position of accessories can be different frame by frame.

Externally mounted accessories

- External accessories provide MCCBs with safe operation and easy maintenance.



Surface type operating handle [TFG]

Extended type operating handle [TFH]



Interpole barrier [TQQ]

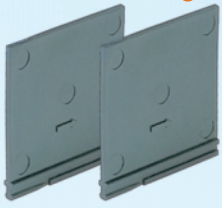

Terminal cover [TCF]

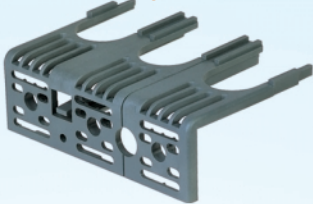

Cage terminal block [CTB]

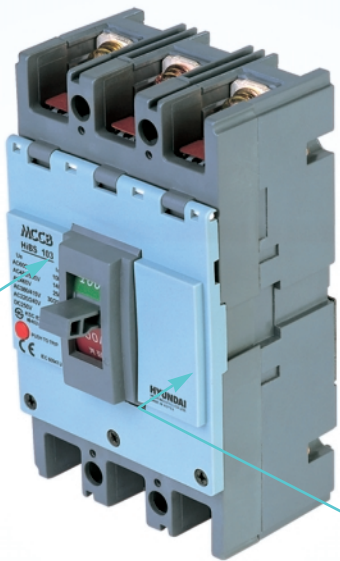

Mounting base for plug-in [TDM]

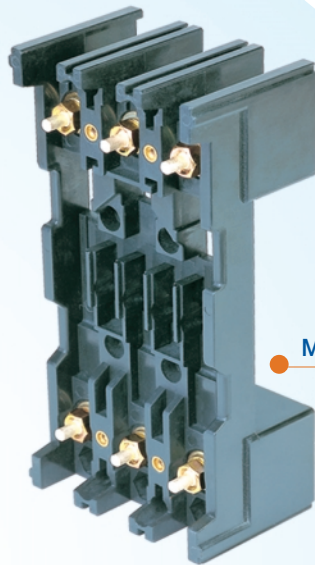

Shunt trip [SHT]



Under voltage trip [UVT]



Cage terminal block [CTB]



Terminal cover [TCF]

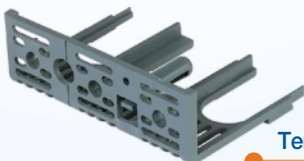

Interpole barrier [TQQ]

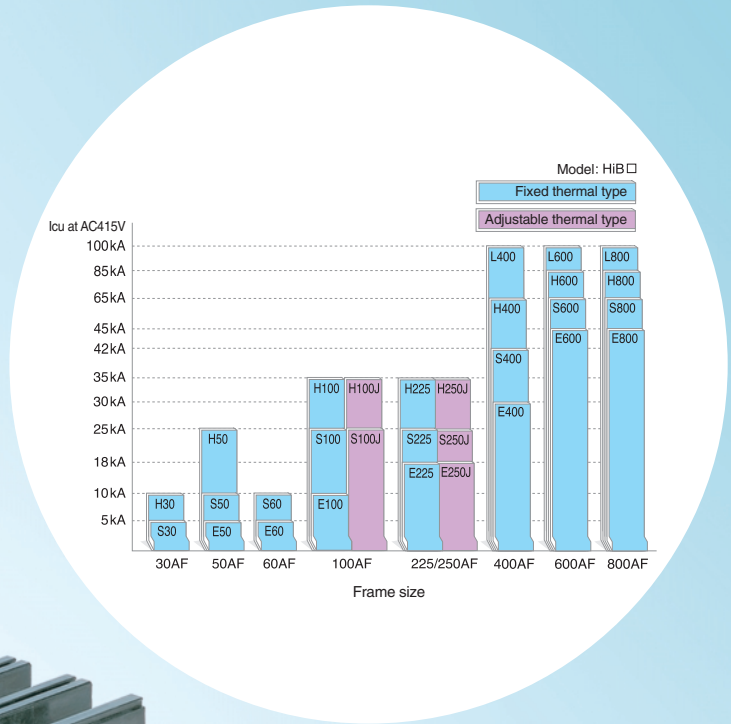

- ◆ For Thermal Adjustable Type MCCB upto 225AF (NT Type)
- ◆ For Electronic Type MCCB upto 225AF (NE Type)

Internal and external accessories layout

Internally mounted accessories

- Cassette type accessories can be easily installed and removed.
- The position of accessories can be different frame by frame.

Externally mounted accessories

- External accessories provide MCCBs with safe operation and easy maintenance.

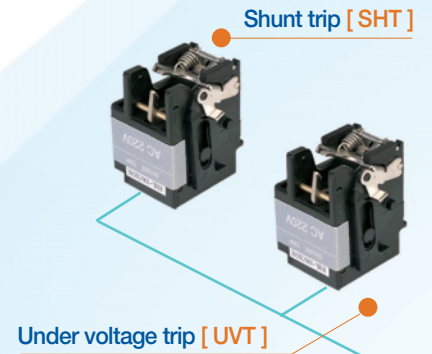

Extension handle [THA]

Motor operator [MOT]

Surface type operating handle [TFG]

Extended type operating handle [TFH]

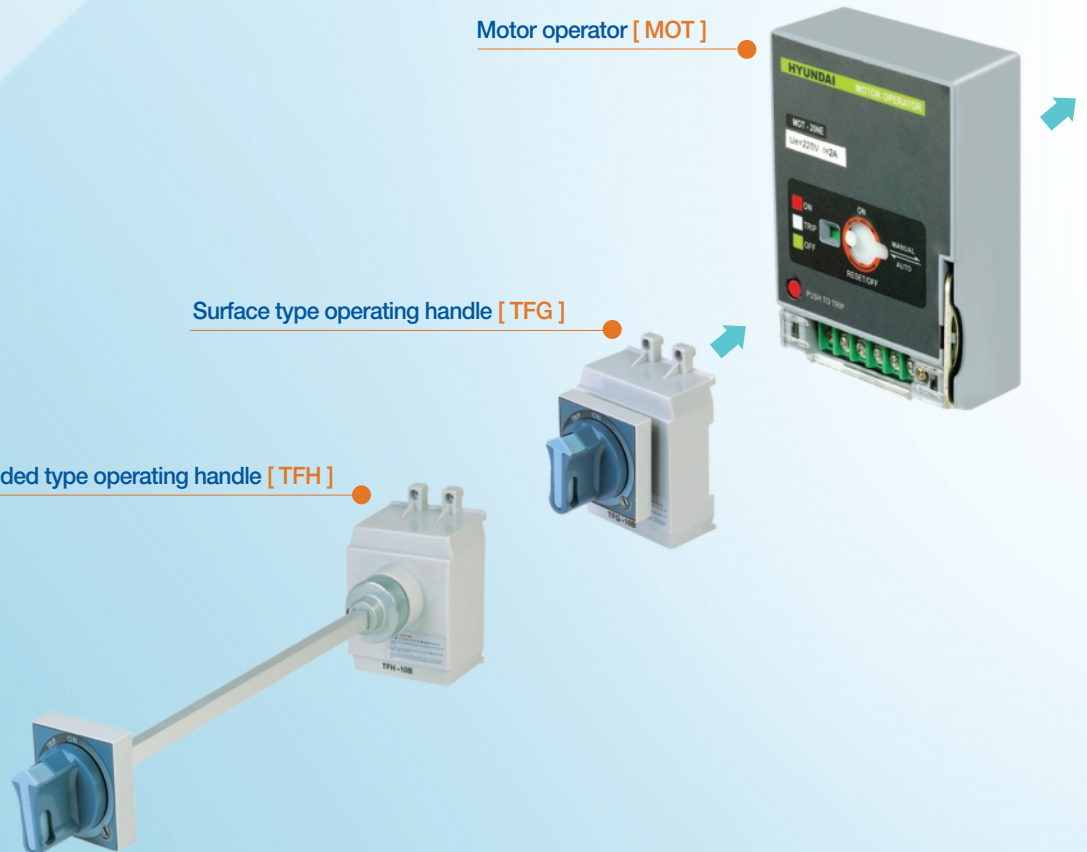

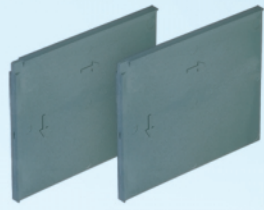

Interpole barrier [TQQ]

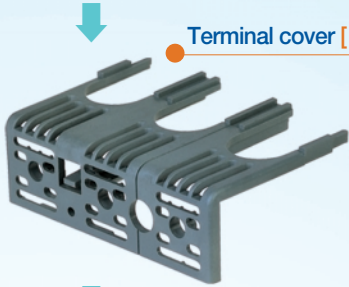

Terminal cover [TCF]

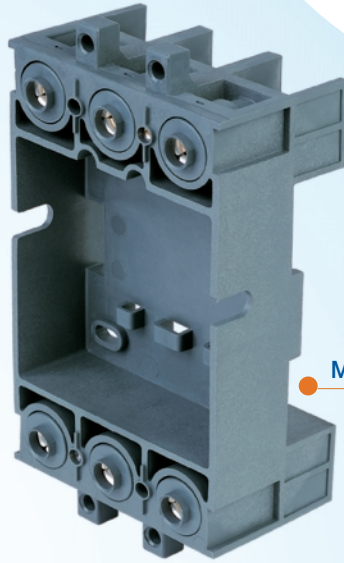
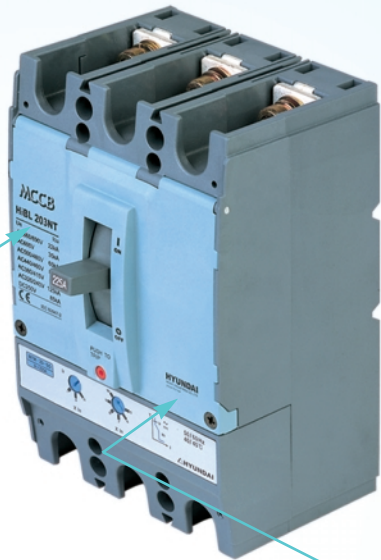

Mounting base for plug-in [TDM]



Terminal cover [TCF]

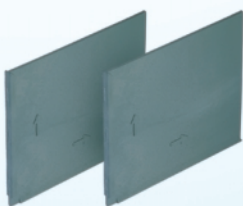

Interpole barrier [TQQ]

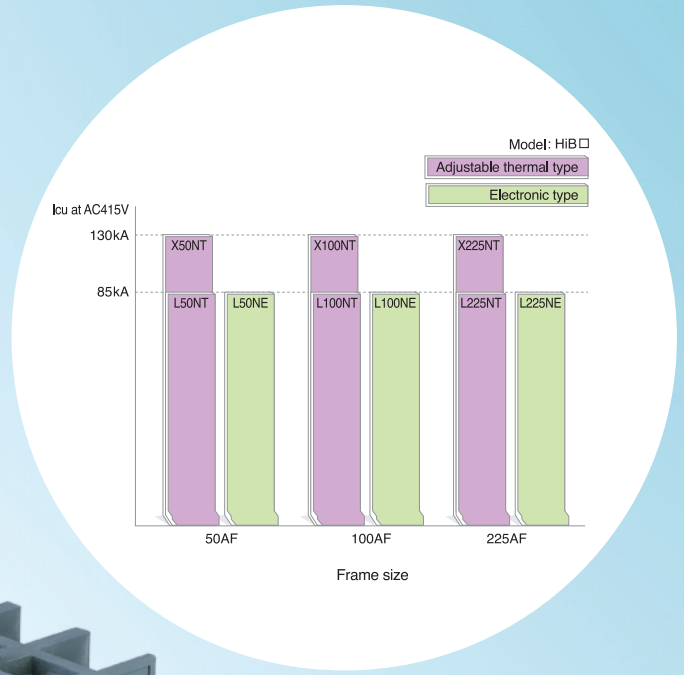

Auxiliary switch [AUX]



Trip alarm switch [ALT]

For Electronic Type MCCB from 400AF to 1200AF

Internal and external accessories layout

Internally mounted accessories

- Cassette type accessories can be easily installed and removed.
- The position of accessories can be different frame by frame.

Externally mounted accessories

- External accessories provide MCCBs with safe operation and easy maintenance.

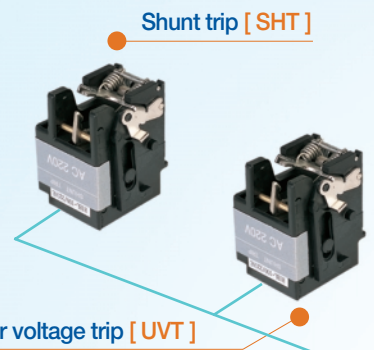
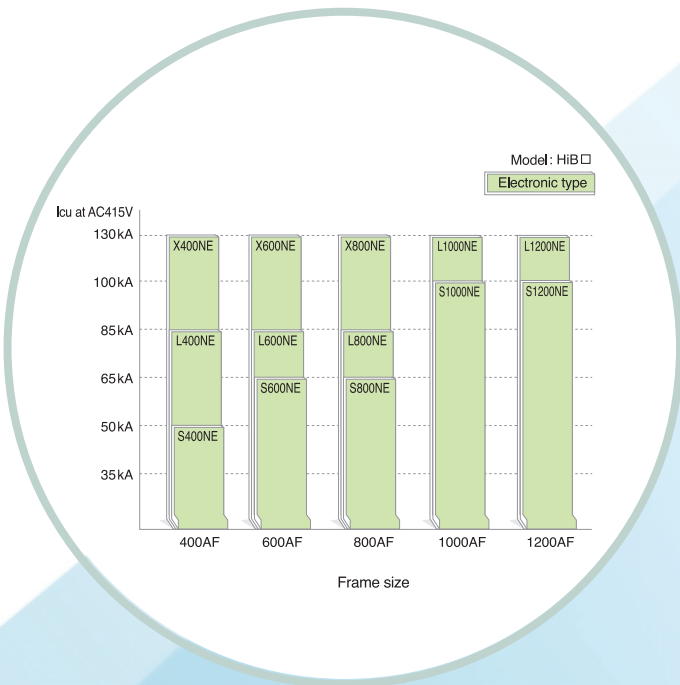

Motor operator [MOT]



Surface type operating handle [TFG]



Extended type operating handle [TFH]



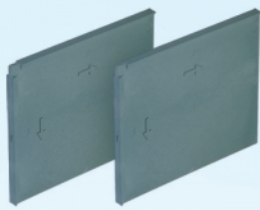

Interpole barrier [TQQ]

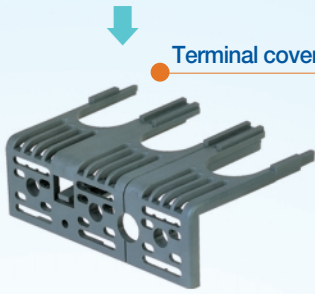

Terminal cover [TCF]

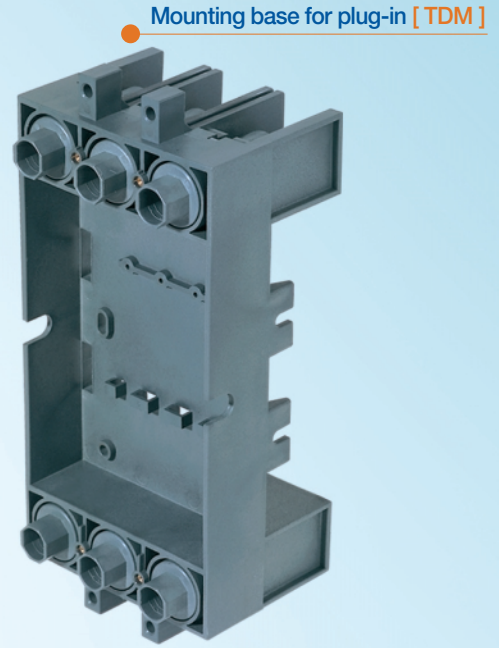

Mounting base for plug-in [TDM]



Extension handle [THA]

Auxiliary switch [AUX]



Trip alarm switch [ALT]

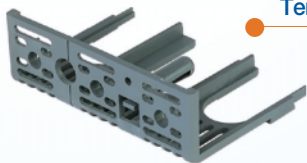

Terminal cover [TCF]

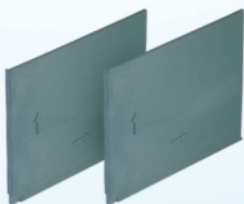

Interpole barrier [TQQ]

Signal Accessories

Schematic diagram

	Accessories			Schematic diagram
	3P	2P	Number of unit	
Auxiliary switch			1	
			2	
			3	
			4	
Trip alarm switch				
Shunt trip			Anti-burnout switch is provided.	
Under voltage trip			For AC	

Operation

	Auxiliary switch	Trip alarm switch
MCCB ON		
MCCB OFF		
MCCB Trip		

■ Auxiliary switch and trip alarm switch (AUX/ALT/AXT)

Applicable MCCB	Auxiliary switch (AUX)			Trip alarm switch (ALT)			Auxiliary & trip alarm switch (AXT)			Category
	Code	Specification	Unit	Code	Specification	Unit	Code	Specification	Unit	
HiBS30, HiBH30, HiBE50, HiBS50 HiBE60, HiBS60, HiBE100	AUX 10A R1	1C, Right-hand-side	40	ALT 10A R1	1C, Right-hand-side	40	AXT 10A R	AUX 1C and ALT 1C	40	MCCB MB
HiBH50, HiBS100, HiBH100 HiBS100J, HiBH100J	AUX 10B L1	1C, Left-hand-side	40	ALT 10B L1	1C, Left-hand-side	40	AXT 10B L	AUX 1C and ALT 1C	40	
HiBE225, HiBS225, HiBH225 HiBE250J, HiBS250J, HiBH250J	AUX 20C L1	1C, Left-hand-side	40	ALT 20C L1	1C, Left-hand-side	40	AXT 20C L	AUX 1C and ALT 1C	40	
HiBE400, HiBS400, HiBH400, HiBL400 HiBE600, HiBS600, HiBH600, HiBL600 HiBE800, HiBS800, HiBH800, HiBL800	AUX 46D	1C		ALT 46D	1C					
HiBL50NT, HiBX50NT, HiBL100NT HiBX100NT, HiBL225NT, HiBX225NT HiBL50NE, HiBL100NE, HiBL225NE	AUX 12NE	1C		ALT 12NE	1C					
HiBS400NE, HiBL400NE, HiBX400NE HiBS600NE, HiBL600NE, HiBX600NE	AUX 46NE	1C	40	ALT 46NE	1C	40				
HiBS800NE, HiBL800NE, HiBX800NE HiBS1000NE, HiBL1000NE HiBS1200NE, HiBL1200NE	AUX 80NE R1	1C	40	ALT 80NE R1	1C	40	AXT 80NE	AUX 1C and ALT 1C		

■ Shunt trip (SHT)

Applicable MCCB	DC24V		DC100-110V		AC100-120V		AC200-230V		AC380-415V		AC440-480V		Unit	Category
	Code	Exciting current (peak value)	Code	Exciting current (peak value)	Code	Exciting current (peak value)	Code	Exciting current (peak value)	Code	Exciting current (peak value)	Code	Exciting current (peak value)		
HiBS30, HiBH30, HiBE50, HiBS50 HiBE60, HiBS60, HiBE100	SHT 10A A	5.2A	SHT 10A C	0.11A	SHT 10A F	0.76A	SHT 10A H	0.28A	SHT 10A B	0.28A	SHT 10A D	0.28A	40	MCCB MB
HiBH50, HiBS100, HiBH100 HiBS100J, HiBH100J	SHT 10B A	5.2A	SHT 10B C	0.2A	SHT 10B F	0.76A	SHT 10B H	0.4A	SHT 10B B	0.4A	SHT 10B D	0.4A	40	
HiBE225, HiBS225, HiBH225 HiBE250J, HiBS250J, HiBH250J	SHT 20C A	5.2A	SHT 20C C	0.2A	SHT 20C F	0.76A	SHT 20C H	0.4A	SHT 20C B	0.4A	SHT 20C D	0.4A	40	
HiBE400, HiBS400, HiBH400, HiBL400 HiBE600, HiBS600, HiBH600, HiBL600 HiBE800, HiBS800, HiBH800, HiBL800	SHT 46D A	0.01A	SHT 46D C	0.2A	SHT 46D F	0.012A	SHT 46D H	0.011A	SHT 46D B	0.01A	SHT 46D D	0.01A		
HiBL50NT, HiBX50NT, HiBL100NT HiBX100NT, HiBL225NT, HiBX225NT HiBL50NE, HiBL100NE, HiBL225NE	SHT 12NE A	0.023A	SHT 12NE C	0.023A	SHT 12NE F	0.023A	SHT 12NE H	0.023A	SHT 12NE B	0.023A	SHT 12NE D	0.023A	40	
HiBS400NE, HiBL400NE, HiBX400NE HiBS600NE, HiBL600NE, HiBX600NE	SHT 46NE A	0.023A	SHT 46NE C	0.023A	SHT 46NE F	0.023A	SHT 46NE H	0.023A	SHT 46NE B	0.023A	SHT 46NE D	0.023A	40	
HiBS800NE, HiBL800NE, HiBX800NE	SHT 80NE A	2A	SHT 80NE C	0.11A	SHT 80NE F	0.24A	SHT 80NE H	0.23A	SHT 80NE B	0.23A	SHT 80NE D	0.23A	40	
HiBS1000NE, HiBL1000NE HiBS1200NE, HiBL1200NE	SHT 120NE A	2A	SHT 120NE C	0.11A	SHT 120NE F	0.24A	SHT 120NE H	0.23A	SHT 120NE B	0.23A	SHT 120NE D	0.23A	40	

※ The permissible operating voltage: 85-110% of rated voltage for AC, 75-125% for DC

Signal Accessories

Under Voltage trip (UVT)

Applicable MCCB	Code						Unit	Category
	DC24V	DC100-110V	AC100-120V	AC200-230V	AC380-415V	AC440-480V		
HiBS30, HiBH30, HiBE50, HiBS50 HiBE60, HiBS60, HiBE100	UVT 10A J	UVT 10A L	UVT 10A N	UVT 10A P	UVT 10A Q	UVT 10A R	40	MCCB MB
HiBH50, HiBS100, HiBH100 HiBS100J, HiBH100J	UVT 10B J	UVT 10B L	UVT 10B N	UVT 10B P	UVT 10B Q	UVT 10B R	40	
HiBE225, HiBS225, HiBH225 HiBE250J, HiBS250J, HiBH250J	UVT 20C J	UVT 20C L	UVT 20C N	UVT 20C P	UVT 20C Q	UVT 20C R	40	
HiBE400, HiBS400, HiBH400, HiBL400 HiBE600, HiBS600, HiBH600, HiBL600 HiBE800, HiBS800, HiBH800, HiBL800	UVT 46D J	UVT 46D L	UVT 46D N	UVT 46D P	UVT 46D Q	UVT 46D R		
HiBL50NT, HiBX50NT, HiBL100NT HiBX100NT, HiBL225NT, HiBX225NT HiBL50NE, HiBL100NE, HiBL225NE	UVT 12NE J	UVT 12NE L	UVT 12NE N	UVT 12NE P	UVT 12NE Q	UVT 12NE R	40	
HiBS400NE, HiBL400NE, HiBX400NE HiBS600NE, HiBL600NE, HiBX600NE	UVT 46NE J	UVT 46NE L	UVT 46NE N	UVT 46NE P	UVT 46NE Q	UVT 46NE R	40	
HiBS800NE, HiBL800NE, HiBX800NE	UVT 80NE J	UVT 80NE L	UVT 80NE N	UVT 80NE P	UVT 80NE Q	UVT 80NE R	40	
HiBS1000NE, HiBL1000NE HiBS1200NE, HiBL1200NE	UVT 120NE J	UVT 120NE L	UVT 120NE N	UVT 120NE P	UVT 120NE Q	UVT 120NE R	40	

- ※ - The permissible operating voltage: 85-110% of rated voltage
- The tripping voltage: 20-70% of rated voltage

Installation configuration of UVT controller

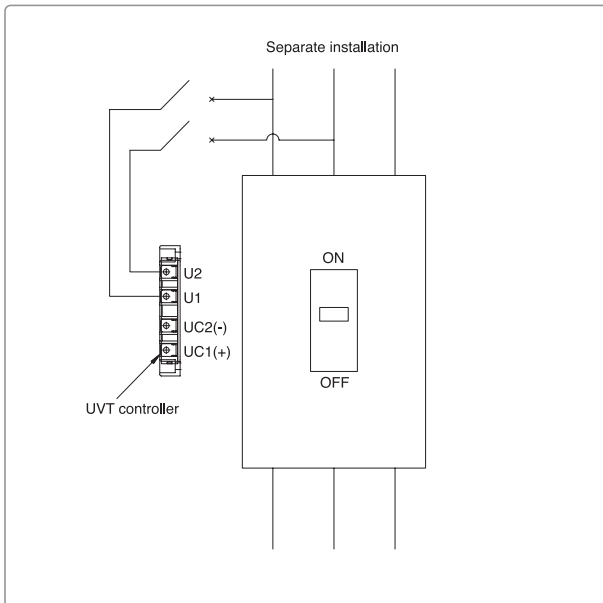

UVT controller, outside dimensions for separate installation

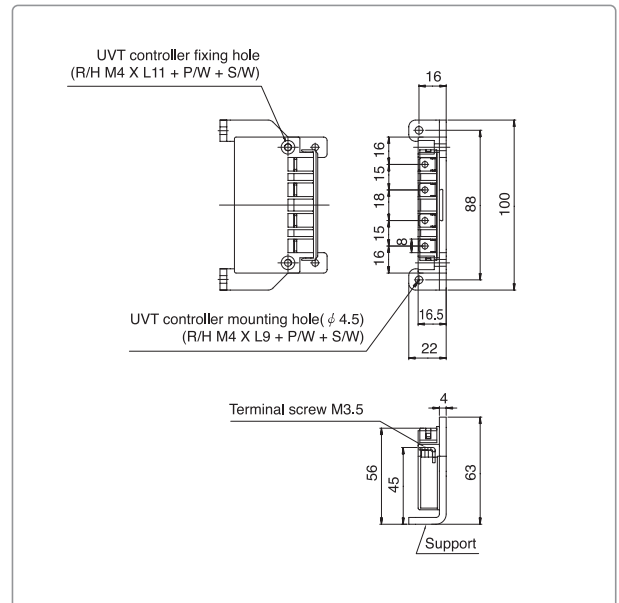

- ※ - If the control voltage of UVT is AC, the UVT controller shall be installed. Standard installation of the UVT controller is on the left side of the breaker. However, the controller can be installed in a separate location. (Please specify)
- Terminal UC1, UC2 are already connected. Cable size: vw-1, 22AWG (0.324mm²) × 700mm (If the other cables are required, please contact HHI representative.)

Operating Accessories

■ Surface type operating handle (TFG)

■ Operating Method when Panel Door is Closed

- 1) If you make MCCB Operating Handle vertical, a breaker becomes ON position. (Fig.1)
- 2) If you make MCCB Operating Handle horizontal, the breaker becomes OFF position. (Fig.2)
- 3) When the breaker trips automatically, Operating Handle indicates the trip position.
- 4) When you make the breaker ON position, you should turn the MCCB Operating Handle toward RESET position. (Fig.3)
- 5) When you want to open the panel door under the ON position of the breaker, turn the release toward the indicated direction (clockwise rotation) with a minus screwdriver. Then, the door is ready to be opened. (Fig.4)

■ Lock and Release of Panel door

- 1) When the breaker is under ON, OFF, TRIP position, MCCB Operating Handle is locked, so the panel door can not be opened.
- 2) When the breaker is under TRIP or OFF position, turn the handle toward the RESET position, to make the door be ready to be opened. (Fig.3)
- 3) If you close the panel door under the ON state of the breaker, the lock is restored automatically. At this time, the handle position must be kept in ON state.

■ Lock of MCCB Operating Handle

- 1) If you necessary, MCCB Operating Handle can be locked with a lock when the breaker is under ON or OFF position. (A lock is not provided.) (Fig.5)
- 2) If you push the arrow mark in front of MCCB Operating Handle, a lock can be hooked. (Fig.5)
- 3) If the breaker trips, while MCCB operating handle is locked, the handle indicates the TRIP position.
- 4) The hook thickness of a lock can be used from $\phi 6$ to $\phi 8$. (Fig.5)

■ A Careful Consideration when You Close the Panel Door.

- 1) After making the ON, TRIP and OFF position of the breaker coincide with the Operating Handle, please close the panel door.

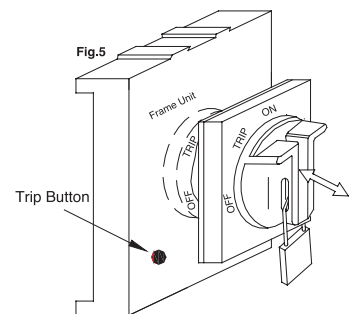
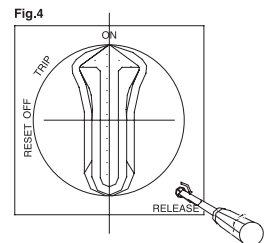
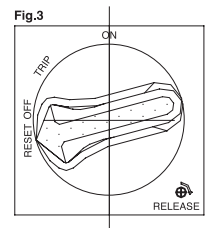
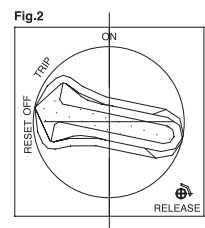
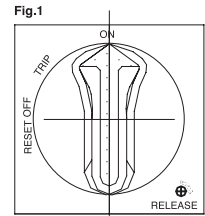

Operating Accessories

■ Surface type operating handle (TFG)

■ TFG type

TFG type is the external operating handle witch is compact due to plastic molding.

TFG type is used, when the breaker is installed on a control center or a switchboard, and when it is manually operated from the outside of the door.

There are 3 special types, in a addition to the standard.

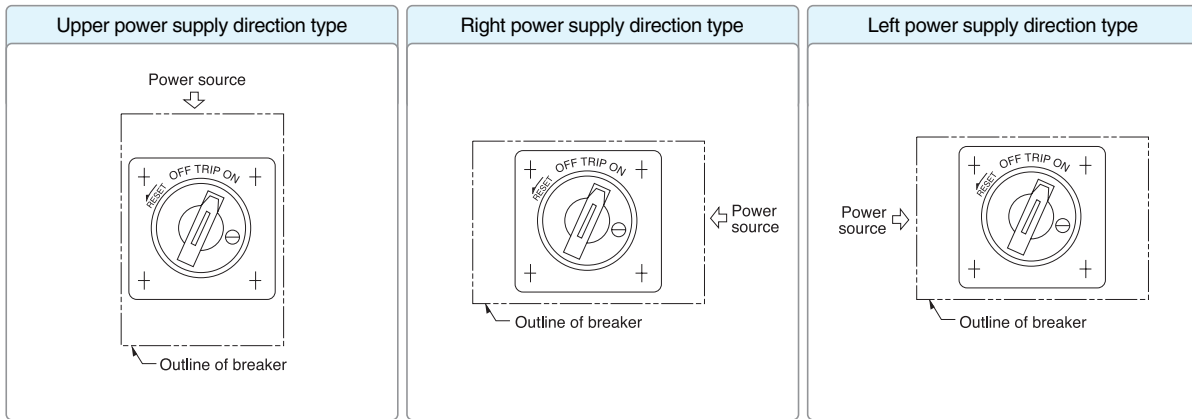

- General type (OFF open type)
The panel can be opened at OFF position.
- Reset open type
The Panel can be opened at RESET position it can not be opened at OFF position.
- Standard type with reverse interlock.
- Reset open type with reverse interlock.

■ Reverse interlock

The reverse interlock is used for locking the breaker to prevent it from switching ON, when the panel is opened.
It also can be unlocked.

■ Panel lock

The externally operating handle keeps the panel door locked when in the "ON" position.

The release knob enables the panel door to be opened with the handle in the "ON" position

To release: Turn the release knob in the direction of the arrow with a flat-bladed screwdriver.

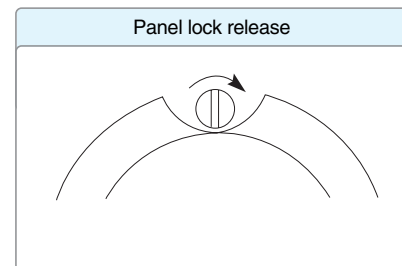

■ Type numbering system (example)

Mounting direction of the breaker			Panel door lock		
U	U	Upper power supply direction	1	1	Off open type
	R	Left power supply direction		2	Off open type with reverse interlock
	L	Right power supply direction		3	Reset open type
		4		Reset open type with reverse interlock (standard)	

※ Please specify your desires TFG type number and breaker type / Specification when ordering

■ TFG 10A / TFG 10B / TFG 20C / TFG 12NE

(Unit: mm)

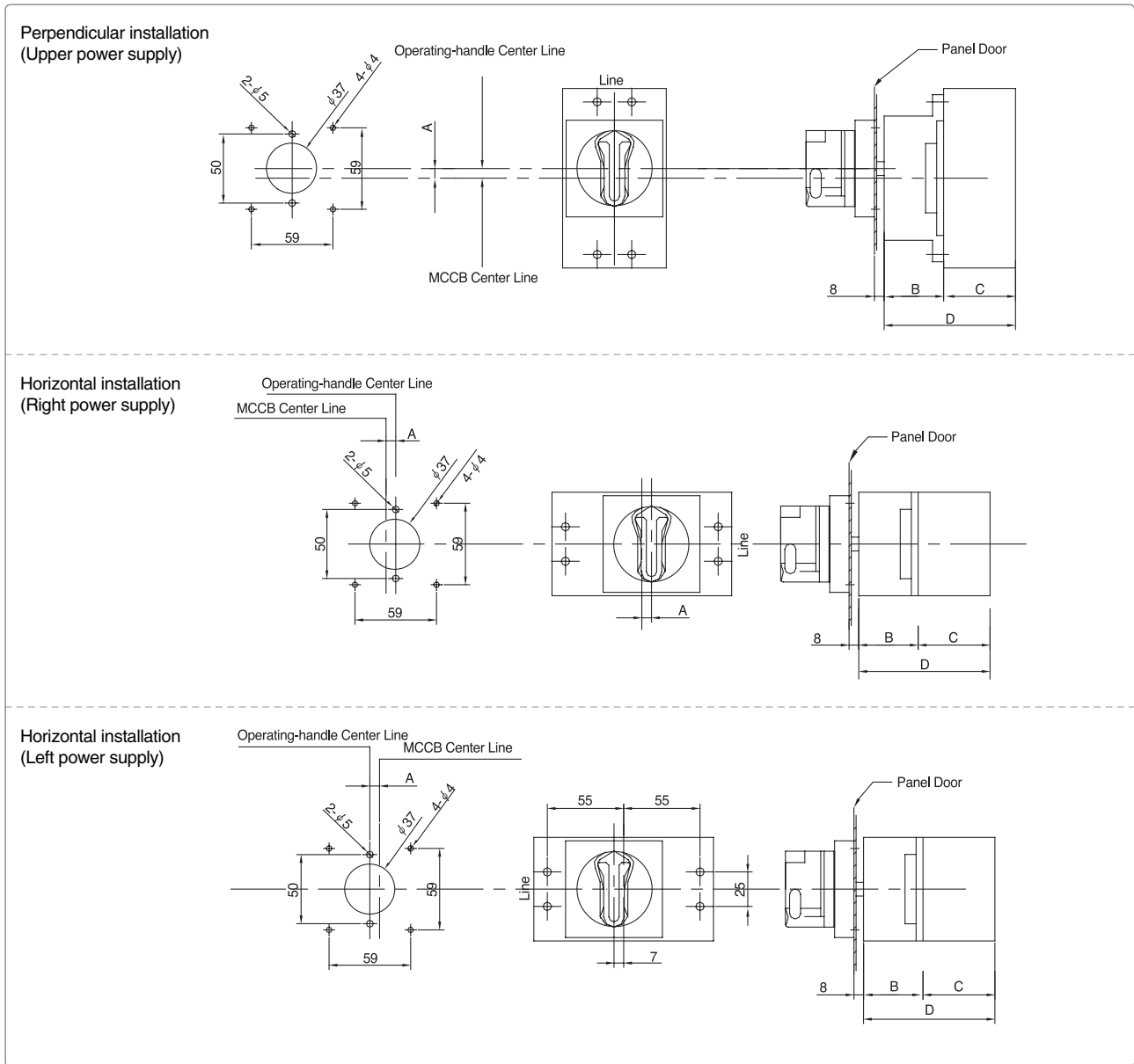

※ Operating handle's pivot must coincide with the processing hole of a panel door.

Applicable MCCB	Code			Unit	Dimensions (mm)				Category	
	Upper power supply direction	Right power supply direction	Left power supply direction		A	B	C	D		
HiBS30, HiBH30, HiBE50, HiBS50 HiBE60, HiBS60, HiBE100	TFG 10A U4	TFG 10A R4	TFG 10A L4	15	7	43	56	99	MCCB	MB
HiBH50, HiBS100, HiBH100 HiBS100J, HiBH100J	TFG 10B U4	TFG 10B R4	TFG 10B L4	15	9	47	56	103		
HiBE225, HiBS225, HiBH225 HiBE250J, HiBS250J, HiBH250J	TFG 20C U4	TFG 20C R4	TFG 20C L4	16	9	47	56	103		
HiBL50NT, HiBX50NT, HiBL100NT HiBX100NT, HiBL225NT, HiBX225NT HiBL50NE, HiBL100NE, HiBL225NE	TFG 12NE U4	TFG 12NE R4	TFG 12NE L4	16	13.5	-	-	129		

Operating Accessories

TFG 46D / TFG 46NE

(Unit: mm)

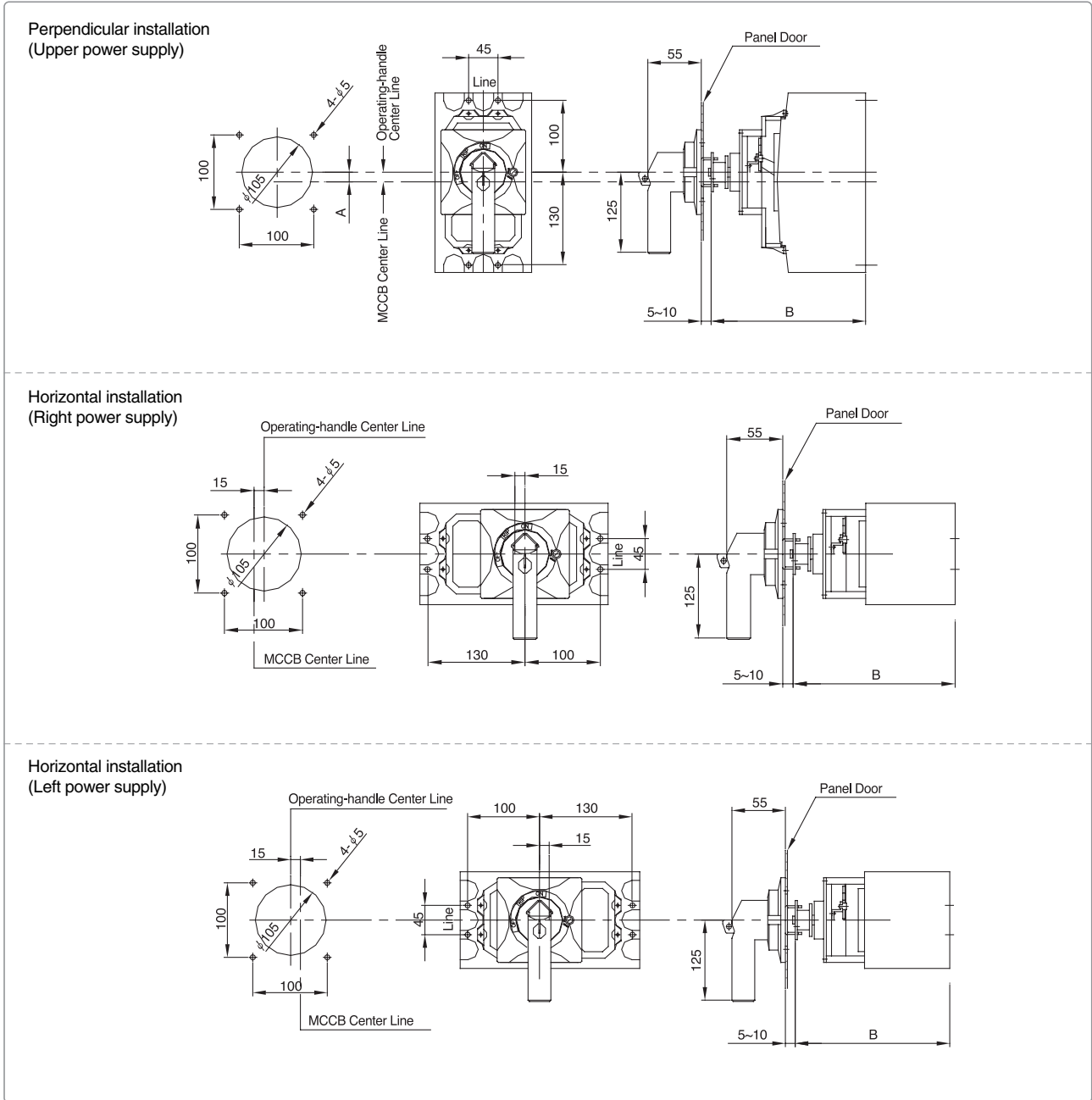

Applicable MCCB	Code			Unit	Dimensions (mm)		Category	
	Upper power supply direction	Right power supply direction	Left power supply direction		A	B		
HiBE400, HiBS400, HiBH400, HiBL400 HiBE600, HiBS600, HiBH600, HiBL600 HiBE800, HiBS800, HiBH800, HiBL800	TFG 46D U4	TFG 46D R4	TFG 46D L4	12	0	210	MCCB	MB
HiBS400NE, HiBL400NE, HiBX400NE HiBS600NE, HiBL600NE, HiBX600NE	TFG 46NE U4	TFG 46NE R4	TFG 46NE L4	10	13	219		

Extended type operating handle (TFH)

Make it possible to operate circuit breakers installed inside switchboard or enclosure from the front. The external operating handle and breaker are mechanically connected by a shaft cut to fit the enclosure depth. This consists of an operating mechanism mounted on the breaker, an operating handle mounted on the panel door and a square shaft to connect the mechanism with the handle. You are able to cut and use the shafts if necessary.

TFH 10A / TFH 10B / TFH 20C / TFH 12NE

(Unit: mm)

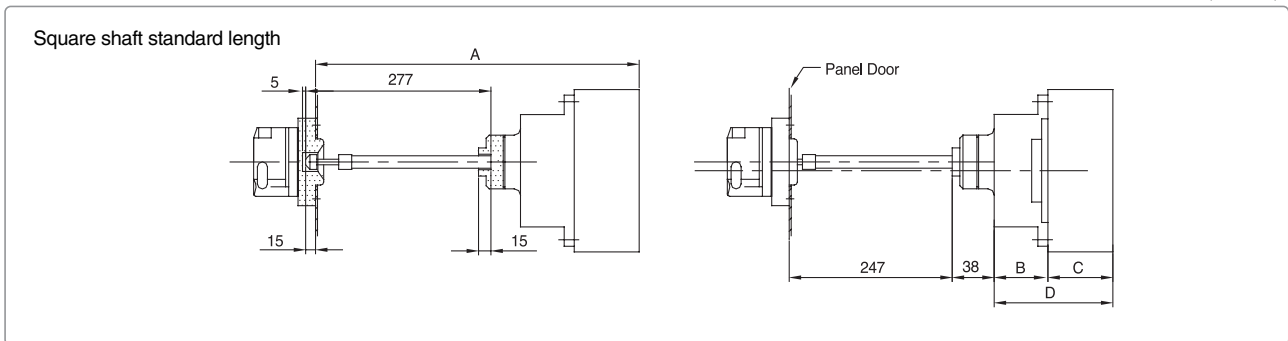

Applicable MCCB	Code	Unit	Dimensions (mm)				Category	
			A	B	C	D		
HiBS30, HiBH30, HiBE50, HiBS50 HiBE60, HiBS60, HiBE100	TFH 10A	40	384-379	43	56	99	MCCB	MB
HiBH50, HiBS100, HiBH100 HiBS100J, HiBH100J	TFH 10B	40	388-383	47	56	103		
HiBE225, HiBS225, HiBH225 HiBE250J, HiBS250J, HiBH250J	TFH 20C	40	388-383	47	56	103		
HiBL50NT, HiBX50NT, HiBL100NT HiBX100NT, HiBL225NT, HiBX225NT HiBL50NE, HiBL100NE, HiBL225NE	TFH 12NE	40	414-419	-	-	129		

TFH 46D / TFH 46NE

(Unit: mm)

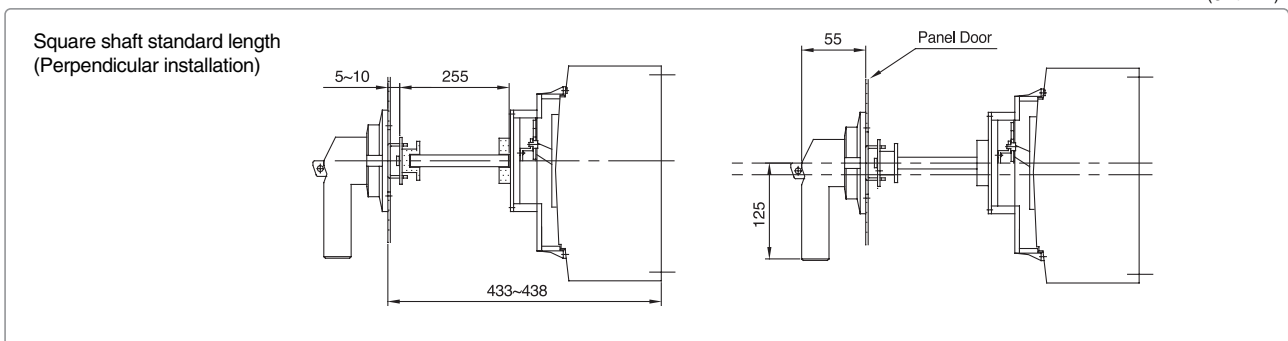

Applicable MCCB	Code	Unit	Category	
HiBE400, HiBS400, HiBH400, HiBL400, HiBE600, HiBS600, HiBH600, HiBL600 HiBE800, HiBS800, HiBH800, HiBL800	TFH 46D	10	MCCB	MB
HiBS400NE, HiBL400NE, HiBX400NE, HiBS600NE, HiBL600NE, HiBX600NE	TFH 46NE	5		

Operating Accessories

Motor operator (MOT)

The Hyundai MCCB Motor Operator, with remote ON and OFF operation, is mainly applied to electric supervision and control systems.

Operation mode can be selected via the Auto/Manual switch. An emergency trip button is an additional feature. The Hyundai MCCB Motor Operator is compatible with the entire Hyundai MCCB series as option item.

Rating and specifications

Model	Applicable MCCB	Control voltage	Operational current (A)	Operation time (ms)		Power consumption (W)	Mechanical life (Times)
				Closing	Opening		
MOT-10A	HiBS30, HiBH30, HiBE50, HiBS50 HiBE60, HiBS60, HiBE100	DC24V AC/DC110V AC/DC220V	≤ 2.5 ≤ 5.0 ≤ 5.0	310	200	14	25,000
MOT-10B	HiBH50, HiBS100, HiBH100 HiBS100J, HiBH100J						
MOT-20C	HiBE225, HiBS225, HiBH225 HiBE225J, HiBS225J, HiBH225J						
MOT-40D	HiBE400, HiBS400, HiBH400, HiBL400	DC24V AC/DC110V AC/DC220V	≤ 5.0 ≤ 3.0 ≤ 2.0	500	350	35	20,000
MOT-68E	HiBE600, HiBS600, HiBH600, HiBL600 HiBE800, HiBS800, HiBH800, HiBL800						
MOT-12NE	HiBL50NT, HiBL100NT, HiBL225NT HiBX50NT, HiBX100NT, HiBX225NT HiBL50NE, HiBL100NE, HiBL225NE	DC24V AC/DC110V AC/DC220V	≤ 2.5 ≤ 0.5 ≤ 5.0	350	230	14	25,000
MOT-46NE	HiBS400NE, HiBL400NE, HiBX400NE HiBS600NE, HiBL600NE, HiBX600NE	DC24V AC/DC110V AC/DC220V	≤ 5.0 ≤ 3.0 ≤ 2.0	700	420	35	15,000
MOT-80NE	HiBS800NE, HiBL800NE, HiBX800NE HiBS1000NE, HiBL1000NE HiBS1200NE, HiBL1200NE	DC24V AC/DC110V AC/DC220V	≤ 5.0 ≤ 3.0 ≤ 2.0	820	500	120	10,000

Control circuit and wiring diagram

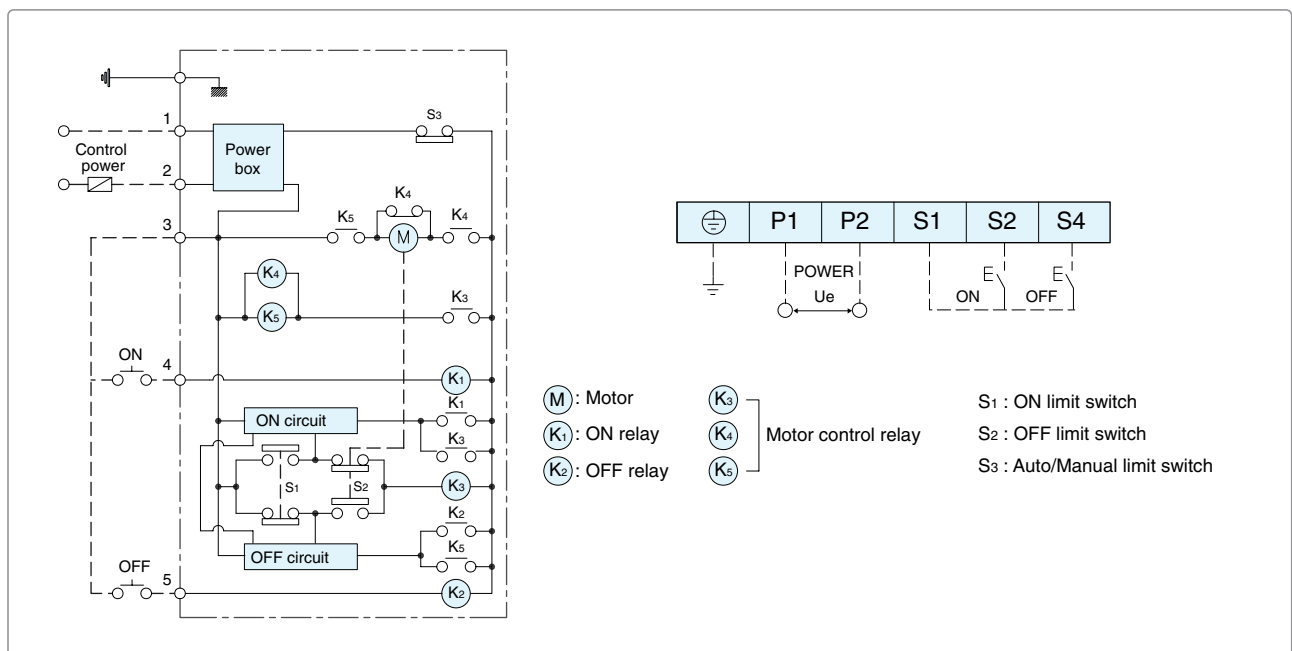

■ Dimensions

Model	Applicable MCCB	Dimensions (mm)			
		A	B	C	D
MOT-10A	HiBS30, HiBH30, HiBE50, HiBS50 HiBE60, HiBS60, HiBE100	90	132	93	30
MOT-10B	HiBH50, HiBS100, HiBH100 HiBS100J, HiBH100J	90	132	93	30
MOT-20C	HiBE225, HiBS225, HiBH225 HiBE250J, HiBS250J, HiBH250J	90	126	93	35
MOT-40D	HiBE400, HiBS400, HiBH400, HiBL400	130	215	150	44
MOT-68E	HiBE600, HiBS600, HiBH600, HiBL600 HiBE800, HiBS800, HiBH800, HiBL800	130	243	137	70
MOT-12NE	HiBL50NT, HiBL100NT, HiBL225NT HiBX50NT, HiBX100NT, HiBX225NT HiBL50NE, HiBL100NE, HiBL225NE	90	144	97	35
MOT-46NE	HiBS400NE, HiBL400NE, HiBX400NE HiBS600NE, HiBL600NE, HiBX600NE	130	130	150	45
MOT-80NE	HiBS800NE, HiBL800NE, HiBX800NE HiBS1000NE, HiBL1000NE HiBS1200NE, HiBL1200NE	130	340	150	70

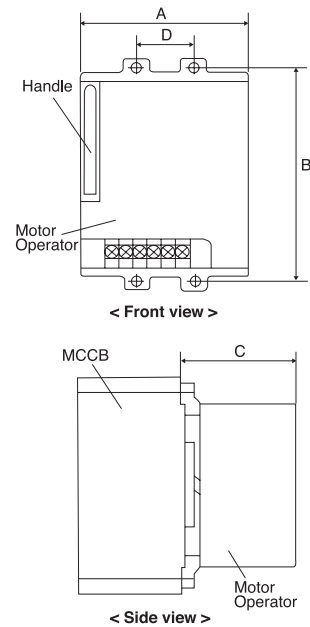





■ Standard order code and unit

Applicable MCCB	Code			Unit	Category
	DC24V	AC/DC110V	AC/DC220V		
HiBS30, HiBH30, HiBE50, HiBS50 HiBE60, HiBS60, HiBE100	MOT 10A DC24	MOT 10A ADC110	MOT 10A ADC220	8	MCCB MB
HiBH50, HiBS100, HiBH100 HiBS100J, HiBH100J	MOT 10B DC24	MOT 10B ADC110	MOT 10B ADC220	8	
HiBE225, HiBS225, HiBH225 HiBE250J, HiBS250J, HiBH250J	MOT 20C DC24	MOT 20C ADC110	MOT 20C ADC220	8	
HiBE400, HiBS400, HiBH400, HiBL400	MOT 40D DC24	MOT 40D ADC110	MOT 40D ADC220	4	
HiBE600, HiBS600, HiBH600, HiBL600 HiBE800, HiBS800, HiBH800, HiBL800	MOT 68E DC24	MOT 68E ADC110	MOT 68E ADC220	4	
HiBL50NT, HiBX50NT, HiBL100NT HiBX100NT, HiBL225NT, HiBX225NT HiBL50NE, HiBL100NE, HiBL225NE	MOT 12NE DC24	MOT 12NE ADC110	MOT 12NE ADC220	8	
HiBS400NE, HiBL400NE, HiBX400NE HiBS600NE, HiBL600NE, HiBX600NE	MOT 46NE DC24	MOT 46NE ADC110	MOT 46NE ADC220	4	
HiBS800NE, HiBL800NE, HiBX800NE HiBS1000NE, HiBL1000NE HiBS1200NE, HiBL1200NE	MOT 80NE DC24	MOT 80NE ADC110	MOT 80NE ADC220	4	

Terminal Accessories

Terminal connection screw (Standard components)

Terminal screw		Applicable MCCB
Form	Screw size	
Clamp screw 	M5	HiBS30, HiBH30, HiBE50, HiBS50, HiBH50 HiBE60, HiBS60, HiBE100 (5-50A)
Pan head screw 	M8	HiBS100, HiBH100, HiBE100 (60-100A), HiBS100J, HiBH100J HiBE225, HiBS225, HiBH225, HiBE250J, HiBS250J, HiBH250J
Hexagon socket head screw 	M8	HiBL50NT, HiBX50NT, HiBL100NT, HiBX100NT, HiBL225NT, HiBX225NT HiBL50NE, HiBL100NE, HiBL225NE
	M10	HiBE400, HiBS400, HiBH400, HiBL400
Hexagon head screw 	M12	HiBE600, HiBS600, HiBH600, HiBL600 HiBE800, HiBS800, HiBH800, HiBL800 HiBS400NE, HiBL400NE, HiBX400NE HiBS600NE, HiBL600NE, HiBX600NE HiBS800NE, HiBL800NE, HiBX800NE HiBS1000NE, HiBL1000NE, HiBS1200NE, HiBL1200NE

Terminal bus bar (TBB)

Applicable MCCB	Code			Unit	Mounting hole	Category	
	2 pole (4EA/SET)	3 pole (6EA/SET)	4 pole (8EA/SET)				
HiBE225, HiBS225, HiBH225 HiBE250J, HiBS250J, HiBH250J	TBB 20C 2	TBB 20C 3	TBB 20C 4		φ 11	MCCB	MB
HiBE400, HiBS400, HiBH400, HiBL400	TBB 4S 2	TBB 4S 3	TBB 4S 4		φ 13		
HiBE600, HiBS600, HiBH600, HiBL600	TBB 6S 2	TBB 6S 3	TBB 6S 4		φ 15		
HiBE800, HiBS800, HiBH800, HiBL800	TBB 8S 2	TBB 8S 3	TBB 8S 4		φ 15		
HiBL50NT, HiBX50NT, HiBL100NT HiBX100NT, HiBL225NT, HiBX225NT HiBL50NE, HiBL100NE, HiBL225NE	-	TBB 12NE 3	TBB 12NE 4		φ 11		
HiBS400NE, HiBL400NE, HiBX400NE	-	TBB 40NE 3	TBB 40NE 4		φ 13		
HiBS600NE, HiBL600NE, HiBX600NE	-	TBB 60NE 3	TBB 60NE 4		φ 13		

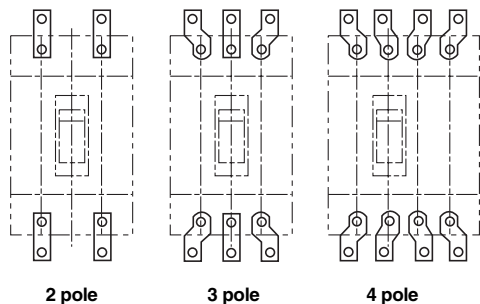

■ Cage terminal block unit (CTB)

(Unit: mm)

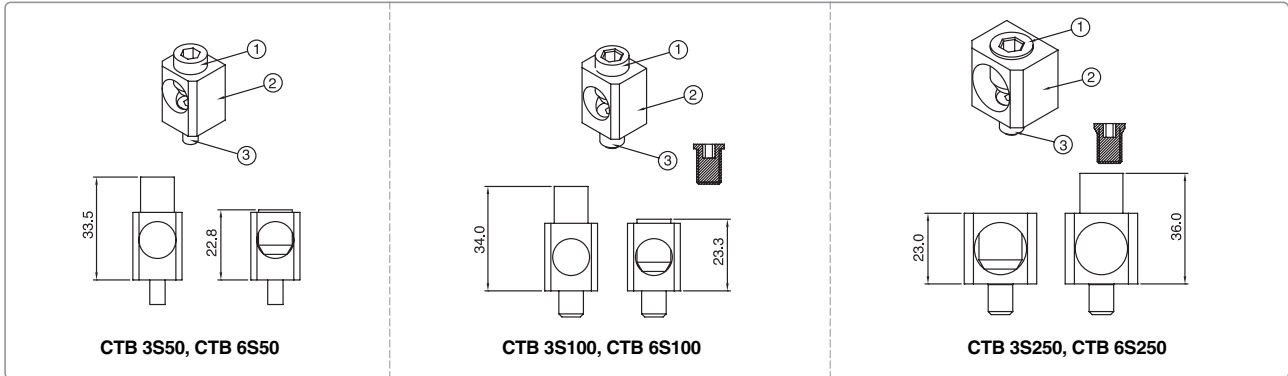

Applicable MCCB	Order information		Connection								Category	
	Code		Fix bolt		Upper bolt		Wire size (mm ²)	Tightening torque (kgf-cm)	Cable connection			
	3EA/SET	6EA/SET	Unit	Screw	Tool	Screw				Tool		
HiBS30, HiBH30, HiBE50, HiBS50 HiBE60, HiBS60, HiBE100	CTB 3S50	CTB 6S50		M5×0.8	5/32 inch wrench	M11×0.75	7/32 inch wrench	1×5.5-50	60	Single	MCCB	MB
HiBH50, HiBS100, HiBH100 HiBS100J, HiBH100J	CTB 3S100	CTB 6S100		M8×1.25	5/32 inch wrench	M11×0.75	7/32 inch wrench	1×8-50	60	Single		
HiBE225, HiBS225, HiBH225 HiBE250J, HiBS250J, HiBH250J	CTB 3S250	CTB 6S250		M8×1.25	5/32 inch wrench	M14×1.5	1/4 inch wrench	1×14-120	140	Single		

■ Rear barrier

Applicable MCCB	Code			Unit	Category	
	2 pole	3 pole	4 pole			
HiBS30, HiBH30, HiBE50, HiBS50 HiBE60, HiBS60, HiBE100	REAR-BR 10A 2	REAR-BR 10A 3	-	MCCB	MB	
HiBH50, HiBS100, HiBH100 HiBS100J, HiBH100J	REAR-BR 10B 2	REAR-BR 10B 3	-			
HiBE225, HiBS225, HiBH225 HiBE250J, HiBS250J, HiBH250J	REAR-BR 20C 3	REAR-BR 20C 3	REAR-BR 20C 4			

※ 1EA/SET for one side of MCCB

■ Terminal cover (TCF)

■ It is used for protection against direct contact with power circuit.

Applicable MCCB	2 pole			3 pole			4 pole			Unit	Category			
	Code	Dimensions(mm)			Code	Dimensions(mm)			Code			Dimensions(mm)		
		A	B	C		A	B	C				A	B	C
HiBS30, HiBH30, HiBE50, HiBS50 HiBE60, HiBS60, HiBE100	TCF 10A 2	50	59	58.5	TCF 10A 3	75	59	58.5	TCF 10A 4	100	59	58.5	MCCB	MB
HiBH50, HiBS100, HiBH100 HiBS100J, HiBH100J	TCF 10B 2	57	28.5	58.5	TCF 10B 3	87	28.5	58.5	TCF 10B 4	117	28.5	58.5		
HiBE225, HiBS225, HiBH225 HiBE250J, HiBS250J, HiBH250J	TCF 20C 3	102	32.5	58.5	TCF 20C 3	102	32.5	58.5	TCF 20C 4	137	32.5	58.5		
HiBL50NT, HiBX50NT, HiBL100NT HiBX100NT, HiBL225NT, HiBX225NT HiBL50NE, HiBL100NE, HiBL225NE	-	-	-	-	TCF 12NE 3	105	29.5	82.5	TCF 12NE 4	140	29.5	82.5		
HiBS400NE, HiBL400NE, HiBX400NE HiBS600NE, HiBL600NE, HiBX600NE	-	-	-	-	TCF 46NE 3	140	35	106.5	TCF 46NE 4	185	35	106.5		

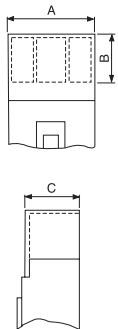

Plug-In Accessories

■ Mounting base

■ For switchboard

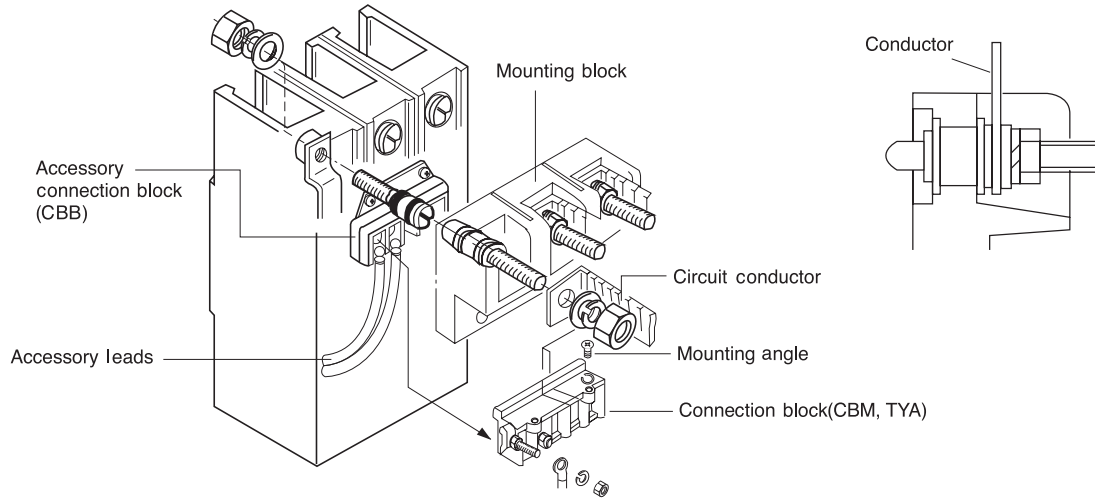

Applicable MCCB	For both line & load side plug-in type 3 pole MCCB							For line side only plug-in type 3 pole MCCB		Category
	Mounting base		Connection block ¹⁾			Conn. block barrier		Mounting base		
	Code	Required quantity	Code	Contact	Required quantity	Code	Required quantity	Code	Required quantity	
HiBS30, HiBH30, HiBE50, HiBS50 HiBE60, HiBS60, HiBE100	TDM 10AP	1EA	CBM 10AB 2	2C	1EA	CBM BARR	1EA	TDM 10AF	1EA	MCCB MB
			CBM 10AB 3	3C	1EA					
HiBH50, HiBS100, HiBH100 HiBS100J, HiBH100J	TDM 10BP	1EA	CBM 10AB 2	2C	1EA	CBM BARR	1EA	TDM 10BF	1EA	
			CBM 10AB 3	3C	1EA					
HiBE225, HiBS225, HiBH225 HiBE250J, HiBS250J, HiBH250J	TDM 20CF	2EA	CBM 20C 2	2C	1EA	-	-	TDM 20CF	1EA	
			CBM 20C 5	5C	1EA					
HiBE400, HiBS400, HiBH400, HiBL400	TDM 4BA	2EA	TYA 5/2 ²⁾	2C	1EA	-	-	TDM 4BA	1EA	
			TYA 5/5 ²⁾	5C	1EA					
HiBE600, HiBS600, HiBH600, HiBL600 HiBE800, HiBS800, HiBH800, HiBL800	TDM 5BA	2EA	TYA 5/2 ²⁾	2C	1EA	-	-	TDM 5BA	1EA	
			TYA 5/5 ²⁾	5C	1EA					
HiBL50NT, HiBX50NT, HiBL100NT HiBX100NT, HiBL225NT, HiBX225NT HiBL50NE, HiBL100NE, HiBL225NE	TDM 12NEP	1EA	CBM 26NE 6	6C	1EA	-	-	TDM 12NEF	1EA	
HiBS400NE, HiBL400NE, HiBX400NE HiBS600NE, HiBL600NE, HiBX600NE	TDM 46NEP	1EA	CBM 26NE 6	6C	1EA	-	-	TDM 46NEF	1EA	

※ - 1) Connection blocks are required for internal accessory installation in both line and load side plug-in type 3 pole MCCB.
 - 2) TYA type connection blocks are to be installed with separate mounting angle. Separate mounting angle is not supplied.

■ For distribution board

Category	ASSY type			Applicable MCCB	Part name	Type of separate order			Q'ty	Mounting screw	Remarks
	Type	Full	Rate			Type	Full	Rate			
Double mounting base	TDA	10AD	ASSY	HiBS53 HiBS63 HiBE103	Mounting base	TDA	10AS		2	M4 * L18 (4EA)-angle for installation	Attached to load side terminal
					Branching conductor	2RT-PH	A		2	M5 * L12 (1EA)-bus bar for installation M4 * L8 (2EA)-branching conductor for fix	for 5-60A
						22S-PH	A		1		for 75, 100A
						22S-PH10	A		1		
					Arc protection barrier	BRAN-BARR	A		2	-	
	Connection plate*	CONN-PL	A		1	M4 * L25 (4EA)	Separate order item				
		ARC-PL	A		1	-					
	TDA	10BD	ASSY	HiBS103 HiBH103	Mounting base	TDA	10BS		2	M5 * L20 (4EA)-angle for installation	Attached to load side terminal
					Branching conductor	2RT-PH			2	M5 * L12 (1EA)-bus bar for installation M4 * L8 (2EA)-branching conductor for fix	for 5-60A
						22S-PH			1		for 75, 100A
22S-PH10								1			
Arc protection barrier					BRAN-BARR			2	-		
Connection plate*	CONN-PL			1	M4 * L25 (4EA)	Separate order item					
	ARC-PL			1	-						
Single mounting base	TDA	10AS	HiBS53 HiBS63 HiBE103	Mounting base	TDA	10AS		1	M4 * L30 (4EA)-angle for installation	Attached to load side terminal	
					Branching conductor**	1R-PH	A		1	M5 * L12 (1EA)-bus bar for installation M4 * L8 (1EA)-branching conductor for fix	for 5-60A (Separate order item)
						1S-PH			1		
						1T-PH			1		
						1R-PH10	A		1		for 75, 100A (Separate order item)
						1S-PH10			1		
	1T-PH10			1							
	TDA	10BS	HiBS103 HiBH103	Mounting base	TDA	10BS		1	M5 * L32 (4EA)-angle for installation	Attached to load side terminal	
					Branching conductor**	1R-PH			1	M5 * L12 (1EA)-bus bar for installation M4 * L8 (1EA)-branching conductor for fix	for 5-60A (Separate order item)
						1S-PH			1		
						1T-PH			1		
						1R-PH10			1		for 75, 100A (Separate order item)
						1S-PH10			1		
1T-PH10								1			

* When ordered double mounting base, connection plate should be purchased separately.

** When ordered single mounting base, branching conductor should be purchased separately.

■ Type of component

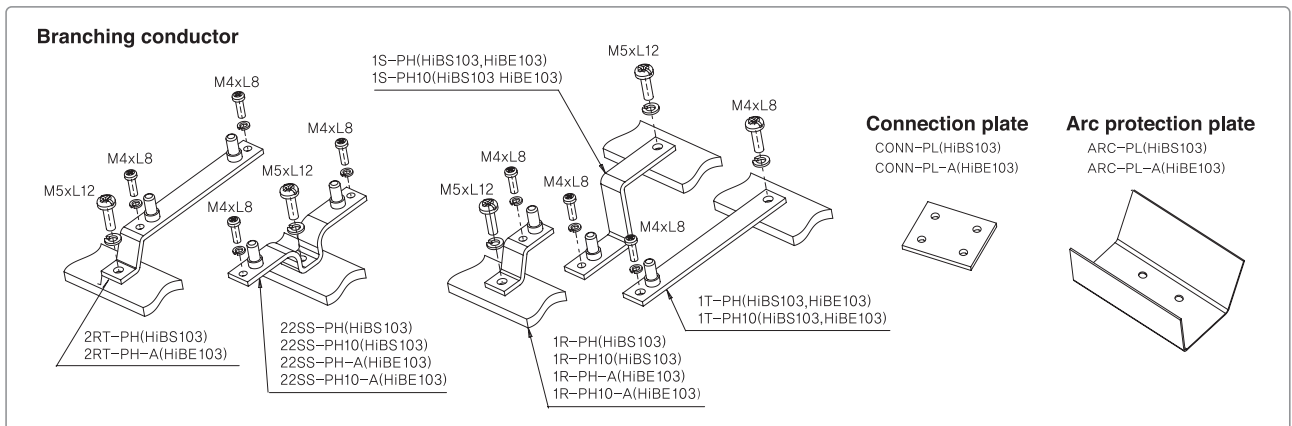

Plug-In Accessories

■ Outline dimension of double mounting base for distribution

(Unit: mm)

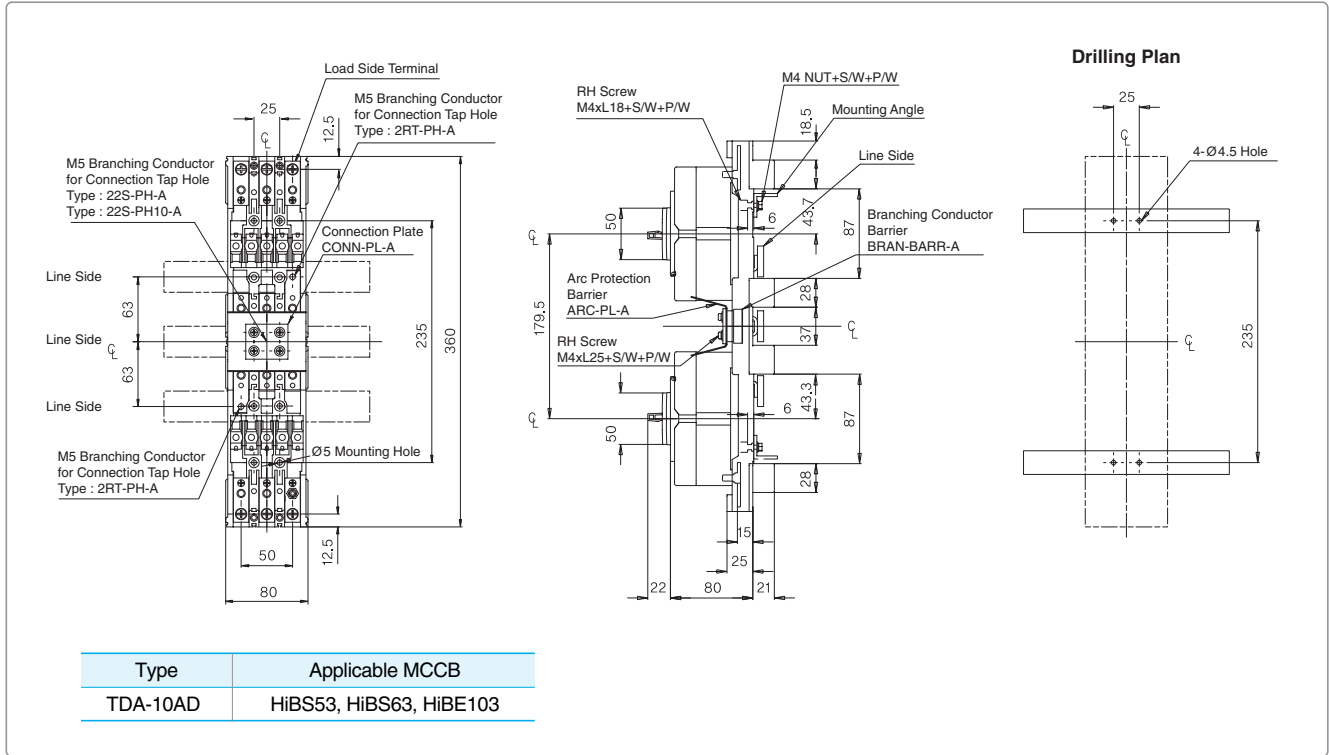

■ Outline dimension of single mounting base for distribution

(Unit: mm)

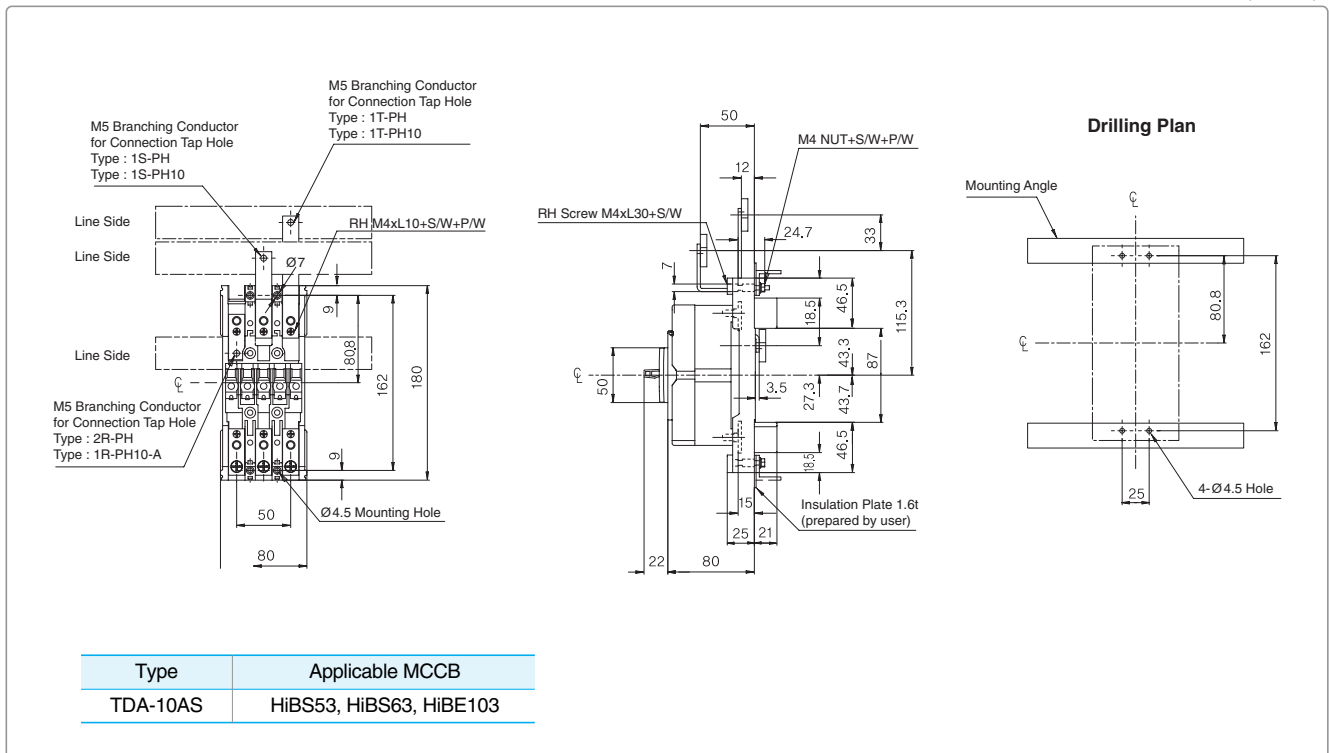

■ Outline dimension of double mounting base for distribution

(Unit: mm)

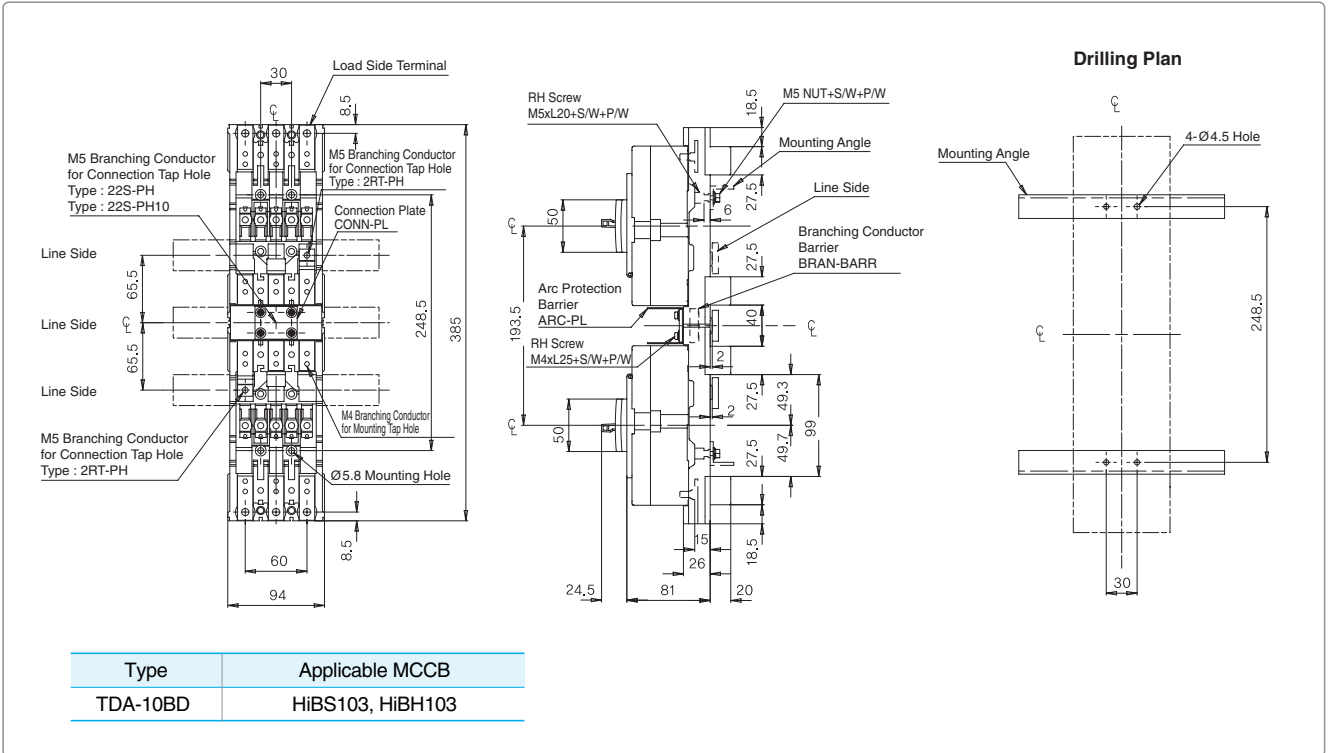

■ Outline dimension of single mounting base for distribution

(Unit: mm)

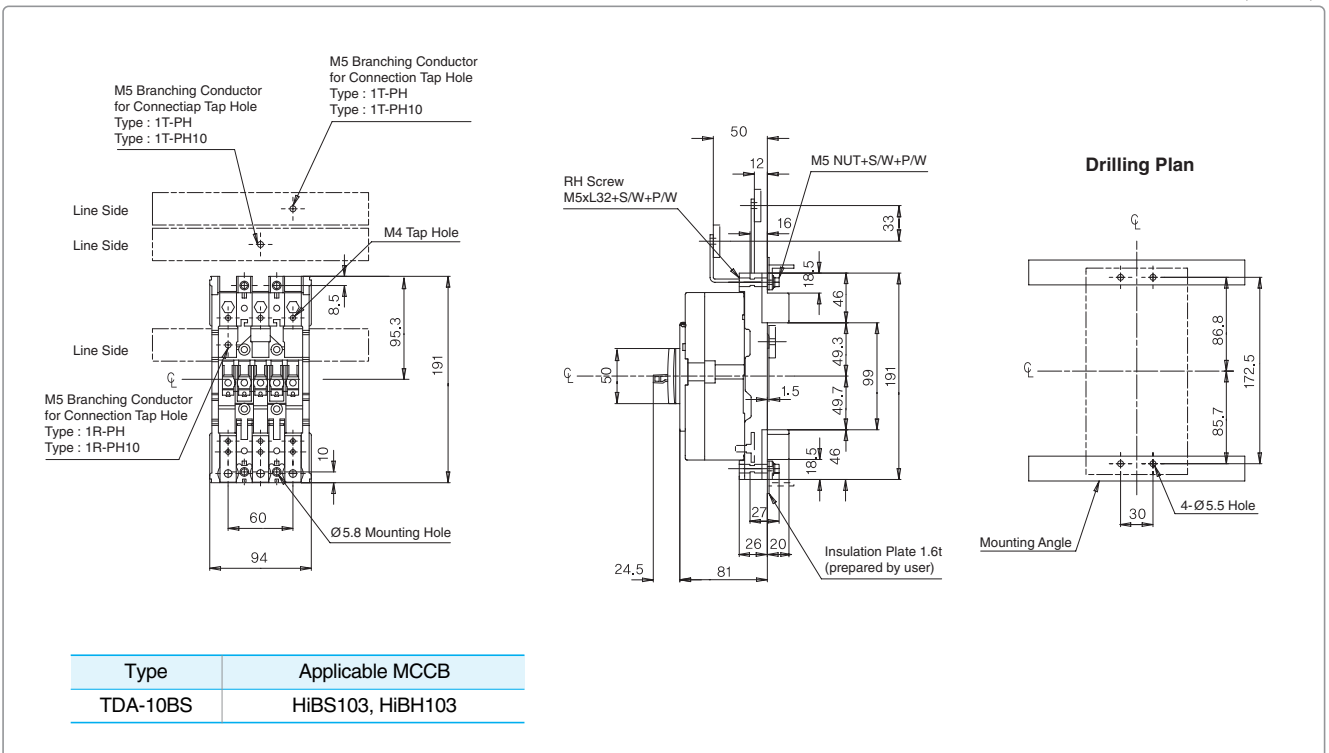

Spare Parts

■ Interpole barrier (TQQ)

■ Interpole barriers completely isolate terminal to prevent accidental short-circuiting between two or more terminals.

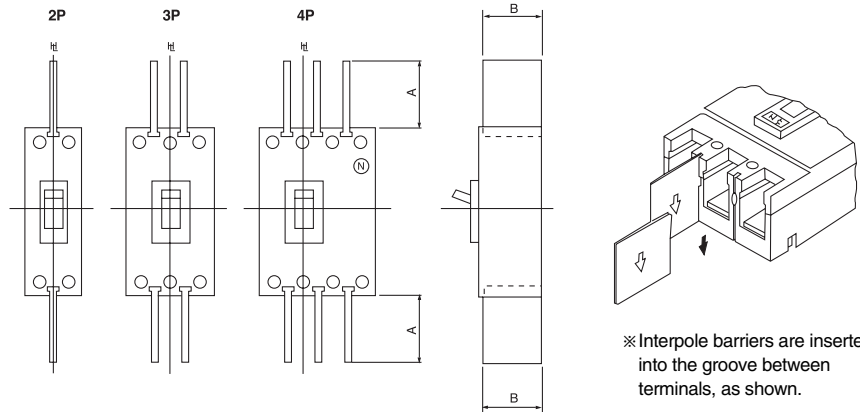

※ Interpole barriers are inserted into the groove between terminals, as shown.

Applicable MCCB	Code	Description	Unit	Required quantity for both line and load side of MCCB			Dimensions (mm)		Category	
				2 pole	3 pole	4 pole	A	B		
HiBS30, HiBH30, HiBE50, HiBS50 HiBE60, HiBS60, HiBE100	TQQ 10A	2EA/SET		2EA	4EA	6EA	50	53	MCCB	MB
HiBH50, HiBS100, HiBH100 HiBS100J, HiBH100J	TQQ 10B	2EA/SET		2EA	4EA	6EA	50	59		
HiBE225, HiBS225, HiBH225 HiBE250J, HiBS250J, HiBH250J	TQQ 20C	2EA/SET		4EA	4EA	6EA	100	60.5		
HiBE400, HiBS400, HiBH400, HiBL400	TQQ 4BA	2EA/SET		4EA	4EA	6EA	120	97		
HiBE600, HiBS600, HiBH600, HiBL600 HiBE800, HiBS800, HiBH800, HiBL800	TQQ 5BA	2EA/SET		4EA	4EA	6EA	110	95		
HiBL50NT, HiBX50NT, HiBL100NT HiBX100NT, HiBL225NT, HiBX225NT HiBL50NE, HiBL100NE, HiBL225NE	TQQ 12NE	4EA/SET		-	4EA	6EA	71	54.5		
HiBS400NE, HiBL400NE, HiBX400NE HiBS600NE, HiBL600NE, HiBX600NE	TQQ 46NE	4EA/SET		-	4EA	6EA	122	103		
HiBS800NE, HiBL800NE, HiBX800NE HiBS1000NE, HiBL1000NE HiBS1200NE, HiBL1200NE	TQQ 80NE	4EA/SET		-	4EA	6EA				

■ Extension handle (THA)

Reduces ON, OFF and RESET operation effort

When using extension handles, do not operate it excessively since it can break.

Applicable MCCB	Code	Unit	Dimensions (mm)		Category	
			A	B	MCCB	MB
HiBE400, HiBS400, HiBH400, HiBL400 HiBE600, HiBS600, HiBH600, HiBL600 HiBE800, HiBS800, HiBH800, HiBL800	THA 46D		42	40	MCCB	MB
HiBL50NT, HiBX50NT, HiBL100NT HiBX100NT, HiBL225NT, HiBX225NT HiBL50NE, HiBL100NE, HiBL225NE	THA 12NE		20	20		
HiBS400NE, HiBL400NE, HiBX400NE HiBS600NE, HiBL600NE, HiBX600NE	THA 46NE		42	30		
HiBS800NE, HiBL800NE, HiBX800NE HiBS1000NE, HiBL1000NE HiBS1200NE, HiBL1200NE	THA 80NE		56	40		

Diagram showing the extension handle (THA) being used on a MCCB terminal, with dimensions A and B and a mounting hole indicated.

Trip Unit Configuration of Adjustable MCCBs

■ Adjustable thermal type (NT type)

■ Protection function of trip unit (225AF from 175A)

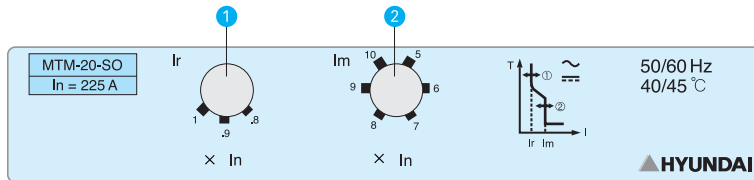

- ① Rated current setting threshold (I_r)
- ② Instantaneous current setting threshold (I_m)

■ Protection function of trip unit (50/100/225AF upto 150A)

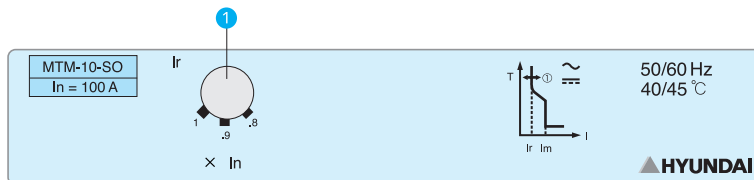

- ① Rated current setting threshold (I_r)

■ Adjustable current range (50/100/225AF)

Ampere frame		50, 100								225					
Rated current (I_r)	Rated current (A)	15	20	30	40	50	60	75	100	125	150	175	200	225	
	Setting range	0.8 X I_n	12	16	24	32	40	48	60	80	100	120	140	160	180
		0.9 X I_n	14	18	27	36	45	54	68	90	113	135	158	180	203
		1.0 X I_n	15	20	30	40	50	60	75	100	125	150	175	200	225
Instantaneous current (I_m)	Tripping method	Fixed										Adjustable			
	Setting range	150	200	300	400	500	600	750	1000	1250	1500	1750	5-10 X I_n		
	Tolerance (%)	±20%										5-6-7-8-9: ±25%			10 : ±10%

Trip Unit Configuration of Adjustable MCCBs

■ Electronic type (NE type)

■ Protection function of trip unit (50/100/225AF)

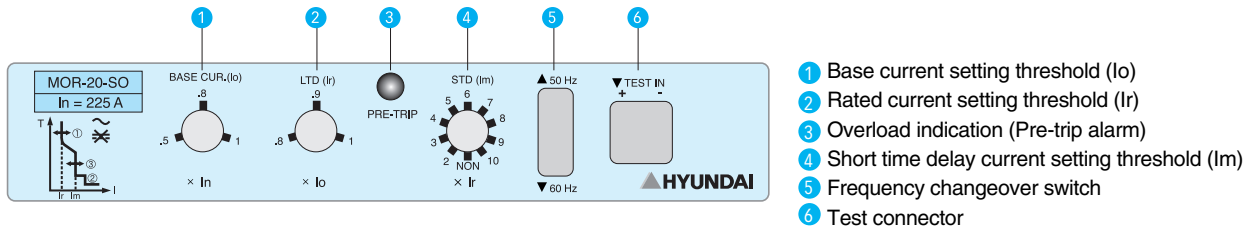

■ Adjustable current range (50/100/225AF)

		In = 50A	MOR-05-SO			In = 100A	MOR-10-SO			In = 225A	MOR-20-SO					
Rated current (LTD)	Setting range	Ir Threshold	0.8	0.9	1	Ir Threshold	0.8	0.9	1	Ir Threshold	0.8	0.9	1			
		Io Threshold	0.5	20A	23A	25A	Io Threshold	0.5	40A	45A	50A	Io Threshold	0.5	90A	100A	115A
			0.8	32A	36A	40A	0.8	65A	70A	80A	0.8	145A	160A	180A		
			1.0	40A	45A	50A	1.0	80A	90A	100A	1.0	180A	200A	225A		
Setting range of short time delay		2, 3, 4, 5, 6, 7, 8, 9, 10 X Ir														

■ Setting procedure

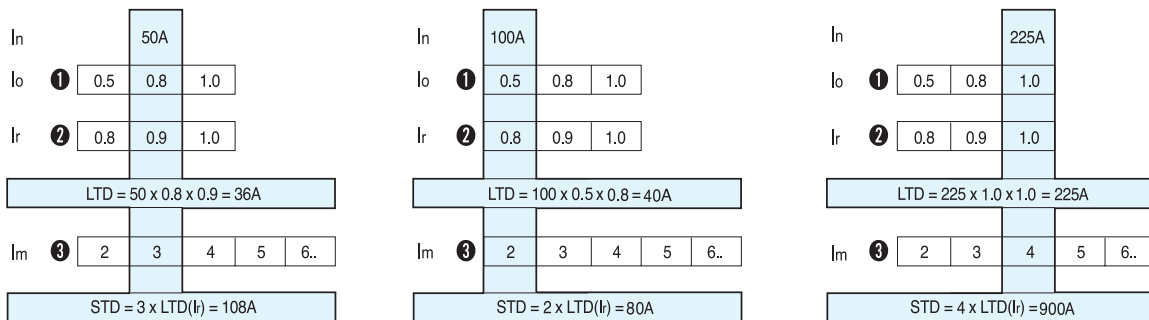

■ Protection function of trip unit (400/600/800/1000/1200AF)

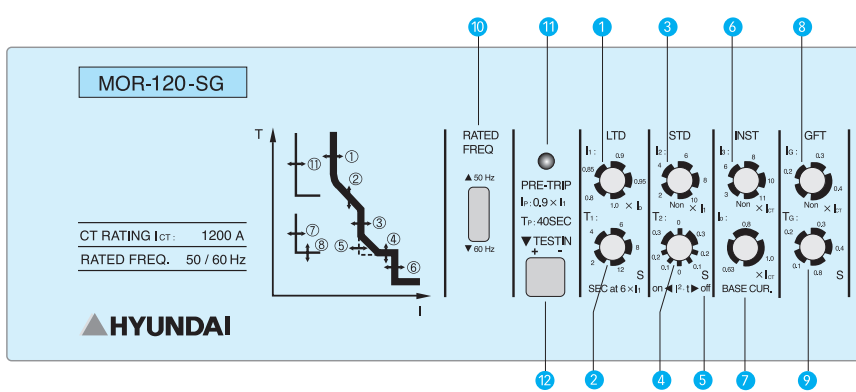

- 1 Long time delay (LTD) protection threshold
- 2 Long time delay (LTD) protection time delay
- 3 Short time delay (STD) protection threshold
- 4 Short time delay (STD) protection time delay
- 5 Short time delay (STD) current I_t characteristic selection switch
- 6 Instantaneous (INST) protection threshold
- 7 Base current (I₀) threshold
- 8 Ground Fault (GFT) protection threshold
- 9 Ground Fault (GFT) protection time delay
- 10 Frequency changeover switch (50→60Hz)
- 11 Overload indication
- 12 Test connector

■ Adjustable current setting (400/600AF)

		MOR-40-SG					MOR-60-SG				
Rated current (LTD)	Setting range	I _{CT} = 400A					I _{CT} = 600A				
		I _t Threshold					I _t Threshold				
		I ₀ Threshold					I ₀ Threshold				
	0.63	200	215	225	240	250	302	320	340	360	380
	0.8	255	270	290	300	320	385	410	430	455	480
	1.0	320	340	360	380	400	480	510	540	570	600
Setting range for short time delay		2-4-6-8-10 X I _t									
Setting range for instantaneous		3-6-8-10-11 X I _{CT}									
Setting range for ground fault trip		0.2-0.3-0.4 X I _{CT}									
Load adjusting range		0.9 X I _t									

■ Setting procedure

I _{CT}	400A				
7	0.63	0.8	1.0		
I ₀	BASE CUR. = 1.0 x 400 (I _{CT}) = 400A				
1	0.8	0.85	0.9	0.95	1.0
I ₁	LTD = 0.9 x 400 (I ₀) = 360A				
3	2	4	6	8	10
I ₂	STD = 6 x 360 (I ₁) = 2160A				
6	3	6	8	10	11
I ₃	INST = 8 x 400 (I _{CT}) = 3200A				
8	0.2	0.3	0.4		
I ₆	GFT = 0.3 x 400 (I _{CT}) = 120A				

I _{CT}	600A				
7	0.63	0.8	1.0		
I ₀	BASE CUR. = 1.0 x 600 (I _{CT}) = 600A				
1	0.8	0.85	0.9	0.95	1.0
I ₁	LTD = 0.9 x 600 (I ₀) = 540A				
3	2	4	6	8	10
I ₂	STD = 6 x 540 (I ₁) = 3240A				
6	3	6	8	10	11
I ₃	INST = 8 x 600 (I _{CT}) = 4800A				
8	0.2	0.3	0.4		
I ₆	GFT = 0.3 x 600 (I _{CT}) = 180A				

Trip Unit Configuration of Adjustable MCCBs

■ Electronic type (NE type)

■ Adjustable current range (800/1000/1200AF)

Rated current (LTD) Setting range	I _{CT} =800A					I _{CT} =1000A					I _{CT} =1200A								
	MOR-80-SG					MOR-100-SG					MOR-120-SG								
	I _r Threshold	0.8	0.85	0.9	0.95	1.0	I _r Threshold	0.8	0.85	0.9	0.95	1.0	I _r Threshold	0.8	0.85	0.9	0.95	1.0	
	I _o Threshold	0.63	405	430	455	480	505	0.63	505	535	565	600	630	0.63	605	645	680	720	755
		0.8	510	545	575	610	640	0.8	640	680	720	760	800	0.8	770	815	865	910	960
		1.0	640	680	720	760	800	1.0	800	850	900	950	1000	1.0	960	1020	1080	1140	1200
Setting range for short time delay		2-4-6-8-10 X I _r																	
Setting range for instantaneous		3-6-8-10-11 X I _{CT}																	
Setting range for ground fault trip		0.2-0.3-0.4 X I _{CT}																	
Load adjusting range		0.9 X I _r																	

■ Setting procedure

I _{CT}	800A				
⑦	0.63	0.8	1.0		
I _o	BASE CUR. = 1.0 x 800(I _{CT}) = 800A				
①	0.8	0.85	0.9	0.95	1.0
I _r	LTD = 0.9 x 800(I _o) = 720A				
④	2	4	6	8	10
I ₂	STD = 6 x 720(I _r) = 4320A				
⑥	3	6	8	10	11
I ₃	INST = 8 x 800(I _{CT}) = 6400A				
⑧	0.2	0.3	0.4		
I _G	GFT = 0.3 x 800(I _{CT}) = 240A				

I _{CT}	1000A				
⑦	0.63	0.8	1.0		
I _o	BASE CUR. = 1.0 x 1000(I _{CT}) = 1000A				
①	0.8	0.85	0.9	0.95	1.0
I _r	LTD = 0.9 x 1000(I _o) = 900A				
④	2	4	6	8	10
I ₂	STD = 6 x 900(I _r) = 5400A				
⑥	3	6	8	10	11
I ₃	INST = 8 x 1000(I _{CT}) = 8000A				
⑧	0.2	0.3	0.4		
I _G	GFT = 0.3 x 1000(I _{CT}) = 300A				

I _{CT}	1200A				
⑦	0.63	0.8	1.0		
I _o	BASE CUR. = 1.0 x 1200(I _{CT}) = 1200A				
①	0.8	0.85	0.9	0.95	1.0
I _r	LTD = 0.9 x 1200(I _o) = 1080A				
④	2	4	6	8	10
I ₂	STD = 6 x 1080(I _r) = 6480A				
⑥	3	6	8	10	11
I ₃	INST = 8 x 1200(I _{CT}) = 9600A				
⑧	0.2	0.3	0.4		
I _G	GFT = 0.3 x 1200(I _{CT}) = 360A				

Capacity and Characteristic

■ Capacity

■ Rated interrupting capacities.

Hyundai MCCBs are rated according to the level of fault current they can interrupt. When applying a circuit breaker, one must be selected which can sustain the largest potential short circuit current which can occur in the selected application. It's more important to select Hyundai MCCBs which have interrupting capacities best suited to the circuits. Short-circuit current values vary according to the transformer capacity and its connecting cables.

■ Operational performance capability

A circuit breaker shall be capable of performing successfully when operated manually or by means of a machine constructed to simulate manual operation for the number of cycles and at rate indicated in related standards.

Table 1 - Number of operating cycles (IEC 60947)

1	2	3	4	5
Rated current* (A)	Number of operating cycles per hour**	Without current	With current***	Total
$I_n \leq 100$	120	8,500	1,500	10,000
$100 < I_n \leq 315$	120	7,000	1,000	8,000
$315 < I_n \leq 630$	60	4,000	1,000	5,000
$630 < I_n \leq 2500$	20	2,500	500	3,000
$2500 < I_n$	10	1,500	500	2,000

* The maximum rated current for a given frame size.

** Column 2 gives the minimum operating rate. This rate may be increased with the consent of the manufacturer; in this case the rate used shall be stated in the test report.

*** During each operating cycle, the circuit-breaker shall remain closed for a sufficient time to ensure that the full current is established, but not exceeding 2s.

Table 2 - Characteristics of the opening operation of inverse time-delay over-current opening releases at the reference temperature (IEC 60947)

All poles loaded		Conventional time (h)
Conventional non-tripping current	Conventional tripping current	
1.05times current setting	1.30times current setting	2
1 hour when $I_n \leq 63A$		

■ Characteristic

■ Long-time delay trip characteristic

The overload trip unit senses and decides when to act by tripping the circuit breaker. The higher the current, the shorter time it takes for the trip mechanism to activate.

Time delay trip characteristic makes it possible for MCCBs to withstand momentary overloads such as motor starting, welding for the set time without tripping, etc.

■ Short-time delay trip characteristic

It establishes the time interval the breaker will wait before responding to the short-circuit current level selected on the short-time trip point adjustment.

■ Instantaneous trip characteristic

The instantaneous trip unit senses and decides when to act by tripping the circuit breaker without intentional time delay. This immediate interruption occurs only as a result of a severe overcurrent condition such as the short-circuit current level, thereby minimizing damage to the electrical system and equipment. A circuit breaker (600AF and more) that has an adjustable instantaneous release also makes it easier for us to get a further refinement of protection coordination between MCCBs and up-stream protective devices such as ACBs or between MCCBs and Magnetic Contactors.

Capacity and Characteristic

■ Time current curves

Time current curves represent the relationship between overcurrents and operating time. Approximate minimum and maximum clearing time is readily determined from the characteristics curves.

■ Current and temperature

The thermal trip action is accomplished by a bimetallic strip. The movement of the bimetal and thus tripping is directly proportional to currents. In other words it responds fast to high currents and it responds slowly to low currents. However, the bimetal is also sensitive to ambient temperature. An enclosure compensated thermal trip is calibrated at the standard ambient temperature of 40°C in consideration of the temperature rise of the equipment (such as panels for control rooms) housing the circuit breaker. Therefore, when it is installed at locations where the ambient temperature drastically differs from the standard(40°C) it will trip at different current values and this must be allowed for making use of compensation.

■ Thermal characteristics of wires

MCCBs are designed to protect insulated cable; therefore, the characteristics of breakers are closely tied to IEC 60947's specified size and type of wire for each rating as well as the load characteristics. Cable sizes must be equal to, or greater than specified by IEC 60947. The cable is used as a heat sink to control the temperature of the bimetal; reducing the size of the conductor raises the temperature and the breaker will carry less current.

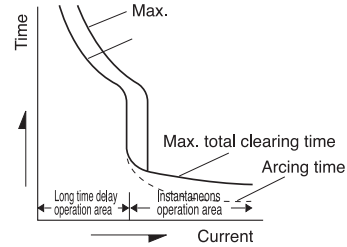

Table 3 - Test copper conductors for test currents up to 400A inclusive (IEC 60947)

Range of test current		Conductor size	
		mm ²	AWG / MCM
0	8	1.0	18
8	12	1.5	16
12	15	2.5	14
15	20	2.5	12
20	25	4.0	10
25	32	6.0	10
32	50	10	8
50	65	16	6
65	85	25	4
85	100	35	3
100	115	35	2
115	130	50	1
130	150	50	0
150	175	70	00
175	200	95	000
200	225	95	0000
225	250	120	250
250	275	150	300
275	300	185	350
300	350	185	400
350	400	240	500

Table 4 - Test copper conductors for test currents above 400A and up to 800A.

Range of test current ¹⁾ (A)		Conductors			
		Metric		MCM	
		Number	Size (mm ²)	Number	Size MCM
400	500	2	150	2	250
500	630	2	185	2	350
630	800	2	240	3	300

※ ¹⁾ The value of test current shall be greater than the first value in the first column and less than or equal to the second value in that column.

Application

■ Application according to transformer capacity

■ AC220V

3-phase transformer capacity (kVA)	kVA ≤ 30	kVA ≤ 50	75 ≤ kVA ≤ 100	150 ≤ kVA ≤ 300	500 ≤ kVA ≤ 750	kVA ≤ 1500				kVA ≤ 2000			
Single-phase 3 wire transformer capacity (kVA)	kVA ≤ 16	kVA ≤ 30	kVA ≤ 50	kVA ≤ 150	kVA ≤ 300								
Breaking capacity (kA) (sym)	2.5		5	10	25	35	42	50	65	85	100	125	
Frame (A)	30	HIBS33		HiBH33									
	50	HiBE53		HiBS53	HiBH53			HiBL53NT					
	60	HiBE63		HiBS63									
	100	HiBE103			HiBS103		HiBH103	HiBL103NT					
	225	HiBE203				HiBS203	HiBH203	HiBL203NT					
	400	HiBE403				HiBS403	HiBH403		HiBL403				
	600	HiBE603					HiBS603			HiBL603			
	800	HiBE803					HiBS803			HiBL803			
	1000-1200	HiBS1003NE, HiBS1203NE										HiBL1003NE HiBL1203NE	

■ AC460V

3-phase transformer capacity (kVA)	kVA ≤ 50	75 ≤ kVA ≤ 200	kVA ≤ 300	kVA ≤ 750	kVA ≤ 1500		kVA ≤ 2000		kVA ≤ 3000			
Breaking capacity (kA) (sym)	1.5		5	10	18	25	35	42	50	65	85	100
Frame (A)	30	HiBH33		HiBS33								
	50	HiBE53		HiBS53	HiBH53			HiBL53NT			HiBX53NT	
	60	HiBE63		HiBS63								
	100	HiBE103			HiBS103		HiBH103	HiBL103NT			HiBX103NT	
	225	HiBE203				HiBS203	HiBH203	HiBL203NT			HiBX203NT	
	400	HiBE403				HiBS403	HiBH403	HiBL403	HiBL403NE		HiBX403NE	
	600	HiBE603					HiBS603		HiBL603	HiBL603NE	HiBX603NE	
	800	HiBE803					HiBS803		HiBX803NE	HiBL803NE	HiBX803NE	
	1000-1200	HiBS1003NE, HiBS1203NE										HiBL1003NE HiBL1203NE

Application

■ MCCB selection for lighting and heating circuit

Full load current should not exceed the rated current of MCCB by 80%

■ AC220V

Full load current (A)	Rated current (A)	Breaking current (kA)										
		sym	2.5	5	10	25	35	50	65	85	100	125
12	15	HiBS33	HiBH33	HiBH53	HiBL53NT	HiBE53	HiBS53	HiBE63	HiBS63	HiBS103	HiBH103	HiBL103NT
16	20											
24	30											
32	40	HiBE103	HiBS103	HiBH103	HiBL103NT	HiBE203	HiBS203	HiBH203	HiBL203NT			
40	50											
48	60	HiBE403	HiBS403	HiBH403	HiBL403	HiBE603	HiBS603	HiBL603				
60	75											
80	100											
100	125	HiBE803	HiBS803	HiBL803	HiBS1003NE	HiBS1203NE	HiBL1003NE	HiBL1203NE				
120	150											
140	175											
160	200	HiBE803	HiBS803	HiBL803	HiBS1003NE	HiBS1203NE	HiBL1003NE	HiBL1203NE				
180	225											
200	250											
240	300	HiBE803	HiBS803	HiBL803	HiBS1003NE	HiBS1203NE	HiBL1003NE	HiBL1203NE				
280	350											
320	400											
400	500	HiBE803	HiBS803	HiBL803	HiBS1003NE	HiBS1203NE	HiBL1003NE	HiBL1203NE				
480	600											
560	700											
640	800	HiBE803	HiBS803	HiBL803	HiBS1003NE	HiBS1203NE	HiBL1003NE	HiBL1203NE				
800	1000											
960	1200											

■ AC460V

Full load current (A)	Rated current (A)	Breaking current (kA)											
		sym	1.5	5	10	18	25	35	42	50	65	85	100
12	15	HiBS33	HiBH33	HiBH53	HiBL53NT	HiBE53	HiBS53	HiBE63	HiBS63	HiBS103	HiBH103	HiBL103NT	HiBX103NT
16	20												
24	30												
32	40	HiBE103	HiBS103	HiBH103	HiBL103NT	HiBE203	HiBS203	HiBH203	HiBL203NT	HiBX203NT			
40	50												
48	60	HiBE403	HiBS403	HiBH403	HiBL403	HiBE603	HiBS603	HiBL603	HiBL603NE	HiBX403NE			
60	75												
80	100												
100	125	HiBE803	HiBS803	HiBL803	HiBS1003NE	HiBS1203NE	HiBL1003NE	HiBL1203NE					
120	150												
140	175												
160	200	HiBE803	HiBS803	HiBL803	HiBS1003NE	HiBS1203NE	HiBL1003NE	HiBL1203NE					
180	225												
200	250												
240	300	HiBE803	HiBS803	HiBL803	HiBS1003NE	HiBS1203NE	HiBL1003NE	HiBL1203NE					
280	350												
320	400												
400	500	HiBE803	HiBS803	HiBL803	HiBS1003NE	HiBS1203NE	HiBL1003NE	HiBL1203NE					
480	600												
560	700												
640	800	HiBE803	HiBS803	HiBL803	HiBS1003NE	HiBS1203NE	HiBL1003NE	HiBL1203NE					
800	1000												
960	1200												

■ Selection of motor protection MCCB

■ The selection of MCCB for motor circuit is carried out as follows.

Schematic diagram	Condition	Allowable current I_w	MCCB rated current I_N
<p> I_M: Load current of motor I_L: Load current of others </p>	$\sum I_M \leq \sum I_L$	$I_w \geq \sum I_M + \sum I_L$	$I_N \leq 3 \sum I_M + \sum I_L$
	$50A \geq \sum I_M > \sum I_L$	$I_w \geq 1.25 \sum I_M + \sum I_L$	$I_N \leq 2.5 I_w$
	$50A < \sum I_M > \sum I_L$	$I_w \geq 1.1 \sum I_M + \sum I_L$	$I_w > 100A$

■ Rated current of MCCBs for AC220V three-phase induction motor

Total motor capacity (kW or less)	Full load current (A or less)	Motor Max. output (kW): Motor capacity (A): Full load current																	
		0.75 4.8	1.5 8	2.2 11.1	3.7 17.4	5.5 26	7.5 34	11 48	15 65	18.5 79	22 93	30 125	37 160	45 190	5 230	75 310	90 360	110 440	132 500
3	15	20	30	30															
4.5	20	30	30	30	50														
6.3	30	40	40	40	50	60													
8.2	40	50	50	50	50	75	100												
12	50	60	60	60	60	75	100												
15.7	75	100	100	100	100	100	100	125	150										
19.5	90	100	100	100	100	100	100	125	150	175									
23.2	100	125	125	125	125	125	125	125	150	175	200								
30	125	150	150	150	150	150	150	150	150	175	225								
37.5	150	175	175	175	175	175	175	175	175	200	225	300							
45	175	200	200	200	200	200	200	200	200	200	225	300	400						
52.5	100	225	225	225	225	225	225	225	225	225	225	300	400	500					
63.7	150	300	300	300	300	300	300	300	300	300	300	300	400	500	500				
75	300	350	350	350	350	350	350	350	350	350	350	350	400	500	500				
86.2	350	400	400	400	400	400	400	400	400	400	400	400	400	500	500	600			
97.5	400	500	500	500	500	500	500	500	500	500	500	500	500	500	500	600	700		
112.5	450	500	500	500	500	500	500	500	500	500	500	500	500	500	500	700	700		
125	500	600	600	600	600	600	600	600	600	600	600	600	600	600	600	700	700	1000	
150	600	700	700	700	700	700	700	700	700	700	700	700	700	700	700	700	800	1000	1000
175	700	800	800	800	800	800	800	800	800	800	800	800	800	800	800	800	800	1000	1000
220	800	900	900	900	900	900	900	900	900	900	900	900	900	900	900	900	900	900	1000

Application

■ Rated current of MCCB for 440V three-phase induction motor

Total motor capacity (kW or less)	Full load current (A or less)	Motor Max. Output (kW): Motor capacity (A): Full load current																	
		0.75 2.4	1.5 4	2.2 5.5	3.7 8.7	5.5 13	7.5 17	11 24	15 32	18.5 39	22 46	30 62	37 808	45 95	5 115	75 155	90 180	110 220	132 250
3	7.5	15	15	15															
4.5	10	15	15	15	30														
6.3	15	20	20	20	30	40													
8.2	20	30	30	30	30	40	50												
12	25	30	30	30	30	40	50												
15.7	38	50	50	50	50	50	50	60	75										
19.5	45	50	50	50	50	50	50	60	75	100									
23.2	50	60	60	60	60	60	60	60	75	100	125								
30	63	75	75	75	75	75	75	75	100	100	125								
37.5	75	100	100	100	100	100	100	100	100	100	125	150							
45	88	100	100	100	100	100	100	100	100	100	125	150	175						
52.5	100	125	125	125	125	125	125	125	125	125	125	150	175	225					
63.7	125	150	150	150	150	150	150	150	150	150	150	150	200	225	250				
75	150	175	175	175	175	175	175	175	175	175	175	175	200	225	250				
86.2	175	200	200	200	200	200	200	200	200	200	200	200	200	225	300	350			
97.5	200	225	225	225	225	225	225	225	225	225	225	225	225	225	300	350	400		
112.5	225	250	250	250	250	250	250	250	250	250	250	250	250	250	300	350	400		
125	250	300	300	300	300	300	300	300	300	300	300	300	300	300	300	350	400	500	
150	300	350	350	350	350	350	350	350	350	350	350	350	350	350	350	350	400	500	500
175	350	400	400	400	400	400	400	400	400	400	400	400	400	400	400	400	500	500	500
200	400	500	500	500	500	500	500	500	500	500	500	500	500	500	500	500	500	500	500
250	500	600	600	600	600	600	600	600	600	600	600	600	600	600	600	600	600	600	600
300	600	700	700	700	700	700	700	700	700	700	700	700	700	700	700	700	700	700	700
350	700	800	800	800	800	800	800	800	800	800	800	800	800	800	800	800	800	800	800
400	700	800	800	800	800	800	800	800	800	800	800	800	800	800	800	800	800	800	800
450	900	1000	1000	1000	1000	1000	1000	1000	1000	1000	1000	1000	1000	1000	1000	1000	1000	1000	1000
500	1000	1200	1200	1200	1200	1200	1200	1200	1200	1200	1200	1200	1200	1200	1200	1200	1200	1200	1200

- ※ - Motor starting condition.
 - Six times the full load current: Within 10sec.
 - Starting rush current: Within 17times the full load current.
- Motor full load current: Indicate the full load current for standard type.
- "The motor having the largest output" includes motors simultaneously being started with this motor.

Insulating Distance from Line End

- When the earthed metal is installed between upper and lower parts of the breakers and on the line end of the breaker as shown in the right hand side figure, proper insulating distance should be kept as below table. This distance is necessary to get rid of arc gas exhausted from the line end, when the breaker would close the short-circuit current. As exposed conductor might cause short-circuit or earthing trouble due to drop of metal piece, abnormal surge voltage on the circuit, dust, metallic dust and salt, it is recommended that it be protected with insulating tube and insulating tape.

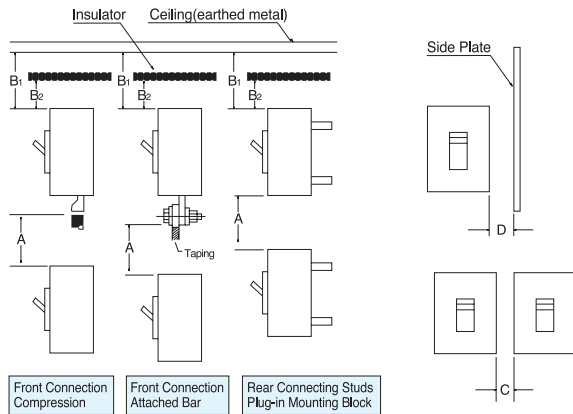

- A: Distance from lower breaker to open charging part of terminal no upper breaker (front connection), or from lower breaker to upper breaker end (rear connection studs and plug-in mounting block)
- B1: Distance from breaker end to ceiling
- B2: Distance from breaker end to insulator
- C: Interval between breakers
- D: Distance from the breaker side to the side plate (earthed metal).

Category	Applicable MCCB	A	B ₁	B ₂	C	D
		Vertical interval of breakers	Exposed ground metal	Insulator & painted plate		
General	HiBS30, HiBH30, HiBE50, HiBS50, HiBE60, HiBS60, HiBE100	75	50	30	Attachable	25
	HiBH50, HiBS100, HiBH100, HiBS100J, HiBH100J	80	50	30	Attachable	25
	HiBE225, HiBS225, HiBH225, HiBE250J, HiBS250J, HiBH250J	80	60	50	Attachable	40
	HiBE400, HiBS400, HiBH400, HiBL400, HiBE600, HiBS600, HiBH600, HiBL600, HiBE800, HiBS800, HiBH800, HiBL800	100	100	80	Attachable	80
Adjustable	HiBL50NT, HiBL100NT, HiBL50NE, HiBL100NE	80	50	30	Attachable	10
	HiBX50NT, HiBX100NT	80	50	30	Attachable	25
	HiBL225NT, HiBL225NE	100	100	70	Attachable	10
	HiBX225NT	100	100	70	Attachable	25
	HiBS400NE, HiBL400NE, HiBX400NE, HiBS600NE, HiBL600NE, HiBX600NE	120	100	80	Attachable	80
	HiBS800NE, HiBL800NE, HiBX800NE, HiBS1000NE, HiBL1000NE, HiBS1200NE, HiBL1200NE	150	120	80	Attachable	80

Mounting pose of ODP type MCCB

MCCB mounting limitation

MCCB type	Installation	Change in rated current values due to the change in mounting angles
HiBE50 (5, 10, 15, 20, 30, 40, 50A) HiBE60 (5, 10, 15, 20, 30, 40, 50, 60A) HiBE100 (5, 10, 15, 20, 30, 40, 50, 60, 75, 100A) HiBS30 (3, 5, 10, 15, 20, 30A) HiBS50 (5, 10, 15, 20, 30, 40, 50A) HiBS60 (5, 10, 15, 20, 30, 40, 50, 60A) HiBH30 (5, 10, 15, 20, 30A)	<p>Breakers are recommended to be mounted within $\pm 10^\circ$ of vertical plane, because the over current trip device can be affected by gravity.</p>	

Characteristic Curves & Dimensions | Fixed & Adjustable Thermal Type



- HiBS30
- HiBH30
- HiBE50
- HiBS50
- HiBE60
- HiBS60
- HiBE100

Time-current characteristic curves

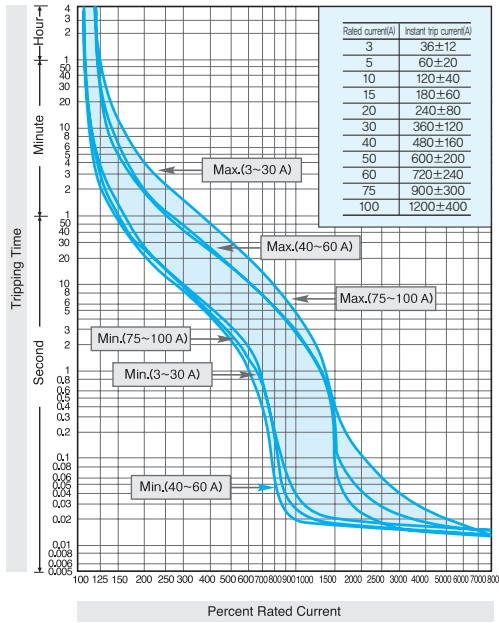

Ambient compensating curves

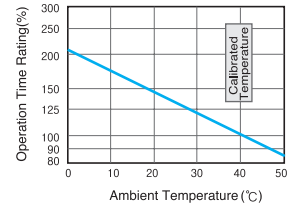

Dimensions

(Unit: mm)

Front-connected

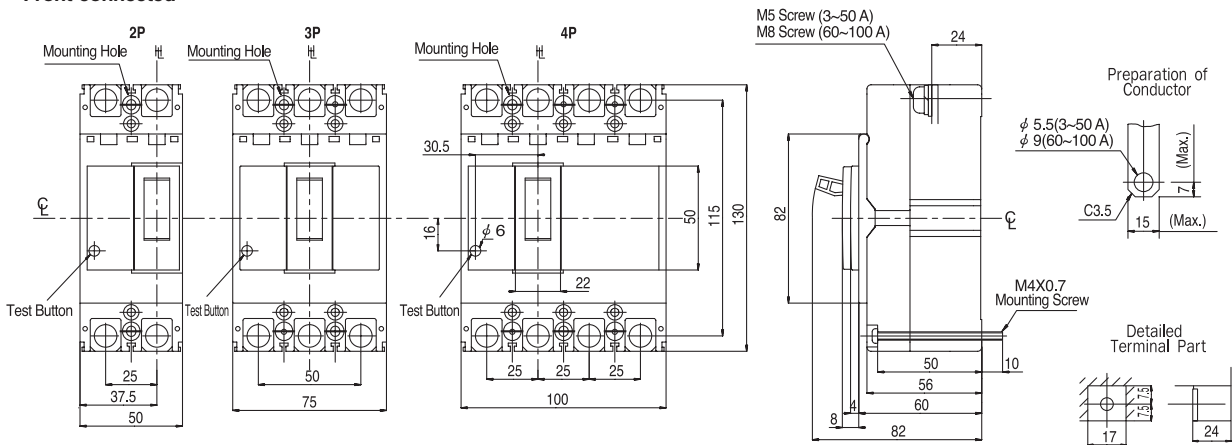

Drilling Plan

Panel Cut-out

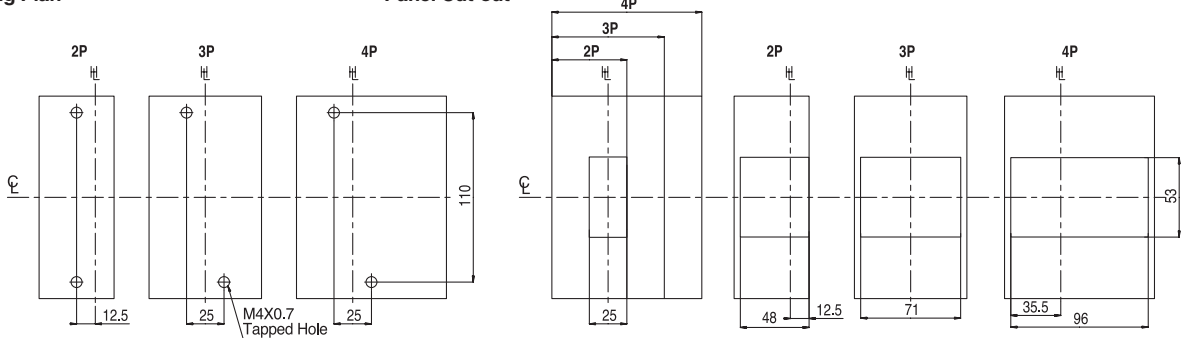

※ C: Center Line H: Handle Frame Center Line • Panel cut-out dimensions shown give an allowance of 1.5mm around the handle escutcheon.

Dimensions

(Unit: mm)

Plug-in

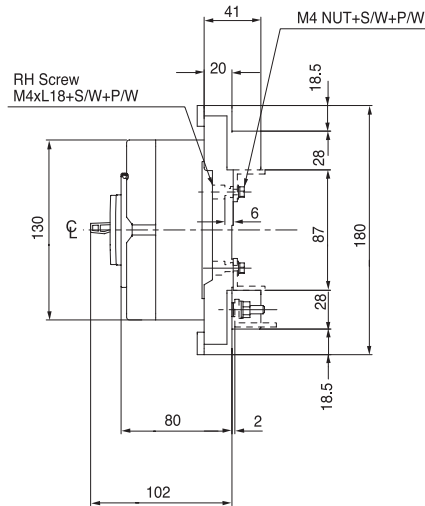
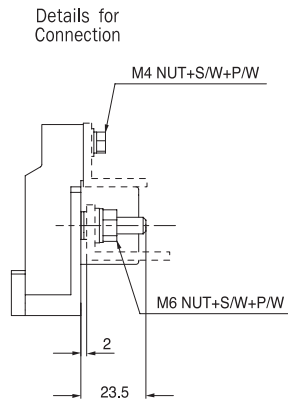

Mounting Block

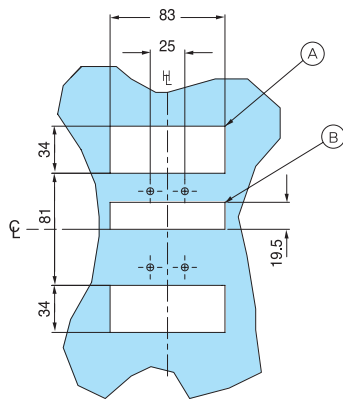
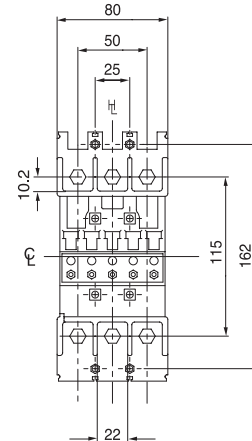

Drilling Plan

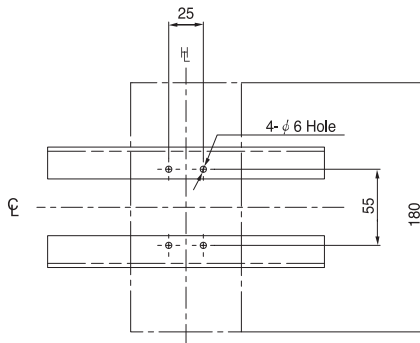

Preparation of Conductor

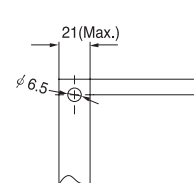

- Ⓐ : Cut-out before assembly of bus bar
- Ⓑ : It is required when combinations of internally mounted accessories.

※ C: Center Line H: Handle Frame Center Line

Combinations of internally mounted accessories

NO. Pole	AUX Auxiliary Switch	ALT Alarm Switch	SHT Shunt Trip	UVT Under-Voltage Trip	AUX ALT	AUX SHT	AUX UVT	ALT SHT	ALT UVT	AXT SHT	AXT UVT
3											

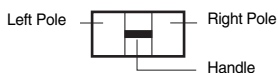

- ※ - AXT is equivalent with AUX and ALT.
- AUX, ALT, AXT, SHT, UVT in a 2 pole-type breaker should be installed into the left pole.
- UVT installation in the 2 pole-type breaker that the middle pole of a 3 pole-type breaker is removed is equal to the 3 pole-type breaker.
- Operating voltage of UVT is of DC rated voltage.

Characteristic Curves & Dimensions | Fixed & Adjustable Thermal Type



- HiBH50
- HiBS100
- HiBH100
- HiBS100J
- HiBH100J

Time-current characteristic curves

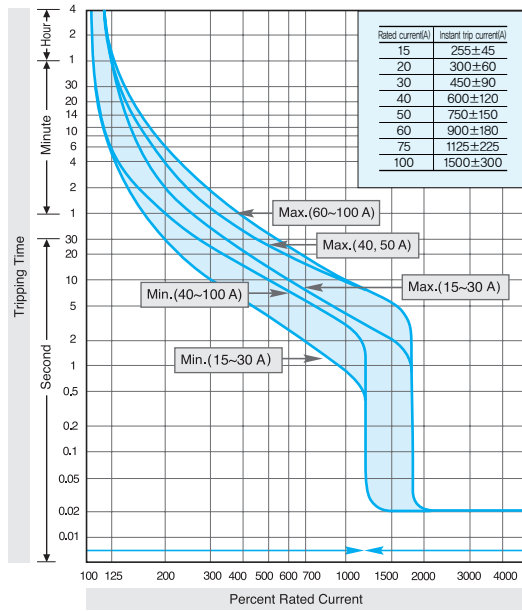

Ambient compensating curves

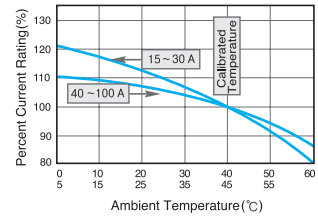

Dimensions

(Unit: mm)

Front-connected

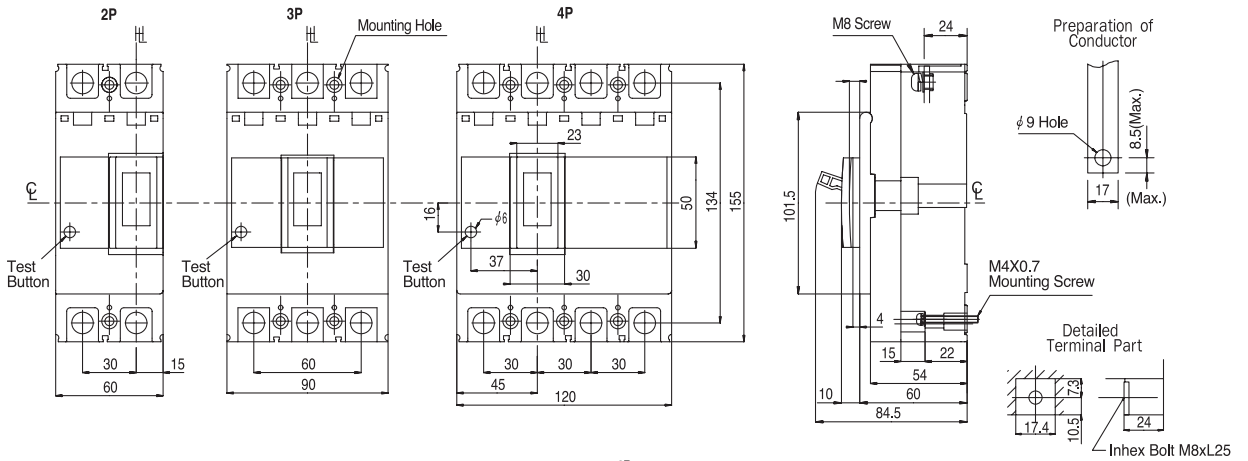

Drilling Plan

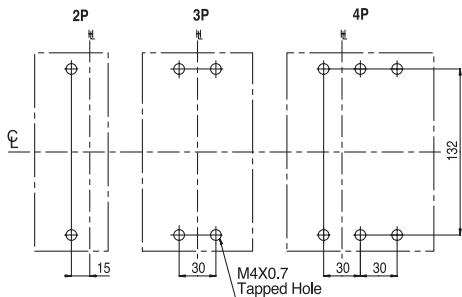

Panel Cut-out

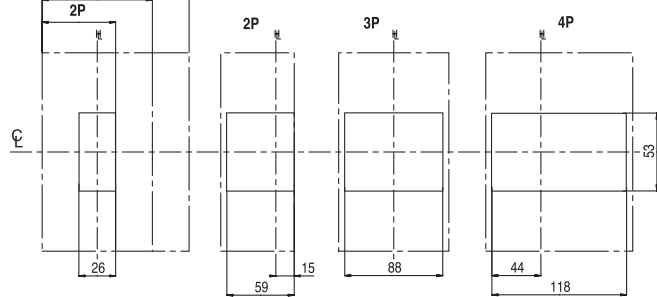

※ C: Center Line H: Handle Frame Center Line • Panel cut-out dimensions shown give an allowance of 1.5mm around the handle escutcheon.

Dimensions

(Unit: mm)

Plug-in

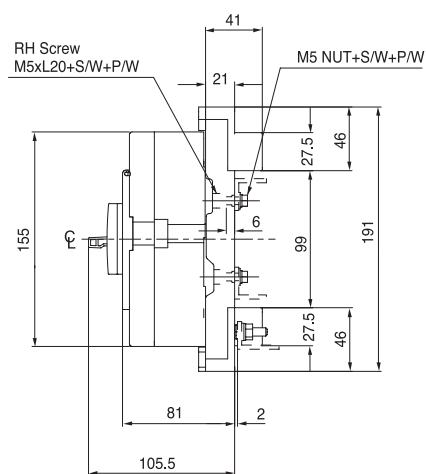
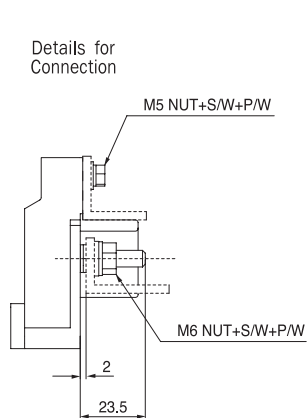

Mounting Block

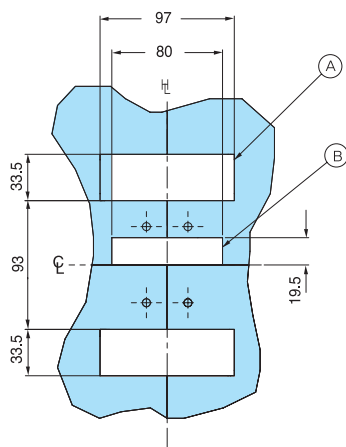
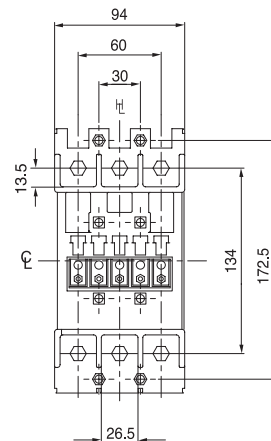

Drilling Plan

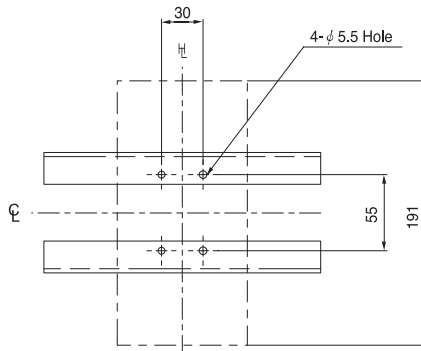

Preparation of Conductor

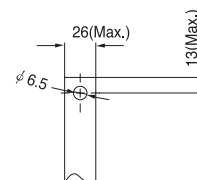

- Ⓐ : Cut-out before assembly of Bus bar
- Ⓑ : It is required when combinations of internally mounted accessories.

※ \odot : Center Line \parallel : Handle Frame Center Line

Combinations of internally mounted accessories

NO. Pole	AUX Auxiliary Switch	ALT Alarm Switch	SHT Shunt Trip	UVT Under-Voltage Trip	AXT	AUX SHT	AUX UVT	ALT SHT	ALT UVT	AXT SHT	AXT UVT
3											

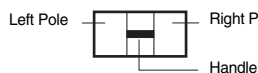

- ※ - AXT is equivalent with AUX and ALT.
- AUX, ALT, AXT, SHT, UVT in a 2 pole-type breaker should be installed into the left pole.
- UVT installation in the 2 pole-type breaker that the middle pole of a 3 pole-type breaker is removed is equal to the 3 pole-type breaker.
- Operating voltage of UVT is of DC rated voltage.

Characteristic Curves & Dimensions | Fixed & Adjustable Thermal Type



- HiBE225
- HiBS225
- HiBH225
- HiBE250J
- HiBS250J
- HiBH250J

Time-current characteristic curves

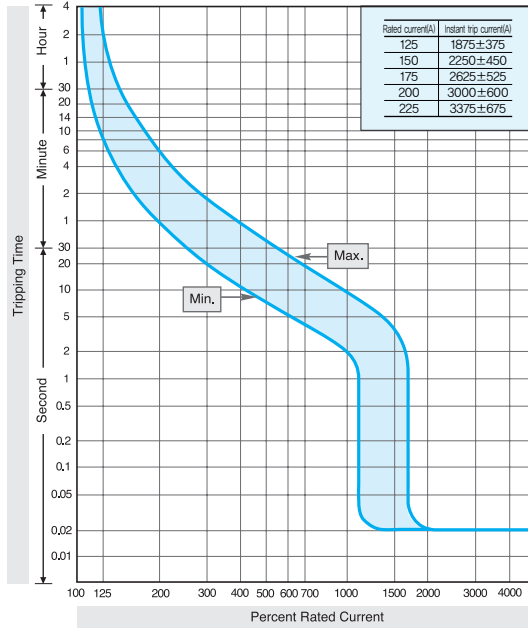

Ambient compensating curves

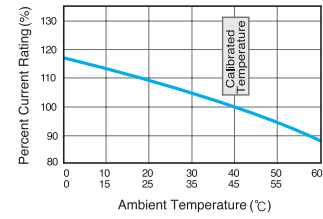

Dimensions

(Unit: mm)

Front-connected

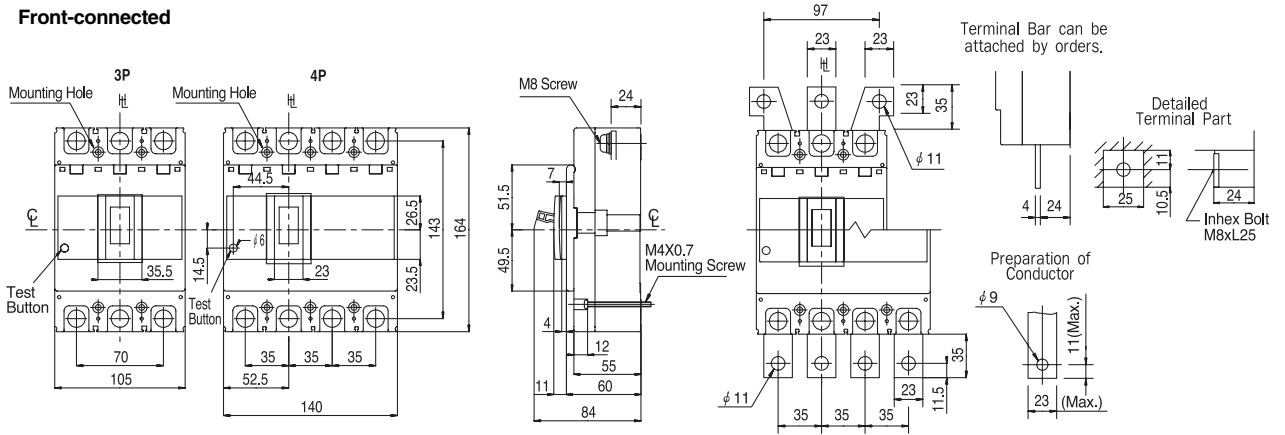

Drilling Plan

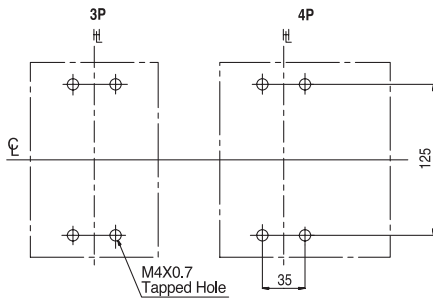

Panel Cut-out

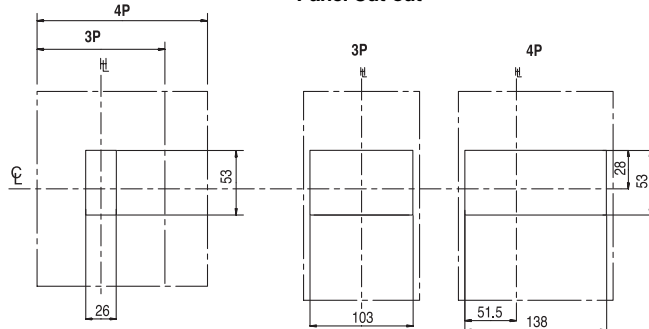

※ C: Center Line H: Handle Frame Center Line • Panel cut-out dimensions shown give an allowance of 1.5mm around the handle escutcheon.

Dimensions

(Unit: mm)

Plug-in

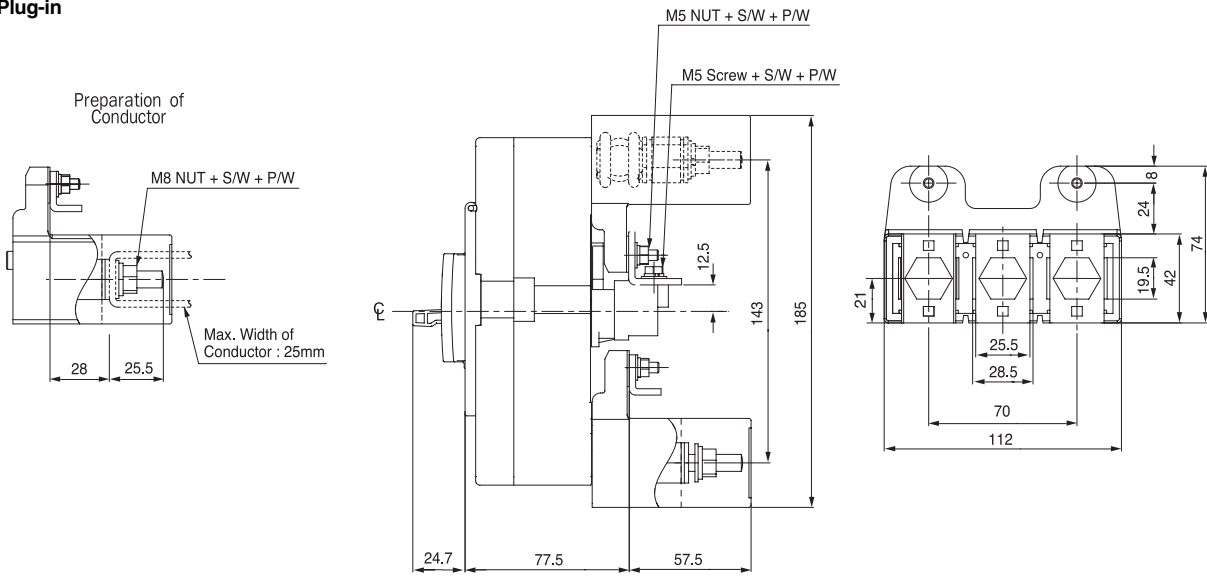

Drilling Plan

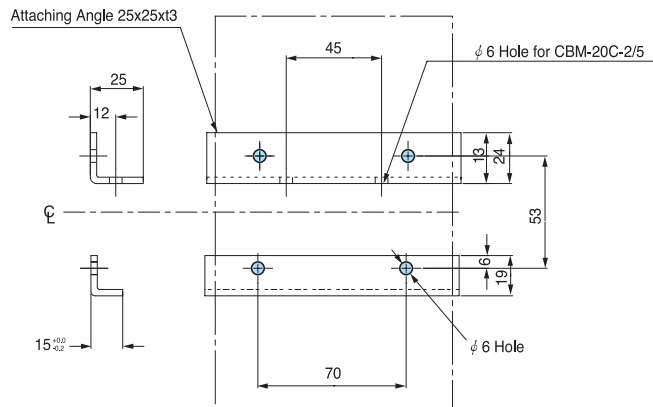

※ C : Center Line H : Handle Frame Center Line

Combinations of internally mounted accessories

NO. Pole	AUX Auxiliary Switch	ALT Alarm Switch	SHT Shunt Trip	UVT Under-Voltage Trip	AXT	AUX SHT	AUX UVT	ALT SHT	ALT UVT	AXT SHT	AXT UVT
3											

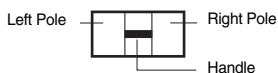

- ※ - AXT is equivalent with AUX and ALT.
- AUX, ALT, AXT, SHT, UVT in a 2 pole-type breaker should be installed into the left pole.
- UVT installation in the 2 pole-type breaker that the middle pole of a 3 pole-type breaker is removed is equal to the 3 pole-type breaker.
- Operating voltage of UVT is of DC rated voltage.

Characteristic Curves & Dimensions | Fixed & Adjustable Thermal Type



- HiBE400
- HiBS400
- HiBH400
- HiBL400

Time-current characteristic curves

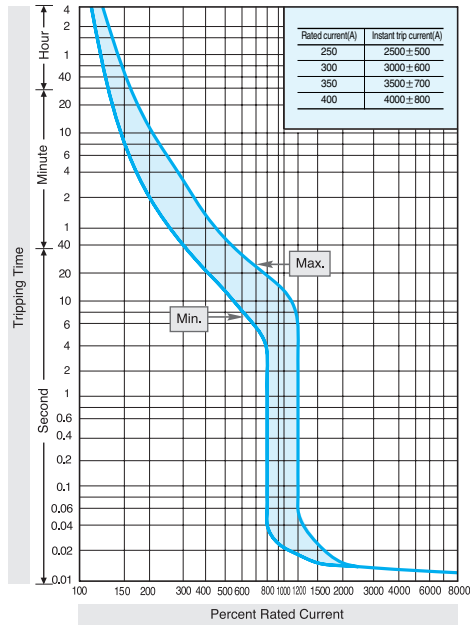

Ambient compensating curves

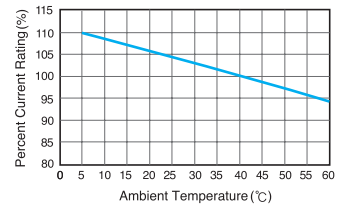

Dimensions

(Unit: mm)

Front-connected

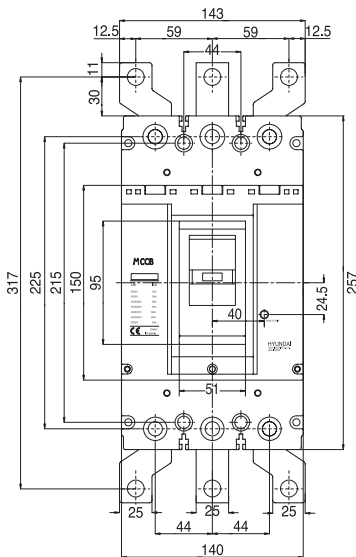

Detailed Terminal Part

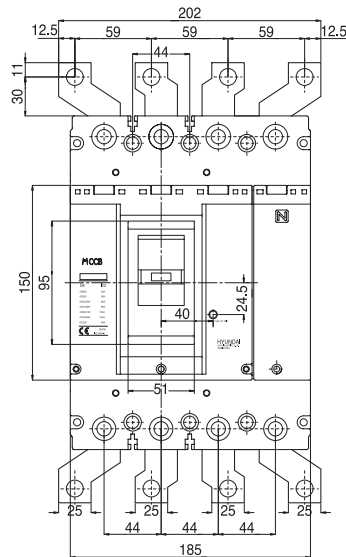
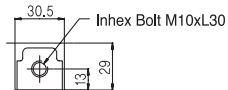

Preparation of Conductor

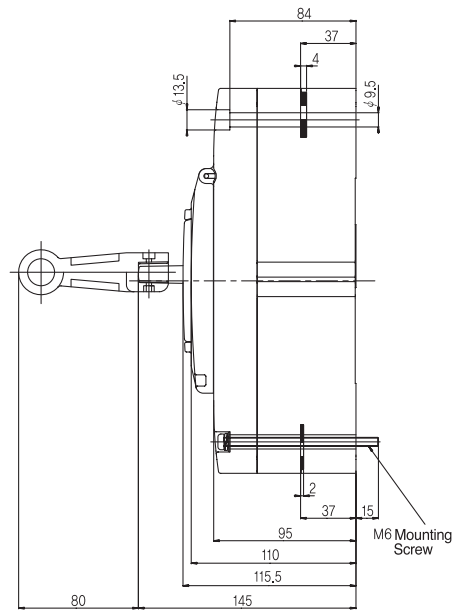
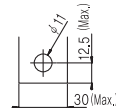

※ C: Center Line H: Handle Frame Center Line

Dimensions

(Unit: mm)

Drilling Plan

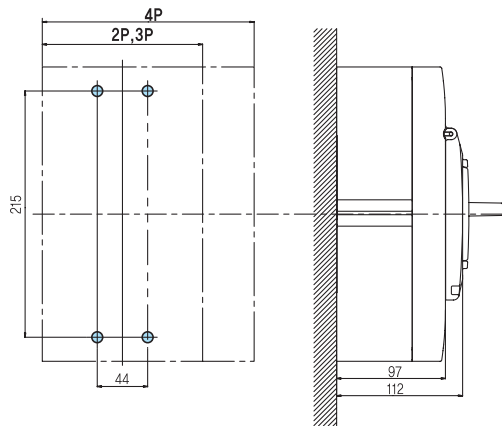

Panel Cut-out

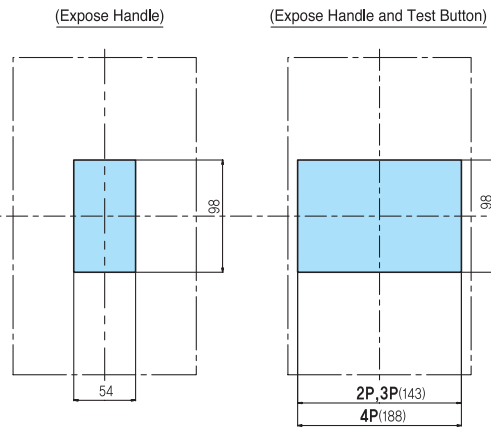

Plug-in

Mounting Block

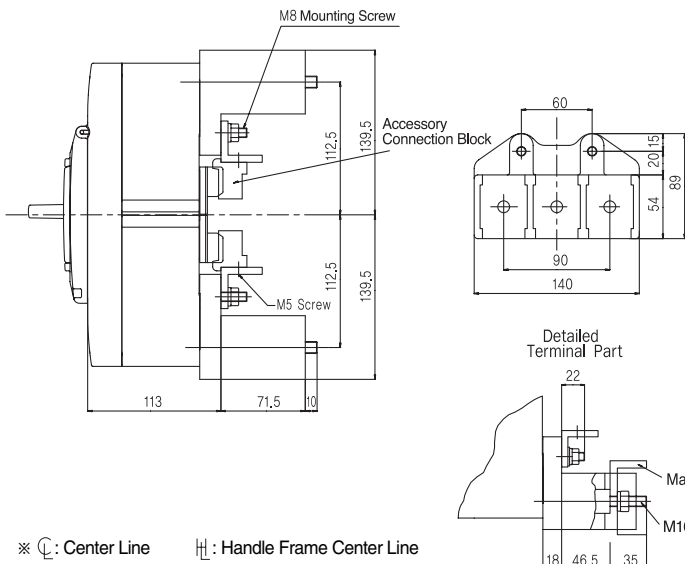

Drilling Plan

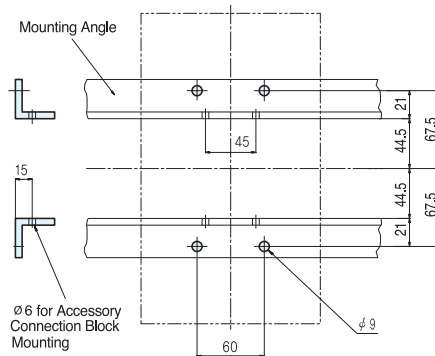

※ C: Center Line H: Handle Frame Center Line

Combinations of internally mounted accessories

NO. Pole	AUX Auxiliary Switch	ALT Alarm Switch	SHT Shunt Trip	UVT Under-Voltage Trip	AUX ALT	AUX SHT	AUX UVT	ALT SHT	ALT UVT	AUX ALT SHT	AUX ALT UVT
3											

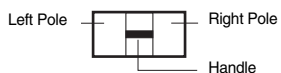

- ※ - AXT is equivalent with AUX and ALT.
- AUX, ALT, AXT, SHT, UVT in a 2 pole-type breaker should be installed into the left pole.
- UVT installation in the 2 pole-type breaker that the middle pole of a 3 pole-type breaker is removed is equal to the 3 pole-type breaker.
- Operating voltage of UVT is of DC rated voltage.

Characteristic Curves & Dimensions | Fixed & Adjustable Thermal Type



- HiBE600
- HiBS600
- HiBH600
- HiBL600

Time-current characteristic curves

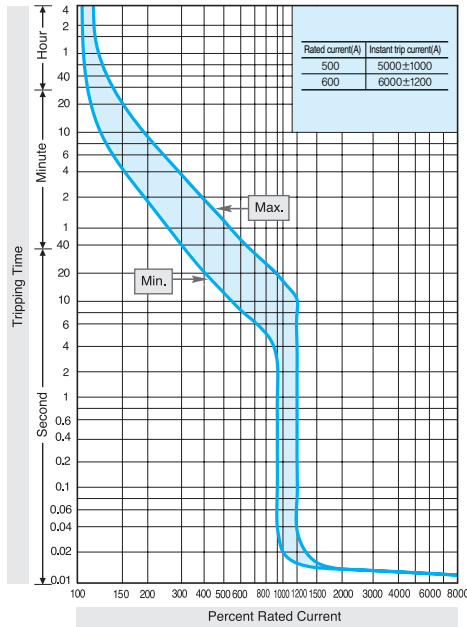

Ambient compensating curves

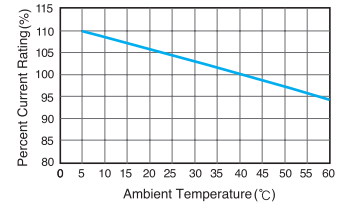

Dimensions

(Unit: mm)

Front-connected

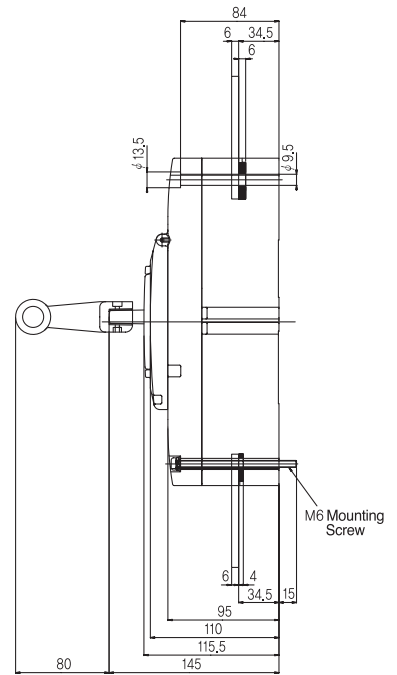
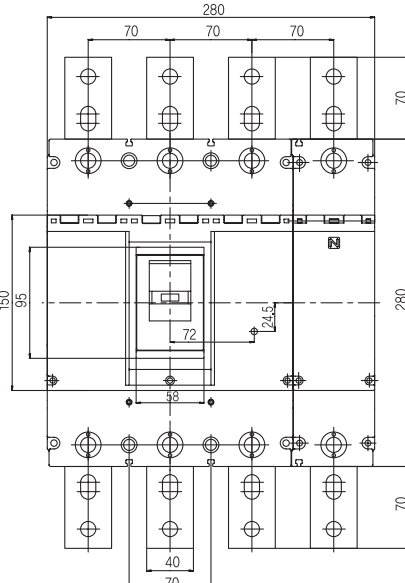
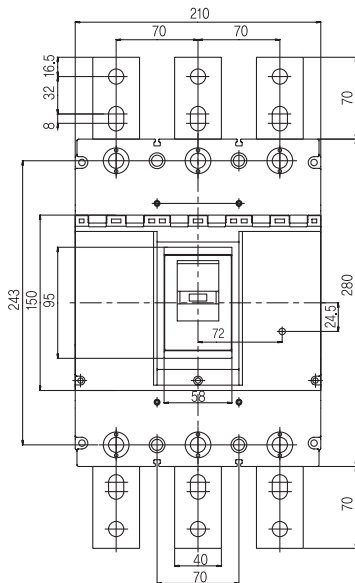

Detailed Terminal Part

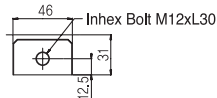

Preparation of Conductor



※ C : Center Line H : Handle Frame Center Line

Dimensions

(Unit: mm)

Drilling Plan

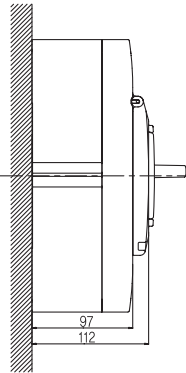
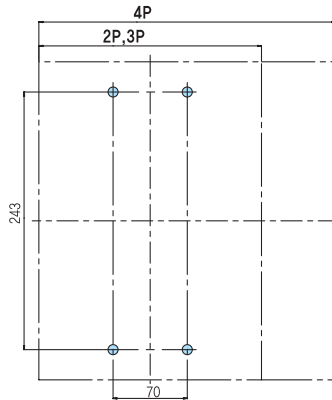

Panel Cut-out

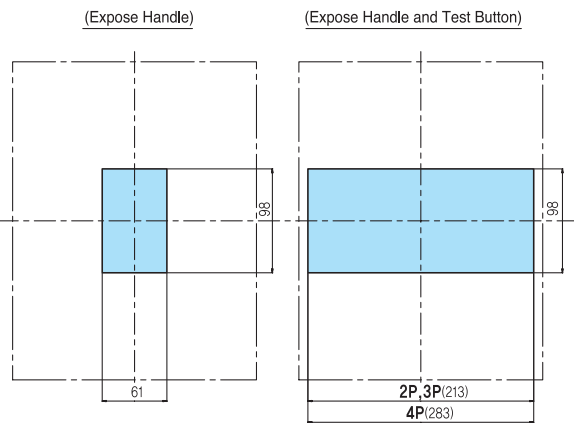

Plug-in

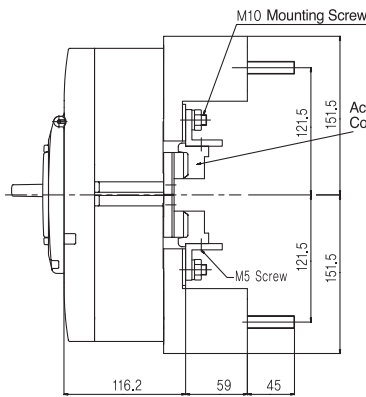

Mounting Block

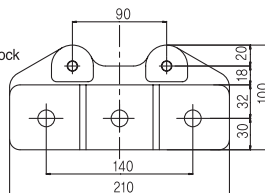

Detailed Terminal Part

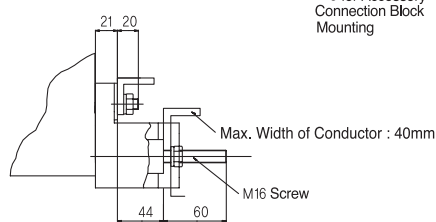

Drilling Plan

"A" Type(Expose Handle)

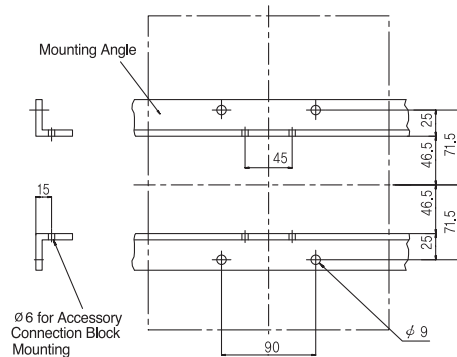

※ C: Center Line H: Handle Frame Center Line

Combinations of internally mounted accessories

NO. Pole	AUX Auxiliary Switch	ALT Alarm Switch	SHT Shunt Trip	UVT Under-Voltage Trip	AUX ALT	AUX SHT	AUX UVT	ALT SHT	ALT UVT	AUX ALT SHT	AUX ALT UVT
3											

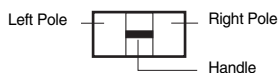

- ※ - AXT is equivalent with AUX and ALT.
- AUX, ALT, AXT, SHT, UVT in a 2 pole-type breaker should be installed into the left pole.
- UVT installation in the 2 pole-type breaker that the middle pole of a 3 pole-type breaker is removed is equal to the 3 pole-type breaker.
- Operating voltage of UVT is of DC rated voltage.

Characteristic Curves & Dimensions | Fixed & Adjustable Thermal Type



- HiBE800
- HiBS800
- HiBH800
- HiBL800

Time-current characteristic curves

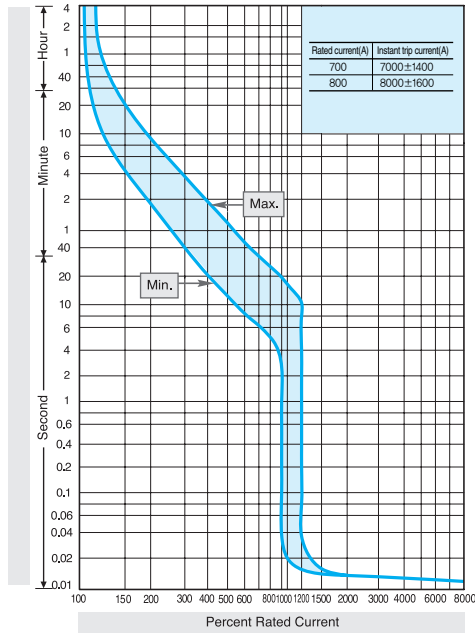

Ambient compensating curves

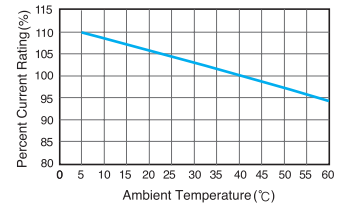

Dimensions

(Unit: mm)

Front-connected

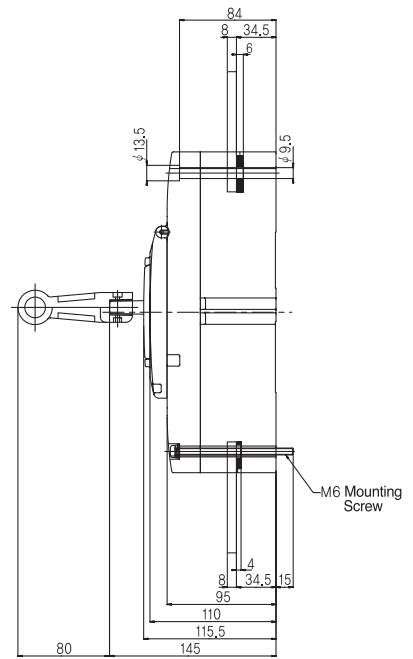
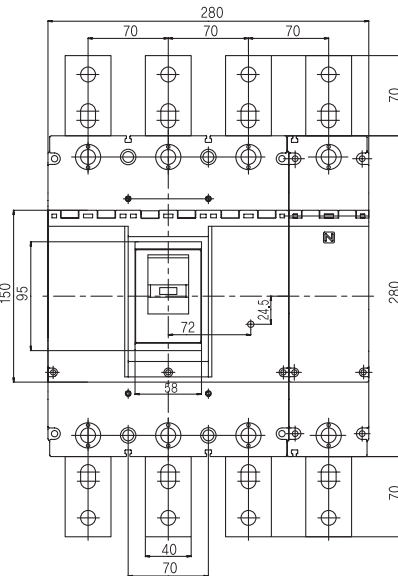
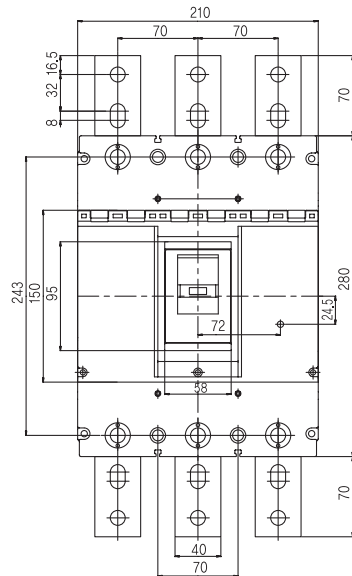

Detailed Terminal Part

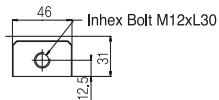

Preparation of Conductor



※ C : Center Line H : Handle Frame Center Line

Dimensions

(Unit: mm)

Drilling Plan

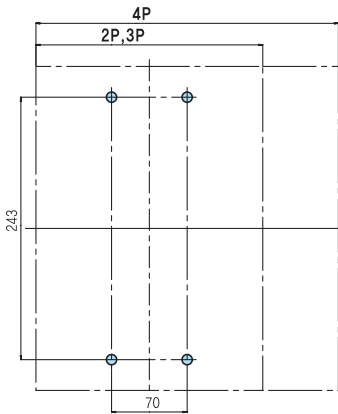

Panel Cut-out

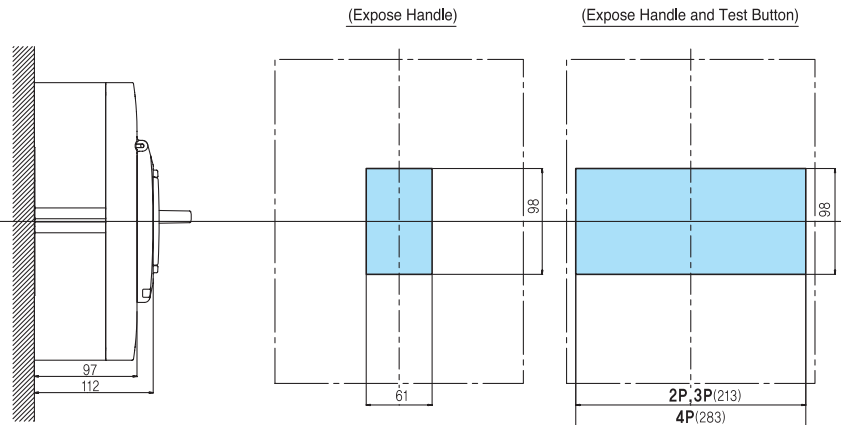

Plug-in

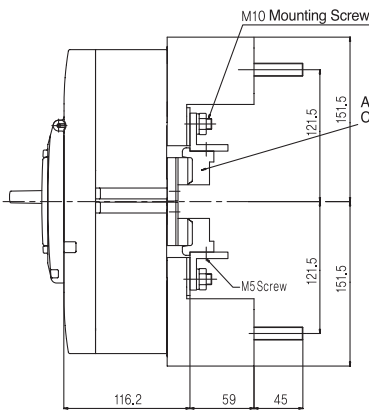

Mounting Block

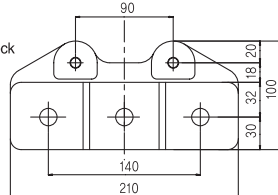

Detailed Terminal Part

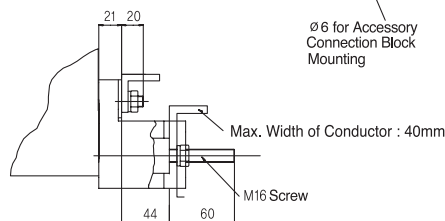

Drilling Plan

"A" Type(Expose Handle)

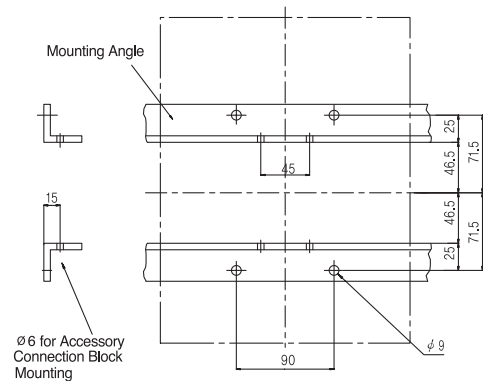

※ C: Center Line H: Handle Frame Center Line

Combinations of internally mounted accessories

NO. Pole	AUX Auxiliary Switch	ALT Alarm Switch	SHT Shunt Trip	UVT Under-Voltage Trip	AUX ALT	AUX SHT	AUX UVT	ALT SHT	ALT UVT	AUX ALT SHT	AUX ALT UVT
3											

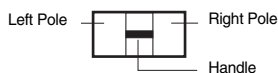

- ※ - AXT is equivalent with AUX and ALT.
- AUX, ALT, AXT, SHT, UVT in a 2 pole-type breaker should be installed into the left pole.
- UVT installation in the 2 pole-type breaker that the middle pole of a 3 pole-type breaker is removed is equal to the 3 pole-type breaker.
- Operating voltage of UVT is of DC rated voltage.

Characteristic Curves & Dimensions | Fixed & Adjustable Thermal Type



- *HiBL50NT*
- *HiBX50NT*
- *HiBL100NT*
- *HiBX100NT*
- *HiBL225NT*
- *HiBX225NT*

Time-current characteristic curves

15-30A

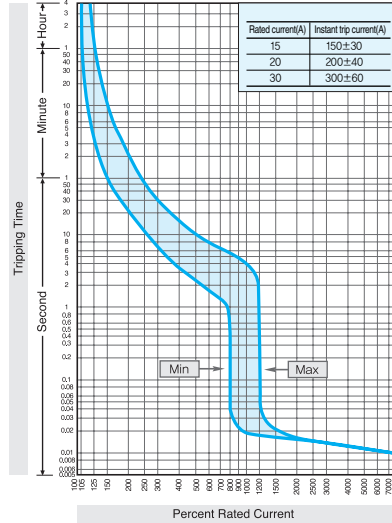

40-50A

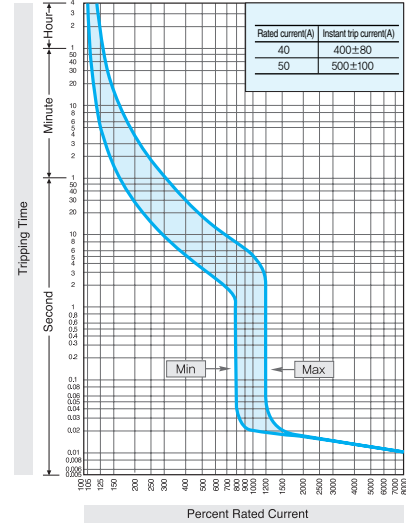

60-100A

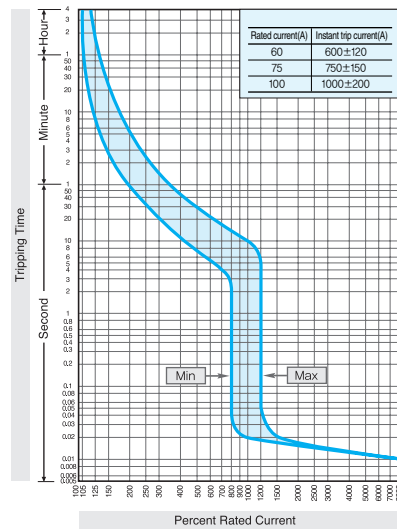

125-175A

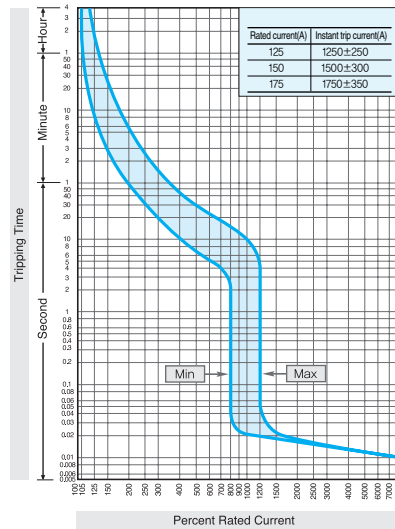

200-225A

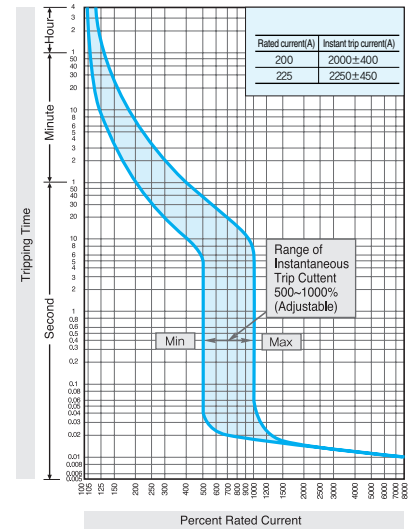

Ambient compensating curves

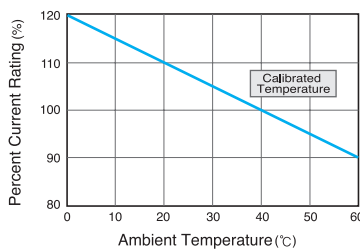

Dimensions

(Unit: mm)

Front-connected

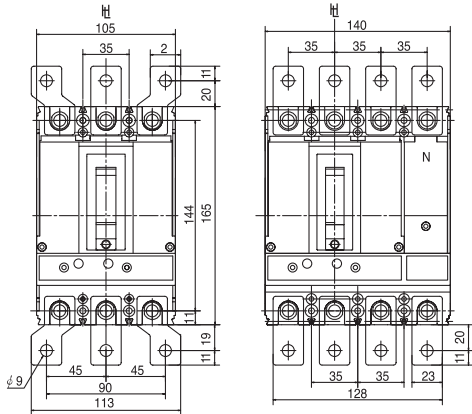

Drilling Plan

Panel Cut-out

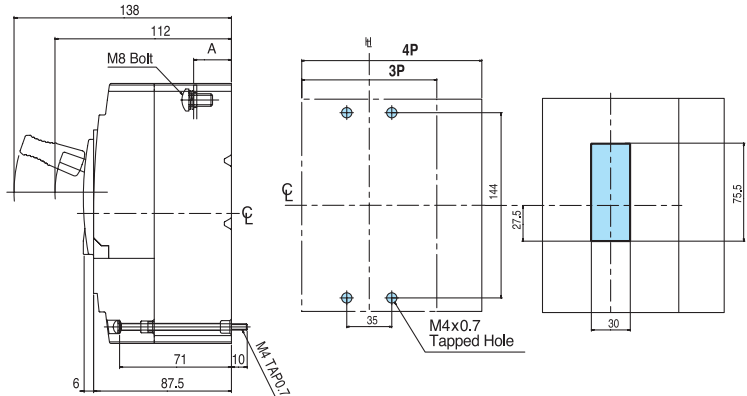

Preparation of Conductor

Detailed Terminal Part

Terminal Bar can be attached by orders.

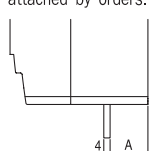
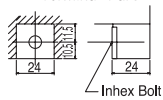
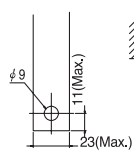

※ A: Terminal Part Height
Line : 24mm(50/100AF)
26mm(225AF)
Load : 24mm(50/100/225AF)

Plug-in

Mounting Block

Panel Cut-out

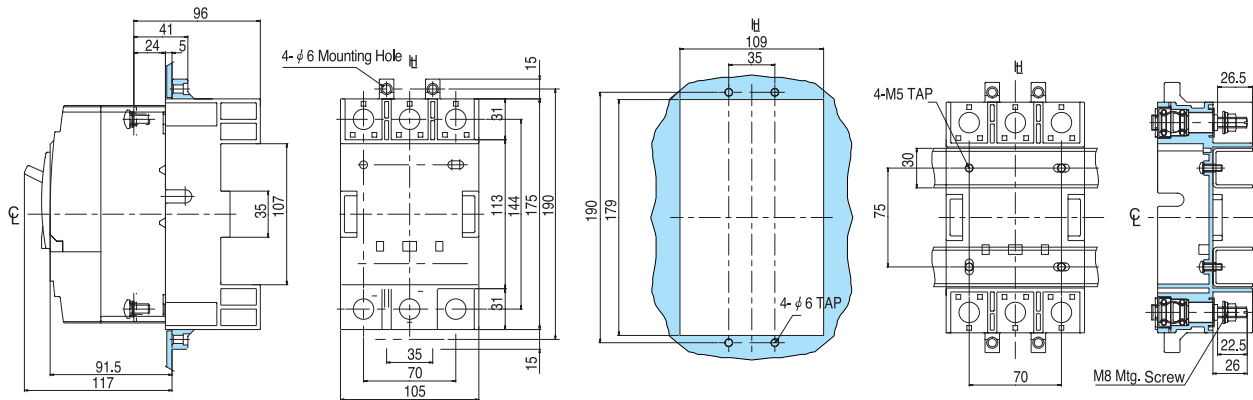

※ C: Center Line

H: Handle Frame Center Line

• Panel cut-out dimensions shown give an allowance of 1.5mm around the handle escutcheon.

Combinations of internally mounted accessories

NO. Pole	AUX Auxiliary Switch	ALT Alarm Switch	SHT Shunt Trip	UVT Under-Voltage Trip	AUX ALT	AUX SHT	AUX UVT	ALT SHT	ALT UVT	AXT SHT	AXT UVT
3											



※ AXT is equivalent with AUX and ALT.

Characteristic Curves & Dimensions | Electronic Type



- HiBL50NE
- HiBL100NE
- HiBL225NE

Time-current characteristic curves / 40 - 225A

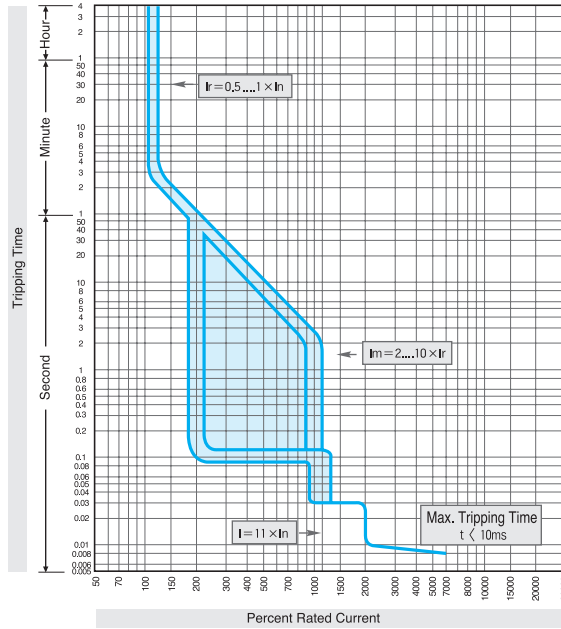

Dimensions

(Unit: mm)

Front-connected

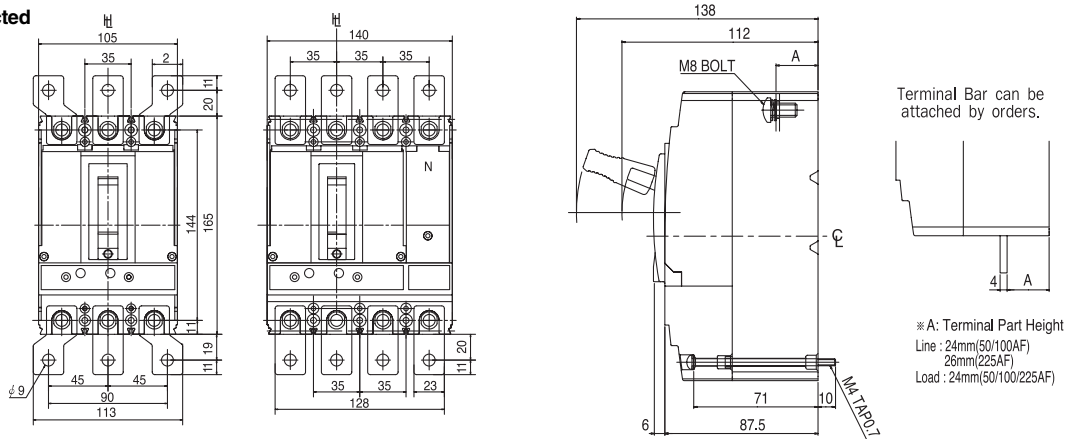

Drilling Plan

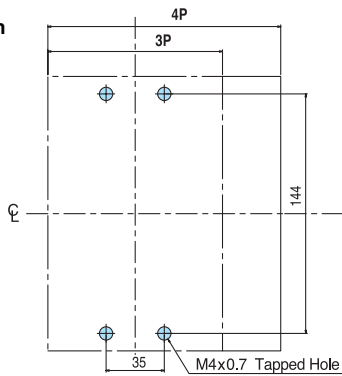

Panel Cut-out

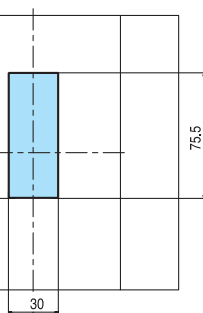

Preparation of Conductor

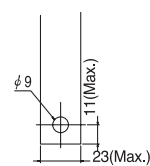

Detailed Terminal Part

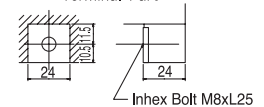

* ϕ : Center Line H_L : Handle Frame Center Line • Panel cut-out dimensions shown give an allowance of 1.5mm around the handle escutcheon.

Dimensions

(Unit: mm)

Plug-in

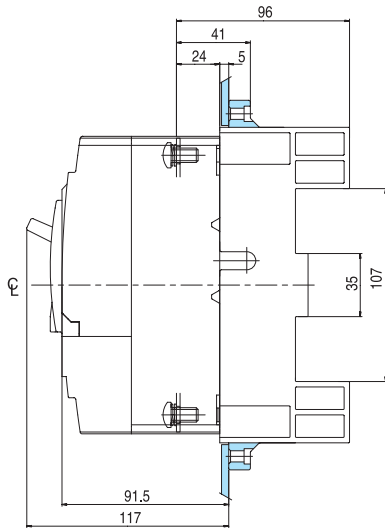

Mounting Block

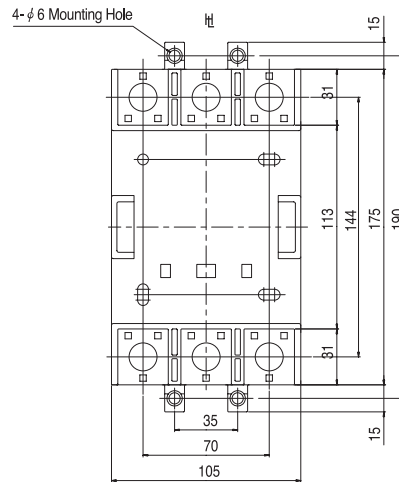

Panel Cut-out

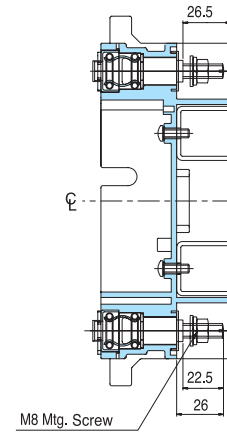
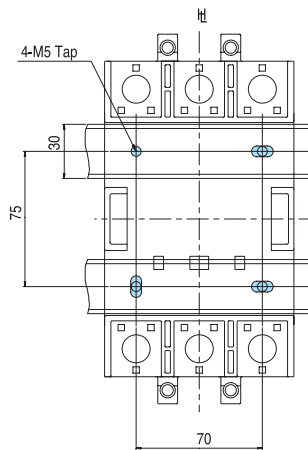
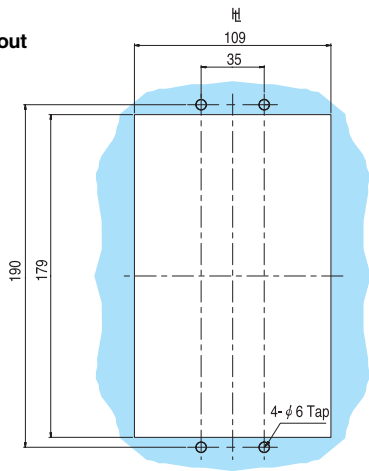

※ \ominus : Center Line \parallel : Handle Frame Center Line

Combinations of internally mounted accessories

NO. Pole	AUX Auxiliary Switch	ALT Alarm Switch	SHT Shunt Trip	UVT Under-Voltage Trip	AUX ALT	AUX SHT	AUX UVT	ALT SHT	ALT UVT	AXT SHT	AXT UVT
3											

Left Pole Right Pole ※ AXT is equivalent with AUX and ALT.
Handle

Characteristic Curves & Dimensions | Electronic Type



- HiBS400NE
- HiBL400NE
- HiBX400NE

Time-current characteristic curves / 200 - 400A

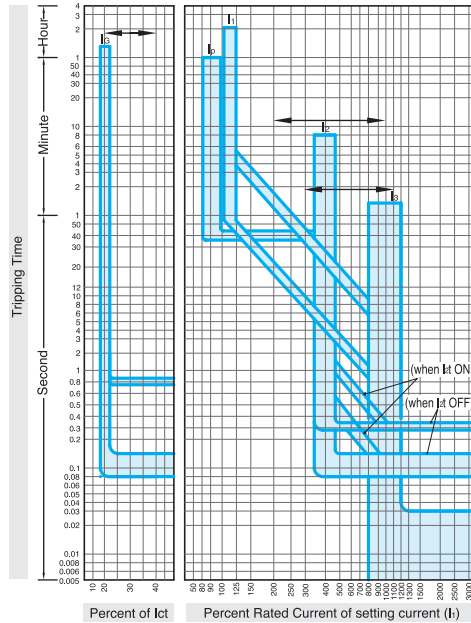

Over current characteristic

CT rated current (A): (I _{CT})	400
Setting rated current (A): (I ₁) (Adjustable)	200, 215, 225, 240, 250, 255, 270, 290, 300, 320, 340, 360, 380, 400
Trip time for long time trip (S): (T ₁)	Adjustable 2, 4, 6, 8, 12sec. for (I ₁)x600% current Tolerance ±20%
Setting current for short time trip (A): (I ₂)	Adjustable (I ₁)x200, 400, 600, 800, 1000% Tolerance ±15%
Setting time for short time trip (S): (T ₂)	Adjustable 0.1, 0.2, 0.3sec. for the definite time trip characteristic. Trip range is between (setting time -20ms) and (setting time +50ms)
Setting current for instantaneous (A): (I ₃)	Adjustable (I _{CT})x300, 600, 800, 1000, 1100% Tolerance ±20%
Setting current for ground fault trip (A): (I _g)	Adjustable (I _{CT})x0.1, 0.2, 0.3, 0.4 Tolerance ±15%
Setting time for ground fault trip (S): (T _g)	Adjustable 0.1, 0.2, 0.3, 0.4, 0.8 sec. for the definite time trip characteristic Trip range is between (setting time -20ms) and (setting time +50ms)
Setting current for PTA (A): (I _g) ^{Option}	(I ₁)x90% Tolerance ±10%
Setting time for PTA (S): (T _g) ^{Option}	Definite time trip characteristic of 40sec. Tolerance ±10%

※ " " is default setting. If required, please adjust the setting according to "adjustable table".

Dimensions

(Unit: mm)

Front-connected

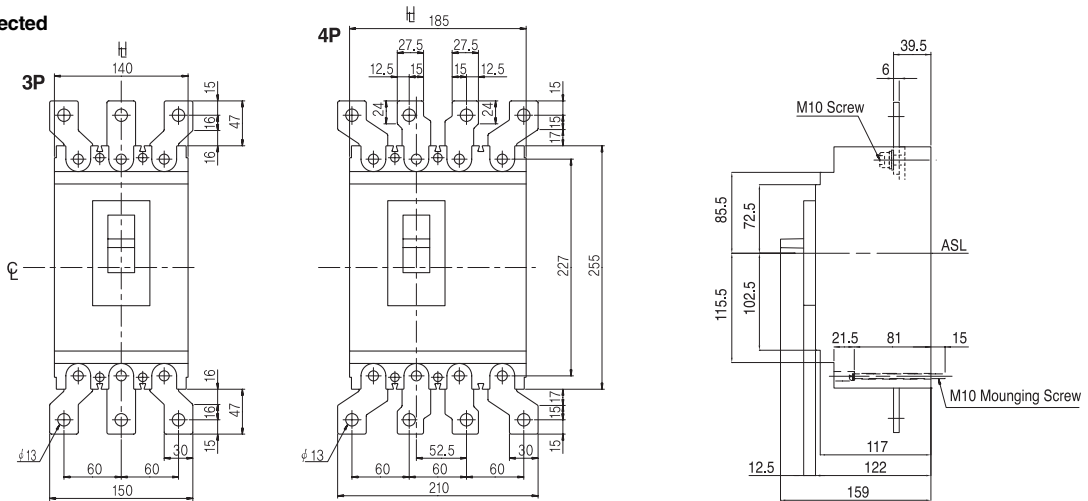

Drilling Plan

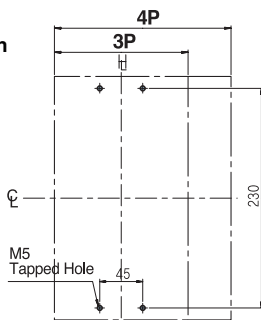

Panel Cut-out

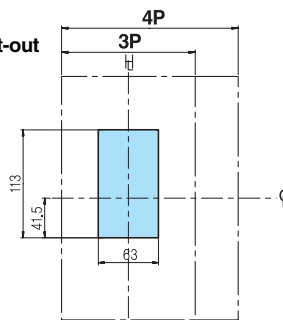

Preparation of Conductor

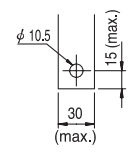

Details for Connection

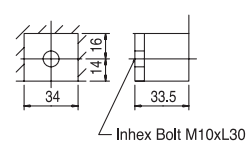

※ C: Center Line H: Handle Frame Center Line

• Panel cut-out dimensions shown give an allowance of 1.5mm around the handle escutcheon.

Dimensions

(Unit: mm)

Plug-in

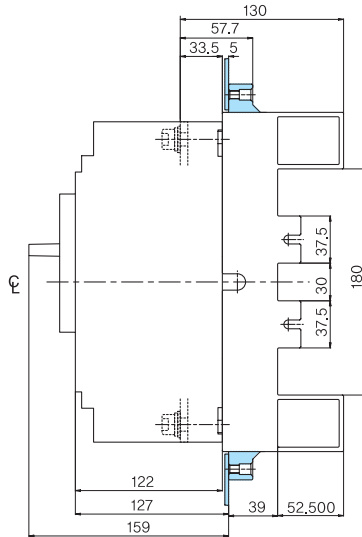

Mounting Block

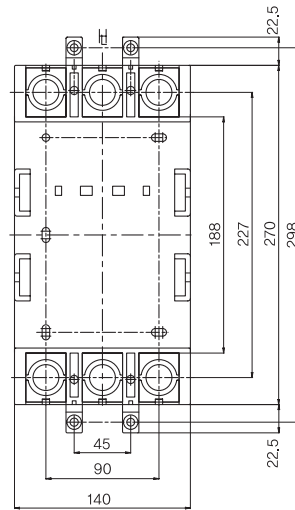

Panel Cut-out

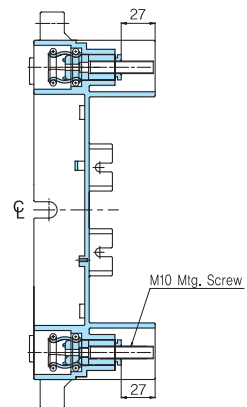
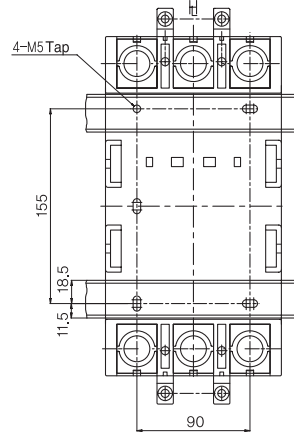
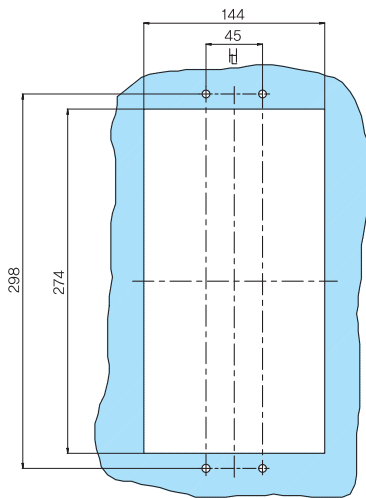

※ \ominus : Center Line H : Handle Frame Center Line

Combinations of internally mounted accessories

NO. Pole	AUX Auxiliary Switch	ALT Alarm Switch	SHT Shunt Trip	UVT Under-Voltage Trip	AUX ALT	AUX SHT	AUX UVT	ALT SHT	ALT UVT	AUX ALT SHT	AUX ALT UVT
3											

Left Pole Right Pole ※ AXT is equivalent with AUX and ALT.
Handle

Characteristic Curves & Dimensions | Electronic Type



- HiBS600NE
- HiBL600NE
- HiBX600NE

Time-current characteristic curves / 302 - 600A

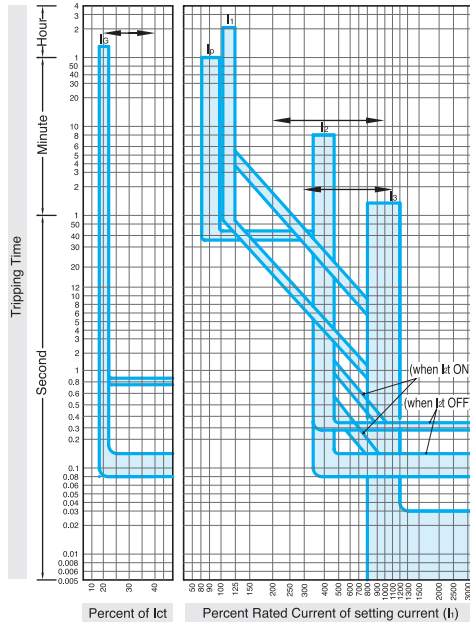

Over current characteristic

CT rated current (A): (I_{ct})	600
Setting rated current (A): (I_1) (Adjustable)	302, 320, 340, 360, 380, 385, 410, 430, 455, 480, 510, 540, 570, 600
Trip time for long time trip (S): (T_1)	Adjustable 2, 4, 6, 8 12sec. for (I_1)x600% current Tolerance $\pm 20\%$
Setting current for short time trip (A): (I_2)	Adjustable (I_1)x200, 400, 600, 800, 1000% Tolerance $\pm 15\%$
Setting time for short time trip (S): (T_2)	Adjustable 0.1, 0.2, 0.3 sec. for the definite time trip characteristic. Trip range is between (setting time -20ms) and (setting time +50ms)
Setting current for instantaneous (A): (I_3)	Adjustable (I_{ct})x300, 600, 800, 1000, 1100% Tolerance $\pm 20\%$
Setting current for ground fault trip (A): (I_4)	Adjustable (I_{ct})x0.1, 0.2, 0.3, 0.4 Tolerance $\pm 15\%$
Setting time for ground fault trip (S): (T_3)	Adjustable 0.1, 0.2, 0.3, 0.4, 0.8 sec. for the definite time trip characteristic Trip range is between (setting time -20ms) and (setting time +50ms)
Setting current for PTA (A): (I_5) ^{Option}	(I_1)x90% Tolerance $\pm 10\%$
Setting time for PTA (S): (T_4) ^{Option}	Definite time trip characteristic of 40sec. Tolerance $\pm 10\%$

※ " " is default setting. If required, please adjust the setting according to "adjustable table".

Dimensions

(Unit: mm)

Front-connected

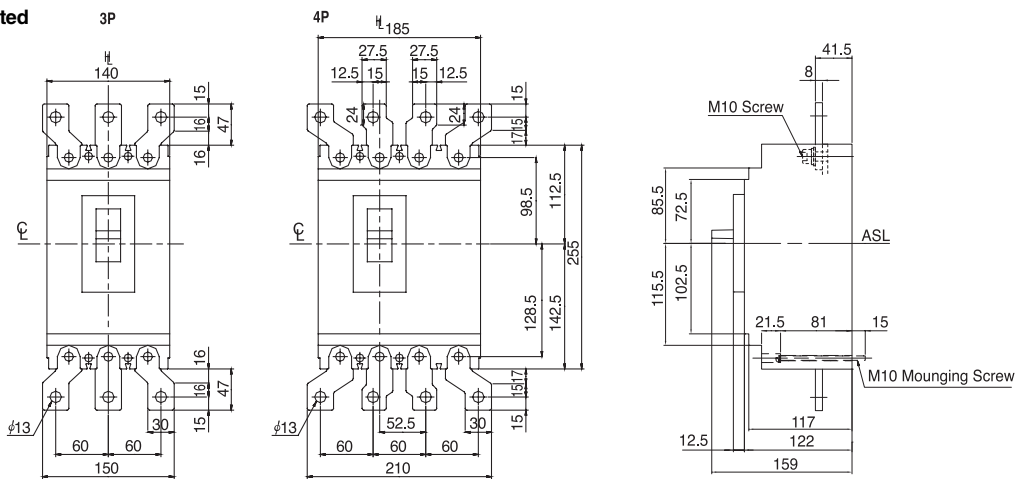

Drilling Plan

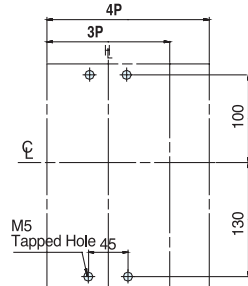

Panel Cut-out

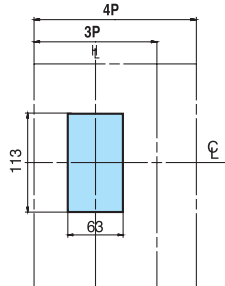

Preparation of Conductor

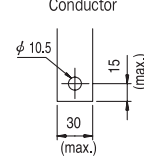

Detailed Terminal Part

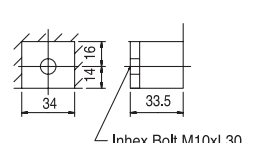

※ ϕ : Center Line \parallel : Handle Frame Center Line

• Panel cut-out dimensions shown give an allowance of 1.5mm around the handle escutcheon.

Dimensions

(Unit: mm)

Plug-in

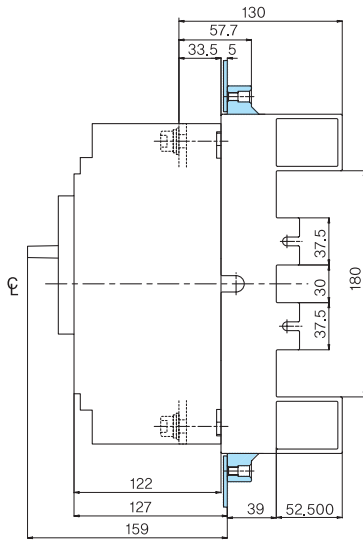

Mounting Block

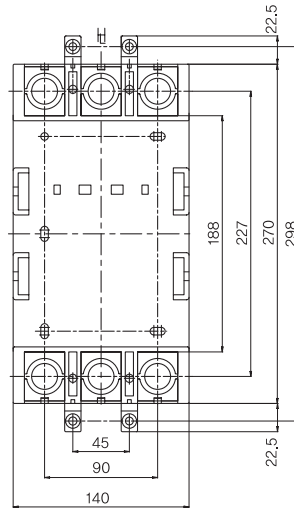

Panel Cut-out

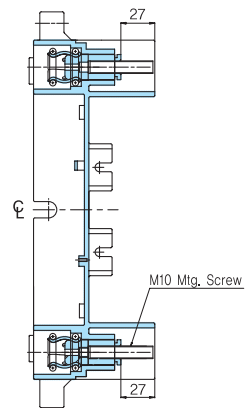
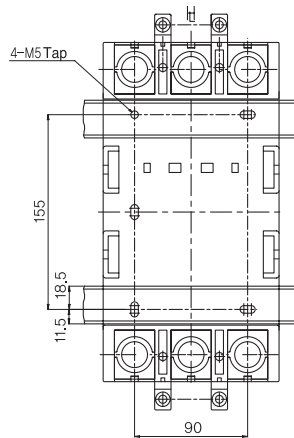
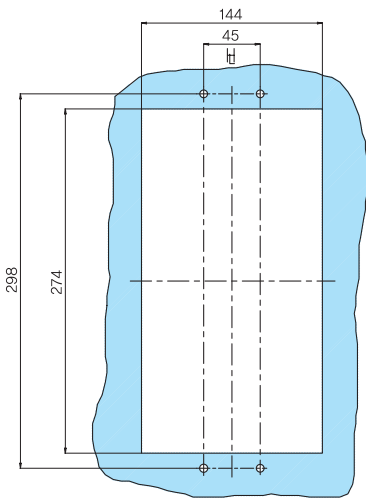

※ C: Center Line H: Handle Frame Center Line

Combinations of internally mounted accessories

NO. Pole	AUX Auxiliary Switch	ALT Alarm Switch	SHT Shunt Trip	UVT Under-Voltage Trip	AUX ALT	AUX SHT	AUX UVT	ALT SHT	ALT UVT	AUX ALT SHT	AUX ALT UVT
3											

Left Pole Right Pole ※ AXT is equivalent with AUX and ALT.
Handle

Characteristic Curves & Dimensions | Electronic Type



- HiBS800NE
- HiBL800NE
- HiBX800NE

Time-current characteristic curves / 405 - 800A

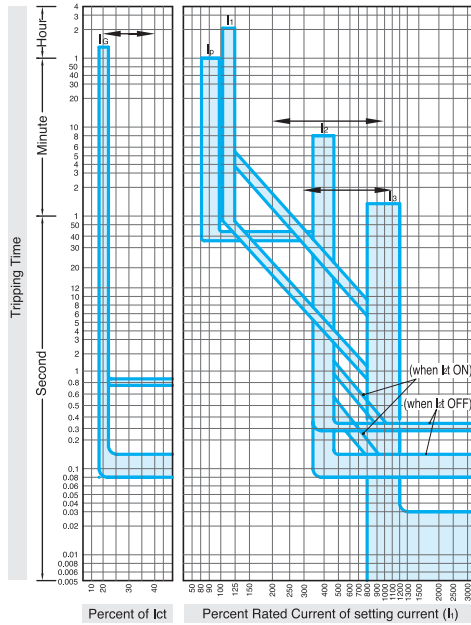

Over current characteristic

CT rated current (A): (I_{ct})	800
Setting rated current (A): (I_h) (Adjustable)	405, 430, 455, 480, 505, 510, 545, 575, 610, 640, 680, 720, 760, 800
Trip time for long time trip (S): (T_1)	Adjustable 2, 4, 6, 8, 12sec. for (I_h)x600% current Tolerance $\pm 20\%$
Setting current for short time trip (A): (I_2)	Adjustable (I_h)x200, 400, 600, 800, 1000% Tolerance $\pm 15\%$
Setting time for short time trip (S): (T_2)	Adjustable 0.1, 0.2, 0.3 sec. for the definite time trip characteristic. Trip range is between (setting time -20ms) and (setting time +50ms)
Setting current for instantaneous (A): (I_a)	Adjustable (I_{ct})x300, 600, 800, 1000, 1100% Tolerance $\pm 20\%$
Setting current for ground fault trip (A): (I_g)	Adjustable (I_{ct})x0.1, 0.2, 0.3, 0.4 Tolerance $\pm 15\%$
Setting time for ground fault trip (S): (T_g)	Adjustable 0.1, 0.2, 0.3, 0.4, 0.8 sec. for the definite time trip characteristic Trip range is between (setting time -20ms) and (setting time +50ms)
Setting current for PTA (A): (I_p) ^{Option}	(I_h)x90% Tolerance $\pm 10\%$
Setting time for PTA (S): (T_p) ^{Option}	Definite time trip characteristic of 40sec. Tolerance $\pm 10\%$

※ " " is default setting. If required, please adjust the setting according to "adjustable table".

Dimensions

(Unit: mm)

Front-connected

HiBS 800NE, HiBL 800NE

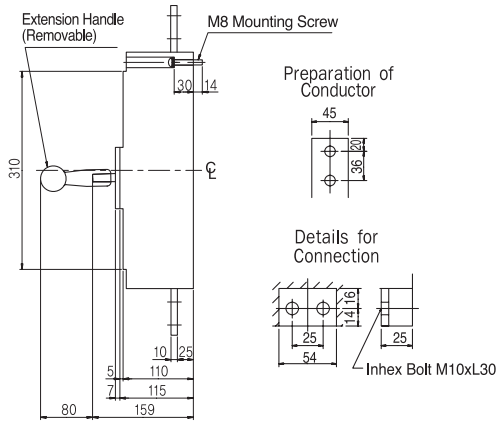
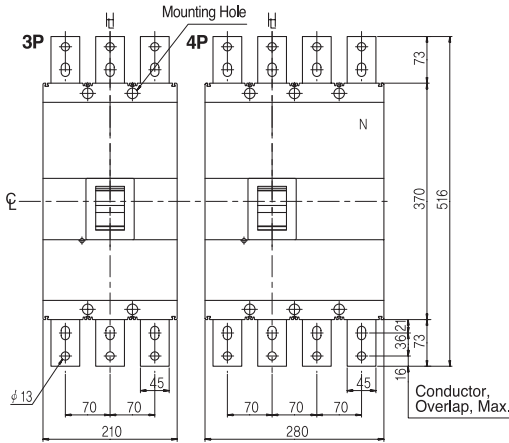

Drilling Plan

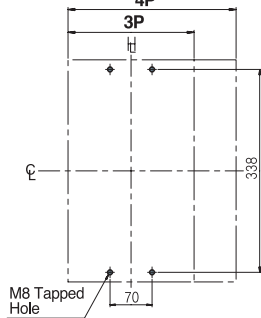

Panel Cut-out

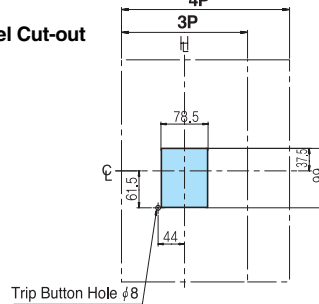

※ \varnothing : Center Line \perp : Handle Frame Center Line

• Panel cut-out dimensions shown give an allowance of 1.5mm around the handle escutcheon.

Dimensions

(Unit: mm)

Front-connected

HiBX 800NE

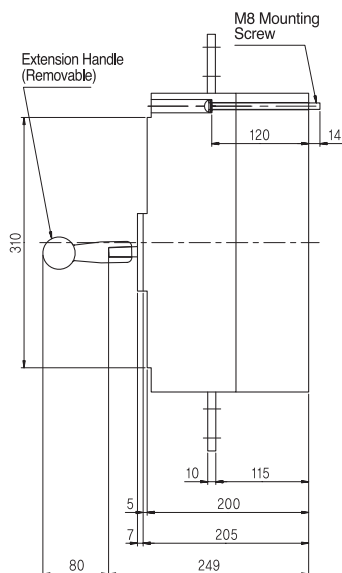
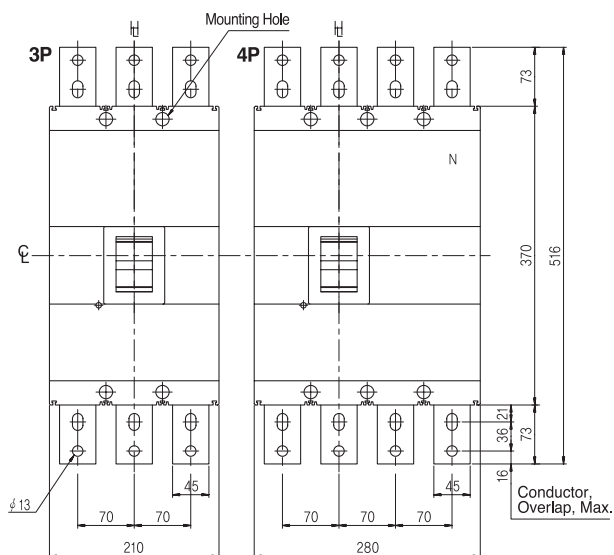

Drilling Plan

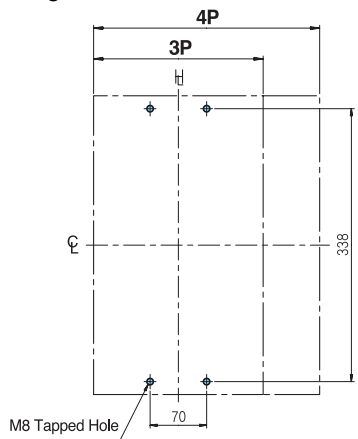

Panel Cut-out

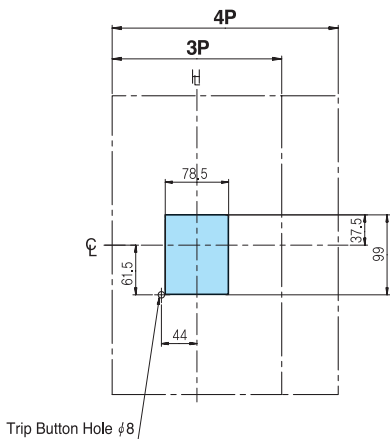

Preparation of Conductor

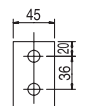

Detailed Terminal Part

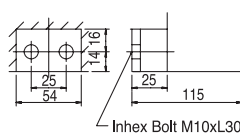

※ C: Center Line H: Handle Frame Center Line • Panel cut-out dimensions shown give an allowance of 1.5mm around the handle escutcheon.

Combinations of internally mounted accessories

NO. Pole	AUX Auxiliary Switch	ALT Alarm Switch	SHT Shunt Trip	UVT Under-Voltage Trip	AUX ALT	AUX SHT	AUX UVT	ALT SHT	ALT UVT	AUX ALT SHT	AUX ALT UVT
3											

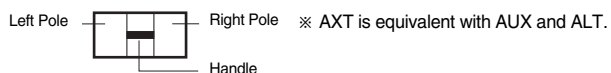

Characteristic Curves & Dimensions | Electronic Type



- HiBS1000NE
- HiBL1000NE

Time-current characteristic curves / 505 - 1000A

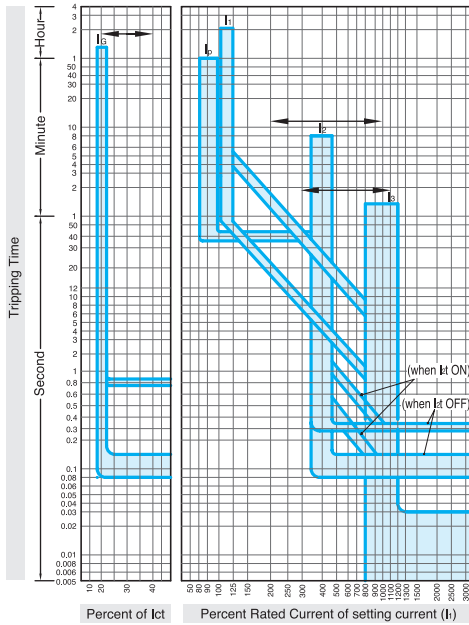

Over current characteristic

CT rated current (A): (I _{ct})	1000
Setting rated current (A): (I ₁) (Adjustable)	505, 535, 565, 580, 630, 640, 680, 720, 760, 800, 850, 900, 950, 1000
Tripping time for long time trip (S): (T ₁)	Adjustable 2, 4, 6, 8, 12sec. for (I ₁)x600% current Tolerance ±20%
Setting current for short time trip (A): (I ₂)	Adjustable (I ₁)x200, 400, 600, 800, 1000% Tolerance ±15%
Setting time for short time trip (S): (T ₂)	Adjustable 0.1, 0.2, 0.3sec. for the definite time trip characteristic. Trip range is between (setting time -20ms) and (setting time +50ms)
Setting current for instantaneous (A): (I ₃)	Adjustable (I _{ct})x300, 600, 800, 1000, 1100% Tolerance ±20%
Setting current for ground fault trip (A): (I _g)	Adjustable (I _{ct})x0.1, 0.2, 0.3, 0.4
Setting time for ground fault trip (S): (T _g)	Adjustable 0.1, 0.2, 0.3, 0.4, 0.8 sec. for the definite time trip characteristic Trip range is between (setting time -20ms) and (setting time +50ms)
Setting current for PTA (A): (I _g) ^{Option}	(I ₁)x90% Tolerance ±10%
Setting time for PTA (S): (T _g) ^{Option}	Definite time trip characteristic of 40sec. Tolerance ±10%

※ " " is default setting. If required, please adjust the setting according to "adjustable table".

Dimensions

(Unit: mm)

Front-connected

HiBS 1000NE

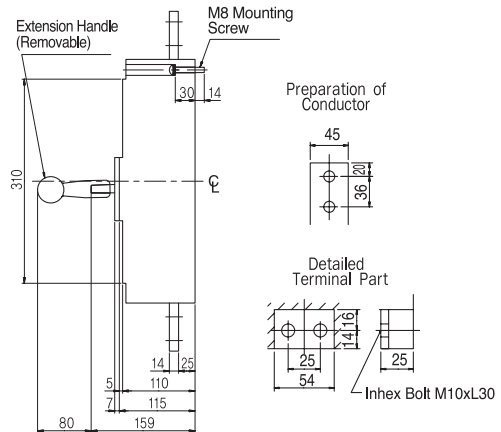
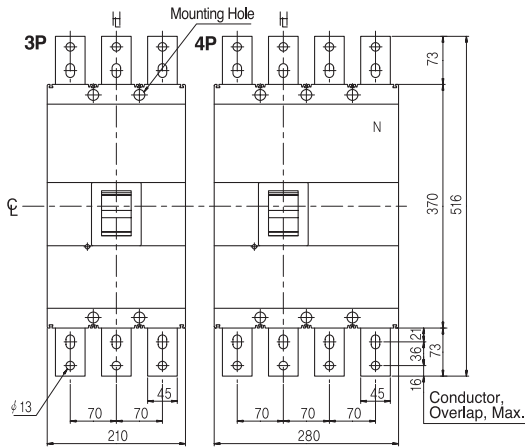

Drilling Plan

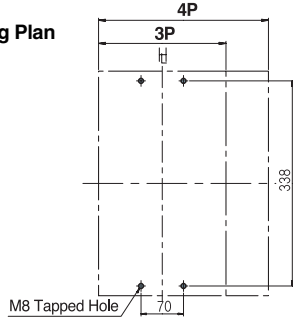

Panel Cut-out

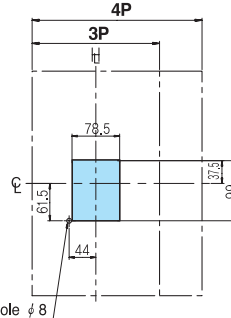

※ C: Center Line H: Handle Frame Center Line • Panel cut-out dimensions shown give an allowance of 1.5mm around the handle escutcheon.

Dimensions

(Unit: mm)

Front-connected **HiBL 1000NE**

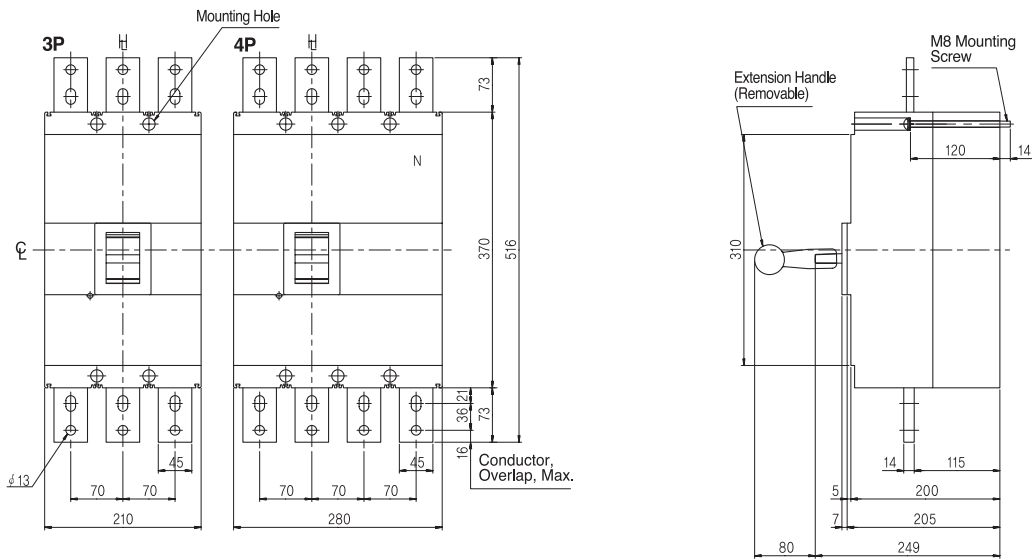

Drilling Plan

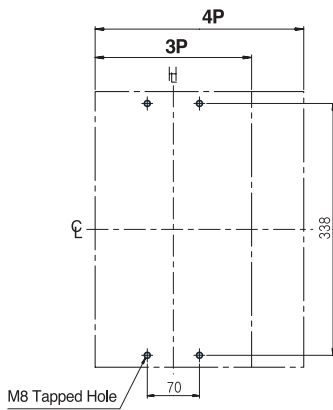

Panel Cut-out

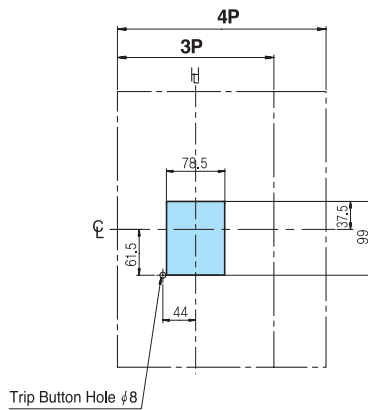

Preparation of Conductor

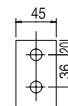

Detailed Terminal Part

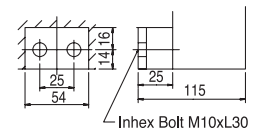

※ C : Center Line H : Handle Frame Center Line • Panel cut-out dimensions shown give an allowance of 1.5mm around the handle escutcheon.

Combinations of internally mounted accessories

NO. Pole	AUX Auxiliary Switch	ALT Alarm Switch	SHT Shunt Trip	UVT Under-Voltage Trip	AUX ALT	AUX SHT	AUX UVT	ALT SHT	ALT UVT	AUX ALT SHT	AUX ALT UVT
3											

Left Pole Right Pole ※ AXT is equivalent with AUX and ALT.
Handle

Characteristic Curves & Dimensions | Electronic Type



- HiBS1200NE
- HiBL1200NE

Time-current characteristic curves / 605 - 1200A

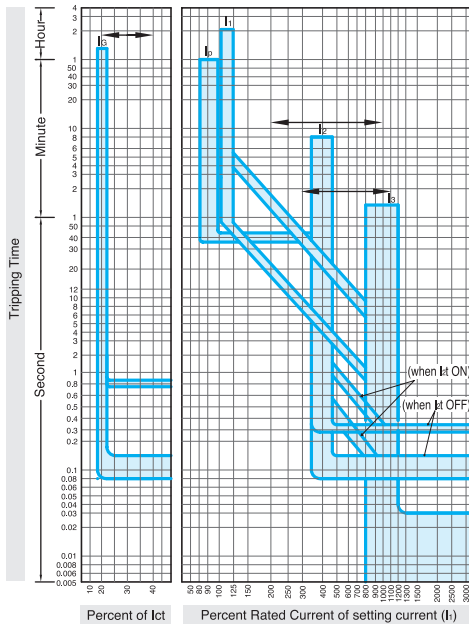

Over current characteristic

CT rated current (A): (I _{CT})	1200
Setting rated current (A): (I ₁) (Adjustable)	605, 645, 680, 720, 755, 770, 815, 865, 910, 960, 1020, 1080, 1140, 1200
Trip time for long time trip (S): (T ₁)	Adjustable 2, 4, 6, 8, 12sec. for (I ₁)x600 % current Tolerance ±20%
Setting current for short time trip (A): (I ₂)	Adjustable (I ₁)x200, 400, 600, 800, 1000% Tolerance ±15%
Setting time for short time trip (S): (T ₂)	Adjustable 0.1, 0.2, 0.3 sec. for the definite time trip characteristic. Trip range is between (setting time -20ms) and (setting time +50ms)
Setting current for instantaneous (A): (I ₃)	Adjustable (I _{CT})x300, 600, 800, 1000, 1100% Tolerance ±20%
Setting current for ground fault trip (A): (I ₄)	Adjustable (I _{CT})x0.1, 0.2, 0.3, 0.4 Tolerance ±15%
Setting time for ground fault trip (S): (T ₃)	Adjustable 0.1, 0.2, 0.3, 0.4, 0.8 sec. for the definite time trip characteristic Trip range is between (setting time -20ms) and (setting time +50ms)
Setting current for PTA (A): (I ₅) ^{Option}	(I ₁)x90% Tolerance ±10%
Setting time for PTA (S): (T ₄) ^{Option}	Definite time trip characteristic of 40sec. Tolerance ±10%

※ " " is default setting. If required, please adjust the setting according to "adjustable table".

Dimensions

(Unit: mm)

Front-connected

HiBS 1200NE

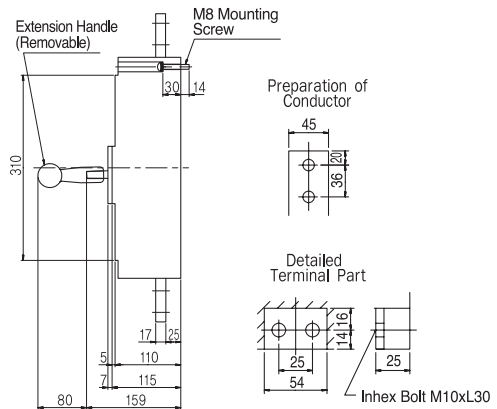
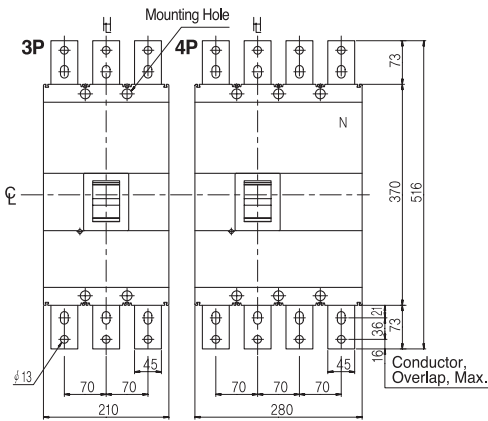

Drilling Plan

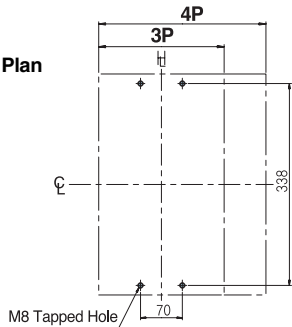

Panel Cut-out

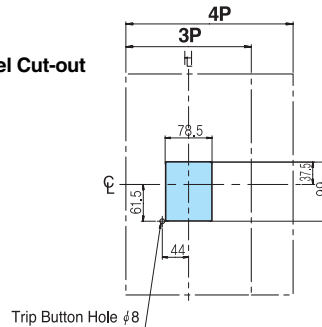

※ C: Center Line H: Handle Frame Center Line • Panel cut-out dimensions shown give an allowance of 1.5mm around the handle escutcheon.

Dimensions

(Unit: mm)

Front-connected **HiBL 1200NE**

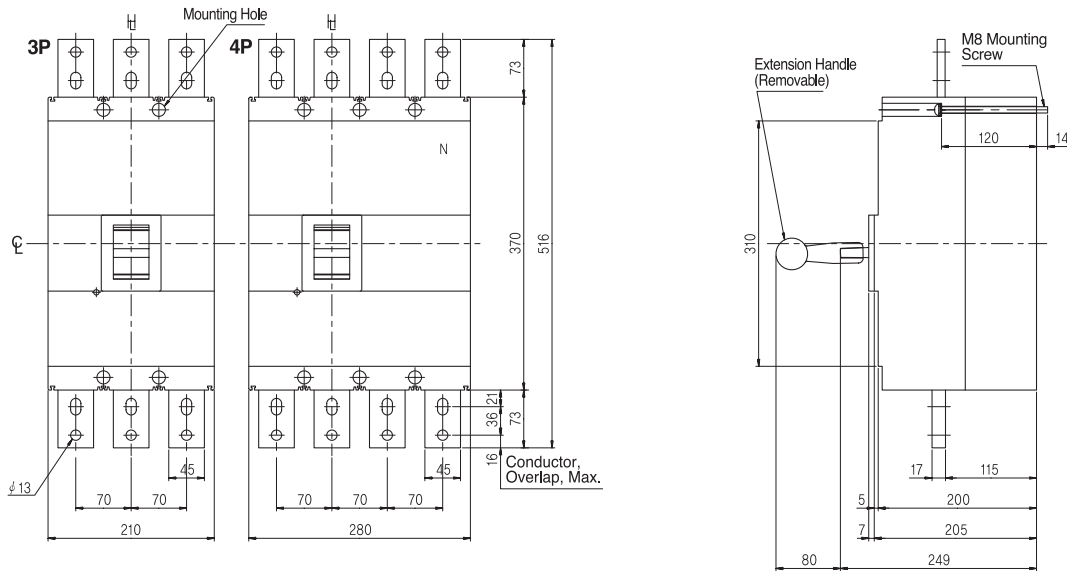

Drilling Plan

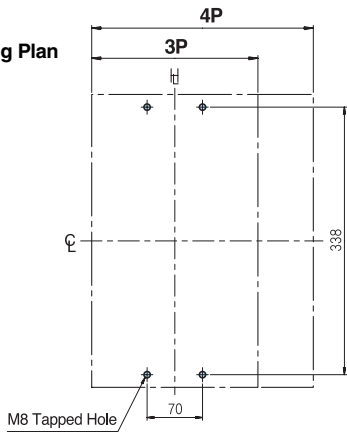

Panel Cut-out

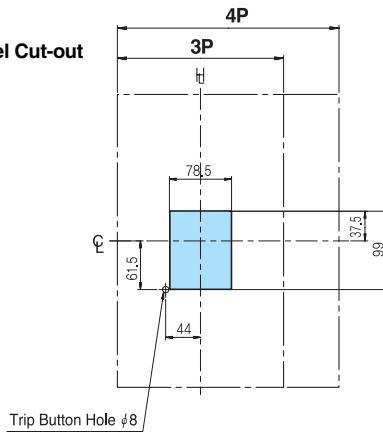

Preparation of Conductor

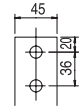

Detailed Terminal Part

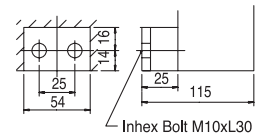

※ C: Center Line H: Handle Frame Center Line • Panel cut-out dimensions shown give an allowance of 1.5mm around the handle escutcheon.

Combinations of internally mounted accessories

NO. Pole	AUX Auxiliary Switch	ALT Alarm Switch	SHT Shunt Trip	UVT Under-Voltage Trip	AXT	AUX SHT	AUX UVT	ALT SHT	ALT UVT	AUX ALT SHT	AUX ALT UVT
3											

Left Pole Right Pole Handle ※ AXT is equivalent with AUX and ALT.

Order Information

Fixed thermal type

HIBS103					
Code	Breaking capacity (AC380/415V)	Ampere frame	Code	Breaking capacity (AC380/415V)	Ampere frame
HIBS32	7.5/5kA	30AF	HIBS402	42kA	400AF
HIBS33			HIBS403		
HIBH32	14/10kA	30AF	HIBS404	65kA	
HIBH33			HIBH402		
HIBE52	7.5/5kA	50AF	HIBH403	65kA	
HIBE53			HIBH404		
HIBS54	14/10kA	50AF	HIBL402	100kA	
HIBE62			HIBL403		
HIBE63	14/10kA	60AF	HIBL404	45kA	
HIBE64			HIBE602		
HIBS62	30/25kA	60AF	HIBE603	45kA	
HIBS63			HIBE604		
HIBS64	30/25kA	100AF	HIBS602	65kA	
HIBE102			HIBS603		
HIBE103	14/10kA	100AF	HIBS604	65kA	
HIBE104			HIBH602		
HIBS102	30/25kA	100AF	HIBH603	85kA	
HIBS103			HIBH604		
HIBS104	42/36kA	100AF	HIBL602	100kA	
HIBH102			HIBL603		
HIBH103	42/36kA	100AF	HIBL604	100kA	
HIBH104			HIBE802		
HIBE202	25/18kA	225AF	HIBE803	45kA	
HIBE203			HIBE804		
HIBE204	35/25kA	225AF	HIBS802	65kA	
HIBS202			HIBS803		
HIBS203	35/25kA	225AF	HIBS804	65kA	
HIBS204			HIBH802		
HIBH202	42/36kA	225AF	HIBH803	85kA	
HIBH203			HIBH804		
HIBH204	42/36kA	400AF	HIBL802	100kA	
HIBE402			HIBL803		
HIBE403	30kA	400AF	HIBL804	100kA	
HIBE404					

3P		T4		S		
Code	Pole	Code	Ambient temperature	Code	Terminal connection	
						Applicable range
2P	2 Pole	T4	40/45°C	S	Screw	Standard
3P	3 Pole	T5	50°C	B	Bus Bar	Available from 225AF
4P	4 Pole			P	Plug-In (Line & Load)	3 pole only
				F	Plug-In (Line only)	3 pole only

Standard order code and unit

Ampere frame	Model/ Breaking capacity at AC380/415V	Rated current	2 pole		3 pole		4 pole		Specification	Category	
			Code	Unit	Code	Unit	Code	Unit			
30	HiBS30 7.5/5kA	3A	HIBS32 2PT 4S0000C 00003	30	HIBS33 3PT 4S0000C 00003	20			40/45°C, Screw type terminal connection, No option, 50/60Hz	MCCB	M1
		5A	HIBS32 2PT 4S0000C 00005	30	HIBS33 3PT 4S0000C 00005	20					
		10A	HIBS32 2PT 4S0000C 00010	30	HIBS33 3PT 4S0000C 00010	20					
		15A	HIBS32 2PT 4S0000C 00015	30	HIBS33 3PT 4S0000C 00015	20					
		20A	HIBS32 2PT 4S0000C 00020	30	HIBS33 3PT 4S0000C 00020	20					
	30A	HIBS32 2PT 4S0000C 00030	30	HIBS33 3PT 4S0000C 00030	20						
	HiBH30 14/10kA	5A	HIBH32 2PT 4S0000C 00005	30	HIBH33 3PT 4S0000C 00005	20					
		10A	HIBH32 2PT 4S0000C 00010	30	HIBH33 3PT 4S0000C 00010	20					
		15A	HIBH32 2PT 4S0000C 00015	30	HIBH33 3PT 4S0000C 00015	20					
		20A	HIBH32 2PT 4S0000C 00020	30	HIBH33 3PT 4S0000C 00020	20					
30A		HIBH32 2PT 4S0000C 00030	30	HIBH33 3PT 4S0000C 00030	20						

00		00		C		00100			
Code	Signal device	Code	Trip device	Code	Frequency	Code	Rated current	Code	Description
00	-	00	-	C	50/60Hz	00003	3A		Standard
10	Auxiliary switch 1C	S1	Shunt trip AC110V			00005	5A	E	Special application
20	Auxiliary switch 2C	S2	Shunt trip AC220V			00010	10A	G	New design
30	Auxiliary switch 3C	S3	Shunt trip AC380V			00015	15A		
40	Auxiliary switch 4C	S4	Shunt trip AC440V			00020	20A		
01	Trip alarm switch 1C	S5	Shunt trip DC24V			00030	30A		
11	Auxiliary 1C+Trip alarm 1C	S6	Shunt trip DC110V			00040	40A		
21	Auxiliary 2C+Trip alarm 1C	U1	Under voltage trip AC110V			00050	50A		
31	Auxiliary 3C+Trip alarm 1C	U2	Under voltage trip AC220V			00060	60A		
41	Auxiliary 4C+Trip alarm 1C	U3	Under voltage trip AC380V			00075	75A		
		U4	Under voltage trip AC440V			00100	100A		
		U5	Under voltage trip DC24V			00125	125A		
		U6	Under voltage trip DC110V			00150	150A		
						00175	175A		
						00200	200A		
						00225	225A		
						00250	250A		
						00300	300A		
						00350	350A		
						00400	400A		
						00500	500A		
						00600	600A		
						00700	700A		
						00800	800A		

Ampere frame	Model/ Breaking capacity at AC380/415V	Rated current	2 pole		3 pole		4 pole		Specification	Category
			Code	Unit	Code	Unit	Code	Unit		
50	HiBE50 7.5/5kA	5A	HIBE52 2PT 4S0000C 00005	30	HIBE53 3PT 4S0000C 00005	20	HIBE54 4PT 4S0000C 00005	16	40/45°C, Screw type terminal connection, No option, 50/60Hz	MCCB M1
		10A	HIBE52 2PT 4S0000C 00010	30	HIBE53 3PT 4S0000C 00010	20	HIBE54 4PT 4S0000C 00010	16		
		15A	HIBE52 2PT 4S0000C 00015	30	HIBE53 3PT 4S0000C 00015	20	HIBE54 4PT 4S0000C 00015	16		
		20A	HIBE52 2PT 4S0000C 00020	30	HIBE53 3PT 4S0000C 00020	20	HIBE54 4PT 4S0000C 00020	16		
		30A	HIBE52 2PT 4S0000C 00030	30	HIBE53 3PT 4S0000C 00030	20	HIBE54 4PT 4S0000C 00030	16		
		40A	HIBE52 2PT 4S0000C 00040	30	HIBE53 3PT 4S0000C 00040	20	HIBE54 4PT 4S0000C 00040	16		
	50A	HIBE52 2PT 4S0000C 00050	30	HIBE53 3PT 4S0000C 00050	20	HIBE54 4PT 4S0000C 00050	16			
	HiBS50 14/10kA	5A	HIBS52 2PT 4S0000C 00005	30	HIBS53 3PT 4S0000C 00005	20	HIBS54 4PT 4S0000C 00005	16		
		10A	HIBS52 2PT 4S0000C 00010	30	HIBS53 3PT 4S0000C 00010	20	HIBS54 4PT 4S0000C 00010	16		
		15A	HIBS52 2PT 4S0000C 00015	30	HIBS53 3PT 4S0000C 00015	20	HIBS54 4PT 4S0000C 00015	16		
		20A	HIBS52 2PT 4S0000C 00020	30	HIBS53 3PT 4S0000C 00020	20	HIBS54 4PT 4S0000C 00020	16		
		30A	HIBS52 2PT 4S0000C 00030	30	HIBS53 3PT 4S0000C 00030	20	HIBS54 4PT 4S0000C 00030	16		
		40A	HIBS52 2PT 4S0000C 00040	30	HIBS53 3PT 4S0000C 00040	20	HIBS54 4PT 4S0000C 00040	16		
	50A	HIBS52 2PT 4S0000C 00050	30	HIBS53 3PT 4S0000C 00050	20	HIBS54 4PT 4S0000C 00050	16			
	HiBH50 30/25kA	15A	HIBH52 2PT 4S0000C 00015	20	HIBH53 3PT 4S0000C 00015	14	HIBH54 4PT 4S0000C 00015	10		
		20A	HIBH52 2PT 4S0000C 00020	20	HIBH53 3PT 4S0000C 00020	14	HIBH54 4PT 4S0000C 00020	10		
		30A	HIBH52 2PT 4S0000C 00030	20	HIBH53 3PT 4S0000C 00030	14	HIBH54 4PT 4S0000C 00030	10		
		40A	HIBH52 2PT 4S0000C 00040	20	HIBH53 3PT 4S0000C 00040	14	HIBH54 4PT 4S0000C 00040	10		
50A		HIBH52 2PT 4S0000C 00050	20	HIBH53 3PT 4S0000C 00050	14	HIBH54 4PT 4S0000C 00050	10			

Order Information

■ Standard order code and unit

Ampere frame	Model/ Breaking capacity at AC380/415V	Rated current	2 pole		3 pole		4 pole		Specification	Category	
			Code	Unit	Code	Unit	Code	Unit			
60	HiBE60 7.5/5kA	5A	HIBE62 2PT4S0000C 00005	30	HIBE63 3PT4S0000C 00005	20	HIBE64 4PT4S0000C 00005	16	40/45°C, Screw type terminal connection, No option, 50/60Hz	MCCB	M1
		10A	HIBE62 2PT4S0000C 00010	30	HIBE63 3PT4S0000C 00010	20	HIBE64 4PT4S0000C 00010	16			
		15A	HIBE62 2PT4S0000C 00015	30	HIBE63 3PT4S0000C 00015	20	HIBE64 4PT4S0000C 00015	16			
		20A	HIBE62 2PT4S0000C 00020	30	HIBE63 3PT4S0000C 00020	20	HIBE64 4PT4S0000C 00020	16			
		30A	HIBE62 2PT4S0000C 00030	30	HIBE63 3PT4S0000C 00030	20	HIBE64 4PT4S0000C 00030	16			
		40A	HIBE62 2PT4S0000C 00040	30	HIBE63 3PT4S0000C 00040	20	HIBE64 4PT4S0000C 00040	16			
		50A	HIBE62 2PT4S0000C 00050	30	HIBE63 3PT4S0000C 00050	20	HIBE64 4PT4S0000C 00050	16			
		60A	HIBE62 2PT4S0000C 00060	30	HIBE63 3PT4S0000C 00060	20	HIBE64 4PT4S0000C 00060	16			
	HiBS60 14/10kA	5A	HIBS62 2PT4S0000C 00005	30	HIBS63 3PT4S0000C 00005	20	HIBS64 4PT4S0000C 00005	16			
		10A	HIBS62 2PT4S0000C 00010	30	HIBS63 3PT4S0000C 00010	20	HIBS64 4PT4S0000C 00010	16			
		15A	HIBS62 2PT4S0000C 00015	30	HIBS63 3PT4S0000C 00015	20	HIBS64 4PT4S0000C 00015	16			
		20A	HIBS62 2PT4S0000C 00020	30	HIBS63 3PT4S0000C 00020	20	HIBS64 4PT4S0000C 00020	16			
		30A	HIBS62 2PT4S0000C 00030	30	HIBS63 3PT4S0000C 00030	20	HIBS64 4PT4S0000C 00030	16			
		40A	HIBS62 2PT4S0000C 00040	30	HIBS63 3PT4S0000C 00040	20	HIBS64 4PT4S0000C 00040	16			
		50A	HIBS62 2PT4S0000C 00050	30	HIBS63 3PT4S0000C 00050	20	HIBS64 4PT4S0000C 00050	16			
		60A	HIBS62 2PT4S0000C 00060	30	HIBS63 3PT4S0000C 00060	20	HIBS64 4PT4S0000C 00060	16			
100	HiBE100 14/10kA	5A	HIBE102 2PT4S0000C 0000	30	HIBE103 3PT4S0000C 00005	20	HIBE104 4PT4S0000C 00005	16	40/45°C, Screw type terminal connection, No option, 50/60Hz	MCCB	M1
		10A	HIBE102 2PT4S0000C 00010	30	HIBE103 3PT4S0000C 00010	20	HIBE104 4PT4S0000C 00010	16			
		15A	HIBE102 2PT4S0000C 00015	30	HIBE103 3PT4S0000C 00015	20	HIBE104 4PT4S0000C 00015	16			
		20A	HIBE102 2PT4S0000C 00020	30	HIBE103 3PT4S0000C 00020	20	HIBE104 4PT4S0000C 00020	16			
		30A	HIBE102 2PT4S0000C 00030	30	HIBE103 3PT4S0000C 00030	20	HIBE104 4PT4S0000C 00030	16			
		40A	HIBE102 2PT4S0000C 00040	30	HIBE103 3PT4S0000C 00040	20	HIBE104 4PT4S0000C 00040	16			
		50A	HIBE102 2PT4S0000C 00050	30	HIBE103 3PT4S0000C 00050	20	HIBE104 4PT4S0000C 00050	16			
		60A	HIBE102 2PT4S0000C 00060	30	HIBE103 3PT4S0000C 00060	20	HIBE104 4PT4S0000C 00060	16			
		75A	HIBE102 2PT4S0000C 00075	30	HIBE103 3PT4S0000C 00075	20	HIBE104 4PT4S0000C 00075	16			
		100A	HIBE102 2PT4S0000C 00100	30	HIBE103 3PT4S0000C 00100	20	HIBE104 4PT4S0000C 00100	16			
	HiBS100 30/25kA	15A	HIBS102 2PT4S0000C 00015	20	HIBS103 3PT4S0000C 00015	14	HIBS104 4PT4S0000C 00015	10			
		20A	HIBS102 2PT4S0000C 00020	20	HIBS103 3PT4S0000C 00020	14	HIBS104 4PT4S0000C 00020	10			
		30A	HIBS102 2PT4S0000C 00030	20	HIBS103 3PT4S0000C 00030	14	HIBS104 4PT4S0000C 00030	10			
		40A	HIBS102 2PT4S0000C 00040	20	HIBS103 3PT4S0000C 00040	14	HIBS104 4PT4S0000C 00040	10			
		50A	HIBS102 2PT4S0000C 00050	20	HIBS103 3PT4S0000C 00050	14	HIBS104 4PT4S0000C 00050	10			
		60A	HIBS102 2PT4S0000C 00060	20	HIBS103 3PT4S0000C 00060	14	HIBS104 4PT4S0000C 00060	10			
		75A	HIBS102 2PT4S0000C 00075	20	HIBS103 3PT4S0000C 00075	14	HIBS104 4PT4S0000C 00075	10			
		100A	HIBS102 2PT4S0000C 00100	20	HIBS103 3PT4S0000C 00100	14	HIBS104 4PT4S0000C 00100	10			
		HiBH100 42/36kA	15A	HIBH102 2PT4S0000C 00015	20	HIBH103 3PT4S0000C 00015	14	HIBH104 4PT4S0000C 00015		10	
			20A	HIBH102 2PT4S0000C 00020	20	HIBH103 3PT4S0000C 00020	14	HIBH104 4PT4S0000C 00020		10	
	30A		HIBH102 2PT4S0000C 00030	20	HIBH103 3PT4S0000C 00030	14	HIBH104 4PT4S0000C 00030	10			
	40A		HIBH102 2PT4S0000C 00040	20	HIBH103 3PT4S0000C 00040	14	HIBH104 4PT4S0000C 00040	10			
	50A		HIBH102 2PT4S0000C 00050	20	HIBH103 3PT4S0000C 00050	14	HIBH104 4PT4S0000C 00050	10			
	60A		HIBH102 2PT4S0000C 00060	20	HIBH103 3PT4S0000C 00060	14	HIBH104 4PT4S0000C 00060	10			
		75A	HIBH102 2PT4S0000C 00075	20	HIBH103 3PT4S0000C 00075	14	HIBH104 4PT4S0000C 00075	10			
		100A	HIBH102 2PT4S0000C 00100	20	HIBH103 3PT4S0000C 00100	14	HIBH104 4PT4S0000C 00100	10			

Order Information

Adjustable thermal type

HIBS103J					
Code	Breaking capacity (AC380/415V)	Ampere frame	Code	Breaking capacity (AC380/415V)	Ampere frame
HIBL53NT	85kA	50AF	HIBL203NT	85kA	225AF
HIBL54NT			HIBL204NT		
HIBX53NT	130kA	50AF	HIBX203NT	130kA	225AF
HIBX54NT			HIBX204NT		
HIBS102J	30/25kA	100AF	HIBE202J	25/18kA	250AF
HIBS103J			HIBE203J		
HIBS104J	42/36kA	100AF	HIBE204J	35/25kA	250AF
HIBH102J			HIBS202J		
HIBH103J	85kA	100AF	HIBS203J	42/36kA	250AF
HIBH104J			HIBS204J		
HIBL103NT	130kA	100AF	HIBH202J	42/36kA	250AF
HIBL104NT			HIBH203J		
HIBX103NT	130kA	100AF	HIBH204J	42/36kA	250AF
HIBX104NT			HIBH204J		

3P		T4		S		
Code	Pole	Code	Ambient temperature	Code	Terminal connection	
						Applicable range
2P	2 Pole	T4	40/45°C	S	Screw	Standard
3P	3 Pole	T5	50°C	B	Bus Bar	Available from 225AF
4P	4 Pole			P	Plug-In (Line & Load)	3 pole only
				F	Plug-In (Line only)	3 pole only

Standard order code and unit

Ampere frame	Model/ Breaking capacity at AC380/415V	Rated current	2 pole		3 pole		4 pole		Specification	Category
			Code	Unit	Code	Unit	Code	Unit		
50	HIBL50NT 85kA	12-15A			HIBL53NT 3PT4S0000C 00015	8	HIBL54NT 4PT4S0000C 00015	6	40/45°C, Screw type terminal connection, No option, 50/60Hz	MCCB M2
		16-20A			HIBL53NT 3PT4S0000C 00020	8	HIBL54NT 4PT4S0000C 00020	6		
		24-30A			HIBL53NT 3PT4S0000C 00030	8	HIBL54NT 4PT4S0000C 00030	6		
		32-40A			HIBL53NT 3PT4S0000C 00040	8	HIBL54NT 4PT4S0000C 00040	6		
		40-50A			HIBL53NT 3PT4S0000C 00050	8	HIBL54NT 4PT4S0000C 00050	6		
	HiBX50NT 130kA	12-15A			HIBX53NT 3PT4S0000C 00015	8	HIBX54NT 4PT4S0000C 00015	6		
		16-20A			HIBX53NT 3PT4S0000C 00020	8	HIBX54NT 4PT4S0000C 00020	6		
		24-30A			HIBX53NT 3PT4S0000C 00030	8	HIBX54NT 4PT4S0000C 00030	6		
		32-40A			HIBX53NT 3PT4S0000C 00040	8	HIBX54NT 4PT4S0000C 00040	6		
		40-50A			HIBX53NT 3PT4S0000C 00050	8	HIBX54NT 4PT4S0000C 00050	6		
100	HIBS100J 30/25kA	12.5-16A	HIBS102J 2PT4S0000C 00016	20	HIBS103J 3PT4S0000C 00016	14	HIBS104J 4PT4S0000C 00016	10	40/45°C, Screw type terminal connection, No option, 50/60Hz	MCCB M2
		16-20A	HIBS102J 2PT4S0000C 00020	20	HIBS103J 3PT4S0000C 00020	14	HIBS104J 4PT4S0000C 00020	10		
		20-25A	HIBS102J 2PT4S0000C 00025	20	HIBS103J 3PT4S0000C 00025	14	HIBS104J 4PT4S0000C 00025	10		
		16-32A	HIBS102J 2PT4S0000C 00032	20	HIBS103J 3PT4S0000C 00032	14	HIBS104J 4PT4S0000C 00032	10		
		32-40A	HIBS102J 2PT4S0000C 00040	20	HIBS103J 3PT4S0000C 00040	14	HIBS104J 4PT4S0000C 00040	10		
		40-50A	HIBS102J 2PT4S0000C 00050	20	HIBS103J 3PT4S0000C 00050	14	HIBS104J 4PT4S0000C 00050	10		
		50-63A	HIBS102J 2PT4S0000C 00063	20	HIBS103J 3PT4S0000C 00063	14	HIBS104J 4PT4S0000C 00063	10		
		63-80A	HIBS102J 2PT4S0000C 00080	20	HIBS103J 3PT4S0000C 00080	14	HIBS104J 4PT4S0000C 00080	10		
		80-100A	HIBS102J 2PT4S0000C 00100	20	HIBS103J 3PT4S0000C 00100	14	HIBS104J 4PT4S0000C 00100	10		
		HIBH100J 42/36kA	12.5-16A	HIBH102J 2PT4S0000C 00016	20	HIBH103J 3PT4S0000C 00016	14	HIBH104J 4PT4S0000C 00016		
	16-20A		HIBH102J 2PT4S0000C 00020	20	HIBH103J 3PT4S0000C 00020	14	HIBH104J 4PT4S0000C 00020	10		
	20-25A		HIBH102J 2PT4S0000C 00025	20	HIBH103J 3PT4S0000C 00025	14	HIBH104J 4PT4S0000C 00025	10		
	16-32A		HIBH102J 2PT4S0000C 00032	20	HIBH103J 3PT4S0000C 00032	14	HIBH104J 4PT4S0000C 00032	10		
	32-40A		HIBH102J 2PT4S0000C 00040	20	HIBH103J 3PT4S0000C 00040	14	HIBH104J 4PT4S0000C 00040	10		
	40-50A		HIBH102J 2PT4S0000C 00050	20	HIBH103J 3PT4S0000C 00050	14	HIBH104J 4PT4S0000C 00050	10		
	50-63A		HIBH102J 2PT4S0000C 00063	20	HIBH103J 3PT4S0000C 00063	14	HIBH104J 4PT4S0000C 00063	10		
	63-80A		HIBH102J 2PT4S0000C 00080	20	HIBH103J 3PT4S0000C 00080	14	HIBH104J 4PT4S0000C 00080	10		
	80-100A		HIBH102J 2PT4S0000C 00100	20	HIBH103J 3PT4S0000C 00100	14	HIBH104J 4PT4S0000C 00100	10		

Order Information

■ Electric type

HIBS403NE					
Code	Breaking capacity (AC380/415V)	Ampere frame	Code	Breaking capacity (AC380/415V)	Ampere frame
HIBL53NE	85kA	50AF	HIBS802NE	65kA	800AF
HIBL54NE			HIBS803NE		
HIBL103NE	85kA	100AF	HIBS808NE	85kA	
HIBL104NE			HIBL802NE		
HIBL203NE	85kA	225AF	HIBL803NE	85kA	
HIBL204NE			HIBL808NE		
HIBS402NE	50kA		HIBX802NE	130kA	
HIBS403NE			HIBX803NE		
HIBS404NE			HIBX808NE		
HIBL402NE	85kA	400AF	HIBS1003NE	100kA	
HIBL403NE			HIBS1004NE		
HIBL404NE			HIBL1003NE		
HIBX402NE			HIBL1004NE		
HIBX403NE	130kA		HIBS1203NE	100kA	
HIBX404NE			HIBS1204NE		
HIBS602NE	65kA		HIBL1203NE	130kA	
HIBS603NE			HIBL1204NE		
HIBS606NE					
HIBL602NE	85kA	600AF			
HIBL603NE					
HIBL606NE					
HIBX602NE					
HIBX603NE	130kA				
HIBX606NE					

3P		ES		S		
Code	Pole	Code	Protection	Code	Terminal connection	
						Applicable range
3P	3 Pole	ES	LTD+STD+INST+PTA (Standard)	S	Screw	Standard up to 600AF
4P	4 Pole			B	Bus Bar	Standard from 800AF
				P	Plug-In (Line & Load)	3 pole only
		EG	ES+GFT	F	Plug-In (Line only)	3 pole only

■ Standard order code and unit

Ampere frame	Model/ Breaking capacity at (AC380/415V)		Rated current	LTD/STD/INST/PTA				Specification	Category		
				3 pole		4 pole					
				Code	Unit	Code	Unit				
50	HiBL50NE	85kA	50A	HIBL53NE 3PESS0000X 00050	8	HIBL54NE 4PESS0000X 00050	6	Screw type terminal connection, No option, 50Hz	MCCB	M3	
100	HiBL100NE	85kA	100A	HIBL103NE 3PESS0000X 00100	8	HIBL104NE 4PESS0000X 00100	6				
125	HiBL225NE	85kA	225A	HIBL203NE 3PESS0000X 00225	8	HIBL204NE 4PESS0000X 00225	6				
400	HiBS400NE	50kA	400A	HIBS403NE 3PESS0000X 00400	3	HIBS404NE 4PESS0000X 00400	2				
	HiBL400NE	85kA	400A	HIBL403NE 3PESS0000X 00400	3	HIBL404NE 4PESS0000X 00400	2				
	HiBX400NE	130kA	400A	HIBX403NE 3PESS0000X 00400	3	HIBX404NE 4PESS0000X 00400	2				
600	HIBS600NE	65kA	600A	HIBS603NE 3PESS0000X 00600	3	HIBS604NE 4PESS0000X 00600	2				
	HIBL600NE	85kA	600A	HIBL603NE 3PESS0000X 00600	3	HIBL604NE 4PESS0000X 00600	2				
	HiBX600NE	130kA	600A	HIBX603NE 3PESS0000X 00600	3	HIBX604NE 4PESS0000X 00600	2				
800	HiBS800NE	65kA	800A	HIBS803NE 3PESS0000X 00800	1	HIBS804NE 4PESS0000X 00800	1		Bus bar type terminal connection, No option, 50Hz	MCCB	M3
	HiBL800NE	85kA	800A	HIBL803NE 3PESS0000X 00800	1	HIBL804NE 4PESS0000X 00800	1				
	HiBX800NE	130kA	800A	HIBX803NE 3PESS0000X 00800	1	HIBX804NE 4PESS0000X 00800	1				
1000	HIBS1000NE	100kA	1000A	HIBS1003NE 3PESS0000X 01000	1	HIBS1004NE 4PESS0000X 01000	1				
	HiBL1000NE	130kA	1000A	HIBL1003NE 3PESS0000X 01000	1	HIBL1004NE 4PESS0000X 01000	1				
1200	HIBS1200NE	100kA	1200A	HIBS1203NE 3PESS0000X 01200	1	HIBS1204NE 4PESS0000X 01200	1				
	HiBL1200NE	130kA	1200A	HIBL1203NE 3PESS0000X 01200	1	HIBL1204NE 4PESS0000X 01200	1				

00		00		X		00400			
Code	Signal device	Code	Trip device	Code	Frequency	Code	Rated Current	Code	Description
00	-	00	-	X	50Hz	00050	20-50A		Standard
10	Auxiliary switch 1C	S1	Shunt trip AC110V	Y	60Hz	00100	40-100A	E	Special application
20	Auxiliary switch 2C	S2	Shunt trip AC220V			00125	90-225A	G	New design
30	Auxiliary switch 3C	S3	Shunt trip AC380V			00400	200-400A		
40	Auxiliary switch 4C	S4	Shunt trip AC440V			00600	302-600A		
01	Trip alarm switch 1C	S5	Shunt trip DC24V			00800	405-800A		
11	Auxiliary 1C+Trip alarm 1C	S6	Shunt trip DC110V			01000	505-1000A		
21	Auxiliary 2C+Trip alarm 1C	U1	Under voltage trip AC110V			01200	605-1200A		
31	Auxiliary 3C+Trip alarm 1C	U2	Under voltage trip AC220V						
41	Auxiliary 4C+Trip alarm 1C	U3	Under voltage trip AC380V						
		U4	Under voltage trip AC440V						
		U5	Under voltage trip DC24V						
		U6	Under voltage trip DC110V						

Ampere frame	Model/ Breaking capacity at (AC380/415V)		Rated current	LTD/STD/INST/PTA/GFT				Specification	Category		
				3 pole		4 pole					
				Code	Unit	Code	Unit				
50	HiBL50NE	85kA	50A								
100	HiBL100NE	85kA	100A								
125	HiBL225NE	85kA	225A								
400	HiBS400NE	50kA	400A	HIBS403NE 3PEGS0000X 00400	3	HIBS404NE 4PEGS0000X 00400	2	Screw type terminal connection, No option, 50Hz	MCCB	M3	
	HiBL400NE	85kA	400A	HIBL403NE 3PEGS0000X 00400	3	HIBL404NE 4PEGS0000X 00400	2				
	HiBX400NE	130kA	400A	HIBX403NE 3PEGS0000X 00400	3	HIBX404NE 4PEGS0000X 00400	2				
600	HiBS600NE	65kA	600A	HIBS603NE 3PEGS0000X 00600	3	HIBS604NE 4PEGS0000X 00600	2				
	HiBL600NE	85kA	600A	HIBL603NE 3PEGS0000X 00600	3	HIBL604NE 4PEGS0000X 00600	2				
	HiBX600NE	130kA	600A	HIBX603NE 3PEGS0000X 00600	3	HIBX604NE 4PEGS0000X 00600	2				
800	HiBS800NE	65kA	800A	HIBS803NE 3PEGB0000X 00800	1	HIBS804NE 4PEGB0000X 00800	1		Bus bar type terminal connection, No option, 50Hz	MCCB	M3
	HiBL800NE	85kA	800A	HIBL803NE 3PEGB0000X 00800	1	HIBL804NE 4PEGB0000X 00800	1				
	HiBX800NE	130kA	800A	HIBX803NE 3PEGB0000X 00800	1	HIBX804NE 4PEGB0000X 00800	1				
1000	HiBS1000NE	100kA	1000A	HIBS1003NE 3PEGB0000X 01000	1	HIBS1004NE 4PEGB0000X 01000	1				
	HiBL1000NE	130kA	1000A	HIBL1003NE 3PEGB0000X 01000	1	HIBL1004NE 4PEGB0000X 01000	1				
1200	HiBS1200NE	100kA	1200A	HIBS1203NE 3PEGB0000X 01200	1	HIBS1204NE 4PEGB0000X 01200	1				
	HiBL1200NE	130kA	1200A	HIBL1203NE 3PEGB0000X 01200	1	HIBL1204NE 4PEGB0000X 01200	1				

Order Information

■ Switch disconnecter type

■ Standard order code and unit

Ampere frame	Model	Rated current	3 pole			Specification	Category	
			Code	Unit	Same dimension			
50	HiSD50	50A	HISD53 3PDSS0000C 00050	20	HiBS53	Screw type terminal connection, 50/60Hz	MCCB	M5
100	HISD103	100A	HISD103 3PDSS0000C 00100	14	HiBS103/103J			
225	HISD203	225A	HISD203 3PDSS0000C 00225	12	HiBS203/203J			
400	HISD403	400A	HISD403 3PDSS0000C 00400	3	HiBS403			
600	HISD603	600A	HISD603 3PDSS0000C 00600	1	HiBS603			
800	HISD803	800A	HISD803 3PDSS0000C 00800	1	HiBS803			
400	HISD403NE	400A	HISD403NE 3PDSS0000C 00400	3	HiBS403NE			
600	HISD603NE	600A	HISD603NE 3PDSS0000C 00600	3	HiBS603NE	Bus bar type terminal connection, 50/60Hz		
800	HISD803NE	800A	HISD803NE 3PDSS0000C 00800	1	HiBS803NE			
1000	HISD1003NE	1000A	HISD1003NE 3PDSS0000C 01000	1	HiBS1003NE			
1200	HISD1203NE	1200A	HISD1203NE 3PDSS0000C 01200	1	HiBS1203NE			

Operation Environment

■ The standard environment for MCCBs is as follows:

■ Ambient temperature

-25°C to +50°C

The average temperature for 24hours must not exceed 35°C

■ Relative humidity

45% to 85%

■ Altitude

Below 2,000m (6,600 feet)

■ Atmosphere

Excessive water vapor, oil vapor, smoke, dust or corrosive gases must not exist.

Sudden change in temperature, condensation, or icing must not occur.

■ Transportation conditions

The MCCB shall not be dropped or gotten strong shock, and the main body shall be holded for the transportation purpose ; not the terminal bus bar nor the lead wire.

■ Installation conditions

When installing the Molded Case Circuit Breaker, refer to the installation instructions in the catalogue and instruction manual.

■ IP protection

The standard protection degree of MCCB is IP20.

■ Storage

Store the breaker in a dry indoor location to prevent condensation due to a sudden change in temperature, which is quite harmful to the breaker insulation.

Store the breaker in a clean place free of corrosive gases, dirt and dust.

⚠ Safety notice

- ◆ This catalog is subject to be up-dated without notice.
- ◆ This catalog shall be applied to only Molded Case Circuit Breaker.
- ◆ Please contact the representative of Hyundai Heavy Industries for further information.

www.hyundai-elec.com



Head Office	1, Jeonha-dong, Dong-gu, Ulsan, Korea Tel: 82-52-202-8101~8 Fax: 82-52-202-8100
Seoul (Sales & Marketing)	140-2, Gye-dong, Jongno-gu, Seoul, Korea Tel: 82-2-746-7510, 8519 Fax: 82-2-746-7647
Orlando	3452 Lake Lynda Drive, Suite 170, Orlando, Florida 32817, U.S.A. Tel: 1-407-249-7350 Fax: 1-407-275-4940
New Jersey	300 Sylvan Avenue, Englewood Cliffs, NJ 07632, U.S.A. Tel: 1-201-816-0286 Fax: 1-201-816-4083
London	2nd Floor, The Triangle, 5-17 Hammersmith Grove, London, W6 0LG, UK Tel: 44-20-8741-0501 Fax: 44-20-8741-5620
Tokyo	8th Fl., Yurakucho Denki Bldg.1-7-1, Yuraku-cho, Chiyoda-gu, Tokyo, 100-0006, Japan Tel: 81-3-3212-2076, 3215-7159 Fax: 81-3-3211-2093
Osaka	I-Room 5th Fl. Nagahori-Plaza Bldg. 2-4-8, Minami Senba, Chuo-Ku, Osaka, 542-0081, Japan Tel: 81-6-6261-5766, 5767 Fax: 81-6-6261-5818
Dubai	Level 2, Unit 205, Emaar Square-Bldg.4 Sheikh Zayed Road, P.O.Box 252458, Dubai, U.A.E. Tel: 971-4-425-7995 Fax: 971-4-425-7996
Sofia	1271, Sofia 41, Rojen Blvd., Bulgaria Tel: 359-2-803-3200 Fax: 359-2-803-3203
Yangzhong	No. 9 Xiandai Road, Xinba Scientific and Technologic Zone, Yangzhong, Jiangsu, P.R.C. Zip: 212212, China Tel: 86-511-8842-0666, 0212 Fax: 86-511-8842-0668, 0231