

2020 OVERHEAD FIELD MAINTENANCE ONLY

Historical Record: 7/24/2020
External Version



GENERAL INFORMATION	100
PRACTICES	200
POLES, ARMS & HARDWARE	300
DISTRIBUTION POLE TOPS	400
TELECOMMUNICATIONS SCADA	500
SECONDARIES, SERVICES	600
CONDUCTOR DATA & ACCESSORIES	700
SAG	800
GUYING	900
GROUNDING, BONDING	1000
TRANSFORMERS, BOOSTERS	1100
SECTIONALIZING, ARRESTERS	1200
CAPACITORS, REGULATORS	1300
CABLE POLES	1400
LIGHTING	1500
WILDLIFE PROTECTION	1600
SPACER CABLE SYSTEM	1700
ENGINEERED STEEL POLES	1800
MISCELLANEOUS EQUIPMENT	1900
COVERED CONDUCTOR	2000
DISCLAIMER & CONTACTS	
SUMMARY OF CHANGES	
LEGACY OVERHEAD FMO	

ATTENTION:

- The contents held within this book are for **field maintenance only**. Every effort should be made, when possible, to upgrade to current standards.
- Due to the age of the documentation, this book is not a 100% search-able at this time. This may be resolved at a later date.

IF YOU HAVE ANY QUESTIONS REGARDING THE CONTENT OF THESE MANUALS PLEASE EMAIL
CONSTRUCTIONSTANDARDSADMINISTRATORS@SEMPRAUTILITIES.COM OR CONTACT:

MANUAL	OWNER	EMAIL ADDRESS	PHONE
Electric Distribution Design Manual	Jon Erickson	jcerickson@sdge.com	(858) 654-8245
Overhead Construction Standards	Greg Walters	gwalters@sdge.com	858) 654-8396
Service Standards & Guide	Israel Juarez	ijuarez@sdge.com	(858) 636-3941
Underground Construction Standards	Eddie Alcobia	ealcobia@sdge.com	(619) 574-4988

100 - GENERAL
INFORMATION

100 - GENERAL
INFORMATION

PAGE(S)

SUBJECT

No FMO content available at this time.

© 1998 - 2020 San Diego Gas & Electric Company. All rights reserved. Removal of this copyright notice without permission is not permitted under law.

REV	CHANGE	BY	DSGN	APPV	DATE	REV	CHANGE	BY	DSGN	APPV	DATE
C						F					
B						E					
A						D					

SHEET 1 OF 1	Indicates Latest Revision	Completely Revised	<input checked="" type="checkbox"/>	New Page	Information Removed	FMO OH101.1
	SDG&E ELECTRIC OVERHEAD FIELD MAINTENANCE ONLY STANDARDS					
	GENERAL INFORMATION TABLE OF CONTENTS					

200 - PRACTICES

200 - PRACTICES

PAGE

SUBJECT

201	TABLE OF CONTENTS
203	DISTRIBUTION STATION NUMBERING
204	OVERHEAD DISTRIBUTION SWITCH NUMBERING
212	GFMS SUMMARY OPERATING MAP SYMBOL
218	POLE GUARD RAIL
220	VERTICAL SEPARATION OF CROSSARMS
221	VERTICAL SEPARATION OF DIFFERENT CIRCUITS
223	AERIAL CABLE, VERTICAL CLEARANCE FROM OPEN WIRE CONDUCTORS ON SAME POLES
269	12KV SINGLE CIRCUIT TRANSPORTATION

© 1998 - 2019 San Diego Gas & Electric Company. All rights reserved. Removal of this copyright notice without permission is not permitted under law.

REV	CHANGE	BY	DSGN	APPV	DATE	REV	CHANGE	BY	DSGN	APPV	DATE
C						F					
B	EDITORIAL CHANGES	PEI	-	-	04/22/2019	E					
A	ORIGINAL ISSUE	JS	IL	MDJ	07/13/2016	D					

SHEET 1 OF 1	Indicates Latest Revision	Completely Revised	New Page <input checked="" type="checkbox"/>	Information Removed	FMO OH201.1
	SDG&E ELECTRIC OVERHEAD CONSTRUCTION STANDARDS				
	PRACTICES SECTION TABLE OF CONTENTS				

FIELD MAINTENANCE ONLY

REVISION HISTORY:

7/13/2016: All versions prior to 2016 are superseded by their current version found inside the Overhead Construction Standard Manual.

© 1998 - 2016 San Diego Gas & Electric Company. All rights reserved. Removal of this copyright notice without permission is not permitted under law.

REV	CHANGE	BY	DSGN	APPV	DATE	REV	CHANGE	BY	DSGN	APPV	DATE
C						F					
B						E					
A	ORIGINAL ISSUE	JS	IL	MDJ	7/13/2016	D					

	Indicates Latest Revision	Completely Revised	New Page	Information Removed
-------------------------------------------------------------------------------------	---------------------------	--------------------	----------	---------------------

**SHEET
1 OF 1**

SDG&E ELECTRIC OVERHEAD STANDARD

DISTRIBUTION STATION NUMBERING

**FMO
OH 203**

I. STATION NUMBERS GIVE A UNIQUE NUMBER TO, AND BRIEFLY DESCRIBE, DISTRIBUTION STATIONS. ALL STATION NUMBERS ARE ASSIGNED BY THE TRANSFORMER CLERK (EXT 1217 OR MICROWAVE 02167).

II. THE STATION NUMBER IS BROKEN UP INTO THREE PARTS: CIRCUIT; NUMBER; AND SUFFIX. 40 - 118 - MRO
CIRCUIT NUMBER SUFFIX

CIRCUIT - THE CIRCUIT DESIGNATION DESCRIBES THE VOLTAGE THAT FEEDS THE STATION. IF IT IS ONLY NUMERIC CHARACTERS, THEN THE CIRCUIT ORIGINATING AT THE SUBSTATION IS 12KV. IF IT HAS ALPHABETIC CHARACTERS IN IT, THEN THE CIRCUIT VOLTAGE IS 4 OR 2.4KV. (SEE NOTE F).

EXAMPLES:

40 - CIRCUIT 40 IS 12KV

NO1 - NORTH OTAY ONE IS 4KV

NUMBER - CONTAINS ONLY NUMERIC CHARACTERS. THIS PART IS ARBITRARY.

EXAMPLES:

118 - NUMBER SELECTED BY TRANSFORMER CLERK

908 - NUMBER SELECTED BY TRANSFORMER CLERK

SUFFIX - THE SUFFIX IS DESCRIPTIVE OF THE STATION, (SEE NOTE C) HIERARCHY (ARRANGEMENT IN SERIES) FOR COMBINING SUFFIXES IS:

- I. NUMERIC CHARACTERS (1-99) (SEE NOTE D)
- II. M, V, B, BU, G, R, L, SW, UP, N
- III. RO, RC, SL
- IV. Y, X, C
- V. S

FOR FIELD MAINTENANCE ONLY

EXAMPLES:

- C - CAPACITOR STATION
- M - 12KV PRIMARY METERED STATION
- MRO - METERED STREET LIGHT STATION
- D - 4 OR 2.4KV STATION THAT IS FED FROM A STEPDOWN STATION SERVING ONLY 1 CUSTOMER OR ONLY PRIMARY METERED CUSTOMER(S)
- 1M - 4 OR 2.4KV PRIMARY METERED STATION FED FROM A STEPDOWN STATION

III. THESE PARTS ARE BROUGHT TOGETHER AS FOLLOWS:

A. WHEN WRITING THE STATION NUMBERS ON OTHER THAN FORMS FOR KEYPUNCH USE, EACH PART OF THE STATION NUMBER IS SEPARATED BY A DASH.

EXAMPLES:

- 40-118 12KV TRANSFORMER STATION
- 40-216-C 12KV CAPACITOR STATION
- NO1-118 4 OR 2.4KV TRANSFORMER STATION
- NO1-216-MRO 4 OR 2.4KV METERED STREET LIGHT STATION
- 40-908-D 12 TO 4KV OR 12 TO 2.4KV STEPDOWN STATION (INDICATED BY D) (SEE NOTES A, B & F)
- 40-118-2G 12KV REGULATOR STATION, 2ND POLE OF 3-1Ø REGULATORS ON 3 POLES.

B. THE FOLLOWING FORMS WILL BE USED FOR KEYPUNCHING AND THE STATION NUMBER IS REQUIRED ON THEM:

- | | | | |
|-------------------------------------------------|-----------|--------------------------------------------------------|-------------|
| 1. APARTMENT LIST | 101-4145A | 7. NEW SERVICE INPUT DOCUMENT | 124-10152 |
| 2. CIS MASTER STATION UPDATE | 124-13152 | 8. STATION FILE CUTOVERS | 111-391 |
| 3. CUSTOMER NEW SERVICE REQUEST | 124-6201 | 9. TRANSFORMER TAG | 120-5240A |
| 4. ELECTRIC CONSTRUCTION ORDER (NO FILE NUMBER) | | 10. TRANSFORMER STATION FILE PUNCH FORM | 110-591/21A |
| 5. ELECTRIC SERVICE ORDER | 107-212L | 11. TAG NOTICE TO ELECTRIC TROUBLEMAN (TEMPORARY FORM) | |
| 6. GAS/ELECTRIC SET ORDER | 124-610 | 12. CURRENT STATION/CUSTOMER TIE (COMPUTER LISTING) | |

	<input checked="" type="checkbox"/> Indicates Latest Revision	<input type="checkbox"/> Completely Revised	<input type="checkbox"/> New Page	<input type="checkbox"/> Information Removed
ISSUE 1993	SDG&E ELECTRIC STANDARDS			OH 299.001
DATE 1-1-89	DISTRIBUTION STATION NUMBERING			UG 3199.001
APPD /				SUPERCEDES 203.1 (1-1-93)

C. THE RULES FOR FILLING IN THE STATION NUMBER ON THESE FORMS ARE AS FOLLOWS:

1. ALL ALPHABETIC CHARACTER O'S ARE TO BE WRITTEN WITH A SLANT MARK; i.e., Ø. THIS IS TO AVOID CONFUSION WITH THE NUMERIC CHARACTER ZERO.
2. INSTRUCTIONS FOR FILLING IN FORMS.
 - a. THE CIRCUIT FIELD (COLUMN). SEE TABLE 1 BELOW. ALPHABETIC CHARACTERS ARE TO BE LEFT JUSTIFIED AND THE NUMERIC CHARACTERS RIGHT JUSTIFIED (SEE NOTE E). IN MOST CASES, THERE WILL BE BLANK COLUMNS IN THIS FIELD.
 - b. THE NUMBER FIELD (COLUMN). SEE TABLE 1 BELOW. THE NUMERIC CHARACTERS ARE RIGHT JUSTIFIED AND ZEROS ARE ADDED TO COMPLETE FIELD.
 - c. THE SUFFIX FIELD (COLUMN). SEE TABLE 1 BELOW. IF STATION NUMBER HAS NO SUFFIX, LEAVE THIS BLANK. THE ENTIRE PROPERLY FORMED SUFFIX IS LEFT JUSTIFIED AND ZEROS ARE ADDED TO COMPLETE FIELD.

EXAMPLES OF STATION NUMBERS WRITTEN ON FORMS:

TABLE 1

CIRCUIT	NUMBER	SUFFIX
0 0 4 0	0 1 1 8	
0 0 4 0	0 2 1 6	C 0 0 0
* N Ø 0 1	0 1 1 8	
* N Ø 0 1	0 2 1 6	M R Ø 0 *
0 0 4 0	0 9 0 8	D 0 0 0
0 0 4 0	0 9 0 8	3 1 0 0

FOR FIELD MAINTENANCE ONLY

NOTES:

- (A) REFER TO THE DISTRIBUTION ENGINEER BEFORE ADDING LOAD TO THESE AREAS TO ENSURE THAT THE STEPDOWN STATION IS NOT OVERLOADED.
- (B) INDICATES A 2.4 OR 4KV STEPDOWN STATION SERVING ONLY ONE CUSTOMER OR ONLY PRIMARY METERED CUSTOMER(S).
- (C) SEE PAGE 299.126 OVERHEAD OR 3199.126 UNDERGROUND – ABBREVIATIONS & CODES, STATION SUFFIX FOR SUFFIX MEANINGS.
- (D) NUMERIC CHARACTERS 1 – 9 ARE RESERVED FOR STATIONS WITH ADDITIONAL SUFFIXES.
- (E) RIGHT AND LEFT JUSTIFICATION MAY BE A NEW TERM FOR MOST PEOPLE. RIGHT JUSTIFIED MEANS TO START WITH THE RIGHT MOST CHARACTER OF THE GROUP AND PUT IT INTO THE RIGHT MOST COLUMN, WORKING LEFT UNTIL ALL CHARACTERS ARE USED UP AND IN ALL REMAINING BLOCKS AND ZEROS. SIMILARLY FOR LEFT JUSTIFIED, ONLY WORK FROM LEFT TO RIGHT AND ADD ZEROS TO FILL UNUSED BLOCKS.

EXAMPLE: RIGHT JUSTIFY: 198 STEP 1

			8
		9	8
	1	9	8

 FINAL STEP 4

0	1	9	8
---	---	---	---

 ADD ZERO IN REMAINING BLOCK(S)

LEFT JUSTIFY ALPHABETIC CHARACTERS, RIGHT JUSTIFY NUMERIC CHARACTERS: NØ1

STEP 1

N			
N	Ø		
N	Ø		1

 FINAL STEP 4

N	Ø	0	1
---	---	---	---

 ALPHABETIC CHARACTERS LEFT JUSTIFIED
 NUMERIC CHARACTER RIGHT JUSTIFIED
 ADD ZERO IN REMAINING BLOCK(S)

- (F) STEPDOWN STATIONS WILL BE GIVEN NAME EXCEPT FOR THOSE SERVING ONLY ONE CUSTOMER OR ONLY PRIMARY METERED CUSTOMER(S)

* SEE III, C, 1.

<input checked="" type="checkbox"/>	Indicates Latest Revision	Completely Revised	New Page	Information Removed
OH 299.002 UG 3199.002 SUPERCEDES 203.2 (1-1-93)	SDG&E ELECTRIC STANDARDS DISTRIBUTION STATION NUMBERING			ISSUE 1993 DATE 1-1-87 APPD /

FIELD MAINTENANCE ONLY

REVISION HISTORY:

8/16/2016: All versions prior to 2016 are superseded by their current version found inside the Overhead Construction Standard Manual.

© 1998 - 2016 San Diego Gas & Electric Company. All rights reserved. Removal of this copyright notice without permission is not permitted under law.

REV	CHANGE	BY	DSGN	APPV	DATE	REV	CHANGE	BY	DSGN	APPV	DATE
C						F					
B						E					
A	ORIGINAL ISSUE	JS	IL	MDJ	8/16/2016	D					

	Indicates Latest Revision	Completely Revised	New Page	Information Removed
-------------------------------------------------------------------------------------	---------------------------	--------------------	----------	---------------------

**SHEET
1 OF 1**

SDG&E ELECTRIC OVERHEAD STANDARD

OVERHEAD DISTRIBUTION SWITCH NUMBERING

**FMO
OH 204**

SCOPE: THIS STANDARD EXPLAINS THE METHOD OF OVERHEAD DISTRIBUTION SWITCH NUMBERING.

1. EACH SWITCH IS IDENTIFIED BY A UNIQUE NUMBER THAT INDICATES THE CIRCUIT(S) ON WHICH IT OPERATES.
2. THERE ARE TWO TYPES OF SWITCH NUMBERS: **LINE** AND **TIE**

2.1 **LINE SWITCH NUMBERS** ARE BROKEN UP INTO TWO PARTS:

CIRCUIT AND NUMBER $\frac{375}{\text{CIRCUIT}} - \frac{40-L}{\text{NUMBER}}$

CIRCUIT – DESCRIBES THE VOLTAGE AND CIRCUIT NUMBER TO WHICH THE LINE SWITCH IS CONNECTED. IF THE CIRCUIT CONTAINS ONLY NUMERIC CHARACTERS, THEN THE CIRCUIT VOLTAGE IS 12KV. IF IT CONTAINS ALPHABETIC CHARACTERS (e.g. CD10), THEN THE CIRCUIT VOLTAGE IS 4 OR 2.4KV.

NUMBER – CONTAINS ONLY NUMERIC CHARACTERS, OR, NUMERIC CHARACTERS FOLLOWED BY AN "L". THE "L" INDICATES THAT THIS IS A LOADBREAK SWITCH. THE NUMERIC PORTION IS ARBITRARY AND EACH NUMBER SHALL NOT BE ASSIGNED TO MORE THAN ONE SWITCH FOR EACH CIRCUIT.

EXAMPLES:

375-40-L INDICATES A LINE SWITCH ON 12KV CIRCUIT 375 WITH AN ARBITRARY NUMBER 40, AND LOADBREAK CAPABILITY.

GAI-2 INDICATES A LINE SWITCH ON 4KV OR 2.4KV CIRCUIT GA 1 WITH AN ARBITRARY NUMBER 2, AND NO LOADBREAK CAPABILITY.

2.2 **TIE SWITCH NUMBERS** ARE BROKEN UP INTO THREE PARTS:

CIRCUIT; ALPHA NUMERIC; AND CIRCUIT $\frac{375}{\text{CIRCUIT}} - \frac{T1}{\text{ALPHA/NUMERIC}} - \frac{376}{\text{CIRCUIT}}$

CIRCUIT – DESCRIBES THE VOLTAGE AND CIRCUIT NUMBERS THE TIE SWITCH CONNECTS **AS STATED ABOVE.**

ALPHA/NUMERIC – ALWAYS CONTAINS THE ALPHA CHARACTER "T" AND IS FOLLOWED BY A BY A NUMBER (1,2,3, ETC.) WHICH IS CONSECUTIVELY ASSIGNED FOR TIE SWITCHES BETWEEN THE SAME TWO CIRCUITS. EACH ALPHA/NUMERIC IDENTIFICATION SHALL NOT BE ASSIGNED TO MORE THAN ONE TIE SWITCH BETWEEN THE SAME TWO CIRCUITS. TIE SWITCHES WITH THE NUMBER FOLLOWED BY AN "L" HAVE LOADBREAK CAPABILITY.

EXAMPLES:

85-T1-380 INDICATES THE FIRST TIE SWITCH BETWEEN CIRCUITS 85 & 380.

86-T2-87-L INDICATES THE SECOND TIE SWITCH, WITH LOADBREAK CAPABILITY, BETWEEN CIRCUITS 86 & 87.

88-T-89 INDICATES THE ONLY TIE SWITCH INSTALLED BEFORE 4-1-77, BETWEEN CIRCUITS 88 & 89. IF INSTALLED AFTER 4-1-77, THIS TIE SWITCH SHALL BE NUMBERED 88-T1-89.

3. WHERE SWITCHES IN PARALLEL ARE INSTALLED AS LINE OR TIE SWITCHES, EACH SWITCH WILL BE ASSIGNED AN INDIVIDUAL NUMBER AS DESCRIBED IN PARAGRAPH 2.
4. SWITCH NUMBERS WILL NOT BE ASSIGNED TO NORMALLY OPEN, BRIDGED, OR FUSED CUTOUTS, UNLESS THEY ARE USED FOR TIE PURPOSES.

FOR FIELD MAINTENANCE ONLY

© 1998 - 2015 San Diego Gas & Electric Company. All rights reserved. Removal of this copyright notice without permission is not permitted under law.

DATE 1-1-96 APPD <i>PA/ROJ</i>	SDG&E ELECTRIC STANDARDS OVERHEAD DISTRIBUTION SWITCH NUMBERING	204
-----------------------------------	--------------------------------------------------------------------	-----

OH212 FIELD MAINTENANCE ONLY

ALL VERSIONS LISTED IN FMO ARE SUPERSEDED BY THEIR CURRENT VERSION FOUND INSIDE THE OVERHEAD CONSTRUCTION STANDARD MANUAL.

REVISION HISTORY:



















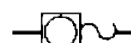









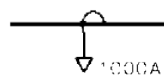

04/22/2019: **FORMATTING UPDATE**

07/13/2016: **MOVED TO FMO.**

© 1998 - 2019 San Diego Gas & Electric Company. All rights reserved. Removal of this copyright notice without permission is not permitted under law.





REV	CHANGE	BY	DSGN	APPV	DATE	REV	CHANGE	BY	DSGN	APPV	DATE
C						F					
B	FORMATTING UPDATE	PEI	-	-	04/22/2019	E					
A	ORIGINAL ISSUE	JS	IL	MDJ	07/13/2016	D					











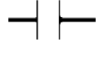

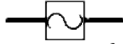
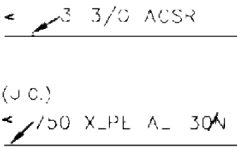





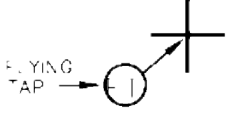

SHEET 1 OF 1	X	Indicates Latest Revision	Completely Revised	New Page	Information Removed	FMO OH212
	SDG&E ELECTRIC OVERHEAD CONSTRUCTION STANDARDS					
	GFMS SUMMARY OPERATING MAP SYMBOL TABLE					

HOCS*/BLOCK (OH)  123-342B 100HR P377016	FUSE BRIDGED (UG)  3 BRGD	PRIMARY METERING STATION (OH)  123-234M P77676	SWITCH (OH) GANG OPERATED  123-412 P77576	OPEN TO ADJACENT CIRCUIT (UG) CIRCUIT 281 OPEN 	
INLINE SWITCH AND FUSE  3 80A 24" 3 P23769	FOR FIELD MAINTENANCE ONLY		FUSE WITH BY-PASS (OH)  123-45 (OPEN) 3 80A P67700	PRIMARY METERING STATION (UG) W/CUS OVER OWNED STRUCTURE  123-345W P234500	
SWITCH (OH) GANG OPERATED (SCADA)  SCADA 95 123-17 P67778	PAD MOUNTED SWITCH AND FUSE  3 80A 48.5" 1"	FUSE D&W  3 80A D&W P234675	CABLE POLE (FUSED)  3 150A P227692	SWITCH ON/OFF (UG)  123-324	
GROUNDING BANK (OH)  123-2540B	SERVICE RESTORER WITH BY-PASS (OH)  123-25 (OPEN) 123-24R P73678	SWITCH-HOOK STICK (OH)  123-234 P76455	NEUTRAL 	FUSE (OH)  1-10A P17723	ELECTRONIC SIGNAL ZER (OH)  3-100A P58961
FAULT INDICATOR  1000A	CAPACITOR (OH) CW - FIXED CW - SWITCHED CW - SWITCHED, N MANUAL MODE  123-435CW 1200KVAR P79707	GROUNDING BANK (UG)  123-3650B	REGULATOR BYPASS WITH DISCONNECTS (OH)  123-123G 100A P47487	FUSE-BRIDGED (OH)  3 BRGD P570164	
CUSTOMER GENERATION  CG103023 CG103023 EF 9.59 COAST BLVD 250 KW	SREA (FOR SAN OND-REF)  000.5 D6954127	CAPACITOR (UG) CW - SWITCHED CW - SWITCHED, N MANUAL MODE  123-234CW 1200KVAR	REGULATOR (OH) ON-BYPASSED  123-123G 100A P67423		
REGULATOR INDUCTION (OH)  123-123G P87219	OPEN TO ADJACENT CIRCUIT (OH) CIRCUIT 123 OPEN 	PAD MOUNTED SUB 	JOHNSON STEP-DOWN 12/4 KV 2000 HPP HIGH FUSING: 1-150A LOW FUSING: NONE FEED: CIR.552 0104329	POLE MOUNTED SUB 	MISSION BEACH STEP-DOWN 12/4 KV 300 HPP HIGH FUSING: 3-30A LOW FUSING: NONE FEED: CIR. 58 P2321269683

© 1998 - 2019 San Diego Gas & Electric Company. All rights reserved. Removal of this copyright notice without permission is not permitted under law.

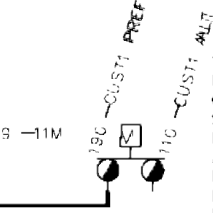
REV	CHANGE	BY	DSGN	APPV	DATE	REV	CHANGE	BY	DSGN	APPV	DATE
C						F					
B	FORMATTING UPDATE	PEI	-	-	04/22/2019	E					
A	ORIGINAL ISSUE	-	TR	MF	10/31/2006	D					

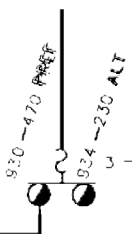
SHEET 1 OF 9	 Indicates Latest Revision	 Completely Revised	 New Page	 Information Removed	FMO OH212.1 UG3112.1
	SDG&E ELECTRIC OVERHEAD AND UNDERGROUND STANDARDS				
	GFMS SUMMARY OPERATING MAP SYMBOL TABLE				

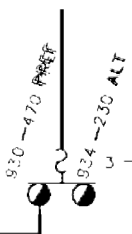
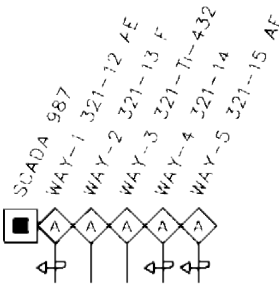
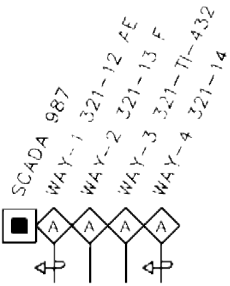
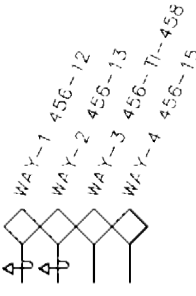
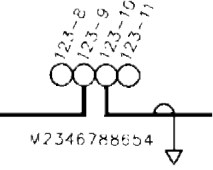





<p>OPEN TO SAME CIRCUIT</p>  <p>OPEN P57769</p>	<p>STEP UP/DN (OH)</p>  <p>144-190SD 12000/4150 P470649</p>	<p>FUSE (UG)</p>  <p>3 30A CI WITH BY-PASS 3-30A CL B"</p>	<p>PRIMARY WRE & CALLOUT (OH)</p>  <p>3 3/0 ACSR (J.C.) 150 X_PL AL 30A</p>	<p>FUSED ON/OFF SWITCHING CAPABILITY</p>  <p>3 600A 287 5</p>
<p>PRIMARY JUMP</p> 	<p>OH GROUP SWITCH SCADA MAIL</p>  <p>SCADA 96 715-16 715-1 P79699</p>	<p>PMLB SWITCH</p>  <p>190-13 3 600A</p>	<p>PADMOUNT SERVICE RESTORER</p>  <p>SCADA 98 57-42</p>	<p>PMF3 SWITCH</p>  <p>SCADA 99 226-7</p>
<p>OH DPOV</p>  <p>107-1 107 DPOV P123456</p>	<p>FLYING TAP</p> 	<p>LOADBREAK GANG OPERATED SWITCH</p>  <p>115-23- P234567</p>	<p>OH SCADA RTU POLE</p>  <p>SCADA 62 P123456A</p>	<p>SUBSTATION EL CALCN SUB 69/12KV</p>  <p>SPRING VALLEY SUB 12/4KV</p> 
<p>BOOST (UG)</p>  <p>280-124B 3750 HHR</p>	<p>THROWOVER W/BUS BAR</p>  <p>109-11M 109 CUST11 PEF 110 CUST11 ALT</p> <p>109 CUST11 PEF: SWI GEAR B LEVEL - SIDE OF BLDG: 24 HR ACCESS PHONE - LOADING DOCK N/E CORNER OF BLDG:</p> <p>AUTO CITY OF SD CUST OWNED L100311</p>		<p>THROWOVER W/O BUS BAR</p>  <p>426-8 ALT 426-18 PEF</p> <p>428-18 PEF: E ST W/O 15TH BASEMENT "B"</p> <p>MAN CITY OF SD SDGE OWNED 02013772340</p>	<p>PADMOUNT THROWOVER SWITCH PM -E STYLE</p>  <p>930-470 PEF: NORTHWEST CORNER OF FACILITY, NEXT TO OUTDOOR CUSTOMER SWITCHGEAR</p> <p>934-230 ALT 3-450A C</p> <p>AUTO U.S. POSTAL SERVICE SDG&E OWNED Y100012</p>
<p>THROWOVER AT A SUBSTATION</p>  <p>AUTO 206-VS PEF 206-VS ALT VS1A SUB 12/4KV</p>	<p>FOR FIELD MAINTENANCE ONLY</p>			<p>THROWOVER W/O BUS BAR</p>  <p>930-470 PEF: NORTHWEST CORNER OF FACILITY, NEXT TO OUTDOOR CUSTOMER SWITCHGEAR</p> <p>934-230 ALT 3-450A C</p> <p>AUTO U.S. POSTAL SERVICE SDG&E OWNED Y100012</p>
<p>5-WAY TRAYER WITH SCADA W/AUTOFUNCTIONAL ZING AND/OR FAULT INTERRUPTION</p>  <p>SCADA 987 WAY-1 321-12 AE WAY-2 321-13 F WAY-3 321-11-432 WAY-4 321-14 WAY-5 321-15 AE</p>	<p>4-WAY TRAYER WITH SCADA W/AUTOFUNCTIONAL ZING AND/OR FAULT INTERRUPTION</p>  <p>SCADA 987 WAY-1 321-12 AE WAY-2 321-13 F WAY-3 321-11-432 WAY-4 321-14</p>	<p>4-WAY TRAYER, MANUAL</p>  <p>WAY-1 456-12 WAY-2 456-13 WAY-3 456-11-458 WAY-4 456-15</p>	<p>SCHEMATIC DETAIL OF A TYPICAL 4-WAY SWITCH</p>  <p>123-8 123-9 123-10 123-11</p> <p>W2346788654</p>	

© 1998 - 2019 San Diego Gas & Electric Company. All rights reserved. Removal of this copyright notice without permission is not permitted under law.

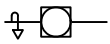
REV	CHANGE	BY	DSGN	APPV	DATE	REV	CHANGE	BY	DSGN	APPV	DATE
C						F					
B	FORMATTING UPDATE	PEI	-	-	04/22/2019	E					
A	ORIGINAL ISSUE	-	TR	MF	12/03/2005	D					

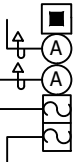
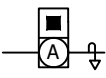
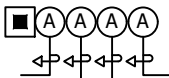
<p>SHEET 2 OF 9</p>	<p>X Indicates Latest Revision</p>	<p>Completely Revised</p>	<p>New Page</p>	<p>Information Removed</p>
	<p>SDG&E ELECTRIC OVERHEAD AND UNDERGROUND STANDARDS</p>			
	<p>GFMS SUMMARY OPERATING MAP SYMBOL TABLE</p>			

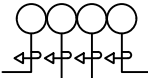
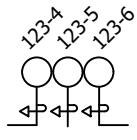
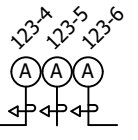
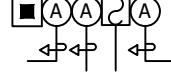
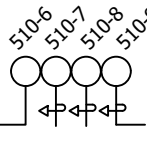
FMO
OH212.2
UG3112.2

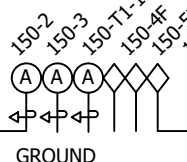
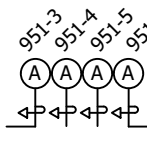
<p>PME-3</p>  <p>712-19 1000A D130145</p>	<p>PME-9</p>  <p>CMPT1 954-27 CMPT2 954-28 CMPT3 3-140A CL CMPT4 3-200A SMA</p> <p>1000A 1000A D130423</p>	<p>PME-9 WITH SCADA W/AUTOSECTIONALIZING</p>  <p>SCADA 999 CMPT1 590-1164 AE 1000A CMPT2 590-1168 AE 1000A CMPT3 3-100A SM4 CMPT4 3-100A SM4</p> <p>D131370</p>
<p>PME-3 WITH SCADA</p>  <p>1000A RTU 178 SCADA 178 435-21 1000A D131755</p>	<p>PME-10 WITH SCADA W/AUTOSECTIONALIZING</p>  <p>SCADA 789 CMPT1 999-1 AE CMPT2 999-2 AE CMPT3 999-3 AD CMPT4 990-T1-999</p> <p>1000A 1000A 1000A 1000A D123456</p>	<p>PME-11</p>  <p>CMPT1 954-29 CMPT2 954-42 CMPT3 3-140A CL CMPT4 954-43</p> <p>1000A 1000A 1000A 1000A D130489</p>
<p>PME-10</p>  <p>CMPT1 999-1 CMPT2 999-2 CMPT3 999-3 CMPT4 999-T-990</p> <p>1000A 1000A 1000A 1000A D123456</p>	<p>3-WAY PADMOUNT SWITCH W/GROUND</p>  <p>123-4 123-5 123-6</p> <p>1000A 1000A 1000A D123477</p>	<p>3-WAY PADMOUNT SWITCH W/GROUND SCADA</p>  <p>RTU 611 D678901</p> <p>123-4 123-5 123-6</p> <p>1000A 1000A 1000A D123477</p>
<p>PME-11 WITH SCADA W/AUTOSECTIONALIZING</p>  <p>SCADA 789 CMPT1 999-1 AD CMPT2 999-2 CMPT3 3-200A SM4 CMPT4 999-3 AE</p> <p>1000A 1000A 1000A RTU 789 D169065</p>	<p>4-WAY SWITCH W/GROUND</p>  <p>510-6 510-7 510-8 510-9</p> <p>1000A 1000A 1000A H775837</p>	<p>PME SOURCE TRANSFER SCADA</p>  <p>CMPT1 426-4 PREF CMPT2 427-8 ALT CMPT3 3-150A CL CMPT4</p> <p>SCADA 56 MAN SDGE OWNED D100896</p>
<p>6-WAY SWITCH W/3 FAULT INTERUPTERS & SCADA</p>  <p>RTU 610</p> <p>150-2 150-3 150-T1-12L 150-4F 150-5F 150-6F</p> <p>1000A 1000A 1000A U123568</p>	<p>4-WAY SWITCH W/GROUND SCADA</p>  <p>RTU 780 D659321</p> <p>951-3 951-4 951-5 951-6</p> <p>1000A 1000A 1000A 1000A H785477</p>	<p>FOR FIELD MAINTENANCE ONLY</p>

© 1998 - 2019 San Diego Gas & Electric Company. All rights reserved. Removal of this copyright notice without permission is not permitted under law.

REV	CHANGE	BY	DSGN	APPV	DATE	REV	CHANGE	BY	DSGN	APPV	DATE
C						F					
B	FORMATTING UPDATE	PEI	-	-	04/22/2019	E					
A	ORIGINAL ISSUE	-	TR	MF	12/03/2005	D					

<p>SHEET 3 OF 9</p>	<p>X Indicates Latest Revision</p>	<p>Completely Revised</p>	<p>New Page</p>	<p>Information Removed</p>	<p>FMO OH212.3 UG3112.3</p>
	<p>SDG&E ELECTRIC OVERHEAD AND UNDERGROUND STANDARDS</p>				
	<p>GFMS SUMMARY OPERATING MAP SYMBOL TABLE</p>				

BOOST STATION 155-76B 3750 HHR D2791269123	600 AMP EXTENSION SPLICE M123456 3-ES	CAPACITOR STATION CW - SWITCHED CM - SWITCHED, IN MANUAL MODE 124-61CW 900 KVAR D2617473210	CIRCUIT (CABLE) 30 #2PECN CU 100.	CONNECTORS LD. BREAK ELBOWS 395-76 D2617673212
CABLE TAPS (LD. BREAK ELBOWS) H2617673212 3314 .3-4	PIGGY BACK ELBOWS 224-73 1-25 HDD D3127573322 2-PB	"T" CONNECTOR W/200 AMP LBE H3217573424 3316 3-T	HAND SPLICE T SPLICE H321773326 3314 .1-HS 1-TS	STRAIGHT CONNECTOR TRANSITION MODULE M321773326 3326 .1-SC 1-TM
"T" CONNECTOR H321773326 3314 .3-T	"Y" CONNECTOR H3217833734 3314 .1-Y	W/200A LB CAPABILITY H225678 3316	PAD MOUNTED SUB JOHNSON STEP-DOWN 12/4 KV 2000 HPP HIGH FUSING: 1-150A LOW FUSING: -NONE FEED: CIR. 552 D104329	
OPEN/SAME CIRCUIT OPEN 44-68 1-500HAL D3112559335	600A JUNCTION BAR W/GROUNDING POINT 3-TG	PASS THROUGH H3227233832 3314 .3-PT	MANHOLE M2468176543 3324	(LIVE FRONT) CONNECTIONS 270-77 1-50 NEP D3237333832
PRIMARY METERING STATION (UG) CUSTOMER OWNED STATION (UG) D123456 CO 123-345M (STRESS CONE)	OPEN/DIFFERENT CIRCUIT CIR 50 OPEN H5470873521 3314 3-4	 D3237433835	PRIMARY HANDHOLE H2735784212 3315	GROUNDING BANK 800-632GB D2175075201
SDGE OWNED D346678 123-456M (600A TEE) (200A LB ELBOW)	STEP DOWNSTATION 125-201 SD 12000/2400/4160Y D2185271210	STEP UP STATION 521-102SU 12000/2400/4160Y D1581210217	SUBSTATION EL CAJON SUB 69/12KV	SUBSTATION SPRING VALLEY 12/4 KV
SUBSURFACE ENCLOSURE S2345678690 3399	SUBSURFACE SWITCH ON/OFF 800-13 M3120560124 3322	FUSED ON/OFF SWITCH PAD MOUNTED 200-10 3-80A D2335479573	HOOKSTICK SWITCH ON A CABLE POLE 122-8 P13064	GANG OPERATED SWITCH ON A CABLE POLE 113-10 P323040













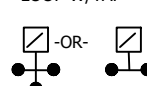





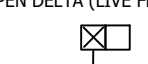
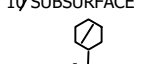

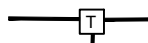
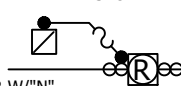
FOR FIELD MAINTENANCE ONLY

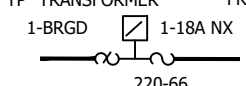
FUSED ELBOWS 1-18A F.E. 900-75 1-25 NDD D2918276127 3-30A F.E. H2617673222 3314 .3-4	CONNECTOR (DEAD FRONT) 155-62 1-75YES S321773324 3399	CUSTOMER GENERATION CG01-310-599	FUSE CABINET 3-80A D3124476143 WITH BY-PASS 3-30A CL BP D1234567890	BRIDGED FUSE 1-BRGD D2454576262 3-BRGD P10450	REGULATOR STATION BYPASS 715-117G 200A D1404575271 3324 UNBYPASS BY1-110G 100A D2147536087 3322
----------------------------------------------------------------------------------------------------------------------	------------------------------------------------------------------------------	------------------------------------------------	-----------------------------------------------------------------------------------------------	----------------------------------------------------------------------	--------------------------------------------------------------------------------------------------------------------------------------------------

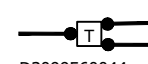
© 1998 - 2019 San Diego Gas & Electric Company. All rights reserved. Removal of this copyright notice without permission is not permitted under law.

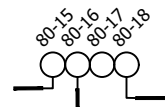
REV	CHANGE	BY	DSGN	APPV	DATE	REV	CHANGE	BY	DSGN	APPV	DATE
C						F					
B	FORMATTING UPDATE	PEI	-	-	04/22/2019	E					
A	ORIGINAL ISSUE	-	MF	JJ	05/22/2007	D					

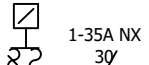

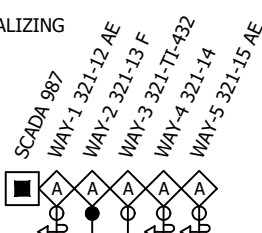
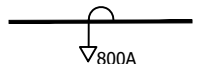
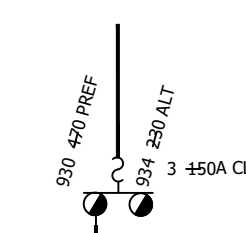
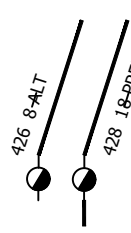
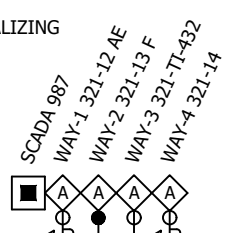
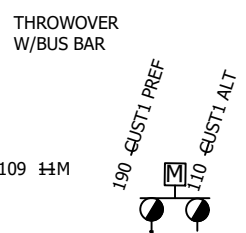
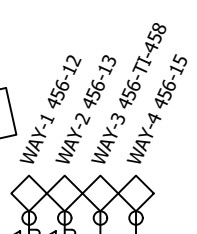







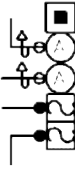

SHEET 4 OF 9	Indicates Latest Revision	Completely Revised	New Page	Information Removed	FMO OH212.4 UG3112.4
	SDG&E ELECTRIC OVERHEAD AND UNDERGROUND STANDARDS				
	GFMS OPERATING MAP SYMBOL TABLE				

<p>1Ø PAD MOUNTED (DEAD FRONT) RADIAL</p>  <p>159-253 1-75 HDD D1479273159</p>	<p>1Ø PAD MOUNTED (DEAD FRONT) LOOP</p>  <p>561-173 1-25 NDD D106009</p>	<p>1Ø PAD MOUNTED (DEAD FRONT) LOOP W/TAP</p>  <p>561-173 1-25 NDL D107077</p>	<p>1Ø PAD MOUNTED (LIVE FRONT)</p>  <p>561-139 1-50 NEP D5114055518</p>	<p>3Ø PAD MOUNTED (DEAD FRONT) RADIAL</p>  <p>561-407 1-75 HZB D118892</p>
<p>3Ø PAD MOUNTED (DEAD FRONT) LOOP</p>  <p>561-410 1-750 HNB D118893</p>	<p>3Ø PAD MOUNTED (LIVE FRONT)</p>  <p>561-233 1-1000 HAP D5109955539</p>	<p>CLOSED DELTA (DEAD FRONT)</p>  <p>100-55 1-25 HDD 2-75 NDD D2125576655</p>	<p>OPEN DELTA (LIVE FRONT)</p>  <p>100-54 1-50 HEP 1-75 HEP D2125576655</p>	<p>1Ø SUBSURFACE</p>  <p>165-65 1-15 WS S3240064800 3399</p>
<p>3Ø PAD MOUNTED OPEN DELTA (DEAD FRONT)</p>  <p>900-75 2-75 HDL D3123560390</p>	<p>3Ø TERMINATOR (LIVE FRONT)</p>  <p>D3108560114</p>	<p>PADMOUNT SERVICE RESTORER</p>  <p>SCADA 98 57-4R D123456 3-C 3-C</p> <p>PMSR W/"N" TRANSFORMER</p>	<p>SIREN (FOR SAN ONOFRE)</p>  <p>OC01 D2461767</p>	<p>UG SCADA RTU</p>  <p>RTU 88 D116890</p>
<p>1Ø PAD MOUNTED "YP" TRANSFORMER (LIVE FRONT)</p>  <p>1-BRGD 1-18A NX 220-66 D3125676082</p>	<p>DEAD FRONT TERMINATOR</p>  <p>D123456 3-4</p>	<p>1Ø TERMINATOR WITH .1-4</p>  <p>D3099560044 1-4</p>	<p>PMES SWITCH</p>  <p>790-13 3-150A D126194</p>	<p>4-WAY SWITCH</p> 
<p>THROWOVER AT A SUBSTATION</p>  <p>VISTA SUB 12/4KV AUTO 206-VS PEF 208-VS ALT</p>	<p>1Ø PAD MOUNTED "YP" (LIVE FRONT)</p>  <p>1-BRGD 3Ø 1-35A NX 700-357 D3215457342 2-SC YØ</p>	<p>PMES3 SWITCH</p>  <p>SCADA 99 228-7 D135790</p>	<p>5-WAY TRAYER WITH SCADA W/AUTOSECTIONALIZING AND/OR FAULT INTERRUPTION</p>  <p>SCADA 987 WAY-1 321-12 AE WAY-2 321-13 F WAY-3 321-TI-432 WAY-4 321-14 WAY-5 321-15 AE</p>	
<p>FAULT INDICATOR</p>  <p>∇800A</p>	<p>VAULT U2743171342</p> <p>PADMOUNT THROWOVER SWITCH PMH 6 STYLE</p>  <p>930 470 PEF 934 230 ALT 3 ±50A CL</p> <p>AUTO U.S. POSTAL SERVICE SDG&E OWNED Y100012</p> <p>930-470 PEF: NORTHWEST CORNER OF FACILITY, NEXT TO OUTDOOR CUSTOMER SWITCHGEAR</p>	<p>THROWOVER W/O BUS BAR</p>  <p>426 8-ALT 428 18-PREF</p> <p>MAN CITY OF SD - POLICE DEPT SDGE OWNED D2013772340</p> <p>428 ±8 PEF: E ST W/O 15TH BASEMENT "B"</p>	<p>4-WAY TRAYER WITH SCADA W/AUTOSECTIONALIZING AND/OR FAULT INTERRUPTION</p>  <p>SCADA 987 WAY-1 321-12 AE WAY-2 321-13 F WAY-3 321-TI-432 WAY-4 321-14</p>	
<p>THROWOVER W/BUS BAR</p>  <p>109 ±M 190 CUST1 PEF 110 CUST1 ALT</p> <p>AUTO CITY OF SD CUST OWNED U100311</p> <p>109 CUST1 PEF: SWI GEAR B LEVEL - SIDE OF BLDG: 24 HR ACCESS PHONE - LOADING DOCK N/E CORNER OF BLDG:</p>	<p>FOR FIELD MAINTENANCE ONLY</p>		<p>4-WAY TRAYER, MANUAL</p>  <p>WAY-1 456-12 WAY-2 456-13 WAY-3 456-TI-458 WAY-4 456-15</p>	

© 1998 - 2019 San Diego Gas & Electric Company. All rights reserved. Removal of this copyright notice without permission is not permitted under law.

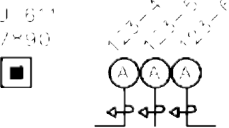
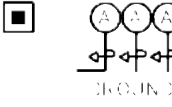
REV	CHANGE	BY	DSGN	APPV	DATE	REV	CHANGE	BY	DSGN	APPV	DATE
C						F					
B	FORMATTING UPDATE	PEI	-	-	04/22/2019	E					
A	ORIGINAL ISSUE	-	TR	MF	10/31/2006	D					

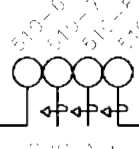
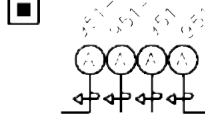
<p>SHEET 5 OF 9</p>	<p>X Indicates Latest Revision</p>	<p>Completely Revised</p>	<p>New Page</p>	<p>Information Removed</p>	<p>FMO OH212.5 UG3112.5</p>
	<p>SDG&E ELECTRIC OVERHEAD AND UNDERGROUND STANDARDS</p>				
	<p>GFMS OPERATING MAP SYMBOL TABLE</p>				

<p>PMI 7</p>  <p>1000A R/L 1/8 166A 1/4 166A 1/4 166A 1/4 166A 1/4 166A 1/4</p>	<p>PMI 8 WITH SCADA & GAV LINK CONNECTOR</p>  <p>1000A R/L 1/8 166A 1/4 166A 1/4 166A 1/4 166A 1/4 166A 1/4</p>	<p>PMI 9</p>  <p>1000A 1000A 1000A 1000A</p>
<p>PMI 9 WITH SCADA</p>  <p>SCADA 999 CMPT1 999-1 166A 1000A CMPT2 999-2 166A 1000A CMPT3 999-3 166A 1000A CMPT4 999-4 166A 1000A</p> <p>1000A 1000A 1000A 1000A</p>	<p>PMI 10</p>  <p>CMPT1 999-1 CMPT2 999-2 CMPT3 999-3 CMPT4 999-4</p> <p>1000A 1000A 1000A 1000A 1000A</p>	<p>PMI 10 WITH SCADA W/AL OS & ANALYZING</p>  <p>SCADA 999 CMPT1 999-1 4E CMPT2 999-2 4E CMPT3 999-3 4E CMPT4 999-4 4E</p> <p>1000A 1000A 1000A 1000A 1000A</p>
<p>PMI 11</p>  <p>CMPT1 999-1 CMPT2 999-2 CMPT3 999-3 CMPT4 999-4</p> <p>1000A 1000A 1000A 1000A</p>	<p>PMI 11 WITH SCADA W/AL OS & ANALYZING</p>  <p>SCADA 999 CMPT1 999-1 4E CMPT2 999-2 4E CMPT3 999-3 4E CMPT4 999-4 4E</p> <p>1000A 1000A 1000A 1000A 1000A</p>	<p>5 WAY PADMOUNT SWICH W/GROUND</p>  <p>1000A 1000A 1000A 1000A 1000A</p>
<p>5 WAY PADMOUNT SWICH W/GROUND SCADA</p>  <p>SCADA 999 CMPT1 999-1 CMPT2 999-2 CMPT3 999-3 CMPT4 999-4 CMPT5 999-5</p> <p>1000A 1000A 1000A 1000A 1000A</p>	<p>5 WAY SWICH W/3 AL IN TERRITORY & SCADA</p>  <p>SCADA 999 CMPT1 999-1 CMPT2 999-2 CMPT3 999-3 CMPT4 999-4 CMPT5 999-5</p> <p>1000A 1000A 1000A 1000A 1000A</p>	<p>5 WAY PADMOUNT SWICH W/GROUND</p>  <p>1000A 1000A 1000A 1000A 1000A</p>
<p>4 WAY SWITCH W/GROUND</p>  <p>SCADA 999 CMPT1 999-1 CMPT2 999-2 CMPT3 999-3 CMPT4 999-4</p> <p>1000A 1000A 1000A 1000A</p>	<p>4 WAY SWITCH W/GROUND SCADA</p>  <p>SCADA 999 CMPT1 999-1 CMPT2 999-2 CMPT3 999-3 CMPT4 999-4</p> <p>1000A 1000A 1000A 1000A</p>	<p>5 WAY PADMOUNT SWICH W/GROUND</p>  <p>SCADA 999 CMPT1 999-1 CMPT2 999-2 CMPT3 999-3 CMPT4 999-4</p> <p>1000A 1000A 1000A 1000A</p>



























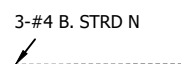



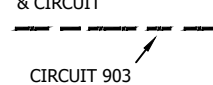

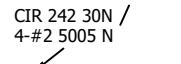











FOR FIELD MAINTENANCE ONLY

© 1998 - 2019 San Diego Gas & Electric Company. All rights reserved. Removal of this copyright notice without permission is not permitted under law.

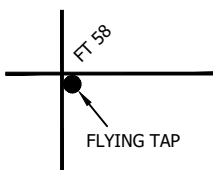
REV	CHANGE	BY	DSGN	APPV	DATE	REV	CHANGE	BY	DSGN	APPV	DATE
C						F					
B	FORMATTING UPDATE	PEI	-	-	04/22/2019	E					
A	ORIGINAL ISSUE	-	TR	MF	05/22/2006	D					

SHEET 6 OF 9	X	Indicates Latest Revision	Completely Revised	New Page	Information Removed
	SDG&E ELECTRIC OVERHEAD AND UNDERGROUND STANDARDS				
	GFMS SUMMARY OPERATING MAP SYMBOL TABLE				

**FMO
OH212.6
UG3112.6**

BOOST STATION (1 PHASE)  242-66B 100HR P76933	BRIDGED FUSE  CIR-242 3- BKGO JP433234	CAPACITOR STATION CF - FIXED CW - SWITCHED CM - SWITCHED, IN MANUAL MODE  242-65 CW/CM 1200 KV/AR P234990	BUCK STATION (3 PHASE)  242-543BU 3750 HHT P43440	OH SCADA CABLE  SCADA 45	POLE MOUNTED SUB  MISSION BEACH STEP-DOWN 12/4 KV P2321269883
GROUNDING BANK STATION  242-74GB 3-50 YF P99032	STREET LIGHT TRANSFORMER STATION  242-85RO 1-25R P45493	SUBSTATION 12/4  POWAY SUB 12/4	OVERHEAD STREET LIGHT  P00710	REGULATOR STATION (3 PHASE)  242-227G 100A P124450	CUSTOMER GENERATION STATION  CG01-16-601 242-16M JP521881
POLE  P567332	STUB POLE  P116740S	REGULATOR STATION (PHASE 1)  242-105G 25A JP55609	SWITCH (GANG)  242-43 JP44302	SECONDARY CIRCUIT & POLE LINE  3-#4 B. STRD N	SWITCH (HOOKSTICK)  242-12 P445760
AVIAN PROTECTION PLAN (APP) WILDLIFE SYMBOL  432-10 1-25 HE P123456	SINGLE PHASE TRANSFORMER STATION  242-65 1-15 HE P44212	SECONDARY CABLE POLE  P990321	TRANSMISSION POLELINE & CIRCUIT  CIRCUIT 903	STEP UP STATION  242-605SU 12000/2400/4160Y P114532	PRIMARY CABLE POLE  P667990
PRIMARY CIRCUIT & POLE LINE  CIR 242 30N / 4-#2 5005 N	STEP DOWN STATION  242-145SD 12000/2400/4160Y P445320	THREE PHASE TRANSFORMER STATION  242-143 3-75HF P554354	PRIMARY METERING STATION  242-60M P993111	SUPERVISORY CABLE 	TERMINATION (SECONDARY DEAD ENDS)  JP556753
SERVICE RESTORER  242-20R P44358	SUBSTATION 69/12  ASH SUB 69/12	TRANSMISSION DOUBLE POLE  Z557090	TRANSMISSION POLE  Z554354	TRANSMISSION TOWER  Z113454	FUSE (CUTOUT)  CIR-242 3-30A P334143
ELECTRONIC SECTIONALIZER (CUTOUT)  CIR-455 3-100A P19926	SCADA ANTENNA POLE  P123456A	OH SCADA RTU POLE  SCADA 62 P123456A	DPQM  107-2 107-DPQM P123456	LOADBREAK GANG OPERATED SWITCH  58-23-L P234567	 FT 58 FLYING TAP
PRIMARY DEAD END (MULTIPLE CIRCUITS SINGLE CIRCUIT OPEN)  CIR-242 OPEN CIR-242 OPEN P435431	PRIMARY DEAD END (MULTIPLE CIRCUITS)  CIR-169 OPEN CIR-242 OPEN P89000	THREE PHASE TRANSFORMER STATION (DBL POLE)  242-241 3-37.5 HGT JP44530	THROWOVER AT A SUBSTATION AUTO 206-VT PREF 208-VT ALT  VISTA SUB 12/4KV	SCADA MATE OH GROUP SWITCH  SCADA 96 715-16 715-1 P79699	

FOR FIELD MAINTENANCE ONLY

© 1998 - 2019 San Diego Gas & Electric Company. All rights reserved. Removal of this copyright notice without permission is not permitted under law.

REV	CHANGE	BY	DSGN	APPV	DATE	REV	CHANGE	BY	DSGN	APPV	DATE
C						F					
B	FORMATTING UPDATE	PEI	-	-	04/22/2019	E					
A	ORIGINAL ISSUE	-	TR	MF	12/05/2005	D					

SHEET
7 OF 9

X Indicates Latest Revision Completely Revised New Page Information Removed

SDG&E ELECTRIC OVERHEAD AND UNDERGROUND STANDARDS

GFMS
STANDARD FACILITY MAP SYMBOL TABLE

FMO
OH212.7
UG3112.7

						23.11E

© 1998 - 2019 San Diego Gas & Electric Company. All rights reserved. Removal of this copyright notice without permission is not permitted under law.

REV	CHANGE	BY	DSGN	APPV	DATE	REV	CHANGE	BY	DSGN	APPV	DATE
C						F					
B	FORMATTING UPDATE	PEI	-	-	04/22/2019	E					
A	ORIGINAL ISSUE	-	TR	MF	05/22/2007	D					

SHEET 8 OF 9	Indicates Latest Revision	Completely Revised	New Page	Information Removed	FMO OH212.8 UG3112.8
	SDG&E ELECTRIC OVERHEAD AND UNDERGROUND STANDARDS				
	GFMS STANDARD FACILITY MAP SYMBOL TABLE				

5-WAY TRAYER WITH SCADA

SCADA 987
 WAY-1 321-12 AE
 WAY-2 321-13 F
 WAY-3 321-11-432
 WAY-4 321-14
 WAY-5 321-15 AE



4 WAY TRAYER WITH SCADA

SCADA 987
 WAY-1 321-12 AE
 WAY-2 321-13 F
 WAY-3 321-11-432
 WAY-4 321-14



4-WAY TRAYER, MANUAL

WAY-1 456-12
 WAY-2 456-13
 WAY-3 456-11-458
 WAY-4 456-15



FOR FIELD MAINTENANCE ONLY

© 1998 - 2019 San Diego Gas & Electric Company. All rights reserved. Removal of this copyright notice without permission is not permitted under law.

REV	CHANGE	BY	DSGN	APPV	DATE	REV	CHANGE	BY	DSGN	APPV	DATE
C						F					
B	FORMATTING UPDATE	PEI	-	-	04/22/2019	E					
A	ORIGINAL ISSUE	-	WT	MC	05/08/2008	D					

SHEET
9 OF 9

Indicates Latest Revision Completely Revised New Page Information Removed

SDG&E ELECTRIC OVERHEAD AND UNDERGROUND STANDARDS

GFMS
STANDARD FACILITY MAP SYMBOL TABLE

FMO
OH212.9
UG3112.9

OH218 FIELD MAINTENANCE ONLY

ALL VERSIONS LISTED IN FMO ARE SUPERSEDED BY THEIR CURRENT VERSION FOUND INSIDE THE OVERHEAD CONSTRUCTION STANDARD MANUAL.

REVISION HISTORY:

04/22/2019: **FORMATTING UPDATE**

07/13/2016: **MOVED TO FMO.**

© 1998 - 2019 San Diego Gas & Electric Company. All rights reserved. Removal of this copyright notice without permission is not permitted under law.

REV	CHANGE	BY	DSGN	APPV	DATE	REV	CHANGE	BY	DSGN	APPV	DATE
C						F					
B	FORMATTING UPDATE	PEI	-	-	04/22/2019	E					
A	ORIGINAL ISSUE	JS	IL	MDJ	07/13/2016	D					

SHEET 1 OF 1	X	Indicates Latest Revision	Completely Revised	New Page	Information Removed	FMO OH218
	SDG&E ELECTRIC OVERHEAD CONSTRUCTION STANDARDS					
	POLE GUARD RAIL					

SCOPE: THIS STANDARD SHOWS THE INSTALLATION OF A POLE GUARD RAIL.

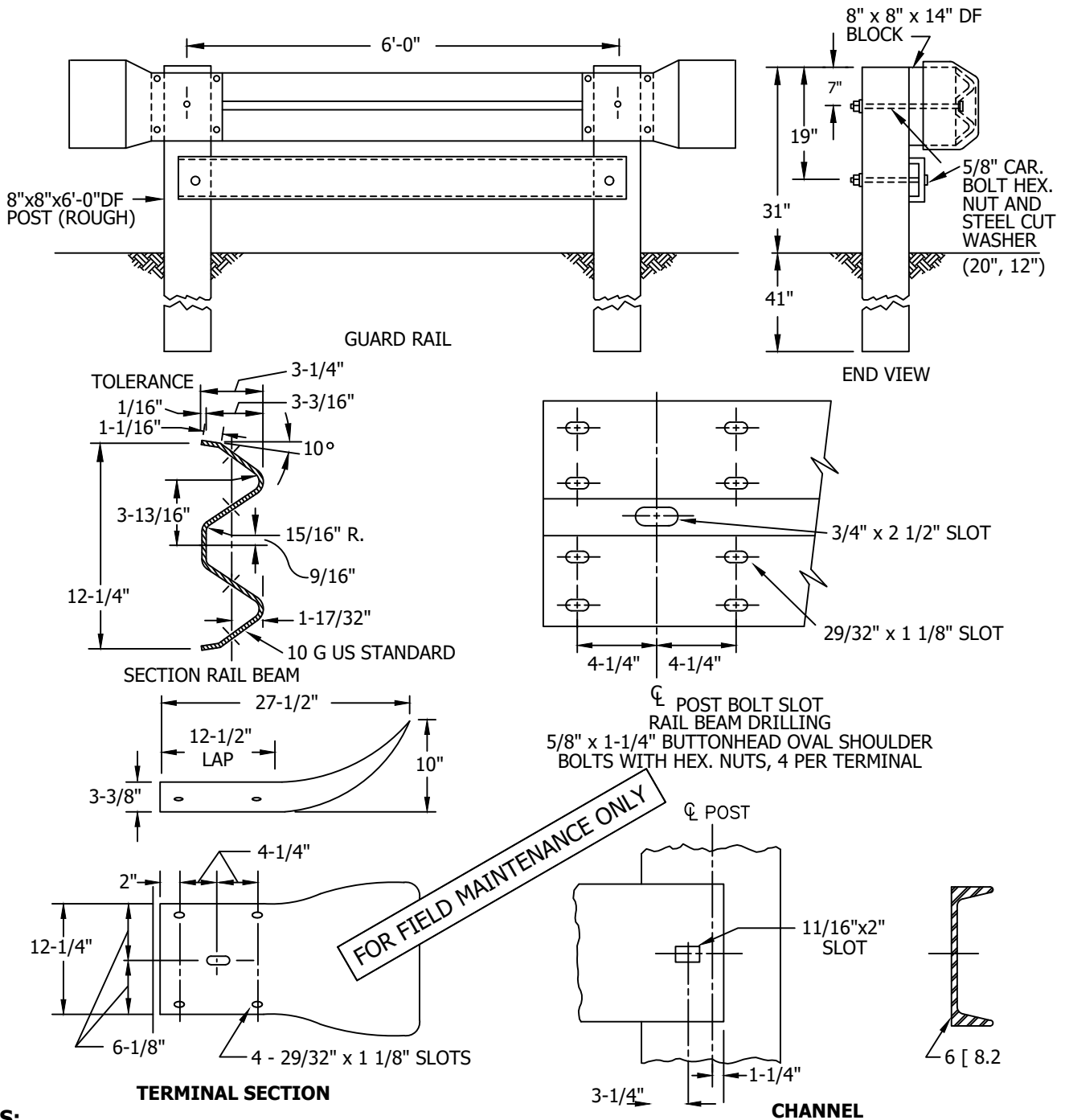

NOTES:

- I. POLE GUARD RAILS ARE DESIGNED TO BE INSTALLED IN PUBLIC R/W'S, NOT PRIVATE PROPERTY, MAINLY TO MAKE A POLE MORE VISIBLE. THEY HAVE LITTLE VALUE IN STOPPING A VEHICLE, AND SHOULD HAVE LIMITED USE.
- II. THE DISTRIBUTION OR TRANSMISSION ENGINEER SHALL SPECIFY OR APPROVE EACH INSTALLATION.

© 1998 - 2019 San Diego Gas & Electric Company. All rights reserved. Removal of this copyright notice without permission is not permitted under law.

REV	CHANGE	BY	DSGN	APPV	DATE	REV	CHANGE	BY	DSGN	APPV	DATE
C						F					
B	FORMATTING UPDATE	PEI	-	-	04/22/2019	E					
A	NO CHANGES REAFFIRMED	JC	IL	-	07/17/2015	D					

**SHEET
1 OF 1**

X Indicates Latest Revision

Completely Revised New Page Information Removed

SDG&E ELECTRIC OVERHEAD CONSTRUCTION STANDARDS

POLE GUARD RAIL

**FMO
OH218.1**

OH220 FIELD MAINTENANCE ONLY

ALL VERSIONS LISTED IN FMO ARE SUPERSEDED BY THEIR CURRENT VERSION FOUND INSIDE THE OVERHEAD CONSTRUCTION STANDARD MANUAL.

REVISION HISTORY:

04/22/2019: MOVED TO FMO - VERSION WITH WOOD CROSSARMS

© 1998 - 2019 San Diego Gas & Electric Company. All rights reserved. Removal of this copyright notice without permission is not permitted under law.

REV	CHANGE	BY	DSGN	APPV	DATE	REV	CHANGE	BY	DSGN	APPV	DATE
C						F					
B						E					
A	ORIGINAL ISSUE	PEI	-	-	04/22/2019	D					

SHEET 1 OF 1	Indicates Latest Revision	Completely Revised	<input checked="" type="checkbox"/>	New Page	Information Removed	FMO OH220
	SDG&E ELECTRIC OVERHEAD CONSTRUCTION STANDARDS					
	VERTICAL SEPARATION OF CROSSARMS ON THE SAME POLE					

LINE ARMS

BUCK ARMS

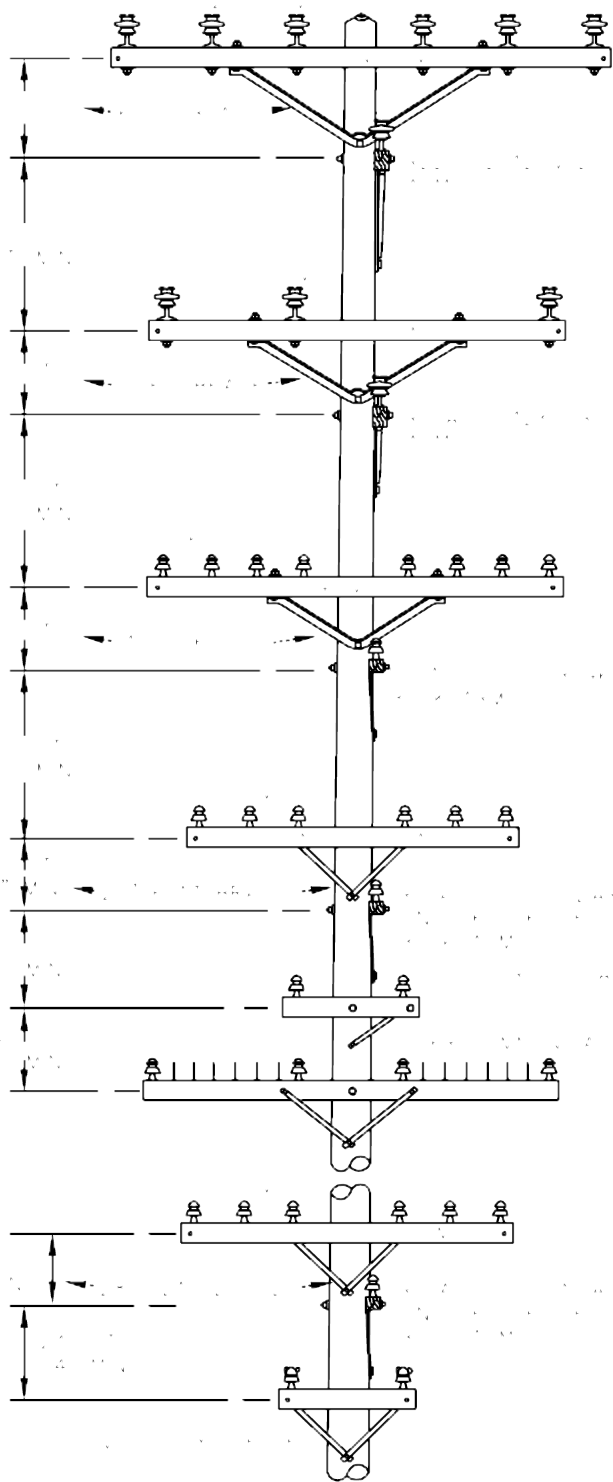
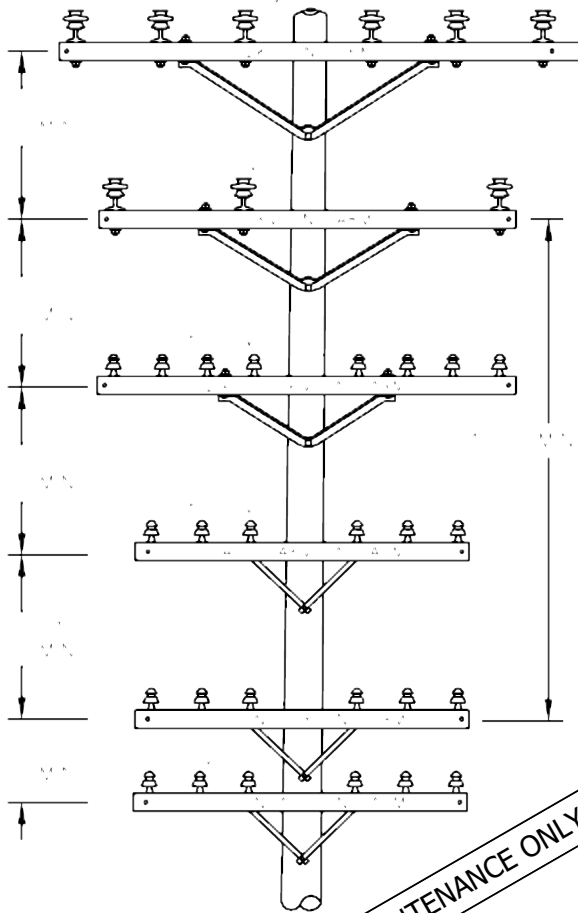

FOR FIELD MAINTENANCE ONLY

NOTES:

- A. STANDARD OR MINIMUM CLEARANCES, AS SHOWN, BETWEEN RELATED CONDUCTORS ON LINE AND BUCK ARMS SHALL NOT BE APPLIED CONSECUTIVELY BOTH ABOVE AND BELOW THE SAME CONDUCTORS.
- B. MINIMUM CLEARANCES SHOWN ARE THOSE SPECIFIED IN G.O. 95, RULE 38, TABLE 2, CASES 8 TO 14 INCLUSIVE. THESE ARE MINIMUM CONDUCTOR RADIAL SEPARATIONS WHICH MUST BE MAINTAINED AT THE POINT OF CONDUCTOR CROSSINGS.
- C. FOR CLIMBING AND WORKING SPACE REQUIREMENTS, SEE OTHER PAGES IN PRACTICES SECTION.
- D. FOR VERTICAL SEPARATION REQUIREMENTS ON VERTICAL CONSTRUCTION, SEE OTHER PAGES IN PRACTICES SECTION.

© 1998 - 2019 San Diego Gas & Electric Company. All rights reserved. Removal of this copyright notice without permission is not permitted under law.

REV	CHANGE	BY	DSGN	APPV	DATE	REV	CHANGE	BY	DSGN	APPV	DATE
C						F					
B	MOVED TO FMO	PEI	-	-	04/22/2019	E					
A	ORIGINAL ISSUE	-	IL	ROJ	01/01/1994	D					

SHEET
1 OF 1

Indicates Latest Revision Completely Revised New Page Information Removed

SDG&E ELECTRIC OVERHEAD CONSTRUCTION STANDARDS

VERTICAL SEPARATION OF CROSSARMS ON THE SAME POLE

FMO
OH220.1

OH221 FIELD MAINTENANCE ONLY

ALL VERSIONS LISTED IN FMO ARE SUPERSEDED BY THEIR CURRENT VERSION FOUND INSIDE THE OVERHEAD CONSTRUCTION STANDARD MANUAL.

REVISION HISTORY:

04/22/2019: MOVED TO FMO - VERSION WITH WOOD CROSSARMS

© 1998 - 2019 San Diego Gas & Electric Company. All rights reserved. Removal of this copyright notice without permission is not permitted under law.

REV	CHANGE	BY	DSGN	APPV	DATE	REV	CHANGE	BY	DSGN	APPV	DATE
C						F					
B						E					
A	ORIGINAL ISSUE	PEI	-	-	04/22/2019	D					

SHEET 1 OF 1	Indicates Latest Revision	Completely Revised	<input checked="" type="checkbox"/> New Page	Information Removed	FMO OH221
	SDG&E ELECTRIC OVERHEAD CONSTRUCTION STANDARDS				
	VERTICAL SEPARATION OF DIFFERENT CIRCUITS ON THE SAME POLE - CROSSARM CONSTRUCTION				

LINE ARMS

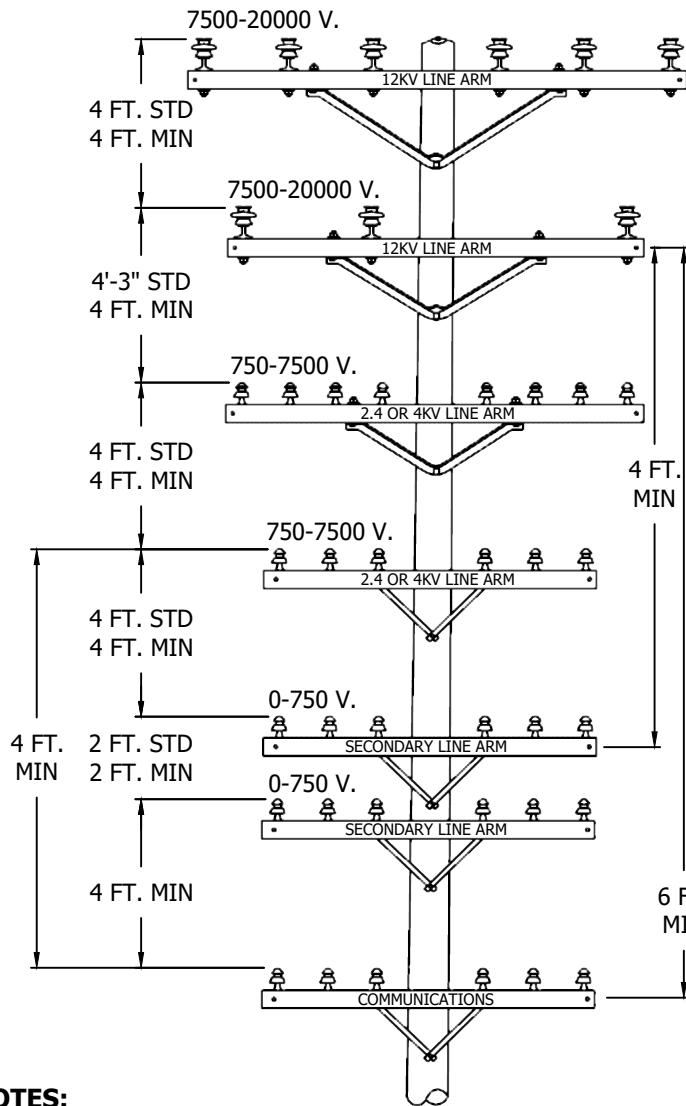

BUCK ARMS

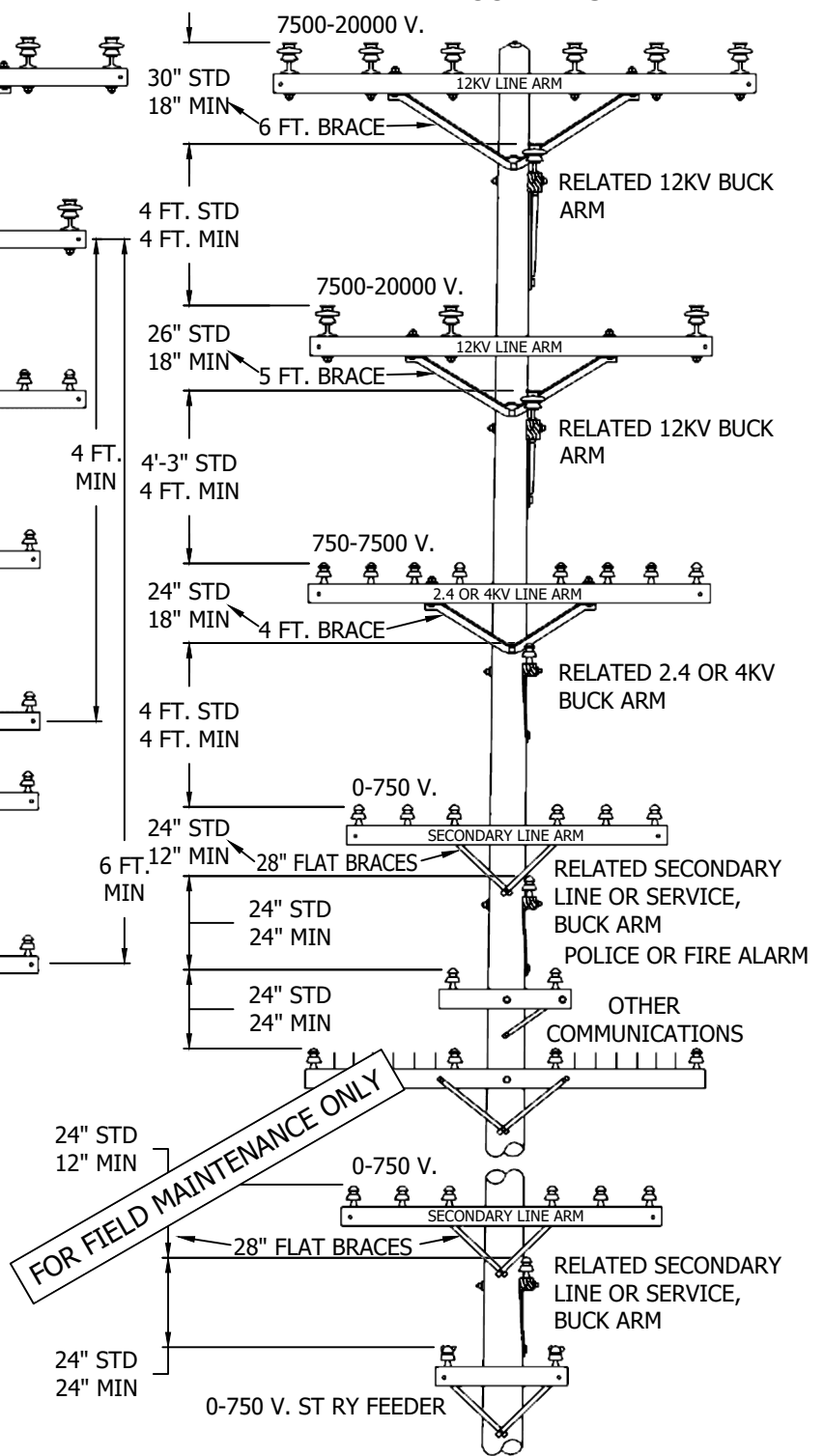

NOTES:

- I. STANDARD OR MINIMUM CLEARANCES, AS SHOWN, BETWEEN RELATED CONDUCTORS ON LINE AND BUCK ARMS SHALL NOT BE APPLIED CONSECUTIVELY BOTH ABOVE AND BELOW THE SAME CONDUCTORS.
- II. MINIMUM CLEARANCES SHOWN ARE THOSE SPECIFIED IN G.O. 95, RULE 38, TABLE 2, CASES 8 TO 14 INCLUSIVE. THESE ARE MINIMUM CONDUCTOR RADIAL SEPARATIONS WHICH MUST BE MAINTAINED AT THE POINT OF CONDUCTOR CROSSINGS.
- III. FOR CLIMBING AND WORKING SPACE REQUIREMENTS, SEE OTHER PAGES IN PRACTICES SECTION. FOR VERTICAL SEPARATION REQUIREMENTS ON VERTICAL CONSTRUCTION, SEE OTHER PAGES IN PRACTICES SECTION.

FOR FIELD MAINTENANCE ONLY

© 1998 - 2019 San Diego Gas & Electric Company. All rights reserved. Removal of this copyright notice without permission is not permitted under law.

REV	CHANGE	BY	DSGN	APPV	DATE	REV	CHANGE	BY	DSGN	APPV	DATE
C						F					
B	MOVED TO FMO	PEI	-	-	04/22/2019	E					
A	ORIGINAL ISSUE	PEI	MEK	PTA/RDJ	01/01/1994	D					

**SHEET
1 OF 1**

X Indicates Latest Revision Completely Revised New Page Information Removed

SDG&E ELECTRIC OVERHEAD CONSTRUCTION STANDARDS

VERTICAL SEPARATION OF DIFFERENT CIRCUITS ON THE SAME POLE - CROSSARM CONSTRUCTION

**FMO
OH221.1**

OH223 FIELD MAINTENANCE ONLY

ALL VERSIONS LISTED IN FMO ARE SUPERSEDED BY THEIR CURRENT VERSION FOUND INSIDE THE OVERHEAD CONSTRUCTION STANDARD MANUAL.

REVISION HISTORY:

04/22/2019: A NEWER VERSION MOVED TO FMO

07/13/2016: MOVED TO FMO

© 1998 - 2019 San Diego Gas & Electric Company. All rights reserved. Removal of this copyright notice without permission is not permitted under law.

REV	CHANGE	BY	DSGN	APPV	DATE	REV	CHANGE	BY	DSGN	APPV	DATE
C						F					
B	EDITORIAL CHANGES	PEI	-	-	04/22/2019	E					
A	ORIGINAL ISSUE	JS	IL	MDJ	07/13/2016	D					

SHEET 1 OF 1	X	Indicates Latest Revision	Completely Revised	New Page	Information Removed	FMO OH223
	SDG&E ELECTRIC OVERHEAD CONSTRUCTION STANDARDS					
	AERIAL CABLE, VERTICAL CLEARANCE FROM OPEN WIRE CONDUCTORS ON SAME POLE					

SCOPE: THIS STANDARD SHOWS THE VERTICAL CLEARANCES BETWEEN OPEN WIRE CONDUCTORS AND CABLE AS REQUIRED BY THE G.O. 95. TYPICAL DRILLING AND GAINING DIMENSIONS ARE INCLUDED.

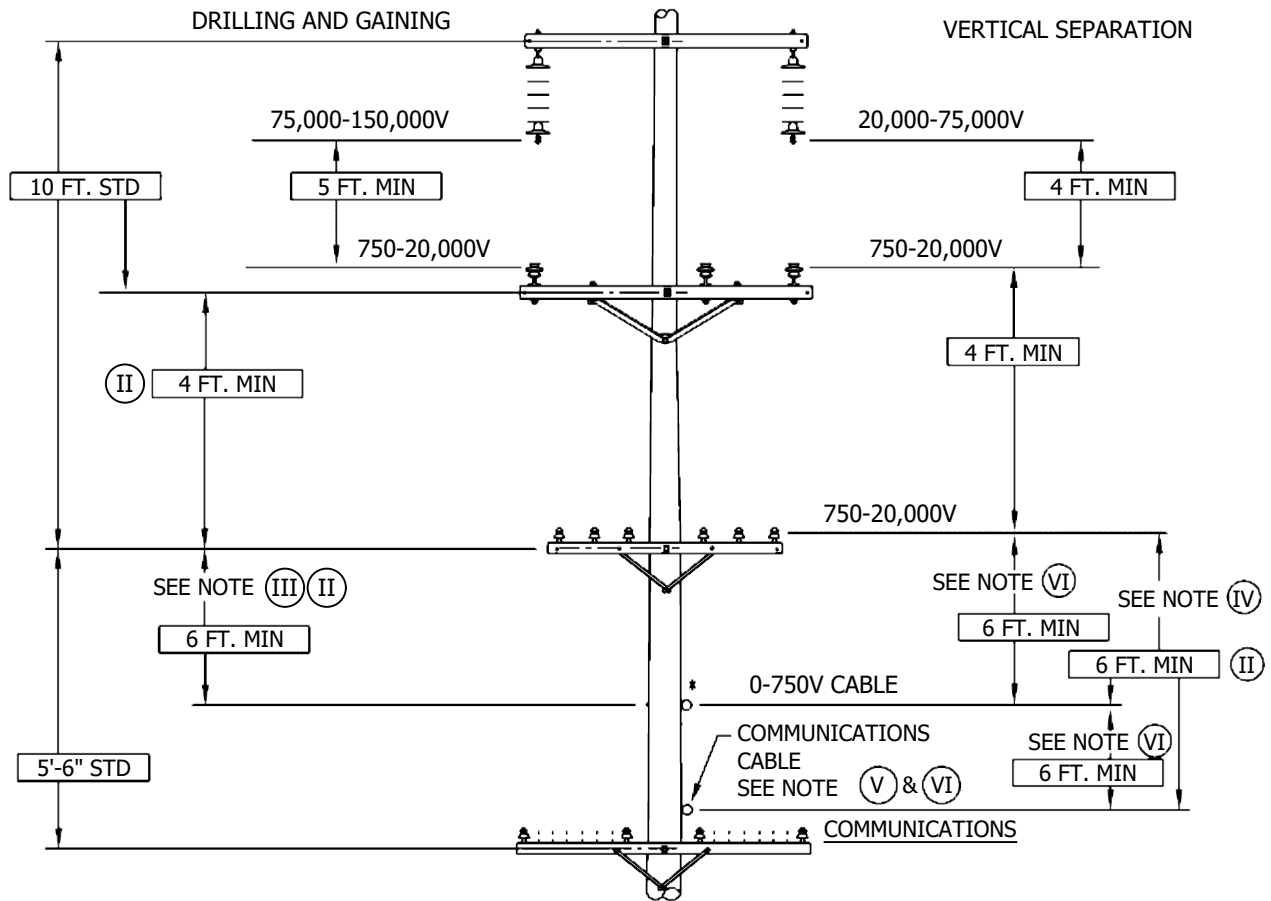

NOTES:

- (I) DIFFERENCES DUE TO SAG OF DIFFERENT SIZE CONDUCTORS MUST BE COMPENSATED FOR AT POINTS OF SUPPORT.
- (II) THIS CLEARANCE MAY INCREASE TO 7 FT. FOR BUCKET TRUCK ACCESS-SEE DESIGN MANUAL PAGE 5122, A.2.
- (III) INSTALLATION OF GUARD ARMS PERMITS A REDUCTION OF 2 FT. (* REPRESENTS GUARD ARM PLACEMENT). (G.O.95, RULE 54.10-C)
- (IV) VERTICAL SEPARATION MAY BE REDUCED 2 FT. IF OPEN WIRE IS 0-750V E.
- (V) 6 FT MINIMUM CLEARANCE IS REQUIRED TO POWER CONDUCTORS IN EXCESS OF 750V.
- (VI) GUARD ARMS MAY BE USED TO REDUCE REQUIRED CLEARANCE BY 2 FT. FOR CABLES OF 0-750V (* REPRESENTS GUARD ARM PLACEMENT). (G.O.95, RULE 54.10-C)

FOR FIELD MAINTENANCE ONLY

© 1998 - 2019 San Diego Gas & Electric Company. All rights reserved. Removal of this copyright notice without permission is not permitted under law.

REV	CHANGE	BY	DSGN	APPV	DATE	REV	CHANGE	BY	DSGN	APPV	DATE
C						F					
B	MOVED TO FMO	PEI	-	-	04/22/2019	E					
A	ORIGINAL ISSUE	-	PTA	MC	03/17/2010	D					

SHEET 1 OF 1	X Indicates Latest Revision	Completely Revised	New Page	Information Removed	FMO OH223.1
	SDG&E ELECTRIC OVERHEAD CONSTRUCTION STANDARDS				
	VERTICAL CLEARANCE FROM OPEN WIRE CONDUCTORS AND CABLE ON SAME POLE				

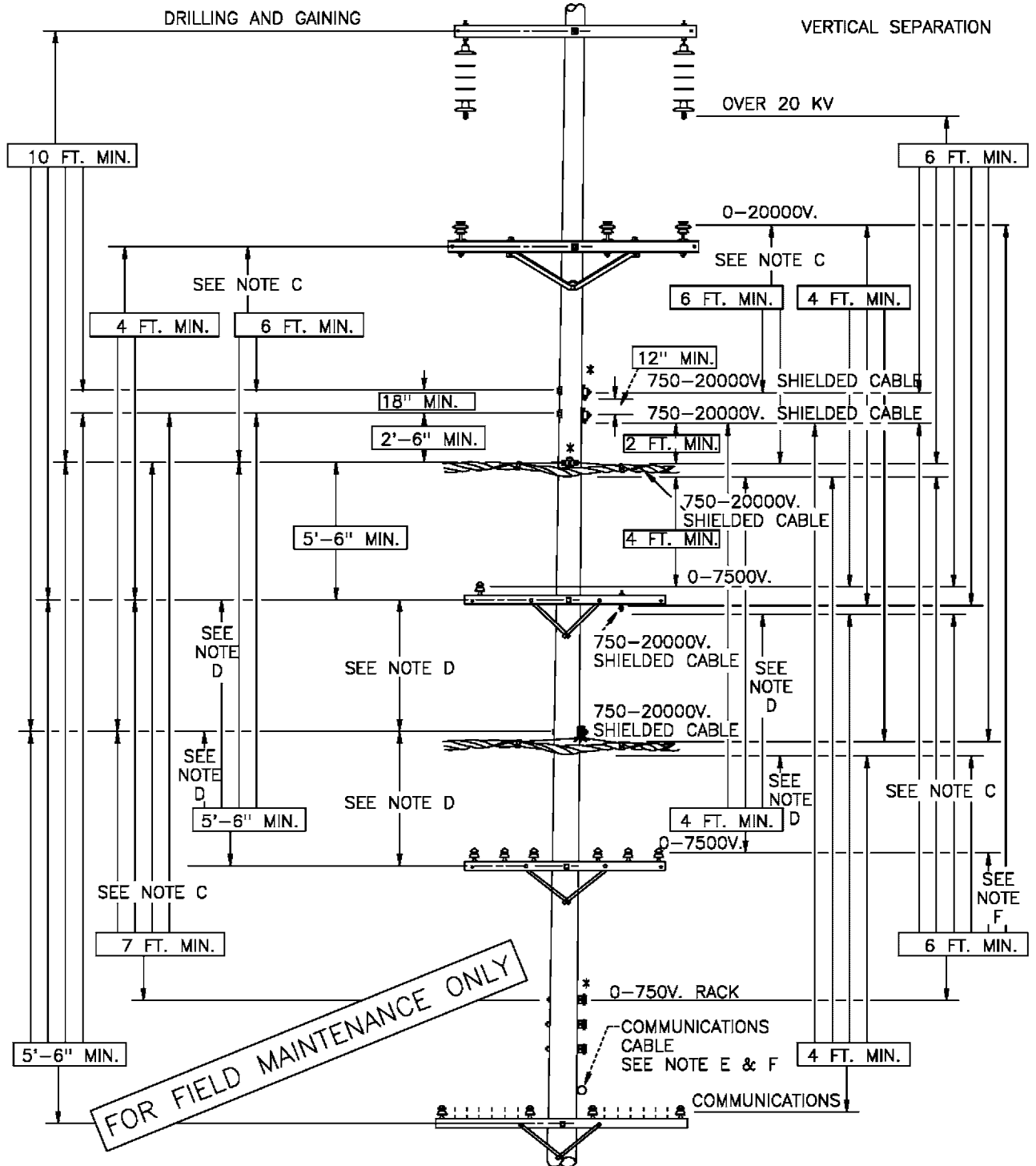

NOTES:

- A. DIFFERENCES DUE TO SAG OF DIFFERENT SIZE CONDUCTORS MUST BE COMPENSATED FOR AT POINTS OF SUPPORT.
- B. VERTICAL SEPARATION OF UNPROTECTED SUPPLY CONDUCTORS FROM 750-7500V SHIELDED AERIAL CABLE WHICH HAS BEEN BONDED AND EFFECTIVELY GROUNDING AS PER GENERAL ORDER 95, RULE 57.8
- (C) INSTALLATION OF GUARD ARMS PERMITS A REDUCTION OF 2 FT. (* REPRESENTS GUARD ARM PLACEMENT). (G.O. 95, RULE 57.4-F)
- (D) VERTICAL SEPARATION MAY BE REDUCED 2 FT. IF OPEN WIRE IS 0-750V
- (E) 6 FT MINIMUM CLEARANCE IS REQUIRED TO POWER CONDUCTORS.
- (F) GUARD ARMS MAY BE USED TO REDUCE REQUIRED CLEARANCE BY 2 FT FOR CONDUCTORS OR CABLES OF 0-750V.

DATE 2-18-74 APPD <i>PA/BJ</i>	SDG&E ELECTRIC STANDARDS AERIAL CABLE, VERTICAL CLEARANCE FROM OPEN WIRE CONDUCTORS ON SAME POLE	299.201 SUPERCEDES 223 (1-1-98)
-----------------------------------	-------------------------------------------------------------------------------------------------------------------------	---------------------------------------

FIELD MAINTENANCE ONLY

REVISION HISTORY:

7/13/2016: All versions prior to 2016 are superseded by their current version found inside the Overhead Construction Standard Manual.

© 1998 - 2016 San Diego Gas & Electric Company. All rights reserved. Removal of this copyright notice without permission is not permitted under law.

REV	CHANGE	BY	DSGN	APPV	DATE	REV	CHANGE	BY	DSGN	APPV	DATE
C						F					
B						E					
A	ORIGINAL ISSUE	JS	IL	MDJ	7/13/2016	D					

	Indicates Latest Revision	Completely Revised	New Page	Information Removed
-------------------------------------------------------------------------------------	---------------------------	--------------------	----------	---------------------

**SHEET
1 OF 1**

SDG&E ELECTRIC OVERHEAD STANDARD
12KV SINGLE CIRCUIT TRANSPOSITION

**FMO
OH 269**

SCOPE: THIS STANDARD ILLUSTRATES VARIOUS METHODS OF 12KV, SINGLE CIRCUIT TRANSPOSITION.

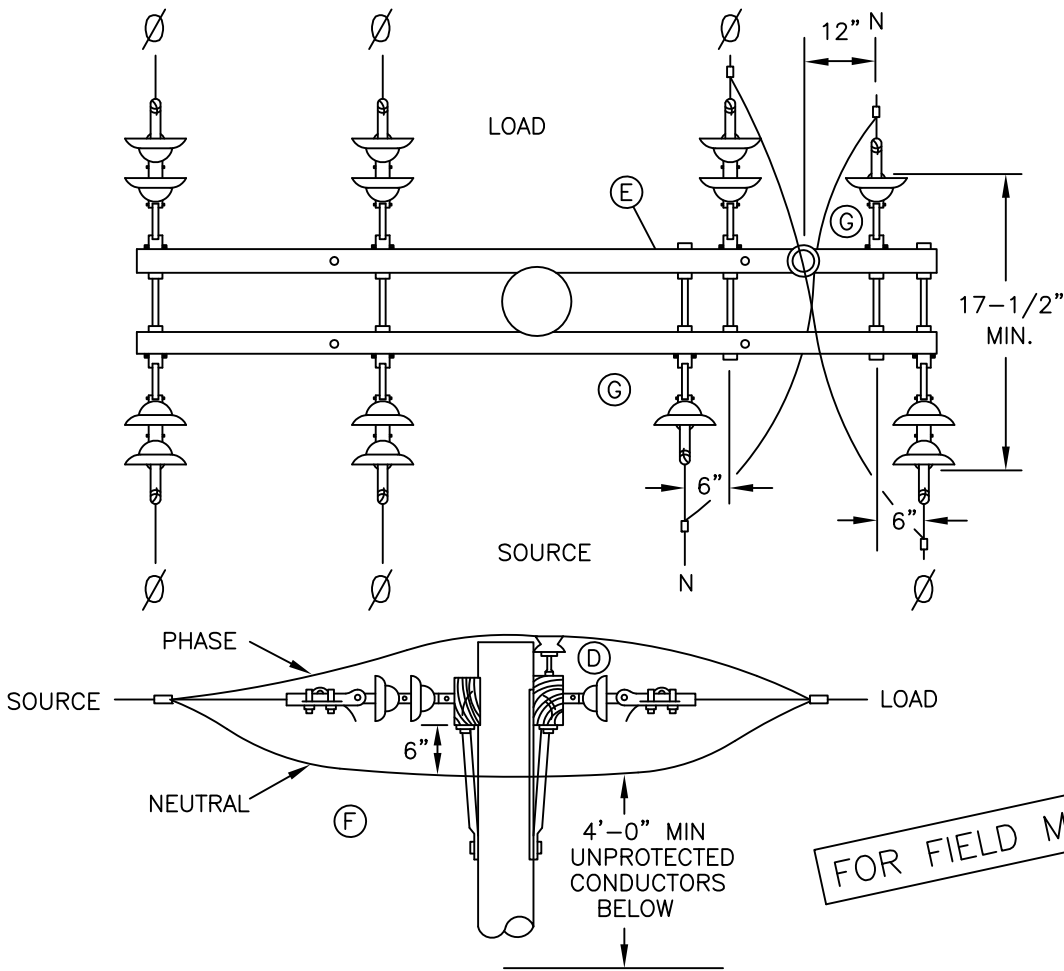

SINGLE POLE-NEUTRAL/PHASE WIRE TRANSPOSITION (PREFERRED)

FIGURE 1

©

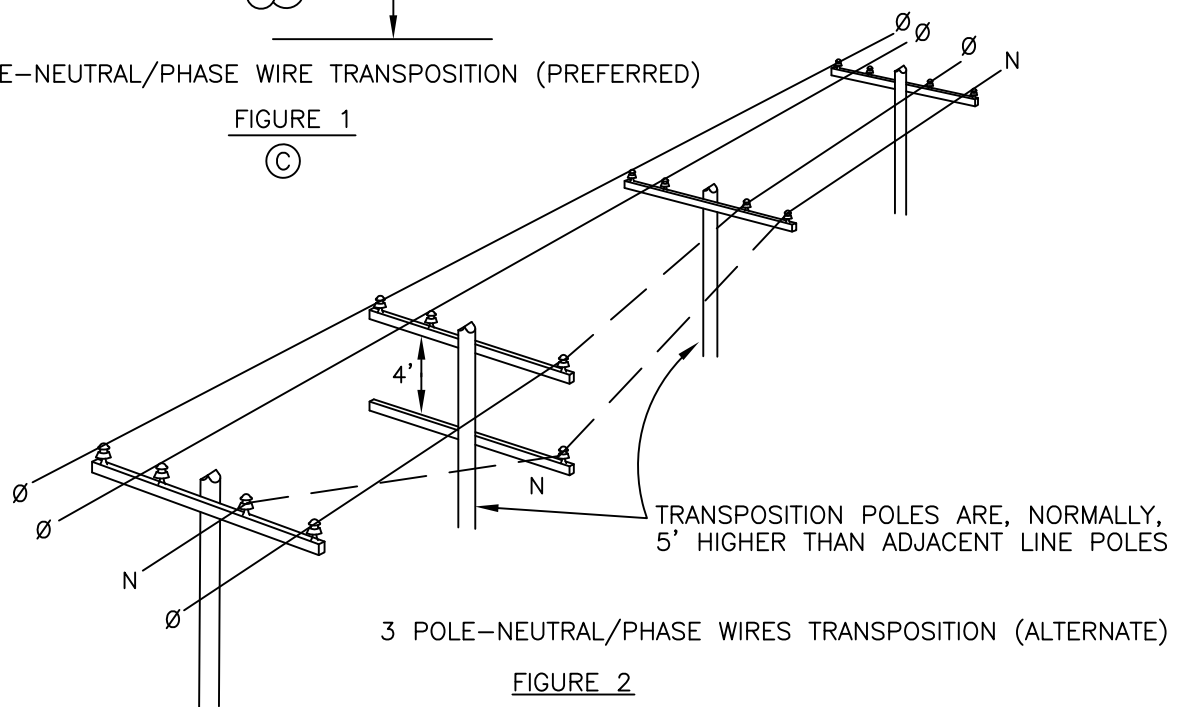

3 POLE-NEUTRAL/PHASE WIRES TRANSPOSITION (ALTERNATE)

FIGURE 2

©

© 1998 - 2013 San Diego Gas & Electric Company. All rights reserved. Removal of this copyright notice without permission is not permitted under law.

	Indicates Latest Revision	Completely Revised	New Page	Information Removed
REVISION	SDG&E ELECTRIC STANDARDS			
DATE 8-29-2013 APPD TQ / DW	12KV SINGLE CIRCUIT TRANSPOSITION			269.1

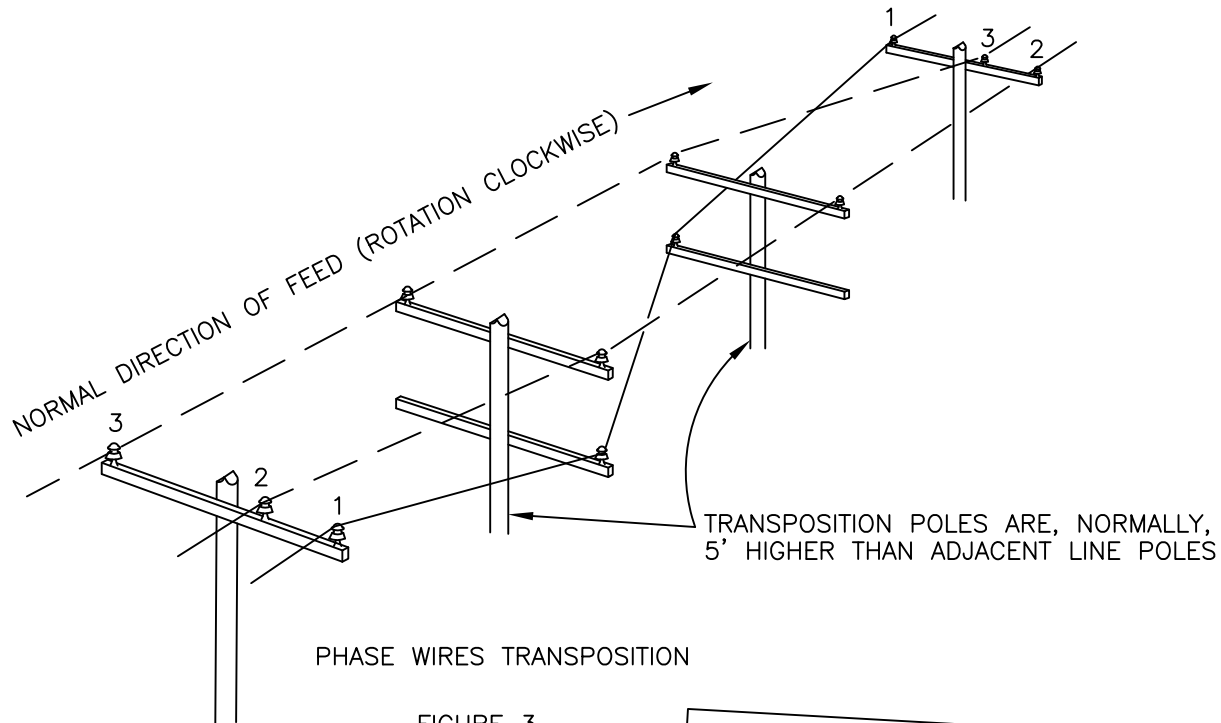

FIGURE 3

(B)

FOR FIELD MAINTENANCE ONLY

INSTALLATION:

- A. ALL PROPOSED 12KV LINE EXTENSIONS CREATING PARALLELS WITH EXISTING OPEN WIRE COMMUNICATION LEADS SHALL BE REFERRED TO THE TELEPHONE COMPANY FOR COORDINATION OF TRANSPOSITIONS IN THE SUPPLY AND COMMUNICATION LINES.
- (B) BUILDING FOUR WIRE, "PHASE WIRE ONLY" TRANSPOSITION, (FIG. 3), OR ADDING FOURTH WIRE (NEUTRAL) TO EXISTING TRANSPOSITION, REQUIRES NO DEVIATION.
- (C) SINGLE POLE-NEUTRAL/PHASE WIRE TRANSPOSITION (FIG. 1) IS PREFERRED OVER THREE POLE NEUTRAL/PHASE WIRE TRANSPOSITION (FIG. 2).
- (D) ON SINGLE POLE-NEUTRAL/PHASE WIRE TRANSPOSITION (FIG. 1), ALWAYS JUMPER PHASE WIRE OVER TOP OF ARM AND TIE INTO PIN AND INSULATOR.
- (E) SINGLE POLE-NEUTRAL/PHASE WIRE TRANSPOSITION (FIG. 1) REQUIRES CROSSARM MINIMUM OF 10' IN LENGTH. IF TRANSPOSITION IS EXTENSION FROM EXISTING 8' CROSSARMS, CHANGE OUT TO 10' CROSSARMS.
- (F) IN SINGLE POLE-NEUTRAL/PHASE WIRE TRANSPOSITION (FIG. 1), INSTALL NEUTRAL JUMPER NO LESS THAN 6" FROM BOTTOM OF CROSSARM.
- (G) ON ALL TRANSPOSITIONS, MARK CROSSARM NEUTRAL POSITION WITH "PN" SIGN, EVEN THOUGH SIGN IS NOT REQUIRED BY STANDARD 208.

© 1998 - 2010 San Diego Gas & Electric Company. All rights reserved. Removal of this copyright notice without permission is not permitted under law.

	Indicates Latest Revision	Completely Revised	New Page	Information Removed
269.2	SDG&E ELECTRIC STANDARDS			REVISION
	12KV SINGLE CIRCUIT TRANSPOSITION			DATE 1-1-93 APPD <i>PIA 1/09</i>

300 - POLES ARMS
& HARDWARE

300 - POLES ARMS
& HARDWARE

PAGES

SUBJECT

388

CROSSARM GAINS

390

TRANSFORMER MOUNTING BRACKETS

392

LINE MATERIALS, BOLT, LAG SCREW

© 1998 - 2019 San Diego Gas & Electric Company. All rights reserved. Removal of this copyright notice without permission is not permitted under law.

REV	CHANGE	BY	DSGN	APPV	DATE	REV	CHANGE	BY	DSGN	APPV	DATE
C	ADDED 392	GW	JS	CZH	9/1/2018	F					
B	ADDED 390	JS	JS	MDJ	9/28/2016	E					
A	ORIGINAL ISSUE	JS	JS	MDJ	9/28/2016	D	ADDED 388	SL	JS	CZH	7/10/2019

SHEET 1 OF 1	<input checked="" type="checkbox"/> Indicates Latest Revision	<input type="checkbox"/> Completely Revised	<input type="checkbox"/> New Page	<input type="checkbox"/> Information Removed	FMO OH 301
	SDG&E ELECTRIC OVERHEAD CONSTRUCTION STANDARDS				
	POLES, ARMS & HARDWARE FMO TABLE OF CONTENTS				

OH388 FIELD MAINTENANCE ONLY

ALL VERSIONS LISTED IN FMO ARE SUPERSEDED BY THEIR CURRENT VERSION FOUND INSIDE THE OVERHEAD
CONSTRUCTION STANDARD MANUAL.

REVISION HISTORY:

7/10/2019: STANDARD MOVED TO FMO

© 1998 - 2019 San Diego Gas & Electric Company. All rights reserved. Removal of this copyright notice without permission is not permitted under law.

REV	CHANGE	BY	DSGN	APPV	DATE	REV	CHANGE	BY	DSGN	APPV	DATE
C						F					
B						E					
A	ORIGINAL ISSUE	SL	JS	CZH	7/10/2019	D					

SHEET 1 OF 1		Indicates Latest Revision		Completely Revised	<input checked="" type="checkbox"/>	New Page		Information Removed	FMO OH388
	SDG&E ELECTRIC OVERHEAD CONSTRUCTION STANDARDS								
	CROSSARM GAINS								

SCOPE: THIS STANDARD ILLUSTRATES AND DESCRIBES THE INSTALLATION OF VARIOUS CROSSARM GAINS.

NOTE: MANUFACTURED CROSSARM GAINS WILL BE USED FOR ALL NEW CROSSARM INSTALLATIONS. GAINS ARE NO LONGER TO BE CUT INTO POLES.

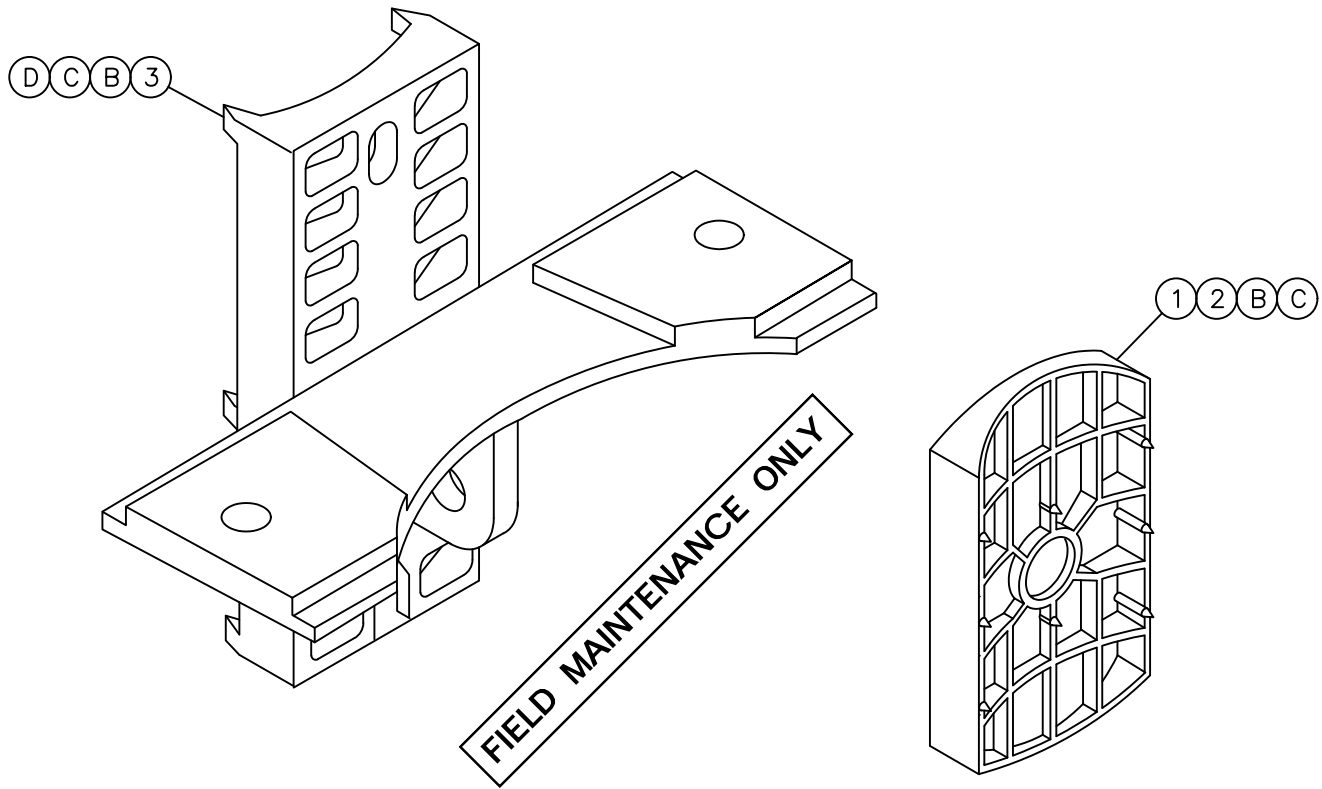

BILL OF MATERIAL:

ITEM	DESCRIPTION	QUANTITY	STOCK NUMBER	AU ID
1	CROSSARM GAIN, PLASTIC, 7" X 4", FOR STANDARD AND HEAVY CROSSARMS	(A)	S369612	PCGAIN
2	CROSSARM GAIN, PLASTIC, 4-3/4" X 3-3/4", FOR SECONDARY CROSSARMS	(A)	S369610	SCGAIN
3	BRACELESS CROSSARM GAIN, GALV STEEL, FOR STANDARD AND HEAVY CROSSARMS (D)	(A)	S369598	BCGAIN

INSTALLATION:

- (A) ONLY ONE CROSSARM GAIN IS NECESSARY AT EACH CROSSARM LEVEL, AND ON ONE SIDE OF A DOUBLE SET OF CROSSARMS ONLY.
- (B) ALL CROSSARM GAINS WILL ACCOMMODATE EITHER A 5/8" OR 3/4" THROUGH-BOLT.
- (C) PLASTIC CROSSARM GAINS CAN BE USED ON WOOD, STEEL OR FIBERGLASS POLES. DO NOT USE A STEEL GAIN ON ANY POLE OTHER THAN WOOD.
- (D) USE A BRACELESS CROSSARM GAIN WHEREVER IT'S DESIRABLE TO ELIMINATE THE UNDERARM BRACE.

© 1998 - 2010 San Diego Gas & Electric Company. All rights reserved. Removal of this copyright notice without permission is not permitted under law.

	Indicates Latest Revision	Completely Revised	New Page	Information Removed
REVISION	SDG&E ELECTRIC STANDARDS			
DATE 11-15-05	CROSSARM GAINS			
APPD PJA/JJ	FMO 388			

FIELD MAINTENANCE ONLY

REVISION HISTORY:

9/28/2016: All versions prior to 2016 are superseded by their current version found inside the Overhead Construction Standard Manual.

© 1998 - 2016 San Diego Gas & Electric Company. All rights reserved. Removal of this copyright notice without permission is not permitted under law.													
REV	CHANGE	BY	DSGN	APPV	DATE	REV	CHANGE	BY	DSGN	APPV	DATE		
C						F							
B						E							
A	ORIGINAL ISSUE	JS	JS	MDJ	9/28/2016	D							
SHEET 1 OF 1		<input checked="" type="checkbox"/>	Indicates Latest Revision		<input type="checkbox"/>	Completely Revised		<input type="checkbox"/>	New Page		<input type="checkbox"/>	Information Removed	
		SDG&E ELECTRIC OVERHEAD STANDARD										FMO OH 390	
		TRANSFORMER MOUNTING BRACKETS											

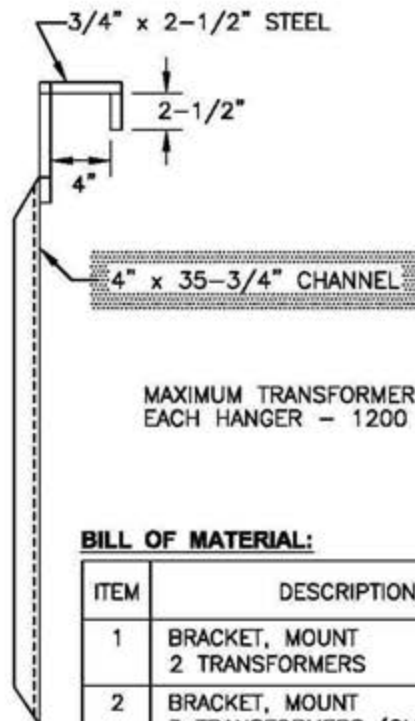
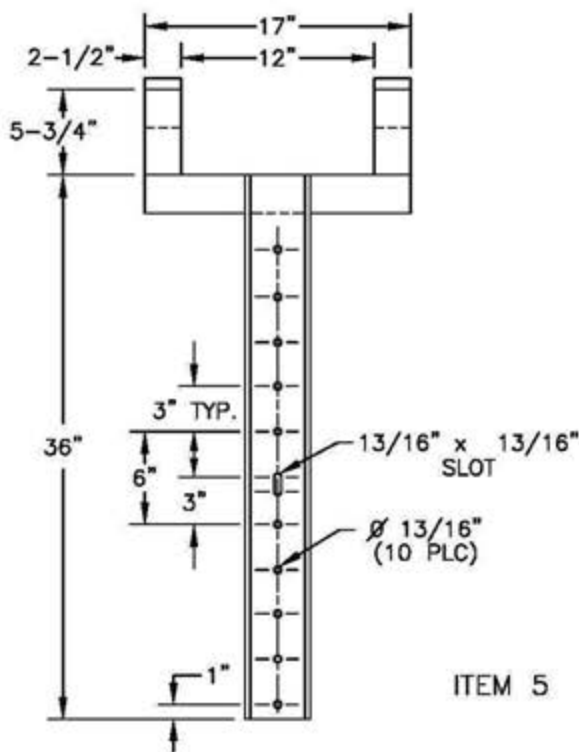
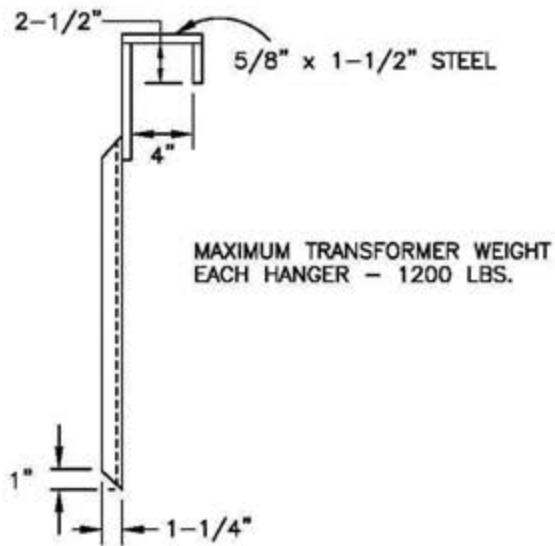
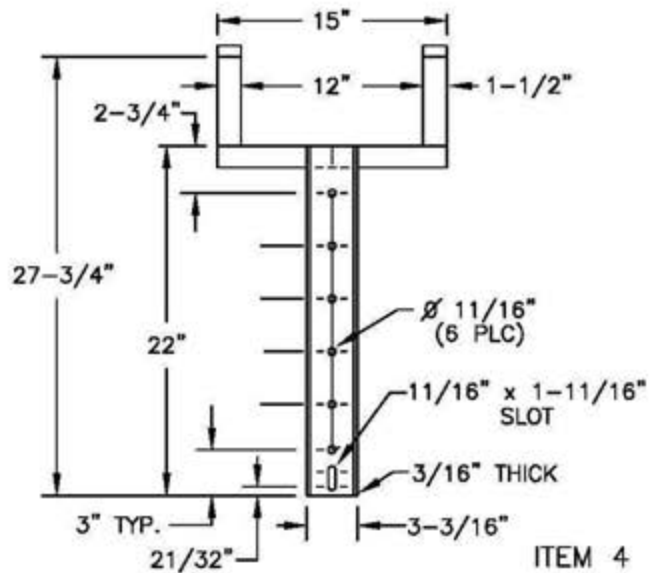

BILL OF MATERIAL:

ITEM	DESCRIPTION	STOCK NUMBER	ASSEMBLY UNITS
1	BRACKET, MOUNT 2 TRANSFORMERS	S402976	UMB
2	BRACKET, MOUNT 3 TRANSFORMERS (CLUSTER)	S403008	CMB
3	BRACKET, HEAVY DUTY, MOUNT 3 TRANSFORMERS (CLUSTER)	S402920	CMBHD
4	CROSSARM TEE HANGER, 22"	S402912	T1HANG
5	CROSSARM TEE HANGER, 36"	S402944	T2HANG

REV	CHANGE	BY	CHKD	APPV	DATE	REV	CHANGE	BY	CHKD	APPV	DATE
A	UPDATED DIMENSION	JC	JH	DW	9/2/2014	D					
B						E					
C						F					

© 1998 - 2014 San Diego Gas & Electric Company. All rights reserved. Removal of this copyright notice without permission is not permitted under law.

Indicates Latest Revision Completely Revised New Page Information Removed

REVISION DATE 9-2-2014 APPD JH / DW	SDG&E ELECTRIC STANDARDS TRANSFORMER MOUNTING BRACKETS	390.2
-------------------------------------------	---------------------------------------------------------------	-------

FIELD MAINTENANCE ONLY

REVISION HISTORY:

9/1/2018: All versions prior to 2018 are superseded by their current version found inside the Overhead Construction Standard Manual.

© 1998 - 2018 San Diego Gas & Electric Company. All rights reserved. Removal of this copyright notice without permission is not permitted under law.

REV	CHANGE	BY	DSGN	APPV	DATE	REV	CHANGE	BY	DSGN	APPV	DATE
C						F					
B						E					
A	ORIGINAL ISSUE	GW	JS	CZH	9/1/2018	D					

<p>SHEET 1 OF 1</p>	<input type="checkbox"/> Indicates Latest Revision	<input type="checkbox"/> Completely Revised	<input checked="" type="checkbox"/> New Page	<input type="checkbox"/> Information Removed	<p>FMO OH 392</p>
	<p>SDG&E ELECTRIC OVERHEAD CONSTRUCTION STANDARDS</p>				
	<p>LINE MATERIALS BOLT, LAG SCREW</p>				

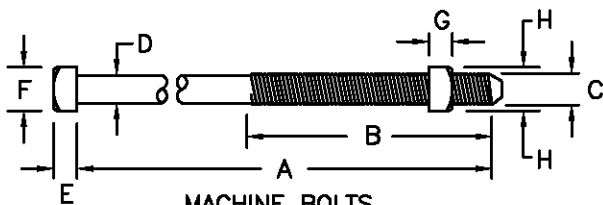

MACHINE BOLTS
ITEMS 1-10

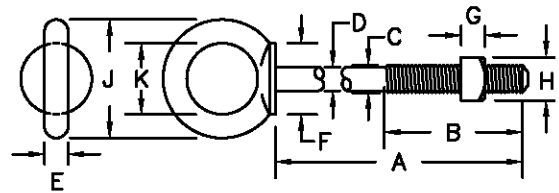

SHOULDER EYE BOLTS
ITEMS 15-18

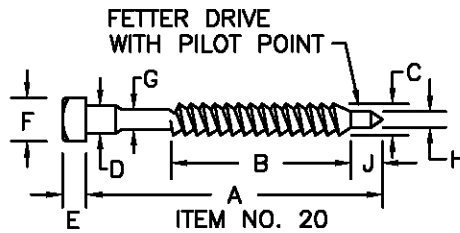

FETTER DRIVE
WITH PILOT POINT
ITEM NO. 20

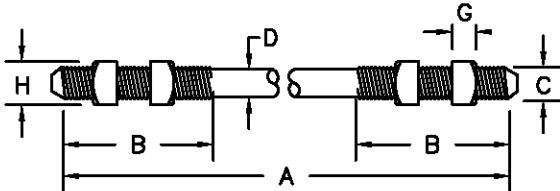

SPACE BOLTS
ITEMS 11-14

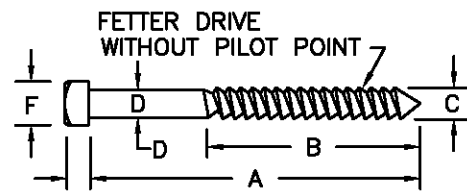

FETTER DRIVE
WITHOUT PILOT POINT
ITEM NO. 21
LAG SCREWS

BOLTS AND LAG SCREWS (DIMENSIONS IN INCHES)

ITEM	LENGTH. A	B. MIN	C	D	E	F	G	H	J	K	ULT. STRGTH	STOCK NUMBERS	
MACHINE BOLTS	1	4-1/2	1-1/2	3/8	11/32	9/32	9/16	5/16	5/8	--	5000 LBS.	158528, WASHERHEAD	
	2	5 TO 8	1-1/2	1/2	29/64	3/8	3/4	3/8	13/16	--	10500 LBS.	153024 - 153152	
	3	8 TO 10	4									153152-153184 & 152736	
	4	5 TO 8	3	5/8	9/16	1/2	15/16	5/8	1-1/16	--	15500 LBS.	155488-155584	
	5	8 TO 14	4									155584 & 155616, 154816 - 154880	
	6	16 TO 36	6									154912, 154944, 155072 - 155200	
BOLTS	7	8 TO 14	4	3/4	11/16	3/4	1-1/8	3/4	1-1/4	--	23000 LBS.	154080, 154112, 153408, 153440	
		14 TO 30	6									153440, 153472, 153504, 153632 - 153760 & 153824	
	8	32 TO 40	6	7/8	13/16	7/8	1-5/16	7/8	1-7/16	--	33500 LBS.	153856, 153888, 153984	
	9	14 TO 18	2-1/2									155712, 155744, 155776	
10	18 TO 30	4	155776 THRU 155904										
SPACE BOLTS	11	16	7	5/8	9/16	--	--	5/8	1-1/16	--	15500 LBS.	156512	
	12	18 TO 30	8									156544 THRU 156736	
	13	16 TO 30	ⓑ	5/8	--	--	--	5/8	1-1/16	--	--	15500 LBS.	--
				3/4	--	--	--	3/4	1-1/4	--	--	26000 LBS.	--
14	36 TO 40	ⓑ	3/4	--	--	--	3/4	1-1/4	--	--	26000 LBS.	156360, 156370	
EYE BOLTS	15	6	4	5/8	5/8	9/16	1-3/4	5/8	1-1/16	2-7/8	1-3/4	12500 LBS.	--
	16	8 TO 20	6									150784, 150816	
	17	6	4	3/4	3/4	11/16	1-3/4	3/4	1-1/4	3-1/8	1-3/4	21500 LBS.	--
18	8 TO 20	6	--										
LAG SCREWS	20	4"	2-1/8	1/2	9/16	5/16	3/4	29/64	7/32	5/8	--	621568	
	21	5"	4	5/8	9/16	1/2	7/8	--	--	--	--	621600	

INSTALLATION:

A. ITEMS 1 THRU 21 GALVANIZED PER A.S.T.M. SPECS. A153-53.

ⓑ COMPLETELY THREADED.

© 1998 - 2005 San Diego Gas & Electric Company. All rights reserved. Removal of this copyright notice without permission is not permitted under law.

	Indicates Latest Revision	Completely Revised	New Page	Information Removed
392.1	SDG&E ELECTRIC STANDARDS			REVISION
	LINE MATERIALS BOLT, LAG SCREW			DATE 7-29-83 APPD PJA 1/2/83

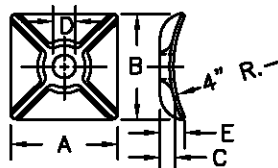

ITEM 30 - 31

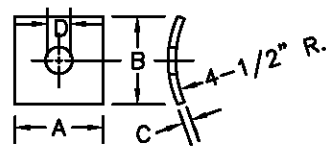

ITEM 32

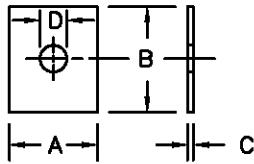

ITEM 35 - 37

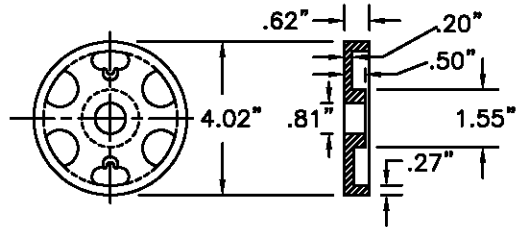

ITEM 52 (C)

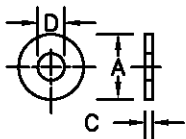

ITEM 41 - 44

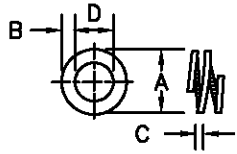

ITEM 47 - 49 (B)

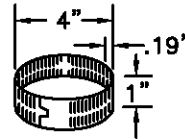

ITEM 53

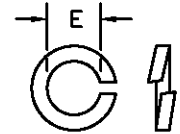

ITEM 54 - 57

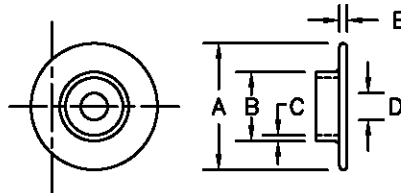

ITEM 58

BILL OF MATERIAL:

SQUARE CURVED WASHERS						STOCK NUMBER	ASSEMBLY UNITS	DOUBLE COIL SPRING WASHERS (B)					STOCK NUMBER	ASSEMBLY UNITS	
ITEM NO.	A	B	C	D	E			ITEM NO.	A	B	C	D			E
30	3"	3"	5/16"	11/16"	5/8"	797792	--	47	1-1/4"	7/32"	11/64"	13/16"	--	798496	SP-WSH
31	4"	4"	7/16"	13/16"	1"	797760	RIBWSH	48	1-1/16"	3/16"	9/64"	11/16"	--	798560	5/8S
32	3"	3"	1/4"	13/16"	--	798912	--	49	27/32"	5/32"	7/64"	17/32"	--	798464	1/2S
SQUARE FLAT WASHERS								MISCELLANEOUS							
35	3 1/2"	3 1/2"	3/8"	15/16"	--	799136	--	52	SHEAR PLATE NO. 2 (C)					262240	SHRPLT
36	3"	3"	1/4"	13/16"	--	799104	SQ-WSH	53	SPLIT RING					599584	SPLT-R
37	2 1/4"	2 1/4"	3/16"	11/16"	--	799040	5/BSQ	54	SPRING LOCK WASHER			3/8"	796832		
								55	SPRING LOCK WASHER			1/2"	796768	--	
								56	SPRING LOCK WASHER			5/8"	796864		
								57	SPRING LOCK WASHER			3/4"	796800	LK-WSH	
ROUND WASHERS								CENTERING WASHER							
41	2"	--	9/64"	13/16"	--	800256	RD-WSH	58	2-3/4"	1-7/16"	1/8"	5/8"	3/16"	795520	CTRWSH
42	1-3/4"	--	1/8"	11/16"	--	800320	5/8R								--
43	1-3/8"	--	7/64"	9/16"	--	800192	1/2R								
44	1"	--	5/64"	7/16"	--	800288	3/8R								

INSTALLATION:

A. ITEMS 30 THRU 44 GALVANIZED PER A.S.T.M. SPECS. A153-53.

(B) BACK OFF ONE-QUARTER TURN AFTER WASHER HAS BEEN FULLY COMPRESSED.

(C) THIS ITEM IS NOT EXEMPT.

© 1998 - 2005 San Diego Gas & Electric Company. All rights reserved. Removal of this copyright notice without permission is not permitted under law.

	Indicates Latest Revision	Completely Revised	New Page	Information Removed
REVISION	SDG&E ELECTRIC STANDARDS			
DATE 1-1-94	LINE MATERIALS WASHER			392.2
APPD PJA/ROJ				

SCOPE: THIS STANDARD SHOWS TYPICAL INSTALLATION OF BOLT AND WASHER ASSEMBLIES ON CROSSARMS AND POLES.

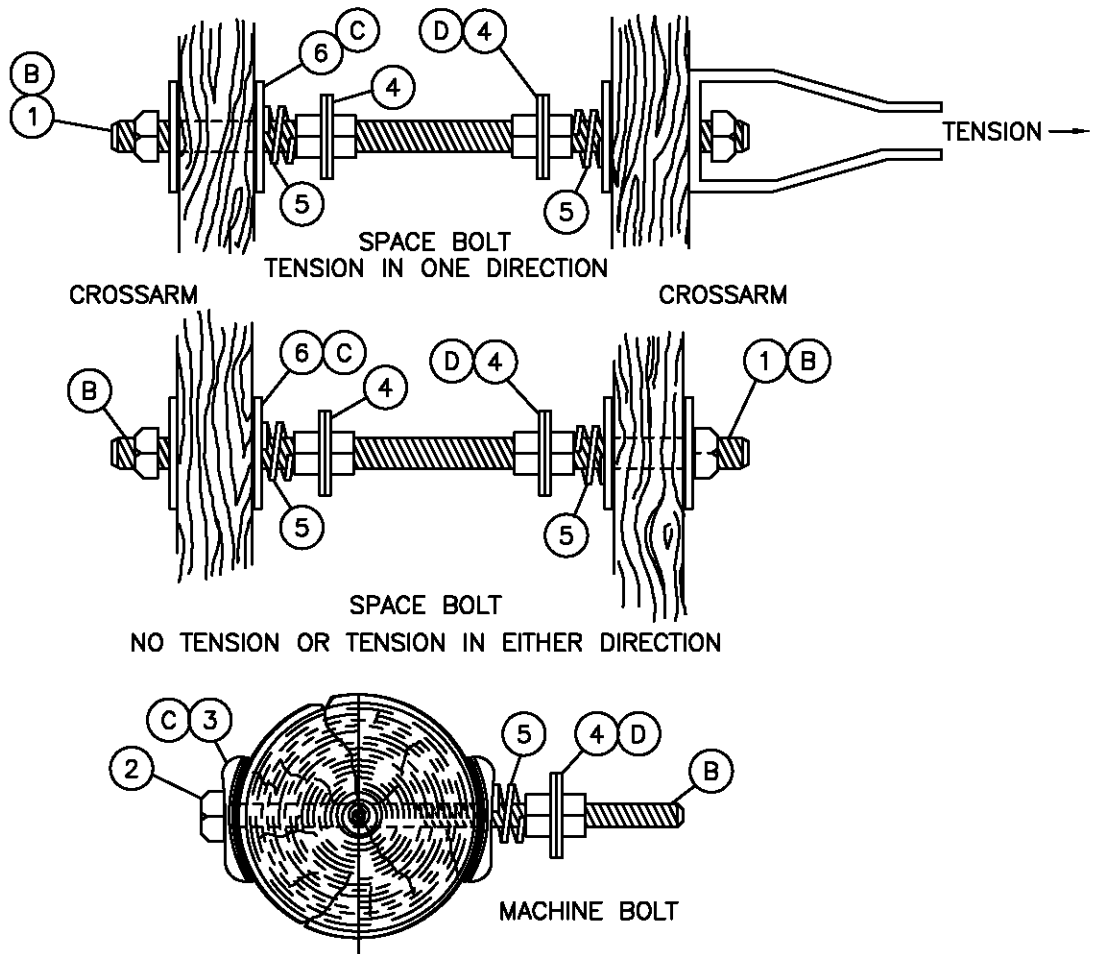

BILL OF MATERIAL:

ITEM	DESCRIPTION	QUANTITY	CONST STD OR PAGE NO.	STOCK NUMBER
1	BOLT, SPACE, GALV, & 6 NUTS (SIZE AS REQ'D)	1	392.1	-
2	BOLT, MACH, GALV, & 2 NUTS (SIZE AS REQ'D)	1	392.1	-
3	WASHER, SQUARE, CURVED, GALV (SIZE AS REQ'D)	2	392.2	-
4	WASHER, ROUND, GALV (SIZE AS REQ'D)	AS REQ'D	392.2	-
5	WASHER, DOUBLE COIL SPRING, GALV (SIZE AS REQ'D)	AS REQ'D	392.2	-
6	WASHER, SQUARE, FLAT, GALV (SIZE AS REQ'D)	4	392.2	-

INSTALLATION:

- A. DOUBLE COIL SPRING LOCK WASHER INSTALLATION.
1. PLACE SQUARE FLAT WASHER AGAINST WOOD.
 2. INSTALL DOUBLE COIL WASHER OF PROPER SIZE ON BOLT
 3. INSTALL NUT AND TIGHTEN UNTIL COIL IS FULLY COMPRESSED.
 4. BACK-OFF NUT APPROXIMATELY 1/4 TURN.
- (B) CUT OFF END OF BOLT WHEN IT PROTRUDES MORE THAN 1 INCH BEYOND NUT IN CLIMBING SPACE.
- (C) USE FLAT SQUARE WASHERS FOR FLAT SURFACES AND FOR BOLTING TRANSFORMERS TO POLES. USE CURVED SQUARE WASHERS ON CURVED SURFACES WHEN HOLDING GUYS OR CONDUCTORS.
- (D) DOUBLE ROUND WASHERS FOR BONDING AND FUTURE BONDING.

© 1998 - 2005 San Diego Gas & Electric Company. All rights reserved. Removal of this copyright notice without permission is not permitted under law.

	Indicates Latest Revision	Completely Revised	New Page	Information Removed
392.3	SDG&E ELECTRIC STANDARDS			REVISION
	TYPICAL BOLT AND WASHER ASSEMBLY			DATE 1-1-86 APPD PJA/RD

SCOPE: THIS STANDARD SHOWS TYPICAL INSTALLATION OF SPLIT RINGS AND STEEL THRUST PLATE ON DOUBLE CROSSARMS.

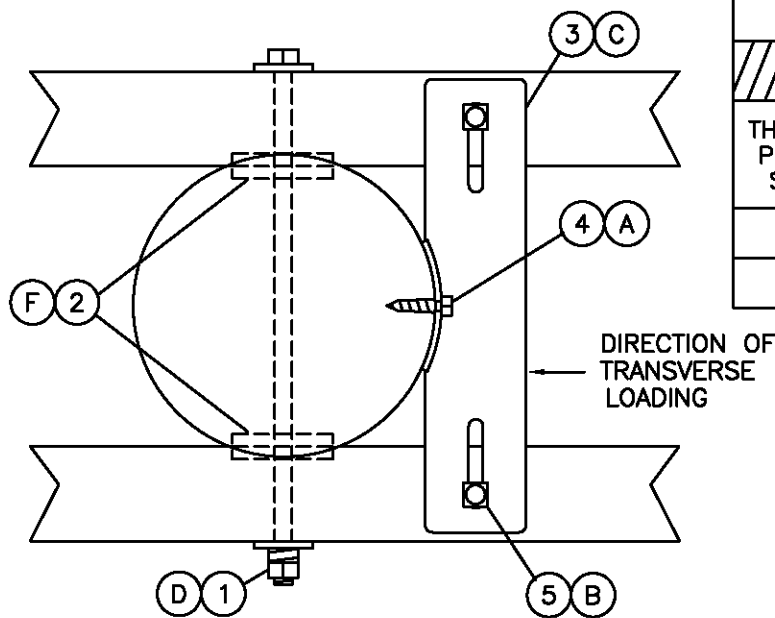

THRUST PLATE APPLICATION				
THRUST PLATE SIZE	DIAMETER OF POLE AT CROSSARM THRU-BOLT (G)			
	STANDARD CROSSARMS		HEAVY CROSSARMS	
	MIN.	MAX.	MIN.	MAX.
18"	7-3/4"	11-3/4"	5-3/4"	9-3/4"
22"	11-3/4"	15-3/4"	9-3/4"	13-3/4"

NOTE: SPLIT RINGS MAY NOT BE REQUIRED. FOR APPLICATION OF THRUST PLATE AND SPLIT RINGS, SEE CONSTRUCTION STANDARD 433.

BILL OF MATERIAL:

ITEM	DESCRIPTION	QUANTITY	CONSTR. STD OR PAGE NO.	STOCK NUMBER	ASSEMBLY UNITS
1	BOLT, MACH, GALV, 3/4" X (LENGTH AS REQ'D), 2 SQUARE AND 1 DOUBLE COIL SPRING WASHER	1	STD 392	-	-
2	SPLIT RING, GALV, 4"	2	-	599584	SPLT-R
3	PLATE, THRUST, GALV, 18" X 4", OR, 22" X 5"	1	-	541210	TPLT18
		1	-	541208	TPLT22
4	SCREW, LAG, GALV, 5/8" X 5"	1	-	621600	-
5	BOLT, MACH, GALV, 3/4" X 9", 1 SQUARE AND 1 DOUBLE COIL SPRING WASHER	2	-	154080	-

INSTALLATION:

- (A) BEFORE DRILLING CROSSARMS FOR BOLTING THRUST PLATE TO CROSSARMS, ENSURE THAT THRUST PLATE IS DRIVEN TIGHT AGAINST POLE WITH LAG SCREW.
- (B) DRILL THRUST PLATE MOUNTING BOLT HOLES ON CROSSARMS CENTERLINE.
- (C) DO NOT BOND STEEL THRUST PLATE OR HARDWARE.
- (D) SEE STANDARD 392.3 FOR TYPICAL BOLT AND WASHER ASSEMBLY.
- (F) CUT POLE GAIN ON BOTH SIDES WHEN SPLIT RINGS ARE INSTALLED.
- (G) ADD 1/2" TO THESE DIMENSIONS IF SPLIT RINGS ARE INSTALLED.

© 1998 - 2005 San Diego Gas & Electric Company. All rights reserved. Removal of this copyright notice without permission is not permitted under law.

	Indicates Latest Revision	Completely Revised	New Page	Information Removed
REVISION	SDG&E ELECTRIC STANDARDS			
DATE 1-1-94 APPD <i>PLA/ROJ</i>	TYPICAL SPLIT RING AND STEEL THRUST PLATE ASSEMBLY			392.4

400 - DISTRIBUTION
POLE TOP

400 - DISTRIBUTION
POLE TOP

PAGES

SUBJECT

413	FIBERGLASS SUPPORT CONSTRUCTION, 12KV AND BELOW
414	POST INSULATOR AND BRACKET CONSTRUCTION, ANGLES 0° TO 5°, 12 AND 12.47KV
415	POST INSULATOR AND BRACKET CONSTRUCTION, ANGLES 5° TO 30°, 12 AND 12.47KV
420	VERTICAL CONSTRUCTION 30° TO 60° ANGLES, 12 AND 12.47KV
421	VERTICAL CONSTRUCTION 60° TO 90° ANGLES, 12 AND 12.47KV
422	POST INSULATOR AND BRACKET CONSTRUCTION, "4 WAY AND 'T' CORNERS", 12 AND 12.47KV
434	750 - 7500 VOLT BUCKARM CORNERS
436	PRIMARY, SINGLE-PHASE TRANSFORMER INSTALLATION, EXISTING LINE AND BUCK
438	NEUTRAL INSTALLATION PIN-TYPE OR DEAD-END, 12KV AND BELOW
439	CROSSARM EXTENSION BRACKET
475	WOOD POLE TOP EXTENSIONS FOR LINE ARMS OR SERVICE CLEARANCE ARMS - LIGHT DUTY
476	POLE TOP EXTENSIONS FOR SERVICE CLEARANCE ARMS

© 1998 - 2016 San Diego Gas & Electric Company. All rights reserved. Removal of this copyright notice without permission is not permitted under law.

REV	CHANGE	BY	DSGN	APPV	DATE	REV	CHANGE	BY	DSGN	APPV	DATE
C	ADDED 438	JS	IL	MDJ	8/11/2016	F					
B	ADDED 436	JS	IL	MDJ	8/11/2016	E	ADDED 475	JS	IL	MDJ	8/11/2016
A	ORIGINAL ISSUE	JS	IL	MDJ	7/13/2016	D	ADDED 439	JS	IL	MDJ	8/11/2016

	Indicates Latest Revision	Completely Revised	New Page	Information Removed
-------------------------------------------------------------------------------------	---------------------------	--------------------	----------	---------------------

**SHEET
1 OF 1**

**SDG&E OVERHEAD STANDARD
DISTRIBUTION POLE TOPS FMO
TABLE OF CONTENTS**

**FMO
OH 401**

FIELD MAINTENANCE ONLY

REVISION HISTORY:

7/13/2016: All versions prior to 2016 are superseded by their current version found inside the Overhead Construction Standard Manual.

© 1998 - 2016 San Diego Gas & Electric Company. All rights reserved. Removal of this copyright notice without permission is not permitted under law.

REV	CHANGE	BY	DSGN	APPV	DATE	REV	CHANGE	BY	DSGN	APPV	DATE
C						F					
B						E					
A	ORIGINAL ISSUE	JS	IL	MDJ	7/13/2016	D					

<p>SHEET 1 OF 1</p>	 Indicates Latest Revision	<input type="checkbox"/> Completely Revised	<input type="checkbox"/> New Page	<input type="checkbox"/> Information Removed	<p>FMO OH 413</p>
	<p>SDG&E ELECTRIC OVERHEAD STANDARD</p>				
	<p>FIBERGLASS SUPPORT CONSTRUCTION, 12KV AND BELOW</p>				

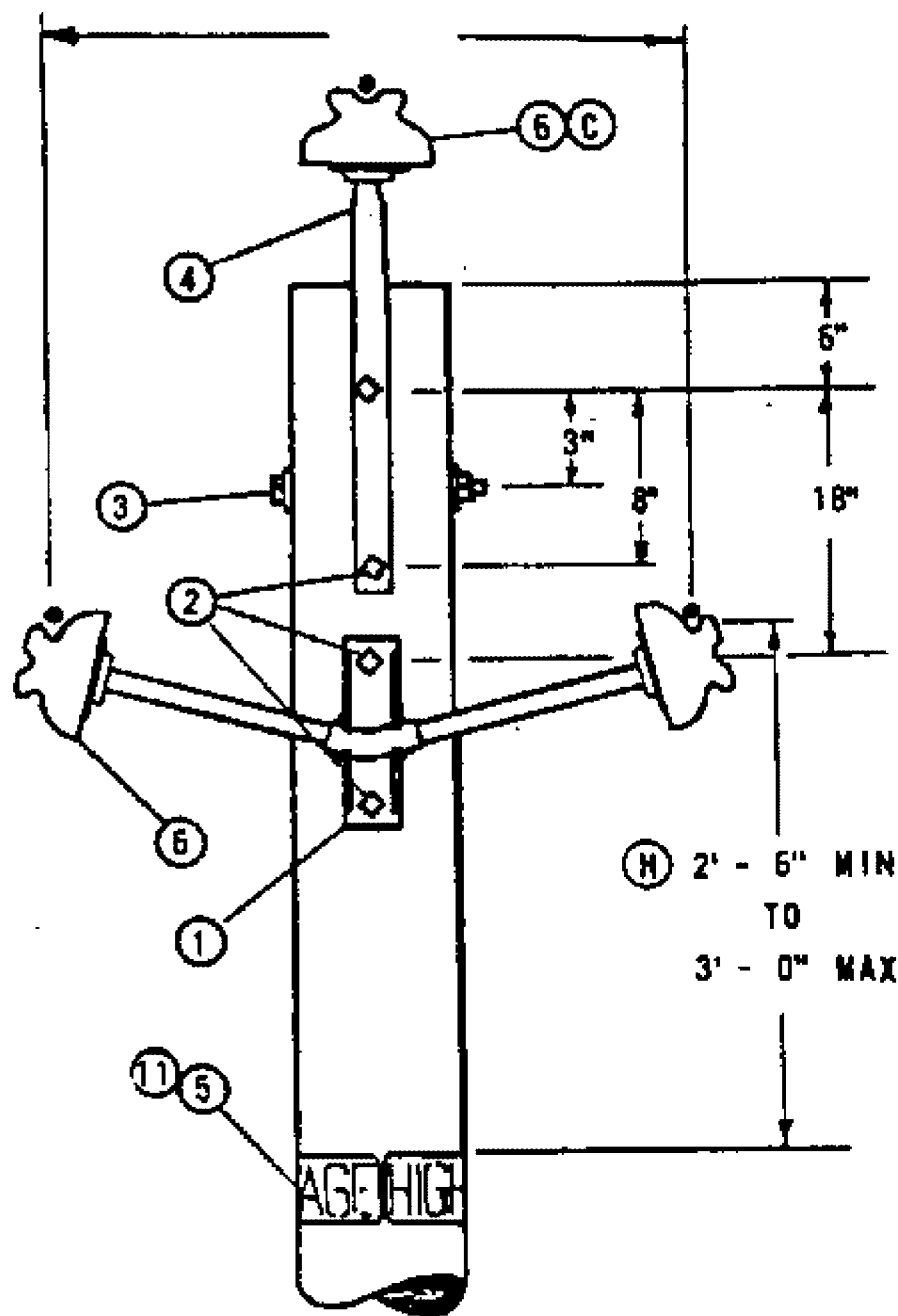

FIGURE 1

WORK ORDER DESIGNATION
"FGS AND PTP"

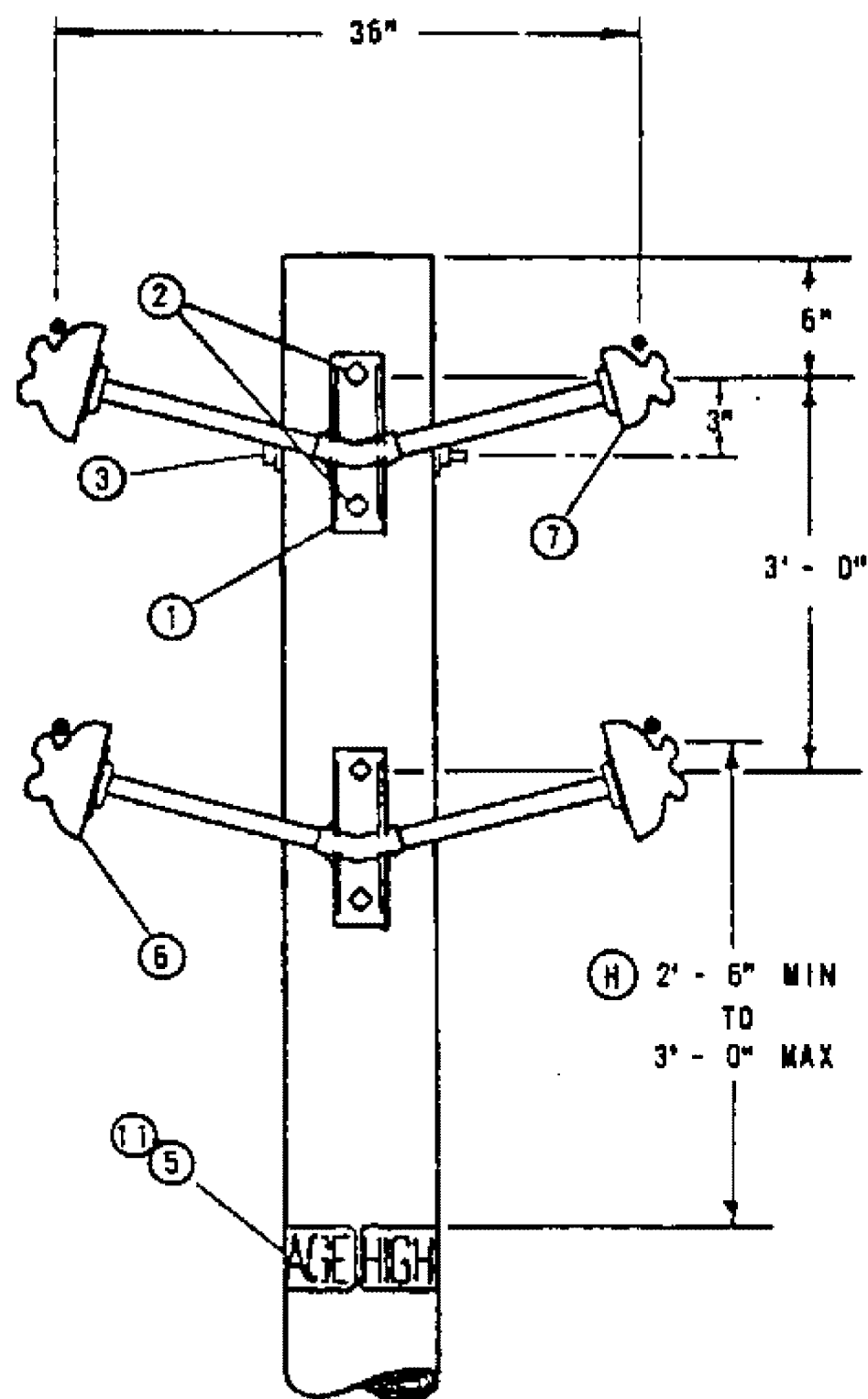

FIGURE 2

WORK ORDER DESIGNATION
"FGS"

NOTES:

- A. USE MAXIMUM ANGLE OF DEVIATION OF 2.25° , BASED ON CLIMBING SPACE REQUIREMENTS (G.O. 95, RULE 54.7A2).
- B. USE IN CONTAMINATION DISTRICTS 2 AND 3 AS DEFINED ON STANDARDS PAGE 287.
- (C) SUBSTITUTE ONE 55-3 FOR ONE 55-5 INSULATOR AND CORRESPONDING PREFORMED TYPE TIE ON NEUTRAL WIRE FOR IDENTIFICATION.
- (E) EXEMPT MATERIALS.
- (F) ITEM 10 IS PREFERRED OVER ITEMS 8 & 9.
- (G) 636 KCM AND 1033.5 KCM CONDUCTORS CANNOT BE USED SINCE NO CLAMP INSULATORS OF THIS TYPE ARE AVAILABLE.
- (H) THESE DIMENSIONS ARE IN ACCORDANCE WITH G.O. 95.
- I MAXIMUM SPAN LENGTH FOR THIS CONSTRUCTION IS 200'. IF SPAN LENGTH IS GREATER, PLEASE CONTACT SYSTEM STANDARDS.

ITEM P O C F D	DESCRIPTION	QUANTITY			STOCK NO. OR CONSTR. STDS.
		FIG. 1		FIG. 2	
		10	30	4 WIRE	
1	BRACKET, 2 PHASE PIN	1	1	2	166912
2	BOLT, MACH 5/8 X _____, 1-2 1/4" FLAT WASH. 1 DBL COIL SPR. WASH. (E)	2	4	4	PGS 139, 140
3	BOLT, MACH 5/8" X _____, 2-2 1/4" FLAT WASH., 1 DBL COIL SPR WASH. (E)	1	1	1	PGS 139, 140
4	PIN, PCLE TOP, 24", 1" LEAD THREADS	-	1	-	532480
5	SIGN, HIGH VOLTAGE (E)	2	2	2	647616
6	INSULATOR, PIN TYPE, CLASS 55-5	2	3	3	429056
7	INSULATOR, PIN TYPE, CLASS 55-3	(C)	(C)	1	429216
8	WIRE TIE. (F)		IF REQ'D.		700 SECTION
9	GUARD, LINE, ALUM CONDUCTOR (F)		IF REQ'D.		700 SECTION
10	TIE, PREFORMED, ALUMINUM CONDUCTORS, (F)	2	3	4	PG 760
11	NAILS, 1 3/4" GALV (E)	16	16	16	492192

SDG & E ELECTRIC STANDARDS

FIBERGLASS SUPPORT CONSTRUCTION, 12KV AND BELOW

APPD *AWK*
SYS STDS ENGR

499.101
SUPERCEDES
413 (1-1-92)

FIELD MAINTENANCE ONLY

REVISION HISTORY:

7/13/2016: All versions prior to 2016 are superseded by their current version found inside the Overhead Construction Standard Manual.

© 1998 - 2016 San Diego Gas & Electric Company. All rights reserved. Removal of this copyright notice without permission is not permitted under law.

REV	CHANGE	BY	DSGN	APPV	DATE	REV	CHANGE	BY	DSGN	APPV	DATE
C						F					
B						E					
A	ORIGINAL ISSUE	JS	IL	MDJ	7/13/2016	D					

	Indicates Latest Revision	Completely Revised	New Page	Information Removed
-------------------------------------------------------------------------------------	---------------------------	--------------------	----------	---------------------

**SHEET
1 OF 1**

SDG&E ELECTRIC OVERHEAD STANDARD
POST INSULATOR AND BRACKET CONSTRUCTION,
ANGLES 0° TO 5°, 12 AND 12.47KV

**FMO
OH 414**

SCOPE: THIS STANDARD SHOWS DISTRIBUTION CONSTRUCTION OF 12 AND 12.47 KV LINES WITH A LINE ANGLE NOT EXCEEDING 5°, USING ARMLESS VERTICAL CONSTRUCTION.

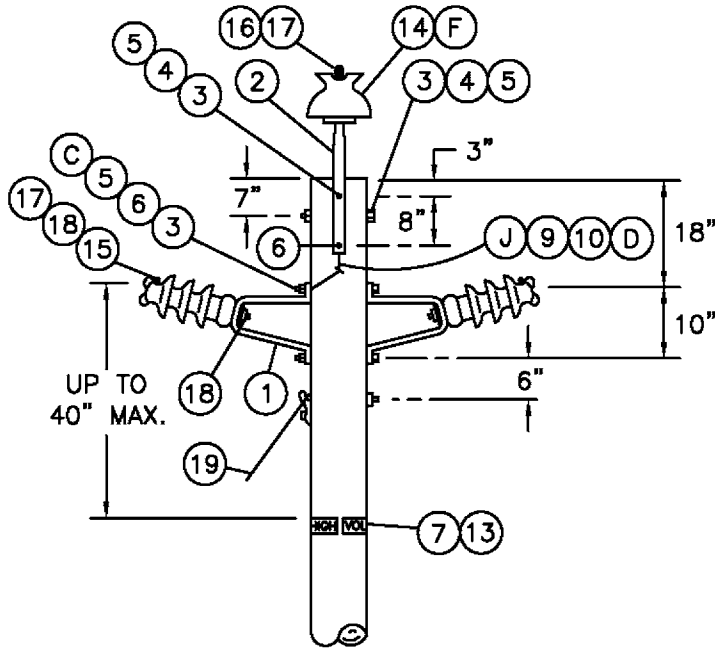

FIGURE 1

POLE TOP POSITION 3 WIRE CIRCUIT,
WORK ORDER DESIGNATION PTP, PIB, & TPI

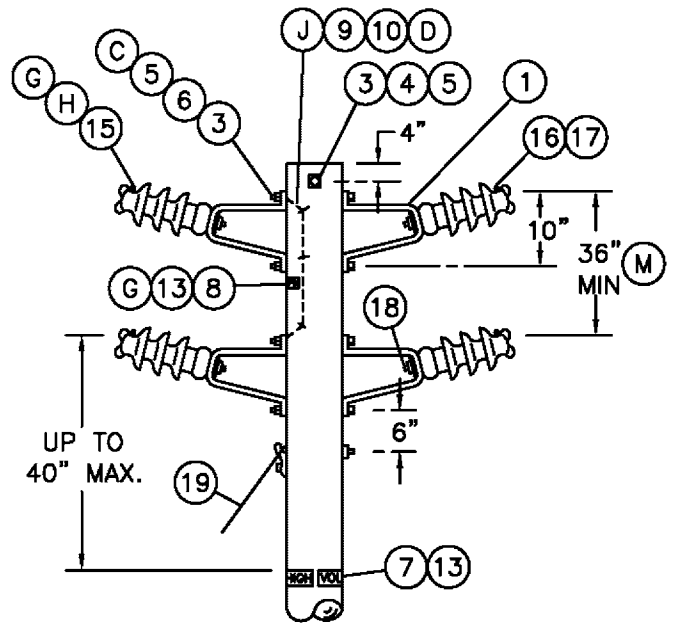

FIGURE 2

POLE TOP POSITION 2, 3, OR 4 WIRE CIRCUIT,
WORK ORDER DESIGNATION PIB & TPI

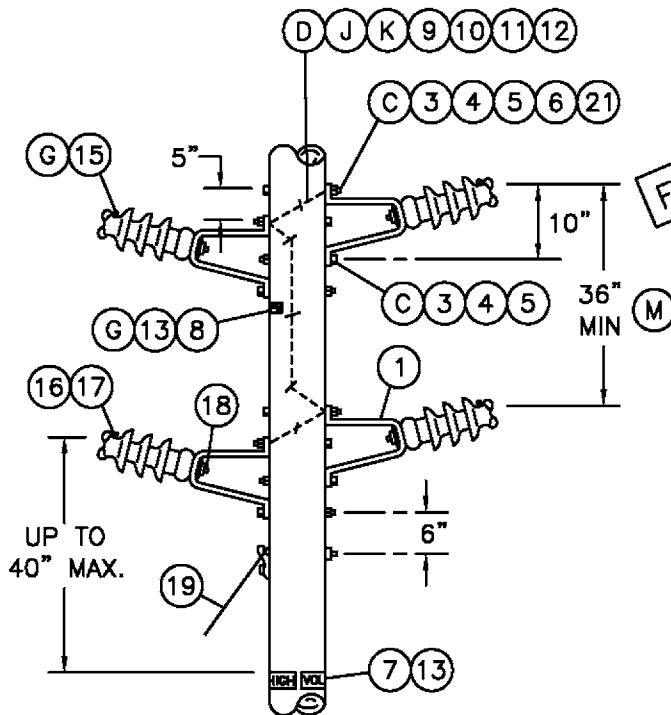

FIGURE 3

BELOW POLE TOP POSITION 2, 3, OR 4 WIRE CIRCUIT
WORK ORDER DESIGNATION PIB & TPI

FOR FIELD MAINTENANCE ONLY

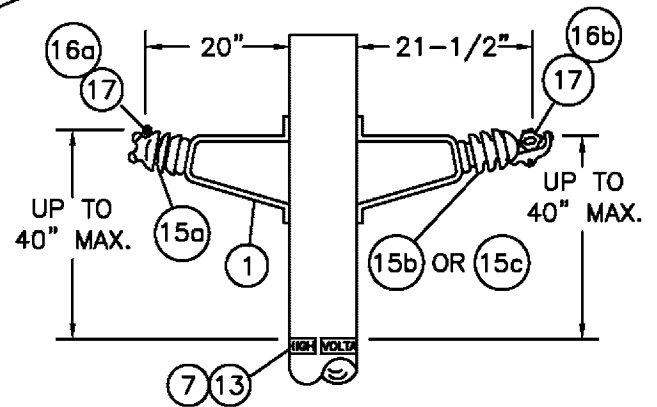

FIGURE 4

HORIZONTAL POST INSULATOR
WORK ORDER DESIGNATION PIB, TPI, & HPI

DATE 1-1-96
APPD *PA/ROJ*

SDG&E ELECTRIC STANDARDS

POST INSULATOR AND BRACKET CONSTRUCTION,
ANGLES 0° TO 5°, 12 AND 12.47KV

499.102
SUPERSEDES
414.1 (1-1-96)

INSTALLATION:

- A. CLIMBING SPACE MUST BE PROVIDED PER STANDARDS PAGE 252.
- B. USE CLAMP TOP LINE POST INSULATORS AND CLAMPS FOR 1033 KCMIL ACSR.
- (C) INSTALL DOUBLE COIL SPRING WASHER SO IT CONTACTS BRACKET.
- (D) BONDING OF THE BRACKETS IS ONLY REQUIRED WITHIN HEAVY CONTAMINATION AREA, DISTRICT 1 ON PAGE 287. USE BONDING PROVISIONS ON BRACKETS, IF THEY ARE FURNISHED.
- (F) SUBSTITUTE A CLASS 55-3 INSULATOR (STOCK NO. 429216) FOR NEUTRAL IDENTIFICATION.
- (G) IF A SMALLER LINE POST INSULATOR IS NOT AVAILABLE FOR NEUTRAL AS COMPARED TO THOSE ON THE PHASE POSITION, THE "PN" SIGN SHALL BE USED TO IDENTIFY THE NEUTRAL.
- (H) RESISTANCE GLAZE (RG) CLAMP TOP POST INSULATORS (STOCK NO 428952) SHALL BE USED WHEN AVAILABLE ON TRIAL APPLICATIONS ON PHASE CONDUCTORS IN HEAVY CONTAMINATION AREAS AS DEFINED ON PAGE 287 AND ONLY USING FIGURE 2 CONSTRUCTION. CONDUCTOR CLAMPS ARE REQUIRED WITH "RG" INSULATORS. INSTALL A "DO NOT WASH" SIGN ABOVE THE POLE TAGS IN SIGHT OF ON-COMING TRAFFIC.
- I. USE FIGURES 2 OR 3 WHERE NEUTRAL MAY BE REQUIRED IN THE FUTURE. CONSULT WITH DISTRICT ENGINEER.
- (J) TO PREVENT RADIO INFLUENCE VOLTAGE (R.I.V.), DO NOT LOCATE BOND WIRE STAPLES WITHIN 1" OF BOLTS.
- (L) ORDER (ITEM 18) FOR HPI ONLY.
- (M) FOR SPAN LENGTHS GREATER THAN 250', THE CONDUCTOR SPACING IS DETERMINED BY THE FORMULA:

$$\text{SPACING} = 3' + \left[\frac{\text{SPAN LENGTH} - 250'}{50} \right]$$
 IF SPAN LENGTH IS GREATER THAN 325', PLEASE CONTACT DISTRIBUTION STANDARDS.
- N. AN INSULATOR MOUNTED DIRECTLY ON THE SIDE OF A POLE SHALL BE CONSIDERED AS IN A HORIZONTAL POSITION (SEE FIG. 4). AN INSULATOR MOUNTED DIRECTLY AT THE TOP OF THE POLE IN A VERTICAL POSITION SHALL BE CONSIDERED AS IN A VERTICAL POSITION (SEE G.O. 95 RULE 54.11 A).

FOR FIELD MAINTENANCE ONLY

BILL OF MATERIAL:

ITEM	DESCRIPTION	QUANTITY						STOCK NO. OR CONSTR STDS	ASSEMBLY UNITS	
		FIG. 1	FIG. 2			FIG. 3				
			2 WIRE	3 WIRE	4 WIRE	2 WIRE	3 WIRE			4 WIRE
1	BRACKET, POST INSULATOR (PIB)	2	2	3	4	2	3	4	166848	PIB
2	PIN, POLE TOP 24", 1" OR 1 3/8" LEAD THREAD AS REQ'D	1	-	-	-	-	-	-	532480	PTP1
3	BOLT, MACH, 5/8" X ___"	5	3	5	5	4	6	8	STD 392	-
4	WASHER, 2 1/4" SQ FLAT	4	2	4	2	4	6	8	STD 392	-
5	WASHER, 5/8" DOUBLE COIL SPRING	5	3	5	5	4	6	8	STD 392	-
6	WASHER, 5/8" ROUND (WHERE BONDING IS REQ'D (D))	4	-	4	4	4	6	8	STD 392	-
7	SIGN, HIGH VOLTAGE	2	2	2	2	2	2	2	647648	HV
8	SIGN, PN (PRIMARY NEUTRAL) IF REQ'D	1	1	1	1	1	1	1	648000	PN
9	WIRE, BARE SOLID ANNEALED COPPER #8 (WHERE BONDING IS REQ'D)	3'	-	6'	6'	2'	6'	8'	812928	BOND8
10	STAPLES, GALV FENCE 1 1/4" (WHERE BONDING IS REQ'D)	2	-	4	4	1	4	5	678528	-
11	MOULDING, 1" HARDWOOD	-	-	-	-	-	2.5	2.5	487200	MLDG
12	STAPLES, MOULDING GALV 3" X 1 1/16" X 1/4"	-	-	-	-	-	2	2	678560	-
13	NAILS, 1 3/4" GALV	AS REQ'D						492192	-	
14	INSULATOR, PIN TYPE, CLASS AS REQ'D	1	-	-	-	-	-	-	700 SECTION	-
15	a TIE TOP (TPI)	2	2	3	4	2	3	4	700 SECTION	-
	b HORIZONTAL CLAMP TOP (HPI)									
	c HORIZONTAL CLAMP TOP RG (HPI) (H)									
16	a FORMED OR WIRE	3	2	3	4	2	3	4	700 SECTION	-
	b CLAMP, HORIZONTAL POST INSULATOR									
17	GUARD, LINE, ALUMINUM, IF REQ'D	3	2	3	4	2	3	4	PG 759	-
18	STUD, LINE POST, 5/8" X 1 3/4" (L)	2	2	3	4	2	3	4	701728	STUD-S
19	GUY	AS REQ'D						900 SECTION	-	
20	SIGN, "DO NOT WASH" (H)	IF REQ'D						648024	NOWASH	
21	NUT, 5/8" GALV	AS REQ'D						506880	-	

DATE 1-1-98 APPD PJA/CKC	SDG&E ELECTRIC STANDARDS	499.103 SUPERSEDES 414.2 (1-1-98)
	POST INSULATOR AND BRACKET CONSTRUCTION, ANGLES 0° TO 5°, 12 AND 12.47KV	

FIELD MAINTENANCE ONLY

REVISION HISTORY:

7/13/2016: All versions prior to 2016 are superseded by their current version found inside the Overhead Construction Standard Manual.

© 1998 - 2016 San Diego Gas & Electric Company. All rights reserved. Removal of this copyright notice without permission is not permitted under law.

REV	CHANGE	BY	DSGN	APPV	DATE	REV	CHANGE	BY	DSGN	APPV	DATE
C						F					
B						E					
A	ORIGINAL ISSUE	JS	IL	MDJ	7/13/2016	D					

	Indicates Latest Revision	Completely Revised	New Page	Information Removed
-------------------------------------------------------------------------------------	---------------------------	--------------------	----------	---------------------

**SHEET
1 OF 1**

SDG&E ELECTRIC OVERHEAD STANDARD

POST INSULATOR AND BRACKET CONSTRUCTION,
ANGLES 5° TO 30°, 12 AND 12.47KV

**FMO
OH 415**

FIELD MAINTENANCE ONLY

REVISION HISTORY:

7/13/2016: All versions prior to 2016 are superseded by their current version found inside the Overhead Construction Standard Manual.

© 1998 - 2016 San Diego Gas & Electric Company. All rights reserved. Removal of this copyright notice without permission is not permitted under law.

REV	CHANGE	BY	DSGN	APPV	DATE	REV	CHANGE	BY	DSGN	APPV	DATE
C						F					
B						E					
A	ORIGINAL ISSUE	JS	IL	MDJ	7/13/2016	D					

	Indicates Latest Revision	Completely Revised	New Page	Information Removed
-------------------------------------------------------------------------------------	---------------------------	--------------------	----------	---------------------

**SHEET
1 OF 1**

SDG&E ELECTRIC OVERHEAD STANDARD

VERTICAL CONSTRUCTION 30° TO 60° ANGLES, 12 AND 12.47KV

**FMO
OH 420**

SCOPE: THIS STANDARD SHOWS DISTRIBUTION CONSTRUCTION OF 12 & 12.47 KV LINES WITH A LINE ANGLE GREATER THAN 30°, BUT NOT EXCEEDING 60°, USING ARMLESS VERTICAL CONSTRUCTION.

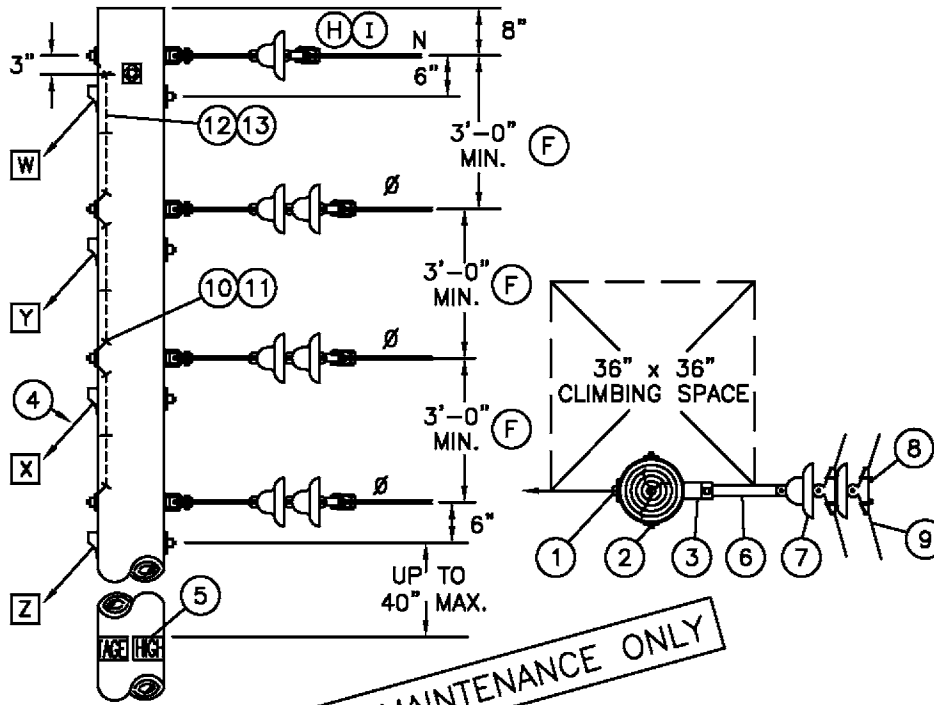

12KV VERTICAL CONSTRUCTION ASSEMBLY - MACRO UNITS			
TYPE	QUANTITY		MU ID
	12KV DE	NDE	
1/2 Y	1	1	HY1N
1/2 Y	2	-	HY2
1/2 Y	2	1	HY2N
1/2 Y	3	-	HY3
1/2 Y	3	1	HY3N
Y	2	2	Y1N
Y	4	-	Y2
Y	4	2	Y2N
Y	6	-	Y3
Y	6	2	Y3N
Z	1	1	Z1N
Z	2	-	Z2
Z	2	1	Z2N
Z	3	-	Z3
Z	3	1	Z3N

FOR FIELD MAINTENANCE ONLY

(F) FOR SPAN LENGTHS GREATER THAN 250', DETERMINE CONDUCTOR SPACING BY THE FORMULA: $SPACING = 3' + \frac{SPAN LENGTH - 250'}{50}$

NOTES:

- A. MINIMUM VERTICAL PHASE TO PHASE SPACING OF TWO FEET MAY BE USED TO ELIMINATE POLE CHANGEOUTS ON FULL TENSION SPANS 100 FEET AND SHORTER.
- B. INSTALL GUYS IN ORDER INDICATED ABOVE (W,X,Y,Z) AS REQUIRED BY THE "GUYING SECTION".
- C. USE BONDING INSULATORS OR INSTALL NON STATIC CLIPS (237648) ON UNBONDED SUSPENSION INSULATORS WHEN THE RESULTANT MAXIMUM GUYING TENSION PER PHASE AT THESE ANGLES IS LESS THAN 1500 POUNDS.
- D. TO PREVENT RADIO INFLUENCE VOLTAGE (R.I.V.), DO NOT LOCATE STAPLES WITHIN 1" OF BOLTS.

IF SPAN IS GREATER THAN 325', PLEASE CONTACT DISTRIBUTION STANDARDS.

- G. THE WORK ORDER DESIGNATION FOR THIS CONSTRUCTION IS "Z-CORNER".
- (H) PER G.O. 95 RULE 54.4 - C4 (b), ONLY TWO CONDUCTORS ARE ALLOWED TO BE DEAD ENDED FOR 4 KV OPERATION.
- (I) ON ALL NEW CONSTRUCTION AND WHEN ADDING TO EXISTING CONSTRUCTION, NEUTRAL TO BE PLACED IN THE TOP OR BOTTOM PIN POSITIONS PER DESIGN MANUAL PAGE 5124.2.

BILL OF MATERIAL:

ITEM	DESCRIPTION	QUANTITY			STOCK NO. OR CONSTR STD
		1Ø	3Ø	3Ø & N	
1	BOLT, MACH, GALV 5/8" X ___", 1-3" SQ CURV WASH., 1 DBL COIL WASHER, 2-5/8" RD WASH. & 1 NUT	2	3	4	STD.392
2	BOLT, MACH, GALV 5/8" X ___", 2-2 1/4" SQ WASH., 1 DBL COIL WASH., 2-5/8" RD WASH.	1	1	1	STD.392
3	CLEVIS, DEADEND 5/8" BOLT STEEL (OPEN TYPE)	2	3	4	235618
4	GUY	AS REQ'D			900 SECTION
5	SIGN, HIGH VOLTAGE & 9 NAILS	2	2	2	647648, 492192
6	LINK, EXTENSION, 12KV, 1/2" X 2" X 12"	2	3	4	466240
7	INSULATOR, SUSPENSION	4	6	7	PG 750
8	CLAMP, SUSPENSION	2	3	4	STD. 776
9	GUARD, LINE, ALUMINUM	2	3	4	STD. 759
10	WIRE, BOND, BARE SOLID ANNEALED, COPPER, #8	4'	6'	8'	812928
11	STAPLE, FENCE	3	6	9	678528
12	MOULDING, HARDWOOD, 1" (OTHER THAN TOP CIRCUIT ON POLE)	3'-6"	5'-6"	7'-6"	487200
13	STAPLES, MOULDING, GALV, 3" X 1 1/16" X 1/4" (OTHER THAN TOP CIRCUIT ON POLE)	2	4	6	678560

SDG&E ELECTRIC STANDARDS

499.201
SUPERSEDES
420 (9-12-05)

VERTICAL CONSTRUCTION 30° TO 60° ANGLES, 12 AND 12.47KV

DATE 9-12-05
APPD PJA/JJ

FIELD MAINTENANCE ONLY

REVISION HISTORY:

7/13/2016: All versions prior to 2016 are superseded by their current version found inside the Overhead Construction Standard Manual.

© 1998 - 2016 San Diego Gas & Electric Company. All rights reserved. Removal of this copyright notice without permission is not permitted under law.

REV	CHANGE	BY	DSGN	APPV	DATE	REV	CHANGE	BY	DSGN	APPV	DATE
C						F					
B						E					
A	ORIGINAL ISSUE	JS	IL	MDJ	7/13/2016	D					

	Indicates Latest Revision	Completely Revised	New Page	Information Removed
-------------------------------------------------------------------------------------	---------------------------	--------------------	----------	---------------------

**SHEET
1 OF 1**

SDG&E ELECTRIC OVERHEAD STANDARD

VERTICAL CONSTRUCTION 60° TO 90° ANGLES, 12 AND 12.47KV

**FMO
OH 421**

SCOPE: THIS STANDARD SHOWS DISTRIBUTION CONSTRUCTION OF 12 & 12.47 KV LINES WITH A LINE ANGLE GREATER THAN 60°, BUT NOT EXCEEDING 90°, USING ARMLESS VERTICAL CONSTRUCTION.

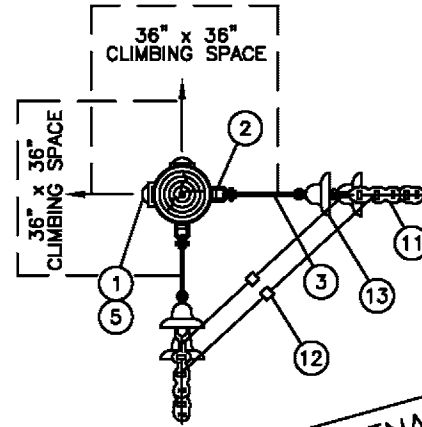
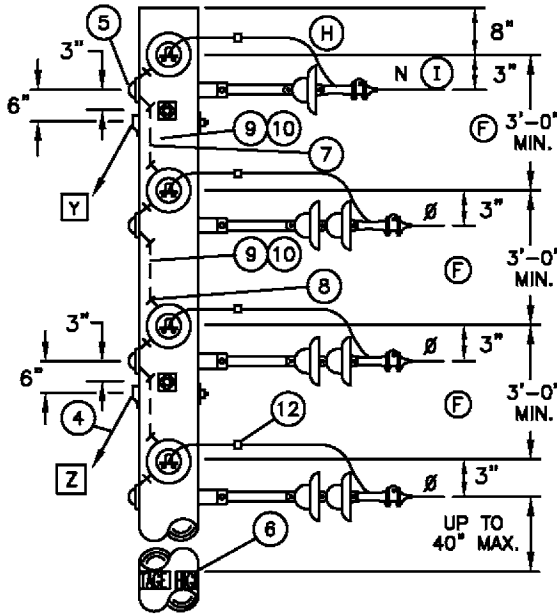

FOR FIELD MAINTENANCE ONLY

INSTALLATION:

- A. MINIMUM VERTICAL PHASE TO PHASE SPACING OF TWO FEET MAY BE USED TO ELIMINATE POLE CHANGEOUTS ON FULL TENSION SPANS 100 FEET AND SHORTER.
- B. INSTALL GUYS IN ORDER INDICATED ABOVE (Y,Z) AS REQUIRED BY THE "GUYING SECTION" AND IN COMPLIANCE WITH G.O. 95 RULE 54.7A4.
- C. USE BONDED INSULATORS WHEN THE MAXIMUM GUYING TENSION IS LESS THAN 1000 POUNDS PER CONDUCTOR.
- D. TO PREVENT RADIO INFLUENCE VOLTAGE (R.I.V.), DO NOT LOCATE STAPLES WITHIN 1" OF BOLT.
- (F) FOR SPAN LENGTHS GREATER THAN 250', DETERMINE CONDUCTOR SPACING BY THE FORMULA: $SPACING = 3' + \frac{SPAN\ LENGTH - 250'}{50}$ IF SPAN LENGTH IS GREATER THAN 325', PLEASE CONTACT DISTRIBUTION STANDARDS.
- G. THE WORK ORDER DESIGNATION FOR THIS CONSTRUCTION IS "Y-CORNER".
- (H) PER G.O. 95 RULE 54.4-C4 (b), ONLY TWO CONDUCTORS ARE ALLOWED TO BE DEAD ENDED FOR 4 KV OPERATION.

REFERENCE:

- (I) ON ALL NEW CONSTRUCTION AND WHEN ADDING TO EXISTING CONSTRUCTION, NEUTRAL TO BE PLACED IN THE TOP OR BOTTOM PIN POSITIONS PER DESIGN MANUAL PAGE 5124.2.

BILL OF MATERIAL:

ITEM	DESCRIPTION	QUANTITY			STOCK NUMBER OR CONSTR. STD.
		1Ø	3Ø	3Ø & N	
1	BOLT, MACH, GALV 5/8" X ___", 1-3" SQ CURV WASH., 1 DBL COIL WASHER, 2-5/8"RD WASH. & 1 NUT	4	6	8	STD 392
2	CLEVIS, DEADEND 5/8" BOLT STEEL (OPEN TYPE)	4	6	8	235618
3	LINK, EXTENSION, 12KV, 1/2" X 2" X 12"	4	6	8	466240
4	GUY	AS REQ'D			900 SECTION
5	COVER, BOLT, PLASTIC, & 6-10 D NAILS	4	6	8	285696, 492192
6	SIGN, HIGH VOLTAGE & 9-10 D NAILS	2	2	2	647648, 492192
7	WIRE, BOND, BARE SOLID ANNEALED, COPPER, #8	4'	7'	8'	812928
8	STAPLES, FENCE, GALV, 1 1/4"	4	7	10	678528
9	MOULDING, HARDWOOD, 1" (OTHER THAN TOP CIRCUIT ON POLE)	2'-6"	4'-6"	6'-6"	487200
10	STAPLES, MOULDING, GALV, 3" X 1 1/16" X 1/4" (OTHER THAN TOP CIRCUIT ON POLE)	2	4	6	678560
11	CLAMP, DEADEND	4	6	8	STDS 741, 743
12	CONNECTOR	2	3	4	700 SECTION
13	INSULATOR, SUSPENSION	8	12	14	PG. 750.4

DATE 9-20-05
 APPD PJA/JJ

SDG&E ELECTRIC STANDARDS

VERTICAL CONSTRUCTION 60° TO 90° ANGLES, 12 AND 12.47KV

499.202
 SUPERSEDES
 421 (9-20-05)

FIELD MAINTENANCE ONLY

REVISION HISTORY:

7/13/2016: All versions prior to 2016 are superseded by their current version found inside the Overhead Construction Standard Manual.

© 1998 - 2016 San Diego Gas & Electric Company. All rights reserved. Removal of this copyright notice without permission is not permitted under law.

REV	CHANGE	BY	DSGN	APPV	DATE	REV	CHANGE	BY	DSGN	APPV	DATE
C						F					
B						E					
A	ORIGINAL ISSUE	JS	IL	MDJ	7/13/2016	D					

	Indicates Latest Revision	Completely Revised	New Page	Information Removed
-------------------------------------------------------------------------------------	---------------------------	--------------------	----------	---------------------

**SHEET
1 OF 1**

SDG&E ELECTRIC OVERHEAD STANDARD

POST INSULATOR AND BRACKET CONSTRUCTION,
"4 WAY AND 'T' CORNERS", 12 AND 12.47KV

**FMO
OH 422**

SCOPE: THIS STANDARD SHOWS DISTRIBUTION CONSTRUCTION OF 12 & 12.47KV LINES OF THE "4 WAY AND 'T' CORNERS" USING ARMLESS VERTICAL CONSTRUCTION.

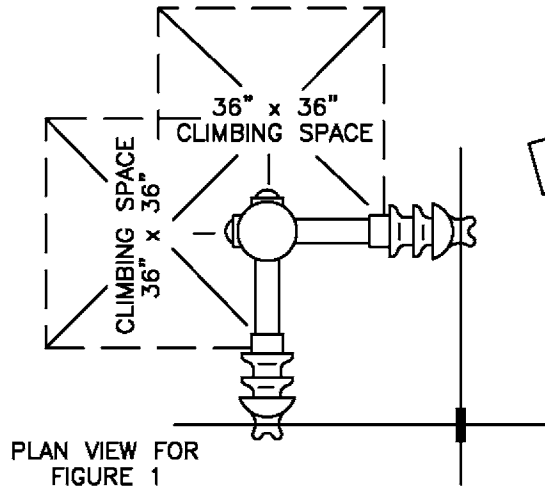

FOR FIELD MAINTENANCE ONLY

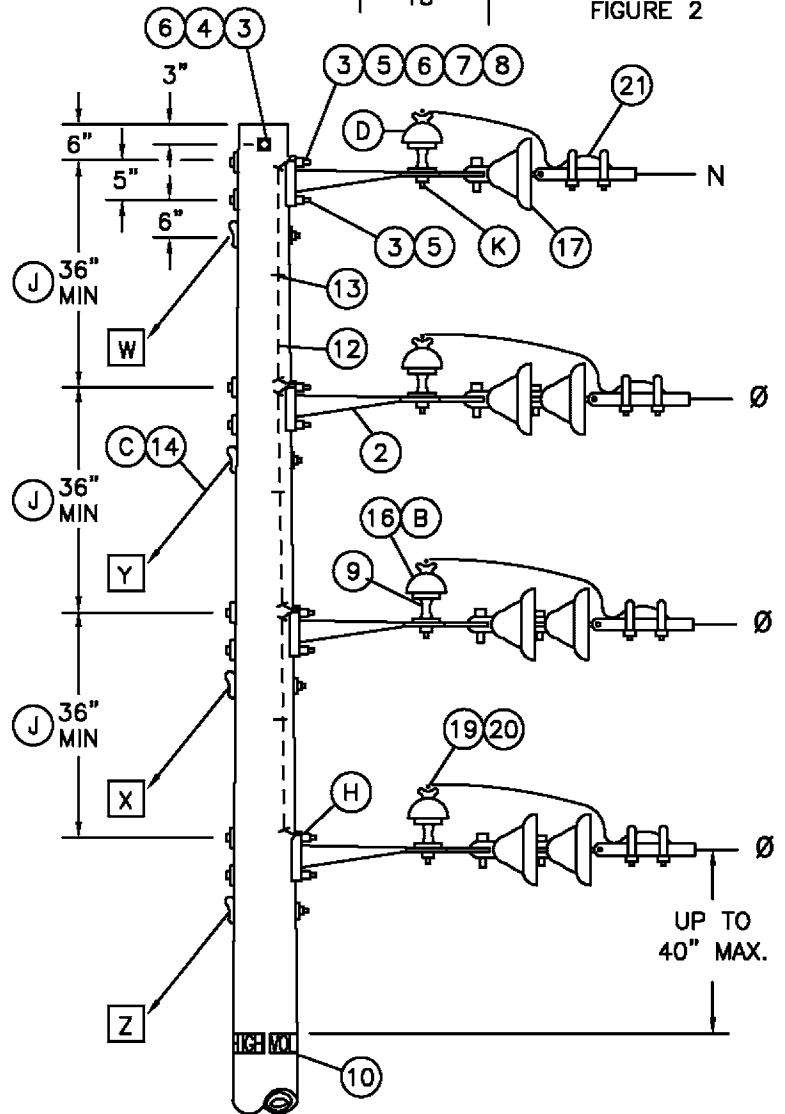
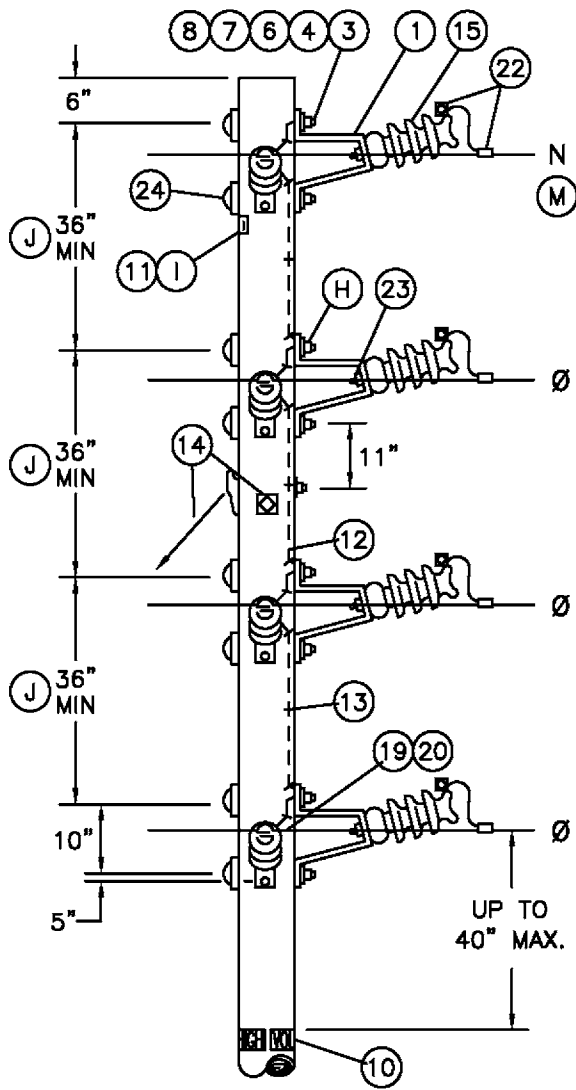
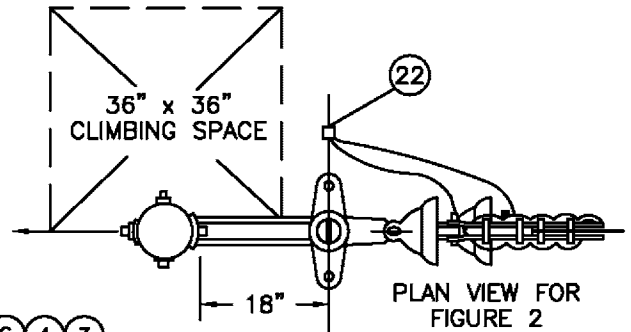

499.203
SUPERSEDES
422.1 (9-13-05)

SDG&E ELECTRIC STANDARDS

POST INSULATOR AND BRACKET CONSTRUCTION,
"4 WAY AND 'T' CORNERS", 12 AND 12.47KV

DATE 9-13-05
APPD PJA/JJ

INSTALLATION:

- A. TO PREVENT RADIO INFLUENCE VOLTAGE (R.I.V.) DO NOT LOCATE BOND WIRE STAPLES WITHIN 1" OF BOLTS.
- B. USE CLAMP TOP LINE POST INSULATORS AND CLAMPS FOR 1033 KCMIL ACSR.
- C. ADD THE GUYS IN ORDER INDICATED (W,X,Y,Z) AS REQUIRED IN THE GUYING SECTION.
- D. SUBSTITUTE A CLASS 55-3 INSULATOR (STOCK NO. 429216) FOR NEUTRAL IDENTIFICATION.
- F. BONDING IS REQUIRED WITHIN HEAVY CONTAMINATION AREA, DISTRICT 1 ON STD. 287. USE BONDING PROVISIONS ON BRACKETS, IF THEY ARE FURNISHED.
- H. INSTALL DOUBLE COIL SPRING WASHER SO IT CONTACTS BRACKET.
- I. IF A SMALLER LINE POST INSULATOR IS NOT AVAILABLE FOR NEUTRAL AS COMPARED TO THOSE IN THE PHASE POSITIONS, THE "PN" SIGN SHALL BE USED TO IDENTIFY THE NEUTRAL.
- J. FOR SPAN LENGTHS GREATER THAN 250', DETERMINE CONDUCTOR SPACING BY THE FORMULA:

$$\text{SPACING} = 3' + \frac{\text{SPAN LENGTH} - 250'}{50}$$

IF SPAN LENGTH IS GREATER THAN 325', PLEASE CONTACT DISTRIBUTION STANDARDS.

- K. IF BONDING IS REQUIRED, ATTACH BOND WIRE TO INSULATOR PIN WITH ADDITIONAL NUT.
- L. TO BE USED FOR NEW CONSTRUCTION ONLY, FOR SIDE TAPS FROM EXISTING CONSTRUCTION, USE PGS. 415.1 & 415.2.

REFERENCE:

- M. ON ALL NEW CONSTRUCTION AND WHEN ADDING TO EXISTING CONSTRUCTION, NEUTRAL TO BE PLACED IN THE TOP OR BOTTOM PIN POSITIONS PER DESIGN MANUAL PAGE 5124.2.

FOR FIELD MAINTENANCE ONLY

12KV VERTICAL CONSTRUCTION ASSEMBLY - TYPE YT MACRO UNITS			
QUANTITY			MU ID
12KV DE	NDE	P & I	
1	1	2/55-5	YT1N
2	-	2/55-5	YT2
2	1	2/55-5 1/55-3	YT2N
3	-	3/55-5	YT3
3	1	3/55-5 1/55-3	YT3N

BILL OF MATERIAL:

ITEM	DESCRIPTION	FIGURE 1			FIGURE 2			STOCK NO. OR CONSTR STD	ASSEMBLY UNITS						
		NEUTRAL WIRE	Ø WIRES			NEUTRAL WIRE	Ø WIRES								
			1	2	3		1	2	3						
1	BRACKET, POST INSULATOR (PIB)	2	2	4	6	-	-	-	-	166848	PIB				
2	BRACKET, 4 HOLE MOUNTING	-	-	-	-	1	1	2	3	166240	4H-BKT				
3	BOLT, 5/8" X ____, GALV MACH	4	4	8	12	2	3	5	7	STD392	-				
4	WASHER, 2 1/2" SQ FLAT	4	4	8	12	-	2	2	2	STD392	-				
5	WASHER, 3" SQ CURVED	-	-	-	-	2	2	4	6	STD392	-				
6	WASHER, 5/8" DBL COIL SPRING	4	4	8	12	1	2	3	4	798560	-				
7	WASHER, 5/8" ROUND (F)	4	4	8	12	2	2	4	6	800320	-				
8	NUT, 5/8" (F)	2	2	4	6	2	2	4	6	506880	-				
9	PIN, SHORT SHANK INSULATOR, 1" OR 1 3/8" LEAD THREADS (B)	-	-	-	-	1	1	2	3	532426/532434	PSS1				
10	SIGN, HIGH VOLTAGE AND 9-10D NAILS	-	2	2	2	-	2	2	2	647648/492192	HV				
11	SIGN, PRIMARY NEUTRAL (PN) AND 4-10D NAILS (I)	2	-	-	-	-	-	-	-	648000/492192	PN				
12	WIRE, BARE SOLID ANNEALED #8 COPPER,	5'	2'	6'	10'	4'	-	4'	8'	812928	BOND8				
13	STAPLES, FENCE 1 1/4"	4	1	5	9	3	-	3	6	678528	-				
14	GUY (C)	-	IF REQ'D			AS REQ'D			900 SECTION			-			
15	INSULATOR, POST	a	TIE TOP			2	2	4	6	-	-	-	-	700 SECTION	-
		b	HORIZONTAL CLAMP TOP												
16	INSULATOR, PIN TYPE, CLASS AS REQ'D (B)	-	-	-	-	1	1	2	3	700 SECTION			-		
17	INSULATOR, SUSPENSION CLEVIS	-	-	-	-	1	2	4	6	STD750, 756			-		
18															
19	GUARD, ALUMINUM IF REQ'D	2	2	4	6	1	1	2	3	STD759			-		
20	TIE	a	FORMED OR WIRE			2	2	4	6	1	1	2	3	700 SECTION	-
		b	CLAMP, HORIZONTAL POST INSULATOR (B)												
21	CLAMP, DEAD END	-	-	-	-	1	1	2	3	STD 741-743			-		
22	CONNECTOR, WIRE	2	2	4	6	1	1	2	3	STD783-787			-		
23	STUD, LINE POST, 5/8" X 1 3/4"	2	2	4	6	-	-	-	-	701728			STUD-S		
24	BOLT, COVER PLASTIC & 6-1 3/4" NAILS	4	4	8	12	-	-	-	-	285696/42919			BCS		

FIELD MAINTENANCE ONLY

REVISION HISTORY:

7/13/2016: All versions prior to 2016 are superseded by their current version found inside the Overhead Construction Standard Manual.

© 1998 - 2016 San Diego Gas & Electric Company. All rights reserved. Removal of this copyright notice without permission is not permitted under law.

REV	CHANGE	BY	DSGN	APPV	DATE	REV	CHANGE	BY	DSGN	APPV	DATE
C						F					
B						E					
A	ORIGINAL ISSUE	JS	IL	MDJ	7/13/2016	D					

SHEET 1 OF 1	 Indicates Latest Revision	Completely Revised	New Page	Information Removed	FMO OH 434
	SDG&E ELECTRIC OVERHEAD STANDARD				
	750 - 7500 VOLT BUCKARM CORNERS				

THIS PAGE FOR FIELD MAINTENANCE ONLY

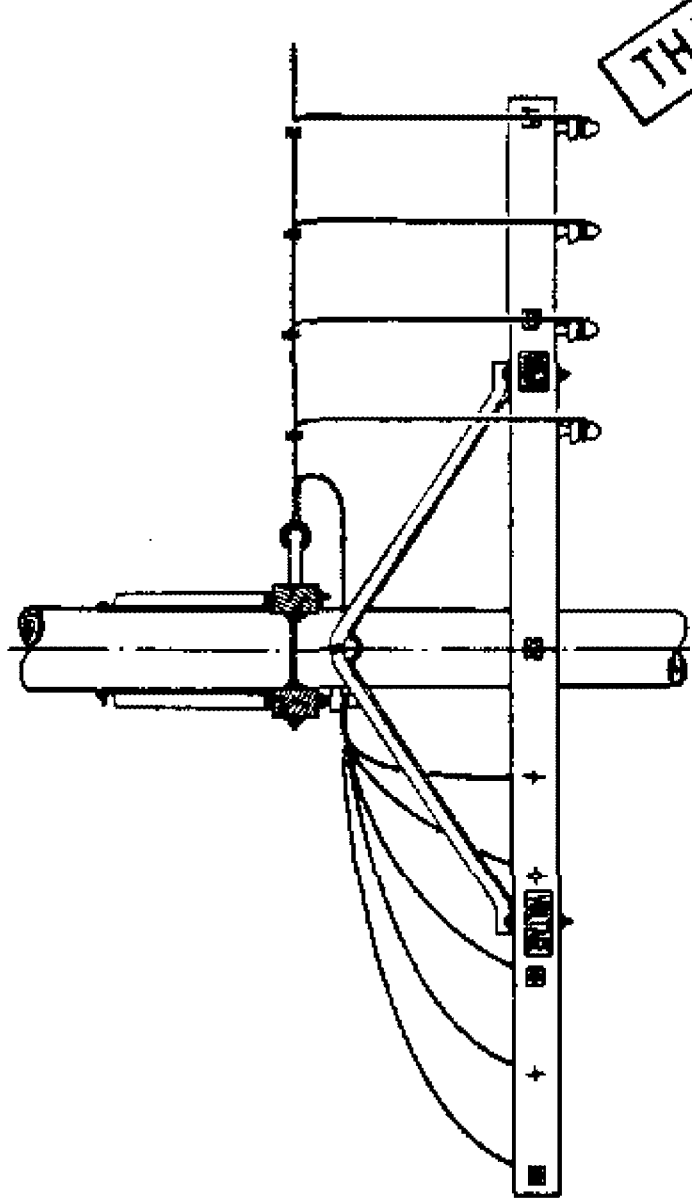
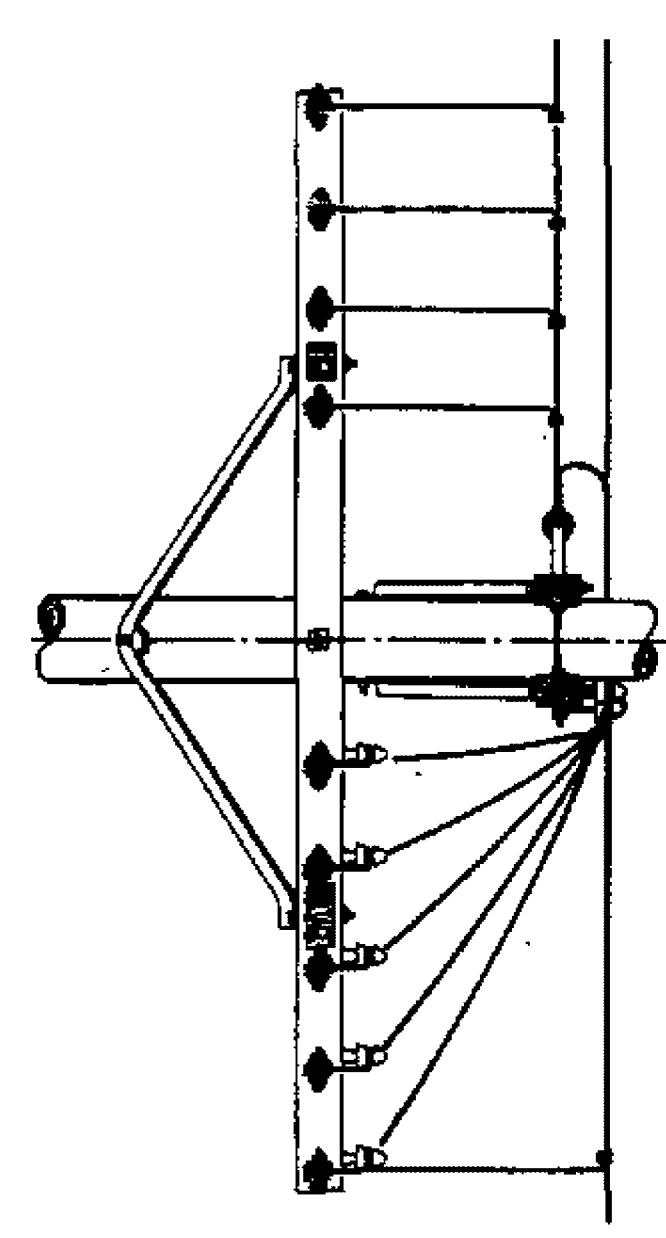
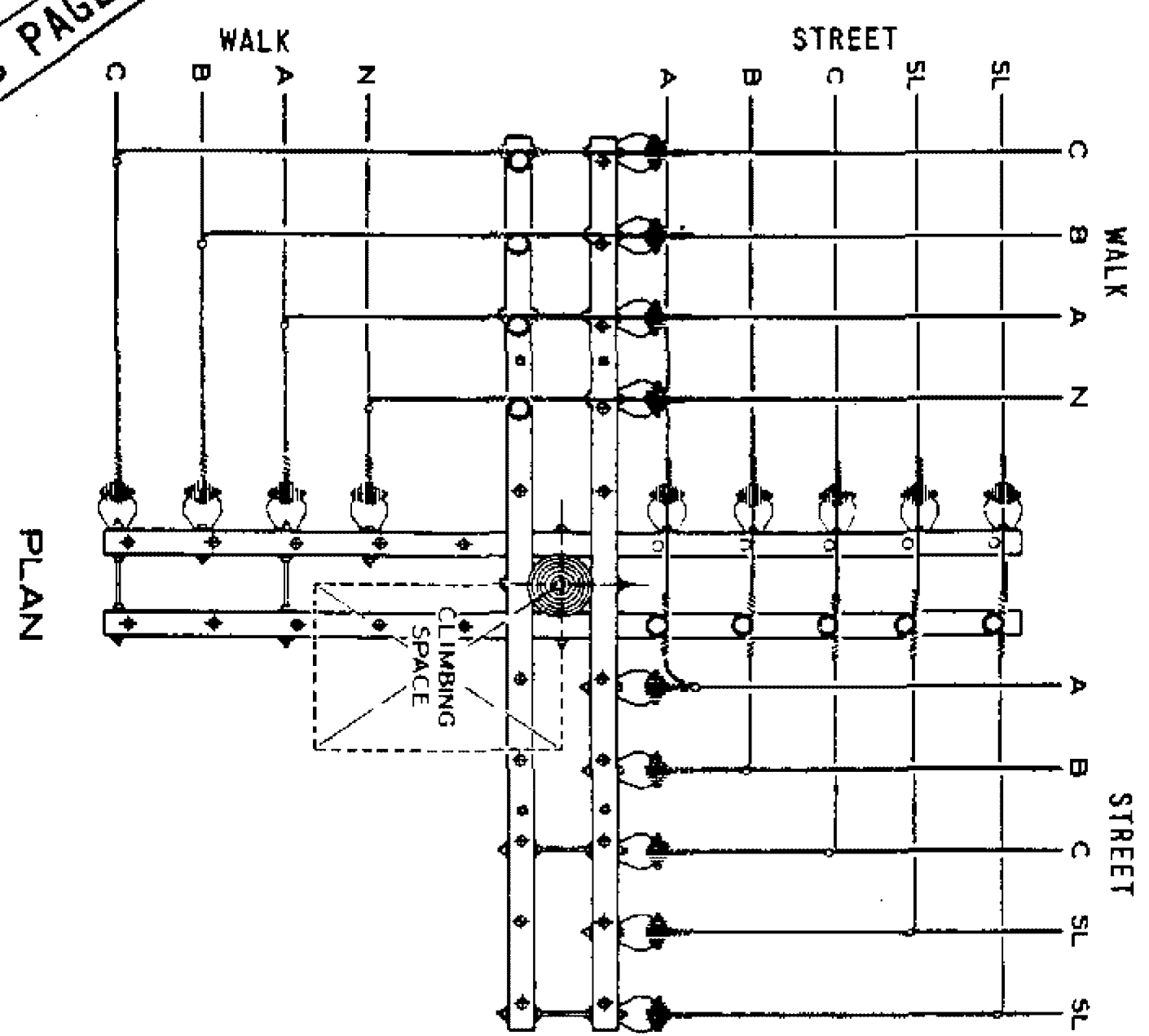
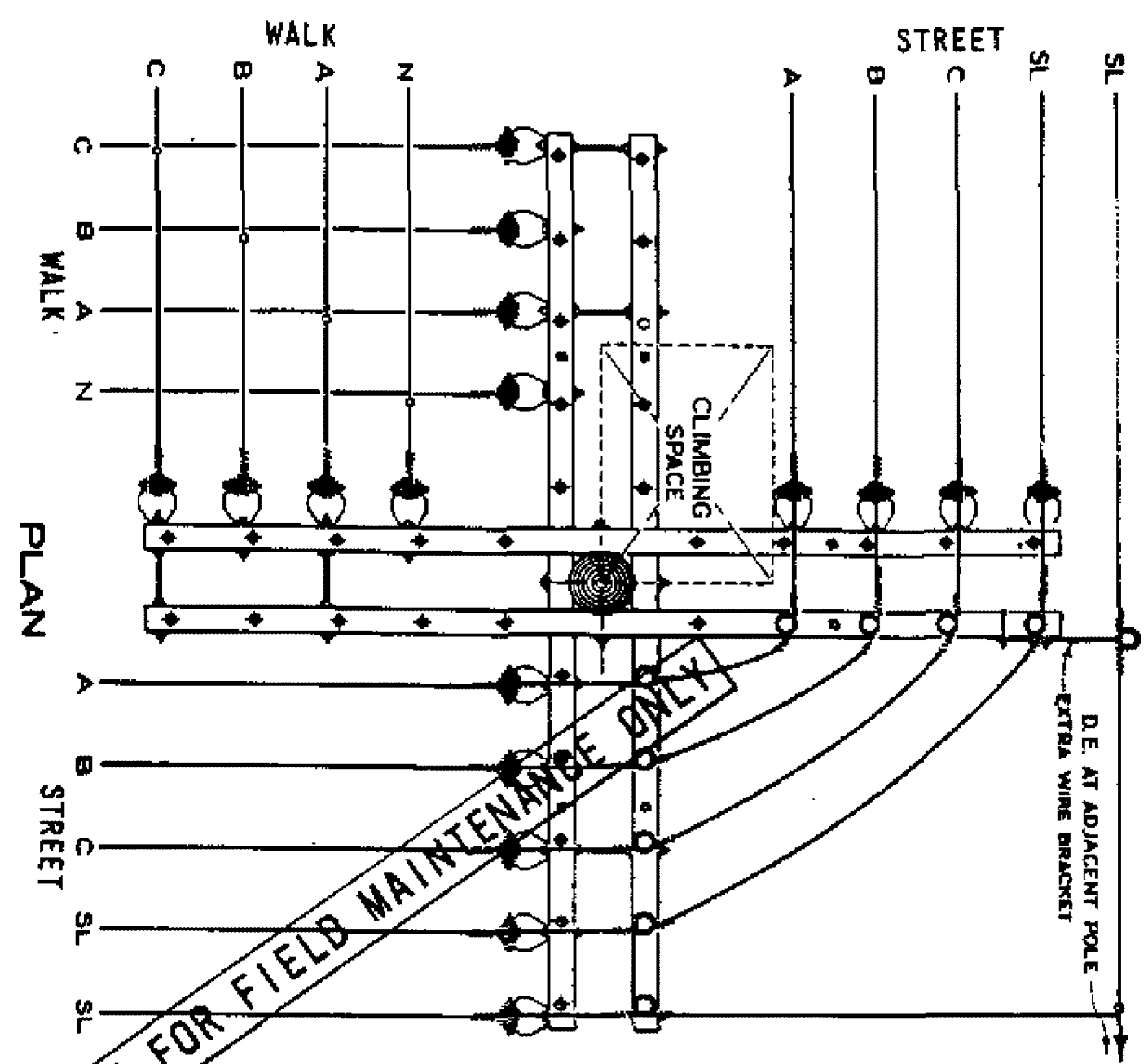

FIGURE 1

FIGURE 2



FIELD MAINTENANCE ONLY

REVISION HISTORY:

5/23/16: SDG&E is no longer hanging transformers on a line and buck pole framing. However, this standard needs to be retained in FMO in event that there are no other options available.

© 1998 - 2016 San Diego Gas & Electric Company. All rights reserved. Removal of this copyright notice without permission is not permitted under law.

REV	CHANGE	BY	DSGN	APPV	DATE	REV	CHANGE	B	S	N	APP	ATE
C						F						
B						E						
A	COMPLIANCE CHANGE	MM	IL	MDJ	5/23/16	D						

<p>SHEET 1 OF 1</p>	<table border="1"> <tr> <td> Indicates Latest Revision</td> <td>Completely Revised</td> <td>New Page</td> <td>Information Removed</td> </tr> </table>	 Indicates Latest Revision	Completely Revised	New Page	Information Removed	<p>FMO OH 436</p>
	 Indicates Latest Revision	Completely Revised	New Page	Information Removed		
	<p>SDG&E ELECTRIC OVERHEAD STANDARD</p>					
<p>PRIMARY, SINGLE-PHASE TRANSFORMER INSTALLATION EXISTING LINE AND BUCK</p>						

SCOPE: THIS STANDARD TO INSTALL A SINGLE PHASE STATION ON AN EXISTING LINE AND BUCK POLE IS TO BE USED ONLY WHEN NECESSARY TO AVOID THE SETTING OF AN ADDITIONAL POLE. **NOTE:** THREE-PHASE INSTALLATIONS REQUIRE A DEVIATION REQUEST.

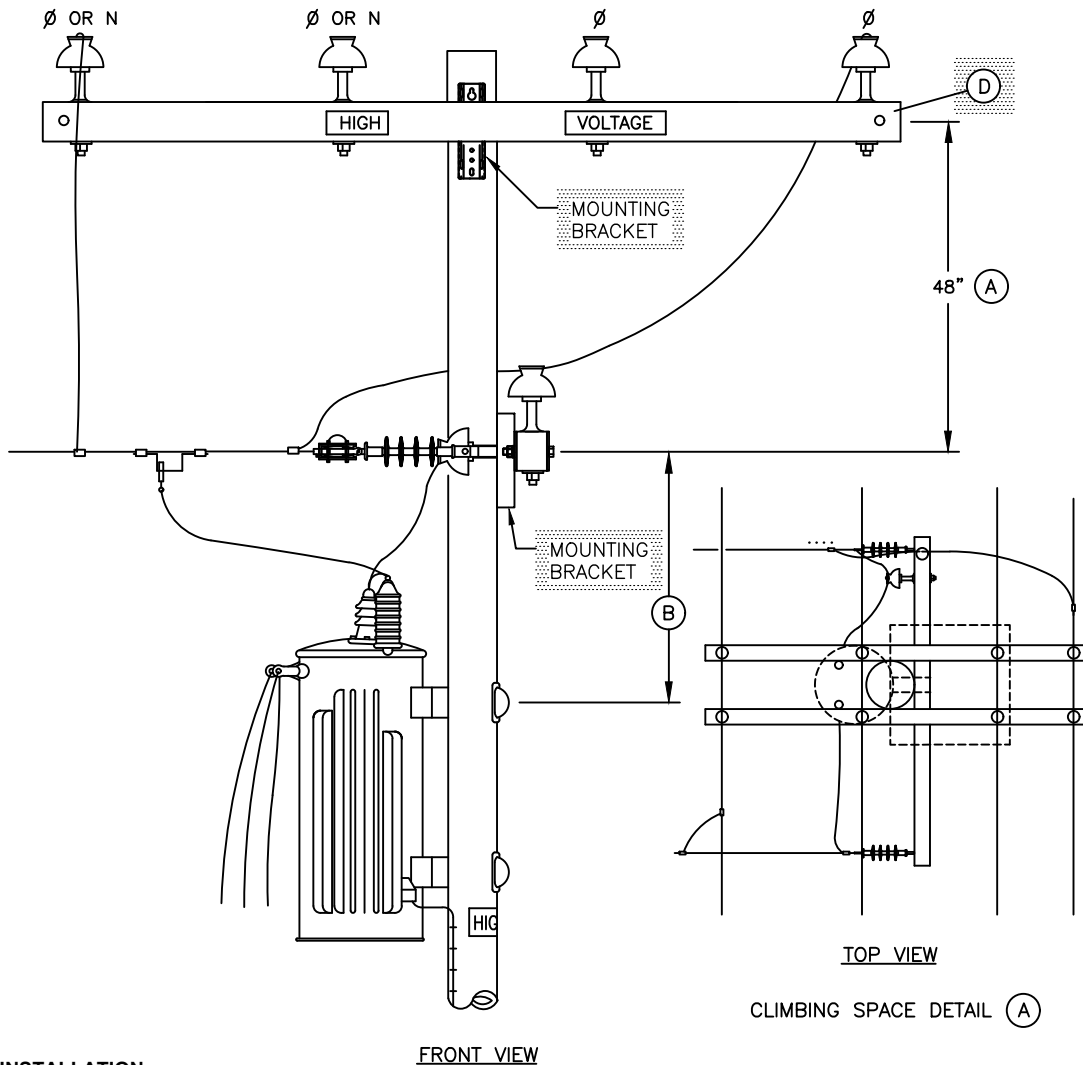

INSTALLATION:

- (A) WHILE IT IS DESIRABLE TO MAINTAIN A MINIMUM OF 48" BETWEEN THE LINE ARM AND BUCK ARM TO MAINTAIN A ONE HALF POLE OF CLIMBING SPACE THROUGH THE BUCK ARM LEVEL AND UP TO THE LINE ARM LEVEL, LESS THAN 48" AND A QUADRANT CLIMBING SPACE IS ALLOWED. (SEE O.H. STANDARD 251).
- (B) FOR TRANSFORMER THRU-BOLT DRILLING DIMENSION, SEE APPROPRIATE CONSTRUCTION STANDARD.
- C. SECTIONALIZING FUSES AND A STATION ARE **NOT** ALLOWED ON THE SAME POLE. A DEVIATION REQUEST WILL NOT BE APPROVED FOR THIS CONSTRUCTION.
- (D) FIBERGLASS CROSSARMS, SEE STANDARD 379.

© 1998 - 2016 San Diego Gas & Electric Company. All rights reserved. Removal of this copyright notice without permission is not permitted under law.

REV	CHANGE	BY	DSGN	APPV	DATE	REV	CHANGE	B	S	N	APP	ATE
C						F						
B						E						
A	CONTENT UPDATED			JS/DW	6/11/2013	D						

Indicates Latest Revision Completely Revised New Page Information Removed

SHEET
1 OF 1

SDG&E ELECTRIC OVERHEAD STANDARD
PRIMARY, SINGLE-PHASE TRANSFORMER INSTALLATION
EXISTING LINE AND BUCK

FMO
OH 436





FIELD MAINTENANCE ONLY

REVISION HISTORY:

5/23/16: Distribution Design Manual 5124 has been rewritten, and has rendered this Overhead Standard obsolete. Also changed scope to include all primary distribution instead of 12KV only.

© 1998 - 2016 San Diego Gas & Electric Company. All rights reserved. Removal of this copyright notice without permission is not permitted under law.

REV	CHANGE	BY	DSGN	APPV	DATE	REV	CHANGE	B	S	N	APP	ATE
C						F						
B						E						
A	COMPLIANCE CHANGE	MM	IL	MDJ	5/23/16	D						

SHEET 1 OF 1	 Indicates Latest Revision	 Completely Revised	 New Page	 Information Removed	FMO OH 438
	SDG&E ELECTRIC OVERHEAD STANDARD				
	NEUTRAL INSTALLATION PIN-TYPE OR DEAD-END, 12KV AND BELOW				

SCOPE: THIS STANDARD SHOWS THE METHOD OF PRIMARY DISTRIBUTION AND BELOW NEUTRAL INSTALLATION.

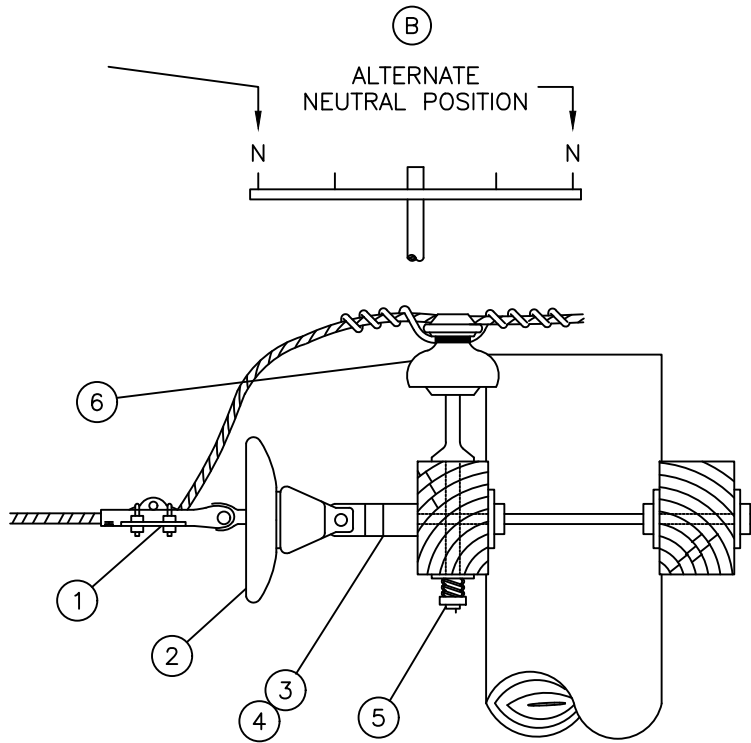

BILL OF MATERIAL:

ITEM	DESCRIPTION	QUANTITY	STOCK NO OR CONSTR STD	ASSEMBLY UNITS
1	CLAMP, STRAIGHT LINE	1	STD 741,743	-
2	INSULATOR, 9", NEMA CLASS 52-2 OR EQUAL	1	431648	52-2
3	CLEVIS, DEAD END, CLOSED TYPE, 5/8" MOUNTING 3/4" MOUNTING	1	235712	-
			235620	DE-C/C
4	CLEVIS, DEAD END, OPEN TYPE, 5/8" MOUNTING 3/4" MOUNTING	1	235618	-
			235616	DE-O/C
5	PIN, 1"	1	532704	PS1
6	INSULATOR, WHITE, NEMA CLASS 55-3 OR EQUAL	1	429216	55-3/I

INSTALLATION:

A. NEUTRAL SIZE WILL NOT NECESSARILY BE ONE WIRE SIZE SMALLER THAN THE PHASE WIRES.

REFERENCE:

(B) ON ALL NEW CONSTRUCTION AND WHEN ADDING TO EXISTING CONSTRUCTION, NEUTRAL TO BE INSTALLED IN OUTSIDE PIN POSITION PER DESIGN MANUAL PAGE 5124.2.

©1998 - 2010 San Diego Gas & Electric Company. All rights reserved. Removal of this copyright notice without permission is not permitted under law.

	Indicates Latest Revision	Completely Revised	New Page	Information Removed
REVISION	SDG&E ELECTRIC STANDARDS			
DATE 9-12-05	NEUTRAL INSTALLATION PIN-TYPE OR DEAD-END, 12KV AND BELOW			FMO OH 438
APPD PA/JJ				

FIELD MAINTENANCE ONLY

REVISION HISTORY:

5/23/16: Crossarm Extension Brackets are no longer allowed as an option for adding additional conductors on an arm.

© 1998 - 2016 San Diego Gas & Electric Company. All rights reserved. Removal of this copyright notice without permission is not permitted under law.

REV	CHANGE	BY	DSGN	APPV	DATE	REV	CHANGE	B	S	N	APP	ATE
C						F						
B						E						
A	COMPLIANCE CHANGE	MM	IL	MDJ	5/23/16	D						

SHEET 1 OF 1	<input type="checkbox"/> Indicates Latest Revision	<input type="checkbox"/> Completely Revised	<input type="checkbox"/> New Page	<input type="checkbox"/> Information Removed	FMO OH 439
	SDG&E ELECTRIC OVERHEAD STANDARD				
	CROSSARM EXTENSION BRACKET				

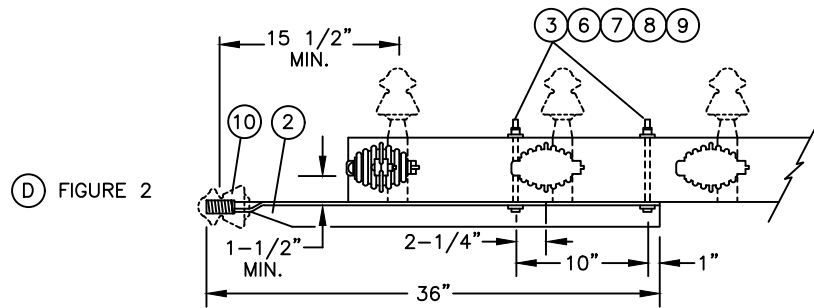
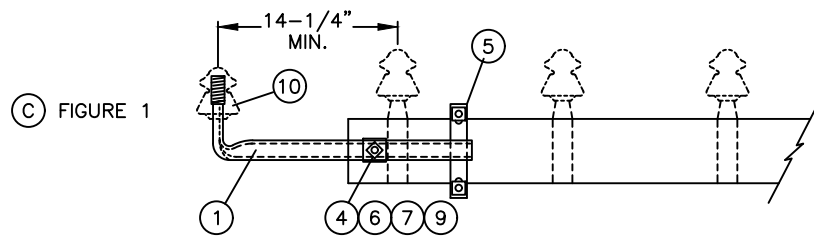

NOTES:

- A. TO AVOID CROSSARM REPLACEMENT, CROSSARM EXTENSIONS SHOULD BE USED WHENEVER PRACTICAL TO SUPPORT EXTENSION OF A SINGLE SERIES CIRCUIT CONDUCTOR OR 0-7500 VOLT LINE CONDUCTOR ON EXISTING CROSSARMS WHERE PIN POSITIONS ARE FILLED OR WHERE CLIMBING SPACE MUST BE MAINTAINED.
- B. CONDUCTOR SIZE IS LIMITED TO #4 COPPER OR #2 5005 ALUMINUM.
- ③ USE CONSTRUCTION SHOWN IN FIGURE 1, WHERE LINE CONDUCTORS ON EXISTING ARMS ARE ON PINS.
- ④ USE CONSTRUCTION SHOWN IN FIGURE 2, TO PROVIDE 1 1/2" HARDWARE CLEARANCE WHERE LINE CONDUCTORS ON EXISTING ARMS ARE DEAD ENDED.
- E. DO NOT USE CROSSARM EXTENSION CONSTRUCTION IN GRADE "A" OR "B" CROSSINGS OVER MAJOR OR MINOR RAILWAYS.

BILL OF MATERIAL:

ITEM	DESCRIPTION	QUANTITY		STOCK NO. OR CONSTR STD	ASSEMBLY UNITS
		FIG.1	FIG.2		
1	BRACKET, CROSSARM EXTENSION	1	-	166048	XAEXT
2	PIN, POLETOP 36" WITH 1" LEAD THREADS	-	1	531648 OR 232512	PTP
3	BOLT, MACH 5/8" X 8"	-	2	155584	-
4	BOLT, MACH 5/8" X 5"	1	-	155488	-
5	BOLT, U	1	-	158368	-
	FOR 3-1/2" X 4-1/2" CROSSARM FOR 3-3/4" X 5-3/4" CROSSARM	1	-	158400	-
6	WASHER, 5/8" ROUND	1	2	800320	-
7	WASHER, 2 1/4" SQUARE	1	2	799040	-
8	WASHER, 5/8" DBL COIL SPRING	-	2	798560	-
9	NUT, 5/8"	1	2	506880	-
10	INSULATOR, PIN TYPE	1	1	429184	-

© 1998 - 2016 San Diego Gas & Electric Company. All rights reserved. Removal of this copyright notice without permission is not permitted under law.

REV	CHANGE	BY	DSGN	APPV	DATE	REV	CHANGE	B	S	N	APP	ATE
C						F						
B						E						
A	ORIGINAL ISSUE			PA/RJ	1/1/1994	D						

Indicates Latest Revision Completely Revised New Page Information Removed

**SHEET
1 OF 1**

SDG&E ELECTRIC OVERHEAD STANDARD

CROSSARM EXTENSION BRACKET

**FMO
OH 439**



FIELD MAINTENANCE ONLY

REVISION HISTORY:

5/23/16: Wood Pole Top Extensions are no longer allowed as an option for adding an additional conductors on an arm.

© 1998 - 2016 San Diego Gas & Electric Company. All rights reserved. Removal of this copyright notice without permission is not permitted under law.

REV	CHANGE	BY	DSGN	APPV	DATE	REV	CHANGE	B	S	N	APP	ATE
C						F						
B						E						
A	COMPLIANCE CHANGE	MM	IL	MDJ	5/23/16	D						

<p>SHEET 1 OF 1</p>	<table border="1"> <tr> <td> Indicates Latest Revision</td> <td>Completely Revised</td> <td>New Page</td> <td>Information Removed</td> </tr> </table>	 Indicates Latest Revision	Completely Revised	New Page	Information Removed	<p>FMO OH 475</p>
	 Indicates Latest Revision	Completely Revised	New Page	Information Removed		
	<p>SDG&E ELECTRIC OVERHEAD STANDARD</p>					
<p>WOOD POLE TOP EXTENSIONS FOR LINE ARMS OR SERVICE CLEARANCE ARMS-LIGHT DUTY</p>						

SCOPE: THIS STANDARD SHOWS POLE TOP EXTENSION FOR LINE ARMS OR SERVICE CLEARANCE ARMS AND IS USED ON EXISTING POLES WHEN ADDITIONAL HEIGHT IS REQUIRED IN LIGHT AND MEDIUM LOADING DISTRICTS TO SAVE THE COST OF REPLACING A POLE WHEN FIELD CONDITIONS PERMIT.

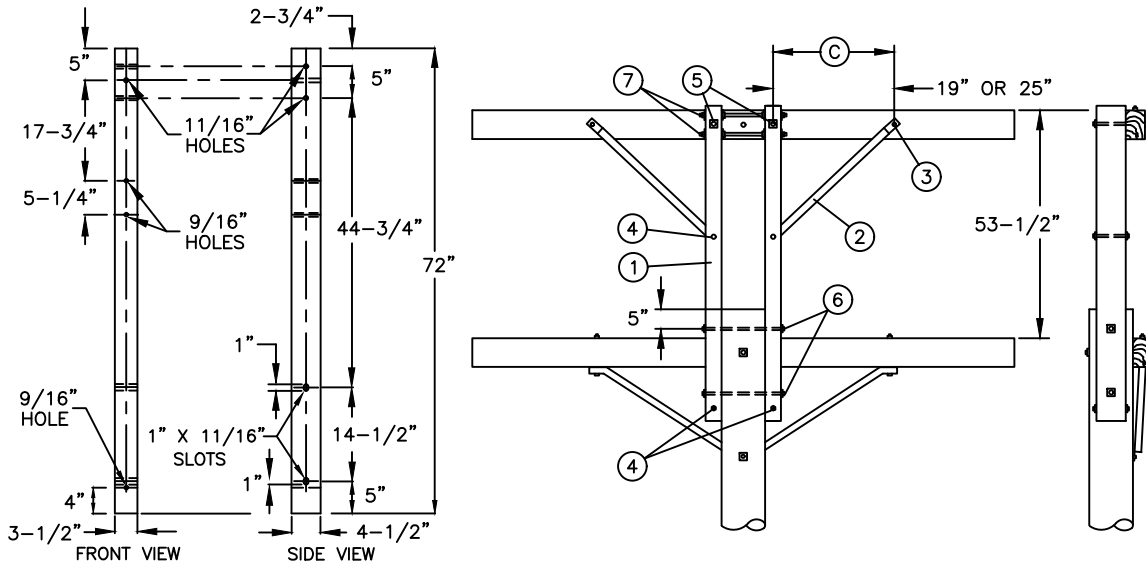

TYPE OF CONDUCTORS	B) MAXIMUM LINE ANGLE OF DEVIATION ALLOWED FOR 4 CONDUCTORS									
	AVERAGE SPAN (FT)									
	100		200		300		400		500	
LOADING DISTRICT	LIGHT	MEDIUM	LIGHT	MEDIUM	LIGHT	MEDIUM	LIGHT	MEDIUM	LIGHT	MEDIUM
#6 COPPER	20°	16°	18°	10°	17°	5°	15°	0°	13°	0°
#4 COPPER	12°	10°	11°	6°	10°	2°	8°	0°	7°	0°
#2 COPPER	7°	6°	6°	3°	5°	1°	4°	0°	3°	0°
1/0 COPPER	4°	3°	4°	2°	3°	0°	2°	0°	1°	0°
#2 ACSR	11°	8°	9°	5°	8°	1°	6°	0°	5°	0°
#1/0 ACSR	7°	5°	6°	2°	4°	0°	3°	0°	2°	0°
#3/0 ACSR	4°	3°	3°	1°	2°	0°	1°	0°	0°	0°
#336.4 26/7 ACSR	2°	1°	1°	0°	0°	0°	0°	0°	0°	0°
636 ACSR (F)	2°	1°	1°	0°	0°	0°	0°	0°	0°	0°
#2 5/2 AWAC	4°	3°	3°	1°	2°	0°	1°	0°	0°	0°

EXAMPLE ANGLE OF DEVIATION

PROBLEM: DETERMINE AVERAGE SPAN LENGTH AND LINE ANGLE OF DEVIATION ON POLE "A" FOR 4 # 6 BARE COPPER WIRE

ASSUME: LIGHT LOADING DISTRICT
SPAN "BA" = 180 FEET AND SPAN "AC" = 230 FEET

SOLUTION: AVERAGE SPAN ON POLE "A" IS $\frac{180 \text{ FT} + 230 \text{ FT}}{2} = 205 \text{ FEET}$

AND THE LINE ANGLE OF DEVIATION $\alpha = 20^\circ$ (USING AN ANGLE FINDER)

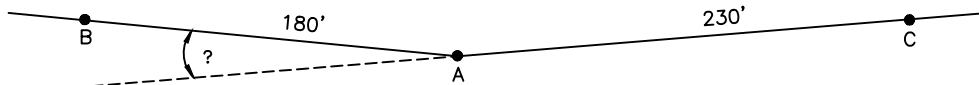

CONCLUSION: FOR AN AVERAGE SPAN LENGTH OF 200 FT. (SEE TABLE) THE MAXIMUM LINE ANGLE OF DEVIATION IS 18°, THEREFORE, THE GIVEN ANGLE OF 20° IS TOO LARGE, AND THIS CONSTRUCTION CAN NOT BE USED. HOWEVER, 3 #6 CU. WIRE WITH A LINE ANGLE DEVIATION OF 23.994° (18° X 1.333) IS ALLOWED.

© 1998 - 2016 San Diego Gas & Electric Company. All rights reserved. Removal of this copyright notice without permission is not permitted under law.

REV	CHANGE	BY	DSGN	APPV	DATE	REV	CHANGE	B	S	APP	ATE
C						F					
B						E					
A	ORIGINAL ISSUE			PA/VR	3/1/2002	D					

Indicates Latest Revision Completely Revised New Page Information Removed

SHEET
1 OF 2

SDG&E ELECTRIC OVERHEAD STANDARD
WOOD POLE TOP EXTENSIONS FOR LINE ARMS
OR SERVICE CLEARANCE ARMS-LIGHT DUTY

FMO
OH 475.1

BILL OF MATERIAL:

ITEM	DESCRIPTION	QUANTITY	CONSTRUCTION STANDARD	STOCK NUMBER	ASSEMBLY UNITS
1	DOUGLAS FIR EXTENSION STRUTS, TWO PER SET, 3 1/2" X 4 1/2" X 72" S4S	1	-	336320	WPTX
2	FLAT CROSSARM BRACE, 28" FOR 8 FT. ARM, 36" FOR 10 FT. ARM	2	-	164192	28FLAT
		2	-	164224	36FLAT
3	MACHINE BOLT, GALV, 3/8" X 4 1/2", AND 1 ROUND WASHER	2	STD 392	-	-
4	MACHINE BOLT, GALV, 1/2 X 5", AND 2 ROUND WASHERS	2	STD 392	-	-
5	MACHINE BOLT, GALV, 5/8" X 9", AND 2 SQ WASHERS	2	STD 392	-	-
6	MACHINE BOLT, GALV, 5/8" X 18", AND 2 SQ WASHERS	2	STD 392	-	-
7	SPACE BOLT, GALV, 5/8" X 18", AND 4 SQ WASHERS	2	STD 392	-	-

INSTALLATION:

- A. NO DEAD-END CONSTRUCTION OR GUY ATTACHMENTS ARE PERMITTED ON THIS LIGHT DUTY WOOD POLE TOP EXTENSION.
- (B) FOR MAXIMUM ALLOWABLE LINE ANGLE OF DEVIATION FOR 2 CONDUCTORS, MULTIPLY TABLE BY 2, AND FOR 3 CONDUCTORS MULTIPLY TABLE BY 1.333.
- (C) 19" FOR 28" BRACES OR 25" FOR 36" BRACES.
- D. TO BE USED IN LIGHT AND MEDIUM LOADING DISTRICTS ONLY.
- (F) 636 ACSR IS NOT TO BE STRUNG ON THIS LIGHT DUTY WOOD POLE TOP EXTENSION. IT IS PERMISSIBLE TO RAISE 636 ACSR WITH THIS LIGHT DUTY WOOD POLE TOP EXTENSION WITH THE APPROVAL OF CONSTRUCTION.

REFERENCE:

- G. INCREASING POLE LENGTH BY USE OF A POLE TOP EXTENSION INCREASES THE BENDING MOMENT AT THE GROUND LINE. POLE MUST HAVE ADEQUATE USABLE STRENGTH TO WITHSTAND THE INCREASED BENDING MOMENT IMPOSED BY THE POLE TOP EXTENSION (SEE STANDARD 344 - 354).
- H. DO NOT USE IN GRADE 'A' CROSSING - G.O. 95 RULE 49.1.
- I. TRANSFORMERS, CAPACITORS AND REGULATORS SHALL NOT BE SUPPORTED ON THIS LIGHT DUTY POLE TOP EXTENSION BECAUSE IT DOES NOT MEET G.O. 95 REQUIREMENTS. SEE RULE 58.1A.

© 1998 - 2016 San Diego Gas & Electric Company. All rights reserved. Removal of this copyright notice without permission is not permitted under law.

REV	CHANGE	BY	DSGN	APPV	DATE	REV	CHANGE	B	S	N	APP	ATE
C						F						
B						E						
A	ORIGINAL ISSUE			PA/CAR	1/1/1998	D						

Indicates Latest Revision
 Completely Revised
 New Page
 Information Removed

SHEET 2 OF 2	SDG&E ELECTRIC OVERHEAD STANDARD	FMO OH 475.2
	WOOD POLE TOP EXTENSIONS FOR LINE ARMS OR SERVICE CLEARANCE ARMS-LIGHT DUTY	

FIELD MAINTENANCE ONLY

REVISION HISTORY:

7/13/2016: All versions prior to 2016 are superseded by their current version found inside the Overhead Construction Standard Manual.

© 1998 - 2016 San Diego Gas & Electric Company. All rights reserved. Removal of this copyright notice without permission is not permitted under law.

REV	CHANGE	BY	DSGN	APPV	DATE	REV	CHANGE	BY	DSGN	APPV	DATE
C						F					
B						E					
A	ORIGINAL ISSUE	JS	IL	MDJ	7/13/2016	D					

	Indicates Latest Revision	Completely Revised	New Page	Information Removed
-------------------------------------------------------------------------------------	---------------------------	--------------------	----------	---------------------

**SHEET
1 OF 1**

SDG&E ELECTRIC OVERHEAD STANDARD

POLE TOP EXTENSIONS
FOR SERVICE CLEARANCE ARMS

**FMO
OH 476**

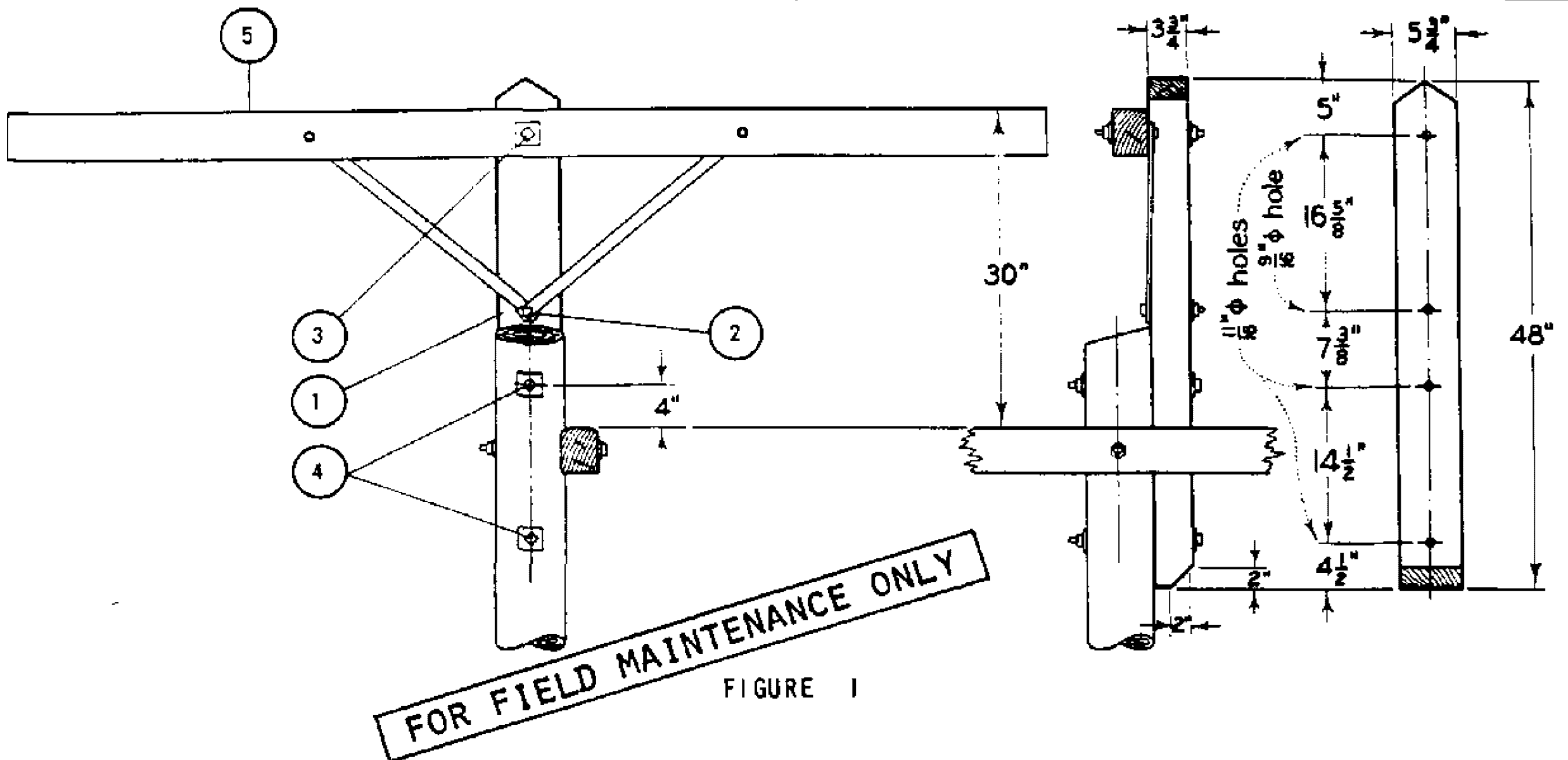

FIGURE 1

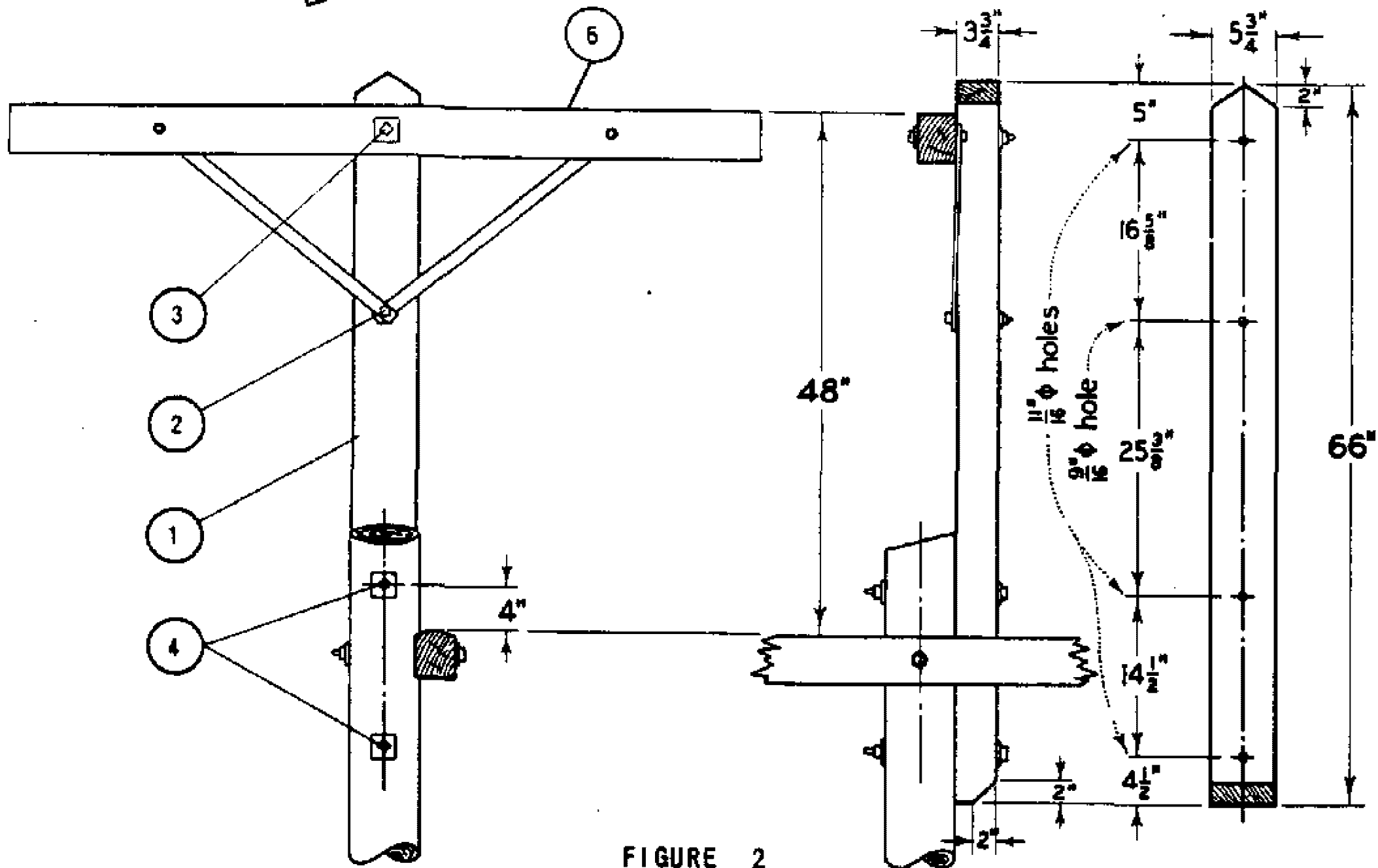

FIGURE 2

INSTALLATION :

A. DO NOT FLATTEN SURFACE OF POLE TO RECEIVE EXTENSION. HOWEVER, SHARP HUMPS OR KNOTS SHOULD BE REMOVED.

(E) EXEMPT MATERIAL.

BILL OF MATERIAL :

ITEM	DESCRIPTION	QUANTITY	STOCK NO. OR CONSTR STD
1	EXTENSION, 3 3/4" X 5 3/4" DOUGLAS FIR POLE TOP, 48" OR 66" LONG	1	336288, 336352
P 2	BOLT, MACHINE 1/2" X 5" GALV, 1 RD WASHER	(E) 1	STD 139, 140
T 3	BOLT, MACHINE 5/8" X 10" GALV, 2 SQ WASHERS	(E) 1	STD 139, 140
F 4	BOLT, MACHINE 5/8" X 16" GALV, 2 SQ WASHERS	(E) 2	STD 139, 140
5	CROSSARM, 3 1/2" X 4 1/2" X 8' - 0"	1	SECTION 300
6	CROSSARM, 3 1/2" X 4 1/2" X 5' - 7"	1	SECTION 300

499.701

SUPERSEDES
476 (9-17-82)

SDG&E ELECTRIC STANDARDS

POLE TOP EXTENSIONS
FOR SERVICE CLEARANCE ARMS

DATE 9-17-82

APPD. *[Signature]*

PAGES

SUBJECT

511	69KV SINGLE CIRCUIT - HORIZONTAL POST INSULATORS
512	138KV SINGLE CIRCUIT - HORIZONTAL POST INSULATORS
513	69KV SINGLE & TWIN CIRCUITS - HORIZONTAL POST INSULATORS
520	TRANSMISSION CONSTRUCTION, 69KV SINGLE CIRCUIT, HORIZONTAL POST INSULATORS
521	TRANSMISSION CONSTRUCTION - 69KV SINGLE CIRCUIT - VERTICAL CONFIGURATION - TYPE Z
522	TRANSMISSION CONSTRUCTION - 69KV SINGLE CIRCUIT - VERTICAL CONFIGURATION - TYPE Y
530	TRANSMISSION CONSTRUCTION, 69KV, SINGLE CIRCUIT, FIGURE "4", TYPE W
531	TRANSMISSION CONSTRUCTION, 69KV, SINGLE CIRCUIT, FIGURE "6", TYPE W
532	TRANSMISSION CONSTRUCTION, 69KV, SINGLE CIRCUIT, FIGURE "4", TYPE X
533	TRANSMISSION CONSTRUCTION, 69KV, SINGLE CIRCUIT, FIGURE "4", TYPE X
535	TRANSMISSION - 69KV TYPE X - Δ STRUCTURE SINGLE CIRCUIT - TRIANGULAR DEAD END
540	SCADA LOAD MONITOR

**THIS SECTION HAS BEEN REMOVED FROM THE EXTERNAL VERSION.
DUE TO CONFIDENTIAL INFORMATION.**

© 1998 - 2016 San Diego Gas & Electric Company. All rights reserved. Removal of this copyright notice without permission is not permitted under law.

REV	CHANGE	BY	DSGN	APPV	DATE	REV	CHANGE	BY	DSGN	APPV	DATE
C						F					
B						E					
A	ORIGINAL ISSUE	JS	IL	MDJ	7/13/2016	D					

SHEET 1 OF 1	X Indicates Latest Revision	Completely Revised	New Page	Information Removed	FMO OH 501
	SDG&E OVERHEAD STANDARD				
	TRANSMISSION FMO TABLE OF CONTENTS				

600 - SECONDARIES,
SERVICES

600 - SECONDARIES,
SERVICES

PAGES

SUBJECT

604	OVERHEAD IN-LINE POWER REGULATOR TRANSFORMER UNIVERSAL TRANSFORMER BRACKET
616	SECONDARY RACK CONSTRUCTION
618	MID - SPAN SERVICES FROM VERTICAL RACK SECONDARY
629	SECONDARY RACKS
631	SERVICE INSULATOR BRACKETS, SINGLE
632	HEAVY DUTY SERVICE INSULATOR BRACKET
635.4	MINI WEDGE CONNECTOR
642	SERVICE DROP ATTACHMENTS TO CONDUIT RISERS
652	CUSTOMER OWNED - 1 & 2 BOX TV AMPLIFIER & 120V, METER INSTALLATION

© 1998 - 2018 San Diego Gas & Electric Company. All rights reserved. Removal of this copyright notice without permission is not permitted under law.

REV	CHANGE	BY	DSGN	APPV	DATE	REV	CHANGE	BY	DSGN	APPV	DATE
C						F					
B	ADDED 604 & 635.4	JS	JS	CZH	9/4/2018	E					
A	ORIGINAL ISSUE	JS	IL	MDJ	7/13/2016	D					

SHEET 1 OF 1	X Indicates Latest Revision	Completely Revised	New Page	Information Removed	FMO OH601
	SDG&E ELECTRIC OVERHEAD CONSTRUCTION STANDARD				
	SECONDARIES, SERVICES FMO TABLE OF CONTENTS				

FIELD MAINTENANCE ONLY

9/4/2018: All versions prior to 2018 are superseded by their current version found inside the Overhead Construction Standard Manual.

© 1998 - 2018 San Diego Gas & Electric Company. All rights reserved. Removal of this copyright notice without permission is not permitted under law.

REV	CHANGE	BY	DSGN	APPV	DATE	REV	CHANGE	BY	DSGN	APPV	DATE
C						F					
B						E					
A	ORIGINAL ISSUE	JS	JS	CZH	9/4/2018	D					

SHEET 1 OF 1	X Indicates Latest Revision	Completely Revised	New Page	Information Removed	FMO OH604
	SDG&E ELECTRIC OVERHEAD CONSTRUCTION STANDARD				
	CONNECTORS, MINI WEDGES				

SCOPE: THIS STANDARD SHOWS THE VARIOUS MINI WEDGE CONNECTORS THAT ARE TO BE USED TO CONNECT DIFFERENT TYPES AND SIZES OF JUMPER AND LINE WIRE FOR SECONDARY AND SERVICE CONDUCTORS FOR THE OVERHEAD.

SDG&E		4/0	2/0	1/0, 1	#2	#4	#6	#8	
STANDARD TRIPLEX FULL ACSR, AAAC OR AAC NEAUTRAL FULL AAC HOT WIRES		4/0 ACSR,AAAC AAC,CU STR	2/0 ACSR,AAAC AAC,CU STR 3/0 AAC CMPT	1/0 #1 ACSR,AAAC AAC,CU STR	#2 ACSR,AAAC AAC,CU STR	#4 ACSR,AAAC AAC,CU STR CMPT AAC,CU #2 SOL	#6 ACSR,AAAC AAC,CU STR CMPT AAC,CU SOL #2 SOL	#8 AAC,CU STR & SOL #6 AL/CU SOL	
#8	#8 AAC/CU STR & SOL #6 AL/CU SOL	STOCK #	S269494	S269460	S269448	S269484	S269476	S269470	S269466
#6	#6 ACSR, AAAC #6 AAC, CU STR #6 CMPT AAC,CU #6 SOL, #4 SOL	STOCK #	S269492	S269458	S269446	S269482	S269474	S269468	-
#4	#4 ACSR, AAAC #4 AAC, CU STR #4 CMPT AAC,CU #2 SOL	STOCK #	S269490	S269456	S269444	S269480	S269472	-	-
#2	#2 ACSR, AAAC #2 AAC, CU STR	STOCK #	S269488	S269454	S269442	S269478	-	-	-
1/0, 1	1/0 ACSR, AAAC 1/0 AAC,CU STR #1 ACSR	STOCK #	S269464	S269452	S269486	-	-	-	-
2/0	2/0 ACSR, AAAC 2/0 AAC,CU STR 3/0 AAC CMPT	STOCK #	S269462	S269450	-	-	-	-	-

© 1998 - 2017 San Diego Gas & Electric Company. All rights reserved. Removal of this copyright notice without permission is not permitted under law.

REV	CHANGE	BY	DSGN	APPV	DATE	REV	CHANGE	BY	DSGN	APPV	DATE
C						F					
B						E					
A	ORIGINAL ISSUE	GW	JS	MDJ	7/25/2017	D					

SHEET 1 OF 1	<input type="checkbox"/> Indicates Latest Revision <input type="checkbox"/> Completely Revised <input checked="" type="checkbox"/> New Page <input type="checkbox"/> Information Removed	OH 604
	SDG&E ELECTRIC OVERHEAD CONSTRUCTION STANDARD	
	CONNECTORS, MINI WEDGES	

FIELD MAINTENANCE ONLY

REVISION HISTORY:

7/13/2016: All versions prior to 2016 are superseded by their current version found inside the Overhead Construction Standard Manual.

© 1998 - 2016 San Diego Gas & Electric Company. All rights reserved. Removal of this copyright notice without permission is not permitted under law.

REV	CHANGE	BY	DSGN	APPV	DATE	REV	CHANGE	BY	DSGN	APPV	DATE
C						F					
B						E					
A	ORIGINAL ISSUE	JS	IL	MDJ	7/13/2016	D					

	Indicates Latest Revision	Completely Revised	New Page	Information Removed
-------------------------------------------------------------------------------------	---------------------------	--------------------	----------	---------------------

**SHEET
1 OF 1**

SDG&E ELECTRIC OVERHEAD STANDARD

SECONDARY RACK CONSTRUCTION

**FMO
OH 616**

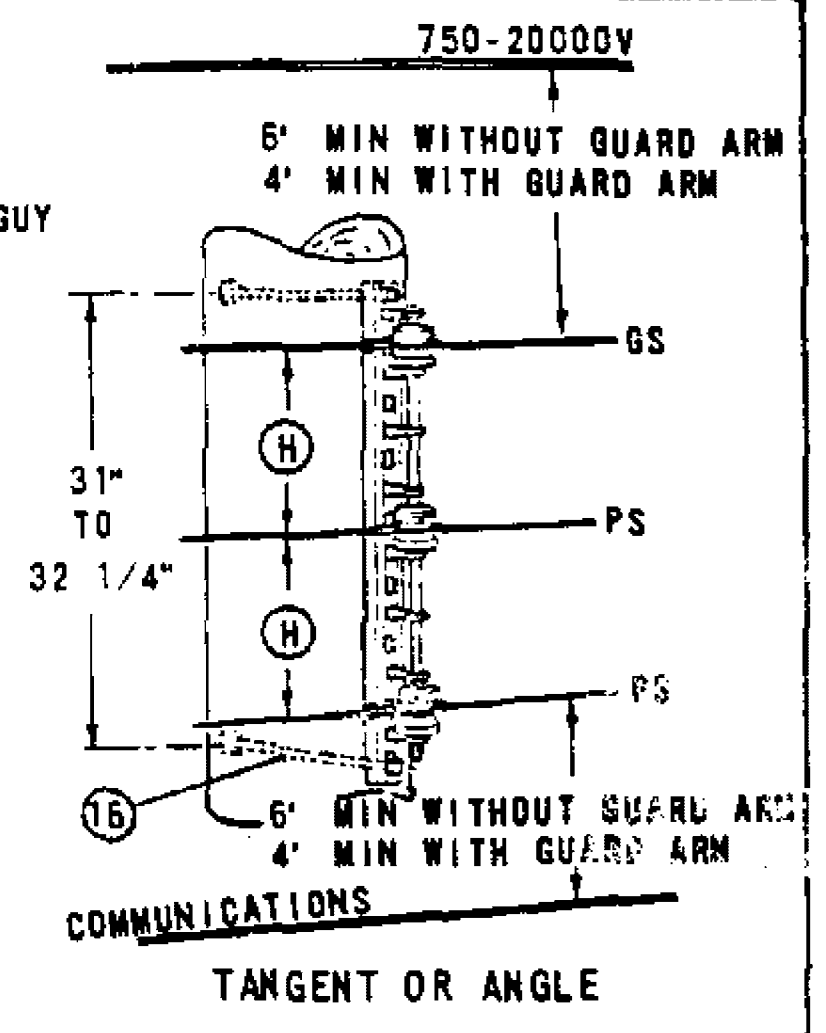
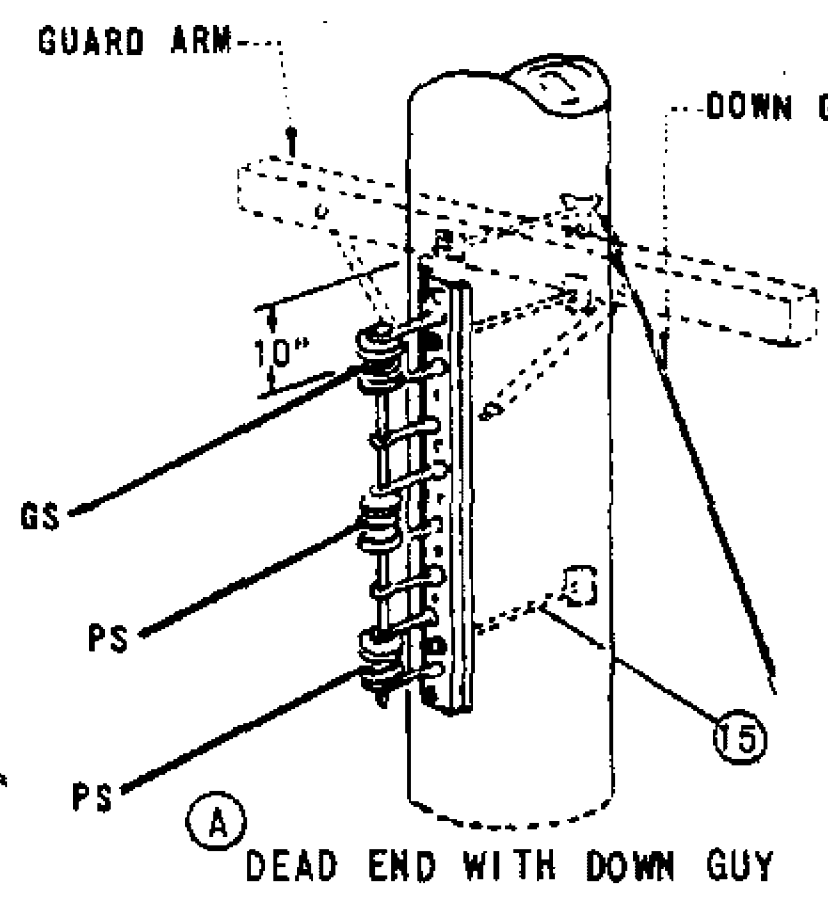
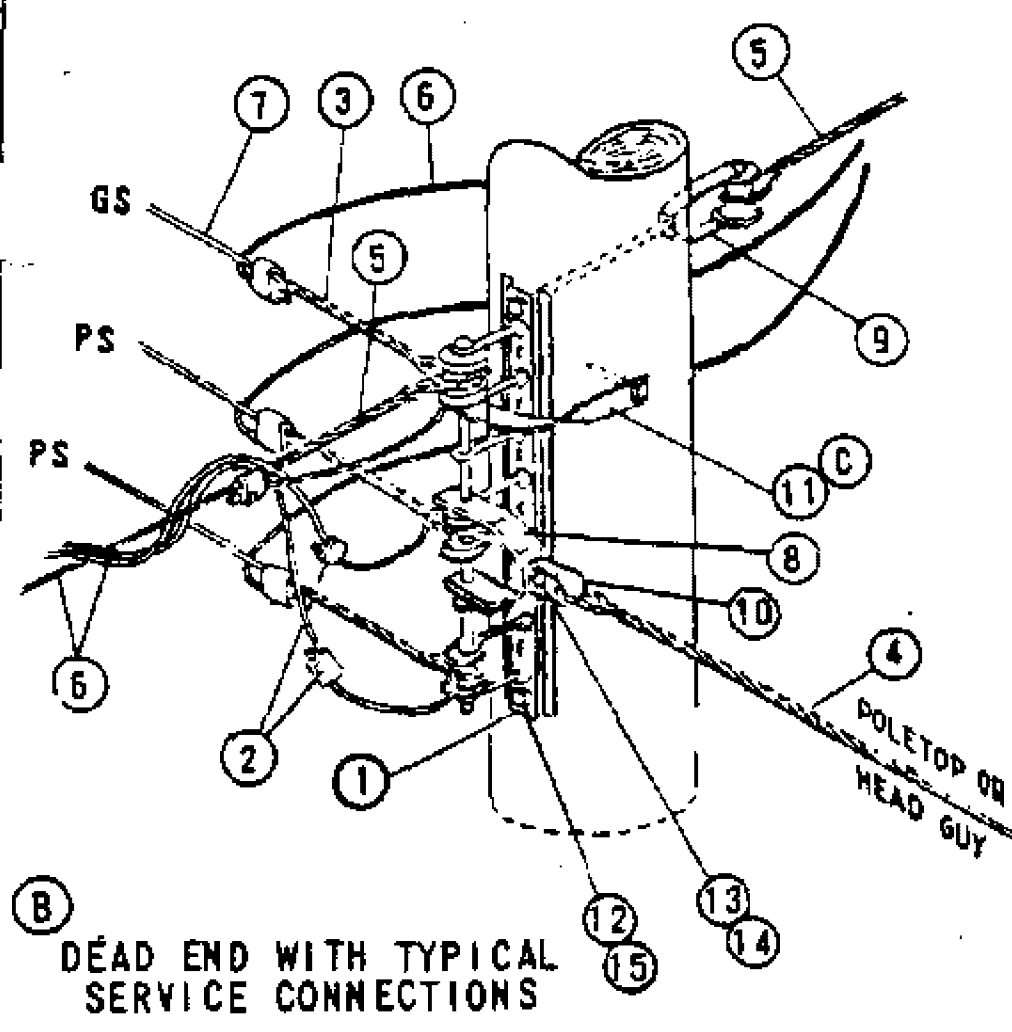

SERVICE DROPS ON POLE SIDE OF VERTICAL PLANE OF LINE CONDUCTORS SHALL NOT BE LESS THAN 15" RADIALY FROM THE SURFACE OF THE POLE.

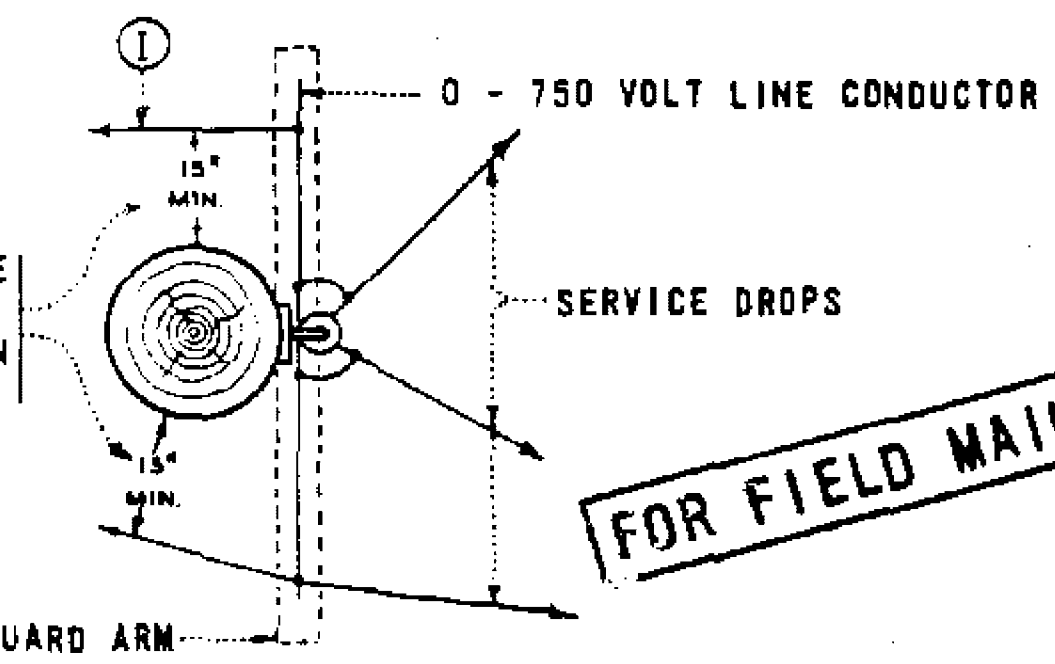

FOR FIELD MAINTENANCE ONLY

- NOTES:
- (A) DEAD END WITH DOWN GUY IS PREFERRED CONSTRUCTION WHERE THERE IS NO FUTURE EXTENSION OF SECONDARY.
 - (B) DEAD END WITH POLETOP OR HEAD GUY IS PREFERRED CONSTRUCTION WHERE FUTURE EXTENSION OF SECONDARY IS EXPECTED.
 - (C) USE DEAD ENDING STRAPS BEHIND EACH CONDUCTOR WHERE RACK GUY CANNOT BE USED, SEE PAGE 629.
 - D. TO OBTAIN RADIAL CLEARANCE BETWEEN SUPPLY CONDUCTORS, OVERHEAD GUYS, AND CLIMBING SPACE USE EXTENSION BRACKET. SEE PAGE 629.
 - E. SEE PAGE 255 FOR CLIMBING SPACE REQUIREMENTS.
 - F. GUARD ARMS ARE REQUIRED WHEN REDUCING CLEARANCE FROM THE NORMAL 6 FT MINIMUM TO A 4 FT MINIMUM BETWEEN THE SECONDARY CABLE AND THE CONDUCTORS ABOVE.
 - G. WHEN USING GUARD ARMS, ADDITIONAL CLEVISES CANNOT BE ADDED TO THE POLE. REPLACE WITH MID-SPAN SERVICES SEE PAGE 618.
 - (H) MINIMUM VERTICAL SEPARATION FOR SPAN LENGTHS 200 FT OR LESS SHALL BE 8 IN. 200 FT THROUGH 330 FT MINIMUM SEPARATION SHALL BE 12 IN.
 - (I) WHEN USING GUARD ARMS, SERVICE DROPS ARE NOT PERMITTED TO PASS ABOVE OR BELOW THE GUARD ARM ON THE POLE SIDE OF THE RACK SECONDARY.

ITEM	DESCRIPTION	QUANTITY	STOCK NO. OR CONSTR STD	ITEM	DESCRIPTION	QUANTITY	STOCK NO. OR CONSTR STD
1	RACK, 3 OR 4 WIRE SECONDARY	1	PG 629	11	STRAP, DEAD ENDING, CURVED	AS REQ'D	PG 629
2	CONNECTORS	AS REQ'D	PGS 783, 787	12	BOLT, MCH, 5/8" X LENGTH AS REQ'D	2	PG 139
3	GRIPS, DEAD END FOR COATED SEC CONDUCTORS	AS REQ'D	PGS 745, 747	13	BOLT, MACH, 5/8" X 2"	1	155040
4	GRIPS, GUY	AS REQ'D	PGS 745, 747	14	WASHER 5/8" LOCK SPRING	1	796864
5	GRIPS, TRIPLEX NEUTRALS SERVICE	AS REQ'D	PGS 745, 747	15	WASHER, 3" SQ CURVED	AS REQ'D	1797792
6	WIRE, TRIPLEX SERVICE	AS REQ'D	PGS 711, 715, 716	16	WASHER, 2 1/4" SQ FLAT	AS REQ'D	799040
7	WIRE, W.P. SECONDARY	AS REQ'D	PGS 711, 715, 716				
8	CLEVIS, 4KV DEAD END	1	235520				
9	CLEVIS, SECONDARY DEAD END	1	235488				
10	EYELET, THIMBLE	1	338176				

SDG & E ELECTRIC STANDARDS

DATE 6-4-82
APPD *[Signature]*

SECONDARY RACK CONSTRUCTION

699.101
SUPERSEDES
616 (6-4-82)





FIELD MAINTENANCE ONLY

REVISION HISTORY:

7/13/2016: All versions prior to 2016 are superseded by their current version found inside the Overhead Construction Standard Manual.

© 1998 - 2016 San Diego Gas & Electric Company. All rights reserved. Removal of this copyright notice without permission is not permitted under law.

REV	CHANGE	BY	DSGN	APPV	DATE	REV	CHANGE	BY	DSGN	APPV	DATE
C						F					
B						E					
A	ORIGINAL ISSUE	JS	IL	MDJ	7/13/2016	D					

<p>SHEET 1 OF 1</p>	 Indicates Latest Revision	 Completely Revised	 New Page	 Information Removed	<p>FMO OH 618</p>
	<p>SDG&E ELECTRIC OVERHEAD STANDARD</p>				
	<p>MID - SPAN SERVICES FROM VERTICAL RACK SECONDARY</p>				

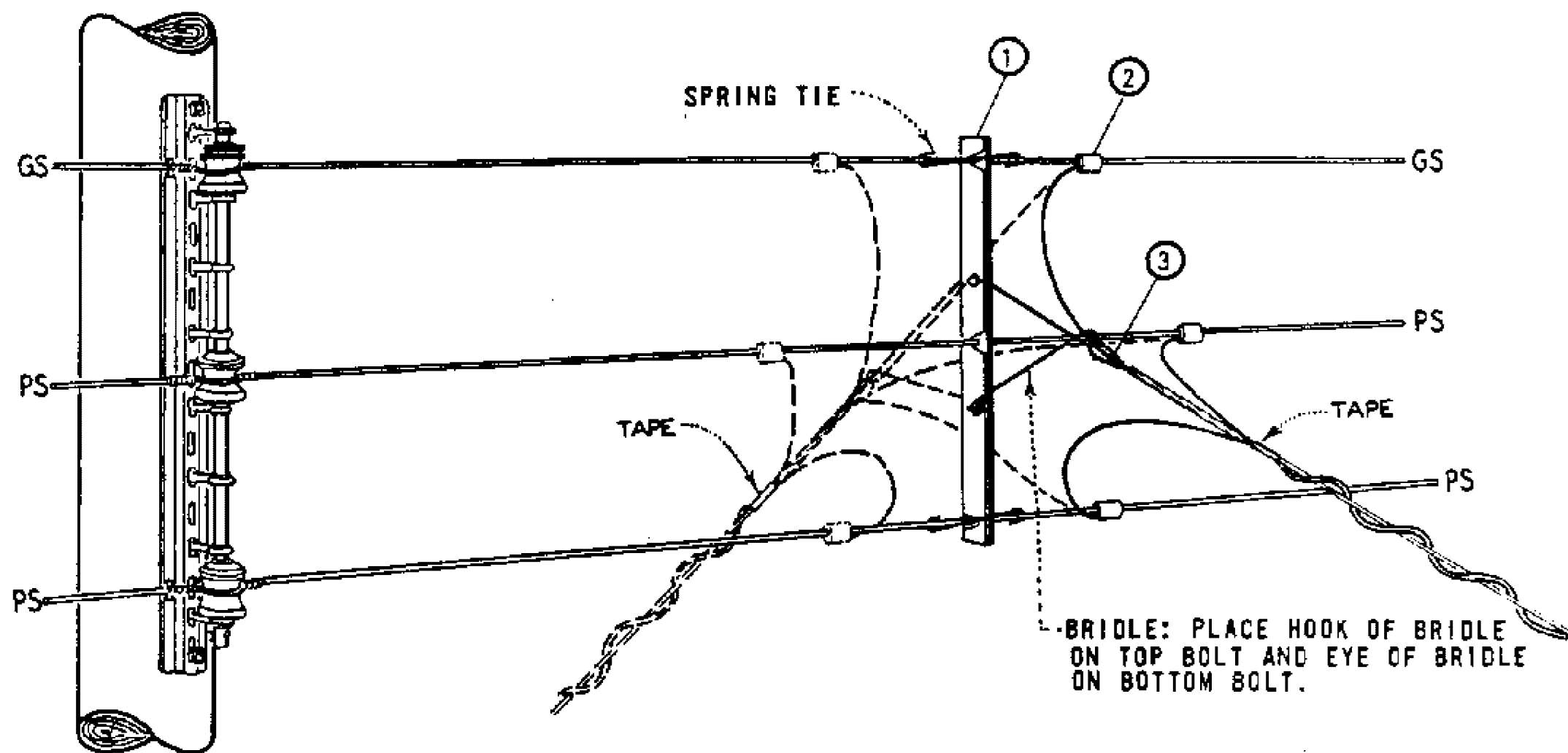

FOR FIELD MAINTENANCE ONLY

SECONDARY CONDUCTOR SPREADER

NO. WIRES	SPACING (IN)	WIRE SLOT (IN)						MATERIAL THICKNESS (IN)	MANUFACTURER			
		TOP		MIDDLE		BOTTOM			NAME	CATALOG NUMBER	NAME	CATALOG NUMBER
		DIA.	MAX. WIRE SIZE	DIA.	MAX. WIRE SIZE	DIA.	MAX. WIRE SIZE					
3	12	1/2	.500	19/32	.594	19/32	.594	1/4	A. T. FLOWER	AF332-93	JOSLYN	32312

NOTES.

- A. FOR USE ON SERVICE DROPS 100 FEET OR LESS IN LENGTH.
- B. WHERE TWO TO FOUR TRIPLEX SERVICE DROPS ARE INSTALLED ON ONE SECONDARY CONDUCTOR SPREADER, CONNECT RESPECTIVE SERVICE CONDUCTORS TO LINE CONDUCTOR WITH ONE COMPRESSION CONNECTOR AS PERMITTED BY STOCKED CONNECTOR SIZES.
- C. SEE OTHER PAGES IN 'SECONDARIES, SERVICES' SECTION FOR RACK CONSTRUCTION DETAILS.

ITEM	DESCRIPTION	QUANTITY	STOCK NO. OR CONSTR. STD.
1	SECONDARY CONDUCTOR SPREADER, COMPLETE WITH 1-SPREADER, BRIDLES AND SPRING TIES	1	670592
2	CONNECTOR, COMPRESSION	AS REQ'D	PGS 783, 7
3	GRIPS, SERVICE	AS REQ'D	PGS 746, 747

699.102
SUPERSEDES
618 (3-25-83)

SDG & E ELECTRIC STANDARDS
MID-SPAN SERVICES FROM VERTICAL RACK SECONDARY

DATE 4-5-83
APPD JNT/QR4

FIELD MAINTENANCE ONLY

REVISION HISTORY:

7/13/2016: All versions prior to 2016 are superseded by their current version found inside the Overhead Construction Standard Manual.

© 1998 - 2016 San Diego Gas & Electric Company. All rights reserved. Removal of this copyright notice without permission is not permitted under law.

REV	CHANGE	BY	DSGN	APPV	DATE	REV	CHANGE	BY	DSGN	APPV	DATE
C						F					
B						E					
A	ORIGINAL ISSUE	JS	IL	MDJ	7/13/2016	D					

<p>SHEET 1 OF 1</p>	 Indicates Latest Revision	Completely Revised	New Page	Information Removed	<p>FMO OH 629</p>
	SDG&E ELECTRIC OVERHEAD STANDARD				
	SECONDARY RACKS				

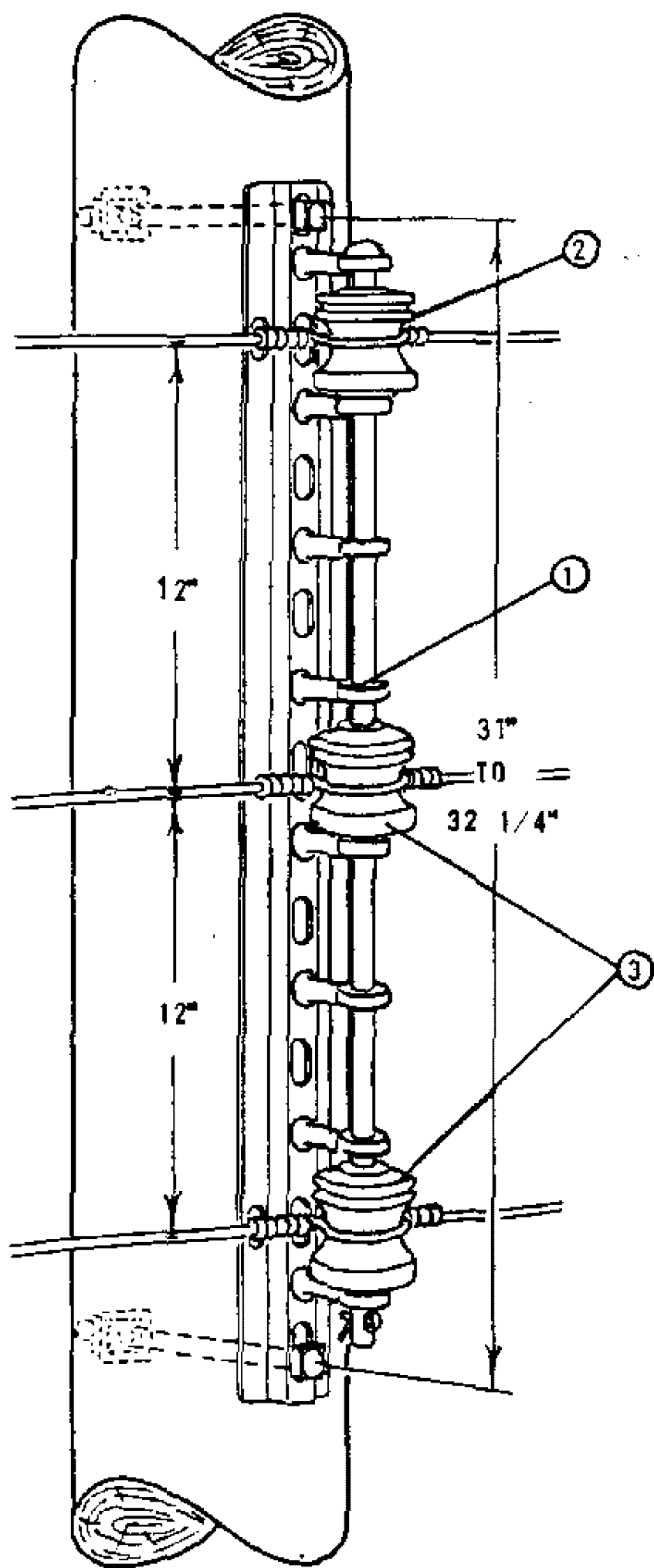

TANGENT OR ANGLE

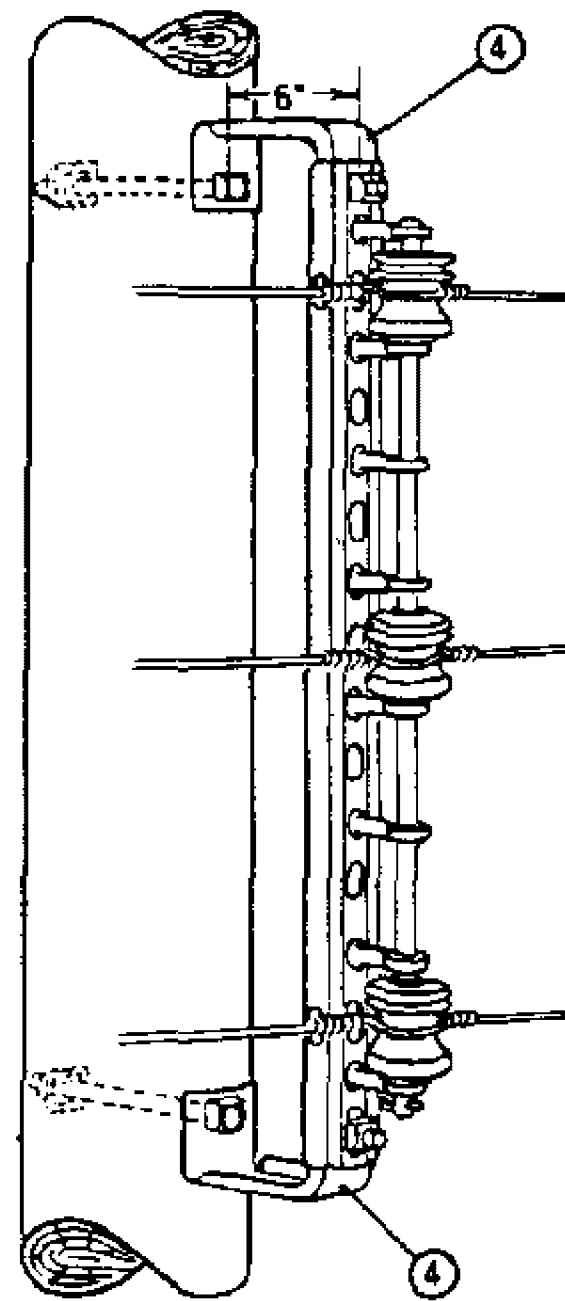

TANGENT OR ANGLE
EXTENSION BRACKET

(A)

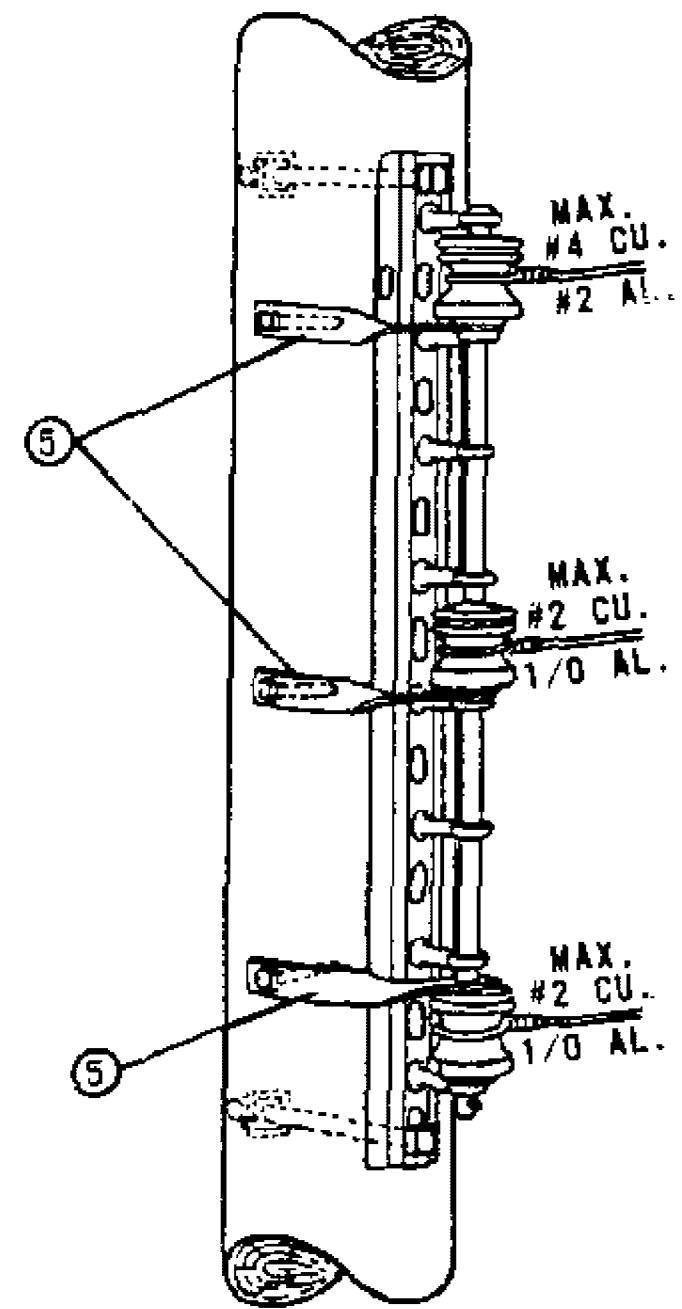

DEAD END ON
SIDE OF POLE

(B)

FOR FIELD MAINTENANCE ONLY

NOTES:

- (A) USED TO OBTAIN RADIAL CLEARANCE BETWEEN SUPPLY CONDUCTORS AND OVERHEAD GUYS, ALSO TO OBTAIN CLIMBING SPACE.
- (B) TO BE USED FOR TANGENT, ANGLE, OR CORNER CONSTRUCTION WHERE SECONDARY MAY BE EXTENDED AND WHERE RACK GUY CANNOT BE USED.

ITEM	DESCRIPTION	CATALOG NUMBER						STOCK NUMBER
		CHANCE	HUBBARD	JOSLYN	KORTICK	McGRW	ED OLIVER	
1	SECONDARY RACK	-	1478	-	K-6748	-	8348	554864
2	SPOOL INSULATOR, (WHITE)	255W	455W	-	-	-	-	430816
3	SPOOL INSULATOR, (BROWN)	-	-	-	-	-	-	430656
4	EXTENSION BRACKET	-	3355	J-2355	K-4830	-	-	166016
5	DEAD ENDING STRAP, CURVED, 1/4" X 1 1/4"	-	1000	J-3120	K-4833	DR4MI	-	696832

SDG & E ELECTRIC STANDARDS

DATE 6-4-82
APPD *CRH*

SECONDARY RACKS

699.201
SUPERSEDES
629 (6-4-82)

FIELD MAINTENANCE ONLY

REVISION HISTORY:

7/13/2016: All versions prior to 2016 are superseded by their current version found inside the Overhead Construction Standard Manual.

© 1998 - 2016 San Diego Gas & Electric Company. All rights reserved. Removal of this copyright notice without permission is not permitted under law.											
REV	CHANGE	BY	DSGN	APPV	DATE	REV	CHANGE	BY	DSGN	APPV	DATE
C						F					
B						E					
A	ORIGINAL ISSUE	JS	IL	MDJ	7/13/2016	D					
SHEET 1 OF 1	 Indicates Latest Revision		Completely Revised		New Page		Information Removed				
	SDG&E ELECTRIC OVERHEAD STANDARD										
	SERVICE INSULATOR BRACKETS, SINGLE										
											FMO OH 631

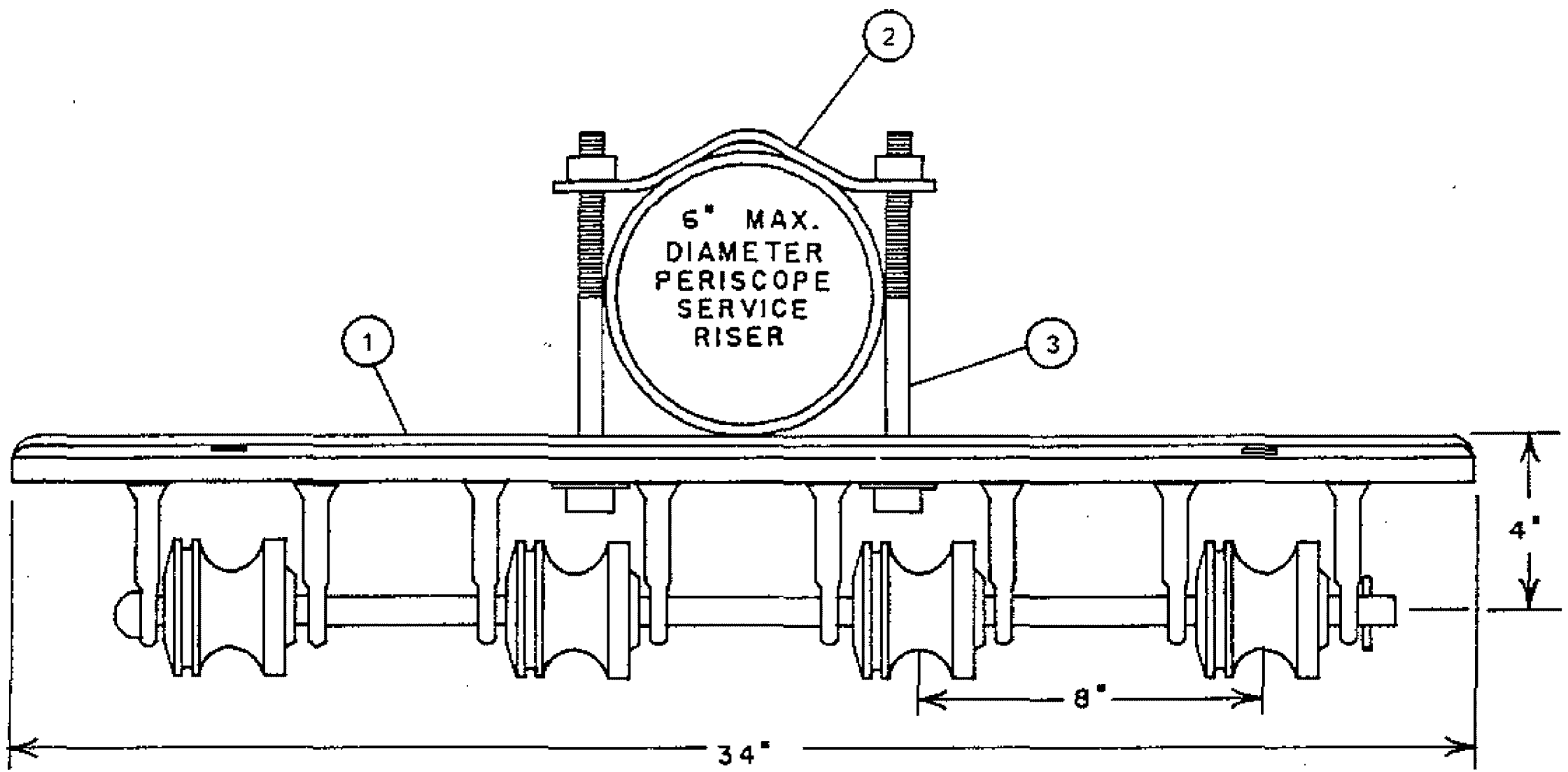

FOUR SPOOL SERVICE INSULATOR BRACKET-ITEMS 1,2,3

FOR FIELD MAINTENANCE ONLY

ITEM	DESCRIPTION	CATALOG NUMBER	QUANTITY	STOCK NO. OR CONST. STD.
1	RACK, FOUR SPOOL SERVICE INSULATOR	HUBBARD 1478	1	564864
		KORTICK K-6748		
		OLIVER 8348		
2	STRAP, CURVED BACK	-	1	698016
3	BOLT, MACH., GALV., 1/2" X [LENGTH AS REQ'D.]	-	2	PG. 139





FIELD MAINTENANCE ONLY

REVISION HISTORY:

7/13/2016: All versions prior to 2016 are superseded by their current version found inside the Overhead Construction Standard Manual.

© 1998 - 2016 San Diego Gas & Electric Company. All rights reserved. Removal of this copyright notice without permission is not permitted under law.

REV	CHANGE	BY	DSGN	APPV	DATE	REV	CHANGE	BY	DSGN	APPV	DATE
C						F					
B						E					
A	ORIGINAL ISSUE	JS	IL	MDJ	7/13/2016	D					

<p>SHEET 1 OF 1</p>	 Indicates Latest Revision	 Completely Revised	 New Page	 Information Removed	<p>FMO OH 632</p>
	<p>SDG&E ELECTRIC OVERHEAD STANDARD</p>				
	<p>HEAVY DUTY SERVICE INSULATOR BRACKET</p>				

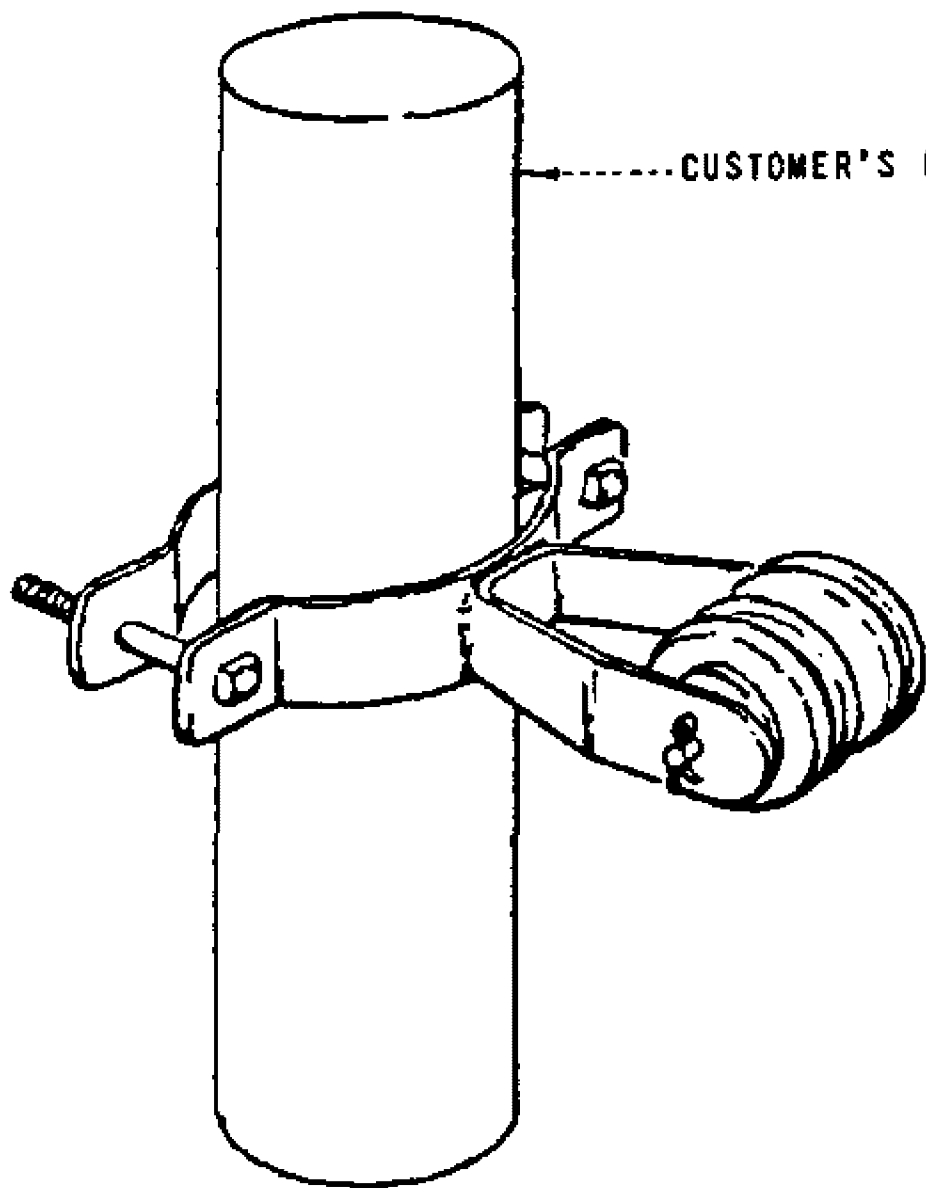

BRACKET ASSEMBLED

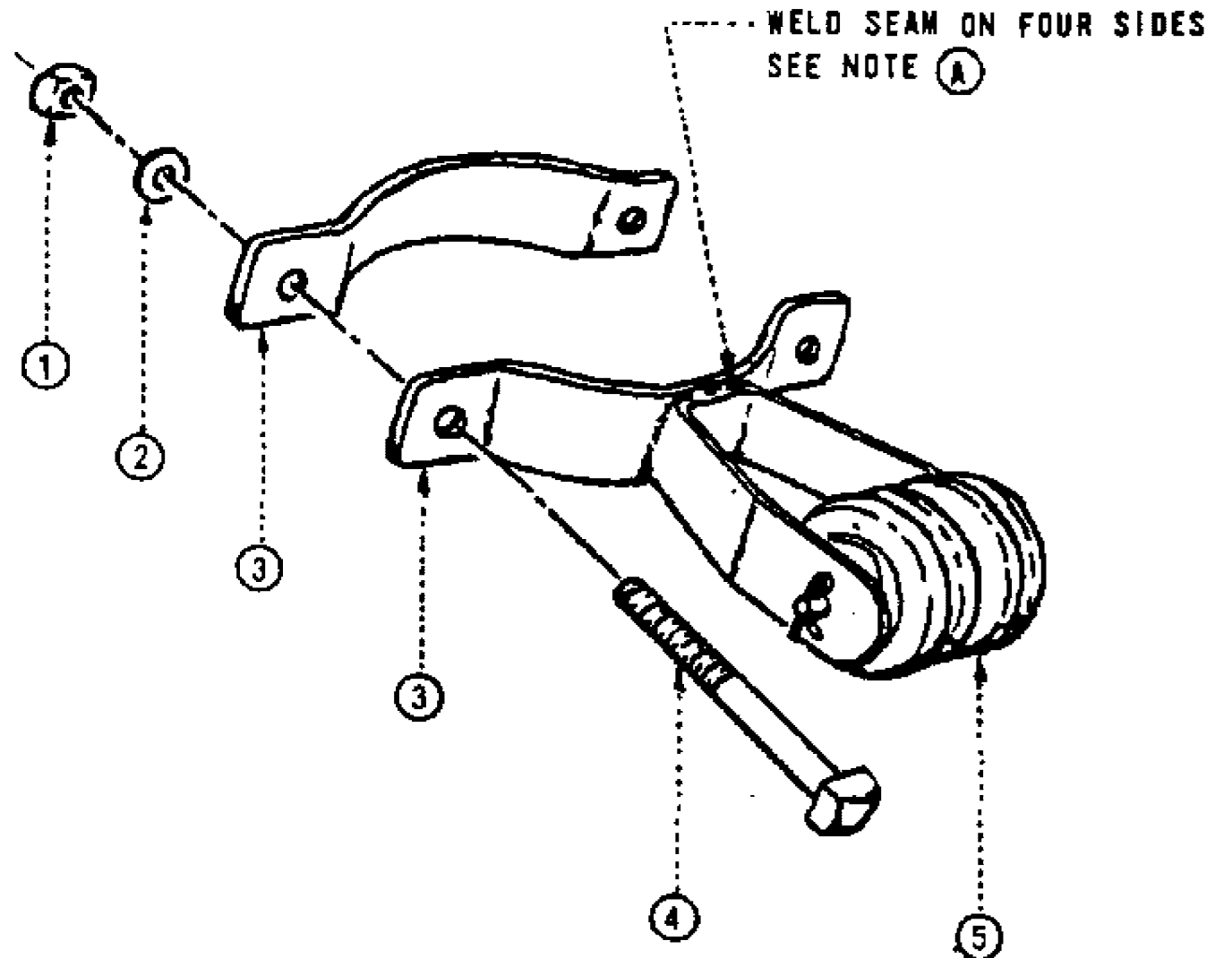

BRACKET EXPLODED

FOR FIELD MAINTENANCE ONLY

NOTES:

- (A) ITEM TO BE GALVALLOY ZINC AT WELDED JOINT OR HOT DIP GALVANIZED AFTER FABRICATION.
- (B) ASSEMBLY WILL ACCOMODATE CUSTOMER'S RISER FROM 3" MINIMUM TO 6" MAXIMUM.

ITEM	DESCRIPTION	QUANTITY	STOCK NO. OR CONSTR STDS
1	NUT, GALV., 1/2" X 13 COURSE THREAD	2	504736
2	WASHER, FLAT, GALV., 1/2" DIAMETER	2	800192
3	STRAP, BACK, CURVED, GALV.	2	698016
4	BOLT, MACH., GALV., 1/2" X (LENGTH AS REQ'D)	2	PG. 139
5	4KV DEADEND ASSEMBLY	1	166128

<p>699,302 SUPERSEDES 632 (9-17-82)</p>	<p>SO G & E ELECTRIC STANDARDS</p> <p>HEAVY DUTY SERVICE INSULATOR BRACKET</p>	<p>DATE 9-17-82 APPD <i>[Signature]</i></p>
-------------------------------------------------	------------------------------------------------------------------------------------	-------------------------------------------------

FIELD MAINTENANCE ONLY

9/4/2018: All versions prior to 2018 are superseded by their current version found inside the Overhead Construction Standard Manual.

© 1998 - 2018 San Diego Gas & Electric Company. All rights reserved. Removal of this copyright notice without permission is not permitted under law.

REV	CHANGE	BY	DSGN	APPV	DATE	REV	CHANGE	BY	DSGN	APPV	DATE
C						F					
B						E					
A	ORIGINAL ISSUE	JS	JS	CZH	9/4/2018	D					

<p>SHEET 1 OF 1</p>	<p>X Indicates Latest Revision</p>	Completely Revised	New Page	Information Removed	<p>FMO OH635.4</p>
	<p>SDG&E ELECTRIC OVERHEAD CONSTRUCTION STANDARD</p>				
	<p>MINI WEDGE CONNECTORS</p>				

SCOPE: THIS STANDARD SHOWS THE VARIOUS MINI WEDGE CONNECTORS THAT ARE TO BE USED TO CONNECT DIFFERENT TYPES AND SIZES OF JUMPER AND LINE WIRE FOR SECONDARY AND SERVICE CONDUCTORS FOR THE OVERHEAD.

SDG&E	STANDARD TRIPLEX FULL ACSR,AAAC OR AAC NEUTRAL FULL AAC HOT WIRES	AU	STOCK #	#8 AAC/CU STR & SOL #6 AL/CU SOL	MW4/08	S269494	MW2/08	MW1/08	#2 ACSR,AAAC AAC,CU STR	MW28	S269484	#4 ACSR,AAAC AAC,CU STR CMPT AAC,CU SOL	MW48	MW68	MW88	S269476	S269470	S269466	#8 ACSR,AAAC AAC,CU STR & SOL #6 AL/CU SOL																																																																																
																				AU	STOCK #	#6 ACSR,AAAC AAC,CU STR CMPT AAC,CU SOL, #4 SOL	MW4/06	S269492	MW2/06	MW1/06	#2 ACSR,AAAC AAC,CU STR	MW26	S269482	MW46	MW66	MW88	S269474	MW66	S269468																																																																
																																				AU	STOCK #	#4 ACSR,AAAC AAC,CU STR CMPT AAC,CU SOL	MW4/04	S269490	MW2/04	MW1/04	#2 ACSR,AAAC AAC,CU STR	MW24	S269480	MW44	MW66	MW88	S269472	MW44	S269472																																																
																																																				AU	STOCK #	#2 ACSR,AAAC AAC,CU STR	MW4/02	S269488	MW2/02	MW1/02	#2 ACSR,AAAC AAC,CU STR	MW22	S269478	MW22	S269480	MW22	S269478	MW22	S269478																																
																																																																				AU	STOCK #	1/0 ACSR,AAAC AAC,CU STR #1 ACSR	MW4/010	S269464	MW2/010	MW1/010	1/0 ACSR,AAAC AAC,CU STR	MW2010	S269452	MW2010	MW2010	MW2010	S269442	MW1/0	S269486																
																																																																																				AU	STOCK #	2/0 ACSR,AAAC AAC,CU STR 3/0 AAC CMPT	MW4/020	S269462	MW2/020	MW1/020	2/0 ACSR,AAAC AAC,CU STR 3/0 AAC CMPT	MW2020	S269450	MW2020	MW2020	MW2020	S269450	MW2020	S269450

© 1998 - 2014 San Diego Gas & Electric Company. All rights reserved. Removal of this copyright notice without permission is not permitted under law.

<input type="checkbox"/>	<input checked="" type="checkbox"/> Indicates Latest Revision	<input type="checkbox"/> Completely Revised	<input checked="" type="checkbox"/> New Page	<input type="checkbox"/> Information Removed
REVISION	SDG&E ELECTRIC STANDARDS			
DATE 1-16-2014	MINI WEDGE CONNECTOR			
APPD TQ/DW	635.4			

FIELD MAINTENANCE ONLY

REVISION HISTORY:

7/13/2016: All versions prior to 2016 are superseded by their current version found inside the Overhead Construction Standard Manual.

© 1998 - 2016 San Diego Gas & Electric Company. All rights reserved. Removal of this copyright notice without permission is not permitted under law.

REV	CHANGE	BY	DSGN	APPV	DATE	REV	CHANGE	BY	DSGN	APPV	DATE
C						F					
B						E					
A	ORIGINAL ISSUE	JS	IL	MDJ	7/13/2016	D					

<input checked="" type="checkbox"/>	Indicates Latest Revision	<input type="checkbox"/>	Completely Revised	<input type="checkbox"/>	New Page	<input type="checkbox"/>	Information Removed
-------------------------------------	---------------------------	--------------------------	--------------------	--------------------------	----------	--------------------------	---------------------

**SHEET
1 OF 1**

SDG&E ELECTRIC OVERHEAD STANDARD

SERVICE DROP ATTACHMENTS CONDUIT RISERS

**FMO
OH 642**

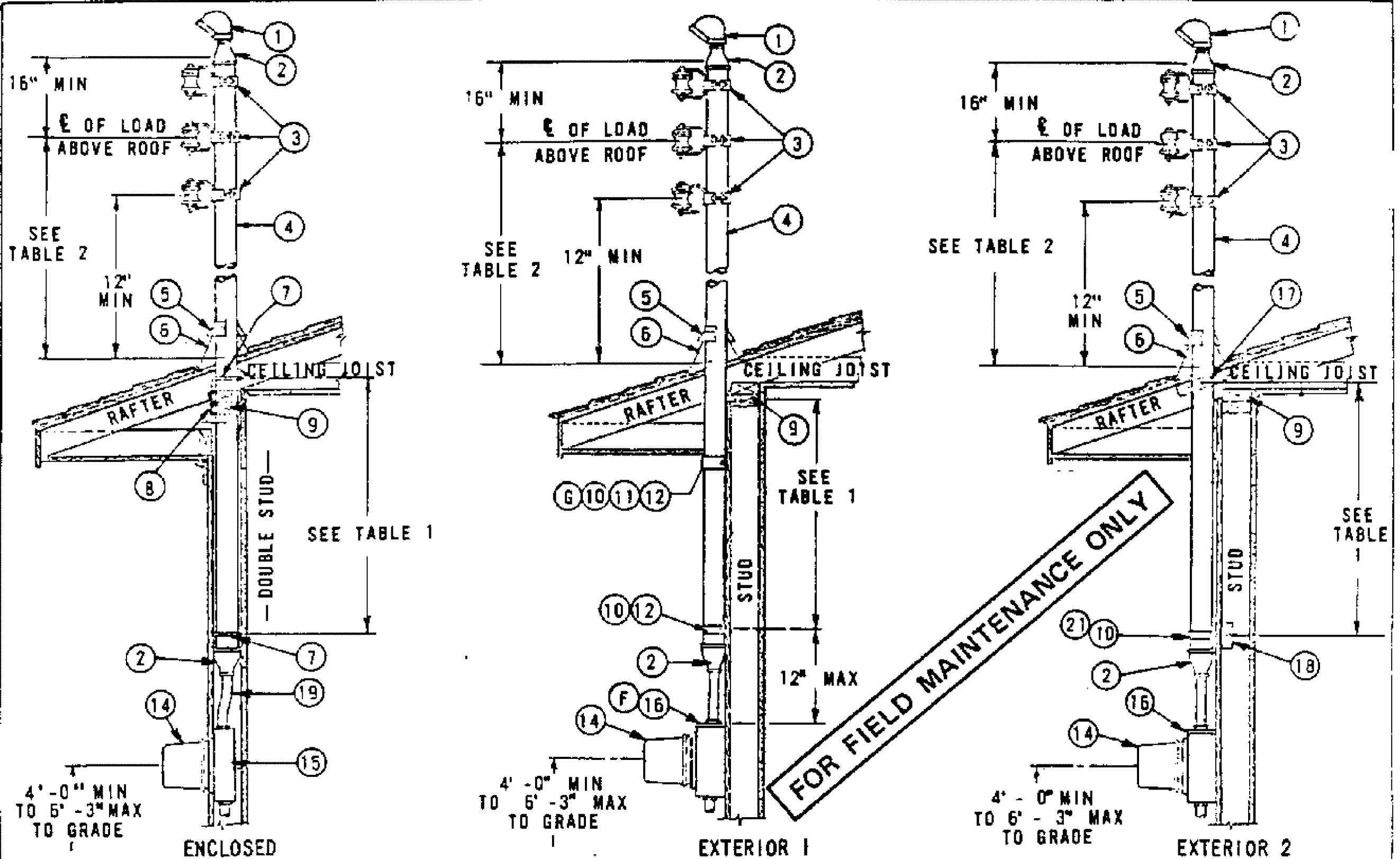

NOTES:

- A. SDG&E WILL NOT BE RESPONSIBLE FOR ANY DAMAGE TO THE BUILDING CAUSED BY RAIN OR STRUCTURAL FAILURE.
- B. THESE METHODS ARE SUGGESTED TO OBTAIN THE REQUIRED GROUND AND ROOF CLEARANCES AS REQUIRED BY THE AUTHORITIES HAVING JURISDICTION. WHEN THIS METHOD IS USED IT WILL BE ACCEPTABLE TO SDG&E PROVIDED THE DIMENSIONS AND CONSTRUCTION DETAILS ARE COMPLIED WITH.
- C. THE DIMENSIONS SHOWN ARE BASED ON A "SLACK SPAN" SERVICE DROP LENGTH OF NOT MORE THAN 100 FEET. FOR SERVICE LENGTH GREATER THAN 100 FEET, SEE STANDARD 644.
- D. NO COUPLINGS WILL BE PERMITTED BETWEEN THE TOP OF THE RISER AND THE LOWEST POINT OF SUPPORT FOR CONDUIT SIZES 1 1/4" TO 2" INCLUSIVE. IF A COUPLING IS NECESSARY IN THE 2 1/2" SIZE CONDUIT TO SECURE THE MAXIMUM HEIGHT, THE COUPLING SHALL BE INSTALLED AT THE UPPER END NEAR THE SERVICE CAP.
- E. THESE CONDUIT RISERS SHALL BE USED FOR ATTACHMENT OF #2 OR LARGER SERVICE DROPS.
- F. METER SOCKET BOX MUST HAVE MINIMUM WIDTH OF 14".
- G. WHEN ROOF CONSTRUCTION HAS NO SOFFIT, MOVE STRAP UP AND LAG INTO PLATE 9. HEAVY DUTY ONE HOLE PIPE STRAP IS ACCEPTABLE IF USED WITH 1/4" X 3 1/2" LAG SCREW INTO WALL STUD.

ITEM	DESCRIPTION	QUANTITY			TABLE 1	
		ENCLOSED	EXTERIOR 1	EXTERIOR 2	CONDUIT SIZE	DISTANCE
1	CAP, SERVICE	1	1	1		
2	REDUCER, PIPE, GALV IRON, IF REQ'D	1	1	1		
3	INSULATOR AND CLAMPS, FURNISHED & INSTALLED BY SDG&E	3	3	3		
4	CONDUIT, GALV RIGID IRON, OR INTERMEDIATE METAL CONDUIT	1	1	1		
5	COLLAR, METAL OR NEOPRENE RAINSHED	1	1	1	1 1/4"	12"
6	FLASHING	1	1	1	1 1/2"	19"
7	BOLT, "U", 3/8"	2	-	-	2"	22"
8	STRAPS ON PLATES	AS REQ'D	-	-	2 1/2"	30"
9	PLATES	-	-	-		
10	STRAP, PIPE, HEAVY DUTY, TWO HOLE (G)	-	2	-		
11	SCREW, LAG, 1/4" X 3 1/2"	-	2	-		
12	BOLT, TOGGLE, 1/4"	-	2	-		
13						
14	METER	1	1	1		
15	BOX, METER SOCKET, FLUSH TYPE	1	-	-		
16	BOX, METER SOCKET, SURFACE MOUNTED TYPE	-	1	1		
17	BLDCKING, 2" X 4", BETWEEN RAFTERS (SOLIDLY INSTALLED)	-	-	AS REQ'D	1 1/4"	30"
18	BLOCKING, 2" X 4", BETWEEN STUDS	-	-	AS REQ'D	1 1/2"	40"
19	NIPPLE, CONDUIT, OFFSET	1	-	-	2"	5' - 0"
20					2 1/2"	8' - 0"
21	SCREW, LAG, 1/4" X 3"	-	-	AS REQ'D		

699.202
SUPERCEDES
642 (1-1-90)

SDG&E ELECTRIC STANDARDS

SERVICE DROP ATTACHMENTS TO CONDUIT RISERS

DATE 1-1-90
APPD *Pia / RA*

FIELD MAINTENANCE ONLY

REVISION HISTORY:

7/13/2016: All versions prior to 2016 are superseded by their current version found inside the Overhead Construction Standard Manual.

© 1998 - 2016 San Diego Gas & Electric Company. All rights reserved. Removal of this copyright notice without permission is not permitted under law.

REV	CHANGE	BY	DSGN	APPV	DATE	REV	CHANGE	BY	DSGN	APPV	DATE
C						F					
B						E					
A	ORIGINAL ISSUE	JS	IL	MDJ	7/13/2016	D					

	Indicates Latest Revision	Completely Revised	New Page	Information Removed
-------------------------------------------------------------------------------------	---------------------------	--------------------	----------	---------------------

**SHEET
1 OF 1**

SDG&E ELECTRIC OVERHEAD STANDARD

CUSTOMER OWNED - 1 & 2 BOX TV AMPLIFIER
& 120V, METER INSTALLATION

**FMO
OH 652**

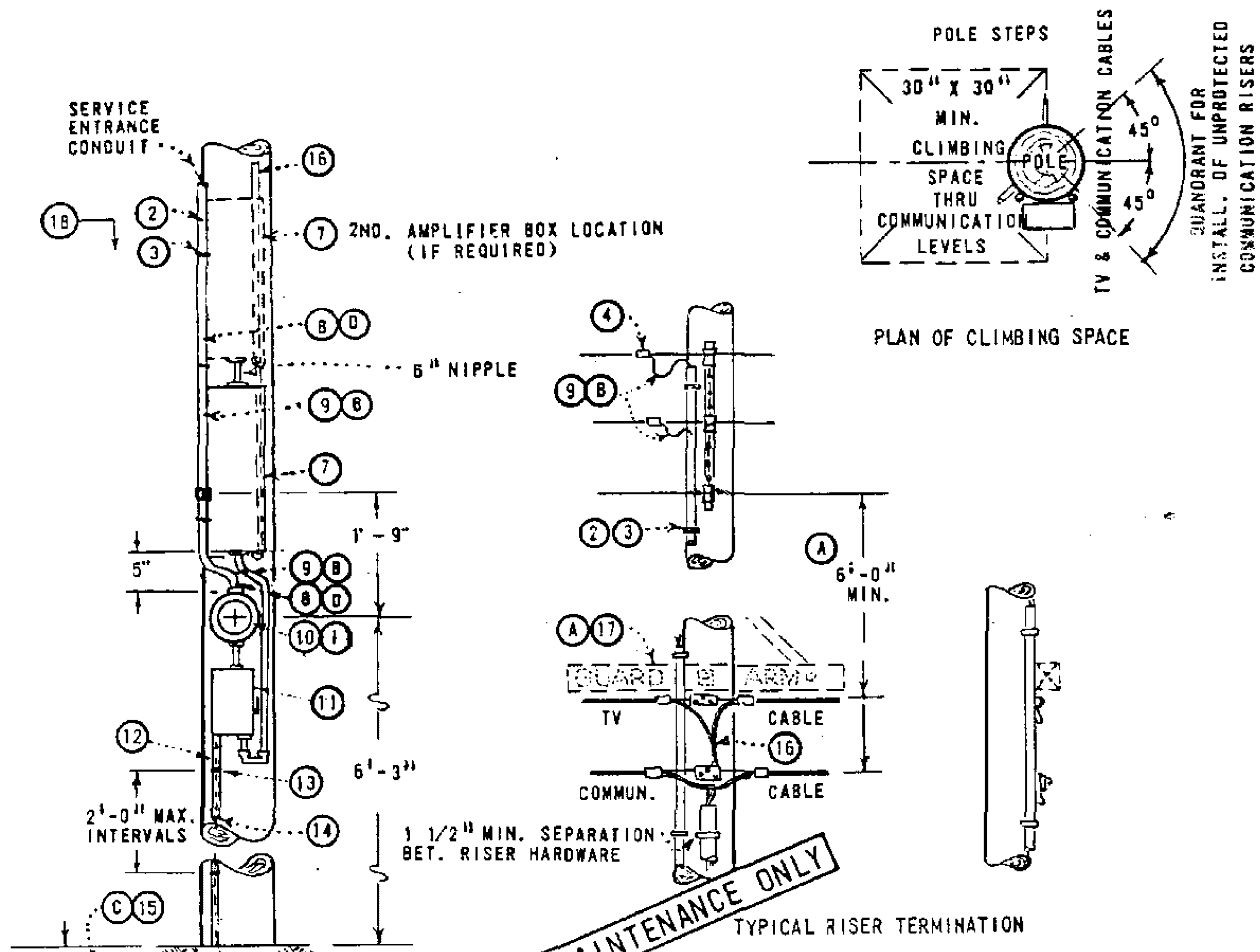

NOTES:

- (A) SEPARATION BETWEEN SECONDARY LINE AND CABLE MAY BE REDUCED TO NOT LESS THAN 4'-0" WHERE A GUARD ARM HAS BEEN INSTALLED IMMEDIATELY ABOVE TV CABLE.
- (B) CUSTOMER'S SERVICE ENTRANCE CONDUCTORS SHALL RUN CONTINUOUSLY WITHOUT SPLICES FROM METER SOCKET TERMINALS TO OVERHEAD SECONDARY LINE AND SHALL BE OF A LENGTH SUFFICIENT TO FORM LOOPS AT TOP OF THE RISER.
- (C) USE TWO GROUND RODS WHERE AN IMPEDANCE OF LESS THAN 25 OHMS CANNOT BE OBTAINED WITH ONE GROUND ROD.
- (D) IF PVC CONDUIT IS USED, ALL EQUIPMENT MOUNTED ON POLE BELOW 8' LEVEL TO BE EFFECTIVELY GROUNDING AND CONDUIT GROUND OMITTED.
- E. THE EQUIPMENT ON LOADSIDE OF THE METER IS SUBJECT TO APPROVAL BY THE LOCAL INSPECTION AUTHORITIES.
- F. ATTACH ONE SET OF LEADS FROM METER TO EXO SWITCH ONLY. LOWER AMPLIFIER MAY BE USED AS A JUNCTION BOX WHEN SECOND AMPLIFIER BOX IS REQUIRED.
- G. THIS INSTALLATION SHALL BE LIMITED TO UTILITY POLES WHICH CONTAIN NO OTHER VERTICAL RUNS.

MATERIAL FURNISHED AND INSTALLED BY SDG&E				MATERIAL FURNISHED AND INSTALLED BY CUSTOMER	
1	METER	1	481840	7	TV AMPLIFIER EQUIPMENT (1 OR 2 BOX INSTALLATION)
2	CONDUIT 3/4" DIAM., PVC, TYPE II, SCH. 80	(E) AS REQ'D	251520	(D) 8	G.I. RIGID OR PVC CONDUIT SCH. 80, WITH FITTINGS (TO 8'-0" LEVEL)
3	STRAPS, PIPE, GALV., 3/4", 2-10d. NAILS	(E) AS REQ'D	697888	(B) 9	WIRE, 600V, #12, TYPE THW, (SERVICE CONDUCTORS)
4	CONNECTORS, WIRE (SIZE AS REQ'D.)	2	783 OR 786	10	APPROVED METER SOCKET
5	COUPLING, PLASTIC. (SIZE AS REQ'D)	1		11	EXO SWITCH, COMPLETE WITH PROTECTION
				12	HARWOOD MOULDING, 1"
				13	PIPE STRAPS, GALV., 1" & 2-10d. NAILS, GALV.
				14	WIRE, BARE STRANDED COPPER, #6
				(C) 15	GROUND ROD AND CLAMP, 5/8" X 8'-0"
				16	CO-AXIAL TV CABLES
				(A) 17	GUARD ARM, 3" X 4 1/4" X 4'-0" (IF REQ'D.) WITH BRACE
				18	POLE STEPS (AS REQ'D) PAGE 363

700 - CONDUCTOR
DATA & ACCESSORIES

700 - CONDUCTOR
DATA & ACCESSORIES

PAGES

SUBJECT

715	COPPER AND COPPERWELD WIRE TABLE
717	COPPER TREE WIRE
720	AUTOMATIC SLEEVES FOR COPPER AND COPPERWELD CONDUCTORS
741	12KV ALUMINUM STRAIGHT STRAIN CLAMP FOR ACSR & 5005 ALUMINUM ALLOY CONDUCTORS
744	GALVANIZED DEAD END STRAIN CLAMPS FOR COPPER CONDUCTORS
756	PORCELAIN SUSPENSION INSULATOR BONDING
776	ANGLE SUSPENSION CLAMPS
785	ALUMINUM PARALLEL GROOVE CLAMPS

© 1998 - 2016 San Diego Gas & Electric Company. All rights reserved. Removal of this copyright notice without permission is not permitted under law.

REV	CHANGE	BY	DSGN	APPV	DATE	REV	CHANGE	BY	DSGN	APPV	DATE
C						F					
B						E					
A	ORIGINAL ISSUE	JS	IL	MDJ	7/13/2016	D					

SHEET 1 OF 1	 Indicates Latest Revision	Completely Revised	New Page	Information Removed	FMO OH 701
	SDG&E OVERHEAD STANDARD				
	CONDUCTOR DATA & ACCESSORIES FMO TABLE OF CONTENTS				

FIELD MAINTENANCE ONLY

REVISION HISTORY:

7/13/2016: All versions prior to 2016 are superseded by their current version found inside the Overhead Construction Standard Manual.

© 1998 - 2016 San Diego Gas & Electric Company. All rights reserved. Removal of this copyright notice without permission is not permitted under law.

REV	CHANGE	BY	DSGN	APPV	DATE	REV	CHANGE	BY	DSGN	APPV	DATE
C						F					
B						E					
A	ORIGINAL ISSUE	JS	IL	MDJ	7/13/2016	D					

SHEET 1 OF 1	 Indicates Latest Revision	Completely Revised	New Page	Information Removed	FMO OH 715
	SDG&E ELECTRIC OVERHEAD STANDARD				
	COPPER AND COPPERWELD WIRE TABLE				

COPPER WIRE (FOR FIELD MAINTENANCE ONLY)

SIZE OF WIRE	AWG	6	1	-	-
	CIRC MILS (CU EQUIV)	26250	83690	250K	400K
STOCK NUMBER		S813536	S812352	S813696	S812416
NUMBER OF STRANDS		3	7	19	19
DIAMETER (INCHES)		.201	.328	.574	.726
WEIGHT (LBS/1000 FT)		82.5	258.4	771.9	1235
ULTIMATE TENSILE STRENGTH (LBS)		1204	3154	9366	13850
AMPACITY (AMPERES) AT 75° C		130	270	540	730
RESISTANCE AT 75° C OHMS/1000 FT		.49	.15	.052	.033

FOR FIELD MAINTENANCE ONLY

COPPERWELD WIRE (FOR FIELD MAINTENANCE ONLY)

SIZE OF WIRE	AWG	6	4		-	-	-	
	CIRC MILS (CU EQUIV)	26250	47140		47124	92667	370100	
STOCK NUMBER		S813120	S813088	S813152	S813216	S813280	S813312	S813184
CW. CONDUCTOR TYPE NO.		6A	4A	4D	4N	3/8 (7 #8)	9/16 (7 #5)	.810E
NUMBER OF STRANDS CW/CU		1/2	1/2	2/1	5/2	40% 7-HS	40% 7-HS	7/12
DIAMETER (INCHES)		.230	.290	.348	.328	.385	.546	.810
WEIGHT (LBS/1000 FT)		101.6	161.5	225.5	240.0	323.9	649.4	1484
ULTIMATE TENSILE STRENGTH (LBS)		2585	3938	7340	8460	10460	18510	34290
AMPACITY (AMPERES) AT 75° C		140	180	190	180	200	305	660
RESISTANCE AT 75° C OHMS/1000 FT		.50	.32	.32	.32	.28	.14	.035

© 1998 - 2011 San Diego Gas & Electric Company. All rights reserved. Removal of this copyright notice without permission is not permitted under law.

799.101
SUPERSEDES
715 (5-6-83)

SDG&E ELECTRIC STANDARDS

COPPER AND COPPERWELD WIRE TABLE

DATE 3-23-2011
APPD PJA/MJC

FIELD MAINTENANCE ONLY

REVISION HISTORY:

7/13/2016: All versions prior to 2016 are superseded by their current version found inside the Overhead Construction Standard Manual.

© 1998 - 2016 San Diego Gas & Electric Company. All rights reserved. Removal of this copyright notice without permission is not permitted under law.

REV	CHANGE	BY	DSGN	APPV	DATE	REV	CHANGE	BY	DSGN	APPV	DATE
C						F					
B						E					
A	ORIGINAL ISSUE	JS	IL	MDJ	7/13/2016	D					

SHEET 1 OF 1	 Indicates Latest Revision	Completely Revised	New Page	Information Removed	FMO OH 717
	SDG&E ELECTRIC OVERHEAD STANDARD				
	COPPER TREE WIRE				

SIZE OF WIRE	A.W.G.	4	2	1/0	3/0	4/0
	CIRCULAR MILS.	41740	66370	105500	167800	211600
STOCK NUMBER		815456	815520	815488	815552	-
NUMBER OF STRANDS		3	7	7	7	7
CONDUCTOR AREA SQUARE INCHES		.0328	.0521	.0829	.1318	.1662
NOMINAL O.D. INCHES		.566	.604	.680	.766	.839
APPROX. WEIGHT LBS. PER M FT.		215	300	440	650	800
ULTIMATE TENSILE STRENGTH - LBS.		1564	2517	3953	6204	7772
CAPACITY AMPERES AT 75° C		125	166	222	294	343
RESISTANCE AT 75° C OHMS M FEET		.32	.20	.12	.079	.062
ASSEMBLY UNITS		TR4	TR2	TR1/0	TR3/0	-

FOR FIELD MAINTENANCE ONLY

DATE 1-1-96 APPD <i>PA/ROJ</i>	SDG&E ELECTRIC STANDARDS	799.102 SUPERSEDES 717 (1-1-96)
	COPPER TREE WIRE	

FIELD MAINTENANCE ONLY

REVISION HISTORY:

7/13/2016: All versions prior to 2016 are superseded by their current version found inside the Overhead Construction Standard Manual.

© 1998 - 2016 San Diego Gas & Electric Company. All rights reserved. Removal of this copyright notice without permission is not permitted under law.

REV	CHANGE	BY	DSGN	APPV	DATE	REV	CHANGE	BY	DSGN	APPV	DATE
C						F					
B						E					
A	ORIGINAL ISSUE	JS	IL	MDJ	7/13/2016	D					

	Indicates Latest Revision	Completely Revised	New Page	Information Removed
-------------------------------------------------------------------------------------	---------------------------	--------------------	----------	---------------------

**SHEET
1 OF 1**

SDG&E ELECTRIC OVERHEAD STANDARD
AUTOMATIC SLEEVES FOR
COPPER AND COPPERWELD CONDUCTORS

**FMO
OH 720**

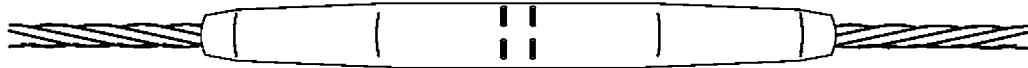

AUTOMATIC COPPER SLEEVE

NOTES:

- SLEEVES SHALL NOT BE INSTALLED IN GRADE A CROSSING SPANS OR IN TRANSMISSION CONSTRUCTION.
- AUTOMATIC SLEEVES DEPEND ON LINE TENSION FOR THEIR OPERATION. THEY SHALL NOT BE USED IN TAPS, JUMPERS, OR REDUCED TENSION.

AUTOMATIC SLEEVES FOR COPPER CONDUCTORS		
WIRE		STOCK NUMBER
SIZE	STRAND	
6	SOLID	S653318
6	3	S653320
4	SOLID	S653320

AUTOMATIC SLEEVES FOR COPPERWELD CONDUCTORS		
WIRE		STOCK NUMBER
SIZE	STRAND	
8A	1/2	S653320
6A	1/2	S653342

FOR FIELD MAINTENANCE ONLY

© 1998 - 2014 San Diego Gas & Electric Company. All rights reserved. Removal of this copyright notice without permission is not permitted under law.

DATE 9-16-2014 APPD IL / DW	SDG&E ELECTRIC STANDARDS	799.103 SUPERSEDES 720.8 (2-11-2014)
	AUTOMATIC SLEEVES FOR COPPER AND COPPERWELD CONDUCTORS	

FIELD MAINTENANCE ONLY

REVISION HISTORY:

7/13/2016: All versions prior to 2016 are superseded by their current version found inside the Overhead Construction Standard Manual.

© 1998 - 2016 San Diego Gas & Electric Company. All rights reserved. Removal of this copyright notice without permission is not permitted under law.

REV	CHANGE	BY	DSGN	APPV	DATE	REV	CHANGE	BY	DSGN	APPV	DATE
C						F					
B						E					
A	ORIGINAL ISSUE	JS	IL	MDJ	7/13/2016	D					

<input checked="" type="checkbox"/>	Indicates Latest Revision	<input type="checkbox"/>	Completely Revised	<input type="checkbox"/>	New Page	<input type="checkbox"/>	Information Removed
-------------------------------------	---------------------------	--------------------------	--------------------	--------------------------	----------	--------------------------	---------------------

**SHEET
1 OF 1**

SDG&E ELECTRIC OVERHEAD STANDARD
12KV ALUMINUM STRAIGHT STRAIN CLAMP
FOR ACSR & 5005 ALUMINUM ALLOY CONDUCTORS

**FMO
OH 741**

SCOPE: THIS STANDARD SHOWS STRAIGHT STRAIN CLAMPS USED TO ATTACH ACSR AND 5005 ALUMINUM ALLOY CONDUCTORS TO DEAD END INSULATORS.

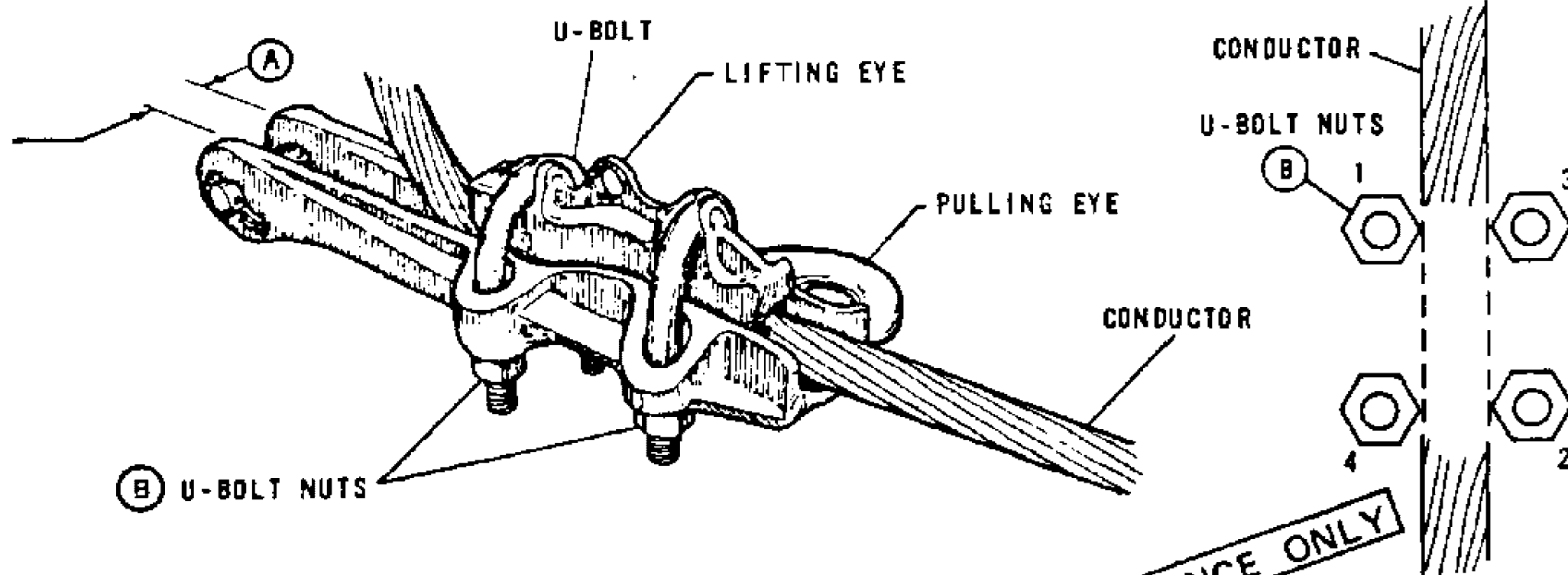

FIG. 1

TORQUING SEQUENCE
FIG. 2

NOTES:

- DO NOT USE STRAIGHT STRAIN CLAMP ON AWAC CONDUCTORS.
- THIS CLAMP MAY BE USED IN ALL LOADING DISTRICTS.

FOR FIELD MAINTENANCE ONLY

BILL OF MATERIAL:

WIRE SIZE								CLAMP RANGE (INCHES)		CLAMP DATA		MFG	CATALOG NUMBER	STOCK NO OR CONSTR STD
ACSR OR 5005 (AWG)			ACSR				5005	MIN	MAX	TORQUE (FT-LBS)	CLEVIS WIDTH (A)			
2/6/1	1/0/6/1	3/0/6/1	336.4 KMIL 18/1	336.4 KMIL 26/7	636 KMIL 24/7	1033.5 KMIL 45/7	394.5 KMIL 19							
X	X	X	-	-	-	-	-	.184	.563	35	5/8	ALCOA	E221.2	230432 (E)
X	X	X	X	X	-	-	X	.316	.814	40	13/16		E222.3	230512
-	-	-	X	X	X	-	X	.522	1.153	40	3/4		E223.4	- (C)
-	-	-	-	-	-	X	-	1.022	1.454	40	3/4		225	- (C)
X	X	-	-	-	-	-	-	.19	.47	25	11/16	BETHEA	ASD-2-N	230432 (E)
-	-	X	X	X	-	-	X	.46	.75	45	3/4		ASD-37-N	230464 (E)
X	X	-	-	-	-	-	-	.191	.447	20	3/4	FARGO	GD-971A	230432 (E)
X	X	X	X	-	-	-	X	.25	.724	45	3/4		GD-972A	230512
X	-	-	-	-	-	-	-	.15	.37	50	11/16	OHIO BRASS	87650	- (C)
X	X	X	-	-	-	-	-	.30	.60	50	3/4		91560	- (C)
-	-	X	X	X	-	-	X	.46	.88	50	7/8		91570	230464 (E)
-	-	-	-	-	X	X	-	.86	1.30	40	1-1/16	ANDERSON	ADE-130-N	230496

INSTALLATION:

- (A) SEE CLAMP DATA COLUMN FOR CLEVIS WIDTH.
- (B) HAND TIGHTEN U-BOLT NUTS AND THEN TORQUE BOLTS AS SHOWN IN FIG. 2 TO THE VALUES IN CLAMP DATA COLUMN.
- (C) SPECIAL ORDER.
- (E) EXEMPT MATERIAL

799.402
SUPERCEDES
741 (1986)

SOG&E ELECTRIC STANDARDS
12KV ALUMINUM STRAIGHT STRAIN CLAMP
FOR ACSR & 5005 ALUMINUM ALLOY CONDUCTORS

DATE 1-1-86
APPD AK/ROB

FIELD MAINTENANCE ONLY

REVISION HISTORY:

7/13/2016: All versions prior to 2016 are superseded by their current version found inside the Overhead Construction Standard Manual.

© 1998 - 2016 San Diego Gas & Electric Company. All rights reserved. Removal of this copyright notice without permission is not permitted under law.

REV	CHANGE	BY	DSGN	APPV	DATE	REV	CHANGE	BY	DSGN	APPV	DATE
C						F					
B						E					
A	ORIGINAL ISSUE	JS	IL	MDJ	7/13/2016	D					

<input checked="" type="checkbox"/>	Indicates Latest Revision	<input type="checkbox"/>	Completely Revised	<input type="checkbox"/>	New Page	<input type="checkbox"/>	Information Removed
-------------------------------------	---------------------------	--------------------------	--------------------	--------------------------	----------	--------------------------	---------------------

**SHEET
1 OF 1**

SDG&E ELECTRIC OVERHEAD STANDARD

GALVANIZED DEAD END STRAIN CLAMPS FOR COPPER CONDUCTORS

**FMO
OH 744**

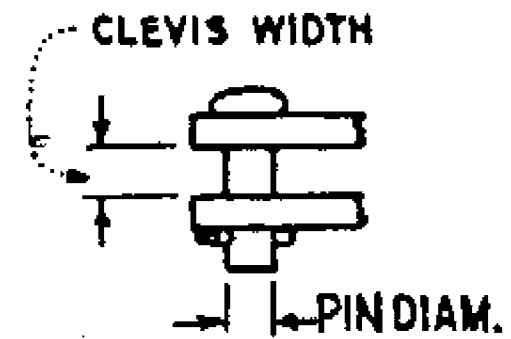
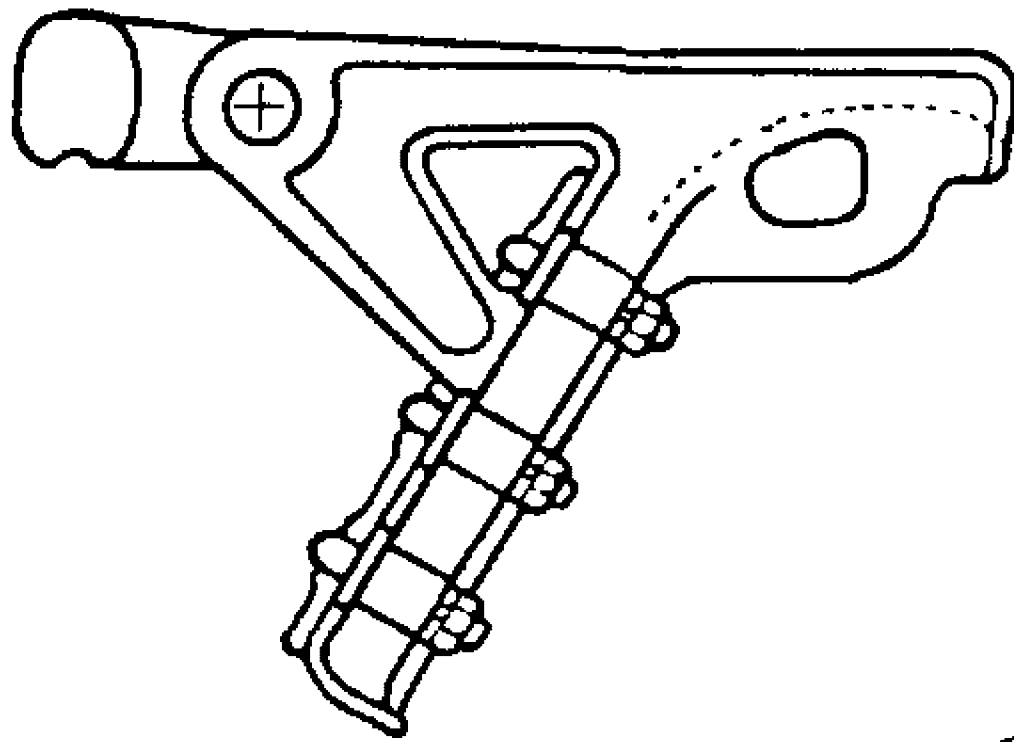

THIS PAGE FOR FIELD MAINTENANCE ONLY

RECOMMENDED U-BOLT NUT TORQUE

- 1/2" = 50 FT. LBS.
- 9/16" = 67 FT. LBS.
- 5/8" = 83 FT. LBS.

NOTES:

- A. REFER TO PAGE 777 FOR CLAMP CONNECTORS.
- B. HAND TIGHTEN U BOLT NUTS AND THEN ALTERNATELY APPLY WRENCH UNTIL DESIRED TORQUE IS ACHIEVED.
- (C) NO LONGER PURCHASED, BUT WILL BE SALVAGED.
- (D) ITEM 231488 IS BRONZE

COPPER WIRE SIZE AND DIAMETER (INCHES)									CLAMP RANGE		CONNECTION	CLEVIS WIDTH	PIN DIAM.	STOCK NO OR CONST STD
4 .254	2 .320	1/0 .368	4/0 .527	250MCM .574	400MCM .726	500MCM .813	750MCM .997	1000MCM 1.151	MIN.	MAX.				
X	X	X	X	-	-	-	-	-	.20	.55	SOCKET	1 1/16"	5/8"	231264
-	-	X	X	X	-	-	-	-	.30	.68	SOCKET	13/16"	5/8"	231328
-	-	-	X	X	X	-	-	-	.48	.84	SOCKET	7/8"	5/8"	231392 (C)
-	-	-	X	X	X	X	-	-	.50	.96	SOCKET	1"	5/8"	231456 (C)
-	-	-	-	-	X	X	X	X	.71	1.30	SOCKET	1 7/16"	3/4"	231488 (D)
-	X	X	X	X	-	-	-	-	.30	.68	NONE	13/16"	5/8"	231136
-	-	-	X	X	X	X	-	-	.48	.84	NONE	7/8"	5/8"	231200 (C)

FIELD MAINTENANCE ONLY

REVISION HISTORY:

7/13/2016: All versions prior to 2016 are superseded by their current version found inside the Overhead Construction Standard Manual.

© 1998 - 2016 San Diego Gas & Electric Company. All rights reserved. Removal of this copyright notice without permission is not permitted under law.

REV	CHANGE	BY	DSGN	APPV	DATE	REV	CHANGE	BY	DSGN	APPV	DATE
C						F					
B						E					
A	ORIGINAL ISSUE	JS	IL	MDJ	7/13/2016	D					

<input checked="" type="checkbox"/>	Indicates Latest Revision	<input type="checkbox"/>	Completely Revised	<input type="checkbox"/>	New Page	<input type="checkbox"/>	Information Removed
-------------------------------------	---------------------------	--------------------------	--------------------	--------------------------	----------	--------------------------	---------------------

**SHEET
1 OF 1**

SDG&E ELECTRIC OVERHEAD STANDARD

PORCELAIN SUSPENSION INSULATOR BONDING

**FMO
OH 756**

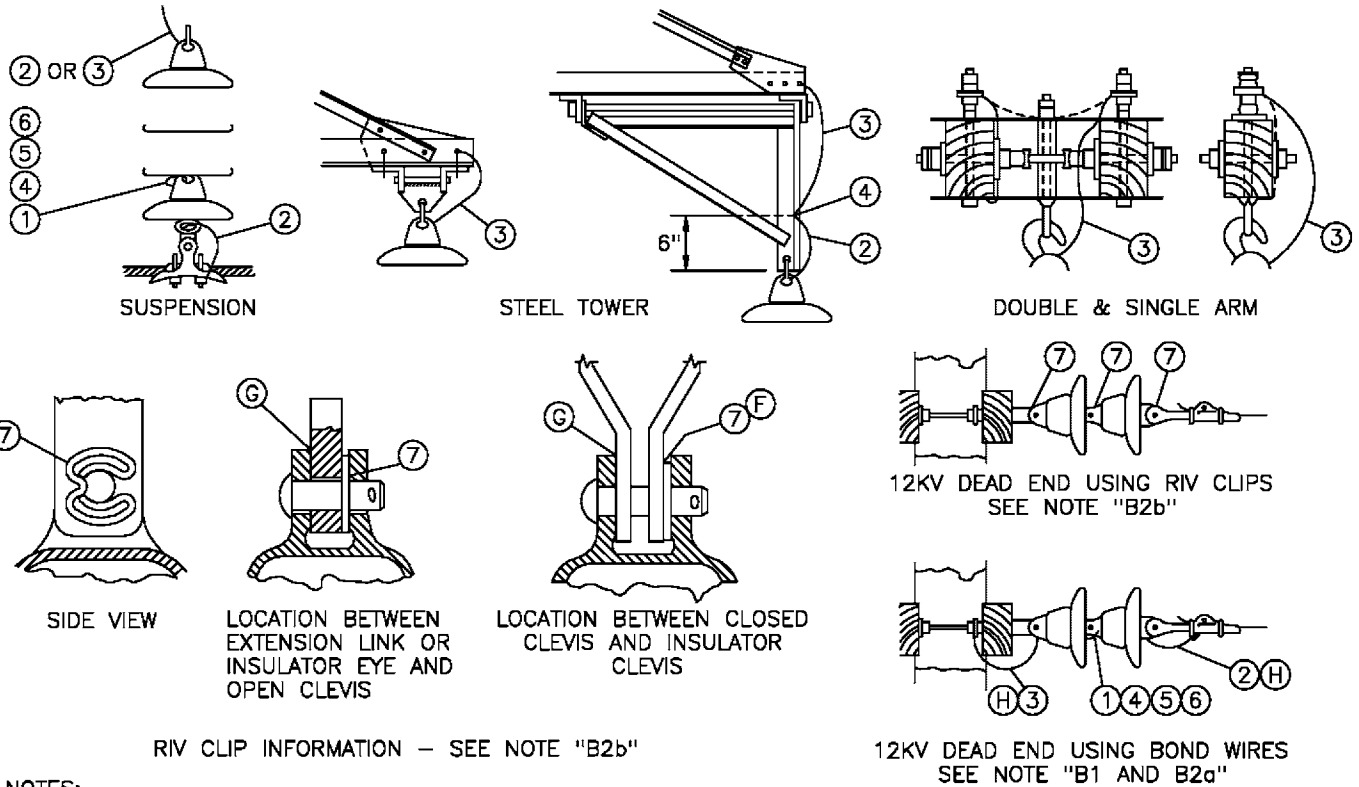

RIV CLIP INFORMATION - SEE NOTE "B2b"

12KV DEAD END USING BOND WIRES
SEE NOTE "B1 AND B2a"

NOTES:

- A. USE BONDED INSULATORS ON 138 AND 69KV WHERE: 1) MAXIMUM GUYING TENSION PER CONDUCTOR IS BELOW 1000 POUNDS, OR 2) THROUGH RESIDENTIAL, COMMERCIAL, AND INDUSTRIAL AREAS. ALSO, WHERE FUTURE DEVELOPMENT OF SIMILAR AREAS ADJACENT TO TRANSMISSION LINES ARE ANTICIPATED.
- B. USE THE FOLLOWING TO DETERMINE WHEN TO USE BONDED OR UNBONDED INSULATORS, AND WHEN RIV CLIPS ARE TO BE ADDED TO UNBONDED INSULATORS ON 12KV AND 12.47KV SYSTEMS IN CONTAMINATION DISTRICTS DESCRIBED ON PAGE 287.
 - 1) SLACK SPANS (SPANS INSTALLED AT MORE THAN NORMAL SAG): IN ALL CONTAMINATION DISTRICTS: USE BONDED INSULATORS.
 - 2) FULL TENSION INSTALLATIONS WHERE MAXIMUM GUYING TENSION PER CONDUCTOR IS 1000 POUNDS OR LESS:
 - a) CONTAMINATION DISTRICT 1, USE BONDED INSULATORS.
 - b) CONTAMINATION DISTRICTS 2 AND 3, USE UNBONDED INSULATORS WITH RIV CLIPS
 - 3) FULL TENSION INSTALLATIONS WHERE MAXIMUM GUYING TENSION PER CONDUCTOR IS OVER 1000 POUNDS: ALL CONTAMINATION DISTRICTS: USE UNBONDED INSULATORS.
- C. INSULATORS BONDED PER SDG&E SPECIFICATION 138 INCLUDE ITEMS 1 THROUGH 6 LISTED BELOW.
- D. SEE STANDARDS PAGE 750.4 FOR SUSPENSION INSULATOR INFORMATION.
- F. INSTALL RIV CLIP BETWEEN CLEVIS AND INSULATOR CAP AS SHOWN.
- G. ADD SECOND RIV CLIP IF ONLY ONE CLIP DOES NOT MAKE TIGHT CONNECTION BETWEEN HARDWARE. NEVER USE MORE THAN 2 RIV CLIPS AT ONE CONNECTION, OR, ON ONE PIN.
- H. ATTACH BOND WIRES LEAVING SHORT LOOPS AS SHOWN. CUT OFF EXCESS BOND WIRE.

BILL OF MATERIAL:

FOR FIELD MAINTENANCE ONLY

ITEM	DESCRIPTION	QUANTITY	STOCK NO. OR CONSTR STDS	ASSEMBLY UNITS
1	WIRE ROPE, 3" STAINLESS STEEL, MACWYTE, 1/16" OD, 7x7 PREFORMED, AIFI TYPE 304	AS REQ'D		
2	WIRE ROPE, 12" STAINLESS STEEL, MACWYTE, 1/16" OD, 7x7 PREFORMED, AIFI TYPE 304	AS REQ'D	606720	12BOND
3	WIRE ROPE, 24" STAINLESS STEEL, MACWYTE, 1/16" OD, 7x7 PREFORMED, AIFI TYPE 304	AS REQ'D		
4	SCREW, 8-32, STAINLESS STEEL, PHILLIPS HEAD	AS REQ'D	622464	-
5	TERMINAL, AMP 322334, #8 STUD, STAINLESS STEEL OR NICKEL	AS REQ'D	732064	-
6	LOCKWASHER, EXTERNAL TOOTH, #8 STUD, STAINLESS STEEL	AS REQ'D	796352	-
7	CLIP, INSULATOR NON STATIC (RIV)	AS REQ'D	237648	RIVCLP

DATE 1-1-94

APPD *PA 1/09*

SDG&E ELECTRIC STANDARDS

PORCELAIN SUSPENSION INSULATOR BONDING

799.501
SUPERSEDES
756 (1-1-98)





FIELD MAINTENANCE ONLY

REVISION HISTORY:

7/13/2016: All versions prior to 2016 are superseded by their current version found inside the Overhead Construction Standard Manual.

© 1998 - 2016 San Diego Gas & Electric Company. All rights reserved. Removal of this copyright notice without permission is not permitted under law.

REV	CHANGE	BY	DSGN	APPV	DATE	REV	CHANGE	BY	DSGN	APPV	DATE
C						F					
B						E					
A	ORIGINAL ISSUE	JS	IL	MDJ	7/13/2016	D					

<p>SHEET 1 OF 1</p>	 Indicates Latest Revision	 Completely Revised	 New Page	 Information Removed	<p>FMO OH 776</p>
	<p>SDG&E ELECTRIC OVERHEAD STANDARD</p>				
	<p>ANGLE SUSPENSION CLAMPS</p>				

SCOPE: THIS PAGE SHOWS THE DIMENSIONS AND ULTIMATE VERTICAL LOADING STRENGTH OF THE ANGLE SUSPENSION CLAMP. THE CLAMP IS TO BE USED IN CONJUNCTION WITH THE CLEVIS OR SOCKET EYE CONNECTORS FOR SUPPORTING CONDUCTORS ON VERTICAL CONSTRUCTION. MAXIMUM ANGLE FOR CONSTRUCTION USING THIS CLAMP IS 30° .

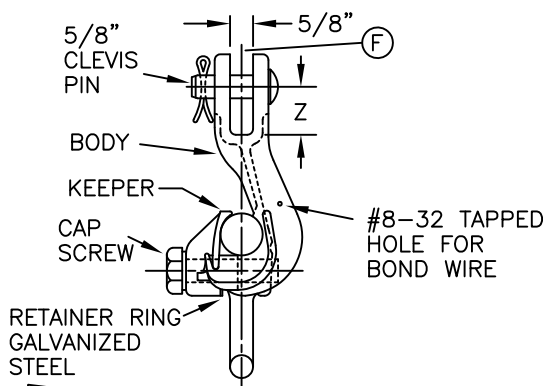
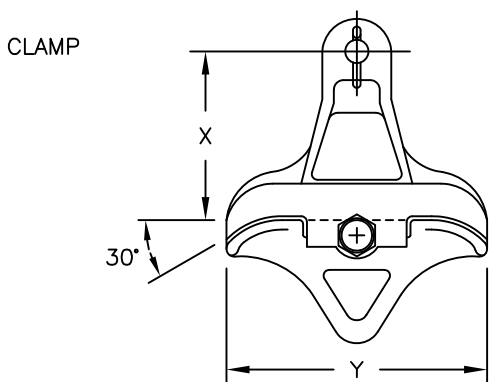

FOR FIELD MAINTENANCE ONLY

INSTALLATION:

- (A) LINE GUARDS ARE TO BE USED WITH CLAMPS.
- B. BONDING IS REQUIRED IN CONTAMINATION DISTRICT 1. (SEE STANDARD 287)

REFERENCE:

- C. TABLE 1 IS TO BE USED TO DETERMINE PHYSICAL DIMENSIONS AND STRENGTHS OF SUSPENSION CLAMPS.
- D. TABLE 2 SHOWS THE PROPER SIZING OF SUSPENSION CLAMPS FOR CONDUCTORS.
- (F) SEE STANDARD 777 FOR USE OF CLEVIS AND SOCKET EYES.

TABLE 1

MANUFACTURER		CLAMP RANGE DIA. (INCHES)		DIMENSIONS (INCHES)			ULTIMATE STRENGTH VERT.LOAD	MATERIAL	STOCK NUMBER
CAT.NO.	NAME	MIN.	MAX.	X	Y	Z			
1301	LINDSEY	.160	.430	3-7/16	5-1/2	1-1/2	18,000	DUCTILE IRON	226662
1305	LINDSEY	.300	.650	4-1/4	6-1/2	1-1/2	18,000	DUCTILE IRON	226664
1308	LINDSEY	.50	.70	4-1/4	7	1-1/4	12,000	ALUM.	232004
1312	LINDSEY	.68	1.00	4-1/4	6-7/8	1	12,000	ALUM.	232008
1316	LINDSEY	1.00	1.313	5-3/8	6-7/8	1-1/4	12,000	ALUM.	232012
1320	LINDSEY	1.24	1.500	5-5/8	7	1-1/4	15,000	ALUM.	226660

TABLE 2

COPPER										COPPERWELD						STOCK NUMBER	ASSEMBLY UNITS
6	4	3 SOL.	2	1	1/0	2/0	3/0	4/0	250 KCM	8A	6	4					
X	X	X	X	X	X	X				X	X	X				226662	SCACS
							X	X	X							226664	SCACL
AWAC (A)		ACSR (A)								5005 (A)					STOCK NUMBER	ASSEMBLY UNITS	
2	1/0	4	2	1/0	3/0	4/0	336/18/1	336/26/7	397	636	4	2	1/0	3/0			394.5
X	X		X	X	X						X	X	X			232004	SC4 SC1/0
					X	X	X							X		232008	-
									X	X					X	232012	SC397
										X						226660	SC636

© 1998 - 2010 San Diego Gas & Electric Company. All rights reserved. Removal of this copyright notice without permission is not permitted under law.

Indicates Latest Revision Completely Revised New Page Information Removed

SDG&E ELECTRIC STANDARDS

776

ANGLE SUSPENSION CLAMPS

REVISION

DATE 1-1-94

APPD PIA / RJA

FIELD MAINTENANCE ONLY

REVISION HISTORY:

7/13/2016: All versions prior to 2016 are superseded by their current version found inside the Overhead Construction Standard Manual.

© 1998 - 2016 San Diego Gas & Electric Company. All rights reserved. Removal of this copyright notice without permission is not permitted under law.

REV	CHANGE	BY	DSGN	APPV	DATE	REV	CHANGE	BY	DSGN	APPV	DATE
C						F					
B						E					
A	ORIGINAL ISSUE	JS	IL	MDJ	7/13/2016	D					

SHEET 1 OF 1	 Indicates Latest Revision	Completely Revised	New Page	Information Removed	FMO OH 785
	SDG&E ELECTRIC OVERHEAD STANDARD				
	ALUMINUM PARALLEL GROOVE CLAMPS				

NOTES: (A) TO CHOOSE THE PROPER GROOVE CLAMP, LOCATE THE TWO WIRE SIZES ON THE CHART, DRAW A HORIZONTAL LINE FROM THE LARGER CONDUCTOR SIZE AND A VERTICAL LINE FROM THE SMALLER SO THAT THEY INTERSECT. THE AREA CONTAINING THE INTERSECTION INDICATES THE CORRECT STOCK NUMBER.

EXAMPLE: FOR CONDUCTOR SIZES 3/0 ACSR AND #2 ACSR, THE CORRECT GROOVE CLAMP STOCK NUMBER IS 227968.

B. THE ADJACENT TABLE CAN BE USED TO DETERMINE THE SPECIFIC MANUFACTURER'S CATALOG NUMBER FOUND UNDER A STOCK NUMBER.

C. BE SURE TO CLEAN CONDUCTOR WHICH WILL BE UNDER CLAMP, CLEAN CONDUCTOR GROOVES OF CLAMP IF NECESSARY, AND FILL THE GROOVES WITH INHIBITOR (247200) BEFORE INSTALLING THE CLAMP.

D. FOR USE WHEN MAKING AL. TO AL. AND AL. TO CU. PERMANENT CONNECTIONS AND WHERE CONNECTIONS MAY BE OPENED OCCASIONALLY FOR OPERATING CONVENIENCE.

F. WHEN MAKING AL. TO CU. CONNECTIONS, LOCATE THE CU. AT THE SAME LEVEL OR BELOW THE AL. CONDUCTOR.

CONDUCTOR		
DIA. IN.	AWG OR KCM	DESCRIPTION
.162	6	SOLID
.184	6	7 STR.
.198	6	ACSR 6/1
.198	6	5005 7W
.199	8A	CUWLD 3 STR.
.202	6	3 STR.
.204	4	SOLID
.229	3	SOLID
.230	6A	CUWLD 3 STR.
.232	4	7 STR.
.250	4	ACSR 6/1
.250	4	5005 7W
.254	4	3 STR.
.258	2	SOLID
.276	6D	CUWLD 3 STR.
.289	1	SOLID
.290	4A	CUWLD 3 STR.
.292	2	7 STR.
.316	2	ACSR 6/1
.316	2	5005 7W
.320	2	3 STR.
.324	1/0	SOLID
.325	2	ACSR 7/1
.328	4N	CUWLD 7 STR.
.330	2	AWAC 5/2
.338	1/0	7 STR. COMP.
.348	4D	CUWLD 3 STR.
.360	1	3 STR.
.368	1/0	7 STR.
.373	1/0	19 STR.
.386	2	AWAC 3/4
.398	1/0	ACSR 6/1
.398	1/0	5005 7W
.409	3/0	SOLID
.414	2/0	7 STR.
.426	3/0	7 STR. COMP.
.447	1/0	AWAC 4/3
.460	4/0	SOLID
.464	3/0	7 STR.
.470	3/0	19 STR.
.502	3/0	ACSR 6/1
.502	3/0	5005 7W
.522	4/0	7 STR.
.528	4/0	19 STR.
.533	4/0	37 STR.
.563	4/0	ACSR 6/1
.575	250	19-37 STR.
.629	300	19-37 STR.
.666	336	19 STR.
.680	350	19-37 STR.
.684	336	ACSR 18/1
.721	336	ACSR 26/7
.721	394	5005 19W
.727	400	19-37 STR.
.743	397	ACSR 18/1
.783	397	ACSR 26/7
.811	500	19 STR.
.977	636	ACSR 24/7
.998	750	37-61 STR.
1.152	1000	61-91 STR.

227936

ASSEMBLY UNITS
PG6C
PG4C
PG2A
PG2C
PG1/0A
PG1/0C

STOCK NUMBER	BOLTS			ALCOA CATALOG NUMBER
	NO.	SIZE IN.	TORQUE LB.-FT.	
227936	1	3/8	13	396.6
227968	2	1/2	25	482.1
228000	3	1/2	25	482.2
228032	2	5/8	40	483.2
228064	3	5/8	40	483.3

(G)

ASSEMBLY UNITS
STK No. 228064
PG397
PG500
PG636
PG750
PG1000

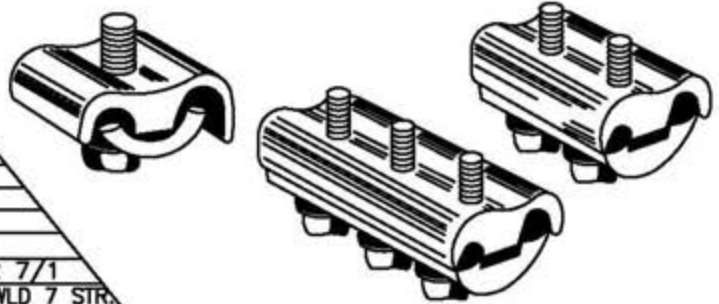

EXAMPLE (A)

EXAMPLE (A)

NO CONNECTOR AVAILABLE

227968

ASSEMBLY UNITS
PG3/0A
PG4/0C

228000

ASSEMBLY UNITS
PG336
PG394
PG400

228032

ASSEMBLY UNITS
PG500-

(G) 228064

© 1998 - 2005 San Diego Gas & Electric Company. All rights reserved. Removal of this copyright notice without permission is not permitted under law.

REVISION	Indicates Latest Revision	Completely Revised	New Page	Information Removed
DATE 1-1-94	SDG&E ELECTRIC STANDARDS			799.801
APPD <i>PA/BJG</i>	ALUMINUM PARALLEL GROOVE CLAMPS			SUPERSEDES 785 (1-20-06)

800-SAG

800-SAG

PAGES

SUBJECT

801	TABLE OF CONTENTS
815	MAXIMUM SAFE SPAN LENGTHS IN FEET, PRIMARY AND SECONDARY CROSSARMS, LIGHT LOADING
816	MAXIMUM SAFE SPAN LENGTHS IN FEET, PRIMARY AND SECONDARY CROSSARMS, MEDIUM LOADING
817	MAXIMUM SAFE SPAN LENGTHS IN FEET, 12KV CROSSARMS, LIGHT LOADING
818	MAXIMUM SAFE SPAN LENGTHS IN FEET, 12KV CROSSARMS, LIGHT LOADING
819	HORIZONTAL CONDUCTOR SPACING GENERAL INFORMATION
820	SLACK SPAN CONSTRUCTION SINGLE/DOUBLE CROSSARMS

© 1998 - 2018 San Diego Gas & Electric Company. All rights reserved. Removal of this copyright notice without permission is not permitted under law.

REV	CHANGE	BY	DSGN	APPV	DATE	REV	CHANGE	BY	DSGN	APPV	DATE
C						F					
B	ADDED 815-820	JS	JS	CZH	9/4/2018	E					
A	ORIGINAL ISSUE	JS	JS	MDJ	9/29/2016	D					

SHEET 1 OF 1	X Indicates Latest Revision	Completely Revised	New Page	Information Removed	FMO OH801
	SDG&E ELECTRIC OVERHEAD CONSTRUCTION STANDARD				
	SAG FMO TABLE OF CONTENTS				

FIELD MAINTENANCE ONLY

9/4/2018: All versions prior to 2018 are superseded by their current version found inside the Overhead Construction Standard Manual.





















© 1998 - 2018 San Diego Gas & Electric Company. All rights reserved. Removal of this copyright notice without permission is not permitted under law.

REV	CHANGE	BY	DSGN	APPV	DATE	REV	CHANGE	BY	DSGN	APPV	DATE
C						F					
B						E					
A	ORIGINAL ISSUE	JS	JS	CZH	9/4/2018	D					

<p>SHEET 1 OF 1</p>	<p>X Indicates Latest Revision</p>	Completely Revised	New Page	Information Removed	<p>FMO OH801</p>
	<p>SDG&E ELECTRIC OVERHEAD CONSTRUCTION STANDARD</p>				
	<p>TABLE OF CONTENTS</p>				

SAG AND TENSION TABLES

CLICK ON BUTTON

Conductor Type	Sag and Tension Tables	Design Stringing Tables	Max.Hor. Tension, lbs	Ruling Span, ft	G.O.95 Light	G.O.95 Heavy	G.O.95 Extra Heavy	NESC 250C Extreme Wind
#2 ACSR Sparrow			850 lbs.	100 ft. to 500 ft.	✓			✓
1/0 ACSR Raven			1240 lbs.	100 ft. to 500 ft.	✓			✓
3/0 ACSR Pigeon			1850 lbs.	100 ft. to 500 ft.	✓			✓
4/0 ACSR Penguin			1000 lbs. to 2400 lbs.	100 ft. to 500 ft.	✓			✓
#2 AWAC 5/2			1600 lbs.	100 ft. to 500 ft.		✓	✓	✓
#2 AWAC ¾			1000 lbs. to 3500 lbs.	100 ft. to 500 ft.		✓	✓	✓
336.4 ACSR			1000 lbs. to 3000 lbs.	100 ft. to 500 ft.	✓	✓	✓	✓
397 ACSR IBIS			1000 lbs. to 3000 lbs.	100 ft. to 500 ft.	✓	✓	✓	✓
636 ACSR Rook			1000 lbs. to 3000 lbs.	100 ft. to 500 ft.	✓	✓	✓	✓
1033 ACSR Ortolan			1000 lbs. to 3000 lbs.	100 ft. to 500 ft.	✓			✓

<u>PAGE</u>	<u>SUBJECT</u>
801	TABLE OF CONTENTS
815	MAXIMUM SAFE SPAN LENGTHS IN FEET, PRIMARY AND SECONDARY CROSSARMS, LIGHT LOADING
816	MAXIMUM SAFE SPAN LENGTHS IN FEET, PRIMARY AND SECONDARY CROSSARMS, MEDIUM LOADING
817	MAXIMUM SAFE SPAN LENGTHS IN FEET, 12KV CROSSARMS, LIGHT LOADING
818	MAXIMUM SAFE SPAN LENGTHS IN FEET, 12KV CROSSARMS, MEDIUM LOADING
819	HORIZONTAL CONDUCTOR SPACING
820	SLACK SPAN CONSTRUCTION, SINGLE/DOUBLE CROSSARMS

© 1998 - 2014 San Diego Gas & Electric Company. All rights reserved. Removal of this copyright notice without permission is not permitted under law.

Indicates Latest Revision Completely Revised New Page Information Removed

REVISION DATE 9-9-2014 APPD JS / DW	SDG&E ELECTRIC STANDARDS SAG SECTION TABLE OF CONTENTS	801.1
-------------------------------------------	---------------------------------------------------------------	-------

PAGE

SUBJECT

801

TABLE OF CONTENTS

805

SAG AND TENSION TABLES

OBSOLETE

© 1998 - 2016 San Diego Gas & Electric Company. All rights reserved. Removal of this copyright notice without permission is not permitted under law.

REV	CHANGE	BY	DSGN	APPV	DATE	REV	CHANGE	BY	DSGN	APPV	DATE
C						F					
B	ADDED 805	GW	JS	MDJ	10/2/2017	E					
A	EDITORIAL CHANGES	GW	JS	MDJ	10/2/2017	D					

<input checked="" type="checkbox"/>	Indicates Latest Revision	<input type="checkbox"/>	Completely Revised	<input type="checkbox"/>	New Page	<input checked="" type="checkbox"/>	Information Removed
-------------------------------------	---------------------------	--------------------------	--------------------	--------------------------	----------	-------------------------------------	---------------------

SHEET
2 OF 2

SDG&E ELECTRIC OVERHEAD CONSTRUCTION STANDARD

SAG SECTION
TABLE OF CONTENTS

801.2



FIELD MAINTENANCE ONLY

9/4/2018: All versions prior to 2018 are superseded by their current version found inside the Overhead Construction Standard Manual.

© 1998 - 2018 San Diego Gas & Electric Company. All rights reserved. Removal of this copyright notice without permission is not permitted under law.

REV	CHANGE	BY	DSGN	APPV	DATE	REV	CHANGE	BY	DSGN	APPV	DATE
C						F					
B						E					
A	ORIGINAL ISSUE	JS	JS	CZH	9/4/2018	D					

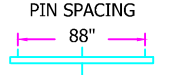
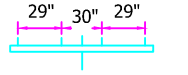
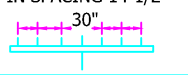
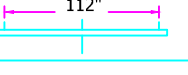
<p>SHEET 1 OF 1</p>	<p>X Indicates Latest Revision</p>	Completely Revised	New Page	Information Removed	<p>FMO OH815</p>
	<p>SDG&E ELECTRIC OVERHEAD CONSTRUCTION STANDARD</p>				
	<p>MAXIMUM SAFE SPAN LENGTHS IN FEET, PRIMARY AND SECONDARY CROSSARMS, LIGHT LOADING</p>				

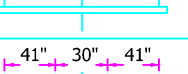
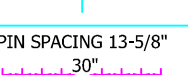
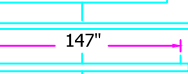
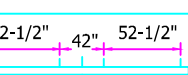
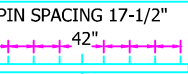
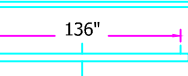
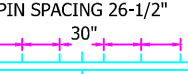
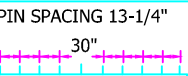
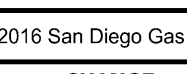
PRIMARY AND SECONDARY CROSSARMS, SINGLE AND DOUBLE MAXIMUM SAFE SPAN LENGTHS IN FEET, VERTICAL LOADING AS LIMITED BY SAG/PIN SPACING RATIOS 123 CROSSARM STRENGTH (123)		LIGHT LOADING																		
		WIRE TYPE	BARE STRANDED HARD DRAWN COPPER						COPPERWELD			D.B. WEATHERPROOF M.H.D. COPPER								
		WIRE SIZE	#6	#4	#2	#1	1/0	2/0	4/0	#6A	#4A	7/16 EHS 30%	#6	#4	#2	1/0	2/0	4/0		
		WT WIRE LBS/1000FT	82.5	127.6	202.9	258.4	326.8	410.9	653.3	101.6	161.5	408.4	103.0	153.5	246.0	388.0	482.9	745.0		
		K FACTOR	2.7	3.3	3.5	3.6	3.7	4.3	6.0	3.3	3.4	7.2	2.8	3.0	3.3	3.4	3.7	6.8		
SAG TABLE NO.	L-312	L-311	L-321	L-313	L-324	L-326	L-356	L-445	L-444	L-449	L-316	L-317	L-320	L-323	L-478	L-477				
6 PIN 8 FT PG 111 IT. 2		SINGLE ARM					(806)	(638)	(402)			(642)			(677)	(544)	(353)			
		DOUBLE ARM	680	790	850	890	940	(1276)	(804)	1040	1100	(1284)	540	620	680	720	780	(706)		
		SINGLE ARM						(475)	(301)			(477)					(405)	(262)		
		DOUBLE ARM	360	440	450	490	500	540	(596)	590	620	(954)	300	340	370	380	430	(524)		
		SINGLE ARM						(314)	(197)			(316)					(268)	(173)		
		DOUBLE ARM	250	290	300	310	330	350	(394)	420	430	(632)	220	230	250	270	280	(346)		
6 PIN 10 FT PG 112 IT. 1		SINGLE ARM					(1064)	(669)			(1070)						(587)			
		DOUBLE ARM	760	890	960	1010	1080	1160	(1338)	1160	1240	(2140)	610	700	770	820	880	(1174)		
		SINGLE ARM							(485)			(776)						(426)		
		DOUBLE ARM	400	490	510	540	570	610	590	650	680	1020	340	380	420	430	480	550		
		SINGLE ARM							(323)			(517)						(283)		
		DOUBLE ARM	280	330	340	360	370	400	400	460	470	720	230	260	280	290	320	370		
8 PIN 10 FT PG 111 IT. 3		SINGLE ARM					(1064)	(669)			(1070)						(587)			
		DOUBLE ARM	760	890	970	1010	1080	1160	(1338)	1160	1210	(2140)	610	700	770	820	880	(1174)		
		SINGLE ARM							(527)			(842)						(462)		
		DOUBLE ARM	370	440	460	490	520	560	550	600	620	950	310	350	380	400	440	500		
		SINGLE ARM							(262)			(419)						(230)		
		DOUBLE ARM	230	280	290	300	320	350	350	400	420	(838)	200	230	240	250	270	320		
8 PIN 13 FT PG 112 IT. 2		SINGLE ARM					(1103)	(875)	(694)	(436)					(735)	(591)	(383)			
		DOUBLE ARM	870	1030	1110		1170	1240	(1388)	(872)	1330	1420	(1396)	700	800	890	950	(1182)	(766)	
		SINGLE ARM							(538)	(338)								(459)	(297)	
		DOUBLE ARM	450	540	560	600	630	670	(676)	710	750	(1082)	370	420	460	490	530	(594)		
		SINGLE ARM							(338)	(268)	(168)							(284)	(228)	(148)
		DOUBLE ARM	280	330	340	360	370		(536)	(336)	460	470	290	330	260	280	290	320	(296)	
10 PIN 12 FT PG 111 IT. 4		SINGLE ARM					(991)	(789)	(496)			(793)					(835)	(672)	(435)	
		DOUBLE ARM	840	1000	1060	1130		1190	(1578)	(992)	1280	1370	(1586)	680	770	850	910	960	(870)	
		SINGLE ARM							(428)	(269)								(365)	(236)	
		DOUBLE ARM	350	410	430	460	480		510	(538)	560	590	(862)	290	330	350	380	400	(472)	
		SINGLE ARM							(256)	(161)								(218)	(141)	
		DOUBLE ARM	230	280	280	300	320		340	(322)	400	410	(514)	200	220	240	250	260	(282)	

© 1998 - 2016 San Diego Gas & Electric Company. All rights reserved. Removal of this copyright notice without permission is not permitted under law.

REV	CHANGE	BY	DSGN	APPV	DATE	REV	CHANGE	BY	DSGN	APPV	DATE
C						F					
B						E					
A	ORIGINAL ISSUE	PEI				D					

SHEET 1 OF 1	<input checked="" type="checkbox"/> Indicates Latest Revision	<input type="checkbox"/> Completely Revised	<input type="checkbox"/> New Page	<input type="checkbox"/> Information Removed
	SDG&E ELECTRIC STANDARDS			
	MAXIMUM SAFE SPAN LENGTHS IN FEET, PRIMARY AND SECONDARY CROSSARMS, LIGHT LOADING			

FIELD MAINTENANCE ONLY

9/4/2018: All versions prior to 2018 are superseded by their current version found inside the Overhead Construction Standard Manual.

© 1998 - 2018 San Diego Gas & Electric Company. All rights reserved. Removal of this copyright notice without permission is not permitted under law.

REV	CHANGE	BY	DSGN	APPV	DATE	REV	CHANGE	BY	DSGN	APPV	DATE
C						F					
B						E					
A	ORIGINAL ISSUE	JS	JS	CZH	9/4/2018	D					

<p>SHEET 1 OF 1</p>	<p>X Indicates Latest Revision</p>	<p>Completely Revised</p>	<p>New Page</p>	<p>Information Removed</p>	<p>FMO OH816</p>
	<p>SDG&E ELECTRIC OVERHEAD CONSTRUCTION STANDARD</p>				
	<p>MAXIMUM SAFE SPAN LENGTHS IN FEET, PRIMARY AND SECONDARY CROSSARMS, MEDIUM LOADING</p>				

PRIMARY AND SECONDARY CROSSARMS, SINGLE AND DOUBLE MAXIMUM SAFE SPAN LENGTHS IN FEET VERTICAL LOADING AS LIMITED BY SAG/PIN SPACING RATIOS 132 CROSSARM STRENGTH (123)	MEDIUM LOADING																
	WIRE TYPE	BARE STRANDED HARD DRAWN COPPER						COPPERWELD			D.B. WEATHER PROOF M.H.D. COPPER						
	WIRE SIZE	#6	#4	#2	#1	1/0	2/0	4/0	#6A	#4A	7/16 EHS 30%	#6	#4	#2	1/0	2/0	4/0
	WT WIRE LBS/1000FT	222.8	284.3	380.2	438.2	527.3	617.4	895.0	250.9	329.0	620.8	270.9	336.1	452.8	635.6	733.9	1035.8
	K FACTOR	2.5	2.7	3.0	3.3	3.4	3.4	4.1	2.6	2.9	-	2.4	2.6	2.9	3.2	4.0	4.1
	SAG TABLE NO.	L-331	L-333	L-337	L-335	L-341	L-343	L-363	L-435	L-443	L-452	L-332	L-334	L-339	L-342	L-345	L-382

6 PIN 8 FT PG 111 IT. 2		SINGLE ARM					(506)	(424)	(293)							(412)	(357)	(253)		
		DOUBLE ARM	340	430	550	600		650	610	(586)	580	680	-	310	380	460	500	(714)	(506)	
		SINGLE ARM						(316)	(218)									(266)	(188)	
		DOUBLE ARM	200	250	310	340	360		340	(436)	350	400	-	180	220	260	280		(376)	
		SINGLE ARM						(209)	(144)									(176)	(125)	
		DOUBLE ARM	140	170	220	230	250		230	(288)	260	300	-	130	150	180	190		(250)	
6 PIN 10 FT PG 112 IT. 1		SINGLE ARM						(488)									(595)	(422)		
		DOUBLE ARM	380	480	620	680	740	690	(976)	640	760	-	350	430	520	570	630	(844)		
		SINGLE ARM							(354)									(306)		
		DOUBLE ARM	220	270	340	370	400	370	430	380	440	-	200	240	280	310	340		390	
		SINGLE ARM							(236)									(204)		
		DOUBLE ARM	150	190	240	250	280	260	300	280	330	-	140	170	200	220	230		270	
8 PIN 10 FT PG 111 IT. 3		SINGLE ARM						(488)									(688)	(595)	(422)	
		DOUBLE ARM	380	480	620	680	740	690	(976)	640	760	-	350	430	520	570	630	(844)		
		SINGLE ARM							(384)									(332)		
		DOUBLE ARM	210	250	320	340	370	340	400	350	410	-	185	220	260	290	320		370	
		SINGLE ARM							(191)									(165)		
		DOUBLE ARM	130	170	210	220	240	220	260	250	300	-	120	150	170	190	200		230	
8 PIN 13 FT PG 112 IT. 2		SINGLE ARM					(550)	(462)	(318)		(865)					(448)	(388)	(275)		
		DOUBLE ARM	430	550	710	770		(825)	(924)	(636)	730	870	-	400	490	590	650	(776)	(550)	
		SINGLE ARM					(427)	(358)	(247)									(301)	(213)	
		DOUBLE ARM	250	300	380	410		440	420	(494)	410	480	-	220	270	310	350	380	(426)	
		SINGLE ARM					(212)	(178)	(123)									(173)	(150)	(106)
		DOUBLE ARM	150	190	240	250		280	260	(246)	280	330	-	140	170	200	220	(300)	(212)	
10 PIN 12 FT PG 111 IT. 4		SINGLE ARM					(625)	(525)	(362)							(510)	(441)	(313)		
		DOUBLE ARM	410	530	680	740		810	760	(724)	700	834	-	390	470	570	620	(882)	(626)	
		SINGLE ARM					(340)	(285)	(197)									(240)	(170)	
		DOUBLE ARM	210	240	300	320		350	320	(394)	340	390	-	170	210	250	270	290	(340)	
		SINGLE ARM					(203)	(170)	(117)									(165)	(143)	(101)
		DOUBLE ARM	130	170	210	220		230	220	(234)	240	290	-	120	150	170	190	200	(202)	

© 1998 - 2010 San Diego Gas & Electric Company. All rights reserved. Removal of this copyright notice without permission is not permitted under law.

	Indicates Latest Revision	Completely Revised	New Page	Information Removed
816	SDG&E ELECTRIC STANDARDS			REVISION
	MAXIMUM SAFE SPAN LENGTHS IN FEET, PRIMARY AND SECONDARY CROSSARMS, MEDIUM LOADING			DATE 1-1-91 APPD PJA/BJG

FIELD MAINTENANCE ONLY

9/4/2018: All versions prior to 2018 are superseded by their current version found inside the Overhead Construction Standard Manual.

© 1998 - 2018 San Diego Gas & Electric Company. All rights reserved. Removal of this copyright notice without permission is not permitted under law.

REV	CHANGE	BY	DSGN	APPV	DATE	REV	CHANGE	BY	DSGN	APPV	DATE
C						F					
B						E					
A	ORIGINAL ISSUE	JS	JS	CZH	9/4/2018	D					

SHEET 1 OF 1	X Indicates Latest Revision	Completely Revised	New Page	Information Removed	FMO OH817
	SDG&E ELECTRIC OVERHEAD CONSTRUCTION STANDARD				
	MAXIMUM SAFE SPAN LENGTHS IN FEET, 12KV CROSSARMS, LIGHT LOADING				

12KV CROSSARMS SINGLE AND DOUBLE MAXIMUM SAFE SPAN LENGTHS IN FEET VERTICAL LOADING

LIGHT LOADING

THIS PAGE FOR FIELD MAINTENANCE ONLY

AS LIMITED BY
SAG/PIN SPACING RATIOS 123
CROSSARM STRENGTH (123)

WIRE TYPE

COPPER

COPPERWELD

WIRE SIZE

#6

#4

#2

#1

1/0

2/0

4/0

250 KCM

#6A

#4A

7/16 EHS 30%

WT WIRE LBS/1000

82.5

127.6

202.9

258.4

325.8

410.9

653.3

771.9

101.6

161.5

408.4

K FACTOR

2.7

3.3

3.5

3.6

3.7

4.3

6.0

6.3

3.3

3.4

7.2

SAG CURVE NUMBER

L-312

L-311

L-321

L-313

L-324

L-326

L-356

L-436

L-445

L-444

L-449

Pin Type	Diagram	Arm Type	Wire Type	Copper								Copperweld				
				#6	#4	#2	#1	1/0	2/0	4/0	250 KCM	#6A	#4A	7/16 EHS 30%		
4 PIN RURAL FMO		4 1/2"X3 1/4" STD. LT. ARM	SINGLE	670	790	850	890	(777)	(616)	(388)	(328)	1030	1100	(620)		
			DOUBLE											950	(1232)	(776)
4 PIN 10 FT FMO		STD. LT. ARM	SINGLE	760	890	950	1010	1070	1150	1080	(672)	(568)	1150	1230	(1074)	
			DOUBLE								(1136)	(1017)			(2034)	1830
	STD. HVY. ARM	SINGLE	420	500	520	560	590	630	610	(502)	(425)	670	700	(807)		
		DOUBLE								(850)	(763)			900	970	
LIGHT		STD. LT. ARM	SINGLE	520	620	650	690	730	790	760	(586)	820	870	(1074)		
			DOUBLE								1150			1290		
STD. HVY. ARM	SINGLE	490	590	610	650	680	740	710	(614)	(386)	(327)	770	810	(617)		
	DOUBLE								(654)	(617)	(1234)			1210		
12 FT 6 PIN FMO		STD. LT. ARM	SINGLE	830	980	1060	1120	1190	1270	(990)	(785)	(494)	(418)	1270	1360	(790)
			DOUBLE							(988)	(836)	(1486)	2020			
STD. HVY. ARM	SINGLE	580	690	730	770	820	880	840	(929)	(786)	(1572)	900	960	(1440)		
	DOUBLE								(1190)	(1572)	(1572)			1440		
LIGHT		STD. LT. ARM	SINGLE	580	690	730	770	820	880	840	(785)	(494)	(418)	900	960	(790)
			DOUBLE								(836)	(786)	(1572)			1440
STD. HVY. ARM	SINGLE	330	400	410	440	450	490	490	(401)	(252)	(213)	543	560	(403)		
	DOUBLE								(426)	(407)	(814)			840		
6 PIN 15 FT FMO		STD. HVY. ARM	SINGLE	930	1110	1190	1260	1340	1420	(1074)	(676)	(572)	1420	1520	(1081)	
			DOUBLE							1420	(1352)	(1144)			(2162)	
HEAVY		STD. HVY. ARM Spcl. Drilling	SINGLE	580	680	730	770	800	870	(554)	(469)	890	950	(886)		
			DOUBLE							(1108)	(938)			(1772)		
HEAVY		STD. HVY. ARM	SINGLE	660	770	830	870	920	990	(676)	(572)	1010	1070	(1081)		
			DOUBLE							921	(1144)			1590		
HEAVY		STD. HVY. ARM Spcl. Drilling	SINGLE	390	470	490	530	550	580	(364)	(308)	630	660	(583)		
			DOUBLE							(728)	(616)			(1166)		
HEAVY		STD. HVY. ARM	SINGLE	330	390	410	440	450	480	(325)	(259)	540	560	(490)		
			DOUBLE							490	(518)			(980)		

© 1998 - 2010 San Diego Gas & Electric Company. All rights reserved. Removal of this copyright notice without permission is not permitted under law.

Indicates Latest Revision | Completely Revised | New Page | Information Removed

REVISION

SDG&E ELECTRIC STANDARDS

DATE 1-1-91

MAXIMUM SAFE SPAN LENGTHS IN FEET,
12KV CROSSARMS, LIGHT LOADING

817

APPD PA/ROJ

FIELD MAINTENANCE ONLY

9/4/2018: All versions prior to 2018 are superseded by their current version found inside the Overhead Construction Standard Manual.

© 1998 - 2018 San Diego Gas & Electric Company. All rights reserved. Removal of this copyright notice without permission is not permitted under law.

REV	CHANGE	BY	DSGN	APPV	DATE	REV	CHANGE	BY	DSGN	APPV	DATE
C						F					
B						E					
A	ORIGINAL ISSUE	JS	JS	CZH	9/4/2018	D					

SHEET 1 OF 1	X Indicates Latest Revision	Completely Revised	New Page	Information Removed	FMO OH818
	SDG&E ELECTRIC OVERHEAD CONSTRUCTION STANDARD				
	MAXIMUM SAFE SPAN LENGTHS IN FEET, 12KV CROSSARMS, MEDIUM LOADING				

12KV CROSSARMS SINGLE AND DOUBLE MAXIMUM SAFE SPAN LENGTHS IN FEET VERTICAL LOADING

MEDIUM LOADING

THIS PAGE FOR FIELD MAINTENANCE ONLY

AS LIMITED BY

SAG/PIN SPACING RATIOS 123
CROSSARM STRENGTH (123)

WIRE TYPE

COPPER

COPPERWELD

WIRE SIZE

#6

#4

#2

#1

1/0

2/0

4/0

250 KCM

#6A

#4A

7/16 EHS 30%

WT WIRE LBS/1000FT

222.8

284.3

380.2

438.2

518.0

617.4

895.0

1028.2

250.9

329.4

620.8

K FACTOR

2.5

2.7

3.0

3.3

3.4

3.4

4.1

2.6

2.9

SAG CURVE NUMBER

L-331

L-333

L-337

L-335

L-341

L-344

L-363

L-435

L-443

4 PIN RURAL FMO	88"	4 1/2"X3 1/4" STD. LT. ARM	SINGLE		340	430	550	(578)	(489)	(410)	(283)	(246)	580	680	(408)
			DOUBLE	DOUBLE				600	650	(820)	(566)	(492)			(816)
4 PIN 10 FT FMO	HEAVY 5 3/4"X 5 3/4"	110"	STD. LT. ARM	SINGLE	380	480	610	670	730	790	780	(711)	(490)	(427)	(707)
			DOUBLE	(854)								(763)	(1414)		
	STD. HVY. ARM	SINGLE	230	280	350	380	420	460	440	(367)	(319)	390	450	-	-
		DOUBLE								(573)	-			-	
LIGHT 5 3/4"X 3 3/4"	18" 37"	STD. LT. ARM	SINGLE	280	340	430	470	510	560	550	(490)	(427)	460	540	-
		DOUBLE	-								(763)	-			
6 PIN 12 FT FMO	HEAVY 5 3/4"X 5 3/4"	134"	STD. LT. ARM	SINGLE	410	530	680	740	810	880	(623)	(522)	(360)	(314)	(519)
			DOUBLE	(720)							(628)	(1038)			
	STD. HVY. ARM	SINGLE	270	320	410	440	480	530	520	(408)	(282)	(245)	440	510	-
		DOUBLE								(490)	(463)	-			
LIGHT 5 3/4"X 3 3/4"	67" 67"	STD. LT. ARM	SINGLE	310	370	480	522	560	620	610	(522)	(360)	(314)	510	590
		DOUBLE	(628)								(591)	-			
STD. HVY. ARM	SINGLE	190	330	290	310	330	370	370	360	-	(318)	(267)	(184)	(160)	(265)
	DOUBLE										(360)	(320)	-		
6 PIN 15 FT FMO	HEAVY 5 3/4"X 5 3/4"	168"	STD. HVY. ARM	SINGLE	450	590	750	820	900	970	(852)	(715)	(493)	(429)	-
			DOUBLE	(900)							(610)	(859)	770	920	-
	STD. HVY. ARM Spcl. Drilling	SINGLE	305	370	480	520	560	620	610	(586)	(404)	(352)	510	590	(583)
		DOUBLE								(704)	-	-			
STD. HVY. ARM	SINGLE	340	420	540	590	640	690	690	(493)	(429)	-	560	660	-	
	DOUBLE								-	-	-				
STD. HVY. ARM Spcl. Drilling	SINGLE	220	260	340	360	390	430	390	(385)	(266)	(231)	370	430	-	
	DOUBLE								(430)	(532)	(462)			-	
STD. HVY. ARM	SINGLE	190	220	290	300	330	370	370	(324)	(223)	(194)	320	370	(322)	
	DOUBLE								(370)	(446)	(388)			-	

© 1998 - 2010 San Diego Gas & Electric Company. All rights reserved. Removal of this copyright notice without permission is not permitted under law.

Indicates Latest Revision | Completely Revised | New Page | Information Removed

818

SDG&E ELECTRIC STANDARDS

MAXIMUM SAFE SPAN LENGTHS IN FEET,
12KV CROSSARMS, MEDIUM LOADING

REVISION

DATE 1-1-91
APPD PA/BJ

FIELD MAINTENANCE ONLY

9/4/2018: All versions prior to 2018 are superseded by their current version found inside the Overhead Construction Standard Manual.

© 1998 - 2018 San Diego Gas & Electric Company. All rights reserved. Removal of this copyright notice without permission is not permitted under law.

REV	CHANGE	BY	DSGN	APPV	DATE	REV	CHANGE	BY	DSGN	APPV	DATE
C						F					
B						E					
A	ORIGINAL ISSUE	JS	JS	CZH	9/4/2018	D					

SHEET 1 OF 1	X Indicates Latest Revision	Completely Revised	New Page	Information Removed	FMO OH819
	SDG&E ELECTRIC OVERHEAD CONSTRUCTION STANDARD				
	HORIZONTAL CONDUCTOR SPACING GENERAL INFORMATION				

SCOPE: THIS STANDARD DESCRIBES HOW TO DETERMINE HORIZONTAL CONDUCTOR SPACING FOR ALUMINUM AND COPPER CONDUCTORS.

THE FOLLOWING PROCEDURES ARE REQUIRED TO DETERMINE HORIZONTAL CONDUCTOR SPACING:

- STEP 1: DETERMINE THE CONDUCTOR SIZE AND TYPE TO BE INSTALLED (SEE SECTION 700).
- STEP 2: DETERMINE THE RULING SPAN, LOADING DISTRICT AND DESIGN TENSION.
- STEP 3: USING APPROVED SOFTWARE, ACQUIRE THE RULING SPAN SAG AT 212° F.
- STEP 4: DETERMINE SAG IN LONGEST SPAN.

$$\text{LONG SPAN SAG} = (\text{RULING SPAN SAG}) * \left(\frac{\text{LONGEST SPAN}}{\text{RULING SPAN}} \right)^2$$

STEP 5: DETERMINE THE REQUIRED HORIZONTAL SPACING USING THE FOLLOWING FORMULA:

$$\text{PIN SPACING} = 3.6 + 8 * \sqrt{\text{LONG SPAN SAG}}$$

STEP 6: SELECT THE CROSSARM FROM STANDARD SECTION 300 WHICH WILL PROVIDE EQUAL OR GREATER CONDUCTOR SPACING THAN DETERMINED IN STEP 5.

NOTE: PROVIDE MINIMUM PIN SPACING AS CALCULATED ON WORK ORDER.

STEP 7: DETERMINE IF THE CROSSARM SELECTED IS STRONG ENOUGH TO SUPPORT THE CONDUCTORS (SEE STANDARD SECTION 300).

EXAMPLE: (SEE FIGURE 1)

PROBLEM: DETERMINE THE REQUIRED HORIZONTAL CONDUCTOR SPACING AT A POLE (D) WITH THE LONGEST ADJACENT SPAN (400').

ASSUMPTIONS: LIGHT LOADING DISTRICT
 WIRE TO BE STRUNG = 4 CONDUCTORS, #336.4 ACSR (LINNET) @ 3,000 LB
 DESIGN TENSION SPAN LENGTHS ARE 300', 250', 350', AND 400'

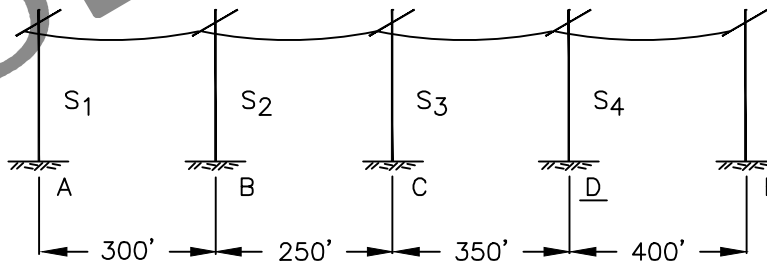

FIGURE 1

DRAFT

© 1998 - 2010 San Diego Gas & Electric Company. All rights reserved. Removal of this copyright notice without permission is not permitted under law.

	<input checked="" type="checkbox"/> Indicates Latest Revision	<input type="checkbox"/> Completely Revised	<input type="checkbox"/> New Page	<input type="checkbox"/> Information Removed
REVISION	SDG&E ELECTRIC STANDARDS			
DATE 6-10-10 APPD WT / MC	HORIZONTAL CONDUCTOR SPACING GENERAL INFORMATION			819.1

SOLUTION: 1)

CALCULATE THE RULING SPAN USING THE FORMULA

$$RS = \sqrt{\frac{S_1^3 + S_2^3 + S_3^3 + S_4^3 + \dots + S_N^3}{S_1 + S_2 + S_3 + S_4 + \dots + S_N}}$$

$$\text{WHERE } RS = \sqrt{\frac{300^3 + 250^3 + 350^3 + 400^3}{300 + 250 + 350 + 400}} = 339$$

USE THE 300' RULING SPAN "FINAL SAG" TABLE.

USING THE SAG AND TENSION STANDARD ACQUIRE THE RULING SPAN SAG ON THE LINE AT 167° F.

RULING SPAN SAG = 5.41

2) DETERMINE SAG IN THE LONGEST SPAN USING THE FORMULA

$$\text{LONGSPANSAG} = \text{RULINGSPANSAG} * \left(\frac{\text{LONGESTSPAN}}{\text{RULINGSPAN}} \right)^2$$

$$\text{Feet} = 5.41 * \left(\frac{400}{339} \right)^2 = 7.53'$$

3) DETERMINE THE REQUIRED HORIZONTAL SPACING USING THE FOLLOWING FORMULA:

$$\text{PINSPACING} = 3.6 + 8 * \sqrt{\text{LONGSPANSAG}}$$

$$\text{PIN SPACING} = 3.6 + 8 * \sqrt{7.53}$$

$$\text{PIN SPACING} = 25.6''$$

OBSOLETE

© 1998 - 2010 San Diego Gas & Electric Company. All rights reserved. Removal of this copyright notice without permission is not permitted under law.

	<input type="checkbox"/> Indicates Latest Revision	<input type="checkbox"/> Completely Revised	<input checked="" type="checkbox"/> New Page	<input type="checkbox"/> Information Removed
819.2	SDG&E ELECTRIC STANDARDS			REVISION
	HORIZONTAL CONDUCTOR SPACING GENERAL INFORMATION			DATE 12-17-09 APPD WT / MC

FIELD MAINTENANCE ONLY

9/4/2018: All versions prior to 2018 are superseded by their current version found inside the Overhead Construction Standard Manual.

© 1998 - 2018 San Diego Gas & Electric Company. All rights reserved. Removal of this copyright notice without permission is not permitted under law.

REV	CHANGE	BY	DSGN	APPV	DATE	REV	CHANGE	BY	DSGN	APPV	DATE
C						F					
B						E					
A	ORIGINAL ISSUE	JS	JS	CZH	9/4/2018	D					

<p>SHEET 1 OF 1</p>	<p>X Indicates Latest Revision</p>	<p>Completely Revised</p>	<p>New Page</p>	<p>Information Removed</p>	<p>FMO OH820</p>
	<p>SDG&E ELECTRIC OVERHEAD CONSTRUCTION STANDARD</p>				
	<p>SLACK SPAN CONSTRUCTION SINGLE/DOUBLE CROSSARMS</p>				

SCOPE: THIS STANDARD DESCRIBES THE METHOD IN DETERMINING MAXIMUM SPAN UP TO 120 FEET, NUMBER OF CROSSARMS AND CLASS OF POLE IN "SLACK SPAN" CONSTRUCTION, ALLOWED IN LIGHT LOADING DISTRICTS ONLY.

- STEP 1: DETERMINE THE FOLLOWING DESIGN CONSTRAINTS:
 A. DETERMINE WHICH CONDUCTOR IS TO BE USED

COPPER	TABLE	ALUMINUM	TABLE
#6 BARE STRANDED	1	#2 ACSR 6/1	5
#4 BARE STRANDED	2	#3/0 ACSR 6/1	6
#2 BARE STRANDED	3		
#1/0 BARE STRANDED	4		

- B. DETERMINE NUMBER OF CONDUCTORS TO BE INSTALLED IN THE STUDY SPAN.
 C. DETERMINE MINIMUM GROUND CLEARANCE REQUIRED FOR VOLTAGE – PER G.O. 95, RULE 37.
 D. DETERMINE LOADING ZONE.

STEP 2: OBTAIN A PROFILE OF THE STUDY SPAN AND DRAW A LINE PARALLEL TO THE GROUND LINE AT THE MINIMUM CLEARANCE ELEVATION (SEE DRAWING ON PAGE 820.2).

STEP 3: DETERMINE AVAILABILITY OF POLES AND SELECT A TRIAL POLE HEIGHT AND A TRIAL SPAN LENGTH BETWEEN 50 FEET AND MAXIMUM 120 FEET.

STEP 4: PLOT SELECTED POLE HEIGHT ON PROFILE OF STUDY SPAN AND LOCATE THE CONDUCTOR ATTACHMENT POINTS. DRAW A STRAIGHT LINE BETWEEN THE ATTACHMENT POINTS ON THE TWO POLES AND MEASURE THE MINIMUM VERTICAL DISTANCE TO THE NEAREST HALF-FOOT BETWEEN THE MINIMUM CLEARANCE LINE FROM STEP 2 AND THE CONDUCTOR ATTACHMENT LINE. THIS DISTANCE IS THE MAXIMUM ALLOWABLE SAG FOR THE SPAN.

STEP 5: ON THE SINGLE CONDUCTOR MAXIMUM TENSION TABLE FOR THE SELECTED CONDUCTOR AND LOADING CONDITION FROM STEP 1, READ ACROSS FROM THE SPAN LENGTH, AS SELECTED IN STEP 3, TO THE COLUMN FROM MAXIMUM SAG AS CALCULATED IN STEP 4. THE VALUE SHOWN IS THE MAXIMUM SINGLE CONDUCTOR TENSION THAT WILL OCCUR IN THE STUDY SPAN.

NOTE: • IF MAXIMUM TENSION EXCEEDS 300 LBS. PER CONDUCTOR (NON-BOLD TENSIONS ON TABLES), OR, MAXIMUM TENSION EXCEEDS THE LONGITUDINAL LOADING PER PIN POSITION ON A SINGLE CROSSARM, DOUBLE CROSSARMS WITH DOUBLE STEEL PINS AND INSULATORS WILL BE USED. GRADES A AND B CONSTRUCTION DO NOT REQUIRE DOUBLE CROSSARMS, (G.O. 95 49.2C2, 49.3C2). TO CALCULATE SINGLE CROSSARM LOADING (REFER TO STD. 383.2), DIVIDE THE LONGITUDINAL LOADING FOR DOUBLE CROSSARMS BY 2 AND AGAIN BY 1.3 (G.O. 95 APP. F-8).

• INSURE THAT MINIMUM HORIZONTAL CONDUCTOR SPACING IS ACHIEVED, PER OH STD. 819.

STEP 6: MULTIPLY THE MAXIMUM SINGLE CONDUCTOR TENSION AS DETERMINED IN STEP 5 BY THE NUMBER OF CONDUCTORS TO BE INSTALLED IN THE STUDY SPAN. THIS VALUE BECOMES THE MAXIMUM TENSION ON POLE FOR THE STUDY SPAN.

STEP 7: ON TABLE 7 (MAXIMUM ALLOWABLE TENSION ON POLES) READ DOWN THE COLUMN UNDER THE SELECTED POLE HEIGHT (FROM STEP 3) UNTIL A TENSION VALUE GREATER THAN OR EQUAL TO THE MAXIMUM TENSION VALUE DETERMINED IN STEP 6 IS ENCOUNTERED. THEN, READ TO THE LEFT TO DETERMINE THE CLASS OF POLE REQUIRED FOR THE HEIGHT SELECTED.

STEP 8: IF LOADS OR TENSIONS EXCEED THE CAPACITIES OF THE POLES OR ARE BEYOND THE LIMITS OF THE TABLES, RETURN TO STEP 3, ADJUST SPAN LENGTH OR POLE HEIGHT AND RECALCULATE TO DETERMINE POLE CLASS.

© 1998 - 2010 San Diego Gas & Electric Company. All rights reserved. Removal of this copyright notice without permission is not permitted under law.

<input checked="" type="checkbox"/>	Indicates Latest Revision	<input type="checkbox"/>	Completely Revised	<input type="checkbox"/>	New Page	<input checked="" type="checkbox"/>	Information Removed
REVISION	SDG&E ELECTRIC STANDARDS						
DATE 12-17-09	SLACK SPAN CONSTRUCTION						820.1
APPD BV / MC	SINGLE/DOUBLE CROSSARMS						

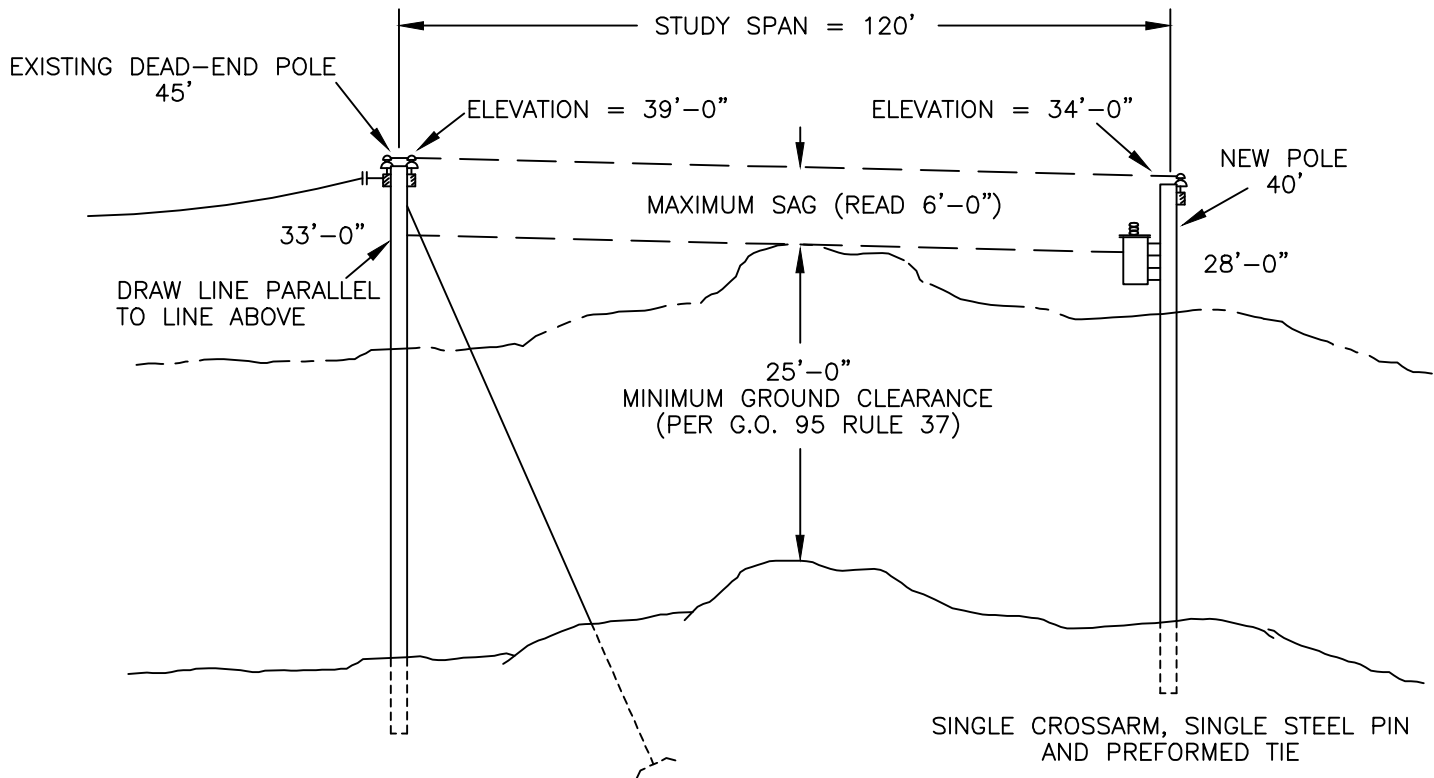

EXAMPLE:

PROBLEM: DETERMINE CLASS AND HEIGHT OF POLE WHICH WILL SUPPORT MAXIMUM ALLOWABLE "SLACK SPAN".

- ASSUME:**
- LIGHT LOADING DISTRICT
 - WIRE TO BE STRUNG = 3 CONDUCTORS, #2 ACSR
 - VOLTAGE = 12KV
 - NEW POLE HEIGHT = 40 FT
 - STUDY SPAN = 120 FT. (SEE DRAWING)

- SOLUTION:**
- 1) ASSURE THAT MINIMUM GROUND CLEARANCE IS MET (PER G.O. 95, RULE 37, TABLE 1).
 - 2) DETERMINE MAXIMUM ALLOWABLE SAG FROM DRAWING (READ = 6' - 0"), THEN SELECT ACTUAL SAG TO BE USED, LESS THAN OR EQUAL TO MAXIMUM ALLOWABLE SAG (E.G. 3' - 0").
 - 3) SEE TABLE 5 FOR #2 ACSR, LIGHT LOADING, FIND 120 FT SPAN AND READ ACROSS TO 3' - 0" SAG COLUMN. READ MAXIMUM TENSION IS 184 LBS.
 - 4) TOTAL TENSION IS 184 X 3 CONDUCTORS = 552 LBS.
 - 5) SEE TABLE 7, FIND 40' POLE HEIGHT AND READ DOWN. FIND TENSION 752 LBS, WHICH IS GREATER THAN 552 LBS. READING TO THE LEFT SHOWS A CLASS 3 POLE.

CONCLUSION: A 40 FT., CLASS 3 POLE, A SINGLE CROSSARM, SINGLE STEEL PIN AND PREFORMED OR PREFABRICATED TIE MEET THE REQUIREMENTS FOR A "SLACK SPAN" OF 120 FT. WITH A SAG OF 3' - 0" FOR 3 CONDUCTORS, #2 ACSR.

© 1998 - 2010 San Diego Gas & Electric Company. All rights reserved. Removal of this copyright notice without permission is not permitted under law.

	Indicates Latest Revision	Completely Revised	New Page	Information Removed
820.2	SDG&E ELECTRIC STANDARDS			REVISION
	SLACK SPAN CONSTRUCTION SINGLE/DOUBLE CROSSARMS			DATE 6-17-09 APPD PJA / MC

TABLE 1

#6 COPPER - 3 STRAND
 SINGLE CONDUCTOR MAXIMUM TENSION TABLE
 LIGHT LOADING CONDITIONS---25° INITIAL WITH NO ICE (A)G
 NOTE: FOR BOLD TENSIONS USE SINGLE CROSSARM CONSTRUCTION.

SPAN (FEET)	SAG AT 130° F -- FINAL									
	1' - 0"	1' - 6"	2' - 0"	2' - 6"	3' - 0"	3' - 6"	4' - 0"	4' - 6"	5' - 0"	5' - 6"
60	188	88	56	-	-	-	-	-	-	-
70	252	130	81	59	50	-	-	-	-	-
80	310	182	113	80	63	52	-	-	-	-
90	354	233	149	107	82	68	58	51	-	-
100	398	281	193	137	106	86	73	63	56	51
110	434	327	236	171	132	107	90	78	69	62
120	473	367	277	208	161	130	109	94	83	74

TABLE 2

#4 COPPER - 3 STRAND
 SINGLE CONDUCTOR MAXIMUM TENSION TABLE
 LIGHT LOADING CONDITIONS---25° INITIAL WITH NO ICE (B)G
 NOTE: FOR BOLD TENSIONS USE SINGLE CROSSARM CONSTRUCTION.

SPAN (FEET)	SAG AT 130° F -- FINAL									
	1' - 0"	1' - 6"	2' - 0"	2' - 6"	3' - 0"	3' - 6"	4' - 0"	4' - 6"	5' - 0"	5' - 6"
60	273	111	71	53	-	-	-	-	-	-
70	376	175	103	75	60	50	-	-	-	-
80	464	251	147	103	81	67	57	50	-	-
90	534	333	201	137	105	86	74	64	57	52
100	598	412	263	179	135	109	93	80	71	64
110	659	482	330	228	171	137	114	99	87	78
120	719	546	397	283	212	168	140	120	105	94

OBSOLETE

© 1998 - 2010 San Diego Gas & Electric Company. All rights reserved. Removal of this copyright notice without permission is not permitted under law.

	<input type="checkbox"/> Indicates Latest Revision	<input type="checkbox"/> Completely Revised	<input type="checkbox"/> New Page	<input checked="" type="checkbox"/> Information Removed
REVISION	SDG&E ELECTRIC STANDARDS			
DATE 6-17-09 APPD PJA/MC	SLACK SPAN CONSTRUCTION SINGLE/DOUBLE CROSSARMS			820.3

TABLE 3

#2 COPPER – 3 STRAND
 SINGLE CONDUCTOR MAXIMUM TENSION TABLE
 LIGHT LOADING CONDITIONS---25° INITIAL WITH NO ICE (CG)
 NOTE: FOR BOLD TENSIONS USE SINGLE CROSSARM CONSTRUCTION.

SPAN (FEET)	SAG AT 130° F --- FINAL									
	1' – 0"	1' – 6"	2' – 0"	2' – 6"	3' – 0"	3' – 6"	4' – 0"	4' – 6"	5' – 0"	5' – 6"
60	400	152	–	–	–	–	–	–	–	–
70	575	243	138	100	–	–	–	–	–	–
80	717	362	196	137	107	–	–	–	–	–
90	830	489	276	184	140	115	100	–	–	–
100	932	622	370	244	181	146	123	107	–	–
110	1029	731	472	316	231	182	152	131	116	104
120	–	829	581	399	287	226	186	159	140	125

TABLE 4

1/0 COPPER – 7 STRAND
 SINGLE CONDUCTOR MAXIMUM TENSION TABLE
 LIGHT LOADING CONDITIONS---25° INITIAL WITH NO ICE (DG)
 NOTE: FOR BOLD TENSIONS USE SINGLE CROSSARM CONSTRUCTION.

SPAN (FEET)	SAG AT 130° F --- FINAL									
	1' – 6"	2' – 0"	2' – 6"	3' – 0"	3' – 6"	4' – 0"	4' – 6"	5' – 0"	5' – 6"	6' – 0"
60	198	121	–	–	–	–	–	–	–	–
70	323	179	128	101	–	–	–	–	–	–
80	530	260	177	137	113	100	–	–	–	–
90	746	378	240	181	147	125	109	100	–	–
100	956	528	321	235	188	158	136	121	109	100
110	1152	699	428	301	236	196	166	148	133	120
120	–	879	556	385	293	241	205	180	160	145

OBSOLETE

© 1998 - 2010 San Diego Gas & Electric Company. All rights reserved. Removal of this copyright notice without permission is not permitted under law.

	<input type="checkbox"/> Indicates Latest Revision	<input type="checkbox"/> Completely Revised	<input type="checkbox"/> New Page	<input checked="" type="checkbox"/> Information Removed
820.4	SDG&E ELECTRIC STANDARDS			REVISION
	SLACK SPAN CONSTRUCTION SINGLE/DOUBLE CROSSARMS			DATE 6-17-09 APPD PJA / MC

TABLE 5

#2 ACSR/AW 6/1 - SPARROW
 SINGLE CONDUCTOR MAXIMUM TENSION TABLE
 LIGHT LOADING CONDITIONS---25° INITIAL WITH NO ICE (F)
 NOTE: FOR BOLD TENSIONS USE SINGLE CROSSARM CONSTRUCTION.

SPAN (FEET)	SAG AT 130° F -- FINAL									
	0' - 6"	1' - 0"	1' - 6"	2' - 0"	2' - 6"	3' - 0"	3' - 6"	4' - 0"	4' - 6"	5' - 0"
60	580	226	-	-	-	-	-	-	-	-
70	665	348	144	-	-	-	-	-	-	-
80	756	449	221	123	-	-	-	-	-	-
90	850	537	306	173	117	-	-	-	-	-
100	-	618	397	232	155	116	-	-	-	-
110	-	695	475	300	199	147	117	-	-	-
120	-	771	546	377	251	184	145	120	103	-

TABLE 6

3/0 ACSR/AW 6/1 - PIGEON
 SINGLE CONDUCTOR MAXIMUM TENSION TABLE
 LIGHT LOADING CONDITIONS---25° INITIAL WITH NO ICE (DG)
 NOTE: FOR BOLD TENSIONS USE SINGLE CROSSARM CONSTRUCTION.

SPAN (FEET)	SAG AT 130° F -- FINAL									
	1' - 0"	1' - 6"	2' - 0"	2' - 6"	3' - 0"	3' - 6"	4' - 0"	4' - 6"	5' - 0"	5' - 6"
60	493	169	107	-	-	-	-	-	-	-
70	825	271	157	114	-	-	-	-	-	-
80	1091	452	223	156	122	101	-	-	-	-
90	-	675	326	209	160	131	112	100	-	-
100	-	923	461	283	207	167	141	122	109	100
110	-	1130	632	376	267	209	175	151	133	119
120	-	-	837	494	339	261	213	183	161	144

OBSOLETE

© 1998 - 2010 San Diego Gas & Electric Company. All rights reserved. Removal of this copyright notice without permission is not permitted under law.

	<input type="checkbox"/> Indicates Latest Revision	<input type="checkbox"/> Completely Revised	<input type="checkbox"/> New Page	<input checked="" type="checkbox"/> Information Removed
REVISION	SDG&E ELECTRIC STANDARDS			820.5
DATE 6-17-09	SLACK SPAN CONSTRUCTION			
APPD <i>PA</i> / MC	SINGLE/DOUBLE CROSSARMS			

TABLE 7

MAXIMUM ALLOWABLE TENSION ON POLES (LBS)							
POLE CLASS	WOOD POLE HEIGHT						
	35'	40'	45'	50'	55'	60'	65'
5	455	472	453	453	440	425	425
3	751	752	714	703	703	700	688
1	1142	1123	1111	1103	1081	1070	1063

NOTE: ALL TENSION CALCULATIONS INCLUDE A SAFETY FACTOR OF 4.0 AND A 500 LB TRANSFORMER INSTALLED ON THE STUDY POLE.

INSTALLATION:

- (A) DO NOT USE A CONDUCTOR TENSION LESS THAN 50 LBS OR GREATER THAN 480 LBS.
- (B) DO NOT USE A CONDUCTOR TENSION LESS THAN 50 LBS OR GREATER THAN 750 LBS.
- (C) DO NOT USE A CONDUCTOR TENSION LESS THAN 100 LBS OR GREATER THAN 1100 LBS.
- (D) DO NOT USE A CONDUCTOR TENSION LESS THAN 100 LBS OR GREATER THAN 1150 LBS.
- (F) DO NOT USE A CONDUCTOR TENSION LESS THAN 100 LBS OR GREATER THAN 850 LBS.
- (G) USE TENSIONS IN BOLD AREA OF TABLES FOR SINGLE CROSSARM DEADEND CONSTRUCTION.

OBSOLETE

© 1998 - 2010 San Diego Gas & Electric Company. All rights reserved. Removal of this copyright notice without permission is not permitted under law.

	<input checked="" type="checkbox"/> Indicates Latest Revision	<input type="checkbox"/> Completely Revised	<input type="checkbox"/> New Page	<input type="checkbox"/> Information Removed
820.6	SDG&E ELECTRIC STANDARDS			REVISION
	SLACK SPAN CONSTRUCTION SINGLE/DOUBLE CROSSARMS			DATE 12-17-09 APPD BV / MC

900 - GUYING

900 - GUYING

<u>PAGE</u>	<u>SUBJECT</u>
962	ALUMOWELD GUY SPLICES
965	COPPER & COPPERWELD GUY GRIPS
967-968	POWER INSTALLED SCREW ANCHORS

© 1998 - 2018 San Diego Gas & Electric Company. All rights reserved. Removal of this copyright notice without permission is not permitted under law.

REV	CHANGE	BY	DSGN	APPV	DATE	REV	CHANGE	BY	DSGN	APPV	DATE
C						F					
B	ADDED 967-968	JK	JS	MDJ	5/1/2018	E					
A	ORIGINAL ISSUE	JS	IL	MDJ	7/13/2016	D					

SHEET 1 OF 1	 Indicates Latest Revision	Completely Revised	New Page	Information Removed	FMO OH 901
	SDG&E ELECTRIC OVERHEAD CONSTRUCTION STANDARD				
	GUYING FMO TABLE OF CONTENTS				

FIELD MAINTENANCE ONLY

REVISION HISTORY:

7/13/2016: All versions prior to 2016 are superseded by their current version found inside the Overhead Construction Standard Manual.

© 1998 - 2016 San Diego Gas & Electric Company. All rights reserved. Removal of this copyright notice without permission is not permitted under law.

REV	CHANGE	BY	DSGN	APPV	DATE	REV	CHANGE	BY	DSGN	APPV	DATE
C						F					
B						E					
A	ORIGINAL ISSUE	JS	IL	MDJ	7/13/2016	D					

<p>SHEET 1 OF 1</p>	 Indicates Latest Revision	Completely Revised	New Page	Information Removed	<p>FMO OH 962</p>
	SDG&E ELECTRIC OVERHEAD STANDARD				
	GUY HARDWARE				

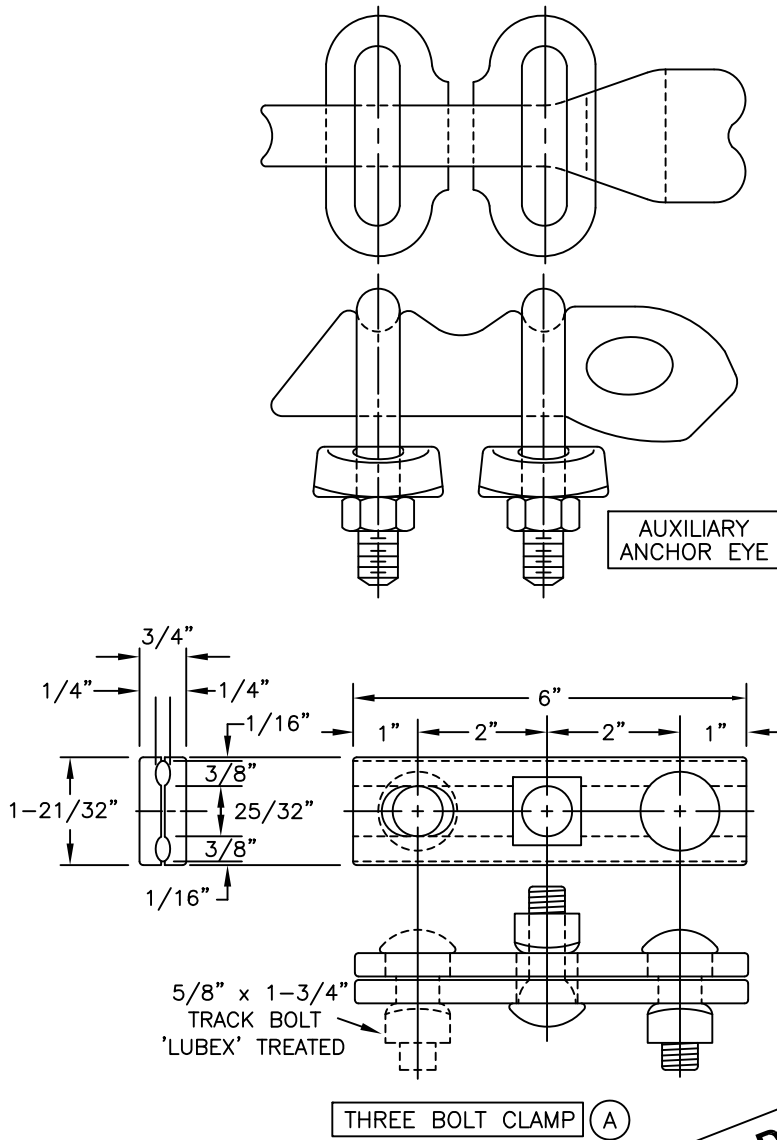

FOR FIELD MAINTENANCE ONLY

INSTALLATION:

- (A) NO LONGER PURCHASED. USE FACTORY GUY GRIP WHEN PRACTICAL. SALVAGE THREE BOLT CLAMP AND USE ONLY WHEN A GUY GRIP CANNOT BE USED.

DESCRIPTION	MOUNTING BOLT SIZE	STOCK NUMBER	ASSEMBLY UNITS
CLAMP, THREE BOLT	-	227296	-
EYE, AUX ANCHOR	-	337536	AUXEYE
THIMBLE, 1/2", OPEN	-	736600	OPTHMB

© 1998 - 2010 San Diego Gas & Electric Company. All rights reserved. Removal of this copyright notice without permission is not permitted under law.

	Indicates Latest Revision	Completely Revised	New Page	Information Removed
962	SDG&E ELECTRIC STANDARDS			REVISION
	GUY HARDWARE			DATE 1-1-96 APPD <i>PLA 1/2/96</i>





FIELD MAINTENANCE ONLY

REVISION HISTORY:

7/13/2016: All versions prior to 2016 are superseded by their current version found inside the Overhead Construction Standard Manual.

© 1998 - 2016 San Diego Gas & Electric Company. All rights reserved. Removal of this copyright notice without permission is not permitted under law.

REV	CHANGE	BY	DSGN	APPV	DATE	REV	CHANGE	BY	DSGN	APPV	DATE
C						F					
B						E					
A	ORIGINAL ISSUE	JS	IL	MDJ	7/13/2016	D					

<p>SHEET 1 OF 1</p>	 Indicates Latest Revision	 Completely Revised	 New Page	 Information Removed	<p>FMO OH 965</p>
	<p>SDG&E ELECTRIC OVERHEAD STANDARD</p>				
	<p>COPPER & COPPERWELD GUY GRIPS</p>				

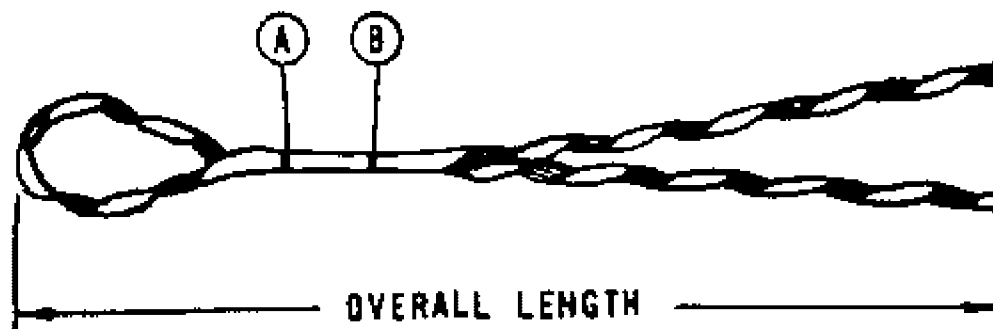

COPPERWELD (M SERIES)

4M	3 WIRE	.209"	WHITE	CDE-8106	18	—	—	(E) 393056
6M	7 WIRE	.237"	YELLOW	CDE-3103	21	—	—	(E) 393088
10M	7 WIRE	.303"	RED	CDE-3109	25	—	—	(E) 392992
18M	7 WIRE	.386"	WHITE	CDE-3115	31	—	—	(E) 393024

COPPERWELD - COPPER & COPPERWELD

#8C	1CW/2CU	.179"	RED	CDE-8102	17	—	—	(E) 393120
#6A	1CW/2CU	.230"	YELLOW	CDE-3103	21	—	—	(E) 393088
#6C	1CW/2CU	.225"	YELLOW	CDE-3103	21	—	—	(E) 393088
#4A	1CW/2CU	.290"	RED	CDE-3109	25	—	—	(E) 392992
#2F	1CW/6CU	.308"	RED	CDE-3109	25	—	—	(E) 392992
—	—	—	—	—	—	—	—	—

FOR FIELD MAINTENANCE ONLY

INSTALLATION:

- (A) COLORED MARK INDICATES CROSSOVER POINT FOR SMALL INSULATORS OR THIMBLEYES.
- (B) COLORED MARK INDICATES CROSSOVER POINT FOR LARGE INSULATORS.
- (E) EXEMPT MATERIAL

DATE 9-17-82
APPD *ADJ*

SDG&E ELECTRIC STANDARDS

COPPER & COPPERWELD GUY GRIPS

999.602
SUPERSEDES
965 (9-17-82)

FIELD MAINTENANCE ONLY

REVISION HISTORY

5/1/2018: All versions prior to 2018 are superseded by their current version found inside the Overhead Construction Standard Manual

© 1998 - 2018 San Diego Gas & Electric Company. All rights reserved. Removal of this copyright notice without permission is not permitted under law.

REV	CHANGE	BY	DSGN	APPV	DATE	REV	CHANGE	BY	DSGN	APPV	DATE
C						F					
B						E					
A	ORIGINAL ISSUE	JK	JS	MDJ	5/1/2018	D					

<p>SHEET 1 OF 1</p>	<p>X Indicates Latest Revision</p>	<p>Completely Revised</p>	<p>New Page</p>	<p>Information Removed</p>	<p>FMO OH 967-968</p>
	<p>SDG&E ELECTRIC OVERHEAD CONSTRUCTION STANDARD</p>				
	<p>POWER INSTALLED SCREW ANCHORS</p>				

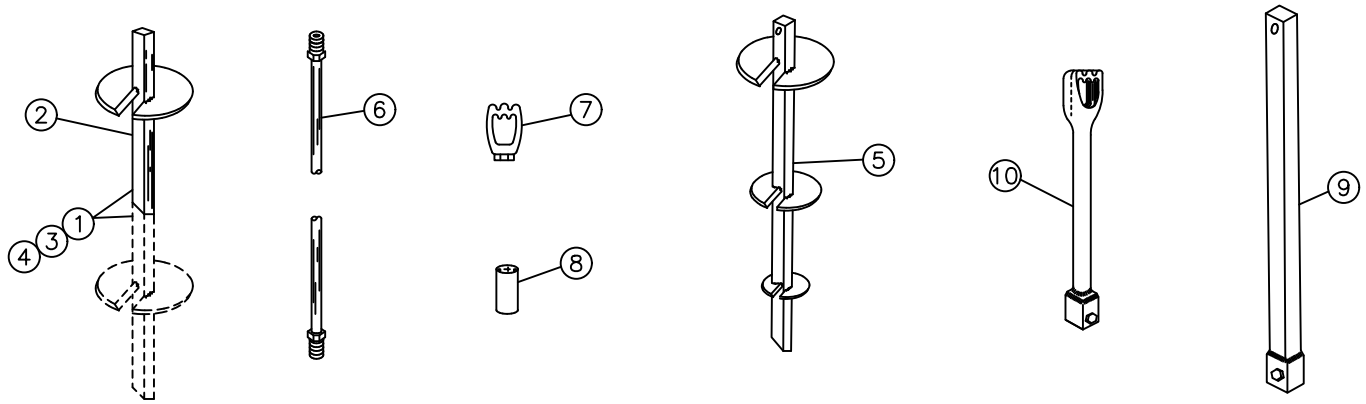

POWER INSTALLED SCREW ANCHORS (PISA)

ITEM	DESCRIPTION	TYPE OF SOIL	HOLDING POWER RANGE Ⓒ Ⓓ	MANUFACTURER	CATALOG NUMBER	STOCK NUMBER	ASSEMBLY UNITS
1	TWO 4 INCH HELIXES Ⓒ	EXTREMELY HARD GROUND ONLY, DECOMPOSED GRANITE, CALECHI (AREAS NOW UTILIZING BACKHOE)	12,500 - 18,000 LBS	A. B. CHANCE	V102-1428	108262	SA2-4
2	ONE 8 INCH HELIX	SAND, FILL, LOOSE SOIL WET CLAYS, SILT	1,000 - 3,500 LBS	A. B. CHANCE	E102-1223	108248	SA1-8
		MEDIUM FIRM, COMPACT GRAVEL, CLAYPAN, ROCK AND GRAVEL AND ALL MEDIUM SOILS.	5,000 - 10,000 LBS				
		HARD GROUND, DENSE CLAY, LAMINATED ROCK, SLATE, SCHIST, SANDSTONE, ROCK AND GRAVEL COMBINATION, ALL ROCK AND HARD GROUND SOILS	11,000 - 18,000 LBS Ⓓ				
		EXTREMELY HARD GROUND, DECOMPOSED GRANITE, CALECHI, ETC. (IF CAN BE INSTALLED)	18,000 LBS Ⓓ				
3	TWO 8 INCH HELIXES	SAND, FILL, LOOSE SOIL, WET CLAYS, SILT	4,000 - 7,500 LBS	A. B. CHANCE	E102-1219	108250	SA2-8
		MEDIUM FIRM, COMPACT GRAVEL, CLAYPAN, ROCK AND GRAVEL AND ALL MEDIUM SOILS	10,000 - 15,000 LBS				
		HARD GROUND, DENSE CLAY, LAMINATED ROCK, SLATE, SCHIST, SANDSTONE ROCK AND CLAY COMBINATION AND ALL ROCK AND HARD GROUND SOILS. (IF CAN BE INSTALLED)	18,000 LBS Ⓓ				
4	TWO 10 INCH HELIXES	SAND, FILL, LOOSE SOIL, WET CLAY, SILT MEDIUM FIRM (IF CAN BE INSTALLED)	7,500 - 12,500 LBS 18,000 LBS Ⓓ	A. B. CHANCE	E102-0823	108272	SA2-10
5	Ⓕ TRIPLE 10 INCH 10" X 11 5/6" X 13 1/2"	SAND, MEDIUM TO SOFT SOIL	6000 - 35,000 LBS.	A. B. CHANCE	012642 EJM	108296	SA3-10

POWER INSTALLED SCREW ANCHOR RODS AND ACCESSORIES

ITEM	DESCRIPTION	MANUFACTURER	CATALOG NUMBER	STOCK NUMBER	ASSEMBLY UNITS
6	1" BY 3-1/2' ROD EXTENSION	A. B. CHANCE	12338 P	601776	EXT3-
	1" BY 7' ROD EXTENSION	A. B. CHANCE	12334 P	601792	EXT7-
7	1" TRIPLEYE EYE NUT	A. B. CHANCE	12585	504016	-
		DIXIE ELEC	D-6567		
		JOSLYN	J-6375		
		KORTICK	K3127		
8	1" ROD COUPLING	A. B. CHANCE	12247 P	279272	RODCPL
9	1-1/2" X 5' ROD EXTENSION WITH COUPLING	A. B. CHANCE	12656	639284	SA5EXT
10	TRIPLEYE STUD WITH SQ. COUPLING	A. B. CHANCE	C 1020025	701550	SA3EYE

INSTALLATION:

- A. PISA ANCHORS ARE NOT TO BE INSTALLED IN CORROSIVE AREAS AS DEFINED ON STD 929. SEE STD. 969 FOR HOLDING POWERS OF PROTECTED CROSSPLATE ANCHORS.
- Ⓒ UNDER NO CIRCUMSTANCES SHOULD THIS ANCHOR BE USED IN ANY SOILS OTHER THAN EXTREMELY HARD GROUND AS NOTED.
- Ⓓ HOLDING POWER RANGES ARE GIVEN AS A GUIDE FOR SELECTING THE REQUIRED ANCHOR. THESE VALUES ARE ESTIMATES. FOR ACTUAL DETERMINATION OF HOLDING POWER, SEE STANDARD 968.
- Ⓕ MAXIMUM RATING OF 1" ANCHOR ROD IS 18,000 LBS.
- Ⓖ THIS ANCHOR REQUIRES A 1-1/2" ROD, M&S 639284.
- Ⓖ A FACTOR OF SAFETY OF TWO HAS BEEN USED.

© 1998 - 2010 San Diego Gas & Electric Company. All rights reserved. Removal of this copyright notice without permission is not permitted under law.

	Indicates Latest Revision	Completely Revised	New Page	Information Removed
REVISION	SDG&E ELECTRIC STANDARDS			
DATE 1-1-94 APPD PIA 1/09	POWER INSTALLED SCREW ANCHORS			967

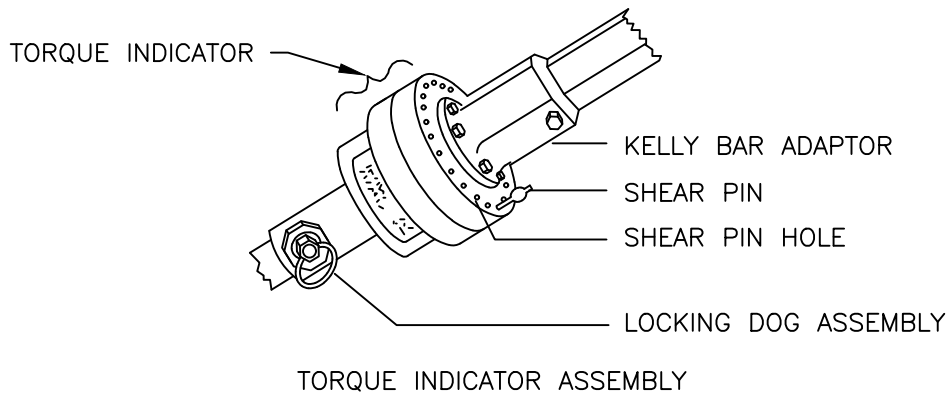

ANCHOR HOLDING POWER (POUNDS)^(F)

NUMBER OF SHEAR PINS	TWO 4 INCH HELIXES 7000 FT-LBS MAX TORQUE	ONE 8 INCH HELIX 7000 FT-LBS MAX TORQUE	TWO 8 INCH HELIXES 7000 FT-LBS MAX TORQUE	TWO 10 INCH HELIXES 5000 FT-LBS MAX TORQUE	TRIPLE HELIX 10"-11 5/16"-13 1/2" 6500 FT-LBS MAX TORQUE
1	(C)	(C)	(C)	(C)	(C)
2	(C)	(C)	(C)	(C)	(C)
3	(C)	(C)	8,500	9,500	7,000
4	(C)	7,000	9,500	10,500	10,000
5	(C)	8,500	10,500	11,500	12,500
6	(C)	9,000	12,000	13,000	15,000
7	(C)	10,500	14,000	15,000	17,500
8	(C)	13,500	15,000	17,000	18,000
9	(C)	15,000	17,000	18,000 (D)	20,500
10	18,000 (D)	16,500	18,000 (D)	18,000 (D)	24,000
11	18,000 (D)	17,500	18,000 (D)	(G)	27,000
12	18,000 (D)	18,000 (D)	18,000 (D)	(G)	30,500
13	18,000 (D)	18,000 (D)	18,000 (D)	(G)	34,500
14	18,000 (D)	18,000 (D)	18,000 (D)	(G)	(G)

NOTES:

- A. USE ONLY SHEAR PINS (STOCK NUMBER 532152) IN TORQUE INDICATOR. EACH SHEAR PIN CAN WITHSTAND 500 FT.LBS. OF TORQUE.
- B. LOAD TORQUE INDICATOR WITH MAXIMUM NUMBER OF SHEAR PINS WHILE DRIVING ANCHOR (THAT IS 14 PINS FOR A 7,000 FT-LB ANCHOR. 13 PINS FOR A 6,500 FT-LB ANCHOR, OR 10 PINS FOR A 5,000 FT-LB ANCHOR). WHEN INDICATOR IS APPROXIMATELY TWO FEET ABOVE GROUND, LEAVE REQUIRED NUMBER OF PINS IN TORQUE INDICATOR AND CONTINUE TO DRIVE ANCHOR. IF PINS SHEAR, THEN YOU HAVE THE HOLDING POWER INDICATED BY THE ABOVE TABLE. IF PINS DO NOT SHEAR, ADD AN EXTENSION, REPLACE THE SHEAR PINS JUST REMOVED, AND CONTINUE DRIVING. DISCARD ANY USED PINS THAT WERE NOT SHEARED DURING INSTALLATION.

- (C) ANCHOR IS NOT CONSIDERED A GOOD INSTALLATION.
- (D) LIMITED BY 1" ROD WHICH HAS A MAXIMUM RATING OF 18,000 LBS.
- (F) A FACTOR OF SAFETY OF TWO HAS BEEN USED ON ALL HOLDING POWER VALUES. MAXIMUM TORQUE VALUES ARE RATINGS FROM MANUFACTURER.
- (G) THIS ANCHOR IS NOT TO BE INSTALLED WITH THIS MANY SHEAR PINS.

© 1998 - 2010 San Diego Gas & Electric Company. All rights reserved. Removal of this copyright notice without permission is not permitted under law.

	Indicates Latest Revision	Completely Revised	New Page	Information Removed
968.1	SDG&E ELECTRIC STANDARDS			REVISION
	INSTALLATION INSTRUCTIONS FOR POWER INSTALLED SCREW ANCHORS			DATE 6-1-79 APPD <i>PA/ROJ</i>

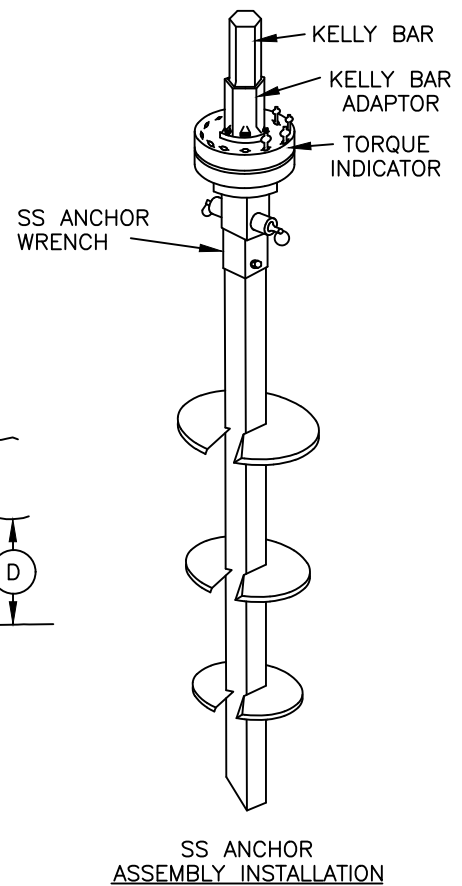
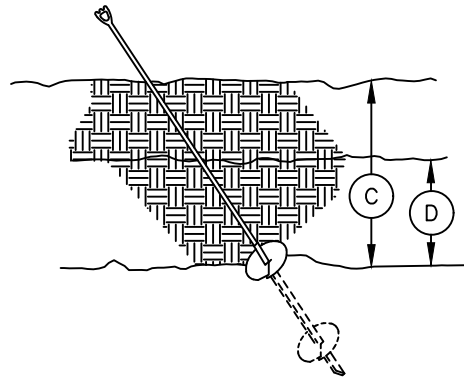
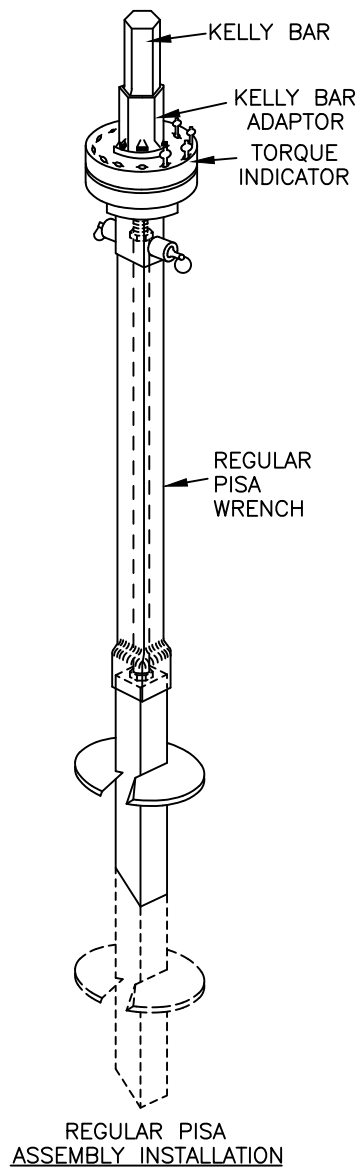

NOTE:

- A. SINGLE AND DOUBLE HELIX ANCHORS ARE INSTALLED WITH A WRENCH. INSTALLATION TORQUE IS TRANSMITTED DIRECTLY TO THE ANCHOR HUB. NO TORQUE IS TRANSFERRED BY THE ROD. NO MORE THAN 14 FEET OF WRENCH IS TO BE USED DUE TO THE EXCESSIVE FORCE REQUIRED TO REMOVE A WRENCH LONGER THAN 14 FEET. THE TRIPLE HELIX ANCHOR REQUIRES A SHORT WRENCH WHICH DOES NOT ENTER THE GROUND. ANCHOR EXTENSIONS MAY BE ADDED UNTIL THE DESIRED TORQUE IS REACHED. THE TRIPLE HELIX ANCHOR ROD WILL WRAP AS IT IS BEING INSTALLED. THIS IS NORMAL FOR THIS ANCHOR. THE ROD MAY WRAP 1 TO 1 1/2 TIMES FOR EVERY FIVE FEET OF LENGTH.
- B. IN EXTREMELY HARD GROUND, TRY TO INSTALL ONE 8 INCH HELIX-TYPE ANCHOR FIRST. IF THE ONE 8 INCH HELIX-TYPE ANCHOR CANNOT BE INSTALLED. TRY A TWO 4 INCH HELIX-TYPE ANCHOR.
- C. THE UPPER HELIX OF A POWER INSTALLED, SCREW ANCHOR MUST BE BELOW GROUND AT LEAST 5 FEET.
- D. THE UPPER HELIX MUST BE COVERED BY AT LEAST TWO FEET OF GOOD ANCHORING SOIL. SOIL WHICH HAS BEEN DISTURBED BY A PREVIOUS ANCHOR INSTALLATION ATTEMPT IS NOT GOOD ANCHORING SOIL.

© 1998 - 2005 San Diego Gas & Electric Company. All rights reserved. Removal of this copyright notice without permission is not permitted under law.

	Indicates Latest Revision	Completely Revised	New Page	Information Removed
REVISION	SDG&E ELECTRIC STANDARDS			
DATE 5-12-78	INSTALLATION INSTRUCTIONS FOR POWER INSTALLED			968.2
APPD <i>PJA/BJG</i>	SCREW ANCHORS			

1000 - GROUNDING,
BONDING

1000 - GROUNDING,
BONDING

PAGE(S)

SUBJECT

No FMO content available at this time.

© 1998 - 2020 San Diego Gas & Electric Company. All rights reserved. Removal of this copyright notice without permission is not permitted under law.

REV	CHANGE	BY	DSGN	APPV	DATE	REV	CHANGE	BY	DSGN	APPV	DATE
C						F					
B						E					
A						D					

SHEET 1 OF 1	Indicates Latest Revision	Completely Revised	<input checked="" type="checkbox"/>	New Page	Information Removed	FMO OH1001.1
	SDG&E ELECTRIC OVERHEAD FIELD MAINTENANCE ONLY STANDARDS					
	GROUNDING & BONDING TABLE OF CONTENTS					

1100 - TRANSFORMER
BOOSTER

1100 - TRANSFORMER
BOOSTER

<u>PAGES</u>	<u>SUBJECT</u>
1121	TRANSFORMER PREFIXES, POLE-MOUNTED, SINGLE PHASE
1128	2.4 OR 4KV SINGLE PHASE TYPE "W" TRANSFORMER INSTALLATION 100 KVA MAXIMUM, ARMLESS TANGENT CONST
1129	2.4 OR 4KV, SINGLE PHASE TYPE "W" TRANSFORMER INSTALLATION 100KVA MAXIMUM, ARMLESS DEAD END CONST
1131	2.4 OR 4KV, SINGLE PHASE, TYPE "WE" TRANSFORMER INSALLATION, 25 KVA MAX, SECONDARY RACK CONSTRUCTION
1132	2.4 OR 4KV, SINGLE PHASE, TYPE "WE" TRANSFORMER INSTALLATION, 25 KVA MAX, SECONDARY LINE ARM CONSTRUCTION
1133	2.4 OR 4KV, SINGLE PHASE TYPE "W" TRANSFORMER INSTALLATION 100 KVA MAXIMUM, C.O. ARM, SECONDARY RACK CONSTRUCTION
1135	2.4 OR 4KV, SINGLE PHASE TYPE "W" TRANSFORMER INSTALLATION, 100 KVA MAXIMUM LINE ARM MOUNTED C.O., SECONDARY RACK CONSTRUCTION
1136	2.4 OR 4KV, SINGLE PHASE TYPE "W" TRANSFORMER INSTALLATION, 100 KVA MAXIMUM LINE ARM MOUNTED C.O., SECONDARY LINE ARM CONSTRUCTION
1138	2.4KV OR 4KV, SINGLE PHASE PARALLELED TRANSFORMER INSTALLATION
1141	7.2 OR 12KV SINGLE PHASE YE, YJ, HE, OR HJ TRANSFORMER INSTALLATION 100 KVA MAXIMUM ARMLESS TANGENT CONSTRUCTION
1142	7.2 OR 12KV SINGLE PHASE YE, YJ, HE, OR HJ TRANSFORMER INSTALLATION 100 KVA MAXIMUM ARMLESS DEAD END CONSTRUCTION
1145	7.2 OR 12KV SINGLE PHASE YE, YJ, HE OR HJ TRANSFORMER INSTALLATION, SECONDARY RACK CONSTRUCTION
1147	12KV, SINGLE PHASE TYPE "H" TRANSFORMER INSTALLATION, C.O. ARM, SECONDARY RACK CONSTRUCTION
1149	12KV SINGLE PHASE TYPE "H" TRANSFORMER INSTALLTION 100KVA MAX, LINE ARM MOUNTED CO'S, SECONDARY RACK CONSTRUCTION
1150	12KV SINGLE PHASE TYPE "H" TRANSFORMER INSTALLATION, 100 KVA MAX, LINE ARM MOUNTED CO'S, SECONDARY LINE ARM CONSTRUCTION
1154	4KV OPEN WYE OR 2.4KV OPEN DELTA TYPE "W" TRANSFORMER INSTALLATION 2-50KVA MAX., ARMLESS TANGENT CONSTRUCTION

© 1998 - 2016 San Diego Gas & Electric Company. All rights reserved. Removal of this copyright notice without permission is not permitted under law.

REV	CHANGE	BY	DSGN	APPV	DATE	REV	CHANGE	BY	DSGN	APPV	DATE
C						F					
B	ADDED 1121	PS	JS	MDJ	1/25/2017	E					
A	ORIGINAL ISSUE	JS	IL	MDJ	7/13/2016	D					

SHEET 1 OF 2	<input checked="" type="checkbox"/> Indicates Latest Revision	<input type="checkbox"/> Completely Revised	<input type="checkbox"/> New Page	<input type="checkbox"/> Information Removed	FMO OH 1101
	SDG&E OVERHEAD STANDARD				
	TRANSFORMER, BOOSTER FMO TABLE OF CONTENTS				

- 1156 4KV OPEN WYE TYPE "W" TRANSFORMER INSTALLATION, SECONDARY LINE ARM CONSTRUCTION
- 1161 12KV OPEN DELTA TYPE "HE" OR "HJ" TRANSFORMER INSTALLATION, 2-50KVA MAX., ARMLESS TANGENT CONSTRUCTION
- 1162 12KV OPEN DELTA TYPE "HE" OR "HJ" TRANSFORMER INSTALLATION 2-50KVA MAX., ARMLESS DEAD END CONSTRUCTION
- 1167 12KV, OPEN DELTA TYPE "HE" OR "HJ" TRANSFORMER INSTALLATION, 2-50 KVA MAX., SECONDARY ARM CONSTRUCTION
- 1172 4KV, THREE PHASE, TYPE "WE" OR "WJ" TRANSFORMER INSTALLATION, 3-25 KVA MAX SECONDARY LINE ARM CONSTRUCTION
- 1174 7.2 AND 12KV THREE-PHASE TRANSFORMER CLUSTER MOUNT INSTALLATION-ALLEY ARM CONSTRUCTION
- 1181 12KV, THREE PHASE, TYPE "H" OR "HF" TRANSFORMER INSTALLATION, THREE 75 KVA MAXIMUM, SECONDARY LINE ARM CONSTRUCTION
- 1184 12KV, THREE PHASE, TYPE "HE" OR "HJ" TRANSFORMER INSTALLATION, THREE 75 KVA MAXIMUM, SECONDARY LINE ARM CONSTRUCTION

© 1998 - 2016 San Diego Gas & Electric Company. All rights reserved. Removal of this copyright notice without permission is not permitted under law.

REV	CHANGE	BY	DSGN	APPV	DATE	REV	CHANGE	BY	DSGN	APPV	DATE
C						F					
B	ADDED 1121	PS	JS	MDJ	1/25/2017	E					
A	ORIGINAL ISSUE	JS	IL	MDJ	7/13/2016	D					

SHEET 2 OF 2	 Indicates Latest Revision	Completely Revised	New Page	Information Removed	FMO OH 1101
	SDG&E OVERHEAD STANDARD				
	TRANSFORMER, BOOSTER FMO TABLE OF CONTENTS				

FIELD MAINTENANCE ONLY

REVISION HISTORY:

1/25/2017: All versions prior to 2016 are superseded by their current version found inside the Overhead Construction Standard Manual.

© 1998 - 2016 San Diego Gas & Electric Company. All rights reserved. Removal of this copyright notice without permission is not permitted under law.

REV	CHANGE	BY	DSGN	APPV	DATE	REV	CHANGE	BY	DSGN	APPV	DATE
C						F					
B						E					
A	ORIGINAL ISSUE	PS	JS	MDJ	1/25/2017	D					

SHEET 1 OF 1	 Indicates Latest Revision	Completely Revised	New Page	Information Removed	FMO OH 1121
	SDG&E ELECTRIC OVERHEAD CONSTRUCTION STANDARD				
	TRANSFORMER PREFIXES, POLE-MOUNTED SINGLE PHASE				

NOTES:

TRANSFORMERS LISTED IN THIS STANDARD ARE FOR EITHER NEW INSTALLATIONS OR FIELD REPLACEMENTS FOR EXISTING UNITS. TRANSFORMERS LISTED IN STANDARDS BEGINNING WITH 1199.201 ARE CLASSIFIED INTO TWO CATEGORIES:

- 1) THOSE THAT ARE FIELD REPLACEMENT FOR EXISTING UNITS (NOT TO BE USED FOR NEW INSTALLATIONS) AND,
- 2) THOSE THAT ARE NO LONGER PURCHASED (INDICATED BY A FOOTNOTE).

TRANSFORMER PREFIXES, POLEMOUNTED, SINGLE PHASE:

PREFIX	VOLTAGE		DESCRIPTION AND APPLICATION	KVA	ⒹⒻ TAPS	STOCK NUMBER	ASSEMBLY UNITS
	PRIMARY	SECONDARY					
X	480	120/240	1∅ SECONDARY	1.5	–	S757712 Ⓒ	X1.5
W	2400/4160Y	120/240	1∅ SECONDARY Ⓚ 3∅ SECONDARY Ⓚ	10	–	S754880	W10
				15	–	S755008	W15
				50	–	S755472	W50
				75	–	S755584	W75
WJ	2400/4160Y	120/240	INTERNALLY FUSED, SECONDARY BREAKER, & LIGHTNING ARRESTERS 1∅ SECONDARY	10	–	S756832	WJ10
				15	–	S756864	WJ15
WF	2400/4160Y	240/480	1∅ SECONDARY Ⓚ 3∅ SECONDARY Ⓚ	10	Ⓑ	S755872	WF10T
				15	Ⓑ	S756000	WF15T
				75	Ⓑ	S756352	WF75T
Y	7200/12470Y	120/240	1∅ SECONDARY Ⓚ 3∅ SECONDARY Ⓚ	10	–	S757946	Y10
				15	–	S757952	Y15
				75	–	S757970	Y75

© 1998 - 2016 San Diego Gas & Electric Company. All rights reserved. Removal of this copyright notice without permission is not permitted under law.

REV	CHANGE	BY	DSGN	APPV	DATE	REV	CHANGE	BY	DSGN	APPV	DATE
C						F					
B						E					
A	INFORMATION MOVED TO FMO	PS				D					

SHEET 1 OF 2	<input checked="" type="checkbox"/> Indicates Latest Revision	<input type="checkbox"/> Completely Revised	<input type="checkbox"/> New Page	<input type="checkbox"/> Information Removed	FMO 1121.1
	SDG&E ELECTRIC OVERHEAD CONSTRUCTION STANDARDS				
	TRANSFORMER PREFIXES, POLE-MOUNTED SINGLE PHASE				

TRANSFORMER PREFIXES, POLEMOUNTED, SINGLE-PHASE: (CONT'D)

PREFIX	VOLTAGE		DESCRIPTION AND APPLICATION	KVA	ⒹⒻ TAPS	STOCK NUMBER	ASSEMBLY UNITS
	PRIMARY	SECONDARY					
YJ	7200/12470Y	120/240	INTERNALLY FUSED, SECONDARY BREAKER & LIGHTNING ARRESTERS 1Ø SECONDARY	10	-	757994	YJ10
				15	-	757998	YJ15
				75	-	758010	YJ75
YF	7200/12470Y	240/480	1Ø SECONDARY 3Ø SECONDARY Ⓚ	10	-	757929Ⓞ	YF10
				15	-	757927Ⓞ	YF15
				25	-	757930	YF25
				50	-	757928	YF50
H	12000	120/240	1Ø SECONDARY 3Ø SECONDARY Ⓚ	10	-	750464	H10
				15	-	750624	H15
				25	-	750816	H25
				50	-	751104	H50
				75	-	751232	H75
				100	-	750528	H100
				167	-	750688	H167
HE	12000	120/240	INTERNALLY FUSED, SECONDARY BREAKER 1Ø SECONDARY	10	-	751904	HE10
				10	Ⓑ	751920Ⓞ	HE10T
				15	-	752032	HE15
				25	-	752096	HE25
				50	-	752352	HE50
HJ	12000	120/240	INTERNALLY FUSED, SECONDARY BREAKER & LIGHTNING ARRESTERS 1Ø SECONDARY	10	-	753280	HJ10
				10	Ⓑ	753296Ⓞ	HJ10T
				15	-	753344	HJ15
				25	-	753440	HJ25
HF	12000	240/480	SINGLE PHASE TRANSFORMER 1Ø SECONDARY 3Ø SECONDARY Ⓚ	100	-	753320	HJ100
				15	-	752688	HF15T
				15	-	752704	HF15
				25	-	752752	HF25
				50	-	752896	HF50
				100	-	752656	HF100
167	-	752720	HF167				

© 1998 - 2016 San Diego Gas & Electric Company. All rights reserved. Removal of this copyright notice without permission is not permitted under law.

REV	CHANGE	BY	DSGN	APPV	DATE	REV	CHANGE	BY	DSGN	APPV	DATE
C						F					
B						E					
A	INFORMATION MOVED TO FMO	PS				D					

SHEET 2 OF 2	<input checked="" type="checkbox"/> Indicates Latest Revision	<input type="checkbox"/> Completely Revised	<input type="checkbox"/> New Page	<input type="checkbox"/> Information Removed	FMO 1121.2
	SDG&E ELECTRIC OVERHEAD CONSTRUCTION STANDARDS				
	TRANSFORMER PREFIXES, POLE-MOUNTED SINGLE PHASE				

FIELD MAINTENANCE ONLY

REVISION HISTORY:

7/13/2016: All versions prior to 2016 are superseded by their current version found inside the Overhead Construction Standard Manual.

© 1998 - 2016 San Diego Gas & Electric Company. All rights reserved. Removal of this copyright notice without permission is not permitted under law.

REV	CHANGE	BY	DSGN	APPV	DATE	REV	CHANGE	BY	DSGN	APPV	DATE
C						F					
B						E					
A	ORIGINAL ISSUE	JS	IL	MDJ	7/13/2016	D					

	Indicates Latest Revision	Completely Revised	New Page	Information Removed
-------------------------------------------------------------------------------------	---------------------------	--------------------	----------	---------------------

**SHEET
1 OF 1**

SDG&E ELECTRIC OVERHEAD STANDARD

2.4 OR 4KV SINGLE PHASE TYPE "W" TRANSFORMER INSTALLATION
100 KVA MAXIMUM, ARMLESS TANGENT CONST

**FMO
OH 1128**

SCOPE: THIS STANDARD SHOWS THE INSTALLATION METHOD OF A TYPE 'W' TRANSFORMER, ON ARMLESS TANGENT CONSTRUCTION.

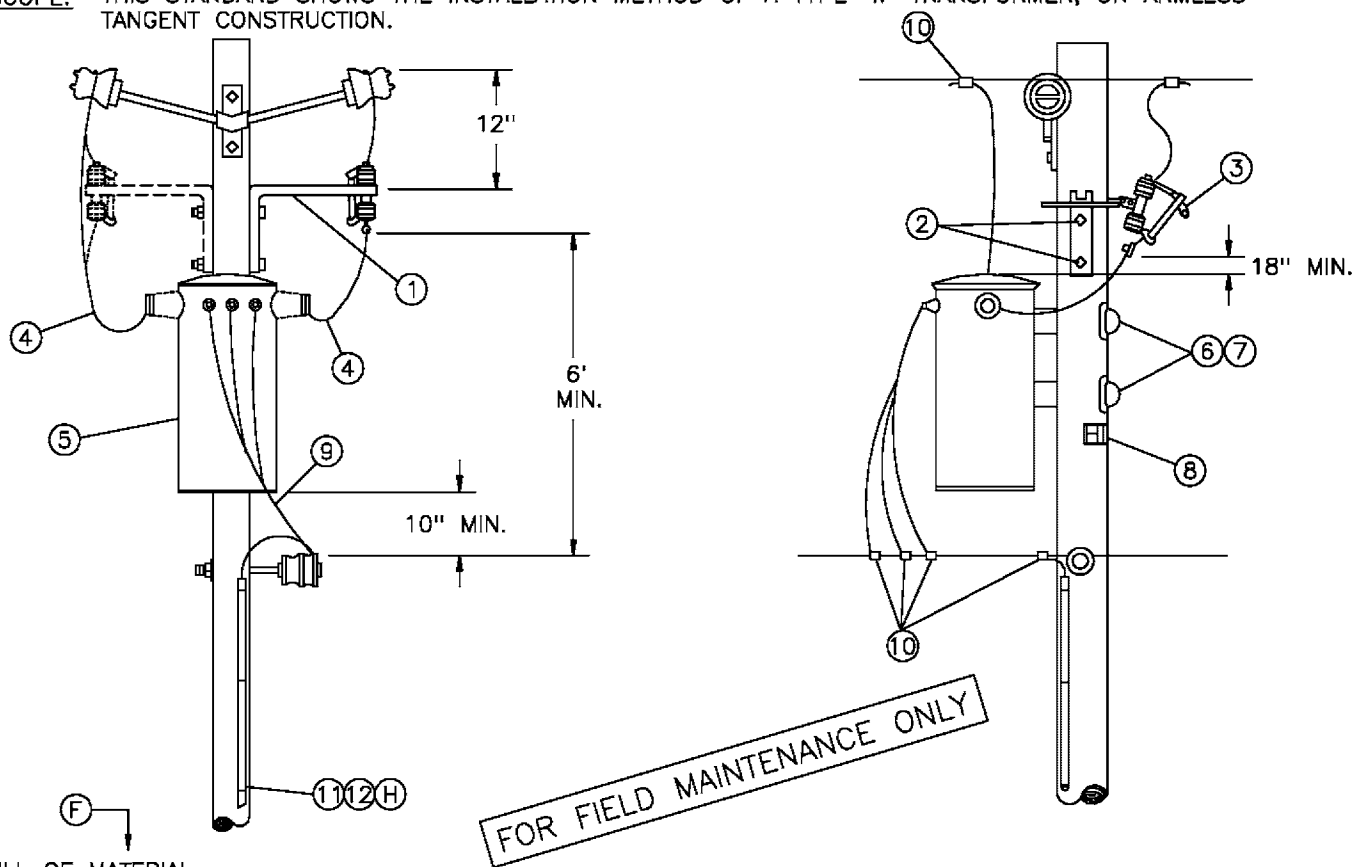

BILL OF MATERIAL:

ITEM	DESCRIPTION	QUANTITY		STOCK NO OR CONSTR STANDARD
		2.4KV	4KV	
1	BRACKET, CUTOUT MOUNTING	2	1	166448
2	BOLT, MACH, GALV, 5/8" X (LENGTH AS REQ'D) & 1 SQ CURVED WASHER	2	2	STD 392
3	CUTOUT, 12KV	2	1	STD 1212
4	WIRE, 5KV INSULATED, XLP, #6 STRANDED COPPER	8'	10'	194304
5	TRANSFORMER, SINGLE PHASE, TYPE W	1	1	STD 1121
6	BOLT, MACH, GALV, 5/8" OR 3/4" X (LENGTH AS REQ'D), 1 SQ CURV & 1 DBL COIL SPRING WASHER	2	2	STD 392
7	COVER, BOLT, PLASTIC & 6 - 10D NAILS, GALV	2	2	285696 491392
8	SIGN, HIGH VOLTAGE & 9 ROOFING NAILS, GALV	1	1	647648 492224
9	WIRE, W.P. (SIZE GOVERNED BY TRANSFORMER CAPACITY)	21'	21'	STD 1125
10	CONNECTORS, WIRE COMPRESSION, CU OR AL, AS REQ'D	AS REQ'D		783-787
11	WIRE, BARE STRANDED, COPPER, #6	42'	42'	813536
12	UNIT GROUND, COMPLETE	1	1	603136

REFERENCE:

- (F) POLE STEPPING - SEE STANDARD 363.
- G. FOR LIGHTNING ARRESTER REQUIREMENTS - SEE STANDARD 1247.
- (H) GROUNDING METHODS - SEE STANDARD 1002.
- I. FOR POLE TOP MATERIAL - SEE DISTRIBUTION POLE TOPS (SECTION 400).

		SDG&E ELECTRIC STANDARDS		
DATE	1-1-86	2.4 OR 4KV SINGLE PHASE TYPE "W" TRANSFORMER INSTALLATION 100 KVA MAXIMUM, ARMLESS TANGENT CONST		1199.208 SUPERSEDES 1128 (1-1-93)
APPD	/			

FIELD MAINTENANCE ONLY

REVISION HISTORY:

7/13/2016: All versions prior to 2016 are superseded by their current version found inside the Overhead Construction Standard Manual.

© 1998 - 2016 San Diego Gas & Electric Company. All rights reserved. Removal of this copyright notice without permission is not permitted under law.

REV	CHANGE	BY	DSGN	APPV	DATE	REV	CHANGE	BY	DSGN	APPV	DATE
C						F					
B						E					
A	ORIGINAL ISSUE	JS	IL	MDJ	7/13/2016	D					

<input checked="" type="checkbox"/>	Indicates Latest Revision	<input type="checkbox"/>	Completely Revised	<input type="checkbox"/>	New Page	<input type="checkbox"/>	Information Removed
-------------------------------------	---------------------------	--------------------------	--------------------	--------------------------	----------	--------------------------	---------------------

**SHEET
1 OF 1**

SDG&E ELECTRIC OVERHEAD STANDARD

2.4 OR 4KV, SINGLE PHASE TYPE "W" TRANSFORMER INSTALLATION
100KVA MAXIMUM, ARMLESS DEAD END CONST

**FMO
OH 1129**

SCOPE: THIS STANDARD SHOWS THE INSTALLATION METHOD OF A TYPE "W" TRANSFORMER, ON ARMLESS DEADEND CONSTRUCTION.

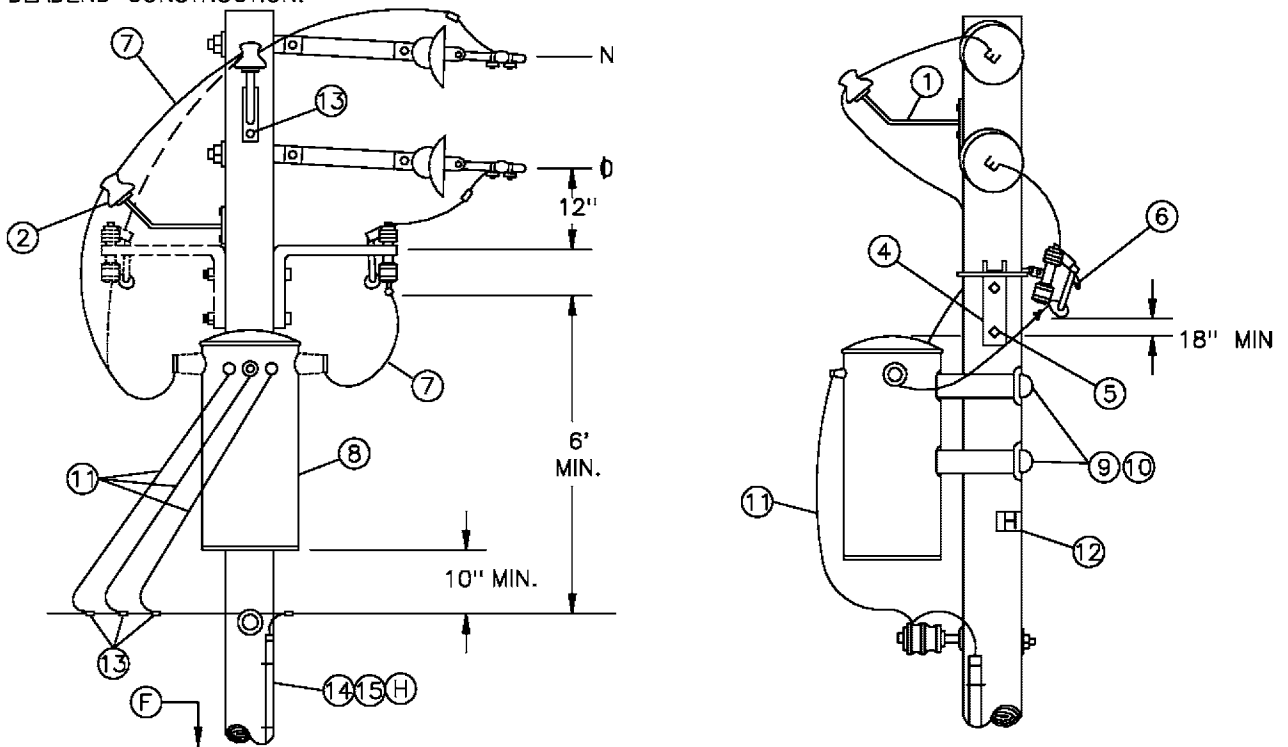

ITEM	DESCRIPTION	QUANTITY		STOCK NO OR CONSTR STANDARD
		2.4KV	4KV	
1	BRACKET, INSULATOR, 1" LEAD THREAD	2	2	166134
2	INSULATOR, CLASS AS REQUIRED	1	2	STD 750
3	SCREW, LAG, GALV. 1/2" X 4"	2	2	621568
4	BRACKET, CUTOUT MOUNTING	2	1	166448
5	BOLT, MACH, GALV, 5/8" X (LENGTH AS REQ'D) & 1 SQ CURVED WASHER	2	2	STD 392
6	CUTOUT, 12KV	2	1	STD 1212
7	WIRE, 5KV INSULATED, XLP, #6 STRANDED COPPER	10'	12'	194304
8	TRANSFORMER, SINGLE PHASE, TYPE W	1	1	STD 1211
9	BOLT, MACH, GALV, 5/8" OR 3/4" X (LENGTH AS REQ'D), 1 SQ CURVED & 1 DBL COIL SPRING WASHER	2	2	STD 392
10	COVER, BOLT, PLASTIC & 6 - 10D NAILS, GALV	2	2	285696 491392
11	WIRE, W.P. (SIZE GOVERNED BY TRANSFORMER CAPACITY)	21'	21'	STD 1125
12	SIGN, HIGH VOLTAGE & 9 ROOFING NAILS, GALV	1	1	647648 492224
13	CONNECTORS, WIRE COMPRESSION, CU OR AL, AS REQ'D	AS REQ'D		783-787
14	WIRE, BARE STRANDED, COPPER, #6	42'	42'	813536
15	UNIT GROUND, COMPLETE	1	1	603136

REFERENCE:

- (F) POLE STEPPING - SEE STANDARD 363.
- G. FOR LIGHTNING ARRESTER REQUIREMENTS - SEE STANDARD 1247.
- (H) GROUNDING METHODS - SEE STANDARD 1002.
- I. FOR POLE TOP MATERIAL - SEE DISTRIBUTION POLE TOPS (SECTION 400).

		SDG&E ELECTRIC STANDARDS	
DATE	1-1-86	2.4 OR 4KV, SINGLE PHASE TYPE "W" TRANSFORMER INSTALLATION 100KVA MAXIMUM, ARMLESS DEAD END CONST	1199.209 SUPERSEDES 1129 (1-1-93)
APPD	/		

FIELD MAINTENANCE ONLY

REVISION HISTORY:

7/13/2016: All versions prior to 2016 are superseded by their current version found inside the Overhead Construction Standard Manual.

© 1998 - 2016 San Diego Gas & Electric Company. All rights reserved. Removal of this copyright notice without permission is not permitted under law.

REV	CHANGE	BY	DSGN	APPV	DATE	REV	CHANGE	BY	DSGN	APPV	DATE
C						F					
B						E					
A	ORIGINAL ISSUE	JS	IL	MDJ	7/13/2016	D					

SHEET 1 OF 1	<input checked="" type="checkbox"/> Indicates Latest Revision	<input type="checkbox"/> Completely Revised	<input type="checkbox"/> New Page	<input type="checkbox"/> Information Removed	FMO OH 1131
	SDG&E ELECTRIC OVERHEAD STANDARD				
	2.4 OR 4KV, SINGLE PHASE, TYPE "WE" TRANSFORMER INSTALLATION, 25 KVA MAX, SECONDARY RACK CONSTRUCTION				

SCOPE: THIS STANDARD SHOWS THE INSTALLATION METHOD OF A TYPE 'WE' TRANSFORMER, ON SECONDARY RACK CONSTRUCTION.

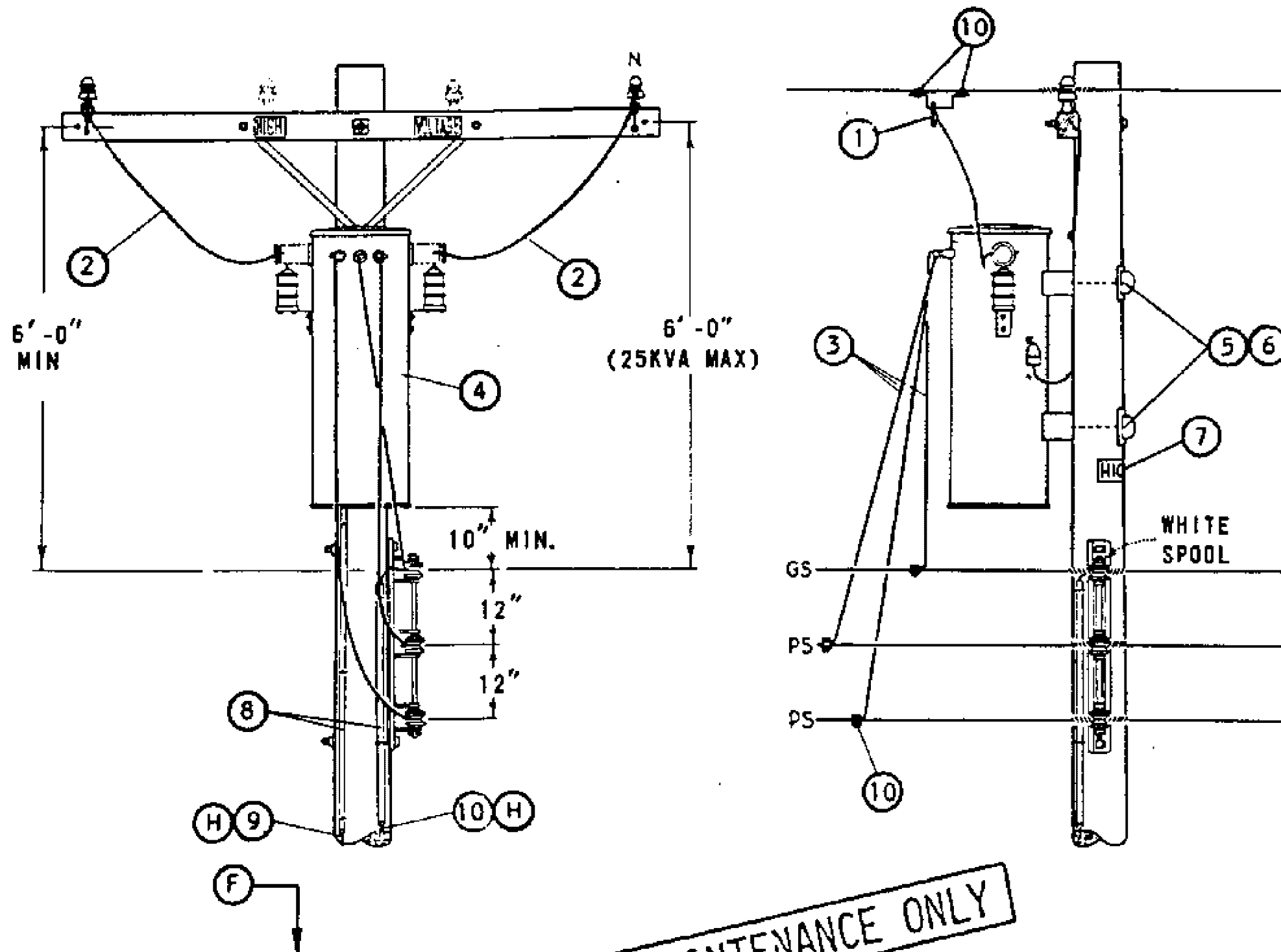

FOR FIELD MAINTENANCE ONLY

BILL OF MATERIAL:

ITEM	DESCRIPTION	QUANTITY	STOCK NO OR CONSTR STANDARD
1	CLAMP, HOTLINE & STIRRUP (E)	2	STD 788
2	WIRE, 5KV INSULATED, XLP, #6 STRANDED COPPER	12'	194304
3	WIRE, W.P., COPPER (SIZE GOVERNED BY TRANSFORMER CAPACITY)	21'	STD 1125
4	TRANSFORMER, SINGLE PHASE (TYPE 'WE' OR 'WJ')	1	STD 1121
5	BOLT, MACH, GALV, 5/8" OR 3/4" X (LENGTH AS REQ'D), 1 SQ CURVED & 1 DBL COIL SPRING WASHER (E)	2	STD 392
6	COVER, BOLT, PLASTIC & 6 - 10D NAILS, GALV (E)	2	285696
		-	491392
7	SIGN, HIGH VOLTAGE & 9 ROOFING NAILS, GALV (E)	1	647648
		-	492224
8	UNIT GROUND, COMPLETE (A)	2	603136
9	WIRE, #4 BARE STRANDED COPPER (A)	42'	813760
10	WIRE, #6 BARE STRANDED COPPER	42'	813536
11	CONNECTORS, WIRE COMPRESSION, CU OR AL, AS REQ'D (E)	AS REQ'D	783-787

INSTALLATION:

- (A) OMIT LIGHTNING ARRESTER GROUND ON TYPE 'WE' TRANSFORMER INSTALLATION.
- (E) EXEMPT MATERIAL.

REFERENCE:

- (F) POLE STEPPING - SEE STANDARD 363.
- G. WHEN LIGHTNING ARRESTERS ARE REQUIRED PER STANDARD 1247, USE TYPE 'WJ' TRANSFORMER.
- (H) GROUNDING METHODS - SEE STANDARD 1002.

FIELD MAINTENANCE ONLY

REVISION HISTORY:

7/13/2016: All versions prior to 2016 are superseded by their current version found inside the Overhead Construction Standard Manual.

© 1998 - 2016 San Diego Gas & Electric Company. All rights reserved. Removal of this copyright notice without permission is not permitted under law.

REV	CHANGE	BY	DSGN	APPV	DATE	REV	CHANGE	BY	DSGN	APPV	DATE
C						F					
B						E					
A	ORIGINAL ISSUE	JS	IL	MDJ	7/13/2016	D					

<input checked="" type="checkbox"/>	Indicates Latest Revision	<input type="checkbox"/>	Completely Revised	<input type="checkbox"/>	New Page	<input type="checkbox"/>	Information Removed
-------------------------------------	---------------------------	--------------------------	--------------------	--------------------------	----------	--------------------------	---------------------

**SHEET
1 OF 1**

SDG&E ELECTRIC OVERHEAD STANDARD

2.4 OR 4KV, SINGLE PHASE, TYPE "WE" TRANSFORMER
INSTALLATION, 25 KVA MAX, SECONDARY LINE ARM CONSTRUCTION

**FMO
OH 1132**

SCOPE: THIS STANDARD SHOWS THE INSTALLATION METHOD OF A TYPE 'WE' TRANSFORMER, ON SECONDARY LINE ARM CONSTRUCTION.

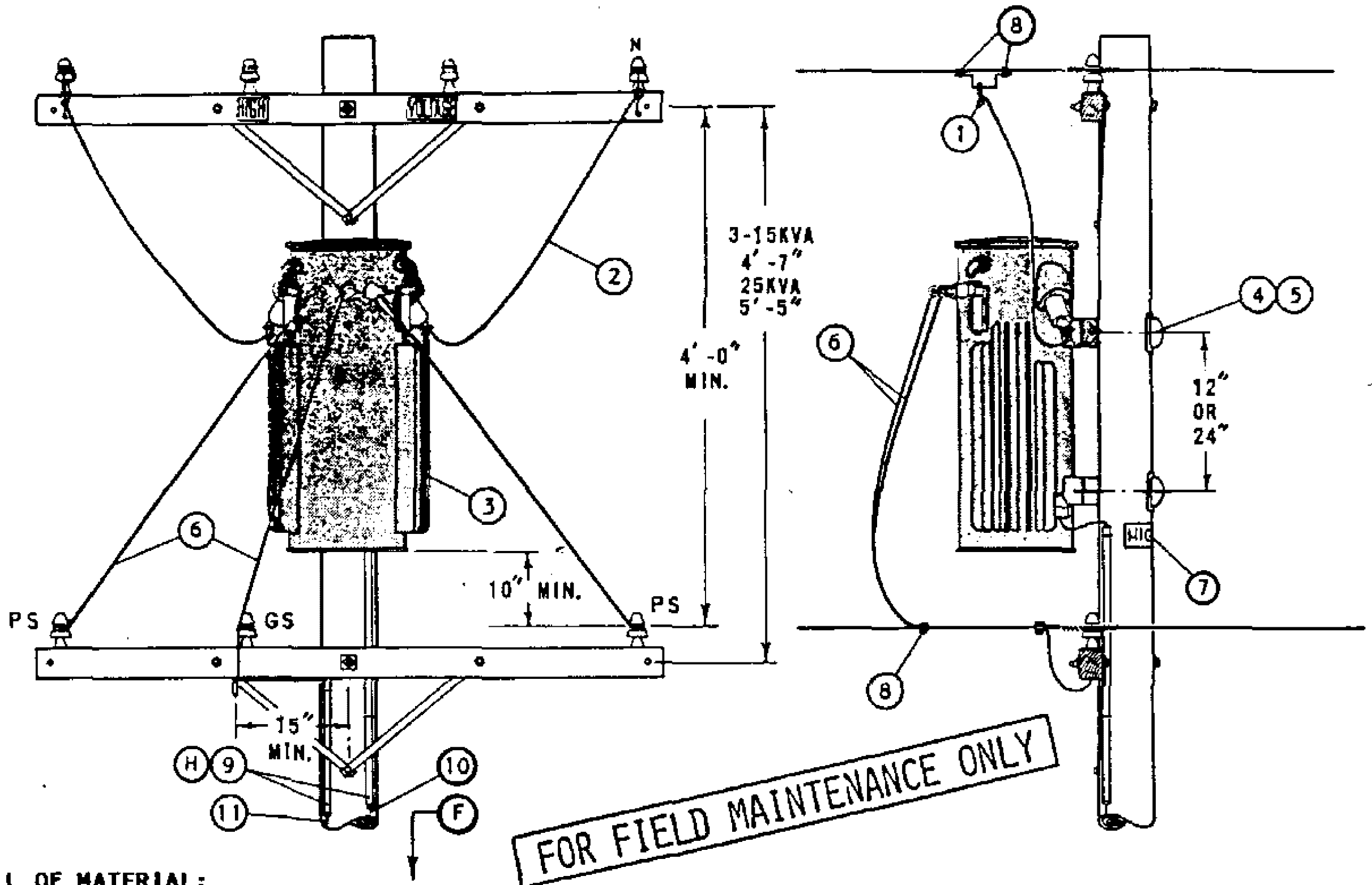

BILL OF MATERIAL:

ITEM	DESCRIPTION		QUANTITY	STOCK NO OR CONSTR STANDARD
1	CLAMP, HOTLINE & STIRRUP	(E)	2	STD 788
2	WIRE, 5KV INSULATED, XLP, #6 STRANDED COPPER		12'	194304
3	TRANSFORMER, SINGLE PHASE (TYPE 'WE' OR 'WJ')		1	STD 1121
4	BOLT, MACH, GALV, 5/8" OR 3/4" X (LENGTH AS REQ'D), 1 SQ CURVED & 1 DBL COIL SPRING WASHER	(E)	2	STD 392
5	COVER, BOLT, PLASTIC & 6 - 10D NAILS, GALV	(E) (E)	2 -	285696 491392
6	WIRE, W.P., COPPER (SIZE GOVERNED BY TRANSFORMER CAPACITY)		21'	STD 1125
7	SIGN, HIGH VOLTAGE & 9 ROOFING NAILS, GALV	(E) (E)	1 -	647648 492224
8	CONNECTORS, WIRE COMPRESSION, CU OR AL, AS REQ'D	(E)	AS REQ'D	783-787
9	UNIT GROUND, COMPLETE	(A)	2	603136
10	WIRE, #4 BARE STRANDED COPPER	(A)	41'	813760
11	WIRE, #6 BARE STRANDED COPPER		42'	813536

INSTALLATION:

- (A) OMIT LIGHTNING ARRESTER GROUND ON TYPE 'WE' TRANSFORMER INSTALLATION.
- (E) EXEMPT MATERIAL.

REFERENCE:

- (F) POLE STEPPING - SEE STANDARD 363.
- G. WHEN LIGHTNING ARRESTERS ARE REQUIRED, PER STANDARD 1247, USE TYPE 'WJ' TRANSFORMER.
- (H) GROUNDING METHODS - SEE STANDARD 1002.

1199.303
SUPERSEDES
1132 (1-1-93)

SDG&E ELECTRIC STANDARDS

2.4 OR 4KV, SINGLE PHASE, TYPE "WE" TRANSFORMER
INSTALLATION, 25 KVA MAX, SECONDARY LINE ARM CONSTRUCTION

DATE 1-1-86
APPD AK/RSB

FIELD MAINTENANCE ONLY

REVISION HISTORY:

7/13/2016: All versions prior to 2016 are superseded by their current version found inside the Overhead Construction Standard Manual.

© 1998 - 2016 San Diego Gas & Electric Company. All rights reserved. Removal of this copyright notice without permission is not permitted under law.

REV	CHANGE	BY	DSGN	APPV	DATE	REV	CHANGE	BY	DSGN	APPV	DATE
C						F					
B						E					
A	ORIGINAL ISSUE	JS	IL	MDJ	7/13/2016	D					

<input checked="" type="checkbox"/>	Indicates Latest Revision	<input type="checkbox"/>	Completely Revised	<input type="checkbox"/>	New Page	<input type="checkbox"/>	Information Removed
-------------------------------------	---------------------------	--------------------------	--------------------	--------------------------	----------	--------------------------	---------------------

**SHEET
1 OF 1**

SDG&E ELECTRIC OVERHEAD STANDARD

2.4 OR 4KV, SINGLE PHASE, TYPE "WE" TRANSFORMER
INSTALLATION, 25 KVA MAX, SECONDARY LINE ARM CONSTRUCTION

**FMO
OH 1133**

SCOPE: THIS STANDARD SHOWS THE INSTALLATION METHOD OF A TYPE 'W' TRANSFORMER, ON SECONDARY RACK CONSTRUCTION.

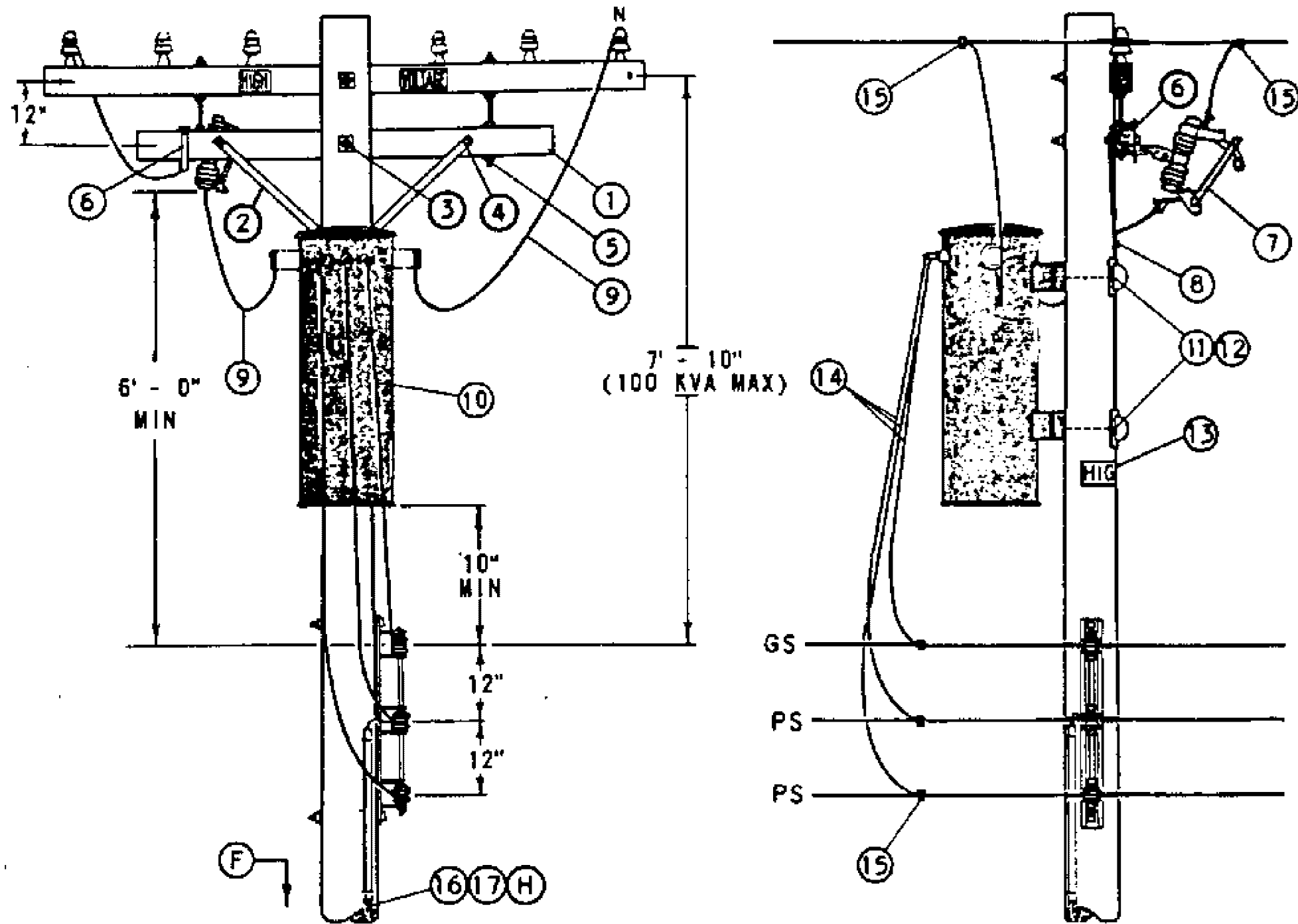

BILL OF MATERIAL:

ITEM	DESCRIPTION	QUANTITY	STOCK NO OR CONSTR STANDARD
1	CROSSARM, 3 1/2" X 4 1/2" X 6' - 0"	1	294112
2	BRACE, FLAT, CROSSARM, 28"	(E) 1	164192
3	BOLT, MACH, GALV, 5/8" X (LENGTH AS REQ'D), 2 SQ & 1 DBL COIL SPRING WASHER	(E) 1	STD 392
4	BOLT, MACH, GALV, 3/8" X 4 1/2", 1 RD & 1 SPRING LOCK WASHER	(E) 2	STD 392
5	BOLT, SPACE, GALV, 5/8" X 20", 4 SQ & 2 DBL COIL SPR WASHERS	(E) 2	STD 392
6	BRACKET, CUTOUT/ARRESTER, FOR CROSSARM MOUNTING	(E) 1	166070
7	CUTOUT, 12KV	(A) 1	STD 1212
8	BOLT, MACH, GALV, 1/2" X (LENGTH AS REQ'D), 1 SQ & 1 DBL COIL SPRING WASHER	(E) 1	STD 392
9	WIRE, 5KV INSULATED, XLP, #6 STRANDED COPPER	12'	194304
10	TRANSFORMER, SINGLE PHASE, TYPE 'W'	1	STD 1121
11	BOLT, MACH, GALV, 5/8" X (LENGTH AS REQ'D), 1 SQ CURVED & 1 DBL COIL SPRING WASHER	(E) 2	STD 392
12	COVER, BOLT, PLASTIC & 6 - 10D NAILS, GALV	(E) 2 (E) -	285696 491392
13	SIGN, HIGH VOLTAGE & 9 ROOFING NAILS, GALV	(E) 1 (E) -	647648 492224
14	WIRE, W.P., COPPER (SIZE GOVERNED BY TRANSFORMER CAPACITY)	21'	STD 1125
15	CONNECTORS, WIRE COMPRESSION, CU OR AL, AS REQ'D	(E) AS REQ'D	783-787
16	WIRE, BARE STRANDED COPPER, #6	42'	813536
17	UNIT GROUND, COMPLETE	1	603136

FOR FIELD MAINTENANCE ONLY

INSTALLATION:

- (A) 2.4KV SINGLE PHASE INSTALLATIONS REQUIRE TWO CUTOUTS.
- (E) EXEMPT MATERIAL.

REFERENCE:

- (F) POLE STEPPING - SEE STANDARD 363.
- G. FOR LIGHTNING ARRESTER REQUIREMENTS - SEE STANDARD 1247.
- (H) GROUNDING METHODS - SEE STANDARD 1002.

SDG&E ELECTRIC STANDARDS

1199.304
SUPERSEDES
1133 (1-1-93)

DATE 1-1-86

APPD AK/ADG

2.4 OR 4KV, SINGLE PHASE TYPE "W" TRANSFORMER INSTALLATION,
100 KVA MAXIMUM, C.O. ARM, SECONDARY RACK CONSTRUCTION

FIELD MAINTENANCE ONLY

REVISION HISTORY:

7/13/2016: All versions prior to 2016 are superseded by their current version found inside the Overhead Construction Standard Manual.

© 1998 - 2016 San Diego Gas & Electric Company. All rights reserved. Removal of this copyright notice without permission is not permitted under law.

REV	CHANGE	BY	DSGN	APPV	DATE	REV	CHANGE	BY	DSGN	APPV	DATE
C						F					
B						E					
A	ORIGINAL ISSUE	JS	IL	MDJ	7/13/2016	D					

	Indicates Latest Revision	Completely Revised	New Page	Information Removed
-------------------------------------------------------------------------------------	---------------------------	--------------------	----------	---------------------

**SHEET
1 OF 1**

SDG&E ELECTRIC OVERHEAD STANDARD
2.4 OR 4KV, SINGLE PHASE, TYPE "W" TRANSFORMER INSTALLATION, 100 KVA
MAXIMUM LINE ARM MOUNTED C.O., SECONDARY RACK CONSTRUCTION

**FMO
OH 1135**

SCOPE: THIS STANDARD SHOWS THE INSTALLATION METHOD OF A TYPE 'W' TRANSFORMER, ON SECONDARY RACK CONSTRUCTION WITH CUTOUT ON LINE ARM.

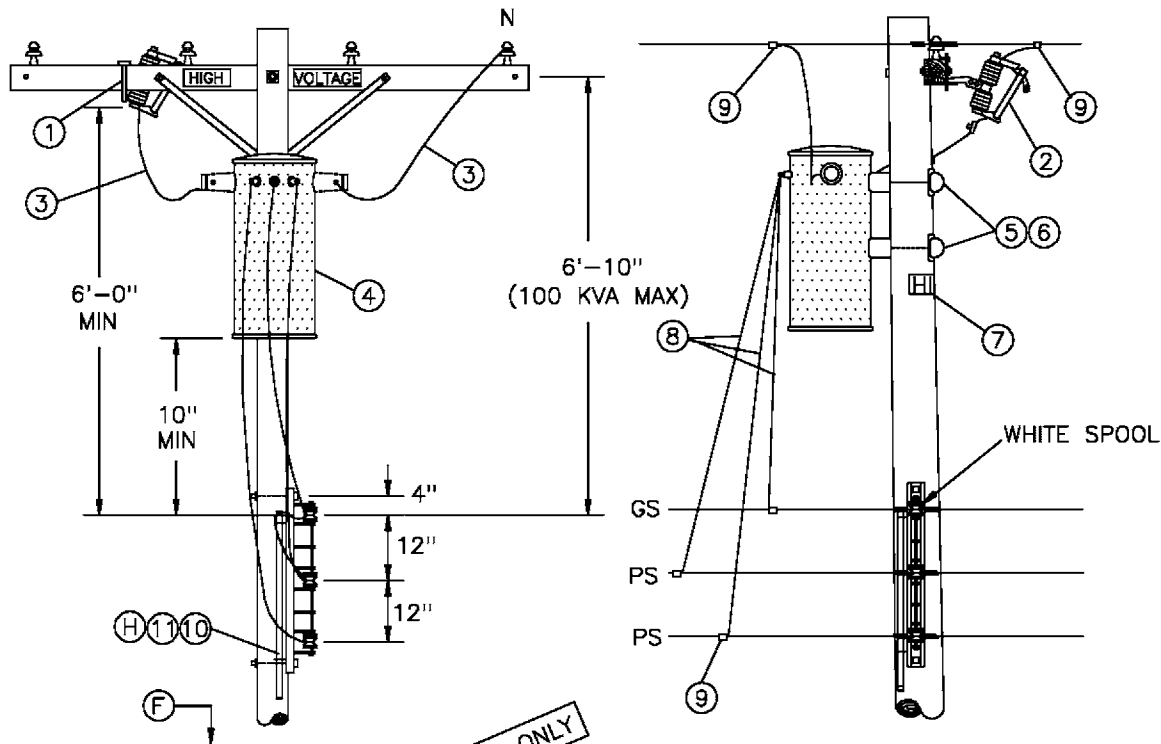

BILL OF MATERIAL:

FOR FIELD MAINTENANCE ONLY

ITEM	DESCRIPTION	QUANTITY	STOCK NO OR CONSTR STANDARD
1	BRACKET, CUTOUT/ARRESTER, FOR CROSSARM MOUNTING	1	166070
2	CUTOUT, 12KV	(A) 1	STD 1212
3	WIRE, 5KV INSULATED, XLP, #6 STRANDED COPPER	12'	194304
4	TRANSFORMER, SINGLE PHASE, TYPE 'W'	1	STD 1121
5	BOLT, MACH, GALV, 5/8" X (LENGTH AS REQ'D), 1 SQ CURVED & 1 DBL COIL SPRING WASHER	2	STD 392
6	COVER, BOLT, PLASTIC & 6 - 10D NAILS, GALV	2	285696 491392
7	SIGN, HIGH VOLTAGE & 9 ROOFING NAILS, GALV	1	647648 492224
8	WIRE, W.P., COPPER (SIZE GOVERNED BY TRANSFORMER CAPACITY)	21'	STD 1125
9	CONNECTORS, WIRE COMPRESSION, CU OR A, AS REQ'D	AS REQ'D	783-787
10	WIRE, BARE STRANDED COPPER, #6	42'	813536
11	UNIT GROUND, COMPLETE	1	603136

INSTALLATION:

(A) 2.4KV SINGLE PHASE INSTALLATIONS REQUIRE TWO CUTOUTS.

REFERENCE:

- (F) POLE STEPPING - SEE STANDARD 363.
- G. FOR LIGHTNING ARRESTER REQUIREMENTS - SEE STANDARD 1247.
- (H) GROUNDING METHODS - SEE STANDARD 1002.

1199.305 SUPERSEDES 1135 (1-1-93)	SDG&E ELECTRIC STANDARDS	DATE 1-1-86 APPD /
	2.4 OR 4KV, SINGLE PHASE TYPE "W" TRANSFORMER INSTALLATION, 100 KVA MAXIMUM LINE ARM MOUNTED C.O., SECONDARY RACK CONSTRUCTION	

FIELD MAINTENANCE ONLY

REVISION HISTORY:

7/13/2016: All versions prior to 2016 are superseded by their current version found inside the Overhead Construction Standard Manual.

© 1998 - 2016 San Diego Gas & Electric Company. All rights reserved. Removal of this copyright notice without permission is not permitted under law.

REV	CHANGE	BY	DSGN	APPV	DATE	REV	CHANGE	BY	DSGN	APPV	DATE
C						F					
B						E					
A	ORIGINAL ISSUE	JS	IL	MDJ	7/13/2016	D					

SHEET 1 OF 1	 Indicates Latest Revision	Completely Revised	New Page	Information Removed	FMO OH 1136
	SDG&E ELECTRIC OVERHEAD STANDARD				
	2.4 OR 4KV, SINGLE PHASE, TYPE "W" TRANSFORMER INSTALLATION, 100 KVA MAXIMUM LINE ARM MOUNTED C.O., SECONDARY LINE ARM CONSTRUCTION				

SCOPE: THIS STANDARD SHOWS THE INSTALLATION METHOD OF A TYPE 'W' TRANSFORMER, WITH SECONDARY LINE ARM CONSTRUCTION AND CUTOUT MOUNTED ON LINE ARM.

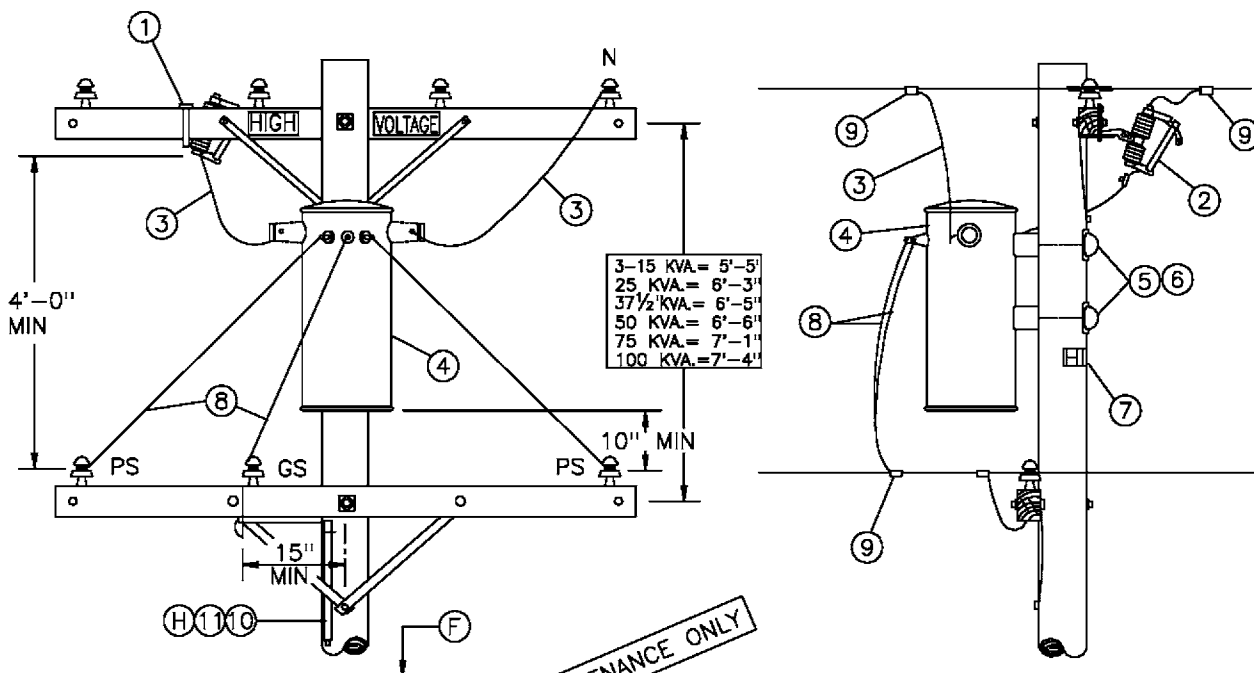

BILL OF MATERIAL:

ITEM	DESCRIPTION	QUANTITY	STOCK NO OR CONSTR STANDARD
1	BRACKET, CUTOUT/ARRESTER, FOR CROSSARM MOUNTING	1	166070
2	CUTOUT, 12KV	(A) 1	STD 1212
3	WIRE, 5KV INSULATED, XLP, #6 STRANDED COPPER	12'	194304
4	TRANSFORMER, SINGLE PHASE, TYPE 'W'	1	STD 1121
5	BOLT, MACH, GALV, 5/8" X (LENGTH AS REQ'D), 1 SQ CURVED & 1 DBL COIL SPRING WASHER	2	STD 392
6	COVER, BOLT, PLASTIC & 6 - 10D NAILS, GALV	2	285696 491392
7	SIGN, HIGH VOLTAGE & 9 ROOFING NAILS, GALV	1	647648 492224
8	WIRE, W.P., COPPER (SIZE GOVERNED BY TRANSFORMER CAPACITY)	21'	STD 1125
9	CONNECTORS, WIRE COMPRESSION, CU OR AL, AS REQ'D	AS REQ'D	783-787
10	WIRE, BARE STRANDED COPPER, #6	42'	813536
11	UNIT GROUND, COMPLETE	1	603136

INSTALLATION:

(A) 2.4KV SINGLE PHASE INSTALLATIONS REQUIRE TWO CUTOUTS.

REFERENCE:

- (F) POLE STEPPING - SEE STANDARD 363.
- G. FOR LIGHTNING ARRESTER REQUIREMENTS - SEE STANDARD 1247.
- (H) GROUNDING METHODS - SEE STANDARD 1002.

DATE 1-1-86 APPD /	SDG&E ELECTRIC STANDARDS	1199.306 SUPERSEDES 1136 (1-1-93)
	2.4 OR 4KV, SINGLE PHASE TYPE "W" TRANSFORMER INSTALLATION, 100 KVA MAXIMUM LINE ARM MOUNTED C.O., SECONDARY LINE ARM CONSTRUCTION	

FIELD MAINTENANCE ONLY

REVISION HISTORY:

7/13/2016: All versions prior to 2016 are superseded by their current version found inside the Overhead Construction Standard Manual.

© 1998 - 2016 San Diego Gas & Electric Company. All rights reserved. Removal of this copyright notice without permission is not permitted under law.

REV	CHANGE	BY	DSGN	APPV	DATE	REV	CHANGE	BY	DSGN	APPV	DATE
C						F					
B						E					
A	ORIGINAL ISSUE	JS	IL	MDJ	7/13/2016	D					

SHEET 1 OF 1	 Indicates Latest Revision	Completely Revised	New Page	Information Removed	FMO OH 1138
	SDG&E ELECTRIC OVERHEAD STANDARD				
	2.4 OR 4KV, SINGLE PHASE PARALLELED TRANSFORMER INSTALLATION				

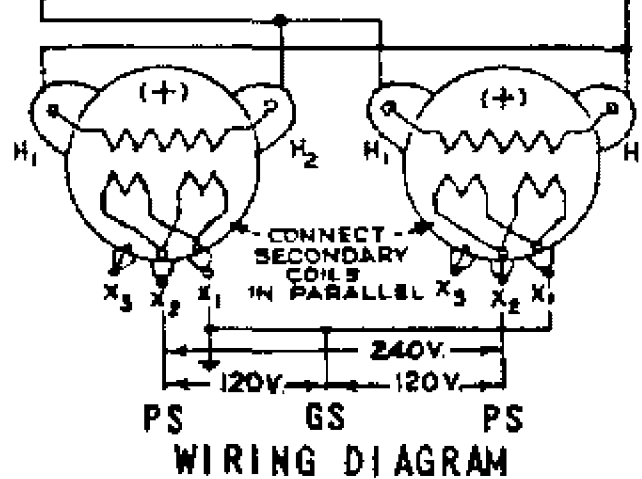
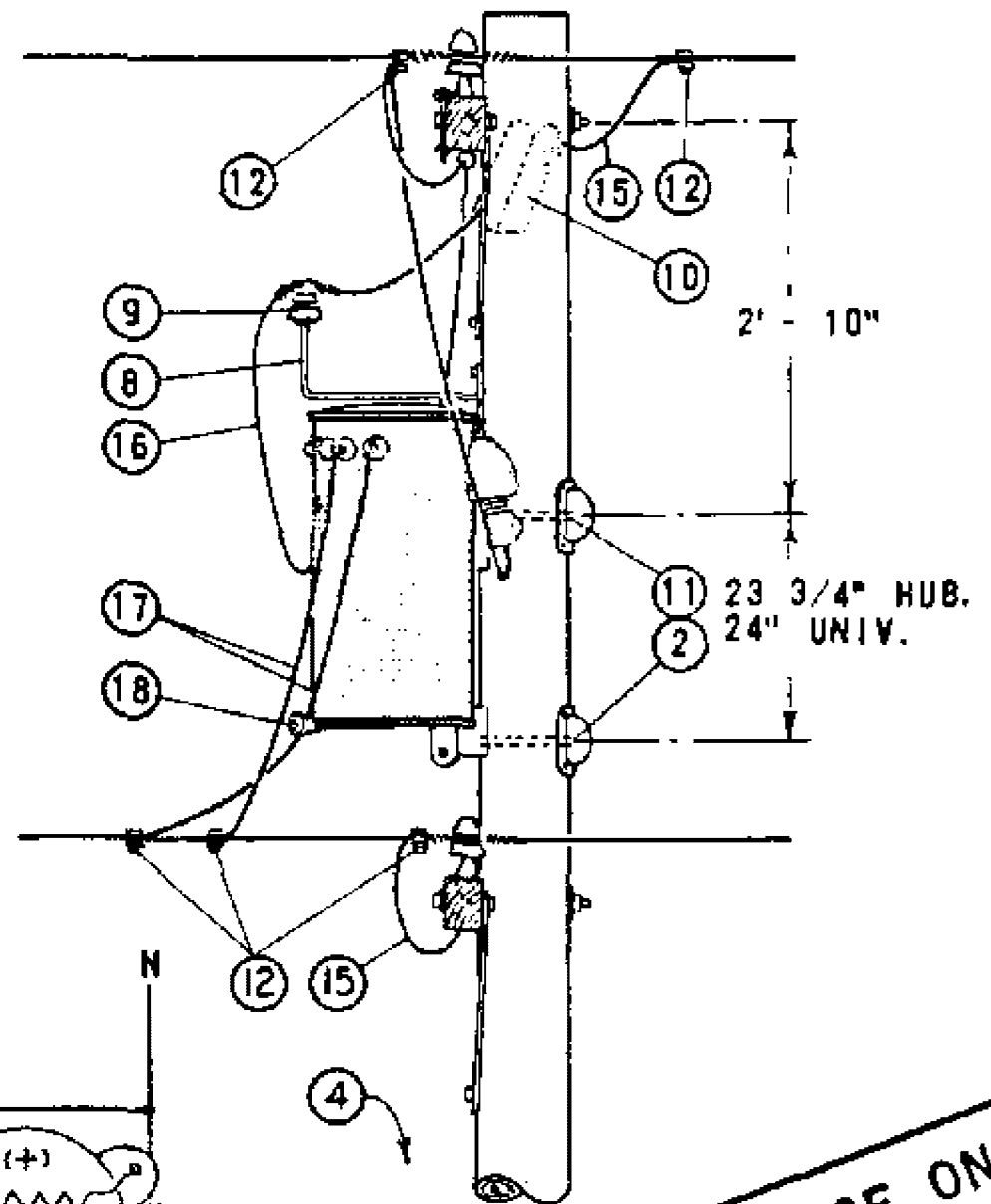
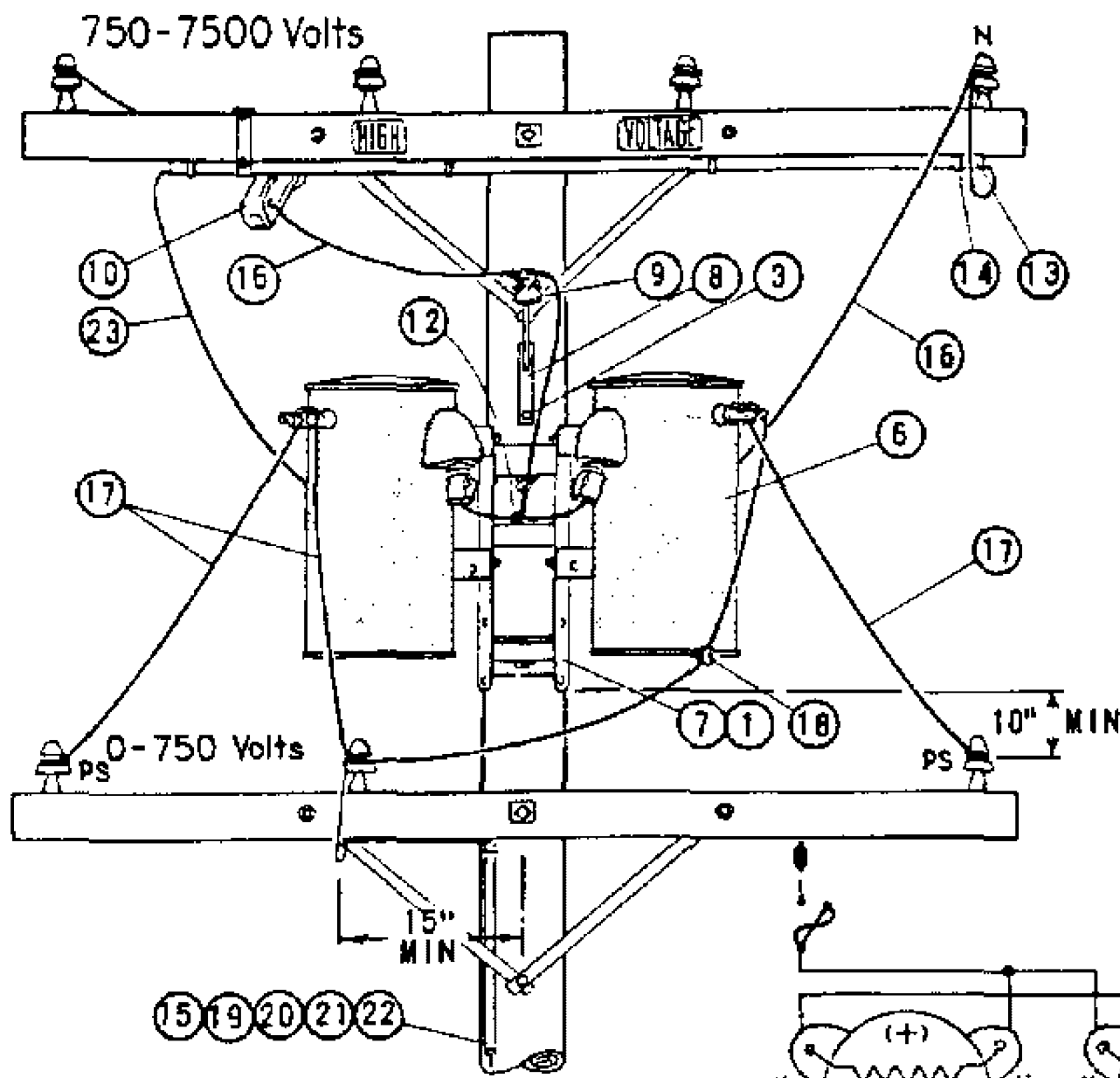

FOR FIELD MAINTENANCE ONLY

NOTES:

- (A) LIMITED TO TWO 15 KVA TRANSFORMERS.
- (B) USE TWO GROUND RODS SPACED A MINIMUM OF 6 FEET APART FOR EACH GROUND UNIT.
- (C) PHASE TO PHASE CONNECTIONS ON 2.4 KV DELTA AND 4 KV WYE SYSTEMS REQUIRE TWO CUTOUTS.
- (D) FUSE FOR COMBINED KVA OF PARALLELED TRANSFORMERS.
- (E) EXEMPT MATERIALS.
- (F) UNIT GROUND COMPLETE ORDER 603120 WITH GRAY MOULDING, 603136 WITH PLAIN MOULDING.

ITEM	DESCRIPTION	QUANTITY	STOCK NO. OR CONSTR STDS
1	BOLT, MACH GALV, 5/8" (E) DR 3/4" X 2", 2 WASH & 1 NUT.	4	PGS 139, 140
2	BOLT, MACH GALV, 3/4" X 10", 1 SQ CURV WASH. & 1 NUT.	2	PGS 139, 140
3	SCREW, LAG GALV, 1/2" X 4"	(E) 2	621568
4	STEP, POLE	(E) 16	692992
5			
6	TRANSFORMER, SINGLE PHASE TYPE W OR OY	(A) 2	PGS 1121.01-1121.12
7	BRACKET, TRANSFORMER MTG	1	402976
8	BRACKET, INSULATOR, 1" OR 1 3/8" THREAD, AS REQ'D	1	156144 / 166176
9	INSULATOR, 12KV	1	700 SECTION
10	CUTOUT, 5KV	(C) 2	PG 1211
11	COVER, THRU BOLT & 6-100 NAILS GALV	2	285696, 491392
12	CONNECTOR, WIRE, AS REQ'D	7	PGS 783-787
13	CONDUIT, PLASTIC PVC, 3/4" SCHEDULE 40, TYPE II	(E) 5'	251328
14	STRAP, PIPE 3/4" & 2-6D NAILS, GALV	(E) 3	697888, 491552
15	WIRE, BARE STRANDED COPPER, #6	48'	813536
16	WIRE, #4 SOLID WP COPPER	8'	814112
17	WIRE, WP COPPER, SIZE GOVERNED BY TRANSFORMER CAPACITY	24'	PG 1125
18	BRACKET, INSULATOR	1	167520
19	ROD & CLAMP, GROUND	(B) (F) 2	603072, 230016 (E)
20	MOULDING, HARDWOOD 1"	(F) 27'	487200
21	STAPLES, MOULDING, GALV 3" X 1 1/16" X 1/4"	(F) (E) 18	678560
22	STAPLES, FENCE, GALV 1 1/4"	(F) (E) 16	678528
23	WIRE, 5KV INSULATED, XLP, #6 STRANDED COPPER	16'	194304

1199.301

SUPERSEDES
1138 (1-1-86)

SDG&E ELECTRIC STANDARDS

2.4KV. OR 4KV, SINGLE PHASE PARALLELED
TRANSFORMER INSTALLATION

DATE 1-1-86

APPD AK 1/2/86

FIELD MAINTENANCE ONLY

REVISION HISTORY:

7/13/2016: All versions prior to 2016 are superseded by their current version found inside the Overhead Construction Standard Manual.

© 1998 - 2016 San Diego Gas & Electric Company. All rights reserved. Removal of this copyright notice without permission is not permitted under law.

REV	CHANGE	BY	DSGN	APPV	DATE	REV	CHANGE	BY	DSGN	APPV	DATE
C						F					
B						E					
A	ORIGINAL ISSUE	JS	IL	MDJ	7/13/2016	D					

<input checked="" type="checkbox"/>	Indicates Latest Revision	<input type="checkbox"/>	Completely Revised	<input type="checkbox"/>	New Page	<input type="checkbox"/>	Information Removed
-------------------------------------	---------------------------	--------------------------	--------------------	--------------------------	----------	--------------------------	---------------------

**SHEET
1 OF 1**

SDG&E ELECTRIC OVERHEAD STANDARD

7.2 OR 12KV SINGLE PHASE YE, YJ, HE, OR HJ TRANSFORMER
INSTALLATION 100 KVA MAXIMUM ARMLESS TANGENT CONSTRUCTION

**FMO
OH 1141**

SCOPE: THIS STANDARD SHOWS THE INSTALLATION METHOD OF A SINGLE PHASE TRANSFORMER, ON ARMLESS TANGENT CONSTRUCTION.

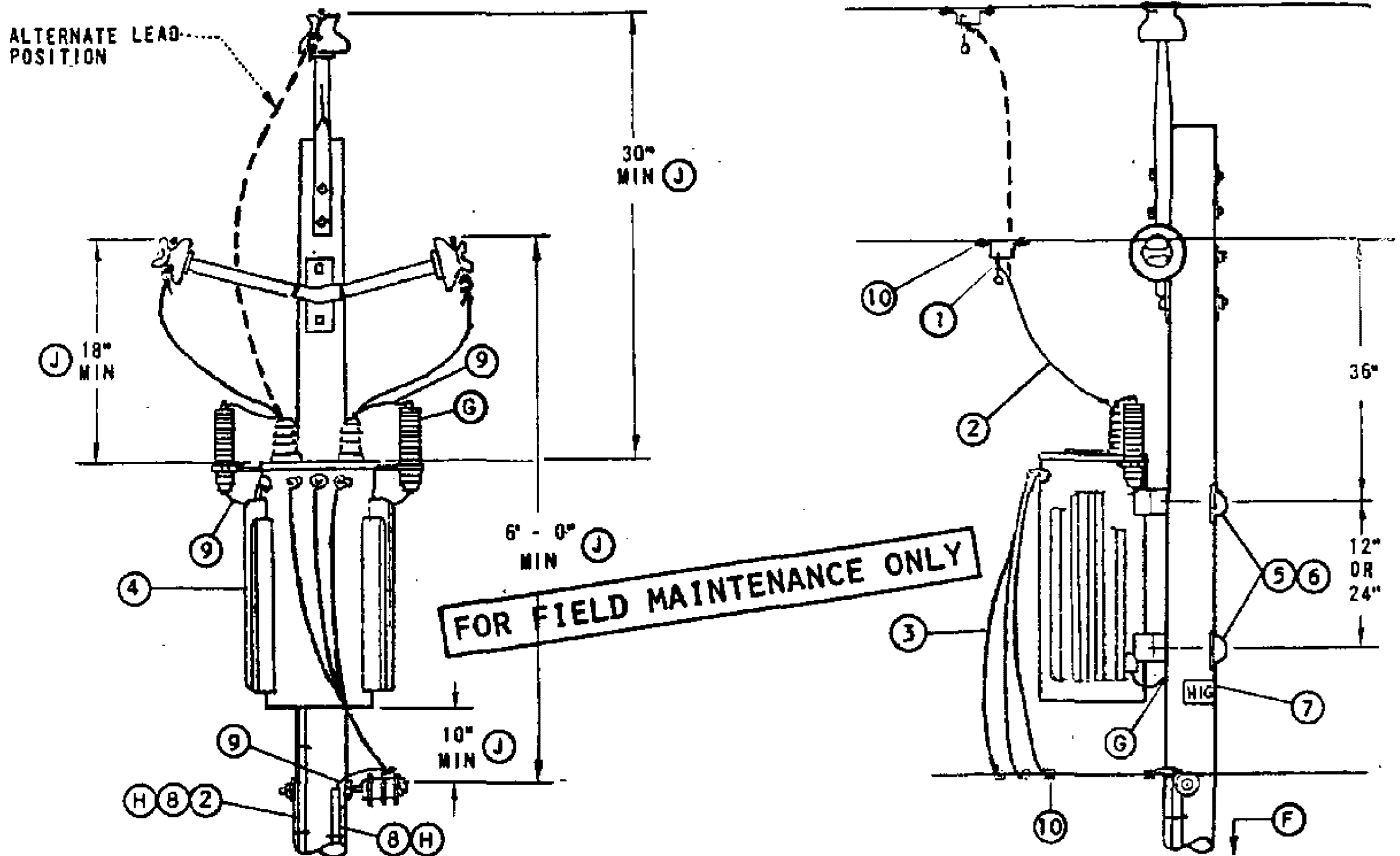

BILL OF MATERIAL:

ITEM	DESCRIPTION	QUANTITY		STOCK NO OR CONSTR STANDARD
		HE, YE	HJ, YJ	
1	CLAMP, HOTLINE & STIRRUP (E)	2	2	STD 788
2	WIRE, #4, BARE STRANDED COPPER	7'	55'	813760
3	WIRE, W.P., COPPER (SIZE GOVERNED BY TRANSFORMER CAPACITY)	21'	21'	STD 1125
4	TRANSFORMER, SINGLE PHASE (TYPE 'HE', 'HJ', 'YE' OR 'YJ')	1	1	STD 1121
5	BOLT, MACH, GALV, 5/8" OR 3/4" X (LENGTH AS REQ'D), 1 SQ CURVED & 1 DBL COIL SPRING WASHER (E)	2	2	STD 392
6	COVER, BOLT, PLASTIC & 6 - 10D NAILS, GALV (E)	2	2	285696
7	SIGN, HIGH VOLTAGE & 8 ROOFING NAILS, GALV (E)	1	1	647648
8	UNIT GROUND, COMPLETE (H)	1	2	603136
9	WIRE, #6 BARE STRANDED COPPER	42'	50'	813536
10	CONNECTORS, WIRE COMPRESSION, CU OR AL, AS REQ'D (E)	AS REQ'D		783-787

INSTALLATION:

A. WHEN INSTALLING A NEW STATION ON THE 7.2/12.47KV SYSTEM IN MEOD, IF NO PRIMARY NEUTRAL GROUND EXISTS ON THE POLE, INCLUDE THE NECESSARY MATERIALS TO INSTALL THE REQUIRED PRIMARY NEUTRAL GROUND. CONNECT TO TRANSFORMER TANK GAP GROUND.

(E) EXEMPT MATERIAL.

REFERENCE:

- (F) POLE STEPPING - SEE STANDARD 363.
- (G) WHEN LIGHTNING ARRESTERS ARE REQUIRED PER STANDARD 1247, USE TYPE 'HJ' OR 'YJ' TRANSFORMERS, AND GROUND TANK GAP.
- (H) GROUNDING METHODS - SEE STANDARD 1002.
- I. FOR POLE TOP MATERIAL - SEE DISTRIBUTION POLE TOPS (SECTION 400). FGS AND PTP ARE SHOWN FOR ILLUSTRATIVE PURPOSES ONLY.
- (J) G.O. 95 MINIMUM REQUIREMENTS.
- K. FOR AERIAL CABLE CONSTRUCTION - SEE SECTION 600.

SDG&E ELECTRIC STANDARDS

DATE 1-1-86

APPD *AK/RB*

7.2 OR 12KV SINGLE PHASE YE, YJ, HE, OR HJ TRANSFORMER
INSTALLATION 100 KVA MAXIMUM ARMLESS TANGENT CONSTRUCTION

1199.401

SUPERSEDES
1141 (1-1-86)

FIELD MAINTENANCE ONLY

REVISION HISTORY:

7/13/2016: All versions prior to 2016 are superseded by their current version found inside the Overhead Construction Standard Manual.

© 1998 - 2016 San Diego Gas & Electric Company. All rights reserved. Removal of this copyright notice without permission is not permitted under law.

REV	CHANGE	BY	DSGN	APPV	DATE	REV	CHANGE	BY	DSGN	APPV	DATE
C						F					
B						E					
A	ORIGINAL ISSUE	JS	IL	MDJ	7/13/2016	D					

	Indicates Latest Revision	Completely Revised	New Page	Information Removed
-------------------------------------------------------------------------------------	---------------------------	--------------------	----------	---------------------

**SHEET
1 OF 1**

SDG&E ELECTRIC OVERHEAD STANDARD
7.2 OR 12KV SINGLE PHASE YE, YJ, HE, OR HJ TRANSFORMER
INSTALLATION 100 KVA MAXIMUM ARMLESS DEAD END CONSTRUCTION

**FMO
OH 1142**

SCOPE: THIS STANDARD SHOWS THE INSTALLATION METHOD OF A SINGLE PHASE TRANSFORMER, ON ARMLESS DEADEND CONSTRUCTION.

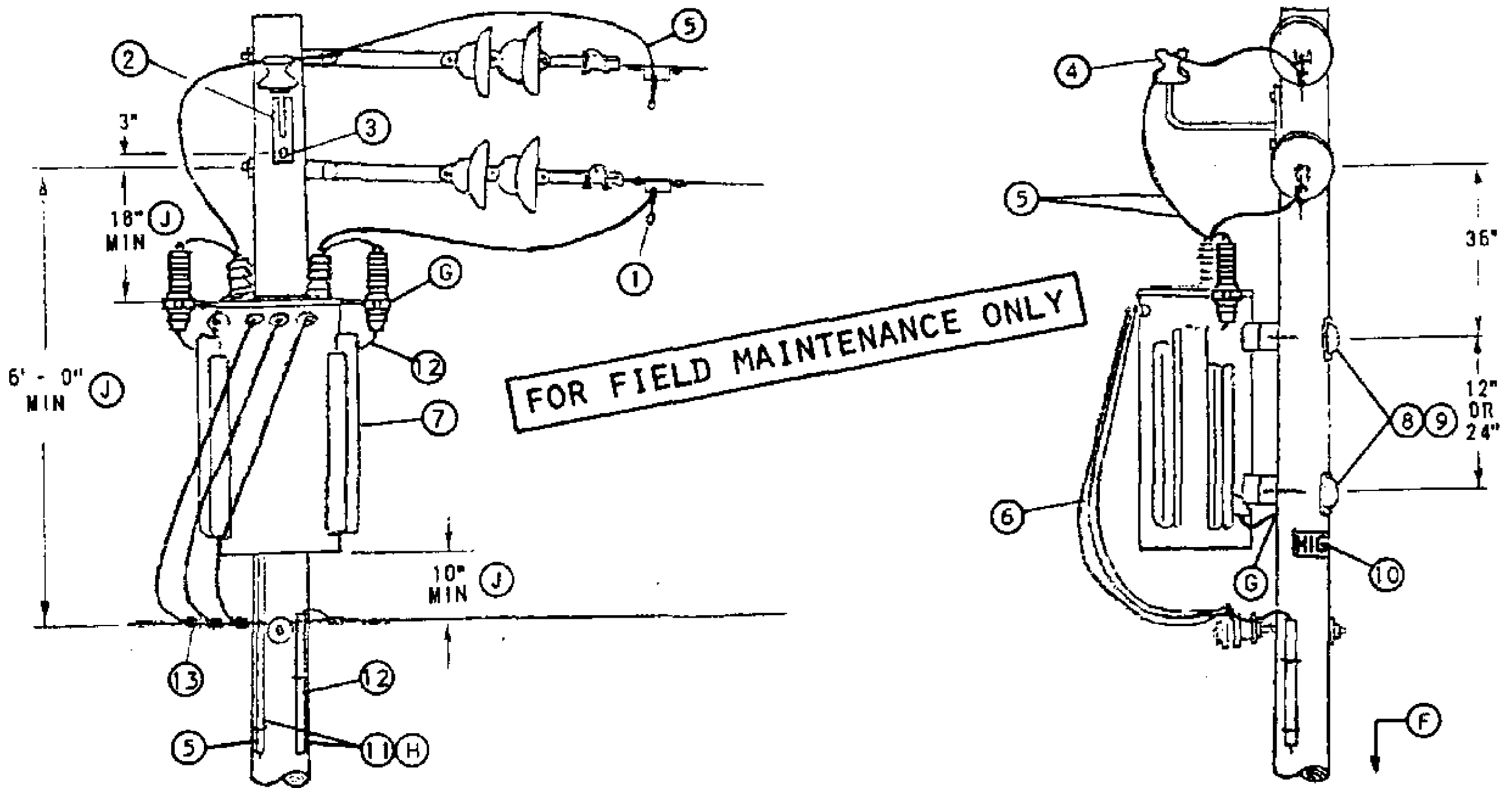

BILL OF MATERIAL:

ITEM	DESCRIPTION	QUANTITY		STOCK NO OR CONSTR STANDARD
		HE, YE	HJ, YJ	
1	CLAMP, HOTLINE & STIRRUP (E)	2	2	STD 788
2	BRACKET, INSULATOR, 1", LEAD THREAD	1	1	166144
3	SCREW, LAG, GALV, 1/2" X 4" (E)	2	2	621568
4	INSULATOR, 12KV, CLASS 55-5	1	1	429056
5	WIRE, #4, BARE STRANDED COPPER	12'	55'	813760
6	WIRE, W.P., COPPER (SIZE GOVERNED BY TRANSFORMER CAPACITY)	21'	21'	STD 1125
7	TRANSFORMER, SINGLE PHASE (TYPE 'HE', 'HJ', 'YE' OR 'YJ')	1	1	STD 1121
8	BOLT, MACH, GALV, 5/8" OR 3/4" X (LENGTH AS REQ'D), 1 SQ CURVED & 1 DBL COIL SPRING WASHER (E)	2	2	STD 392
9	COVER, BOLT, PLASTIC & 6 - 10D NAILS, GALV (E)	2	2	285696 491392
10	SIGN, HIGH VOLTAGE & 8 ROOFING NAILS, GALV (E)	1	1	647648 492224
11	UNIT GROUND, COMPLETE (H)	1	2	603136
12	WIRE, #6 BARE STRANDED COPPER	42'	50'	813536
13	CONNECTORS, WIRE COMPRESSION, CU OR AL, AS REQ'D (E)	AS REQ'D		783-787

INSTALLATION:

- A. WHEN INSTALLING A NEW STATION ON THE 7.2/12.47KV SYSTEM IN MEOD, AND IF NO PRIMARY NEUTRAL GROUND EXIST ON THE POLE, INCLUDE THE NECESSARY MATERIALS TO INSTALL THE REQUIRED PRIMARY NEUTRAL GROUND. CONNECT TO TRANSFORMER TANK GAP GROUND.
- B. FOR USE ONLY WHERE FUTURE EXTENSION IS UNLIKELY, SUCH AS CUL-DE-SACS.
- (E) EXEMPT MATERIAL.

REFERENCE:

- (F) POLE STEPPING - SEE STANDARD 363.
- (G) WHEN LIGHTNING ARRESTERS ARE REQUIRED PER STANDARD 1247, USE TYPE 'HJ' OR 'YJ' TRANSFORMERS, AND GROUND TANK GAP.
- (H) GROUNDING METHODS - SEE STANDARD 1002.
- (I) FOR POLE TOP MATERIAL - SEE DISTRIBUTION POLE TOPS (SECTION 400).
- (J) G.O. 95 MINIMUM REQUIREMENTS.
- (K) FOR AERIAL CABLE CONSTRUCTION - SEE SECTION 600.

1199.402
SUPERSEDES
1142 (1-1-86)

SDG&E ELECTRIC STANDARDS

7.2 OR 12KV SINGLE PHASE YE, YJ, HE, OR HJ TRANSFORMER
INSTALLATION 100 KVA MAXIMUM ARMLESS DEAD END CONSTRUCTION

ISSUE 1993

DATE 1-1-86

APPD AK/RSS

FIELD MAINTENANCE ONLY

REVISION HISTORY:

7/13/2016: All versions prior to 2016 are superseded by their current version found inside the Overhead Construction Standard Manual.

© 1998 - 2016 San Diego Gas & Electric Company. All rights reserved. Removal of this copyright notice without permission is not permitted under law.

REV	CHANGE	BY	DSGN	APPV	DATE	REV	CHANGE	BY	DSGN	APPV	DATE
C						F					
B						E					
A	ORIGINAL ISSUE	JS	IL	MDJ	7/13/2016	D					

SHEET 1 OF 1	 Indicates Latest Revision	Completely Revised	New Page	Information Removed	FMO OH 1145
	SDG&E ELECTRIC OVERHEAD STANDARD				
	7.2 OR 12KV SINGLE PHASE YE, YJ, HE, OR HJ TRANSFORMER INSTALLATION, SECONDARY RACK CONSTRUCTION				

SCOPE: THIS STANDARD SHOWS THE INSTALLATION METHOD OF A SINGLE PHASE TRANSFORMER, WITH SECONDARY RACK CONSTRUCTION.

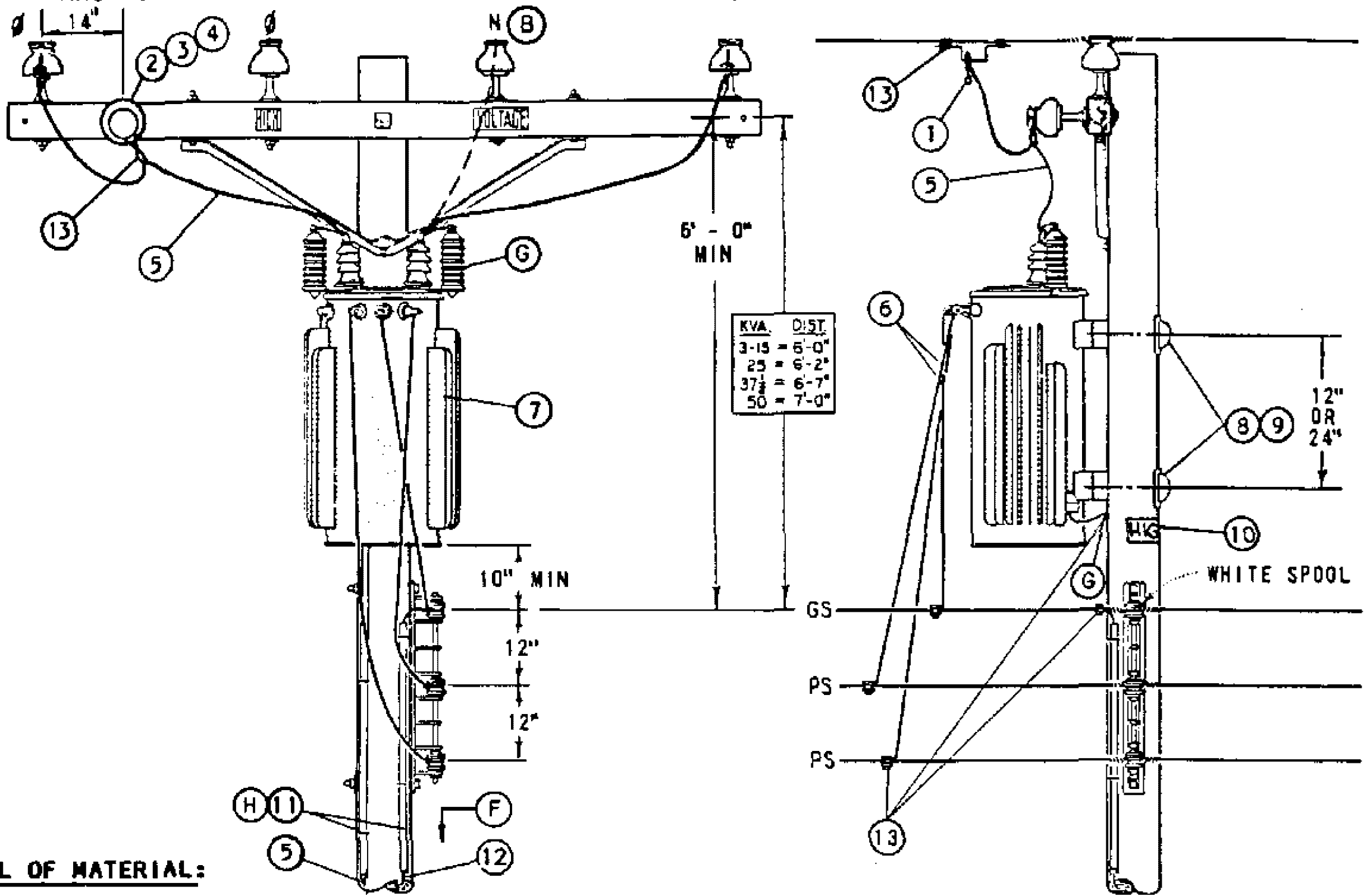

BILL OF MATERIAL:

ITEM	DESCRIPTION	QUANTITY		STOCK NO OR CONSTR STANDARD
		HE, YE	HJ, YJ	
1	CLAMP, HOTLINE & STIRRUP (E)	2	2	STD 788
2	BOLT, MACH, GALV, 5/8" X (LENGTH AS REQ'D), 2 SQ WASHERS & 1 DBL COIL SPRING WASHER (E)	1	1	STD 392
3	PIN, TRANSFORMER LEAD ADAPTER 1" OR 1 3/8" (E)	1	1	529248
		1	1	529216
4	INSULATOR, 12KV, 1" OR 1 3/8" PIN (E)	1	1	STD 750
5	WIRE, #4, BARE STRANDED COPPER	14'	55'	813760
6	WIRE, W.P., COPPER (SIZE GOVERNED BY TRANSFORMER CAPACITY)	21'	21'	STD 1125
7	TRANSFORMER, SINGLE PHASE (TYPE HE, HJ, OR YJ, YE)	1	1	STD 1121
8	BOLT, MACH, GALV, 5/8" OR 3/4" X (LENGTH AS REQ'D), 1 SQ CURVED & 1 DBL COIL SPRING WASHER (E)	2	2	STD 392
9	COVER, BOLT, PLASTIC & 6 - 10D NAILS, GALV (E)	2	2	285696
		-	-	491392
10	SIGN, HIGH VOLTAGE & 9 ROOFING NAILS, GALV (E)	1	1	647648
		-	-	492224
11	UNIT GROUND, COMPLETE (H)	1	2	603136
12	WIRE, #6 BARE STRANDED COPPER	42'	50'	813536
13	CONNECTORS, WIRE COMPRESSION, CU OR AL, AS REQ'D (E)	AS REQ'D		783-787

FOR FIELD MAINTENANCE ONLY

INSTALLATION:

A. WHEN INSTALLING A NEW STATION ON THE 7.2/12.47KV SYSTEM IN MEOD IF NO PRIMARY NEUTRAL GROUND EXISTS ON THE POLE, INCLUDE THE NECESSARY MATERIALS TO INSTALL THE REQUIRED PRIMARY NEUTRAL GROUND. CONNECT TO TRANSFORMER TANK GAP GROUND.

- (B) YE & YJ TRANSFORMERS ARE TO BE CONNECTED PHASE TO NEUTRAL.
- (E) EXEMPT MATERIAL.

REFERENCE:

- (F) POLE STEPPING - SEE STANDARD 363.
- (G) WHEN LIGHTNING ARRESTERS ARE REQUIRED PER STANDARD 1247, USE 'HJ' OR 'YJ' TYPE TRANSFORMER WITH TANK GAP GROUND.
- (H) GROUNDING METHODS - SEE STANDARD 1002.

SDG&E ELECTRIC STANDARDS

DATE 1-1-86
APPD AK/RD

7.2 OR 12KV SINGLE Ø YE, YJ, HE OR HJ TRANSFORMER
INSTALLATION, SECONDARY RACK CONSTRUCTION

1199.403
SUPERSEDES
1145 (1-1-93)

FIELD MAINTENANCE ONLY

REVISION HISTORY:

7/13/2016: All versions prior to 2016 are superseded by their current version found inside the Overhead Construction Standard Manual.

© 1998 - 2016 San Diego Gas & Electric Company. All rights reserved. Removal of this copyright notice without permission is not permitted under law.

REV	CHANGE	BY	DSGN	APPV	DATE	REV	CHANGE	BY	DSGN	APPV	DATE
C						F					
B						E					
A	ORIGINAL ISSUE	JS	IL	MDJ	7/13/2016	D					

<input checked="" type="checkbox"/>	Indicates Latest Revision	<input type="checkbox"/>	Completely Revised	<input type="checkbox"/>	New Page	<input type="checkbox"/>	Information Removed
-------------------------------------	---------------------------	--------------------------	--------------------	--------------------------	----------	--------------------------	---------------------

**SHEET
1 OF 1**

SDG&E ELECTRIC OVERHEAD STANDARD

12KV, SINGLE PHASE TYPE "H" TRANSFORMER INSTALLATION,
C.O. ARM, SECONDARY RACK CONSTRUCTION

**FMO
OH 1147**

SCOPE: THIS STANDARD SHOWS THE INSTALLATION METHOD OF A TYPE 'H' TRANSFORMER, WITH CUTOUT ARM AND SECONDARY RACK CONSTRUCTION.

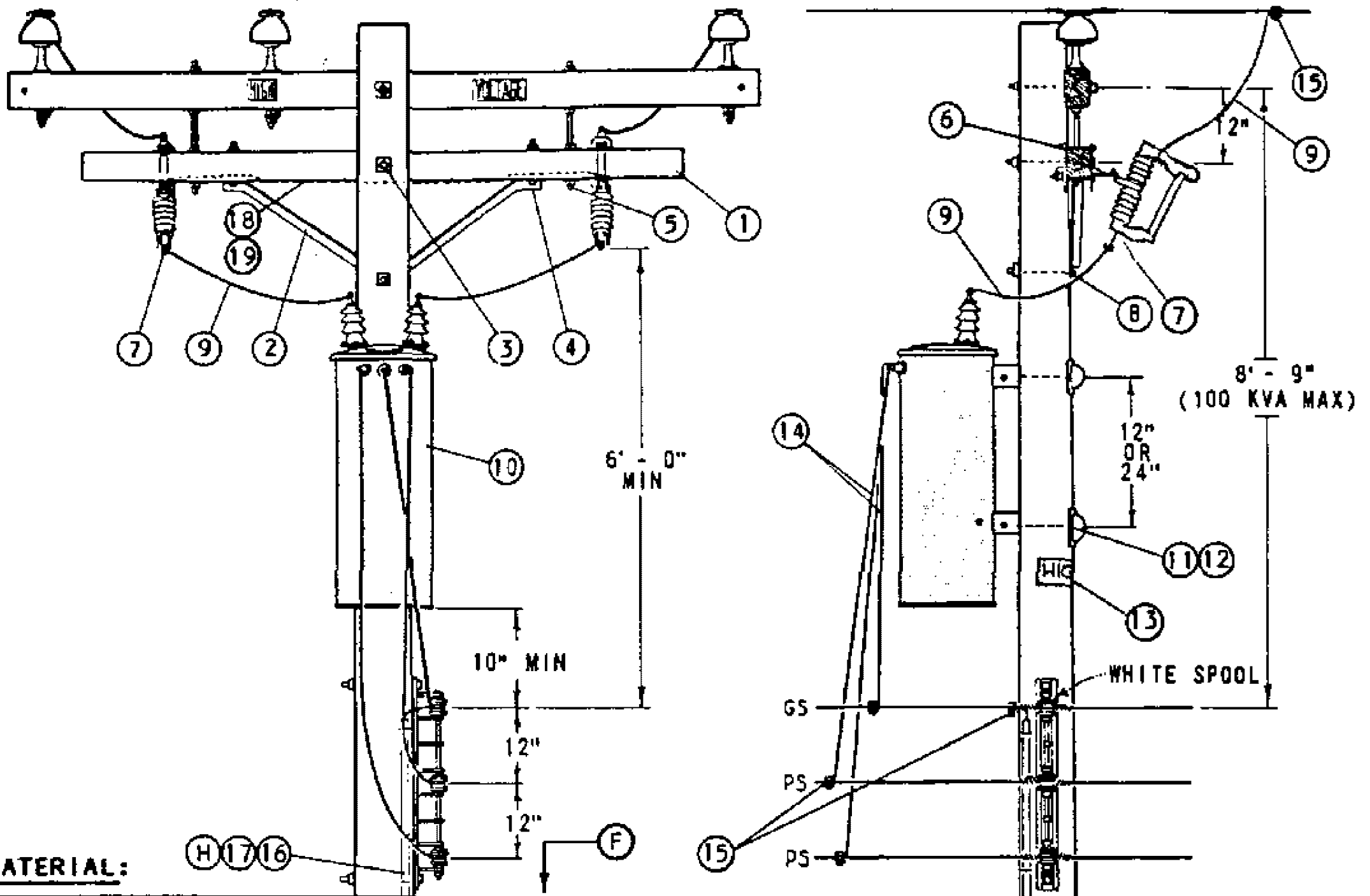

BILL OF MATERIAL:

ITEM	DESCRIPTION	QUANTITY	STOCK NO. OR CONSTR STANDARD
1	CROSSARM, 3 1/2" X 4 1/2" X 8' - 0"	1	293680
2	BRACE, ANGLE, CROSSARM, 4' - 0"	1	164032
3	BOLT, MACH, GALV, 5/8" X (LENGTH AS REQ'D), 2 SQ & 1 DBL COIL SPRING WASHER	(E) 1	STD 392
4	BOLT, MACH, GALV, 1/2" X 7", 1 RD & 1 SPRING LOCK WASHER	(E) 2	STD 392
5	BOLT, SPACE, GALV, 5/8" X 20", 4 SQ & 2 DBL COIL SPR WASHERS	(E) 2	STD 392
6	BRACKET, CUTOUT/ARRESTER, FOR CROSSARM MOUNTING	(E) 2	166070
7	CUTOUT, 12KV	2	STD 1212
8	BOLT, MACH, GALV, 5/8" X (LENGTH AS REQ'D), 1 SQ & 1 DBL COIL SPRING WASHER	(E) 1	STD 392
9	WIRE, #4 BARE STRANDED COPPER	14'	813760
10	TRANSFORMER, SINGLE PHASE, TYPE 'H'	1	STD 1121
11	BOLT, MACH, GALV, 5/8" OR 3/4" X (LENGTH AS REQ'D), 1 SQ CURVED & 1 DBL COIL SPRING WASHER	(E) 2	STD 392
12	COVER, BOLT, PLASTIC & 6 - 10D NAILS, GALV	(E) 2	285696
		(E) -	491392
13	SIGN, HIGH VOLTAGE & 9 ROOFING NAILS, GALV	(E) 1	647648
		(E) -	492224
14	WIRE, W.P., COPPER (SIZE GOVERNED BY TRANSFORMER CAPACITY)	21'	STD 1125
15	CONNECTORS, WIRE COMPRESSION, CU OR AL, AS REQ'D	(E) AS REQ'D	783-787
16	WIRE, #6 BARE STRANDED COPPER	40'	813536
17	UNIT GROUND, COMPLETE	(H) 1	603136
18	WIRE, #8 BARE SOLID ANNEALED COPPER	(I) 8'	812928
19	STAPLES, FENCE, GALV, 1 1/4"	(I) (E) AS REQ'D	678528

FOR FIELD MAINTENANCE ONLY

INSTALLATION:

(E) EXEMPT MATERIAL.

REFERENCE:

(F) POLE STEPPING - SEE STANDARD 363.

(G) FOR LIGHTNING ARRESTER REQUIREMENTS - SEE STANDARD 1247.

(H) GROUNDING METHODS - SEE STANDARD 1002.

(I) BOND ALL CUTOUTS IN HEAVY CONTAMINATION DISTRICT AS IDENTIFIED ON STANDARDS PAGE 287. IF BONDING IS REQUIRED, ORDER ADDITIONAL ITEMS 18 & 19.

1199.404
SUPERSEDES
1147 (1-1-93)

SDG&E ELECTRIC STANDARDS

12KV, SINGLE PHASE TYPE "H" TRANSFORMER INSTALLATION,
C.O. ARM, SECONDARY RACK CONSTRUCTION

DATE 1-1-86

APPD *AK/RS*

FIELD MAINTENANCE ONLY

REVISION HISTORY:

7/13/2016: All versions prior to 2016 are superseded by their current version found inside the Overhead Construction Standard Manual.

© 1998 - 2016 San Diego Gas & Electric Company. All rights reserved. Removal of this copyright notice without permission is not permitted under law.

REV	CHANGE	BY	DSGN	APPV	DATE	REV	CHANGE	BY	DSGN	APPV	DATE
C						F					
B						E					
A	ORIGINAL ISSUE	JS	IL	MDJ	7/13/2016	D					

	Indicates Latest Revision	Completely Revised	New Page	Information Removed
-------------------------------------------------------------------------------------	---------------------------	--------------------	----------	---------------------

**SHEET
1 OF 1**

SDG&E ELECTRIC OVERHEAD STANDARD

12KV SINGLE PHASE TYPE "H" TRANSFORMER INSTALLATION 100 KVA
MAX, LINE ARM MOUNTED CO'S, SECONDARY RACK CONSTRUCTION

**FMO
OH 1149**

SCOPE: THIS STANDARD SHOWS THE INSTALLATION METHOD OF A TYPE 'H' TRANSFORMER, WITH THE CUTOUTS MOUNTED ON THE LINE ARM AND SECONDARY RACK CONSTRUCTION.

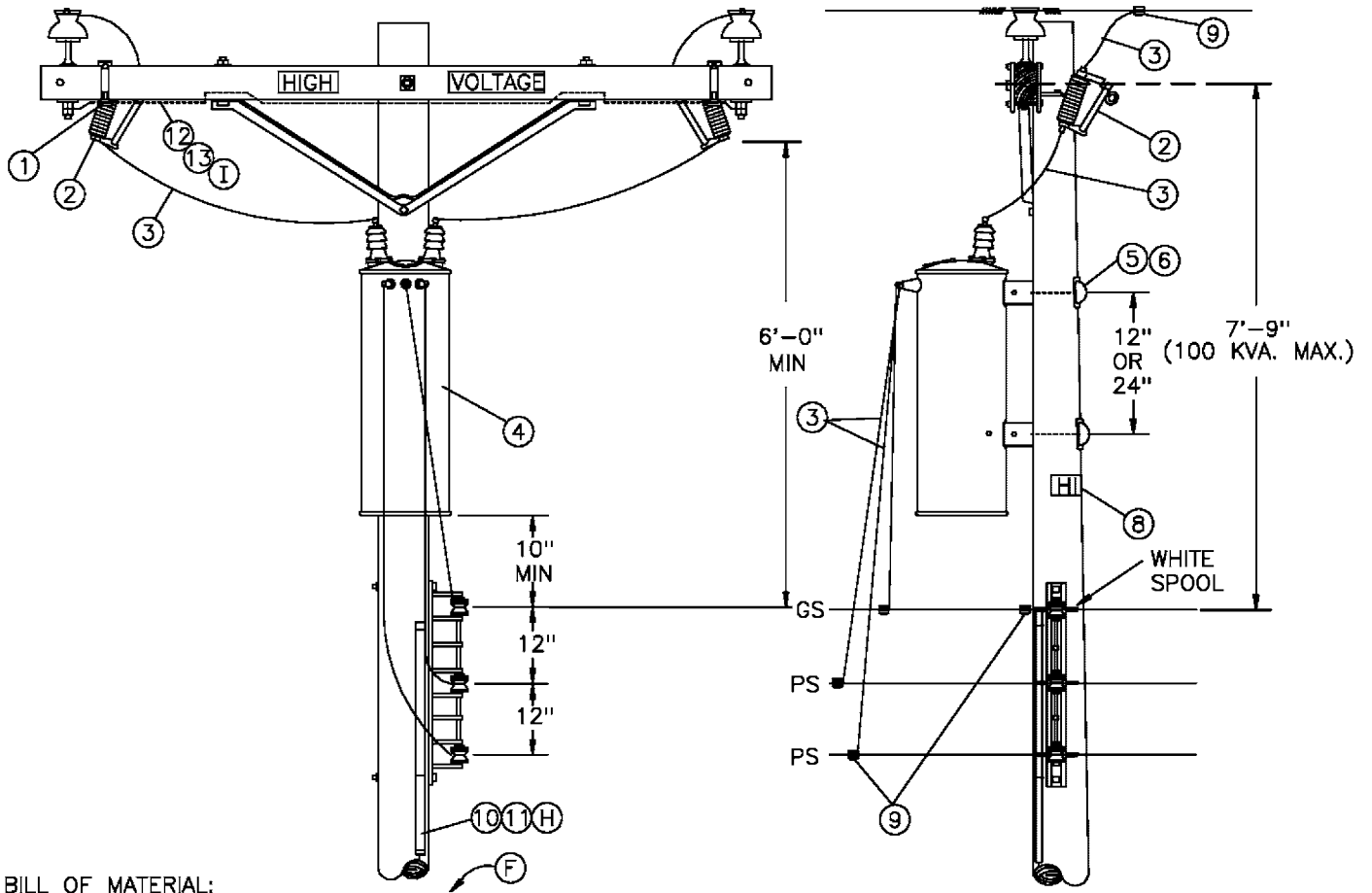

BILL OF MATERIAL:

ITEM	DESCRIPTION	QUANTITY	STOCK NO. OR CONSTR STANDARD
1	BRACKET, CUTOUT/ARRESTER, FOR CROSSARM MOUNTING	2	166070
2	CUTOUT, 12KV	2	STD 1212
3	WIRE, #4 BARE STRANDED COPPER	14'	813760
4	TRANSFORMER, SINGLE PHASE, TYPE 'H'	1	STD 1121
5	BOLT, MACH, GALV, 5/8" OR 3/4" X (LENGTH AS REQ'D), 1 SQ CURVED & 1 DBL COIL SPRING WASHER	2	STD 392
6	COVER, BOLT, PLASTIC & 6 - 10D NAILS, GALV	2	285696 491392
7	WIRE, W.P., COPPER (SIZE GOVERNED BY TRANSFORMER CAPACITY)	21'	STD 1125
8	SIGN, HIGH VOLTAGE & 8 ROOFING NAILS, GALV	1	647648 492224
9	CONNECTORS, WIRE COMPRESSION, CU OR AL, AS REQ'D	AS REQ'D	783-787
10	WIRE, #6 BARE STRANDED COPPER	40'	813536
11	UNIT GROUND, COMPLETE	1	603136
12	WIRE, #8 BARE SOLID ANNEALED COPPER	10'	812928
13	STAPLES, FENCE, GALV, 1 1/4"	AS REQ'D	678528

REFERENCE:

- (F) POLE STEPPING - SEE STANDARD 363.
- G. FOR LIGHTNING ARRESTER REQUIREMENTS - SEE STANDARD 1247.
- (H) GROUNDING METHODS - SEE STANDARD 1002.
BOND ALL CUTOUTS IN HEAVY CONTAMINATION DISTRICT AS IDENTIFIED ON STANDARDS PAGE 827.
- (I) IF BONDING IS REQUIRED, ORDER ADDITIONAL ITEMS 12 & 13.

FOR FIELD MAINTENANCE ONLY

SDG&E ELECTRIC STANDARDS		1199.405 SUPERSEDES 1149 (1-1-93)
DATE 1-1-86 APPD /	12KV SINGLE PHASE TYPE "H" TRANSFORMER INSTALLATION 100KVA MAX, LINE ARM MOUNTED CO'S, SECONDARY RACK CONSTRUCTION	

FIELD MAINTENANCE ONLY

REVISION HISTORY:

7/13/2016: All versions prior to 2016 are superseded by their current version found inside the Overhead Construction Standard Manual.

© 1998 - 2016 San Diego Gas & Electric Company. All rights reserved. Removal of this copyright notice without permission is not permitted under law.

REV	CHANGE	BY	DSGN	APPV	DATE	REV	CHANGE	BY	DSGN	APPV	DATE
C						F					
B						E					
A	ORIGINAL ISSUE	JS	IL	MDJ	7/13/2016	D					

	Indicates Latest Revision	Completely Revised	New Page	Information Removed
-------------------------------------------------------------------------------------	---------------------------	--------------------	----------	---------------------

**SHEET
1 OF 1**

SDG&E ELECTRIC OVERHEAD STANDARD

12KV SINGLE PHASE TYPE "H" TRANSFORMER INSTALLATION, 100 KVA MAX,
LINE ARM MOUNTED CO'S, SECONDARY LINE ARM CONSTRUCTION

**FMO
OH 1150**

SCOPE: THIS STANDARD SHOWS THE INSTALLATION METHOD OF A TYPE 'H' TRANSFORMER, WITH THE CUTOUTS MOUNTED ON THE LINE ARM AND SECONDARY CROSSARM CONSTRUCTION.

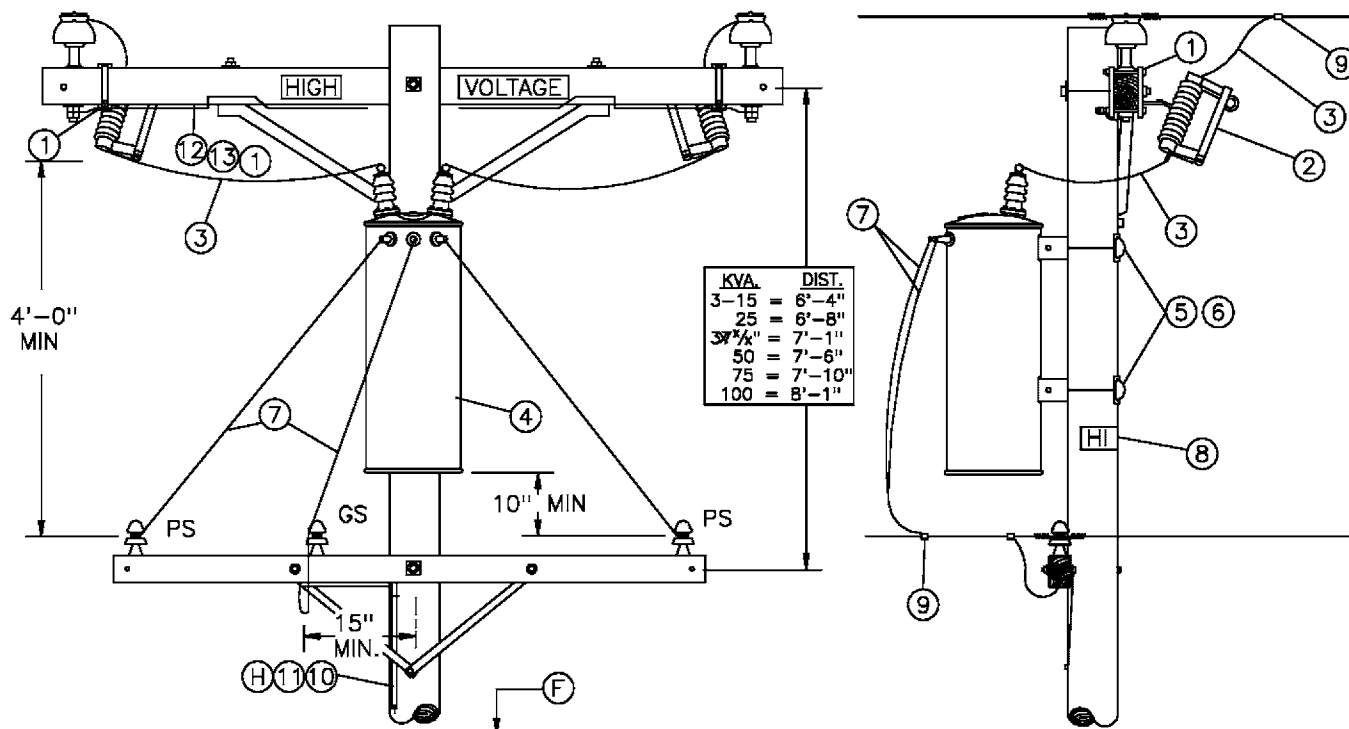

BILL OF MATERIAL:

ITEM	DESCRIPTION	QUANTITY	STOCK NO. OR CONTR STANDARD
1	BRACKET, CUTOUT/ARRESTER, FOR CROSSARM MOUNTING	2	166070
2	CUTOUT, 12KV	2	STD 1212
3	WIRE, #4 BARE STRANDED COPPER	14'	813536
4	TRANSFORMER, SINGLE PHASE, TYPE 'H'	1	STD 1121
5	BOLT, MACH, GALV, 5/8" OR 3/4" X (LENGTH AS REQ'D), 1 SQ CURVED & 1 DBL COIL SPRING WASHER	2	STD 392
6	COVER, BOLT, PLASTIC & 6 - 10D NAILS, GALV	2	285696 491392
7	WIRE, W.P., COPPER (SIZE GOVERNED BY TRANSFORMER CAPACITY)	21'	STD 1125
8	SIGN, HIGH VOLTAGE & 8 ROOFING NAILS, GALV	1	647648 492224
9	CONNECTORS, WIRE COMPRESSION, CU OR AL, AS REQ'D	AS REQ'D	783-787
10	WIRE, #6 BARE STRANDED COPPER	40'	813536
11	UNIT GROUND, COMPLETE	1	603136
12	WIRE, #8 BARE SOLID ANNEALED COPPER	10'	812928
13	STAPLES, FENCE, GALV, 1 1/4"	AS REQ'D	678528

FOR FIELD MAINTENANCE ONLY

REFERENCE:

- (F) POLE STEPPING - SEE STANDARD 363.
- G. FOR LIGHTNING ARRESTER REQUIREMENTS - SEE STANDARD 1247.
- (H) GROUNDING METHODS - SEE STANDARD 1002.
- (I) BOND ALL CUTOUTS IN HEAVY CONTAMINATION DISTRICT AS IDENTIFIED ON STANDARDS PAGE 287. IF BONDING IS REQUIRED, ORDER ADDITIONAL ITEMS 12 & 13.

SDG&E ELECTRIC STANDARDS		1199.503 SUPERSEDES 1150 (1-1-93)
DATE 1-1-86 APPD /	12KV SINGLE PHASE TYPE "H" TRANSFORMER INSTALLATION, 100 KVA MAX, LINE ARM MOUNTED CO'S, SECONDARY LINE ARM CONSTRUCTION	

FIELD MAINTENANCE ONLY

REVISION HISTORY:

7/13/2016: All versions prior to 2016 are superseded by their current version found inside the Overhead Construction Standard Manual.

© 1998 - 2016 San Diego Gas & Electric Company. All rights reserved. Removal of this copyright notice without permission is not permitted under law.

REV	CHANGE	BY	DSGN	APPV	DATE	REV	CHANGE	BY	DSGN	APPV	DATE
C						F					
B						E					
A	ORIGINAL ISSUE	JS	IL	MDJ	7/13/2016	D					

	Indicates Latest Revision	Completely Revised	New Page	Information Removed
-------------------------------------------------------------------------------------	---------------------------	--------------------	----------	---------------------

**SHEET
1 OF 1**

SDG&E ELECTRIC OVERHEAD STANDARD

4KV OPEN WYE OR 2.4KV OPEN DELTA TYPE "W" TRANSFORMER
INSTALLATION 2-50KVA MAX., ARMLESS TANGENT CONSTRUCTION

**FMO
OH 1154**

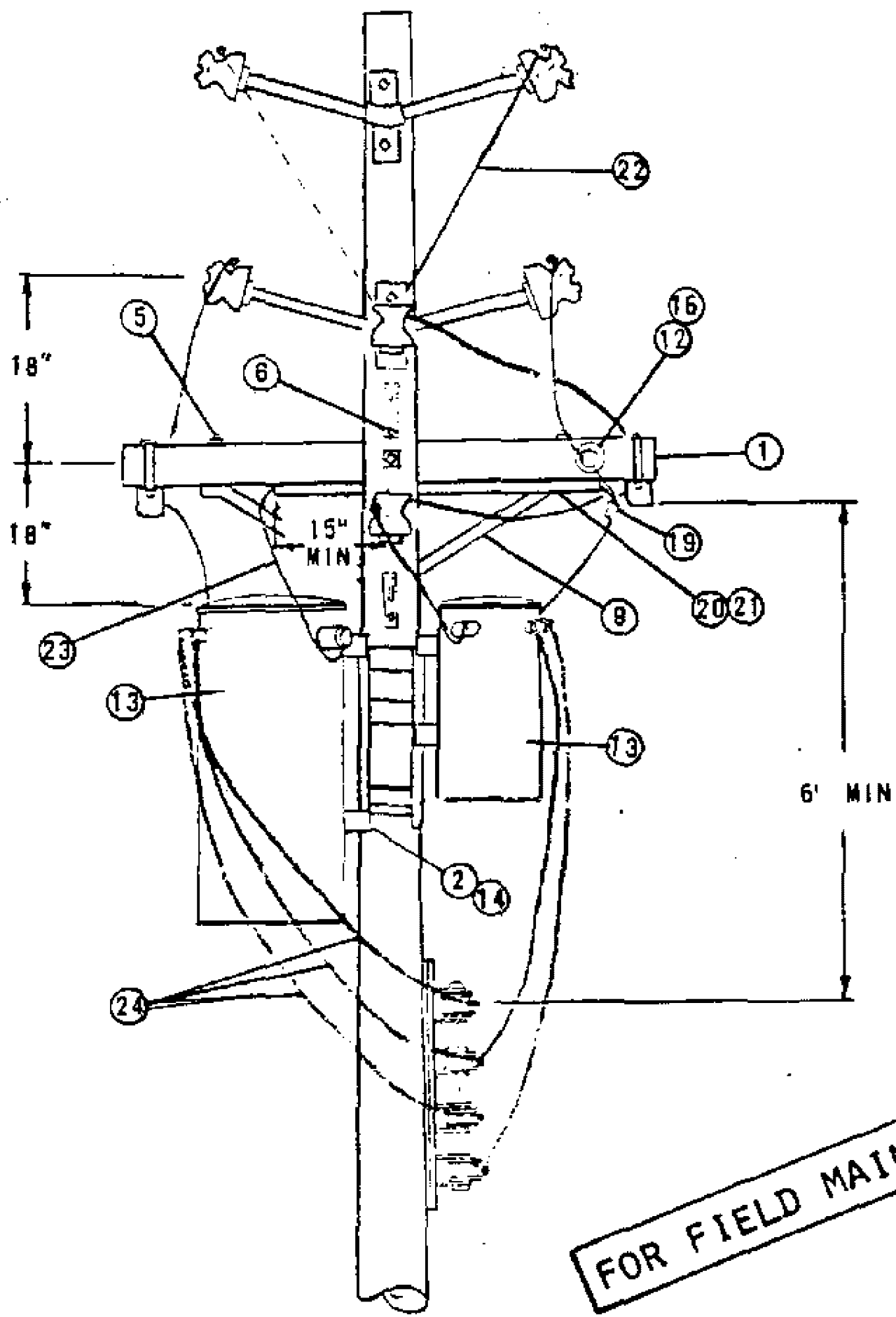

FOR FIELD MAINTENANCE ONLY

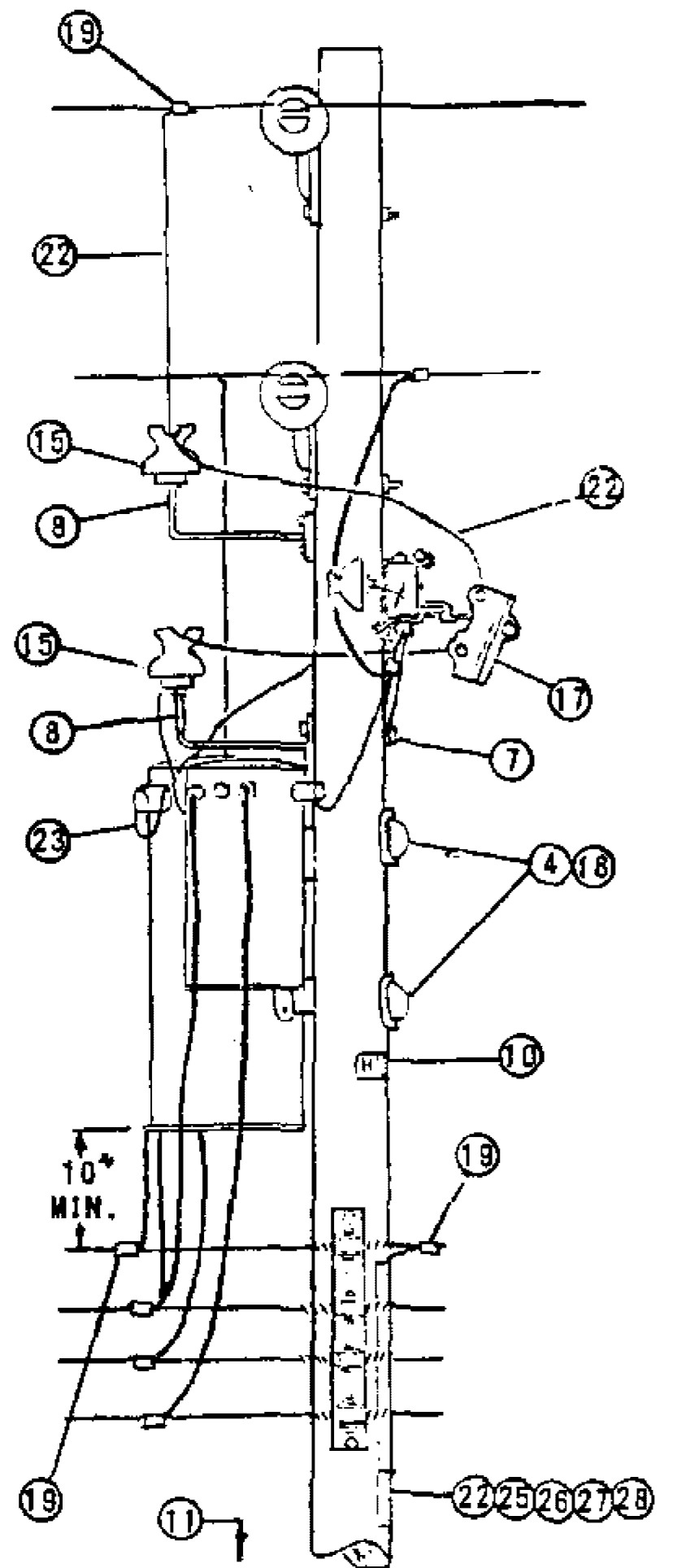

SDG&E ELECTRIC STANDARDS

DATE 1-1-86

APPD *AK/RDA*

4KV OPEN WYE OR 2.4KV OPEN DELTA TYPE "W" TRANSFORMER
INSTALLATION 2-50KVA MAX., ARMLESS TANGENT CONSTRUCTION

1199.501

SUPERSEDES
1154.1 (1-1-86)

NOTES:

- (A) LIMITED TO TWO 50KVA MAXIMUM TRANSFORMER BECAUSE OF ENCRoACHMENT INTO CLIMBING SPACE.
- (B) USE TWO GROUND RODS SPACED A MINIMUM OF 6 FEET APART FOR EACH GROUND UNIT.
- (C) 2.4KV 3Ø OPEN DELTA INSTALLATIONS REQUIRE THREE CUTOUTS. FOR CONNECTIONS SEE PAGES 1117 AND 1118.
- D. DO NOT USE OPEN DELTA OR OPEN WYE CONSTRUCTION WHERE SIZE OF A SINGLE 3Ø MOTOR IS 15 HP OR LARGER.
- (E) EXEMPT MATERIAL.
- F. SEE DISTRIBUTION POLE TOPS SECTION FOR POLE TOP MATERIAL.
- (G) UNIT GROUND COMPLETE ORDER 603120 WITH GRAY MOULDING, 603136 WITH PLAIN MOULDING.
- H. SEE ARRESTER SECTION FOR ARRESTER REQUIREMENTS.

ITEM		DESCRIPTION	QUANTITY	STOCK NO. OR CONSTR STD.
PTF	LT1			
1		CROSSARM, 3 1/2" X 4 1/2" X 6'-0"	1	PG
2		BOLT, MACH., GALV., 5/8" (E) OR 3/4" X 2", 1 LOCK SPR WASH.	4	PGS 139, 140
3		BOLT, MACH., GALV., 5/8" X _____, 2 SQ WASH. 1 DBL. COIL SPR. WASH. (E)	1	PGS 139, 140
4		BOLT, MACH., GALV., 3/4" X _____, 1 SQ. CURV. WASH. WASH & 1 DBL COIL SPR. WASH.	2	PGS 139, 140
5		BOLT, MACH., GALV., 1/2" X 6", 1 RD WASH., 1 DBL. COIL SPR. WASH. (E)	2	153088
6		SCREW, LAG. GALV., 1/2" X 4" (E)	4	621568
7		SCREW, LAG. GALV., 5/8" X 5" (E)	1	621600
8		BRACKET, INSULATOR, 1"	2	166144
9		BRACE, CROSSARM, ANGLE 4'-0"	1	164032
10		SIGN, HIGH VOLTAGE & B ROOFING NAILS, GALV. (E)	1	647648, 492224
11		STEPS, POLE (E)	16	692992
12		BOLT, MACH. 5/8" X 5" (E)	1	155488
13		TRANSFORMER, SINGLE PHASE	2	PGS 1121.1-1121.12
14		BRACKET, TRANSFORMER MOUNTING	1	402976
15		INSULATOR (E)	2	429024, 429216
16		PIN ADAPTER, 1 INCH THREAD	1	529248
17		CUTOUT, 5KV (C)	2	PG 1211
18		COVER, PLASTIC THRU BOLT & 2-20D NAILS, GALV. (E)	2	285696, 491392
19		CONNECTORS, WIRE COMPRESSION	9	PGS 783-787
20		CONDUIT, PVC, 3/4", SCHEDULE 40, TYPE 11 (E)	4'-0"	251328
21		STRAPS, PIPE, 3/4", 2-6D NAILS, GALV. (E)	3	697888
22		WIRE, BARE STRANDED COPPER #6	41'	813536
23		WIRE, INSULATED, XLP, STRANDED COPPER, 5KV, #6	30'	194304
24		WIRE, W.P., COPPER, (SIZE GOVERNED BY TRANSFORMER CAPACITY)	30'	PG 1125
25		ROD, GROUND & CLAMP (B) (G)	2	603072, 230016 (E)
26		MOULDING, HARDWOOD, 1" (G)	27'	487200
27		STAPLES, MOULDING, GALV., 3" X 1 1/16" X 1/4" (G) (E)	18	678550
28		STAPLES, FENCE, GALV., 1 1/4" (G) (E)	20	678528
29				

FOR FIELD MAINTENANCE ONLY

FIELD MAINTENANCE ONLY

REVISION HISTORY:

7/13/2016: All versions prior to 2016 are superseded by their current version found inside the Overhead Construction Standard Manual.

© 1998 - 2016 San Diego Gas & Electric Company. All rights reserved. Removal of this copyright notice without permission is not permitted under law.

REV	CHANGE	BY	DSGN	APPV	DATE	REV	CHANGE	BY	DSGN	APPV	DATE
C						F					
B						E					
A	ORIGINAL ISSUE	JS	IL	MDJ	7/13/2016	D					

	Indicates Latest Revision	Completely Revised	New Page	Information Removed
-------------------------------------------------------------------------------------	---------------------------	--------------------	----------	---------------------

**SHEET
1 OF 1**

SDG&E ELECTRIC OVERHEAD STANDARD

4KV OPEN WYE TYPE "W" TRANSFORMER
INSTALLATION, SECONDARY LINE ARM CONSTRUCTION

**FMO
OH 1156**

SCOPE: THIS STANDARD SHOWS THE INSTALLATION METHOD OF A 4KV OPEN WYE WITH TYPE "W" TRANSFORMERS, AND SECONDARY LINE ARM CONSTRUCTION.

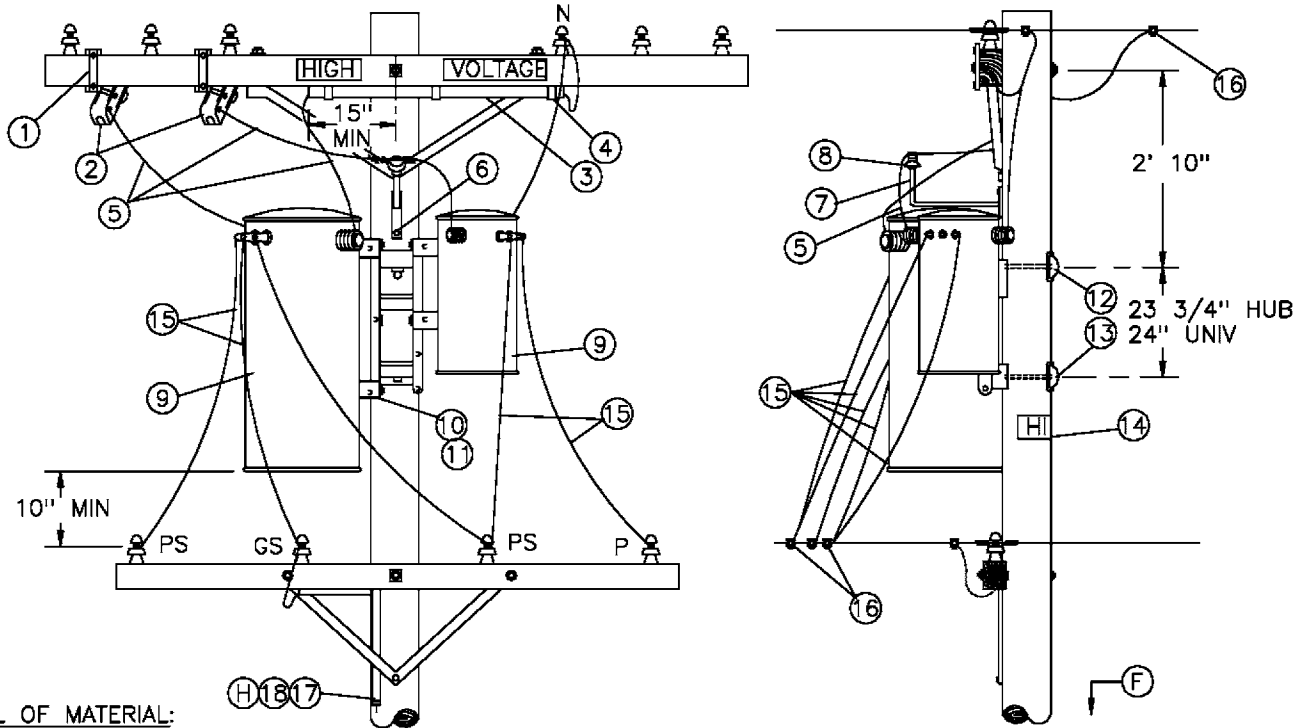

BILL OF MATERIAL:

ITEM	DESCRIPTION	QUANTITY	STOCK NO OR CONSTR STANDARD
1	BRACKET, CUTOUT/ARRESTER, FOR CROSSARM MOUNTING	2	166070
2	CUTOUT, 12KV	2	STD 1212
3	CONDUIT, PVC, 3/4" X 4", SCHED 40, TYPE 2	1	251328
4	STRAP, CONDUIT, 3/4", GALV & 2 - 6D NAILS, GALV	3	697888 491552
5	WIRE, 5KV INSULATED, XLP, #6 STRANDED COPPER	25'	194304
6	SCREW, LAG, 1/2" X 4"	2	621568
7	BRACKET, INSULATOR, 1" LEAD THREAD	1	166134
8	INSULATOR, 12KV NEUTRAL	1	429216
9	TRANSFORMER, SINGLE PHASE, TYPE W	1	STD 1121
10	BRACKET, TRANSFORMER MOUNTING	1	402976
11	BOLT, MACH, GALV, 5/8" OR 3/4" X 2", 2 RD & 1 LOCK WASHER	4	STD 392
12	BOLT, MACH, GALV, 3/4" X (LENGTH AS REQ'D), 1 SQ CURV & 1 DBL COIL SPRING WASHER	2	STD 392
13	COVER, VOLT, PLASTIC & 6 - 10D NAILS, GALV	2	285696 491392
14	SIGN, HIGH VOLTAGE & 8 ROOFING NAILS, GALV	1	647648 492224
15	WIRE, W.P. (SIZE GOVERNED BY TRANSFORMER CAPACITY)	35'	STD 1125
16	CONNECTORS, WIRE COMPRESSION, CU OR AL, AS REQ'D	AS REQ'D	783-787
17	WIRE, BARE STRANDED, COPPER, #6	40'	813536
18	UNIT GROUND, COMPLETE	1	603136

INSTALLATION:

- (A) LIMITED TO 50 KVA MAXIMUM TRANSFORMER BECAUSE OF ENCROACHMENT INTO CLIMBING SPACE.
- (B) 2.4KV 3Ø OPEN DELTA INSTALLATIONS REQUIRE THREE CUTOUTS. FOR CONNECTIONS SEE PAGE 1117.
- C. DO NOT USE OPEN DELTA OR OPEN WYE CONSTRUCTION WHERE SIZE OF A SINGLE 3Ø MOTOR IS 15 HP OR LARGER.

REFERENCE:

- (F) POLE-STEPPING - SEE STANDARD 363.
- G. FOR LIGHTNING ARRESTER REQUIREMENTS - SEE STANDARD 1247.
- (H) GROUNDING METHODS - SEE STANDARD 1002.
- I. BOND ALL CUTOUTS IN HEAVY CONTAMINATION DISTRICTS AS IDENTIFIED ON STANDARD 287.

1199.504
SUPERSEDES
1156 (1-1-93)

SDG&E ELECTRIC STANDARDS

4KV OPEN WYE TYPE "W" TRANSFORMER
INSTALLATION, SECONDARY LINE ARM CONSTRUCTION

DATE 1-1-86
APPD /

FIELD MAINTENANCE ONLY

REVISION HISTORY:

7/13/2016: All versions prior to 2016 are superseded by their current version found inside the Overhead Construction Standard Manual.

© 1998 - 2016 San Diego Gas & Electric Company. All rights reserved. Removal of this copyright notice without permission is not permitted under law.

REV	CHANGE	BY	DSGN	APPV	DATE	REV	CHANGE	BY	DSGN	APPV	DATE
C						F					
B						E					
A	ORIGINAL ISSUE	JS	IL	MDJ	7/13/2016	D					

	Indicates Latest Revision	Completely Revised	New Page	Information Removed
-------------------------------------------------------------------------------------	---------------------------	--------------------	----------	---------------------

**SHEET
1 OF 1**

SDG&E ELECTRIC OVERHEAD STANDARD

12KV OPEN DELTA TYPE "HE" OR "HJ" TRANSFORMER
INSTALLATION, 2-50KVA MAX., ARMLESS TANGENT CONSTRUCTION

**FMO
OH 1161**

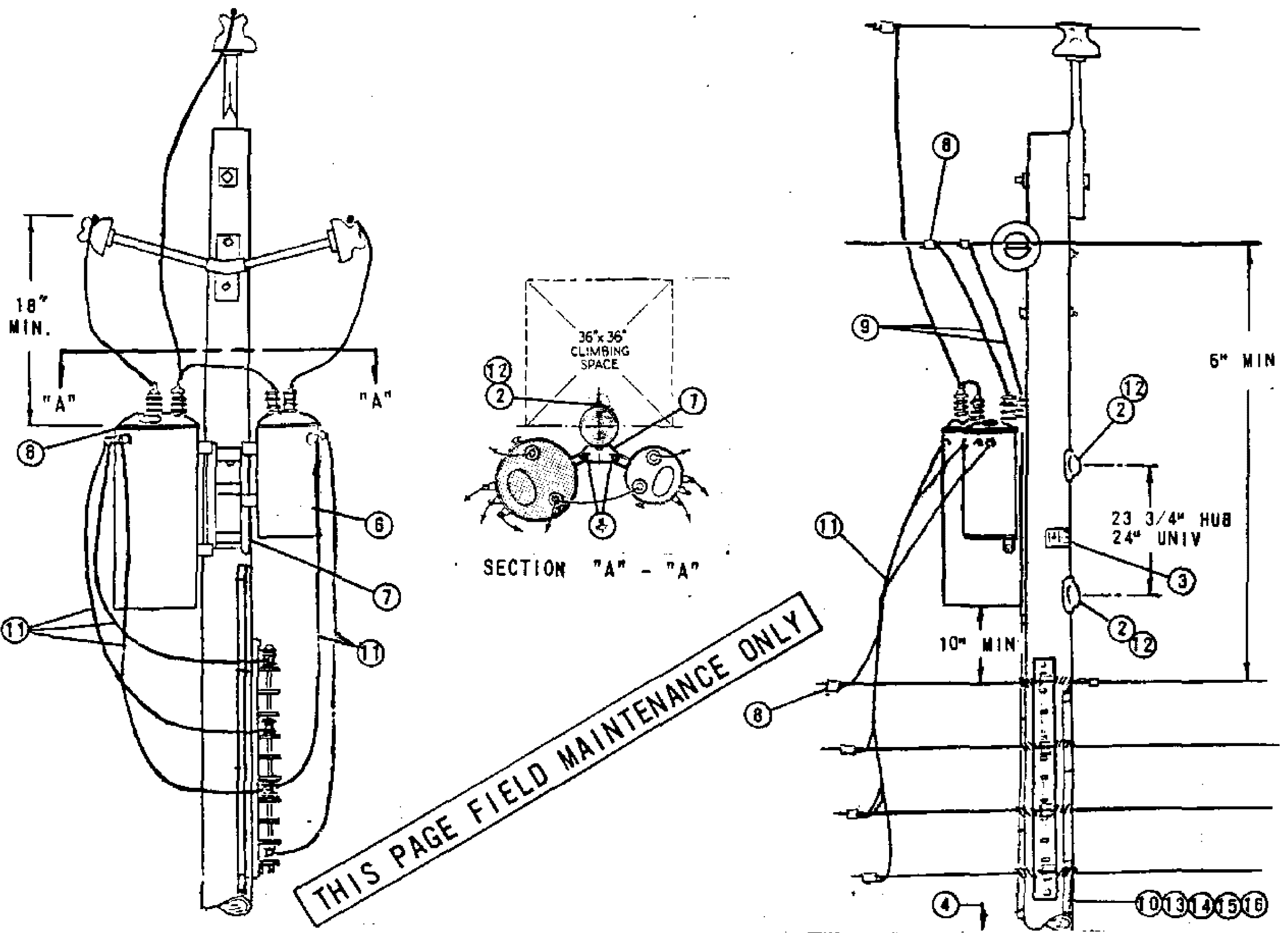

NOTES:

- (A) UNIT GROUND COMPLETE ORDER 603120 WITH GRAY MOULDING, 603136 WITH PLAIN MOULDING.
- (B) USE TWO ROD GROUND.
- C. SEE DISTRIBUTION POLE TOP SECTION FOR POLE TOP MATERIAL.
- D. LIMITED TO TWO 50KVA MAXIMUM TRANSFORMER BECAUSE OF ENCROACHMENT INTO CLIMBING SPACE.
- (E) EXEMPT MATERIAL.
- F. WHEN ARRESTERS ARE REQUIRED PER STANDARDS PAGE 1247, USE TYPE 'HJ' TRANSFORMERS.

ITEM	DESCRIPTION	QUANTITY		STOCK NO. OR CONSTR. STD.
		HE	HJ	
	BOLT, MACH., GALV., 5/8" (E) OR 3/4" X 2", 1 SQ. CURV WASH, 1 LOCK SPR WASH.	4	4	PGS 139, 140
2	BOLT, MACH., GALV., 3/4" X _____ 1 SQ. CURV. WASH, 1 DBL COIL SPR WASH.	2	2	PGS 139, 140
3	SIGN, HIGH VOLTAGE & 8 ROOFING NAILS, GALV	(E) 1	1	647648, 492192
4	STEPS, POLE	(E) 16	16	692992
5				
6	TRANSFORMER, SELF PROTECTED TYPE, SINGLE PHASE (HE or HJ)	2	2	PGS 1121, 01-1121.12
7	BRACKET, TRANSFORMER MOUNTING	1	1	402976
8	CONNECTORS, WIRE, COMPRESSION	10	11	PGS 783, 787
9	WIRE, BARE STRANDED, COPPER, #6	70'	70'	813536
10	WIRE, BARE STRANDED, COPPER, #2	—	40'	813664
11	WIRE, W.P. COPPER, (SIZE GOVERNED BY TRANSFORMER CAPACITY)	30'	30'	PG 1125
12	COVER, PVC THRU BOLT & 6-100. NAILS, GALV.	(E) 2	2	285696, 491392
13	ROD, GROUND & CLAMP (B)	(A) 2	4	603072, 230016 (E)
14	MOULDING, HARDWOOD, 1"	(A) 27'	57'	487200
15	STAPLES, MOULDING, GALV., 3" X 1 1/16" X 1/4"	(A) (E) 20	38	678560
16	STAPLES, FENCE, GALV., 1 1/4"	(A) (E) 25	50	678528
17				

FIELD MAINTENANCE ONLY

REVISION HISTORY:

7/13/2016: All versions prior to 2016 are superseded by their current version found inside the Overhead Construction Standard Manual.

© 1998 - 2016 San Diego Gas & Electric Company. All rights reserved. Removal of this copyright notice without permission is not permitted under law.

REV	CHANGE	BY	DSGN	APPV	DATE	REV	CHANGE	BY	DSGN	APPV	DATE
C						F					
B						E					
A	ORIGINAL ISSUE	JS	IL	MDJ	7/13/2016	D					

	Indicates Latest Revision	Completely Revised	New Page	Information Removed
-------------------------------------------------------------------------------------	---------------------------	--------------------	----------	---------------------

**SHEET
1 OF 1**

SDG&E ELECTRIC OVERHEAD STANDARD

12KV OPEN DELTA TYPE "HE" OR "HJ" TRANSFORMER INSTALLATION
2-50KVA MAX., ARMLESS DEAD END CONSTRUCTION

**FMO
OH 1162**

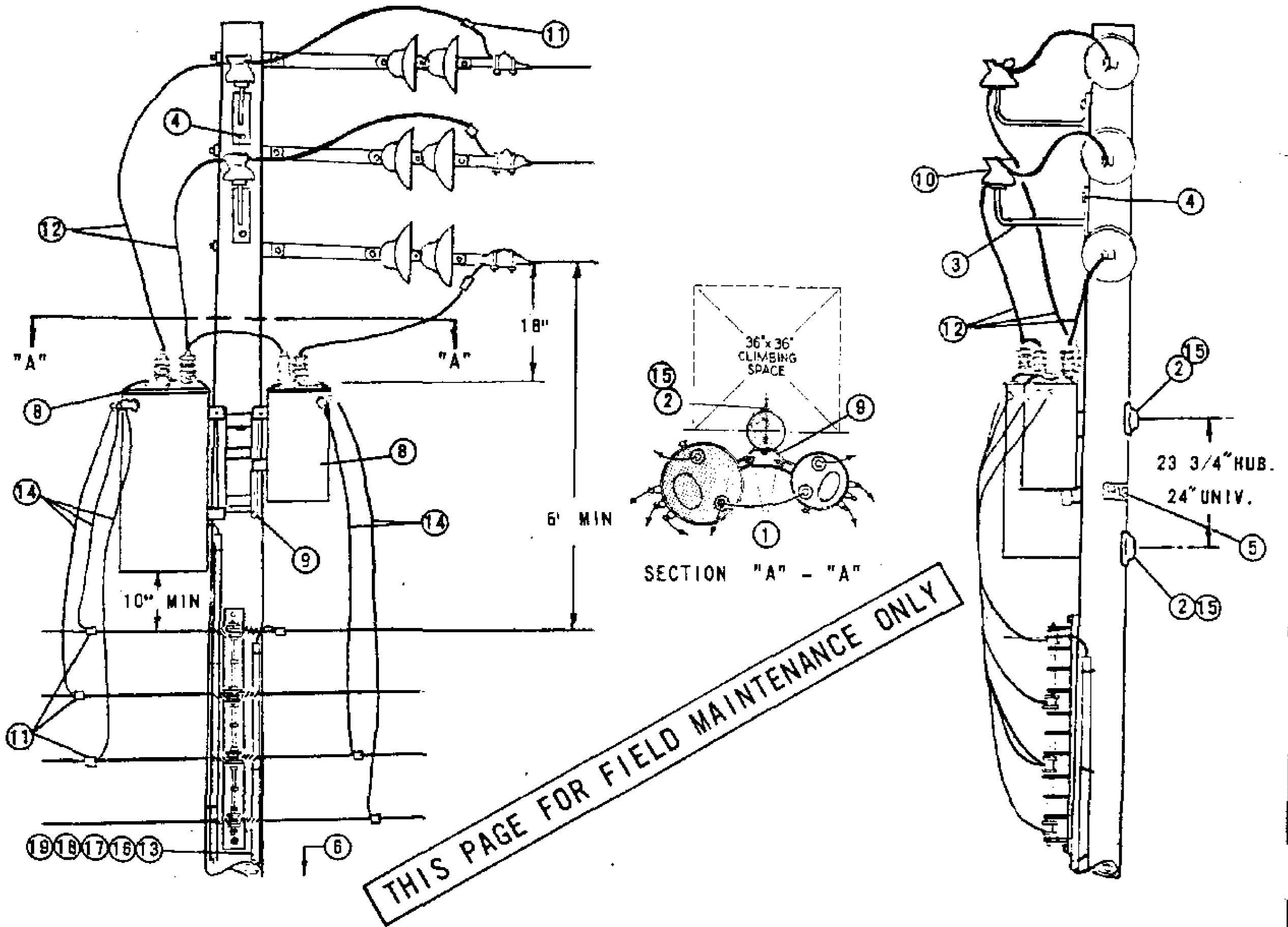

NOTES:

- (A) UNIT GROUND COMPLETE ORDER 603120 WITH GRAY MOULDING, 603136 WITH PLAIN MOULDING.
- (B) USE TWO ROD GROUND.
- C. SEE DISTRIBUTION POLE TOP SECTION FOR POLE TOP MATERIAL.
- D. LIMITED TO TWO 50KVA MAXIMUM TRANSFORMER BECAUSE OF ENCROACHMENT INTO CLIMBING SPACE.
- (E) EXEMPT MATERIAL.
- F. WHEN ARRESTERS ARE REQUIRED PER STANDARDS PAGE 1247, USE TYPE 'HJ' TRANSFORMERS.

ITEM	DESCRIPTION		QUANTITY		STOCK NO. OR CONSTR STD
			HE	HJ	
1	PTF	LTI	BOLT, MACH., GALV., 5/8" (E) OR 3/4" X 2", 1 SQ. CURV WASH., 1 LOCK SPR WASH.		PGS 139, 140
2			BOLT, MACH., GALV., 3/4" X 1 SQ. CURV WASH., 1 DBL. COIL SPR. WASH.		PGS 139, 140
3			BRACKET, INSULATOR, 1" OR 1 3/8" LEAD THREAD		166144-166176
4			SCREW, LAG, GALV., 1/2" X 4"		621568
5			SIGN, HIGH VOLTAGE, & 8 ROOFING NAILS, GALV.		647648, 492192
6			STEPS, POLE		692992
7					
8			TRANSFORMER, SELF PROTECTED TYPE, SINGLE PHASE, (HE or HJ)		PGS 1121.01-1121.12
9			BRACKET, TRANSFORMER MOUNTING		402976
10			INSULATOR, 12KV, (CLASS 55-5 OR 56-1)		PG 750
11			CONNECTORS, WIRE COMPRESSION		PGS 783-787
12			WIRE, BARE STRANDED, COPPER #8		813536
13			WIRE, BARE STRANDED, COPPER #2		813664
14			WIRE, W.P. COPPER (SIZE GOVERNED BY TRANSFORMER CAPACITY)		PG 1125
15			COVER, PVC THRU BOLT & 6-100 NAILS, GALV.		285696, 491392
16			ROD, GROUND & CLAMP (B)		603072, 230016 (E)
17			MOULDING, HARDWOOD, 1"		487200
18			STAPLES, MOULDING GALV., 3" X 1 1/16" X 1/4"		678560
19			STAPLES, FENCE, GALV., 1 1/4"		678528

1199.602
SUPERSEDES
1162 (1-1-86)

SDG&E ELECTRIC STANDARDS

12KV OPEN DELTA TYPE "HE" OR "HJ" TRANSFORMER INSTALLATION
2-50KVA MAX., ARMLESS DEAD END CONSTRUCTION

DATE 1-1-86

APPD AK/RS

FIELD MAINTENANCE ONLY

REVISION HISTORY:

7/13/2016: All versions prior to 2016 are superseded by their current version found inside the Overhead Construction Standard Manual.

© 1998 - 2016 San Diego Gas & Electric Company. All rights reserved. Removal of this copyright notice without permission is not permitted under law.

REV	CHANGE	BY	DSGN	APPV	DATE	REV	CHANGE	BY	DSGN	APPV	DATE
C						F					
B						E					
A	ORIGINAL ISSUE	JS	IL	MDJ	7/13/2016	D					

	Indicates Latest Revision	Completely Revised	New Page	Information Removed
-------------------------------------------------------------------------------------	---------------------------	--------------------	----------	---------------------

**SHEET
1 OF 1**

SDG&E ELECTRIC OVERHEAD STANDARD

12KV OPEN DELTA TYPE "HE" OR "HJ" TRANSFORMER INSTALLATION
2-50KVA MAX., SECONDARY ARM CONSTRUCTION

**FMO
OH 1167**

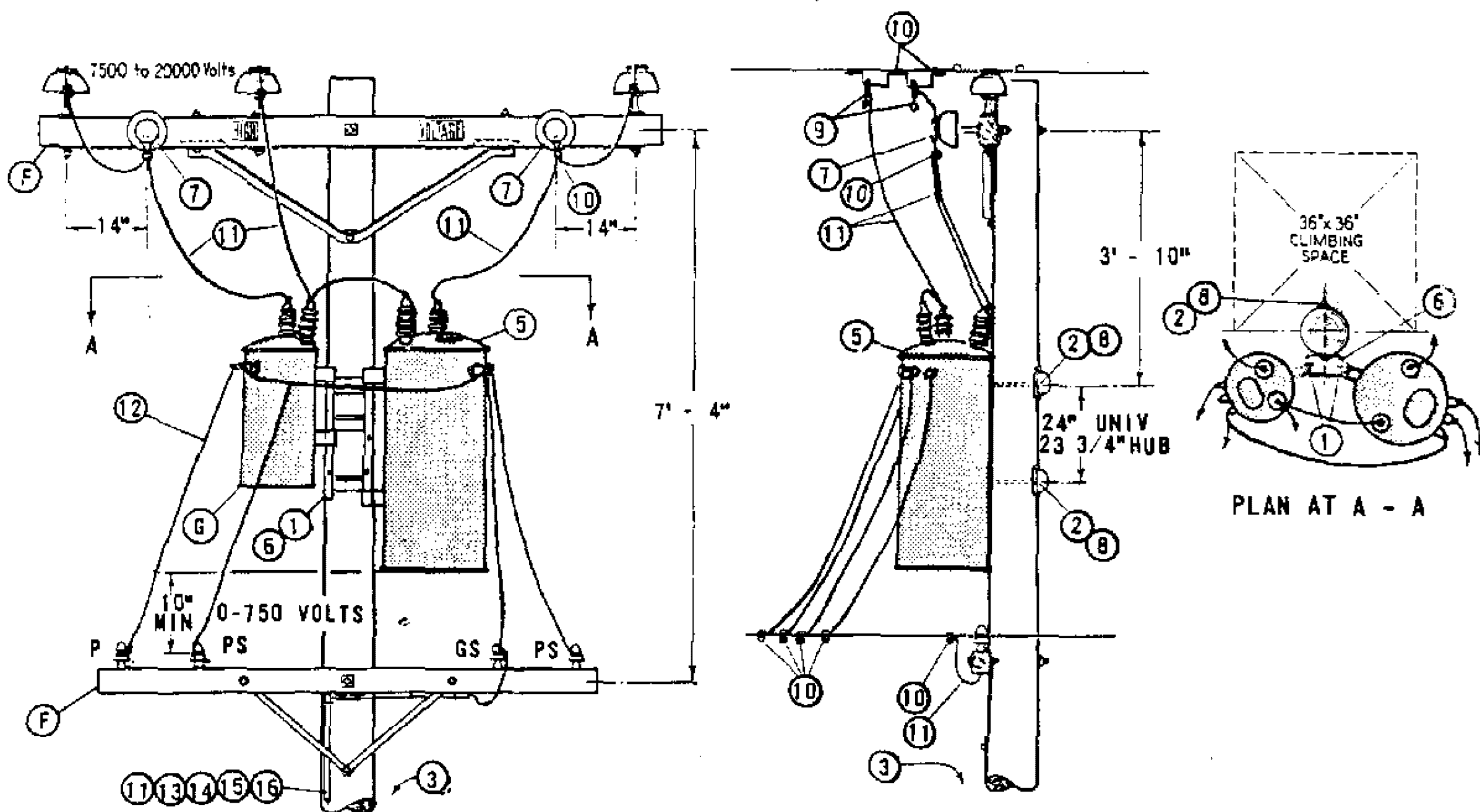

- NOTES:
- A. USE PAGE 1165 FOR NEW CONSTRUCTION. THIS CONSTRUCTION MAY BE USED TO ELIMINATE POLE CHANGEOUTS ON EXISTING POLES WITH THE PRIMARY ALREADY ON ARMS.
 - B. LIMITED TO TWO 50 KVA MAXIMUM TRANSFORMERS BECAUSE OF ENCROACHMENT ON CLIMBING SPACE. 75 KVA TRANSFORMERS MAY BE USED IF THEY HAVE SMALL CASES.
 - C. USE TWO GROUND RODS SPACED NOT LESS THAN 6 FEET APART.
 - D. UNIT GROUND COMPLETE ORDER 603120 WITH GRAY MOULDING, 603136 WITH PLAIN MOULDING.
 - E. EXEMPT MATERIAL.
 - F. PRIMARY AND SECONDARY CONSTRUCTION SHOWN ARE TYPICAL, AND THEIR MATERIALS ARE NOT INCLUDED. MAY BE INSTALLED WITH ARMLESS PRIMARY, RACK SECONDARY, ETC.
 - G. POWER TRANSFORMER TO BE HUNG ON THE SAME SIDE OF POLE AS 2 PHASE WIRES TO PREVENT PHASING PROBLEMS WHEN CLOSING DELTA.

ITEM	DESCRIPTION	QUANTITY	STOCK NO OR CONSTR STDS
P T F	L T I		
1	BOLT, MACH GALV, 5/8" (E) OR 3/4" X 2", 1 RD WASH. & 1 NUT, 1 DBL COIL SPR WASH.	4	PGS 139, 140
2	BOLT, MACH GALV, 3/4" X 10", 1 SQ CURVE WASH., 1 NUT & 1 DBL COIL SPR WASH.	2	PGS 139, 140
3	STEP, POLE (E)	19	692992
4			
5	TRANSFORMER, SELF PROTECTED TYPE, SINGLE PHASE (HE, HJ) (B)	2	PGS 1121.01-1121.12
6	BRACKET, TRANSFORMER MTG	1	402976
7	INSULATOR & PIN, 12KV	2	700 SECTION
8	COVER, PVC THRU BOLT & 6-10D NAILS, GALV (E)	2	285696, 491392
9	CLAMP, HOT LINE (E) & STIRRUP	3	PG 788
10	CONNECTORS, WIRE, COPPER, AS REQ'D	13	PGS 783-787
11	WIRE, STRANDED #6 COPPER	70'	813536
12	WIRE, WP COPPER (SIZE GOVERNED BY TRANSFORMER CAPACITY)	30'	PG 1125
13	ROD & CLAMP, GROUND (D) (C)	2	603072, 230016(E)
14	MOULDING, HARDWOOD 1" (D)	30'	487200
15	STAPLES, MOULDING GALV, 3" X 1 1/16" X 1/4" (D) (E)	20	678560
16	STAPLES, FENCE GALV, 1 1/4" (D) (E)	25	678528

FOR FIELD MAINTENANCE ONLY

DATE 1-1-86
APPD AK/AD

SDG&E ELECTRIC STANDARDS

12KV, OPEN DELTA TYPE "HE" OR "HJ" TRANSFORMER INSTALLATION,
2-50 KVA MAX, SECONDARY ARM CONSTRUCTION

1199.603
SUPERSEDES
1167 (1-1-86)

FIELD MAINTENANCE ONLY

REVISION HISTORY:

7/13/2016: All versions prior to 2016 are superseded by their current version found inside the Overhead Construction Standard Manual.

© 1998 - 2016 San Diego Gas & Electric Company. All rights reserved. Removal of this copyright notice without permission is not permitted under law.

REV	CHANGE	BY	DSGN	APPV	DATE	REV	CHANGE	BY	DSGN	APPV	DATE
C						F					
B						E					
A	ORIGINAL ISSUE	JS	IL	MDJ	7/13/2016	D					

SHEET 1 OF 1	<input checked="" type="checkbox"/> Indicates Latest Revision	<input type="checkbox"/> Completely Revised	<input type="checkbox"/> New Page	<input type="checkbox"/> Information Removed	FMO OH 1172
	SDG&E ELECTRIC OVERHEAD STANDARD				
	4KV, THREE PHASE, TYPE "WE" OR "WJ" TRANSFORMER INSTALLATION, 3-25 KVA MAX SECONDARY LINE ARM CONSTRUCTION				

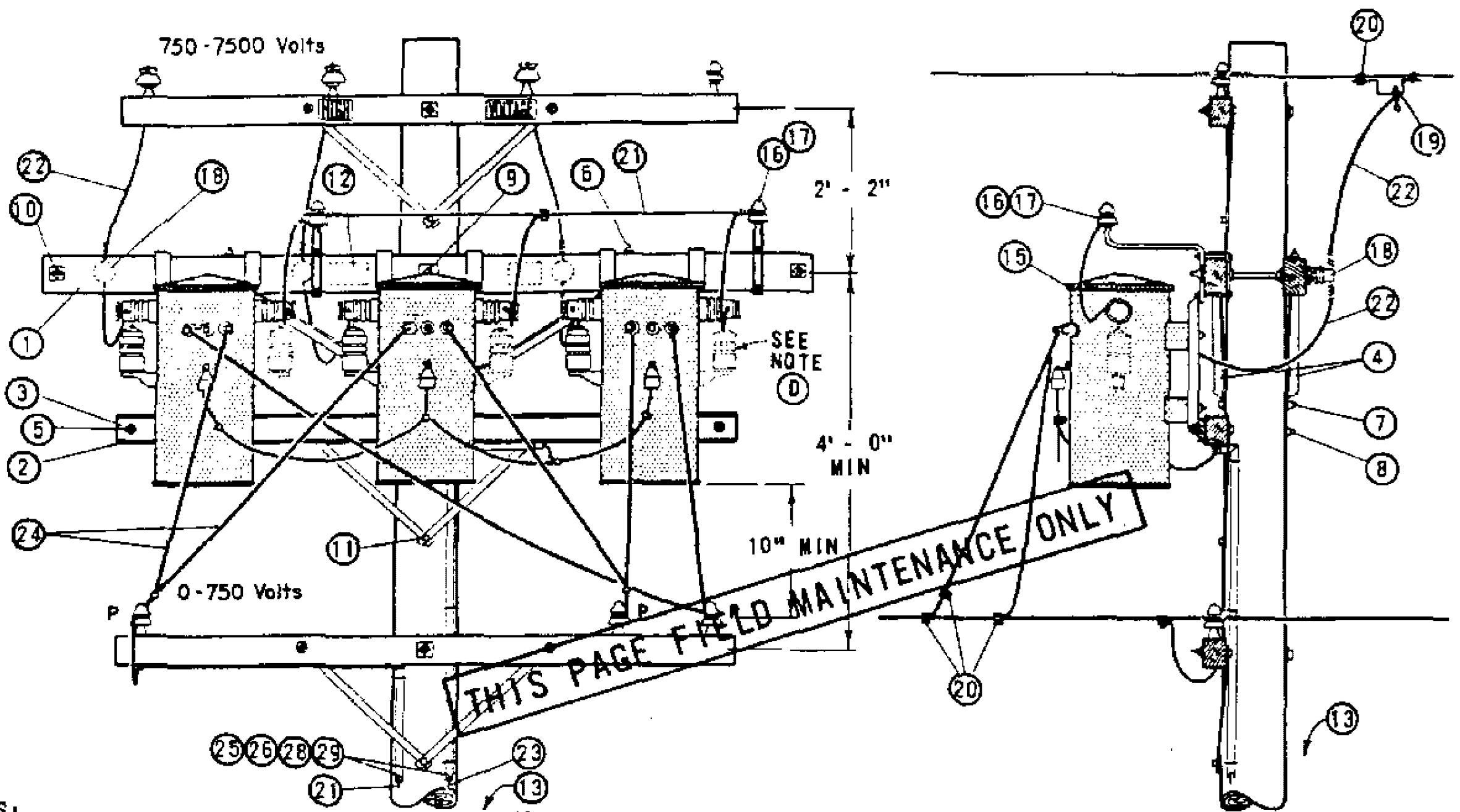

THIS PAGE FIELD MAINTENANCE ONLY

- NOTES:
- (A) UNIT GROUND COMPLETE ORDER 603120 WITH GRAY MOULDING, 603136 WITH PLAIN MOULDING.
 - B. SEE DISTRIBUTION POLE TOP SECTION FOR POLE TOP MATERIALS.
 - (C) USE TWO ROD GROUND
 - (D) REMOVE RIGHT HAND LIGHTNING ARRESTERS BEFORE INSTALLING TRANSFORMERS.
 - (E) EXEMPT MATERIAL.
 - F. WHEN ARRESTERS ARE REQUIRED PER STANDARDS PAGE 1247, USE TYPE "WJ" TRANSFORMERS.
 - G. SEE STANDARDS PAGE 1118 FOR TRANSFORMER CONNECTION DIAGRAMS. CONNECTION SHOWN IS FOR ILLUSTRATIVE PURPOSES ONLY.

ITEM	DESCRIPTION	QUANTITY	STOCK NO. OR CONSTR STD
1	CROSSARM, 3 1/4" X 5 3/4" X 10" - 0"	2	PG 111 IT. 2
2	CROSSARM, KICK 3 3/4" X 5 3/4" X 8" - 0"	1	PG 116 IT. 1
3	COVER STRIP, 1 5/8" X 4 1/2" X 8" - 0" (2X4 S4S)	1	699328
4	BRACE, ANGLE CROSSARM	2	164128
5	BOLT, MACH GALV 3/8" X 6", 2 RD WASH. & 1 NUT	(E) 2	PGS 139, 140
6	BOLT, MACH GALV 1/2" X 7", 1 RD WASH. & 1 NUT	(E) 4	PGS 139, 140
7	BOLT, MACH GALV 5/8" X 10"	(E) 1	PGS 139, 140
8	BOLT, MACH GALV 5/8" X 14", 2 SQ WASH. & 1 NUT	(E) 1	PGS 139, 140
9	BOLT, MACH GALV 5/8" X 18", 2 - 3 SQ WASH & 1 NUT	(E) 1	PGS 139, 140
10	BOLT, SPACE GALV 5/8" X 20", 4 WASH. & 4 NUTS	(E) 2	PGS 139, 140
11	SCREW, LAG GALV 1/2" X 4"	(E) 1	621568
12	SIGN, HIGH VOLTAGE & 8 ROOFING NAILS, GALV	(E) 1	647648, 492224
13	STEPS, POLE	(E) 16	692992
14			
15	TRANSFORMER, SINGLE PHASE TYPE WE OR WJ, #1 TEE HANGER	3	PGS 1121.01-1121.12
16	BRACKET, INSULATOR, 1"	2	166208
17	INSULATOR, 5KV	2	428960
18	HOLDER, WIRE	3	413792
19	CLAMP, HOT LINE (E) & STIRRUP	3	PG 788
20	CONNECTOR, WIRE, AS REQ'D	12	PGS 783-787
21	WIRE, #6 BARE STRANDED COPPER	60'	813536
22	CABLE, 5KV, 1/C #6 STRANDED COPPER	34'	194304
23	WIRE #2 BARE STRANDED COPPER, TANK GROUND	50'	813664
24	WIRE, W.P. COPPER, SIZE GOVERNED BY TRANSFORMER CAPACITY	45'	PG 1125
25	ROD & CLAMP, GROUND	(A) (C) 4	603072, 230016 (E)
26	MOULDING, HARDWOOD, 1"	(A) 64'	487200
27			
28	STAPLES, 3" X 1 1/16" X 1/4" MOULDING, GALV	(A) (E) 40	678560
29	STAPLES, 1 1/4" FENCE, GALV	(A) (E) 36	578528

1199,701
SUPERSEDES
1172 (1-1-86)

SAN DIEGO GAS & ELECTRIC CO OVERHEAD STANDARDS
4KV, THREE PHASE, TYPE "WE" OR "WJ" TRANSFORMER INSTALLATION,
3-25 KVA MAX SECONDARY LINE ARM CONSTRUCTION

DATE 1-1-86
APPD AK/RS

FIELD MAINTENANCE ONLY

REVISION HISTORY:

7/13/2016: All versions prior to 2016 are superseded by their current version found inside the Overhead Construction Standard Manual.

© 1998 - 2016 San Diego Gas & Electric Company. All rights reserved. Removal of this copyright notice without permission is not permitted under law.

REV	CHANGE	BY	DSGN	APPV	DATE	REV	CHANGE	BY	DSGN	APPV	DATE
C						F					
B						E					
A	ORIGINAL ISSUE	JS	IL	MDJ	7/13/2016	D					

	Indicates Latest Revision	Completely Revised	New Page	Information Removed
-------------------------------------------------------------------------------------	---------------------------	--------------------	----------	---------------------

**SHEET
1 OF 1**

SDG&E ELECTRIC OVERHEAD STANDARD
7.2 AND 12KV THREE-PHASE TRANSFORMER
CLUSTER MOUNT INSTALLATION-ALLEY ARM CONSTRUCTION

**FMO
OH 1174**

SCOPE: THIS STANDARD SHOWS THE INSTALLATION OF 7.2 AND 12KV, 3Ø TRANSFORMERS, ALLEY ARM CONSTRUCTION, WITH CLUSTER MOUNTING BRACKET AND SECONDARY RACK CONSTRUCTION.

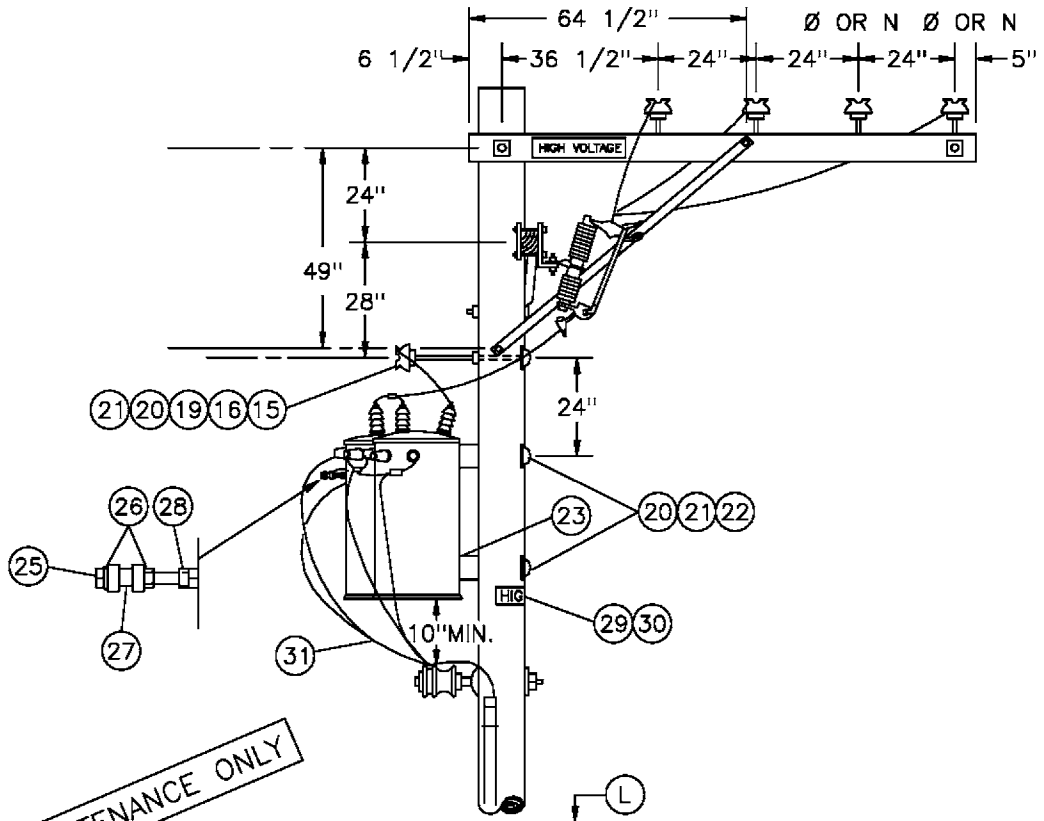

FOR FIELD MAINTENANCE ONLY

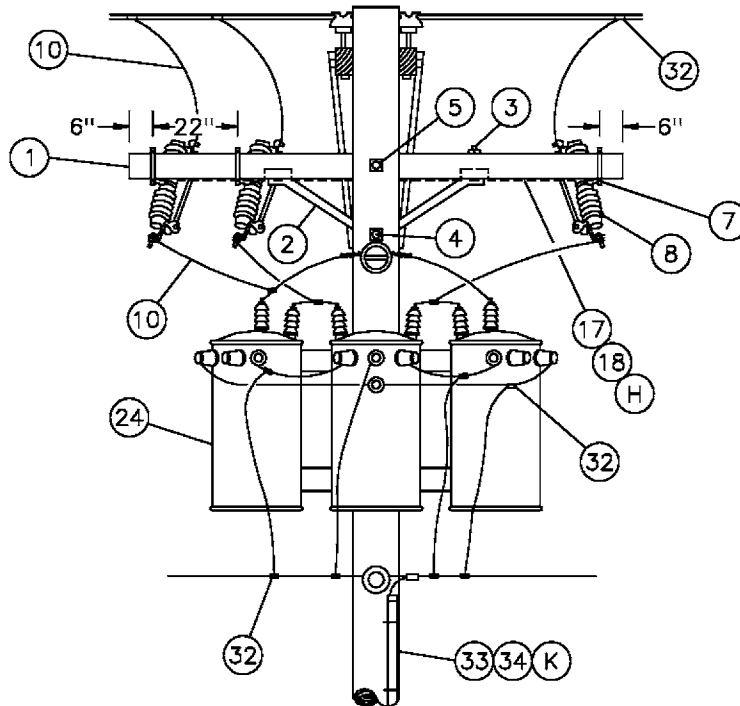

DELTA PRIMARY CONNECTION

DATE 1-1-89 APPD <i>PA</i> / DTE	SDG&E ELECTRIC STANDARDS	1199.704 SUPERSEDES 1174.1 (1-1-93)
	7.2 AND 12KV THREE-PHASE TRANSFORMER CLUSTER MOUNT INSTALLATION-ALLEY ARM CONSTRUCTION	

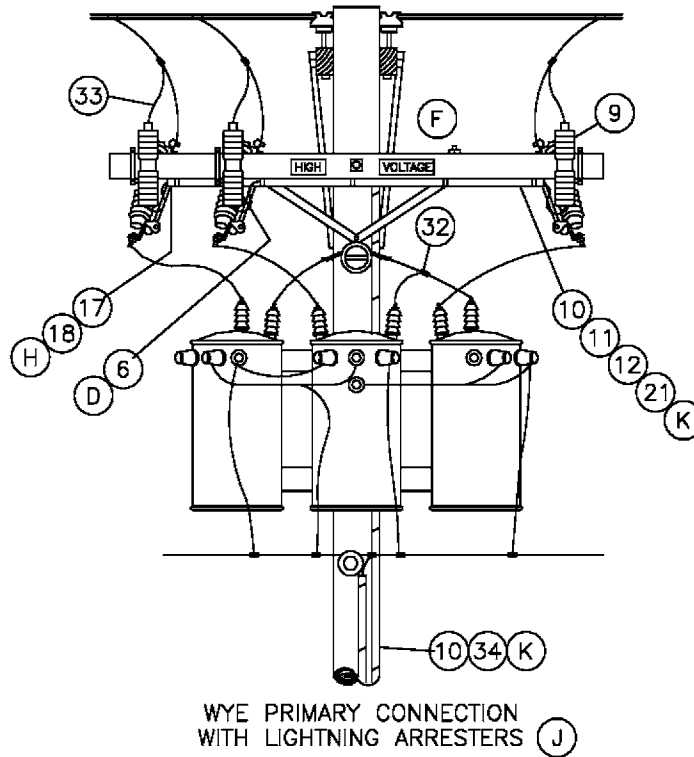
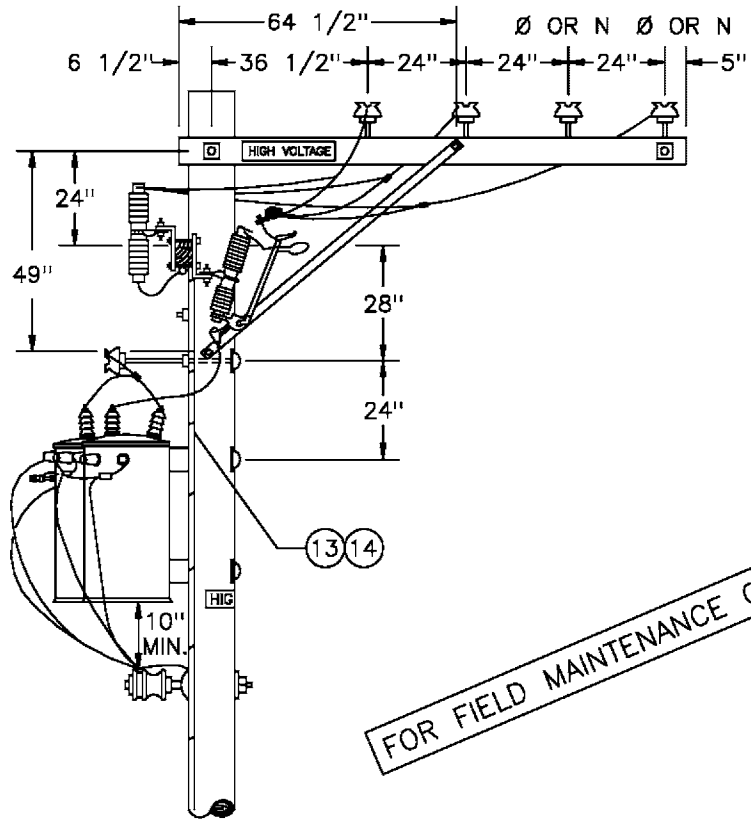

SDG&E ELECTRIC STANDARDS

DATE 1-1-91
 APPD *PA/ROJ*

7.2 AND 12KV THREE-PHASE TRANSFORMER
 CLUSTER MOUNT INSTALLATION-ALLEY ARM CONSTRUCTION

1199.705
 SUPERSEDES
 1174.2 (1-1-93)

BILL OF MATERIAL:

ITEM	DESCRIPTION	QUANTITY		STOCK NUMBER OR CONSTR STANDARD
		STATION WITH ARRESTERS (J)	STATION WITHOUT ARRESTERS	
1	CROSSARM, 3 3/4" X 5 3/4" X 10' - 0"	1	1	294128
2	BRACE, ANGLE, CROSSARM, 4'	1	1	164032
3	BOLT, MACH, GALV, 1/2" X 7", 1 RD & 1 DBL COIL SPRING WASHER (E)	2	2	STD. 392
4	BOLT, MACH, GALV, 5/8" X (LENGTH AS REQ'D), 1 SQUARE & 1 DOUBLE COIL SPRING WASHER (E)	1	1	STD. 392
5	BOLT, MACH, GALV, 5/8" X (LENGTH AS REQ'D), 2 SQUARE & 1 DOUBLE COIL SPRING WASHER (E)	1	1	STD. 392
6	BRACKET, DOUBLE, CUTOUT/ARRESTER, FOR CROSSARM MOUNTING (E)	3	-	165442
7	BRACKET, CUTOUT/ARRESTER, FOR CROSSARM MOUNTING (E)	-	3	166070
8	CUTOUT, 12KV, WITH LOADBUSTER HOOK	3	3	STD. 1212
9	ARRESTER, LIGHTNING	3	-	113248
10	WIRE, #4 BARE STRANDED COPPER	FT 100 LB 13	40 5	813760
11	CONDUIT, PVC, TYPE 2, SCHEDULE 40, 1" X 10' (E)	1	-	251200
12	STRAPS, PIPE, GALV, 1" (E)	AS REQ'D	-	697792
13				
14				
15	INSULATOR, PIN TYPE, CLASS AS REQ'D	1	1	STD. 750
16	WIRE, TIE (E)	1	1	815232
17	WIRE, #8 BARE SOLID ANNEALED COPPER (G) (E)	FT 15 LB 1	15 1	812928
18	STAPLES, 1 1/4", FENCE, GALV (G) (E)	AS REQ'D	AS REQ'D	678528
19	BRACKET, INSULATOR, 1" OR 1 3/8" THREAD (AS REQ'D)	1 1	1 1	166144 166176
20	COVER, BOLT, PLASTIC (E)	3	3	285696
21	NAILS, GALV, 1 3/4" ROOFING (E)	AS REQ'D	AS REQ'D	492192
22	BOLT, MACH, GALV, 3/4" X (LENGTH AS REQ'D), 1 SQUARE CURVED & 1 DOUBLE COIL SPRING WASHER (E)	2	2	STD. 392
23	BRACKET, TRANSFORMER CLUSTER MOUNTING	1	1	403008
24	TRANSFORMER, SINGLE PHASE, TYPE 'Y', 'YF', 'H' OR 'HF'	3	3	STD. 1121
25	BOLT, MACH, GALV, 1/2" X 5" (E)	1	1	153024
26	WASHER, GALV, 1/2", ROUND (E)	2	2	800192
27	INSULATOR, SECONDARY, SPOOL, PORCELAIN (E)	1	1	430752
28	NUT, GALV, 1/2" (E)	1	1	504736
29	SIGN, HIGH VOLTAGE (E)	3	1	647648
30	NAILS, GALV, 7/8" ROOFING (E)	27	9	492224

FOR FIELD MAINTENANCE ONLY

1199.706	SDG&E ELECTRIC STANDARDS	
SUPERSEDES 1174.3 (1-1-93)	7.2 AND 12KV THREE-PHASE TRANSFORMER CLUSTER MOUNT INSTALLATION-ALLEY ARM CONSTRUCTION	DATE 1-1-91 APPD <i>PA/109</i>

BILL OF MATERIAL: (CONT'D)

ITEM	DESCRIPTION	QUANTITY		STOCK NUMBER OR CONSTR STANDARD
		STATION WITH ARRESTERS (J)	STATION WITHOUT ARRESTERS	
31	WIRE, THW COPPER, SIZED PER TRANSFORMER CAPACITY	35'	35'	STD 1125
32	CONNECTOR, WIRE, COMPRESSION, CU OR AL AS REQ'D (E)	AS REQ'D	AS REQ'D	783-786
33	WIRE, #6, 3 STRAND, BARE COPPER	FT	55	813536
		LB	4	
34	UNIT, GROUND, COMPLETE (K)	2	1	603136
35	CONDUIT, PVC, TYPE 2, SCHEDULE 40, 1/2" (E)	10'	-	251168
36	STRAPS, PIPE, GALV. 1/2" AND 1-3/4" ROOFING NAILS (E)	AS REQ'D	-	697728

INSTALLATION:

- A. USE THIS CONSTRUCTION FOR TRANSFORMERS RATED 12KV AND BELOW WHICH HAVE HIGH VOLTAGE BUSHINGS MOUNTED ON TOP OF COVER.
- B. LIMITED TO TRANSFORMERS 100 KVA AND SMALLER, EACH WEIGHING 1200 POUNDS OR LESS.
- C. WHEN PRACTICAL, BOLT TRANSFORMERS TO BRACKET ON THE GROUND AND INSTALL THEM AS A PREWIRED ASSEMBLY.
- (D) DRILL THROUGH CROSSARM 1" UP FROM LOWER EDGE SO THAT LOWER CROSSARM MOUNTING BRACKET BOLT DOES NOT INTERFERE WITH PVC CONDUIT.
- (E) EXEMPT MATERIAL.
- (F) INSTALL LA/CO CROSSARM ON SAME SIDE OF POLE AS TRANSFORMERS.
- (H) BOND ALL CUTOUTS IN HEAVY CONTAMINATION DISTRICT, AS IDENTIFIED ON STANDARD 287. IN AREAS WHERE BONDING IS REQUIRED, TO AVOID BONDWIRE AND LIGHTNING ARRESTER GROUNDWIRE ON THE ON THE SAME CROSSARM, USE TWO CROSSARMS; ONE FOR CUTOUTS AND ONE FOR LIGHTNING ARRESTERS

REFERENCE:

- I. PRIMARY AND SECONDARY CONNECTIONS ARE SHOWN FOR ILLUSTRATIVE PURPOSES. SEE STANDARD 1118-1119 FOR SPECIFIC CONNECTION DIAGRAMS.
- (J) LIGHTNING ARRESTER APPLICATION, SEE STANDARD 1247.
- (K) GROUNDING METHOD AND APPLICATION, SEE STANDARD 1002.
- (L) POLE STEPPING, SEE STANDARD 363.

FOR FIELD MAINTENANCE ONLY

DATE 1-1-91 APPD PJA / DTE	SDG&E ELECTRIC STANDARDS	1199.707 SUPERSEDES 1174.4 (1-1-93)
	7.2 AND 12KV THREE PHASE TRANSFORMER CLUSTER MOUNT INSTALLATION-ALLEY ARM CONSTRUCTION	

SCOPE: THIS STANDARD SHOWS THE INSTALLATION OF 7.2 AND 12KV, 3Ø TRANSFORMERS, ALLEY ARM CONSTRUCTION, WITH CLUSTER MOUNTING BRACKET AND SECONDARY RACK CONSTRUCTION.

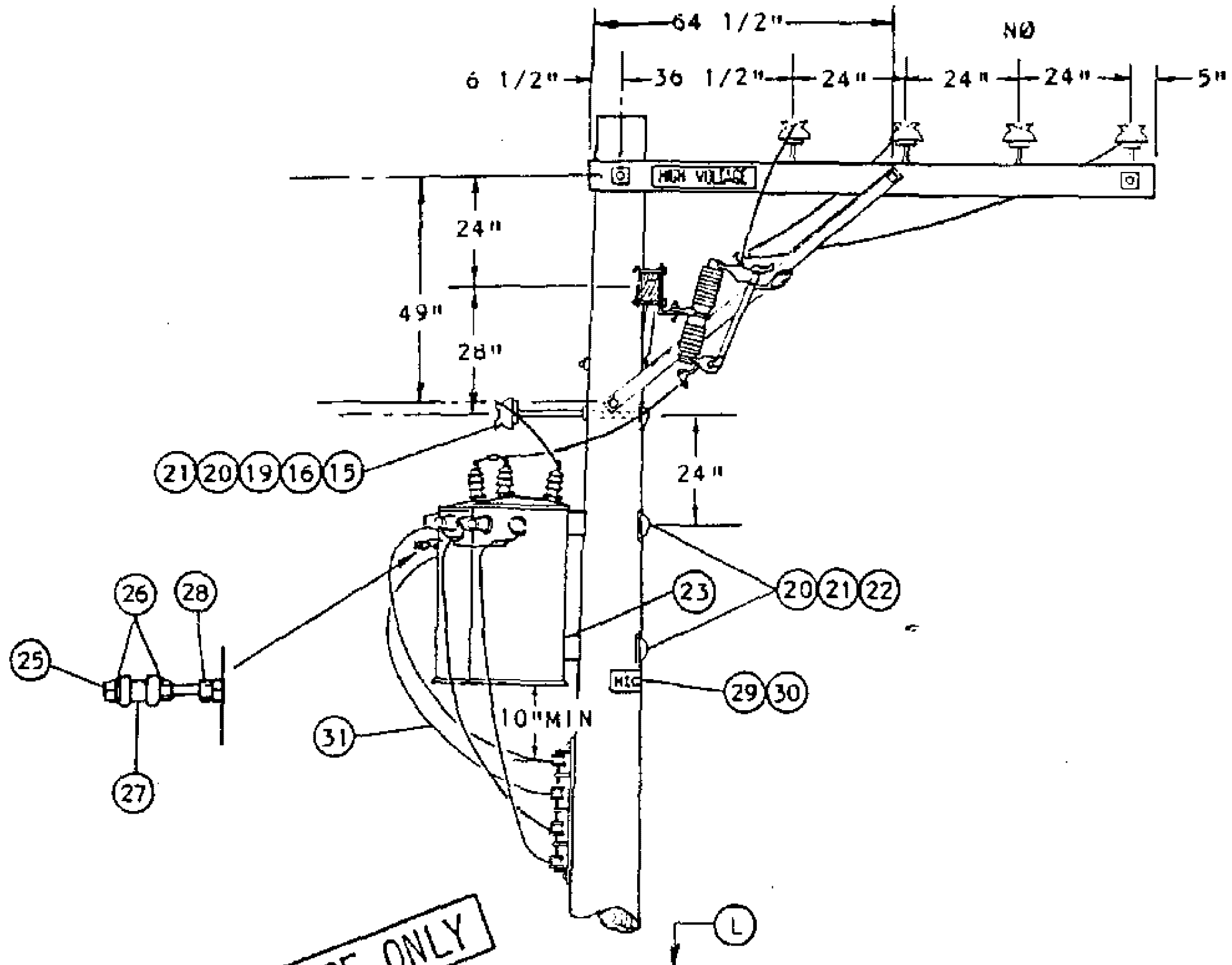

FOR FIELD MAINTENANCE ONLY

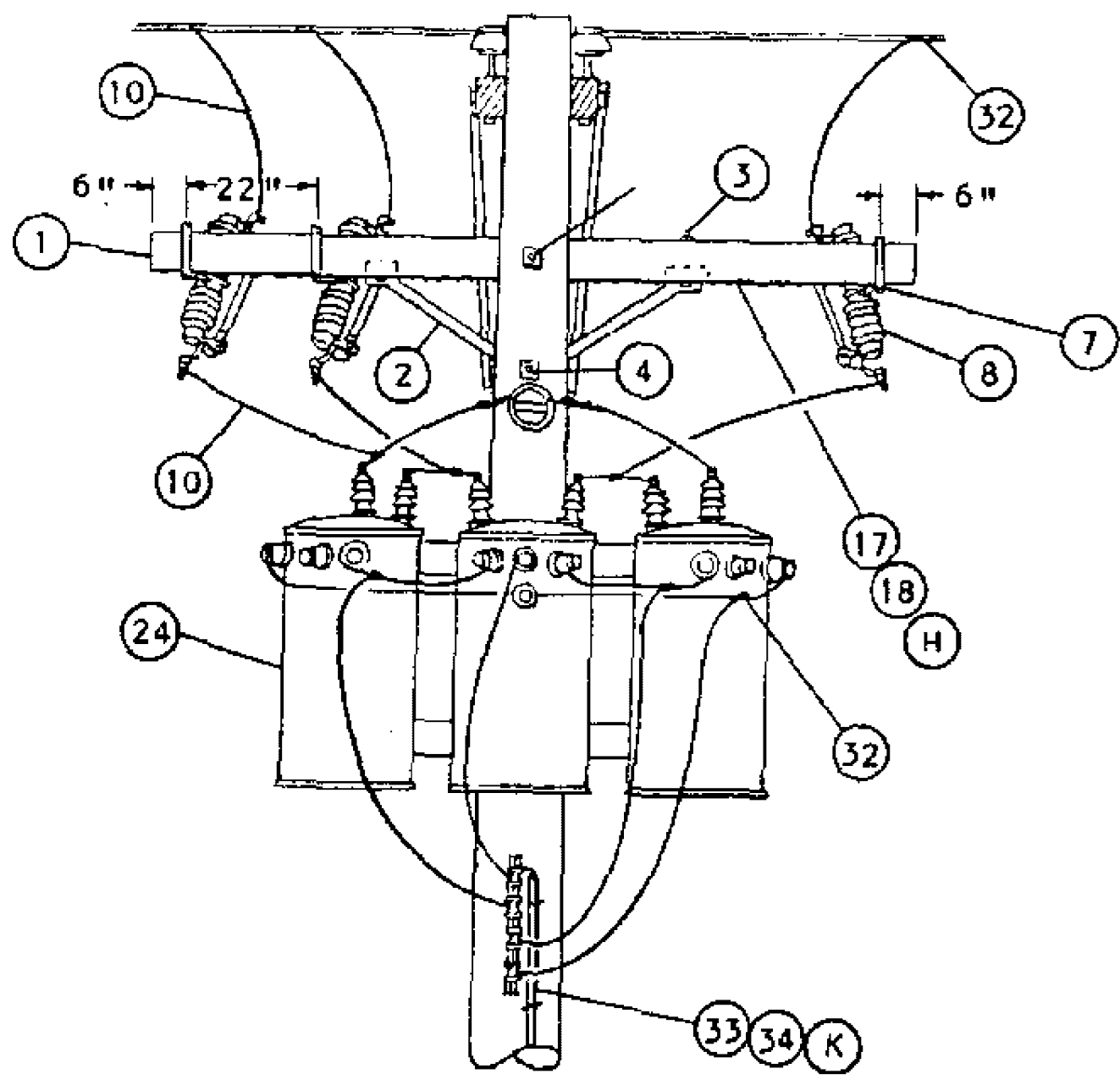

DELTA PRIMARY CONNECTION

DATE 1-1-89
APPD PJA/OTE

SDG&E ELECTRIC STANDARDS
7.2 AND 12KV THREE PHASE TRANSFORMER
CLUSTER MOUNT INSTALLATION-ALLEY ARM CONSTRUCTION

1199.8C3
SUPERSEDES
1174.1 (1-1-93)

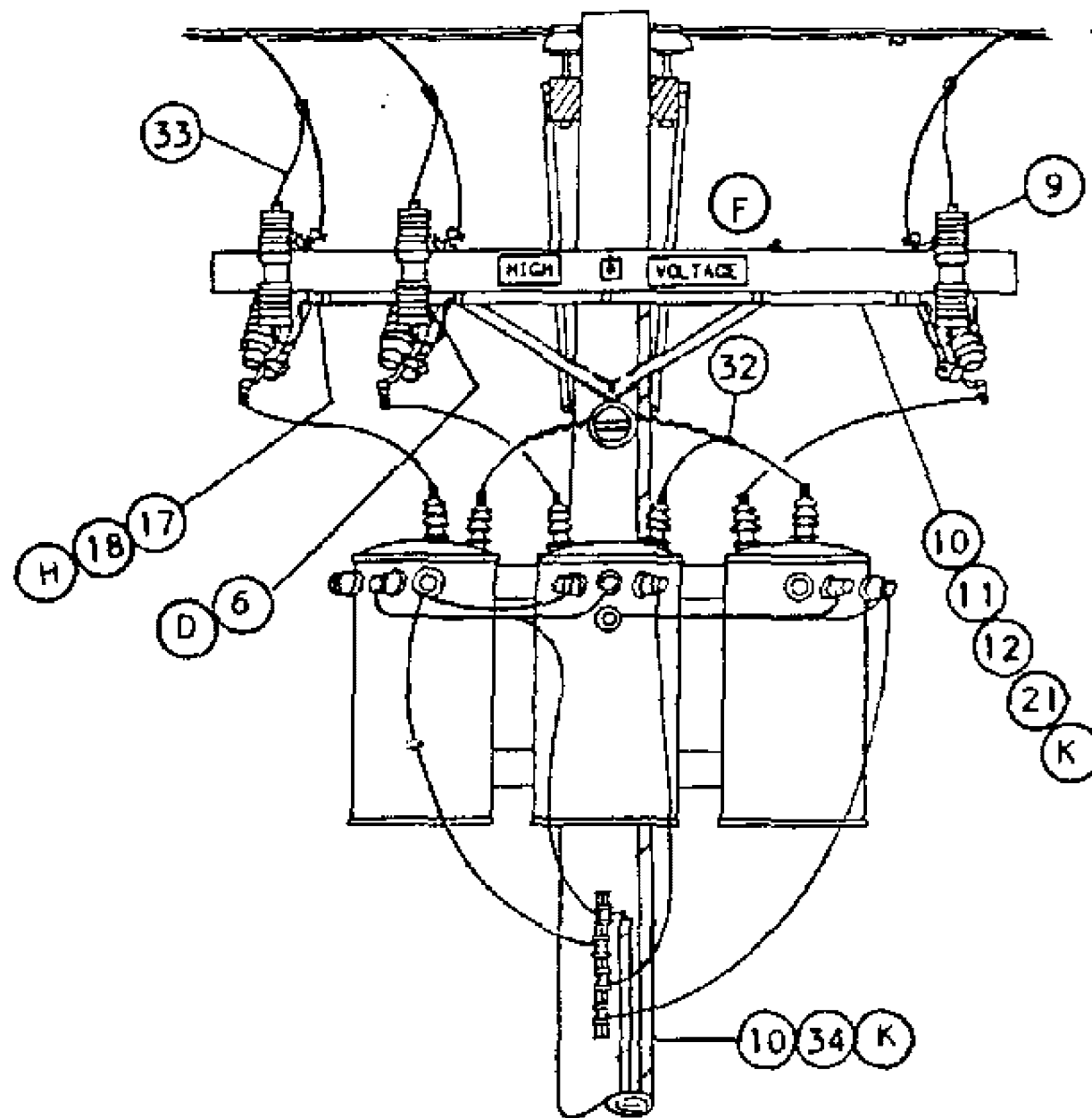
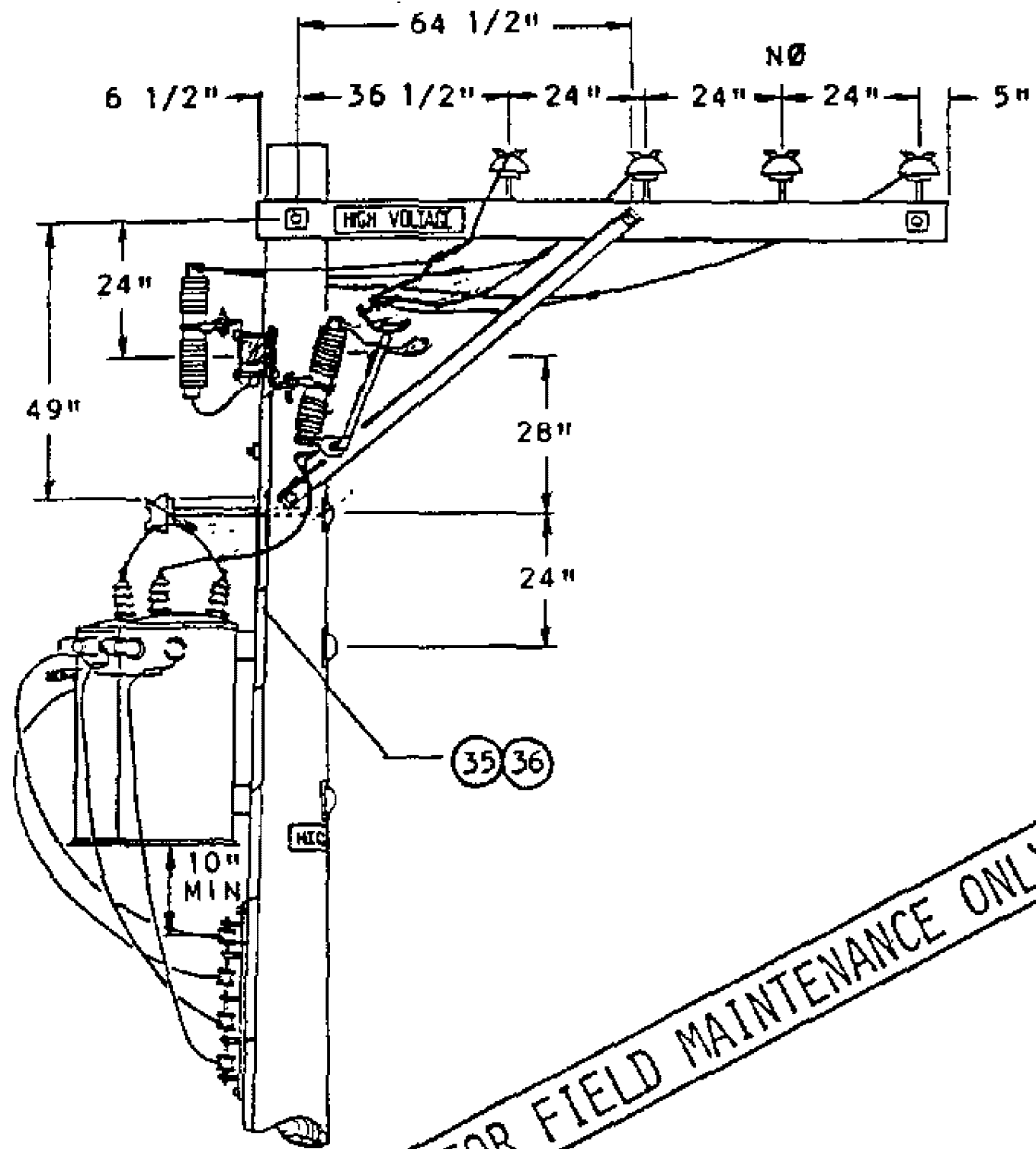

WYE PRIMARY CONNECTION
WITH LIGHTNING ARRESTERS (J)

SDG&E ELECTRIC STANDARDS

1199.804
SUPERSEDES
1174.2 (1-1-93)

7.2 AND 12KV THREE PHASE TRANSFORMER
CLUSTER MOUNT INSTALLATION-ALLEY ARM CONSTRUCTION

DATE 1-1-91
APPD P/A/R

BILL OF MATERIAL:

ITEM	DESCRIPTION	QUANTITY		STOCK NUMBER OR CONSTR STANDARD
		STATION WITH ARRESTERS	STATION WITHOUT ARRESTERS	
1	CROSSARM, 3 3/4" X 5 3/4" X 10' - 0"	1	1	294128
2	BRACE, ANGLE, CROSSARM, 4'	1	1	164032
3	BOLT, MACH, GALV, 1/2" X 7", 1 RD & 1 DBL COIL SPRING WASHER (E)	2	2	STD. 392
4	BOLT, MACH, GALV, 5/8" X (LENGTH AS REQ'D), 1 SQUARE & 1 DOUBLE COIL SPRING WASHER (E)	1	1	STD. 392
5	BOLT, MACH, GALV, 5/8" X (LENGTH AS REQ'D), 2 SQUARE & 1 DOUBLE COIL SPRING WASHER (E)	1	1	STD. 392
6	BRACKET, DOUBLE, CUTOUT/ARRESTER, FOR CROSSARM MOUNTING (E)	3	-	165442
7	BRACKET, CUTOUT/ARRESTER, FOR CROSSARM MOUNTING (E)	-	3	166070
8	CUTOUT, 12KV, WITH LOADBUSTER HOOK	3	3	STD. 1212
9	ARRESTER, LIGHTNING	3	-	113248
10	WIRE, #4 BARE STRANDED COPPER	FT LB 100 13	40 5	813760
11	CONDUIT, PVC, TYPE 2, SCHEDULE 40, 1" X 10' (E)	1	-	251200
12	STRAPS, PIPE, GALV, " (E)	AS REQ'D	-	697792
13				
14				
15	INSULATOR, PIN TYPE, CLASS AS REQ'D	1	1	STD. 750
16	WIRE, TIE (E)	1	1	815232
17	WIRE, #8 BARE SOLID ANNEALED COPPER (G) FT LB 15 1	15	15	812928
18	STAPLES, 1 1/4", FENCE, GALV (G) (E)	AS REQ'D	AS REQ'D	678528
19	BRACKET, INSULATOR, 1" OR 1 3/8" THREAD (AS REQ'D)	1 1	1 1	166144 166176
20	COVER, BOLT, PLASTIC (E)	3	3	285696
21	NAILS, GALV, 1 3/4" ROOFING (E)	AS REQ'D	AS REQ'D	492192
22	BOLT, MACH, GALV, 3/4" X (LENGTH AS REQ'D), 1 SQUARE CURVED & 1 DOUBLE COIL SPRING WASHER (E)	2	2	STD. 392
23	BRACKET, TRANSFORMER CLUSTER MOUNTING	1	1	403008
24	TRANSFORMER, SINGLE PHASE, TYPE 'Y', 'YF', 'H' OR 'HF'	3	3	STD 1121
25	BOLT, MACH, GALV, 1/2" X 5" (E)	1	1	153024
26	WASHER, GALV, 1/2", ROUND (E)	2	2	800192
27	INSULATOR, SECONDARY, SPOOL, PORCELAIN (E)	1	1	430752
28	NUT, GALV, 1/2" (E)	1	1	504736
29	SIGN, HIGH VOLTAGE (E)	3	1	647648
30	NAILS, GALV, 7/8" ROOFING (E)	27	9	492224

FOR FIELD MAINTENANCE ONLY

BILL OF MATERIAL: (CONT'D)

ITEM	DESCRIPTION	QUANTITY		STOCK NUMBER OR CONSTR STANDAR
		STATION WITH ARRESTERS	STATION WITHOUT ARRESTERS	
31	WIRE, W.P. COPPER, SIZED PER TRANSFORMER CAPACITY	35'	35'	STD 1125
32	CONNECTOR, WIRE, COMPRESSION, CU OR AL AS REQ'D	(E) AS REQ'D	AS REQ'D	783-786
33	WIRE, #6, 3 STRAND, BARE COPPER	FT LB 55 4	40 3	813536
34	UNIT, GROUND, COMPLETE	(K) 2	1	603136
35	CONDUIT, PVC, TYPE 2, SCHEDULE 40, 1/2"	(E) 10'	-	251.168
36	STRAPS, PIPE, GALV. 1/2" AND 1 3/4" ROOFING NAILS	(E) AS REQ'D.	-	697728

INSTALLATION:

- A. USE THIS CONSTRUCTION FOR TRANSFORMERS RATED 12KV AND BELOW WHICH HAVE HIGH VOLTAGE BUSHINGS MOUNTED ON TOP OF COVER.
- B. LIMITED TO TRANSFORMERS 100 KVA AND SMALLER, EACH WEIGHING 1200 POUNDS OR LESS.
- C. WHEN PRACTICAL, BOLT TRANSFORMERS TO BRACKET ON THE GROUND AND INSTALL THEM AS A PREWIRED ASSEMBLY.
- (D) DRILL THROUGH CROSSARM 1" UP FROM LOWER EDGE SO THAT LOWER CROSSARM MOUNTING BRACKET BOLT DOES NOT INTERFERE WITH PVC CONDUIT.
- (E) EXEMPT MATERIAL.
- (F) INSTALL LA/CO CROSSARM ON SAME SIDE OF POLE AS TRANSFORMERS.
- (H) BOND ALL CUTOUTS IN HEAVY CONTAMINATION DISTRICT, AS IDENTIFIED ON STANDARD 287. IN AREAS WHERE BONDING IS REQUIRED, TO AVOID BONDWIRE AND LIGHTNING ARRESTER GROUNDWIRE ON THE SAME CROSSARM, USE TWO CROSSARMS; ONE FOR CUTOUTS AND ONE FOR LIGHTNING ARRESTERS.

REFERENCE:

- I. PRIMARY AND SECONDARY CONNECTIONS ARE SHOWN FOR ILLUSTRATIVE PURPOSES. SEE STANDARD 1118-1119 FOR SPECIFIC CONNECTION DIAGRAMS.
- (J) LIGHTNING ARRESTER APPLICATION, SEE STANDARD 1247.
- (K) GROUNDING METHOD AND APPLICATION, SEE STANDARD 1002.
- (L) POLE STEPPING, SEE STANDARD 363.

FOR FIELD MAINTENANCE ONLY

1199.806

SDG&E ELECTRIC STANDARDS

SUPERSEDES
1174.4 (1-1-93)

**7.2 AND 12KV THREE PHASE TRANSFORMER
CLUSTER MOUNT INSTALLATION-ALLEY ARM CONSTRUCTION**

DATE 1-1-89

APPD *PEA/DTC*

FIELD MAINTENANCE ONLY

REVISION HISTORY:

7/13/2016: All versions prior to 2016 are superseded by their current version found inside the Overhead Construction Standard Manual.

© 1998 - 2016 San Diego Gas & Electric Company. All rights reserved. Removal of this copyright notice without permission is not permitted under law.

REV	CHANGE	BY	DSGN	APPV	DATE	REV	CHANGE	BY	DSGN	APPV	DATE
C						F					
B						E					
A	ORIGINAL ISSUE	JS	IL	MDJ	7/13/2016	D					

	Indicates Latest Revision	Completely Revised	New Page	Information Removed
-------------------------------------------------------------------------------------	---------------------------	--------------------	----------	---------------------

**SHEET
1 OF 1**

SDG&E ELECTRIC OVERHEAD STANDARD

12KV, THREE PHASE, TYPE "H" OR "HF" TRANSFORMER INSTALLATION,
THREE 75 KVA MAXIMUM, SECONDARY LINE ARM CONSTRUCTION

**FMO
OH 1181**

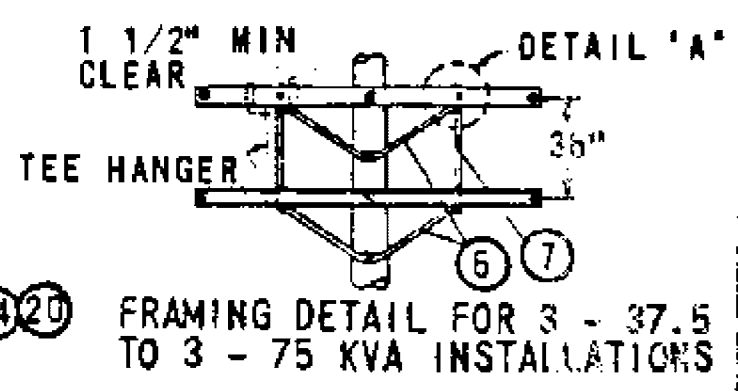
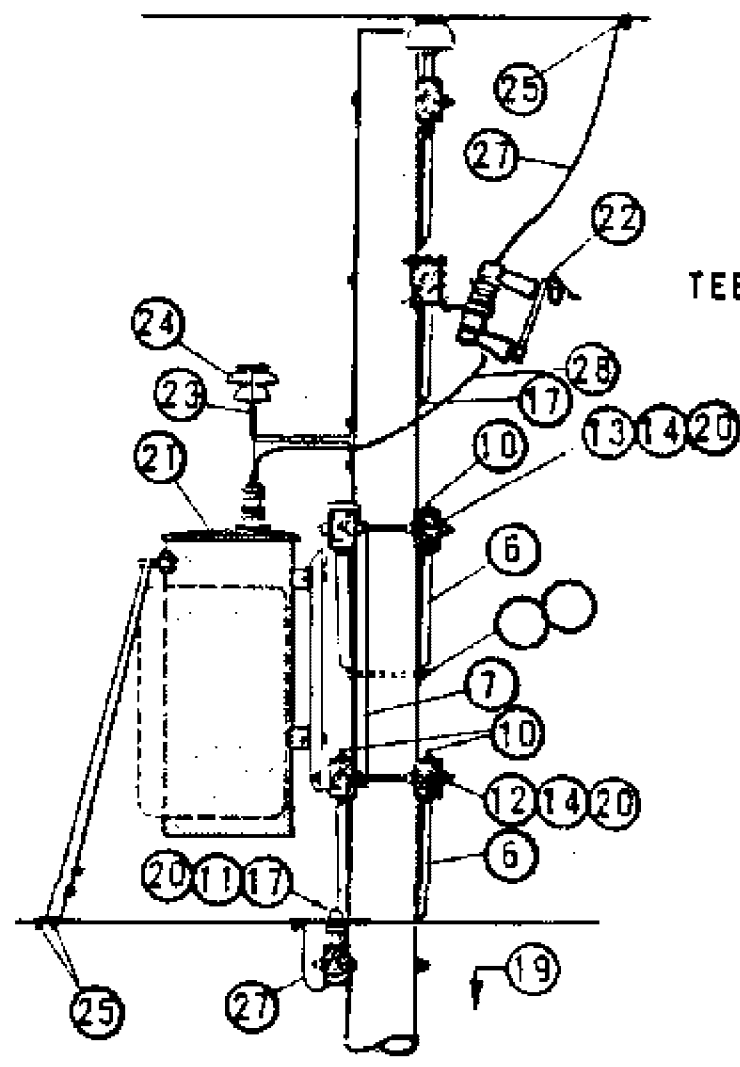
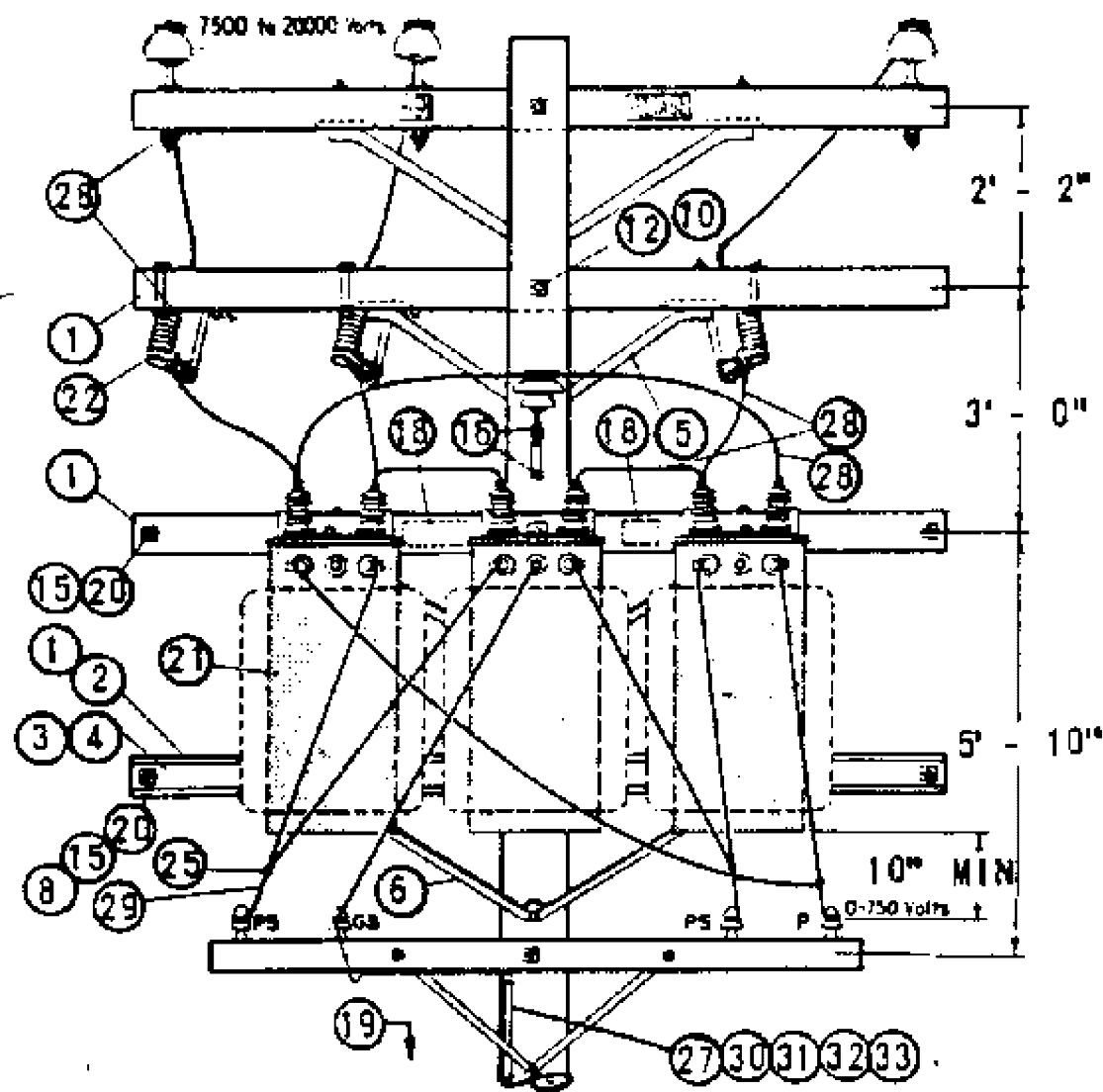

FRAMING DETAIL FOR 3 - 37.5 TO 3 - 75 KVA INSTALLATIONS

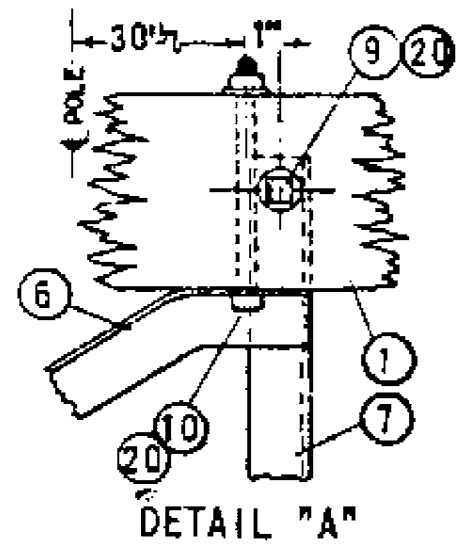

- NOTES:
- (A) UNIT GROUND COMPLETE ORDER 603120 WITH GRAY MOULDING, 603136 WITH PLAIN MOULDING.
 - B. SEE ARRESTER SECTION FOR ARRESTER REQUIREMENTS.
 - (C) USE TWO ROD GROUND.
 - D. BOND ALL CUTOUTS IN HEAVY CONTAMINATION DISTRICTS AS IDENTIFIED ON STANDARDS PAGE 287.
 - (E) EXEMPT MATERIAL

- F. USE EXTRA HEAVY CLASS ONE POLES WITH 10" MINIMUM TOP DIAMETER ON NEW CONSTRUCTION FOR 3 - 37.5 TO 3 - 75 KVA TRANSFORMER INSTALLATIONS.
- G. LIMITED TO TRANSFORMERS WEIGHING 1200# OR LESS.
- H. SPACING OF TRANSFORMERS TO BE AS CLOSE AS PRACTICABLE BUT NOT TO EXCEED 33.5" CENTER TO CENTER.
- I. SEE STANDARDS PAGE 1119 FOR SPECIFIC TRANSFORMER CONNECTIONS. 240V, 4 WIRE DELTA IS SHOWN FOR ILLUSTRATIVE PURPOSES ONLY.

ITEM	DESCRIPTION	QUANTITY		STOCK NO. OR CONSTR STD
		5 TO 25 KVA	37.5 TO 75 KVA	
1	CROSSARM, 3 3/4" X 5 3/4" X 10' - 0"	3	5	PG. 119 IT. 2
2	CROSSARM, 3 3/4" X 5 3/4" X 8' - 0"	1	0	PG. 116 IT. 1
3	COVER STRIP, 1 5/8" X 3 5/8" X 8' - 0" (2X4S4S)	1	0	699328
4	COVER STRIP, 1 5/8" X 3 5/8" X 10' - 0" (2X4S4S)	0	1	699360
5	BRACE, ANGLE CROSSARM, GALV, 4' - 0"	1	1	164032
6	BRACE, ANGLE CROSSARM, GALV, 5' - 0"	2	4	164128
7	BRACE, VERTICAL 36"	0	2	164256
8	BOLT, MACH GALV, 3/8" X 6", 2 RD WASH & 1 NUT	(E) 2	0	PGS 139, 140
9	BOLT, MACH GALV, 5/8" X 5", 1 RD WASH & 1 NUT	(E) 0	4	PGS 139, 140
10	BOLT, MACH GALV, 1/2" X 8", 1 RD WASH & 1 NUT	(E) 6	10	PGS 139, 140
11	BOLT, MACH GALV, 5/8" X " , 1 NUT	(E) 1	2	PGS 139, 140
12	BOLT, MACH GALV, 5/8" X 14", 2 SQ WASH & 1 NUT	(E) 2	1	PGS 139, 140
13	BOLT, MACH GALV, 5/8" X 20", 2 - 3" SQ WASH & 1 NUT	(E) 1	0	PGS 139, 140
14	BOLT, MACH GALV, 3/4" X 20", 2 - 3" SQ WASH & 1 NUT	(E) 0	2	PGS 139, 140
15	BOLT, SPACE GALV, 5/8" X " , 4 SQ WASH. & 4 NUTS	(E) 2	4	PGS 139, 140
16	SCREW, LAG GALV, 1/2" X 4"	(E) 3	2	621568
17	SCREW, LAG GALV, 5/8" X 5"	(E) 1	1	621600
18	SIGN, HIGH VOLTAGE & 8 ROOFING NAILS, GALV	(E) 1	1	647648, 492224
19	STEP, POLE	(E) 19	19	692992
20	WASHER, DOUBLE COIL SPRING, FOR ITEMS 8 THRU 15	AS REQ'D		PG 140
21	TRANSFORMER, SINGLE PHASE, TYPE H OR HF	3	3	PGS 1121.01-1121.12
22	CUTOUT, 12KV	3	3	PGS 1212, 1213
23	BRACKET, INSULATOR	1	1	166176
24	INSULATOR, 12KV	1	1	429152
25	CONNECTOR, WIRE	11	11	PGS 783-787
26	WIRE, BARE SOLID ANNEALED COPPER #8	AS REQ'D		812928
27	WIRE, BARE STRANDED COPPER #6	70'	70'	813536
28	WIRE, SOLID W.P. COPPER #4	10'	10'	813536
29	WIRE, W.P. COPPER, SIZE GOVERNED BY TRANSFORMER CAPACITY	60'	60'	PG 1125
30	ROD & CLAMP	(A) 2	(C) 2	603072, 230016 (E)
31	MOULDING, HARDWOOD 1"	(A) 27'	(A) 27'	487200
32	STAPLES, MOULDING GALV, 3" X 1 1/16" X 1/4"	(A) 18	(E) 18	678560
33	STAPLES, FENCE GALV, 1 1/4"	(A) 17	(E) 17	678528

FOR FIELD MAINTENANCE ONLY

FIELD MAINTENANCE ONLY

REVISION HISTORY:

7/13/2016: All versions prior to 2016 are superseded by their current version found inside the Overhead Construction Standard Manual.

© 1998 - 2016 San Diego Gas & Electric Company. All rights reserved. Removal of this copyright notice without permission is not permitted under law.

REV	CHANGE	BY	DSGN	APPV	DATE	REV	CHANGE	BY	DSGN	APPV	DATE
C						F					
B						E					
A	ORIGINAL ISSUE	JS	IL	MDJ	7/13/2016	D					

SHEET 1 OF 1	 Indicates Latest Revision	Completely Revised	New Page	Information Removed	FMO OH 1184
	SDG&E ELECTRIC OVERHEAD STANDARD				
	12KV, THREE PHASE, TYPE "HE" OR "HJ" TRANSFORMER INSTALLATION, THREE 75 KVA MAXIMUM, SECONDARY LINE ARM CONSTRUCTION				

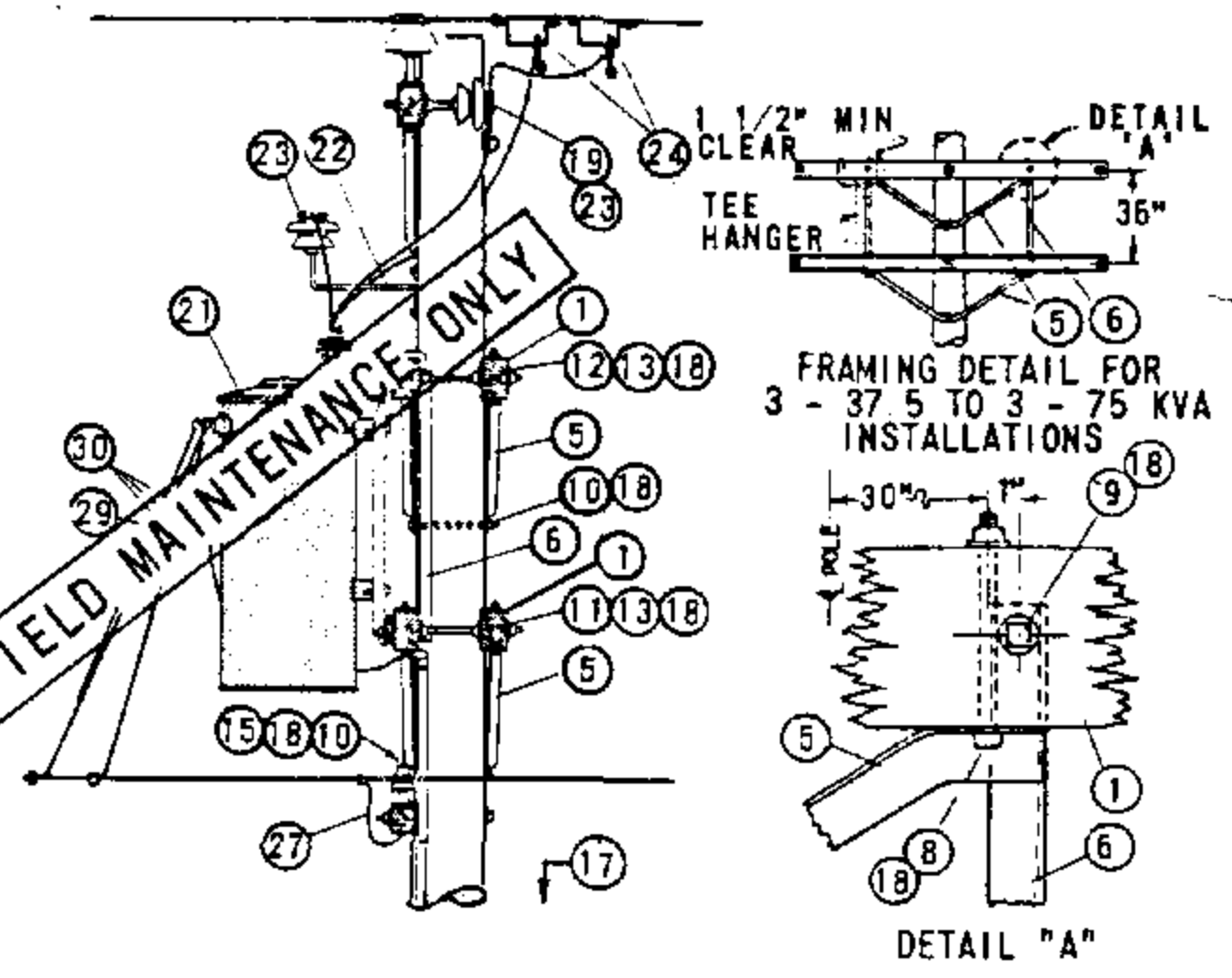
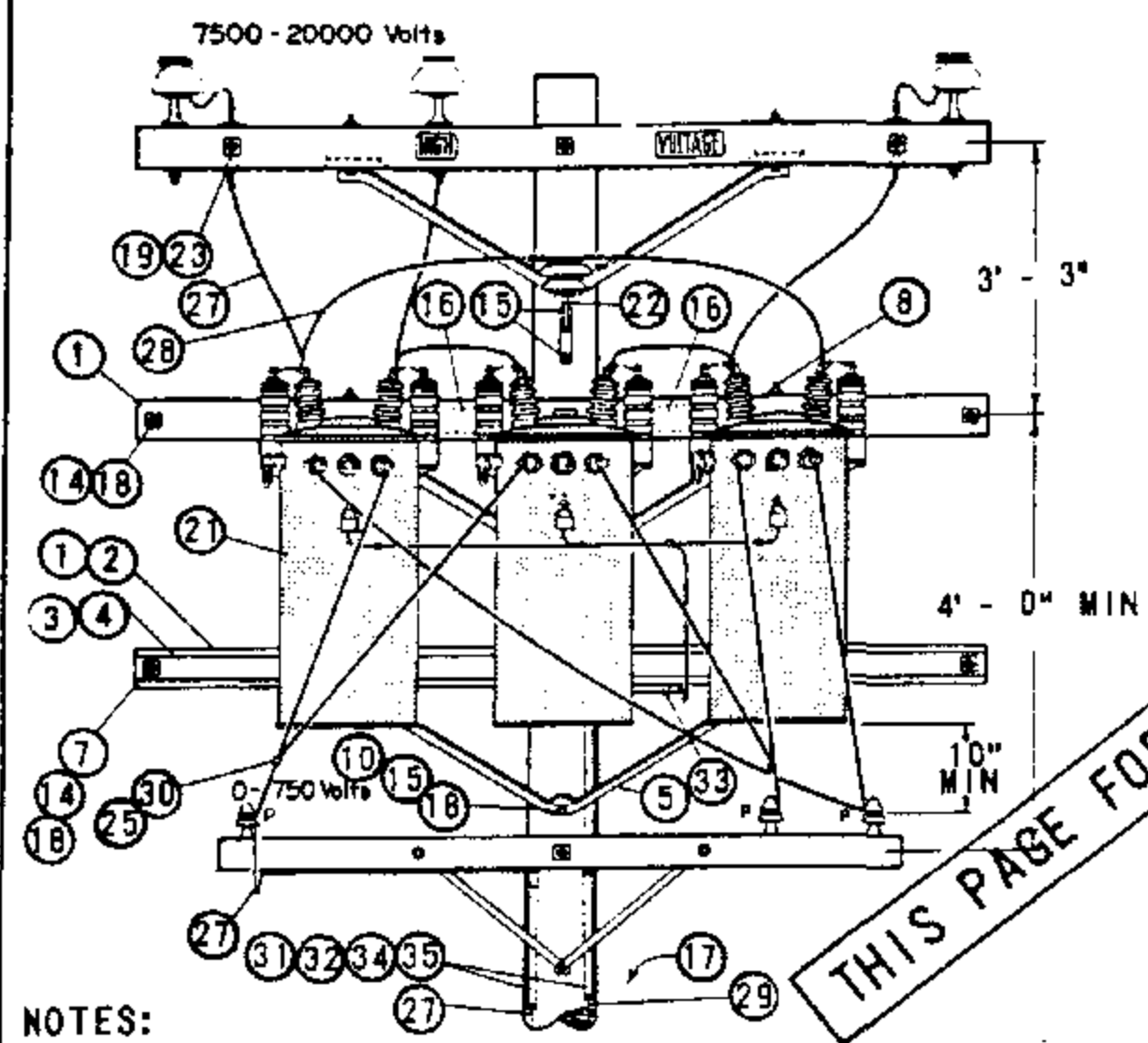

NOTES:

- (A) UNIT GROUND COMPLETE ORDER 603120 WITH GRAY MOULDING, 603136 WITH PLAIN MOULDING.
- (B) USE TWO ROD GROUND.
- C. THIS PAGE FOR FIELD MAINTENANCE ONLY. USE TYPE "H" TRANSFORMERS ON NEW INSTALLATIONS.
- D. USE EXTRA HEAVY CLASS ONE POLES WITH 10" MINIMUM TOP DIAMETER ON NEW CONSTRUCTION FOR 3 - 37.5 TO 3 - 75 KVA TRANSFORMER INSTALLATIONS.
- (E) EXEMPT MATERIALS
- F. LIMITED TO TRANSFORMERS WEIGHING 1200# OR LESS.
- G. SPACING OF TRANSFORMERS TO BE AS CLOSE AS PRACTICABLE BUT NOT TO EXCEED 33.5" CENTER TO CENTER.
- H. SEE DISTRIBUTION POLE TOPS SECTION FOR POLE TOP MATERIALS.
- I. OMIT LIGHTNING ARRESTER TANK GAP GROUNDING MATERIAL WHERE INSTALLING TRANSFORMERS NOT EQUIPPED WITH ARRESTERS.

ITEM	DESCRIPTION	QUANTITY		STOCK NO. OR CONSTR STD
		5 TO 25 KVA	37.5 TO 75 KVA	
1	CROSSARMS, 3 3/4" X 5 3/4" X 10' - 0"	2	4	PG 119 IT. 2
2	CROSSARMS, 3 1/2" X 4 1/2" X 8' - 0"	1	0	PG 111 IT. 2
3	COVER STRIP, 1 5/8" X 3 5/8" X 8' - 0" (2X4S4S)	1	0	699328
4	COVER STRIP, 1 5/8" X 3 5/8" X 10' - 0" (2X4S4S)	0	1	699360
5	BRACE, ANGLE CROSSARM 5' - 0"	2	4	154128
6	BRACE, VERTICAL 35"	0	2	154256
7	BOLT, MACH GALV, 3/8" X 6", 2 RD WASH.	(E) 2	0	PGS 139, 140
8	BOLT, MACH GALV, 1/2" X 8", 1 RD WASH	(E) 4	8	PGS 139, 140
9	BOLT, MACH GALV, 5/8" X 5", 1 RD WASH.	(E) 0	4	PGS 139, 140
10	BOLT, MACH GALV, 5/8" X "	(E) 1	2	PGS 139, 140
11	BOLT, MACH GALV, 5/8" X 14", 2 SQ WASH.	(E) 1	0	PGS 139, 140
12	BOLT, MACH GALV, 5/8" X 20", 2 - 3" SQ WASH.	(E) 1	0	PGS 139, 140
13	BOLT, MACH GALV, 3/4" X 20", 2 - 3" SQ WASH.	0	2	PGS 139, 140
14	BOLT, SPACE GALV, 5/8" X ", 4 SQ WASH	(E) 2	4	PGS 139, 140
15	SCREW, LAG GALV, 1/2" X 4"	(E) 3	2	621568
16	SIGN, HIGH VOLTAGE & 8 ROOFING NAILS, GALV	(E) 1	1	647548, 492224
17	STEP, POLE	(E) 19	19	692992
18	WASHER, DOUBLE COIL SPRING FOR ITEMS 7 THRU 14	AS REQ'D		PG 140
19	PIN, INSULATOR 12KV, SIZE PER ITEM 23, 1 / 1 3/8"	2	2	531072/532448
20				
21	TRANSFORMER, SINGLE PHASE, TYPE HE OR HJ	3	3	PGS 1121.01-1121.12
22	BRACKET, INSULATOR, SIZE PER ITEM 23	1	1	PG 152
23	INSULATOR, 12KV, CLASS AS REQ'D	3	3	PG 750
24	CLAMP, HOT LINE (E) AND STIRRUP	7	7	PG 788
25	CONNECTOR, WIRE	7	7	PGS 783-787
26				
27	WIRE, BARE STRANDED COPPER #6	76'	76'	813536
28	WIRE, BARE STRANDED COPPER #4	8'	8'	813760
29	WIRE, BARE STRANDED COPPER #2	50'	50'	813664
30	WIRE, W.P. COPPER, SIZE GOVERNED BY TRANSFORMER CAPACITY	60'	60'	PG 1125
31	ROD AND CLAMP, GROUND	(A) (B) 4	4	603072, 230016 (E)
32	MOULDING, HARDWOOD 1"	(A) 64'	64'	487200
33				
34	STAPLES, MOULDING GALV 1 1/4" X 3 1/16" X 1/4"	(A) (E) 40	40	678560
35	STAPLES, FENCE GALV 1 1/4"	(A) (E) 36	36	678528

1199.802
SUPERSEDES
1184 (1-1-86)

SAN DIEGO GAS & ELECTRIC CO OVERHEAD STANDARDS
12KV, THREE PHASE, TYPE "HE" OR "HJ" TRANSFORMER INSTALLATION,
THREE 75 KVA MAXIMUM, SECONDARY LINE ARM CONSTRUCTION

DATE 1-1-86
APPD AK/RDS

1200 - SECTIONALIZING,
ARRESTOR

1200 - SECTIONALIZING,
ARRESTOR

PAGE

SUBJECT

1206	PRIMARY CURRENT-LIMITING FUSE INSTALLATION
1207	FUSES USED IN OVERHEAD CONSTRUCTION
1212	4KV AND 12KV CUTOUT ASSEMBLY AND FUSE INSTALLATION
1213	6.9, 7.2 & 12KV FAULT TAMEER INSTALLATION
1220	IN-LINE DISCONNECT SWITCHES WEDGE TAP CONNECTED- 12K AND BELOW
1221	POLE TOP SWITCH INSTALLATION 4KV DISCONNECT SWITCH. HOOK STCK OPERATED
1225	LINE TENSION DISCONNECT SWITCH HOOK STICK OPERATED
1226	LINE TENSION DISCONNECT SWITCH HOOK STICK OPERATED ARMLESS
1228	POLE TOP SWITCH 12KV VERTICAL BREAK TYPE SINGLE CIRCUIT HORIZONTAL CONFIGURATION
1229	POLE TOP SWITCH 12KV VERTICAL BREAK TYPE SINGLE CIRCUIT HORIZONTAL CONFIGURATION - DOUBLE DEADEND
1230	POLE TOP SWITCH INSTALLATION 12KV SINGLE CIRCUIT HORIZONTAL CONFIGURATION
1231	POLE TOP SWITCH INSTALLATION 12KV SINGLE CIRCUIT VERTICAL CONFIGURATION
1236	POLE TOP SWITCH INSTALLATION 12KV SINGLE CIRCUIT TRIANGULAR CONFIGURATION
1240	POLE TOP SWITCH INSTALLATION 4KV WESTINGHOUSE OIL SWITCH, TYPE F011
1270	SERVICE RESTORER WITH CUTOUT DISCONNECT
1271	SERVICE RESTORER WITH HOOK STICK SWITCH DISCONNECT

© 1998 - 2020 San Diego Gas & Electric Company. All rights reserved. Removal of this copyright notice without permission is not permitted under law.

REV	CHANGE	BY	DSGN	APPV	DATE	REV	CHANGE	BY	DSGN	APPV	DATE
C	ADDED 1208	JC	JS	CZH	03/18/2019	F					
B	ADDED 1213	SL	JS	MDJ	09/19/2017	E	REMOVED 1208 FROM FMO	RSL	JES	CZH	03/09/2020
A	ORIGINAL ISSUE	JS	IL	MDJ	07/13/2016	D	EDITORIAL CHANGES	JCE	JES	CZH	04/21/2019

SHEET 1 OF 1	Indicates Latest Revision	Completely Revised	New Page <input checked="" type="checkbox"/>	Information Removed	FMO OH1201
	SDG&E ELECTRIC OVERHEAD FIELD MAINTENANCE ONLY STANDARDS				
	SECTIONALIZING, ARRESTER FMO TABLE OF CONTENTS				

FIELD MAINTENANCE ONLY

REVISION HISTORY:

7/13/2016: All versions prior to 2016 are superseded by their current version found inside the Overhead Construction Standard Manual.

© 1998 - 2016 San Diego Gas & Electric Company. All rights reserved. Removal of this copyright notice without permission is not permitted under law.

REV	CHANGE	BY	DSGN	APPV	DATE	REV	CHANGE	BY	DSGN	APPV	DATE
C						F					
B						E					
A	ORIGINAL ISSUE	JS	IL	MDJ	7/13/2016	D					

SHEET 1 OF 1	 Indicates Latest Revision	Completely Revised	New Page	Information Removed	FMO OH 1206
	SDG&E ELECTRIC OVERHEAD STANDARD				
	OVERHEAD 12KV CURRENT-LIMITING FUSE INSTALLATION				

Back-up current-limiting fuses, such as the Chance K-Mate fuse, shall be permanently installed only at the direction of the Protection Engineer in conjunction with expulsion fuses. Current-limiting fuses have the ability to limit high values of fault current so it remains within the interrupting capability of some cutouts. Back-up type current-limiting fuses are used in series with expulsion fuses in order to clear both low and high values of fault current. The back-up current-limiting fuse insures clearing of high current and the expulsion fuse, low current faults.

If a small amount of fault current passes through the two fuses (expulsion fuse in the cutout and current-limiting fuse), only the expulsion fuse will operate and the fuse tube will drop out as normal. At higher fault currents, both fuses will operate, but only the expulsion fused cutout will give the visual indication that it has operated. If the expulsion fuse has operated, always check the current-limiting fuse. To do this, remove the current-limiting fuse, and check for continuity.

The recommended method of installing these current-limiting fuses (Stock No. 365634) is to insert the stud end into the transformer cover mounted high voltage bushing terminal and connect the transformer riser in the eye bolt connector furnished with the current-limiting fuse, as shown below.

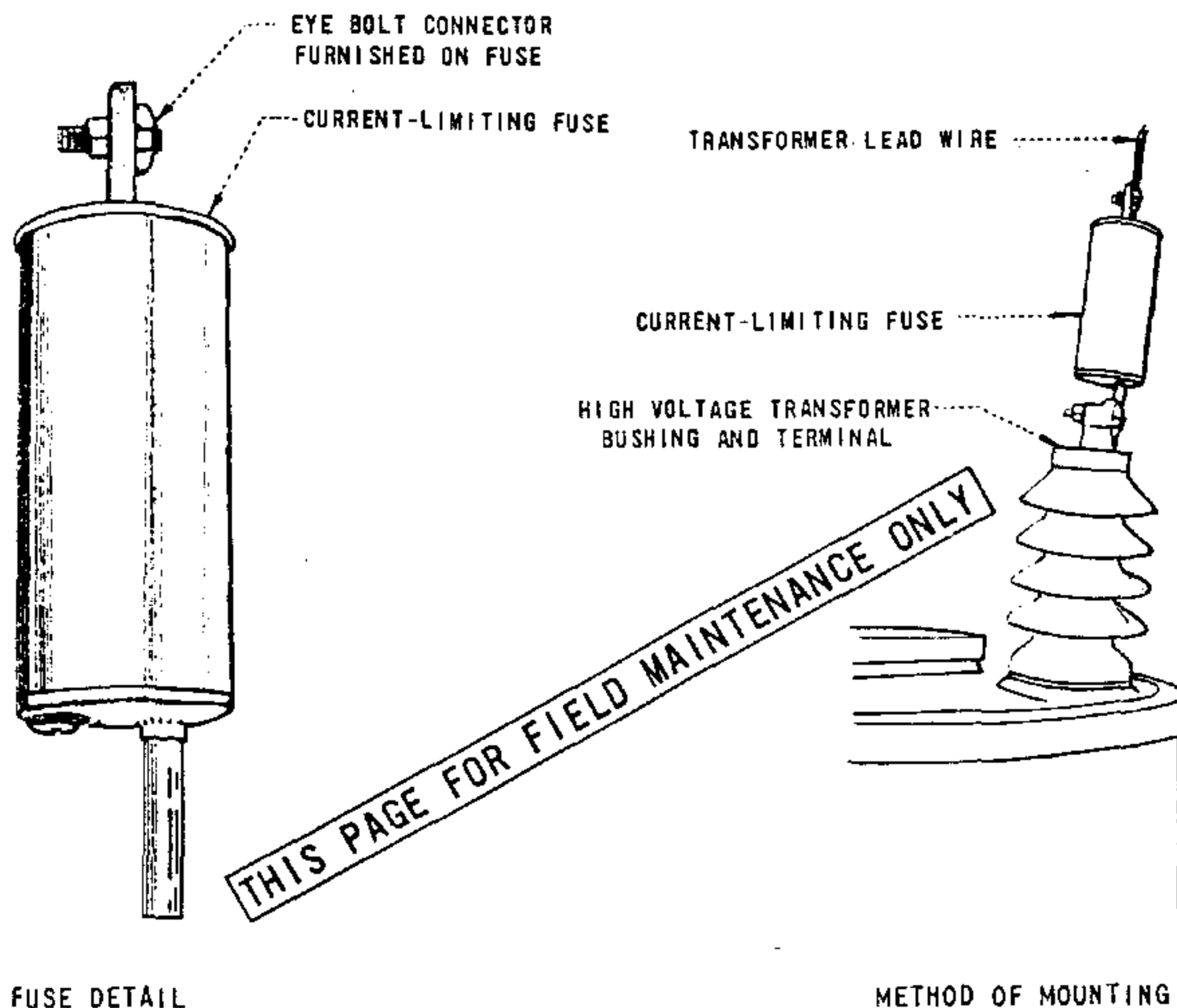

FUSE DETAIL

METHOD OF MOUNTING

OH1207 UG4308 FIELD MAINTENANCE ONLY

ALL VERSIONS LISTED IN THE FMO ARE SUPERSEDED BY THEIR CURRENT VERSION FOUND INSIDE THE OVERHEAD CONSTRUCTION STANDARDS MANUAL.

REVISION HISTORY:

04/21/2019: MOVED TO FMO

© 1998 - 2019 San Diego Gas & Electric Company. All rights reserved. Removal of this copyright notice without permission is not permitted under law.

REV	CHANGE	BY	DSGN	APPV	DATE	REV	CHANGE	BY	DSGN	APPV	DATE
C						F					
B						E					
A	ORIGINAL ISSUE	JCE	JS	CZH	04/21/2019	D					

SHEET 1 OF 1	Indicates Latest Revision	Completely Revised	<input checked="" type="checkbox"/> New Page	Information Removed	FMO OH1207 UG4308
	SDG&E ELECTRIC OVERHEAD AND UNDERGROUND FIELD MAINTENANCE ONLY STANDARDS				
	FUSES USED IN OVERHEAD CONSTRUCTION				

TABLE 6

FAULT TAMER FUSE LIMITERS TCC 123-8			
SIZE (AMPS)	TYPE	STOCK NUMBER	ASSEMBLY UNIT
5	FAULT TAMER	S365810	FT5
10	FAULT TAMER	S365811	FT10
15	FAULT TAMER	S365812	FT15
20	FAULT TAMER	S365813	FT20
N/A	FAULT TAMER BACK-UP LIMITER	S365822	FTBL

FOR FIELD MAINTENANCE ONLY

NOTES:

I. THESE FUSES ARE CAL-FIRE EXEMPT. THEY WILL BE USED IN TIER 2 & TIER 3 AREAS.

© 1998 - 2019 San Diego Gas & Electric Company. All rights reserved. Removal of this copyright notice without permission is not permitted under law.

REV	CHANGE	BY	DSGN	APPV	DATE	REV	CHANGE	BY	DSGN	APPV	DATE
C	MOVED TO FMO	JCE	JES	CZH	04/21/2019	F					
B	EDITORIAL CHANGES	KN	JS	MDJ	07/25/2017	E					
A	UPDATED MATERIALS	DS	JS	MDJ	01/25/2017	D					

SHEET 2 OF 2	X	Indicates Latest Revision	Completely Revised	New Page	Information Removed	FMO OH1207.2 UG4308.2
	SDG&E ELECTRIC OVERHEAD AND UNDERGROUND FIELD MAINTENANCE ONLY STANDARDS					
	FUSES USED IN OVERHEAD CONSTRUCTION					

OH1212 UG4306 FIELD MAINTENANCE ONLY

ALL VERSIONS LISTED IN THE FMO ARE SUPERSEDED BY THEIR CURRENT VERSION FOUND INSIDE THE OVERHEAD CONSTRUCTION STANDARDS MANUAL.

REVISION HISTORY:

04/21/2019: MOVED TO FMO

© 1998 - 2019 San Diego Gas & Electric Company. All rights reserved. Removal of this copyright notice without permission is not permitted under law.

REV	CHANGE	BY	DSGN	APPV	DATE	REV	CHANGE	BY	DSGN	APPV	DATE
C						F					
B						E					
A	ORIGINAL ISSUE	JCE	JS	CZH	04/21/2019	D					

SHEET 1 OF 1	Indicates Latest Revision	Completely Revised	<input checked="" type="checkbox"/> New Page	Information Removed	FMO OH1212 UG4306
	SDG&E ELECTRIC OVERHEAD AND UNDERGROUND FIELD MAINTENANCE ONLY STANDARDS				
	4KV, 12KV CUT OUT ASSEMBLY AND FUSE INSTALLATION				

SCOPE: THIS STANDARD SHOWS THE FAULT TAMER FUSE TUBE AND BACK-UP LIMITER, AND IT'S APPLICATION.

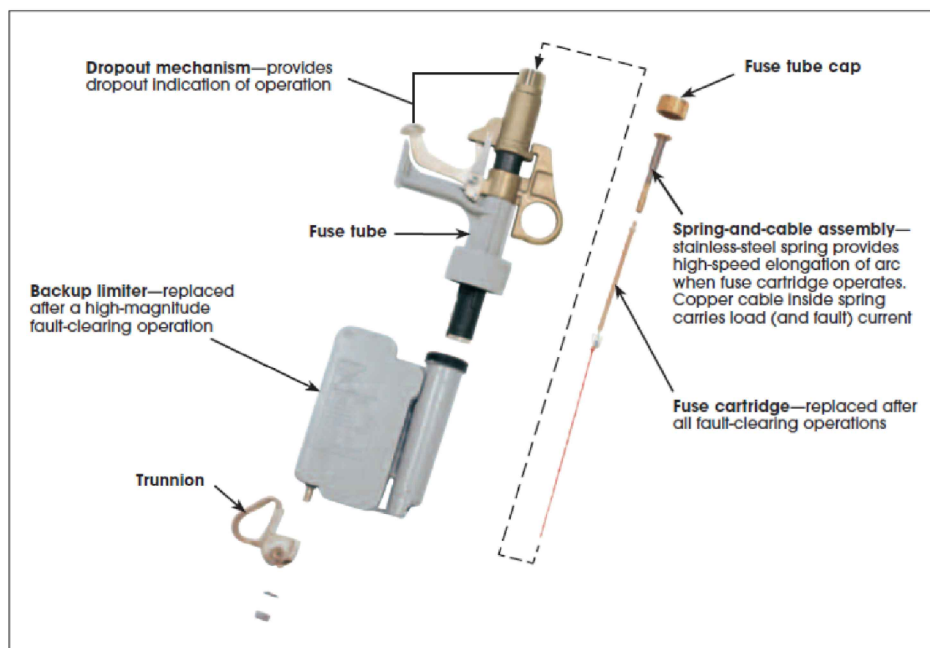
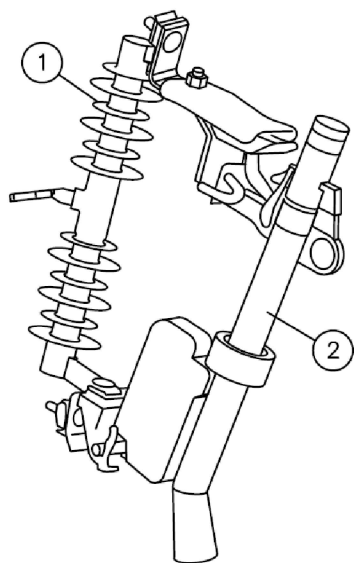

BILL OF MATERIALS:

ITEM	CURRENT RANGE	DESCRIPTION	STOCK NUMBER	ASSEMBLY UNITS	UG	ASSEMBLY UNITS	OH
1	0 - 300A	INTERCHANGEABLE CUTOUT BODY, WITHOUT FUSEHOLDER (III)	S298020	--			NPCO
2	FUSE THRU 20A 5	FAULT TAMER, INCLUDES FUSE TUBE & BACK-UP LIMITER (I)	S365820	--			FTAMER

NOTES:

- (I) SEE TABLE 1 FOR FUSES
- II. CUTOUTS SHALL BE BONDED IF INSTALLED IN CONTAMINATION DISTRICT 1 AS SHOWN IN OH STANDARD 287
- (III) CROSSARM MOUNTING BRACKETS ARE INCLUDED WITH THE MATERIALS SUPPLIED BY THE OH ASSEMBLY UNITS (USED ON "DESIGN BY LOCATION" JOBS). BRACKETS MUST BE ORDERED SEPARATELY ON MANUALLY PREPARED FIELD MEMO JOBS.
 - DOUBLE CUTOUT & ARRESTER MOUNTING BRACKET, USE S165442
 - CUTOUT OR ARRESTER MOUNTING BRACKET, USE S166070
- IV. USE ON 6.9KV - 12KV ONLY

REFERENCE:

- e. SEE ELECTRIC STANDARD PRACTICE 321 S&C FAULT TAMER® FUSE LIMITER.
- f. SEE S&C FAULT TAMER INSTALLATION INSTRUCTIONS 451-500.

FOR FIELD MAINTENANCE ONLY

© 1998 - 2019 San Diego Gas & Electric Company. All rights reserved. Removal of this copyright notice without permission is not permitted under law.

REV	CHANGE	BY	DSGN	APPV	DATE	REV	CHANGE	BY	DSGN	APPV	DATE
C						F					
B	MOVED TO FMO	JCE	JES	CZH	04/21/2019	E					
A	ORIGINAL ISSUE	GW	JS	MDJ	04/01/2018	D					

SHEET 3 OF 3	X Indicates Latest Revision	Completely Revised	New Page	Information Removed
	SDG&E ELECTRIC OVERHEAD AND UNDERGROUND FIELD MAINTENANCE ONLY STANDARDS			
	4KV, 12KV CUT OUT ASSEMBLY AND FUSE INSTALLATION			
				FMO OH1212.3 UG4306.3

FIELD MAINTENANCE ONLY

REVISION HISTORY:

9/19/2017: All versions prior to 2017 are superseded by their current version found inside the Overhead Construction Standard Manual.

© 1998 - 2016 San Diego Gas & Electric Company. All rights reserved. Removal of this copyright notice without permission is not permitted under law.

REV	CHANGE	BY	DSGN	APPV	DATE	REV	CHANGE	BY	DSGN	APPV	DATE
C						F					
B						E					
A	ORIGINAL ISSUE	SL	JS	MDJ	9/19/2017	D					

<p>SHEET 1 OF 1</p>	<input type="checkbox"/> Indicates Latest Revision	<input type="checkbox"/> Completely Revised	<input checked="" type="checkbox"/> New Page	<input type="checkbox"/> Information Removed	<p>FMO OH 1213</p>
	<p>SDG&E ELECTRIC OVERHEAD STANDARD</p>				
	<p>6.9, 7.2 & 12KV FAULT TAMER INSTALLATION</p>				

SCOPE: THIS STANDARD SHOWS THE FAULT TAMER FUSE TUBE AND BACK-UP LIMITER, AND IT'S APPLICATION.

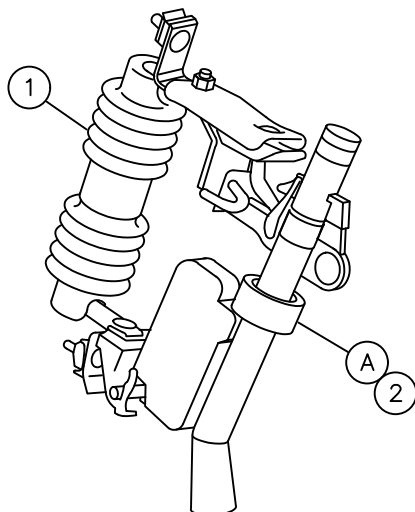

BILL OF MATERIAL:

ITEM	CURRENT RANGE	DESCRIPTION		STOCK NUMBER	ASSEMBLY UNITS UG	ASSEMBLY UNITS OH
1	0 - 300A	INTERCHANGEABLE CUTOUT BODY, WITHOUT FUSEHOLDER	HIGH LEAKAGE, CONTAMINATION DISTRICTS 1 ONLY (C)	S297956	-	X-CO
			STANDARD LEAKAGE, CONTAMINATION DISTRICTS 2 AND 3 (C)	S297960	-	CO-X
2	FUSE 5A THRU 20A	FAULT TAMER, INCLUDES FUSE TUBE & BACK-UP LIMITER (A)		S365820	-	FTAMER

TABLE 1 FAULT TAMER FUSE LIMITERS

SIZE (AMPS)	TYPE	MANUFACTURER	CATALOG NUMBER	STOCK NUMBER	ASSEMBLY UNITS
5	FAULT TAMER	S&C ELECTRIC	527005	S365810	FT5
10	FAULT TAMER	S&C ELECTRIC	527010	S365811	FT10
15	FAULT TAMER	S&C ELECTRIC	527015	S365812	FT15
20	FAULT TAMER	S&C ELECTRIC	527020	S365813	FT20
N/A	FAULT TAMER BACK-UP LIMITER	S&C ELECTRIC	98218	S365822	FTBL

INSTALLATION:

- (A) SEE TABLE 1 FOR FUSES.
- B. CUTOUTS SHALL BE BONDED IF INSTALLED IN CONTAMINATION DISTRICT 1 AS SHOWN ON STANDARD 287.
- (C) CROSSARM MOUNTING BRACKETS ARE INCLUDED WITH THE MATERIALS SUPPLIED BY THE OH ASSEMBLY UNITS (USED ON "DESIGN BY LOCATION" JOBS). BRACKETS MUST BE ORDERED SEPARATELY ON MANUALLY PREPARED FIELD MEMO JOBS.
 - DOUBLE CUTOUT & ARRESTER MOUNTING BRACKET, USE S165442
 - CUTOUT OR ARRESTER MOUNTING BRACKET, USE S166070

REFERENCE:

- D. SEE ELECTRIC STANDARD PRACTICE 321 S & C FAULT TAMER® FUSE LIMITER.
- E. SEE S&C FAULT TAMER INSTALLATION INSTRUCTIONS 451-500.

© 1998 - 2013 San Diego Gas & Electric Company. All rights reserved. Removal of this copyright notice without permission is not permitted under law.

X	Indicates Latest Revision	C	Completely Revised	N	New Page	I	Information Removed
REVISION		SDG&E ELECTRIC STANDARDS					
DATE 8-15-2013		6.9, 7.2 & 12KV FAULT TAMER INSTALLATION				OH 1213	
APPD TQ / DW							





FIELD MAINTENANCE ONLY

REVISION HISTORY:

7/13/2016: All versions prior to 2016 are superseded by their current version found inside the Overhead Construction Standard Manual.

© 1998 - 2016 San Diego Gas & Electric Company. All rights reserved. Removal of this copyright notice without permission is not permitted under law.

REV	CHANGE	BY	DSGN	APPV	DATE	REV	CHANGE	BY	DSGN	APPV	DATE
C						F					
B						E					
A	ORIGINAL ISSUE	JS	IL	MDJ	7/13/2016	D					

<p>SHEET 1 OF 1</p>	 Indicates Latest Revision	 Completely Revised	 New Page	 Information Removed	<p>FMO OH 1220</p>
	<p>SDG&E ELECTRIC OVERHEAD STANDARD</p>				
	<p>IN-LINE DISCONNECT SWITCHES WEDGE TAP CONNECTED-12K AND BELOW</p>				

SCOPE: THIS STANDARD SHOWS THE INSTALLATION OF PRIMARY IN-LINE HOOKSTICK DISCONNECTS, WEDGE TAP CONNECTED. THIS IS A PREFERRED METHOD FOR EXISTING PIN AND INSULATOR CONSTRUCTION. THESE SWITCHES CAN BE INSTALLED ON 336 AND 636 ACSR CONDUCTOR ONLY.

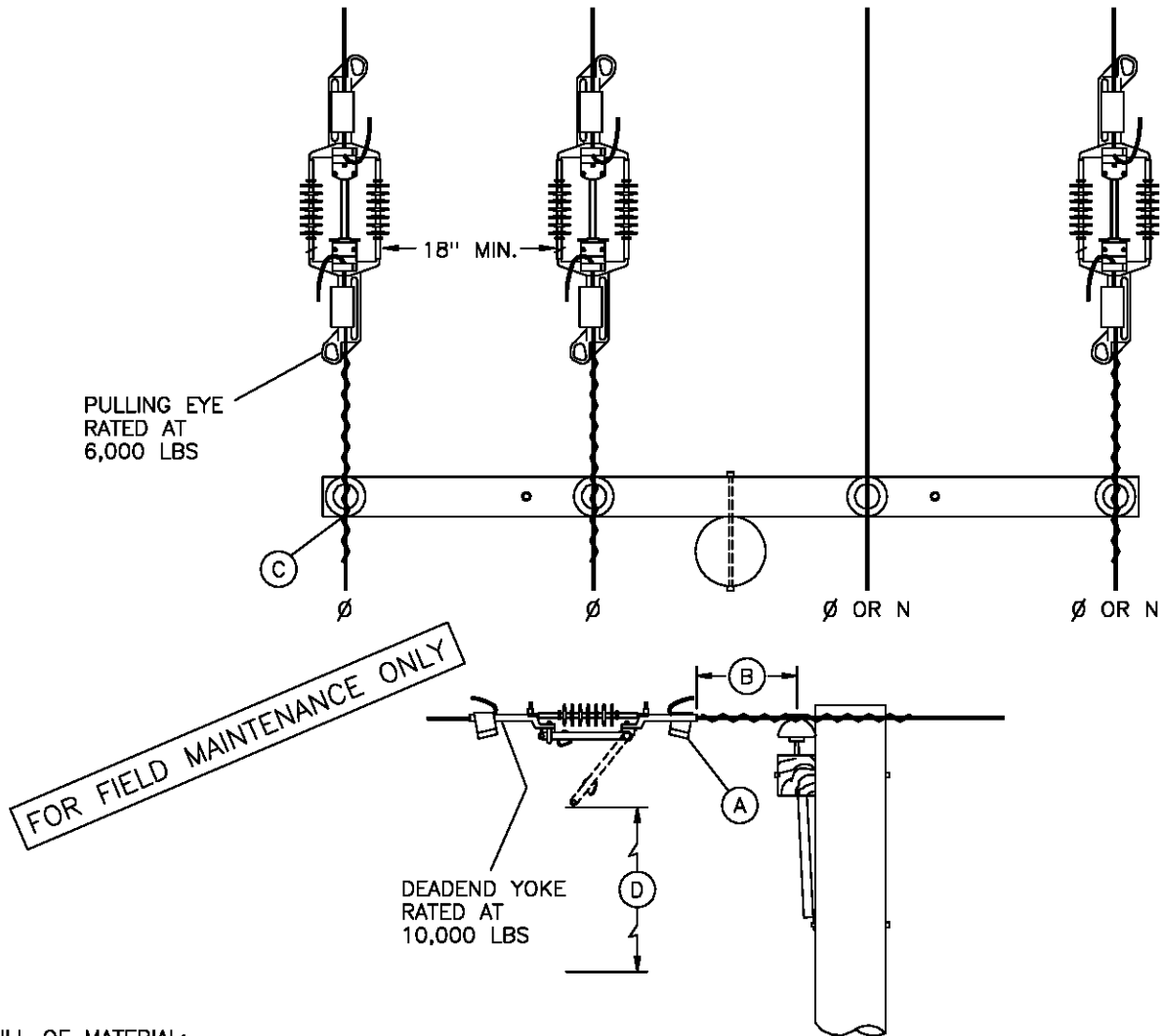

BILL OF MATERIAL:

ITEM	DESCRIPTION	QUANTITY	STOCK NUMBER	ASSEMBLY UNITS	
1	SWITCH, DISCONNECT, IN-LINE, 900A INCLUDING 2 WEDGE TYPE TAP CONNECTORS	336.4 ACSR	3	707010	ILD336
		636 ACSR	3	707012	ILD636
2	TAP CONNECTORS, WEDGE TYPE, (REPLACEMENT) (A)	AS REQ'D	336.4 ACSR	265940	-
			636 ACSR	265942	-

INSTALLATION:

- (A) WHEN INSTALLING SWITCH, USE ONLY WEDGE TYPE DEADEND TAP CONNECTORS SUPPLIED WITH SWITCH, OR EQUIVALENT REPLACEMENT ITEM. **DO NOT REUSE DEADEND TAP CONNECTORS.** IF REINSTALLING SWITCH, USE NEW DEADEND TAP CONNECTORS.
- (B) WHEN INSTALLING, POSITION SWITCH ON CONDUCTOR 18 INCHES FROM INSULATOR PIN TO SWITCH PULLING EYE, OR, 18 INCHES FROM DEADEND CLAMP PULLING EYE TO SWITCH PULLING EYE.
- (C) IF TIE WIRE EXISTING, REPLACE WITH PREFORMED TIE. DO NOT REPLACE EXISTING CLAMP TOP INSULATOR.
- (D) 4'-0" MIN. CLEARANCE TO NEAREST CONDUCTOR BELOW WHEN SWITCH IS OPEN. WHERE CONSTRUCTION IS REQUIRED BELOW SWITCH, IT SHALL NOT INTERFERE WITH OPERATION OF ANY SWITCH FROM THE POLE.

DATE 1-1-98 APPD <i>PA/OKK</i>	SDG&E ELECTRIC STANDARDS	1299.207 SUPERSEDES 1220 (4-30-99)
	IN-LINE DISCONNECT SWITCHES WEDGE TAP CONNECTED-12K AND BELOW	

FIELD MAINTENANCE ONLY

REVISION HISTORY:

7/13/2016: All versions prior to 2016 are superceded by their current version found inside the Overhead Construction Standard Manual.

2/20/2019: Install S706680 in place of old style Disconnect Switch.

© 1998 - 2019 San Diego Gas & Electric Company. All rights reserved. Removal of this copyright notice without permission is not permitted under law.

REV	CHANGE	BY	DSGN	APPV	DATE	REV	CHANGE	BY	DSGN	APPV	DATE
C						F					
B	EDITORIAL CHANGES	GLW	JES	CZH	2/20/2019	E					
A	ORIGINAL ISSUE	JS	IL	MDJ	7/13/2016	D					

<p>SHEET 1 OF 1</p>	<p>X Indicates Latest Revision</p>	Completely Revised	New Page	Information Removed	<p>FMO OH 1221</p>
	<p>SDG&E ELECTRIC OVERHEAD CONSTRUCTION STANDARDS</p>				
	<p>POLE TOP SWITCH INSTALLATION 4KV DISCONNECT SWITCH, HOOK STICK OPERATED</p>				

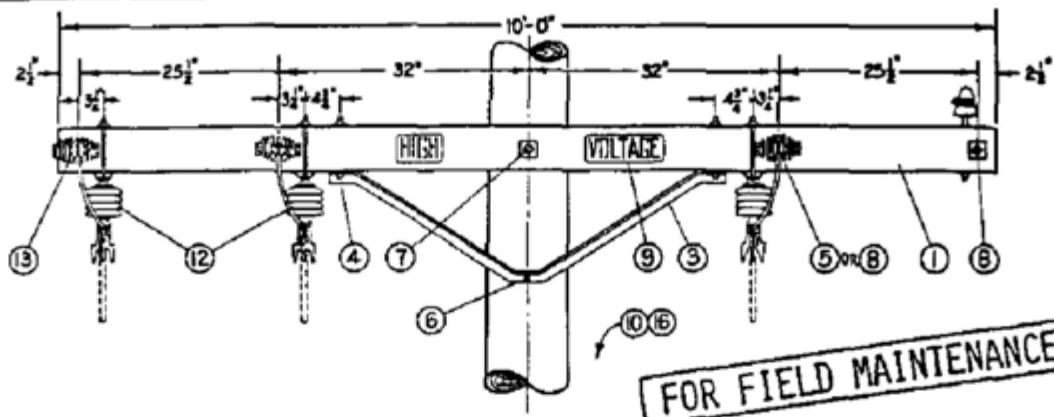

FIGURE 1
SPREAD CONSTRUCTION

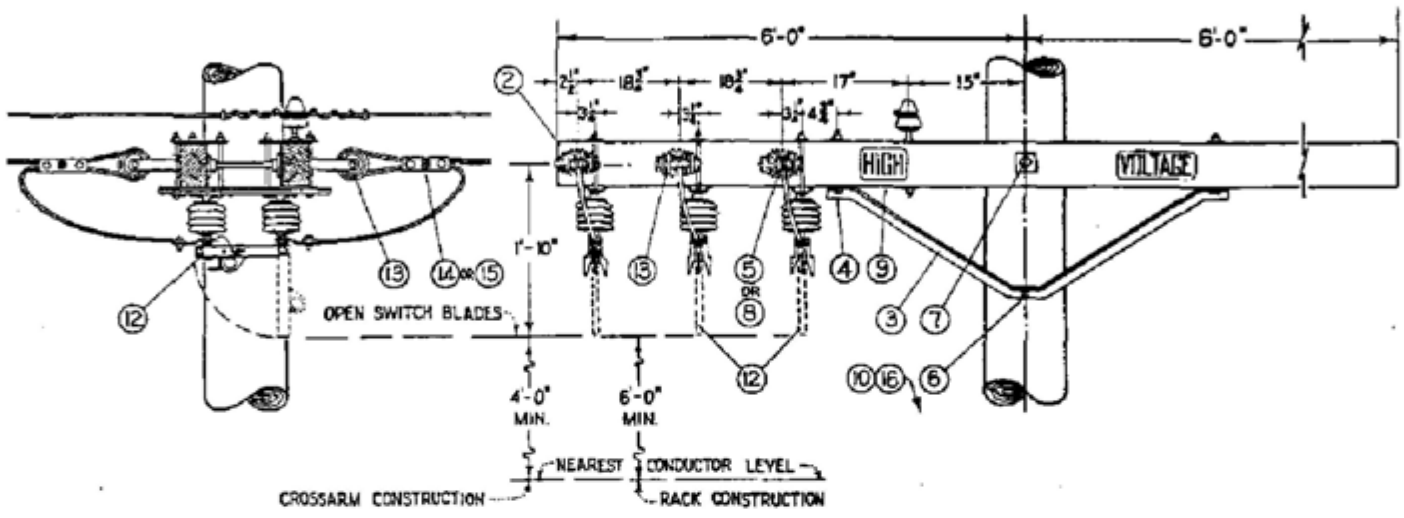

FIGURE 2
TWIN CIRCUIT CONSTRUCTION

NOTE:

A. FOR ARM-END CONSTRUCTION, REDRILL CROSSARMS IN FIELD AS SPECIFIED BY FIGURE 2

ITEM	DESCRIPTION	QUANTITY				STOCK NO. OR CONSTR. STDS.
		FIGURE 1		FIGURE 2		
		#4 or SMALLER	#2 or LARGER	#4 or SMALLER	#2 or LARGER	
P T & F	1 Crossarm, 3 3/4" X 3 3/4" X 10'-0"	2	2	-	-	PG 119 IL 2
	2 Crossarm, 3 3/4" X 5 3/4" X 12'-0"	-	-	2	2	PG 119 IL 4
	3 Angle Crossarm Brace, 4'-0"	2	2	2	2	164032
	4 Mach. Bolt, Galv., 1/2" X 7", 1-rd. wash. & 1-nut	4	4	4	4	PGS 139, 140
	5 Mach. Bolt, Galv., 5/8" X 5", 1-sq. wash. & 1-nut	4	-	4	-	PGS 139, 140
	6 Mach. Bolt, Galv., 5/8" X 10", 1-nut	1	1	1	1	PGS 139, 140
	7 Mach. Bolt, Galv., 5/8" X 12", 2-sq. wash. & 1-nut	1	1	1	1	PGS 139, 140
	8 Space Bolt, Galv., 5/8" X 20", 4-sq. wash. & 4-nuts	2	4	2	4	PGS 139, 140
	9 High Voltage Sign & B-Roofing Nails, Galv.	2	2	2	2	647776, 492192
	10 Pole Steps	17	17	17	17	692992
	11					
O C & D	12 Disconnect Switch, 14.4 KV, 600 A, S.P.S.T., with Hanger Straps and Bolts	3	3	3	3	707008
	13 Insulator, D. E.	6	6	6	6	235520
	14 Wire Connector, Split Bolt	12	-	12	-	PGS 783, 786
	15 Wire Connector, 3-Bolt Clamp	-	6	-	6	227296
	16 Switch Tag	2	2	2	2	-

1299.204
SUPERSEDES
1221 (1-1-87)

SDG&E ELECTRIC STANDARDS
POLE TOP SWITCH INSTALLATION
4KV DISCONNECT SWITCH, HOOK STICK OPERATED

DATE 1-1-87
APPD AK/RS

FIELD MAINTENANCE ONLY

REVISION HISTORY:

7/13/2016: All versions prior to 2016 are superceded by their current version found inside the Overhead Construction Standard Manual.

2/20/2019: Install S706680 in place of old style Disconnect Switch.

© 1998 - 2019 San Diego Gas & Electric Company. All rights reserved. Removal of this copyright notice without permission is not permitted under law.

REV	CHANGE	BY	DSGN	APPV	DATE	REV	CHANGE	BY	DSGN	APPV	DATE
C						F					
B	EDITORIAL CHANGES	GLW	JES	CZH	2/20/2019	E					
A	ORIGINAL ISSUE	JS	IL	MDJ	7/13/2016	D					

SHEET 1 OF 1	X Indicates Latest Revision	Completely Revised	New Page	Information Removed	FMO OH 1225
	SDG&E ELECTRIC OVERHEAD CONSTRUCTION STANDARDS				
	LINE TENSION DISCONNECT SWITCH HOOK STICK OPERATED				

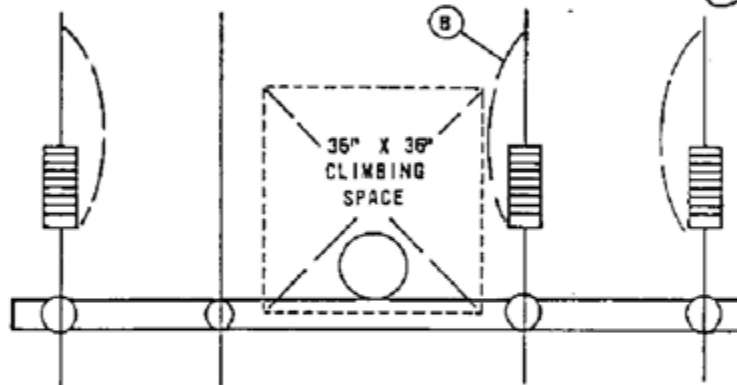
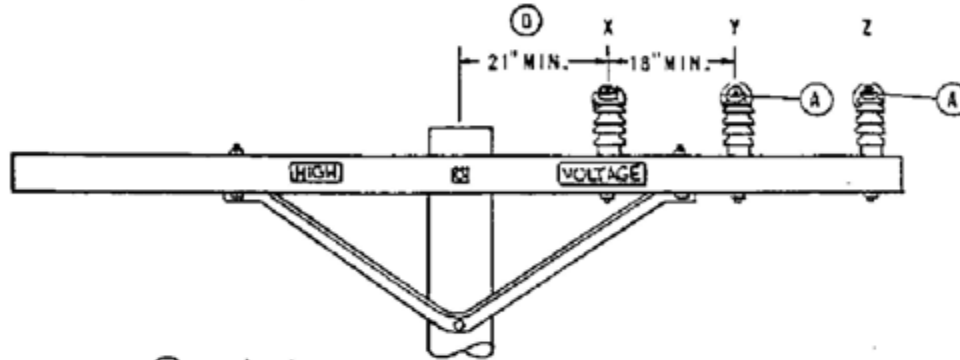
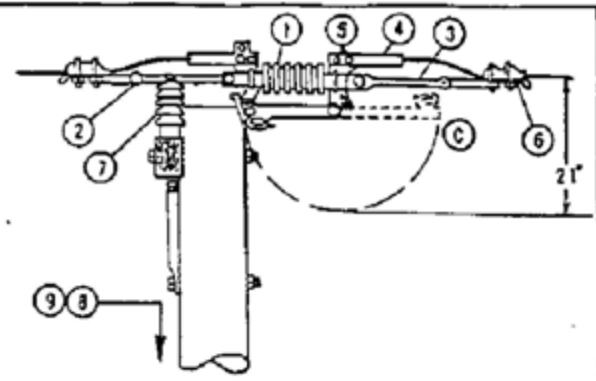
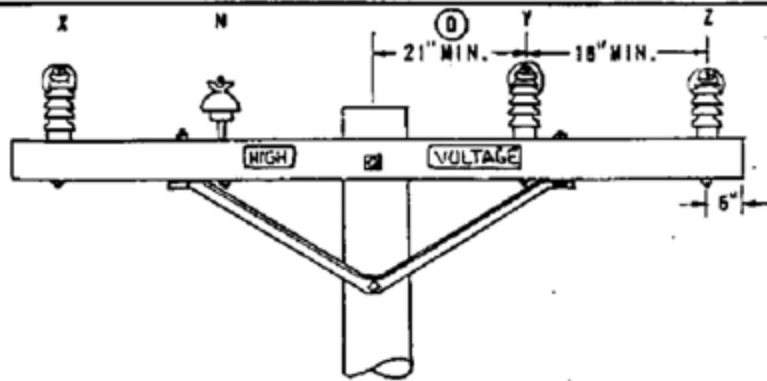

FOR FIELD MAINTENANCE ONLY

NOTES:

- (A) ROTATE DISCONNECTS TOWARD THE POLE USING ADJUSTABLE TRUNNION LINKS TO PERMIT EASE OF OPERATION.
- (B) KEEP THIS DISCONNECT VERTICAL TO KEEP IT OUT OF THE CLIMBING SPACE.
- (C) LOCK AS SHOWN WHEN LEFT IN THE OPEN POSITION.
- (D) G.O. 95 MINIMUM SPACING REQUIREMENT. THIS DIMENSION WILL ALLOW A 36" CLIMBING SPACE ON THE SAME SIDE OF THE POLE AS THE SWITCHES.
- (E) EXEMPT MATERIAL.
- F. INSTALL ONLY IN FULL TENSION SPANS OF 3/0 ACSR, 3/0 500S, 1/0 COPPER, OR LARGER CONDUCTOR.
- (G) SEE 400 SECTION FOR POLE TOP MATERIALS.
- H. 80ND INSULATOR STUDS IN CONTAMINATION DISTRICT 1.

ITEM	DESCRIPTION	QUANTITY	STOCK NO. OR CONSTR. STD.
PTF	OCB		
1	SWITCH, LINE TENSION DISCONNECT, 15KV, 600 AMPS	3	707014
2	LINK, ADJUSTABLE TRUNNION, 12"	3	465550
3	LINK, EXTENSION, GALV., 1/2" X 1-3/4" X 12"	3	456272
4	TERMINAL, ALUMINUM COMPRESSION, 2-HOLE	6	700 SECTION
5	BOLT, WASH, STAINLESS STEEL, ASSEMBLY, 1/2" X 1 1/2"	(E) 12	148672
6	CLAMPS, DEAD-END	6	700 SECTION
7	INSULATOR, VERTICAL POST CLAMP TYPE (ITEM 2 CONTAINS CLAMP)	3	700 SECTION
8	STEPS, POLE	(E) AS REQ'D.	592992
9	TAG, SWITCH NUMBER	(E) 2	300 SECTION
10	STUD 7 1/2"	3	701760
11	WASHER, 5/8" DOUBLE COIL SPRING	(E) 3	798560
12	WASHER, 2 1/4" X 2 1/4" FLAT	(E) 3	799040

SOG&E ELECTRIC STANDARDS

DATE 2-3-78
APPD JAF

LINE TENSION DISCONNECT SWITCH HOOK STICK OPERATED

1299.205
SUPERSEDES
1225 (1-1-92)

FIELD MAINTENANCE ONLY

REVISION HISTORY:

7/13/2016: All versions prior to 2016 are superceded by their current version found inside the Overhead Construction Standard Manual.

2/20/2019: Install S706672 in place of old style Disconnect Switch.

© 1998 - 2019 San Diego Gas & Electric Company. All rights reserved. Removal of this copyright notice without permission is not permitted under law.

REV	CHANGE	BY	DSGN	APPV	DATE	REV	CHANGE	BY	DSGN	APPV	DATE
C						F					
B	EDITORIAL CHANGES	GLW	JES	CZH	2/20/2019	E					
A	ORIGINAL ISSUE	JS	IL	MDJ	7/13/2016	D					

SHEET 1 OF 1	X Indicates Latest Revision	Completely Revised	New Page	Information Removed	FMO OH 1226
	SDG&E ELECTRIC OVERHEAD CONSTRUCTION STANDARDS				
	LINE TENSION DISCONNECT SWITCH HOOK OPERATED ARMLESS				

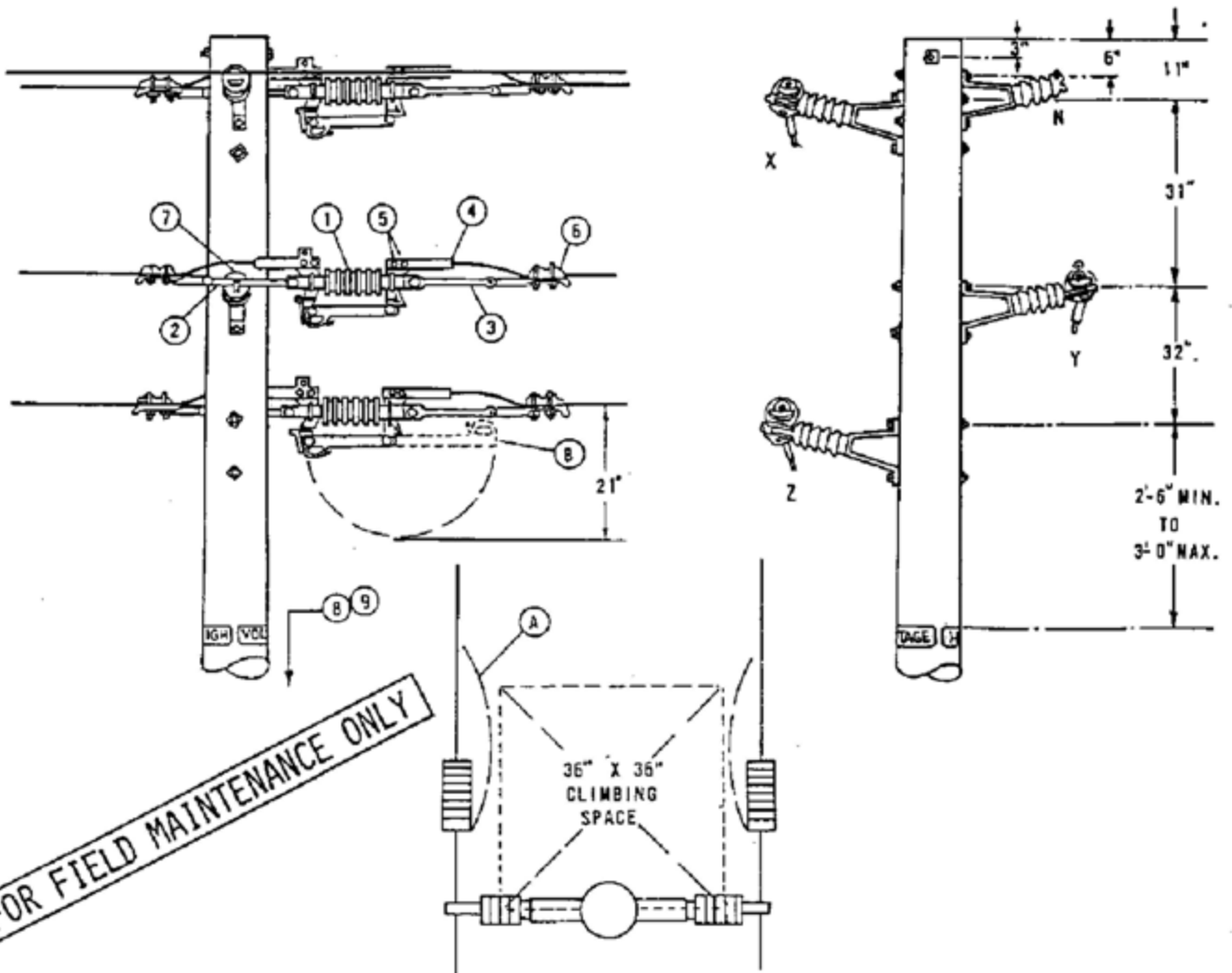

FOR FIELD MAINTENANCE ONLY

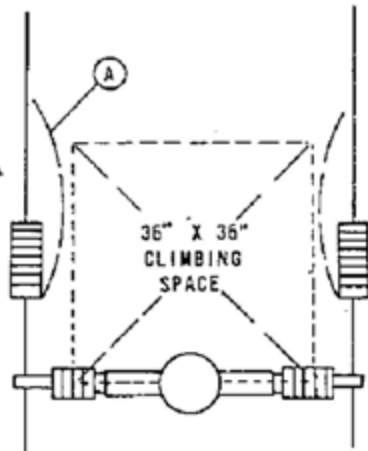

NOTES:

- (A) ROTATE DISCONNECTS AS SHOWN USING ADJUSTABLE TRUNNION LINK FOR EASE OF OPERATION, KEEPING BLADE OUT OF CLIMBING SPACE.
- (B) LOCK AS SHOWN WHEN LEFT IN THE OPEN POSITION.
- C. INSTALL ONLY IN FULL TENSION SPANS OF 3/0 ACSR, 3/0 5005, 1/0 COPPER OR LARGER CONDUCTOR.
- D. SEE 400 SECTION FOR POLE TOP MATERIALS, SPAN LIMITATIONS AND OTHER REQUIREMENTS.
- (E) EXEMPT MATERIAL.
- F. BOND INSULATOR BRACKETS IN CONTAMINATION DISTRICT 1.

ITEM	DESCRIPTION	QUANTITY	STOCK NO. OR CONSTR. STD.
1	SWITCH, LINE TENSION DISCONNECT, 15KV, 600 AMPS	3	707014
2	LINK, ADJUSTABLE, TRUNNION, 12"	3	465550
3	LINK, EXTENSION, GALV., 1/2" X 1 3/4" X 12"	3	456272
4	TERMINAL, ALUMINUM COMPRESSION, 2-HOLE	6	700 SECTION
5	BOLT, MACH, STAINLESS STEEL, ASSEMBLY, 1/2" X 1 1/2"	(E) 12	148672
6	CLAMPS, DEAD END	6	700 SECTION
7	INSULATOR, HORIZONTAL POST CLAMP TYPE (ITEM 2 CONTAINS CLAMP)	3	700 SECTION
8	STEPS, POLE	(C) AS REQ'D.	692992
9	TAG, SWITCH NUMBER	(E) 2	300 SECTION

FIELD MAINTENANCE ONLY

REVISION HISTORY:

7/13/2016: All versions prior to 2016 are superseded by their current version found inside the Overhead Construction Standard Manual.

© 1998 - 2016 San Diego Gas & Electric Company. All rights reserved. Removal of this copyright notice without permission is not permitted under law.

REV	CHANGE	BY	DSGN	APPV	DATE	REV	CHANGE	BY	DSGN	APPV	DATE
C						F					
B						E					
A	ORIGINAL ISSUE	JS	IL	MDJ	7/13/2016	D					

SHEET 1 OF 1	 Indicates Latest Revision	Completely Revised	New Page	Information Removed	FMO OH 1228
	SDG&E ELECTRIC OVERHEAD STANDARD				
	POLE TOP SWITCH 12KV VERTICAL BREAK TYPE SINGLE CIRCUIT HORIZONTAL CONFIGURATION				

SCOPE: THIS STANDARD SHOWS A GANG OPERATED POLE TOP SWITCH FOR CIRCUIT TIES OR SECTIONALIZING PURPOSES AND IS TO BE USED FOR TANGENT AND DEAD-END CONFIGURATIONS.

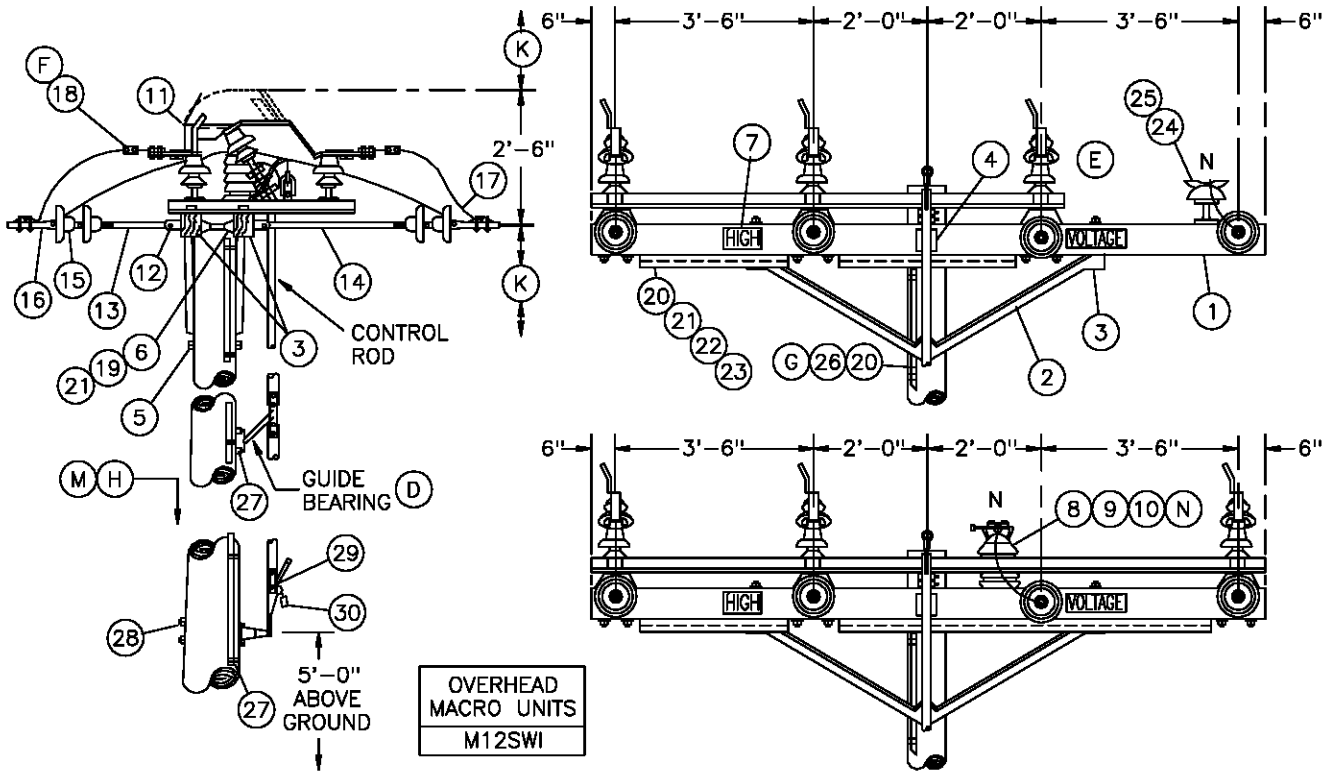

BILL OF MATERIAL:

ITEM	DESCRIPTION	QUANTITY	STOCK NO. OR CONSTR STANDARD	ASSEMBLY UNITS
1	CROSSARM, 3 3/4" x 5 3/4" x 12"-0"	2	294160	6-
2	BRACE, ANGLE, 6'-0"	2	164160	6HUB
3	BOLT, MACH, GALV, 1/2" X 7", 1 ROUND AND 1 DOUBLE COIL SPRING WASHER	16	STD 392	-
4	BOLT, MACH, GALV, 5/8" x (LENGTH AS REQ'D), 2 SQUARE AND 1 DOUBLE COIL SPRING WASHER	1	STD 392	-
5	BOLT, MACH, GALV, 5/8" x (LENGTH AS REQ'D) AND 1 DOUBLE COIL SPRING WASHER	1	STD 392	-
6	BOLT, SPACE, GALV, 5/8" (LENGTH AS REQ'D), 2 SQUARE, 2 ROUND, 2 DOUBLE COIL SPRING WASHERS AND 1 NUT	4	STD 392	-
7	SIGN, HIGH VOLTAGE, AND 9 ROOFING NAILS, GALV	2 18	647648 492224	HV -
8	STUD, 5/8" x 7 1/2" AND 1 DOUBLE COIL SPRING WASHER	1 1	701760 798560	STUD-W -
9	INSULATOR, VERTICAL POST	1	428608	VPI
10	CLAMP, POST INSULATOR	1	STD 773	-
11	SWITCH T.P.S.T. 600 AMP, INCLUDING 31' OF CONTROL ROD	1	709254	MEMCO
	ADDITIONAL INTERMEDIATE 10'-6" CONTROL ROD WITH GUIDE BEARING AND END FITTINGS	AS REQ'D	604432	FC-ROD
	REPLACEMENT UPPER CONTROL ROD WITH END FITTINGS	AS REQ'D	604434	-
	REPLACEMENT LOWER CONTROL ROD WITH END FITTINGS	AS REQ'D	604436	-
12	CLEVIS, DEAD END, 5/8" BOLT STEEL (OPEN TYPE)	8	235618	-

FOR FIELD MAINTENANCE ONLY

<p>1299.208 SUPERSEDES 1228.1 (8-1-00)</p>	<p>SDG&E ELECTRIC STANDARDS</p> <p>POLE TOP SWITCH 12KV VERTICAL BREAK TYPE SINGLE CIRCUIT HORIZONTAL CONFIGURATION</p>	<p>DATE 1-1-96 APPD <i>PIA 1/09</i></p>
----------------------------------------------------	---------------------------------------------------------------------------------------------------------------------------------	---------------------------------------------

BILL OF MATERIAL: (CON'T)

ITEM	DESCRIPTION	QUANTITY	STOCK NO. OR CONSTR STANDARD	ASSEMBLY UNITS
13	LINK, EXTENSION, GALV, 1/2" X 2" X 12" (C)	4	466240	DEEXT
14	STRAP, EXTENSION, GALV, 1/2" X 1 1/2" X 28" (C)	4	696864	-
15	INSULATOR, SUSPENSION (C)	14	STD 750	-
16	CLAMP, STRAIGHT LINE, D.E. (C)	8	741-743	-
17	CONNECTOR, WIRE COMPRESSION (SIZE AS REQ'D)	AS REQ'D	783-786	-
18	TERMINAL, COMPRESSION LUG (F)	6	794-795	-
19	WIRE, #8 BARE SOLID ANNEALED COPPER	15'	812928	BOND8
20	WIRE, BARE STRANDED, #4	65'	813760	BS4
21	STAPLE, FENCE, GALV, 1 1/4"	AS REQ'D	678528	-
22	MOULDING, OAK HARDWOOD, 1"	10'	487200	MLDG
23	STRAPS, GALV, 3/4" AND 2-1 3/4" ROOFING NAILS	AS REQ'D	697888	-
24	PIN, INSULATOR, STRAIGHT, 12KV, 1"	1	532704	PS1
25	INSULATOR, LINE, 12KV, NEUTRAL	1	429216	55-3/1
26	GROUND UNIT, COMPLETE	1	603136	GND4
27	SCREW, LAG, GALV, 1/2" X 4"	2	621568	-
28	BOLT, MACH, GALV, 5/8" X (LENGTH AS REQ'D), 1 SQUARE AND 1 DOUBLE COIL SPRING WASHER	2	STD 392	-
29	TAG, SWITCH NUMBER	2	STD 204	-
30	PADLOCK, SCHLAGE ELECTRIC SERIES	1	514848	-

FOR FIELD MAINTENANCE ONLY

INSTALLATION:

- A. CONTROL ROD AND SWITCH HANDLE ARE NOT ALLOWED IN THE CLIMBING SPACE (G.O. 95, 54.7-A4).
- B. ATTACH GROUND WIRE TO SWITCH MOUNTING BOLTS BY USING AN ADDITIONAL ROUND WASHER.
- (C) REDUCE QUANTITIES AS REQUIRED WHEN NOT USING NEUTRAL.
- (D) GUIDE BEARING PIVOTS THROUGH 90°. IN THE OPENED AND CLOSED POSITIONS THE GUIDE BEARING MAKES A 45° ANGLE WITH THE POLE.
- (E) CUT OFF EXCESS INTERPHASE SHAFT.
- (F) WHEN ATTACHING 1/0 AND 4/0 COPPER CONDUCTORS TO A POLE TOP SWITCH, USE A BRONZE CABLE TAP LUG, STOCK NUMBER 471296. IF EXCESSIVE VIBRATION OR WHIPPING COULD OCCUR, USE TWO LUGS IN SERIES.

REFERENCES:

- (G) GROUNDING METHODS - SEE STANDARD 1002.
- (H) POLE STEPPING - SEE STANDARD 363.
- I. SEE STANDARD 1443 FOR SINGLE DEADEND CONFIGURATION.
- J. SEE DESIGN MANUAL PAGE 6111 - FEEDER CIRCUIT SECTIONALIZING AND PROTECTION.
- (K) SEE SECTION 200 FOR MINIMUM VERTICAL SEPARATION.
- (L) SEE STANDARD 759 FOR USE OF LINE GUARD.
- (M) REFLECTOR STRIPS ARE REQUIRED ON ALL SECTIONALIZING/TIELINE SWITCHES AND SERVICE RESTORER POLES. (SEE STD. 208.3 ITEM 12).
- (N) NEUTRALS SHALL BE SOLIDLY TIED TOGETHER AT ALL SWITCHES REGARDLESS WHETHER THEY ARE NORMALLY OPEN OR CLOSED. THIS INCLUDES TIE SWITCHES TO CIRCUITS EMANATING FROM DIFFERENT SUBSTATIONS. (SEE DESIGN MANUAL STANDARD PAGE 6221.2, D.3).

DATE 1-1-93 APPD <i>PA/ROJ</i>	SDG&E ELECTRIC STANDARDS	1299.209 SUPERSEDES 1228.2 (8-1-00)
	POLE TOP SWITCH 12KV VERTICAL BREAK TYPE SINGLE CIRCUIT HORIZONTAL CONFIGURATION	

INSTALLATIONS:

- A. CONTROL ROD AND SWITCH HANDLE ARE NOT ALLOWED IN THE CLIMBING SPACE. (G.O. 95 54.7-A4)
- B. ATTACH GROUND WIRE TO SWITCH MOUNTING BOLTS BY USING AN ADDITIONAL ROUND WASHER.
- (C) REDUCE QUANTITIES AS REQUIRED WHEN NOT USING NEUTRAL.
- (D) POSITION OF BELL CRANK ASSEMBLY WITH SWITCH IN OPEN POSITION.
- (E) EXEMPT MATERIAL.
- (F) POSITION OF BELL CRANK ASSEMBLY WITH SWITCH IN CLOSED POSITION.
- (G) GUIDE BEARING PIVOTS THROUGH 90°. IN THE OPENED AND CLOSED POSITIONS THE GUIDE BEARING MAKES A 45° ANGLE WITH THE POLE.
- (H) POLES ARE TO BE STEPPED PER STANDARD 363.
- (I) USE TWO GROUND RODS SPACED A MINIMUM OF 6' APART PER G.O. 95 RULE 21.1.

REFERENCES:

- J. SEE STANDARD 1443 FOR SINGLE DEADEND CONFIGURATION.
- K. SEE STANDARD 1205 TO DETERMINE WHEN TO USE GANG OR HOOKSTICK SWITCHES.
- L. SEE DESIGN MANUAL PAGE 5621 - CRITERIA AND GENERAL PRACTICES FOR SECTIONALIZING.
- (M) SEE SECTIONS 200 AND 500 FOR MINIMUM VERTICAL SEPARATION.
- (N) SEE STANDARD 759 FOR USE OF LINE GUARD.

FOR FIELD MAINTENANCE ONLY

ITEM	DESCRIPTION	QUANTITY	STOCK NO. OR CONSTR. STDS.
1	CROSSARM, 3 3/4" X 5 3/4" X 12'-0"	2	300 SECTION
2	BRACE, ANGLE, 6'-0"	-	164160
3	BRACE, 4' SPECIAL	4	163808
4	BOLT, MACH, GALV, 1/2" X 7"; 1-RD WASH, & 1-DBL COIL WASH	(E) -	100 SECTION
5	BOLT, MACH, GALV, 5/8" X ___; & 1-DBL COIL WASH	(E) 1	100 SECTION
6	BOLT, MACH, GALV, 5/8" X ___; 2-SQ WASH & 1-DBL COIL WASH	(E) 1	100 SECTION
7	BOLT, SPACE, GALV, 5/8" X ___; 4-SQ WASH & 2- DBL COIL WASH	(C) (E) 2	100 SECTION
8	BOLT, MACH, GALV, 5/8" X ___; 1-SQ WASH & 1-DBL COIL WASH	(E) 16	100 SECTION
P 9	BOLT, MACH, GALV, 5/8" X 5"; 1-RD WASH & 1-DBL COIL WASH	(E) 4	100 SECTION
T 10	SCREW, LAG, GALV, 1/2" X 4"	(E) 2	621568
F 11	SIGN, HIGH VOLTAGE AND NAILS, 9 ROOFING, GALV	(E) 2	647648, 492224
12	STEPS, POLE	(H) (E) 16	692992
13	PIN, INSULATOR, STRAIGHT, 12KV, 1" & 1-DBL COIL WASH	(C) 2	532704, 798560 (E)
14	STUD, 7 1/2" & 1-DBL COIL WASH	(C) -	701760, 798560 (E)
15			
16	CLEVIS, DEAD END, 5/8" BOLT STEEL (OPEN TYPE)	(C) (E) -	235618
17	LINK, EXTENSION GALV, 1/2" X 2" X 12"	(C) -	466240
18	STRAP, EXTENSION GALV, 1/2" X 1 1/2" X 28"	(C) -	696864
19	GROUND UNIT (GRAY OR PLAIN)	1	603120, 603136
20	MOULDING, HARDWOOD 1" (GRAY OR PLAIN)	24'	487184, 487200
21	STAPLE, FENCE, GALV, 1 1/4"	(E) 30	678528
22	WIRE, BARE STRANDED, #6	5 LBS	813536
23	TERMINAL, COMPRESSION LUG	6	700 SECTION
24	PADLOCK	1	514848
25	INSULATOR, LINE, 12KV NEUTRAL	(C) (E) 2	429216
O 26	TAG, SWITCH NUMBER	2	300 SECTION
C 27	CLAMP, STRAIGHT LINE, D.E.	(C) 6	700 SECTION
D 28	CLAMP, POST INSULATOR	(N) (C) -	700 SECTION
29	INSULATOR, VERTICAL POST	(C) -	428608
30	INSULATOR, SUSPENSION	(C) -	700 SECTION
31	SWITCH, T.P.S.T., 600 AMP	1	709246
32	SWITCH, T.P.S.T., 600 AMP	-	709250
33	STAPLES, MOULDING, GALV, 3" X 1 1/16" X 1/4"	(E) AS REQD	678560
34	CONNECTOR, WIRE COMPRESSION (SIZE AS REQ'D)	(C) -	700 SECTION

DATE 1-1-87	SOG&E ELECTRIC STANDARDS	1299.203
APPD <i>AK/RD</i>	POLE TOP SWITCH 12KV VERTICAL BREAK TYPE SINGLE CIRCUIT HORIZONTAL CONFIGURATION	SUPERSEDES 1228.3 (1-1-87)

FIELD MAINTENANCE ONLY

REVISION HISTORY:

7/13/2016: All versions prior to 2016 are superseded by their current version found inside the Overhead Construction Standard Manual.

© 1998 - 2016 San Diego Gas & Electric Company. All rights reserved. Removal of this copyright notice without permission is not permitted under law.

REV	CHANGE	BY	DSGN	APPV	DATE	REV	CHANGE	BY	DSGN	APPV	DATE
C						F					
B						E					
A	ORIGINAL ISSUE	JS	IL	MDJ	7/13/2016	D					

	Indicates Latest Revision	Completely Revised	New Page	Information Removed
-------------------------------------------------------------------------------------	---------------------------	--------------------	----------	---------------------

**SHEET
1 OF 1**

SDG&E ELECTRIC OVERHEAD STANDARD

POLE TOP SWITCH 12KV VERTICAL BREAK TYPE SINGLE CIRCUIT
HORIZONTAL CONFIGURATION - DOUBLE DEAD END

**FMO
OH 1229**

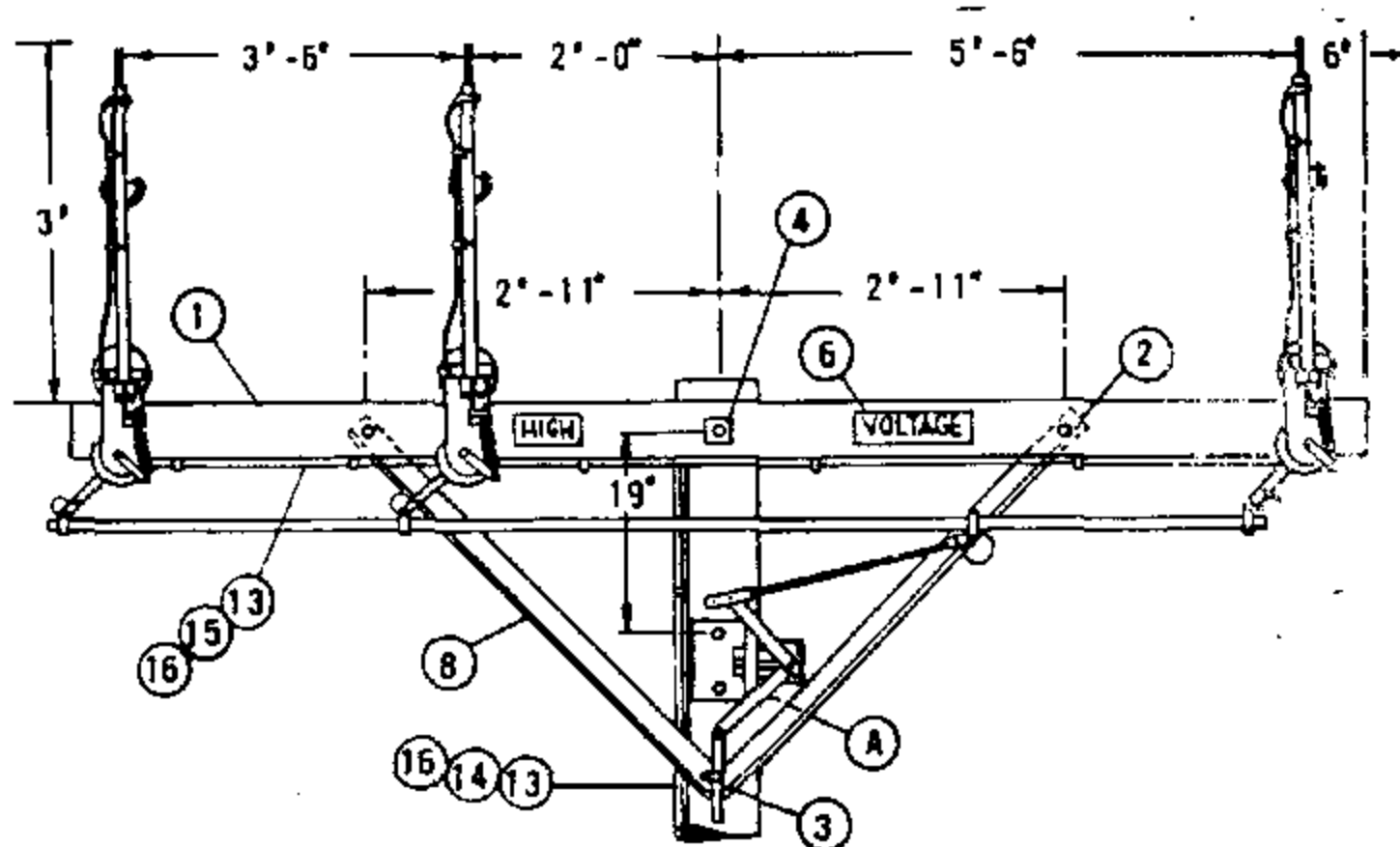
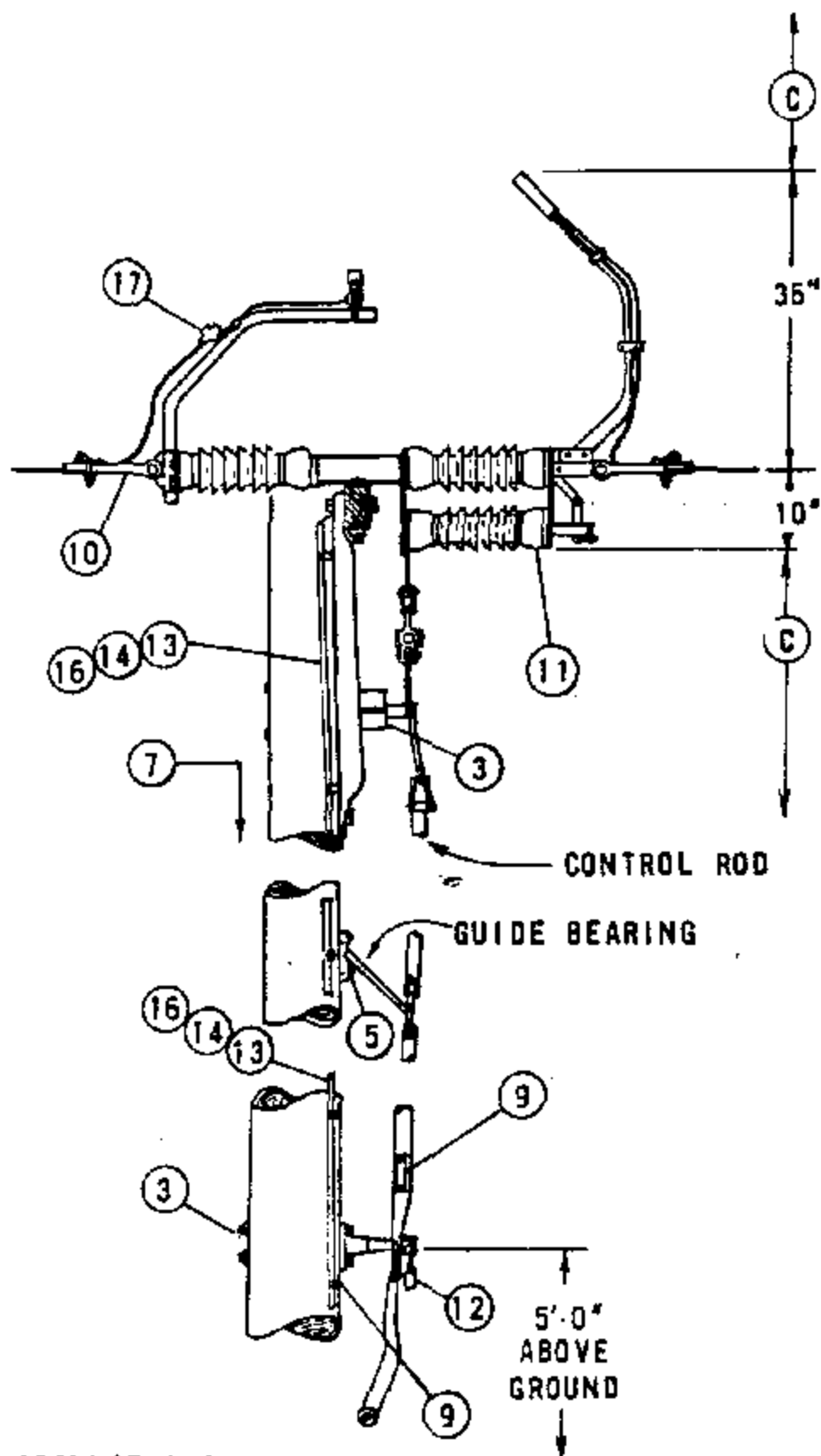

THIS PAGE FOR FIELD MAINTENANCE ONLY

INSTALLATIONS:

- (A) POSITION OF BELL CRANK ASSEMBLY WITH SWITCH IN OPEN POSITION.
- (E) EXEMPT MATERIAL

REFERENCES:

- B. SEE PAGE 1230 TO DETERMINE WHEN THIS SWITCH SHALL BE USED.
- (C) SEE SECTIONS 200 AND 500 FOR MINIMUM VERTICAL SEPARATION.

ITEM	DESCRIPTION	QUANTITY	STOCK NO. OR CONST. STDS.
P T F	1 CROSSARM, 3 3/4" X 5 3/4" X 12'-0"	1	300 SECTION
	2 BOLT, MACH, GALV, 5/8" X 5", 1-RD WASH, & 1-DBL COIL WASH (E)	2	100 SECTION
	3 BOLT, MACH, GALV, 5/8" X ____; 1-DBL COIL WASH & 1-SQ WASH (E)	5	100 SECTION
	4 BOLT, MACH, GALV, 5/8" X ____; 2-SQ WASH, & 1-DBL COIL WASH (E)	1	100 SECTION
	5 SCREW, LAG, GALV, 1/2" X 4" (E)	2	621568
	6 SIGN, HIGH VOLTAGE AND NAILS, 9 ROOFING, GALV (E)	2	647648, 492224
	7 STEPS, POLE (E)	16	692992
	8 BRACE, 4' SPECIAL (E)	2	163808
	9 TAG, SWITCH NUMBER (E)	2	300 SECTION
D C D	10 CLAMP, STRAIGHT LINE, D.E.	6	700 SECTION
	11 SWITCH, T.P.S.T., 600 AMP	1	709248
	12 PADLOCK	1	514848
	13 WIRE, BARE STRANDED, #6	55'	813536
	14 GROUND UNIT, (GRAY OR PLAIN)	1	603120, 603136
	15 MOULDING, HARDWOOD 1" (GRAY OR PLAIN)	24'	487184, 487200
	16 STAPLE, FENCE, GALV, 1 1/4" (E)	30	678528
17 TERMINAL, COMPRESSION LUG	6	700 SECTION	

SDG&E ELECTRIC STANDARDS

DATE 6-4-82
APPD *JEH*

POLE TOP SWITCH 12KV VERTICAL BREAK TYPE SINGLE CIRCUIT
HORIZONTAL CONFIGURATION - DOUBLE DEAD END

1299.201
SUPERSEDES
1229 (6-4-82)

FIELD MAINTENANCE ONLY

REVISION HISTORY:

7/13/2016: All versions prior to 2016 are superseded by their current version found inside the Overhead Construction Standard Manual.

© 1998 - 2016 San Diego Gas & Electric Company. All rights reserved. Removal of this copyright notice without permission is not permitted under law.

REV	CHANGE	BY	DSGN	APPV	DATE	REV	CHANGE	BY	DSGN	APPV	DATE
C						F					
B						E					
A	ORIGINAL ISSUE	JS	IL	MDJ	7/13/2016	D					

	Indicates Latest Revision	Completely Revised	New Page	Information Removed
-------------------------------------------------------------------------------------	---------------------------	--------------------	----------	---------------------

**SHEET
1 OF 1**

SDG&E ELECTRIC OVERHEAD STANDARD

POLE TOP SWITCH INSTALLATION 12KV SINGLE CIRCUIT
HORIZONTAL CONFIGURATION

**FMO
OH 1230**

SCOPE: THIS STANDARD SHOWS A HORIZONTAL BREAK GANG OPERATED POLE TOP SWITCH FOR CIRCUIT TIES OR SECTIONALIZING PURPOSES. THIS INSTALLATION IS PREFERRED OVER STANDARD 1228.

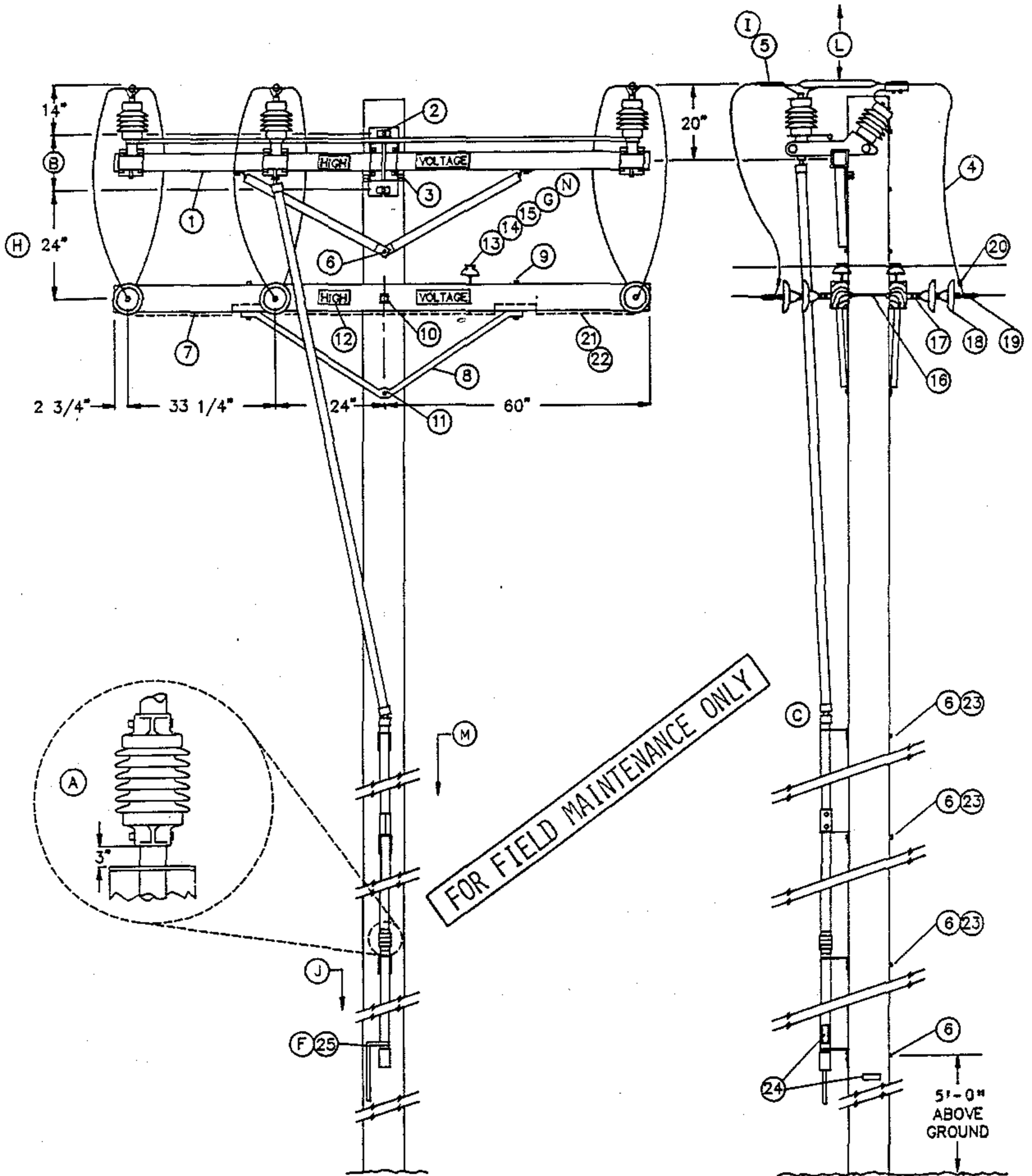

FOR FIELD MAINTENANCE ONLY

SDG&E ELECTRIC STANDARDS

DATE 1-1-93
 APPD *PA/BG*

POLE TOP SWITCH 12KV HORIZONTAL BREAK TYPE SINGLE CIRCUIT
 HORIZONTAL CONFIGURATION

1299.307
 SUPERSEDES
 1230.1 (1-1-92)

BILL OF MATERIAL:

ITEM	DESCRIPTION	QUANTITY	CONSTR. STD	STOCK NUMBER
1	SWITCH, T.P.S.T., 600 AMP, INCLUDING 40' OF CONTROL ROD (C)	1	-	709250
	ADDITIONAL 10'-6" CONTROL ROD WITH GUIDE BEARING AND COUPLING	AS REQ'D	-	604428
2	BOLT, MACH, GALV, 3/4" X (LENGTH AS REQ'D), 1 SQUARE AND 1 DOUBLE COIL SPRING WASHER (E)	2	392	-
3	SCREW, LAG, GALV, 1/2" X 4" (E)	2	-	621568
4	WIRE, BARE STRANDED CU OR AL (SIZE AS REQ'D)	33'	711-715	-
5	TERMINAL, COMPRESSION LUG (I) (E)	6	794-795	-
6	BOLT, MACH, GALV, 5/8" X (LENGTH AS REQ'D), 1 SQUARE AND 1 DOUBLE COIL SPRING WASHER (E)	5	392	-
7	CROSSARM, 3 3/4" X 5 3/4" X 10' - 0"	2	-	294128
8	BRACE, ANGLE, 5' - 0"	2	-	164128
9	BOLT, MACH, GALV, 1/2" X 7", 1 ROUND AND 1 DOUBLE COIL SPRING WASHER (E)	4	392	-
10	BOLT, MACH, GALV, 5/8" X (LENGTH AS REQ'D), 2 SQUARE AND 1 DOUBLE COIL SPRING WASHER (E)	1	392	-
11	BOLT, MACH, GALV, 5/8" X (LENGTH AS REQ'D) AND 1 DOUBLE COIL SPRING WASHER (E)	1	392	-
12	SIGN, HIGH VOLTAGE, AND 9 ROOFING NAILS, GALV	(E)	-	647648
		(E)	-	492224
13	PIN, INSULATOR, STRAIGHT, 12KV, 1" (G) (E)	2	-	532704
14	INSULATOR, 12KV NEUTRAL (G)	2	-	429216
15	WIRE, TIE (DOUBLE) (G) (E)	1	760-764	-
16	BOLT, SPACE, GALV, 5/8" X (LENGTH AS REQ'D), 2 SQUARE, 2 ROUND, 2 DOUBLE COIL SPRING WASHERS AND 1 NUT (E)	3	392	-
17	CLEVIS, DEAD END, 5/8" BOLT STEEL (CLOSED TYPE) (E)	6	-	235712
18	INSULATOR, SUSPENSION, 12KV, CLEVIS	12	750	-
19	CLAMP, STRAIGHT LINE, D.E.	6	741-743	-
20	CONNECTOR, WIRE COMPRESSION (SIZE AS REQ'D) (E)	AS REQ'D	783-786	-
21	WIRE, #8 BARE SOLID ANNEALED COPPER	12'	-	812928
22	STAPLE, FENCE, GALV, 1 1/4" (E)	AS REQ'D	-	678528
23	SCREW, LAG, GALV, 5/8" X 5" (E)	2	-	621600
24	TAG, SWITCH NUMBER	2	204	-
25	PADLOCK, MEDECO	1	-	514862

FOR FIELD MAINTENANCE ONLY

1299.308
SUPERSEDES
1230.2 (1-1-92)

SDG&E ELECTRIC STANDARDS
POLE TOP SWITCH 12KV HORIZONTAL BREAK TYPE SINGLE CIRCUIT
HORIZONTAL CONFIGURATION

DATE 11-1-93
APPD MVA/BJ

INSTALLATION:

- (A) INSTALL CONTROL PIPE INSULATOR THREE INCHES ABOVE THE NEXT GUIDE BEARING UP FROM THE SWITCH HANDLE.
- (B) USE THE FOLLOWING THROUGH-BOLT DRILLING DIMENSIONS: A.B. CHANCE = 13-1/4", S&C = 14".
- (C) SWITCHES ARE FURNISHED WITH 40 FEET OF OPERATING CONTROL ROD. THE TOP SECTION OF THE CONTROL ROD IS MADE OF FIBER GLASS, THE LOWER SECTIONS ARE MADE OF GALVANIZED PIPE.
- D. SWITCH CONTROL MECHANISM DOES NOT REQUIRE GROUNDING.
- (E) EXEMPT MATERIAL.
- (F) THE SWITCH IS SHIPPED FACTORY ADJUSTED. HOWEVER, THE SWITCH HANDLE LOCK SEGMENTS WILL REQUIRE ADJUSTMENT. REFER TO INSTALLATION INSTRUCTIONS PROVIDED WITH SWITCH.
- (G) REDUCE QUANTITIES AS REQUIRED WHEN NOT USING NEUTRAL.
- (H) SWITCH MAY BE INSTALLED BELOW LINEARM. DRILL SWITCH ARM UPPER MOUNTING BOLT HOLE 36" BELOW LINE ARM THRU BOLT (SEE STANDARD 1444).
- (I) WHEN ATTACHING 1/0 AND 4/0 COPPER CONDUCTORS TO A POLE TOP SWITCH, USE A BRONZE CABLE TAP LUG, STOCK NUMBER 471296. IF EXCESSIVE VIBRATION OR WHIPPING COULD OCCUR, USE TWO LUGS IN SERIES.

REFERENCES:

- (J) POLE STEPPING - SEE STANDARD 363.
- K. SEE DESIGN MANUAL PAGE 6111 - FEEDER CIRCUIT SECTIONALIZING AND PROTECTION.
- (L) SEE SECTION 200 FOR MINIMUM VERTICAL SEPARATION.
- (M) REFLECTOR STRIPS ARE REQUIRED ON ALL SECTIONALIZING/TIELINE SWITCHES AND SERVICE RESTORER POLES. (SEE STD. 208.3 ITEM 12)
- (N) NEUTRALS SHALL BE SOLIDLY TIED TOGETHER AT ALL SWITCHES REGARDLESS WHETHER THEY ARE NORMALLY OPEN OR CLOSED. THIS INCLUDES TIE SWITCHES TO CIRCUITS EMANATING FROM DIFFERENT SUBSTATIONS. (SEE DESIGN MANUAL STANDARD PAGE 6221.2, D.3).
- O. CONTROL PIPE AND SWITCH HANDLE ARE NOT ALLOWED IN THE CLIMBING SPACE (G.O. 95, 54.7-A4).

FOR FIELD MAINTENANCE ONLY

DATE 1-1-93 APPD <i>PA/ROJ</i>	SDG&E ELECTRIC STANDARDS	1299.309
	POLE TOP SWITCH 12KV HORIZONTAL BREAK TYPE SINGLE CIRCUIT HORIZONTAL CONFIGURATION	SUPERSEDES 1230.3 (1-1-92)

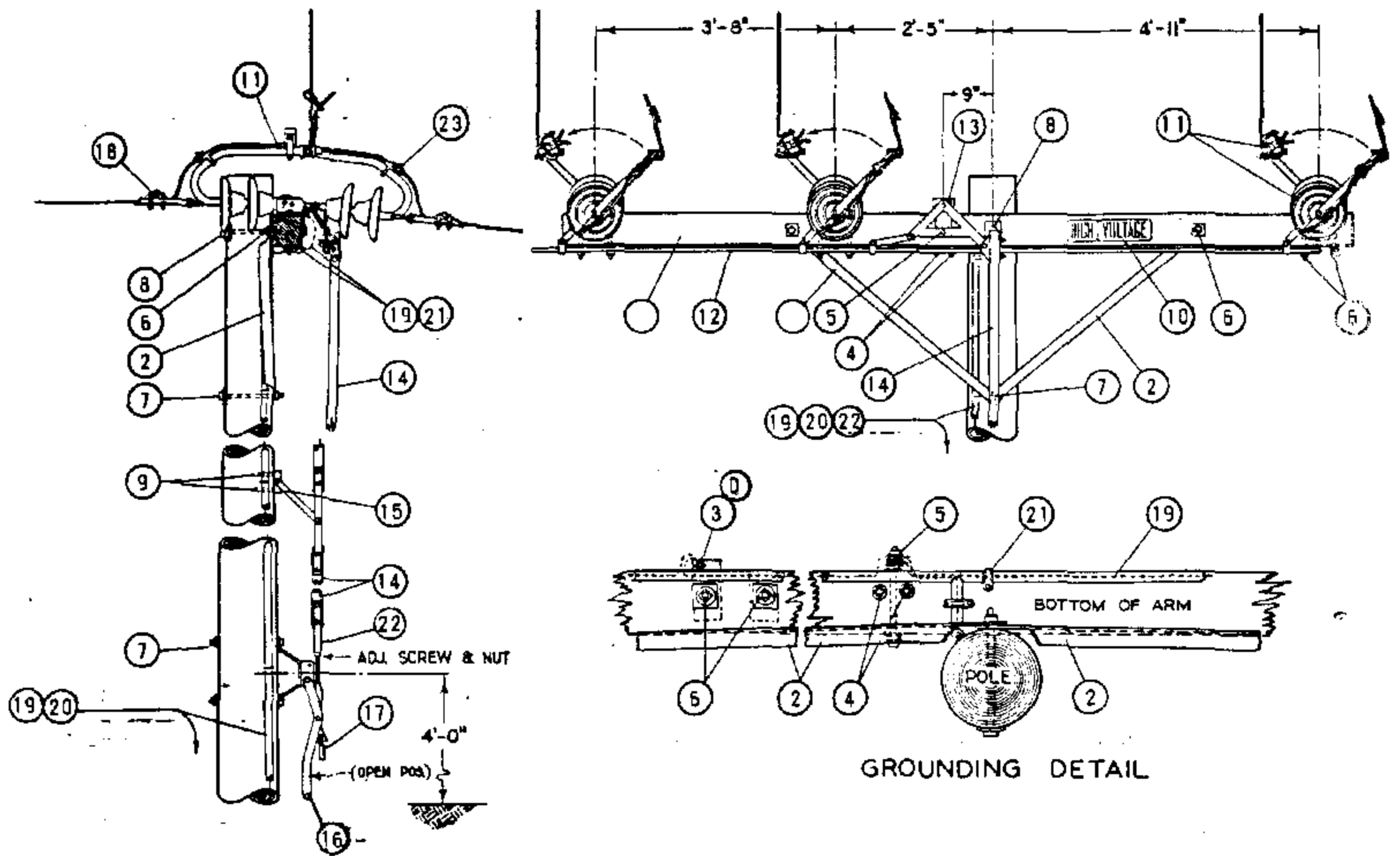

FOR FIELD MAINTENANCE ONLY

NOTES:

- A. MAXIMUM VERTICAL ANGLE SHALL NOT EXCEED 7° FOR ANY CONDUCTOR SIZE.
- B. WHERE THE VERTICAL ANGLE EXCEEDS 7° OR THE HORIZONTAL ANGLE EXCEEDS THE VALUE SHOWN IN THE TABLE BELOW, USE SWITCH CONSTRUCTION PG. 1229.
- C. IF THE MAXIMUM DESIGN TENSION IS GREATER THAN 3000 LBS, THE ANGLE CAN BE CALCULATED BY:

$$\text{THE SINE OF THE ANGLE} = \frac{200}{\text{TENSION}}$$
 THE ANGLE THEN CAN BE DETERMINED FROM TRIGONOMETRIC FUNCTION TABLES.
- D. ITEM 3 IS A BOLT USED TO GROUND THE SWITCH MOUNTING HARDWARE.

MAXIMUM ALLOWABLE LINE ANGLE FOR SWITCHES

CONDUCTOR SIZE AWG OR KCM	COPPER				COPPERWELD COPPER		5005				ACSR						
	4	2	1/0	4/0	4A	4N	2	1/0	3/0	394.5	2 6/1	1/0 6/1	3/0 6/1	336.4 18/1	336.4 26/7	636 24/7	1033 45/7
LINE ANGLE DEGREES	15	9	6	5	7	3	16	11	8	4	13	9	6	5	4	4	4
MAXIMUM DESIGN TENSION LBS/CONDUCTOR	752	1218	1900	2424	1575	3384	717	1050	1480	2898	845	1300	1860	2450	3000	3000	3000

DATE 1-1-87
 APPD *AK/RS*

SDG&E ELECTRIC STANDARDS
 POLE TOP SWITCH INSTALLATION 12KV SINGLE CIRCUIT
 HORIZONTAL CONFIGURATION

1299.301
 SUPERSEDES
 1230.1 (1-1-87)

METHOD OF ADJUSTING SWITCH

- A. FIRST CLOSE SWITCH AND TIGHTEN SWITCH UNIT CRANK CLAMPS TO INTERPHASE CONNECTING PIPE (12)
- B. THEN OPEN SWITCH UNTIL SWITCH UNIT CRANK CLAMPS ARE PERPENDICULAR TO ARM.
- C. WITH SHORT ARM BELL CRANK (13) ALSO PERPENDICULAR TO ARM, TIGHTEN BELL CRANK CLAMP.
- D. WHILE CRANKS ARE PERPENDICULAR TO ARM, CONNECT WOODEN CONTROL ROD (14) TO LONG LEG OF BELL CRANK, CLAMP GUIDES (15) AND CONTROL HANDLE (16) SHOULD BE PERPENDICULAR TO POLE AND HOLD DOWN HOLES (9) DRILLED WHILE IN THIS POSITION
- (E) EXEMPT MATERIAL
- F. LUBRICATE MOVING PARTS WITH A THIN LAYER OF #89 MEDIUM SILICONE GREASE OR EQUIVALENT.
- G. GIVE SWITCH A FEW TRAIL OPERATIONS AND MAKE ADJUSTMENTS ON ADJUSTING SCREW AS NECESSARY.
- H. 400 AMP SWITCHES MAY BE USED WITH 336.4 KCMIL AND SMALLER CONDUCTORS. 600 AMP SWITCHES SHALL BE USED ON 636 KCMIL CONDUCTOR AND 1200 AMP SWITCHES SHALL BE USED ON 1033.5 KCMIL CONDUCTOR.

FOR FIELD MAINTENANCE ONLY

ITEM	DESCRIPTION	QUAN.	STOCK NO. OR CONSTR. STD.
P T B F	1 CROSSARM, 5 3/4" X 5 3/4" X 12'-0"	1	294016
	2 BRACE, ALLEY ARM, 4'-0"	2	163808
	3 BOLT, MACH., GALV., 1/2" X 1 1/2", 2-RD., 1-LOCK WASH. & 1-NUT (E)	3	100 SECTION
	4 BOLT, MACH., GALV., 1/2" X 8", 1-RD., 1-DBL. COIL SPR. WASH & 1-NUT (E)	2	100 SECTION
	5 BOLT, MACH., GALV., 1/2" X 8", 3-RD., 1-DBL. COIL SPR. WASH. & 2-NUTS (E)	1	100 SECTION
	6 BOLT, MACH., GALV., 5/8" X 8", 1-2 1/4" SQ., 1-DBL. COIL SPR. WASH. & 1-NUT (E)	8	100 SECTION
	7 BOLT, MACH., GALV., 5/8" X (LENGTH AS REQ'D), 1-DBL. COIL SPR. WASH. & 1-NUT (E)	3	100 SECTION
	8 BOLT, MACH., GALV., 3/4" X 16", 1-3" SQ., 1-FLAT, 1-CURV., 1-DBL. COIL SPR. WASH & 1-NUT	1	100 SECTION
	9 SCREW, LAG, GALV., 1/2" X 4" (E)	4	621568
	10 SIGN, HIGH VOLTAGE, 8-ROOFING NAILS, GALV. (E)	2	647648, 492192
O C B D	11 POLE TOP SWITCH, 15KV, T.P.S.T., HORIZONTALLY MOUNTED, RIGID DISC. INSULATORS ARCING HORNS & INCLUDING ITEMS #13 THRU #17.	1	709168 400A 709184 600A 709280 1200A
	12 PIPE, INTERPHASE CONNECTING, GALV., 1/2" X 11'-6" OR WOOD 1 3/4" X 1 3/4" X 11'-6"	1	-
	13 BELL CRANK ASSEMBLY	1	290624
	14 ROD, CONTROL, 1 3/4" X 1 3/4" X 10'-0", LAMINATED WOOD	4	602938
	15 GUIDE BEARING, INTERMEDIATE	3	398688
	16 OPERATING LEVER ASSEMBLY COMPLETE WITH ADJUSTING SCREW & NUT	1	-
	17 PADLOCK, ELECTRIC FF	1	514848
	18 CLAMP, STRAIGHT LINE D.E.	6	700 SECTION
	19 WIRE, BARE STRANDED COPPER, #6 BONDING & GROUNDING WIRE	60'	813536
	20 GROUND UNIT (GRAY OR PLAIN)	1	603120, 603136
	21 PIPE STRAP, 3/4" & 2-8D NAILS, GALV. (E)	9	697888, 491584
	22 TAGS, SWITCH NUMBER (E)	2	720704
	23 CONNECTOR, COPPER TO ALUMINUM #1/0-336.4 MCM ACSR OR 5005, WHERE REQ'D.	6	700 SECTION

SCOPE: THIS STANDARD SHOWS A HORIZONTAL BREAK GANG OPERATED POLE TOP SWITCH FOR CIRCUIT TIES OR SECTIONALIZING PURPOSES. THIS INSTALLATION IS PREFERRED OVER STANDARD 1228.

NOTE: SWITCH AND CONTROL ROD MAY BE INSTALLED ON EITHER SIDE OF POLE. IF INSTALLATION IS LIMITED TO ONE SIDE OF POLE ONLY, AND SWITCH DOES NOT MATCH EXISTING PHASE POSITIONS, SEE FIGURE 2 SWITCH.

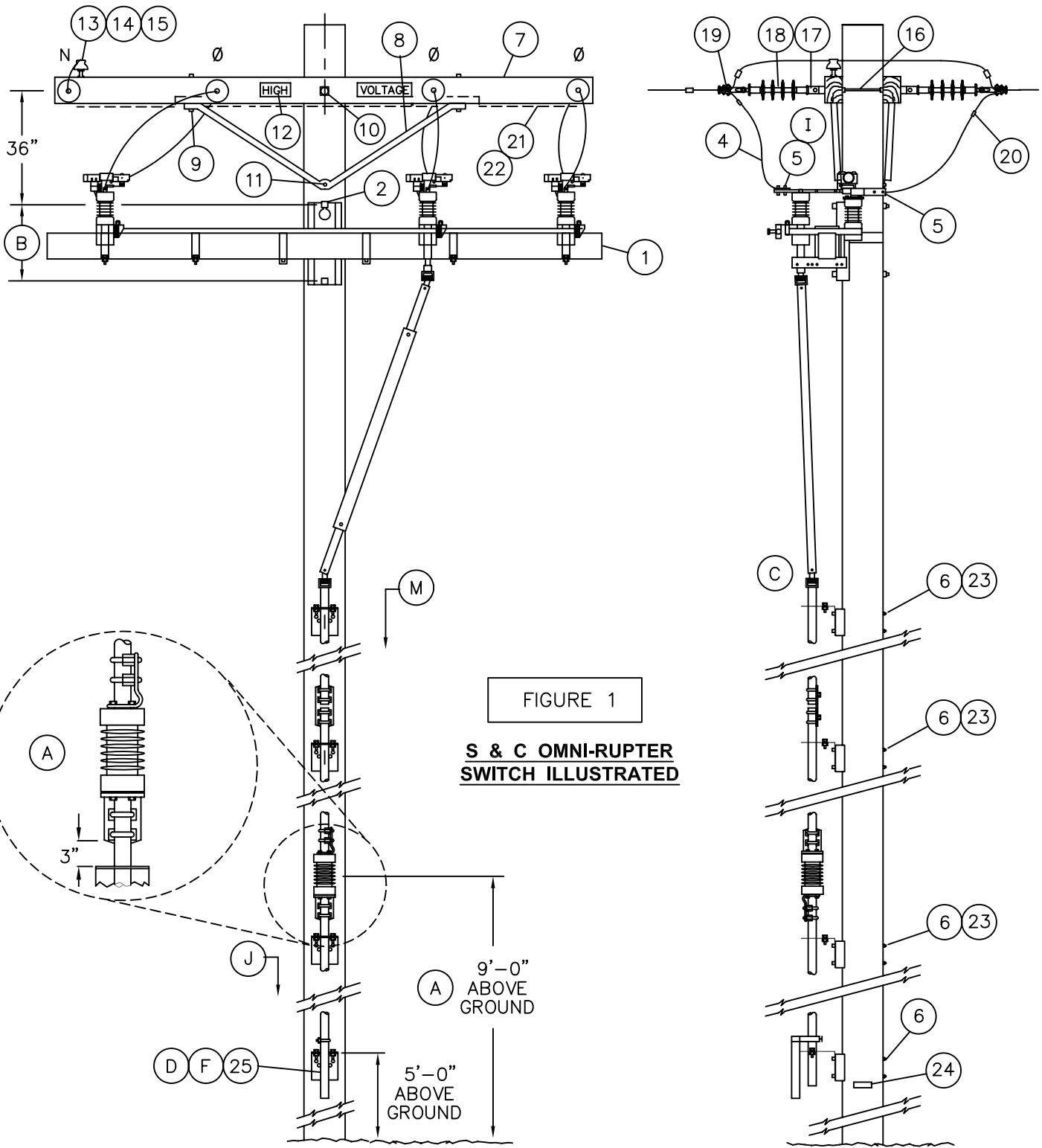

FIGURE 1

S & C OMNI-RUPTER SWITCH ILLUSTRATED

© 1998 - 2005 San Diego Gas & Electric Company. All rights reserved. Removal of this copyright notice without permission is not permitted under law.

	Indicates Latest Revision	Completely Revised	New Page	Information Removed
1230.1	SDG&E ELECTRIC STANDARDS			REVISION DATE 1-1-2000 APPD <i>PIA / CAK</i>
	POLE TOP SWITCH 12KV HORIZONTAL LOADBREAK TYPE SINGLE CIRCUIT HORIZONTAL CONFIGURATION			

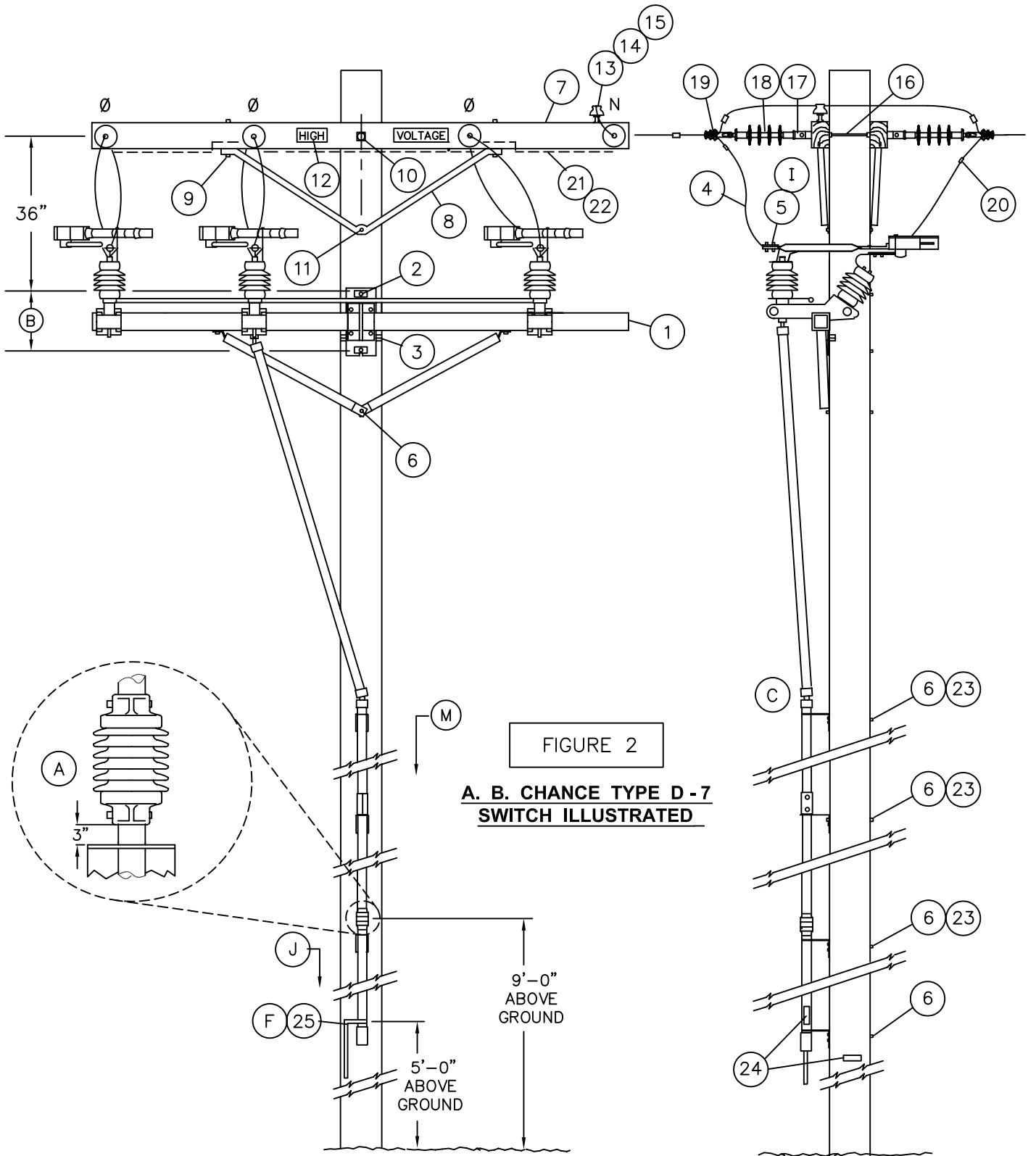

FIGURE 2
**A. B. CHANCE TYPE D - 7
 SWITCH ILLUSTRATED**

© 1998 - 2005 San Diego Gas & Electric Company. All rights reserved. Removal of this copyright notice without permission is not permitted under law.

	Indicates Latest Revision	Completely Revised	New Page	Information Removed
REVISION	SDG&E ELECTRIC STANDARDS			
DATE 1-1-2000	POLE TOP SWITCH 12KV			1230.2
APPD <i>PJA / CAK</i>	HORIZONTAL LOADBREAK TYPE SINGLE CIRCUIT HORIZONTAL CONFIGURATION			

BILL OF MATERIAL:

ITEM	DESCRIPTION	QUANTITY	CONST STD OR PAGE NO	STOCK NUMBER	ASSEMBLY UNITS		
1	SWITCH, GANG-OPERATED, 15KV, 600 AMP, WITH INTERRUPTERS, INCLUDING 40' OF CONTROL ROD	FIG. 1	S&C	1	-	709252	GANG-S
		FIG. 2	CHANCE	1	-	709258	GANG-C
	ADDITIONAL 10'-6" CONTROL ROD WITH GUIDE BEARING AND COUPLING		S&C	AS REQ'D	-	602934	S-ROD
			CHANCE	AS REQ'D	-	604428	C-ROD
	LOAD INTERRUPTER-A.B. CHANCE SWITCH ONLY IF RETRO-FITTING REQUIRED		TYPE D		3	-	433794
		TYPE S		3	-	433796	LDBRKS
2	BOLT, MACH, GALV, 3/4" X (LENGTH AS REQ'D), 1 SQUARE AND 1 DOUBLE COIL SPRING WASHER	2		392	-	-	-
3	SCREW, LAG, GALV, 1/2" X 4"	2		-	621568	-	-
4	WIRE, BARE STRANDED CU OR AL (SIZE AS REQ'D)	33'		711-715	-	-	-
5	TERMINAL, COMPRESSION LUG	6	(I)	794-795	-	-	-
6	BOLT, MACH, GALV, 5/8" X (LENGTH AS REQ'D), 1 SQUARE AND 1 DOUBLE COIL SPRING WASHER	AS REQ'D		392	-	-	-
7	CROSSARM, 3 3/4" X 5 3/4" X 10' - 0"	2		-	294128	4-	-
8	BRACE, ANGLE, 5' - 0"	2		-	164128	5HUB	-
9	BOLT, MACH, GALV, 1/2" X 7", 1 ROUND AND 1 DOUBLE COIL SPRING WASHER	4		392	-	-	-
10	BOLT, MACH, GALV, 5/8" X (LENGTH AS REQ'D), 2 SQUARE AND 1 DOUBLE COIL SPRING WASHER	1		392	-	-	-
11	BOLT, MACH, GALV, 5/8" X (LENGTH AS REQ'D) AND 1 DOUBLE COIL SPRING WASHER	1		392	-	-	-
12	SIGN, HIGH VOLTAGE, AND 9 ROOFING NAILS, GALV	2		-	647648	HV	-
		-		-	492224	-	-
13	PIN, INSULATOR, STRAIGHT, 12KV, 1"	2	(G)	-	532704	PS1	-
14	INSULATOR, 12KV NEUTRAL	2	(G)	-	429216	55-3/I	-
15	WIRE, TIE (DOUBLE)	1	(G)	760-764	-	-	-
16	BOLT, SPACE, GALV, 5/8" X (LENGTH AS REQ'D), 3 SQUARE, 2 ROUND, 2 DOUBLE COIL SPRING WASHERS AND 1 NUT	4	(G)	392	-	-	-
17	CLEVIS, DEAD END, 5/8" BOLT STEEL (CLOSED TYPE)	8	(G)	-	235712	-	-
18	INSULATOR, SUSPENSION, 12KV, CLEVIS	8	(G)	750	431650	-	-
19	CLAMP, STRAIGHT LINE, D.E.	8	(G)	741-743	-	-	-
20	CONNECTOR, WIRE COMPRESSION (SIZE AS REQ'D)	AS REQ'D		783-786	-	-	-
21	WIRE, #8 BARE SOLID ANNEALED COPPER	12'		-	812928	BOND8	-
22	STAPLE, FENCE, GALV, 1 1/4"	AS REQ'D		-	678528	-	-
23	SCREW, LAG, GALV, 5/8" X 5"	2		-	621600	-	-
24	TAG, SWITCH NUMBER	2		204	-	-	-
25	PADLOCK, SCHLAGE ELECTRIC SERIES	1		-	514848	-	-

OVERHEAD MACRO UNITS	
FIG. 1	S12SWI
FIG. 2	C12SWI

© 1998 - 2005 San Diego Gas & Electric Company. All rights reserved. Removal of this copyright notice without permission is not permitted under law.

	Indicates Latest Revision	Completely Revised	New Page	Information Removed
1230.3	SDG&E ELECTRIC STANDARDS			REVISION
	POLE TOP SWITCH 12KV HORIZONTAL BREAK TYPE SINGLE CIRCUIT HORIZONTAL CONFIGURATION			DATE 1-1-2000 APPD PJA/CRK

INSTALLATION:

- (A) INSTALL CONTROL PIPE INSULATOR THREE INCHES ABOVE GUIDE BEARING AND A MINIMUM OF 9'-0" ABOVE GROUND.
- (B) USE THE FOLLOWING THROUGH-BOLT DRILLING DIMENSIONS: A.B. CHANCE = 13-1/4", S&C = 14".
- (C) SWITCHES ARE FURNISHED WITH 40 FEET OF OPERATING CONTROL ROD. THE TOP SECTION OF THE CONTROL ROD IS MADE OF FIBER GLASS, THE LOWER SECTIONS ARE MADE OF GALVANIZED PIPE.
- (D) DO NOT GROUND SWITCH CONTROL MECHANISM.
- (F) THE SWITCH IS SHIPPED FACTORY ADJUSTED. HOWEVER, THE SWITCH HANDLE LOCK SEGMENTS WILL REQUIRE ADJUSTMENT. REFER TO INSTALLATION INSTRUCTIONS PROVIDED WITH SWITCH.
NOTE: SUBSTANTIAL PRESSURE MUST BE APPLIED TO THE SWITCH HANDLE IN THE CLOSING DIRECTION TO PLACE "WIND - UP" TENSION IN THE CONTROL ROD BEFORE DROPPING HANDLE INTO CLOSED - POSITION SLOT.
- (G) REDUCE QUANTITIES AS REQUIRED WHEN NOT USING NEUTRAL.
- (I) WHEN ATTACHING 1/0 AND 4/0 COPPER CONDUCTORS TO A POLE TOP SWITCH, USE A BRONZE CABLE TAP LUG, STOCK NUMBER 471296. IF EXCESSIVE VIBRATION OR WHIPPING COULD OCCUR, USE TWO LUGS IN SERIES.

REFERENCE:

- (J) POLE STEPPING – SEE STANDARD 363.
- K. SEE DESIGN MANUAL PAGE 6111 – FEEDER CIRCUIT SECTIONALIZING AND PROTECTION.
- L. SWITCH OPERATING RODS MAY EXTEND ONE-HALF THEIR DIAMETER INTO THE CLIMBING SPACE (G.O. 95, 54.7-A3).
- (M) REFLECTOR STRIPS ARE REQUIRED ON ALL SECTIONALIZING/TIELINE SWITCHES AND SERVICE RESTORER POLES. (SEE STD. 208.3 ITEM 12)
- (N) NEUTRALS SHALL BE SOLIDLY TIED TOGETHER AT ALL SWITCHES REGARDLESS WHETHER THEY ARE NORMALLY OPEN OR CLOSED. THIS INCLUDES TIE SWITCHES TO CIRCUITS EMANATING FROM DIFFERENT SUBSTATIONS. (SEE DESIGN MANUAL STANDARD PAGE 6221.2, D.3).

© 1998 - 2005 San Diego Gas & Electric Company. All rights reserved. Removal of this copyright notice without permission is not permitted under law.

	Indicates Latest Revision	Completely Revised	New Page	Information Removed
REVISION	SDG&E ELECTRIC STANDARDS			
DATE 1-1-2000	POLE TOP SWITCH 12KV HORIZONTAL BREAK TYPE SINGLE CIRCUIT			1230.4
APPD <i>PSA / CAK</i>	HORIZONTAL CONFIGURATION			

FIELD MAINTENANCE ONLY

REVISION HISTORY:

7/13/2016: All versions prior to 2016 are superseded by their current version found inside the Overhead Construction Standard Manual.

© 1998 - 2016 San Diego Gas & Electric Company. All rights reserved. Removal of this copyright notice without permission is not permitted under law.

REV	CHANGE	BY	DSGN	APPV	DATE	REV	CHANGE	BY	DSGN	APPV	DATE
C						F					
B						E					
A	ORIGINAL ISSUE	JS	IL	MDJ	7/13/2016	D					

	Indicates Latest Revision	Completely Revised	New Page	Information Removed
-------------------------------------------------------------------------------------	---------------------------	--------------------	----------	---------------------

**SHEET
1 OF 1**

SDG&E ELECTRIC OVERHEAD STANDARD

POLE TOP SWITCH INSTALLATION 12KV SINGLE CIRCUIT
VERTICAL CONFIGURATION

**FMO
OH 1231**

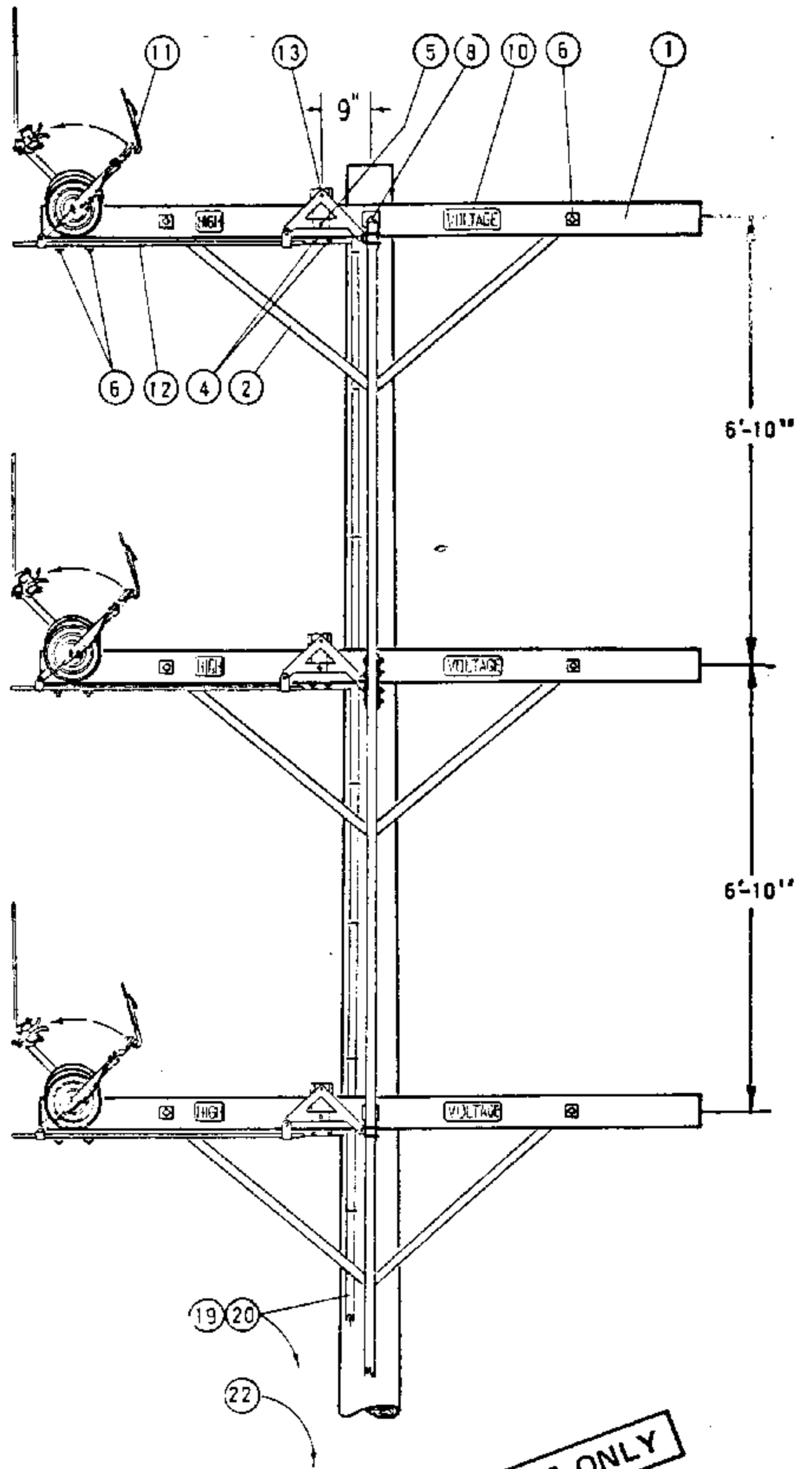
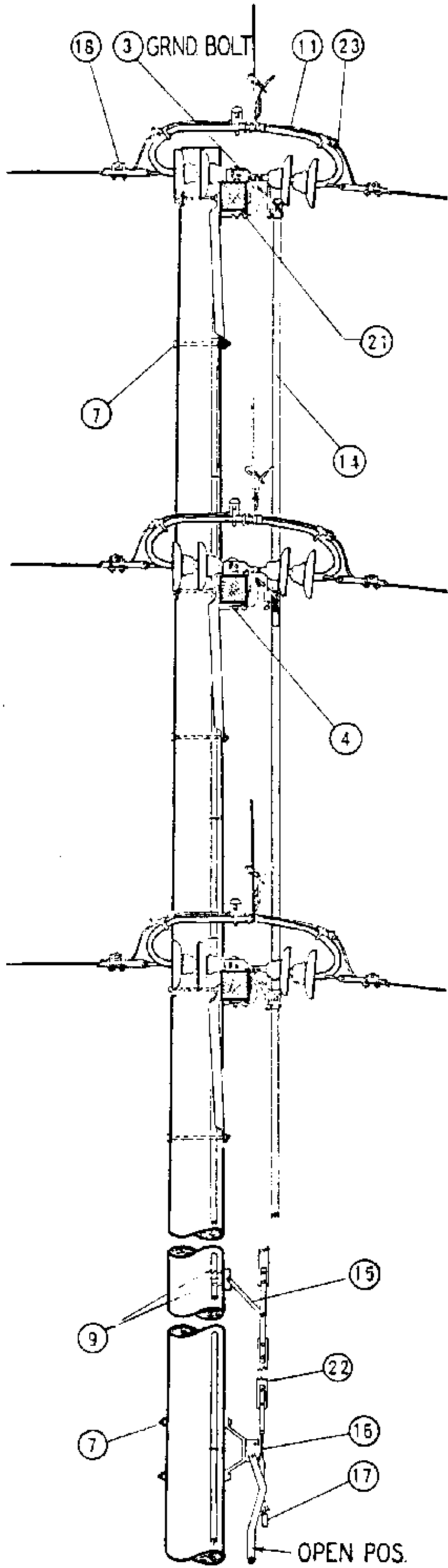

DATE 1-1-87
 APPD *AK*

SAN DIEGO GAS & ELECTRIC CO OVERHEAD STANDARDS
 POLE TOP SWITCH INSTALLATION 12KV SINGLE CIRCUIT
 VERTICAL CONFIGURATION

1299.303
 SUPERSEDES
 1231.1 (1-1-87)

FOR FIELD MAINTENANCE ONLY

NOTES:
 A. FOR METHOD OF ADJUSTING SWITCH, SEE PAGE 1230.
 (E) EXEMPT MATERIAL.

ITEM	DESCRIPTION	QUAN.	STOCK NO. OR CONSTR. STD.
P T B F	1 CROSSARM, 5 3/4" X 5 3/4" X 10'-0"	3	294016
	2 BRACE, ALLEY ARM, 4'-0"	6	163808
	3 BOLT, MACH., GALV., 1/2" X 1 1/2", 2-RD., 1-LOCK WASH. & 1-NUT (E)	3	100 SECTION
	4 BOLT, MACH., GALV., 1/2" X 8", 1-RD., 1-DBL. COIL SPR. WASH & 1-NUT (E)	6	100 SECTION
	5 BOLT, MACH., GALV., 1/2" X 8", 3-RD., 1-DBL. COIL SPR. WASH. & 1-NUT (E)	3	100 SECTION
	6 BOLT, MACH., GALV., 5/8" X 8", 1-2 1/4" SQ., 1-DBL. COIL SPR. WASH. & 1-NUT (E)	12	100 SECTION
	7 BOLT, MACH., GALV., 5/8" X (LENGTH AS REQ'D), 1-DBL. COIL SPR. WASH. & 1-NUT (E)	5	100 SECTION
	8 BOLT, MACH., GALV., 3/4" X 16", 1-3" SQ., 1-FLAT, 1-CURV., 1-DBL. COIL SPR. WASH & 1-NUT	3	100 SECTION
	9 SCREW, LAG, GALV., 1/2" X 4" (E)	6	621568
	10 SIGN, HIGH VOLTAGE, 8-ROOFING NAILS, GALV. (E)	6	647648, 492192
D C B D	11 POLE TOP SWITCH, 15KV, T.P.S.T., VERTICALLY MOUNTED, RIGID DISC. INSULATORS ARCING HORNS & INCLUDING ITEMS #13 THRU #17.	1	709168 400A 709184 600A
	12 PIPE, INTERPHASE CONNECTING, GALV., 1/2" X 4'-6"	3	-
	13 BELL CRANK ASSEMBLY	3	290624
	14 ROD, CONTROL, 1 3/4" X 1 3/4" X 10'-0", LAMINATED WOOD	6	602938
	15 GUIDE BEARING, INTERMEDIATE,	4	398688
	16 OPERATING LEVER ASSEMBLY COMPLETE WITH ADJUSTING SCREW & NUT	1	-
	17 PADLOCK, ELECTRIC FF	1	514848
	18 CLAMP, STRAIGHT LINE D.E.	6	700 SECTION
	19 WIRE, BARE STRANDED COPPER, #6	70'	813536
	20 GROUND UNIT (GRAY OR PLAIN)	1	603120, 603136
	21 PIPE STRAP, 3/4" & 2-8D NAILS, GALV. (E)	9	697888, 491584
	22 TAGS, SWITCH NUMBER (E)	2	720704
	23 CONNECTOR, COPPER TO ALUMINUM #1/0-336.4 MCM ACSR OR 5005, WHERE REQ'D.	6	700 SECTION

1299.304 SUPERSEDES 1231.2 (1-1-87)	SDG&E ELECTRIC STANDARDS POLE TOP SWITCH INSTALLATION 12KV SINGLE CIRCUIT VERTICAL CONFIGURATION	DATE 1-1-87 APPD <i>AK</i>
--------------------------------------------------	---------------------------------------------------------------------------------------------------------------------------------	-------------------------------

FIELD MAINTENANCE ONLY

REVISION HISTORY:

7/13/2016: All versions prior to 2016 are superseded by their current version found inside the Overhead Construction Standard Manual.

© 1998 - 2016 San Diego Gas & Electric Company. All rights reserved. Removal of this copyright notice without permission is not permitted under law.

REV	CHANGE	BY	DSGN	APPV	DATE	REV	CHANGE	BY	DSGN	APPV	DATE
C						F					
B						E					
A	ORIGINAL ISSUE	JS	IL	MDJ	7/13/2016	D					

SHEET 1 OF 1	 Indicates Latest Revision	Completely Revised	New Page	Information Removed	FMO OH 1236
	SDG&E ELECTRIC OVERHEAD STANDARD				
	POLE TOP SWITCH INSTALLATION 69KV SINGLE CIRCUIT TRIANGULAR CONFIGURATION				

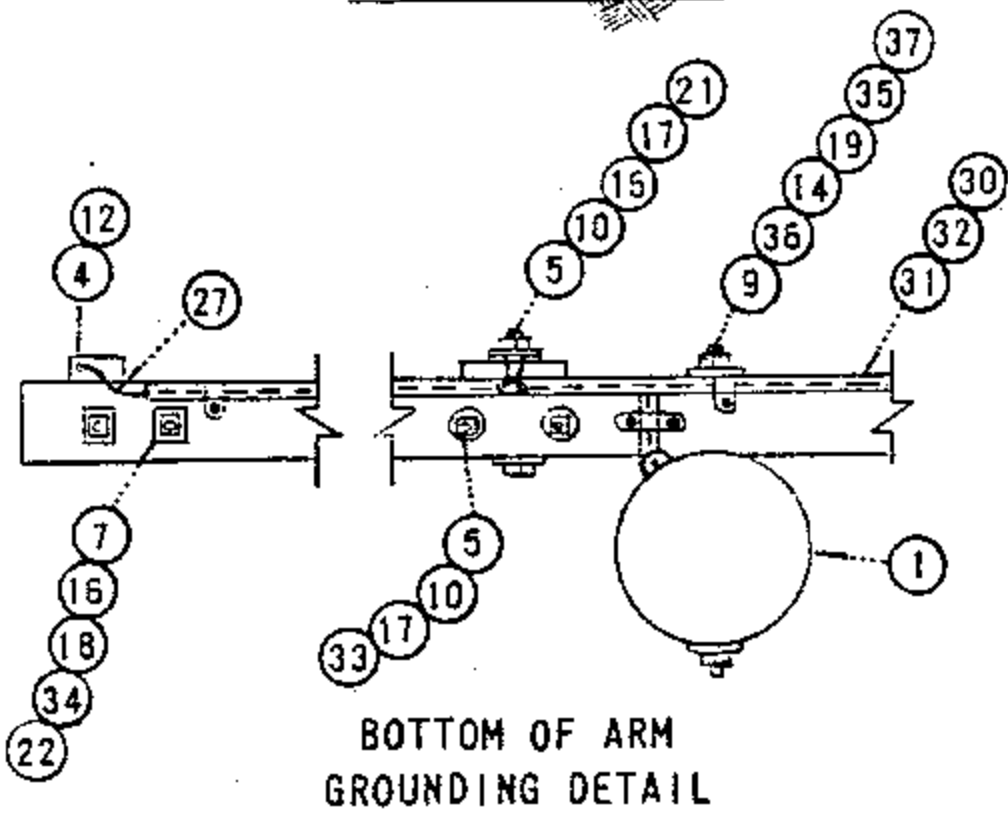
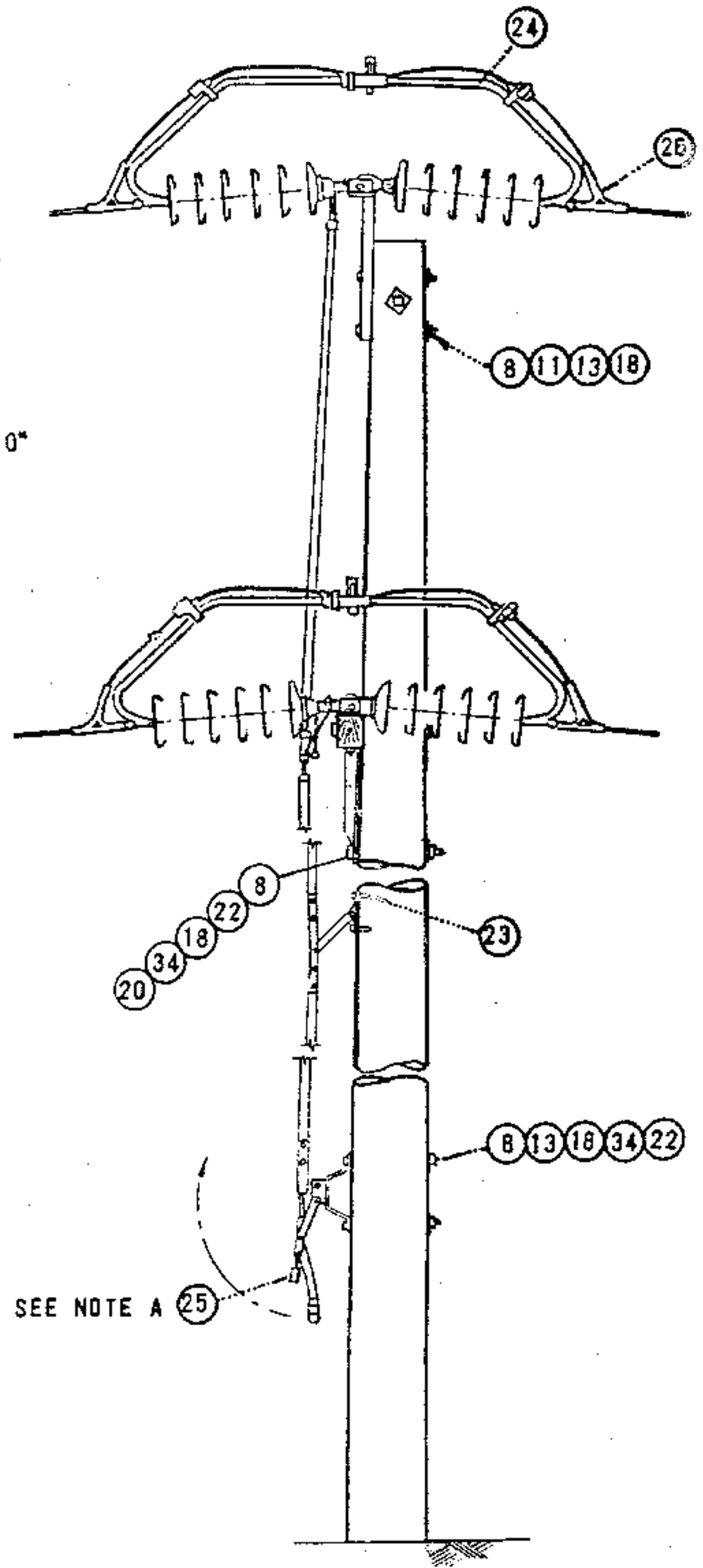
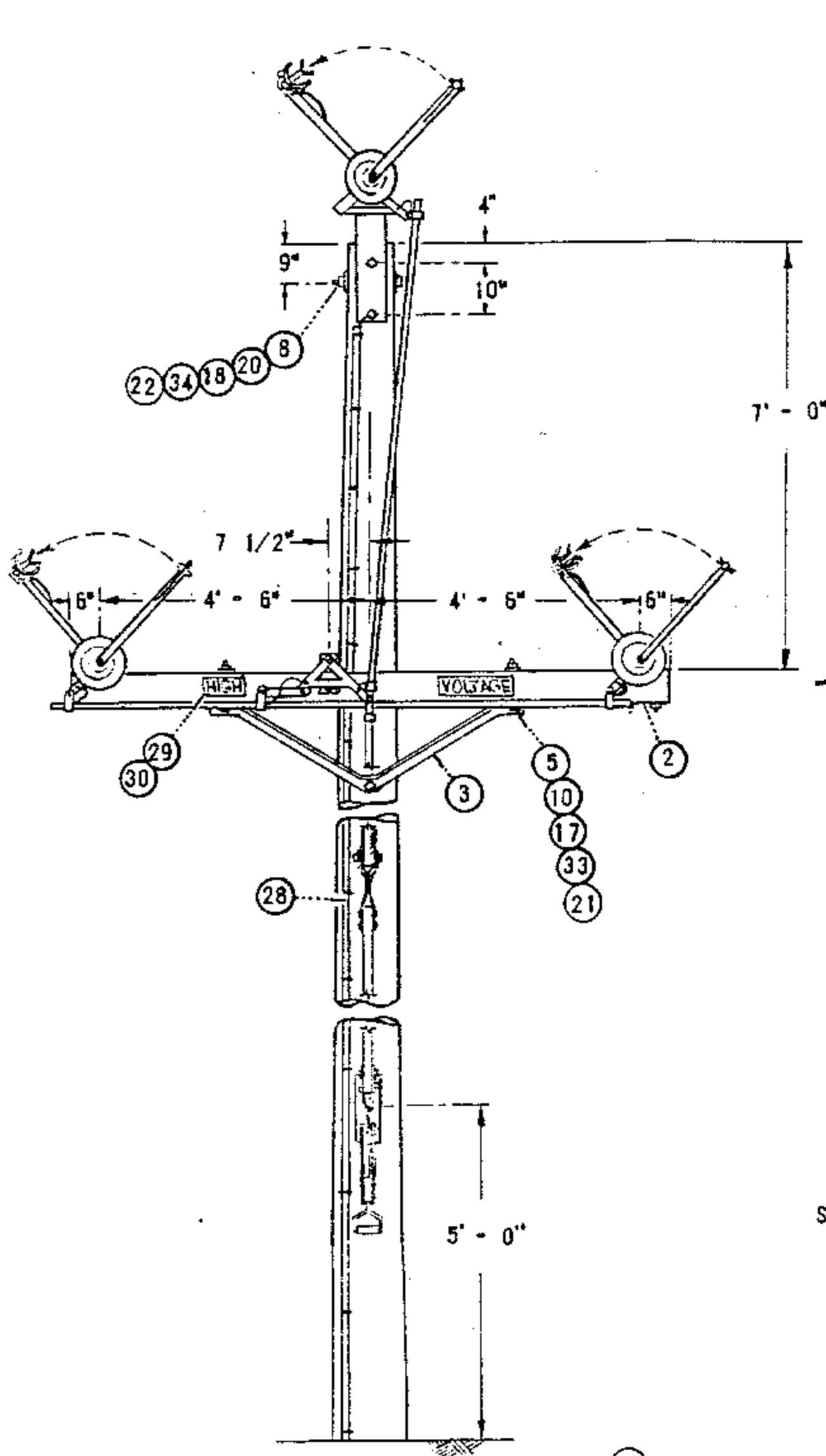

FOR FIELD MAINTENANCE ONLY

DATE 1-1-87
 APPD *AK/ROB*

SAN DIEGO GAS & ELECTRIC CO OVERHEAD STANDARDS
 POLE TOP SWITCH INSTALLATION 69KV
 SINGLE CIRCUIT TRIANGULAR CONFIGURATION

1299.305
 SUPERSEDES
 1236.1 (1-1-87)

FOR FIELD MAINTENANCE ONLY

NOTES:

- A. SWITCH HANDLE SHOWN IN OPEN POSITION.
- B. REFER TO PAGE 1230 FOR METHOD OF ADJUSTING SWITCH AND FOR DETERMINING MAXIMUM LINE ANGLE PERMITTED FOR SWITCH.
- C. THE 600 AMP SWITCH MAY BE USED ON SINGLE CIRCUIT 636 KCMIL AND SMALLER CONDUCTORS.
- (E) EXEMPT MATERIAL.

ITEM		MATERIAL	QUANTITY	STOCK NO OR CONSTR STD.
PTF	TOC			
1		POLE, CLASS AND HEIGHT (AS REQ'D)	1	300 SECTION
2		CROSSARM, 5 3/4" X 5 3/4" X 10' - 0" (CELLON OR GRAY)	1	294144 OR 294304
3		BRACE, CROSSARM 5' - 0" ANGLE STEEL	1	164128
4		BOLT, MACH. 1/2" X 1 1/2" (E)	3	152608
5		BOLT, MACH. 1/2" X 8" (E)	5	153152
6				
7		BOLT, MACH. 5/8" X 8" (E)	4	155584
8		BOLT, MACH. 5/8" X (LENGTH AS REQ'D) (E)	6	100 SECTION
9		BOLT, MACH 3/4" X (LENGTH AS REQ'D)	1	100 SECTION
10		WASHER, 1/2" ROUND (E)	11	800192
11		WASHER, 5/8" ROUND (E)	2	800320
12		WASHER, 1/2" LOCK (E)	3	796768
13		WASHER, 3" SQUARE CURVED RIB (E)	5	797792
14		WASHER, 4" SQUARE CURVED RIB	1	797760
15				
16		WASHER, 2 1/4" SQUARE FLAT (E)	7	799040
17		WASHER, SPRING DOUBLE COIL 1/2" (E)	5	798464
18		WASHER, SPRING DOUBLE COIL 5/8" (E)	12	798560
19		WASHER, SPRING DOUBLE COIL 3/4"	1	798496
20		WASHER, 3" SQUARE CURVED	2	798912
21		NUT, 1/2" (E)	8	504736
22		NUT 5/8" (E)	12	506880
23		SCREW, LAG 1/2" X 4" (E)	2	621568
24		POLE TOP SWITCH, 69KV, 600 AMP	1	709088
25		PAD LOCK, ELECTRIC FF	1	514848
26		CLAMPS, STRAIN	6	700 SECTION
27		WIRE, BARE STRANDED COPPER, #6	60'	813536
28		ROD, GROUND UNIT (GRAY OR PLAIN)	1	603120, 603136
29		SIGN, HIGH VOLTAGE (E)	2	647648
30		NAILS, ROOFING 8 GALV. (E)	28	492192
31		CONDUIT, SCH. 40, 1/2" (E)	9'	251168
32		STRAP, 1/2" PIPE (E)	6	697728
33		LOCKNUT, M-F 1/2" (E)	5	504544
34		LOCKNUT, M-F 5/8" (E)	10	504608
35		LOCKNUT, M-F 3/4"	1	504576
36		WASHER, 3" SQUARE FLAT	1	799104
37		NUT, 3/4	1	100 SECTION
38		TAGS, SWITCH NUMBER	2	720704

FIELD MAINTENANCE ONLY

REVISION HISTORY:

7/13/2016: All versions prior to 2016 are superseded by their current version found inside the Overhead Construction Standard Manual.

© 1998 - 2016 San Diego Gas & Electric Company. All rights reserved. Removal of this copyright notice without permission is not permitted under law.

REV	CHANGE	BY	DSGN	APPV	DATE	REV	CHANGE	BY	DSGN	APPV	DATE
C						F					
B						E					
A	ORIGINAL ISSUE	JS	IL	MDJ	7/13/2016	D					

	Indicates Latest Revision	Completely Revised	New Page	Information Removed
-------------------------------------------------------------------------------------	---------------------------	--------------------	----------	---------------------

**SHEET
1 OF 1**

SDG&E ELECTRIC OVERHEAD STANDARD
POLE TOP SWITCH INSTALLATION
4KV WESTINGHOUSE OIL SWITCH, TYPE F011

**FMO
OH 1240**

THIS PAGE FOR FIELD MAINTENANCE ONLY

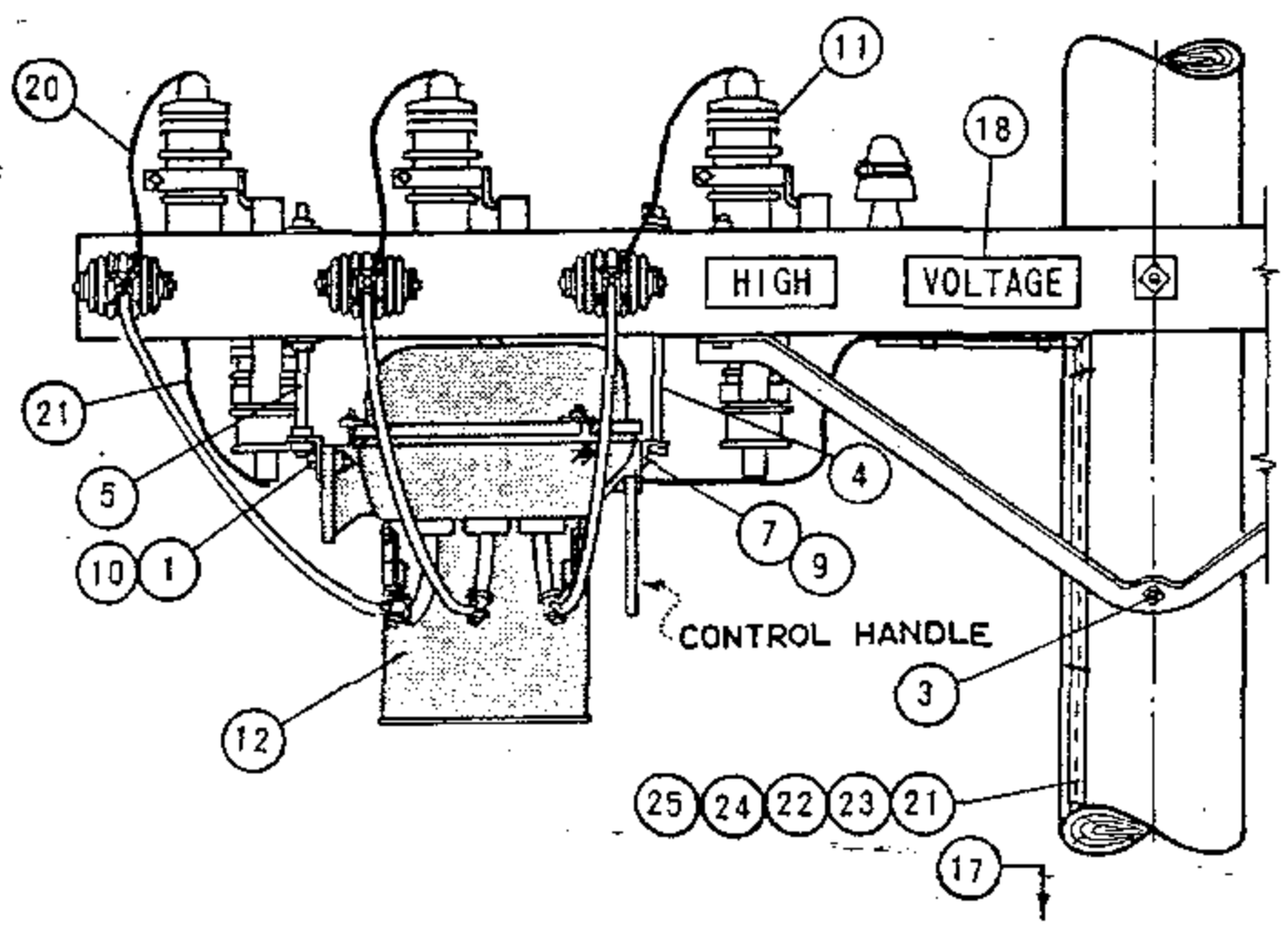
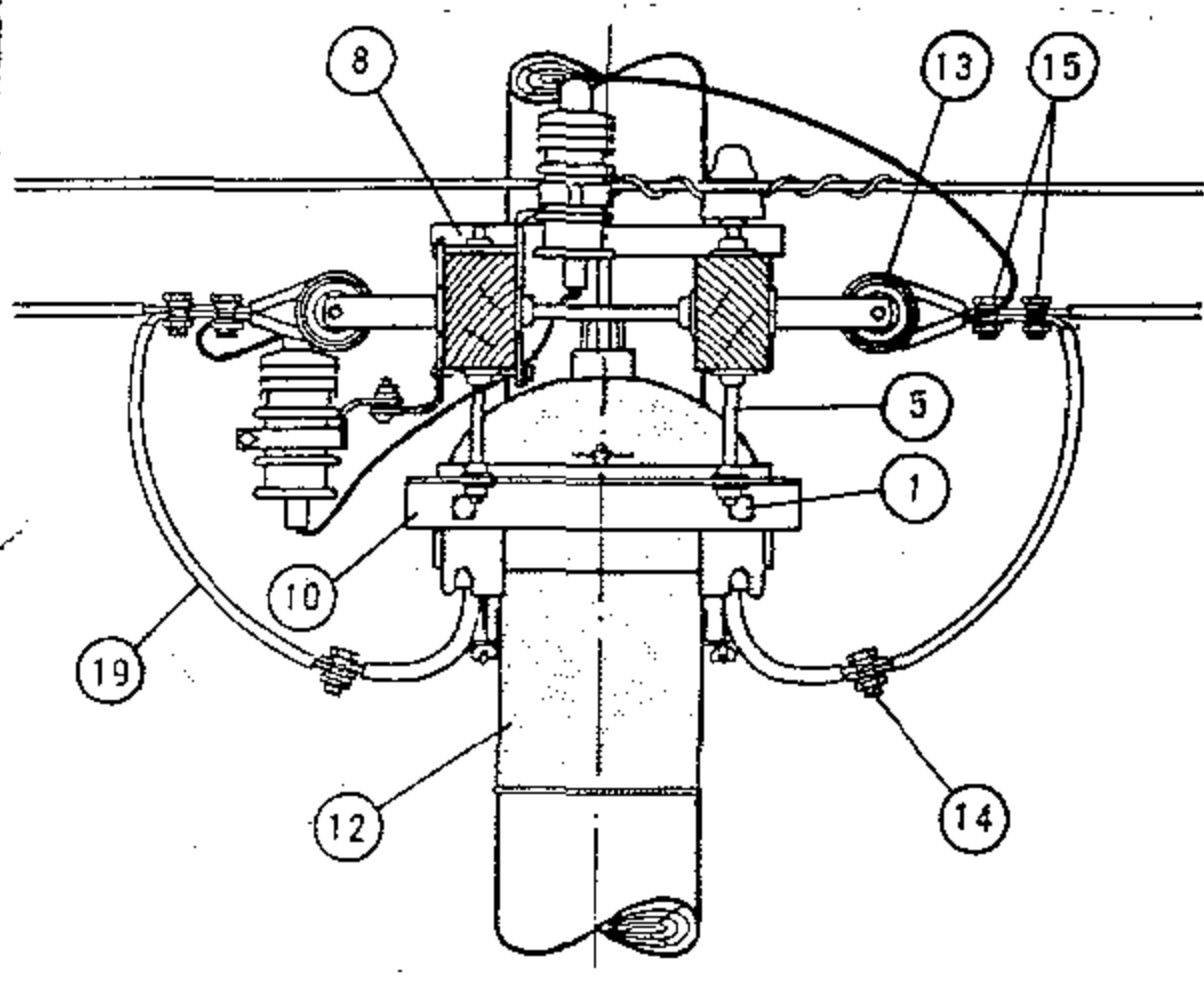
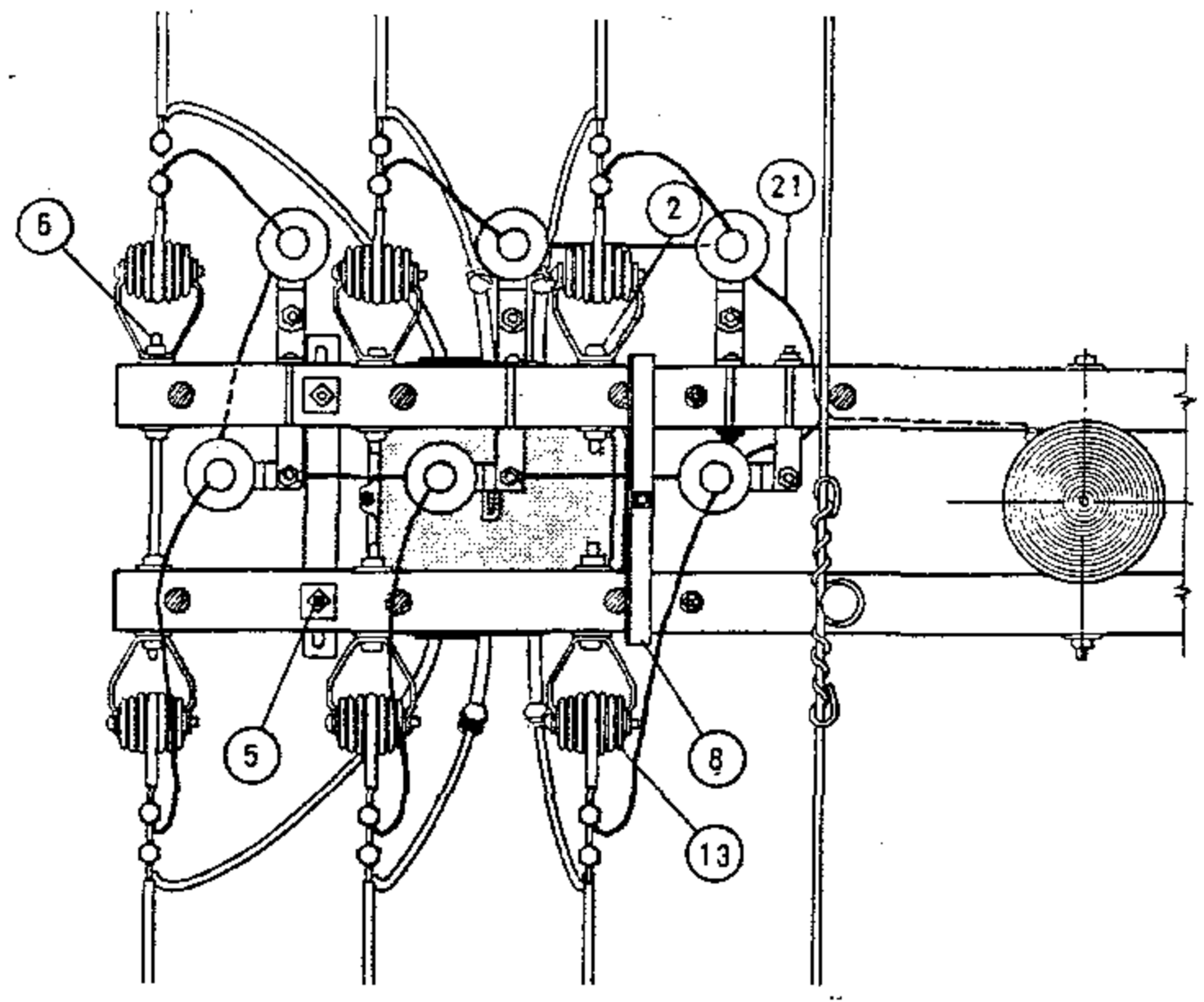

A. BETWEEN SWITCH CASE AND ARRESTER, 1 1/2 INCH CLEARANCE MUST BE MAINTAINED. USE LONGER BOLTS FOR SWITCH SUPPORTS IF REQUIRED.

(E) EXEMPT MATERIAL

ITEM	DESCRIPTION	QUANTITY #5 OR #4	#2 UP	STOCK NO. OR CONSTR STD	ITEM	DESCRIPTION	QUANTITY #5 OR #4	#2 UP	STOCK NO. OR CONSTR STD
1	MACH BOLT, GALV, 5/8" X 2" 1 RD WASHER & 1 NUT	(E) 2	2	PGS 139, 140	14	WIRE CONNECTOR, SPLIT BOLT, SIZE AS REQUIRED	(E) 19	7	PG 783
2	MACH BOLT, GALV, 5/8" X 5" 1-2 1/2" SQ WASHER & 1 NUT	(E) 4	0	PGS 139, 140	15	WIRE CLAMP OR D.E.	0	6	PGS 743, 787
3	MACH BOLT, GALV, 5/8" X 10" TO 16", 1 NUT	(E) 1	1	PGS 139, 140	16				
4	MACH BOLT, GALV, 5/8" X 14", 1 NUT	(E) 1	1	PGS 139, 140	17	POLE STEPS	(E) 17	17	692992
5	SPACE BOLT, GALV, 5/8" X 16", 2 RD & 2 SQ WASH & 2 NUTS	(E) 2	2	PGS 139, 140	18	SIGN, HIGH VOLTAGE & ROOFING NAILS	(E) 2	2	647648, 492224
6	SPACE BOLT, GALV, 5/8" X 16" TO 24", 4 SQ WASHER & 4 NUTS	(E) 2	2	PGS 139, 140	19	WIRE SAME SIZE AS LINE	15'	15'	PGS 711 716
7	CAP SCREW, GALV, 3/8" X 3/4"	2	2	619328	20	WIRE, BARE COPPER #6	12	12	813536
8	MOUNTING BRACKET, OIL SWITCH	1	1	166464	21	WIRE, BARE COPPER #2	AS REQ'D		813664
9	MOUNTING BRACKET, OIL SWITCH	1	1	166464	22	MOULDING, 1" HARDWOOD	AS REQ'D		487200
9	MOUNTING BRACKET, OIL SWITCH	1	1	166464	23	STAPLES, FENCE GALV 1 1/4"	(E) AS REQ'D		678528
11	ARRESTER, 3KV	6	6	PG 1247	24	STAPLES, 3" GALV	(E) AS REQ'D		678560
12	POLETOP SWITCH, WEST. TYPE FO 11, 5KV, 400 A	1	1	171584	25	ROD, GROUND & CLAMP	2	2	603072, 230015 (E)
13	INSULATOR, 4KV D.E. WITH CLEVIS	(E) 6	6	430848					

SDG & E ELECTRIC STANDARDS

DATE 6-4-82
APPD *SRH*

POLE TOP SWITCH INSTALLATION
4 KV WESTINGHOUSE OIL SWITCH, TYPE FO11

1299.401
SUPERSEDES
1240 (6-4-82)

FIELD MAINTENANCE ONLY

REVISION HISTORY:

7/13/2016: All versions prior to 2016 are superceded by their current version found inside the Overhead Construction Standard Manual.

2/20/2019: Install S706670 in place of old style Cut Out.

© 1998 - 2019 San Diego Gas & Electric Company. All rights reserved. Removal of this copyright notice without permission is not permitted under law.

REV	CHANGE	BY	DSGN	APPV	DATE	REV	CHANGE	BY	DSGN	APPV	DATE
C						F					
B	EDITORIAL CHANGES	GLW	JES	CZH	2/20/2019	E					
A	ORIGINAL ISSUE	JS	IL	MDJ	7/13/2016	D					

SHEET 1 OF 1	X Indicates Latest Revision	Completely Revised	New Page	Information Removed	FMO OH 1270
	SDG&E ELECTRIC OVERHEAD CONSTRUCTION STANDARDS				
	SERVICE RESTORER WITH CUTOUT DISCONNECT				

SCOPE: THIS STANDARD SHOWS THE INSTALLATION METHOD OF A DISTRIBUTION SERVICE RESTORER WHICH MAY BE USED WITH #3/0 ACSR OR #1/0 COPPER AND SMALLER CONDUCTORS.

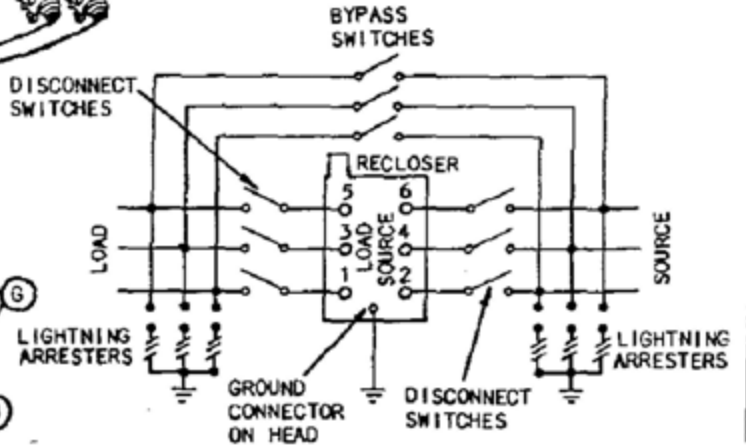
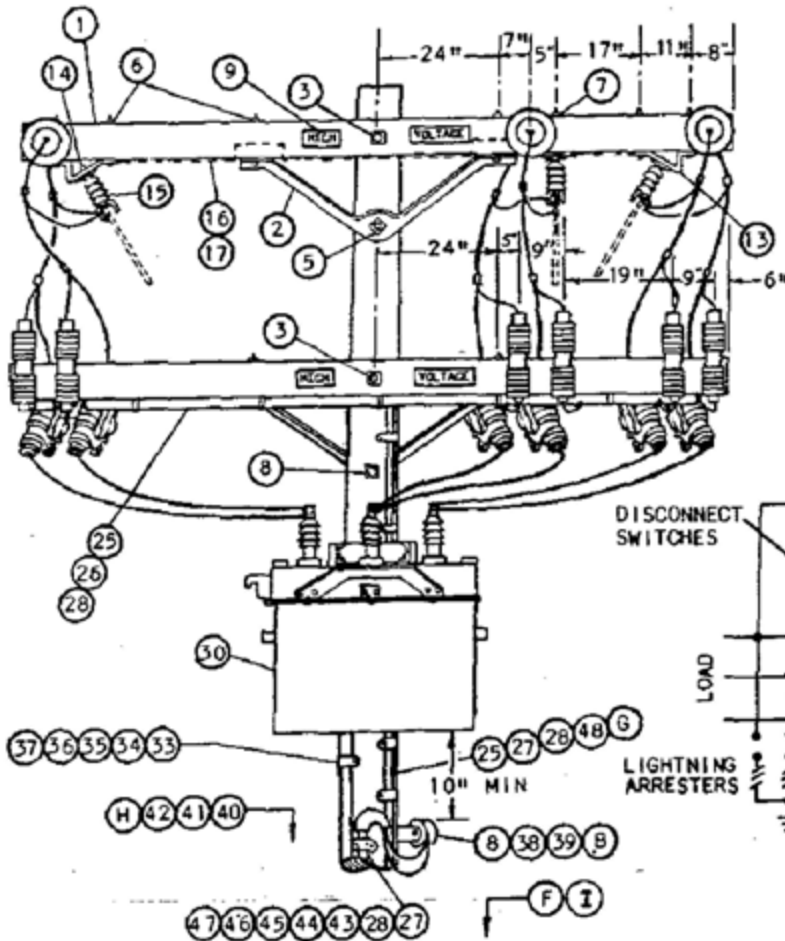

SCHEMATIC DIAGRAM

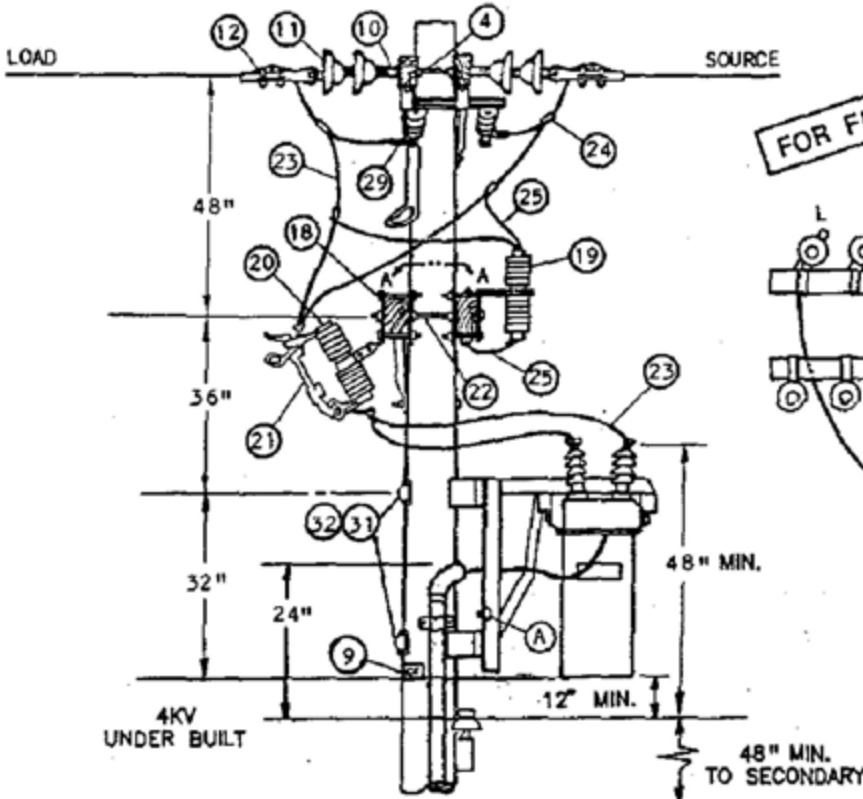

FOR FIELD MAINTENANCE ONLY

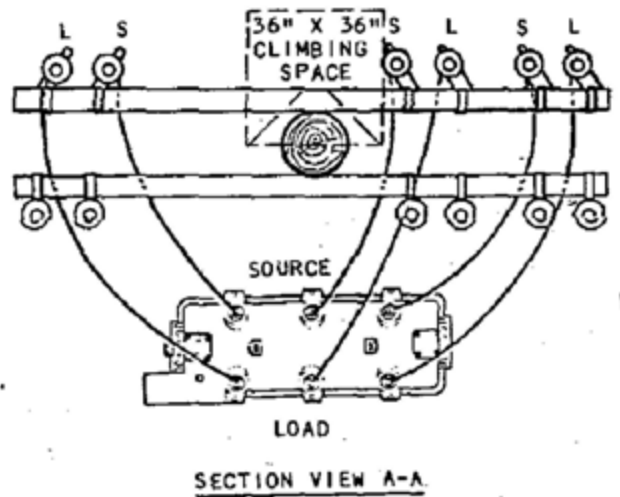

SECTION VIEW A-A

1299.701
SUPERSEDES
1270.1 (1-1-90)

SDG&E ELECTRIC STANDARDS

SERVICE RESTORER WITH CUTOUT DISCONNECT

DATE 1-1-90
APPD *PA/OTE*

BILL OF MATERIAL:

ITEM	DESCRIPTION	QUANTITY	CONST STD OR PAGE NO	STOCK NUMBER
1	CROSSARM, 3 3/4" X 5 3/4" X 12' - 0"	4	-	294160
2	BRACE, 4', ANGLE, GALV	3	-	164032
3	BOLT, MACH, GALV, 5/8" X (LENGTH AS REQ'D), 2 SQUARE AND 1 DOUBLE COIL SPRING WASHERS (E)	2	392	-
4	BOLT, SPACE, GALV, 5/8" X (LENGTH AS REQ'D), 2 ROUND, 2 SQUARE, 2 DOUBLE COIL SPRING WASHERS AND 1 NUT (E)	3	392	-
5	BOLT, MACH, GALV, 5/8" X (LENGTH AS REQ'D) AND 1 DOUBLE COIL SPRING WASHER (E)	1	392	-
6	BOLT, MACH, GALV, 1/2" X 7", 1 ROUND AND 1 DOUBLE COIL SPRING WASHER (E)	14	392	-
7	BOLT, MACH, GALV, 1/2" X 8", 1 ROUND AND 1 DOUBLE COIL SPRING WASHER (E)	2	392	-
8	BOLT, MACH, GALV, 5/8" X (LENGTH AS REQ'D), 1 SQUARE AND 1 DOUBLE COIL SPRING WASHER (E)	2	392	-
9	SIGN, HIGH VOLTAGE & 9 ROOFING NAILS, GALV (E)	5	-	647648
		-	-	492224
10	CLEVIS, DEAD-END, 5/8", BOLT STEEL (CLOSED TYPE)	6	-	235712
11	INSULATOR, SUSPENSION, 12KV, CLEVIS	12	-	431616
12	CLAMP, STRAIGHT LINE, D.E.	6	741-743	-
13	BRACKET, DISCONNECT, ANGLE MOUNTING	4	-	166542
14	BOLT, MACH, GALV, 3/8" X 2", 2 ROUND & 1 LOCK WASHER (E)	4	392	-
15	SWITCH, DISCONNECT, 14.4KV, 600A	3	-	707008
16	WIRE, BARE SOLID ANNEALED COPPER, #8	30'	-	812928
17	STAPLES, FENCE, GALV, 1 1/4" (E)	AS REQ'D	-	678528
18	BRACKET, CUTOUT/ARRESTER, FOR CROSSARM MOUNTING (E)	12	-	166070
19	ARRESTER, LIGHTNING, 12KV	6	-	113248
20	CUTOUT BODY, 12KV	6	1212	297956
21	SOLID BLADE, 300A, 12KV CUTOUT	6	1212	138850
22	BOLT, SPACE, GALV, 5/8" X (LENGTH AS REQ'D), 2 ROUND, 4 SQUARE, 2 DOUBLE COIL SPRING WASHERS AND 1 NUT (E)	2	392	-
23	WIRE, BARE STRANDED COPPER, 1/0	75'	-	813568
24	CONNECTOR, WIRE, COMPRESSION (SIZE AS REQ'D) (E)	AS REQ'D	783-787	-
25	WIRE, BARE STRANDED COPPER, #4	105'	-	813760
26	CONDUIT, PVC, TYPE 2, SCHEDULE 40, 1" X 10', AND STRAPS, PIPE, GALV, 1" AND 2-1 3/4" ROOFING NAILS (E)	1	-	251200
		AS REQ'D	-	697792
27	CONDUIT, PVC, TYPE 2, SCHEDULE 80, 3/4" X 10' (E)	3	-	251520
28	STRAPS, PIPE, GALV, 3/4" AND 2 - 6D NAILS, GALV (E)	AS REQ'D	-	697888
		AS REQ'D	-	491552
29	TERMINAL, COMPRESSION, CU OR AL (SIZE AS REQ'D) (E)	6	794/795	-
30	RECLOSER, MCGRAW-EDISON, 560A, TYPE WE (INCLUDING BRACKET) (C)	1	-	572110

FOR FIELD MAINTENANCE ONLY

DATE 1-1-90
 APPD PA/DTC

SDG&E ELECTRIC STANDARDS

SERVICE RESTORER WITH CUTOUT DISCONNECT

1299.702
 SUPERSEDES
 1270.2 (1-1-90)

BILL OF MATERIAL:

ITEM	DESCRIPTION	QUANTITY	CONST STD OR PAGE NO	STOCK NUMBER
31	BOLT, MACH, GALV, 3/4" X (LENGTH AS REQ'D), 1 SQUARE CURVE RIBBED AND 1 DOUBLE COIL SPRING WASHER (E)	2	392	-
32	COVER, BOLT, PLASTIC AND 6 10-D NAILS, GALV (E)	2	-	285696
		-	-	491392
33	CONTROL CABLE FOR McGRAW-EDISON RECLOSER (H)	1	-	192010
34	CONDUIT, PVC, SCHEDULE 40, 2" X 10' (E)	2	-	251296
35	ELBOW, PVC, SCHEDULE 40, 2" (E)	2	-	321792
36	ELBOW, PVC, SCHEDULE 40, 2", 12" RADIUS (E)	1	-	321816
37	STRAP, PIPE, GALV, 2" AND 2 - 10D NAILS, GALV, (E)	AS REQ'D	-	697856
		AS REQ'D	-	491392
38	BRACKET, SERVICE INSULATOR	1	-	166128
39	WIRE, COPPER #8, 600 VOLT, DUPLEX (B)	AS REQ'D	-	196432
40	CONTROLLER, RECLOSER, McGRAW-EDISON (H)	1	-	273928
41	SCREW, LAG, GALV, 1/2" X 4" (E)	2	-	621568
42	PADLOCK, CORBIN #27 (FF KEY) (E)	1	-	514848
43	COVER, PVC, DRIP LOOP, 3/4" (E)	1	-	287248
44	COUPLING, PVC, 3/4" (E)	2	-	280416
45	TERMINAL, ADAPTOR, PVC, 3/4"	1	-	102754
46	ELBOW, 90 , PULLING, PVC, 3/4" (E)	2	-	-
47	NIPPLE, PIPE SCREW, GALV, 3/4" X 1"	1	-	-
48	UNIT, GROUND, COMPLETE	1	-	603136

INSTALLATION:

- (A) CONNECT RECLOSER RACK GROUND LEAD TO LIGHTNING ARRESTER GROUND.
- (B) RECLOSER CONTROL REQUIRES 120 VOLT SUPPLY, PREFERABLY COMING FROM THE SOURCE SIDE.
- (C) THE 400A, TYPE RXE RECLOSER (S/N 572100) IS NO LONGER PURCHASED.
- (E) EXEMPT MATERIAL.

FOR FIELD MAINTENANCE ONLY

REFERENCE:

- (F) POLE STEPPING - SEE STANDARD 363.
- (G) GROUNDING METHODS - SEE STANDARD 1002. (INSTALL GROUND MOUNDING IN SUCH A MANNER AS NOT TO INTERFERE WITH A LADDER WHEN PLACED AGAINST THE POLE).
- (H) CONTROL INSTALLATION TO BE DONE BY SUBSTATION CONSTRUCTION AND MAINTENANCE AND IS TO BE INSTALLED A MINIMUM OF 13'-6" ABOVE GROUND LEVEL.
- (I) REFLECTOR STRIPS ARE REQUIRED ON ALL SECTIONALIZING/TIELINE SWITCHES AND SERVICE RESTORER POLES. (SEE STD. 208.3 ITEM 12)

1299.703 SUPERSEDES 1270.3 (1-1-90)	SDG&E ELECTRIC STANDARDS SERVICE RESTORER WITH CUTOUT DISCONNECT	DATE 1-1-90 APPD <i>PEA/OTS</i>
-------------------------------------------	----------------------------------------------------------------------------	------------------------------------

FIELD MAINTENANCE ONLY

REVISION HISTORY:

7/13/2016: All versions prior to 2016 are superseded by their current version found inside the Overhead Construction Standard Manual.

© 1998 - 2016 San Diego Gas & Electric Company. All rights reserved. Removal of this copyright notice without permission is not permitted under law.

REV	CHANGE	BY	DSGN	APPV	DATE	REV	CHANGE	BY	DSGN	APPV	DATE
C						F					
B						E					
A	ORIGINAL ISSUE	JS	IL	MDJ	7/13/2016	D					

SHEET 1 OF 1	 Indicates Latest Revision	Completely Revised	New Page	Information Removed	FMO OH 1271
	SDG&E ELECTRIC OVERHEAD STANDARD				
	SERVICE RESTORER WITH HOOK STICK SWITCH DISCONNECT				

SCOPE: THIS STANDARD SHOWS THE INSTALLATION METHOD OF A DISTRIBUTION SERVICE RESTORER TO BE USED WITH ALL CONDUCTOR SIZES.

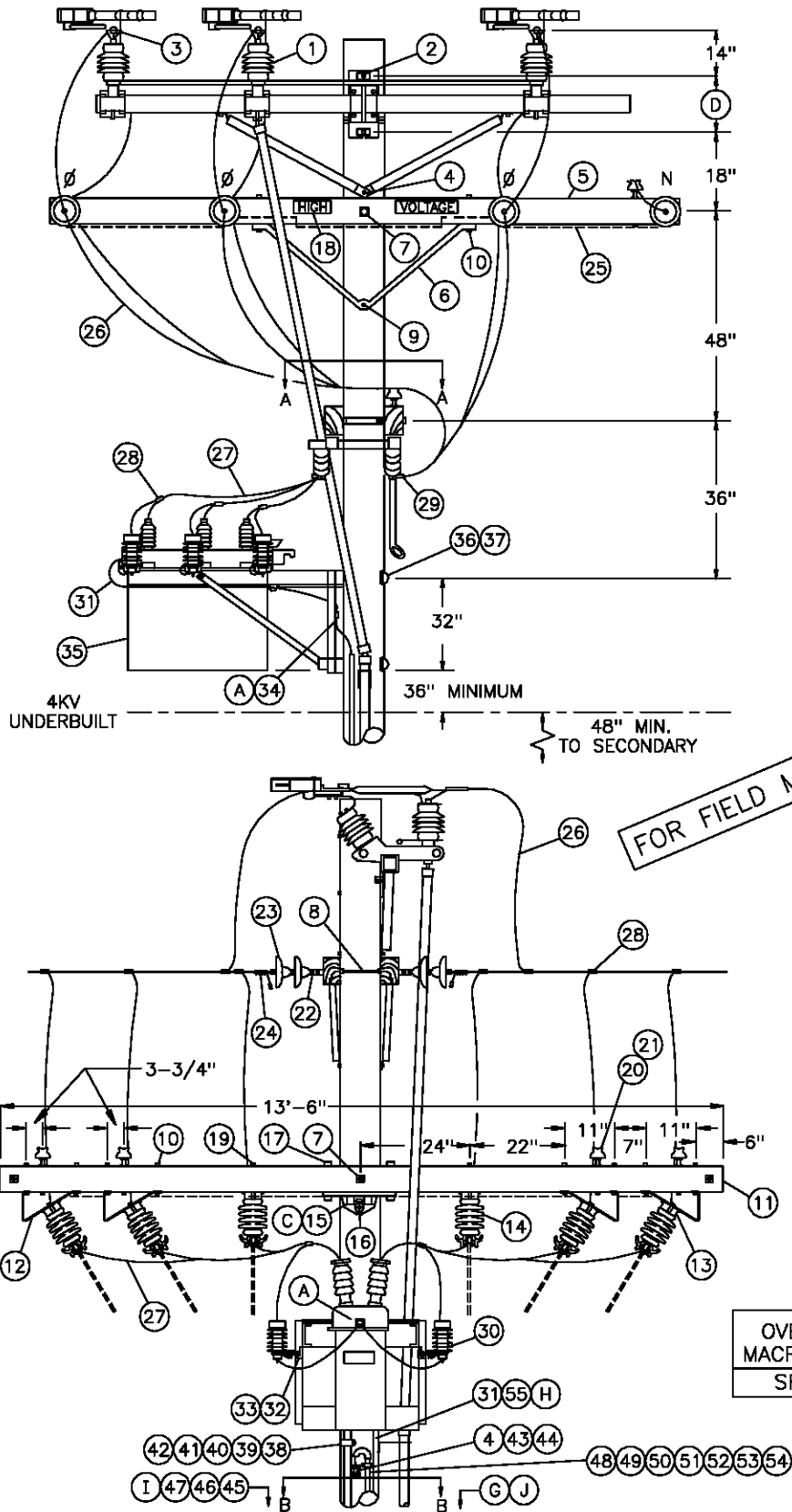

1299.707
SUPERSEDES
1271.1 (1-1-98)

SDG&E ELECTRIC STANDARDS
SERVICE RESTORER-BUCK POSITION
HOOKSTICK SWITCH DISCONNECT
LOADBREAK GANG SWITCH BY-PASS

DATE 1-1-98
APPD PEA / CMK

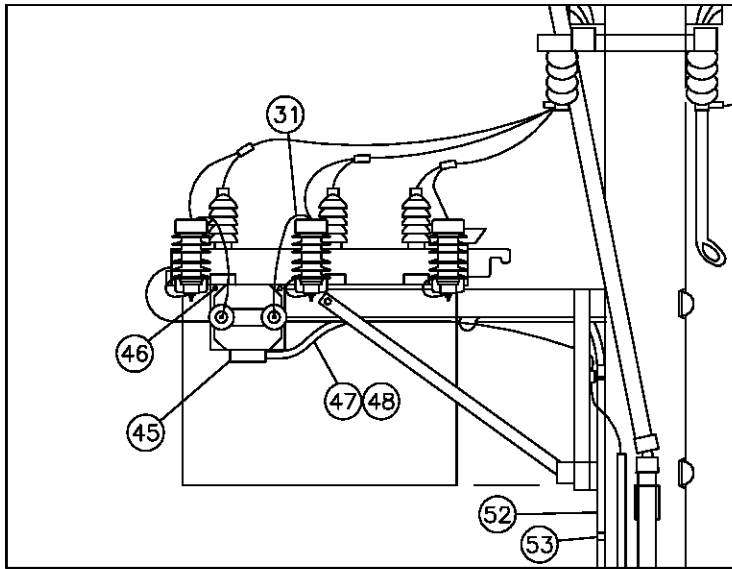

OVERHEAD
MACRO UNIT
SRSEC

POTENTIAL TRANSFORMER-SECONDARY POWER SOURCE (B)

STREET SIDE (PREFERRED)

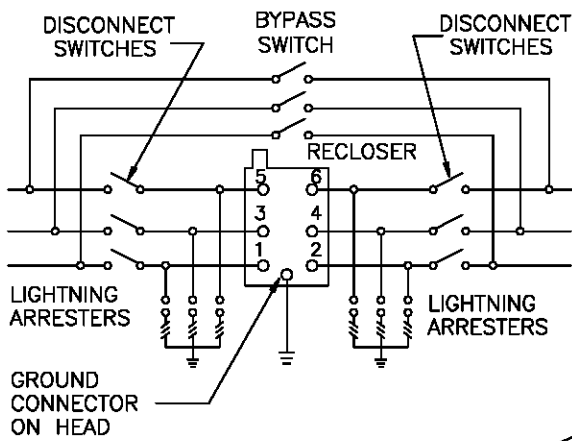

SCHEMATIC DIAGRAM

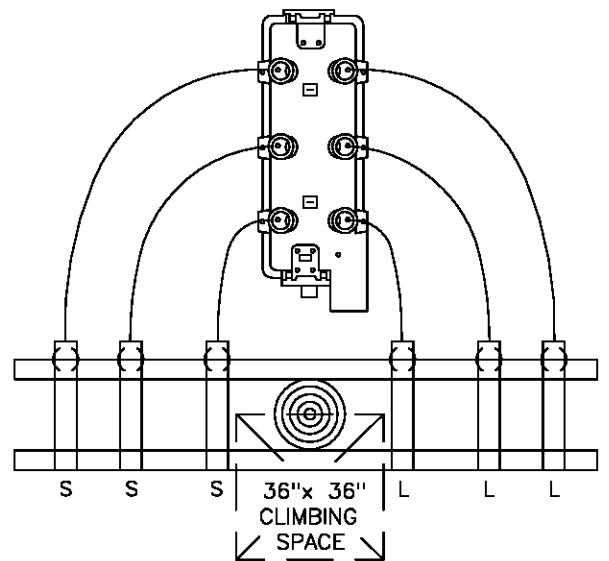

SECTION VIEW A-A

FOR FIELD MAINTENANCE ONLY

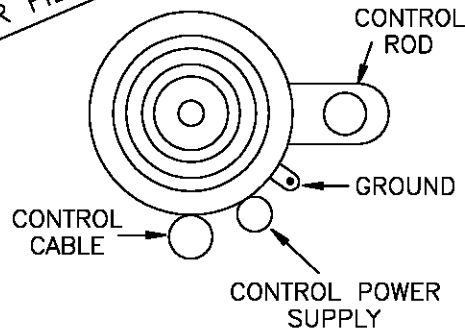

SECTION VIEW B-B

DATE 1-1-98
APPD *PA/CCK*

SDG&E ELECTRIC STANDARDS

BUCK POSITION SERVICE RESTORER
HOOKSTICK SWITCH DISCONNECT
LOADBREAK GANG SWITCH BY-PASS

1299.708
SUPERSEDES
1271.2 (1-1-98)

BILL OF MATERIAL:

ITEM	DESCRIPTION	QUANTITY	CONST STANDARD OR PAGE NO.	STOCK NUMBER	ASSEMBLY UNITS
1	SWITCH, GANG-OPERATED, 15KV, 600AMP, WITH DUOGAP INTERRUPTERS, INCLUDING 40' OF CONTROL ROD	1	-	709250	CHANCE
2	BOLT, MACH, GALV, 3/4" X (LENGTH AS REQ'D), 1 SQUARE & 1 DOUBLE COIL SPRING WASHER	2	392	-	-
3	LUG, EYEBOLT TERMINAL, BRONZE	12	-	471296	-
4	BOLT, MACH, GALV, 5/8" X (LENGTH AS REQ'D), 1 SQUARE & 1 DOUBLE COIL SPRING WASHERS	2	392	-	-
5	CROSSARM, 3 3/4" X 5 3/4" X 12' - 0"	2	-	294160	6-
6	BRACE, ANGLE, CROSSARM, 4' - 0"	2	392	164032	4HUB
7	BOLT, MACH, GALV, 5/8" X (LENGTH AS REQ'D), 2 SQUARE & 1 DOUBLE COIL SPRING WASHERS	2	392	-	-
8	BOLT, SPACE, GALV, 5/8" X (LENGTH AS REQ'D) 2 SQUARE, 2 ROUND & 2 DOUBLE COIL SPRING WASHERS	6	392	-	-
9	BOLT, MACH, GALV, 5/8" X (LENGTH AS REQ'D) & 1 DOUBLE COIL SPRING WASHERS	1	392	-	-
10	BOLT, MACH, GALV, 1/2" X 7", 1 ROUND & 1 DOUBLE COIL SPRING WASHERS	20	392	-	-
11	CROSSARM 3-3/4" X 5-3/4" X 13'-6"	2	-	294368	13SWI-
12	BRACKET, DISCONNECT, ANGLE MOUNTING	8	-	166542	ABRKT
13	BOLT, MACH, GALV, 3/8" X 2", 2 ROUND & 1 LOCK WASHER	8	392	-	-
14	SWITCH, DISCONNECT, 14.4KV, 600A	6	-	707008	D600
15	GAIN, CROSSARM, BRACELESS	1	-	369598	BCGAIN
16	BOLT, MACH, GALV, 5/8" X (LENGTH AS REQ'D) 1 SQUARE, 1 ROUND & 1 DOUBLE COIL SPRING WASHER	1	392	-	-
17	BOLT, MACH, GALV, 5/8" X 7", 1 ROUND & 1 DOUBLE COIL SPRING WASHER	2	392	-	-
18	SIGN, HIGH VOLTAGE & 9 ROOFING NAILS, GALV	2	-	647648	HV
		AS REQ'D	-	492224	-
19	BOLT, MACH, 1/2" X 9", 1 ROUND AND 1 DOUBLE COIL SPRING WASHER	4	392	-	-
20	PIN, INSULATOR, STRAIGHT, 12KV 1" OR 1-3/8" THREAD	5	396	-	-
21	INSULATOR, LINE, 12KV	5	750	-	-
22	CLEVIS, DEAD-END, 5/8", BOLT STEEL (CLOSED TYPE)	8	-	235712	-
23	INSULATOR, SUSPENSION, 12KV, CLEVIS	14	-	431616	6DE
24	CLAMP, STRAIGHT LINE, D.E.	8	739-743	-	-
25	WIRE, #8, BARE SOLID ANNEALED COPPER, AND STAPLES, FENCE, GALV, 1 1/4"	30'	-	812928	BOND8
		1.5# AS REQ'D	-	678528	-
26	WIRE, BARE STRANDED CU OR AL (SIZE AS REQ'D)	90'	711-715	-	-
27	WIRE, BARE STRANDED COPPER, (SIZE AS REQ'D WITH MINIMUM SIZE EQUAL TO LINE CONDUCTOR AMPACITY, OR GREATER)	25'	715	-	-
28	CONNECTOR, WIRE, COMPRESSION (SIZE AS REQ'D)	AS REQ'D	783-787	-	-
29	TERMINAL, COMPRESSION, CU OR AL (SIZE AS REQ'D)	12	794-795	-	-
30	ARRESTER, LIGHTNING, 12KV	6	-	113248	LA12
31	WIRE, #4, BARE STRANDED COPPER	100'	-	813760	(E)
		13#	-	-	-

FOR FIELD MAINTENANCE ONLY

BILL OF MATERIAL:

ITEM	DESCRIPTION	QUANTITY	CONST STD OR PAGE NO	STOCK NUMBER	ASSEMBLY UNITS	
32	Z-BRACKET, GALV, 1-5/8"	6	-	703168	-	
33	BOLT, MACH, GALV, 1/2" X 2", 1 ROUND & 1 LOCK WASHER	12	392	-	-	
34	CONNECTOR, SPLIT BOLT, #2	2	-	269536	-	
35	RECLOSER, MCGRAW-EDISON, 560A, TYPE WE (INCLUDING BRACKET)	1	-	572110	SR560	
36	BOLT, MACH, GALV, 3/4" X (LENGTH AS REQ'D), 1 SQUARE CURVED RIBBED & 1 DOUBLE COIL SPRING WASHER	2	392	-	-	
37	COVER, BOLT, PLASTIC & 6 - 10D NAILS, GALV	2	-	285696	-	
		AS REQ'D	-	491392	-	
38	CONTROL CABLE, FOR MCGRAW-EDISON RECLOSER, 35'	①	1	-	192010	⑤
39	CONDUIT, PVC, SCHED 40, 2" X 10'	①	2	-	251296	⑤
40	ELBOW, PVC, SCHED 40, 2", 12" RADIUS	①	1	-	321816	⑤
41	ELBOW, PVC, SCHED 40, 2"	①	2	-	-	-
42	STRAPS, PIPE, GALV, 2" & 2 - 10 D NAILS, GALV	①	AS REQ'D	-	697856	-
		①	AS REQ'D	-	491392	-
43	BRACKET, SERVICE INSULATOR	1	-	166128	-	
44	WIRE, COPPER, #8, 600 VOLT, DUPLEX	②	AS REQ'D	-	196432	DX8C
45	POTENTIAL TRANSFORMER, 12000/120 VOLTS	②	1	-	762722	SRPT
46	BOLT, MACH, GALV, 3/8" X 1-1/2", AND 1 LOCK WASHER	②	2	-	154144	-
47	CONDUIT, 3/4", FLEXABLE STEEL	②	6'	-	250112	-
48	WIRE, THHN, #12, WHITE	②	40'	-	808704	THW12W
	WIRE, THHN, #12, BLACK	②	40'	-	808096	THW12
49	CONTROLLER, RECLOSER, COOPER, MODEL KME5	①	1	-	273930	C/RSTR
50	SCREW, LAG, GALV, 1/2" X 4"	2	-	621568	-	
51	PADLOCK, SCHLAGE ELECTRIC SERIES	1	-	514848	⑤	
52	CONDUIT, PVC, TYPE 2, SCHEDULE 80, 3/4" X 10'	3	-	251520	⑤	
53	STRAPS, PIPE, GALV, 3/4" & 2 - 6D NAILS, GALV	AS REQ'D	-	697888	-	
		AS REQ'D	-	491552	-	
54	COVER, PVC, DRIPLOOP, 3/4"	1	-	287248	⑤	
55	COUPLING, PVC, 3/4"	2	-	280416	⑤	
56	TERMINAL, ADAPTOR, PVC, 3/4"	1	-	102754	⑤	
57	ELBOW, 90°, PULLING, PVC, 3/4"	2	-	-	-	
58	NIPPLE, PIPE SCREW, GALV, 3/4" X 1"	1	-	-	-	
59	UNIT, GROUND, COMPLETE	1	-	603136	⑤	

FOR FIELD MAINTENANCE ONLY

DATE 1-1-2000 APPD <i>PA/Vcl</i>	SDG&E ELECTRIC STANDARDS BUCK POSITION SERVICE RESTORER HOOKSTICK SWITCH DISCONNECT LOADBREAK GANG SWITCH BY-PASS	1299.710 SUPERSEDES 1271.4 (1-1-2000)
-------------------------------------	----------------------------------------------------------------------------------------------------------------------------	---------------------------------------------

INSTALLATION:

- (A) CONNECT GROUND LEAD TO RECLOSER MOUNTING FRAME. CONNECT LIGHTNING ARRESTER GROUND LEADS AND GROUND CONNECTOR ON HEAD TO RECLOSER MOUNTING FRAME.
- (B) RECLOSER CONTROL REQUIRES 120 VOLT SUPPLY, PREFERABLY COMING FROM THE SOURCE SIDE. IF IMPRACTICAL, POWER MAY ORIGINATE FROM THE LOAD SIDE.

NOTE: IF SECONDARY POWER SOURCE NOT AVAILABLE, OR WOULD BE DIFFICULT TO INSTALL, POWER MAY BE SUPPLIED BY MOUNTING POTENTIAL TRANSFORMER ON SERVICE RESTORER FRAME.
- (C) DO NOT CUT GAINS IN THE POLE WHEN INSTALLING THE HORIZONTALLY MOUNTED SECTIONALIZING SWITCH ARMS. THE GAIN HARDWARE USED HERE MAKE CUT GAINS UNNECESSARY.
- (D) USE THE FOLLOWING THRU-BOLT DRILLING DIMENSIONS: A.B. CHANCE=13-1/4", S&C=14".
- (E) THESE MATERIAL ITEMS INCLUDED WITH CONTROLLER ASSEMBLY UNIT "C/RSTR".

REFERENCE:

- F. DETERMINE MINIMUM POLE CLASS DUE TO SERVICE RESTORER MOUNTED IN THE BUCK POSITION—SEE STANDARD 347.
- (G) POLE STEPPING – SEE STANDARD 363.
- (H) GROUNDING METHODS – SEE STANDARD 1002.
- (I) CONTROL INSTALLATION TO BE DONE BY SUBSTATION CONSTRUCTION AND MAINTENANCE, AND, IS TO BE INSTALLED 14'-0" FROM GROUND LEVEL TO BOTTOM OF CONTROLLER WHEN LOCATED ON STREET SIDE OF POLE. CONTROLLER LOCATED ON PROPERTY SIDE OF POLE WILL BE MOUNTED NO MORE THAN 9' FROM GROUND LEVEL TO BOTTOM OF CONTROLLER. STANDARD CONTROL CABLE LENGTH IS 35'. HOWEVER, LONGER CABLE LENGTHS ARE AVAILABLE IF REQUIRED. INSTALLER WILL SUPPLY CONDUIT ITEMS 39 THROUGH 42.
- (J) REFLECTOR STRIPS ARE REQUIRED ON ALL SECTIONALIZING/TIELINE SWITCHES AND SERVICE RESTORER POLES. (SEE STD. 208.3 ITEM 12)
- K. POLE TOP SWITCH INSTALLATION—SEE STANDARD 1230.

FOR FIELD MAINTENANCE ONLY

1299.711 SUPERSEDES 1271.5 (1-1-98)	SDG&E ELECTRIC STANDARDS BUCK POSITION SERVICE RESTORER HOOKSTICK SWITCH DISCONNECT LOADBREAK GANG SWITCH BY-PASS	DATE 1-1-98 APPD PJA / CMK
-------------------------------------------	----------------------------------------------------------------------------------------------------------------------------	-------------------------------

SCOPE: THIS STANDARD SHOWS THE INSTALLATION METHOD OF A DISTRIBUTION SERVICE RESTORER TO BE USED WITH ALL CONDUCTOR SIZES

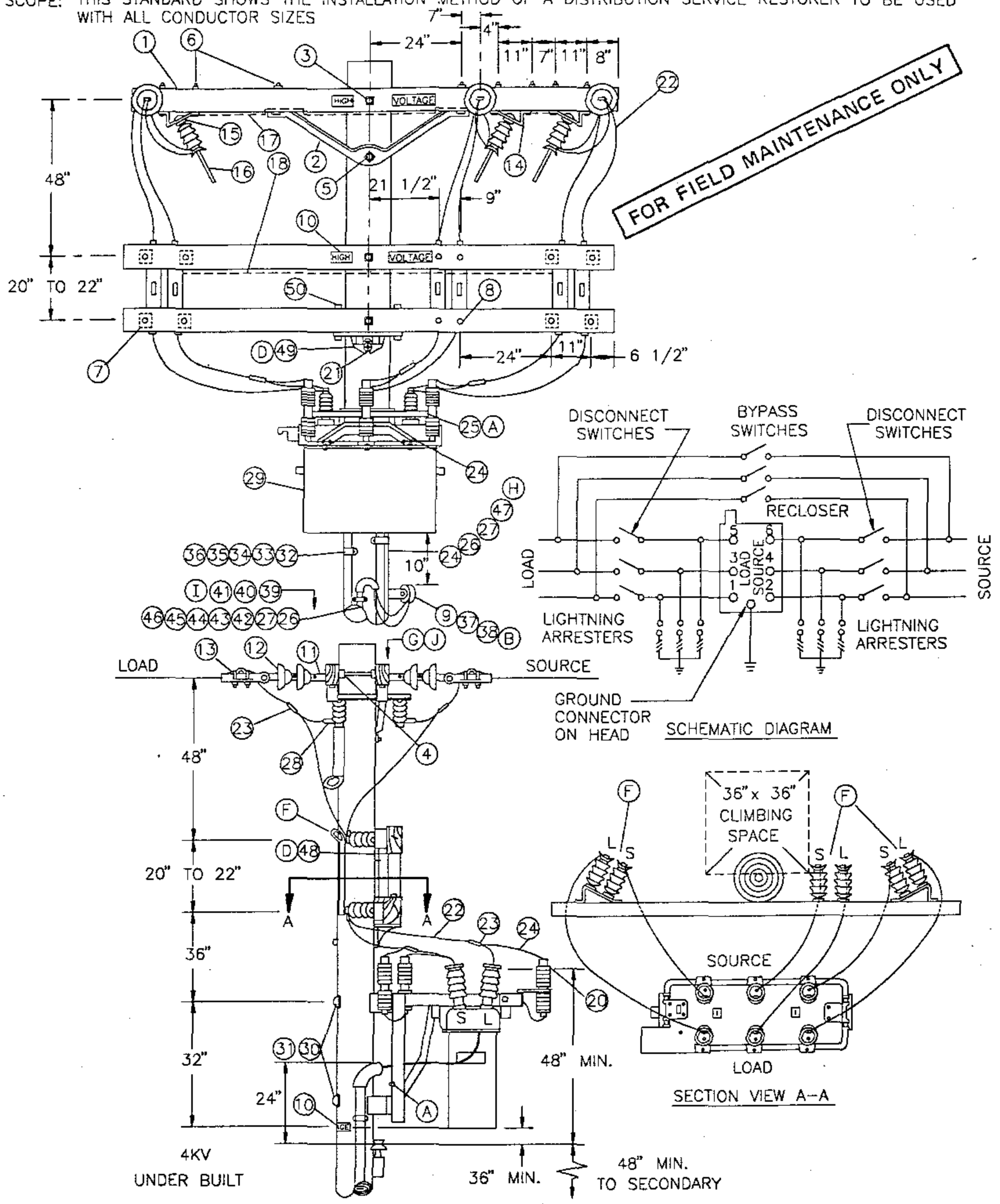

FOR FIELD MAINTENANCE ONLY

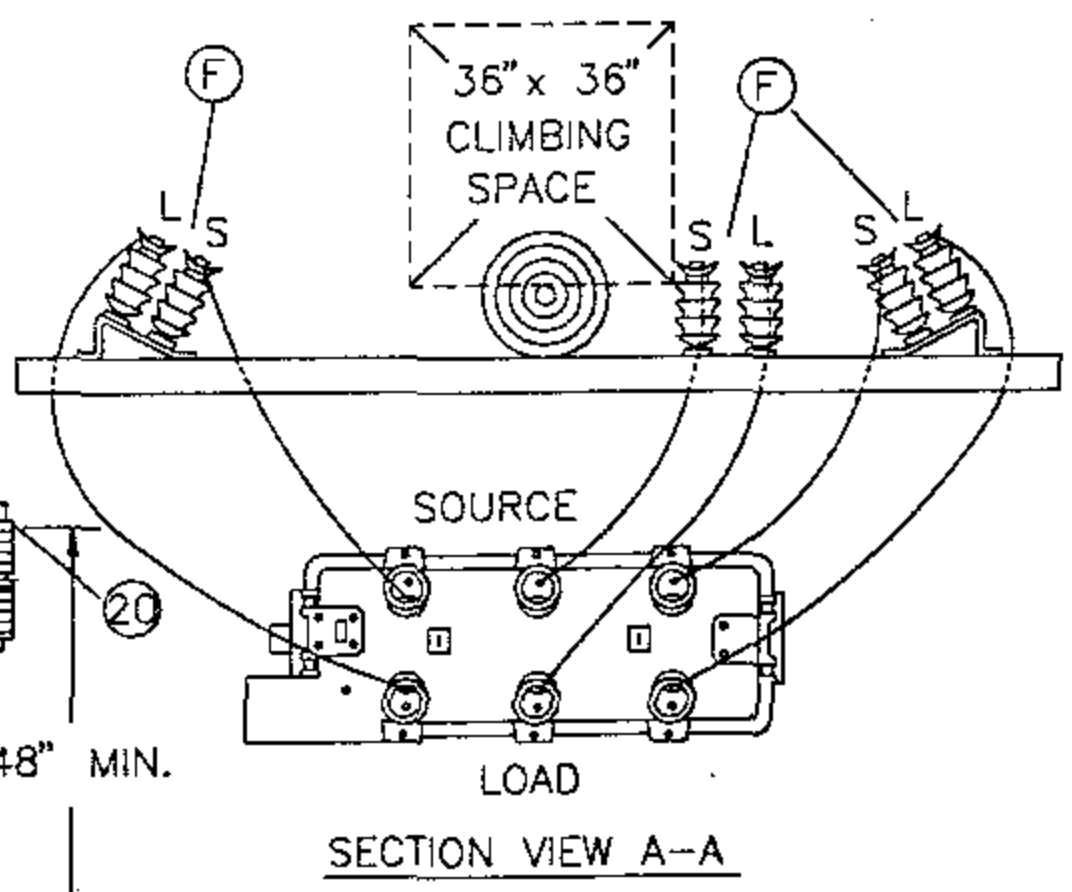
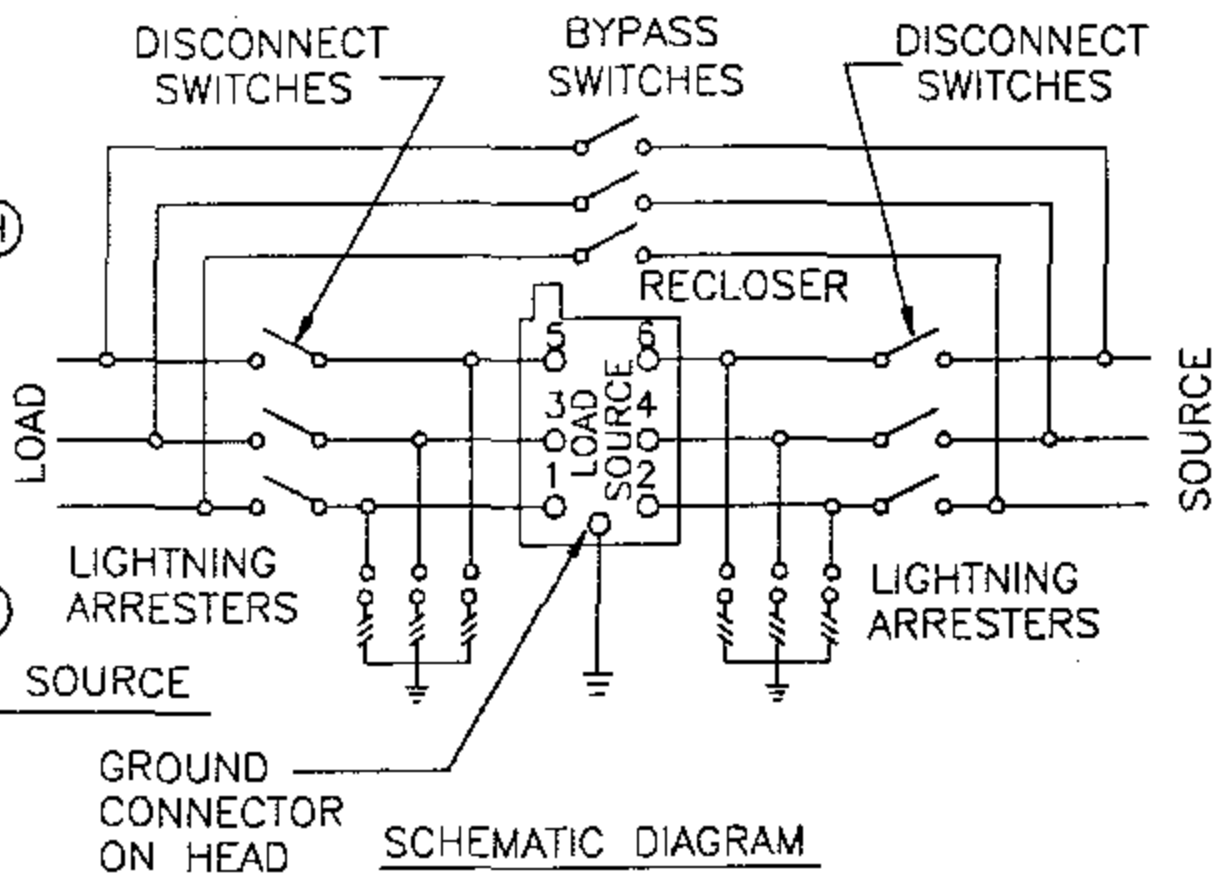

4KV UNDER BUILT 36" MIN. 48" MIN. TO SECONDARY

SDG&E ELECTRIC STANDARDS

DATE 1-1-93
 APPD PAA/BOG

SERVICE RESTORER
 WITH HOOK STICK SWITCH DISCONNECT

1299.704
 SUPERSEDES
 1271.1 (1-1-94)

BILL OF MATERIAL:

ITEM	DESCRIPTION	QUANTITY	CONST STANDARD OR PAGE NO.	STOCK NUMBER
1	CROSSARM, 3 3/4" X 5 3/4" X 12' - 0"	5	-	294160
2	BRACE, ANGLE, CROSSARM, 4' - 0"	2	-	164032
3	BOLT, MACH, GALV, 5/8" X (LENGTH AS REQ'D), 2 SQUARE & 1 DOUBLE COIL SPRING WASHERS	3	392	-
4	BOLT, SPACE, GALV, 5/8" X (LENGTH AS REQ'D) 2 SQUARE, 2 ROUND & 2 DOUBLE COIL SPRING WASHERS	3	392	-
5	BOLT, MACH, GALV, 5/8" X (LENGTH AS REQ'D) & 1 DOUBLE COIL SPRING WASHERS	1	392	-
6	BOLT, MACH, GALV, 1/2" X 7", 1 ROUND & 1 DOUBLE COIL SPRING WASHERS	16	392	-
7	BOLT, MACH, GALV, 1/2" X 5", 1 ROUND & 1 DOUBLE COIL SPRING WASHERS	8	392	-
8	BOLT, MACH, GALV, 3/8" X 6", 1 ROUND & 1 DOUBLE COIL SPRING WASHERS	4	392	-
9	BOLT, MACH, GALV, 5/8" X (LENGTH AS REQ'D), 1 SQUARE & 1 DOUBLE COIL SPRING WASHERS	1	392	-
10	SIGN, HIGH VOLTAGE & 9 ROOFING NAILS, GALV	5	-	647648
		AS REQ'D	-	492224
11	CLEVIS, DEAD-END, 5/8", BOLT STEEL (CLOSED TYPE)	6	-	235712
12	INSULATOR, SUSPENSION, 12KV, CLEVIS	12	-	431616
13	CLAMP, STRAIGHT LINE, D.E.	6	741-743	-
14	BRACKET, DISCONNECT, ANGLE MOUNTING	10	-	166542
15	BOLT, MACH, GALV, 3/8" X 2", 2 ROUND & 1 LOCK WASHER	14	392	-
16	SWITCH, DISCONNECT, 14.4KV, 600A	9	-	707008
17	WIRE, #8, BARE SOLID ANNEALED COPPER	30'	-	812928
18	STAPLES, FENCE, GALV, 1 1/4"	AS REQ'D	-	678528
19				
20	ARRESTER, LIGHTNING, 12KV	6	-	113248
21	BOLT, MACH, GALV, 5/8" X (LENGTH AS REQ'D) 1 SQUARE, 1 ROUND & 1 DOUBLE COIL SPRING WASHER	1	392	-
22	WIRE, BARE STRANDED COPPER, (SIZE AS REQ'D WITH MINIMUM SIZE EQUAL TO LINE CONDUCTOR AMPACITY, OR GREATER) ©	75'	715	-
23	CONNECTOR, WIRE, COMPRESSION (SIZE AS REQ'D)	AS REQ'D	783-787	-
24	WIRE, #4, BARE STRANDED COPPER	100'	-	813760
25	CONNECTOR, SPLIT BOLT, #2	2	-	269536
26	CONDUIT, PVC, TYPE 2, SCHEDULE 80, 3/4" X 10'	3	-	251520
27	STRAPS, PIPE, GALV, 3/4" & 2 - 6D NAILS, GALV	AS REQ'D	-	697888
		AS REQ'D	-	491552
28	TERMINAL, COMPRESSION, CU OR AL (SIZE AS REQ'D)	6	794/795	-
29	RECLOSER, MCGRAW-EDISON, 560A, TYPE WE (INCLUDING BRACKET) ©	1	-	572110

FOR FIELD MAINTENANCE ONLY

1299.705
SUPERSEDES
1271.2 (1-1-94)

SDG&E ELECTRIC STANDARDS

SERVICE RESTORER
WITH HOOK STICK SWITCH DISCONNECT

DATE 1-1-90

APPD *[Signature]*

BILL OF MATERIAL:

ITEM	DESCRIPTION	QUANTITY	CONST STD OR PAGE NO	STOCK NUMBER
30	BOLT, MACH, GALV, 3/4" X (LENGTH AS REQ'D), 1 SQUARE CURVED RIBBED & 1 DOUBLE COIL SPRING WASHER	2	392	-
31	COVER, BOLT, PLASTIC & 6 - 10D NAILS, GALV	2	-	285696
		AS REQ'D	-	491392
32	CONTROL CABLE, FOR MCGRAW-EDISON RECLOSER (I)	1	-	192010
33	CONDUIT, PVC, SCHED 40, 2" X 10' (I)	2	-	251296
34	ELBOW, PVC, SCHED 40, 2", 12" RADIUS (I)	1	-	321816
35	ELBOW, PVC, SCHED 40, 2" (I)	2	-	-
36	STRAPS, PIPE, GALV, 2" & 2 - 10 D NAILS, GALV (I)	AS REQ'D	-	697856
		AS REQ'D	-	491392
37	BRACKET, SERVICE INSULATOR	1	-	166128
38	WIRE, COPPER, #8, 600 VOLT, DUPLEX (B)	AS REQ'D	-	196432
39	CONTROLLER, RECLOSER, MCGRAW-EDISON (I)	1	-	273928
40	SCREW, LAG, GALV, 1/2" X 4"	2	-	621568
41	PADLOCK, CORBIN #27 (FF KEY)	1	-	514848
42	COVER, PVC, DRIPLOOP, 3/4"	1	-	287248
43	COUPLING, PVC, 3/4"	2	-	280416
44	TERMINAL, ADAPTOR, PVC, 3/4"	1	-	102754
45	ELBOW, 90°, PULLING, PVC, 3/4"	2	-	-
46	NIPPLE, PIPE SCREW, GALV, 3/4" X 1"	1	-	-
47	UNIT, GROUND, COMPLETE	1	-	603136
48	GAIN, CROSSARM (D)	1	-	369596
49	GAIN, CROSSARM, BRACELESS (D)	1	-	369598
50	BOLT, MACH, GALV, 5/8" X 7" 1 ROUND & 1 DOUBLE COIL SPRING WASHER	2	392	-

FOR FIELD MAINTENANCE ONLY

INSTALLATION:

- (A) CONNECT GROUND LEAD TO RECLOSER MOUNTING FRAME. CONNECT LIGHTNING ARRESTER GROUND LEADS TO LIGHTNING ARRESTER MOUNTING BRACKETS. CONNECT GROUND CONNECTOR ON HEAD TO RECLOSER MOUNTING FRAME.
- (B) RECLOSER CONTROL REQUIRES 120 VOLT SUPPLY, PREFERABLY COMING FROM THE SOURCE SIDE.
- (C) THE 400A, TYPE RXE RECLOSER (S/N 572100) IS NO LONGER PURCHASED.
- (D) DO NOT CUT GAINS IN THE POLE WHEN INSTALLING THE VERTICALLY MOUNTED SECTIONALIZING SWITCH ARMS. THE GAIN HARDWARE USED HERE MAKE CUT GAINS UNNECESSARY.
- (F) IT IS NECESSARY TO CUT OFF INSIDE LOAD BREAK EARS ON EACH PAIR OF VERTICALLY MOUNTED DISCONNECT SWITCHES TO PREVENT PHYSICAL CONTACT.

REFERENCE:

- (G) POLE STEPPING - SEE STANDARD 363.
- (H) GROUNDING METHODS - SEE STANDARD 1002.
- (I) CONTROL INSTALLATION TO BE DONE BY SUBSTATION CONSTRUCTION AND MAINTENANCE AND IS TO BE INSTALLED A MINIMUM OF 13'-6" ABOVE GROUND LEVEL. INSTALLER WILL SUPPLY CONDUIT ITEMS 33 THRU 36.
- (J) REFLECTOR STRIPS ARE REQUIRED ON ALL SECTIONALIZING/TIELINE SWITCHES AND SERVICE RESTORER POLES. (SEE STD. 208.3 ITEM 12)

DATE 1-1-93

APPD *PA/BJ*

SDG&E ELECTRIC STANDARDS

SERVICE RESTORER
WITH HOOK STICK SWITCH DISCONNECT1299.706
SUPERSEDES
1271.3 (1-1-94)

1300 - CAPACITORS,
REGULATORS

1300 - CAPACITORS,
REGULATORS

<u>PAGES</u>	<u>SUBJECT</u>
1302	CAPACITOR MARKING INSTRUCTIONS DECALS AND TAGS
1311	CAPACITOR INFORMATION
1312	VOLTAGE REGULATOR INFORMATION
1314	CAPACITOR CONNECTION 4KV WYE
1315	CAPACITOR INSTALLATION 4KV-WYE-150 KVAR MAXIMUM
1316	CAPACITOR INSTALLATION 4KV-WYE-300 KVAR MAXIMUM
1317	CAPACITOR INSTALLATION 4KV-WYE-450 KVAR MAXIMUM
1318	FIXED CAPACITOR INSTALLATION, 4.16KV DELTA UNDERGROUND RACK
1319	SWITCHED CAPACITOR INSTALLATION 4.16KV DELTA - 2 OIL SWITCHES
1321	SWITCHED CAPACITOR INSTALLATION 4.16KV WYE - 3 OIL SWITCHES
1322	CAPACITOR INSTALLATIONS, 12KV-WYE-900 KVAR MAX
1323	FIXED CAPACITOR INSTALLATION, 4KV WYE GROUNDED RACK
1324	12 & 12.47KV SWITCHED CAPACITOR INSTALLATION 3 OIL SWITCHES IN LINE
1325	12 & 12.47KV SWITCHED CAPACITOR INSTALLATION 2 OIL SWITCHES IN CAPACITOR NEUTRAL
1326	SWITCHED CAPACITORS - CURRENT SENSOR 12 & 12.47KV
1330	CAPACITOR CONTROL MATERIAL AND INSTALLATION VOLTAGE WITH TIME BIAS (TYPE 'TB')
1348	STEP-VOLTAGE REGULATOR STATION, OPEN DELTA, 12KV
1349	STEP-VOLTAGE REGULATOR STATION, CLOSED DELTA, 12KV, TWO POLES
1350	STEP-VOLTAGE REGULATOR STATION, CLOSED DELTA, 12KV, TWO POLES

© 1998 - 2016 San Diego Gas & Electric Company. All rights reserved. Removal of this copyright notice without permission is not permitted under law.

REV	CHANGE	BY	DSGN	APPV	DATE	REV	CHANGE	BY	DSGN	APPV	DATE
C	UPDATES TO 1312	JS	JS	MDJ	1/25/2017	F					
B	ADDED 1312	KR	JS	MDJ	12/2/2016	E					
A	ORIGINAL ISSUE	JS	IL	MDJ	7/13/2016	D					

SHEET 1 OF 1	<input checked="" type="checkbox"/> Indicates Latest Revision	<input type="checkbox"/> Completely Revised	<input type="checkbox"/> New Page	<input type="checkbox"/> Information Removed	FMO OH 1301
	SDG&E OVERHEAD STANDARD				
	CAPACITORS, REGULATORS FMO TABLE OF CONTENTS				

FIELD MAINTENANCE ONLY

REVISION HISTORY:

7/13/2016: All versions prior to 2016 are superseded by their current version found inside the Overhead Construction Standard Manual.

© 1998 - 2016 San Diego Gas & Electric Company. All rights reserved. Removal of this copyright notice without permission is not permitted under law.

REV	CHANGE	BY	DSGN	APPV	DATE	REV	CHANGE	BY	DSGN	APPV	DATE
C						F					
B						E					
A	ORIGINAL ISSUE	JS	IL	MDJ	7/13/2016	D					

<p>SHEET 1 OF 1</p>	<p> Indicates Latest Revision</p>	<p>Completely Revised</p>	<p>New Page</p>	<p>Information Removed</p>	<p>FMO OH 1302</p>
	<p>SDG&E ELECTRIC OVERHEAD STANDARD</p>				
	<p>CAPACITOR MARKING INSTRUCTIONS DECALS AND TAGS</p>				

SCOPE: THIS STANDARD DESCRIBES CAPACITOR MARKING AND HANDLING PROCEDURES.

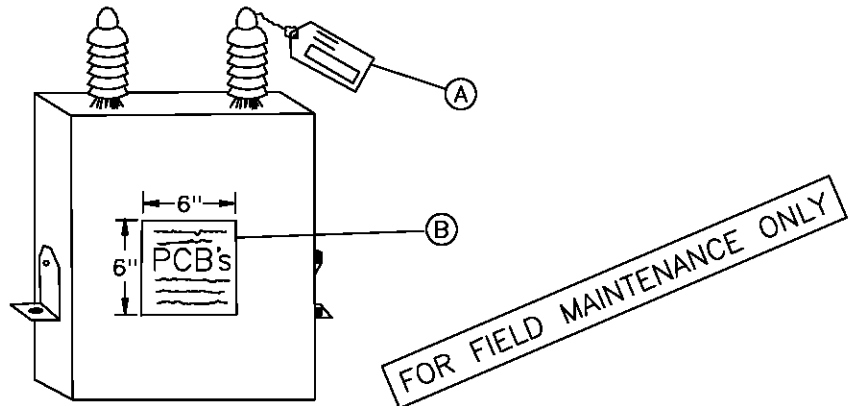

(A) CAPACITOR TAGS

THIS IDENTIFICATION TAG (SDG&E FORM 120-7240, STK. NO. 043450) IS USED FOR TRACKING THE CAPACITOR DURING REMOVAL/RETIREMENT AND INSTALLATION. IT SHALL BE USED ON ALL CAPACITORS, PCB UNITS AND NON-PCB UNITS.

EACH CAPACITOR UNIT IN STOCK WILL BE AFFIXED WITH A CAPACITOR IDENTIFICATION TAG BEFORE IT IS REMOVED FROM STOCK. THIS TAG IS TO BE COMPLETED BY THE FIELD PERSONNEL WHO EITHER REMOVES OR INSTALLS A CAPACITOR UNIT. ONE SIDE OF THIS TAG IS USED FOR REMOVAL AND THE OTHER FOR INSTALLATION.

1. INSTALLATION

THE DISTRICT STOCKKEEPER SHALL COMPLETE AS MUCH OF THE CAPACITOR TAG(S) AS POSSIBLE ON THE INSTALLATION SIDE OF THE TAG AND ATTACH TO THE SPECIFIC UNIT. WHEN THE INSTALLATION IS COMPLETED, THE CREW FOREMAN SHALL REMOVE THE TAG AND COMPLETE THE REQUESTED INFORMATION.

2. REPLACEMENT

WHEN A CAPACITOR UNIT IS REPLACING ONE THAT IS BEING REMOVED, THE FOREMAN SHALL FILL OUT BOTH SIDES OF THE TAG.

IF REMOVAL AND REPLACEMENT IS NOT COMPLETED WITHIN TWO CONSECUTIVE WORKDAYS, TWO FORMS ARE TO BE COMPLETED, ONE FOR A REMOVAL, AND ANOTHER FOR INSTALLATION.

IF REPLACEMENT IS DUE TO FAILURE OF ONE OR MORE UNITS, AN EQUIPMENT FAILURE REPORT IS REQUIRED.

3. REMOVAL

WHEN A CAPACITOR UNIT IS REMOVED, THE CREW FOREMAN SHALL COMPLETE THE REMOVAL PORTION ONLY. IF TAGS ARE NOT STORED ON THE TRUCKS, THE DISPATCHER SHALL PROVIDE THE CREW WITH SUFFICIENT TAGS FOR EACH CAPACITOR UNIT TO BE REMOVED.

DATE 1-1-2000 APPD <i>PA/ROJ</i>	SDG&E ELECTRIC STANDARDS	OH 1399.001
	CAPACITOR MARKING INSTRUCTIONS DECALS AND TAGS	UG 3899.001 SUPERSEDES 1302.1 (1-1-86)

4. RETIREMENT

WHEN A CAPACITOR UNIT IS RETIRED, THE RETIRED PORTION OF THE CAPACITOR TAG MUST BE FILLED OUT BY THE PERSONNEL RETIRING THE UNIT.

5. DISPOSITION

IT SHALL BE THE DISPATCHER'S RESPONSIBILITY TO SEE THAT THE COMPLETED TAGS ARE SENT TO THE DISTRICT'S RECORDS SECTION, ATTENTION OF THE ENGINEERING CLERK, WITHIN ONE WORKING DAY AFTER THE CAPACITOR UNITS HAVE BEEN INSTALLED OR REMOVED.

ⓑ DECAL

THIS DECAL (STOCK NO. 301880) IS TO BE PLACED ON ALL CAPACITOR UNITS WHICH CONTAIN PCB'S.

FIELD PERSONNEL AND STOCKKEEPERS SHOULD MAKE EVERY EFFORT TO INSURE THAT ALL PCB UNITS HAVE A DECAL, AND THAT ALL WORN, WEATHERED DECALS BE REPLACED WITH NEW DECALS. THE DECAL IS BLACK PRINT ON EITHER YELLOW OR WHITE BACKGROUND.

1. MARKING

EVERY CAPACITOR IN SERVICE OR IN STORAGE, WHICH USES AN INSULATING FLUID CONTAINING PCB'S, SHALL BE LABELED WITH THE DECAL (STOCK NO. 301880).

EVERY PCB CAPACITOR WHICH IS REMOVED FROM SERVICE AND DOES NOT HAVE THE DECAL (STOCK NO. 301880) SHALL HAVE THE DECAL PUT ON IT AT THE TIME IT IS REMOVED FROM SERVICE. THIS SHALL BE DONE BY THE WORK CREW THAT REMOVES THE UNIT. IF A PCB UNIT ARRIVES AT A STOREYARD WITH NO PCB DECAL, THE STOCKKEEPER SHALL PUT A DECAL ON.

NOTE: ALL CAPACITOR UNITS PURCHASED BEFORE 1977 USED AN INSULATING FLUID WHICH CONTAINED PCB'S. THE UNITS WITH THE PCB FLUIDS CAN BE IDENTIFIED BY THE WORDS "NON-FLAMMABLE LIQUID" ON NAMEPLATE OR BY THE MANUFACTURER'S TRADE NAMES WHICH ARE:

- G.E. - PYRANOL
- WESTINGHOUSE - INERTEEN
- MCGRAW-EDISON - ELEMEX
- CORNEL DUBILIER OR FEDERAL PACIFIC - DYKANOL
- SANGAMO - DIACHLOR
- ALLIS CHALMERS - CHLOREXTOL

FOR FIELD MAINTENANCE ONLY

ALL OF THE CAPACITOR UNITS RECEIVED THAT DO NOT CONTAIN PCB INSULATING FLUIDS HAVE THE WORDS "CONTAINS A NON-PCB INSULATING FLUID" ON THE NAMEPLATE OR ON A BLUE TANK DECAL.

2. HANDLING CAPACITORS CONTAINING POLYCHLORINATED BIPHENYLS (PCB)

CAPACITORS CONTAINING PCB SHALL BE HANDLED AS SPECIFIED IN THE PCB HANDLING AND PERSONAL SAFETY PROCEDURES. (SEE CONSTRUCTION MANAGEMENT STANDARD PRACTICE 107).

3. RETIRING RUPTURED OR DAMAGED UNITS

WHENEVER TRANSPORTATION OR KEARNY MAINTENANCE RETIRES A CAPACITOR AND DISPOSES OF IT, SPECIFIC DATA (I.E. SERIAL NUMBER, PCB OR NON-PCB, MANUFACTURER, SIZE, ETC.) MUST BE RECORDED ON THE CAPACITOR TAG AND SENT TO THE DISTRICT'S RECORDS SECTION, ATTENTION OF THE ENGINEERING CLERK.

OH 1399.002
~~UG 3899.002~~
SUPERSEDES
1302.2 (1-1-86)

SDG&E ELECTRIC STANDARDS

CAPACITOR MARKING INSTRUCTIONS
DECALS AND TAGS

DATE 1-1-2000
APPD *PA 1/09*

C. PRECAUTIONARY MEASURES – DAMAGED CAPACITOR UNITS

DAMAGED CAPACITOR UNITS WITH BULGED CASES MAY HAVE EXCESSIVE PRESSURE INSIDE. THE UNITS MAY RUPTURE WHEN HANDLED OR BUMPED. SINCE THE INSULATING LIQUID IN THE UNITS IS TOXIC, CARE SHALL BE EXERCISED WHEN WORKING WITH BULGED OR OTHERWISE DAMAGED UNITS. UNITS WITH BULGED OR DAMAGED CASES SHALL NOT BE RE-ENERGIZED.

D. CAPACITOR NAMEPLATES

THE CAPACITOR NAMEPLATE AND UNIT SHALL REMAIN INTACT. UNDER NO CIRCUMSTANCES SHALL THE NAMEPLATE BE REMOVED FROM THE CAPACITOR UNIT.

F. SERIES STREET LIGHTING TRANSFORMERS

THE TROUBLEMAN AND/OR CREW SHALL CHECK THE NAMEPLATE OF ANY RUPTURED 2400 VOLT, CONSTANT CURRENT STREET LIGHTING TRANSFORMER TO DETERMINE IF IT CONTAINS AN INTERNAL CAPACITOR. IF NO CAPACITOR IS SHOWN ON THE NAMEPLATE, THE TRANSFORMER IS TO BE TREATED AS ANY OTHER TRANSFORMER ON THE SYSTEM, NO SPECIAL HANDLING OR DISPOSAL IS REQUIRED. IF IT DOES, IT SHALL BE TREATED AS ANY PCB CONTAINING DEVICE UNTIL IT REACHES KEARNY MAINTENANCE. (SEE CONSTRUCTION MANAGEMENT STANDARD PRACTICE 107).

KEARNY SHALL REMOVE THE INTERNAL CAPACITOR IMMEDIATELY AND CHECK TO SEE IF IT HAS LEAKED. IF IT HAS NOT LEAKED, THE CAPACITOR SHALL BE DISPOSED OF IN ACCORDANCE WITH THE EPA REGULATIONS. THE TRANSFORMER MAY THEN RE-ENTER THE SYSTEM AS AN RO UNIT OR BE SCRAPPED.

IF PCB CONTAMINATION OF THE TRANSFORMER OIL IS SUSPECTED, KEARNY MAINTENANCE SHALL HAVE THE BEST LAB VERIFY THE LEVEL OF CONTAMINATION. IF IT IS 500PPM OR GREATER, THE OIL AND THE TRANSFORMER SHALL BE DISPOSED OF ACCORDING TO EPA REGULATIONS.

FOR FIELD MAINTENANCE ONLY

DATE 1-1-2000 APPD <i>PA 1/09</i>	SDG&E ELECTRIC STANDARDS CAPACITOR MARKING INSTRUCTIONS DECALS AND TAGS	OH 1399.003 UG 3899.003 SUPERSEDES 1302.3 (1-1-86)
--------------------------------------	-------------------------------------------------------------------------------	------------------------------------------------------------------------

FIELD MAINTENANCE ONLY

REVISION HISTORY:

7/13/2016: All versions prior to 2016 are superseded by their current version found inside the Overhead Construction Standard Manual.

© 1998 - 2016 San Diego Gas & Electric Company. All rights reserved. Removal of this copyright notice without permission is not permitted under law.											
REV	CHANGE	BY	DSGN	APPV	DATE	REV	CHANGE	BY	DSGN	APPV	DATE
C						F					
B						E					
A	ORIGINAL ISSUE	JS	IL	MDJ	7/13/2016	D					
SHEET 1 OF 1	 Indicates Latest Revision		Completely Revised		New Page		Information Removed				
	SDG&E ELECTRIC OVERHEAD STANDARD										FMO OH 1311
	CAPACITOR INFORMATION										

SCOPE: THIS STANDARD LISTS THE INFORMATION NEEDED TO DETERMINE PROPER CAPACITOR APPLICATIONS.

PREFIX	PHASE	VOLTAGE	DESCRIPTION		KVAR	STOCK NUMBER	ASSEMBLY UNITS	
C	1	2400/4160Y	CAPACITOR UNITS		100	(A) 207330	-	
CT	3	2400/4160Y	FIXED CAPACITOR RACK CONSISTING OF 3 100KVAR 1Ø UNITS, 4 WIRE CONNECTED WYE.		300	564772	CT3F	
			SWITCHED CAPACITOR RACK CONSISTING OF 3-100KVAR 1Ø UNITS AND 3 OIL SWITCHES WITH 2.4KV POTENTIAL TRANSFORMER.		300	564773	CT3S	
CTD	3	4160 Δ	SWITCHED CAPACITOR RACK CONSISTING OF 3-200 KVAR, 7200V UNITS DELTA CONNECTED AND A POTENTIAL TRANSFORMER RATED AT 2400-120V FOR USE ON 4KV SYSTEM.		200	(B) 564758	CTD2S	
			FIXED CAPACITOR RACK CONSISTING OF 3-200 KVAR, 7200V UNITS DELTA CONNECTED FOR USE ON 4KV SYSTEM.		(B) 200	564759	CTD2F	
YC	1	7200/12470Y	CAPACITOR UNITS		150	(A) 207344	YC150	
HC	3	7200/12470Y	CAPACITOR UNITS		300	(A) 207336	-	
HCT	3	7200/12470Y	FIXED CAPACITOR RACK CONSISTING OF 3-400 KVAR, 7200V UNITS WYE CONNECTED FOR USE ON 4KV SYSTEM.		130	564776	HCT1F	
			SWITCHED CAPACITOR RACK CONSISTING OF 6-150KVAR 1Ø UNITS WITH 7.2KV POTENTIAL TRANSFORMER		3 - OIL SWITCHES	900	(A)564706	-
			SWITCHED CAPACITOR RACK CONSISTING OF 6-150KVAR 1Ø UNITS WITH 12KV POTENTIAL TRANSFORMER		2 - OIL SWITCHES	900	(A)564708	-
			SWITCHED CAPACITOR RACK CONSISTING OF 6-150KVAR 1Ø UNITS WITH 12KV POTENTIAL TRANSFORMER		3 - OIL SWITCHES	900	(A)564704	-
			FIXED CAPACITOR RACK CONSISTING OF 6-150 KVAR 1Ø UNITS			900	(A)564680	900F
			SWITCHED CAPACITOR RACK CONSISTING OF 9-150KVAR 1Ø UNITS WITH 7.2KV POTENTIAL TRANSFORMER		3 - OIL SWITCHES	1350	(A)564754	-
			SWITCHED CAPACITOR RACK CONSISTING OF 9-150KVAR 1Ø UNITS WITH 12KV POTENTIAL TRANSFORMER		2 - OIL SWITCHES	1350	(A)564756	-
			SWITCHED CAPACITOR RACK CONSISTING OF 9-150KVAR 1Ø UNITS WITH 12KV POTENTIAL TRANSFORMER		3 - OIL SWITCHES	1350	(A)564752	-
			FIXED CAPACITOR RACK CONSISTING OF 9-150KVAR 1Ø UNITS			1350	(A)564744	1350F

FOR FIELD MAINTENANCE ONLY

INSTALLATION:

- (A) NO LONGER PURCHASED.
- (B) THE KVAR RATING OF 7200 VOLT CAPACITORS IS REDUCED BY A FACTOR OF THREE WHEN WIRED IN DELTA AND CONNECTED TO THE 4160 VOLT SYSTEM.

1399.101A SUPERSEDES 1311 (12-1-98)	SDG&E ELECTRIC STANDARDS	DATE 2-9-2012 APPD <i>PA 1/20</i>
	CAPACITOR INFORMATION	

SCOPE: THIS STANDARD LISTS THE INFORMATION NEEDED TO DETERMINE PROPER CAPACITOR APPLICATIONS.

PREFIX	PHASE	VOLTAGE	DESCRIPTION		KVAR	STOCK NUMBER	ASSEMBLY UNITS
YC	1	7200/12470Y	CAPACITOR UNITS		200	207350	YC200
					400	207348	-
HCT	3	2400/4160Y	FIXED CAPACITOR RACK CONSISTING OF 3-400 KVAR, 7200V UNITS WYE CONNECTED FOR USE ON 4KV SYSTEM.		130	564776	HCT1F
	3	2400/4160Y	FIXED CAPACITOR RACK CONSISTING OF 3-200 KVAR, 7200V UNITS WYE CONNECTED FOR USE ON 4KV SYSTEM.		65	564759	HCT6F
	3	7200/12470Y	SWITCHED CAPACITOR RACK CONSISTING OF 3-200 KVAR SINGLE-PHASE UNITS WITH 12KV POTENTIAL TRANSFORMER		600	564761	600S
	3	7200/12470Y	FIXED CAPACITOR RACK CONSISTING OF 3-200 KVAR SINGLE-PHASE UNITS.		600	564763	600F
	3	7200/12470Y	SWITCHED CAPACITOR RACK CONSISTING OF 3-400KVAR SINGLE-PHASE UNITS WITH 12KV POTENTIAL TRANSFORMER	2 - OIL SWITCHES	1200	564770	1200S
FIXED CAPACITOR RACK CONSISTING OF 3-400 KVAR SINGLE-PHASE UNITS			1200	564764	1200F		

FOR FIELD MAINTENANCE ONLY

DATE 1-1-2000 APPD <i>PA/Ver</i>	SDG&E ELECTRIC STANDARDS	1399.101B SUPERSEDES 1311 (12-1-98)
	CAPACITOR INFORMATION	

FIELD MAINTENANCE ONLY

REVISION HISTORY:

1/25/2017: All versions prior to 2016 are superseded by their current version found inside the Overhead Construction Standard Manual.

© 1998 - 2016 San Diego Gas & Electric Company. All rights reserved. Removal of this copyright notice without permission is not permitted under law.

REV	CHANGE	BY	DSGN	APPV	DATE	REV	CHANGE	BY	DSGN	APPV	DATE
C						F					
B						E					
A	ORIGINAL ISSUE	JS	JS	MDJ	1/25/2017	D					

<p>SHEET 1 OF 1</p>	<input type="checkbox"/> Indicates Latest Revision	<input type="checkbox"/> Completely Revised	<input checked="" type="checkbox"/> New Page	<input type="checkbox"/> Information Removed	<p>FMO OH 1312</p>
	<p>SDG&E ELECTRIC OVERHEAD CONSTRUCTION STANDARDS</p>				
	<p>VOLTAGE REGULATOR INFORMATION</p>				

SCOPE: THIS STANDARD SHOWS THE PREFIXES, PURCHASING STATUS, STOCK NUMBERS, AND BUCK OR BOOST CAPABILITIES OF VOLTAGE REGULATORS.

VOLTAGE REGULATORS

PREFIX	PHASE	VOLTAGE	DESCRIPTION	KVA	AMPS	STOCK NUMBER	ASSEMBLY UNITS
G	1	2400/4160Y	FEEDER VOLTAGE REGULATOR	24	-	(A) S581248	-
				36	150	(A) S581312	-
				37.5	150	(A) S581344	-
				48	-	(A) S581375	-
				72	300	(A) S581440	-
GT	3	4160/2400	FEEDER VOLTAGE REGULATOR	34.6	90	(A) S581856	-
				36	90	(A) S581888	-
				72	60	(A) S581920	-
				100	250	(A) S581728	-
				108	250	(A) S581760	-
				125	300	(A) S581792	-
				144	-	(A) S581824	-
GH	1	12,000	FEEDER VOLTAGE REGULATOR	72	100	(A)(B) S581488	-
				60	50	(A)(D) S581504	-
GHT	3	12,000	FEEDER VOLTAGE REGULATOR	50	40	(A) S581632	-
				160	130	(A) S581536	-
				239	200	(A) S581568	-
				312	260	(A) S581600	-
				600	500	(A) S581664	-
GU	1	120/240	UNIREG, SEC. VOLTAGE REG.	750	625	(A) S581696	-
				-	-	(A) -	-
GY	1	7200/12,470Y	FEEDER VOLTAGE REGULATOR	19	25	(D)(A) -	-
				57.2	75	(D) S581936	GY57
GR	1	7200/12,470Y	FEEDER VOLTAGE REGULATOR REVERSIBLE FEED	72	100	(D)(A) S581714	GR100A
GS	1	7200/12,470Y	FEEDER VOLTAGE REGULATOR	72	100	(D) S581715	GS100A
GC	1	12,000	FEEDER VOLTAGE REGULATOR REVERSIBLE FEED	120	100	(D)(A) S581476	GC100A
				240	200	(D)(A) S581478	GC200A

INSTALLATION:

- (A) NO LONGER PURCHASED.
- (B) 4 - 1 1/2% STEPS BELOW OR ABOVE NEUTRAL.
- (D) 16 - 5/8% STEPS BELOW AND ABOVE NEUTRAL.

© 1998 - 2010 San Diego Gas & Electric Company. All rights reserved. Removal of this copyright notice without permission is not permitted under law.

	Indicates Latest Revision	Completely Revised	New Page	Information Removed
1312	SDG&E ELECTRIC STANDARDS			REVISION
	VOLTAGE REGULATOR INFORMATION			DATE 11-11-08 APPD PJA/MC

FIELD MAINTENANCE ONLY

REVISION HISTORY:

7/13/2016: All versions prior to 2016 are superseded by their current version found inside the Overhead Construction Standard Manual.

© 1998 - 2016 San Diego Gas & Electric Company. All rights reserved. Removal of this copyright notice without permission is not permitted under law.

REV	CHANGE	BY	DSGN	APPV	DATE	REV	CHANGE	BY	DSGN	APPV	DATE
C						F					
B						E					
A	ORIGINAL ISSUE	JS	IL	MDJ	7/13/2016	D					

SHEET 1 OF 1	 Indicates Latest Revision	Completely Revised	New Page	Information Removed	FMO OH 1314
	SDG&E ELECTRIC OVERHEAD STANDARD				
	CAPACITOR CONNECTION 4KV WYE				

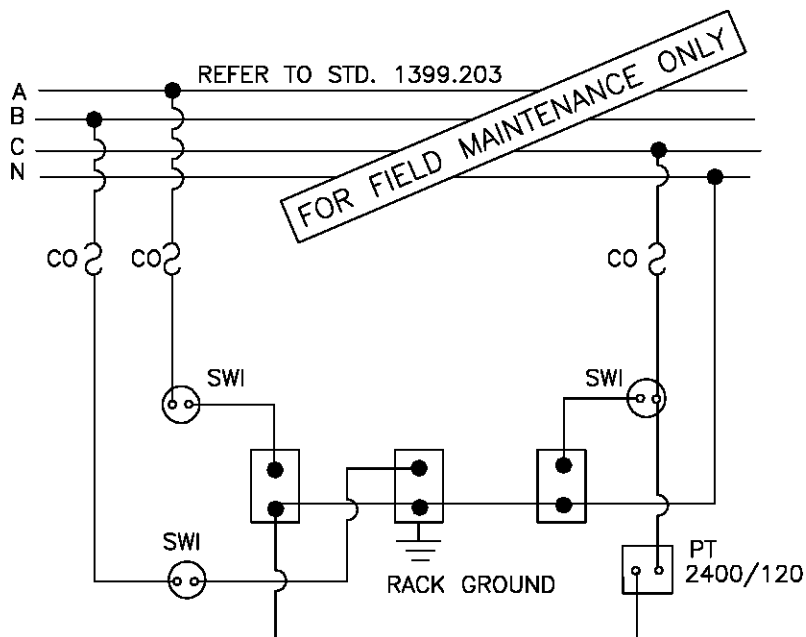
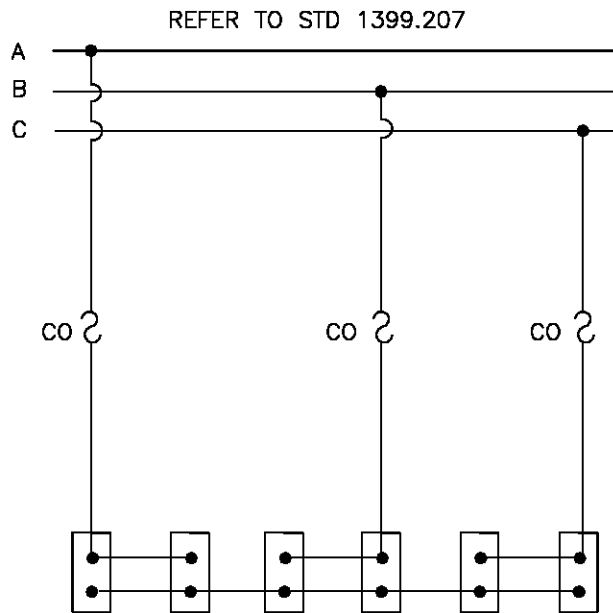

DIAGRAM OF 4KV WYE CONNECTED SWITCHED 300KVAR (3-100KVAR UNITS)

NOTE:

- DO NOT GROUND THE CAPACITOR NEUTRAL BUS. IT IS ALREADY GROUNDED THROUGH THE 4KV NEUTRAL SYSTEM.



SCHEMATIC DIAGRAM

600 KVAR (6-100 KVAR UNITS)
 300 KVAR (6-50 KVAR UNITS)
 150 KVAR (6-25 KVAR UNITS)

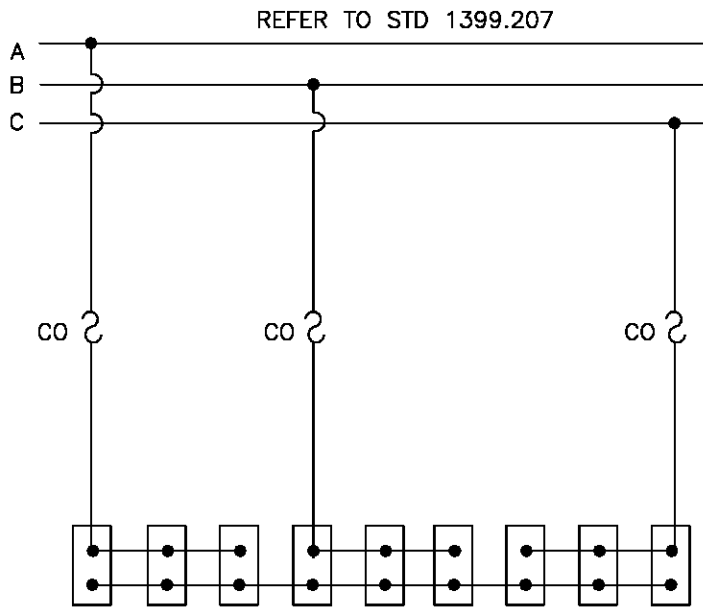

SCHEMATIC DIAGRAM

900 KVAR (9-100 KVAR UNITS)
 450 KVAR (9-50 KVAR UNITS)
 225 KVAR (9-25 KVAR UNITS)

DATE 12-1-98 APPD <i>PA/BJ</i>	SDG&E ELECTRIC STANDARDS	1399.104 SUPERSEDES 1314.3 (12-1-98)
	CAPACITOR CONNECTION 4KV WYE	

REFER TO STD 1399.207

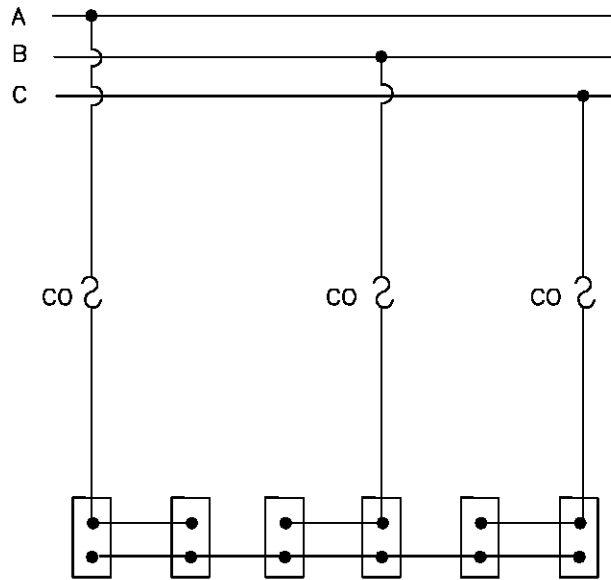

SCHEMATIC DIAGRAM

600 KVAR (6-100 KVAR UNITS)
300 KVAR (6-50 KVAR UNITS)
150 KVAR (6-25 KVAR UNITS)

FOR FIELD MAINTENANCE ONLY

REFER TO STD 1399.207

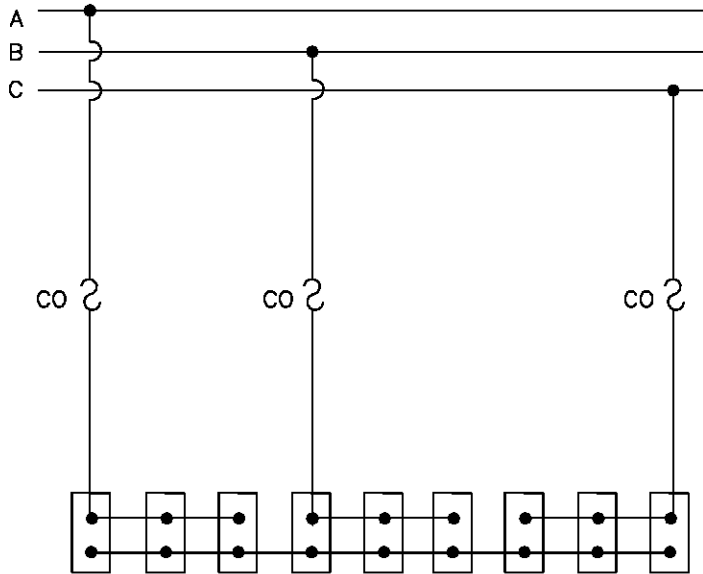

SCHEMATIC DIAGRAM

900 KVAR (9-100 KVAR UNITS)
450 KVAR (9-50 KVAR UNITS)
225 KVAR (9-25 KVAR UNITS)

NOTE:

-SEE STD. 1309 FOR CAPACITOR FUSING.

1399.105

SUPERSEDES
1314.4 (12-1-98)

SDG&E ELECTRIC STANDARDS

CAPACITOR CONNECTION 12KV-WYE (FIXED)

DATE 12-1-98

APPD *PA/BJ*

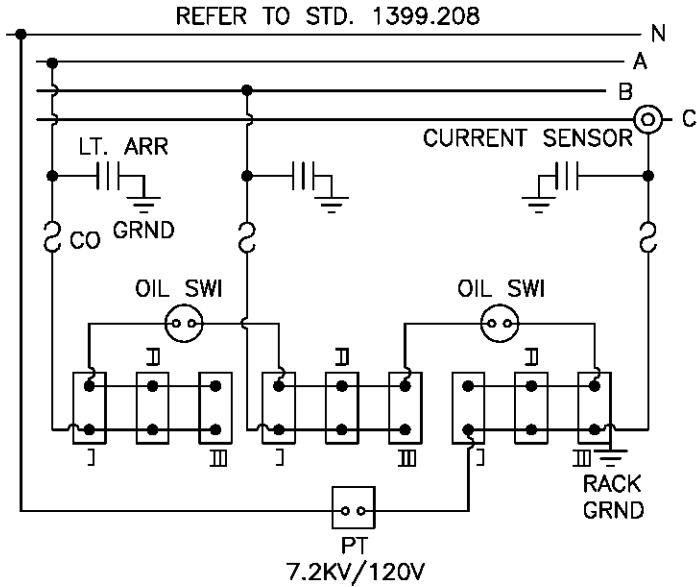

SCHEMATIC DIAGRAM

- 1350 KVAR (9-150 KVAR UNITS) I, II, III
- 1200 KVAR (6-200 KVAR UNITS) I & III
- 900 KVAR (6-150 KVAR UNITS) I & III
- 600 KVAR (3-200 KVAR UNITS) II

FOR FIELD MAINTENANCE ONLY

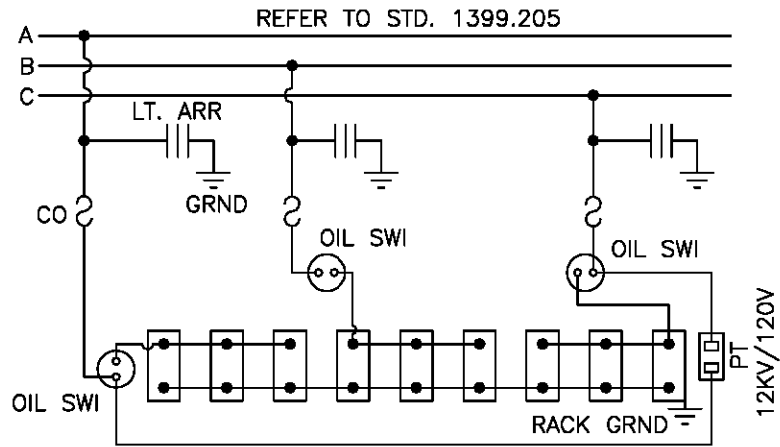

SCHEMATIC DIAGRAM
1350 KVAR (9-150 KVAR UNITS)
WITH 3 OIL SWITCHES

NOTE:

-SEE STD. 1309 FOR CAPACITOR FUSING.

DATE 12-1-98 APPD <i>PA/1008</i>	SDG&E ELECTRIC STANDARDS	1399.106 SUPERSEDES 1314.5 (12-1-98)
	CAPACITOR CONNECTION 12 & 12.47KV-WYE (SWITCHED)	

FIELD MAINTENANCE ONLY

REVISION HISTORY:

7/13/2016: All versions prior to 2016 are superseded by their current version found inside the Overhead Construction Standard Manual.

© 1998 - 2016 San Diego Gas & Electric Company. All rights reserved. Removal of this copyright notice without permission is not permitted under law.

REV	CHANGE	BY	DSGN	APPV	DATE	REV	CHANGE	BY	DSGN	APPV	DATE
C						F					
B						E					
A	ORIGINAL ISSUE	JS	IL	MDJ	7/13/2016	D					

<input checked="" type="checkbox"/>	Indicates Latest Revision	<input type="checkbox"/>	Completely Revised	<input type="checkbox"/>	New Page	<input type="checkbox"/>	Information Removed
-------------------------------------	---------------------------	--------------------------	--------------------	--------------------------	----------	--------------------------	---------------------

**SHEET
1 OF 1**

SDG&E ELECTRIC OVERHEAD STANDARD

CAPACITOR INSTALLATION 4KV-WYE-150 KVAR MAXIMUM

**FMO
OH 1315**

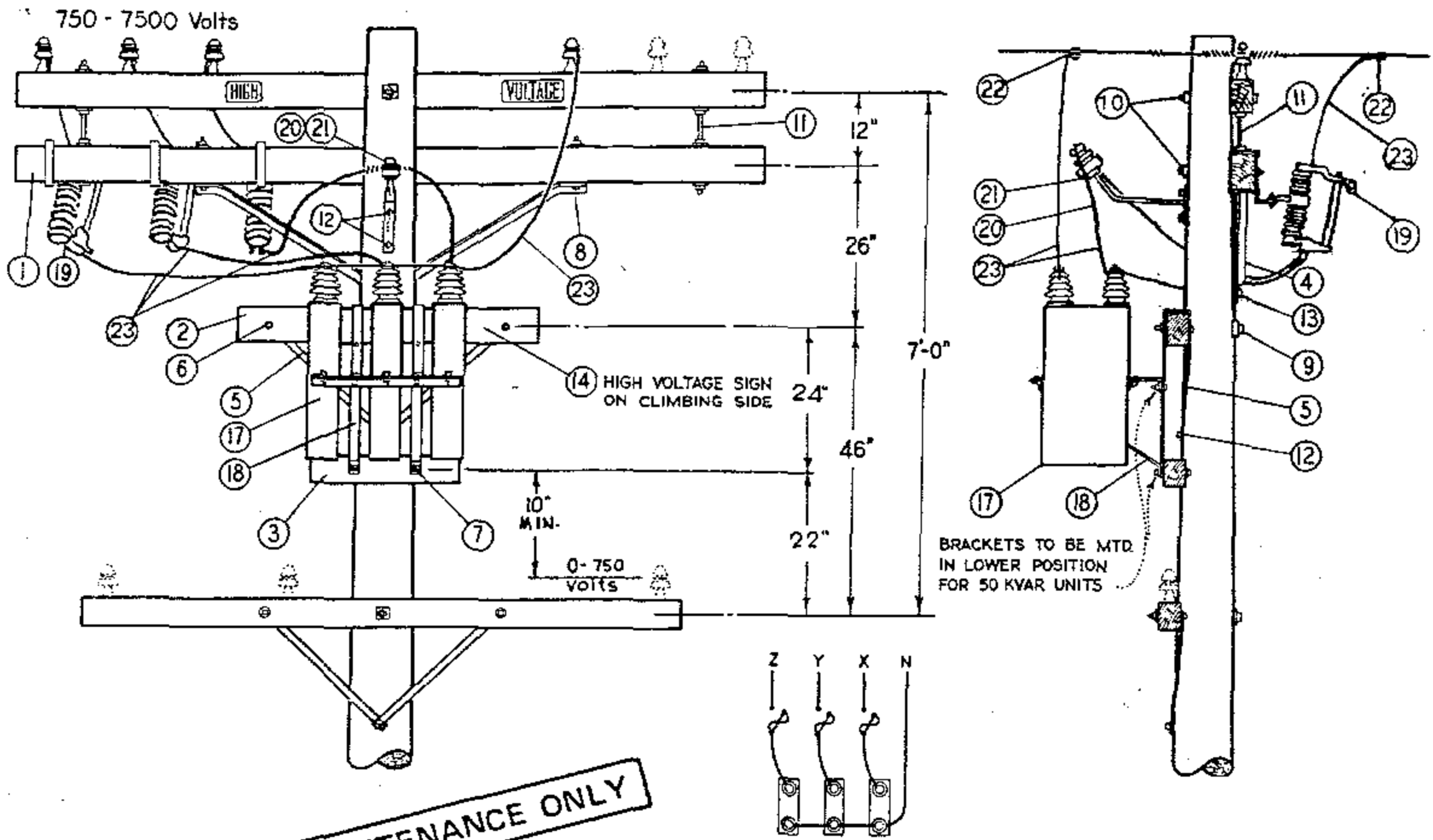

FOR FIELD MAINTENANCE ONLY

DIAGRAM OF 4 KV. WYE CONNECTIONS
 150 KVAR (3-50 KVAR UNITS)
 75 KVAR (3-25 KVAR UNITS)
 45 KVAR (3-15 KVAR UNITS)

INSTALLATION:

- A. CAPACITOR RACK TO BE MOUNTED ON OPPOSITE SIDE OF LINE AND CUTOUT ARMS.
- (B) NO LONGER PURCHASED.
- C. FOR POLE STEPPING REFER TO STD. 363.
- (E) EXEMPT MATERIAL.

ITEM	DESCRIPTION	QUANTITY	STOCK NO. OR CONSTR. STD.
1	CROSSARM, 3 3/4" X 5 3/4" X 10' - 0"	1	PG 380.01 IT.2
2	CROSSARM, 3 3/4" X 5 3/4" X 4' - 0"	1	PG 380.05 IT.3
3	CROSSARM, 3 1/2" X 4 1/2" X 2' - 0"	1	PG 380.05 IT.1
4	BRACE, ANGLE CROSSARM, 5' - 0"	1	164128
5	BRACE, FLAT CROSSARM, 28"	2	164192
6	BOLT, MACH., GALV., 3/8" X 4 1/2", 1 RD. WASH. & 1 NUT	2	STD 139, 140 (E)
7	BOLT, MACH., GALV., 1/2" X 5", 1 RD. WASH. & 1 NUT	2	STD 139, 140 (E)
8	BOLT, MACH., GALV., 1/2" X 7", 1 RD. WASH. & 1 NUT	2	STD 139, 140 (E)
9	BOLT, MACH., GALV., 5/8" X (AS REQ'D) 3 SQ. WASH, 1 FLAT, 1 CURV & 1 NUT	1	STD 139, 140 (E)
10	BOLT, MACH., GALV., 5/8" X (AS REQ'D) 2-2 1/4" SQ WASH & 1 NUT	2	STD 139, 140 (E)
11	BOLT, SPACE, GALV., 5/8" X 22", 4 SQ. WASH. & 4 NUTS	2	STD 139, 140 (E)
12	LAG SCREW, GALV., 1/2" X 4"	3	621568 (E)
13	LAG SCREW, GALV., 5/8" X 5"	1	621600 (E)
14	SIGN, HIGH VOLTAGE & 8 ROOFING NAILS	1	647648-492224 (E)
15			
16			
17	CAPACITOR UNIT (2.4KV, 50 KVAR ILLUSTRATED)	(B) 3	207200
18	RACK, CAPACITOR	1	402624
19	CUTOUT, 12KV, 100A, HEAVY DUTY, WITH LOADBUSTER HOOKS	3	297888
20	BRACKET, INSULATOR 1" LEAD THREAD	1	166134
21	INSULATOR, PIN TYPE, CLASS AS REQUIRED	1	PG 750.3
22	CONNECTOR, COMPRESSION	4	PGS 786, 783 (E)
23	WIRE, BARE STRANDED, #6	30'	813536

SDG&E ELECTRIC STANDARDS

1399.101
 SUPERSEDES
 1315 (1-1-87)

CAPACITOR INSTALLATION 4KV-WYE-150 KVAR MAXIMUM

DATE 1-1-87
 APPD AK/RD

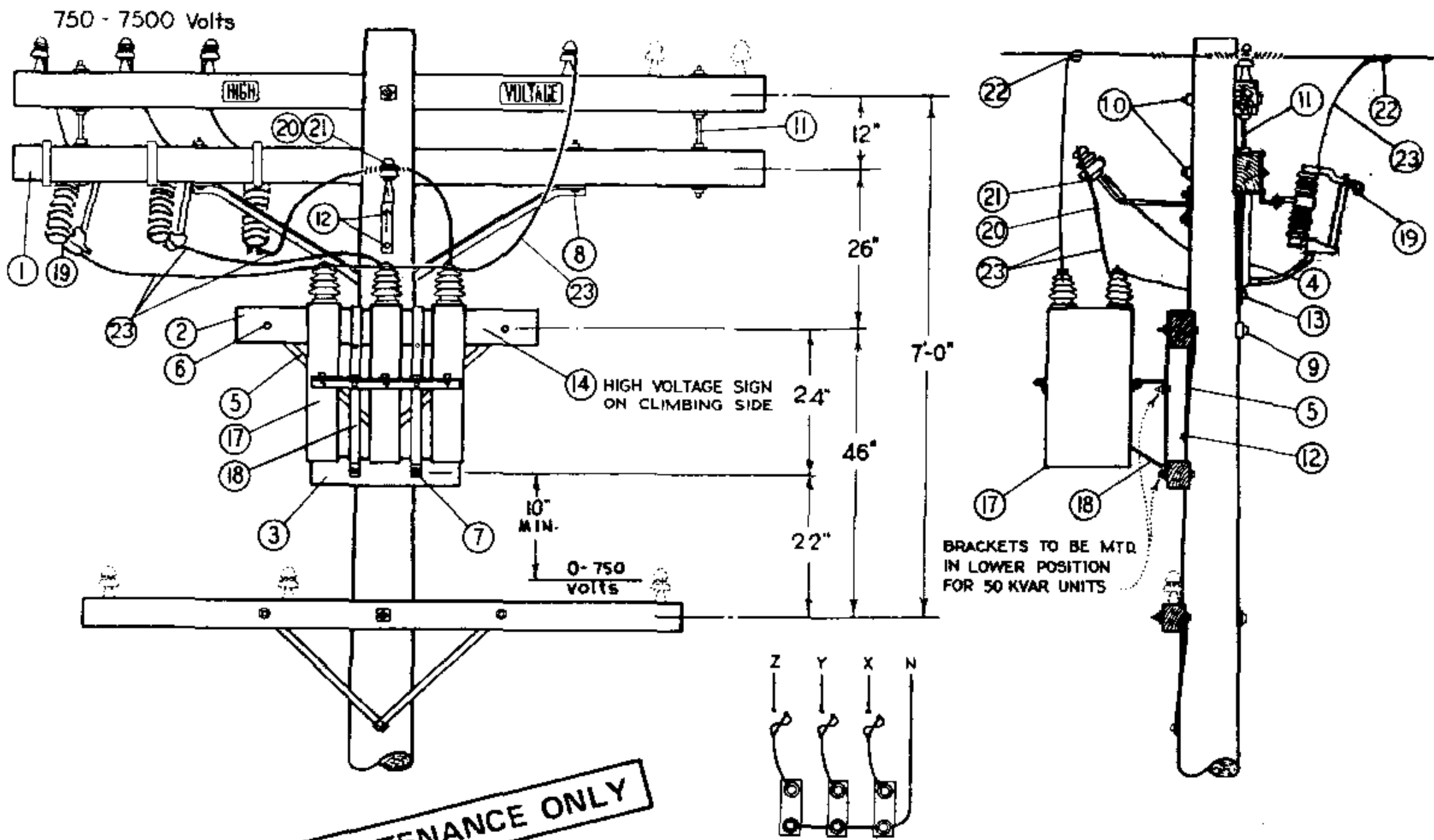

FOR FIELD MAINTENANCE ONLY

DIAGRAM OF 4KV. WYE CONNECTIONS
 150 KVAR (3-50 KVAR UNITS)
 75 KVAR (3-25 KVAR UNITS)
 45 KVAR (3-15 KVAR UNITS)

INSTALLATION:

- A. CAPACITOR RACK TO BE MOUNTED ON OPPOSITE SIDE OF LINE AND CUTOUT ARMS.
- (B) NO LONGER PURCHASED.
- C. FOR POLE STEPPING REFER TO STD. 363.
- (E) EXEMPT MATERIAL.

ITEM	DESCRIPTION	QUANTITY	STOCK NO. OR CONSTR. STD.
1	CROSSARM, 3 3/4" X 5 3/4" X 10' - 0"	1	PG 380.01 IT. 2
2	CROSSARM, 3 3/4" X 5 3/4" X 4' - 0"	1	PG 380.05 IT. 3
3	CROSSARM, 3 1/2" X 4 1/2" X 2' - 0"	1	PG 380.05 IT. 1
4	BRACE, ANGLE CROSSARM, 5' - 0"	1	164128
5	BRACE, FLAT CROSSARM, 28"	2	164192
6	BOLT, MACH., GALV., 3/8" X 4 1/2", 1 RD. WASH. & 1 NUT	2	STD 139, 140 (E)
7	BOLT, MACH., GALV., 1/2" X 5", 1 RD. WASH. & 1 NUT	2	STD 139, 140 (E)
8	BOLT, MACH., GALV., 1/2" X 7", 1 RD. WASH. & 1 NUT	2	STD 139, 140 (E)
9	BOLT, MACH., GALV., 5/8" X (AS REQ'D) 3 SQ. WASH, 1 FLAT, 1 CURV & 1 NUT	1	STD 139, 140 (E)
10	BOLT, MACH., GALV., 5/8" X (AS REQ'D) 2-2 1/4" SQ WASH & 1 NUT	2	STD 139, 140 (E)
11	BOLT, SPACE, GALV., 5/8" X 22", 4 SQ. WASH. & 4 NUTS	2	STD 139, 140 (E)
12	LAG SCREW, GALV., 1/2" X 4"	3	621568 (E)
13	LAG SCREW, GALV., 5/8" X 5"	1	621600 (E)
14	SIGN, HIGH VOLTAGE & 8 ROOFING NAILS	1	647648-492224(E)
15			
16			
17	CAPACITOR UNIT (2.4KV, 50 KVAR ILLUSTRATED)	(B) 3	207200
18	RACK, CAPACITOR	1	402624
19	CUTOUT, 12KV, 100A, HEAVY DUTY, WITH LOADBUSTER HOOKS	3	297888
20	BRACKET, INSULATOR 1" LEAD THREAD	1	166134
21	INSULATOR, PIN TYPE, CLASS AS REQUIRED	1	PG 750.3
22	CONNECTOR, COMPRESSION	4	PGS 786, 783 (E)
23	WIRE, BARE STRANDED, #6	30'	813536

FIELD MAINTENANCE ONLY

REVISION HISTORY:

7/13/2016: All versions prior to 2016 are superseded by their current version found inside the Overhead Construction Standard Manual.

© 1998 - 2016 San Diego Gas & Electric Company. All rights reserved. Removal of this copyright notice without permission is not permitted under law.

REV	CHANGE	BY	DSGN	APPV	DATE	REV	CHANGE	BY	DSGN	APPV	DATE
C						F					
B						E					
A	ORIGINAL ISSUE	JS	IL	MDJ	7/13/2016	D					

SHEET 1 OF 1	 Indicates Latest Revision	Completely Revised	New Page	Information Removed	FMO OH 1316
	SDG&E ELECTRIC OVERHEAD STANDARD				
	CAPACITOR INSTALLATION 4KV-WYE-300 KVAR MAXIMUM				

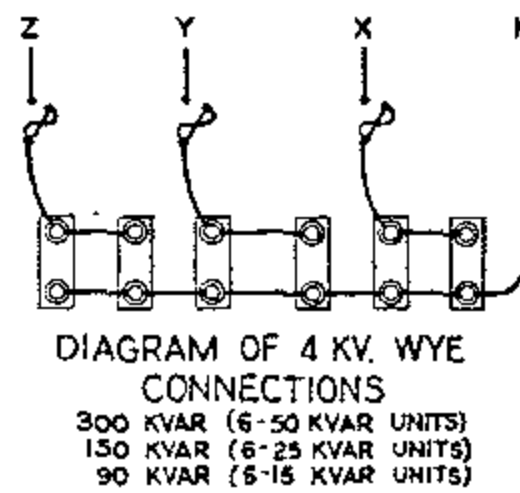
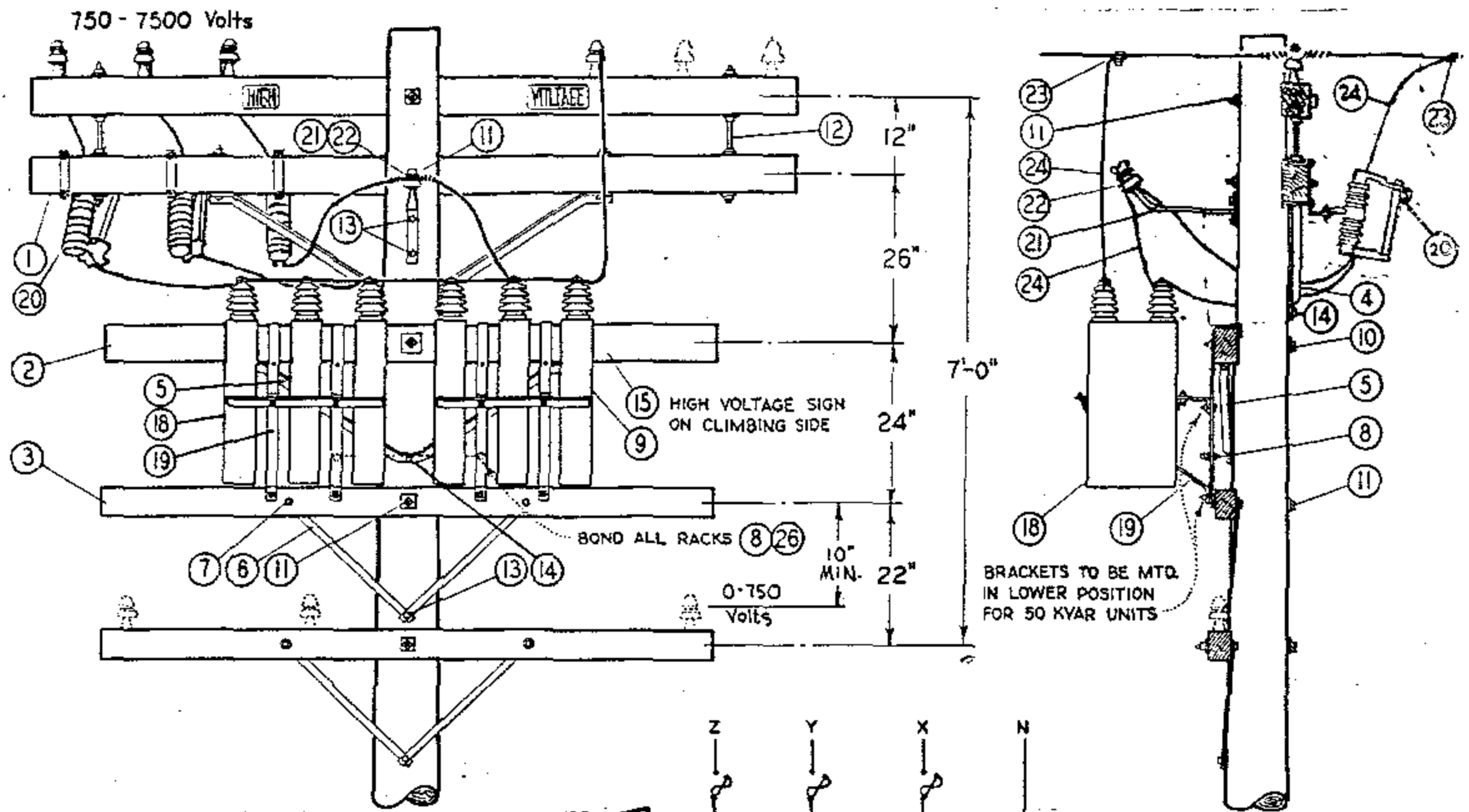

INSTALLATION:

- A. CAPACITOR RACKS TO BE MOUNTED ON OPPOSITE SIDE OF LINE AND CUTOUT ARMS.
- (B) NO LONGER PURCHASED.
- C. FOR POLE STEPPING REFER TO STD. 363.
- (E) EXEMPT MATERIAL.

ITEM	DESCRIPTION	QUANTITY	STOCK NO. OR CONSTR. STD.
1	CROSSARM, 3 3/4" X 5 3/4" X 10' - 0"	1	PG. 380.01
2	CROSSARM, 3 3/4" X 5 3/4" X 8' - 0"	1	PG. 380.05
3	CROSSARM, 3 1/2" X 4 1/2" X 8 - 0	1	PG. 380.05
4	BRACE, ANGLE CROSSARM, 5' - 0"	1	164128
5	BRACE, ANGLE CROSSARM, 4' - 0"	1	164032
6	BRACE, FLAT CROSSARM, 28"	2	164192
7	BOLT, MACH., GALV., 3/8" X 4 1/2", 1 RD. WASH. & 1 NUT	2	STD 139, 140(E)
8	BOLT, MACH., GALV., 1/2" X 1 1/2", 2 RD. WASH. & 1 NUT	2	STD 139, 140(E)
9	BOLT, MACH., GALV., 1/2" X 7", 1 RD. WASH. & 1 NUT	4	STD 139, 140(E)
10	BOLT, MACH., GALV., 5/8" X (AS REQ'D) 3 SQ. WASH., 1 FLAT, 1 CURV. & 1 NUT	1	STD 139, 140(E)
11	BOLT, MACH., GALV., 5/8" X (AS REQ'D) 2-2 1/4 SQ. WASH. & 1 NUT	2	STD 139, 140(E)
12	BOLT, SPACE, GALV., 5/8" X 22", 4 SQ. WASH. & 4 NUTS	2	STD 139, 140(E)
13	LAG SCREW, GALV., 1/2" X 4"	3	621568 (E)
14	LAG SCREW, GALV., 5/8" X 5"	2	621500 (E)
15	SIGN, HIGH VOLTAGE & ROOFING NAILS	1	647648-492224(E)
16			
17			
18	CAPACITOR UNIT (2.4KV, 50 KVAR ILLUSTRATED)	(B) 6	207200
19	RACK, CAPACITOR	(B) 2	402620
20	CUTOUT, 12KV 100A, HEAVY DUTY, WITH LOADBUSTER HOOKS	3	297888
21	BRACKET, INSULATOR 1" LEAD THREAD	1	166134
22	INSULATOR, PIN TYPE, CLASS AS REQUIRED	1	PG. 750.3
23	CONNECTOR, COMPRESSION	4	STD 786, 783(E)
24	WIRE, #6 BARE STRANDED COPPER	30'	813536
25			
26	WIRE, BARE SOLID ANNEALED COPPER #8	2' - 6"	812928
27			

SDG&E ELECTRIC STANDARDS

DATE 1-1-87
 APPD AK/AD

CAPACITOR INSTALLATION 4KV - WYE - 300 KVAR MAXIMUM

1399.102
 SUPERSEDES
 1316 (1-1-87)

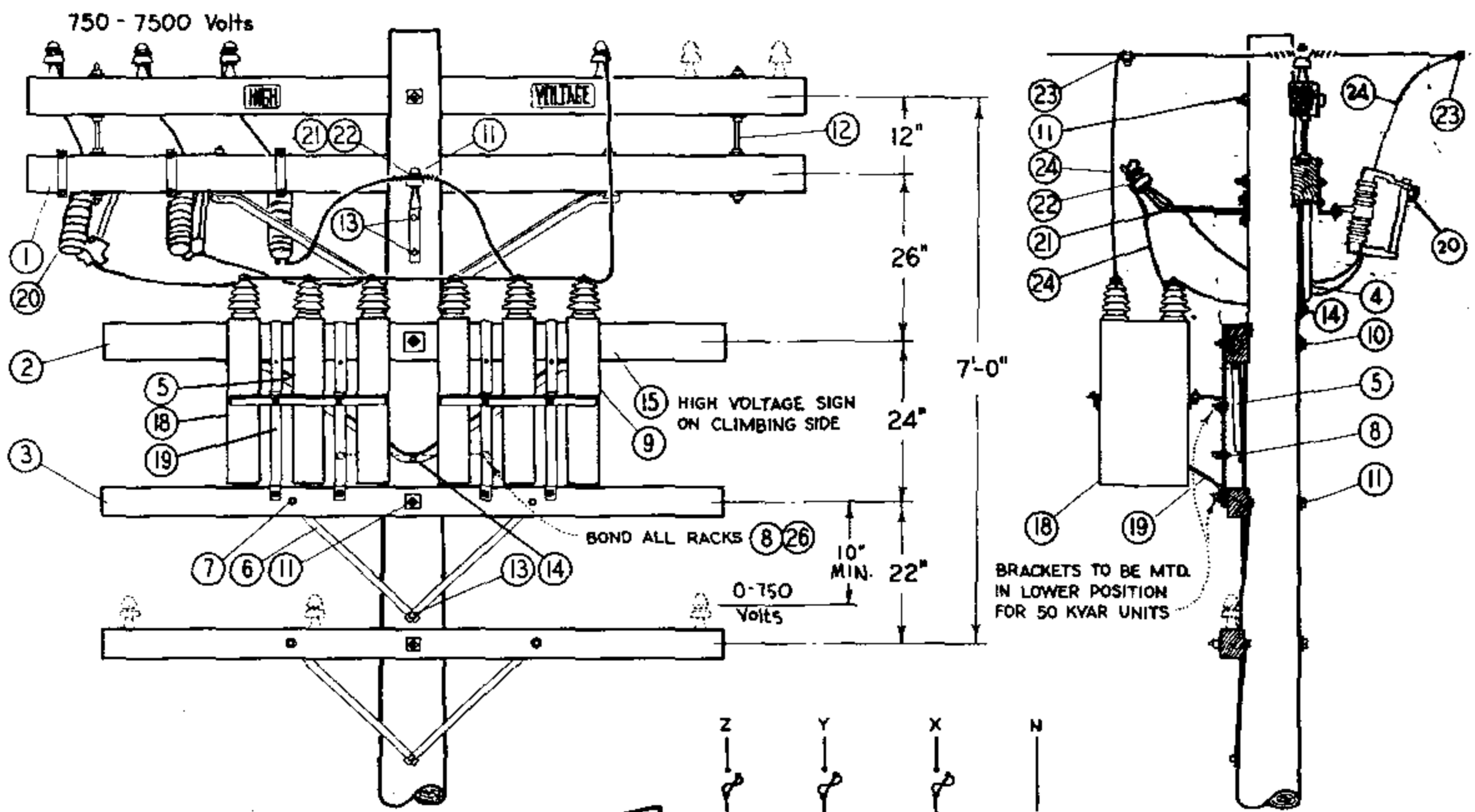

FOR FIELD MAINTENANCE ONLY

INSTALLATION:

- A. CAPACITOR RACKS TO BE MOUNTED ON OPPOSITE SIDE OF LINE AND CUTOUT ARMS.
- (B) NO LONGER PURCHASED.
- C. FOR POLE STEPPING REFER TO STD. 363.
- (E) EXEMPT MATERIAL.

ITEM	DESCRIPTION	QUANTITY	STOCK NO. OR CONSTR. STD.
1	CROSSARM, 3 3/4" X 5 3/4" X 10' - 0"	1	PG. 380.01
2	CROSSARM, 3 3/4" X 5 3/4" X 8' - 0"	1	PG. 380.05
3	CROSSARM, 3 1/2" X 4 1/2" X 8' - 0"	1	PG. 380.05
4	BRACE, ANGLE CROSSARM, 5' - 0"	1	164128
5	BRACE, ANGLE CROSSARM, 4' - 0"	1	164032
6	BRACE, FLAT CROSSARM, 28"	2	164192
7	BOLT, MACH., GALV., 3/8" X 4 1/2", 1 RD. WASH. & 1 NUT	2	STD 139, 140(E)
8	BOLT, MACH., GALV., 1/2" X 1 1/2", 2 RD. WASH. & 1 NUT	2	STD 139, 140(E)
9	BOLT, MACH., GALV., 1/2" X 7", 1 RD. WASH. & 1 NUT	4	STD 139, 140(E)
10	BOLT, MACH., GALV., 5/8" X (AS REQ'D) 3 SQ. WASH., 1 FLAT, 1 CURV. & 1 NUT	1	STD 139, 140(E)
11	BOLT, MACH., GALV., 5/8" X (AS REQ'D) 2-2 1/4 SQ. WASH. & 1 NUT	2	STD 139, 140(E)
12	BOLT, SPACE, GALV., 5/8" X 22", 4 SQ. WASH. & 4 NUTS	2	STD 139, 140(E)
13	LAG SCREW, GALV., 1/2" X 4"	3	621568 (E)
14	LAG SCREW, GALV., 5/8" X 5"	2	621600 (E)
15	SIGN, HIGH VOLTAGE & ROOFING NAILS	1	647648-492224(E)
16			
17			
18	CAPACITOR UNIT (2.4KV, 50 KVAR ILLUSTRATED)	(B) 6	207200
19	RACK, CAPACITOR	(B) 2	402620
20	CUTOUT, 12KV 100A, HEAVY DUTY, WITH LOADBUSTER HOOKS	3	297888
21	BRACKET, INSULATOR 1" LEAD THREAD	1	166134
22	INSULATOR, PIN TYPE, CLASS AS REQUIRED	1	PG. 750.3
23	CONNECTOR, COMPRESSION	4	STD 786, 783(E)
24	WIRE, #6 BARE STRANDED COPPER	30'	813536
25			
26	WIRE, BARE SOLID ANNEALED COPPER #8	2' - 6"	812928
27			

SDG&E ELECTRIC STANDARDS

DATE 1-1-87
APPD AK/AD

CAPACITOR INSTALLATION 4KV - WYE - 300 KVAR MAXIMUM

1399.108
SUPERSEDES
1516 (1-1-87)





FIELD MAINTENANCE ONLY

REVISION HISTORY:

7/13/2016: All versions prior to 2016 are superseded by their current version found inside the Overhead Construction Standard Manual.

© 1998 - 2016 San Diego Gas & Electric Company. All rights reserved. Removal of this copyright notice without permission is not permitted under law.

REV	CHANGE	BY	DSGN	APPV	DATE	REV	CHANGE	BY	DSGN	APPV	DATE
C						F					
B						E					
A	ORIGINAL ISSUE	JS	IL	MDJ	7/13/2016	D					

<p>SHEET 1 OF 1</p>	 Indicates Latest Revision	 Completely Revised	 New Page	 Information Removed	<p>FMO OH 1317</p>
	<p>SDG&E ELECTRIC OVERHEAD STANDARD</p>				
	<p>CAPACITOR INSTALLATION 4KV-WYE-450 KVAR MAXIMUM</p>				

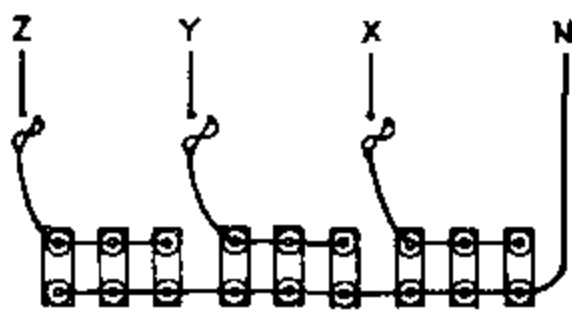
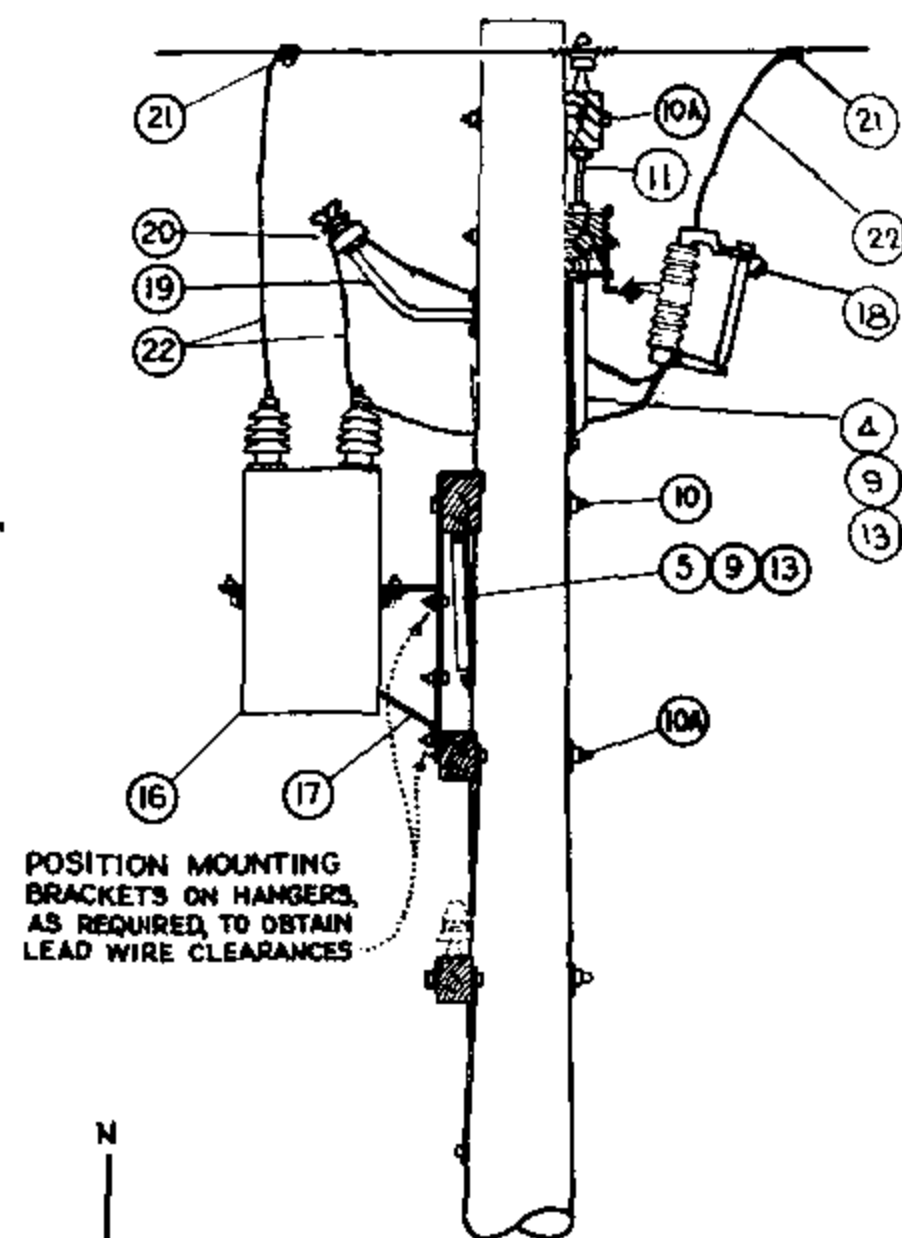
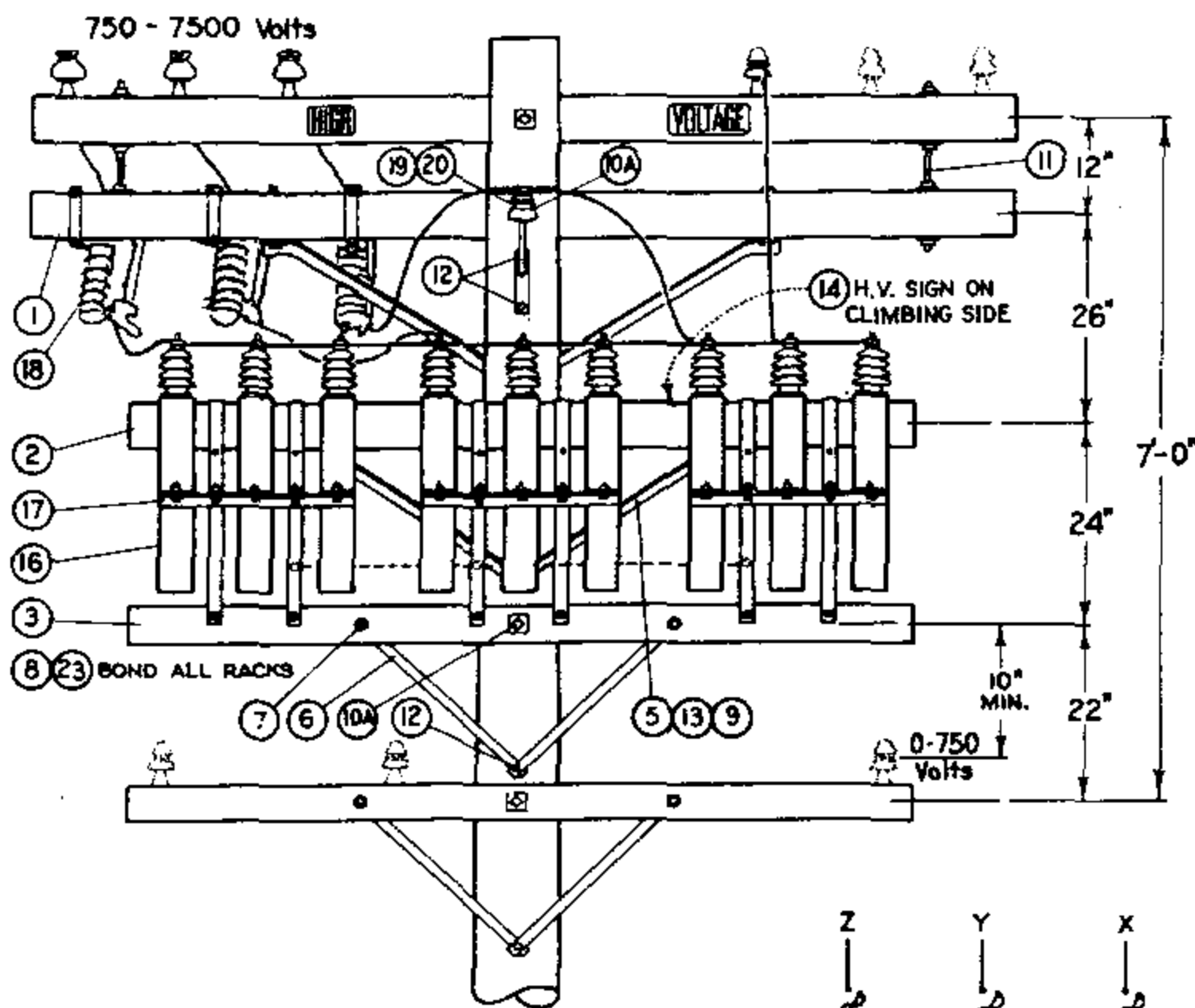

FOR FIELD MAINTENANCE ONLY

INSTALLATION:

- A. CAPACITOR RACKS TO BE MOUNTED ON OPPOSITE SIDE OF LINE AND CUTOUT ARMS.
- (B) NO LONGER PURCHASED.
- C. FOR POLE STEPPING REFER TO STD. 363.
- (E) EXEMPT MATERIAL.

ITEM	DESCRIPTION	QUANTITY	STOCK NO. OR CONSTR. STD.
1	CROSSARM, 3 3/4" X 5 3/4" X 10' - 0"	1	380.01
2	CROSSARM, 3 3/4" X 5 3/4" X 8' - 0"	1	380.05
3	CROSSARM, 3 1/2" X 4 1/2" X 8' - 0"	1	380.05
4	BRACE, ANGLE CROSSARM, 5' - 0"	1	164128
5	BRACE, ANGLE CROSSARM, 4' - 0"	1	164032
6	BRACE, FLAT CROSSARM, 28"	2	164192
7	BOLT, MACH., GALV., 3/8" X 4 1/2", 1 RD. WASH. & 1 NUT	2	STD 139, 140(E)
8	BOLT, MACH., GALV., 1/2" X 1 1/2", 2 RD. WASH. & 1 NUT	3	STD 139, 140(E)
9	BOLT, MACH., GALV., 1/2" X 7", 1 RD. WASH. & 1 NUT	4	STD 139, 140(E)
10	BOLT, MACH., GALV., 5/8" X (AS REQ'D) 3" SQ. WASH., 1 FLAT, 1 CURV., & 1 NUT	1	STD 139, 140(E)
10A	BOLT, MACH., GALV., 5/8" X (AS REQ'D) 2-2 1/4" SQ. WASH. & 1 NUT	2	STD 139, 140(E)
11	BOLT, SPACE, GALV., 5/8" X 22", 4 SQ. WASH. & 4 NUTS	2	STD 139, 140(E)
12	LAG SCREW, GALV., 1/2" X 4"	3	621568 (E)
13	LAG SCREW, GALV., 5/8" X 5"	2	621600 (E)
14	SIGN, HIGH VOLTAGE, & ROOFING NAILS	(E) 1	647648-492224
15			
16	CAPACITOR UNIT, 2.4KV, (50 KVAR UNITS ILLUSTRATED)	(B) 9	207200
17	RACK, CAPACITOR	3	402624
18	CUTOUT 12KV, 100A, HEAVY DUTY, WITH LOADBUSTER HOOKS	3	297888
19	BRACKET, INSULATOR 1" LEAD THREAD	1	166134
20	INSULATOR, PIN TYPE, CLASS AS REQUIRED	1	750.3
21	CONNECTOR, COMPRESSION	4	PGS 786, 783(E)
22	WIRE, #6 BARE STRANDED COPPER	30'	813536
23	WIRE, BARE SOLID ANNEALED COPPER #8	6'	812928
24			
25			
26			

1399.109
SUPERSEDES
1317 (1-1-87)

SDG&E ELECTRIC STANDARDS
CAPACITOR INSTALLATION 4KV - WYE - 450 KVAR MAXIMUM

DATE 1-1-87
APPD *AK/RB*

FIELD MAINTENANCE ONLY

REVISION HISTORY:

7/13/2016: All versions prior to 2016 are superseded by their current version found inside the Overhead Construction Standard Manual.

© 1998 - 2016 San Diego Gas & Electric Company. All rights reserved. Removal of this copyright notice without permission is not permitted under law.

REV	CHANGE	BY	DSGN	APPV	DATE	REV	CHANGE	BY	DSGN	APPV	DATE
C						F					
B						E					
A	ORIGINAL ISSUE	JS	IL	MDJ	7/13/2016	D					

<input checked="" type="checkbox"/>	Indicates Latest Revision	<input type="checkbox"/>	Completely Revised	<input type="checkbox"/>	New Page	<input type="checkbox"/>	Information Removed
-------------------------------------	---------------------------	--------------------------	--------------------	--------------------------	----------	--------------------------	---------------------

**SHEET
1 OF 1**

SDG&E ELECTRIC OVERHEAD STANDARD

FIXED CAPACITOR INSTALLATION, 4.16KV DELTA
UNGROUNDDED RACK

**FMO
OH 1318**

SCOPE: THIS STANDARD SHOWS THE INSTALLATION METHOD OF A 4.16KV DELTA FIXED CAPACITOR.

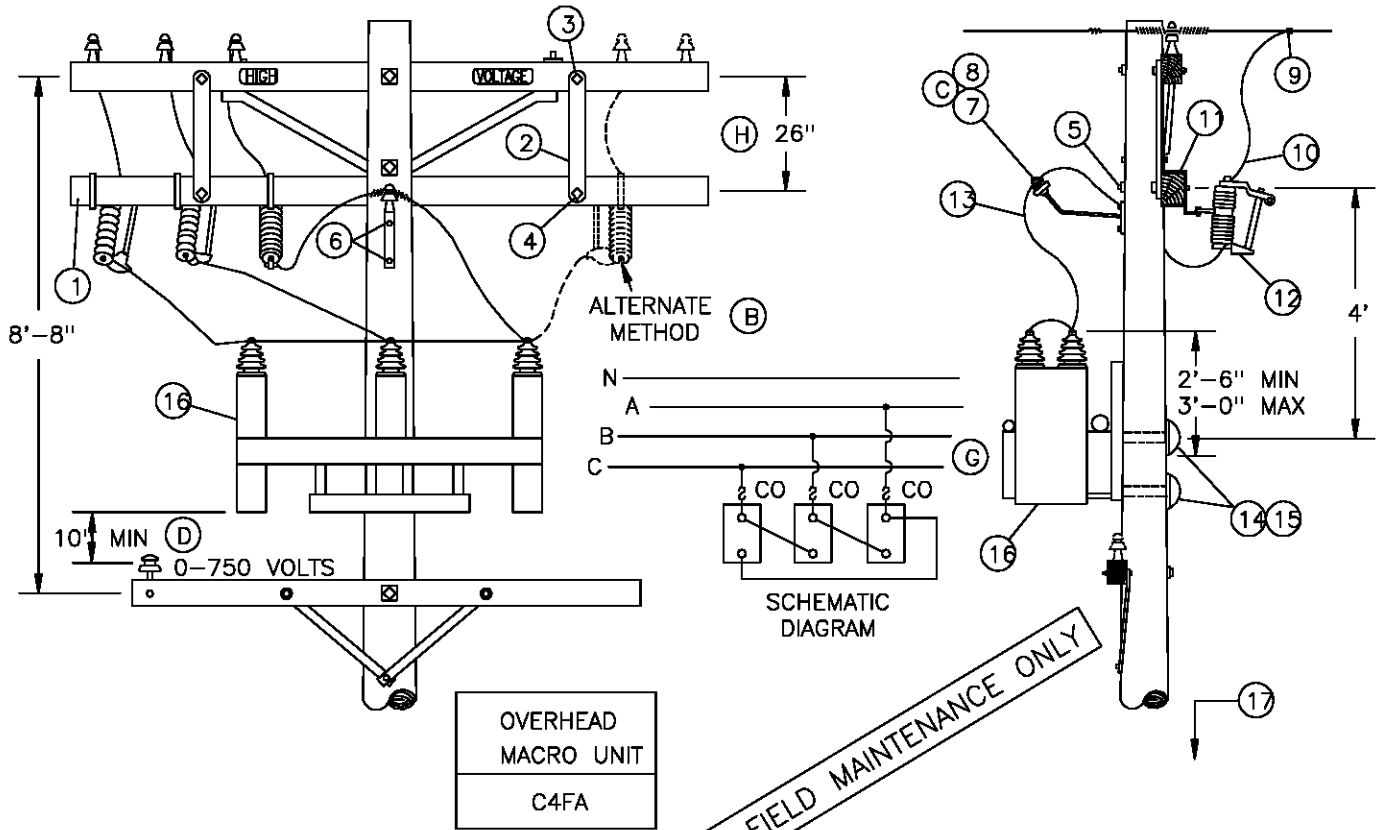

BILL OF MATERIAL:

ITEM	DESCRIPTION	QUANTITY	CONST STD OR PAGE NO	STOCK NUMBER
1	CROSSARM 3 3/4" X 5 3/4" X 10' - 0"	1	-	294128
2	BRACE, FLAT, CROSSARM, 28"	2	-	164192
3	BOLT, MACH, GALV, 1/2" X 5", 1 ROUND AND 1 DOUBLE COIL SPRING WASHER	2	392	-
4	BOLT, MACH, GALV, 3/8" X 4 1/2", 1 RD & 1 SPRING WASHER	2	392	-
5	BOLT, MACH, GALV, 5/8" X (LENGTH AS REQ'D), 2 SQUARE FLAT AND 1 DOUBLE COIL SPRING WASHER	1	392	-
6	LAG SCREW, GALV, 1/2" X 4"	2	-	621568
7	BRACKET, INSULATOR, 1" LEAD THREAD	1	-	166134
8	INSULATOR, PIN TYPE, CLASS AS REQUIRED	1	750	-
9	CONNECTOR, COMPRESSION, CU OR AL (SIZE AS REQ'D)	AS REQ'D	783, 786	-
10	WIRE, BARE STRANDED, #6, COPPER	9'	-	813536
11	BRACKET, CUTOUT/ARRESTER, FOR CROSSARM MOUNTING	3	-	166070
12	CUTOUT, 12KV, 100A, HVY DUTY, WITH LOADBUSTER HOOK	3	-	297888
13	WIRE, BARE STRANDED, #4 COPPER	12'	-	813760
14	BOLT, MACH, GALV, 3/4" X (LENGTH AS REQ'D), 1 SQUARE CURVED AND 1 DOUBLE COIL SPRING WASHER	2	392	-
15	COVER, THRU BOLT, PLASTIC & 6-10D NAILS, GALV	2	-	285696
		-	-	491392
16	RACK, CAPACITOR (4.16KV, 200 KVAR)	1	-	564759
17	TAG, STATION NUMBER	1	200 SECT	-

DATE 12-1-98
 APPD *PA/BJ*

SDG&E ELECTRIC STANDARDS

FIXED CAPACITOR INSTALLATION, 4.16KV DELTA
 UNGROUNDED RACK

1399.110
 SUPERSEDES
 1318.1 (12-1-98)

INSTALLATION:

- A. CAPACITOR RACKS TO BE MOUNTED ON OPPOSITE SIDE OF LINE AND CUTOUT ARMS.
- ⓑ INSTALL ONE CUTOUT AS SHOWN ON THE ALTERNATE METHOD IF THE 4KV CONDUCTORS ARE SPREAD OUT.
- ⓒ OMIT ITEMS 6, 7, & 8 IF ALTERNATE METHOD ⓑ IS USED.
- ⓓ FROM BOTTOM OF THE CAPACITOR RACK OR THE CASE, WHICHEVER IS LOWER.
- F. CAPACITOR MUST BE INSTALLED ON POLES ACCESSIBLE BY BUCKET TRUCK.
- ⓖ THE KVAR RATING OF 7200 VOLT CAPACITORS IS REDUCED BY A FACTOR OF THREE WHEN WIRED IN DELTA AND CONNECTED TO THE 4160 VOLT SYSTEM.
- ⓓ IF ADDITIONAL SPACE IS REQUIRED BELOW THE CUTOUT ARM, THE SEPARATION BETWEEN THE LINE ARM AND CUTOUT ARM MAY BE REDUCED TO 12" WITH THE USE OF SPACE BOLTS.

FOR FIELD MAINTENANCE ONLY

1399.111 SUPERSEDES 1318.2 (12-1-98)	SDG&E ELECTRIC STANDARDS FIXED CAPACITOR INSTALLATION, 4.16KV DELTA UNGROUND RACK	DATE 12-1-98 APPD PJA / CAK
--------------------------------------------	-----------------------------------------------------------------------------------------	--------------------------------

FIELD MAINTENANCE ONLY

REVISION HISTORY:

7/13/2016: All versions prior to 2016 are superseded by their current version found inside the Overhead Construction Standard Manual.

© 1998 - 2016 San Diego Gas & Electric Company. All rights reserved. Removal of this copyright notice without permission is not permitted under law.

REV	CHANGE	BY	DSGN	APPV	DATE	REV	CHANGE	BY	DSGN	APPV	DATE
C						F					
B						E					
A	ORIGINAL ISSUE	JS	IL	MDJ	7/13/2016	D					

	Indicates Latest Revision	Completely Revised	New Page	Information Removed
-------------------------------------------------------------------------------------	---------------------------	--------------------	----------	---------------------

**SHEET
1 OF 1**

SDG&E ELECTRIC OVERHEAD STANDARD
SWITCHED CAPACITOR INSTALLATION
4.16 KV DELTA - 2 OIL SWITCHES

**FMO
OH 1319**

SCOPE: THIS STANDARD SHOWS THE INSTALLATION METHOD OF A 4.16KV DELTA SWITCHED CAPACITOR.

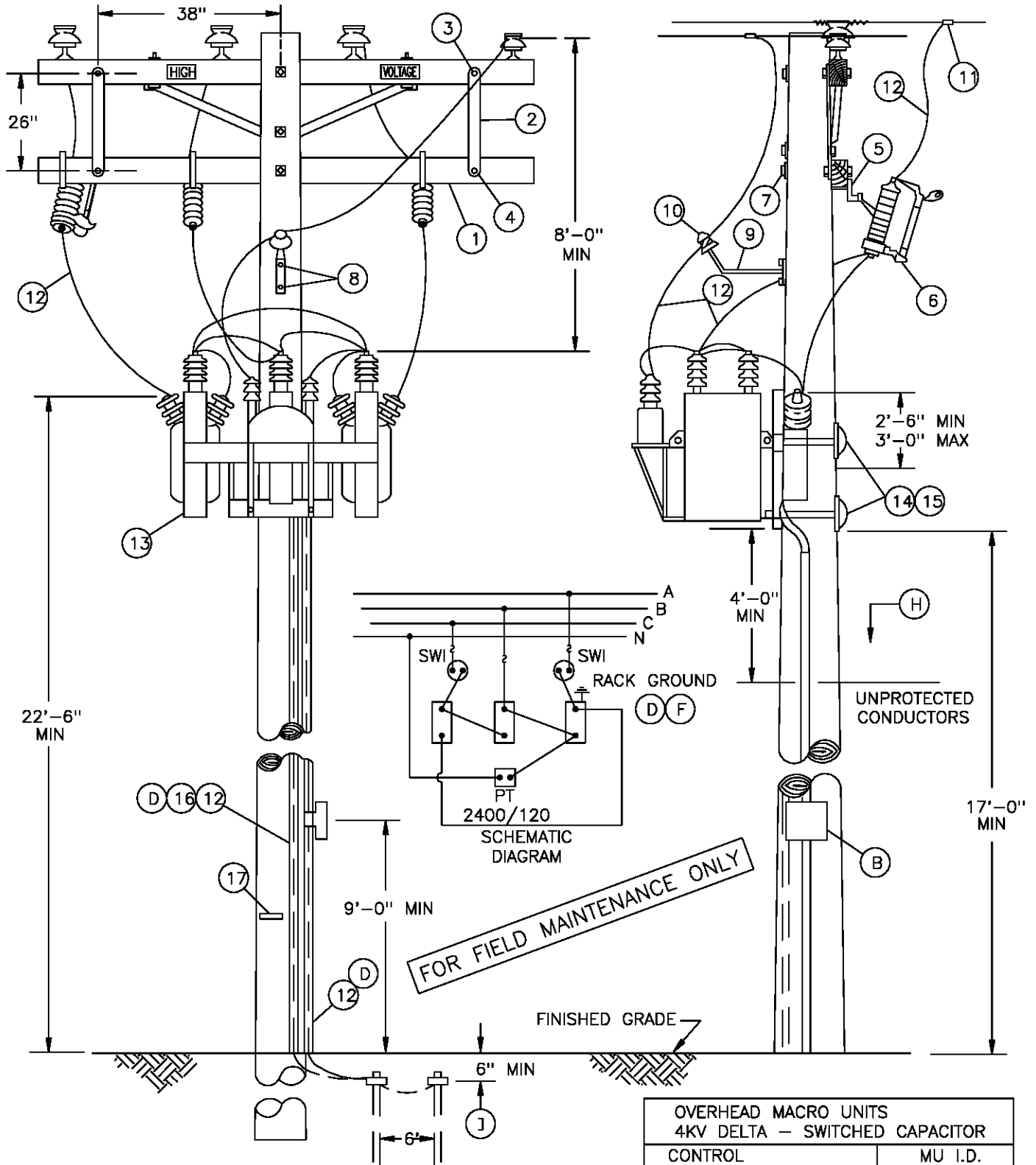

NOTES:

- CLASS OF POLE TO BE DETERMINED PER STANDARD 344-354.

SDG&E ELECTRIC STANDARDS

DATE 12-1-98
APPD PJA/CAK

SWITCHED CAPACITOR INSTALLATION
4.16 KV DELTA - 2 OIL SWITCHES

1399.112
SUPERSEDES
1319.1 (12-1-98)

BILL OF MATERIAL:

ITEM	DESCRIPTION	QUANTITY	CONST STD OR PAGE NO	STOCK NUMBER
1	CROSSARM, 3 3/4" X 5 3/4" X 10' - 0"	1	--	249128
2	BRACE, FLAT, CROSSARM, 28"	2	--	164192
3	BOLT, MACH, GALV, 3/8" X 4 1/2", 1 SPR WASH & 1 RD WASH	2	392	--
4	BOLT, MACH, GALV, 1/2 X 5", 1 RD WASH, 1 DBL COIL WASH	2	392	--
5	BRACKET, CUTOUT/ARRESTER, FOR CROSSARM MOUNTING	3	--	166070
6	CUTOUT, 12KV, 100A, HEAVY DUTY, WITH LOADBUSTER HOOKS	3	1212	--
7	BOLT, MACH, GALV, 5/8" X (LENGTH AS REQ'D) 2 SQ WASH & 1 DBL COIL WASH	1	392	--
8	LAG SCREW, GALV, 1/2" X 4"	2	--	621568
9	BRACKET, INSULATOR, 1" LEAD THREAD	1	--	166134
10	INSULATOR, PIN TYPE, CLASS AS REQUIRED	1	750	--
11	CONNECTOR, WIRE, COMPRESSION, CU OR AL, AS REQ'D	AS REQ'D	783-786	--
12	WIRE, BARE STRANDED, #4, COPPER	100'	--	813760
13	RACK, SWITCHED CAPACITOR, COMPLETE WITH SWITCHES AND POTENTIAL TRANSFORMER, (4.16KV, 200KVAR) (F)	1	--	564758
14	BOLT, MACH, GALV, 3/4" X (LENGTH AS REQ'D), 1 SQ CURVE RIB WASH & 1 DBL COIL SPR WASH	2	392	--
15	COVER, BOLT, PLASTIC & 6 - 1 3/4" NAILS, GALV	2	--	285696
		--	--	492192
16	UNIT GROUND, COMPLETE	1	--	603136
17	TAG, STATION NUMBER	1	200 SECT.	--

FOR FIELD MAINTENANCE ONLY

INSTALLATION:

- A. CAPACITOR RACKS TO BE MOUNTED ON OPPOSITE SIDE OF LINE AND CUTOUT ARMS.
- (B) SHOWN FOR ILLUSTRATIVE PURPOSES ONLY. SEE STANDARD 1330 FOR CONTROL INSTALLATION AND MATERIAL.
- C. CAUTION: OPEN OIL SWITCHES BEFORE OPENING CUTOUTS.
- (D) CONNECT CAPACITOR RACK GROUND LEAD TO GROUND ROD. A SECOND GROUND WIRE IS REQUIRED FOR THE CONTROL PANEL TO BE CONNECTED ON THE SAME GROUND ROD. COIL LOOSE END OF CONTROL PANEL GROUND WIRE AND STAPLE TO POLE (TO BE WORKED BY SERVICE CREW).
- (F) THE KVAR RATING OF 7200 VOLT CAPACITORS IS REDUCED BY A FACTOR OF THREE WHEN WIRED IN DELTA AND CONNECTED TO THE 4160 VOLT SYSTEM.
- G. CAPACITOR MUST BE INSTALLED ON POLES ACCESSIBLE BY BUCKET TRUCK.

REFERENCE:

- (H) POLE STEPPING - SEE STANDARD 363.
- (I) GROUNDING METHODS - SEE STANDARD 1002.
- J. PVC CONDUIT IS NOT PERMITTED IN THE CLIMBING SPACE - G.O. 95 RULE 22.2 (C).

1399.113 SUPERSEDES 1319.2 (12-1-98)	SDG&E ELECTRIC STANDARDS SWITCHED CAPACITOR INSTALLATION 4.16 KV DELTA - OIL SWITCHES	DATE 12-1-98 APPD <i>PSA/CMK</i>
--------------------------------------------	---------------------------------------------------------------------------------------------	-------------------------------------

FIELD MAINTENANCE ONLY

REVISION HISTORY:

7/13/2016: All versions prior to 2016 are superseded by their current version found inside the Overhead Construction Standard Manual.

© 1998 - 2016 San Diego Gas & Electric Company. All rights reserved. Removal of this copyright notice without permission is not permitted under law.

REV	CHANGE	BY	DSGN	APPV	DATE	REV	CHANGE	BY	DSGN	APPV	DATE
C						F					
B						E					
A	ORIGINAL ISSUE	JS	IL	MDJ	7/13/2016	D					

	Indicates Latest Revision	Completely Revised	New Page	Information Removed
-------------------------------------------------------------------------------------	---------------------------	--------------------	----------	---------------------

**SHEET
1 OF 1**

SDG&E ELECTRIC OVERHEAD STANDARD

SWITCHED CAPACITOR INSTALLATION
4.16 KV WYE - 3 OIL SWITCHES

**FMO
OH 1321**

BILL OF MATERIAL:

ITEM	DESCRIPTION	QUANTITY	CONST STD OR PAGE NO	STOCK NUMBER
1	CROSSARM, 3 3/4" X 5 3/4" X 10' - 0"	1	-	294128
2	BRACE, FLAT, CROSSARM, 28"	2	-	164192
3	BOLT, MACH, GALV, 3/8" X 4 1/2", 1 SPR & 1 RD WASHER	2	392	-
4	BOLT, MACH, GALV, 1/2" X 5", 1 ROUND & 1 DOUBLE COIL SPRING WASHER	2	392	-
5	BOLT, MACH, GALV, 5/8" X (LENGTH AS REQ'D) 2 SQUARE & 1 DOUBLE COIL SPRING WASHER	1	392	-
6	CONNECTOR, WIRE, COMPRESSION, CU OR AL, AS REQ'D	AS REQ'D	783, 786	-
7	WIRE, #4, BARE STRANDED COPPER	95'	-	813760
8	BRACKET, CUTOUT/ARRESTER, FOR CROSSARM MOUNTING	3	-	166070
9	CUTOUT, 12KV, 100A, HEAVY DUTY, WITH LOADBUSTER HOOKS	3	1212	-
10	INSULATOR, PIN TYPE, CLASS AS REQUIRED	1	-	429216
11	BRACKET, INSULATOR, 1" LEAD THREAD	1	-	166134
12	LAG SCREW, GALV, 1/2" X 4"	2	-	621568
13	RACK, SWITCHED CAPACITOR, COMPLETE WITH SWITCHES AND POTENTIAL TRANSFORMER, (4.16KV, 300KVAR)	1	-	564773
14	BOLT, MACH, GALV, 3/4" X (LENGTH AS REQ'D), 1 SQUARE CURVE RIBBED & 1 DOUBLE COIL SPRING WASHER	2	392	-
15	COVER, BOLT, PLASTIC & 6 - 1 3/4" NAILS, GALV	2	-	285696
		-	-	492192
16	UNIT GROUND, COMPLETE	1	-	603136
17	TAG, STATION NUMBER	1	338	-

FOR FIELD MAINTENANCE ONLY

OVERHEAD MACRO UNITS 4KV WYE - SWITCHED CAPACITOR	
CONTROL	MU I.D.
VAR/VOLT OVERRIDE	C4S3DV
VOLT W/TIME BIAS	C4S3TD

INSTALLATION:

- A. CAPACITOR RACKS TO BE MOUNTED ON OPPOSITE SIDE OF LINE AND CUTOUT ARMS.
- B. CAUTION: OPEN OIL SWITCHES BEFORE OPENING CUTOUTS.
- C. CONNECT CAPACITOR RACK GROUND LEAD TO GROUND ROD. A SECOND GROUND WIRE IS REQUIRED FOR THE CONTROL PANEL TO BE CONNECTED ON THE SAME GROUND ROD. COIL LOOSE END OF CONTROL PANEL GROUND WIRE AND STAPLE TO POLE (TO BE WORKED BY SERVICE CREW).

REFERENCE:

- F. SHOWN FOR ILLUSTRATIVE PURPOSES ONLY. SEE STANDARD 1330 FOR CONTROL INSTALLATION AND MATERIAL.
- G. POLE STEPPING, SEE STANDARD 363.
- H. GROUNDING METHOD, SEE STANDARD 1002.
 - I. PVC CONDUIT IS NOT PERMITTED IN THE CLIMBING SPACE - G.O. 95 RULE 22.2 (C).
 - J. CAPACITOR MUST BE INSTALLED ON POLES ACCESSIBLE BY BUCKET TRUCK. SEE DESIGN STANDARDS PAGE 5811.5.

1399.204 SUPERSEDES 1321.2 (12-1-98)	SDG&E ELECTRIC STANDARDS SWITCHED CAPACITOR INSTALLATION 4.16 KV WYE - 3 OIL SWITCHES	DATE 12-1-98 APPD <i>PLA/CAK</i>
--------------------------------------------	---------------------------------------------------------------------------------------------	-------------------------------------

FIELD MAINTENANCE ONLY

REVISION HISTORY:

7/13/2016: All versions prior to 2016 are superseded by their current version found inside the Overhead Construction Standard Manual.

© 1998 - 2016 San Diego Gas & Electric Company. All rights reserved. Removal of this copyright notice without permission is not permitted under law.

REV	CHANGE	BY	DSGN	APPV	DATE	REV	CHANGE	BY	DSGN	APPV	DATE
C						F					
B						E					
A	ORIGINAL ISSUE	JS	IL	MDJ	7/13/2016	D					

<p>SHEET 1 OF 1</p>	 Indicates Latest Revision	Completely Revised	New Page	Information Removed	<p>FMO OH 1322</p>
	SDG&E ELECTRIC OVERHEAD STANDARD				
	CAPACITOR INSTALLATIONS, 12KV-WYE-900 KVAR MAX				

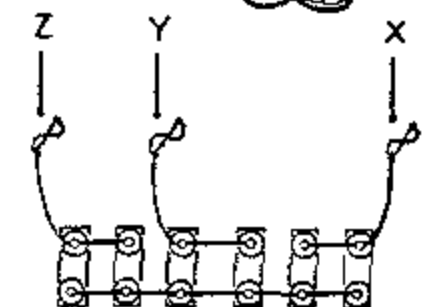
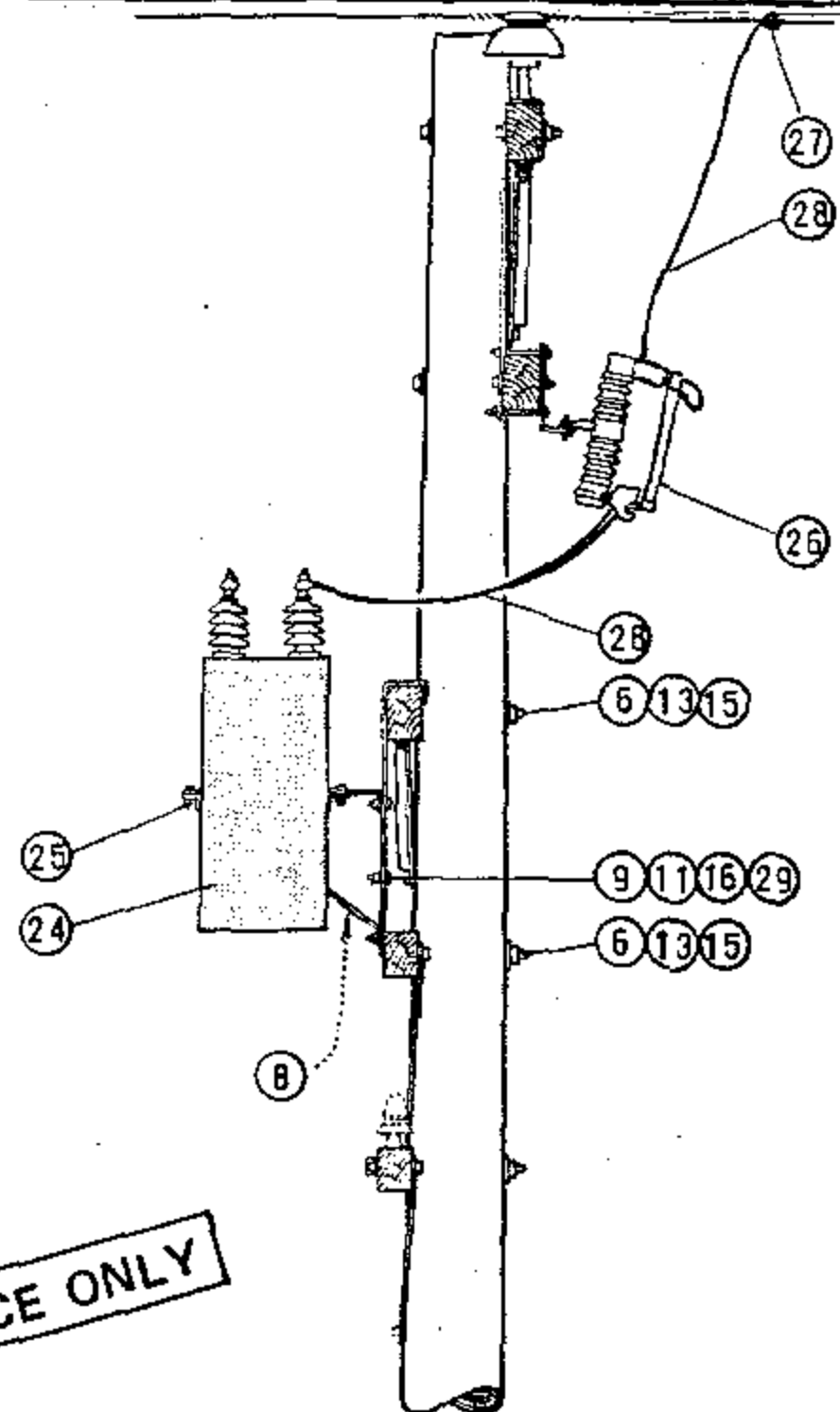
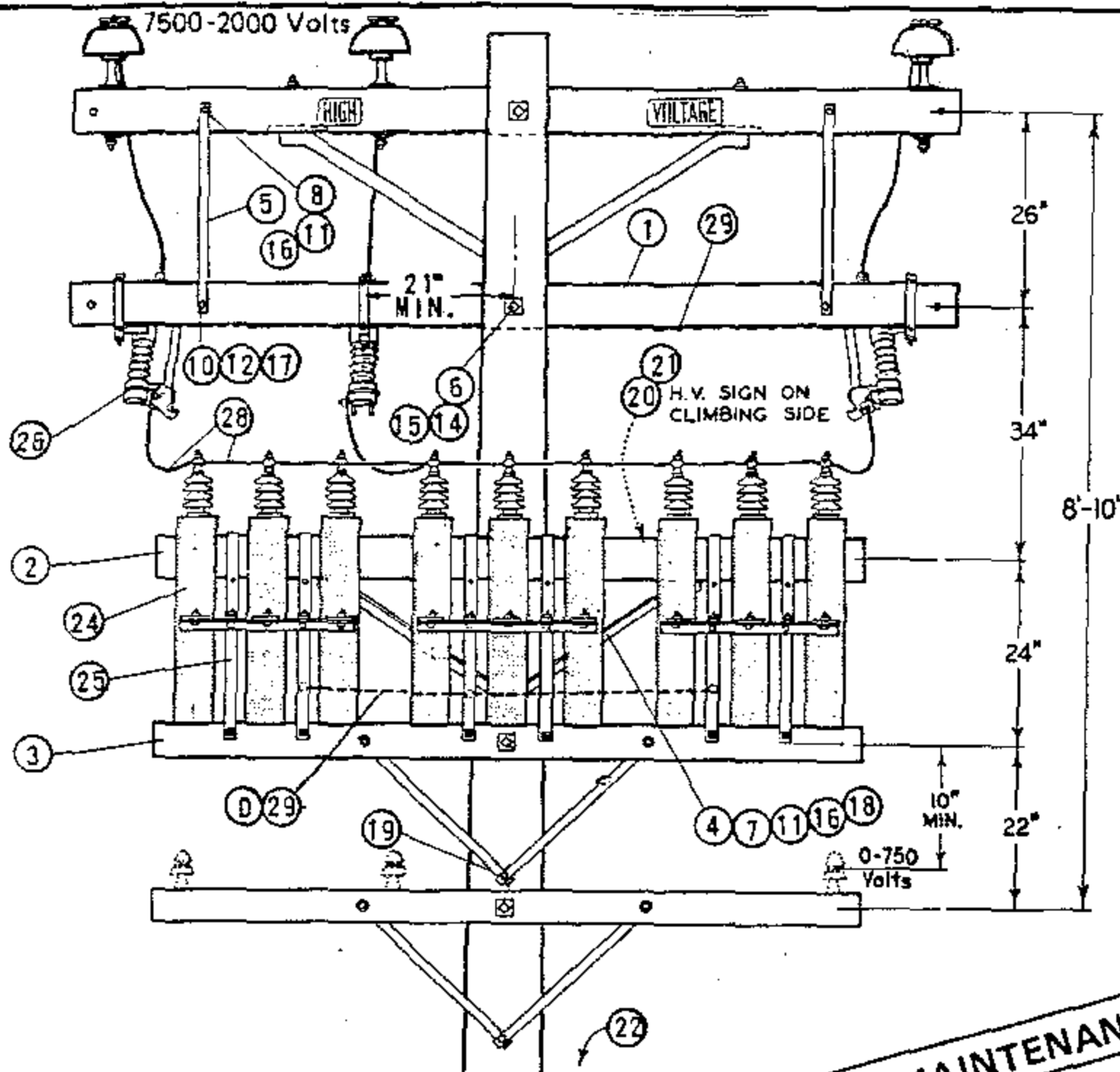

DIAGRAM OF 12KV WYE CONNECTIONS
 600 KVAR (8-100 KVAR UNITS)
 300 KVAR (6-50 KVAR UNITS)
 150 KVAR (6-25 KVAR UNITS)

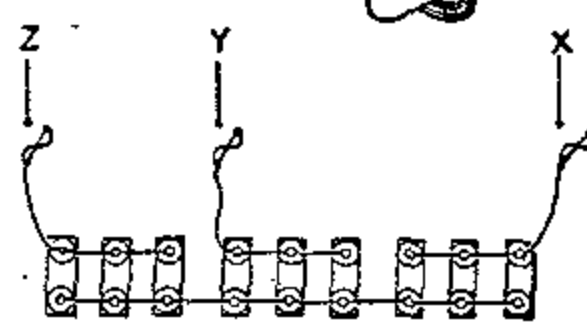

DIAGRAM OF 12KV WYE CONNECTIONS
 900 KVAR (9-100 KVAR UNITS)
 450 KVAR (9-50 KVAR UNITS)
 225 KVAR (9-25 KVAR UNITS)

FOR FIELD MAINTENANCE ONLY

INSTALLATION:

- (A) QUANTITY BASED ON 45' POLE.
- (B) BRACKETS TO BE MOUNTED IN LOWER POSITION FOR 50 AND 100 KVAR UNITS.
- (C) BOND ALL 12KV HARDWARE WITHIN 3 MILES OF COAST.
- (D) BOND ALL RACKS AS SHOWN IN ILLUSTRATION.
- (E) EXEMPT MATERIAL.
- (F) NO LONGER PURCHASED.
- (G) SEE PAGE 1323 FOR MATERIAL NEEDED FOR LIGHTING ARRESTERS ON 900 KVAR INSTALLATIONS.

ITEM	DESCRIPTION	QUANTITY		STOCK NO. OR CONSTR. STD.	ITEM	DESCRIPTION	QUANTITY		STOCK NO. OR CONSTR. STD.
		6	9				6	9	
1	CROSSARM, 3 3/4" X 5 3/4" X 10' - 0"	1	1	380.01	16	WASHER, 1/2" SPRING DBL COIL	6	6	798464 (E)
2	CROSSARM, 3 3/4" X 5 3/4" X 8' - 0"	1	1	380.05	17	WASHER, 3/8" SPRING DBL COIL	2	2	798528 (E)
3	CROSSARM, 3 1/2" X 4 1/2" X 8' - 0"	1	1	380.05	18	SCREW, LAG GALV. 5/8" X 5"	1	1	621600 (E)
4	BRACE, ANGLE CROSSARM, 4' - 0"	1	1	164032	19	SCREW, LAG GALV. 1/2" X 4"	1	1	621568 (E)
5	BRACE, FLAT CROSSARM, 28"	2	2	164192	20	SIGN, HIGH VOLTAGE	1	1	647548 (E)
6	BOLT, MACH. GALV. 5/8" X (LENGTH AS REQ'D) & 1 NUT	3	3	139 (E)	21	NAILS, ROOFING #8 GALV.	8	8	492224 (E)
7	BOLT, MACH. 1/2" X 7" & 1 NUT	2	2	153120 (E)	22	STEPS, POLE (A)	16	16	692992 (E)
8	BOLT, MACH. GALV. 1/2" X 5" & 1 NUT	2	2	153024 (E)	23				
9	BOLT, MACH. GALV. 1/2" X 1 1/2" & 1 NUT	2	3	152608 (E)	24	CAPACITOR, UNIT 7.2KV (100 KVAR UNITS ILLUSTRATED)	6	9	207232 (F)
10	BOLT, MACH. GALV. 3/8" X 5" & 1 NUT	2	2	154368 (E)	25	RACK, CAPACITOR	2	3	402656
11	WASHER, 1/2" ROUND	10	8	800192 (E)	26	CUTOUT, 12KV, 100A HEAVY DUTY WITH LOADBUSTER HOOKS	3	3	297888
12	WASHER, 3/8" ROUND	2	2	800288 (E)	27	CONNECTORS, COMPRESSION	3	3	786, 783 (E)
13	WASHER, 3" SQ. CURVED	4	4	798912 (E)	28	WIRE, #6 BARE STRANDED COPPER	33'	35'	813536
14	WASHER, 2 1/4" SQ. FLAT	2	2	799040 (E)	29	WIRE, #8 BARE SOLID ANNEALED COPPER	13'	15'	812928
15	WASHER, 5/8" SPRING DBL COIL	3	3	798560 (E)	30				

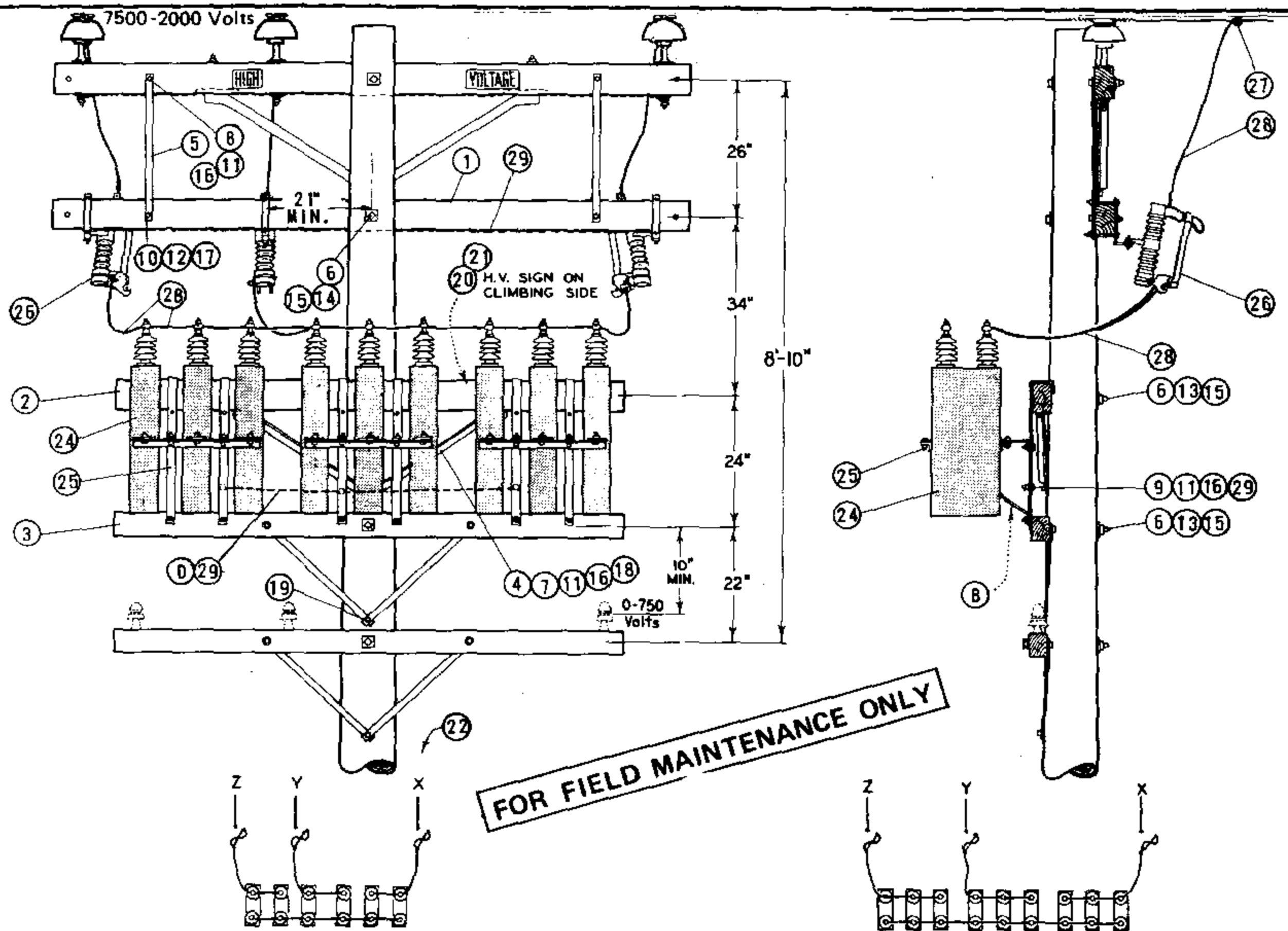

FOR FIELD MAINTENANCE ONLY

DIAGRAM OF 12KV WYE CONNECTIONS
 600 KVAR (6-100 KVAR UNITS)
 300 KVAR (6-50 KVAR UNITS)
 150 KVAR (6-25 KVAR UNITS)

DIAGRAM OF 12KV WYE CONNECTIONS
 900 KVAR (9-100 KVAR UNITS)
 450 KVAR (9-50 KVAR UNITS)
 225 KVAR (9-25 KVAR UNITS)

INSTALLATION:

- (A) QUANTITY BASED ON 45' POLE.
- (B) BRACKETS TO BE MOUNTED IN LOWER POSITION FOR 50 AND 100 KVAR UNITS.
- (C) BOND ALL 12KV HARDWARE WITHIN 3 MILES OF COAST.
- (D) BOND ALL RACKS AS SHOWN IN ILLUSTRATION.
- (E) EXEMPT MATERIAL.
- (F) NO LONGER PURCHASED.
- G. SEE PAGE 1323 FOR MATERIAL NEEDED FOR LIGHTING ARRESTERS ON 900 KVAR INSTALLATIONS.

ITEM	DESCRIPTION	QUANTITY		STOCK NO. OR CONSTR. STD.	ITEM	DESCRIPTION	QUANTITY		STOCK NO. OR CONSTR. STD.
		6	9				6	9	
1	CROSSARM, 3 3/4" X 5 3/4" X 10' - 0"	1	1	380.01	16	WASHER, 1/2" SPRING DBL COIL	6	6	798464 (E)
2	CROSSARM, 3 3/4" X 5 3/4" X 8' - 0"	1	1	380.05	17	WASHER, 3/8" SPRING DBL COIL	2	2	798528 (E)
3	CROSSARM, 3 1/2" X 4 1/2" X 8' - 0"	1	1	380.05	18	SCREW, LAG GALV. 5/8" X 5"	1	1	621600 (E)
4	BRACE, ANGLE CROSSARM, 4' - 0"	1	1	164032	19	SCREW, LAG GALV. 1/2" X 4"	1	1	621568 (E)
5	BRACE, FLAT CROSSARM, 28"	2	2	164192	20	SIGN, HIGH VOLTAGE	1	1	647648 (E)
6	BOLT, MACH. GALV. 5/8" X (LENGTH AS REQ'D) & 1 NUT	3	3	139 (E)	21	NAILS, ROOFING #8 GALV.	8	8	492224 (E)
7	BOLT, MACH. 1/2" X 7" & 1 NUT	2	2	153120 (E)	22	STEPS, POLE (A)	16	16	692992 (E)
8	BOLT, MACH. GALV. 1/2" X 5" & 1 NUT	2	2	153024 (E)	23				
9	BOLT, MACH. GALV. 1/2" X 1 1/2" & 1 NUT	2	3	152608 (E)	24	CAPACITOR, UNIT 7.2KV (100 KVAR (F) UNITS ILLUSTRATED)	6	9	207232
10	BOLT, MACH. GALV. 3/8" X 5" & 1 NUT	2	2	154368 (E)	25	RACK, CAPACITOR	2	3	402656
11	WASHER, 1/2" ROUND	10	8	800192 (E)	26	CUTOUT, 12KV, 100A HEAVY DUTY WITH LOADBUSTER HOOKS	3	3	297888
12	WASHER, 3/8" ROUND	2	2	800288 (E)	27	CONNECTORS, COMPRESSION	3	3	786, 783 (E)
13	WASHER, 3" SQ. CURVED	4	4	798912 (E)	28	WIRE, #6 BARE STRANDED COPPER	33'	35'	813536
14	WASHER, 2 1/4" SQ. FLAT	2	2	799040 (E)	29	WIRE, #8 BARE SOLID ANNEALED COPPER	13'	15'	812928
15	WASHER, 5/8" SPRING DBL COIL	3	3	798560 (E)	30				

SDG & E ELECTRIC STANDARDS

DATE 11-5-82
 APPD *JAT/REH*

CAPACITOR INSTALLATIONS, 12KV - WYE - 900 KVAR MAX.

1399.207
 SUPERSEDES
 1322 (11-5-82)





FIELD MAINTENANCE ONLY

REVISION HISTORY:

7/13/2016: All versions prior to 2016 are superseded by their current version found inside the Overhead Construction Standard Manual.

© 1998 - 2016 San Diego Gas & Electric Company. All rights reserved. Removal of this copyright notice without permission is not permitted under law.

REV	CHANGE	BY	DSGN	APPV	DATE	REV	CHANGE	BY	DSGN	APPV	DATE
C						F					
B						E					
A	ORIGINAL ISSUE	JS	IL	MDJ	7/13/2016	D					

<p>SHEET 1 OF 1</p>	 Indicates Latest Revision	 Completely Revised	 New Page	 Information Removed	<p>FMO OH 1323</p>
	<p>SDG&E ELECTRIC OVERHEAD STANDARD</p>				
	<p>FIXED CAPACITOR INSTALLATION, 4KV WYE</p>				

SCOPE: THIS STANDARD SHOWS THE PREFERRED METHOD OF CONSTRUCTION FOR A FIXED CAPACITOR WHEN A NEW POLE IS REQUIRED.

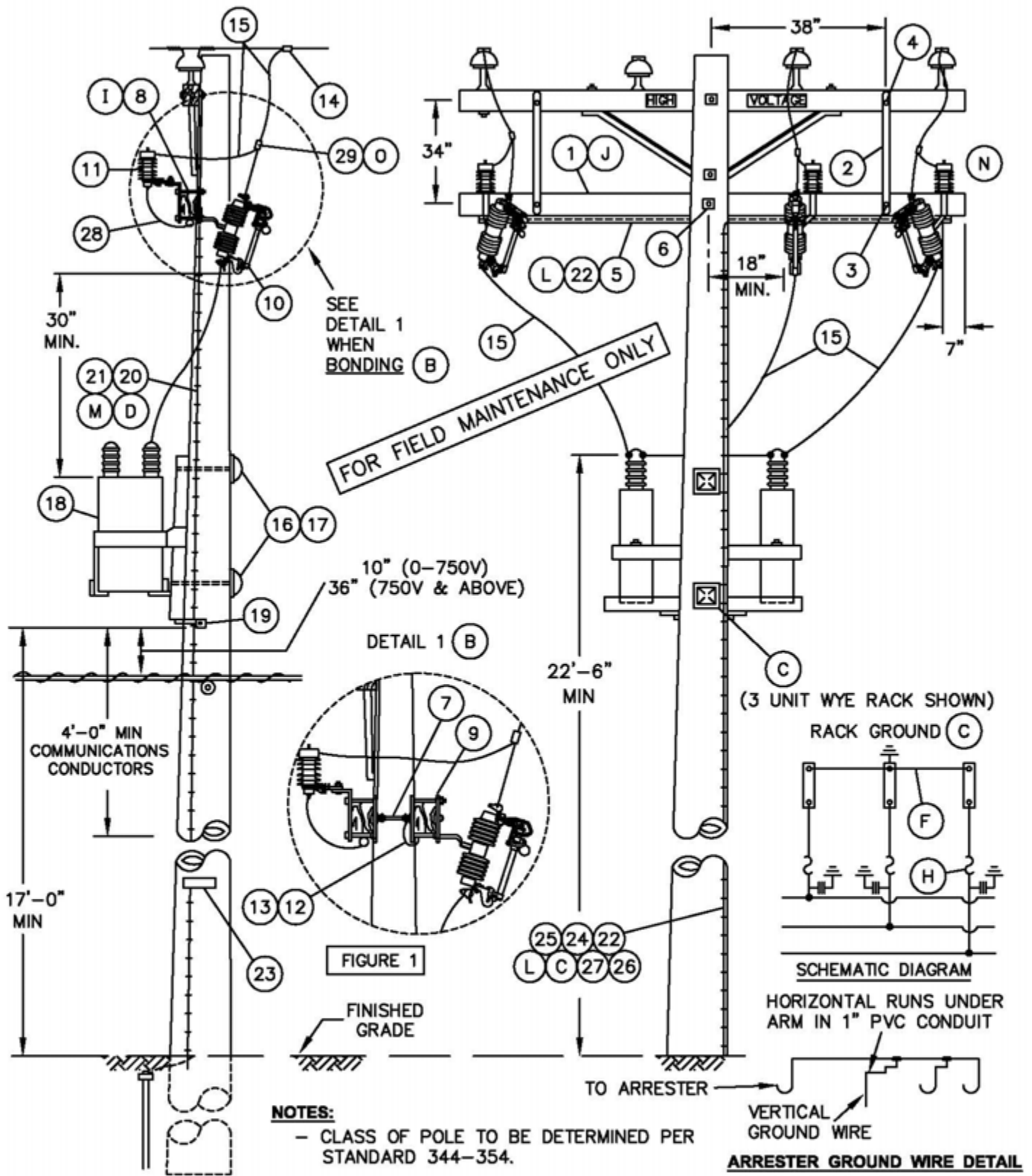

© 1998 - 2005 San Diego Gas & Electric Company. All rights reserved. Removal of this copyright notice without permission is not permitted under law.

1399.504
4299.507
SUPERSEDES
1323.1 (10-15-05)

SDG&E ELECTRIC STANDARDS
FIXED CAPACITOR INSTALLATION, 4KV WYE
GROUNDED RACK

DATE 10-15-05
APPD PJA / JJ

SCOPE: THIS STANDARD SHOWS AN ALTERNATE METHOD OF INSTALLING A FIXED CAPACITOR ON AN EXISTING POLE OF PROPER CLASS BUT WITH INSUFFICIENT HEIGHT TO PERMIT THE CONSTRUCTION AS SHOWN ON PAGE 1323.1 FIGURE 1.

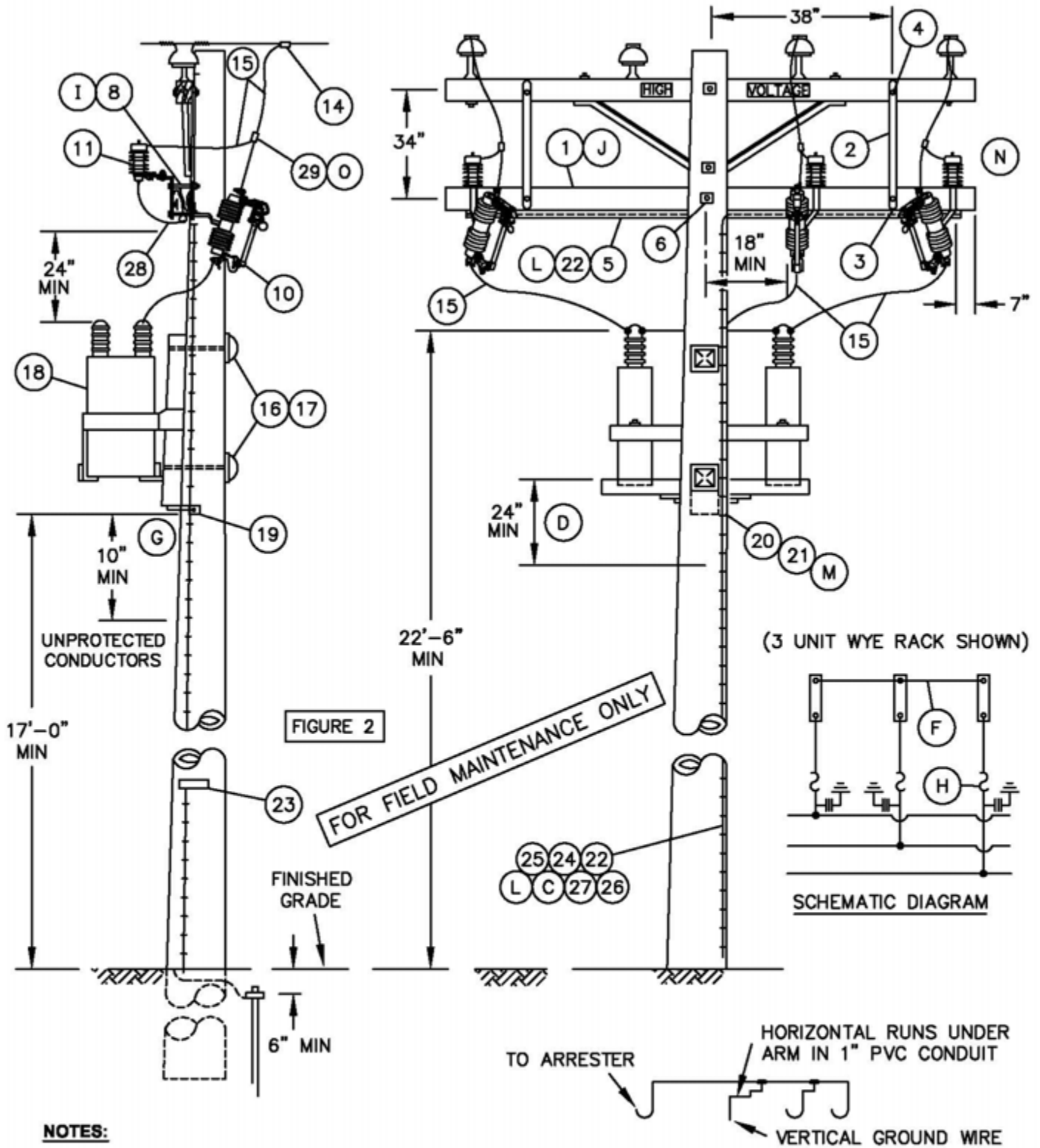

NOTES:

- CLASS OF POLE TO BE DETERMINED PER STANDARD 344-354.

© 1998 - 2005 San Diego Gas & Electric Company. All rights reserved. Removal of this copyright notice without permission is not permitted under law.

DATE 10-3-2012
APPD TQ/MJC

SDG&E ELECTRIC STANDARDS
FIXED CAPACITOR INSTALLATION, 4KV WYE
UNGROUND RACK -- ALTERNATE

1399.505
4299.508
SUPERSEDES
1323.2 (10-15-05)

BILL OF MATERIAL:

ITEM	DESCRIPTION	QUANTITY (B)		STOCK NO. OR CONSTR STANDARD	ASSEMBLY UNIT		
		UNBONDED	BONDED				
1	CROSSARM, 3 3/4" X 5 3/4" X 10' - 0" (B)	1	2	294128	-		
2	BRACE, FLAT, CROSSARM, 36" (J)	2	2	164224	-		
3	BOLT, MACH, GALV, 3/8" X 4 1/2", 1 ROUND & 1 LOCK WASHER (J)	2	2	STD 392	-		
4	BOLT, MACH, GALV, 1/2" X 5", 1 ROUND & 1 DBL COIL SPR WASH (J)	2	2	STD 392	-		
5	CONDUIT, PVC, TYPE 2, SCHEDULE 40, 1" AND STRAPS, PIPE, GALV. 1" WITH 1 3/4" ROOFING NAILS	10'	10'	251200	-		
		AS REQ'D		697792	-		
6	BOLT, MACH, GALV, 5/8" X (LENGTH AS REQ'D), 2 SQUARE & 1 DBL COIL SPRING WASHER	1	1	STD 392	-		
7	BOLT, SPACE, GALV, 5/8" X (LENGTH AS REQ'D), 2 ROUND 4 SQUARE, 2 DOUBLE COIL SPRING WASHERS & 2 NUTS	-	2	STD 392	-		
8	BRACKET, DOUBLE CUTOUT/ARRESTER, FOR CROSSARM MOUNTING.	3	-	165442	-		
9	BRACKET, ARRESTER OR CUTOUT	-	6	166070	-		
10	CUTOUT, 12KV, 100A, WITH LOADBUSTER HOOKS	3	3	STD 1212	-		
11	ARRESTER, LIGHTNING (SEE STD. 1247 FOR 4KV APPLICATION) OR	4 KV	3	113216	-		
		12 KV	3	113248	-		
12	WIRE, #8 BARE SOLID ANNEALED COPPER (B)	FT	-	15	812928		
		LB	-	1			
13	STAPLES, WIRE, GALV, 1 1/4" (B)	AS REQ'D		678528	-		
14	CONNECTOR, WIRE COMPRESSION, CU OR AL (SIZE AS REQ'D)	AS REQ'D		783-786	-		
15	WIRE, #4 BARE STRANDED COPPER	FT	100		813760		
		LB	13				
16	BOLT, MACH, GALV, 3/4" X (LENGTH AS REQ'D), 1 SQ CURV RIBBED & 1 DBL COIL SPRING WASHER	2	2	STD 392	-		
17	COVER, BOLT PLASTIC & 6 - 1 3/4" NAILS, GALV	2	2	285696	-		
		-	-	492192	-		
18	CAPACITOR RACK - COMPLETE WITH CAPACITORS	4KV	65 KVAR (3 @ 200 KVAR)	1	1	564759	-
			130 KVAR (3 @ 400 KVAR)	1	1	564776	-
		12KV	600 KVAR (3 @ 200 KVAR)	1	1	564763	-
			1200 KVAR (3 @ 400 KVAR)	1	1	564764	-
19	SCREW, LAG, GALV, 4"	2	2	621568	-		
20	CONDUIT, PVC, TYPE 2, SCHEDULE 40, 1/2" (D)	10'	10'	251168	-		
21	STRAPS, PIPE, GALV, 1/2", AND 2- 1 3/4" ROOFING NAILS, GALV.	AS REQ'D		697728	-		
		-	-	492192	-		
22	#4 CU SOLID GROUND WIRE, PVC COVERED	50'	50'	812490	GNDPVC		
23	TAG, STATION NUMBER	1	1	200 SECT.	-		
24	GROUND ROD, 5/8" X 8", COPPERWELD	1	1	603072	GNDPVC		
25	COPPER BONDED GROUND CONNECTOR	1	1	259010	-		
26	GROUND ENHANCING POWER SOLUTION (GEM)	AS REQ'D		424390	-		
27	GALVANIZED STAPLES FOR PVC COVERED GROUND WIRE	AS REQ'D		678562	-		
28	FLEXIBLE ARRESTER GROUND STRAP	AS REQ'D		698754	-		
29	HOT LINE CLAMP	3	3	227680	-		

FOR FIELD MAINTENANCE ONLY

© 1998 - 2005 San Diego Gas & Electric Company. All rights reserved. Removal of this copyright notice without permission is not permitted under law.

Indicates Latest Revision Completely Revised New Page Information Removed

SDG&E ELECTRIC STANDARDS

FIXED CAPACITOR INSTALLATION, 4KV WYE

DATE 10-15-05

APPD PJA / JJ

1399.506
4299.509
SUPERSEDES
1323.3 (10-15-05)

OVERHEAD MACRO UNITS 12KV/4KV CAPACITOR STATIONS		
FIXED – GROUNDED (FIG. 1)		
KV	KVAR	MU I.D.
12	600	C6FP
12	1200	C12FP
FIXED-UNGROUNDED (FIG. 2)		
4	65	C4FA
4	130	C4F3P
12	600	C6FA
12	1200	C12FA

FOR FIELD MAINTENANCE ONLY

INSTALLATION:

- A. CAPACITORS MUST BE INSTALLED ON POLES ACCESSIBLE BY BUCKET TRUCK.
- (B) BOND CUTOUTS IN HEAVY CONTAMINATION DISTRICTS AS SHOWN ON STANDARD 287. IN AREAS WHERE BONDING IS REQUIRED, TO AVOID BONDWIRE AND LIGHTNING ARRESTER GROUNDWIRE ON THE SAME CROSSARM, USE TWO CROSSARMS; ONE FOR CUTOUTS AND ONE FOR LIGHTNING ARRESTERS.
- (C) CONNECT CAPACITOR RACK GROUND LEAD TO LIGHTNING ARRESTER GROUND (FIGURE 1 ONLY).
- (D) RUN 1/2" SCHEDULE 40 PVC CONDUIT WITH LIGHTNING ARRESTER GROUND FROM LIGHTNING ARRESTER ARM TO A MINIMUM OF 2 FEET BELOW CAPACITOR RACK, THEN CONTINUE DOWN THE POLE USING PVC COVERED GROUND WIRE.
- (F) DO NOT TIE CAPACITOR BANK NEUTRAL TO 12KV CIRCUIT NEUTRAL. IT IS TO REMAIN FLOATING.
- (G) TEN INCHES FROM 0-750V CONDUCTORS BELOW, 12 INCHES FOR CONDUCTORS OF 750-7500V, 18 INCHES FOR CONDUCTORS OF 7500-22,500V PER G.O. 95 RULE 58.1-D.
- (H) FUSE STATION ACCORDING TO CAPACITOR FUSING TABLE, STANDARD 1309.
- (I) DRILL THROUGH CROSSARM 1" UP FROM LOWER EDGE SO THAT LOWER CROSSARM MOUNTING BRACKET BOLT DOES NOT INTERFERE WITH PVC CONDUIT.
- (J) WHEN LA/CO CROSSARM AND CAPACITORS CANNOT BE INSTALLED ON THE SAME SIDE OF THE POLE AS AN EXISTING LINEARM, DELETE ITEMS 2, 3, & 4. INSTEAD, FIELD DRILL LA/CO CROSSARM FOR 2-36" FLATBRACES. SECURE BRACES TO POLE WITH A LAG SCREW. (SEE STD. 380.1, ITEM 1)

REFERENCE:

- (L) FOR GROUNDING REQUIREMENTS AND APPLICATION – SEE STANDARD 1002.
- (M) PVC CONDUIT IS NOT PERMITTED IN THE CLIMBING SPACE PER G. O. 95, RULE 22.2B.
- (N) SECTIONALIZING CUTOUT INSTALLATION MAY VARY WITH POSITION OF NEUTRAL CONDUCTOR – SEE STANDARD 1240.
- (O) FOR HOT LINE CLAMP CONNECTION, SEE STANDARD 788.

©1998 - 2005 San Diego Gas & Electric Company. All rights reserved. Removal of this copyright notice without permission is not permitted under law.

	Indicates Latest Revision	Completely Revised	New Page	Information Removed
SDG&E ELECTRIC STANDARDS				
DATE 10-15-05 APPD PJA/JJ	FIXED CAPACITOR INSTALLATION, 4KV WYE/12KV WYE			1399.507 4299.510 SUPERSEDES 1323.4 (10-15-05)

FIELD MAINTENANCE ONLY

REVISION HISTORY:

7/13/2016: All versions prior to 2016 are superseded by their current version found inside the Overhead Construction Standard Manual.

© 1998 - 2016 San Diego Gas & Electric Company. All rights reserved. Removal of this copyright notice without permission is not permitted under law.

REV	CHANGE	BY	DSGN	APPV	DATE	REV	CHANGE	BY	DSGN	APPV	DATE
C						F					
B						E					
A	ORIGINAL ISSUE	JS	IL	MDJ	7/13/2016	D					

SHEET 1 OF 1	 Indicates Latest Revision	Completely Revised	New Page	Information Removed	FMO OH 1324
	SDG&E ELECTRIC OVERHEAD STANDARD				
	12 & 12.47 KV SWITCHED CAPACITOR INSTALLATION 3 OIL SWITCHES IN LINE				

APPLICATION:

THIS CONSTRUCTION SHALL BE USED FOR ALL VOLTAGE, TIME, OR TIME-VOLTAGE SWITCHED CAPACITORS WITH THREE OIL SWITCHES.

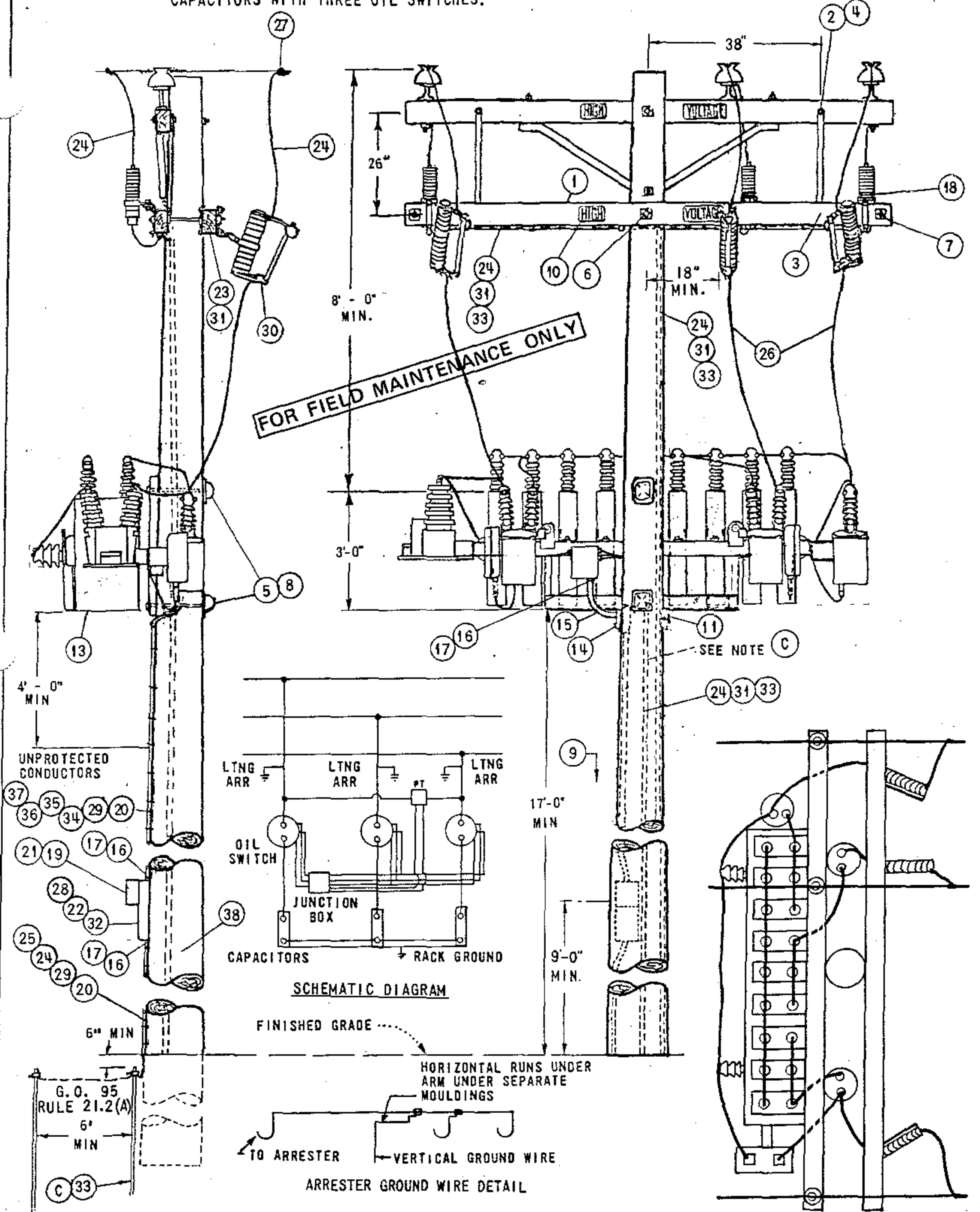

DATE 9-17-82
APPD JAT

SDG&E ELECTRIC STANDARDS
12 & 12.47 KV SWITCHED CAPACITOR INSTALLATION
3 OIL SWITCHES IN LINE

1399.201
SUPERSEDES
1324.1 (9-17-82)

NOTES:

- A. CAUTION: OPEN OIL SWITCHES BEFORE OPENING CUTOUTS.
- B. BOND CUTOUTS IN HEAVY CONTAMINATION DISTRICTS. AS IDENTIFIED ON STANDARDS PAGE 287.
- (C) ONE GROUND IS REQUIRED FOR THE CAPACITOR RACK, ONE IS REQUIRED FOR THE ARRESTERS, AND A THIRD FOR THE CONTROL PANEL. THESE GROUNDS ARE NOT TO BE INTERCONNECTED.
- D. DO NOT TIE CAPACITOR BANK NEUTRAL TO 12KV CIRCUIT NEUTRAL. IT IS TO REMAIN FLOATING.
- (E) EXEMPT MATERIALS.
- (F) TO BE INSTALLED BY KEARNY ELECTRIC MAINTENANCE.
- G. INSTALL CONTROL ON SAME SIDE OF POLE AS CAPACITOR RACK.
- H. RACKS THAT CONTAIN PT'S WITH METAL TANKS TO BE INSULATED FROM RACK BY KEARNY MAINTENANCE BEFORE REINSTALLATION.
- (I) THE POTENTIAL TRANSFORMERS FOR THIS INSTALLATION ARE CONNECTED PHASE-TO-PHASE. FOR POTENTIAL TRANSFORMERS CONNECTED PHASE-TO-NEUTRAL, SEE PAGE 1326.
- J. PVC CONDUIT IS NOT PERMITTED IN THE CLIMBING SPACE. G.O. 95 RULE 22.2(C).
- K. CAPACITORS MUST BE INSTALLED ON POLES ACCESSIBLE BY BUCKET TRUCK.

ITEM	DESCRIPTION	QUANTITY	STOCK NO. OR CONSTR. STD.
1	CROSSARM, 3 3/4" X 5 3/4" X 10' - 0"	2	300 SECTION
2	BRACE, FLAT CROSSARM 28"	2	164192
3	BOLT, MACHINE, GALV., 3/8" X 4 1/2" & 1 SPRING LOCK WASH.	(E) 2	PGS 139, 140
4	BOLT, MACHINE, GALV., 1/2" X 5", 1 RD. WASH, 1 DBL. COIL SPR. WASH	(E) 2	PGS 139, 140
5	BOLT, MACHINE, GALV., 3/4" X___, 1 SQ CURV RIB WASH, 1 DBL COIL SPR WASH	2	PGS 139, 140
6	BOLT, MACHINE, GALV, 5/8" X___, 2 SQ WASH, 1 DBL COIL SPR WASH	(E) 1	PGS 139, 140
7	BOLT, SPACE, GALV., 5/8" X___, 4 SQ WASH, 2 DBL COIL SPR WASH, 2 RD WASH.	(E) 2	PGS 139, 140
8	COVER, BOLT, PLASTIC, 10 D NAILS, GALV	(E) 2	285696
9	STEPS, POLE	(E) 16	692992
10	SIGN, HIGH VOLTAGE & NAILS, GALV.	(E) 4	647648, 492224
11	SCREW, LAG, GALV, 4"	(E) 2	621568
12			
13	SWITCHED CAPACITOR RACK, COMPLETE WITH CAPACITORS, SWITCHES & POTENTIAL TRANSFORMER	900 KVAR (6 @ 150 KVAR) 1350 KVAR (9 @ 150 KVAR)	1 1 564704 564752
14	ACCESS FITTING BODY TYPE LB PVC 3/4"	(F) (E) 1	146384
15	ELBOW, STANDARD RADIUS PVC 3/4"	(F) 1	322166
16	REDUCER COUPLING PVC 3/4" TO 1"	(F) 3	573410
17	TERMINAL ADAPTOR PVC 1"	(F) 3	102756
18	ARRESTERS, LIGHTNING, 12KV	3	113248
19	CONTROL, CAPACITOR (SELECT TYPE AS REQ'D)	a TIME SWITCH	(F) 1 706160
		b TIME SWITCH W VOLTAGE OVERRIDE	(F) 1 706176
		c VOLTAGE	(F) 1 273984
20	CONDUIT, PVC, SCHEDULE 40, 3/4"	(F) (E) 40'	251328
21	PADLOCK, MASTER 7	1	514912
22	BRACKETS, CONTROL MOUNTING	(F) 2	SHOP MADE
23	WIRE, #8 SOL, ANNEALED BARE COPPER	10' (1/2#)	812928
24	WIRE, BARE STRANDED COPPER, #6	110'	813536
25	ROD & CLAMP, GROUND	2	603072, 230016 (E)
26	WIRE, #4 COPPER, WP	20'	812480
27	CONNECTORS, WIRE, COMPRESSION, COPPER OR ALUMINUM AS REQ'D	(E) 6	PGS 786, 783
28	SCREW, 1/4" X 2" LAG	(F) 4	621888
29	STRAPS, PIPE GALV, 3/4", 6D NAILS, GALV.	(F) (E) AS REQ'D	697888
30	CUTOUTS 12KV 100A WITH LOADBUSTER HOOKS	3	1200 SECTION
31	STAPLES, WIRE GALV, 1 1/4"	(E) AS REQ'D	678528
32	BOX, METER SOCKET SAFETY, 5 TERMINAL, 100 AMP	(F) 1	161856
33	UNIT GROUND COMPLETE (WITH PLAIN MLDG, WITH GRAY MLDG)	2	603136, 603120
34	WIRE, THW #12 WHITE	(F) 30'	808704
35	WIRE, THW #12 BLACK	(F) 30'	808096
36	WIRE, THW #12 RED	(F) 30'	808576
37	WIRE, THW #12 BLUE	(F) 30'	808416
38	TAG, STATION NUMBER	1	300 SECTION

FOR FIELD MAINTENANCE ONLY

APPLICATION:

THIS CONSTRUCTION SHALL BE USED FOR ALL VOLTAGE, TIME, OR TIME-VOLTAGE SWITCHED CAPACITORS WITH THREE OIL SWITCHES.

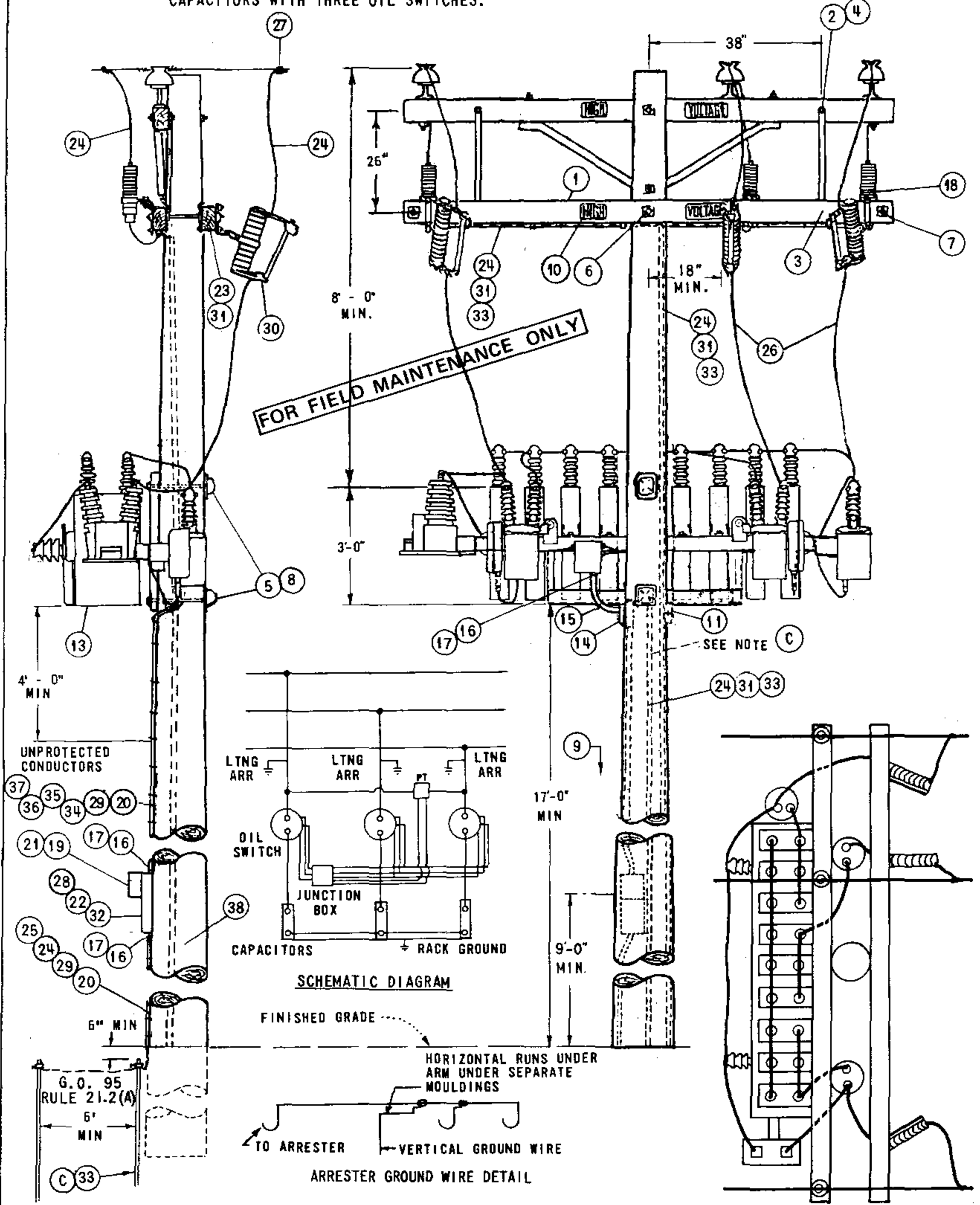

DATE 9-17-82
APPD JNT

SDG&E ELECTRIC STANDARDS
12 & 12.47 KV SWITCHED CAPACITOR INSTALLATION
3 OIL SWITCHES IN LINE

1399.205
SUPERSEDES
1324.1 (9-17-82)

NOTES:

- A. CAUTION: OPEN OIL SWITCHES BEFORE OPENING CUTOUTS.
- B. BOND CUTOUTS IN HEAVY CONTAMINATION DISTRICTS. AS IDENTIFIED ON STANDARDS PAGE 287.
- ⓐ ONE GROUND IS REQUIRED FOR THE CAPACITOR RACK, ONE IS REQUIRED FOR THE ARRESTERS, AND A THIRD FOR THE CONTROL PANEL. THESE GROUNDS ARE NOT TO BE INTERCONNECTED.
- D. DO NOT TIE CAPACITOR BANK NEUTRAL TO 12KV CIRCUIT NEUTRAL. IT IS TO REMAIN FLOATING.
- ⓔ EXEMPT MATERIALS.
- ⓕ TO BE INSTALLED BY KEARNY ELECTRIC MAINTENANCE.
- G. INSTALL CONTROL ON SAME SIDE OF POLE AS CAPACITOR RACK.
- H. RACKS THAT CONTAIN PT'S WITH METAL TANKS TO BE INSULATED FROM RACK BY KEARNY MAINTENANCE BEFORE REINSTALLATION.
- ⓓ THE POTENTIAL TRANSFORMERS FOR THIS INSTALLATION ARE CONNECTED PHASE-TO-PHASE. FOR POTENTIAL TRANSFORMERS CONNECTED PHASE-TO-NEUTRAL. SEE PAGE 1326.
- J. PVC CONDUIT IS NOT PERMITTED IN THE CLIMBING SPACE. G.O. 95 RULE 22.2(C).
- K. CAPACITORS MUST BE INSTALLED ON POLES ACCESSIBLE BY BUCKET TRUCK.

ITEM	DESCRIPTION	QUANTITY	STOCK NO. OR CONSTR. STD.
1	CROSSARM, 3 3/4" X 5 3/4" X 10' - 0"	2	300 SECTION
2	BRACE, FLAT CROSSARM 28"	2	164192
3	BOLT, MACHINE, GALV., 3/8" X 4 1/2" & 1 SPRING LOCK WASH.	ⓔ 2	PGS 139, 140
4	BOLT, MACHINE, GALV., 1/2" X 5", 1 RD. WASH, 1 DBL. COIL SPR. WASH	ⓔ 2	PGS 139, 140
5	BOLT, MACHINE, GALV., 3/4" X ____, 1 SQ CURV RIB WASH, 1 DBL COIL SPR WASH	2	PGS 139, 140
6	BOLT, MACHINE, GALV., 5/8" X ____, 2 SQ WASH, 1 DBL COIL SPR WASH	ⓔ 1	PGS 139, 140
7	BOLT, SPACE, GALV., 5/8" X ____, 4 SQ WASH, 2 DBL COIL SPR WASH, 2 RD WASH.	ⓔ 2	PGS 139, 140
8	COVER, BOLT, PLASTIC, 10 D NAILS, GALV	ⓔ 2	285696
9	STEPS, POLE	ⓔ 16	692992
10	SIGN, HIGH VOLTAGE & NAILS, GALV.	ⓔ 4	647648, 492224
11	SCREW, LAG, GALV, 4"	ⓔ 2	621568
12			
13	SWITCHED CAPACITOR RACK, COMPLETE WITH CAPACITORS, SWITCHES & POTENTIAL TRANSFORMER	900 KVAR (6 @ 150 KVAR) 1350 KVAR (9 @ 150 KVAR)	1 1 564704 564752
14	ACCESS FITTING BODY TYPE LB PVC 3/4"	ⓕ ⓔ 1	146384
15	ELBOW, STANDARD RADIUS PVC 3/4"	ⓕ 1	322166
16	REDUCER COUPLING PVC 3/4" TO 1"	ⓕ 3	573410
17	TERMINAL ADAPTOR PVC 1"	ⓕ 3	102756
18	ARRESTERS, LIGHTNING, 12KV	3	113248
19	CONTROL, CAPACITOR (SELECT TYPE AS REQ'D)	a TIME SWITCH b TIME SWITCH W/ VOLTAGE OVERRIDE c VOLTAGE	ⓕ 1 ⓕ 1 ⓕ 1 706160 706176 273984
20	CONDUIT, PVC, SCHEDULE 40, 3/4"	ⓕ ⓔ 40'	251328
21	PADLOCK, MASTER 7	1	514912
22	BRACKETS, CONTROL MOUNTING	ⓕ 2	SHOP MADE
23	WIRE, #8 SOL, ANNEALED BARE COPPER	10' (1/2#)	812928
24	WIRE, BARE STRANDED COPPER, #6	110'	813536
25	ROD & CLAMP, GROUND	2	603072, 230016 ⓔ
26	WIRE, #4 COPPER, WP	20'	812480
27	CONNECTORS, WIRE, COMPRESSION, COPPER OR ALUMINUM AS REQ'D	ⓔ 6	PGS 786, 783
28	SCREW, 1/4" X 2" LAG	ⓕ 4	621888
29	STRAPS, PIPE GALV, 3/4", 6D NAILS, GALV.	ⓕ ⓔ AS REQ'D	697888
30	CUTOUTS 12KV 100A WITH LOADBUSTER HOOKS	3	1200 SECTION
31	STAPLES, WIRE GALV, 1 1/4"	ⓔ AS REQ'D	678528
32	BOX, METER SOCKET SAFETY, 5 TERMINAL, 100 AMP	ⓕ 1	161856
33	UNIT GROUND COMPLETE (WITH PLAIN MLDG, WITH GRAY MLDG)	2	603136, 603120
34	WIRE, THW #12 WHITE	ⓕ 30'	808704
35	WIRE, THW #12 BLACK	ⓕ 30'	808096
36	WIRE, THW #12 RED	ⓕ 30'	808576
37	WIRE, THW #12 BLUE	ⓕ 30'	808416
38	TAG, STATION NUMBER	1	300 SECTION

FOR FIELD MAINTENANCE ONLY

FIELD MAINTENANCE ONLY

REVISION HISTORY:

7/13/2016: All versions prior to 2016 are superseded by their current version found inside the Overhead Construction Standard Manual.

© 1998 - 2016 San Diego Gas & Electric Company. All rights reserved. Removal of this copyright notice without permission is not permitted under law.

REV	CHANGE	BY	DSGN	APPV	DATE	REV	CHANGE	BY	DSGN	APPV	DATE
C						F					
B						E					
A	ORIGINAL ISSUE	JS	IL	MDJ	7/13/2016	D					

	Indicates Latest Revision	Completely Revised	New Page	Information Removed
-------------------------------------------------------------------------------------	---------------------------	--------------------	----------	---------------------

**SHEET
1 OF 1**

SDG&E ELECTRIC OVERHEAD STANDARD

12 & 12.47KV SWITCHED CAPACITOR INSTALLATION
2 OIL SWITCHES IN CAPACITOR NEUTRAL

**FMO
OH 1325**

SCOPE: THIS CONSTRUCTION SHALL BE USED FOR ALL 12KV CAPACITOR STATIONS WITH TWO OIL SWITCHES.

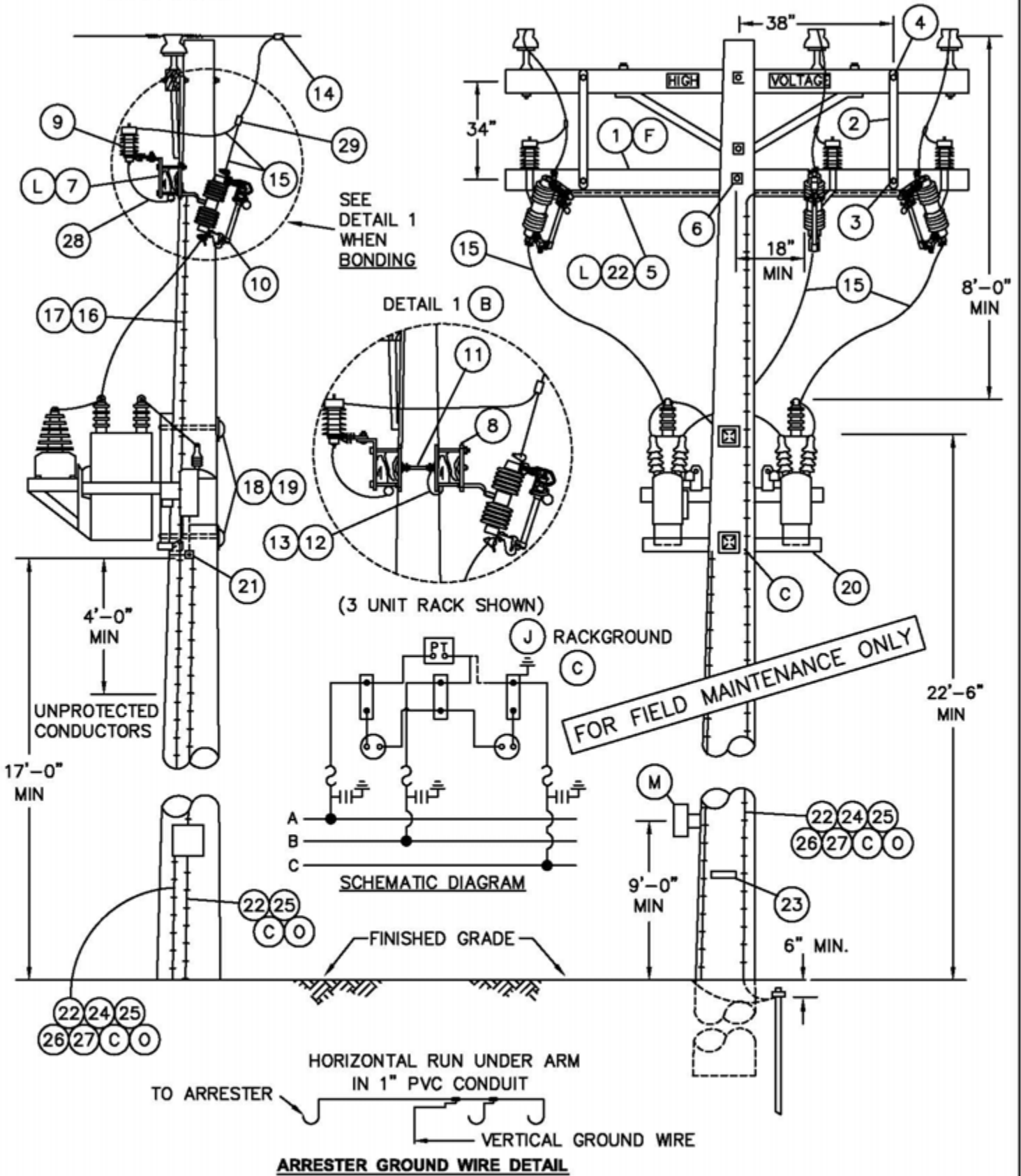

© 1998 - 2005 San Diego Gas & Electric Company. All rights reserved. Removal of this copyright notice without permission is not permitted under law.

<p>1399.508 SUPERSEDES 1325.1 (10-15-05)</p>	<p>SDG&E ELECTRIC STANDARDS</p> <p>12 & 12.47KV SWITCHED CAPACITOR INSTALLATION 2 OIL SWITCHES IN CAPACITOR NEUTRAL</p>	<p>DATE 10-15-05 APPD PJA/JJ</p>
------------------------------------------------------	-------------------------------------------------------------------------------------------------------------------------------------	--------------------------------------

NOTE:

- CLASS OF POLE TO BE DETERMINED PER STANDARD 344-354.

FOR FIELD MAINTENANCE ONLY

BILL OF MATERIAL:

ITEM	DESCRIPTION	QUANTITY (B)		STOCK NO. OR CONSTR STANDARD	ASSEMBLY UNIT	
		UNBONDED	BONDED			
1	CROSSARM, 3 3/4" X 5 3/4" X 10' - 0" (B)	1	2	294128	-	
2	BRACE, FLAT, CROSSARM, 36" (F)	2	2	164224	-	
3	BOLT, MACH, GALV, 3/8" X 4 1/2", 1 ROUND & 1 LOCK WASHER (F)	2	2	STD 392	-	
4	BOLT, MACH, GALV, 1/2" X 5", 1 ROUND & 1 DBL COIL SPR WASH (F)	2	2	STD 392	-	
5	CONDUIT, PVC, TYPE 2, SCHEDULE 40, 1" AND STRAPS PIPE, GALV, 1" WITH 2- 1 3/4" ROOFING NAILS.	10'	10'	251200	-	
		AS REQ'D		697792	-	
6	BOLT, MACH, GALV, 5/8" X (LENGTH AS REQ'D), 2 SQUARE & 1 DBL COIL SPRING WASHER	1	1	STD 392	-	
7	BRACKET, DOUBLE CUTOUT/ARRESTER, FOR CROSSARM MOUNTING.	3	-	165442	-	
8	BRACKET, ARRESTER, OR CUTOUT	-	6	166070	-	
9	ARRESTER, LIGHTNING, 12KV	3	3	113248	-	
10	CUTOUT, 12KV, 100A, WITH LOADBUSTER HOOKS	3	3	STD 1212	-	
11	BOLT, SPACE, GALV, 5/8" X (LENGTH AS REQ'D), 2 ROUND, 4 SQUARE, 2 DOUBLE COIL SPRING WASHERS & 2 NUTS	-	2	STD 392	-	
12	WIRE, #8 BARE SOLID ANNEALED COPPER (B)	FT	15	812928	-	
		LB	1			
13	STAPLES, WIRE, GALV, 1 1/4" (B)	AS REQ'D		678528	-	
14	CONNECTOR, WIRE COMPRESSION, CU OR AL (SIZE AS REQ'D)	AS REQ'D		783-786	-	
15	WIRE, #4 BARE STRANDED COPPER	FT	110	813760	-	
		LB	14			
16	CONDUIT, PVC, TYPE 2, SCHEDULE 40, 1/2"	10'	10'	251168	-	
17	STRAPS, PIPE, GALV, 1/2" WITH 2- 1 3/4" ROOFING NAILS.	AS REQ'D		697728	-	
18	BOLT, MACH, GALV, 3/4" X (LENGTH AS REQ'D), 1 SQ CURV RIBBED & 1 DBL COIL SPRING WASHER	2	2	STD 392	-	
19	COVER, BOLT PLASTIC & 6- 1 3/4" NAILS, GALV, ROOFING.	2	2	285696	-	
		-	-	492192	-	
20	SWITCHED CAPACITOR RACK, COMPLETE WITH CAPACITORS, SWITCHES AND POTENTIAL TRANSFORMER	600 KVAR (3 @ 200 KVAR)	1	1	564761	-
		1200 KVAR (3 @ 400 KVAR)	1	1	564770	-
21	SCREW, LAG, GALV, 4"	2	2	621568	-	
22	#4 CU SOLID GROUND WIRE, PVC COVERED	50'	50'	812490	GNDPVC	
23	TAG, STATION NUMBER	1	1	STD. 208	-	
24	GROUND ROD, 5/8" X 8', COPPERWELD	1	1	603072	GNDPVC	
25	COPPER BONDED GROUND CONNECTOR	1	1	259010	-	
26	GROUND ENHANCING POWER SOLUTION (GEM)	AS REQ'D		424390	-	
27	GALVANIZED STAPLES FOR PVC COVERED GROUND WIRE	AS REQ'D		678562	-	
28	FLEXIBLE ARRESTER GROUND STRAP	AS REQ'D		698754	-	
29	HOT LINE CLAMP	3	3	227680	-	

©1998 - 2005 San Diego Gas & Electric Company. All rights reserved. Removal of this copyright notice without permission is not permitted under law.

DATE 10-15-05 APPD PJA / JJ	SDG&E ELECTRIC STANDARDS	1399.509 SUPERSEDES 1325.2 (10-15-05)
	12 & 12.47KV SWITCHED CAPACITOR INSTALLATION 2 OIL SWITCHES IN CAPACITOR NEUTRAL	

OVERHEAD MACRO UNITS 12KV - SWITCHED NEUTRAL CAPACITOR		
KVAR	CONTROL	MU I.D.
600	VOLT/TIME, DIGITAL, PROGRAMMABLE	C6SCT
1200	VOLT/TIME, DIGITAL, PROGRAMMABLE	C12SCT

FOR FIELD MAINTENANCE ONLY

INSTALLATION:

- (A) CAUTION: OPEN OIL SWITCHES BEFORE OPENING CUTOUTS.
- (B) BOND CUTOUTS IN HEAVY CONTAMINATION DISTRICTS AS SHOWN ON STANDARD 287. IN AREAS WHERE BONDING IS REQUIRED, TO AVOID BONDWIRE AND LIGHTNING ARRESTER GROUNDWIRE ON THE SAME CROSSARM, USE TWO CROSSARMS; ONE FOR CUTOUTS AND ONE FOR LIGHTNING ARRESTERS.
- (C) CONNECT CAPACITOR RACK GROUND LEAD TO LIGHTNING ARRESTER GROUND. A SECOND GROUND WIRE IS REQUIRED FOR THE CONTROL PANEL TO BE CONNECTED ON THE SAME GROUND ROD. COIL LOOSE END OF THE CONTROL PANEL GROUND WIRE AND STAPLE TO POLE (TO BE WORKED BY SERVICE CREW).
- D. DO NOT TIE CAPACITOR BANK NEUTRAL TO 12KV CIRCUIT NEUTRAL. IT IS TO REMAIN FLOATING.
- (F) WHEN LA/CO CROSSARM AND CAPACITORS CANNOT BE INSTALLED ON THE SAME SIDE OF THE POLE AS AN EXISTING LINEARM, DELETE ITEMS 2, 3, & 4. INSTEAD, FIELD DRILL LA/CO CROSSARM FOR 2-36" FLAT BRACES, SECURE BRACES TO POLE WITH A LAG SCREW. (SEE STD. 380.1, ITEM 1 FOR DRILLING MEASUREMENTS).
- G. RACKS THAT CONTAIN POTENTIAL TRANSFORMERS (PT'S) WITH METAL TANKS ARE TO BE INSULATED FROM RACK BEFORE REINSTALLATION.
- H. CAPACITORS MUST BE INSTALLED ON POLES ACCESSIBLE BY BUCKET TRUCK.
- (J) PT CAN BE CONNECTED TO CENTER PHASE OR OUTSIDE PHASE DEPENDING ON FIELD CONDITION.
- K. THE PT FOR THIS INSTALLATION IS CONNECTED PHASE-TO-PHASE.
- (L) DRILL THROUGH CROSSARM 1" UP FROM LOWER EDGE SO THAT LOWER CROSSARM MOUNTING BRACKET BOLT DOES NOT INTERFERE WITH PVC CONDUIT.

REFERENCE:

- (M) SHOWN FOR ILLUSTRATIVE PURPOSES ONLY. SEE STANDARD 1330 FOR CONTROL INSTALLATION AND MATERIAL.
- (N) PVC CONDUIT IS NOT PERMITTED IN THE CLIMBING SPACE PER G.O. 95 RULE 22.2C.
- (O) FOR GROUNDING REQUIREMENTS AND APPLICATION, SEE STANDARD 1002.

© 1998 - 2005 San Diego Gas & Electric Company. All rights reserved. Removal of this copyright notice without permission is not permitted under law.

DATE 1-1-2000 APPD <i>PA/VR</i>	SDG&E ELECTRIC STANDARDS	1399.510 SUPERSEDES 1325.3 (10-15-05)
	12 & 12.47KV SWITCHED CAPACITOR INSTALLATION 2 OIL SWITCHES IN CAPACITOR NEUTRAL	

FIELD MAINTENANCE ONLY

REVISION HISTORY:

7/13/2016: All versions prior to 2016 are superseded by their current version found inside the Overhead Construction Standard Manual.

© 1998 - 2016 San Diego Gas & Electric Company. All rights reserved. Removal of this copyright notice without permission is not permitted under law.

REV	CHANGE	BY	DSGN	APPV	DATE	REV	CHANGE	BY	DSGN	APPV	DATE
C						F					
B						E					
A	ORIGINAL ISSUE	JS	IL	MDJ	7/13/2016	D					

	Indicates Latest Revision	Completely Revised	New Page	Information Removed
-------------------------------------------------------------------------------------	---------------------------	--------------------	----------	---------------------

**SHEET
1 OF 1**

SDG&E ELECTRIC OVERHEAD STANDARD

SWITCHED CAPACITORS - CURRENT SENSOR
12 & 12.47KV

**FMO
OH 1326**

SCOPE: THIS CONSTRUCTION SHALL BE USED FOR ALL SWITCHED CAPACITOR BANKS REQUIRING A CURRENT SENSOR.

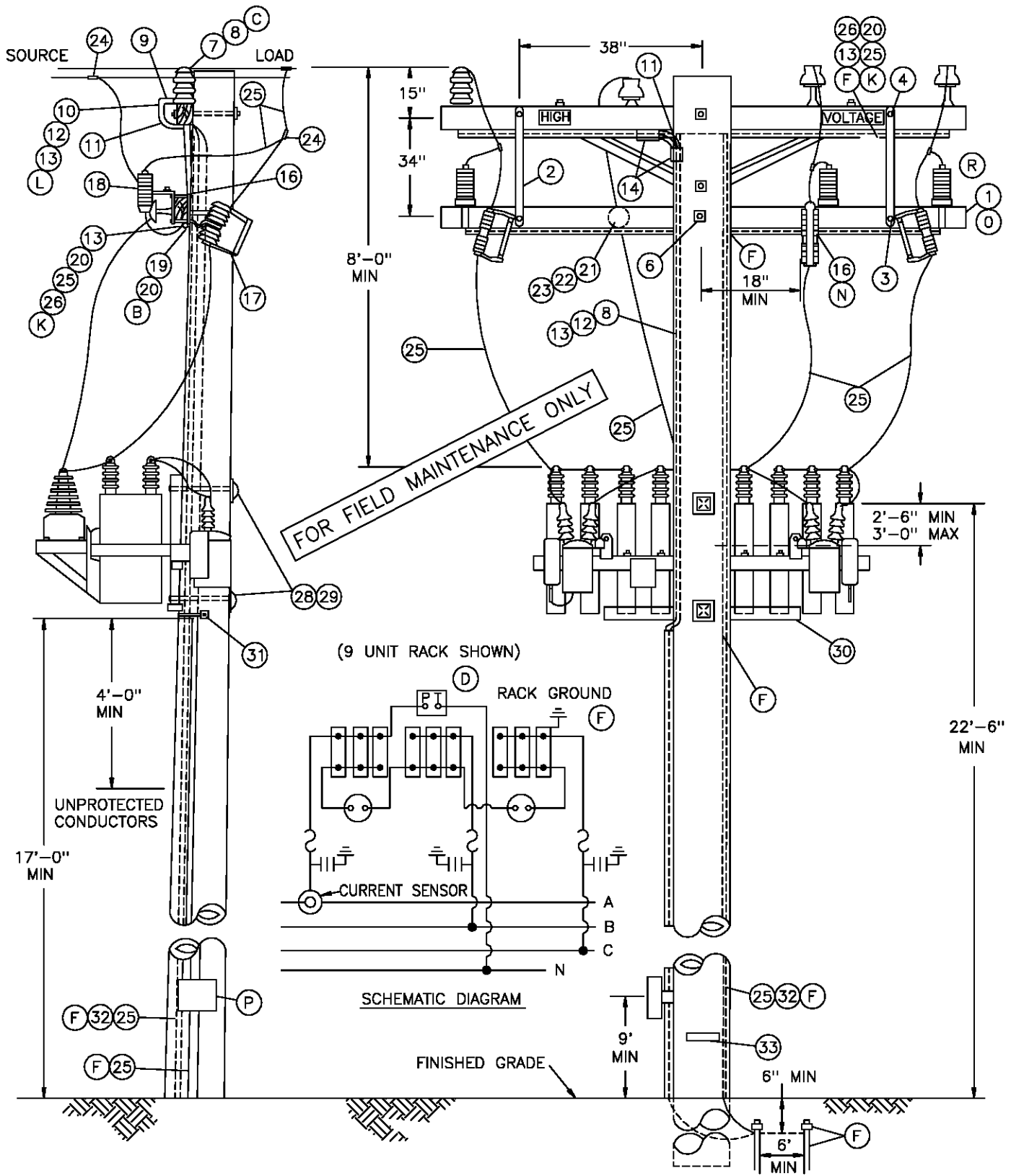

1399.208

SUPERSEDES
1326.1 (12-1-98)

SDG&E ELECTRIC STANDARDS

SWITCHED CAPACITORS - CURRENT SENSOR
12 & 12.47KV

DATE 12-1-98

APPD PJA / CLK

NOTES:

- SENSOR PRODUCES ONE VOLT FOR EACH 60 AMPERES OF LINE CURRENT. OPEN CIRCUIT VOLTAGE IS NOT SIGNIFICANTLY HIGH.
- CLASS OF POLE IS TO BE DETERMINED PER STANDARD 344-354.

BILL OF MATERIAL:

ITEM	DESCRIPTION	QUANTITY	STOCK NO. OR CONSTR STANDARD	
1	CROSSARM, 3 3/4" X 5 3/4' X 10' - 0" (B)	1	294128	
2	BRACE, FLAT, CROSSARM, 28" (O)	2	164192	
3	BOLT, MACH, GALV, 3/8" X 4 1/2", 1 ROUND & 1 LOCK WASHER (O)	2	STD 392	
4	BOLT, MACH, GALV, 1/2" X 5", 1 ROUND & 1 DBL COIL SPR WASH (O)	2	STD 392	
5				
6	BOLT, MACH, GALV, 5/8" X (LENGTH AS REQ'D), 2 SQUARE & 1 DBL COIL SPRING WASHER	1	STD 392	
7	STUD, INSULATOR	1	701760	
8	SENSOR, CURRENT, COMPLETE WITH WHITE, GREEN AND BLACK INSULATED CONTROL WIRE	1	635820	
9	TERMINAL ADAPTOR, PVC, 3/4"	1	102754	
10	SLIP ELBOW, 90 PVC, 3/4"	2	322174	
11	ELBOW, STANDARD RADIUS, PVC, 3/4"	2	322166	
12	CONDUIT, PVC, TYPE 2, SCHED 40, 3/4"	15'	251328	
13	STRAPS, PIPE, GALV, 3/4" & 2 - 1 3/4" ROOFING NAILS, GALV.	AS REQ'D	697888	
		-	492192	
14	COUPLING, PVC, 3/4"	2	280416	
15				
16	BRACKET, DOUBLE CUTOUT/ARRESTER, FOR CROSSARM MOUNTING.	3	165442	
17	CUTOUT, 12KV, 100A, WITH LOADBUSTER HOOKS	3	STD 1212	
18	ARRESTER, LIGHTNING, 12KV	3	113248	
19	WIRE, #8 BARE SOLID ANNEALED COPPER (B)	15' OR 1 LB	812928	
20	STAPLES, WIRE, GALV, 1 1/4" (B)	AS REQ'D	678528	
21	BOLT, MACH, GALV, 5/8" X (LENGTH AS REQ'D) 2 SQUARE AND 1 DOUBLE COIL SPRING WASHER	1	STD 392	
22	PIN, TRANSFORMER ADAPTOR, 1" LEAD THREAD	1	529248	
23	INSULATOR, LINE, 12KV NEUTRAL	1	429216	
24	CONNECTOR, WIRE COMPRESSION, CU OR AL (SIZE AS REQ'D)	AS REQ'D	783-786	
25	WIRE, #4 BARE STRANDED COPPER	130' OR 17 LBS	813760	
26	MOULDING, OAK HARDWOOD, 1" X 8'	2	487200	
27				
28	BOLT, MACH, GALV, 3/4" X (LENGTH AS REQ'D), 1 SQ CURV RIBBED & 1 DBL COIL SPRING WASHER	2	STD 392	
29	COVER, BOLT PLASTIC & 6 - 1 3/4" NAILS, GALV	2	285696	
		-	492192	
30	CAPACITOR RACK - COMPLETE WITH CAPACITORS	600 KVAR (3 @ 200 KVAR)	1	564761
		900 KVAR (6 @ 150 KVAR) (J)	1	564706
		1200 KVAR (3 @ 400 KVAR) (M)	1	564770
		1350 KVAR (9 @ 150 KVAR) (J)	1	564754
31	SCREW, LAG, GALV, 4"	2	621568	
32	UNIT GROUND, COMPLETE	1	603136	
33	TAG, STATION NUMBER	1	200 SECT.	

FOR FIELD MAINTENANCE ONLY

DATE 12-1-98	SDG&E ELECTRIC STANDARDS	1399.209
APPD PJA / CMK	SWITCHED CAPACITORS - CURRENT SENSOR 12 & 12.47KV	SUPERSEDES 1326.2 (12-1-98)

OVERHEAD MACRO UNITS 12KV SWITCHED CAPACITOR W/CURRENT SENSOR		
KVAR	CONTROL	MU I.D.
600	VAR/VOLT OVERRIDE	C6CV
600	VOLT W/TIME BIAS	C6CTB
900	VAR/VOLT OVERRIDE	C9CV
900	VOLT W/TIME BIAS	C9CTB
1200	VAR/VOLT OVERRIDE	C12CV
1200	VOLT W/TIME BIAS	C12CTB
1350	VAR/VOLT OVERRIDE	C13CV
1350	VOLT W/TIME BIAS	C13CTB

INSTALLATION:

- A. CAUTION: OPEN OIL SWITCHES BEFORE OPENING CUTOUTS.
- ⓑ BOND CUTOUTS IN HEAVY CONTAMINATION DISTRICTS AS SHOWN ON STANDARD 287. IN AREAS WHERE BONDING IS REQUIRED, TO AVOID BONDWIRE AND LIGHTNING ARRESTER GROUNDWIRE ON THE SAME CROSSARM, USE TWO CROSSARMS; ONE FOR CUTOUTS AND ONE FOR LIGHTNING ARRESTER.
- ⓒ THE CONTROL IS POLARITY SENSITIVE. WIRE AS SHOWN, ALWAYS FACE NIPPLE OF CURRENT SENSOR TOWARD LOAD, AND INSTALL CUTOUTS ON THE SOURCE SIDE.
- ⓓ THE H1 TERMINAL OF THE POTENTIAL TRANSFORMER MUST BE CONNECTED TO THE SAME PHASE AS THE CURRENT SENSOR.
- ⓔ CONNECT CAPACITOR RACK GROUND LEAD, CURRENT SENSOR BASE AND ALL INSULATOR PINS GROUND LEAD TO LIGHTNING ARRESTER GROUND. A SECOND GROUND WIRE IS REQUIRED FOR THE CONTROL PANEL TO BE CONNECTED ON THE SAME GROUND ROD. COIL LOOSE END OF CONTROL PANEL GROUND WIRE AND STAPLE TO POLE (TO BE WORKED BY SERVICE CREW).
- G. DO NOT TIE CAPACITOR BANK NEUTRAL TO 12KV CIRCUIT NEUTRAL. IT IS TO REMAIN FLOATING.
- H. RACKS THAT CONTAIN POTENTIAL TRANSFORMERS WITH METAL TANKS ARE TO BE INSULATED FROM RACK BEFORE REINSTALLATION.
- I. CAPACITORS MUST BE INSTALLED ON POLES ACCESSIBLE BY BUCKET TRUCKS.
- ⓙ NO LONGER PURCHASED.
- Ⓚ PVC CONDUIT 3/4" SCHEDULE 40 MAY BE USED IN PLACE OF HARDWOOD MOULDING.
- Ⓛ REMOVE STEEL NIPPLE FROM CURRENT SENSOR BASE.
- Ⓜ ON VAR CONTROL BANKS, REPLACE 12,000 – 120 POTENTIAL TRANSFORMER (STOCK #762708) WITH 7200–120 POTENTIAL TRANSFORMER (STOCK #762734).
- Ⓝ DRILL THROUGH CROSSARM 1" UP FROM LOWER EDGE SO THAT LOWER CROSSARM MOUNTING BRACKET BOLT DOES NOT INTERFERE WITH PVC CONDUIT.
- Ⓞ WHEN LA/CO CROSSARM AND CAPACITORS CANNOT BE INSTALLED ON THE SAME SIDE OF THE POLE AS AN EXISTING LINEARM, DELETE ITEMS 2, 3, & 4. INSTEAD, FIELD DRILL LA/CO CROSSARM FOR 2 – 36" FLAT BRACES. SECURE BRACES TO POLE WITH A LAG SCREW. (SEE STD. 380.1, ITEM 1 FOR DRILLING MEASUREMENTS).

FOR FIELD MAINTENANCE ONLY

REFERENCE:

- Ⓟ SHOWN FOR ILLUSTRATIVE PURPOSES ONLY. SEE STANDARD 1330 FOR CONTROL INSTALLATION AND MATERIAL.
- Ⓠ PVC CONDUIT IS NOT PERMITTED IN THE CLIMBING SPACE, G.O. 95 RULE 22.2(C).
- Ⓡ SECTIONALIZING CUTOUT INSTALLATION MAY VARY WITH POSITION OF NEUTRAL CONDUCTOR – SEE STANDARD 1240.

<p>1399.210 SUPERSEDES 1326.3 (12-1-98)</p>	<p>SDG&E ELECTRIC STANDARDS</p> <p>SWITCHED CAPACITORS – CURRENT SENSOR</p> <p>12 & 12.47KV</p>	<p>DATE 12-1-98 APPD <i>PA/BJ</i></p>
-----------------------------------------------------	---------------------------------------------------------------------------------------------------------	-------------------------------------------

FIELD MAINTENANCE ONLY

REVISION HISTORY:

7/13/2016: All versions prior to 2016 are superseded by their current version found inside the Overhead Construction Standard Manual.

© 1998 - 2016 San Diego Gas & Electric Company. All rights reserved. Removal of this copyright notice without permission is not permitted under law.

REV	CHANGE	BY	DSGN	APPV	DATE	REV	CHANGE	BY	DSGN	APPV	DATE
C						F					
B						E					
A	ORIGINAL ISSUE	JS	IL	MDJ	7/13/2016	D					

	Indicates Latest Revision	Completely Revised	New Page	Information Removed
-------------------------------------------------------------------------------------	---------------------------	--------------------	----------	---------------------

**SHEET
1 OF 1**

SDG&E ELECTRIC OVERHEAD STANDARD

CAPACITOR CONTROL MATERIAL AND INSTALLATION
VOLTAGE WITH TIME BIAS (TYPE 'TB')

**FMO
OH 1330**

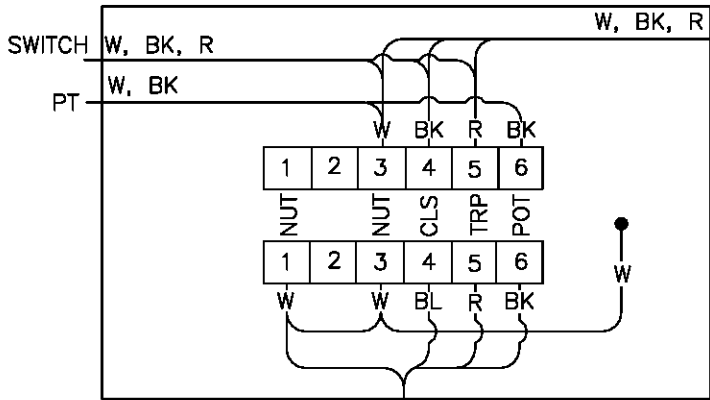

JUNCTION BOX

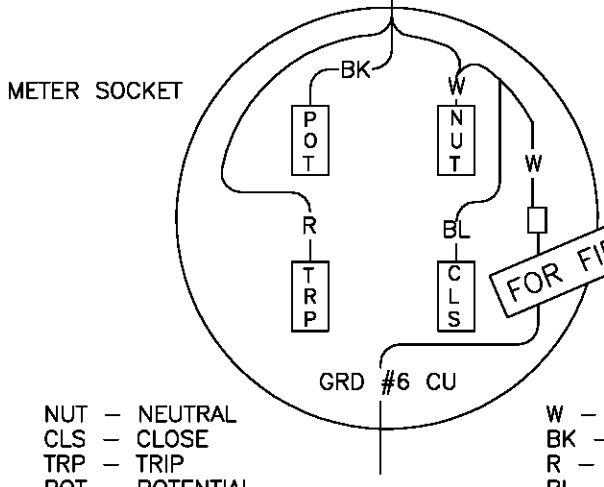

- NUT - NEUTRAL
- CLS - CLOSE
- TRP - TRIP
- POT - POTENTIAL
- W - WHITE
- BK - BLACK
- R - RED
- BL - BLUE

CAPACITOR CONTROL WIRING
VOLTAGE W/TIME BIAS

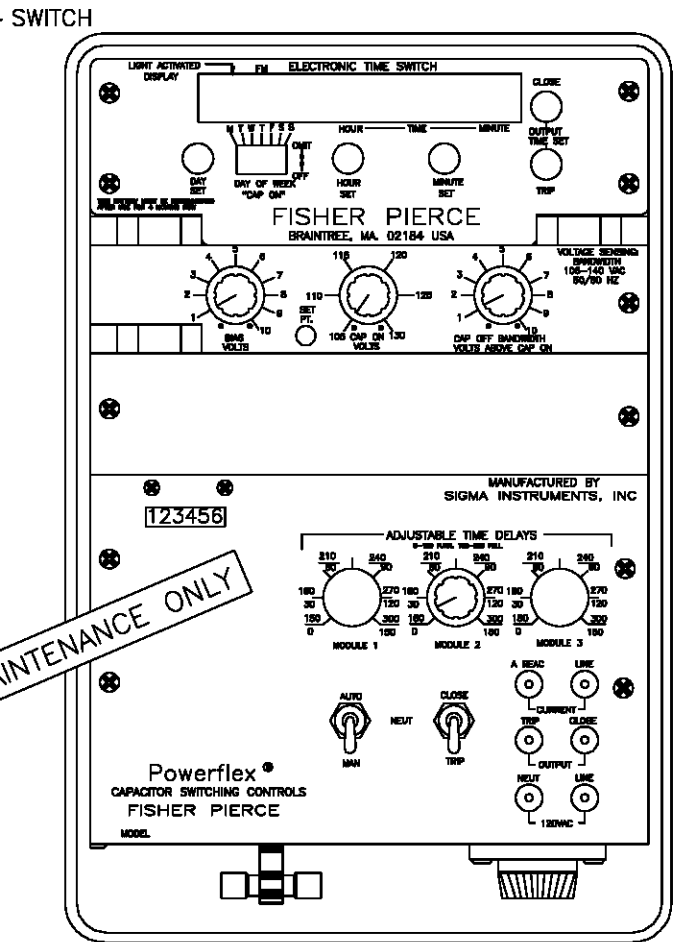

CONTROL PANEL
FISHER PIERCE (MODEL 2416)

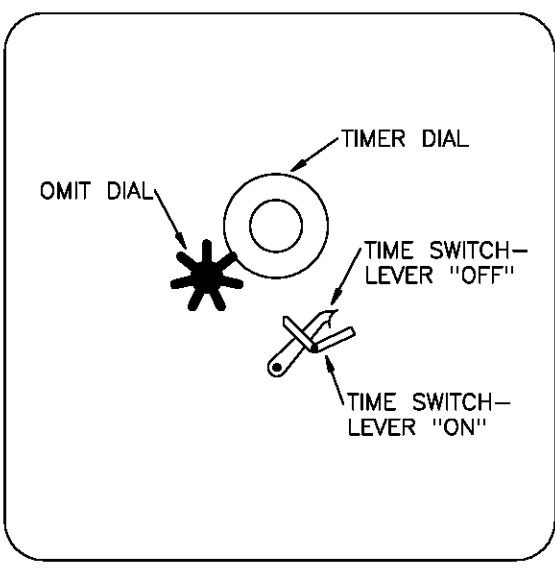

CONTROL PANEL - SANGAMO (MODEL VS)

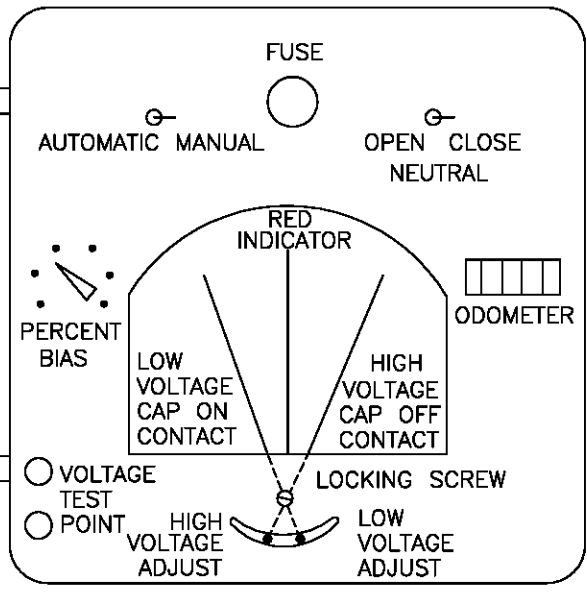

FUSE REPLACEMENT 10 AMP BUSS FNM10

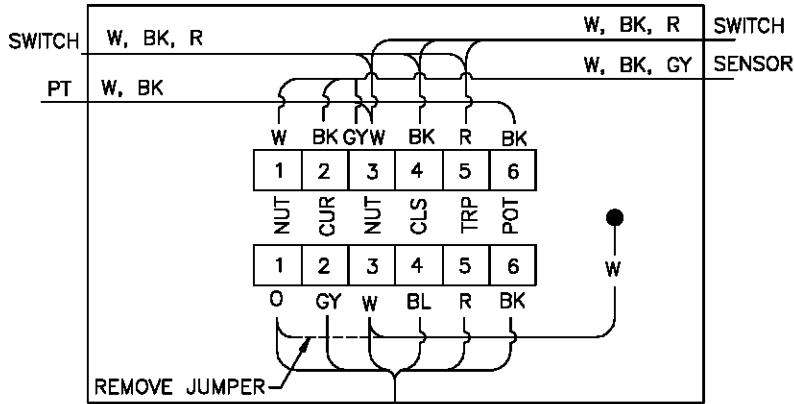

TO GROUND OUT SENSOR,
INSTALL JUMPER WHEN
CONTROL IS REMOVED.

JUNCTION BOX
METER SOCKET

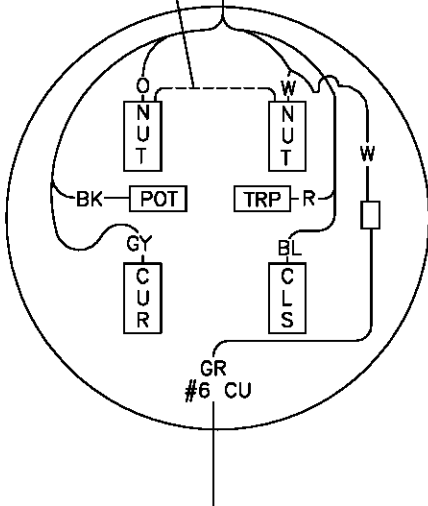

AC VOLTMETER
<5V

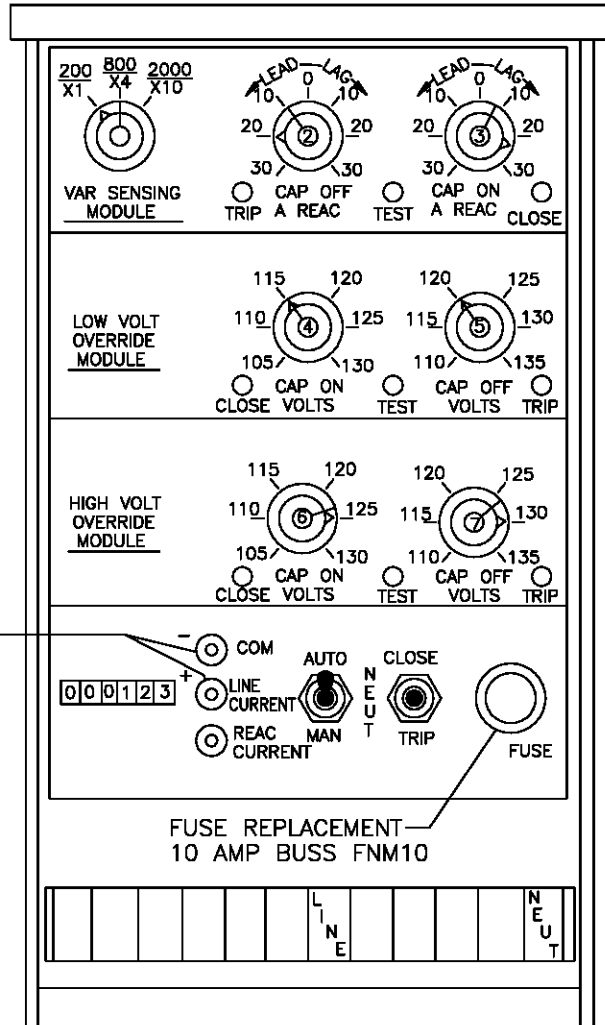

CONTROL WIRE LEGEND

- NUT - NEUTRAL
- CUR - CURRENT SENSOR POTENTIAL
- CLS - CLOSE
- TRP - TRIP
- POT - POTENTIAL

- W - WHITE
- BK - BLACK
- GY - GREEN
- R - RED
- O - ORANGE
- BL - BLUE

FOR FIELD MAINTENANCE ONLY

**CONTROL PANEL
FISHER PIERCE (MODEL 4604)**

**CAPACITOR CONTROL WIRING
VAR W/VOLTAGE OVERRIDE**

1399.302
SUPERSEDES
1330.3 (1-1-90)

SDG&E ELECTRIC STANDARDS
CAPACITOR CONTROL MATERIAL AND INSTALLATION
TYPE 'VAR'

DATE 1-1-2000
APPD *PA/BDJ*

SCOPE: THIS STANDARD SHOWS TYPES OF CONTROLS, MATERIAL AND INSTALLATION OF A CAPACITOR CONTROL UNIT. THIS IS TO BE USED ON ALL SWITCHED CAPACITOR STATIONS.

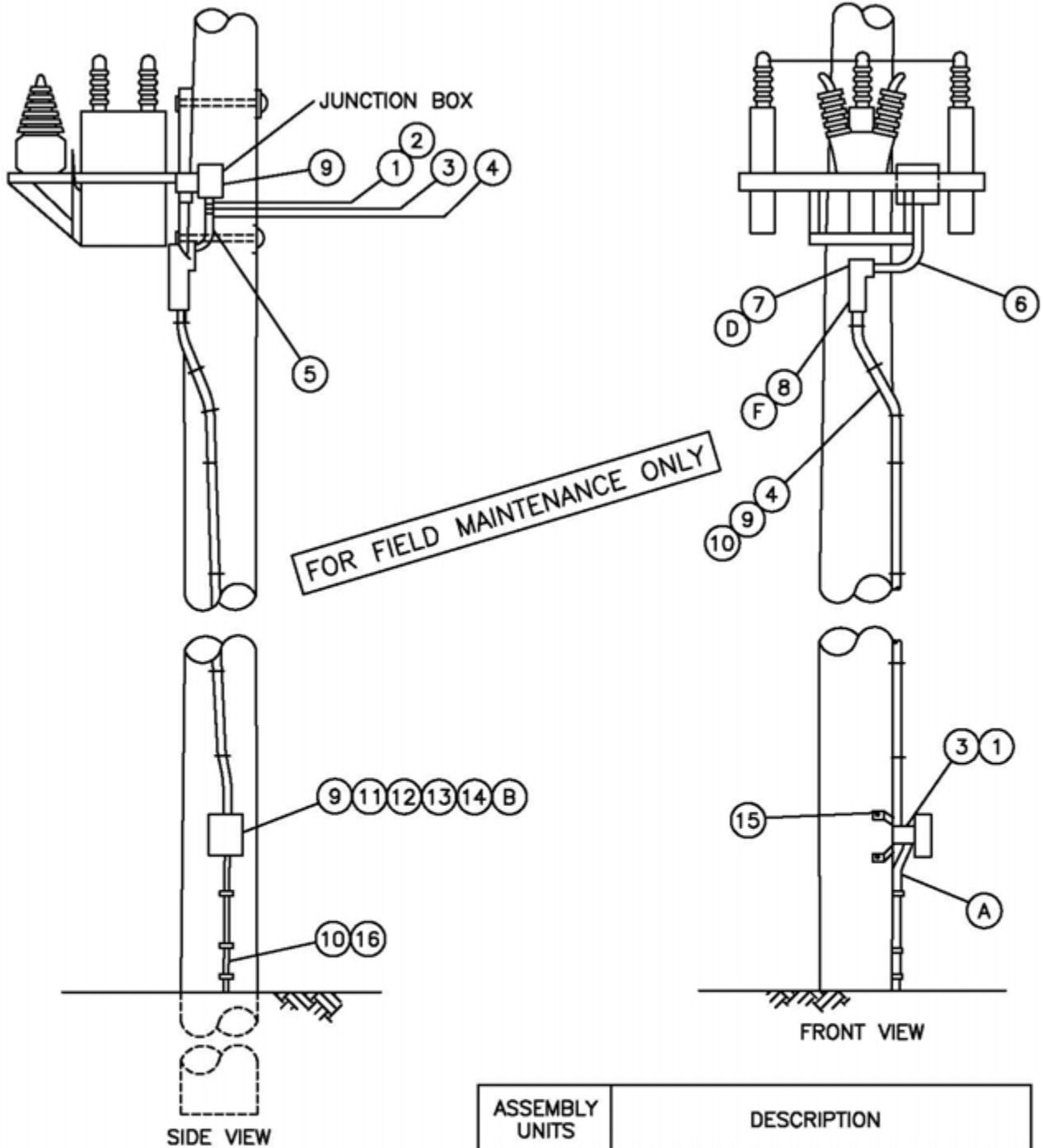

ASSEMBLY UNITS	DESCRIPTION
C/CTIM	CONTROL-DIGITAL, PROGRAMMABLE

- NOTE:**
- SEE PAGE 1330.4 FOR BILL OF MATERIAL
 - MATERIALS ORDERED ARE BASED ON A 50' POLE.

© 1998 - 2010 San Diego Gas & Electric Company. All rights reserved. Removal of this copyright notice without permission is not permitted under law.

DATE 1-1-2000 APPD <i>PA/Val</i>	SDG&E ELECTRIC STANDARDS	1399.511 SUPERSEDES 1330.1 (1-1-2000)
	CAPACITOR CONTROL MATERIAL AND INSTALLATION	

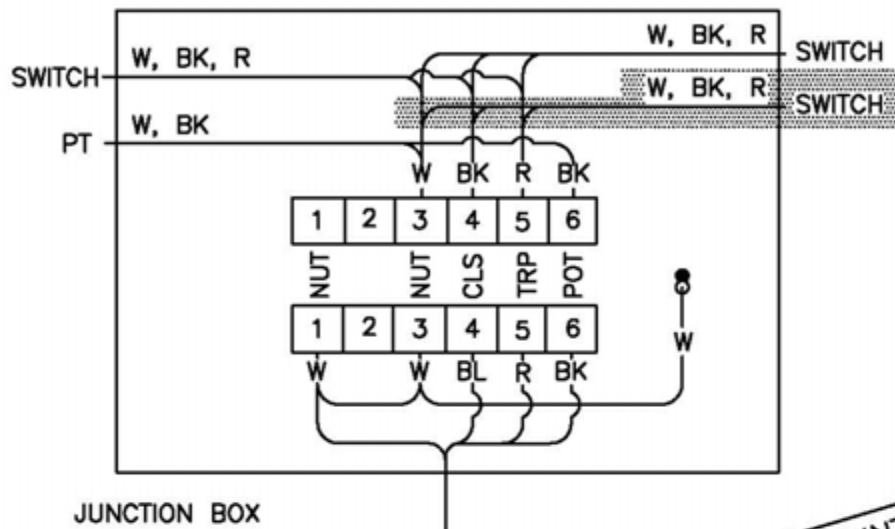

FOR FIELD MAINTENANCE ONLY

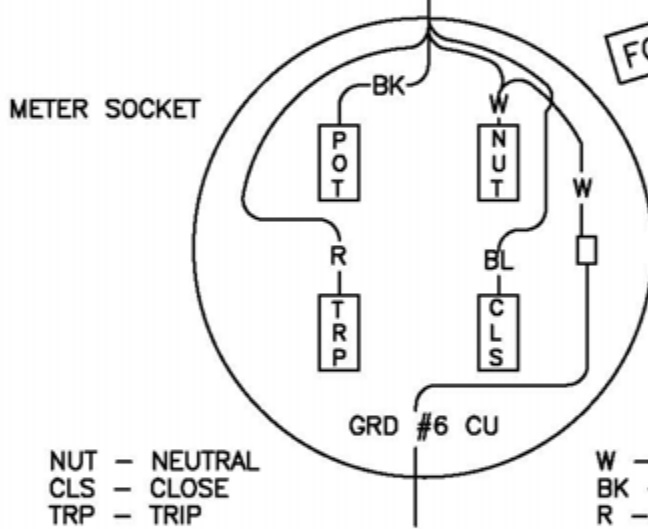

- NUT - NEUTRAL
- CLS - CLOSE
- TRP - TRIP
- POT - POTENTIAL
- W - WHITE
- BK - BLACK
- R - RED
- BL - BLUE

CAPACITOR CONTROL WIRING

CONTROL PANEL
(FACING METER SOCKET)

© 1998 - 2012 San Diego Gas & Electric Company. All rights reserved. Removal of this copyright notice without permission is not permitted under law.

1399.512
SUPERSEDES
1330.2 (4-3-09)

SDG&E ELECTRIC STANDARDS

CAPACITOR CONTROL MATERIAL AND INSTALLATION
VOLTAGE WITH TIME BIAS (TYPE 'TB')

DATE 4-3-09
APPD *PA* / BV

BILL OF MATERIAL: (FOR CONTROL PORTION OF SWITCHED CAPACITOR JOBS)

ITEM	DESCRIPTION	QUANTITY	STOCK NUMBER
1	TERMINAL ADAPTER, PVC 1"	2	102756
2	LOCKNUT, GALV. 1"	1	468896
3	REDUCER, PVC 1" X 3/4"	2	573410
4	CONDUIT, PVC 3/4" SCHEDULE 40	25'	251328
5	COUPLING, PVC 3/4"	1	280416
6	ELBOW 90° , PVC 3/4"	1	322166
7	ACCESS FITTING BODY TYPE "T" PVC 3/4" (D)	1	147792
8	ACCESS FITTING BODY TYPE "LB" PVC 3/4" (F)	1	146384
9	WIRE TW #12 WHITE	30'	808704
	WIRE TW #12 BLACK	30'	808096
	WIRE TW #12 BLUE	30'	808416
	WIRE TW #12 RED	30'	808576
10	STRAPS, PIPE GALV 3/4", 6 D NAILS, GALV	AS REQ'D	697888/490656
11	METER SOCKET	1	161898
12	RING, STAINLESS STEEL, METER SEALING	1	599034
13A	DIGITAL, PROGRAMMABLE CONTROL (C)	1	706176
13B	FISHER PIERCE 2416 CONTROL REPLACEMENT BATTERY KIT (G)(H)	-	126800
14	PADLOCK, MASTER 7	1	514912
15	SCREW, LAG 1/4" X 2"	4	621888
16	CONDUIT, PVC 3/4" SCHEDULE 80	9	251520

FOR FIELD MAINTENANCE ONLY

INSTALLATION:

- (A) ATTACH GROUND WIRE (ALREADY PROVIDED) TO GROUND TERMINAL OF METER SOCKET.
- (B) INSTALL CONTROL 90' FROM FRONT SIDE OF CAPACITOR RACK.
- (C) CONTROLS TO BE CONFIGURED/PROGRAMED PER THE DISTRIBUTION CAPACITOR INSTRUCTION, SETTING AND SURVEY INFORMATION MANUALS.
- (D) FOR USE WHEN CURRENT SENSOR IS REQUIRED.
- (E) NEW INSTALLATIONS MUST BE AUTHORIZED BY PLANNING ENGINEER.
- (F) FOR USE WITHOUT CURRENT SENSOR.
- (G) REPLACEMENT KIT INCLUDES: ONE 6 VOLT RECHARGEABLE LEAD ACID BATTERY, 2-30 INCH WIRES WITH CONNECTORS ON BOTH ENDS, DOUBLE SIDED ADHESIVE TAPE.
- (H) IF BATTERY IS INSTALLED ON CIRCUIT BOARD BEHIND CONTROL PANEL, INSTALL NEW BATTERY ON RIGHT HAND SIDE OF CONTROL DOOR. DO NOT ATTEMPT TO REMOVE OLD BATTERY FROM CIRCUIT BOARD BECAUSE BOARD MAY BE DAMAGED.

REFERENCE:

- I. SEE STANDARD 1325 FOR A TWO OIL SWITCH INSTALLATION WITH CONTROL UNIT.
- J. SEE FMO STANDARD 1399.208 FOR A SWITCH CAPACITOR USING A CURRENT SENSOR AND CONTROL UNIT.
- K. SEE ELECTRIC STANDARD PRACTICE 302 FOR PROPER OPERATION OF CAPACITOR STATION AND CONTROL TESTING.
- L. PVC CONDUIT IS NOT PERMITTED IN THE CLIMBING SPACE-SEE G.O. 95 RULE 22.2(C).

© 1998 - 2005 San Diego Gas & Electric Company. All rights reserved. Removal of this copyright notice without permission is not permitted under law.

DATE 1-28-02 APPD <i>PBA/vcl</i>	SDG&E ELECTRIC STANDARDS CAPACITOR CONTROL MATERIAL AND INSTALLATION	1399.513 SUPERSEDES 1330.3 (8-31-99)
-------------------------------------	-----------------------------------------------------------------------------------------------	---------------------------------------------------

FIELD MAINTENANCE ONLY

REVISION HISTORY:

7/13/2016: All versions prior to 2016 are superseded by their current version found inside the Overhead Construction Standard Manual.

© 1998 - 2016 San Diego Gas & Electric Company. All rights reserved. Removal of this copyright notice without permission is not permitted under law.

REV	CHANGE	BY	DSGN	APPV	DATE	REV	CHANGE	BY	DSGN	APPV	DATE
C						F					
B						E					
A	ORIGINAL ISSUE	JS	IL	MDJ	7/13/2016	D					

<input checked="" type="checkbox"/>	Indicates Latest Revision	<input type="checkbox"/>	Completely Revised	<input type="checkbox"/>	New Page	<input type="checkbox"/>	Information Removed
-------------------------------------	---------------------------	--------------------------	--------------------	--------------------------	----------	--------------------------	---------------------

**SHEET
1 OF 1**

SDG&E ELECTRIC OVERHEAD STANDARD

STEP-VOLTAGE REGULATOR STATION, OPEN DELTA, 12KV

**FMO
OH 1348**

SCHEMATIC DIAGRAM OF A 12KV OPEN DELTA REGULATOR STATION

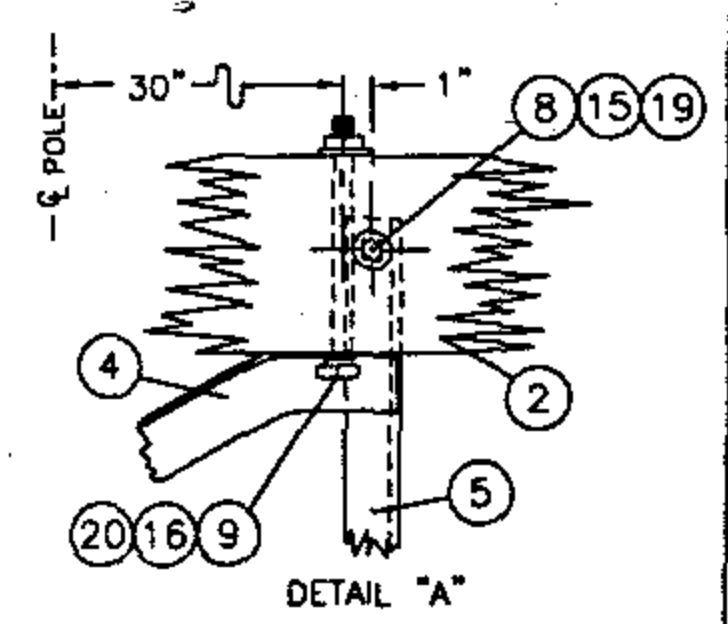
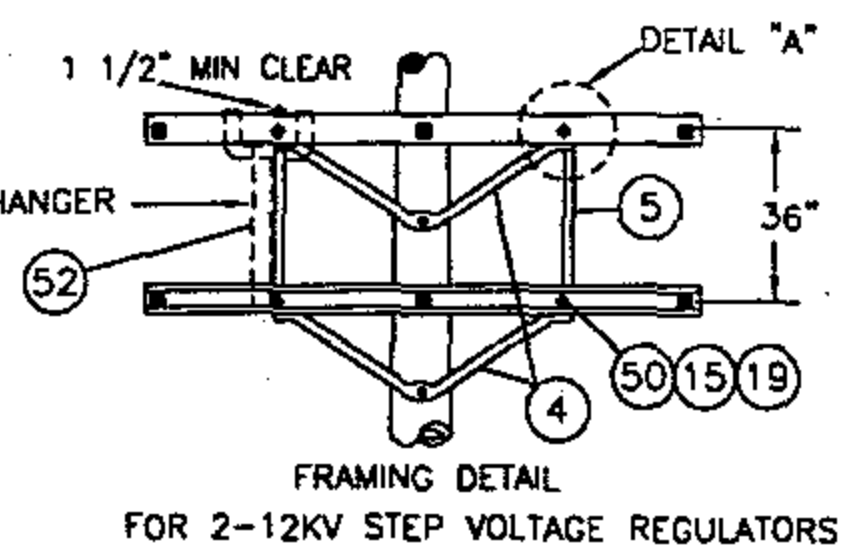
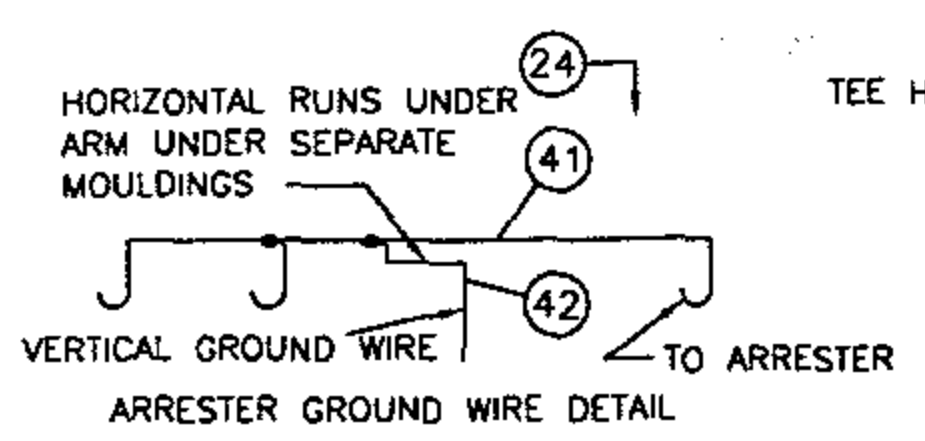
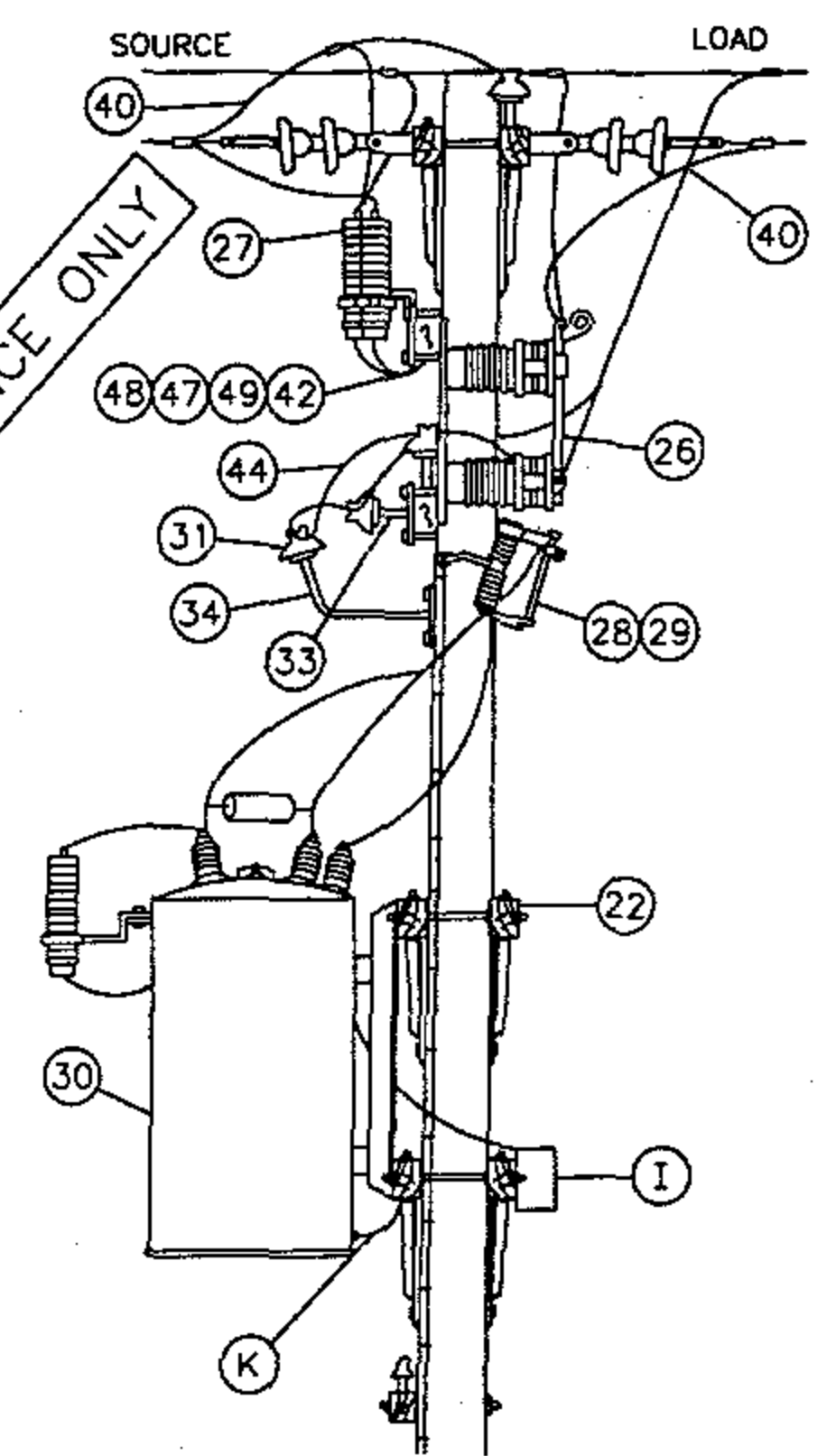
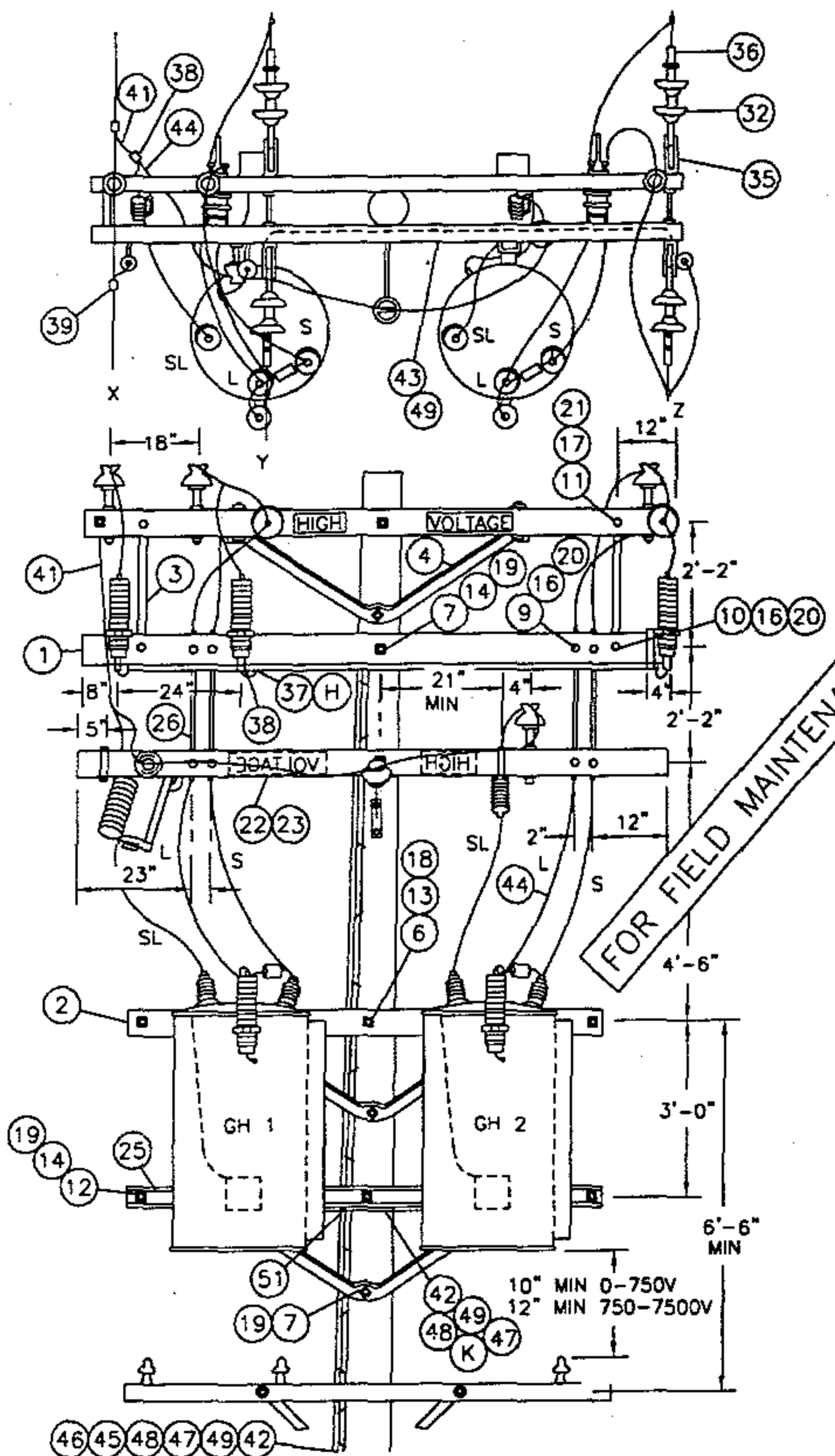
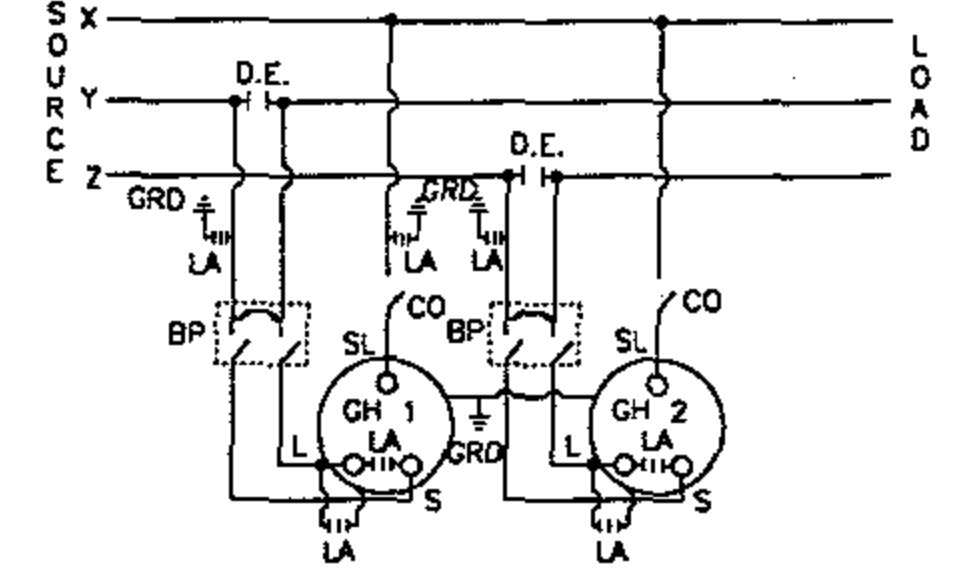

SDG&E ELECTRIC STANDARDS

1399.401
SUPERSEDES
1348.1 1-1-96

STEP-VOLTAGE REGULATOR STATION, OPEN DELTA, 12KV

DATE 1-1-96
APPD PIA 1009

NOTES:

- A. **CAUTION:** WHEN CONNECTING A STATION, REGULATORS MUST BE ON NEUTRAL. CLOSE CUTOUT TO SL BUSHING BEFORE CLOSING BYPASS DISCONNECT ON THAT POLE. WHEN DISCONNECTING A STATION, PUT REGULATORS ON NEUTRAL, AND OPEN BYPASS DISCONNECT BEFORE OPENING CUTOUT TO SL BUSHING. THIS AVOIDS A SERIOUS OVERLOAD CONDITION.
- B. ON NEW CONSTRUCTION, USE AN EXTRA HEAVY CLASS ONE POLE WITH 10" MIN TOP DIA.
- C. USE TWO GROUND RODS FOR THE ARRESTERS AND TANKS. ALL GROUND RODS SHOULD BE SPACED A MINIMUM OF SIX FEET APART.
- D. UNIT GROUND COMPLETE, ORDER 603136.
- F. BOND ALL CUTOUTS IN HEAVY CONTAMINATION DISTRICT AS IDENTIFIED ON STANDARDS PAGE 287.
- G. BOND DEAD-END HARDWARE
- H. INTERCONNECT ARRESTER GROUND LEAD DISCONNECTS WITH #6 BARE COPPER AND GROUND IT WITH #2 BARE COPPER NEAR CENTER ARRESTER.
- I. CONTROLS WILL BE MOUNTED BY KEARNY MAINTENANCE.
- J. INSTALL DOUBLE COIL SPRING WASHER ON END OF BOLT WHICH ATTACHES TO LARGEST METALLIC OBJECT, SUCH AS A BRACKET OR BRACE.
- K. REGULATOR TANKS SHALL BE PERMANENTLY GROUNDED.

ITEM			DESCRIPTION	QUANTITY	STOCK NO. OR CONSTR STD
PTF	LTI	OCD			
1			CROSSARM 3 3/4" X 5 3/4" X 10' - 0"	3	380
2			CROSSARM 3 3/4" X 5 3/4" X 8' - 0"	4	380
3			BRACE, FLAT CROSSARM 28"	2	164192
4			BRACE, ANGLE CROSSARM 5' - 0"	5	164128
5			BRACE, VERTICAL 36"	2	164256
6			BOLT, MACH 3/4" X ---	2	100 SECTION
7			BOLT, MACH 5/8" X ---	4	100 SECTION
8			BOLT, MACH 5/8" X 5"	2	155488
9			BOLT, MACH 1/2" X 7"	16	153120
10			BOLT, MACH 1/2" X 5"	2	153024
11			BOLT, MACH 3/8" X 5"	2	154368
12			BOLT, SPACE 5/8" X ---	7	100 SECTION
13			WASHER, 3" SQ FLAT	4	799104
14			WASHER, 2 1/4" SQ FLAT	28	799040
15			WASHER, 5/8" ROUND	4	800320
16			WASHER, 1/2" ROUND	20	800192
17			WASHER, 3/8" ROUND	2	800288
18			WASHER, 3/4" SPRING DBL COIL	2	798496
19			WASHER, 5/8" SPRING DBL COIL	21	798560
20			WASHER, 1/2" SPRING DBL COIL	20	798464
21			WASHER, 3/8" SPRING DBL COIL	2	798528
22			SIGN, HIGH VOLTAGE	2	647648
23			NAILS, ROOFING #8 GALV	16	492224
24			STEPS, POLE	19	692992
25			STRIP, COVER 1 1/8" X 3 5/8" X 8' - 0" (2X4S4S)	1	699328
26			SWITCH BYPASS	2	706944
27			ARRESTER, LIGHTNING (12KV)	3	113248
28			CUTOUT, 12KV 100 AMP WITH LOAD BUSTER HOOKS	2	1200 SECTION
29			BLADE, DISCONNECT CUTOUT	2	1200 SECTION
30			REGULATOR, STEP VOLTAGE 1Ø, COMPLETE WITH HANGERS	2	1300 SECTION
31			INSULATOR, PIN TYPE (CLASS AS REQ'D)	3	700 SECTION
		32	INSULATOR, SUSPENSION	8	700 SECTION
33			PIN, INSULATOR (AS REQUIRED BY ITEM 31)	2	532---
34			BRACKET, INSULATOR (AS REQUIRED BY ITEM 31)	1	100 SECTION
		35	CLEVIS, DEAD END CLOSED	4	235712
		36	CLAMPS, DEAD END	4	700 SECTION
37			CONNECTOR, COMPRESSION (#2 TO #6)	2	257792
38			CONNECTOR, COMPRESSION (#6 TO #6)	2	257952
39			CONNECTORS, WIRE	6	700 SECTION
40			WIRE, BARE STRANDED COPPER #4	(2.5#) 20'	813760
41			WIRE, BARE STRANDED COPPER #6	(2.5#) 30'	813536
42			WIRE, BARE STRANDED COPPER #2	(9.2#) 45'	813664
43			WIRE, #8 ANNEALED SOLID COPPER	(.75#) 15'	812928
44			WIRE, #4 SOLID WP COPPER	(5.0#) 36'	812480
45			ROD, GROUND	2	603072
46			CLAMP, GROUND ROD	2	230016
47			MOULDING, HARDWOOD #1	50'	487200
48			STAPLES, GALV 3" X 1 1/16" X 1/4"	35	678560
49			STAPLES, FENCE GALV 1 1/4"	30	678528
50			BOLT, MACH 5/8" X 7"	2	155552
51			CONNECTOR, COMPRESSION (#2 TO #2)	1	257760
52			HANGER, TRANSFORMER T-2	2	402944

FOR FIELD MAINTENANCE ONLY

SDG&E ELECTRIC STANDARDS

DATE 1-1-96

APPD PA/ROJ

STEP VOLTAGE REGULATOR STATION, OPEN DELTA, 12KV

1399.402
SUPERSEDES
1348.2 1-1-96

FIELD MAINTENANCE ONLY

REVISION HISTORY:

7/13/2016: All versions prior to 2016 are superseded by their current version found inside the Overhead Construction Standard Manual.

© 1998 - 2016 San Diego Gas & Electric Company. All rights reserved. Removal of this copyright notice without permission is not permitted under law.

REV	CHANGE	BY	DSGN	APPV	DATE	REV	CHANGE	BY	DSGN	APPV	DATE
C						F					
B						E					
A	ORIGINAL ISSUE	JS	IL	MDJ	7/13/2016	D					

SHEET 1 OF 1	 Indicates Latest Revision	Completely Revised	New Page	Information Removed	FMO OH 1349
	SDG&E ELECTRIC OVERHEAD STANDARD				
	STEP-VOLTAGE REGULATOR STATION, CLOSED DELTA, 12KV, TWO POLES				

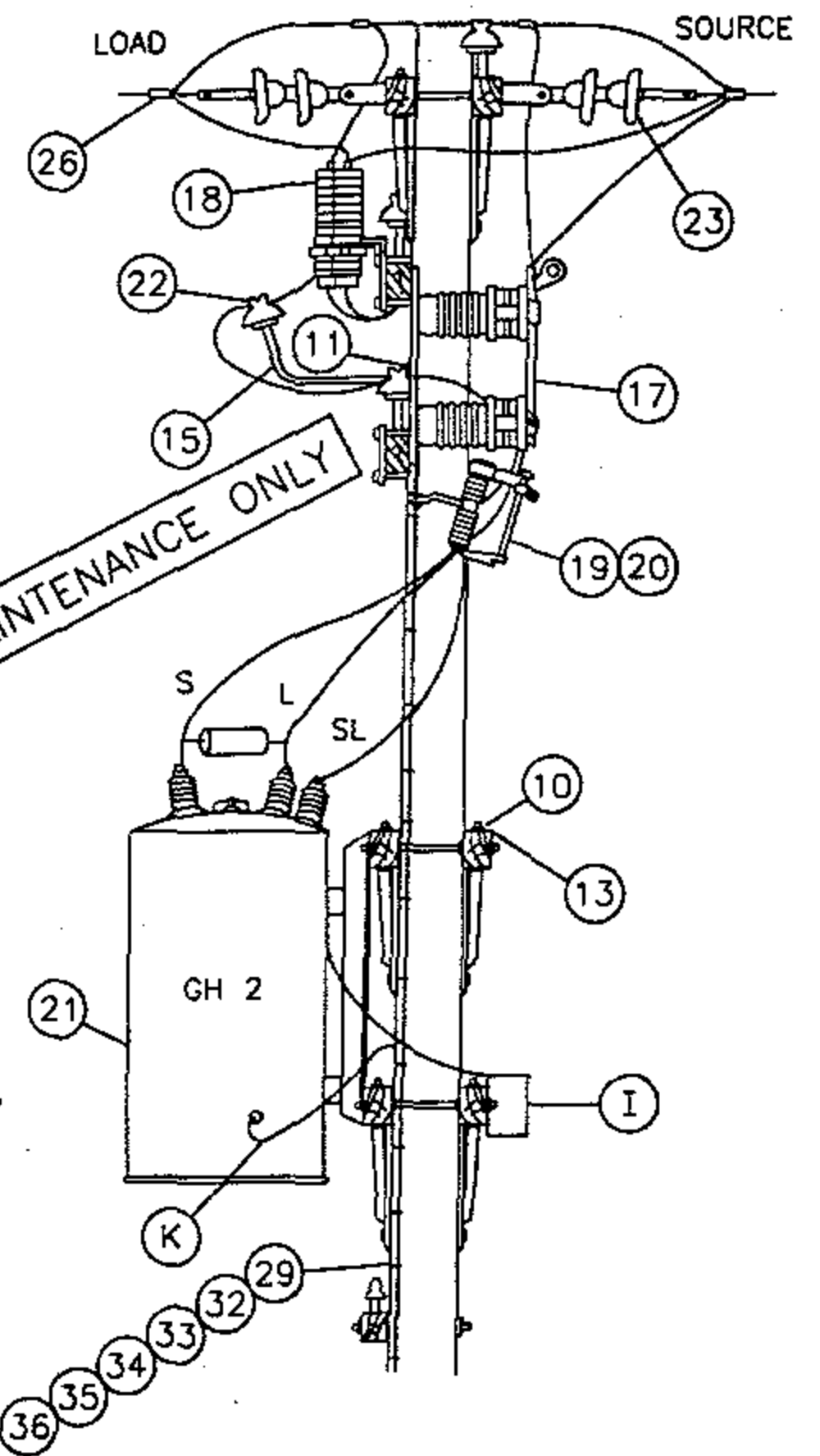
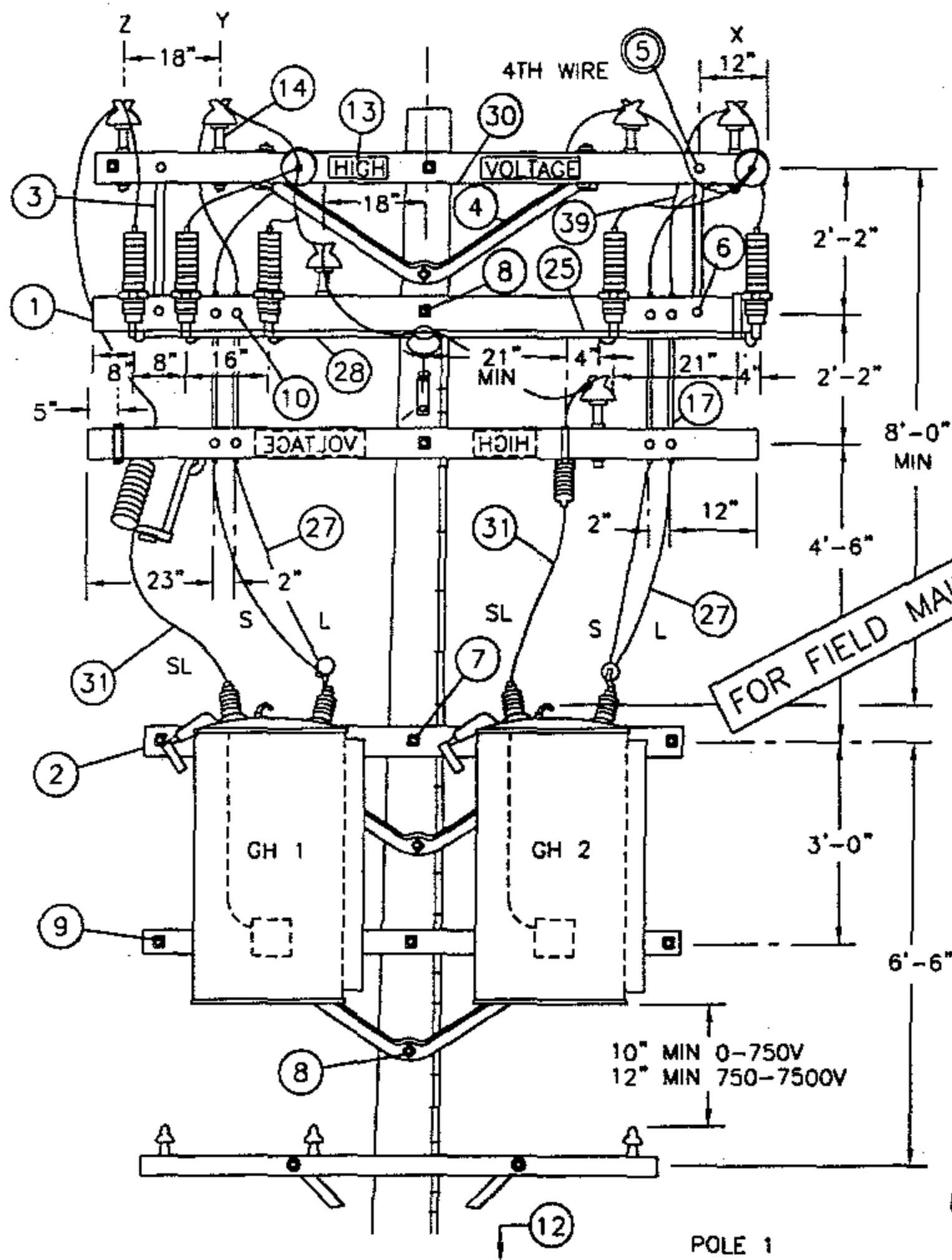
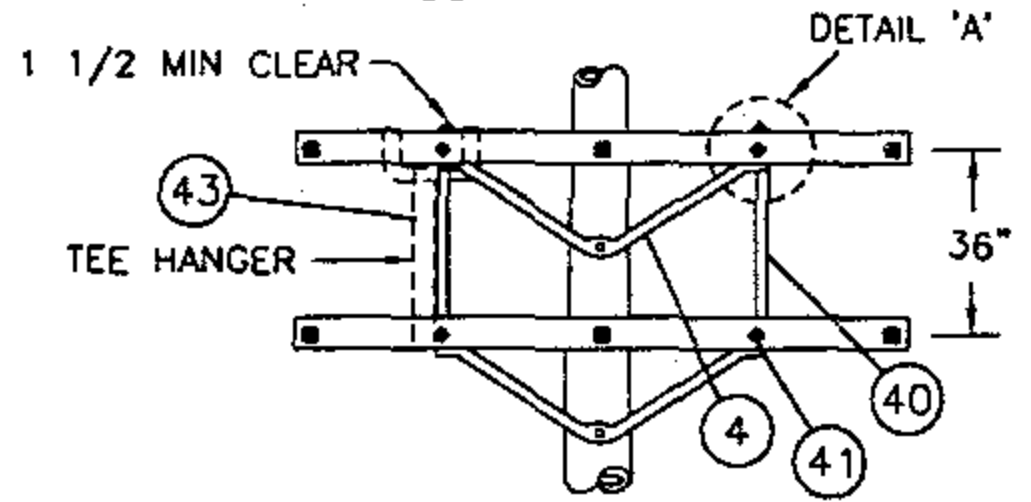
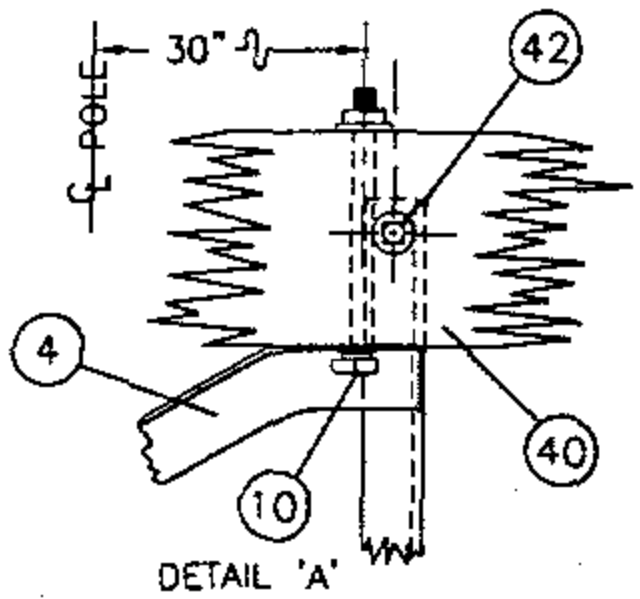
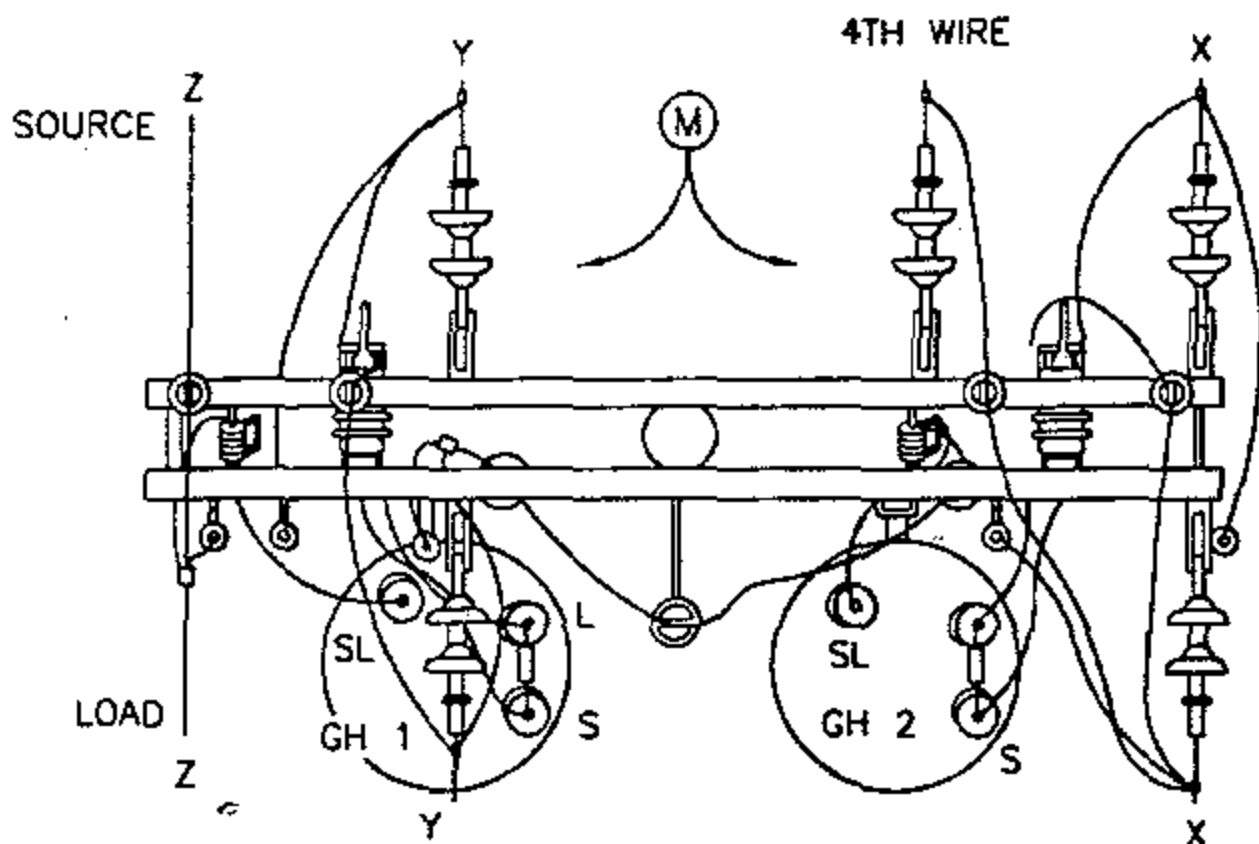

FOR FIELD MAINTENANCE ONLY

SDG&E ELECTRIC STANDARDS

DATE 1-1-96
APPD PJA/BJG

STEP-VOLTAGE REGULATOR STATION, CLOSED DELTA,
12KV, TWO POLES

1399.403
SUPERSEDES
1349.1 1-1-96

SCHEMATIC DIAGRAM OF A 12KV CLOSED DELTA
REGULATOR STATION

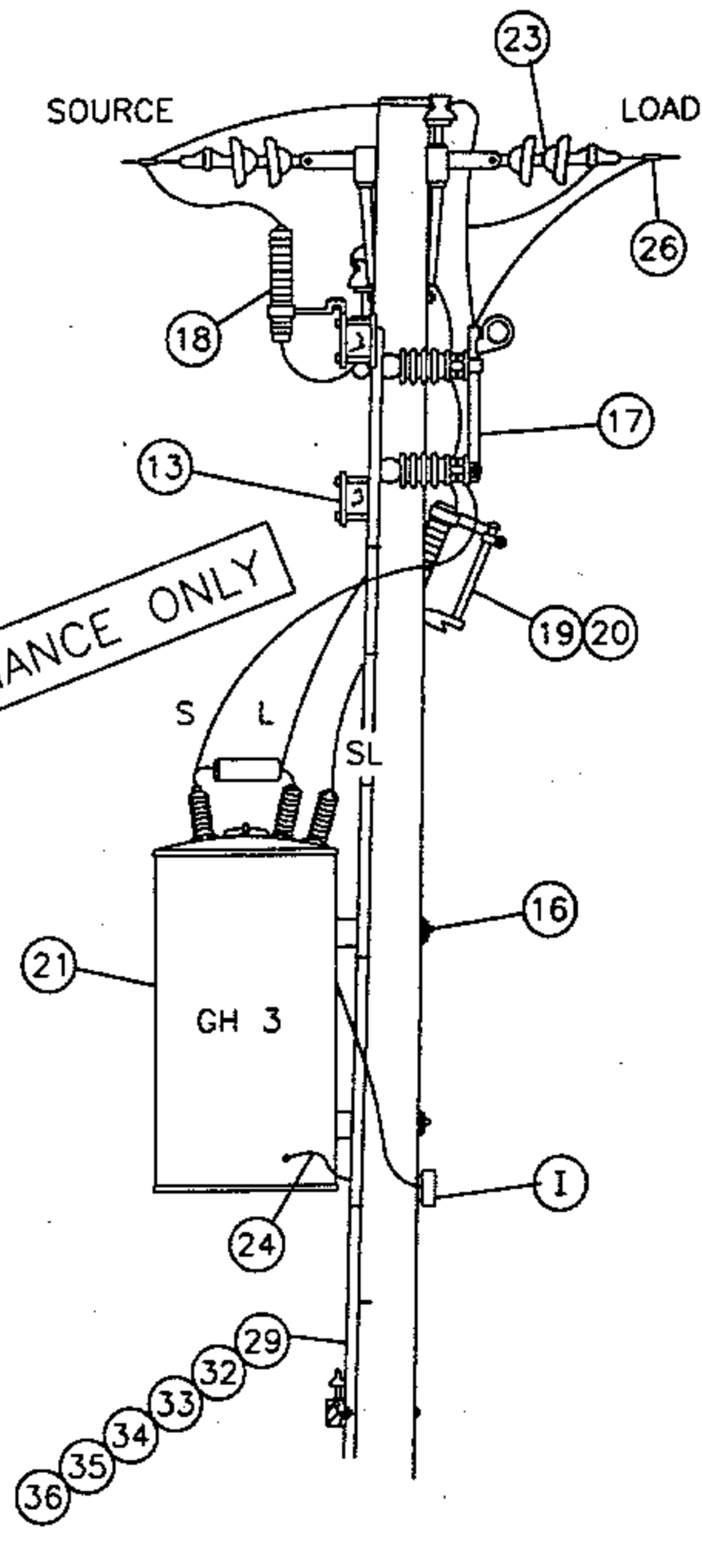
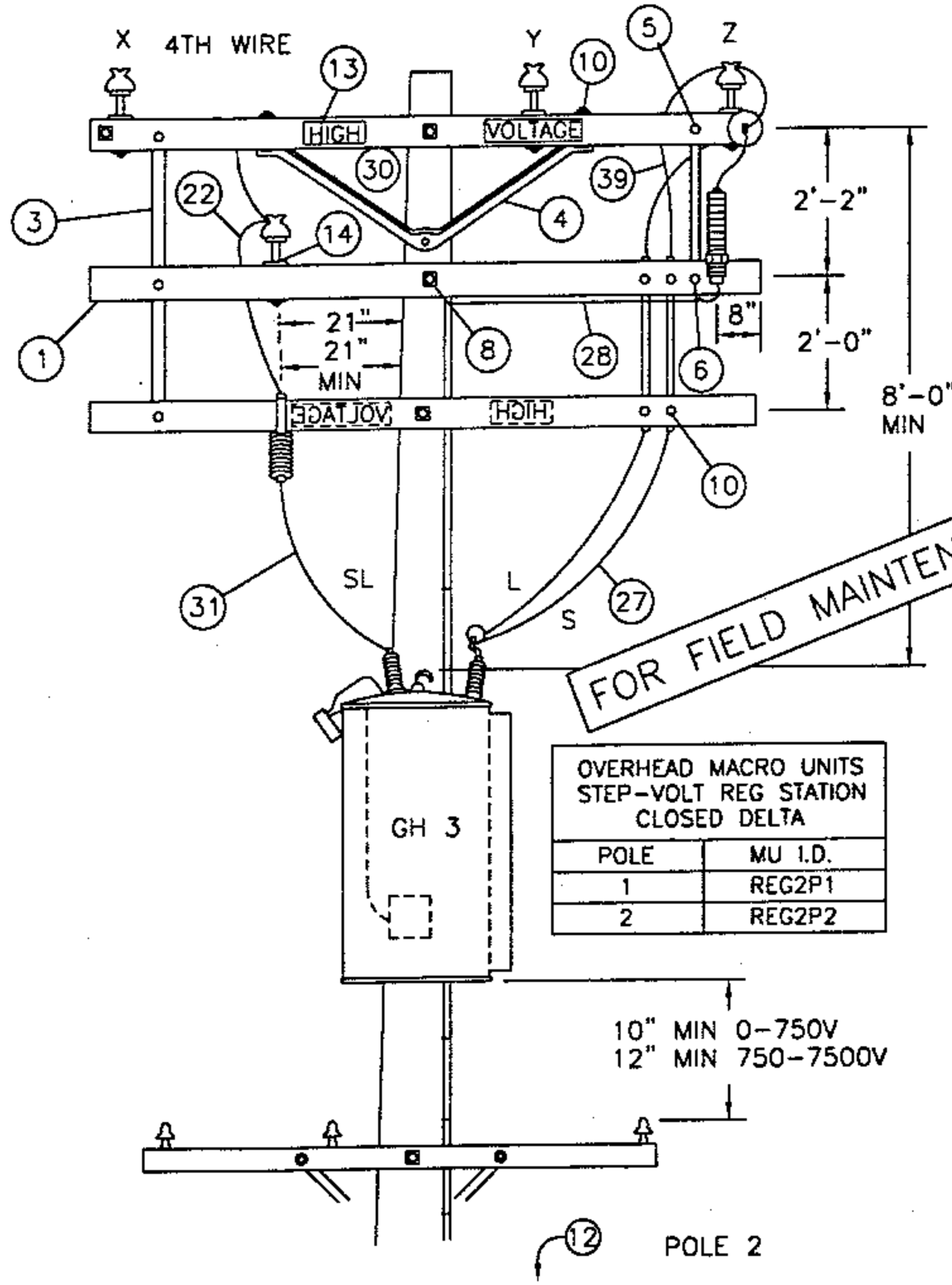
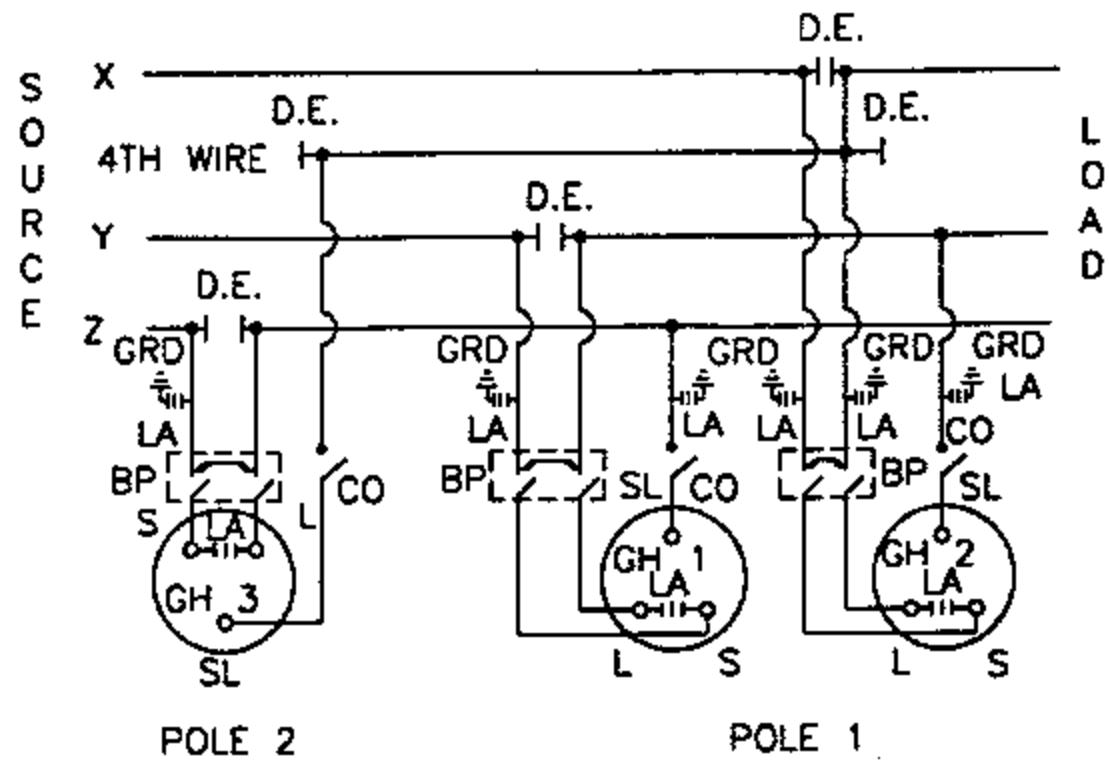
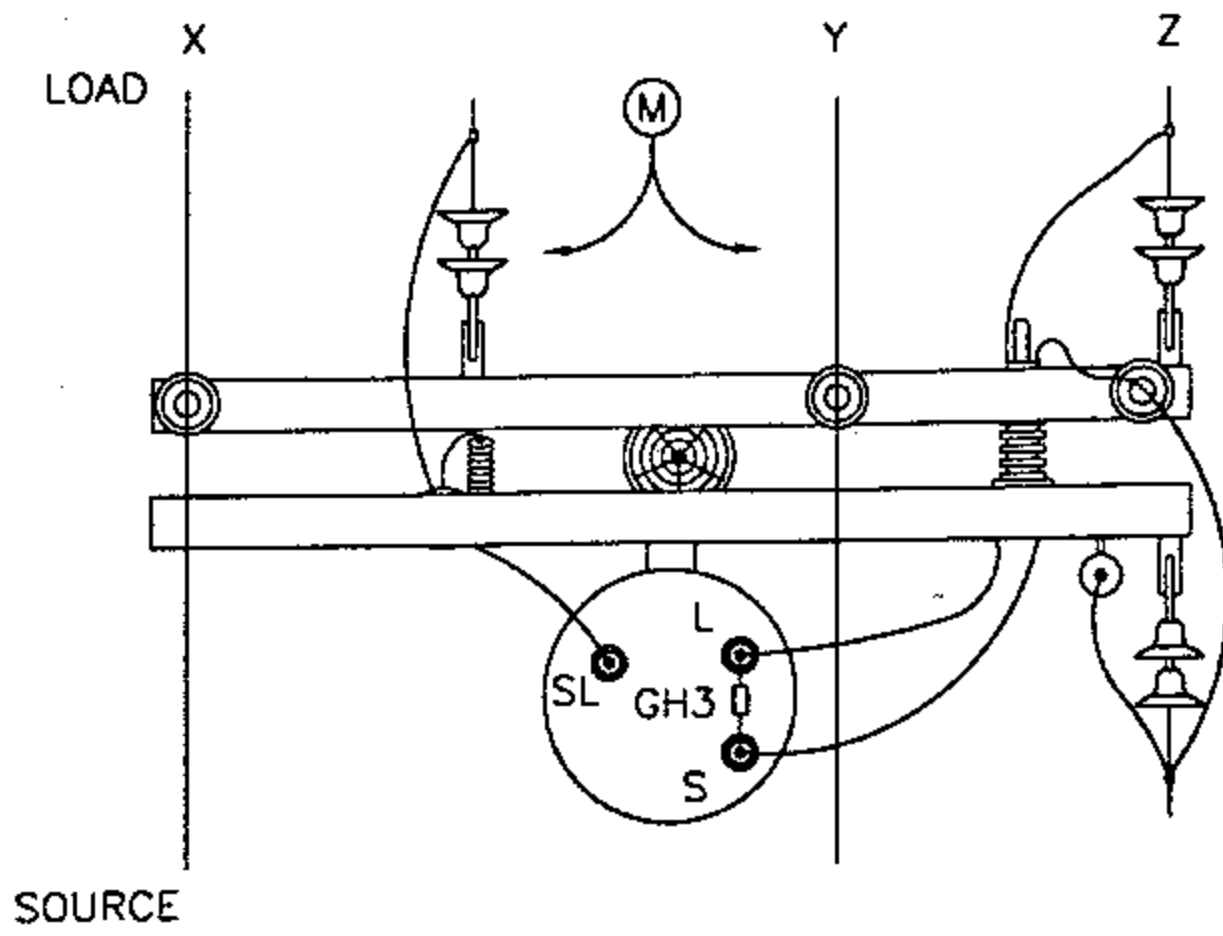

OVERHEAD MACRO UNITS
STEP-VOLT REG STATION
CLOSED DELTA

POLE	MU I.D.
1	REG2P1
2	REG2P2

10" MIN 0-750V
12" MIN 750-7500V

SDG&E ELECTRIC STANDARDS

STEP-VOLTAGE REGULATOR STATION, CLOSED DELTA,
12KV, TWO POLES

1399.404
SUPERSEDES
1349.2 1-1-96

DATE 1-1-96
APPD PFA 1/2/96

NOTES:

- A. CAUTION: WHEN CONNECTING A STATION, REGULATORS MUST BE ON NEUTRAL. CLOSE CUTOUT TO SL BUSHING BEFORE CLOSING BYPASS DISCONNECT ON THAT POLE. WHEN DISCONNECTING A STATION, PUT REGULATORS ON NEUTRAL, AND OPEN BYPASS DISCONNECT BEFORE OPENING CUTOUT TO SL BUSHING. THIS AVOIDS A SERIOUS OVERVOLTAGE CONDITION.
- B. USE EXTRA HEAVY CLASS ONE POLE WITH 10" MIN TOP DIA FOR POLE #1, AND A CLASS ONE FOR POLE #2.
- C. USE TWO GROUND RODS FOR THE ARRESTERS AND TANKS. ALL GROUND RODS SHOULD BE SPACED A MINIMUM OF SIX FEET APART.
- D. UNIT GROUND COMPLETE, ORDER 603136.
- F. BOND ALL CUTOUTS IN HEAVY CONTAMINATION DISTRICT AS IDENTIFIED ON STANDARDS PAGE 287.
- G. BOND DEAD-END HARDWARE.
- H. INTERCONNECT ARRESTER GROUND LEAD DISCONNECTS WITH #6 BARE COPPER AND GROUND IT WITH #2 BARE COPPER NEAR CENTER ARRESTER.
- I. CONTROLS WILL BE MOUNTED BY KEARNY MAINTENANCE.
- J. INSTALL DOUBLE COIL SPRING WASHER ON END OF BOLT WHICH ATTACHES TO LARGEST METALLIC OBJECT, SUCH AS A BRACKET OR BRACE.
- K. REGULATOR TANKS SHALL BE PERMANENTLY GROUNDED.
- M. THIS CONSTRUCTION TO BE USED WHEN CENTER PHASE WIRE IS TO THE RIGHT OF THE POLE WHEN LOOKING TOWARD THE LOAD.

ITEM	DESCRIPTION	QUANTITY		STOCK NO. OR
		POLE 1	POLE 2	CONSTR. STD.
1	CROSSARM, 3 3/4" X 5 3/4" X 10' - 0"	3	3	380
2	CROSSARM, 3 3/4" X 5 3/4" X 8' - 0"	4	-	380
3	BRACE, FLAT CROSSARM 28"	2	3	164192
4	BRACE, ANGLE CROSSARM 5'-0"	5	1	164128
5	BOLT, MACHINE, 3/8" X 5", 1 RD. WASH., 1 DBL. COIL SPR. WASH.	2	2	392
6	BOLT, MACHINE, 1/2" X 5", 1 RD. WASH., 1 DBL. COIL SPR. WASH.	2	3	392
7	BOLT, MACHINE, 3/4" X --, 1 SQ. CURV. WASH., 1 DBL. COIL SPR. WASH.	2	-	392
8	BOLT, MACHINE, 5/8" X --, 2 FLAT WASH., 1 DBL. COIL SPR. WASH.	4	2	392
9	BOLT, SPACE, 5/8" X --, 4 WASH & 4 NUTS, 2 DBL. COIL SPR. WASH.	7	3	392
10	BOLT, MACHINE, 1/2" X 7", 1 RD. WASH., 1 DBL. COIL SPR. WASH.	18	6	392
11	SCREW, LAG, 5/8" X 5"	2	-	621600
12	STEPS, POLE	19	19	692992
13	SIGN, HIGH VOLTAGE & NAILS, GALV.	3	3	647648, 492224
14	PIN, INSULATOR (AS REQUIRED BY ITEM 22)	3	1	532---
15	BRACKET, INSULATOR (AS REQUIRED BY ITEM 22)	1	-	1661--
16	COVER, BOLT, PLASTIC	-	2	285696
17	SWITCH, BYPASS	2	1	706944
18	ARRESTER, LIGHTNING (12KV)	5	1	113248
19	CUTOUT, 12KV 100 AMP WITH LOAD BUSTER HOOKS	2	1	297888
20	BLADE, DISCONNECT CUTOUT	2	1	1200 SECTION
21	REGULATOR, STEP VOLTAGE 1Ø	2	1	1300 SECTION
22	INSULATOR, PIN TYPE (CLASS AS REQUIRED)	3	1	700 SECTION
23	INSULATOR, SUSPENSION	10	6	700 SECTION
24	CONNECTOR, COMPRESSION (#2 TO #6)	1	2	257792
25	CONNECTOR, COMPRESSION (#6 TO #6)	3	-	257952
26	CONNECTORS, WIRE	9	4	700 SECTION
27	WIRE, 2/0 WP COPPER	(12.4#) 24'	(6.2#) 12'	808944
28	WIRE, BARE STRANDED COPPER #6	(1.8#) 24'	(1.8#) 22'	813536
29	WIRE, BARE STRANDED COPPER #2	(9.2#) 45'	(9.8#) 45'	813664
30	WIRE, #8 ANNEALED SOLID COPPER	(.25#) 5'	(.25#) 5'	812928
31	WIRE, #4 SOLID WP COPPER	(1.8#) 10'	(.75#) 4'	812480
32	ROD, GROUND	(C) (D) 2	2	603072
33	CLAMP, GROUND ROD	(D) 2	2	230016
34	MOULDING, HARDWOOD 1"	(D) 45'	48'	487200
35	STAPLES, GALV. 3" X 1 1/16" X 1/4"	(D) 32	35	678560
36	STAPLES, FENCE GALV. 1 1/4"	(D) 28	30	678528
37	CLEVIS, DEAD END CLOSED	5	3	235712
38	CLAMPS, DEAD END	5	3	700 SECTION
39	WIRE, BARE STRANDED COPPER #1/0	(3.3#) 10'	(3.3#) 10'	813568
40	BRACE, VERTICAL, 36"	2	-	164256
41	BOLT, MACHINE, 5/8" X 7", 1 RD. WASH., 1 DBL. COIL SPR. WASH.	2	-	100 SECTION
42	BOLT, MACHINE, 5/8" X 5", 1 RD. WASH., 1 DBL. COIL SPR. WASH.	2	-	100 SECTION
43	HANGER, TRANSFORMER T-2	2	-	402944

FOR FIELD MAINTENANCE ONLY

DATE 1-1-96
APPD PJA/ROJ

SDG&E ELECTRIC STANDARDS

STEP-VOLTAGE REGULATOR STATION, CLOSED DELTA
12KV TWO POLES

1399.405
SUPERSEDES
1349.3 1-1-96

FIELD MAINTENANCE ONLY

REVISION HISTORY:

7/13/2016: All versions prior to 2016 are superseded by their current version found inside the Overhead Construction Standard Manual.

© 1998 - 2016 San Diego Gas & Electric Company. All rights reserved. Removal of this copyright notice without permission is not permitted under law.

REV	CHANGE	BY	DSGN	APPV	DATE	REV	CHANGE	BY	DSGN	APPV	DATE
C						F					
B						E					
A	ORIGINAL ISSUE	JS	IL	MDJ	7/13/2016	D					

SHEET 1 OF 1	 Indicates Latest Revision	Completely Revised	New Page	Information Removed	FMO OH 1350
	SDG&E ELECTRIC OVERHEAD STANDARD				
	STEP-VOLTAGE REGULATOR STATION, CLOSED DELTA, 12KV, TWO POLES				

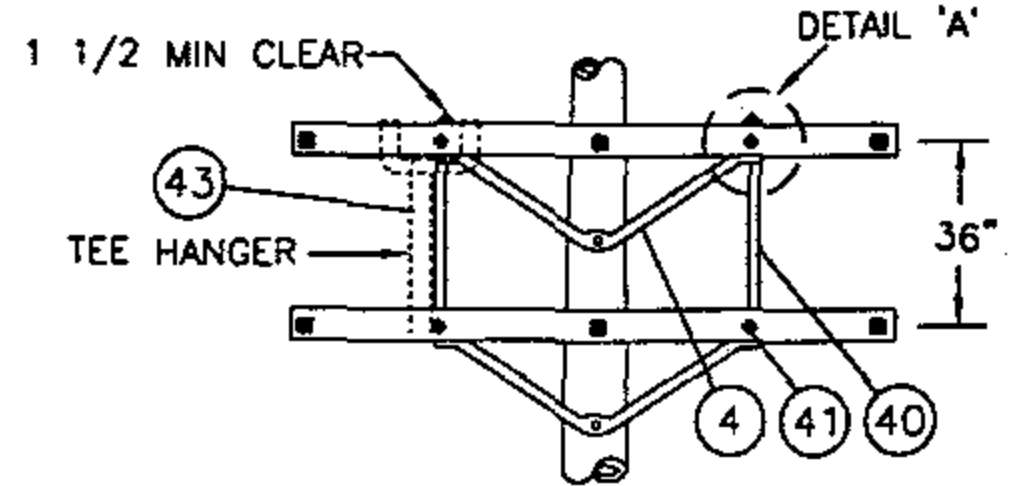
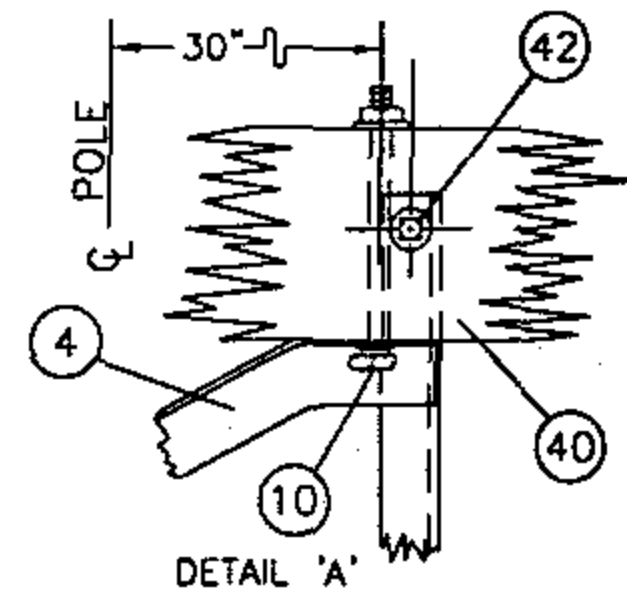
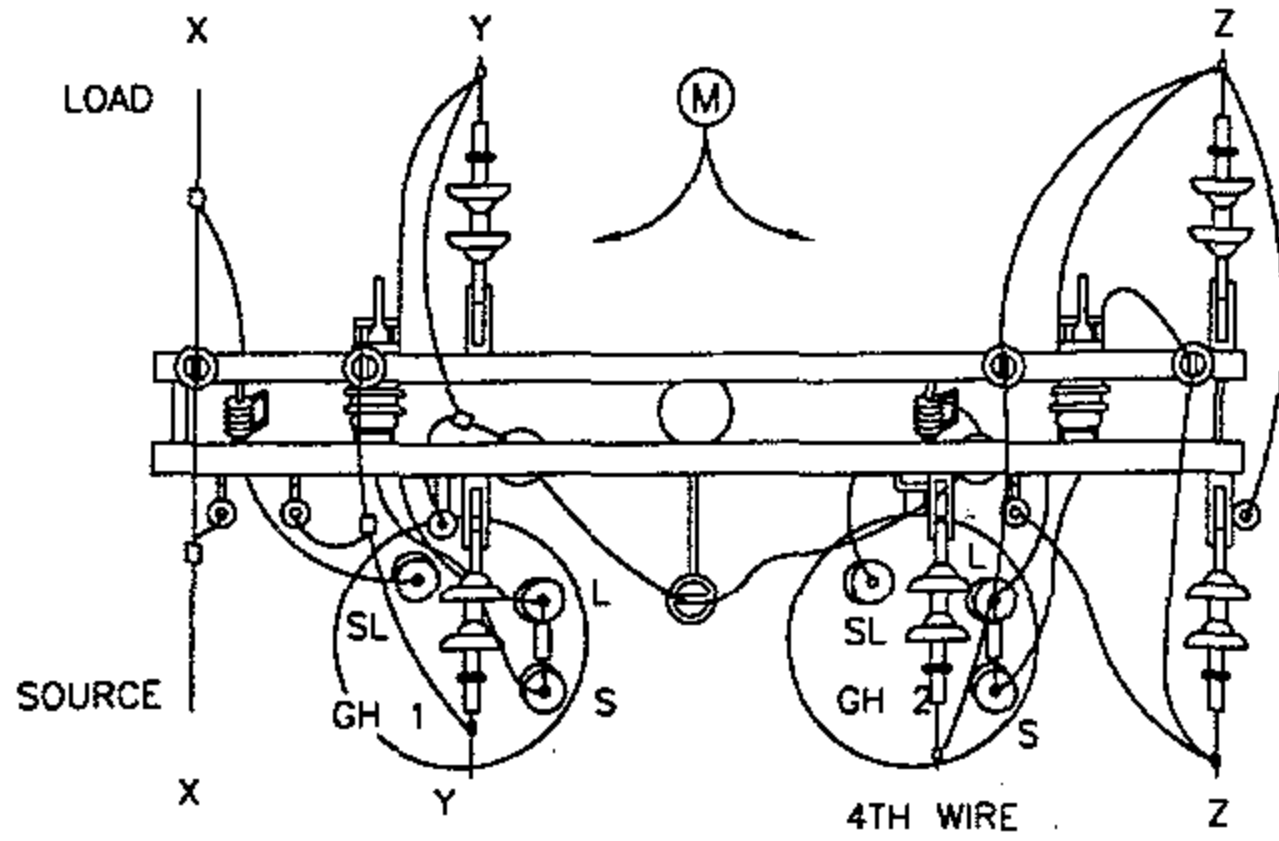

FRAMING DETAIL FOR 2-12KV STEP-VOLTAGE REGULATORS

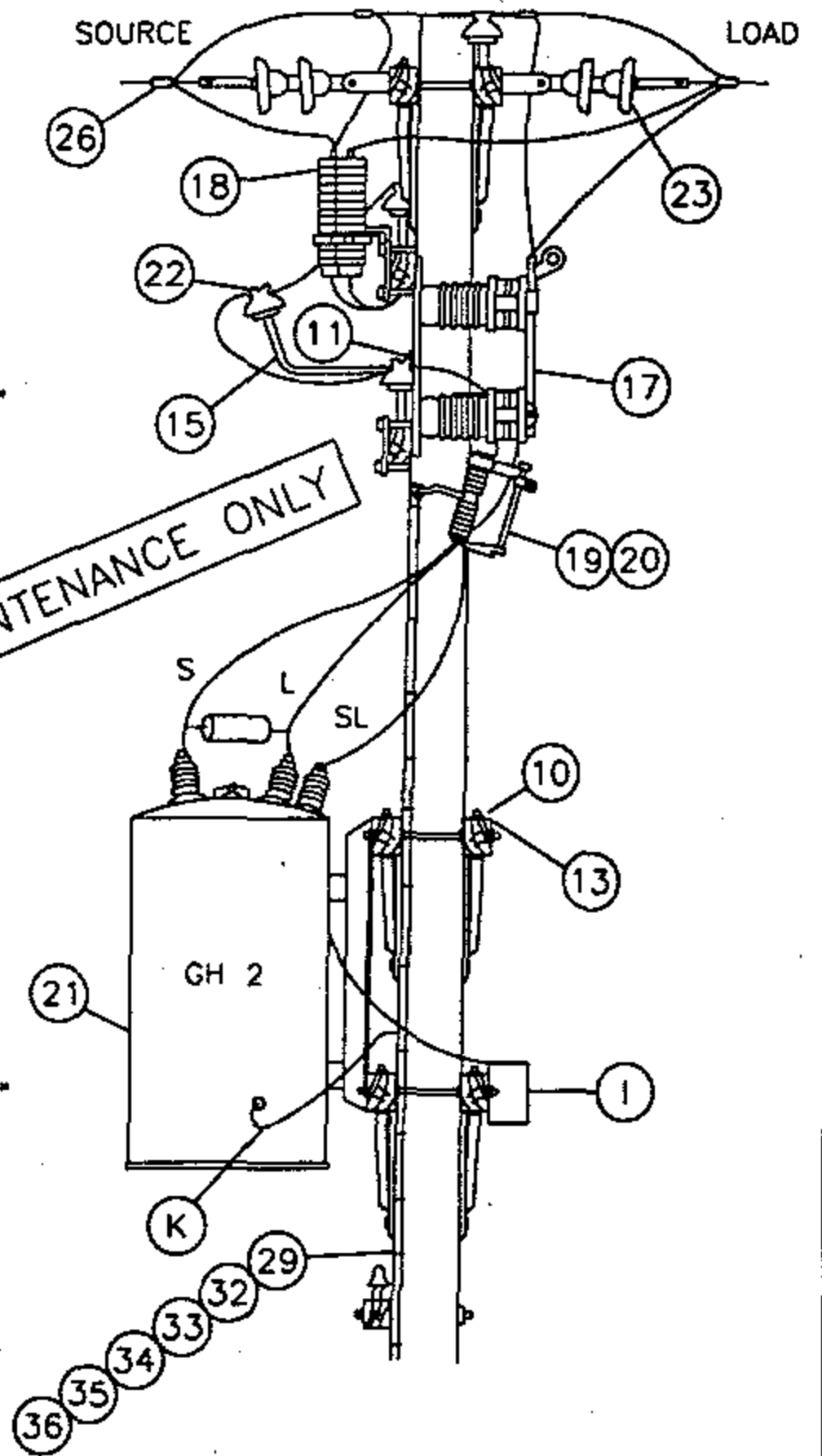
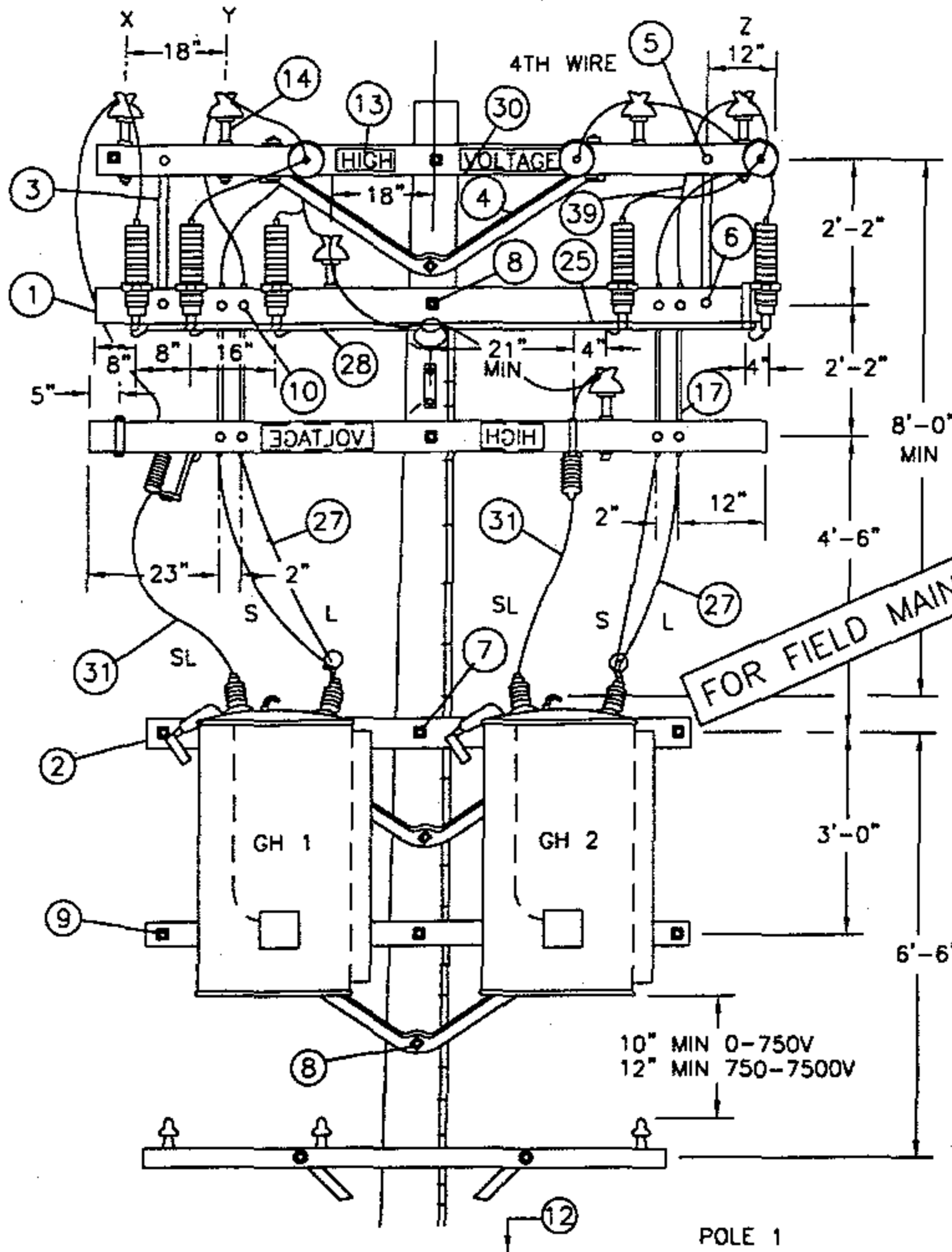

1399.501
SUPERSEDES
1350.1 1-1-96

SDG&E ELECTRIC STANDARDS

STEP-VOLTAGE REGULATOR STATION, CLOSED DELTA
12KV, TWO POLES

DATE 1-1-96

APPD *PA 1008*

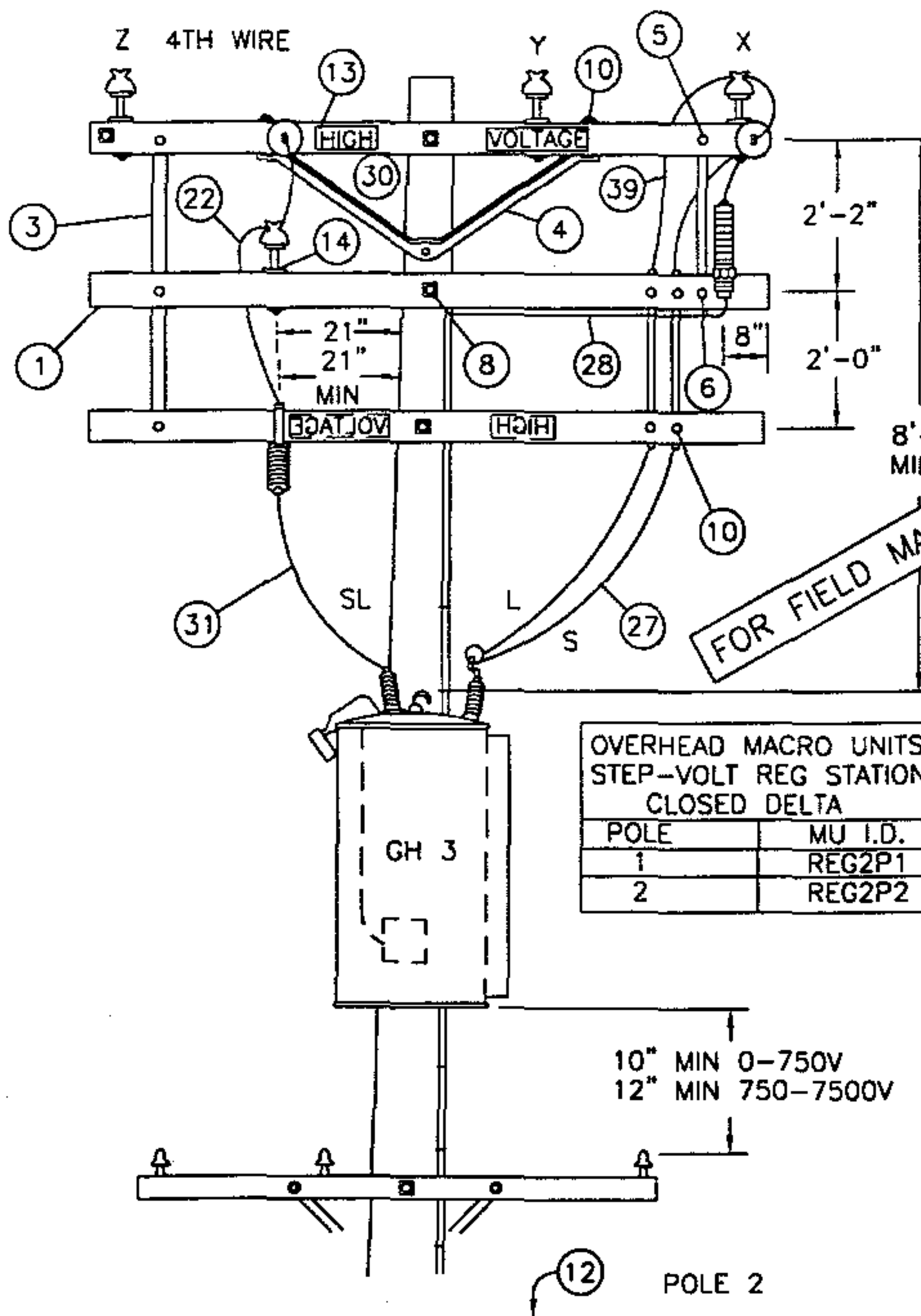
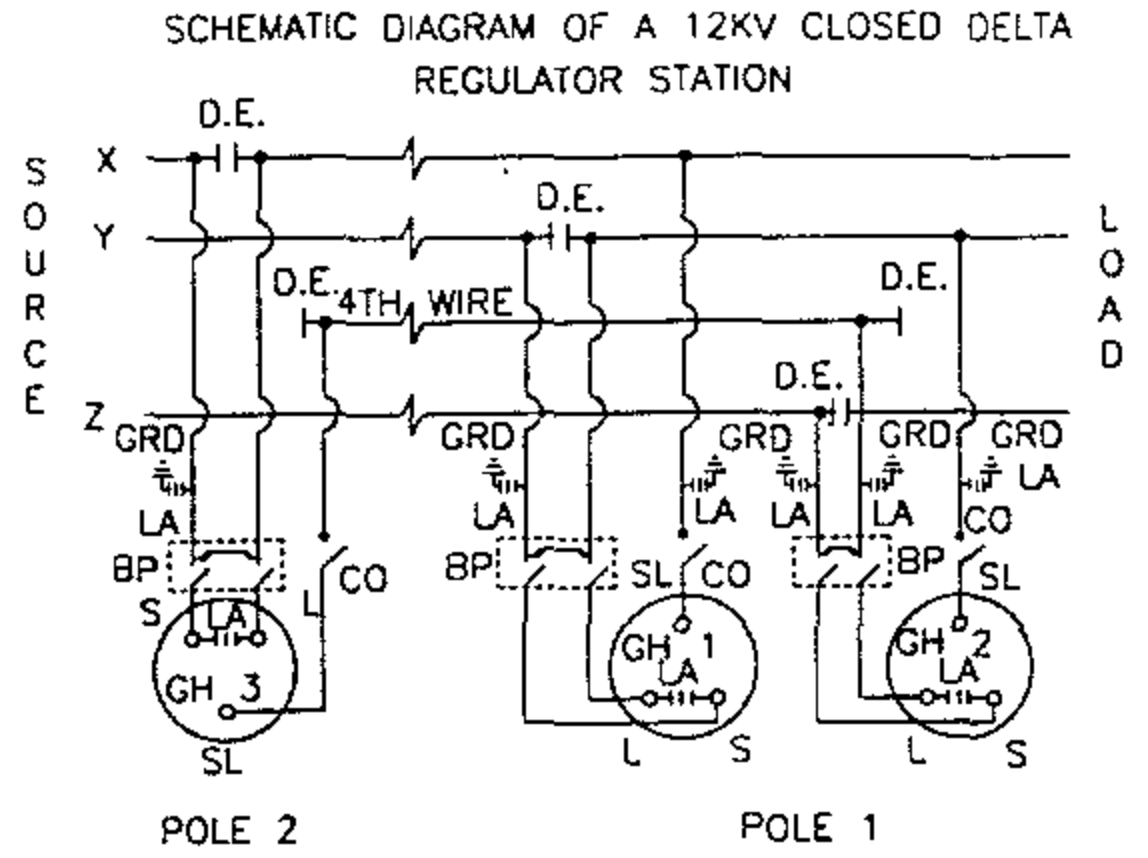
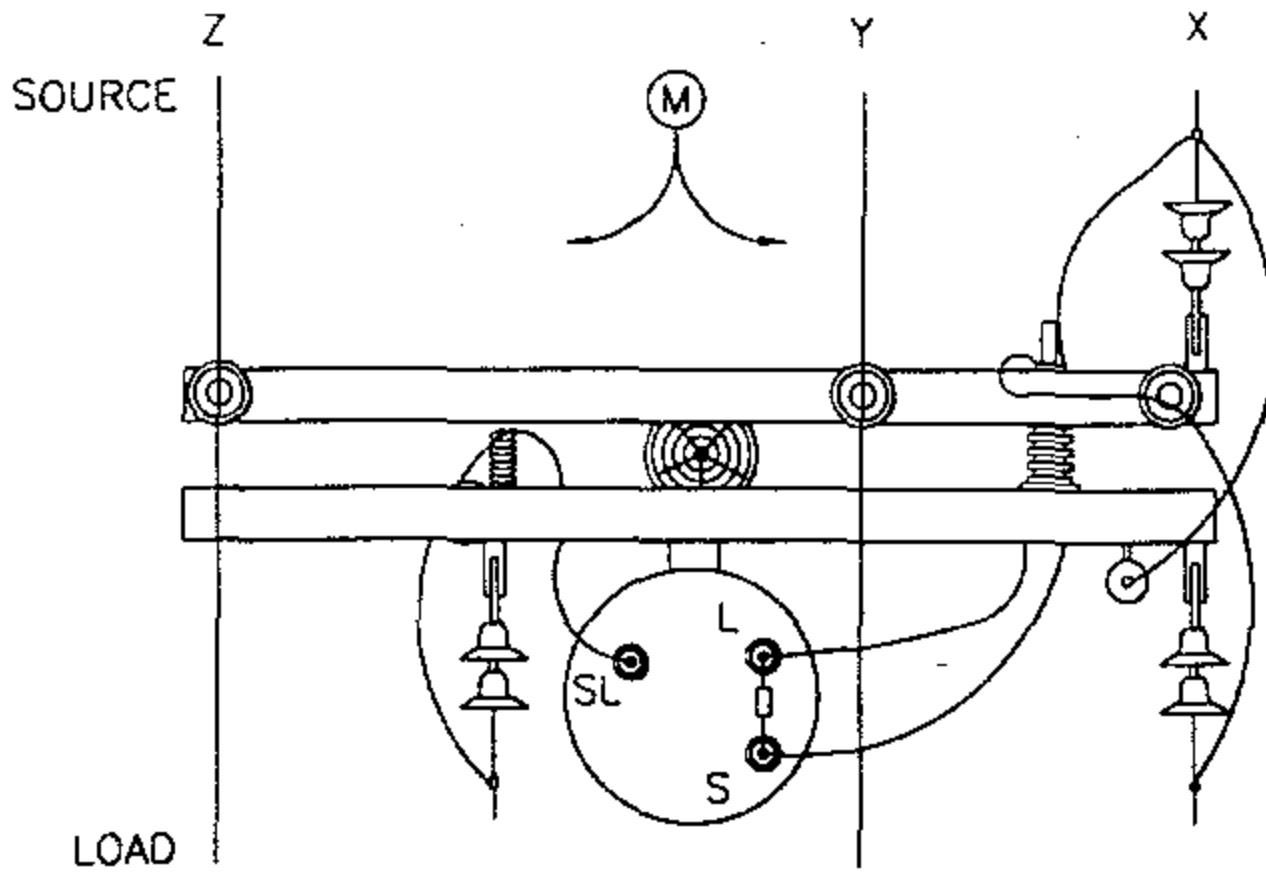

OVERHEAD MACRO UNITS
STEP-VOLT REG STATION
CLOSED DELTA

POLE	MU I.D.
1	REG2P1
2	REG2P2

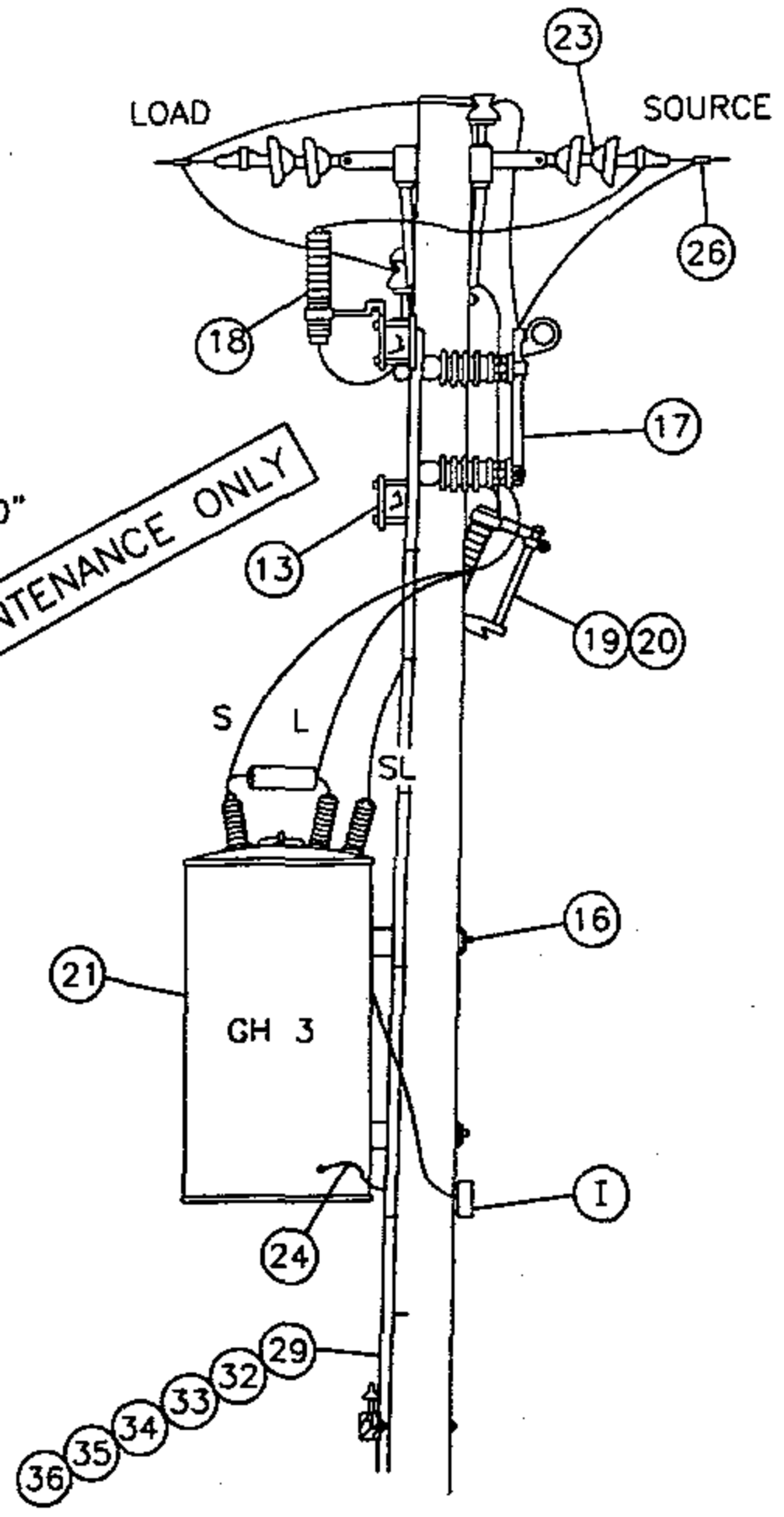

DATE 1-1-96
APPD *PA/1008*

SDG&E ELECTRIC STANDARDS
STEP-VOLTAGE REGULATOR STATION, CLOSED DELTA,
12KV, TWO POLES

1399.502
SUPERSEDES
1350.2 1-1-96

NOTES:

- A. CAUTION: WHEN CONNECTING A STATION, REGULATORS MUST BE ON NEUTRAL. CLOSE CUTOUT TO SL BUSHING BEFORE CLOSING BYPASS DISCONNECT ON THAT POLE. WHEN DISCONNECTING A STATION, PUT REGULATORS ON NEUTRAL, AND OPEN BYPASS DISCONNECT BEFORE OPENING CUTOUT TO SL BUSHING. THIS AVOIDS A SERIOUS OVERVOLTAGE CONDITION.
- B. USE EXTRA HEAVY CLASS ONE POLE WITH 10" MIN TOP DIA FOR POLE #1, AND A CLASS ONE FOR POLE #2.
- (C) USE TWO GROUND RODS FOR THE ARRESTERS AND TANKS. ALL GROUND RODS SHOULD BE SPACED A MINIMUM OF SIX FEET APART.
- (D) UNIT GROUND COMPLETE, ORDER 603136.
- F. BOND ALL CUTOUTS IN HEAVY CONTAMINATION DISTRICT AS IDENTIFIED ON STANDARDS PAGE 287.
- G. BOND DEAD-END HARDWARE.
- (H) INTERCONNECT ARRESTER GROUND LEAD DISCONNECTS WITH #6 BARE COPPER AND GROUND IT WITH #2 BARE COPPER NEAR CENTER ARRESTER.
- (I) CONTROLS WILL BE MOUNTED BY KEARNY MAINTENANCE.
- J. INSTALL DOUBLE COIL SPRING WASHER ON END OF BOLT WHICH ATTACHES TO LARGEST METALLIC OBJECT, SUCH AS A BRACKET OR BRACE.
- (K) REGULATOR TANKS SHALL BE PERMANENTLY GROUNDED.
- (M) THIS CONSTRUCTION TO BE USED WHEN CENTER PHASE WIRE IS TO THE LEFT OF THE POLE WHEN LOOKING TOWARD THE LOAD.

ITEM	DESCRIPTION	QUANTITY		STOCK NO. OR CONSTR. STD
		POLE 1	POLE 2	
1	CROSSARM 3 3/4" X 5 3/4" X 10' - 0"	3	3	380
2	CROSSARM, 3 3/4" X 5 3/4" X 8'-0"	4	-	380
3	BRACE, FLAT CROSSARM 28"	2	3	164192
4	BRACE, ANGLE CROSSARM 5'-0"	5	1	164128
5	BOLT, MACHINE, 3/8" X 5", 1 RD. WASH., 1 DBL. COIL SPR. WASH.	2	2	392
6	BOLT, MACHINE, 1/2" X 5", 1 RD. WASH., 1 DBL. COIL SPR. WASH.	2	3	392
7	BOLT, MACHINE, 3/4" X --, 1 SQ. CURV. WASH., 1 DBL. COIL SPR. WASH.	2	-	392
8	BOLT, MACHINE, 5/8" X --, 2 FLAT WASH., 1 DBL. COIL SPR. WASH.	4	2	392
9	BOLT, SPACE, 5/8" X --, 4 WASH. & 4 NUTS, 2 DBL. COIL SPR. WASH.	7	3	392
10	BOLT, MACHINE, 1/2" X 7", 1 RD. WASH., 1 DBL. COIL SPR. WASH.	18	6	392
11	SCREW, LAG, 5/8" X 5"	2	-	621600
12	STEPS, POLE	19	19	692992
13	SIGN, HIGH VOLTAGE & 8 NAILS, GALV.	3	3	647648, 492224
14	PIN, INSULATOR (AS REQUIRED BY ITEM 22)	3	1	532---
15	BRACKET, INSULATOR (AS REQUIRED BY ITEM 22)	1	-	1661--
16	COVER, BOLT, PLASTIC	-	2	285696
17	SWITCH, BYPASS	2	1	706944
18	ARRESTER, LIGHTNING (12KV)	5	1	113248
19	CUTOUT, 12KV 100 AMP WITH LOAD BUSTER HOOKS	2	1	297888
20	BLADE, DISCONNECT CUTOUT	2	1	1200 SECTION
21	REGULATOR, STEP VOLTAGE 1Ø	2	1	1300 SECTION
22	INSULATOR, PIN TYPE (CLASS AS REQUIRED)	3	1	700 SECTION
23	INSULATOR, SUSPENSION	10	6	700 SECTION
24	CONNECTOR, COMPRESSION (#2 TO #6)	1	2	257792
25	CONNECTOR, COMPRESSION (#6 TO #6)	3	-	257952
26	CONNECTORS, WIRE	9	4	700 SECTION
27	WIRE, 2/0 WP COPPER	(12.4#) 24'	(6.2#) 12'	808944
28	WIRE, BARE STRANDED COPPER #6	(1.8#) 24'	(1.8#) 22'	813536
29	WIRE, BARE STRANDED COPPER #2	(9.2#) 45'	(9.8#) 45'	813664
30	WIRE, #8 ANNEALED SOLID COPPER	(.25#) 5'	(.25#) 5'	812928
31	WIRE, #4 SOLID WP COPPER	(1.8#) 10'	(.75#) 4'	812480
32	ROD, GROUND	2	2	603072
33	CLAMP, GROUND ROD	(C)(D) 2	2	230016
34	MOULDING, HARDWOOD 1"	(D) 45'	48'	487200
35	STAPLES, GALV. 3" X 1 1/16" X 1/4"	(D) 32	35	678560
36	STAPLES, FENCE GALV. 1 1/4"	(D) 28	30	678528
37	CLEVIS, DEAD END CLOSED	(D) 5	3	235712
38	CLAMPS, DEAD END	5	3	700 SECTION
39	WIRE, BARE STRANDED COPPER #1/0	(3.3#) 10'	(3.3#) 10'	813568
40	BRACE, VERTICAL, 36"	2	-	164256
41	BOLT, MACHINE, 5/8" X 7", 1 RD. WASH., 1 DBL. COIL SPR. WASH.	2	-	392
42	BOLT, MACHINE, 5/8" X 5", 1 RD. WASH., 1 DBL. COIL SPR. WASH.	2	-	392
43	HANGER, TRANSFORMER T-2	2	-	402944

FOR FIELD MAINTENANCE ONLY

1399.503
SUPERSEDES
1350.3 1-1-96

SDG&E ELECTRIC STANDARDS

STEP-VOLTAGE REGULATOR STATION, CLOSED DELTA
12KV TWO POLES

DATE 1-1-96
APPD PJA / BSA

1400 - CABLE POLES

1400 - CABLE POLES

PAGES

SUBJECT

1402	JOINT CABLE POLE RISERS USING WOODEN LADDER ARMS
1407	CABLE POLE TERMINAL MOUNTING INFORMATION (PORCELAIN TERMINATIONS) (FOR CONTAMINATION DISTRICT 1)
1415	0-750V CUSTOMER OWNED UNDERGROUND SERVICE FROM AN OVERHEAD LINE, ONE DUCT
1417	0-750V CUSTOMER OWNED UNDERGROUND SERVICE FROM AN OVERHEAD LINE, TWO DUCTS
1418	0-750V CUSTOMER OWNED UNDERGROUND SERVICE FROM AN OVERHEAD LINE, THREE AND FOUR DUCTS
1428	CROSSARM MOUNTED TERMINALS 4KV 4 WIRE WYE
1429	12.47KV AND BELOW 3 ϕ CABLE POLE 1/C PER ϕ , UPSWEEP BRACKET CONSTRUCTION
1432	12.47KV AND BELOW CABLE POLE, UPSWEEP BRACKET, THREE-PHASE 1/C PER PHASE, LINE ARM MOUNTED DISCONNECTS, NON-PORCELAIN TERMINALS
1437	BRACKET MOUNTED TERMINALS, 12KV 3 WIRE ARMLESS TANGENT CONSTRUCTION
1438	BRACKET MOUNTED TERMINALS, 12KV 3 WIRE ARMLESS DEADEND CONSTRUCTION
1439	CROSSARM CABLE POLE, 3 ϕ , 1/C PER PHASE DEADEND CONSTRUCTION, 12.47KV AND BELOW
1441	12.47KV AND BELOW DEADEND CABLE POLE ARM, 3 ϕ , 1/C PER ϕ , HOOKSTICK SWITCHED
1443	12.47KV AND BELOW DEADEND CABLE POLE THREE-PHASE, 1/C PER PHASE, GANG OPERATED SWITCHED, NON-PORCELAIN TERMINALS
1445	12.47KV DEADEND CABLE POLE THREE-PHASE WITH NEUTRAL, HORIZONTAL SCADA-MATE SWITCH
1451	12.47KV AND BELOW DEADEND CABLE POLE, 6 OR 7 OH CONDUCTORS, 1 OR 2 TERMINALS PER CONDUCTOR, HOOKSTICK SWITCHED
1481	POLETOP METERING, 2.4KV SINGLE PHASE
1482	POLETOP METERING, 2.4KV OPEN DELTA
1483	POLETOP METERING, 4KV SINGLE-PHASE
1484	POLETOP METERING INSTALLATION, 4KV, 3 PHASE, 3 WIRE UG & OH SERVICES
1485	POLETOP METERING INSTALLATION, 4KV, 3 PHASE, 4 WIRE UG & OH SERVICES
1486	POLETOP METERING INSTALLATION, 12KV, 3 PHASE, 3 WIRE UG & OH SERVICES
1487	REVISED CT & PT POLETOP METERING INSTALLATION, 12KV, OH & UG SERVICES
1489	METERING RACK, CUSTOMER OWNED, CONSTRUCTION DETAILS
1490	4KV METERING INSTALLATION ON RACK, FOR 3 WIRE AND 4 WIRE, 30 SERVICES

© 1998 - 2020 San Diego Gas & Electric Company. All rights reserved. Removal of this copyright notice without permission is not permitted under law.

REV	CHANGE	BY	DSGN	APPV	DATE	REV	CHANGE	BY	DSGN	APPV	DATE
C						F					
B	EDITORIAL CHANGES	RSL	JES	CZH	04/13/2020	E					
A	ORIGINAL ISSUE	JS	IL	MDJ	07/25/2016	D					

**SHEET
1 OF 1**

X	Indicates Latest Revision	Completely Revised	New Page	Information Removed
SDG&E ELECTRIC OVERHEAD FIELD MAINTENANCE ONLY STANDARDS				
CABLE POLES FMO TABLE OF CONTENTS				

**FMO
OH1401.1**

FIELD MAINTENANCE ONLY

REVISION HISTORY:

7/13/2016: All versions prior to 2016 are superseded by their current version found inside the Overhead Construction Standard Manual.

© 1998 - 2016 San Diego Gas & Electric Company. All rights reserved. Removal of this copyright notice without permission is not permitted under law.

REV	CHANGE	BY	DSGN	APPV	DATE	REV	CHANGE	BY	DSGN	APPV	DATE
C						F					
B						E					
A	ORIGINAL ISSUE	JS	IL	MDJ	7/13/2016	D					

<input checked="" type="checkbox"/>	Indicates Latest Revision	<input type="checkbox"/>	Completely Revised	<input type="checkbox"/>	New Page	<input type="checkbox"/>	Information Removed
-------------------------------------	---------------------------	--------------------------	--------------------	--------------------------	----------	--------------------------	---------------------

**SHEET
1 OF 1**

SDG&E ELECTRIC OVERHEAD STANDARD

JOINT CABLE POLE RISERS USING WOODEN LADDER ARMS

**FMO
OH 1402**

SCOPE: THIS STANDARD: 1) SHOWS THE STANDARD CABLE POLE RISER POSITIONS FOR SDG&E, TELCO, AND CATV COMPANIES, IT IS FOR RISER PLACEMENT ONLY (SEE SECTION 1400/4200 FOR SPECIFIC CONSTRUCTION DETAILS).

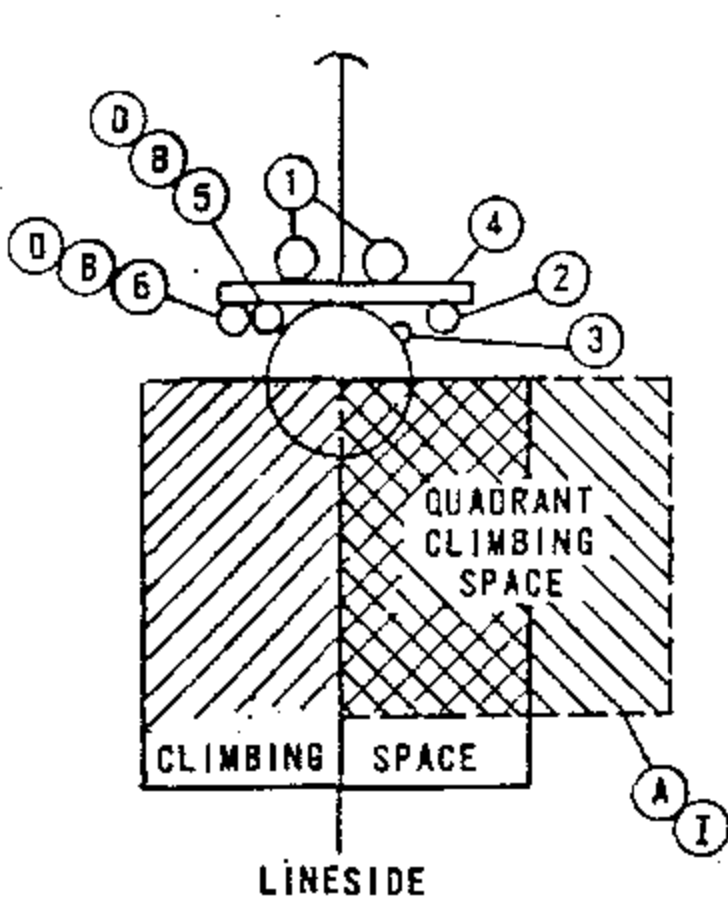

LINESIDE

FIGURE 1

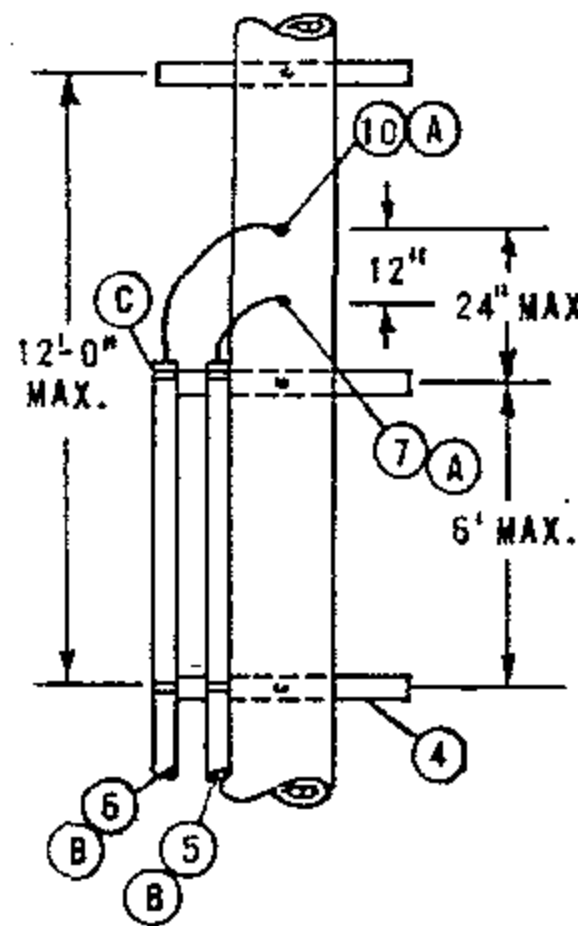

FIGURE 2

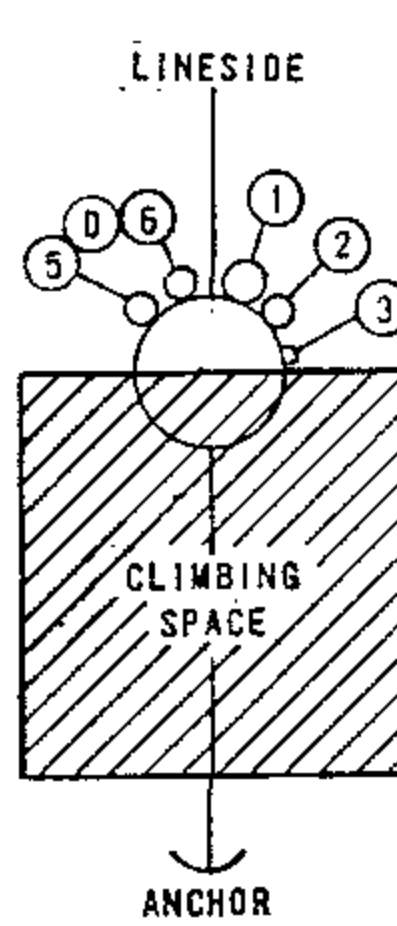

FIGURE 3

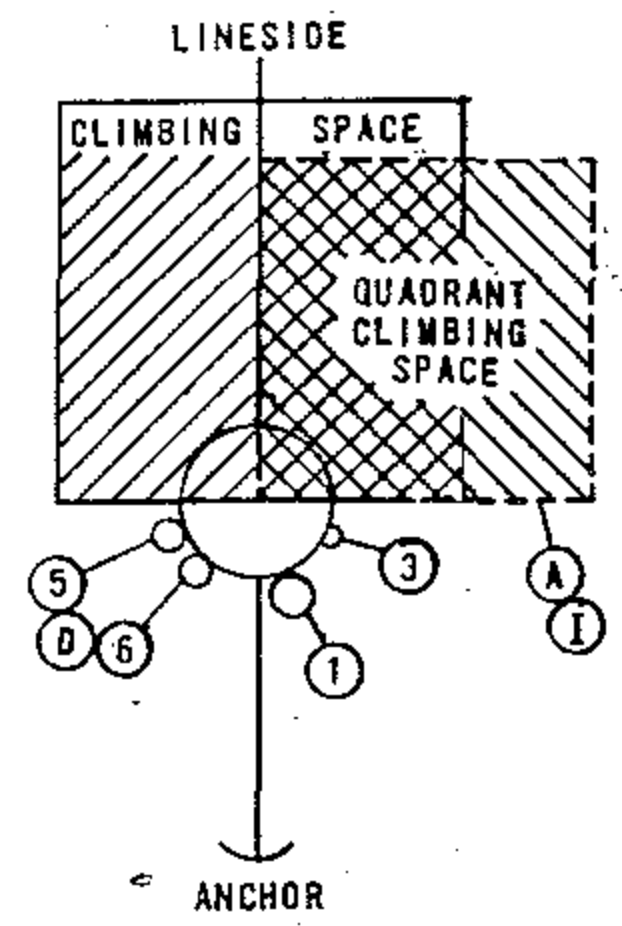

FIGURE 4

DEAD END CONSTRUCTION

FOR FIELD MAINTENANCE ONLY

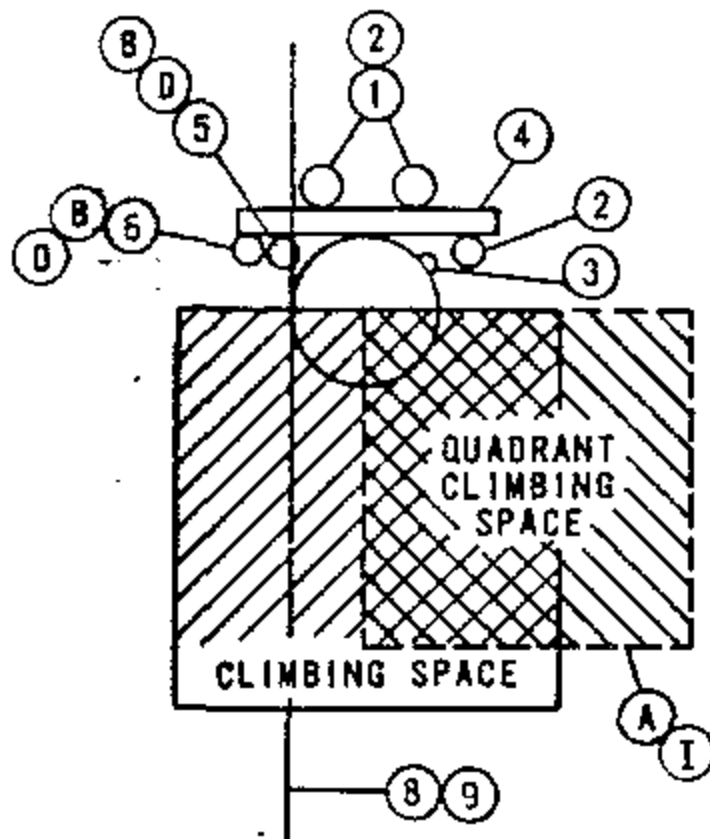

FIGURE 5

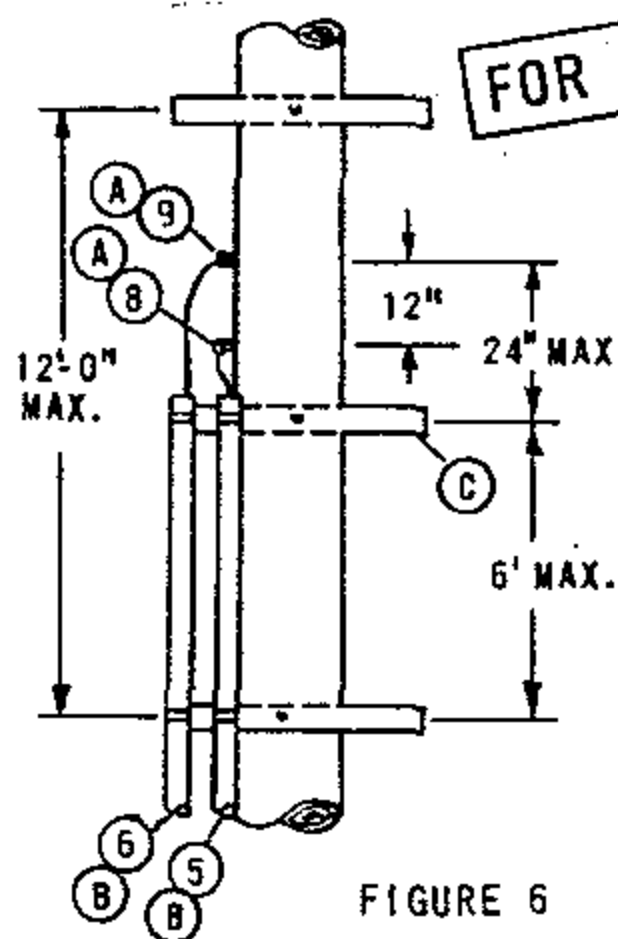

FIGURE 6

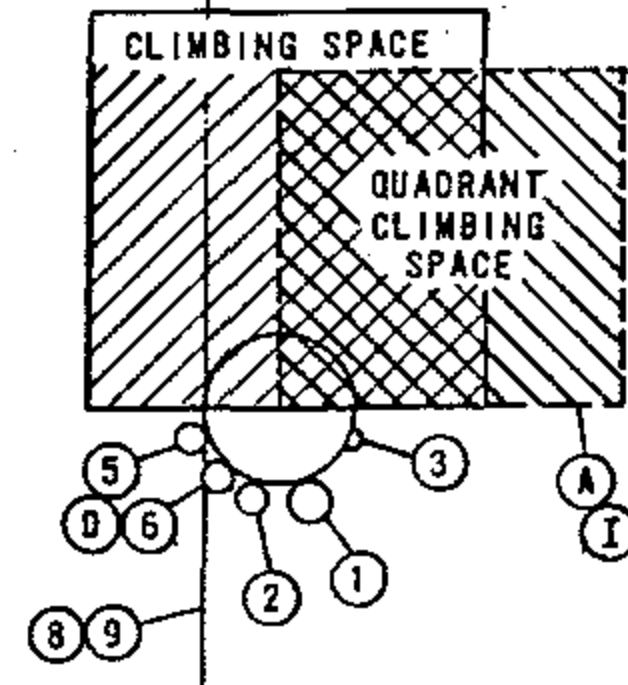

FIGURE 7

TANGENT CONSTRUCTION

INSTALLATION:

- (A) QUADRANT CLIMBING SPACE PROVIDED THROUGH CATV AND TELCO AERIAL ATTACHMENT LEVELS ONLY.
- (B) C.A.T.V. AND TELCO TO ATTACH CONDUIT TO BACK SIDE OF RISER LADDER ARMS.
- (C) C.A.T.V. OR TELCO TO PLACE RISER LADDER ARM TO HOLD TOP OF OWN CONDUIT.
- (D) C.A.T.V. AND TELCO TO ALWAYS BE IN SAME QUADRANT.
- F. CONDUIT RISER AT BASE OF POLE NOT TO INFRINGE ON CURB OR SIDEWALK POSITIONS.

REFERENCES:

- G. PVC RISERS ARE NOT PERMITTED WITHIN THE CLIMBING SPACE PER G.O. 95 RULE 22.2C.
- H. G.O. 95 RULE 91.3-A1C REQUIRES POLE STEPS ON ALL JOINTLY USED CABLE POLES (SEE STANDARD 363).
- I. SEE SECTION 200 FOR ALLOWABLE G.O. 95 CLIMBING SPACE OBSTRUCTIONS.
- J. NO CATV OR TELCO JUMPERS ALLOWED IN QUADRANT CLIMBING SPACE PER G.O. 95 RULE 84.7.

ITEM	DESCRIPTION	ITEM	DESCRIPTION
1	SDG&E PRIMARY RISER	6	C.A.T.V. RISER POSITION
2	SDG&E SECONDARY RISER	7	TELCO DEAD END ATTACHMENT
3	SDG&E ELECTRIC GROUND	8	TELCO TANGENT (THRU) POSITION
4	RISER LADDER ARM	9	C.A.T.V. TANGENT (THRU) POSITION
5	TELCO RISER POSITION	10	C.A.T.V. DEAD END ATTACHMENT

SDG&E ELECTRIC STANDARDS

DATE 11-16-81
APPD JCY

JOINT CABLE POLE RISERS USING WOODEN LADDER ARMS

OH 1499.001
~~UG 4299.001~~
SUPERSEDES
1402.1 (11-16-81)

FIELD MAINTENANCE ONLY

REVISION HISTORY:

7/13/2016: All versions prior to 2016 are superseded by their current version found inside the Overhead Construction Standard Manual.

© 1998 - 2016 San Diego Gas & Electric Company. All rights reserved. Removal of this copyright notice without permission is not permitted under law.

REV	CHANGE	BY	DSGN	APPV	DATE	REV	CHANGE	BY	DSGN	APPV	DATE
C						F					
B						E					
A	ORIGINAL ISSUE	JS	IL	MDJ	7/13/2016	D					

<input checked="" type="checkbox"/>	Indicates Latest Revision	<input type="checkbox"/>	Completely Revised	<input type="checkbox"/>	New Page	<input type="checkbox"/>	Information Removed
-------------------------------------	---------------------------	--------------------------	--------------------	--------------------------	----------	--------------------------	---------------------

**SHEET
1 OF 1**

SDG&E ELECTRIC OVERHEAD STANDARD
CABLE POLE TERMINAL MOUNTING INFORMATION
(PORCELAIN TERMINATIONS)
(FOR CONTAMINATION DISTRICT 1)

**FMO
OH 1407**

SCOPE: THIS STANDARD SHOWS VARIOUS METHODS OF CABLE TERMINATION BRACKETS USED TO CONNECT UNDERGROUND CABLES TO OVERHEAD CONDUCTORS.

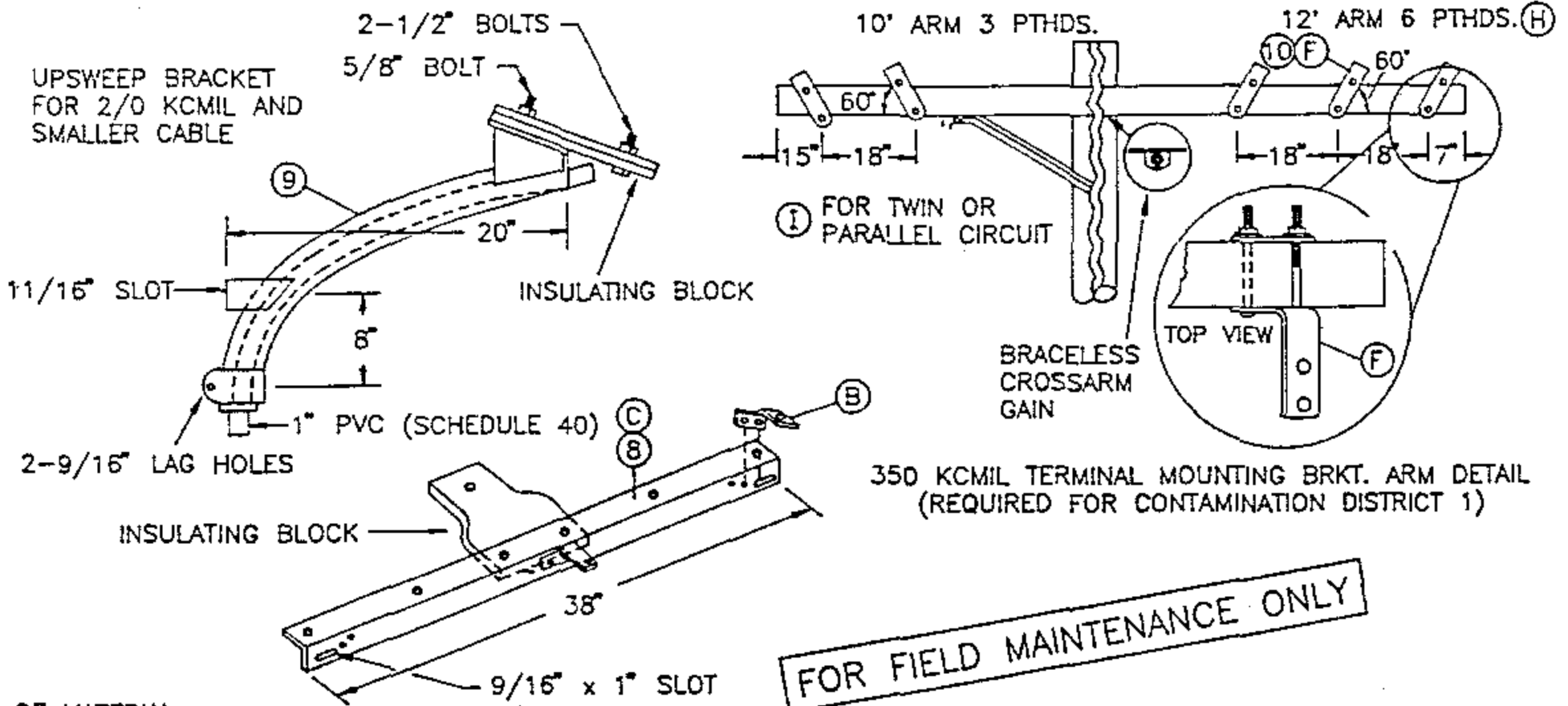
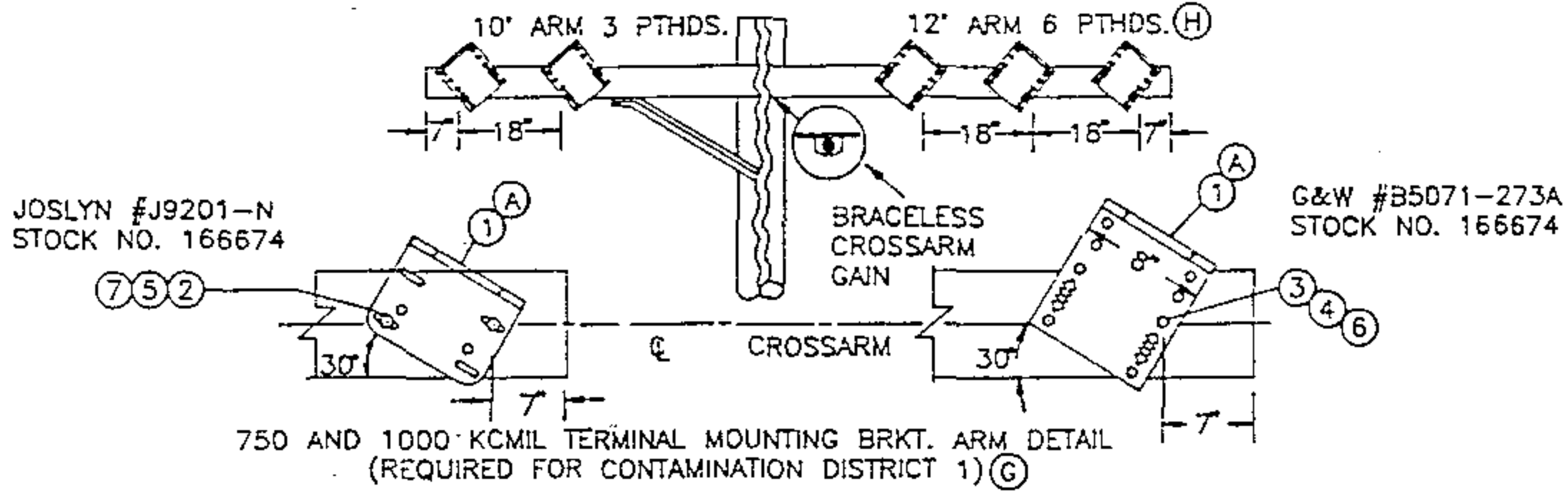

BILL OF MATERIAL:

ITEM	DESCRIPTION	QUANTITY	STOCK NO. OR CONSTR STD	ASSEMBLY UNITS
1	BRACKET, POTHEAD MOUNTING	3 OR 6	166674	P-X-BK
2	BOLT, MACHINE, GALV. 1/2" x 5" (E)	2	153024	-
3	BOLT, MACHINE, GALV. 3/8" x 5" (E)	2	154368	-
4	WASHER, 3/8" ROUND (E)	4	800288	-
5	WASHER, 1/2" ROUND (E)	4	800192	-
6	WASHER, 3/8" DBL COIL (E)	2	798528	-
7	WASHER, 1/2" DBL COIL (E)	2	798464	-
8	BRACKET TRIPLE TERMINAL (C)	1	166676	(OVERHEAD) TTB
9	BRACKET GALV. TERMINAL UPSWEEP	1	166856	(OVERHEAD) USB
10	BRACKET, CROSSARM TERMINAL	3 OR 6	166060	-

INSTALLATION:

- (A) HOLES IN ARM FOR POTHEAD MOUNTING BRACKETS ARE DRILLED BY OVERHEAD CREWS.
- (B) THREE OF THESE BRACKETS ARE SUPPLIED WITH THE TRIPLE TERMINAL BRACKET (ITEM 8).
- (C) THIS CONSTRUCTION TO BE USED ONLY FOR CABLE SIZES 2/0 AND BELOW.
- (E) EXEMPT MATERIAL.
- (F) TURN TOP OF BRACKET OUTWARD TO OBTAIN APPROX. 60° ANGLE.

REFERENCE:

- (G) FOR CONSTRUCTION IN CONTAMINATION DISTRICTS 2 AND 3, SEE STANDARD 1407.2/4207.2.
- (H) SEE STANDARD 1407.2/4207.2 FOR TERMINAL AND LIGHTNING ARRESTER DETAIL.
- (I) SEE STANDARD 1442.1/4242.1 FOR 3-350 KCMIL POTHEADS ON A 10 FOOT CROSSARM.

12' ARM 6 PTHS AND 6 ARRESTORS

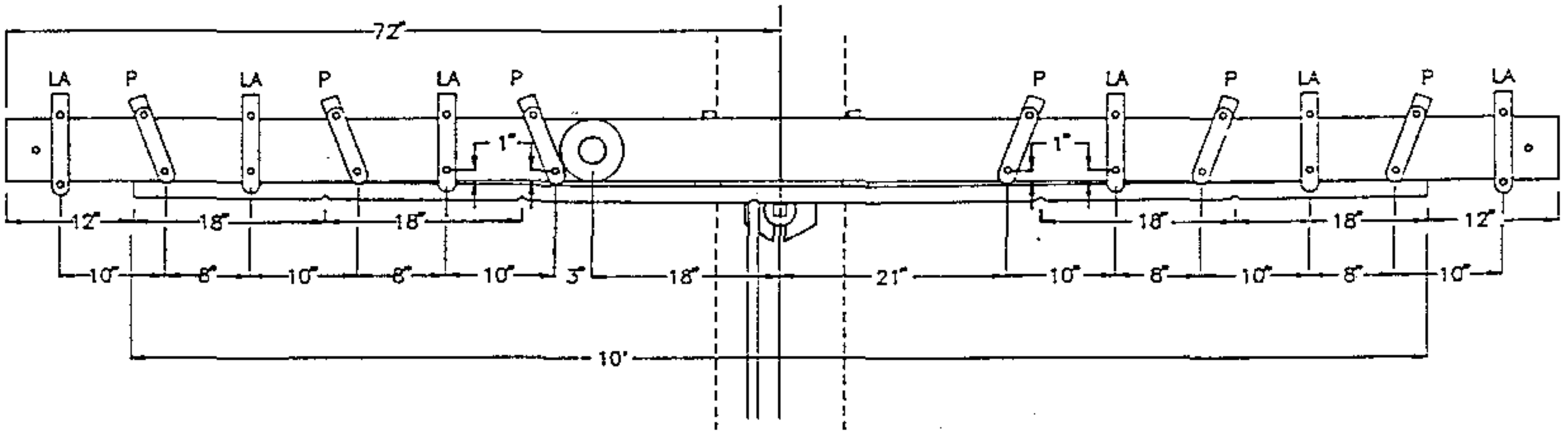

350 KCMIL TERMINAL AND LIGHTNING ARRESTER BRACKETS MOUNTING DETAIL

P=POTHEAD BRACKET

LA=LIGHTNING ARRESTER BRACKET

FOR FIELD MAINTENANCE ONLY

12' ARM 6 PTHS AND 6 ARRESTORS

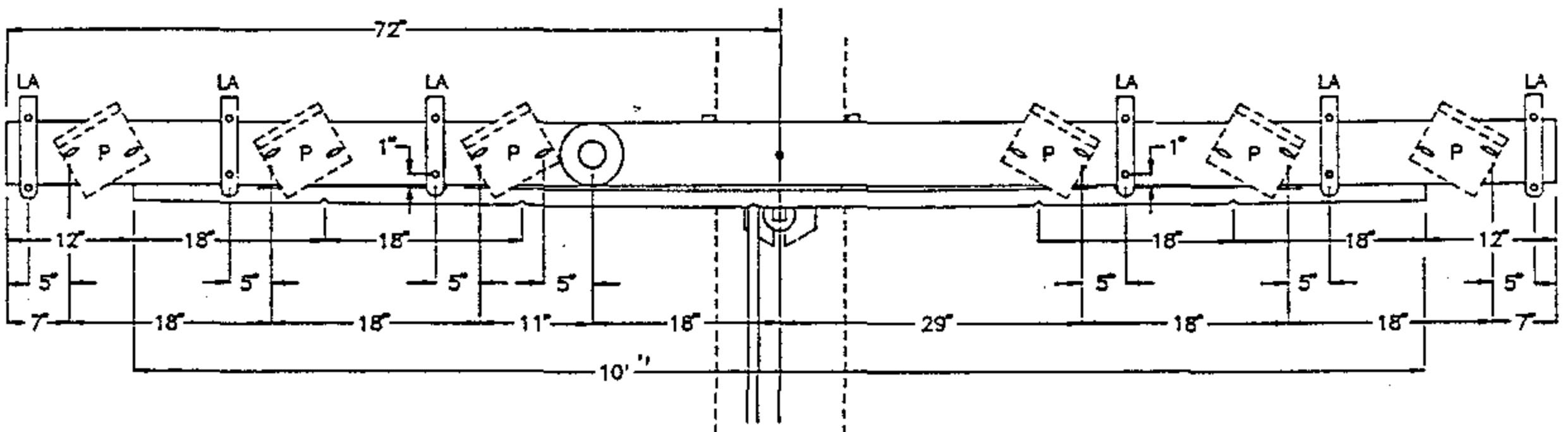

750 AND 1000 KCMIL TERMINAL AND LIGHTNING ARRESTER BRACKETS MOUNTING DETAIL

SDG&E ELECTRIC STANDARDS

CABLE POLE TERMINAL MOUNTING INFORMATION
(PORCELAIN TERMINATIONS)
(FOR CONTAMINATION DISTRICT 1)

DATE 1-1-93

APPD *JLB/ROJ*

OH 1499.011
~~UG 4299.011~~
SUPERCEDES
1407.2 (1-1-93)

SCOPE: THIS STANDARD SHOWS VARIOUS METHODS OF INSTALLING CABLE TERMINATING MOUNTING BRACKETS FOR NON-PORCELAIN TERMINALS.

CROSSARM
CONSTRUCTION FOR
350 KCMIL AND
LARGER CABLE

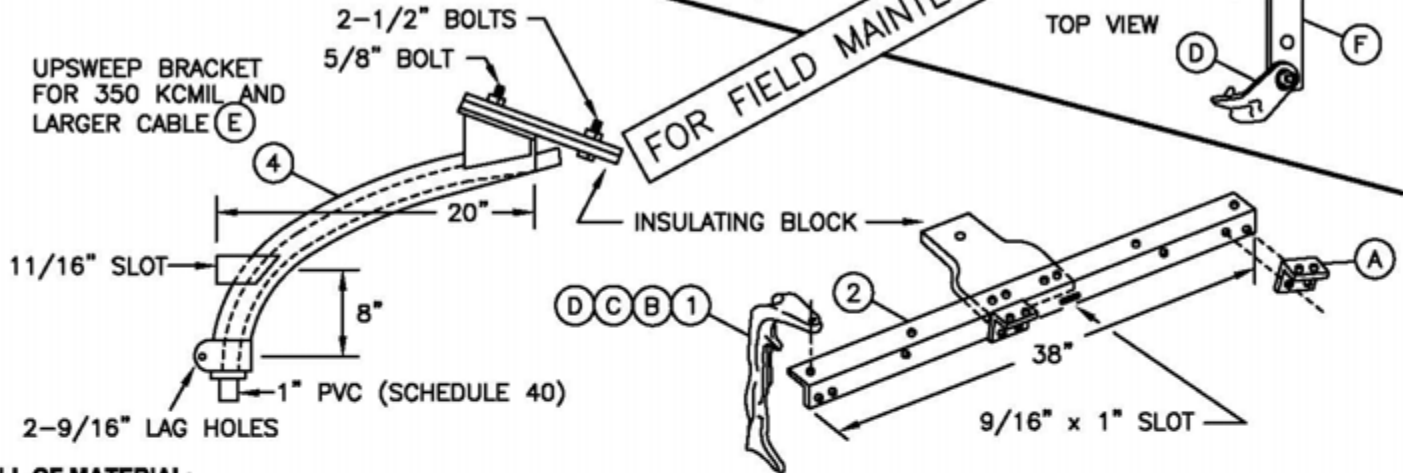
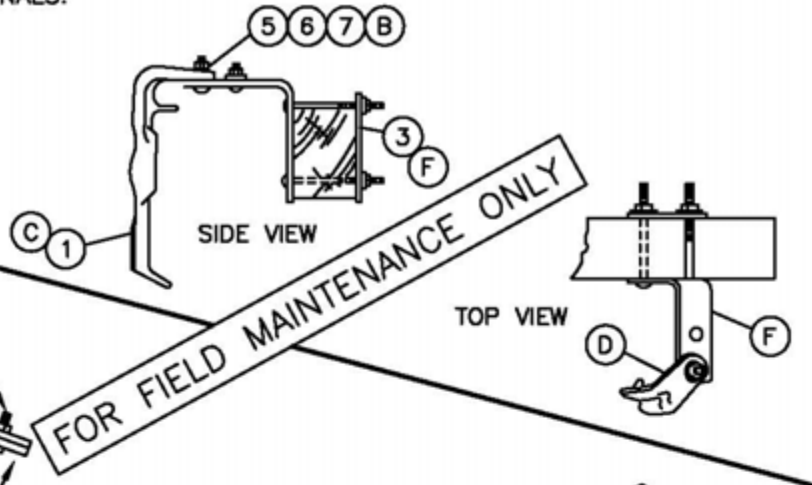
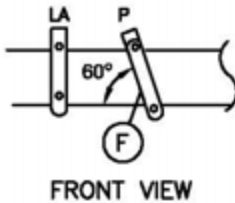

BILL OF MATERIAL:

ITEM	DESCRIPTION	QUANTITY	CONST STD OR PAGE NO	STOCK NUMBER	ASSEMBLY UNITS
1	BRACKET, MOUNTING CS 820	3 OR 6	4111	166064	NP-BKT
2	BRACKET, TRIPLE TERMINAL (E)	1	-	166676	(OVERHEAD) TTB
3	BRACKET, CROSSARM TERMINAL	3 OR 6	-	166060	(OVERHEAD) 2/OBKT
4	BRACKET, TERMINAL UPSWEEP, GALV (E)	1	-	166856	(OVERHEAD) USB
5	BOLT, MACHINE, GALV 1/2" x 2"	3 OR 6	392.1	152832	
6	WASHER, ROUND 1/2"	3 OR 6	392.2	800192	
7	WASHER, SPRING LOCK 1/2"	3 OR 6	392.2	796768	

NOTES:
- PORCELAIN TERMINALS (POTHEADS) ARE REQUIRED IN SUBSTATIONS (ALL DISTRICTS). SEE NOTE (I).

- INSTALLATION:**
- (A) THREE BRACKETS ARE SUPPLIED WITH THE TRIPLE TERMINAL BRACKET.
 - (B) CS 820 MOUNTING BRACKETS SHALL BE BOLTED TO THE TOP OF THE TRIPLE TERMINAL BRACKET OR CROSSARM TERMINAL BRACKET.
 - (C) FOLLOW MANUFACTURES INSTRUCTIONS FOR SECURING CABLE TO MOUNTING BRACKET.
 - (D) MOUNTING BRACKET CS 820 TO BE POSITIONED TO CONFIRM WITH THE LAY OF THE CABLE.
 - (E) THESE ITEMS FIELD MAINTENANCE ONLY.
 - (F) TURN TOP OF BRACKET OUTWARD TO OBTAIN APPROX 60 ANGLE.

REFERENCE:
H. SEE STD. 4111 FOR OUTDOOR CABLE TERMINALS, FOR POLYETHYLENE CABLES.
(I) SEE STD. PG. 1499.010/4299.010 FOR PORCELAIN MOUNTING BRACKETS.

© 1998 - 2010 San Diego Gas & Electric Company. All rights reserved. Removal of this copyright notice without permission is not permitted under law.

FIELD MAINTENANCE ONLY

REVISION HISTORY:

7/13/2016: All versions prior to 2016 are superseded by their current version found inside the Overhead Construction Standard Manual.

© 1998 - 2016 San Diego Gas & Electric Company. All rights reserved. Removal of this copyright notice without permission is not permitted under law.

REV	CHANGE	BY	DSGN	APPV	DATE	REV	CHANGE	BY	DSGN	APPV	DATE
C						F					
B						E					
A	ORIGINAL ISSUE	JS	IL	MDJ	7/13/2016	D					

	Indicates Latest Revision	Completely Revised	New Page	Information Removed
-------------------------------------------------------------------------------------	---------------------------	--------------------	----------	---------------------

**SHEET
1 OF 1**

SDG&E ELECTRIC OVERHEAD STANDARD

0-750V CUSTOMER OWNED UNDERGROUND SERVICE
FROM AN OVERHEAD LINE, ONE DUCT

**FMO
OH 1415**

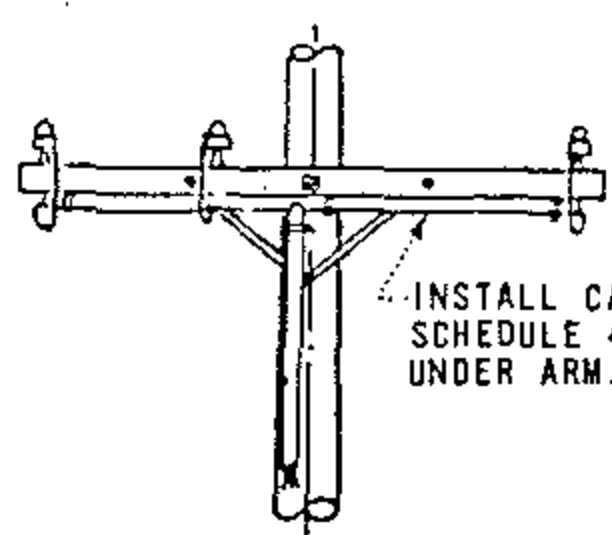
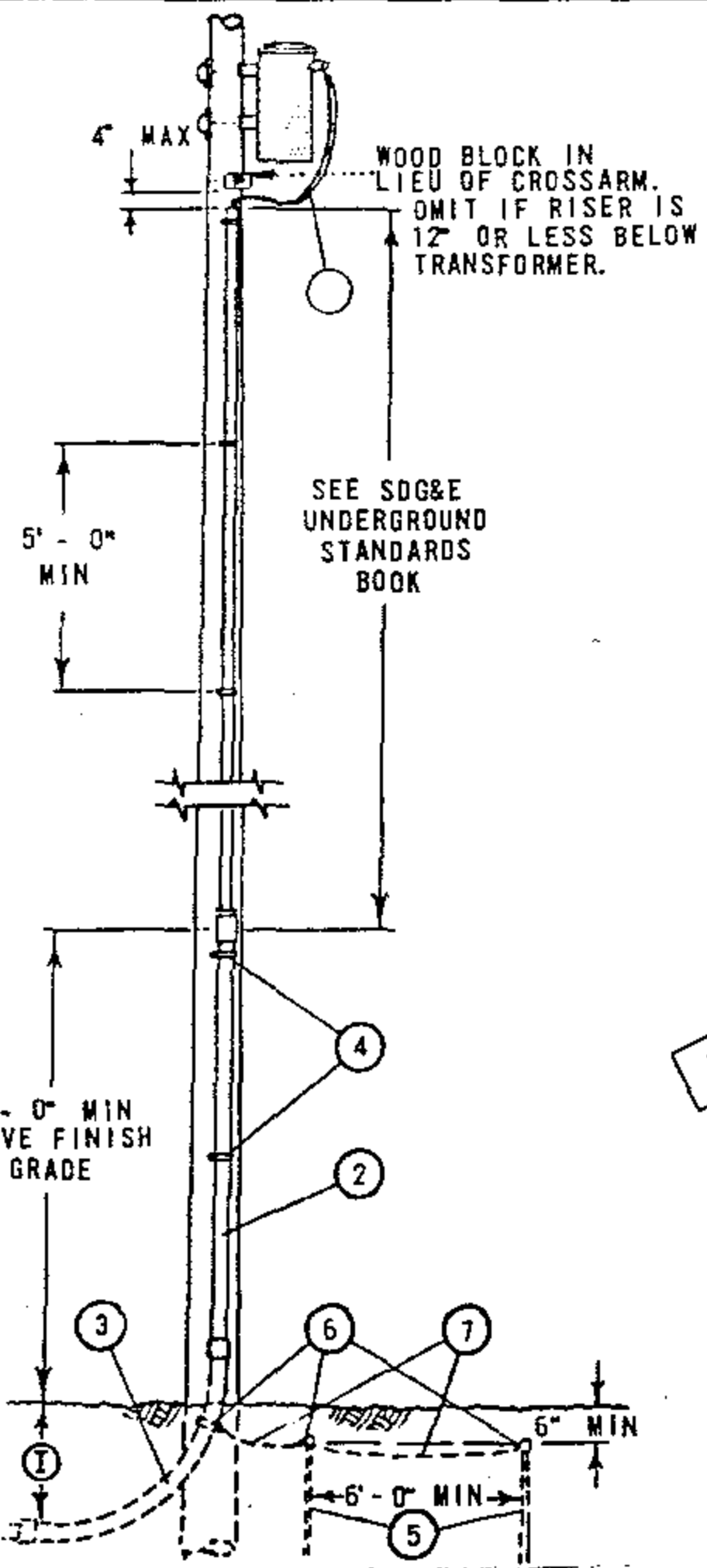

CROSSARM CONSTRUCTION

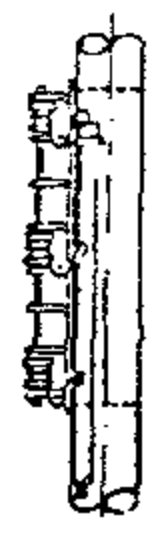

RACK CONSTRUCTION

FOR FIELD MAINTENANCE ONLY

NOTES:

- (A) SEE PAGE 7404 / 4204 FOR RISER CONSTRUCTION.
- (B) CUSTOMER'S SERVICE ENTRANCE CONDUCTORS SHALL RUN CONTINUOUSLY WITHOUT SPLICES FROM SERVICE EQUIPMENT TO SECONDARY OR TRANSFORMER TERMINALS AND SHALL BE OF A LENGTH SUFFICIENT TO FORM DRIP LOOPS AT THE TOP OF THE RISER. CONTRACTOR SHALL IDENTIFY SERVICE ENTRANCE CONDUCTORS WITH CODING OR TAGGING FOR PURPOSE OF PARALLELING PHASES AND NEUTRALS. MAXIMUM SIZE OF EACH CONDUCTOR, SINGLE OR PARALLELED RUNS, SHALL NOT EXCEED 500 KCM.
- (C) WHEN ITEMS 2 AND 3 ARE SCHEDULE 80 PVC OMIT ITEMS 5, 6, AND 7. (SEE SDG&E UNDERGROUND STANDARDS BOOK)
- (D) OMIT ITEMS 5, 6, AND 7 WHERE CUSTOMER'S UNDERGROUND CONDUIT RUN IS AN APPROVED METALLIC CONDUIT.
- (E) OMIT ITEM 5, AND 7 WHERE #6 BARE COPPER BONDING WIRE IS INSTALLED BETWEEN ITEMS 3 AND CUSTOMER'S SERVICE ENTRANCE EQUIPMENT.
- (G) USE TWO ROD GROUND SPACED A MINIMUM OF 6 FEET APART.
- H. APPROVED METALLIC CONDUIT OR #6 BARE COPPER BONDING WIRE SHALL BE GROUNDED AT THE SERVICE ENTRANCE IN ACCORDANCE WITH REQUIREMENTS OF THE LOCAL INSPECTION AUTHORITY.
- (I) 18" MIN DEPTH ON PRIVATE AND PUBLIC PROPERTY OTHER THAN STREETS AND ALLEYS. 24" MIN DEPTH ACROSS STREETS AND ALLEYS. 24" MIN TO BE MAINTAINED CONTINUOUSLY WHERE DUCTS TRAVERSE BOTH STREETS (AND ALLEYS) AND PRIVATE PROPERTY. 24" MIN DEPTH FOR NON-METALLIC CONDUITS.

MATERIAL FURNISHED AND INSTALLED BY CUSTOMER

ITEM	DESCRIPTION (A)
1	CUSTOMER'S SERVICE ENTRANCE CONDUCTORS (B)
2	CONDUIT, GALV. IRON RIGID RISER (C)
3	CONDUIT, GALV IRON BEND, 90°, 36" RADIUS (C)
4	STRAP, PIPE GALV, 2-10D GALV NAILS
5	RODS, 5/8" X 8'-0" COPPERCLAD STEEL GROUND (D) (E) (G)
6	CLAMPS, APPROVED TYPE GROUNDING (D)
7	WIRE, #6 BARE STRANDED COPPER (D) (F)

OH 1499.101
 UG 4299.101
 SUPERSEDES
 1415 (11-16-81)

SDG&E ELECTRIC STANDARDS
 0-750V CUSTOMER OWNED UNDERGROUND SERVICE
 FROM AN OVERHEAD LINE, ONE DUCT

DATE 11-16-81
 APPD *[Signature]*

FIELD MAINTENANCE ONLY

REVISION HISTORY:

7/13/2016: All versions prior to 2016 are superseded by their current version found inside the Overhead Construction Standard Manual.

© 1998 - 2016 San Diego Gas & Electric Company. All rights reserved. Removal of this copyright notice without permission is not permitted under law.

REV	CHANGE	BY	DSGN	APPV	DATE	REV	CHANGE	BY	DSGN	APPV	DATE
C						F					
B						E					
A	ORIGINAL ISSUE	JS	IL	MDJ	7/13/2016	D					

	Indicates Latest Revision	Completely Revised	New Page	Information Removed
-------------------------------------------------------------------------------------	---------------------------	--------------------	----------	---------------------

**SHEET
1 OF 1**

SDG&E ELECTRIC OVERHEAD STANDARD

0-750V CUSTOMER OWNED UNDERGROUND SERVICE
FROM AN OVERHEAD LINE, TWO DUCTS

**FMO
OH 1417**

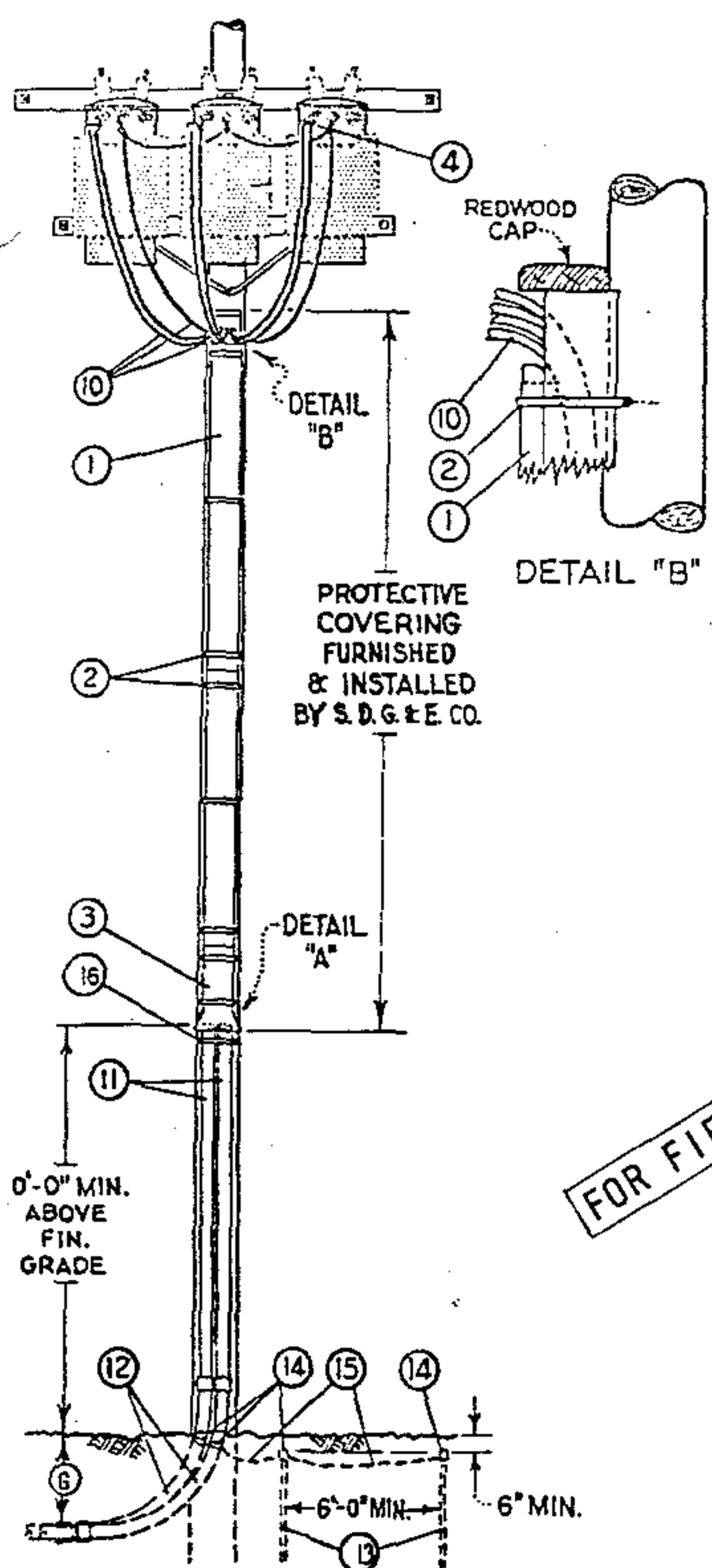

MATERIAL FURNISHED AND INSTALLED BY SDG&E			
ITEM	DESCRIPTION	QUANT.	STOCK NO. OR CONSTR STD
1	REDWOOD BOX MOULDING, SIZE AS REQUIRED	16'	PG 143
2	MOULDING STRAPS, SIZE AS REQ'D	6	PG 143
3	REDWOOD MOULDING BASE FOR 5 1/4" X 6 3/8", INSIDE DIMENSIONS, RDWD. BOX MOULDING	AS REQ'D	PG 143
4	MULTIPLE TAP CONNECTORS, 2 LUG	AS REQ'D	PG 793
7	BOX NAILS, GALV., 10D	1/2#	491392
8	BOX NAILS, GALV., 16D	1/2#	491424

QUANTITIES SHOWN ARE BASED ON A 45' POLE AND TRANSFORMER SECONDARIES CONNECTED 120-208V. WYE.

MATERIAL FURNISHED AND INSTALLED BY CUSTOMER (A)		
10	CUSTOMER'S SERVICE ENTRANCE CONDUCTORS (B)	SEE SDG&E UNDERGROUND STANDARD BOOK
11	G.I. RIGID CONDUIT RISERS	
12	G.I. RIGID CONDUIT BENDS, 90°, 36" RADIUS	
13	5/8" DIAM. X 8'-0" COPPERCLAD STEEL GRND. RODS (C)(D)(E)	
14	APPROVED TYPE GROUNDING CLAMPS (C)	
15	#6 BARE STRANDED COPPER GROUND WIRE (C)(D)	
16	HEAVY PLUMBERS TAPE, HOT-DIP GALVANIZED	

FOR FIELD MAINTENANCE ONLY

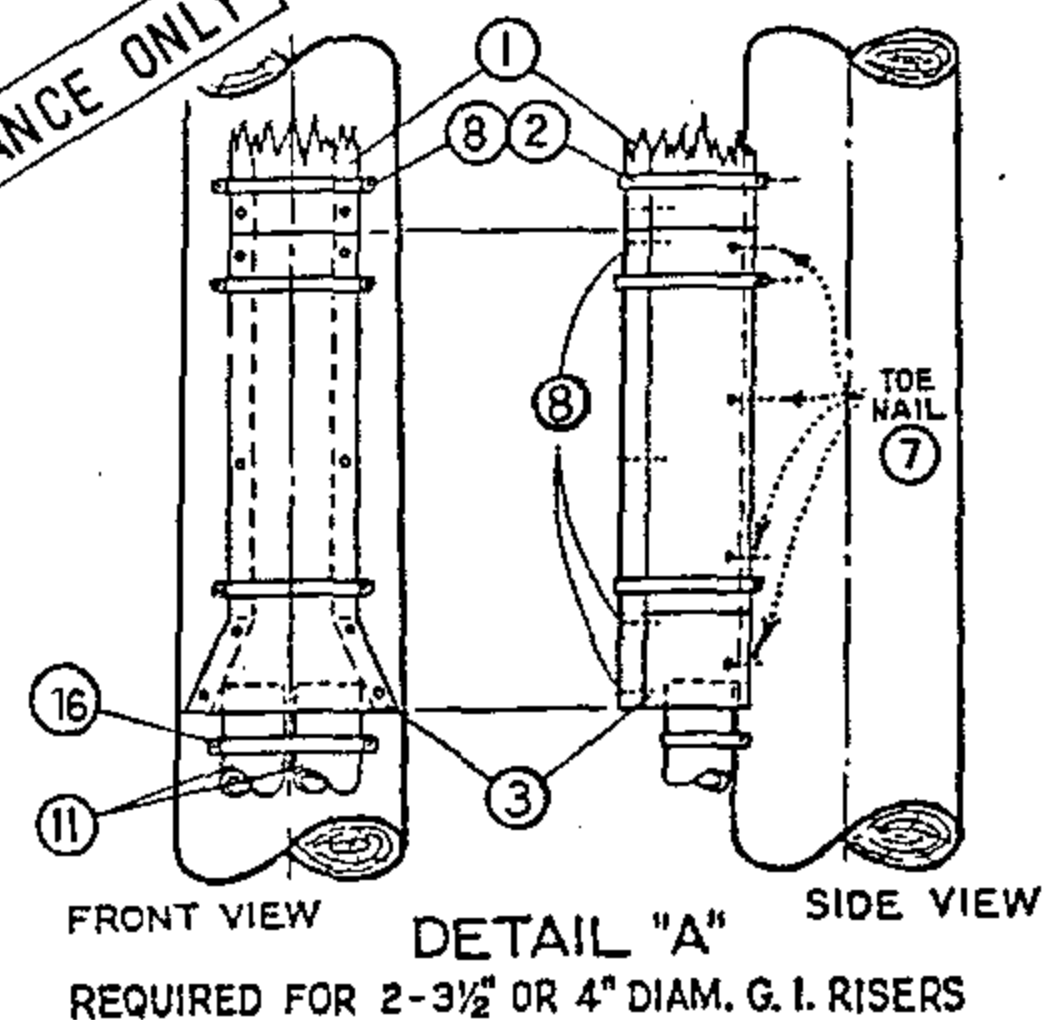

- NOTES:
- (A) SEE SDG&E UNDERGROUND STANDARDS BOOK FOR CABLE CONDUIT SIZING INFORMATION.
 - (B) CUSTOMER'S SERVICE ENTRANCE CONDUCTORS SHALL RUN CONTINUOUSLY WITHOUT SPLICES FROM SERVICE EQUIPMENT TO TRANSFORMER TERMINALS AND SHALL BE OF A LENGTH SUFFICIENT TO FORM DRIP LOOPS AT THE TOP OF THE RISER. CONTRACTOR SHALL IDENTIFY SERVICE ENTRANCE CONDUCTORS WITH CODING OR TAGGING FOR PURPOSE OF PARALLELING PHASES AND NEUTRALS. MAXIMUM SIZE OF EACH CONDUCTOR, SINGLE OR PARALLELED RUNS, SHALL NOT EXCEED 500 KCM.
 - (C) OMIT ITEMS 13, 14, AND 15 WHERE CUSTOMER'S UNDERGROUND CONDUIT RUN IS AN APPROVED METALLIC CONDUIT.
 - (D) OMIT ITEM NUMBERS 13 AND 15 WHERE #6 BARE COPPER BONDING WIRE IS INSTALLED BETWEEN ITEM 12 AND CUSTOMER'S SERVICE ENTRANCE EQUIPMENT.
 - (E) USE TWO ROD GROUND.
 - (F) APPROVED METALLIC CONDUIT OR #6 BARE COPPER BONDING WIRE SHALL BE GROUNDED AT THE SERVICE ENTRANCE IN ACCORDANCE WITH REQUIREMENTS OF THE LOCAL INSPECTION AUTHORITY.
 - (G) 18" MIN DEPTH ON PRIVATE AND PUBLIC PROPERTY OTHER THAN STREETS AND ALLEYS. 24" MIN DEPTH ACROSS STREETS AND ALLEYS. 24" MIN TO BE MAINTAINED CONTINUOUSLY WHERE DUCTS TRAVERSE BOTH STREETS (AND ALLEYS) AND PRIVATE PROPERTY. 24" MIN DEPTH FOR NON-METALLIC CONDUITS.

FIELD MAINTENANCE ONLY

REVISION HISTORY:

7/13/2016: All versions prior to 2016 are superseded by their current version found inside the Overhead Construction Standard Manual.

© 1998 - 2016 San Diego Gas & Electric Company. All rights reserved. Removal of this copyright notice without permission is not permitted under law.

REV	CHANGE	BY	DSGN	APPV	DATE	REV	CHANGE	BY	DSGN	APPV	DATE
C						F					
B						E					
A	ORIGINAL ISSUE	JS	IL	MDJ	7/13/2016	D					

SHEET 1 OF 1	 Indicates Latest Revision	Completely Revised	New Page	Information Removed	FMO OH 1418
	SDG&E ELECTRIC OVERHEAD STANDARD				
	0-750V CUSTOMER OWNED UNDERGROUND SERVICE FROM AN OVERHEAD LINE, THREE AND FOUR DUCTS				

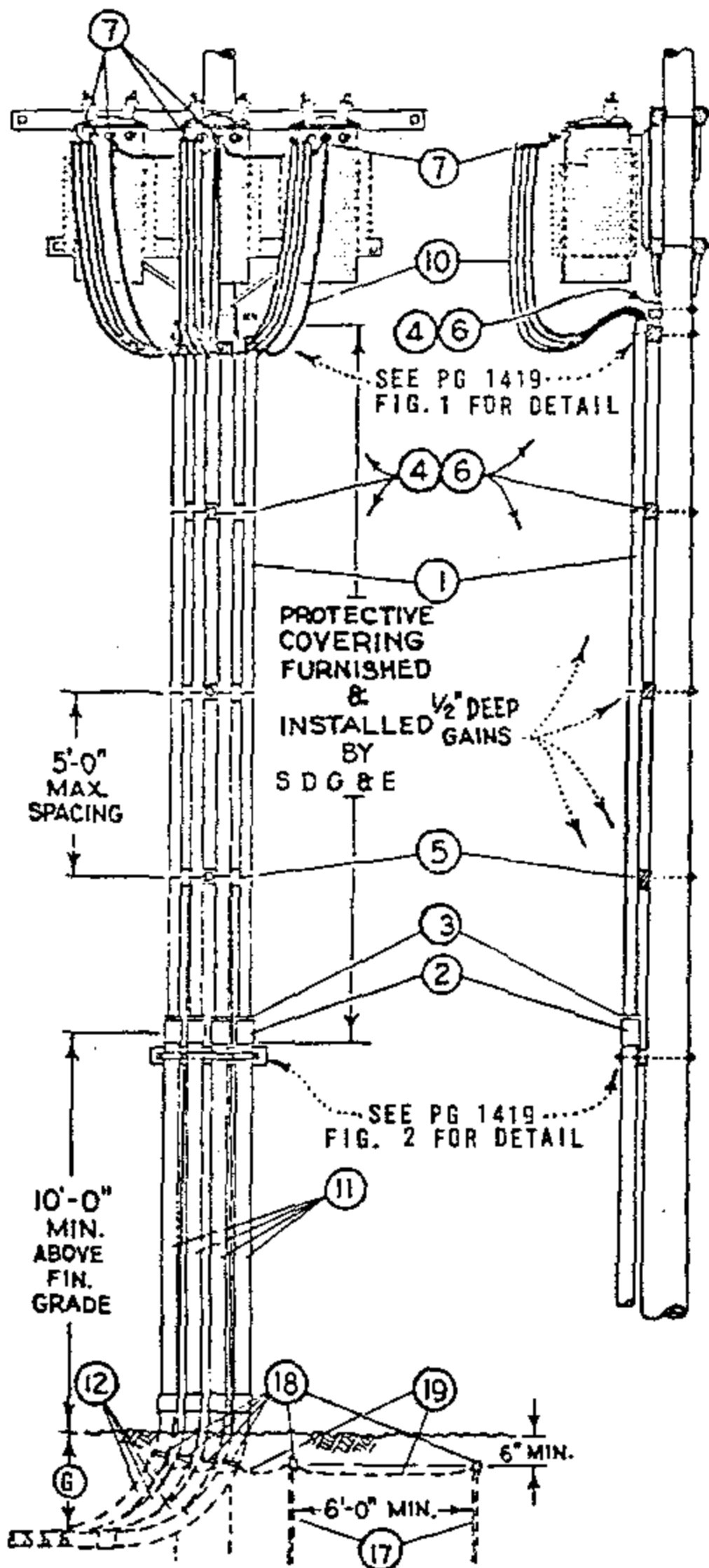

MATERIAL FURNISHED AND INSTALLED BY SDG&E					
ITEM	DESCRIPTION	QUANTITY		STOCK NO. OR CONSTR STD	
		3	4	3"	4"
①	3" OR 4" DIAM. PLASTIC CONDUIT, PVC TYPE II, SCHEDULE 40, 20' LENGTHS	60'	80'	251552	251584
②	COUPLINGS, PLASTIC, SIZE AS REQUIRED	3	4	280448	280480
③	BUSHINGS, PLASTIC, 4" OR 3 1/2" X 3" DIAM FOR REDUCING CUSTOMER'S CONDUIT RISERS, WHERE REQUIRED	3	4	3 1/2" X 3" 181024, 4" X 3" - 181056	
4	RISER SUPPORT BLOCKS, 3 1/2" X 4 1/2" X 2'-0"	5	5	PG 1419 IT. 4	
5	1/2" BOLT, 1 SQ WASHER	12	16	PGS 139, 140	
6	MACH. BOLT, GALV, 5/8" X 16"-20, 2 SQ. WASHERS & 1 NUT	5	5	PGS 139, 140	
7	MULTIPLE TAP CONNECTORS, SPECIFY NUMBER OF LUGS	6	6	PG 793	

⊙ QUANTITIES SHOWN ARE BASED ON A 45' POLE AND TRANSFORMER SECONDARIES CONNECTED 120/208V WYE.
 † UNTHREADED FOR SLIP FIT OVER RIGID CONDUIT RISER.

MATERIAL FURNISHED AND INSTALLED BY CUSTOMER		
ITEM	DESCRIPTION (A)	STOCK NO.
10	CUSTOMER'S SERVICE ENTRANCE CONDUCTORS (B)	SEE SDG&E UNDERGROUND STANDARD BOOK
11	G.I. RIGID CONDUIT RISERS	
12	G.I. RIGID CONDUIT BENDS, 90°, 36" RADIUS	
13	SPACER BLOCK	
14	STRAP, GALV	
15	FOUR 1/2" X 9" MACH. BOLTS, GALV, 1 RD. WASHER	
16	ONE 5/8" X 20" MACH. BOLT, GALV, 2-2" SQ. WASHERS	
17	5/8" X 8'-0" COPPERCLAD STEEL GROUND RODS (C)(D)(E)	
18	APPROVED TYPE GROUNDING CLAMPS (C)	
19	#6 BARE STRANDED COPPER GROUND WIRE (C)(D)	

FOR FIELD MAINTENANCE ONLY

NOTES:

- (A) SEE UNDERGROUND STANDARDS BOOK FOR CABLE CONDUIT SIZING INFORMATION.
- (B) CUSTOMER'S SERVICE ENTRANCE CONDUCTORS SHALL RUN CONTINUOUSLY WITHOUT SPLICES FROM SERVICE EQUIPMENT TO TRANSFORMER TERMINALS AND SHALL BE OF A LENGTH SUFFICIENT TO FORM DRIP LOOPS AT THE TOP OF THE RISER. CONTRACTOR SHALL IDENTIFY SERVICE ENTRANCE CONDUCTORS WITH CODING OR TAGGING FOR PURPOSE OF PARALLELING PHASES AND NEUTRALS. MAXIMUM SIZE OF EACH CONDUCTOR, SINGLE OR PARALLELED RUNS, SHALL NOT EXCEED 500 KCM.
- (C) OMIT ITEM 17, 18, AND 19 WHERE CUSTOMER'S UNDERGROUND CONDUIT RUN IS AN APPROVED METALLIC CONDUIT.
- (D) OMIT ITEM 17, AND 19 WHERE #6 BARE COPPER BONDING WIRE IS INSTALLED BETWEEN ITEM 12 AND CUSTOMER'S SERVICE ENTRANCE IN ACCORDANCE WITH REQUIREMENTS OF THE LOCAL INSPECTION AUTHORITY.
- (E) USE TWO ROD GROUND.
- F. APPROVED METALLIC CONDUIT OR #6 BARE COPPER BONDING WIRE SHALL BE GROUNDED AT THE SERVICE ENTRANCE IN ACCORDANCE WITH REQUIREMENTS OF THE LOCAL INSPECTION AUTHORITY.
- (G) 18" MIN DEPTH ON PRIVATE AND PUBLIC PROPERTY OTHER THAN STREETS OR ALLEYS. 24" MIN DEPTH ACROSS STREETS AND ALLEYS. 24" MIN TO BE MAINTAINED CONTINUOUSLY WHERE DUCTS TRAVERSE BOTH STREETS (AND ALLEYS) AND PRIVATE PROPERTY. 24" MIN DEPTH FOR NON-METALLIC CONDUITS.

1499.103
 SUPERSEDES
 1418 (11-16-81)

SDG&E ELECTRIC STANDARDS
 0-750V CUSTOMER OWNED UNDERGROUND SERVICE
 FROM AN OVERHEAD LINE, THREE AND FOUR DUCTS

DATE: 11-15-81
 APPD: [Signature]

FIELD MAINTENANCE ONLY

REVISION HISTORY:

7/13/2016: All versions prior to 2016 are superseded by their current version found inside the Overhead Construction Standard Manual.

© 1998 - 2016 San Diego Gas & Electric Company. All rights reserved. Removal of this copyright notice without permission is not permitted under law.

REV	CHANGE	BY	DSGN	APPV	DATE	REV	CHANGE	BY	DSGN	APPV	DATE
C						F					
B						E					
A	ORIGINAL ISSUE	JS	IL	MDJ	7/13/2016	D					

SHEET 1 OF 1	 Indicates Latest Revision	Completely Revised	New Page	Information Removed	FMO OH 1428
	SDG&E ELECTRIC OVERHEAD STANDARD				
	CROSSARM MOUNTED TERMINALS 4KV 4 WIRE WYE				

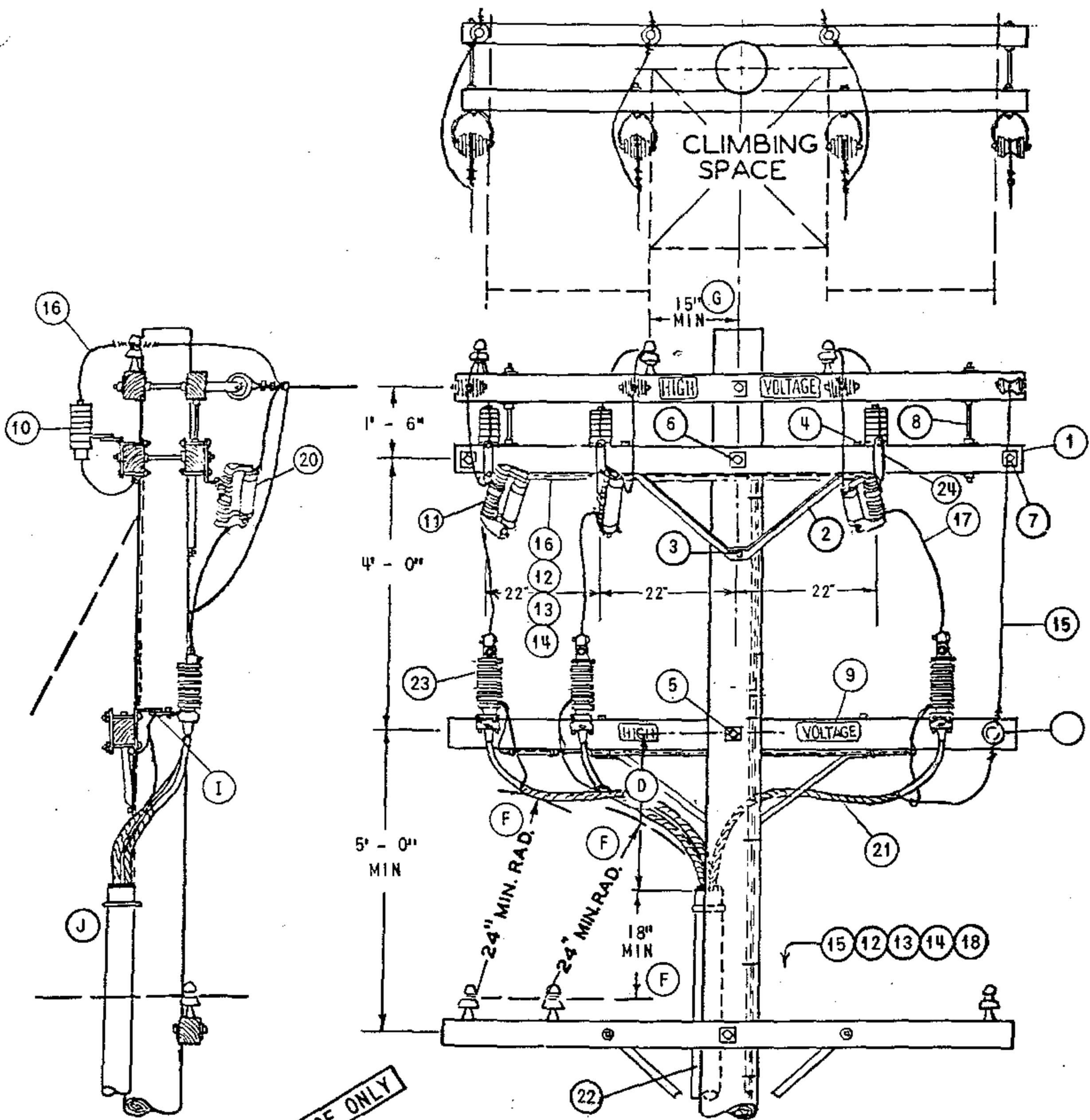

FOR FIELD MAINTENANCE ONLY

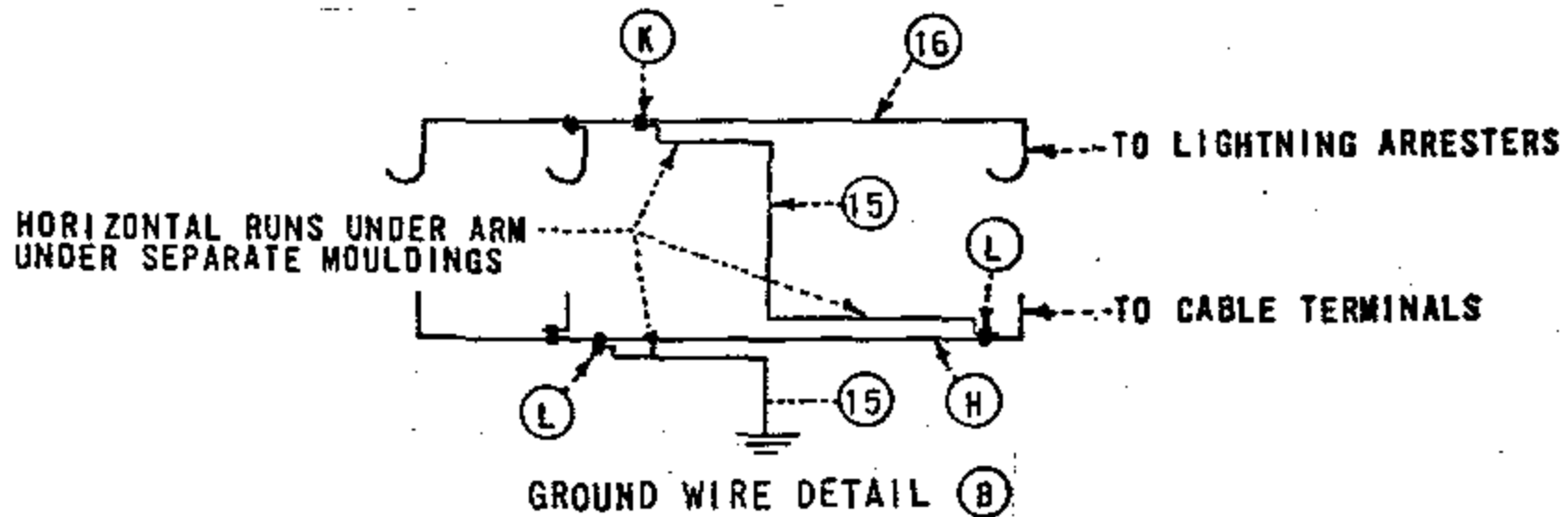

NOTES:

- (A) UNIT GROUND COMPLETE ORDER 603120 WITH GRAY MOULDING, 603136 WITH PLAIN MOULDING
- (B) INTERCONNECT ARRESTER GROUND LEAD DISCONNECTS WITH #6 BARE COPPER AND GROUND IT WITH #2 BARE COPPER NEAR CENTER ARRESTER.
- (C) USE TWO GROUND RODS SPACED A MINIMUM OF 6' APART.
- (D) 3 FOOT MINIMUM DIMENSION, 4 FOOT DIMENSION PREFERRED FOR 750 KCM AND LARGER 15KV CABLE.
- (E) EXEMPT MATERIAL.
- (F) G.O. 95 MINIMUM DIMENSION.
- (G) G.O. 95 MINIMUM DIMENSION FOR 4KV. USE 18" MIN IF BUILT WITH 15KV CABLE.
- (H) USE #2 BARE STRANDED COPPER OR LARGER AS REQUIRED.
- (I) CONNECT NEUTRAL, TERMINAL AND SHIELDED CABLE GROUNDS TO LIGHTNING ARRESTER GROUND.
- (J) INSTALL RISER ON FACE OF POLE OPPOSITE CLIMBING SPACE AND IN A POSITION NEAREST THE END OF ARM ON WHICH THE TWO 4KV PHASES ARE LOCATED.
- (K) CONNECT #2 BARE STRANDED COPPER CONDUCTOR TO #6 BARE STRANDED COPPER CONDUCTOR AT POINT NEAR CENTER LIGHTNING ARRESTER.
- (L) CONNECT #2 BARE STRANDED COPPER CONDUCTOR TO REQUIRED CONDUCTOR AT POINT NEAR CENTER TERMINAL AND END TERMINAL.

FOR FIELD MAINTENANCE ONLY

ITEM	DESCRIPTION	QUANTITY	STOCK NO. OR CONSTR STDS
P T F	1 CROSSARM, 3 3/4" X 5 3/4" X 10' - 0"	3	300 SECTION
	2 BRACE, ANGLE CROSSARM 4' - 0"	2	164032
	3 SCREW, LAG GALV, 5/8" X 5"	(E) 2	621600
	4 BOLT, MACH GALV, 1/2" X 7", 1 RD WASH. & 1 DBL COIL WASH.	(E) 4	PGS 139, 140
	5 BOLT, MACH GALV, 5/8" X 14", 2 - 3" SQ WASH. & 1 DBL COIL WASH.	(E) 1	PGS 139, 140
	6 BOLT, MACH GALV, 5/8" X 20", 2 - 3" SQ WASH. & 1 DBL COIL WASH.	(E) 1	PGS 139, 140
	7 BOLT, SPACE GALV, 5/8" X 20", 4 SQ WASH. & 4 DBL COIL WASH.	(E) 2	PGS 139, 140
	8 BOLT, SPACE GALV, 5/8" X 28", 4 SQ WASH. & 4 DBL COIL WASH.	(E) 2	PGS 139, 140
	9 SIGN, HIGH VOLTAGE & 8 ROOFING NAILS	(E) 1	647648, 492224
U C D	10 ARRESTER, LIGHTNING 3KV	3	113216
	11 CUTOUT, FOR CURRENT-LIMITING FUSE	3	1200 SECTION
	12 STAPLES, FENCE GALV, 1 1/4"	(A) (E) 25	678528
	13 MOULDING, HARDWOOD 1"	(A) 55'	487200
	14 STAPLES, MOULDING GALV, 3" X 1 1/16" X 1/4"	(A) (E) 25	678560
	15 WIRE, #2 BARE STRANDED COPPER	(B) 44'	813664
	16 WIRE, #6 BARE STRANDED COPPER	(B) 18'	813536
	17 WIRE, COPPER, SIZED PER U.G. CABLE AMPACITY.	8'	81
	18 ROD & CLAMP, GROUND	(A) (C) 2	603072, 230016
	19 INSULATOR, 4KV WIRE HOLDER	1	413792
	20 FUSE, CURRENT-LIMITING SIZE AS SPECIFIED ON WORK ORDER	3	1200 SECTION
	21 CABLE, POLYETHYLENE, CONCENTRIC NEUTRAL PRIMARY	AS REQ'D	SEE UG STDS
	22 RISER CONSTRUCTION	AS REQ'D	1400/4200 SECTION
	23 TERMINAL CABLE	3	UG BOOK
	24 BRACKET, CUTOUT /ARRESTER CROSSARM MOUNTING	(E) 3	166070
	25		

FIELD MAINTENANCE ONLY

REVISION HISTORY:

7/13/2016: All versions prior to 2016 are superseded by their current version found inside the Overhead Construction Standard Manual.

© 1998 - 2016 San Diego Gas & Electric Company. All rights reserved. Removal of this copyright notice without permission is not permitted under law.

REV	CHANGE	BY	DSGN	APPV	DATE	REV	CHANGE	BY	DSGN	APPV	DATE
C						F					
B						E					
A	ORIGINAL ISSUE	JS	IL	MDJ	7/13/2016	D					

SHEET 1 OF 1	 Indicates Latest Revision	Completely Revised	New Page	Information Removed	FMO OH 1429
	SDG&E ELECTRIC OVERHEAD STANDARD				
	12.47KV AND BELOW 3Ø CABLE POLE 1/C PER Ø, UPSWEEP BRACKET CONSTRUCTION				

SCOPE: THIS STANDARD SHOWS TANGENT LINE (FIG.1) AND DEAD-END CONSTRUCTION (FIG.2) FOR 12.47 KV AND BELOW, 3Ø CABLE POLE WITH UPSWEEP BRACKET MOUNTED TERMINALS FOR #2/0 AND SMALLER UG CABLE.

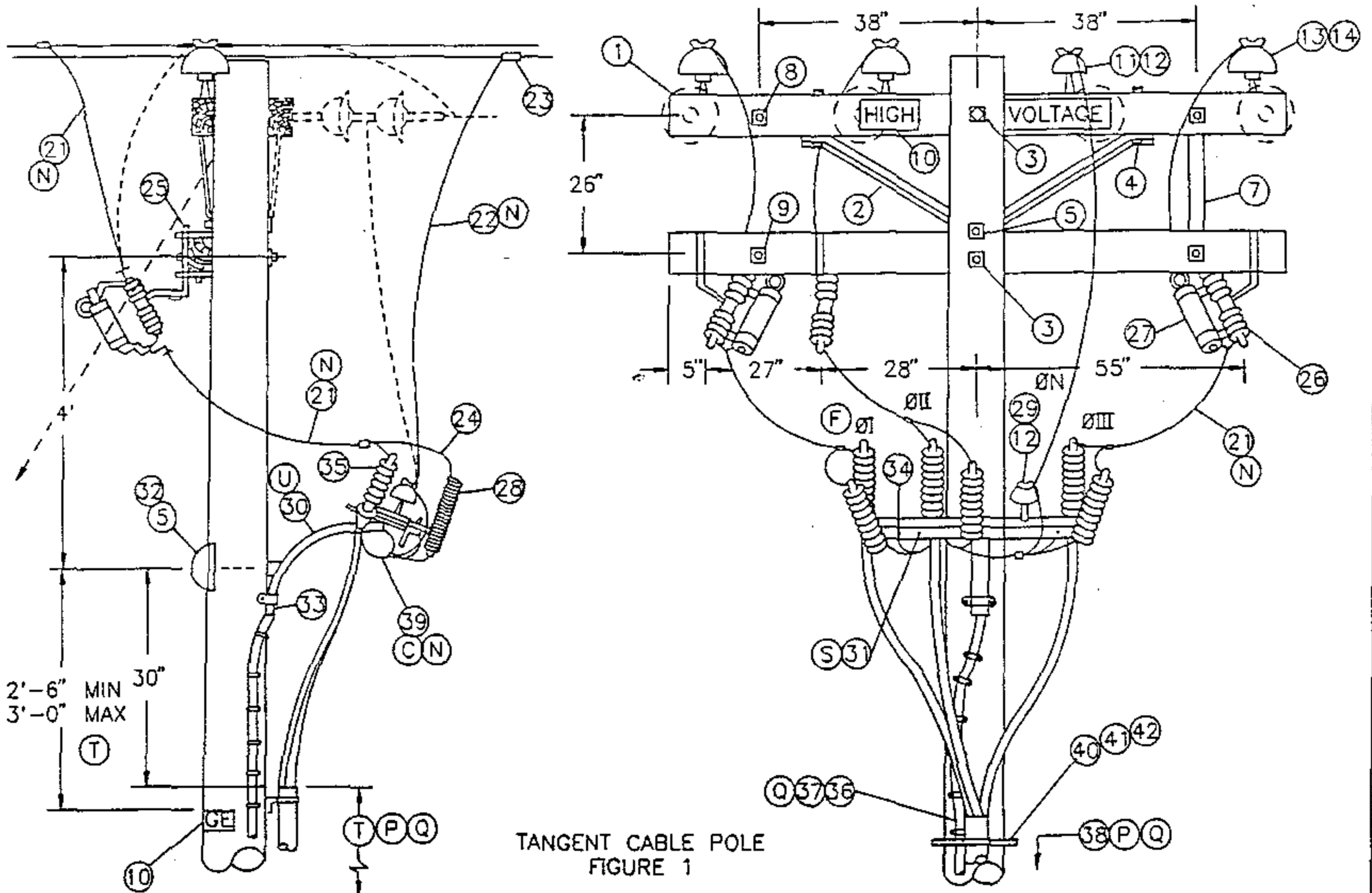

TANGENT CABLE POLE
FIGURE 1

GROUND CLEARANCE

NOTE:

- TANGENT CABLE POLE (FIG.1) OR DEAD-END CABLE POLE (DOTTED LINE) IS TO BE USED WHEN FURTHER LINE EXTENSION IS EXPECTED.
- DO NOT USE THIS UPSWEEP BRACKET CONSTRUCTION FOR 4KV, 3Ø CABLE POLE. INSTEAD, USE STANDARD 1439/4239.

FOR FIELD MAINTENANCE ONLY

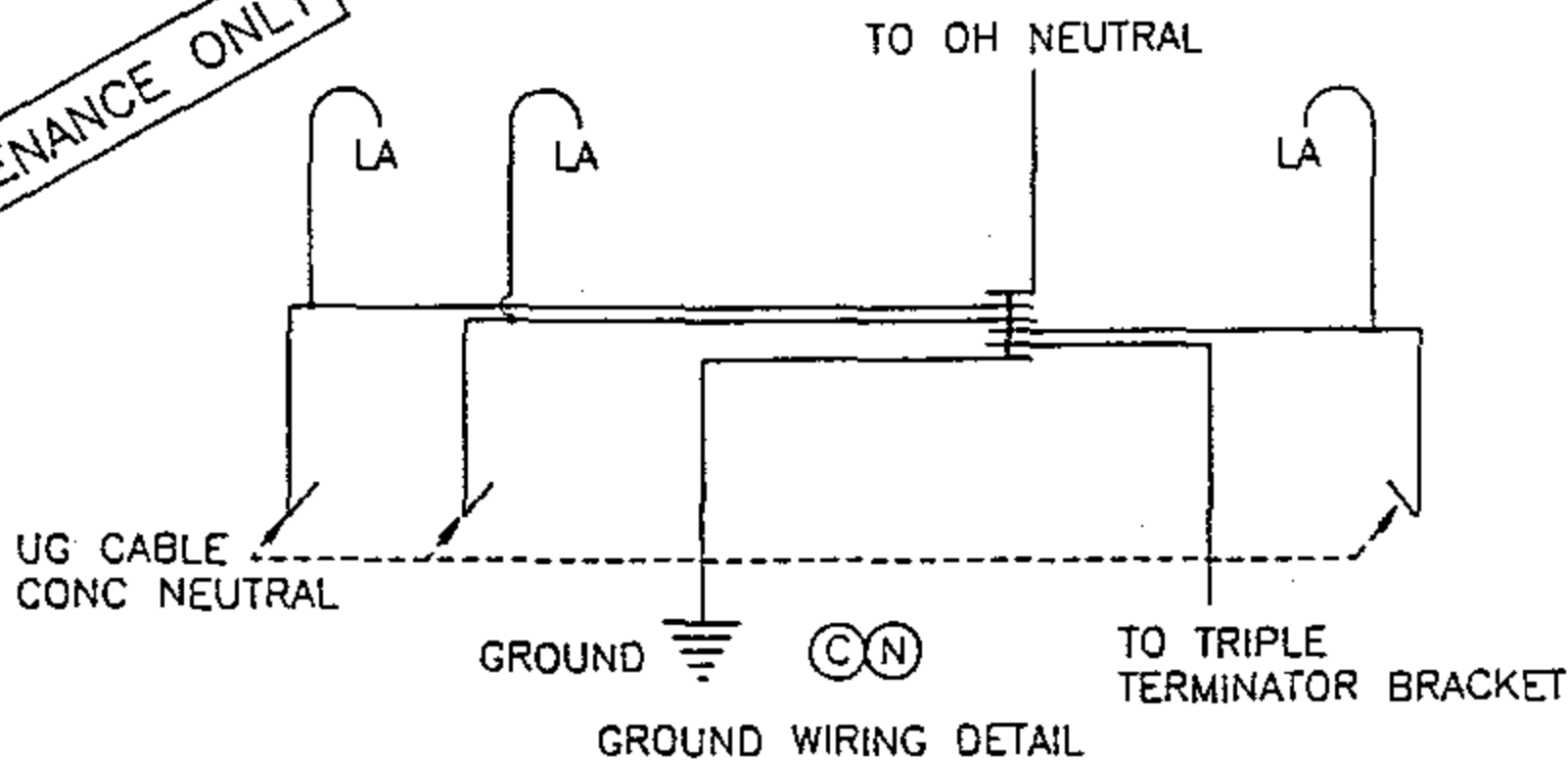

GROUND WIRING DETAIL

DATE 1-1-93
APPD *JLB/BJ*

SDG&E ELECTRIC STANDARDS

12.47KV AND BELOW 3Ø CABLE POLE 1/C PER Ø,
UPSWEPT BRACKET CONSTRUCTION

OH 1499.203
~~UG 4299.203~~
SUPERCEDES
1429.1 (1-1-93)

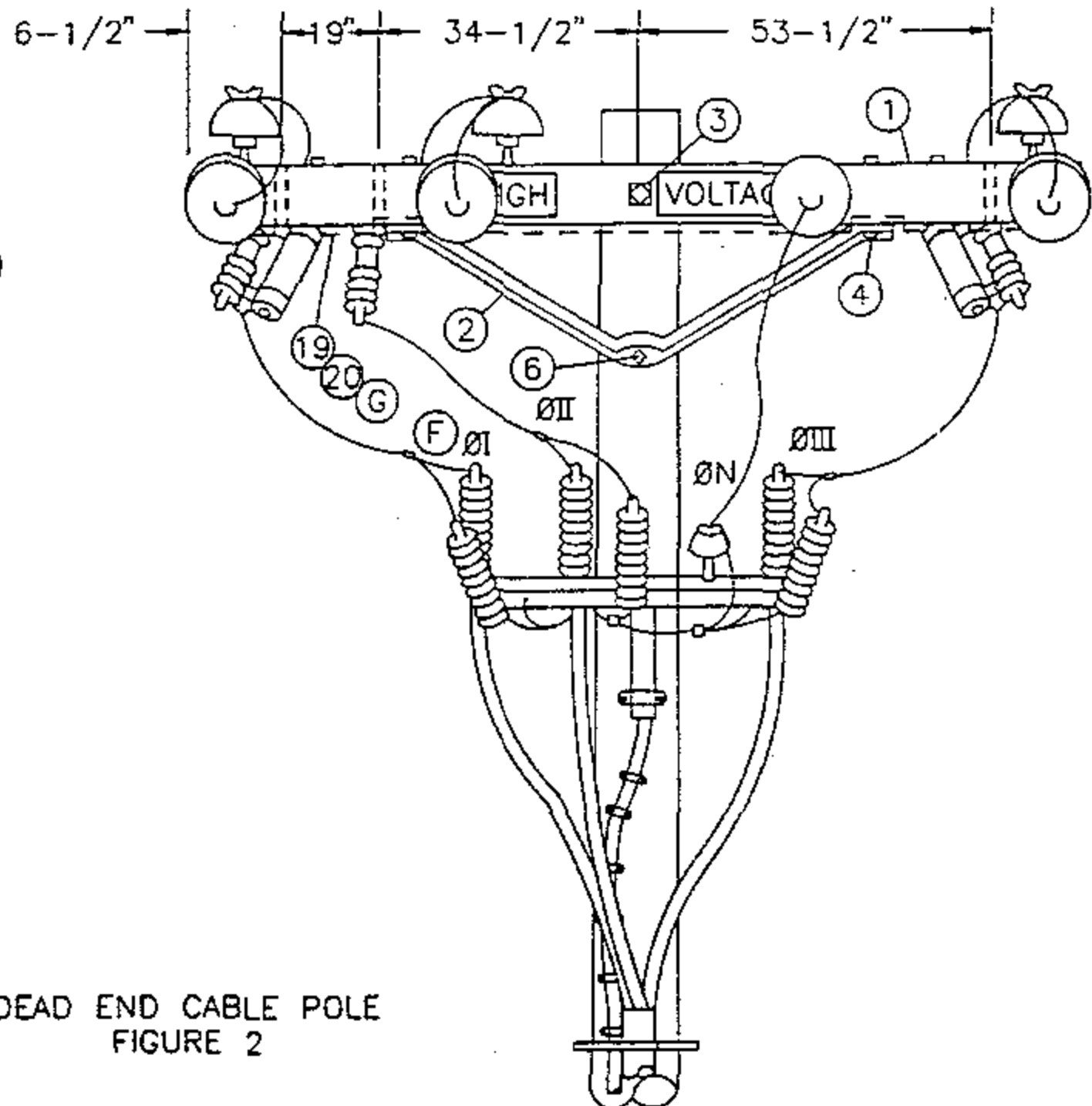
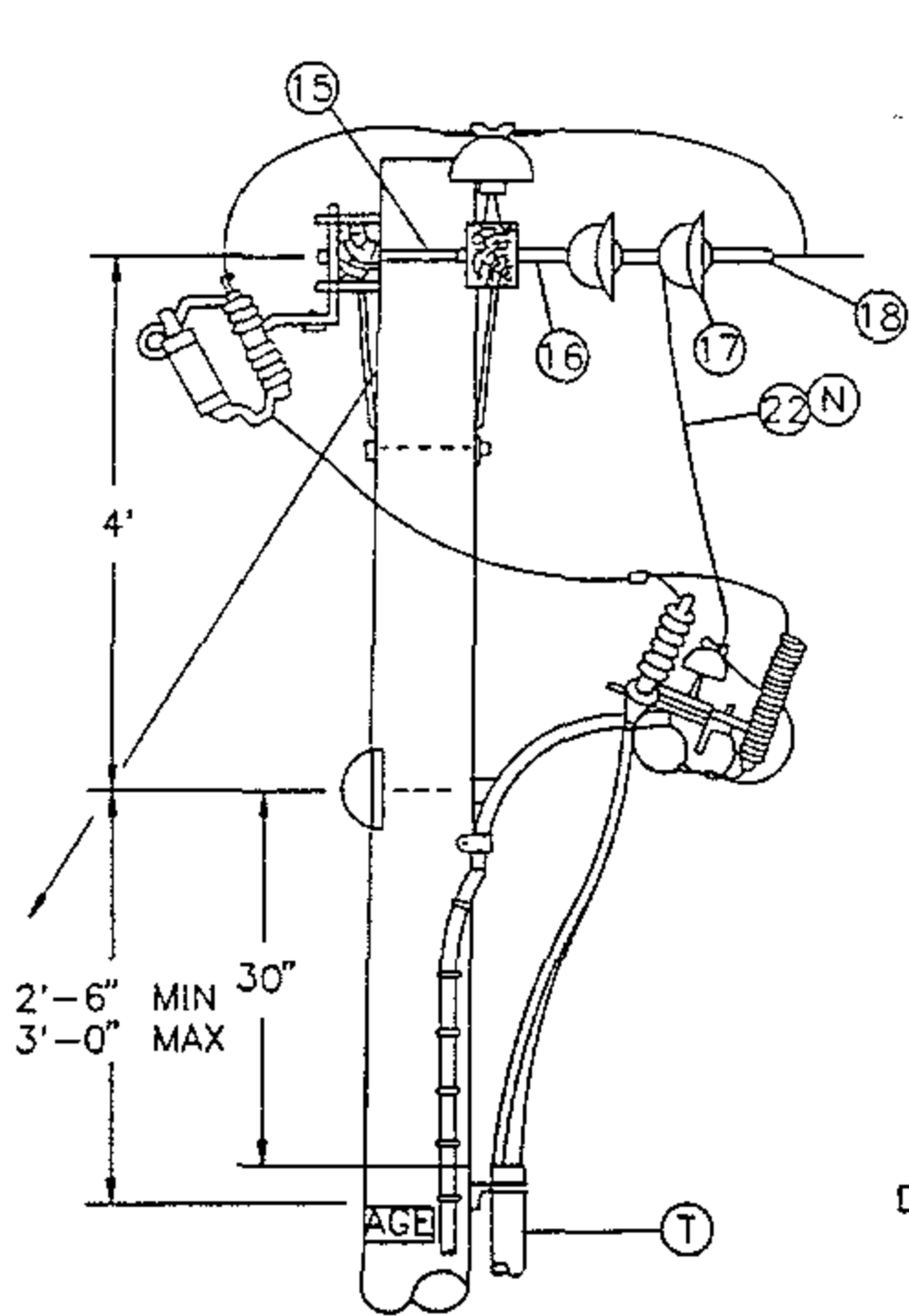

DEAD END CABLE POLE
FIGURE 2

NOTE:

-- DEAD END CABLE POLE (FIG.2) IS TO BE USED ONLY WHEN NO FURTHER LINE EXTENSION OR NO RECONDUCTING IS EXPECTED.

FOR FIELD MAINTENANCE ONLY

OH 1499.204
~~UG 4299.204~~
SUPERCEDES
1429.2 (1-1-93)

SDG&E ELECTRIC STANDARDS

12.47KV AND BELOW 3Ø CABLE POLE 1/C PER Ø
UPSWEEP BRACKET CONSTRUCTION

DATE 1-1-93

APPD *JLB/BJ*

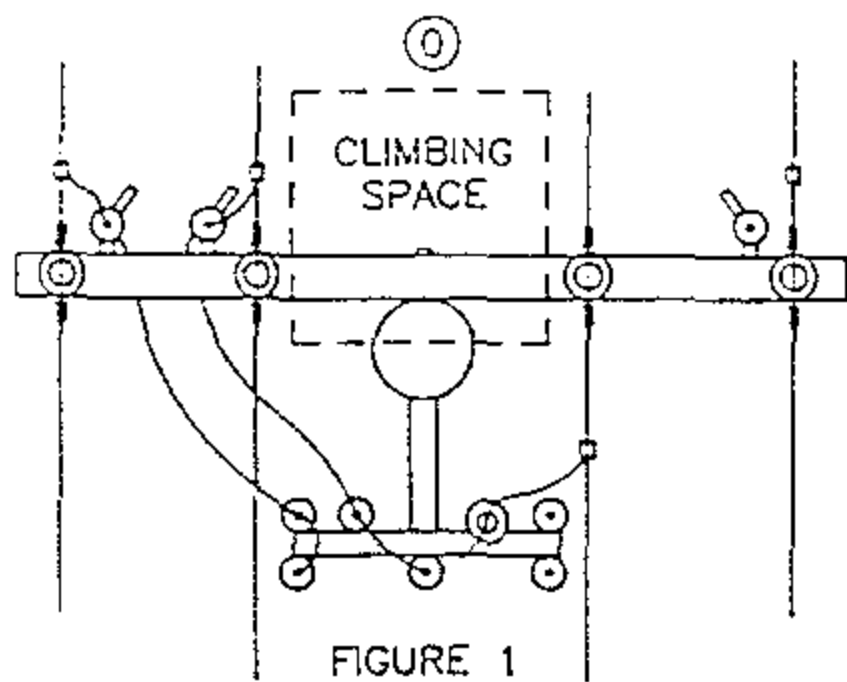

FIGURE 1

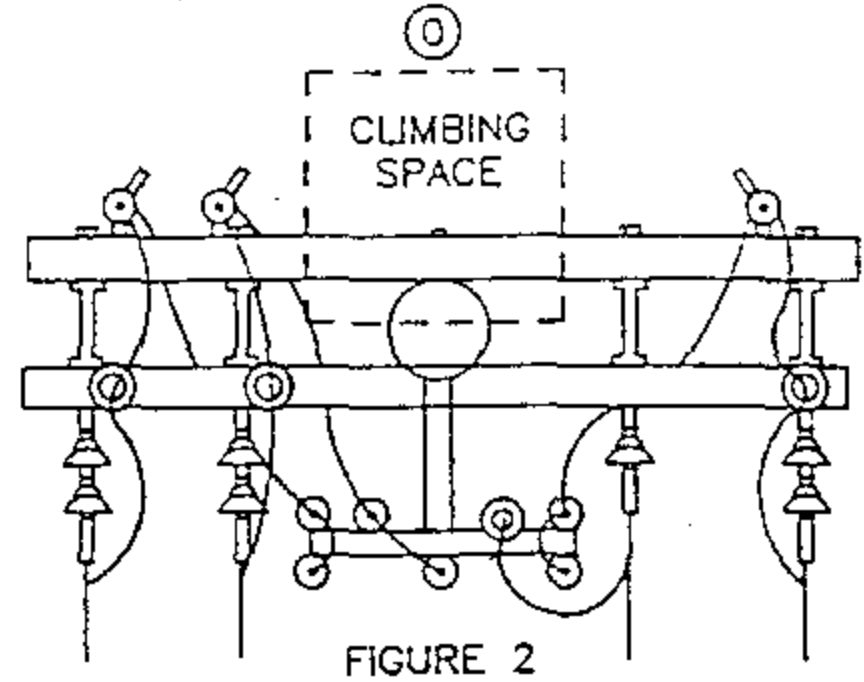

FIGURE 2

CLIMBING SPACE

BILL OF MATERIAL:

FOR FIELD MAINTENANCE ONLY

ITEM	DESCRIPTION	QUANTITY		CONST STD OR PAGE NO	STOCK NUMBER
		FIG.1	FIG.2		
1	CROSSARM, 3-3/4" X 5-3/4" X 10'-0"	2	2	-	294128
2	BRACE, ANGLE, CROSSARM, 5'	1	2	-	164128
3	BOLT, MACH, GALV, 5/8" X (LENGTH AS REQ'D), 2 SQUARE & 1 DOUBLE COIL SPRING WASHER (E)	2	1	392	-
4	BOLT, MACH, GALV, 1/2" X 7", 1 ROUND & 1 DOUBLE COIL SPRING WASHER (E)	2	4	392	-
5	BOLT, MACH, GALV, 5/8" X (LENGTH AS REQ'D), 1 SQUARE & 1 DOUBLE COIL SPRING WASHER (E)	2	1	392	-
6	BOLT, MACH, GALV, 5/8" X (LENGTH AS REQ'D), 1 DOUBLE COIL SPRING WASHER (E)	-	1	392	-
7	BRACE, FLAT, CROSSARM, 28" (E)	2	-	-	164192
8	BOLT, MACH, GALV, 3/8" X (LENGTH AS REQ'D), 1 ROUND & 1 SPRING WASHER (E)	2	-	392	-
9	BOLT, MACH, GALV, 1/2" X (LENGTH AS REQ'D), 1 ROUND & 1 DOUBLE COIL SPRING WASHER (E)	2	-	392	-
10	SIGN, HIGH VOLTAGE AND 9 ROOFING NAILS, GALV (E)	3	3	-	647648
		AS REQ'D		-	492224
11	PIN, INSULATOR, STRAIGHT, 12KV, 1" LEAD THREAD (D) (E)	1	-	-	532704
12	INSULATOR, LINE, 12KV, NEUTRAL (D) (E)	2	1	-	429216
13	PIN, INSULATOR, STRAIGHT, 12KV, 1" OR 1-3/8" LEAD THREAD (E)	3	3	-	532704
		3	3	-	532448
14	INSULATOR, LINE, 12KV, 1" OR 1-3/8" PIN (E)	3	3	750	-
15	BOLT, SPACE, 5/8" X (LENGTH AS REQ'D) 3 SQ, 2 RD, 2 DOUBLE COIL SPRING WASHERS & 1 NUT (D) (E)	-	4	392	-
16	CLEVIS, DEAD END, 5/8" BOLT, STEEL (D) (E)	-	4	-	235712
17	INSULATOR, SUSPENSION, 12KV, CLEVIS (D)	-	7	750	-
18	CLAMP, STRAIGHT LINE, D.E. (D) (E)	-	4	741	-
19	WIRE, #8, BARE SOLID ANNEALED COPPER	10'	10'	-	812928
20	STAPLES, FENCE, GALV, 1-1/4" (E)	AS REQ'D		-	678528
21	WIRE, BARE STRANDED COPPER (OH JUMPER) (N)	21'	25'	715-716	-
22	WIRE, BARE STRANDED CU OR AL (OH NEUT JUMPER) (N)	9'	7'	711-716	-
23	CONNECTOR, WIRE COMPRESSION (SIZE AS REQ'D) (D) (E)	AS REQ'D		785-787	-

CABLE SIZE	UG MACRO UNIT PORCELAIN	
	W/O LADDER ARMS	W/LADDER ARMS
3C-#2 AL	CP-3#2	CP3#2L
3C-#2/0	CP#2/0	CP2/0L

DATE 1-1-93
APPD *JLB/ROJ*

SDG&E ELECTRIC STANDARDS
12.47KV AND BELOW 3Ø CABLE POLE 1/C PER Ø
UPSWEPT BRACKET CONSTRUCTION

OH 1499.205
~~UG 4299.205~~
SUPERCEDES
1429.3 (1-1-93)

BILL OF MATERIAL: (CONTINUED)

ITEM	DESCRIPTION	QUANTITY		CONSTR. STD OR PAGE NO.	STOCK NUMBER	
		FIG. 1	FIG. 2			
24	WIRE, #6, BARE STRANDED COPPER	9'	9'	-	813536	
25	BRACKET, CUTOUT/ARRESTER, FOR CROSSARM MOUNTING (E)	3	3	-	166070	
26	CUTOUT BODY FOR CURRENT LIMITING FUSE	3	3	-	297952	
27	FUSE, CURRENT-LIMITING, SIZE AS REQ'D	3	3	1206	-	
28	ARRESTER, LIGHTNING	3	3	1247	-	
29	PIN, SHORT SHANK, 1" LEAD THREAD (D) (E)	1	1	-	534426	
30	BRACKET, GALV. TERMINAL, UPSWEEP	1	1	-	166856	
31	BRACKET, TRIPLE TERMINATOR (S)	1	1	-	166676	
32	COVER, BOLT, PLASTIC & 6 - 100 NAILS, GALV	(E)	1	1	-	285696
		(E)	-	-	-	491392
33	SCREW, LAG, GALV, 1/2" X 4"	(E)	2	2	-	621568
34	BOLT, MACH, GALV, 5/8" X 1 1/2", 1 ROUND AND 1 LOCK WASHER (E)	1	1	392	-	
35	TERMINALS AND UNDERGROUND CABLE	3	3	4111	-	
36	WIRE, #4, BARE STRANDED COPPER	50'	45'	-	813760	
37	UNIT GROUND, COMPLETE (Q)	1	1	--	603136	
38	RISER CONSTRUCTION	-	-	1400/4200	-	
39	WIRE, COPPER BARE STRANDED (CABLE POLE NEUTRAL) (N)	5'	5'	715/716	-	
40	BRACKET, LADDER ARM (E)	AS REQ'D		1404/4204	167184	
41	NUT, CLAMPING CHANNEL, W/SPRING, 1/2" (E)	AS REQ'D		1404/4204	503488	
42	CHANNEL, DOUBLE GALV, 24" (E)	AS REQ'D		1404/4204	216700	

INSTALLATION:

- A. NEW CABLE POLES SHALL HAVE A STANDARD DEPTH OF 9'. IN MOST CASES THIS WILL REQUIRE A 5' TALLER POLE.
- B. THIS CONSTRUCTION TO BE USED WITH 2/0 AND SMALLER UNDERGROUND CABLE.
- (C) CONNECT OVERHEAD NEUTRAL, TRIPLE TERMINAL BRACKET, AND CONCENTRIC CABLE NEUTRAL CONDUCTOR TO LIGHTNING ARRESTER GROUND.
- (D) REDUCE QUANTITIES AS REQUIRED WHEN NOT USING NEUTRAL.
- (E) EXEMPT MATERIAL.
- (F) OMIT PHASE II AND PHASE N FOR SINGLE PHASE 12KV CABLE POLE; OMIT PHASE I AND PHASE II FOR SINGLE PHASE 6.9 KV CABLE POLE.
- (G) INTERCONNECT CUTOUTS AND DEADEND BONDS PER G.O. 95 RULE 52.7D. BONDING SHOULD BE DONE IN ACCORDANCE WITH RULE 53.4.

(N)

UG CABLE SIZE AWG OR KCMIL, AL	OH JUMPER COND SIZE, AWG OR KCMIL, CU	OH NEUT JUMPER SIZE			CABLE POLE NEUT SIZE (CU) UNDER POTHEAD ARM OR TRIPLE TERM BRKT
		CU	AL		
2	4	6	2	-	#6 PER PHASE
2/0	4	6	2	-	#6 PER PHASE
350	4/0	1/0	3/0	-	#2 PER PHASE
750	500	4/0	336.4	OR SAME SIZE AS O.H. NEUT CONDUCTOR	1/0 PER PHASE
1000	500	4/0	336.4		1/0 PER PHASE

REFERENCE:

- (O) ALLOWABLE WORKING AND CLIMBING SPACE - SEE STANDARD 251.
- (P) POLE STEPPING - SEE STANDARD 363/4205.
- (Q) GROUNDING METHODS - SEE PAGE 1002.5.
- R. SEE STANDARD SECTION 1200/4300 FOR FUSING.
- S. RISER POSITIONS - SEE STANDARD 1402/4202.
- (T) MINIMUM VERTICAL SEPARATION AS PER G.O. 95 - SEE STANDARD 1406/4206.
- (U) SEE STANDARD 1407/4207 FOR PORCELAIN AND NON-PORCELAIN TERMINAL MOUNTING BRACKET INSTALLATIONS AND MATERIALS.

FOR FIELD MAINTENANCE ONLY

OH 1499.206 UG 4299.206 SUPERCEDES 1429.4 (1-1-93)	SDG&E ELECTRIC STANDARDS 12.47KV AND BELOW 3 PHASE, CABLE POLE, 1/C PER PHASE, UPSWEEP BRACKET CONSTRUCTION	DATE 1-1-93 APPD <i>JLB/BJ</i>
------------------------------------------------------------------------	-----------------------------------------------------------------------------------------------------------------------	-----------------------------------

FIELD MAINTENANCE ONLY

REVISION HISTORY:

7/13/2016: All versions prior to 2016 are superceded by their current version found inside the Overhead Construction Standard Manual.

2/20/2019: Install S706680 in place of old style Disconnect Switch.

© 1998 - 2019 San Diego Gas & Electric Company. All rights reserved. Removal of this copyright notice without permission is not permitted under law.

REV	CHANGE	BY	DSGN	APPV	DATE	REV	CHANGE	BY	DSGN	APPV	DATE
C						F					
B	EDITORIAL CHANGES	GLW	JES	CZH	2/20/2019	E					
A	ORIGINAL ISSUE	JS	IL	MDJ	7/13/2016	D					

<p>SHEET 1 OF 1</p>	<p>X Indicates Latest Revision</p>	<p>Completely Revised</p>	<p>New Page</p>	<p>Information Removed</p>	<p>FMO OH 1432</p>
	<p>SDG&E ELECTRIC OVERHEAD CONSTRUCTION STANDARDS</p>				
	<p>12.47KV AND BELOW CABLE POLE, UPSWEEP BRACKET, THREE-PHASE 1/C PER PHASE, LINE ARM MOUNTED DISCONNECTS, NON-PORCELAIN TERMINALS</p>				

SCOPE: THIS STANDARD SHOWS THREE-PHASE CABLE POLE CONSTRUCTION USING NON-PORCELAIN TERMINALS FOR 350 KCMIL AND LARGER UG CABLE. (H)

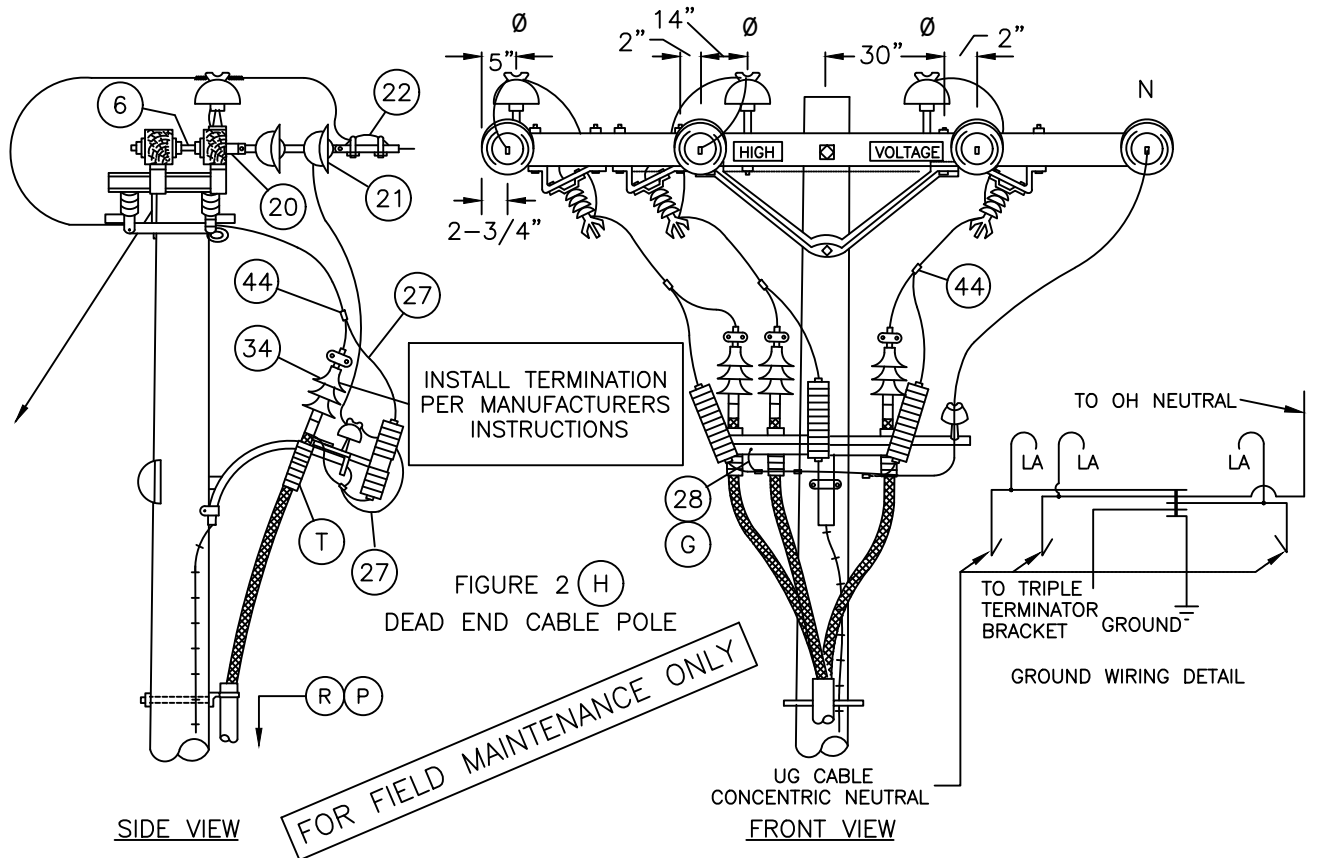
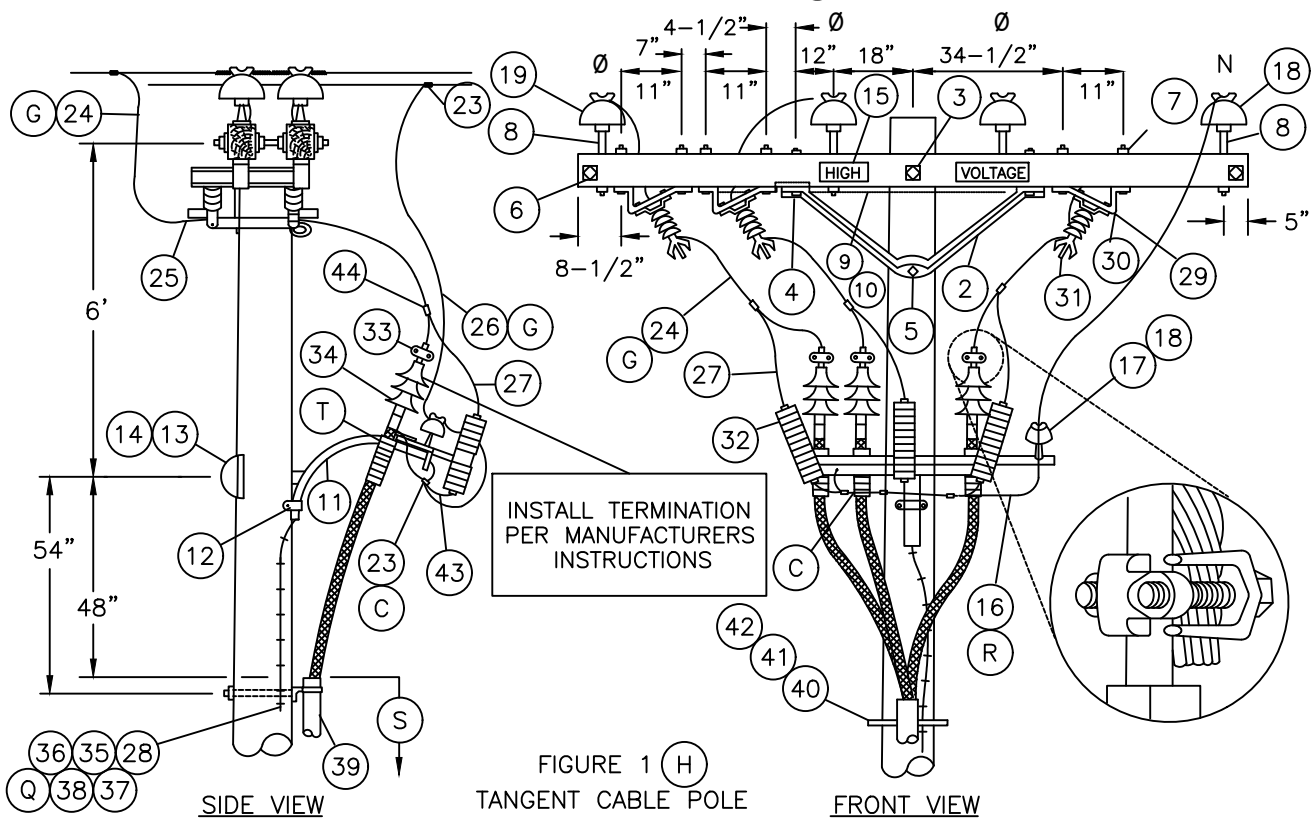

© 1998 - 2010 San Diego Gas & Electric Company. All rights reserved. Removal of this copyright notice without permission is not permitted under law.

DATE 10-20-05 APPD PJA/JJ	SDG&E ELECTRIC STANDARDS 12.47KV AND BELOW CABLE POLE, UPSWEEP BRACKET, THREE-PHASE 1/C PER PHASE, LINE ARM MOUNTED DISCONNECTS, NON-PORCELAIN TERMINALS	OH 1499.310 UG 4299.310 SUPERSEDES 1432.1 (10-20-05)
------------------------------	-------------------------------------------------------------------------------------------------------------------------------------------------------------------	---------------------------------------------------------------

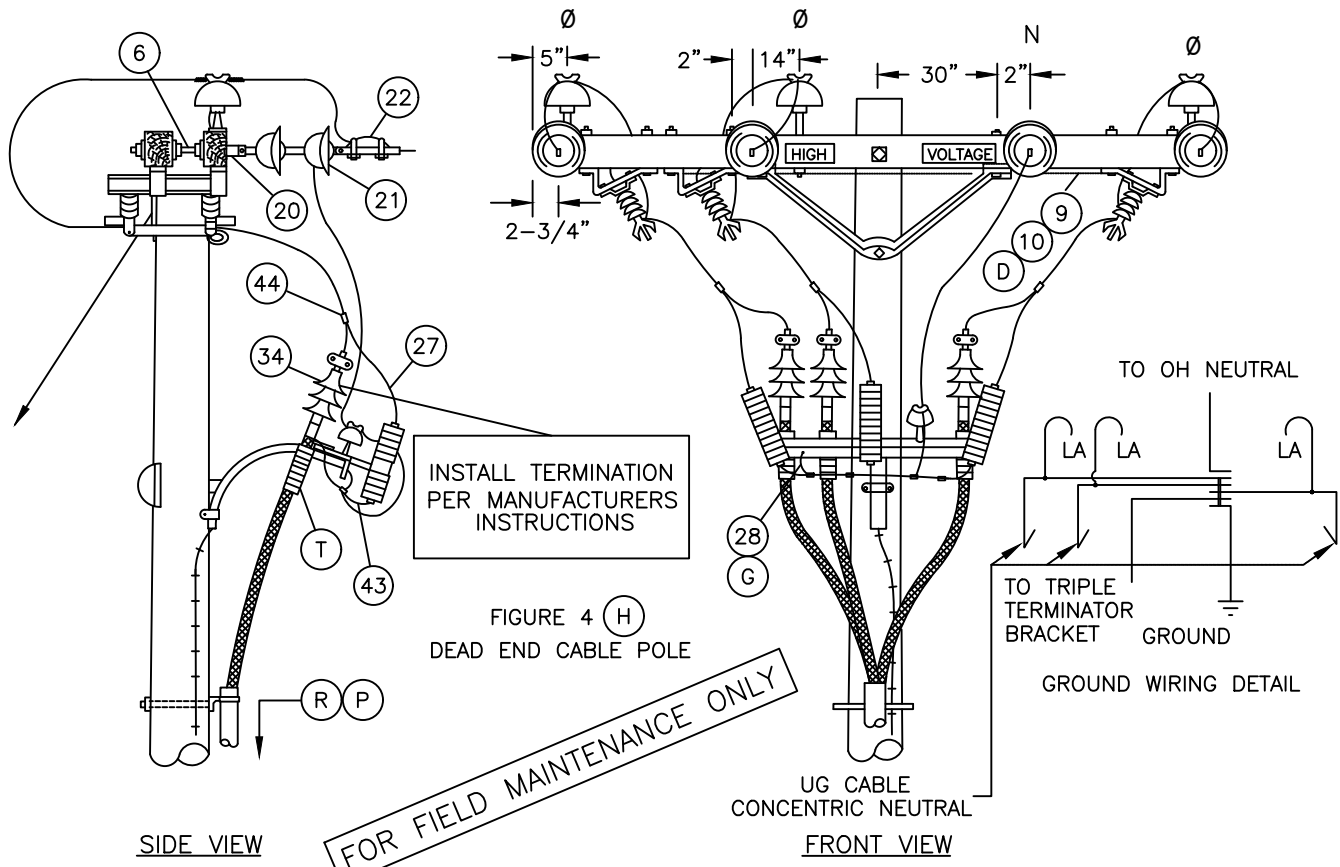
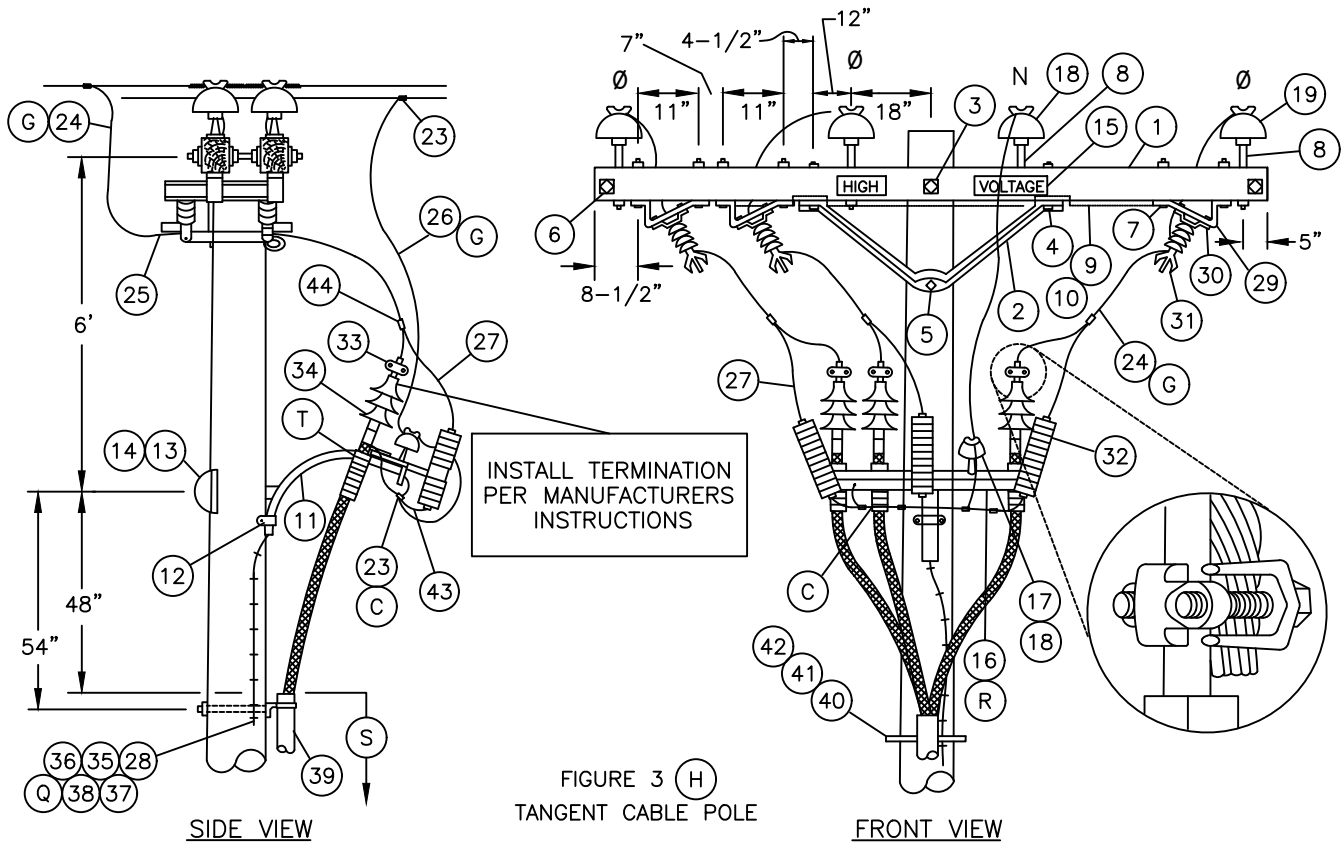

© 1998 - 2005 San Diego Gas & Electric Company. All rights reserved. Removal of this copyright notice without permission is not permitted under law.

DATE 10-20-05 APPD <i>PA/JJ</i>	SDG&E ELECTRIC STANDARDS 12.47KV AND BELOW CABLE POLE, UPSWEEP BRACKET, THREE-PHASE 1/C PER PHASE, LINE ARM MOUNTED DISCONNECTS, NON-PORCELAIN TERMINALS	OH 1499.311 UG 4299.311 SUPERSEDES 1432.2 (10-20-05)
------------------------------------	-------------------------------------------------------------------------------------------------------------------------------------------------------------------	---------------------------------------------------------------

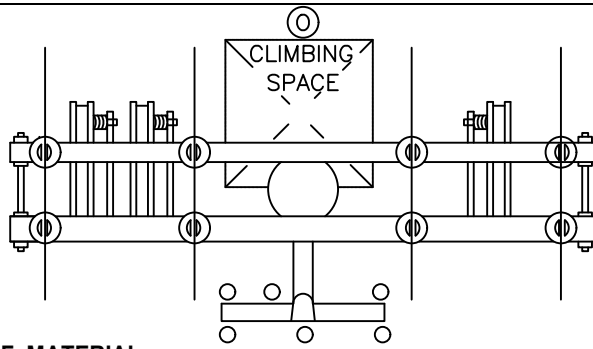

FIGURE 1

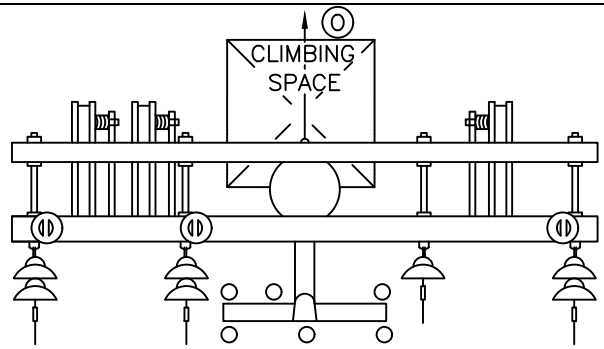

FIGURE 2

BILL OF MATERIAL:

ITEM	DESCRIPTION	QUANTITY		CONSTR STANDARD	STOCK NUMBER
		FIG 1	FIG 2		
1	CROSSARM, 3-3/4" X 5-3/4" X 12'-0" (F)	2	2		294160
2	BRACE, ANGLE, CROSSARM, 5'	2	2	-	164128
3	BOLT, MACH., GALV, 5/8" X (LENGTH AS REQ'D), 2 SQUARE AND 1 DOUBLE COIL SPRING WASHERS	1	1	392	-
4	BOLT, MACH, GALV, 1/2" X 7", 1 RD, 1 DBL COIL SPR WASH	4	4	392	-
5	BOLT, MACH, GALV, 5/8" X (LENGTH AS REQ'D), AND 1 DOUBLE COIL SPRING WASHER	1	1	392	-
6	BOLT, SPACE, GALV, 5/8" X (LENGTH AS REQ'D), 4 SQUARE, 2 ROUND AND 2 DOUBLE COIL SPRING WASHERS (E)	2	4	392	-
7	BOLT, MACH, GALV, 1/2" X 8", 1 ROUND AND 1 DOUBLE COIL SPRING WASHER	12	12	392	-
8	PIN, INSULATOR, STRAIGHT, 12KV, 1" OR 1-3/8" (E)	8	3	-	532704
		8	3	-	532448
9	WIRE, #8, BARE SOLID ANNEALED COPPER	15'	15'	-	812928
10	STAPLES, FENCE, GALV, 1-1/4"	AS REQ'D		-	678528
11	BRACKET, GALV, TERMINAL UPSWEEP (Q)	1	1	-	166856
12	SCREW, LAG, GALV, 4"	2	2	-	621568
13	BOLT, MACH, GALV, 5/8" X (LENGTH AS REQ'D), 1 SQUARE AND 1 DOUBLE COIL SPRING WASHER	1	1	392	-
14	COVER, BOLT, PLASTIC, AND 6 - 10D NAILS, GALV	1	1	-	285696
					491392
15	SIGN, HIGH VOLTAGE, AND 9 ROOFING NAILS, GALV	2	2	-	647648
					492224
16	BRACKET, TRIPLE TERMINATOR	1	1	-	166676
17	PIN, SHORT SHANK, 1" LEAD THREAD (E)	1	1	-	532426
18	INSULATOR, 12KV, NEUTRAL (E)	3	1	-	429216
19	INSULATOR, LINE, 12KV, 1" OR 1-3/8" PIN	6	3	750	-
20	CLEVIS, DEAD END, 5/8" BOLT, STEEL (E)	-	4	-	235712
21	INSULATOR, SUSPENSION, 12KV, CLEVIS (E)	-	7	750	-
22	CLAMP, STRAIGHT LINE, D.E. (E)	-	4	741	-

FOR FIELD MAINTENANCE ONLY

BILL OF MATERIAL: (CONT'D)

ITEM	DESCRIPTION	QUANTITY		CONSTR STANDARD	STOCK NUMBER	ASSEMBLY UNIT
		FIG 1	FIG 2			
23	CONNECTOR, WIRE COMPRESSION, (SIZE AS REQ'D)	AS REQ'D		783-786	-	-
24	WIRE, BARE STRANDED COPPER, (OH JUMPER) (C)	21'	30'	715	-	-
25	TERMINAL, COMPRESSION (SIZE AS REQ'D)	6	6	794-795	-	-
26	WIRE, BARE STRANDED COPPER, (OH NEUT JUMPER) (C)	9'	9'	715	-	-
27	WIRE, #6, BARE STRANDED COPPER	12'	12'	-	813536	-
28	#4 CU SOLID GROUND WIRE, PVC COVERED	50'	50'	-	812490	GNDPVC
29	BRACKET, DISCONNECT, ANGLE MOUNTING	6	6	-	166542	-
30	BOLT, MACH, GALV, 3/8" X 3", 2 RD WASH & 1 LOCK WASH	6	6	392	-	-
31	SWITCH, HOOKSTICK DISCONNECT, 14.4KV, 600 A OR 1200 A	3	3	1222	-	-
32	ARRESTER, LIGHTNING	3	3	1247	-	-
33	CONNECTOR, TWO BOLT, BRONZE (SIZE AS REQ'D)	3	3	4111	-	-
34	TERMINALS, UNDERGROUND CABLE (T)	3	3	4111	-	-
35	GROUND ROD, 5/8" X 8', COPPERWELD	1	1	-	603072	GNDPVC
36	COPPER BONDED GROUND CONNECTOR	1	1	-	259010	-
37	GROUND ENHANCING POWER SOLUTION (GEM)	AS REQ'D		-	424390	-
38	GALVANIZED STAPLES FOR PVC COVERED GROUND WIRE	AS REQ'D		-	678562	-
39	RISER CONSTRUCTION	AS REQ'D		1400/4200	-	-
40	BRACKET, LADDER ARM	AS REQ'D		1404/4204	167184	-
41	NUT, CLAMPING CHANNEL, W/SPRING, 1/2"	AS REQ'D		1404/4204	503488	-
42	CHANNEL, DOUBLE GALV., 24"	AS REQ'D		1404/4204	216700	-
43	FLEXIBLE ARRESTER GROUND STRAP	AS REQ'D		-	698754	-
44	HOT LINE CLAMP	3	3	788	227680	-

FOR FIELD MAINTENANCE ONLY

OVERHEAD MACRO UNIT
3NS-B

INSTALLATION:

- A. NEW CABLE POLES SHALL HAVE A STANDARD DEPTH OF 9'. IN MOST CASES, THIS WILL REQUIRE A 5' TALLER POLE.
- B. THIS CONSTRUCTION TO BE USED WITH 350 KCMIL AND LARGER UNDERGROUND CABLE.
- (C) INTERCONNECT OVERHEAD NEUTRAL, TRIPLE TERMINAL BRACKET AND CONCENTRIC CABLE NEUTRAL TO LIGHTNING ARRESTER GROUND.
- (D) INTERCONNECT SWITCH AND DEAD END BONDS PER G.O. 95 RULE 52.7 D.
- (E) REDUCE QUANTITIES AS REQUIRED WHEN NOT USING NEUTRAL.
- (F) WHEN ADDING THIS CONSTRUCTION TO AN EXISTING POLE WITH A 10' LINE ARM, AND SUFFICIENT POLE HEIGHT EXISTS, INSTALL 10' SWITCH ARMS AND ASSOCIATED HARDWARE BELOW THE LINE ARM TO AVOID CHANGING LINE ARM FROM 10' TO 12' (SEE O.H. STANDARD 1222. FIG. 1-B).

DATE 10-20-05 APPD PJA / JJ	SDG&E ELECTRIC STANDARDS	OH 1499.313 UG 4299.313 SUPERSEDES 1432.4 (10-20-05)
	12.47KV AND BELOW CABLE POLE, UPSWEEP BRACKET, THREE-PHASE 1/C PER PHASE, LINE ARM MOUNTED DISCONNECTS, NON-PORCELAIN TERMINALS	

INSTALLATION: (CON'T)

G	UG CABLE SIZE AWG OR KCMIL, AL	OH JUMPER COND SIZE, AWG OR KCMIL, CU	OH NEUT JUMPER SIZE			CABLE POLE NEUT SIZE (CU) UNDER POTHEAD ARM OR TRIPLE TERM BRKT
			CU	AL		
	350	4/0	1/0	3/0	-	#2 PER PHASE
	750	500	4/0	336.4	OR SAME SIZE AS O.H. NEUT CONDUCTOR	1/0 PER PHASE
	1000	500	4/0	336.4		1/0 PER PHASE

BECAUSE THE PROPER SIZE CONNECTOR IS NOT ALWAYS AVAILABLE, THE JUMPER FROM THE OVERHEAD LINE CONDUCTOR TO THE HOOKSTICK SWITCH CAN BE THE SAME SIZE AS, OR LARGER THAN THAT OF THE OVERHEAD CONDUCTOR.

- H) - USE FIGURE ONE AND TWO FOR ALL **NE** CONSTRUCTION AND WHEN ADDING TO EXISTING CONSTRUCTION WITH NEUTRAL ON OUTSIDE PIN POSITION. SEE DESIGN MANUAL PAGE 5124.2.
- USE FIGURE THREE AND FOUR ON EXISTING CONSTRUCTION WITH NEUTRAL ON INSIDE PIN POSITION.

REFERENCE:

- O) ALLOWABLE WORKING AND CLIMBING SPACE - SEE STD. 251
- P) POLE STEPPING - SEE STD. 363.
- Q) GROUNDING METHODS - SEE PAGE 1002.5.
- R) RISER POSITIONS - SEE STANDARD 1402/4202.
- S) MINIMUM VERTICAL SEPARATION AS PER G.O. 95 SEE STD. 1406/4206.
- T) SEE STANDARD 1407/4207 FOR NON PORCELAIN TERMINAL MOUNTING INSTRUCTIONS AND MATERIALS.

FOR FIELD MAINTENANCE ONLY

OH 1499.314 UG 4299.314 SUPERSEDES 1432.5 (10-20-05)	SDG&E ELECTRIC STANDARDS 12.47KV AND BELOW CABLE POLE, UPSWEEP BRACKET, THREE-PHASE 1/C PER PHASE, LINE ARM MOUNTED DISCONNECTS, NON-PORCELAIN TERMINALS	DATE 9-20-05 APPD <i>PLA</i> / JJ
---------------------------------------------------------------	-------------------------------------------------------------------------------------------------------------------------------------------------------------------	--------------------------------------

FIELD MAINTENANCE ONLY

REVISION HISTORY:

7/13/2016: All versions prior to 2016 are superseded by their current version found inside the Overhead Construction Standard Manual.

© 1998 - 2016 San Diego Gas & Electric Company. All rights reserved. Removal of this copyright notice without permission is not permitted under law.

REV	CHANGE	BY	DSGN	APPV	DATE	REV	CHANGE	BY	DSGN	APPV	DATE
C						F					
B						E					
A	ORIGINAL ISSUE	JS	IL	MDJ	7/13/2016	D					

	Indicates Latest Revision	Completely Revised	New Page	Information Removed
-------------------------------------------------------------------------------------	---------------------------	--------------------	----------	---------------------

**SHEET
1 OF 1**

SDG&E ELECTRIC OVERHEAD STANDARD
BRACKET MOUNTED TERMINALS,
12KV 3 WIRE ARMLESS TANGENT CONSTRUCTION

**FMO
OH 1437**

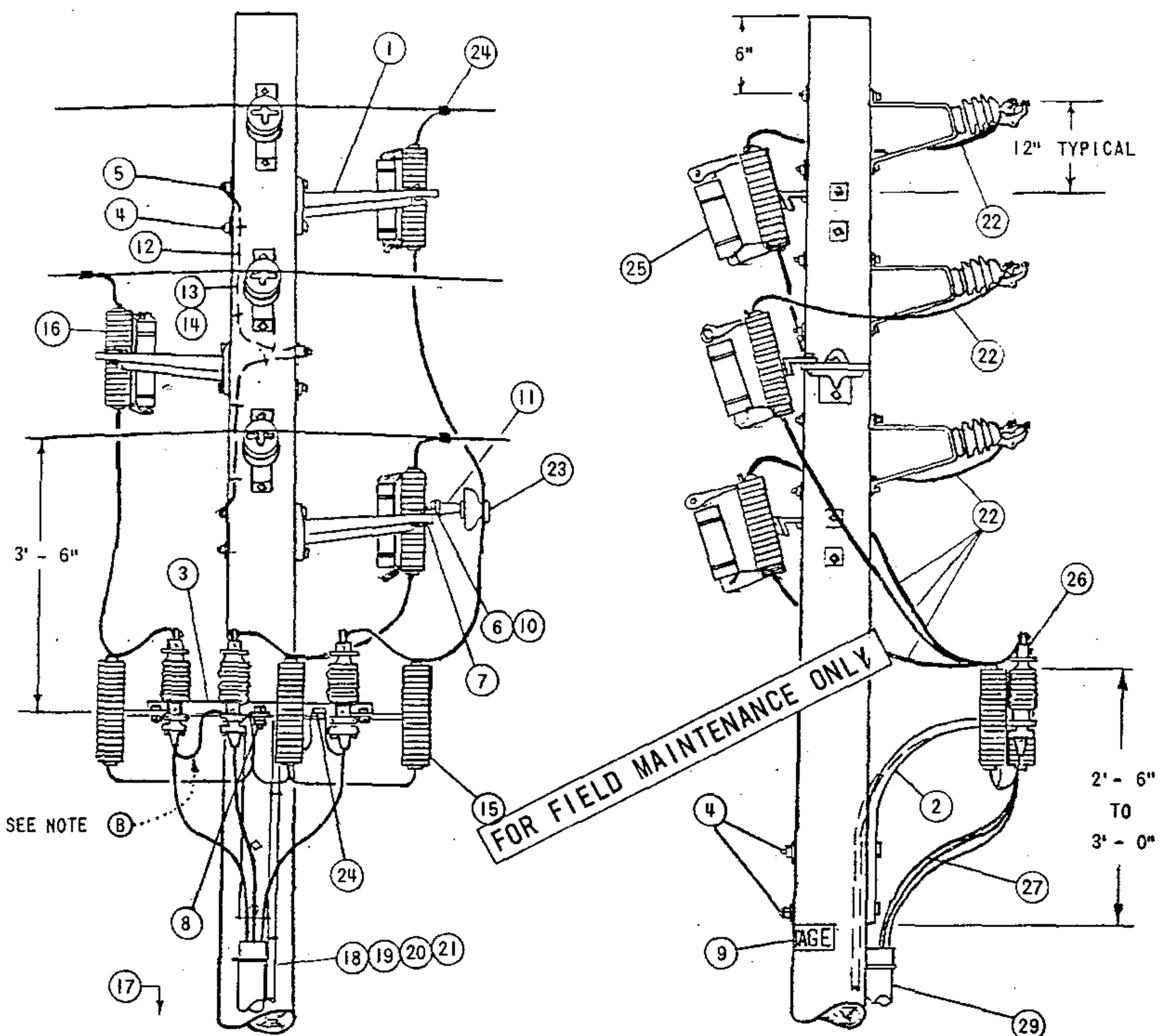

FOR FIELD MAINTENANCE ONLY

SEE NOTE B

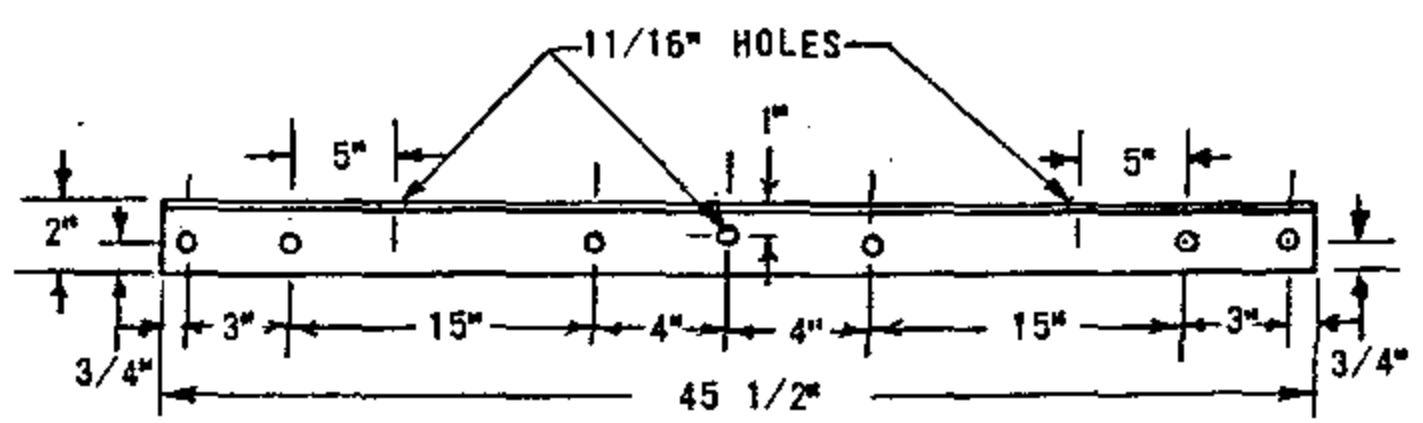

ALL HOLES 9/16" EXCEPT AS NOTED

FABRICATE FROM 2" X 2" X 3/16" STEEL ANGLE
HOT DIP GALVANIZE AFTER FABRICATION

ARMLESS TERMINAL MOUNTING BRACKET

DATE 8-27-82
APPD DRH

SDG&E ELECTRIC STANDARDS
BRACKET MOUNTED TERMINALS,
12KV 3 WIRE ARMLESS TANGENT CONSTRUCTION

OH 1499.301
UG 4299.301
SUPERSEDES
1437.1(11-16-81)

NOTES:

- (A) UNIT GROUND, COMPLETE, ORDER 603120 WITH GRAY MOULDING, 603135 WITH PLAIN MOULDING.
- (B) THE FIBERGLASS UPSWEEP TERMINAL BRACKET IS TO BE USED FOR UNDERGROUND CONDUCTORS 4/0 OR SMALLER. DO NOT USE FOR 500 KCM AND LARGER CONDUCTORS.
- (C) USE TWO-ROD GROUND SPACED A MINIMUM OF 6 FEET APART.
- D. CONNECT ONE STRAND OF CONCENTRIC NEUTRAL TO TERMINAL BOLT WITH DOUBLE NUT.
- (E) EXEMPT MATERIAL

FOR FIELD MAINTENANCE ONLY

ITEM	DESCRIPTION	QUANTITY	STOCK NO. OR CONSTR STD
1	BRACKET, GALV., 4-HOLE, MOUNTING	3	166240
2	BRACKET, FIBERGLASS, TERMINAL, UPSWEEP SEE NOTE (F)	1	166864
3	BRACKET, ARMLESS, TERMINAL MOUNTING, SEE DETAIL PAGE 1437.1	1	166672
4	MACH. BOLT, GALV., 5/8" X LENGTH AS REQ'D., 1-SQ. CURV. WASH., 1-DBL. COIL SPR. WASH. & 1-NUT (E)	5	PGS 139, 140
5	MACH. BOLT, GALV., 5/8" X LENGTH AS REQ'D., 1-SQ., CURV. WASH., 1-DBL. COIL SPR. WASH., 2-FLAT RD. WASH. & 2-NUTS (E)	3	PGS 139, 140
6	MACH. BOLT, GALV., 5/8" X 1 1/2", 1-LOCK WASH. (E)	1	PGS 139, 140
7	MACH. BOLT, GALV., 1/2" X 1 1/2", 1-LOCK WASH. & 1-NUT (E)	1	PGS 139, 140
8	MACH. BOLT, GALV., 5/8" X 2 1/2", 1-LOCK, 2-RD. WASH. & 2-NUTS (E)	1	PGS 139, 140
9	HIGH VOLTAGE SIGN & 8-ROOFING NAILS, GALV. (E)	2	647648, 492224
10	BRACKET, INSULATOR, MOUNTING ANGLE	1	166208
11	PIN, INSULATOR, 12KV, 1" OR 1 3/8" LEAD THREAD	1	529248-529216
12	WIRE, BOND, BARE SOLID ANNEALED, #8	6'	812928
13	HARDWOOD MOULDING, 1" (OTHER THAN TOP CIRCUIT ON POLE)	6'	487200
14	MOULDING STAPLES, GALV., 3" X 1 1/16" X 1/4" (OTHER THAN TOP CIRCUIT ON POLE)	6	678560
15	LIGHTNING ARRESTER, 12KV	3	113248
16	CUTOUT, FOR CURRENT-LIMITING FUSE	3	1200 SECTION
17	GROUND ROD & CLAMP (A) (C)	2	603072-230016 (E)
18	HARDWOOD MOULDING, 1" (A)	36'	487200
19	STAPLES, MOULDING, GALV., 3" X 1 1/16" X 1/4" (A) (E)	24	678560
20	STAPLES, FENCE, GALV., 1 1/4" (A) (E)	1/3#	678528
21	WIRE, BARE STRANDED COPPER, #2 (B)	50'	813664
22	WIRE, BARE STRANDED, COPPER, (SIZE AS REQ'D)	25'	
23	INSULATOR, 12KV, PIN TYPE (CLASS AS REQ'D)	1	429056-429152
24	CONNECTOR, WIRE, COMPRESSION (SIZE AS REQ'D)	4	
25	FUSE, CURRENT-LIMITING SIZE AS SPECIFIED ON WORK ORDER	3	1200 SECTION
26	CABLE TERMINAL	3	SEE UG STDS
27	CABLE, PRIMARY	AS REQ'D	SEE UG STDS
28			
29	RISER CONSTRUCTION	AS REQ'D	1400/4200 SECTION

INSTALLED BY OH CREWS UG CREWS

FIELD MAINTENANCE ONLY

REVISION HISTORY:

7/13/2016: All versions prior to 2016 are superseded by their current version found inside the Overhead Construction Standard Manual.

© 1998 - 2016 San Diego Gas & Electric Company. All rights reserved. Removal of this copyright notice without permission is not permitted under law.

REV	CHANGE	BY	DSGN	APPV	DATE	REV	CHANGE	BY	DSGN	APPV	DATE
C						F					
B						E					
A	ORIGINAL ISSUE	JS	IL	MDJ	7/13/2016	D					

	Indicates Latest Revision	Completely Revised	New Page	Information Removed
-------------------------------------------------------------------------------------	---------------------------	--------------------	----------	---------------------

**SHEET
1 OF 1**

SDG&E ELECTRIC OVERHEAD STANDARD

BRACKET MOUNTED TERMINALS, 12KV 3 WIRE,
ARMLESS DEAD END CONSTRUCTION

**FMO
OH 1438**

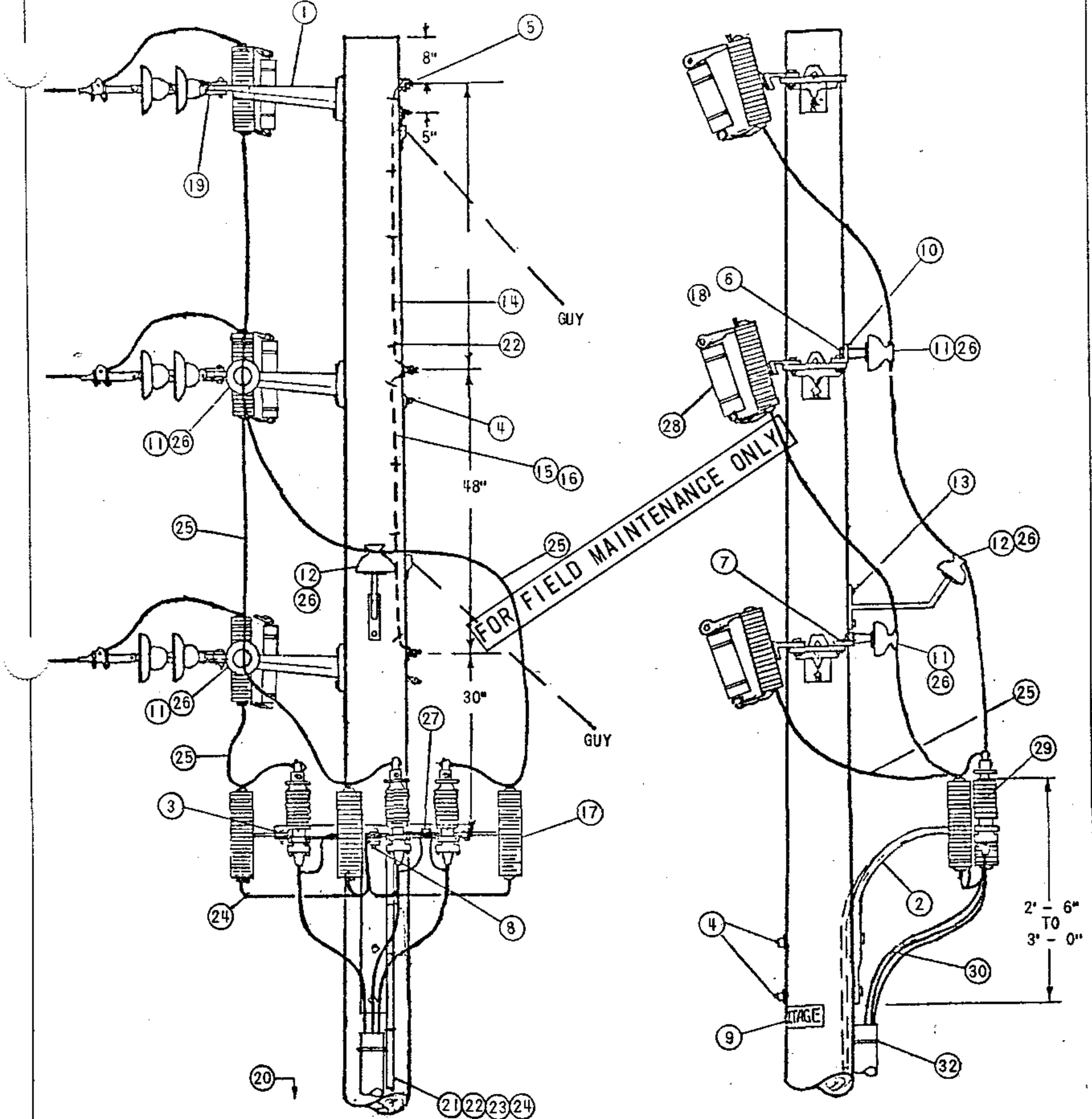

(DEAD ENDS OMITTED FOR CLARITY)

DATE 8-27-82
 APPD *LRH*

SDG&E ELECTRIC STANDARDS
 BRACKET MOUNTED TERMINALS, 12KV 3 WIRE,
 ARMLESS DEAD END CONSTRUCTION

OH 1499.303
 UG 4299.303
 SUPERSEDES
 1438.1(11-16-81)

NOTES:

- (A) UNIT GROUND COMPLETE ORDER 503120 WITH GRAY MOULDING, 603136 WITH PLAIN MOULDING.
- B. UNTWIST SUFFICIENT LENGTH OF #2 STRANDED WIRE TO CONNECT EACH ARRESTER AND POTHEAD (TERMINAL) GROUND WITH A SINGLE STRAND.
- (C) USE TWO-ROD GROUND SPACED A MINIMUM OF 6 FEET APART.
- D. THIS CONFIGURATION NOT TO BE USED WHERE A FUTURE EXTENSION IS ANTICIPATED
- (E) EXEMPT MATERIALS.
- F. THIS INSTALLATION DOES NOT INCLUDE GUYING MATERIAL
- (G) THE FIBERGLASS UPSWEEP TERMINAL BRACKET IS TO BE USED FOR UNDERGROUND CONDUCTORS 4/0 OR SMALLER. DO NOT USE FOR 500 KCM AND LARGER CONDUCTORS

FOR FIELD MAINTENANCE ONLY

ITEM	DESCRIPTION	QUANT	STOCK NO. OR CONSTR STDS
OH & F	1	BRACKET, GALV., 4-HOLE, MOUNTING SEE NOTE (G)	3 166240
	2	BRACKET, FIBERGLASS, TERMINAL, UPSWEEP	1 166864
	3	BRACKET, ARMLESS, TERMINAL MOUNTING (SEE DETAIL PG. 1437.1)	1 166672
	4	MACH. BOLT, GALV., 5/8" X LENGTH AS REQ'D., 1-SQ. CURV. WASH., 1-DBL. COIL SPR. WASH. & 1-NUT (E)	5 PGS 139, 140
	5	MACH. BOLT, GALV., 5/8" X LENGTH AS REQ'D., 1-SQ. CURV. WASH., 1-DBL. COIL SPR. WASH., 2-FLAT RD. WASH. & 2-NUTS (E)	3 PGS 139, 140
	6	MACH. BOLT, GALV., 5/8" X 1 1/2" (E)	2 PGS 139, 140
	7	MACH. BOLT, GALV., 1/2" X 1 1/2" (E)	2 PGS 139, 140
	8	MACH. BOLT, GALV., 5/8" X 2 1/2", 1-LOCK, 2-rd. WASH. & 2-NUTS (E)	1 PGS 139, 140
	9	HIGH VOLTAGE SIGN & 8-ROOFING NAILS, GALV. (E)	2 647648, 492192
	10	BRACKET, INSULATOR, MOUNTING ANGLE	2 PG 151
	11	PIN, INSULATOR, 12KV, 1" OR 1 3/8" LEAD THREAD	2 529248-529216
	12	BRACKET, INSULATOR, 1" OR 1 3/8" LEAD THREAD	1 166144-166176
	13	SCREW, LAG, GALV., 1/2" X 4" (E)	2 621568
	14	WIRE, BOND, BARE SOLID ANNEALED, #8	10' 812928
	15	HARDWOOD MOULDING, 1", (OTHER THAN TOP CIRCUIT ON POLE)	10' 487200
	U & D	16	MOULDING STAPLES, GALV., 3" X 1 1/16" X 1/4" (OTHER THAN TOP CIRCUIT ON POLE) (E)
17		LIGHTNING ARRESTER, 12KV	3 113248
18		CUTOUT, FOR CURRENT-LIMITING FUSE	3 1200 SECTION
19		CLEVIS	3 235776
20		GROUND ROD & CLAMP (C)	2 603072, 230016 (A)(E)
21		HARDWOOD MOULDING, 1"	36' 487200 (A)
22		STAPLES, MOULDING, GALV., 3" X 1 1/16" X 1/4" (E)	24 678560 (A)
23		STAPLES, FENCE, GALV., 1 1/4" (E)	32 678528 (A)
24		WIRE, BARE STRANDED, COPPER, #2	50' 813664
25		WIRE, BARE STRANDED, COPPER, (SIZE AS REQ'D)	25' PGS 715-717
26		INSULATOR, 12KV, PIN TYPE, (CLASS 55-5 OR 56-1)	3 429056-429152
UG CREWS		27	CONNECTOR, WIRE, COMPRESSION, (SIZE AS REQ'D)
	28	FUSE, CURRENT-LIMITING AS SPECIFIED ON WORK ORDER	3 1200 SECTION
	29	CABLE TERMINAL	3 SEE UG STDS
	30	CABLE, PRIMARY	AS REQ'D SEE UG STDS
	31		
	32	RISER CONSTRUCTION	AS REQ'D 1400/4200 SECTION

OH 1499,304
~~UG 4299,304~~
 SUPERSEDES
 1438,2 (11-16-81)

SD&E ELECTRIC STANDARDS
 BRACKET MOUNTED TERMINALS, 12KV 3 WIRE,
 ARMLESS DEAD END CONSTRUCTION

DATE 8-27-82
 APPD *LRH*

FIELD MAINTENANCE ONLY

REVISION HISTORY:

7/13/2016: All versions prior to 2016 are superseded by their current version found inside the Overhead Construction Standard Manual.

© 1998 - 2016 San Diego Gas & Electric Company. All rights reserved. Removal of this copyright notice without permission is not permitted under law.

REV	CHANGE	BY	DSGN	APPV	DATE	REV	CHANGE	BY	DSGN	APPV	DATE
C						F					
B						E					
A	ORIGINAL ISSUE	JS	IL	MDJ	7/13/2016	D					

	Indicates Latest Revision	Completely Revised	New Page	Information Removed
-------------------------------------------------------------------------------------	---------------------------	--------------------	----------	---------------------

**SHEET
1 OF 1**

SDG&E ELECTRIC OVERHEAD STANDARD
CROSSARM CABLE POLE, 3Ø, 1/C PER PHASE
DEAD END CONSTRUCTION, 12.47KV AND BELOW

**FMO
OH 1439**

SCOPE: THIS STANDARD SHOWS DEADEND CONSTRUCTION FOR 12.47KV AND BELOW, 3 PHASE CABLE POLE WITH CROSSARM MOUNTED TERMINALS FOR #2/0 AND SMALLER U.G. CABLE. THIS CONSTRUCTION IS TO BE USED IN CONTAMINATION DISTRICT 1 ONLY.

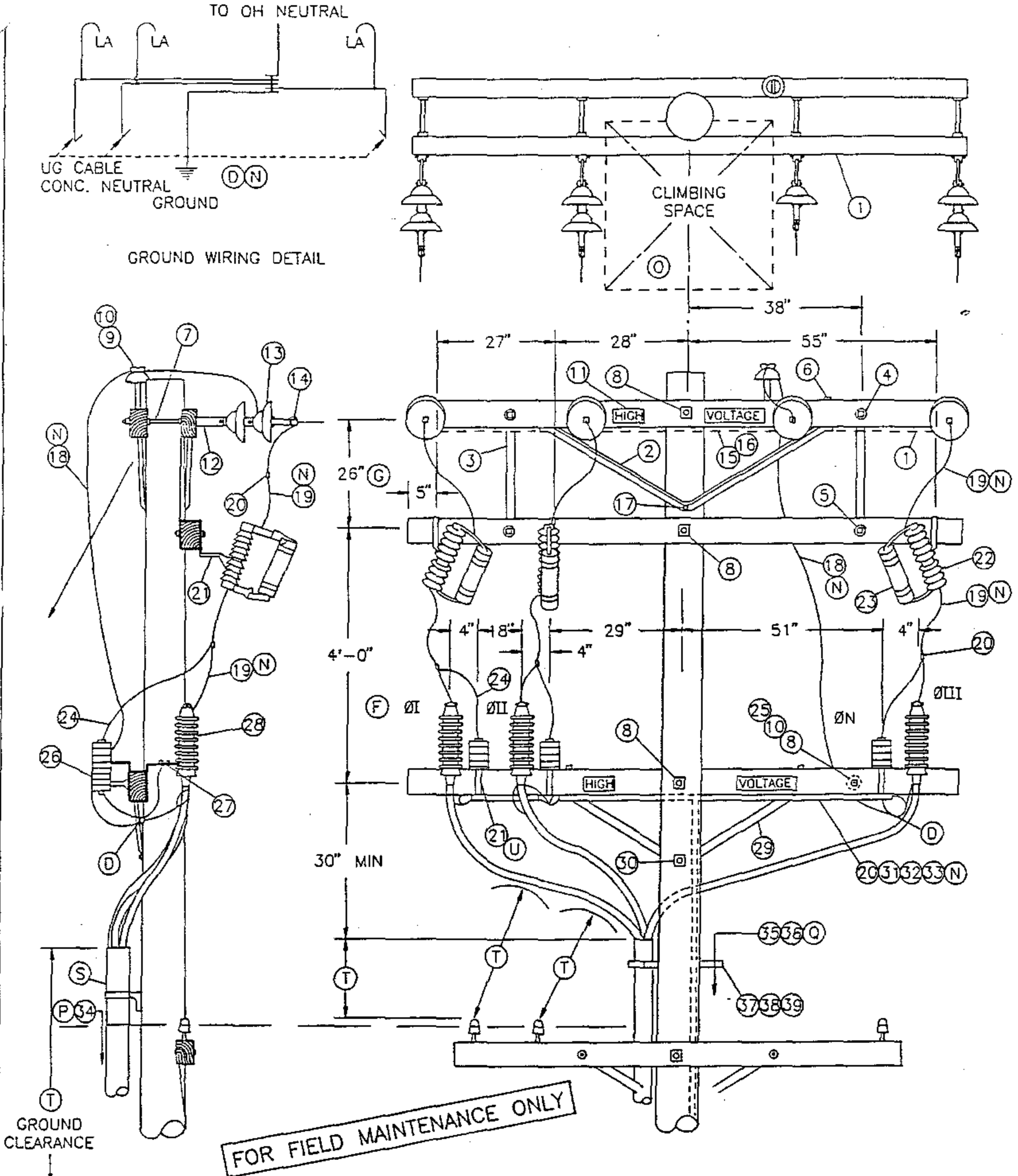

DATE 1-1-93
 APPD *JLB/ROJ*

SDG&E ELECTRIC STANDARDS
 CROSSARM CABLE POLE, 3Ø, 1/C PER PHASE
 DEADEND CONSTRUCTION, 12.47KV AND BELOW

OH 1499.307
~~UG 4299.307~~
 SUPERCEDES
 1439.1 (1-1-93)

BILL OF MATERIAL:

ITEM	DESCRIPTION	QUANTITY	CONST STD OR PAGE NO	STOCK NUMBER
1	CROSSARM, 3-3/4" X 5-3/4" X 10' - 0"	4	-	294128
2	BRACE, ANGLE, CROSSARM, 5' - 0"	2	-	164128
3	BRACE, FLAT, CROSSARM, 28"	2	-	164192
4	BOLT, WASHERHEAD, GALV, 3/8" X 4-1/2", 1 ROUND & 1 SPRING WASHER	2	392	-
5	BOLT, MACH, GALV, 1/2-1 X 5", 1 ROUND & 1 DOUBLE COIL, SPRING WASHER	2	392	-
6	BOLT, MACH, GALV, 1/2" X 7", 1 ROUND & 1 DOUBLE COIL SPRING WASHER	6	392	-
7	BOLT, SPACE, GALV, 5/8" X (LENGTH AS REQ'D), 2 ROUND, 4 SQUARE & 2 DOUBLE COIL SPRING WASHERS	4	392	-
8	BOLT, MACH, GALV, 5/8" X (LENGTH AS REQ'D), 2 SQUARE & 1 DOUBLE COIL SPRING WASHER	4	392	-
9	PIN, INSULATOR, STRAIGHT, 12KV, 1"	1	-	532704
10	INSULATOR, LINE, 12KV NEUTRAL	2	-	429216
11	SIGN, HIGH VOLTAGE & 9 ROOFING NAILS, GALV	4	-	647648
12	CLEVIS, DEAD END, 5/8" BOLT STEEL	4	-	235712
13	INSULATOR, SUSPENSION, 12KV, CLEVIS	7	750	-
14	CLAMP, STRAIGHT LINE, D.E.	4	741	-
15	WIRE, #8, BARE SOLID ANNEALED COPPER	10'	-	812928
16	STAPLES, FENCE, GALV, 1-1/4"	AS REQ'D	-	678528
17	BOLT, MACH, GALV, 5/3" X (LENGTH AS REQ'D) & 1 DOUBLE COIL SPRING WASHER	1	392	-
18	WIRE, COPPER, BARE STRANDED OR ACSR/AW BARE (OH NEUTRAL JUMPER)	10'	711-715	-
19	WIRE, COPPER, BARE STRANDED (OH JUMPERS)	18'	715	-
20	CONNECTOR, WIRE, COMPRESSION (SIZE AS REQ'D)	AS REQ'D	783-787	-
21	BRACKET, CUTOUT/ARRESTER, FOR CROSSARM MOUNTING	6	-	166070
22	CUTOUT, FOR CURRENT-LIMITING FUSE	3	1212	-
23	FUSE, CURRENT-LIMITING (SIZE AS SPECIFIED ON WORK ORDER)	3	1207	-
24	WIRE, BARE STRANDED COPPER, #6	14'	-	813536
25	PIN, TRANSFORMER ADAPTER, 1" LEAD THREAD	1	-	529248
26	ARRESTER, LIGHTNING	3	1247	-
27	BRACKET, CROSSARM, TERM (FOR #2 & #2/0 AL CABLE ONLY)	3	-	166060
28	TERMINALS, UNDERGROUND CABLE	3	4111	-
29	BRACE, ANGLE, CROSSARM, 4' - 0"	1	-	164032
30	BOLT, MACH, GALV, 5/8" X (LENGTH AS REQ'D), 1 SQUARE & 1 DOUBLE COIL SPRING WASHER	1	392	-
31	WIRE, BARE STRANDED COPPER (UNDER POTHEAD ARM) (CABLE POLE NEUTRAL)	10'	715	-
32	CONDUIT, PVC TYPE 2, SCHEDULE 40, 1"	10'	-	251200
33	STRAPS, PIPE, GALV, 1" & 2 - 6D NAILS, GALV	AS REQ'D	-	697792
34	RISER CONSTRUCTION	AS REQ'D	1400/4200	-
35	WIRE, #4, BARE STRANDED COPPER	45'	-	813760
36	UNIT GROUND, COMPLETE	1	-	603136
37	BRACKET, LADDER ARM	AS REQ'D	1404/4204	167184
38	NUT, CLAMPING CHANNEL, W/SPRING, 1/2"	AS REQ'D	1404/4204	503488
39	CHANNEL, DOUBLE GALV, 24"	AS REQ'D	1404/4204	216700

FOR FIELD MAINTENANCE ONLY

CABLE SIZE	UG MACRO UNIT	
	PORCELAIN W/LADDER ARMS	W/O LADDER ARMS
3C #2/0 AL	CP2/0L	CP#2/0
3C-3#2 AL	CP3#2L	CP-3#2

OH 1499.308
~~UG 4299.308~~
 SUPERCEDES
 1439.2 (1-1-93)

SDG&E ELECTRIC STANDARDS

CROSSARM CABLE POLE, 3Ø, 1/c PER PHASE
 DEADEND CONSTRUCTION, 12.47KV AND BELOW

DATE 1-1-93
 APPD *JLB/BJ*

INSTALLATION:

- A. NEW CABLE POLES SHALL HAVE A STANDARD DEPTH OF 9'. IN MOST CASES THIS WILL REQUIRE A 5' TALLER POLE.
- (B) REDUCE QUANTITIES AS REQUIRED WHEN NOT USING NEUTRAL.
- C. USE THIS CONSTRUCTION FOR 2/0 AND SMALLER UNDERGROUND CABLE.
- (D) INTERCONNECT OVERHEAD NEUTRAL, TERMINAL BASE, AND CONCENTRIC CABLE NEUTRAL CONDUCTOR TO LIGHTNING ARRESTER GROUND.
- (E) EXEMPT MATERIAL.
- (F) OMIT Ø II AND Ø N FOR SINGLE Ø 12KV CABLE POLE, OMIT Ø I AND Ø II FOR SINGLE Ø 6.9KV CABLE POLE.

(N)

UG CABLE SIZE AWG OR KCMIL, AL	OH JUMPER COND SIZE, AWG OR KCMIL, CU	OH NEUT JUMPER SIZE			CABLE POLE NEUT SIZE (CU) UNDER POTHEAD ARM OR TRIPLE TERM BRKT
		CU	AL		
2	4	6	2	-	#6 PER PHASE
2/0	4	6	2	-	#6 PER PHASE
350	4/0	1/0	3/0	-	#2 PER PHASE
750	500	4/0	336.4	OR SAME SIZE AS O.H. NEUT CONDUCTOR	1/0 PER PHASE
1000	500	4/0	336.4		1/0 PER PHASE

REFERENCE:

- (O) ALLOWABLE WORKING AND CLIMBING SPACE - SEE STD. 251.
- (P) POLE STEPPING - SEE STD. 363/4205.
- (Q) GROUNDING METHODS - SEE PAGE 1002.5.
- R. SEE STANDARD SECTION 1200/4300 FOR FUSING.
- (S) RISER POSITIONS - SEE STANDARD 1402/4202.
- (T) MINIMUM VERTICAL SEPARATION AS PER G.O. 95 - SEE STD. 1406/4206.
- (U) SEE STANDARD 1407/4207 FOR PORCELAIN TERMINAL MOUNTING BRACKET INSTRUCTIONS AND MATERIALS.

FOR FIELD MAINTENANCE ONLY

DATE 1-1-93 APPD <i>JLB/BJG</i>	SDG&E ELECTRIC STANDARDS CROSSARM CABLE POLE, 3Ø, 1/C PER PHASE DEADEND CONSTRUCTION, 12.47KV AND BELOW	OH 1499.309 UG 4299.309 SUPERCEDES 1439.3 (1-1-93)
------------------------------------	-------------------------------------------------------------------------------------------------------------------	------------------------------------------------------------------------

FIELD MAINTENANCE ONLY

REVISION HISTORY:

7/13/2016: All versions prior to 2016 are superceded by their current version found inside the Overhead Construction Standard Manual.

2/20/2019: Install S706680 in place of old style Disconnect Switch.

© 1998 - 2019 San Diego Gas & Electric Company. All rights reserved. Removal of this copyright notice without permission is not permitted under law.

REV	CHANGE	BY	DSGN	APPV	DATE	REV	CHANGE	BY	DSGN	APPV	DATE
C						F					
B	EDITORIAL CHANGES	GLW	JES	CZH	2/20/2019	E					
A	ORIGINAL ISSUE	JS	IL	MDJ	7/13/2016	D					

SHEET 1 OF 1	X Indicates Latest Revision	Completely Revised	New Page	Information Removed	FMO OH 1441
	SDG&E ELECTRIC OVERHEAD CONSTRUCTION STANDARDS				
	12.47 KV AND BELOW DEAD END CABLE POLE ARM, 3Ø, 1/C PER Ø, HOOKSTICK SWITCHED				

SCOPE: THIS STANDARD SHOWS CABLE POLE CONSTRUCTION USING PORCELAIN TERMINATIONS FOR 750 AND LARGER UNDERGROUND CABLE. (SEE STANDARD 1407/4207 FOR 350 KCMIL TERMINAL MOUNTING INFORMATION).

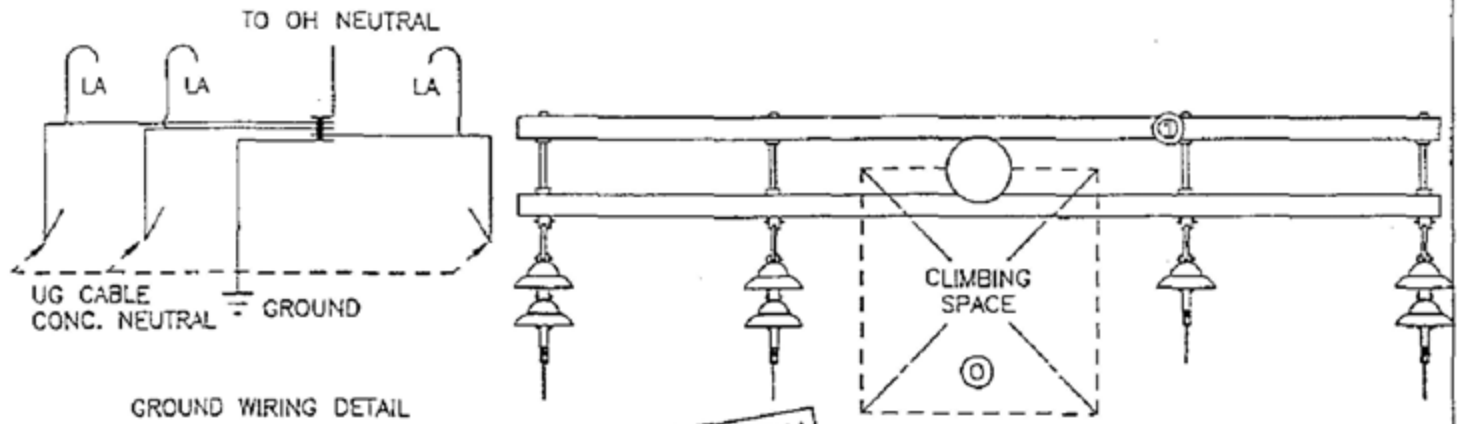

FOR FIELD MAINTENANCE ONLY

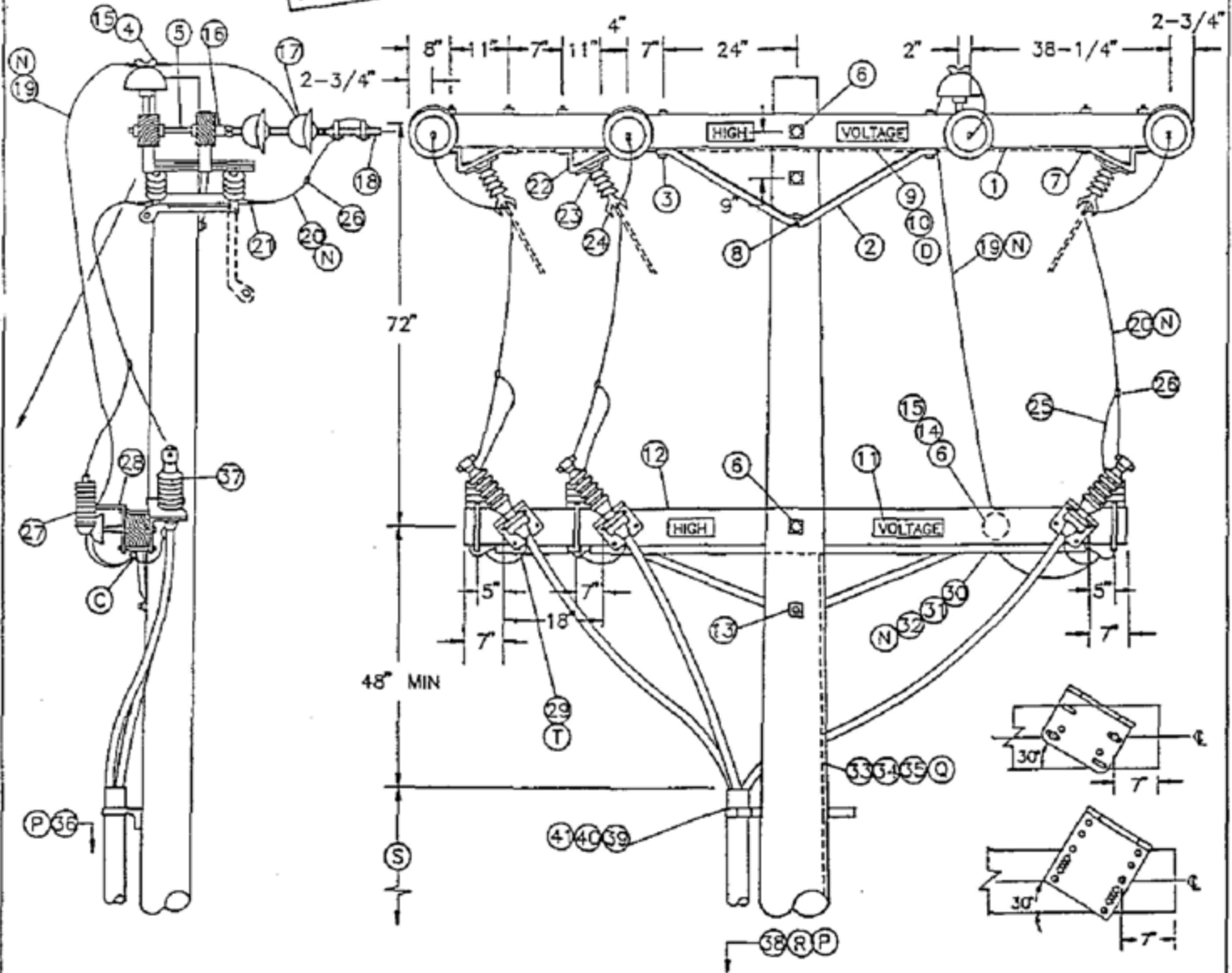

SDG&E ELECTRIC STANDARDS

DATE 1-1-93

APPO *JLB/BG*

12.47 KV AND BELOW DEAD END CABLE POLE
ARM, 3Ø, 1/C PER Ø, HOOKSTICK SWITCHED

OH 1499.401
UG 4299.401
SUPERCEDES
1441.1 (1-1-93)

BILL OF MATERIAL:

ITEM	DESCRIPTION	QUANTITY	CONSTR STANDARD	STOCK NUMBER
1	CROSSARM, 3-3/4" X 5-3/4" X 12'-0" (G)	2	-	294160
2	BRACE, ANGLE, CROSSARM, 4'-0"	3	-	164032
3	BOLT, MACH, GALV, 1/2" X 7", 1 ROUND AND 1 DOUBLE COIL SPRING WASHER (E)	6	392	-
4	PIN, INSULATOR, STRAIGHT, 12KV, 1" LEAD THREAD (F)(E)	1	-	532704
5	BOLT, SPACE, GALV, 5/8" X (LENGTH AS REQ'D), 3 SQUARE, 2 ROUND AND 2 DOUBLE COIL SPRING WASHERS (F)(E)	4	392	-
6	BOLT, MACH, GALV, 5/8" X (LENGTH AS REQ'D), 2 SQUARE AND 1 DOUBLE COIL SPRING WASHERS (F)(E)	3	392	-
7	BOLT, MACH, GALV, 1/2" X 8", 1 ROUND AND 1 DOUBLE COIL SPRING WASHER (E)	12	392	-
8	BOLT, MACH, GALV, 5/8" X (LENGTH AS REQ'D) AND 1 DOUBLE COIL SPRING WASHER (E)	1	392	-
9	WIRE, #8, BARE SOLID ANNEALED COPPER	15'	-	812928
10	STAPLES, FENCE, GALV, 1-1/4" (E)	AS REQ'D	-	678528
11	SIGN, HIGH VOLTAGE AND 9 ROOFING NAILS, GALV (E)	4	-	647648 492224
12	CROSSARM, 3-3/4" X 5-3/4" X 10'-0"	1	-	294128
13	BOLT, MACH, GALV, 5/8" X (LENGTH AS REQ'D), 1 SQUARE AND 1 DOUBLE COIL SPRING WASHER (E)	1	392	-
14	PIN, TRANSFORMER LEAD ADAPTER, 1" (F)(E)	1	-	529248
15	INSULATOR, 12KV, NEUTRAL (F)(E)	2	-	429216
16	CLEVIS, DEAD END, 5/8" BOLT STEEL (F)(E)	4	-	235712
17	INSULATOR, SUSPENSION, 12KV, CLEVIS (F)	7	750	-
18	CLAMP, STRAIGHT LINE, D.E. (F)	4	741	-
19	WIRE, BARE STRANDED CU OR AL (OH NEUT JUMPER) (N)(F)	12'	711-715	-
20	WIRE, BARE STRANDED COPPER (OH JUMPER) (N)	25'	715	-
21	TERMINAL, COMPRESSION (E)	6	794-795	-
22	BRACKET, DISCONNECT, ANGLE MOUNTING	6	-	166542
23	BOLT, MACH, GALV, 3/8" X 3", 2 ROUND & 1 LOCK WASHER (E)	6	392	-
24	SWITCH, HOOKSTICK DISCONNECT, 14.4KV, 600 A OR 1200 A	3	1222	-
25	WIRE, #8, BARE STRANDED COPPER	12'	-	813536
26	CONNECTOR, WIRE, COMPRESSION (SIZE AS REQ'D) (E)	AS REQ'D	783-787	-
27	ARRESTER, LIGHTNING (N)	3	-	113248
28	BRACKET, CUTOFF/ARRESTER (E)	3	-	166070
29	BRACKET, TERMINAL MOUNTING	3	-	166674
30	CONDUIT, PVC TYPE 2, SCHEDULE 40, 1" (E)	10'	-	251200
31	STRAPS, PIPE, GALV, 1" AND 2 - 6D NAILS, GALV (E)	AS REQ'D	-	697792 491552
32	WIRE, BARE STRANDED COPPER (CP NEUT-UNDER POTHEAD ARM) (N)	15'	715	-
33	WIRE, #4, BARE STRANDED COPPER	45'	-	813760
34	STAPLES, FENCE, GALV, 1-1/4" (E)	AS REQ'D	-	678528
35	UNIT GROUND, COMPLETE (Q)	1	-	603136
36	TAGS, SWITCH NUMBER (E)	2	-	720704
37	TERMINALS, UNDERGROUND CABLE	3	4111	-
38	RISER CONSTRUCTION	AS REQ'D	1400/4200	-
39	BRACKET, LADDER ARM (E)	AS REQ'D	1404/4204	167184
40	NUT, CLAMPING CHANNEL, W/SPRING, 1/2" (E)	AS REQ'D	1404/4204	503488
41	CHANNEL, DOUBLE GALV, 24" (E)	AS REQ'D	1404/4204	216700

FOR FIELD MAINTENANCE ONLY

CABLE SIZE	UG MACRO UNIT
	W/LADDER ARMS
3C-#350	CP350L
3C-#750	CP750L
3C-#1000	CP-1KL

OH 1499.402
UG 4299.402
SUPERCEDES
1441.2 (1-1-93)

SDG&E ELECTRIC STANDARDS

12.47KV AND BELOW DEAD END CABLE POLE
ARM, 3Φ, 1/C PER Φ, HOTSTICK SWITCHED

DATE 1-1-93

APPD *[Signature]*

INSTALLATION:

- A. NEW CABLE POLES SHALL HAVE A STANDARD SETTING DEPTH OF 9'. IN MOST CASES THIS WILL REQUIRE A 5' TALLER POLE.
- B. THIS CONSTRUCTION TO BE USED WITH 350 KCMIL AND LARGER UNDERGROUND CABLE.
- C. INTERCONNECT OVERHEAD NEUTRAL, TERMINAL BASE, AND CONCENTRIC CABLE NEUTRAL CONDUCTOR TO LIGHTNING ARRESTER GROUND.
- D. INTERCONNECT SWITCH AND DEADEND BONDS PER G.O. 95 RULE 52.7D. BONDING SHOULD BE DONE IN ACCORDANCE WITH RULE 53.4.
- E. EXEMPT MATERIAL.
- F. REDUCE QUANTITIES AS REQUIRED WHEN NOT USING NEUTRAL.
- G. WHEN ADDING THIS CONSTRUCTION TO AN EXISTING POLE WITH A 10' LINE ARM, AND SUFFICIENT POLE HEIGHT EXISTS, INSTALL 10' SWITCH ARMS AND ASSOCIATED HARDWARE BELOW THE LINE ARM TO AVOID CHANGING LINE ARM FROM 10' TO 12' (SEE O.H. STANDARD 1222, FIG. 1-B).

(N)

UG CABLE SIZE AWG OR KCMIL, AL	OH JUMPER COND SIZE, AWG OR KCMIL, CU	OH NEUT JUMPER SIZE			CABLE POLE NEUT SIZE (CU) UNDER POTHEAD ARM OR TRIPLE TERM BRKT
		CU	AL		
2	4	6	2	--	#6 PER PHASE
2/0	4	6	2	--	#6 PER PHASE
350	4/0	1/0	3/0	-	#2 PER PHASE
750	500	4/0	336.4	OR SAME SIZE AS O.H. NEUT CONDUCTOR	1/0 PER PHASE
1000	500	4/0	336.4		1/0 PER PHASE

REFERENCE:

- (O) ALLOWABLE WORKING AND CLIMBING SPACE - SEE STANDARD 251.
- (P) POLE STEPPING - SEE STANDARD 363.
- (Q) GROUNDING METHODS - SEE STANDARD 1002.
- (R) RISER POSITIONS - SEE STANDARD 1402/4202.
- (S) MINIMUM VERTICAL SEPARATION AS PER G.O. 95 - SEE STANDARD 1406/4206.
- (T) SEE STANDARD 1407/4207 FOR PORCELAIN AND NON PORCELAIN TERMINAL MOUNTING BRACKET INSTRUCTIONS AND MATERIALS.

FOR FIELD MAINTENANCE ONLY

DATE 1-1-93 APPD <i>JLB/BJ</i>	SDG&E ELECTRIC STANDARDS 12.47KV AND BELOW DEAD END CABLE POLE ARM, 3Ø, 1/C PER Ø, HOOKSTICK SWITCHED	OH 1499.403 UG 4299.403 SUPERCEDES 1441.3 (1-1-93)
-----------------------------------	-------------------------------------------------------------------------------------------------------------	------------------------------------------------------------------------

FIELD MAINTENANCE ONLY

REVISION HISTORY:

7/13/2016: All versions prior to 2016 are superseded by their current version found inside the Overhead Construction Standard Manual.

© 1998 - 2016 San Diego Gas & Electric Company. All rights reserved. Removal of this copyright notice without permission is not permitted under law.

REV	CHANGE	BY	DSGN	APPV	DATE	REV	CHANGE	BY	DSGN	APPV	DATE
C						F					
B						E					
A	ORIGINAL ISSUE	JS	IL	MDJ	7/13/2016	D					

<input checked="" type="checkbox"/>	Indicates Latest Revision	<input type="checkbox"/>	Completely Revised	<input type="checkbox"/>	New Page	<input type="checkbox"/>	Information Removed
-------------------------------------	---------------------------	--------------------------	--------------------	--------------------------	----------	--------------------------	---------------------

**SHEET
1 OF 1**

SDG&E ELECTRIC OVERHEAD STANDARD
12.47 KV AND BELOW DEAD END CABLE POLE THREE-PHASE,
1/C PER PHASE, GANG OPERATED SWITCHED,
NON-PORCELAIN TERMINALS

**FMO
OH 1443**

SCOPE: THIS STANDARD SHOWS A DEADEND CONSTRUCTION FOR 12.47 KV AND BELOW, THREE-PHASE CABLE POLE USING NON-PORCELAIN TERMINALS WITH A MEMCO GANG OPERATED SWITCH FOR 350 KCMIL AND LARGER U.G. CABLE.

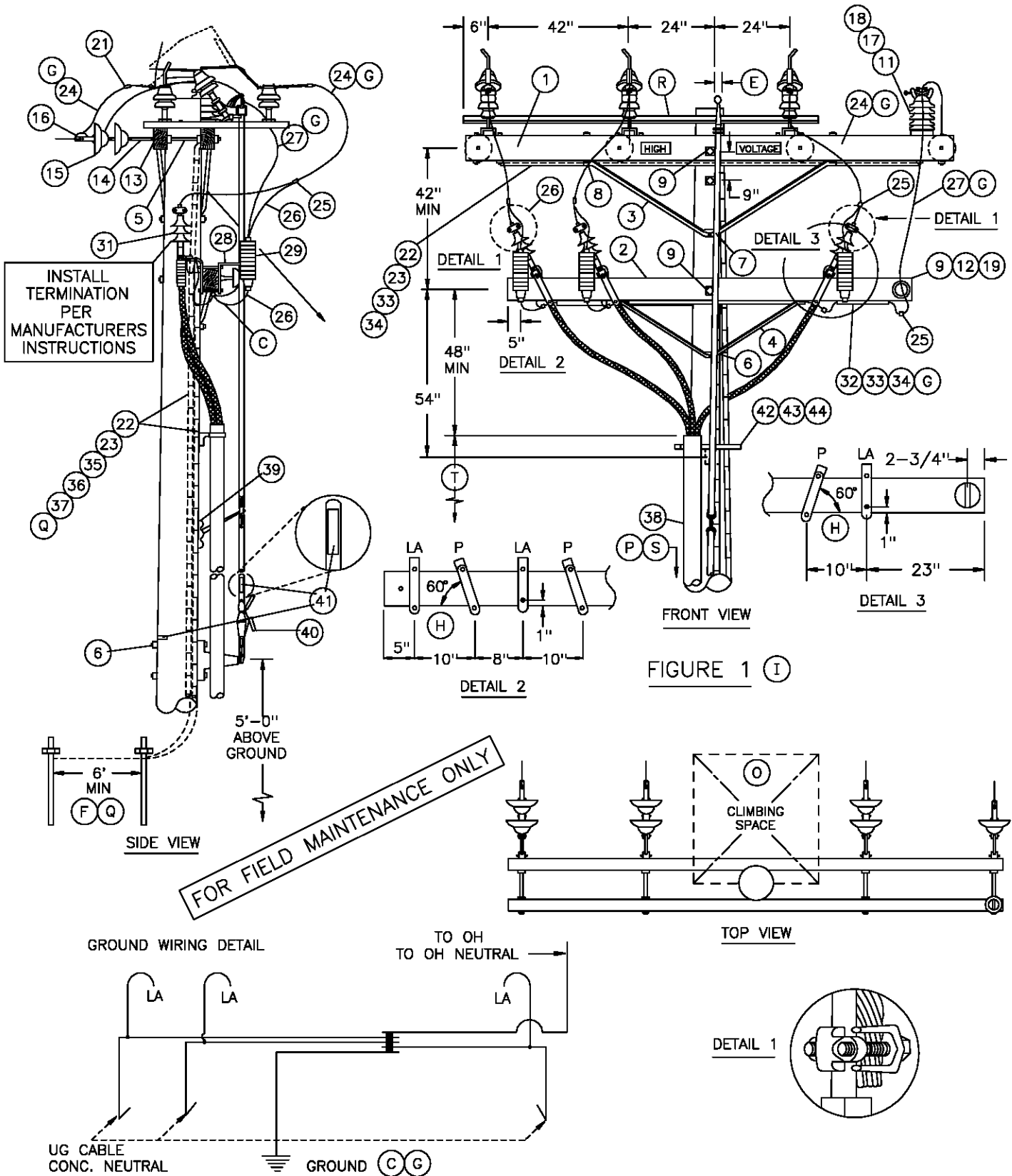

FIGURE 1 (I)

OH 1499.404
 UG 4299.404
 SUPERSEDES
 1443.1 (9-1-00)

SDG&E ELECTRIC STANDARDS
 12.47KV AND BELOW DEAD END CABLE POLE THREE-PHASE,
 1/C PER PHASE, GANG OPERATED SWITCHED,
 NON-PORCELAIN TERMINALS

DATE 1-1-96
 APPD PJA / CMK

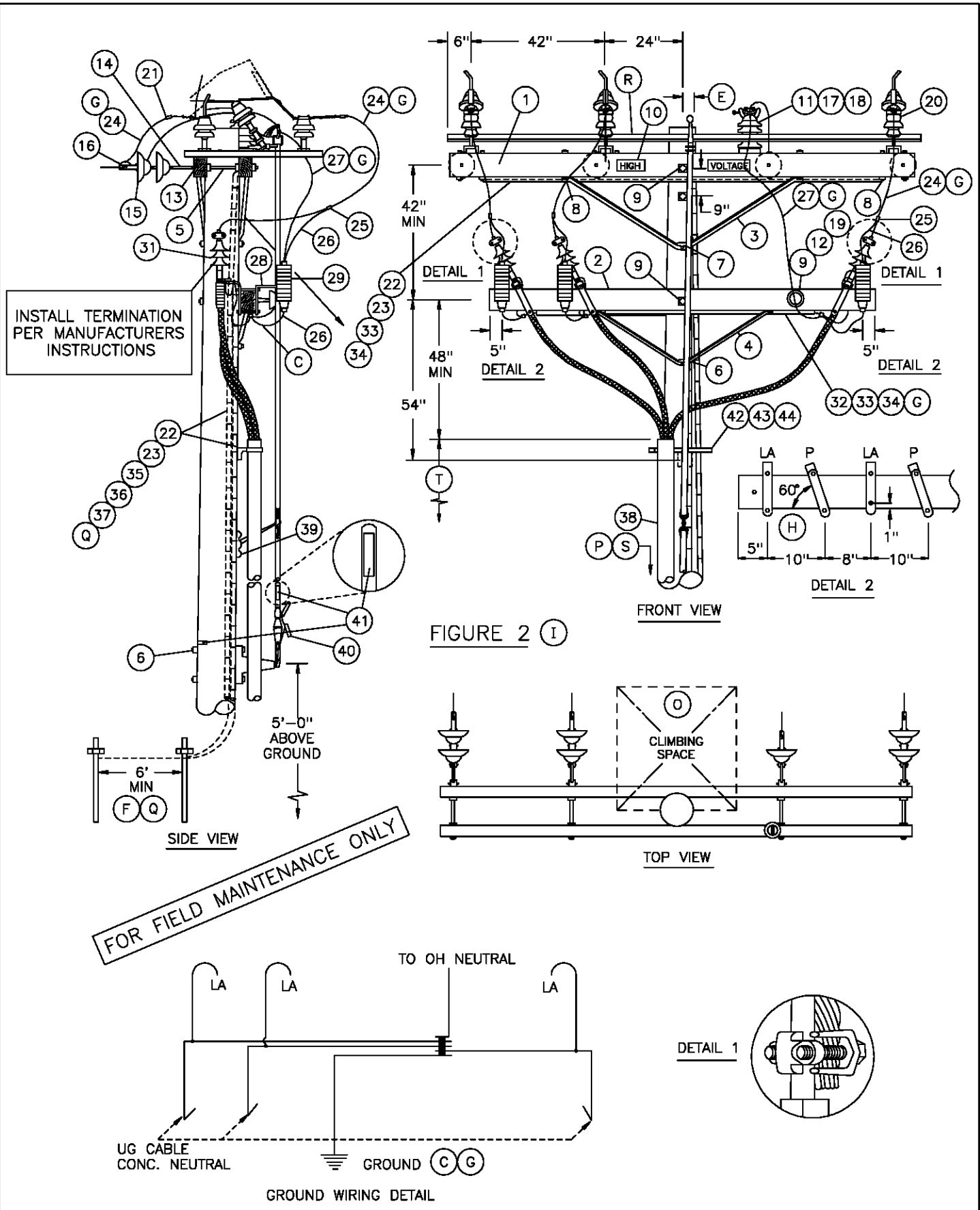

FIGURE 2 (I)

INSTALL TERMINATION PER MANUFACTURERS INSTRUCTIONS

FOR FIELD MAINTENANCE ONLY

DATE 1-1-96
APPD PJA/CLK

SDG&E ELECTRIC STANDARDS
12.47KV AND BELOW DEAD END CABLE POLE THREE-PHASE,
1/C PER PHASE, GANG OPERATED SWITCHED,
NON-PORCELAIN TERMINALS

OH 1499.405
UG 4299.405
SUPERSEDES
1443.2 (9-1-00)

BILL OF MATERIAL:

ITEM	DESCRIPTION	QUANTITY	CONST STD OR PAGE NO	STOCK NUMBER
1	CROSSARM, 3-3/4" X 5-3/4" X 12'-0"	2	380.2	-
2	CROSSARM, 3-3/4" X 5-3/4" X 10'-0"	1	380.2	-
3	BRACE, 6', ANGLE, GALV	2	-	164160
4	BRACE, 4', ANGLE, GALV	1	-	164032
5	BOLT, SPACE, GALV, 5/8" X (LENGTH AS REQ'D), 3 SQ WASH & 2 DBL COIL SPRING WASH (D)	4	392.1 &.2	-
6	BOLT, MACH, GALV, 5/8" X (LENGTH AS REQ'D), 1 SQ WASH & 1 DBL COIL SPRING WASH	3	392.1 &.2	-
7	BOLT, MACH, GALV, 5/8" X (LENGTH AS REQ'D) & 1 DBL COIL SPRING WASH	1	392.1 &.2	-
8	BOLT, MACH, GALV, 1/2" X 7", 1 RD WASH & 1 DBL COIL SPRING WASH	18	392.1 &.2	-
9	BOLT, MACH, GALV, 5/8" X (LENGTH AS REQ'D), 2 SQ WASH & 1 DBL COIL SPRING WASH	3	392.1 &.2	-
10	SIGN, HIGH VOLTAGE & 9 ROOFING NAILS, GALV	2	-	647648 492224
11	STUD, 7-1/2" X 5/8" & 1 DBL COIL SPRING WASH (D)	1	-	701760 798560
12	PIN, TRANSFORMER ADAPTER, 1", LEAD THREAD (D)	1	-	529248
13	CLEVIS, DEAD END, 5/8", BOLT STEEL (OPEN TYPE) (D)	4	-	235618
14	LINK, EXTENSION, 1/2" X 2" X 12" (D)	4	-	466240
15	INSULATOR, SUSPENSION, 12KV, CLEVIS (D)	7	750.3	-
16	CLAMP, STRAIGHT LINE, D.E. (D)	4	741-743	-
17	INSULATOR, VERTICAL POST (D)	1	-	428608
18	CLAMP, POST INSULATOR (D)	1	-	227824
19	INSULATOR, LINE, 12KV NEUTRAL (D)	1	-	429216
20	SWITCH, TPST TILTING INSULATOR, 600 AMP	1	-	709254
21	TERMINAL, COMPRESSION	6	794-795	-
22	WIRE, #4, BARE STRANDED, COPPER	110'	-	813760
23	STAPLES, FENCE, GALV, 1-1/4"	AS REQ'D	-	678528
24	WIRE, BARE STRANDED COPPER (OH JUMPERS) (D)	20'	715	-
25	CONNECTOR, WIRE, COMPRESSION (SIZE AS REQ'D)	AS REQ'D	783-787	-
26	WIRE, #6, BARE STRANDED COPPER	12'	-	813536
27	WIRE, BARE STRANDED CU OR ACSR/AW BARE (OH NEUT JUMPER) (D)(G)	10'	711-715	-

FOR FIELD MAINTENANCE ONLY

OVERHEAD MACRO UNIT
3NGMXP

UG MACRO UNIT	
CABLE SIZE	ON LADDER ARMS
3C-#350	NP350L
3C-#750C	NP750L
3C-#1000	N1000L

OH 1499.406
~~UG 4299.406~~
 SUPERSEDES
 1443.3 (9-1-00)

SDG&E ELECTRIC STANDARDS

12.4KV AND BELOW DEAD END CABLE POLE THREE-PHASE,
 1/C PER PHASE, GANG OPERATED SWITCHED,
 NON-PORCELAIN TERMINALS

DATE 1-1-98

APPD *PA/CAC*

BILL OF MATERIAL: (CONTINUED)

ITEM	DESCRIPTION	QUANTITY	CONSTR STANDARD	STOCK NUMBER
28	BRACKET, CUTOUT/ARRESTER, FOR CROSSARM MOUNTING	3	-	166070
29	ARRESTER, LIGHTNING	3	1247	-
30				
31	TERMINALS & UNDERGROUND CABLE (U)	3	4111	-
32	WIRE, BARE STRANDED COPPER (UNDER POTHEAD ARM) (G)	20'	715	-
33	CONDUIT, PVC, TYPE 2, SCHEDULE 40, 1-1/2"	21'	-	251232
34	STRAPS, PIPE, GALV, 1-1/2" & 6-D NAILS	AS REQ'D	-	697664 491552
35	MOULDING, OAK HARDWOOD, 1" X 8' LONG	11'	-	487200
36	STAPLES, MOULDING, GALV, 3" X 1-1/16" X 1/4"	AS REQ'D	-	678560
37	ROD & CLAMP, GROUND	2 2	-	230016 603072
38	RISER CONSTRUCTION	AS REQ'D	1400/4200	-
39	SCREW, LAG, 1/2" X 4"	2	-	621568
40	PADLOCK, MEDECO	1	-	514862
41	TAGS, SWITCH NUMBER	2	204/3104	-
42	BRACKET, LADDER ARM	AS REQ'D	1404/4204	167184
43	NUT, CLAMPING CHANNEL, W/SPRING, 1/2"	AS REQ'D	1404/4204	503488
44	CHANNEL, DOUBLE GALV, 24"	AS REQ'D	1404/4204	216700

FOR FIELD MAINTENANCE ONLY

INSTALLATION:

- A. NEW CABLE POLES SHALL HAVE A STANDARD SETTING DEPTH OF 9'. IN MOST CASES, THIS WILL REQUIRE A 5' TALLER POLE.
- B. THIS CONSTRUCTION TO BE USED WITH 350 KCMIL AND LARGER UNDERGROUND CABLE.
- (C) INTERCONNECT OVERHEAD NEUTRAL, TERMINAL BASE, AND CONCENTRIC CABLE NEUTRAL CONDUCTOR TO LIGHTNING ARRESTER GROUND.
- (D) REDUCE QUANTITIES AS REQUIRED WHEN NOT USING NEUTRAL.
- (E) OFFSET AS REQUIRED TO CLEAR ANCHOR GUY.
- (F) SWITCH GROUND AND LIGHTNING ARRESTER GROUND TO BE CONNECTED ON THE SAME GROUND ROD.

(G)

UG CABLE SIZE AWG OR KCMIL, AL	OH JUMPER COND SIZE, AWG OR KCMIL, CU	OH NEUT JUMPER SIZE			CABLE POLE NEUT SIZE (CU) UNDER POTHEAD ARM OR TRIPLE TERM BRKT
		CU	AL		
350	4/0	1/0	3/0	-	#2 PER PHASE
750	500	4/0	336.4	OR SAME SIZE AS O.H. NEUT CONDUCTOR	1/0 PER PHASE
1000	500	4/0	336.4		1/0 PER PHASE

- (H) TURN TOP OF BRACKET OUTWARD TO OBTAIN APPROX. 60° ANGLE.

	Indicates Latest Revision	Completely Revised	New Page	Information Removed
DATE 1-1-93 APPD <i>JLB/ROJ</i>	SDG&E ELECTRIC STANDARDS 12.4KV AND BELOW DEAD END CABLE POLE THREE-PHASE, 1/C PER PHASE, GANG OPERATED SWITCHED, NON-PORCELAIN TERMINALS			OH 1499.407 UG 4299.407 SUPERSEDES 1443.4 (9-1-00)

INSTALLATION: (CON'T)

- ① - USE FIGURE ONE FOR ALL **NEW** CONSTRUCTION AND WHEN ADDING TO EXISTING CONSTRUCTION WITH NEUTRAL ON OUTSIDE PIN POSITION.
- USE FIGURE TWO ON EXISTING CONSTRUCTION WITH NEUTRAL ON INSIDE PIN POSITION.

REFERENCE:

- ⓐ ALLOWABLE WORKING AND CLIMBING SPACE - SEE STD. 251.
- ⓑ POLE STEPPING - SEE STD. 363.
- ⓒ GROUNDING METHODS - SEE PAGE 1002.5.
- ⓓ GANG OPERATED SWITCH MOUNTING INSTRUCTIONS - SEE STD. SECTION 1200.
- ⓔ RISER POSITION - SEE STANDARD 1402/4202.
- ⓕ MINIMUM VERTICAL SEPARATION AS PER G.O. 95 - SEE STD. 1406/4206.
- ⓖ SEE STANDARD 1407/4207 FOR NON-PORCELAIN TERMINAL MOUNTING BRACKET INSTRUCTIONS AND MATERIALS.

FOR FIELD MAINTENANCE ONLY

	Indicates Latest Revision	Completely Revised	New Page	Information Removed
OH 1499.408 UC 4299.408 SUPERSEDES 1443.5 (9-1-00)	SDG&E ELECTRIC STANDARDS			DATE 1-1-93 APPD <i>JLB/ROJ</i>
	12.4KV AND BELOW DEAD END CABLE POLE THREE-PHASE, 1/C PER PHASE, GANG OPERATED SWITCHED, NON-PORCELAIN TERMINALS			

FIELD MAINTENANCE ONLY

REVISION HISTORY:

7/13/2016: All versions prior to 2016 are superseded by their current version found inside the Overhead Construction Standard Manual.

© 1998 - 2016 San Diego Gas & Electric Company. All rights reserved. Removal of this copyright notice without permission is not permitted under law.

REV	CHANGE	BY	DSGN	APPV	DATE	REV	CHANGE	BY	DSGN	APPV	DATE
C						F					
B						E					
A	ORIGINAL ISSUE	JS	IL	MDJ	7/13/2016	D					

<input checked="" type="checkbox"/>	Indicates Latest Revision	<input type="checkbox"/>	Completely Revised	<input type="checkbox"/>	New Page	<input type="checkbox"/>	Information Removed
-------------------------------------	---------------------------	--------------------------	--------------------	--------------------------	----------	--------------------------	---------------------

**SHEET
1 OF 1**

SDG&E ELECTRIC OVERHEAD STANDARD

12.47 KV DEAD END CABLE POLE, THREE-PHASE
WITH NEUTRAL, HORIZONTAL SCADA-MATE SWITCH

**FMO
OH 1445**

SCOPE: THIS STANDARD SHOWS A DEADEND CONSTRUCTION FOR 12.47 KV, THREE-PHASE CABLE POLE, WITH NEUTRAL, AND A HORIZONTAL MOUNTED SCADA-MATE SWITCH. (B)

NOTE: THIS INSTALLATION REQUIRES TRUCK ACCESS. CONTACT TELECOMMUNICATIONS BEFORE DESIGN BEGINS TO DETERMINE COMMUNICATIONS REQUIREMENT.

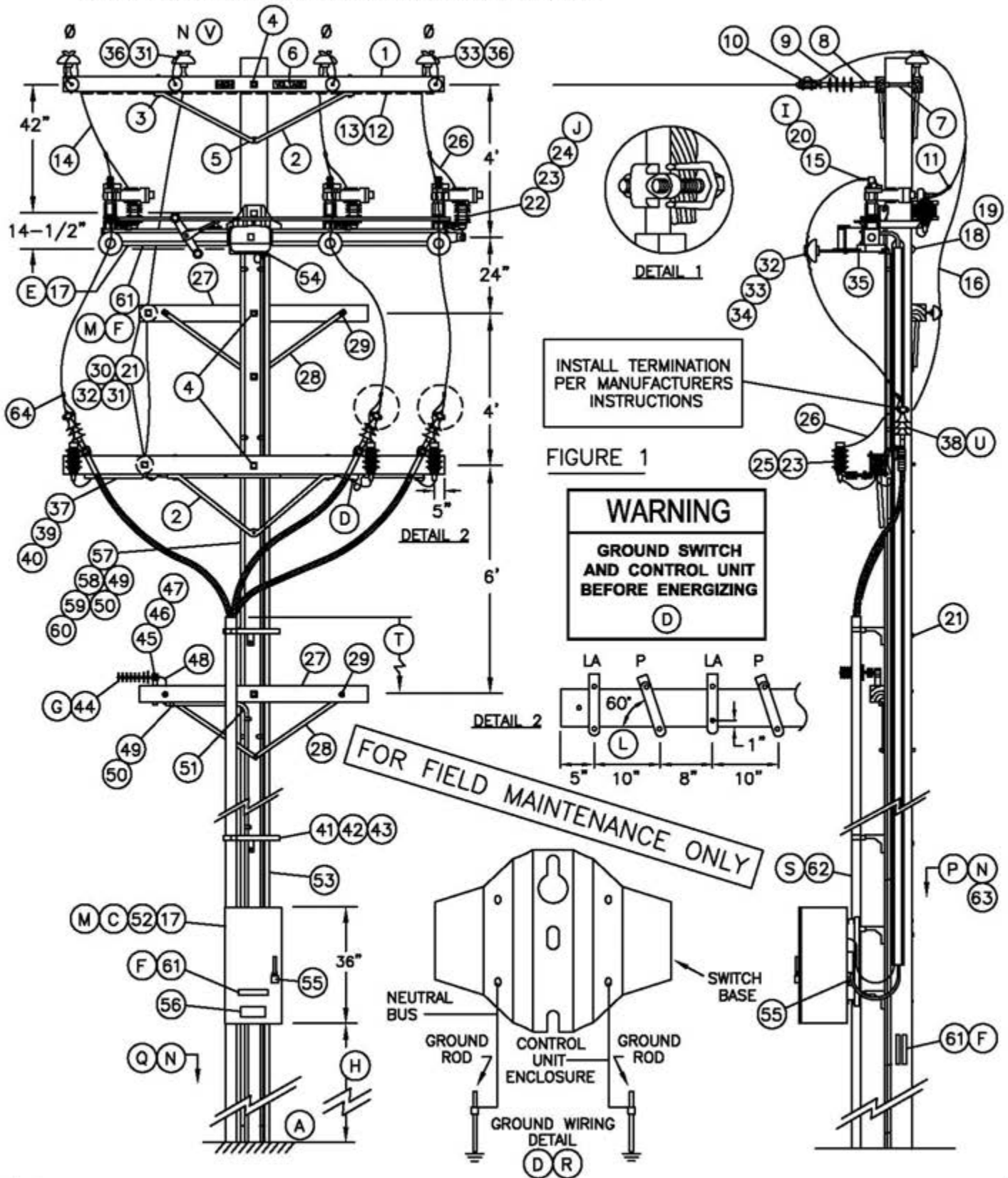

© 1998 - 2010 San Diego Gas & Electric Company. All rights reserved. Removal of this copyright notice without permission is not permitted under law.

1499.601
4299.601
SUPERSEDES
1445.1 (10-20-05)

SDG&E ELECTRIC STANDARDS

12.47 KV DEAD END CABLE POLE, THREE-PHASE WITH NEUTRAL, HORIZONTAL SCADA-MATE SWITCH

DATE 10-20-05
APPD PJA/JJ

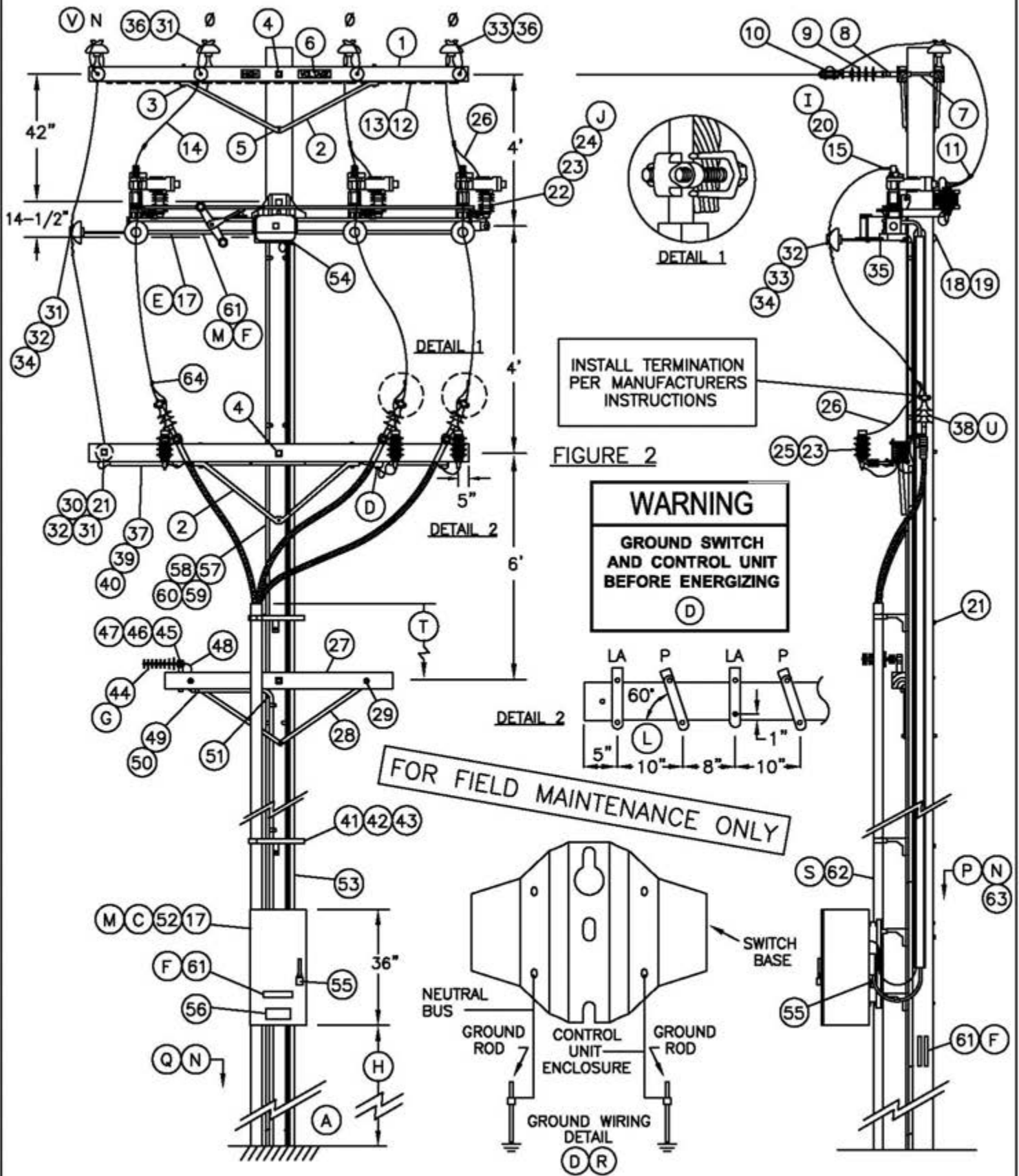

© 1998 - 2010 San Diego Gas & Electric Company. All rights reserved. Removal of this copyright notice without permission is not permitted under law.

DATE 10-20-05 APPD PJA/JJ	SDG&E ELECTRIC STANDARDS 12.47 KV DEAD END CABLE POLE, THREE-PHASE WITH NEUTRAL, HORIZONTAL SCADA-MATE SWITCH	1499.602 4299.602 SUPERSEDES 1445.2 (10-20-05)
------------------------------	---------------------------------------------------------------------------------------------------------------------	---------------------------------------------------------

BILL OF MATERIAL:

ITEM	DESCRIPTION	QUANTITY	CONSTR. STD	STOCK NUMBER	ASSEMBLY UNITS	
1	CROSSARM, 3-3/4" X 5-3/4" X 10'-0"	3	-	294128	4-	
2	BRACE, ANGLE, LINEARM=5'-0", PH ARM=4'-0"	4'	1	391	164032	4HUB
		5'	2	391	164128	5HUB
3	BOLT, MACH, GALV, 1/2" X 7", 1 ROUND AND 1 DOUBLE COIL SPRING WASHER	6	392	-	-	
4	BOLT, MACH, GALV, 5/8" X (LENGTH AS REQ'D), 2 SQUARE AND 1 DOUBLE COIL SPRING WASHER	4	392	-	-	
5	BOLT, MACH, GALV, 5/8" X (LENGTH AS REQ'D) AND 1 DOUBLE COIL SPRING WASHER	1	392	-	-	
6	SIGN, HIGH VOLTAGE, AND 9 ROOFING NAILS, GALV	2	-	647648	HV	
		-	-	492224		
7	BOLT, SPACE, GALV, 5/8" X (LENGTH AS REQ'D), 3 SQUARE, 2 ROUND, 2 DOUBLE COIL SPRING WASHERS AND 1 NUT	4	392	-	-	
8	CLEVIS, DEAD END, 5/8" BOLT STEEL (CLOSED TYPE)	4	-	235712	-	
9	INSULATOR, SUSPENSION, 12KV, CLEVIS	4	750	431650	4DE	
10	CLAMP, STRAIGHT LINE, D.E.	4	741-743	-	-	
11	CONNECTOR, WIRE COMPRESSION (SIZE AS REQ'D)	AS REQ'D	783-786	-	-	
12	WIRE, #8 BARE SOLID ANNEALED COPPER	12'	-	812928	BOND8	
13	STAPLE, FENCE, GALV, 1-1/4"	AS REQ'D	-	678528		
14	WIRE, BARE STRANDED COPPER (OH JUMPERS) (K)	45'	715	-	-	
15	TERMINAL, COMPRESSION LUG (I)	6	794-795	-	-	
16	WIRE, BARE STRANDED CU OR ACSR/AW BARE (OH NEUT JUMPER) (K)	14'	711-715	-	-	
17	SWITCH, SCADA-MATE, 14.4 KV, POLE MOUNTED, INCLUDING 35' CONTROL CABLE, CONTROL UNIT AND RTU (E)	1	-	704690	AUTOSW (F)	
18	BOLT, MACH, GALV, 5/8" X (LENGTH AS REQ'D), 1 SQUARE CURVED RIBBED AND 1 DOUBLE COIL SPRING WASHER	2	392	-	-	
19	COVER, BOLT, PLASTIC & 6 - 10D NAILS, GALV	2	-	285696	-	
		AS REQ'D	-	491392	-	
20	BOLT, STAINLESS STEEL, 1/2" X 1-1/2" WITH 2 FLAT & (I) 2 BELLEVILLE WASHERS & SILICONE BRONZE NUT	12	392	148672	-	
21	BOLT, MACH, GALV, 5/8" X (LENGTH AS REQ'D), 2 SQUARE & 1 DBL COIL SPRING WASHER	AS REQ'D	392	-	-	
22	BOLT, MACH, GALV, 1/2 X 2-1/2", 1 ROUND AND 1 LOCK WASHER	3	392	-	-	
23	ARRESTER, LIGHTNING (J)	6	-	113248	LA12C	
24	SERVICE POST CONNECTOR	3	-	262560	-	
25	BRACKET, CUTOUT/ARRESTER, FOR CROSSARM MOUNTING	3	-	166070	LA/B-C	
26	WIRE, #6, BARE STRANDED COPPER	FT	18'	715	813536	BS6C
		LB	2			
27	CROSSARM, 3-1/2" X 4-1/2" X 6'-0"	2	380.2	294112	2S	
28	BRACE, FLAT, CROSSARM, 28"	4	-	164192		
29	BOLT, MACH, GALV, 3/8" X 4-1/2" & 1 ROUND WASHER	4	392.2	-	-	
30	PIN, TRANSFORMER LEAD ADAPTER, 1"	2	-	529248	PS/01	
31	INSULATOR, 12KV NEUTRAL	3	-	429216	55-3C	
32	WIRE, TIE	AS REQ'D	760-764	-	-	
33	INSULATOR, 12KV, 55-5	6	750	429056	55-5C	
34	INSULATOR STANDOFF BRACKET, 1" X 30"	3 OR 4	394	166144	KBKT30	
35	"L" BRACKET, 2-1/2" X 2-1/2", GALV	3	-	166208	-	
36	INSULATOR PIN, 12KV, 1"	4	396	532704	PS1	
37	WIRE, BARE STRANDED COPPER (UNDER POTHEAD ARM) (K)	12'	715	-	-	

FOR FIELD MAINTENANCE ONLY

© 1998 - 2010 San Diego Gas & Electric Company. All rights reserved. Removal of this copyright notice without permission is not permitted under law.

1499.603
4299.603
SUPERSEDES
1445.3 (10-20-05)

SDG&E ELECTRIC STANDARDS

12.47 KV DEAD END CABLE POLE, THREE-PHASE
WITH NEUTRAL, HORIZONTAL SCADA-MATE SWITCH

DATE 7-9-03

APPD *PLA/MPB*

BILL OF MATERIAL: (CONT)

ITEM	DESCRIPTION	QUANTITY	CONSTR. STD	STOCK NUMBER	ASSEMBLY UNITS	
38	TERMINALS AND UNDERGROUND CABLE (U)	3	4111	-	-	
39	CONDUIT, PVC, TYPE 2, SCHEDULE 40, 1-1/2"	10'	-	251232	P11/2C	
40	STRAPS, PIPE, GALV, 1-1/2", & 2 - 6D NAILS, GALV	AS REQ'D	-	697664	-	
		AS REQ'D	-	491552		
41	BRACKET, LADDER ARM	AS REQ'D	1404/4204	167184	RSRARM	
42	NUT, CLAMPING CHANNEL, W/SPRING, 1/2"	AS REQ'D	1404/4204	503488		
43	CHANNEL, DOUBLE GALV, 24"	AS REQ'D	1404/4204	216700		
44	ANTENNA, SCADA, COMMUNICATION, BROADBAND AND CONNECTORS	1	-	109570	ANT	
45	NIPPLE, PIPE 2" X 7", ALUM.	1	-	-	ANTXMB	
46	BOLT, MACH, GALV. 1/2" X 9"	1	-	153184		
47	CENTERING WASHER, GALV.	2	-	795520		
48	CABLE, FLEXIBLE 1/2" COAXIAL SCADA ANTENNA	AS REQ'D	-	191906	ANTCAB	
49	CONDUIT, PVC, SCHEDULE 40, 1/2"	150'	-	251168	P1/2-C	
50	STRAPS, PIPE GALV, 1/2", & 6D NAILS, GALV	AS REQ'D	-	697728	-	
		AS REQ'D	-	490656	-	
51	ELBOW, PVC, 1/2"	1	-	-	-	
52	TRANSCEIVER, 12V DC	1	-	749500	SOTRAN	
53	U-GUARD, 2" X 10', POLYETHYLENE	3	-	249940	ZUMOLD	
54	GRIP, CONTROL CABLE	1	-	394018	-	
55	PADLOCK, SCHLAGE ELECTRIC SERIES	2	-	514848	-	
56	DECAL "SCADA" "INFORM S.C.O. UPON ENTRY"	1	207	301934	-	
57	WIRE, #2 BARE STRANDED COPPER	FT	100'	-	813664	BS2R
		LB	20#			
58	STAPLES, FENCE, GALV, 1-1/4" STAPLES, MOULDING, GALV, 3" X 1-1/16" X 1/4"	AS REQ'D	-	678528	-	
		AS REQ'D	-	678560	-	
59	GROUND ROD, 5/8" X 8' (D)(R)	2	1002	603072	ROD8	
60	COPPER BONDED GROUND CONNECTOR	2	1002	259010	-	
61	TAG, SWITCH NUMBER (F)	5	204	-	-	
62	RISER CONSTRUCTION (S)	AS REQ'D	1400/4200	-	-	
63	VISIBILITY STRIP (N)	4	208	304064	VSTRIP	
64	HOT LINE CLAMP	3	788	227680	-	

FOR FIELD MAINTENANCE ONLY

OH MACRO UNITS		
FIG.	NEUTRAL POSITION	MU
1	INSIDE	SMCPNI
2	OUTSIDE	SMCPNO

UG MACRO UNITS	
CABLE SIZE	W/LADDER ARMS
3C-#350	NP350L
3C-#750C	NP750L
3C-#1000	N1000L

INSTALLATION:

- (A) NEW CABLE POLES SHALL HAVE A STANDARD SETTING DEPTH OF 9'. IN MOST CASES, THIS WILL REQUIRE A 5' TALLER POLE.
- (B) THIS CONSTRUCTION TO BE USED WITH 350 KCMIL AND LARGER UNDERGROUND CABLE.
- (C) SCADA SWITCH CONTROL IS SELF POWERED FROM POLE TOP SWITCH UNIT. NO LOCAL SECONDARY IS REQUIRED. FAULT INDICATION IS INTEGRATED WITH THE SWITCH CONTROL - NO EXTERNAL FAULT INDICATORS ARE REQUIRED.

©1998 - 2010 San Diego Gas & Electric Company. All rights reserved. Removal of this copyright notice without permission is not permitted under law.

DATE 10-20-05 APPD PJA/JJ	SDG&E ELECTRIC STANDARDS	1499.604 4299.604 SUPERSEDES 1445.4 (10-20-05)
	12.47 KV DEAD END CABLE POLE, THREE-PHASE WITH NEUTRAL, HORIZONTAL SCADA-MATE SWITCH	

- (D) **NOTE:** BEFORE ENERGIZING SWITCH, CONNECT GROUND LEADS TO THE GROUNDING POINT PROVIDED ON SWITCH MOUNTING BRACKET. INTERCONNECT OVERHEAD NEUTRAL, TERMINAL BASE AND CONCENTRIC CABLE CONDUCTOR TO LIGHTNING ARRESTER GROUND. INSTALL TWO SEPARATE GROUND RUNS FROM BASE OF SWITCH TO BASE OF POLE, UNDER SEPARATE COVERS, IN ADJACENT POLE QUADRANTS. CONNECT EACH RUN TO A SEPARATE SET OF GROUND RODS. CONNECT CONTROL UNIT ENCLOSURE GROUND WIRE TO ONE OF THE GROUND RUNS AND POTHEAD UNDERARM NEUTRAL BUS TO THE OTHER. – SEE GROUND WIRING DETAIL.
- (E) WHEN MOUNTING SCADA SWITCH TO POLE, DISCARD POLE BAND. **DO NOT INSTALL POLE BAND.**
- (F) SCADA SWITCH ASSEMBLY UNIT WILL GENERATE TWO SWITCH NUMBERS—ONE FOR THE SF6 INTERRUPTER AND ANOTHER FOR THE MANUALLY OPERATED DISCONNECT. THE VISUAL BREAK, MANUALLY OPERATED DISCONNECT WILL ALWAYS BE A LINE SWITCH, NORMALLY CLOSED AND ASSIGNED THE LOWER OF THE SWITCH ASSIGNMENT NUMBERS. A TAG FOR THE MANUALLY OPERATED DISCONNECT WILL BE INSTALLED AT THE BASE OF THE POLE AND ON THE UNDERSIDE OF THE SWITCH BASE NEAR THE OPERATING LEVER. THE SF6 INTERRUPTER CAN BE EITHER A LINE SWITCH OR A TIE SWITCH. TAGS FOR THE SF6 INTERRUPTER WILL BE INSTALLED IN THREE LOCATIONS; AT THE BASE OF THE POLE, OUTSIDE OF THE CONTROL CABINET DOOR AND ANOTHER ON THE INSIDE OF THE DOOR. AN INTERRUPTER OPEN/CLOSED INDICATOR IS LOCATED ON ONE END OF THE SWITCH ARM.
- (G) PLANNER TO SPECIFY QUADRANT OF POLE FOR ANTENNA MOUNT WITH DATA FROM STANDARDS. POINTS LIST TO BE COMPLETED BY PLANNER AND SENT TO SENIOR ENGINEER, DISTRIBUTION OPERATIONS. SEE ELECTRIC STANDARDS TEAM FOR POINTS LIST FORMS.
- (H) RTU TO BE MOUNTED AT 10' FROM GROUND LEVEL TO BOTTOM OF RTU CABINET WHEN NOT SUBJECT TO TRAFFIC CONTACT. IF VULNERABLE TO VEHICLE DAMAGE, MOUNT RTU AT 13' – 6" FROM GROUND LEVEL TO BOTTOM OF RTU CABINET. CONSIDER LARGE VEHICLES PARKING PARALLEL TO CURB.
- (I) IF ATTACHING 1/0 OR 4/0 COPPER JUMPERS TO SCADA-MATE SWITCH, USE TWO BRONZE CABLE TAP LUGS (S/N 471296) IN PLACE OF BOLTS AND COMPRESSION LUG.
- (J) INSTALL LIGHTNING ARRESTERS ON THE VOLTAGE SENSOR SIDE OF SCADA-MATE SWITCH IN THE PARTIAL ARRESTER PROTECTION AREA. INSTALL LIGHTNING ARRESTERS ON BOTH SIDES OF SCADA-MATE SWITCH IN THE GENERAL ARRESTER PROTECTION AREA. REFER TO STANDARD PAGE 1247.2 FOR LIGHTNING ARRESTER APPLICATION MAP. LIGHTNING ARRESTERS ARE TO BE GROUNDED THROUGH THE SWITCH BASE.
- (K)

UG CABLE SIZE AWG OR KCMIL, AL	OH JUMPER COND SIZE, AWG OR KCMIL, CU	OH NEUT JUMPER SIZE			CABLE POLE NEUT SIZE (CU) UNDER POTHEAD ARM OR TRIPLE TERM BRKT
		CU	AL		
350	4/0	1/0	3/0	–	#2 PER PHASE
750	500	4/0	336.4	OR SAME SIZE AS O.H. NEUT CONDUCTOR	1/0 PER PHASE
1000	500	4/0	336.4		1/0 PER PHASE

- (L) TURN TOP OF BRACKET OUTWARD TO OBTAIN APPROXIMATELY 60° ANGLE.
- (M) CONTROL AND ANTENNA CONNECTIONS TO BE MADE BY SCADA PROJECT CREW. LINE CREW MOUNTS SWITCH TO POLE AND LEAVES CONTROL CABLE ON SITE.

REFERENCE:

- (N) REFLECTOR STRIPS ARE REQUIRED ON ALL SECTIONALIZING/TIELINE SWITCHES – SEE STANDARD 208.
- O. FOR OPERATION OF SCADA-MATE SWITCH – SEE STANDARD PRACTICE 311.
- (P) ALLOWABLE WORKING AND CLIMBING SPACE – SEE STANDARD 251.
- (Q) POLE STEPPING – SEE O.H. STANDARD 363.
- (R) GROUNDING METHODS – SEE O.H. STANDARD 1002.
- (S) RISER POSITION – SEE STANDARD 1402/4202.
- (T) MINIMUM VERTICAL SEPARATION AS PER G.O. 95 – SEE STANDARD 1406/4206.
- (U) SEE STANDARD 1407/4207 FOR NON-PORCELAIN TERMINAL MOUNTING BRACKET INSTRUCTIONS AND MATERIALS.
- (V) ON ALL NEW CONSTRUCTION AND WHEN ADDING TO EXISTING CONSTRUCTION, NEUTRAL TO BE INSTALLED IN OUTSIDE PIN POSITION PER DESIGN MANUAL PAGE 5124.2.

FOR FIELD MAINTENANCE ONLY

© 1998 - 2010 San Diego Gas & Electric Company. All rights reserved. Removal of this copyright notice without permission is not permitted under law.

DATE 9-13-05 APPD PJA/JJ	SDG&E ELECTRIC STANDARDS	1499.605
	12.47 KV DEAD END CABLE POLE, THREE-PHASE WITH NEUTRAL, HORIZONTAL SCADA-MATE SWITCH	4299.605 SUPERSEDES 1445.5 (10-20-05)

FIELD MAINTENANCE ONLY

REVISION HISTORY:

7/13/2016: All versions prior to 2016 are superceded by their current version found inside the Overhead Construction Standard Manual.

2/20/2019: Install S706680 in place of old style Disconnect Switch.

© 1998 - 2019 San Diego Gas & Electric Company. All rights reserved. Removal of this copyright notice without permission is not permitted under law.

REV	CHANGE	BY	DSGN	APPV	DATE	REV	CHANGE	BY	DSGN	APPV	DATE
C						F					
B	EDITORIAL CHANGES	GLW	JES	CZH	2/20/2019	E					
A	ORIGINAL ISSUE	JS	IL	MDJ	7/13/2016	D					

SHEET 1 OF 1	X Indicates Latest Revision	Completely Revised	New Page	Information Removed	FMO OH 1451
	SDG&E ELECTRIC OVERHEAD CONSTRUCTION STANDARDS				
	12.47 KV AND BELOW DEAD END CABLE POLE, 6 OR 7 OH CONDUCTORS, 1 OR 2 TERMINALS PER CONDUCTOR, HOOKSTICK SWITCHED				

SCOPE: THIS STANDARD SHOWS 6 OR 7 CONDUCTOR DEAD END CABLE POLE WITH HOOKSTICK SWITCHES FOR 750 KCMIL AND LARGER U.G. CABLE. (SEE STANDARD 1407/4207 FOR 350 KCMIL TERMINAL MOUNTING INFORMATION).

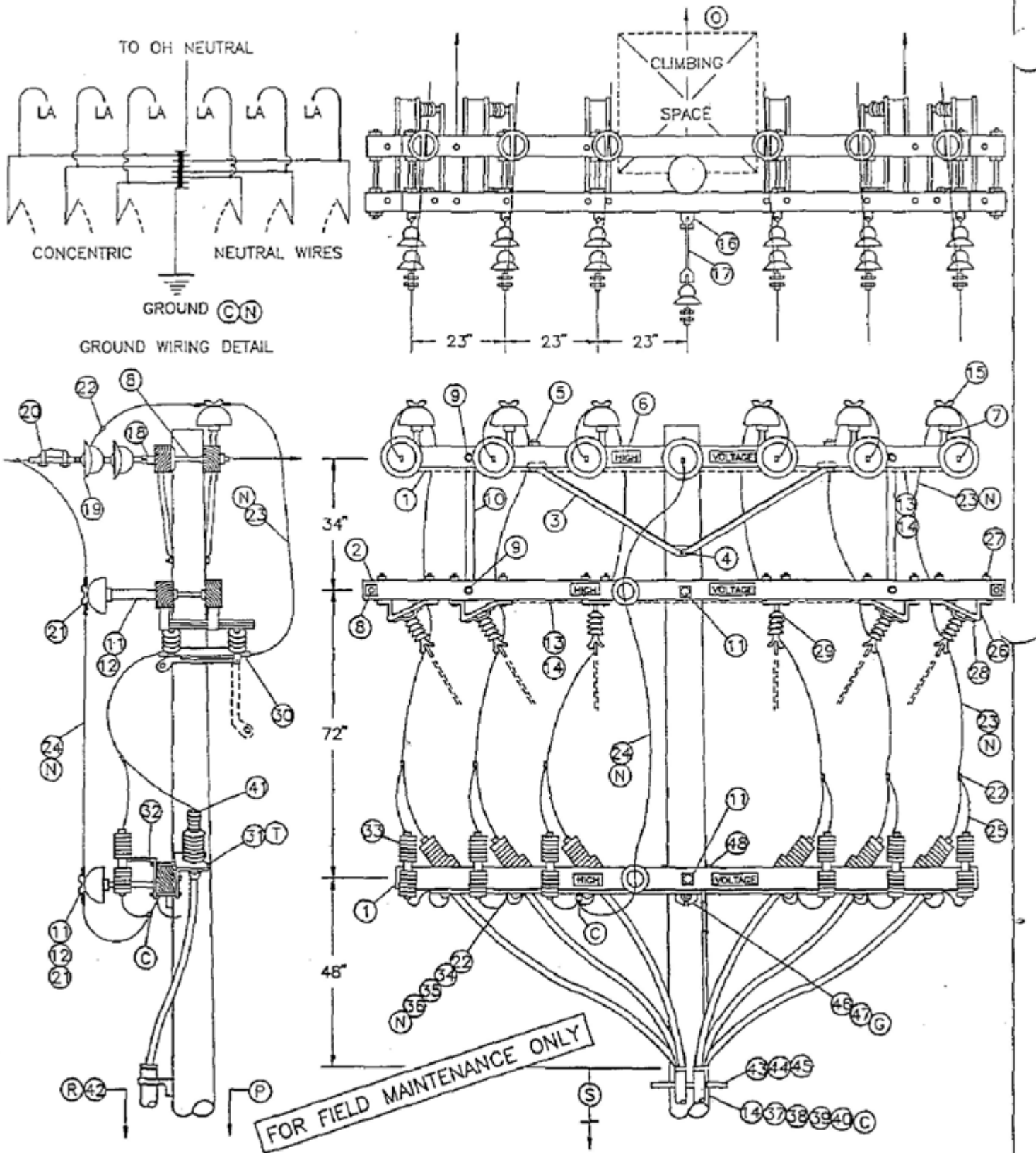

OH 1499.504
~~UG 4299.504~~
 SUPERCEDES
 1451.1 (1-1-93)

SDG&E ELECTRIC STANDARDS
 12.47KV AND BELOW DEAD END CABLE POLE, 6 OR 7 OH
 CONDUCTORS, 1 OR 2 TERMINALS PER CONDUCTOR,
 HOOKSTICK SWITCHED

DATE 1-1-93

APPD *J.B./R.D.*

BILL OF MATERIAL:

ITEM	DESCRIPTION	QUANTITY	CONST STD OR PG NO	STOCK NUMBER
1	CROSSARM, 3-3/4" X 5-3/4" X 12'-0"	3	-	294160
2	CROSSARM, 3-3/4" X 5-3/4" X 13'-6"	2	-	294368
3	BRACE, ANGLE, CROSSARM, 6"	3	-	164160
4	BOLT, MACH, GALV, 5/8" X (LENGTH AS REQ'D), 1 DBL COIL WASH	(E) 1	392.1&2	-
5	BOLT, MACH, GALV, 1/2" X 7", 1 RD & 1 DBL COIL WASH	(E) 4	392.1&2	-
6	SIGN, HIGH VOLTAGE & 8 ROOFING NAILS	(E) 6	-	647648 492224
7	PIN, INSULATOR, STRAIGHT, 12KV, 1" OR 1 3/8"	(E) 6	-	532704 532448
8	BOLT, SPACE, 5/8" X (LENGTH AS REQ'D), 3 SQ WASH & 2 DBL COIL WASH	(E) 8	392.1&2	-
9	BOLT, MACH, GALV, 5/8" X (LENGTH AS REQ'D), 1 RD WASH & 1 DBL COIL WASH	(E) 8	392.1&2	-
10	BRACE, VERTICAL, 3/8"	(E) 4	-	164224
11	BOLT, MACH, GALV, 5/8" X (LENGTH AS REQ'D), 2 SQ FLAT WASH & 1 DBL COIL WASH	(E) 5	392.1&2	-
12	PIN, TRANSFORMER ADAPTER, 1" LEAD THREAD	(D) (E) 2	-	529248
13	WIRE, #8, BARE SOLID ANNEALED COPPER	2 LB	-	812928
14	STAPLES, FENCE, GALV, 1-1/4"	(D) (E) AS REQ'D	-	878528
15	INSULATOR, LINE, 12KV, 1" OR 1-3/8" PIN	6	750	-
16	CLEVIS, DEAD END, 3/4" BOLT, STEEL (OPEN TYPE)	(D) (E) 1	-	235618
17	LINK, EXTENSION, 1/2" X 1-1/2" X 12"	(D) 1	-	466240
18	CLEVIS, DEAD END, 5/8" BOLT, STEEL (CLOSED TYPE)	(E) 6	-	235712
19	INSULATOR, SUSPENSION, 12KV	(D) 13	750	-
20	CLAMP, STRAIGHT LINE, D.E.	(D) 7	742-743	-
21	INSULATOR, LINE, 12KV, NEUTRAL	(D) (E) 2	-	429216
22	CONNECTOR, WIRE, (SIZE & TYPE AS REQ'D)	(E) AS REQ'D	783-787	-
23	WIRE, BARE STRANDED COPPER, (OH JUMPER)	(N) 72'	715-716	-
24	WIRE, BARE STRANDED CU OR AL, (OH NEUT JUMPER)	(N) 12'	711-716	-
25	WIRE, #6, BARE STRANDED COPPER	25'	-	813536
26	BRACKET, DISCONNECT, ANGLE MOUNTING, 1/4" X 3"	8	-	166542
27	BOLT, MACH, GALV, 1/2" X 8", 1 RD & 1 DBL COIL WASH	(D) 24	392.1&2	-
28	BOLT, MACH, GALV, 3/8" X 3"	(E) 8	392.1&2	-
29	SWITCH, DISCONNECT, 14.4KV, 600 A OR 1200 A	6	1205	-
30	COMPRESSION TERMINALS, CU, 2 HOLE (SIZE AS REQ'D)	12	794-795	-
31	BRACKET, POTHEAD MOUNTING	6	1400/4200	-
32	BRACKET, CUTOFF/ARRESTER, FOR CROSSARM MOUNTING	(E) 6	-	168070
33	ARRESTER, LIGHTNING	6	1247	-
34	CONDUIT, PVC, SCHEDULE 40, 1-1/2"	(E) 10'	-	251232
35	STRAPS, PIPE, GALV, 1" & 6D NAILS, GALV	(E) AS REQ'D	-	697792 491552
36	WIRE, BARE STRANDED CU, (C.P. NEUTRAL SIZE)	(N) 35'	715-716	-
37	WIRE, #4, BARE STRANDED COPPER	45'	-	813760
38	STAPLES, MOULDING, GALV, 3" X 1-1/16" X 1/4"	(D) (E) AS REQ'D	-	678560
39	UNIT GROUND, COMPLETE	(D) 1	-	603136
40	CLAMP, 5/8", GROUND ROD	(E) 2	-	230016
41	TERMINALS, UNDERGROUND CABLE	6	4111	-
42	RISER CONSTRUCTION	AS REQ'D	1400/4200	-
43	BRACKET, LADDER ARM	(E) AS REQ'D	1404/4204	167184
44	NUT, CLAMPING CHANNEL, W/SPRING, 1/2"	(E) AS REQ'D	1404/4204	503488
45	CHANNEL, DOUBLE GALV, 24"	(E) AS REQ'D	1404/4204	216700
46	BOLT, MACH, GALV, 5/8" X (LENGTH AS REQ'D), 1 SQUARE, 1 ROUND & 1 DOUBLE COIL SPRING WASHER	(E) 1	392	-
47	GAIN, CROSSARM, BRACELESS	(G) 1	-	369598
48	BOLT, MACH, GALV, 5/8" X 7", 1 ROUND & 1 DOUBLE COIL SPRING WASHER	(E) 2	392	-

FOR FIELD MAINTENANCE ONLY

CABLE SIZE	UG MACRO UNIT PORCELAIN
	W/LADDER ARMS
3C-#750 AL TWO RUNS	2R750L
3C-#1000 AL TWO RUNS	2R-1KL

DATE 1-1-93	SDG&E ELECTRIC STANDARDS	OH 1499.505
APPD <i>JLB/ROJ</i>	12.47KV AND BELOW DEAD END CABLE POLE, 6 OR 7 OH CONDUCTORS 1 OR 2 TERMINALS PER CONDUCTOR, HOOKSTICK SWITCHED	UG 4299.505
		SUPERCEDES 1451.2 (1-1-93)

INSTALLATION:

- A. NEW CABLE POLES SHALL HAVE A STANDARD DEPTH OF 9'. IN MOST CASES THIS WILL REQUIRE A 5' TALLER POLE.
- B. THIS CONSTRUCTION TO BE USED WITH 350 KCMIL AND LARGER UNDERGROUND CABLE.
- C. INTERCONNECT OVERHEAD NEUTRAL, TERMINAL BASE, AND CONCENTRIC CABLE NEUTRAL CONDUCTOR TO LIGHTNING ARRESTER GROUND.
- D. REDUCE QUANTITIES AS REQUIRED WHEN NOT USING NEUTRAL .
- E. EXEMPT MATERIAL.
- F. INSTRUCTIONS TO INSTALL POTHEAD MOUNTING BRACKETS AND LIGHTNING ARRESTER BRACKETS.
- G. DO NOT CUT GAINS IN THE POLE WHEN INSTALLING THE VERTICALLY MOUNTED SECTIONALIZING SWITCH ARMS. THE GAIN HARDWARE USED HERE MAKE CUT GAINS UNNECESSARY.

(N)

UG CABLE SIZE AWG OR KCMIL, AL	OH JUMPER COND SIZE, AWG OR KCMIL, CU	OH NEUTRAL JUMPER SIZE CU OR AL	CABLE POLE NEUT SIZE (CU) UNDER POTHEAD ARM OR TRIPLE TERM BRKT
350	4/0	SAME SIZE	#2 PER PHASE
750	500	AS O.H. NEUT	1/0 PER PHASE
1000	500	CONDUCTOR	1/0 PER PHASE

REFERENCE:

- (O) ALLOWABLE WORKING AND CLIMBING SPACE - SEE STD. 251.
- (P) POLE STEPPING - SEE STD. 363.
- (Q) GROUNDING METHODS - SEE PAGE 1002.5.
- (R) RISER POSITIONS - SEE STANDARD 1402/4202.
- (S) MINIMUM VERTICAL SEPARATION AS PER G.O. 95 - SEE STD. 1406/4206.
- (T) SEE STANDARD 1407/4207 FOR PORCELAIN AND NON PORCELAIN TERMINAL MOUNTING BRACKET INSTRUCTIONS AND MATERIALS.

FOR FIELD MAINTENANCE ONLY

OH 1499.506 UG 4299.506 SUPERCEDES 1451.3 (1-1-93)	SDG&E ELECTRIC STANDARDS 12.47KV AND BELOW DEAD END CABLE POLE, 6 OR 7 OH CONDUCTORS 1 OR 2 TERMINALS PER CONDUCTOR, HOOKSTICK SWITCHED	DATE 1-1-93 APPD <i>JAB/ROD</i>
------------------------------------------------------------------------	--------------------------------------------------------------------------------------------------------------------------------------------------	------------------------------------

FIELD MAINTENANCE ONLY

REVISION HISTORY:

7/13/2016: All versions prior to 2016 are superseded by their current version found inside the Overhead Construction Standard Manual.

© 1998 - 2016 San Diego Gas & Electric Company. All rights reserved. Removal of this copyright notice without permission is not permitted under law.													
REV	CHANGE	BY	DSGN	APPV	DATE	REV	CHANGE	BY	DSGN	APPV	DATE		
C						F							
B						E							
A	ORIGINAL ISSUE	JS	IL	MDJ	7/13/2016	D							
SHEET 1 OF 1		<input checked="" type="checkbox"/>	Indicates Latest Revision		<input type="checkbox"/>	Completely Revised		<input type="checkbox"/>	New Page		<input type="checkbox"/>	Information Removed	
		SDG&E ELECTRIC OVERHEAD STANDARD										FMO OH 1481	
		POLETOP METERING, 2.4KV SINGLE PHASE											

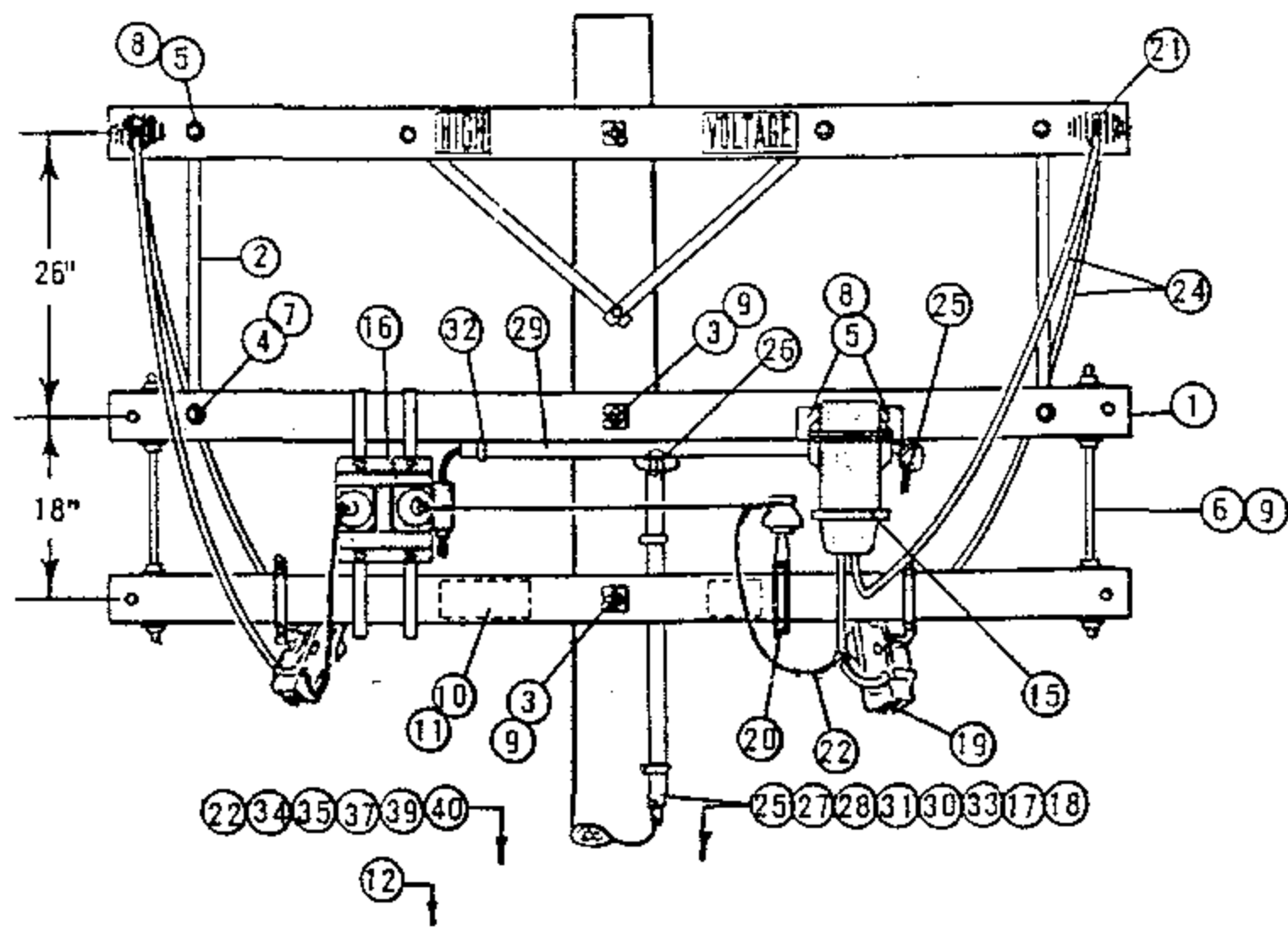

ELEVATION - LOAD SIDE

FOR FIELD MAINTENANCE ONLY

NOTE:

(A) NOT REQUIRED WHERE METER BOX HAS HUB.

ITEM P T F	M I	DESCRIPTION	QUANTITY	STOCK NO. OR CONSTR STD	ITEM P T F	M I	DESCRIPTION	QUANTITY	STOCK NO. OR CONSTR STD
2	BRACE, FLAT CROSSARM 26"	2	164192	25	WIRE, #12 TYPE TW CODED COPPER, 3 CONDUCTORS, 4' EACH	123'	-		
3	BOLT, MACH 5/8" X 14"	2	154880	26	BODY, CONDUIT, 3/4" PVC TYPE "T", BLANK COVER	1	147654		
4	BOLT, MACH 1/2" X 5"	2	153024	27	BODY, CONDUIT, 3/4" PVC TYPE LB, BLANK COVER (A)	1	146384		
5	BOLT, MACH 3/8" X 4 1/2"	4	154368	28	CONDUIT, 3/4" PVC SCH 80	3'	251520		
6	BOLT, SPACE 5/8" X 24"	2	156640	29	CONDUIT, 1" PVC SCH 40	4'	251200		
7	WASHER, 1/2" ROUND	2	800192	30	CONDUIT, 2" PVC SCH 40	20'	251296		
8	WASHER, 3/8" ROUND	4	800288	31	STRAP, PIPE 3/4" & 2-10D GALV NAILS	7	697888.491392		
9	WASHER, 3" SQ FLAT	12	799072	32	STRAP, PIPE 1" & 2-8D GALV. NAILS	3	697792.491584		
10	SIGN, HIGH VOLTAGE	1	647648	33	STRAP, PIPE 2" & 2-10D GALV NAILS	12	697856.491392		
11	NAILS, ROOFING #8 GALV	8	492224	34	ROD, AND CLAMP, GROUND	1	630072.230016		
12	POLE STEP	16	692992	35	MOULDING, HARDWOOD	3'	487200		
13				36					
14				37	STAPLES, MOULDING 3" X 1 1/16" X 1/4"	2	678560		
15	TRANSFORMER, CURRENT, WEST. TYPE WD 5KV, 5A	1	-	38					
16	TRANSFORMER, POTENTIAL, WEST. PTO, 2400/120V, HANGERS & BOLTS	1	-	39	NAILS, 20D, GALV	4	491456		
17	METER, SINGLE PHASE POWER	1	-	40	STAPLES, FENCE 1 1/4" GALV	5	678528		
18	CABINET, METER, TEST SWITCH, LAG SCREWS	1	161312	41					
19	CUTOUT, 5KV	2	PG 1211	42					
20	BRACKET, INSULATOR STAND OFF	1	166208						
21	CONNECTORS, SPLIT BOLT	7	PG 787						
22	WIRE, #6 BARE STRANDED COPPER	20'	813536						
23									

SDG & E ELECTRIC STANDARDS

POLETOP METERING, 2.4KV SINGLE PHASE

DATE 2-28-83
APPD JMT/ARH

1499.801
SUPERSEDES
1481 (2-28-83)





FIELD MAINTENANCE ONLY

REVISION HISTORY:

7/13/2016: All versions prior to 2016 are superseded by their current version found inside the Overhead Construction Standard Manual.

© 1998 - 2016 San Diego Gas & Electric Company. All rights reserved. Removal of this copyright notice without permission is not permitted under law.

REV	CHANGE	BY	DSGN	APPV	DATE	REV	CHANGE	BY	DSGN	APPV	DATE
C						F					
B						E					
A	ORIGINAL ISSUE	JS	IL	MDJ	7/13/2016	D					

<p>SHEET 1 OF 1</p>	 Indicates Latest Revision	 Completely Revised	 New Page	 Information Removed	<p>FMO OH 1482</p>
	<p>SDG&E ELECTRIC OVERHEAD STANDARD</p>				
	<p>POLETOP METERING, 2.4KV OPEN DELTA</p>				

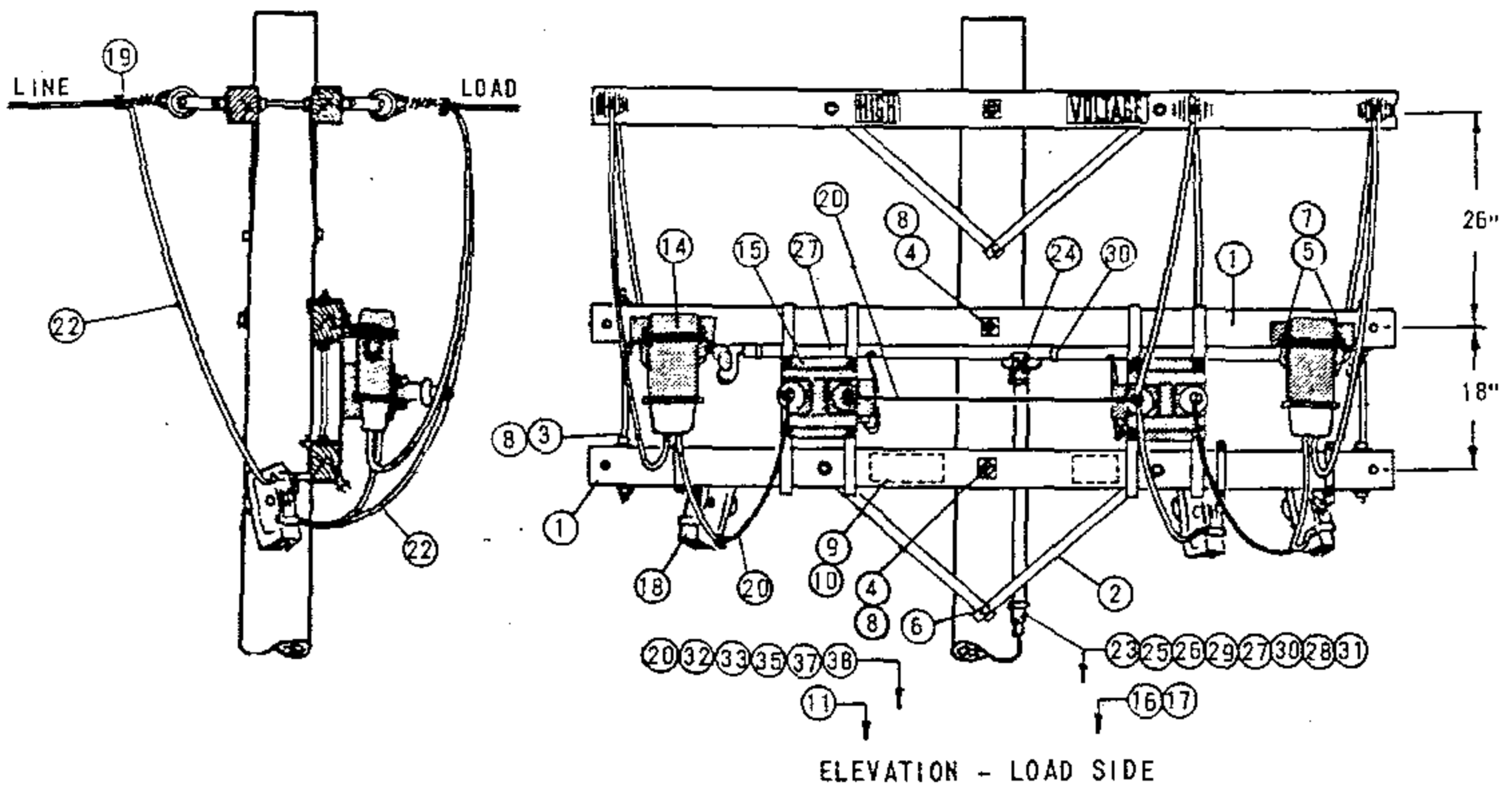

FOR FIELD MAINTENANCE ONLY

NOTE:
 (A) NOT REQUIRED WHERE METER BOX HAS HUB.

ITEM	DESCRIPTION	QUANTITY	STOCK NO. OR CONSTR STD	ITEM	DESCRIPTION	QUANTITY	STOCK NO. OR CONSTR STD
1	CROSSARM, 3 1/2" X 4 1/2" X 8' - 0"	2	PG 111 IT. 6	21			
2	BRACE, FLAT CROSSARM 28"	2	164192	22	WIRE, WP STRANDED COPPER, 5KV (SAME SIZE AS PRIMARY)	34'	700 SECTION
3	BOLT, SPACE 5/8" X "	2	PG 139	23	WIRE, #12 TYPE TW CODED CU 5 CONDUCTORS 46" EACH	230'	-
4	BOLT, MACH 5/8" X "	2	PG 139	24	BODY, CONDUIT, 3/4" PVC TYPE 'T', BLANK COVER	1	147664
5	BOLT, MACH 3/8" X 4 1/2"	4	154368	25	BODY, CONDUIT 3/4" PVC TYPE LB, BLANK COVER (A)	1	146384
6	SCREW, LAG 1/2" X 4"	1	621568	26	CONDUIT, 3/4" PVC SCH 80	31'	251520
7	WASHER, 3/8" ROUND	4	800288	27	CONDUIT, 1" PVC SCH 40	5'	251200
8	WASHER, 3" SQUARE FLAT	12	799072	28	CONDUIT, 2" PVC SCH 40	20'	251296
9	SIGN, HIGH VOLTAGE	1	647648	29	STRAP, 3/4" PIPE & 2-100 NAILS	7	697888, 491392
10	NAILS, ROOFING #8 GALV	8	492224	30	STRAP, 1" PIPE & 2-80 NAILS	3	697792, 491584
11	POLE STEPS	16	692992	31	STRAP, 2" PIPE & 2-100 NAILS	12	697856, 491392
12				32	ROD & CLAMP, GROUND	1	630072, 230016
13				33	MOULDING, HARDWOOD	3'	487200
14	TRANSFORMER, CURRENT WEST. TYPE CTD 5KV 5A, HANGERS & BOLTS	2	-	34			
15	TRANSFORMER, POTENTIAL WEST TYPE PTD 2400/120V, HANGER & BOLTS	2	-	35	STAPLES, MOULDING	2	678560
16	METER, THREE PHASE POWER	1	-	36			
17	CABINET, METER TEST SWITCH; LAG SCREWS FOR MOUNTING	1	161312	37	NAILS, 20D GALV	4	491456
18	CUTOUT, 5KV	2	PG 1211	38	STAPLES, FENCE 1 1/4" GALV	6	678528
19	CONNECTORS, SPLIT BOLT	9	PG 787				
20	WIRE, #6 BR STRANDED COPPER	18'	813536				

SDG & E ELECTRIC STANDARDS

POLETOP METERING, 2.4KV OPEN DELTA

1499.802
 SUPERSEDES
 1482 (2-28-82)

DATE 2-28-83
 APPD *WJ/ARH*

FIELD MAINTENANCE ONLY

REVISION HISTORY:

7/13/2016: All versions prior to 2016 are superseded by their current version found inside the Overhead Construction Standard Manual.

© 1998 - 2016 San Diego Gas & Electric Company. All rights reserved. Removal of this copyright notice without permission is not permitted under law.											
REV	CHANGE	BY	DSGN	APPV	DATE	REV	CHANGE	BY	DSGN	APPV	DATE
C						F					
B						E					
A	ORIGINAL ISSUE	JS	IL	MDJ	7/13/2016	D					
SHEET 1 OF 1	 Indicates Latest Revision		Completely Revised		New Page		Information Removed		FMO OH 1483		
	SDG&E ELECTRIC OVERHEAD STANDARD										
	POLETOP METERING, 4KV SINGLE PHASE										

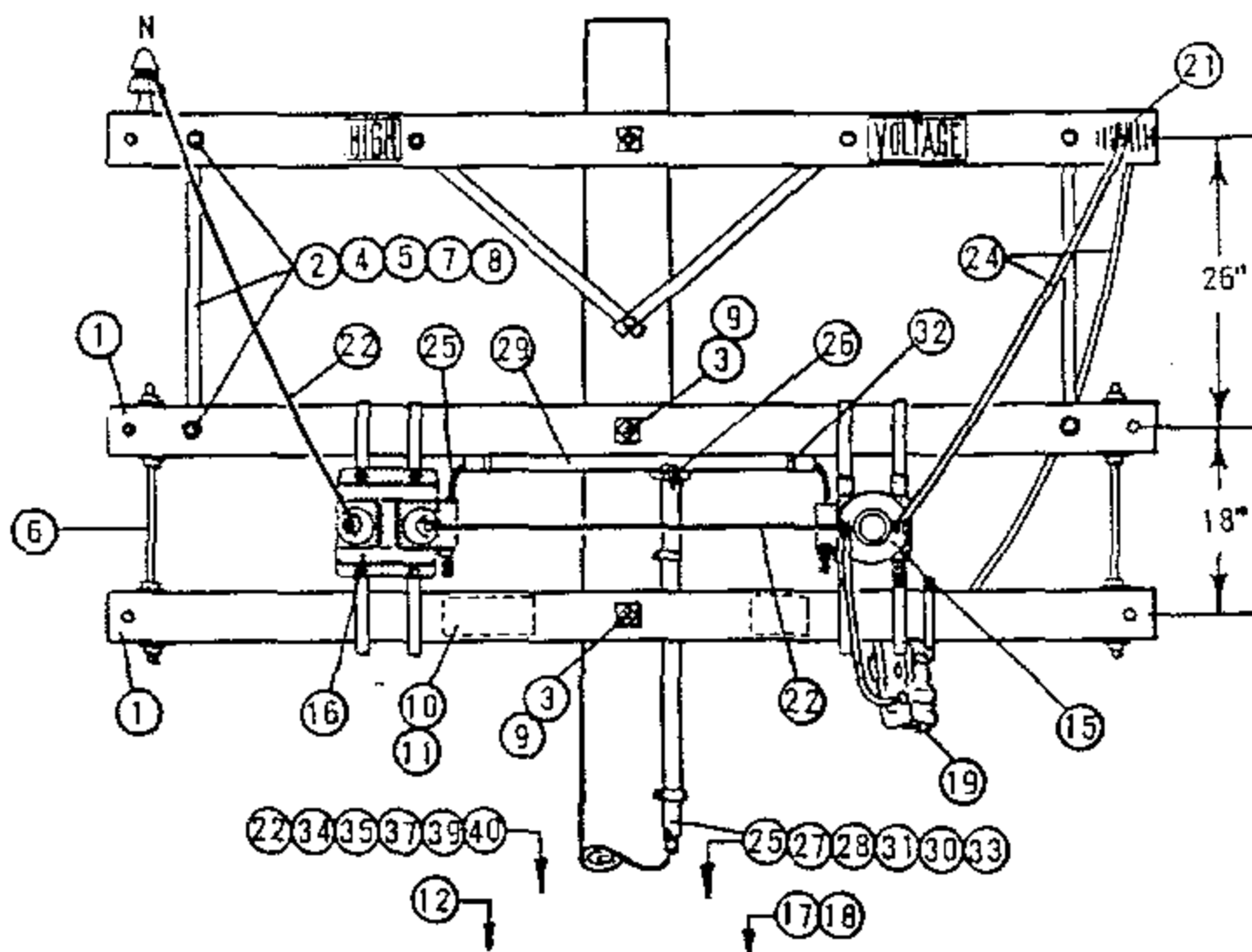

ELEVATION - LOAD SIDE

FOR FIELD MAINTENANCE ONLY

NOTE:

(A) NOT REQUIRED WHERE METER BOX HAS HUB.

ITEM	DESCRIPTION	QUANTITY	STOCK NO. OR CONSTR STD	ITEM	DESCRIPTION	QUANTITY	STOCK NO. OR CONSTR STD
1	CROSSARM, 3 1/2" X 4 1/2" X 8' - 0"	2	PG 111 I.F. 2	24	WIRE, WP STRANDED (SAME SIZE AS PRIMARY)	24'	700 SECTION
2	BRACE, FLAT CROSSARM 28"	2	164192	25	WIRE, #12 TYPE TW CODED COPPER, 3 CONDUCTORS, 41' EACH	123'	-
3	BOLT, MACH 5/8" X 14"	2	154880	26	BODY, CONDUIT, 3/4" PVC TYPE "T", BLANK COVER	1	147664
4	BOLT, MACH 1/2" X 5"	2	153024	27	BODY, CONDUIT, 3/4" PVC TYPE LB, BLANK COVER (A)	1	146384
5	BOLT, MACH 3/8" X 4 1/2"	4	154368	28	CONDUIT, 3/4" PVC SCH 80	3'	251520
6	BOLT, SPACE 5/8" X 24"	2	156640	29	CONDUIT, 1" PVC SCH 40	4'	251200
7	WASHER, 1/2" ROUND	2	800192	30	CONDUIT, 2" PVC SCH 40	20'	251296
8	WASHER, 3/8" ROUND	4	800288	31	STRAP, PIPE 3/4" & 2-100 GALV NAILS	7	697888.491392
9	WASHER, 3" SQ FLAT	12	799072	32	STRAP, PIPE 1" & 2-8D GALV. NAILS	3	697792.491584
10	SIGN, HIGH VOLTAGE	1	647648	33	STRAP, PIPE 2" & 2-100 GALV NAILS	12	697856.491392
11	NAILS, ROOFING #8 GALV	8	492224	34	ROD, AND CLAMP, GROUND	1	630072.230016
12	POLE STEP	16	692992	35	MOULDING, HARDWOOD	3'	487200
13				36			486976.487008
14				37	STAPLES, MOULDING 3" X 1 1/16" X 1/4"	2	678560
15	TRANSFORMER, CURRENT WEST. TYPE WO 5KV, 5A	1	-	38			
16	TRANSFORMER, POTENTIAL, WEST. PTO, 2400/120V, HANGERS & BOLTS	1	-	39	NAILS, 20D, GALV	4	491456
17	METER, SINGLE PHASE POWER	1	-	40	STAPLES, FENCE 1 1/4" GALV	5	678528
18	CABINET, METER, TEST SWITCH, LAG SCREWS	1	161312	41			
19	CUTOUT, 5KV	2	PG 1211	42			
20							
21	CONNECTORS, SPLIT BOLT	7	PG 787				
22	WIRE, #6 BARE STRANDED COPPER	20'	819536				
23		10'	194304				

SDG & E ELECTRIC STANDARDS

DATE 2-28-83
APPD *WNT/ARH*

POLETOP METERING, 4KV SINGLE PHASE

1499.803
SUPERSEDES
1483 (2-28-83)

FIELD MAINTENANCE ONLY

REVISION HISTORY:

7/13/2016: All versions prior to 2016 are superseded by their current version found inside the Overhead Construction Standard Manual.

© 1998 - 2016 San Diego Gas & Electric Company. All rights reserved. Removal of this copyright notice without permission is not permitted under law.

REV	CHANGE	BY	DSGN	APPV	DATE	REV	CHANGE	BY	DSGN	APPV	DATE
C						F					
B						E					
A	ORIGINAL ISSUE	JS	IL	MDJ	7/13/2016	D					

SHEET 1 OF 1	 Indicates Latest Revision	Completely Revised	New Page	Information Removed	FMO OH 1484
	SDG&E ELECTRIC OVERHEAD STANDARD				
	POLETOP METERING INSTALLATION, 4KV, 3 PHASE, 3 WIRE UG & OH SERVICES				

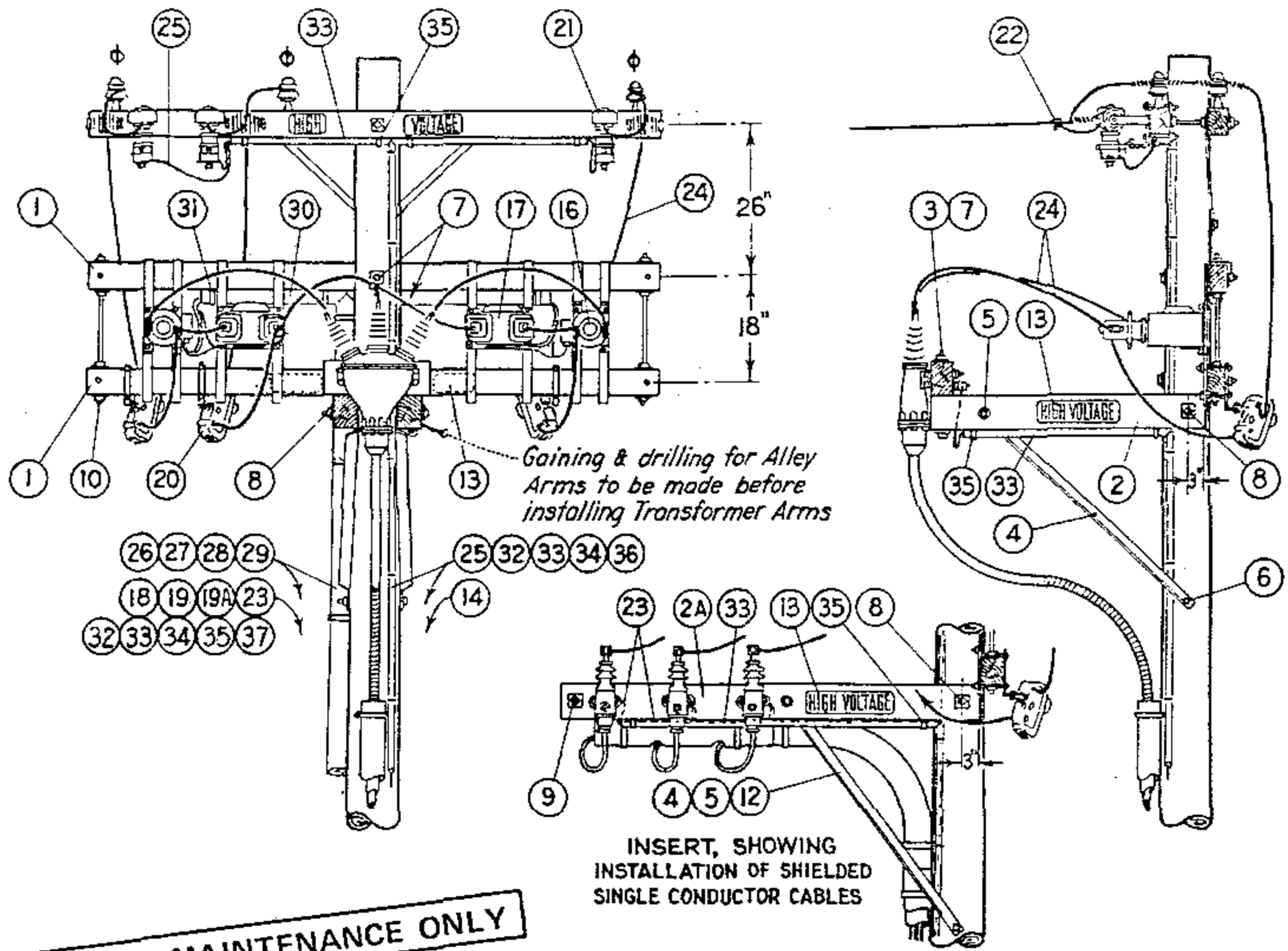

FOR FIELD MAINTENANCE ONLY

UNDERGROUND SERVICE

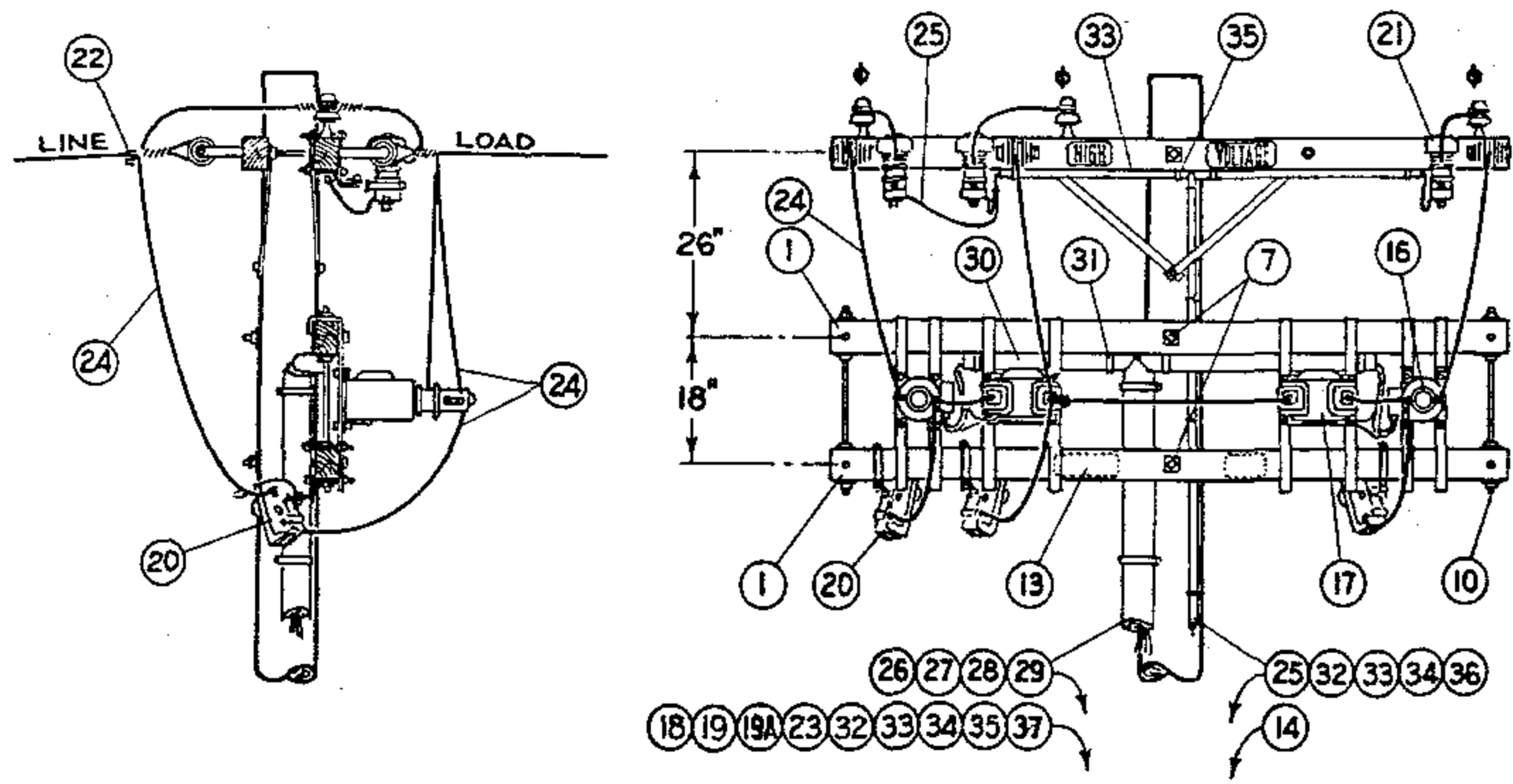

OVERHEAD SERVICE

FOR FIELD MAINTENANCE ONLY

NOTES:

- (A) USE ONLY ONE GROUND ROD FOR LIGHTNING ARRESTER GROUND AND ONE GROUND ROD FOR METER GROUND WHERE A RESISTANCE OF LESS THAN 25 OHMS CAN BE OBTAINED WITH EACH ROD.
- (B) DOUBLE METER CABINETS ARE REQUIRED FOR RKYAH METERING INSTALLATIONS.
- (C) UNTWIST SUFFICIENT LENGTH OF #2 STRANDED WIRE TO CONNECT EACH ARRESTER AND POTHEAD GROUND WITH A SINGLE STRAND.

ITEM	DESCRIPTION	QUANTITY			STOCK NO. OR CONSTR STDS	
		U.G. SERVICE		O.H.		
		P.I.L.C.	RUBBER LIKE	SERV.		
P. T. & F.	1	3 1/2" x 4 1/2" x 8'-0" Crossarm, 6 Pin	2	2	2	PG 111 IT. 2
	2	3 3/4" x 5 3/4" x 4'-0" Pothead Alley Arm	2	-	-	PG 112 IT. 3
	2A	3 3/4" x 5 3/4" x 6'-0" (10 Pin arm, cut in half)	-	2	-	PG 111 IT. 4
	3	3 3/4" x 5 3/4" x 18" Wood Block, Pothead Support	1	-	-	-
	4	Pothead Alley Arm Brace, 4'-0"	2	1	-	163808
	5	Mach. Bolt, Galv. 5/8" x 5", 1 rd. Washer & 1 Nut	2	1	-	PGS 139, 140
	6	Mach. Bolt, Galv., 5/8" x 10"	1	-	-	PGS 139, 154816
	7	Mach. Bolt, Galv. 5/8" x 14", 2 Sq. Washers & 1 Nut	4	2	2	PGS 139, 140
	8	Mach. Bolt, Galv. 5/8" x 18", 2 Sq. Washers & 1 Nut	1	1	-	PGS 139, 140
	9	Space Bolt, Galv. 5/8" x 20", 4 Sq. Washers & 4 Nuts	-	1	-	PGS 139, 140
	10	Space Bolts, Galv. 5/8" x 26", 4 Sq. Washers & 4 Nuts	2	2	2	PGS 139, 140
	11					
	12	Lag Screw, Galv. 5/8" x 5"	-	1	-	621600
	13	High Voltage Sign & Galv. Roofing Nails	3	3	1	647648, 492224
	14	Pole Steps	16	16	16	692992
15						
M. I.	16	Current Transformer, 5 Kv, Hangers & Bolts	2	2	2	-
	17	Potential Transformers, 4800/120V, Hangers & Bolts	2	2	2	-
	18	Meter Three Phase Power	1	1	1	-
	19	Meter Cabinet; Single, 15" x 30" x 10 1/2"; Double, 30" x 30" x 10 1/2"; Lag Screws for Mounting (B)	1	1	1	SINGLE 161312. DOUBLE 161184
	19A	Test Switch	1	1	1	710880-711008
	20	Cutout, Expulsion Fuse	3	3	3	PG 1211
	21	Lightning Arrester, 3 Kv.	3	3	3	113216
	22	Wire Connectors	5	5	8	PGS 783, 786
	23	#6 Bare Stranded Copper Wire, Meter Ground	14'	14'	14'	813536
	24	Bare Stranded Copper Wire, Size as Required	35'	35'	50'	PGS 715, 716, 717
	25	#2 Bare Stranded Copper Wire, L.A. Pothead Ground (C)	52'	52'	52'	813664
	26	#12 Type TW Coded Wire, 5 Conductors, 40' Each	200'	200'	200'	-
	27	Redwood Moulding	26'	26'	26'	PG 143 IT 1
	28	Moulding Straps, Galv.	13	13	13	697024
	29	3/4" Conduit, Rigid Iron; Pipe Strap & 2-8d Nails, Galv.	10'	10'	10'	251008, 696704
	30	2" Fibre Conduit	5'	5'	5'	251618
	31	2" Fibre Conduit Strap & 2-8d Nails, Galv.	4	4	4	PG 143, 491584
	32	Ground Rod and Clamp, incl. Conduit Ground Clamp (A)	4	4	4	603072, 230016
	33	Hardwood Moulding	52'	54'	49'	487200
	34	Moulding Staples, Galv., 3" x 1 1/8" x 1/4"	24	22	22	678560
	35	3/4" Pipe Straps, Galv. & 2 8d Nails, Galv.	8	9	6	697888, 491584
	36	1/4" Fence Staples, Galv.	14	12	12	678528
	37	3/4" Type "LB" Condulet	1	1	1	146144
38						

SDG & E ELECTRIC STANDARDS

**POLETOP METERING INSTALLATION, 4KV, 3 PHASE,
3 WIRE UG & OH SERVICES**

DATE 2-28-83

APPD *JAT/ARH*

1499.805

SUPERSEDES
1484.2 (2-28-83)

FIELD MAINTENANCE ONLY

REVISION HISTORY:

7/13/2016: All versions prior to 2016 are superseded by their current version found inside the Overhead Construction Standard Manual.

© 1998 - 2016 San Diego Gas & Electric Company. All rights reserved. Removal of this copyright notice without permission is not permitted under law.

REV	CHANGE	BY	DSGN	APPV	DATE	REV	CHANGE	BY	DSGN	APPV	DATE
C						F					
B						E					
A	ORIGINAL ISSUE	JS	IL	MDJ	7/13/2016	D					

<input checked="" type="checkbox"/>	Indicates Latest Revision	<input type="checkbox"/>	Completely Revised	<input type="checkbox"/>	New Page	<input type="checkbox"/>	Information Removed
-------------------------------------	---------------------------	--------------------------	--------------------	--------------------------	----------	--------------------------	---------------------

**SHEET
1 OF 1**

SDG&E ELECTRIC OVERHEAD STANDARD
**POLETOP METERING INSTALLATION,
4KV, 3 PHASE, 4 WIRE UG & OH SERVICES**

**FMO
OH 1485**

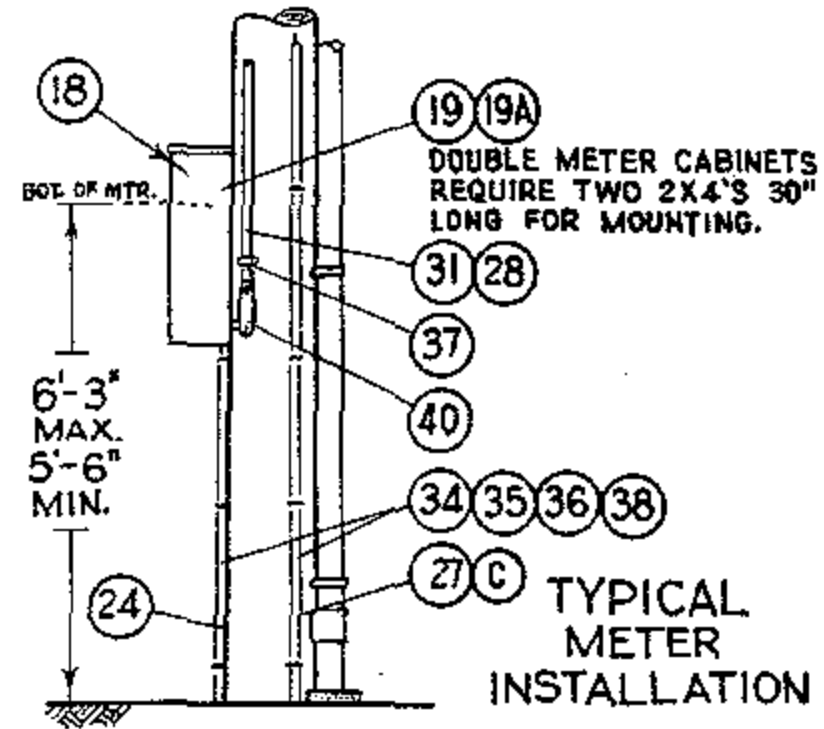
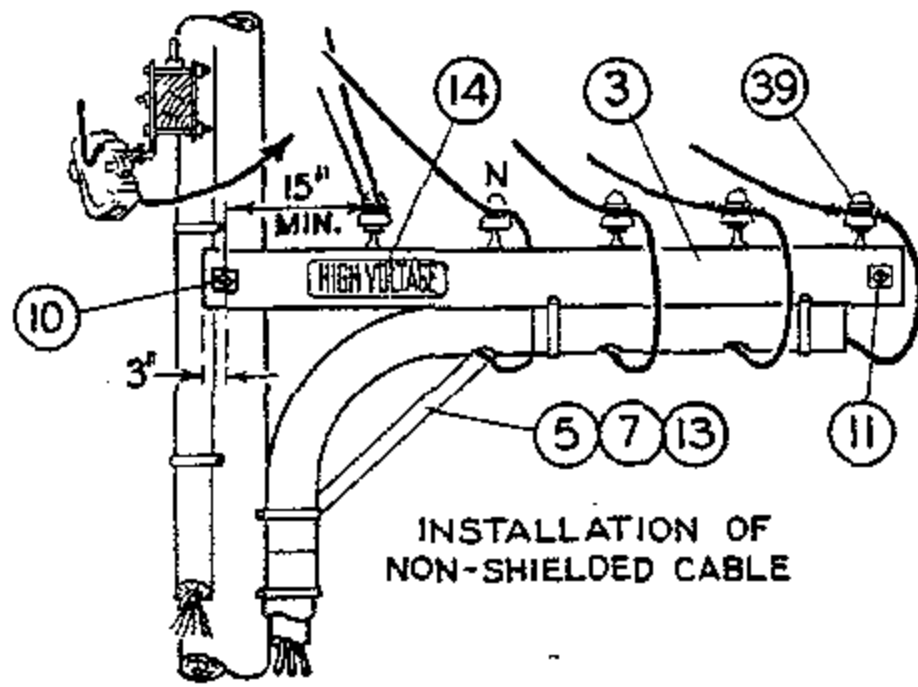

FOR FIELD MAINTENANCE ONLY

NOTES:

- (A) USE ONLY ONE GROUND ROD FOR LIGHTNING ARRESTER GROUND AND ONE GROUND ROD FOR METER GROUND WHERE A RESISTANCE OF LESS THAN 25 OHMS CAN BE OBTAINED WITH EACH ROD.
- (B) DOUBLE METER CABINETS ARE REQUIRED FOR RKVH METERING INSTALLATIONS.
- (C) UNTWIST SUFFICIENT LENGTH OF #2 STRANDED WIRE TO CONNECT EACH ARRESTER AND POTHEAD GROUND WITH A SINGLE STRAND.

ITEM	DESCRIPTION	QUANTITY				STOCK NO. OR CONSTR STDS
		U. G. SERVICE			O. H. SERV.	
		P. I. L. C.	SHIELD.	NON SHIELD.		
1	3 3/4" x 5 3/4" x 10'- 0" Standard Arm	2	2	2	2	PG 119 IT. 2
2	3 3/4" x 5 3/4" x 4'- 0" Pothead Alley Arm	2	-	-	-	PG 112 IT. 3
3	3 3/4" x 5 3/4" x 12'- 0" (12Kv. Arm, Cut in Half	-	1	1	-	PG 119 IT. 4
4	3 3/4" x 5 3/4" x 18" Wood Block, Pothead Support	1	-	-	-	-
5	Pothead Alley Arm Brace, 4'- 0"	2	1	1	-	16 38 08
6						
7	Machine Bolt, Galv., 5/8" x 5", 1 Round Washer & Nut	2	1	1	-	PGS 139, 140
8	Machine Bolt, Galv., 5/8" x 10"	1	-	-	-	PGS 139, 140
9	Machine Bolt, Galv., 5/8" x 14", 2 Square Washers & Nut	4	2	2	2	PGS 139, 140
10	Machine Bolt, Galv., 5/8" x 18", 2 Square Washers & Nut	1	1	1	-	PGS 139, 140
11	Space Bolt, Galv., 5/8" x 20", 4 Square Washers & 4 Nuts	-	1	1	-	PGS 139, 140
12	Space Bolt, Galv., 5/8" x 26", 4 Square Washers & 4 Nuts	2	2	2	2	PGS 139, 140
13	Lag Screw, Galv., 5/8" x 5"	-	1	1	-	6 21600
14	High Voltage Sign & Galv. Roofing Nails	3	3	3	1	6 476 48, 49 222 4
15	Pole Steps	16	16	16	17	6 9 299 2
16	Current Transformer, 5Kv., Hangers & Bolts	3	3	3	3	-
17	Potential Transformer, 2400/120V, Hangers & Bolts	3	3	3	3	-
18	Meter, Three Phase, Maximum Demand and/or Rkvah Recording	1	1	1	1	-
19	Meter Cabinet; Single, 15" x 30" x 10 1/2"; Double, 30" x 30" x 10 1/2", Four Lag Screws for Mounting	(B) 1	1	1	1	SINGLE 16 1312, DOUBLE 16 118 4
19A	Test Switch	1	1	1	1	7 10880 - 7 11008
20	Cutout, Expulsion Fuse	3	3	3	3	PG 1211
21	Lightning Arrester, 3Kv.	3	3	3	3	113216
22	Standoff Bracket	-	-	-	2	165144
23	Wire Connectors	6	6	6	13	PGS 783, 786
24	#8 Bare Stranded Copper Wire, Meter Ground	14'	14'	14'	14'	8 13536
25	Bare Stranded Copper Wire, Same Size as Line Neutral	14'	14'	14'	14'	PGS 715-717
26	Bare Stranded Copper Wire, Size as Required	47'	52'	33'	33'	PGS 715-717
27	#2 Bare Stranded Copper Wire, L. A. & Pothead Ground	(C) 52'	52'	52'	52'	8 1366 4
28	#12 Type TW Coded Wire, 7 Conductors, 40' Each	280'	280'	280'	280'	-
29	Redwood Moulding	20'	20'	20'	20'	PG 143 IT 1
30	Moulding Strap, Galv.	11	11	11	11	6 970 24
31	3/4" Conduit, Rigid Iron; Pipe Straps & 8d Nails; Galv.	10'	10'	10'	10'	251008, 696704, 491584
32	2" Fibre Conduit	8'	8'	8'	8'	251616
33	2" Fibre Conduit Straps & 2 8d Nails; Galv.	6	6	4	4	PG 143, 491584
34	Ground Rod & Clamp, Including Conduit Ground Clamp	(A) 4	(A) 4	(A) 4	(A) 4	603072, 230016
35	Hardwood Moulding, 1"	52'	55'	49'	49'	487200
36	Moulding Staples, Galv., 3" x 1 1/8" x 1/4"	25	25	25	25	678560
37	3/4" Pipe Straps, Galv. & 2 8d Nails, Galv.	8	9	8	8	697888, 491584
38	1 1/4" Fence Staples, Galv.	14	12	12	12	678528
39	Insulator, 4Kv. and Steel Pin	2	2	5	2	PG 750, 532608
40	3/4" Type "LB" Condulet	1	1	1	1	146144
41						
42						

FIELD MAINTENANCE ONLY

REVISION HISTORY:

7/13/2016: All versions prior to 2016 are superseded by their current version found inside the Overhead Construction Standard Manual.

© 1998 - 2016 San Diego Gas & Electric Company. All rights reserved. Removal of this copyright notice without permission is not permitted under law.

REV	CHANGE	BY	DSGN	APPV	DATE	REV	CHANGE	BY	DSGN	APPV	DATE
C						F					
B						E					
A	ORIGINAL ISSUE	JS	IL	MDJ	7/13/2016	D					

	Indicates Latest Revision	Completely Revised	New Page	Information Removed
-------------------------------------------------------------------------------------	---------------------------	--------------------	----------	---------------------

**SHEET
1 OF 1**

SDG&E ELECTRIC OVERHEAD STANDARD

POLETOP METERING INSTALLATION, 12KV, 3 PHASE,
3 WIRE UG & OH SERVICES

**FMO
OH 1486**

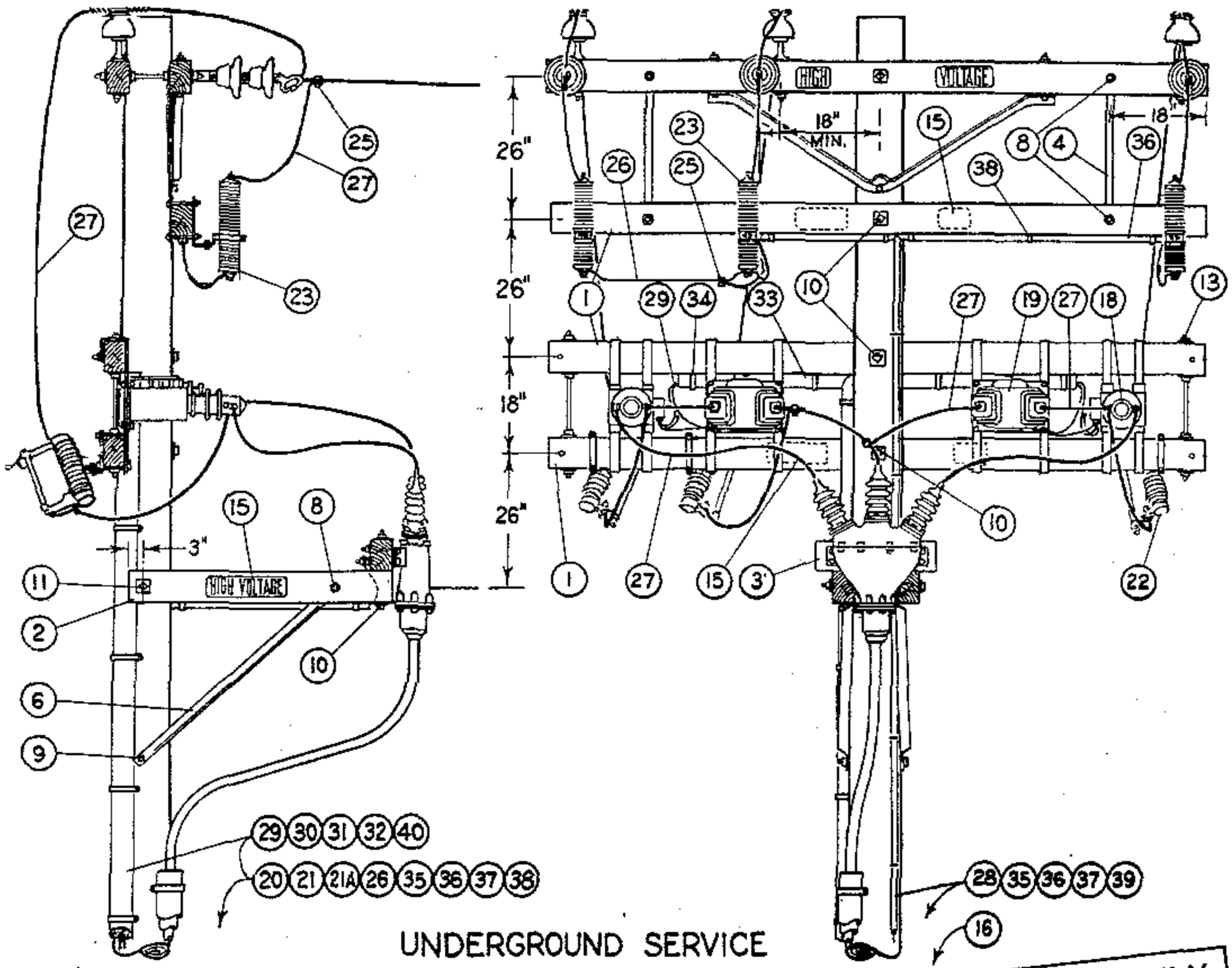

UNDERGROUND SERVICE

FOR FIELD MAINTENANCE ONLY

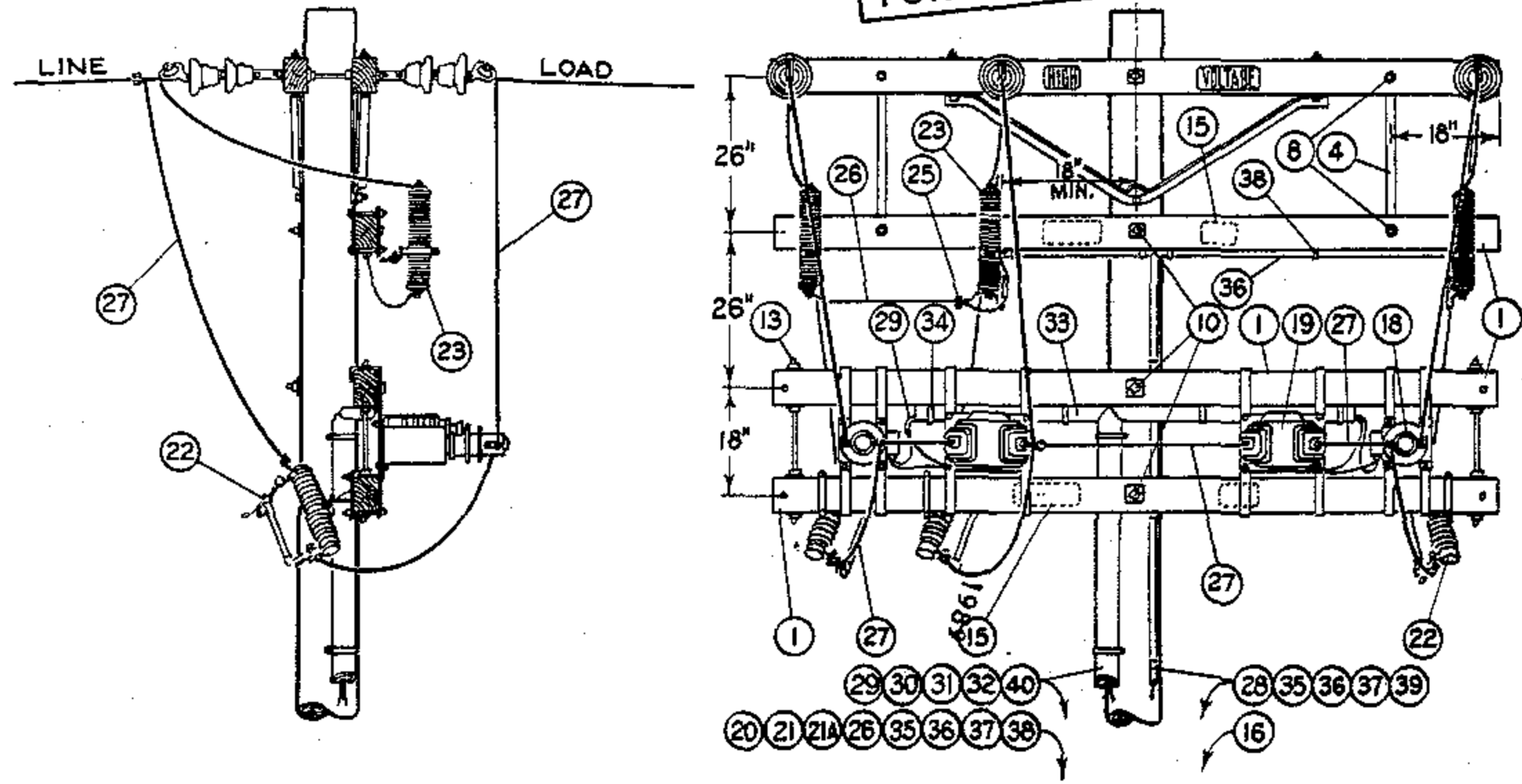

OVERHEAD SERVICE

SDG & E ELECTRIC STANDARDS

POLETOP METERING INSTALLATION, 12KV, 3 PHASE,
3 WIRE U.G. & O.H. SERVICES

1499.808
SUPERSEDES
1486.1 (2-28-83)

DATE 2-28-83
APPD *[Signature]*

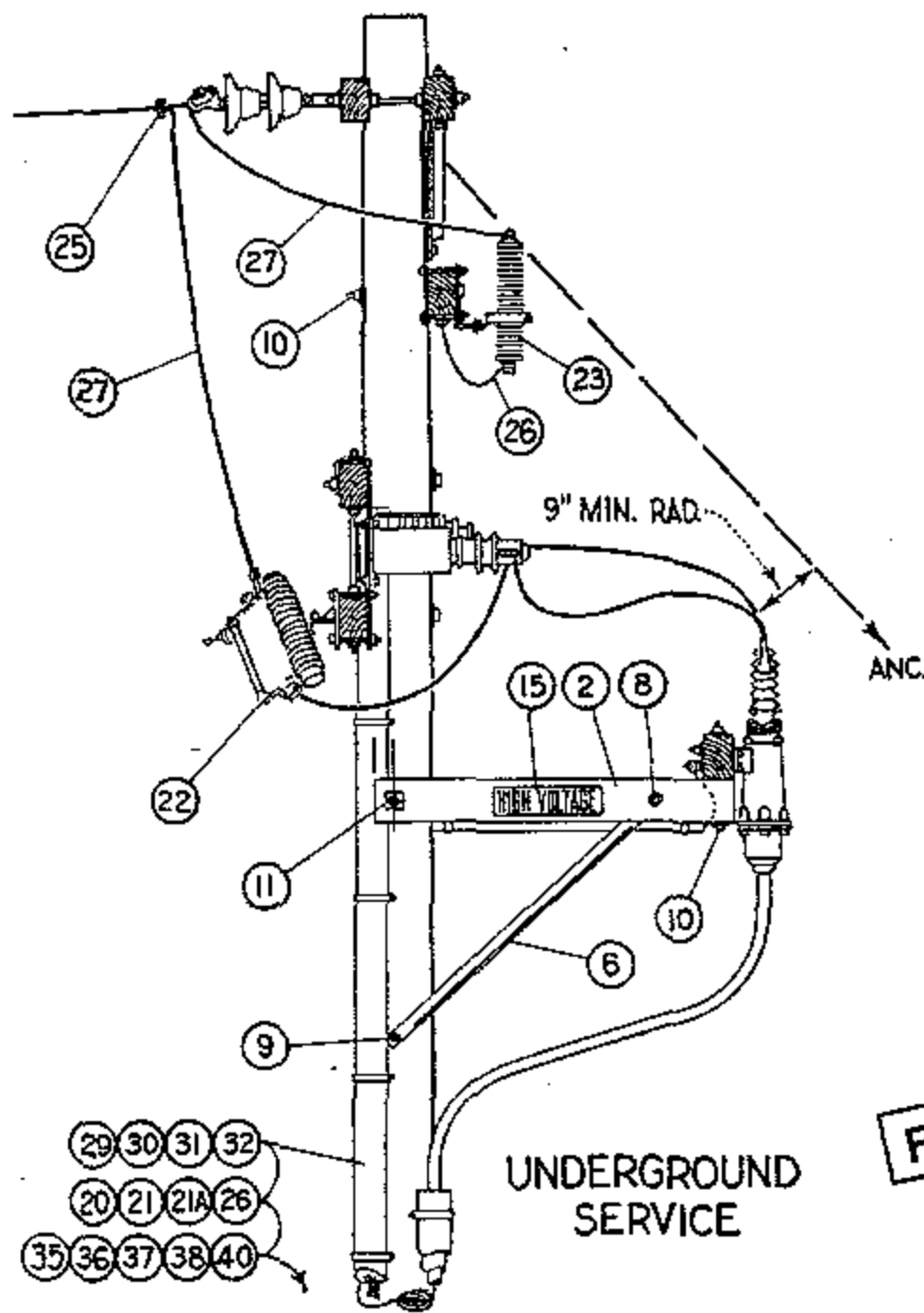

FOR FIELD MAINTENANCE ONLY

NOTES:

- (A) USE ONLY ONE GROUND ROD FOR LIGHTNING ARRESTER GROUND AND ONE GROUND ROD FOR METER GROUND WHERE RESISTANCE OF LESS THAN 25 OHMS CAN BE OBTAINED WITH EACH ROD.
- (B) DOUBLE METER CABINETS ARE REQUIRED FOR RKVH METERING INSTALLATIONS.

ITEM	DESCRIPTION	QUANTITY		STOCK NO. OR CONSTR STDS
		U.G. SERV.	O.H. SERV.	
1	3 3/4" x 5 3/4" x 10'-0" Standard Arm	3	3	PG 119 IT. 2
2	3 3/4" x 5 3/4" x 4'-0" Pothead Alley Arm	2	-	PG 112 IT. 3
3	3 3/4" x 5 3/4" x 22" Wood Block, Pothead Support	1	-	-
4	Flat Crossarm Brace, 36"	2	2	164224
5				
6	Pothead Alley Arm Brace, 4'-0"	2	-	163808
7				
8	Mach. Bolt, Galv., 5/8" x 5", 1 rd Washer, & 1 Nut	9	4	PGS 139, 140
9	Mach. Bolt, Galv., 5/8" x 10"	1	-	PGS 139, 140
10	Mach. Bolt, Galv., 5/8" x 14", 2 Sq. Washers & 1 Nut	5	3	PGS 139, 140
11	Mach. Bolt, Galv., 5/8" x 18", 2 Sq. Washers & 1 Nut	1	-	PGS 139, 140
12				
13	Space Bolt, Galv., 5/8" x 26", 4 Sq. Washers & 4 Nuts	2	2	PGS 139, 140
14				PGS 1212, 1213
15	High Voltage Sign & Galv. Roofing Nails	2	2	647648, 492224
16	Pole Steps	14	15	692992
17				
18	Current Transformer, 15 KV, Hangers & Bolts	2	2	-
19	Potential Transformer, 12000/120 v, Hangers & Bolts	2	2	-
20	Meter, Three Phase Power	1	1	-
21	Meter Cabinet; Single, 15" x 30" x 10 1/2"; Double, 30" x 30" x 10 1/2"; Lag Screws for Mounting	1	1	SINGLE 161312, DOUBLE 161184
21A	Test Switch	1	1	710880-711008
22	Cutout, Expulsion Fuse	3	3	PGS 1212, 1213
23	Lightning Arrester, 12 Kv.	3	3	113216
24				
25	Wire Connectors	5	8	PGS 783, 786
26	#6 Bare Stranded Copper Wire - Meter Grnd. & L.A. Lateral	27'	27'	813536
27	Bare Stranded Copper Wire, Size as Required	55'	65'	PGS 715-717
28	#2 Bare Stranded Copper, Lightning Arrester Ground	54'	45'	813664
29	#12 Type TW Coded Copper Wire, 5 Conductors @ 34"	170'	170'	-
30	Redwood Moulding, C-54.1 #1	16'	16'	PG 143 IT. 1
31	Moulding Strap, Galv., C-54.1 #1A	8	8	697024
32	3/4" Conduit, Rigid Iron; Pipe Strap & 2-8d Nails, Galv.	10'	10'	251008, 696704, 491584
33	2" Fibre Conduit	6'	6'	251616
34	2" Pipe Straps & 2-8d Nails, Galv.	4	4	697856, 491584
35	Ground Rod & Clamp	(A) 4	(A) 4	603072, 230016
36	Hardwood Moulding, 1"	49'	45'	487200
37	Moulding Staples, Galv., 3" x 1 1/8" x 1/4"	30	30	678560
38	3/4" Pipe Strap & 2-8d Nails, Galv.	10	8	597888, 491584
39	1 1/4" Fence Staples, Galv.	12	12	678528
40	3/4" Type "LB" Condulet	1	1	146144

DATE 2-28-83 APPD <i>JNT/KRH</i>	SDG & E ELECTRIC STANDARDS POLETOP METERING INSTALLATION, 12KV, 3 PHASE, 3 WIRE U.G. & O.H. SERVICES	1499.809 SUPERSEDES 1486.2 (2-28-83)
-------------------------------------	-----------------------------------------------------------------------------------------------------------------------------------------	---------------------------------------------------

OH1487/UG4287 FIELD MAINTENANCE ONLY

ALL VERSIONS IN FMO ARE SUPERSEDED BY THEIR CURRENT VERSION FOUND INSIDE THE OVERHEAD CONSTRUCTION STANDARD MANUAL.

REVISION HISTORY:

04/13/2020: CREATED IN FMO

© 1998 - 2020 San Diego Gas & Electric Company. All rights reserved. Removal of this copyright notice without permission is not permitted under law.

REV	CHANGE	BY	DSGN	APPV	DATE	REV	CHANGE	BY	DSGN	APPV	DATE
C						F					
B						E					
A	ORIGINAL ISSUE	RSL	JES	CZH	04/13/2020	D					

SHEET 1 OF 1	Indicates Latest Revision	Completely Revised	<input checked="" type="checkbox"/>	New Page	Information Removed	FMO OH1487 UG4287
	SDG&E ELECTRIC OVERHEAD AND UNDERGROUND FIELD MAINTENANCE ONLY STANDARDS					
	REVISED CT & PT POLETOP METERING INSTALLATION, 12KV, O.H. & U.G. SERVICES					

SCOPE: PRIMARY METERED DISTRIBUTION POLE: THIS STANDARD ILLUSTRATES A PRIMARY METERED OVERHEAD AND UNDERGROUND DISTRIBUTION POLE AND HARDWARE.

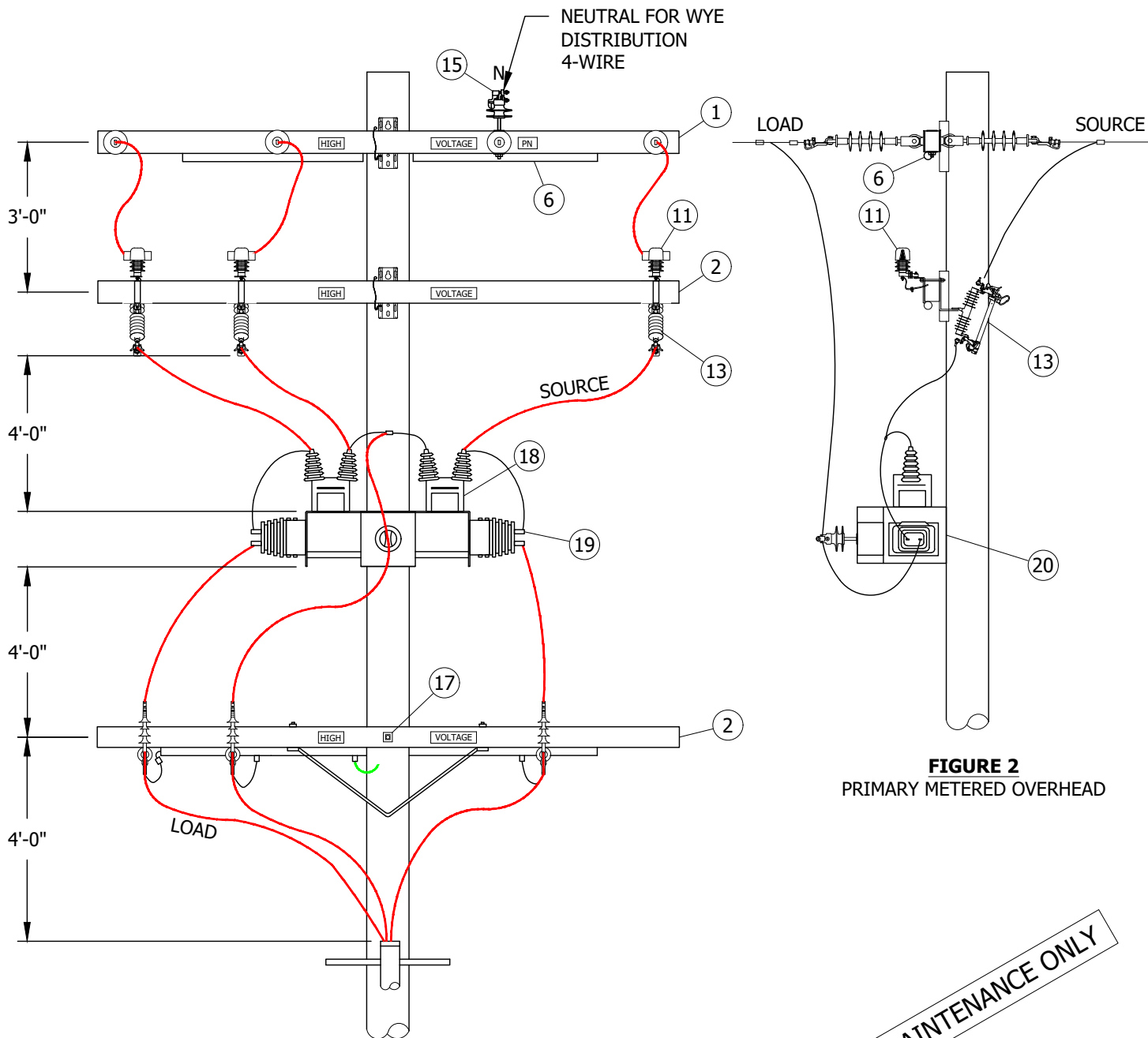

FIGURE 1
PRIMARY METERED UNDERGROUND CABLE POLE

FIGURE 2
PRIMARY METERED OVERHEAD

FIELD MAINTENANCE ONLY

INSTALLATION: NONE

© 1998 - 2020 San Diego Gas & Electric Company. All rights reserved. Removal of this copyright notice without permission is not permitted under law.

REV	CHANGE	BY	DSGN	APPV	DATE	REV	CHANGE	BY	DSGN	APPV	DATE
C						F					
B						E					
A	ORIGINAL ISSUE	RSL	JES	CZH	04/13/2020	D					

SHEET
1 OF 2

X Indicates Latest Revision

Completely Revised New Page Information Removed

SDG&E ELECTRIC OVERHEAD AND UNDERGROUND FIELD MAINTENANCE ONLY STANDARDS

REVISED CT & PT POLETOP METERING INSTALLATION,
12KV, O.H. & U.G. SERVICES

FMO
OH1487.1
UG4287.1

BILL OF MATERIALS:

ITEM	DESCRIPTION (a)	QUANTITY	STANDARD PAGE	STOCK NUMBER	DESIGN UNITS	
1	CROSSARM, FG, DEADEND	AS REQ'D	-	AS REQ'D	-	
2	CROSSARM, FG, TANGENT, EQUIPMENT	AS REQ'D	-	AS REQ'D	-	
3	DBL ARRESTOR/CUTOUT BRACKET	3	-	S165422	-	
4	28" STRAP BRACE	2	-	S164192	-	
5	LIGHTNING ARRESTOR GROUND STRAP	3	-	S698754	-	
6	1" PVC	AS REQ'D	-	S251200	-	
7	#6 BS	AS REQ'D	-	S813536	-	
8	#4 BS	AS REQ'D	-	S813764	-	
9	#4 PVC COVERED GROUND WIRE	AS REQ'D	-	S812480	-	
10	GROUND WIRE STAPLES	AS REQ'D	-	S678562	-	
11	12KV LIGHTNING ARRESTER	3	1247	S113248	LA12	
12	CUTOUT, INTERCHANGEABLE, NON-PORC	ZONE 1 ZONE 2	3	-	AS-REQ'D	-
13	FUSE HOLDER, SMU, FOR SMD30 CUTOUT BODY (100A)	3	-	S368674	-	
14	STAND - OFF PIN, 1"	AS REQ'D	-	S529248	-	
15	INSULATOR, VICE-TOP	1	-	S429060	IPCN1	
16	FUSE (SIZE AS REQ'D)	AS REQ'D	-	AS REQ'D	-	
17	SPACE BOLTS 5/8" X 26", SQUARE WASHERS & NUTS	AS REQ'D	392	-	-	
18	12KV POTENTIAL TRANSFORMER	AS REQ'D	-	-	-	
19	12KV CURRENT TRANSFORMER	AS REQ'D	-	-	-	
20	P.T./C.T. BRACKET	1	-	S165380	-	
21	C/O / LADDER BRACKET	AS-REQ'D	-	S166070	-	
22	INDICATOR, CUTOUT, FIREFLY	3	-	S423606	-	
23	COVER, CUTOUT, AVIAN PROTECTION	3	-	S298682	-	

NOTES:

- I. DISTRIBUTION CONSTRUCTION CREW TO INSTALL ALL HIGH SIDE CONNECTORS, JUMPERS AND EQUIPMENT. AMO TO INSTALL LOW SIDE CONNECTORS AND CONDUCTORS.
- II. MAXIMUM WEIGHT FOR PT AND CT TRANSFORMERS IS 85 LBS. EACH.

REFERENCE:

- (a) THE ITEMS CONTAINED IN THE BILL OF MATERIALS REPRESENT WOOD CONSTRUCTION STANDARD, FOR STEEL CONSTRUCTION SEE CURRENT STANDARD.
- b. FOR GROUNDING SEE STANDARD 1002.
- c. CONTACT EMO FOR FUSING CORDINATION AND PT CT SELECTION.

FIELD MAINTENANCE ONLY

© 1998 - 2020 San Diego Gas & Electric Company. All rights reserved. Removal of this copyright notice without permission is not permitted under law.

REV	CHANGE	BY	DSGN	APPV	DATE	REV	CHANGE	BY	DSGN	APPV	DATE
C						F					
B						E					
A	ORIGINAL ISSUE	RSL	JES	CZH	04/13/2020	D					

**SHEET
2 OF 2**

X Indicates Latest Revision
 Completely Revised New Page Information Removed
 SDG&E ELECTRIC OVERHEAD AND UNDERGROUND FIELD MAINTENANCE ONLY STANDARDS
 REVISED CT & PT POLETOP METERING INSTALLATION,
 12KV, O.H. & U.G. SERVICES

**FMO
OH1487.2
UG4287.2**

FIELD MAINTENANCE ONLY

REVISION HISTORY:

7/13/2016: All versions prior to 2016 are superseded by their current version found inside the Overhead Construction Standard Manual.

© 1998 - 2016 San Diego Gas & Electric Company. All rights reserved. Removal of this copyright notice without permission is not permitted under law.

REV	CHANGE	BY	DSGN	APPV	DATE	REV	CHANGE	BY	DSGN	APPV	DATE
C						F					
B						E					
A	ORIGINAL ISSUE	JS	IL	MDJ	7/13/2016	D					

SHEET 1 OF 1	 Indicates Latest Revision	Completely Revised	New Page	Information Removed	FMO OH 1489
	SDG&E ELECTRIC OVERHEAD STANDARD				
	METERING RACK, CUSTOMER OWNED, CONSTRUCTION DETAILS				

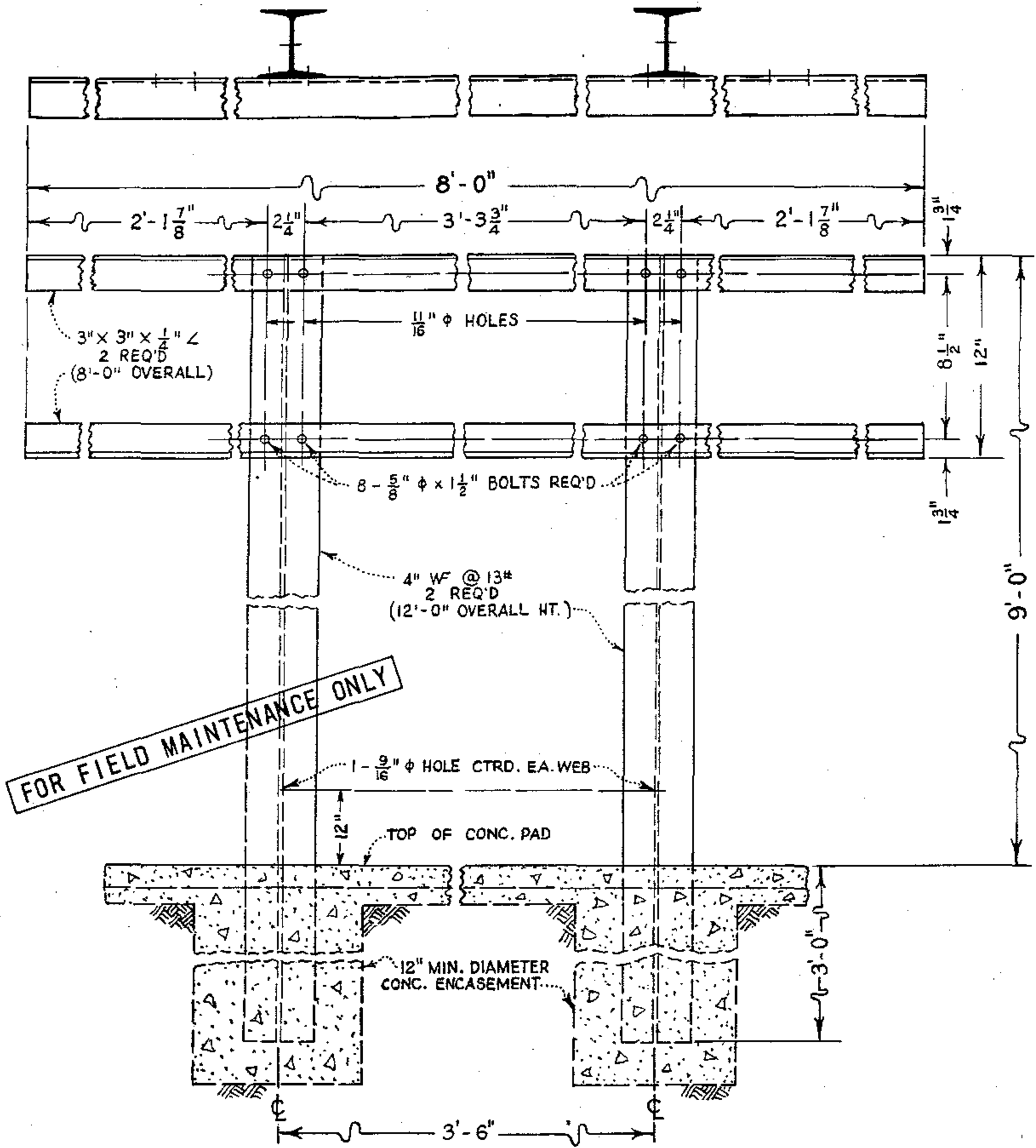

ALL STEEL TO BE HOT-DIP GALV. AFTER FABRICATION.

1499.810
SUPERSEDES
1489 (1-6-82)

SDG&E ELECTRIC STANDARDS

METERING RACK, CUSTOMER OWNED, CONSTRUCTION DETAILS

DATE 2-28-83
APPD *[Signature]*

FIELD MAINTENANCE ONLY

REVISION HISTORY:

7/13/2016: All versions prior to 2016 are superseded by their current version found inside the Overhead Construction Standard Manual.

© 1998 - 2016 San Diego Gas & Electric Company. All rights reserved. Removal of this copyright notice without permission is not permitted under law.

REV	CHANGE	BY	DSGN	APPV	DATE	REV	CHANGE	BY	DSGN	APPV	DATE
C						F					
B						E					
A	ORIGINAL ISSUE	JS	IL	MDJ	7/13/2016	D					

	Indicates Latest Revision	Completely Revised	New Page	Information Removed
-------------------------------------------------------------------------------------	---------------------------	--------------------	----------	---------------------

**SHEET
1 OF 1**

SDG&E ELECTRIC OVERHEAD STANDARD

4KV METERING INSTALLATION ON RACK, FOR 3 WIRE AND 4 WIRE,
3Ø SERVICES

**FMO
OH 1490**

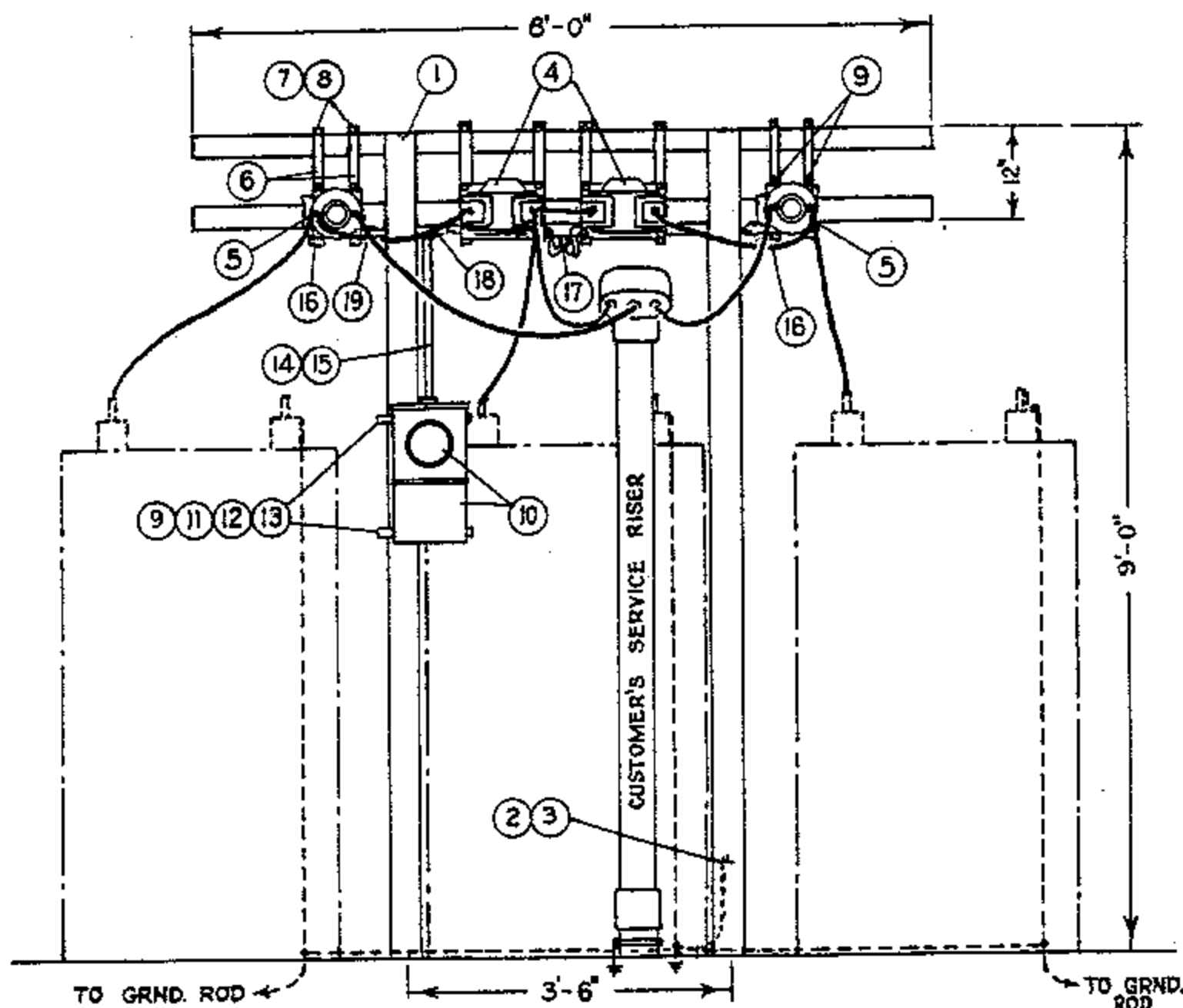

ELEVATION
3 WIRE, 3 ϕ SERVICE

FOR FIELD MAINTENANCE ONLY

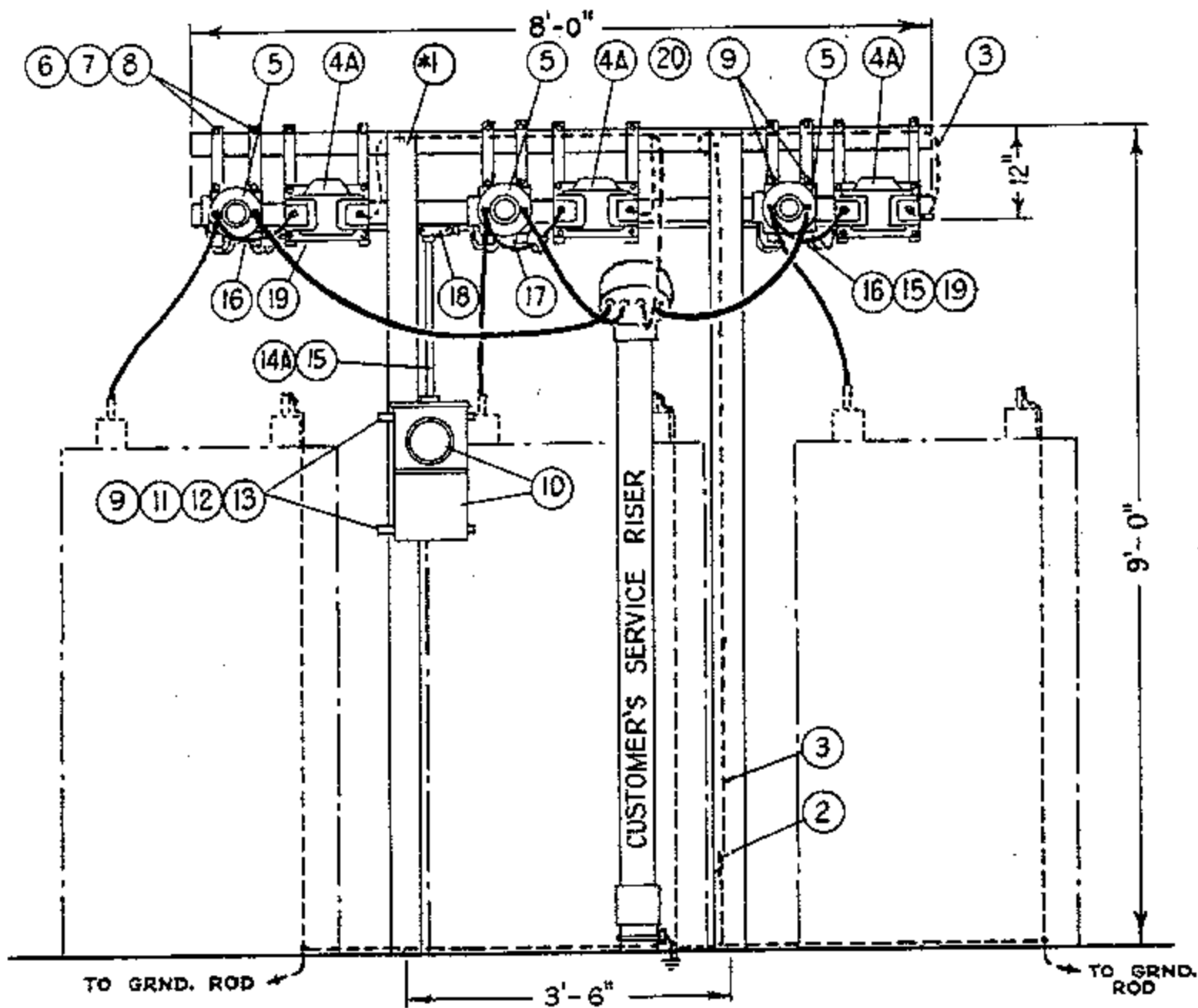

ELEVATION
4 WIRE, 3 ϕ SERVICE

SDG&E ELECTRIC STANDARDS

4KV METERING INSTALLATION ON RACK, FOR 3 WIRE AND 4 WIRE,
3 ϕ SERVICES

DATE 11-16-81
APPD *jes*

1499.901
SUPERSEDES
1490.1(11-16-81)

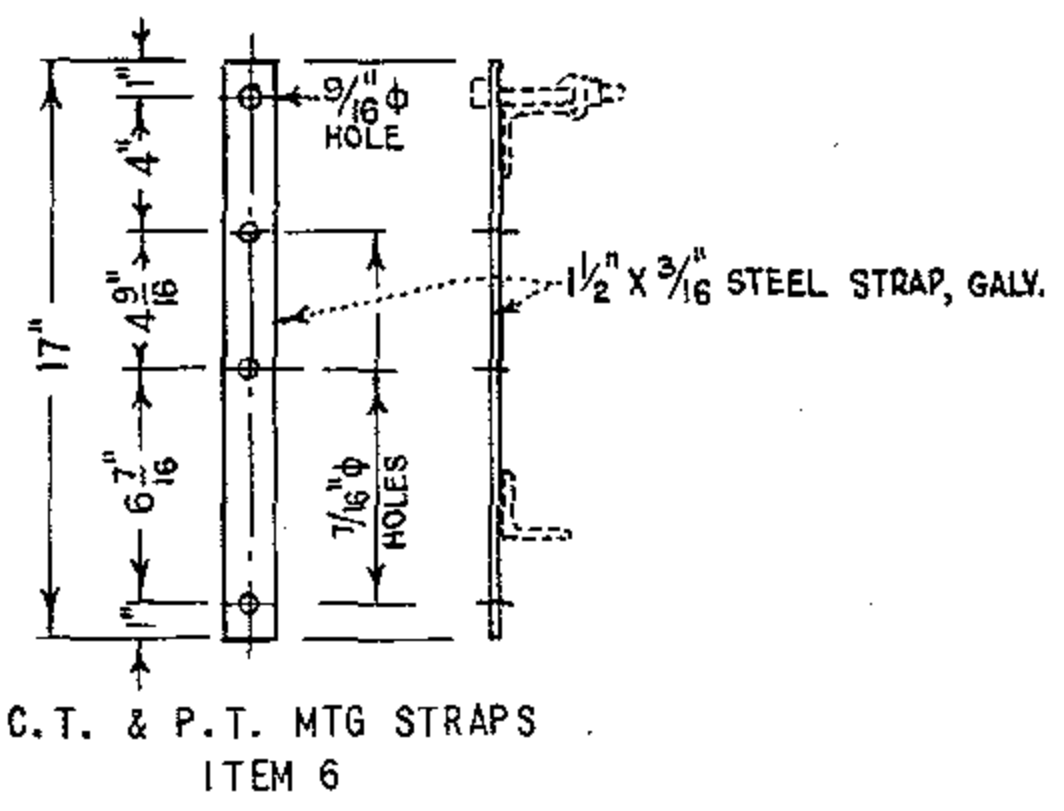
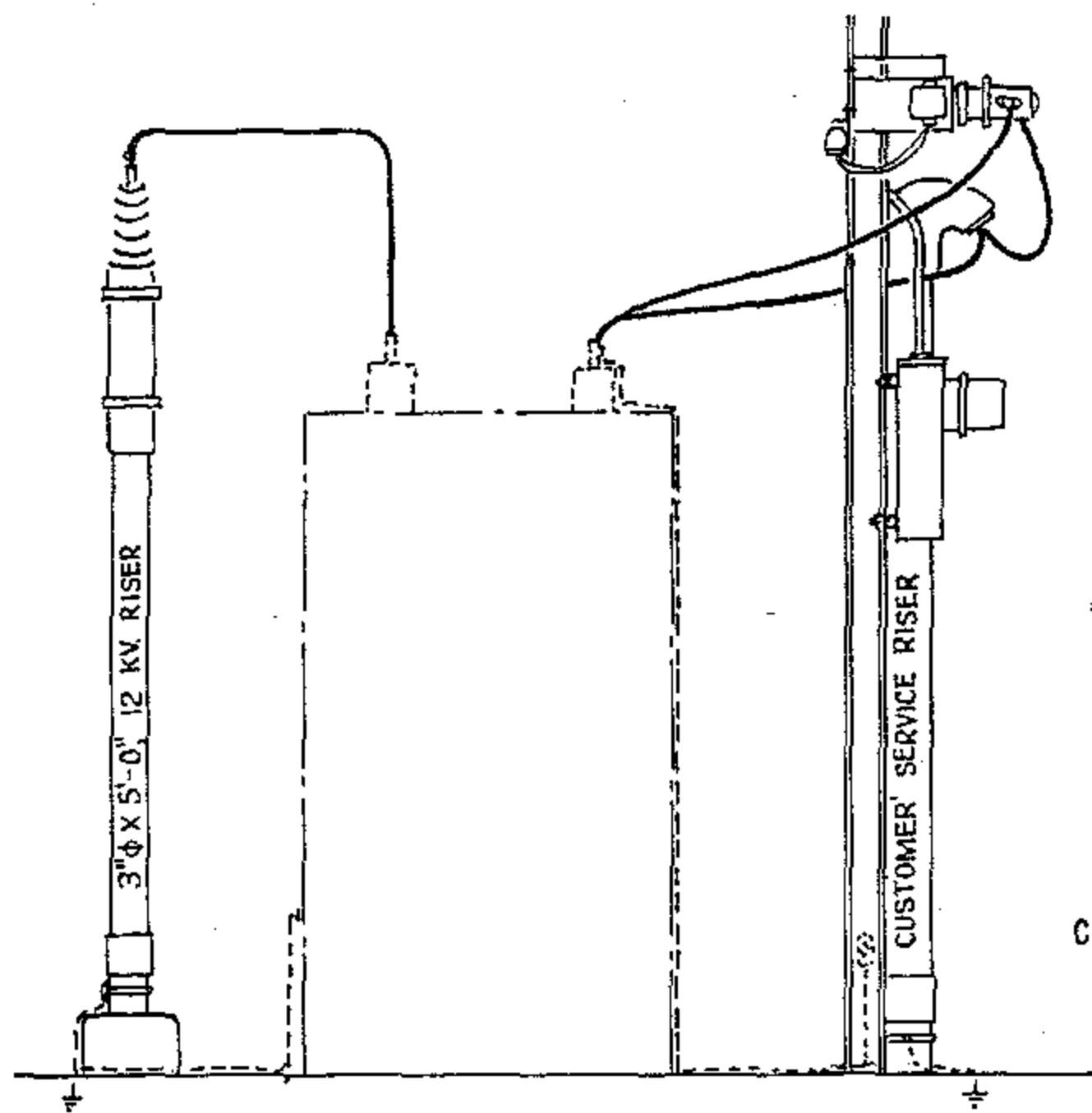

ELEVATION

FOR FIELD MAINTENANCE ONLY

NOTE:
 (A) TO BE FURNISHED AND INSTALLED BY CUSTOMER.

ITEM	DESCRIPTION	QUANTITY		STOCK NO. OR CONSTR STDS
		3 Wire	4 Wire	
1	Galv. Steel Metering Rack	(A) 1	(A) 1	PG 1479
2	Ground Connector, 1 bolt, single groove	1	1	230016
3	Ground Wire. Bare Strd. copper	5'	20'	PGS 715-716
4	Potential Transformer, 4800/120V, Base Mounted	2	-	-
4A	Potential Transformer, 2400/120V, Base Mounted	-	3	-
5	Current Transformer, 5 Kv. Base Mounted	2	3	-
6	P.T. & C.T. Straps, Galv., per detail	8	12	-
7	Mach. Bolts, Galv., 1/2" x 4", 2 washers & 1 nut	8	12	PG 139, 140
8	Nut Seats, Delta-Star	8	12	-
9	Mach. Bolts, Galv., 3/8" diam. X 1", 1 washer & 1 nut	20	24	PGS 139, 140
10	Meter & Meter Socket Box	1	1	-
11	Unistrut, type P-4000, galv.	30"	30"	-
12	Beam Grip, Delta-Star	4	4	392384
13	Cap Screw, Galv., 1/2" diam. x 13/16"	4	4	620320
14	5 - 1c #12 type TW Coded Wire	40"	-	-
14A	7 - 1c #12 type TW Coded Wire	-	64'	-
15	3/4" Conduit, Galv., Rigid Iron	6'	8'	251008
16	3/4" Condulet, Galv., Type "E" with 4 hole comp. cover	2	2	145568, 145376
17	3/4" Condulet, Galv., Type "C" with 4 hole comp. cover	1	1	145088, 145376
18	3/4" Condulet, Galv., Type "TR" with blank cover	1	1	-
19	Galv. steel conduit clamp	4	4	227104
20	Wire Connectors	-	2	PGS 783, 786

1499,902 SUPERSEDES 1490.2 (11-16-81)	SOG&E ELECTRIC STANDARDS 4KV METERING INSTALLATION ON RACK, FOR 3 WIRE AND 4 WIRE, 3Ø SERVICES	DATE 11-16-81 APPD <i>JEM</i>
---------------------------------------------	-----------------------------------------------------------------------------------------------------------------------	----------------------------------

1500 - LIGHTING

1500 - LIGHTING

PAGE

SUBJECT

1511	REPLACEMENT REFRACTORS
1519	LIGHTING INSTALLATION
1520	MERCURY VAPOR CONVENTIONAL LUMINAIRES AND REPLACEMENT REFRACTORS
1521	HIGH PRESSURE AND LOW PRESSURE SODIUM VAPOR LUMINAIRE, REPLACEMENT BALLAST AND STARTER
1555	SERIES CONTROLLED REGULATED OUTPUT STREET LIGHT TRANSFORMER INSTALLATION REMOTE CONTROL OUTDOOR CIRCUIT SWITCH CAPACITOR 4KV
1556	SERIES CONTROLLED R.O. STREET LIGHT TRANSFORMER AND R.C.O.C. SWITCH, LINE ARM POSITION, 4KV
1562	P.E. CONTROLLED R.D. STREET LIGHT TRANSFORMER INSTALLATION, 12KV

© 1998 - 2020 San Diego Gas & Electric Company. All rights reserved. Removal of this copyright notice without permission is not permitted under law.

REV	CHANGE	DR	BY	DSN	APV	DATE	REV	CHANGE	DR	BY	DSN	APV	DATE
C							F						
B	EDITORIAL CHANGES	GLC	JK	GLW	CZH	6/8/2020	E						
A	ORIGINAL ISSUE	-	JS	IL	MDJ	7/25/2016	D						

SHEET 1 OF 1	X Indicates Latest Revision	Completely Revised	New Page	Information Removed	FMO OH1501.1
	SDG&E ELECTRIC OVERHEAD FIELD MAINTENANCE ONLY STANDARDS				
	LIGHTING FMO TABLE OF CONTENTS				

OH1511 UG4411 FIELD MAINTENANCE ONLY

ALL VERSIONS LISTED IN FMO ARE SUPERSEDED BY THEIR CURRENT VERSION FOUND INSIDE THE OVERHEAD AND UNDERGROUND CONSTRUCTION STANDARD MANUAL.

REVISION HISTORY:

6/8/2020: MOVED TO FMO

© 1998 - 2020 San Diego Gas & Electric Company. All rights reserved. Removal of this copyright notice without permission is not permitted under law.

REV	CHANGE	DR	BY	DSN	APV	DATE	REV	CHANGE	DR	BY	DSN	APV	DATE
C							F						
B							E						
A	ORIGINAL ISSUE	GLC	JKI	GLW	CZH	6/8/2020	D						

SHEET 1 OF 1	Indicates Latest Revision	Completely Revised	<input checked="" type="checkbox"/> New Page	Information Removed	FMO OH1511 UG4411
	SDG&E ELECTRIC OVERHEAD AND UNDERGROUND FIELD MAINTENANCE ONLY STANDARDS				
	REPLACEMENT REFRACTORS				

SCOPE: NONE

INSTALLATION:

- (A) A GLASS OR LEXAN REFRACTOR MAY BE USED ON THESE LUMINAIRES.
- B. LEXAN REFRACTORS TO BE USED IN HIGH VANDALISM AREAS ONLY.

BILL OF MATERIALS:

TABLE 1. REPLACEMENT REFRACTORS FOR LUMINAIRES ON PAGES 1521/4421						
CONVENTIONAL LUMINAIRES		LAMP TYPE	LAMP WATTAGE	REPLACEMENT REFRACTOR		
MANUFACTURER	TYPE			TYPE	CATALOG NUMBER	STOCK NUMBER
GENERAL ELECTRIC	M250R2	HPSV	70, 100, 150	GLASS	35-962560-21	S579104
GENERAL ELECTRIC	M400R2	HPSV	200, 250, 400	GLASS	35-962620-05	S579102
GENERAL ELECTRIC	M1000	HPSV	1000	GLASS	35-130170R02	S579100
AMERICAN ELECTRIC	SERIES 113	HPSV	70, 100, 150	GLASS	13-2-A	S579110
AMERICAN ELECTRIC	SERIES 125	HPSV	200, 250, 400	GLASS	25-3-A	S579108
AMERICAN ELECTRIC	SERIES 327	HPSV	1000	GLASS	27-3-A	S79106

TABLE 1. REPLACEMENT REFRACTORS FOR LUMINAIRES ON PAGES 4422						
DECORATIVE LUMINAIRES		LAMP TYPE	LAMP WATTAGE	REPLACEMENT REFRACTOR		
MANUFACTURER	TYPE			TYPE	CATALOG NUMBER	STOCK NUMBER
GENERAL ELECTRIC	MISSION BELL (A)	HPSV	70, 100, 150	GLASS	35-130583R01	S579264
				LEXAN	35-130707R01	S579248
		HPSV	250, 400	GLASS	35-2311374R1	S579296
				LEXAN	35-130015R02	S579312
GENERAL ELECTRIC	DECASHIELD	HPSV	250, 400	GLASS	35-962880-23	S578702
MCGRAW EDISON	CONCOURSE STYLE A	HPSV	70, 100, 150	GLASS	LO-340X1	S578694
			250, 400	GLASS	LO-340X2	S578696
GARDCO	FORM 10P	HPSV	70, 100, 150	GLASS	P1413	S578698
			250, 400	GLASS	P1913	S578700
GARDCO	FORM 10P	HPSV	250, 400	GLASS	P1913	S578700
KIM	SQUARE	HPSV	70, 200	GLASS	84044	S578730
BIEBER	SQUARE	HPSV	70	GLASS	BH-HP-GLASS	S578730

FIELD MAINTENANCE ONLY

© 1998 - 2020 San Diego Gas & Electric Company. All rights reserved. Removal of this copyright notice without permission is not permitted under law.

REV	CHANGE	DR	BY	DSN	APV	DATE	REV	CHANGE	DR	BY	DSN	APV	DATE
C	MOVED TO FMO	GLC	JIK	GLW	CZH	6/8/2020	F						
B	DRAWING UPDATE	PEI	-	-	-	02/04/2019	E						
A	ORIGINAL ISSUE	-	-	RDW	CAK	01/01/1998	D						

SHEET 1 OF 2	X	Indicates Latest Revision	Completely Revised	New Page	Information Removed	FMO OH1511.1 UG4411.1
	SDG&E ELECTRIC OVERHEAD AND UNDERGROUND FIELD MAINTENANCE ONLY STANDARDS					
	REPLACEMENT REFRACTORS					

BILL OF MATERIALS CONT'D:

TABLE 3. REPLACEMENT REFRACTORS FOR LUMINAIRES ON PAGES 4423 AND 4424

POST TOP & DW LUMINAIRES		LAMP TYPE	LAMP WATTAGE	REPLACEMENT REFRACTOR		
MANUFACTURER	TYPE			TYPE	CATALOG NUMBER	STOCK NUMBER
MCGRAW EDISON	LAWNIAIRE	HPSV	50, 70, 100, 150	ACRYLIC	LO-307X1	S77920
MCGRAW EDISON	TRADITIONAL TYPE III	HPSV	100, 150	ACRYLIC	LT-144X11	S579232 (I)
				ACRYLIC	LT-148X11	S579220 (II)
				ACRYLIC	LT-144X12	S579228 (III)
				ACRYLIC	LT-144X13	S579224 (IV)
MCGRAW EDISON	TRADITIONAL TYPE V	HPSV	50, 70	ACRYLIC	LT-144X11	S577920 (V)
GENERAL ELECTRIC	TC-100R AND TC-100R MANSARD	HPSV	70, 150	ACRYLIC	35-963160-01	S579204 (VI)
HOLOPHANE	RSL-350	HPSV	100, 150	GLASS	3313	S578728
AMERON	VICTORIAN TYPE III	HPSV	70,200	GLASS	80645E	S578720

TABLE 4. REPLACEMENT REFRACTORS FOR LUMINAIRES ON PAGES 1533

FLOOD LIGHT LUMINAIRES	LAMP TYPE	LAMP WATTAGE	REPLACEMENT REFRACTOR		
MANUFACTURER			TYPE	CATALOG NUMBER	STOCK NUMBER
GENERAL ELECTRIC	HPSV	250, 400, 1000	GLASS	35-964960-21	S78712

NOTES:

- (I) REFRACTOR PANEL TO BE INSTALLED ON STREET SIDE.
- (II) REFRACTOR PANEL TO BE INSTALLED ON HOUSE SIDE.
- (III) REFRACTOR PANEL TO BE INSTALLED ON RIGHT SIDE.
- (IV) REFRACTOR PANEL TO BE INSTALLED ON LEFT SIDE.
- (V) REFRACTOR PANEL TO BE INSTALLED ON ALL FOUR SIDES.
- (VI) REFRACTOR PANEL TO BE INSTALLED PER DESIGNATED SIDE.

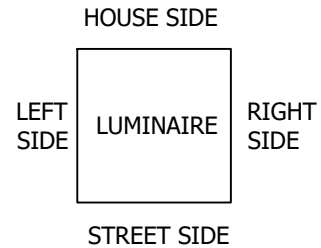

REFERENCE: NONE

FIELD MAINTENANCE ONLY

© 1998 - 2020 San Diego Gas & Electric Company. All rights reserved. Removal of this copyright notice without permission is not permitted under law.

REV	CHANGE	DR	BY	DSN	APV	DATE	REV	CHANGE	DR	BY	DSN	APV	DATE
C	MOVED TO FMO	GLC	JIK	GLW	CZH	6/8/2020	F						
B	DRAWING UPDATE	PEI	-	-	-	02/04/2019	E						
A	ORIGINAL ISSUE	-	-	RDW	CAK	01/01/1998	D						

**SHEET
2 OF 2**

Indicates Latest Revision Completely Revised New Page Information Removed

SDG&E ELECTRIC OVERHEAD AND UNDERGROUND FIELD MAINTENANCE ONLY STANDARDS

REPLACEMENT REFRACTORS

**FMO
OH1511.2
UG4411.2**

FIELD MAINTENANCE ONLY

REVISION HISTORY:

7/13/2016: All versions prior to 2016 are superseded by their current version found inside the Overhead Construction Standard Manual.

© 1998 - 2016 San Diego Gas & Electric Company. All rights reserved. Removal of this copyright notice without permission is not permitted under law.

REV	CHANGE	BY	DSGN	APPV	DATE	REV	CHANGE	BY	DSGN	APPV	DATE
C						F					
B						E					
A	ORIGINAL ISSUE	JS	IL	MDJ	7/13/2016	D					

<p>SHEET 1 OF 1</p>	 Indicates Latest Revision	Completely Revised	New Page	Information Removed	<p>FMO OH 1519</p>
	SDG&E ELECTRIC OVERHEAD STANDARD				
	LIGHTING INSTALLATION				

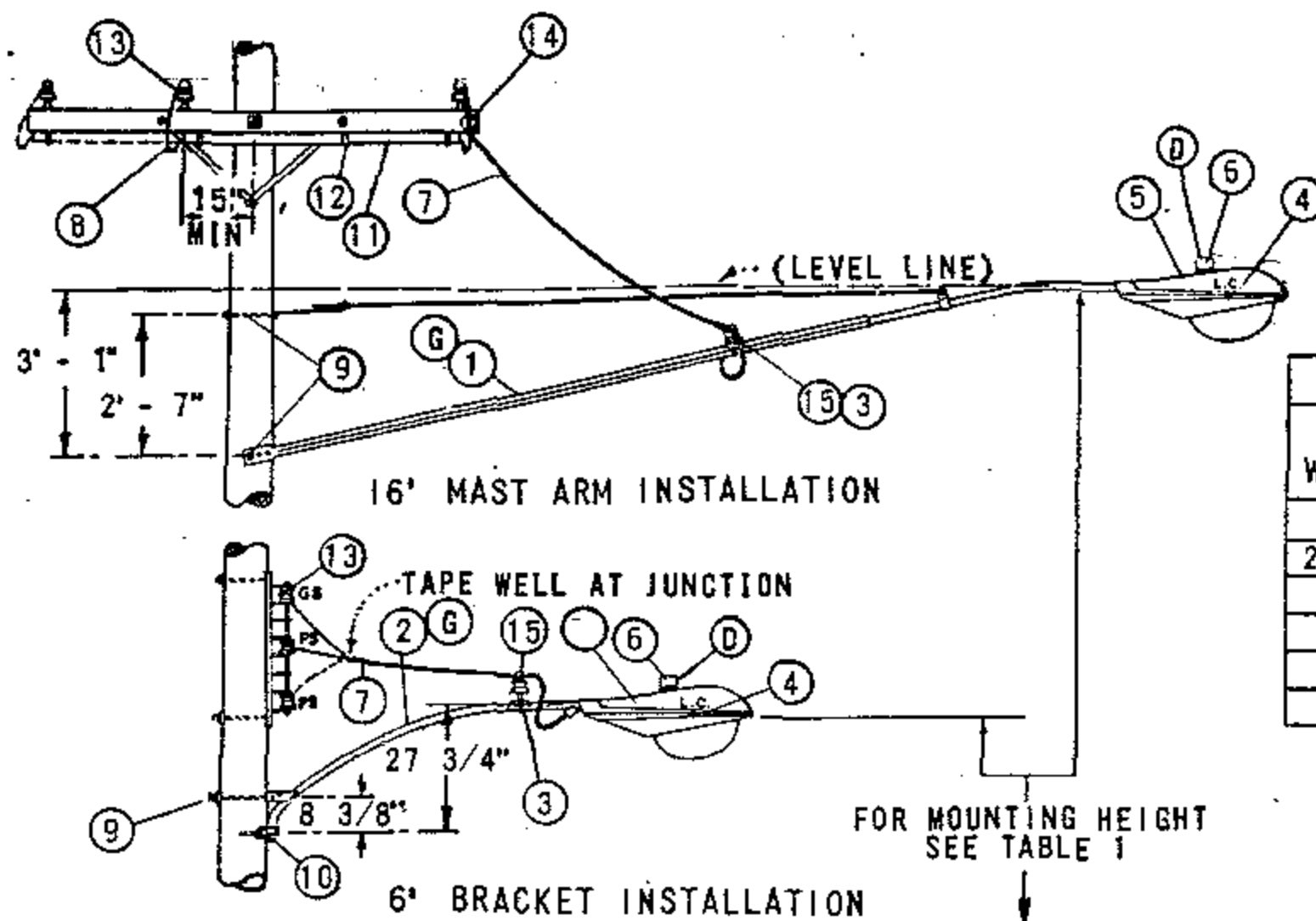

LAMP WATTAGE	MERCURY VAPOR MOUNTING HEIGHT
175	25' - 28'
250-400	30' - 32'
1000	35' - 37'

FOR FIELD MAINTENANCE ONLY

TABLE 2 (F)
MERCURY VAPOR STREET LIGHTING CODE

WATTS	LUMEN	MERCURY VAPOR STREET LIGHTING CODE			
		REGULATOR BALLAST		REACTOR BALLAST	
		BRACKET 6'	MAST ARM 16'	BRACKET 6'	MAST ARM 16'
175	7000	6AG	16AG	6AR	16AR
250	10000	6BG	16BG	6BR	16BR
400	20000	6CG	16CG	-	-
1000	55000	6DG	16DG		

NOTES:

- (A) REQUIRED FOR SECONDARY LINE ARM CONSTRUCTION ONLY.
- B. SEE STANDARDS PAGE 1509 FOR CLEARANCES.
- (C) 30" STREET LIGHTING BRACKET, STOCK NUMBER 167200 MAY BE SUBSTITUTED.
- (D) APPERTURE OF PHOTOELECTRIC CELL MUST BE SET TO FACE NORTH.
- (E) EXEMPT MATERIALS.
- (F) TABLE 2 IS PROVIDED FOR IDENTIFICATION OF LIGHTING INSTALLATIONS ON MAPS AND WORK ORDERS.
- (G) A MAXIMUM OF ONE HALF OF MOUNTING BRACKET MAY BE INSTALLED IN CLIMBING SPACE.

ITEM	DESCRIPTION	QUANTITY				STOCK NO. OR CONSTR STDS
		BALLAST				
		REGULATOR		REACTOR		
		6AG, 6BG, 6CG, 6DG	16AG, 16BG, 16CG, 16DG	6AR, 6BR	16AR, 16BR	
1	ARM, UPSWEEP MAST, 1 1/4" DIA, 16' - 0"	-	1	-	1	110880
2	BRACKET, UPSWEEP, 1 1/4" DIA, 6' - 0" (C)	1	-	1	-	167264
3	PIN, INSULATOR CLAMP (SUPPLIED WITH MAST ARM)	1	1	1	1	-
4	LAMP	1	1	1	1	PG. 1510
5	LUMINAIRE	1	1	1	1	PG. 1520, 1521
6	CONTROL, PHOTOELECTRIC, TWISTLOCK BASE 105 TO 280 VOLT	1	1	1	1	273888
7	WIRE, #8, 600V, FLEXIBLE R.C. DUPLEX	AS REQ'D				811776
8	WIRE, #12, TYPE THW, 600V, INSULATED COPPER (A)	25'	25'	25'	25'	810272
9	BOLT, MACH, GALV, 5/8" X 10", 2 SQ WASH. & 1 NUT (E)	1	2	1	2	PGS 139, 140
10	SCREW, LAG, GALV, 1/2" X 4" (E)	2	-	2	-	621568
11	CONDUIT, PLASTIC, PVC, TYPE 11, SCHEDULE 40 3/4" (A) (E)	7' - 4"	7' - 4"	7' - 4"	7' - 4"	251328
12	STRAP, PIPE, GALV, 2-100 NAILS, GALV, 3/4" (A) (E)	3	3	4	4	PG 143
13	CONNECTOR, WIRE (E)	2	2	2	2	PGS 783-787
14	CLEVIS, SECONDARY DEAD END (A)	1	1	1	1	235488
15	INSULATOR, PIN TYPE, TOP TIE, 4KV (CLASS 55-1) WHITE (E)	1	1	1	1	429024

SDG & E ELECTRIC STANDARDS

DATE 11-5-82
APPD JMT/ARA

LIGHTING INSTALLATION

1599.102
SUPERSEDES
1519 (11-5-82)

FIELD MAINTENANCE ONLY

REVISION HISTORY:

7/13/2016: All versions prior to 2016 are superseded by their current version found inside the Overhead Construction Standard Manual.

© 1998 - 2016 San Diego Gas & Electric Company. All rights reserved. Removal of this copyright notice without permission is not permitted under law.

REV	CHANGE	BY	DSGN	APPV	DATE	REV	CHANGE	BY	DSGN	APPV	DATE
C						F					
B						E					
A	ORIGINAL ISSUE	JS	IL	MDJ	7/13/2016	D					

	Indicates Latest Revision	Completely Revised	New Page	Information Removed
-------------------------------------------------------------------------------------	---------------------------	--------------------	----------	---------------------

**SHEET
1 OF 1**

SDG&E ELECTRIC OVERHEAD STANDARD

MERCURY VAPOR CONVENTIONAL LUMINAIRES
AND REPLACEMENT REFRACTORS

**FMO
OH 1520**

SCOPE: THIS STANDARD SHOWS MERCURY VAPOR LUMINAIRES USED TO PROVIDE ROADWAY AND DUSK TO DAWN LIGHTING, AND REPLACEMENT REFRACTORS.

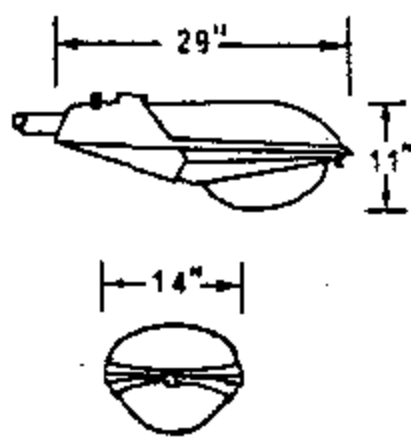

GENERAL ELECTRIC
M-250A POWR/DOOR

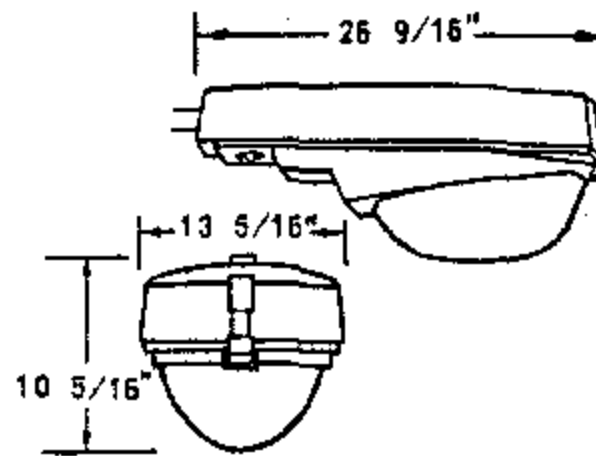

MCGRAW EDISON
UNIDOR 250

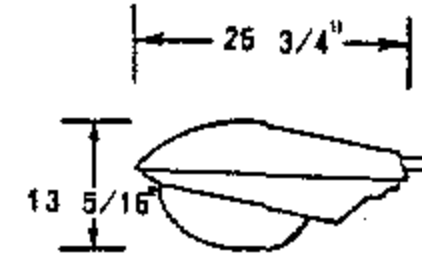

WESTINGHOUSE
OV-15

FIGURE 1

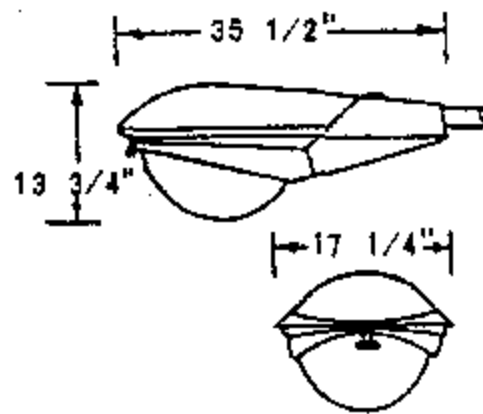

GENERAL ELECTRIC
M-400A POWR/DOOR

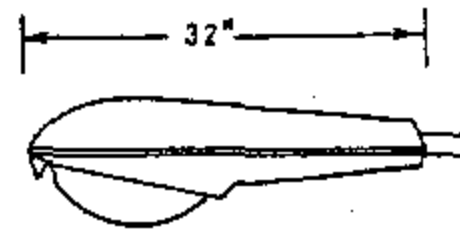

WESTINGHOUSE
OV-25

FOR FIELD MAINTENANCE ONLY

FIGURE 2

BILL OF MATERIAL:

FIG. NO.	STOCK NUMBER	LAMP SIZE WATTS	BALLAST		MANUFACTURER AND CATALOG NUMBER							
			TYPE	SOURCE VOLTAGE	GENERAL ELECTRIC		MCGRAW EDISON		WESTINGHOUSE		UNICORN ELECTRIC	
					TYPE	CAT. NO.	TYPE	CAT. NO.	TYPE	CAT. NO.	TYPE	CAT. NO.
1	473920	175	REGULATOR	120/240 (A)	M-250A	C727G002 (B)	UNIDOR	UU1104-120R	OV-15	B11A208G04		
	474048		REACTOR NPF	240	POWR/DOOR	C727G014 (B)	250	UU-1154R		B11A208G20		
	473910		SERIES	6.8 AMPS	M-250-R2	M2AR17CXSIGMS31038						
2	474208	400	REGULATOR	120/240 (A)	M-400A	C723G001 (B)			OV-25	658A303G04		
	473912		SERIES	6.8 AMPS	M-250-R2	M4AR40CXSIGMN32043						

REPLACEMENT REFRACTORS FOR MERCURY VAPOR LUMINAIRES						
CONVENTIONAL LUMINAIRES		LAMP TYPE	LAMP WATTAGE	REPLACEMENT REFRACTOR		
MANUFACTURER	TYPE			TYPE	CATALOG NUMBER	STOCK NUMBER
GENERAL ELECTRIC	M-250A (C)	MV	175,250	GLASS	35-130583-01	579264
GENERAL ELECTRIC	M-400A (C)	MV	400	GLASS	35-231137-01	579298
				LEXAN	35-130015-02	579312
AMERICAN ELECTRIC	23 SERIES (C)	MV	175,250	GLASS	23-002	579264
AMERICAN ELECTRIC	25 SERIES (C)	MV	400	GLASS	25-003	578928 (F)
				LEXAN	25-003-8	- (F)
AMERICAN ELECTRIC	327 SERIES	MV	1000	GLASS	27-003	578938 (F)
WESTINGHOUSE	OV-15	MV	175,250	GLASS	464-D067-H01	578976 (F)
WESTINGHOUSE	OV-25 (C)	MV	400	GLASS	464-D336-H02	578040
				LEXAN	6716-D13-H01	579058 (F)

INSTALLATION:

- (A) FACTORY WIRED FOR 120 VOLTS, DO NOT WIRE FOR 240 VOLTS ON NEW INSTALLATIONS.
- (B) ASTRODOME UNITS ARE EQUIPPED WITH BUILT-IN PHOTOELECTRIC CELL, FOR REPLACEMENT SEE PAGE 1512/4412.
- (C) A GLASS OR A LEXAN REFRACTOR MAY BE USED ON THESE LUMINAIRES.
- D. LEXAN REFRACTORS TO BE USED IN HIGH VANDALISM AREAS ONLY.
- (F) ITEM IS NO LONGER PURCHASED.

OH 1599.201
UG 4499.201
SUPERSEDES
1520.1 (11-5-82)

SDG&E ELECTRIC STANDARDS

MERCURY VAPOR CONVENTIONAL LUMINAIRES
AND REPLACEMENT REFRACTORS

DATE 1-1-89
APPD PEA/DTE

FIELD MAINTENANCE ONLY

REVISION HISTORY:

10/3/2016: All versions prior to 2016 are suspended by their current version found inside the Overhead Construction Standard Manual

© 1998 - 2016 San Diego Gas & Electric Company. All rights reserved. Removal of this copyright notice without permission is not permitted under law.

REV	CHANGE	BY	DSGN	APPV	DATE	REV	CHANGE	BY	DSGN	APPV	DATE
C						F					
B						E					
A	ORIGINAL ISSUE	JS	JS	MDJ	10/3/2016	D					

<p>SHEET 1 OF 1</p>	<input type="checkbox"/> Indicates Latest Revision	<input type="checkbox"/> Completely Revised	<input checked="" type="checkbox"/> New Page	<input type="checkbox"/> Information Removed	<p>FMO OH 1521</p>
	<p>SDG&E ELECTRIC OVERHEAD CONSTRUCTION STANDARDS</p>				
	<p>HIGH PRESSURE AND LOW PRESSURE SODIUM VAPOR LUMINAIRE, REPLACEMENT BALLAST AND STARTER</p>				

SCOPE: THIS STANDARD SHOWS HIGH PRESSURE AND LOW PRESSURE SODIUM VAPOR LUMINAIRES USED TO PROVIDE ROADWAY AND DUSK TO DAWN LIGHTING, AND STARTER.

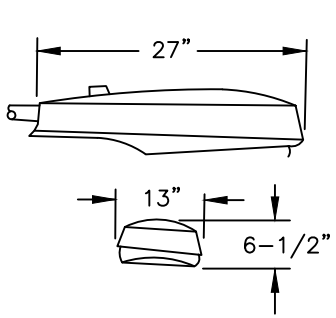

AMERICAN ELECTRIC
SERIES 115 CUTOFF
NON-POWER/PAD

FIGURE □

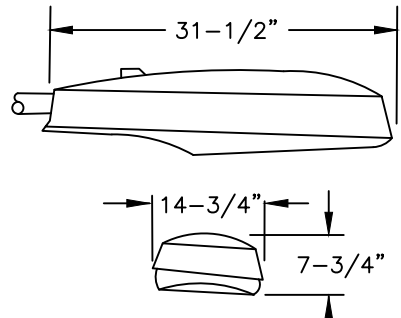

AMERICAN ELECTRIC
SERIES 125

FIGURE □

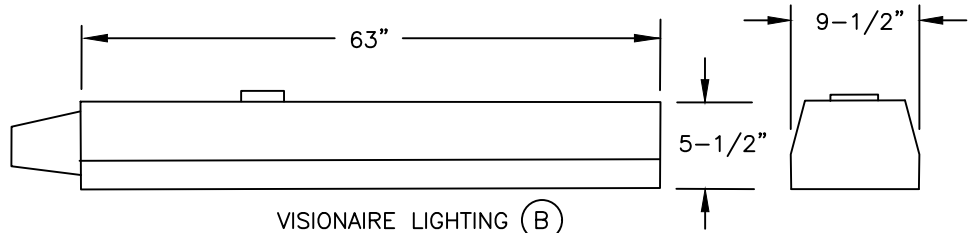

VISIONAIRE LIGHTING (B)
ROADWAY RDW-3 (135, 180W SHOWN)

FIGURE □

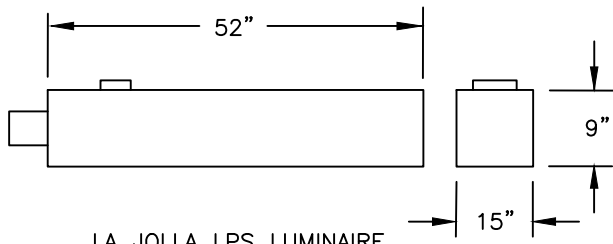

LA JOLLA LPS LUMINAIRE
(180W SHOWN)

FIGURE □

© 1998 - 2006 San Diego Gas & Electric Company. All rights reserved. Removal of this copyright notice without permission is not permitted under law.

	<input type="checkbox"/> Indicates Latest Revision <input checked="" type="checkbox"/> Completely Revised <input type="checkbox"/> New Page <input checked="" type="checkbox"/> Information Removed
OH 1521.1 UG 4421.1	SDG&E ELECTRIC STANDARDS HIGH PRESSURE AND LOW PRESSURE SODIUM VAPOR LUMINAIRE, REPLACEMENT BALLAST AND STARTER
	REVISION DATE 2-3-06 APPD PJA / JJ

D TABLE **HIGH PRESSURE SODIUM VAPOR LUMINAIRE COMPLETE ASSEMBLY INCLUDING LAMP**

FIG. NO.	MANUFACTURER	LAMP SIZE WATTS	BALLAST		STOCK NUMBER
	TYPE		TYPE	SOURCE VOLTAGE	
1	SERIES 115	70	REACTOR-NPF	120	473400
	SERIES 115	100			473402
	SERIES 115	150			473404
2	SERIES 125	200	HIGH REACTANCE-NPF	120	473406
		250	HIGH REACTANCE-NPF		473408
		400	CWA		473410

TABLE **REPLACEMENT STARTER ONLY FOR HIGH PRESSURE SODIUM VAPOR LUMINAIRE**

FIGURE NUMBER	MANUFACTURER	TYPE	LAMP SIZE WATTS	SOURCE VOLTAGE	STOCK NUMBER
1	AMERICAN ELECTRIC	SERIES 115	50-150	120	679142
2	AMERICAN ELECTRIC	SERIES 125	200-400	120	679144

© 1998 - 2010 San Diego Gas & Electric Company. All rights reserved. Removal of this copyright notice without permission is not permitted under law.

	Indicates Latest Revision	Completely Revised	New Page	Information Removed
REVISION	SDG&E ELECTRIC STANDARDS			
DATE 2-3-06 APPD <i>PA</i> / JJ	HIGH PRESSURE AND LOW PRESSURE SODIUM VAPOR LUMINAIRE, REPLACEMENT BALLAST AND STARTER			OH 1521.2 UG 4421.2

TABLE 1 LO PRESSURE SODIUM VAPOR LUMINAIRES COMPLETE ASSEMBLY INCLUDING LAMP

FIG. NO.	MAX. LENGTH (IN INCHES)	LAMP SIZE (WATTS)	BALLAST		STOCK NUMBER
			TYPE	SOURCE VOLTAGE	
3 & 4	34	55	H P F REACTOR	120	473800
	39	90	H P F REACTOR	120	473802
	63	135	H P F REACTOR	120	473804
	63	180	H P F REACTOR	120	473806

INSTALLATION:

- A. ALL LUMINAIRES ARE TO BE WIRED FOR 120 VOLTS ONLY. APPLICATION OF 240 VOLTS TO THESE UNITS WILL CAUSE SEVERE BALLAST DAMAGE.
- (B) THE VISIONAIRE LUMINAIRE WILL ACCEPT BOTH 35 WATT AND 55 WATT LAMPS.
- C. CUTOFF LUMINAIRES SHALL BE INSTALLED WITH THE OPTICAL ASSEMBLY (GLASSWARE) HORIZONTAL.
- (D) STOCK NUMBERS IN TABLES 1 AND 3 ARE FOR COMPLETE LUMINAIRE UNITS.

REFERENCE:

- J. SEE STANDARD 1512/4412 FOR PHOTOELECTRIC CONTROL.
- K. SEE PAGE 1511.1/4411.1 FOR REPLACEMENT REFRACTORS.
- L. SEE STANDARD 1514/4414 FOR IDENTIFICATION DECAL.

© 1998 - 2010 San Diego Gas & Electric Company. All rights reserved. Removal of this copyright notice without permission is not permitted under law.

	 Indicates Latest Revision	Completely Revised	New Page	Information Removed
REVISION	SDG&E ELECTRIC STANDARDS			OH 1521.3 UG 4421.3
DATE 2-3-06 APPD <i>PA</i> / JJ	HIGH PRESSURE AND LOW PRESSURE SODIUM VAPOR LUMINAIRE, REPLACEMENT BALLAST AND STARTER			

FIELD MAINTENANCE ONLY

REVISION HISTORY:

7/13/2016: All versions prior to 2016 are superseded by their current version found inside the Overhead Construction Standard Manual.

© 1998 - 2016 San Diego Gas & Electric Company. All rights reserved. Removal of this copyright notice without permission is not permitted under law.

REV	CHANGE	BY	DSGN	APPV	DATE	REV	CHANGE	BY	DSGN	APPV	DATE
C						F					
B						E					
A	ORIGINAL ISSUE	JS	IL	MDJ	7/13/2016	D					

SHEET 1 OF 1	<input checked="" type="checkbox"/> Indicates Latest Revision	<input type="checkbox"/> Completely Revised	<input type="checkbox"/> New Page	<input type="checkbox"/> Information Removed	FMO OH 1555
	SDG&E ELECTRIC OVERHEAD STANDARD				
	SERIES CONTROLLED REGULATED OUTPUT STREET LIGHT TRANSFORMER INSTALLATION REMOTE CONTROL OUTDOOR CIRCUIT SWITCH CAPACITOR 4KV				

SCOPE: THIS STANDARD SHOWS 4KV CONSTANT CURRENT SERIES LIGHTING TRANSFORMER INSTALLATION AND SHALL ONLY BE USED WHEN AN EXISTING TRANSFORMER INSTALLATION MUST BE RELOCATED OR REBUILT TO MAINTAIN SERVICE TO AN EXISTING SERIES STREET LIGHTING SYSTEM.

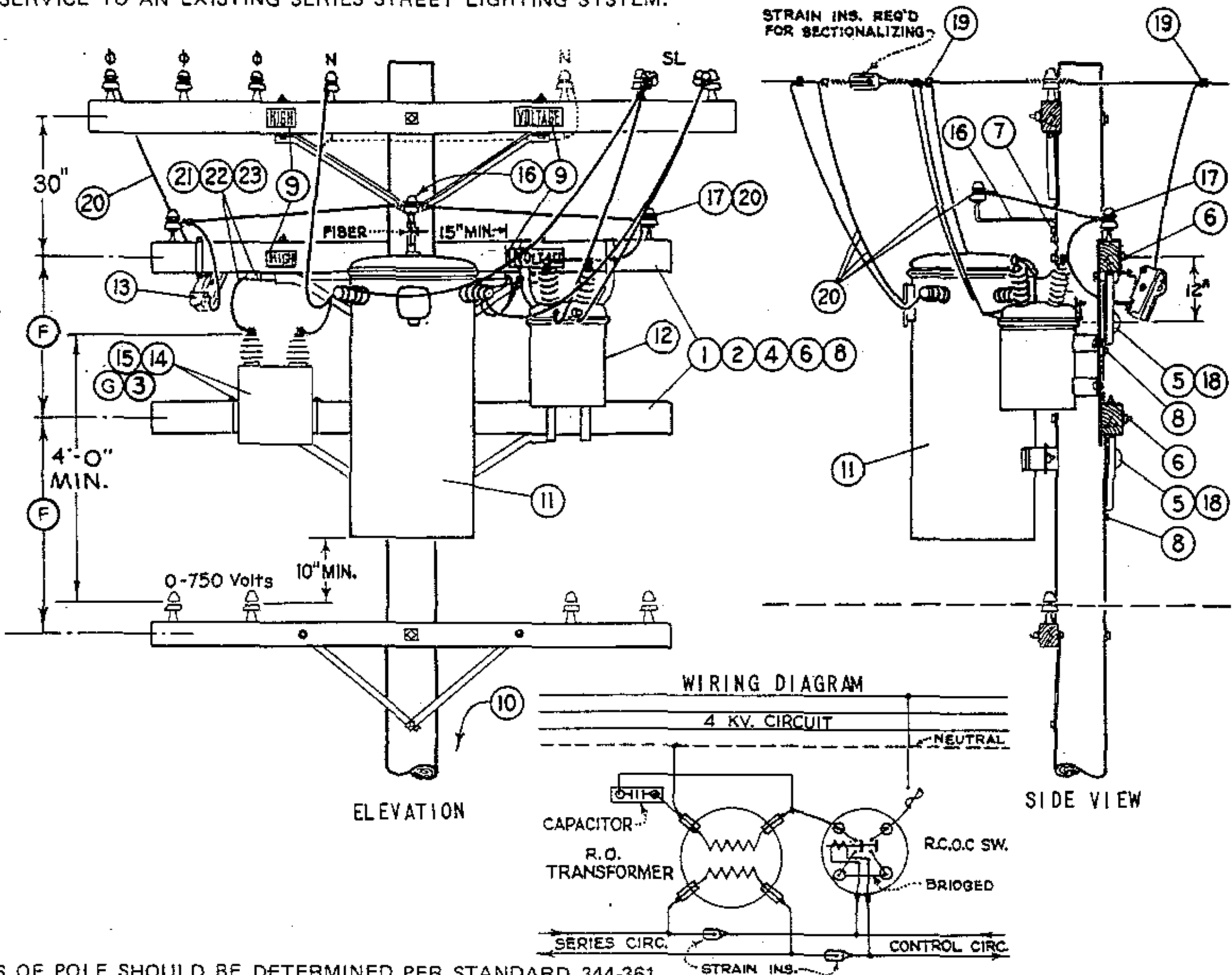

NOTES:

- CLASS OF POLE SHOULD BE DETERMINED PER STANDARD 344-361.

BILL OF MATERIAL:

ITEM	DESCRIPTION	QUANT.	CONST STD OR PAGE NO	STOCK NO.
1	3 3/4" x 5 3/4" x 8'-0" Transformer Arm	2	PAGE 380.5 IT.4	294960
2	Angle Crossarm Brace, 4'-0"	2		164032
3	Mach. Bolt, Galv., 3/8" x 1 1/2", 2 rd. washers & 1 nut (E)	2	STDS 392	
4	Mach. Bolt, Galv., 1/2" x 7", 1 rd. washer & 1 nut (E)	4	STDS 392	
5	Mach. Bolt, Galv., 5/8" x 12", 1 sq. curv. wash. & 1 nut (E)	2	STDS 392	
6	Mach. Bolt, Galv., 5/8" x 14", 2 sq. washers & 1 nut (E)	2	STDS 392	
7	Lag Screw, Galv., 1/2" x 4"	1		621568
8	Lag Screw, Galv., 5/8" x 5"	2		621600
9	High Voltage Sign & 9 galv. roofing nails (E)	1		647648, 492224
10	POLE STEPS (SEE STANDARD 363) (E)	-		692992
11	R.O. Transformer with 2 pole bolt Adapter Plates & bolts	1	PG 1121	
12	R.C.O.C. Switch, paired hangers, adapter plates where req'd	1		274656 (A) (B)
13	Expulsion Fuse Indicating Cutout, 5 kv, 50A. (D)	1	SECTION 1200	
14	Capacitor, 2.4 kv., 15 or 25 kvar. (A)	1		207392 OR 207168
15	Mounting Strap and 1- 1/2" phi x 3 3/4" x 5 3/4" U" bolt (A) (C)	2		158432
16	Stand-Off Bracket with Insulator	1		166144, 429216 (E)
17	Insulator and 1" steel pin (E)	2	PG 750	532608
18	Cover Thru Bolt Plastic & Nails, Galv. (E)	2		285696, 492192
19	Wire Connector (E)	7	STDS. 783 - 787	
20	#6 D. B. W. R. Copper Wire	55'		812512
21	#6 R.C. Strand. Copper Wire, 5 kv.	7'		194304
22	1" PVC Conduit (E)	4'		251200
23	1 1/4" Pipe Strap and 2-6d nails, galv. (E)	3		697696, 491552

INSTALLATION:

- (A) NO LONGER PURCHASED.
- (B) KEARNY MAINTENANCE WILL SUPPLY.
- (C) SALVAGE FROM EXISTING INSTALLATIONS, MIRAMAR SALVAGE YARD HAS LIMITED SUPPLY.
- (D) CAN BE SUBSTITUTED WITH 12KV 100A CUTOUT.
- (E) EXEMPT MATERIAL.
- (F) SPACE KICK ARM & BRACE TO CLEAR LOWER TRANSFORMERS THRU BOLT COVER.
- (G) IF CAPACITOR FAILS OR STATION IS RELOCATED, DO NOT REPLACE CAPACITOR.

SDG&E ELECTRIC STANDARDS

1599.502
SUPERCEDES
1555.1 (1-1-92)

SERIES CONTROLLED REGULATED OUTPUT STREET LIGHT
TRANSFORMER INSTALLATION REMOTE CONTROL
OUTDOOR CIRCUIT SWITCH CAPACITOR 4KV

DATE 1-1-87

APPD AK/RDB

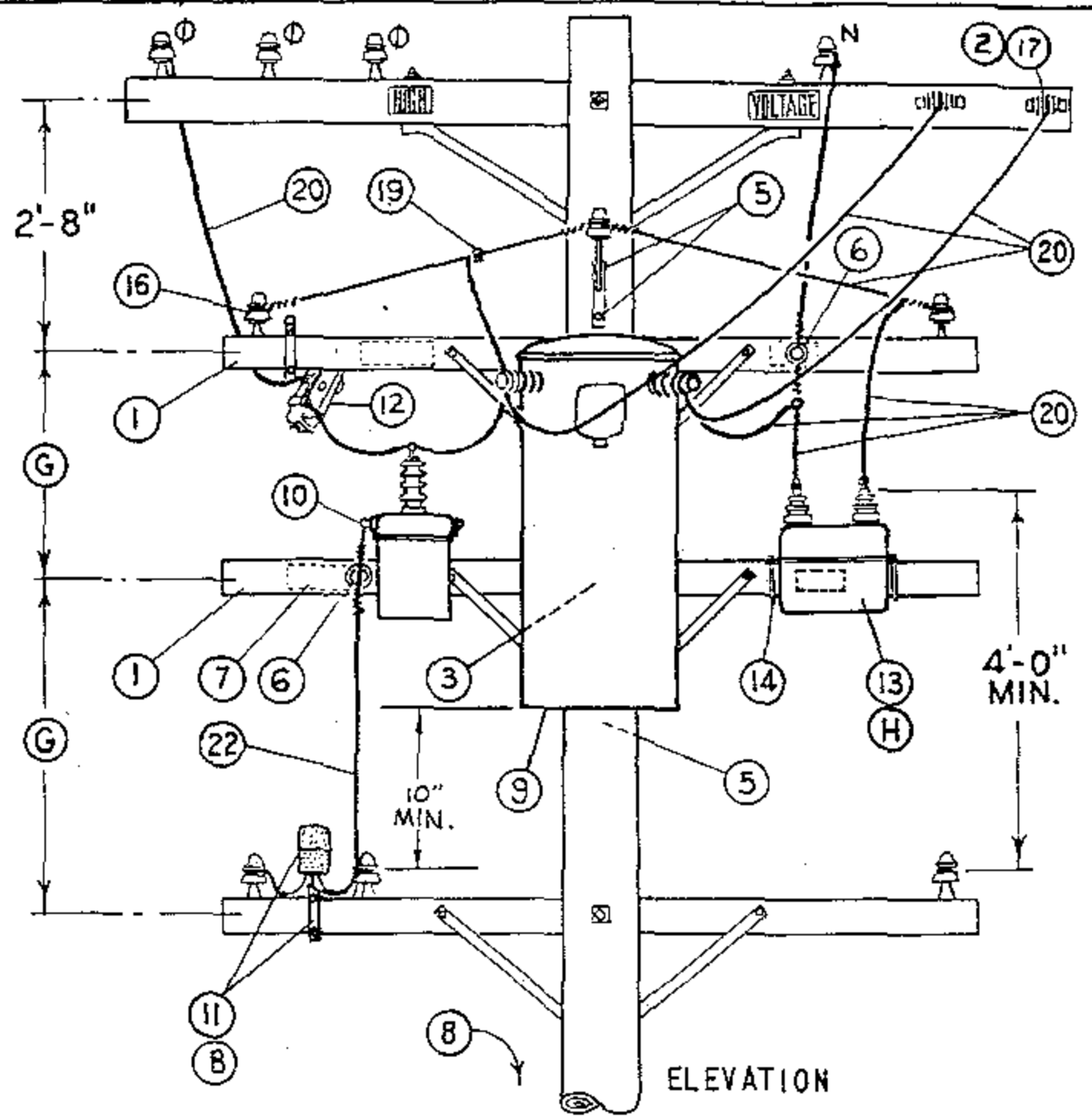
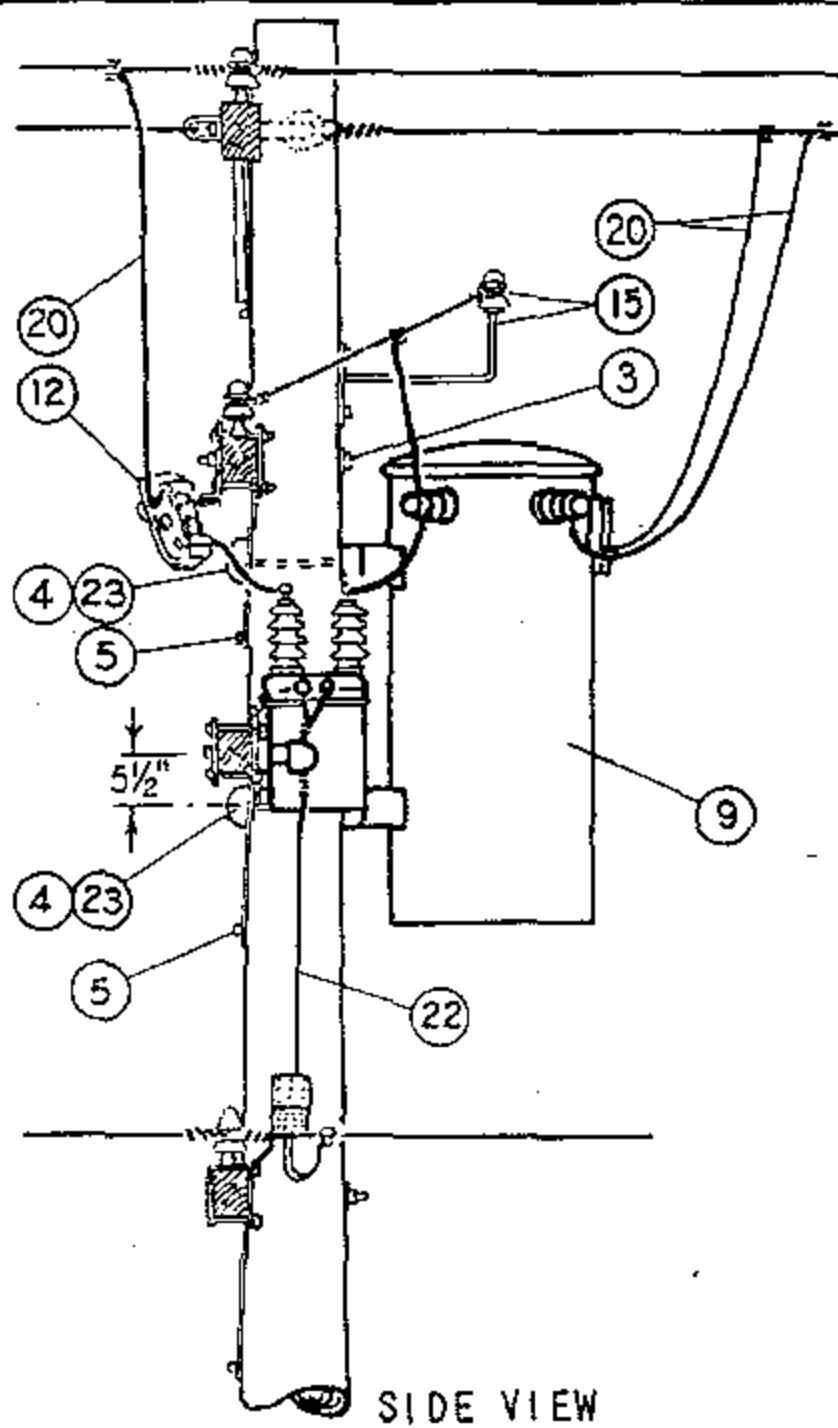

NOTES:

- CLASS OF POLE SHOULD BE DETERMINED PER STANDARD 344-361.

INSTALLATION:

- A. ROTATE COVER OF OIL SWITCH 180°, WHERE NECESSARY, TO POSITION MANUAL OPERATING LEVER ADJACENT TO CLIMBING SPACE.
- (B) FACE PHOTO CELL TO THE NORTH.
- (C) NO LONGER PURCHASED. SALVAGE FROM EXISTING INSTALLATION OR OBTAIN FROM KEARNY MAINTENANCE.
- (D) NO LONGER PURCHASED. SALVAGE FROM EXISTING INSTALLATION OR OBTAIN FROM MIRAMAR SALVAGE YARD.
- (E) EXEMPT MATERIAL.
- (F) CAN BE SUBSTITUTED WITH 12KV 100A CUTOUT.
- (G) SPACE KICK ARM & BRACE TO CLEAR LOWER TRANSFORMER THRU BOLT COVER.
- (H) IF CAPACITOR FAILS OR STATION IS RELOCATED, DO NOT REPLACE CAPACITOR.

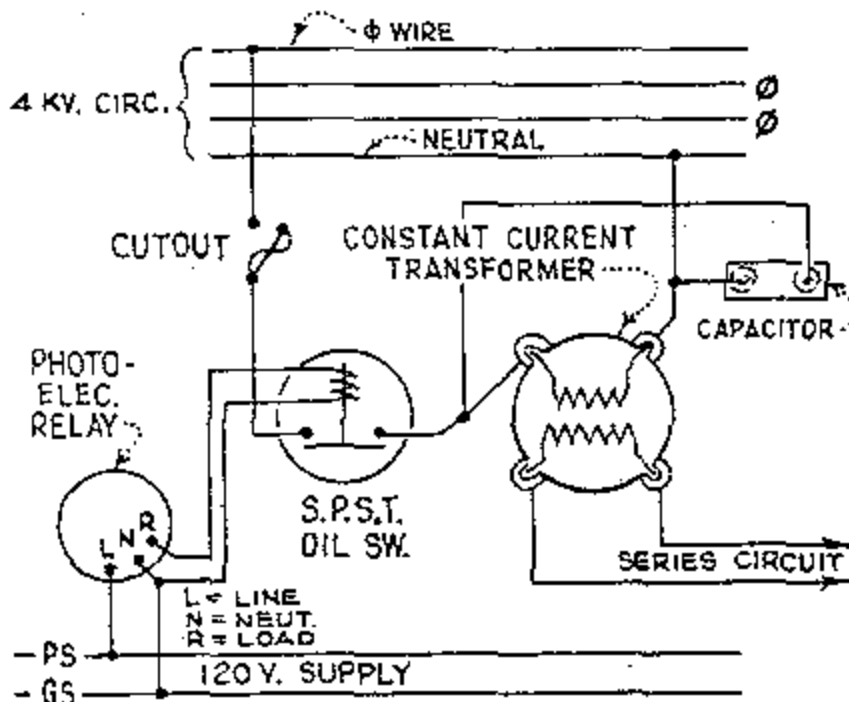

WIRING DIAGRAM

C.C. TRNSFMR. KW	CAPACITOR KVAR
7 1/2 (D)	15
10 (D)	15
15 (D)	15
25	25

ITEM	DESCRIPTION	QUANTITY	STOCK NO. OR CONSTR STDS
P. 1	3 1/2" x 4 1/2" x 8'-0" Crossarm	2	PG. 380.03 IT.1
2	Mach. Bolt, Galv., 5/8" x 6", 1 sq. washer & 1 nut (E)	2	STD 139. 140
T. 3	Mach. Bolt, Galv., 5/8" x 16", 2 sq. washers & 1 nut (E)	2	STD 139. 140
4	Mach. Bolt, Galv., 3/4" x 12", 1 sq. curved washers & 1 nut (E)	2	STD 139. 140
& 5	Lag Screw, Galv., 1/2" x 4" (E)	4	6 21568
F. 6	Pin, Transformer, Lead 1" Leadthread (E)	2	529248
7	High Voltage Sign & 8 galv. roofing nails (E)	2	6 477 44. 49 222 4
8	Pole Steps (E)	15	69 299 2
9	C. C. Transformer, 2.4 kv., incl. 2 pole bolt adapter plates	1	PG -1121.12
10	South Bend Controller Co. Oil Switch, S. P. S. T., 75 A., 2.4 kv. type SPR-1-120 spec. 6210 with #6222 X-arm Mtg. Bracket	1	27 4528 (C)
S. 11	Photoelectric Relay, 1000 W. min., 120 V.	1	273888 166432
L. 12	Cutout, 5 kv., 50 A. (F)	1	Section 1200
13	Capacitor, Size per Table, 2.4 kv., 2-3/8" x 1" Mtg. Bolts & Washers (H)	1	207 328. 207 188
& 14	Capacitor Mounting Strap & "U" Bolt (D)	2	597... 158432
15	Stand-Off Bracket with Insulator	1	166 144
S. 16	Insulator and 1" steel pin (E)	2	532608
S. 17	D.E. 4 kv. (E)	2	235520
18			
19	Wire Connector	9	STD 783-787
20	#6 B. Strand. Copper Wire	50'	813536
21			
22	2-C #16, 600 V. Type "S" Neoprene Jacketed Super Service Cord	5'	814400
23	Cover Thru Bolt Plastics & 4 - 10d Nails, galv. (E)	2	285696, 492192

SDG & E ELECTRIC STANDARDS

DATE 11-5-82
APPD JH7/ARH

PHOTOELECTRIC CONTROLLED REGULATED OUTPUT STREET LIGHT TRANSFORMER INSTALLATION, 4KV

1599.503
SUPERCEDES
1555.2 (1-1-92)

FIELD MAINTENANCE ONLY

REVISION HISTORY:

7/13/2016: All versions prior to 2016 are superseded by their current version found inside the Overhead Construction Standard Manual.

© 1998 - 2016 San Diego Gas & Electric Company. All rights reserved. Removal of this copyright notice without permission is not permitted under law.

REV	CHANGE	BY	DSGN	APPV	DATE	REV	CHANGE	BY	DSGN	APPV	DATE
C						F					
B						E					
A	ORIGINAL ISSUE	JS	IL	MDJ	7/13/2016	D					

<p>SHEET 1 OF 1</p>	 Indicates Latest Revision	Completely Revised	New Page	Information Removed	<p>FMO OH 1556</p>
	<p>SDG&E ELECTRIC OVERHEAD STANDARD</p>				
	<p>SERIES CONTROLLED R.O. STREET LIGHT TRANSFORMER AND R.C.O.C. SWITCH, LINE ARM POSITION, 4KV</p>				

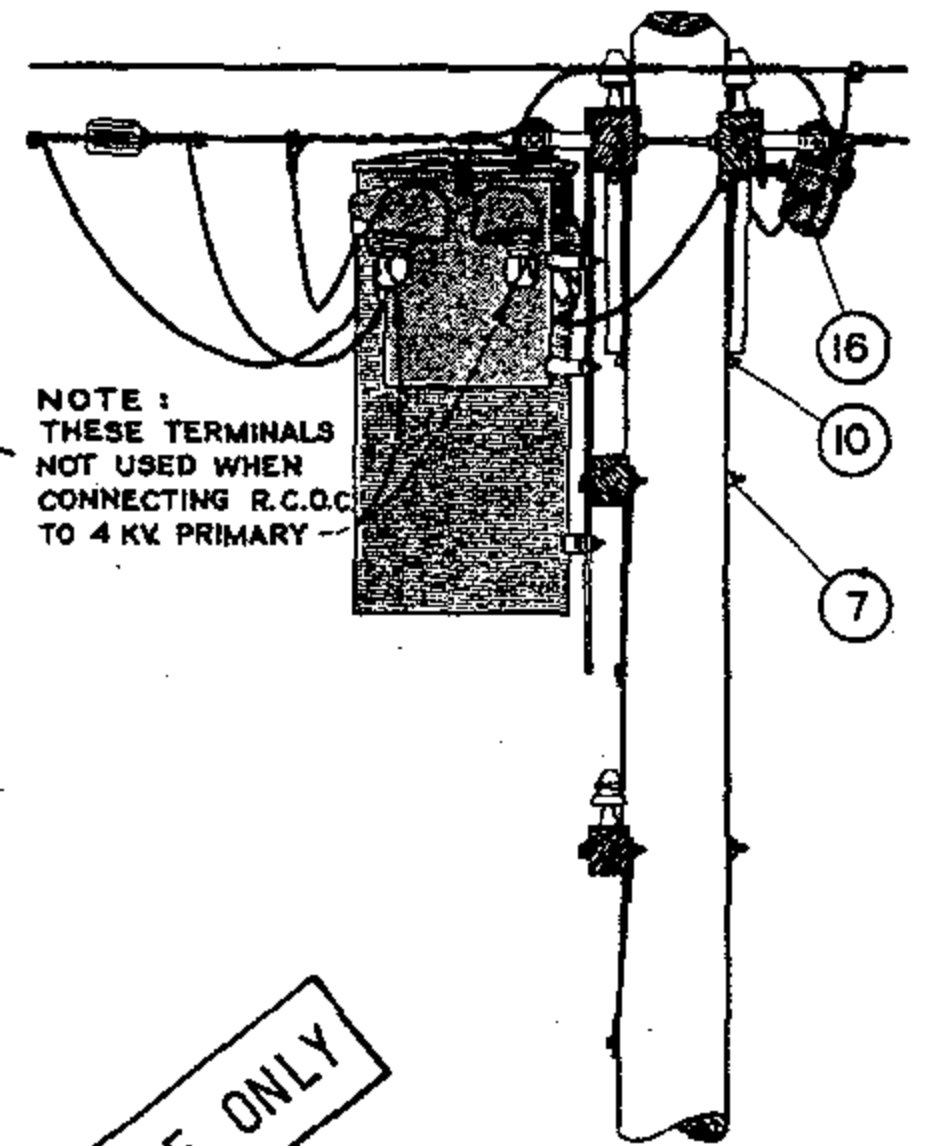
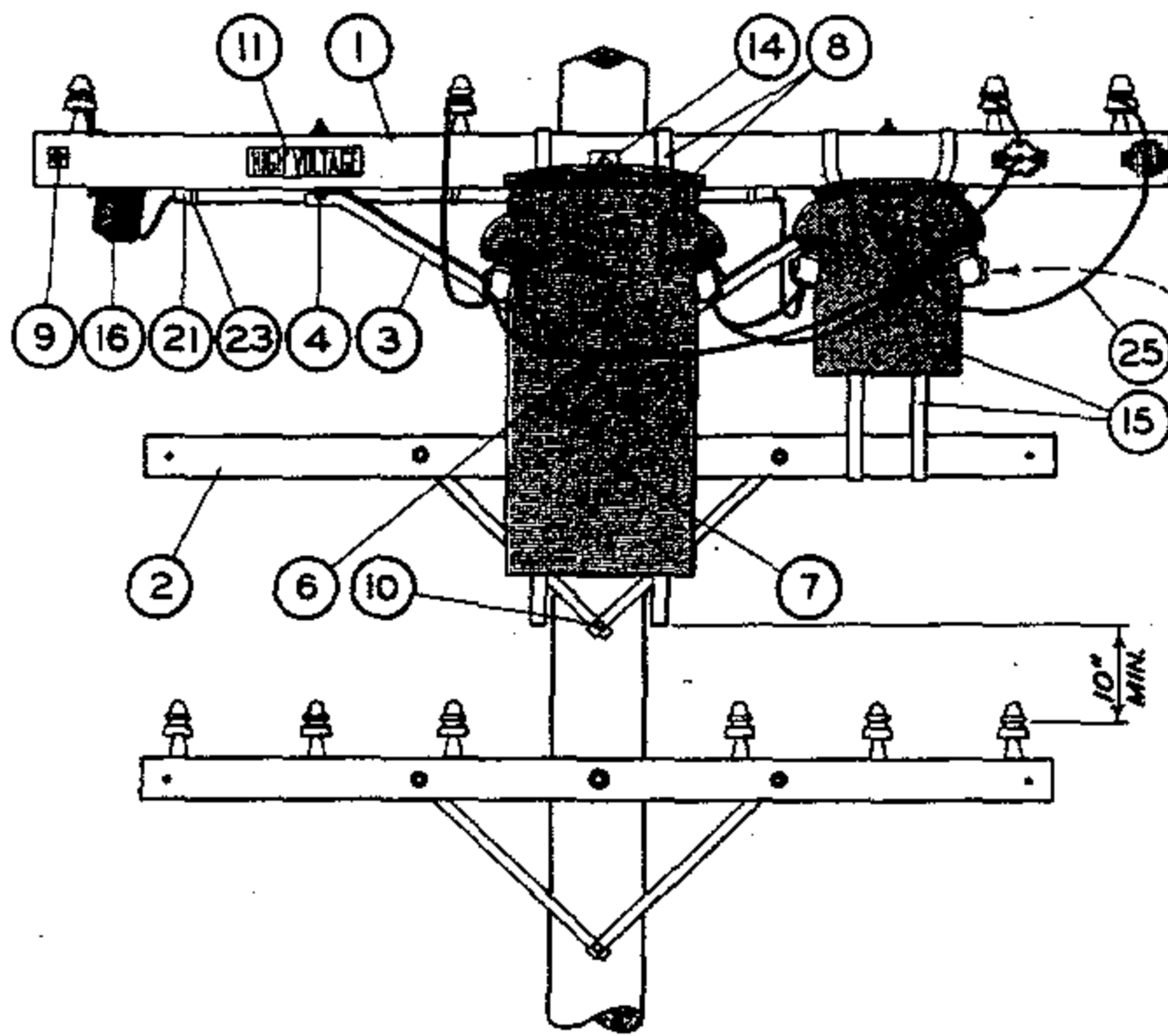

NOTE:
THESE TERMINALS
NOT USED WHEN
CONNECTING R.C.O.C.
TO 4 KV PRIMARY

THIS PAGE FOR FIELD MAINTENANCE ONLY

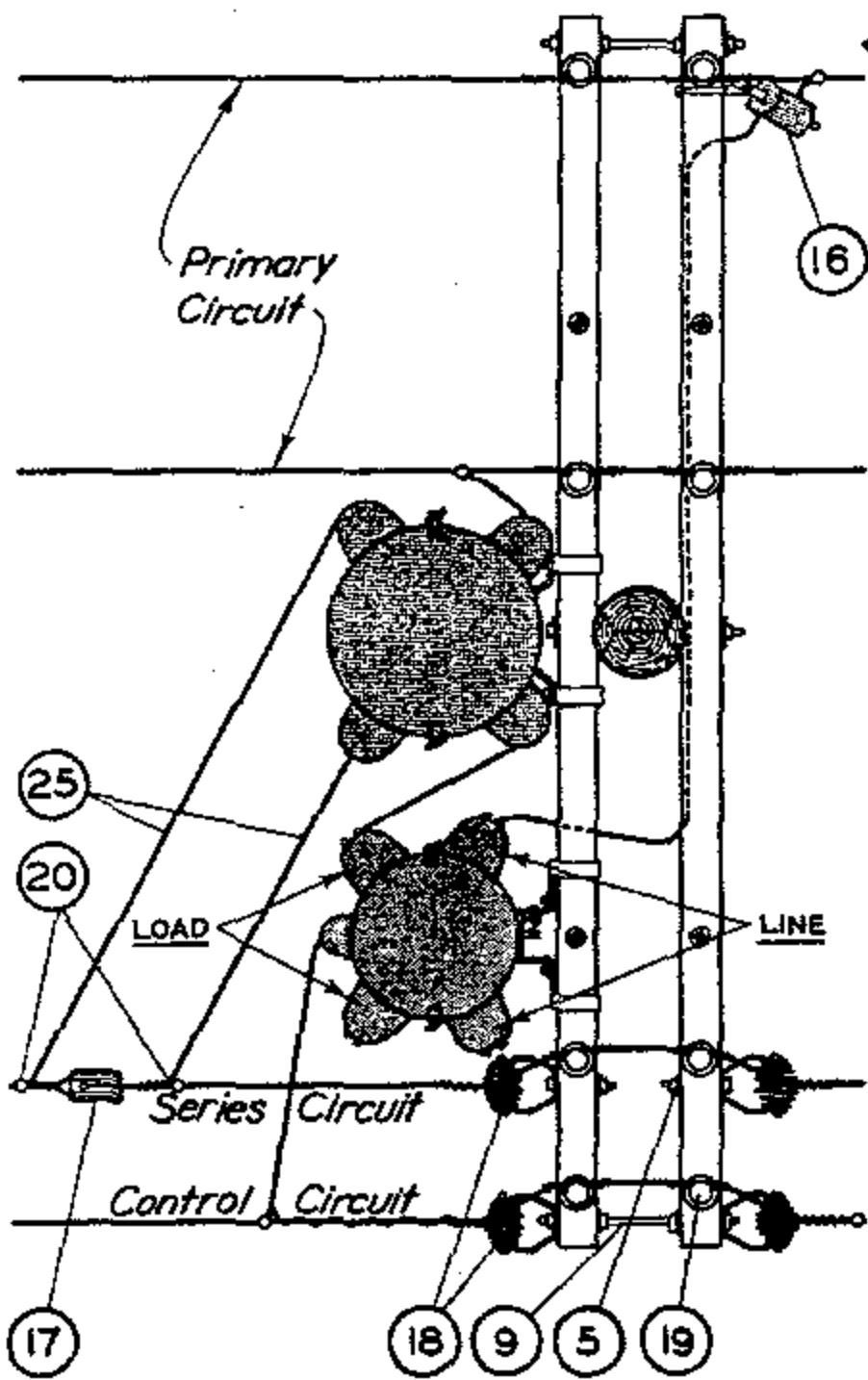

ITEM	DESCRIPTION	QUANTITY	CONSTR STDS STOCK NO OR
1	3-3/4"x 5-3/4"x 10'-0" Crossarm - 8 pin	2	PG 111 IT. 3
2	3-1/2"x 4-1/2"x 8'-0" Kick Arm	1	PG 111 IT. 2
3	Angle Crossarm Brace - 4' or 5'	2	16 40 32 OR 16 41 28
4	Mach. Bolt, Galv. 1/2"x 7" - 1 rd. washer & 1 nut	4	PGS 139. 140
5	Mach. Bolt, Galv. 5/8"x 5" - 1 rd. washer & 1 nut	2	PGS 139. 140
6	Mach. Bolt, Galv. 5/8"x 10" - 1 nut	1	PGS 139. 140
7	Mach. Bolt, Galv. 5/8"x 14" - 2 sq. washers & 1 nut	1	PGS 139. 140
8	Mach. Bolt, Galv. 5/8"x 18" - 2-3"x 4" washers & 1 nut	1	PGS 139. 140
9	Space Bolt, Galv. 5/8"x 18" - 4 washers & 4 nuts	2	PGS 139. 140
10	Lag Screw, Galv. 1/2"x 4"	1	6 21 56 8
11	High Voltage Sign & Nails #8, Roofing	1	6 47 6 48, 49 22 2 4
12	Pole Step	16	6 9 29 9 2
13			
14	R.O. Transformer & Hangers	1	PGS 1121.00-1121.12
15	R.C.O.C. Switch	1	27 4 5 6 0
16	G.E. Expulsion Fuse Cutout	1	PG 12 1 1
17	Insulator, Strain #508	1	4 3 0 8 8 0
18	Insulator, 4 Kv. D.E.	4	2 3 5 5 2 0
19	Insulator, D.G.D.P.	4	4 2 8 9 6 0
20	#6 Wire Connector Split Bolt	6	2 6 9 0 5 6
21	PVC Conduit, 1" diam.	5'	2 5 1 2 0 0
23	1-1/4" Pipe Strap with 2 - 6d Nails	3	6 9 7 6 9 6, 4 9 1 5 5 2
25	#6 R.C. Strand. Copper Wire - 5 Kv.	42'	8 1 4 1 1 2

DATE 4-30-82
APPD *UPH*

SDG&E ELECTRIC STANDARDS
SERIES CONTROLLED R.O. STREET LIGHT TRANSFORMER
AND R.C.O.C. SWITCH, LINE ARM POSITION, 4KV

1599.501
SUPERSEDES
1556 (4-30-82)

FIELD MAINTENANCE ONLY

REVISION HISTORY:

7/13/2016: All versions prior to 2016 are superseded by their current version found inside the Overhead Construction Standard Manual.

© 1998 - 2016 San Diego Gas & Electric Company. All rights reserved. Removal of this copyright notice without permission is not permitted under law.

REV	CHANGE	BY	DSGN	APPV	DATE	REV	CHANGE	BY	DSGN	APPV	DATE
C						F					
B						E					
A	ORIGINAL ISSUE	JS	IL	MDJ	7/13/2016	D					

SHEET 1 OF 1	 Indicates Latest Revision	Completely Revised	New Page	Information Removed	FMO OH 1562
	SDG&E ELECTRIC OVERHEAD STANDARD				
	P.E. CONTROLLED R.D. STREET LIGHT TRANSFORMER INSTALLATION, 12KV				

SCOPE : THIS STANDARD SHOWS A CONSTANT CURRENT SERIES LIGHTING R.D. TRANSFORMER INSTALLATION. IT IS TO BE USED ON EXISTING INSTALLATIONS.

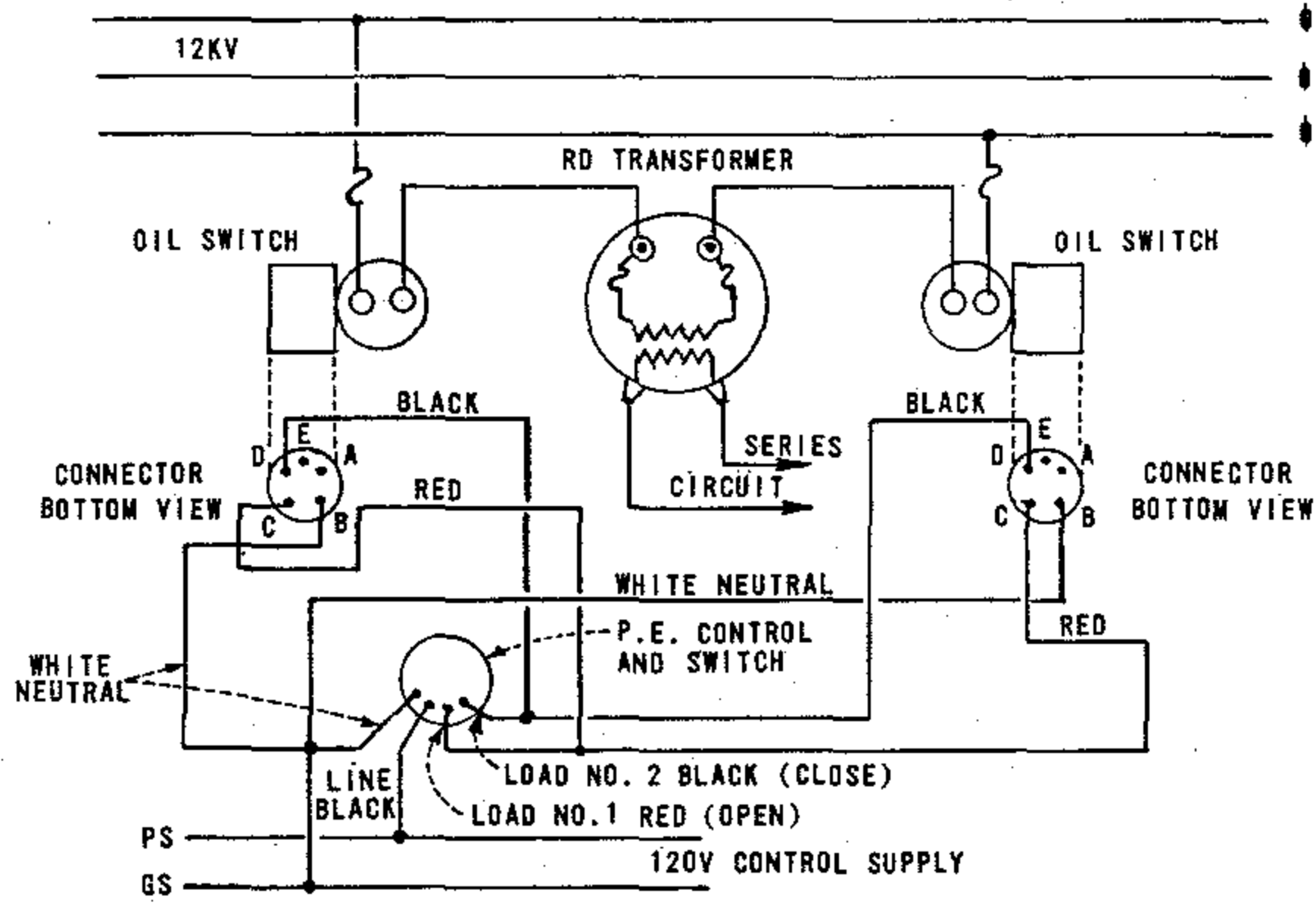
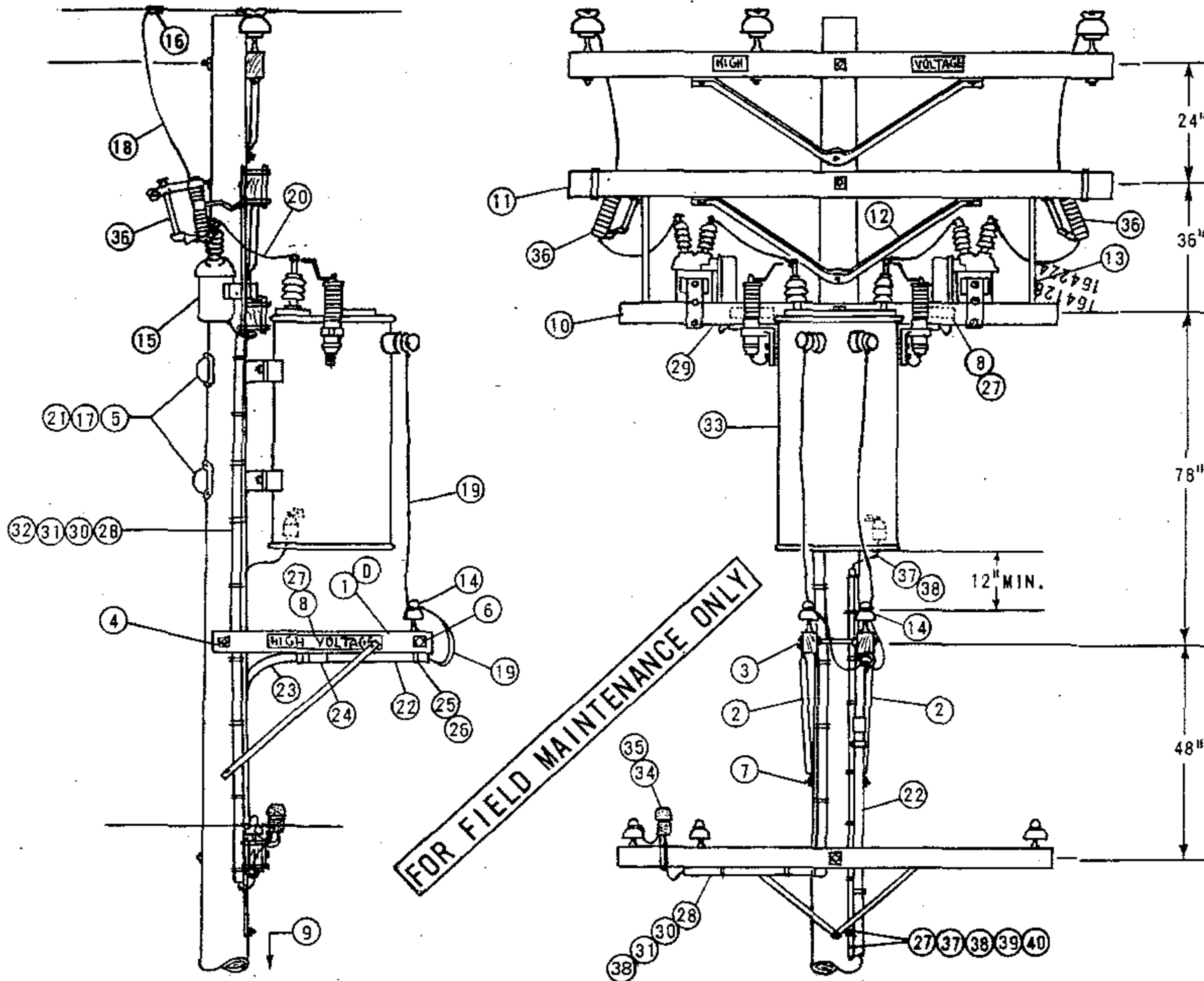

WIRING DIAGRAM

1599.601
SUPERSEDES
1562.1 (4-30-82)

SDG&E ELECTRIC STANDARDS

P.E. CONTROLLED
R.D. STREET LIGHT TRANSFORMER INSTALLATION, 12KV

DATE 4-30-82
APPD *URH*

BILL OF MATERIAL :

ITEM		DESCRIPTION	QUANTITY	STOCK NO. OR CONSTR. STDS.
PTF	SL&SS			
1		CROSSARM, 3 1/2" X 4 1/2" X 4'-0" (D)	1	STD 380.05 IT. 3
2		BRACE, ALLEY ARM, 4'-0"	2	163808
3		BOLT, MACH. GALV., 5/8" X 5", 1 RD. WASHER & 1 NUT (E)	1	STD 139, 140
4		BOLT, MACH. GALV., 5/8" X 18", 2 SQ. WASHERS & 1 NUT (E)	1	STD 139, 140
5		BOLT, MACH. GALV., 3/4" X 12", 1 SQ. CURVED WASHER & 1 NUT	2	STD 139, 140
6		BOLT, SPACE, GALV., 5/8" X 20", 4 SQ. WASHERS & 4 NUTS (E)	1	STD 139, 140
7		SCREW, LAG, GALV., 5/8" X 5" (E)	1	621600
8		SIGN, HIGH VOLTAGE & NAILS, GALV ROOFING (E)	3	647648,
9		STEPS, POLE (E)	15	692992
10		CROSSARM, 3 3/4" X 5 3/4" X 8'	1	STD 380.01
11		CROSSARM, 3 3/4" X 5 3/4" X 10'	1	STD 380.1
12		BRACE, 5'-0"	1	
13		BRACE, STRUT, 36"	2	
14		INSULATOR, 4KV (E)	2	700 SECTION
15		SWITCH, OIL, NR, 15KV, 200 AMP	2	705568
16		CONNECTORS, COMPRESSION (E)	2	700 SECTION
17		NAILS, GALV, 10d (E)	6	491392
18		WIRE, COPPER #6/3 STRAND	10'	813536
19		CABLE, 1/C #6, 5KV XLP	60'	194304
20		WIRE, COPPER, #4 SOLID W.P.	10'	812480
21		COVER, PVC THRU BOLT (E)	2	285696
22		PIPE, PLASTIC 1 1/2" DIAM., PVC TYPE II, SCHEDULE 80, 20' LENGTHS (E)	1	251456
23		PIPE, 1 1/2" DIAM. PLASTIC, 90° ELBOW, PVC TYPE II, SCHEDULE 80	1	322464
24		COUPLING, 1 1/2" DIAM. PLASTIC PIPE, PVC (E)	3	280512
25		STRAP, PIPE 1 1/2" DIAM., GALV. (E)	AS REQ'D.	697664
26		NAILS, 10d GALV. (E)	AS REQ'D.	491392
27		CLAMP, GROUND ROD (E)	2	230016
28		CONDUIT, PVC, TYPE II, SCHEDULE 80, 1" (E)	25'	251424
29		PLUG, DISCONNECT CONDUCTOR, 5 TERMINAL (F)	2	544838
30		WIRE, COPPER, #12 TW, STRANDED WP, WHITE (F)	25'	810016
31		WIRE, COPPER, #12 TW, STRANDED WP, RED (F)	25'	809920
32		WIRE, COPPER, #12 TW, STRANDED WP, BLACK (F)	25'	809504
33		TRANSFORMER, R.D., 12KV, 25KVA	1	763426
34		MOUNTING BRACKET	1	166432
35		PHOTO ELECTRIC RELAY, 120 V., 1000 W MIN.	1	273920
36		CUTOUT, 12KV 100A	2	297888
37		WIRE, COPPER #6 B. STRD.	50'	813644
38		UNIT, GROUND (LTN'G ARR.) PLAIN/GREY	1	603136, 603120
39		STAPLE, FENCE 1 1/4" (E)	AS REQ'D	678520
40		STAPLE, MOULDING 3" X 1 1/16" X 1/4" (E)	AS REQ'D	678560

FOR FIELD MAINTENANCE ONLY

INSTALLATION :

- A. CLASS OF POLES SHOULD BE DETERMINED PER STDS 344-361.
- B. APERTURE OF PHOTOELECTRIC CELL MUST BE SET TO FACE NORTH.
- C. 12KV/6.6A CONSTANT CURRENT TRANSFORMER HAS INTERNAL FUSES.
- (D) WHEN THERE IS NO SECONDARY ON A POLE, A 6 PIN COMBINATION ARM FOR THE TWO WIRE SERIES AND THE SECONDARY MAY BE USED. THE 4' ALLEY ARMS WILL NOT BE NEEDED. IDENTIFY THE SECONDARY WITH 0-750 VOLT SIGNS.
- (E) EXEMPT MATERIAL.
- (F) 5 TERMINAL PLUGS AND WIRE TO BE FABRICATED BY KEARNY MAINTENANCE.
- G.
- H.

REFERENCE :

- I. G. O. 95 RULE 58.2 REQUIRES PRIMARY CONSTANT CURRENT SERIES LIGHTING CIRCUITS BE TREATED AS MORE THAN 750 VOLTS.
- J. S D G & E RULE DOES NOT ALLOW FOR CONSTANT CURRENT SERIES LIGHTING CIRCUITS OVER 750 VOLTS TO BE PLACED ON THE SAME ARM WITH 12KV.

DATE 4-30-82
APPD *ARH*

S D G & E ELECTRIC STANDARDS
P. E. CONTROLLED
R. D. STREET LIGHT TRANSFORMER INSTALLATION, 12KV

1599.602
SUPERSEDES
1562.2 (4-30-82)

1600 - WILDLIFE
PROTECTION

1600 - WILDLIFE
PROTECTION

PAGE(S)

SUBJECT

No FMO content available at this time.

© 1998 - 2020 San Diego Gas & Electric Company. All rights reserved. Removal of this copyright notice without permission is not permitted under law.

REV	CHANGE	BY	DSGN	APPV	DATE	REV	CHANGE	BY	DSGN	APPV	DATE
C						F					
B						E					
A						D					

SHEET 1 OF 1	Indicates Latest Revision	Completely Revised	<input checked="" type="checkbox"/>	New Page	Information Removed	FMO OH1601.1
	SDG&E ELECTRIC OVERHEAD FIELD MAINTENANCE ONLY STANDARDS					
	WILDLIFE PROTECTION TABLE OF CONTENTS					

1700 - SPACER
CABLE SYSTEM

1700 - SPACER
CABLE SYSTEM

PAGE(S)

SUBJECT

1705

STEEP GRADE LINE ANGLES: 0 TO 6 DEGREES

© 1998 - 2019 San Diego Gas & Electric Company. All rights reserved. Removal of this copyright notice without permission is not permitted under law.

REV	CHANGE	BY	DSGN	APPV	DATE	REV	CHANGE	BY	DSGN	APPV	DATE
C						F					
B						E					
A	ORIGINAL ISSUE	JK	JS	CZH	2/1/2019	D					

SHEET 1 OF 1	<input type="checkbox"/> Indicates Latest Revision <input type="checkbox"/> Completely Revised <input checked="" type="checkbox"/> New Page <input type="checkbox"/> Information Removed	FMO OH1701
	SDG&E ELECTRIC UNDERGROUND CONSTRUCTION STANDARD	
	SPACER CABLE SYSTEM FMO TABLE OF CONTENTS	

OH1705 FIELD MAINTENANCE ONLY

ALL VERSIONS LISTED IN FMO ARE SUPERSEDED BY THEIR CURRENT VERSION FOUND INSIDE THE OVERHEAD
CONSTRUCTION STANDARD MANUAL.

REVISION HISTORY:

07/08/2019: MOVED TO FMO

© 1998 - 2019 San Diego Gas & Electric Company. All rights reserved. Removal of this copyright notice without permission is not permitted under law.

REV	CHANGE	BY	DSGN	APPV	DATE	REV	CHANGE	BY	DSGN	APPV	DATE
C						F					
B						E					
A	ORIGINAL ISSUE	JES	JES	CZH	07/08/2019	D					

SHEET 1 OF 1	Indicates Latest Revision	Completely Revised	<input checked="" type="checkbox"/> New Page	Information Removed	FMO OH1705
	SDG&E ELECTRIC OVERHEAD FIELD MAINTENANCE ONLY STANDARDS				
	STEEP GRADE LINE ANGLES: 0 TO 6 DEGREES				

SCOPE: FOR SLOPES LESS THAN 10 DEGREES, AND LINE ANGLES FROM 0 TO 6 DEGREES.

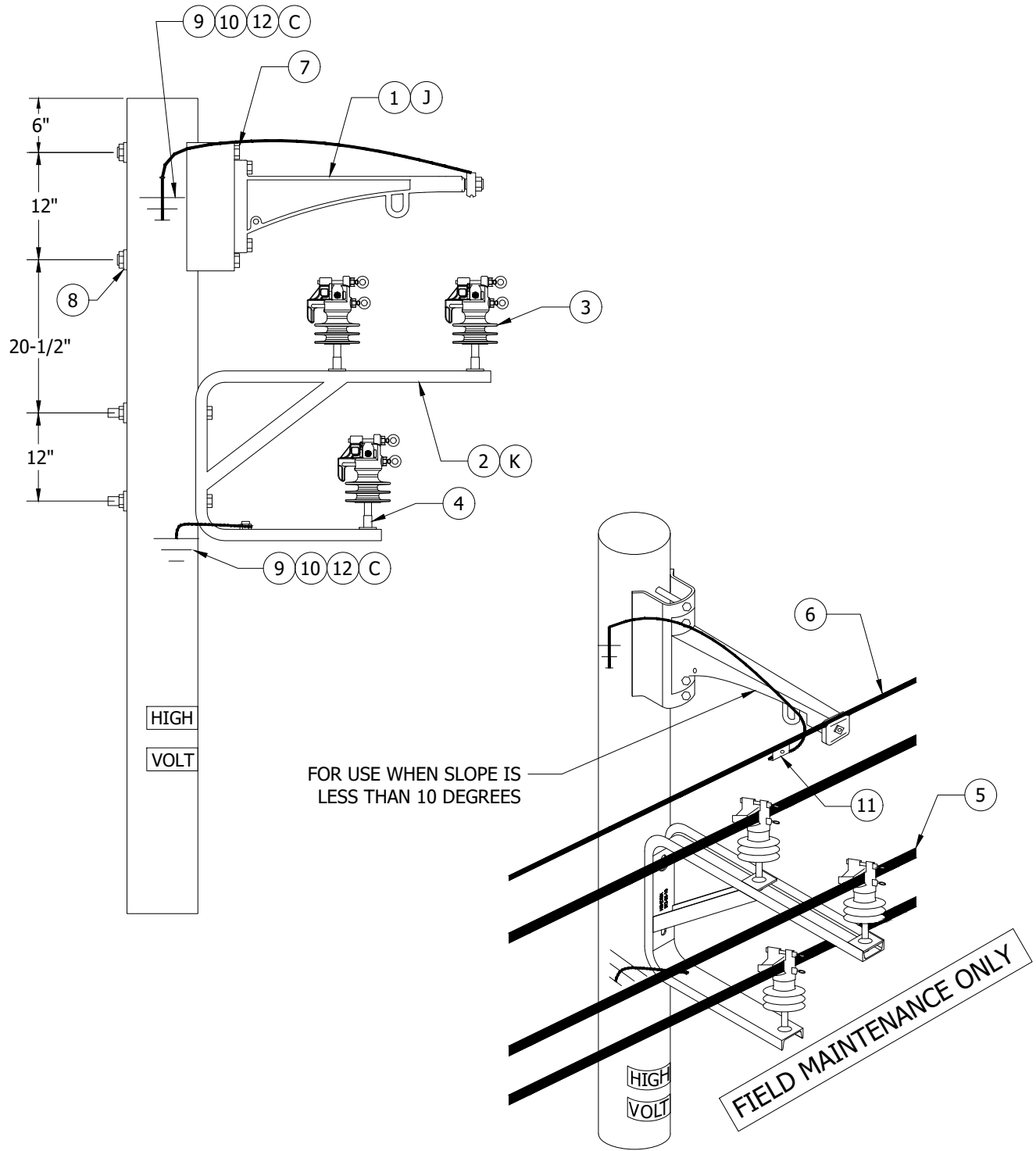

© 1998 - 2019 San Diego Gas & Electric Company. All rights reserved. Removal of this copyright notice without permission is not permitted under law.

REV	CHANGE	BY	DSGN	APPV	DATE	REV	CHANGE	BY	DSGN	APPV	DATE
C	DRAWING UPDATES	PEI	-	-	01/15/2019	F					
B	EDITORIAL CHANGES	JS	JS	CZH	08/01/2018	E					
A	ORIGINAL ISSUE	-	JC	IL	11/07/2014	D	MOVED TO FMO	JES	JES	CZH	07/08/2019

X Indicates Latest Revision Completely Revised New Page Information Removed

SHEET
1 OF 2

SDG&E ELECTRIC OVERHEAD FIELD MAINTENANCE ONLY STANDARDS

STEEP GRADE LINE ANGLES: 0 TO 6 DEGREES

FMO
OH1705.1

INSTALLATION:

- A. WHEN A GO95 SPACER IS REQUIRED FOR USE ON A MIDSPAN SLOPE GREATER THAN 20 DEGREES, A RTL-GO95DM SPACER (S663282) MUST BE USED INSTEAD.
- B. REFERENCE STANDARDS PAGE 1706 FOR BEFORE & AFTER SLOPES THAT ARE EQUAL, IF NOT REFERENCE STANDARDS PAGE 1707.
- C REFER TO WOOD AND STEEL POLE GROUNDING STANDARD 1002.
- D. WHEN INSTALLING SPACER CABLE WIRE ABOVE OR IN THE PRESENCE OF 3-PHASE EQUIPMENT, REFERENCE STANDARD 1710 FOR CLEARANCE AND HARDWARE. SPACER CABLE WIRE MUST BE A MINIMUM OF 7 FEET FROM 3-PHASE EQUIPMENT.
- E. WHEN INSTALLING SPACER CABLE WIRE ABOVE OR IN THE PRESENCE OF SINGLE-PHASE EQUIPMENT REFERENCE STANDARD 1710 FOR SINGLE-PHASE EQUIPMENT CLEARANCES AND HARDWARE. SPACER CABLE WIRE MUST BE A MINIMUM OF 7 FEET FROM SINGLE-PHASE EQUIPMENT.
- F. LOWEST SPACER CABLE WIRE MUST BE INSTALLED A MINIMUM OF 6 FEET FROM FIBER/TELCO.
- G. FOR EXTRA HEAVY LOADING CONDITIONS USE 127AWA MESSENGER (S814055) WITH DEAD-END MESSENGER GRIP ME-4179 (S392940) COLOR CODED, BLACK.
- H. REFERENCE G.O. 95 CLEARANCES.
- J TANGENT BRACKET - BRACKETS DESIGNED TO SUPPORT THE SPACER CABLE MESSENGER WIRE. THEY ARE USED ON TANGENT POLES AND FOR TRANSVERSE ANGLES UP TO 6 DEGREES.
- K THESE BRACKETS MAINTAIN THE DIAMOND CONFIGURATION OF THE PHASE CONDUCTORS ON THE POLE.

BILL OF MATERIALS:

ITEM	DESCRIPTION	QUANTITY	STANDARD PAGE	STOCK NUMBER	ASSEMBLY UNITS
1	TANGENT BRACKET	2	-	S166150	GUYARM
2	BRACKET, "C", TRANSFORMER TAP	1	-	S166152	C-BKT
3	INSULATOR, PIN TYPE	3	750.2	S429060	IPC1
4	INSULATOR PIN, SHORT SHANK, 1" LEAD THREAD	3	396	S532426	PSS1
5	SPACER CABLE (SIZE AND VOLTAGE RATING AS REQ.)	AS REQ	1702	-	-
6	MESSENGER (SIZE AND TYPE AS REQUIRED)	AS REQ	1702	-	-
7	MACHINE BOLT, 3/4" X REQ. LENGTH	AS REQ	392.1	-	-
8	WASHER, CURVED, SQUARE	AS REQ	392.2	S797760	-
9	#4, 7 STRAND, COVERED JUMPER WIRE	AS REQ	718	S815044	POLY4J
10	RIVNUT, THREADED, 1/2" X 13	AS REQ	1002.2	S692998	-
11	CONNECTOR, WEDGE (SIZE AND TYPE AS REQ.)	AS REQ	784.5	-	-
12	CONNECTOR, SPLIT BOLT, BRONZE 1/2" X 13	AS REQ	1002.3	S26148	SPCONN

NOTES:

NONE

REFERENCE:

NONE

FIELD MAINTENANCE ONLY

© 1998 - 2019 San Diego Gas & Electric Company. All rights reserved. Removal of this copyright notice without permission is not permitted under law.

REV	CHANGE	BY	DSGN	APPV	DATE	REV	CHANGE	BY	DSGN	APPV	DATE
C	DRAWING UPDATES	PEI	-	-	01/15/2019	F					
B	EDITORIAL CHANGES	JS	JS	CZH	08/01/2018	E					
A	ORIGINAL ISSUE	-	JC	IL	11/07/2014	D	MOVED TO FMO	JES	JES	CZH	07/08/2019

SHEET 2 OF 2	X	Indicates Latest Revision	Completely Revised	New Page	Information Removed	FMO OH1705.2
	SDG&E ELECTRIC OVERHEAD FIELD MAINTENANCE ONLY STANDARDS					
	STEEP GRADE LINE ANGLES: 0 TO 6 DEGREES					

1800 - ENGINEERED STEEL POLES

1800 - ENGINEERED STEEL POLES

PAGE(S)

SUBJECT

No FMO content available at this time.

© 1998 - 2020 San Diego Gas & Electric Company. All rights reserved. Removal of this copyright notice without permission is not permitted under law.

REV	CHANGE	BY	DSGN	APPV	DATE	REV	CHANGE	BY	DSGN	APPV	DATE
C						F					
B						E					
A						D					

Indicates Latest Revision

Completely Revised



New Page

Information Removed

**SHEET
1 OF 1**

SDG&E ELECTRIC OVERHEAD FIELD MAINTENANCE ONLY STANDARDS

ENGINEERED STEEL POLES
TABLE OF CONTENTS

**FMO
OH1801.1**

1900 -
MISCELLANEOUS
EQUIPMENT

1900 -
MISCELLANEOUS
EQUIPMENT

PAGE(S)

SUBJECT

No FMO content available at this time.

© 1998 - 2020 San Diego Gas & Electric Company. All rights reserved. Removal of this copyright notice without permission is not permitted under law.

REV	CHANGE	BY	DSGN	APPV	DATE	REV	CHANGE	BY	DSGN	APPV	DATE
C						F					
B						E					
A						D					

SHEET 1 OF 1	Indicates Latest Revision	Completely Revised	<input checked="" type="checkbox"/> New Page	Information Removed	FMO OH1901.1
	SDG&E ELECTRIC OVERHEAD FIELD MAINTENANCE ONLY STANDARDS				
	MISCELLANEOUS EQUIPMENT TABLE OF CONTENTS				

**2000-COVERED
CONDUCTOR**

**2000-COVERED
CONDUCTOR**

PAGE(S)

SUBJECT

No FMO content available at this time.

© 1998 - 2020 San Diego Gas & Electric Company. All rights reserved. Removal of this copyright notice without permission is not permitted under law.

REV	CHANGE	BY	DSGN	APPV	DATE	REV	CHANGE	BY	DSGN	APPV	DATE
C						F					
B						E					
A						D					

SHEET 1 OF 1	Indicates Latest Revision	Completely Revised	<input checked="" type="checkbox"/>	New Page	Information Removed	FMO OH2001.1
	SDG&E ELECTRIC OVERHEAD FIELD MAINTENANCE ONLY STANDARDS					
	COVERED CONDUCTOR TABLE OF CONTENTS					

OH LEGACY FMO

OH LEGACY FMO

LEGACY OVERHEAD FIELD MAINTENANCE ONLY

<u>PAGES</u>	<u>SUBJECT</u>
200-400	DISTRIBUTION POLE TOPS
500	TRANSMISSION
600-900	SECONDARIES, CONDUCTOR, GUYING
1100	TRANSFORMERS
1200	SECTIONALIZING
1300	CAPACITORS, REGULATORS
1400-1500	CABLE POLES, LIGHTING

© 1998 - 2019 San Diego Gas & Electric Company. All rights reserved. Removal of this copyright notice without permission is not permitted under law.

REV	CHANGE	BY	DSGN	APPV	DATE	REV	CHANGE	BY	DSGN	APPV	DATE
C						F					
B						E					
A	ORIGINAL ISSUE	JIK	JES	CZH	10/20/2019	D					

SHEET 1 OF 1	Indicates Latest Revision	Completely Revised <input checked="" type="checkbox"/>	New Page	Information Removed	OH LEGACY OHL100.1
	SDG&E ELECTRIC OVERHEAD FIELD MAINTENANCE ONLY STANDARDS				
	LEGACY OVERHEAD FIELD MAINTENANCE MAIN TABLE OF CONTENTS				

200-400 DISTRIBUTION
POLE TOPS

200-400 DISTRIBUTION
POLE TOPS

<u>PAGE</u>	<u>SUBJECT</u>
203	DISTRIBUTION STATION NUMBERING
204	OVERHEAD DISTRIBUTION SWITCH NUMBERING
212	GFMS SUMMARY OPERATING, UNDERGROUND OPERATING AND FACILITY MAPS
218	POLE TOP RAIL
269	12KV SINGLE CIRCUIT TRANSPOSITION
299.201	AERIAL CABLE CLEARANCE
399.401	PROTECTIVE COVERINGS, MOLDINGS AND STRAPS
399.402	"J" BOLT FOR CABLE POLE RISERS
399.501	CAPACITOR MOUNTING STRAP
399.502	MOUNTING BRACKETS
399.503-.504	HORIZONTAL AND VERTICAL POLE LOADING
399.701-.702	REINFORCING WOOD POLES WITH STEEL SLEEVES
399.703	REINFORCING WOOD POLES WITH FIBERGLASS WRAP
499.101	FIBERGLASS SUPPORT CONSTRUCTION, 12KV AND BELOW
499.102-.103	POST INSULATOR AND BRACKET CONSTRUCTION, ANGLES 0° TO 5°, 12 AND 12.47KV
499.104-.105	POST INSULATOR AND BRACKET CONSTRUCTION, ANGLES 5° TO 30°, 12 AND 12.47KV
499.201	VERTICAL CONSTRUCTION 30° TO 60° ANGLES, 12 AND 12.47KV
499.202	VERTICAL CONSTRUCTION 60° TO 90° ANGLES, 12 AND 12.47KV
499.203-.204	POST INSULATOR AND BRACKET CONSTRUCTION, "4 WAY AND 'T' CORNERS", 12 AND 12.47KV
499.301	750-7500 VOLT BUCKARM CORNERS
499.701	POLE TOP EXTENSION, FOR SERVICE CLEARANCE ARMS

© 1998 - 2019 San Diego Gas & Electric Company. All rights reserved. Removal of this copyright notice without permission is not permitted under law.

REV	CHANGE	BY	DSGN	APPV	DATE	REV	CHANGE	BY	DSGN	APPV	DATE
C						F					
B	COMPLETELY REVISED	JK	JS	CZH	10/15/2019	E					
A	ORIGINAL ISSUE	JK	JS	CZH	6/13/2019	D					

SHEET 1 OF 1	Indicates Latest Revision <input checked="" type="checkbox"/> Completely Revised <input type="checkbox"/> New Page <input type="checkbox"/> Information Removed	OH LEGACY OHL201.1
	SDG&E ELECTRIC OVERHEAD FIELD MAINTENANCE ONLY STANDARDS	
	LEGACY OVERHEAD FIELD MAINTENANCE TABLE OF CONTENTS DISTRIBUTION POLE TOPS	

I. STATION NUMBERS GIVE A UNIQUE NUMBER TO, AND BRIEFLY DESCRIBE, DISTRIBUTION STATIONS. ALL STATION NUMBERS ARE ASSIGNED BY THE TRANSFORMER CLERK (EXT 1217 OR MICROWAVE 02167).

II. THE STATION NUMBER IS BROKEN UP INTO THREE PARTS: CIRCUIT; NUMBER; AND SUFFIX. 40 - 118 - MRO
CIRCUIT NUMBER SUFFIX

CIRCUIT - THE CIRCUIT DESIGNATION DESCRIBES THE VOLTAGE THAT FEEDS THE STATION. IF IT IS ONLY NUMERIC CHARACTERS, THEN THE CIRCUIT ORIGINATING AT THE SUBSTATION IS 12KV. IF IT HAS ALPHABETIC CHARACTERS IN IT, THEN THE CIRCUIT VOLTAGE IS 4 OR 2.4KV. (SEE NOTE F).

EXAMPLES:

40 - CIRCUIT 40 IS 12KV

NO1 - NORTH OTAY ONE IS 4KV

NUMBER - CONTAINS ONLY NUMERIC CHARACTERS. THIS PART IS ARBITRARY.

EXAMPLES:

118 - NUMBER SELECTED BY TRANSFORMER CLERK

908 - NUMBER SELECTED BY TRANSFORMER CLERK

SUFFIX - THE SUFFIX IS DESCRIPTIVE OF THE STATION, (SEE NOTE C) HIERARCHY (ARRANGEMENT IN SERIES) FOR COMBINING SUFFIXES IS:

- I. NUMERIC CHARACTERS (1-99) (SEE NOTE D)
- II. M, V, B, BU, G, R, L, SW, UP, N
- III. RO, RC, SL
- IV. Y, X, C
- V. S

EXAMPLES:

- C - CAPACITOR STATION
- M - 12KV PRIMARY METERED STATION
- MRO - METERED STREET LIGHT STATION
- D - 4 OR 2.4KV STATION THAT IS FED FROM A STEPDOWN STATION SERVING ONLY 1 CUSTOMER OR ONLY PRIMARY METERED CUSTOMER(S)
- 1M - 4 OR 2.4KV PRIMARY METERED STATION FED FROM A STEPDOWN STATION

FOR FIELD MAINTENANCE ONLY

III. THESE PARTS ARE BROUGHT TOGETHER AS FOLLOWS:

A. WHEN WRITING THE STATION NUMBERS ON OTHER THAN FORMS FOR KEYPUNCH USE, EACH PART OF THE STATION NUMBER IS SEPARATED BY A DASH.

EXAMPLES:

- 40-118 12KV TRANSFORMER STATION
- 40-216-C 12KV CAPACITOR STATION
- NO1-118 4 OR 2.4KV TRANSFORMER STATION
- NO1-216-MRO 4 OR 2.4KV METERED STREET LIGHT STATION
- 40-908-D 12 TO 4KV OR 12 TO 2.4KV STEPDOWN STATION (INDICATED BY D) (SEE NOTES A, B & F)
- 40-118-2G 12KV REGULATOR STATION, 2ND POLE OF 3-1Ø REGULATORS ON 3 POLES.

B. THE FOLLOWING FORMS WILL BE USED FOR KEYPUNCHING AND THE STATION NUMBER IS REQUIRED ON THEM:

- | | | | |
|---------------------------------|------------------|-----------------------------------------|--------------------|
| 1. APARTMENT LIST | 101-4145A | 7. NEW SERVICE INPUT DOCUMENT | 124-10152 |
| 2. CIS MASTER STATION UPDATE | 124-13152 | 8. STATION FILE CUTOVERS | 111-391 |
| 3. CUSTOMER NEW SERVICE REQUEST | 124-6201 | 9. TRANSFORMER TAG | 120-5240A |
| 4. ELECTRIC CONSTRUCTION ORDER | (NO FILE NUMBER) | 10. TRANSFORMER STATION FILE PUNCH FORM | 110-591/21A |
| 5. ELECTRIC SERVICE ORDER | 107-212L | 11. TAG NOTICE TO ELECTRIC TROUBLEMAN | (TEMPORARY FORM) |
| 6. GAS/ELECTRIC SET ORDER | 124-610 | 12. CURRENT STATION/CUSTOMER TIE | (COMPUTER LISTING) |

	<input checked="" type="checkbox"/> Indicates Latest Revision	<input type="checkbox"/> Completely Revised	<input type="checkbox"/> New Page	<input type="checkbox"/> Information Removed
ISSUE 1993	SDG&E ELECTRIC STANDARDS			OH 299.001
DATE 1-1-89	DISTRIBUTION STATION NUMBERING			UG 3199.001
APPD /				SUPERCEDES 203.1 (1-1-93)

C. THE RULES FOR FILLING IN THE STATION NUMBER ON THESE FORMS ARE AS FOLLOWS:

1. ALL ALPHABETIC CHARACTER O'S ARE TO BE WRITTEN WITH A SLANT MARK; i.e., Ø. THIS IS TO AVOID CONFUSION WITH THE NUMERIC CHARACTER ZERO.
2. INSTRUCTIONS FOR FILLING IN FORMS.
 - a. THE CIRCUIT FIELD (COLUMN). SEE TABLE 1 BELOW. ALPHABETIC CHARACTERS ARE TO BE LEFT JUSTIFIED AND THE NUMERIC CHARACTERS RIGHT JUSTIFIED (SEE NOTE E). IN MOST CASES, THERE WILL BE BLANK COLUMNS IN THIS FIELD.
 - b. THE NUMBER FIELD (COLUMN). SEE TABLE 1 BELOW. THE NUMERIC CHARACTERS ARE RIGHT JUSTIFIED AND ZEROS ARE ADDED TO COMPLETE FIELD.
 - c. THE SUFFIX FIELD (COLUMN). SEE TABLE 1 BELOW. IF STATION NUMBER HAS NO SUFFIX, LEAVE THIS BLANK. THE ENTIRE PROPERLY FORMED SUFFIX IS LEFT JUSTIFIED AND ZEROS ARE ADDED TO COMPLETE FIELD.

EXAMPLES OF STATION NUMBERS WRITTEN ON FORMS:

TABLE 1

CIRCUIT	NUMBER	SUFFIX
0 0 4 0	0 1 1 8	
0 0 4 0	0 2 1 6	C 0 0 0
* N Ø 0 1	0 1 1 8	
* N Ø 0 1	0 2 1 6	M R Ø 0 *
0 0 4 0	0 9 0 8	D 0 0 0
0 0 4 0	0 9 0 8	3 1 0 0

FOR FIELD MAINTENANCE ONLY

NOTES:

- (A) REFER TO THE DISTRIBUTION ENGINEER BEFORE ADDING LOAD TO THESE AREAS TO ENSURE THAT THE STEPDOWN STATION IS NOT OVERLOADED.
- (B) INDICATES A 2.4 OR 4KV STEPDOWN STATION SERVING ONLY ONE CUSTOMER OR ONLY PRIMARY METERED CUSTOMER(S).
- (C) SEE PAGE 299.126 OVERHEAD OR 3199.126 UNDERGROUND – ABBREVIATIONS & CODES, STATION SUFFIX FOR SUFFIX MEANINGS.
- (D) NUMERIC CHARACTERS 1 – 9 ARE RESERVED FOR STATIONS WITH ADDITIONAL SUFFIXES.
- (E) RIGHT AND LEFT JUSTIFICATION MAY BE A NEW TERM FOR MOST PEOPLE. RIGHT JUSTIFIED MEANS TO START WITH THE RIGHT MOST CHARACTER OF THE GROUP AND PUT IT INTO THE RIGHT MOST COLUMN, WORKING LEFT UNTIL ALL CHARACTERS ARE USED UP AND IN ALL REMAINING BLOCKS AND ZEROS. SIMILARLY FOR LEFT JUSTIFIED, ONLY WORK FROM LEFT TO RIGHT AND ADD ZEROS TO FILL UNUSED BLOCKS.

EXAMPLE: RIGHT JUSTIFY: 198 STEP 1

			8
		9	8
	1	9	8

 FINAL STEP 4

0	1	9	8
---	---	---	---

 ADD ZERO IN REMAINING BLOCK(S)

LEFT JUSTIFY ALPHABETIC CHARACTERS, RIGHT JUSTIFY NUMERIC CHARACTERS: NØ1

STEP 1

N			
---	--	--	--

 STEP 2 *

N	Ø		
---	---	--	--

 ALPHABETIC CHARACTERS LEFT JUSTIFIED
 STEP 3 *

N	Ø		1
---	---	--	---

 NUMERIC CHARACTER RIGHT JUSTIFIED
 FINAL STEP 4

N	Ø	0	1
---	---	---	---

 ADD ZERO IN REMAINING BLOCK(S)

- (F) STEPDOWN STATIONS WILL BE GIVEN NAME EXCEPT FOR THOSE SERVING ONLY ONE CUSTOMER OR ONLY PRIMARY METERED CUSTOMER(S)

* SEE III, C, 1.

<input checked="" type="checkbox"/>	Indicates Latest Revision	Completely Revised	New Page	Information Removed
OH 299.002 UG 3199.002 SUPERCEDES 203.2 (1-1-93)				SDG&E ELECTRIC STANDARDS DISTRIBUTION STATION NUMBERING ISSUE 1993 DATE 1-1-87 APPD /

SCOPE: THIS STANDARD EXPLAINS THE METHOD OF OVERHEAD DISTRIBUTION SWITCH NUMBERING.

1. EACH SWITCH IS IDENTIFIED BY A UNIQUE NUMBER THAT INDICATES THE CIRCUIT(S) ON WHICH IT OPERATES.
2. THERE ARE TWO TYPES OF SWITCH NUMBERS: **LINE** AND **TIE**

2.1 **LINE SWITCH NUMBERS** ARE BROKEN UP INTO TWO PARTS:

CIRCUIT AND NUMBER $\frac{375}{\text{CIRCUIT}} - \frac{40-L}{\text{NUMBER}}$

CIRCUIT – DESCRIBES THE VOLTAGE AND CIRCUIT NUMBER TO WHICH THE LINE SWITCH IS CONNECTED. IF THE CIRCUIT CONTAINS ONLY NUMERIC CHARACTERS, THEN THE CIRCUIT VOLTAGE IS 12KV. IF IT CONTAINS ALPHABETIC CHARACTERS (e.g. CD10), THEN THE CIRCUIT VOLTAGE IS 4 OR 2.4KV.

NUMBER – CONTAINS ONLY NUMERIC CHARACTERS, OR, NUMERIC CHARACTERS FOLLOWED BY AN "L". THE "L" INDICATES THAT THIS IS A LOADBREAK SWITCH. THE NUMERIC PORTION IS ARBITRARY AND EACH NUMBER SHALL NOT BE ASSIGNED TO MORE THAN ONE SWITCH FOR EACH CIRCUIT.

EXAMPLES:

375-40-L INDICATES A LINE SWITCH ON 12KV CIRCUIT 375 WITH AN ARBITRARY NUMBER 40, AND LOADBREAK CAPABILITY.

GAI-2 INDICATES A LINE SWITCH ON 4KV OR 2.4KV CIRCUIT GA 1 WITH AN ARBITRARY NUMBER 2, AND NO LOADBREAK CAPABILITY.

2.2 **TIE SWITCH NUMBERS** ARE BROKEN UP INTO THREE PARTS:

CIRCUIT; ALPHA NUMERIC; AND CIRCUIT $\frac{375}{\text{CIRCUIT}} - \frac{T1}{\text{ALPHA/NUMERIC}} - \frac{376}{\text{CIRCUIT}}$

CIRCUIT – DESCRIBES THE VOLTAGE AND CIRCUIT NUMBERS THE TIE SWITCH CONNECTS **AS STATED ABOVE.**

ALPHA/NUMERIC – ALWAYS CONTAINS THE ALPHA CHARACTER "T" AND IS FOLLOWED BY A BY A NUMBER (1,2,3, ETC.) WHICH IS CONSECUTIVELY ASSIGNED FOR TIE SWITCHES BETWEEN THE SAME TWO CIRCUITS. EACH ALPHA/NUMERIC IDENTIFICATION SHALL NOT BE ASSIGNED TO MORE THAN ONE TIE SWITCH BETWEEN THE SAME TWO CIRCUITS. TIE SWITCHES WITH THE NUMBER FOLLOWED BY AN "L" HAVE LOADBREAK CAPABILITY.

EXAMPLES:

85-T1-380 INDICATES THE FIRST TIE SWITCH BETWEEN CIRCUITS 85 & 380.

86-T2-87-L INDICATES THE SECOND TIE SWITCH, WITH LOADBREAK CAPABILITY, BETWEEN CIRCUITS 86 & 87.































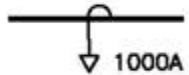

88-T-89 INDICATES THE ONLY TIE SWITCH INSTALLED BEFORE 4-1-77, BETWEEN CIRCUITS 88 & 89. IF INSTALLED AFTER 4-1-77, THIS TIE SWITCH SHALL BE NUMBERED 88-T1-89.

3. WHERE SWITCHES IN PARALLEL ARE INSTALLED AS LINE OR TIE SWITCHES, EACH SWITCH WILL BE ASSIGNED AN INDIVIDUAL NUMBER AS DESCRIBED IN PARAGRAPH 2.
4. SWITCH NUMBERS WILL NOT BE ASSIGNED TO NORMALLY OPEN, BRIDGED, OR FUSED CUTOUTS, UNLESS THEY ARE USED FOR TIE PURPOSES.

FOR FIELD MAINTENANCE ONLY





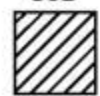







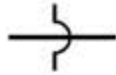

© 1998 - 2015 San Diego Gas & Electric Company. All rights reserved. Removal of this copyright notice without permission is not permitted under law.



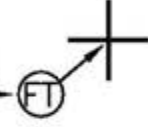

DATE 1-1-96 APPD <i>PA/ROJ</i>	SDG&E ELECTRIC STANDARDS OVERHEAD DISTRIBUTION SWITCH NUMBERING	204
-----------------------------------	--------------------------------------------------------------------	-----

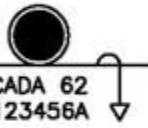
<p>BOOST/BUCK (OH)</p>  <p>123-342B 100HR P377016</p>	<p>FUSE-BRIDGED (UG)</p>  <p>3-BRGD</p>	<p>PRIMARY METERING STATION (OH)</p>  <p>123-234M P77676</p>	<p>SWITCH: (OH) GANG OPERATED</p>  <p>123-412 P77676</p>	<p>OPEN TO ADJACENT CIRCUIT (UG)</p>  <p>CIRCUIT 281 OPEN</p>	
<p>INLINE SWITCH AND FUSE</p>  <p>3-80A 241-3 P23769</p>	<p>TIE FUSE</p>  <p>AM1-T1-RD3 P123456</p>	<p>CABLE POLE</p>  <p>P233679</p>	<p>FUSE WITH BY-PASS (OH)</p>  <p>123-45 (OPEN) 3-60A P677001</p>	<p>PRIMARY METERING STATION (UG) W/CUSTOMER OWNED STRUCTURE</p>  <p>123-345M D12345 CO</p>	
<p>SWITCH: (OH) GANG OPERATED (SCADA)</p>  <p>SCADA 95 123-17 P67778</p>	<p>PAD MOUNTED SWITCH AND FUSE</p>  <p>3-80A 463-11</p>	<p>FUSE - D&W</p>  <p>3-80A D&W P234673</p>	<p>CABLE POLE (FUSED)</p>  <p>3-150A P227692</p>	<p>SWITCH - ON/OFF (UG)</p>  <p>123-324</p>	
<p>GROUNDING BANK (OH)</p>  <p>123-254GB</p>	<p>SERVICE RESTORER WITH BY-PASS (OH)</p>  <p>123-25 (OPEN) 123-24R P75678</p>	<p>SWITCH-HOOK STICK (OH)</p>  <p>123-234 P76455</p>	<p>NEUTRAL</p> 	<p>FUSE (OH)</p>  <p>1-10A P17723</p>	<p>ELECTRONIC SECTIONALIZER (OH)</p>  <p>3-100A P58961</p>
<p>FAULT INDICATOR</p>  <p>1000A</p>	<p>CAPACITOR (OH) CF - FIXED CW - SWITCHED CM - SWITCHED, IN MANUAL MODE</p>  <p>123-435CW 1200KVAR P79707</p>	<p>GROUNDING BANK (UG)</p>  <p>123-365GB</p>	<p>REGULATOR BYPASS WITH DISCONNECTS (OH)</p>  <p>123-123G 100A P47487</p>	<p>FUSE-BRIDGED (O.H.)</p>  <p>3-BRGD P570164</p>	
<p>CUSTOMER GENERATION</p>  <p>CG103023</p> <p>CG103023 EFI 939 COAST BLVD 250 KW</p>	<p>SIREN (FOR SAN ONOFRE)</p>  <p>0C03 D6954127</p>	<p>CAPACITOR (UG) CW - SWITCHED CM - SWITCHED, IN MANUAL MODE</p>  <p>123-234CW 1200KVAR</p>	<p>REGULATOR (OH) UN-BYPASSED</p>  <p>123-123G 100A P67423</p>		
<p>REGULATOR INDUCTION (OH)</p>  <p>123-123G P87219</p>	<p>OPEN TO ADJACENT CIRCUIT (OH)</p>  <p>CIRCUIT 123 OPEN</p>	<p>PAD MOUNTED SUB</p>  <p>JOHNSON STEP-DOWN 12/4 KV 2000 HPP HIGH FUSING: 1-150A LOW FUSING: -NONE FEED: CIR.552 D104329</p>	<p>POLE MOUNTED SUB</p>  <p>MISSION BEACH STEP-DOWN 12/4 KV 300 HO HIGH FUSING: 3-30A LOW FUSING: -NONE FEED: CIR. 58 P2321269883</p>		

© 1998 - 2005 San Diego Gas & Electric Company. All rights reserved. Removal of this copyright notice without permission is not permitted under law.

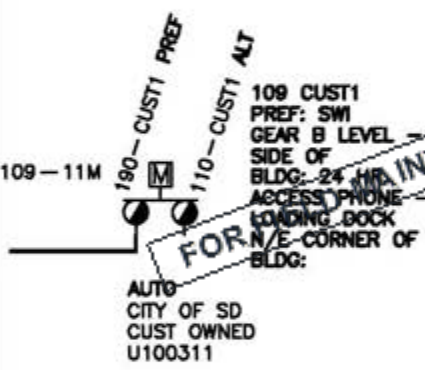
<input checked="" type="checkbox"/>	Indicates Latest Revision	<input type="checkbox"/>	Completely Revised	<input type="checkbox"/>	New Page	<input type="checkbox"/>	Information Removed
<p>REVISION</p> <p>DATE 12-3-05</p> <p>APPD TR/ MF</p>	<p>SDG&E ELECTRIC STANDARDS</p> <p>GFMS</p> <p>SUMMARY OPERATING MAP SYMBOL TABLE</p>					<p>OH 212.1</p> <p>UG 3112.1</p>	





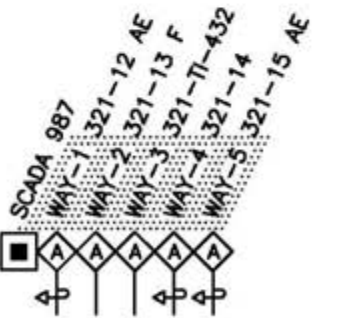
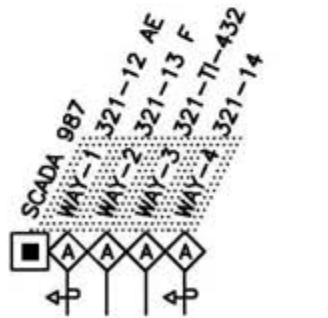
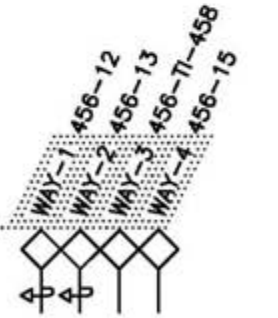
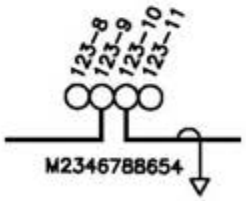



<p>OPEN TO SAME CIRCUIT</p>  <p>OPEN P57769</p>	<p>STEP UP/DN (OH)</p>  <p>144-190SD 12000/4160 P470649</p>	<p>FUSE (UG)</p>  <p>3-30A CL WITH BY-PASS 3-30A CL BP</p>	<p>PRIMARY WIRE & CALLOUT (OH)</p> <p>< 3-3/0 ACSR ></p> <p>(U.G.)</p> <p>< 750 XLPE AL-3ØN ></p>	<p>FUSED ON/OFF SWITCHING CABINET</p>  <p>3-600A 287-5</p>
<p>PRIMARY JUMP</p> 	<p>OH GROUP SWITCH SCADA MATE</p>  <p>SCADA 96 715-16 715-1 P79699</p>	<p>PME5 SWITCH</p>  <p>790-13 3-600A</p>	<p>PADMOUNT SERVICE RESTORER</p>  <p>SCADA 98 57-42</p>	<p>PME3 SWITCH</p>  <p>SCADA 99 228-7</p>
<p>OH DPQM</p>  <p>107-1 107-DPQM P123456</p>	<p>FLYING TAP</p> 	<p>LOADBREAK GANG OPERATED SWITCH</p>  <p>715-23-L P234567</p>	<p>OH SCADA RTU POLE</p>  <p>SCADA 62 P123456A</p>	<p>SUBSTATION EL CAJON SUB 69/12KV</p>  <p>SPRING VALLEY SUB 12/4KV</p> 

<p>BOOST (UG)</p>  <p>280-124B 3750 HHR</p>	<p>THROWOVER W/BUS BAR</p> 	<p>THROWOVER W/O BUS BAR</p> 	<p>PADMOUNT THROWOVER SWITCH PMH-6 STYLE</p> 
<p>THROWOVER AT A SUBSTATION</p>  <p>AUTO 206-VS PREF 208-VS ALT VISTA SUB 12/4KV</p>			

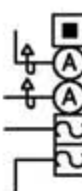
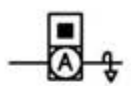
<p>5-WAY TRAYER WITH SCADA W/AUTOSECTIONALIZING AND/OR FAULT INTERRUPTION</p> 	<p>4-WAY TRAYER WITH SCADA W/AUTOSECTIONALIZING AND/OR FAULT INTERRUPTION</p> 	<p>4-WAY TRAYER, MANUAL</p> 	<p>SCHEMATIC DETAIL OF A TYPICAL 4 WAY SWITCH</p> 
------------------------------------------------------------------------------------------------------------------------------------------------------------------	-------------------------------------------------------------------------------------------------------------------------------------------------------------------	------------------------------------------------------------------------------------------------------------------	-----------------------------------------------------------------------------------------------------------------------------------------



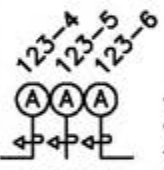
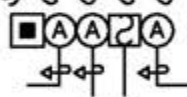
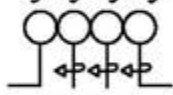

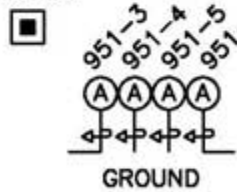





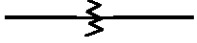
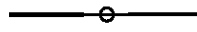

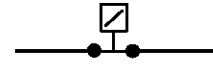
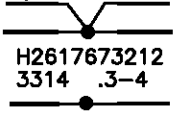
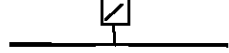
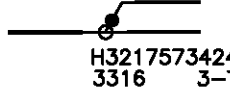
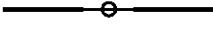
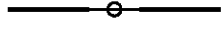
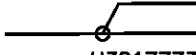
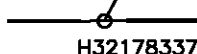
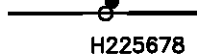

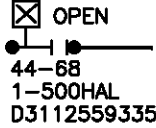

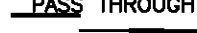

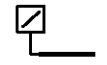

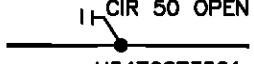

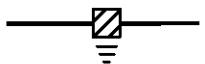
© 1998 - 2006 San Diego Gas & Electric Company. All rights reserved. Removal of this copyright notice without permission is not permitted under law.

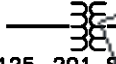
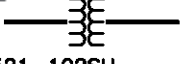
<p>OH 212.2 UG 3112.2</p>	<p>SDG&E ELECTRIC STANDARDS</p> <p>GFMS</p> <p>SUMMARY OPERATING MAP SYMBOL TABLE</p>	<p>REVISION</p> <p>DATE 10-31-06</p> <p>APPD TR/ MF</p>
<p>X Indicates Latest Revision Completely Revised New Page Information Removed</p>		



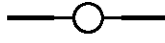

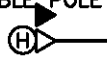



















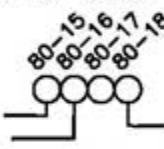
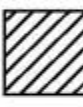

<p>PME-3</p>  <p>712-19 1000A D130145</p>	<p>PME-9</p>  <p>1000A 1000A D130423</p> <p>CMPT1 954-27 CMPT2 954-28 CMPT3 3-140A CL CMPT4 3-200A SMA</p>	<p>PME-9 WITH SCADA W/AUTOSECTIONALIZING</p>  <p>SCADA 999 CMPT1 590-1164 AE 1000A CMPT2 590-1168 AE 1000A CMPT3 3-100A SM4 CMPT4 3-100A SM4</p> <p>D131370</p>
<p>PME-3 WITH SCADA</p>  <p>1000A RTU 178 SCADA 178 435-21 1000A D131755</p>	<p>PME-10 WITH SCADA W/AUTOSECTIONALIZING</p>  <p>1000A 1000A 1000A 1000A D123456</p> <p>SCADA 789 CMPT1 999-1 AE CMPT2 999-2 AE CMPT3 999-3 AD CMPT4 990-11-999</p>	<p>PME-11</p>  <p>1000A 1000A 1000A D130489</p> <p>CMPT1 954-29 CMPT2 954-42 CMPT3 3-140A CL CMPT4 954-43</p>
<p>PME-10</p>  <p>1000A 1000A 1000A 1000A D123456</p> <p>CMPT1 999-1 CMPT2 999-2 CMPT3 999-3 CMPT4 999-T-990</p>	<p>3-WAY PADMOUNT SWITCH W/GROUND</p>  <p>1000A 1000A 1000A D123477</p> <p>123-4 123-5 123-6</p> <p>FOR FIELD MAINTENANCE ONLY</p>	<p>3-WAY PADMOUNT SWITCH W/GROUND SCADA</p>  <p>1000A 1000A 1000A D123477</p> <p>RTU 611 D678901</p> <p>123-4 123-5 123-6</p>
<p>PME-11 WITH SCADA W/AUTOSECTIONALIZING</p>  <p>1000A 1000A 1000A RTU 789 D169065</p> <p>SCADA 789 CMPT1 999-1 AD CMPT2 999-2 CMPT3 3-200A SM4 CMPT4 999-3 AE</p>	<p>4-WAY SWITCH W/GROUND</p>  <p>1000A 1000A 1000A H775837</p> <p>510-6 510-7 510-8 510-9</p>	<p>PME SOURCE TRANSFER SCADA</p>  <p>SCADA 56 MAN SDGE OWNED D100896</p> <p>CMPT1 426-4 PREF CMPT2 427-8 ALT CMPT3 3-150A CL CMPT4</p>
<p>6-WAY SWITCH W/3 FAULT INTERUPTERS & SCADA</p>  <p>1000A 1000A 1000A U123568</p> <p>RTU 610 150-2 150-3 150-T1-12L 150-4F 150-5F 150-6F</p>	<p>4-WAY SWITCH W/GROUND SCADA</p>  <p>1000A 1000A 1000A 1000A H785477</p> <p>RTU 780 D659321</p> <p>951-3 951-4 951-5 951-6</p>	

© 1998 - 2005 San Diego Gas & Electric Company. All rights reserved. Removal of this copyright notice without permission is not permitted under law.

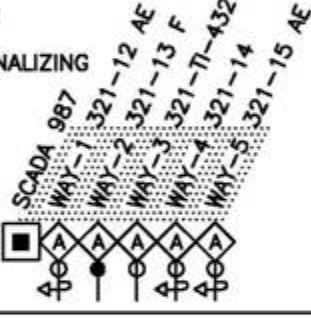
<p>REVISION</p> <p>DATE 12-3-05</p> <p>APPD TR/ MF</p>	<p>SDG&E ELECTRIC STANDARDS</p> <p>GFMS</p> <p>SUMMARY OPERATING MAP SYMBOL TABLE</p>	<p>OH 212.3</p> <p>UG 3112.3</p>	
<p><input checked="" type="checkbox"/> Indicates Latest Revision</p>	<p><input type="checkbox"/> Completely Revised</p>	<p><input type="checkbox"/> New Page</p>	<p><input type="checkbox"/> Information Removed</p>



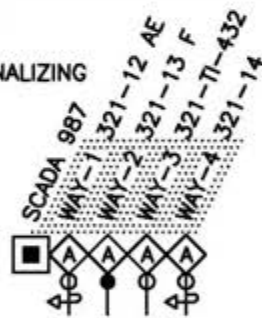

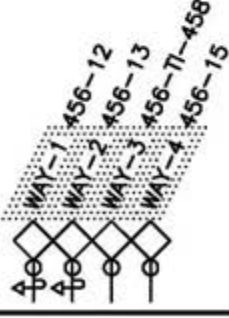



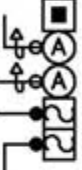

BOOST STATION  155-76B 3750 HHR D2791269123	600 AMP EXTENSION SPLICE  M123456 3-ES	CAPACITOR STATION CW - SWITCHED CM - SWITCHED, IN MANUAL MODE  124-61CW 900 KVAR D2617473210	CIRCUIT (CABLE)  30/ #2PECN CU 100.	CONNECTORS LD. BREAK ELBOWS  395-76 D2617673212
CABLE TAPS (LD. BREAK ELBOWS)  H2617673212 3314 .3-4	PIGGY BACK ELBOWS  224-73 1-25 HDD D3127573322 2-PB	"T" CONNECTOR W/200 AMP LBE  H3217573424 3316 3-T	HAND SPLICE T SPLICE  H321773326 3314 .1-HS 1-TS	STRAIGHT CONNECTOR TRANSITION MODULE  M321773326 3326 .1-SC 1-TM
"T" CONNECTOR  H321773326 3314 .3-T	"Y" CONNECTOR  H3217833734 3314 .1-Y	W/200A LB CAPABILITY  H225678 3316	PAD MOUNTED SUB  JOHNSON STEP-DOWN 12/4 KV 2000 HPP HIGH FUSING: 1-150A LOW FUSING: -NONE FEED: CIR. 552 D104329	
OPEN/SAME CIRCUIT  44-68 1-500HAL D3112559335	600A JUNCTION BAR W/GROUNDING POINT  3-TG	PASS THROUGH  H3227233832 3314 .3-PT	MANHOLE  M2468176543 3324	(LIVE FRONT) CONNECTIONS  270-77 1-50 NEP D3237333832
PRIMARY METERING STATION (UG) CUSTOMER OWNED STATION (UG) D123456 CO. 123-345M  (STRESS CONE)	OPEN/DIFFERENT CIRCUIT  CIR 50 OPEN H5470873521 3314 3-4	PAD  D3407672348	PRIMARY HANDHOLE  H2735784212 3315	GROUNDING BANK  800-632GB D2175075201
SDGE OWNED D346678 123-456M  (600A TEE)  (200A LB ELBOW)	STEP DOWNSTATION  125-201 SB 12000/2400/4160Y D2185271210	STEP UP STATION  521-102SU 12000/2400/4160Y D1581210217	SUBSTATION  EL CAJON SUB 69/12KV	SUBSTATION  SPRING VALLEY 12/4 KV
SUBSURFACE ENCLOSURE  S2345678690 3399	SUBSURFACE SWITCH ON/OFF  800-13 M3120560124 3322	FUSED ON/OFF SWITCH PAD MOUNTED  200-10 3-80A D2335479573	HOOKESTICK SWITCH ON A CABLE POLE  122-8 P13064	GANG OPERATED SWITCH ON A CABLE POLE  113-10 P323040

 Indicates Latest Revision	Completely Revised	New Page	Information Removed
SDG&E ELECTRIC STANDARDS GFMS UNDERGROUND OPERATING MAP SYMBOL TABLE			
OH 212.4 UG 3112.4			REVISION DATE 12-5-05 APPD <i>MF</i> JJ

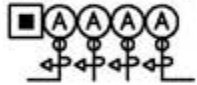
<p>1Ø PAD MOUNTED (DEAD FRONT) RADIAL</p>  <p>159-253 1-75 HDD D1479273159</p>	<p>1Ø PAD MOUNTED (DEAD FRONT) LOOP</p>  <p>561-173 1-25 NDD D106009</p>	<p>1Ø PAD MOUNTED (DEAD FRONT) LOOP W/TAP</p>  <p>561-173 1-25 NDL D107077</p>	<p>1Ø PAD MOUNTED (LIVE FRONT)</p>  <p>561-139 1-50 NEP D5114055518</p>	<p>3Ø PAD MOUNTED (DEAD FRONT) RADIAL</p>  <p>561-407 1-75 HZB D118892</p>
<p>3Ø PAD MOUNTED (DEAD FRONT) LOOP</p>  <p>561-410 1-750 HNB D118893</p>	<p>3Ø PAD MOUNTED (LIVE FRONT)</p>  <p>561-233 1-1000 HAP D5109955539</p>	<p>CLOSED DELTA (DEAD FRONT)</p>  <p>100-55 1-25 HDD 2-75 NDD D2125576655</p>	<p>OPEN DELTA (LIVE FRONT)</p>  <p>100-54 1-50 HEP 1-75 HEP D2125576655</p>	<p>1Ø SUBSURFACE</p>  <p>165-65 1-15 WS S3240064800 3399</p>
<p>3Ø PAD MOUNTED OPEN DELTA (DEAD FRONT)</p>  <p>900-75 2-75 HDL D3123560390</p>	<p>3Ø TERMINATOR (LIVE FRONT)</p>  <p>D3108560114</p>	<p>PADMOUNT SERVICE RESTORER</p>  <p>SCADA 98 57-4R D123456 3-C 3-C</p> <p>PMSR W/"N" TRANSFORMER</p>	<p>SIREN (FOR SAN ONOFRE)</p>  <p>OC01 D2461767</p>	<p>UG SCADA RTU</p>  <p>RTU 88 D116890</p>
<p>1Ø PAD MOUNTED (LIVE FRONT) "YP" TRANSFORMER</p>  <p>1-BRGD 1-18A NX 220-66 D3125676082</p>	<p>DEAD FRONT TERMINATOR</p>  <p>D123456 3-4</p>	<p>1Ø TERMINATOR WITH .1-4</p>  <p>D3099560044 1-4</p>	<p>PME5 SWITCH</p>  <p>790-13 3-150A D126194</p>	<p>4-WAY SWITCH</p> 
<p>THROWOVER AT A SUBSTATION</p>  <p>VISTA SUB 12/4KV AUTO 206-VS PREF 208-VS ALT</p>	<p>1Ø PAD MOUNTED "YP" (LIVE FRONT)</p>  <p>1-BRGD 1-35A NX 3Ø 3Ø 700-357 D321545730</p>	<p>PME3 SWITCH</p>  <p>228-7 D135790</p>	<p>5-WAY TRAYER WITH SCADA W/AUTOSECTIONALIZING AND/OR FAULT INTERRUPTION</p> 	
<p>FAULT INDICATOR</p>  <p>800A</p>	<p>Vault U2743171342</p> <p>PADMOUNT THROWOVER SWITCH PMH_6 STYLE</p>  <p>930-470 PREF 934-230 ALT 3-150A CL</p>	<p>THROWOVER W/O BUS BAR</p>  <p>426-8 ALT 428-18 PREF</p>	<p>4-WAY TRAYER WITH SCADA W/AUTOSECTIONALIZING AND/OR FAULT INTERRUPTION</p> 	
<p>THROWOVER W/BUS BAR</p>  <p>109-11M 190-CUST1 PREF 170-CUST1 ALT</p> <p>AUTO CITY OF SD CUST OWNED U100311</p> <p>109 CUST1 PREF: SWI GEAR B LEVEL - SIDE OF BLDG: 24 HR ACCESS PHONE - LOADING DOCK N/E CORNER OF BLDG:</p>	<p>AUTO U.S. POSTAL SERVICE SDG&E OWNED Y100012</p> <p>930-470 PREF: NORTHWEST CORNER OF FACILITY, NEXT TO OUTDOOR CUSTOMER SWITCHGEAR</p>	<p>MAN CITY OF SD - POLICE DEPT SDGE OWNED D2013772340</p> <p>428-18 PREF: E ST W/O 15TH BASEMENT "B"</p>	<p>4-WAY TRAYER, MANUAL</p> 	

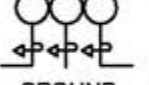
© 1998 - 2006 San Diego Gas & Electric Company. All rights reserved. Removal of this copyright notice without permission is not permitted under law.



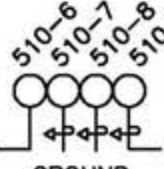
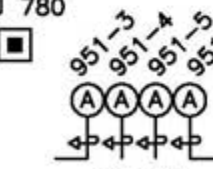























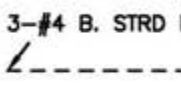



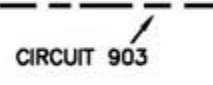

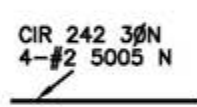



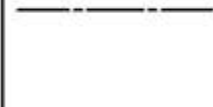



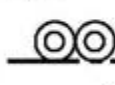

	Indicates Latest Revision	Completely Revised	New Page	Information Removed
REVISION	SDG&E ELECTRIC STANDARDS			OH 212.5 UG 3112.5
DATE 10-31-06	GFMS			
APPD TR/ MF	UNDERGROUND OPERATING MAP SYMBOL TABLE			

<p>PME-3</p>  <p>712-19 1000A D130145</p>	<p>PME-3 WITH SCADA & CAM-LINK CONNECTOR</p>  <p>1000A RTU 178 SCADA 178 435-21 1000A D131755 3-C</p>	<p>PME-9</p>  <p>CMPT1 954-27 CMPT2 954-28 CMPT3 3-140A CL CMPT4 3-200A SMA</p> <p>1000A 1000A D130423</p>
<p>PME-9 WITH SCADA</p>  <p>SCADA 999 CMPT1 590-1164 1000A CMPT2 590-1168 1000A CMPT3 3-100A SM4 CMPT4 3-100A SM4</p> <p>D131370</p>	<p>PME-10</p>  <p>CMPT1 999-1 CMPT2 999-2 CMPT3 999-3 CMPT4 999-1-990</p> <p>1000A 1000A 1000A 1000A D123456</p>	<p>PME-10 WITH SCADA W/AUTOSECTIONALIZING</p>  <p>SCADA 789 CMPT1 999-1 AE CMPT2 999-2 AE CMPT3 999-3 AD CMPT4 990-11-999</p> <p>1000A 1000A 1000A 1000A D123456</p>
<p>PME-11</p>  <p>CMPT1 954-29 CMPT2 954-42 CMPT3 3-140A CL CMPT4 954-43</p> <p>1000A 1000A 1000A D130489</p>	<p>PME-11 WITH SCADA W/AUTOSECTIONALIZING</p>  <p>SCADA 789 CMPT1 999-1 AE CMPT2 999-2 AD CMPT3 3-200A SM4 CMPT4 999-3 AE</p> <p>1000A 1000A 1000A RTU 789 D169065</p>	<p>3-WAY PADMOUNT SWITCH W/GROUND</p>  <p>123-4 123-5 123-6</p> <p>1000A 1000A 1000A D123477</p>
<p>3-WAY PADMOUNT SWITCH W/GROUND SCADA</p>  <p>RTU 611 D678901</p> <p>123-4 123-5 123-6</p> <p>1000A 1000A 1000A GROUND D123477</p>	<p>6-WAY SWITCH W/3 FAULT INTERRUPTERS & SCADA</p>  <p>RTU 610</p> <p>150-2 150-3 150-11-12L 150-4F 150-5F 150-6F</p> <p>1000A 1000A 1000A GROUND D123568</p>	<p>PME SOURCE TRANSFER SCADA</p>  <p>CMPT1 426-4 PREF CMPT2 427-8 ALT CMPT3 3-150A CL CMPT4</p> <p>SCADA 56 MAN SDGE OWNED D100896</p>
<p>4-WAY SWITCH W/GROUND</p>  <p>510-6 510-7 510-8 510-9</p> <p>1000A 1000A 1000A 1000A GROUND H775837</p>	<p>4-WAY SWITCH W/GROUND SCADA</p>  <p>RTU 780</p> <p>951-3 951-4 951-5 951-6</p> <p>1000A 1000A 1000A 1000A GROUND H785477</p>	

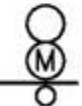
FOR FIELD MAINTENANCE ONLY

© 1998 - 2005 San Diego Gas & Electric Company. All rights reserved. Removal of this copyright notice without permission is not permitted under law.

<p>OH 212.6 UG 3112.6</p>	<p style="text-align: center;">SDG&E ELECTRIC STANDARDS</p> <p style="text-align: center;">GFMS</p> <p style="text-align: center;">UNDERGROUND OPERATING MAP SYMBOL TABLE</p>	<p style="text-align: center;">REVISION</p> <p style="text-align: center;">DATE 5-22-06</p> <p style="text-align: center;">APPD TR/ MF</p>
-------------------------------	-----------------------------------------------------------------------------------------------------------------------------------------------------------------------------------	--------------------------------------------------------------------------------------------------------------------------------------------

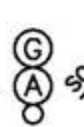
BOOST STATION (1 PHASE)  242-86B 100HR P76933	BRIDGED FUSE  CIR 242 3- BRGD JP4-33234	CAPACITOR STATION CF - FIXED CW - SWITCHED CM - SWITCHED, IN MANUAL MODE  242-85 CW/CM 1200 KVAR P234990	BUCK STATION (3 PHASE)  242-5A3BU 3750 HHT P43440	OH SCADA CABLE  SCADA 45	POLE MOUNTED SUB  MISSION BEACH STEP-DOWN 12/4 KV P2321269883
GROUNDING BANK STATION  242-74GB 3-50 YF P99032	STREET LIGHT TRANSFORMER STATION  242-85RO 1-25R P45433	SUBSTATION 12/4  POWAY SUB 12/4	OVERHEAD STREET LIGHT  P00710	REGULATOR STATION (3 PHASE)  242-227G 100A P124450	CUSTOMER GENERATION STATION  CG01-16-601 242-16M JP-321881
POLE  P567332	STUB POLE  P1167405	REGULATOR STATION (PHASE 1)  242-105G 25A JP55609	SWITCH (GANG)  242-43 JP44302	SECONDARY CIRCUIT & POLE LINE  3-#4 B. STRD N	SWITCH (HOOKSTICK)  242-12 P445760
AVIAN PROTECTION PLAN (APP) WILDLIFE SYMBOL  432-10 1-25 HE P123456	SINGLE PHASE TRANSFORMER STATION  242-85 1-15 HE P44212	SECONDARY CABLE POLE  P990321	TRANSMISSION POLELINE & CIRCUIT  CIRCUIT 903	STEP UP STATION  242-80SU 12000/2400/4160Y P114552	PRIMARY CABLE POLE  P667990
PRIMARY CIRCUIT & POLE LINE  CIR 242 3ØN 4-#2 5005 N	STEP DOWN STATION  242-14SD 12000/2400/4160Y P445520	THREE PHASE TRANSFORMER STATION  242-14 1-1-75HF P554354	PRIMARY METERING STATION  242-60M P993111	SUPERVISORY CABLE 	TERMINATION (SECONDARY DEAD ENDS)  JP556753
SERVICE RESTORER  242-20R P44358	SUBSTATION 69/12  ASH SUB 69/12	TRANSMISSION DOUBLE POLE  Z557090	TRANSMISSION POLE  Z554354	TRANSMISSION TOWER  Z113454	FUSE (CUTOUT)  CIR 242 3-30A P334143
ELECTRONIC SECTIONALIZER (CUTOUT)  CIR 455 1-100A P19926	SCADA ANTENNA POLE  P123456A	OH SCADA RTU POLE  SCADA 62 P123456A	DPQM  107-2 107-DPQM P123456	LOADBREAK GANG OPERATED SWITCH  58-23-L P234567	FLYING TAP  FT 58
PRIMARY DEAD END (MULTIPLE CIRCUITS SINGLE CIRCUIT OPEN)  CIR 242 OPEN CIR 242 OPEN P435431	PRIMARY DEAD END (MULTIPLE CIRCUITS)  CIR 169 OPEN CIR 242 OPEN P89000	THREE PHASE TRANSFORMER STATION (DBL POLE)  242-241 3-37.5 HGT JP44530	THROWOVER AT A SUBSTATION  AUTO 208-VT PREF 208-VT ALT VISTA SUB 12/4KV	SCADA MATE OH GROUP SWITCH  SCADA 96 715-16 715-1 P79699	

© 1998 - 2005 San Diego Gas & Electric Company. All rights reserved. Removal of this copyright notice without permission is not permitted under law.

<input checked="" type="checkbox"/>	Indicates Latest Revision	<input type="checkbox"/>	Completely Revised	<input type="checkbox"/>	New Page	<input type="checkbox"/>	Information Removed
REVISION DATE 12-5-05 APPD TR/ MF	SDG&E ELECTRIC STANDARDS GFMS OH STANDARD FACILITY MAP SYMBOL TABLE					OH 212.7 UG 3112.7	

PAD MOUNTED SUB JOHNSON STEP-DOWN 12/4 KV D104329	SERVICE POINT SP	BOOST STATION (3 PHASE) 242-231B 3150 HHR D2234375400	CUSTOMER GENERATION CG01-310-599 242-439M D2345267898	DUCT BANK SECONDARY -----	ATLAS TEXT 23.11E
DUCT BANK (PRIMARY) 1 DB 3" 210'	CAPACITOR CW - SWITCHED CM - SWITCHED, IN MANUAL MODE 242-35CW 1200 KVAC D2617473210	DUCT BANK (STREET LIGHT) -----	PAD D2335479431	STEP DOWN STATION (3 PHASE) 242-89SD 12000/7200 D2233175212	SWITCH ON-OFF 242-21 H2133276443 3314
DUCT BANK (SUPERVISORY) -----	PRIMARY CIRCUIT CIR 242 2ØN #2 PECN AL XY 120' 1 DB 3" 242-439M D2617473210	SUBSURFACE ENCLOSURE S2341175331 3399	DUCT BANK (TRANSMISSION) & CIRCUIT CIR 696	PRIMARY HANDHOLE H2345977612 3316	TERMINATOR D2312275112
BRIDGED FUSE CIR 242 3-BRGD D2362174182	PRIMARY METERING STATION W/CUSTOMER OWNED STRUCTURE 242-439M D2617473210	SWITCH-FUSE (PAD MOUNTED) CIR 242 2-80A 242-10 D2212376221	FUSE CABINET CIR 242 2-150A D2241472001	REGULATOR STATION (3 PHASE) 242-70G 200A D2432176221	THREE PHASE TRANSFORMER (OPEN DELTA) 242-231 1-150 NDD 1-175 NDD D1983275321
FUSED ELBOW CIR 242 3-30A F.E. H2362174182	SECONDARY CIRCUIT 3/0 SIDA	THREE PHASE TRANSFORMER 242-121 1-150 HMP D2112572121	GROUP SWITCH 242-8 242-9 242-10 242-11 M2578668752 3324	SECONDARY HANDHOLE A7-35 1-100WS 1-1 S1990272028 3399 3-T	SUBSURFACE TRANSFORMER (THREE PHASE) A7-35 1-100WS 1-1 S1990272028 3399 3-T
MANHOLE M2354622132 3324	SINGLE PHASE TRANSFORMER 242-1021 1-25 HDD D2001275843	THREE PHASE TRANSFORMER (CLOSED DELTA) 242-71 1-25 HDD 2-175 NDD D2315476411	OPEN (CALLOUT ONLY) CIR 242 OPEN CIR 242 OPEN H2234576212 3314	STEP UP STATION (1 PHASE) 242-43SU 2400/7200 D2376377291	VAULT U2311476125
UNDERGROUND STREETLIGHT 2344341GM7 (OLD) L100996G7 (NEW)	THROWOVER 100-2 ALT 100-1 PREF M111111 3324	UG SCADA CABLE SCADA CABLE 100' 1 DB 4"	PADMOUNT SERVICE RESTORER 57-4R D123456		
PME3 SCADA 99 228-7 D135790	GROUPS SWITCH W/SCADA SCADA 56 115-87-6 115-5 115-5 U1985071902	SCADA RTU RTU 88 D105276	PME5 SWITCH 790-13 3-800A D126194		

Indicates Latest Revision
 Completely Revised
 New Page
 Information Removed

5-WAY TRAYER WITH SCADA

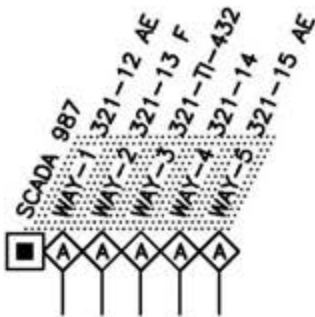

4-WAY TRAYER WITH SCADA

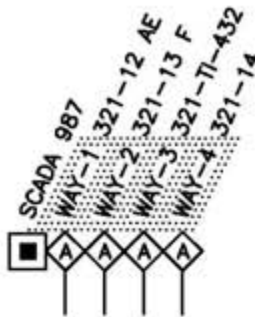

4-WAY TRAYER, MANUAL

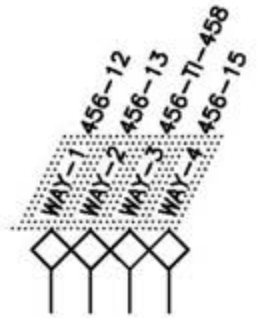

FOR FIELD MAINTENANCE ONLY

© 1998 - 2006 San Diego Gas & Electric Company. All rights reserved. Removal of this copyright notice without permission is not permitted under law.

Indicates Latest Revision Completely Revised New Page Information Removed

REVISION DATE 10-31-06 APPD TR/ MF	SDG&E ELECTRIC STANDARDS GFMS UG STANDARD FACILITY MAP SYMBOL TABLE	OH 212.9 UG 3112.9
------------------------------------------	---------------------------------------------------------------------------	-----------------------

SCOPE: THIS STANDARD SHOWS THE INSTALLATION OF A POLE GUARD RAIL.

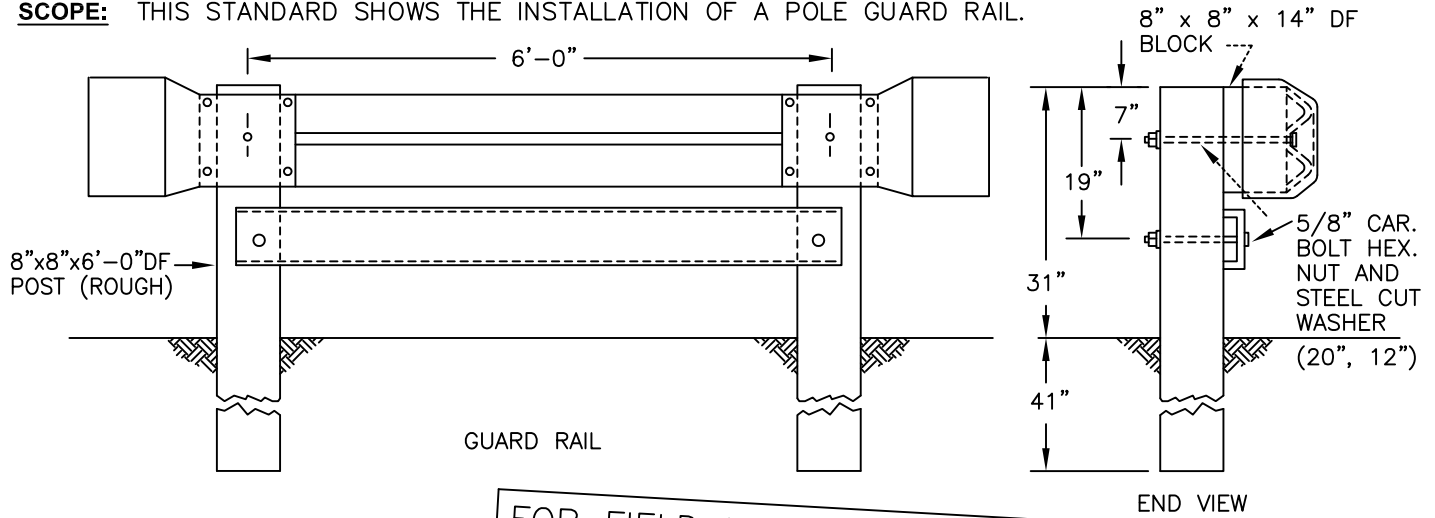

FOR FIELD MAINTENANCE ONLY

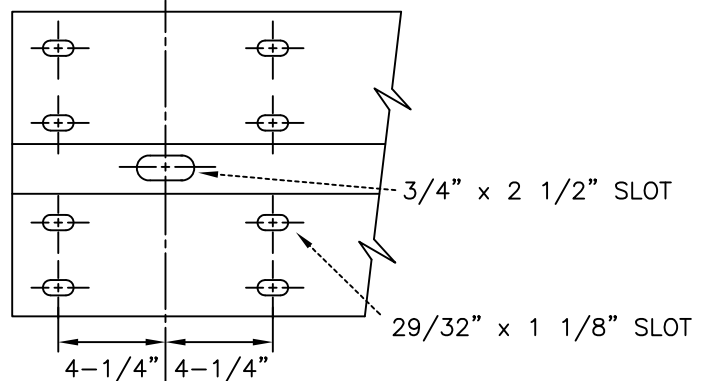
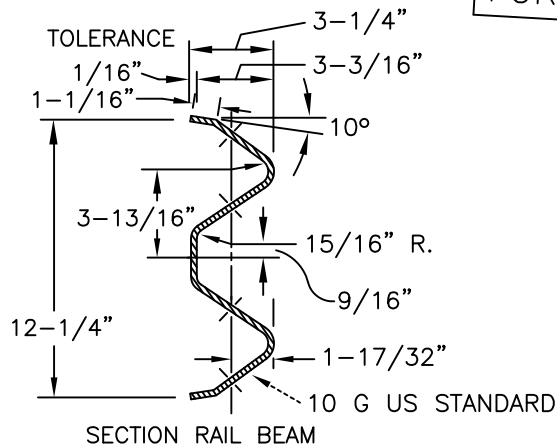

☉ POST BOLT SLOT

RAIL BEAM DRILLING
5/8" x 1-1/4" BUTTONHEAD OVAL SHOULDER BOLTS WITH HEX. NUTS, 4 PER TERMINAL

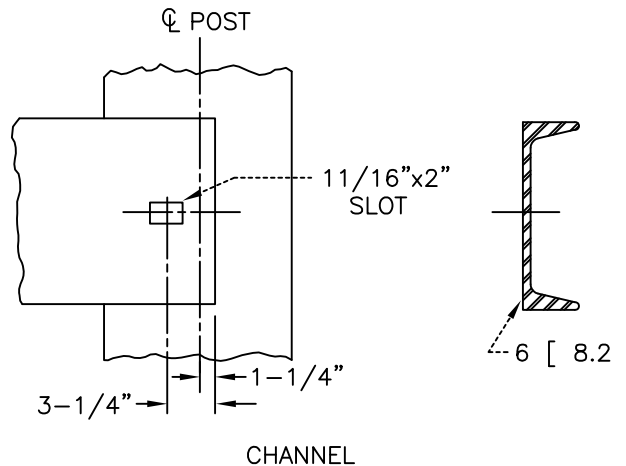
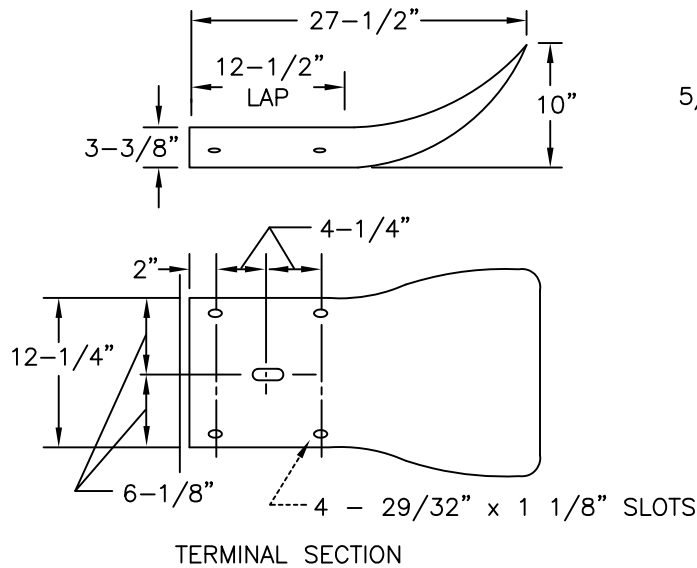

NOTES:

- POLE GUARD RAILS ARE DESIGNED TO BE INSTALLED IN PUBLIC R/W'S, NOT PRIVATE PROPERTY, MAINLY TO MAKE A POLE MORE VISIBLE. THEY HAVE LITTLE VALUE IN STOPPING A VEHICLE, AND SHOULD HAVE LIMITED USE.
- THE DISTRIBUTION OR TRANSMISSION ENGINEER SHALL SPECIFY OR APPROVE EACH INSTALLATION.

© 1998 - 2015 San Diego Gas & Electric Company. All rights reserved. Removal of this copyright notice without permission is not permitted under law.

SDG&E ELECTRIC STANDARDS

DATE 3-2-84
APPD PJA/BJG

POLE GUARD RAIL

218

SCOPE: THIS STANDARD ILLUSTRATES VARIOUS METHODS OF 12KV, SINGLE CIRCUIT TRANSPOSITION.

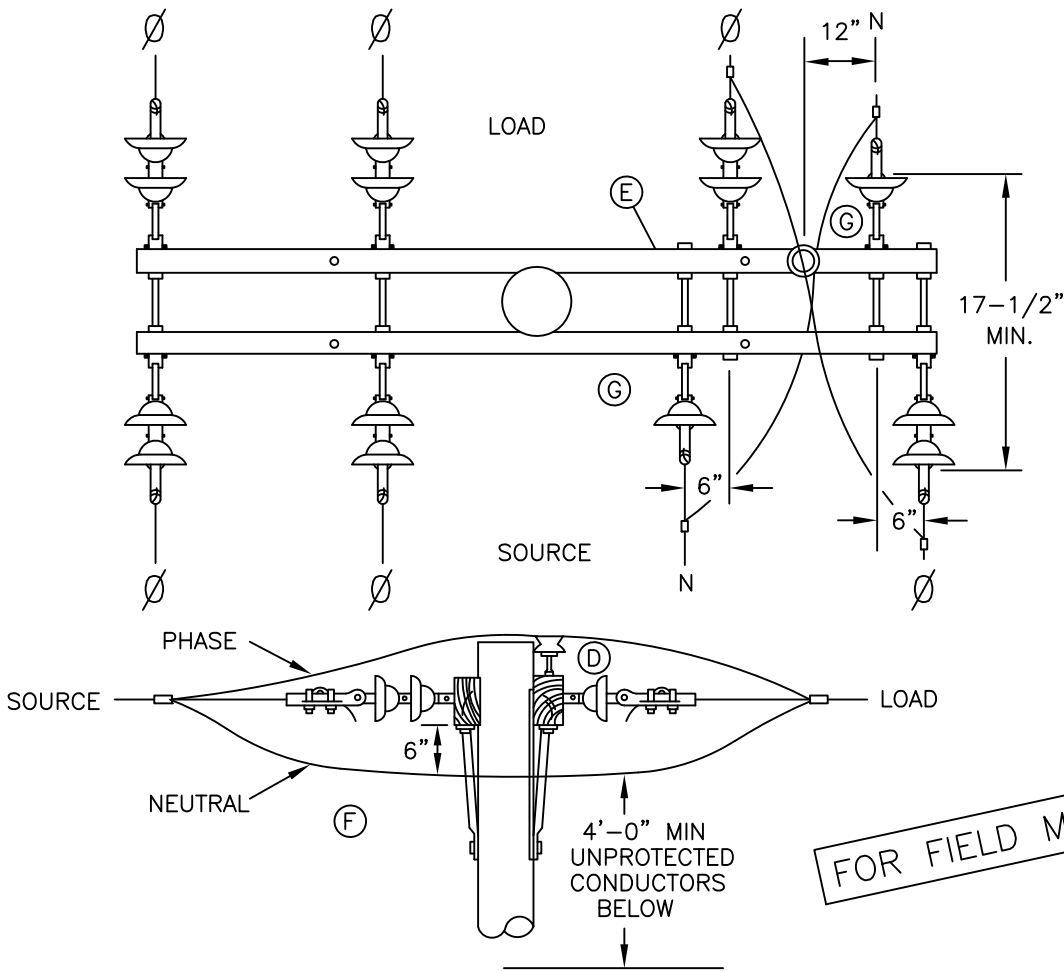

SINGLE POLE-NEUTRAL/PHASE WIRE TRANSPOSITION (PREFERRED)

FIGURE 1

©

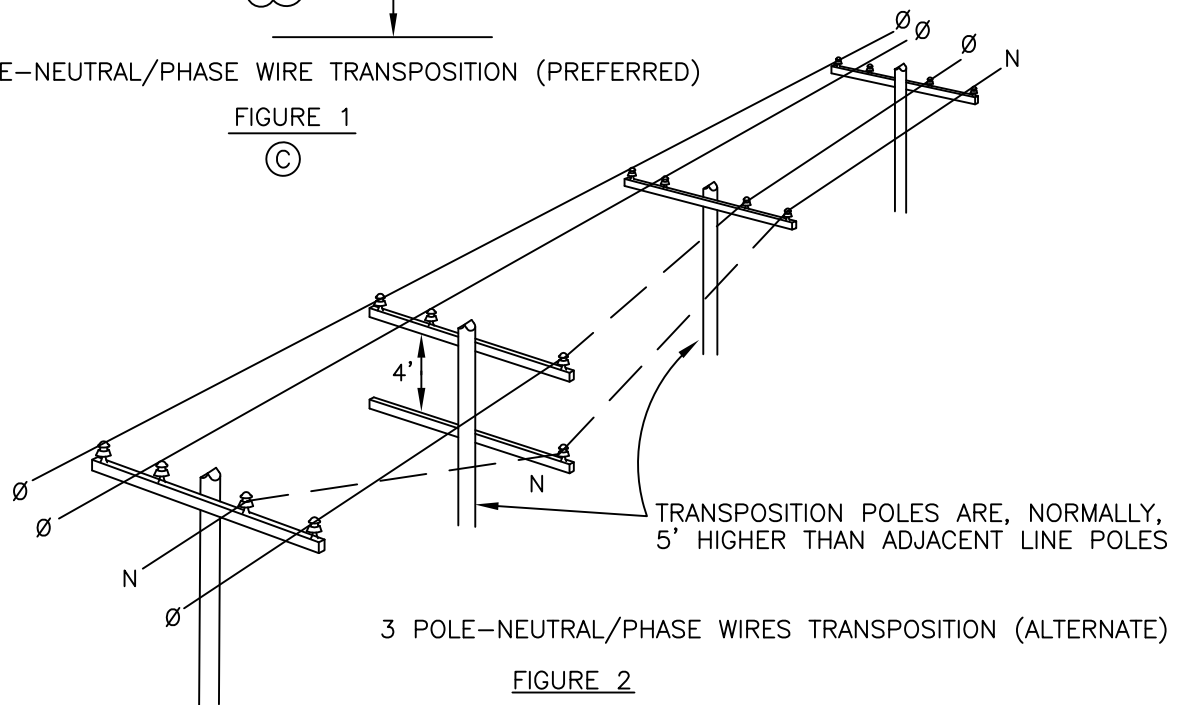

3 POLE-NEUTRAL/PHASE WIRES TRANSPOSITION (ALTERNATE)

FIGURE 2

©

© 1998 - 2013 San Diego Gas & Electric Company. All rights reserved. Removal of this copyright notice without permission is not permitted under law.

	Indicates Latest Revision	Completely Revised	New Page	Information Removed
REVISION	SDG&E ELECTRIC STANDARDS			
DATE 8-29-2013 APPD TQ / DW	12KV SINGLE CIRCUIT TRANSPOSITION			269.1

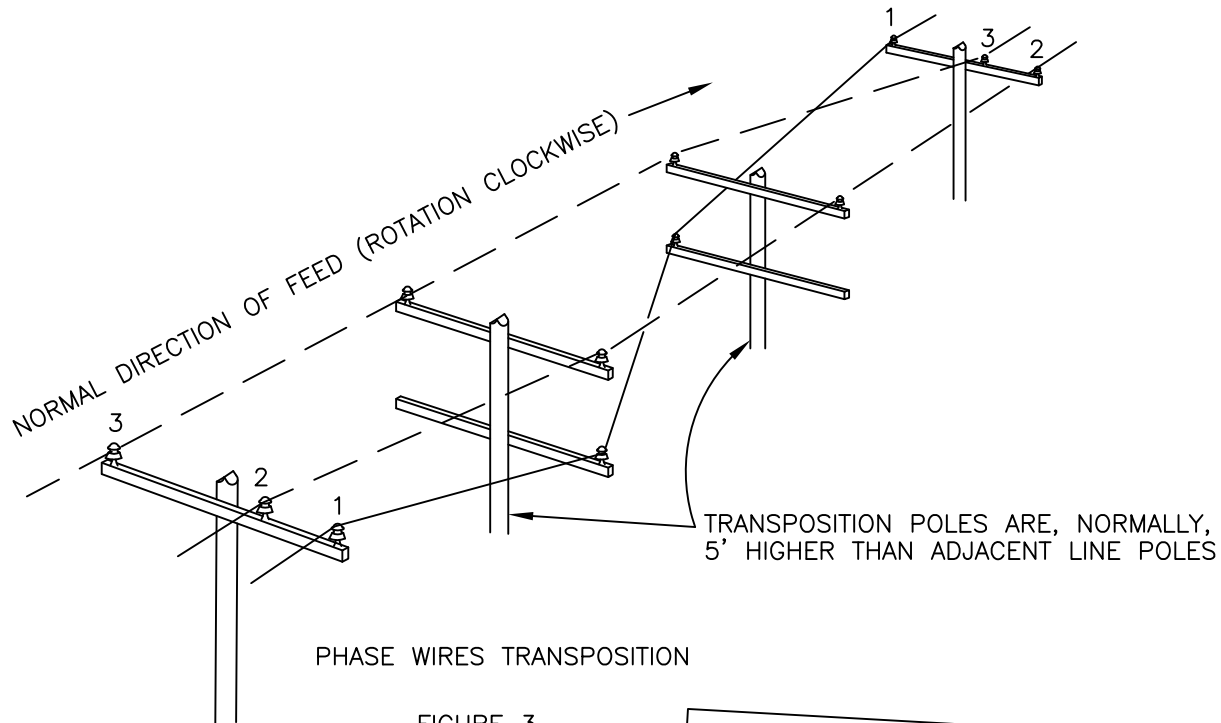

FIGURE 3

(B)

FOR FIELD MAINTENANCE ONLY

INSTALLATION:

- A. ALL PROPOSED 12KV LINE EXTENSIONS CREATING PARALLELS WITH EXISTING OPEN WIRE COMMUNICATION LEADS SHALL BE REFERRED TO THE TELEPHONE COMPANY FOR COORDINATION OF TRANSPOSITIONS IN THE SUPPLY AND COMMUNICATION LINES.
- (B) BUILDING FOUR WIRE, "PHASE WIRE ONLY" TRANSPOSITION, (FIG. 3), OR ADDING FOURTH WIRE (NEUTRAL) TO EXISTING TRANSPOSITION, REQUIRES NO DEVIATION.
- (C) SINGLE POLE-NEUTRAL/PHASE WIRE TRANSPOSITION (FIG. 1) IS PREFERRED OVER THREE POLE NEUTRAL/PHASE WIRE TRANSPOSITION (FIG. 2).
- (D) ON SINGLE POLE-NEUTRAL/PHASE WIRE TRANSPOSITION (FIG. 1), ALWAYS JUMPER PHASE WIRE OVER TOP OF ARM AND TIE INTO PIN AND INSULATOR.
- (E) SINGLE POLE-NEUTRAL/PHASE WIRE TRANSPOSITION (FIG. 1) REQUIRES CROSSARM MINIMUM OF 10' IN LENGTH. IF TRANSPOSITION IS EXTENSION FROM EXISTING 8' CROSSARMS, CHANGE OUT TO 10' CROSSARMS.
- (F) IN SINGLE POLE-NEUTRAL/PHASE WIRE TRANSPOSITION (FIG. 1), INSTALL NEUTRAL JUMPER NO LESS THAN 6" FROM BOTTOM OF CROSSARM.
- (G) ON ALL TRANSPOSITIONS, MARK CROSSARM NEUTRAL POSITION WITH "PN" SIGN, EVEN THOUGH SIGN IS NOT REQUIRED BY STANDARD 208.

© 1998 - 2010 San Diego Gas & Electric Company. All rights reserved. Removal of this copyright notice without permission is not permitted under law.

	Indicates Latest Revision	Completely Revised	New Page	Information Removed
269.2	SDG&E ELECTRIC STANDARDS			REVISION
	12KV SINGLE CIRCUIT TRANSPOSITION			DATE 1-1-93 APPD <i>PIA 1/09</i>

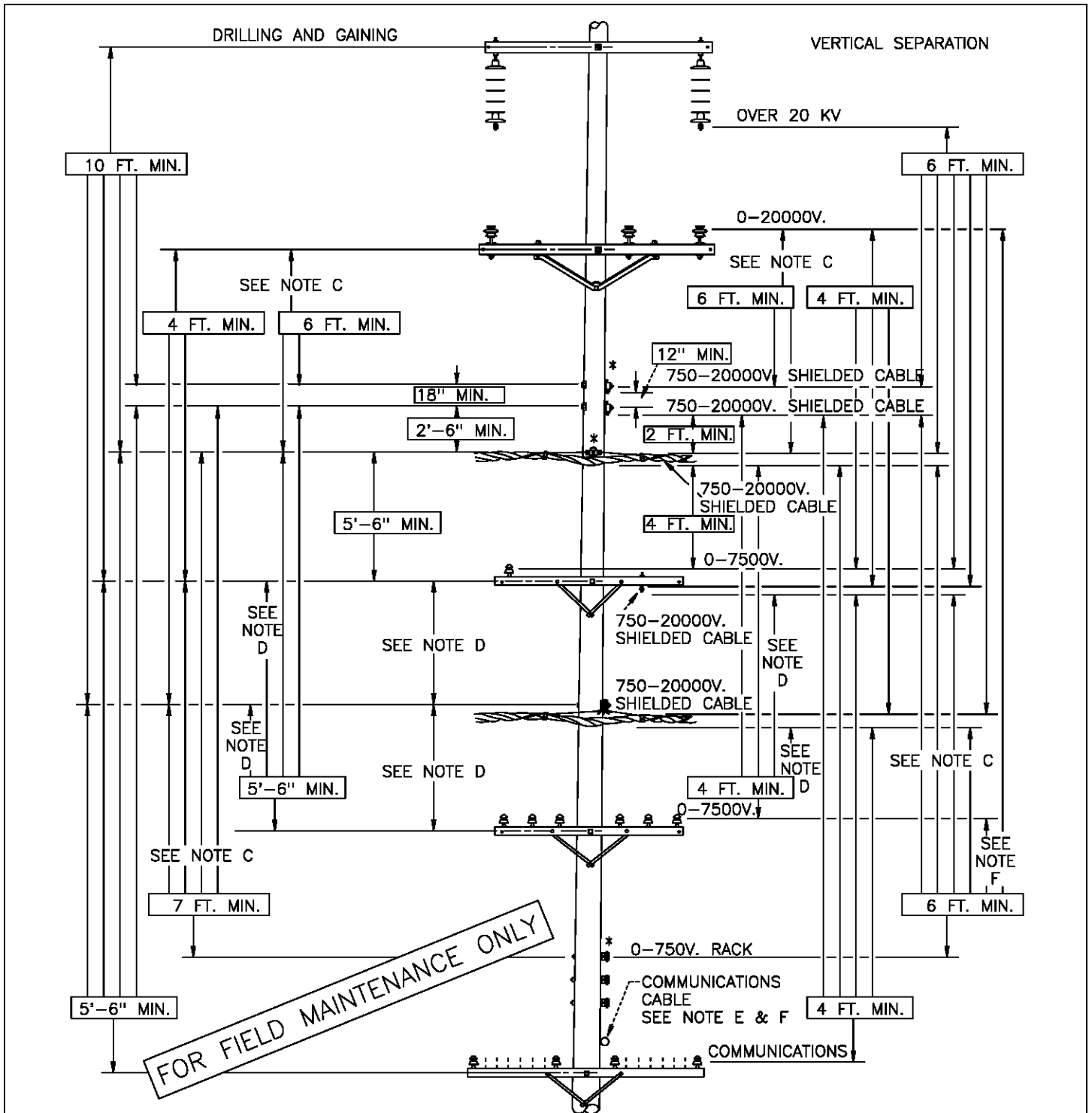

NOTES:

- A. DIFFERENCES DUE TO SAG OF DIFFERENT SIZE CONDUCTORS MUST BE COMPENSATED FOR AT POINTS OF SUPPORT.
- B. VERTICAL SEPARATION OF UNPROTECTED SUPPLY CONDUCTORS FROM 750-7500V SHIELDED AERIAL CABLE WHICH HAS BEEN BONDED AND EFFECTIVELY GROUNDING AS PER GENERAL ORDER 95, RULE 57.8
- (C) INSTALLATION OF GUARD ARMS PERMITS A REDUCTION OF 2 FT. (* REPRESENTS GUARD ARM PLACEMENT). (G.O. 95, RULE 57.4-F)
- (D) VERTICAL SEPARATION MAY BE REDUCED 2 FT. IF OPEN WIRE IS 0-750V
- (E) 6 FT MINIMUM CLEARANCE IS REQUIRED TO POWER CONDUCTORS.
- (F) GUARD ARMS MAY BE USED TO REDUCE REQUIRED CLEARANCE BY 2 FT FOR CONDUCTORS OR CABLES OF 0-750V.

	SDG&E ELECTRIC STANDARDS	
DATE 2-18-74 APPD <i>PA/BG</i>	AERIAL CABLE, VERTICAL CLEARANCE FROM OPEN WIRE CONDUCTORS ON SAME POLE	299.201 SUPERCEDES 223 (1-1-98)

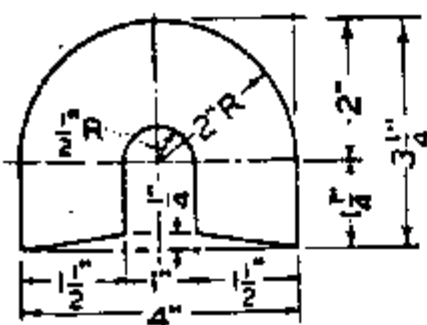

ITEM NO. 1
FOR 0-600V VERTICAL RUNS
MAX. CONDR. SIZE 3-#1/0

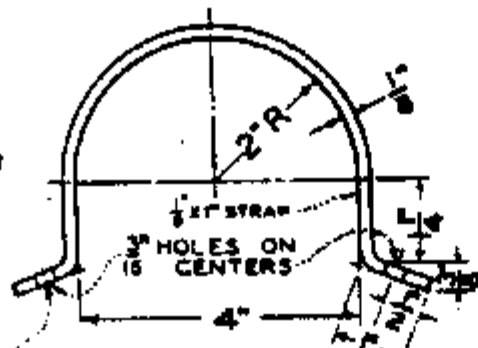

ITEM NO. 1A
USE GALV. 10D COMM. NAILS

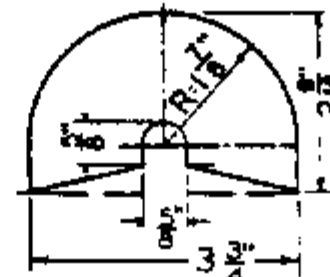

ITEM NO. 2
FOR GROUND WIRE

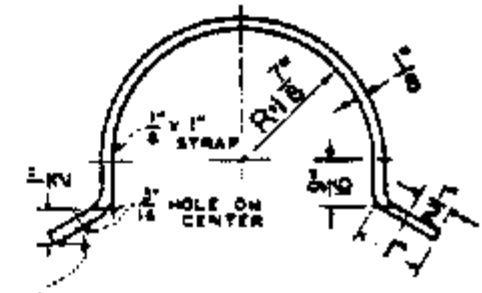

ITEM NO. 2A
USE GALV. 10D COMM. NAILS

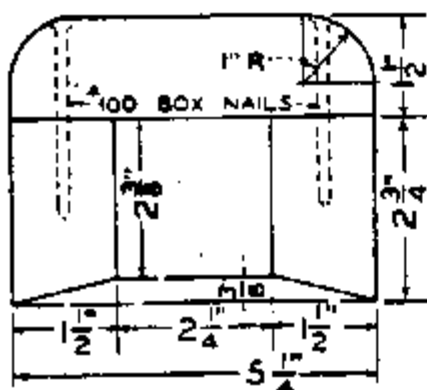

ITEM NO. 3, FOR CABLE AND CONDUITS UP TO 1 1/2" DIAMETER

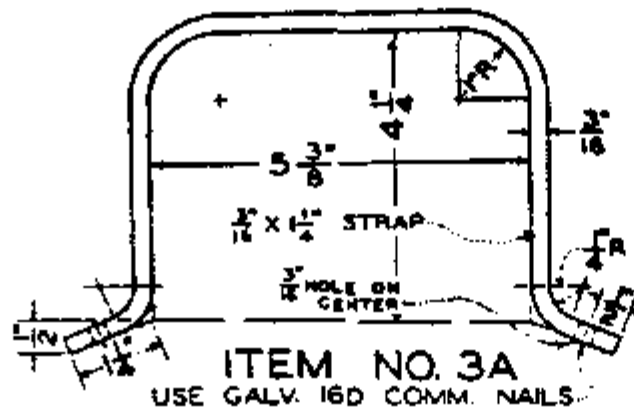

ITEM NO. 3A
USE GALV. 16D COMM. NAILS

FOR FIELD MAINTENANCE ONLY

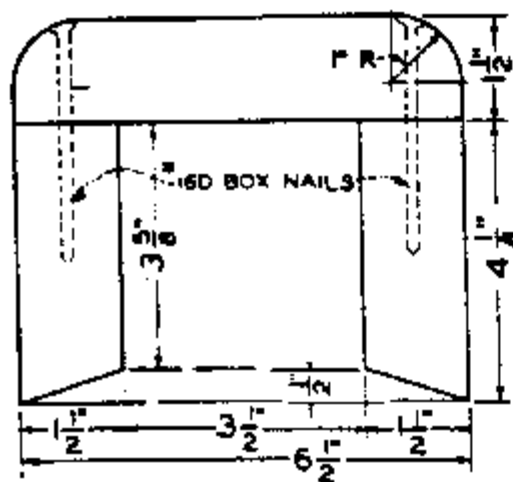

ITEM NO. 5, FOR CABLE AND CONDUITS 1 3/4" TO 2 1/2" DIAMETER

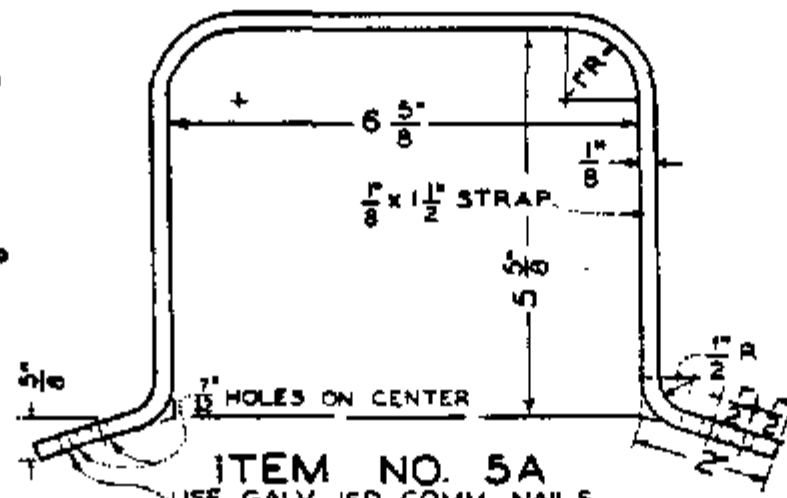

ITEM NO. 5A
USE GALV. 16D COMM. NAILS

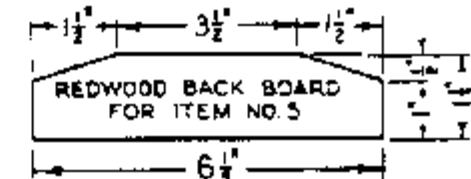

ITEM NO. 5B

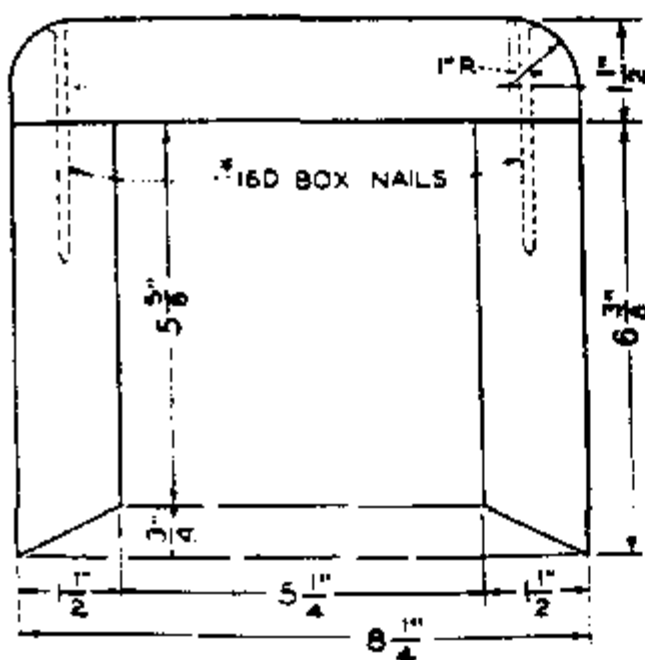

ITEM NO. 6, FOR CABLE AND CONDUITS 2 3/4" TO 4" DIAMETER

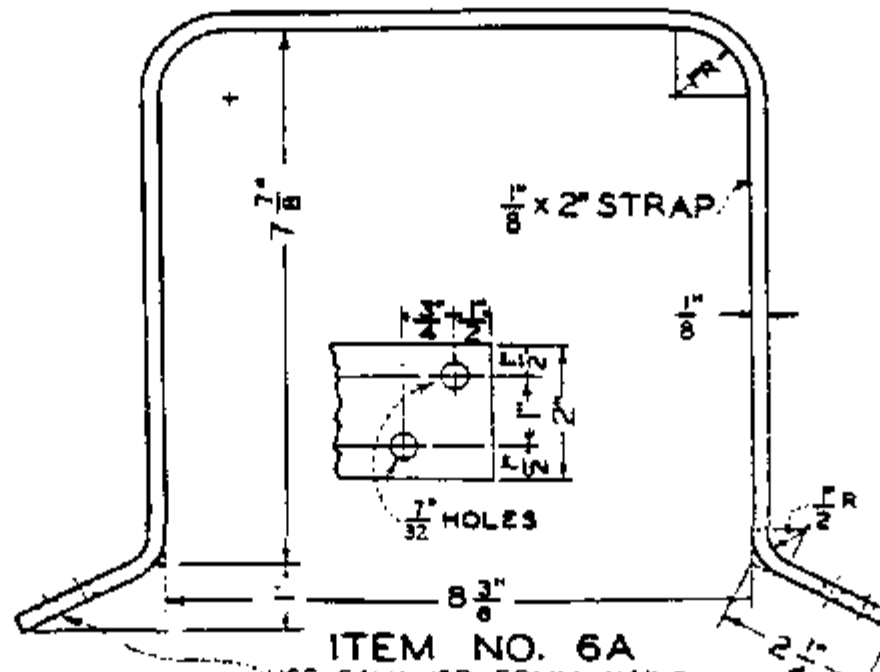

ITEM NO. 6A
USE GALV. 16D COMM. NAILS

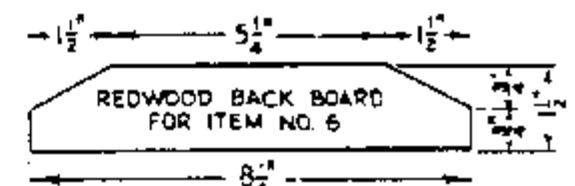

ITEM NO. 6B

- A. ITEMS 1, 3, 5 & 6 TO BE MADE FROM SELECT REDWOOD HEART IN FULL 8' LENGTHS.
- B. ITEM 2 TO BE MADE FROM SELECT REDWOOD HEART IN FULL 4' LENGTHS.
- C.
- D. ITEMS 5B & 6B TO BE MADE FROM SELECT REDWOOD HEART IN FULL 10' LENGTHS.
- F. GALV. NAILS IN EDGES OF BOX COVERS TO BE SPACED 12" APART.

ITEM	DESCRIPTION	STOCK NO.	ITEM	DESCRIPTION	STOCK NO.
1	MOULDING	487232	5	MOULDING	487072
1A	STRAP	697024	5A	STRAP	697056
2	MOULDING, FIELD MAINTENANCE ONLY		5B	MOULDING, BACK BOARD	486976
2A	STRAP, FIELD MAINTENANCE ONLY		6	MOULDING	487104
3	MOULDING, FIELD MAINTENANCE ONLY	487040	6A	STRAP	697088
3A	STRAP, FIELD MAINTENANCE ONLY	697120	6B	MOULDING, BACK BOARD	487008

SDG & E ELECTRIC STANDARDS

PROTECTIVE COVERINGS
MOULDINGS AND STRAPS

399,401

SUPERSEDES
143 (12-10-82)

DATE 12-10-82

APPD *[Signature]*

FOR FIELD MAINTENANCE ONLY

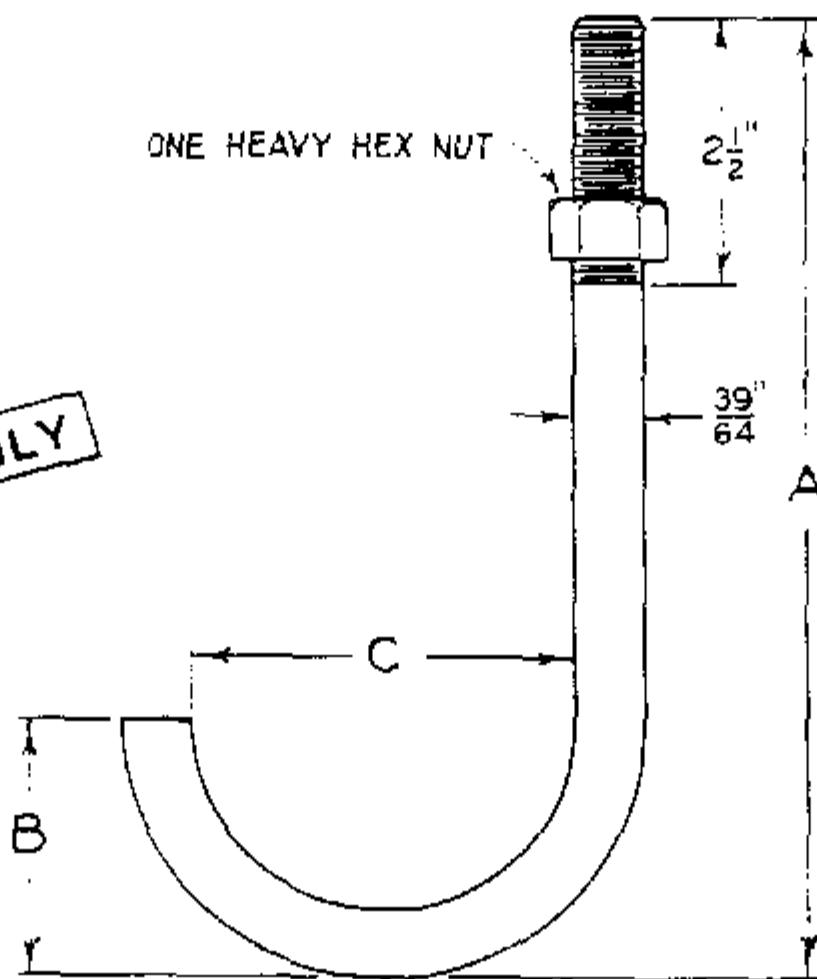

"J" BOLT
FOR SECURING PIPE RISERS TO SUPPORT ARMS
ON CABLE POLES.

CONDUIT SIZE INCHES	DIMENSIONS - INCHES			DESCRIPTION	STOCK NO.	CONDUIT SIZE INCHES	DIMENSIONS - INCHES			DESCRIPTION	STOCK NO.
	A	B	C				A	B	C		
2	8	1 7/8	2 7/16		-						
3	9	2 3/8	3 9/16		151360						
4	10	2 7/8	4 9/16		151392						

NOTE:

- ABOVE ITEM TO BE HOT DIP GALVANIZED PER A.S.T.M. SPECS. A153 - 53.

SDG & E ELECTRIC STANDARDS

399,402
SUPERSEDES
144 (12-10-82)

'J' BOLT FOR CABLE POLE RISERS

DATE 12-10-82
APPD. JMT/AR4

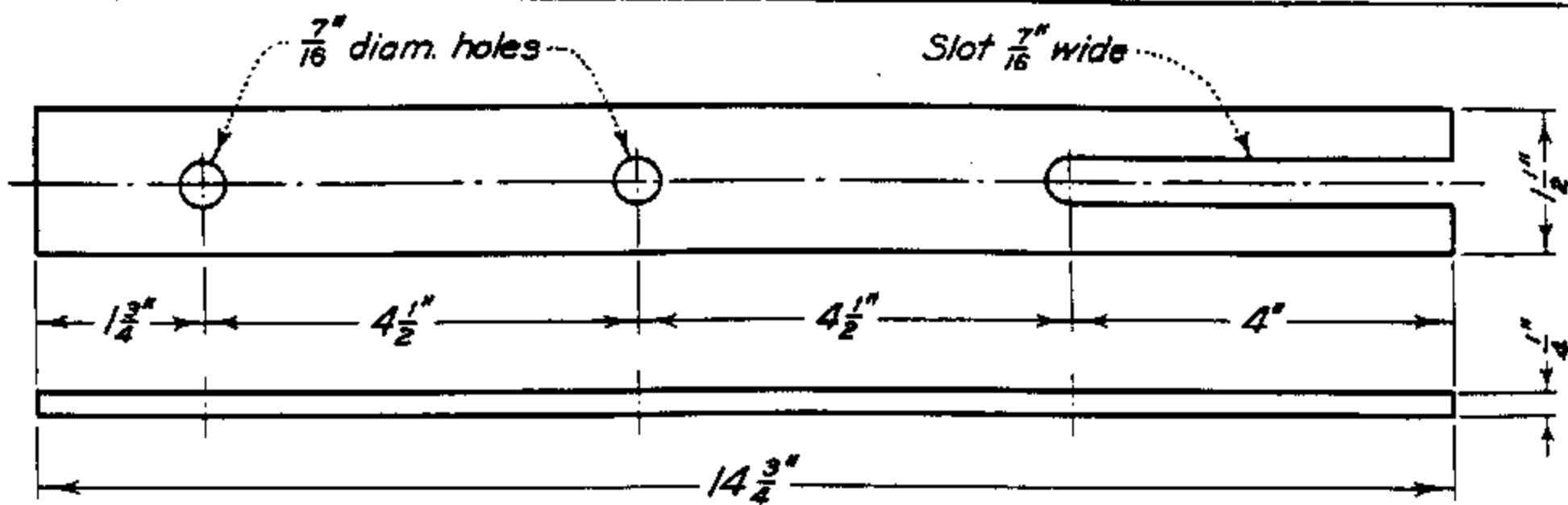

ITEM NO. 1
G. I. STRAP FOR MTG. 15 OR 25 KVAR CAPTR. UNITS BET. X-ARMS

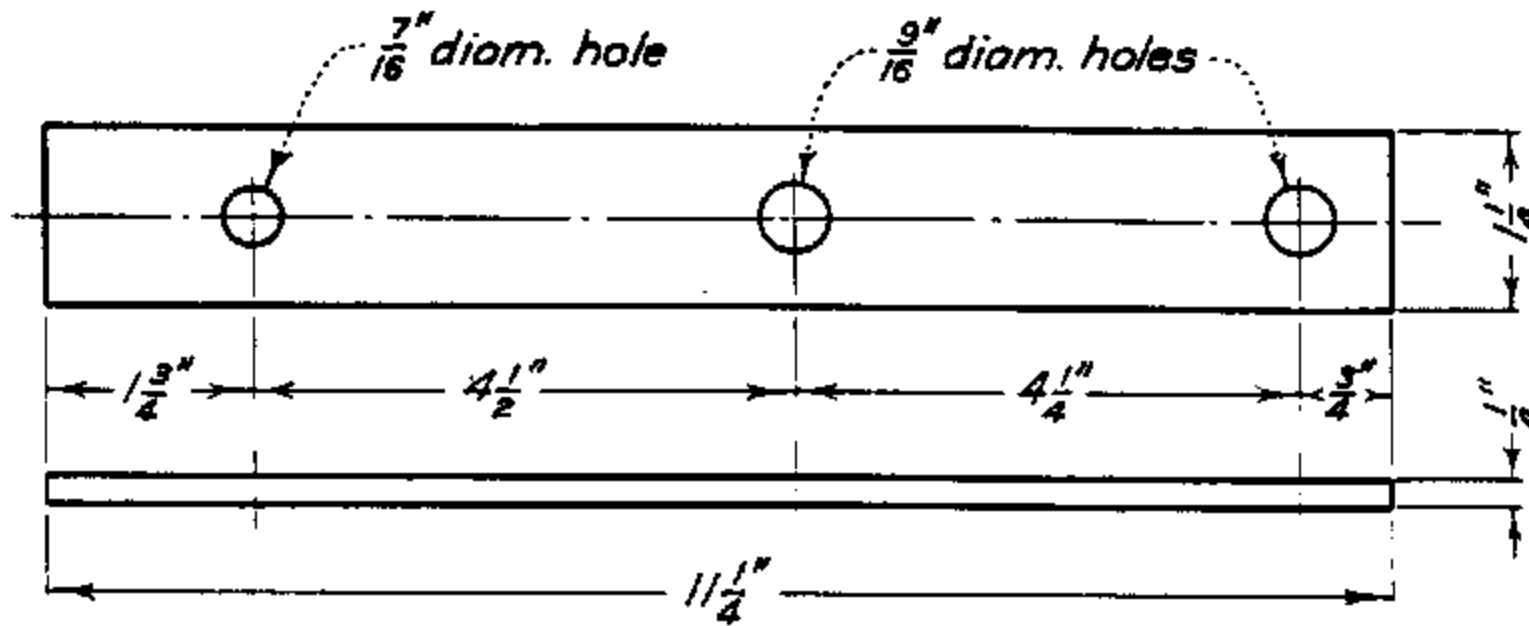

ITEM NO. 2
G. I. STRAP FOR MTG. A 15 OR 25 KVAR CAPTR. UNIT ON FACE OF X-ARM

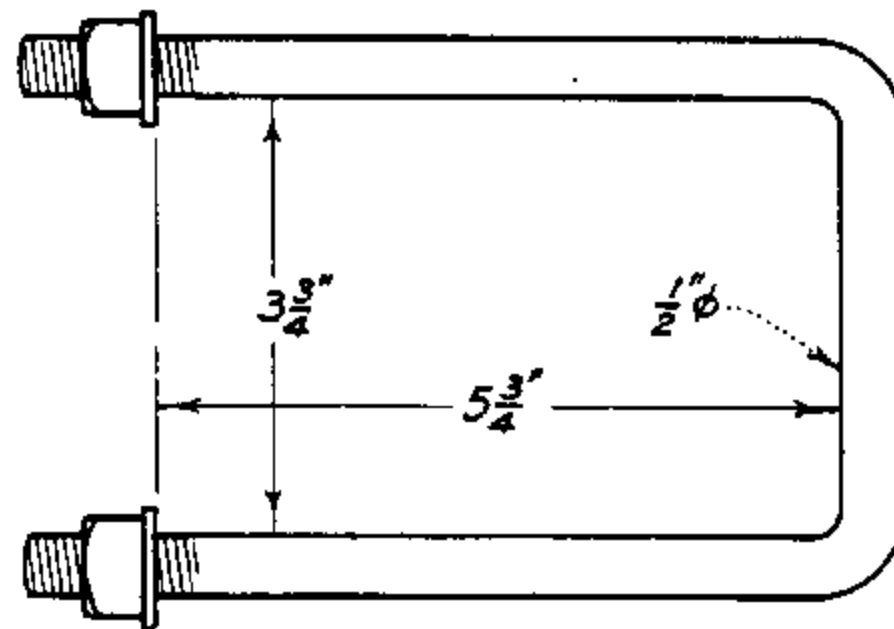

ITEM NO. 3
HORIZ. MTG. "U" BOLT FOR ITEM NO. 2
FOR 3 3/4 X 5 3/4 CROSSARMS

FOR FIELD MAINTENANCE ONLY

ITEM	DESCRIPTION	STOCK NO.	ITEM	DESCRIPTION	STOCK NO.
1	STRAP, FIELD MAINTENANCE ONLY	697216			
	STRAP	697184			
3	BOLT, "U"	158432			

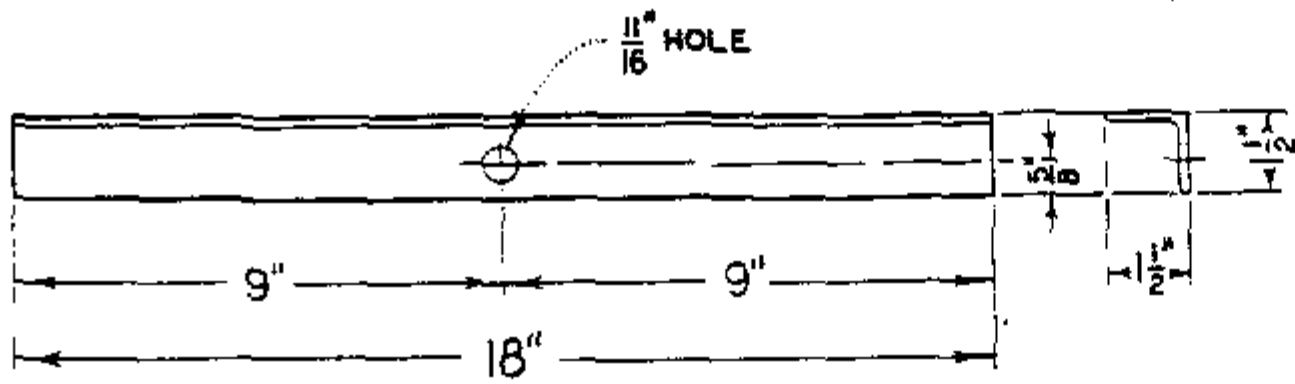

ITEM NO. 1
 $1\frac{1}{2}$ " X $1\frac{1}{2}$ " X $\frac{3}{16}$ " Angle, Galv.

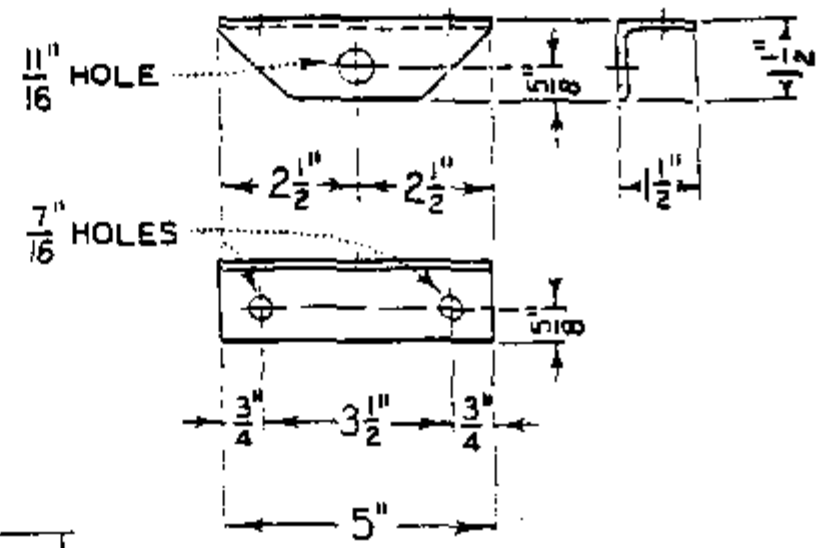

ITEM NO. 2
 $1\frac{1}{2}$ " X $1\frac{1}{2}$ " X $\frac{3}{16}$ " Angle, Galv.

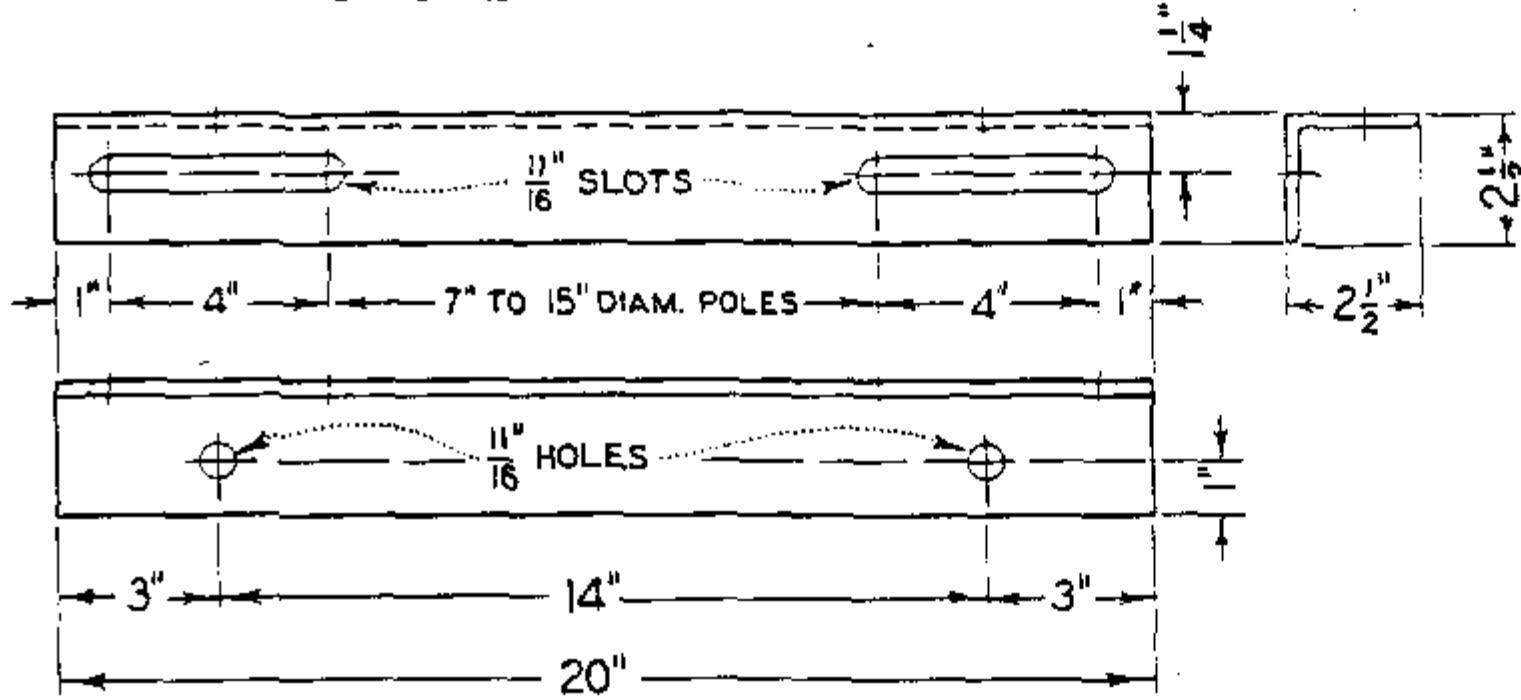

ITEM NO. 3
 $2\frac{1}{2}$ " X $2\frac{1}{2}$ " X $\frac{1}{4}$ " Angle, Galv.

FOR FIELD MAINTENANCE ONLY

NOTE:

A, STOCK NUMBER 166464 CONSIST OF ITEMS 1, 2 & 3 ABOVE.

399,502
 SUPERSEDES
 158 (12-10-82)

SDG&E ELECTRIC STANDARDS

MOUNTING BRACKETS

DATE 12-10-82
 APPD *[Signature]*

SCOPE: THIS STANDARD LISTS VARIOUS TYPES OF CHEMICALLY TREATED POLES WITH THEIR USABLE STRENGTHS, WEIGHTS AND PHYSICAL DIMENSIONS.

L E N G T H F T	C L A S S	H E I G H T F T	TREATMENT (H)			WIND LOADING USABLE STRENGTH			VERTICAL LOADING USABLE STRENGTH			WEIGHT		M I N T O P D I A I N	DIA 6' FROM BUTT	
			STOCK NUMBER			FT. - LBS.			LBS.			(F)	(G)		D O U G. F I R	P O N D. P I N E
			(F) N A T U R A L	C R E O S O T E	(F) G R A Y	SF=4	SF=3	SF=2	SF=4	SF=3	SF=2	LBS	LBS			
25	205	1	559984	550910	551966	19677	26672	40663	26944	35982	54060	600	846	8.6	10.7	12.0
		2	(C)	(C)	-	15925	21640	33070	20354	27186	40849	521	693	8.0	10.0	-
		3	(C)	(C)	552034	13191	17964	27510	14965	19991	30044	456	576	7.3	9.4	10.3
		4	-	(C)	-	10727	14650	22497	11037	14748	22169	-	490	6.7	8.8	9.5
		5	550432	551760	552062	8292	11372	17530	7737	10343	15555	342	419	6.1	8.1	8.9
		6	-	(C)	-	5914	8170	12680	4908	6567	9884	-	360	5.4	7.3	8.1
30	250	1	550000	550912	551970	24368	33159	50742	21222	28365	42651	806	1093	8.6	11.6	12.7
		2	(C)	(C)	-	19416	26510	40699	15899	21257	31972	707	924	8.0	10.8	11.9
		3	550336	551472	552038	16255	22249	34239	11793	15773	23731	612	787	7.3	10.2	11.1
		4	-	(C)	-	12484	17175	26557	8418	11265	16959	-	670	6.7	9.4	10.3
		5	550448	551776	552066	10146	14012	21743	6104	8172	12308	464	564	6.1	8.8	9.5
		6	-	(C)	-	7416	10325	16144	3936	5275	7954	-	470	5.4	8.0	8.9
35	300	1	550016	550928	551974	29226	39958	61422	16764	22433	33769	1041	1340	8.6	12.4	13.5
		2	(C)	(C)	-	23598	32387	49966	12672	16965	25550	908	1148	8.0	11.6	12.7
		3	550352	551488	552042	18757	25859	40064	9121	12219	18415	787	987	7.3	10.8	11.9
		4	-	(C)	-	14560	20196	31468	6563	8800	13275	-	858	6.7	10.0	11.0
		5	550464	551792	552070	11074	15476	24278	4582	6152	9291	597	736	6.1	9.2	10.2
		6	-	(C)	-	8863	12467	19675	3120	4195	6345	-	635	5.4	8.6	9.5
40	345	1	550032	550944	551978	33331	45779	70674	14074	18858	28425	1300	1610	8.6	13.1	14.3
		2	(C)	(C)	-	27171	37477	58090	10533	14123	21303	1129	1387	8.0	12.2	13.5
		3	550368	551504	552046	21827	30254	47110	7768	10424	15736	984	1199	7.3	11.5	12.6
		4	-	(C)	-	17192	23987	37576	5639	7576	11450	-	1042	6.7	10.7	11.6
		5	550480	551808	552074	13251	18535	29403	3976	5350	8099	745	905	6.1	9.9	10.8
		6	-	(C)	-	9899	14077	22434	2605	3515	5336	-	787	5.4	9.1	10.0
45	390	1	550048	550960	551982	36856	50881	78930	11968	16062	24250	1573	1899	8.6	13.7	15.1
		2	(C)	(C)	-	30245	41954	65371	9155	12296	18578	1372	1633	8.0	12.9	14.2
		3	550384	551520	552050	23099	32290	50672	6446	8671	13123	1189	1422	7.3	11.9	13.2
		4	-	(C)	-	18242	25701	40619	4695	6327	9589	-	1234	6.7	11.1	12.3
		5	550496	551824	552078	14114	20074	31994	3320	4484	6813	904	1089	6.1	10.3	11.5
50	435	1	550064	550976	551986	40595	56327	87793	10402	13987	21158	1873	2209	8.6	14.3	15.8
		2	(C)	(C)	-	32663	45605	71489	7871	10596	16044	1630	1892	8.0	13.4	14.8
		3	550400	551536	552054	25102	35356	55863	5568	7510	11395	1417	1645	7.3	12.4	13.8
		5	550512	551840	552082	15521	22287	35820	2891	3920	5978	1075	1277	6.1	10.8	11.9
55	480	1	550080	550992	551990	43538	60768	95228	9063	12217	18525	2193	2558	8.6	14.8	16.4
		2	(C)	(C)	-	34308	48274	76207	6882	9290	14105	1908	2193	8.0	13.9	15.4
		3	550416	551552	552058	27190	38588	61384	4892	6618	10071	1664	1880	7.3	12.9	14.3
		4	-	(C)	-	21642	31020	49776	3589	4869	7428	-	1653	6.7	12.1	13.4
		5	(C)	(C)	-	15873	23125	37628	3160	4286	6539	-	1480	6.1	-	-

INSTALLATION:

- A. ULTIMATE FIBER STRESS 8000 PSI FOR DOUGLAS FIR AND 6000 PSI FOR PONDEROSA PINE.
- B. BENDING MOMENT DUE TO WIND ON THE POLE HAS BEEN DEDUCTED FROM TOTAL POLE STRENGTH.
- (C) DENOTES NOT A STOCK ITEM, BUT IS IN SERVICE.
- D. USE SALVAGED CREOSOTE POLES IN PREFERENCE TO CELLON TREATED POLES IN APPROVED LOCATIONS.
- (F) PRESSURE TREATMENT DONE BY THE CELLON OR DOW PROCESS.
- (G) CREOSOTE TREATED POLES.

FOR FIELD MAINTENANCE ONLY

REFERENCE:

(H) SEE PAGE 354.1 TO 354.3 FOR PENTA-IN-OIL TREATED POLES.

ISSUE 1993

DATE 1-1-86

APPD *AK/PS*

SDG&E ELECTRIC STANDARDS

HORIZONTAL AND VERTICAL POLE LOADING

399.503

LENGTH FT	CLASS	HEIGHT FT	TREATMENT (H)			WIND LOADING USABLE STRENGTH FT. - LBS.			VERTICAL LOADING USABLE STRENGTH LBS			WEIGHT		MIN TOP DIA IN	DIA 6' FROM BUTT	
			STOCK NUMBER			SF=4	SF=3	SF=2	SF=4	SF=3	SF=2	(F)	(G)		DOUG. FIR	POND. PINE
			(F) NATURAL	CREOSOTE	(F) GRAY							LBS	LBS			
60	1	530	550096	551008	551994	47095	66158	104285	7845	10610	16139	2535	2949	8.6	15.3	17.0
			550224	(C)	-	37271	52832	83953	5888	7978	12158	2204	2515	8.0	14.3	16.1
			(C)	(C)	-	29687	42481	68069	4264	5792	3848	1923	2146	7.3	13.4	14.8
			(C)	(C)	-	16933	25009	41162	2549	3497	5393	-	1888	6.7	11.5	12.6
65	1	57.5	550112	551024	551998	50278	71052	112600	7004	9509	14519	2892	3431	8.6	15.8	17.5
			(C)	(C)	-	39965	57033	91170	5283	7185	10989	2516	2855	8.0	14.8	16.4
			(C)	(C)	-	31115	44941	72590	3779	5156	7910	2193	2405	7.3	13.8	15.3
			(C)	(C)	-	17827	26675	44371	2259	3121	4846	-	2152	6.7	11.9	13.4
70	1	62.5	550128	551040	552002	52892	75325	120190	6109	8338	12796	3268	3948	8.6	16.2	18.0
			(C)	(C)	-	43163	62049	99823	4693	6414	9855	2846	3231	8.0	15.3	16.9
			(C)	(C)	-	33760	49166	79980	3371	4623	7125	2473	2687	7.3	14.3	15.8
			(C)	(C)	-	18890	28677	48252	1901	2656	4166	-	2405	6.7	12.1	13.5
75	1	67.0	550144	551056	552006	56261	80606	129296	5546	7608	11730	3659	4442	8.6	16.7	18.5
			(C)	(C)	-	43880	63719	103396	4152	5708	8821	3196	3619	8.0	15.6	17.3
			(C)	(C)	-	34292	50537	83028	2984	4119	6389	-	3000	7.3	14.6	16.2
80	1	72.0	550160	551072	552010	60261	86901	140182	4975	6869	10655	4074	5013	8.6	17.2	18.9
			(C)	(C)	-	47191	69036	112727	3739	5175	8046	3553	4050	8.0	16.1	17.8
85	1	76.5	550176	551088	552014	61163	89003	144684	4424	6161	9633	4514	5640	8.6		19.4
			(C)	(C)	-	47844	70750	116563	3336	4655	7294	3929	4500	8.0	16.4	18.1
90	1	81.5	550192	551104	552018	62481	91842	150565	3871	5454	8619	4967	6376	8.6	17.8	19.9
			(C)	(C)	-	51259	76367	126581	3023	4257	6726	4321	5017	8.0	16.9	18.6
95	1	86.0	550208	551120	552022	62352	92458	152677	3517	4986	7926	5734	6559	8.6	18.1	20.2
			(C)	(C)	-	51097	76894	128488	2693	3841	6138	4735	5608	8.0	17.2	18.9
100	HI	91.0	549954	-	-	76453	118928	-	4171	5951	9510	8675	-	9.2	19.7	22.0
			549952	550816	552026	66415	99155	-	3192	4578	7350	5917	7229	8.6	18.6	20.7
			(C)	(C)	-	52001	79254	-	2389	3451	5574	-	6000	8.0	17.5	19.4
110	HI	100	549970	-	-	86151	134013	-	3387	4982	8174	10672	-	9.2	20.5	22.8
			549968	550832	552030	70199	106952	-	2501	3736	6208	6950	9240	8.6	19.3	21.5
			(C)	(C)	-	53483	83784	-	1782	2723	4604	-	8000	8.0	18.1	20.0

FOR FIELD MAINTENANCE ONLY

INSTALLATION:

- A. ULTIMATE FIBER STRESS 8000 PSI FOR DOUGLAS FIR AND 6000 PSI FOR PONDEROSA PINE.
- B. BENDING MOMENT DUE TO WIND ON THE POLE HAS BEEN DEDUCTED FROM TOTAL POLE STRENGTH.
- (C) DENOTES NOT A STOCK ITEM, BUT IS IN SERVICE.
- D. USE SALVAGED CREOSOTE POLES IN PREFERENCE TO CELLON TREATED POLES IN APPROVED LOCATIONS.
- (F) PRESSURE TREATMENT DONE BY THE CELLON OR DOW PROCESS.
- (B) CREOSOTE TREATED POLES.

REFERENCE:

(H) SEE PAGE 354.1 TO 354.3 FOR PENTA-IN-OIL TREATED POLES.

SCOPE: THIS STANDARD SHOWS A METHOD OF REINFORCING DETERIORATED WOOD POLES USING A STEEL SLEEVE.

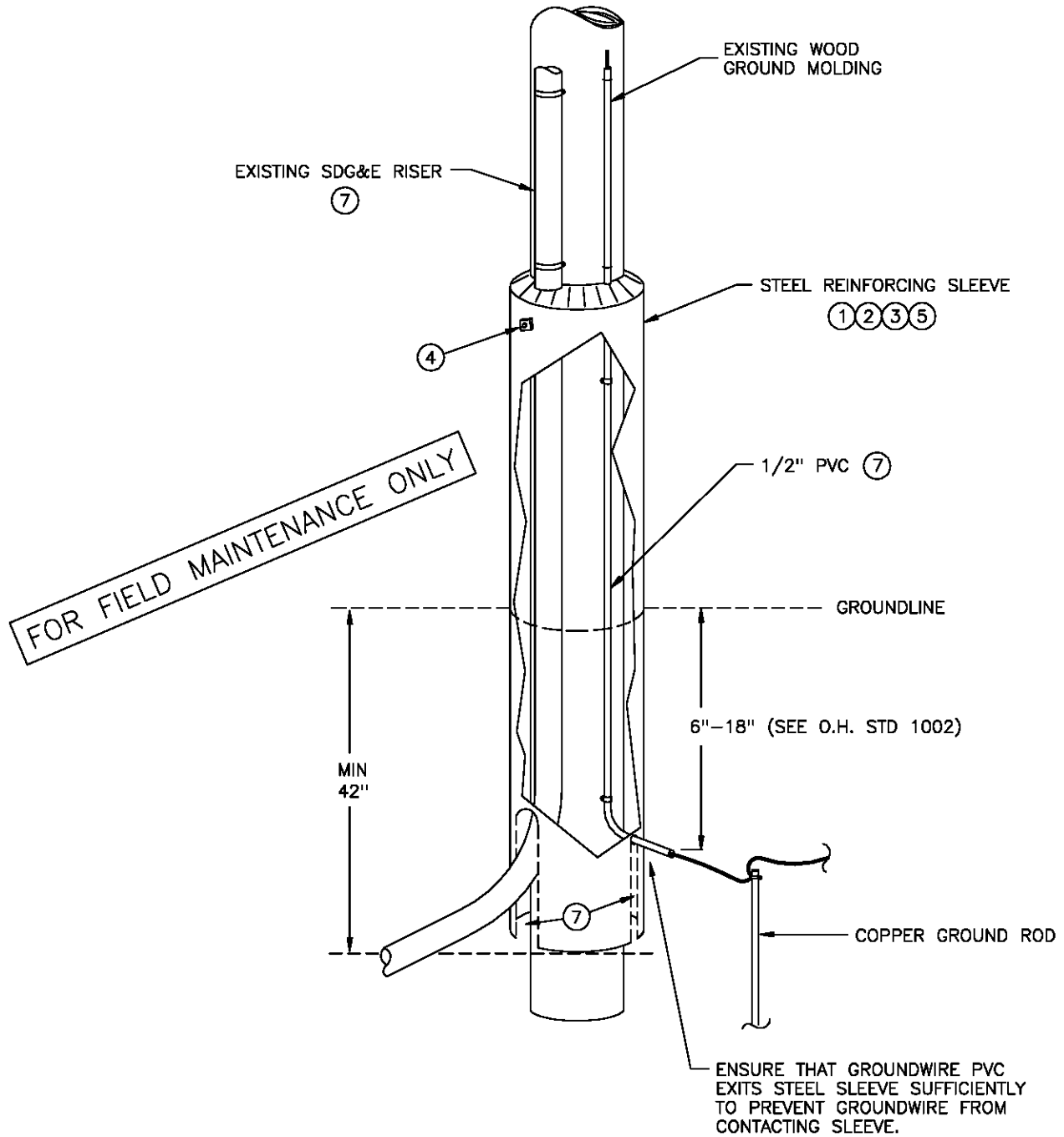

NOTES:

- PRESENTLY ALL STEEL SLEEVES ARE INSTALLED BY OUTSIDE CONTRACTORS AS PART OF GROUND LINE TREATMENT AND REINFORCEMENT PROGRAM.
- FOR USE ON POLES SUFFERING FROM BUTT ROT ONLY OR WHERE VEHICLE CONTACT HAS WEAKENED THE POLE AT GROUND LINE SUFFICIENTLY TO REQUIRE RESTORATION.

DATE 1-1-96 APPD <i>PA 1/20/96</i>	SDG&E ELECTRIC STANDARDS	399.701
	REINFORCING WOOD POLES WITH STEEL SLEEVES	

MINIMUM REQUIREMENTS FOR POLE

-POLE MUST NOT BE PART OF A GRADE "A" CONSTRUCTION PER G.O. 95 RULE 42 AND RULE 49.1.

MINIMUM REQUIREMENTS FOR INSTALLATION

-COMPLETE WOOD TREATMENT, REINFORCING MATERIALS AND METHOD OF INSTALLATION REQUIREMENTS ARE OUTLINED IN "TECHNICAL SPECIFICATION FOR THE GROUNDLINE RESTORATION OF DETERIORATED WOOD POLES".

-INCLUDED IN THE SPECIFICATION ARE, BUT NOT LIMITED TO, THE FOLLOWING REQUIREMENTS: (CONTACT CONSTRUCTION STANDARDS FOR A COMPLETE COPY)

1. THE MINIMUM DIAMETER OF THE SLEEVE SHALL BE 5 INCHES GREATER THAN THE GROUNDLINE DIAMETER OF THE POLE.
2. THE SLEEVE SHALL BE OF SUFFICIENT LENGTH THAT:
 - FROM THE TOP OF THE INSTALLED SLEEVE TO A POINT MEASURED 18 INCHES BELOW THE TOP OF THE INSTALLED SLEEVE, THE MINIMUM GOOD WOOD SHELL THICKNESS OF THE POLE IS 2 INCHES.
 - THERE IS AT LEAST 42 INCHES OF SLEEVE BURIED WITH A MINIMUM OF 30" DEEP ANNULUS.
 - THERE IS AT LEAST 42 INCHES OF SLEEVE ABOVE GROUND.
3. THE INSTALLED SLEEVE SHALL BE PLACED CONCENTRICALLY ABOUT THE POLE SUCH THAT THE RADIAL DISTANCE FROM THE SURFACE OF THE POLE TO THE INSIDE EDGE OF THE SLEEVE DOES NOT VARY MORE THAN 1/2 INCH.
4. CLIMBING STEP ATTACHMENTS:
 - A MINIMUM OF TWO 5/8 INCH SQUARE STEEL NUTS SHALL BE WELDED TO THE EXTERIOR OF THE SLEEVE AT 18 INCH INTERVALS, 90 DEGREES APART, FOR THE PURPOSE OF TEMPORARY STEP ATTACHMENT.
 - REMOVE ANY PERMANENT POLE STEPS ATTACHED TO THE POLE WHICH ARE WITHIN 8 FEET OF THE TOP OF THE SLEEVE.
5. THE SLEEVE SHALL BE PAINTED ACCORDING TO THE SPECIFICATION.
6. WHEN THE POLE IS WITHIN 12 FEET OF A TRAVELED ROADWAY, OR IN AN ALLEY OR PARKING AREA, REFLECTIVE STRIPS MUST BE ATTACHED TO THE STEEL SLEEVE AS NOTED IN SPECIFICATION.
7. IF THE SLEEVE IS TO BE INSTALLED ON A POLE WITH EXISTING GROUND RUNS OR POLE MOUNTED RISERS, THE HOLE MUST BE HAND DUG AND THE SLEEVE NOTCHED SO AS NOT TO DISTURB THE UNDERGROUND CONDUITS. THE GROUND WIRE MUST BE ENCASED IN A 1/2" PVC CONDUIT BEFORE BEING ENCAPSULATED IN THE EPOXY AND AGGREGATE FILLER AS NOTED IN DRAWING.

FOR FIELD MAINTENANCE ONLY

ADDING RISERS OR GROUND RUNS TO POLE WITH EXISTING STEEL SLEEVE

-WHEN ADDING A RISER TO A POLE WITH AN EXISTING STEEL SLEEVE, RISER MUST BE ATTACHED TO LADDER ARM BRACKETS (SEE STANDARD 1404/4204).

-ADDING A GROUND RUN TO A POLE WITH AN EXISTING STEEL SLEEVE SHOULD BE AVOIDED. IF THERE IS NO ALTERNATIVE, CONTACT CONSTRUCTION STANDARDS FOR INSTALLATION METHOD.

399.702	SDG&E ELECTRIC STANDARDS	DATE 1-1-96 APPD <i>PIA 1/20/96</i>
	REINFORCING WOOD POLES WITH STEEL SLEEVES	

SCOPE: THIS STANDARD SHOWS A METHOD OF REINFORCING DETERIORATED WOOD POLES USING A FIBERGLASS WRAP.

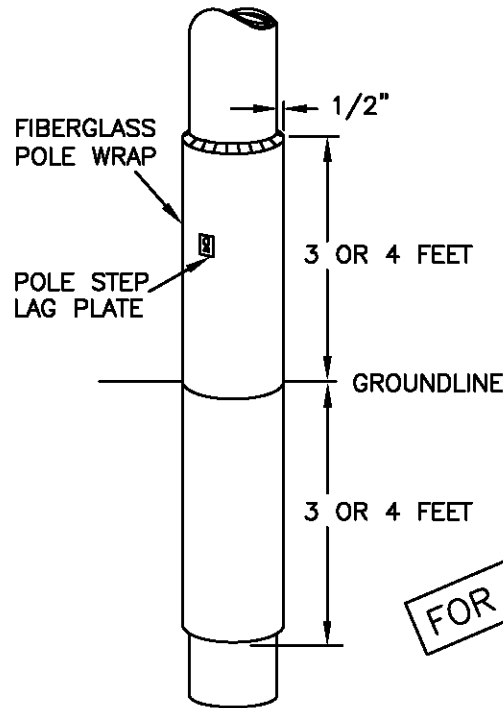

FOR FIELD MAINTENANCE ONLY

NOTES:

- ALL FIBERGLASS POLE WRAPS ARE INSTALLED BY AN OUTSIDE CONTRACTOR AS PART OF A GROUNDLINE TREATMENT AND REINFORCEMENT PROGRAM.
- FOR USE ON POLES SUFFERING FROM BUTT ROT ONLY OR WHERE VEHICLE CONTACT HAS WEAKENED THE POLE AT GROUNDLINE SUFFICIENTLY TO REQUIRE RESTORATION.

MINIMUM REQUIREMENTS FOR POLE

- POLE MUST NOT BE PART OF A GRADE "A" CONSTRUCTION PER G.O. 95 RULE 42 AND 49.1.

MINIMUM REQUIREMENTS FOR INSTALLATION

- COMPLETE WOOD TREATMENT, REINFORCING MATERIALS AND METHOD OF INSTALLATION REQUIREMENTS ARE OUTLINED IN "TECHNICAL SPECIFICATION FOR GROUNDLINE RESTORATION OF DETERIORATED WOOD POLES."
- THE FIBERGLASS WRAP TYPICALLY EXTENDS 3 TO 4 FEET ABOVE AND BELOW GROUNDLINE, BUT IT CAN EXTEND AS FAR UP THE POLE AS NEEDED TO A POINT WHERE THERE IS AN AVERAGE SHELL THICKNESS OF 4 INCHES.
- PRIOR TO THE POLE BEING WRAPPED, IT WILL BE TREATED WITH APPROVED PRESERVATIVES AND FUMIGANT TO STOP THE DECAY PROCESS.
- THE FIBERWRAP WILL EXTEND OUT FROM THE POLE NO MORE THAN 1/2".
- THE INSTALLATION CONTRACTOR WILL INSTALL POLE STEP LAG PLATES (S/N 541212) IN ACCORDANCE WITH G.O. 95 RULE 51.7.
- IF THE FIBERWRAP IS TO BE INSTALLED ON A POLE WITH EXISTING GROUND RUN, MOLDINGS AND STAPLES WILL BE REMOVED AND THE GROUNDWIRE PULLED AWAY FROM THE POLE. AFTER THE RESIN HAS GELLED, THE GROUNDWIRE WILL BE PLACED AGAINST THE POLE, AND COVERED WITH MOLDING BY PRE-DRILLING FOR THE MOLDING STAPLES. A NEW GROUND RUN MAY BE ATTACHED TO A POLE WITH EXISTING FIBER- WRAP USING THE SAME METHOD.
- EXISTING RISERS ATTACHED TO THE POLE WILL BE MOVED OUT BY SDG&E CREW PRIOR TO FIBERWRAP INSTALLATION, AND RE-ATTACHED AFTER INSTALLATION.

© 1998 - 2005 San Diego Gas & Electric Company. All rights reserved. Removal of this copyright notice without permission is not permitted under law.

DATE 1-1-96
APPD *PA/ROJ*

SDG&E ELECTRIC STANDARDS
REINFORCING WOOD POLES
WITH FIBERGLASS WRAP

399.703
SUPERSEDES
375 (1-1-96)

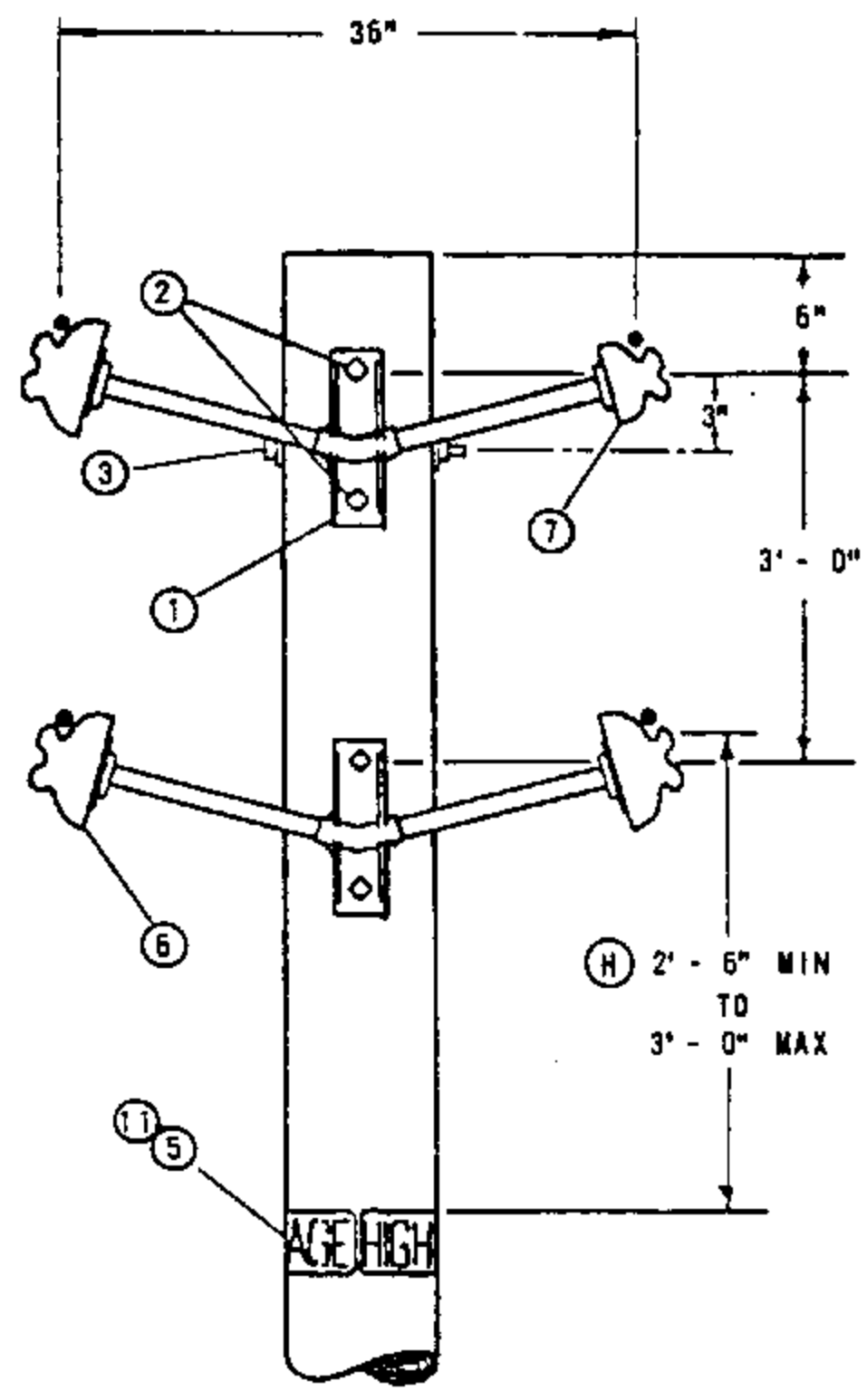
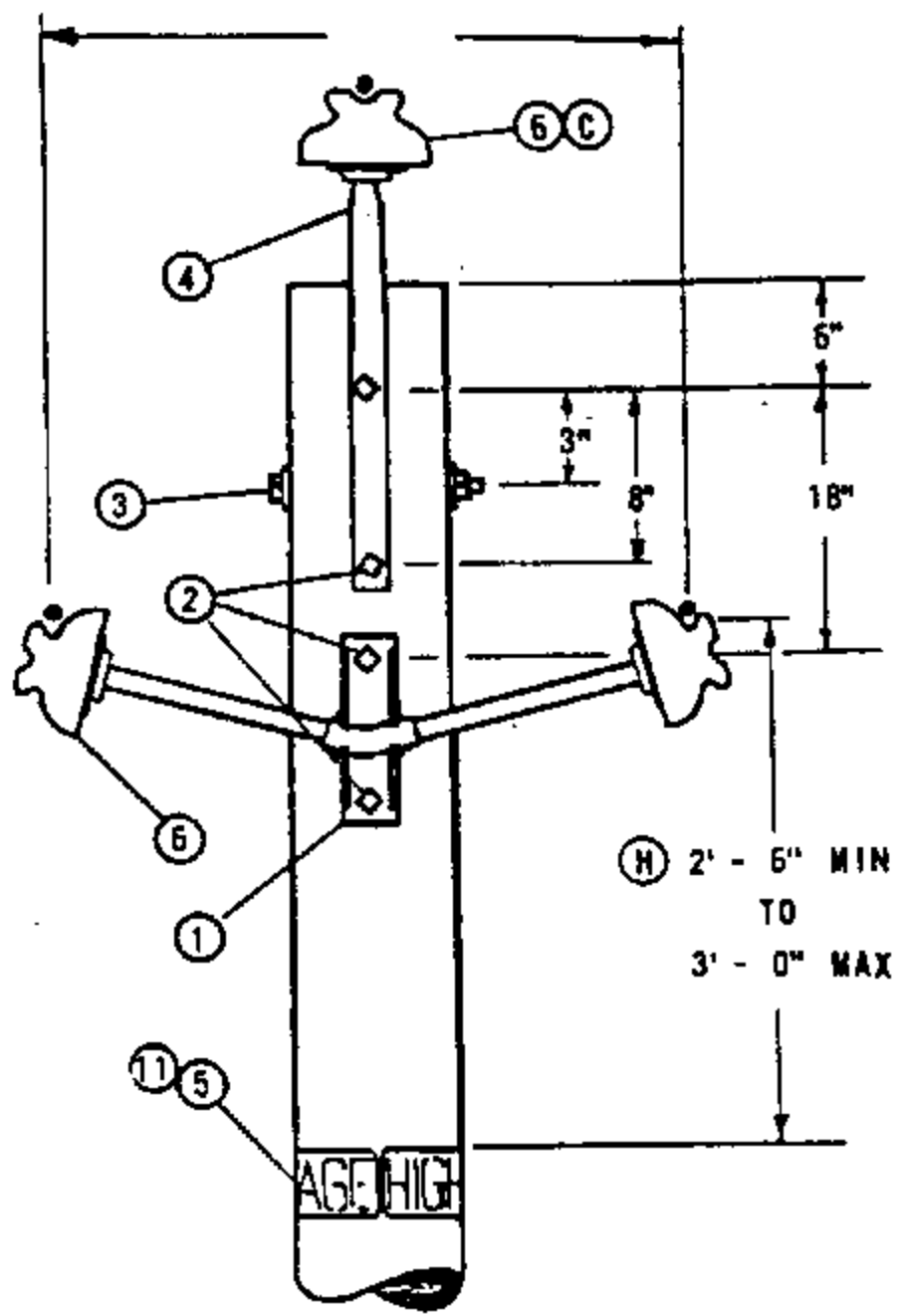

FIGURE 1
WORK ORDER DESIGNATION
"FGS AND PTP"

FIGURE 2
WORK ORDER DESIGNATION
"FGS"

NOTES:

- A. USE MAXIMUM ANGLE OF DEVIATION OF 2.25° , BASED ON CLIMBING SPACE REQUIREMENTS (G.O. 95, RULE 54.7A2).
- B. USE IN CONTAMINATION DISTRICTS 2 AND 3 AS DEFINED ON STANDARDS PAGE 287.
- C. SUBSTITUTE ONE 55-3 FOR ONE 55-5 INSULATOR AND CORRESPONDING PREFORMED TYPE TIE ON NEUTRAL WIRE FOR IDENTIFICATION.
- E. EXEMPT MATERIALS.
- F. ITEM 10 IS PREFERRED OVER ITEMS 8 & 9.
- G. 636 KCM AND 1033.5 KCM CONDUCTORS CANNOT BE USED SINCE NO CLAMP INSULATORS OF THIS TYPE ARE AVAILABLE.
- H. THESE DIMENSIONS ARE IN ACCORDANCE WITH G.O. 95.
- I. MAXIMUM SPAN LENGTH FOR THIS CONSTRUCTION IS 200'. IF SPAN LENGTH IS GREATER, PLEASE CONTACT SYSTEM STANDARDS.

ITEM	DESCRIPTION	QUANTITY			STOCK NO. OR CONSTR. STDS.
		FIG. 1		FIG. 2	
		10	30	4 WIRE	
1	BRACKET, 2 PHASE PIN	1	1	2	166912
2	BOLT, MACH 5/8 X <u> </u> ". 1-2 1/4" FLAT WASH. 1 DBL COIL SPR. WASH. (E)	2	4	4	PGS 139, 140
3	BOLT, MACH 5/8 X <u> </u> ". 2-2 1/4" FLAT WASH. 1 DBL COIL SPR WASH. (E)	1	1	1	PGS 139, 140
4	PIN, POLE TOP, 24", 1" LEAD THREADS	-	1	-	532480
5	SIGN. HIGH VOLTAGE (E)	2	2	2	647616
6	INSULATOR, PIN TYPE, CLASS 55-5	2	3	3	429056
7	INSULATOR, PIN TYPE, CLASS 55-3	(C)	(C)	1	429216
8	WIRE TIE (F)		IF REQ'D.		700 SECTION
9	GUARD, LINE, ALUM CONDUCTOR (F)		IF REQ'D.		700 SECTION
10	TIE, PREFORMED, ALUMINUM CONDUCTORS, (F)	2	3	4	PG 760
11	NAILS, 1 3/4" GALV (E)	16	16	16	492192

SDG & E ELECTRIC STANDARDS

FIBERGLASS SUPPORT CONSTRUCTION, 12KV AND BELOW

APPD *ALUK*
SYS STDS ENGR

499.101
SUPERCEDES
413 (1-1-92)

SCOPE: THIS STANDARD SHOWS DISTRIBUTION CONSTRUCTION OF 12 AND 12.47 KV LINES WITH A LINE ANGLE NOT EXCEEDING 5°, USING ARMLESS VERTICAL CONSTRUCTION.

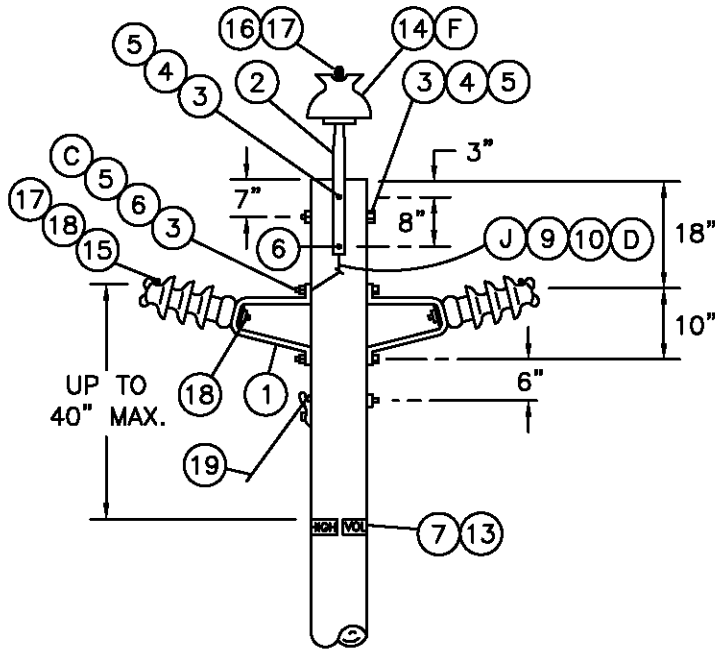

FIGURE 1

POLE TOP POSITION 3 WIRE CIRCUIT,
WORK ORDER DESIGNATION PTP, PIB, & TPI

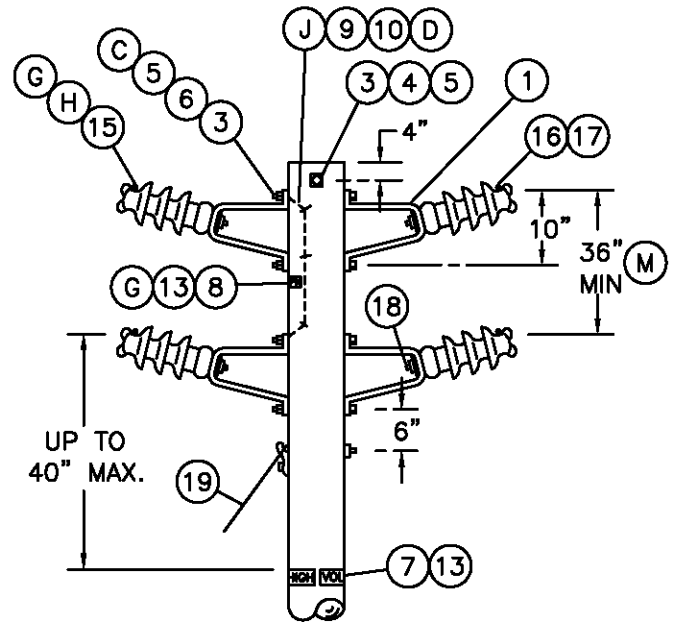

FIGURE 2

POLE TOP POSITION 2, 3, OR 4 WIRE CIRCUIT,
WORK ORDER DESIGNATION PIB & TPI

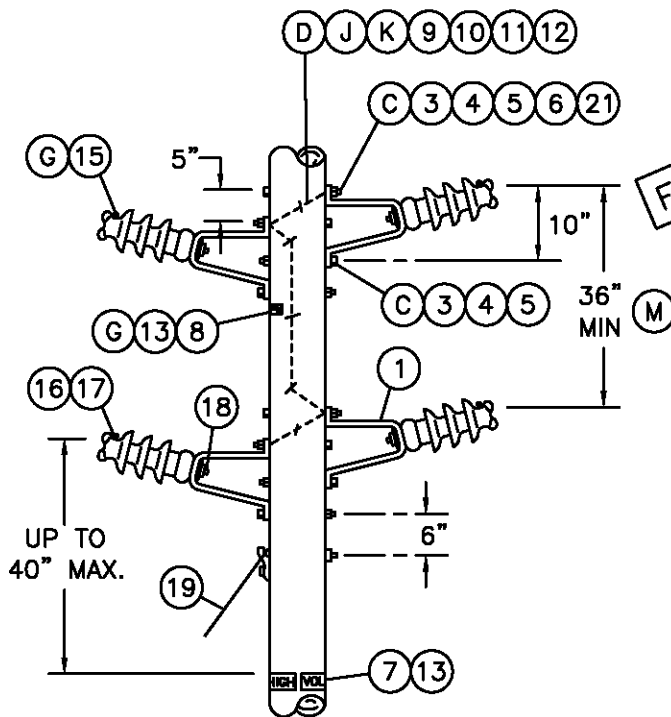

FIGURE 3

BELOW POLE TOP POSITION 2, 3, OR 4 WIRE CIRCUIT
WORK ORDER DESIGNATION PIB & TPI

FOR FIELD MAINTENANCE ONLY

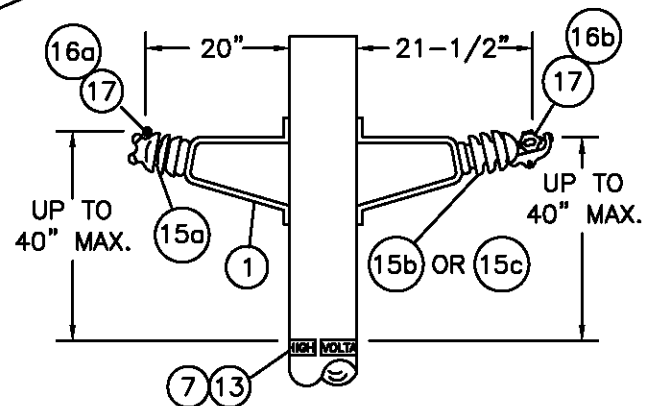

FIGURE 4

HORIZONTAL POST INSULATOR
WORK ORDER DESIGNATION PIB, TPI, & HPI

DATE 1-1-96
APPD *PA/ROJ*

SDG&E ELECTRIC STANDARDS

POST INSULATOR AND BRACKET CONSTRUCTION,
ANGLES 0° TO 5°, 12 AND 12.47KV

499.102
SUPERSEDES
414.1 (1-1-96)

INSTALLATION:

- A. CLIMBING SPACE MUST BE PROVIDED PER STANDARDS PAGE 252.
- B. USE CLAMP TOP LINE POST INSULATORS AND CLAMPS FOR 1033 KCMIL ACSR.
- (C) INSTALL DOUBLE COIL SPRING WASHER SO IT CONTACTS BRACKET.
- (D) BONDING OF THE BRACKETS IS ONLY REQUIRED WITHIN HEAVY CONTAMINATION AREA, DISTRICT 1 ON PAGE 287. USE BONDING PROVISIONS ON BRACKETS, IF THEY ARE FURNISHED.
- (F) SUBSTITUTE A CLASS 55-3 INSULATOR (STOCK NO. 429216) FOR NEUTRAL IDENTIFICATION.
- (G) IF A SMALLER LINE POST INSULATOR IS NOT AVAILABLE FOR NEUTRAL AS COMPARED TO THOSE ON THE PHASE POSITION, THE "PN" SIGN SHALL BE USED TO IDENTIFY THE NEUTRAL.
- (H) RESISTANCE GLAZE (RG) CLAMP TOP POST INSULATORS (STOCK NO 428952) SHALL BE USED WHEN AVAILABLE ON TRIAL APPLICATIONS ON PHASE CONDUCTORS IN HEAVY CONTAMINATION AREAS AS DEFINED ON PAGE 287 AND ONLY USING FIGURE 2 CONSTRUCTION. CONDUCTOR CLAMPS ARE REQUIRED WITH "RG" INSULATORS. INSTALL A "DO NOT WASH" SIGN ABOVE THE POLE TAGS IN SIGHT OF ON-COMING TRAFFIC.
- I. USE FIGURES 2 OR 3 WHERE NEUTRAL MAY BE REQUIRED IN THE FUTURE. CONSULT WITH DISTRICT ENGINEER.
- (J) TO PREVENT RADIO INFLUENCE VOLTAGE (R.I.V.), DO NOT LOCATE BOND WIRE STAPLES WITHIN 1" OF BOLTS.
- (L) ORDER (ITEM 18) FOR HPI ONLY.
- (M) FOR SPAN LENGTHS GREATER THAN 250', THE CONDUCTOR SPACING IS DETERMINED BY THE FORMULA:

$$\text{SPACING} = 3' + \left[\frac{\text{SPAN LENGTH} - 250'}{50} \right]$$
 IF SPAN LENGTH IS GREATER THAN 325', PLEASE CONTACT DISTRIBUTION STANDARDS.
- N. AN INSULATOR MOUNTED DIRECTLY ON THE SIDE OF A POLE SHALL BE CONSIDERED AS IN A HORIZONTAL POSITION (SEE FIG. 4). AN INSULATOR MOUNTED DIRECTLY AT THE TOP OF THE POLE IN A VERTICAL POSITION SHALL BE CONSIDERED AS IN A VERTICAL POSITION (SEE G.O. 95 RULE 54.11 A).

FOR FIELD MAINTENANCE ONLY

BILL OF MATERIAL:

ITEM	DESCRIPTION	QUANTITY						STOCK NO. OR CONSTR STDS	ASSEMBLY UNITS	
		FIG. 1	FIG. 2			FIG. 3				
			2 WIRE	3 WIRE	4 WIRE	2 WIRE	3 WIRE			4 WIRE
1	BRACKET, POST INSULATOR (PIB)	2	2	3	4	2	3	4	166848	PIB
2	PIN, POLE TOP 24", 1" OR 1 3/8" LEAD THREAD AS REQ'D	1	-	-	-	-	-	-	532480	PTP1
3	BOLT, MACH, 5/8" X ___"	5	3	5	5	4	6	8	STD 392	-
4	WASHER, 2 1/4" SQ FLAT	4	2	4	2	4	6	8	STD 392	-
5	WASHER, 5/8" DOUBLE COIL SPRING	5	3	5	5	4	6	8	STD 392	-
6	WASHER, 5/8" ROUND (WHERE BONDING IS REQ'D (D))	4	-	4	4	4	6	8	STD 392	-
7	SIGN, HIGH VOLTAGE	2	2	2	2	2	2	2	647648	HV
8	SIGN, PN (PRIMARY NEUTRAL) IF REQ'D	1	1	1	1	1	1	1	648000	PN
9	WIRE, BARE SOLID ANNEALED COPPER #8 (WHERE BONDING IS REQ'D)	3'	-	6'	6'	2'	6'	8'	812928	BOND8
10	STAPLES, GALV FENCE 1 1/4" (WHERE BONDING IS REQ'D)	2	-	4	4	1	4	5	678528	-
11	MOULDING, 1" HARDWOOD	-	-	-	-	-	2.5	2.5	487200	MLDG
12	STAPLES, MOULDING GALV 3" X 1 1/16" X 1/4"	-	-	-	-	-	2	2	678560	-
13	NAILS, 1 3/4" GALV	AS REQ'D						492192		-
14	INSULATOR, PIN TYPE, CLASS AS REQ'D	1	-	-	-	-	-	-	700 SECTION	-
15	INSULATOR, POST	a	TIE TOP (TPI)						700 SECTION	-
		b	HORIZONTAL CLAMP TOP (HPI)							
		c	HORIZONTAL CLAMP TOP RG (HPI) (H)							
16	TIE	a	FORMED OR WIRE						700 SECTION	-
		b	CLAMP, HORIZONTAL POST INSULATOR							
17	GUARD, LINE, ALUMINUM, IF REQ'D	3	2	3	4	2	3	4	PG 759	-
18	STUD, LINE POST, 5/8" X 1 3/4" (L)	2	2	3	4	2	3	4	701728	STUD-S
19	GUY	AS REQ'D						900 SECTION		-
20	SIGN, "DO NOT WASH" (H)	IF REQ'D						648024		NOWASH
21	NUT, 5/8" GALV	AS REQ'D						506880		-

DATE 1-1-98 APPD <i>PA/CAC</i>	SDG&E ELECTRIC STANDARDS POST INSULATOR AND BRACKET CONSTRUCTION, ANGLES 0° TO 5°, 12 AND 12.47KV	499.103 SUPERSEDES 414.2 (1-1-98)
-----------------------------------	---------------------------------------------------------------------------------------------------------	-----------------------------------------

SCOPE: THIS STANDARD SHOWS DISTRIBUTION CONSTRUCTION OF 12 AND 12.47KV LINES WITH A LINE ANGLE GREATER THAN 5°, BUT NOT EXCEEDING 30°, USING ARMLESS VERTICAL CONSTRUCTION.

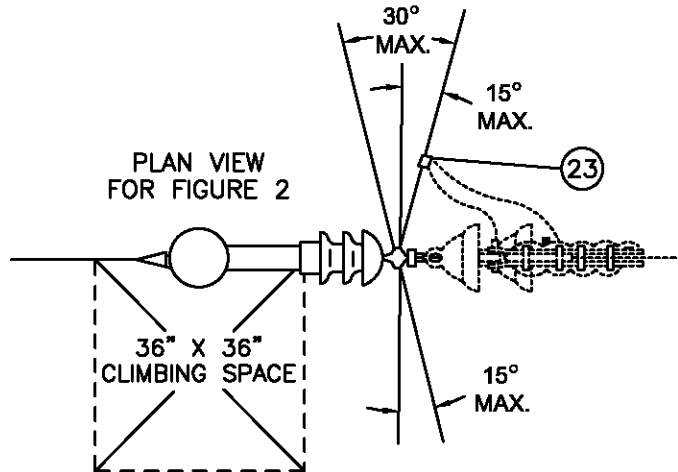
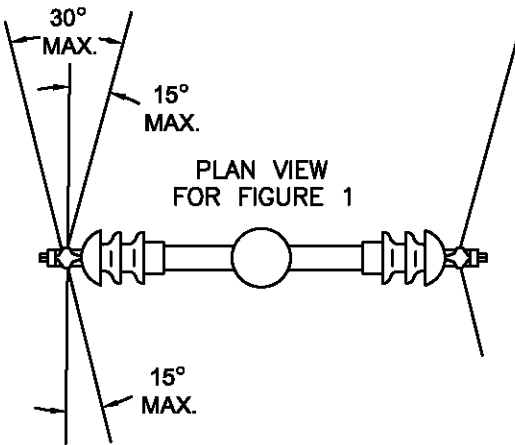

FOR FIELD MAINTENANCE ONLY

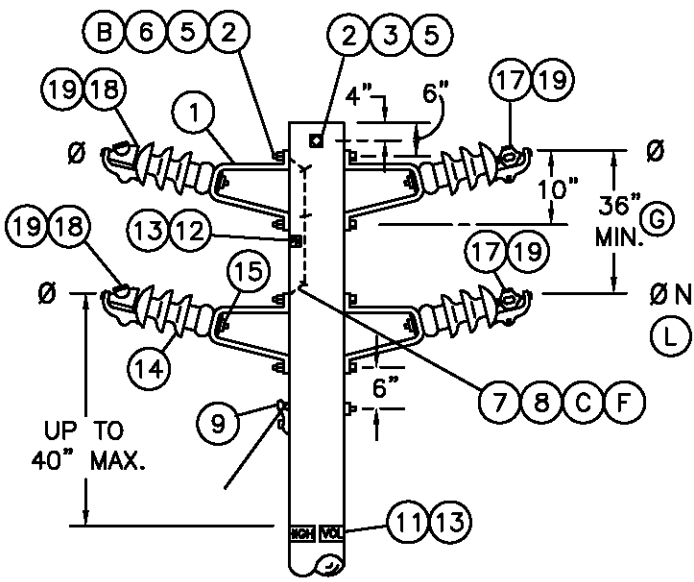

FIGURE 1 (J)

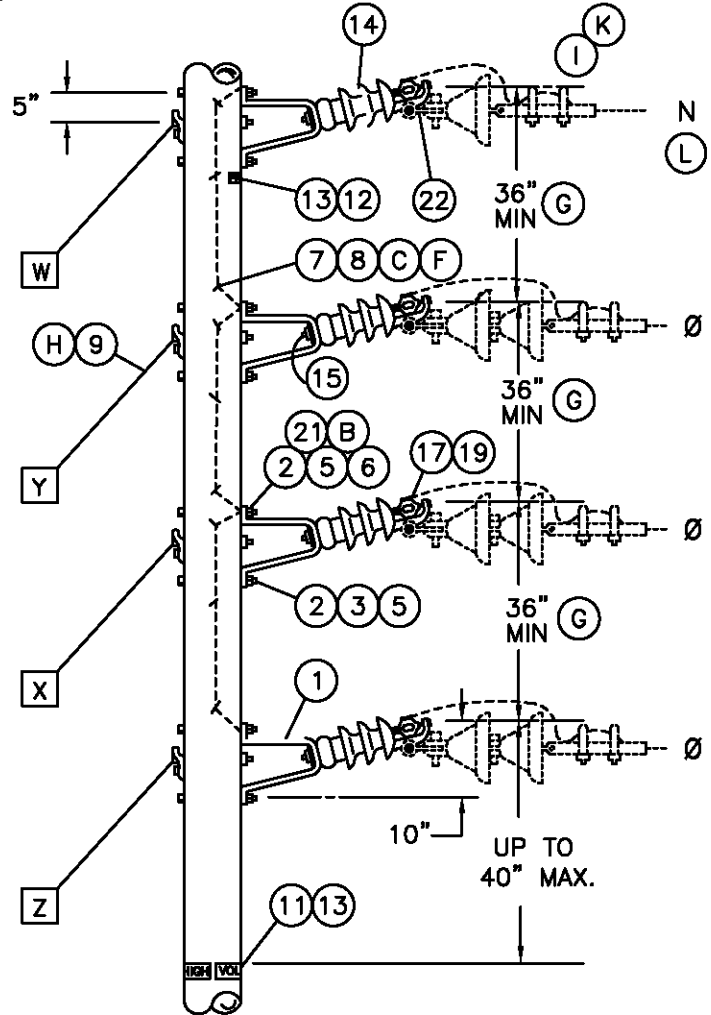

FIGURE 2

2, 3, OR 4 WIRE CIRCUIT,
 ANGLES TO 30° BELOW POLE TOP
 WORK ORDER DESIGNATION PIB & HPI

499.104
 SUPERSEDES
 415.1 (9-13-05)

SDG&E ELECTRIC STANDARDS
 POST INSULATOR AND BRACKET CONSTRUCTION,
 ANGLES 5° TO 30°, 12 AND 12.47KV

DATE 9-13-05
 APPD PJA/JJ

INSTALLATION:

- A. CLIMBING SPACE MUST BE MAINTAINED PER STANDARD 252.
- (B) INSTALL DOUBLE COIL SPRING WASHER SO IT CONTACTS BRACKET.
- (C) BONDING OF THE BRACKETS IS ONLY REQUIRED WITHIN HEAVY CONTAMINATION AREA, DISTRICT 1, AS SHOWN ON STANDARD 287. USE BONDING PROVISIONS ON BRACKETS, IF THEY ARE FURNISHED.
- (D) RESISTANCE GLAZE (RG) CLAMP TOP POST INSULATORS SHALL BE USED ONLY ON FIGURE 1 CONSTRUCTION WHEN AVAILABLE ON TRIAL APPLICATION ON PHASE CONDUCTORS IN HEAVY CONTAMINATION AREA. INSTALL A "DO NOT WASH" SIGN ABOVE THE POLE TAGS IN SIGHT OF ON-COMING TRAFFIC.
- (F) TO PREVENT RADIO INFLUENCE VOLTAGE (R.I.V.) DO NOT LOCATE BOND WIRE STAPLES WITHIN 1" OF BOLTS.
- (G) FOR SPAN LENGTHS GREATER THAN 250', DETERMINE CONDUCTOR SPACING BY THE FORMULA:

$$\text{SPACING} = 3' + \left[\frac{\text{SPAN LENGTH} - 250'}{50} \right]$$
 IF SPAN LENGTH IS GREATER THAN 325', PLEASE CONTACT DISTRIBUTION STANDARDS.
- (H) ADD THE GUYS IN ORDER INDICATED (W,X,Y,Z) AS REQUIRED IN THE GUYING SECTION.
- (I) WHERE REQUIRED TO ADD A TAP TO THIS CONSTRUCTION, ATTACH DEADEND ASSEMBLY ON PAGE 422.1 AND 422.2 TO HPIs WITH DEADEND CLEVIS. IF PAGE 756 REQUIRES THIS ASSEMBLY TO BE BONDED, CONTACT DISTRIBUTION STANDARDS.
- (J) WHERE REQUIRED TO ADD A TAP TO THIS CONSTRUCTION, USE FIG. 2.
- (K) PER G.O.-95 RULE 54.4-C4 (b), ONLY TWO CONDUCTORS ARE ALLOWED TO BE DEAD ENDED FOR 4 KV OPERATION.

REFERENCE:

- (L) ON ALL NEW CONSTRUCTION AND WHEN ADDING TO EXISTING CONSTRUCTION, NEUTRAL TO BE PLACED IN THE TOP OR BOTTOM PIN POSITIONS PER DESIGN MANUAL PAGE 5124.2.

FOR FIELD MAINTENANCE ONLY

BILL OF MATERIAL:

ITEM	P T F	O C D	DESCRIPTION	QUANTITY						STOCK NO. OR CONSTR STD
				FIGURE 1			FIGURE 2			
				2 WIRE	3 WIRE	4 WIRE	2 WIRE	3 WIRE	4 WIRE	
1			BRACKET, POST INSULATOR (PIB)	2	3	4	2	3	4	166848
2			BOLT, MACH, 5/8" X ___"	2	4	4	4	6	8	STD.139
3			WASHER, 2 1/4" FLAT SQ WASH.	-	2	-	2	2	4	799040
4			WASHER, 3" CURVED SQ WASH.	-	-	-	2	4	4	797792
5			WASHER, 5/8" DBL COIL SPRING	2	4	4	4	6	8	798560
6			WASHER, 5/8" ROUND	-	4	4	4	6	8	800320
7			WIRE, #8 SOLID BARE ANNEALED COPPER	-	5'	5'	2'	8'	8'	812928
8			STAPLES, 1 1/4" FENCE	-	3	3	1	4	5	678528
9			GUY	AS REQ'D						900 SECTION
10										
11			SIGN, HIGH VOLTAGE	2	2	2	2	2	2	647648
12			SIGN, PRIMARY NEUTRAL, (PN)	2 IF REQ'D	2 IF REQ'D	2	2 IF REQ'D	2 IF REQ'D	2	648000
13			NAILS, 1 3/4"	24	24	24	24	24	24	492192
14			INSULATOR				2	3	4	700 SECTION
			CLAMP TOP POST	a HORIZONTAL						
				b HORIZONTAL RG (D)	2	3	4	-	-	
15			STUD, LINE POST, 5/8" X 1 3/4"	2	3	4	2	3	4	701728
16										
17			CLAMP, POST INSULATOR, STANDARD	1	2	2	1	2	2	STD. 773
18			CLAMP, POST INSULATOR, ANGLE	1	1	2	1	1	2	STD. 773
19			GUARD, LINE, ALUMINUM, IF REQ'D	2	3	4	2	3	4	STD. 759
20			SIGN "DO NOT WASH" & 8 NAILS (IF REQ'D)(D)	1	1	1	1	1	1	648024/492192
21			NUT, 5/8" GALV	AS REQ'D						506880
22			CLEVIS, DEADEND (I)	2	3	4	2	3	4	235776
23			CONNECTOR, WIRE	-	-	-	4	6	8	STD. 783-787

DATE 9-20-05	SDG&E ELECTRIC STANDARDS	499.105
APPD PJA/JJ	POST INSULATOR AND BRACKET CONSTRUCTION, ANGLES 5° TO 30°, 12 AND 12.47KV	SUPERSEDES 415.2 (9-20-05)

SCOPE: THIS STANDARD SHOWS DISTRIBUTION CONSTRUCTION OF 12 & 12.47 KV LINES WITH A LINE ANGLE GREATER THAN 30°, BUT NOT EXCEEDING 60°, USING ARMLESS VERTICAL CONSTRUCTION.

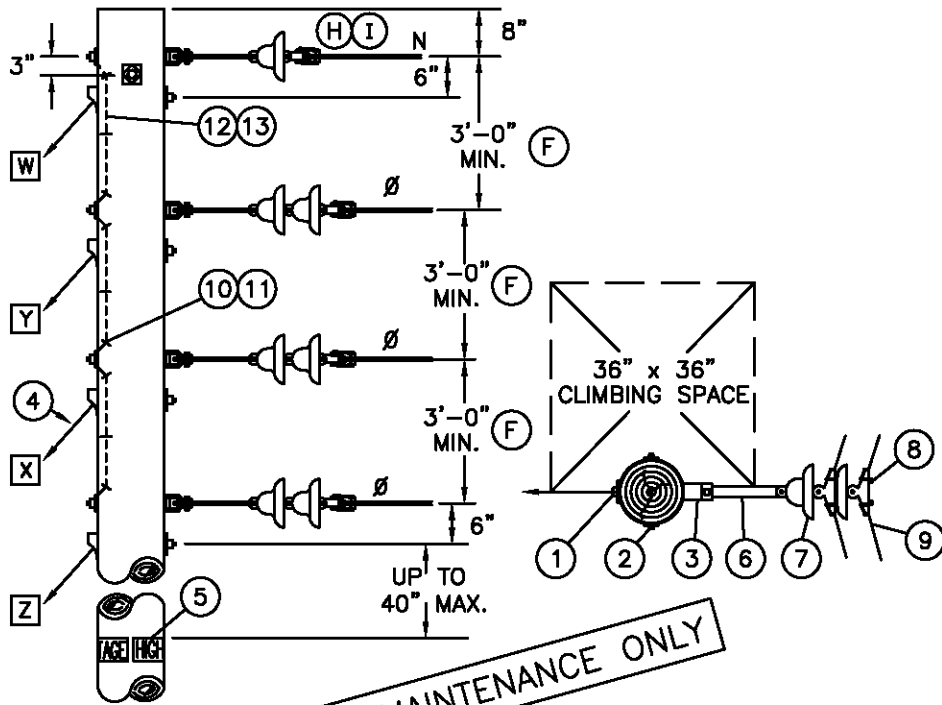

12KV VERTICAL CONSTRUCTION ASSEMBLY - MACRO UNITS			
TYPE	QUANTITY		MU ID
	12KV DE	NDE	
1/2 Y	1	1	HY1N
1/2 Y	2	-	HY2
1/2 Y	2	1	HY2N
1/2 Y	3	-	HY3
1/2 Y	3	1	HY3N
Y	2	2	Y1N
Y	4	-	Y2
Y	4	2	Y2N
Y	6	-	Y3
Y	6	2	Y3N
Z	1	1	Z1N
Z	2	-	Z2
Z	2	1	Z2N
Z	3	-	Z3
Z	3	1	Z3N

FOR FIELD MAINTENANCE ONLY

(F) FOR SPAN LENGTHS GREATER THAN 250', DETERMINE CONDUCTOR SPACING BY THE FORMULA: $SPACING = 3' + \frac{SPAN LENGTH - 250'}{50}$

NOTES:

- A. MINIMUM VERTICAL PHASE TO PHASE SPACING OF TWO FEET MAY BE USED TO ELIMINATE POLE CHANGEOUTS ON FULL TENSION SPANS 100 FEET AND SHORTER.
- B. INSTALL GUYS IN ORDER INDICATED ABOVE (W,X,Y,Z) AS REQUIRED BY THE "GUYING SECTION".
- C. USE BONDING INSULATORS OR INSTALL NON STATIC CLIPS (237648) ON UNBONDED SUSPENSION INSULATORS WHEN THE RESULTANT MAXIMUM GUYING TENSION PER PHASE AT THESE ANGLES IS LESS THAN 1500 POUNDS.
- D. TO PREVENT RADIO INFLUENCE VOLTAGE (R.I.V.), DO NOT LOCATE STAPLES WITHIN 1" OF BOLTS.

IF SPAN IS GREATER THAN 325', PLEASE CONTACT DISTRIBUTION STANDARDS.

- G. THE WORK ORDER DESIGNATION FOR THIS CONSTRUCTION IS "Z-CORNER".
- (H) PER G.O. 95 RULE 54.4 - C4 (b), ONLY TWO CONDUCTORS ARE ALLOWED TO BE DEAD ENDED FOR 4 KV OPERATION.
- (I) ON ALL NEW CONSTRUCTION AND WHEN ADDING TO EXISTING CONSTRUCTION, NEUTRAL TO BE PLACED IN THE TOP OR BOTTOM PIN POSITIONS PER DESIGN MANUAL PAGE 5124.2.

BILL OF MATERIAL:

ITEM	DESCRIPTION	QUANTITY			STOCK NO. OR CONSTR STD
		1Ø	3Ø	3Ø & N	
1	BOLT, MACH, GALV 5/8" X __", 1-3" SQ CURV WASH., 1 DBL COIL WASHER, 2-5/8" RD WASH. & 1 NUT	2	3	4	STD.392
2	BOLT, MACH, GALV 5/8" X __", 2-2 1/4" SQ WASH., 1 DBL COIL WASH., 2-5/8" RD WASH.	1	1	1	STD.392
3	CLEVIS, DEADEND 5/8" BOLT STEEL (OPEN TYPE)	2	3	4	235618
4	GUY	AS REQ'D			900 SECTION
5	SIGN, HIGH VOLTAGE & 9 NAILS	2	2	2	647648, 492192
6	LINK, EXTENSION, 12KV, 1/2" X 2" X 12"	2	3	4	466240
7	INSULATOR, SUSPENSION	4	6	7	PG 750
8	CLAMP, SUSPENSION	2	3	4	STD. 776
9	GUARD, LINE, ALUMINUM	2	3	4	STD. 759
10	WIRE, BOND, BARE SOLID ANNEALED, COPPER, #8	4'	6'	8'	812928
11	STAPLE, FENCE	3	6	9	678528
12	MOULDING, HARDWOOD, 1" (OTHER THAN TOP CIRCUIT ON POLE)	3'-6"	5'-6"	7'-6"	487200
13	STAPLES, MOULDING, GALV, 3" X 1 1/16" X 1/4" (OTHER THAN TOP CIRCUIT ON POLE)	2	4	6	678560

SDG&E ELECTRIC STANDARDS

499.201
SUPERSEDES
420 (9-12-05)

VERTICAL CONSTRUCTION 30° TO 60° ANGLES, 12 AND 12.47KV

DATE 9-12-05
APPD PJA/JJ

SCOPE: THIS STANDARD SHOWS DISTRIBUTION CONSTRUCTION OF 12 & 12.47 KV LINES WITH A LINE ANGLE GREATER THAN 60°, BUT NOT EXCEEDING 90°, USING ARMLESS VERTICAL CONSTRUCTION.

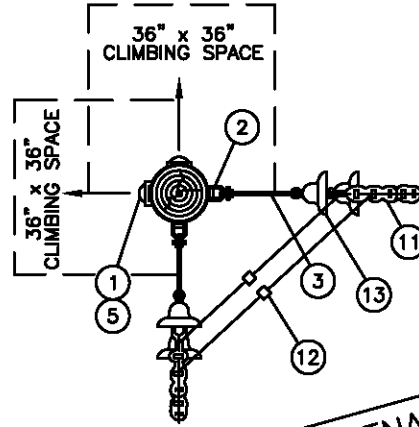
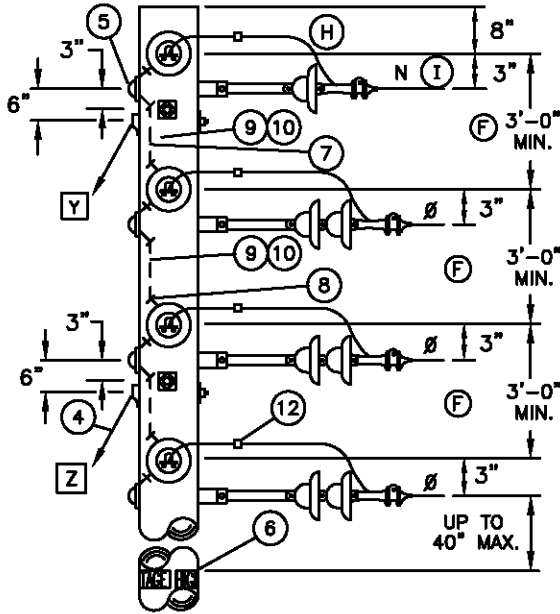

FOR FIELD MAINTENANCE ONLY

INSTALLATION:

- A. MINIMUM VERTICAL PHASE TO PHASE SPACING OF TWO FEET MAY BE USED TO ELIMINATE POLE CHANGEOUTS ON FULL TENSION SPANS 100 FEET AND SHORTER.
- B. INSTALL GUYS IN ORDER INDICATED ABOVE (Y,Z) AS REQUIRED BY THE "GUYING SECTION" AND IN COMPLIANCE WITH G.O. 95 RULE 54.7A4.
- C. USE BONDED INSULATORS WHEN THE MAXIMUM GUYING TENSION IS LESS THAN 1000 POUNDS PER CONDUCTOR.
- D. TO PREVENT RADIO INFLUENCE VOLTAGE (R.I.V.), DO NOT LOCATE STAPLES WITHIN 1" OF BOLT.
- F. FOR SPAN LENGTHS GREATER THAN 250', DETERMINE CONDUCTOR SPACING BY THE FORMULA: $SPACING = 3' + \frac{SPAN\ LENGTH - 250'}{50}$ IF SPAN LENGTH IS GREATER THAN 325', PLEASE CONTACT DISTRIBUTION STANDARDS.
- G. THE WORK ORDER DESIGNATION FOR THIS CONSTRUCTION IS "Y-CORNER".
- H. PER G.O. 95 RULE 54.4-C4 (b), ONLY TWO CONDUCTORS ARE ALLOWED TO BE DEAD ENDED FOR 4 KV OPERATION.

REFERENCE:

- I. ON ALL NEW CONSTRUCTION AND WHEN ADDING TO EXISTING CONSTRUCTION, NEUTRAL TO BE PLACED IN THE TOP OR BOTTOM PIN POSITIONS PER DESIGN MANUAL PAGE 5124.2.

BILL OF MATERIAL:

ITEM	DESCRIPTION	QUANTITY			STOCK NUMBER OR CONSTR. STD.
		1Ø	3Ø	3Ø & N	
1	BOLT, MACH, GALV 5/8" X ___", 1-3" SQ CURV WASH., 1 DBL COIL WASHER, 2-5/8"RD WASH. & 1 NUT	4	6	8	STD 392
2	CLEVIS, DEADEND 5/8" BOLT STEEL (OPEN TYPE)	4	6	8	235618
3	LINK, EXTENSION, 12KV, 1/2" X 2" X 12"	4	6	8	466240
4	GUY	AS REQ'D			900 SECTION
5	COVER, BOLT, PLASTIC, & 6-10 D NAILS	4	6	8	285696, 492192
6	SIGN, HIGH VOLTAGE & 9-10 D NAILS	2	2	2	647648, 492192
7	WIRE, BOND, BARE SOLID ANNEALED, COPPER, #8	4'	7'	8'	812928
8	STAPLES, FENCE, GALV, 1 1/4"	4	7	10	678528
9	MOULDING, HARDWOOD, 1" (OTHER THAN TOP CIRCUIT ON POLE)	2'-6"	4'-6"	6'-6"	487200
10	STAPLES, MOULDING, GALV, 3" X 1 1/16" X 1/4" (OTHER THAN TOP CIRCUIT ON POLE)	2	4	6	678560
11	CLAMP, DEADEND	4	6	8	STDS 741, 743
12	CONNECTOR	2	3	4	700 SECTION
13	INSULATOR, SUSPENSION	8	12	14	PG. 750.4

DATE 9-20-05
 APPD PJA/JJ

SDG&E ELECTRIC STANDARDS
 VERTICAL CONSTRUCTION 60° TO 90° ANGLES, 12 AND 12.47KV

499.202
 SUPERSEDES
 421 (9-20-05)

SCOPE: THIS STANDARD SHOWS DISTRIBUTION CONSTRUCTION OF 12 & 12.47KV LINES OF THE "4 WAY AND 'T' CORNERS" USING ARMLESS VERTICAL CONSTRUCTION.

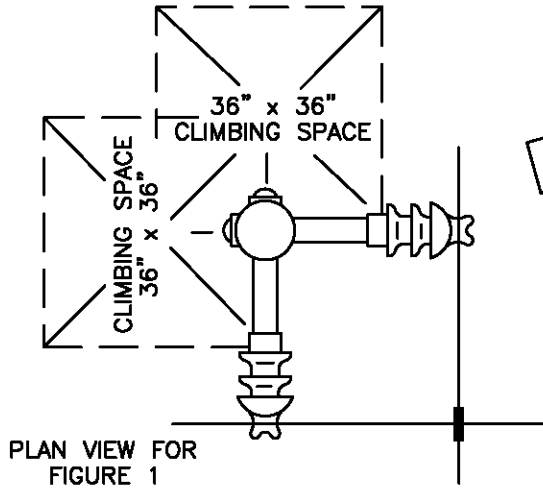

FOR FIELD MAINTENANCE ONLY

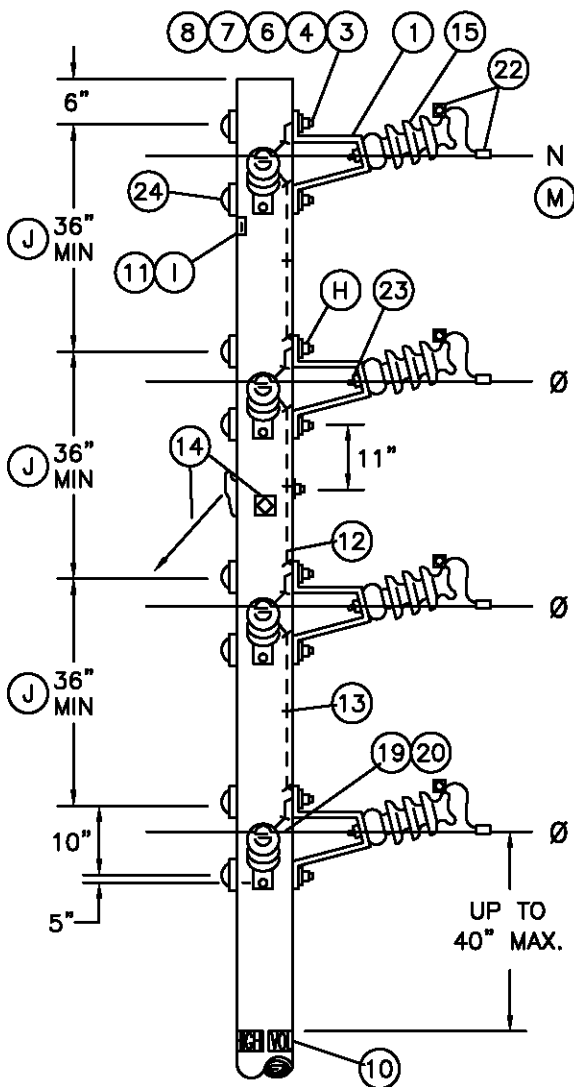
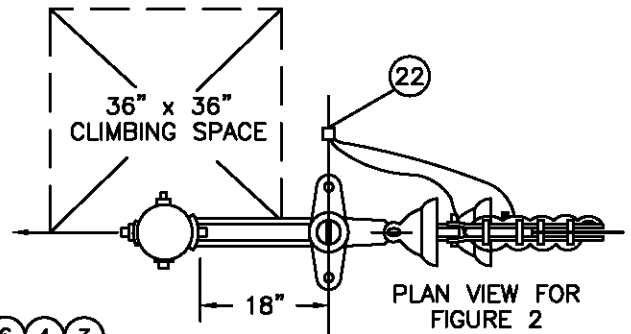

FIGURE 1
4 WAY CORNER

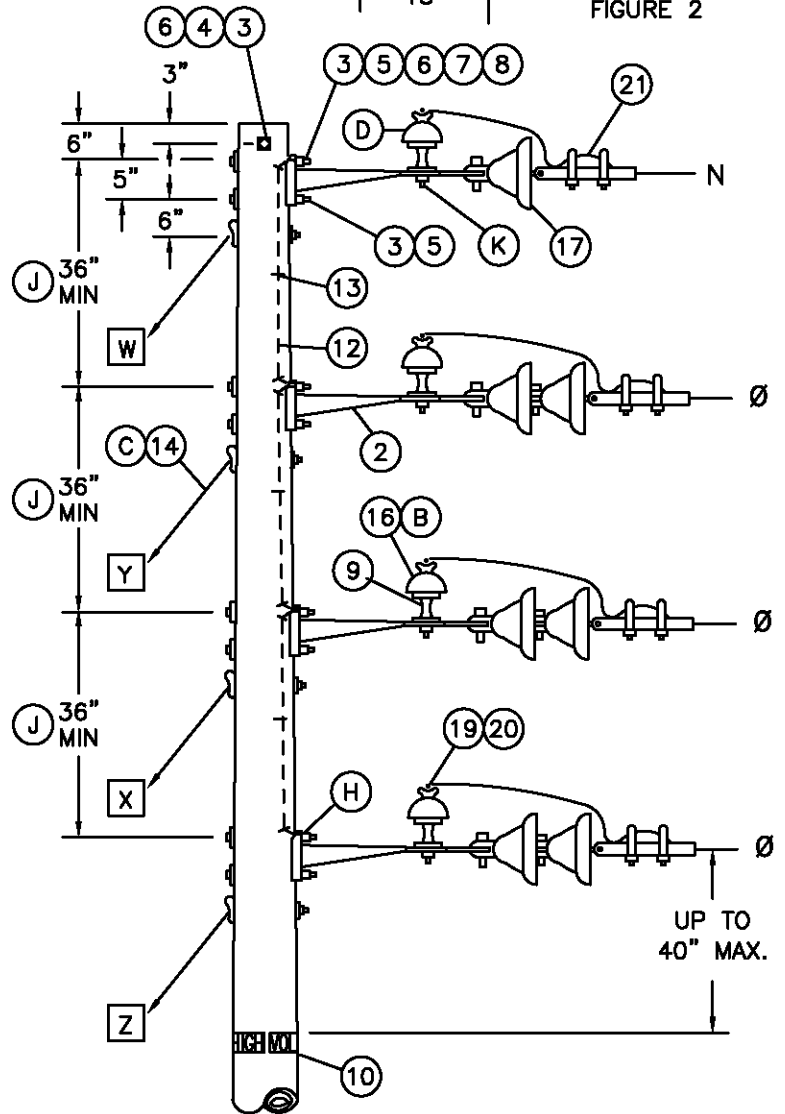

FIGURE 2 (L)
THROUGH CIRCUIT WITH SIDE TAP
'T' CORNER

499.203
SUPERSEDES
422.1 (9-13-05)

SDG&E ELECTRIC STANDARDS

POST INSULATOR AND BRACKET CONSTRUCTION,
"4 WAY AND 'T' CORNERS", 12 AND 12.47KV

DATE 9-13-05
APPD PJA/JJ

INSTALLATION:

- A. TO PREVENT RADIO INFLUENCE VOLTAGE (R.I.V.) DO NOT LOCATE BOND WIRE STAPLES WITHIN 1" OF BOLTS.
- (B) USE CLAMP TOP LINE POST INSULATORS AND CLAMPS FOR 1033 KCMIL ACSR.
- (C) ADD THE GUYS IN ORDER INDICATED (W,X,Y,Z) AS REQUIRED IN THE GUYING SECTION.
- (D) SUBSTITUTE A CLASS 55-3 INSULATOR (STOCK NO. 429216) FOR NEUTRAL IDENTIFICATION.
- F. BONDING IS REQUIRED WITHIN HEAVY CONTAMINATION AREA, DISTRICT 1 ON STD. 287. USE BONDING PROVISIONS ON BRACKETS, IF THEY ARE FURNISHED.
- (H) INSTALL DOUBLE COIL SPRING WASHER SO IT CONTACTS BRACKET.
- (I) IF A SMALLER LINE POST INSULATOR IS NOT AVAILABLE FOR NEUTRAL AS COMPARED TO THOSE IN THE PHASE POSITIONS, THE "PN" SIGN SHALL BE USED TO IDENTIFY THE NEUTRAL.
- (J) FOR SPAN LENGTHS GREATER THAN 250', DETERMINE CONDUCTOR SPACING BY THE FORMULA:

$$\text{SPACING} = 3' + \frac{\text{SPAN LENGTH} - 250'}{50}$$

IF SPAN LENGTH IS GREATER THAN 325', PLEASE CONTACT DISTRIBUTION STANDARDS.

- (K) IF BONDING IS REQUIRED, ATTACH BOND WIRE TO INSULATOR PIN WITH ADDITIONAL NUT.
- L TO BE USED FOR NEW CONSTRUCTION ONLY, FOR SIDE TAPS FROM EXISTING CONSTRUCTION, USE PGS. 415.1 & 415.2.

REFERENCE:

- (M) ON ALL NEW CONSTRUCTION AND WHEN ADDING TO EXISTING CONSTRUCTION, NEUTRAL TO BE PLACED IN THE TOP OR BOTTOM PIN POSITIONS PER DESIGN MANUAL PAGE 5124.2.

FOR FIELD MAINTENANCE ONLY

12KV VERTICAL CONSTRUCTION ASSEMBLY - TYPE YT MACRO UNITS			
QUANTITY			MU ID
12KV DE	NDE	P & I	
1	1	2/55-5	YT1N
2	-	2/55-5	YT2
2	1	2/55-5 1/55-3	YT2N
3	-	3/55-5	YT3
3	1	3/55-5 1/55-3	YT3N

BILL OF MATERIAL:

ITEM	DESCRIPTION	FIGURE 1			FIGURE 2			STOCK NO. OR CONSTR STD	ASSEMBLY UNITS						
		NEUTRAL WIRE	Ø WIRES			NEUTRAL WIRE	Ø WIRES								
			1	2	3		1			2	3				
1	BRACKET, POST INSULATOR (PIB)	2	2	4	6	-	-	-	-	166848	PIB				
2	BRACKET, 4 HOLE MOUNTING	-	-	-	-	1	1	2	3	166240	4H-BKT				
3	BOLT, 5/8" X __", GALV MACH	4	4	8	12	2	3	5	7	STD392	-				
4	WASHER, 2 1/2" SQ FLAT	4	4	8	12	-	2	2	2	STD392	-				
5	WASHER, 3" SQ CURVED	-	-	-	-	2	2	4	6	STD392	-				
6	WASHER, 5/8" DBL COIL SPRING	4	4	8	12	1	2	3	4	798560	-				
7	WASHER, 5/8" ROUND (F)	4	4	8	12	2	2	4	6	800320	-				
8	NUT, 5/8" (F)	2	2	4	6	2	2	4	6	506880	-				
9	PIN, SHORT SHANK INSULATOR, 1" OR 1 3/8" LEAD THREADS (B)	-	-	-	-	1	1	2	3	532426/532434	PSS1				
10	SIGN, HIGH VOLTAGE AND 9-10D NAILS	-	2	2	2	-	2	2	2	647648/492192	HV				
11	SIGN, PRIMARY NEUTRAL (PN) AND 4-10D NAILS (I)	2	-	-	-	-	-	-	-	648000/492192	PN				
12	WIRE, BARE SOLID ANNEALED #8 COPPER,	5'	2'	6'	10'	4'	-	4'	8'	812928	BOND8				
13	STAPLES, FENCE 1 1/4"	4	1	5	9	3	-	3	6	678528	-				
14	GUY (C)	-	IF REQ'D			AS REQ'D			-	-	900 SECTION	-			
15	INSULATOR, POST	a	TIE TOP			2	2	4	6	-	-	-	-	700 SECTION	-
		b	HORIZONTAL CLAMP TOP			-	-	-	-	-	-	-	-	-	-
16	INSULATOR, PIN TYPE, CLASS AS REQ'D (B)	-	-	-	-	1	1	2	3	700 SECTION	-				
17	INSULATOR, SUSPENSION CLEVIS	-	-	-	-	1	2	4	6	STD750, 756	-				
18															
19	GUARD, ALUMINUM IF REQ'D	2	2	4	6	1	1	2	3	STD759	-				
20	TIE	a	FORMED OR WIRE			2	2	4	6	1	1	2	3	700 SECTION	-
		b	CLAMP, HORIZONTAL POST INSULATOR (B)			-	-	-	-	-	-	-	-	-	-
21	CLAMP, DEAD END	-	-	-	-	1	1	2	3	STD 741-743	-				
22	CONNECTOR, WIRE	2	2	4	6	1	1	2	3	STD783-787	-				
23	STUD, LINE POST, 5/8" X 1 3/4"	2	2	4	6	-	-	-	-	701728	STUD-S				
24	BOLT, COVER PLASTIC & 6-1 3/4" NAILS	4	4	8	12	-	-	-	-	285696/42919	BCS				

THIS PAGE FOR FIELD MAINTENANCE ONLY

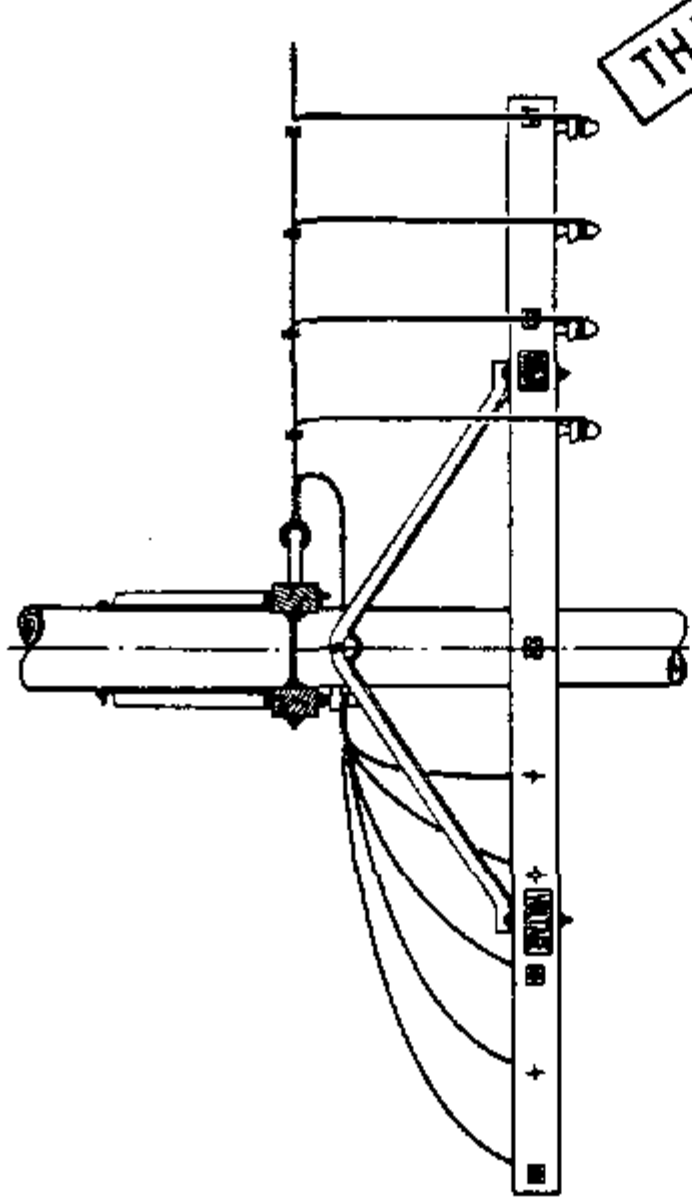
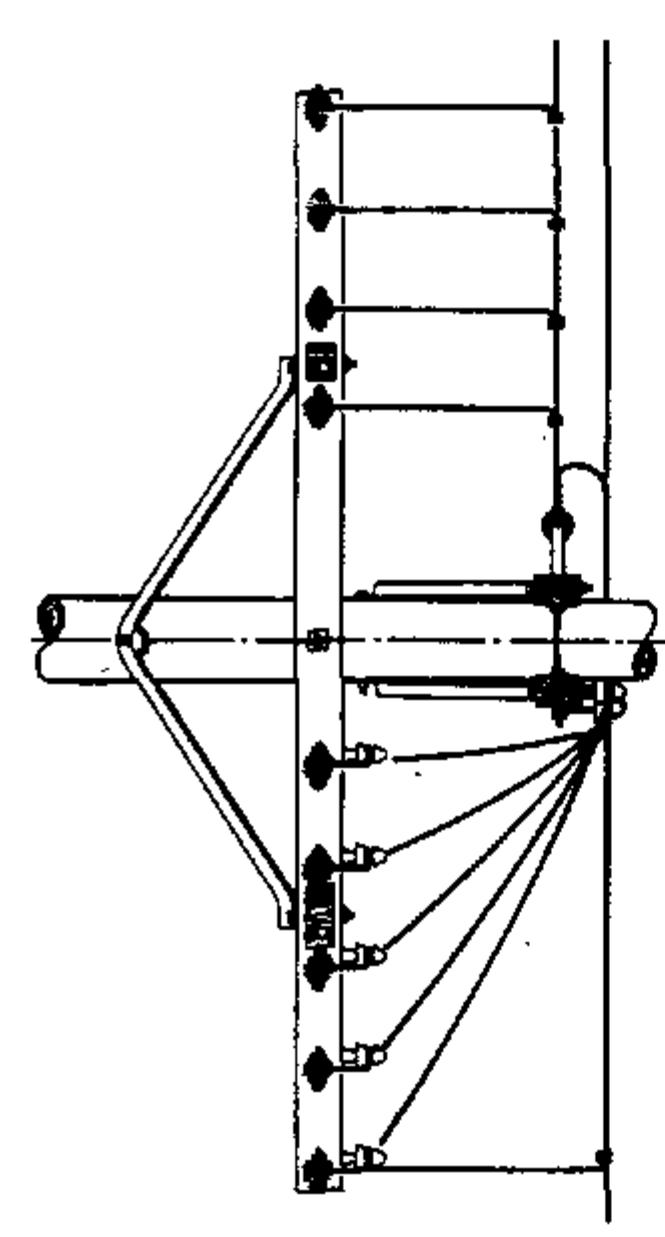
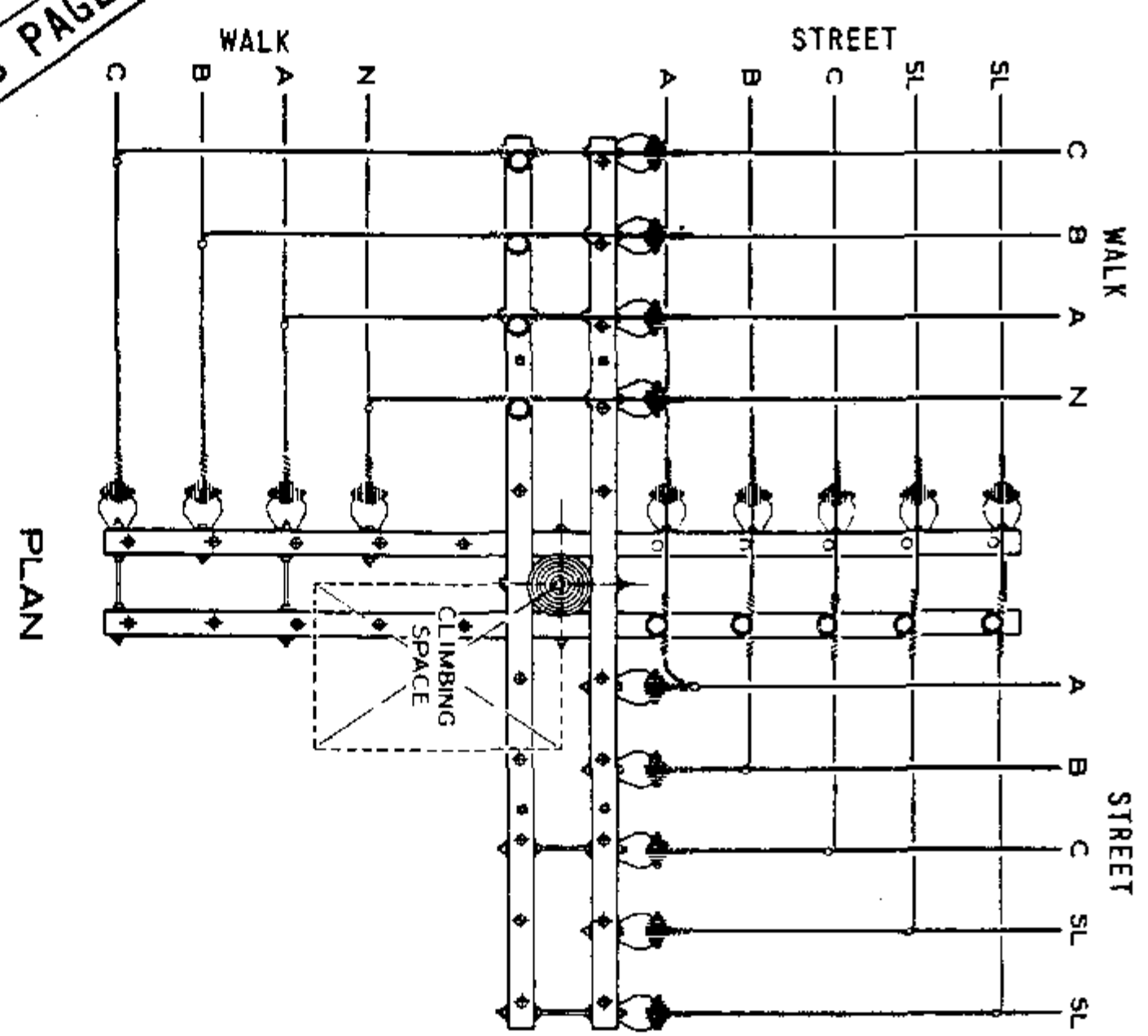
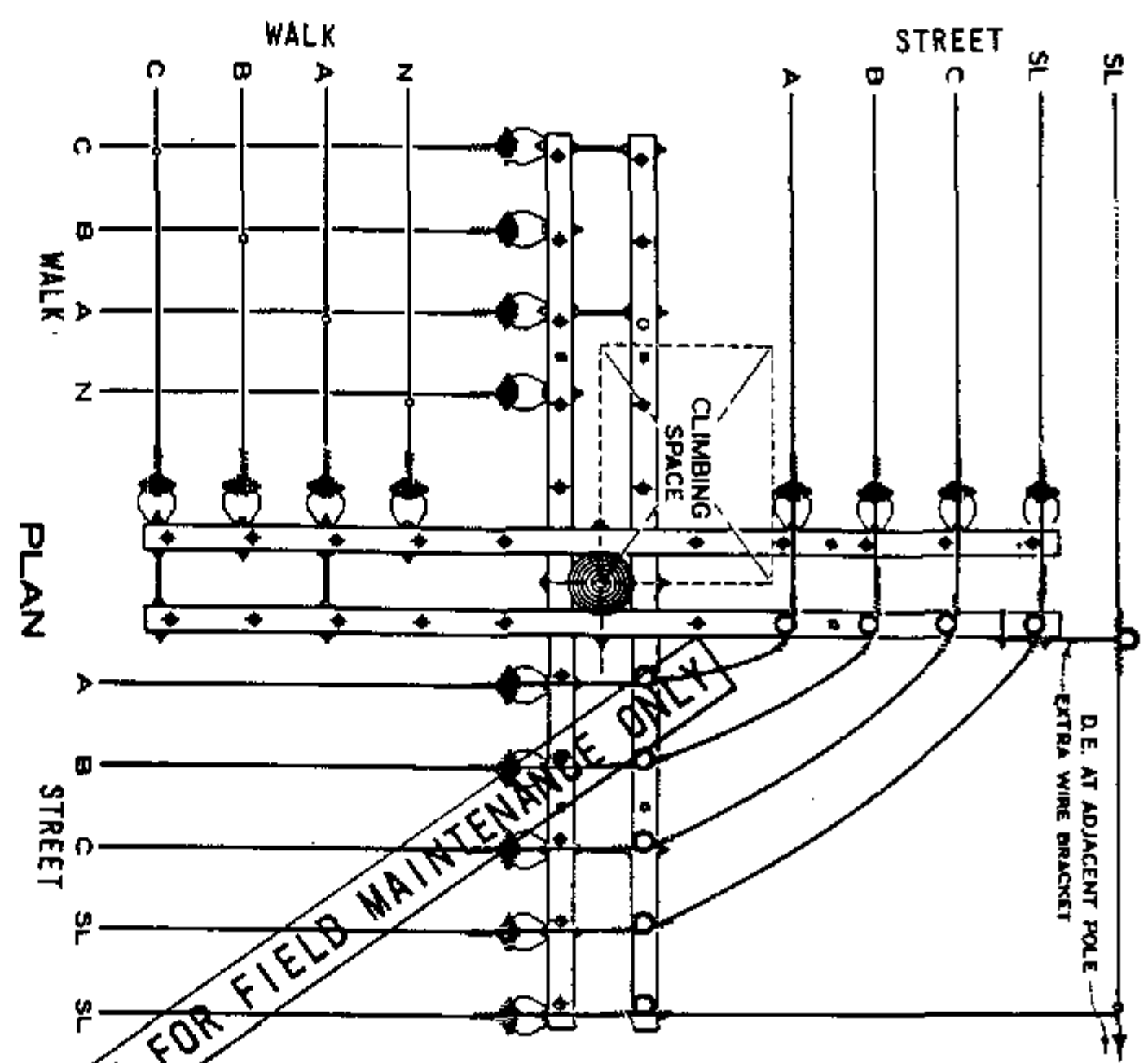

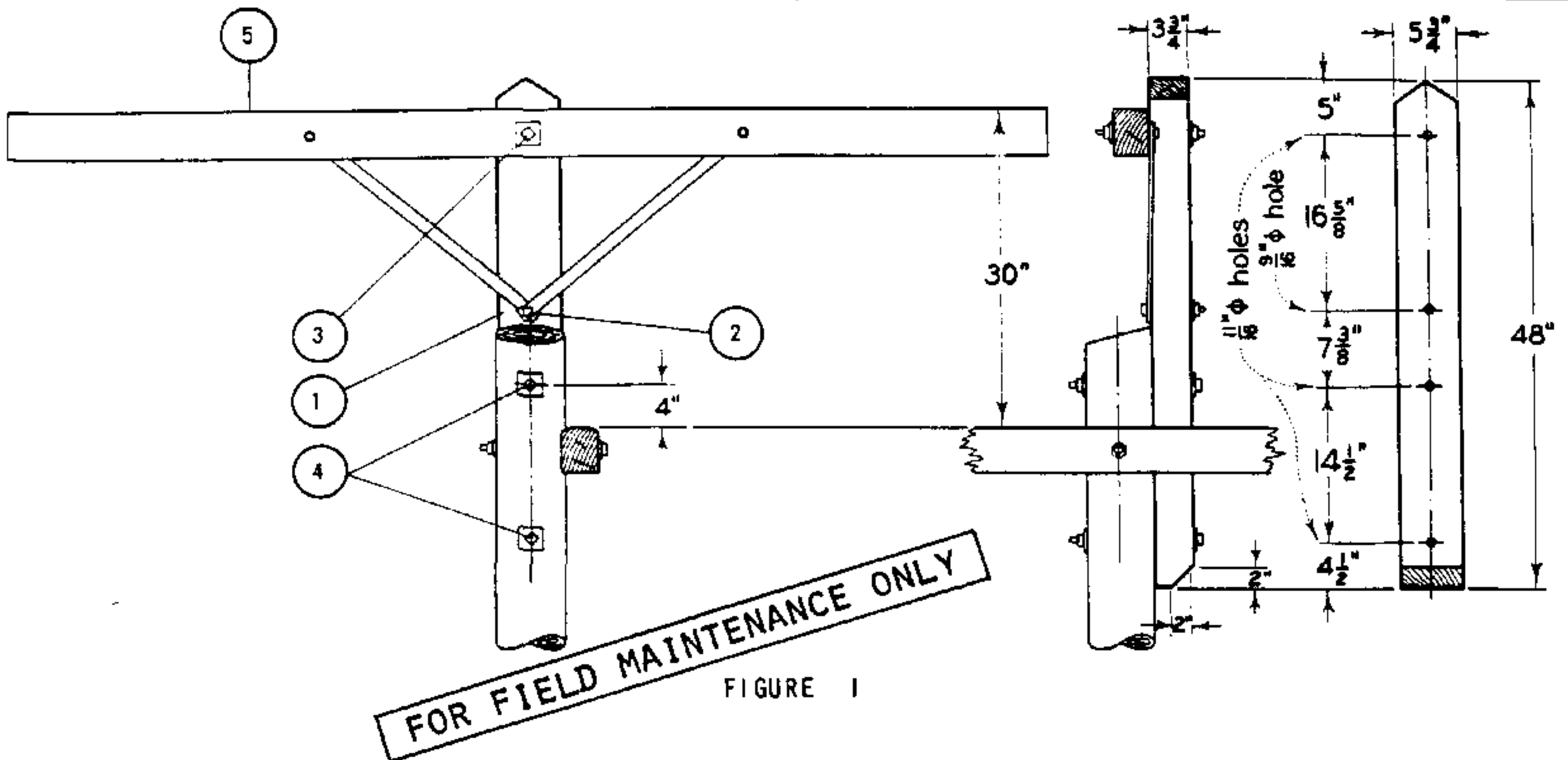

FIGURE 1

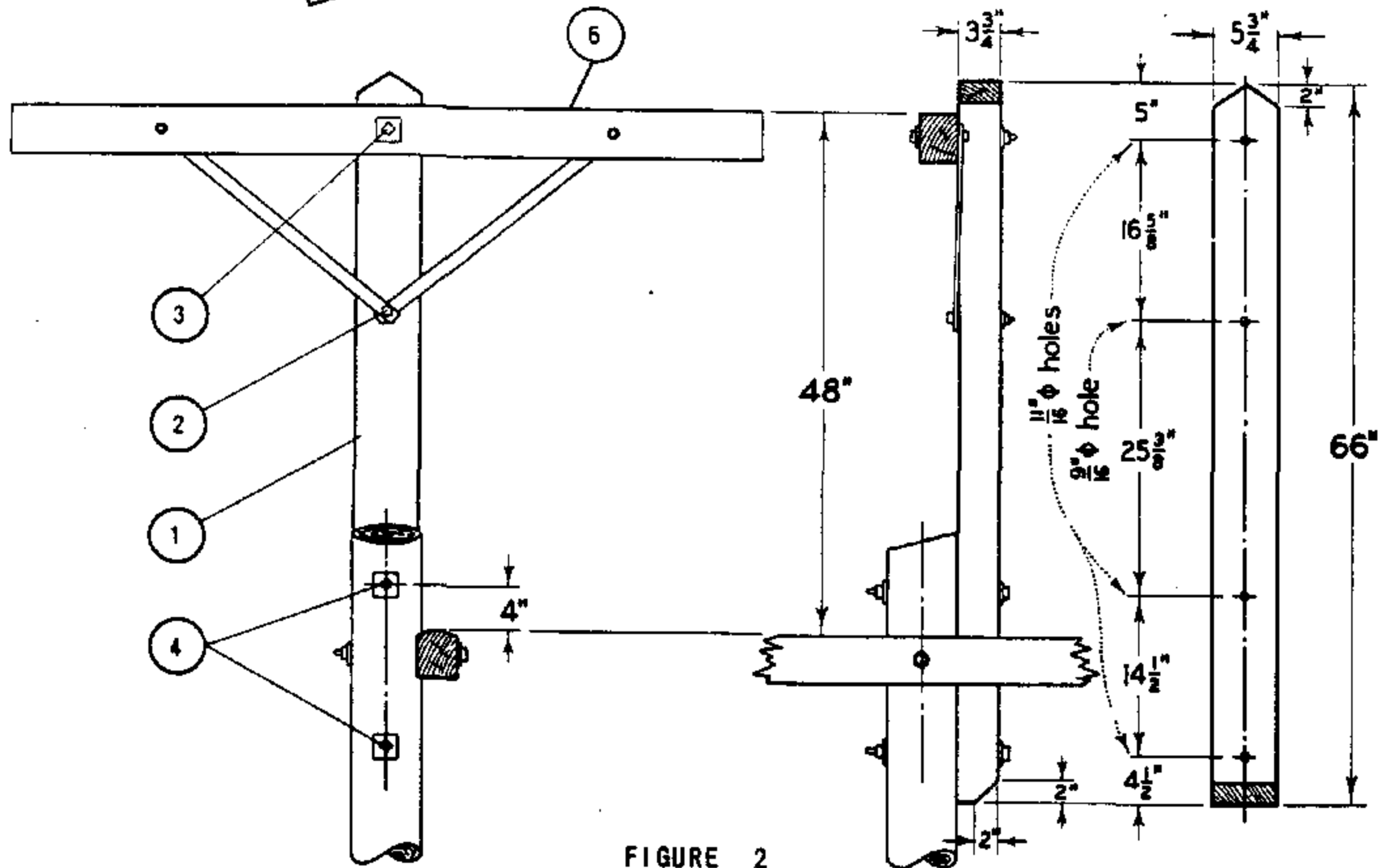

FIGURE 2

INSTALLATION :

A. DO NOT FLATTEN SURFACE OF POLE TO RECEIVE EXTENSION. HOWEVER, SHARP HUMPS OR KNOTS SHOULD BE REMOVED.

(E) EXEMPT MATERIAL.

BILL OF MATERIAL :

ITEM	DESCRIPTION	QUANTITY	STOCK NO. OR CONSTR STD
1	EXTENSION, 3 3/4" X 5 3/4" DOUGLAS FIR POLE TOP, 48" OR 66" LONG	1	336288, 336352
P 2	BOLT, MACHINE 1/2" X 5" GALV, 1 RD WASHER	(E) 1	STD 139, 140
T 3	BOLT, MACHINE 5/8" X 10" GALV, 2 SQ WASHERS	(E) 1	STD 139, 140
F 4	BOLT, MACHINE 5/8" X 16" GALV, 2 SQ WASHERS	(E) 2	STD 139, 140
5	CROSSARM, 3 1/2" X 4 1/2" X 8' - 0"	1	SECTION 300
6	CROSSARM, 3 1/2" X 4 1/2" X 5' - 7"	1	SECTION 300

499.701

SUPERSEDES
476 (9-17-82)

SDG&E ELECTRIC STANDARDS

POLE TOP EXTENSIONS
FOR SERVICE CLEARANCE ARMS

DATE 9-17-82

APPD. *[Signature]*

500 TRANSMISSION

500 TRANSMISSION

<u>PAGE</u>	<u>SUBJECT</u>
599.001-.005	TRANSMISSION CROSSARMS - 69KV
599.006-.007	TRANSMISSION SUSPENSION INSULATORS
599.101-.103	TRANSMISSION HORIZONTAL POST INSULATORS
599.104	TRANSMISSION POST INSULATOR STUDS
599.105	TRANSMISSION STEEL TOWER GROUNDING
599.106	TRANSMISSION HARDWARE
599.201-.305	TRANSMISSION CONSTRUCTION
599.306-.310	OVERHEAD SCADA SWITCH, 12KV, HORIZONTAL LOADBREAK TYPE, SINGLE CIRCUIT, MOTOR OPERATED
599.501	TRANSMISSION LINE INSULATION TABLE
599.901	TRANSMISSION HARDWARE CROSSARM TIE-PLATE
599.902	TRANSMISSION HARDWARE "J" BOLT, HEXAGONAL C.I. FILLER
599.903-.905	SCADA LOAD MONITOR

© 1998 - 2019 San Diego Gas & Electric Company. All rights reserved. Removal of this copyright notice without permission is not permitted under law.

REV	CHANGE	BY	DSGN	APPV	DATE	REV	CHANGE	BY	DSGN	APPV	DATE
C						F					
B	COMPLETELY REVISED	JK	JS	CZH	10/15/2019	E					
A	ORIGINAL ISSUE	JK	JS	CZH	6/13/2019	D					

Indicates Latest Revision Completely Revised New Page Information Removed

**SHEET
1 OF 1**

SDG&E ELECTRIC OVERHEAD FIELD MAINTENANCE ONLY STANDARDS

LEGACY OVERHEAD FIELD MAINTENANCE
TABLE OF CONTENTS
TRANSMISSION

**OH LEGACY
OHL501.1**



ITEM 1

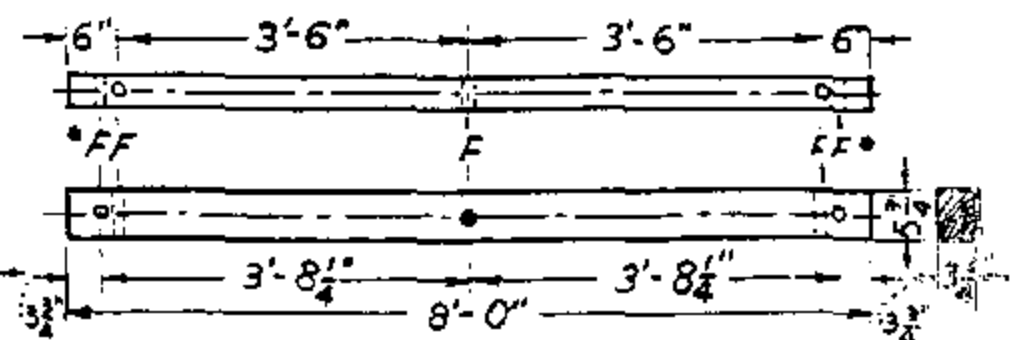

ITEM 2

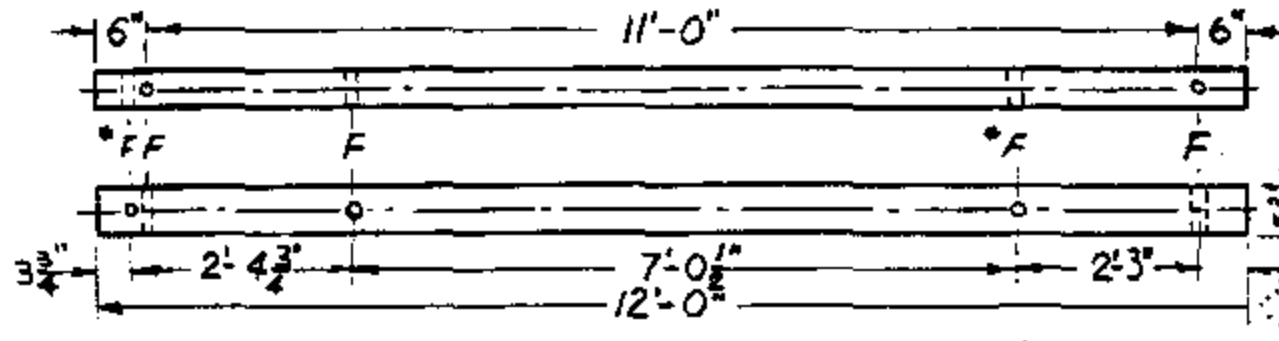

ITEM 3

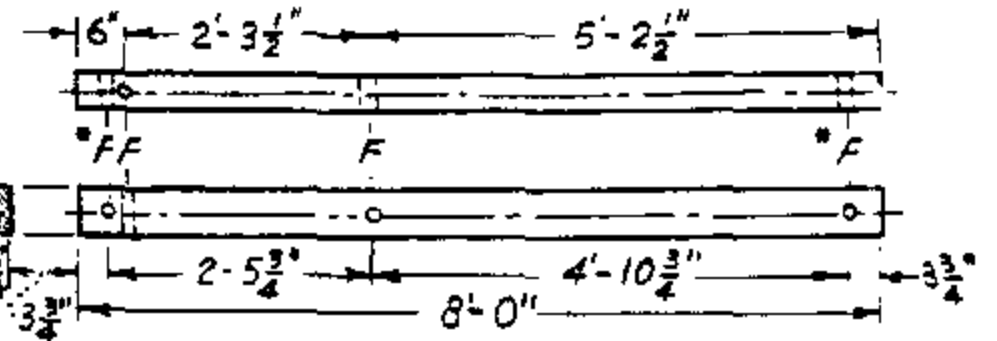

ITEM 2A

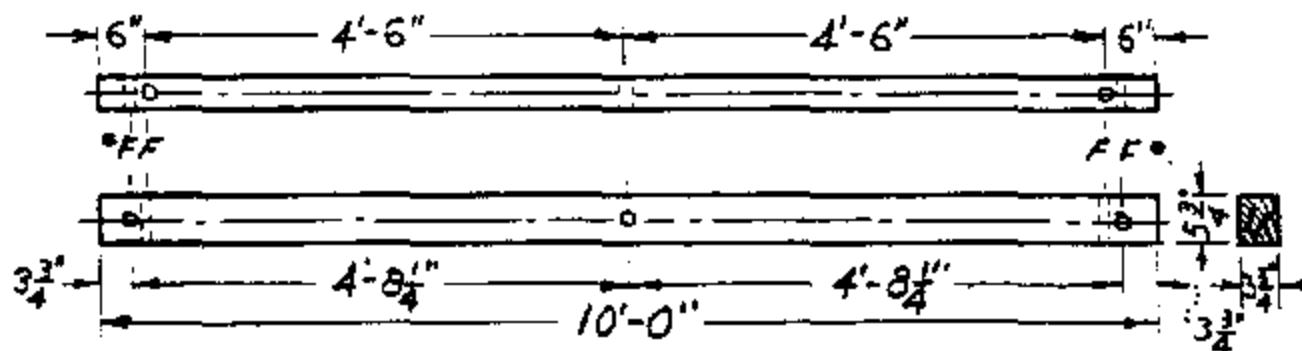

ITEM 4

FOR FIELD MAINTENANCE ONLY

REFERENCE

- F - 11/16 DIA. HOLES
- * TO BE DRILLED IN THE FIELD.



ITEM 5

ITEM	DESCRIPTION	STOCK NO.	ITEM	DESCRIPTION	STOCK NO.
1	CELLON	294352	5	CREOSOTE	294528
	CREOSOTE	294496			
2	FIELD MAINTENANCE ONLY	-			
2A	FIELD MAINTENANCE ONLY	-			
3	FIELD MAINTENANCE ONLY	-			
4	FIELD MAINTENANCE ONLY	-			
5					
	CELLON	294368			

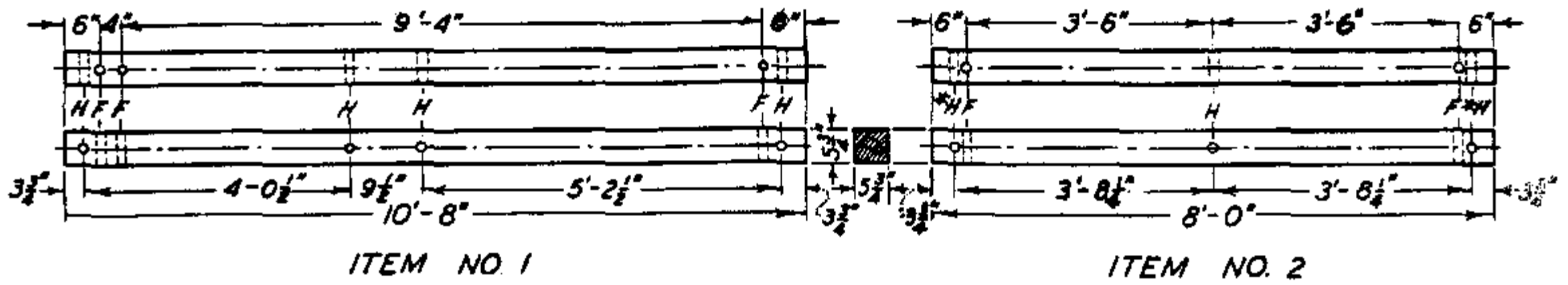

ITEM NO. 1

ITEM NO. 2

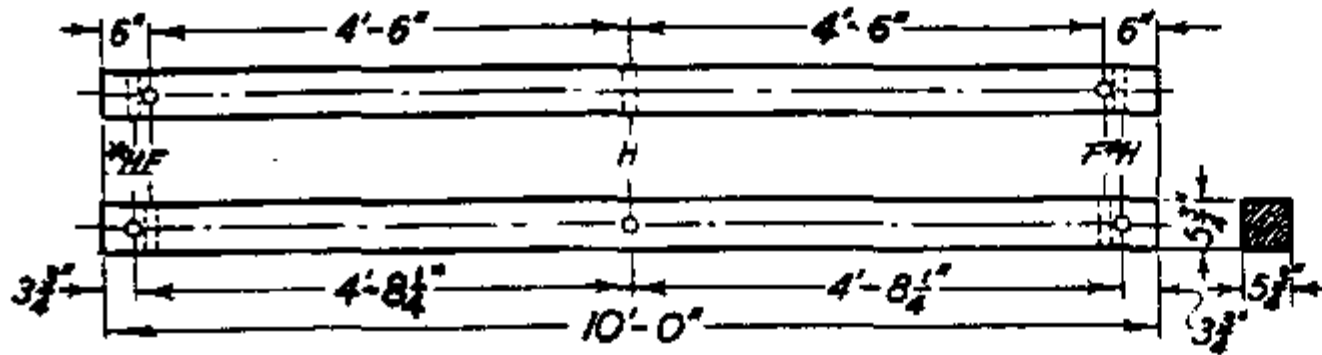

ITEM NO. 3

REFERENCE

F - 1/16" DIAM. HOLES
 H - 13/16" " " "

* TO BE DRILLED IN THE FIELD.

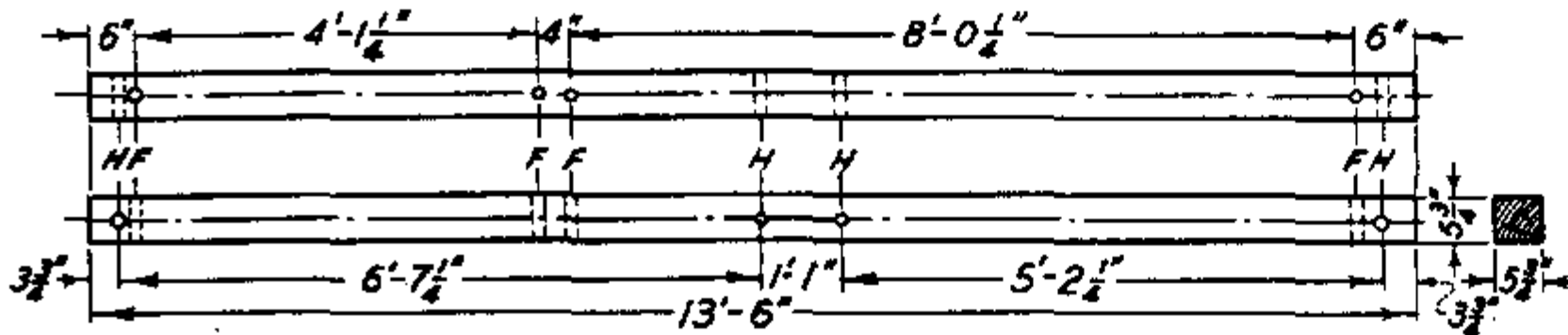

ITEM NO. 4

FOR FIELD MAINTENANCE ONLY

ITEM	DESCRIPTION	STOCK NO.	ITEM	DESCRIPTION	STOCK NO.
1	FIELD MAINTENANCE ONLY	—			
2	CREOSOTE, FIELD MAINTENANCE ONLY	294816			
3	FIELD MAINTENANCE ONLY	—			
4	CREOSOTE, FIELD MAINTENANCE ONLY	294800			

DATE 1-1-86
 APPD AK/ROD

SDG&E ELECTRIC STANDARDS

TRANSMISSION HEAVY CROSSARMS - 69KV

599,002
 SUPERCEDES
 380.7 (1986)

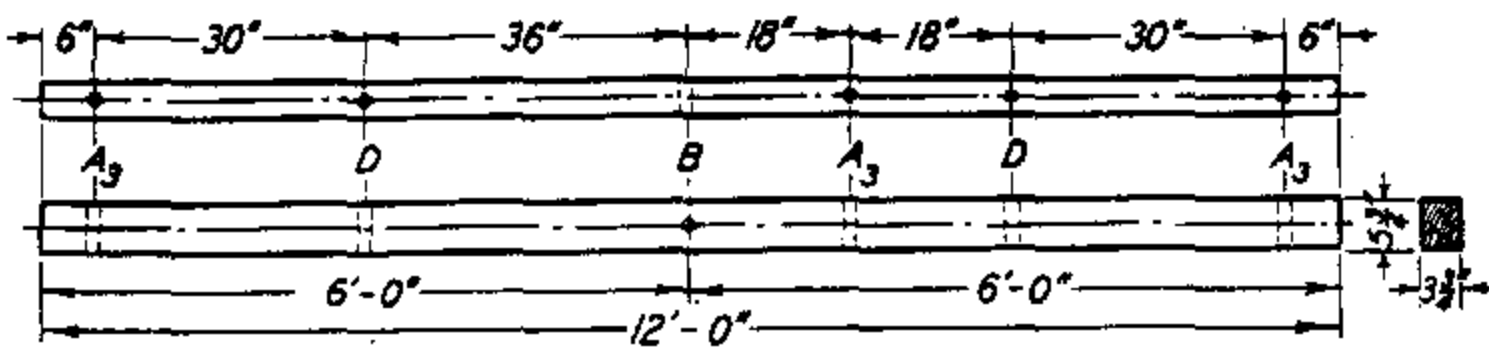

ITEM NO. 1 - LINE POST TANGENT ARM - 0° TO 3° ANGLES
(6' BRACE)

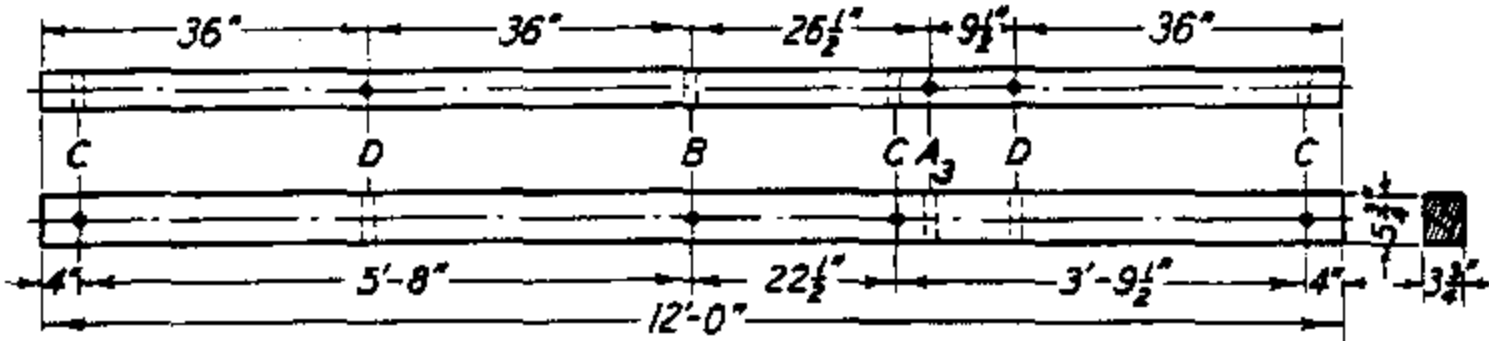

ITEM NO. 2 - LINE POST DEAD END ARM
(6' BRACE)

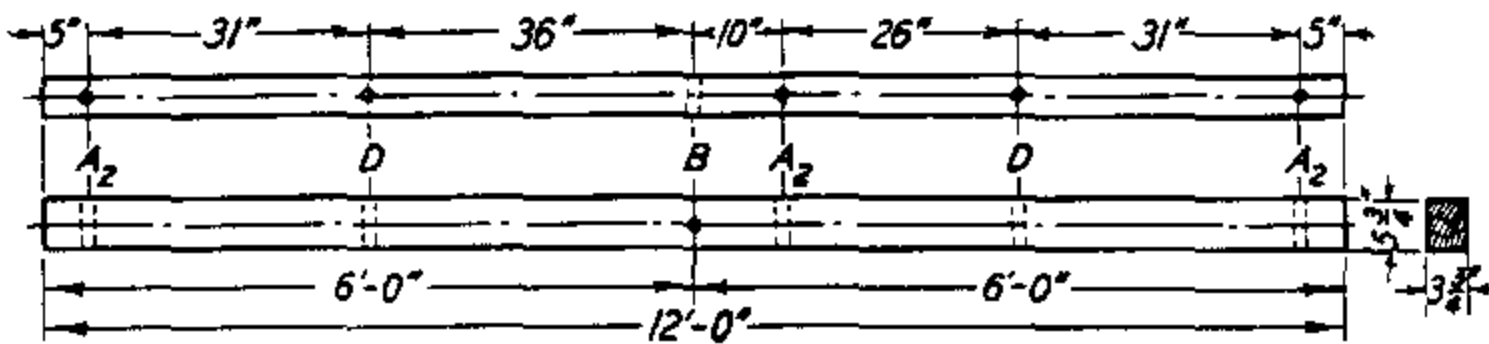

ITEM NO. 3 - LINE POST ANGLE PIN ARM - 3° TO 9° ANGLES
(6' BRACE)

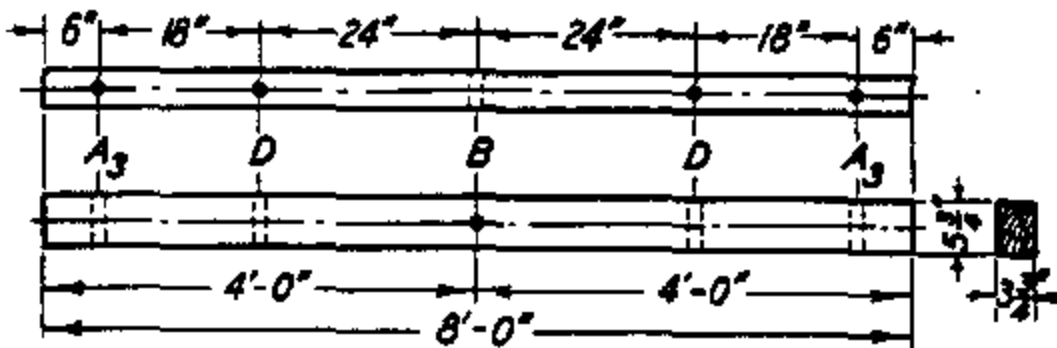

ITEM NO. 4 - LINE POST ARM
69KV ARM FOR TRIANGULAR CONSTRUCTION
(4' BRACE)

ITEMS 1, 2 & 3 ARE 69KV ARMS
FOR HORIZONTAL CONSTRUCTION

REFERENCES	
A ₂	- PIN HOLES 1 ³ / ₁₆ " DIAM.
A ₃	- PIN HOLES 1 ⁵ / ₁₆ " DIAM.
B	- THRU BOLT HOLES 1 ¹ / ₁₆ " DIAM.
C	- SPACE BOLT HOLES 1 ¹ / ₁₆ " DIAM.
D	- BRACE BOLT HOLES 1 ¹ / ₁₆ " DIAM.

FOR FIELD MAINTENANCE ONLY

ITEM	DESCRIPTION	STOCK NO.	ITEM	DESCRIPTION	STOCK NO.
1	FIELD MAINTENANCE ONLY	---			
2	FIELD MAINTENANCE ONLY	---			
3	FIELD MAINTENANCE ONLY	---			
4	---	---			

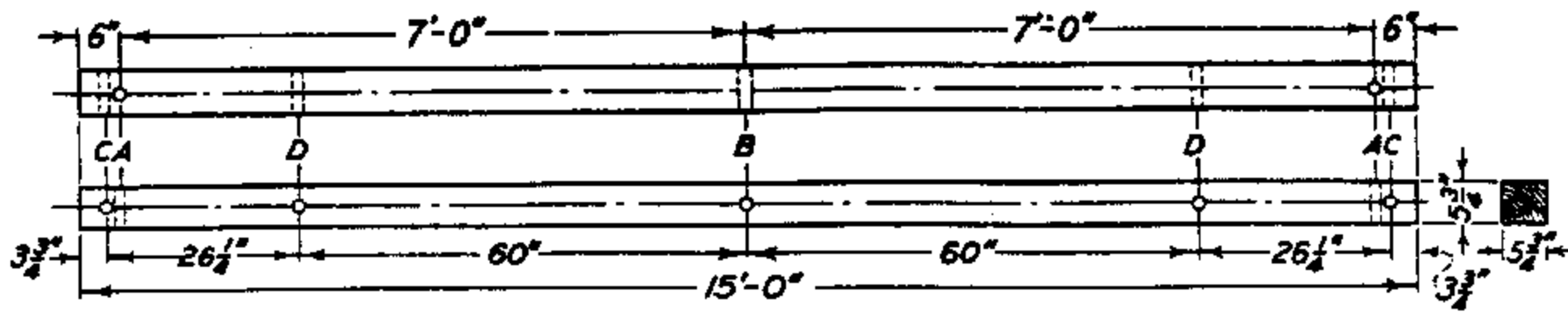

ITEM NO. 1 - LONG SPAN CROSSARM
(6'-9" BRACES, SEE PAGE 599.106 ITEM 2)

REFERENCES

- A - BRACKET BOLT HOLES $\frac{1}{16}$ " DIAM.
- B - THRU BOLT HOLE $\frac{13}{16}$ " DIAM.
- C - SPACE BOLT HOLES $\frac{13}{16}$ " DIAM.
- D - BRACE BOLT HOLES $\frac{1}{16}$ " DIAM.

FOR FIELD MAINTENANCE ONLY

ITEM	DESCRIPTION	STOCK NO.	ITEM	DESCRIPTION	STOCK NO.
1	—	—			

SAN DIEGO GAS & ELECTRIC CO OVERHEAD STANDARDS

DATE 1-1-87
APPD AK/RDS

TRANSMISSION CROSSARMS -69KV TRIANGULAR CONFIGURATION

599.004
SUPERCEDES
380.09 (1986)

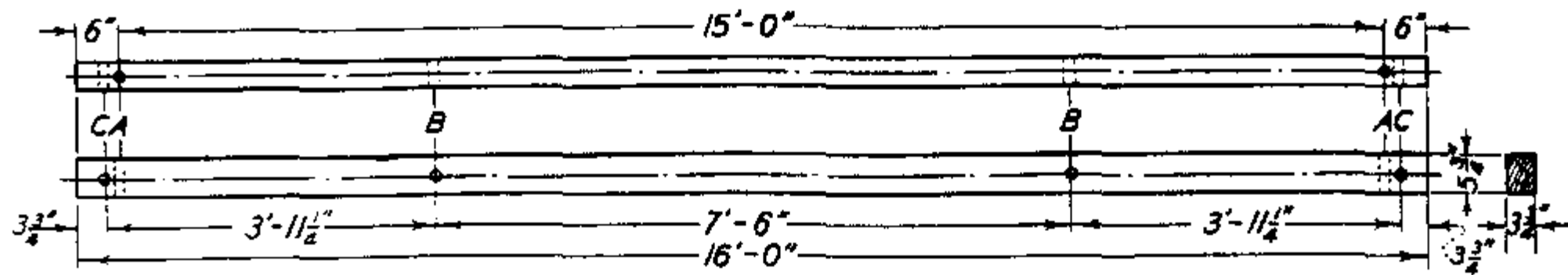

ITEM NO. 1 - 16 FT. TANGENT ARM - 0° TO 3° ANGLES

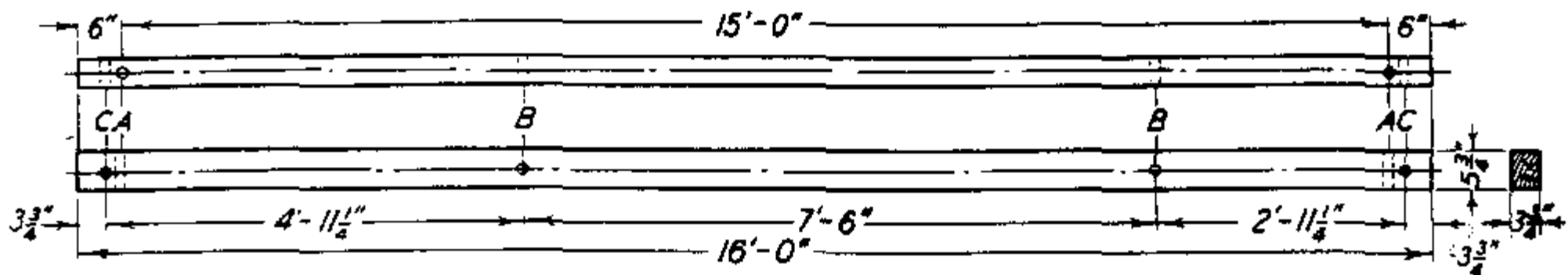

ITEM NO. 2 - 3° TO 15° ANGLE CROSSARM

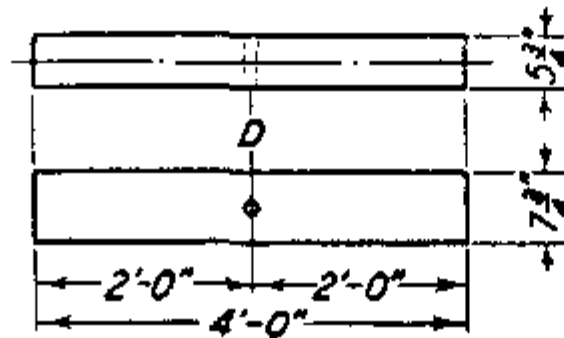

ITEM NO. 3 - BEARING BLOCK

REFERENCE

- A - 3" BOLT HOLES 1/16" DIAM.
- B - THRU BOLT HOLES 1/16" DIAM.
- C - SPLIT BOLT HOLES 9/16" DIAM.
- D - BEARING BLOCK HOLES 13/16" DIAM.

FOR FIELD MAINTENANCE ONLY

ITEM	DESCRIPTION	STOCK NO.	ITEM	DESCRIPTION	STOCK NO.
1	CREOSOTE, UNDRILLED	294896			
2	CREOSOTE, UNDRILLED	284896			
3		-			

SCOPE: THIS STANDARD SHOWS THE VARIOUS TYPES OF INSULATORS USED IN THE TRANSMISSION SYSTEM.

HORIZONTAL POST TYPE INSULATORS

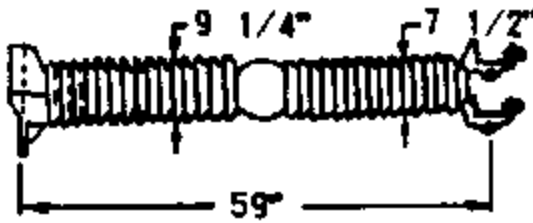
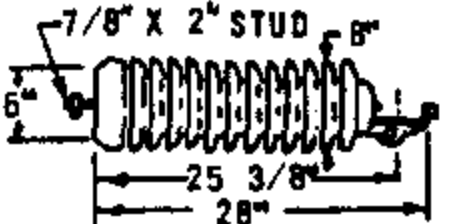
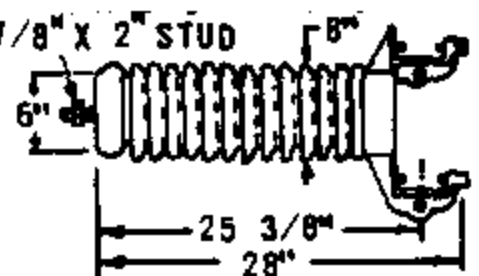
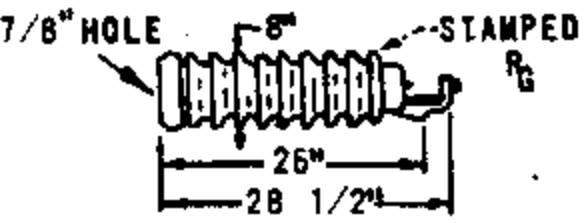
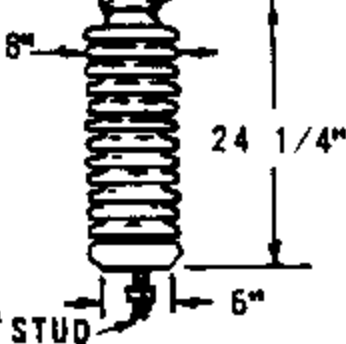
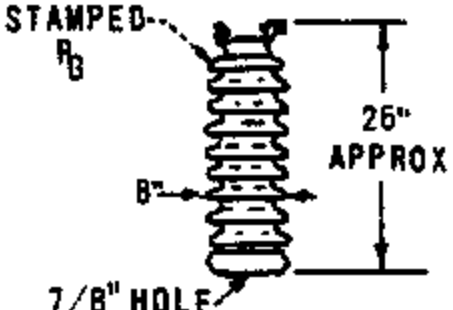
APPLICATION	DESCRIPTION	COLOR	MANUFACTURER	CATALOG NUMBER	STOCK NUMBER
138KV FOR GENERAL APPLICATION CODE 138P		GRAY	LAPP (SHOWN) NGK (ONE PC PORCELAIN)	70149 DAB5205Y	429780
138KV FOR GENERAL BUNDLED APPLICATION CODE 138PB		GRAY	LAPP	93349-70	429296
69KV FOR GENERAL APPLICATION CODE 69P		GRAY	LAPP NGK OHIO BRASS	F4688-C-70 DAB5192Z 48539-7100 (D)	429312
69KV FOR GENERAL BUNDLED APPLICATION CODE 69PB		GRAY	LAPP	F-97517-70	429328
69KV USE IN CONTAMINATION DISTRICT 1, TRIAL APPLI- CATION - CODE 69PR (A) (F)		GRAY	LAPP	F-510188	-
69KV FOR GENERAL APPLICATION CODE 69V		GRAY	LAPP	4288-70	428672 (C)
69KV USE IN CONTAMINATION DISTRICT 1, TRIAL APPLICATION CODE 69VR (A) (F)		GRAY	LAPP	510088	-

INSTALLATION:

- (A) USE THIS INSULATOR WHICH HAS A SPECIAL RESISTIVE GLAZE, AVAILABLE ON A TRIAL BASIS, TO REDUCE FLASHOVER PROBLEMS. BASES MUST BE BONDED AND INSULATORS MUST NOT BE MIXED WITH OTHER TYPES ON PHASE WIRES ON ONE POLE. DO NOT WASH OR INSULGREASE THESE INSULATORS. FOR THREE PHASE APPLICATION ONLY.
- B. LINE POST INSULATORS FOR DISTRIBUTION USE HAVE A 3/4" HOLE FOR MOUNTING STUD, WHILE 69 & 88KV POSTS HAVE A 7/8" HOLE. STUDS ARE STOCKED BY REFERENCING THE SIZE OF THE STUD WHICH MATES WITH THE REST OF THE STRUCTURE. THEREFORE, USE 3/4" STUDS FOR DISTRIBUTION AND 7/8" STUDS FOR TRANSMISSION. SEE PAGE 751.
- (C) NO LONGER PURCHASED.
- (D) NO LONGER MANUFACTURED.

REFERENCE:

- (F) CONTAMINATION DISTRICTS IDENTIFIED ON STANDARDS PAGE 287.

FOR FIELD MAINTENANCE ONLY









SDG&E ELECTRIC STANDARDS

DATE 1-1-86

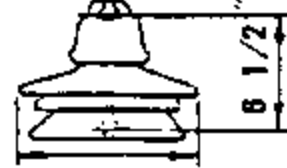
APPD AK/BJA

INSULATORS

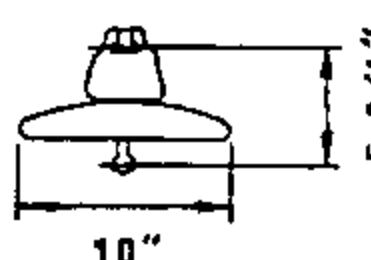
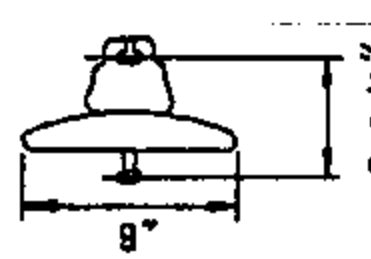
599.006

APPLICATION	DESCRIPTION OF SUSPENSION TYPE INSULATORS				MANUFACTURER	CATALOG NUMBER	STOCK NUMBER
	DIMENSIONS	WORKING LOAD/ M&E RATING	BONDING	COLOR			
69 AND 138KV SUSPENSION INSTALLATIONS CONTAMINATION DISTRICT 1 CODE FB6	10 1/2" LAPP NGK 	7,500/ 15,000	BONDED	GRAY	LAPP LOCKE NGK OHIO BRASS	98392-70 18134 DWG#21852 47360 (B)	431296 (A)
	10 1/2" LOCKE 			BROWN	LAPP	98392	431300 (A)
69 AND 138KV SUSPENSION INSTALLATIONS CONTAMINATION DISTRICT 1 CODE F6	10" OHIO BRASS 	15,000	UN-BONDED	GRAY	LAPP LOCKE OHIO BRASS	98392-70 18134 47360 (B)	431328 (A)
				BROWN	LAPP	98392	431332 (A)
69 AND 138KV SUSPENSION INSTALLATIONS CONTAMINATION DISTRICT 1 CODE FB5	10 1/2" LAPP 	7,500/ 15,000	BONDED	GRAY	LAPP LOCKE OHIO BRASS	98391-70 20S185 47350 (B)	431344
	10 3/8" LOCKE 						
	10" OHIO BRASS 						
69 AND 138KV DEAD END INSTALLATIONS USE FOR TENSIONS ABOVE 5000 POUNDS PER PHASE CODE DH	10" 	12,500/ 25,000	UN-BONDED	GRAY	CHANCE LAPP LOCKE NGK OHIO BRASS	C907-1005 5960G-70 30S255 CA 500 MQ 47410 (B)	431776
				BROWN	LAPP LOCKE OHIO BRASS	5960G 30S255 47410 (B)	431376 (A)
69 AND 138KV SUSPENSIONS INSTALLATIONS CONTAMINATION DISTRICTS 2 AND 3 & FOR DEAD ENDS BELOW 1000 POUNDS TENSION PER PHASE EVERYWHERE CODE DB	9" 	7,500/ 15,000	BONDED	GRAY	CHANCE LAPP LOCKE NGK	C907-1903 74165-70 15S419 CA 557 MH	431520
				BROWN	LAPP	74165	431524 (A)
69 AND 138KV DEAD ENDS ABOVE 1000 POUNDS TENSION PER PHASE EVERYWHERE CODE D	9 1/2" OHIO BRASS 9" LAPP LOCKE 	7,500/ 15,000	UN-BONDED	GRAY	LAPP LOCKE OHIO BRASS	74165-70 15S419 48008 (B)	431424
				BROWN	LAPP	74165	431420 (A)

FOR FIELD MAINTENANCE ONLY

INSTALLATION:

- (A) NO LONGER PURCHASED. BROWN INSULATORS SHALL BE USED ON BROWN POLES TO ELIMINATE STOCK. DO NOT MIX BROWN AND GRAY SUSPENSION INSULATORS AT A GIVEN LEVEL ON A POLE.
- (B) NO LONGER MANUFACTURED.
- C. USE BONDED INSULATORS IN SUSPENSION APPLICATIONS THROUGH RESIDENTIAL AND COMMERCIAL AREAS.

REFERENCE:

- F. CONTAMINATION DISTRICTS IDENTIFIED ON STANDARDS PAGE 287.
- G. SEE STANDARDS PAGE 599.501 FOR TRANSMISSION LINE INSULATION TABLE.

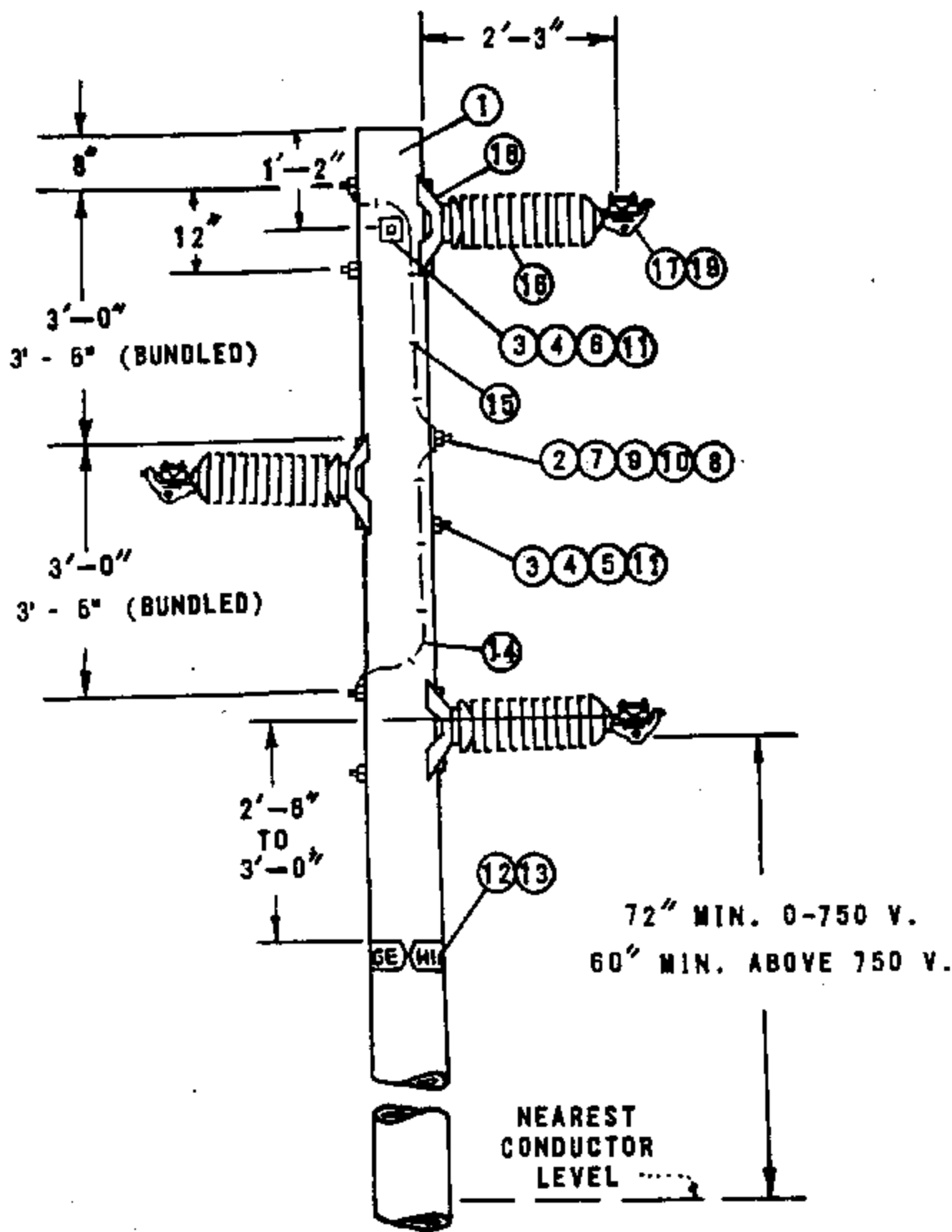

WORK ORDER DESIGNATION "69KV WPI"

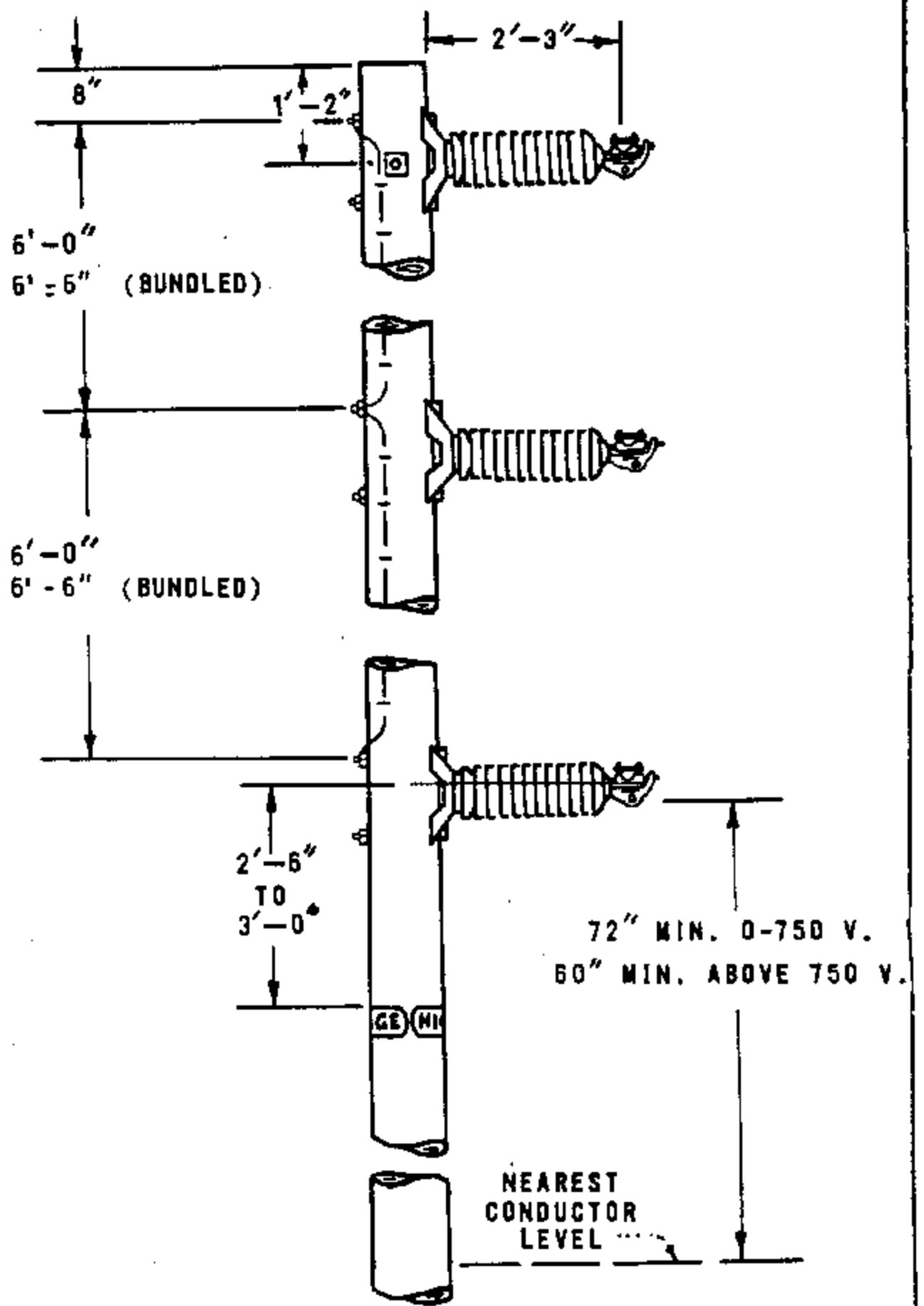

WORK ORDER DESIGNATION "69 KV ZPI"

NOTES:

- A. FOR USE ON LINE ANGLES 0 TO 30 DEGREES.
- B. FOR LINE ANGLE CONSTRUCTION, GUY AS REQUIRED.
- (E) EXEMPT MATERIALS.

ITEM		DESCRIPTION	QUANTITY	STOCK NO. OR CONSTR STD
TPF	TOC			
1		POLE, CLASS AND HEIGHT (AS REQUIRED)	1	300 SECTION
2		BOLT, MACHINE 3/4" (LENGTH AS REQ'D)	3	100 SECTION
3		BOLT, MACHINE 5/8" (LENGTH AS REQ'D)	(E) 4	100 SECTION
4		WASHER, 3" SQUARE CURVED RIB	(E) 2	797782
5		WASHER, 3" SQ. CURV	3	798912
6		WASHER, SPRING DBL COIL 5/8"	(E) 4	798560
7		WASHER, 4" SQUARE CURVED RIB	6	797760
8		WASHER, RD. FLAT 3/4"	6	800256
9		NUTS, 3/4"	3	504768
10		LOCKNUT, M-F 3/4"	3	504578
11		LOCKNUT, M-F 5/8"	4	504608
12		SIGN, HIGH VOLTAGE	(E) 2	647648
13		NAILS, ROOFING 8 GALV.	(E) 16	492224
14		WIRE, #8 B. SOLID ANNEALED COPPER	1 LB	812928
15		STAPLES, 1 1/4", FENCE, GALV.	(E) AS REQ'D	678528
	16	INSULATOR, 88KV HORIZ, SINGLE CONDUCTOR/BUNDLED	3	429312/42932R
	17	CLAMP, CONDUCTOR	3	700 SECTION
	18	INSULATOR BASE	3	12572B
	19	GUARD LINE (FOR ALUMINUM CONDUCTORS)	3 SETS	700 SECTION

FOR FIELD MAINTENANCE ONLY

DATE 7-1-84
APPD. *RPB/GRH*

SDG&E ELECTRIC STANDARDS
69KV SINGLE CIRCUIT - HORIZONTAL POST INSULATORS

599.101
SUPERSEDES
511 (1985)

SCOPE: THIS STANDARD SHOWS 138KV CONSTRUCTION USED WHEN DESIGNING SINGLE CIRCUIT TRANSMISSION LINES USING HORIZONTAL POST INSULATORS.

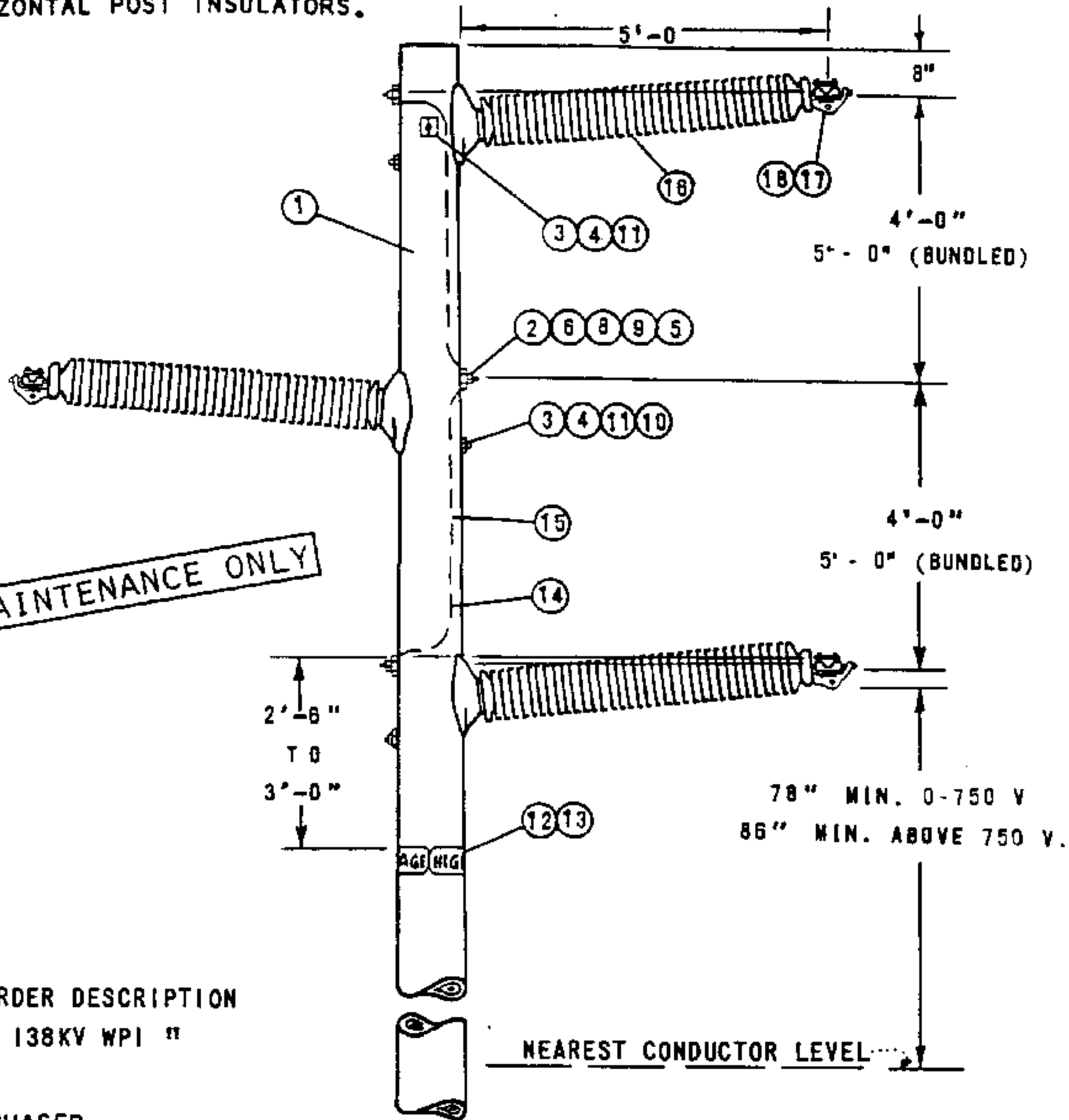

WORK ORDER DESCRIPTION
" 138KV WPI "

INSTALLATION:

- (A) NO LONGER PURCHASED.
- (E) EXEMPT MATERIAL.

ITEM NUMBER		DESCRIPTION	QUANTITY	STOCK NO. OR CONSTR. STD.
T.P.F.	T.O.C.			
1		POLE, CLASS AND HEIGHT (AS REQUIRED)	1	STD 361
2		BOLT, MACHINE 3/4" (LENGTH AS REQUIRED)	3	STD 139
3		BOLT, MACHINE 5/8" (LENGTH AS REQUIRED)	(E) 4	STD 139
4		WASHER, 3" SQUARE CURVED RIB	(E) 2	797792
5		WASHER, RD FLAT 3/4"	(E) 6	800256
6		WASHER, 4" SQUARE, CURVED RIB	(E) 3	797780
7		WASHER, 3" SQ. CURVED	(A)(E) 3	800384
8		NUTS 3/4"	(E) 6	504768
9		LOCKNUT, M-F 3/4"	(E) 3	504576
10		LOCKNUT, M-F 5/8"	(E) 3	504608
11		WASHER, SPRING DBL COIL 5/8"	(E) 3	798560
12		SIGN, HIGH VOLTAGE	(E) 2	547548
13		NAILS, ROOFING 8 GALV.	(E) 18	492192
14		WIRE, #8 B. SOLID ANNEALED COPPER	1 LB	812828
15		STAPLES, 1 1/4" FENCE, GALV.	(E) AS REQ'D	878528
	18	INSULATOR, 138KV, SINGLE CONDUCTOR/BUNDLED	3	429280/429296
	17	CONDUCTOR CLAMP	3	STD 775, 776
	18	GUARD, LINE (FOR ALUMINUM CONDUCTORS)	3	STD 759

599.102
SUPERSEDES
512 (1985)

SDG & E ELECTRIC STANDARDS

138KV SINGLE CIRCUIT - HORIZONTAL POST INSULATORS

ISSUE 1993
DATE 7-1-84
APPD. *[Signature]*

SCOPE: THIS STANDARD SHOWS 69KV CONSTRUCTION USED WHEN DESIGNING SINGLE AND TWIN CIRCUIT TRANSMISSION LINES USING HORIZONTAL POST INSULATORS.

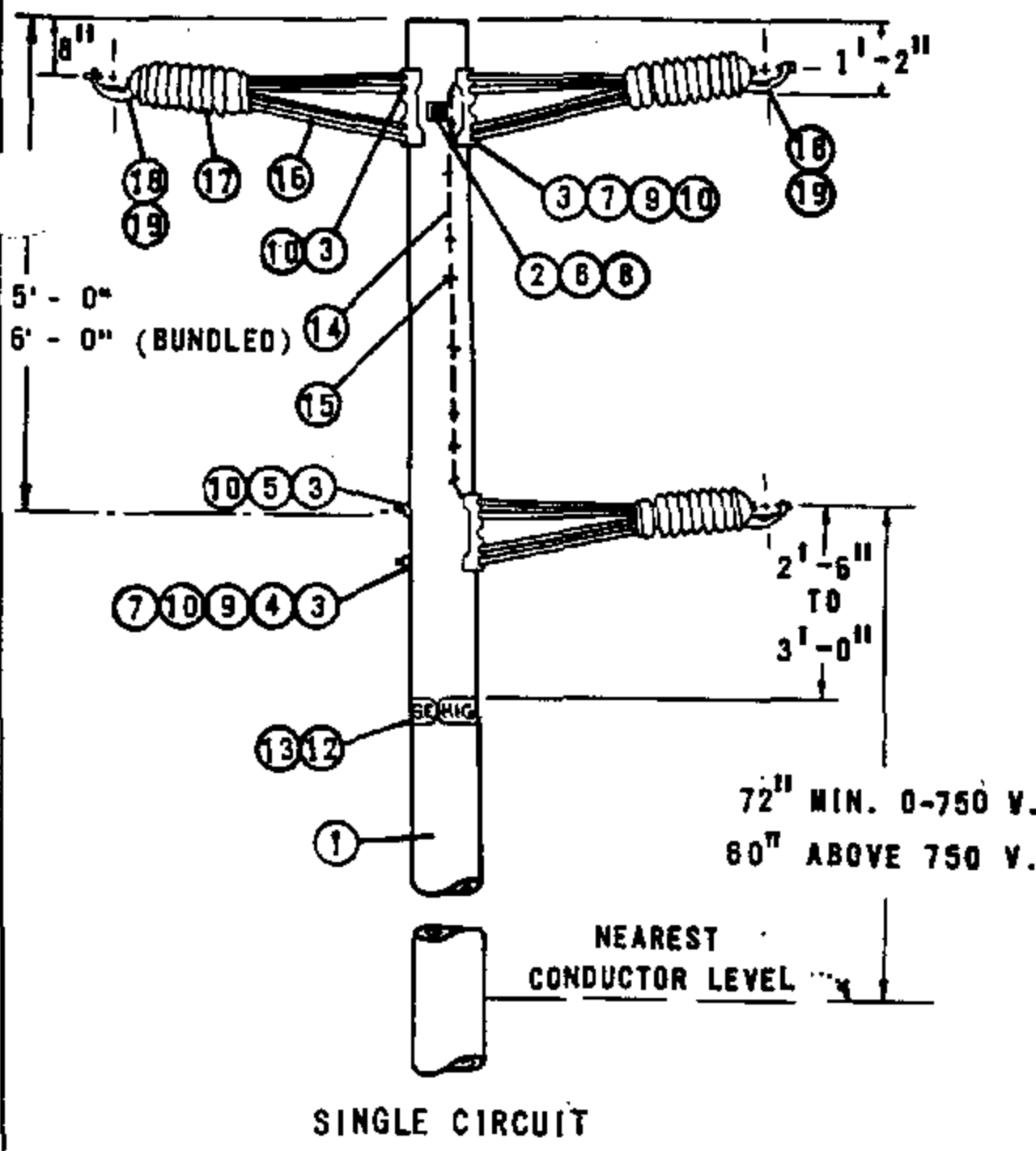

SINGLE CIRCUIT
WORK ORDER DESIGNATION "69 KV 2/1 WPI"

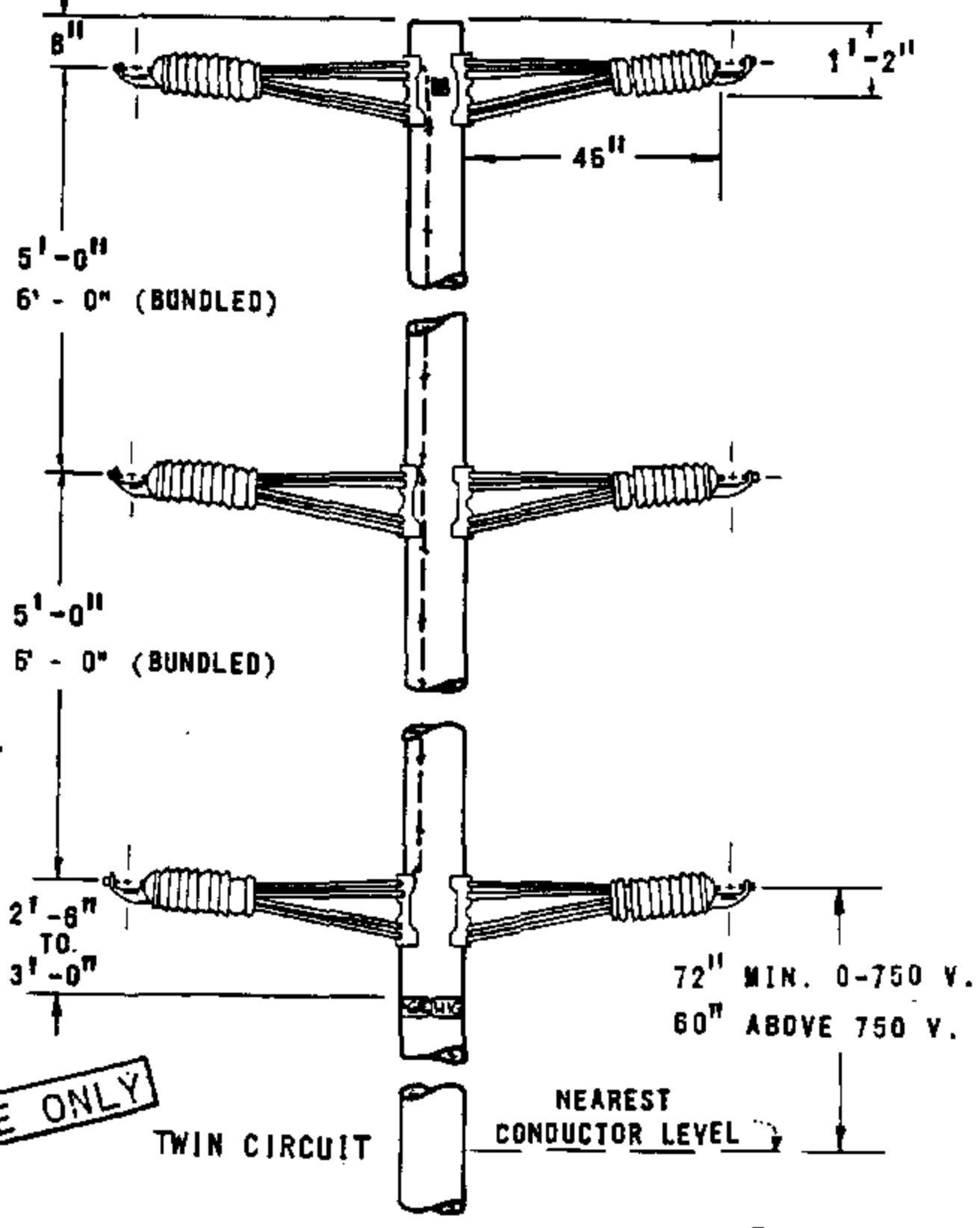

TWIN CIRCUIT
WORK ORDER DESIGNATION "69KV T.C. WPI"

FOR FIELD MAINTENANCE ONLY

INSTALLATION:

Ⓢ EXEMPT MATERIALS.

ITEM	DESCRIPTION	QUANTITY		STOCK NO. OR CONSTR STD
		SGL CIR	DBL CIR	
1	POLE, CLASS AND HEIGHT (AS REQ'D)	1	1	PG. 361
2	BOLT, MACHINE 5/8" X (LENGTH AS REQ'D)	Ⓢ 1	1	PG. 139
3	BOLT, MACHINE 3/4" X (LENGTH AS REQ'D)	4	6	PG. 139
4	WASHER, 3" SQUARE CURVED	Ⓢ 1	-	798912
5	WASHER, 4" SQUARE CURVED RIB	Ⓢ 1	-	797760
6	WASHER, 3" SQUARE CURVED RIB	Ⓢ 2	2	797792
7	WASHER, SPRING DBL. COIL 3/4"	Ⓢ 2	3	798496
8	WASHER, SPRING DBL. COIL 5/8"	Ⓢ 1	1	798560
9	WASHER, 3/4" ROUND	Ⓢ 3	6	800256
10	LOCKNUT, M-F 3/4"	Ⓢ 4	6	504576
11				
12	SIGN, HIGH VOLTAGE	Ⓢ 2	2	647648
13	NAILS, ROOFING 8 GALV.	Ⓢ 16	16	492224
14	WIRE, #8 B. SOLID ANNEALED COPPER	.5 lb	1 lb.	812928
15	STAPLES, 1 1/4", FENCE GALV.	Ⓢ 6	12	678528
16	ARM, EXTENSION	3	6	110752
17	INSULATOR, 88KV HORIZ. LINE POST W/STUD	3	6	429312
18	CLAMP, CONDUCTOR	3	6	PG 775, 776
19	GUARD, LINE (FOR ALUMINUM CONDUCTORS)	3 SETS	6 SETS	PG. 759

SCOPE: THIS STANDARD SHOWS THE PROPER ASSEMBLY OF TRANSMISSION POST INSULATOR STUDS.

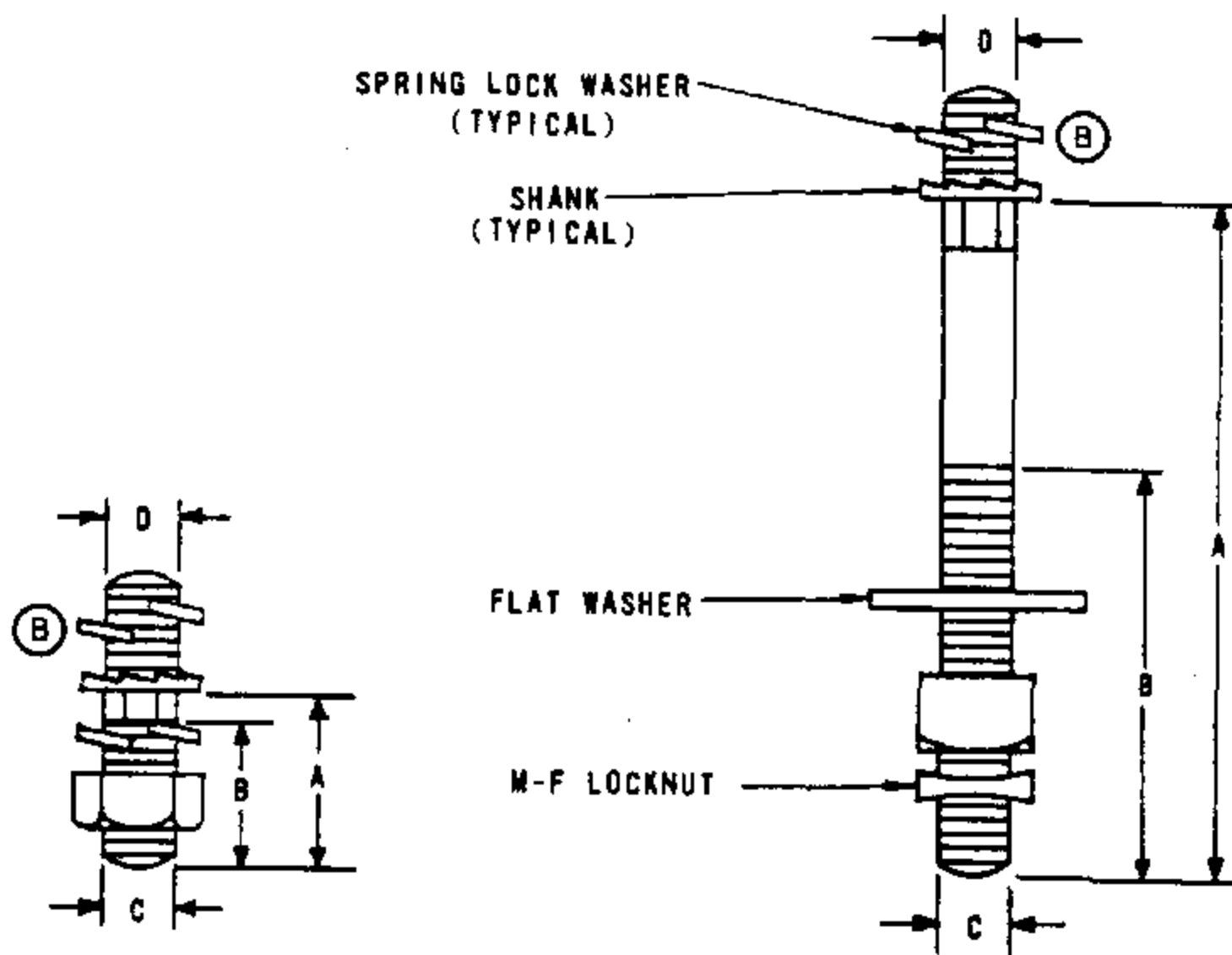

FIG. 1
FOR STEEL CROSS ARM
OR BRACKET

FIG. 2
FOR WOOD CROSS ARM

FOR FIELD MAINTENANCE ONLY

BILL OF MATERIAL:

SIZE OF INSULATOR STUD				FIGURE NUMBER	VOLTAGE CLASSIFICATION	JOSLYN CATALOG NUMBER	LAPP CATALOG NUMBER	STOCK NUMBER
A	B	C	D					
2"	1 11/16"	7/8"	7/8"	1	88KV	-	301616	701776 (A)
8"	4"	7/8"	7/8"	2	88KV	-	10362A	701792 (A)

INSTALLATION:

- (A) NOT NORMALLY PURCHASED.
- (B) WHEN ASSEMBLING STUD TO INSULATOR, MOVE A LOCKWASHER TO THE TOP OF THE STUD.

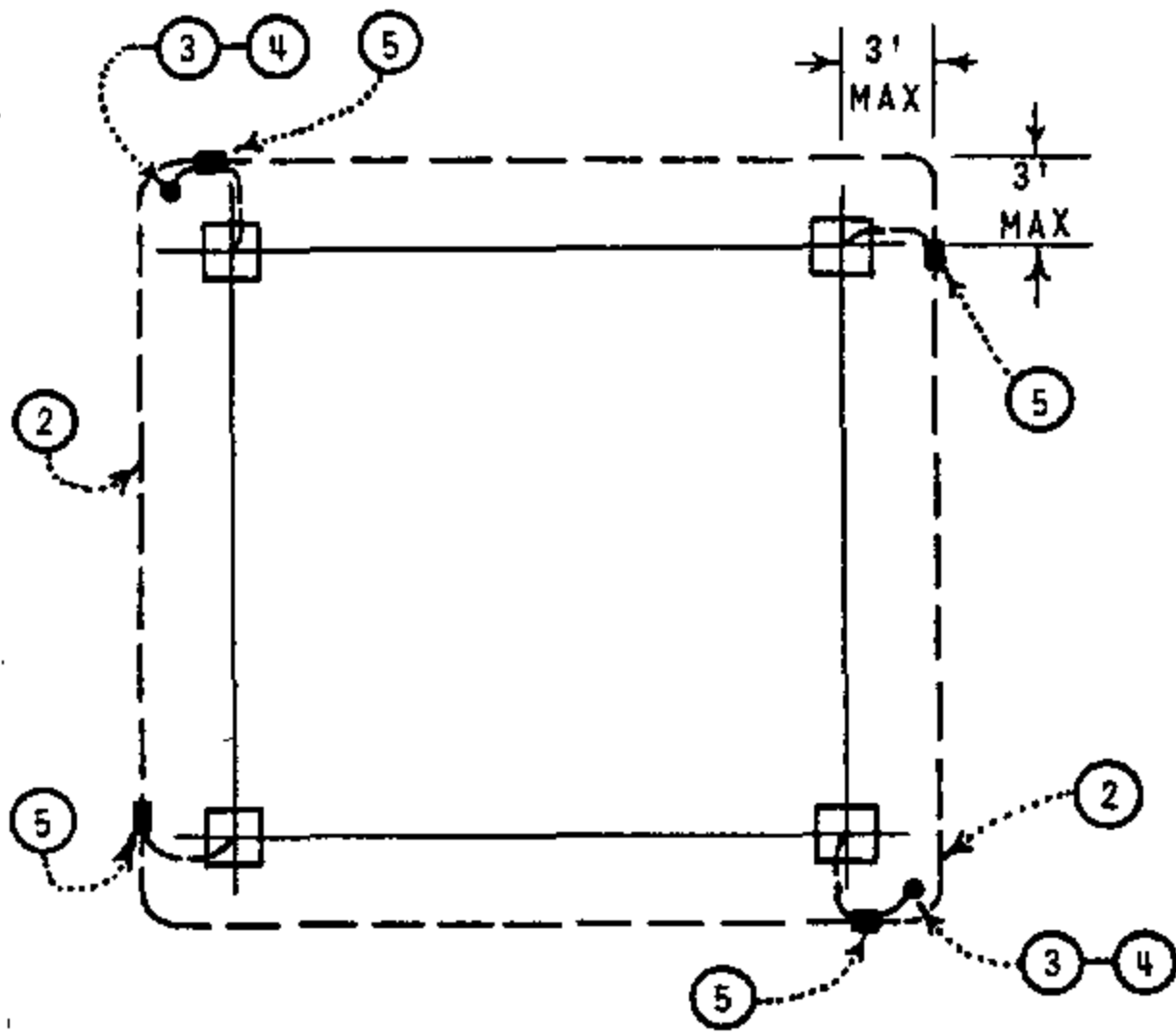

PLAN

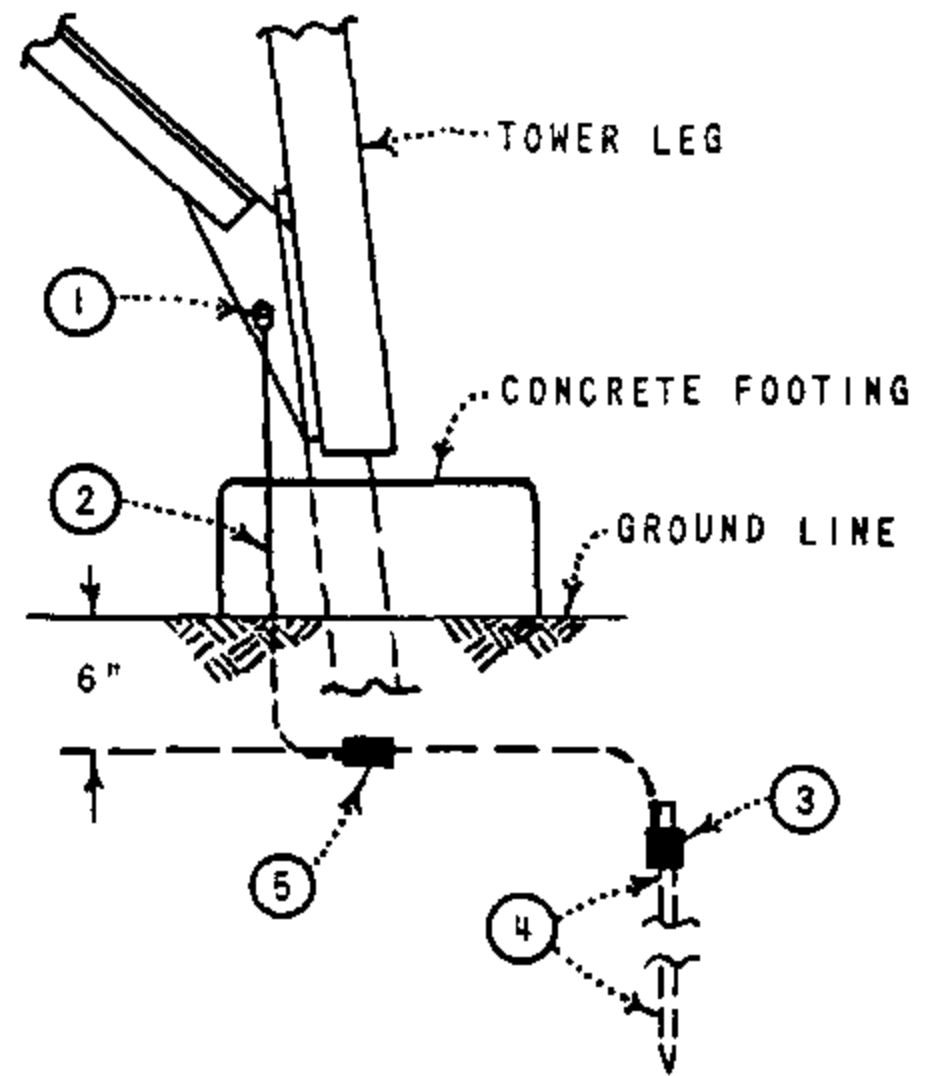

ELEVATION

FOR FIELD MAINTENANCE ONLY

ITEM	DESCRIPTION	QUANTITY	STOCK NUMBER
1	CONNECTOR, FLAT GROUND	4	261600
2	WIRE, #2 BARE SOLID COPPERWELD	as req'd	813056
3	CONNECTOR, COMPRESSION	2	257888
4	RDD: GROUND. COPPERWELD 5/8" X 8' - 0"	2	603072
	CONNECTOR, COMPRESSION	4	257792

DATE 1-1-86
 APPD AK/RA

SDG&E ELECTRIC STANDARDS

STEEL TOWER GROUNDING

599.105
 SUPERCEDES
 1011 (1986)

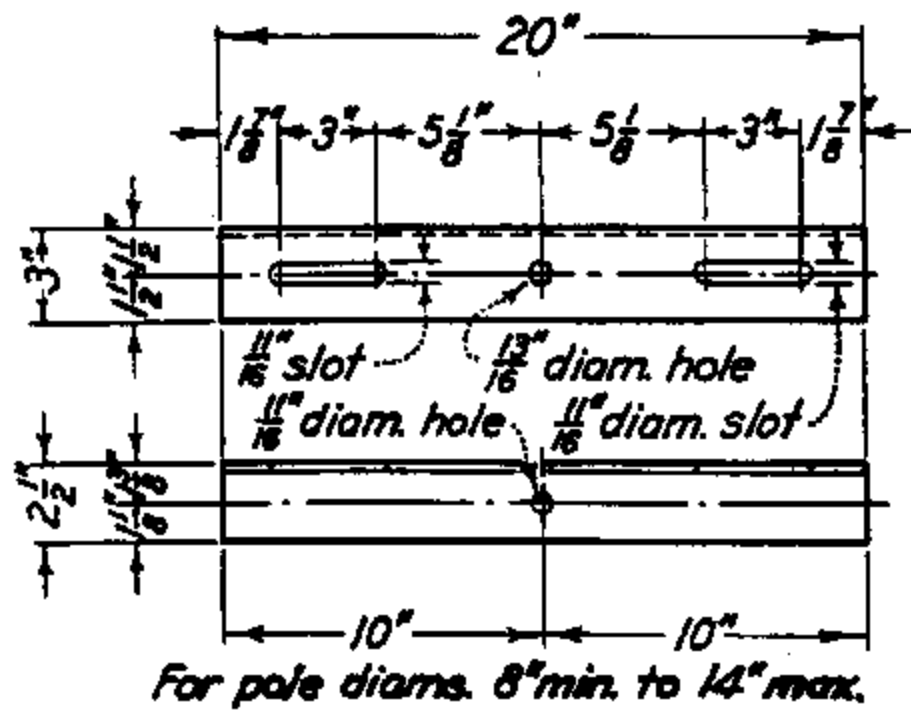

ITEM 1
3" X 2 1/2" X 5/16" ANGLE BRACKET

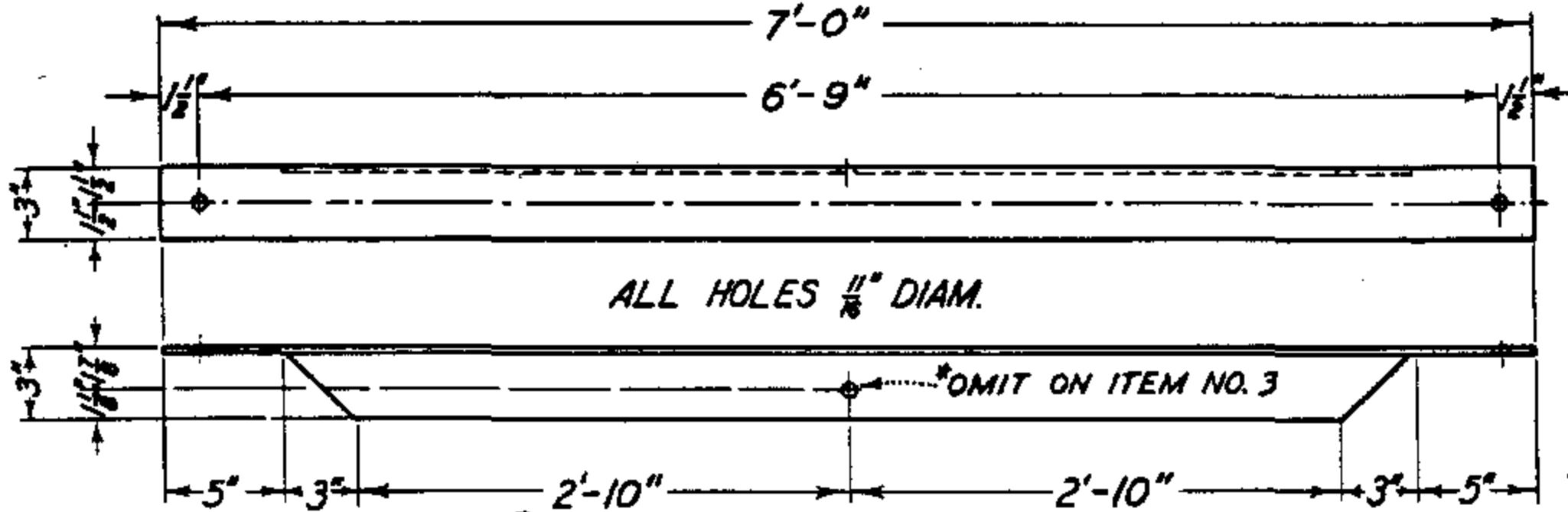

ITEM 2
3" X 3" X 1/4" HORIZONTAL ANGLE BRACE

FOR FIELD MAINTENANCE ONLY

ITEM 3
SAME AS ITEM 2, EXCEPT *OMIT CENTER HOLE

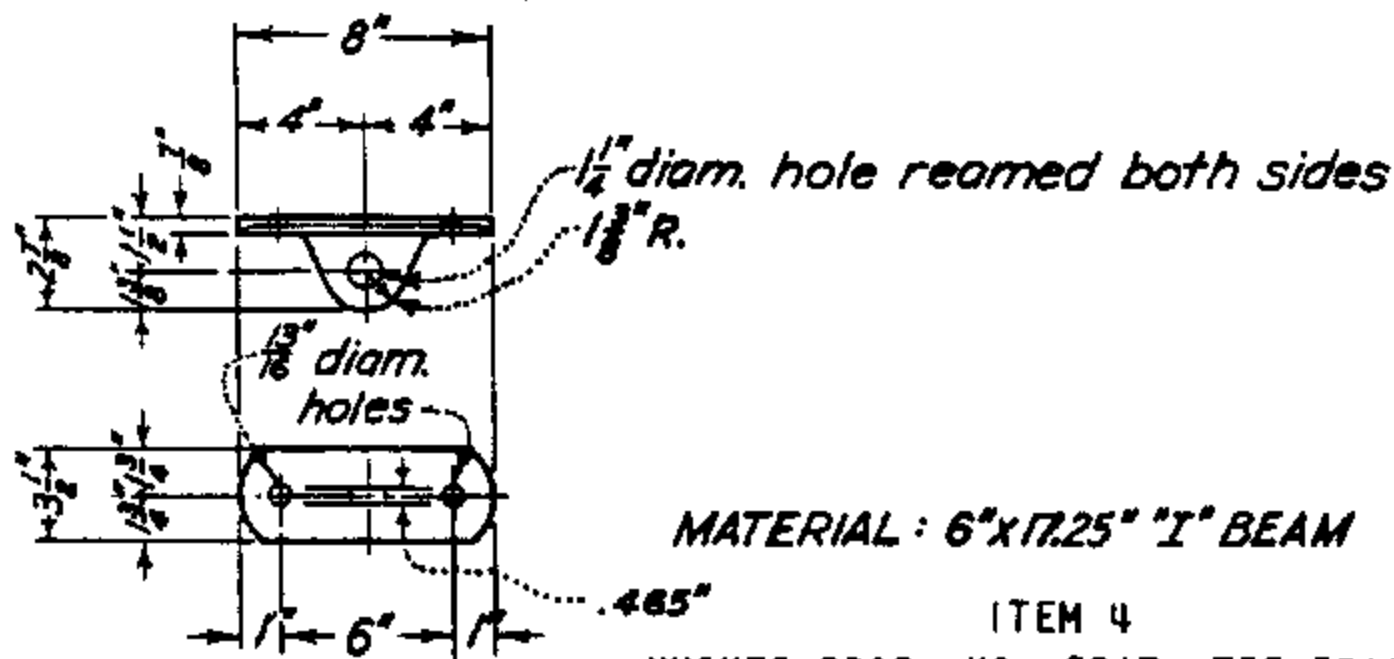

MATERIAL: 6" X 17.25" "I" BEAM
ITEM 4
HUGHES BROS. NO. 2817, TEE BRACKET

INSTALLATION:

- A. ITEMS TO BE MADE OF STEEL, HOT-DIP GALVANIZED AFTER FABRICATION.
- (E) EXEMPT MATERIAL.

ITEM	DESCRIPTION	STOCK NO.	ITEM	DESCRIPTION	STOCK NO.
1	BRACKET (DOUBLE ARMING)	165376			
2	HORIZONTAL ANGLE CROSSARM BRACE (E)	164416			
3	HORIZONTAL ANGLE X-ARM BRACE (E)	164416			
4	TEE BRACKET FOR DEAD END ATTACHMENT	723968			

SCOPE: THIS PAGE IS TO BE USED WHEN DESIGNING SINGLE CIRCUIT, 69KV TRANSMISSION LINES USING HORIZONTAL POST INSULATORS.

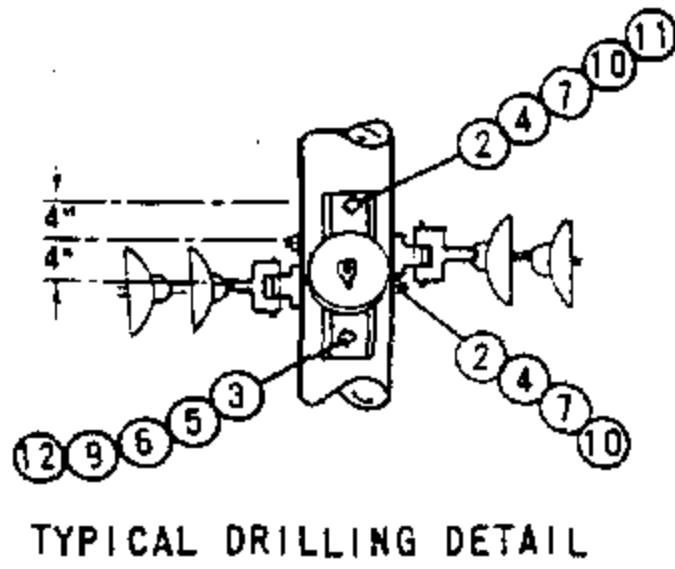

TYPICAL DRILLING DETAIL

SINGLE CIRCUIT
WORK ORDER DESIGNATION
"69KV YP1"

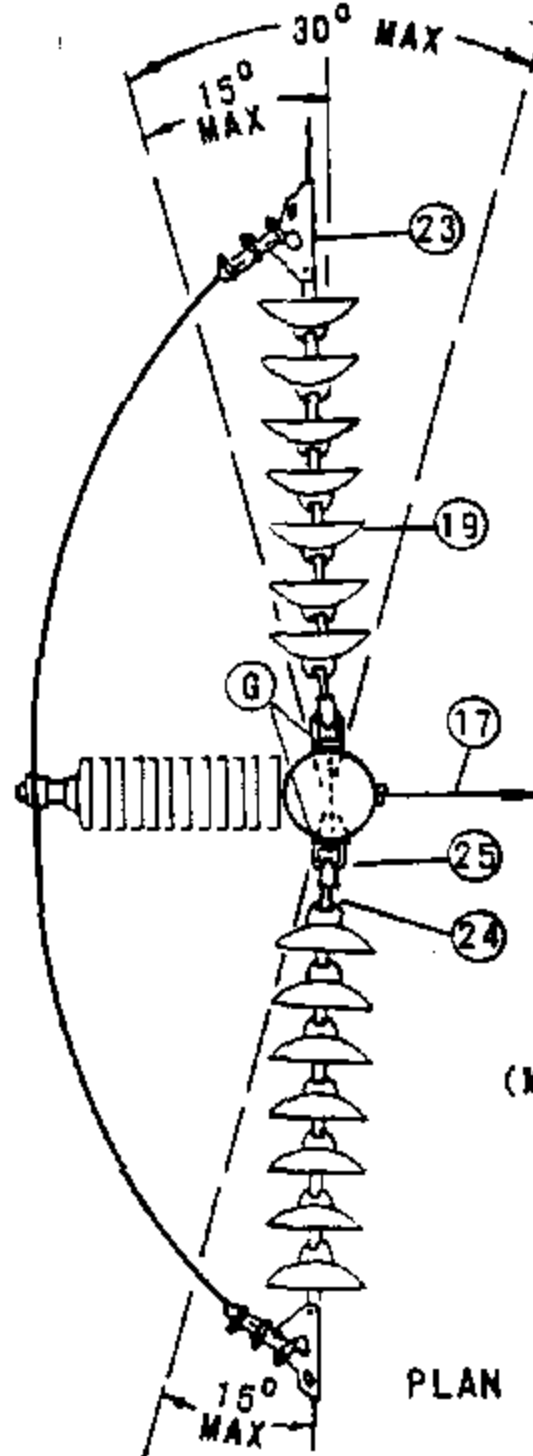

PLAN

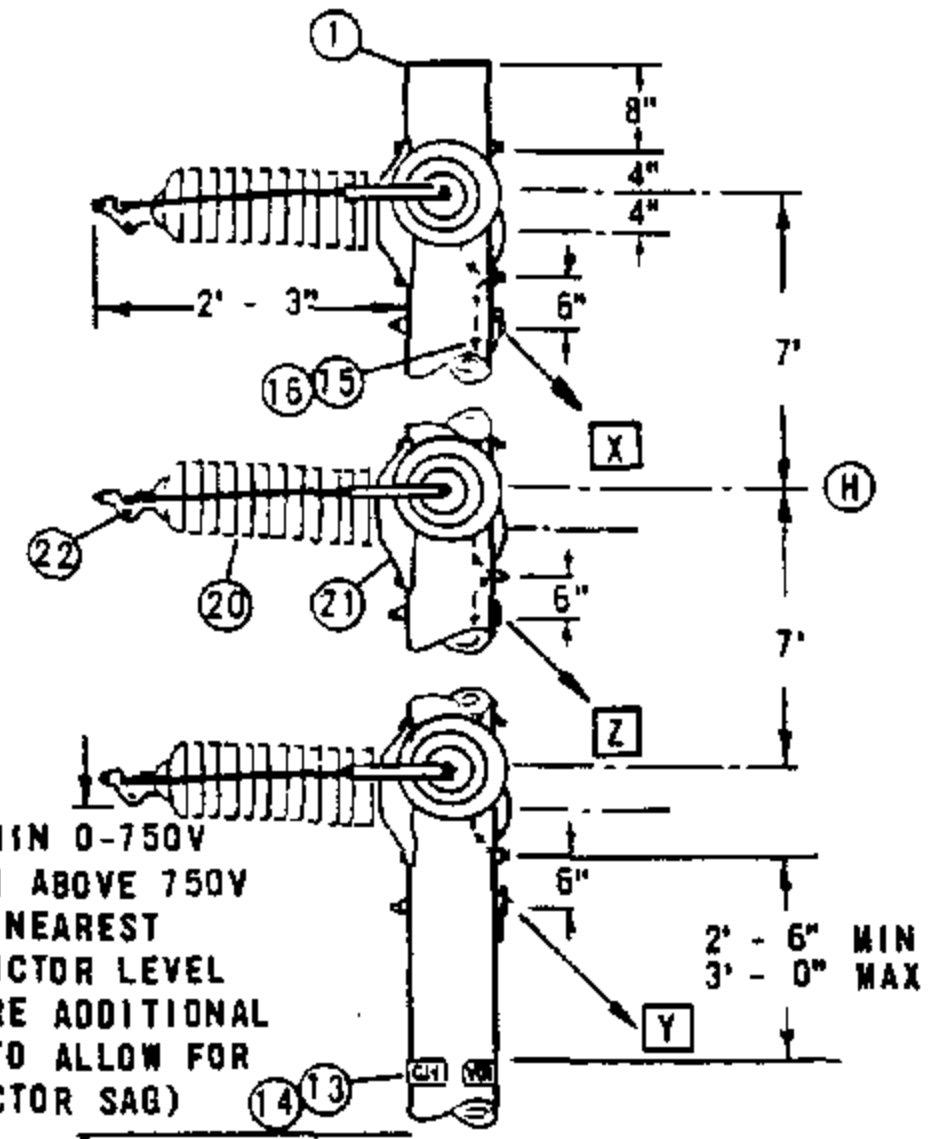

ELEVATION

72" MIN 0-750V
60" MIN ABOVE 750V
TO NEAREST
CONDUCTOR LEVEL
(MAY REQUIRE ADDITIONAL
SPACING TO ALLOW FOR
CONDUCTOR SAG)

INSTALLATION:

- A. FOR USE ON ANGLES UP TO 30° AND FOR TANGENT POLES WITH SEVERE UPLIFT OR DOWN PULL.
- B. GUY UPLIFT POLES IF UPLIFT IS GREATER THAN 80% OF STRUCTURE WEIGHT.
- (C) ADD THE GUYS ON EITHER SIDE IN THE ORDER INDICATED ABOVE (X, Y, Z) AS REQUIRED BY THE GUYING SECTION.
- D. POLE BANDS MAY BE SUBSTITUTED FOR MACHINE BOLTS WHEN ADDITIONAL STRENGTH IS REQUIRED UNDER HIGH TENSION. CONDITIONS WHEN SPECIFIED BY THE TRANSMISSION ENGINEER.
- (E) EXEMPT MATERIALS.
- (F) CONTACT TRANSMISSION ENGINEERING WHEN USING BUNDLED CONDUCTOR.
- (G) THRU BOLTS TO BE IN LINE WITH INSULATOR STRING.
- (H) USE 7' FOR BOTH BUNDLED AND SINGLE CONDUCTOR INSTALLATIONS.

ITEM	DESCRIPTION	QUANTITY	STOCK NO. OR CONSTR. STD
1	POLE, CLASS AND HEIGHT (AS REQ'D)	1	STDS 353,354
2	BOLT, MACH 3/4" X "	9	STD 139
3	BOLT, MACH 5/8" X "	4	STD 139
4	WASHER, 4" SQUARE CURVED RIB	12	797760
5	WASHER, 3" SQUARE CURVED RIB	2	797792
6	WASHER, 3" SQUARE CURVED	3	798912
7	WASHER, 3/4" ROUND	18	800256
9	WASHER, SPRING DBL COIL 5/8"	4	798560
10	NUT, 3/4"	9	504768
11	LOCKNUT, M-F 3/4"	3	504578
12	LOCKNUT, M-F 5/8"	4	504608
13	SIGN, HIGH VOLTAGE	2	647648
14	NAILS, ROOFING 8 GALV	16	492224
15	WIRE #8 BARE SOLID ANNEALED COPPER	2.0#	812928
16	STAPLES, 1 1/4" FENCE, GALV	10	678528
17	GUY	AS REQ'D	900 SECTION
18			
19	INSULATOR, SUSPENSION B/S DISC	AS REQ'D	STD 750
20	INSULATOR, 8KV HORIZ LINE POST W/STUD	3	429312
21	INSULATOR, BASE	3	125728
22	CLAMP, 1 CONDUCTOR/BUNDLED	3	STD 773/(F)
23	CLAMP, STRAIN WITH SOCKET EYE	6	STDS 742,744
24	CLEVIS, BALL	6	235392
25	EYELET, STANDARD	6	235648

FOR FIELD MAINTENANCE ONLY

599.201
SUPERSEDES
520 (1985)

SDB&E ELECTRIC STANDARDS
TRANSMISSION CONSTRUCTION,
69KV SINGLE CIRCUIT, HORIZONTAL POST INSULATORS

DATE 7-1-84
APPD [Signature]

SCOPE: THIS PAGE IS TO BE USED WHEN DESIGNING SINGLE CIRCUIT 69KV TRANSMISSION LINES USING 'Z' TYPE VERTICAL CONSTRUCTION.

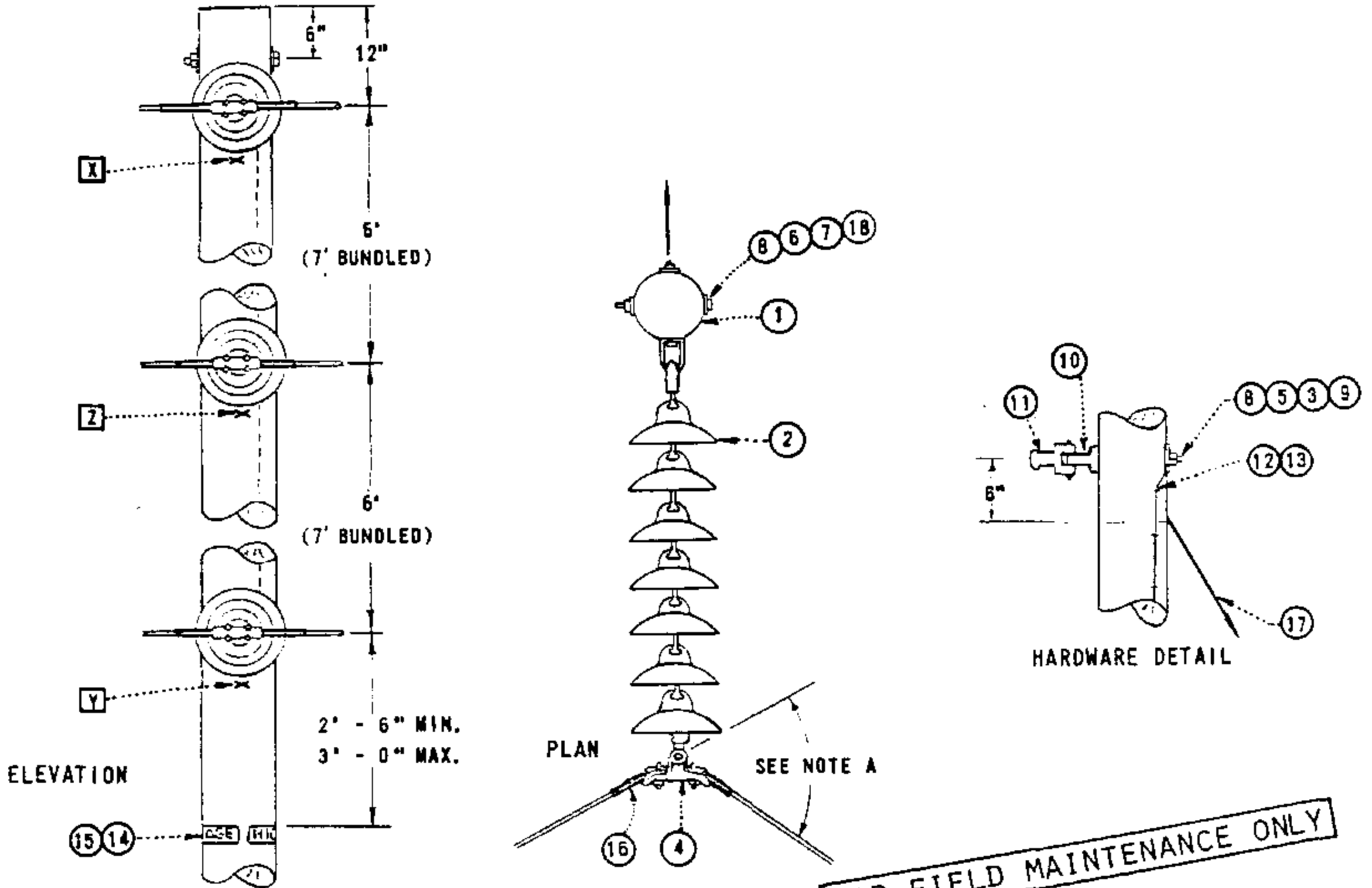

FOR FIELD MAINTENANCE ONLY

STALLATION

- A. FOR USE WITH LINE ANGLES FROM 30° - 60°.
- B. POLE BANDS MAY BE SUBSTITUTED FOR MACHINE BOLTS WHEN ADDITIONAL STRENGTH IS REQUIRED UNDER HIGH TENSION CONDITIONS WHEN SPECIFIED BY THE TRANSMISSION ENGINEER.
- C. ADD THE GUYS IN ORDER INDICATED ABOVE (X, Y, Z) AS REQUIRED BY THE GUYING SECTION.
- (E) EXEMPT MATERIAL.

ITEM NUMBER		DESCRIPTION	QUANTITY	STOCK NO. OR CONSTR. STD.
T.P.F.	T.O.C.			
1		POLE, CLASS AND HEIGHT (AS REQ'D)	1	300 SECTION
	2	INSULATOR, SUSPENSION, B/S DISC.	AS REQ'D	700 SECTION
3		WASHER, 3/4" ROUND (E)	6	800256
	4	CLAMP, SUSPENSION	3	700 SECTION
5		WASHER, 4" SQUARE CURVED RIB (E)	3	797760
6		WASHER, SPRING DBL. COIL 3/4" (E)	1	798496
7		WASHER, 3" X 3" SQUARE CURVE (E)	2	798912
8		BOLT, MACHINE 3/4" X (LENGTH AS REQ'D)	4	STD 139
9		NUTS 3/4" (E)	3	504768
	10	EYELET, STANDARD (E)	3	235648
	11	CLEVIS, BALL (E)	3	235392
12		WIRE, #8 B. SOLID ANNEALED COPPER	1.5 LB	812928
13		STAPLES, 1 1/4", FENCE, GALV. (E)	10	678528
14		SIGN, HIGH VOLTAGE (E)	2	647648
15		NAILS, ROOFING, 8 GALV. (E)	16	492192
16		GUARD, LINE	3 SETS	STD 759
17		BUY (SEE NOTE C)	AS REQ'D.	900 SECTION
18		LOCKNUT, M-F 3/4" (E)	1	504576

DATE 7-1-84
APPD *SPR/DRH*

SDG&E ELECTRIC STANDARDS
TRANSMISSION CONSTRUCTION - 69KV
SINGLE CIRCUIT - VERTICAL CONFIGURATION - TYPE Z

599,202
SUPERSEDES
521 (1985)

SCOPE: THIS PAGE IS TO BE USED WHEN DESIGNING SINGLE CIRCUIT 69KV TRANSMISSION LINES USING 'Y' TYPE VERTICAL CONSTRUCTION.

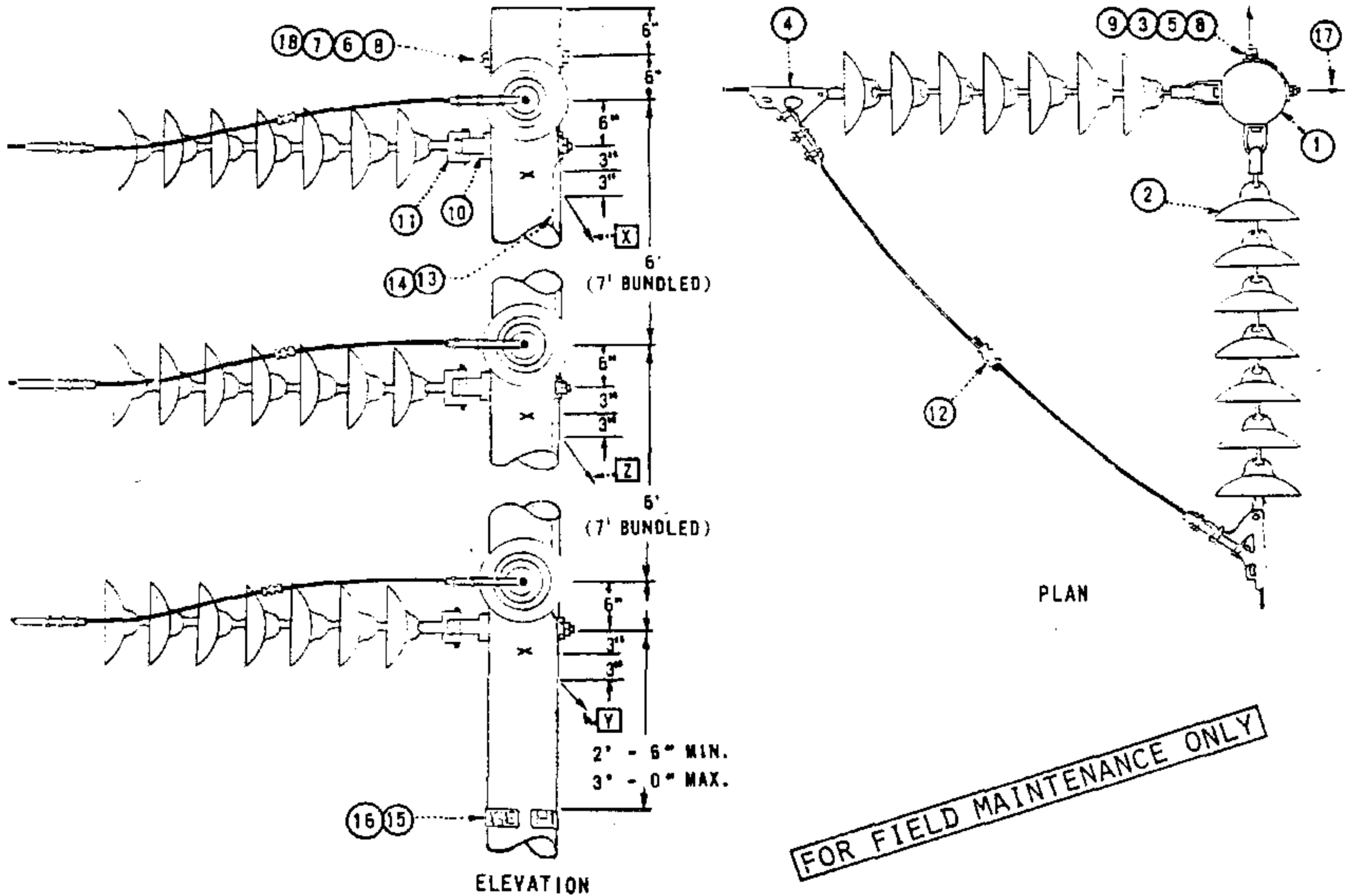

INSTALLATION:

- A. FOR USE WITH LINE ANGLES GREATER THAN 60°.
- B. POLE BANDS MAY BE SUBSTITUTED FOR MACHINE BOLTS WHEN ADDITIONAL STRENGTH IS REQUIRED UNDER HIGH TENSION CONDITIONS WHEN SPECIFIED BY THE TRANSMISSION ENGINEER.
- C. ADD THE GUYS ON EITHER SIDE IN THE ORDER INDICATED ABOVE (X, Y, Z) AS REQUIRED BY THE BUYING SECTION.
- (E) EXEMPT MATERIAL

ITEM NUMBER		DESCRIPTION	QUANTITY	STOCK NO. OR CONSTR. STD.
T.P.F.	T.O.C.			
1		POLE, CLASS AND HEIGHT (AS REQ'D)	1	300 SECTION
	2	INSULATOR, SUSPENSION, B/S DISC.	AS REQ'D	700 SECTION
3		WASHER, 3/4" ROUND	(E) 12	800256
	4	CLAMP, STRAIN. WITH SOCKET EYE	6	700 SECTION
5		WASHER, 4" SQUARE CURVED RIB	(E) 6	797760
6		WASHER, SPRING DBL COIL, 3/4"	(E) 1	798496
7		WASHER, 3" X 3" SQUARE CURVED	(E) 2	798912
8		BOLT, MACHINE 3/4" X (LENGTH AS REQ'D)	7	100 SECTION
9		NUTS, 3/4"	(E) 6	504768
	10	EYELET, STANDARD	(E) 6	235648
	11	CLEVIS, BALL	(E) 6	235392
	12	CONNECTOR, COMPRESSION	3	700 SECTION
13		WIRE #8 B. SOLID ANNEALED COPPER	1.5 LB	812928
14		STAPLES, 1 1/4" FENCE, GALV.	(E) 10	678528
15		SIGN, HIGH VOLTAGE	(E) 2	647648
16		NAILS, ROOFING 8 GALV.	(E) 16	492192
17		GUY (SEE NOTE C)	AS REQ'D	900 SECTION
18		LOCKNUT, M-F 3/4"	(E) 1	504576

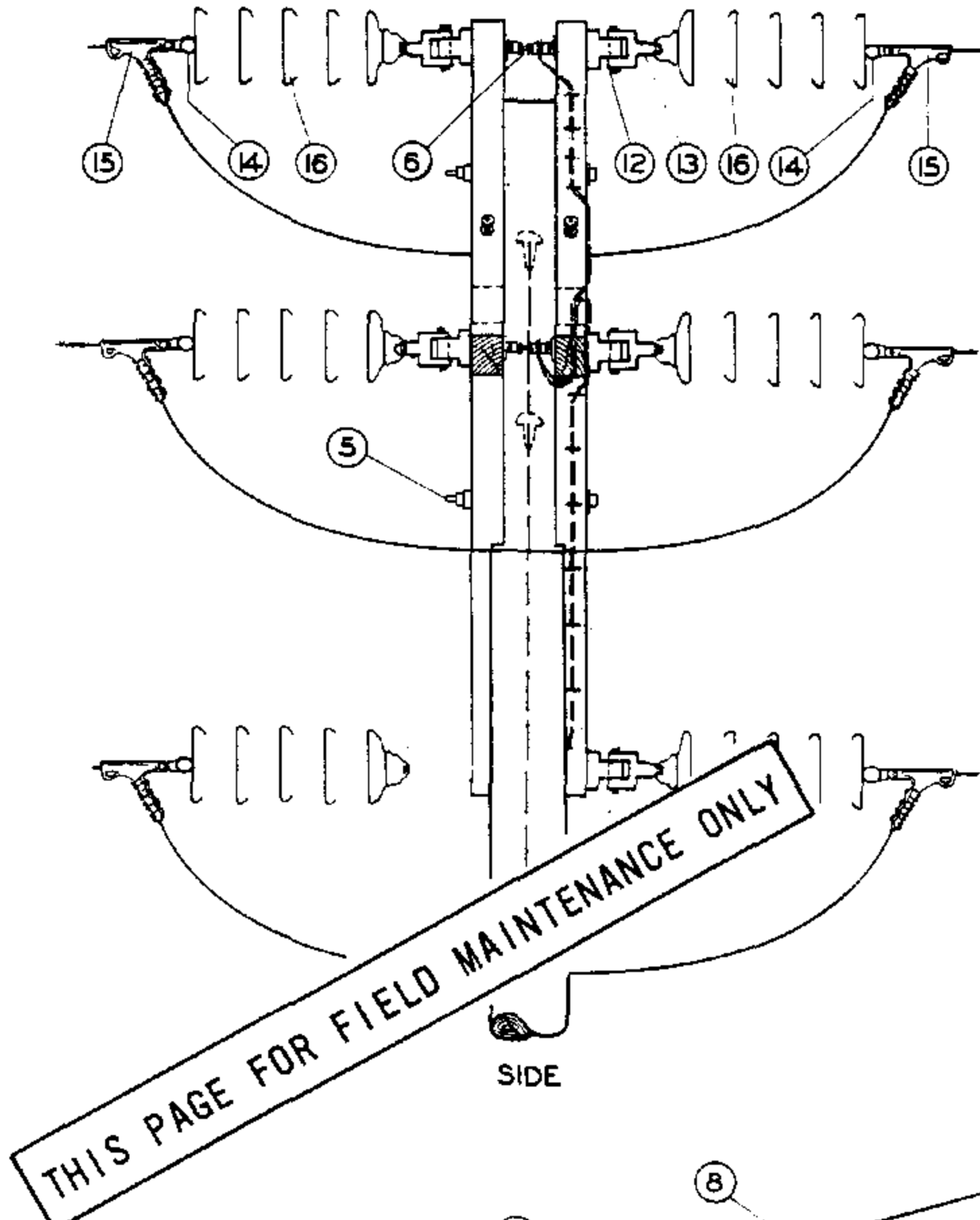

SIDE

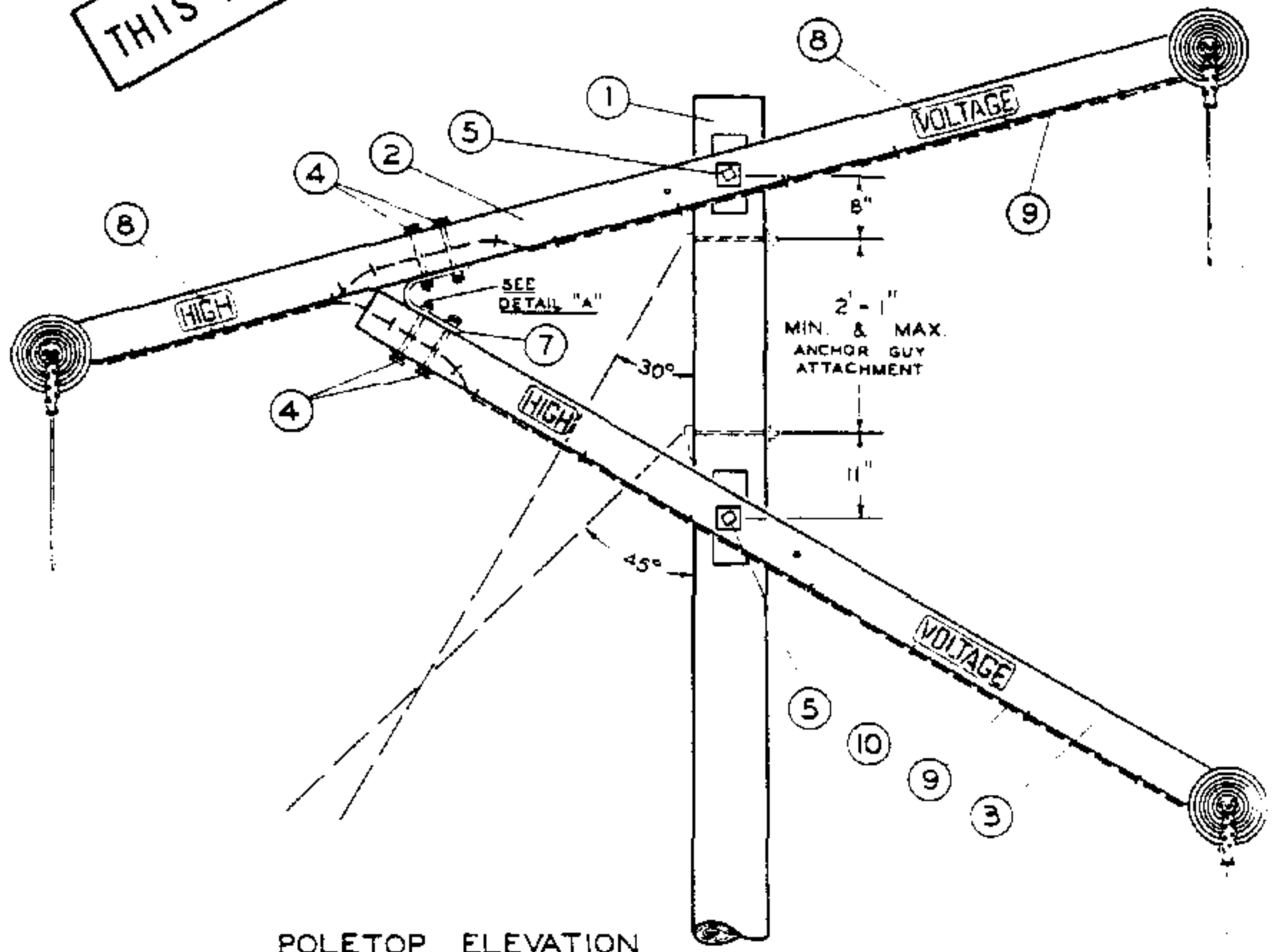

ISSUE 1993
 DATE 7-1-84
 APPE *APL ORH*

SDG&E ELECTRIC STANDARDS
 TRANSMISSION CONSTRUCTION, 69KV, SINGLE CIRCUIT,
 FIGURE "4", TYPE X

599.301
 SUPERSEDES
 532 (4-1-74)

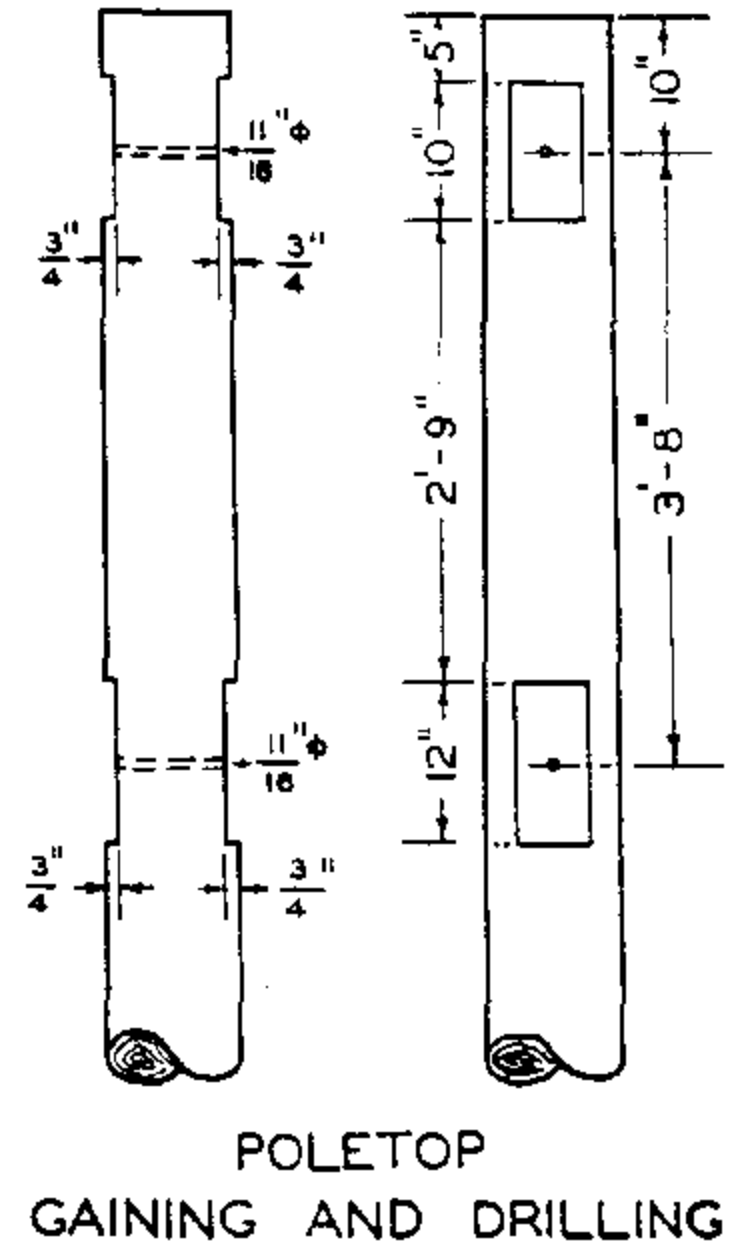
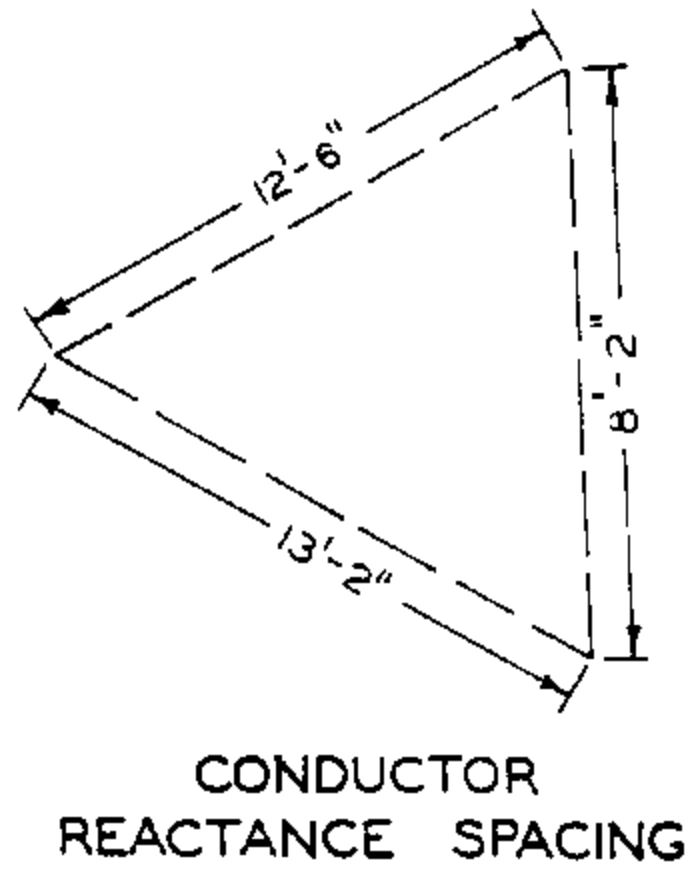
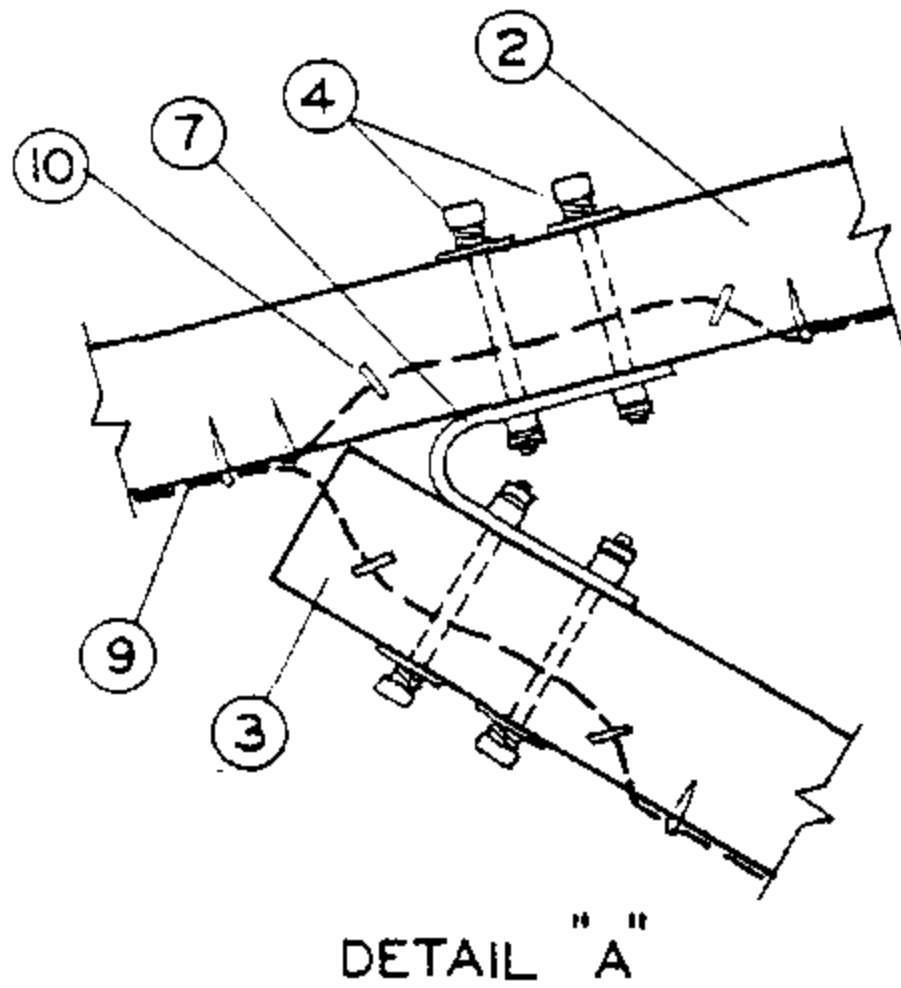

THIS PAGE FOR FIELD MAINTENANCE ONLY

ITEM	DESCRIPTION	QUANT.	STOCK NO. OR CONSTR STDS
1	Pole, Class and Height as required	1	SECTION 300
2	3 3/4" X 5 3/4" X 13'-6" Crossarm	2	STD 120 1T 5
3	3 3/4" X 5 3/4" X 10'-8" Crossarm	2	STD 120 1T 5
4	Mach. Bolt, Galv., 5/8" X 8", 1-3" sq. wash., 1-dbl. coil spr. wash., 1-nut & 1-MF lock nut	8	STDS 138 140
5	Mach. Bolt, Galv., 5/8" X 18", 2-3" sq. wash., 1-flat spr. wash., 1-nut & 1-MF lock nut	2	STDS 139 140
6	Space Bolt, Galv., 5/8" X 20", 4-3" sq. wash., 5-nuts, 2-dbl. coil spr. wash., 2-rd. wash., & 2-MF lock nuts	3	STDS 138 140
7	Crossarm Tie Plate, Galv.	2	543200
8	High Voltage Sign & 8 roofing nails, Galv.	4	647648, 492224
9	#8 Bare Solid Annealed Copper Wire	1 1/2#	812928
10	1 1/4" Fence Staples, Galv.	23	678528
11			
12	EYELET, STANDARD	6	235848
13	CLEVIS, BALL	6	235392
14	Socket Eye	6	-
15	Clamp, Strain	6	STD 742
16	Suspension Insulator, Ball & Socket	as reqd	STD 750
17			

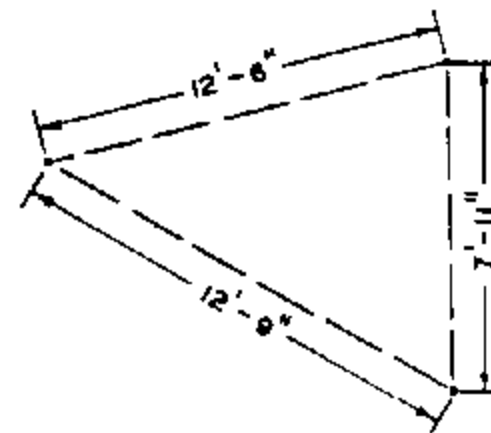
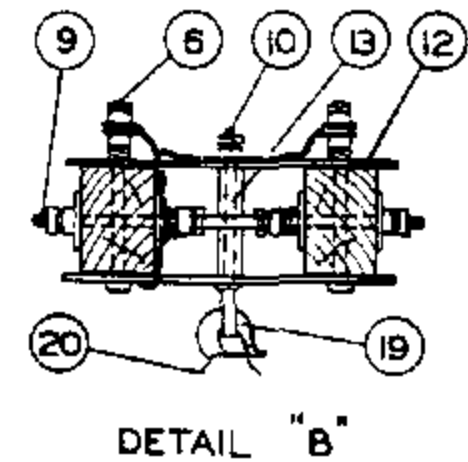
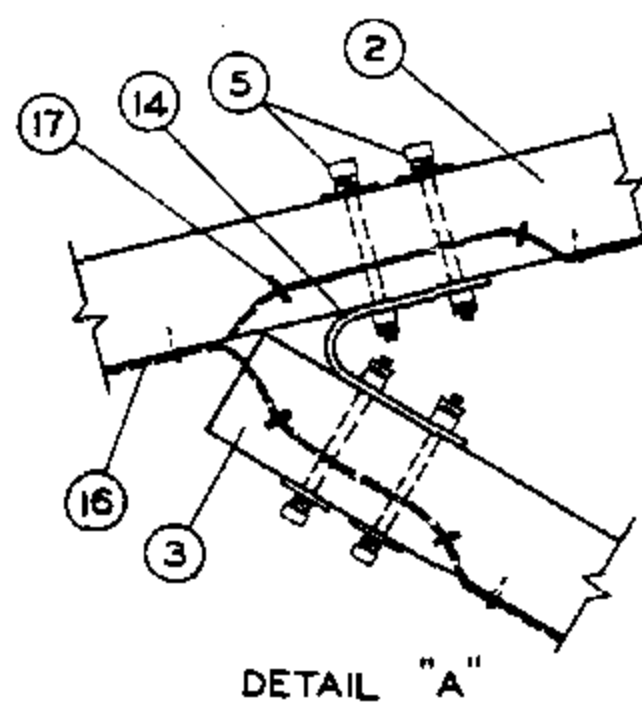
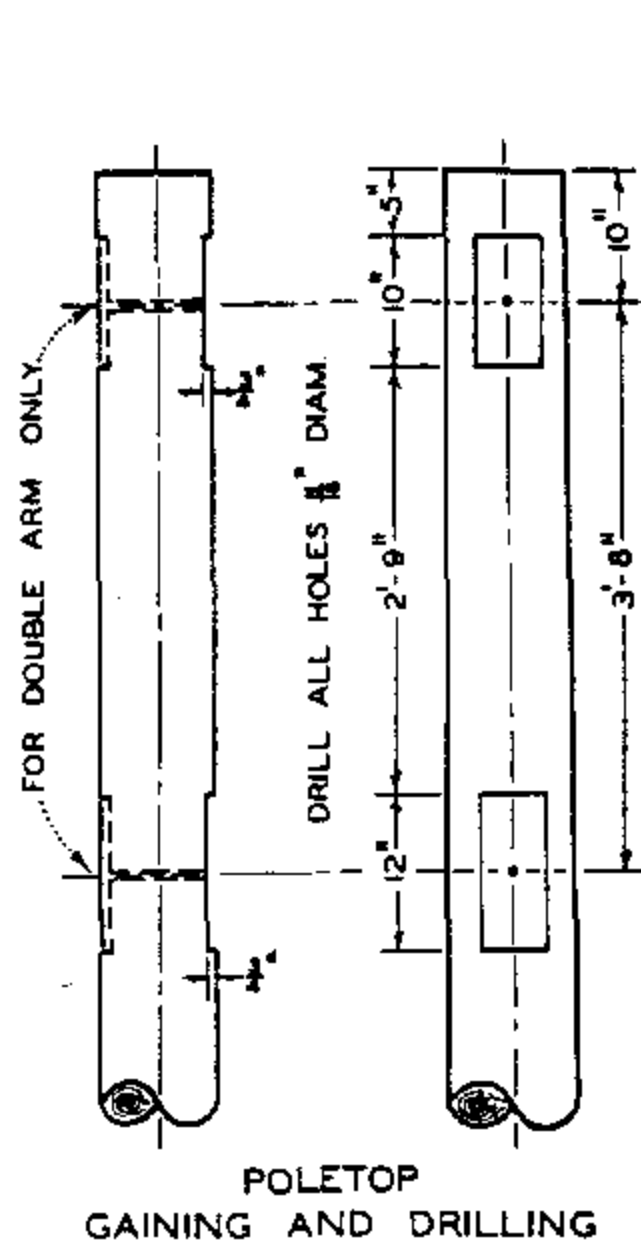

THIS PAGE FOR FIELD MAINTENANCE ONLY

ITEM	DESCRIPTION	QUANTITY		STOCK NO. OR CONSTR STDS
		SINGLE ARM	DOUBLE ARM	
1	Pole, Class and Height as required	1	1	SECTION 300
2	3 3/4" X 5 3/4" X 13'-6" Crossarm	1	1	PG 120 IT. 5
3	3 3/4" X 5 3/4" X 10'-8" Crossarm	1	2	PG 120 IT. 1
4	Mach. Bolt, Galv., 5/8" X 6", 2-3" sq. wash., 1-dbl. coil spr. wash., 1-nut & 1-MF lock nut	3	2	PGS 139, 140
5	Mach. Bolt, Galv., 5/8" X 8", 1-2" sq. wash., 1-dbl. coil spr. wash., 1-nut & 1-MF lock nut	4	3	PGS 139, 140
6	Mach. Bolt, Galv., 5/8" X 9", 1-dbl. coil spr. wash., 2-nuts, 2-rd. wash., & 1-MF lock nut	2	3	PGS 139, 140
7	Mach. Bolt, Galv., 5/8" X 14", 2-3" sq. wash., 1-flat spr. wash., 1-nut & 1-MF lock nut	2	2	PGS 139, 140
8	Mach. Bolt, Galv., 5/8" X 13", 2-3" sq. wash., 1-flat spr. wash., 1-nut & 1-MF lock nut	2	2	PGS 139, 140
9	Space Bolt, Galv., 5/8" X 30", 4-3" sq. wash., 4-nuts, 2-dbl. coil spr. wash., 4-MF lock nuts	2	3	PGS 139, 140
10	Shoulder Eye Bolt, Galv., 5/8" X 9", 1-rd. wash., 1-nut & 1-MF lock nut	2	3	PGS 139, 140
11	Shoulder Eye Bolt, Galv., 5/8" X 9", 1-2 1/4" sq. wash., 1-dbl. coil spr. wash., 2-rd. wash., 2-nuts & 1-MF lock nut	3	2	PGS 139, 140
12	Double Aiming Plate, 4" X 1/4" X 17"	2	3	541088
13	Spacer, 3/4" diameter X 5 3/4" pipe, Galv.	2	3	663552
14	Crossarm Die Plate, Galv.	1	2	543200
15	High Voltage Sign & 8 roofing nails, Galv.	4	4	647648, 492224
16	#8 Bare Solid Annealed Copper Wire	1 1/2"	1 1/2"	812928
17	1 1/4" Fence Staples, Galv.	23	23	678528
18				
T. O. C.	19 Ball Hook, short	3	2	414880 OR 414912
	20 Suspension Insulator, Ball & Socket	as required		PG 750
	21 Suspension Clamp, complete with socket eye	3	2	PGS 775, 776
	22			

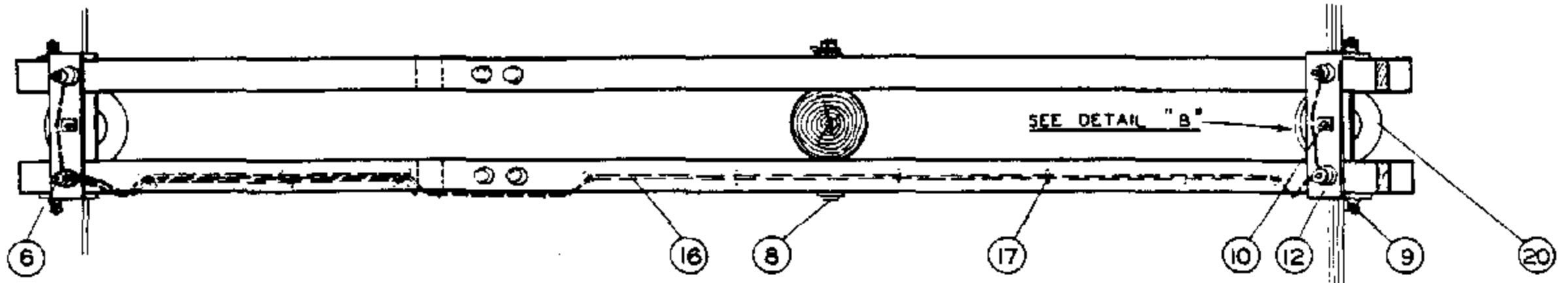

PLAN - DOUBLE ARM

THIS PAGE FOR FIELD MAINTENANCE ONLY

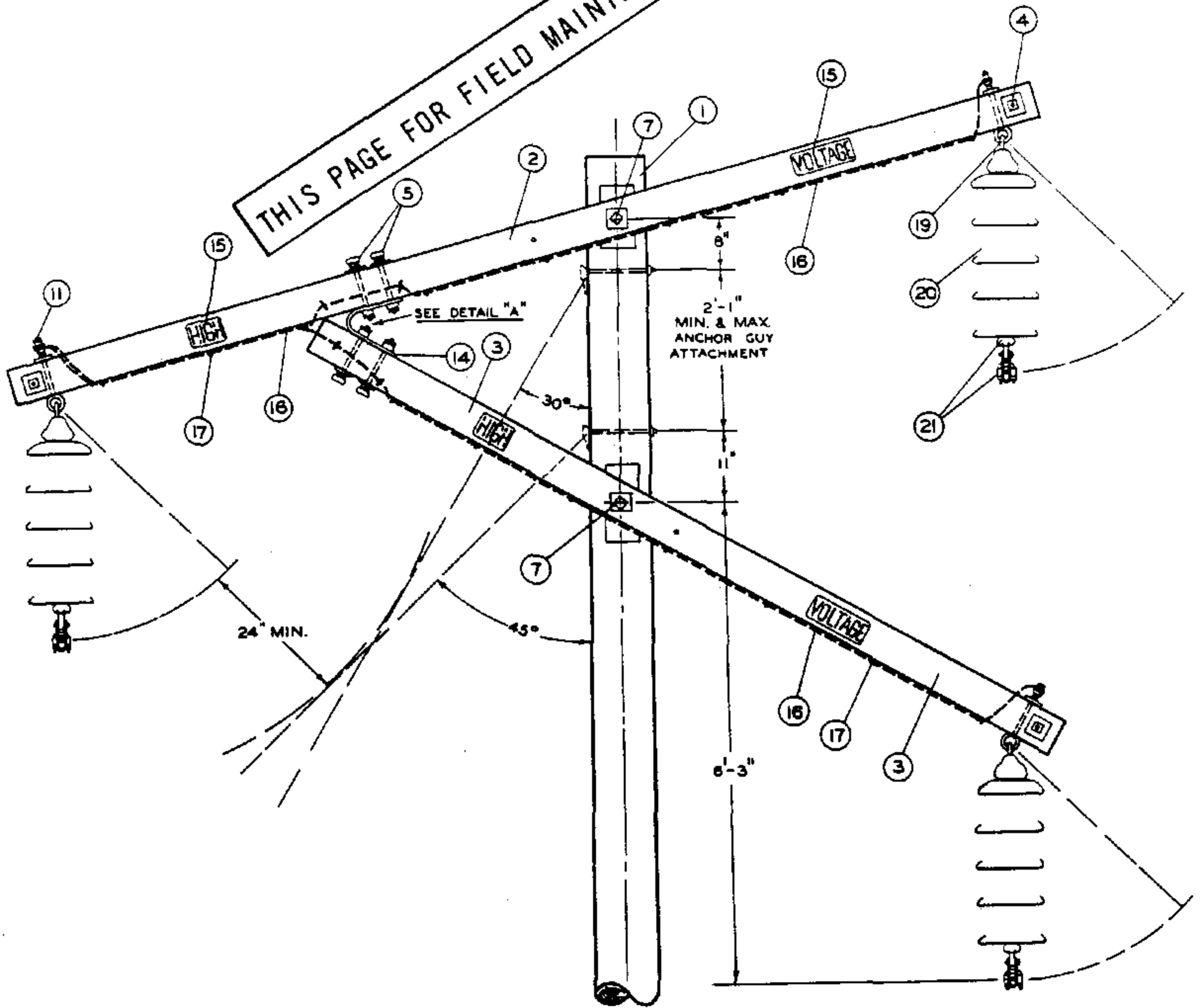

POLETOP ELEVATION - SINGLE ARM

599,304
 SUPERSEDES
 530 (4-1-74)

SDG&E ELECTRIC STANDARDS
 TRANSMISSION CONSTRUCTION,
 69KV, SINGLE CIRCUIT, FIGURE "4", TYPE W

DATE 7-1-84
 APPD *AEH/DEH*

SCOPE: THIS PAGE IS TO BE USED WHEN DESIGNING SINGLE CIRCUIT 69KV TRANSMISSION LINES USING TYPE X- Δ TRIANGULAR DEADEND CONFIGURATION

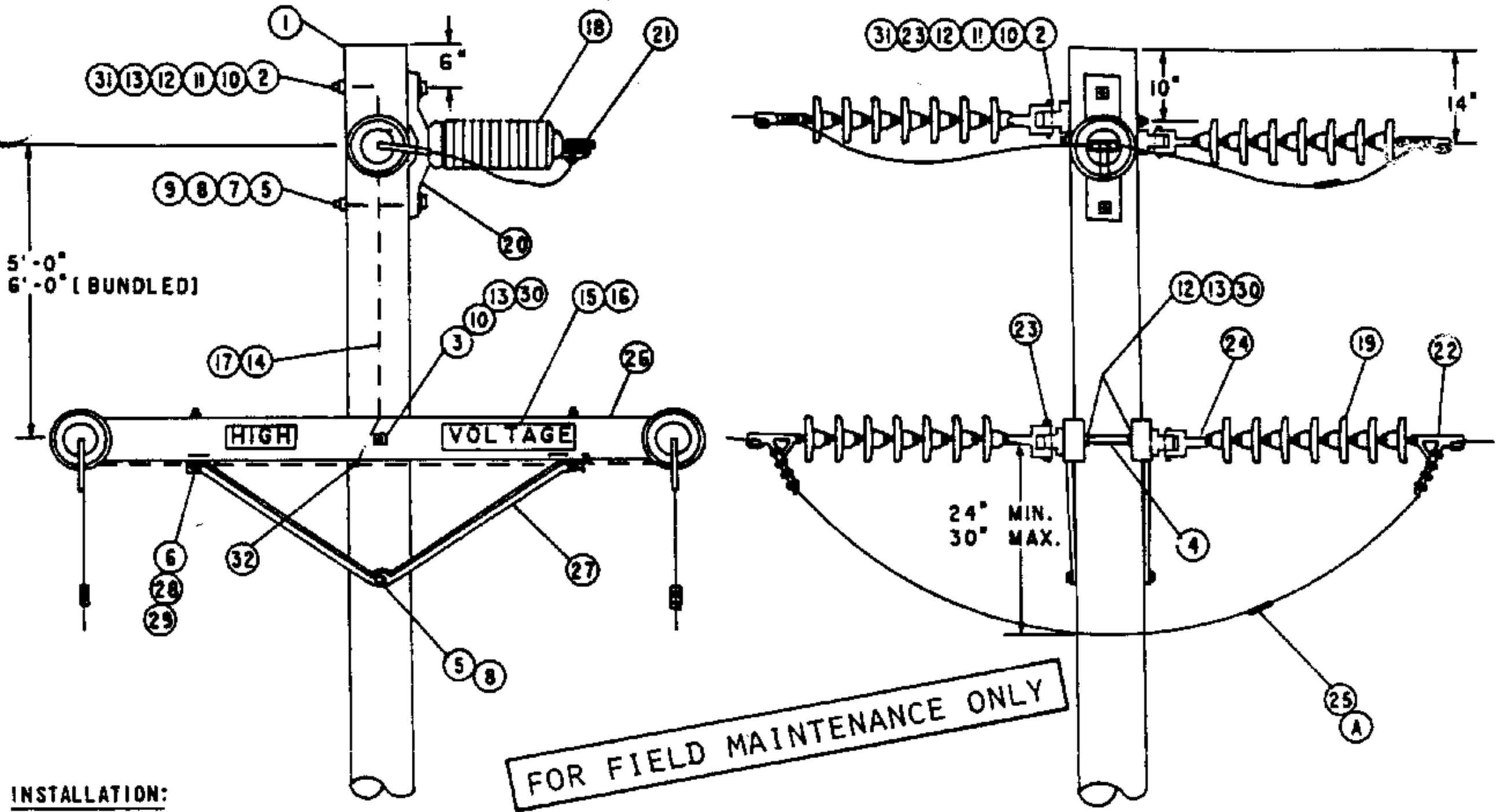

FOR FIELD MAINTENANCE ONLY

INSTALLATION:

- (A) USE ONLY FOR CONDUCTOR REPLACEMENT. MAKE CONTINUOUS JUMPERS ON NEW CONSTRUCTION.
- (E) EXEMPT ITEM.

ITEM	DESCRIPTION	QUANTITY	STOCK NO. OR CONST. STD.
1	POLE, CLASS AND HEIGHT AS REQ'D.	1	STDS 353, 354
2	BOLT, MACH., 3/4" X 14"	3	153440
3	BOLT, MACH., 3/4" X 26"	1	153728
4	BOLT, SPACE, 3/4" X 26"	2	156288
5	BOLT, MACH., 5/8" X 14", WITH NUT	2	154880
6	WASHER, ROUND 1/2" FLAT	(E) 2	800192
7	WASHER, 3" SQ. CURVED, 5/8"	(E) 1	798912
8	WASHER, 5/8" DBL. COIL SPRING	(E) 2	798560
9	LOCKNUT, M-F 5/8"	(E) 2	504608
10	LOCKNUT, M-F 3/4"	(E) 12	504576
11	WASHER, 4" SQ. CURVED, 3/4" RIB	3	797760
12	WASHER, ROUND 3/4" FLAT	1	800256
13	WASHER, 3/4" DBL. COIL SPRING	6	798496
14	WIRE, #8 B. SOLID ANNEALED COPPER	1.5 LB.	812928
15	SIGN, HIGH VOLTAGE	(E) 2	647648
16	NAILS, ROOFING, #8 GALV.	(E) 16	492224
17	STAPLES, 1 1/4" FENCE, GALV.	(E) 20	498528
18	INSULATOR, 88KV HORIZ. POST	1	429312
19	INSULATOR, SUSPENSION 8/S DISC.	AS REQ'D	PG. 750.4
20	BASE, INSULATOR	1	125728
21	CLAMP, CONDUCTOR POST INSULATOR	1	STD 773
22	CLAMP, CONDUCTOR STRAIN	6	STDS 742, 744
23	EYELET, STANDARD	(E) 6	235648
24	CLEVIS, BALL	6	235392
25	SLEEVE, JUMPER	(A) 3	700 SECTION
26	CROSSARM 3 3/4" X 5 3/4" X 10'	2	294128
27	BRACE, ANGLE 5'	2	164128
28	BOLT, MACH. 1/2" X 7" WITH NUT	(E) 2	153120
29	WASHER, DBL. COIL, 1/2"	(E) 2	798464
30	WASHER, 3" SQ. FLAT	(E) 10	799104
31	NUTS, MACHINE, 3/4"	17	504768
32	CONNECTOR, SPLIT BOLT	(E) 1	269632

SDG&E ELECTRIC STANDARDS

DATE 7-1-84
APPD RES/ORH

TRANSMISSION - 69KV TYPE X- Δ
STRUCTURE SINGLE CIRCUIT - TRIANGULAR DEADEND

599,305
SUPERSEDES
535 (1985)

SCOPE: THIS STANDARD SHOWS A MOTOR OPERATED HORIZONTAL BREAK GANG OPERATED POLE TOP SWITCH FOR SCADA.

NOTE:

- A. B. CHANGE TYPE "D" SWITCH ILLUSTRATED.

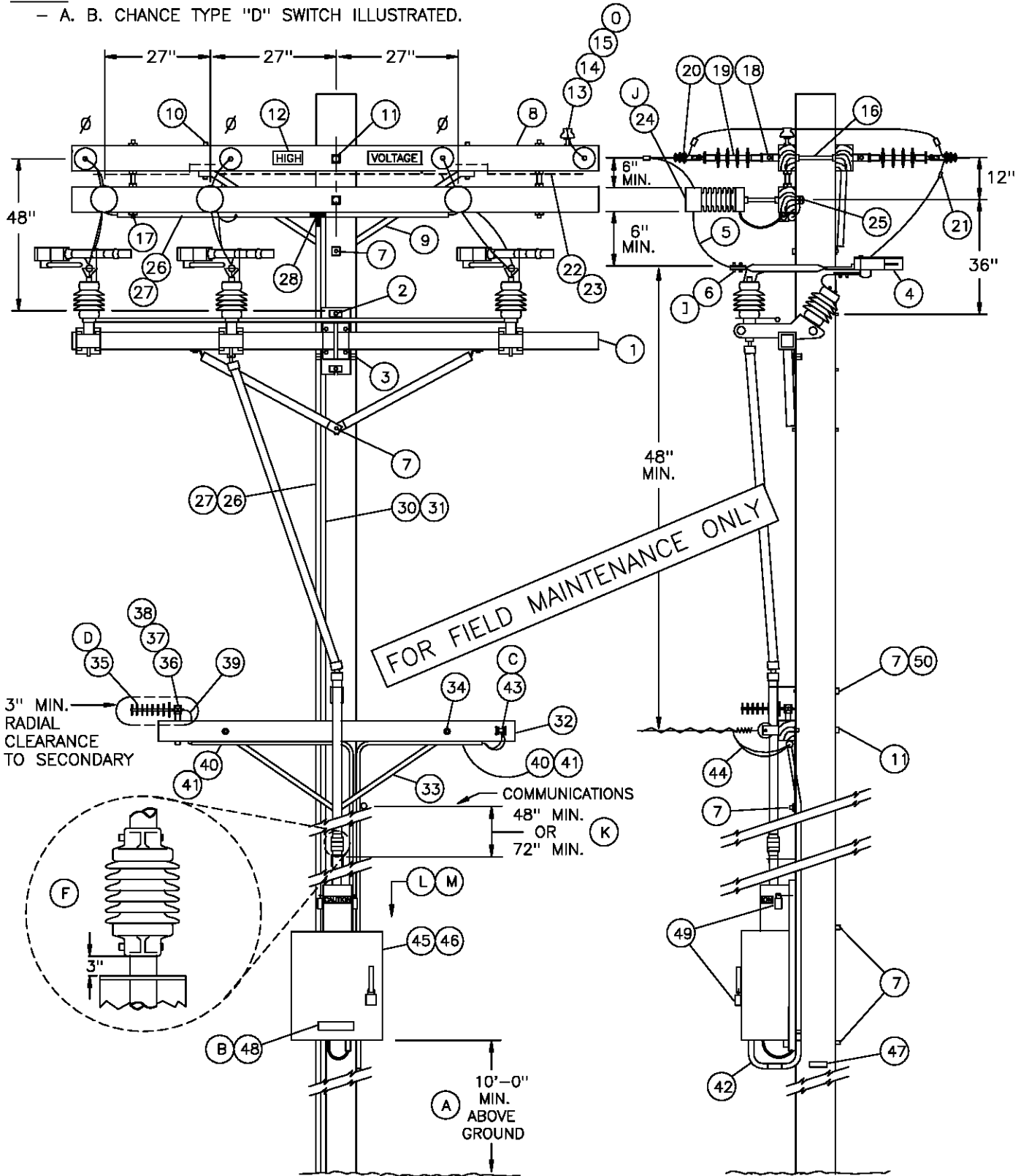

599.306
 SUPERSEDES
 535.1 (11-1-98)

SDG&E ELECTRIC STANDARDS
 OVERHEAD SCADA SWITCH 12KV
 HORIZONTAL LOADBREAK TYPE SINGLE CIRCUIT
 MOTOR OPERATED

DATE 11-1-98
 APPD PJA / CJK

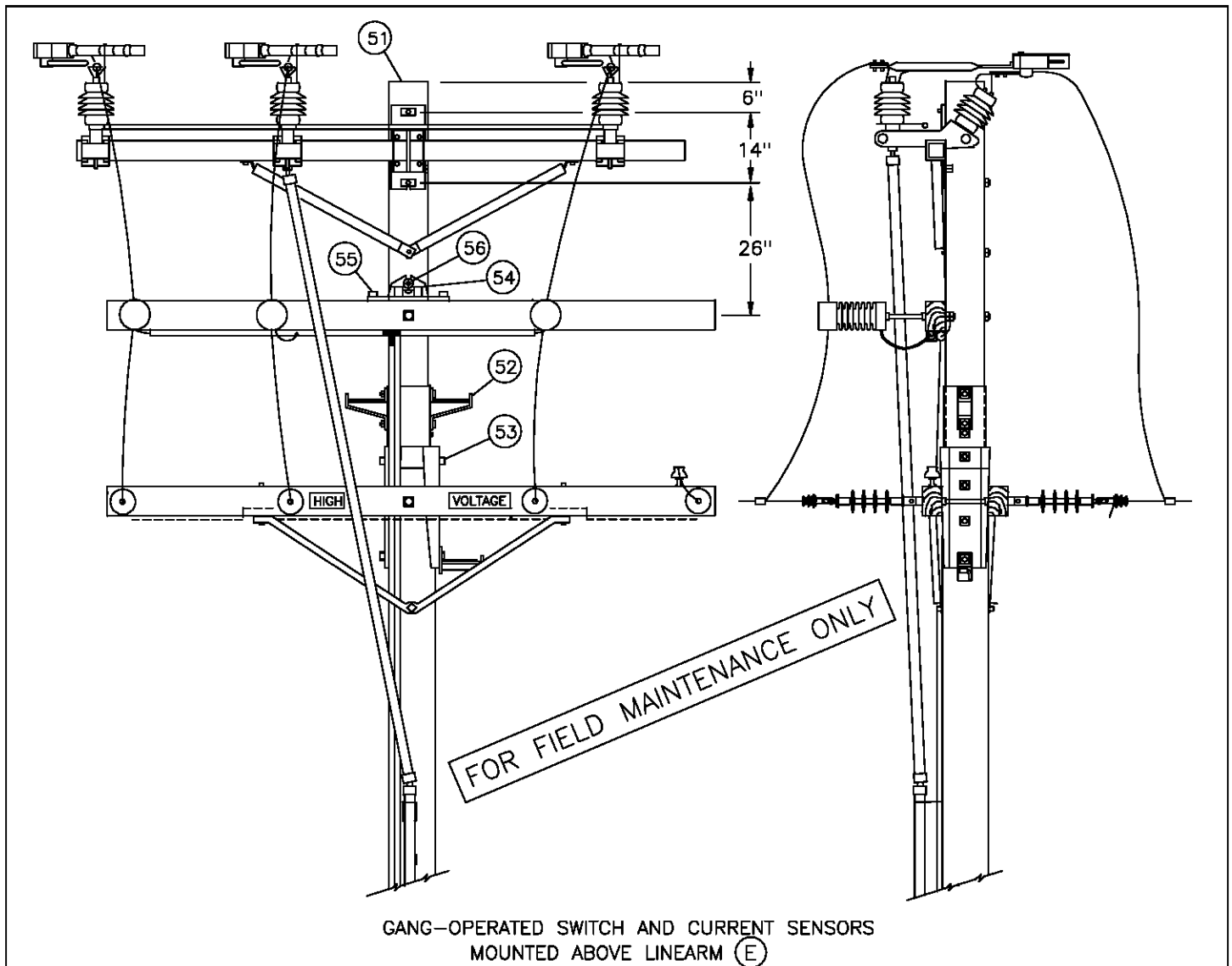

BILL OF MATERIAL:

ITEM	DESCRIPTION	QUANTITY	CONSTR. STD. OR PAGE NO.	STOCK NUMBER	ASSEMBLY UNITS	
1	SWITCH, GANG-OPERATED, 15KV, 600 AMP, WITH LOAD INTERRUPTERS, INCLUDING 40' OF CONTROL ROD (G)	1	-	709258	GANG-S	
	ADDITIONAL 10'-6" CONTROL ROD WITH GUIDE BEARING AND COUPLING	A. B. CHANCE S & C	AS REQ'D AS REQ'D	- -	604428 602934	C-ROD S-ROD
2	BOLT, MACH, GALV, 3/4" X (LENGTH AS REQ'D), 1 SQUARE AND 1 DOUBLE COIL SPRING WASHER	2	392	-	-	
3	SCREW, LAG, GALV, 1/2" X 4" (CHANCE SWITCH ONLY)	2	-	621568	-	
4	LOAD INTERRUPTER-A. B. CHANCE SWITCH ONLY IF RETRO-FITTING REQUIRED	TYPE D	3	-	433794	LDBRKD
		TYPE S	3	-	433796	LDBRKS
5	WIRE, BARE STRANDED CU OR AL (SIZE AS REQ'D)	33'	711-715	-	-	
6	TERMINAL, COMPRESSION LUG (I)	6	794-795	-	-	

CONTINUED NEXT PAGE:

DATE 12-1-98 APPD <i>PA/CLK</i>	SDG&E ELECTRIC STANDARDS OVERHEAD SCADA SWITCH 12KV HORIZONTAL LOADBREAK TYPE SINGLE CIRCUIT MOTOR OPERATED	599.307 SUPERSEDES 535.2 (12-1-98)
------------------------------------	----------------------------------------------------------------------------------------------------------------------	------------------------------------------

BILL OF MATERIAL, CON'T:

ITEM	DESCRIPTION	QUANTITY	CONSTR. STD. OR PAGE NO.	STOCK NUMBER	ASSEMBLY UNITS
7	BOLT, MACH, GALV, 5/8" X (LENGTH AS REQ'D), 1 SQUARE AND 1 DOUBLE COIL SPRING WASHER	6	392	-	-
8	CROSSARM, 3 3/4" X 5 3/4" X 10' - 0"	3	-	294128	4-
9	BRACE, ANGLE, 5' - 0"	1	-	164128	5HUB
10	BOLT, MACH, GALV, 1/2" X 7", 1 ROUND AND 1 DOUBLE COIL SPRING WASHER	2	392	-	-
11	BOLT, MACH, GALV, 5/8" X (LENGTH AS REQ'D), 2 SQUARE AND 1 DOUBLE COIL SPRING WASHER	3	392	-	-
12	SIGN, HIGH VOLTAGE, AND 9 ROOFING NAILS, GALV	2	-	647648	HV
		-	-	492224	-
13	PIN, INSULATOR, STRAIGHT, 12KV, 1" (H)	2	-	532704	PS1
14	INSULATOR, 12KV NEUTRAL (H)	2	-	429216	55-3/I
15	WIRE, TIE (DOUBLE) (H)	1	760-764	-	-
16	BOLT, SPACE, GALV, 5/8" X (LENGTH AS REQ'D), 3 SQUARE, 2 ROUND, 2 DOUBLE COIL SPRING WASHERS AND 1 NUT (H)	4	392	-	-
17	BOLT SPACE GALV. 5/8" X (LENGTH AS REQ'D) 4 SQUARE & 2 DOUBLE COIL SPRING WASHERS	2	392	-	-
18	CLEVIS, DEAD END, 5/8" BOLT STEEL (CLOSED TYPE) (H)	8	-	235712	-
19	INSULATOR, SUSPENSION, 12KV, CLEVIS, NON PORC (H)	8	750	-	-
20	CLAMP, STRAIGHT LINE, D.E. (H)	8	741-743	-	-
21	CONNECTOR, WIRE COMPRESSION (SIZE AS REQ'D)	AS REQ'D	783-786	-	-
22	WIRE, #8 BARE SOLID ANNEALED COPPER	12'	-	812928	BOND8
23	STAPLE, FENCE, GALV, 1 1/4"	AS REQ'D	-	678528	-
24	LINE POST CURRENT SENSOR & 50' CABLE ASSEMBLY (J)	3	-	116000	CURSEN
25	BOLT, SPACE, GALV, 3/4" X (LENGTH AS REQ'D) 2 SQUARE, 2 ROUND & 2 DBL COIL SPRING WASHERS	3	392	-	-
26	CONDUIT, PVC, SCHED 40, 1"	40'	-	251200	PVC-1
27	STRAPS, PIPE, GALV, 1", AND 2-6D NAILS, GALV.	AS REQ'D	-	697792	-
		AS REQ'D	-	490656	-
28	ACCESS FITTING BODY, TYPE "T", PVC, 1"	1	-	348900	TEE-1
29	UNIT GROUND, COMPLETE, AND #6 B.S. COPPER WIRE (N)	1	-	603136	GND6
		6 LBS	-	813536	-
30	CONDUIT, PVC, SCHEDULE 40, 1/2"	20'	-	251168	PVC1/2
31	STRAPS, PIPE, GALV, 1/2", AND 6D NAILS, GALV.	AS REQ'D	-	697728	-
		AS REQ'D	-	490656	-
32	CROSSARM, 3-1/2" X 4-1/2" X 6'-0"	1	380.2	294112	2S

FOR FIELD MAINTENANCE ONLY

CONTINUED NEXT PAGE:

599.308 SUPERSEDES 535.3 (11-1-98)	SDG&E ELECTRIC STANDARDS OVERHEAD SCADA SWITCH 12KV HORIZONTAL LOADBREAK TYPE SINGLE CIRCUIT MOTOR OPERATED	DATE 11-1-98 APPD PJA / CMK
------------------------------------------	----------------------------------------------------------------------------------------------------------------------	--------------------------------

BILL OF MATERIAL, CON'T:

ITEM	DESCRIPTION	QUANTITY	CONSTR. STD. OR PAGE NO.	STOCK NUMBER	ASSEMBLY UNITS
33	BRACE, 28", FLAT, CROSSARM	2	-	164192	-
34	BOLT, MACH, GALV, 3/8" X 4-1/2" & 1 RD. WASHER	2	392.2	-	-
35	ANTENNA, BROADBAND, YAGI (D)	1	-	109570	ANT
36	NIPPLE, PIPE 2" X 6", GALV	1	-	500960	ANTXMB
37	BOLT, MACH, GALV, 1/2" X 9"	1	392.2	153184	
38	CENTERING WASHER, GALV.	2	-	795520	
39	CABLE, SUPERFLEX, ANTENNA	AS REQ'D	-	197810	ANTCAB
40	CONDUIT, PVC, SCHEDULE 40, 3/4"	40'	-	251328	PVC3/4
41	STRAPS, PIPE, GALV, 3/4", AND 2-6D NAILS, GALV.	AS REQ'D	-	697888	-
		AS REQ'D	-	490656	-
42	ELBOW, PVC, 3/4"	4	-	322166	EL3/4
43	SECONDARY DEADEND (C)	1	-	235488	1SDE
44	WIRE, THW, #12, BLACK	100'	-	808096	THW12
45	MOTOR OPERATOR, INCLUDING COUPLING AND RTU	1	-	509580	ADMO
46	TRANSCEIVER, FIXED CHANNEL OR	1	-	749500	FCTRAN
	TRANSCEIVER SPREAD SPECTRUM	1	-	749504	SSTRAN
47	TAG, SWITCH NUMBER	2	204	-	-
48	TAG, RTU NUMBER	1	208.5	(B)	TAGRE
49	PADLOCK, SCHLAGE ELECTRIC SERIES	3	-	514848	-
50	SCREW, LAG, GALV, 5/8" X 5"	2	-	621600	-
51	6' WOOD POLE TOP EXTENSION	1	473	336324	WPTX6
52	POLE STEP KIT	1	473	692950	-
53	BOLT, MACH, GALV, 5/8" X (LENGTH AS REQ'D) AND 1 DOUBLE COIL SPRING WASHER	3	392	-	-
54	GAIN, CROSSARM, BRACELESS	1	-	369598	BCGAIN
55	BOLT, MACH, GALV, 5/8" X 7" 1 ROUND AND 1 DOUBLE COIL SPRING WASHER	2	392	-	-
56	BOLT, MACH, GALV, 5/8" X (LENGTH AS REQ'D) 1 SQUARE, 1 ROUND & 1 DOUBLE COIL SPRING WASHER	1	392	-	-

FOR FIELD MAINTENANCE ONLY

INSTALLATION:

- (A) MOTOR OPERATOR TO BE MOUNTED AT (13'-6") FROM GROUND-LEVEL TO BOTTOM OF CABINET WHEN LOCATED ON STREET-SIDE OF POLE. IF NOT VULNERABLE TO VEHICLE DAMAGE, MOUNT RTU AT 10' FROM GROUND-LEVEL TO BOTTOM OF CABINET.
- (B) RTU NUMBER TO BE ASSIGNED BY DISTRIBUTION OPERATIONS AND ADDED TO JOB WITH DPSS NOTE.
- (C) THIS ITEM NOT NECESSARY IF EXISTING SECONDARY RACK CONSTRUCTION.

DATE 11-1-98 APPD PEA / OAK	SDG&E ELECTRIC STANDARDS	599.309 SUPERSEDES 535.4 (11-1-98)
	OVERHEAD SCADA SWITCH 12KV HORIZONTAL LOADBREAK TYPE SINGLE CIRCUIT MOTOR OPERATED	

INSTALLATION:

- Ⓓ PLANNER TO SPECIFY WHICH SIDE OF POLE FOR ANTENNA MOUNT WITH DATA FROM STANDARDS. POINTS LIST TO BE COMPLETED BY PLANNER AND SENT TO SENIOR ENGINEER, DISTRIBUTION OPERATIONS. SEE ELECTRIC STANDARDS TEAM FOR POINTS LIST FORMS AND COMMUNICATIONS REQUIREMENTS.
- Ⓔ IF INSUFFICIENT CLEARANCE BELOW THE LINEARM, MOUNT THE GANG-OPERATED SWITCH AND CURRENT SENSOR ARM ABOVE THE LINEARM USING A POLE TOP EXTENSION (SEE STANDARD 473). THIS CONFIGURATION MAY ALSO BE USED IF DISTRIBUTION IS UNDERBUILT ON A TRANSMISSION POLE.
- Ⓕ INSTALL CONTROL PIPE INSULATOR THREE INCHES ABOVE NEXT GUIDE BEARING ABOVE MOTOR OPERATOR
- Ⓖ SWITCHES ARE FURNISHED WITH 40 FEET OF OPERATING CONTROL ROD. THE TOP SECTION OF THE CONTROL ROD IS MADE OF FIBER GLASS, THE LOWER SECTIONS ARE MADE OF GALVANIZED PIPE.
- Ⓗ REDUCE QUANTITIES AS REQUIRED WHEN NOT USING NEUTRAL.
- Ⓘ WHEN ATTACHING 1/0 AND 4/0 COPPER CONDUCTORS TO A POLE TOP SWITCH, USE A BRONZE CABLE TAP LUG, STOCK NUMBER 471296. IF EXCESSIVE VIBRATION OR WHIPPING COULD OCCUR, USE TWO LUGS IN SERIES.
- Ⓙ NOTE: BEFORE ENERGIZING SENSORS, GROUND ALL CURRENT SENSOR BASES BY ATTACHING GROUND WIRE TO MOUNTING BOLT ON BACKSIDE OF CROSSARM.
- Ⓚ THE MINIMUM CLEARANCE FROM GROUNDED METAL BOXES, HARDWARE AND EQUIPMENT AT THE COMMUNICATIONS LEVEL TO THE UPPERMOST GROUNDED PORTION OF THE CONTROL ROD IS 72". IF NO GROUNDED METAL BOXES, HARDWARE OR EQUIPMENT ARE PRESENT, CLEARANCE MAY BE REDUCED TO 48".

REFERENCES:

- Ⓛ POLE STEPPING – SEE STANDARD 363.
- Ⓜ REFLECTOR STRIPS ARE REQUIRED ON ALL SECTIONALIZING/TIELINE SWITCHES AND SERVICE RESTORER POLES. (SEE STD. 208.3 ITEM 12)
- Ⓝ NEUTRALS SHALL BE SOLIDLY TIED TOGETHER AT ALL SWITCHES REGARDLESS WHETHER THEY ARE NORMALLY OPEN OR CLOSED. THIS INCLUDES TIE SWITCHES TO CIRCUITS EMANATING FROM DIFFERENT SUBSTATIONS. (SEE DESIGN MANUAL STANDARD PAGE 6221.2, D.3).
- Ⓞ GROUNDING METHODS – SEE STANDARDS 1002.

FOR FIELD MAINTENANCE ONLY

599.310 SUPERSEDES 535.5 (11-1-98)	SDG&E ELECTRIC STANDARDS	DATE 12-1-98 APPD <i>PEA / CAK</i>
	OVERHEAD SCADA SWITCH 12KV HORIZONTAL LOADBREAK TYPE SINGLE CIRCUIT MOTOR OPERATED	

INSULATION TABLE FOR TRANSMISSION LINES

V O L T A G E	INSULATION DISTRICT (A)						
	STRUCTURE	HEAVY CONTAMINATION		MEDIUM CONTAMINATION		LIGHT CONTAMINATION	
		INSULATOR UNITS AND TYPE					
KV	TYPE	SUSPENSION	DEAD END	SUSPENSION	DEAD END	SUSPENSION	DEAD END
69	WOOD POLES & STRUCTURES	5 FOGS	7 DISCS	5 DISCS	6 DISCS	4 DISCS	5 DISCS
69	STEEL TOWERS & STRUCTURES	6 FOGS	8 DISCS	6 DISCS	7 DISCS	5 DISCS	6 DISCS
138	WOOD POLES & STRUCTURES	9 FOGS	11 DISCS	9 DISCS	11 DISCS	8 DISCS	10 DISCS
138	STEEL TOWERS & STRUCTURES	10 FOGS	12 DISCS	10 DISCS	12 DISCS	9 DISCS	11 DISCS

NOTES:

- (A) CONTAMINATION DISTRICTS IDENTIFIED ON STANDARD PAGE 287.
- B. USE BONDED SUSPENSION UNITS THROUGH RESIDENTIAL AND COMMERCIAL AREAS.
- C. SEE STANDARDS PAGE 750.4 FOR SUSPENSION INSULATORS.
- D. FOR BONDING DETAILS SEE STANDARDS PAGE 756.

FOR FIELD MAINTENANCE ONLY

DATE 1-1-86 APPD	SDG&E ELECTRIC STANDARDS	599.501 SUPERSEDES 755 (1986)
	TRANSMISSION LINE INSULATION TABLE	

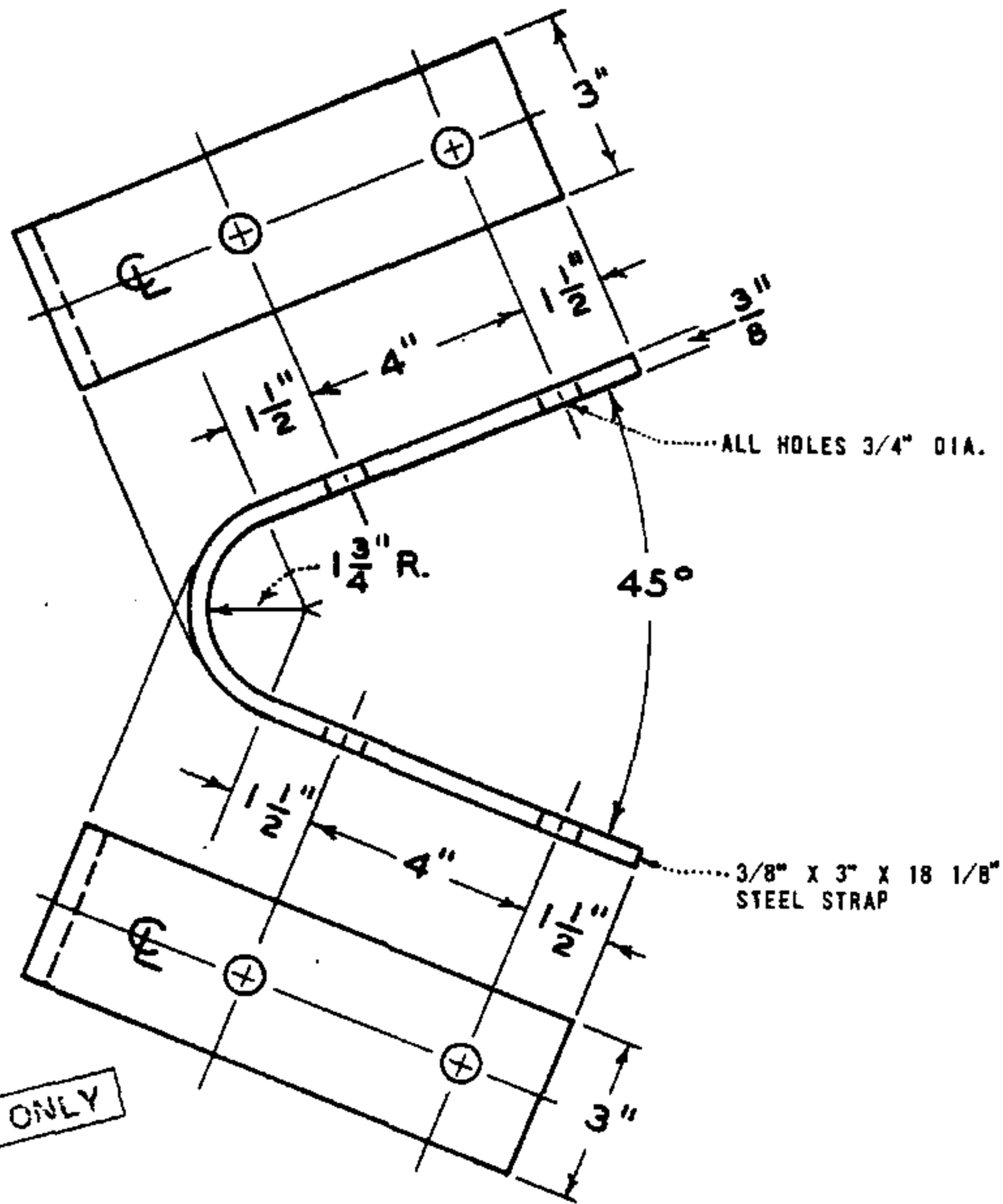

ITEM NO. 1

TO BE HOT-DIP GALV. AFTER FABRICATION

ITEM	DESCRIPTION	STOCK NO.	ITEM	DESCRIPTION	STOCK NO.
1	CROSSARM TIE-PLATE (FIGURE 4 CONSTRUCTION)	543200			

SDG & E ELECTRIC STANDARDS

DATE 1-1-86

APPD AK/AD

TRANSMISSION HARDWARE CROSSARM TIE-PLATE

599.901
SUPERSEDES
172 (12-10-82)

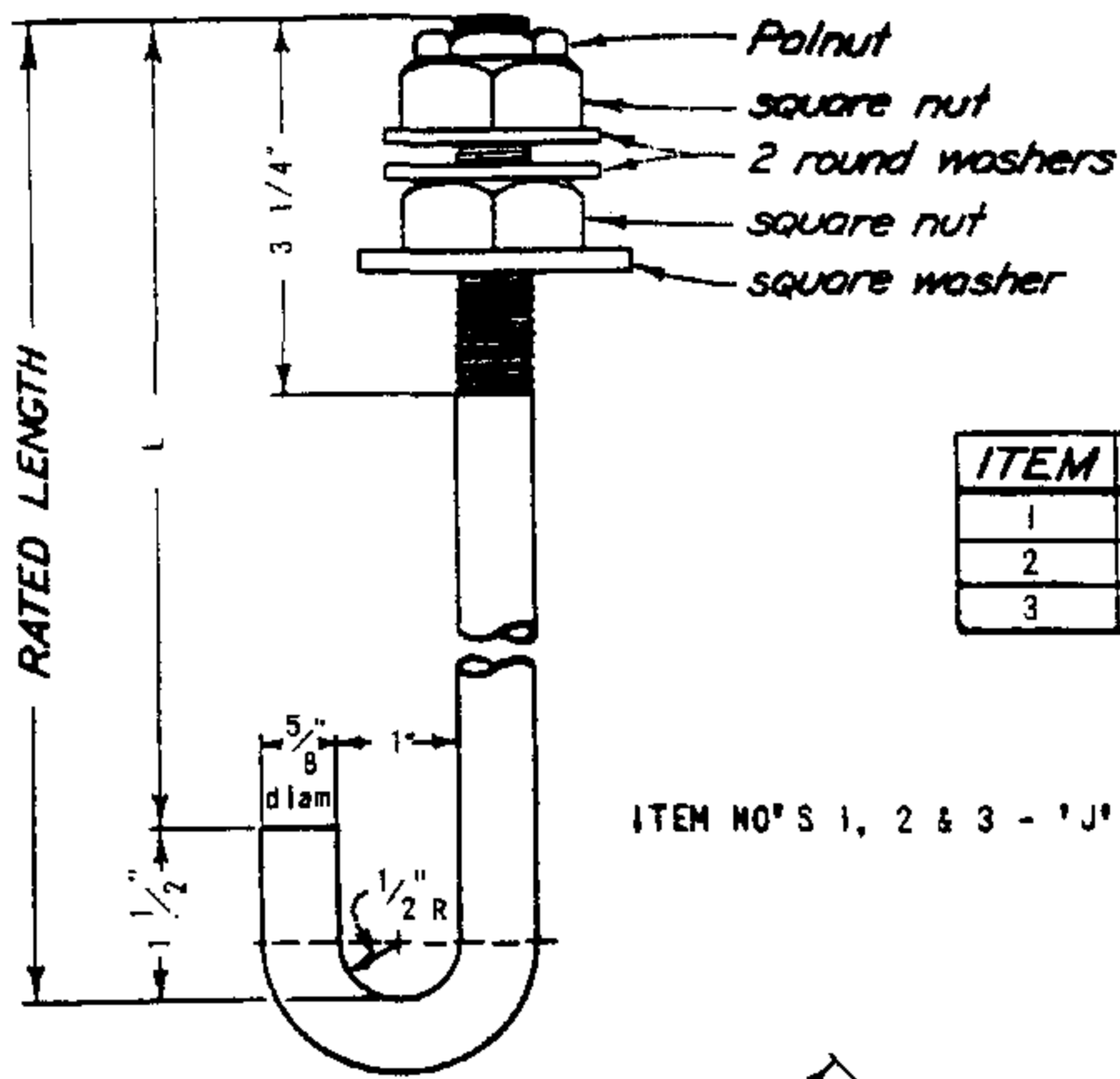

ITEM	FOR CROSSARM	"L"	RATED LENGTH
1	5 3/4" deep	8"	9 1/2"
2	6 3/4" deep	9"	10 1/2"
3	7 3/4" deep	10"	11 1/2"

ITEM NO'S 1, 2 & 3 - 'J' BOLT

FOR FIELD MAINTENANCE ONLY

Encircled figures represent thickness at that point

Two studs on each side

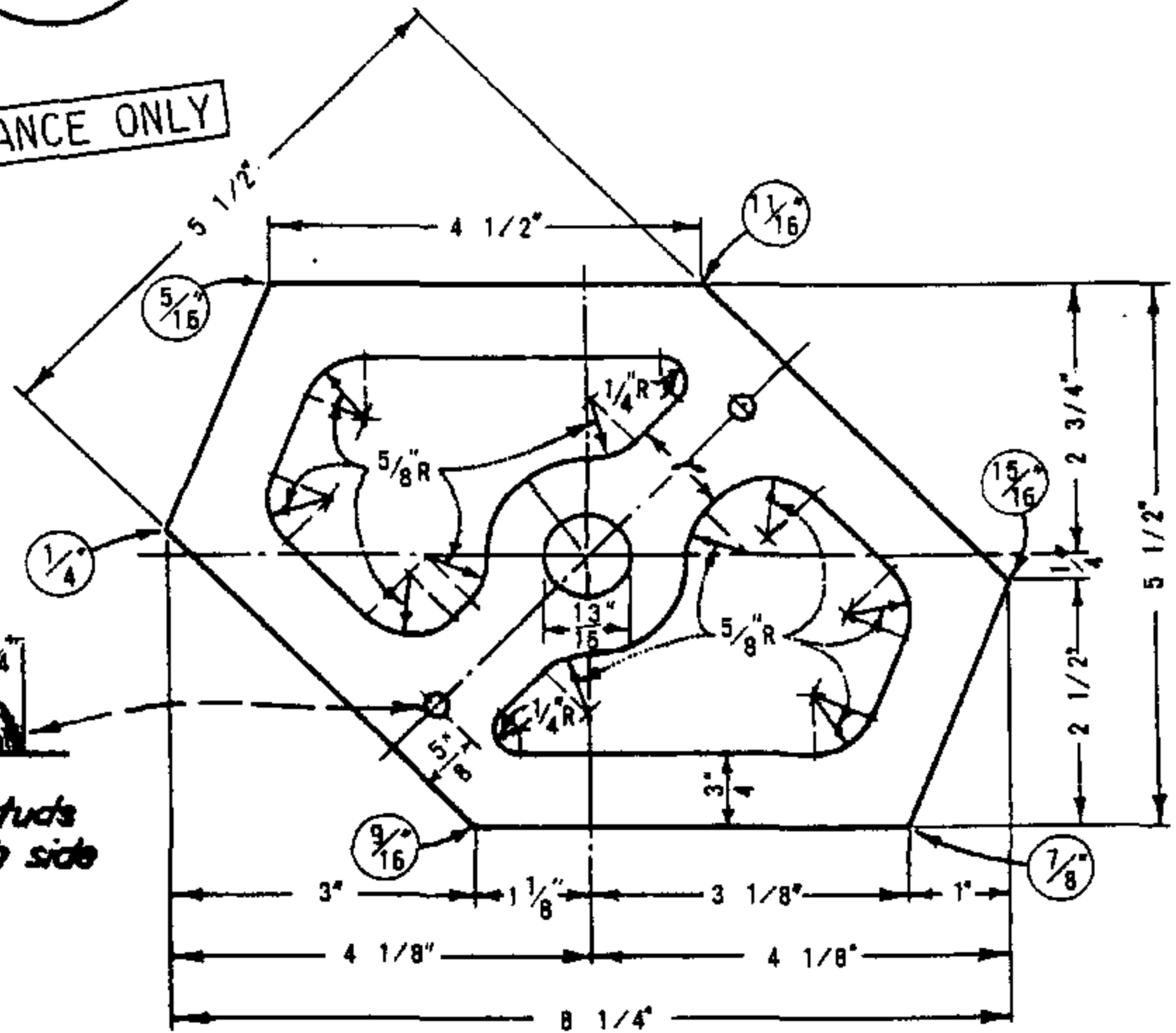

ITEM NO. 4 - HEXAGONAL C. I. FILLER, GALV.

ITEM	DESCRIPTION	STOCK NO.	ITEM	DESCRIPTION	STOCK NO.
1	FIELD MAINTENANCE ONLY	151328			
2	FIELD MAINTENANCE ONLY	151296			
3	FIELD MAINTENANCE ONLY	-			
4	FIELD MAINTENANCE ONLY	542400			

599.902

SUPERSEDES
173 (12-10-82)

SDG&E ELECTRIC STANDARDS

TRANSMISSION HARDWARE 'J' BOLT, HEXAGONAL C. I. FILLER

DATE 1-1-86

APPC *A.K. HADY*

SCOPE: THIS STANDARD SHOWS THE INSTALLATION OF A SCADA LOAD MONITOR WITH VARIOUS CONFIGURATIONS OF POWER SOURCE AND ANTENNA MOUNTING.

NOTES:

- CONTACT STANDARDS BEFORE DESIGN BEGINS TO DETERMINE COMMUNICATIONS REQUIREMENT.

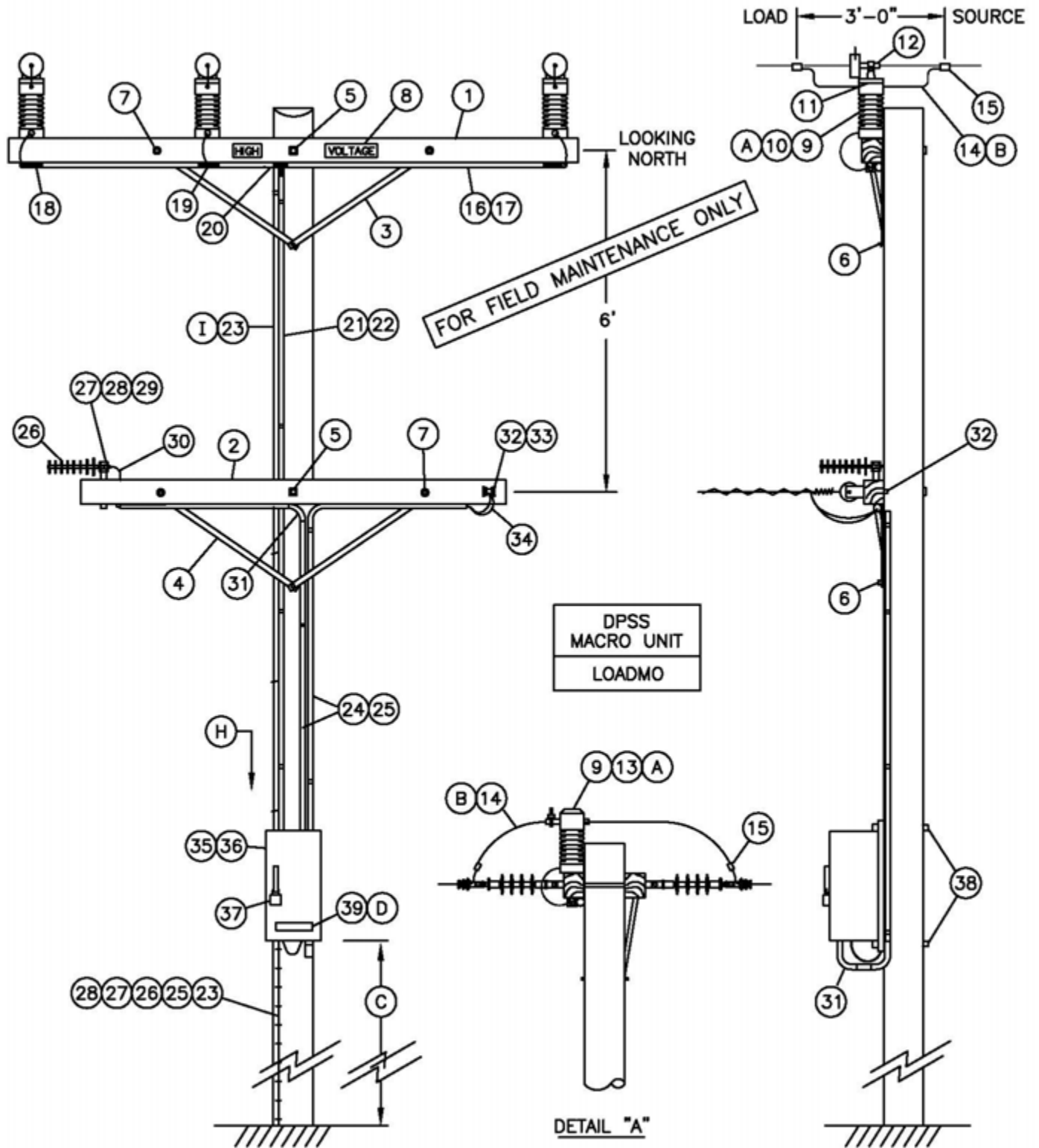

© 1998 - 2005 San Diego Gas & Electric Company. All rights reserved. Removal of this copyright notice without permission is not permitted under law.

DATE 9-30-05 APPD <i>PA/ROJ</i>	SDG&E ELECTRIC STANDARDS SCADA LOAD MONITOR	599.903 SUPERCEDES 540.1 (9-30-05)
------------------------------------	----------------------------------------------------	------------------------------------------

BILL OF MATERIAL:

ITEM	DESCRIPTION	QUANTITY	CONSTR. STD OR PAGE NO.	STOCK NUMBER	ASSEMBLY UNITS
1	CROSSARM, 3-3/4" X 5-3/4" X 10'-0"	1	380.2	294128	-
2	CROSSARM, 3-1/2" X 4-1/2" X 6'-0"	1	380.2	294112	2S
3	BRACE, 36", FLAT, CROSSARM	2	-	164224	36FLAT
4	BRACE, 28", FLAT, CROSSARM	2	-	164192	-
5	BOLT, MACH. GALV, 5/8" X (LENGTH AS REQ'D), 2 SQUARE AND 1 DOUBLE COIL SPRING WASHER	2	392.2	-	-
6	BOLT, LAG, GALV, 1/2" X 4"	2	392.2	-	-
7	BOLT, MACH, GALV, 3/8" X 4-1/2" & 1 RD. WASHER	4	392.2	-	-
8	SIGN, HIGH VOLTAGE & 9 ROOFING NAILS, GALV.	2	-	647648	HV
		-	-	492224	-
9	VIP STUD, 7-1/2"	3	-	701760	STUD-W
10	LINE POST VOLTAGE/CURRENT SENSOR (CLAMP TOP TYPE) AND 45' CONNECTOR CABLE (A)	3	-	635902	C/VCT
11	TRUNION CLAMP ADAPTER WITH HARDWARE	3	-	102926	
12	TRUNION CLAMP, #2-336 ACSR OR AWAC CONDUCTOR	3	-	229250	TRU336
	OR TRUNION CLAMP, 636 ACSR CONDUCTOR	3	-	229256	TRU636
	OR TRUNION CLAMP, #4-4/0 CU CONDUCTOR	3	-	229252	TRU4/0
	OR TRUNION CLAMP, 500 KCMIL CU CONDUCTOR	3	-	229258	TRU500
13	LINE POST VOLTAGE/CURRENT SENSOR (SUBSTATION TYPE) AND 45' CONNECTOR CABLE (A)	3	-	635904	C/VSUB
14	WIRE, JUMPER, SAME SIZE & TYPE AS LINE WIRE	12'	711-715	(B)	-
15	CONNECTOR, WIRE, COMPRESSION (SIZE AS REQ'D)	AS REQ'D	783-787	-	-
16	CONDUIT, PVC, SCHEDULE 40, 3/4"	10'	-	251328	PVC3/4
17	STRAPS, PIPE, GALV. 3/4", AND 6D NAILS, GALV.	AS REQ'D	-	697888	-
		AS REQ'D	-	490656	-
18	ACCESS FITTING BODY, TYPE "T", PVC, 3/4"	2	-	147792	-
19	ACCESS FITTING BODY, TYPE "LL" PVC, 3/4" AND TYPE "LR", PVC, 3/4"	1	-	(F)	-
		1	-	(F)	-
20	ACCESS FITTING BODY, TYPE "T", PVC, 1" AND (2) 3/4" REDUCERS	1	-	(F)	-
21	CONDUIT, PVC, SCHED 40, 1"	30'	-	251200	PVC-1
22	STRAPS, PIPE, GALV, 1", AND 2-6D NAILS, GALV.	AS REQ'D	-	697792	-
		AS REQ'D	-	490656	-
23	#4 CU SOLID GROUND WIRE, PVC COVERED	50'	-	812490	GNDPVC
24	CONDUIT, PVC, SCHEDULE 40, 1/2"	60'	-	251168	PVC1/2
25	GROUND ROD, 5/8" X 8', COPPERWELD	1	-	603072	GNDPVC
26	COPPER BONDED GROUND CONNECTOR	1	-	259010	-
27	GROUND ENHANCING POWER SOLUTION (GEM)	AS REQ'D	-	424390	-
28	GALVANIZED STAPLES FOR PVC COVERED GROUND WIRE	AS REQ'D	-	678562	-

FOR FIELD MAINTENANCE ONLY

© 1998 - 2005 San Diego Gas & Electric Company. All rights reserved. Removal of this copyright notice without permission is not permitted under law.

DATE 9-30-05
APPD *PA/ROJ*

SDG&E ELECTRIC STANDARDS

SCADA LOAD MONITOR

599.904
SUPERCEDES 540.2
(9-30-05)

BILL OF MATERIAL: CONT:

ITEM	DESCRIPTION	QUANTITY	CONSTR. STD OR PAGE NO.	STOCK NUMBER	ASSEMBLY UNITS
25	STRAPS, PIPE, GALV, 1/2", AND 6D NAILS, GALV.	AS REQ'D	-	697728	-
		AS REQ'D	-	490656	-
26	ANTENNA, BROADBAND, YAGI (E)	1	-	109570	ANT
27	NIPPLE, PIPE 2" X 6", GALV	1	-	500960	ANTXMB
28	BOLT, MACH, GALV. 1/2" X 9"	1	392.2	153184	
29	CENTERING WASHER, GALV.	2	-	795520	
30	CABLE, SUPERFLEX, ANTENNA	AS REQ'D	-	197810	ANTCAB
31	ELBOW, PVC. 1/2"	AS REQ'D	-	-	-
32	BOLT, MACHINE, GALV, 5/8" X (LENGTH AS REQ'D) 1 SQ. & 1 DOUBLE COIL SPRING WASHER	1	392.2	-	-
33	SECONDARY DEADEND	1	-	235488	1SDE
34	WIRE, THW, #12, BLACK	100'	-	808096	THW12
35	TRANSCEIVER, 12V DC	1	-	905390	-
	SPREAD SPECTRUM RADIO	1	-	749504	-
36	RTU	1	-	(F) 484600	LMRTU
37	PADLOCK, SCHLAGE ELECTRIC SERIES	1	-	514848	-
38	BOLT, MACHINE, GALV, 5/8" X (LENGTH AS REQ'D) 1 SQUARE AND 1 DOUBLE COIL SPRING WASHER	2	392.2	-	-
39	TAG, RTU NUMBER	1	208.5	(D)	TAGRE

FOR FIELD MAINTENANCE ONLY

INSTALLATION:

- (A) THE RANGE OF WIRE FOR THE CLAMP TOP TYPE VOLTAGE/CURRENT SENSOR IS .25" TO .8". THE APPLICATION OF THIS STANDARD TO EXISTING #6 LINE WIRE REQUIRES USE OF THE SUBSTATION STYLE VOLTAGE/CURRENT SENSOR AND FOR THE LINE WIRE TO BE DEAD-ENDED (SEE DETAIL "A"). ANY SIZE EXISTING DEAD-ENDED LINE WIRE CONSTRUCTION REQUIRES THE USE OF SUBSTATION STYLE VOLTAGE/CURRENT SENSORS.

NOTE: BEFORE ENERGIZING SENSORS, GROUND ALL VOLTAGE/CURRENT SENSOR BASES BY ATTACHING GROUND WIRE TO MOUNTING STUD, ON BOTTOM OF CROSSARM. WHEN INSTALLING SENSORS, IT IS PREFERRED THAT THE SENSOR CABLE CONNECTOR GO ON THE LOADSIDE. THIS WOULD PLACE THE "H1" LABEL ON THE SOURCE (LINE) SIDE.

- (B) ALWAYS USE JUMPER WIRE OF AMPACITY EQUAL TO THAT OF THE MAIN CONDUCTOR.
- (C) RTU TO BE MOUNTED AT 10' FROM GROUND LEVEL TO BOTTOM OF RTU CABINET WHEN NOT SUBJECT TO TRAFFIC CONTACT. IF VULNERABLE TO VEHICLE DAMAGE, MOUNT RTU AT 13' - 6" FROM GROUND LEVEL TO BOTTOM OF RTU CABINET. CONSIDER LARGE VEHICLES PARKING PARALLEL TO CURB. IN REMOTE AREAS WHERE VEHICLE ACCESS IS NOT POSSIBLE, MOUNT RTU AT 5' FROM GROUND LEVEL TO BOTTOM OF RTU CABINET.
- (D) RTU NUMBER TO BE ASSIGNED BY DISTRIBUTION OPERATIONS AND ADDED TO JOB WITH DPSS NOTE.
- (E) PLANNER TO SPECIFY QUADRANT OF POLE FOR ANTENNA MOUNT WITH DATA FROM STANDARDS. POINTS LIST TO BE COMPLETED BY PLANNER AND SENT TO SENIOR ENGINEER, DISTRIBUTION OPERATIONS. SEE ELECTRIC STANDARDS TEAM FOR POINTS LIST FORMS AND COMMUNICATIONS REQUIREMENTS.
- (F) THESE ITEMS SUPPLIED BY SCADA PROJECT CREW (KEARNY). 120V SUPPLY, ANTENNA CONNECTIONS AND SENSOR CONNECTIONS TO BE MADE BY SCADA PROJECT CREW (KEARNY). LINE CREW MOUNTS RTU TO POLE.

REFERENCE:

- (H) POLE STEPPING - SEE STANDARDS 363.
- (I) GROUNDING METHODS - SEE STANDARDS 1002.

© 1998 - 2005 San Diego Gas & Electric Company. All rights reserved. Removal of this copyright notice without permission is not permitted under law.

DATE 9-30-05

APPD *PA/ROJ*

SDG&E ELECTRIC STANDARDS

SCADA LOAD MONITOR

599.905

SUPERCEDES 540.3
(9-30-05)

600-900 SECONDARIES,
CONDUCTOR, GUYING

600-900 SECONDARIES,
CONDUCTOR, GUYING

<u>PAGE</u>	<u>SUBJECT</u>
699.101	SECONDARY RACK CONSTRUCTION
699.102	MID-SPAN SERVICES
699.201	SECONDARY RACKS
699.202	SERVICE DROP ATTACHMENTS
699.301	SERVICE INSULATING BRACKETS, SINGLE
699.302	HEAVY DUTY SERVICE INSULATOR BRACKET
699.500	TV AMPLIFIER AND 120V METER INSTALLATION
776	ANGLE SUSPENSION CLAMPS
799.101	COPPER AND COPPERWELD WIRE TABLE
799.102	COPPER TREE WIRE
799.103	AUTOMATIC SLEEVES FOR COPPER & COPPERWELD CONDUCTORS
799.401	GALVANIZED DEAD END STRAIN CLAMP FOR COPPER CONDUCTORS
799.402	12KV AL STRAIGHT STRAIN CLAMP FOR ACSR & 5005 AL ALLOY CONDUCTORS
799.501	PORCELAIN SUSPENSION INSULATOR BONDING
799.801	ALUMINUM PARALLEL GROVE CLAMPS
962	GUY HARDWARE
999.601	ALUMOWELD GUY WIRE
999.602	COPPER & COPPERWELD GUY GRIPS
999.603	ALUMOWELD GUY GRIPS
999.604	ALUMINUM GUY SPLICES

© 1998 - 2019 San Diego Gas & Electric Company. All rights reserved. Removal of this copyright notice without permission is not permitted under law.

REV	CHANGE	BY	DSGN	APPV	DATE	REV	CHANGE	BY	DSGN	APPV	DATE
C						F					
B	COMPLETELY REVISED	JK	JS	CZH	10/15/2019	E					
A	ORIGINAL ISSUE	JK	JS	CZH	6/13/2019	D					

SHEET 1 OF 1	<input type="checkbox"/> Indicates Latest Revision <input checked="" type="checkbox"/> Completely Revised <input type="checkbox"/> New Page <input type="checkbox"/> Information Removed	OH LEGACY OHL601.1
	SDG&E ELECTRIC OVERHEAD FIELD MAINTENANCE ONLY STANDARDS	
	LEGACY OVERHEAD FIELD MAINTENANCE TABLE OF CONTENTS SECONDARIES, CONDUCTORS, GUYING	

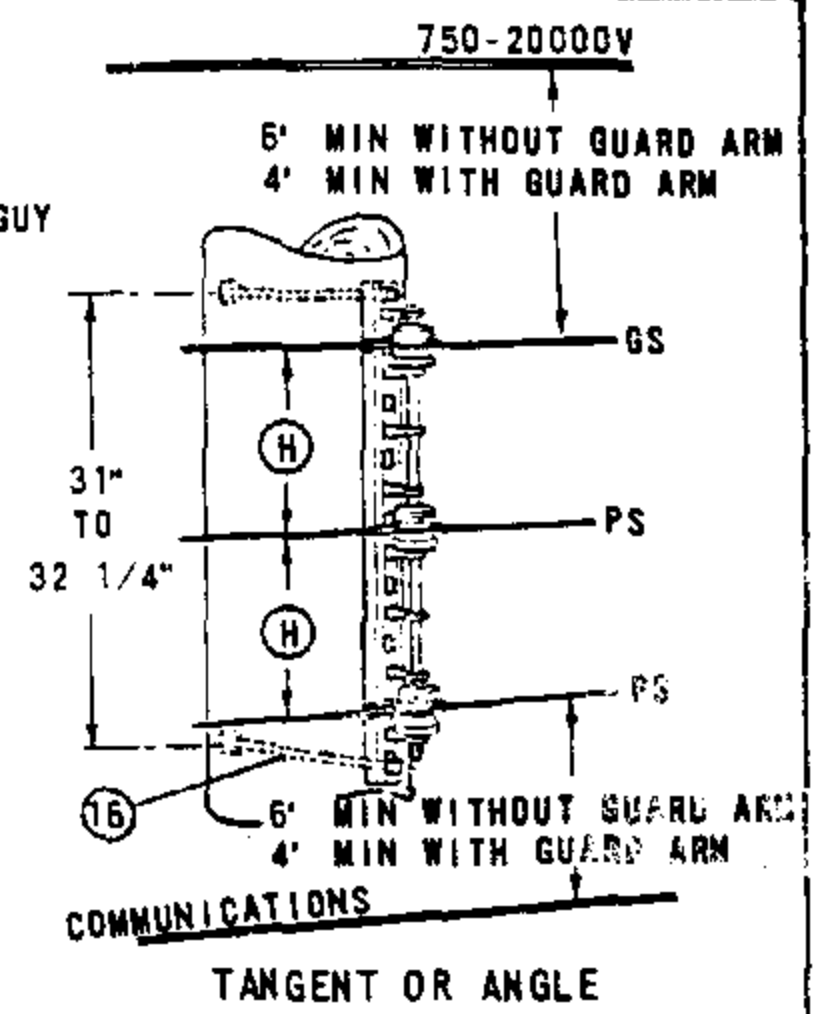
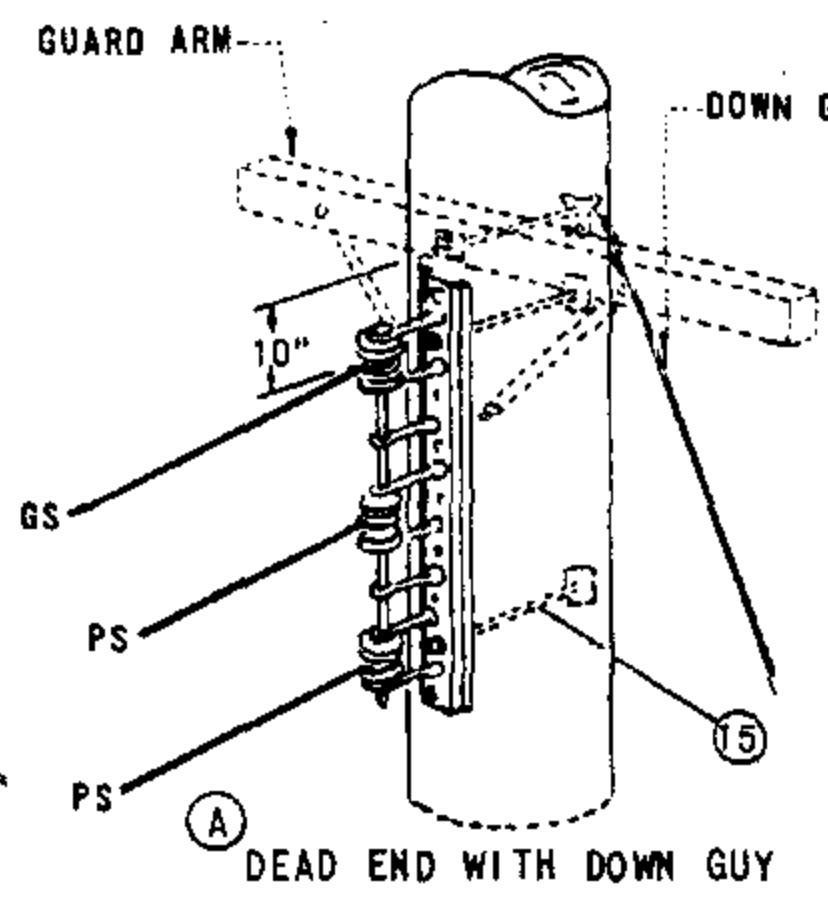
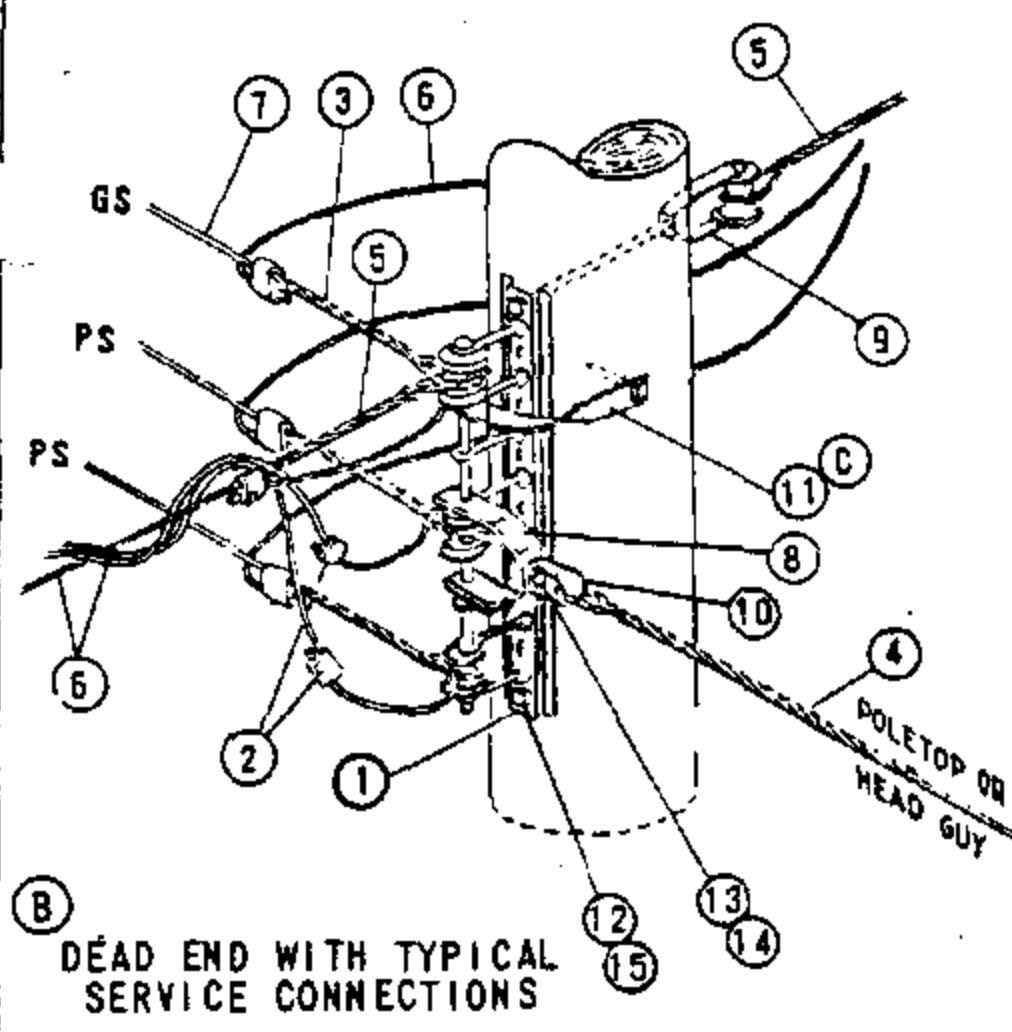

SERVICE DROPS ON POLE SIDE OF VERTICAL PLANE OF LINE CONDUCTORS SHALL NOT BE LESS THAN 15" RADIALLY FROM THE SURFACE OF THE POLE.

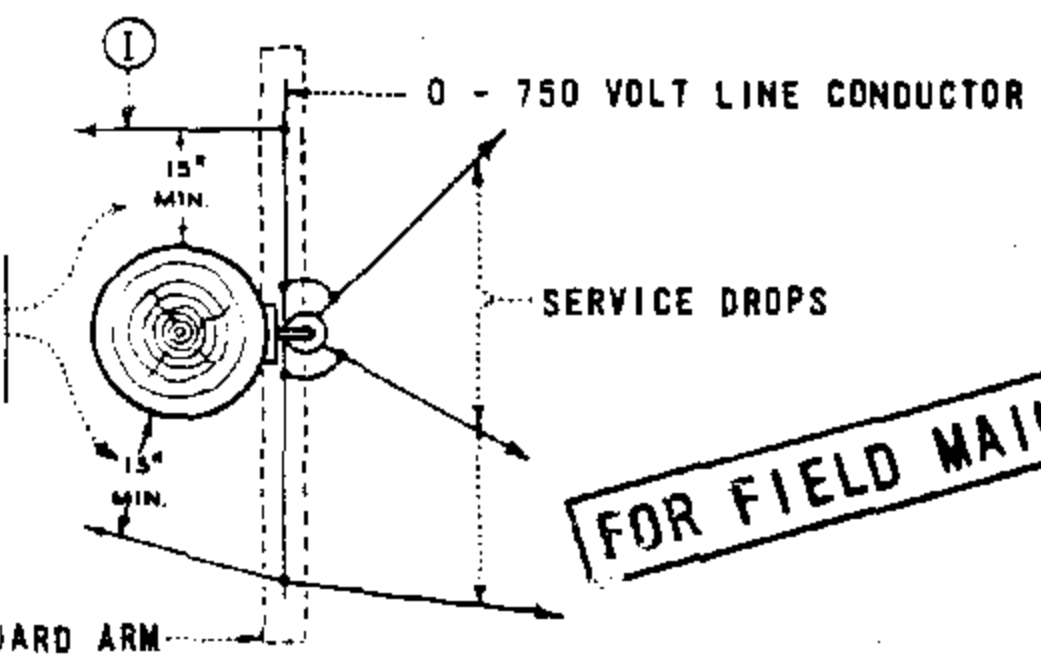

FOR FIELD MAINTENANCE ONLY

- NOTES:
- (A) DEAD END WITH DOWN GUY IS PREFERRED CONSTRUCTION WHERE THERE IS NO FUTURE EXTENSION OF SECONDARY.
 - (B) DEAD END WITH POLETOP OR HEAD GUY IS PREFERRED CONSTRUCTION WHERE FUTURE EXTENSION OF SECONDARY IS EXPECTED.
 - (C) USE DEAD ENDING STRAPS BEHIND EACH CONDUCTOR WHERE RACK GUY CANNOT BE USED, SEE PAGE 629.
 - (D) TO OBTAIN RADIAL CLEARANCE BETWEEN SUPPLY CONDUCTORS, OVERHEAD GUYS, AND CLIMBING SPACE USE EXTENSION BRACKET. SEE PAGE 629.
 - (E) SEE PAGE 255 FOR CLIMBING SPACE REQUIREMENTS.
 - (F) GUARD ARMS ARE REQUIRED WHEN REDUCING CLEARANCE FROM THE NORMAL 6 FT MINIMUM TO A 4 FT MINIMUM BETWEEN THE SECONDARY CABLE AND THE CONDUCTORS ABOVE.
 - (G) WHEN USING GUARD ARMS, ADDITIONAL CLEVISES CANNOT BE ADDED TO THE POLE. REPLACE WITH MID-SPAN SERVICES SEE PAGE 618.
 - (H) MINIMUM VERTICAL SEPARATION FOR SPAN LENGTHS 200 FT OR LESS SHALL BE 8 IN. 200 FT THROUGH 330 FT MINIMUM SEPARATION SHALL BE 12 IN.
 - (I) WHEN USING GUARD ARMS, SERVICE DROPS ARE NOT PERMITTED TO PASS ABOVE OR BELOW THE GUARD ARM ON THE POLE SIDE OF THE RACK SECONDARY.

ITEM	DESCRIPTION	QUANTITY	STOCK NO. OR CONSTR STD	ITEM	DESCRIPTION	QUANTITY	STOCK NO. OR CONSTR STD
P O C F T D				P O C F T D			
1	RACK, 3 OR 4 WIRE SECONDARY	1	PG 629	11	STRAP, DEAD ENDING, CURVED	AS REQ'D	PG 629
2	CONNECTORS	AS REQ'D	PGS 783, 787	12	BOLT, MCH, 5/8" X LENGTH AS REQ'D	2	PG 139
3	GRIPS, DEAD END FOR COATED SEC CONDUCTORS	AS REQ'D	PGS 745, 747	13	BOLT, MACH, 5/8" X 2"	1	155040
4	GRIPS, GUY	AS REQ'D	PGS 745, 747	14	WASHER 5/8" LOCK SPRING	1	796864
5	GRIPS, TRIPLEX NEUTRALS SERVICE	AS REQ'D	PGS 745, 747	15	WASHER, 3" SQ CURVED	AS REQ'D	1797792
6	WIRE, TRIPLEX SERVICE	AS REQ'D	PGS 711, 715, 716	16	WASHER, 2 1/4" SQ FLAT	AS REQ'D	799040
7	WIRE, W.P. SECONDARY	AS REQ'D	PGS 711, 715, 716				
8	CLEVIS, 4KV DEAD END	1	235520				
9	CLEVIS, SECONDARY DEAD END	1	235488				
10	EYELET, THIMBLE	1	338176				

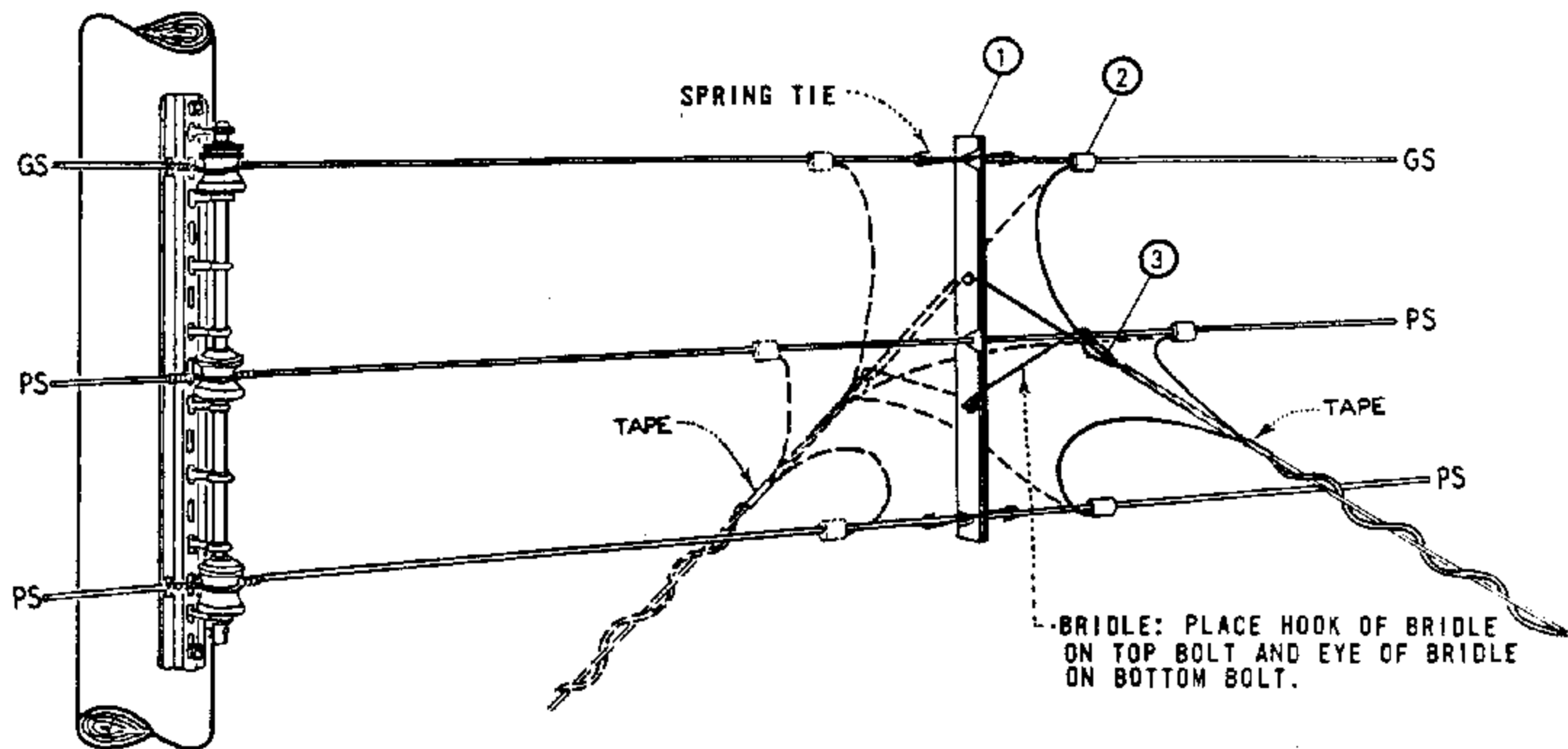

FOR FIELD MAINTENANCE ONLY

SECONDARY CONDUCTOR SPREADER

NO. WIRES	SPACING (IN)	WIRE SLOT (IN)						MATERIAL THICKNESS (IN)	MANUFACTURER			
		TOP		MIDDLE		BOTTOM			NAME	CATALOG NUMBER	NAME	CATALOG NUMBER
		DIA.	MAX. WIRE SIZE	DIA.	MAX. WIRE SIZE	DIA.	MAX. WIRE SIZE					
3	12	1/2	.500	19/32	.594	19/32	.594	1/4	A. T. FLOWER	AF332-93	JOSLYN	32312

NOTES.

- A. FOR USE ON SERVICE DROPS 100 FEET OR LESS IN LENGTH.
- B. WHERE TWO TO FOUR TRIPLEX SERVICE DROPS ARE INSTALLED ON ONE SECONDARY CONDUCTOR SPREADER, CONNECT RESPECTIVE SERVICE CONDUCTORS TO LINE CONDUCTOR WITH ONE COMPRESSION CONNECTOR AS PERMITTED BY STOCKED CONNECTOR SIZES.
- C. SEE OTHER PAGES IN 'SECONDARIES, SERVICES' SECTION FOR RACK CONSTRUCTION DETAILS.

ITEM	DESCRIPTION	QUANTITY	STOCK NO. OR CONSTR. STD.
1	SECONDARY CONDUCTOR SPREADER, COMPLETE WITH 1-SPREADER, BRIDLES AND SPRING TIES	1	670592
2	CONNECTOR, COMPRESSION	AS REQ'D	PGS 783, 7
3	GRIPS, SERVICE	AS REQ'D	PGS 746, 747

699.102
SUPERSEDES
618 (3-25-83)

SDG&E ELECTRIC STANDARDS
MID-SPAN SERVICES FROM VERTICAL RACK SECONDARY

DATE 4-5-83
APPD JMT/QR4

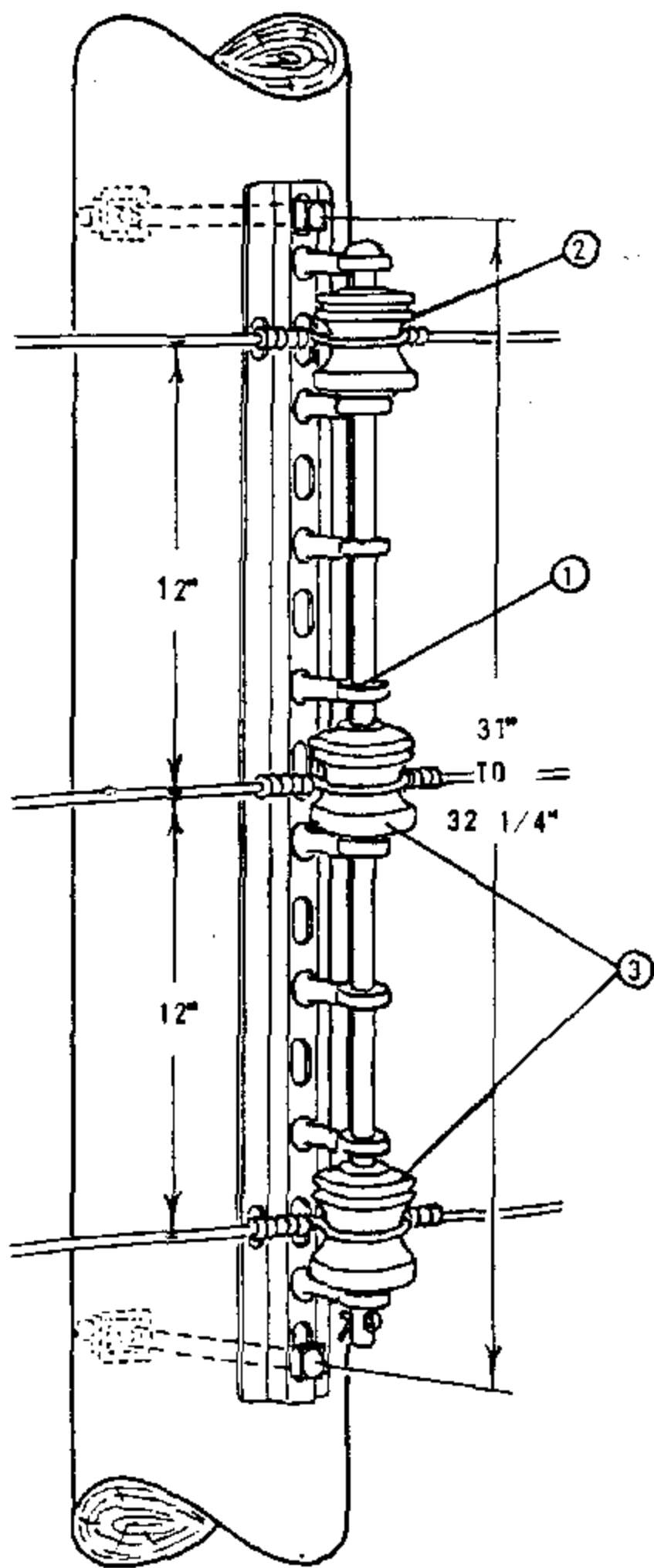

TANGENT OR ANGLE

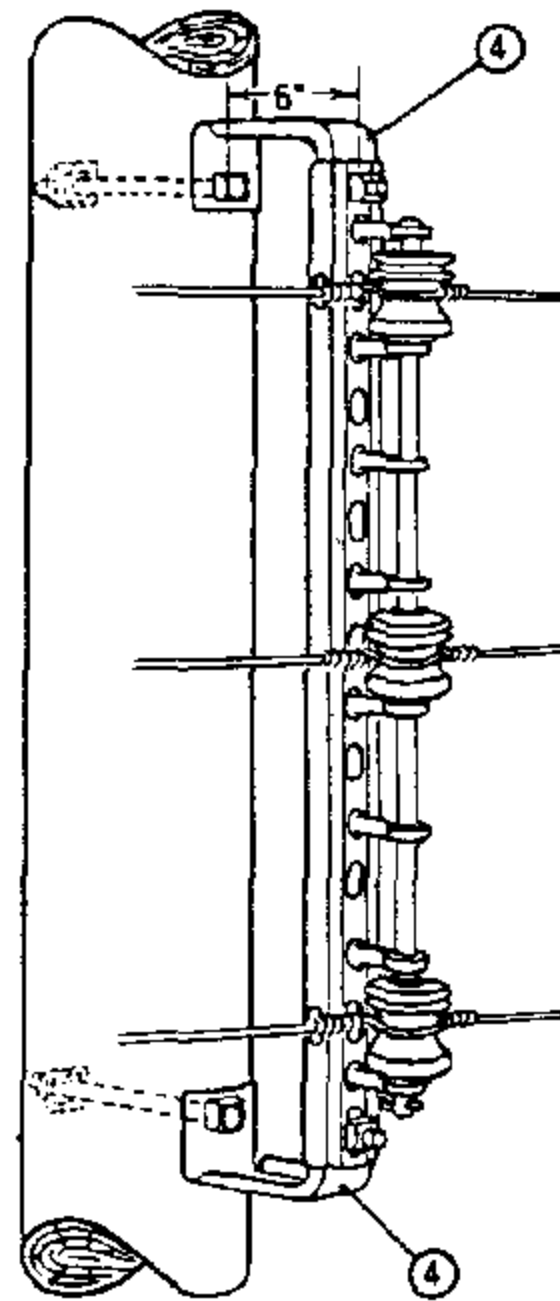

TANGENT OR ANGLE
EXTENSION BRACKET

(A)

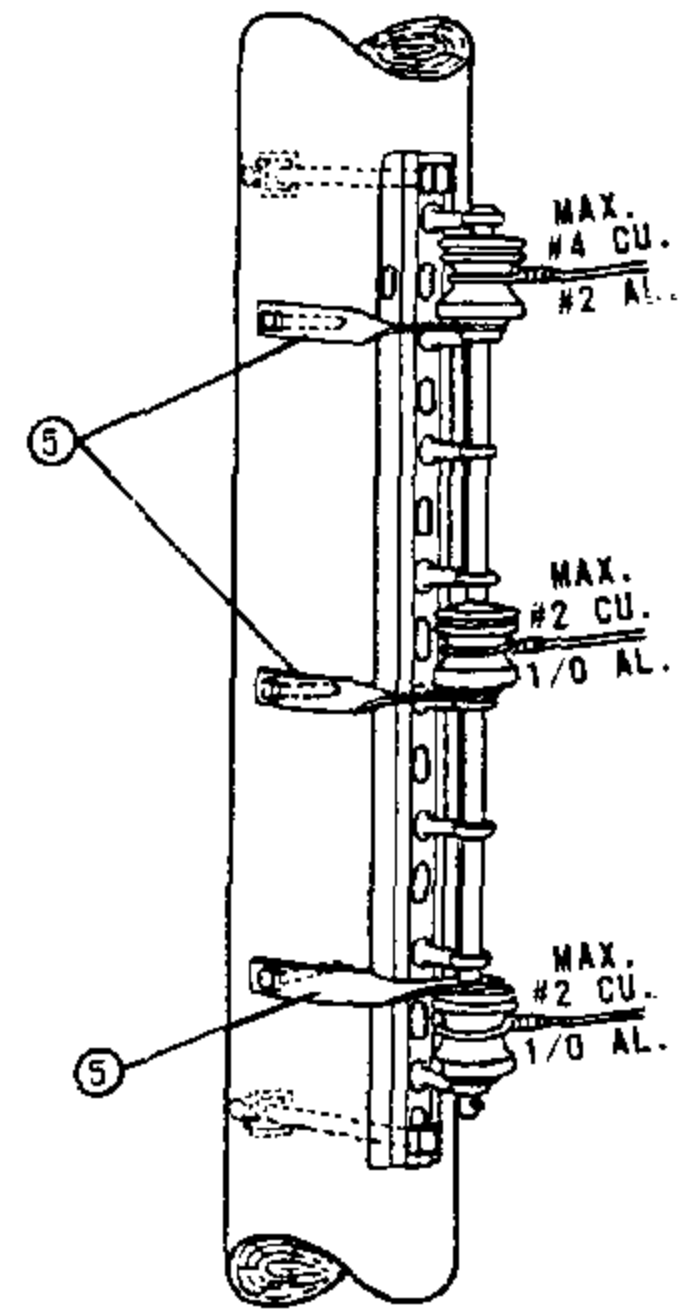

DEAD END ON
SIDE OF POLE

(B)

FOR FIELD MAINTENANCE ONLY

NOTES:

- (A) USED TO OBTAIN RADIAL CLEARANCE BETWEEN SUPPLY CONDUCTORS AND OVERHEAD GUYS, ALSO TO OBTAIN CLIMBING SPACE.
- (B) TO BE USED FOR TANGENT, ANGLE, OR CORNER CONSTRUCTION WHERE SECONDARY MAY BE EXTENDED AND WHERE RACK GUY CANNOT BE USED.

ITEM	DESCRIPTION	CATALOG NUMBER						STOCK NUMBER
		CHANCE	HUBBARD	JOSLYN	KORTICK	McGRW ED	OLIVER	
1	SECONDARY RACK	-	1478	-	K-6748	-	8348	554864
2	SPOOL INSULATOR, (WHITE)	255W	455W	-	-	-	-	430816
3	SPOOL INSULATOR, (BROWN)	-	-	-	-	-	-	430656
4	EXTENSION BRACKET	-	3355	J-2355	K-4830	-	-	166016
5	DEAD ENDING STRAP, CURVED, 1/4" X 1 1/4"	-	1000	J-3120	K-4833	DR4MI	-	696832

SDG & E ELECTRIC STANDARDS

DATE 6-4-82
APPD *CRH*

SECONDARY RACKS

699.201
SUPERSEDES
629 (6-4-82)

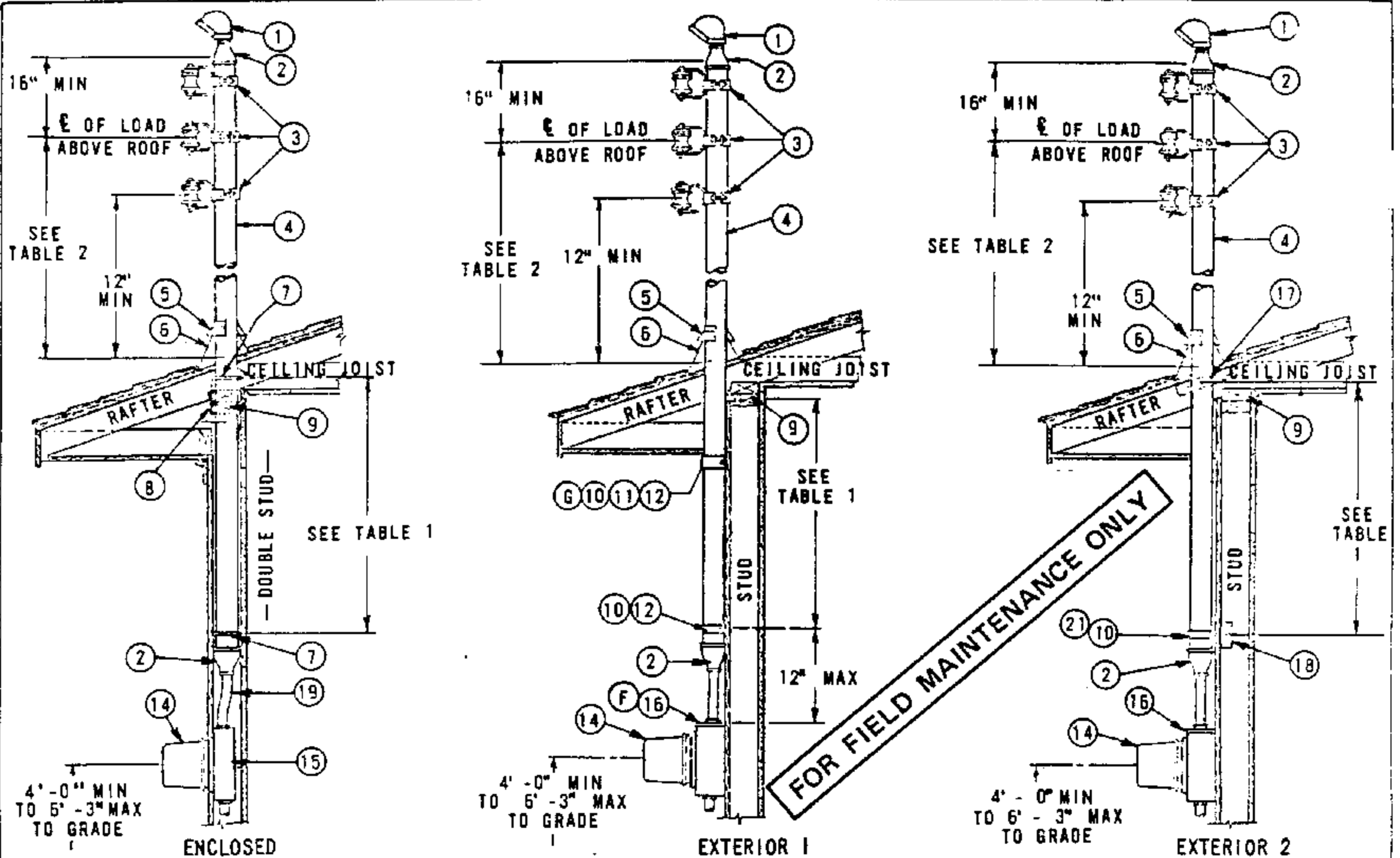

- NOTES:
- A. SDG&E WILL NOT BE RESPONSIBLE FOR ANY DAMAGE TO THE BUILDING CAUSED BY RAIN OR STRUCTURAL FAILURE.
 - B. THESE METHODS ARE SUGGESTED TO OBTAIN THE REQUIRED GROUND AND ROOF CLEARANCES AS REQUIRED BY THE AUTHORITIES HAVING JURISDICTION. WHEN THIS METHOD IS USED IT WILL BE ACCEPTABLE TO SDG&E PROVIDED THE DIMENSIONS AND CONSTRUCTION DETAILS ARE COMPLIED WITH.
 - C. THE DIMENSIONS SHOWN ARE BASED ON A "SLACK SPAN" SERVICE DROP LENGTH OF NOT MORE THAN 100 FEET. FOR SERVICE LENGTH GREATER THAN 100 FEET, SEE STANDARD 644.
 - D. NO COUPLINGS WILL BE PERMITTED BETWEEN THE TOP OF THE RISER AND THE LOWEST POINT OF SUPPORT FOR CONDUIT SIZES 1 1/4" TO 2" INCLUSIVE. IF A COUPLING IS NECESSARY IN THE 2 1/2" SIZE CONDUIT TO SECURE THE MAXIMUM HEIGHT, THE COUPLING SHALL BE INSTALLED AT THE UPPER END NEAR THE SERVICE CAP.
 - E. THESE CONDUIT RISERS SHALL BE USED FOR ATTACHMENT OF #2 OR LARGER SERVICE DROPS.
 - F. METER SOCKET BOX MUST HAVE MINIMUM WIDTH OF 14".
 - G. WHEN ROOF CONSTRUCTION HAS NO SOFFIT, MOVE STRAP UP AND LAG INTO PLATE 9. HEAVY DUTY ONE HOLE PIPE STRAP IS ACCEPTABLE IF USED WITH 1/4" X 3 1/2" LAG SCREW INTO WALL STUD.

ITEM	DESCRIPTION	QUANTITY			TABLE 1	
		ENCLOSED	EXTERIOR 1	EXTERIOR 2	CONDUIT SIZE	DISTANCE
1	CAP, SERVICE	1	1	1	MIN. DISTANCE BETWEEN SUPPORTS SHOWN	
2	REDUCER, PIPE, GALV IRON, IF REQ'D	1	1	1	1 1/4"	12"
3	INSULATOR AND CLAMPS, FURNISHED & INSTALLED BY SDG&E	3	3	3	1 1/2"	19"
4	CONDUIT, GALV RIGID IRON, OR INTERMEDIATE METAL CONDUIT	1	1	1	2"	22"
5	COLLAR, METAL OR NEOPRENE RAINSHED	1	1	1	2 1/2"	30"
6	FLASHING	1	1	1		
7	BOLT, "U", 3/8"	2	-	-		
8	STRAPS ON PLATES	AS REQ'D	-	-		
9	PLATES	-	-	-		
10	STRAP, PIPE, HEAVY DUTY, TWO HOLE (G)	-	2	-	TABLE 2	
11	SCREW, LAG, 1/4" X 3 1/2"	-	2	-	MAX DISTANCE OF Q OF LOAD ABOVE ROOF	
12	BOLT, TOGGLE, 1/4"	-	2	-		
13						
14	METER	1	1	1		
15	BOX, METER SOCKET, FLUSH TYPE	1	-	-		
16	BOX, METER SOCKET, SURFACE MOUNTED TYPE	-	1	1		
17	BLOCKING, 2" X 4", BETWEEN RAFTERS (SOLIDLY INSTALLED)	-	-	AS REQ'D	1 1/4"	30"
18	BLOCKING, 2" X 4", BETWEEN STUDS	-	-	AS REQ'D	1 1/2"	40"
19	NIPPLE, CONDUIT, OFFSET	1	-	-	2"	5' - 0"
20					2 1/2"	8' - 0"
21	SCREW, LAG, 1/4" X 3"	-	-	AS REQ'D		

699.202
SUPERCEDES
642 (1-1-90)

SDG&E ELECTRIC STANDARDS

SERVICE DROP ATTACHMENTS TO CONDUIT RISERS

DATE 1-1-90
APPD *Pia / AD*

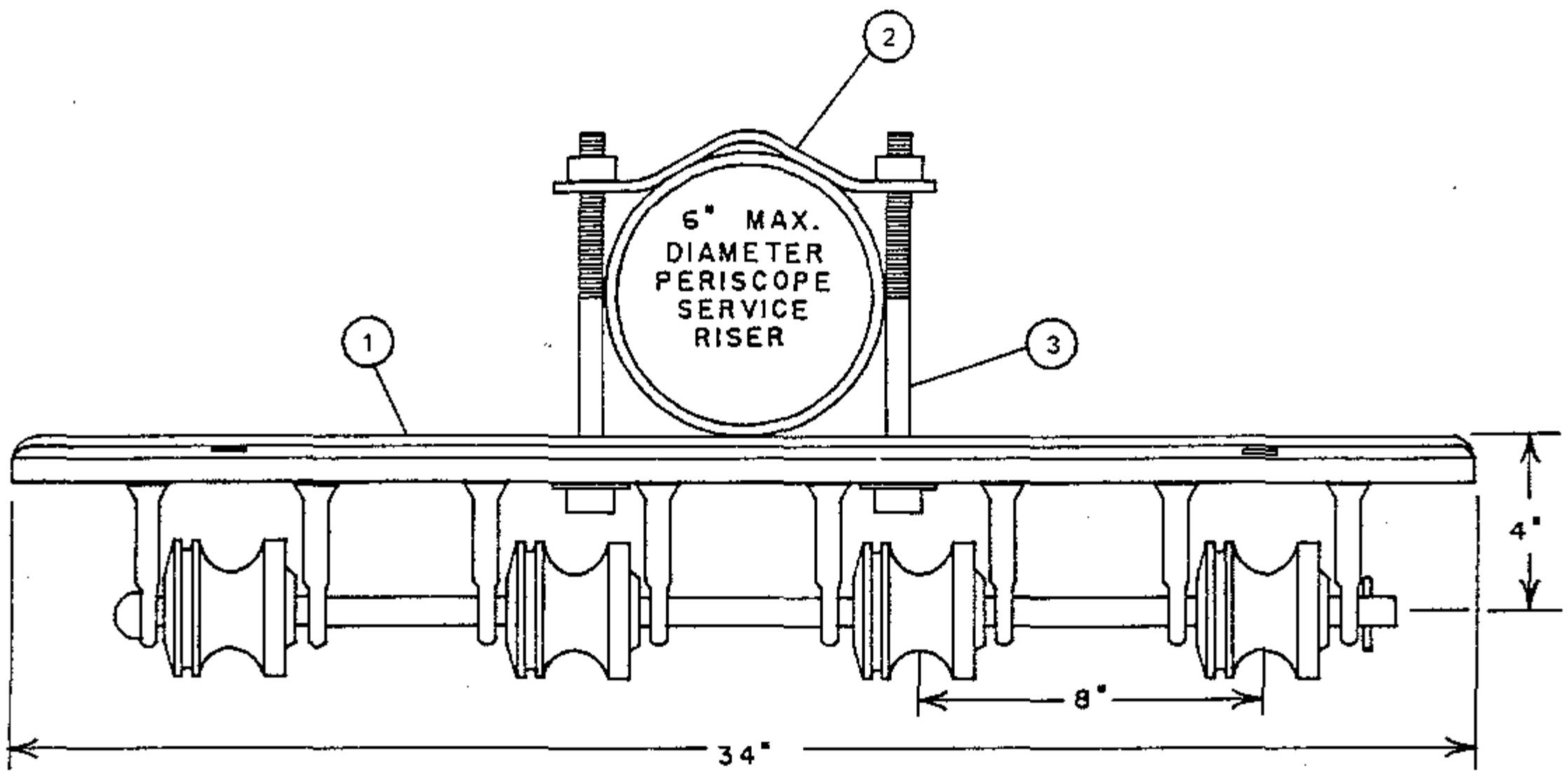

FOUR SPOOL SERVICE INSULATOR BRACKET-ITEMS 1,2,3

FOR FIELD MAINTENANCE ONLY

ITEM	DESCRIPTION	CATALOG NUMBER	QUANTITY	STOCK NO. OR CONST. STD.
1	RACK, FOUR SPOOL SERVICE INSULATOR	HUBBARD 1478	1	564864
		KORTICK K-6748		
		OLIVER 8348		
2	STRAP, CURVED BACK	-	1	698016
3	BOLT, MACH., GALV., 1/2" X [LENGTH AS REQ'D.]	-	2	PG. 139

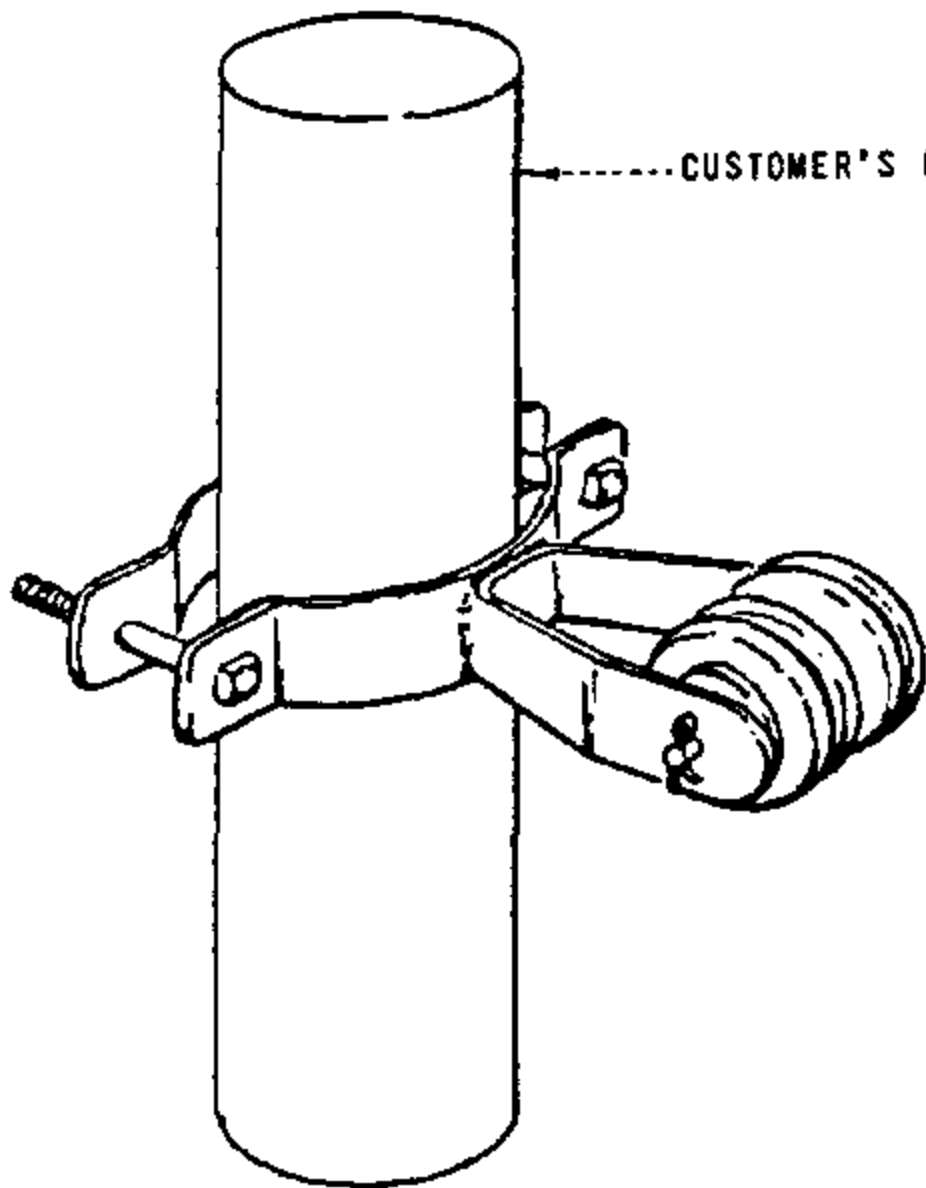

BRACKET ASSEMBLED

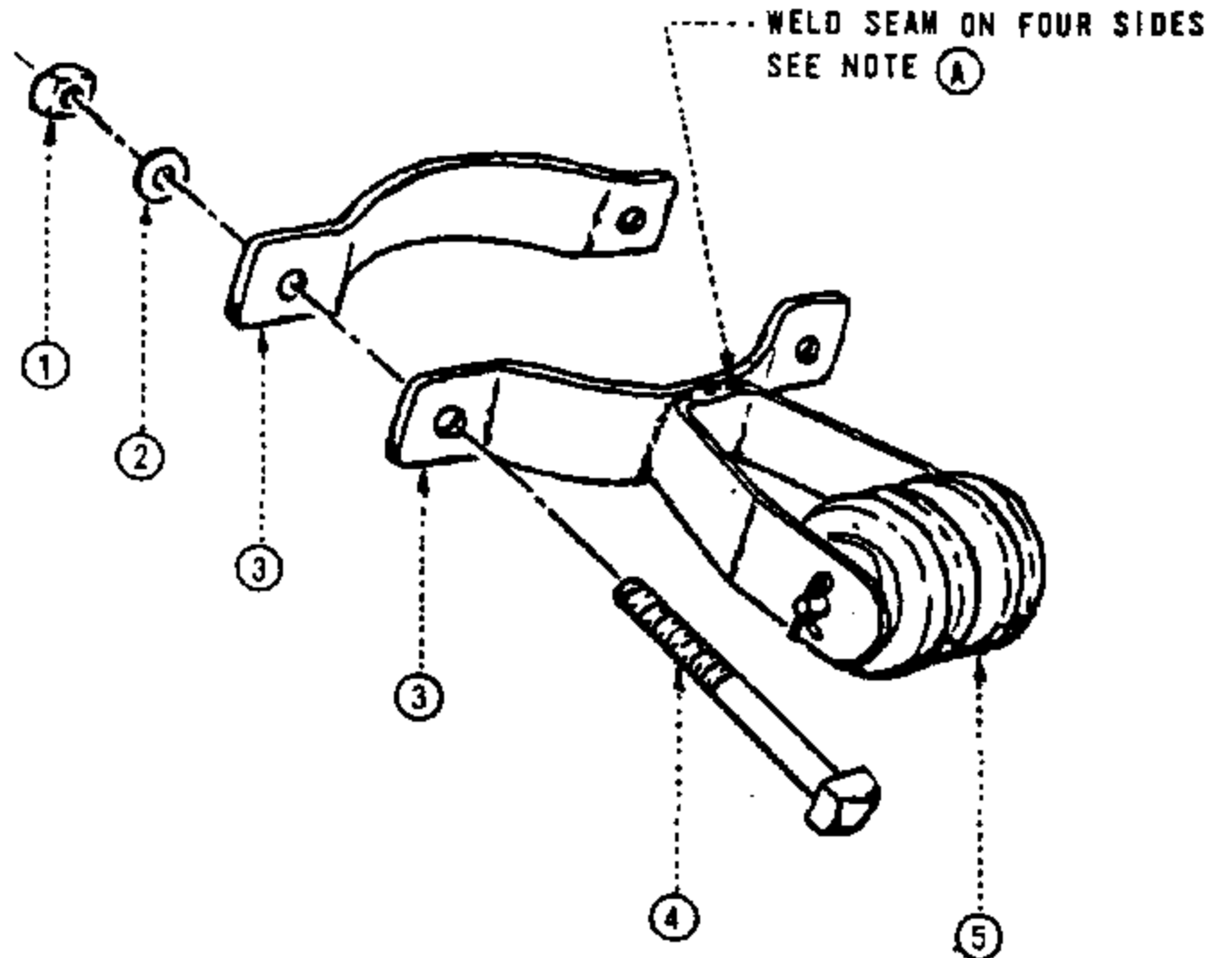

BRACKET EXPLODED

FOR FIELD MAINTENANCE ONLY

NOTES:

- (A) ITEM TO BE GALVALLOY ZINC AT WELDED JOINT OR HOT DIP GALVANIZED AFTER FABRICATION.
- (B) ASSEMBLY WILL ACCOMODATE CUSTOMER'S RISER FROM 3" MINIMUM TO 6" MAXIMUM.

ITEM	DESCRIPTION	QUANTITY	STOCK NO. OR CONSTR STDS
1	NUT, GALV., 1/2" X 13 COURSE THREAD	2	504736
2	WASHER, FLAT, GALV., 1/2" DIAMETER	2	800192
3	STRAP, BACK, CURVED, GALV.	2	698016
4	BOLT, MACH., GALV., 1/2" X (LENGTH AS REQ'D)	2	PG. 139
5	4KV DEADEND ASSEMBLY	1	166128

<p>699,302 SUPERSEDES 632 (9-17-82)</p>	<p>SOG & E ELECTRIC STANDARDS</p> <p>HEAVY DUTY SERVICE INSULATOR BRACKET</p>	<p>DATE 9-17-82 APPD <i>[Signature]</i></p>
-------------------------------------------------	-----------------------------------------------------------------------------------	-------------------------------------------------

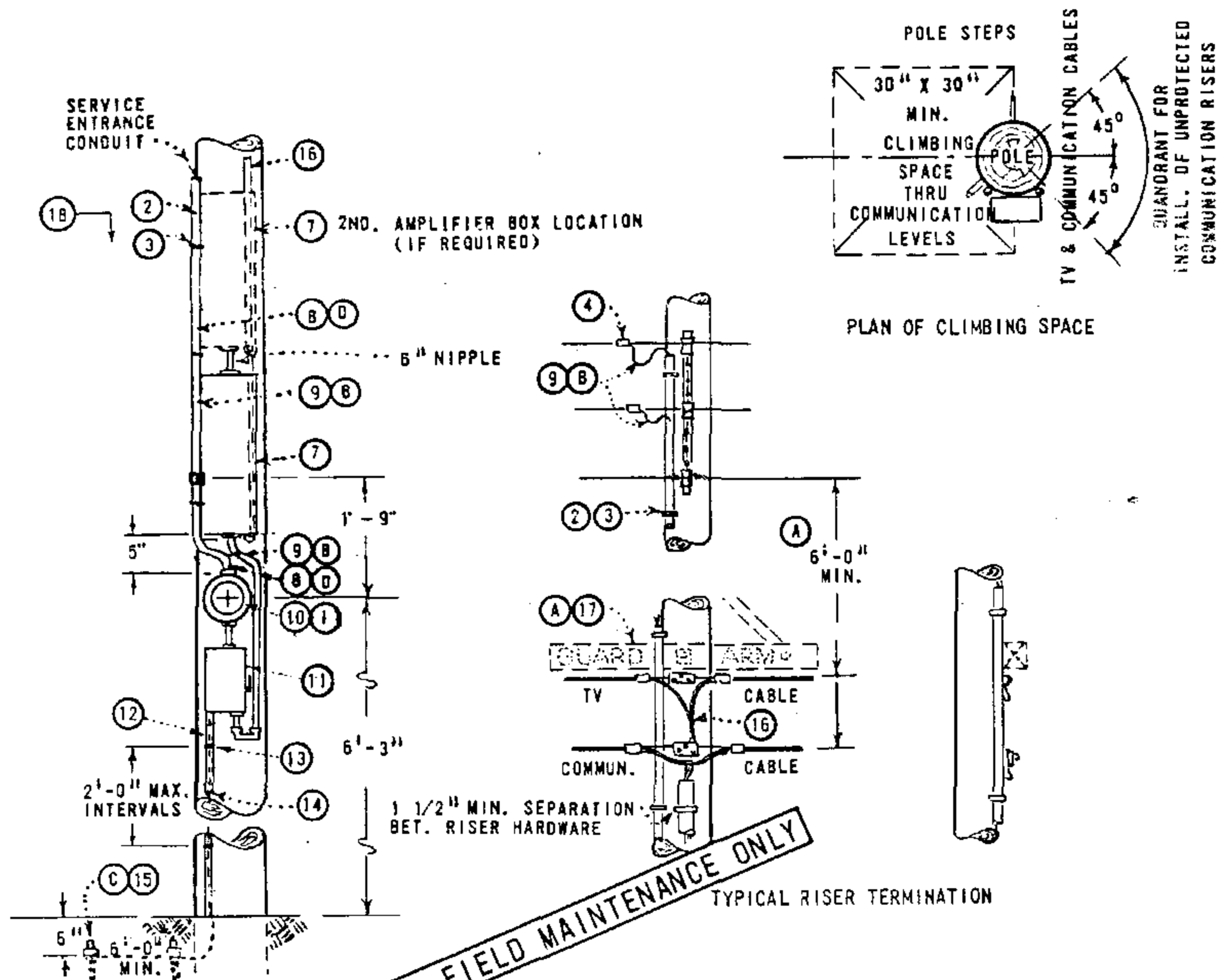

NOTES:

- (A) SEPARATION BETWEEN SECONDARY LINE AND COMMUNICATION CABLE MAY BE REDUCED TO NOT LESS THAN 4'-0" WHERE A GUARD ARM HAS BEEN INSTALLED IMMEDIATELY ABOVE TV CABLE.
- (B) CUSTOMER'S SERVICE ENTRANCE CONDUCTORS SHALL RUN CONTINUOUSLY WITHOUT SPLICES FROM METER SOCKET TERMINALS TO OVERHEAD SECONDARY LINE AND SHALL BE OF A LENGTH SUFFICIENT TO FORM LOOPS AT TOP OF THE RISER.
- (C) USE TWO GROUND RODS WHERE AN IMPEDANCE OF LESS THAN 25 OHMS CANNOT BE OBTAINED WITH ONE GROUND ROD.
- (D) IF PVC CONDUIT IS USED, ALL EQUIPMENT MOUNTED ON POLE BELOW 8' LEVEL TO BE EFFECTIVELY GROUNDING AND CONDUIT GROUND OMITTED.
- E. THE EQUIPMENT ON LOADSIDE OF THE METER IS SUBJECT TO APPROVAL BY THE LOCAL INSPECTION AUTHORITIES.
- F. ATTACH ONE SET OF LEADS FROM METER TO EXO SWITCH ONLY. LOWER AMPLIFIER MAY BE USED AS A JUNCTION BOX WHEN SECOND AMPLIFIER BOX IS REQUIRED.
- G. THIS INSTALLATION SHALL BE LIMITED TO UTILITY POLES WHICH CONTAIN NO OTHER VERTICAL RUNS.

MATERIAL FURNISHED AND INSTALLED BY SDG&E				MATERIAL FURNISHED AND INSTALLED BY CUSTOMER	
1	METER	1	481840	7	TV AMPLIFIER EQUIPMENT (1 OR 2 BOX INSTALLATION)
2	CONDUIT 3/4" DIAM., PVC, TYPE II, SCH. 80	(E) AS REQ'D	251520	(D) 8	G.I. RIGID OR PVC CONDUIT SCH. 80, WITH FITTINGS (TO 8'-0" LEVEL)
3	STRAPS, PIPE, GALV., 3/4", 2-10d. NAILS	(E) AS REQ'D	697888	(B) 9	WIRE, 600V, #12, TYPE THW, (SERVICE CONDUCTORS)
4	CONNECTORS, WIRE (SIZE AS REQ'D.)	2	783 OR 786	10	APPROVED METER SOCKET
5	COUPLING, PLASTIC. (SIZE AS REQ'D)	1		11	EXO SWITCH, COMPLETE WITH PROTECTION
				12	HARDWOOD MOULDING, 1"
				13	PIPE STRAPS, GALV., 1" & 2-10d. NAILS, GALV.
				14	WIRE, BARE STRANDED COPPER, #6
				(C) 15	GROUND ROD AND CLAMP, 5/8" X 8'-0"
				16	CO-AXIAL TV CABLES
				(A) 17	GUARD ARM, 3" X 4 1/4" X 4'-0" (IF REQ'D.) WITH BRACE
				18	POLE STEPS (AS REQ'D) PAGE 363

SCOPE: THIS PAGE SHOWS THE DIMENSIONS AND ULTIMATE VERTICAL LOADING STRENGTH OF THE ANGLE SUSPENSION CLAMP. THE CLAMP IS TO BE USED IN CONJUNCTION WITH THE CLEVIS OR SOCKET EYE CONNECTORS FOR SUPPORTING CONDUCTORS ON VERTICAL CONSTRUCTION. MAXIMUM ANGLE FOR CONSTRUCTION USING THIS CLAMP IS 30° .

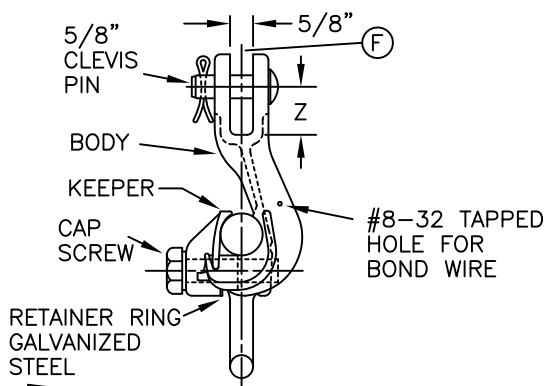
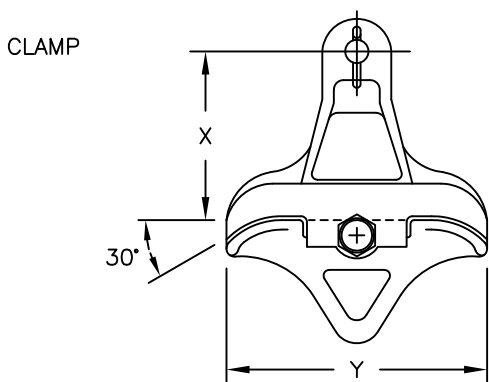

FOR FIELD MAINTENANCE ONLY

INSTALLATION:

- (A) LINE GUARDS ARE TO BE USED WITH CLAMPS.
- B. BONDING IS REQUIRED IN CONTAMINATION DISTRICT 1. (SEE STANDARD 287)

REFERENCE:

- C. TABLE 1 IS TO BE USED TO DETERMINE PHYSICAL DIMENSIONS AND STRENGTHS OF SUSPENSION CLAMPS.
- D. TABLE 2 SHOWS THE PROPER SIZING OF SUSPENSION CLAMPS FOR CONDUCTORS.
- (F) SEE STANDARD 777 FOR USE OF CLEVIS AND SOCKET EYES.

TABLE 1

MANUFACTURER		CLAMP RANGE DIA. (INCHES)		DIMENSIONS (INCHES)			ULTIMATE STRENGTH VERT.LOAD	MATERIAL	STOCK NUMBER
CAT.NO.	NAME	MIN.	MAX.	X	Y	Z			
1301	LINDSEY	.160	.430	3-7/16	5-1/2	1-1/2	18,000	DUCTILE IRON	226662
1305	LINDSEY	.300	.650	4-1/4	6-1/2	1-1/2	18,000	DUCTILE IRON	226664
1308	LINDSEY	.50	.70	4-1/4	7	1-1/4	12,000	ALUM.	232004
1312	LINDSEY	.68	1.00	4-1/4	6-7/8	1	12,000	ALUM.	232008
1316	LINDSEY	1.00	1.313	5-3/8	6-7/8	1-1/4	12,000	ALUM.	232012
1320	LINDSEY	1.24	1.500	5-5/8	7	1-1/4	15,000	ALUM.	226660

TABLE 2

COPPER										COPPERWELD						STOCK NUMBER	ASSEMBLY UNITS
6	4	3 SOL.	2	1	1/0	2/0	3/0	4/0	250 KCM	8A	6	4					
X	X	X	X	X	X	X				X	X	X				226662	SCACS
							X	X	X							226664	SCACL
AWAC (A)		ACSR (A)								5005 (A)					STOCK NUMBER	ASSEMBLY UNITS	
2	1/0	4	2	1/0	3/0	4/0	336/18/1	336/26/7	397	636	4	2	1/0	3/0			394.5
X	X		X	X	X						X	X	X			232004	SC4 SC1/0
					X	X	X							X		232008	-
									X	X					X	232012	SC397
										X						226660	SC636

© 1998 - 2010 San Diego Gas & Electric Company. All rights reserved. Removal of this copyright notice without permission is not permitted under law.

Indicates Latest Revision Completely Revised New Page Information Removed

SDG&E ELECTRIC STANDARDS

776

ANGLE SUSPENSION CLAMPS

REVISION

DATE 1-1-94

APPD PIA / RJA

COPPER WIRE (FOR FIELD MAINTENANCE ONLY)

SIZE OF WIRE	AWG	6	1	-	-
	CIRC MILS (CU EQUIV)	26250	83690	250K	400K
STOCK NUMBER		S813536	S812352	S813696	S812416
NUMBER OF STRANDS		3	7	19	19
DIAMETER (INCHES)		.201	.328	.574	.726
WEIGHT (LBS/1000 FT)		82.5	258.4	771.9	1235
ULTIMATE TENSILE STRENGTH (LBS)		1204	3154	9366	13850
AMPACITY (AMPERES) AT 75° C		130	270	540	730
RESISTANCE AT 75° C OHMS/1000 FT		.49	.15	.052	.033

FOR FIELD MAINTENANCE ONLY

COPPERWELD WIRE (FOR FIELD MAINTENANCE ONLY)

SIZE OF WIRE	AWG	6	4		-	-	-	
	CIRC MILS (CU EQUIV)	26250	47140		47124	92667	370100	
STOCK NUMBER		S813120	S813088	S813152	S813216	S813280	S813312	S813184
CW. CONDUCTOR TYPE NO.		6A	4A	4D	4N	3/8 (7 #8)	9/16 (7 #5)	.810E
NUMBER OF STRANDS CW/CU		1/2	1/2	2/1	5/2	40% 7-HS	40% 7-HS	7/12
DIAMETER (INCHES)		.230	.290	.348	.328	.385	.546	.810
WEIGHT (LBS/1000 FT)		101.6	161.5	225.5	240.0	323.9	649.4	1484
ULTIMATE TENSILE STRENGTH (LBS)		2585	3938	7340	8460	10460	18510	34290
AMPACITY (AMPERES) AT 75° C		140	180	190	180	200	305	660
RESISTANCE AT 75° C OHMS/1000 FT		.50	.32	.32	.32	.28	.14	.035

© 1998 - 2011 San Diego Gas & Electric Company. All rights reserved. Removal of this copyright notice without permission is not permitted under law.

799.101
SUPERSEDES
715 (5-6-83)

SDG&E ELECTRIC STANDARDS

COPPER AND COPPERWELD WIRE TABLE

DATE 3-23-2011
APPD *PA* / MJC

SIZE OF WIRE	A.W.G.	4	2	1/0	3/0	4/0
	CIRCULAR MILS.	41740	66370	105500	167800	211600
STOCK NUMBER		815456	815520	815488	815552	-
NUMBER OF STRANDS		3	7	7	7	7
CONDUCTOR AREA SQUARE INCHES		.0328	.0521	.0829	.1318	.1662
NOMINAL O.D. INCHES		.566	.604	.680	.766	.839
APPROX. WEIGHT LBS. PER M FT.		215	300	440	650	800
ULTIMATE TENSILE STRENGTH - LBS.		1564	2517	3953	6204	7772
CAPACITY AMPERES AT 75° C		125	166	222	294	343
RESISTANCE AT 75° C OHMS M FEET		.32	.20	.12	.079	.062
ASSEMBLY UNITS		TR4	TR2	TR1/0	TR3/0	-

FOR FIELD MAINTENANCE ONLY

DATE 1-1-96 APPD <i>PA/ROJ</i>	SDG&E ELECTRIC STANDARDS	799.102 SUPERSEDES 717 (1-1-96)
	COPPER TREE WIRE	

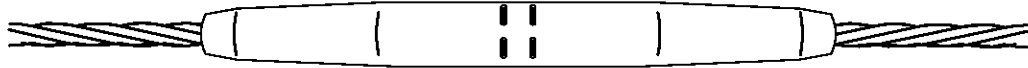

AUTOMATIC COPPER SLEEVE

NOTES:

- SLEEVES SHALL NOT BE INSTALLED IN GRADE A CROSSING SPANS OR IN TRANSMISSION CONSTRUCTION.
- AUTOMATIC SLEEVES DEPEND ON LINE TENSION FOR THEIR OPERATION. THEY SHALL NOT BE USED IN TAPS, JUMPERS, OR REDUCED TENSION.

AUTOMATIC SLEEVES FOR COPPER CONDUCTORS		
WIRE		STOCK NUMBER
SIZE	STRAND	
6	SOLID	S653318
6	3	S653320
4	SOLID	S653320

AUTOMATIC SLEEVES FOR COPPERWELD CONDUCTORS		
WIRE		STOCK NUMBER
SIZE	STRAND	
8A	1/2	S653320
6A	1/2	S653342

FOR FIELD MAINTENANCE ONLY

© 1998 - 2014 San Diego Gas & Electric Company. All rights reserved. Removal of this copyright notice without permission is not permitted under law.

DATE 9-16-2014
APPD IL / DW

SDG&E ELECTRIC STANDARDS
AUTOMATIC SLEEVES FOR
COPPER AND COPPERWELD CONDUCTORS

799.103
SUPERSEDES
720.8 (2-11-2014)

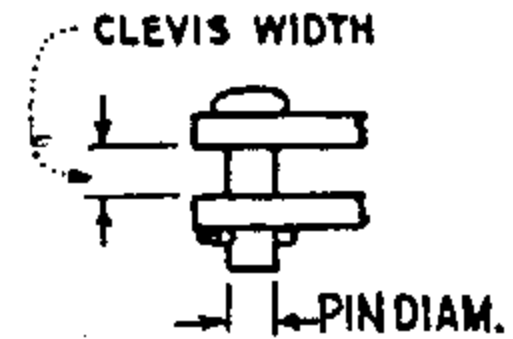
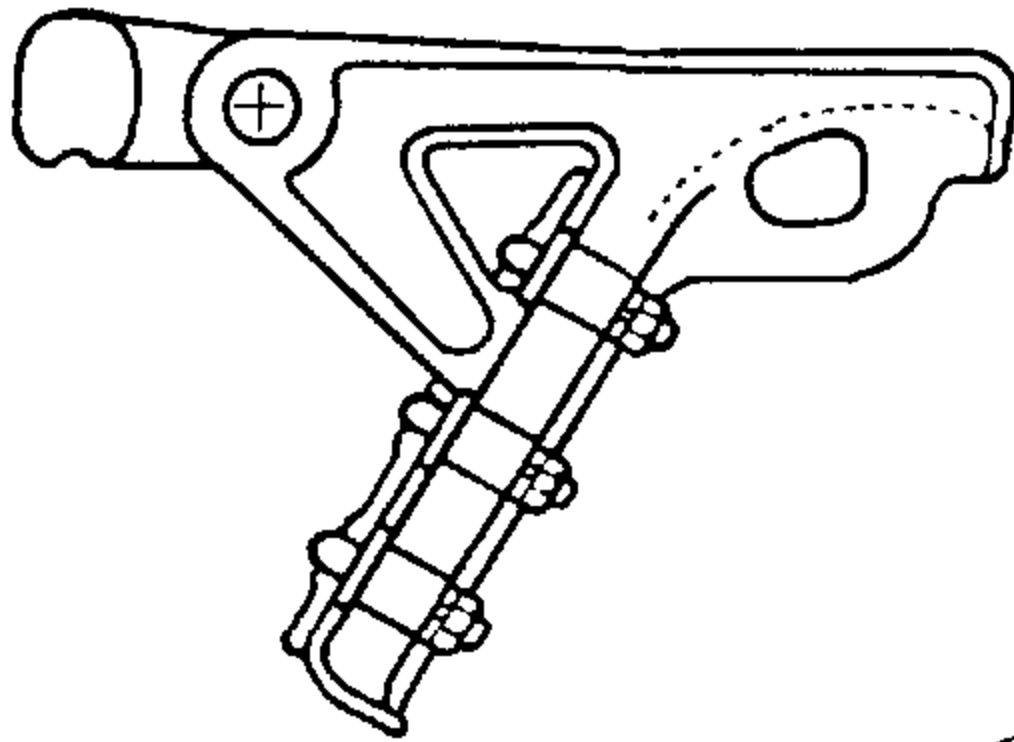

THIS PAGE FOR FIELD MAINTENANCE ONLY

RECOMMENDED U-BOLT NUT TORQUE

- 1/2" = 50 FT. LBS.
- 9/16" = 67 FT. LBS.
- 5/8" = 83 FT. LBS.

NOTES:

- A. REFER TO PAGE 777 FOR CLAMP CONNECTORS.
- B. HAND TIGHTEN U BOLT NUTS AND THEN ALTERNATELY APPLY WRENCH UNTIL DESIRED TORQUE IS ACHIEVED.
- (C) NO LONGER PURCHASED, BUT WILL BE SALVAGED.
- (D) ITEM 231488 IS BRONZE

COPPER WIRE SIZE AND DIAMETER (INCHES)									CLAMP RANGE		CONNECTION	CLEVIS WIDTH	PIN DIAM.	STOCK NO OR CONST STD
4 .254	2 .320	1/0 .368	4/0 .527	250MCM .574	400MCM .726	500MCM .813	750MCM .997	1000MCM 1.151	MIN.	MAX.				
X	X	X	X	-	-	-	-	-	.20	.55	SOCKET	1 1/16"	5/8"	231264
-	-	X	X	X	-	-	-	-	.30	.68	SOCKET	1 3/16"	5/8"	231328
-	-	-	X	X	X	-	-	-	.48	.84	SOCKET	7/8"	5/8"	231392 (C)
-	-	-	X	X	X	X	-	-	.50	.96	SOCKET	1"	5/8"	231456 (C)
-	-	-	-	-	X	X	X	X	.71	1.30	SOCKET	1 7/16"	3/4"	231488 (D)
-	X	X	X	X	-	-	-	-	.30	.68	NONE	1 3/16"	5/8"	231136
-	-	-	X	X	X	X	-	-	.48	.84	NONE	7/8"	5/8"	231200 (C)

SCOPE: THIS STANDARD SHOWS STRAIGHT STRAIN CLAMPS USED TO ATTACH ACSR AND 5005 ALUMINUM ALLOY CONDUCTORS TO DEAD END INSULATORS.

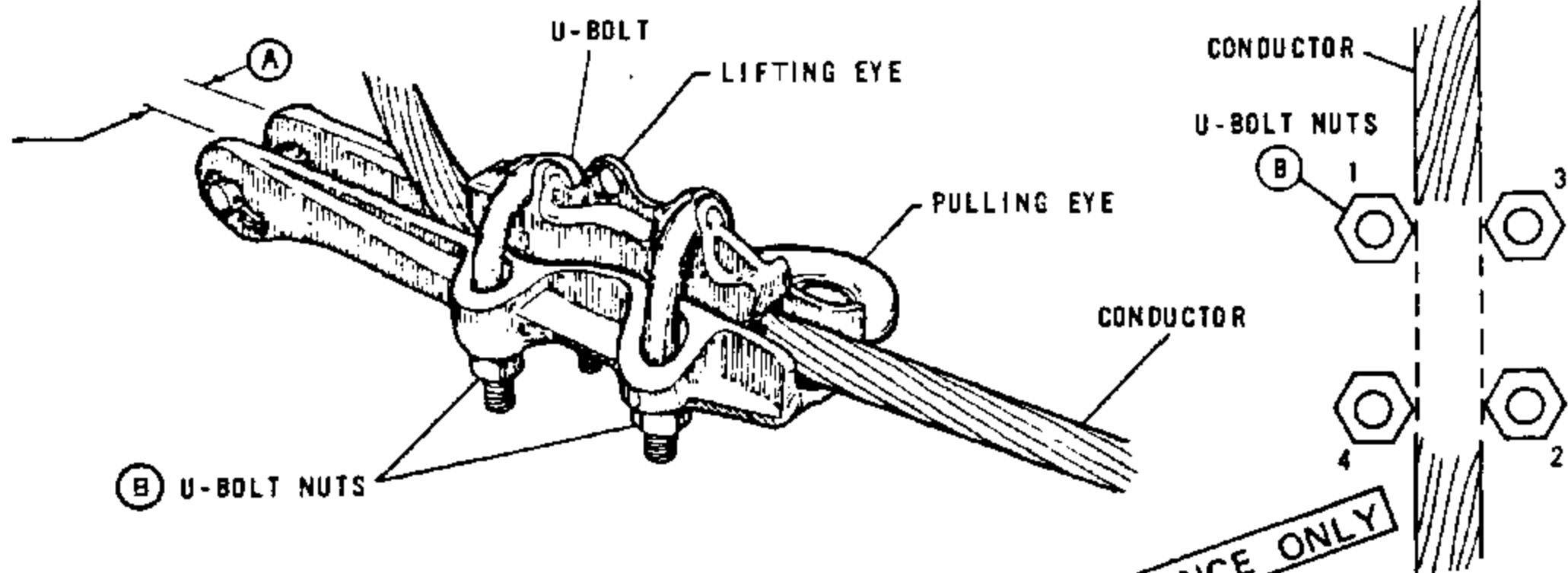

FIG. 1

TORQUING SEQUENCE
FIG. 2

NOTES:

- DO NOT USE STRAIGHT STRAIN CLAMP ON AWAC CONDUCTORS.
- THIS CLAMP MAY BE USED IN ALL LOADING DISTRICTS.

FOR FIELD MAINTENANCE ONLY

BILL OF MATERIAL:

WIRE SIZE								CLAMP RANGE (INCHES)		CLAMP DATA		MFG	CATALOG NUMBER	STOCK NO OR CONSTR STD
ACSR OR 5005 (AWG)			ACSR				5005	MIN	MAX	TORQUE (FT-LBS)	CLEVIS WIDTH (A)			
2/6/1	1/0/6/1	3/0/6/1	336.4 KCMIL 18/1	336.4 KCMIL 26/7	636 KCMIL 24/7	1033.5 KCMIL 45/7	394.5 KCMIL 19							
X	X	X	-	-	-	-	-	.184	.563	35	5/8	ALCOA	E221.2	230432 (E)
X	X	X	X	X	-	-	X	.316	.814	40	13/16		E222.3	230512
-	-	-	X	X	X	-	X	.522	1.153	40	3/4		E223.4	- (C)
-	-	-	-	-	-	X	-	1.022	1.454	40	3/4		225	- (C)
X	X	-	-	-	-	-	-	.19	.47	25	11/16	BETHEA	ASD-2-N	230432 (E)
-	-	X	X	X	-	-	X	.46	.75	45	3/4		ASD-37-N	230464 (E)
X	X	-	-	-	-	-	-	.191	.447	20	3/4	FARGO	GD-971A	230432 (E)
X	X	X	X	-	-	-	X	.25	.724	45	3/4		GD-972A	230512
X	-	-	-	-	-	-	-	.15	.37	50	11/16	OHIO BRASS	87650	- (C)
X	X	X	-	-	-	-	-	.30	.60	50	3/4		91560	- (C)
-	-	X	X	X	-	-	X	.46	.88	50	7/8		91570	230464 (E)
-	-	-	-	-	X	X	-	.86	1.30	40	1-1/16	ANDERSON	ADE-130-N	230496

INSTALLATION:

- (A) SEE CLAMP DATA COLUMN FOR CLEVIS WIDTH.
- (B) HAND TIGHTEN U-BOLT NUTS AND THEN TORQUE BOLTS AS SHOWN IN FIG. 2 TO THE VALUES IN CLAMP DATA COLUMN.
- (C) SPECIAL ORDER.
- (E) EXEMPT MATERIAL

799.402
SUPERCEDES
741 (1986)

SDG&E ELECTRIC STANDARDS
12KV ALUMINUM STRAIGHT STRAIN CLAMP
FOR ACSR & 5005 ALUMINUM ALLOY CONDUCTORS

DATE 1-1-86
APPD AK/ROB

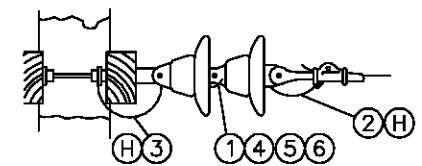
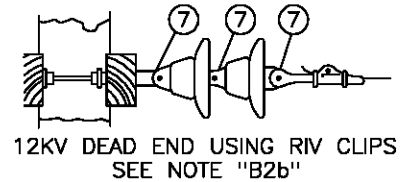
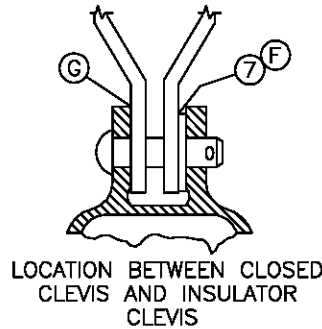
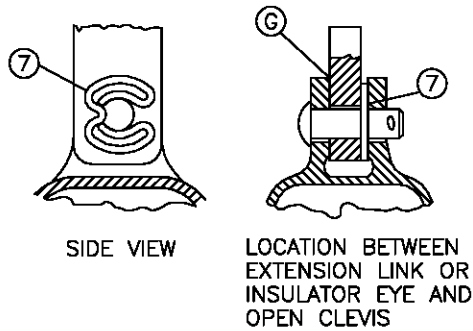
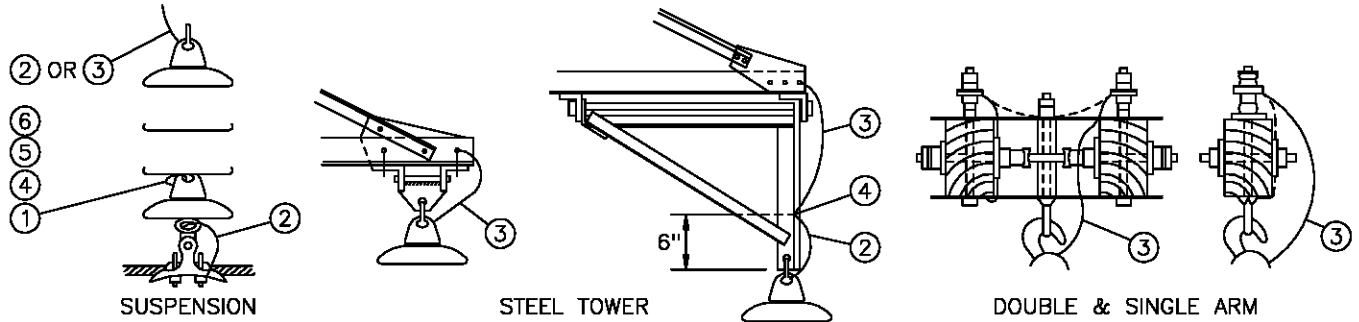

RIV CLIP INFORMATION - SEE NOTE "B2b"

12KV DEAD END USING BOND WIRES
SEE NOTE "B1 AND B2a"

NOTES:

- A. USE BONDED INSULATORS ON 138 AND 69KV WHERE: 1) MAXIMUM GUYING TENSION PER CONDUCTOR IS BELOW 1000 POUNDS, OR 2) THROUGH RESIDENTIAL, COMMERCIAL, AND INDUSTRIAL AREAS. ALSO, WHERE FUTURE DEVELOPMENT OF SIMILAR AREAS ADJACENT TO TRANSMISSION LINES ARE ANTICIPATED.
- B. USE THE FOLLOWING TO DETERMINE WHEN TO USE BONDED OR UNBONDED INSULATORS, AND WHEN RIV CLIPS ARE TO BE ADDED TO UNBONDED INSULATORS ON 12KV AND 12.47KV SYSTEMS IN CONTAMINATION DISTRICTS DESCRIBED ON PAGE 287.
 - 1) SLACK SPANS (SPANS INSTALLED AT MORE THAN NORMAL SAG): IN ALL CONTAMINATION DISTRICTS: USE BONDED INSULATORS.
 - 2) FULL TENSION INSTALLATIONS WHERE MAXIMUM GUYING TENSION PER CONDUCTOR IS 1000 POUNDS OR LESS:
 - a) CONTAMINATION DISTRICT 1, USE BONDED INSULATORS.
 - b) CONTAMINATION DISTRICTS 2 AND 3, USE UNBONDED INSULATORS WITH RIV CLIPS
 - 3) FULL TENSION INSTALLATIONS WHERE MAXIMUM GUYING TENSION PER CONDUCTOR IS OVER 1000 POUNDS: ALL CONTAMINATION DISTRICTS: USE UNBONDED INSULATORS.
- C. INSULATORS BONDED PER SDG&E SPECIFICATION 138 INCLUDE ITEMS 1 THROUGH 6 LISTED BELOW.
- D. SEE STANDARDS PAGE 750.4 FOR SUSPENSION INSULATOR INFORMATION.
- F. INSTALL RIV CLIP BETWEEN CLEVIS AND INSULATOR CAP AS SHOWN.
- G. ADD SECOND RIV CLIP IF ONLY ONE CLIP DOES NOT MAKE TIGHT CONNECTION BETWEEN HARDWARE. NEVER USE MORE THAN 2 RIV CLIPS AT ONE CONNECTION, OR, ON ONE PIN.
- H. ATTACH BOND WIRES LEAVING SHORT LOOPS AS SHOWN. CUT OFF EXCESS BOND WIRE.

BILL OF MATERIAL:

FOR FIELD MAINTENANCE ONLY

ITEM	DESCRIPTION	QUANTITY	STOCK NO. OR CONSTR STDS	ASSEMBLY UNITS
1	WIRE ROPE, 3" STAINLESS STEEL, MACWYTE, 1/16" OD, 7x7 PREFORMED, AIFI TYPE 304	AS REQ'D		
2	WIRE ROPE, 12" STAINLESS STEEL, MACWYTE, 1/16" OD, 7x7 PREFORMED, AIFI TYPE 304	AS REQ'D	606720	12BOND
3	WIRE ROPE, 24" STAINLESS STEEL, MACWYTE, 1/16" OD, 7x7 PREFORMED, AIFI TYPE 304	AS REQ'D		
4	SCREW, 8-32, STAINLESS STEEL, PHILLIPS HEAD	AS REQ'D	622464	-
5	TERMINAL, AMP 322334, #8 STUD, STAINLESS STEEL OR NICKEL	AS REQ'D	732064	-
6	LOCKWASHER, EXTERNAL TOOTH, #8 STUD, STAINLESS STEEL	AS REQ'D	796352	-
7	CLIP, INSULATOR NON STATIC (RIV)	AS REQ'D	237648	RIVCLP

DATE 1-1-94

APPD *PA 1/09*

SDG&E ELECTRIC STANDARDS

PORCELAIN SUSPENSION INSULATOR BONDING

799.501
SUPERSEDES
756 (1-1-98)

NOTES: (A) TO CHOOSE THE PROPER GROOVE CLAMP, LOCATE THE TWO WIRE SIZES ON THE CHART, DRAW A HORIZONTAL LINE FROM THE LARGER CONDUCTOR SIZE AND A VERTICAL LINE FROM THE SMALLER SO THAT THEY INTERSECT. THE AREA CONTAINING THE INTERSECTION INDICATES THE CORRECT STOCK NUMBER.

EXAMPLE: FOR CONDUCTOR SIZES 3/0 ACSR AND #2 ACSR, THE CORRECT GROOVE CLAMP STOCK NUMBER IS 227968.

B. THE ADJACENT TABLE CAN BE USED TO DETERMINE THE SPECIFIC MANUFACTURER'S CATALOG NUMBER FOUND UNDER A STOCK NUMBER.

C. BE SURE TO CLEAN CONDUCTOR WHICH WILL BE UNDER CLAMP, CLEAN CONDUCTOR GROOVES OF CLAMP IF NECESSARY, AND FILL THE GROOVES WITH INHIBITOR (247200) BEFORE INSTALLING THE CLAMP.

D. FOR USE WHEN MAKING AL. TO AL. AND AL. TO CU. PERMANENT CONNECTIONS AND WHERE CONNECTIONS MAY BE OPENED OCCASIONALLY FOR OPERATING CONVENIENCE.

F. WHEN MAKING AL. TO CU. CONNECTIONS, LOCATE THE CU. AT THE SAME LEVEL OR BELOW THE AL. CONDUCTOR.

CONDUCTOR		
DIA. IN.	AWG OR KCM	DESCRIPTION
.162	6	SOLID
.184	6	7 STR.
.198	6	ACSR 6/1
.198	6	5005 7W
.199	8A	CUWLD 3 STR.
.202	6	3 STR.
.204	4	SOLID
.229	3	SOLID
.230	6A	CUWLD 3 STR.
.232	4	7 STR.
.250	4	ACSR 6/1
.250	4	5005 7W
.254	4	3 STR.
.258	2	SOLID
.276	6D	CUWLD 3 STR.
.289	1	SOLID
.290	4A	CUWLD 3 STR.
.292	2	7 STR.
.316	2	ACSR 6/1
.316	2	5005 7W
.320	2	3 STR.
.324	1/0	SOLID
.325	2	ACSR 7/1
.328	4N	CUWLD 7 STR.
.330	2	AWAC 5/2
.338	1/0	7 STR. COMP.
.348	4D	CUWLD 3 STR.
.360	1	3 STR.
.368	1/0	7 STR.
.373	1/0	19 STR.
.386	2	AWAC 3/4
.398	1/0	ACSR 6/1
.398	1/0	5005 7W
.409	3/0	SOLID
.414	2/0	7 STR.
.426	3/0	7 STR. COMP.
.447	1/0	AWAC 4/3
.460	4/0	SOLID
.464	3/0	7 STR.
.470	3/0	19 STR.
.502	3/0	ACSR 6/1
.502	3/0	5005 7W
.522	4/0	7 STR.
.528	4/0	19 STR.
.533	4/0	37 STR.
.563	4/0	ACSR 6/1
.575	250	19-37 STR.
.629	300	19-37 STR.
.666	336	19 STR.
.680	350	19-37 STR.
.684	336	ACSR 18/1
.721	336	ACSR 26/7
.721	394	5005 19W
.727	400	19-37 STR.
.743	397	ACSR 18/1
.783	397	ACSR 26/7
.811	500	19 STR.
.977	636	ACSR 24/7
.998	750	37-61 STR.
1.152	1000	61-91 STR.

227936

ASSEMBLY UNITS
PG6C
PG4C
PG2A
PG2C
PG1/OA
PG1/OC

STOCK NUMBER	BOLTS			ALCOA CATALOG NUMBER
	NO.	SIZE IN.	TORQUE LB.-FT.	
227936	1	3/8	13	396.6
227968	2	1/2	25	482.1
228000	3	1/2	25	482.2
228032	2	5/8	40	483.2
228064	3	5/8	40	483.3

(G)

ASSEMBLY UNITS
STK No. 228064
PG397
PG500
PG636
PG750
PG1000

EXAMPLE (A)

EXAMPLE (A)

227968

ASSEMBLY UNITS
PG3/OA
PG4/OC

228000

ASSEMBLY UNITS
PG336
PG394
PG400

228032

ASSEMBLY UNITS
PG500-

(G)

NO CONNECTOR AVAILABLE

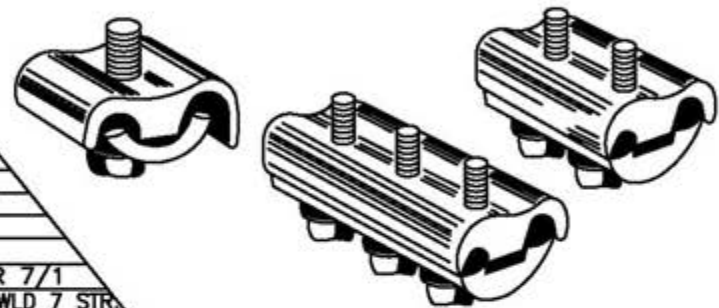

© 1998 - 2005 San Diego Gas & Electric Company. All rights reserved. Removal of this copyright notice without permission is not permitted under law.

REVISION	Indicates Latest Revision	Completely Revised	New Page	Information Removed
DATE 1-1-94	SDG&E ELECTRIC STANDARDS			799.801 SUPERSEDES 785 (1-20-06)
APPD <i>PA 1/09</i>	ALUMINUM PARALLEL GROOVE CLAMPS			

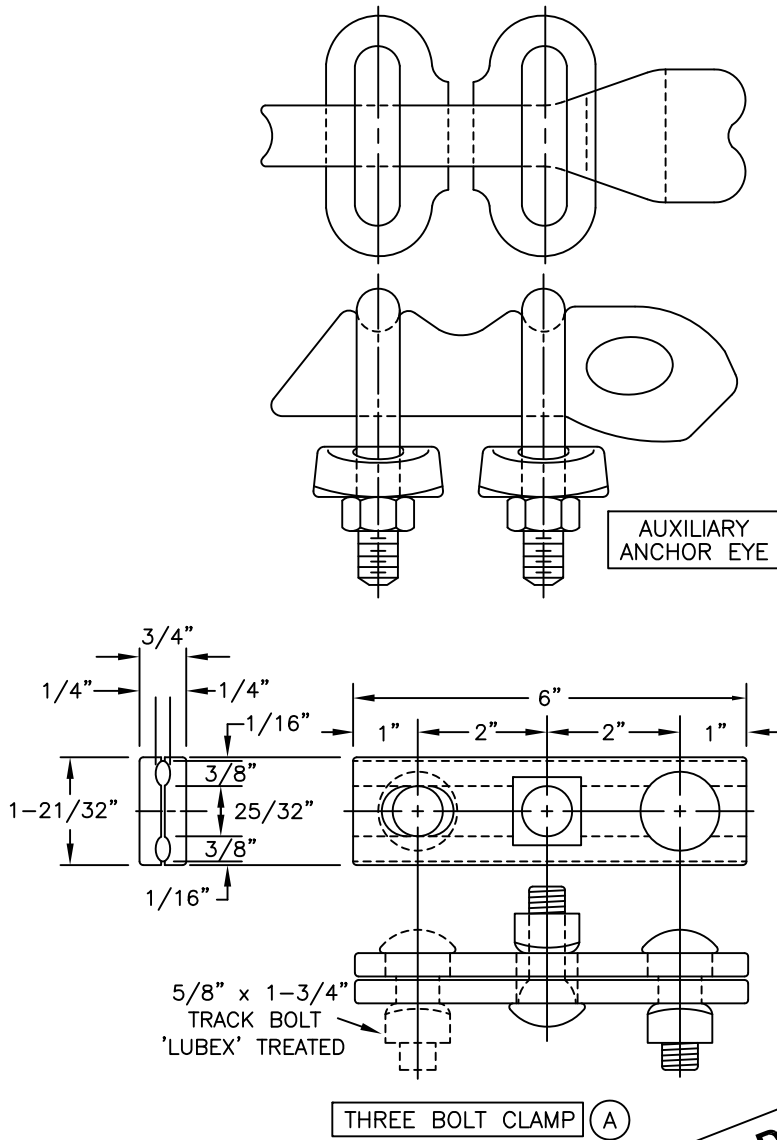

FOR FIELD MAINTENANCE ONLY

INSTALLATION:

- (A) NO LONGER PURCHASED. USE FACTORY GUY GRIP WHEN PRACTICAL. SALVAGE THREE BOLT CLAMP AND USE ONLY WHEN A GUY GRIP CANNOT BE USED.

DESCRIPTION	MOUNTING BOLT SIZE	STOCK NUMBER	ASSEMBLY UNITS
CLAMP, THREE BOLT	-	227296	-
EYE, AUX ANCHOR	-	337536	AUXEYE
THIMBLE, 1/2", OPEN	-	736600	OPTHMB

© 1998 - 2010 San Diego Gas & Electric Company. All rights reserved. Removal of this copyright notice without permission is not permitted under law.

	Indicates Latest Revision	Completely Revised	New Page	Information Removed
962	SDG&E ELECTRIC STANDARDS			REVISION
	GUY HARDWARE			DATE 1-1-96 APPD <i>PLA 1/2/96</i>

SCOPE: THIS STANDARD LISTS TYPES AND SIZES OF GUY STRAND WIRE USED IN DISTRIBUTION CONSTRUCTION.

ALUMOWELD GUY STRAND (A)				
TYPE DESIGNATION	4M	6M	10M	16M
STOCK NUMBER	810944	810976	811008	811040
ASSEMBLY UNITS	4M	6M	10M	16M
NOMINAL DIAMETER (INCHES)	.220	.242	.306	.386
NUMBER OF STRANDS	3	7	7	7
STRAND DIAMETER (INCHES)	.102	.081	.102	.128
POUNDS PER 100 FEET	7	10.4	16.5	26.2
FEET PER POUND	14.3	9.6	6.1	3.8
WORKING STRENGTH (LBS) (C)	2000	3000	5000	8000 (B)

INSTALLATION:

- (A) ALUMOWELD GUY STRAND WIRE IS PREFERRED IN CONTAMINATION DISTRICT 1, BUT IS LEFT TO THE DISCRETION OF THE DISTRICT.
- (B) WHEN STRAIN INSULATORS ARE USED TO SECTIONALIZE GUY WIRE, THE LOADING MUST NOT EXCEED THE WORKING STRENGTH OF THE INSULATOR, 6,000 LBS FOR 54-2, 10,000 LBS FOR THE 54-3.
- (C) A SAFETY FACTOR OF TWO IS INCLUDED IN THE WORKING STRENGTH VALUE.

REFERENCE:

F. CONTAMINATION DISTRICTS ARE DEFINED ON STANDARDS PAGE 287.

FOR FIELD MAINTENANCE ONLY

999.601	SDG&E ELECTRIC STANDARDS	DATE 1-1-94 APPD <i>PIA 1/2/94</i>
	ALUMOWELD GUY WIRE	

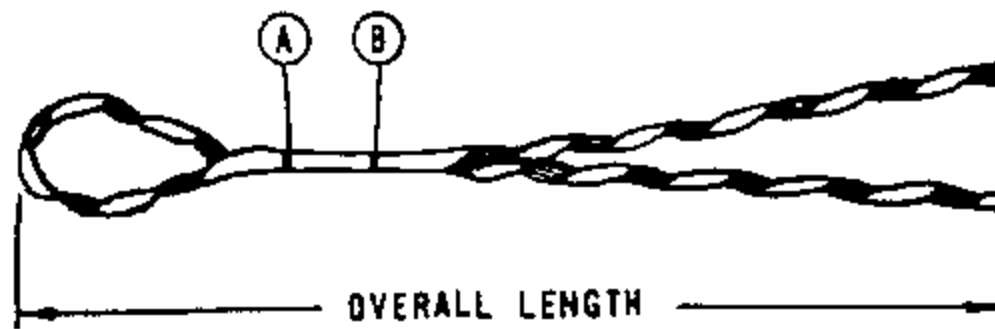

COPPERWELD (M SERIES)

4M	3 WIRE	.209"	WHITE	CDE-8106	18	—	—	(E) 393056
6M	7 WIRE	.237"	YELLOW	CDE-3103	21	—	—	(E) 393088
10M	7 WIRE	.303"	RED	CDE-3109	25	—	—	(E) 392992
18M	7 WIRE	.386"	WHITE	CDE-3115	31	—	—	(E) 393024

COPPERWELD - COPPER & COPPERWELD

#8C	1CW/2CU	.179"	RED	CDE-8102	17	—	—	(E) 393120
#6A	1CW/2CU	.230"	YELLOW	CDE-3103	21	—	—	(E) 393088
#6C	1CW/2CU	.225"	YELLOW	CDE-3103	21	—	—	(E) 393088
#4A	1CW/2CU	.290"	RED	CDE-3109	25	—	—	(E) 392992
#2F	1CW/6CU	.308"	RED	CDE-3109	25	—	—	(E) 392992
—	—	—	—	—	—	—	—	—

FOR FIELD MAINTENANCE ONLY

INSTALLATION:

- (A) COLORED MARK INDICATES CROSSOVER POINT FOR SMALL INSULATORS OR THIMBLEYES.
- (B) COLORED MARK INDICATES CROSSOVER POINT FOR LARGE INSULATORS.
- (E) EXEMPT MATERIAL

SCOPE: THIS STANDARD LISTS TYPES AND SIZES OF GUY GRIPS USED TO ATTACH GUY WIRE TO SUPPORT EQUIPMENT.

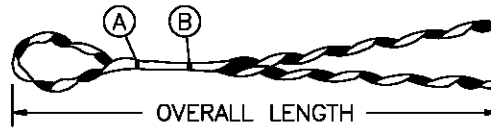

FORMED GUY GRIPS

ALUMOWELD STRAND

GUY WIRE STRAND DATA		MEAN DIAM	COLOR CODE	MANUFACTURER				STOCK NO. OR CONSTR STD	ASSEMBLY UNITS
SIZE	STRANDING			PREFORMED		CHANCE			
				CAT. NO.	LENGTH(IN)	CAT. NO.	LENGTH(IN)		
4M	3 WIRE	.220"	GREEN	AWDE-4108	21	4M-AWSBG	18	392928	-
6M	7 WIRE	.242"	YELLOW	AWDE-4110	22	6M-AWSBG	21	392960	GR6M
10M	7 WIRE	.306"	BLACK	AWDE-4116	26	10M-AWSBG	25	392864	GR10M
16M	7 WIRE	.386"	ORANGE	AWDE-4122	32	16M-AWSBG	30 1/2	392896	GR16M

INSTALLATION:

- Ⓐ COLORED MARK INDICATES CROSSOVER POINT FOR SMALL INSULATORS OR THIMBLEYES.
- Ⓑ COLORED MARK INDICATES CROSSOVER POINT FOR LARGE INSULATORS.

FOR FIELD MAINTENANCE ONLY

999.603

SDG&E ELECTRIC STANDARDS

ALUMOWELD GUY GRIPS

DATE 1-1-98

APPD *PA/CKK*

SCOPE: THIS STANDARD LISTS TYPES AND SIZES OF GUY SPLICES USED TO SPLICE GUY WIRE.

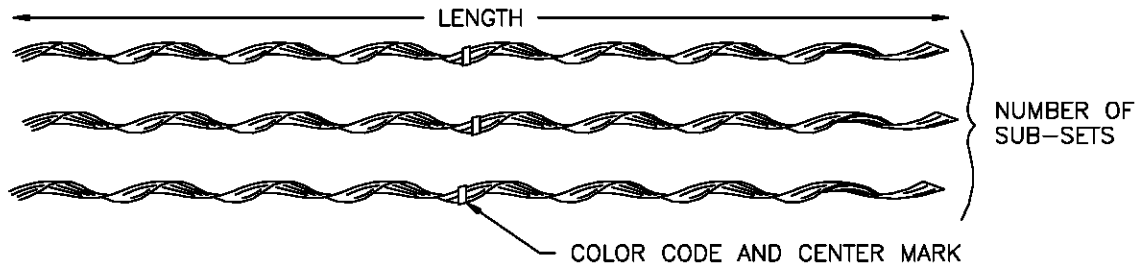

NOTES:

- A. INDIVIDUAL RODS ARE ASSEMBLED INTO SUBSETS AND GRITTED INTO GROUPS OF TWO, THREE, OR FOUR.
- B. CENTER MARK ESTABLISHES ALIGNMENT OF RODS DURING APPLICATION.
- C. COLOR CODE AND LENGTH ASSIST IN IDENTIFICATION OF STRAND SIZE.

FORMED SPLICES											
ALUMOWELD STRAND											
GUY WIRE STRAND DATA			COLOR CODE	NO. SUBSETS		MANUFACTURER				STOCK NO. OR CONSTR STD	ASSEMBLY UNITS
SIZE	STRANDING	MEAN DIAM.				PREFORMED		FANNER			
				PLP	FAN	CAT. NO.	LENGTH(IN)	CAT. NO.	LENGTH(IN)		
4M	3 WIRE	.220"	GREEN	2	2	AWLS-4108	24	4MAWFS	23	667488	-
6M	7 WIRE	.242"	YELLOW	2	2	AWLS-4110	25	6MAWFS	24	667520	SP6M
10M	7 WIRE	.306"	BLACK	3	2	AWLS-4116	30	10MAWFS	29	667424	SP10M
16M	7 WIRE	.386"	ORANGE	3	3	AWLS-4122	38	16MAWFS	38	667456	SP16M

FOR FIELD MAINTENANCE ONLY

DATE 1-1-98 APPD <i>PA/CAK</i>	SDG&E ELECTRIC STANDARDS	999.604
	ALUMOWELD GUY SPLICES	

1100 TRANSFORMERS

1100 TRANSFORMERS

PAGE

SUBJECT

1199.201-.207	PREFIXES
1199.208-.209	2.4KV OR 4KV, SINGLE PHASE TRANSFORMER INSTALLATION
1199.301-.306	2.4KV OR 4KV, SINGLE PHASE TRANSFORMER INSTALLATION, CONTINUED
1199.401-.405	7.2KV OR 12KV, SINGLE TRANSFORMER INSTALLATION
1199.501-.504	4KV OPEN WYE OR 2.4KV OPEN DELTA TRANSFORMER INSTALLATION
1199.601-.603	12KV OPEN DELTA TRANSFORMER INSTALLATION
1199.701	4KV, THREE PHASE INSTALLATION, SINGLE PHASE TRANSFORMERS
1199.704-.707	7.2 & 12KV THREE-PHASE TRANSFORMER CLUSTER MOUNT INSTALLATION - ALLEY ARM CONSTRUCTION
1199.801-.806	12KV, THREE PHASE INSTALLATION, SINGLE PHASE TRANSFORMERS
1199.901-.902	GROUNDING BANK INSTALLATION

© 1998 - 2019 San Diego Gas & Electric Company. All rights reserved. Removal of this copyright notice without permission is not permitted under law.

REV	CHANGE	BY	DSGN	APPV	DATE	REV	CHANGE	BY	DSGN	APPV	DATE
C						F					
B	COMPLETELY REVISED	JK	JS	CZH	10/15/2019	E					
A	ORIGINAL ISSUE	JK	JS	CZH	6/13/2019	D					

SHEET 1 OF 1	Indicates Latest Revision <input checked="" type="checkbox"/> Completely Revised <input type="checkbox"/> New Page <input type="checkbox"/> Information Removed	OH LEGACY OHL1101.1
	SDG&E ELECTRIC OVERHEAD FIELD MAINTENANCE ONLY STANDARDS	
	LEGACY OVERHEAD FIELD MAINTENANCE TABLE OF CONTENTS TRANSFORMERS	

PREFIX	VOLTAGE		DESCRIPTION AND APPLICATION	KVA	D (F) TAPS	STOCK NUMBER
	PRIMARY	SECONDARY				
A	240	120	1Ø SECONDARY	1	-	- (A)
				3	-	750368 (G)
BB	240/120	240/120	AUTO TRANSF'MR 5% BUCK OR BOOST, DRY TYPE	25	-	750400 (G)
				37.5	-	- (A)
X	480	120/240	1Ø SECONDARY	2	-	757792 (A)
				3	(H)	757824 (A)
				5	(H)	757856 (A)
				10	(H)	757760 (A)
				1.5	-	- (A)
				2	-	- (A)
				3	-	755296 (A)
				3	(J)	755328 (A)
				5	-	755424 (A)
				5	(J)	755456 (A)
				7.5	-	755520 (A)
				7.5	(J)	755552 (A)
				10	(J)	754912 (A)
				15	(B)&(J)	755040 (A)
				20	-	755136 (A)
				25	(J)	755200 (A)
				30	-	- (A)
				37.5	-	755360 (A)
				37.5	(J)	755392 (A)
				40	-	- (A)
				50	(B)&(J)	755488 (A)
				75	(B)&(J)	755616 (A)
				100	(J)	754976 (A)
				150	-	- (A)
				167	(J)	755104 (A)
				200	-	- (A)
				250	(J)	775264 (A)
WE	2400/4160Y	120/240	INTERNALLY FUSED, SECONDARY BREAKER, 1Ø SECONDARY 3Ø SECONDARY (K)	10	-	755696 (A)
				15	-	755712 (A)
				25	-	755728 (A)
				50	-	755776 (A)
				50	(J)	755808 (A)
WJ	2400/4160Y	120/240	INTERNALLY FUSED, SECONDARY BREAKER, LIGHTNING ARRESTER, 1Ø SECONDARY 3Ø SECONDARY (K)	1.5	-	756800 (A)
				3	-	756928 (A)
				3	(J)	756960 (A)
				5	-	757024 (A)
				7.5	-	757056 (A)
				7.5	(J)	757088 (A)
				10	(J)	756848 (A)
				15	(J)	756880 (A)
				25	(J)	756912 (A)
				37.5	-	756992 (A)
WF	2400/4160Y	240/480	SINGLE-PHASE TRANSFORMER 1Ø SECONDARY 3Ø SECONDARY (K)	10	-	755840 (A)
				15	-	755968 (A)
				25	-	756128 (A)
				37.5	-	756192 (A)
				37.5	(B)	756224 (A)
				50	-	756288 (A)
				75	-	756336 (A)
				100	-	755904 (A)
				200	(J)	756096 (A)

FOR FIELD MAINTENANCE ONLY

SDG&E ELECTRIC STANDARDS

1199.201

TRANSFORMER PREFIXES, POLE-MOUNTED
SINGLE PHASE

DATE 1-1-88

APPD *AK/RS*

PREFIX	VOLTAGE		DESCRIPTION AND APPLICATION	KVA	D (F) TAPS	STOCK NUMBER	
	PRIMARY	SECONDARY					
WFY	2400/4160Y	277	1Ø TRANSFORMER, 1Ø SEC, 3Ø SEC (K)	25	-	-	(A)
OY	4160	120/240	1Ø SECONDARY 3Ø SECONDARY (K)	15	(J)	754656	(A)
				37.5	-	754688	(A)
				37.5	(J)	754720	(A)
				50	(J)	754752	(A)
				75	-	754784	(A)
				75	(J)	754800	(A)
				100	(J)	754620	(A)
				167	-	-	(A)
WYN	7200 X 2400	120/240-277	PORTABLE SUBSTATION FOR GT GENERATOR	-	-	-	(A)
YNG	7200 X 2400	277 X 120	PORTABLE	250	-	-	(A)
Y	7200/12470Y	120/240	3Ø SECONDARY (K)	1.5	-	757936	(A)
				3	-	757988	(A)
				3	(I & J)	757990	(A)
				5	-	757960	(A)
				5	(B, I, J)	757986	(A)
				7.5	(I & J)	757964	(A)
				10	(I & J)	757948	(A)
				15	(J)	757954	(A)
				25	(J)	757984	(A)
				50	(J)	757980	(A)
				10	-	757923	(A)
				15	-	757924	(A)
YE	7200/12470Y	120/240	INTERNALLY FUSED, SECONDARY BREAKER 1Ø SECONDARY 3Ø SECONDARY (K)	25	-	757992	(G)
				25	(B)	757993	(A)
				25	(J)	750432	(A)
				50	-	757925	(A)
				75	-	757926	(A)
				3	(J)	758002	(A)
				5	-	758006	(A)
YJ	7200/12470Y	120/240	INTERNALLY FUSED, SECONDARY BREAKER LIGHTNING ARRESTER, 1Ø SECONDARY 3Ø SECONDARY (K)	5	(J)	758008	(A)
				7.5	(J)	758014	(A)
				10	(J)	757995	(A)
				15	(J)	757999	(A)
				25	(J)	758001	(A)
				37.5	-	758004	(A)
				37.5	(J)	758005	(A)
				50	(J)	758013	(A)
				75	(J)	758011	(A)
				1	-	-	(A)
H	12000	120/240	3Ø SECONDARY (K)	2.5	-	750752	(A)
				3	-	750880	(A)
				3	(J)	750912	(A)
				5	-	751040	(A)
				5	(J)	751072	(A)
				7.5	-	751200	(A)
				7.5	(J)	751216	(A)
				10	(J)	750496	(A)
				15	(J)	750656	(A)
				25	(J)	750848	(A)

FOR FIELD MAINTENANCE ONLY

PREFIX	VOLTAGE		DESCRIPTION AND APPLICATION	KVA	D & F TAPS	STOCK NUMBER				
	PRIMARY	SECONDARY								
H	12000	120/240	3Ø SECONDARY (K)	37.5	-	750976 (A)				
				37.5	(J)	751008 (A)				
				50	(J)	751136 (A)				
				75	(J)	751264 (A)				
				100	(J)	750560 (A)				
				200	-	750784 (A)				
				200	(B)	750800 (G)				
				250	(B)	750864 (G)				
				333	-	750944 (G)				
				500	-	751168 (G)				
				HE	12000	120/240	INTERNALLY FUSED, SECONDARY BREAKER 1Ø SECONDARY FOR FIELD MAINTENANCE ONLY	3	-	752160 (A)
3	(J)	752192 (A)								
5	-	752288 (A)								
5	(J)	752320 (A)								
10	(J)	751936 (A)								
15	(J)	752064 (A)								
25	(J)	752128 (A)								
37.5	-	752224 (A)								
37.5	(J)	752256 (A)								
50	(J)	752384 (A)								
75	(J)	752448 (A)								
100	-	751968 (G)								
100	(J)	752000 (G)								
HEB	12000	120/240	INTERNALLY FUSED, SECONDARY BREAKER, USED ON BANKED SECONDARY SYSTEM, 1Ø SECONDARY					10	-	752480 (A)
								10	(J)	752512 (A)
				15	-	752544 (A)				
				15	(J)	752576 (A)				
				25	-	752608 (A)				
HF	12000	240/480	SINGLE PHASE TRANSFORMER 1Ø SECONDARY 3Ø SECONDARY (K)	25	(J)	752640 (A)				
				37.5	(J)	752864 (A)				
				75	-	- (A)				
				250	(B) & (J)	752800 (G)				
				333	(B)	752832 (G)				
HJ	12000	120/240	INTERNALLY FUSED, SECONDARY BREAKER LIGHTNING ARRESTER, 1Ø SECONDARY	500	(B)	752960 (G)				
				2.5	-	- (A)				
				2.5	(J)	753408 (A)				
				3	-	- (A)				
				3	(J)	753504 (A)				
				5	-	753536 (A)				
				5	(J)	753568 (A)				
				7.5	-	- (A)				
				7.5	(J)	753600 (A)				
				10	(J)	753312 (A)				
				15	(J)	753376 (A)				
				25	(J)	753472 (A)				
				50	(J)	- (A)				
				75	-	- (A)				
				75	(J)	- (A)				
HY	12000	277	SINGLE PHASE TRANSFORMER 1Ø SECONDARY 3Ø SECONDARY (K)	100	(J)	753328 (A)				
				100	(B)	754602 (G)				
				333	(B)	754604 (G)				
				500	(B)	754608 (G)				

SDG & E ELECTRIC STANDARDS

1199.203

TRANSFORMER PREFIXES, POLE-MOUNTED
SINGLE PHASE

DATE 1-1-88

APPD AX/1/88

PREFIX	VOLTAGE		DESCRIPTION AND APPLICATION	KVA	D F TAPS	STOCK NUMBER
	PRIMARY	SECONDARY				
HD	12000	480X2400	SINGLE PHASE TRANSFORMER, STEPDOWN 1Ø SECONDARY 3Ø SECONDARY (K)	50	-	751808 (A)
				100	-	751584 (A)
				100	(J)	751616 (A)
				200	-	751680 (A)
				200	(H)	751712 (A)
				250	-	- (A)
				333	-	751744 (A)
				333	(J)	751776 (A)
				500	(J)	751840 (A)
				HO	12000	2400/4160Y
150	-	753888 (A)				
150	(J)	- (A)				
200	(J)	753984 (A)				
250	-	754048 (A)				
250	(B)	754080 (A)				
333	-	754112 (A)				
500	-	754208 (A)				
833	-	754304 (A)				
1250	-	753856 (A)				
HOY	12000	7200X2400	SINGLE PHASE TRANSFORMER STEPDOWN	100	-	754528 (A)
				100	(B)	754560 (A)
				333	(B)	754592 (A)

FOR FIELD MAINTENANCE ONLY

TRANSFORMER PREFIXES, STREETLIGHT:

PREFIX	COIL RATING	DESCRIPTION & APPLICATION	KVA	TAPS D	STOCK NUMBER
RCA	240 - 6.6A	CONSTANT CURRENT WITH BUILT-IN CAPACITOR	4.95	-	763424 (G)
R	2400 - 6.6A	CONSTANT CURRENT	5	-	763296 (G)
			7.5	-	763328 (G)
			10	-	763168 (G)
			15	-	763200 (G)
			20	-	- (G)
			30	-	763264 (G)
RC	2400 - 6.6A	CONSTANT CURRENT WITH BUILT-IN CAPACITOR	10	-	763360 (G)
			15	-	763392 (G)
RH	12000 - 6.6A	CONSTANT CURRENT	20	-	763504 (G)
RS	2400 - 6.6A	SUBWAY TYPE, CONSTANT CURRENT	5	-	- (G)
			10	-	763616 (G)
			15	-	763648 (G)
			25	(J)	763712 (G)
			30	-	763744 (G)
RR	2400 - 20A	CONSTANT CURRENT	10	-	763528 (G)
			30	-	763584 (G)
RRS	2400 - 20A	SUBWAY TYPE, CONSTANT CURRENT	30	(J)	763746 (G)
L	6.6A - 6.6A	CONSTANT CURRENT	.5	-	- (G)
			1	-	762976 (G)
			2	-	763040 (G)
			3	-	763072 (G)
			4	-	763104 (G)
			5	-	763136 (G)
			10	-	763008 (G)

SDG & E ELECTRIC STANDARDS

TRANSFORMER PREFIXES, POLE-MOUNTED
SINGLE PHASE

1199.204

DATE 1-1-94

APPD *AK/ADG*

PREFIX	VOLTAGE		DESCRIPTION AND APPLICATION	KVA	D (F) TAPS	STOCK NUMBER	
	PRIMARY	SECONDARY					
WT	2400X4160Y	240/480	THREE-PHASE TRANSFORMER WITH A 120V TERMINAL RATED 5% OF KVA RATING WHEN CONNECTED FOR 240V OPERATION	10	-	-	(A)
				15	-	-	(A)
				25	-	-	(A)
				30	-	-	(A)
				37.5	-	757600	(A)
				45	-	-	(A)
				50	-	-	(A)
				75	-	757632	(A)
				100	-	757568	(A)
				112.5	-	-	(A)
WAT	2400/4160Y	240	THREE-PHASE TRANSFORMER WITH A TERMINAL RATED 5% OF KVA RATING	30	-	755664	(A)
				45	-	755680	(A)
WFT	2400X4160Y	240/480	THREE-PHASE TRANSFORMER	25	-	756480	(A)
				25	(H)	756512	(A)
				30	-	756544	(A)
				30	(H)	756576	(A)
				37.5	-	756608	(A)
				37.5	(H)	756640	(A)
				45	-	756672	(A)
				45	(H)	756704	(A)
				50	-	756736	(A)
				50	(H)	756768	(A)
HGT	12000	208Y/120	THREE-PHASE TRANSFORMER	75	(H)	753152	(A)
				150	(B)	753056	(A)
				225	(J)	753072	(A)
				300	(B)	753104	(A)
				500	(B)	753136	(G)
				750	(B)	753184	(G)
HZT	12000	208Y/120	INTERNALLY FUSED, SECONDARY BREAKER	75	-	754616	(A)
				75	(B)	754618	(A)
				150	-	754612	(A)
				150	(B)	754614	(A)

FOR FIELD MAINTENANCE ONLY

PREFIX	VOLTAGE		DESCRIPTION AND APPLICATION	KVA	D F TAPS	STOCK NUMBER
	PRIMARY	SECONDARY				
HAT	12000	240	THREE-PHASE TRANSFORMER INCLUDES A 120V TERMINAL RATED 5% OF KVA RATING	30	C & H	751328 (A)
				45	H	751392 (A)
				150	-	751296 (A)
				500	-	- (A)
HBT	12000	240 X 480	THREE-PHASE TRANSFORMER INCLUDES A 120V TERMINAL RATED 5% OF KVA RATING WHEN CONNECTED FOR 240V OPERATION	10	-	- (A)
				15	-	- (A)
				25	-	- (A)
				30	-	751424 (A)
				30	C	751456 (A)
				37.5	-	- (A)
				45	C	751488 (A)
				50	-	- (A)
				75	-	751520 (A)
				75	C	751552 (A)
HLT	12000	240 X 480	THREE-PHASE TRANSFORMER	25	-	- (A)
				25	C	753696 (A)
				37.5	-	- (A)
				100	-	753664 (A)
HMT	12000	480	THREE-PHASE TRANSFORMER	45	-	- (A)
HJM	12000	480	THREE PHASE TRANSFORMER INTERNALLY FUSED, SECONDARY BREAKER LIGHTNING ARRESTER	45	-	753632 (A)
HNT	12000	480Y/277	THREE-PHASE TRANSFORMER	225	B	- (G)
				300	B	- (G)
				500	B	753760 (G)
				750	B	753792 (G)
				1000	B	753728 (G)

FOR FIELD MAINTENANCE ONLY

PREFIX	VOLTAGE		DESCRIPTION AND APPLICATION	KVA	D (F) TAPS	STOCK NUMBER
	PRIMARY	SECONDARY				
HOT	12000	4160Y/2400	THREE PHASE TRANSFORMER STEPDOWN	150	-	754368 (G)
				1250	(B)	754336 (G)
				1500		754400 (G)
				2000	(B)	754432 (G)
				2500	-	754464 (G)
				3750	-	- (G)
				5000/ 6250	(B)	754496 (G)

FOR FIELD MAINTENANCE ONLY

TRANSFORMER PREFIXES, SUBSTATION:

PREFIX	VOLTAGE		DESCRIPTION AND APPLICATION
	PRIMARY	SECONDARY	
KO	69000	4160	SUBSTATION USE 1Ø
K	69000	12000	SUBSTATION USE 1Ø
KOT	69000	4160	SUBSTATION USE 3Ø
KT	69000	12000	SUBSTATION USE 3Ø
KHT	69000 X 33000	12000/4160Y	SUBSTATION USE 3Ø
KK	138000	69000	SUBSTATION USE 1Ø
KNT	138000	12000	SUBSTATION USE 3Ø
KKT	138000	69000	SUBSTATION USE 3Ø
KLT	230000	69000	SUBSTATION USE 3Ø
KMT	230000	138000	SUBSTATION USE 3Ø
KXX	-	-	NON-STANDARD ALL VOLTAGE GENERATING STATION USE ONLY

INSTALLATION:

- (A) NO LONGER PURCHASED.
- (B) TWO 2 1/2% TAPS ABOVE AND BELOW.
- (C) ONE 5% TAP ABOVE AND BELOW.
- (D) WHEN MIRAMAR SUBSTITUTES TAPPED TRANSFORMERS FOR UNTAPPED ONES, THEY SHALL BE USED IN THE FLAT (STRAIGHT OR NEUTRAL) TAP POSITION.
- (F) AUTHORIZATION FROM DISTRICT ENGINEERING REQUIRED BEFORE USING TAPS. IF AFTER NORMAL WORKING HOURS, AND TAPS MUST BE USED, INFORM DISTRICT ENGINEERING OF THE USE AND TAP SETTING THE NEXT DAY.
- (G) SPECIAL ORDER.
- (H) TWO 5% TAPS BELOW.
- (I) THREE 4 1/2% TAPS BELOW.
- (J) FOUR 2 1/2% TAPS BELOW.
- (K) 3Ø SECONDARY AVAILABLE WHEN BANKED.

REFERENCE:

L. FOR SINGLE AND THREE PHASE PAD-MOUNTS, AND SUBSURFACE TRANSFORMERS, SEE UG STANDARDS BOOK.

SCOPE: THIS STANDARD SHOWS THE INSTALLATION METHOD OF A TYPE 'W' TRANSFORMER, ON ARMLESS TANGENT CONSTRUCTION.

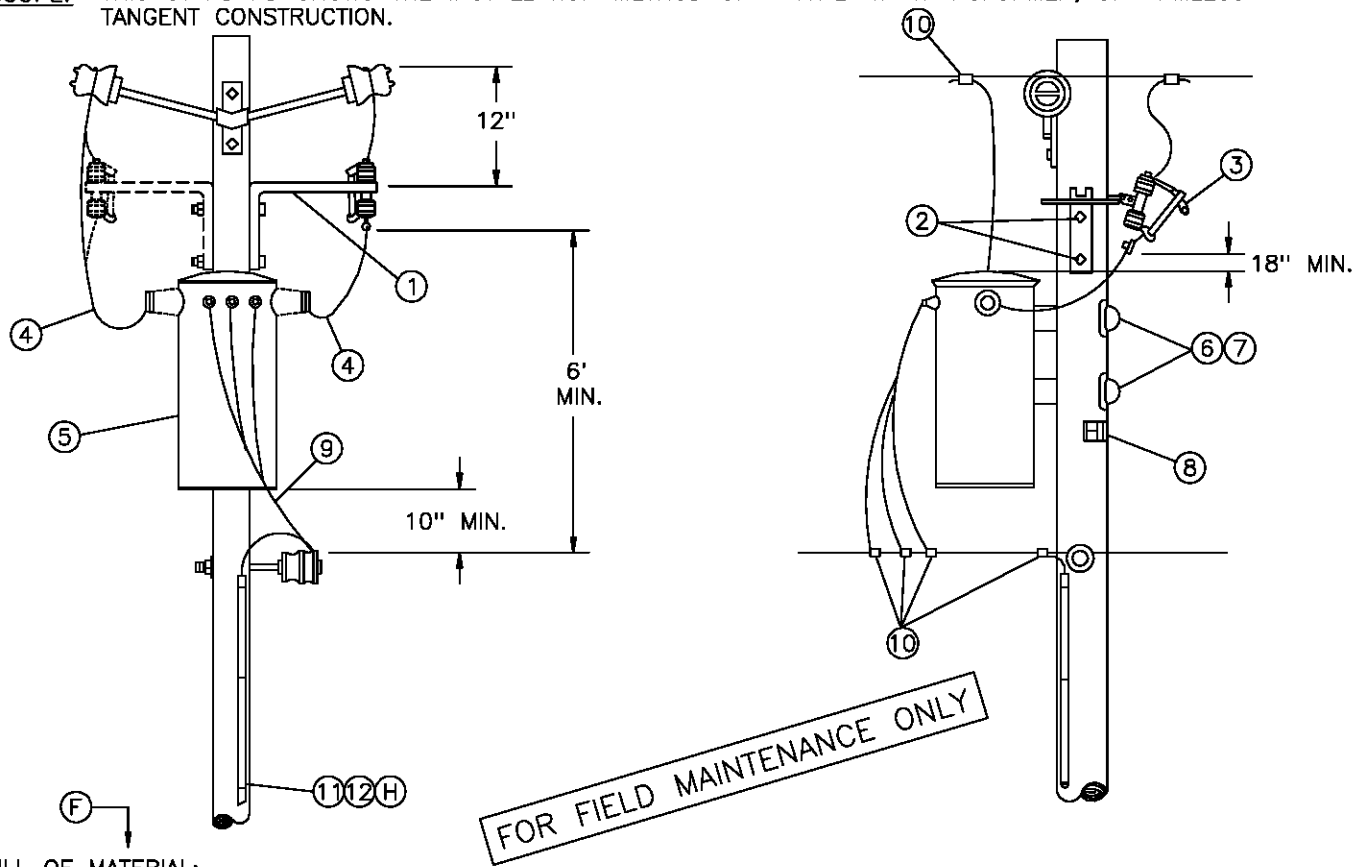

BILL OF MATERIAL:

ITEM	DESCRIPTION	QUANTITY		STOCK NO OR CONSTR STANDARD
		2.4KV	4KV	
1	BRACKET, CUTOUT MOUNTING	2	1	166448
2	BOLT, MACH, GALV, 5/8" X (LENGTH AS REQ'D) & 1 SQ CURVED WASHER	2	2	STD 392
3	CUTOUT, 12KV	2	1	STD 1212
4	WIRE, 5KV INSULATED, XLP, #6 STRANDED COPPER	8'	10'	194304
5	TRANSFORMER, SINGLE PHASE, TYPE W	1	1	STD 1121
6	BOLT, MACH, GALV, 5/8" OR 3/4" X (LENGTH AS REQ'D), 1 SQ CURV & 1 DBL COIL SPRING WASHER	2	2	STD 392
7	COVER, BOLT, PLASTIC & 6 - 10D NAILS, GALV	2	2	285696 491392
8	SIGN, HIGH VOLTAGE & 9 ROOFING NAILS, GALV	1	1	647648 492224
9	WIRE, W.P. (SIZE GOVERNED BY TRANSFORMER CAPACITY)	21'	21'	STD 1125
10	CONNECTORS, WIRE COMPRESSION, CU OR AL, AS REQ'D	AS REQ'D		783-787
11	WIRE, BARE STRANDED, COPPER, #6	42'	42'	813536
12	UNIT GROUND, COMPLETE	1	1	603136

REFERENCE:

- (F) POLE STEPPING - SEE STANDARD 363.
- G. FOR LIGHTNING ARRESTER REQUIREMENTS - SEE STANDARD 1247.
- (H) GROUNDING METHODS - SEE STANDARD 1002.
- I. FOR POLE TOP MATERIAL - SEE DISTRIBUTION POLE TOPS (SECTION 400).

		SDG&E ELECTRIC STANDARDS		
DATE	1-1-86	2.4 OR 4KV SINGLE PHASE TYPE "W" TRANSFORMER INSTALLATION 100 KVA MAXIMUM, ARMLESS TANGENT CONST		1199.208 SUPERSEDES 1128 (1-1-93)
APPD	/			

SCOPE: THIS STANDARD SHOWS THE INSTALLATION METHOD OF A TYPE 'W' TRANSFORMER, ON ARMLESS DEADEND CONSTRUCTION.

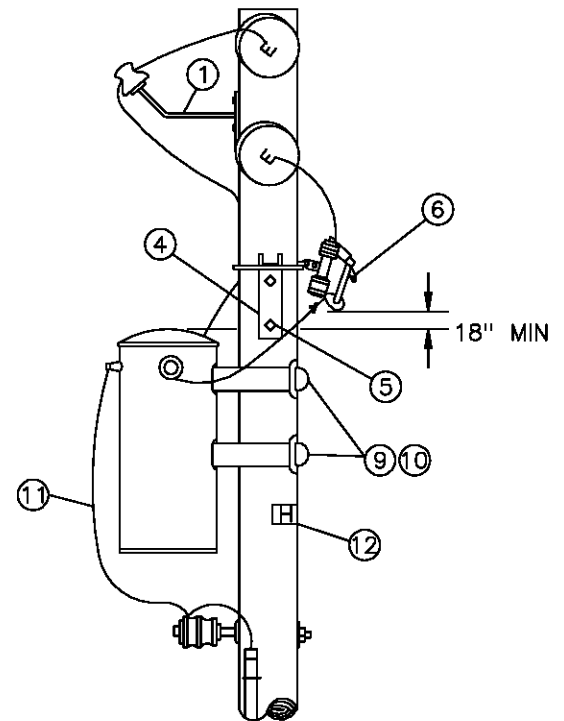
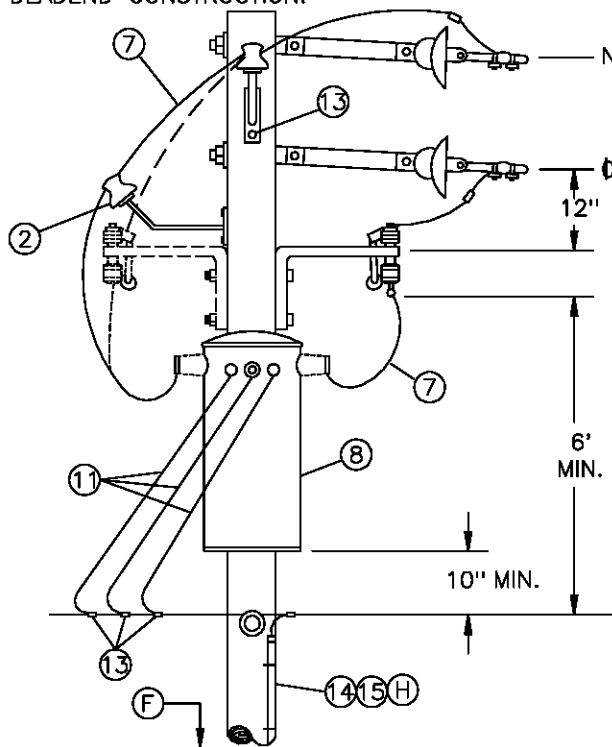

ITEM	DESCRIPTION	QUANTITY		STOCK NO OR CONSTR STANDARD
		2.4KV	4KV	
1	BRACKET, INSULATOR, 1" LEAD THREAD	2	2	166134
2	INSULATOR, CLASS AS REQUIRED	1	2	STD 750
3	SCREW, LAG, GALV. 1/2" X 4"	2	2	621568
4	BRACKET, CUTOUT MOUNTING	2	1	166448
5	BOLT, MACH, GALV, 5/8" X (LENGTH AS REQ'D) & 1 SQ CURVED WASHER	2	2	STD 392
6	CUTOUT, 12KV	2	1	STD 1212
7	WIRE, 5KV INSULATED, XLP, #6 STRANDED COPPER	10'	12'	194304
8	TRANSFORMER, SINGLE PHASE, TYPE W	1	1	STD 1211
9	BOLT, MACH, GALV, 5/8" OR 3/4" X (LENGTH AS REQ'D), 1 SQ CURVED & 1 DBL COIL SPRING WASHER	2	2	STD 392
10	COVER, BOLT, PLASTIC & 6 - 10D NAILS, GALV	2	2	285696 491392
11	WIRE, W.P. (SIZE GOVERNED BY TRANSFORMER CAPACITY)	21'	21'	STD 1125
12	SIGN, HIGH VOLTAGE & 9 ROOFING NAILS, GALV	1	1	647648 492224
13	CONNECTORS, WIRE COMPRESSION, CU OR AL, AS REQ'D	AS REQ'D		783-787
14	WIRE, BARE STRANDED, COPPER, #6	42'	42'	813536
15	UNIT GROUND, COMPLETE	1	1	603136

REFERENCE:

- (F) POLE STEPPING - SEE STANDARD 363.
- G. FOR LIGHTNING ARRESTER REQUIREMENTS - SEE STANDARD 1247.
- (H) GROUNDING METHODS - SEE STANDARD 1002.
- I. FOR POLE TOP MATERIAL - SEE DISTRIBUTION POLE TOPS (SECTION 400).

		SDG&E ELECTRIC STANDARDS		
DATE	1-1-86	2.4 OR 4KV, SINGLE PHASE TYPE "W" TRANSFORMER INSTALLATION 100KVA MAXIMUM, ARMLESS DEAD END CONST		1199.209 SUPERSEDES 1129 (1-1-93)
APPD	/			

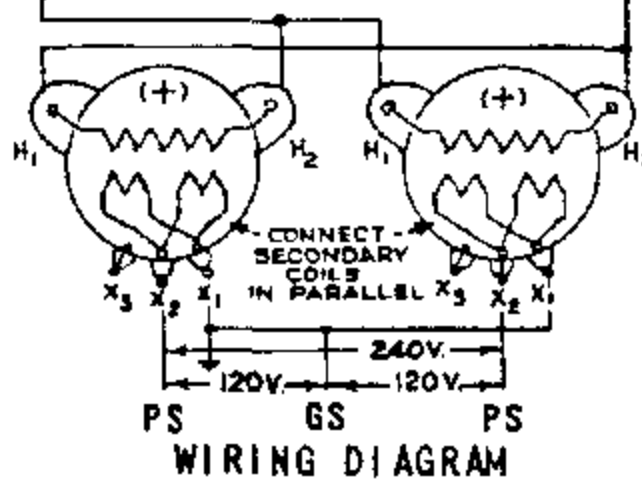
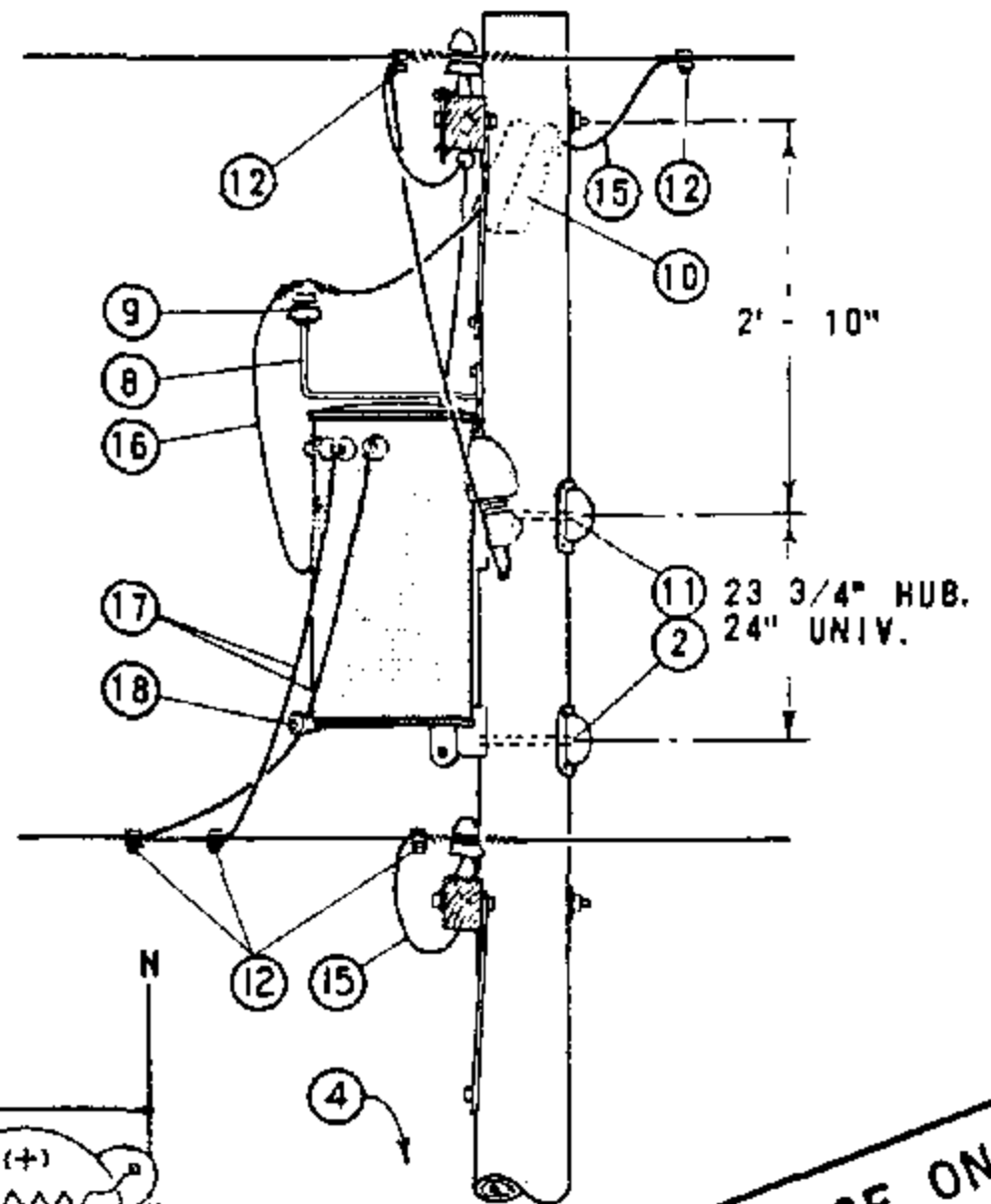
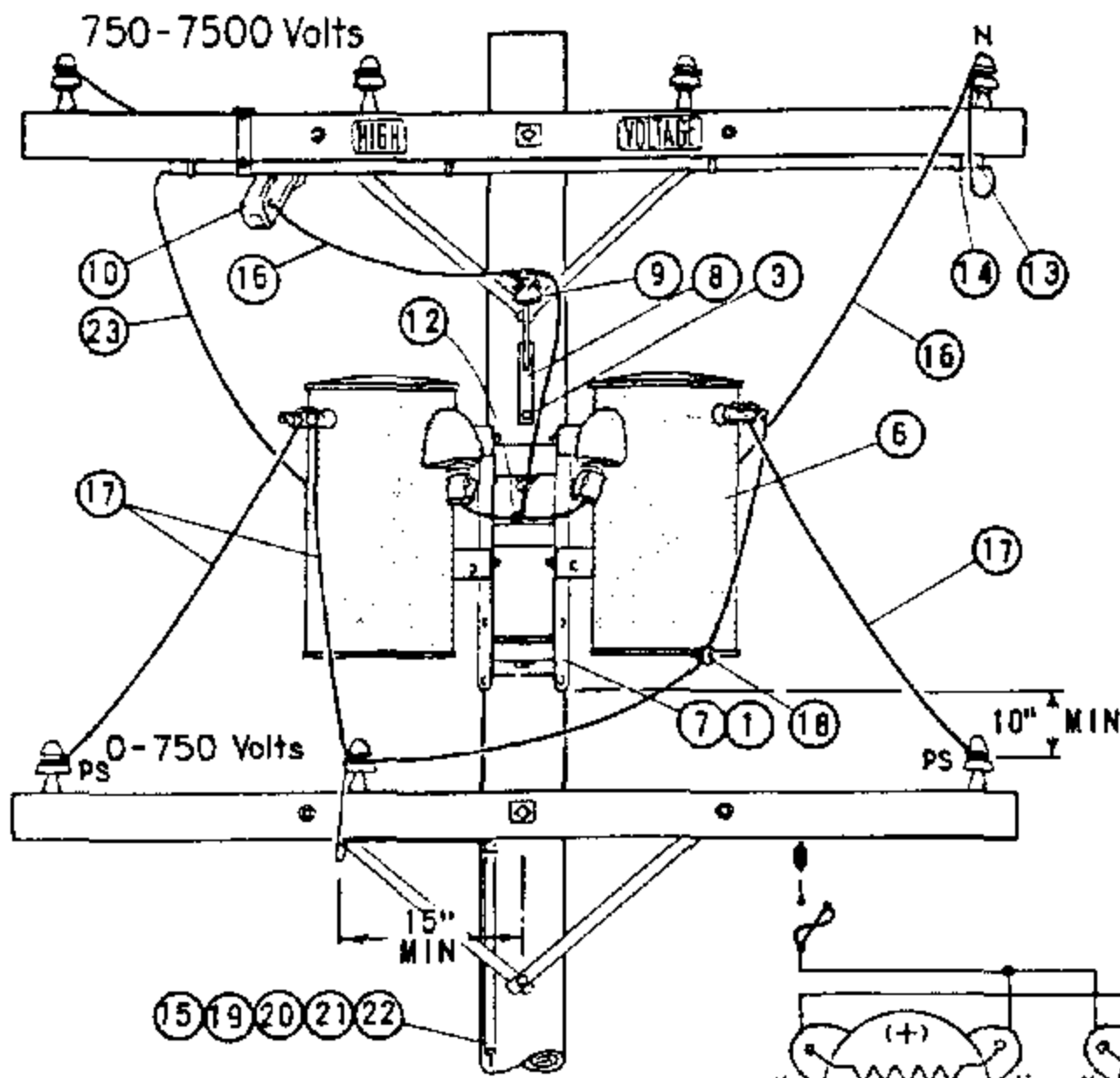

FOR FIELD MAINTENANCE ONLY

NOTES:

- (A) LIMITED TO TWO 15 KVA TRANSFORMERS.
- (B) USE TWO GROUND RODS SPACED A MINIMUM OF 6 FEET APART FOR EACH GROUND UNIT.
- (C) PHASE TO PHASE CONNECTIONS ON 2.4 KV DELTA AND 4 KV WYE SYSTEMS REQUIRE TWO CUTOUPS.
- (D) FUSE FOR COMBINED KVA OF PARALLELED TRANSFORMERS.
- (E) EXEMPT MATERIALS.
- (F) UNIT GROUND COMPLETE ORDER 603120 WITH GRAY MOULDING, 603136 WITH PLAIN MOULDING.

ITEM	DESCRIPTION	QUANTITY	STOCK NO. OR CONSTR STDS					
				P	L	T	F	I
1	BOLT, MACH GALV, 5/8" (E) DR 3/4" X 2", 2 WASH & 1 NUT.	4	PGS 139, 140					
2	BOLT, MACH GALV, 3/4" X 10", 1 SQ CURV WASH. & 1 NUT.	2	PGS 139, 140					
3	SCREW, LAG GALV, 1/2" X 4"	(E) 2	621568					
4	STEP, POLE	(E) 16	692992					
5								
6	TRANSFORMER, SINGLE PHASE TYPE W OR OY	(A) 2	PGS 1121.01-1121.12					
7	BRACKET, TRANSFORMER MTG	1	402976					
8	BRACKET, INSULATOR, 1" OR 1 3/8" THREAD, AS REQ'D	1	156144 / 166176					
9	INSULATOR, 12KV	1	700 SECTION					
10	CUTOUP, 5KV	(C) 2	PG 1211					
11	COVER, THRU BOLT & 6-10D NAILS GALV	2	285696, 491392					
12	CONNECTOR, WIRE, AS REQ'D	7	PGS 783-787					
13	CONDUIT, PLASTIC PVC, 3/4" SCHEDULE 40, TYPE II	(E) 5'	251328					
14	STRAP, PIPE 3/4" & 2-6D NAILS, GALV	(E) 3	697888, 491552					
15	WIRE, BARE STRANDED COPPER, #6	48'	813536					
16	WIRE, #4 SOLID WP COPPER	8'	814112					
17	WIRE, WP COPPER, SIZE GOVERNED BY TRANSFORMER CAPACITY	24'	PG 1125					
18	BRACKET, INSULATOR	1	167520					
19	ROD & CLAMP, GROUND	(B) (F) 2	603072, 230016 (E)					
20	MOULDING, HARDWOOD 1"	(F) 27'	487200					
21	STAPLES, MOULDING, GALV 3" X 1 1/16" X 1/4"	(F) (E) 18	678560					
22	STAPLES, FENCE, GALV 1 1/4"	(F) (E) 16	678528					
23	WIRE, 5KV INSULATED, XLP, #6 STRANDED COPPER	16'	194304					

1199.301
SUPERSEDES
1138 (1-1-86)

SDG&E ELECTRIC STANDARDS
2.4KV. OR 4KV, SINGLE PHASE PARALLELED
TRANSFORMER INSTALLATION

DATE 1-1-86
APPD AK 1/25

SCOPE: THIS STANDARD SHOWS THE INSTALLATION METHOD OF A TYPE 'WE' TRANSFORMER, ON SECONDARY RACK CONSTRUCTION.

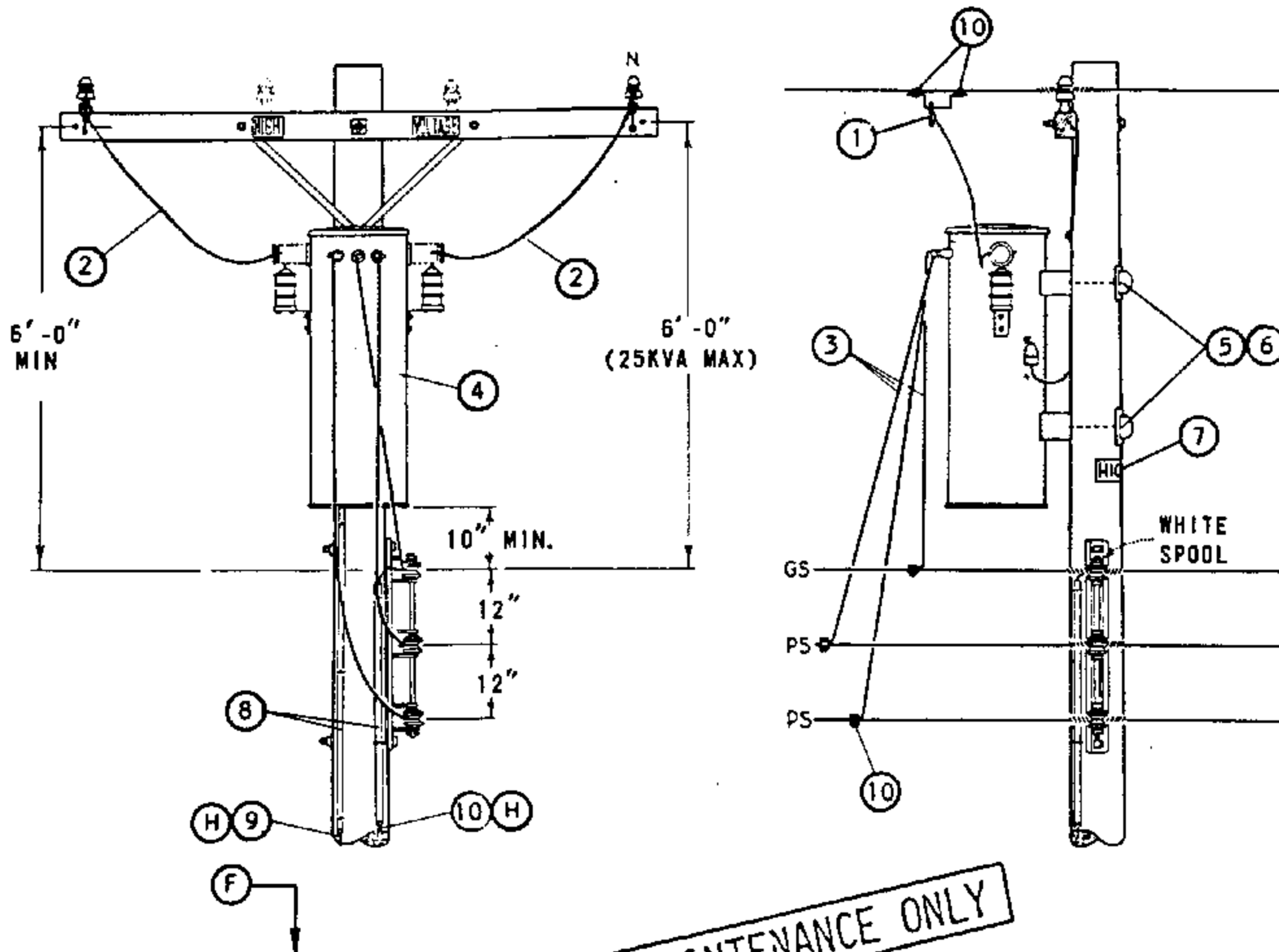

FOR FIELD MAINTENANCE ONLY

BILL OF MATERIAL:

ITEM	DESCRIPTION	QUANTITY	STOCK NO OR CONSTR STANDARD
1	CLAMP, HOTLINE & STIRRUP (E)	2	STD 788
2	WIRE, 5KV INSULATED, XLP, #6 STRANDED COPPER	12'	194304
3	WIRE, W.P., COPPER (SIZE GOVERNED BY TRANSFORMER CAPACITY)	21'	STD 1125
4	TRANSFORMER, SINGLE PHASE (TYPE 'WE' OR 'WJ')	1	STD 1121
5	BOLT, MACH, GALV, 5/8" OR 3/4" X (LENGTH AS REQ'D), 1 SQ CURVED & 1 DBL COIL SPRING WASHER (E)	2	STD 392
6	COVER, BOLT, PLASTIC & 6 - 10D NAILS, GALV (E)	2	285696
		-	491392
7	SIGN, HIGH VOLTAGE & 9 ROOFING NAILS, GALV (E)	1	647648
		-	492224
8	UNIT GROUND, COMPLETE (A)	2	603136
9	WIRE, #4 BARE STRANDED COPPER (A)	42'	813760
10	WIRE, #6 BARE STRANDED COPPER	42'	813536
11	CONNECTORS, WIRE COMPRESSION, CU OR AL, AS REQ'D (E)	AS REQ'D	783-787

INSTALLATION:

- (A) OMIT LIGHTNING ARRESTER GROUND ON TYPE 'WE' TRANSFORMER INSTALLATION.
- (E) EXEMPT MATERIAL.

REFERENCE:

- (F) POLE STEPPING - SEE STANDARD 363.
- G. WHEN LIGHTNING ARRESTERS ARE REQUIRED PER STANDARD 1247, USE TYPE 'WJ' TRANSFORMER.
- (H) GROUNDING METHODS - SEE STANDARD 1002.

SCOPE: THIS STANDARD SHOWS THE INSTALLATION METHOD OF A TYPE 'WE' TRANSFORMER, ON SECONDARY LINE ARM CONSTRUCTION.

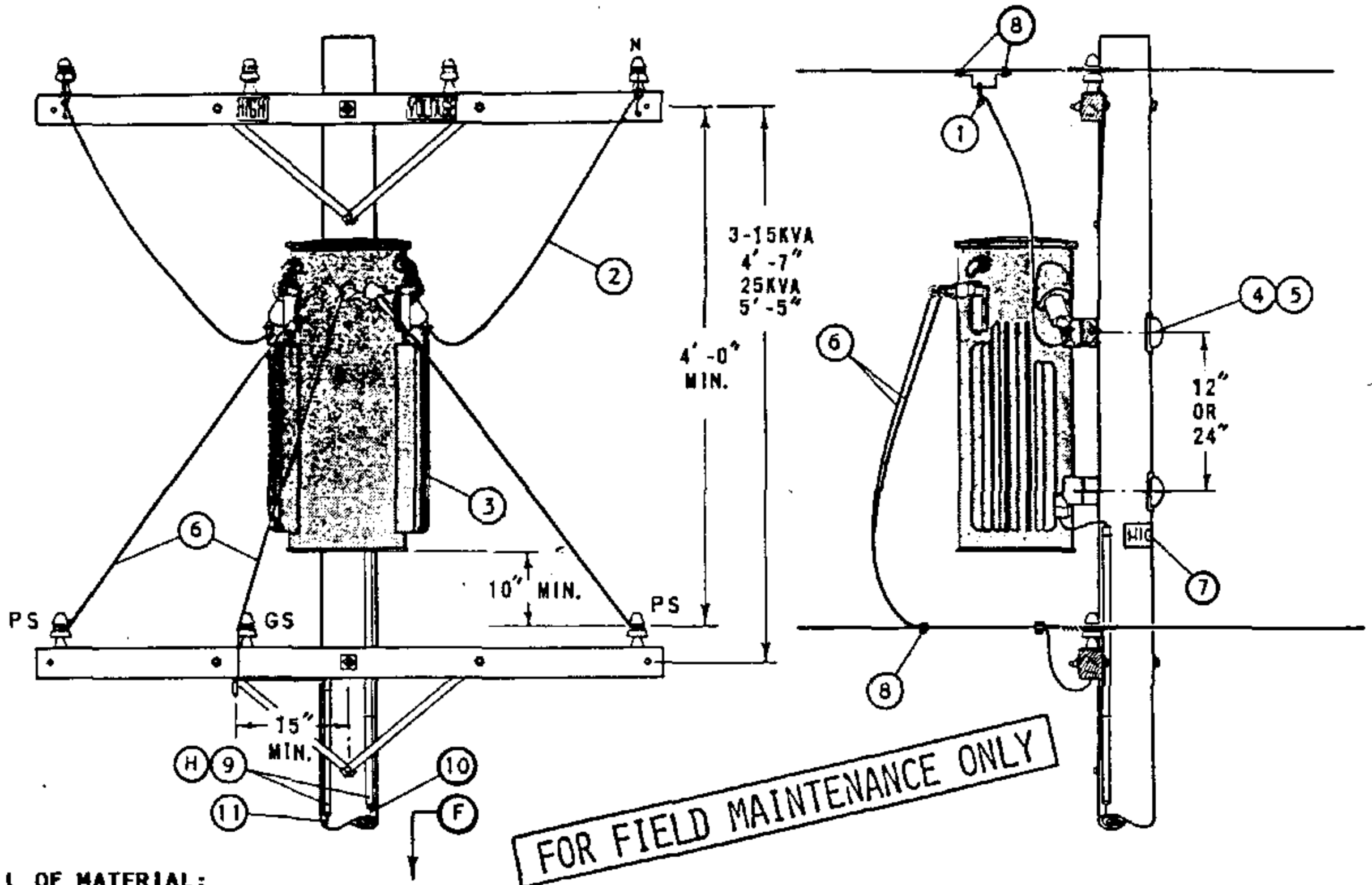

BILL OF MATERIAL:

ITEM	DESCRIPTION		QUANTITY	STOCK NO OR CONSTR STANDARD
1	CLAMP, HOTLINE & STIRRUP	(E)	2	STD 788
2	WIRE, 5KV INSULATED, XLP, #6 STRANDED COPPER		12'	194304
3	TRANSFORMER, SINGLE PHASE (TYPE 'WE' OR 'WJ')		1	STD 1121
4	BOLT, MACH, GALV, 5/8" OR 3/4" X (LENGTH AS REQ'D), 1 SQ CURVED & 1 DBL COIL SPRING WASHER	(E)	2	STD 392
5	COVER, BOLT, PLASTIC & 6 - 10D NAILS, GALV	(E) (E)	2 -	285696 491392
6	WIRE, W.P., COPPER (SIZE GOVERNED BY TRANSFORMER CAPACITY)		21'	STD 1125
7	SIGN, HIGH VOLTAGE & 9 ROOFING NAILS, GALV	(E) (E)	1 -	647648 492224
8	CONNECTORS, WIRE COMPRESSION, CU OR AL, AS REQ'D	(E)	AS REQ'D	783-787
9	UNIT GROUND, COMPLETE	(A)	2	603136
10	WIRE, #4 BARE STRANDED COPPER	(A)	41'	813760
11	WIRE, #6 BARE STRANDED COPPER		42'	813536

INSTALLATION:

- (A) OMIT LIGHTNING ARRESTER GROUND ON TYPE 'WE' TRANSFORMER INSTALLATION.
- (E) EXEMPT MATERIAL.

REFERENCE:

- (F) POLE STEPPING - SEE STANDARD 363.
- G. WHEN LIGHTNING ARRESTERS ARE REQUIRED, PER STANDARD 1247, USE TYPE 'WJ' TRANSFORMER.
- (H) GROUNDING METHODS - SEE STANDARD 1002.

1199.303
SUPERSEDES
1132 (1-1-93)

SDG&E ELECTRIC STANDARDS

2.4 OR 4KV, SINGLE PHASE, TYPE "WE" TRANSFORMER
INSTALLATION, 25 KVA MAX, SECONDARY LINE ARM CONSTRUCTION

DATE 1-1-86
APPD AK/RSS

SCOPE: THIS STANDARD SHOWS THE INSTALLATION METHOD OF A TYPE 'W' TRANSFORMER, ON SECONDARY RACK CONSTRUCTION.

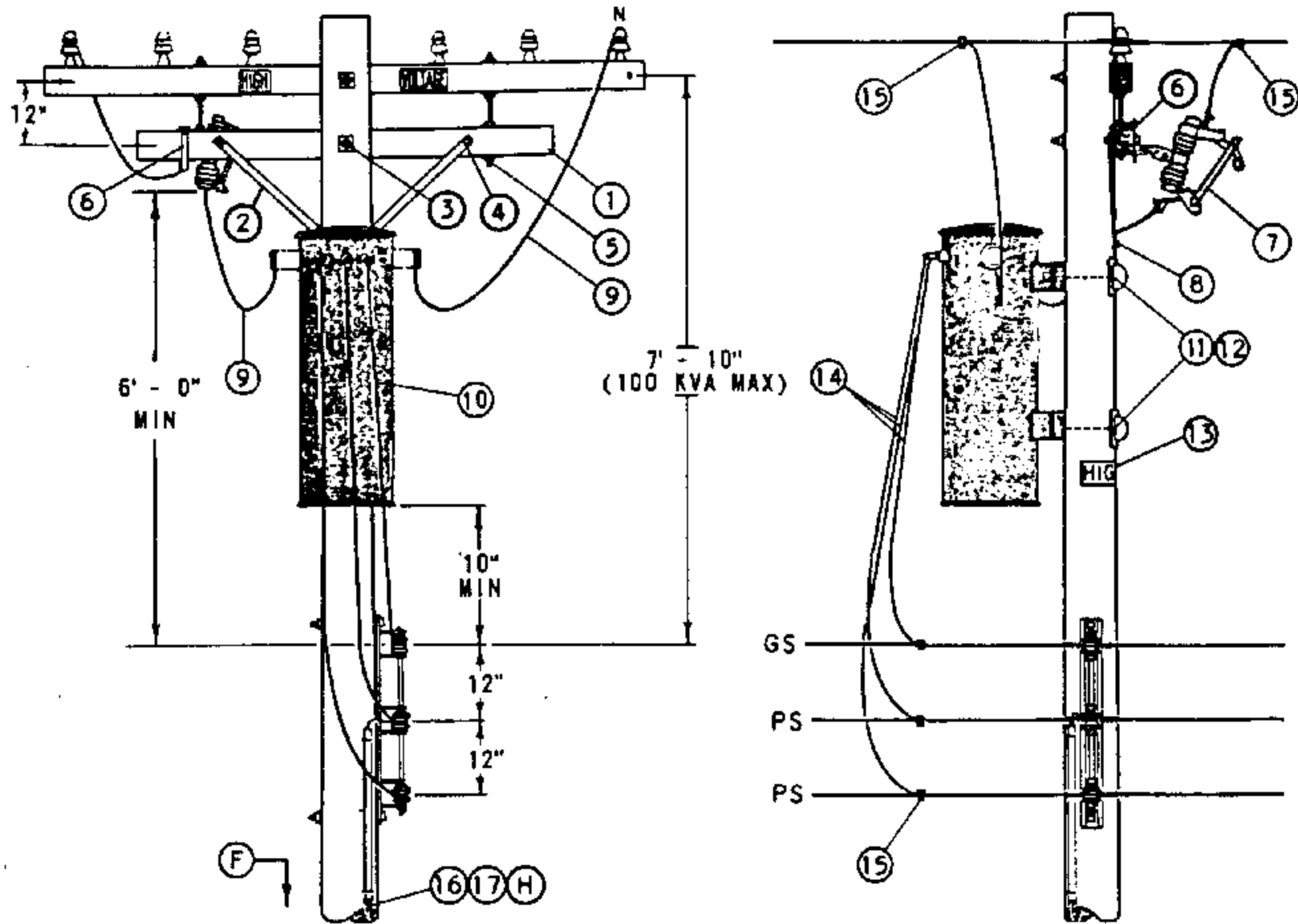

BILL OF MATERIAL:

ITEM	DESCRIPTION	QUANTITY	STOCK NO OR CONSTR STANDARD
1	CROSSARM, 3 1/2" X 4 1/2" X 6' - 0"	1	294112
2	BRACE, FLAT, CROSSARM, 28"	(E) 1	164192
3	BOLT, MACH, GALV, 5/8" X (LENGTH AS REQ'D), 2 SQ & 1 DBL COIL SPRING WASHER	(E) 1	STD 392
4	BOLT, MACH, GALV, 3/8" X 4 1/2", 1 RD & 1 SPRING LOCK WASHER	(E) 2	STD 392
5	BOLT, SPACE, GALV, 5/8" X 20", 4 SQ & 2 DBL COIL SPR WASHERS	(E) 2	STD 392
6	BRACKET, CUTOUT/ARRESTER, FOR CROSSARM MOUNTING	(E) 1	166070
7	CUTOUT, 12KV	(A) 1	STD 1212
8	BOLT, MACH, GALV, 1/2" X (LENGTH AS REQ'D), 1 SQ & 1 DBL COIL SPRING WASHER	(E) 1	STD 392
9	WIRE, 5KV INSULATED, XLP, #6 STRANDED COPPER	12'	194304
10	TRANSFORMER, SINGLE PHASE, TYPE 'W'	1	STD 1121
11	BOLT, MACH, GALV, 5/8" X (LENGTH AS REQ'D), 1 SQ CURVED & 1 DBL COIL SPRING WASHER	(E) 2	STD 392
12	COVER, BOLT, PLASTIC & 6 - 10D NAILS, GALV	(E) 2	285696
13	SIGN, HIGH VOLTAGE & 9 ROOFING NAILS, GALV	(E) 1	647648
14	WIRE, W.P., COPPER (SIZE GOVERNED BY TRANSFORMER CAPACITY)	21'	STD 1125
15	CONNECTORS, WIRE COMPRESSION, CU OR AL, AS REQ'D	(E) AS REQ'D	783-787
16	WIRE, BARE STRANDED COPPER, #6	42'	813536
17	UNIT GROUND, COMPLETE	1	603136

FOR FIELD MAINTENANCE ONLY

INSTALLATION:

- (A) 2.4KV SINGLE PHASE INSTALLATIONS REQUIRE TWO CUTOUTS.
- (E) EXEMPT MATERIAL.

REFERENCE:

- (F) POLE STEPPING - SEE STANDARD 363.
- G. FOR LIGHTNING ARRESTER REQUIREMENTS - SEE STANDARD 1247.
- (H) GROUNDING METHODS - SEE STANDARD 1002.

SDG&E ELECTRIC STANDARDS

DATE 1-1-86
APPD AK/ADG

2.4 OR 4KV, SINGLE PHASE TYPE "W" TRANSFORMER INSTALLATION,
100 KVA MAXIMUM, C.O. ARM, SECONDARY RACK CONSTRUCTION

1199.304
SUPERSEDES
1133 (1-1-93)

SCOPE: THIS STANDARD SHOWS THE INSTALLATION METHOD OF A TYPE 'W' TRANSFORMER, ON SECONDARY RACK CONSTRUCTION WITH CUTOUT ON LINE ARM.

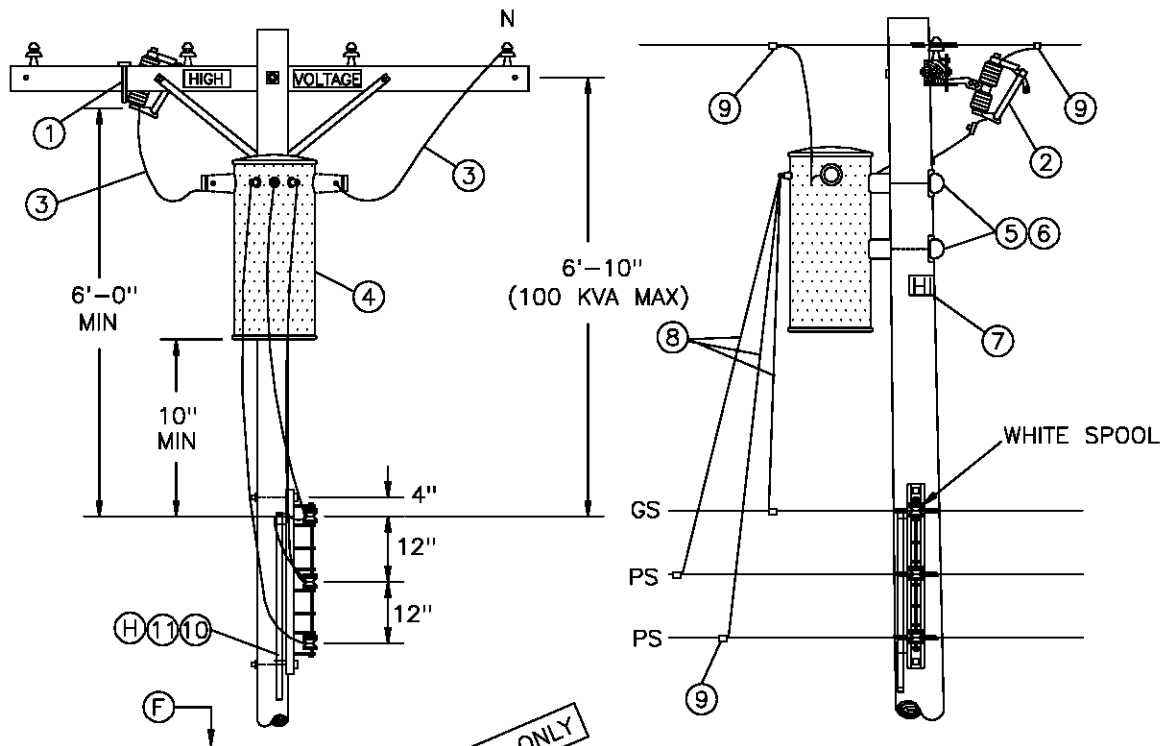

FOR FIELD MAINTENANCE ONLY

BILL OF MATERIAL:

ITEM	DESCRIPTION	QUANTITY	STOCK NO OR CONSTR STANDARD
1	BRACKET, CUTOUT/ARRESTER, FOR CROSSARM MOUNTING	1	166070
2	CUTOUT, 12KV	(A) 1	STD 1212
3	WIRE, 5KV INSULATED, XLP, #6 STRANDED COPPER	12'	194304
4	TRANSFORMER, SINGLE PHASE, TYPE 'W'	1	STD 1121
5	BOLT, MACH, GALV, 5/8" X (LENGTH AS REQ'D), 1 SQ CURVED & 1 DBL COIL SPRING WASHER	2	STD 392
6	COVER, BOLT, PLASTIC & 6 - 10D NAILS, GALV	2	285696 491392
7	SIGN, HIGH VOLTAGE & 9 ROOFING NAILS, GALV	1	647648 492224
8	WIRE, W.P., COPPER (SIZE GOVERNED BY TRANSFORMER CAPACITY)	21'	STD 1125
9	CONNECTORS, WIRE COMPRESSION, CU OR A, AS REQ'D	AS REQ'D	783-787
10	WIRE, BARE STRANDED COPPER, #6	42'	813536
11	UNIT GROUND, COMPLETE	1	603136

INSTALLATION:

(A) 2.4KV SINGLE PHASE INSTALLATIONS REQUIRE TWO CUTOUTS.

REFERENCE:

- (F) POLE STEPPING - SEE STANDARD 363.
- G. FOR LIGHTNING ARRESTER REQUIREMENTS - SEE STANDARD 1247.
- (H) GROUNDING METHODS - SEE STANDARD 1002.

1199.305 SUPERSEDES 1135 (1-1-93)	SDG&E ELECTRIC STANDARDS	DATE 1-1-86 APPD /
	2.4 OR 4KV, SINGLE PHASE TYPE "W" TRANSFORMER INSTALLATION, 100 KVA MAXIMUM LINE ARM MOUNTED C.O., SECONDARY RACK CONSTRUCTION	

SCOPE: THIS STANDARD SHOWS THE INSTALLATION METHOD OF A TYPE 'W' TRANSFORMER, WITH SECONDARY LINE ARM CONSTRUCTION AND CUTOUT MOUNTED ON LINE ARM.

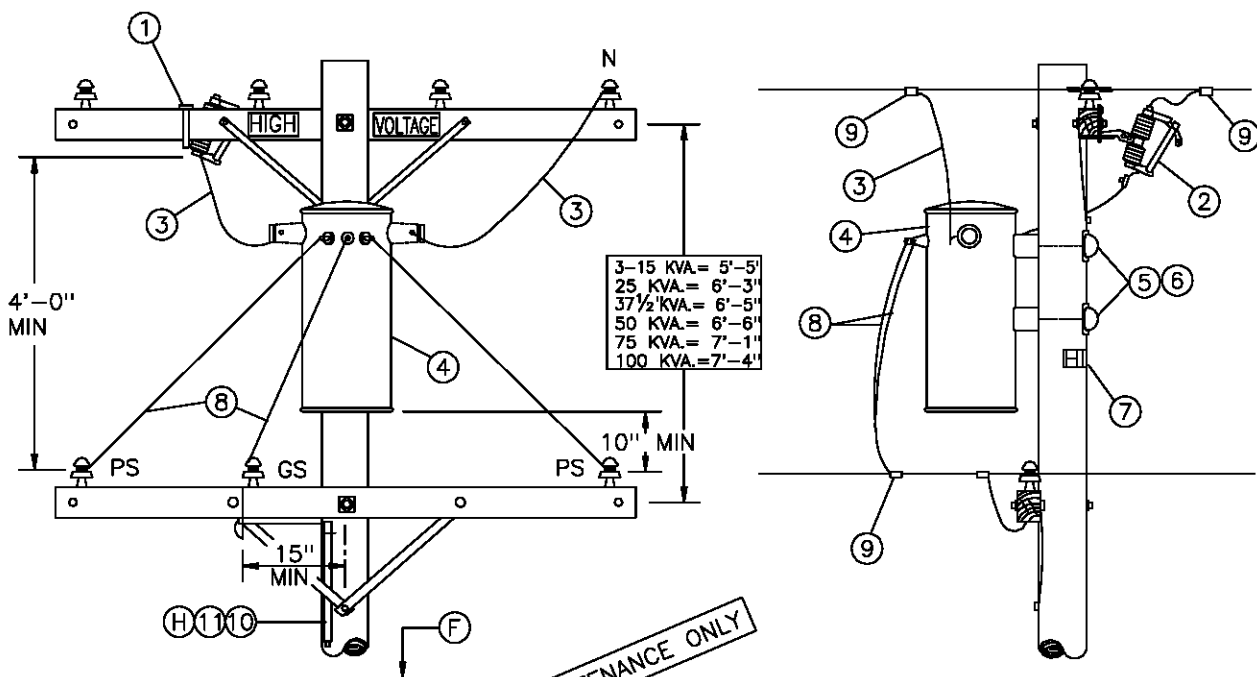

FOR FIELD MAINTENANCE ONLY

BILL OF MATERIAL:

ITEM	DESCRIPTION	QUANTITY	STOCK NO OR CONSTR STANDARD
1	BRACKET, CUTOUT/ARRESTER, FOR CROSSARM MOUNTING	1	166070
2	CUTOUT, 12KV	(A) 1	STD 1212
3	WIRE, 5KV INSULATED, XLP, #6 STRANDED COPPER	12'	194304
4	TRANSFORMER, SINGLE PHASE, TYPE 'W'	1	STD 1121
5	BOLT, MACH, GALV, 5/8" X (LENGTH AS REQ'D), 1 SQ CURVED & 1 DBL COIL SPRING WASHER	2	STD 392
6	COVER, BOLT, PLASTIC & 6 - 10D NAILS, GALV	2	285696 491392
7	SIGN, HIGH VOLTAGE & 9 ROOFING NAILS, GALV	1	647648 492224
8	WIRE, W.P., COPPER (SIZE GOVERNED BY TRANSFORMER CAPACITY)	21'	STD 1125
9	CONNECTORS, WIRE COMPRESSION, CU OR AL, AS REQ'D	AS REQ'D	783-787
10	WIRE, BARE STRANDED COPPER, #6	42'	813536
11	UNIT GROUND, COMPLETE	1	603136

INSTALLATION:

(A) 2.4KV SINGLE PHASE INSTALLATIONS REQUIRE TWO CUTOUTS.

REFERENCE:

- (F) POLE STEPPING - SEE STANDARD 363.
- G. FOR LIGHTNING ARRESTER REQUIREMENTS - SEE STANDARD 1247.
- (H) GROUNDING METHODS - SEE STANDARD 1002.

DATE 1-1-86 APPD /	SDG&E ELECTRIC STANDARDS	1199.306 SUPERSEDES 1136 (1-1-93)
	2.4 OR 4KV, SINGLE PHASE TYPE "W" TRANSFORMER INSTALLATION, 100 KVA MAXIMUM LINE ARM MOUNTED C.O., SECONDARY LINE ARM CONSTRUCTION	

SCOPE: THIS STANDARD SHOWS THE INSTALLATION METHOD OF A SINGLE PHASE TRANSFORMER, ON ARMLESS TANGENT CONSTRUCTION.

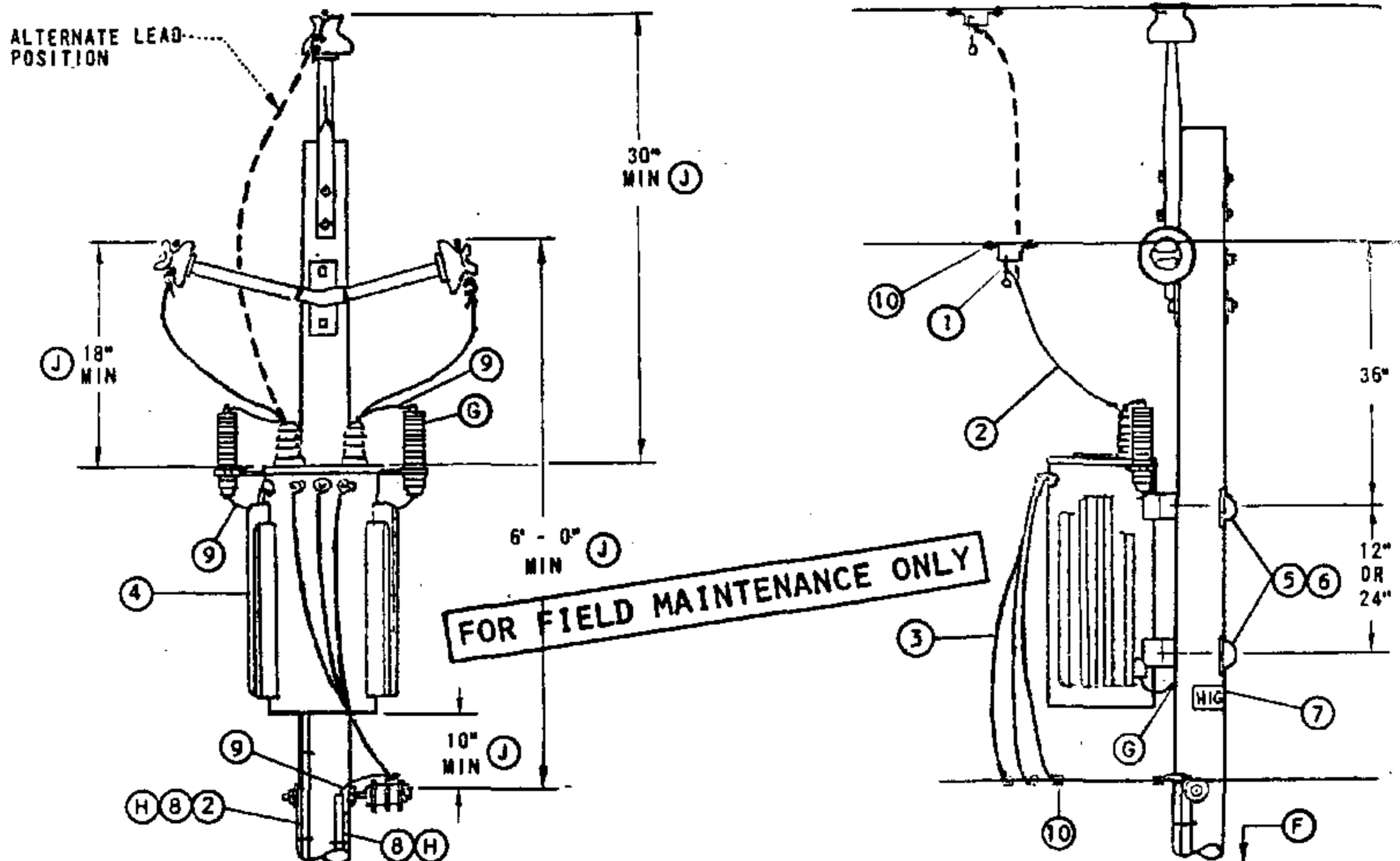

BILL OF MATERIAL:

ITEM	DESCRIPTION	QUANTITY		STOCK NO OR CONSTR STANDARD
		HE, YE	HJ, YJ	
1	CLAMP, HOTLINE & STIRRUP (E)	2	2	STD 788
2	WIRE, #4, BARE STRANDED COPPER	7'	55'	813760
3	WIRE, W.P., COPPER (SIZE GOVERNED BY TRANSFORMER CAPACITY)	21'	21'	STD 1125
4	TRANSFORMER, SINGLE PHASE (TYPE 'HE', 'HJ', 'YE' OR 'YJ')	1	1	STD 1121
5	BOLT, MACH, GALV, 5/8" OR 3/4" X (LENGTH AS REQ'D), 1 SQ CURVED & 1 DBL COIL SPRING WASHER (E)	2	2	STD 392
6	COVER, BOLT, PLASTIC & 6 - 10D NAILS, GALV (E)	2	2	285696
7	SIGN, HIGH VOLTAGE & 8 ROOFING NAILS, GALV (E)	1	1	647648
8	UNIT GROUND, COMPLETE (H)	1	2	603136
9	WIRE, #6 BARE STRANDED COPPER	42'	50'	813536
10	CONNECTORS, WIRE COMPRESSION, CU OR AL, AS REQ'D (E)	AS REQ'D		783-787

INSTALLATION:

A. WHEN INSTALLING A NEW STATION ON THE 7.2/12.47KV SYSTEM IN MEOD, IF NO PRIMARY NEUTRAL GROUND EXISTS ON THE POLE, INCLUDE THE NECESSARY MATERIALS TO INSTALL THE REQUIRED PRIMARY NEUTRAL GROUND. CONNECT TO TRANSFORMER TANK GAP GROUND.

(E) EXEMPT MATERIAL.

REFERENCE:

(F) POLE STEPPING - SEE STANDARD 363.

(G) WHEN LIGHTNING ARRESTERS ARE REQUIRED PER STANDARD 1247, USE TYPE 'HJ' OR 'YJ' TRANSFORMERS, AND GROUND TANK GAP.

(H) GROUNDING METHODS - SEE STANDARD 1002.

I. FOR POLE TOP MATERIAL - SEE DISTRIBUTION POLE TOPS (SECTION 400). FGS AND PTP ARE SHOWN FOR ILLUSTRATIVE PURPOSES ONLY.

(J) G.O. 95 MINIMUM REQUIREMENTS.

K. FOR AERIAL CABLE CONSTRUCTION - SEE SECTION 600.

SDG&E ELECTRIC STANDARDS

DATE 1-1-86

APPD AK/RB

7.2 OR 12KV SINGLE PHASE YE, YJ, HE, OR HJ TRANSFORMER
INSTALLATION 100 KVA MAXIMUM ARMLESS TANGENT CONSTRUCTION

1199.401

SUPERSEDES
1141 (1-1-86)

SCOPE: THIS STANDARD SHOWS THE INSTALLATION METHOD OF A SINGLE PHASE TRANSFORMER, ON ARMLESS DEADEND CONSTRUCTION.

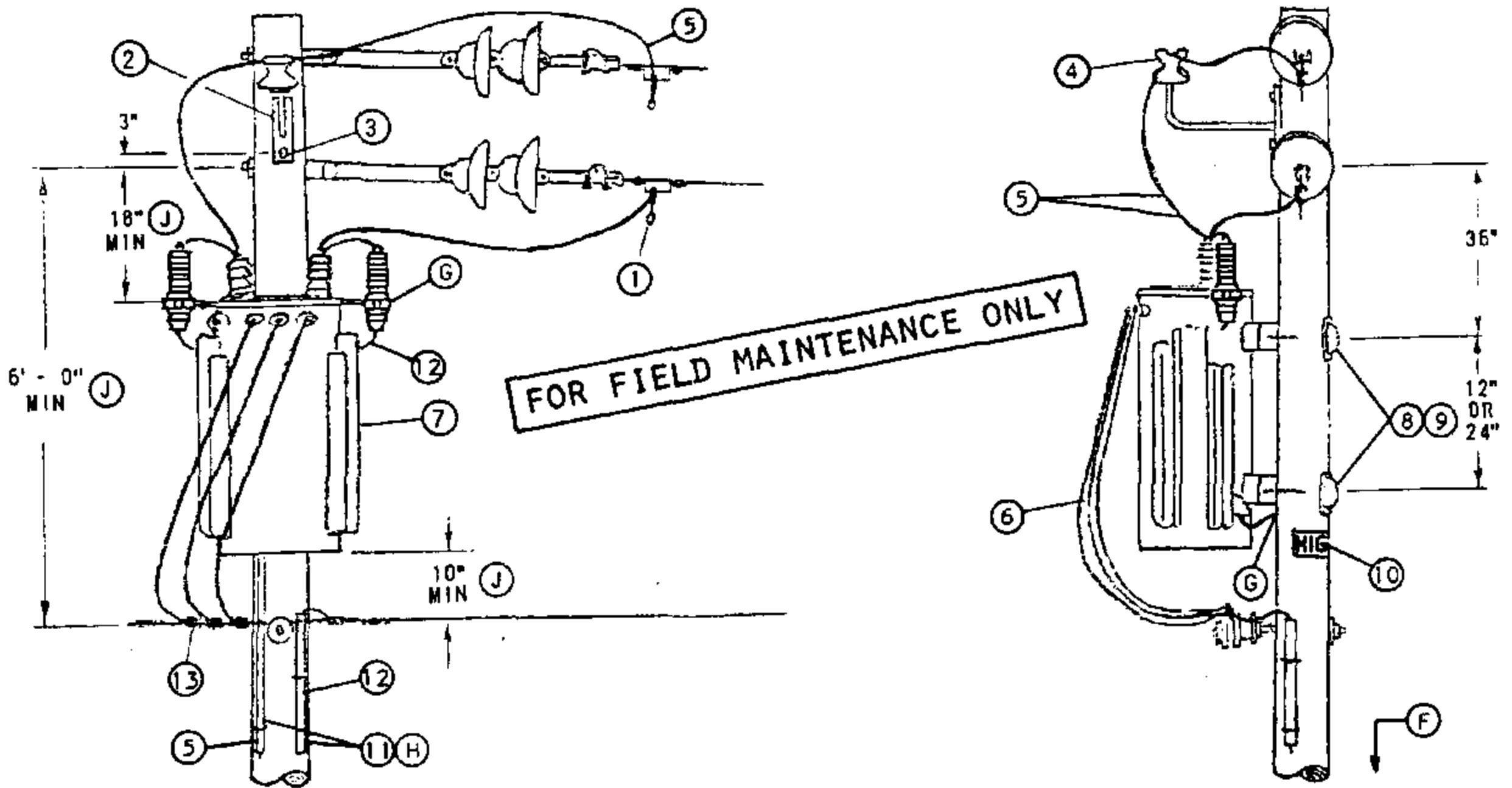

BILL OF MATERIAL:

ITEM	DESCRIPTION	QUANTITY		STOCK NO OR CONSTR STANDARD
		HE, YE	HJ, YJ	
1	CLAMP, HOTLINE & STIRRUP (E)	2	2	STD 788
2	BRACKET, INSULATOR, 1", LEAD THREAD	1	1	166144
3	SCREW, LAG, GALV, 1/2" X 4" (E)	2	2	621568
4	INSULATOR, 12KV, CLASS 55-5	1	1	429056
5	WIRE, #4, BARE STRANDED COPPER	12'	55'	813760
6	WIRE, W.P., COPPER (SIZE GOVERNED BY TRANSFORMER CAPACITY)	21'	21'	STD 1125
7	TRANSFORMER, SINGLE PHASE (TYPE 'HE', 'HJ', 'YE' OR 'YJ')	1	1	STD 1121
8	BOLT, MACH, GALV, 5/8" OR 3/4" X (LENGTH AS REQ'D), 1 SQ CURVED & 1 DBL COIL SPRING WASHER (E)	2	2	STD 392
9	COVER, BOLT, PLASTIC & 6 - 10D NAILS, GALV (E)	2	2	285696
		-	-	491392
10	SIGN, HIGH VOLTAGE & 8 ROOFING NAILS, GALV (E)	1	1	647648
		-	-	492224
11	UNIT GROUND, COMPLETE (H)	1	2	603136
12	WIRE, #6 BARE STRANDED COPPER	42'	50'	813536
13	CONNECTORS, WIRE COMPRESSION, CU OR AL, AS REQ'D (E)	AS REQ'D		783-787

INSTALLATION:

- A. WHEN INSTALLING A NEW STATION ON THE 7.2/12.47KV SYSTEM IN MEOD, AND IF NO PRIMARY NEUTRAL GROUND EXIST ON THE POLE, INCLUDE THE NECESSARY MATERIALS TO INSTALL THE REQUIRED PRIMARY NEUTRAL GROUND. CONNECT TO TRANSFORMER TANK GAP GROUND.
- B. FOR USE ONLY WHERE FUTURE EXTENSION IS UNLIKELY, SUCH AS CUL-DE-SACS.
- (E) EXEMPT MATERIAL.

REFERENCE:

- (F) POLE STEPPING - SEE STANDARD 363.
- (G) WHEN LIGHTNING ARRESTERS ARE REQUIRED PER STANDARD 1247, USE TYPE 'HJ' OR 'YJ' TRANSFORMERS, AND GROUND TANK GAP.
- (H) GROUNDING METHODS - SEE STANDARD 1002.
- (I) FOR POLE TOP MATERIAL - SEE DISTRIBUTION POLE TOPS (SECTION 400).
- (J) G.O. 95 MINIMUM REQUIREMENTS.
- (K) FOR AERIAL CABLE CONSTRUCTION - SEE SECTION 600.

1199.402
SUPERSEDES
1142 (1-1-86)

SDG&E ELECTRIC STANDARDS
7.2 OR 12KV SINGLE PHASE YE, YJ, HE, OR HJ TRANSFORMER
INSTALLATION 100 KVA MAXIMUM ARMLESS DEAD END CONSTRUCTION

ISSUE 1993
DATE 1-1-86
APPD AK/ROB

SCOPE: THIS STANDARD SHOWS THE INSTALLATION METHOD OF A SINGLE PHASE TRANSFORMER, WITH SECONDARY RACK CONSTRUCTION.

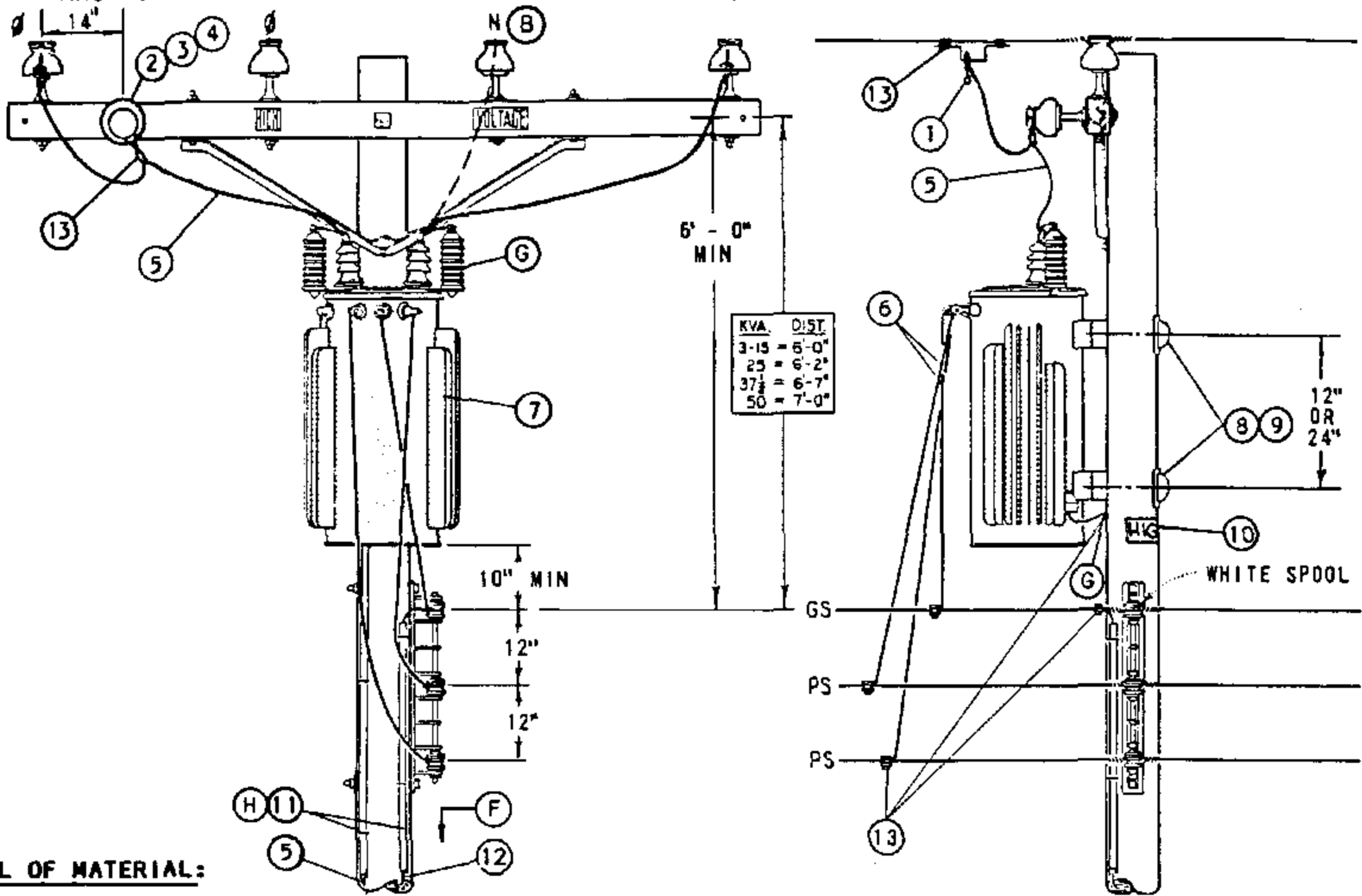

BILL OF MATERIAL:

ITEM	DESCRIPTION	QUANTITY		STOCK NO OR CONSTR STANDARD
		HE, YE	HJ, YJ	
1	CLAMP, HOTLINE & STIRRUP (E)	2	2	STD 788
2	BOLT, MACH, GALV, 5/8" X (LENGTH AS REQ'D), 2 SQ WASHERS & 1 DBL COIL SPRING WASHER (E)	1	1	STD 392
3	PIN, TRANSFORMER LEAD ADAPTER 1" OR 1 3/8" (E)	1	1	529248
		1	1	529216
4	INSULATOR, 12KV, 1" OR 1 3/8" PIN (E)	1	1	STD 750
5	WIRE, #4, BARE STRANDED COPPER	14'	55'	813760
6	WIRE, W.P., COPPER (SIZE GOVERNED BY TRANSFORMER CAPACITY)	21'	21'	STD 1125
7	TRANSFORMER, SINGLE PHASE (TYPE HE, HJ, OR YJ, YE)	1	1	STD 1121
8	BOLT, MACH, GALV, 5/8" OR 3/4" X (LENGTH AS REQ'D), 1 SQ CURVED & 1 DBL COIL SPRING WASHER (E)	2	2	STD 392
9	COVER, BOLT, PLASTIC & 6 - 10D NAILS, GALV (E)	2	2	285696
		-	-	491392
10	SIGN, HIGH VOLTAGE & 9 ROOFING NAILS, GALV (E)	1	1	647648
		-	-	492224
11	UNIT GROUND, COMPLETE (H)	1	2	603136
12	WIRE, #6 BARE STRANDED COPPER	42'	50'	813536
13	CONNECTORS, WIRE COMPRESSION, CU OR AL, AS REQ'D (E)	AS REQ'D		783-787

FOR FIELD MAINTENANCE ONLY

INSTALLATION:

A. WHEN INSTALLING A NEW STATION ON THE 7.2/12.47KV SYSTEM IN MEOD IF NO PRIMARY NEUTRAL GROUND EXISTS ON THE POLE, INCLUDE THE NECESSARY MATERIALS TO INSTALL THE REQUIRED PRIMARY NEUTRAL GROUND. CONNECT TO TRANSFORMER TANK GAP GROUND.

- (B) YE & YJ TRANSFORMERS ARE TO BE CONNECTED PHASE TO NEUTRAL.
- (E) EXEMPT MATERIAL.

REFERENCE:

- (F) POLE STEPPING - SEE STANDARD 363.
- (G) WHEN LIGHTNING ARRESTERS ARE REQUIRED PER STANDARD 1247, USE 'HJ' OR 'YJ' TYPE TRANSFORMER WITH TANK GAP GROUND.
- (H) GROUNDING METHODS - SEE STANDARD 1002.

SDG&E ELECTRIC STANDARDS

DATE 1-1-86
APPD AK/RD

7.2 OR 12KV SINGLE Ø YE, YJ, HE OR HJ TRANSFORMER
INSTALLATION, SECONDARY RACK CONSTRUCTION

1199.403
SUPERSEDES
1145 (1-1-93)

SCOPE: THIS STANDARD SHOWS THE INSTALLATION METHOD OF A TYPE 'H' TRANSFORMER, WITH CUTOUT ARM AND SECONDARY RACK CONSTRUCTION.

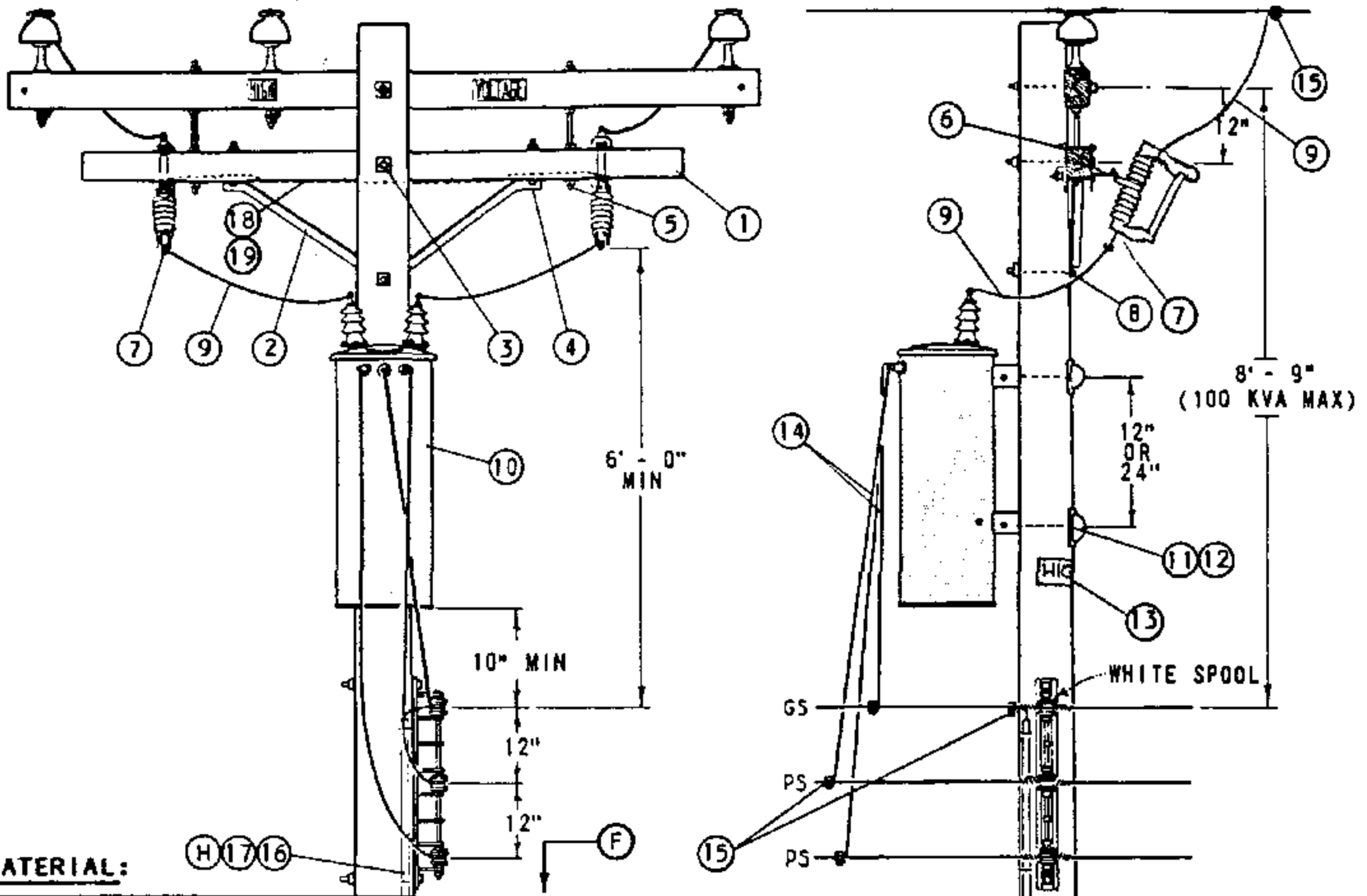

BILL OF MATERIAL:

ITEM	DESCRIPTION	QUANTITY	STOCK NO. OR CONSTR STANDARD
1	CROSSARM, 3 1/2" X 4 1/2" X 8' - 0"	1	293680
2	BRACE, ANGLE, CROSSARM, 4' - 0"	1	164032
3	BOLT, MACH, GALV, 5/8" X (LENGTH AS REQ'D), 2 SQ & 1 DBL COIL SPRING WASHER	(E) 1	STD 392
4	BOLT, MACH, GALV, 1/2" X 7", 1 RD & 1 SPRING LOCK WASHER	(E) 2	STD 392
5	BOLT, SPACE, GALV, 5/8" X 20", 4 SQ & 2 DBL COIL SPR WASHERS	(E) 2	STD 392
6	BRACKET, CUTOUT/ARRESTER, FOR CROSSARM MOUNTING	(E) 2	166070
7	CUTOUT, 12KV	2	STD 1212
8	BOLT, MACH, GALV, 5/8" X (LENGTH AS REQ'D), 1 SQ & 1 DBL COIL SPRING WASHER	(E) 1	STD 392
9	WIRE, #4 BARE STRANDED COPPER	14'	813760
10	TRANSFORMER, SINGLE PHASE, TYPE 'H'	1	STD 1121
11	BOLT, MACH, GALV, 5/8" OR 3/4" X (LENGTH AS REQ'D), 1 SQ CURVED & 1 DBL COIL SPRING WASHER	(E) 2	STD 392
12	COVER, BOLT, PLASTIC & 6 - 10D NAILS, GALV	(E) 2	285696
13	SIGN, HIGH VOLTAGE & 9 ROOFING NAILS, GALV	(E) 1	647648
14	WIRE, W.P., COPPER (SIZE GOVERNED BY TRANSFORMER CAPACITY)	21'	STD 1125
15	CONNECTORS, WIRE COMPRESSION, CU OR AL, AS REQ'D	(E) AS REQ'D	783-787
16	WIRE, #6 BARE STRANDED COPPER	40'	813536
17	UNIT GROUND, COMPLETE	(H) 1	603136
18	WIRE, #8 BARE SOLID ANNEALED COPPER	(I) 8'	812928
19	STAPLES, FENCE, GALV, 1 1/4"	(I) (E) AS REQ'D	678528

FOR FIELD MAINTENANCE ONLY

INSTALLATION:

(E) EXEMPT MATERIAL.

REFERENCE:

(F) POLE STEPPING - SEE STANDARD 363.

(G) FOR LIGHTNING ARRESTER REQUIREMENTS - SEE STANDARD 1247.

(H) GROUNDING METHODS - SEE STANDARD 1002.

(I) BOND ALL CUTOUTS IN HEAVY CONTAMINATION DISTRICT AS IDENTIFIED ON STANDARDS PAGE 287. IF BONDING IS REQUIRED, ORDER ADDITIONAL ITEMS 18 & 19.

1199.404
SUPERSEDES
1147 (1-1-93)

SDG&E ELECTRIC STANDARDS

12KV, SINGLE PHASE TYPE "H" TRANSFORMER INSTALLATION,
C.O. ARM, SECONDARY RACK CONSTRUCTION

DATE 1-1-86

APPD *AK/BS*

SCOPE: THIS STANDARD SHOWS THE INSTALLATION METHOD OF A TYPE 'H' TRANSFORMER, WITH THE CUTOUTS MOUNTED ON THE LINE ARM AND SECONDARY RACK CONSTRUCTION.

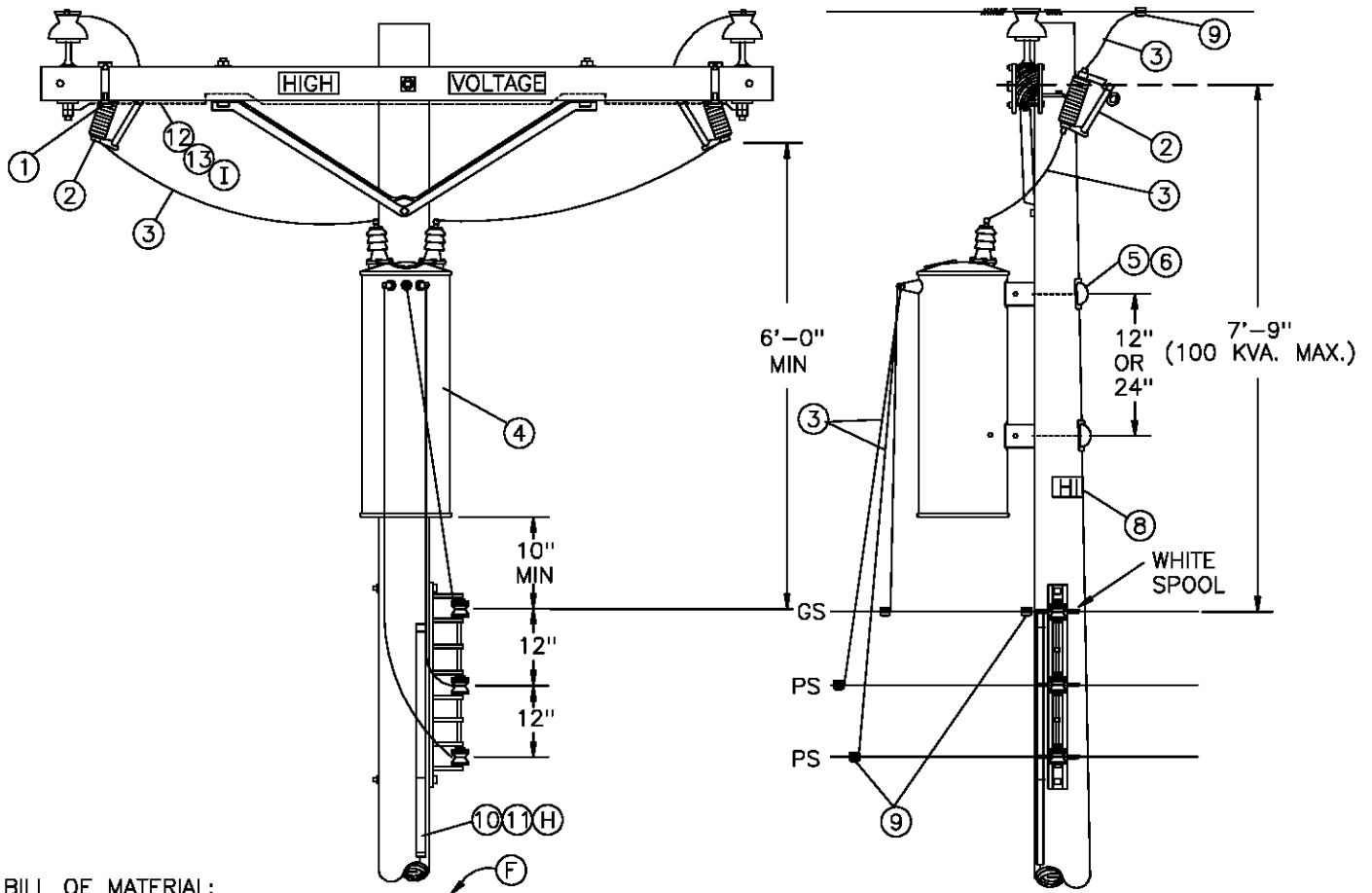

BILL OF MATERIAL:

ITEM	DESCRIPTION	QUANTITY	STOCK NO. OR CONSTR STANDARD
1	BRACKET, CUTOUT/ARRESTER, FOR CROSSARM MOUNTING	2	166070
2	CUTOUT, 12KV	2	STD 1212
3	WIRE, #4 BARE STRANDED COPPER	14'	813760
4	TRANSFORMER, SINGLE PHASE, TYPE 'H'	1	STD 1121
5	BOLT, MACH, GALV, 5/8" OR 3/4" X (LENGTH AS REQ'D), 1 SQ CURVED & 1 DBL COIL SPRING WASHER	2	STD 392
6	COVER, BOLT, PLASTIC & 6 - 10D NAILS, GALV	2	285696 491392
7	WIRE, W.P., COPPER (SIZE GOVERNED BY TRANSFORMER CAPACITY)	21'	STD 1125
8	SIGN, HIGH VOLTAGE & 8 ROOFING NAILS, GALV	1	647648 492224
9	CONNECTORS, WIRE COMPRESSION, CU OR AL, AS REQ'D	AS REQ'D	783-787
10	WIRE, #6 BARE STRANDED COPPER	40'	813536
11	UNIT GROUND, COMPLETE	1	603136
12	WIRE, #8 BARE SOLID ANNEALED COPPER	10'	812928
13	STAPLES, FENCE, GALV, 1 1/4"	AS REQ'D	678528

FOR FIELD MAINTENANCE ONLY

REFERENCE:

- (F) POLE STEPPING - SEE STANDARD 363.
- G. FOR LIGHTNING ARRESTER REQUIREMENTS - SEE STANDARD 1247.
- (H) GROUNDING METHODS - SEE STANDARD 1002.
BOND ALL CUTOUTS IN HEAVY CONTAMINATION DISTRICT AS IDENTIFIED ON STANDARDS PAGE 827.
- (I) IF BONDING IS REQUIRED, ORDER ADDITIONAL ITEMS 12 & 13.

DATE 1-1-86 APPD /	SDG&E ELECTRIC STANDARDS	1199.405 SUPERSEDES 1149 (1-1-93)
	12KV SINGLE PHASE TYPE "H" TRANSFORMER INSTALLATION 100KVA MAX, LINE ARM MOUNTED CO'S, SECONDARY RACK CONSTRUCTION	

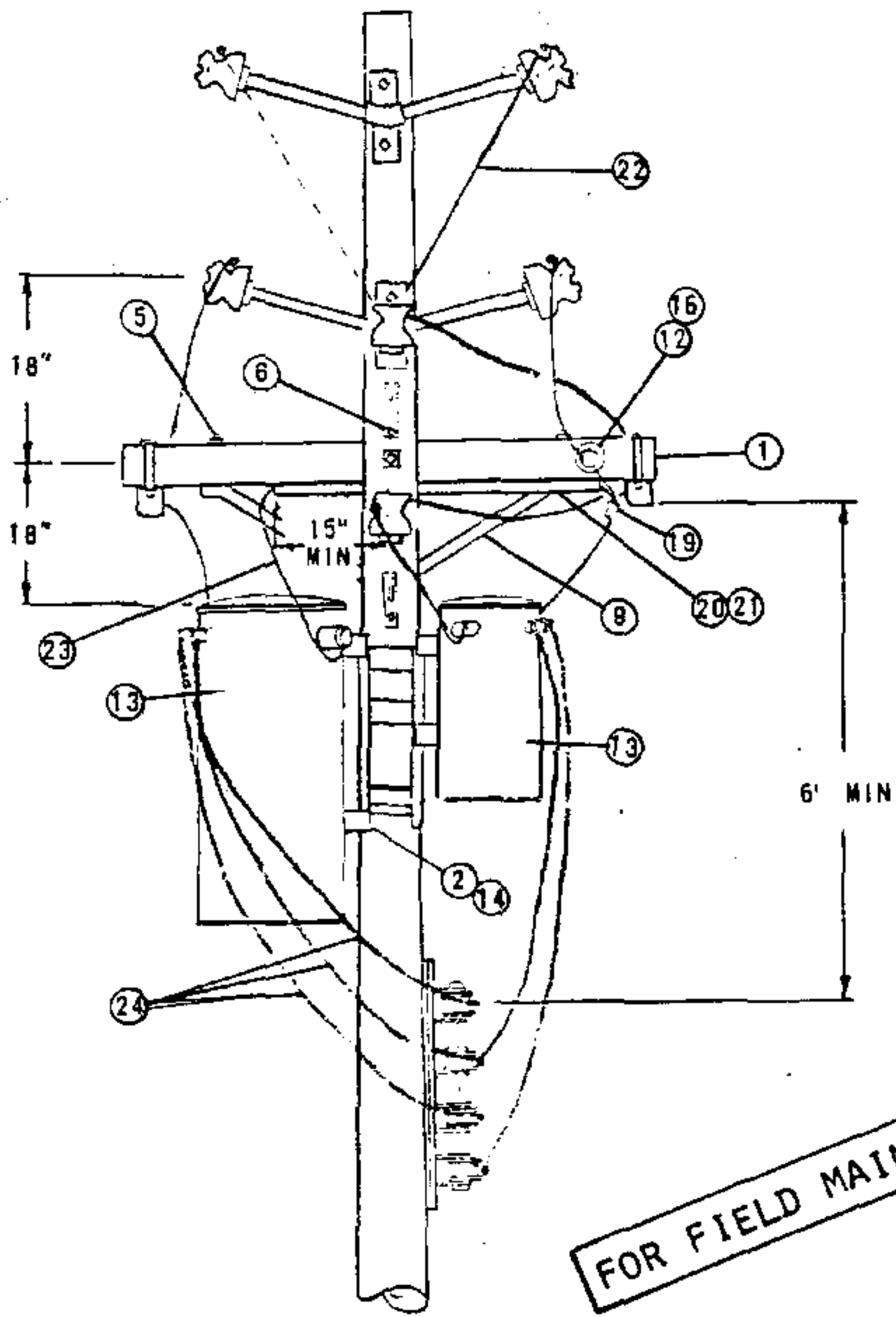

FOR FIELD MAINTENANCE ONLY

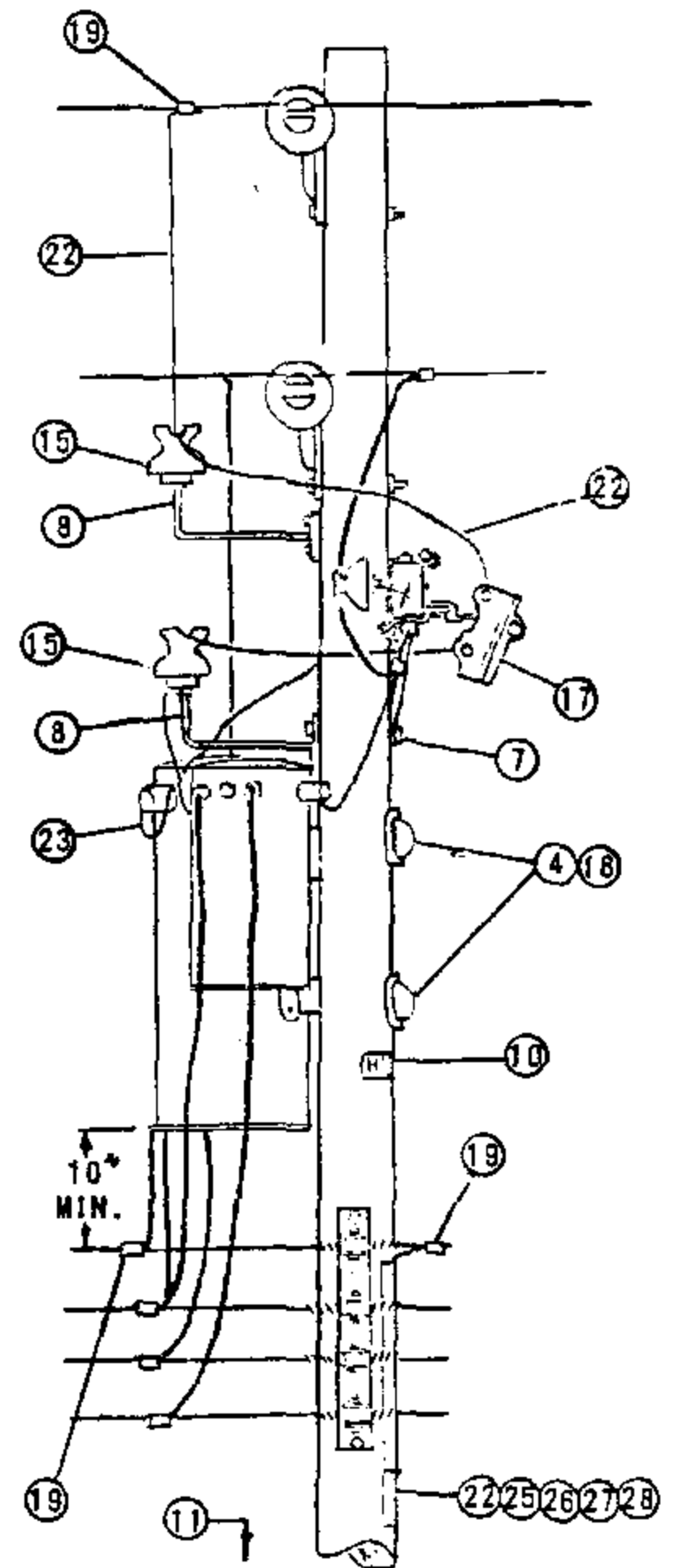

DATE 1-1-86

APPD *AK/RDA*

SDG&E ELECTRIC STANDARDS

4KV OPEN WYE OR 2.4KV OPEN DELTA TYPE "W" TRANSFORMER
INSTALLATION 2-50KVA MAX., ARMLESS TANGENT CONSTRUCTION

1199.501

SUPERSEDES
1154.1 (1-1-86)

NOTES:

- (A) LIMITED TO TWO 50KVA MAXIMUM TRANSFORMER BECAUSE OF ENCROACHMENT INTO CLIMBING SPACE.
- (B) USE TWO GROUND RODS SPACED A MINIMUM OF 6 FEET APART FOR EACH GROUND UNIT.
- (C) 2.4KV 3Ø OPEN DELTA INSTALLATIONS REQUIRE THREE CUTOOTS. FOR CONNECTIONS SEE PAGES 1117 AND 1118.
- D. DO NOT USE OPEN DELTA OR OPEN WYE CONSTRUCTION WHERE SIZE OF A SINGLE 3Ø MOTOR IS 15 HP OR LARGER.
- (E) EXEMPT MATERIAL.
- F. SEE DISTRIBUTION POLE TOPS SECTION FOR POLE TOP MATERIAL.
- (G) UNIT GROUND COMPLETE ORDER 603120 WITH GRAY MOULDING, 603136 WITH PLAIN MOULDING.
- H. SEE ARRESTER SECTION FOR ARRESTER REQUIREMENTS.

ITEM		DESCRIPTION	QUANTITY	STOCK NO. OR CONSTR STD.
PTF	LTI			
1		CROSSARM, 3 1/2" X 4 1/2" X 6' -0"	1	PG
2		BOLT, MACH., GALV., 5/8" (E) OR 3/4" X 2", 1 LOCK SPR WASH.	4	PGS 139, 140
3		BOLT, MACH., GALV., 5/8" X _____, 2 SQ WASH. 1 DBL COIL SPR. WASH. (E)	1	PGS 139, 140
4		BOLT, MACH., GALV., 3/4" X _____, 1 SQ CURV. WASH. WASH & 1 DBL COIL SPR. WASH.	2	PGS 139, 140
5		BOLT, MACH., GALV., 1/2" X 6", 1 RD WASH., 1 DBL COIL SPR. WASH. (E)	2	153088
6		SCREW, LAG. GALV., 1/2" X 4" (E)	4	621568
7		SCREW, LAG. GALV., 5/8" X 5" (E)	1	621600
8		BRACKET, INSULATOR, 1"	2	166144
9		BRACE, CROSSARM, ANGLE 4' -0"	1	164032
10		SIGN, HIGH VOLTAGE & B ROOFING NAILS, GALV. (E)	1	647648, 492224
11		STEPS, POLE (E)	16	692992
12		BOLT, MACH. 5/8" X 5" (E)	1	155488
13		TRANSFORMER, SINGLE PHASE	2	PGS 1121.1-1121.12
14		BRACKET, TRANSFORMER MOUNTING	1	402976
15		INSULATOR (E)	2	429024, 429216
16		PIN ADAPTER, 1 INCH THREAD	1	529248
17		CUTOOT, 5KV (C)	2	PG 1211
18		COVER, PLASTIC THRU BOLT & 2-20D NAILS, GALV. (E)	2	285696, 491392
19		CONNECTORS, WIRE COMPRESSION	9	PGS 783-787
20		CONDUIT, PVC, 3/4", SCHEDULE 40, TYPE 11 (E)	4'-0"	251328
21		STRAPS, PIPE, 3/4", 2-6D NAILS, GALV. (E)	3	697888
22		WIRE, BARE STRANDED COPPER #6	41'	813536
23		WIRE, INSULATED, XLP, STRANDED COPPER, 5KV, #6	30'	194304
24		WIRE, W.P., COPPER, (SIZE GOVERNED BY TRANSFORMER CAPACITY)	30'	PG 1125
25		ROD, GROUND & CLAMP (B) (G)	2	603072, 230016 (E)
26		MOULDING, HARDWOOD, 1" (G)	27'	487200
27		STAPLES, MOULDING, GALV., 3" X 1 1/16" X 1/4" (G) (E)	18	678560
28		STAPLES, FENCE, GALV., 1 1/4" (G) (E)	20	678528
29				

FOR FIELD MAINTENANCE ONLY

SCOPE: THIS STANDARD SHOWS THE INSTALLATION METHOD OF A TYPE 'H' TRANSFORMER, WITH THE CUTOUTS MOUNTED ON THE LINE ARM AND SECONDARY CROSSARM CONSTRUCTION.

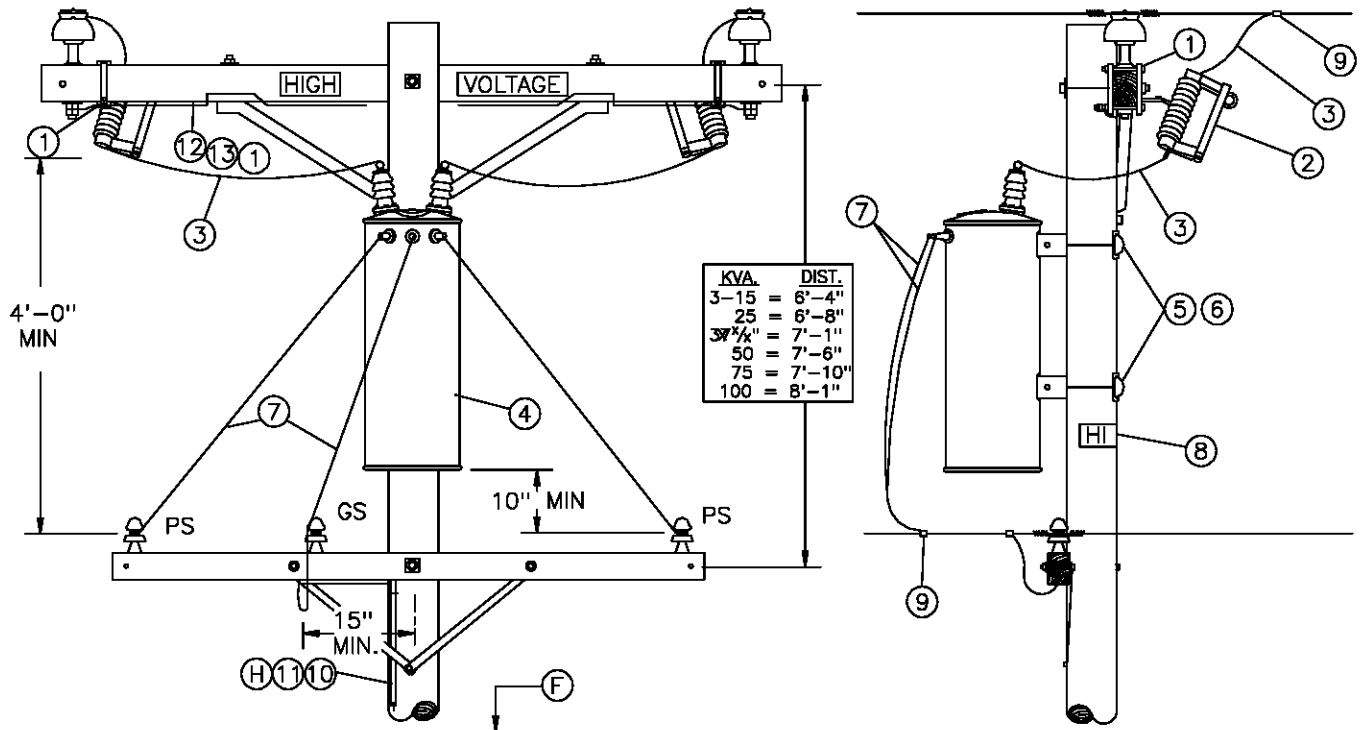

BILL OF MATERIAL:

ITEM	DESCRIPTION	QUANTITY	STOCK NO. OR CONTR STANDARD
1	BRACKET, CUTOUT/ARRESTER, FOR CROSSARM MOUNTING	2	166070
2	CUTOUT, 12KV	2	STD 1212
3	WIRE, #4 BARE STRANDED COPPER	14'	813536
4	TRANSFORMER, SINGLE PHASE, TYPE 'H'	1	STD 1121
5	BOLT, MACH, GALV, 5/8" OR 3/4" X (LENGTH AS REQ'D), 1 SQ CURVED & 1 DBL COIL SPRING WASHER	2	STD 392
6	COVER, BOLT, PLASTIC & 6 - 10D NAILS, GALV	2	285696 491392
7	WIRE, W.P., COPPER (SIZE GOVERNED BY TRANSFORMER CAPACITY)	21'	STD 1125
8	SIGN, HIGH VOLTAGE & 8 ROOFING NAILS, GALV	1	647648 492224
9	CONNECTORS, WIRE COMPRESSION, CU OR AL, AS REQ'D	AS REQ'D	783-787
10	WIRE, #6 BARE STRANDED COPPER	40'	813536
11	UNIT GROUND, COMPLETE	1	603136
12	WIRE, #8 BARE SOLID ANNEALED COPPER	10'	812928
13	STAPLES, FENCE, GALV, 1 1/4"	AS REQ'D	678528

FOR FIELD MAINTENANCE ONLY

REFERENCE:

- (F) POLE STEPPING - SEE STANDARD 363.
- G. FOR LIGHTNING ARRESTER REQUIREMENTS - SEE STANDARD 1247.
- (H) GROUNDING METHODS - SEE STANDARD 1002.
- (I) BOND ALL CUTOUTS IN HEAVY CONTAMINATION DISTRICT AS IDENTIFIED ON STANDARDS PAGE 287. IF BONDING IS REQUIRED, ORDER ADDITIONAL ITEMS 12 & 13.

SDG&E ELECTRIC STANDARDS		1199.503 SUPERSEDES 1150 (1-1-93)
DATE 1-1-86 APPD /	12KV SINGLE PHASE TYPE "H" TRANSFORMER INSTALLATION, 100 KVA MAX, LINE ARM MOUNTED CO'S, SECONDARY LINE ARM CONSTRUCTION	

SCOPE: THIS STANDARD SHOWS THE INSTALLATION METHOD OF A 4KV OPEN WYE WITH TYPE "W" TRANSFORMERS, AND SECONDARY LINE ARM CONSTRUCTION.

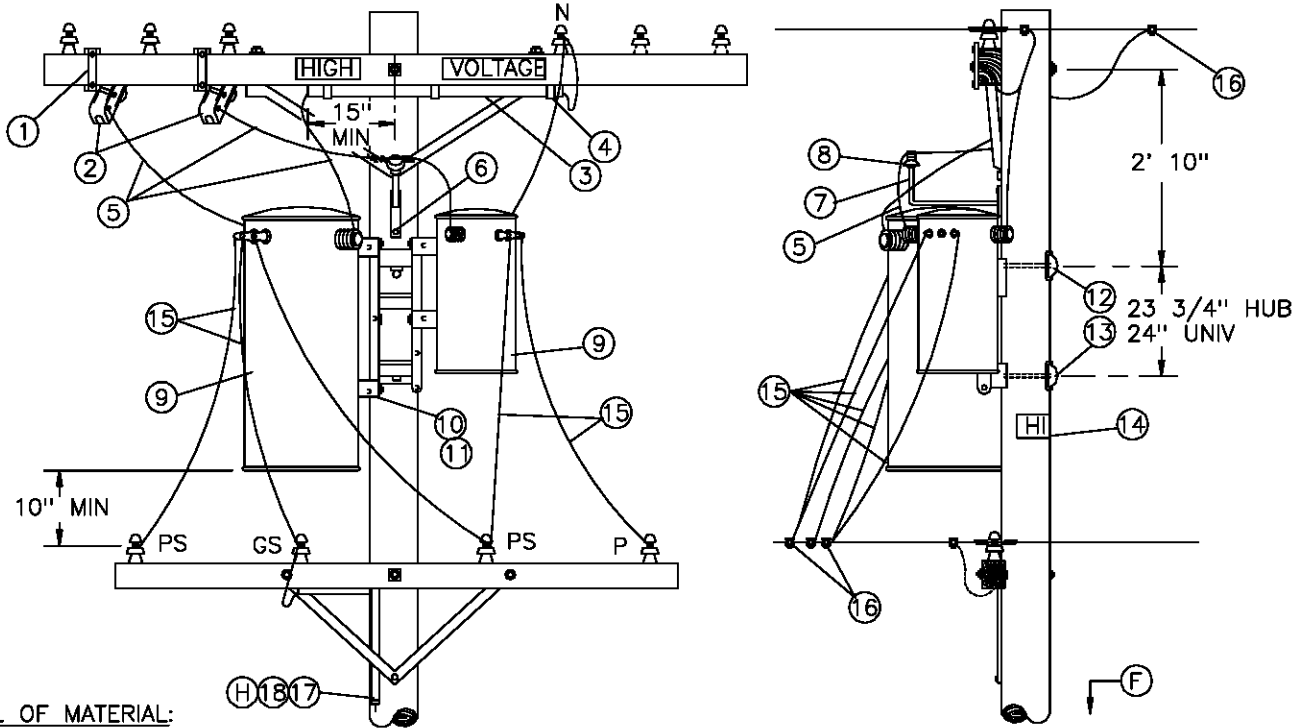

BILL OF MATERIAL:

ITEM	DESCRIPTION	QUANTITY	STOCK NO OR CONSTR STANDARD
1	BRACKET, CUTOUT/ARRESTER, FOR CROSSARM MOUNTING	2	166070
2	CUTOUT, 12KV	2	STD 1212
3	CONDUIT, PVC, 3/4" X 4', SCHED 40, TYPE 2	1	251328
4	STRAP, CONDUIT, 3/4", GALV & 2 - 6D NAILS, GALV	3	697888 491552
5	WIRE, 5KV INSULATED, XLP, #6 STRANDED COPPER	25'	194304
6	SCREW, LAG, 1/2" X 4"	2	621568
7	BRACKET, INSULATOR, 1" LEAD THREAD	1	166134
8	INSULATOR, 12KV NEUTRAL	1	429216
9	TRANSFORMER, SINGLE PHASE, TYPE W	1	STD 1121
10	BRACKET, TRANSFORMER MOUNTING	1	402976
11	BOLT, MACH, GALV, 5/8" OR 3/4" X 2", 2 RD & 1 LOCK WASHER	4	STD 392
12	BOLT, MACH, GALV, 3/4" X (LENGTH AS REQ'D), 1 SQ CURV & 1 DBL COIL SPRING WASHER	2	STD 392
13	COVER, VOLT, PLASTIC & 6 - 10D NAILS, GALV	2	285696 491392
14	SIGN, HIGH VOLTAGE & 8 ROOFING NAILS, GALV	1	647648 492224
15	WIRE, W.P. (SIZE GOVERNED BY TRANSFORMER CAPACITY)	35'	STD 1125
16	CONNECTORS, WIRE COMPRESSION, CU OR AL, AS REQ'D	AS REQ'D	783-787
17	WIRE, BARE STRANDED, COPPER, #6	40'	813536
18	UNIT GROUND, COMPLETE	1	603136

INSTALLATION:

- (A) LIMITED TO 50 KVA MAXIMUM TRANSFORMER BECAUSE OF ENCROACHMENT INTO CLIMBING SPACE.
- (B) 2.4KV 30 OPEN DELTA INSTALLATIONS REQUIRE THREE CUTOUTS. FOR CONNECTIONS SEE PAGE 1117.
- C. DO NOT USE OPEN DELTA OR OPEN WYE CONSTRUCTION WHERE SIZE OF A SINGLE 3Ø MOTOR IS 15 HP OR LARGER.

REFERENCE:

- (F) POLE-STEPPING - SEE STANDARD 363.
- G. FOR LIGHTNING ARRESTER REQUIREMENTS - SEE STANDARD 1247.
- (H) GROUNDING METHODS - SEE STANDARD 1002.
- I. BOND ALL CUTOUTS IN HEAVY CONTAMINATION DISTRICTS AS IDENTIFIED ON STANDARD 287.

1199.504
SUPERSEDES
1156 (1-1-93)

SDG&E ELECTRIC STANDARDS

4KV OPEN WYE TYPE "W" TRANSFORMER
INSTALLATION, SECONDARY LINE ARM CONSTRUCTION

DATE 1-1-86
APPD /

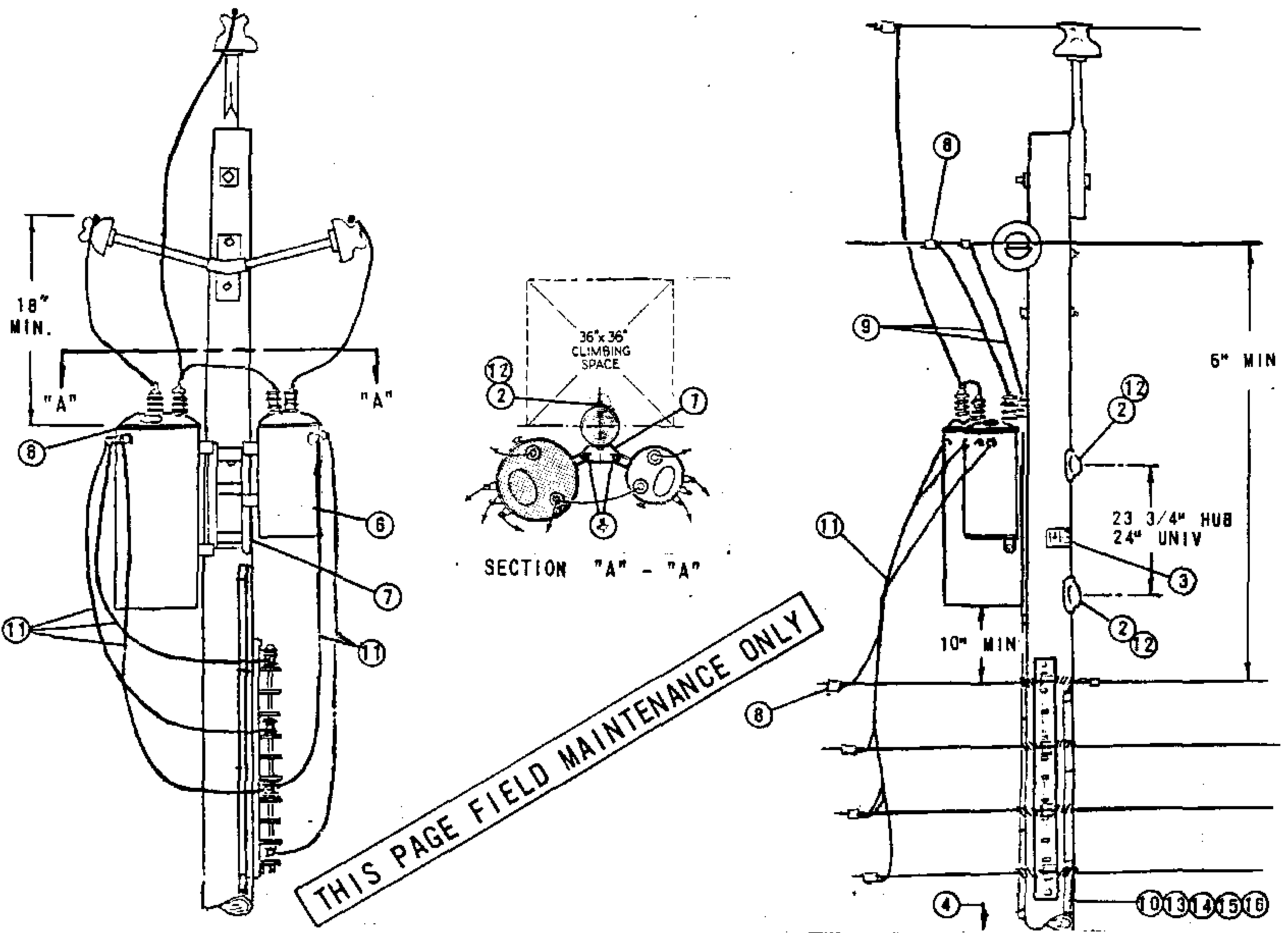

NOTES:

- (A) UNIT GROUND COMPLETE ORDER 603120 WITH GRAY MOULDING, 603136 WITH PLAIN MOULDING.
- (B) USE TWO ROD GROUND.
- C. SEE DISTRIBUTION POLE TOP SECTION FOR POLE TOP MATERIAL.
- D. LIMITED TO TWO 50KVA MAXIMUM TRANSFORMER BECAUSE OF ENCROACHMENT INTO CLIMBING SPACE.
- (E) EXEMPT MATERIAL.
- F. WHEN ARRESTERS ARE REQUIRED PER STANDARDS PAGE 1247, USE TYPE 'HJ' TRANSFORMERS.

ITEM	DESCRIPTION	QUANTITY		STOCK NO. OR CONSTR. STD.
		HE	HJ	
	BOLT, MACH., GALV., 5/8" (E) OR 3/4" X 2", 1 SQ. CURV WASH, 1 LOCK SPR WASH.	4	4	PGS 139, 140
2	BOLT, MACH., GALV., 3/4" X _____ 1 SQ. CURV. WASH, 1 DBL COIL SPR WASH.	2	2	PGS 139, 140
3	SIGN, HIGH VOLTAGE & 8 ROOFING NAILS, GALV	(E) 1	1	647648, 492192
4	STEPS, POLE	(E) 16	16	692992
5				
6	TRANSFORMER, SELF PROTECTED TYPE, SINGLE PHASE (HE or HJ)	2	2	PGS 1121, 01-1121.12
7	BRACKET, TRANSFORMER MOUNTING	1	1	402976
8	CONNECTORS, WIRE, COMPRESSION	10	11	PGS 783, -787
9	WIRE, BARE STRANDED, COPPER, #6	70'	70'	813536
10	WIRE, BARE STRANDED, COPPER, #2	—	40'	813664
11	WIRE, W.P. COPPER, (SIZE GOVERNED BY TRANSFORMER CAPACITY)	30'	30'	PG 1125
12	COVER, PVC THRU BOLT & 6-100. NAILS, GALV.	(E) 2	2	285696, 491392
13	ROD, GROUND & CLAMP (B)	(A) 2	4	603072, 230016 (E)
14	MOULDING, HARDWOOD, 1"	(A) 27'	57'	487200
15	STAPLES, MOULDING, GALV., 3" X 1 1/16" X 1/4"	(A) (E) 20	38	678560
16	STAPLES, FENCE, GALV., 1 1/4"	(A) (E) 25	50	678528
17				

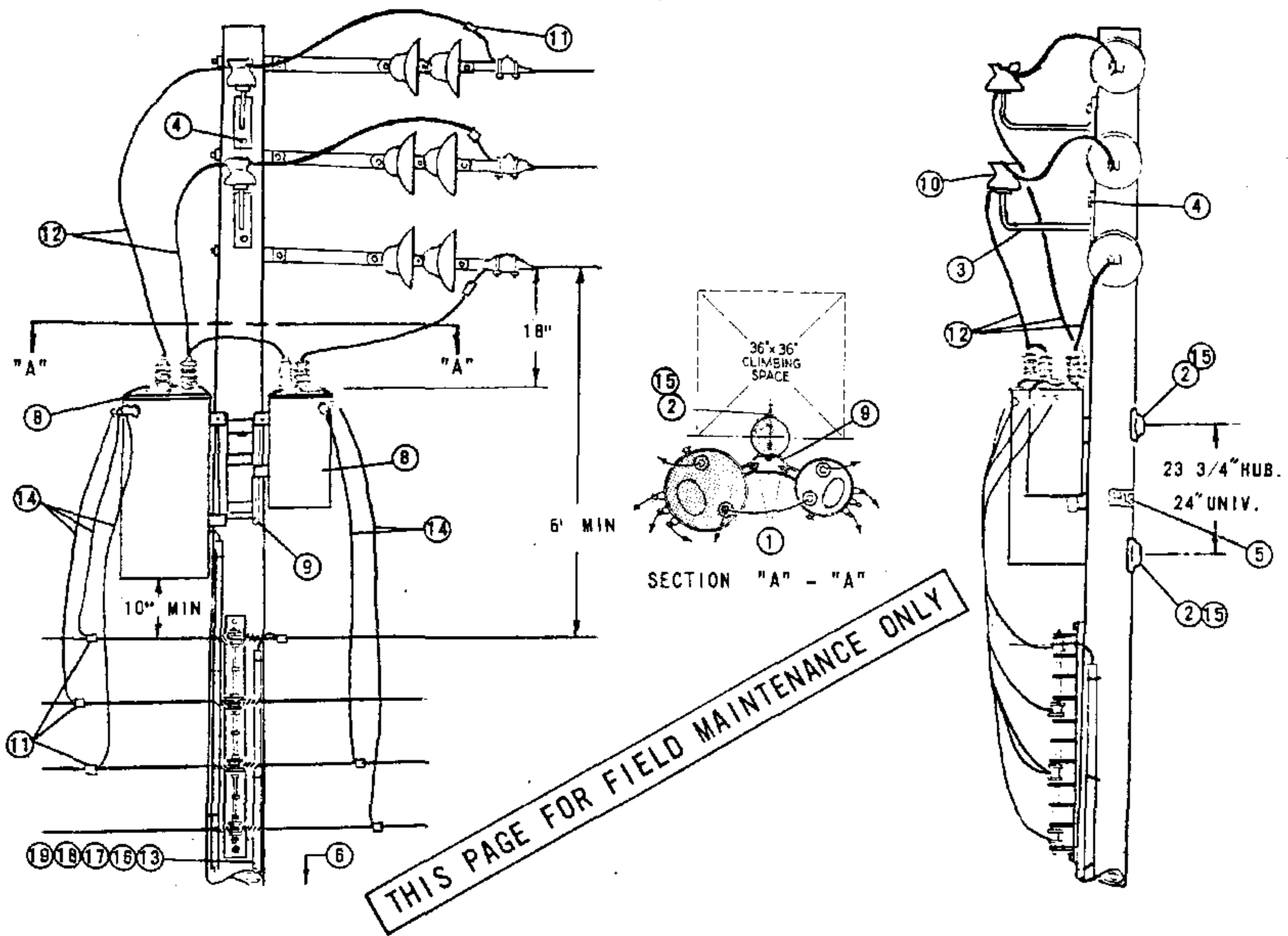

NOTES:

- (A) UNIT GROUND COMPLETE ORDER 603120 WITH GRAY MOULDING, 603136 WITH PLAIN MOULDING.
- (B) USE TWO ROD GROUND.
- C. SEE DISTRIBUTION POLE TOP SECTION FOR POLE TOP MATERIAL.
- D. LIMITED TO TWO 50KVA MAXIMUM TRANSFORMER BECAUSE OF ENCROACHMENT INTO CLIMBING SPACE.
- (E) EXEMPT MATERIAL.
- F. WHEN ARRESTERS ARE REQUIRED PER STANDARDS PAGE 1247, USE TYPE 'HJ' TRANSFORMERS.

ITEM	DESCRIPTION		QUANTITY		STOCK NO. OR CONSTR STD	
			HE	HJ		
1	PTF	LTI	BOLT, MACH., GALV., 5/8" (E) DR 3/4" X 2", 1 SQ. CURV WASH., 1 LOCK SPR WASH.	4	4	PGS 139, 140
2			BOLT, MACH., GALV., 3/4" X 1 SQ. CURV WASH., 1 DBL. COIL SPR. WASH.	2	2	PGS 139, 140
3			BRACKET, INSULATOR, 1" OR 1 3/8" LEAD THREAD	2	2	166144-166176
4			SCREW, LAG, GALV., 1/2" X 4"	(E) 4	4	621568
5			SIGN, HIGH VOLTAGE, & 8 ROOFING NAILS, GALV.	(E) 1	1	647648, 492192
6			STEPS, POLE	(E) 16	16	692992
7						
8			TRANSFORMER, SELF PROTECTED TYPE, SINGLE PHASE, (HE or HJ)	2	2	PGS 1121.01-1121.12
9			BRACKET, TRANSFORMER MOUNTING	1	1	402976
10			INSULATOR, 12KV, (CLASS 55-5 OR 56-1)	2	2	PG 750
11			CONNECTORS, WIRE COMPRESSION	9	9	PGS 783-787
12			WIRE, BARE STRANDED, COPPER #8	70'	70'	813536
13			WIRE, BARE STRANDED, COPPER #2		40'	813664
14			WIRE, W.P. COPPER (SIZE GOVERNED BY TRANSFORMER CAPACITY)	30'	30'	PG 1125
15			COVER, PVC THRU BOLT & 6-100 NAILS, GALV.	2	2	285696, 491392
16			ROD, GROUND & CLAMP (B)	(A) 2	4	603072, 230016 (E)
17			MOULDING, HARDWOOD, 1"	(A) 27'	57'	487200
18			STAPLES, MOULDING GALV., 3" X 1 1/16" X 1/4"	(A) (E) 20	38	678560
19			STAPLES, FENCE, GALV., 1 1/4"	(A) (E) 25	50	678528

1199.602
SUPERSEDES
1162 (1-1-86)

SDG&E ELECTRIC STANDARDS
12KV OPEN DELTA TYPE "HE" OR "HJ" TRANSFORMER INSTALLATION
2-50KVA MAX., ARMLESS DEAD END CONSTRUCTION

DATE 1-1-86
APPD AK/RS

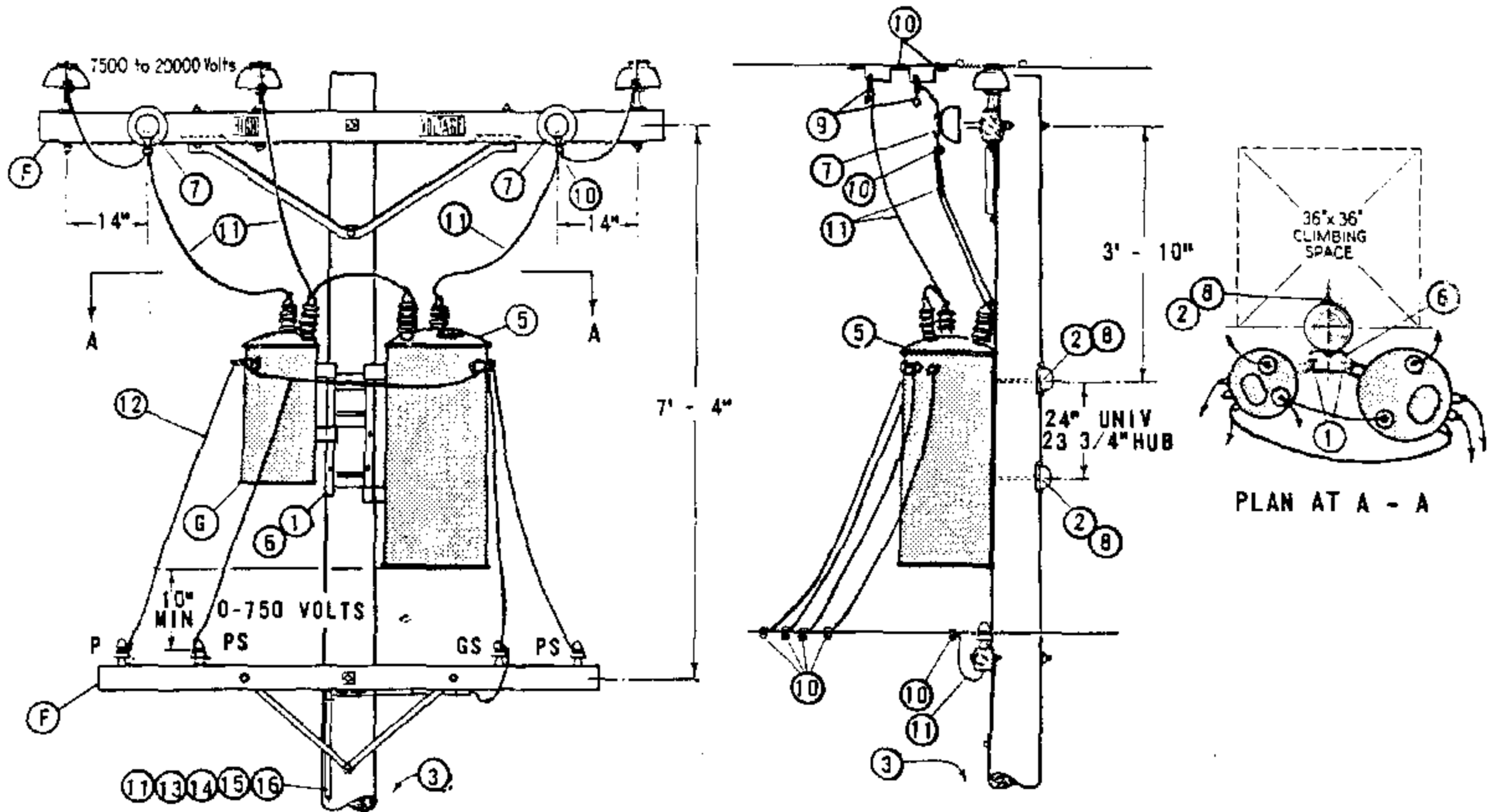

- NOTES:**
- A. USE PAGE 1165 FOR NEW CONSTRUCTION. THIS CONSTRUCTION MAY BE USED TO ELIMINATE POLE CHANGEOUTS ON EXISTING POLES WITH THE PRIMARY ALREADY ON ARMS.
 - B. LIMITED TO TWO 50 KVA MAXIMUM TRANSFORMERS BECAUSE OF ENCROACHMENT ON CLIMBING SPACE. 75 KVA TRANSFORMERS MAY BE USED IF THEY HAVE SMALL CASES.
 - C. USE TWO GROUND RODS SPACED NOT LESS THAN 6 FEET APART.
 - D. UNIT GROUND COMPLETE ORDER 603120 WITH GRAY MOULDING, 603136 WITH PLAIN MOULDING.
 - E. EXEMPT MATERIAL.
 - F. PRIMARY AND SECONDARY CONSTRUCTION SHOWN ARE TYPICAL, AND THEIR MATERIALS ARE NOT INCLUDED. MAY BE INSTALLED WITH ARMLESS PRIMARY, RACK SECONDARY, ETC.
 - G. POWER TRANSFORMER TO BE HUNG ON THE SAME SIDE OF POLE AS 2 PHASE WIRES TO PREVENT PHASING PROBLEMS WHEN CLOSING DELTA.

ITEM	DESCRIPTION	QUANTITY	STOCK NO OR CONSTR STDS
1	BOLT, MACH GALV, 5/8" (E) OR 3/4" X 2", 1 RD WASH. & 1 NUT, 1 DBL COIL SPR WASH.	4	PGS 139, 140
2	BOLT, MACH GALV, 3/4" X 10", 1 SQ CURVE WASH., 1 NUT & 1 DBL COIL SPR WASH.	2	PGS 139, 140
3	STEP, POLE (E)	19	692992
4			
5	TRANSFORMER, SELF PROTECTED TYPE, SINGLE PHASE (HE, HJ) (B)	2	PGS 1121.01-1121.12
6	BRACKET, TRANSFORMER MTG	1	402976
7	INSULATOR & PIN, 12KV	2	700 SECTION
8	COVER, PVC THRU BOLT & 6-10D NAILS, GALV (E)	2	285696, 491392
9	CLAMP, HOT LINE (E) & STIRRUP	3	PG 788
10	CONNECTORS, WIRE, COPPER, AS REQ'D	13	PGS 783-787
11	WIRE, STRANDED #6 COPPER	70'	813536
12	WIRE, WP COPPER (SIZE GOVERNED BY TRANSFORMER CAPACITY)	30'	PG 1125
13	ROD & CLAMP, GROUND (D) (C)	2	603072, 230016(E)
14	MOULDING, HARDWOOD 1" (D)	30'	487200
15	STAPLES, MOULDING GALV, 3" X 1 1/16" X 1/4" (D) (E)	20	678560
16	STAPLES, FENCE GALV, 1 1/4" (D) (E)	25	678528

FOR FIELD MAINTENANCE ONLY

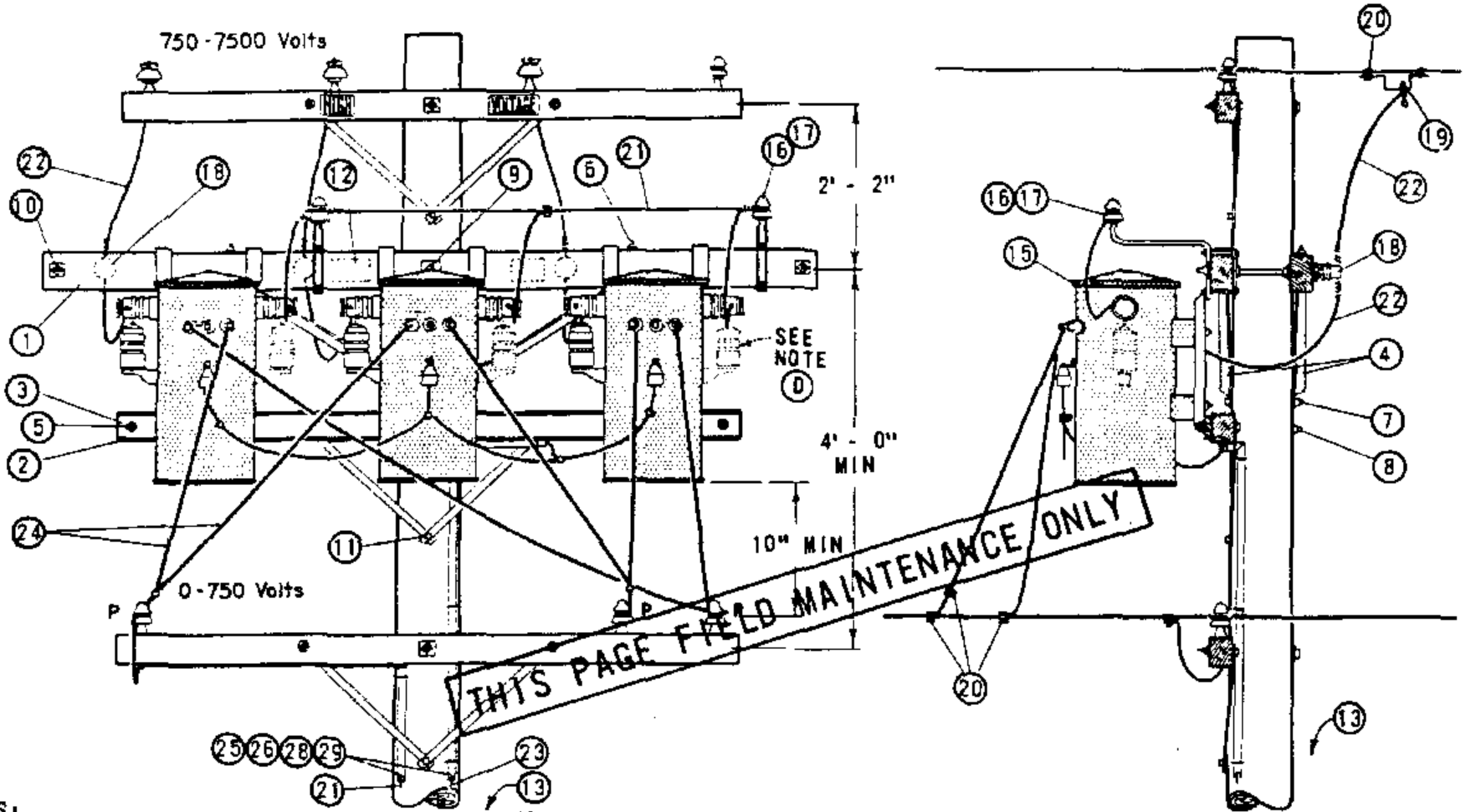

THIS PAGE FIELD MAINTENANCE ONLY

- NOTES:
- (A) UNIT GROUND COMPLETE ORDER 603120 WITH GRAY MOULDING, 603136 WITH PLAIN MOULDING.
 - B. SEE DISTRIBUTION POLE TOP SECTION FOR POLE TOP MATERIALS.
 - (C) USE TWO ROD GROUND
 - (D) REMOVE RIGHT HAND LIGHTNING ARRESTERS BEFORE INSTALLING TRANSFORMERS.
 - (E) EXEMPT MATERIAL.
 - F. WHEN ARRESTERS ARE REQUIRED PER STANDARDS PAGE 1247, USE TYPE "WJ" TRANSFORMERS.
 - G. SEE STANDARDS PAGE 1118 FOR TRANSFORMER CONNECTION DIAGRAMS. CONNECTION SHOWN IS FOR ILLUSTRATIVE PURPOSES ONLY.

ITEM	DESCRIPTION	QUANTITY	STOCK NO. OR CONSTR STD
1	CROSSARM, 3 1/4" X 5 3/4" X 10" - 0"	2	PG 111 IT. 2
2	CROSSARM, KICK 3 3/4" X 5 3/4" X 8" - 0"	1	PG 116 IT. 1
3	COVER STRIP, 1 5/8" X 4 1/2" X 8" - 0" (2X4 S4S)	1	699328
4	BRACE, ANGLE CROSSARM	2	164128
5	BOLT, MACH GALV 3/8" X 6", 2 RD WASH. & 1 NUT	(E) 2	PGS 139, 140
6	BOLT, MACH GALV 1/2" X 7", 1 RD WASH. & 1 NUT	(E) 4	PGS 139, 140
7	BOLT, MACH GALV 5/8" X 10"	(E) 1	PGS 139, 140
8	BOLT, MACH GALV 5/8" X 14", 2 SQ WASH. & 1 NUT	(E) 1	PGS 139, 140
9	BOLT, MACH GALV 5/8" X 18", 2 - 3 SQ WASH & 1 NUT	(E) 1	PGS 139, 140
10	BOLT, SPACE GALV 5/8" X 20", 4 WASH. & 4 NUTS	(E) 2	PGS 139, 140
11	SCREW, LAG GALV 1/2" X 4"	(E) 1	621568
12	SIGN, HIGH VOLTAGE & 8 ROOFING NAILS, GALV	(E) 1	647648, 492224
13	STEPS, POLE	(E) 16	692992
14			
15	TRANSFORMER, SINGLE PHASE TYPE WE OR WJ, #1 TEE HANGER	3	PGS 1121.01-1121.12
16	BRACKET, INSULATOR, 1"	2	166208
17	INSULATOR, 5KV	2	428960
18	HOLDER, WIRE	3	413792
19	CLAMP, HOT LINE (E) & STIRRUP	3	PG 788
20	CONNECTOR, WIRE, AS REQ'D	12	PGS 783-787
21	WIRE, #6 BARE STRANDED COPPER	60'	813536
22	CABLE, 5KV, 1/C #6 STRANDED COPPER	34'	194304
23	WIRE #2 BARE STRANDED COPPER, TANK GROUND	50'	813664
24	WIRE, W.P. COPPER, SIZE GOVERNED BY TRANSFORMER CAPACITY	45'	PG 1125
25	ROD & CLAMP, GROUND	(A) (C) 4	603072, 230016 (E)
26	MOULDING, HARDWOOD, 1"	(A) 64'	487200
27			
28	STAPLES, 3" X 1 1/16" X 1/4" MOULDING, GALV	(A) (E) 40	678560
29	STAPLES, 1 1/4" FENCE, GALV	(A) (E) 36	578528

1199.701
SUPERSEDES
1172 (1-1-86)

SAN DIEGO GAS & ELECTRIC CO OVERHEAD STANDARDS
4KV, THREE PHASE, TYPE "WE" OR "WJ" TRANSFORMER INSTALLATION,
3-25 KVA MAX SECONDARY LINE ARM CONSTRUCTION

DATE 1-1-86
APPD AK/RS

SCOPE: THIS STANDARD SHOWS THE INSTALLATION OF 7.2 AND 12KV, 3Ø TRANSFORMERS, ALLEY ARM CONSTRUCTION, WITH CLUSTER MOUNTING BRACKET AND SECONDARY RACK CONSTRUCTION.

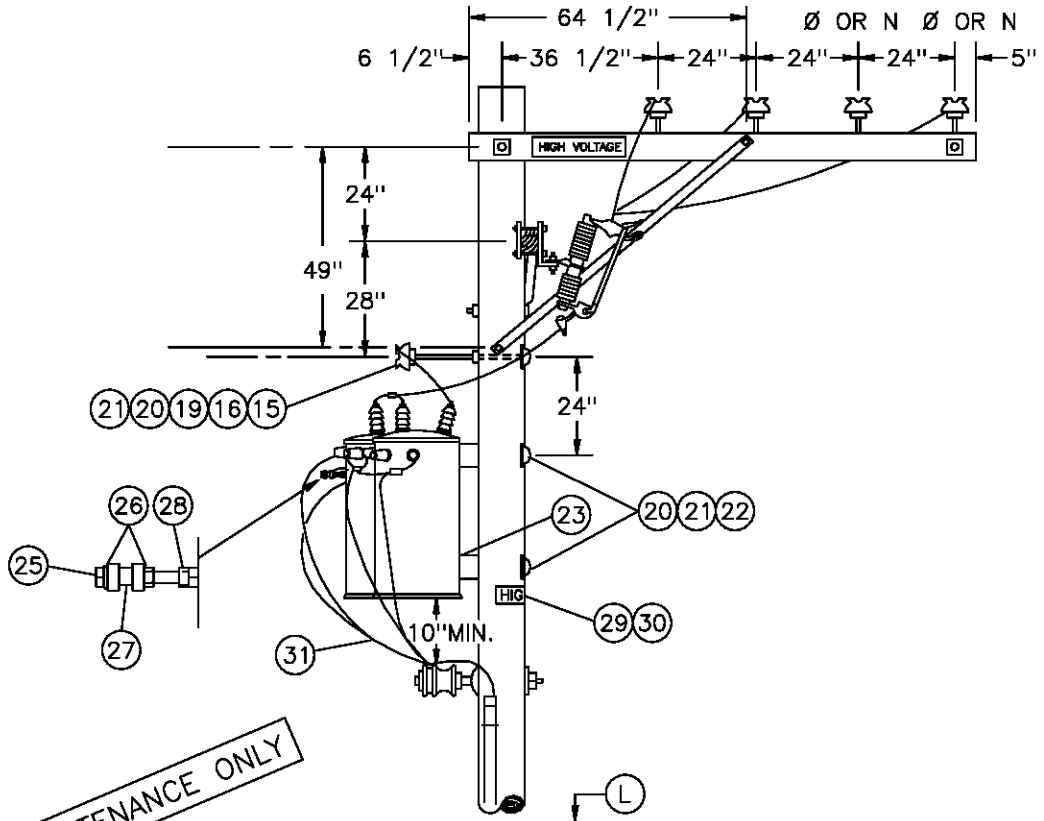

FOR FIELD MAINTENANCE ONLY

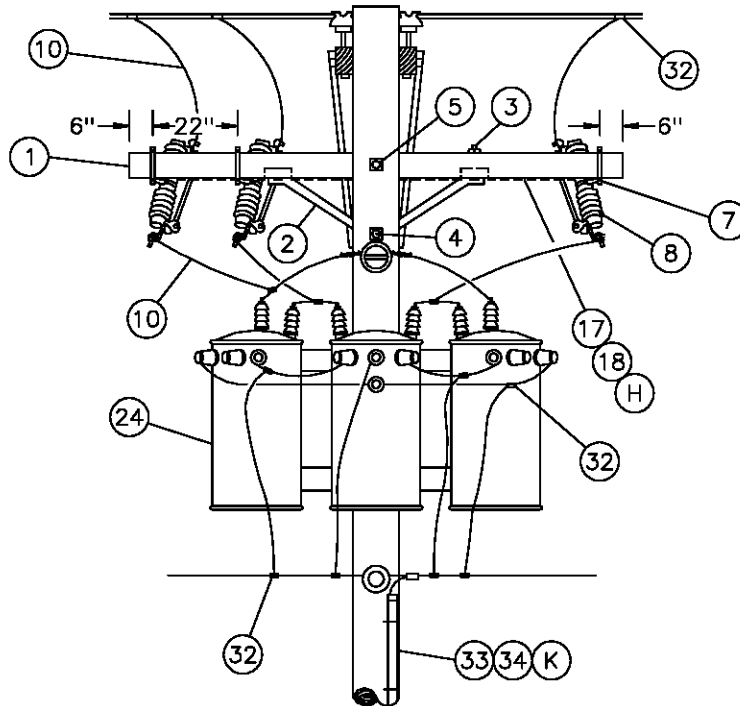

DELTA PRIMARY CONNECTION

DATE 1-1-89
 APPD PJA / DTE

SDG&E ELECTRIC STANDARDS
 7.2 AND 12KV THREE-PHASE TRANSFORMER
 CLUSTER MOUNT INSTALLATION-ALLEY ARM CONSTRUCTION

1199.704
 SUPERSEDES
 1174.1 (1-1-93)

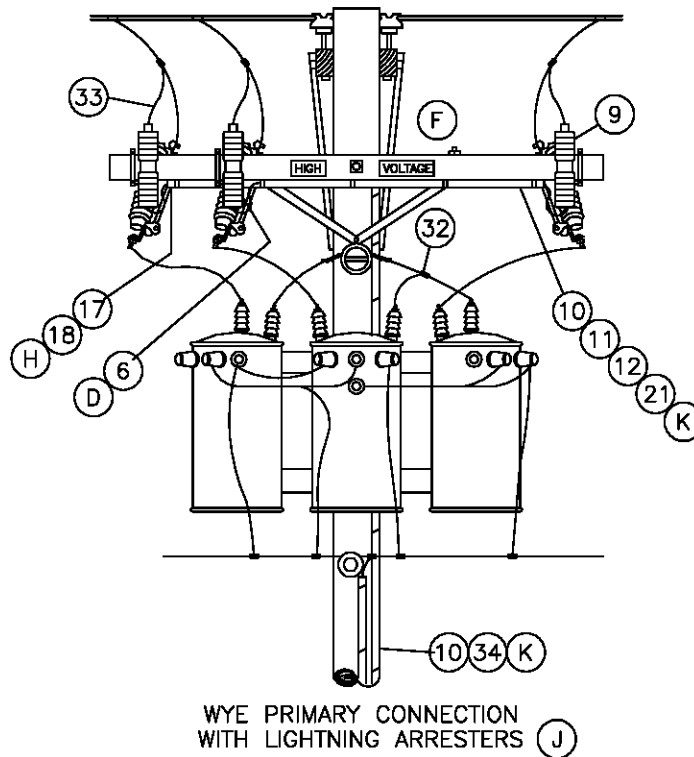
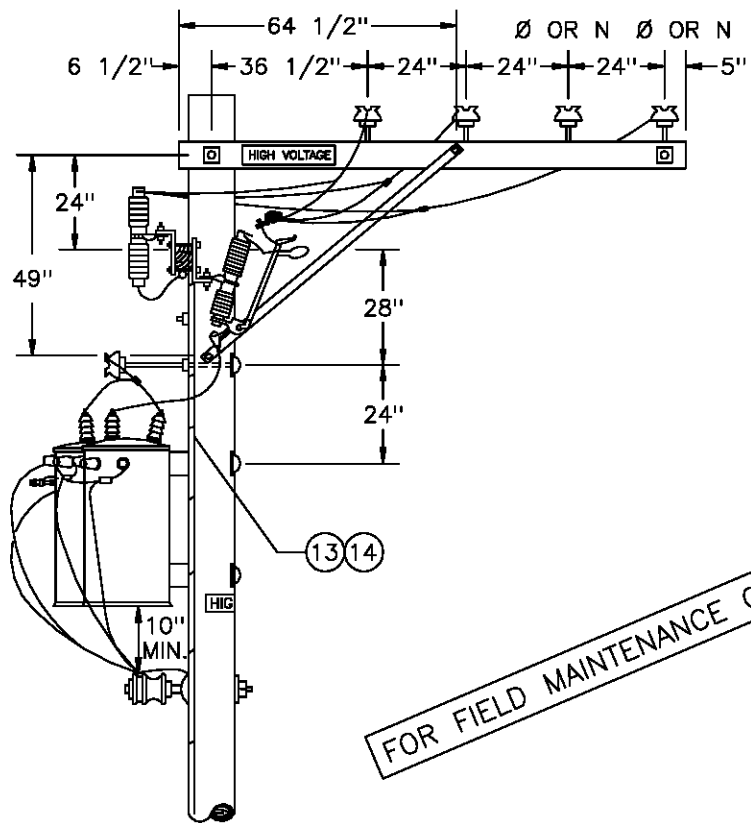

SDG&E ELECTRIC STANDARDS

DATE 1-1-91
 APPD *PA/ROJ*

7.2 AND 12KV THREE-PHASE TRANSFORMER
 CLUSTER MOUNT INSTALLATION-ALLEY ARM CONSTRUCTION

1199.705
 SUPERSEDES
 1174.2 (1-1-93)

BILL OF MATERIAL:

ITEM	DESCRIPTION	QUANTITY		STOCK NUMBER OR CONSTR STANDARD
		STATION WITH ARRESTERS (J)	STATION WITHOUT ARRESTERS	
1	CROSSARM, 3 3/4" X 5 3/4" X 10' - 0"	1	1	294128
2	BRACE, ANGLE, CROSSARM, 4'	1	1	164032
3	BOLT, MACH, GALV, 1/2" X 7", 1 RD & 1 DBL COIL SPRING WASHER (E)	2	2	STD. 392
4	BOLT, MACH, GALV, 5/8" X (LENGTH AS REQ'D), 1 SQUARE & 1 DOUBLE COIL SPRING WASHER (E)	1	1	STD. 392
5	BOLT, MACH, GALV, 5/8" X (LENGTH AS REQ'D), 2 SQUARE & 1 DOUBLE COIL SPRING WASHER (E)	1	1	STD. 392
6	BRACKET, DOUBLE, CUTOUT/ARRESTER, FOR CROSSARM MOUNTING (E)	3	-	165442
7	BRACKET, CUTOUT/ARRESTER, FOR CROSSARM MOUNTING (E)	-	3	166070
8	CUTOUT, 12KV, WITH LOADBUSTER HOOK	3	3	STD. 1212
9	ARRESTER, LIGHTNING	3	-	113248
10	WIRE, #4 BARE STRANDED COPPER	FT	100	813760
		LB	13	
11	CONDUIT, PVC, TYPE 2, SCHEDULE 40, 1" X 10' (E)	1	-	251200
12	STRAPS, PIPE, GALV, 1" (E)	AS REQ'D	-	697792
13				
14				
15	INSULATOR, PIN TYPE, CLASS AS REQ'D	1	1	STD. 750
16	WIRE, TIE (E)	1	1	815232
17	WIRE, #8 BARE SOLID ANNEALED COPPER (G)	FT	15	812928
		LB	1	
18	STAPLES, 1 1/4", FENCE, GALV (G)(E)	AS REQ'D	AS REQ'D	678528
19	BRACKET, INSULATOR, 1" OR 1 3/8" THREAD (AS REQ'D)	1	1	166144
		1	1	166176
20	COVER, BOLT, PLASTIC (E)	3	3	285696
21	NAILS, GALV, 1 3/4" ROOFING (E)	AS REQ'D	AS REQ'D	492192
22	BOLT, MACH, GALV, 3/4" X (LENGTH AS REQ'D), 1 SQUARE CURVED & 1 DOUBLE COIL SPRING WASHER (E)	2	2	STD. 392
23	BRACKET, TRANSFORMER CLUSTER MOUNTING	1	1	403008
24	TRANSFORMER, SINGLE PHASE, TYPE 'Y', 'YF', 'H' OR 'HF'	3	3	STD. 1121
25	BOLT, MACH, GALV, 1/2" X 5" (E)	1	1	153024
26	WASHER, GALV, 1/2", ROUND (E)	2	2	800192
27	INSULATOR, SECONDARY, SPOOL, PORCELAIN (E)	1	1	430752
28	NUT, GALV, 1/2" (E)	1	1	504736
29	SIGN, HIGH VOLTAGE (E)	3	1	647648
30	NAILS, GALV, 7/8" ROOFING (E)	27	9	492224

FOR FIELD MAINTENANCE ONLY

1199.706 SUPERSEDES 1174.3 (1-1-93)	SDG&E ELECTRIC STANDARDS	DATE 1-1-91 APPD <i>PA/109</i>
	7.2 AND 12KV THREE-PHASE TRANSFORMER CLUSTER MOUNT INSTALLATION-ALLEY ARM CONSTRUCTION	

BILL OF MATERIAL: (CONT'D)

ITEM	DESCRIPTION	QUANTITY		STOCK NUMBER OR CONSTR STANDARD
		STATION WITH ARRESTERS (J)	STATION WITHOUT ARRESTERS	
31	WIRE, THW COPPER, SIZED PER TRANSFORMER CAPACITY	35'	35'	STD 1125
32	CONNECTOR, WIRE, COMPRESSION, CU OR AL AS REQ'D (E)	AS REQ'D	AS REQ'D	783-786
33	WIRE, #6, 3 STRAND, BARE COPPER	FT	55	813536
		LB	4	
34	UNIT, GROUND, COMPLETE (K)	2	1	603136
35	CONDUIT, PVC, TYPE 2, SCHEDULE 40, 1/2" (E)	10'	-	251168
36	STRAPS, PIPE, GALV. 1/2" AND 1-3/4" ROOFING NAILS (E)	AS REQ'D	-	697728

INSTALLATION:

- A. USE THIS CONSTRUCTION FOR TRANSFORMERS RATED 12KV AND BELOW WHICH HAVE HIGH VOLTAGE BUSHINGS MOUNTED ON TOP OF COVER.
- B. LIMITED TO TRANSFORMERS 100 KVA AND SMALLER, EACH WEIGHING 1200 POUNDS OR LESS.
- C. WHEN PRACTICAL, BOLT TRANSFORMERS TO BRACKET ON THE GROUND AND INSTALL THEM AS A PREWIRED ASSEMBLY.
- (D) DRILL THROUGH CROSSARM 1" UP FROM LOWER EDGE SO THAT LOWER CROSSARM MOUNTING BRACKET BOLT DOES NOT INTERFERE WITH PVC CONDUIT.
- (E) EXEMPT MATERIAL.
- (F) INSTALL LA/CO CROSSARM ON SAME SIDE OF POLE AS TRANSFORMERS.
- (H) BOND ALL CUTOUTS IN HEAVY CONTAMINATION DISTRICT, AS IDENTIFIED ON STANDARD 287. IN AREAS WHERE BONDING IS REQUIRED, TO AVOID BONDWIRE AND LIGHTNING ARRESTER GROUNDWIRE ON THE ON THE SAME CROSSARM, USE TWO CROSSARMS; ONE FOR CUTOUTS AND ONE FOR LIGHTNING ARRESTERS

REFERENCE:

- I. PRIMARY AND SECONDARY CONNECTIONS ARE SHOWN FOR ILLUSTRATIVE PURPOSES. SEE STANDARD 1118-1119 FOR SPECIFIC CONNECTION DIAGRAMS.
- (J) LIGHTNING ARRESTER APPLICATION, SEE STANDARD 1247.
- (K) GROUNDING METHOD AND APPLICATION, SEE STANDARD 1002.
- (L) POLE STEPPING, SEE STANDARD 363.

FOR FIELD MAINTENANCE ONLY

DATE 1-1-91 APPD PJA / DTE	SDG&E ELECTRIC STANDARDS	1199.707 SUPERSEDES 1174.4 (1-1-93)
	7.2 AND 12KV THREE PHASE TRANSFORMER CLUSTER MOUNT INSTALLATION-ALLEY ARM CONSTRUCTION	

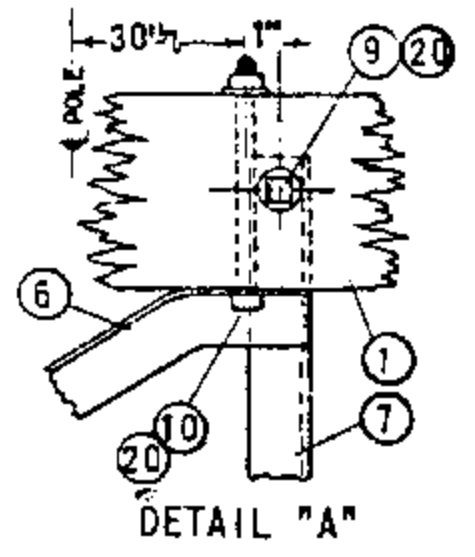
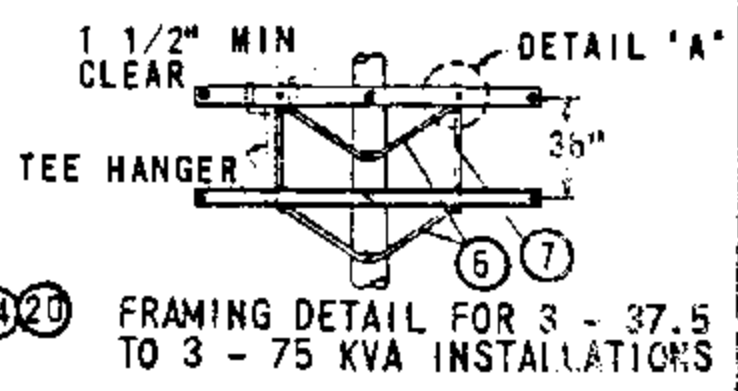
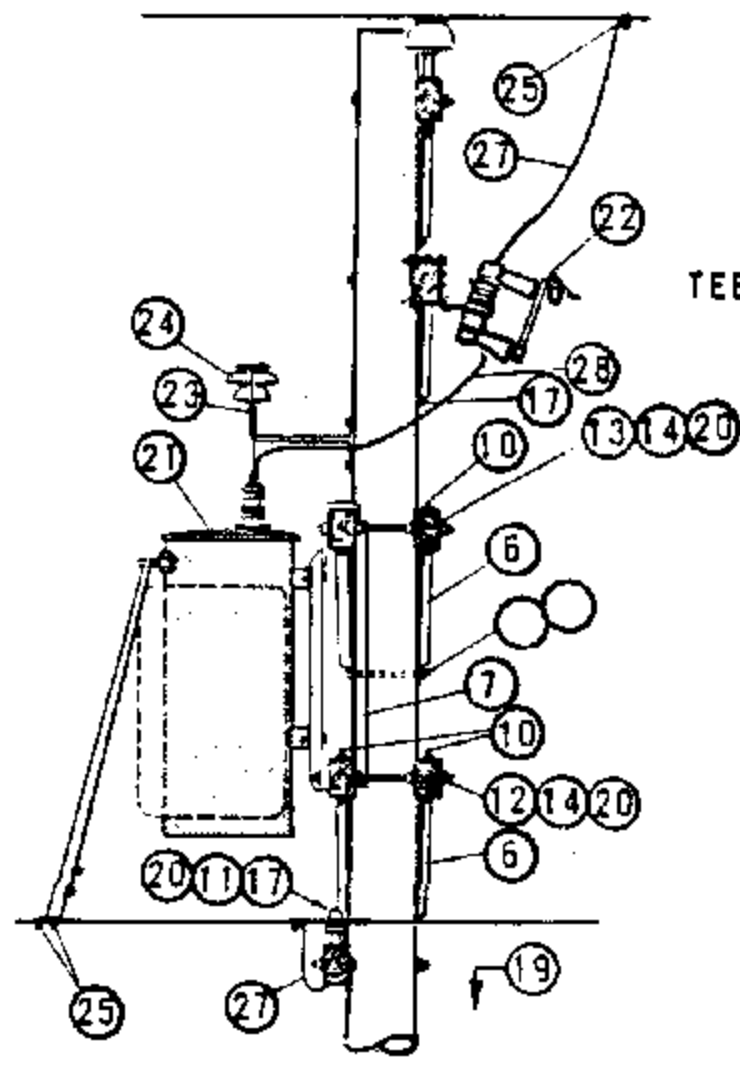
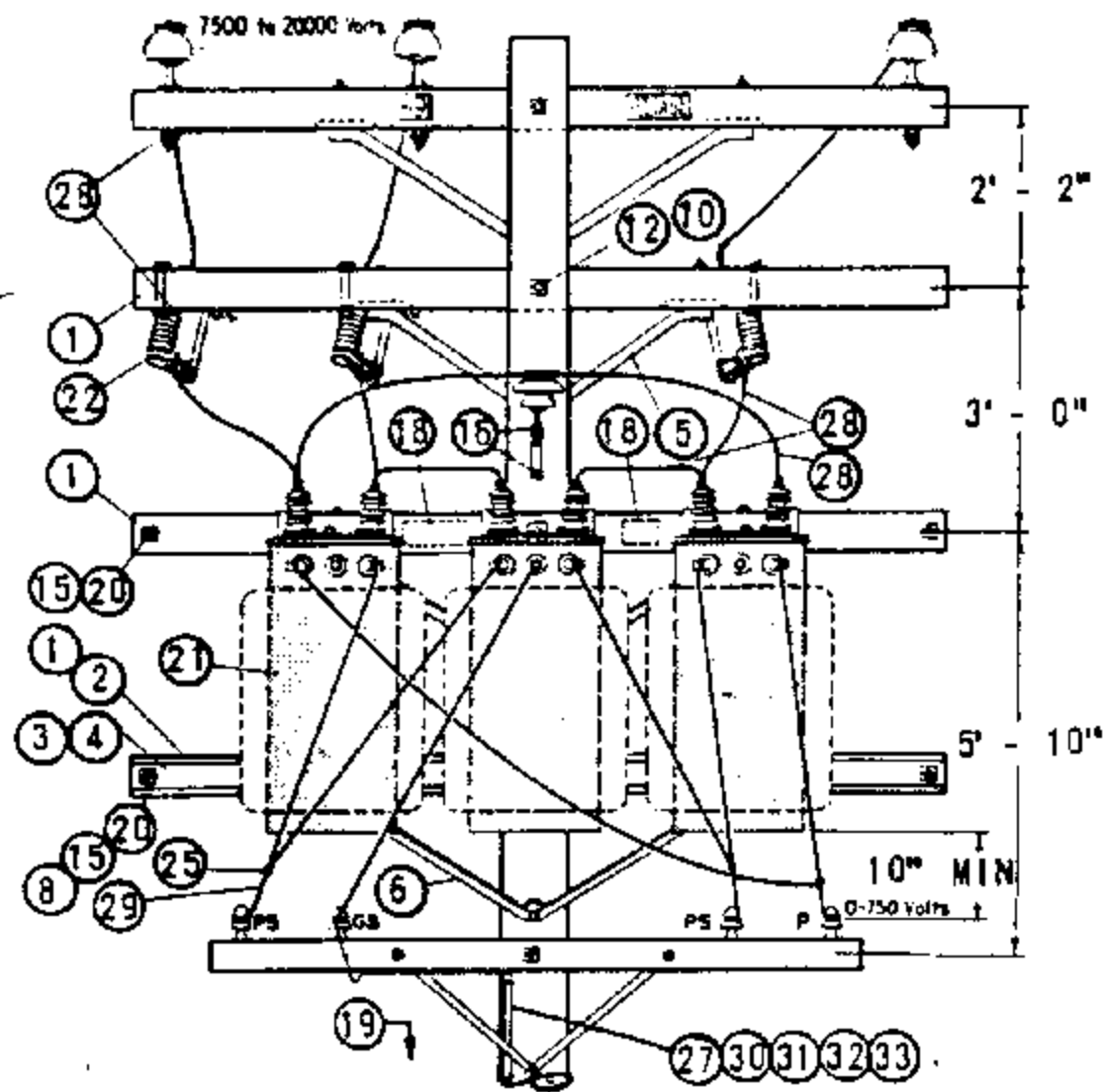

- NOTES:
- (A) UNIT GROUND COMPLETE ORDER 603120 WITH GRAY MOULDING, 603136 WITH PLAIN MOULDING.
 - B. SEE ARRESTER SECTION FOR ARRESTER REQUIREMENTS.
 - (C) USE TWO ROD GROUND.
 - D. BOND ALL CUTOUTS IN HEAVY CONTAMINATION DISTRICTS AS IDENTIFIED ON STANDARDS PAGE 287.
 - (E) EXEMPT MATERIAL
 - F. USE EXTRA HEAVY CLASS ONE POLES WITH 10" MINIMUM TOP DIAMETER ON NEW CONSTRUCTION FOR 3 - 37.5 TO 3 - 75 KVA TRANSFORMER INSTALLATIONS.
 - G. LIMITED TO TRANSFORMERS WEIGHING 1200# OR LESS.
 - H. SPACING OF TRANSFORMERS TO BE AS CLOSE AS PRACTICABLE BUT NOT TO EXCEED 33.5" CENTER TO CENTER.
 - I. SEE STANDARDS PAGE 1119 FOR SPECIFIC TRANSFORMER CONNECTIONS. 240V, 4 WIRE DELTA IS SHOWN FOR ILLUSTRATIVE PURPOSES ONLY.

ITEM	DESCRIPTION	QUANTITY		STOCK NO. OR CONSTR STD
		5 TO 25 KVA	37.5 TO 75 KVA	
1	CROSSARM, 3 3/4" X 5 3/4" X 10' - 0"	3	5	PG. 119 IT. 2
2	CROSSARM, 3 3/4" X 5 3/4" X 8' - 0"	1	0	PG. 116 IT. 1
3	COVER STRIP, 1 5/8" X 3 5/8" X 8' - 0" (2X4S4S)	1	0	699328
4	COVER STRIP, 1 5/8" X 3 5/8" X 10' - 0" (2X4S4S)	0	1	699360
5	BRACE, ANGLE CROSSARM, GALV, 4' - 0"	1	1	164032
6	BRACE, ANGLE CROSSARM, GALV, 5' - 0"	2	4	164128
7	BRACE, VERTICAL 35"	0	2	164256
8	BOLT, MACH GALV, 3/8" X 6", 2 RD WASH & 1 NUT	(E) 2	0	PGS 139, 140
9	BOLT, MACH GALV, 5/8" X 5", 1 RD WASH & 1 NUT	(E) 0	4	PGS 139, 140
10	BOLT, MACH GALV, 1/2" X 8", 1 RD WASH & 1 NUT	(E) 6	10	PGS 139, 140
11	BOLT, MACH GALV, 5/8" X " , 1 NUT	(E) 1	2	PGS 139, 140
12	BOLT, MACH GALV, 5/8" X 14", 2 SQ WASH & 1 NUT	(E) 2	1	PGS 139, 140
13	BOLT, MACH GALV, 5/8" X 20", 2 - 3" SQ WASH & 1 NUT	(E) 1	0	PGS 139, 140
14	BOLT, MACH GALV, 3/4" X 20", 2 - 3" SQ WASH & 1 NUT	(E) 0	2	PGS 139, 140
15	BOLT, SPACE GALV, 5/8" X " , 4 SQ WASH. & 4 NUTS	(E) 2	4	PGS 139, 140
16	SCREW, LAG GALV, 1/2" X 4"	(E) 3	2	621568
17	SCREW, LAG GALV, 5/8" X 5"	(E) 1	1	621600
18	SIGN, HIGH VOLTAGE & 8 ROOFING NAILS, GALV	(E) 1	1	647648, 492224
19	STEP, POLE	(E) 19	19	692992
20	WASHER, DOUBLE COIL SPRING, FOR ITEMS 8 THRU 15	AS REQ'D		PG 140
21	TRANSFORMER, SINGLE PHASE, TYPE H OR HF	3	3	PGS 1121.01-1121.12
22	CUTOUT, 12KV	3	3	PGS 1212, 1213
23	BRACKET, INSULATOR	1	1	166176
24	INSULATOR, 12KV	1	1	429152
25	CONNECTOR, WIRE	11	11	PGS 783-787
26	WIRE, BARE SOLID ANNEALED COPPER #8	AS REQ'D		812928
27	WIRE, BARE STRANDED COPPER #6	70'	70'	813536
28	WIRE, SOLID W.P. COPPER #4	10'	10'	813536
29	WIRE, W.P. COPPER, SIZE GOVERNED BY TRANSFORMER CAPACITY	60'	60'	PG 1125
30	ROD & CLAMP	(A) 2	(C) 2	603072, 230016 (E)
31	MOULDING, HARDWOOD 1"	(A) 27'	(A) 27'	487200
32	STAPLES, MOULDING GALV, 3" X 1 1/16" X 1/4"	(A) 18	(E) 18	678560
33	STAPLES, FENCE GALV, 1 1/4"	(A) 17	(E) 17	678528

FOR FIELD MAINTENANCE ONLY

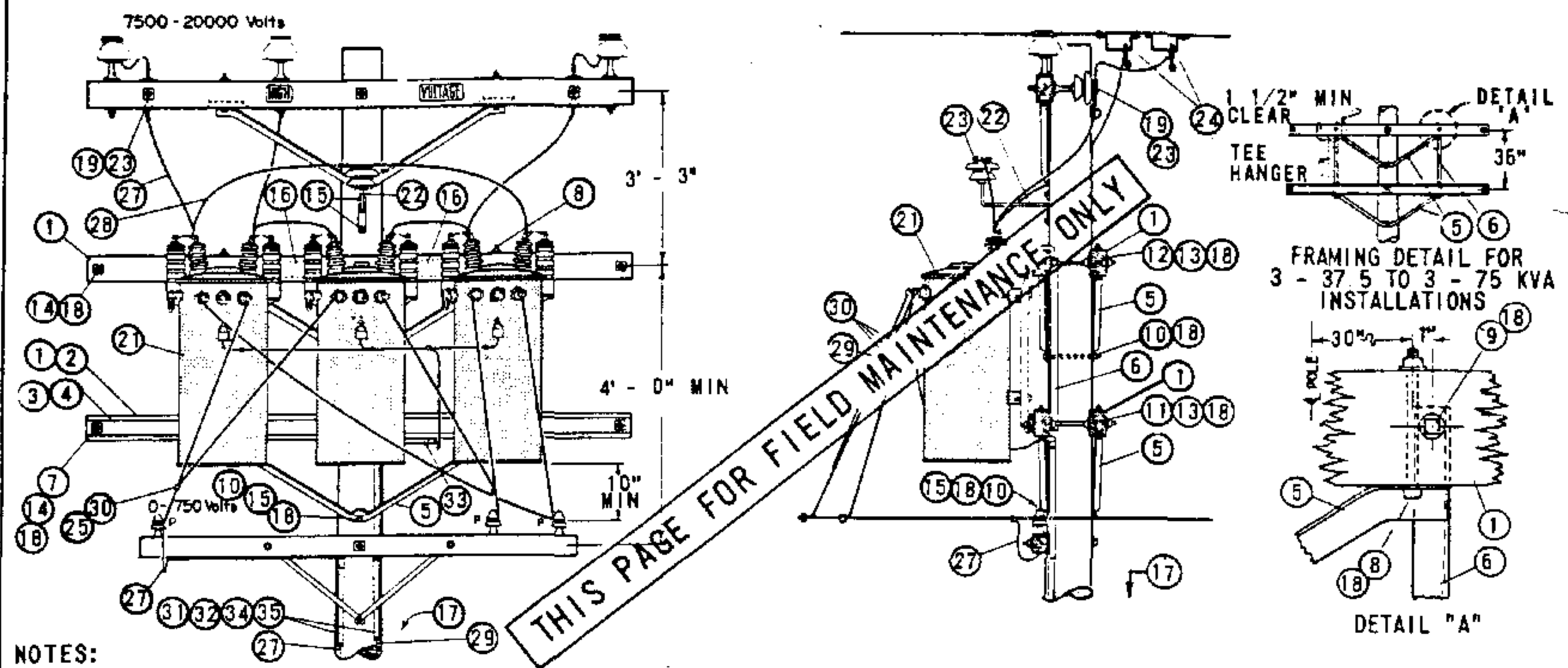

THIS PAGE FOR FIELD MAINTENANCE ONLY

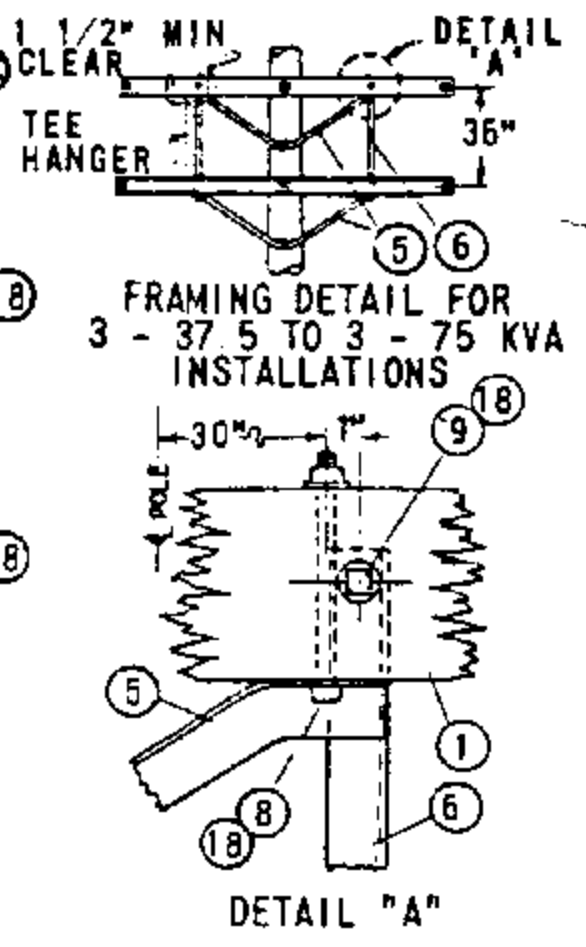

NOTES:

- (A) UNIT GROUND COMPLETE ORDER 603120 WITH GRAY MOULDING, 603136 WITH PLAIN MOULDING.
- (B) USE TWO ROD GROUND.
- C. THIS PAGE FOR FIELD MAINTENANCE ONLY. USE TYPE "H" TRANSFORMERS ON NEW INSTALLATIONS.
- D. USE EXTRA HEAVY CLASS ONE POLES WITH 10" MINIMUM TOP DIAMETER ON NEW CONSTRUCTION FOR 3 - 37.5 TO 3 - 75 KVA TRANSFORMER INSTALLATIONS.
- (E) EXEMPT MATERIALS
- F. LIMITED TO TRANSFORMERS WEIGHING 1200# OR LESS.
- G. SPACING OF TRANSFORMERS TO BE AS CLOSE AS PRACTICABLE BUT NOT TO EXCEED 33.5" CENTER TO CENTER.
- H. SEE DISTRIBUTION POLE TOPS SECTION FOR POLE TOP MATERIALS.
- I. OMIT LIGHTNING ARRESTER TANK GAP GROUNDING MATERIAL WHERE INSTALLING TRANSFORMERS NOT EQUIPPED WITH ARRESTERS.

ITEM	DESCRIPTION	QUANTITY		STOCK NO. OR CONSTR STD
		5 TO 25 KVA	37.5 TO 75 KVA	
1	CROSSARMS, 3 3/4" X 5 3/4" X 10' - 0"	2	4	PG 119 IT. 2
2	CROSSARMS, 3 1/2" X 4 1/2" X 8' - 0"	1	0	PG 111 IT. 2
3	COVER STRIP, 1 5/8" X 3 5/8" X 8' - 0" (2X4S4S)	1	0	699328
4	COVER STRIP, 1 5/8" X 3 5/8" X 10' - 0" (2X4S4S)	0	1	699360
5	BRACE, ANGLE CROSSARM 5' - 0"	2	4	154128
6	BRACE, VERTICAL 35"	0	2	154256
7	BOLT, MACH GALV, 3/8" X 6", 2 RD WASH.	(E) 2	0	PGS 139, 140
8	BOLT, MACH GALV, 1/2" X 8", 1 RD WASH	(E) 4	8	PGS 139, 140
9	BOLT, MACH GALV, 5/8" X 5", 1 RD WASH.	(E) 0	4	PGS 139, 140
10	BOLT, MACH GALV, 5/8" X "	(E) 1	2	PGS 139, 140
11	BOLT, MACH GALV, 5/8" X 14", 2 SQ WASH.	(E) 1	0	PGS 139, 140
12	BOLT, MACH GALV, 5/8" X 20", 2 - 3" SQ WASH.	(E) 1	0	PGS 139, 140
13	BOLT, MACH GALV, 3/4" X 20", 2 - 3" SQ WASH.	0	2	PGS 139, 140
14	BOLT, SPACE GALV, 5/8" X " 4 SQ WASH	(E) 2	4	PGS 139, 140
15	SCREW, LAG GALV, 1/2" X 4"	(E) 3	2	621568
16	SIGN, HIGH VOLTAGE & 8 ROOFING NAILS, GALV	(E) 1	1	647548, 492224
17	STEP, POLE	(E) 19	19	692992
18	WASHER, DOUBLE COIL SPRING FOR ITEMS 7 THRU 14	AS REQ'D		PG 140
19	PIN, INSULATOR 12KV, SIZE PER ITEM 23, 1 / 1 3/8"	2	2	531072/532448
20				
21	TRANSFORMER, SINGLE PHASE, TYPE HE OR HJ	3	3	PGS 1121.01-1121.12
22	BRACKET, INSULATOR, SIZE PER ITEM 23	1	1	PG 152
23	INSULATOR, 12KV, CLASS AS REQ'D	3	3	PG 750
24	CLAMP, HOT LINE (E) AND STIRRUP	7	7	PG 788
25	CONNECTOR, WIRE	7	7	PGS 783-787
26				
27	WIRE, BARE STRANDED COPPER #6	76'	76'	813536
28	WIRE, BARE STRANDED COPPER #4	8'	8'	813760
29	WIRE, BARE STRANDED COPPER #2	50'	50'	813664
30	WIRE, W.P. COPPER, SIZE GOVERNED BY TRANSFORMER CAPACITY	60'	60'	PG 1125
31	ROD AND CLAMP, GROUND	(A) (B) 4	4	603072, 230016 (E)
32	MOULDING, HARDWOOD 1"	(A) 64'	64'	487200
33				
34	STAPLES, MOULDING GALV 1 1/4" X 3 1/16" X 1/4"	(A) (E) 40	40	678560
35	STAPLES, FENCE GALV 1 1/4"	(A) (E) 36	36	678528

1199.802
SUPERSEDES
1184 (1-1-86)

SAN DIEGO GAS & ELECTRIC CO OVERHEAD STANDARDS

12KV, THREE PHASE, TYPE "HE" OR "HJ" TRANSFORMER INSTALLATION,
THREE 75 KVA MAXIMUM, SECONDARY LINE ARM CONSTRUCTION

DATE 1-1-86
APPD AK/RDS

SCOPE: THIS STANDARD SHOWS THE INSTALLATION OF 7.2 AND 12KV, 3Ø TRANSFORMERS, ALLEY ARM CONSTRUCTION, WITH CLUSTER MOUNTING BRACKET AND SECONDARY RACK CONSTRUCTION.

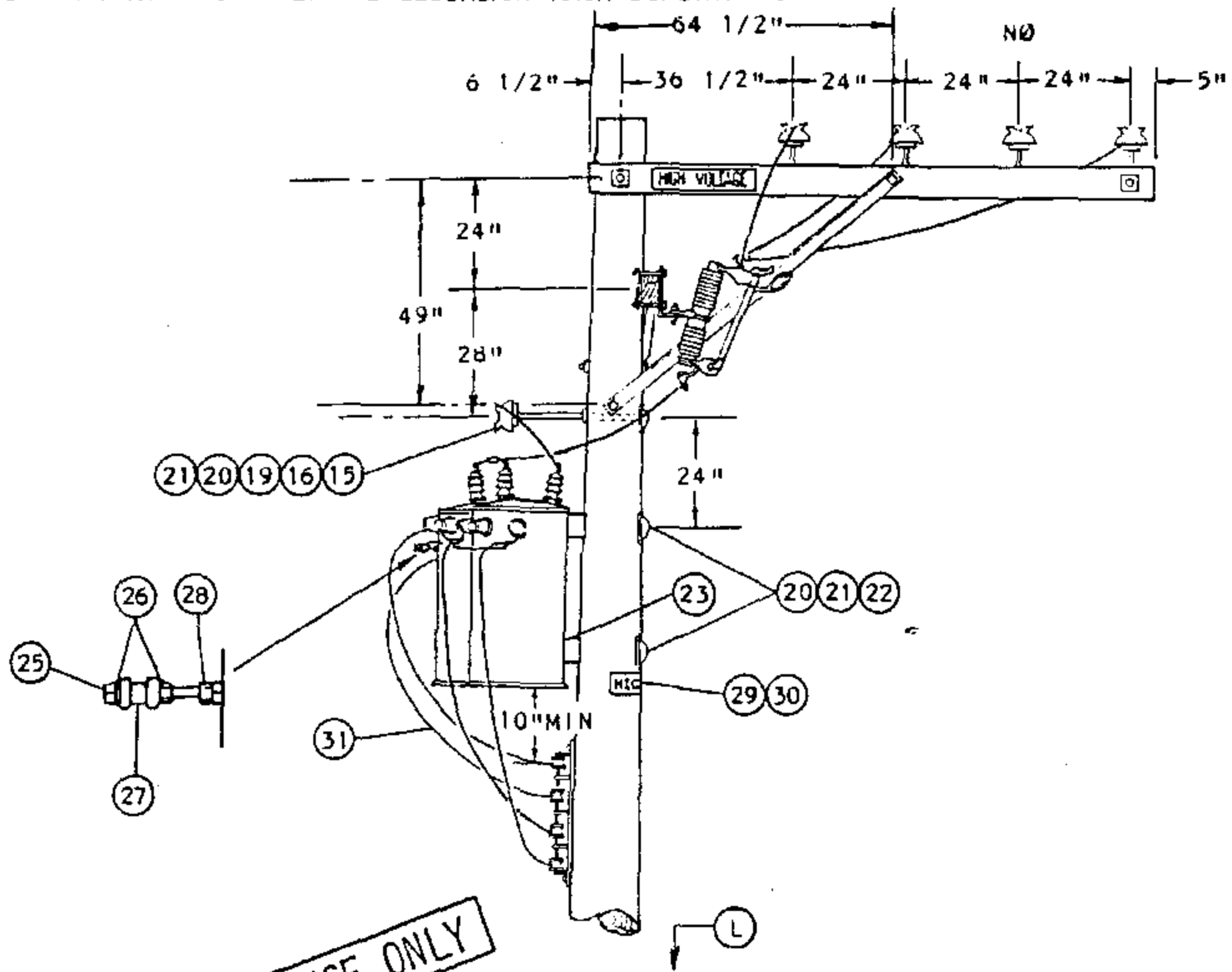

FOR FIELD MAINTENANCE ONLY

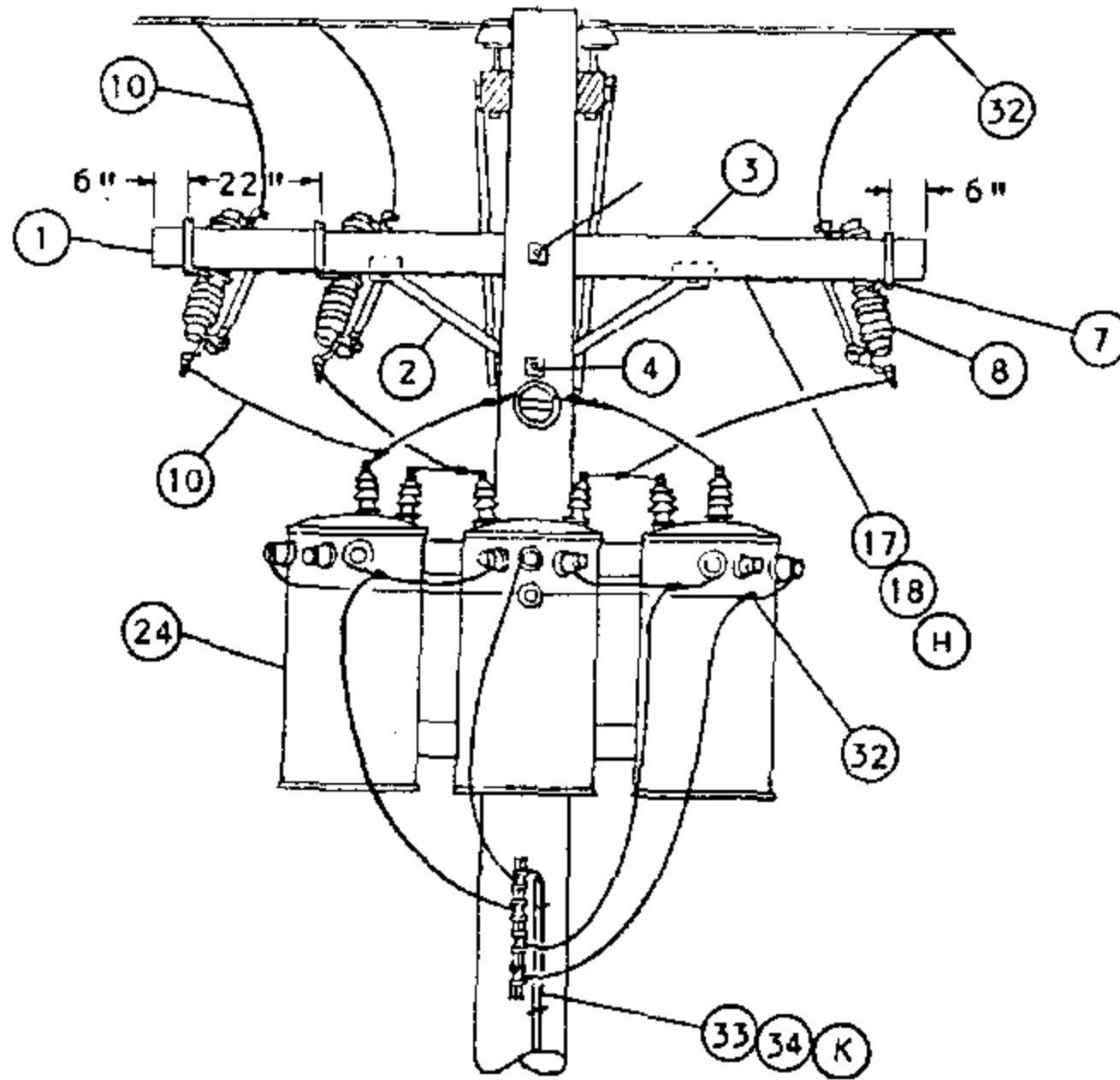

DELTA PRIMARY CONNECTION

SDG&E ELECTRIC STANDARDS

7.2 AND 12KV THREE PHASE TRANSFORMER
 CLUSTER MOUNT INSTALLATION-ALLEY ARM CONSTRUCTION

1199.8C3
 SUPERSEDES
 1174.1 (1-1-93)

DATE 1-1-89
 APPD PJA/OTE

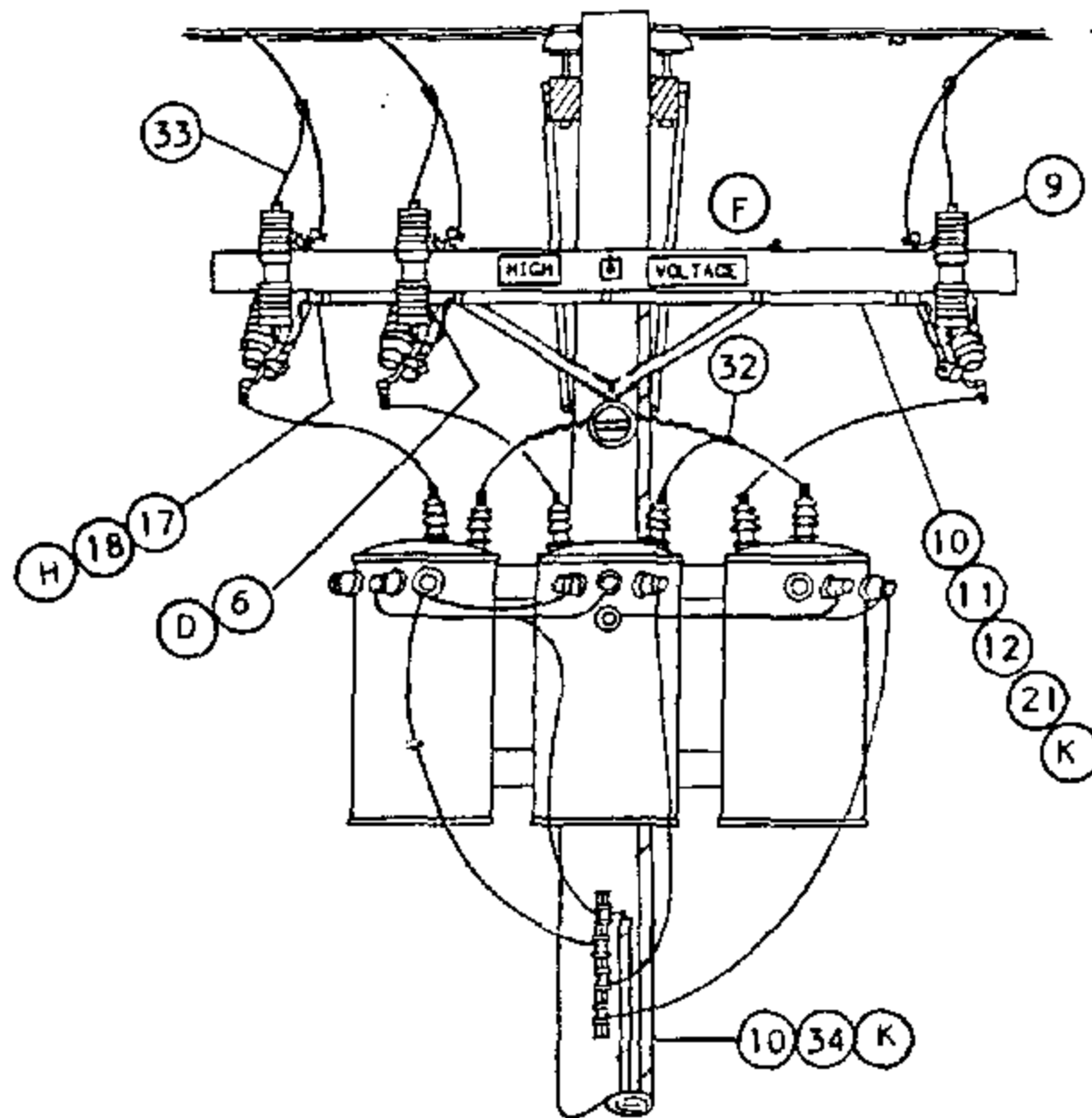
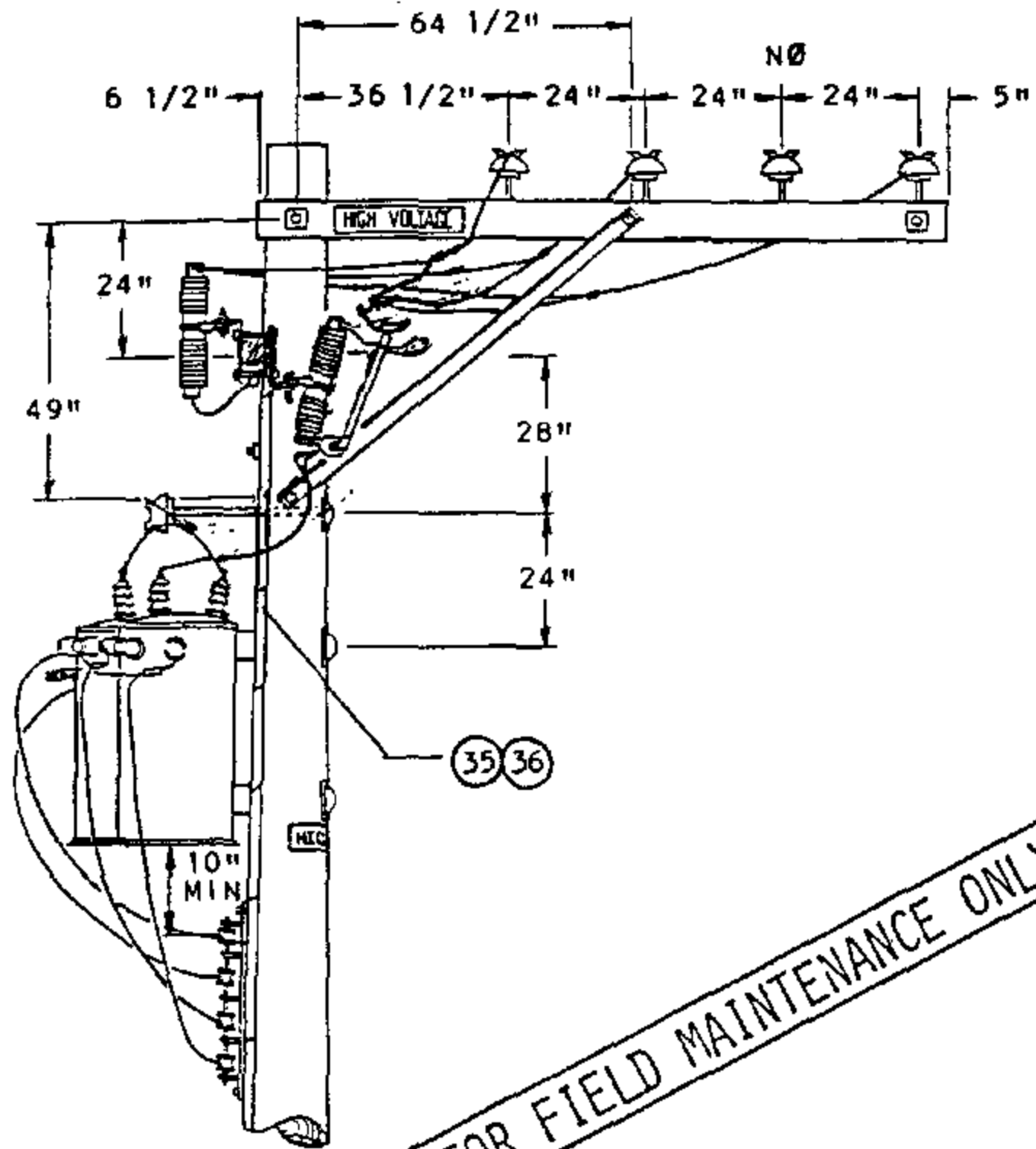

WYE PRIMARY CONNECTION
WITH LIGHTNING ARRESTERS (J)

SDG&E ELECTRIC STANDARDS

1199.804
SUPERSEDES
1174.2 (1-1-93)

7.2 AND 12KV THREE PHASE TRANSFORMER
CLUSTER MOUNT INSTALLATION-ALLEY ARM CONSTRUCTION

DATE 1-1-91
APPD P/A/R

BILL OF MATERIAL:

ITEM	DESCRIPTION	QUANTITY		STOCK NUMBER OR CONSTR STANDARD
		STATION WITH ARRESTERS	STATION WITHOUT ARRESTERS	
1	CROSSARM, 3 3/4" X 5 3/4" X 10' - 0"	1	1	294128
2	BRACE, ANGLE, CROSSARM, 4'	1	1	164032
3	BOLT, MACH, GALV, 1/2" X 7", 1 RD & 1 DBL COIL SPRING WASHER (E)	2	2	STD. 392
4	BOLT, MACH, GALV, 5/8" X (LENGTH AS REQ'D), 1 SQUARE & 1 DOUBLE COIL SPRING WASHER (E)	1	1	STD. 392
5	BOLT, MACH, GALV, 5/8" X (LENGTH AS REQ'D), 2 SQUARE & 1 DOUBLE COIL SPRING WASHER (E)	1	1	STD. 392
6	BRACKET, DOUBLE, CUTOUT/ARRESTER, FOR CROSSARM MOUNTING (E)	3	-	165442
7	BRACKET, CUTOUT/ARRESTER, FOR CROSSARM MOUNTING (E)	-	3	166070
8	CUTOUT, 12KV, WITH LOADBUSTER HOOK	3	3	STD. 1212
9	ARRESTER, LIGHTNING	3	-	113248
10	WIRE, #4 BARE STRANDED COPPER	FT LB 100 13	40 5	813760
11	CONDUIT, PVC, TYPE 2, SCHEDULE 40, 1" X 10' (E)	1	-	251200
12	STRAPS, PIPE, GALV, " (E)	AS REQ'D	-	697792
13				
14				
15	INSULATOR, PIN TYPE, CLASS AS REQ'D	1	1	STD. 750
16	WIRE, TIE (E)	1	1	815232
17	WIRE, #8 BARE SOLID ANNEALED COPPER (G) FT LB 15 1	15	15	812928
18	STAPLES, 1 1/4", FENCE, GALV (G) (E)	AS REQ'D	AS REQ'D	678528
19	BRACKET, INSULATOR, 1" OR 1 3/8" THREAD (AS REQ'D)	1 1	1 1	166144 166176
20	COVER, BOLT, PLASTIC (E)	3	3	285696
21	NAILS, GALV, 1 3/4" ROOFING (E)	AS REQ'D	AS REQ'D	492192
22	BOLT, MACH, GALV, 3/4" X (LENGTH AS REQ'D), 1 SQUARE CURVED & 1 DOUBLE COIL SPRING WASHER (E)	2	2	STD. 392
23	BRACKET, TRANSFORMER CLUSTER MOUNTING	1	1	403008
24	TRANSFORMER, SINGLE PHASE, TYPE 'Y', 'YF', 'H' OR 'HF'	3	3	STD 1121
25	BOLT, MACH, GALV, 1/2" X 5" (E)	1	1	153024
26	WASHER, GALV, 1/2", ROUND (E)	2	2	800192
27	INSULATOR, SECONDARY, SPOOL, PORCELAIN (E)	1	1	430752
28	NUT, GALV, 1/2" (E)	1	1	504736
29	SIGN, HIGH VOLTAGE (E)	3	1	647648
30	NAILS, GALV, 7/8" ROOFING (E)	27	9	492224

FOR FIELD MAINTENANCE ONLY

BILL OF MATERIAL: (CONT'D)

ITEM	DESCRIPTION	QUANTITY		STOCK NUMBER OR CONSTR STANDAR
		STATION WITH ARRESTERS	STATION WITHOUT ARRESTERS	
31	WIRE, W.P. COPPER, SIZED PER TRANSFORMER CAPACITY	35'	35'	STD 1125
32	CONNECTOR, WIRE, COMPRESSION, CU OR AL AS REQ'D (E)	AS REQ'D	AS REQ'D	783-786
33	WIRE, #6, 3 STRAND, BARE COPPER	55 4	40 3	813536
34	UNIT, GROUND, COMPLETE (K)	2	1	603136
35	CONDUIT, PVC, TYPE 2, SCHEDULE 40, 1/2" (E)	10'	-	251.168
36	STRAPS, PIPE, GALV. 1/2" AND 1 3/4" ROOFING NAILS (E)	AS REQ'D.	-	697728

INSTALLATION:

- A. USE THIS CONSTRUCTION FOR TRANSFORMERS RATED 12KV AND BELOW WHICH HAVE HIGH VOLTAGE BUSHINGS MOUNTED ON TOP OF COVER.
- B. LIMITED TO TRANSFORMERS 100 KVA AND SMALLER, EACH WEIGHING 1200 POUNDS OR LESS.
- C. WHEN PRACTICAL, BOLT TRANSFORMERS TO BRACKET ON THE GROUND AND INSTALL THEM AS A PREWIRED ASSEMBLY.
- (D) DRILL THROUGH CROSSARM 1" UP FROM LOWER EDGE SO THAT LOWER CROSSARM MOUNTING BRACKET BOLT DOES NOT INTERFERE WITH PVC CONDUIT.
- (E) EXEMPT MATERIAL.
- (F) INSTALL LA/CO CROSSARM ON SAME SIDE OF POLE AS TRANSFORMERS.
- (H) BOND ALL CUTOUTS IN HEAVY CONTAMINATION DISTRICT, AS IDENTIFIED ON STANDARD 287. IN AREAS WHERE BONDING IS REQUIRED, TO AVOID BONDWIRE AND LIGHTNING ARRESTER GROUNDWIRE ON THE SAME CROSSARM, USE TWO CROSSARMS; ONE FOR CUTOUTS AND ONE FOR LIGHTNING ARRESTERS.

REFERENCE:

- I. PRIMARY AND SECONDARY CONNECTIONS ARE SHOWN FOR ILLUSTRATIVE PURPOSES. SEE STANDARD 1118-1119 FOR SPECIFIC CONNECTION DIAGRAMS.
- (J) LIGHTNING ARRESTER APPLICATION, SEE STANDARD 1247.
- (K) GROUNDING METHOD AND APPLICATION, SEE STANDARD 1002.
- (L) POLE STEPPING, SEE STANDARD 363.

FOR FIELD MAINTENANCE ONLY

1199.806

SUPERSEDES
1174.4 (1-1-93)

SDG&E ELECTRIC STANDARDS

**7.2 AND 12KV THREE PHASE TRANSFORMER
CLUSTER MOUNT INSTALLATION-ALLEY ARM CONSTRUCTION**

DATE 1-1-89

APPD *PEA/DTC*

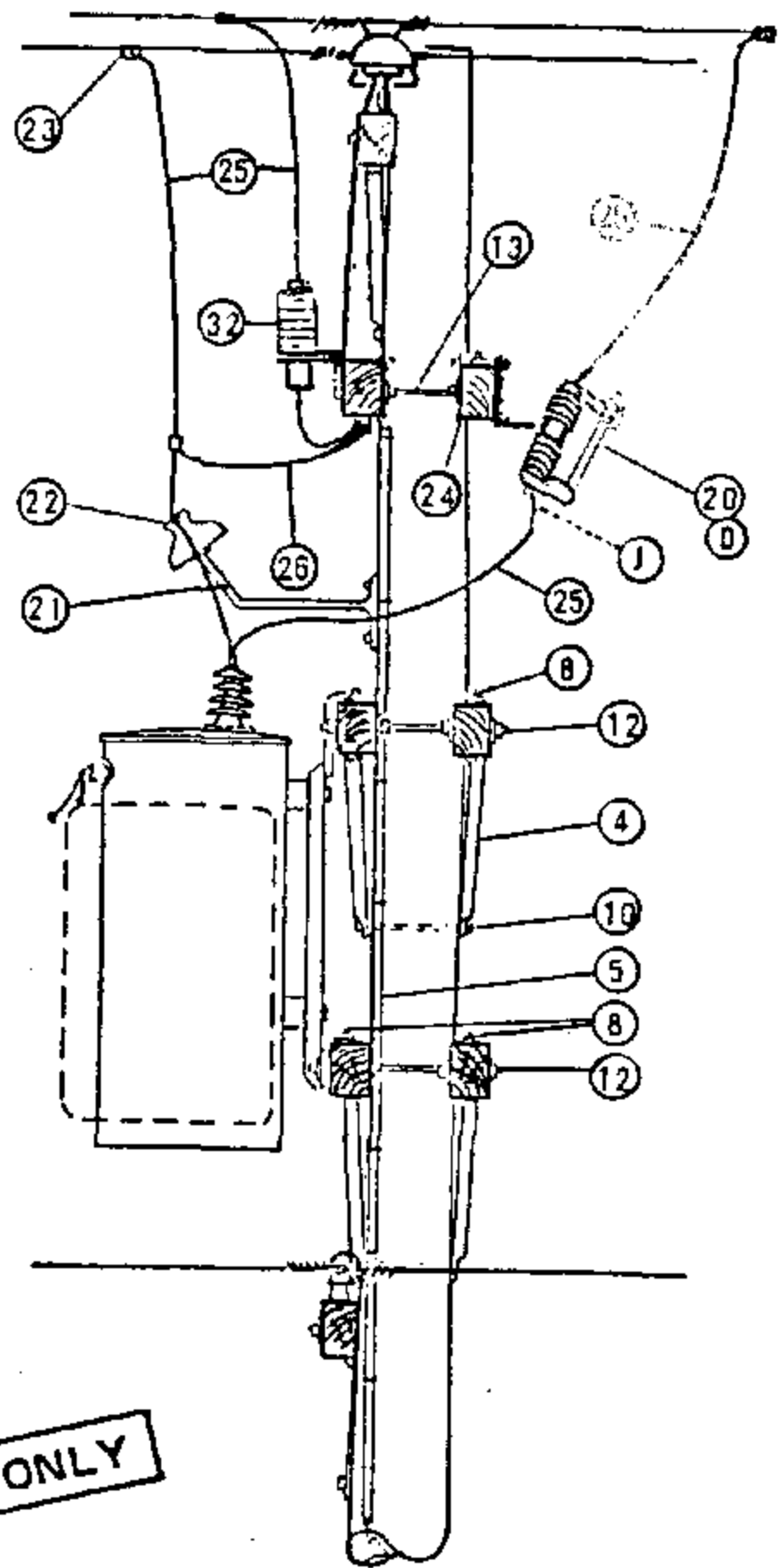
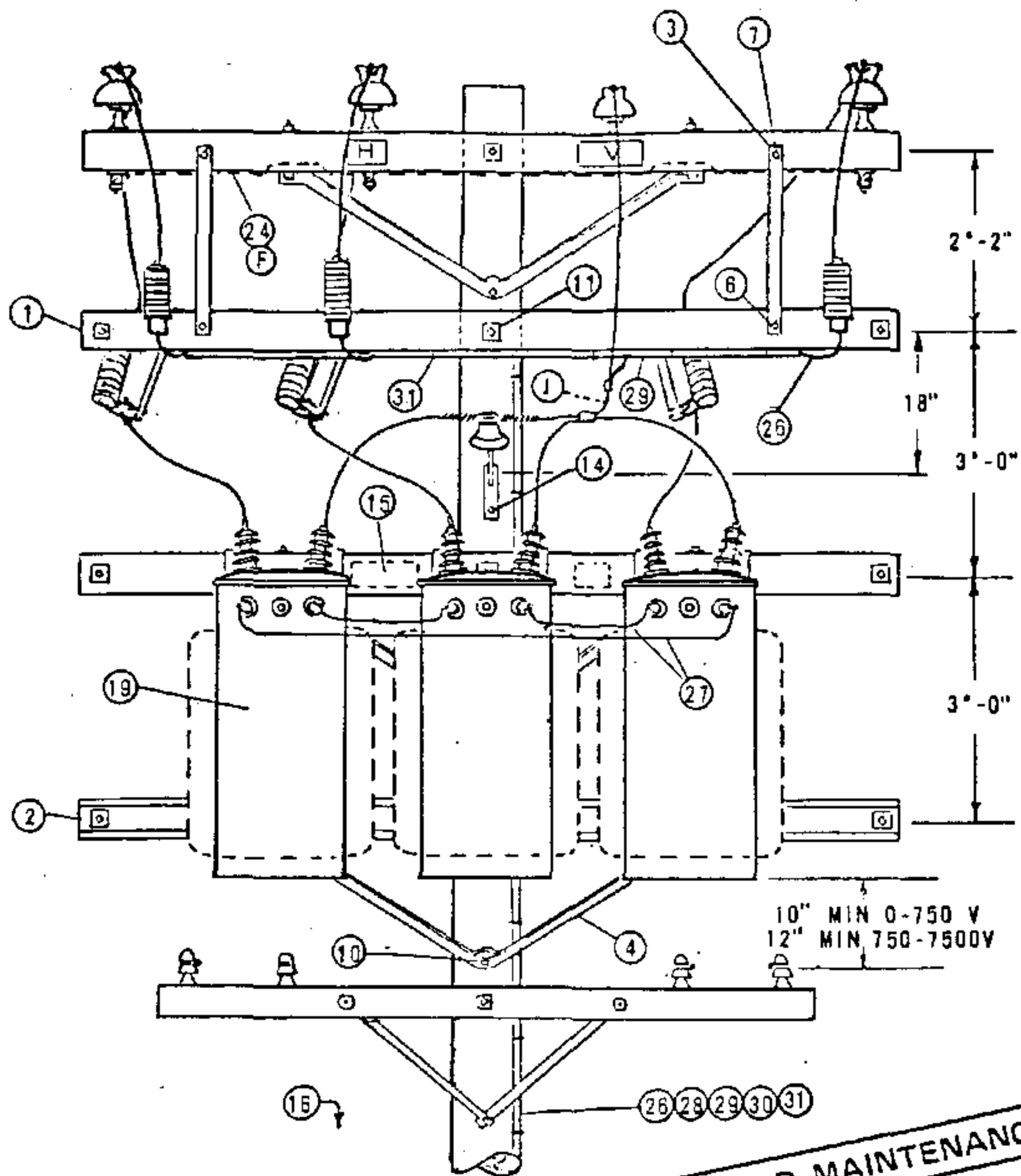

FOR FIELD MAINTENANCE ONLY

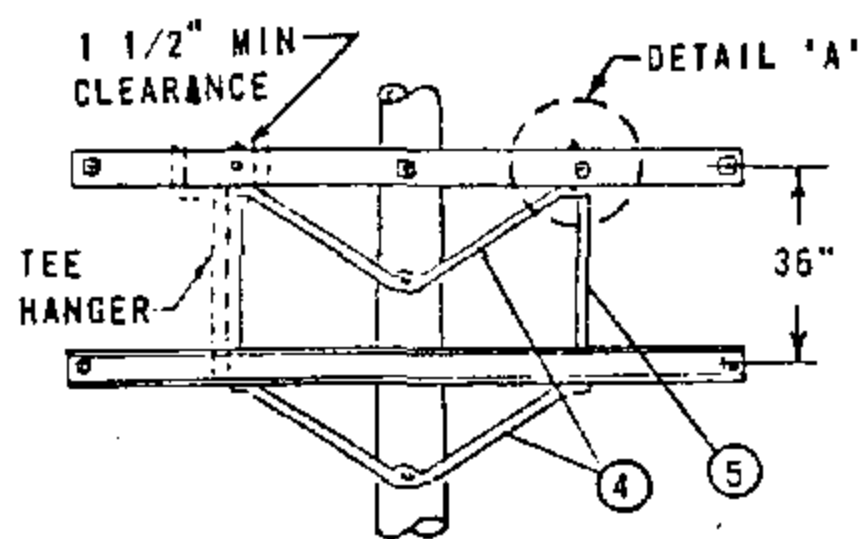

FRAMING DETAIL

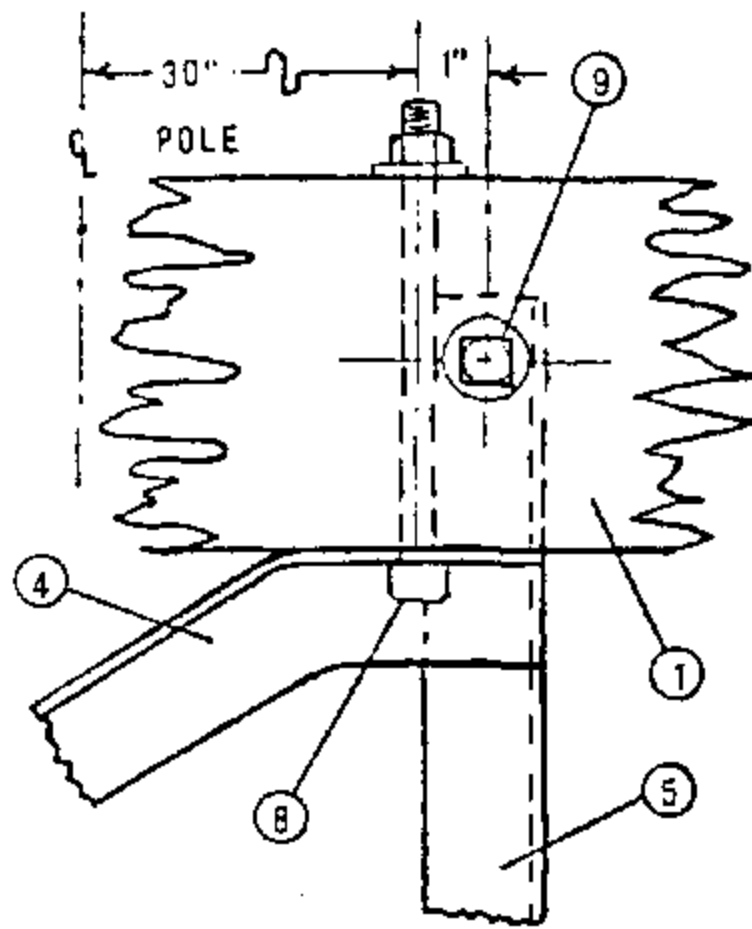

DETAIL "A"

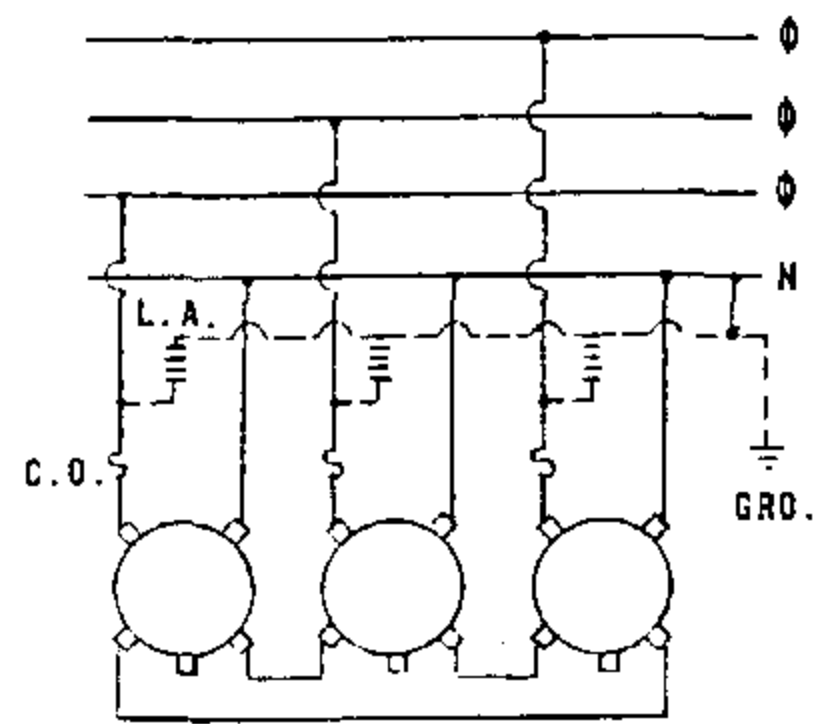

SCHEMATIC WIRING DIAGRAM

DATE 1-1-88
 APPD *AK/RS*

SDG&E ELECTRIC STANDARDS

12KV GROUNDING BANK INSTALLATION

1199.901

NOTES:

- A. USE EXTRA HEAVY CLASS ONE POLE WITH 10" MIN. TOP DIAMETER ON NEW CONSTRUCTION.
- ⓑ CONSTRUCT USING 3-50 OR 3-75 KVA TRANSFORMERS WEIGHING 1200# OR LESS APIECE.
- C. SPACING OF TRANSFORMERS TO BE AS CLOSE AS PRACTICAL AND NOT TO EXCEED 33 1/2" CENTER TO CENTER.
- Ⓓ FUSE ALL INSTALLATIONS AT 15 AMP.
- E. DO NOT GROUND SECONDARY.
- Ⓕ BOND ALL CUTOUTS AND LINE HARDWARE WITHIN 3 MILES OF COAST.
- G. BOND ALL DEADEND HARDWARE EVERYWHERE.
- H. USE TWO ROD GROUNDS.
- Ⓘ UNIT GROUND COMPLETE, ORDER 603120 (WITH GRAY MOULDING) OR 603136 (WITH PLAIN MOULDING).
- Ⓣ BARE 2" OF WIRE TO PERMIT APPLICATION OF TEMPORARY WORKING GROUNDS. NEUTRAL WORKING GROUND MAY BE ATTACHED TO BARE CONDUCTOR.

FOR FIELD MAINTENANCE ONLY

ITEM	DESCRIPTION	QUANTITY	STOCK NO. OR STD. PAGE
1	CROSSARM, 3 3/4" X 5 3/4" X 10'-0"	6	PG 119 IT 2
2	COVER STRIP, 1 5/8" X 3 5/8" X 10'-0" (2X4S4S)	1	699360
3	FLAT CROSSARM BRACE, 28"	2	164192
4	ANGLE CROSSARM BRACE, 5'-0"	4	164128
5	VERTICAL BRACE, 36"	2	164256
6	MACH. BOLT, GALV., 3/8" X 5", 1-RD. WASH. & 1 NUT	2	PGS 139, 140
7	MACH. BOLT, GALV., 1/2" X 5", 1-RD. WASH. & 1 NUT	2	PGS 139, 140
8	MACH. BOLT GALV., 1/2" X 8", 1-RD. WASH. & 1 NUT	8	PGS 139, 140
9	MACH. BOLT, GALV., 5/8" X 5", 1-RD. WASH 1 DBL COIL SPR WASH & 1 NUT	4	PGS 139, 140
10	MACH. BOLT, GALV., 5/8" X 10" OR 12", 1 DBL COIL SPR WASH & 1 NUT	2	PGS 139, 140
11	MACH. BOLT, GALV., 5/8" X 20", 2-3" SQ. WASH. 1 DBL COIL SPR WASH & 1 NUT	1	PGS 139, 140
12	MACH. BOLT, GALV., 3/4" X 20", 2-3" SQ. WASH. 1 DBL COIL SPR WASH & 1 NUT	2	PGS 139, 140
13	SPACE BOLT, GALV., 5/8" X 20" OR 22", 4-SQ. WASH. 2 DBL COIL SPR WASH & 2 NUTS	6	PGS 139, 140
14	LAG SCREW, GALV., 1/2" X 4"	2	621568
15	HIGH VOLTAGE SIGN & 8-ROOFING NAILS, GALV.	1	647778-492224
16	POLE STEPS	19	692992
17			
18			
19	TRANSFORMER, SINGLE PHASE (WITH T HANGERS) HF OR YF	3	PG 1121 ⓑ
20	CUTOUT, 12KV, HEAVY DUTY, 100A.	3	PGS 1212, 1213
21	INSULATOR BRACKET, 1" LEAD THREAD	1	166144
22	INSULATOR, 12KV, (CLASS 55-3)	1	429152-429152
23	WIRE CONNECTORS, COMPRESSION (SIZE AS REQ'D)	9	PGS 783, 786
24	WIRE, BARE SOLID ANNEALED, #8	AS REQ'D	812928
25	WIRE, #4 CU WP	AS REQ'D	812480
26	WIRE, BARE STRANDED, #2	55'	813664
27	WIRE, COPPER, POLYETHYLENE, 3-50KVA - 1/0 W.P. 3-75KVA - 4/0	10 LBS 15 LBS	812576 812640
28	GROUND ROD AND CLAMP	2	603072-230018 Ⓛ
29	HARDWOOD MOULDING, 1"	47'	487200 Ⓛ
30	MOULDING STAPLES, GALV., 3" X 1 1/16" X 1/4"	35	678560 Ⓛ
31	FENCE STAPLES, GALV., 1 1/4"	30	678528 Ⓛ
32	ARRESTER LIGHTNING, 12KV	3	113248
33			

P
T
&
F

L
T
I

1200 SECTIONALIZING

1200 SECTIONALIZING

PAGE

SUBJECT

1299.001	OVERHEAD 12KV CURRENT - LIMITING FUSE INSTALLATION
1299.101	12KV EXPULSION FUSED CUTOUT
1299.201-.203	POLE TOP SWITCH VERTICAL BREAK TYPE SINGLE CIRCUIT HORIZONTAL CONFIGURATION
1299.204	POLE TOP SWITCH INSTALLATION, 4KV DISCONNECT SWITCH, HOOKSTICK OPERATED
1299.205-.206	LINE TENSION DISCONNECT SWITCH - HOOKSTICK OPERATED
1299.207	IN-LINE DISCONNECT SWITCHES WEDGE TAP CONNECTED - 12KV AND BELOW
1299.208-.209	POLE TOP SWITCH 12KV VERTICAL BREAK TYPE SINGLE CIRCUIT HORIZONTAL CONFIGURATION
1299.301-.304	POLE TOP SWITCH INSTALLATION, 12KV SINGLE CIRCUIT, HORIZONTAL AND VERTICAL CONFIGURATION
1299.305-.306	POLE TOP SWITCH INSTALLATION, 69KV SINGLE CIRCUIT, TRIANGULAR CONFIGURATION
1299.307-.309	POLE TOP SWITCH INSTALLATION, 12KV, HORIZONTAL BREAK
1299.401	POLE TOP SWITCH INSTALLATION, 4KV WESTINGHOUSE OIL SWITCH, TYPE FO 11
1299.701-.703	SERVICE RESTORER WITH CUTOUT DISCONNECT
1299.704-.706	SERVICE RESTORER WITH HOOKSTICK SWITCH DISCONNECT
1299.707-.711	SERVICE RESTORER BUCK POSITION, HOOKSTICK SWITCH

© 1998 - 2019 San Diego Gas & Electric Company. All rights reserved. Removal of this copyright notice without permission is not permitted under law.

REV	CHANGE	BY	DSGN	APPV	DATE	REV	CHANGE	BY	DSGN	APPV	DATE
C						F					
B	COMPLETELY REVISED	JK	JS	CZH	10/15/2019	E					
A	ORIGINAL ISSUE	JK	JS	CZH	6/13/2019	D					

SHEET 1 OF 1	<input type="checkbox"/> Indicates Latest Revision <input checked="" type="checkbox"/> Completely Revised <input type="checkbox"/> New Page <input type="checkbox"/> Information Removed	OH LEGACY OHL1201.1
	SDG&E ELECTRIC OVERHEAD FIELD MAINTENANCE ONLY STANDARDS	
	LEGACY OVERHEAD FIELD MAINTENANCE TABLE OF CONTENTS SECTIONALIZING	

Back-up current-limiting fuses, such as the Chance K-Mate fuse, shall be permanently installed only at the direction of the Protection Engineer in conjunction with expulsion fuses. Current-limiting fuses have the ability to limit high values of fault current so it remains within the interrupting capability of some cutouts. Back-up type current-limiting fuses are used in series with expulsion fuses in order to clear both low and high values of fault current. The back-up current-limiting fuse insures clearing of high current and the expulsion fuse, low current faults.

If a small amount of fault current passes through the two fuses (expulsion fuse in the cutout and current-limiting fuse), only the expulsion fuse will operate and the fuse tube will drop out as normal. At higher fault currents, both fuses will operate, but only the expulsion fused cutout will give the visual indication that it has operated. If the expulsion fuse has operated, always check the current-limiting fuse. To do this, remove the current-limiting fuse, and check for continuity.

The recommended method of installing these current-limiting fuses (Stock No. 365634) is to insert the stud end into the transformer cover mounted high voltage bushing terminal and connect the transformer riser in the eye bolt connector furnished with the current-limiting fuse, as shown below.

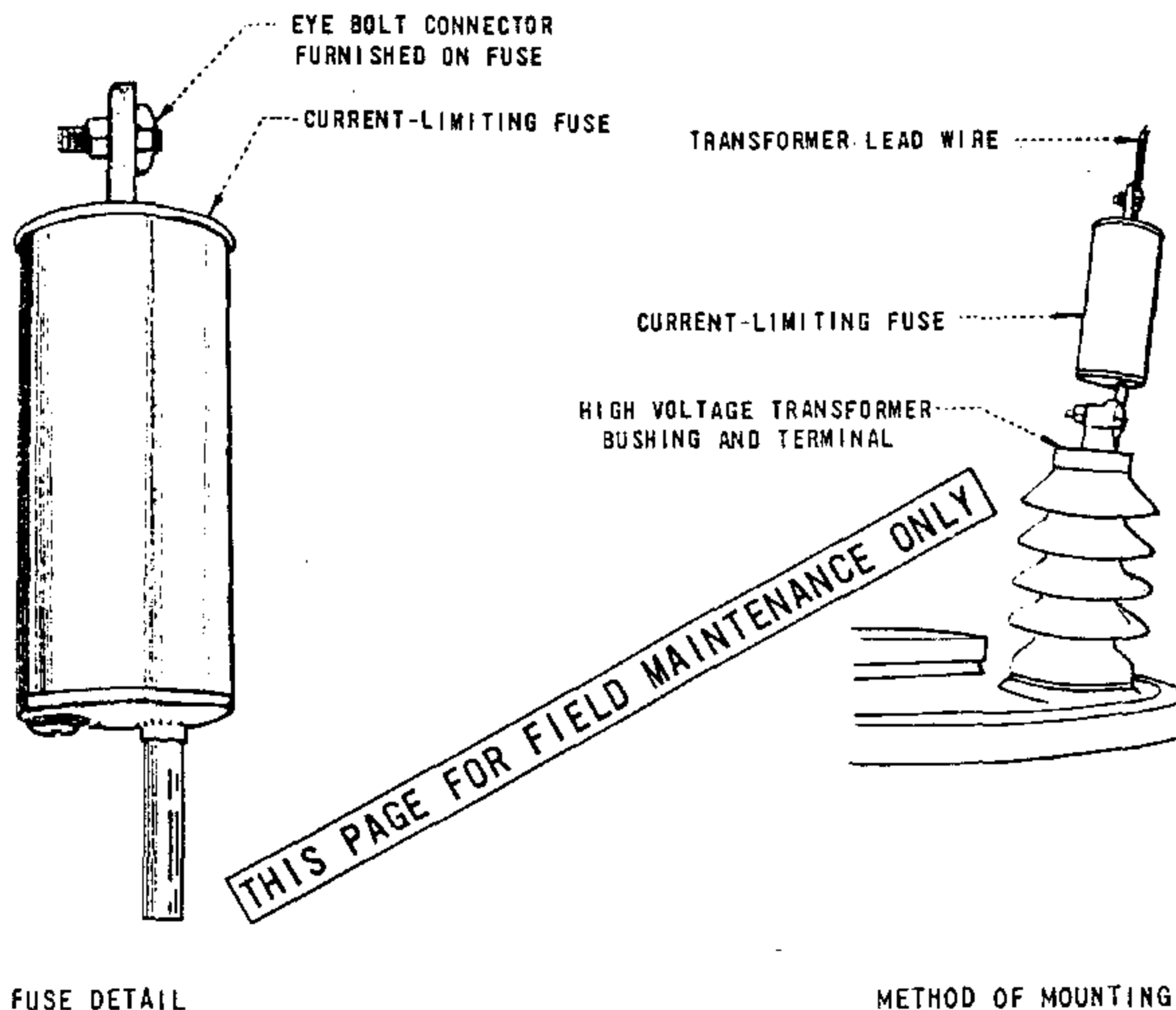

FUSE DETAIL

METHOD OF MOUNTING

SCOPE: THIS STANDARD SHOWS A 12KV STANDARD LEAKAGE EXPULSION FUSED CUTOUT AND THE GENERAL APPLICATION.

FOR FIELD MAINTENANCE ONLY

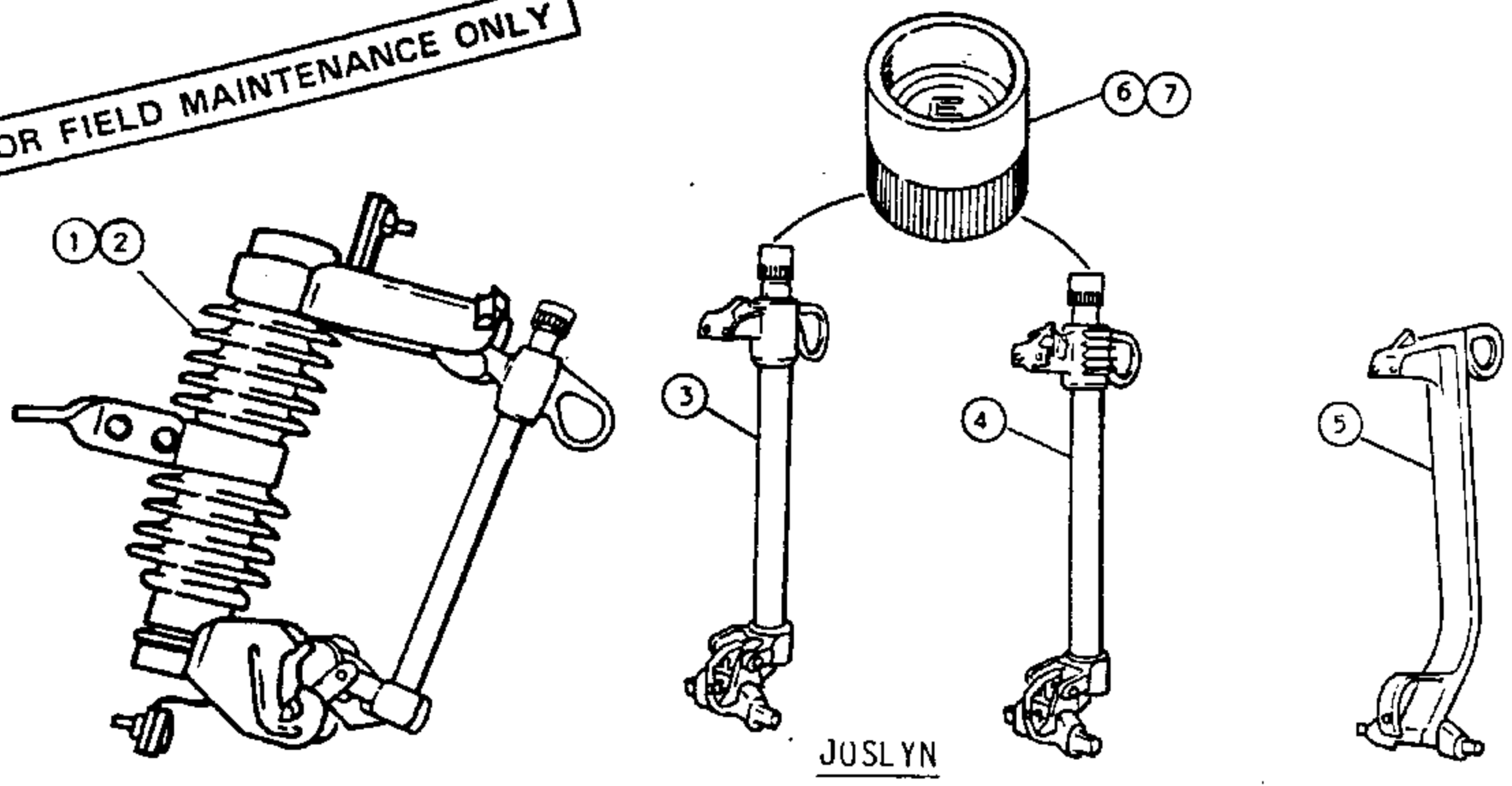

BILL OF MATERIAL:

ITEM	CURRENT RANGE	CONTAMINATION DISTRICT	DESCRIPTION	STOCK NUMBER
1	FUSE 5 THRU 100A	2 & 3	CUTOUT BODY, STANDARD LEAKAGE, JOSLYN, COMPLETE WITH 100A HD FUSEHOLDER (A)(C)(D)(F)	297888
2	FUSE 125 THRU 200A	2 & 3	CUTOUT BODY, STANDARD LEAKAGE, JOSLYN, COMPLETE WITH 200A HD FUSEHOLDER (A)(C)(D)(F)	297920
3	FUSE 5 THRU 100A	2 & 3	FUSEHOLDER ONLY, 100A WITH EXPENDABLE CAP, REPLACEMENT PART FOR CUTOUT BODY ITEM #1 (F)	413192
4	FUSE 125 THRU 200A	2 & 3	FUSEHOLDER ONLY, 200A WITH EXPENDABLE CAP, REPLACEMENT PART FOR CUTOUT BODY ITEM #2 (F)	413194
5	SOLID 5 THRU 300A	2 & 3	SOLID BLADE 300A, FOR USE IN CUTOUT BODY ITEM #1 OR #2	138816
6	FUSE 5 THRU 100A	ALL	CAP, 100A, DOUBLE VENTING, EXPENDABLE REPLACEMENT PART FOR FUSEHOLDER ITEM #1 & #3 (E)	203882
7	FUSE 125 THRU 200A	ALL	CAP, 200A, DOUBLE VENTING, EXPENDABLE REPLACEMENT PART FOR FUSEHOLDER ITEM #2 & #4 (E)	203890

INSTALLATION:

- (A) NO LONGER PURCHASED OR SALVAGED.
- B. HIGH LEAKAGE CUTOUTS SHALL BE USED ON ALL NEW CABLE POLES IN ALL CONTAMINATION DISTRICTS.
- (C) HIGH LEAKAGE CUTOUTS SHALL BE USED WHEN CUTOUTS ARE MOUNTED ON A COMMON METAL BRACKET OR WHEN THEIR MOUNTING BRACKET IS BONDED OR GROUNDED.
- (D) HIGH LEAKAGE CUTOUTS SHALL BE USED IN CONTAMINATION DISTRICT 1, AND MAY BE USED IN CONTAMINATION DISTRICTS 2 & 3 IF STANDARD LEAKAGE CUTOUTS ARE NOT AVAILABLE.
- (E) EXEMPT MATERIAL.
- (F) ALL JOSLYN CUTOUTS AND FUSE HOLDERS PURCHASED PRIOR TO JULY 1984 HAVE NON EXPENDABLE CAPS. IF THE FAULT DUTY EXCEEDS 8000 AMPS REPLACE THE NON EXPENDABLE CAPS WITH EXPENDABLE CAPS, ITEM (6) OR (7) AS REQUIRED.
- G. CUTOUT BODIES OF ITEM (1) AND (2) ARE THE SAME.
- H. CUTOUTS ARE PURCHASED WITHOUT CROSSARM MOUNTING BRACKETS - THESE BRACKETS (UNDER STOCK #166070) ARE EXEMPT MATERIALS.

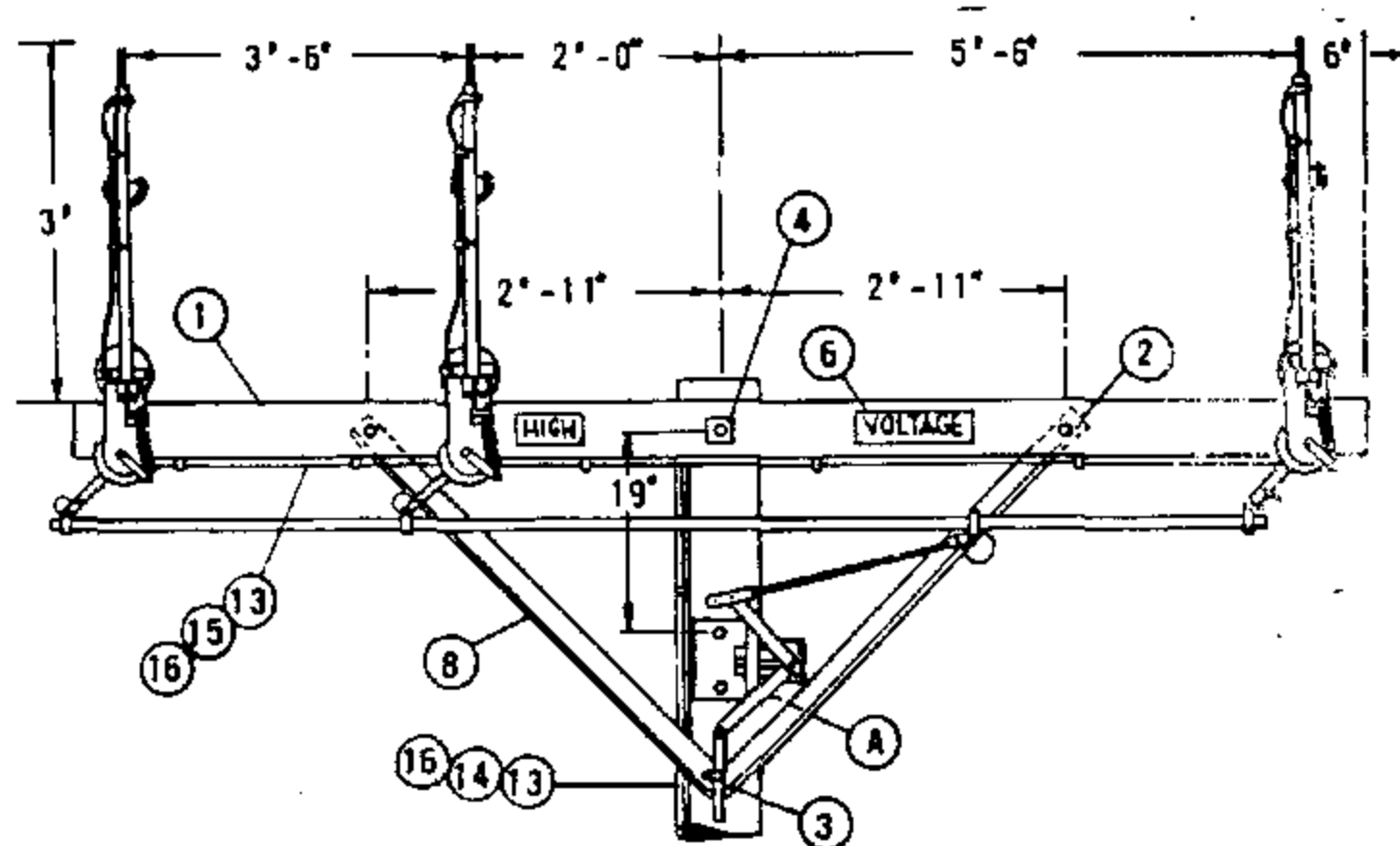
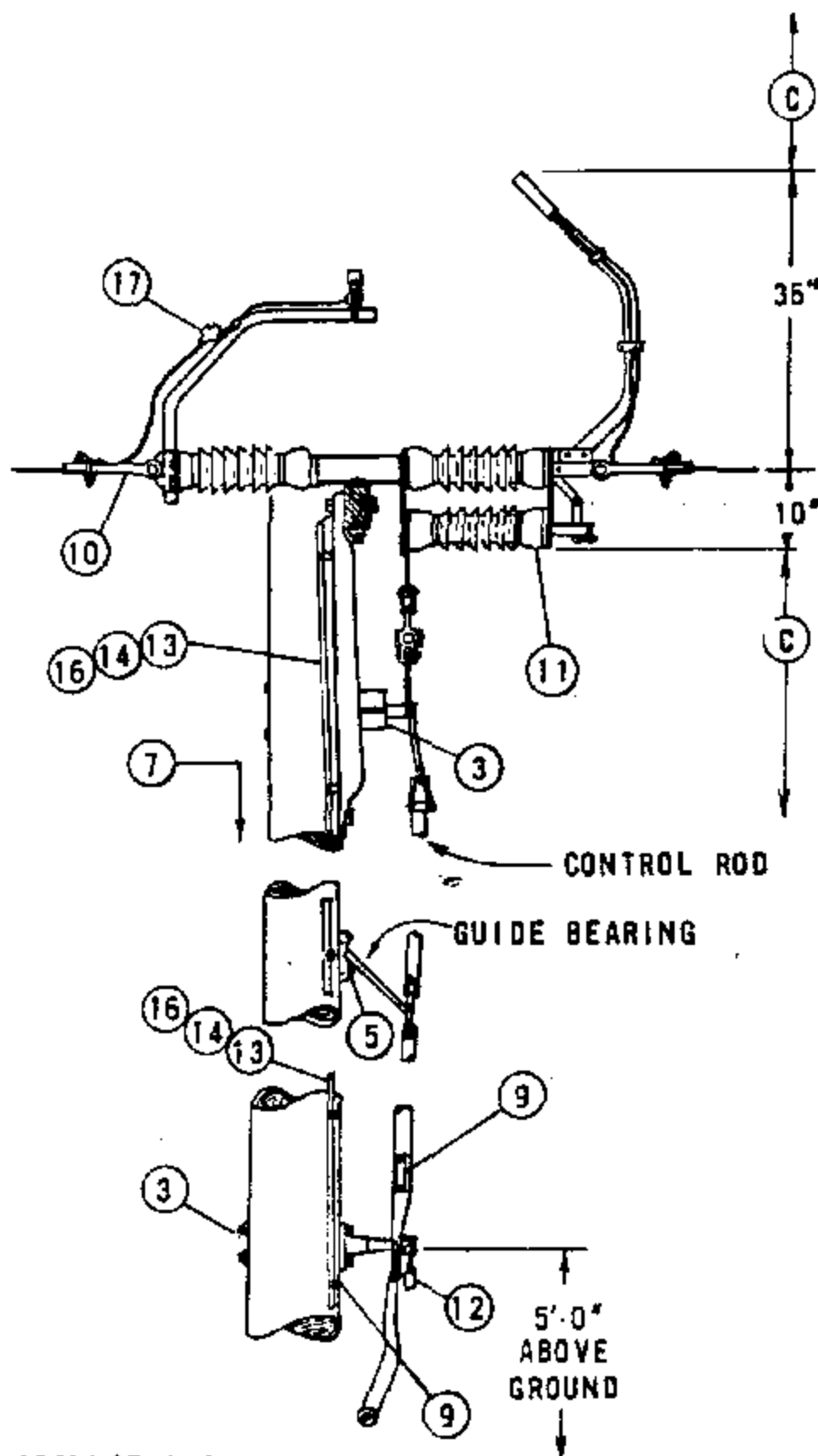

THIS PAGE FOR FIELD MAINTENANCE ONLY

INSTALLATIONS:

- (A) POSITION OF BELL CRANK ASSEMBLY WITH SWITCH IN OPEN POSITION.
- (E) EXEMPT MATERIAL

REFERENCES:

- B. SEE PAGE 1230 TO DETERMINE WHEN THIS SWITCH SHALL BE USED.
- (C) SEE SECTIONS 200 AND 500 FOR MINIMUM VERTICAL SEPARATION.

ITEM	DESCRIPTION	QUANTITY	STOCK NO. OR CONST. STDS.
P T F	1 CROSSARM, 3 3/4" X 5 3/4" X 12'-0"	1	300 SECTION
	2 BOLT, MACH, GALV, 5/8" X 5", 1-RD WASH, & 1-DBL COIL WASH (E)	2	100 SECTION
	3 BOLT, MACH, GALV, 5/8" X ____; 1-DBL COIL WASH & 1-SQ WASH (E)	5	100 SECTION
	4 BOLT, MACH, GALV, 5/8" X ____; 2-SQ WASH, & 1-DBL COIL WASH (E)	1	100 SECTION
	5 SCREW, LAG, GALV, 1/2" X 4" (E)	2	621568
	6 SIGN, HIGH VOLTAGE AND NAILS, 9 ROOFING, GALV (E)	2	647648, 492224
	7 STEPS, POLE (E)	16	692992
	8 BRACE, 4' SPECIAL (E)	2	163808
	9 TAG, SWITCH NUMBER (E)	2	300 SECTION
D C D	10 CLAMP, STRAIGHT LINE, D.E.	6	700 SECTION
	11 SWITCH, T.P.S.T., 600 AMP	1	709248
	12 PADLOCK	1	514848
	13 WIRE, BARE STRANDED, #6	55'	813536
	14 GROUND UNIT, (GRAY OR PLAIN)	1	603120, 603136
	15 MOULDING, HARDWOOD 1" (GRAY OR PLAIN)	24'	487184, 487200
	16 STAPLE, FENCE, GALV, 1 1/4" (E)	30	678528
17 TERMINAL, COMPRESSION LUG	6	700 SECTION	

SDG&E ELECTRIC STANDARDS

DATE 6-4-82
APPD *[Signature]*

POLE TOP SWITCH 12KV VERTICAL BREAK TYPE SINGLE CIRCUIT
HORIZONTAL CONFIGURATION - DOUBLE DEAD END

1299.201
SUPERSEDES
1229 (6-4-82)

SCOPE: THIS SWITCH IS TO BE USED FOR TANGENT CONFIGURATIONS. IT IS TO BE USED FOR CIRCUIT TIES AND FOR SECTIONALIZING PURPOSES. MAXIMUM ALLOWABLE LINE ANGLE FOR THIS SWITCH IS 6 DEGREES.

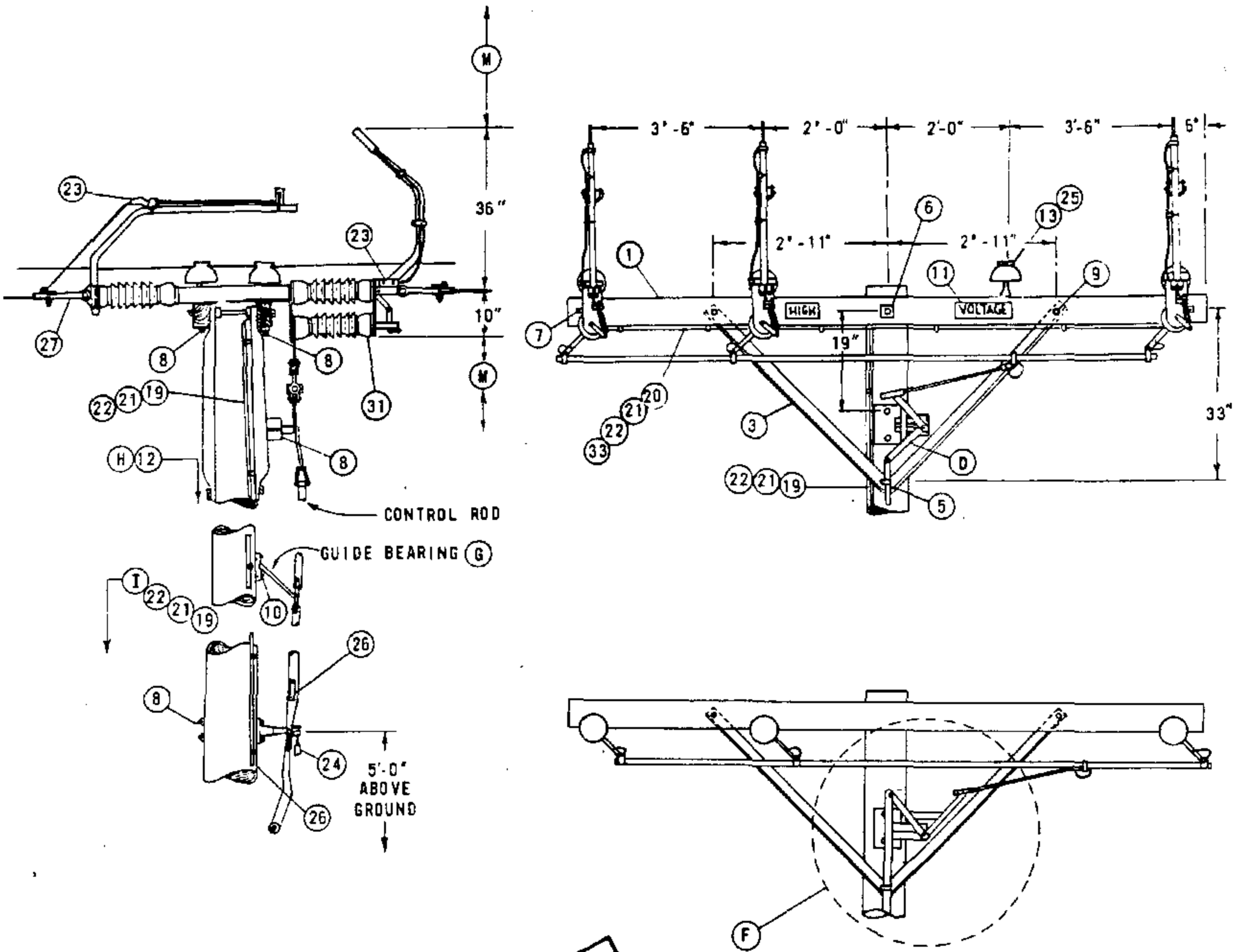

FOR FIELD MAINTENANCE ONLY

SEE PAGE 1299.203 FOR NOTES AND BILL OF MATERIAL.

SDG&E ELECTRIC STANDARDS

1299.202

POLE TOP SWITCH 12KV VERTICAL BREAK TYPE SINGLE CIRCUIT
HORIZONTAL CONFIGURATION

DATE 1-1-87
APPD. AK / RDS

INSTALLATIONS:

- A. CONTROL ROD AND SWITCH HANDLE ARE NOT ALLOWED IN THE CLIMBING SPACE. (G.O. 95 54.7-A4)
- B. ATTACH GROUND WIRE TO SWITCH MOUNTING BOLTS BY USING AN ADDITIONAL ROUND WASHER.
- (C) REDUCE QUANTITIES AS REQUIRED WHEN NOT USING NEUTRAL.
- (D) POSITION OF BELL CRANK ASSEMBLY WITH SWITCH IN OPEN POSITION.
- (E) EXEMPT MATERIAL.
- (F) POSITION OF BELL CRANK ASSEMBLY WITH SWITCH IN CLOSED POSITION.
- (G) GUIDE BEARING PIVOTS THROUGH 90°. IN THE OPENED AND CLOSED POSITIONS THE GUIDE BEARING MAKES A 45° ANGLE WITH THE POLE.
- (H) POLES ARE TO BE STEPPED PER STANDARD 363.
- (I) USE TWO GROUND RODS SPACED A MINIMUM OF 6' APART PER G.O. 95 RULE 21.1.

REFERENCES:

- J. SEE STANDARD 1443 FOR SINGLE DEADEND CONFIGURATION.
- K. SEE STANDARD 1205 TO DETERMINE WHEN TO USE GANG OR HOOKSTICK SWITCHES.
- L. SEE DESIGN MANUAL PAGE 5621 - CRITERIA AND GENERAL PRACTICES FOR SECTIONALIZING.
- (M) SEE SECTIONS 200 AND 500 FOR MINIMUM VERTICAL SEPARATION.
- (N) SEE STANDARD 759 FOR USE OF LINE GUARD.

FOR FIELD MAINTENANCE ONLY

ITEM	DESCRIPTION	QUANTITY	STOCK NO. OR CONSTR. STDS.
1	CROSSARM, 3 3/4" X 5 3/4" X 12'-0"	2	300 SECTION
2	BRACE, ANGLE, 6'-0"	-	164160
3	BRACE, 4' SPECIAL	4	163808
4	BOLT, MACH, GALV, 1/2" X 7"; 1-RD WASH, & 1-DBL COIL WASH	(E) -	100 SECTION
5	BOLT, MACH, GALV, 5/8" X ___; & 1-DBL COIL WASH	(E) 1	100 SECTION
6	BOLT, MACH, GALV, 5/8" X ___; 2-SQ WASH & 1-DBL COIL WASH	(E) 1	100 SECTION
7	BOLT, SPACE, GALV, 5/8" X ___; 4-SQ WASH & 2- DBL COIL WASH	(C) (E) 2	100 SECTION
8	BOLT, MACH, GALV, 5/8" X ___; 1-SQ WASH & 1-DBL COIL WASH	(E) 16	100 SECTION
P 9	BOLT, MACH, GALV, 5/8" X 5"; 1-RD WASH & 1-DBL COIL WASH	(E) 4	100 SECTION
T 10	SCREW, LAG, GALV, 1/2" X 4"	(E) 2	621568
F 11	SIGN, HIGH VOLTAGE AND NAILS, 9 ROOFING, GALV	(E) 2	647648, 492224
12	STEPS, POLE	(H) (E) 16	692992
13	PIN, INSULATOR, STRAIGHT, 12KV, 1" & 1-DBL COIL WASH	(C) 2	532704, 798560 (E)
14	STUD, 7 1/2" & 1-DBL COIL WASH	(C) -	701760, 798560 (E)
15			
16	CLEVIS, DEAD END, 5/8" BOLT STEEL (OPEN TYPE)	(C) (E) -	235618
17	LINK, EXTENSION GALV, 1/2" X 2" X 12"	(C) -	466240
18	STRAP, EXTENSION GALV, 1/2" X 1 1/2" X 28"	(C) -	696864
19	GROUND UNIT (GRAY OR PLAIN)	1	603120, 603136
20	MOULDING, HARDWOOD 1" (GRAY OR PLAIN)	24'	487184, 487200
21	STAPLE, FENCE, GALV, 1 1/4"	(E) 30	678528
22	WIRE, BARE STRANDED, #6	5 LBS	813536
23	TERMINAL, COMPRESSION LUG	6	700 SECTION
24	PADLOCK	1	514848
25	INSULATOR, LINE, 12KV NEUTRAL	(C) (E) 2	429216
O 26	TAG, SWITCH NUMBER	2	300 SECTION
C 27	CLAMP, STRAIGHT LINE, D.E.	(C) 6	700 SECTION
D 28	CLAMP, POST INSULATOR	(N) (C) -	700 SECTION
29	INSULATOR, VERTICAL POST	(C) -	428608
30	INSULATOR, SUSPENSION	(C) -	700 SECTION
31	SWITCH, T.P.S.T., 600 AMP	1	709246
32	SWITCH, T.P.S.T., 600 AMP	-	709250
33	STAPLES, MOULDING, GALV, 3" X 1 1/16" X 1/4"	(E) AS REQD	678560
34	CONNECTOR, WIRE COMPRESSION (SIZE AS REQ'D)	(C) -	700 SECTION

DATE 1-1-87	SOG&E ELECTRIC STANDARDS	1299.203
APPD <i>AK/RD</i>	POLE TOP SWITCH 12KV VERTICAL BREAK TYPE SINGLE CIRCUIT HORIZONTAL CONFIGURATION	SUPERSEDES 1228.3 (1-1-87)

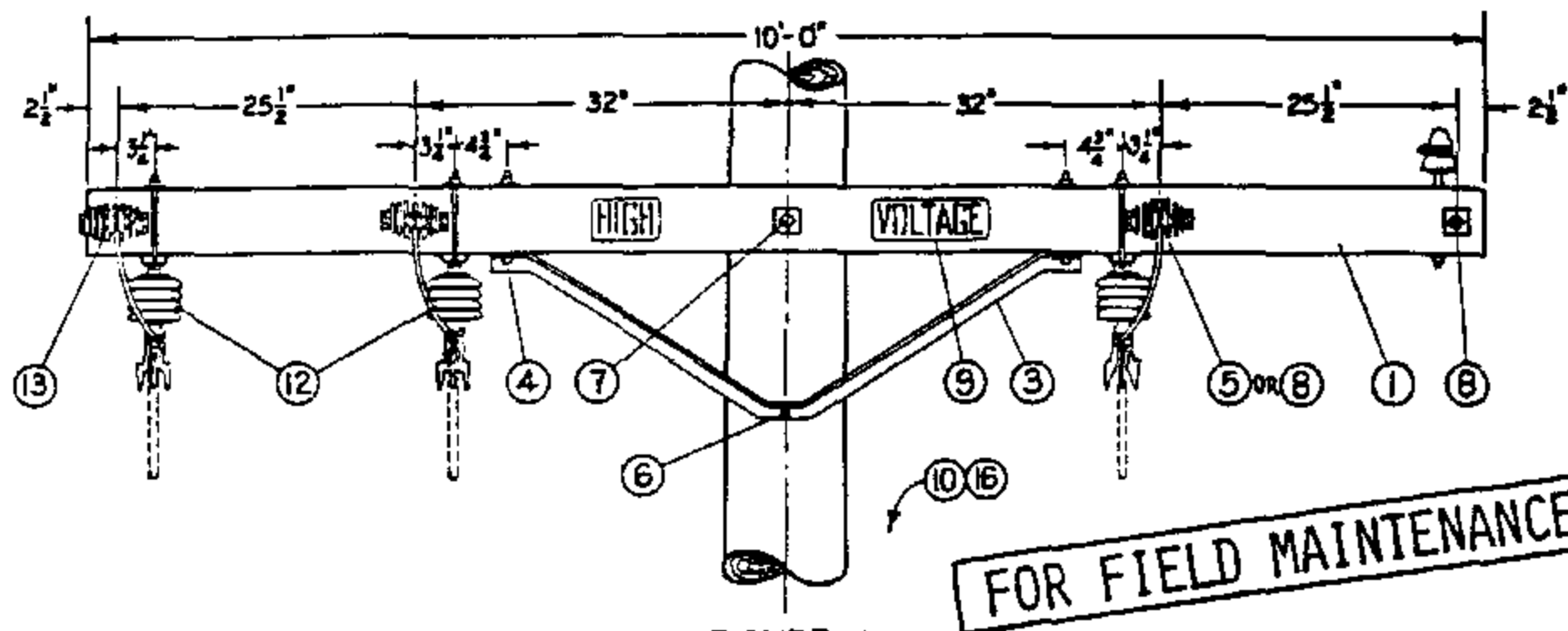

FIGURE 1
SPREAD CONSTRUCTION

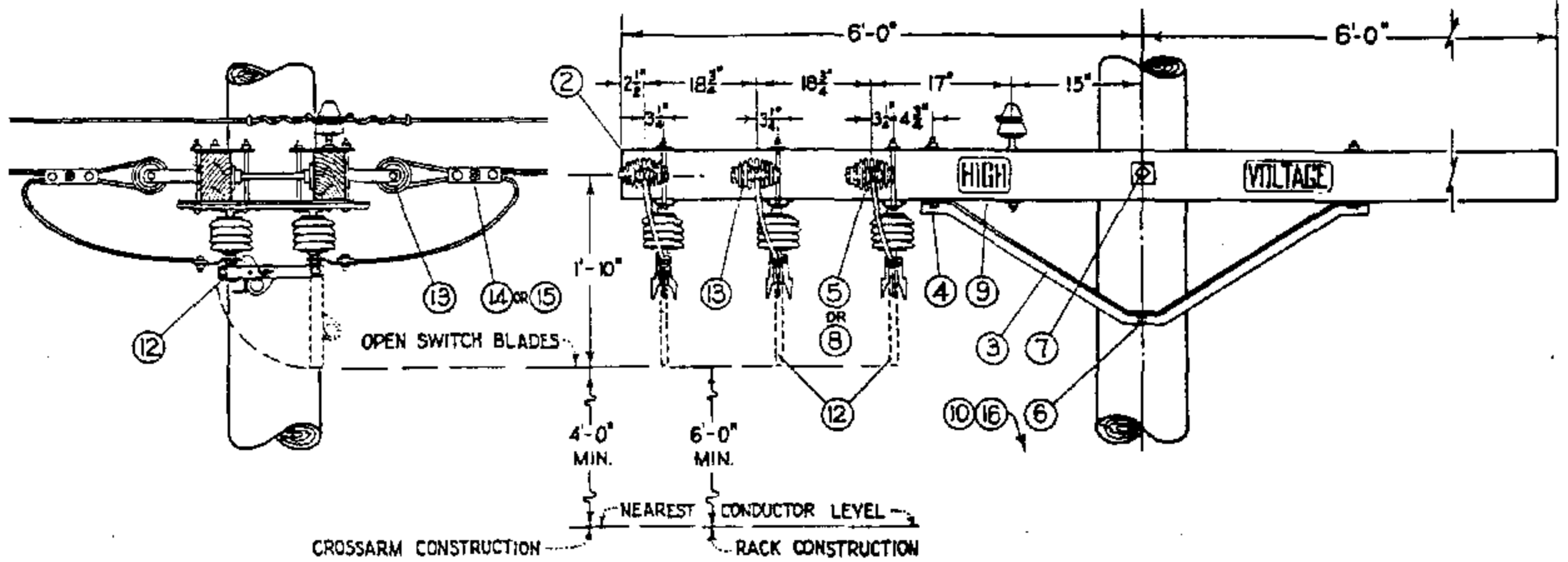

FIGURE 2
TWIN CIRCUIT CONSTRUCTION

NOTE:

A. FOR ARM-END CONSTRUCTION, REDRILL CROSSARMS IN FIELD AS SPECIFIED BY FIGURE 2

ITEM	DESCRIPTION	QUANTITY				STOCK NO. OR CONSTR. STDS.
		FIGURE 1		FIGURE 2		
		#4 or SMALLER	#2 or LARGER	#4 or SMALLER	#2 or LARGER	
P T & F	1 Crossarm, 3 3/4" X 5 3/4" X 10'-0"	2	2	-	-	PG 118 II. 2
	2 Crossarm, 3 3/4" X 5 3/4" X 12'-0"	-	-	2	2	PG 119 II. 4
	3 Angle Crossarm Brace, 4'-0"	2	2	2	2	164032
	4 Mach. Bolt, Galv., 1/2" X 7", 1-rd. wash. & 1-nut	4	4	4	4	PBS 139, 140
	5 Mach. Bolt, Galv., 5/8" X 5", 1-sq. wash. & 1-nut	4	-	4	-	PBS 139, 140
	6 Mach. Bolt, Galv., 5/8" X 10", 1-nut	1	1	1	1	PBS 139, 140
	7 Mach. Bolt, Galv., 5/8" X 18", 2-sq. wash. & 1-nut	1	1	1	1	PBS 139, 140
	8 Space Bolt, Galv., 5/8" X 20", 4-sq. wash & 4-nuts	2	4	2	4	PBS 139, 140
	9 High Voltage Sign & B-Roofing Nails, Galv.	2	2	2	2	647776, 492192
	10 Pole Steps	17	17	17	17	692992
11						
O C & D	12 Disconnect Switch, 14.4 KV, 600 A, S.P.S.T., with Hanger Straps and Bolts	3	3	3	3	707008
	13 Insulator, D. E.	6	6	6	6	235520
	14 Wire Connector, Split Bolt	12	-	12	-	PBS 783, 786
	15 Wire Connector, 3-Bolt Clamp	-	6	-	6	227296
	16 Switch Tag	2	2	2	2	-

1299.204
SUPERSEDES
1221 (1-1-87)

SDG&E ELECTRIC STANDARDS

POLE TOP SWITCH INSTALLATION
4KV DISCONNECT SWITCH, HOOK STICK OPERATED

DATE 1-1-87
APPD AK/RS

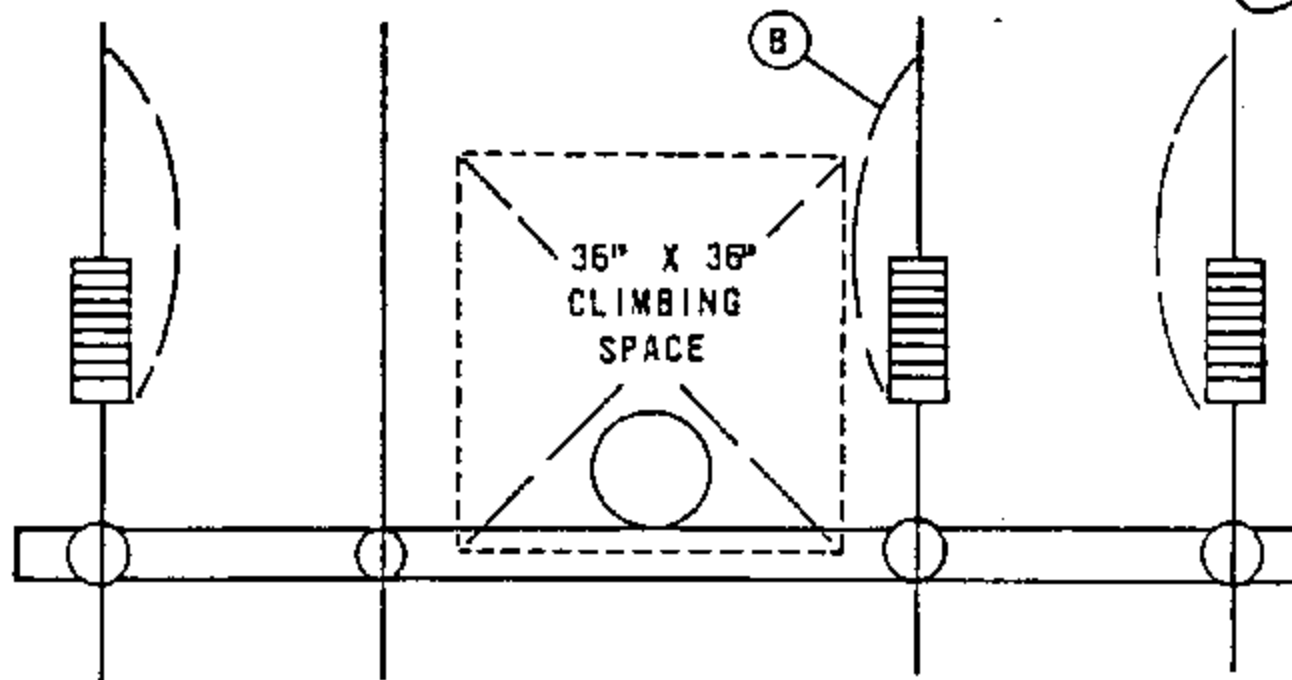
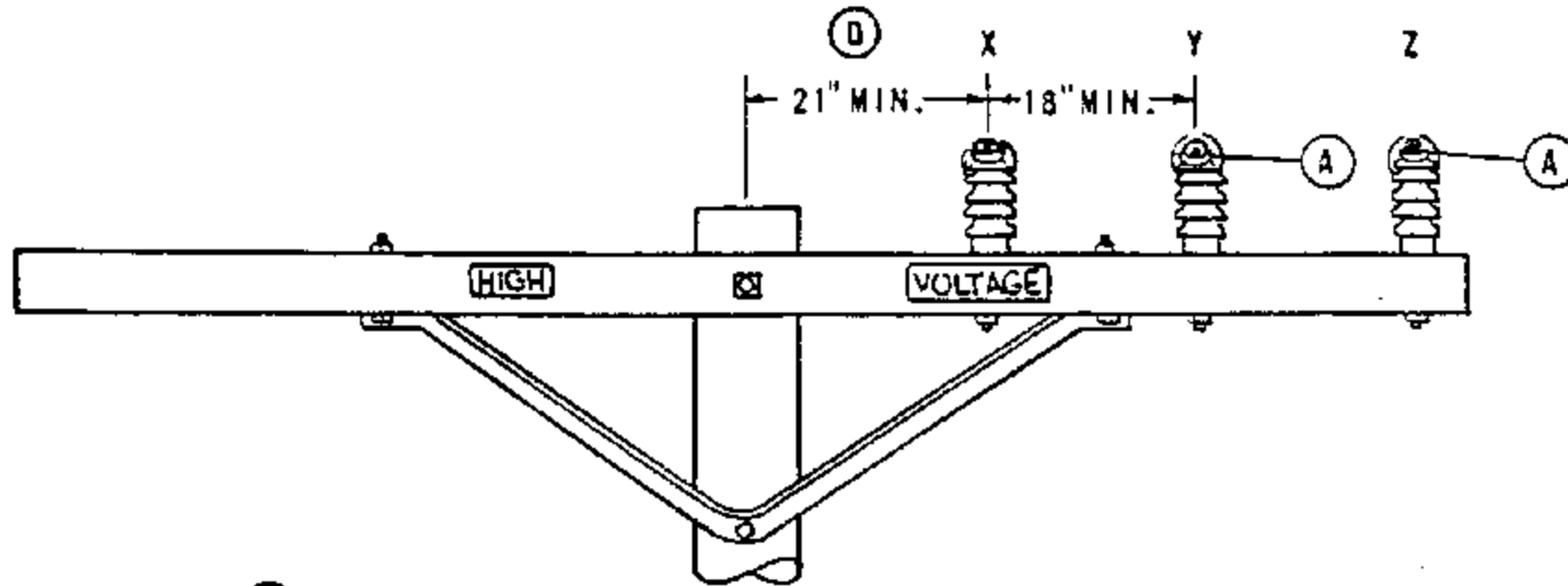
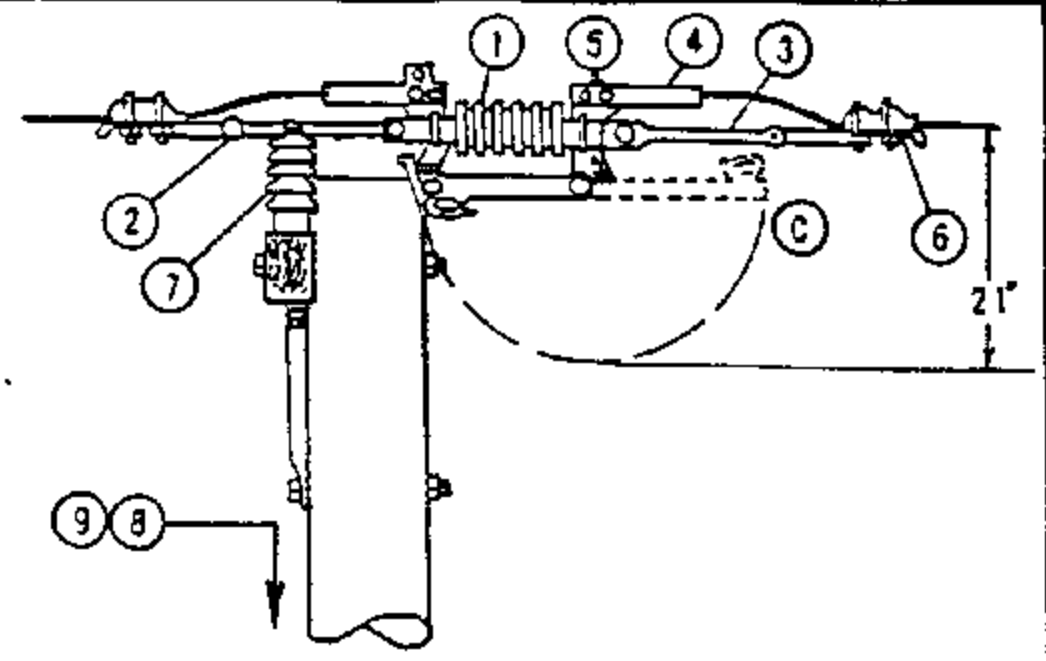
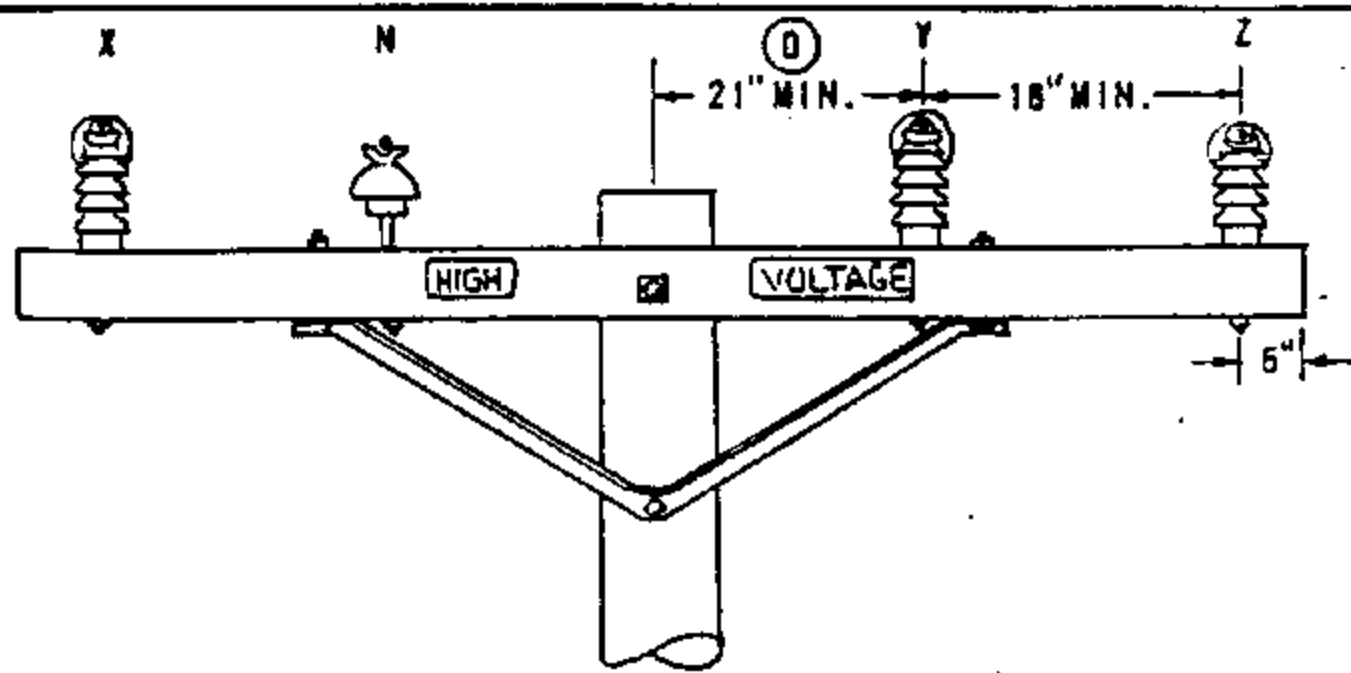

FOR FIELD MAINTENANCE ONLY

NOTES:

- (A) ROTATE DISCONNECTS TOWARD THE POLE USING ADJUSTABLE TRUNNION LINKS TO PERMIT EASE OF OPERATION.
- (B) KEEP THIS DISCONNECT VERTICAL TO KEEP IT OUT OF THE CLIMBING SPACE.
- (C) LOCK AS SHOWN WHEN LEFT IN THE OPEN POSITION.
- (D) G.O. 95 MINIMUM SPACING REQUIREMENT. THIS DIMENSION WILL ALLOW A 36" CLIMBING SPACE ON THE SAME SIDE OF THE POLE AS THE SWITCHES.
- (E) EXEMPT MATERIAL.
- F. INSTALL ONLY IN FULL TENSION SPANS OF 3/0 ACSR, 3/0 5005, 1/0 COPPER, OR LARGER CONDUCTOR.
- (G) SEE 400 SECTION FOR POLE TOP MATERIALS.
- H. BOND INSULATOR STUDS IN CONTAMINATION DISTRICT 1.

ITEM	DESCRIPTION	QUANTITY	STOCK NO. OR CONSTR. STD.
PTF	QCD		
	1	SWITCH, LINE TENSION DISCONNECT, 15KV, 600 AMPS	3 707014
	2	LINK, ADJUSTABLE TRUNNION, 12"	3 465550
	3	LINK, EXTENSION, GALV., 1/2" X 1-3/4" X 12"	3 466272
	4	TERMINAL, ALUMINUM COMPRESSION, 2-HOLE	6 700 SECTION
	5	BOLT, MACH, STAINLESS STEEL, ASSEMBLY, 1/2" X 1 1/2"	(E) 12 148672
	6	CLAMPS, DEAD-END	6 700 SECTION
	7	INSULATOR, VERTICAL POST CLAMP TYPE (ITEM 2 CONTAINS CLAMP)	3 700 SECTION
	8	STEPS, POLE	(E) AS REQ'D. 692992
	9	TAG, SWITCH NUMBER	(E) 2 300 SECTION
	10	STUD 7 1/2"	3 701760
	11	WASHER, 5/8" DOUBLE COIL SPRING	(E) 3 798560
	12	WASHER, 2 1/4" X 2 1/4" FLAT	(E) 3 799040

SOG & E ELECTRIC STANDARDS

DATE 2-3-78
APPD JAF

LINE TENSION DISCONNECT SWITCH HOOK STICK OPERATED

1299.205
SUPERSEDES
1225 (1-1-92)

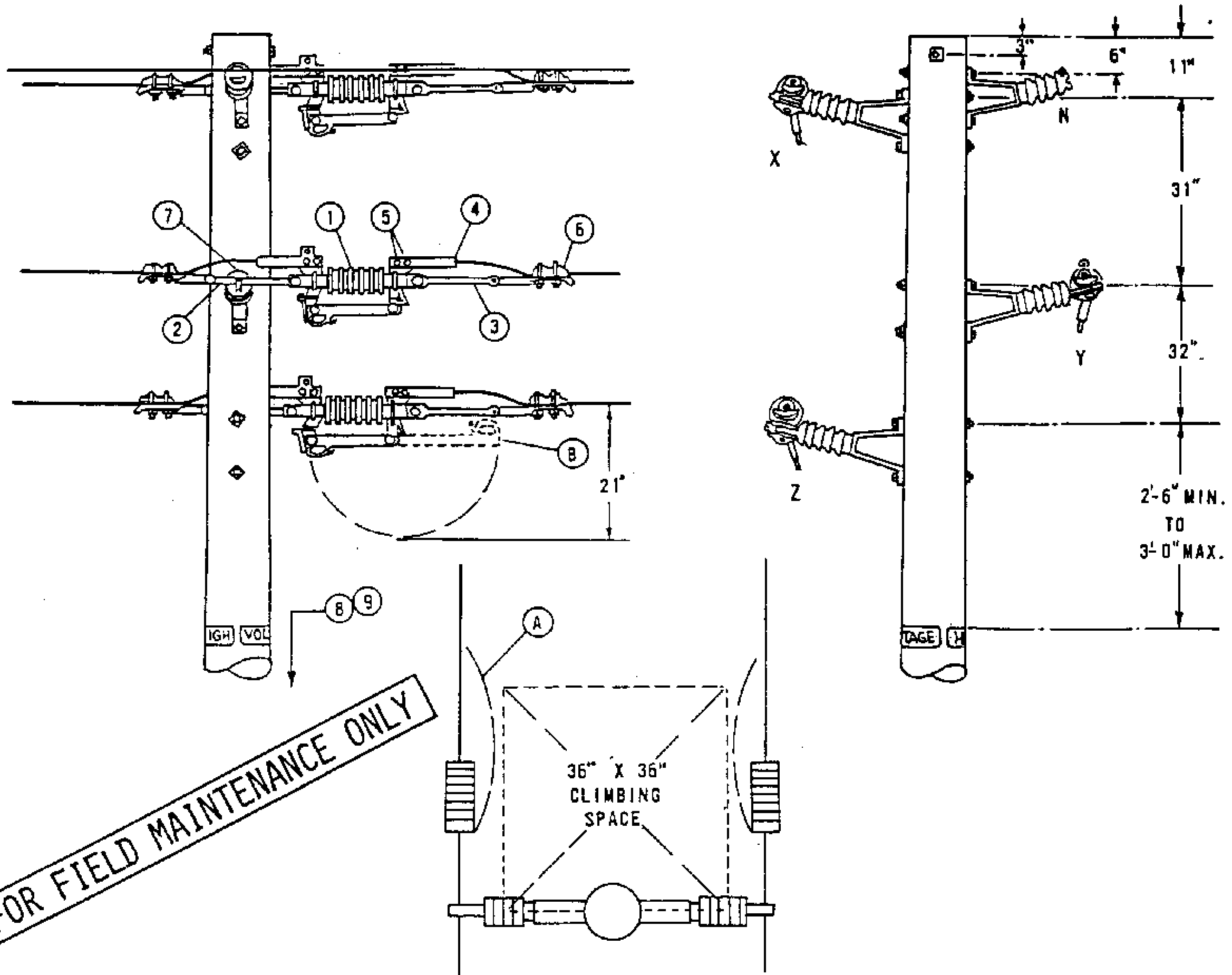

- NOTES:
- (A) ROTATE DISCONNECTS AS SHOWN USING ADJUSTABLE TRUNNION LINK FOR EASE OF OPERATION, KEEPING BLADE OUT OF CLIMBING SPACE.
 - (B) LOCK AS SHOWN WHEN LEFT IN THE OPEN POSITION.
 - C. INSTALL ONLY IN FULL TENSION SPANS OF 3/0 ACSR, 3/0 5005, 1/0 COPPER OR LARGER CONDUCTOR.
 - D. SEE 400 SECTION FOR POLE TOP MATERIALS, SPAN LIMITATIONS AND OTHER REQUIREMENTS.
 - (E) EXEMPT MATERIAL.
 - F. BOND INSULATOR BRACKETS IN CONTAMINATION DISTRICT 1.

ITEM	DESCRIPTION	QUANTITY	STOCK NO. OR CONSTR. STD.
PTF	OCD		
	1	SWITCH, LINE TENSION DISCONNECT, 15KV, 600 AMPS	3 707014
	2	LINK, ADJUSTABLE, TRUNNION, 12"	3 465550
	3	LINK, EXTENSION, GALV., 1/2" X 1 3/4" X 12"	3 466272
	4	TERMINAL, ALUMINUM COMPRESSION, 2-HOLE	6 700 SECTION
	5	BOLT, MACH, STAINLESS STEEL, ASSEMBLY, 1/2" X 1 1/2"	(E) 12 148672
	6	CLAMPS, DEAD END	6 700 SECTION
	7	INSULATOR, HORIZONTAL POST CLAMP TYPE (ITEM 2 CONTAINS CLAMP)	3 700 SECTION
8		STEPS, POLE	(E) AS REQ'D. 692992
9		TAG, SWITCH NUMBER	(E) 2 300 SECTION

1299.206
 SUPERSEDES
 1226 (1-1-92)

SDG&E ELECTRIC STANDARDS
 LINE TENSION DISCONNECT SWITCH HOOK OPERATED
 ARMLESS

DATE 2-3-78
 APPD TAF

SCOPE: THIS STANDARD SHOWS THE INSTALLATION OF PRIMARY IN-LINE HOOKSTICK DISCONNECTS, WEDGE TAP CONNECTED. THIS IS A PREFERRED METHOD FOR EXISTING PIN AND INSULATOR CONSTRUCTION. THESE SWITCHES CAN BE INSTALLED ON 336 AND 636 ACSR CONDUCTOR ONLY.

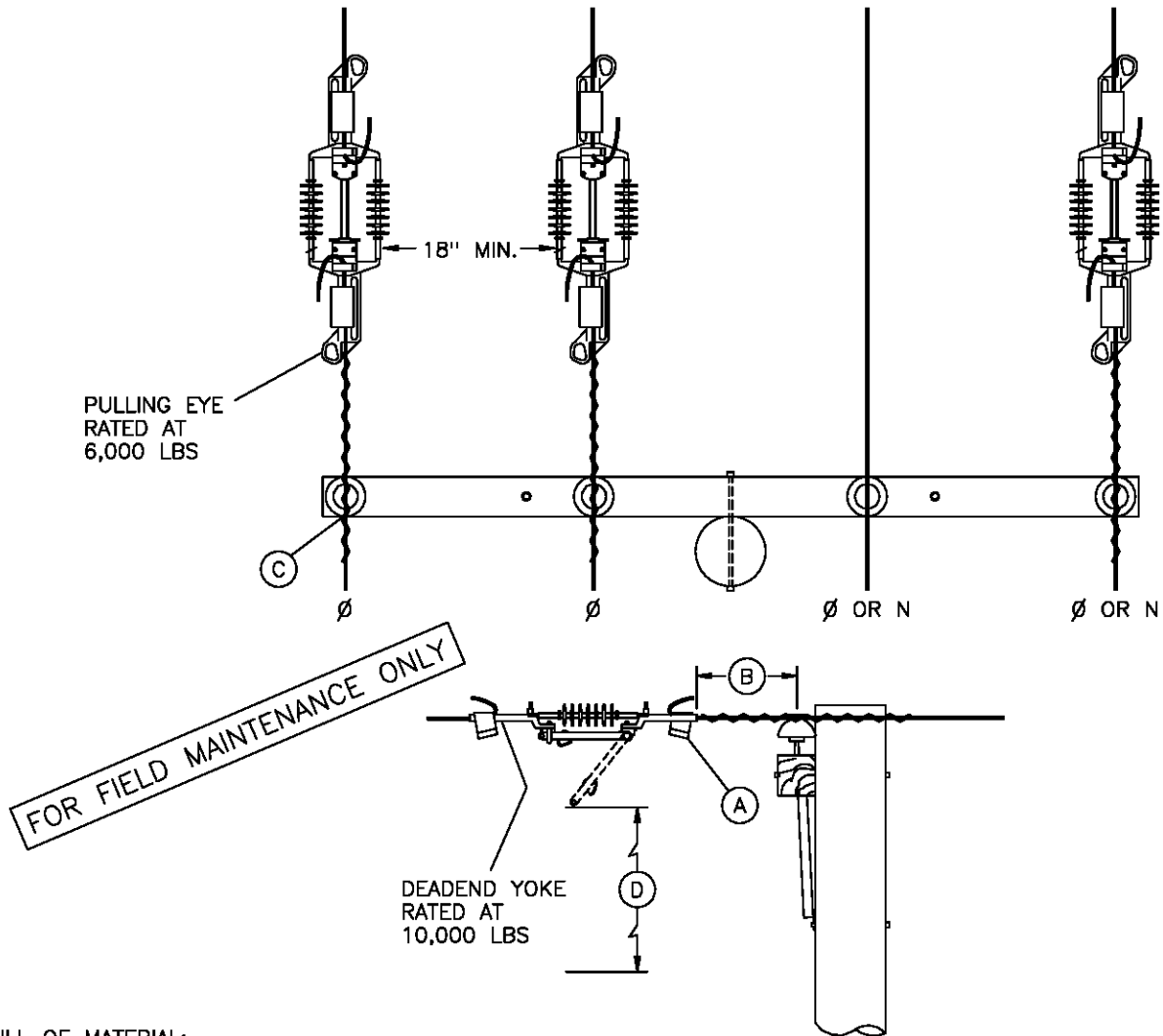

BILL OF MATERIAL:

ITEM	DESCRIPTION	QUANTITY	STOCK NUMBER	ASSEMBLY UNITS	
1	SWITCH, DISCONNECT, IN-LINE, 900A INCLUDING 2 WEDGE TYPE TAP CONNECTORS	336.4 ACSR	3	707010	ILD336
		636 ACSR	3	707012	ILD636
2	TAP CONNECTORS, WEDGE TYPE, (REPLACEMENT) (A)	336.4 ACSR	AS REQ'D	265940	-
		636 ACSR		265942	-

INSTALLATION:

- (A) WHEN INSTALLING SWITCH, USE ONLY WEDGE TYPE DEADEND TAP CONNECTORS SUPPLIED WITH SWITCH, OR EQUIVALENT REPLACEMENT ITEM. **DO NOT REUSE DEADEND TAP CONNECTORS.** IF REINSTALLING SWITCH, USE NEW DEADEND TAP CONNECTORS.
- (B) WHEN INSTALLING, POSITION SWITCH ON CONDUCTOR 18 INCHES FROM INSULATOR PIN TO SWITCH PULLING EYE, OR, 18 INCHES FROM DEADEND CLAMP PULLING EYE TO SWITCH PULLING EYE.
- (C) IF TIE WIRE EXISTING, REPLACE WITH PREFORMED TIE. DO NOT REPLACE EXISTING CLAMP TOP INSULATOR.
- (D) 4'-0" MIN. CLEARANCE TO NEAREST CONDUCTOR BELOW WHEN SWITCH IS OPEN. WHERE CONSTRUCTION IS REQUIRED BELOW SWITCH, IT SHALL NOT INTERFERE WITH OPERATION OF ANY SWITCH FROM THE POLE.

DATE 1-1-98 APPD <i>PA/OKK</i>	SDG&E ELECTRIC STANDARDS	1299.207 SUPERSEDES 1220 (4-30-99)
	IN-LINE DISCONNECT SWITCHES WEDGE TAP CONNECTED-12K AND BELOW	

SCOPE: THIS STANDARD SHOWS A GANG OPERATED POLE TOP SWITCH FOR CIRCUIT TIES OR SECTIONALIZING PURPOSES AND IS TO BE USED FOR TANGENT AND DEAD-END CONFIGURATIONS.

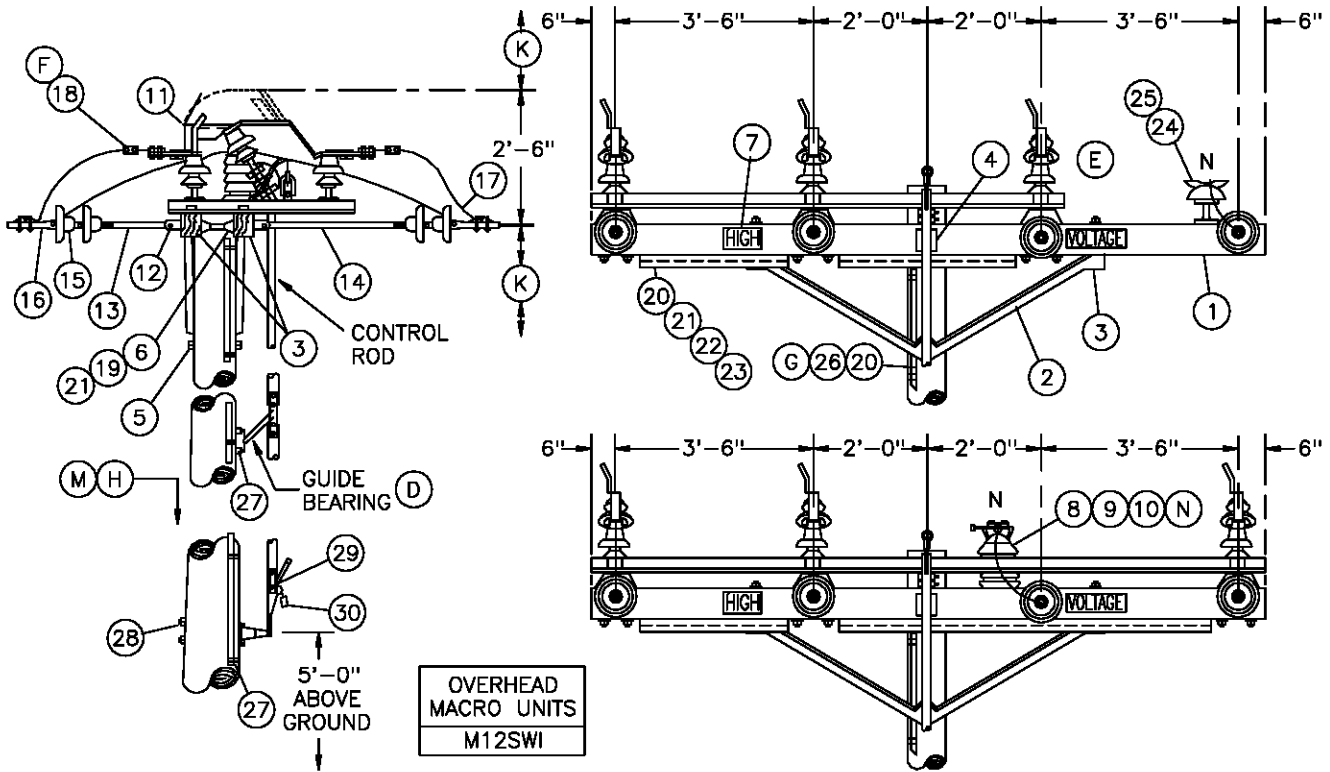

BILL OF MATERIAL:

ITEM	DESCRIPTION	QUANTITY	STOCK NO. OR CONSTR STANDARD	ASSEMBLY UNITS
1	CROSSARM, 3 3/4" x 5 3/4" x 12"-0"	2	294160	6-
2	BRACE, ANGLE, 6'-0"	2	164160	6HUB
3	BOLT, MACH, GALV, 1/2" X 7", 1 ROUND AND 1 DOUBLE COIL SPRING WASHER	16	STD 392	-
4	BOLT, MACH, GALV, 5/8" x (LENGTH AS REQ'D), 2 SQUARE AND 1 DOUBLE COIL SPRING WASHER	1	STD 392	-
5	BOLT, MACH, GALV, 5/8" x (LENGTH AS REQ'D) AND 1 DOUBLE COIL SPRING WASHER	1	STD 392	-
6	BOLT, SPACE, GALV, 5/8" (LENGTH AS REQ'D), 2 SQUARE, 2 ROUND, 2 DOUBLE COIL SPRING WASHERS AND 1 NUT	4	STD 392	-
7	SIGN, HIGH VOLTAGE, AND 9 ROOFING NAILS, GALV	2 18	647648 492224	HV -
8	STUD, 5/8" x 7 1/2" AND 1 DOUBLE COIL SPRING WASHER	1 1	701760 798560	STUD-W -
9	INSULATOR, VERTICAL POST	1	428608	VPI
10	CLAMP, POST INSULATOR	1	STD 773	-
11	SWITCH T.P.S.T. 600 AMP, INCLUDING 31' OF CONTROL ROD	1	709254	MEMCO
	ADDITIONAL INTERMEDIATE 10'-6" CONTROL ROD WITH GUIDE BEARING AND END FITTINGS	AS REQ'D	604432	FC-ROD
	REPLACEMENT UPPER CONTROL ROD WITH END FITTINGS	AS REQ'D	604434	-
	REPLACEMENT LOWER CONTROL ROD WITH END FITTINGS	AS REQ'D	604436	-
12	CLEVIS, DEAD END, 5/8" BOLT STEEL (OPEN TYPE)	8	235618	-

FOR FIELD MAINTENANCE ONLY

<p>1299.208 SUPERSEDES 1228.1 (8-1-00)</p>	<p>SDG&E ELECTRIC STANDARDS</p> <p>POLE TOP SWITCH 12KV VERTICAL BREAK TYPE SINGLE CIRCUIT HORIZONTAL CONFIGURATION</p>	<p>DATE 1-1-96 APPD <i>PIA 1/09</i></p>
----------------------------------------------------	---------------------------------------------------------------------------------------------------------------------------------	---------------------------------------------

BILL OF MATERIAL: (CON'T)

ITEM	DESCRIPTION	QUANTITY	STOCK NO. OR CONSTR STANDARD	ASSEMBLY UNITS
13	LINK, EXTENSION, GALV, 1/2" X 2" X 12" (C)	4	466240	DEEXT
14	STRAP, EXTENSION, GALV, 1/2" X 1 1/2" X 28" (C)	4	696864	-
15	INSULATOR, SUSPENSION (C)	14	STD 750	-
16	CLAMP, STRAIGHT LINE, D.E. (C)	8	741-743	-
17	CONNECTOR, WIRE COMPRESSION (SIZE AS REQ'D)	AS REQ'D	783-786	-
18	TERMINAL, COMPRESSION LUG (F)	6	794-795	-
19	WIRE, #8 BARE SOLID ANNEALED COPPER	15'	812928	BOND8
20	WIRE, BARE STRANDED, #4	65'	813760	BS4
21	STAPLE, FENCE, GALV, 1 1/4"	AS REQ'D	678528	-
22	MOULDING, OAK HARDWOOD, 1"	10'	487200	MLDG
23	STRAPS, GALV, 3/4" AND 2-1 3/4" ROOFING NAILS	AS REQ'D	697888	-
24	PIN, INSULATOR, STRAIGHT, 12KV, 1"	1	532704	PS1
25	INSULATOR, LINE, 12KV, NEUTRAL	1	429216	55-3/1
26	GROUND UNIT, COMPLETE	1	603136	GND4
27	SCREW, LAG, GALV, 1/2" X 4"	2	621568	-
28	BOLT, MACH, GALV, 5/8" X (LENGTH AS REQ'D), 1 SQUARE AND 1 DOUBLE COIL SPRING WASHER	2	STD 392	-
29	TAG, SWITCH NUMBER	2	STD 204	-
30	PADLOCK, SCHLAGE ELECTRIC SERIES	1	514848	-

FOR FIELD MAINTENANCE ONLY

INSTALLATION:

- A. CONTROL ROD AND SWITCH HANDLE ARE NOT ALLOWED IN THE CLIMBING SPACE (G.O. 95, 54.7-A4).
- B. ATTACH GROUND WIRE TO SWITCH MOUNTING BOLTS BY USING AN ADDITIONAL ROUND WASHER.
- (C) REDUCE QUANTITIES AS REQUIRED WHEN NOT USING NEUTRAL.
- (D) GUIDE BEARING PIVOTS THROUGH 90°. IN THE OPENED AND CLOSED POSITIONS THE GUIDE BEARING MAKES A 45° ANGLE WITH THE POLE.
- (E) CUT OFF EXCESS INTERPHASE SHAFT.
- (F) WHEN ATTACHING 1/0 AND 4/0 COPPER CONDUCTORS TO A POLE TOP SWITCH, USE A BRONZE CABLE TAP LUG, STOCK NUMBER 471296. IF EXCESSIVE VIBRATION OR WHIPPING COULD OCCUR, USE TWO LUGS IN SERIES.

REFERENCES:

- (G) GROUNDING METHODS - SEE STANDARD 1002.
- (H) POLE STEPPING - SEE STANDARD 363.
- I. SEE STANDARD 1443 FOR SINGLE DEADEND CONFIGURATION.
- J. SEE DESIGN MANUAL PAGE 6111 - FEEDER CIRCUIT SECTIONALIZING AND PROTECTION.
- (K) SEE SECTION 200 FOR MINIMUM VERTICAL SEPARATION.
- (L) SEE STANDARD 759 FOR USE OF LINE GUARD.
- (M) REFLECTOR STRIPS ARE REQUIRED ON ALL SECTIONALIZING/TIELINE SWITCHES AND SERVICE RESTORER POLES. (SEE STD. 208.3 ITEM 12).
- (N) NEUTRALS SHALL BE SOLIDLY TIED TOGETHER AT ALL SWITCHES REGARDLESS WHETHER THEY ARE NORMALLY OPEN OR CLOSED. THIS INCLUDES TIE SWITCHES TO CIRCUITS EMANATING FROM DIFFERENT SUBSTATIONS. (SEE DESIGN MANUAL STANDARD PAGE 6221.2, D.3).

DATE 1-1-93 APPD <i>PA/ROJ</i>	SDG&E ELECTRIC STANDARDS	1299.209 SUPERSEDES 1228.2 (8-1-00)
	POLE TOP SWITCH 12KV VERTICAL BREAK TYPE SINGLE CIRCUIT HORIZONTAL CONFIGURATION	

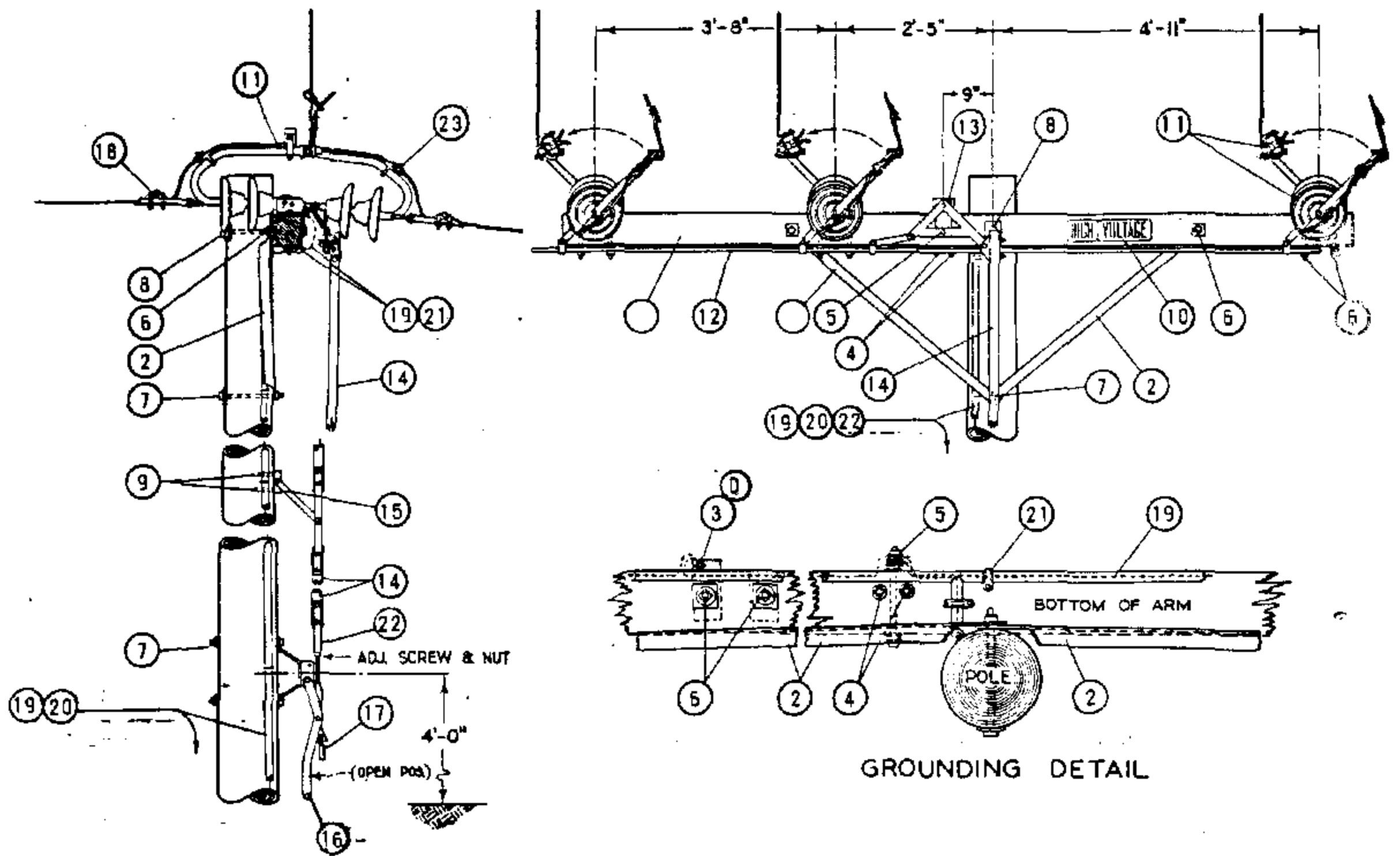

FOR FIELD MAINTENANCE ONLY

- NOTES:**
- A. MAXIMUM VERTICAL ANGLE SHALL NOT EXCEED 7° FOR ANY CONDUCTOR SIZE.
 - B. WHERE THE VERTICAL ANGLE EXCEEDS 7° OR THE HORIZONTAL ANGLE EXCEEDS THE VALUE SHOWN IN THE TABLE BELOW, USE SWITCH CONSTRUCTION PG. 1229.
 - C. IF THE MAXIMUM DESIGN TENSION IS GREATER THAN 3000 LBS, THE ANGLE CAN BE CALCULATED BY:

$$\text{THE SINE OF THE ANGLE} = \frac{200}{\text{TENSION}}$$
 THE ANGLE THEN CAN BE DETERMINED FROM TRIGONOMETRIC FUNCTION TABLES.
 - D. ITEM 3 IS A BOLT USED TO GROUND THE SWITCH MOUNTING HARDWARE.

MAXIMUM ALLOWABLE LINE ANGLE FOR SWITCHES

CONDUCTOR SIZE AWG OR KCM	COPPER				COPPERWELD COPPER		5005				ACSR						
	4	2	1/0	4/0	4A	4N	2	1/0	3/0	394.5	2 6/1	1/0 6/1	3/0 6/1	336.4 18/1	336.4 26/7	636 24/7	1033 45/7
LINE ANGLE DEGREES	15	9	6	5	7	3	16	11	8	4	13	9	6	5	4	4	4
MAXIMUM DESIGN TENSION LBS/CONDUCTOR	752	1218	1900	2424	1575	3384	717	1050	1480	2898	845	1300	1860	2450	3000 ^C	3000 ^C	3000 ^C

DATE 1-1-87
APPD AK/AD

SDG&E ELECTRIC STANDARDS
POLE TOP SWITCH INSTALLATION 12KV SINGLE CIRCUIT
HORIZONTAL CONFIGURATION

1299.301
SUPERSEDES
1230.1 (1-1-87)

METHOD OF ADJUSTING SWITCH

- A. FIRST CLOSE SWITCH AND TIGHTEN SWITCH UNIT CRANK CLAMPS TO INTERPHASE CONNECTING PIPE (12)
- B. THEN OPEN SWITCH UNTIL SWITCH UNIT CRANK CLAMPS ARE PERPENDICULAR TO ARM.
- C. WITH SHORT ARM BELL CRANK (13) ALSO PERPENDICULAR TO ARM, TIGHTEN BELL CRANK CLAMP.
- D. WHILE CRANKS ARE PERPENDICULAR TO ARM, CONNECT WOODEN CONTROL ROD (14) TO LONG LEG OF BELL CRANK, CLAMP GUIDES (15) AND CONTROL HANDLE (16) SHOULD BE PERPENDICULAR TO POLE AND HOLD DOWN HOLES (9) DRILLED WHILE IN THIS POSITION
- (E) EXEMPT MATERIAL
- F. LUBRICATE MOVING PARTS WITH A THIN LAYER OF #89 MEDIUM SILICONE GREASE OR EQUIVALENT.
- G. GIVE SWITCH A FEW TRAIL OPERATIONS AND MAKE ADJUSTMENTS ON ADJUSTING SCREW AS NECESSARY.
- H. 400 AMP SWITCHES MAY BE USED WITH 336.4 KCMIL AND SMALLER CONDUCTORS. 600 AMP SWITCHES SHALL BE USED ON 636 KCMIL CONDUCTOR AND 1200 AMP SWITCHES SHALL BE USED ON 1033.5 KCMIL CONDUCTOR.

FOR FIELD MAINTENANCE ONLY

ITEM	DESCRIPTION	QUAN.	STOCK NO. OR CONSTR. STD.
P T B F	1 CROSSARM, 5 3/4" X 5 3/4" X 12'-0"	1	294016
	2 BRACE, ALLEY ARM, 4'-0"	2	163808
	3 BOLT, MACH., GALV., 1/2" X 1 1/2", 2-RD., 1-LOCK WASH. & 1-NUT (E)	3	100 SECTION
	4 BOLT, MACH., GALV., 1/2" X 8", 1-RD., 1-DBL. COIL SPR. WASH & 1-NUT (E)	2	100 SECTION
	5 BOLT, MACH., GALV., 1/2" X 8", 3-RD., 1-DBL. COIL SPR. WASH. & 2-NUTS (E)	1	100 SECTION
	6 BOLT, MACH., GALV., 5/8" X 8", 1-2 1/4" SQ., 1-DBL. COIL SPR. WASH. & 1-NUT (E)	8	100 SECTION
	7 BOLT, MACH., GALV., 5/8" X (LENGTH AS REQ'D), 1-DBL. COIL SPR. WASH. & 1-NUT (E)	3	100 SECTION
	8 BOLT, MACH., GALV., 3/4" X 16", 1-3" SQ., 1-FLAT, 1-CURV., 1-DBL. COIL SPR. WASH & 1-NUT	1	100 SECTION
	9 SCREW, LAG, GALV., 1/2" X 4" (E)	4	621568
	10 SIGN, HIGH VOLTAGE, 8-ROOFING NAILS, GALV. (E)	2	647648, 492192
O C B D	11 POLE TOP SWITCH, 15KV, T.P.S.T., HORIZONTALLY MOUNTED, RIGID DISC. INSULATORS ARCING HORNS & INCLUDING ITEMS #13 THRU #17.	1	709168 400A 709184 600A 709280 1200A
	12 PIPE, INTERPHASE CONNECTING, GALV., 1/2" X 11'-6" OR WOOD 1 3/4" X 1 3/4" X 11'-6"	1	-
	13 BELL CRANK ASSEMBLY	1	290624
	14 ROD, CONTROL, 1 3/4" X 1 3/4" X 10'-0", LAMINATED WOOD	4	602938
	15 GUIDE BEARING, INTERMEDIATE	3	398688
	16 OPERATING LEVER ASSEMBLY COMPLETE WITH ADJUSTING SCREW & NUT	1	-
	17 PADLOCK, ELECTRIC FF	1	514848
	18 CLAMP, STRAIGHT LINE D.E.	6	700 SECTION
	19 WIRE, BARE STRANDED COPPER, #6 BONDING & GROUNDING WIRE	60'	813536
	20 GROUND UNIT (GRAY OR PLAIN)	1	603120, 603136
	21 PIPE STRAP, 3/4" & 2-8D NAILS, GALV. (E)	9	697888, 491584
	22 TAGS, SWITCH NUMBER (E)	2	720704
	23 CONNECTOR, COPPER TO ALUMINUM #1/0-336.4 MCM ACSR OR 5005, WHERE REQ'D.	6	700 SECTION

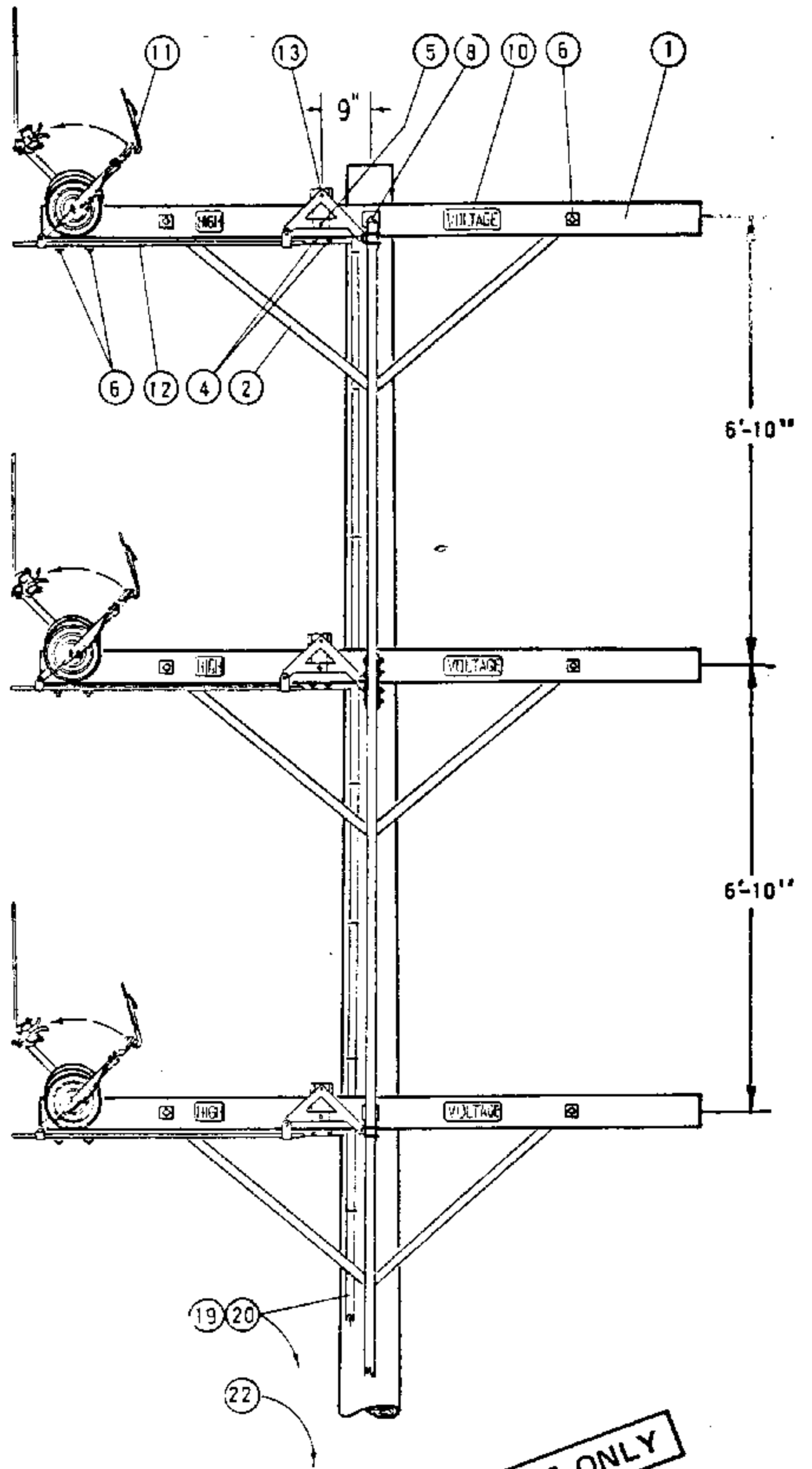
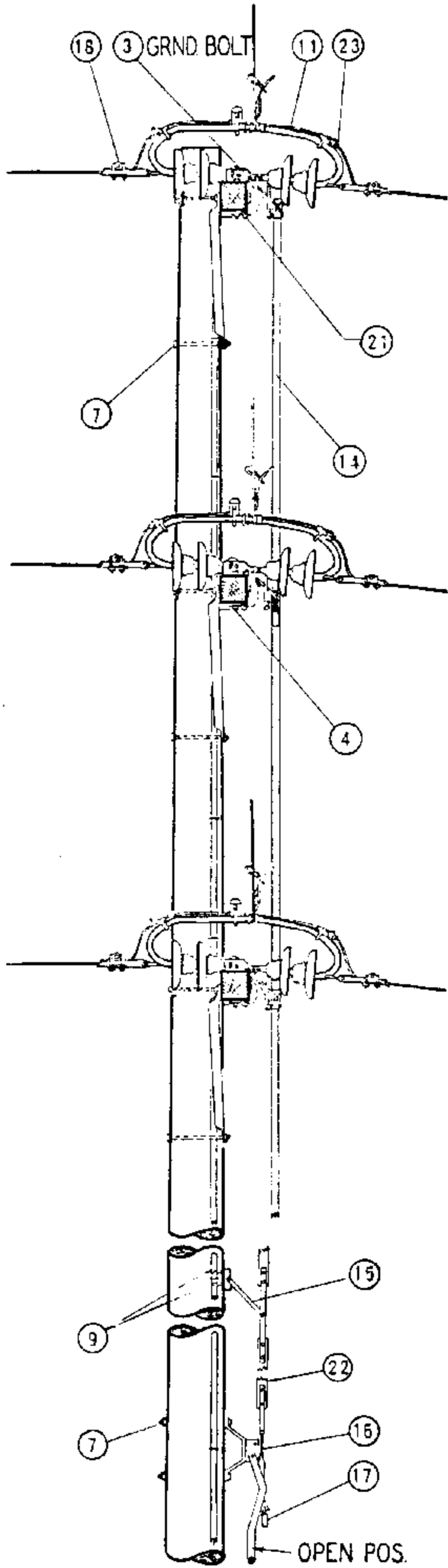

FOR FIELD MAINTENANCE ONLY

DATE 1-1-87
 APPD *AK*

SAN DIEGO GAS & ELECTRIC CO OVERHEAD STANDARDS
 POLE TOP SWITCH INSTALLATION 12KV SINGLE CIRCUIT
 VERTICAL CONFIGURATION

1299.303
 SUPERSEDES
 1231.1 (1-1-87)

FOR FIELD MAINTENANCE ONLY

NOTES:
 A. FOR METHOD OF ADJUSTING SWITCH, SEE PAGE 1230.
 (E) EXEMPT MATERIAL.

ITEM	DESCRIPTION	QUAN.	STOCK NO. OR CONSTR. STD.
P T B F	1 CROSSARM, 5 3/4" X 5 3/4" X 10'-0"	3	294016
	2 BRACE, ALLEY ARM, 4'-0"	6	163808
	3 BOLT, MACH., GALV., 1/2" X 1 1/2", 2-RD., 1-LOCK WASH. & 1-NUT (E)	3	100 SECTION
	4 BOLT, MACH., GALV., 1/2" X 8", 1-RD., 1-DBL. COIL SPR. WASH & 1-NUT (E)	6	100 SECTION
	5 BOLT, MACH., GALV., 1/2" X 8", 3-RD., 1-DBL. COIL SPR. WASH. & 1-NUT (E)	3	100 SECTION
	6 BOLT, MACH., GALV., 5/8" X 8", 1-2 1/4" SQ., 1-DBL. COIL SPR. WASH. & 1-NUT (E)	12	100 SECTION
	7 BOLT, MACH., GALV., 5/8" X (LENGTH AS REQ'D), 1-DBL. COIL SPR. WASH. & 1-NUT (E)	5	100 SECTION
	8 BOLT, MACH., GALV., 3/4" X 16", 1-3" SQ., 1-FLAT, 1-CURV., 1-DBL. COIL SPR. WASH & 1-NUT	3	100 SECTION
	9 SCREW, LAG, GALV., 1/2" X 4" (E)	6	621568
	10 SIGN, HIGH VOLTAGE, 8-ROOFING NAILS, GALV. (E)	6	647648, 492192
D C B D	11 POLE TOP SWITCH, 15KV, T.P.S.T., VERTICALLY MOUNTED, RIGID DISC. INSULATORS ARCING HORNS & INCLUDING ITEMS #13 THRU #17.	1	709168 400A 709184 600A
	12 PIPE, INTERPHASE CONNECTING, GALV., 1/2" X 4'-6"	3	-
	13 BELL CRANK ASSEMBLY	3	290624
	14 ROD, CONTROL, 1 3/4" X 1 3/4" X 10'-0", LAMINATED WOOD	6	602938
	15 GUIDE BEARING, INTERMEDIATE,	4	398688
	16 OPERATING LEVER ASSEMBLY COMPLETE WITH ADJUSTING SCREW & NUT	1	-
	17 PADLOCK, ELECTRIC FF	1	514848
	18 CLAMP, STRAIGHT LINE D.E.	6	700 SECTION
	19 WIRE, BARE STRANDED COPPER, #6	70'	813536
	20 GROUND UNIT (GRAY OR PLAIN)	1	603120, 603136
	21 PIPE STRAP, 3/4" & 2-8D NAILS, GALV. (E)	9	697888, 491584
	22 TAGS, SWITCH NUMBER (E)	2	720704
	23 CONNECTOR, COPPER TO ALUMINUM #1/0-336.4 MCM ACSR OR 5005, WHERE REQ'D.	6	700 SECTION

1299.304 SUPERSEDES 1231.2 (1-1-87)	SDG&E ELECTRIC STANDARDS POLE TOP SWITCH INSTALLATION 12KV SINGLE CIRCUIT VERTICAL CONFIGURATION	DATE 1-1-87 APPD <i>AK</i>
--------------------------------------------------	---------------------------------------------------------------------------------------------------------------------------------	-------------------------------

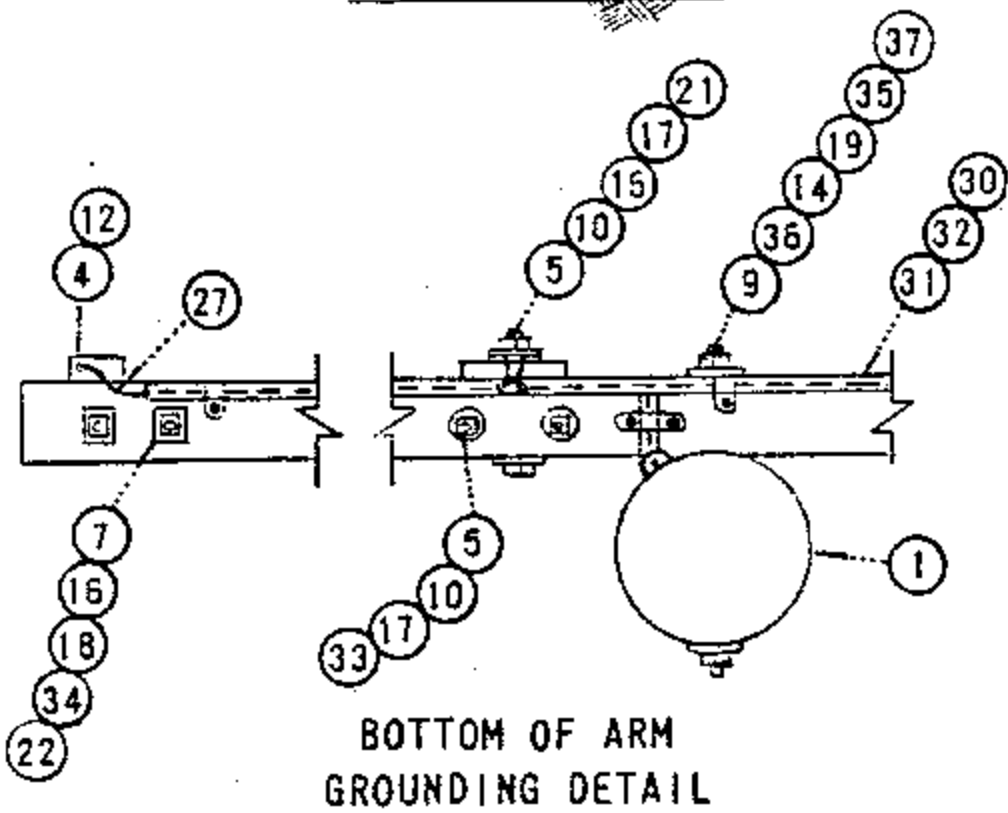
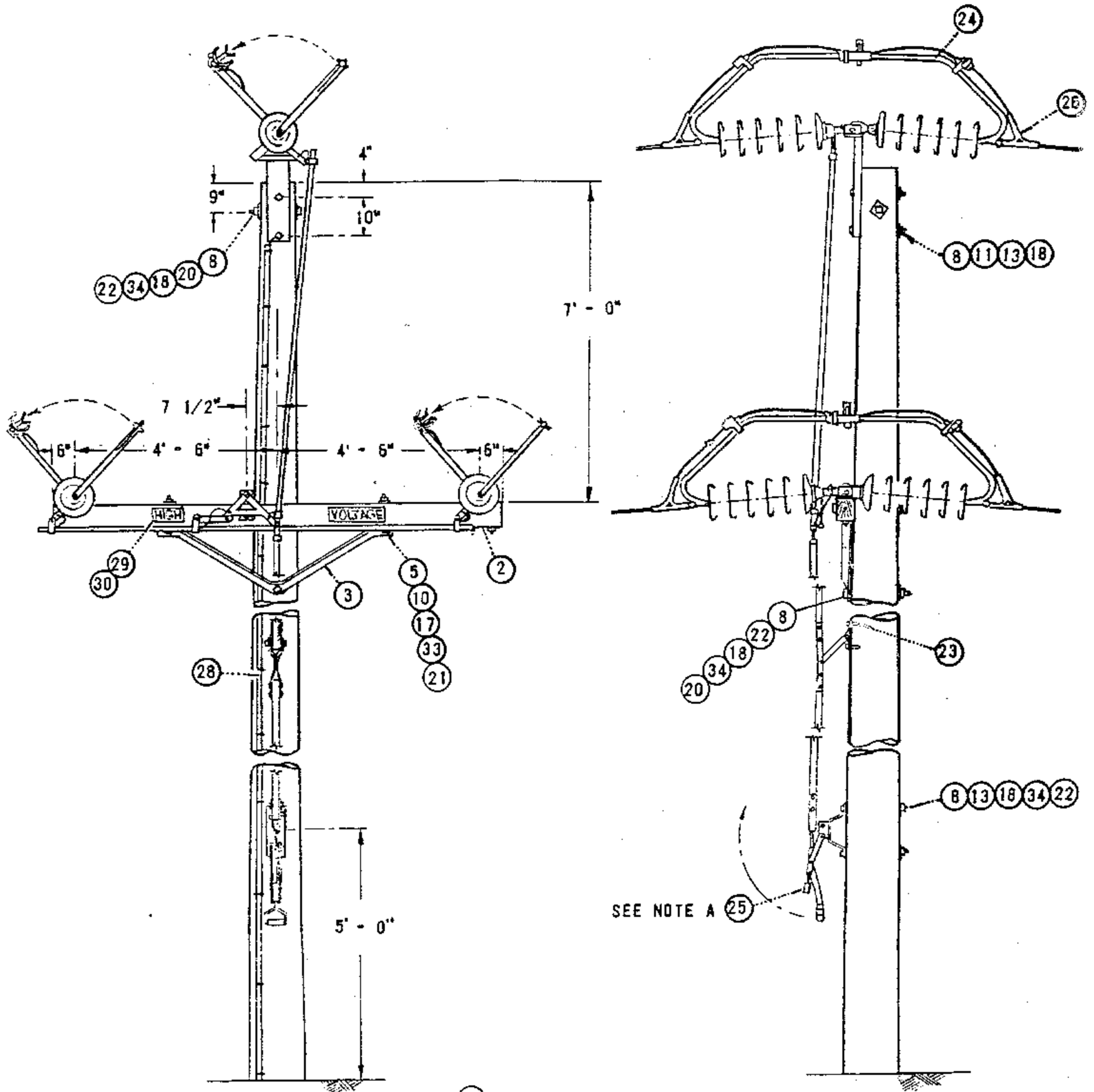

FOR FIELD MAINTENANCE ONLY

FOR FIELD MAINTENANCE ONLY

NOTES:

- A. SWITCH HANDLE SHOWN IN OPEN POSITION.
- B. REFER TO PAGE 1230 FOR METHOD OF ADJUSTING SWITCH AND FOR DETERMINING MAXIMUM LINE ANGLE PERMITTED FOR SWITCH.
- C. THE 600 AMP SWITCH MAY BE USED ON SINGLE CIRCUIT 636 KCMIL AND SMALLER CONDUCTORS.
- (E) EXEMPT MATERIAL.

ITEM		MATERIAL	QUANTITY	STOCK NO OR CONSTR STD.
PTF	TOC			
1		POLE, CLASS AND HEIGHT (AS REQ'D)	1	300 SECTION
2		CROSSARM, 5 3/4" X 5 3/4" X 10' - 0" (CELLON OR GRAY)	1	294144 OR 294304
3		BRACE, CROSSARM 5' - 0" ANGLE STEEL	1	164128
4		BOLT, MACH. 1/2" X 1 1/2" (E)	3	152608
5		BOLT, MACH. 1/2" X 8" (E)	5	153152
6				
7		BOLT, MACH. 5/8" X 8" (E)	4	155584
8		BOLT, MACH. 5/8" X (LENGTH AS REQ'D) (E)	6	100 SECTION
9		BOLT, MACH 3/4" X (LENGTH AS REQ'D)	1	100 SECTION
10		WASHER, 1/2" ROUND (E)	11	800192
11		WASHER, 5/8" ROUND (E)	2	800320
12		WASHER, 1/2" LOCK (E)	3	796768
13		WASHER, 3" SQUARE CURVED RIB (E)	5	797792
14		WASHER, 4" SQUARE CURVED RIB	1	797760
15				
16		WASHER, 2 1/4" SQUARE FLAT (E)	7	799040
17		WASHER, SPRING DOUBLE COIL 1/2" (E)	5	798464
18		WASHER, SPRING DOUBLE COIL 5/8" (E)	12	798560
19		WASHER, SPRING DOUBLE COIL 3/4"	1	798496
20		WASHER, 3" SQUARE CURVED	2	798912
21		NUT, 1/2" (E)	8	504736
22		NUT 5/8" (E)	12	506880
23		SCREW, LAG 1/2" X 4" (E)	2	621568
24		POLE TOP SWITCH, 69KV, 600 AMP	1	709088
25		PAD LOCK, ELECTRIC FF	1	514848
26		CLAMPS, STRAIN	6	700 SECTION
27		WIRE, BARE STRANDED COPPER, #6	60'	813536
28		ROD, GROUND UNIT (GRAY OR PLAIN)	1	603120, 603136
29		SIGN, HIGH VOLTAGE (E)	2	647648
30		NAILS, ROOFING 8 GALV. (E)	28	492192
31		CONDUIT, SCH. 40, 1/2" (E)	9'	251168
32		STRAP, 1/2" PIPE (E)	6	697728
33		LOCKNUT, M-F 1/2" (E)	5	504544
34		LOCKNUT, M-F 5/8" (E)	10	504608
35		LOCKNUT, M-F 3/4"	1	504576
36		WASHER, 3" SQUARE FLAT	1	799104
37		NUT, 3/4	1	100 SECTION
38		TAGS, SWITCH NUMBER	2	720704

SCOPE: THIS STANDARD SHOWS A HORIZONTAL BREAK GANG OPERATED POLE TOP SWITCH FOR CIRCUIT TIES OR SECTIONALIZING PURPOSES. THIS INSTALLATION IS PREFERRED OVER STANDARD 1228.

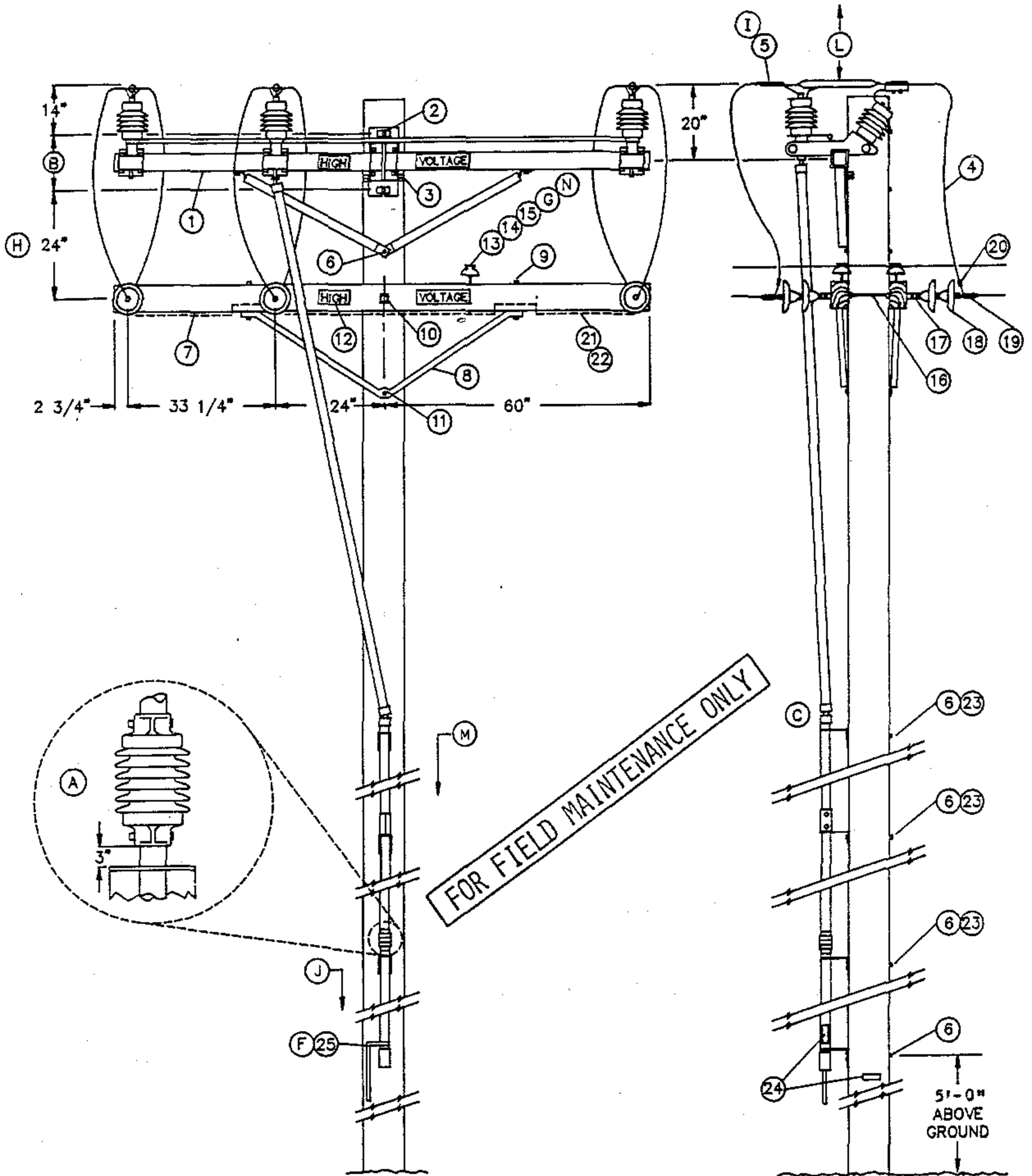

SDG&E ELECTRIC STANDARDS

DATE 1-1-93
 APPD *PA/BG*

POLE TOP SWITCH 12KV HORIZONTAL BREAK TYPE SINGLE CIRCUIT
 HORIZONTAL CONFIGURATION

1299.307
 SUPERSEDES
 1230.1 (1-1-92)

BILL OF MATERIAL:

ITEM	DESCRIPTION	QUANTITY	CONSTR. STD	STOCK NUMBER
1	SWITCH, T.P.S.T., 600 AMP, INCLUDING 40' OF CONTROL ROD (C)	1	-	709250
	ADDITIONAL 10'-6" CONTROL ROD WITH GUIDE BEARING AND COUPLING	AS REQ'D	-	604428
2	BOLT, MACH, GALV, 3/4" X (LENGTH AS REQ'D), 1 SQUARE AND 1 DOUBLE COIL SPRING WASHER (E)	2	392	-
3	SCREW, LAG, GALV, 1/2" X 4" (E)	2	-	621568
4	WIRE, BARE STRANDED CU OR AL (SIZE AS REQ'D)	33'	711-715	-
5	TERMINAL, COMPRESSION LUG (I) (E)	6	794-795	-
6	BOLT, MACH, GALV, 5/8" X (LENGTH AS REQ'D), 1 SQUARE AND 1 DOUBLE COIL SPRING WASHER (E)	5	392	-
7	CROSSARM, 3 3/4" X 5 3/4" X 10' - 0"	2	-	294128
8	BRACE, ANGLE, 5' - 0"	2	-	164128
9	BOLT, MACH, GALV, 1/2" X 7", 1 ROUND AND 1 DOUBLE COIL SPRING WASHER (E)	4	392	-
10	BOLT, MACH, GALV, 5/8" X (LENGTH AS REQ'D), 2 SQUARE AND 1 DOUBLE COIL SPRING WASHER (E)	1	392	-
11	BOLT, MACH, GALV, 5/8" X (LENGTH AS REQ'D) AND 1 DOUBLE COIL SPRING WASHER (E)	1	392	-
12	SIGN, HIGH VOLTAGE, AND 9 ROOFING NAILS, GALV	(E)	-	647648
		(E)	-	492224
13	PIN, INSULATOR, STRAIGHT, 12KV, 1" (G) (E)	2	-	532704
14	INSULATOR, 12KV NEUTRAL (G)	2	-	429216
15	WIRE, TIE (DOUBLE) (G) (E)	1	760-764	-
16	BOLT, SPACE, GALV, 5/8" X (LENGTH AS REQ'D), 2 SQUARE, 2 ROUND, 2 DOUBLE COIL SPRING WASHERS AND 1 NUT (E)	3	392	-
17	CLEVIS, DEAD END, 5/8" BOLT STEEL (CLOSED TYPE) (E)	6	-	235712
18	INSULATOR, SUSPENSION, 12KV, CLEVIS	12	750	-
19	CLAMP, STRAIGHT LINE, D.E.	6	741-743	-
20	CONNECTOR, WIRE COMPRESSION (SIZE AS REQ'D) (E)	AS REQ'D	783-786	-
21	WIRE, #8 BARE SOLID ANNEALED COPPER	12'	-	812928
22	STAPLE, FENCE, GALV, 1 1/4" (E)	AS REQ'D	-	678528
23	SCREW, LAG, GALV, 5/8" X 5" (E)	2	-	621600
24	TAG, SWITCH NUMBER	2	204	-
25	PADLOCK, MEDECO	1	-	514862

FOR FIELD MAINTENANCE ONLY

1299.308
SUPERSEDES
1230.2 (1-1-92)

SDG&E ELECTRIC STANDARDS
POLE TOP SWITCH 12KV HORIZONTAL BREAK TYPE SINGLE CIRCUIT
HORIZONTAL CONFIGURATION

DATE 11-1-93
APPD MVA/BJ

INSTALLATION:

- (A) INSTALL CONTROL PIPE INSULATOR THREE INCHES ABOVE THE NEXT GUIDE BEARING UP FROM THE SWITCH HANDLE.
- (B) USE THE FOLLOWING THROUGH-BOLT DRILLING DIMENSIONS: A.B. CHANCE = 13-1/4", S&C = 14".
- (C) SWITCHES ARE FURNISHED WITH 40 FEET OF OPERATING CONTROL ROD. THE TOP SECTION OF THE CONTROL ROD IS MADE OF FIBER GLASS, THE LOWER SECTIONS ARE MADE OF GALVANIZED PIPE.
- D. SWITCH CONTROL MECHANISM DOES NOT REQUIRE GROUNDING.
- (E) EXEMPT MATERIAL.
- (F) THE SWITCH IS SHIPPED FACTORY ADJUSTED. HOWEVER, THE SWITCH HANDLE LOCK SEGMENTS WILL REQUIRE ADJUSTMENT. REFER TO INSTALLATION INSTRUCTIONS PROVIDED WITH SWITCH.
- (G) REDUCE QUANTITIES AS REQUIRED WHEN NOT USING NEUTRAL.
- (H) SWITCH MAY BE INSTALLED BELOW LINEARM. DRILL SWITCH ARM UPPER MOUNTING BOLT HOLE 36" BELOW LINE ARM THRU BOLT (SEE STANDARD 1444).
- (I) WHEN ATTACHING 1/0 AND 4/0 COPPER CONDUCTORS TO A POLE TOP SWITCH, USE A BRONZE CABLE TAP LUG, STOCK NUMBER 471296. IF EXCESSIVE VIBRATION OR WHIPPING COULD OCCUR, USE TWO LUGS IN SERIES.

REFERENCES:

- (J) POLE STEPPING - SEE STANDARD 363.
- K. SEE DESIGN MANUAL PAGE 6111 - FEEDER CIRCUIT SECTIONALIZING AND PROTECTION.
- (L) SEE SECTION 200 FOR MINIMUM VERTICAL SEPARATION.
- (M) REFLECTOR STRIPS ARE REQUIRED ON ALL SECTIONALIZING/TIELINE SWITCHES AND SERVICE RESTORER POLES. (SEE STD. 208.3 ITEM 12)
- (N) NEUTRALS SHALL BE SOLIDLY TIED TOGETHER AT ALL SWITCHES REGARDLESS WHETHER THEY ARE NORMALLY OPEN OR CLOSED. THIS INCLUDES TIE SWITCHES TO CIRCUITS EMANATING FROM DIFFERENT SUBSTATIONS. (SEE DESIGN MANUAL STANDARD PAGE 6221.2, D.3).
- O. CONTROL PIPE AND SWITCH HANDLE ARE NOT ALLOWED IN THE CLIMBING SPACE (G.O. 95, 54.7-A4).

FOR FIELD MAINTENANCE ONLY

DATE 1-1-93 APPD <i>PA/ROJ</i>	SDG&E ELECTRIC STANDARDS POLE TOP SWITCH 12KV HORIZONTAL BREAK TYPE SINGLE CIRCUIT HORIZONTAL CONFIGURATION	1299.309 SUPERSEDES 1230.3 (1-1-92)
-----------------------------------	-------------------------------------------------------------------------------------------------------------------	-------------------------------------------

THIS PAGE FOR FIELD MAINTENANCE ONLY

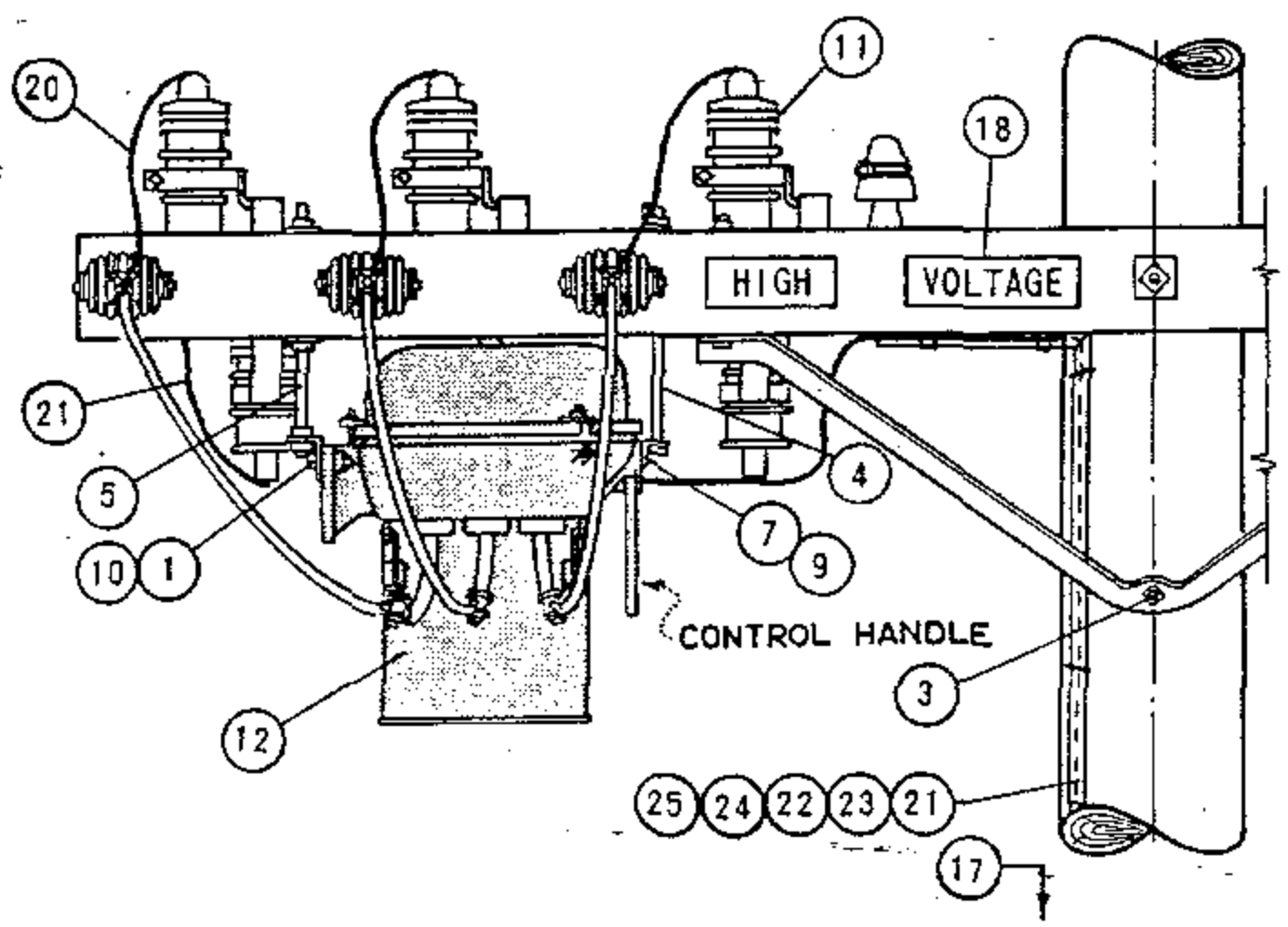
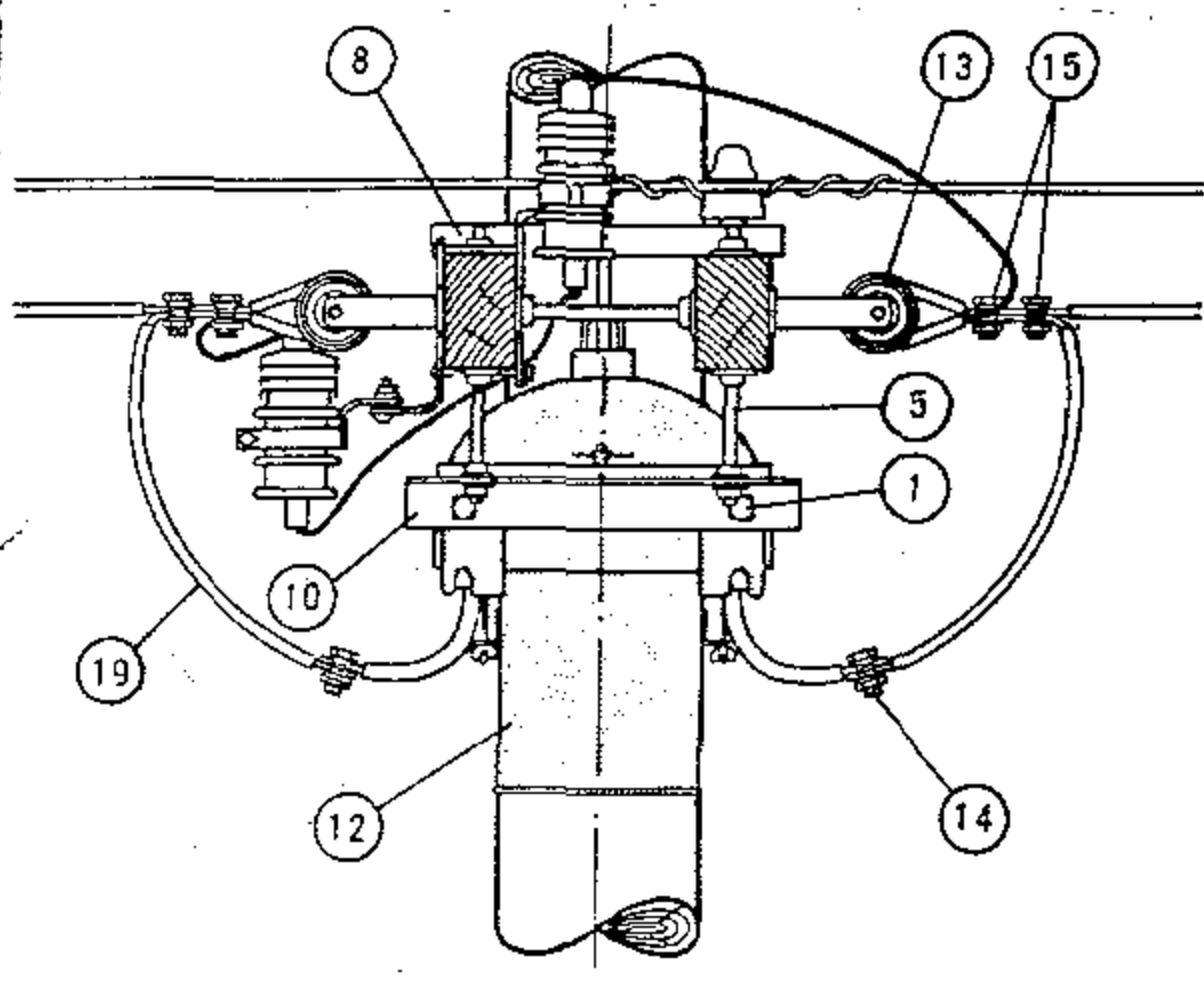
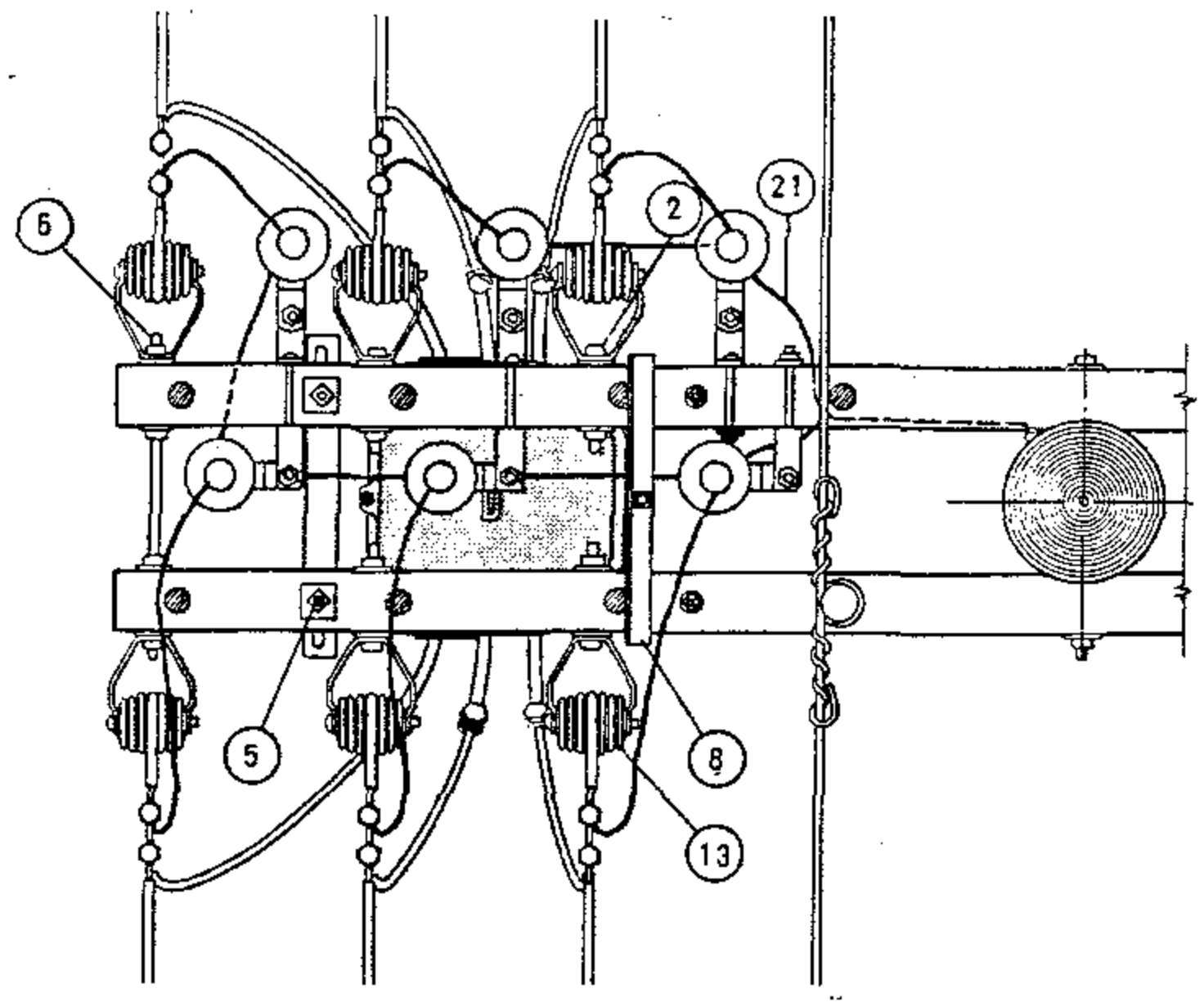

A. BETWEEN SWITCH CASE AND ARRESTER, 1 1/2 INCH CLEARANCE MUST BE MAINTAINED. USE LONGER BOLTS FOR SWITCH SUPPORTS IF REQUIRED.

(E) EXEMPT MATERIAL

ITEM	DESCRIPTION	QUANTITY #5 OR #4	#2 UP	STOCK NO. OR CONSTR STD	ITEM	DESCRIPTION	QUANTITY #5 OR #4	#2 UP	STOCK NO. OR CONSTR STD
1	MACH BOLT, GALV, 5/8" X 2" 1 RD WASHER & 1 NUT	(E) 2	2	PGS 139, 140	14	WIRE CONNECTOR, SPLIT BOLT, SIZE AS REQUIRED	(E) 19	7	PG 783
2	MACH BOLT, GALV, 5/8" X 5" 1-2 1/2" SQ WASHER & 1 NUT	(E) 4	0	PGS 139, 140	15	WIRE CLAMP OR D.E.	0	6	PGS 743, 787
3	MACH BOLT, GALV, 5/8" X 10" TO 16"; 1 NUT	(E) 1	1	PGS 139, 140	16				
4	MACH BOLT, GALV, 5/8" X 14"; 1 NUT	(E) 1	1	PGS 139, 140	17	POLE STEPS	(E) 17	17	692992
5	SPACE BOLT, GALV, 5/8" X 16", 2 RD & 2 SQ WASH & 2 NUTS	(E) 2	2	PGS 139, 140	18	SIGN, HIGH VOLTAGE & ROOFING NAILS	(E) 2	2	647648, 492224
6	SPACE BOLT, GALV, 5/8" X 16" TO 24"; 4 SQ WASHER & 4 NUTS	(E) 2	2	PGS 139, 140	19	WIRE SAME SIZE AS LINE	15'	15'	PGS 711 716
7	CAP SCREW, GALV, 3/8" X 3/4"	2	2	619328	20	WIRE, BARE COPPER #6	12	12	813536
8	MOUNTING BRACKET, OIL SWITCH	1	1	166464	21	WIRE, BARE COPPER #2	AS REQ'D		813664
9	MOUNTING BRACKET, OIL SWITCH	1	1	166464	22	MOULDING, 1" HARDWOOD	AS REQ'D		487200
10	MOUNTING BRACKET, OIL SWITCH	1	1	166464	23	STAPLES, FENCE GALV 1 1/4"	(E) AS REQ'D		678528
11	ARRESTER, 3KV	6	6	PG 1247	24	STAPLES, 3" GALV	(E) AS REQ'D		678560
12	POLETOP SWITCH, WEST. TYPE FO 11, 5KV, 400 A	1	1	171584	25	ROD, GROUND & CLAMP	2	2	603072, 230015 (E)
13	INSULATOR, 4KV D.E. WITH CLEVIS	(E) 6	6	430848					

SDG & E ELECTRIC STANDARDS

DATE 6-4-82
APPD *SRH*

POLE TOP SWITCH INSTALLATION
4 KV WESTINGHOUSE OIL SWITCH, TYPE FO11

1299.401
SUPERSEDES
1240 (6-4-82)

SCOPE: THIS STANDARD SHOWS THE INSTALLATION METHOD OF A DISTRIBUTION SERVICE RESTORER WHICH MAY BE USED WITH #3/0 ACSR OR #1/0 COPPER AND SMALLER CONDUCTORS.

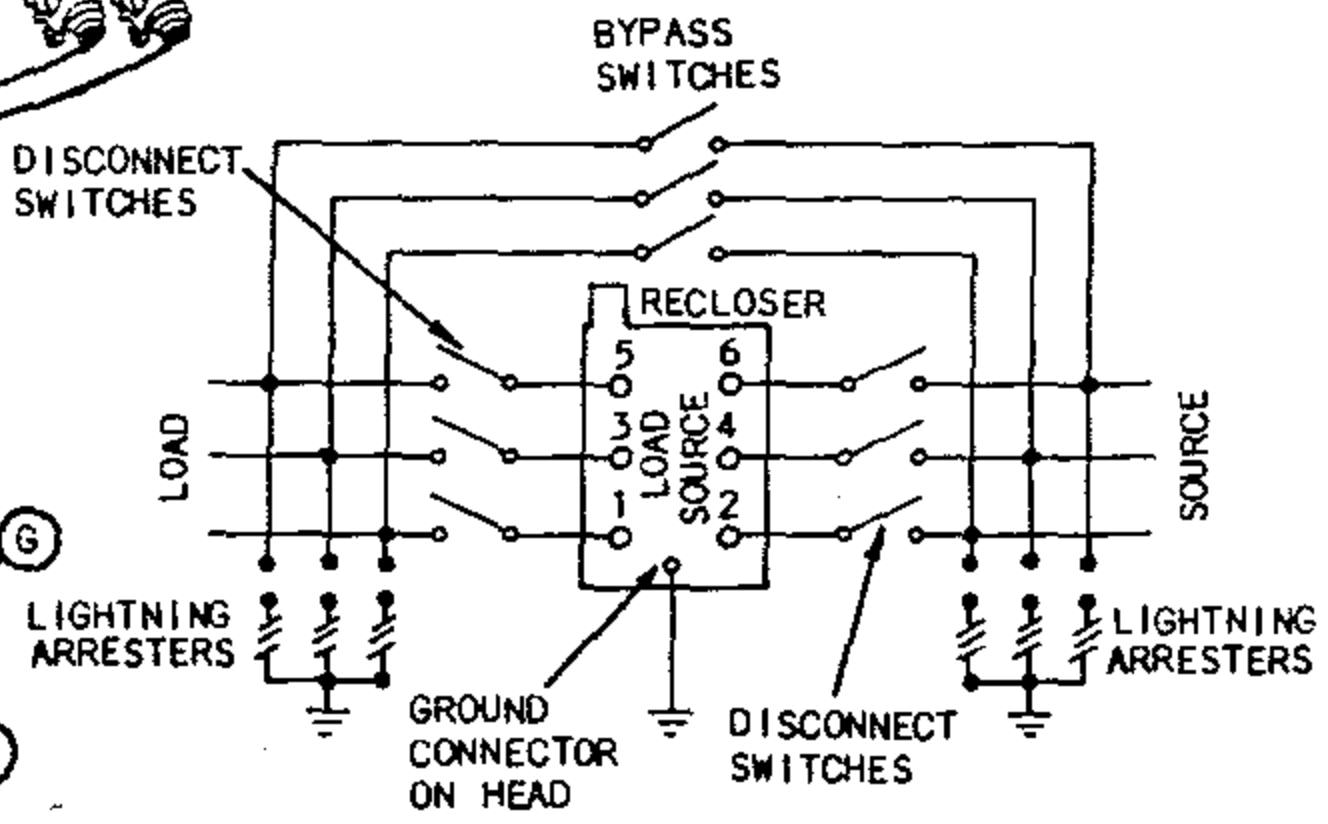
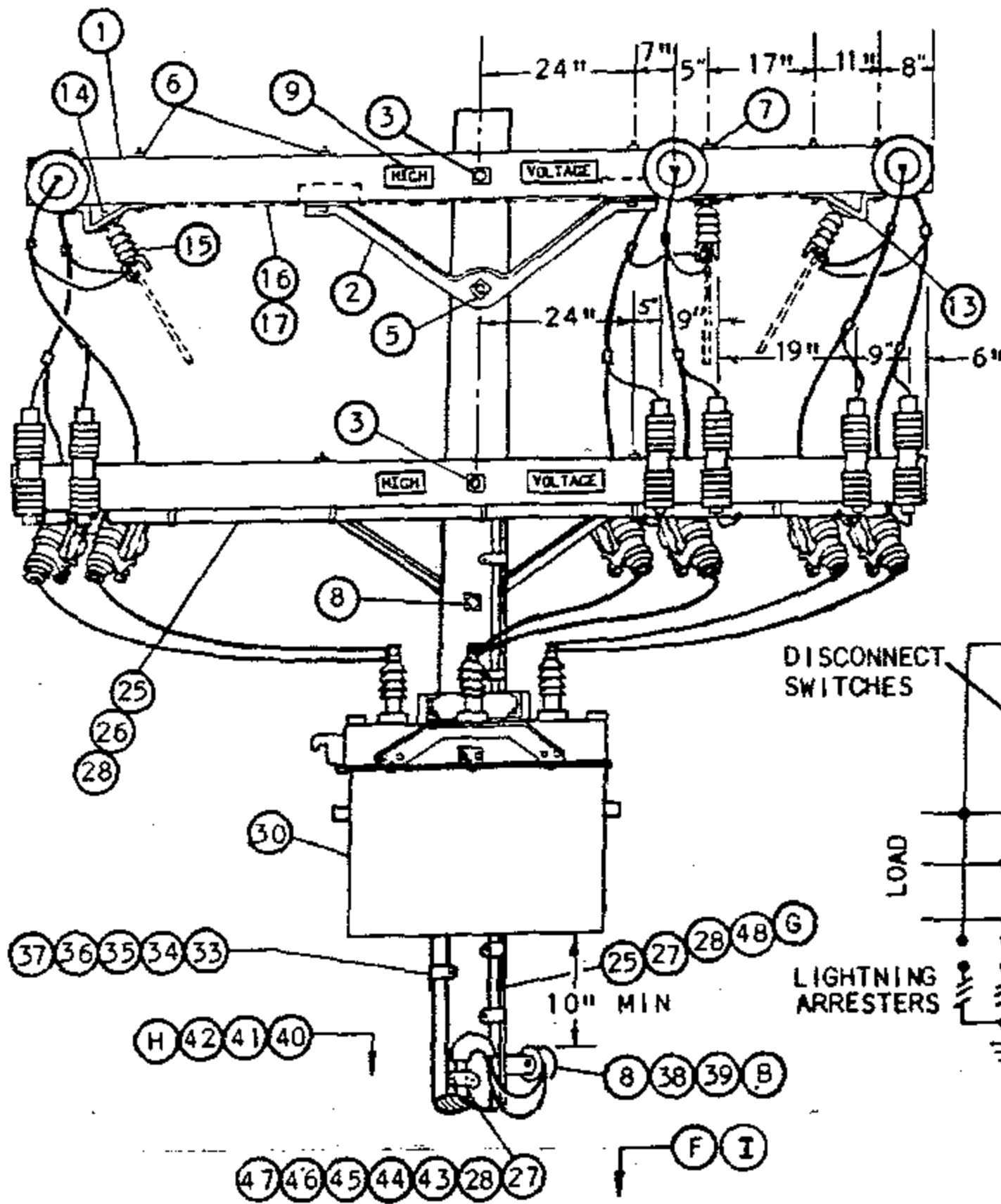

SCHEMATIC DIAGRAM

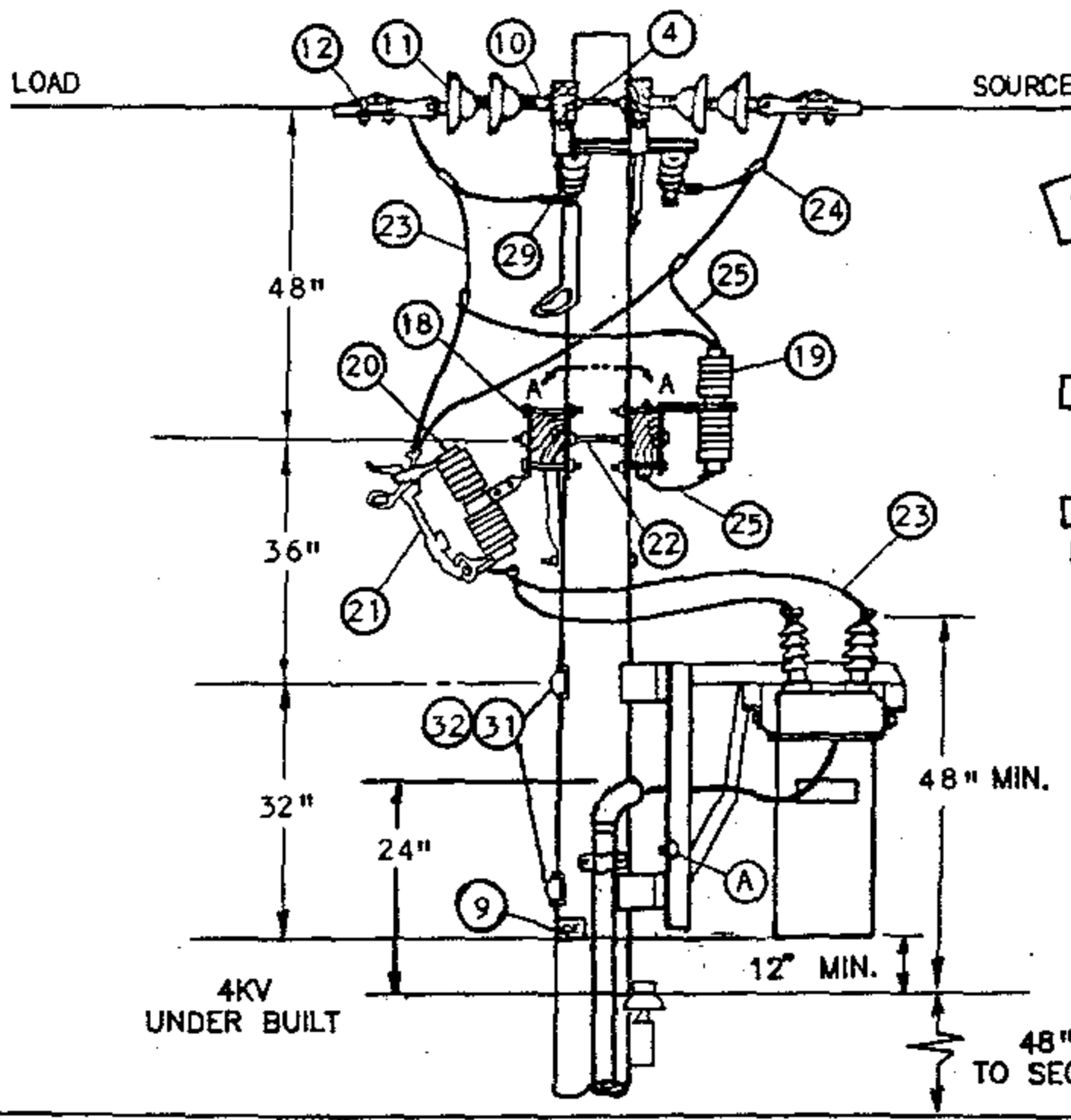

FOR FIELD MAINTENANCE ONLY

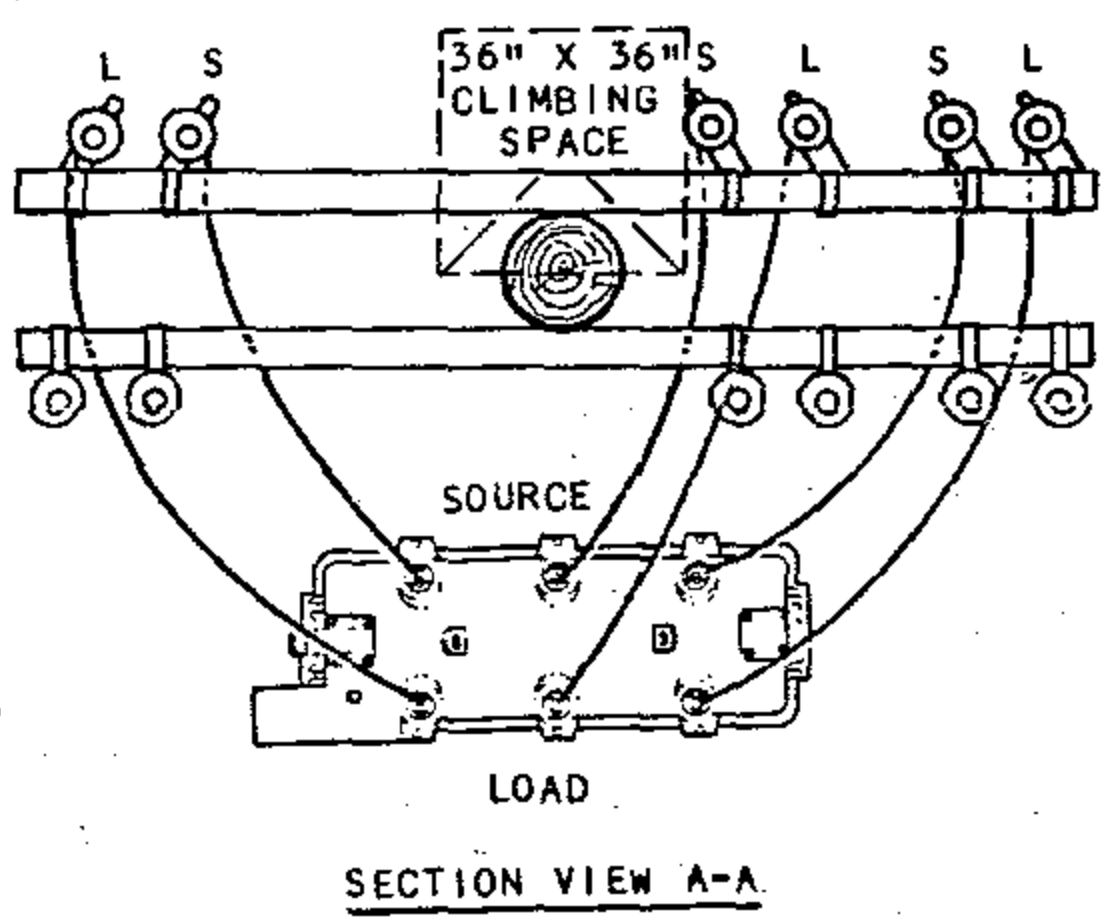

SECTION VIEW A-A

1299.701
SUPERSEDES
1270.1 (1-1-90)

SDG&E ELECTRIC STANDARDS

SERVICE RESTORER WITH CUTOUT DISCONNECT

DATE 1-1-90
APPD PJA / JTB

BILL OF MATERIAL:

ITEM	DESCRIPTION	QUANTITY	CONST STD OR PAGE NO	STOCK NUMBER
1	CROSSARM, 3 3/4" X 5 3/4" X 12' - 0"	4	-	294160
2	BRACE, 4', ANGLE, GALV	3	-	164032
3	BOLT, MACH, GALV, 5/8" X (LENGTH AS REQ'D), 2 SQUARE AND 1 DOUBLE COIL SPRING WASHERS (E)	2	392	-
4	BOLT, SPACE, GALV, 5/8" X (LENGTH AS REQ'D), 2 ROUND, 2 SQUARE, 2 DOUBLE COIL SPRING WASHERS AND 1 NUT (E)	3	392	-
5	BOLT, MACH, GALV, 5/8" X (LENGTH AS REQ'D) AND 1 DOUBLE COIL SPRING WASHER (E)	1	392	-
6	BOLT, MACH, GALV, 1/2" X 7", 1 ROUND AND 1 DOUBLE COIL SPRING WASHER (E)	14	392	-
7	BOLT, MACH, GALV, 1/2" X 8", 1 ROUND AND 1 DOUBLE COIL SPRING WASHER (E)	2	392	-
8	BOLT, MACH, GALV, 5/8" X (LENGTH AS REQ'D), 1 SQUARE AND 1 DOUBLE COIL SPRING WASHER (E)	2	392	-
9	SIGN, HIGH VOLTAGE & 9 ROOFING NAILS, GALV (E)	5	-	647648
		-	-	492224
10	CLEVIS, DEAD-END, 5/8", BOLT STEEL (CLOSED TYPE)	6	-	235712
11	INSULATOR, SUSPENSION, 12KV, CLEVIS	12	-	431616
12	CLAMP, STRAIGHT LINE, D.E.	6	741-743	-
13	BRACKET, DISCONNECT, ANGLE MOUNTING	4	-	166542
14	BOLT, MACH, GALV, 3/8" X 2", 2 ROUND & 1 LOCK WASHER (E)	4	392	-
15	SWITCH, DISCONNECT, 14.4KV, 600A	3	-	707008
16	WIRE, BARE SOLID ANNEALED COPPER, #8	30'	-	812928
17	STAPLES, FENCE, GALV, 1 1/4" (E)	AS REQ'D	-	678528
18	BRACKET, CUTOUT/ARRESTER, FOR CROSSARM MOUNTING (E)	12	-	166070
19	ARRESTER, LIGHTNING, 12KV	6	-	113248
20	CUTOUT BODY, 12KV	6	1212	297956
21	SOLID BLADE, 300A, 12KV CUTOUT	6	1212	138850
22	BOLT, SPACE, GALV, 5/8" X (LENGTH AS REQ'D), 2 ROUND, 4 SQUARE, 2 DOUBLE COIL SPRING WASHERS AND 1 NUT (E)	2	392	-
23	WIRE, BARE STRANDED COPPER, 1/0	75'	-	813568
24	CONNECTOR, WIRE, COMPRESSION (SIZE AS REQ'D) (E)	AS REQ'D	783-787	-
25	WIRE, BARE STRANDED COPPER, #4	105'	-	813760
26	CONDUIT, PVC, TYPE 2, SCHEDULE 40, 1" X 10', AND STRAPS, PIPE, GALV, 1" AND 2-1 3/4" ROOFING NAILS (E)	1	-	251200
		AS REQ'D	-	697792
27	CONDUIT, PVC, TYPE 2, SCHEDULE 80, 3/4" X 10' (E)	3	-	251520
28	STRAPS, PIPE, GALV, 3/4" AND 2 - 6D NAILS, GALV (E)	AS REQ'D	-	697888
		AS REQ'D	-	491552
29	TERMINAL, COMPRESSION, CU OR AL (SIZE AS REQ'D) (E)	6	794/795	-
30	RECLOSER, MCGRAW-EDISON, 560A, TYPE WE (INCLUDING BRACKET) (C)	1	-	572110

FOR FIELD MAINTENANCE ONLY

SDG&E ELECTRIC STANDARDS

DATE 1-1-90

APPD PA/DTS

SERVICE RESTORER WITH CUTOUT DISCONNECT

1299.702

SUPERSEDES 1270.2 (1-1-90)

BILL OF MATERIAL:

ITEM	DESCRIPTION	QUANTITY	CONST STD OR PAGE NO	STOCK NUMBER
31	BOLT, MACH, GALV, 3/4" X (LENGTH AS REQ'D), 1 SQUARE CURVE RIBBED AND 1 DOUBLE COIL SPRING WASHER (E)	2	392	-
32	COVER, BOLT, PLASTIC AND 6 10-D NAILS, GALV (E)	2	-	285696
		-	-	491392
33	CONTROL CABLE FOR MCGRAW-EDISON RECLOSER (H)	1	-	192010
34	CONDUIT, PVC, SCHEDULE 40, 2" X 10' (E)	2	-	251296
35	ELBOW, PVC, SCHEDULE 40, 2" (E)	2	-	321792
36	ELBOW, PVC, SCHEDULE 40, 2", 12" RADIUS (E)	1	-	321816
37	STRAP, PIPE, GALV, 2" AND 2 - 100 NAILS, GALV, (E)	AS REQ'D	-	697856
		AS REQ'D	-	491392
38	BRACKET, SERVICE INSULATOR	1	-	166128
39	WIRE, COPPER #8, 600 VOLT, DUPLEX (B)	AS REQ'D	-	196432
40	CONTROLLER, RECLOSER, MCGRAW-EDISON (H)	1	-	273928
41	SCREW, LAG, GALV, 1/2" X 4" (E)	2	-	621568
42	PADLOCK, CORBIN #27 (FF KEY) (E)	1	-	514848
43	COVER, PVC, DRIP LOOP, 3/4" (E)	1	-	287248
44	COUPLING, PVC, 3/4" (E)	2	-	280416
45	TERMINAL, ADAPTOR, PVC, 3/4"	1	-	102754
46	ELBOW, 90 , PULLING, PVC, 3/4" (E)	2	-	-
47	NIPPLE, PIPE SCREW, GALV, 3/4" X 1"	1	-	-
48	UNIT, GROUND, COMPLETE	1	-	603136

INSTALLATION:

- (A) CONNECT RECLOSER RACK GROUND LEAD TO LIGHTNING ARRESTER GROUND.
- (B) RECLOSER CONTROL REQUIRES 120 VOLT SUPPLY, PREFERABLY COMING FROM THE SOURCE SIDE.
- (C) THE 400A, TYPE RXE RECLOSER (S/N 572100) IS NO LONGER PURCHASED.
- (E) EXEMPT MATERIAL.

FOR FIELD MAINTENANCE ONLY

REFERENCE:

- (F) POLE STEPPING - SEE STANDARD 363.
- (G) GROUNDING METHODS - SEE STANDARD 1002. (INSTALL GROUND MOULDING IN SUCH A MANNER AS NOT TO INTERFERE WITH A LADDER WHEN PLACED AGAINST THE POLE).
- (H) CONTROL INSTALLATION TO BE DONE BY SUBSTATION CONSTRUCTION AND MAINTENANCE AND IS TO BE INSTALLED A MINIMUM OF 13'-6" ABOVE GROUND LEVEL.
- (I) REFLECTOR STRIPS ARE REQUIRED ON ALL SECTIONALIZING/TIELINE SWITCHES AND SERVICE RESTORER POLES. (SEE STD. 208.3 ITEM 12)

SDG&E ELECTRIC STANDARDS

1299.703
SUPERSEDES
1270.3(1-1-90)

SERVICE RESTORER WITH CUTOUT DISCONNECT

DATE 1-1-90
APPD PJA/DTS

SCOPE: THIS STANDARD SHOWS THE INSTALLATION METHOD OF A DISTRIBUTION SERVICE RESTORER TO BE USED WITH ALL CONDUCTOR SIZES

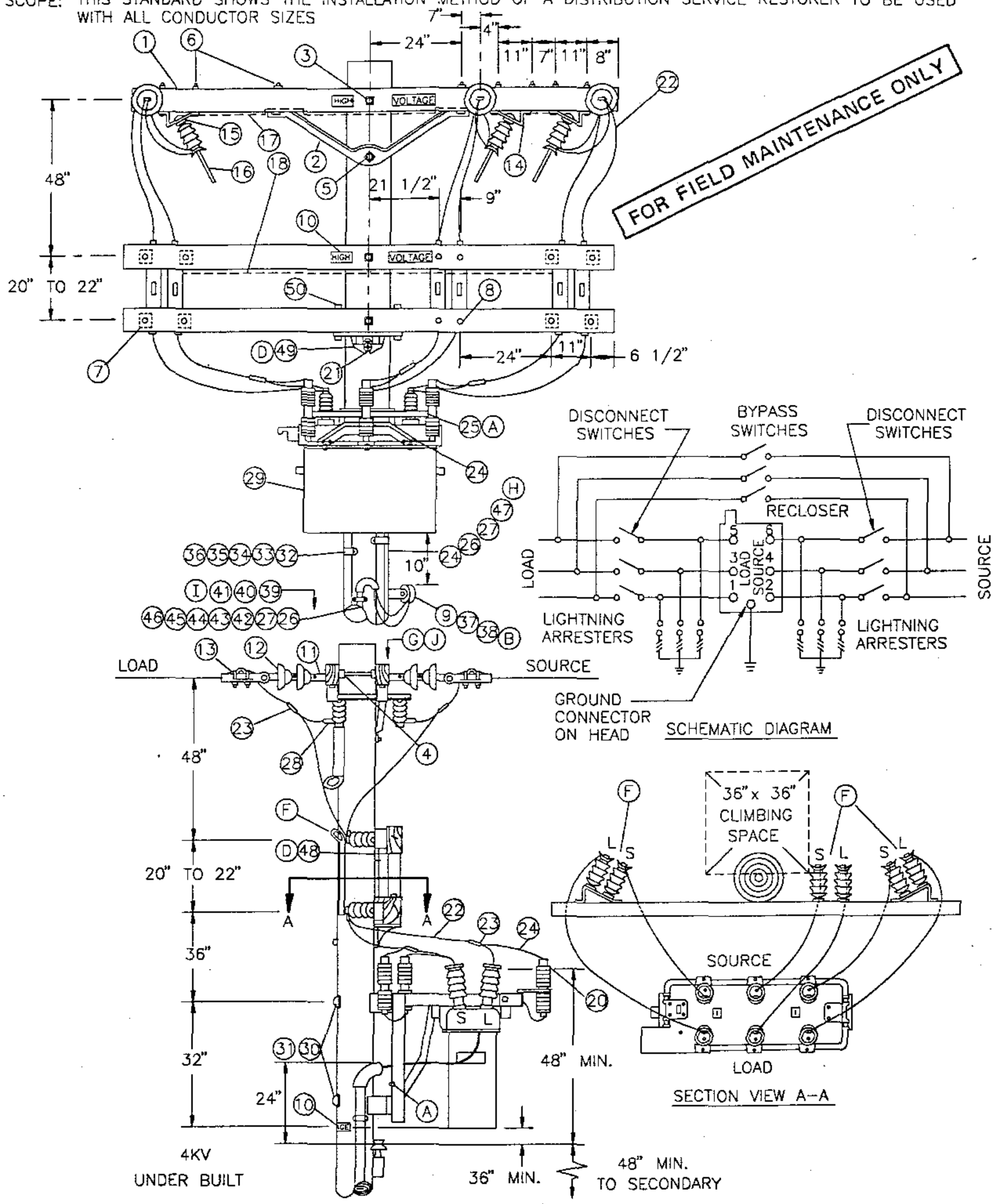

SDG&E ELECTRIC STANDARDS

DATE 1-1-93
 APPD *PA/BOJ*

SERVICE RESTORER
 WITH HOOK STICK SWITCH DISCONNECT

1299.704
 SUPERSEDES
 1271.1 (1-1-94)

BILL OF MATERIAL:

ITEM	DESCRIPTION	QUANTITY	CONST STANDARD OR PAGE NO.	STOCK NUMBER
1	CROSSARM, 3 3/4" X 5 3/4" X 12' - 0"	5	-	294160
2	BRACE, ANGLE, CROSSARM, 4' - 0"	2	-	164032
3	BOLT, MACH, GALV, 5/8" X (LENGTH AS REQ'D), 2 SQUARE & 1 DOUBLE COIL SPRING WASHERS	3	392	-
4	BOLT, SPACE, GALV, 5/8" X (LENGTH AS REQ'D) 2 SQUARE, 2 ROUND & 2 DOUBLE COIL SPRING WASHERS	3	392	-
5	BOLT, MACH, GALV, 5/8" X (LENGTH AS REQ'D) & 1 DOUBLE COIL SPRING WASHERS	1	392	-
6	BOLT, MACH, GALV, 1/2" X 7", 1 ROUND & 1 DOUBLE COIL SPRING WASHERS	16	392	-
7	BOLT, MACH, GALV, 1/2" X 5", 1 ROUND & 1 DOUBLE COIL SPRING WASHERS	8	392	-
8	BOLT, MACH, GALV, 3/8" X 6", 1 ROUND & 1 DOUBLE COIL SPRING WASHERS	4	392	-
9	BOLT, MACH, GALV, 5/8" X (LENGTH AS REQ'D), 1 SQUARE & 1 DOUBLE COIL SPRING WASHERS	1	392	-
10	SIGN, HIGH VOLTAGE & 9 ROOFING NAILS, GALV	5	-	647648
		AS REQ'D	-	492224
11	CLEVIS, DEAD-END, 5/8", BOLT STEEL (CLOSED TYPE)	6	-	235712
12	INSULATOR, SUSPENSION, 12KV, CLEVIS	12	-	431616
13	CLAMP, STRAIGHT LINE, D.E.	6	741-743	-
14	BRACKET, DISCONNECT, ANGLE MOUNTING	10	-	166542
15	BOLT, MACH, GALV, 3/8" X 2", 2 ROUND & 1 LOCK WASHER	14	392	-
16	SWITCH, DISCONNECT, 14.4KV, 600A	9	-	707008
17	WIRE, #8, BARE SOLID ANNEALED COPPER	30'	-	812928
18	STAPLES, FENCE, GALV, 1 1/4"	AS REQ'D	-	678528
19				
20	ARRESTER, LIGHTNING, 12KV	6	-	113248
21	BOLT, MACH, GALV, 5/8" X (LENGTH AS REQ'D) 1 SQUARE, 1 ROUND & 1 DOUBLE COIL SPRING WASHER	1	392	-
22	WIRE, BARE STRANDED COPPER, (SIZE AS REQ'D WITH MINIMUM SIZE EQUAL TO LINE CONDUCTOR AMPACITY, OR GREATER) ©	75'	715	-
23	CONNECTOR, WIRE, COMPRESSION (SIZE AS REQ'D)	AS REQ'D	783-787	-
24	WIRE, #4, BARE STRANDED COPPER	100'	-	813760
25	CONNECTOR, SPLIT BOLT, #2	2	-	269536
26	CONDUIT, PVC, TYPE 2, SCHEDULE 80, 3/4" X 10'	3	-	251520
27	STRAPS, PIPE, GALV, 3/4" & 2 - 6D NAILS, GALV	AS REQ'D	-	697888
		AS REQ'D	-	491552
28	TERMINAL, COMPRESSION, CU OR AL (SIZE AS REQ'D)	6	794/795	-
29	RECLOSER, MCGRAW-EDISON, 560A, TYPE WE (INCLUDING BRACKET) ©	1	-	572110

FOR FIELD MAINTENANCE ONLY

<p>1299.705 SUPERSEDES 1271.2 (1-1-94)</p>	<p>SDG&E ELECTRIC STANDARDS</p> <p>SERVICE RESTORER WITH HOOK STICK SWITCH DISCONNECT</p>	<p>DATE 1-1-90 APPD <i>[Signature]</i></p>
----------------------------------------------------	---------------------------------------------------------------------------------------------------	------------------------------------------------

BILL OF MATERIAL:

ITEM	DESCRIPTION	QUANTITY	CONST STD OR PAGE NO	STOCK NUMBER
30	BOLT, MACH, GALV, 3/4" X (LENGTH AS REQ'D), 1 SQUARE CURVED RIBBED & 1 DOUBLE COIL SPRING WASHER	2	392	-
31	COVER, BOLT, PLASTIC & 6 - 10D NAILS, GALV	2	-	285696
		AS REQ'D	-	491392
32	CONTROL CABLE, FOR MCGRAW-EDISON RECLOSER (I)	1	-	192010
33	CONDUIT, PVC, SCHED 40, 2" X 10' (I)	2	-	251296
34	ELBOW, PVC, SCHED 40, 2", 12" RADIUS (I)	1	-	321816
35	ELBOW, PVC, SCHED 40, 2" (I)	2	-	-
36	STRAPS, PIPE, GALV, 2" & 2 - 10 D NAILS, GALV (I)	AS REQ'D	-	697856
		AS REQ'D	-	491392
37	BRACKET, SERVICE INSULATOR	1	-	166128
38	WIRE, COPPER, #8, 600 VOLT, DUPLEX (B)	AS REQ'D	-	196432
39	CONTROLLER, RECLOSER, MCGRAW-EDISON (I)	1	-	273928
40	SCREW, LAG, GALV, 1/2" X 4"	2	-	621568
41	PADLOCK, CORBIN #27 (FF KEY)	1	-	514848
42	COVER, PVC, DRIPLOOP, 3/4"	1	-	287248
43	COUPLING, PVC, 3/4"	2	-	280416
44	TERMINAL, ADAPTOR, PVC, 3/4"	1	-	102754
45	ELBOW, 90°, PULLING, PVC, 3/4"	2	-	-
46	NIPPLE, PIPE SCREW, GALV, 3/4" X 1"	1	-	-
47	UNIT, GROUND, COMPLETE	1	-	603136
48	GAIN, CROSSARM (D)	1	-	369596
49	GAIN, CROSSARM, BRACELESS (D)	1	-	369598
50	BOLT, MACH, GALV, 5/8" X 7" 1 ROUND & 1 DOUBLE COIL SPRING WASHER	2	392	-

FOR FIELD MAINTENANCE ONLY

INSTALLATION:

- (A) CONNECT GROUND LEAD TO RECLOSER MOUNTING FRAME. CONNECT LIGHTNING ARRESTER GROUND LEADS TO LIGHTNING ARRESTER MOUNTING BRACKETS. CONNECT GROUND CONNECTOR ON HEAD TO RECLOSER MOUNTING FRAME.
- (B) RECLOSER CONTROL REQUIRES 120 VOLT SUPPLY, PREFERABLY COMING FROM THE SOURCE SIDE.
- (C) THE 400A, TYPE RXE RECLOSER (S/N 572100) IS NO LONGER PURCHASED.
- (D) DO NOT CUT GAINS IN THE POLE WHEN INSTALLING THE VERTICALLY MOUNTED SECTIONALIZING SWITCH ARMS. THE GAIN HARDWARE USED HERE MAKE CUT GAINS UNNECESSARY.
- (F) IT IS NECESSARY TO CUT OFF INSIDE LOAD BREAK EARS ON EACH PAIR OF VERTICALLY MOUNTED DISCONNECT SWITCHES TO PREVENT PHYSICAL CONTACT.

REFERENCE:

- (G) POLE STEPPING - SEE STANDARD 363.
- (H) GROUNDING METHODS - SEE STANDARD 1002.
- (I) CONTROL INSTALLATION TO BE DONE BY SUBSTATION CONSTRUCTION AND MAINTENANCE AND IS TO BE INSTALLED A MINIMUM OF 13'-6" ABOVE GROUND LEVEL. INSTALLER WILL SUPPLY CONDUIT ITEMS 33 THRU 36.
- (J) REFLECTOR STRIPS ARE REQUIRED ON ALL SECTIONALIZING/TIELINE SWITCHES AND SERVICE RESTORER POLES. (SEE STD. 208.3 ITEM 12)

DATE 1-1-93

APPD *PA/BJ*

SDG&E ELECTRIC STANDARDS

SERVICE RESTORER
WITH HOOK STICK SWITCH DISCONNECT1299.706
SUPERSEDES
1271.3 (1-1-94)

SCOPE: THIS STANDARD SHOWS THE INSTALLATION METHOD OF A DISTRIBUTION SERVICE RESTORER TO BE USED WITH ALL CONDUCTOR SIZES.

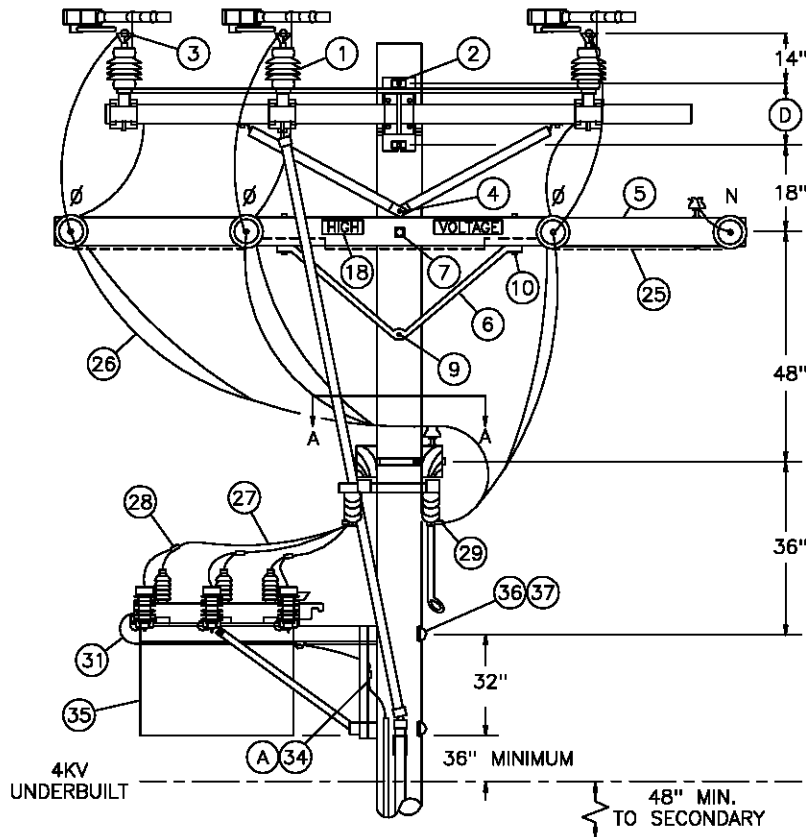

FOR FIELD MAINTENANCE ONLY

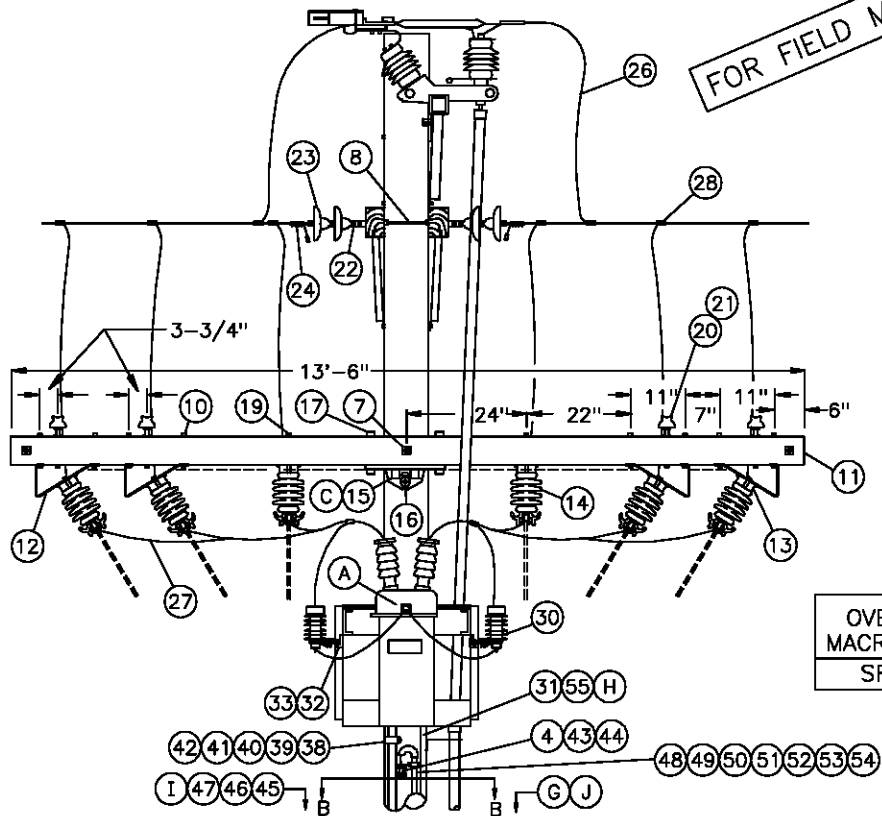

OVERHEAD
MACRO UNITS
SR560S

1299.707
SUPERSEDES
1271.1 (1-1-98)

SDG&E ELECTRIC STANDARDS
SERVICE RESTORER-BUCK POSITION
HOOKSTICK SWITCH DISCONNECT
LOADBREAK GANG SWITCH BY-PASS

DATE 1-1-98
APPD PEA / OAK

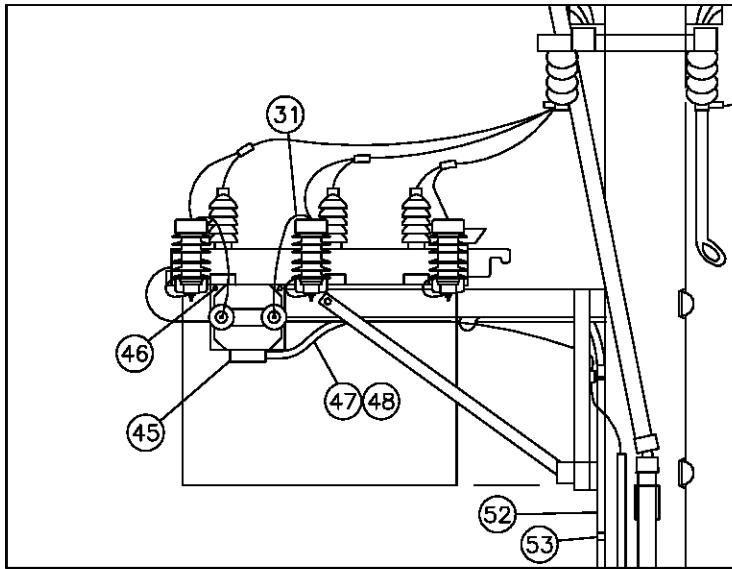

OVERHEAD
MACRO UNIT
SRSEC

POTENTIAL TRANSFORMER-SECONDARY POWER SOURCE (B)

STREET SIDE (PREFERRED)

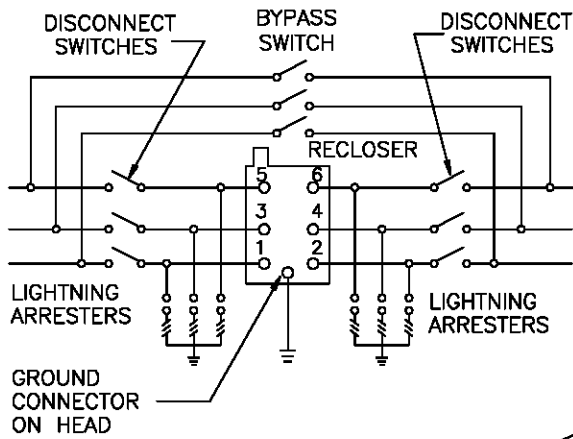

SCHEMATIC DIAGRAM

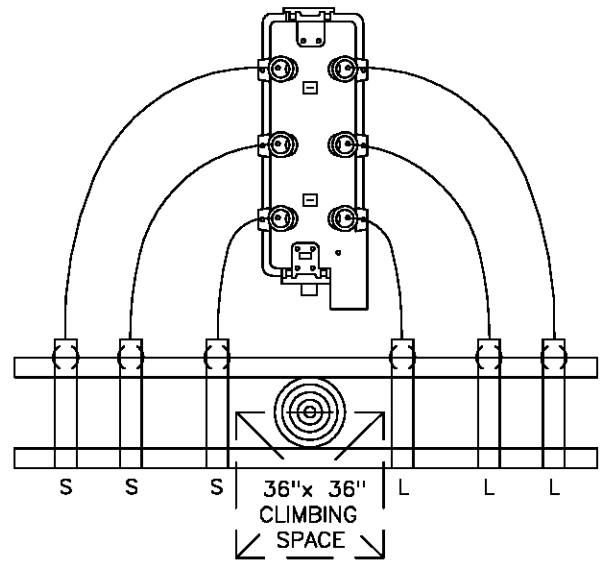

SECTION VIEW A-A

FOR FIELD MAINTENANCE ONLY

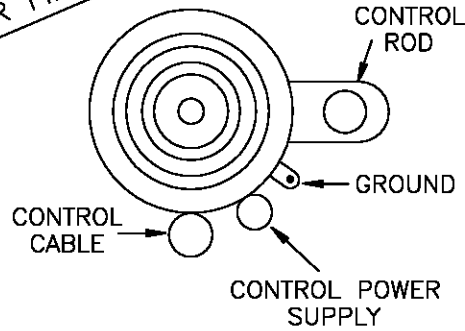

SECTION VIEW B-B

DATE 1-1-98
APPD PJA / CMK

SDG&E ELECTRIC STANDARDS

BUCK POSITION SERVICE RESTORER
HOOKSTICK SWITCH DISCONNECT
LOADBREAK GANG SWITCH BY-PASS

1299.708
SUPERSEDES
1271.2 (1-1-98)

BILL OF MATERIAL:

ITEM	DESCRIPTION	QUANTITY	CONST STANDARD OR PAGE NO.	STOCK NUMBER	ASSEMBLY UNITS
1	SWITCH, GANG-OPERATED, 15KV, 600AMP, WITH DUOGAP INTERRUPTERS, INCLUDING 40' OF CONTROL ROD	1	-	709250	CHANCE
2	BOLT, MACH, GALV, 3/4" X (LENGTH AS REQ'D), 1 SQUARE & 1 DOUBLE COIL SPRING WASHER	2	392	-	-
3	LUG, EYEBOLT TERMINAL, BRONZE	12	-	471296	-
4	BOLT, MACH, GALV, 5/8" X (LENGTH AS REQ'D), 1 SQUARE & 1 DOUBLE COIL SPRING WASHERS	2	392	-	-
5	CROSSARM, 3 3/4" X 5 3/4" X 12' - 0"	2	-	294160	6-
6	BRACE, ANGLE, CROSSARM, 4' - 0"	2	392	164032	4HUB
7	BOLT, MACH, GALV, 5/8" X (LENGTH AS REQ'D), 2 SQUARE & 1 DOUBLE COIL SPRING WASHERS	2	392	-	-
8	BOLT, SPACE, GALV, 5/8" X (LENGTH AS REQ'D) 2 SQUARE, 2 ROUND & 2 DOUBLE COIL SPRING WASHERS	6	392	-	-
9	BOLT, MACH, GALV, 5/8" X (LENGTH AS REQ'D) & 1 DOUBLE COIL SPRING WASHERS	1	392	-	-
10	BOLT, MACH, GALV, 1/2" X 7", 1 ROUND & 1 DOUBLE COIL SPRING WASHERS	20	392	-	-
11	CROSSARM 3-3/4" X 5-3/4" X 13'-6"	2	-	294368	13SWI-
12	BRACKET, DISCONNECT, ANGLE MOUNTING	8	-	166542	ABRKT
13	BOLT, MACH, GALV, 3/8" X 2", 2 ROUND & 1 LOCK WASHER	8	392	-	-
14	SWITCH, DISCONNECT, 14.4KV, 600A	6	-	707008	D600
15	GAIN, CROSSARM, BRACELESS	1	-	369598	BCGAIN
16	BOLT, MACH, GALV, 5/8" X (LENGTH AS REQ'D) 1 SQUARE, 1 ROUND & 1 DOUBLE COIL SPRING WASHER	1	392	-	-
17	BOLT, MACH, GALV, 5/8" X 7", 1 ROUND & 1 DOUBLE COIL SPRING WASHER	2	392	-	-
18	SIGN, HIGH VOLTAGE & 9 ROOFING NAILS, GALV	2	-	647648	HV
		AS REQ'D	-	492224	-
19	BOLT, MACH, 1/2" X 9", 1 ROUND AND 1 DOUBLE COIL SPRING WASHER	4	392	-	-
20	PIN, INSULATOR, STRAIGHT, 12KV 1" OR 1-3/8" THREAD	5	396	-	-
21	INSULATOR, LINE, 12KV	5	750	-	-
22	CLEVIS, DEAD-END, 5/8", BOLT STEEL (CLOSED TYPE)	8	-	235712	-
23	INSULATOR, SUSPENSION, 12KV, CLEVIS	14	-	431616	6DE
24	CLAMP, STRAIGHT LINE, D.E.	8	739-743	-	-
25	WIRE, #8, BARE SOLID ANNEALED COPPER, AND STAPLES, FENCE, GALV, 1 1/4"	30'	-	812928	BOND8
		1.5# AS REQ'D	-	678528	-
26	WIRE, BARE STRANDED CU OR AL (SIZE AS REQ'D)	90'	711-715	-	-
27	WIRE, BARE STRANDED COPPER, (SIZE AS REQ'D WITH MINIMUM SIZE EQUAL TO LINE CONDUCTOR AMPACITY, OR GREATER)	25'	715	-	-
28	CONNECTOR, WIRE, COMPRESSION (SIZE AS REQ'D)	AS REQ'D	783-787	-	-
29	TERMINAL, COMPRESSION, CU OR AL (SIZE AS REQ'D)	12	794-795	-	-
30	ARRESTER, LIGHTNING, 12KV	6	-	113248	LA12
31	WIRE, #4, BARE STRANDED COPPER	100'	-	813760	(E)
		13#	-	-	-

FOR FIELD MAINTENANCE ONLY

BILL OF MATERIAL:

ITEM	DESCRIPTION	QUANTITY	CONST STD OR PAGE NO	STOCK NUMBER	ASSEMBLY UNITS	
32	Z-BRACKET, GALV, 1-5/8"	6	-	703168	-	
33	BOLT, MACH, GALV, 1/2" X 2", 1 ROUND & 1 LOCK WASHER	12	392	-	-	
34	CONNECTOR, SPLIT BOLT, #2	2	-	269536	-	
35	RECLOSER, MCGRAW-EDISON, 560A, TYPE WE (INCLUDING BRACKET)	1	-	572110	SR560	
36	BOLT, MACH, GALV, 3/4" X (LENGTH AS REQ'D), 1 SQUARE CURVED RIBBED & 1 DOUBLE COIL SPRING WASHER	2	392	-	-	
37	COVER, BOLT, PLASTIC & 6 - 10D NAILS, GALV	2	-	285696	-	
		AS REQ'D	-	491392	-	
38	CONTROL CABLE, FOR MCGRAW-EDISON RECLOSER, 35'	①	1	-	192010	⑤
39	CONDUIT, PVC, SCHED 40, 2" X 10'	①	2	-	251296	⑤
40	ELBOW, PVC, SCHED 40, 2", 12" RADIUS	①	1	-	321816	⑤
41	ELBOW, PVC, SCHED 40, 2"	①	2	-	-	-
42	STRAPS, PIPE, GALV, 2" & 2 - 10 D NAILS, GALV	①	AS REQ'D	-	697856	-
		①	AS REQ'D	-	491392	-
43	BRACKET, SERVICE INSULATOR	1	-	166128	-	
44	WIRE, COPPER, #8, 600 VOLT, DUPLEX	②	AS REQ'D	-	196432	DX8C
45	POTENTIAL TRANSFORMER, 12000/120 VOLTS	②	1	-	762722	SRPT
46	BOLT, MACH, GALV, 3/8" X 1-1/2", AND 1 LOCK WASHER	②	2	-	154144	-
47	CONDUIT, 3/4", FLEXABLE STEEL	②	6'	-	250112	-
48	WIRE, THHN, #12, WHITE	②	40'	-	808704	THW12W
	WIRE, THHN, #12, BLACK	②	40'	-	808096	THW12
49	CONTROLLER, RECLOSER, COOPER, MODEL KME5	①	1	-	273930	C/RSTR
50	SCREW, LAG, GALV, 1/2" X 4"	2	-	621568	-	
51	PADLOCK, SCHLAGE ELECTRIC SERIES	1	-	514848	⑤	
52	CONDUIT, PVC, TYPE 2, SCHEDULE 80, 3/4" X 10'	3	-	251520	⑤	
53	STRAPS, PIPE, GALV, 3/4" & 2 - 6D NAILS, GALV	AS REQ'D	-	697888	-	
		AS REQ'D	-	491552	-	
54	COVER, PVC, DRIPLOOP, 3/4"	1	-	287248	⑤	
55	COUPLING, PVC, 3/4"	2	-	280416	⑤	
56	TERMINAL, ADAPTOR, PVC, 3/4"	1	-	102754	⑤	
57	ELBOW, 90°, PULLING, PVC, 3/4"	2	-	-	-	
58	NIPPLE, PIPE SCREW, GALV, 3/4" X 1"	1	-	-	-	
59	UNIT, GROUND, COMPLETE	1	-	603136	⑤	

FOR FIELD MAINTENANCE ONLY

DATE 1-1-2000 APPD <i>PA/Vcl</i>	SDG&E ELECTRIC STANDARDS BUCK POSITION SERVICE RESTORER HOOKSTICK SWITCH DISCONNECT LOADBREAK GANG SWITCH BY-PASS	1299.710 SUPERSEDES 1271.4 (1-1-2000)
-------------------------------------	----------------------------------------------------------------------------------------------------------------------------	---------------------------------------------

INSTALLATION:

- (A) CONNECT GROUND LEAD TO RECLOSER MOUNTING FRAME. CONNECT LIGHTNING ARRESTER GROUND LEADS AND GROUND CONNECTOR ON HEAD TO RECLOSER MOUNTING FRAME.
- (B) RECLOSER CONTROL REQUIRES 120 VOLT SUPPLY, PREFERABLY COMING FROM THE SOURCE SIDE. IF IMPRACTICAL, POWER MAY ORIGINATE FROM THE LOAD SIDE.

NOTE: IF SECONDARY POWER SOURCE NOT AVAILABLE, OR WOULD BE DIFFICULT TO INSTALL, POWER MAY BE SUPPLIED BY MOUNTING POTENTIAL TRANSFORMER ON SERVICE RESTORER FRAME.
- (C) DO NOT CUT GAINS IN THE POLE WHEN INSTALLING THE HORIZONTALLY MOUNTED SECTIONALIZING SWITCH ARMS. THE GAIN HARDWARE USED HERE MAKE CUT GAINS UNNECESSARY.
- (D) USE THE FOLLOWING THRU-BOLT DRILLING DIMENSIONS: A.B. CHANCE=13-1/4", S&C=14".
- (E) THESE MATERIAL ITEMS INCLUDED WITH CONTROLLER ASSEMBLY UNIT "C/RSTR".

REFERENCE:

- F. DETERMINE MINIMUM POLE CLASS DUE TO SERVICE RESTORER MOUNTED IN THE BUCK POSITION—SEE STANDARD 347.
- (G) POLE STEPPING – SEE STANDARD 363.
- (H) GROUNDING METHODS – SEE STANDARD 1002.
- (I) CONTROL INSTALLATION TO BE DONE BY SUBSTATION CONSTRUCTION AND MAINTENANCE, AND, IS TO BE INSTALLED 14'-0" FROM GROUND LEVEL TO BOTTOM OF CONTROLLER WHEN LOCATED ON STREET SIDE OF POLE. CONTROLLER LOCATED ON PROPERTY SIDE OF POLE WILL BE MOUNTED NO MORE THAN 9' FROM GROUND LEVEL TO BOTTOM OF CONTROLLER. STANDARD CONTROL CABLE LENGTH IS 35'. HOWEVER, LONGER CABLE LENGTHS ARE AVAILABLE IF REQUIRED. INSTALLER WILL SUPPLY CONDUIT ITEMS 39 THROUGH 42.
- (J) REFLECTOR STRIPS ARE REQUIRED ON ALL SECTIONALIZING/TIELINE SWITCHES AND SERVICE RESTORER POLES. (SEE STD. 208.3 ITEM 12)
- K. POLE TOP SWITCH INSTALLATION—SEE STANDARD 1230.

FOR FIELD MAINTENANCE ONLY

1299.711 SUPERSEDES 1271.5 (1-1-98)	SDG&E ELECTRIC STANDARDS BUCK POSITION SERVICE RESTORER HOOKSTICK SWITCH DISCONNECT LOADBREAK GANG SWITCH BY-PASS	DATE 1-1-98 APPD PJA / CMK
-------------------------------------------	----------------------------------------------------------------------------------------------------------------------------	-------------------------------

1300 CAPACITORS,
REGULATORS

1300 CAPACITORS,
REGULATORS

PAGE**SUBJECT**

1399.001-.003	CAPACITOR MARKING INSTRUCTION, DECALS & TAGS
1399.101	CAPACITOR INFORMATION
1399.102-.106	CAPACITOR CONNECTION
1399.107-.109	CAPACITOR INSTALLATION, 4KV WYE, 150-450 KVAR
1399.110-.111	FIXED CAPACITOR INSTALLATION, 4.16KV DELTA, UNGROUNDED RACK
1399.112-.113	SWITCH CAPACITOR INSTALLATION, 4.16KV DELTA - 2 OIL SWITCHES
1399.201-.202	FIXED CAPACITOR INSTALLATION, 4.16KV WYE, 300 KVAR - GROUNDED RACK
1399.203-.204	SWITCHED CAPACITOR INSTALLATION, 4.16KV - WYE - 3 OIL SWITCHES
1399.205-.206	12 & 12.47KV SWITCHED CAPACITOR INSTALLATION, 3 OIL SWITCHES INLINE
1399.207	CAPACITOR INSTALLATIONS, 12KV - WYE - 900 KVAR MAX
1399.208-.210	SWITCHED CAPACITORS - CURRENT SENSOR 12 & 12.47KV
1399.211-.213	FIXED CAPACITOR INSTALLATION, 4KV WYE 4KV WYE GROUNDED RACK
1399.301	CAPACITOR CONTROL MATERIAL AND INSTALLATIONS VOLTAGE WITH TIME BIAS (TYPE 'TB')
1399.302	CAPACITOR CONTROL MATERIAL AND INSTALLATION TYPE 'VAR'
1399.401	STEP VOLTAGE REGULATOR STATION, OPEN DELTA, 12KV
1399.402	STEP VOLTAGE REGULATOR STATION, OPEN DELTA, 12KV
1399.403	STEP VOLTAGE REGULATOR STATION, CLOSED DELTA, 12KV, TWO POLES
1399.404	STEP VOLTAGE REGULATOR STATION, CLOSED DELTA, 12KV, TWO POLES
1399.405	STEP VOLTAGE REGULATOR STATION, CLOSED DELTA, 12KV, TWO POLES
1399.501	STEP VOLTAGE REGULATOR STATION, CLOSED DELTA, 12KV, TWO POLES
1399.502	STEP VOLTAGE REGULATOR STATION, CLOSED DELTA, 12KV, TWO POLES
1399.503	STEP VOLTAGE REGULATOR STATION, CLOSED DELTA, 12KV, TWO POLES
1399.504-.507	FIXED CAPACITOR INSTALLATION, 4KV WYE GROUNDED RACK
1399.508-.510	12 & 12.47 SWITCHED CAPACITOR INSTALLATION 2 OIL SWITCHES IN CAPACITOR NEUTRAL
1399.511-.513	CAPACITOR CONTROL MATERIAL AND INSTALLATION

© 1998 - 2019 San Diego Gas & Electric Company. All rights reserved. Removal of this copyright notice without permission is not permitted under law.

REV	CHANGE	BY	DSGN	APPV	DATE	REV	CHANGE	BY	DSGN	APPV	DATE
C						F					
B	COMPLETELY REVISED	JK	JS	CZH	10/15/2019	E					
A	ORIGINAL ISSUE	JK	JS	CZH	6/13/2019	D					

Indicates Latest Revision Completely Revised New Page Information Removed

**SHEET
1 OF 1**

SDG&E ELECTRIC OVERHEAD FIELD MAINTENANCE ONLY STANDARDS
LEGACY OVERHEAD FIELD MAINTENANCE
TABLE OF CONTENTS
CAPACITORS, REGULATORS

**OH LEGACY
OHL1301.1**

SCOPE: THIS STANDARD DESCRIBES CAPACITOR MARKING AND HANDLING PROCEDURES.

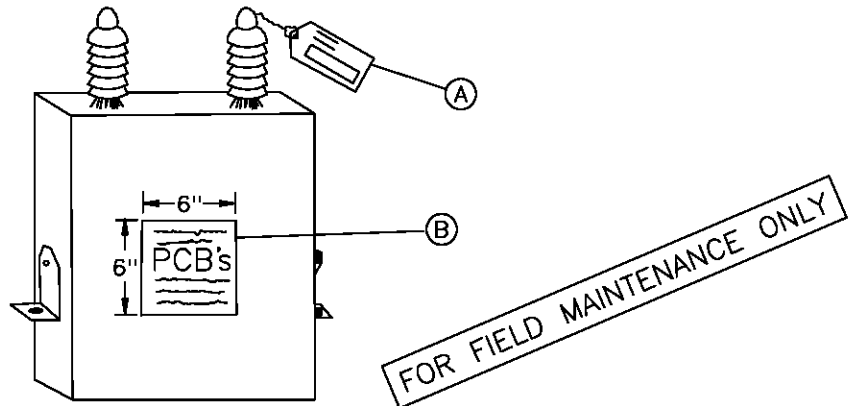

(A) CAPACITOR TAGS

THIS IDENTIFICATION TAG (SDG&E FORM 120-7240, STK. NO. 043450) IS USED FOR TRACKING THE CAPACITOR DURING REMOVAL/RETIREMENT AND INSTALLATION. IT SHALL BE USED ON ALL CAPACITORS, PCB UNITS AND NON-PCB UNITS.

EACH CAPACITOR UNIT IN STOCK WILL BE AFFIXED WITH A CAPACITOR IDENTIFICATION TAG BEFORE IT IS REMOVED FROM STOCK. THIS TAG IS TO BE COMPLETED BY THE FIELD PERSONNEL WHO EITHER REMOVES OR INSTALLS A CAPACITOR UNIT. ONE SIDE OF THIS TAG IS USED FOR REMOVAL AND THE OTHER FOR INSTALLATION.

1. INSTALLATION

THE DISTRICT STOCKKEEPER SHALL COMPLETE AS MUCH OF THE CAPACITOR TAG(S) AS POSSIBLE ON THE INSTALLATION SIDE OF THE TAG AND ATTACH TO THE SPECIFIC UNIT. WHEN THE INSTALLATION IS COMPLETED, THE CREW FOREMAN SHALL REMOVE THE TAG AND COMPLETE THE REQUESTED INFORMATION.

2. REPLACEMENT

WHEN A CAPACITOR UNIT IS REPLACING ONE THAT IS BEING REMOVED, THE FOREMAN SHALL FILL OUT BOTH SIDES OF THE TAG.

IF REMOVAL AND REPLACEMENT IS NOT COMPLETED WITHIN TWO CONSECUTIVE WORKDAYS, TWO FORMS ARE TO BE COMPLETED, ONE FOR A REMOVAL, AND ANOTHER FOR INSTALLATION.

IF REPLACEMENT IS DUE TO FAILURE OF ONE OR MORE UNITS, AN EQUIPMENT FAILURE REPORT IS REQUIRED.

3. REMOVAL

WHEN A CAPACITOR UNIT IS REMOVED, THE CREW FOREMAN SHALL COMPLETE THE REMOVAL PORTION ONLY. IF TAGS ARE NOT STORED ON THE TRUCKS, THE DISPATCHER SHALL PROVIDE THE CREW WITH SUFFICIENT TAGS FOR EACH CAPACITOR UNIT TO BE REMOVED.

DATE 1-1-2000 APPD <i>PA/ROJ</i>	SDG&E ELECTRIC STANDARDS	OH 1399.001
	CAPACITOR MARKING INSTRUCTIONS DECALS AND TAGS	UG 3899.001 SUPERSEDES 1302.1 (1-1-86)

4. RETIREMENT

WHEN A CAPACITOR UNIT IS RETIRED, THE RETIRED PORTION OF THE CAPACITOR TAG MUST BE FILLED OUT BY THE PERSONNEL RETIRING THE UNIT.

5. DISPOSITION

IT SHALL BE THE DISPATCHER'S RESPONSIBILITY TO SEE THAT THE COMPLETED TAGS ARE SENT TO THE DISTRICT'S RECORDS SECTION, ATTENTION OF THE ENGINEERING CLERK, WITHIN ONE WORKING DAY AFTER THE CAPACITOR UNITS HAVE BEEN INSTALLED OR REMOVED.

ⓑ DECAL

THIS DECAL (STOCK NO. 301880) IS TO BE PLACED ON ALL CAPACITOR UNITS WHICH CONTAIN PCB'S.

FIELD PERSONNEL AND STOCKKEEPERS SHOULD MAKE EVERY EFFORT TO INSURE THAT ALL PCB UNITS HAVE A DECAL, AND THAT ALL WORN, WEATHERED DECALS BE REPLACED WITH NEW DECALS. THE DECAL IS BLACK PRINT ON EITHER YELLOW OR WHITE BACKGROUND.

1. MARKING

EVERY CAPACITOR IN SERVICE OR IN STORAGE, WHICH USES AN INSULATING FLUID CONTAINING PCB'S, SHALL BE LABELED WITH THE DECAL (STOCK NO. 301880).

EVERY PCB CAPACITOR WHICH IS REMOVED FROM SERVICE AND DOES NOT HAVE THE DECAL (STOCK NO. 301880) SHALL HAVE THE DECAL PUT ON IT AT THE TIME IT IS REMOVED FROM SERVICE. THIS SHALL BE DONE BY THE WORK CREW THAT REMOVES THE UNIT. IF A PCB UNIT ARRIVES AT A STOREYARD WITH NO PCB DECAL, THE STOCKKEEPER SHALL PUT A DECAL ON.

NOTE: ALL CAPACITOR UNITS PURCHASED BEFORE 1977 USED AN INSULATING FLUID WHICH CONTAINED PCB'S. THE UNITS WITH THE PCB FLUIDS CAN BE IDENTIFIED BY THE WORDS "NON-FLAMMABLE LIQUID" ON NAMEPLATE OR BY THE MANUFACTURER'S TRADE NAMES WHICH ARE:

- G.E. - PYRANOL
- WESTINGHOUSE - INERTEEN
- MCGRAW-EDISON - ELEMEX
- CORNEL DUBILIER OR FEDERAL PACIFIC - DYKANOL
- SANGAMO - DIACHLOR
- ALLIS CHALMERS - CHLOREXTOL

FOR FIELD MAINTENANCE ONLY

ALL OF THE CAPACITOR UNITS RECEIVED THAT DO NOT CONTAIN PCB INSULATING FLUIDS HAVE THE WORDS "CONTAINS A NON-PCB INSULATING FLUID" ON THE NAMEPLATE OR ON A BLUE TANK DECAL.

2. HANDLING CAPACITORS CONTAINING POLYCHLORINATED BIPHENYLS (PCB)

CAPACITORS CONTAINING PCB SHALL BE HANDLED AS SPECIFIED IN THE PCB HANDLING AND PERSONAL SAFETY PROCEDURES. (SEE CONSTRUCTION MANAGEMENT STANDARD PRACTICE 107).

3. RETIRING RUPTURED OR DAMAGED UNITS

WHENEVER TRANSPORTATION OR KEARNY MAINTENANCE RETIRES A CAPACITOR AND DISPOSES OF IT, SPECIFIC DATA (I.E. SERIAL NUMBER, PCB OR NON-PCB, MANUFACTURER, SIZE, ETC.) MUST BE RECORDED ON THE CAPACITOR TAG AND SENT TO THE DISTRICT'S RECORDS SECTION, ATTENTION OF THE ENGINEERING CLERK.

OH 1399.002
~~UG 3899.002~~
SUPERSEDES
1302.2 (1-1-86)

SDG&E ELECTRIC STANDARDS

CAPACITOR MARKING INSTRUCTIONS
DECALS AND TAGS

DATE 1-1-2000
APPD *PA 1/09*

C. PRECAUTIONARY MEASURES - DAMAGED CAPACITOR UNITS

DAMAGED CAPACITOR UNITS WITH BULGED CASES MAY HAVE EXCESSIVE PRESSURE INSIDE. THE UNITS MAY RUPTURE WHEN HANDLED OR BUMPED. SINCE THE INSULATING LIQUID IN THE UNITS IS TOXIC, CARE SHALL BE EXERCISED WHEN WORKING WITH BULGED OR OTHERWISE DAMAGED UNITS. UNITS WITH BULGED OR DAMAGED CASES SHALL NOT BE RE-ENERGIZED.

D. CAPACITOR NAMEPLATES

THE CAPACITOR NAMEPLATE AND UNIT SHALL REMAIN INTACT. UNDER NO CIRCUMSTANCES SHALL THE NAMEPLATE BE REMOVED FROM THE CAPACITOR UNIT.

F. SERIES STREET LIGHTING TRANSFORMERS

THE TROUBLEMAN AND/OR CREW SHALL CHECK THE NAMEPLATE OF ANY RUPTURED 2400 VOLT, CONSTANT CURRENT STREET LIGHTING TRANSFORMER TO DETERMINE IF IT CONTAINS AN INTERNAL CAPACITOR. IF NO CAPACITOR IS SHOWN ON THE NAMEPLATE, THE TRANSFORMER IS TO BE TREATED AS ANY OTHER TRANSFORMER ON THE SYSTEM, NO SPECIAL HANDLING OR DISPOSAL IS REQUIRED. IF IT DOES, IT SHALL BE TREATED AS ANY PCB CONTAINING DEVICE UNTIL IT REACHES KEARNY MAINTENANCE. (SEE CONSTRUCTION MANAGEMENT STANDARD PRACTICE 107).

KEARNY SHALL REMOVE THE INTERNAL CAPACITOR IMMEDIATELY AND CHECK TO SEE IF IT HAS LEAKED. IF IT HAS NOT LEAKED, THE CAPACITOR SHALL BE DISPOSED OF IN ACCORDANCE WITH THE EPA REGULATIONS. THE TRANSFORMER MAY THEN RE-ENTER THE SYSTEM AS AN RO UNIT OR BE SCRAPPED.

IF PCB CONTAMINATION OF THE TRANSFORMER OIL IS SUSPECTED, KEARNY MAINTENANCE SHALL HAVE THE BEST LAB VERIFY THE LEVEL OF CONTAMINATION. IF IT IS 500PPM OR GREATER, THE OIL AND THE TRANSFORMER SHALL BE DISPOSED OF ACCORDING TO EPA REGULATIONS.

FOR FIELD MAINTENANCE ONLY

DATE 1-1-2000 APPD <i>PA 1/09</i>	SDG&E ELECTRIC STANDARDS CAPACITOR MARKING INSTRUCTIONS DECALS AND TAGS	OH 1399.003 UG 3899.003 SUPERSEDES 1302.3 (1-1-86)
--------------------------------------	-------------------------------------------------------------------------------	------------------------------------------------------------------------

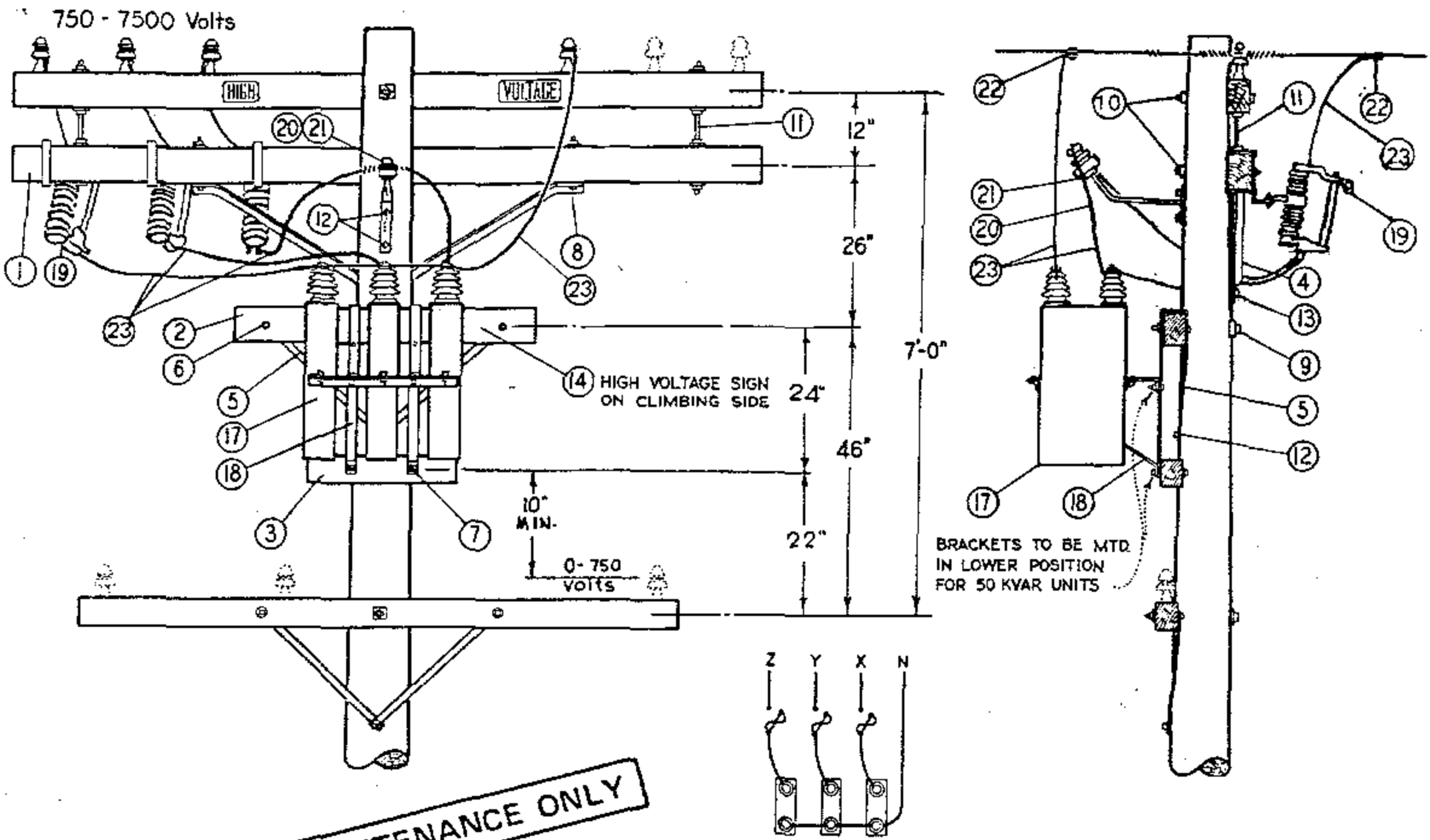

FOR FIELD MAINTENANCE ONLY

DIAGRAM OF 4 KV. WYE CONNECTIONS
 150 KVAR (3-50 KVAR UNITS)
 75 KVAR (3-25 KVAR UNITS)
 45 KVAR (3-15 KVAR UNITS)

INSTALLATION:

- A. CAPACITOR RACK TO BE MOUNTED ON OPPOSITE SIDE OF LINE AND CUTOUT ARMS.
- (B) NO LONGER PURCHASED.
- C. FOR POLE STEPPING REFER TO STD. 363.
- (E) EXEMPT MATERIAL.

ITEM	DESCRIPTION	QUANTITY	STOCK NO. OR CONSTR. STD.
1	CROSSARM, 3 3/4" X 5 3/4" X 10' - 0"	1	PG 380.01 IT.2
2	CROSSARM, 3 3/4" X 5 3/4" X 4' - 0"	1	PG 380.05 IT.3
3	CROSSARM, 3 1/2" X 4 1/2" X 2' - 0"	1	PG 380.05 IT.1
4	BRACE, ANGLE CROSSARM, 5' - 0"	1	164128
5	BRACE, FLAT CROSSARM, 28"	2	164192
6	BOLT, MACH., GALV., 3/8" X 4 1/2", 1 RD. WASH. & 1 NUT	2	STD 139, 140 (E)
7	BOLT, MACH., GALV., 1/2" X 5", 1 RD. WASH. & 1 NUT	2	STD 139, 140 (E)
8	BOLT, MACH., GALV., 1/2" X 7", 1 RD. WASH. & 1 NUT	2	STD 139, 140 (E)
9	BOLT, MACH., GALV., 5/8" X (AS REQ'D) 3 SQ. WASH, 1 FLAT, 1 CURV & 1 NUT	1	STD 139, 140 (E)
10	BOLT, MACH., GALV., 5/8" X (AS REQ'D) 2-2 1/4" SQ WASH & 1 NUT	2	STD 139, 140 (E)
11	BOLT, SPACE, GALV., 5/8" X 22", 4 SQ. WASH. & 4 NUTS	2	STD 139, 140 (E)
12	LAG SCREW, GALV., 1/2" X 4"	3	621568 (E)
13	LAG SCREW, GALV., 5/8" X 5"	1	621600 (E)
14	SIGN, HIGH VOLTAGE & 8 ROOFING NAILS	1	647648-492224 (E)
15			
16			
17	CAPACITOR UNIT (2.4KV, 50 KVAR ILLUSTRATED)	(B) 3	207200
18	RACK, CAPACITOR	1	402624
19	CUTOUT, 12KV, 100A, HEAVY DUTY, WITH LOADBUSTER HOOKS	3	297888
20	BRACKET, INSULATOR 1" LEAD THREAD	1	166134
21	INSULATOR, PIN TYPE, CLASS AS REQUIRED	1	PG 750.3
22	CONNECTOR, COMPRESSION	4	PGS 786, 783 (E)
23	WIRE, BARE STRANDED, #6	30'	813536

SDG&E ELECTRIC STANDARDS

1399.101
 SUPERSEDES
 1315 (1-1-87)

CAPACITOR INSTALLATION 4KV-WYE-150 KVAR MAXIMUM

DATE 1-1-87
 APPD AK/RD

SCOPE: THIS STANDARD LISTS THE INFORMATION NEEDED TO DETERMINE PROPER CAPACITOR APPLICATIONS.

PREFIX	PHASE	VOLTAGE	DESCRIPTION		KVAR	STOCK NUMBER	ASSEMBLY UNITS	
C	1	2400/4160Y	CAPACITOR UNITS		100	(A) 207330	-	
CT	3	2400/4160Y	FIXED CAPACITOR RACK CONSISTING OF 3 100KVAR 1Ø UNITS, 4 WIRE CONNECTED WYE.		300	564772	CT3F	
			SWITCHED CAPACITOR RACK CONSISTING OF 3-100KVAR 1Ø UNITS AND 3 OIL SWITCHES WITH 2.4KV POTENTIAL TRANSFORMER.		300	564773	CT3S	
CTD	3	4160 Δ	SWITCHED CAPACITOR RACK CONSISTING OF 3-200 KVAR, 7200V UNITS DELTA CONNECTED AND A POTENTIAL TRANSFORMER RATED AT 2400-120V FOR USE ON 4KV SYSTEM.		200	(B) 564758	CTD2S	
			FIXED CAPACITOR RACK CONSISTING OF 3-200 KVAR, 7200V UNITS DELTA CONNECTED FOR USE ON 4KV SYSTEM.		(B) 200	564759	CTD2F	
YC	1	7200/12470Y	CAPACITOR UNITS		150	(A) 207344	YC150	
HC	3	7200/12470Y	CAPACITOR UNITS		300	(A) 207336	-	
HCT	3	7200/12470Y	FIXED CAPACITOR RACK CONSISTING OF 3-400 KVAR, 7200V UNITS WYE CONNECTED FOR USE ON 4KV SYSTEM.		130	564776	HCT1F	
			SWITCHED CAPACITOR RACK CONSISTING OF 6-150KVAR 1Ø UNITS WITH 7.2KV POTENTIAL TRANSFORMER		3 - OIL SWITCHES	900	(A)564706	-
			SWITCHED CAPACITOR RACK CONSISTING OF 6-150KVAR 1Ø UNITS WITH 12KV POTENTIAL TRANSFORMER		2 - OIL SWITCHES	900	(A)564708	-
			SWITCHED CAPACITOR RACK CONSISTING OF 6-150KVAR 1Ø UNITS WITH 12KV POTENTIAL TRANSFORMER		3 - OIL SWITCHES	900	(A)564704	-
			FIXED CAPACITOR RACK CONSISTING OF 6-150 KVAR 1Ø UNITS			900	(A)564680	900F
			SWITCHED CAPACITOR RACK CONSISTING OF 9-150KVAR 1Ø UNITS WITH 7.2KV POTENTIAL TRANSFORMER		3 - OIL SWITCHES	1350	(A)564754	-
			SWITCHED CAPACITOR RACK CONSISTING OF 9-150KVAR 1Ø UNITS WITH 12KV POTENTIAL TRANSFORMER		2 - OIL SWITCHES	1350	(A)564756	-
			SWITCHED CAPACITOR RACK CONSISTING OF 9-150KVAR 1Ø UNITS WITH 12KV POTENTIAL TRANSFORMER		3 - OIL SWITCHES	1350	(A)564752	-
			FIXED CAPACITOR RACK CONSISTING OF 9-150KVAR 1Ø UNITS			1350	(A)564744	1350F

FOR FIELD MAINTENANCE ONLY

INSTALLATION:

- (A) NO LONGER PURCHASED.
- (B) THE KVAR RATING OF 7200 VOLT CAPACITORS IS REDUCED BY A FACTOR OF THREE WHEN WIRED IN DELTA AND CONNECTED TO THE 4160 VOLT SYSTEM.

1399.101A SUPERSEDES 1311 (12-1-98)	SDG&E ELECTRIC STANDARDS	DATE 2-9-2012 APPD <i>PA 1/20</i>
	CAPACITOR INFORMATION	

SCOPE: THIS STANDARD LISTS THE INFORMATION NEEDED TO DETERMINE PROPER CAPACITOR APPLICATIONS.

PREFIX	PHASE	VOLTAGE	DESCRIPTION		KVAR	STOCK NUMBER	ASSEMBLY UNITS
YC	1	7200/12470Y	CAPACITOR UNITS		200	207350	YC200
					400	207348	-
HCT	3	2400/4160Y	FIXED CAPACITOR RACK CONSISTING OF 3-400 KVAR, 7200V UNITS WYE CONNECTED FOR USE ON 4KV SYSTEM.		130	564776	HCT1F
	3	2400/4160Y	FIXED CAPACITOR RACK CONSISTING OF 3-200 KVAR, 7200V UNITS WYE CONNECTED FOR USE ON 4KV SYSTEM.		65	564759	HCT6F
	3	7200/12470Y	SWITCHED CAPACITOR RACK CONSISTING OF 3-200 KVAR SINGLE-PHASE UNITS WITH 12KV POTENTIAL TRANSFORMER		600	564761	600S
	3	7200/12470Y	FIXED CAPACITOR RACK CONSISTING OF 3-200 KVAR SINGLE-PHASE UNITS.		600	564763	600F
	3	7200/12470Y	SWITCHED CAPACITOR RACK CONSISTING OF 3-400KVAR SINGLE-PHASE UNITS WITH 12KV POTENTIAL TRANSFORMER	2 - OIL SWITCHES	1200	564770	1200S
FIXED CAPACITOR RACK CONSISTING OF 3-400 KVAR SINGLE-PHASE UNITS			1200	564764	1200F		

FOR FIELD MAINTENANCE ONLY

DATE 1-1-2000 APPD <i>PA/Ver</i>	SDG&E ELECTRIC STANDARDS	1399.101B SUPERSEDES 1311 (12-1-98)
	CAPACITOR INFORMATION	

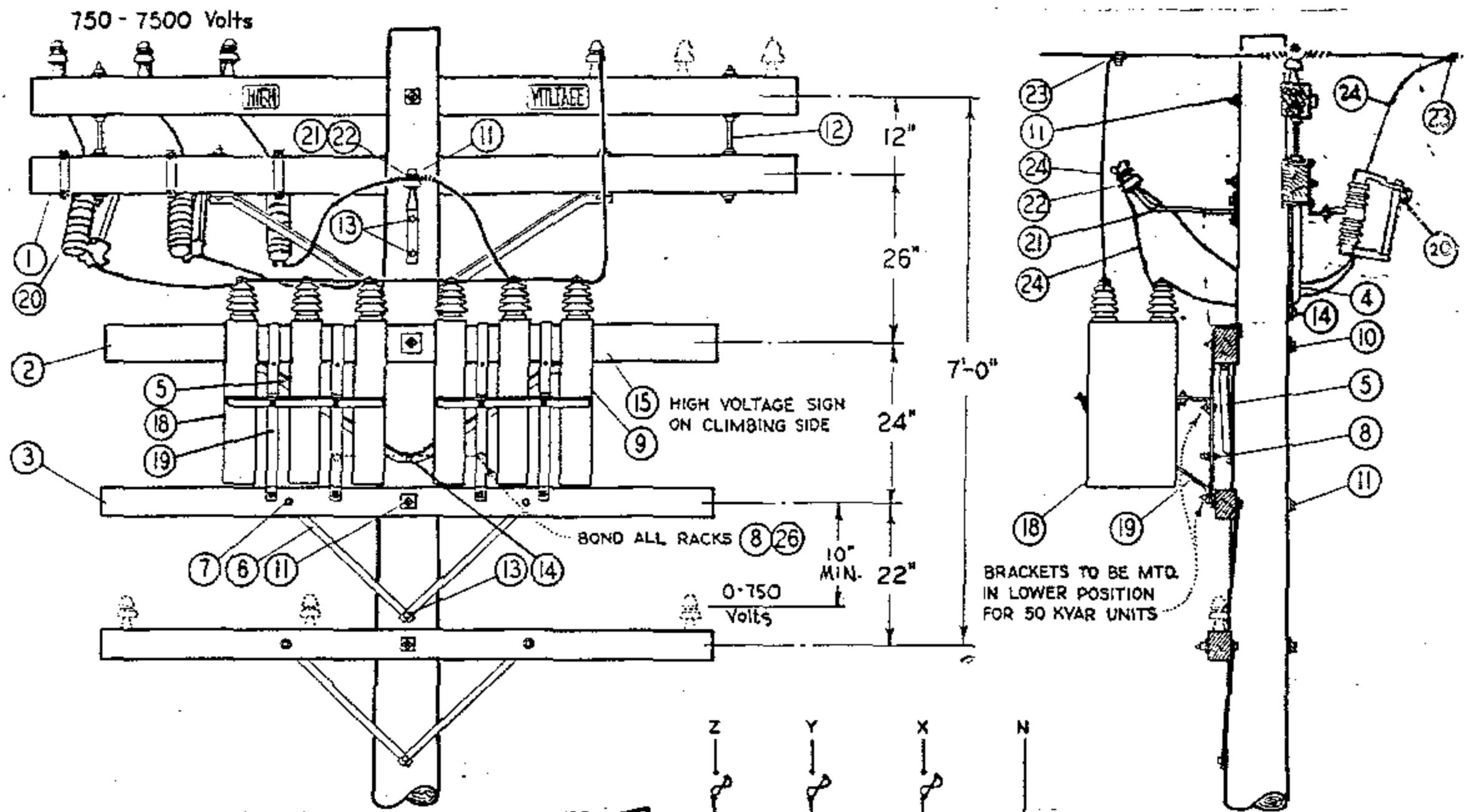

FOR FIELD MAINTENANCE ONLY

DIAGRAM OF 4 KV. WYE CONNECTIONS
 300 KVAR (6-50 KVAR UNITS)
 150 KVAR (6-25 KVAR UNITS)
 90 KVAR (6-15 KVAR UNITS)

INSTALLATION:

- A. CAPACITOR RACKS TO BE MOUNTED ON OPPOSITE SIDE OF LINE AND CUTOUT ARMS.
- (B) NO LONGER PURCHASED.
- C. FOR POLE STEPPING REFER TO STD. 363.
- (E) EXEMPT MATERIAL.

ITEM	DESCRIPTION	QUANTITY	STOCK NO. OR CONSTR. STD.
1	CROSSARM, 3 3/4" X 5 3/4" X 10' - 0"	1	PG. 380.01
2	CROSSARM, 3 3/4" X 5 3/4" X 8' - 0"	1	PG. 380.05
3	CROSSARM, 3 1/2" X 4 1/2" X 8 - 0	1	PG. 380.05
4	BRACE, ANGLE CROSSARM, 5' - 0"	1	164128
5	BRACE, ANGLE CROSSARM, 4' - 0"	1	164032
6	BRACE, FLAT CROSSARM, 28"	2	164192
7	BOLT, MACH., GALV., 3/8" X 4 1/2", 1 RD. WASH. & 1 NUT	2	STD 139, 140(E)
8	BOLT, MACH., GALV., 1/2" X 1 1/2", 2 RD. WASH. & 1 NUT	2	STD 139, 140(E)
9	BOLT, MACH., GALV., 1/2" X 7", 1 RD. WASH. & 1 NUT	4	STD 139, 140(E)
10	BOLT, MACH., GALV., 5/8" X (AS REQ'D) 3 SQ. WASH., 1 FLAT, 1 CURV. & 1 NUT	1	STD 139, 140(E)
11	BOLT, MACH., GALV., 5/8" X (AS REQ'D) 2-2 1/4 SQ. WASH. & 1 NUT	2	STD 139, 140(E)
12	BOLT, SPACE, GALV., 5/8" X 22", 4 SQ. WASH. & 4 NUTS	2	STD 139, 140(E)
13	LAG SCREW, GALV., 1/2" X 4"	3	621568 (E)
14	LAG SCREW, GALV., 5/8" X 5"	2	621500 (E)
15	SIGN, HIGH VOLTAGE & ROOFING NAILS	1	647648-492224(E)
16			
17			
18	CAPACITOR UNIT (2.4KV, 50 KVAR ILLUSTRATED)	(B) 6	207200
19	RACK, CAPACITOR	(B) 2	402620
20	CUTOUT, 12KV 100A, HEAVY DUTY, WITH LOADBUSTER HOOKS	3	297888
21	BRACKET, INSULATOR 1" LEAD THREAD	1	166134
22	INSULATOR, PIN TYPE, CLASS AS REQUIRED	1	PG. 750.3
23	CONNECTOR, COMPRESSION	4	STD 786, 783(E)
24	WIRE, #6 BARE STRANDED COPPER	30'	813536
25			
26	WIRE, BARE SOLID ANNEALED COPPER #8	2' - 6"	812928
27			

SDG&E ELECTRIC STANDARDS

DATE 1-1-87
 APPD AK/AD

CAPACITOR INSTALLATION 4KV - WYE - 300 KVAR MAXIMUM

1399.102
 SUPERSEDES
 1316 (1-1-87)

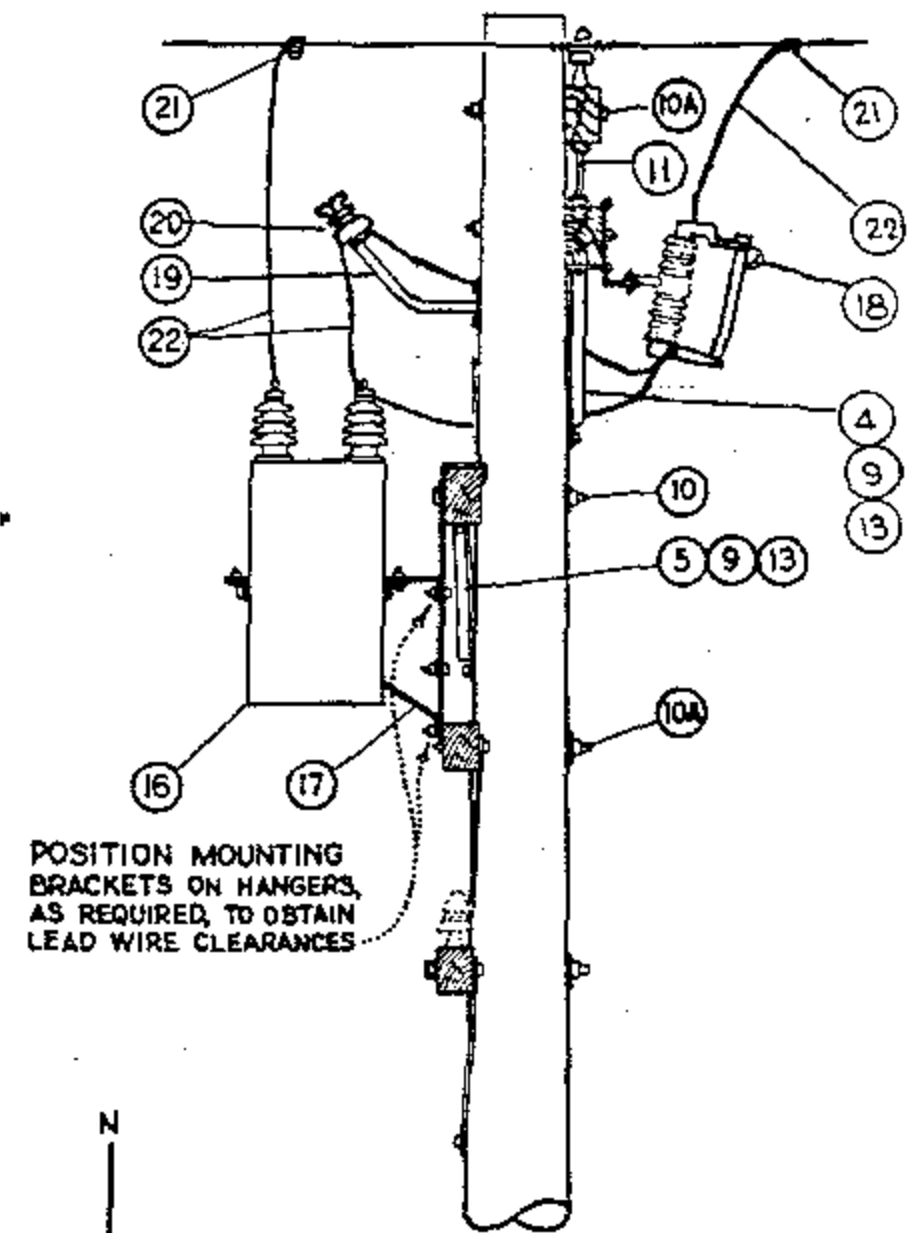
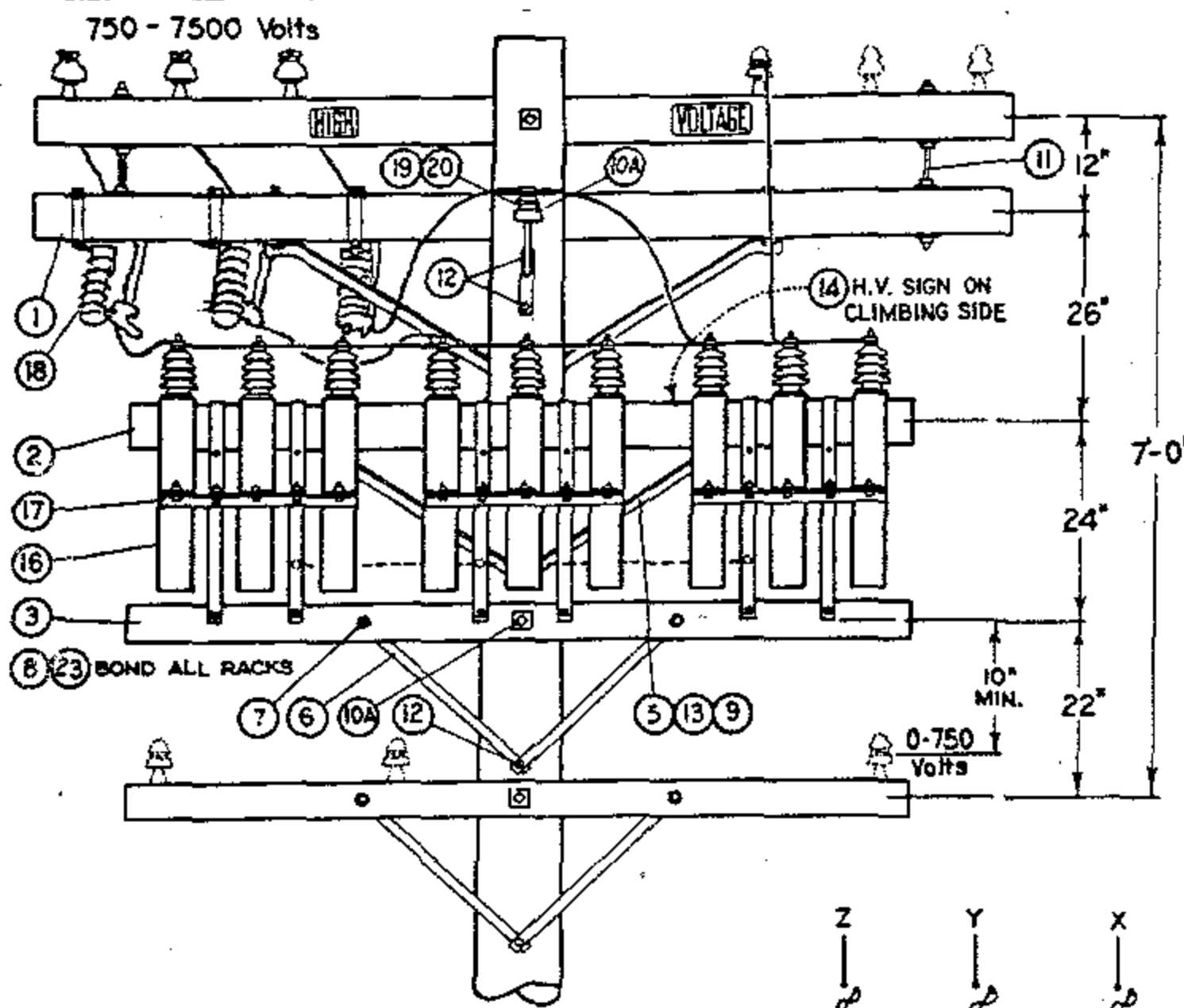

FOR FIELD MAINTENANCE ONLY

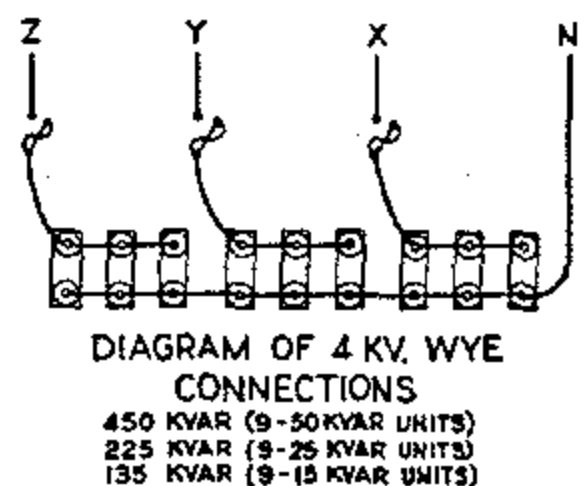

INSTALLATION:

- A. CAPACITOR RACKS TO BE MOUNTED ON OPPOSITE SIDE OF LINE AND CUTOUT ARMS.
- (B) NO LONGER PURCHASED.
- C. FOR POLE STEPPING REFER TO STD. 363.
- (E) EXEMPT MATERIAL.

ITEM	DESCRIPTION	QUANTITY	STOCK NO. OR CONSTR. STD.
1	CROSSARM, 3 3/4" X 5 3/4" X 10' - 0"	1	380.01
2	CROSSARM, 3 3/4" X 5 3/4" X 8' - 0"	1	380.05
3	CROSSARM, 3 1/2" X 4 1/2" X 8' - 0"	1	380.05
4	BRACE, ANGLE CROSSARM, 5' - 0"	1	164128
5	BRACE, ANGLE CROSSARM, 4' - 0"	1	164032
6	BRACE, FLAT CROSSARM, 28"	2	164192
7	BOLT, MACH., GALV., 3/8" X 4 1/2", 1 RD. WASH. & 1 NUT	2	STD 139, 140(E)
8	BOLT, MACH., GALV., 1/2" X 1 1/2", 2 RD. WASH. & 1 NUT	3	STD 139, 140(E)
9	BOLT, MACH., GALV., 1/2" X 7", 1 RD. WASH. & 1 NUT	4	STD 139, 140(E)
10	BOLT, MACH., GALV., 5/8" X (AS REQ'D) 3" SQ. WASH., 1 FLAT, 1 CURV., & 1 NUT	1	STD 139, 140(E)
10A	BOLT, MACH., GALV., 5/8" X (AS REQ'D) 2-2 1/4" SQ. WASH. & 1 NUT	2	STD 139, 140(E)
11	BOLT, SPACE, GALV., 5/8" X 22", 4 SQ. WASH. & 4 NUTS	2	STD 139, 140(E)
12	LAG SCREW, GALV. 1/2" X 4"	3	621568 (E)
13	LAG SCREW, GALV. 5/8" X 5"	2	621600 (E)
14	SIGN, HIGH VOLTAGE, & ROOFING NAILS	(E) 1	647648-492224
15			
16	CAPACITOR UNIT, 2.4KV, (50 KVAR UNITS ILLUSTRATED)	(B) 9	207200
17	RACK, CAPACITOR	3	402624
18	CUTOUT 12KV, 100A, HEAVY DUTY, WITH LOADBUSTER HOOKS	3	297888
19	BRACKET, INSULATOR 1" LEAD THREAD	1	166134
20	INSULATOR, PIN TYPE, CLASS AS REQUIRED	1	750.3
21	CONNECTOR, COMPRESSION	4	PGS 786, 783(E)
22	WIRE, #6 BARE STRANDED COPPER	30'	813536
23	WIRE, BARE SOLID ANNEALED COPPER #8	6'	812928
24			
25			
26			

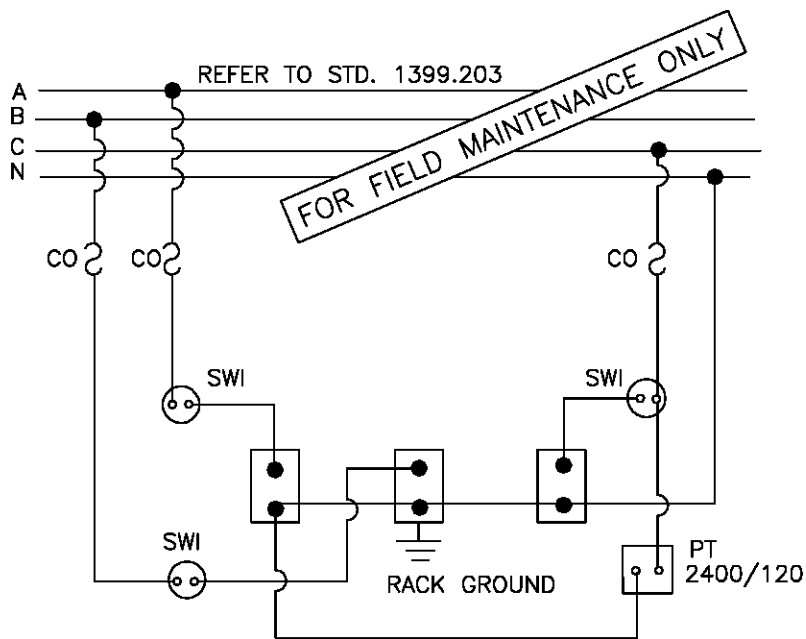
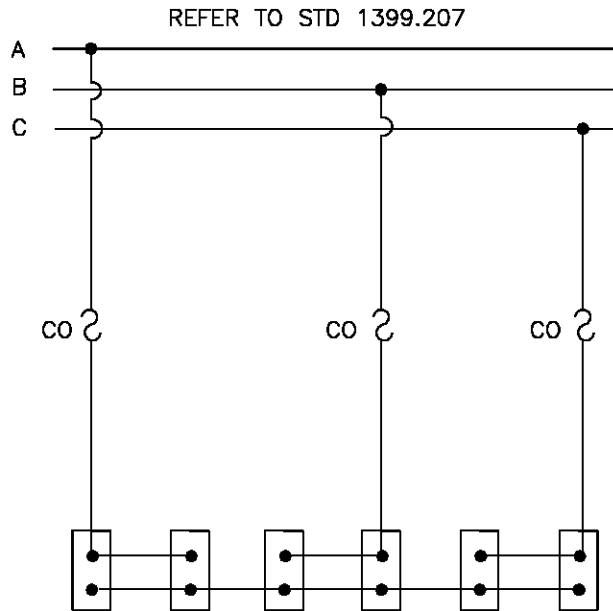

DIAGRAM OF 4KV WYE CONNECTED SWITCHED 300KVAR (3-100KVAR UNITS)

NOTE:

- DO NOT GROUND THE CAPACITOR NEUTRAL BUS. IT IS ALREADY GROUNDED THROUGH THE 4KV NEUTRAL SYSTEM.



SCHMATIC DIAGRAM

600 KVAR (6-100 KVAR UNITS)
 300 KVAR (6-50 KVAR UNITS)
 150 KVAR (6-25 KVAR UNITS)

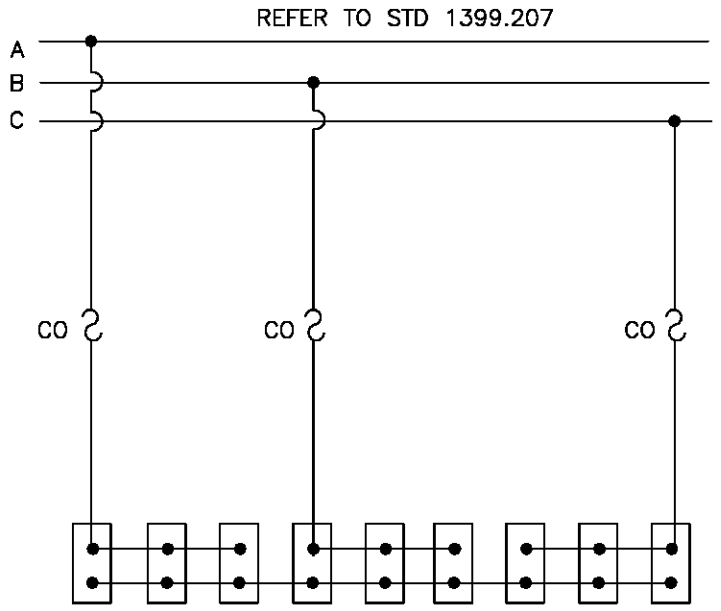

SCHMATIC DIAGRAM

900 KVAR (9-100 KVAR UNITS)
 450 KVAR (9-50 KVAR UNITS)
 225 KVAR (9-25 KVAR UNITS)

DATE 12-1-98 APPD <i>PA/BJ</i>	SDG&E ELECTRIC STANDARDS	1399.104 SUPERSEDES 1314.3 (12-1-98)
	CAPACITOR CONNECTION 4KV WYE	

REFER TO STD 1399.207

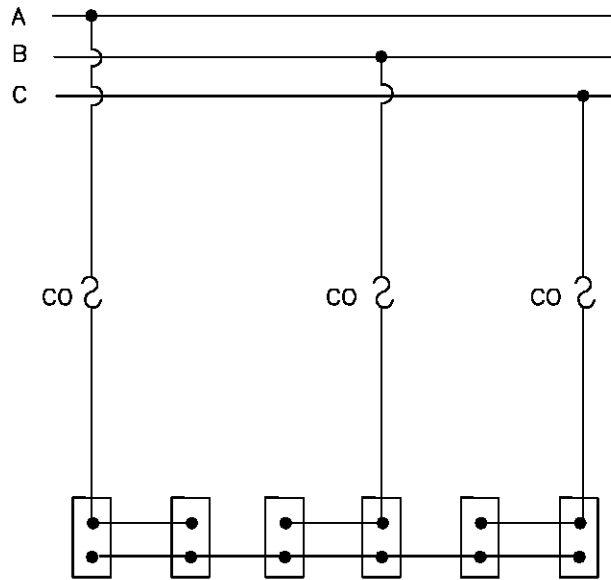

SCHEMATIC DIAGRAM

600 KVAR (6-100 KVAR UNITS)
300 KVAR (6-50 KVAR UNITS)
150 KVAR (6-25 KVAR UNITS)

FOR FIELD MAINTENANCE ONLY

REFER TO STD 1399.207

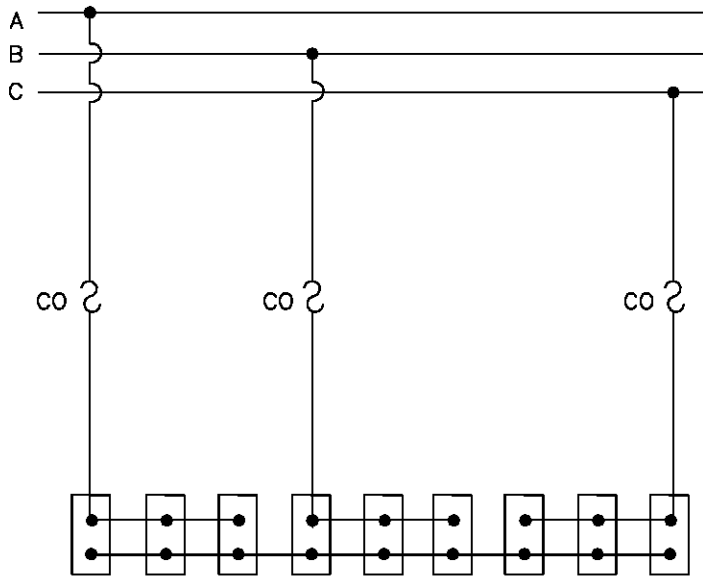

SCHEMATIC DIAGRAM

900 KVAR (9-100 KVAR UNITS)
450 KVAR (9-50 KVAR UNITS)
225 KVAR (9-25 KVAR UNITS)

NOTE:

-SEE STD. 1309 FOR CAPACITOR FUSING.

1399.105

SUPERSEDES
1314.4 (12-1-98)

SDG&E ELECTRIC STANDARDS

CAPACITOR CONNECTION 12KV-WYE (FIXED)

DATE 12-1-98

APPD PA/BDJ

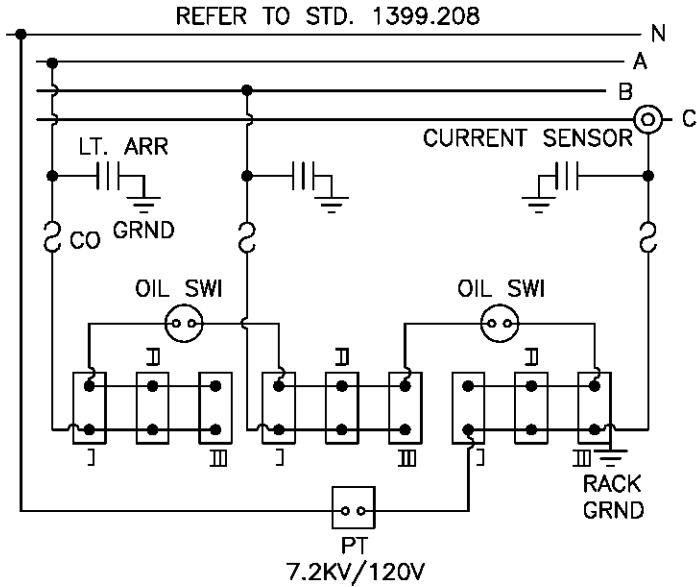

SCHEMATIC DIAGRAM

- 1350 KVAR (9-150 KVAR UNITS) I, II, III
- 1200 KVAR (6-200 KVAR UNITS) I & III
- 900 KVAR (6-150 KVAR UNITS) I & III
- 600 KVAR (3-200 KVAR UNITS) II

FOR FIELD MAINTENANCE ONLY

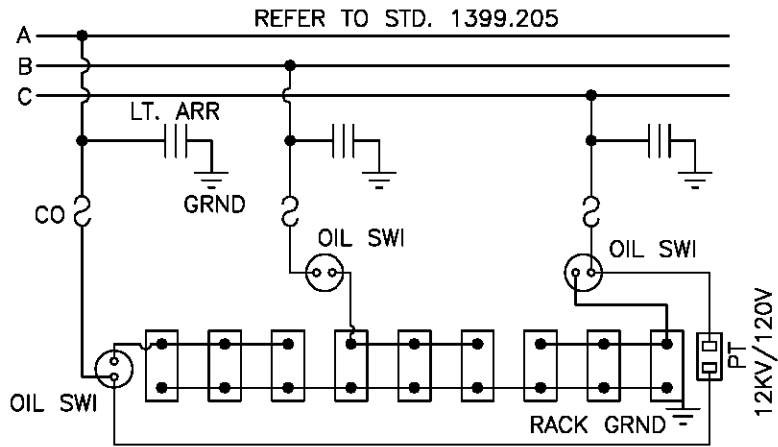

SCHEMATIC DIAGRAM
1350 KVAR (9-150 KVAR UNITS)
WITH 3 OIL SWITCHES

NOTE:

-SEE STD. 1309 FOR CAPACITOR FUSING.

SDG&E ELECTRIC STANDARDS

DATE 12-1-98
APPD *PA/1008*

CAPACITOR CONNECTION 12 & 12.47KV-WYE (SWITCHED)

1399.106
SUPERSEDES
1314.5 (12-1-98)

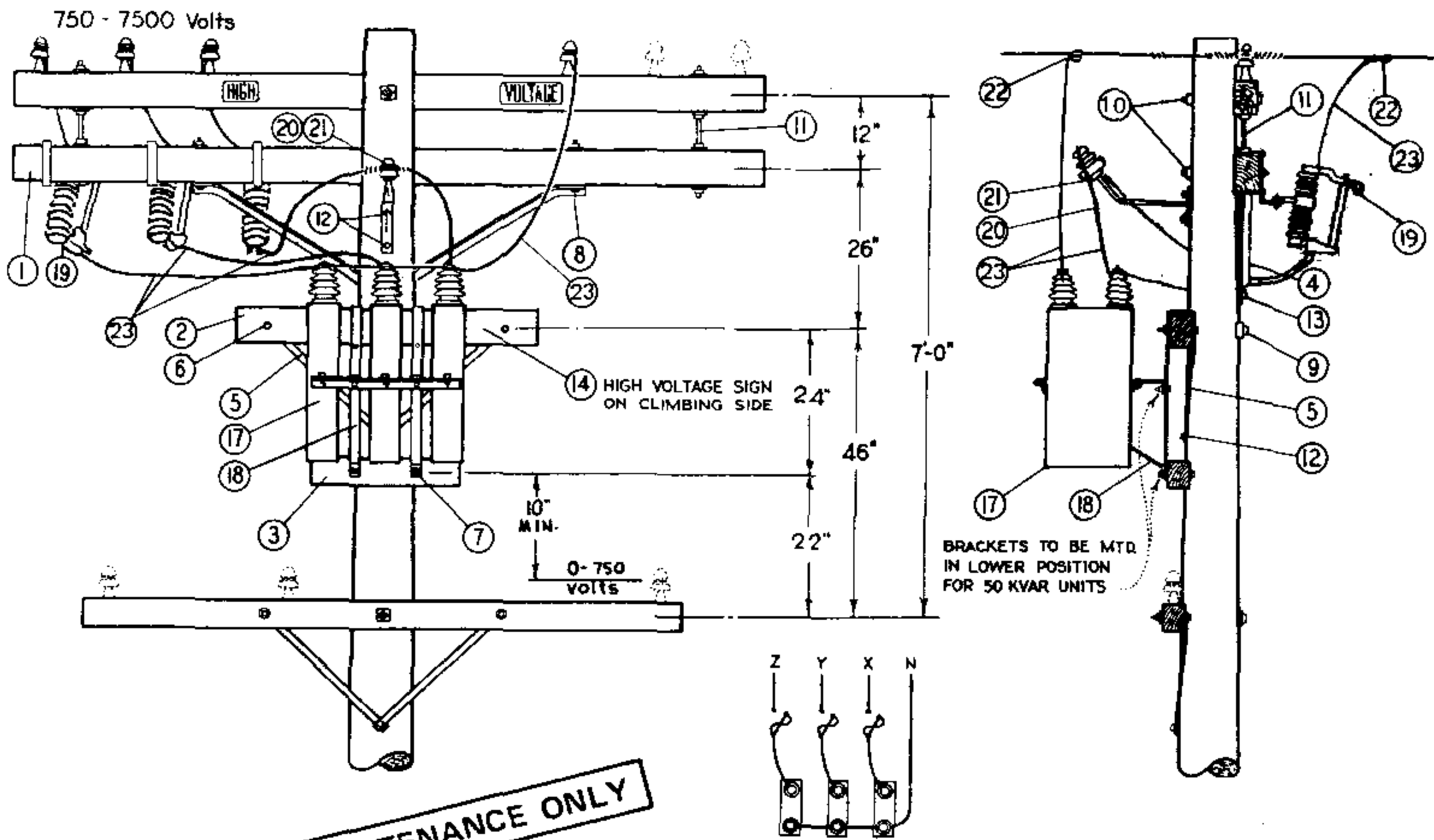

FOR FIELD MAINTENANCE ONLY

DIAGRAM OF 4KV. WYE CONNECTIONS
 150 KVAR (3-50 KVAR UNITS)
 75 KVAR (3-25 KVAR UNITS)
 45 KVAR (3-15 KVAR UNITS)

INSTALLATION:

- A. CAPACITOR RACK TO BE MOUNTED ON OPPOSITE SIDE OF LINE AND CUTOUT ARMS.
- (B) NO LONGER PURCHASED.
- C. FOR POLE STEPPING REFER TO STD. 363.
- (E) EXEMPT MATERIAL.

ITEM	DESCRIPTION	QUANTITY	STOCK NO. OR CONSTR. STD.
1	CROSSARM, 3 3/4" X 5 3/4" X 10' - 0"	1	PG 380.01 IT. 2
2	CROSSARM, 3 3/4" X 5 3/4" X 4' - 0"	1	PG 380.05 IT. 3
3	CROSSARM, 3 1/2" X 4 1/2" X 2' - 0"	1	PG 380.05 IT. 1
4	BRACE, ANGLE CROSSARM, 5' - 0"	1	164128
5	BRACE, FLAT CROSSARM, 28"	2	164192
6	BOLT, MACH., GALV., 3/8" X 4 1/2", 1 RD. WASH. & 1 NUT	2	STD 139, 140 (E)
7	BOLT, MACH., GALV., 1/2" X 5", 1 RD. WASH. & 1 NUT	2	STD 139, 140 (E)
8	BOLT, MACH., GALV., 1/2" X 7", 1 RD. WASH. & 1 NUT	2	STD 139, 140 (E)
9	BOLT, MACH., GALV., 5/8" X (AS REQ'D) 3 SQ. WASH, 1 FLAT, 1 CURV & 1 NUT	1	STD 139, 140 (E)
10	BOLT, MACH., GALV., 5/8" X (AS REQ'D) 2-2 1/4" SQ WASH & 1 NUT	2	STD 139, 140 (E)
11	BOLT, SPACE, GALV., 5/8" X 22", 4 SQ. WASH. & 4 NUTS	2	STD 139, 140 (E)
12	LAG SCREW, GALV., 1/2" X 4"	3	621568 (E)
13	LAG SCREW, GALV., 5/8" X 5"	1	621600 (E)
14	SIGN, HIGH VOLTAGE & 8 ROOFING NAILS	1	647648-492224(E)
15			
16			
17	CAPACITOR UNIT (2.4KV, 50 KVAR ILLUSTRATED)	(B) 3	207200
18	RACK, CAPACITOR	1	402624
19	CUTOUT, 12KV, 100A, HEAVY DUTY, WITH LOADBUSTER HOOKS	3	297888
20	BRACKET, INSULATOR 1" LEAD THREAD	1	166134
21	INSULATOR, PIN TYPE, CLASS AS REQUIRED	1	PG 750.3
22	CONNECTOR, COMPRESSION	4	PGS 786, 783 (E)
23	WIRE, BARE STRANDED, #6	30'	813536

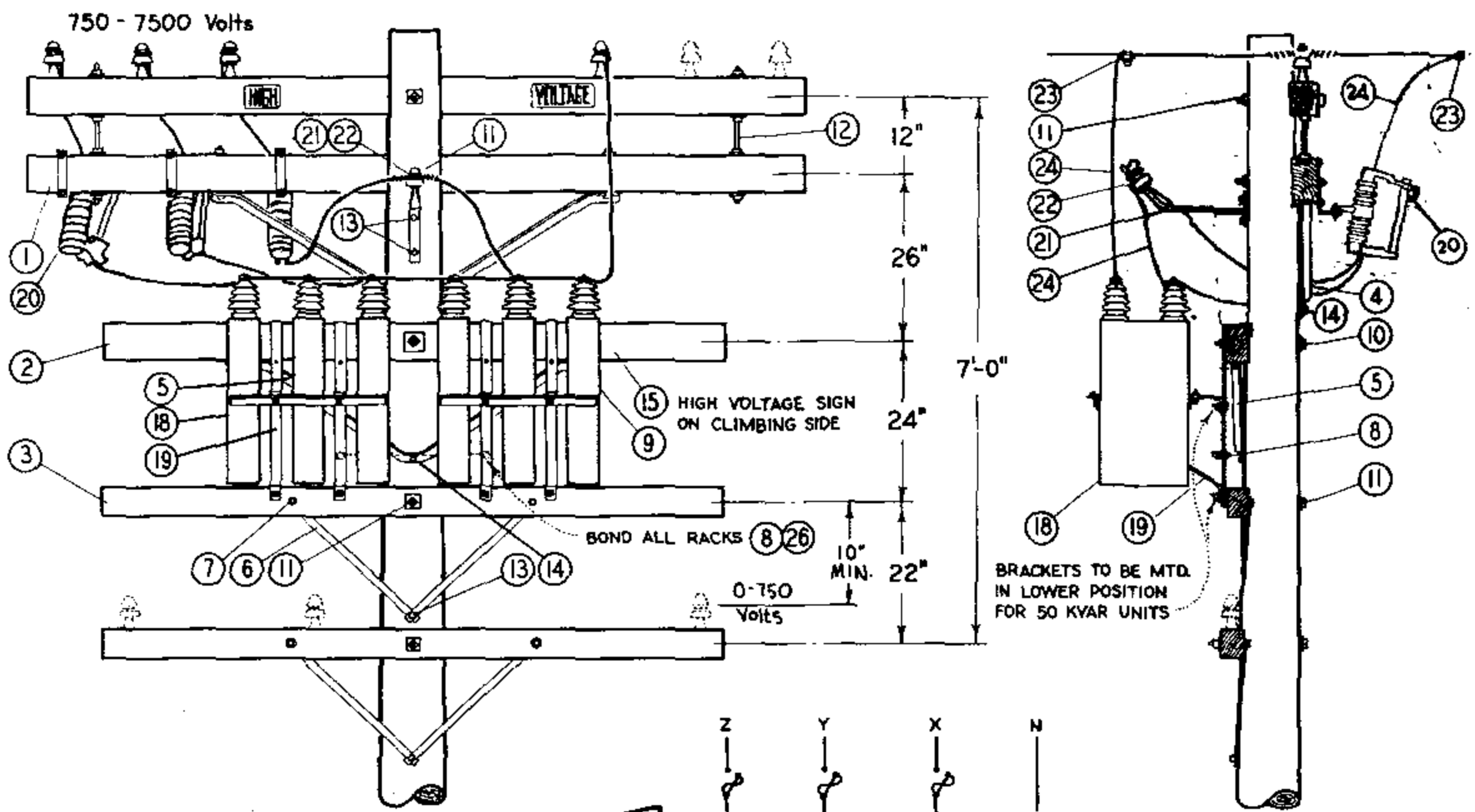

FOR FIELD MAINTENANCE ONLY

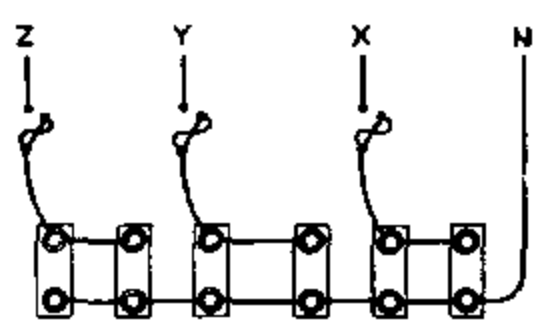

DIAGRAM OF 4 KV. WYE CONNECTIONS
 300 KVAR (6-50 KVAR UNITS)
 150 KVAR (8-25 KVAR UNITS)
 90 KVAR (6-15 KVAR UNITS)

INSTALLATION:

- A. CAPACITOR RACKS TO BE MOUNTED ON OPPOSITE SIDE OF LINE AND CUTOUT ARMS.
- (B) NO LONGER PURCHASED.
- C. FOR POLE STEPPING REFER TO STD. 363.
- (E) EXEMPT MATERIAL.

ITEM	DESCRIPTION	QUANTITY	STOCK NO. OR CONSTR. STD.
1	CROSSARM, 3 3/4" X 5 3/4" X 10' - 0"	1	PG. 380.01
2	CROSSARM, 3 3/4" X 5 3/4" X 8' - 0"	1	PG. 380.05
3	CROSSARM, 3 1/2" X 4 1/2" X 8' - 0"	1	PG. 380.05
4	BRACE, ANGLE CROSSARM, 5' - 0"	1	164128
5	BRACE, ANGLE CROSSARM, 4' - 0"	1	164032
6	BRACE, FLAT CROSSARM, 28"	2	164192
7	BOLT, MACH., GALV., 3/8" X 4 1/2", 1 RD. WASH. & 1 NUT	2	STD 139, 140(E)
8	BOLT, MACH., GALV., 1/2" X 1 1/2", 2 RD. WASH. & 1 NUT	2	STD 139, 140(E)
9	BOLT, MACH., GALV., 1/2" X 7", 1 RD. WASH. & 1 NUT	4	STD 139, 140(E)
10	BOLT, MACH., GALV., 5/8" X (AS REQ'D) 3 SQ. WASH., 1 FLAT, 1 CURV. & 1 NUT	1	STD 139, 140(E)
11	BOLT, MACH., GALV., 5/8" X (AS REQ'D) 2-2 1/4 SQ. WASH. & 1 NUT	2	STD 139, 140(E)
12	BOLT, SPACE, GALV., 5/8" X 22", 4 SQ. WASH. & 4 NUTS	2	STD 139, 140(E)
13	LAG SCREW, GALV., 1/2" X 4"	3	621568 (E)
14	LAG SCREW, GALV., 5/8" X 5"	2	621600 (E)
15	SIGN, HIGH VOLTAGE & ROOFING NAILS	1	647648-492224(E)
16			
17			
18	CAPACITOR UNIT (2.4KV, 50 KVAR ILLUSTRATED)	(B) 6	207200
19	RACK, CAPACITOR	(B) 2	402620
20	CUTOUT, 12KV 100A, HEAVY DUTY, WITH LOADBUSTER HOOKS	3	297888
21	BRACKET, INSULATOR 1" LEAD THREAD	1	166134
22	INSULATOR, PIN TYPE, CLASS AS REQUIRED	1	PG. 750.3
23	CONNECTOR, COMPRESSION	4	STD 786, 783(E)
24	WIRE, #6 BARE STRANDED COPPER	30'	813536
25			
26	WIRE, BARE SOLID ANNEALED COPPER #8	2' - 6"	812928
27			

SDG&E ELECTRIC STANDARDS

DATE 1-1-87
 APPD AK/AD

CAPACITOR INSTALLATION 4KV - WYE - 300 KVAR MAXIMUM

1399.108
 SUPERSEDES
 1516 (1-1-87)

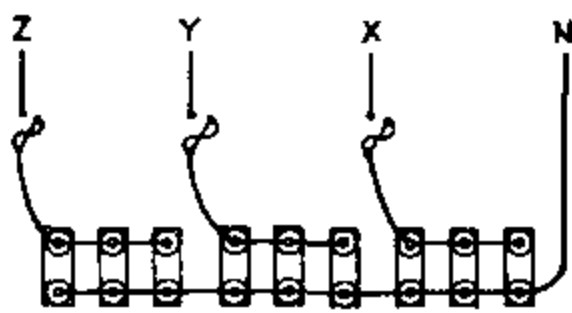
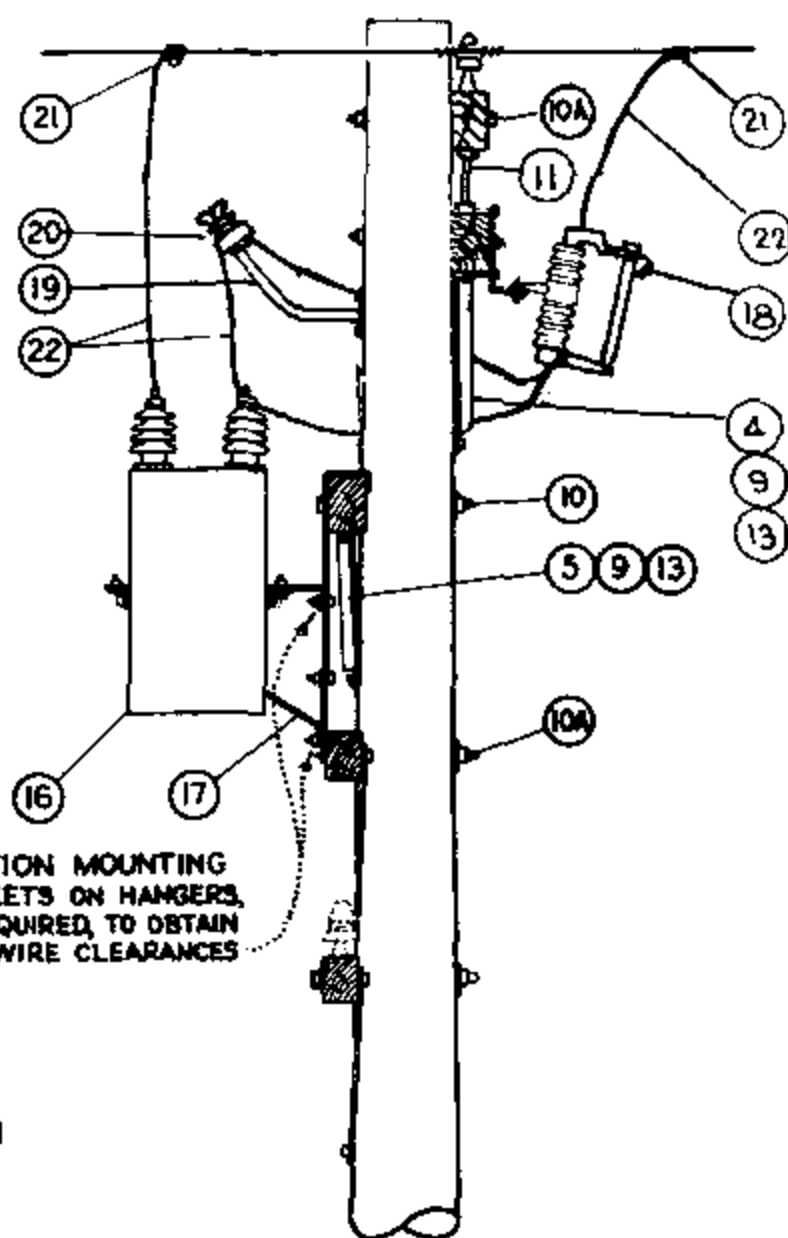
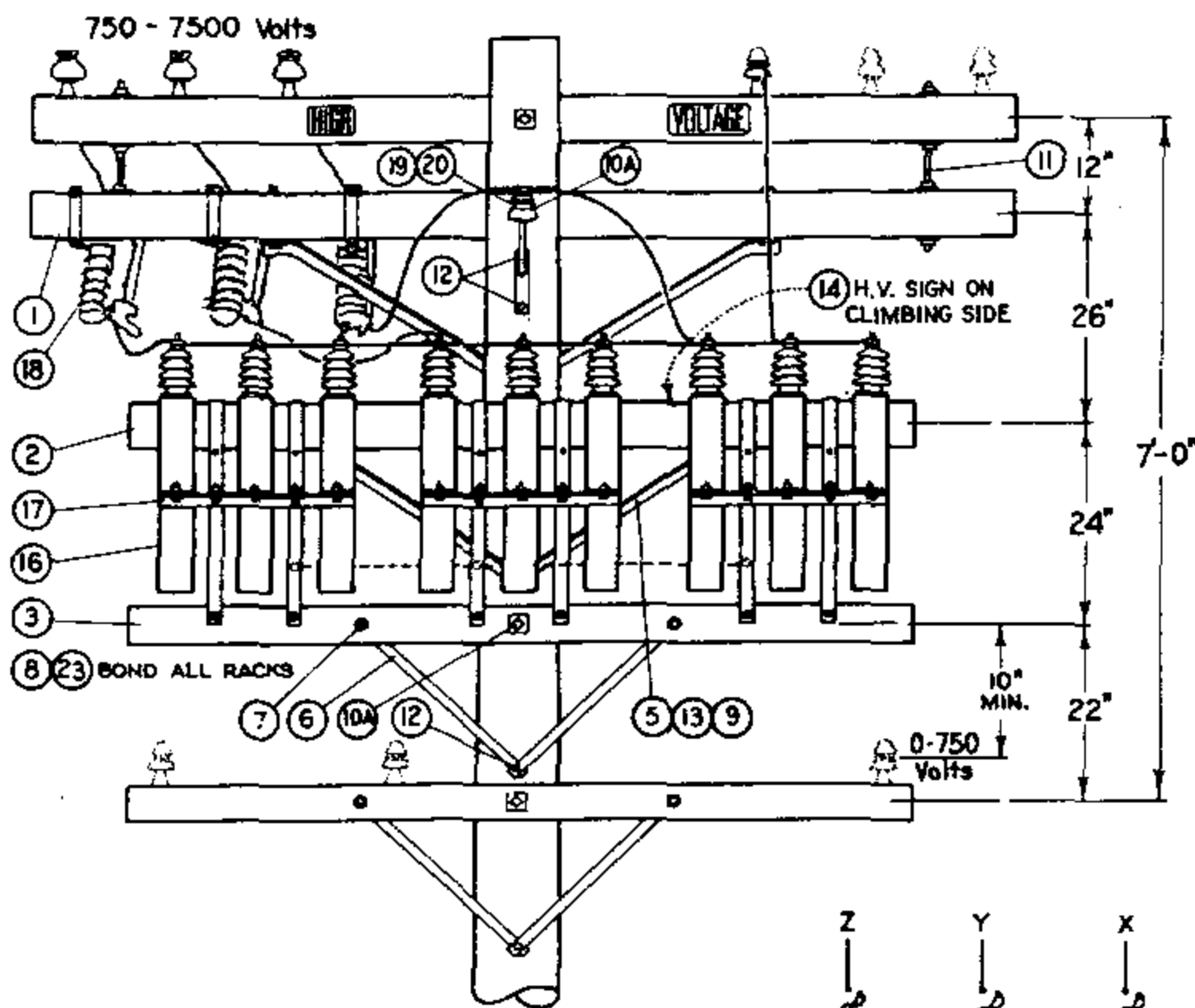

FOR FIELD MAINTENANCE ONLY

INSTALLATION:

- A. CAPACITOR RACKS TO BE MOUNTED ON OPPOSITE SIDE OF LINE AND CUTOUT ARMS.
- (B) NO LONGER PURCHASED.
- C. FOR POLE STEPPING REFER TO STD. 363.
- (E) EXEMPT MATERIAL.

ITEM	DESCRIPTION	QUANTITY	STOCK NO. OR CONSTR. STD.
1	CROSSARM, 3 3/4" X 5 3/4" X 10' - 0"	1	380.01
2	CROSSARM, 3 3/4" X 5 3/4" X 8' - 0"	1	380.05
3	CROSSARM, 3 1/2" X 4 1/2" X 8' - 0"	1	380.05
4	BRACE, ANGLE CROSSARM, 5' - 0"	1	164128
5	BRACE, ANGLE CROSSARM, 4' - 0"	1	164032
6	BRACE, FLAT CROSSARM, 28"	2	164192
7	BOLT, MACH., GALV., 3/8" X 4 1/2", 1 RD. WASH. & 1 NUT	2	STD 139, 140(E)
8	BOLT, MACH., GALV., 1/2" X 1 1/2", 2 RD. WASH. & 1 NUT	3	STD 139, 140(E)
9	BOLT, MACH., GALV., 1/2" X 7", 1 RD. WASH. & 1 NUT	4	STD 139, 140(E)
10	BOLT, MACH., GALV., 5/8" X (AS REQ'D) 3" SQ. WASH., 1 FLAT, 1 CURV., & 1 NUT	1	STD 139, 140(E)
10A	BOLT, MACH., GALV., 5/8" X (AS REQ'D) 2-2 1/4" SQ. WASH. & 1 NUT	2	STD 139, 140(E)
11	BOLT, SPACE, GALV., 5/8" X 22", 4 SQ. WASH. & 4 NUTS	2	STD 139, 140(E)
12	LAG SCREW, GALV., 1/2" X 4"	3	621568 (E)
13	LAG SCREW, GALV., 5/8" X 5"	2	621600 (E)
14	SIGN, HIGH VOLTAGE, & ROOFING NAILS	(E) 1	647648-492224
15			
16	CAPACITOR UNIT, 2.4KV, (50 KVAR UNITS ILLUSTRATED)	(B) 9	207200
17	RACK, CAPACITOR	3	402624
18	CUTOUT 12KV, 100A, HEAVY DUTY, WITH LOADBUSTER HOOKS	3	297888
19	BRACKET, INSULATOR 1" LEAD THREAD	1	166134
20	INSULATOR, PIN TYPE, CLASS AS REQUIRED	1	750.3
21	CONNECTOR, COMPRESSION	4	PGS 786, 783(E)
22	WIRE, #6 BARE STRANDED COPPER	30'	813536
23	WIRE, BARE SOLID ANNEALED COPPER #8	6'	812928
24			
25			
26			

1399.109
SUPERSEDES
1317 (1-1-87)

SDG&E ELECTRIC STANDARDS
CAPACITOR INSTALLATION 4KV - WYE - 450 KVAR MAXIMUM

DATE 1-1-87
APPD *AK/RB*

SCOPE: THIS STANDARD SHOWS THE INSTALLATION METHOD OF A 4.16KV DELTA FIXED CAPACITOR.

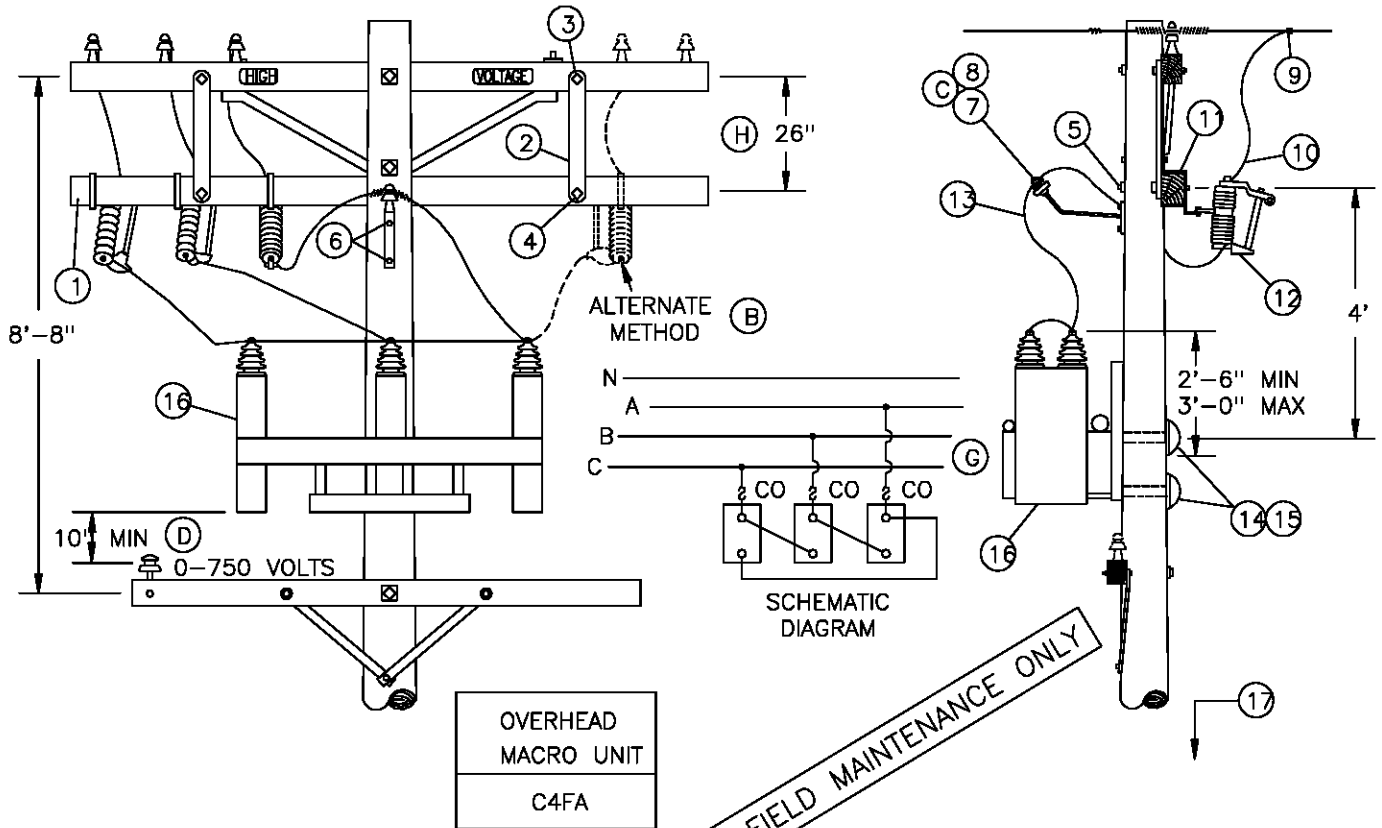

BILL OF MATERIAL:

ITEM	DESCRIPTION	QUANTITY	CONST STD OR PAGE NO	STOCK NUMBER
1	CROSSARM 3 3/4" X 5 3/4" X 10' - 0"	1	-	294128
2	BRACE, FLAT, CROSSARM, 28"	2	-	164192
3	BOLT, MACH, GALV, 1/2" X 5", 1 ROUND AND 1 DOUBLE COIL SPRING WASHER	2	392	-
4	BOLT, MACH, GALV, 3/8" X 4 1/2", 1 RD & 1 SPRING WASHER	2	392	-
5	BOLT, MACH, GALV, 5/8" X (LENGTH AS REQ'D), 2 SQUARE FLAT AND 1 DOUBLE COIL SPRING WASHER	1	392	-
6	LAG SCREW, GALV, 1/2" X 4"	2	-	621568
7	BRACKET, INSULATOR, 1" LEAD THREAD	1	-	166134
8	INSULATOR, PIN TYPE, CLASS AS REQUIRED	1	750	-
9	CONNECTOR, COMPRESSION, CU OR AL (SIZE AS REQ'D)	AS REQ'D	783, 786	-
10	WIRE, BARE STRANDED, #6, COPPER	9'	-	813536
11	BRACKET, CUTOUT/ARRESTER, FOR CROSSARM MOUNTING	3	-	166070
12	CUTOUT, 12KV, 100A, HVY DUTY, WITH LOADBUSTER HOOK	3	-	297888
13	WIRE, BARE STRANDED, #4 COPPER	12'	-	813760
14	BOLT, MACH, GALV, 3/4" X (LENGTH AS REQ'D), 1 SQUARE CURVED AND 1 DOUBLE COIL SPRING WASHER	2	392	-
15	COVER, THRU BOLT, PLASTIC & 6-10D NAILS, GALV	2	-	285696
		-	-	491392
16	RACK, CAPACITOR (4.16KV, 200 KVAR)	1	-	564759
17	TAG, STATION NUMBER	1	200 SECT	-

DATE 12-1-98
 APPD *PA/BJ*

SDG&E ELECTRIC STANDARDS
 FIXED CAPACITOR INSTALLATION, 4.16KV DELTA
 UNGROUNDED RACK

1399.110
 SUPERSEDES
 1318.1 (12-1-98)

INSTALLATION:

- A. CAPACITOR RACKS TO BE MOUNTED ON OPPOSITE SIDE OF LINE AND CUTOUT ARMS.
- ⓑ INSTALL ONE CUTOUT AS SHOWN ON THE ALTERNATE METHOD IF THE 4KV CONDUCTORS ARE SPREAD OUT.
- ⓒ OMIT ITEMS 6, 7, & 8 IF ALTERNATE METHOD ⓑ IS USED.
- ⓓ FROM BOTTOM OF THE CAPACITOR RACK OR THE CASE, WHICHEVER IS LOWER.
- F. CAPACITOR MUST BE INSTALLED ON POLES ACCESSIBLE BY BUCKET TRUCK.
- ⓖ THE KVAR RATING OF 7200 VOLT CAPACITORS IS REDUCED BY A FACTOR OF THREE WHEN WIRED IN DELTA AND CONNECTED TO THE 4160 VOLT SYSTEM.
- ⓓ IF ADDITIONAL SPACE IS REQUIRED BELOW THE CUTOUT ARM, THE SEPARATION BETWEEN THE LINE ARM AND CUTOUT ARM MAY BE REDUCED TO 12" WITH THE USE OF SPACE BOLTS.

FOR FIELD MAINTENANCE ONLY

1399.111 SUPERSEDES 1318.2 (12-1-98)	SDG&E ELECTRIC STANDARDS FIXED CAPACITOR INSTALLATION, 4.16KV DELTA UNGROUND RACK	DATE 12-1-98 APPD <i>PSA/CAL</i>
--------------------------------------------	-----------------------------------------------------------------------------------------	-------------------------------------

SCOPE: THIS STANDARD SHOWS THE INSTALLATION METHOD OF A 4.16KV DELTA SWITCHED CAPACITOR.

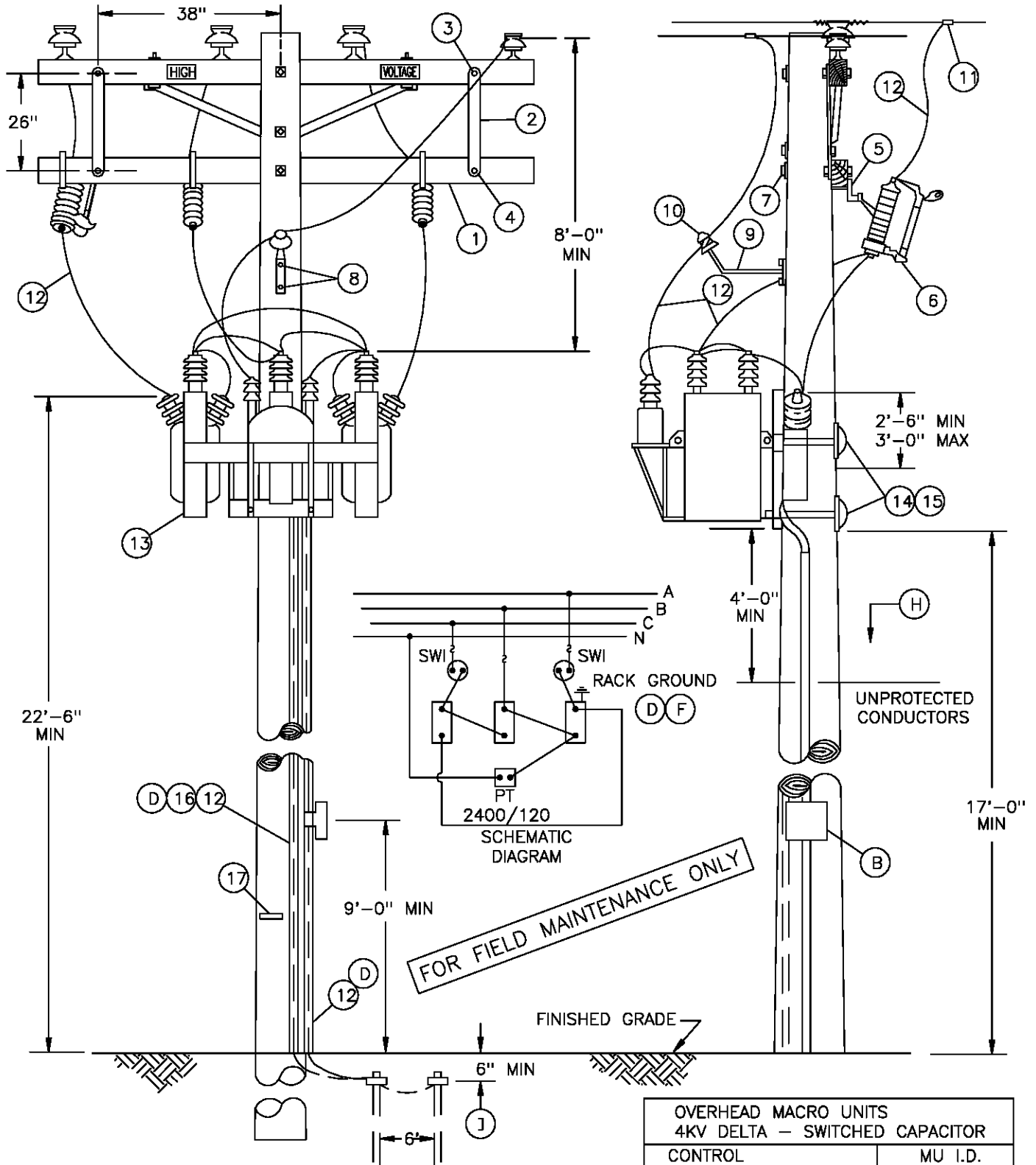

NOTES:

- CLASS OF POLE TO BE DETERMINED PER STANDARD 344-354.

OVERHEAD MACRO UNITS 4KV DELTA - SWITCHED CAPACITOR	
CONTROL	MU I.D.
VAR/VOLT OVERRIDE	C4SDV
VOLT W/TIME BIAS	C4STD

SDG&E ELECTRIC STANDARDS

DATE 12-1-98
APPD PJA/CAK

SWITCHED CAPACITOR INSTALLATION
4.16 KV DELTA - 2 OIL SWITCHES

1399.112
SUPERSEDES
1319.1 (12-1-98)

BILL OF MATERIAL:

ITEM	DESCRIPTION	QUANTITY	CONST STD OR PAGE NO	STOCK NUMBER
1	CROSSARM, 3 3/4" X 5 3/4" X 10' - 0"	1	--	249128
2	BRACE, FLAT, CROSSARM, 28"	2	--	164192
3	BOLT, MACH, GALV, 3/8" X 4 1/2", 1 SPR WASH & 1 RD WASH	2	392	--
4	BOLT, MACH, GALV, 1/2 X 5", 1 RD WASH, 1 DBL COIL WASH	2	392	--
5	BRACKET, CUTOUT/ARRESTER, FOR CROSSARM MOUNTING	3	--	166070
6	CUTOUT, 12KV, 100A, HEAVY DUTY, WITH LOADBUSTER HOOKS	3	1212	--
7	BOLT, MACH, GALV, 5/8" X (LENGTH AS REQ'D) 2 SQ WASH & 1 DBL COIL WASH	1	392	--
8	LAG SCREW, GALV, 1/2" X 4"	2	--	621568
9	BRACKET, INSULATOR, 1" LEAD THREAD	1	--	166134
10	INSULATOR, PIN TYPE, CLASS AS REQUIRED	1	750	--
11	CONNECTOR, WIRE, COMPRESSION, CU OR AL, AS REQ'D	AS REQ'D	783-786	--
12	WIRE, BARE STRANDED, #4, COPPER	100'	--	813760
13	RACK, SWITCHED CAPACITOR, COMPLETE WITH SWITCHES AND POTENTIAL TRANSFORMER, (4.16KV, 200KVAR) (F)	1	--	564758
14	BOLT, MACH, GALV, 3/4" X (LENGTH AS REQ'D), 1 SQ CURVE RIB WASH & 1 DBL COIL SPR WASH	2	392	--
15	COVER, BOLT, PLASTIC & 6 - 1 3/4" NAILS, GALV	2	--	285696
		--	--	492192
16	UNIT GROUND, COMPLETE	1	--	603136
17	TAG, STATION NUMBER	1	200 SECT.	--

FOR FIELD MAINTENANCE ONLY

INSTALLATION:

- A. CAPACITOR RACKS TO BE MOUNTED ON OPPOSITE SIDE OF LINE AND CUTOUT ARMS.
- (B) SHOWN FOR ILLUSTRATIVE PURPOSES ONLY. SEE STANDARD 1330 FOR CONTROL INSTALLATION AND MATERIAL.
- C. CAUTION: OPEN OIL SWITCHES BEFORE OPENING CUTOUTS.
- (D) CONNECT CAPACITOR RACK GROUND LEAD TO GROUND ROD. A SECOND GROUND WIRE IS REQUIRED FOR THE CONTROL PANEL TO BE CONNECTED ON THE SAME GROUND ROD. COIL LOOSE END OF CONTROL PANEL GROUND WIRE AND STAPLE TO POLE (TO BE WORKED BY SERVICE CREW).
- (F) THE KVAR RATING OF 7200 VOLT CAPACITORS IS REDUCED BY A FACTOR OF THREE WHEN WIRED IN DELTA AND CONNECTED TO THE 4160 VOLT SYSTEM.
- G. CAPACITOR MUST BE INSTALLED ON POLES ACCESSIBLE BY BUCKET TRUCK.

REFERENCE:

- (H) POLE STEPPING - SEE STANDARD 363.
- (I) GROUNDING METHODS - SEE STANDARD 1002.
- J. PVC CONDUIT IS NOT PERMITTED IN THE CLIMBING SPACE - G.O. 95 RULE 22.2 (C).

1399.113	SDG&E ELECTRIC STANDARDS	
SUPERSEDES 1319.2 (12-1-98)	SWITCHED CAPACITOR INSTALLATION 4.16 KV DELTA - OIL SWITCHES	DATE 12-1-98 APPD <i>PSA/CMK</i>

APPLICATION:

THIS CONSTRUCTION SHALL BE USED FOR ALL VOLTAGE, TIME, OR TIME-VOLTAGE SWITCHED CAPACITORS WITH THREE OIL SWITCHES.

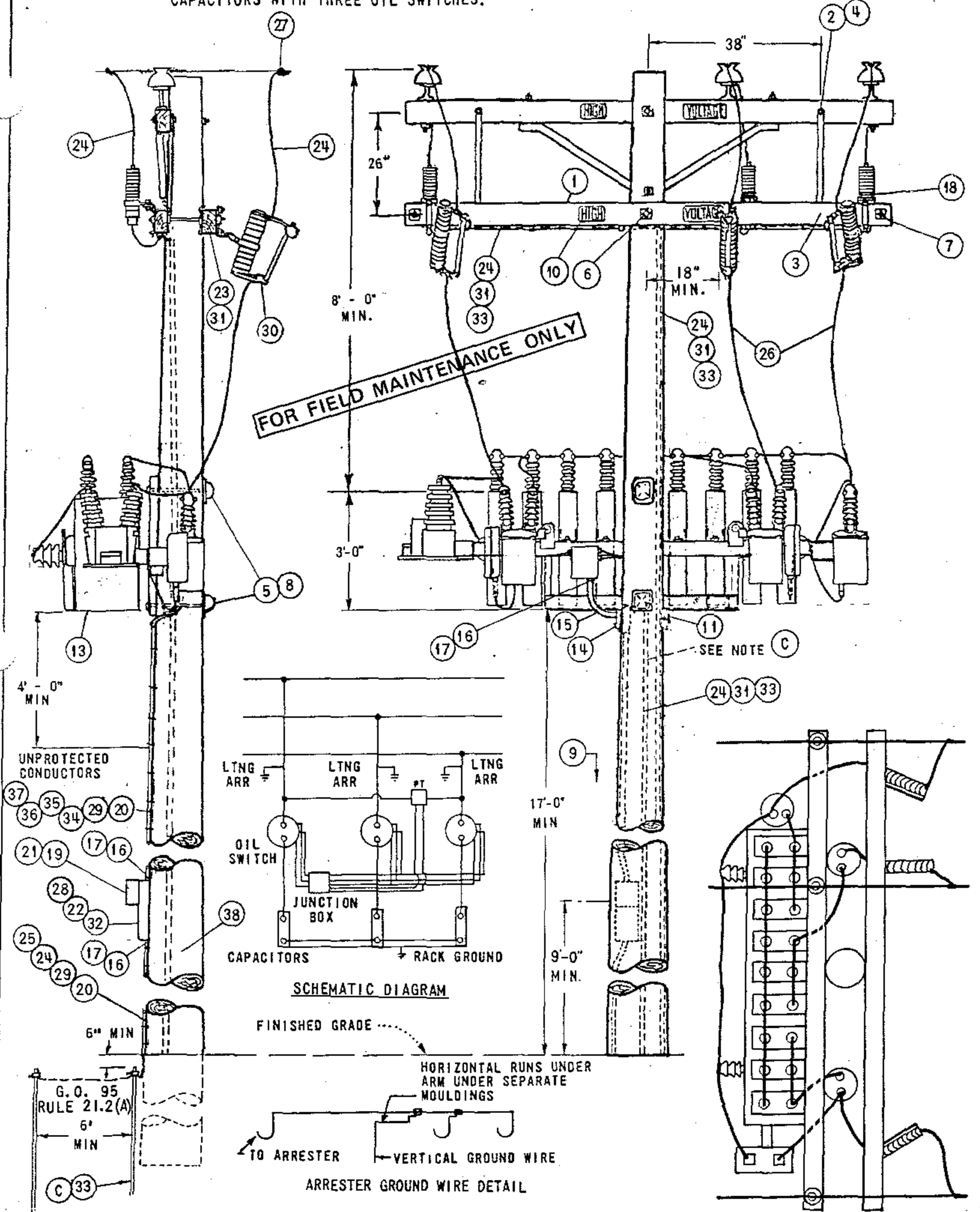

DATE 9-17-82
APPD JAT

SDG&E ELECTRIC STANDARDS
12 & 12.47 KV SWITCHED CAPACITOR INSTALLATION
3 OIL SWITCHES IN LINE

1399.201
SUPERSEDES
1324.1 (9-17-82)

NOTES:

- A. CAUTION: OPEN OIL SWITCHES BEFORE OPENING CUTOUTS.
- B. BOND CUTOUTS IN HEAVY CONTAMINATION DISTRICTS. AS IDENTIFIED ON STANDARDS PAGE 287.
- (C) ONE GROUND IS REQUIRED FOR THE CAPACITOR RACK, ONE IS REQUIRED FOR THE ARRESTERS, AND A THIRD FOR THE CONTROL PANEL. THESE GROUNDS ARE NOT TO BE INTERCONNECTED.
- D. DO NOT TIE CAPACITOR BANK NEUTRAL TO 12KV CIRCUIT NEUTRAL. IT IS TO REMAIN FLOATING.
- (E) EXEMPT MATERIALS.
- (F) TO BE INSTALLED BY KEARNY ELECTRIC MAINTENANCE.
- G. INSTALL CONTROL ON SAME SIDE OF POLE AS CAPACITOR RACK.
- H. RACKS THAT CONTAIN PT'S WITH METAL TANKS TO BE INSULATED FROM RACK BY KEARNY MAINTENANCE BEFORE REINSTALLATION.
- (I) THE POTENTIAL TRANSFORMERS FOR THIS INSTALLATION ARE CONNECTED PHASE-TO-PHASE. FOR POTENTIAL TRANSFORMERS CONNECTED PHASE-TO-NEUTRAL, SEE PAGE 1326.
- J. PVC CONDUIT IS NOT PERMITTED IN THE CLIMBING SPACE. G.O. 95 RULE 22.2(C).
- K. CAPACITORS MUST BE INSTALLED ON POLES ACCESSIBLE BY BUCKET TRUCK.

ITEM	DESCRIPTION	QUANTITY	STOCK NO. OR CONSTR. STD.
1	CROSSARM, 3 3/4" X 5 3/4" X 10' - 0"	2	300 SECTION
2	BRACE, FLAT CROSSARM 28"	2	164192
3	BOLT, MACHINE, GALV., 3/8" X 4 1/2" & 1 SPRING LOCK WASH.	(E) 2	PGS 139, 140
4	BOLT, MACHINE, GALV., 1/2" X 5", 1 RD. WASH, 1 DBL. COIL SPR. WASH	(E) 2	PGS 139, 140
5	BOLT, MACHINE, GALV., 3/4" X___, 1 SQ CURV RIB WASH, 1 DBL COIL SPR WASH	2	PGS 139, 140
6	BOLT, MACHINE, GALV, 5/8" X___, 2 SQ WASH, 1 DBL COIL SPR WASH	(E) 1	PGS 139, 140
7	BOLT, SPACE, GALV., 5/8" X___, 4 SQ WASH, 2 DBL COIL SPR WASH, 2 RD WASH.	(E) 2	PGS 139, 140
8	COVER, BOLT, PLASTIC, 10 D NAILS, GALV	(E) 2	285696
9	STEPS, POLE	(E) 16	692992
10	SIGN, HIGH VOLTAGE & NAILS, GALV.	(E) 4	647648, 492224
11	SCREW, LAG, GALV, 4"	(E) 2	621568
12			
13	SWITCHED CAPACITOR RACK, COMPLETE WITH CAPACITORS, SWITCHES & POTENTIAL TRANSFORMER	900 KVAR (6 @ 150 KVAR) 1350 KVAR (9 @ 150 KVAR)	1 1 564704 564752
14	ACCESS FITTING BODY TYPE LB PVC 3/4"	(F) (E) 1	146384
15	ELBOW, STANDARD RADIUS PVC 3/4"	(F) 1	322166
16	REDUCER COUPLING PVC 3/4" TO 1"	(F) 3	573410
17	TERMINAL ADAPTOR PVC 1"	(F) 3	102756
18	ARRESTERS, LIGHTNING, 12KV	3	113248
19	CONTROL, CAPACITOR (SELECT TYPE AS REQ'D)	a TIME SWITCH	(F) 1 706160
		b TIME SWITCH W VOLTAGE OVERRIDE	(F) 1 706176
		c VOLTAGE	(F) 1 273984
20	CONDUIT, PVC, SCHEDULE 40, 3/4"	(F) (E) 40'	251328
21	PADLOCK, MASTER 7	1	514912
22	BRACKETS, CONTROL MOUNTING	(F) 2	SHOP MADE
23	WIRE, #8 SOL, ANNEALED BARE COPPER	10' (1/2#)	812928
24	WIRE, BARE STRANDED COPPER, #6	110'	813536
25	ROD & CLAMP, GROUND	2	603072, 230016 (E)
26	WIRE, #4 COPPER, WP	20'	812480
27	CONNECTORS, WIRE, COMPRESSION, COPPER OR ALUMINUM AS REQ'D	(E) 6	PGS 786, 783
28	SCREW, 1/4" X 2" LAG	(F) 4	621888
29	STRAPS, PIPE GALV, 3/4", 6D NAILS, GALV.	(F) (E) AS REQ'D	697888
30	CUTOUTS 12KV 100A WITH LOADBUSTER HOOKS	3	1200 SECTION
31	STAPLES, WIRE GALV, 1 1/4"	(E) AS REQ'D	678528
32	BOX, METER SOCKET SAFETY, 5 TERMINAL, 100 AMP	(F) 1	161856
33	UNIT GROUND COMPLETE (WITH PLAIN MLDG, WITH GRAY MLDG)	2	603136, 603120
34	WIRE, THW #12 WHITE	(F) 30'	808704
35	WIRE, THW #12 BLACK	(F) 30'	808096
36	WIRE, THW #12 RED	(F) 30'	808576
37	WIRE, THW #12 BLUE	(F) 30'	808416
38	TAG, STATION NUMBER	1	300 SECTION

FOR FIELD MAINTENANCE ONLY

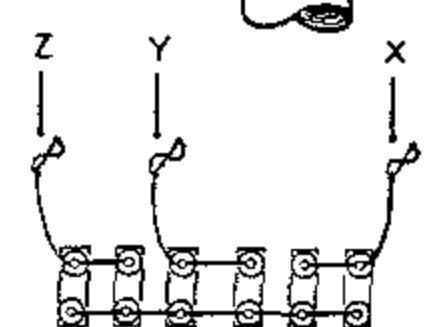
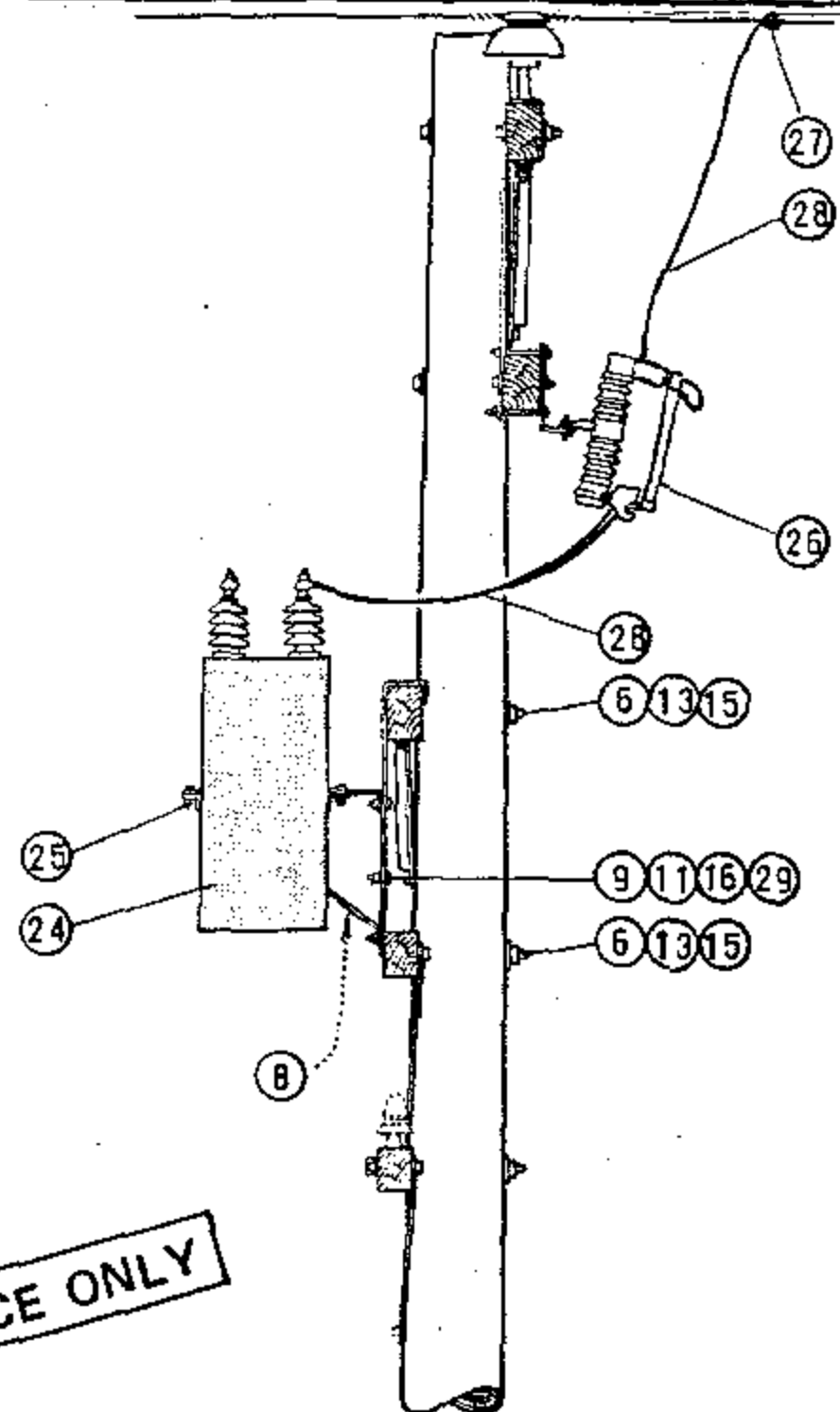
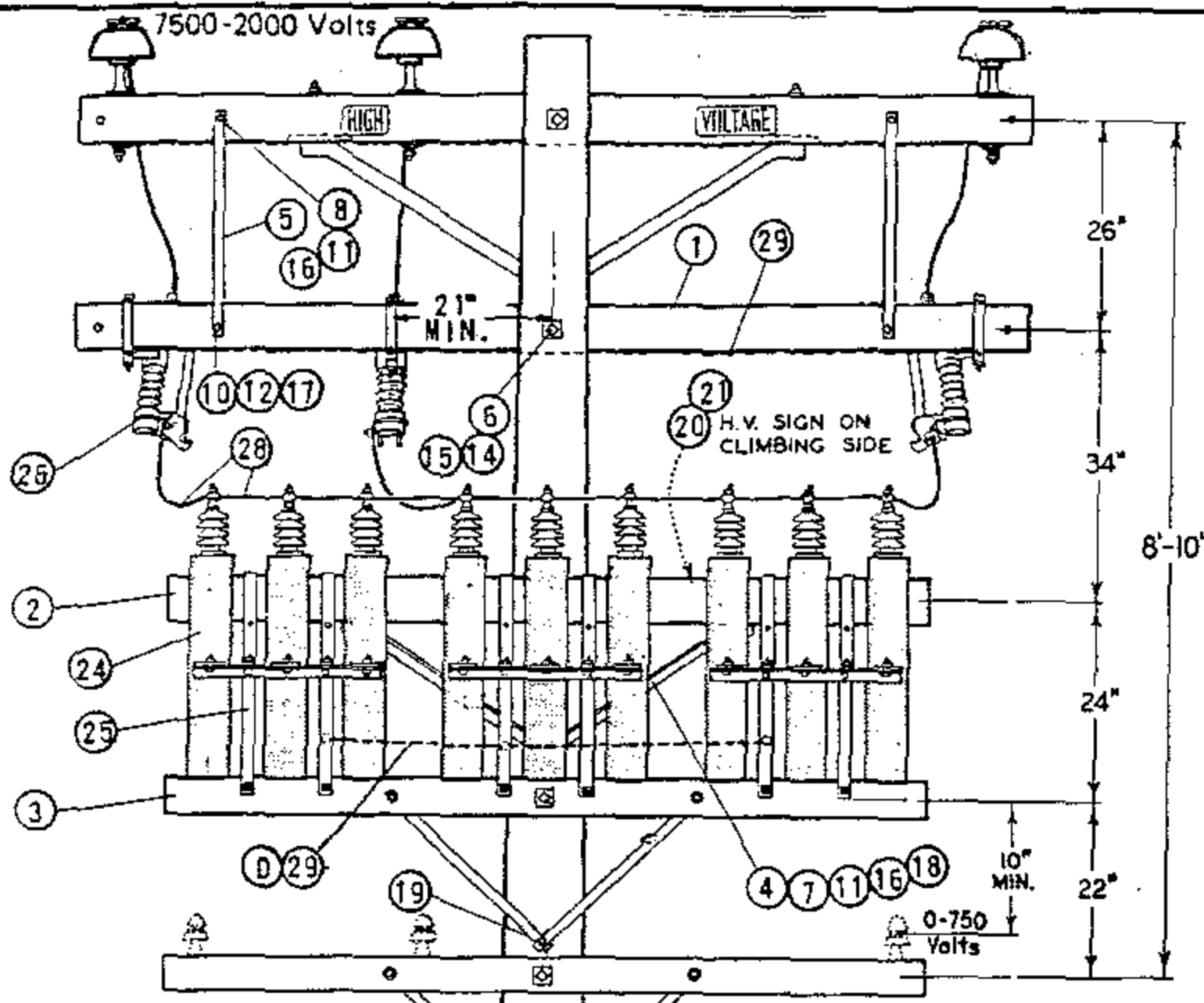

DIAGRAM OF 12KV WYE CONNECTIONS
 600 KVAR (8-100 KVAR UNITS)
 300 KVAR (6-50 KVAR UNITS)
 150 KVAR (6-25 KVAR UNITS)

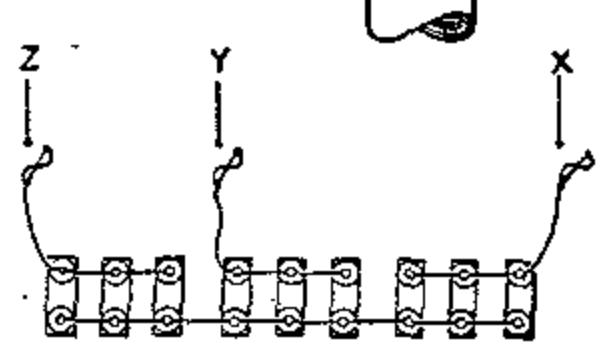

DIAGRAM OF 12KV WYE CONNECTIONS
 900 KVAR (9-100 KVAR UNITS)
 450 KVAR (9-50 KVAR UNITS)
 225 KVAR (9-25 KVAR UNITS)

FOR FIELD MAINTENANCE ONLY

INSTALLATION:

- (A) QUANTITY BASED ON 45' POLE.
- (B) BRACKETS TO BE MOUNTED IN LOWER POSITION FOR 50 AND 100 KVAR UNITS.
- (C) BOND ALL 12KV HARDWARE WITHIN 3 MILES OF COAST.
- (D) BOND ALL RACKS AS SHOWN IN ILLUSTRATION.
- (E) EXEMPT MATERIAL.
- (F) NO LONGER PURCHASED.
- (G) SEE PAGE 1323 FOR MATERIAL NEEDED FOR LIGHTING ARRESTERS ON 900 KVAR INSTALLATIONS.

ITEM	DESCRIPTION	QUANTITY		STOCK NO. OR CONSTR. STD.	ITEM	DESCRIPTION	QUANTITY		STOCK NO. OR CONSTR. STD.
		6	9				6	9	
1	CROSSARM, 3 3/4" X 5 3/4" X 10' - 0"	1	1	380.01	16	WASHER, 1/2" SPRING DBL COIL	6	6	798464 (E)
2	CROSSARM, 3 3/4" X 5 3/4" X 8' - 0"	1	1	380.05	17	WASHER, 3/8" SPRING DBL COIL	2	2	798528 (E)
3	CROSSARM, 3 1/2" X 4 1/2" X 8' - 0"	1	1	380.05	18	SCREW, LAG GALV. 5/8" X 5"	1	1	621600 (E)
4	BRACE, ANGLE CROSSARM, 4' - 0"	1	1	164032	19	SCREW, LAG GALV. 1/2" X 4"	1	1	621568 (E)
5	BRACE, FLAT CROSSARM, 28"	2	2	164192	20	SIGN, HIGH VOLTAGE	1	1	647548 (E)
6	BOLT, MACH. GALV. 5/8" X (LENGTH AS REQ'D) & 1 NUT	3	3	139 (E)	21	NAILS, ROOFING #8 GALV.	8	8	492224 (E)
7	BOLT, MACH. 1/2" X 7" & 1 NUT	2	2	153120 (E)	22	STEPS, POLE (A)	16	16	692992 (E)
8	BOLT, MACH. GALV. 1/2" X 5" & 1 NUT	2	2	153024 (E)	23				
9	BOLT, MACH. GALV. 1/2" X 1 1/2" & 1 NUT	2	3	152608 (E)	24	CAPACITOR, UNIT 7.2KV (100 KVAR UNITS ILLUSTRATED)	6	9	207232 (F)
10	BOLT, MACH. GALV. 3/8" X 5" & 1 NUT	2	2	154368 (E)	25	RACK, CAPACITOR	2	3	402656
11	WASHER, 1/2" ROUND	10	8	800192 (E)	26	CUTOUT, 12KV, 100A HEAVY DUTY WITH LOADBUSTER HOOKS	3	3	297888
12	WASHER, 3/8" ROUND	2	2	800288 (E)	27	CONNECTORS, COMPRESSION	3	3	786, 783 (E)
13	WASHER, 3" SQ. CURVED	4	4	798912 (E)	28	WIRE, #6 BARE STRANDED COPPER	33'	35'	813536
14	WASHER, 2 1/4" SQ. FLAT	2	2	799040 (E)	29	WIRE, #8 BARE SOLID ANNEALED COPPER	13'	15'	812928
15	WASHER, 5/8" SPRING DBL COIL	3	3	798560 (E)	30				

BILL OF MATERIAL:

ITEM	DESCRIPTION	QUANTITY	CONST STD OR PAGE NO	STOCK NUMBER
1	CROSSARM, 3 3/4" X 5 3/4" X 10' - 0"	1	-	294128
2	BRACE, FLAT, CROSSARM, 28"	2	-	164192
3	BOLT, MACH, GALV, 3/8" X 4 1/2", 1 SPR & 1 RD WASHER	2	392	-
4	BOLT, MACH, GALV, 1/2" X 5", 1 ROUND & 1 DOUBLE COIL SPRING WASHER	2	392	-
5	BOLT, MACH, GALV, 5/8" X (LENGTH AS REQ'D) 2 SQUARE & 1 DOUBLE COIL SPRING WASHER	1	392	-
6	CONNECTOR, WIRE, COMPRESSION, CU OR AL, AS REQ'D	AS REQ'D	783, 786	-
7	WIRE, #4, BARE STRANDED COPPER	95'	-	813760
8	BRACKET, CUTOUT/ARRESTER, FOR CROSSARM MOUNTING	3	-	166070
9	CUTOUT, 12KV, 100A, HEAVY DUTY, WITH LOADBUSTER HOOKS	3	1212	-
10	INSULATOR, PIN TYPE, CLASS AS REQUIRED	1	-	429216
11	BRACKET, INSULATOR, 1" LEAD THREAD	1	-	166134
12	LAG SCREW, GALV, 1/2" X 4"	2	-	621568
13	RACK, SWITCHED CAPACITOR, COMPLETE WITH SWITCHES AND POTENTIAL TRANSFORMER, (4.16KV, 300KVAR)	1	-	564773
14	BOLT, MACH, GALV, 3/4" X (LENGTH AS REQ'D), 1 SQUARE CURVE RIBBED & 1 DOUBLE COIL SPRING WASHER	2	392	-
15	COVER, BOLT, PLASTIC & 6 - 1 3/4" NAILS, GALV	2	-	285696
		-	-	492192
16	UNIT GROUND, COMPLETE	1	-	603136
17	TAG, STATION NUMBER	1	338	-

FOR FIELD MAINTENANCE ONLY

OVERHEAD MACRO UNITS 4KV WYE - SWITCHED CAPACITOR	
CONTROL	MU I.D.
VAR/VOLT OVERRIDE	C4S3DV
VOLT W/TIME BIAS	C4S3TD

INSTALLATION:

- A. CAPACITOR RACKS TO BE MOUNTED ON OPPOSITE SIDE OF LINE AND CUTOUT ARMS.
- B. CAUTION: OPEN OIL SWITCHES BEFORE OPENING CUTOUTS.
- C. CONNECT CAPACITOR RACK GROUND LEAD TO GROUND ROD. A SECOND GROUND WIRE IS REQUIRED FOR THE CONTROL PANEL TO BE CONNECTED ON THE SAME GROUND ROD. COIL LOOSE END OF CONTROL PANEL GROUND WIRE AND STAPLE TO POLE (TO BE WORKED BY SERVICE CREW).

REFERENCE:

- F. SHOWN FOR ILLUSTRATIVE PURPOSES ONLY. SEE STANDARD 1330 FOR CONTROL INSTALLATION AND MATERIAL.
- G. POLE STEPPING, SEE STANDARD 363.
- H. GROUNDING METHOD, SEE STANDARD 1002.
 - I. PVC CONDUIT IS NOT PERMITTED IN THE CLIMBING SPACE - G.O. 95 RULE 22.2 (C).
 - J. CAPACITOR MUST BE INSTALLED ON POLES ACCESSIBLE BY BUCKET TRUCK. SEE DESIGN STANDARDS PAGE 5811.5.

1399.204 SUPERSEDES 1321.2 (12-1-98)	SDG&E ELECTRIC STANDARDS SWITCHED CAPACITOR INSTALLATION 4.16 KV WYE - 3 OIL SWITCHES	DATE 12-1-98 APPD <i>PLA/CAK</i>
--------------------------------------------	-------------------------------------------------------------------------------------------------	-------------------------------------

APPLICATION:

THIS CONSTRUCTION SHALL BE USED FOR ALL VOLTAGE, TIME, OR TIME-VOLTAGE SWITCHED CAPACITORS WITH THREE OIL SWITCHES.

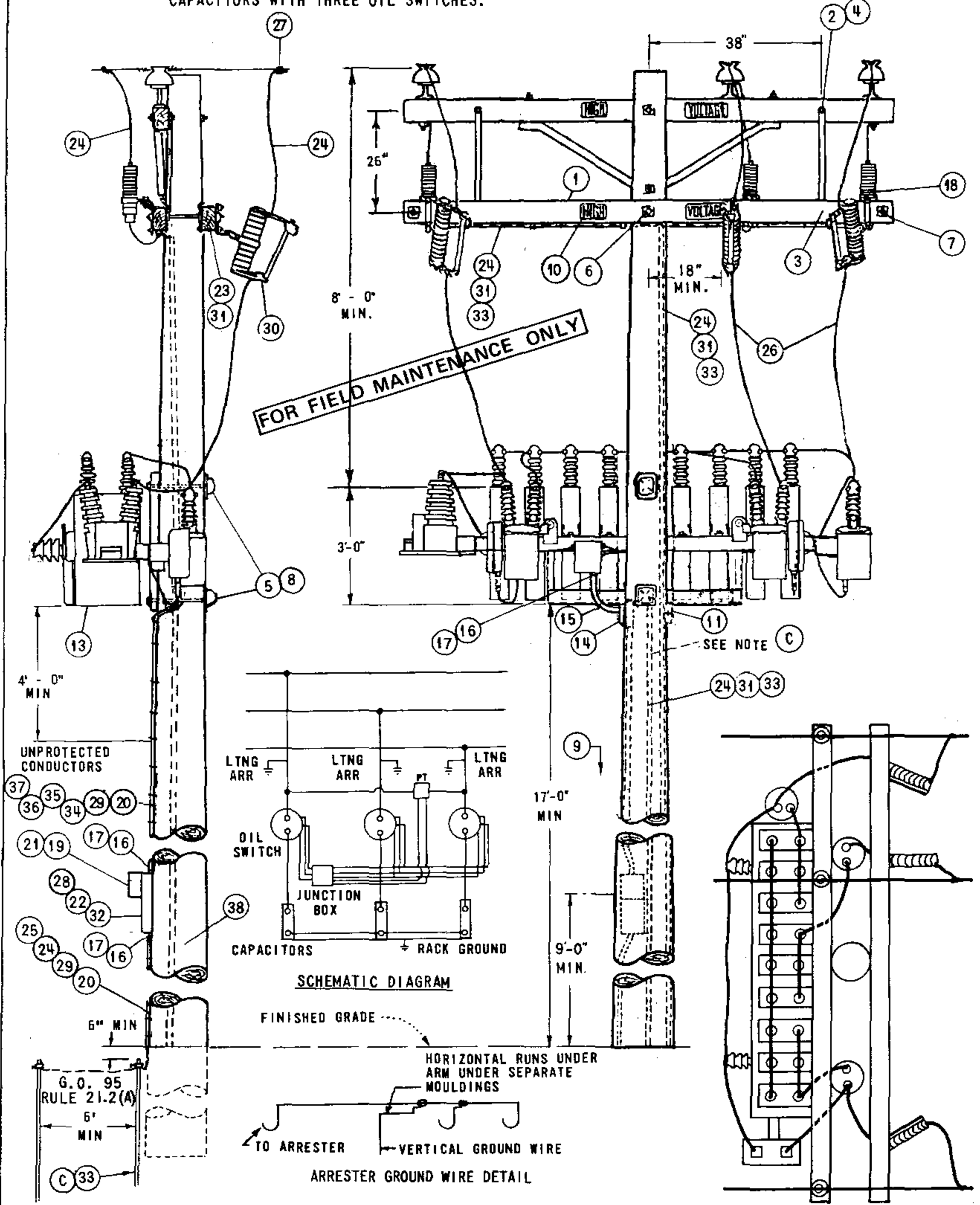

DATE 9-17-82
 APPD *JNT*

SDG&E ELECTRIC STANDARDS
 12 & 12.47 KV SWITCHED CAPACITOR INSTALLATION
 3 OIL SWITCHES IN LINE

1399.205
 SUPERSEDES
 1324.1 (9-17-82)

NOTES:

- A. CAUTION: OPEN OIL SWITCHES BEFORE OPENING CUTOUTS.
- B. BOND CUTOUTS IN HEAVY CONTAMINATION DISTRICTS. AS IDENTIFIED ON STANDARDS PAGE 287.
- ⓐ ONE GROUND IS REQUIRED FOR THE CAPACITOR RACK, ONE IS REQUIRED FOR THE ARRESTERS, AND A THIRD FOR THE CONTROL PANEL. THESE GROUNDS ARE NOT TO BE INTERCONNECTED.
- D. DO NOT TIE CAPACITOR BANK NEUTRAL TO 12KV CIRCUIT NEUTRAL. IT IS TO REMAIN FLOATING.
- ⓔ EXEMPT MATERIALS.
- ⓕ TO BE INSTALLED BY KEARNY ELECTRIC MAINTENANCE.
- G. INSTALL CONTROL ON SAME SIDE OF POLE AS CAPACITOR RACK.
- H. RACKS THAT CONTAIN PT'S WITH METAL TANKS TO BE INSULATED FROM RACK BY KEARNY MAINTENANCE BEFORE REINSTALLATION.
- ⓓ THE POTENTIAL TRANSFORMERS FOR THIS INSTALLATION ARE CONNECTED PHASE-TO-PHASE. FOR POTENTIAL TRANSFORMERS CONNECTED PHASE-TO-NEUTRAL. SEE PAGE 1326.
- J. PVC CONDUIT IS NOT PERMITTED IN THE CLIMBING SPACE. G.O. 95 RULE 22.2(C).
- K. CAPACITORS MUST BE INSTALLED ON POLES ACCESSIBLE BY BUCKET TRUCK.

ITEM	DESCRIPTION	QUANTITY	STOCK NO. OR CONSTR. STD.
1	CROSSARM, 3 3/4" X 5 3/4" X 10' - 0"	2	300 SECTION
2	BRACE, FLAT CROSSARM 28"	2	164192
3	BOLT, MACHINE, GALV., 3/8" X 4 1/2" & 1 SPRING LOCK WASH.	ⓔ 2	PGS 139, 140
4	BOLT, MACHINE, GALV., 1/2" X 5", 1 RD. WASH, 1 DBL. COIL SPR. WASH	ⓔ 2	PGS 139, 140
5	BOLT, MACHINE, GALV., 3/4" X ____, 1 SQ CURV RIB WASH, 1 DBL COIL SPR WASH	2	PGS 139, 140
6	BOLT, MACHINE, GALV., 5/8" X ____, 2 SQ WASH, 1 DBL COIL SPR WASH	ⓔ 1	PGS 139, 140
7	BOLT, SPACE, GALV., 5/8" X ____, 4 SQ WASH, 2 DBL COIL SPR WASH, 2 RD WASH.	ⓔ 2	PGS 139, 140
8	COVER, BOLT, PLASTIC, 10 D NAILS, GALV	ⓔ 2	285696
9	STEPS, POLE	ⓔ 16	692992
10	SIGN, HIGH VOLTAGE & NAILS, GALV.	ⓔ 4	647648, 492224
11	SCREW, LAG, GALV, 4"	ⓔ 2	621568
12			
13	SWITCHED CAPACITOR RACK, COMPLETE WITH CAPACITORS, SWITCHES & POTENTIAL TRANSFORMER	900 KVAR (6 @ 150 KVAR) 1350 KVAR (9 @ 150 KVAR)	1 1 564704 564752
14	ACCESS FITTING BODY TYPE LB PVC 3/4"	ⓕ ⓔ 1	146384
15	ELBOW, STANDARD RADIUS PVC 3/4"	ⓕ 1	322166
16	REDUCER COUPLING PVC 3/4" TO 1"	ⓕ 3	573410
17	TERMINAL ADAPTOR PVC 1"	ⓕ 3	102756
18	ARRESTERS, LIGHTNING, 12KV	3	113248
19	CONTROL, CAPACITOR (SELECT TYPE AS REQ'D)	a TIME SWITCH b TIME SWITCH W/ VOLTAGE OVERRIDE c VOLTAGE	ⓕ 1 ⓕ 1 ⓕ 1 706160 706176 273984
20	CONDUIT, PVC, SCHEDULE 40, 3/4"	ⓕ ⓔ 40'	251328
21	PADLOCK, MASTER 7	1	514912
22	BRACKETS, CONTROL MOUNTING	ⓕ 2	SHOP MADE
23	WIRE, #8 SOL, ANNEALED BARE COPPER	10' (1/2#)	812928
24	WIRE, BARE STRANDED COPPER, #6	110'	813536
25	ROD & CLAMP, GROUND	2	603072, 230016 ⓔ
26	WIRE, #4 COPPER, WP	20'	812480
27	CONNECTORS, WIRE, COMPRESSION, COPPER OR ALUMINUM AS REQ'D	ⓔ 6	PGS 786, 783
28	SCREW, 1/4" X 2" LAG	ⓕ 4	621888
29	STRAPS, PIPE GALV, 3/4", 6D NAILS, GALV.	ⓕ ⓔ AS REQ'D	697888
30	CUTOUTS 12KV 100A WITH LOADBUSTER HOOKS	3	1200 SECTION
31	STAPLES, WIRE GALV, 1 1/4"	ⓔ AS REQ'D	678528
32	BOX, METER SOCKET SAFETY, 5 TERMINAL, 100 AMP	ⓕ 1	161856
33	UNIT GROUND COMPLETE (WITH PLAIN MLDG, WITH GRAY MLDG)	2	603136, 603120
34	WIRE, THW #12 WHITE	ⓕ 30'	808704
35	WIRE, THW #12 BLACK	ⓕ 30'	808096
36	WIRE, THW #12 RED	ⓕ 30'	808576
37	WIRE, THW #12 BLUE	ⓕ 30'	808416
38	TAG, STATION NUMBER	1	300 SECTION

FOR FIELD MAINTENANCE ONLY

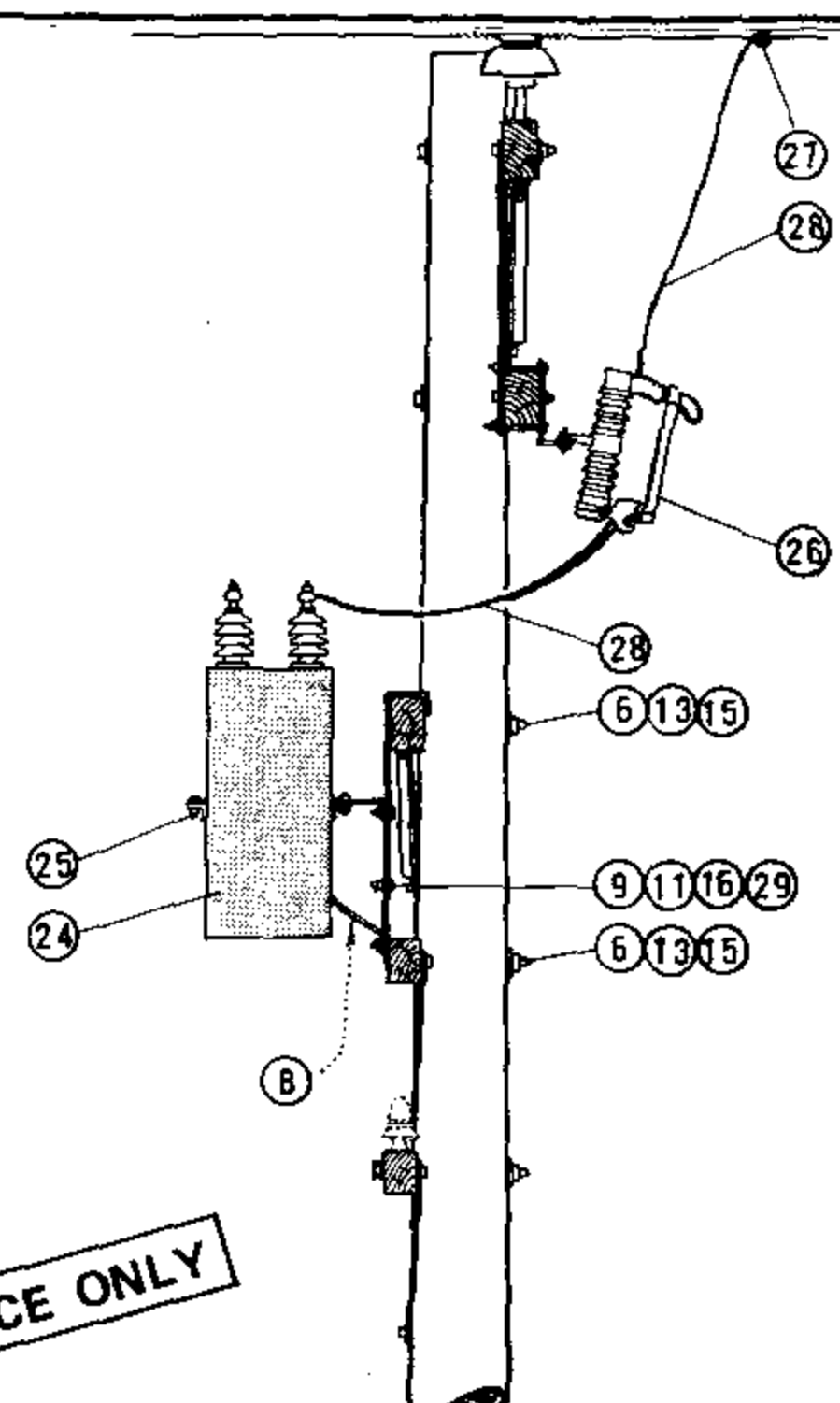
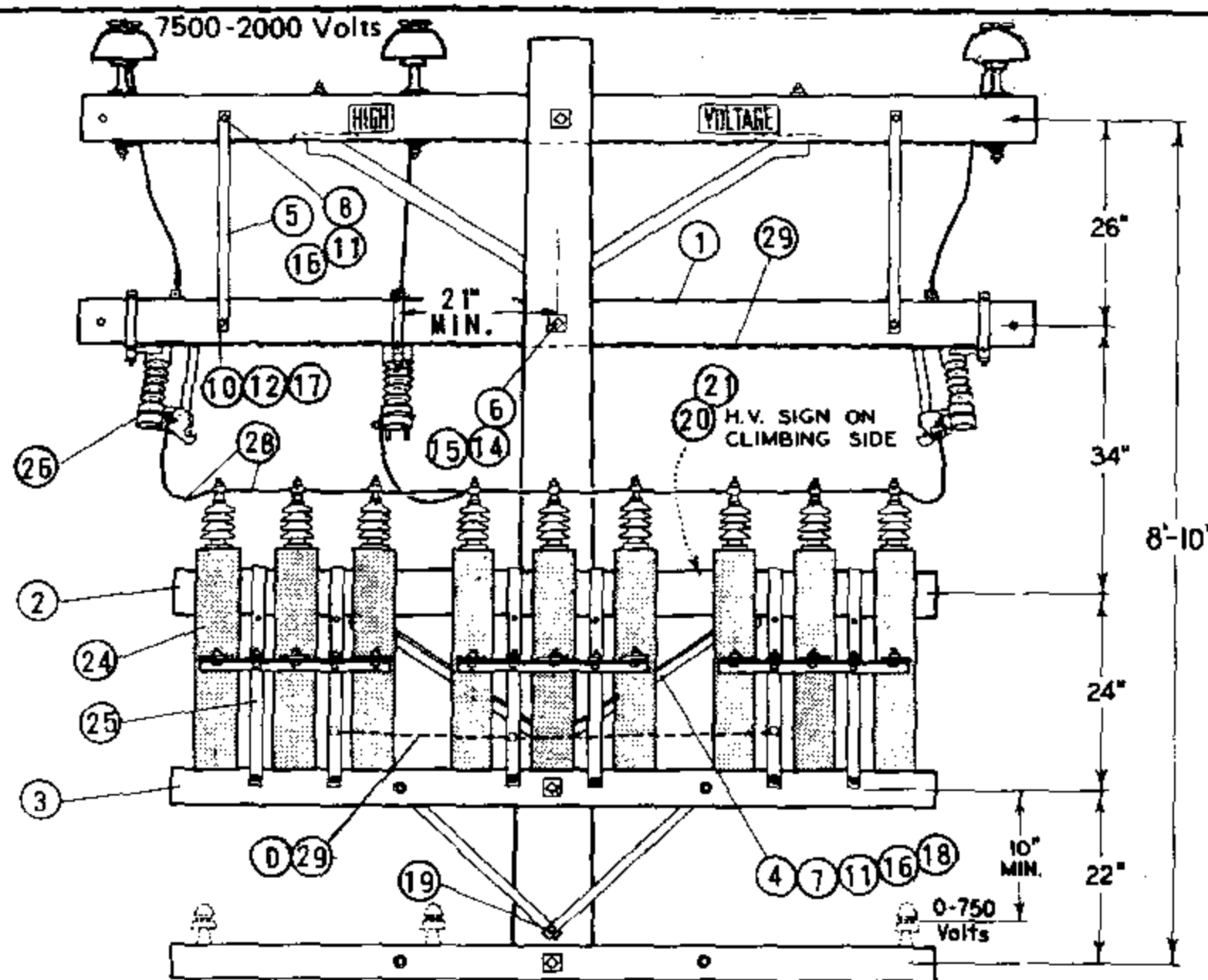

DIAGRAM OF 12KV WYE CONNECTIONS

600 KVAR (6-100 KVAR UNITS)
300 KVAR (6-50 KVAR UNITS)
150 KVAR (6-25 KVAR UNITS)

DIAGRAM OF 12KV WYE CONNECTIONS

900 KVAR (9-100 KVAR UNITS)
450 KVAR (9-50 KVAR UNITS)
225 KVAR (9-25 KVAR UNITS)

FOR FIELD MAINTENANCE ONLY

INSTALLATION:

- (A) QUANTITY BASED ON 45' POLE.
- (B) BRACKETS TO BE MOUNTED IN LOWER POSITION FOR 50 AND 100 KVAR UNITS.
- C. BOND ALL 12KV HARDWARE WITHIN 3 MILES OF COAST.
- (D) BOND ALL RACKS AS SHOWN IN ILLUSTRATION.
- (E) EXEMPT MATERIAL.
- (F) NO LONGER PURCHASED.
- G. SEE PAGE 1323 FOR MATERIAL NEEDED FOR LIGHTING ARRESTERS ON 900 KVAR INSTALLATIONS.

ITEM	DESCRIPTION	QUANTITY		STOCK NO. OR CONSTR. STD.	ITEM	DESCRIPTION	QUANTITY		STOCK NO. OR CONSTR. STD.
		6	9				6	9	
1	CROSSARM, 3 3/4" X 5 3/4" X 10' - 0"	1	1	380.01	16	WASHER, 1/2" SPRING DBL COIL	6	6	798464 (E)
2	CROSSARM, 3 3/4" X 5 3/4" X 8' - 0"	1	1	380.05	17	WASHER, 3/8" SPRING DBL COIL	2	2	798528 (E)
3	CROSSARM, 3 1/2" X 4 1/2" X 8' - 0"	1	1	380.05	18	SCREW, LAG GALV. 5/8" X 5"	1	1	621600 (E)
4	BRACE, ANGLE CROSSARM, 4' - 0"	1	1	164032	19	SCREW, LAG GALV. 1/2" X 4"	1	1	621568 (E)
5	BRACE, FLAT CROSSARM, 28"	2	2	164192	20	SIGN, HIGH VOLTAGE	1	1	647648 (E)
6	BOLT, MACH. GALV. 5/8" X (LENGTH AS REQ'D) & 1 NUT	3	3	139 (E)	21	NAILS, ROOFING #8 GALV.	8	8	492224 (E)
7	BOLT, MACH. 1/2" X 7" & 1 NUT	2	2	153120 (E)	22	STEPS, POLE (A)	16	16	692992 (E)
8	BOLT, MACH. GALV. 1/2" X 5" & 1 NUT	2	2	153024 (E)	23				
9	BOLT, MACH. GALV. 1/2" X 1 1/2" & 1 NUT	2	3	152608 (E)	24	CAPACITOR, UNIT 7.2KV (100 KVAR (E) UNITS ILLUSTRATED)	6	9	207232
10	BOLT, MACH. GALV. 3/8" X 5" & 1 NUT	2	2	154368 (E)	25	RACK, CAPACITOR	2	3	402656
11	WASHER, 1/2" ROUND	10	8	800192 (E)	26	CUTOUT, 12KV, 100A HEAVY DUTY WITH LOADBUSTER HOOKS	3	3	297888
12	WASHER, 3/8" ROUND	2	2	800288 (E)	27	CONNECTORS, COMPRESSION	3	3	786, 783 (E)
13	WASHER, 3" SQ. CURVED	4	4	798912 (E)	28	WIRE, #6 BARE STRANDED COPPER	33'	35'	813536
14	WASHER, 2 1/4" SQ. FLAT	2	2	799040 (E)	29	WIRE, #8 BARE SOLID ANNEALED COPPER	13'	15'	812928
15	WASHER, 5/8" SPRING DBL COIL	3	3	798560 (E)	30				

SDG & E ELECTRIC STANDARDS

DATE 11-5-82
APPD *JAT/REH*

CAPACITOR INSTALLATIONS, 12KV - WYE - 900 KVAR MAX.

1399.207
SUPERSEDES
1322 (11-5-82)

SCOPE: THIS CONSTRUCTION SHALL BE USED FOR ALL SWITCHED CAPACITOR BANKS REQUIRING A CURRENT SENSOR.

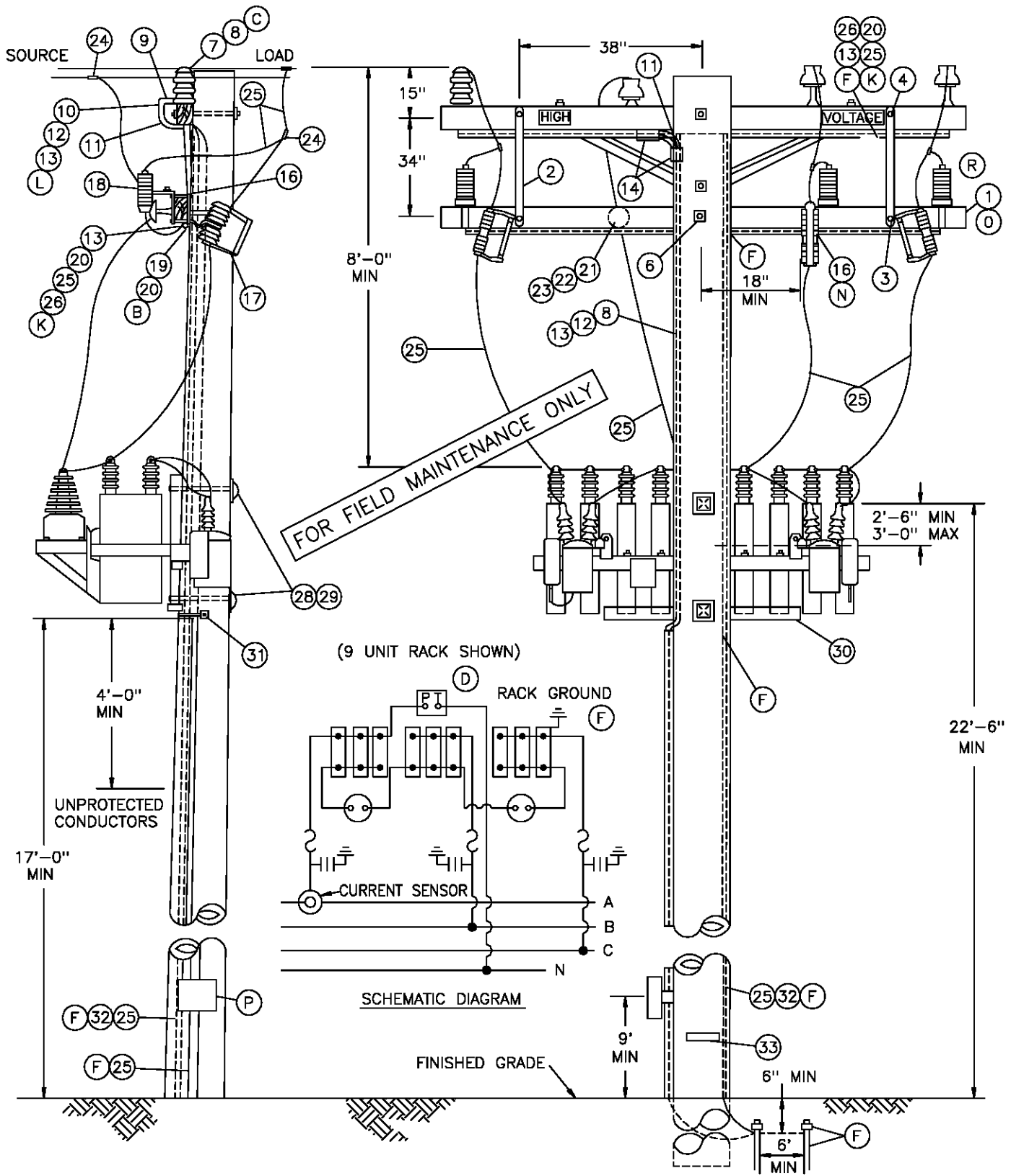

1399.208

SUPERSEDES
1326.1 (12-1-98)

SDG&E ELECTRIC STANDARDS

SWITCHED CAPACITORS - CURRENT SENSOR
12 & 12.47KV

DATE 12-1-98

APPD PJA / CLK

NOTES:

- SENSOR PRODUCES ONE VOLT FOR EACH 60 AMPERES OF LINE CURRENT. OPEN CIRCUIT VOLTAGE IS NOT SIGNIFICANTLY HIGH.
- CLASS OF POLE IS TO BE DETERMINED PER STANDARD 344-354.

BILL OF MATERIAL:

ITEM	DESCRIPTION	QUANTITY	STOCK NO. OR CONSTR STANDARD	
1	CROSSARM, 3 3/4" X 5 3/4' X 10' - 0" (B)	1	294128	
2	BRACE, FLAT, CROSSARM, 28" (O)	2	164192	
3	BOLT, MACH, GALV, 3/8" X 4 1/2", 1 ROUND & 1 LOCK WASHER (O)	2	STD 392	
4	BOLT, MACH, GALV, 1/2" X 5", 1 ROUND & 1 DBL COIL SPR WASH (O)	2	STD 392	
5				
6	BOLT, MACH, GALV, 5/8" X (LENGTH AS REQ'D), 2 SQUARE & 1 DBL COIL SPRING WASHER	1	STD 392	
7	STUD, INSULATOR	1	701760	
8	SENSOR, CURRENT, COMPLETE WITH WHITE, GREEN AND BLACK INSULATED CONTROL WIRE	1	635820	
9	TERMINAL ADAPTOR, PVC, 3/4"	1	102754	
10	SLIP ELBOW, 90 PVC, 3/4"	2	322174	
11	ELBOW, STANDARD RADIUS, PVC, 3/4"	2	322166	
12	CONDUIT, PVC, TYPE 2, SCHED 40, 3/4"	15'	251328	
13	STRAPS, PIPE, GALV, 3/4" & 2 - 1 3/4" ROOFING NAILS, GALV.	AS REQ'D	697888	
14	COUPLING, PVC, 3/4"	2	280416	
15				
16	BRACKET, DOUBLE CUTOUT/ARRESTER, FOR CROSSARM MOUNTING.	3	165442	
17	CUTOUT, 12KV, 100A, WITH LOADBUSTER HOOKS	3	STD 1212	
18	ARRESTER, LIGHTNING, 12KV	3	113248	
19	WIRE, #8 BARE SOLID ANNEALED COPPER (B)	15' OR 1 LB	812928	
20	STAPLES, WIRE, GALV, 1 1/4" (B)	AS REQ'D	678528	
21	BOLT, MACH, GALV, 5/8" X (LENGTH AS REQ'D) 2 SQUARE AND 1 DOUBLE COIL SPRING WASHER	1	STD 392	
22	PIN, TRANSFORMER ADAPTOR, 1" LEAD THREAD	1	529248	
23	INSULATOR, LINE, 12KV NEUTRAL	1	429216	
24	CONNECTOR, WIRE COMPRESSION, CU OR AL (SIZE AS REQ'D)	AS REQ'D	783-786	
25	WIRE, #4 BARE STRANDED COPPER	130' OR 17 LBS	813760	
26	MOULDING, OAK HARDWOOD, 1" X 8'	2	487200	
27				
28	BOLT, MACH, GALV, 3/4" X (LENGTH AS REQ'D), 1 SQ CURV RIBBED & 1 DBL COIL SPRING WASHER	2	STD 392	
29	COVER, BOLT PLASTIC & 6 - 1 3/4" NAILS, GALV	2	285696	
		-	492192	
30	CAPACITOR RACK - COMPLETE WITH CAPACITORS	600 KVAR (3 @ 200 KVAR)	1	564761
		900 KVAR (6 @ 150 KVAR) (J)	1	564706
		1200 KVAR (3 @ 400 KVAR) (M)	1	564770
		1350 KVAR (9 @ 150 KVAR) (J)	1	564754
31	SCREW, LAG, GALV, 4"	2	621568	
32	UNIT GROUND, COMPLETE	1	603136	
33	TAG, STATION NUMBER	1	200 SECT.	

FOR FIELD MAINTENANCE ONLY

DATE 12-1-98	SDG&E ELECTRIC STANDARDS	1399.209
APPD PJA / CMK	SWITCHED CAPACITORS - CURRENT SENSOR 12 & 12.47KV	SUPERSEDES 1326.2 (12-1-98)

OVERHEAD MACRO UNITS 12KV SWITCHED CAPACITOR W/CURRENT SENSOR		
KVAR	CONTROL	MU I.D.
600	VAR/VOLT OVERRIDE	C6CV
600	VOLT W/TIME BIAS	C6CTB
900	VAR/VOLT OVERRIDE	C9CV
900	VOLT W/TIME BIAS	C9CTB
1200	VAR/VOLT OVERRIDE	C12CV
1200	VOLT W/TIME BIAS	C12CTB
1350	VAR/VOLT OVERRIDE	C13CV
1350	VOLT W/TIME BIAS	C13CTB

INSTALLATION:

- A. CAUTION: OPEN OIL SWITCHES BEFORE OPENING CUTOUTS.
- ⓑ BOND CUTOUTS IN HEAVY CONTAMINATION DISTRICTS AS SHOWN ON STANDARD 287. IN AREAS WHERE BONDING IS REQUIRED, TO AVOID BONDWIRE AND LIGHTNING ARRESTER GROUNDWIRE ON THE SAME CROSSARM, USE TWO CROSSARMS; ONE FOR CUTOUTS AND ONE FOR LIGHTNING ARRESTER.
- ⓒ THE CONTROL IS POLARITY SENSITIVE. WIRE AS SHOWN, ALWAYS FACE NIPPLE OF CURRENT SENSOR TOWARD LOAD, AND INSTALL CUTOUTS ON THE SOURCE SIDE.
- ⓓ THE H1 TERMINAL OF THE POTENTIAL TRANSFORMER MUST BE CONNECTED TO THE SAME PHASE AS THE CURRENT SENSOR.
- ⓔ CONNECT CAPACITOR RACK GROUND LEAD, CURRENT SENSOR BASE AND ALL INSULATOR PINS GROUND LEAD TO LIGHTNING ARRESTER GROUND. A SECOND GROUND WIRE IS REQUIRED FOR THE CONTROL PANEL TO BE CONNECTED ON THE SAME GROUND ROD. COIL LOOSE END OF CONTROL PANEL GROUND WIRE AND STAPLE TO POLE (TO BE WORKED BY SERVICE CREW).
- G. DO NOT TIE CAPACITOR BANK NEUTRAL TO 12KV CIRCUIT NEUTRAL. IT IS TO REMAIN FLOATING.
- H. RACKS THAT CONTAIN POTENTIAL TRANSFORMERS WITH METAL TANKS ARE TO BE INSULATED FROM RACK BEFORE REINSTALLATION.
- I. CAPACITORS MUST BE INSTALLED ON POLES ACCESSIBLE BY BUCKET TRUCKS.
- ⓙ NO LONGER PURCHASED.
- Ⓚ PVC CONDUIT 3/4" SCHEDULE 40 MAY BE USED IN PLACE OF HARDWOOD MOULDING.
- Ⓛ REMOVE STEEL NIPPLE FROM CURRENT SENSOR BASE.
- Ⓜ ON VAR CONTROL BANKS, REPLACE 12,000 – 120 POTENTIAL TRANSFORMER (STOCK #762708) WITH 7200–120 POTENTIAL TRANSFORMER (STOCK #762734).
- Ⓝ DRILL THROUGH CROSSARM 1" UP FROM LOWER EDGE SO THAT LOWER CROSSARM MOUNTING BRACKET BOLT DOES NOT INTERFERE WITH PVC CONDUIT.
- Ⓞ WHEN LA/CO CROSSARM AND CAPACITORS CANNOT BE INSTALLED ON THE SAME SIDE OF THE POLE AS AN EXISTING LINEARM, DELETE ITEMS 2, 3, & 4. INSTEAD, FIELD DRILL LA/CO CROSSARM FOR 2 – 36" FLAT BRACES. SECURE BRACES TO POLE WITH A LAG SCREW. (SEE STD. 380.1, ITEM 1 FOR DRILLING MEASUREMENTS).

FOR FIELD MAINTENANCE ONLY

REFERENCE:

- Ⓟ SHOWN FOR ILLUSTRATIVE PURPOSES ONLY. SEE STANDARD 1330 FOR CONTROL INSTALLATION AND MATERIAL.
- Ⓠ PVC CONDUIT IS NOT PERMITTED IN THE CLIMBING SPACE, G.O. 95 RULE 22.2(C).
- Ⓡ SECTIONALIZING CUTOUT INSTALLATION MAY VARY WITH POSITION OF NEUTRAL CONDUCTOR – SEE STANDARD 1240.

<p>1399.210 SUPERSEDES 1326.3 (12-1-98)</p>	<p>SDG&E ELECTRIC STANDARDS</p> <p>SWITCHED CAPACITORS – CURRENT SENSOR</p> <p>12 & 12.47KV</p>	<p>DATE 12-1-98 APPD <i>PA/BJ</i></p>
-----------------------------------------------------	---------------------------------------------------------------------------------------------------------	-------------------------------------------

SCOPE: THIS STANDARD SHOWS THE PREFERRED METHOD OF CONSTRUCTION FOR A FIXED CAPACITOR WHEN A NEW POLE IS REQUIRED.

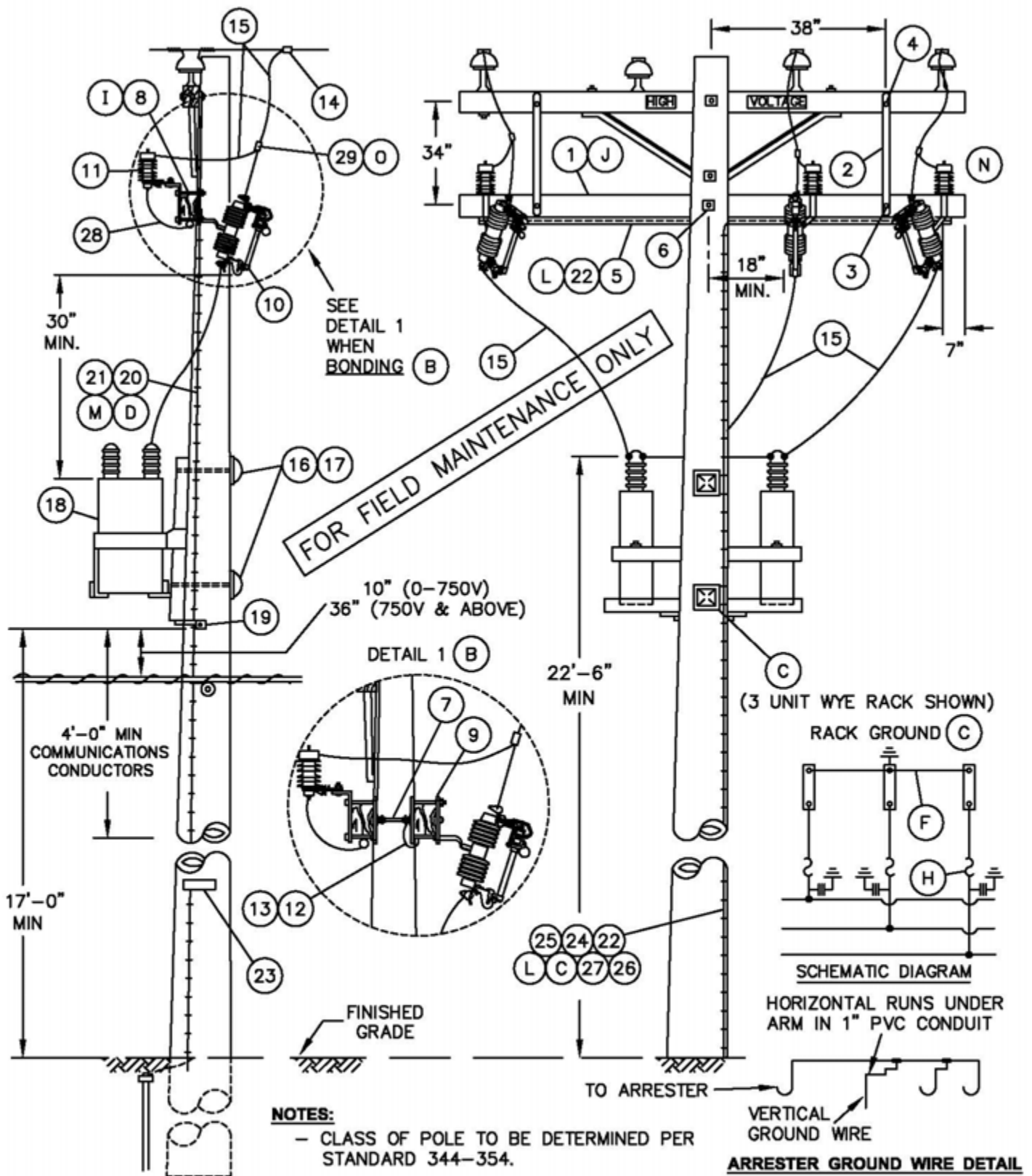

SDG&E ELECTRIC STANDARDS

1399.211

FIXED CAPACITOR INSTALLATION, 4KV WYE
4KV WYEGROUNDED RACK

DATE 6-9-09
APPD PJA/ MC

OVERHEAD MACRO UNITS 4KV CAPACITOR STATIONS		
FIXED-UNGROUNDED (FIG. 2)		
4	130	C4F3P

FOR FIELD MAINTENANCE ONLY

INSTALLATION:

- A. CAPACITORS MUST BE INSTALLED ON POLES ACCESSIBLE BY BUCKET TRUCK.
- (B) BOND CUTOUTS IN HEAVY CONTAMINATION DISTRICTS AS SHOWN ON STANDARD 287. IN AREAS WHERE BONDING IS REQUIRED, TO AVOID BONDWIRE AND LIGHTNING ARRESTER GROUNDWIRE ON THE SAME CROSSARM, USE TWO CROSSARMS; ONE FOR CUTOUTS AND ONE FOR LIGHTNING ARRESTERS.
- (C) CONNECT CAPACITOR RACK GROUND LEAD TO LIGHTNING ARRESTER GROUND
- (D) RUN 1/2" SCHEDULE 40 PVC CONDUIT WITH LIGHTNING ARRESTER GROUND FROM LIGHTNING ARRESTER ARM TO A MINIMUM OF 2 FEET BELOW CAPACITOR RACK, THEN CONTINUE DOWN THE POLE USING PVC COVERED GROUND WIRE.
- (G) TEN INCHES FROM 0-750V CONDUCTORS BELOW, 12 INCHES FOR CONDUCTORS OF 750-7500V, 18 INCHES FOR CONDUCTORS OF 7500-22,500V PER G.O. 95 RULE 58.1-D.
- (H) FUSE STATION ACCORDING TO CAPACITOR FUSING TABLE, STANDARD 1309.
- (I) DRILL THROUGH CROSSARM 1" UP FROM LOWER EDGE SO THAT LOWER CROSSARM MOUNTING BRACKET BOLT DOES NOT INTERFERE WITH PVC CONDUIT.
- (J) WHEN LA/CO CROSSARM AND CAPACITORS CANNOT BE INSTALLED ON THE SAME SIDE OF THE POLE AS AN EXISTING LINEARM, DELETE ITEMS 2, 3, & 4. INSTEAD, FIELD DRILL LA/CO CROSSARM FOR 2-36" FLATBRACES. SECURE BRACES TO POLE WITH A LAG SCREW. (SEE STD. 380.1, ITEM 1)

REFERENCE:

- (L) FOR GROUNDING REQUIREMENTS AND APPLICATION - SEE STANDARD 1002.
- (M) PVC CONDUIT IS NOT PERMITTED IN THE CLIMBING SPACE PER G. O. 95, RULE 22.2B.
- (N) SECTIONALIZING CUTOUT INSTALLATION MAY VARY WITH POSITION OF NEUTRAL CONDUCTOR - SEE STANDARD 1240.
- (O) FOR HOT LINE CLAMP CONNECTION, SEE STANDARD 788.

DATE 6-9-09 APPD <i>PSA</i> /MC	SDG&E ELECTRIC STANDARDS	
	FIXED CAPACITOR INSTALLATION, 4KV WYE	1399.212

BILL OF MATERIAL:

ITEM	DESCRIPTION			QUANTITY (B)		STOCK NO. OR CONSTR STANDARD	ASSEMBLY UNIT
				UNBONDED	BONDED		
1	CROSSARM, 3 3/4" X 5 3/4" X 10' - 0" (B)			1	2	294128	-
2	BRACE, FLAT, CROSSARM, 36" (J)			2	2	164224	-
3	BOLT, MACH, GALV, 3/8" X 4 1/2", 1 ROUND & 1 LOCK WASHER (J)			2	2	STD 392	-
4	BOLT, MACH, GALV, 1/2" X 5", 1 ROUND & 1 DBL COIL SPR WASH (J)			2	2	STD 392	-
5	CONDUIT, PVC, TYPE 2, SCHEDULE 40, 1" AND STRAPS, PIPE, GALV. 1" WITH 1 3/4" ROOFING NAILS			10'	10'	251200	-
				AS REQ'D		697792	-
6	BOLT, MACH, GALV, 5/8" X (LENGTH AS REQ'D), 2 SQUARE & 1 DBL COIL SPRING WASHER			1	1	STD 392	-
7	BOLT, SPACE, GALV, 5/8" X (LENGTH AS REQ'D), 2 ROUND 4 SQUARE, 2 DOUBLE COIL SPRING WASHERS & 2 NUTS			-	2	STD 392	-
8	BRACKET, DOUBLE CUTOUT/ARRESTER, FOR CROSSARM MOUNTING.			3	-	165442	-
9	BRACKET, ARRESTER OR CUTOUT			-	6	166070	-
10	CUTOUT, 12KV, 100A, WITH LOADBUSTER HOOKS			3	3	STD 1212	-
11	ARRESTER, LIGHTNING (SEE STD. 1247 FOR 4KV APPLICATION) OR			4 KV	3	113216	-
				12 KV	3	113248	-
12	WIRE, #8 BARE SOLID ANNEALED COPPER (B)			FT	15	812928	-
				LB	1		
13	STAPLES, WIRE, GALV, 1 1/4" (B)			AS REQ'D		678528	-
14	CONNECTOR, WIRE COMPRESSION, CU OR AL (SIZE AS REQ'D)			AS REQ'D		783-786	-
15	WIRE, #4 BARE STRANDED COPPER			FT	100	813760	-
				LB	13		
16	BOLT, MACH, GALV, 3/4" X (LENGTH AS REQ'D), 1 SQ CURV RIBBED & 1 DBL COIL SPRING WASHER			2	2	STD 392	-
17	COVER, BOLT PLASTIC & 6 - 1 3/4" NAILS, GALV			2	2	285696	-
				-	-	492192	-
18	CAPACITOR RACK - COMPLETE WITH CAPACITORS	4KV	130 KVAR (3 @ 400 KVAR)	1	1	564776	-
19	SCREW, LAG, GALV, 4"			2	2	621568	-
20	CONDUIT, PVC, TYPE 2, SCHEDULE 40, 1/2" (D)			10'	10'	251168	-
21	STRAPS, PIPE, GALV, 1/2", AND 2- 1 3/4" ROOFING NAILS, GALV.			AS REQ'D		697728	-
				-	-	492192	-
22	#4 CU SOLID GROUND WIRE, PVC COVERED			50'	50'	812490	GNDPVC
23	TAG, STATION NUMBER			1	1	200 SECT.	-
24	GROUND ROD, 5/8" X 8", COPPERWELD			1	1	603072	GNDPVC
25	COPPER BONDED GROUND CONNECTOR			1	1	259010	-
26	GROUND ENHANCING POWER SOLUTION (GEM)			AS REQ'D		424390	-
27	GALVANIZED STAPLES FOR PVC COVERED GROUND WIRE			AS REQ'D		678562	-
28	FLEXIBLE ARRESTER GROUND STRAP			AS REQ'D		698754	-
29	HOT LINE CLAMP			3	3	227680	-

FOR FIELD MAINTENANCE ONLY

1399.213	SDG&E ELECTRIC STANDARDS		DATE 6-9-09 APPD PJA/MC
	FIXED CAPACITOR INSTALLATION, 4KV WYE		

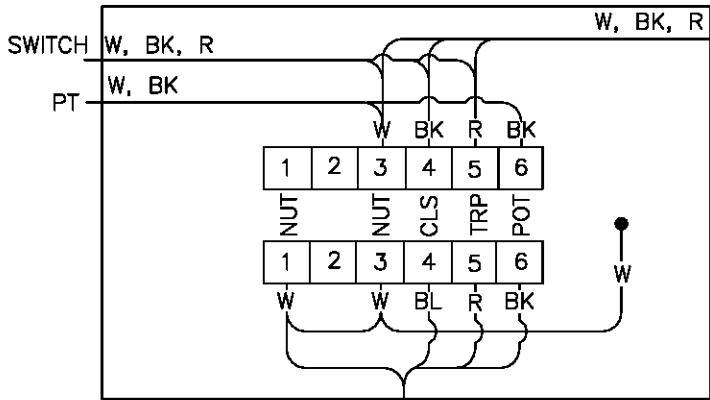

JUNCTION BOX

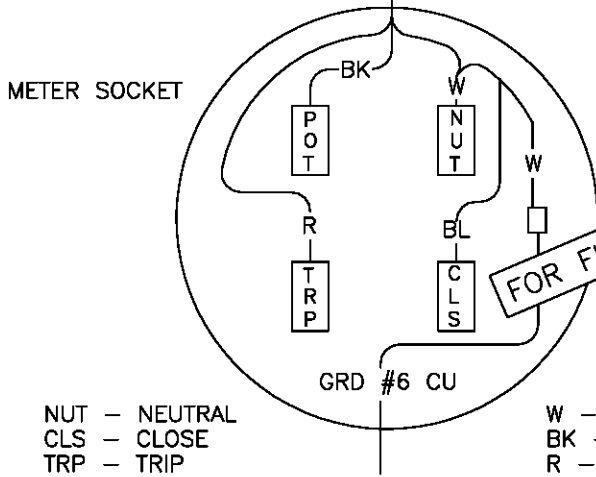

- NUT - NEUTRAL
- CLS - CLOSE
- TRP - TRIP
- POT - POTENTIAL
- W - WHITE
- BK - BLACK
- R - RED
- BL - BLUE

CAPACITOR CONTROL WIRING
VOLTAGE W/TIME BIAS

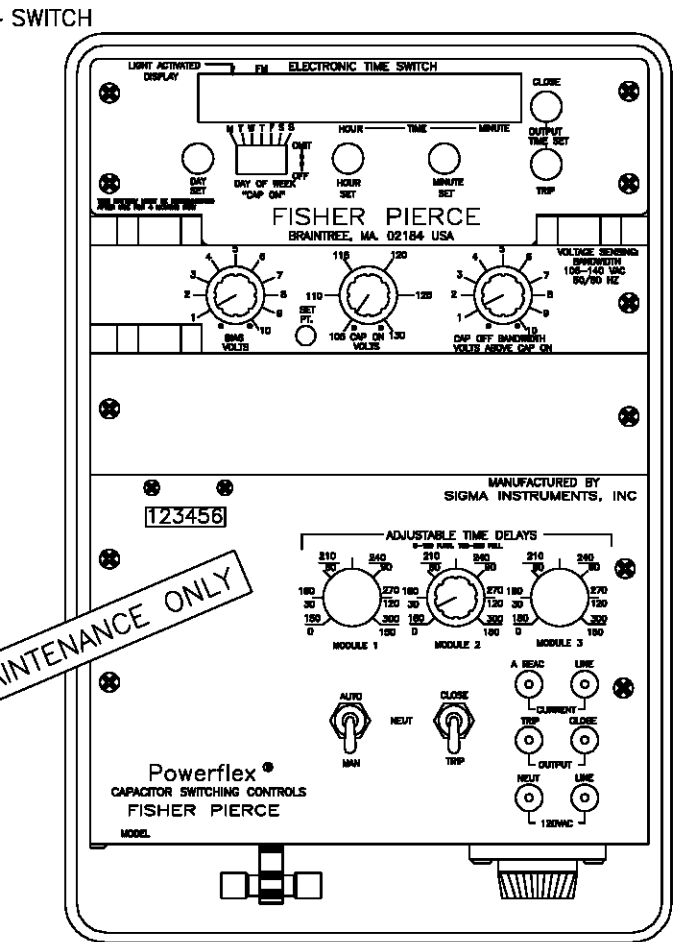

CONTROL PANEL
FISHER PIERCE (MODEL 2416)

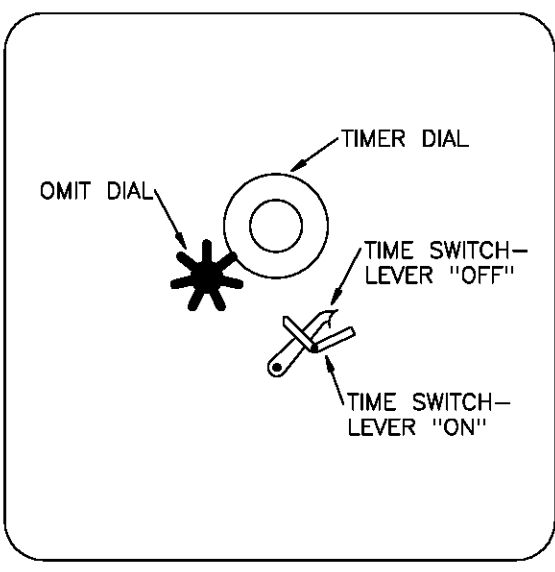

CONTROL PANEL - SANGAMO (MODEL VS)

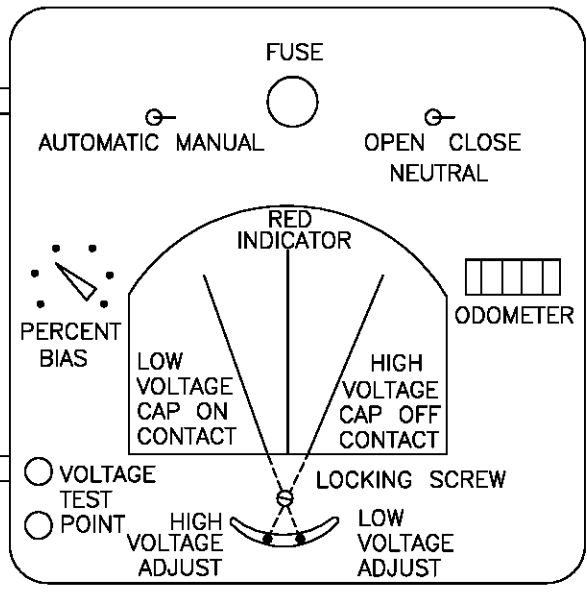

FUSE REPLACEMENT 10 AMP BUSS FNM10

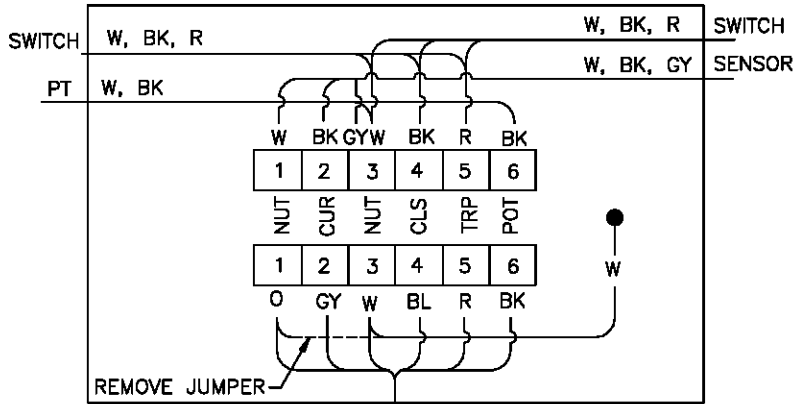

TO GROUND OUT SENSOR,
INSTALL JUMPER WHEN
CONTROL IS REMOVED.

JUNCTION BOX
METER SOCKET

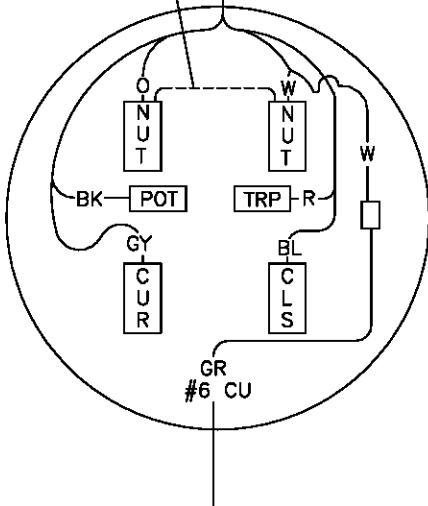

AC VOLTMETER
<5V

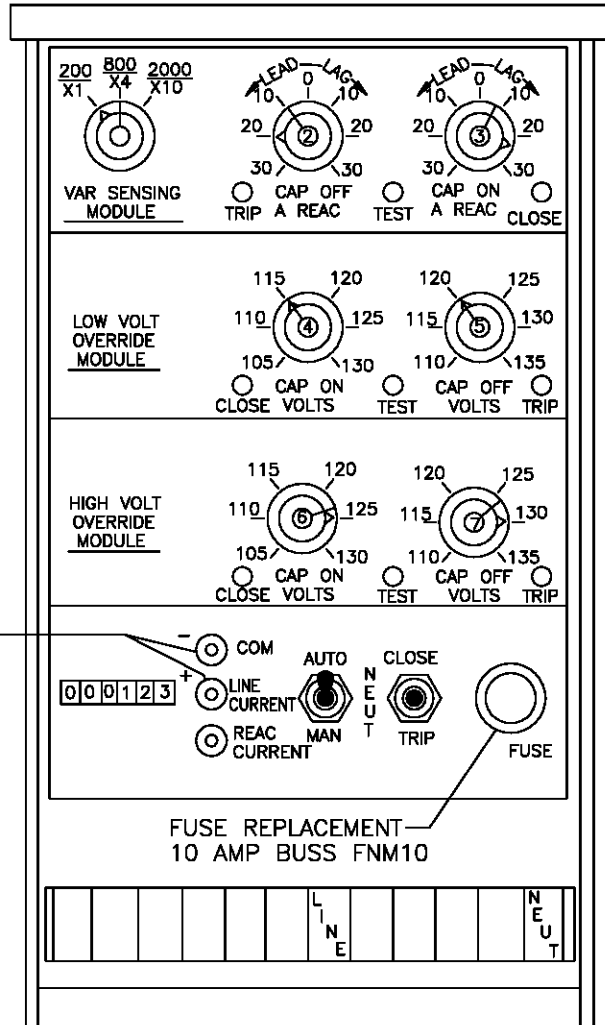

CONTROL WIRE LEGEND

- NUT - NEUTRAL
- CUR - CURRENT SENSOR POTENTIAL
- CLS - CLOSE
- TRP - TRIP
- POT - POTENTIAL

- W - WHITE
- BK - BLACK
- GY - GREEN
- R - RED
- O - ORANGE
- BL - BLUE

FOR FIELD MAINTENANCE ONLY

**CONTROL PANEL
FISHER PIERCE (MODEL 4604)**

**CAPACITOR CONTROL WIRING
VAR W/VOLTAGE OVERRIDE**

1399.302
SUPERSEDES
1330.3 (1-1-90)

SDG&E ELECTRIC STANDARDS

CAPACITOR CONTROL MATERIAL AND INSTALLATION
TYPE 'VAR'

DATE 1-1-2000
APPD *PA/BJ*

SCHEMATIC DIAGRAM OF A 12KV OPEN DELTA REGULATOR STATION

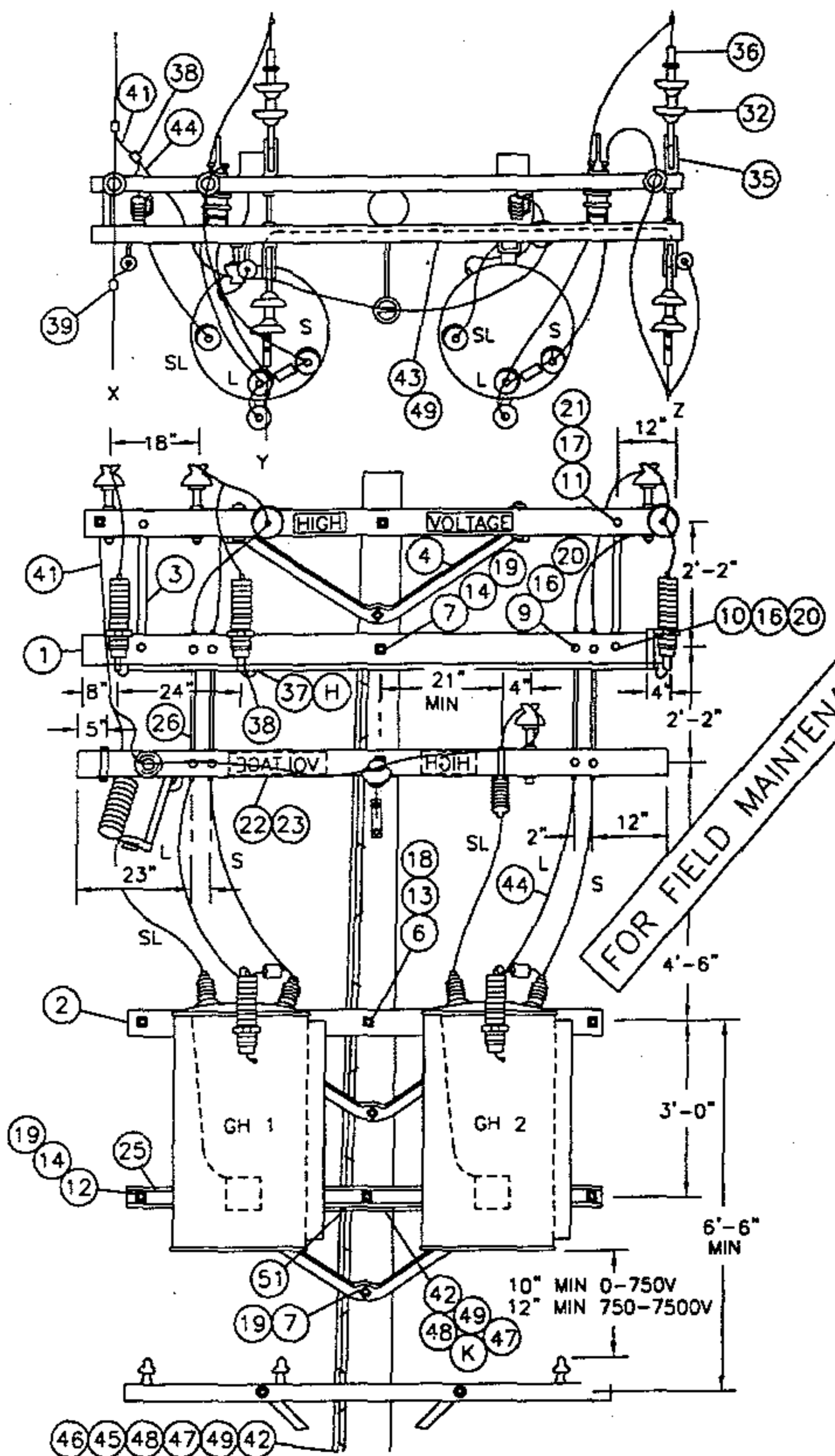
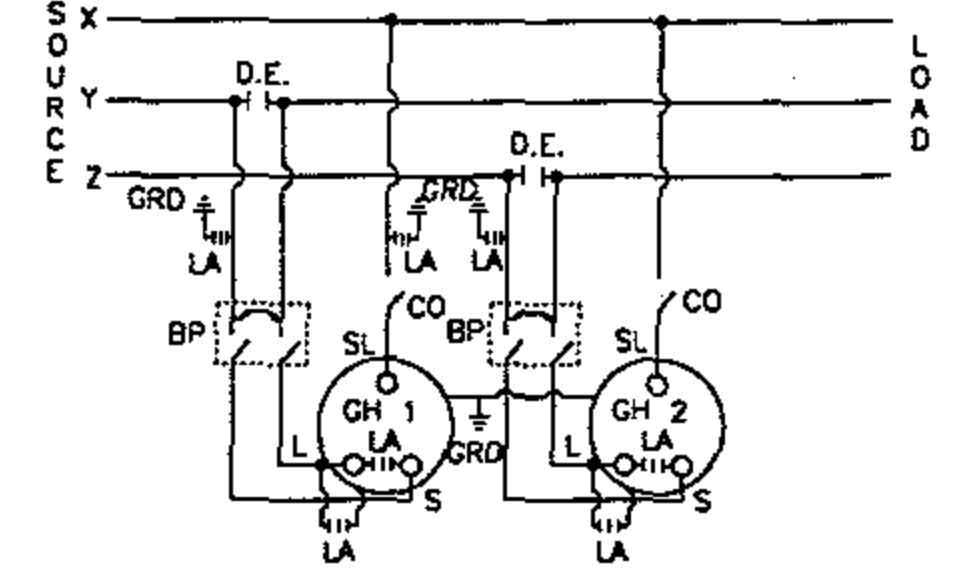

FOR FIELD MAINTENANCE ONLY

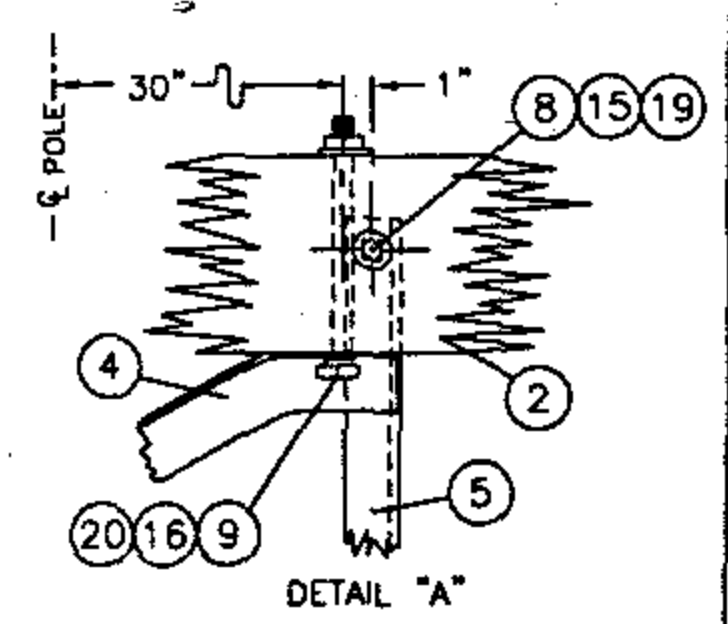
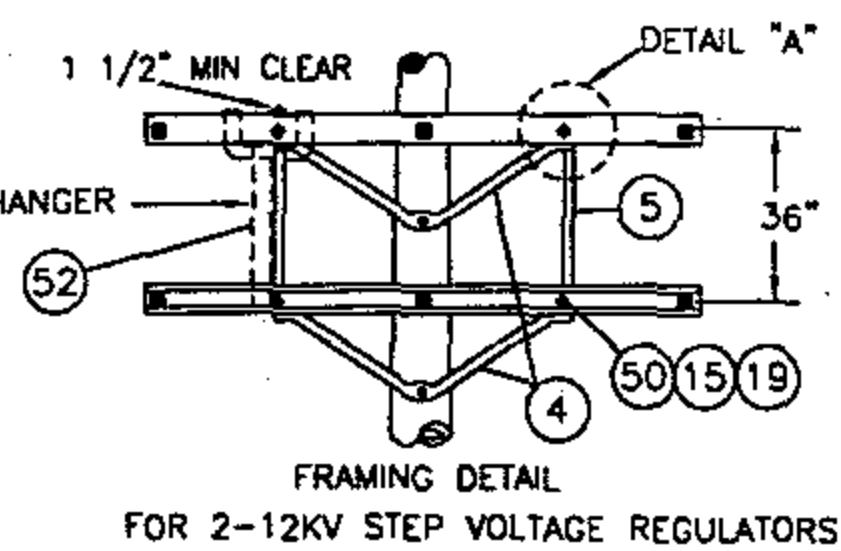
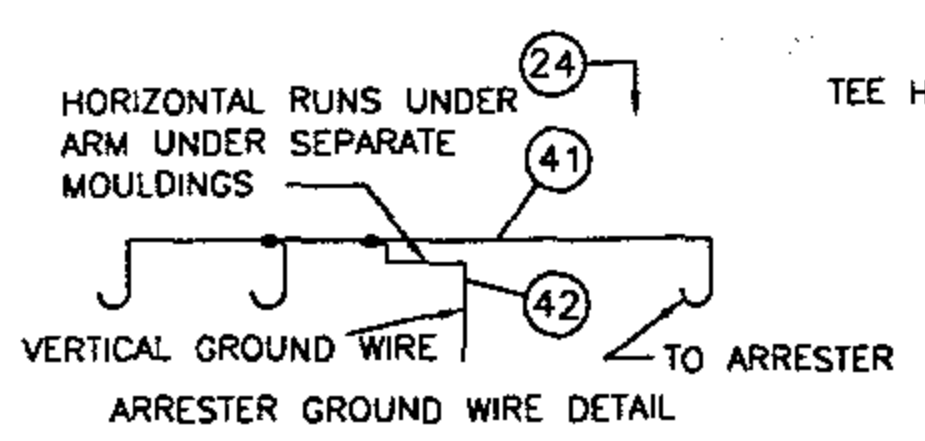
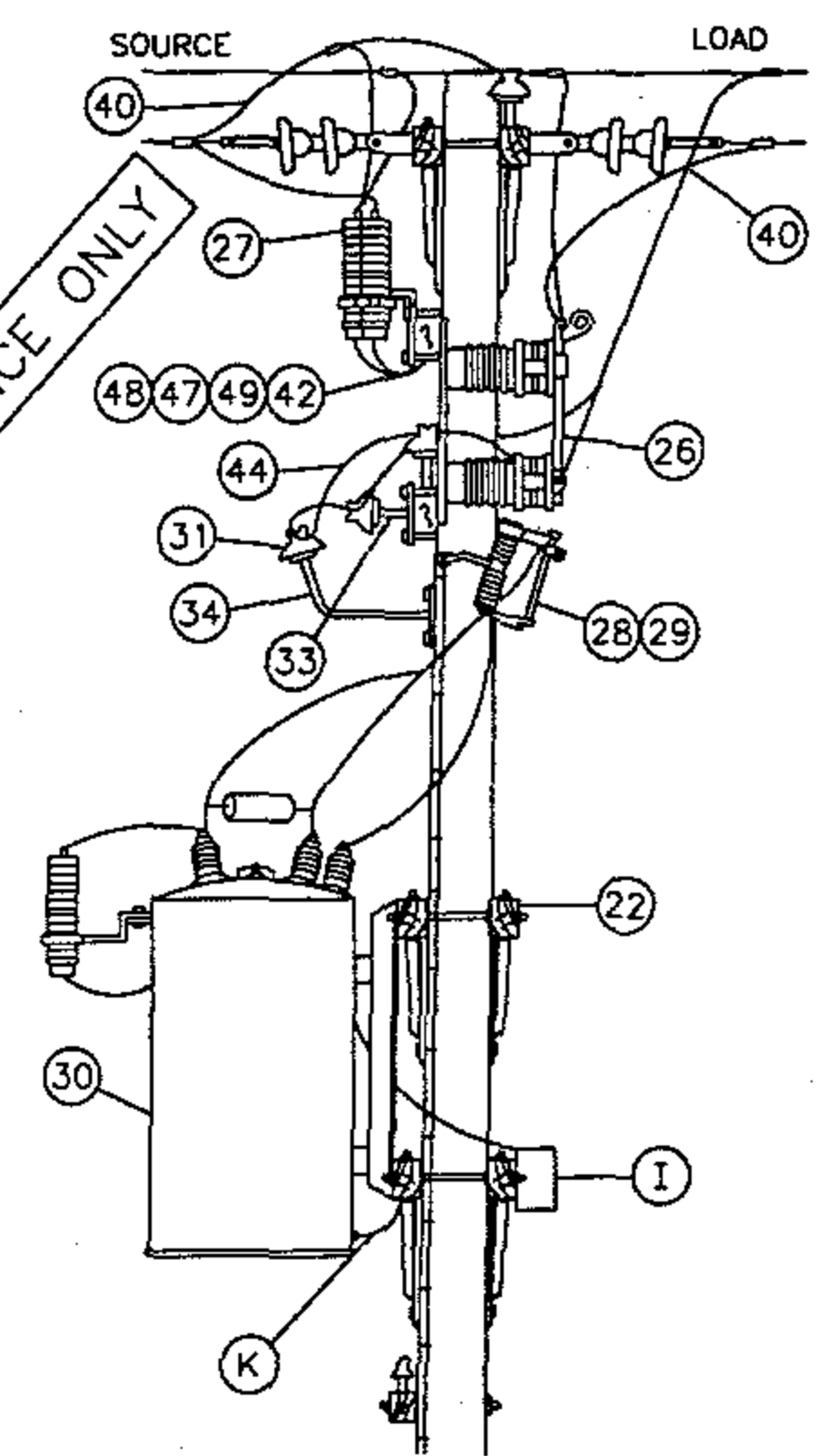

SDG&E ELECTRIC STANDARDS

1399.401
SUPERSEDES
1348.1 1-1-96

STEP-VOLTAGE REGULATOR STATION, OPEN DELTA, 12KV

DATE 1-1-96
APPD PIA 1009

NOTES:

- A. CAUTION: WHEN CONNECTING A STATION, REGULATORS MUST BE ON NEUTRAL. CLOSE CUTOUT TO SL BUSHING BEFORE CLOSING BYPASS DISCONNECT ON THAT POLE. WHEN DISCONNECTING A STATION, PUT REGULATORS ON NEUTRAL, AND OPEN BYPASS DISCONNECT BEFORE OPENING CUTOUT TO SL BUSHING. THIS AVOIDS A SERIOUS OVERLOAD CONDITION.
- B. ON NEW CONSTRUCTION, USE AN EXTRA HEAVY CLASS ONE POLE WITH 10" MIN TOP DIA.
- C. USE TWO GROUND RODS FOR THE ARRESTERS AND TANKS. ALL GROUND RODS SHOULD BE SPACED A MINIMUM OF SIX FEET APART.
- D. UNIT GROUND COMPLETE, ORDER 603136.
- F. BOND ALL CUTOUTS IN HEAVY CONTAMINATION DISTRICT AS IDENTIFIED ON STANDARDS PAGE 287.
- G. BOND DEAD-END HARDWARE
- H. INTERCONNECT ARRESTER GROUND LEAD DISCONNECTS WITH #6 BARE COPPER AND GROUND IT WITH #2 BARE COPPER NEAR CENTER ARRESTER.
- I. CONTROLS WILL BE MOUNTED BY KEARNY MAINTENANCE.
- J. INSTALL DOUBLE COIL SPRING WASHER ON END OF BOLT WHICH ATTACHES TO LARGEST METALLIC OBJECT, SUCH AS A BRACKET OR BRACE.
- K. REGULATOR TANKS SHALL BE PERMANENTLY GROUNDED.

ITEM			DESCRIPTION	QUANTITY	STOCK NO. OR CONSTR STD
PTF	LTI	OCD			
1			CROSSARM 3 3/4" X 5 3/4" X 10' - 0"	3	380
2			CROSSARM 3 3/4" X 5 3/4" X 8' - 0"	4	380
3			BRACE, FLAT CROSSARM 28"	2	164192
4			BRACE, ANGLE CROSSARM 5' - 0"	5	164128
5			BRACE, VERTICAL 36"	2	164256
6			BOLT, MACH 3/4" X ---	2	100 SECTION
7			BOLT, MACH 5/8" X ---	4	100 SECTION
8			BOLT, MACH 5/8" X 5"	2	155488
9			BOLT, MACH 1/2" X 7"	16	153120
10			BOLT, MACH 1/2" X 5"	2	153024
11			BOLT, MACH 3/8" X 5"	2	154368
12			BOLT, SPACE 5/8" X ---	7	100 SECTION
13			WASHER, 3" SQ FLAT	4	799104
14			WASHER, 2 1/4" SQ FLAT	28	799040
15			WASHER, 5/8" ROUND	4	800320
16			WASHER, 1/2" ROUND	20	800192
17			WASHER, 3/8" ROUND	2	800288
18			WASHER, 3/4" SPRING DBL COIL	2	798496
19			WASHER, 5/8" SPRING DBL COIL	21	798560
20			WASHER, 1/2" SPRING DBL COIL	20	798464
21			WASHER, 3/8" SPRING DBL COIL	2	798528
22			SIGN, HIGH VOLTAGE	2	647648
23			NAILS, ROOFING #8 GALV	16	492224
24			STEPS, POLE	19	692992
25			STRIP, COVER 1 1/8" X 3 5/8" X 8' - 0" (2X4S4S)	1	699328
26			SWITCH BYPASS	2	706944
27			ARRESTER, LIGHTNING (12KV)	3	113248
28			CUTOUT, 12KV 100 AMP WITH LOAD BUSTER HOOKS	2	1200 SECTION
29			BLADE, DISCONNECT CUTOUT	2	1200 SECTION
30			REGULATOR, STEP VOLTAGE 1Ø, COMPLETE WITH HANGERS	2	1300 SECTION
31			INSULATOR, PIN TYPE (CLASS AS REQ'D)	3	700 SECTION
		32	INSULATOR, SUSPENSION	8	700 SECTION
33			PIN, INSULATOR (AS REQUIRED BY ITEM 31)	2	532---
34			BRACKET, INSULATOR (AS REQUIRED BY ITEM 31)	1	100 SECTION
		35	CLEVIS, DEAD END CLOSED	4	235712
		36	CLAMPS, DEAD END	4	700 SECTION
37			CONNECTOR, COMPRESSION (#2 TO #6)	2	257792
38			CONNECTOR, COMPRESSION (#6 TO #6)	2	257952
39			CONNECTORS, WIRE	6	700 SECTION
40			WIRE, BARE STRANDED COPPER #4	(2.5#) 20'	813760
41			WIRE, BARE STRANDED COPPER #6	(2.5#) 30'	813536
42			WIRE, BARE STRANDED COPPER #2	(9.2#) 45'	813664
43			WIRE, #8 ANNEALED SOLID COPPER	(.75#) 15'	812928
44			WIRE, #4 SOLID WP COPPER	(5.0#) 36'	812480
45			ROD, GROUND	2	603072
46			CLAMP, GROUND ROD	2	230016
47			MOULDING, HARDWOOD #1	50'	487200
48			STAPLES, GALV 3" X 1 1/16" X 1/4"	35	678560
49			STAPLES, FENCE GALV 1 1/4"	30	678528
50			BOLT, MACH 5/8" X 7"	2	155552
51			CONNECTOR, COMPRESSION (#2 TO #2)	1	257760
52			HANGER, TRANSFORMER T-2	2	402944

FOR FIELD MAINTENANCE ONLY

SDG&E ELECTRIC STANDARDS

DATE 1-1-96

APPD PA/ROJ

STEP VOLTAGE REGULATOR STATION, OPEN DELTA, 12KV

1399.402
SUPERSEDES
1348.2 1-1-96

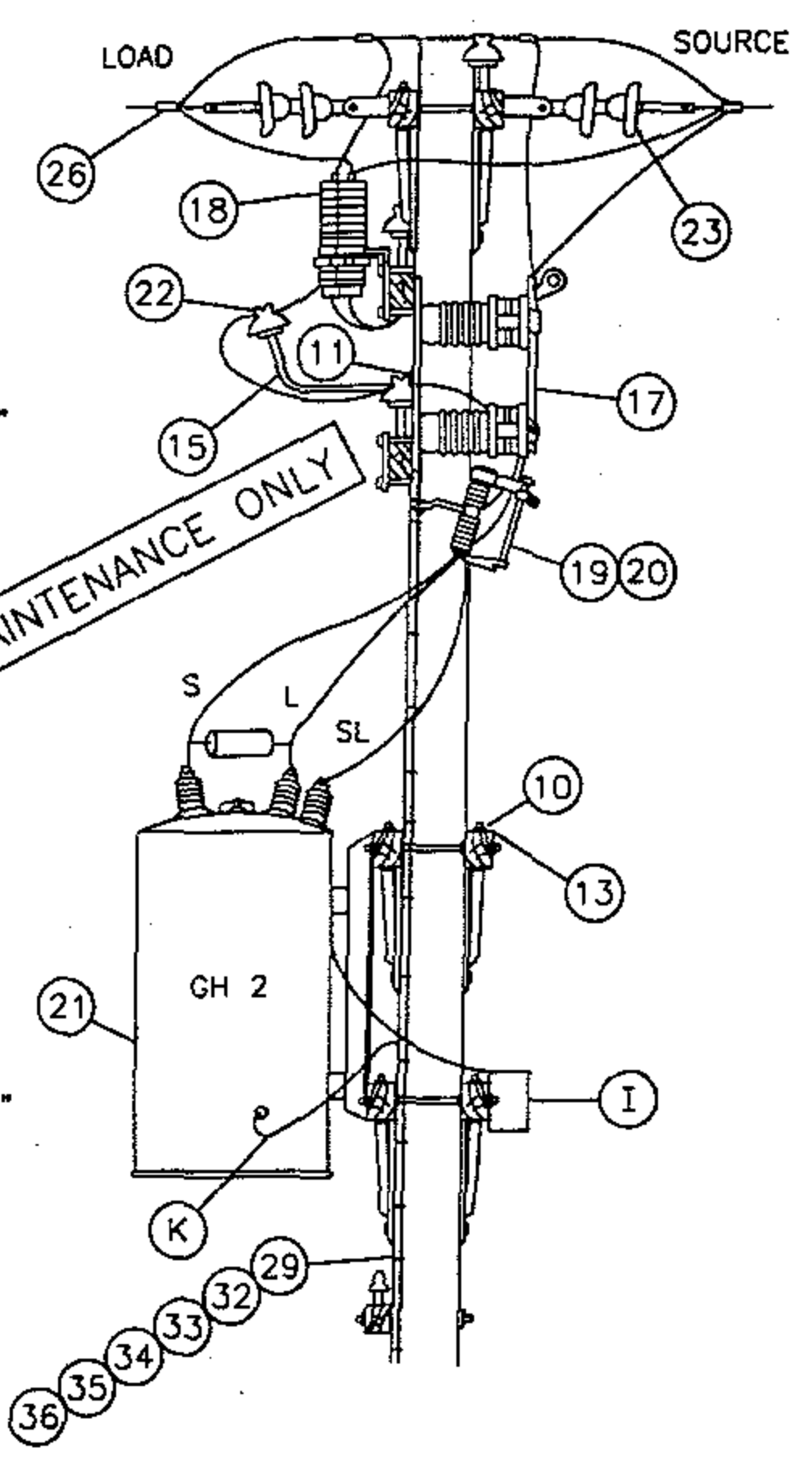
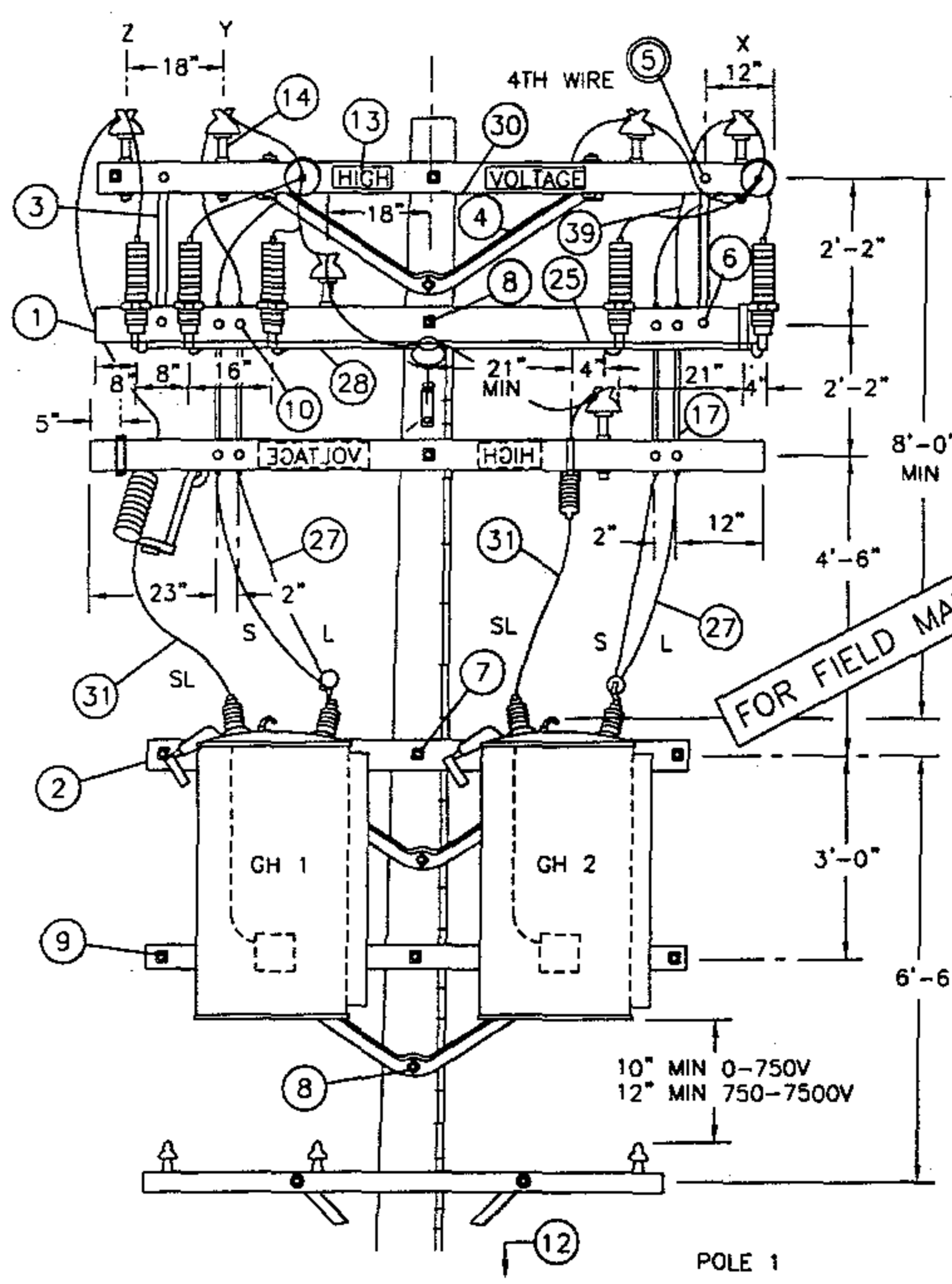
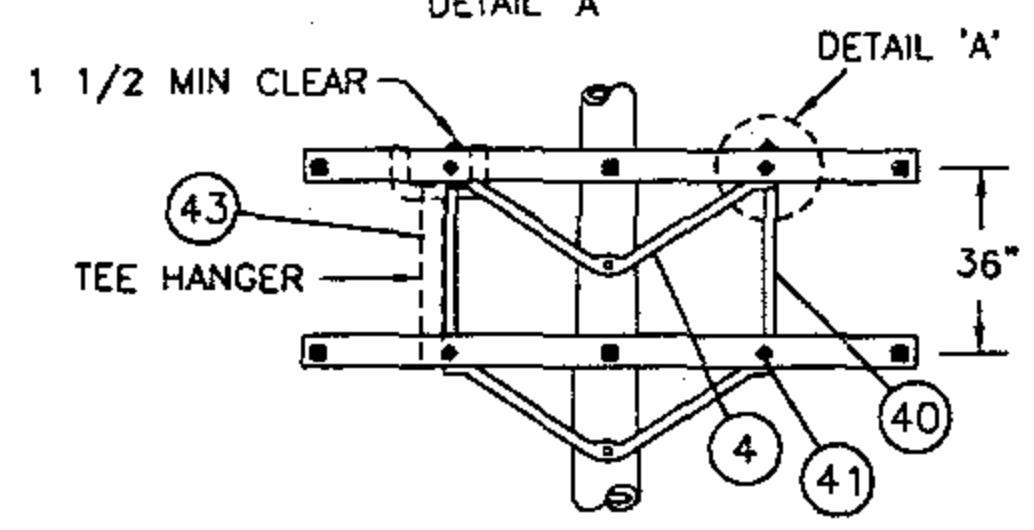
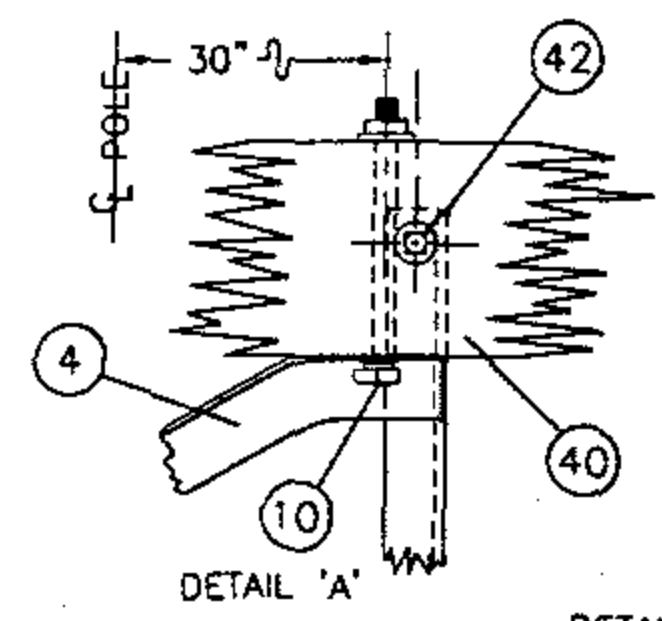
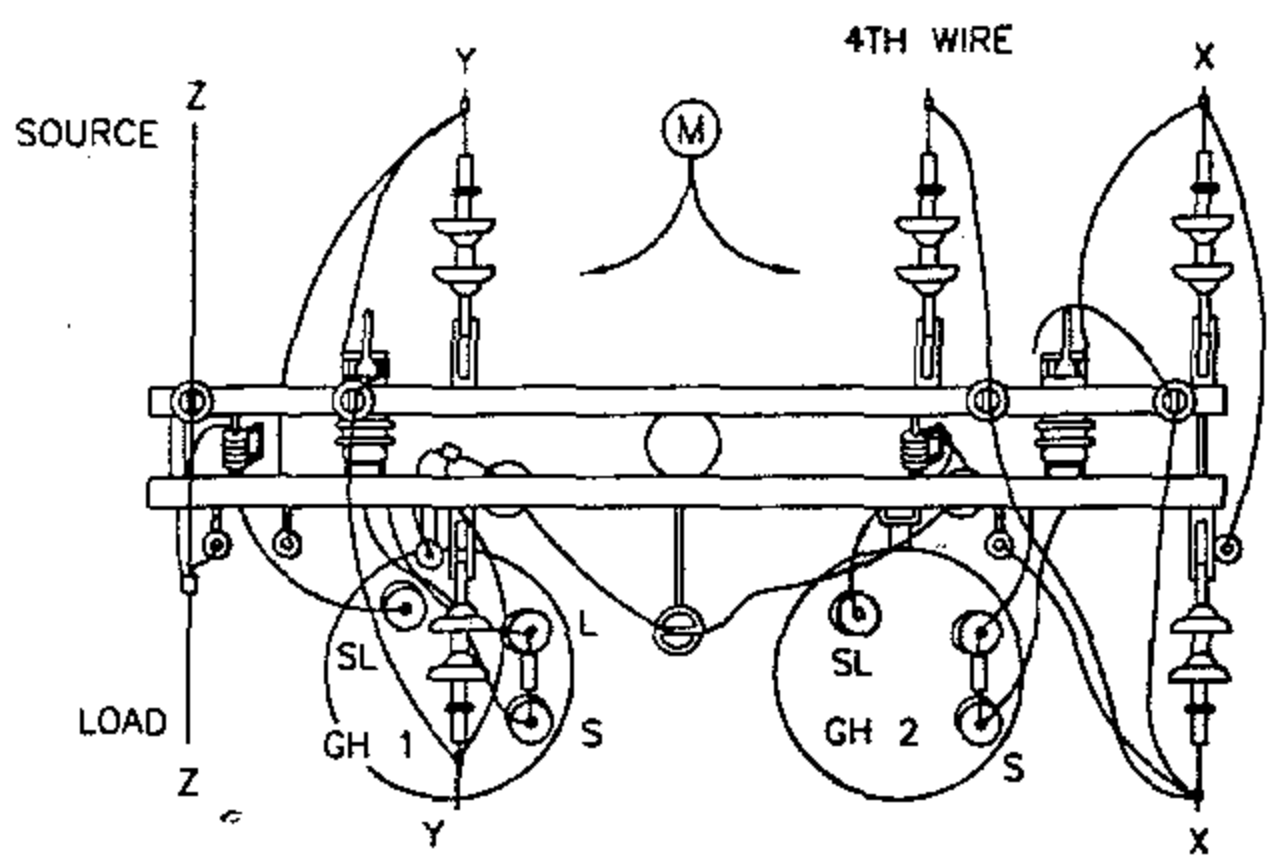

SDG&E ELECTRIC STANDARDS

DATE 1-1-96
APPD PIA/BJG

STEP-VOLTAGE REGULATOR STATION, CLOSED DELTA,
12KV, TWO POLES

1399.403
SUPERSEDES
1349.1 1-1-96

SCHEMATIC DIAGRAM OF A 12KV CLOSED DELTA
REGULATOR STATION

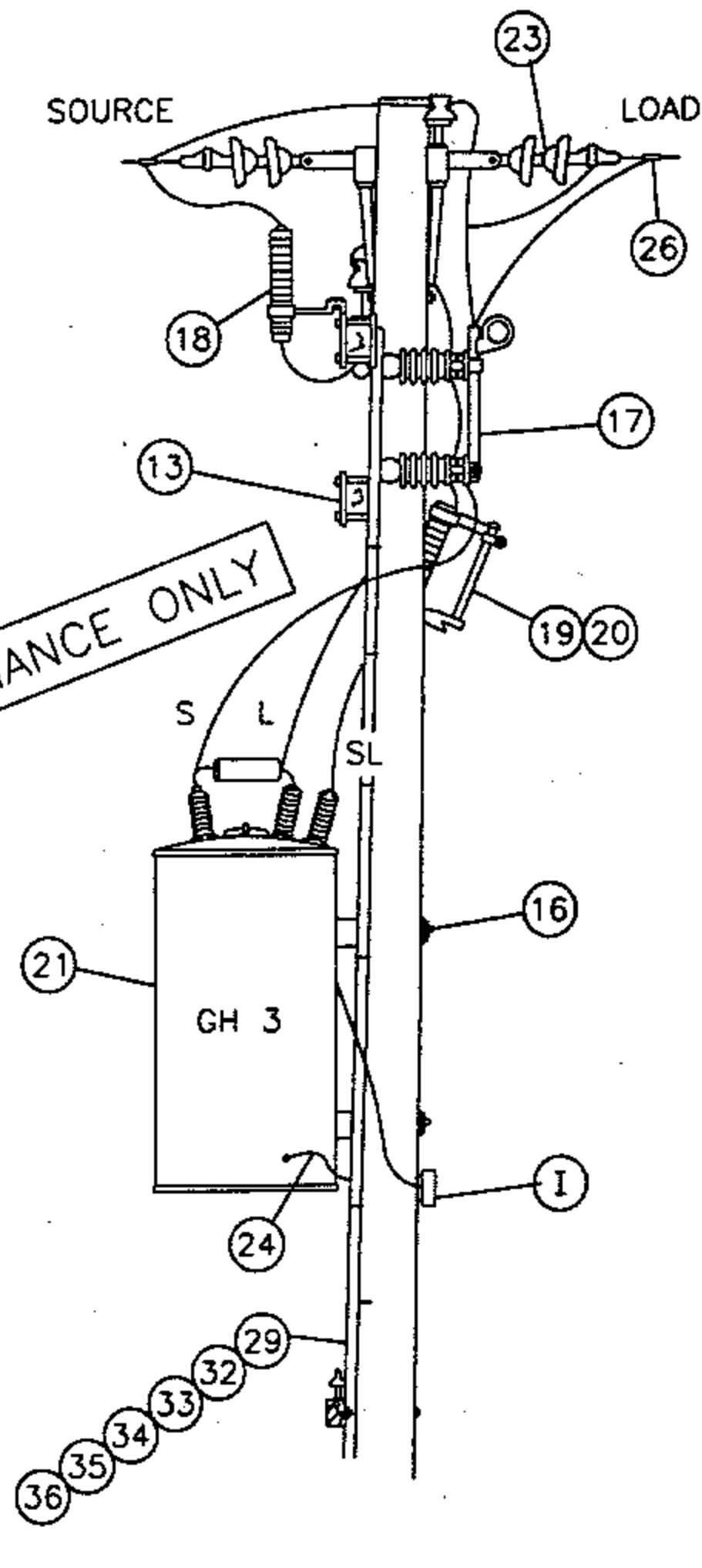
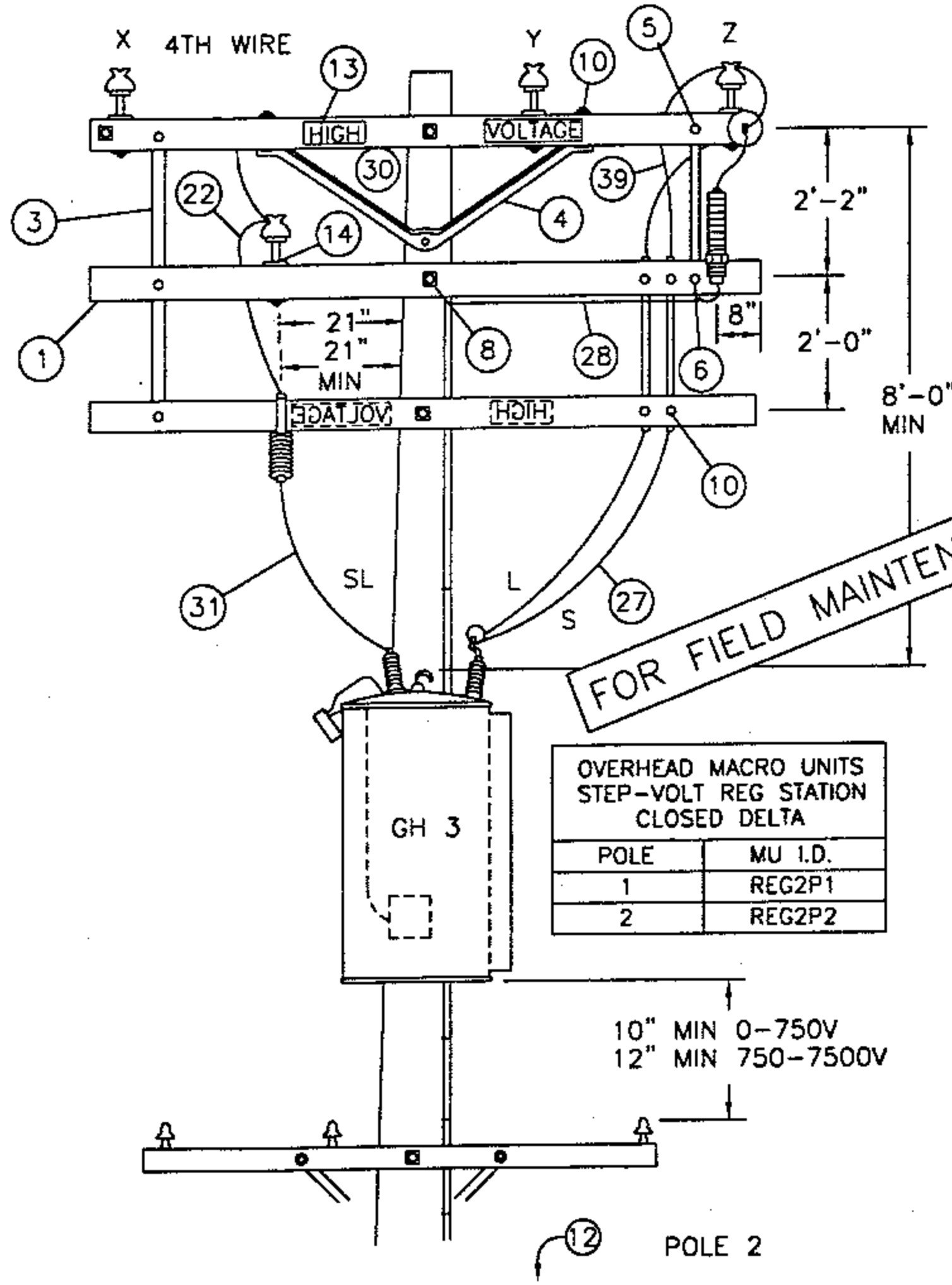
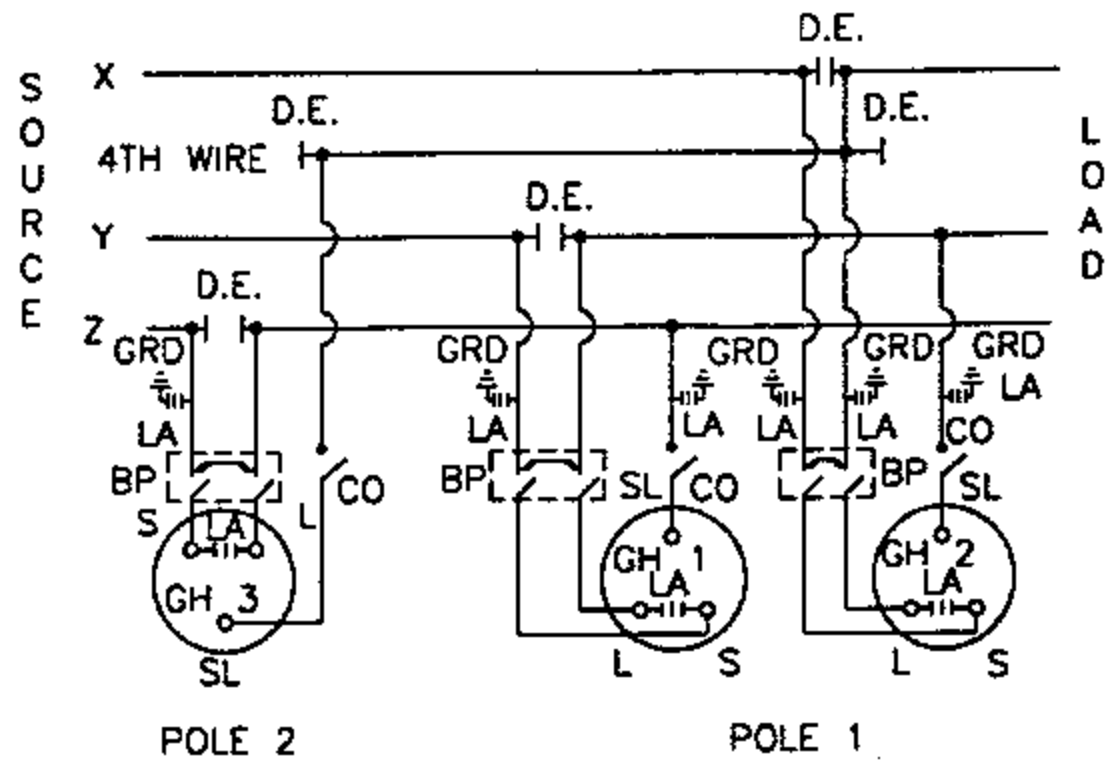
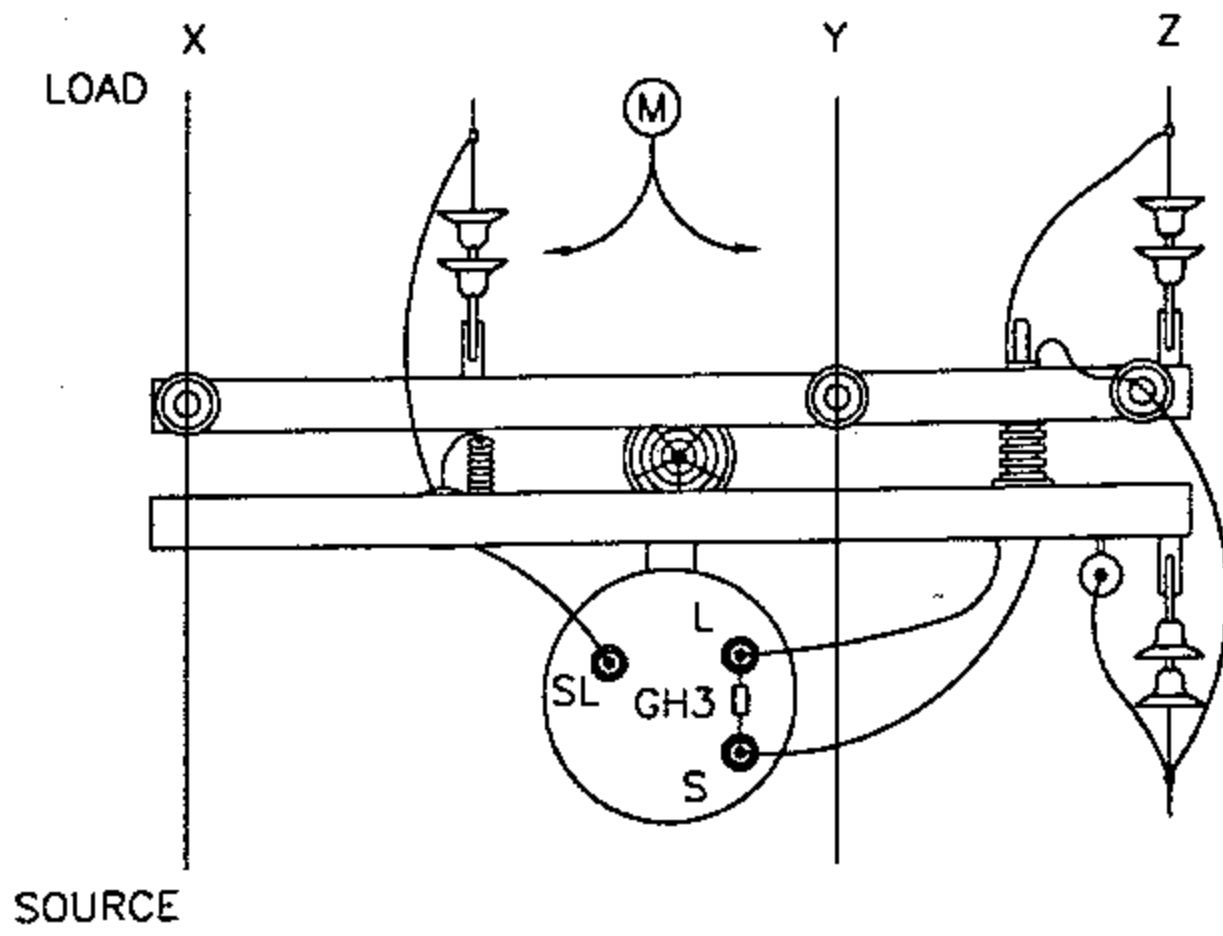

OVERHEAD MACRO UNITS
STEP-VOLT REG STATION
CLOSED DELTA

POLE	MU I.D.
1	REG2P1
2	REG2P2

10" MIN 0-750V
12" MIN 750-7500V

1399.404
SUPERSEDES
1349.2 1-1-96

SDG&E ELECTRIC STANDARDS

STEP-VOLTAGE REGULATOR STATION, CLOSED DELTA,
12KV, TWO POLES

DATE 1-1-96

APPD *PA 1/2/96*

NOTES:

- A. CAUTION: WHEN CONNECTING A STATION, REGULATORS MUST BE ON NEUTRAL. CLOSE CUTOUT TO SL BUSHING BEFORE CLOSING BYPASS DISCONNECT ON THAT POLE. WHEN DISCONNECTING A STATION, PUT REGULATORS ON NEUTRAL, AND OPEN BYPASS DISCONNECT BEFORE OPENING CUTOUT TO SL BUSHING. THIS AVOIDS A SERIOUS OVERVOLTAGE CONDITION.
- B. USE EXTRA HEAVY CLASS ONE POLE WITH 10" MIN TOP DIA FOR POLE #1, AND A CLASS ONE FOR POLE #2.
- C. USE TWO GROUND RODS FOR THE ARRESTERS AND TANKS. ALL GROUND RODS SHOULD BE SPACED A MINIMUM OF SIX FEET APART.
- D. UNIT GROUND COMPLETE, ORDER 603136.
- F. BOND ALL CUTOUTS IN HEAVY CONTAMINATION DISTRICT AS IDENTIFIED ON STANDARDS PAGE 287.
- G. BOND DEAD-END HARDWARE.
- H. INTERCONNECT ARRESTER GROUND LEAD DISCONNECTS WITH #6 BARE COPPER AND GROUND IT WITH #2 BARE COPPER NEAR CENTER ARRESTER.
- I. CONTROLS WILL BE MOUNTED BY KEARNY MAINTENANCE.
- J. INSTALL DOUBLE COIL SPRING WASHER ON END OF BOLT WHICH ATTACHES TO LARGEST METALLIC OBJECT, SUCH AS A BRACKET OR BRACE.
- K. REGULATOR TANKS SHALL BE PERMANENTLY GROUNDED.
- M. THIS CONSTRUCTION TO BE USED WHEN CENTER PHASE WIRE IS TO THE RIGHT OF THE POLE WHEN LOOKING TOWARD THE LOAD.

ITEM	DESCRIPTION	QUANTITY		STOCK NO. OR
		POLE 1	POLE 2	CONSTR. STD.
1	CROSSARM, 3 3/4" X 5 3/4" X 10' - 0"	3	3	380
2	CROSSARM, 3 3/4" X 5 3/4" X 8' - 0"	4	-	380
3	BRACE, FLAT CROSSARM 28"	2	3	164192
4	BRACE, ANGLE CROSSARM 5'-0"	5	1	164128
5	BOLT, MACHINE, 3/8" X 5", 1 RD. WASH., 1 DBL. COIL SPR. WASH.	2	2	392
6	BOLT, MACHINE, 1/2" X 5", 1 RD. WASH., 1 DBL. COIL SPR. WASH.	2	3	392
7	BOLT, MACHINE, 3/4" X --, 1 SQ. CURV. WASH., 1 DBL. COIL SPR. WASH.	2	-	392
8	BOLT, MACHINE, 5/8" X --, 2 FLAT WASH., 1 DBL. COIL SPR. WASH.	4	2	392
9	BOLT, SPACE, 5/8" X --, 4 WASH & 4 NUTS, 2 DBL. COIL SPR. WASH.	7	3	392
10	BOLT, MACHINE, 1/2" X 7", 1 RD. WASH., 1 DBL. COIL SPR. WASH.	18	6	392
11	SCREW, LAG, 5/8" X 5"	2	-	621600
12	STEPS, POLE	19	19	692992
13	SIGN, HIGH VOLTAGE & NAILS, GALV.	3	3	647648, 492224
14	PIN, INSULATOR (AS REQUIRED BY ITEM 22)	3	1	532---
15	BRACKET, INSULATOR (AS REQUIRED BY ITEM 22)	1	-	1661--
16	COVER, BOLT, PLASTIC	-	2	285696
17	SWITCH, BYPASS	2	1	706944
18	ARRESTER, LIGHTNING (12KV)	5	1	113248
19	CUTOUT, 12KV 100 AMP WITH LOAD BUSTER HOOKS	2	1	297888
20	BLADE, DISCONNECT CUTOUT	2	1	1200 SECTION
21	REGULATOR, STEP VOLTAGE 1Ø	2	1	1300 SECTION
22	INSULATOR, PIN TYPE (CLASS AS REQUIRED)	3	1	700 SECTION
23	INSULATOR, SUSPENSION	10	6	700 SECTION
24	CONNECTOR, COMPRESSION (#2 TO #6)	1	2	257792
25	CONNECTOR, COMPRESSION (#6 TO #6)	3	-	257952
26	CONNECTORS, WIRE	9	4	700 SECTION
27	WIRE, 2/0 WP COPPER	(12.4#) 24'	(6.2#) 12'	808944
28	WIRE, BARE STRANDED COPPER #6	(1.8#) 24'	(1.8#) 22'	813536
29	WIRE, BARE STRANDED COPPER #2	(9.2#) 45'	(9.8#) 45'	813664
30	WIRE, #8 ANNEALED SOLID COPPER	(.25#) 5'	(.25#) 5'	812928
31	WIRE, #4 SOLID WP COPPER	(1.8#) 10'	(.75#) 4'	812480
32	ROD, GROUND	(C) (D) 2	2	603072
33	CLAMP, GROUND ROD	(D) 2	2	230016
34	MOULDING, HARDWOOD 1"	(D) 45'	48'	487200
35	STAPLES, GALV. 3" X 1 1/16" X 1/4"	(D) 32	35	678560
36	STAPLES, FENCE GALV. 1 1/4"	(D) 28	30	678528
37	CLEVIS, DEAD END CLOSED	5	3	235712
38	CLAMPS, DEAD END	5	3	700 SECTION
39	WIRE, BARE STRANDED COPPER #1/0	(3.3#) 10'	(3.3#) 10'	813568
40	BRACE, VERTICAL, 36"	2	-	164256
41	BOLT, MACHINE, 5/8" X 7", 1 RD. WASH., 1 DBL. COIL SPR. WASH.	2	-	100 SECTION
42	BOLT, MACHINE, 5/8" X 5", 1 RD. WASH., 1 DBL. COIL SPR. WASH.	2	-	100 SECTION
43	HANGER, TRANSFORMER T-2	2	-	402944

FOR FIELD MAINTENANCE ONLY

DATE 1-1-96
APPD PJA/ROJ

SDG&E ELECTRIC STANDARDS

STEP-VOLTAGE REGULATOR STATION, CLOSED DELTA
12KV TWO POLES

1399.405
SUPERSEDES
1349.3 1-1-96

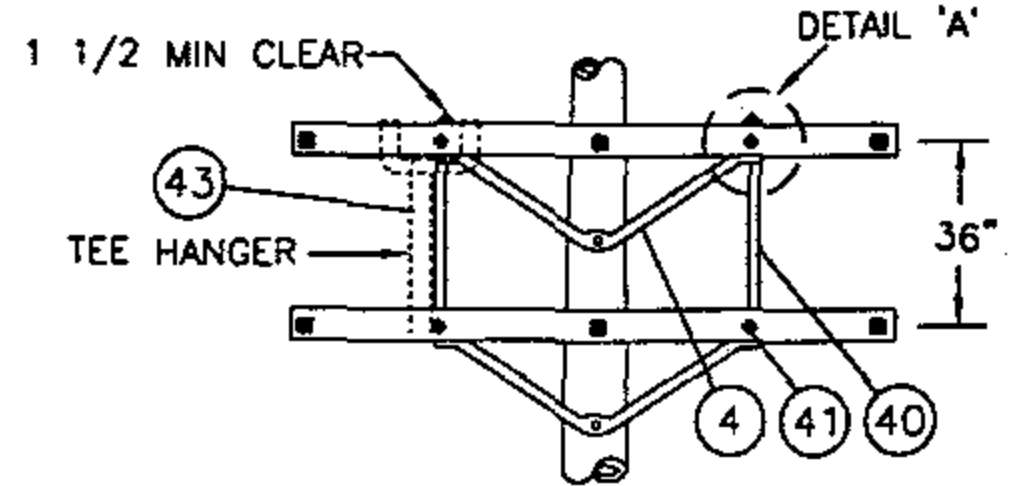
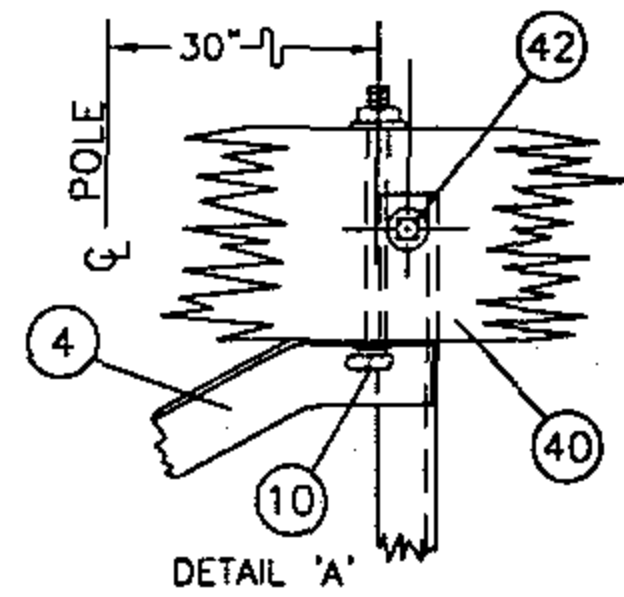
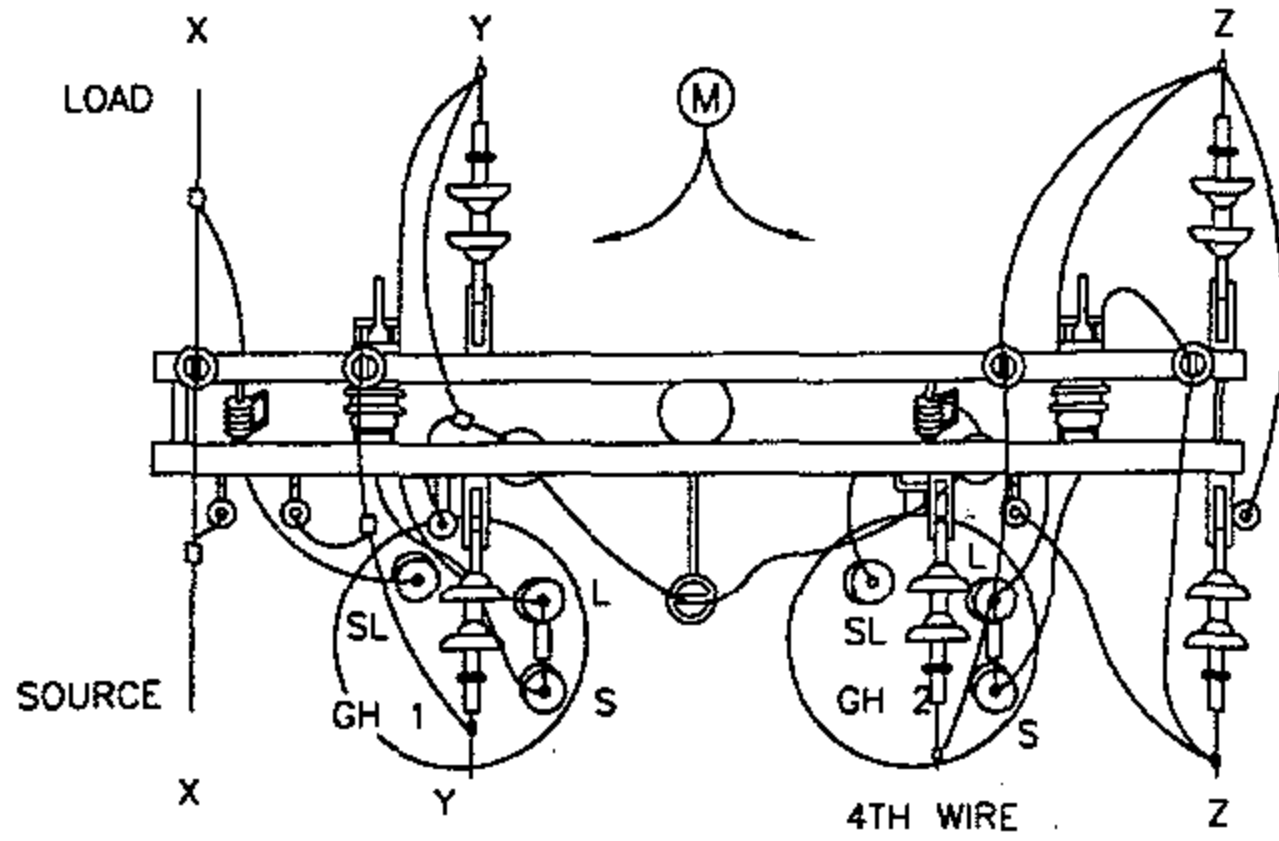

FRAMING DETAIL FOR 2-12KV STEP-VOLTAGE REGULATORS

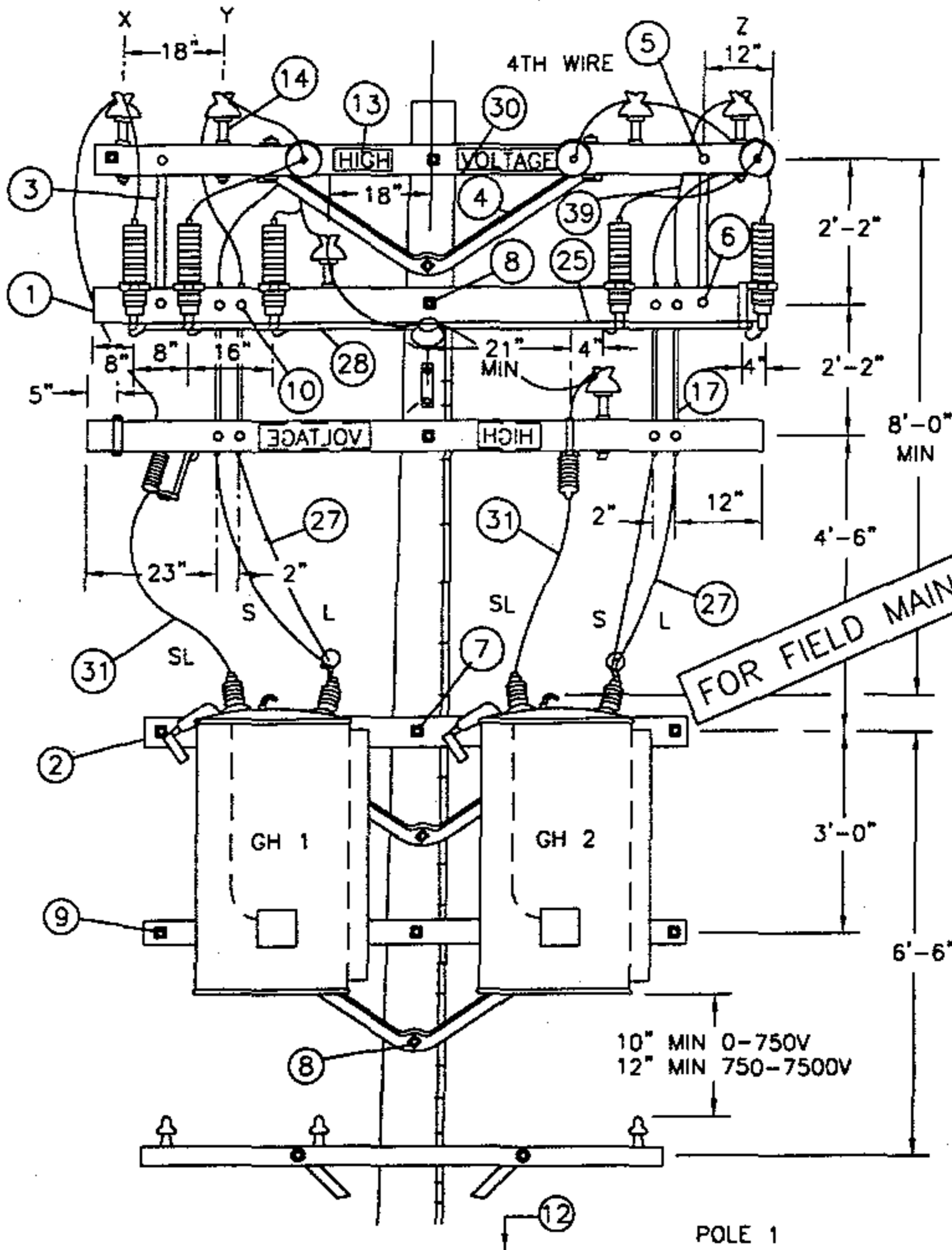
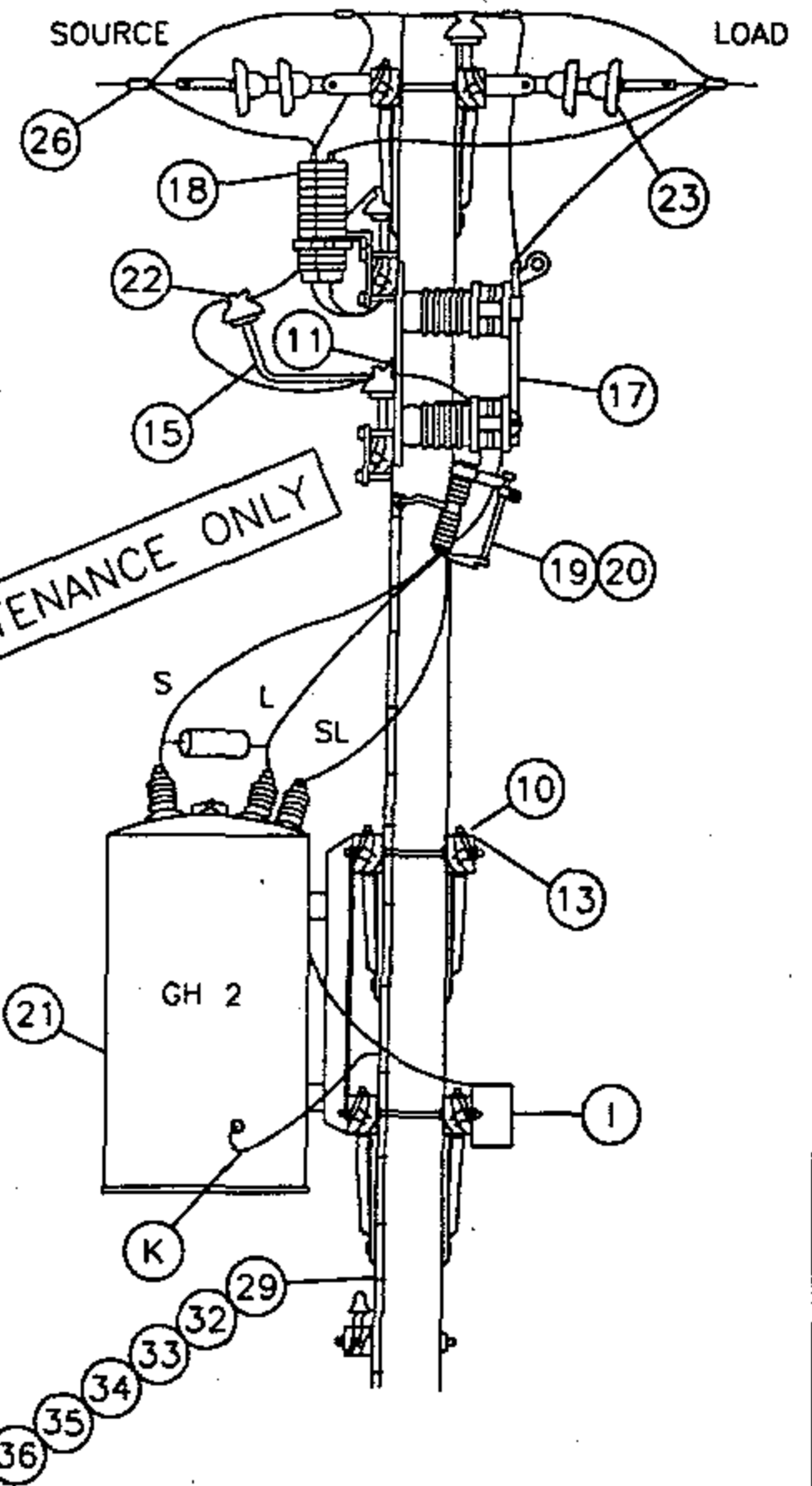

1399.501
SUPERSEDES
1350.1 1-1-96

SDG&E ELECTRIC STANDARDS

STEP-VOLTAGE REGULATOR STATION, CLOSED DELTA
12KV, TWO POLES

DATE 1-1-96

APPD *PA 1/2/96*

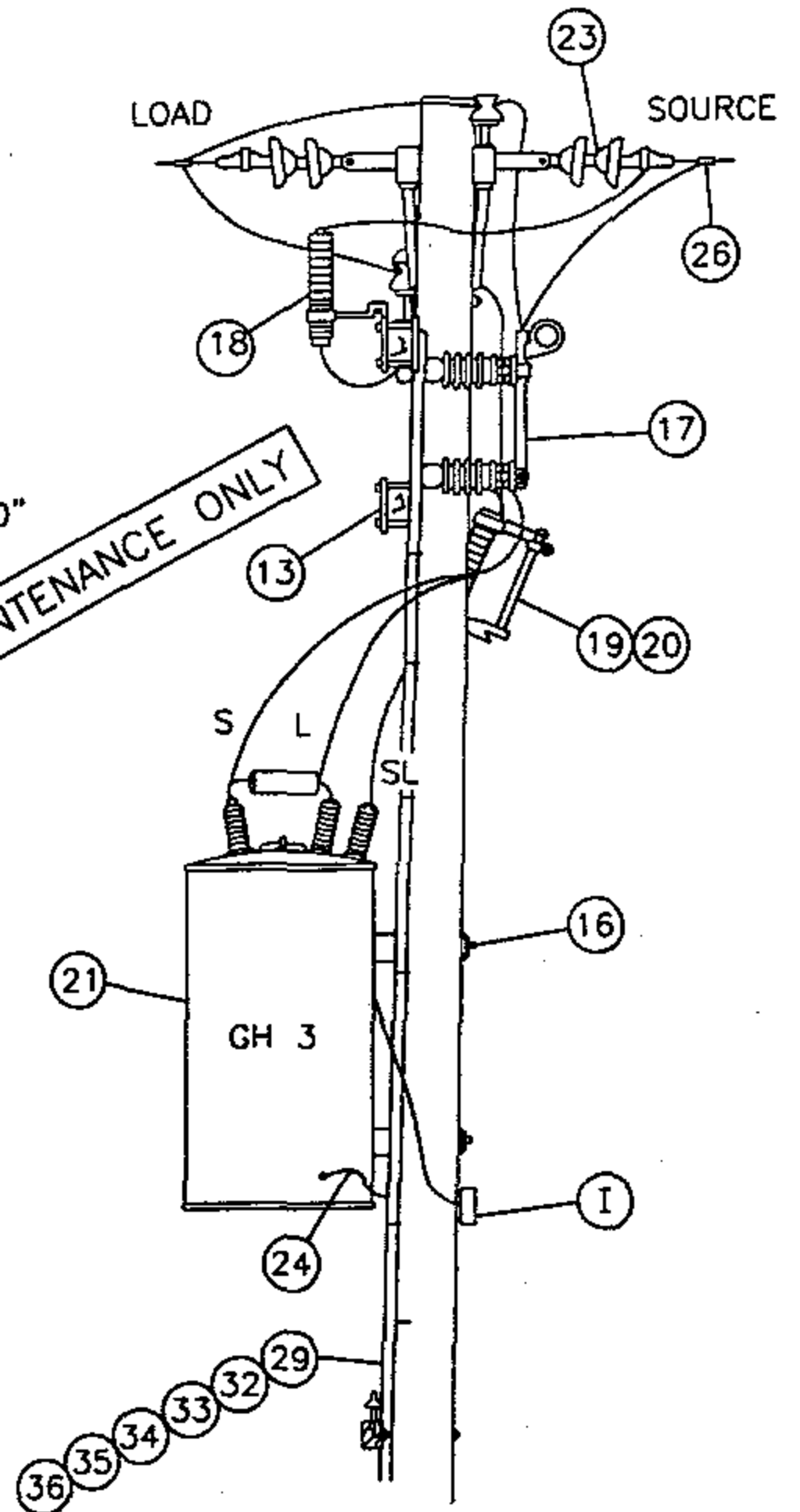
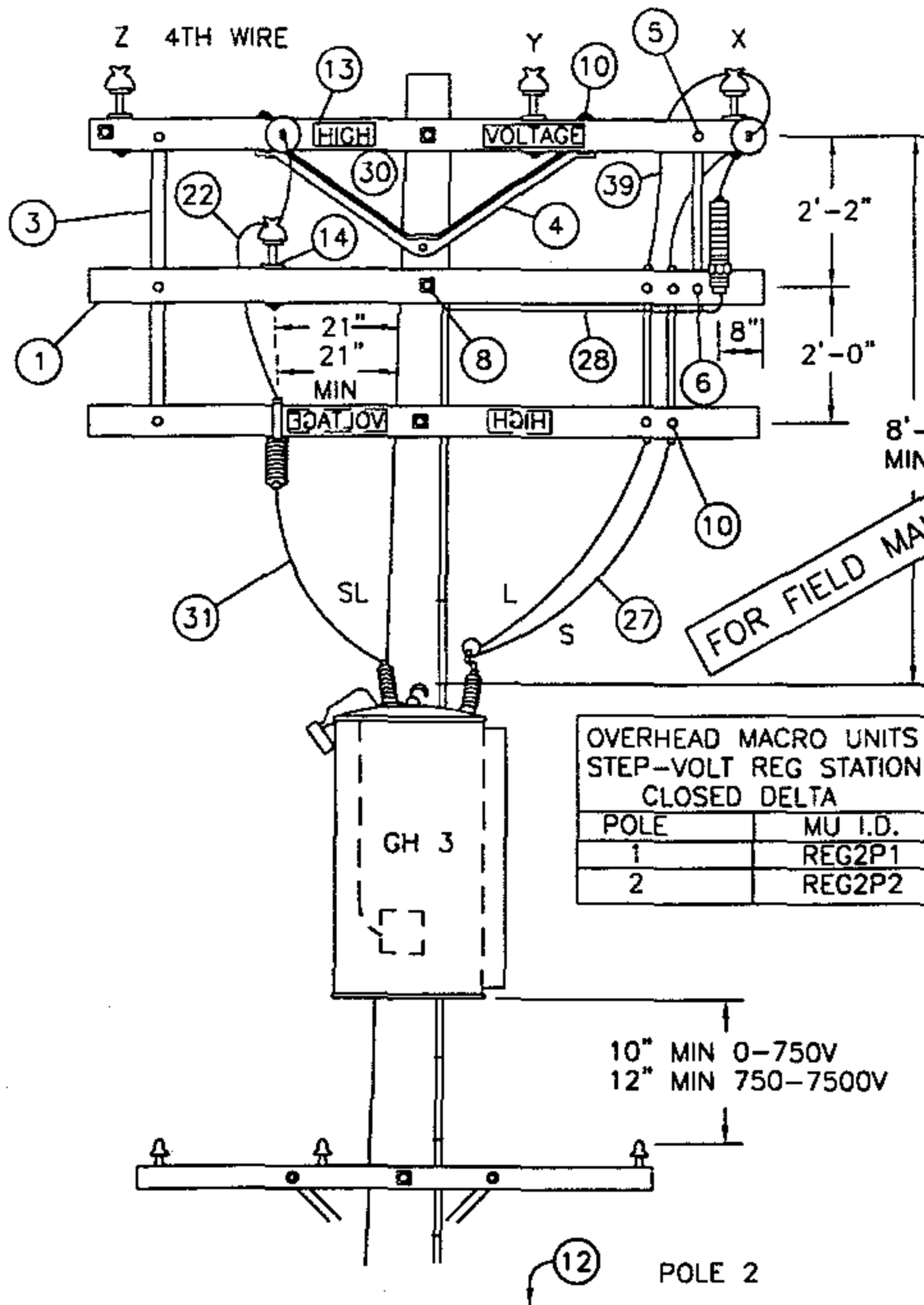
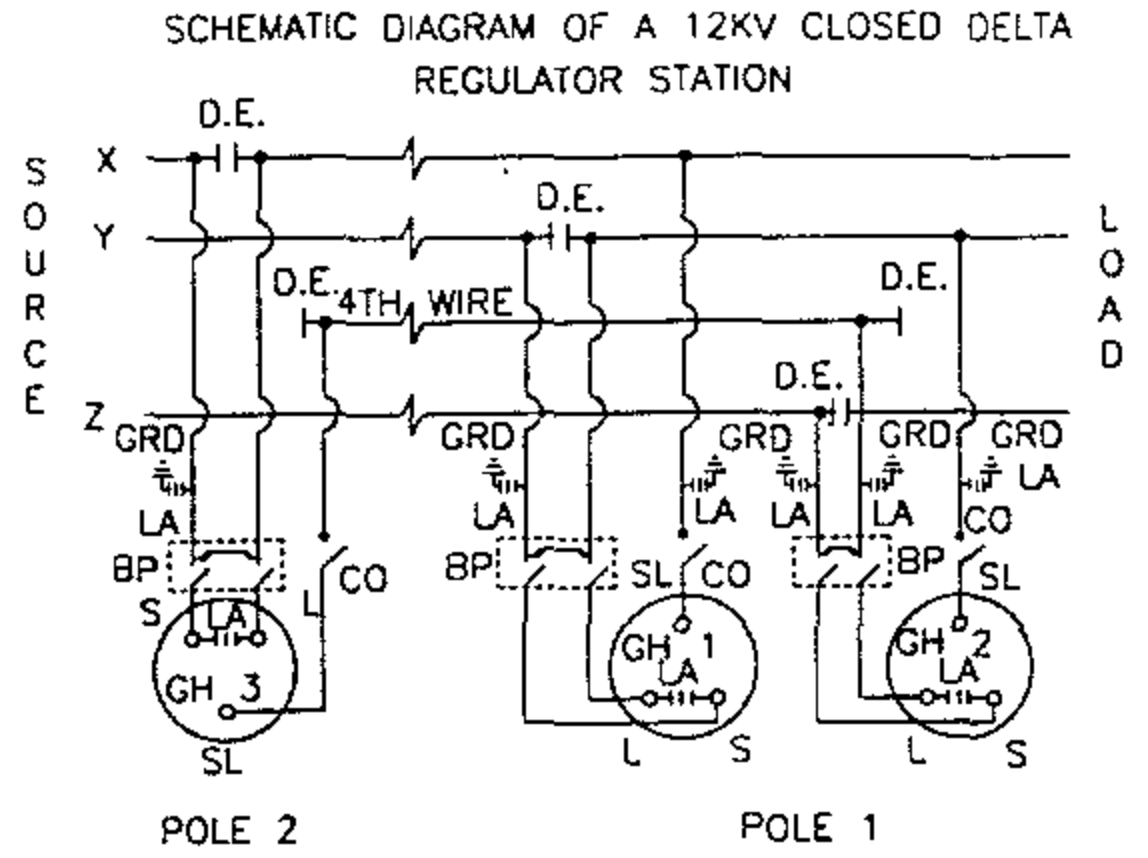
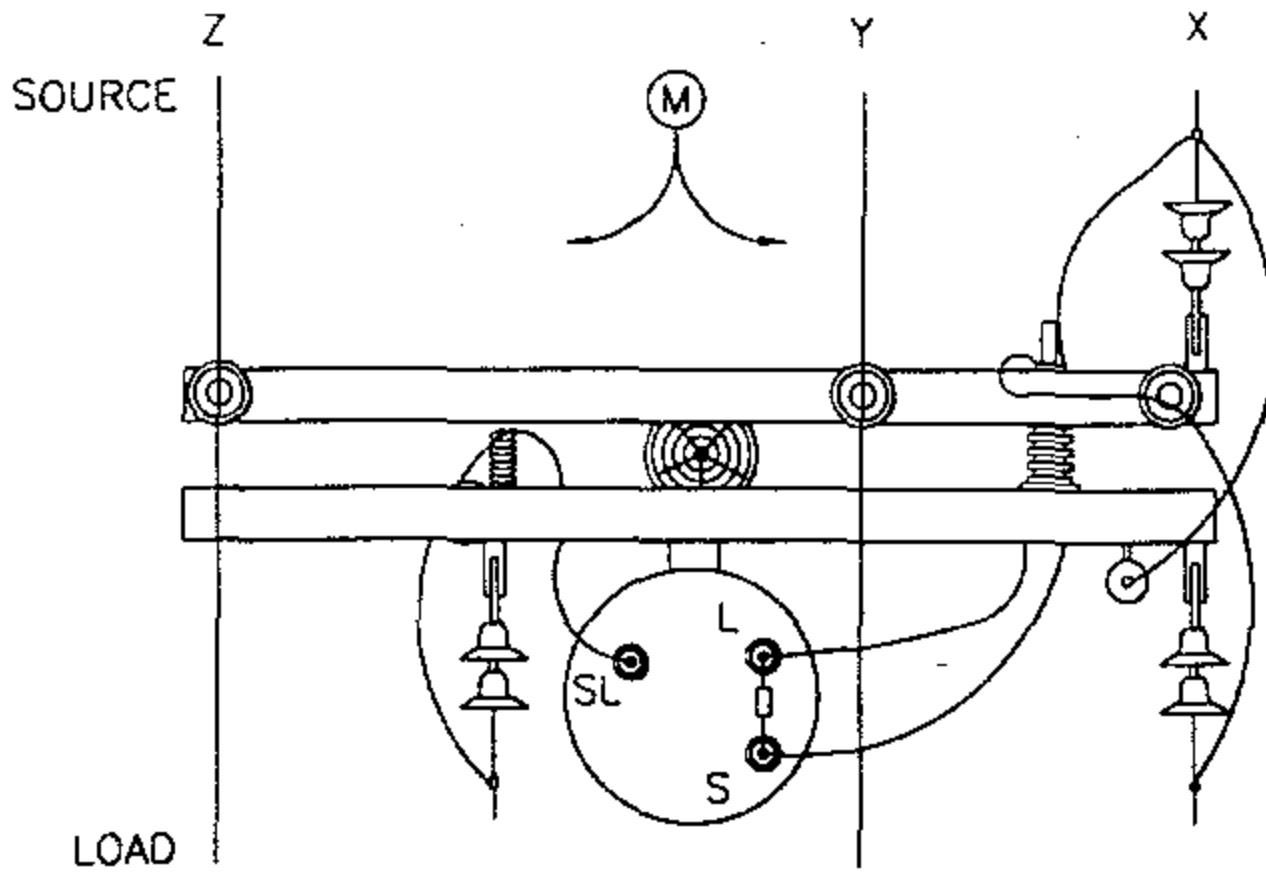

DATE 1-1-96
APPD *PA/1008*

SDG&E ELECTRIC STANDARDS
STEP-VOLTAGE REGULATOR STATION, CLOSED DELTA,
12KV, TWO POLES

1399.502
SUPERSEDES
1350.2 1-1-96

NOTES:

- A. CAUTION: WHEN CONNECTING A STATION, REGULATORS MUST BE ON NEUTRAL. CLOSE CUTOUT TO SL BUSHING BEFORE CLOSING BYPASS DISCONNECT ON THAT POLE. WHEN DISCONNECTING A STATION, PUT REGULATORS ON NEUTRAL, AND OPEN BYPASS DISCONNECT BEFORE OPENING CUTOUT TO SL BUSHING. THIS AVOIDS A SERIOUS OVERVOLTAGE CONDITION.
- B. USE EXTRA HEAVY CLASS ONE POLE WITH 10" MIN TOP DIA FOR POLE #1, AND A CLASS ONE FOR POLE #2.
- Ⓒ USE TWO GROUND RODS FOR THE ARRESTERS AND TANKS. ALL GROUND RODS SHOULD BE SPACED A MINIMUM OF SIX FEET APART.
- Ⓓ UNIT GROUND COMPLETE, ORDER 603136.
- F. BOND ALL CUTOUTS IN HEAVY CONTAMINATION DISTRICT AS IDENTIFIED ON STANDARDS PAGE 287.
- G. BOND DEAD-END HARDWARE.
- Ⓗ INTERCONNECT ARRESTER GROUND LEAD DISCONNECTS WITH #6 BARE COPPER AND GROUND IT WITH #2 BARE COPPER NEAR CENTER ARRESTER.
- Ⓘ CONTROLS WILL BE MOUNTED BY KEARNY MAINTENANCE.
- J. INSTALL DOUBLE COIL SPRING WASHER ON END OF BOLT WHICH ATTACHES TO LARGEST METALLIC OBJECT, SUCH AS A BRACKET OR BRACE.
- Ⓚ REGULATOR TANKS SHALL BE PERMANENTLY GROUNDED.
- Ⓛ THIS CONSTRUCTION TO BE USED WHEN CENTER PHASE WIRE IS TO THE LEFT OF THE POLE WHEN LOOKING TOWARD THE LOAD.

ITEM	DESCRIPTION	QUANTITY		STOCK NO. OR CONSTR. STD
		POLE 1	POLE 2	
1	CROSSARM 3 3/4" X 5 3/4" X 10' - 0"	3	3	380
2	CROSSARM, 3 3/4" X 5 3/4" X 8'-0"	4	-	380
3	BRACE, FLAT CROSSARM 28"	2	3	164192
4	BRACE, ANGLE CROSSARM 5'-0"	5	1	164128
5	BOLT, MACHINE, 3/8" X 5", 1 RD. WASH., 1 DBL. COIL SPR. WASH.	2	2	392
6	BOLT, MACHINE, 1/2" X 5", 1 RD. WASH., 1 DBL. COIL SPR. WASH.	2	3	392
7	BOLT, MACHINE, 3/4" X --, 1 SQ. CURV. WASH., 1 DBL. COIL SPR. WASH.	2	-	392
8	BOLT, MACHINE, 5/8" X --, 2 FLAT WASH., 1 DBL. COIL SPR. WASH.	4	2	392
9	BOLT, SPACE, 5/8" X --, 4 WASH. & 4 NUTS, 2 DBL. COIL SPR. WASH.	7	3	392
10	BOLT, MACHINE, 1/2" X 7", 1 RD. WASH., 1 DBL. COIL SPR. WASH.	18	6	392
11	SCREW, LAG, 5/8" X 5"	2	-	621600
12	STEPS, POLE	19	19	692992
13	SIGN, HIGH VOLTAGE & 8 NAILS, GALV.	3	3	647648, 492224
14	PIN, INSULATOR (AS REQUIRED BY ITEM 22)	3	1	532---
15	BRACKET, INSULATOR (AS REQUIRED BY ITEM 22)	1	-	1661--
16	COVER, BOLT, PLASTIC	-	2	285696
17	SWITCH, BYPASS	2	1	706944
18	ARRESTER, LIGHTNING (12KV)	5	1	113248
19	CUTOUT, 12KV 100 AMP WITH LOAD BUSTER HOOKS	2	1	297888
20	BLADE, DISCONNECT CUTOUT	2	1	1200 SECTION
21	REGULATOR, STEP VOLTAGE 1Ø	2	1	1300 SECTION
22	INSULATOR, PIN TYPE (CLASS AS REQUIRED)	3	1	700 SECTION
23	INSULATOR, SUSPENSION	10	6	700 SECTION
24	CONNECTOR, COMPRESSION (#2 TO #6)	1	2	257792
25	CONNECTOR, COMPRESSION (#6 TO #6)	3	-	257952
26	CONNECTORS, WIRE	9	4	700 SECTION
27	WIRE, 2/0 WP COPPER	(12.4#) 24'	(6.2#) 12'	808944
28	WIRE, BARE STRANDED COPPER #6	(1.8#) 24'	(1.8#) 22'	813536
29	WIRE, BARE STRANDED COPPER #2	(9.2#) 45'	(9.8#) 45'	813664
30	WIRE, #8 ANNEALED SOLID COPPER	(.25#) 5'	(.25#) 5'	812928
31	WIRE, #4 SOLID WP COPPER	(1.8#) 10'	(.75#) 4'	812480
32	ROD, GROUND	2	2	603072
33	CLAMP, GROUND ROD	ⒸⒹ 2	2	230016
34	MOULDING, HARDWOOD 1"	Ⓓ 45'	48'	487200
35	STAPLES, GALV. 3" X 1 1/16" X 1/4"	Ⓓ 32	35	678560
36	STAPLES, FENCE GALV. 1 1/4"	Ⓓ 28	30	678528
37	CLEVIS, DEAD END CLOSED	Ⓓ 5	3	235712
38	CLAMPS, DEAD END	5	3	700 SECTION
39	WIRE, BARE STRANDED COPPER #1/0	(3.3#) 10'	(3.3#) 10'	813568
40	BRACE, VERTICAL, 36"	2	-	164256
41	BOLT, MACHINE, 5/8" X 7", 1 RD. WASH., 1 DBL. COIL SPR. WASH.	2	-	392
42	BOLT, MACHINE, 5/8" X 5", 1 RD. WASH., 1 DBL. COIL SPR. WASH.	2	-	392
43	HANGER, TRANSFORMER T-2	2	-	402944

FOR FIELD MAINTENANCE ONLY

1399.503
SUPERSEDES
1350.3 1-1-96

SDG&E ELECTRIC STANDARDS

STEP-VOLTAGE REGULATOR STATION, CLOSED DELTA
12KV TWO POLES

DATE 1-1-96
APPD PJA / BSA

SCOPE: THIS STANDARD SHOWS THE PREFERRED METHOD OF CONSTRUCTION FOR A FIXED CAPACITOR WHEN A NEW POLE IS REQUIRED.

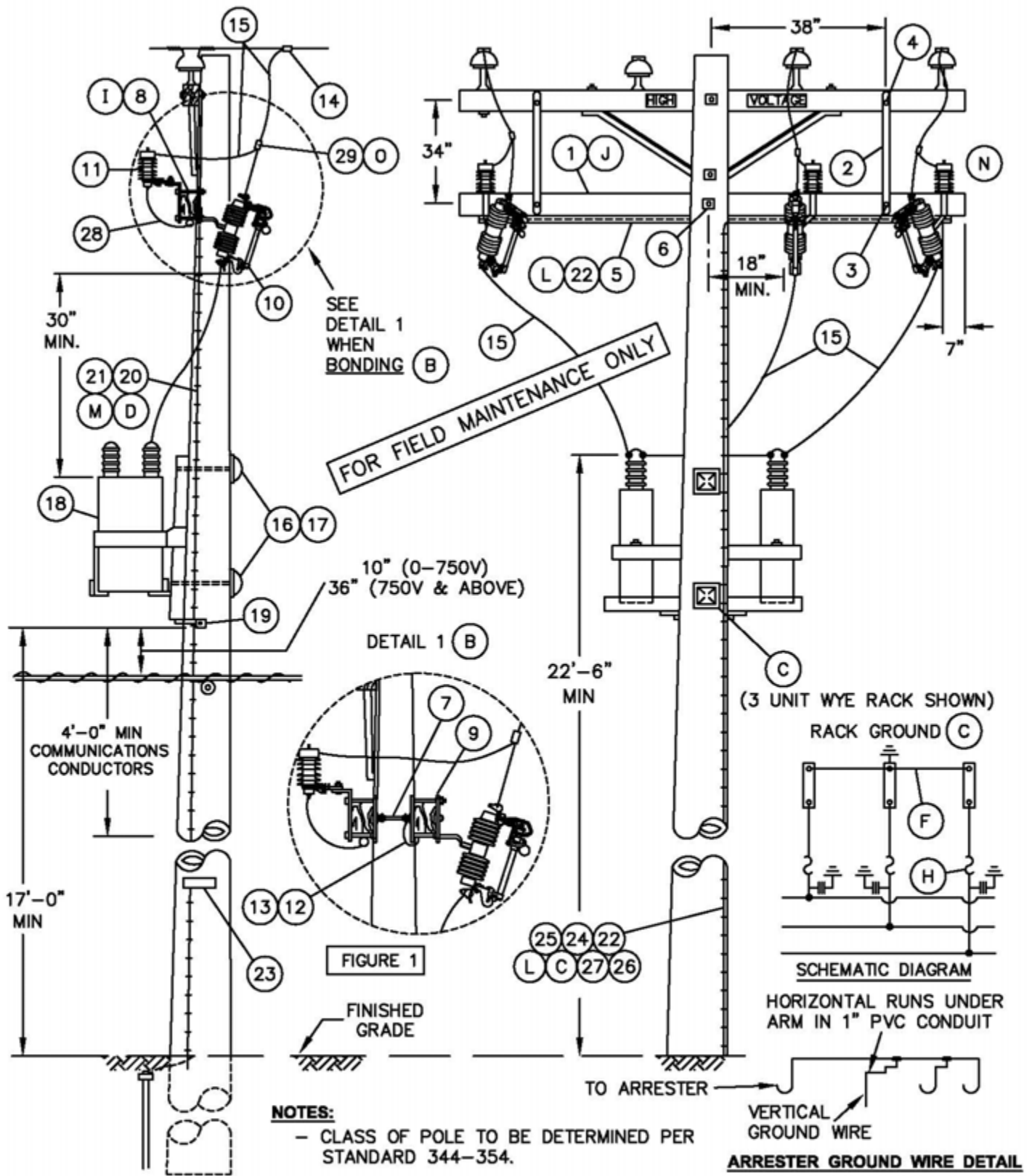

© 1998 - 2005 San Diego Gas & Electric Company. All rights reserved. Removal of this copyright notice without permission is not permitted under law.

1399.504
4299.507
SUPERSEDES
1323.1 (10-15-05)

SDG&E ELECTRIC STANDARDS
FIXED CAPACITOR INSTALLATION, 4KV WYE
GROUNDED RACK

DATE 10-15-05
APPD PJA / JJ

SCOPE: THIS STANDARD SHOWS AN ALTERNATE METHOD OF INSTALLING A FIXED CAPACITOR ON AN EXISTING POLE OF PROPER CLASS BUT WITH INSUFFICIENT HEIGHT TO PERMIT THE CONSTRUCTION AS SHOWN ON PAGE 1323.1 FIGURE 1.

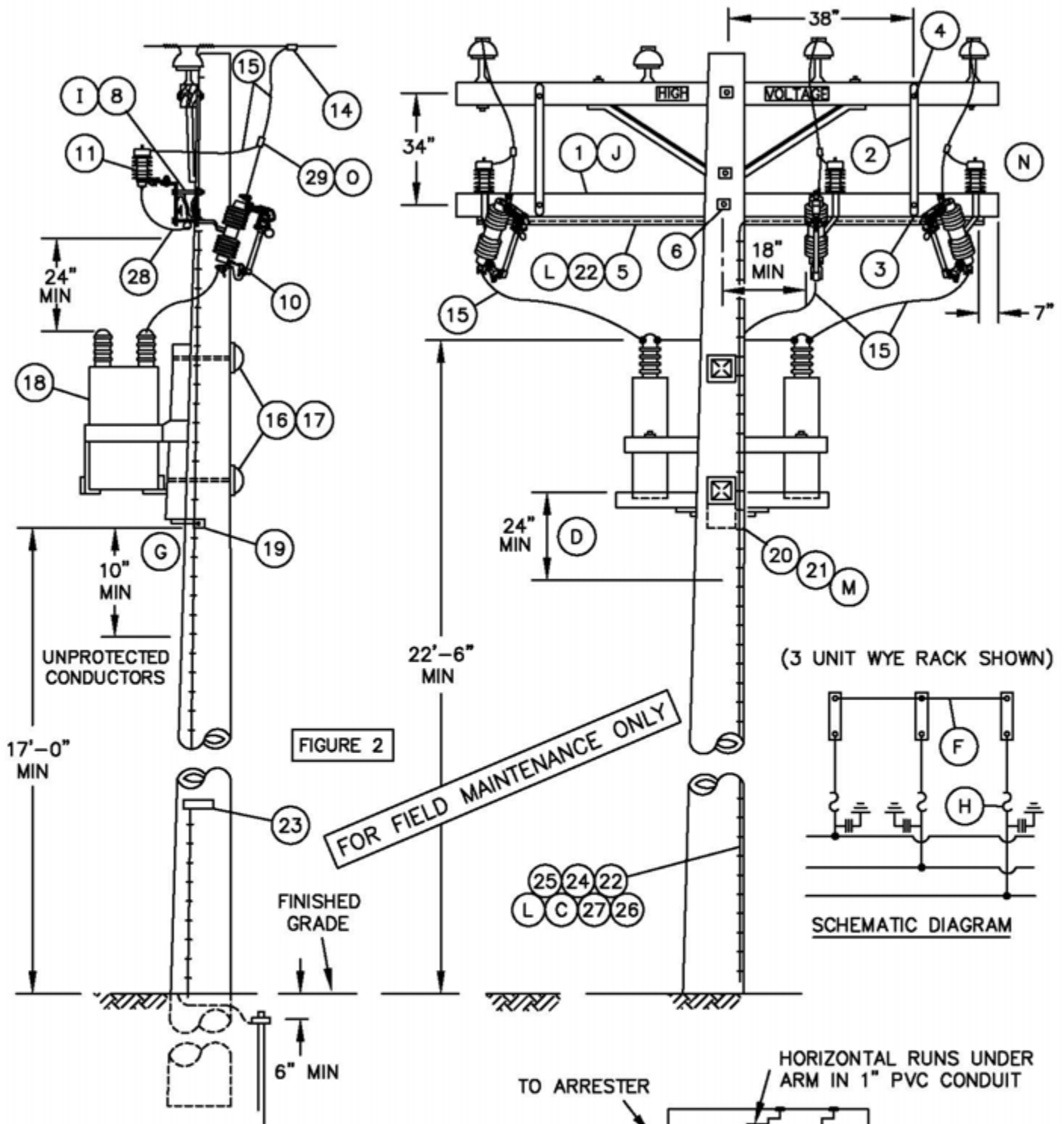
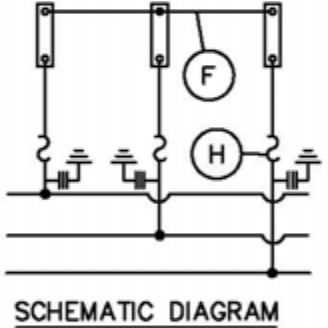

FIGURE 2

(3 UNIT WYE RACK SHOWN)



SCHEMATIC DIAGRAM

NOTES:

- CLASS OF POLE TO BE DETERMINED PER STANDARD 344-354.

ARRESTER GROUND WIRE DETAIL

© 1998 - 2005 San Diego Gas & Electric Company. All rights reserved. Removal of this copyright notice without permission is not permitted under law.

DATE 10-3-2012 APPD TQ/MJC	SDG&E ELECTRIC STANDARDS	1399.505 4299.508 SUPERSEDES 1323.2 (10-15-05)
	FIXED CAPACITOR INSTALLATION, 4KV WYE UNGROUND RACK -- ALTERNATE	

BILL OF MATERIAL:

ITEM	DESCRIPTION	QUANTITY (B)		STOCK NO. OR CONSTR STANDARD	ASSEMBLY UNIT		
		UNBONDED	BONDED				
1	CROSSARM, 3 3/4" X 5 3/4" X 10' - 0" (B)	1	2	294128	-		
2	BRACE, FLAT, CROSSARM, 36" (J)	2	2	164224	-		
3	BOLT, MACH, GALV, 3/8" X 4 1/2", 1 ROUND & 1 LOCK WASHER (J)	2	2	STD 392	-		
4	BOLT, MACH, GALV, 1/2" X 5", 1 ROUND & 1 DBL COIL SPR WASH (J)	2	2	STD 392	-		
5	CONDUIT, PVC, TYPE 2, SCHEDULE 40, 1" AND STRAPS, PIPE, GALV. 1" WITH 1 3/4" ROOFING NAILS	10'	10'	251200	-		
		AS REQ'D		697792	-		
6	BOLT, MACH, GALV, 5/8" X (LENGTH AS REQ'D), 2 SQUARE & 1 DBL COIL SPRING WASHER	1	1	STD 392	-		
7	BOLT, SPACE, GALV, 5/8" X (LENGTH AS REQ'D), 2 ROUND 4 SQUARE, 2 DOUBLE COIL SPRING WASHERS & 2 NUTS	-	2	STD 392	-		
8	BRACKET, DOUBLE CUTOUT/ARRESTER, FOR CROSSARM MOUNTING.	3	-	165442	-		
9	BRACKET, ARRESTER OR CUTOUT	-	6	166070	-		
10	CUTOUT, 12KV, 100A, WITH LOADBUSTER HOOKS	3	3	STD 1212	-		
11	ARRESTER, LIGHTNING (SEE STD. 1247 FOR 4KV APPLICATION) OR	4 KV	3	113216	-		
		12 KV	3	113248	-		
12	WIRE, #8 BARE SOLID ANNEALED COPPER (B)	FT	-	15	812928		
		LB	-	1			
13	STAPLES, WIRE, GALV, 1 1/4" (B)	AS REQ'D		678528	-		
14	CONNECTOR, WIRE COMPRESSION, CU OR AL (SIZE AS REQ'D)	AS REQ'D		783-786	-		
15	WIRE, #4 BARE STRANDED COPPER	FT	100		813760		
		LB	13				
16	BOLT, MACH, GALV, 3/4" X (LENGTH AS REQ'D), 1 SQ CURV RIBBED & 1 DBL COIL SPRING WASHER	2	2	STD 392	-		
17	COVER, BOLT PLASTIC & 6 - 1 3/4" NAILS, GALV	2	2	285696	-		
		-	-	492192	-		
18	CAPACITOR RACK - COMPLETE WITH CAPACITORS	4KV	65 KVAR (3 @ 200 KVAR)	1	1	564759	-
			130 KVAR (3 @ 400 KVAR)	1	1	564776	-
		12KV	600 KVAR (3 @ 200 KVAR)	1	1	564763	-
			1200 KVAR (3 @ 400 KVAR)	1	1	564764	-
19	SCREW, LAG, GALV, 4"	2	2	621568	-		
20	CONDUIT, PVC, TYPE 2, SCHEDULE 40, 1/2" (D)	10'	10'	251168	-		
21	STRAPS, PIPE, GALV, 1/2", AND 2- 1 3/4" ROOFING NAILS, GALV.	AS REQ'D		697728	-		
		-	-	492192	-		
22	#4 CU SOLID GROUND WIRE, PVC COVERED	50'	50'	812490	GNDPVC		
23	TAG, STATION NUMBER	1	1	200 SECT.	-		
24	GROUND ROD, 5/8" X 8", COPPERWELD	1	1	603072	GNDPVC		
25	COPPER BONDED GROUND CONNECTOR	1	1	259010	-		
26	GROUND ENHANCING POWER SOLUTION (GEM)	AS REQ'D		424390	-		
27	GALVANIZED STAPLES FOR PVC COVERED GROUND WIRE	AS REQ'D		678562	-		
28	FLEXIBLE ARRESTER GROUND STRAP	AS REQ'D		698754	-		
29	HOT LINE CLAMP	3	3	227680	-		

FOR FIELD MAINTENANCE ONLY

© 1998 - 2005 San Diego Gas & Electric Company. All rights reserved. Removal of this copyright notice without permission is not permitted under law.

Indicates Latest Revision Completely Revised New Page Information Removed

1399.506
4299.509
SUPERSEDES
1323.3 (10-15-05)

SDG&E ELECTRIC STANDARDS

FIXED CAPACITOR INSTALLATION, 4KV WYE

DATE 10-15-05
APPD PJA/JJ

OVERHEAD MACRO UNITS 12KV/4KV CAPACITOR STATIONS		
FIXED – GROUNDED (FIG. 1)		
KV	KVAR	MU I.D.
12	600	C6FP
12	1200	C12FP
FIXED-UNGROUNDED (FIG. 2)		
4	65	C4FA
4	130	C4F3P
12	600	C6FA
12	1200	C12FA

FOR FIELD MAINTENANCE ONLY

INSTALLATION:

- A. CAPACITORS MUST BE INSTALLED ON POLES ACCESSIBLE BY BUCKET TRUCK.
- (B) BOND CUTOUTS IN HEAVY CONTAMINATION DISTRICTS AS SHOWN ON STANDARD 287. IN AREAS WHERE BONDING IS REQUIRED, TO AVOID BONDWIRE AND LIGHTNING ARRESTER GROUNDWIRE ON THE SAME CROSSARM, USE TWO CROSSARMS; ONE FOR CUTOUTS AND ONE FOR LIGHTNING ARRESTERS.
- (C) CONNECT CAPACITOR RACK GROUND LEAD TO LIGHTNING ARRESTER GROUND (FIGURE 1 ONLY).
- (D) RUN 1/2" SCHEDULE 40 PVC CONDUIT WITH LIGHTNING ARRESTER GROUND FROM LIGHTNING ARRESTER ARM TO A MINIMUM OF 2 FEET BELOW CAPACITOR RACK, THEN CONTINUE DOWN THE POLE USING PVC COVERED GROUND WIRE.
- (F) DO NOT TIE CAPACITOR BANK NEUTRAL TO 12KV CIRCUIT NEUTRAL. IT IS TO REMAIN FLOATING.
- (G) TEN INCHES FROM 0-750V CONDUCTORS BELOW, 12 INCHES FOR CONDUCTORS OF 750-7500V, 18 INCHES FOR CONDUCTORS OF 7500-22,500V PER G.O. 95 RULE 58.1-D.
- (H) FUSE STATION ACCORDING TO CAPACITOR FUSING TABLE, STANDARD 1309.
- (I) DRILL THROUGH CROSSARM 1" UP FROM LOWER EDGE SO THAT LOWER CROSSARM MOUNTING BRACKET BOLT DOES NOT INTERFERE WITH PVC CONDUIT.
- (J) WHEN LA/CO CROSSARM AND CAPACITORS CANNOT BE INSTALLED ON THE SAME SIDE OF THE POLE AS AN EXISTING LINEARM, DELETE ITEMS 2, 3, & 4. INSTEAD, FIELD DRILL LA/CO CROSSARM FOR 2-36" FLATBRACES. SECURE BRACES TO POLE WITH A LAG SCREW. (SEE STD. 380.1, ITEM 1)

REFERENCE:

- (L) FOR GROUNDING REQUIREMENTS AND APPLICATION – SEE STANDARD 1002.
- (M) PVC CONDUIT IS NOT PERMITTED IN THE CLIMBING SPACE PER G. O. 95, RULE 22.2B.
- (N) SECTIONALIZING CUTOUT INSTALLATION MAY VARY WITH POSITION OF NEUTRAL CONDUCTOR – SEE STANDARD 1240.
- (O) FOR HOT LINE CLAMP CONNECTION, SEE STANDARD 788.

©1998 - 2005 San Diego Gas & Electric Company. All rights reserved. Removal of this copyright notice without permission is not permitted under law.

	Indicates Latest Revision	Completely Revised	New Page	Information Removed
	SDG&E ELECTRIC STANDARDS			
DATE 10-15-05 APPD PJA/JJ	FIXED CAPACITOR INSTALLATION, 4KV WYE/12KV WYE			1399.507 4299.510 SUPERSEDES 1323.4 (10-15-05)

SCOPE: THIS CONSTRUCTION SHALL BE USED FOR ALL 12KV CAPACITOR STATIONS WITH TWO OIL SWITCHES.

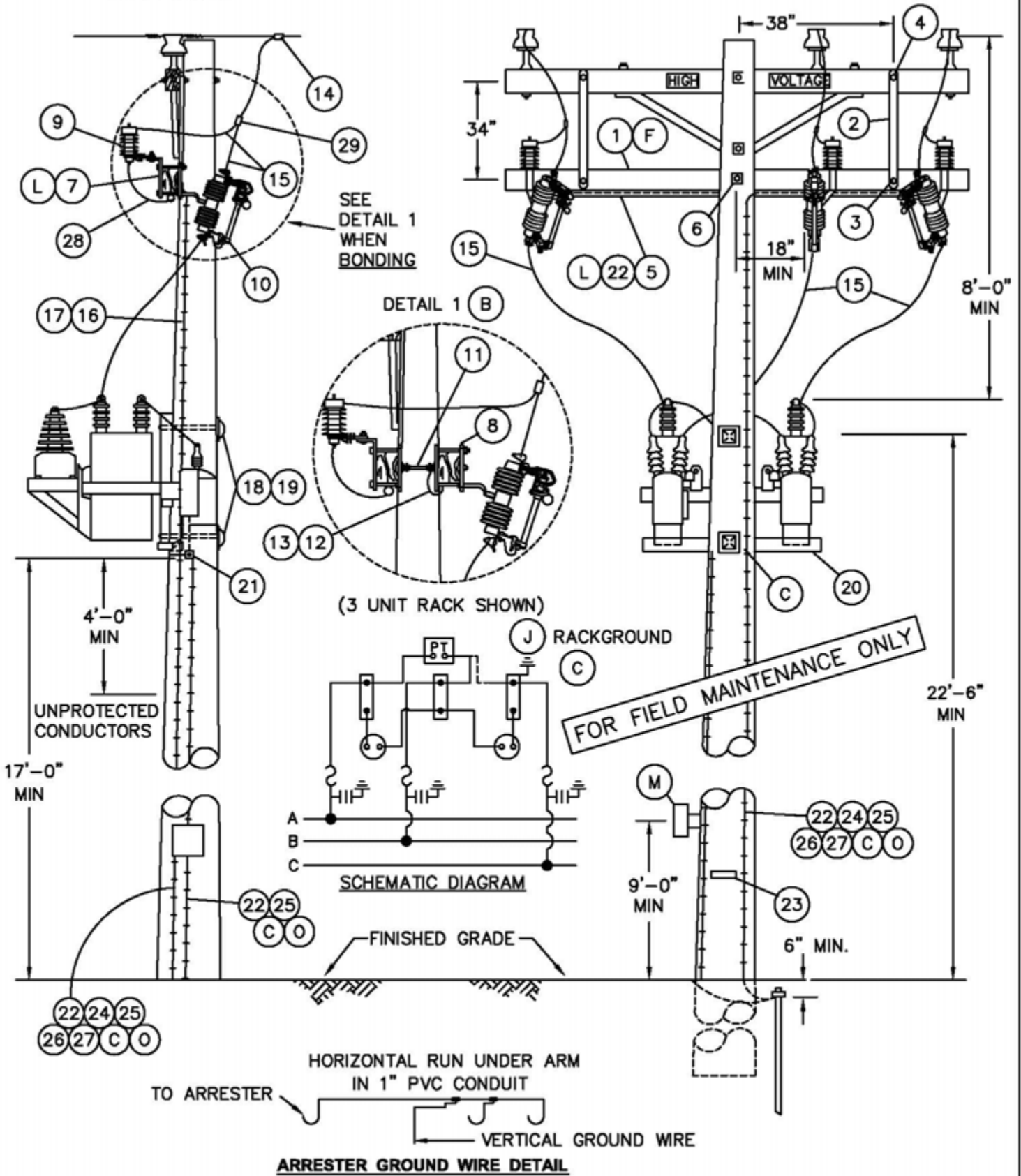

© 1998 - 2005 San Diego Gas & Electric Company. All rights reserved. Removal of this copyright notice without permission is not permitted under law.

<p>1399.508 SUPERSEDES 1325.1 (10-15-05)</p>	<p>SDG&E ELECTRIC STANDARDS</p> <p>12 & 12.47KV SWITCHED CAPACITOR INSTALLATION 2 OIL SWITCHES IN CAPACITOR NEUTRAL</p>	<p>DATE 10-15-05 APPD PJA / JJ</p>
------------------------------------------------------	-------------------------------------------------------------------------------------------------------------------------------------	----------------------------------------

NOTE:

- CLASS OF POLE TO BE DETERMINED PER STANDARD 344-354.

FOR FIELD MAINTENANCE ONLY

BILL OF MATERIAL:

ITEM	DESCRIPTION	QUANTITY (B)		STOCK NO. OR CONSTR STANDARD	ASSEMBLY UNIT
		UNBONDED	BONDED		
1	CROSSARM, 3 3/4" X 5 3/4" X 10' - 0" (B)	1	2	294128	-
2	BRACE, FLAT, CROSSARM, 36" (F)	2	2	164224	-
3	BOLT, MACH, GALV, 3/8" X 4 1/2", 1 ROUND & 1 LOCK WASHER (F)	2	2	STD 392	-
4	BOLT, MACH, GALV, 1/2" X 5", 1 ROUND & 1 DBL COIL SPR WASH (F)	2	2	STD 392	-
5	CONDUIT, PVC, TYPE 2, SCHEDULE 40, 1" AND STRAPS PIPE, GALV, 1" WITH 2- 1 3/4" ROOFING NAILS.	10'	10'	251200	-
		AS REQ'D		697792	-
6	BOLT, MACH, GALV, 5/8" X (LENGTH AS REQ'D), 2 SQUARE & 1 DBL COIL SPRING WASHER	1	1	STD 392	-
7	BRACKET, DOUBLE CUTOUT/ARRESTER, FOR CROSSARM MOUNTING.	3	-	165442	-
8	BRACKET, ARRESTER, OR CUTOUT	-	6	166070	-
9	ARRESTER, LIGHTNING, 12KV	3	3	113248	-
10	CUTOUT, 12KV, 100A, WITH LOADBUSTER HOOKS	3	3	STD 1212	-
11	BOLT, SPACE, GALV, 5/8" X (LENGTH AS REQ'D), 2 ROUND, 4 SQUARE, 2 DOUBLE COIL SPRING WASHERS & 2 NUTS	-	2	STD 392	-
12	WIRE, #8 BARE SOLID ANNEALED COPPER (B)	FT	15	812928	-
		LB	1		
13	STAPLES, WIRE, GALV, 1 1/4" (B)	AS REQ'D		678528	-
14	CONNECTOR, WIRE COMPRESSION, CU OR AL (SIZE AS REQ'D)	AS REQ'D		783-786	-
15	WIRE, #4 BARE STRANDED COPPER	FT	110	813760	-
		LB	14		
16	CONDUIT, PVC, TYPE 2, SCHEDULE 40, 1/2"	10'	10'	251168	-
17	STRAPS, PIPE, GALV, 1/2" WITH 2- 1 3/4" ROOFING NAILS.	AS REQ'D		697728	-
18	BOLT, MACH, GALV, 3/4" X (LENGTH AS REQ'D), 1 SQ CURV RIBBED & 1 DBL COIL SPRING WASHER	2	2	STD 392	-
19	COVER, BOLT PLASTIC & 6- 1 3/4" NAILS, GALV, ROOFING.	2	2	285696	-
		-	-	492192	-
20	SWITCHED CAPACITOR RACK, COMPLETE WITH CAPACITORS, SWITCHES AND POTENTIAL TRANSFORMER	600 KVAR (3 @ 200 KVAR)		564761	-
		1200 KVAR (3 @ 400 KVAR)		564770	-
21	SCREW, LAG, GALV, 4"	2	2	621568	-
22	#4 CU SOLID GROUND WIRE, PVC COVERED	50'	50'	812490	GNDPVC
23	TAG, STATION NUMBER	1	1	STD. 208	-
24	GROUND ROD, 5/8" X 8', COPPERWELD	1	1	603072	GNDPVC
25	COPPER BONDED GROUND CONNECTOR	1	1	259010	-
26	GROUND ENHANCING POWER SOLUTION (GEM)	AS REQ'D		424390	-
27	GALVANIZED STAPLES FOR PVC COVERED GROUND WIRE	AS REQ'D		678562	-
28	FLEXIBLE ARRESTER GROUND STRAP	AS REQ'D		698754	-
29	HOT LINE CLAMP	3	3	227680	-

©1998 - 2005 San Diego Gas & Electric Company. All rights reserved. Removal of this copyright notice without permission is not permitted under law.

DATE 10-15-05 APPD PJA / JJ	SDG&E ELECTRIC STANDARDS	1399.509 SUPERSEDES 1325.2 (10-15-05)
	12 & 12.47KV SWITCHED CAPACITOR INSTALLATION 2 OIL SWITCHES IN CAPACITOR NEUTRAL	

OVERHEAD MACRO UNITS 12KV - SWITCHED NEUTRAL CAPACITOR		
KVAR	CONTROL	MU I.D.
600	VOLT/TIME, DIGITAL, PROGRAMMABLE	C6SCT
1200	VOLT/TIME, DIGITAL, PROGRAMMABLE	C12SCT

FOR FIELD MAINTENANCE ONLY

INSTALLATION:

- (A) CAUTION: OPEN OIL SWITCHES BEFORE OPENING CUTOUTS.
- (B) BOND CUTOUTS IN HEAVY CONTAMINATION DISTRICTS AS SHOWN ON STANDARD 287. IN AREAS WHERE BONDING IS REQUIRED, TO AVOID BONDWIRE AND LIGHTNING ARRESTER GROUNDWIRE ON THE SAME CROSSARM, USE TWO CROSSARMS; ONE FOR CUTOUTS AND ONE FOR LIGHTNING ARRESTERS.
- (C) CONNECT CAPACITOR RACK GROUND LEAD TO LIGHTNING ARRESTER GROUND. A SECOND GROUND WIRE IS REQUIRED FOR THE CONTROL PANEL TO BE CONNECTED ON THE SAME GROUND ROD. COIL LOOSE END OF THE CONTROL PANEL GROUND WIRE AND STAPLE TO POLE (TO BE WORKED BY SERVICE CREW).
- D. DO NOT TIE CAPACITOR BANK NEUTRAL TO 12KV CIRCUIT NEUTRAL. IT IS TO REMAIN FLOATING.
- (F) WHEN LA/CO CROSSARM AND CAPACITORS CANNOT BE INSTALLED ON THE SAME SIDE OF THE POLE AS AN EXISTING LINEARM, DELETE ITEMS 2, 3, & 4. INSTEAD, FIELD DRILL LA/CO CROSSARM FOR 2-36" FLAT BRACES, SECURE BRACES TO POLE WITH A LAG SCREW. (SEE STD. 380.1, ITEM 1 FOR DRILLING MEASUREMENTS).
- G. RACKS THAT CONTAIN POTENTIAL TRANSFORMERS (PT'S) WITH METAL TANKS ARE TO BE INSULATED FROM RACK BEFORE REINSTALLATION.
- H. CAPACITORS MUST BE INSTALLED ON POLES ACCESSIBLE BY BUCKET TRUCK.
- (J) PT CAN BE CONNECTED TO CENTER PHASE OR OUTSIDE PHASE DEPENDING ON FIELD CONDITION.
- K. THE PT FOR THIS INSTALLATION IS CONNECTED PHASE-TO-PHASE.
- (L) DRILL THROUGH CROSSARM 1" UP FROM LOWER EDGE SO THAT LOWER CROSSARM MOUNTING BRACKET BOLT DOES NOT INTERFERE WITH PVC CONDUIT.

REFERENCE:

- (M) SHOWN FOR ILLUSTRATIVE PURPOSES ONLY. SEE STANDARD 1330 FOR CONTROL INSTALLATION AND MATERIAL.
- (N) PVC CONDUIT IS NOT PERMITTED IN THE CLIMBING SPACE PER G.O. 95 RULE 22.2C.
- (O) FOR GROUNDING REQUIREMENTS AND APPLICATION, SEE STANDARD 1002.

© 1998 - 2005 San Diego Gas & Electric Company. All rights reserved. Removal of this copyright notice without permission is not permitted under law.

DATE 1-1-2000 APPD <i>PA/VR</i>	SDG&E ELECTRIC STANDARDS	1399.510 SUPERSEDES 1325.3 (10-15-05)
	12 & 12.47KV SWITCHED CAPACITOR INSTALLATION 2 OIL SWITCHES IN CAPACITOR NEUTRAL	

SCOPE: THIS STANDARD SHOWS TYPES OF CONTROLS, MATERIAL AND INSTALLATION OF A CAPACITOR CONTROL UNIT. THIS IS TO BE USED ON ALL SWITCHED CAPACITOR STATIONS.

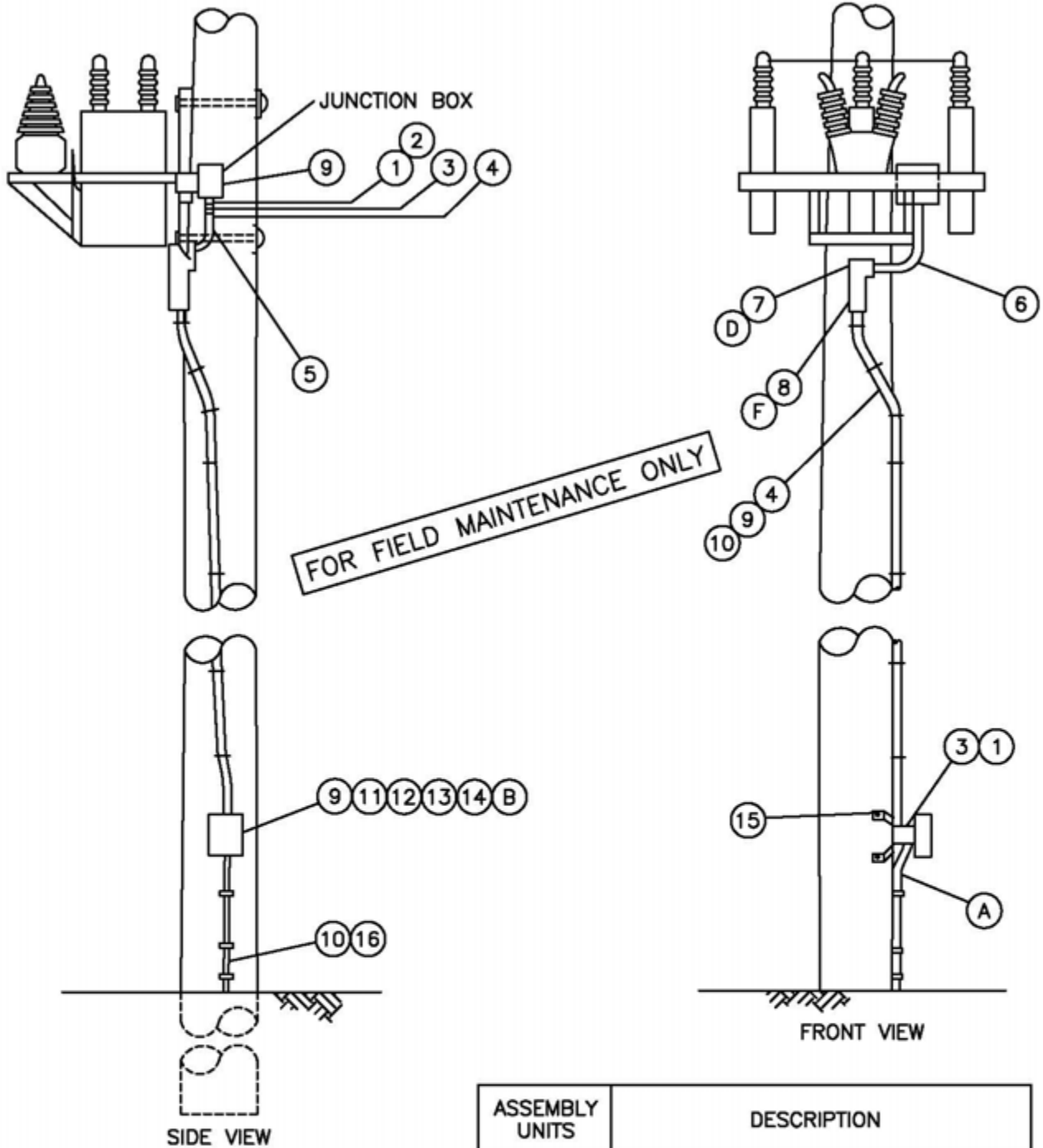

ASSEMBLY UNITS	DESCRIPTION
C/CTIM	CONTROL-DIGITAL, PROGRAMMABLE

NOTE:

- SEE PAGE 1330.4 FOR BILL OF MATERIAL
- MATERIALS ORDERED ARE BASED ON A 50' POLE.

© 1998 - 2010 San Diego Gas & Electric Company. All rights reserved. Removal of this copyright notice without permission is not permitted under law.

DATE 1-1-2000 APPD <i>PA/Val</i>	SDG&E ELECTRIC STANDARDS	1399.511 SUPERSEDES 1330.1 (1-1-2000)
	CAPACITOR CONTROL MATERIAL AND INSTALLATION	

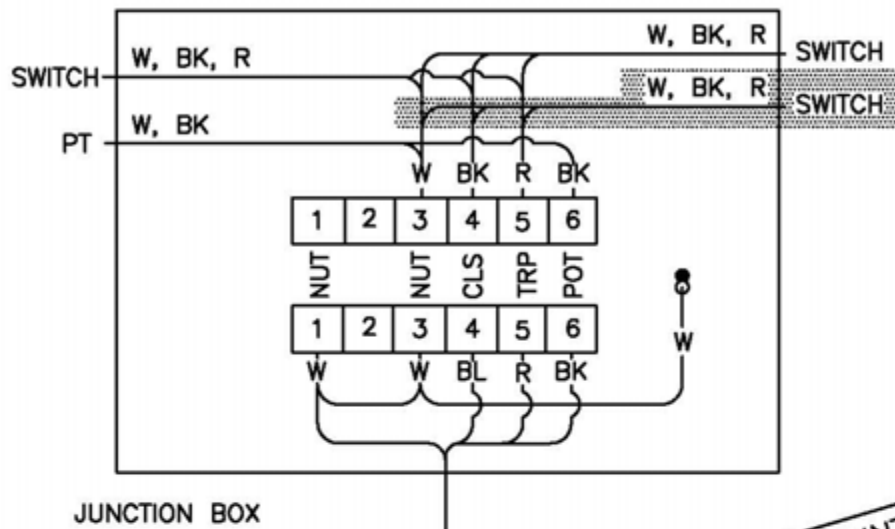

FOR FIELD MAINTENANCE ONLY

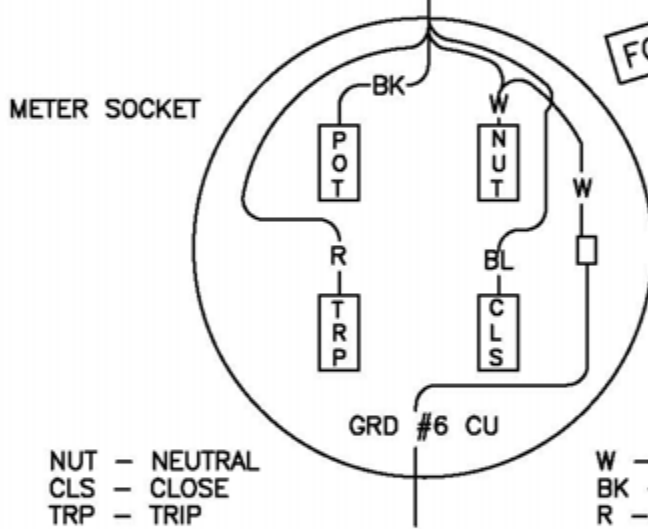

- NUT - NEUTRAL
- CLS - CLOSE
- TRP - TRIP
- POT - POTENTIAL
- W - WHITE
- BK - BLACK
- R - RED
- BL - BLUE

CAPACITOR CONTROL WIRING

CONTROL PANEL
(FACING METER SOCKET)

© 1998 - 2012 San Diego Gas & Electric Company. All rights reserved. Removal of this copyright notice without permission is not permitted under law.

1399.512
SUPERSEDES
1330.2 (4-3-09)

SDG&E ELECTRIC STANDARDS

CAPACITOR CONTROL MATERIAL AND INSTALLATION
VOLTAGE WITH TIME BIAS (TYPE 'TB')

DATE 4-3-09
APPD *PA* / BV

BILL OF MATERIAL: (FOR CONTROL PORTION OF SWITCHED CAPACITOR JOBS)

ITEM	DESCRIPTION	QUANTITY	STOCK NUMBER
1	TERMINAL ADAPTER, PVC 1"	2	102756
2	LOCKNUT, GALV. 1"	1	468896
3	REDUCER, PVC 1" X 3/4"	2	573410
4	CONDUIT, PVC 3/4" SCHEDULE 40	25'	251328
5	COUPLING, PVC 3/4"	1	280416
6	ELBOW 90° , PVC 3/4"	1	322166
7	ACCESS FITTING BODY TYPE "T" PVC 3/4" (D)	1	147792
8	ACCESS FITTING BODY TYPE "LB" PVC 3/4" (F)	1	146384
9	WIRE TW #12 WHITE	30'	808704
	WIRE TW #12 BLACK	30'	808096
	WIRE TW #12 BLUE	30'	808416
	WIRE TW #12 RED	30'	808576
10	STRAPS, PIPE GALV 3/4", 6 D NAILS, GALV	AS REQ'D	697888/490656
11	METER SOCKET	1	161898
12	RING, STAINLESS STEEL, METER SEALING	1	599034
13A	DIGITAL, PROGRAMMABLE CONTROL (C)	1	706176
13B	FISHER PIERCE 2416 CONTROL REPLACEMENT BATTERY KIT (G)(H)	-	126800
14	PADLOCK, MASTER 7	1	514912
15	SCREW, LAG 1/4" X 2"	4	621888
16	CONDUIT, PVC 3/4" SCHEDULE 80	9	251520

FOR FIELD MAINTENANCE ONLY

INSTALLATION:

- (A) ATTACH GROUND WIRE (ALREADY PROVIDED) TO GROUND TERMINAL OF METER SOCKET.
- (B) INSTALL CONTROL 90' FROM FRONT SIDE OF CAPACITOR RACK.
- (C) CONTROLS TO BE CONFIGURED/PROGRAMED PER THE DISTRIBUTION CAPACITOR INSTRUCTION, SETTING AND SURVEY INFORMATION MANUALS.
- (D) FOR USE WHEN CURRENT SENSOR IS REQUIRED.
- (E) NEW INSTALLATIONS MUST BE AUTHORIZED BY PLANNING ENGINEER.
- (F) FOR USE WITHOUT CURRENT SENSOR.
- (G) REPLACEMENT KIT INCLUDES: ONE 6 VOLT RECHARGEABLE LEAD ACID BATTERY, 2-30 INCH WIRES WITH CONNECTORS ON BOTH ENDS, DOUBLE SIDED ADHESIVE TAPE.
- (H) IF BATTERY IS INSTALLED ON CIRCUIT BOARD BEHIND CONTROL PANEL, INSTALL NEW BATTERY ON RIGHT HAND SIDE OF CONTROL DOOR. DO NOT ATTEMPT TO REMOVE OLD BATTERY FROM CIRCUIT BOARD BECAUSE BOARD MAY BE DAMAGED.

REFERENCE:

- I. SEE STANDARD 1325 FOR A TWO OIL SWITCH INSTALLATION WITH CONTROL UNIT.
- J. SEE FMO STANDARD 1399.208 FOR A SWITCH CAPACITOR USING A CURRENT SENSOR AND CONTROL UNIT.
- K. SEE ELECTRIC STANDARD PRACTICE 302 FOR PROPER OPERATION OF CAPACITOR STATION AND CONTROL TESTING.
- L. PVC CONDUIT IS NOT PERMITTED IN THE CLIMBING SPACE-SEE G.O. 95 RULE 22.2(C).

© 1998 - 2005 San Diego Gas & Electric Company. All rights reserved. Removal of this copyright notice without permission is not permitted under law.

DATE 1-28-02

APPD PBA/VGR

SDG&E ELECTRIC STANDARDS

CAPACITOR CONTROL MATERIAL AND INSTALLATION

1399.513
SUPERSEDES
1330.3 (8-31-99)

1400-1500 CABLE POLES,
LIGHTING

1400-1500 CABLE POLES,
LIGHTING

PAGE

SUBJECT

1499.001	CABLE POLE INSTALLATION INFORMATION
1499.002-.008	CABLE POLE RISER INSTALLATION, CABLE-IN-CONDUIT
1499.009	CABLE POLE RISER INSTALLATION, MODIFICATION FROM SINGLE TO DOUBLE RISER FOR EXISTING CABLE POLES
1499.010-.012	CABLE POLE TERMINAL MOUNTING INFORMATION (PORCELAIN TERMINALS) (FOR CONTAMINATION DISTRICT 1)
1499.101-.104	0-750 UNDERGROUND SERVICE AND RISERS
1499.201-.202	4KV CABLE POLE CONSTRUCTION
1499.203-.206	12.47KV AND BELOW 3 PHASE CABLE POLE 1/C PER PHASE UPSWEEP BRACKET CONSTRUCTION
1499.207-.212	BRACKET MOUNTED TERMINALS, 12.47KV AND BELOW SINGLE-PHASE ARMLESS TANGENT CONSTRUCTION, NON-PORCELAIN TERMINALS "4 WAY AND 'T' CORNERS", 12 AND 12.47KV
1499.301-.304	12KV ARMLESS CABLE POLE CONSTRUCTION
1499.305-.306	12.47KV AND BELOW CABLE POLE, UPSWEEP BRACKET, THREE-PHASE, 1/C PER PHASE, LINEARM MOUNTED DISCONNECTS
1499.307-.309	CROSS ARM CABLE POLE 3 PHASE, 1/C PER PHASE DEADEND CONSTRUCTION, 12.47KV AND BELOW
1499.310-.314	12.47KV AND BELOW CABLE POLE UPSWEEP BRACKET
1499.401-.403	12.47KV AND BELOW DEAD END CABLE POLE ARM, 3 PHASE, 1/C PER PHASE, HOOKSTICK SWITCHED
1499.404-.413	12.47KV AND BELOW DEAD END CABLE POLE THREE-PHASE, 1/C PER PHASE, GANG OPERATED SWITCHED NON-PORCELAIN TERMINALS
1499.501-.503	CABLE POLE, STEEL, LIGHT DUTY
1499.504-.506	12.47KV AND BELOW DEAD END CABLE POLE, 6 OR 7 OH CONDUCTORS, 1 OR 2 TERMINALS PER CONDUCTOR, HOOKSTICK SWITCHED
1499.601-.605	12.47KV DEAD END CABLE POLE, THREE-PHASE WITH NEUTRAL, HORIZONTAL SCADA-MATE SWITCH
1499.801-.902	METERING
1599.102	LIGHTING INSTALLATION
1599.201	MERCURY VAPOR CONVENTIONAL LUMINAIRES
1599.203-.204	HIGH PRESSURE SODIUM VAPOR LUMINAIRE AND REPLACEMENT BALLAST
1599.210	LOW PRESSURE SODIUM VAPOR LUMINAIRE AND REPLACEMENT BALLAST
1599.501	SERIES CONTROLLED R.O. STREET LIGHT TRANSFORMER INSTALLATIONS
1599.502	SERIES CONTROLLED, REGULATED OUTPUT STREET LIGHT TRANSFORMER INSTALLATION, REMOTE CONTROL OUTDOOR CIRCUIT, SWITCH CAPACITOR, 4KV
1599.503	PHOTOELECTRIC CONTROLLED, REGULATED OUTPUT, STREET LIGHT TRANSFORMER INSTALLATION, 4KV
1599.601-.602	PHOTOELECTRIC CONTROLLED R.O. STREET LIGHT TRANSFORMERS INSTALLATION, 12KV

© 1998 - 2019 San Diego Gas & Electric Company. All rights reserved. Removal of this copyright notice without permission is not permitted under law.

REV	CHANGE	BY	DSGN	APPV	DATE	REV	CHANGE	BY	DSGN	APPV	DATE
C						F					
B	COMPLETELY REVISED	JK	JS	CZH	10/15/2019	E					
A	ORIGINAL ISSUE	JK	JS	CZH	6/13/2019	D					

SHEET 1 OF 1	Indicates Latest Revision <input checked="" type="checkbox"/> Completely Revised	<input type="checkbox"/> New Page	<input type="checkbox"/> Information Removed	OH LEGACY OHL1401.1
	SDG&E ELECTRIC OVERHEAD FIELD MAINTENANCE ONLY STANDARDS			
	LEGACY OVERHEAD FIELD MAINTENANCE TABLE OF CONTENTS CABLE POLES, LIGHTING			

SCOPE: THIS STANDARD: 1) SHOWS THE STANDARD CABLE POLE RISER POSITIONS FOR SDG&E, TELCO, AND CATV COMPANIES, IT IS FOR RISER PLACEMENT ONLY (SEE SECTION 1400/4200 FOR SPECIFIC CONSTRUCTION DETAILS).

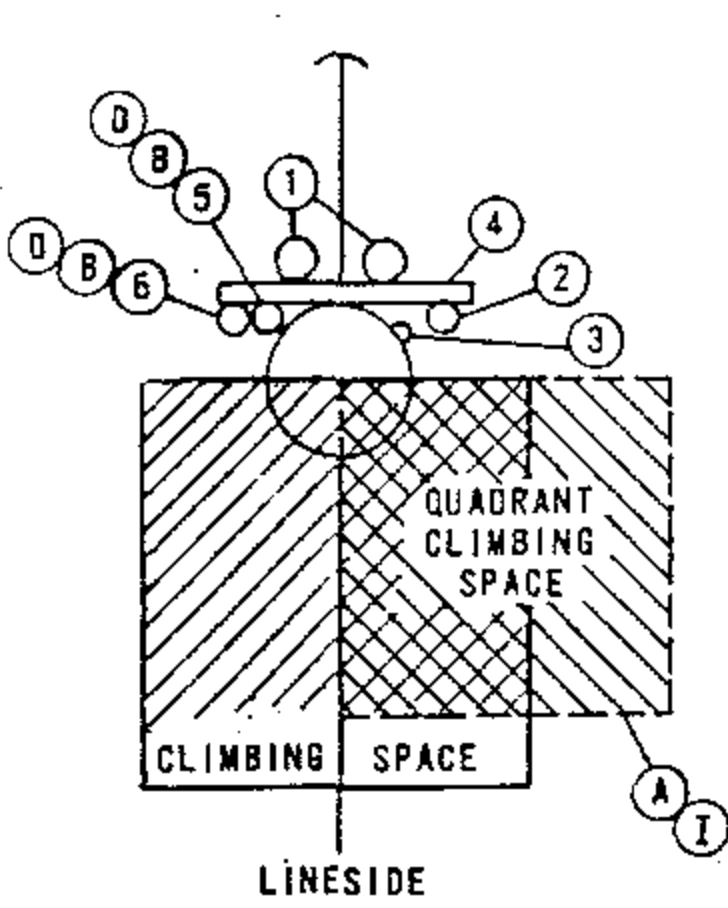

LINESIDE

FIGURE 1

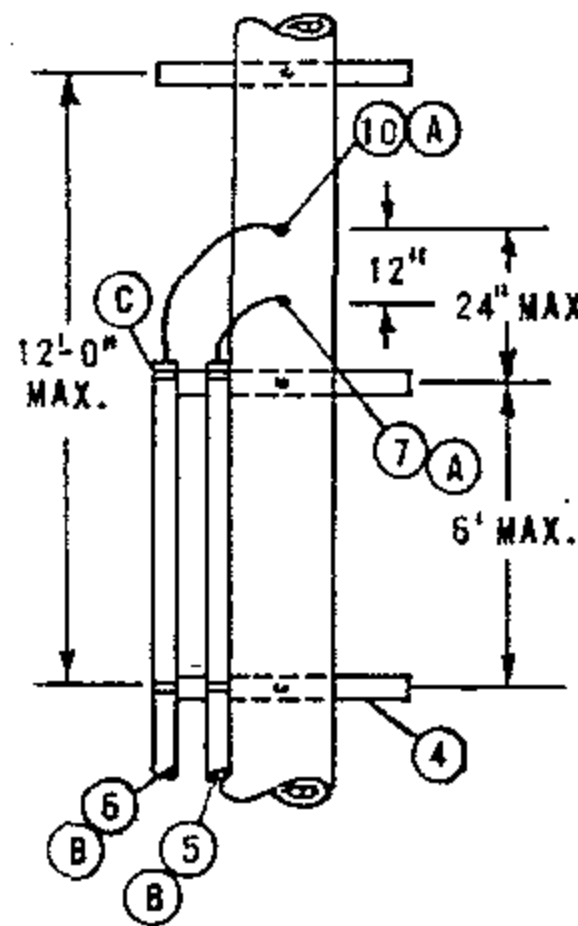

FIGURE 2

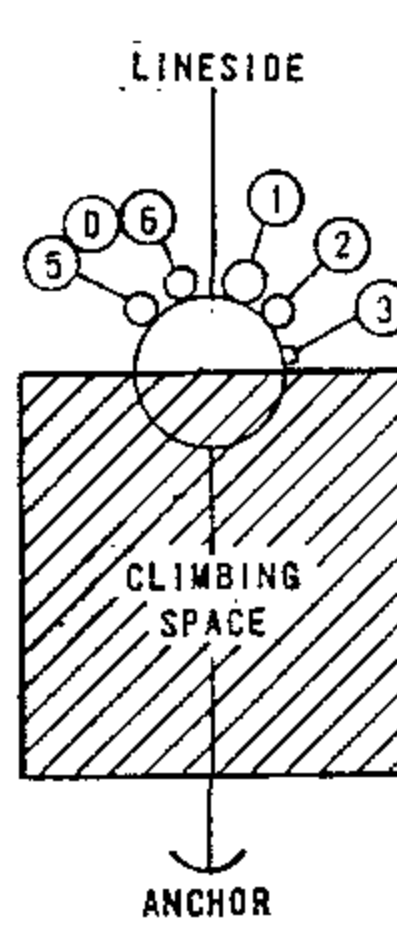

FIGURE 3

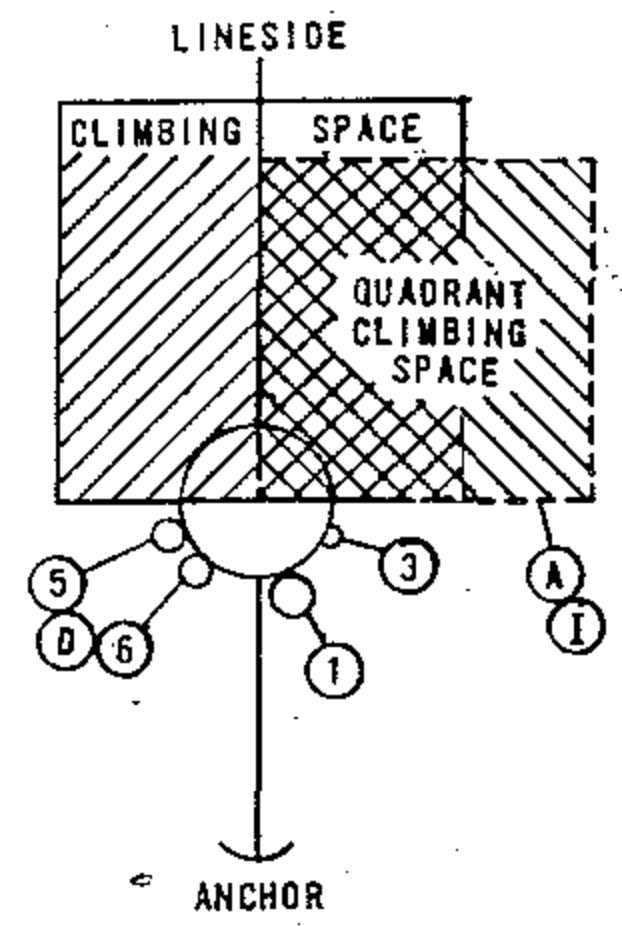

FIGURE 4

DEAD END CONSTRUCTION

FOR FIELD MAINTENANCE ONLY

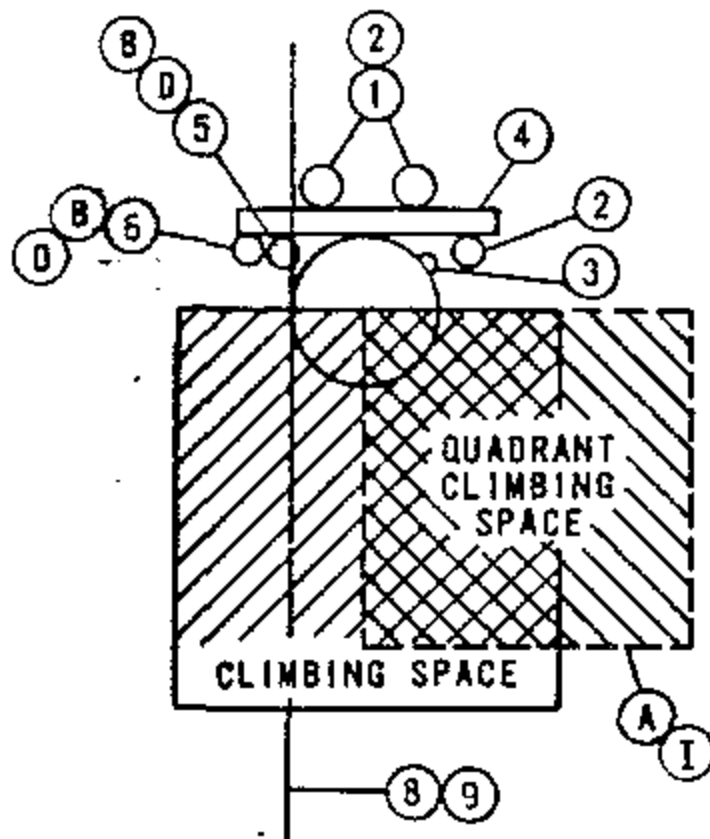

FIGURE 5

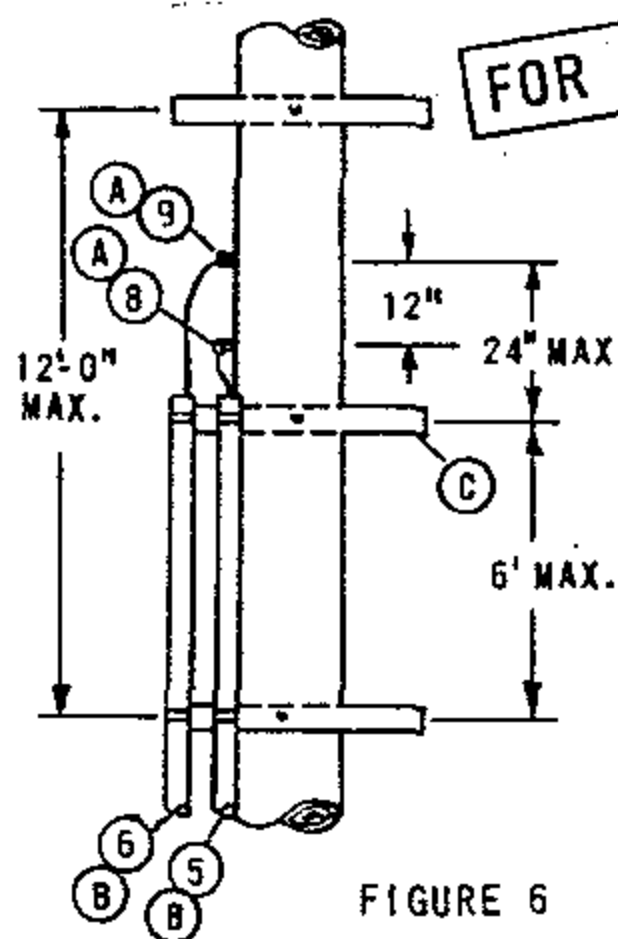

FIGURE 6

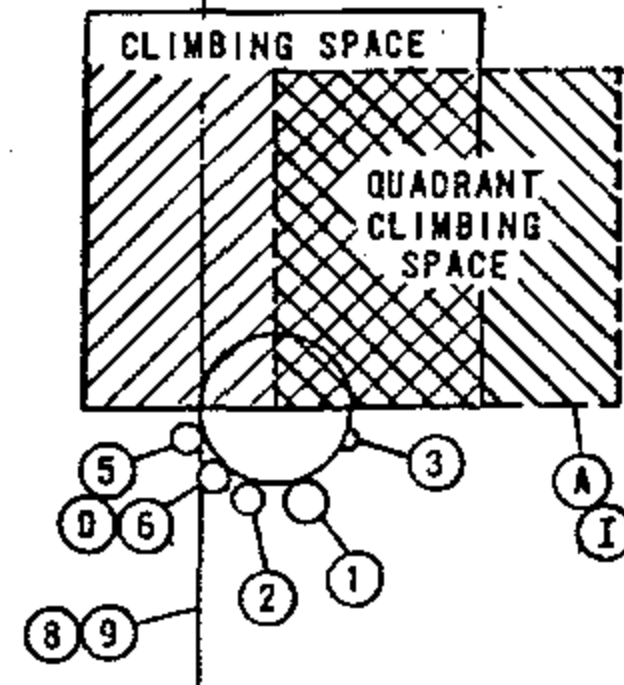

FIGURE 7

TANGENT CONSTRUCTION

INSTALLATION:

- (A) QUADRANT CLIMBING SPACE PROVIDED THROUGH CATV AND TELCO AERIAL ATTACHMENT LEVELS ONLY.
- (B) C.A.T.V. AND TELCO TO ATTACH CONDUIT TO BACK SIDE OF RISER LADDER ARMS.
- (C) C.A.T.V. OR TELCO TO PLACE RISER LADDER ARM TO HOLD TOP OF OWN CONDUIT.
- (D) C.A.T.V. AND TELCO TO ALWAYS BE IN SAME QUADRANT.
- F. CONDUIT RISER AT BASE OF POLE NOT TO INFRINGE ON CURB OR SIDEWALK POSITIONS.

REFERENCES:

- G. PVC RISERS ARE NOT PERMITTED WITHIN THE CLIMBING SPACE PER G.O. 95 RULE 22.2C.
- H. G.O. 95 RULE 91.3-A1C REQUIRES POLE STEPS ON ALL JOINTLY USED CABLE POLES (SEE STANDARD 363).
- I. SEE SECTION 200 FOR ALLOWABLE G.O. 95 CLIMBING SPACE OBSTRUCTIONS.
- J. NO CATV OR TELCO JUMPERS ALLOWED IN QUADRANT CLIMBING SPACE PER G.O. 95 RULE 84.7.

ITEM	DESCRIPTION	ITEM	DESCRIPTION
1	SDG&E PRIMARY RISER	6	C.A.T.V. RISER POSITION
2	SDG&E SECONDARY RISER	7	TELCO DEAD END ATTACHMENT
3	SDG&E ELECTRIC GROUND	8	TELCO TANGENT (THRU) POSITION
4	RISER LADDER ARM	9	C.A.T.V. TANGENT (THRU) POSITION
5	TELCO RISER POSITION	10	C.A.T.V. DEAD END ATTACHMENT

SDG&E ELECTRIC STANDARDS

DATE 11-16-81
APPD JCY

JOINT CABLE POLE RISERS USING WOODEN LADDER ARMS

OH 1499.001
~~UG 4299.001~~
SUPERSEDES
1402.1 (11-16-81)

SCOPE: THIS STANDARD SHOWS THE CONSTRUCTION FOR SINGLE-PHASE PRIMARY AND SECONDARY CABLE-IN-CONDUIT (CIC) INSTALLATIONS.

CABLE AND CONDUIT TABLE

RISER EXTENSION	CABLE POLE RISER	PRIMARY IN CONDUIT (PID)	SECONDARY IN CONDUIT (SIDA)
3"	3" (D)	1	1- (2-3/0, 1-1/0 & SMALLER)
4"	3"	2	1- (2-350 KCMIL, 1-1/0) (B)
5"	3"	(H)	2- (2-3/0, 1-1/0 ONLY) (C)

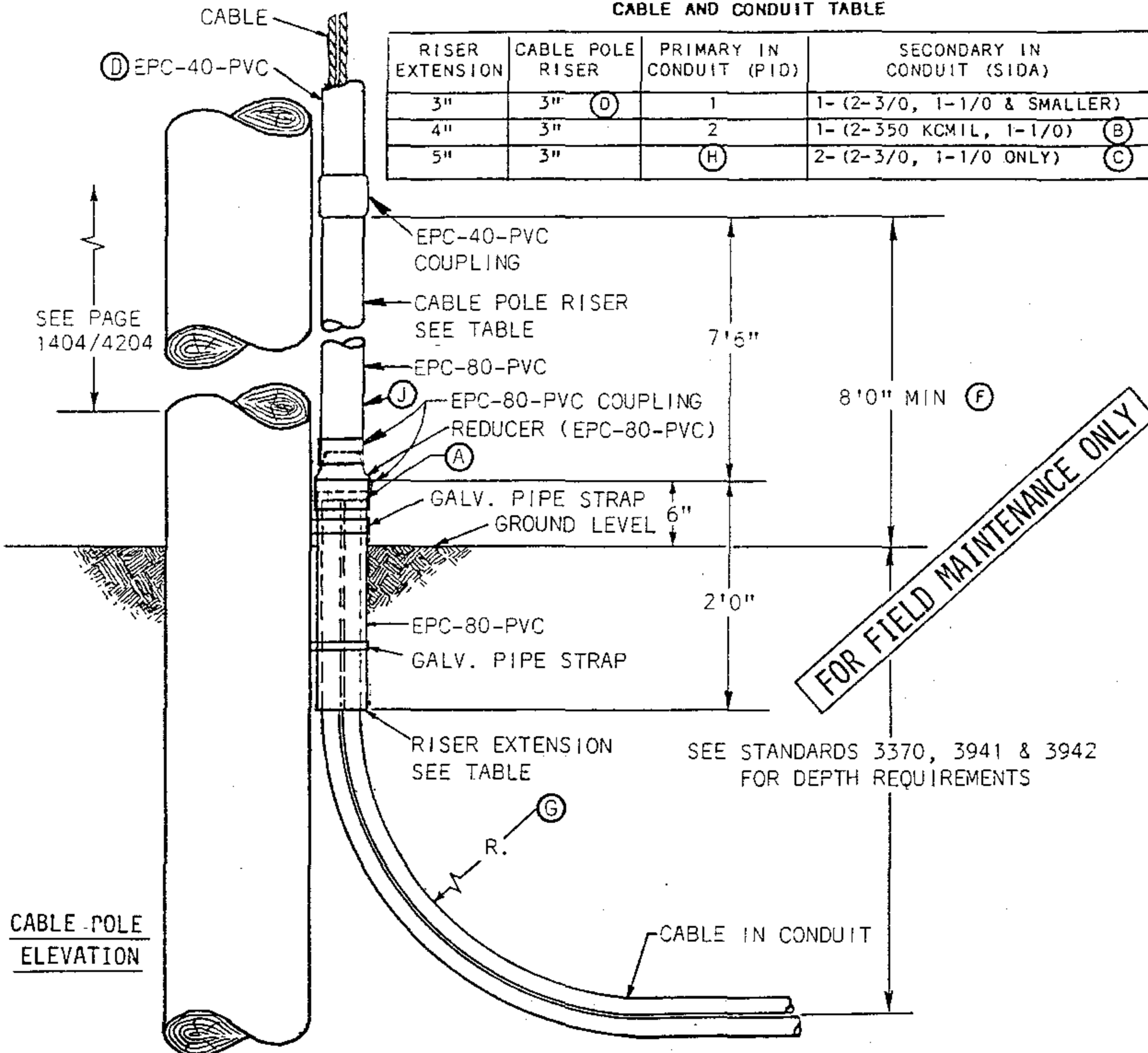

NOTES: NO MORE THAN TWO CIC CONDUITS FOR A RIGID CONDUIT RISER IS ALLOWED.

INSTALLATION:

- (A) CUT CONDUIT FROM CABLE-IN-CONDUIT 4 INCHES ABOVE GROUND LEVEL.
- (B) THE 350 KCMIL CABLE-IN-CONDUIT (SIDA) SHALL NOT BE USED FOR SERVICES. IF A SERVICE REQUIRES 350 CABLE, USA CABLE AND RIGID CONDUIT MUST BE USED.
- (C) FOR 2 RUNS OF SIDA IN ONE RISER, DERATE AMPACITY 20%.
- (D) FOR 3/0 AND SMALLER SIDA, REDUCE THE TOP PORTION OF THE RISER ABOVE THE 8 FOOT LEVEL TO 2 INCH CONDUIT.

REFERENCE:

- (F) RISERS OF PLASTIC PIPE SHALL BE EPC-80-PVC (SCHEDULE 80) WITH A MINIMUM NOMINAL PIPE SIZE OF 3 INCHES FROM THE GROUND LINE TO A LEVEL NOT LESS THAN 8 FEET ABOVE THE GROUND LINE PER G.O. 95, RULE 54.6-E.
- (G) SEE PAGE 3380.2 FOR CABLE-IN-CONDUIT MINIMUM BENDING RADIUS.
- (H) SEE PAGES 1403.2/4203.2 THRU 1403.7/4203.7 FOR THREE-PHASE PRIMARY CABLE IN CONDUIT INSTALLATION WHICH REQUIRES 'U' SHAPED MOULDING.
- (I) SEE PAGE 1404.2/4204.2 FOR CABLE POLE RISER BILL OF MATERIAL.
- (J) SEE PAGES 1405.1/4205.1 THRU 1405.3/4205.3 FOR MULTIPLE RISER INSTALLATION.

OH 1499.002

~~UG 4299.002~~

SUPERCEDES 4203.1
(3-2-84)

SDG&E ELECTRIC STANDARDS

CABLE POLE RISER INSTALLATION
CABLE-IN-CONDUIT

DATE 1-1-87

APPD. *JLB/RDB*

SCOPE: THIS STANDARD SHOWS THE MATERIALS AND PROCEDURES FOR TERMINATING THREE PREASSEMBLED CABLE-IN-CONDUIT ON RISER POLE.

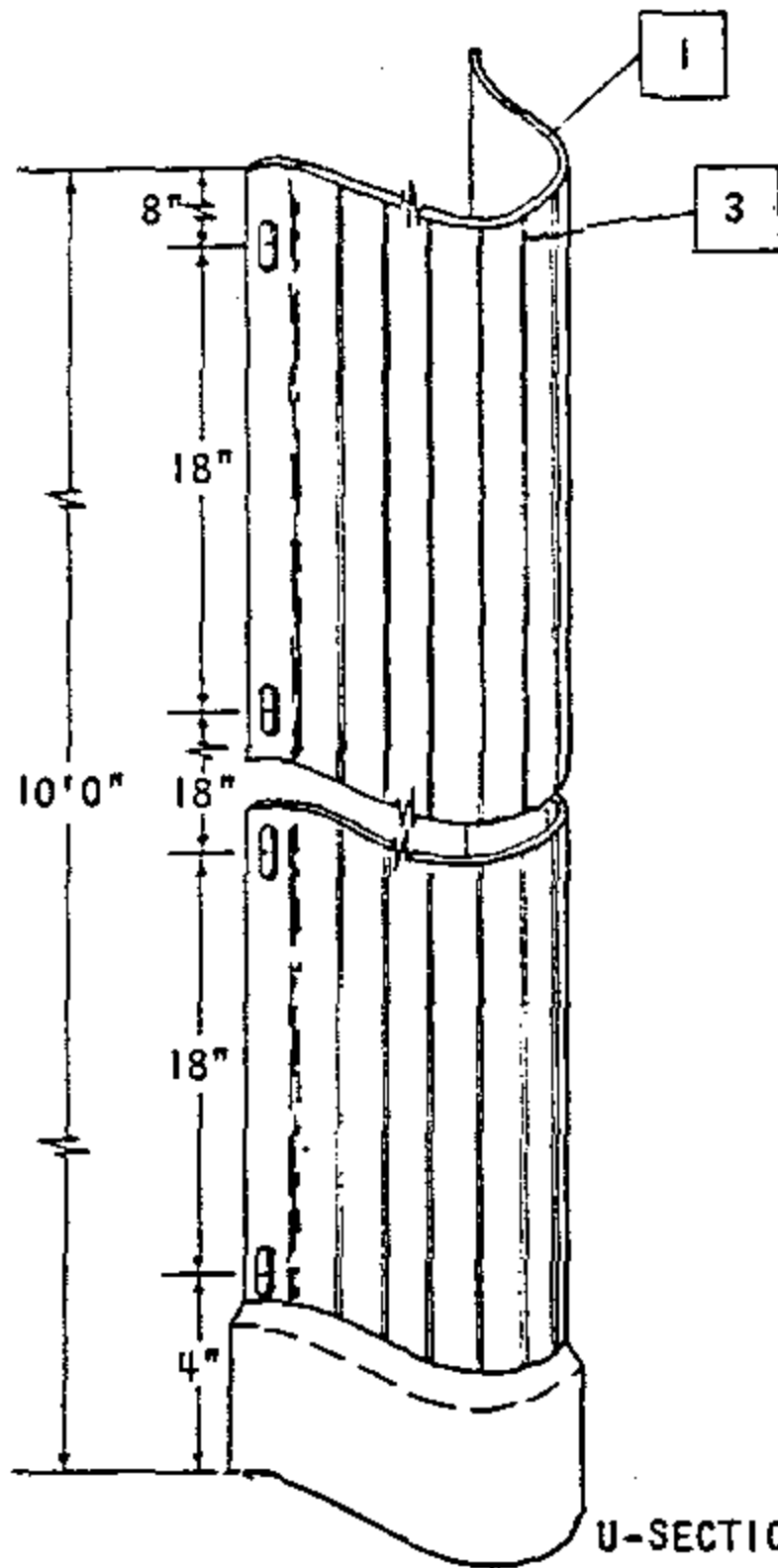

U-SECTION

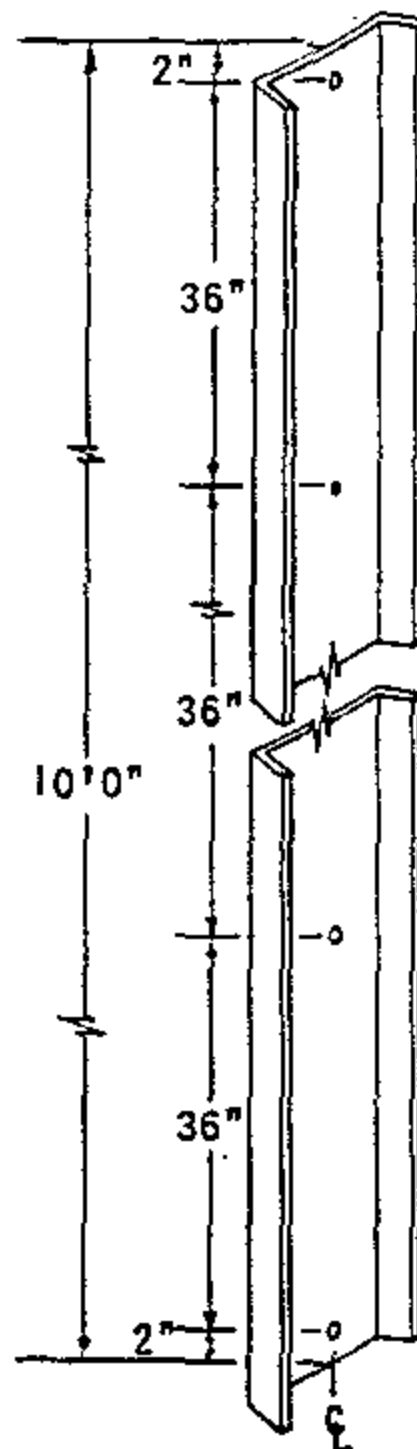

BACKUP PLATE

FOR FIELD MAINTENANCE ONLY

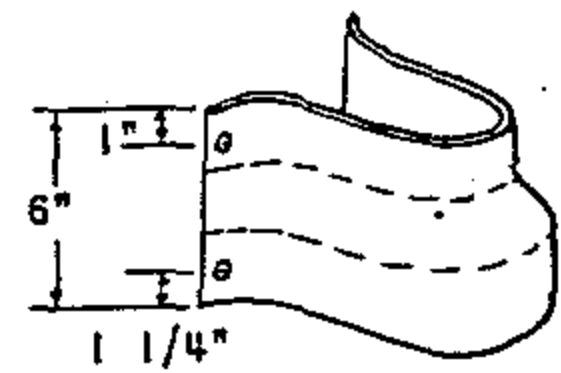

REDUCER BOOT

NOTE: DIMENSIONS A, B, & C HAVE A TOLERANCE OF $\pm .13$.
BILL OF MATERIAL:

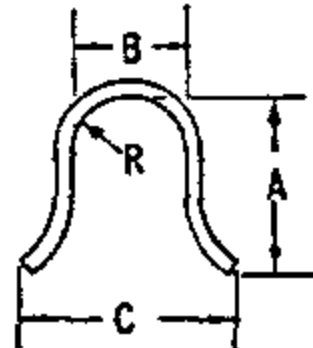
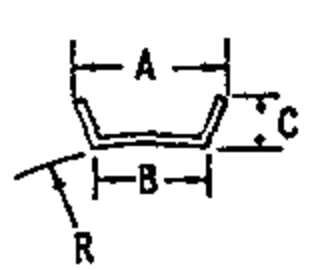
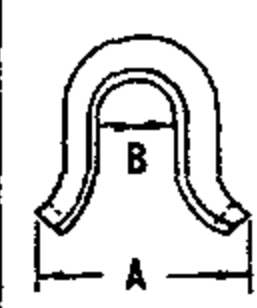
							
	U-SECTION MOLDING			BACKUP PLATE		REDUCER BOOT	
SIZE	3"	3"	4"	3"	4"	3" TO 4"	
SCHEDULE	80	30	40	N/A	N/A	N/A	
LENGTH	10'0"	10'0"	10'0"	10'0"	10'0"	6"	
M & S NO.	600064	600032	600096	542992	542994	160608	
A	3 3/8"	3 3/8"	4 1/8"	3 1/4"	4 1/4"	8 1/4"	
B	3"	3"	4"	2 5/8"	3 5/8"	2 5/8"	
C	6 1/4"	6 1/4"	7 1/4"	7/8"	1"	--	
R	1 7/16"	1 19/32"	2"	5"	5"	--	
WALL THICKNESS	.300"	.150"	.237"	.063"	.063"	.150"	
TOLERANCE	-0" +.036"	-0" +.020"	-0" +.020"	$\pm .015$ "	$\pm .015$ "	-0" +.015"	

SDG&E ELECTRIC STANDARDS

3Ø CABLE POLE RISER INSTALLATION
CABLE-IN-CONDUIT

DATE 1-1-87
APPD J.Y.S./R.D.S.

OH 1499.003
~~UG 4299.003~~
SUPERCEDES 4203.2
(1-4-80)

SEQUENCE FOR INSPECTION

SEQ	DESCRIPTION/DIMENSIONS	TOLERANCE
1	WALL THICKNESS	
	U-Sections	
	3" Sch. 80 .300	-.0" + .036"
	3" Sch. 30 .150"	-.0" + .020"
	4" Sch. 40 .237"	-.0" + .020"

Above wall thicknesses are in accordance with G.O. 95 Rule 54.6D2.

2 GENERAL APPEARANCE ALL SURFACES

U-Sections, Backup Plates and Reducer Boot

Free from warpage, cuts, blemishes and protrusions.

FOR FIELD MAINTENANCE ONLY

3 SCRIBE MARK

Scribe mark indicating minimum overlap distance should be visible 1" from the plain end of the U-Section.

BILL OF MATERIAL:

ITEM	*QUANTITY REQUIRED	DESCRIPTION	USE BELOW 8 FT.	USE ABOVE 8 FT.	STOCK NO. OR CONST. STDS.
1	3'	Riser, U-Section 4"x10' Sch. 40	yes	no	600096
2	1	Riser, U-Section 3"x10' Sch. 80	yes	no**	600064
3	2	Riser, U-Section 3"x10' Sch. 40	no	yes	600032
4	1	Boot, Reducer 4" to 3"	yes	no	160608
5	3	Plate, Backup 3"x10'	yes	yes	542992
6	3'	Plate, Backup 4"x10'	yes	no	542994
7	1	Screw, Lag, Sq. Head 1/2"x4" (E)	no	yes	621568
8	42	Screw, Lag, Sq. Head 1/4"x 2 1/2" (E)	yes	yes	621856
9	42	Washer, Std. Flat Round 1/4" (E)	yes	yes	799520
10	46	6d Galvanized Nails (E)	yes	yes	—
11	3	Grip, Cable 5 1/4"x12"	no	yes	394336

(E) Exempt Material

* This quantity is a typical 40' riser installation, if pole height varies from this distance adjust appropriate material accordingly.

** Only excess portion of 1 - 10 ft. 3" Sch. 80 U-Section is allowed above the 8 ft. level.

OH 1499.004
~~UG 4299.004~~
 SUPERCEDES 4203.3
 (11-16-81)

SDG&E ELECTRIC STANDARDS

**3Ø CABLE POLE RISER INSTALLATION
 CABLE-IN-CONDUIT**

DATE 1-1-87
 APPD *JLB/RTJ*

INSTALLATION INSTRUCTIONS

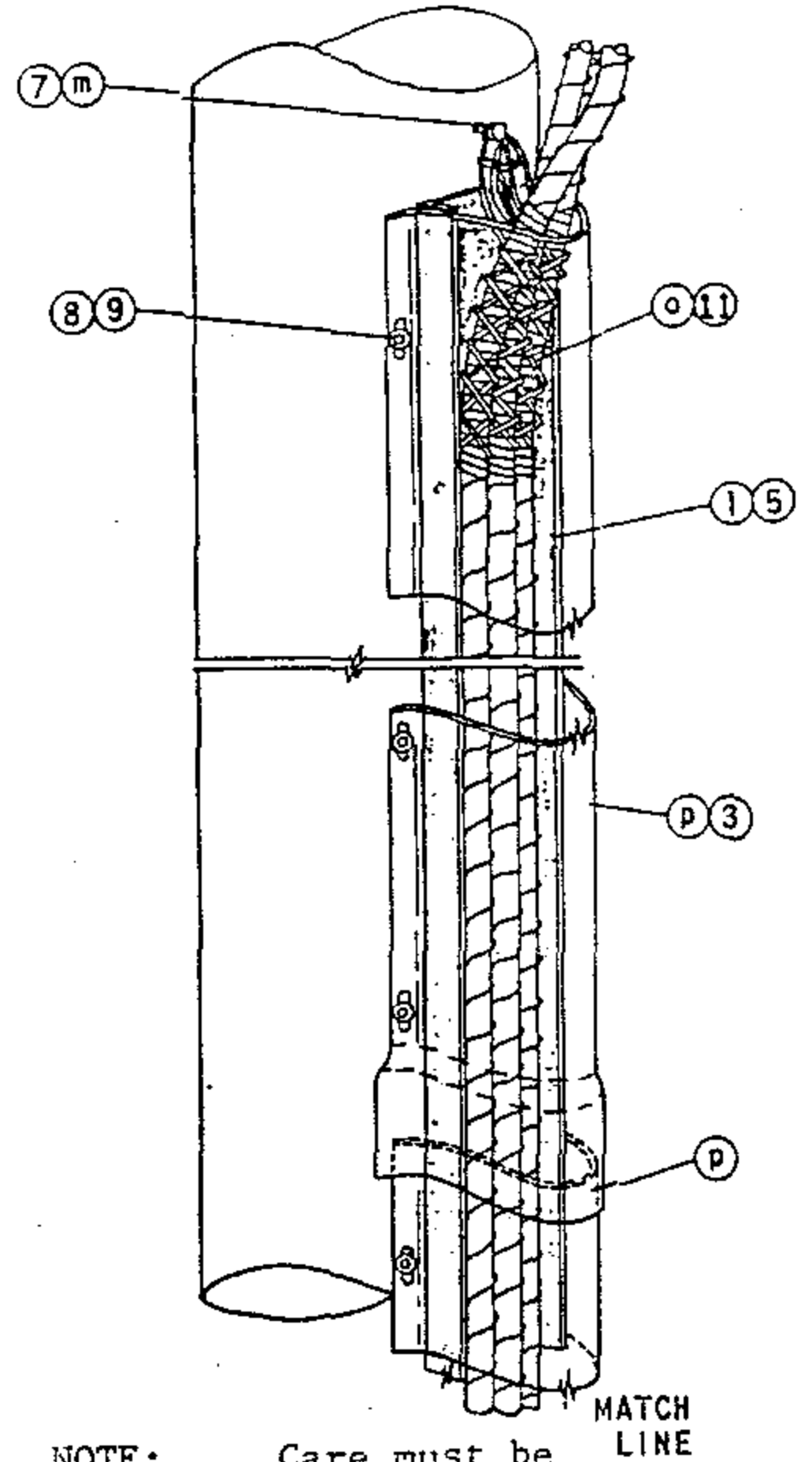
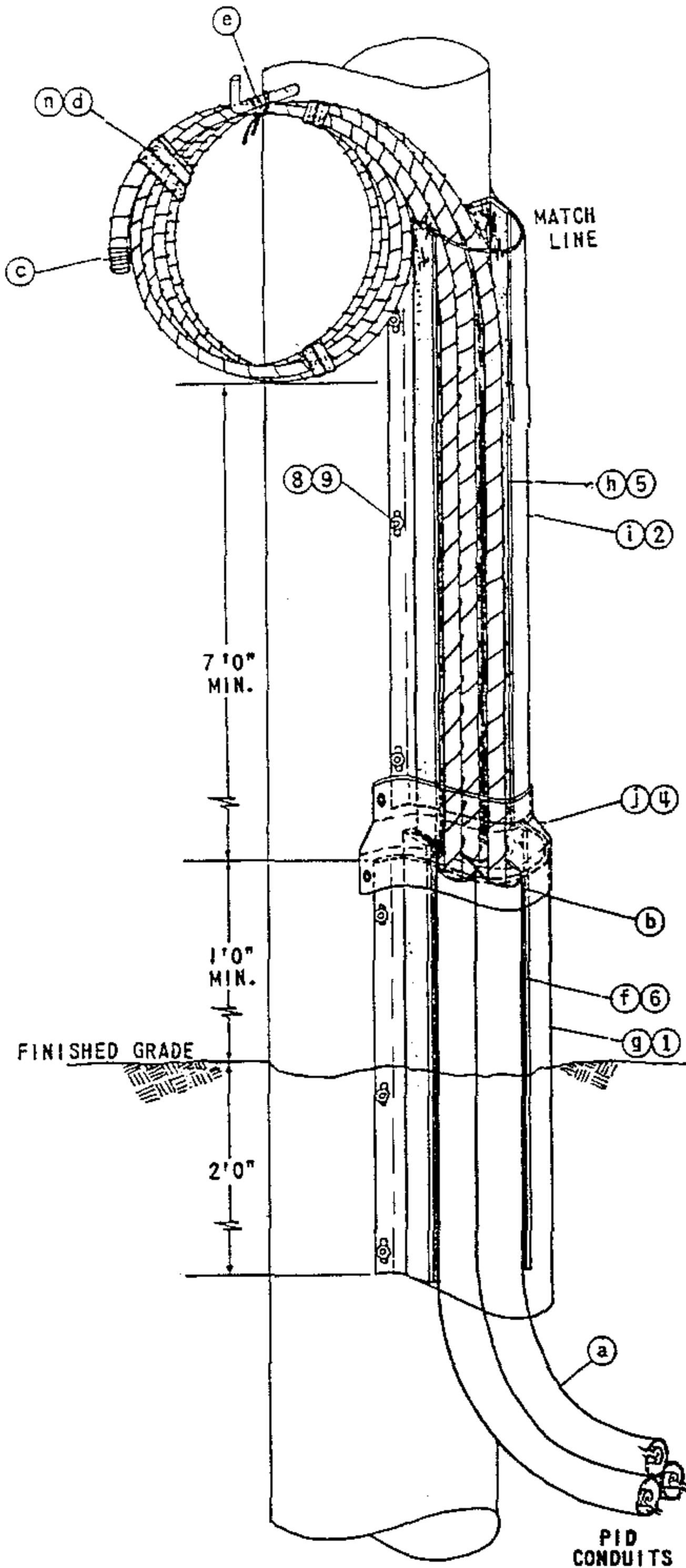

NOTE:

Care must be taken not to spike conductors with linemans hooks while performing installation, ascending or descending a riser pole.

FOR FIELD MAINTENANCE ONLY

DATE 1-1-87
 APPD *[Signature]*

SDG&E ELECTRIC STANDARDS
3Ø CABLE POLE RISER INSTALLATION
CABLE-IN-CONDUIT

OH 1499.005
~~UG 4299.005~~
 SUPERCEDES 4203.4
 (1-23-80)

FOR FIELD MAINTENANCE ONLY

U-SECTION MOLDING LOCATION

Verify that the quadrant selected by Designer/Planner for the cable pole riser meets the following requirements. If the following requirements cannot be met, contact the Designer or Planner who requested the installation:

Clearances

The U-section molding shall not enter climbing space per G.O. 95 Rule 22.2D. See O.H. Standard page 251 for allowable working and climbing space requirements.

Location of U-section molding in relation to TELCO and CATV (per Overhead Standards page 1402).

U-SECTION MOLDING INSTALLATION

Material Installation Sequence

Note: If installation can be completed sequentially, steps c, d and n, can be eliminated.

- (a) Terminate PID at cable pole by forming a 36" minimum radius bend with the cable-in-conduit at the base of the pole. Provide sufficient cable-in-conduit needed to terminate cable with drip loop at terminal level before cutting cable-in-conduit from cable reel.
- (b) Cut and remove excess pvc conduit from the PID run so the remaining conduit terminates 1' above finished grade. When removing excess pvc conduit, carefully slide excess conduit away from primary conductors.
- (c) To prevent moisture from entering exposed conductors, always seal exposed ends of conductors with "Aquaseal" and pvc tape.
- (d) Individually coil each primary conductor making sure coil is not less than 2' in diameter. Secure each coil in several places with a gray gas wrap tape to prevent conductors from uncoiling.
- (e) Secure coils to the bottom of the pole step with rope to prevent conductors from damage when the pole is climbed. If pole steps are not available, install lag screws (M&S 621856) in place of pole steps. Bottom of each coil must be 8' above existing grade to prevent vandalism.
- (f) Install a 3' section of 4" backup plate with 2' extended below finished grade and 1' extended above finished grade. Temporarily push conductors to one side of the riser quadrant and secure 4" backup plate to pole with 6d galvanized nails at each end and in the middle. Because holes are not provided nails must be driven through backup plate.

OH 1499.006
~~UG 4299.006~~
SUPERCEDES 4203.5
(1-23-80)

SDG&E ELECTRIC STANDARDS
3Ø CABLE POLE RISER INSTALLATION
CABLE-IN-CONDUIT

DATE 1-1-87
APPD. *YB IRD*

- ⑧ Install a 3' section of 4" U-section molding over the previously installed backup plate (step f) encasing the conduits. Nail 4" U-section molding to pole every 18" using lag screws and washers, (items 8 and 9 from bill of materials).
- ⑨ Install a 10' section of 3" backup plate behind primary conductors and mate to previously installed backup plate. Temporarily push conductors to one side of the riser quadrant to prevent damage to conductors. Use 6d galvanized nails to attach backup plate to pole starting and ending at each end.
- ⑩ Install a 10' section of 3" U-section molding schedule 80, over previously installed backup plate (step h) encasing primary conductors. To permit thermal expansion, do not drive lag screws tight and leave approximately 1/4" gap between the 3" and 4" U-section moldings. Secure U-section molding to pole every 18" with lag screw and washers (item 8 and 9 from bill of materials).
- ⑪ Install reducer boot over 3" and 4" U-section moldings using 6d galvanized nails. Make sure reducer boot is securely over each section.
- ⑫ When the contractor provides trench, the area around the riser bend at base of pole must be backfilled and compacted to 90% and a distance equal to the depth of the trench by the crew to prevent damage to conductors.
- ⑬ Install remaining backup plate from termination point in (step h) to elevation of pole where U-section molding will terminate. Refer to Overhead Standards page 1406 for elevation of U-section molding termination. Nail backup plate to pole with 6d galvanized nails every 18".
- ⑭ Install lag screw (item 7 from bill of materials) 2" beyond termination of U-section molding for cable grip support.
- ⑮ Remove each conductor coil from pole step, and remove binding tape. Uncoil each conductor carefully to prevent bending conductor.
- ⑯ Install one cable grip approximately 2' from the end of each conductor, (item 11 from bill of materials). Hoist each conductor and hang cable grip on lag screw installed by (step m). Adjust cable grips to determine optimum support positions, tie cables temporarily to pole and slide cable grip below final position. Tape over concentric neutral at final position where grip will seat with half lapped layers of glass tape (720256) and vinyl plastic (720580) over glass tape to assure positive grip. Position cable grip over taped area and attach cable grip to lag screw installed in (step m).
- ⑰ Install required amount of 3" U-section schedule 30 sections needed to cover backup plate and encase conductors to the termination point of the riser installation. Install belled end of U-section molding over a plain end of previously installed U-section molding. Line up edge of belled end with scribe mark 1" from plain end to ensure that sufficient spacing is provided between U-sections for thermal expansion. Nail U-section molding to pole with lag screws and washers (item 8 and 9 from bill of materials) every 36". Lag screws should be snug but not tight, this is also to allow thermal expansion of U-section. Additional lag screws may be needed at 18" intervals if U-section molding separates more than 1/16" away from pole.

FOR FIELD MAINTENANCE ONLY

DATE 1-1-87
APPD JLB/ROT

SDG&E ELECTRIC STANDARDS
30 CABLE POLE RISER INSTALLATION
CABLE-IN-CONDUIT

OH 1499.007 -
~~UG 4299.007~~
SUPERCEDES 4203.6
(6-14-83)

MAINTENANCE REQUIREMENTS

Inspection

The U-section molding installation shall be inspected periodically for the following:

Warpage of U-Section Exposing Conductors

For Separation of U-Section Molding From Pole More than 1/16"

Cracks or Damage in U-Sections Which Expose Conductors

FOR FIELD MAINTENANCE ONLY

OH 1499.008-
~~UG 4299.008~~
SUPERCEDES 4203.7
(12-23-

SDG&E ELECTRIC STANDARDS

3Ø CABLE POLE RISER INSTALLATION
CABLE-IN-CONDUIT

DATE 1-1-87
APPD JWB RDT

SCOPE: THIS STANDARD SHOWS THE CONSTRUCTION USED WHEN MODIFYING AN EXISTING SINGLE RISER CABLE POLE WHERE A SECOND RISER IS ADDED.

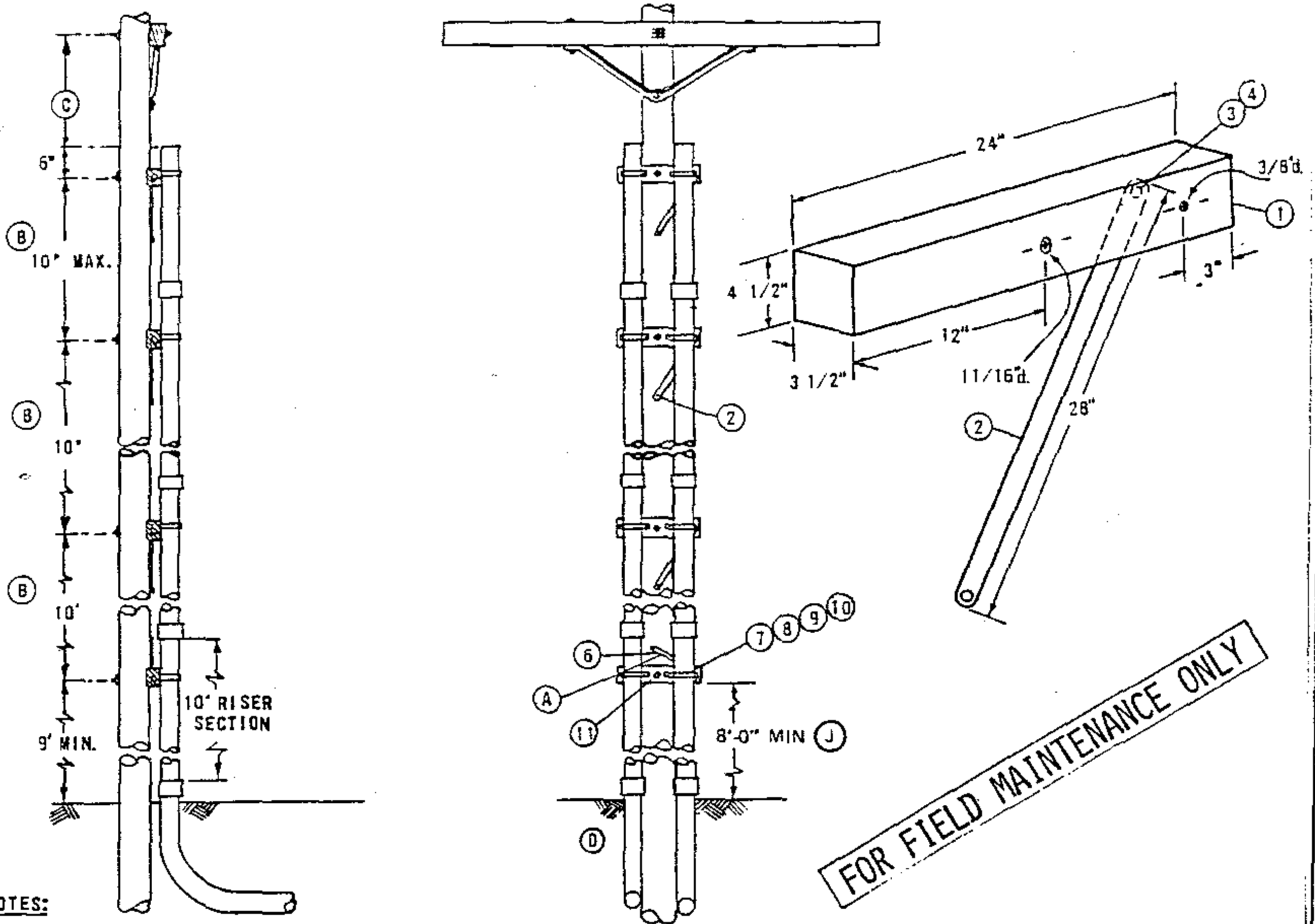

NOTES:

- THIS CONSTRUCTION IS RESTRICTED TO A MAXIMUM OF TWO SDG&E RISERS, (PRIMARY OR SECONDARY).
- WHENEVER POSSIBLE RISERS SHOULD BE INSTALLED ON THE SIDE OF THE POLE OPPOSITE TRAFFIC FLOW.
- SPARE DUCT SHALL BE CAPPED JUST ABOVE GROUND LEVEL TO PREVENT MOISTURE ENTRY AND NOT TO BE CONSIDERED AS A RISER.

BILL OF MATERIAL:

ITEM	DESCRIPTION	QUANTITY	STOCK NO. OR CONST. STDS.	ITEM	DESCRIPTION	QUANTITY	STOCK NO. OR CONST. STDS.
P 1	CROSSARM, 3-1/2" x 4-1/2" x 2'-0"	AS REQ'D.	380.05 IT.1	P 8	STRAP, PIPE, 2 HOLE, GALV., 4"	AS REQ'D.	697952 (E)
P 2	BRACE, FLAT 28"	AS REQ'D.	164192	P 9	STRAP, PIPE, 2 HOLE, GALV., 5"	AS REQ'D.	697984 (E)
T 3	BOLT, WASHER HEAD 3/8" X 4 1/2"	AS REQ'D.	158528 (E)	T 10	NAILS, FLATHEAD, STEEL GALV. 16D	AS REQ'D.	491424 (E)
T & 4	WASHER, 3/8" SPRING LOCK	AS REQ'D.	796832 (E)	T & 11	BOLT, MACH. GALV., 5/8" X (LENGTH AS REQ'D), 2-SQ. WASH 1-OBL COIL WASH	AS REQ'D.	PG. 392.1 (E) 392.2
F 5							
F 6	SCREW, LAG 1/2" X 4"	AS REQ'D.	621568 (E)				
F 7	STRAP, PIPE, 2 HOLE, GALV., 3"	AS REQ'D.	697920 (E)				

INSTALLATION:

- (A) LADDER ARMS TO BE INSTALLED BY U.G. CREWS. MOUNT LOWEST ARM NO LOWER THAN 9 FEET AND INSTALL THE FLAT BRACE ABOVE THE FIRST ARM AS SHOWN.
- (B) INSTALL AT LEAST ONE BRACKET FOR EACH JOINT OF CONDUIT.
- (C) 48 INCHES MINIMUM FOR 350 OR LARGER UG CABLE, 30 INCHES MINIMUM FOR 2/0 AND SMALLER CABLE. THIS DIMENSION APPLIES TO THE TRIPLE TERMINATOR BRACKET AS WELL AS CROSSARMS.
- (D) EXCAVATION MIGHT BE REQUIRED AROUND EXISTING RISER TO FACILITATE THE INSTALLATION OF LADDER ARMS.
- (E) EXEMPT MATERIAL.

REFERENCE:

- F. SEE PAGE 1402.1/4202.1 FOR POSITION OF RISERS INVOLVING MORE THAN ONE UTILITY.
- G. POLES ARE TO BE STEPPED PER STANDARD 363.
- H. SEE PAGE 1404.1 FOR INSTALLATION OF ONE CABLE RISER.
- I. PVC RISERS ARE NOT PERMITTED WITHIN THE CLIMBING SPACE PER G.O. 95 RULE 22.2C.
- (J) RISERS OF PLASTIC PIPE SHALL BE EPC-80-PVC SCHEDULE 80, WITH A MINIMUM NORMAL PIPE SIZE OF 2-1/2 INCHES, FROM THE GROUND LINE TO A LEVEL NOT LESS THAN 8 FEET ABOVE THE GROUND LINE PER G.O. 95 RULE 54-6-E.

SCOPE: THIS STANDARD SHOWS VARIOUS METHODS OF CABLE TERMINATION BRACKETS USED TO CONNECT UNDERGROUND CABLES TO OVERHEAD CONDUCTORS.

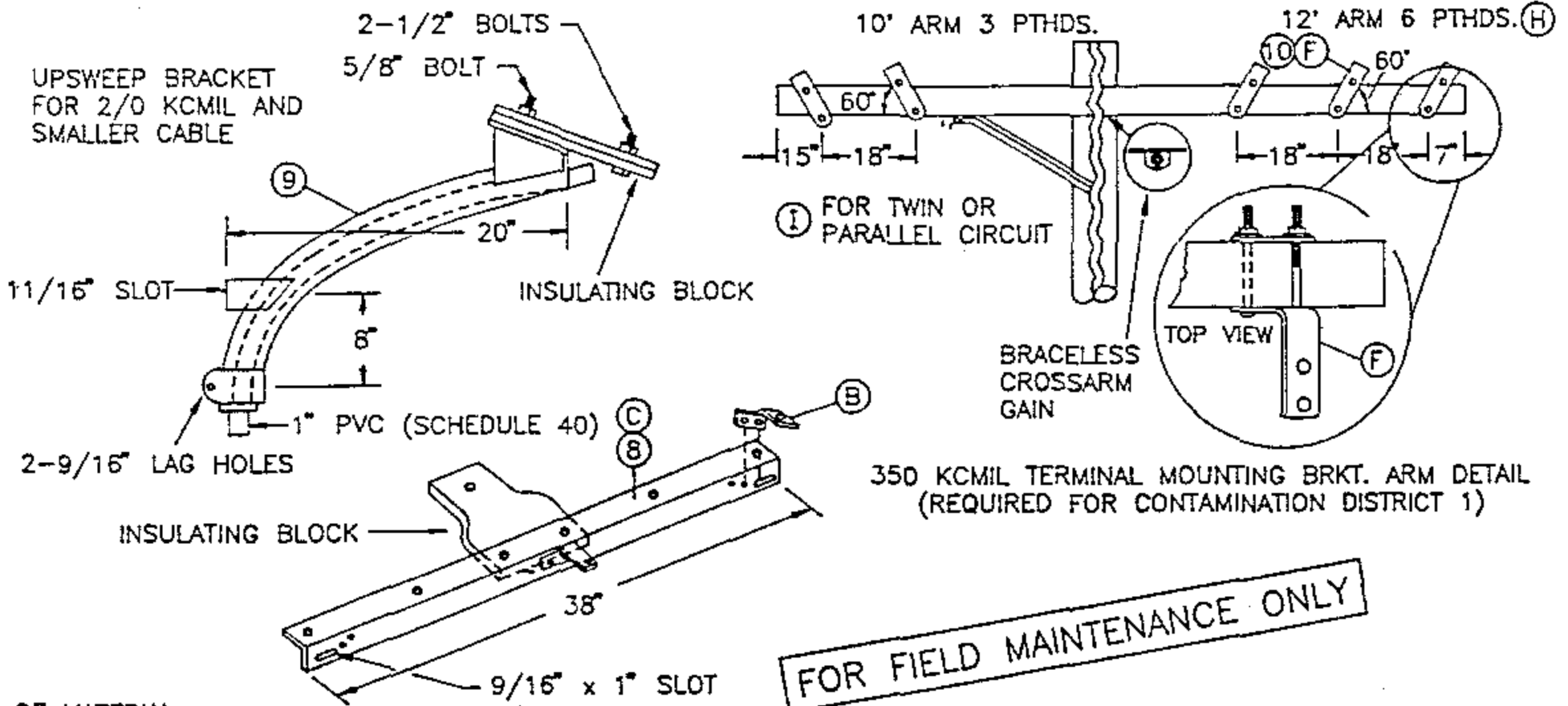
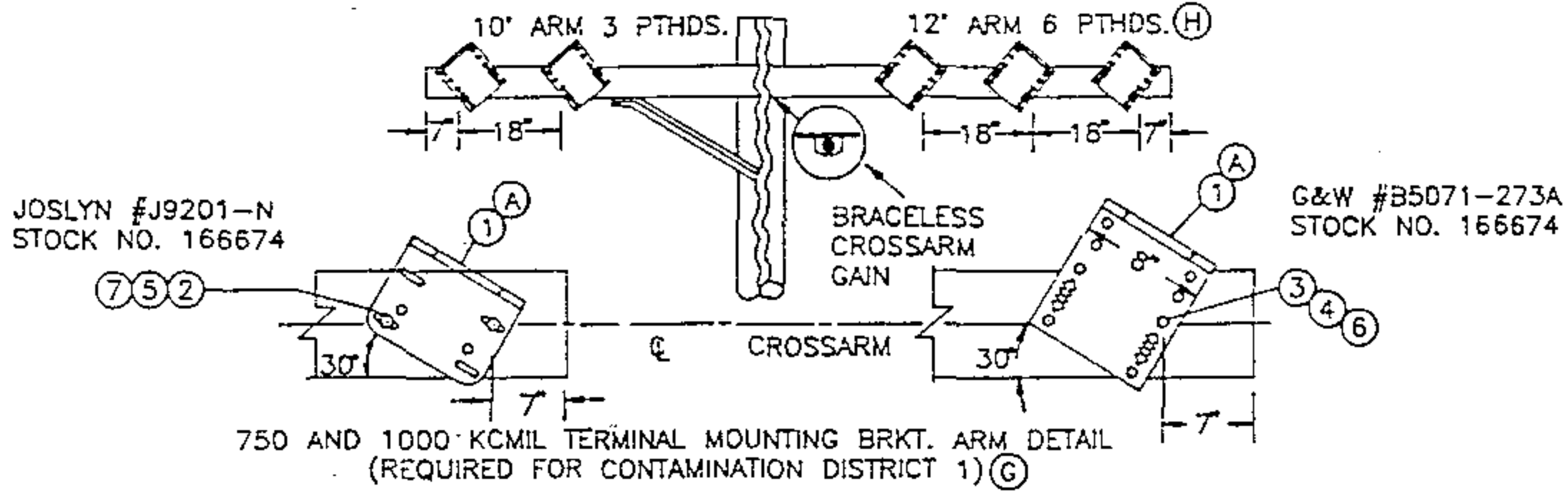

BILL OF MATERIAL:

ITEM	DESCRIPTION	QUANTITY	STOCK NO. OR CONSTR STD	ASSEMBLY UNITS
1	BRACKET, POTHEAD MOUNTING	3 OR 6	166674	P-X-BK
2	BOLT, MACHINE, GALV. 1/2" x 5" (E)	2	153024	-
3	BOLT, MACHINE, GALV. 3/8" x 5" (E)	2	154368	-
4	WASHER, 3/8" ROUND (E)	4	800288	-
5	WASHER, 1/2" ROUND (E)	4	800192	-
6	WASHER, 3/8" DBL COIL (E)	2	798528	-
7	WASHER, 1/2" DBL COIL (E)	2	798464	-
8	BRACKET TRIPLE TERMINAL (C)	1	166676	(OVERHEAD) TTB
9	BRACKET GALV. TERMINAL UPSWEEP	1	166856	(OVERHEAD) USB
10	BRACKET, CROSSARM TERMINAL	3 OR 6	166060	-

INSTALLATION:

- (A) HOLES IN ARM FOR POTHEAD MOUNTING BRACKETS ARE DRILLED BY OVERHEAD CREWS.
- (B) THREE OF THESE BRACKETS ARE SUPPLIED WITH THE TRIPLE TERMINAL BRACKET (ITEM 8).
- (C) THIS CONSTRUCTION TO BE USED ONLY FOR CABLE SIZES 2/0 AND BELOW.
- (E) EXEMPT MATERIAL.
- (F) TURN TOP OF BRACKET OUTWARD TO OBTAIN APPROX. 60° ANGLE.

REFERENCE:

- (G) FOR CONSTRUCTION IN CONTAMINATION DISTRICTS 2 AND 3, SEE STANDARD 1407.2/4207.2.
- (H) SEE STANDARD 1407.2/4207.2 FOR TERMINAL AND LIGHTNING ARRESTER DETAIL.
- (I) SEE STANDARD 1442.1/4242.1 FOR 3-350 KCMIL POTHEADS ON A 10 FOOT CROSSARM.

OH 1499.010
~~UG 4299.010~~
 SUPERCEDES
 1407.1 (1-1-93)

SDG&E ELECTRIC STANDARDS
 CABLE POLE TERMINAL MOUNTING INFORMATION
 (PORCELAIN TERMINATIONS)
 (FOR CONTAMINATION DISTRICT 1)

DATE 1-1-93
 APPD *JLB/BJG*

12' ARM 6 PTHS AND 6 ARRESTORS

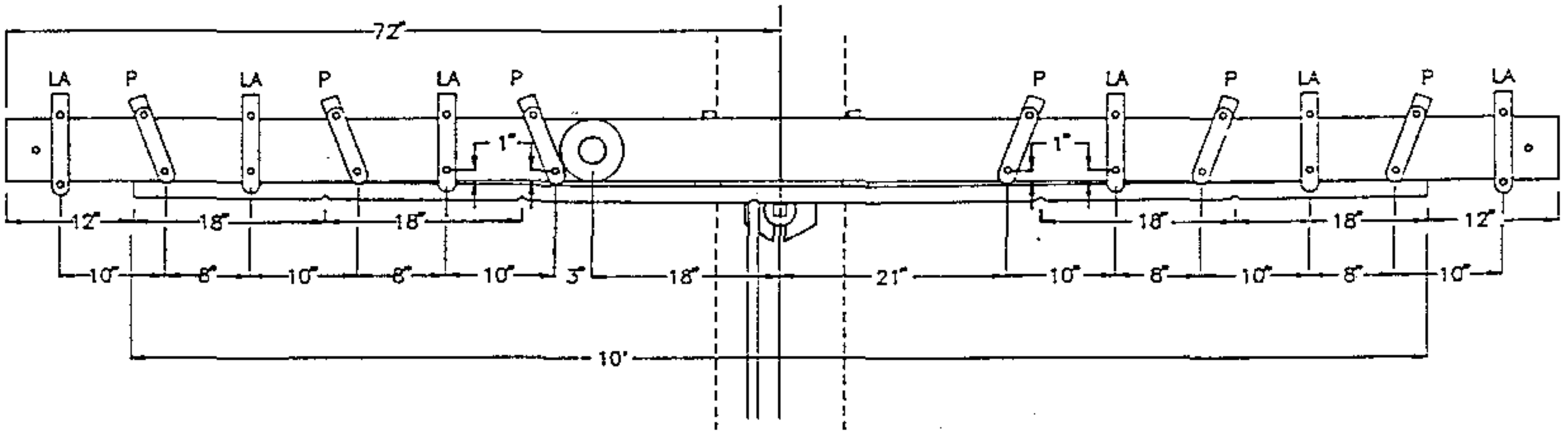

350 KCMIL TERMINAL AND LIGHTNING ARRESTER BRACKETS MOUNTING DETAIL

P=POTHEAD BRACKET

LA=LIGHTNING ARRESTER BRACKET

FOR FIELD MAINTENANCE ONLY

12' ARM 6 PTHS AND 6 ARRESTORS

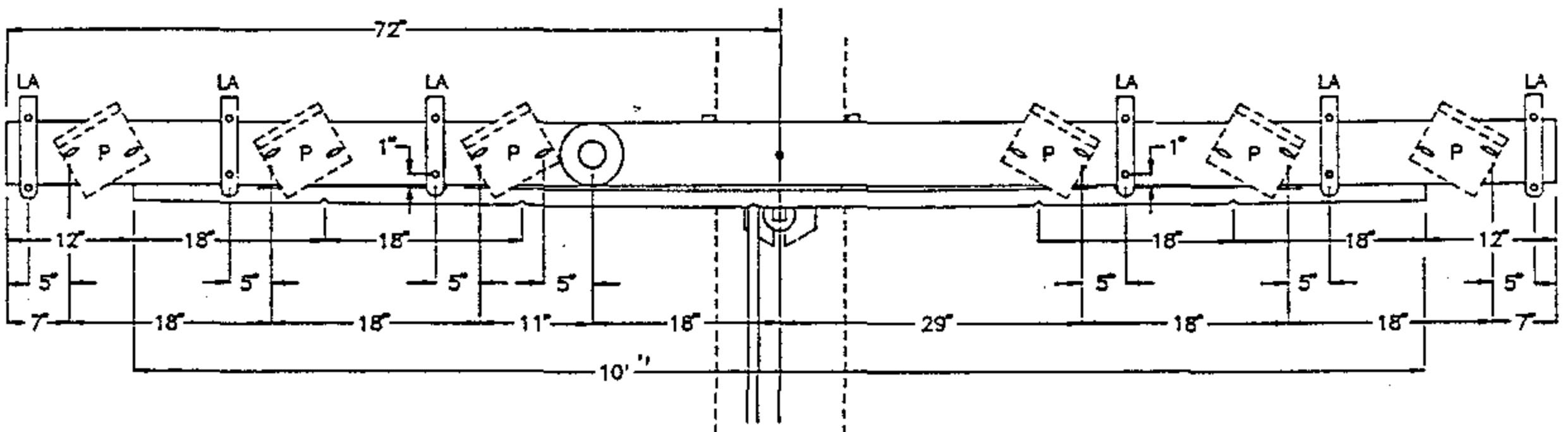

750 AND 1000 KCMIL TERMINAL AND LIGHTNING ARRESTER BRACKETS MOUNTING DETAIL

SDG&E ELECTRIC STANDARDS

CABLE POLE TERMINAL MOUNTING INFORMATION
(PORCELAIN TERMINATIONS)
(FOR CONTAMINATION DISTRICT 1)

DATE 1-1-93

APPD *JLB/ROJ*

OH 1499.011
~~UG 4299.011~~
SUPERCEDES
1407.2 (1-1-93)

SCOPE: THIS STANDARD SHOWS VARIOUS METHODS OF INSTALLING CABLE TERMINATING MOUNTING BRACKETS FOR NON-PORCELAIN TERMINALS.

CROSSARM
CONSTRUCTION FOR
350 KCMIL AND
LARGER CABLE

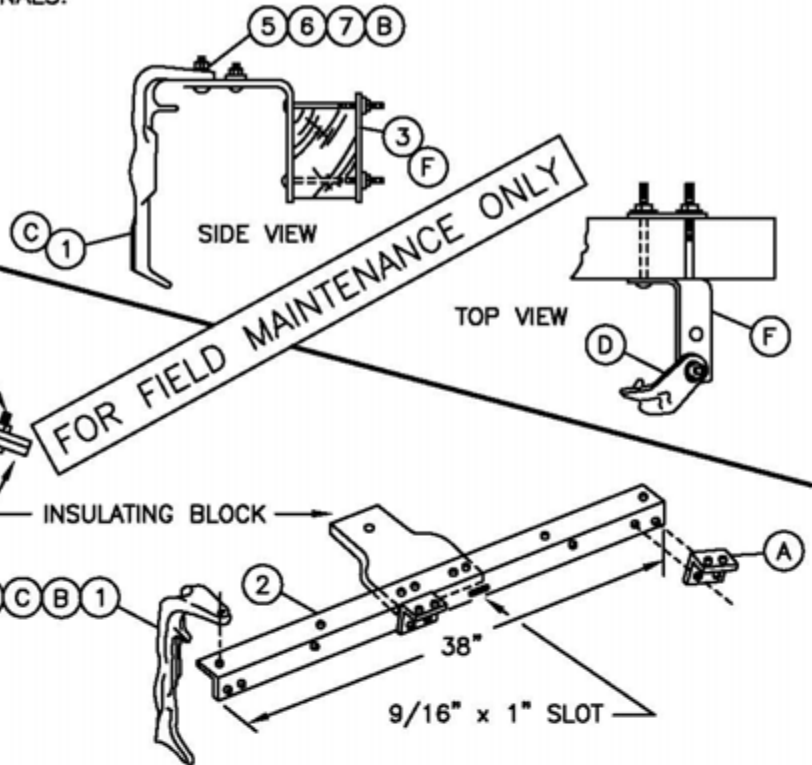
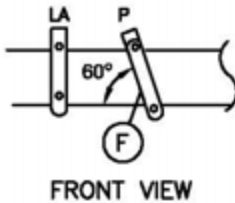

BILL OF MATERIAL:

ITEM	DESCRIPTION	QUANTITY	CONST STD OR PAGE NO	STOCK NUMBER	ASSEMBLY UNITS
1	BRACKET, MOUNTING CS 820	3 OR 6	4111	166064	NP-BKT
2	BRACKET, TRIPLE TERMINAL (E)	1	-	166676	(OVERHEAD) TTB
3	BRACKET, CROSSARM TERMINAL	3 OR 6	-	166060	(OVERHEAD) 2/OBKT
4	BRACKET, TERMINAL UPSWEEP, GALV (E)	1	-	166856	(OVERHEAD) USB
5	BOLT, MACHINE, GALV 1/2" x 2"	3 OR 6	392.1	152832	
6	WASHER, ROUND 1/2"	3 OR 6	392.2	800192	
7	WASHER, SPRING LOCK 1/2"	3 OR 6	392.2	796768	

NOTES:
- PORCELAIN TERMINALS (POTHEADS) ARE REQUIRED IN SUBSTATIONS (ALL DISTRICTS). SEE NOTE (I).

- INSTALLATION:**
- (A) THREE BRACKETS ARE SUPPLIED WITH THE TRIPLE TERMINAL BRACKET.
 - (B) CS 820 MOUNTING BRACKETS SHALL BE BOLTED TO THE TOP OF THE TRIPLE TERMINAL BRACKET OR CROSSARM TERMINAL BRACKET.
 - (C) FOLLOW MANUFACTURES INSTRUCTIONS FOR SECURING CABLE TO MOUNTING BRACKET.
 - (D) MOUNTING BRACKET CS 820 TO BE POSITIONED TO CONFIRM WITH THE LAY OF THE CABLE.
 - (E) THESE ITEMS FIELD MAINTENANCE ONLY.
 - (F) TURN TOP OF BRACKET OUTWARD TO OBTAIN APPROX 60 ANGLE.

REFERENCE:
H. SEE STD. 4111 FOR OUTDOOR CABLE TERMINALS, FOR POLYETHYLENE CABLES.
(I) SEE STD. PG. 1499.010/4299.010 FOR PORCELAIN MOUNTING BRACKETS.

© 1998 - 2010 San Diego Gas & Electric Company. All rights reserved. Removal of this copyright notice without permission is not permitted under law.

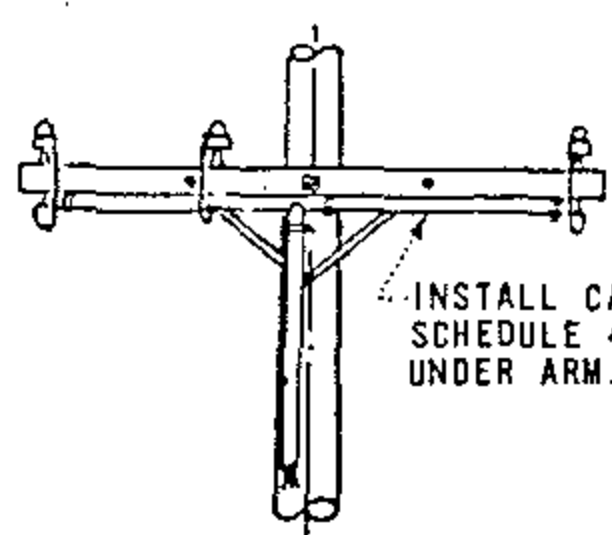
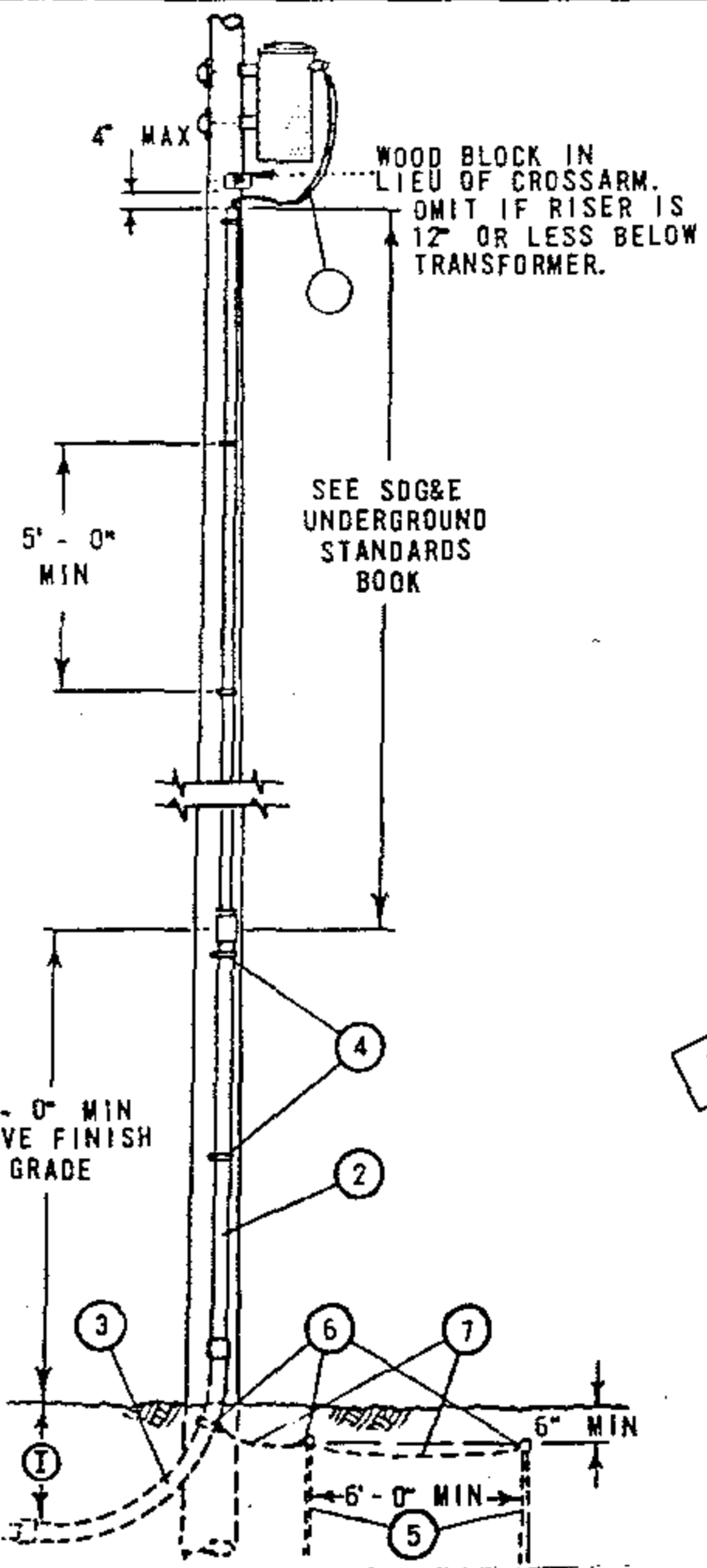

CROSSARM CONSTRUCTION

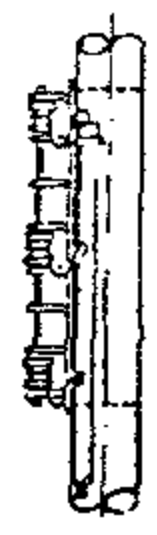

RACK CONSTRUCTION

FOR FIELD MAINTENANCE ONLY

NOTES:

- (A) SEE PAGE 7404 / 4204 FOR RISER CONSTRUCTION.
- (B) CUSTOMER'S SERVICE ENTRANCE CONDUCTORS SHALL RUN CONTINUOUSLY WITHOUT SPLICES FROM SERVICE EQUIPMENT TO SECONDARY OR TRANSFORMER TERMINALS AND SHALL BE OF A LENGTH SUFFICIENT TO FORM DRIP LOOPS AT THE TOP OF THE RISER. CONTRACTOR SHALL IDENTIFY SERVICE ENTRANCE CONDUCTORS WITH CODING OR TAGGING FOR PURPOSE OF PARALLELING PHASES AND NEUTRALS. MAXIMUM SIZE OF EACH CONDUCTOR, SINGLE OR PARALLELED RUNS, SHALL NOT EXCEED 500 KCM.
- (C) WHEN ITEMS 2 AND 3 ARE SCHEDULE 80 PVC OMIT ITEMS 5, 6, AND 7. (SEE SDG&E UNDERGROUND STANDARDS BOOK)
- (D) OMIT ITEMS 5, 6, AND 7 WHERE CUSTOMER'S UNDERGROUND CONDUIT RUN IS AN APPROVED METALLIC CONDUIT.
- (E) OMIT ITEM 5, AND 7 WHERE #6 BARE COPPER BONDING WIRE IS INSTALLED BETWEEN ITEMS 3 AND CUSTOMER'S SERVICE ENTRANCE EQUIPMENT.
- (G) USE TWO ROD GROUND SPACED A MINIMUM OF 6 FEET APART.
- H. APPROVED METALLIC CONDUIT OR #6 BARE COPPER BONDING WIRE SHALL BE GROUNDED AT THE SERVICE ENTRANCE IN ACCORDANCE WITH REQUIREMENTS OF THE LOCAL INSPECTION AUTHORITY.
- (I) 18" MIN DEPTH ON PRIVATE AND PUBLIC PROPERTY OTHER THAN STREETS AND ALLEYS. 24" MIN DEPTH ACROSS STREETS AND ALLEYS. 24" MIN TO BE MAINTAINED CONTINUOUSLY WHERE DUCTS TRAVERSE BOTH STREETS (AND ALLEYS) AND PRIVATE PROPERTY. 24" MIN DEPTH FOR NON-METALLIC CONDUITS.

MATERIAL FURNISHED AND INSTALLED BY CUSTOMER

ITEM	DESCRIPTION (A)	
1	CUSTOMER'S SERVICE ENTRANCE CONDUCTORS	(B)
2	CONDUIT, GALV. IRON RIGID RISER	(C)
3	CONDUIT, GALV IRON BEND, 90°, 36" RADIUS	(C)
4	STRAP, PIPE GALV, 2-10D GALV NAILS	
5	RODS, 5/8" X 8'-0" COPPERCLAD STEEL GROUND	(D) (E) (G)
6	CLAMPS, APPROVED TYPE GROUNDING	(D)
7	WIRE, #6 BARE STRANDED COPPER	(D) (F)

OH 1499.101
~~UG 4299.101~~
 SUPERSEDES
 1415 (11-16-81)

SDG&E ELECTRIC STANDARDS
 0-750V CUSTOMER OWNED UNDERGROUND SERVICE
 FROM AN OVERHEAD LINE, ONE DUCT

DATE 11-16-81
 APPD *SEY*

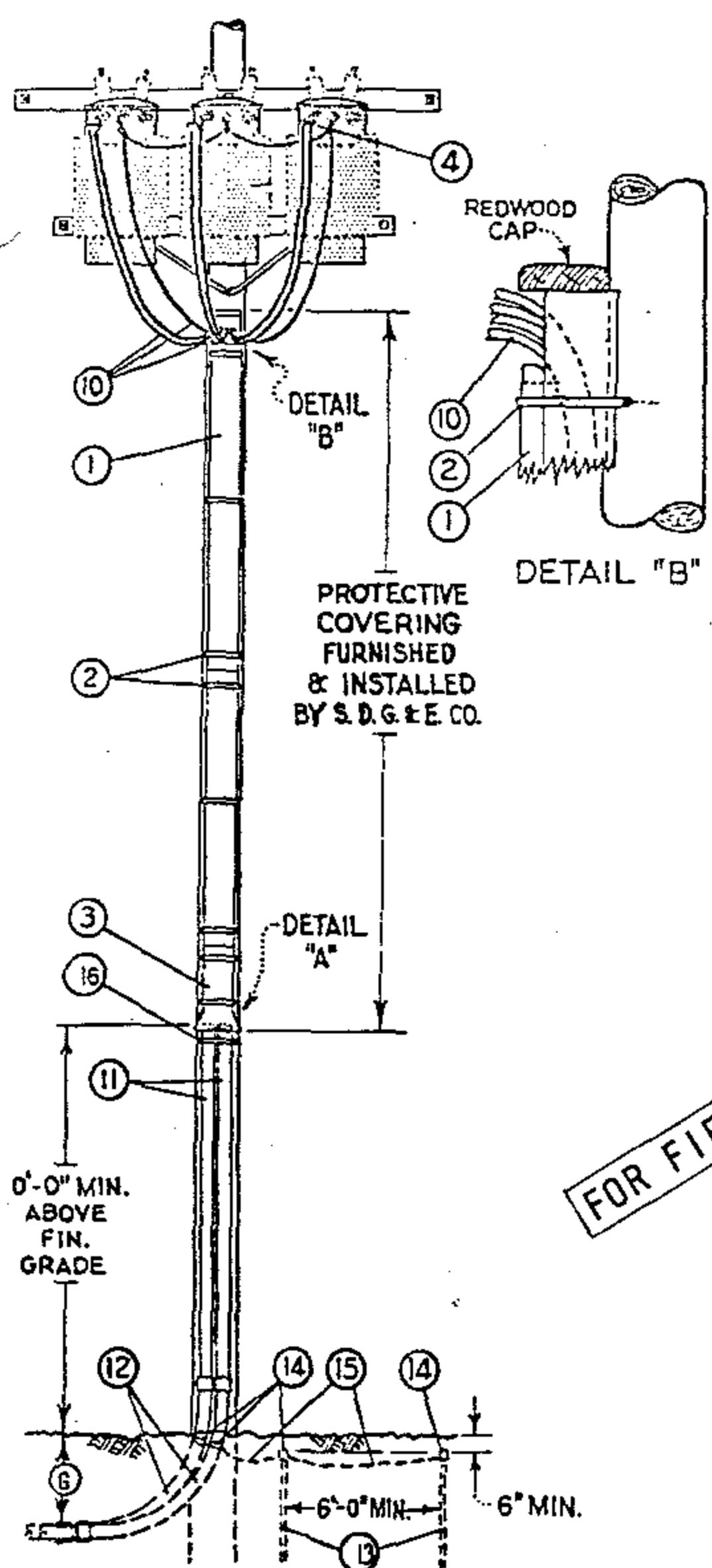

MATERIAL FURNISHED AND INSTALLED BY SDG&E			
ITEM	DESCRIPTION	QUANT.	STOCK NO. OR CONSTR STD
1	REDWOOD BOX MOULDING, SIZE AS REQUIRED	16'	PG 143
2	MOULDING STRAPS, SIZE AS REQ'D	6	PG 143
3	REDWOOD MOULDING BASE FOR 5 1/4" X 6 3/8", INSIDE DIMENSIONS, RDWD. BOX MOULDING	AS REQ'D	PG 143
4	MULTIPLE TAP CONNECTORS, 2 LUG	AS REQ'D	PG 793
7	BOX NAILS, GALV., 10D	1/2#	491392
8	BOX NAILS, GALV., 16D	1/2#	491424

QUANTITIES SHOWN ARE BASED ON A 45' POLE AND TRANSFORMER SECONDARIES CONNECTED 120-208V. WYE.

MATERIAL FURNISHED AND INSTALLED BY CUSTOMER (A)		
10	CUSTOMER'S SERVICE ENTRANCE CONDUCTORS (B)	SEE SDG&E UNDERGROUND STANDARD BOOK
11	G.I. RIGID CONDUIT RISERS	
12	G.I. RIGID CONDUIT BENDS, 90°, 36" RADIUS	
13	5/8" DIAM. X 8'-0" COPPERCLAD STEEL GRND. RODS (C)(D)(E)	
14	APPROVED TYPE GROUNDING CLAMPS (C)	
15	#6 BARE STRANDED COPPER GROUND WIRE (C)(D)	
16	HEAVY PLUMBERS TAPE, HOT-DIP GALVANIZED	

FOR FIELD MAINTENANCE ONLY

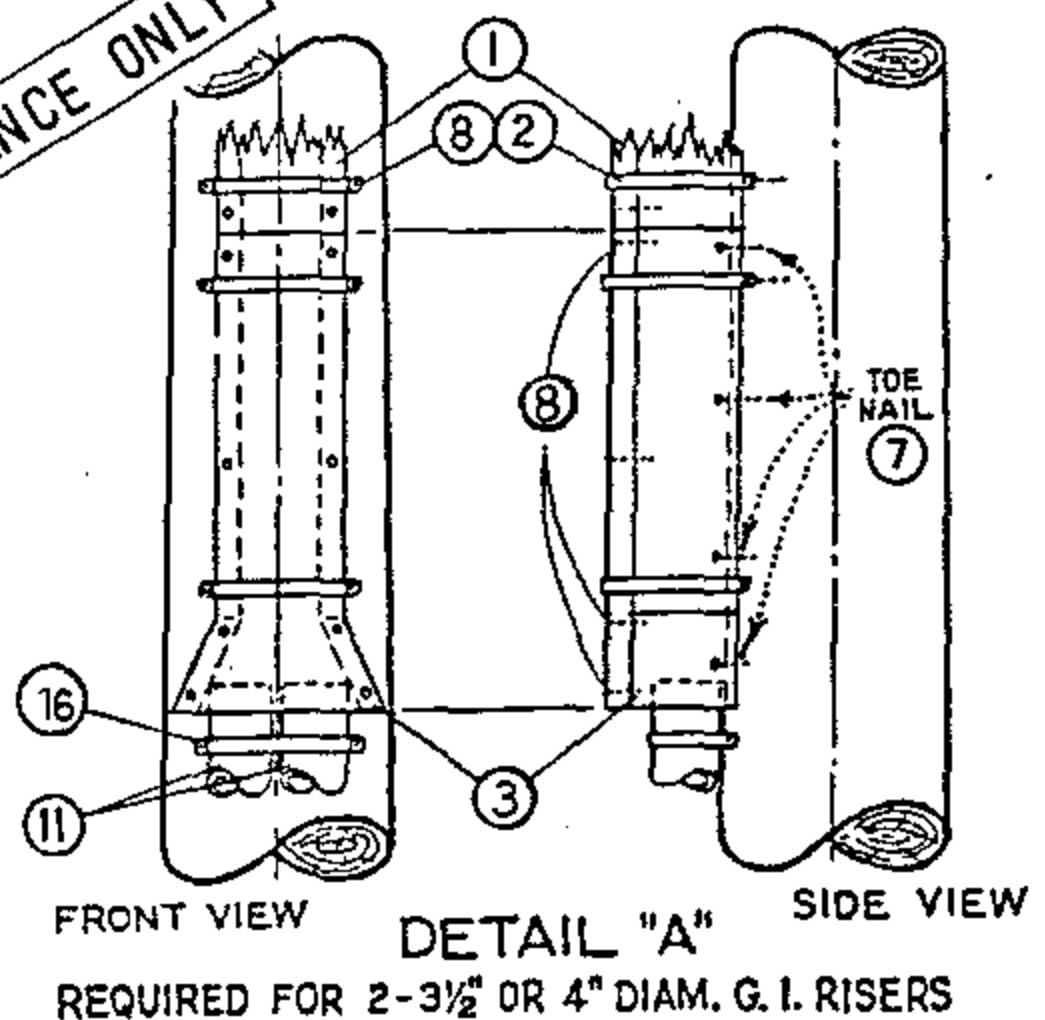

- NOTES:
- (A) SEE SDG&E UNDERGROUND STANDARDS BOOK FOR CABLE CONDUIT SIZING INFORMATION.
 - (B) CUSTOMER'S SERVICE ENTRANCE CONDUCTORS SHALL RUN CONTINUOUSLY WITHOUT SPLICES FROM SERVICE EQUIPMENT TO TRANSFORMER TERMINALS AND SHALL BE OF A LENGTH SUFFICIENT TO FORM DRIP LOOPS AT THE TOP OF THE RISER. CONTRACTOR SHALL IDENTIFY SERVICE ENTRANCE CONDUCTORS WITH CODING OR TAGGING FOR PURPOSE OF PARALLELING PHASES AND NEUTRALS. MAXIMUM SIZE OF EACH CONDUCTOR, SINGLE OR PARALLELED RUNS, SHALL NOT EXCEED 500 KCM.
 - (C) OMIT ITEMS 13, 14, AND 15 WHERE CUSTOMER'S UNDERGROUND CONDUIT RUN IS AN APPROVED METALLIC CONDUIT.
 - (D) OMIT ITEM NUMBERS 13 AND 15 WHERE #6 BARE COPPER BONDING WIRE IS INSTALLED BETWEEN ITEM 12 AND CUSTOMER'S SERVICE ENTRANCE EQUIPMENT.
 - (E) USE TWO ROD GROUND.
 - (F) APPROVED METALLIC CONDUIT OR #6 BARE COPPER BONDING WIRE SHALL BE GROUNDED AT THE SERVICE ENTRANCE IN ACCORDANCE WITH REQUIREMENTS OF THE LOCAL INSPECTION AUTHORITY.
 - (G) 18" MIN DEPTH ON PRIVATE AND PUBLIC PROPERTY OTHER THAN STREETS AND ALLEYS. 24" MIN DEPTH ACROSS STREETS AND ALLEYS. 24" MIN TO BE MAINTAINED CONTINUOUSLY WHERE DUCTS TRAVERSE BOTH STREETS (AND ALLEYS) AND PRIVATE PROPERTY. 24" MIN DEPTH FOR NON-METALLIC CONDUITS.

DATE 11-16-81
APPD JEM

SDG&E ELECTRIC STANDARDS
0-750V CUSTOMER OWNED UNDERGROUND SERVICE
FROM AN OVERHEAD LINE, TWO DUCTS

1499.102
SUPERSEDES
1417 (11-16-81)

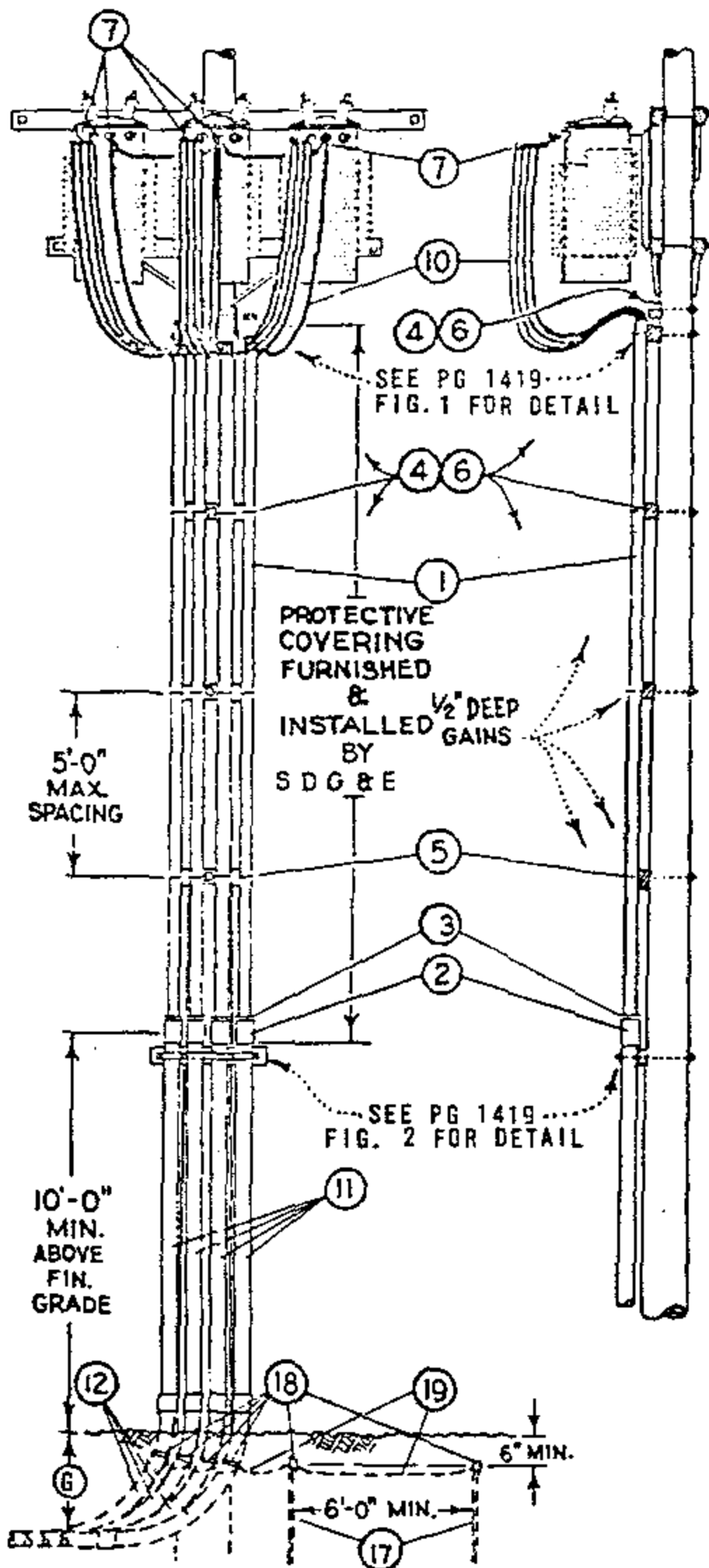

MATERIAL FURNISHED AND INSTALLED BY SDG&E					
ITEM	DESCRIPTION	QUANTITY		STOCK NO. OR CONSTR STD	
		3	4	3"	4"
①	3" OR 4" DIAM. PLASTIC CONDUIT, PVC TYPE II, SCHEDULE 40, 20' LENGTHS	60'	80'	251552	251584
②	COUPLINGS, PLASTIC, SIZE AS REQUIRED	3	4	280448	280480
③	BUSHINGS, PLASTIC, 4" OR 3 1/2" X 3" DIAM FOR REDUCING CUSTOMER'S CONDUIT RISERS, WHERE REQUIRED	3	4	3 1/2" X 3" 181024, 4" X 3" - 181056	
4	RISER SUPPORT BLOCKS, 3 1/2" X 4 1/2" X 2'-0"	5	5	PG 1419 IT. 4	
5	1/2" BOLT, 1 SQ WASHER	12	16	PGS 139, 140	
6	MACH. BOLT, GALV, 5/8" X 16"-20, 2 SQ. WASHERS & 1 NUT	5	5	PGS 139, 140	
7	MULTIPLE TAP CONNECTORS, SPECIFY NUMBER OF LUGS	6	6	PG 793	

⊙ QUANTITIES SHOWN ARE BASED ON A 45' POLE AND TRANSFORMER SECONDARIES CONNECTED 120/208V WYE.
 † UNTHREADED FOR SLIP FIT OVER RIGID CONDUIT RISER.

MATERIAL FURNISHED AND INSTALLED BY CUSTOMER		
ITEM	DESCRIPTION (A)	STOCK NO.
10	CUSTOMER'S SERVICE ENTRANCE CONDUCTORS (B)	SEE SDG&E UNDERGROUND STANDARD BOOK
11	G.I. RIGID CONDUIT RISERS	
12	G.I. RIGID CONDUIT BENDS, 90°, 36" RADIUS	
13	SPACER BLOCK	
14	STRAP, GALV	
15	FOUR 1/2" X 9" MACH. BOLTS, GALV, 1 RD. WASHER	
16	ONE 5/8" X 20" MACH. BOLT, GALV, 2-2" SQ. WASHERS	
17	5/8" X 8'-0" COPPERCLAD STEEL GROUND RODS (C, D, E)	
18	APPROVED TYPE GROUNDING CLAMPS (C)	
19	#6 BARE STRANDED COPPER GROUND WIRE (C, D)	

FOR FIELD MAINTENANCE ONLY

NOTES:

- (A) SEE UNDERGROUND STANDARDS BOOK FOR CABLE CONDUIT SIZING INFORMATION.
- (B) CUSTOMER'S SERVICE ENTRANCE CONDUCTORS SHALL RUN CONTINUOUSLY WITHOUT SPLICES FROM SERVICE EQUIPMENT TO TRANSFORMER TERMINALS AND SHALL BE OF A LENGTH SUFFICIENT TO FORM DRIP LOOPS AT THE TOP OF THE RISER. CONTRACTOR SHALL IDENTIFY SERVICE ENTRANCE CONDUCTORS WITH CODING OR TAGGING FOR PURPOSE OF PARALLELING PHASES AND NEUTRALS. MAXIMUM SIZE OF EACH CONDUCTOR, SINGLE OR PARALLELED RUNS, SHALL NOT EXCEED 500 KCM.
- (C) OMIT ITEM 17, 18, AND 19 WHERE CUSTOMER'S UNDERGROUND CONDUIT RUN IS AN APPROVED METALLIC CONDUIT.
- (D) OMIT ITEM 17, AND 19 WHERE #6 BARE COPPER BONDING WIRE IS INSTALLED BETWEEN ITEM 12 AND CUSTOMER'S SERVICE ENTRANCE IN ACCORDANCE WITH REQUIREMENTS OF THE LOCAL INSPECTION AUTHORITY.
- (E) USE TWO ROD GROUND.
- F. APPROVED METALLIC CONDUIT OR #6 BARE COPPER BONDING WIRE SHALL BE GROUNDED AT THE SERVICE ENTRANCE IN ACCORDANCE WITH REQUIREMENTS OF THE LOCAL INSPECTION AUTHORITY.
- (G) 18" MIN DEPTH ON PRIVATE AND PUBLIC PROPERTY OTHER THAN STREETS OR ALLEYS. 24" MIN DEPTH ACROSS STREETS AND ALLEYS. 24" MIN TO BE MAINTAINED CONTINUOUSLY WHERE DUCTS TRAVERSE BOTH STREETS (AND ALLEYS) AND PRIVATE PROPERTY. 24" MIN DEPTH FOR NON-METALLIC CONDUITS.

1499.103
 SUPERSEDES
 1418 (11-16-81)

SDG&E ELECTRIC STANDARDS
 0-750V CUSTOMER OWNED UNDERGROUND SERVICE
 FROM AN OVERHEAD LINE, THREE AND FOUR DUCTS

DATE: 11-15-81
 APPD: [Signature]

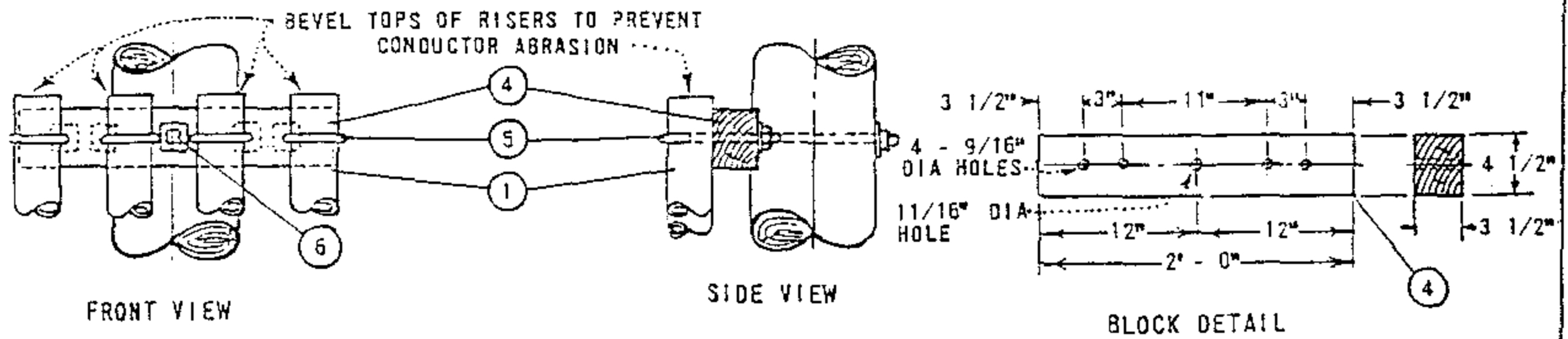

FIGURE 1
PLASTIC PIPE RISER SUPPORT DETAILS

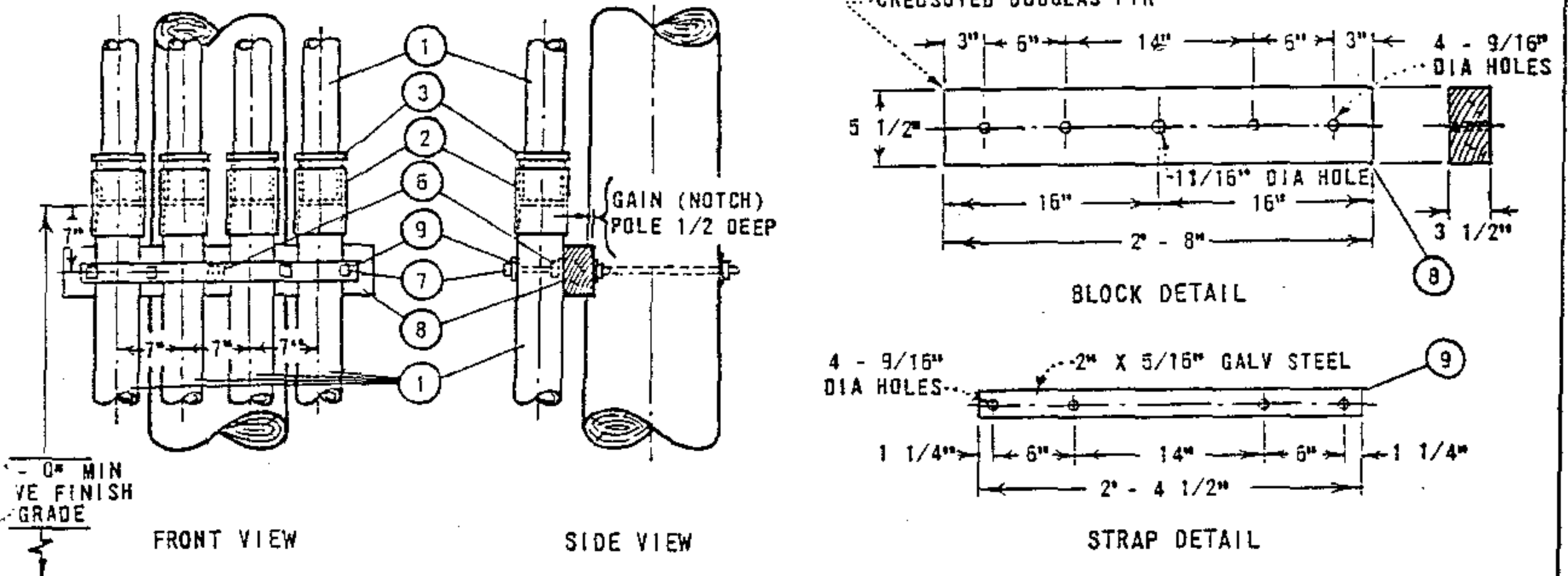

FIGURE 2
GALVANIZED PIPE RISER SUPPORT DETAIL

FOR FIELD MAINTENANCE ONLY

NOTES:

- A. SEE UNDERGROUND STANDARDS BOOK FOR CABLE, CONDUIT SIZING INFORMATION.
- (E) EXEMPT MATERIALS.

ITEM	DESCRIPTION	QUANTITY		STOCK NO. OR CONSTR STD
		NUMBER OF RISERS		
		3"	4"	
1	CONDUIT, PVC SIZE AS REQUIRED	AS REQ'D		3" - 251552, 4" - 251584
2	COUPLINGS, PLASTIC SIZE AS REQ'D	AS REQ'D		3" - 280448, 4" - 280480
3	BUSHINGS, PLASTIC REDUCER 3 1/2" OR 4" X 3"	3	4	3 1/2" - 181024, 4" - 573408
4	BLOCKS, RISER SUPPORT (SEE FIGURE 1)	1	1	-
5	BOLT, "J" 1 SQ WASH.	3	4	PGS 140, 144
6	BOLT, MACH 5/8" X 1/2", 2 - 2" SQ WASH. (E)	1	1	PGS 139, 140
7	BOLT MACH 1/2" X 9", 1 RD WASH. (E)	3	4	153184, 800192
8	BLOCK, SPACER (SEE FIGURE 2)	1	1	-
9	STRAP, GALV STEEL (SEE FIGURE 2)	1	1	-

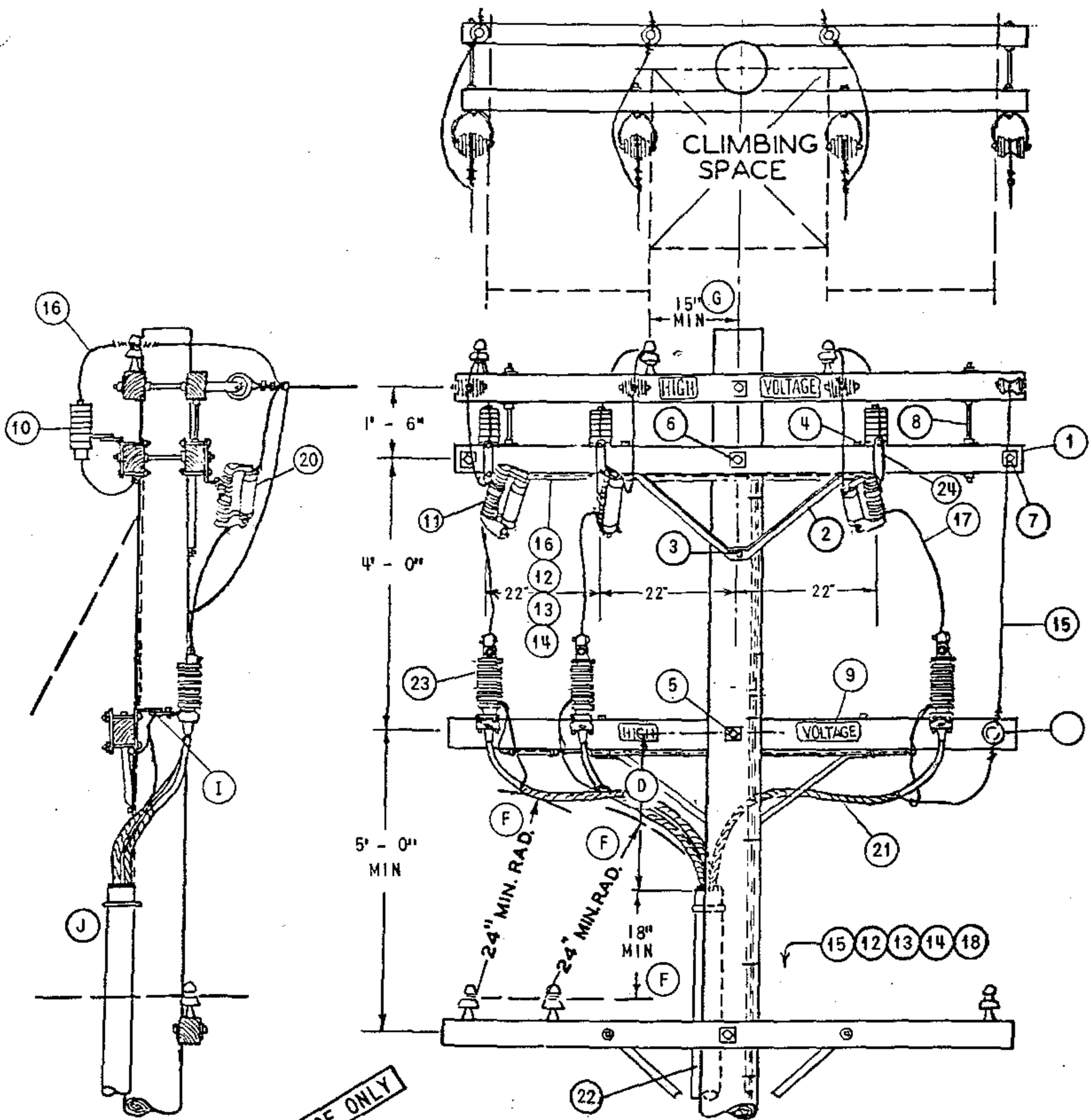

FOR FIELD MAINTENANCE ONLY

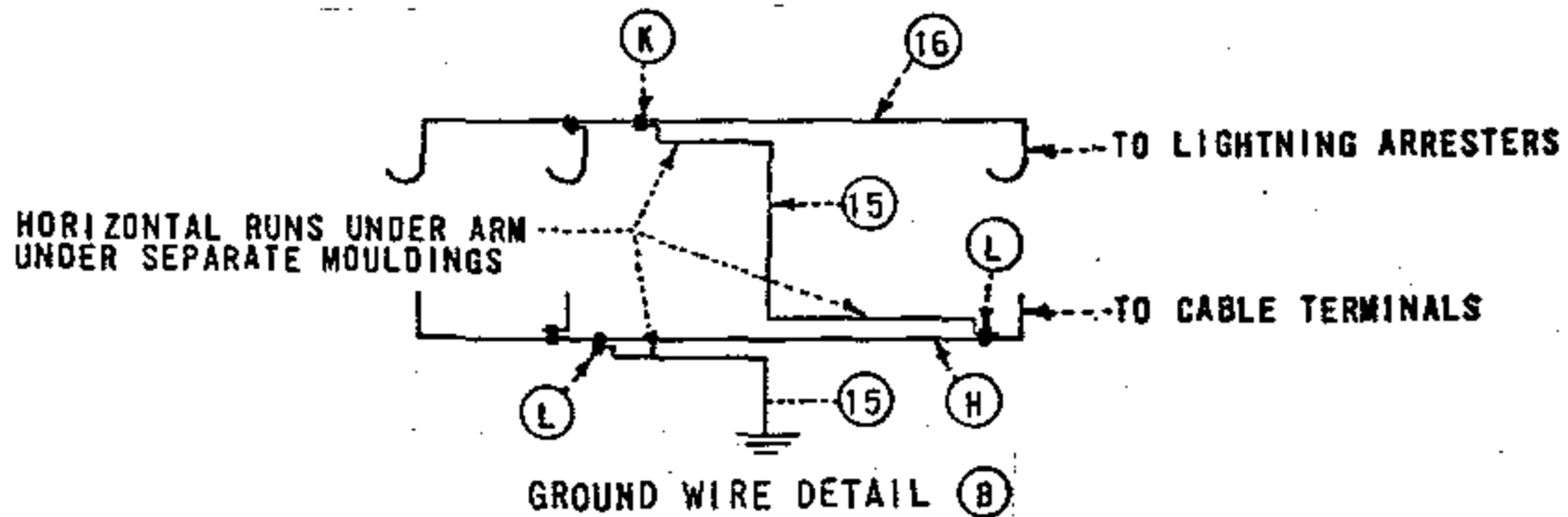

NOTES:

- (A) UNIT GROUND COMPLETE ORDER 603120 WITH GRAY MOULDING, 603136 WITH PLAIN MOULDING
- (B) INTERCONNECT ARRESTER GROUND LEAD DISCONNECTS WITH #6 BARE COPPER AND GROUND IT WITH #2 BARE COPPER NEAR CENTER ARRESTER.
- (C) USE TWO GROUND RODS SPACED A MINIMUM OF 6' APART.
- (D) 3 FOOT MINIMUM DIMENSION, 4 FOOT DIMENSION PREFERRED FOR 750 KCM AND LARGER 15KV CABLE.
- (E) EXEMPT MATERIAL.
- (F) G.O. 95 MINIMUM DIMENSION.
- (G) G.O. 95 MINIMUM DIMENSION FOR 4KV. USE 18" MIN IF BUILT WITH 15KV CABLE.
- (H) USE #2 BARE STRANDED COPPER OR LARGER AS REQUIRED.
- (I) CONNECT NEUTRAL, TERMINAL AND SHIELDED CABLE GROUNDS TO LIGHTNING ARRESTER GROUND.
- (J) INSTALL RISER ON FACE OF POLE OPPOSITE CLIMBING SPACE AND IN A POSITION NEAREST THE END OF ARM ON WHICH THE TWO 4KV PHASES ARE LOCATED.
- (K) CONNECT #2 BARE STRANDED COPPER CONDUCTOR TO #6 BARE STRANDED COPPER CONDUCTOR AT POINT NEAR CENTER LIGHTNING ARRESTER.
- (L) CONNECT #2 BARE STRANDED COPPER CONDUCTOR TO REQUIRED CONDUCTOR AT POINT NEAR CENTER TERMINAL AND END TERMINAL.

FOR FIELD MAINTENANCE ONLY

ITEM	DESCRIPTION	QUANTITY	STOCK NO. OR CONSTR STDS
P T F	1 CROSSARM, 3 3/4" X 5 3/4" X 10' - 0"	3	300 SECTION
	2 BRACE, ANGLE CROSSARM 4' - 0"	2	164032
	3 SCREW, LAG GALV, 5/8" X 5"	(E) 2	621600
	4 BOLT, MACH GALV, 1/2" X 7", 1 RD WASH. & 1 DBL COIL WASH.	(E) 4	PGS 139, 140
	5 BOLT, MACH GALV, 5/8" X 14", 2 - 3" SQ WASH. & 1 DBL COIL WASH.	(E) 1	PGS 139, 140
	6 BOLT, MACH GALV, 5/8" X 20", 2 - 3" SQ WASH. & 1 DBL COIL WASH.	(E) 1	PGS 139, 140
	7 BOLT, SPACE GALV, 5/8" X 20", 4 SQ WASH. & 4 DBL COIL WASH.	(E) 2	PGS 139, 140
	8 BOLT, SPACE GALV, 5/8" X 28", 4 SQ WASH. & 4 DBL COIL WASH.	(E) 2	PGS 139, 140
	9 SIGN, HIGH VOLTAGE & 8 ROOFING NAILS	(E) 1	647648, 492224
U C D	10 ARRESTER, LIGHTNING 3KV	3	113216
	11 CUTOUT, FOR CURRENT-LIMITING FUSE	3	1200 SECTION
	12 STAPLES, FENCE GALV, 1 1/4"	(A) (E) 25	678528
	13 MOULDING, HARDWOOD 1"	(A) 55'	487200
	14 STAPLES, MOULDING GALV, 3" X 1 1/16" X 1/4"	(A) (E) 25	678560
	15 WIRE, #2 BARE STRANDED COPPER	(B) 44'	813664
	16 WIRE, #6 BARE STRANDED COPPER	(B) 18'	813536
	17 WIRE, COPPER, SIZED PER U.G. CABLE AMPACITY.	8'	81
	18 ROD & CLAMP, GROUND	(A) (C) 2	603072, 230016
	19 INSULATOR, 4KV WIRE HOLDER	1	413792
	20 FUSE, CURRENT-LIMITING SIZE AS SPECIFIED ON WORK ORDER	3	1200 SECTION
	21 CABLE, POLYETHYLENE, CONCENTRIC NEUTRAL PRIMARY	AS REQ'D	SEE UG STDS
	22 RISER CONSTRUCTION	AS REQ'D	1400/4200 SECTION
	23 TERMINAL CABLE	3	UG BOOK
	24 BRACKET, CUTOUT /ARRESTER CROSSARM MOUNTING	(E) 3	166070
	25		

SCOPE: THIS STANDARD SHOWS TANGENT LINE (FIG.1) AND DEAD-END CONSTRUCTION (FIG.2) FOR 12.47 KV AND BELOW, 3Ø CABLE POLE WITH UPSWEEP BRACKET MOUNTED TERMINALS FOR #2/0 AND SMALLER UG CABLE.

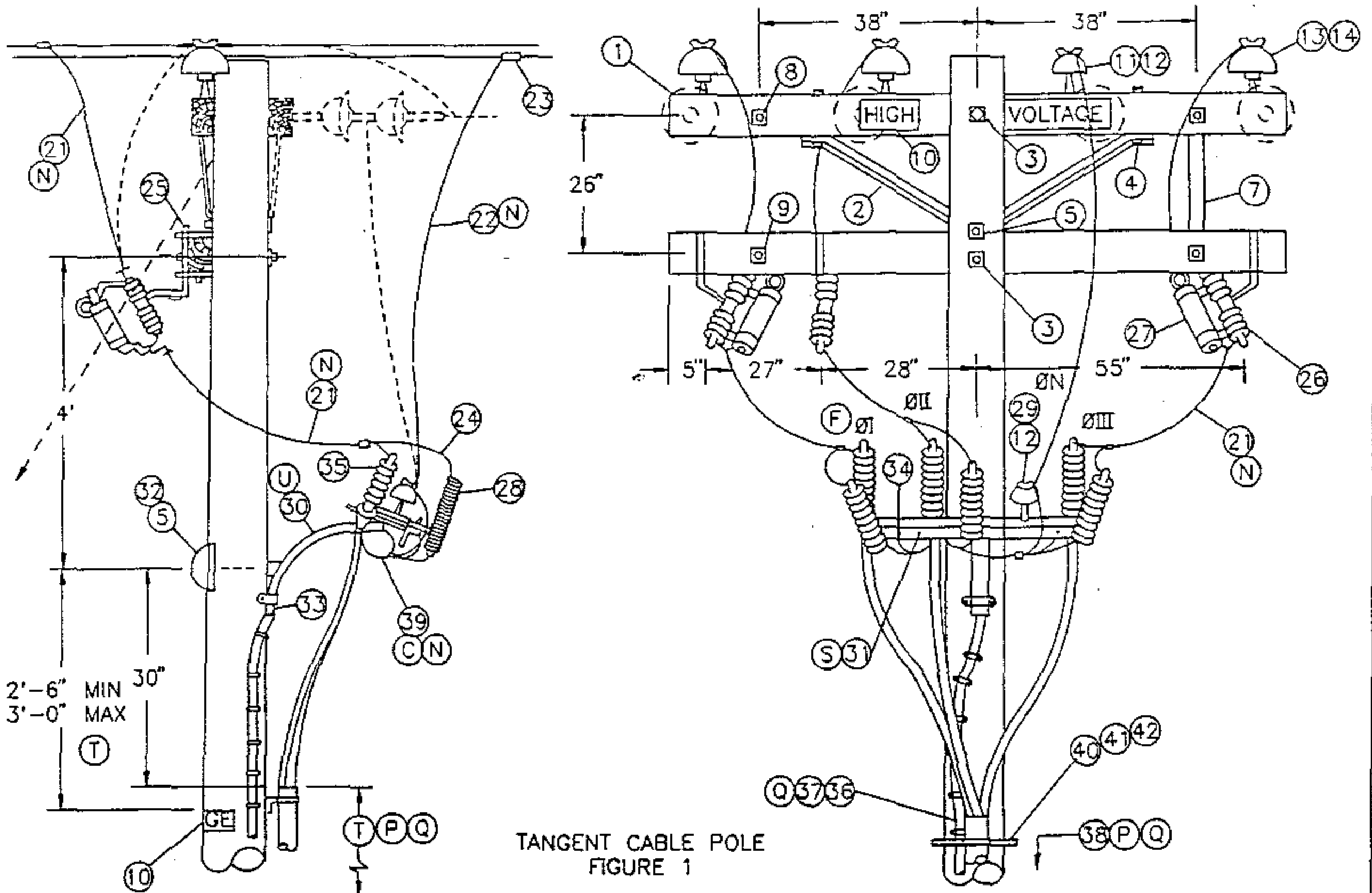

TANGENT CABLE POLE
FIGURE 1

GROUND CLEARANCE

NOTE:

- TANGENT CABLE POLE (FIG.1) OR DEAD-END CABLE POLE (DOTTED LINE) IS TO BE USED WHEN FURTHER LINE EXTENSION IS EXPECTED.
- DO NOT USE THIS UPSWEEP BRACKET CONSTRUCTION FOR 4KV, 3Ø CABLE POLE. INSTEAD, USE STANDARD 1439/4239.

FOR FIELD MAINTENANCE ONLY

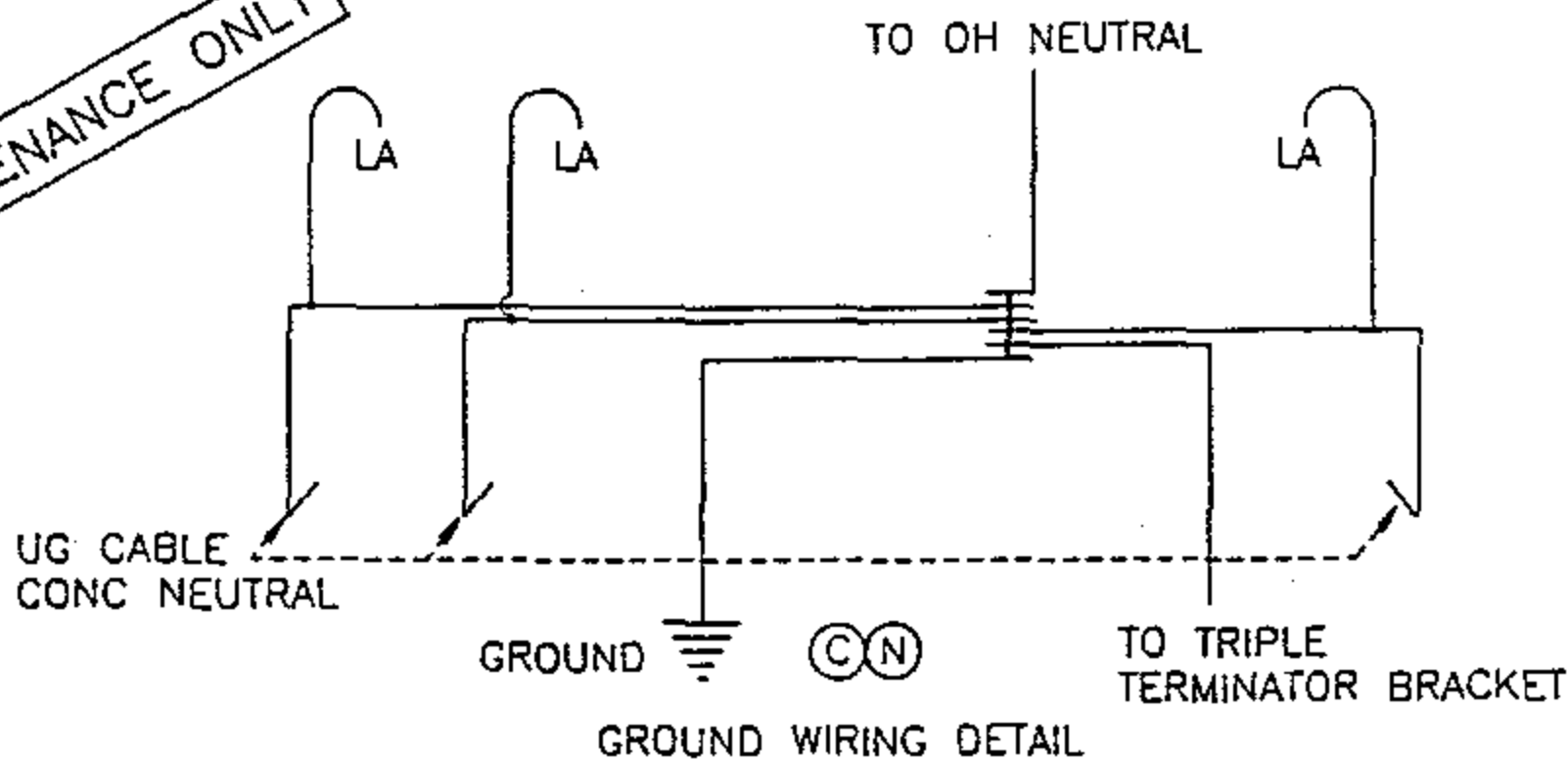

GROUND WIRING DETAIL

DATE 1-1-93
APPD *JLB/BJ*

SDG&E ELECTRIC STANDARDS

12.47KV AND BELOW 3Ø CABLE POLE 1/C PER Ø,
UPSWEPT BRACKET CONSTRUCTION

OH 1499.203
~~UG 4299.203~~
SUPERCEDES
1429.1 (1-1-93)

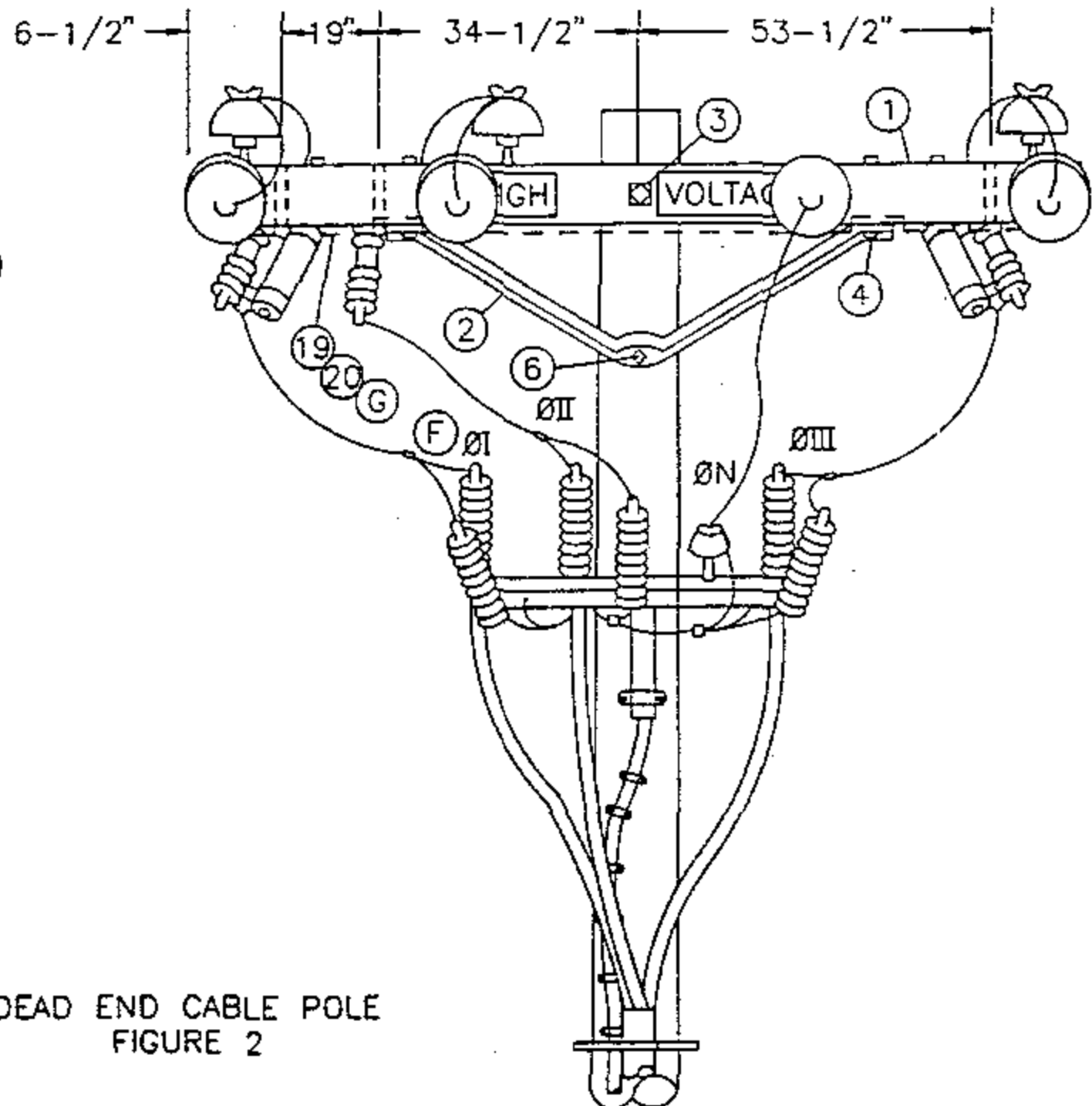
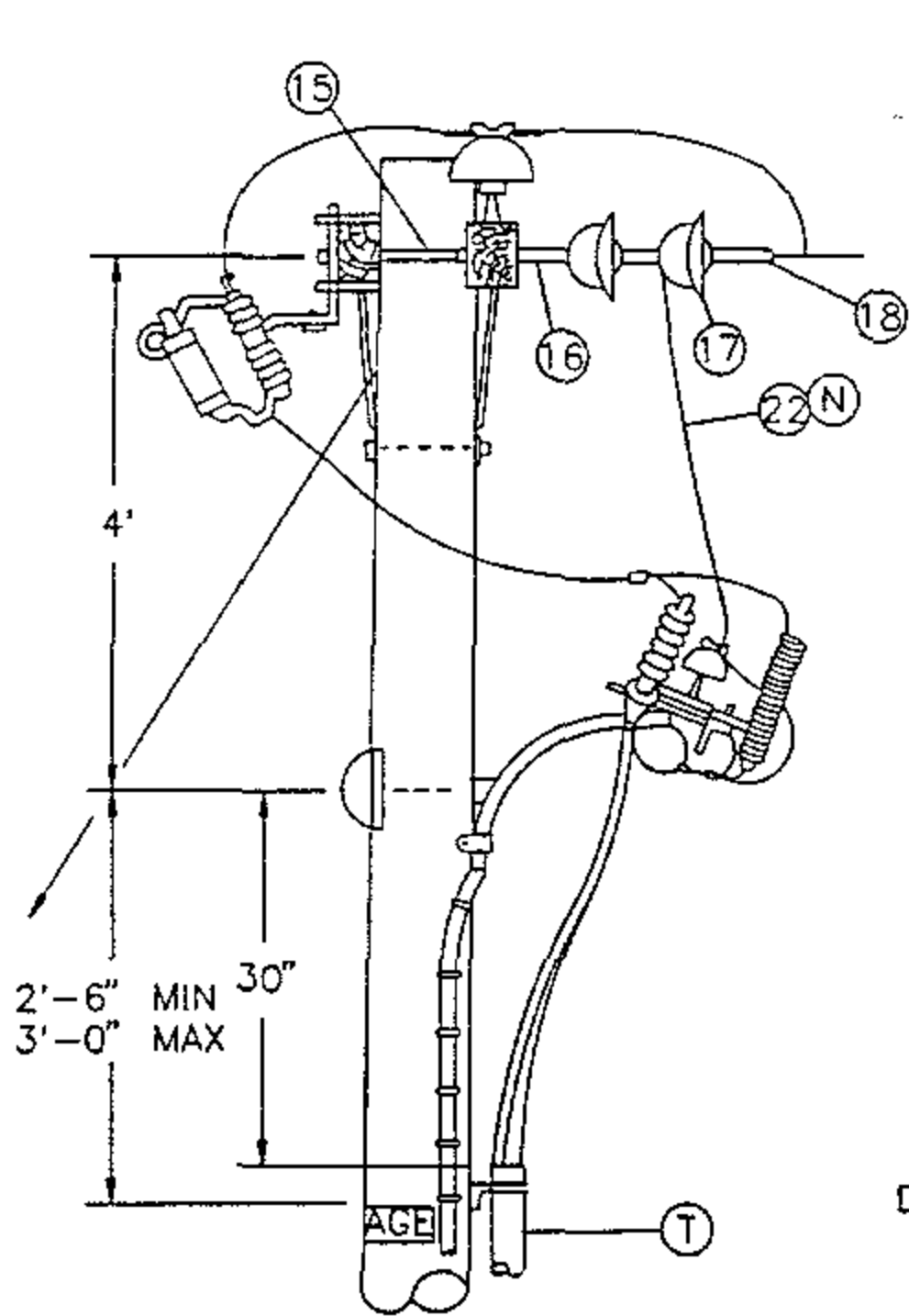

DEAD END CABLE POLE
FIGURE 2

NOTE:

-- DEAD END CABLE POLE (FIG.2) IS TO BE USED ONLY WHEN NO FURTHER LINE EXTENSION OR NO RECONDUCTING IS EXPECTED.

FOR FIELD MAINTENANCE ONLY

OH 1499.204
~~UG 4299.204~~
SUPERCEDES
1429.2 (1-1-93)

SDG&E ELECTRIC STANDARDS

12.47KV AND BELOW 3Ø CABLE POLE 1/C PER Ø
UPSWEEP BRACKET CONSTRUCTION

DATE 1-1-93

APPD *JYB/BJ*

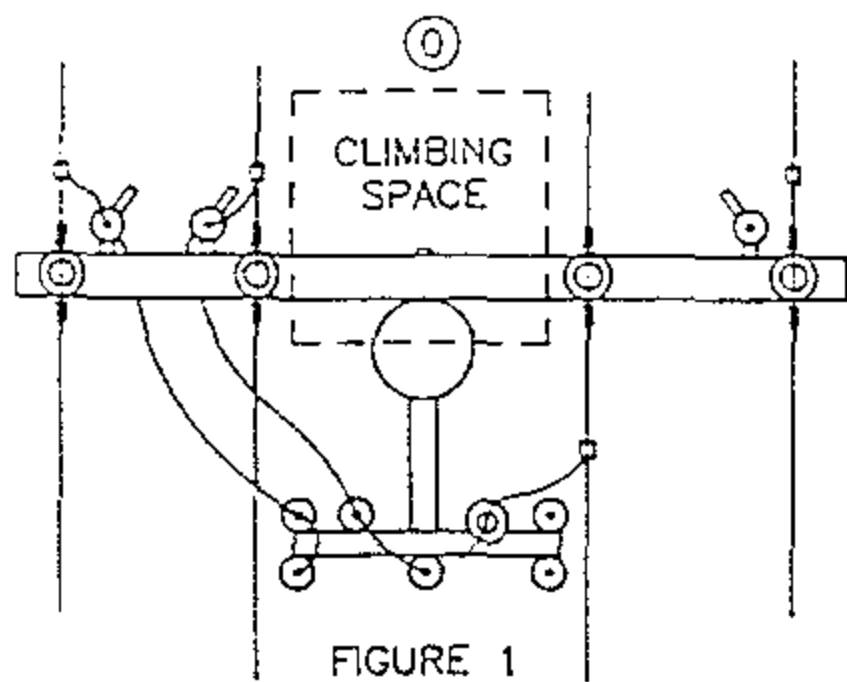

FIGURE 1

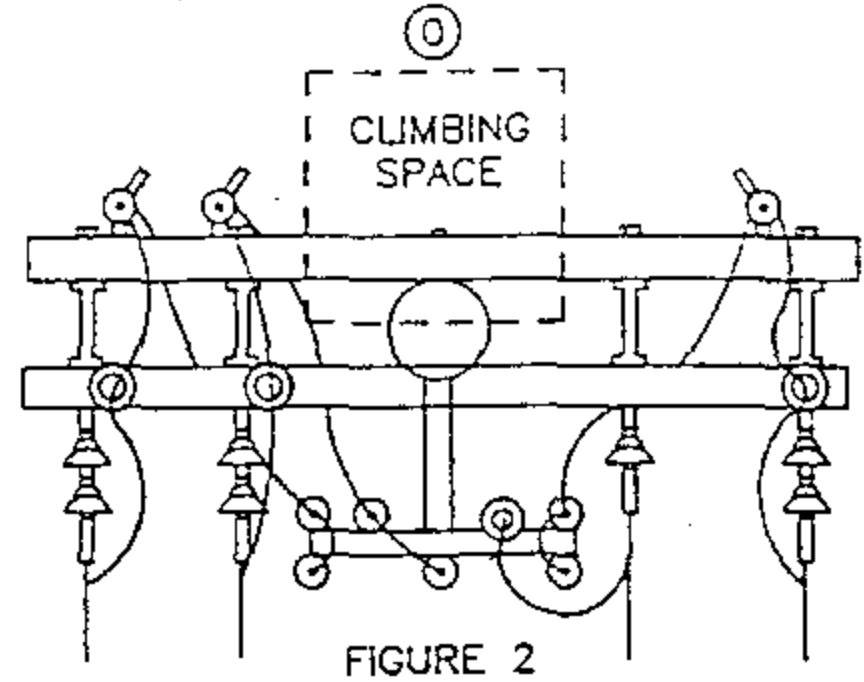

FIGURE 2

CLIMBING SPACE

BILL OF MATERIAL:

FOR FIELD MAINTENANCE ONLY

ITEM	DESCRIPTION	QUANTITY		CONST STD OR PAGE NO	STOCK NUMBER
		FIG.1	FIG.2		
1	CROSSARM, 3-3/4" X 5-3/4" X 10'-0"	2	2	-	294128
2	BRACE, ANGLE, CROSSARM, 5'	1	2	-	164128
3	BOLT, MACH, GALV, 5/8" X (LENGTH AS REQ'D), 2 SQUARE & 1 DOUBLE COIL SPRING WASHER (E)	2	1	392	-
4	BOLT, MACH, GALV, 1/2" X 7", 1 ROUND & 1 DOUBLE COIL SPRING WASHER (E)	2	4	392	-
5	BOLT, MACH, GALV, 5/8" X (LENGTH AS REQ'D), 1 SQUARE & 1 DOUBLE COIL SPRING WASHER (E)	2	1	392	-
6	BOLT, MACH, GALV, 5/8" X (LENGTH AS REQ'D), 1 DOUBLE COIL SPRING WASHER (E)	-	1	392	-
7	BRACE, FLAT, CROSSARM, 28" (E)	2	-	-	164192
8	BOLT, MACH, GALV, 3/8" X (LENGTH AS REQ'D), 1 ROUND & 1 SPRING WASHER (E)	2	-	392	-
9	BOLT, MACH, GALV, 1/2" X (LENGTH AS REQ'D), 1 ROUND & 1 DOUBLE COIL SPRING WASHER (E)	2	-	392	-
10	SIGN, HIGH VOLTAGE AND 9 ROOFING NAILS, GALV (E)	3	3	-	647648
		AS REQ'D		-	492224
11	PIN, INSULATOR, STRAIGHT, 12KV, 1" LEAD THREAD (D) (E)	1	-	-	532704
12	INSULATOR, LINE, 12KV, NEUTRAL (D) (E)	2	1	-	429216
13	PIN, INSULATOR, STRAIGHT, 12KV, 1" OR 1-3/8" LEAD THREAD (E)	3	3	-	532704
		3	3	-	532448
14	INSULATOR, LINE, 12KV, 1" OR 1-3/8" PIN (E)	3	3	750	-
15	BOLT, SPACE, 5/8" X (LENGTH AS REQ'D) 3 SQ, 2 RD, 2 DOUBLE COIL SPRING WASHERS & 1 NUT (D) (E)	-	4	392	-
16	CLEVIS, DEAD END, 5/8" BOLT, STEEL (D) (E)	-	4	-	235712
17	INSULATOR, SUSPENSION, 12KV, CLEVIS (D)	-	7	750	-
18	CLAMP, STRAIGHT LINE, D.E. (D) (E)	-	4	741	-
19	WIRE, #8, BARE SOLID ANNEALED COPPER	10'	10'	-	812928
20	STAPLES, FENCE, GALV, 1-1/4" (E)	AS REQ'D		-	678528
21	WIRE, BARE STRANDED COPPER (OH JUMPER) (N)	21'	25'	715-716	-
22	WIRE, BARE STRANDED CU OR AL (OH NEUT JUMPER) (N)	9'	7'	711-716	-
23	CONNECTOR, WIRE COMPRESSION (SIZE AS REQ'D) (D) (E)	AS REQ'D		785-787	-

CABLE SIZE	UG MACRO UNIT PORCELAIN	
	W/O LADDER ARMS	W/LADDER ARMS
3C-#2 AL	CP-3#2	CP3#2L
3C-#2/0	CP#2/0	CP2/0L

DATE 1-1-93

APPD *JLB/ROJ*

SDG&E ELECTRIC STANDARDS

12.47KV AND BELOW 3Ø CABLE POLE 1/C PER Ø UPSWEEP BRACKET CONSTRUCTION

OH 1499.205

~~UG 4299.205~~

SUPERCEDES 1429.3 (1-1-93)

BILL OF MATERIAL: (CONTINUED)

ITEM	DESCRIPTION	QUANTITY		CONSTR. STD OR PAGE NO.	STOCK NUMBER	
		FIG. 1	FIG. 2			
24	WIRE, #6, BARE STRANDED COPPER	9'	9'	-	813536	
25	BRACKET, CUTOUT/ARRESTER, FOR CROSSARM MOUNTING (E)	3	3	-	166070	
26	CUTOUT BODY FOR CURRENT LIMITING FUSE	3	3	-	297952	
27	FUSE, CURRENT-LIMITING, SIZE AS REQ'D	3	3	1206	-	
28	ARRESTER, LIGHTNING	3	3	1247	-	
29	PIN, SHORT SHANK, 1" LEAD THREAD (D) (E)	1	1	-	534426	
30	BRACKET, GALV. TERMINAL, UPSWEEP	1	1	-	166856	
31	BRACKET, TRIPLE TERMINATOR (S)	1	1	-	166676	
32	COVER, BOLT, PLASTIC & 6 - 100 NAILS, GALV	(E)	1	1	-	285696
		(E)	-	-	-	491392
33	SCREW, LAG, GALV, 1/2" X 4"	(E)	2	2	-	621568
34	BOLT, MACH, GALV, 5/8" X 1 1/2", 1 ROUND AND 1 LOCK WASHER (E)	1	1	392	-	
35	TERMINALS AND UNDERGROUND CABLE	3	3	4111	-	
36	WIRE, #4, BARE STRANDED COPPER	50'	45'	-	813760	
37	UNIT GROUND, COMPLETE (Q)	1	1	--	603136	
38	RISER CONSTRUCTION	-	-	1400/4200	-	
39	WIRE, COPPER BARE STRANDED (CABLE POLE NEUTRAL) (N)	5'	5'	715/716	-	
40	BRACKET, LADDER ARM (E)	AS REQ'D		1404/4204	167184	
41	NUT, CLAMPING CHANNEL, W/SPRING, 1/2" (E)	AS REQ'D		1404/4204	503488	
42	CHANNEL, DOUBLE GALV, 24" (E)	AS REQ'D		1404/4204	216700	

INSTALLATION:

- A. NEW CABLE POLES SHALL HAVE A STANDARD DEPTH OF 9'. IN MOST CASES THIS WILL REQUIRE A 5' TALLER POLE.
- B. THIS CONSTRUCTION TO BE USED WITH 2/0 AND SMALLER UNDERGROUND CABLE.
- (C) CONNECT OVERHEAD NEUTRAL, TRIPLE TERMINAL BRACKET, AND CONCENTRIC CABLE NEUTRAL CONDUCTOR TO LIGHTNING ARRESTER GROUND.
- (D) REDUCE QUANTITIES AS REQUIRED WHEN NOT USING NEUTRAL.
- (E) EXEMPT MATERIAL.
- (F) OMIT PHASE II AND PHASE N FOR SINGLE PHASE 12KV CABLE POLE; OMIT PHASE I AND PHASE II FOR SINGLE PHASE 6.9 KV CABLE POLE.
- (G) INTERCONNECT CUTOUTS AND DEADEND BONDS PER G.O. 95 RULE 52.7D. BONDING SHOULD BE DONE IN ACCORDANCE WITH RULE 53.4.

(N)

UG CABLE SIZE AWG OR KCMIL, AL	OH JUMPER COND SIZE, AWG OR KCMIL, CU	OH NEUT JUMPER SIZE			CABLE POLE NEUT SIZE (CU) UNDER POTHEAD ARM OR TRIPLE TERM BRKT
		CU	AL		
2	4	6	2	-	#6 PER PHASE
2/0	4	6	2	-	#6 PER PHASE
350	4/0	1/0	3/0	-	#2 PER PHASE
750	500	4/0	336.4	OR SAME SIZE AS O.H. NEUT CONDUCTOR	1/0 PER PHASE
1000	500	4/0	336.4		1/0 PER PHASE

REFERENCE:

- (O) ALLOWABLE WORKING AND CLIMBING SPACE - SEE STANDARD 251.
- (P) POLE STEPPING - SEE STANDARD 363/4205.
- (Q) GROUNDING METHODS - SEE PAGE 1002.5.
- R. SEE STANDARD SECTION 1200/4300 FOR FUSING.
- S. RISER POSITIONS - SEE STANDARD 1402/4202.
- (T) MINIMUM VERTICAL SEPARATION AS PER G.O. 95 - SEE STANDARD 1406/4206.
- (U) SEE STANDARD 1407/4207 FOR PORCELAIN AND NON-PORCELAIN TERMINAL MOUNTING BRACKET INSTALLATIONS AND MATERIALS.

FOR FIELD MAINTENANCE ONLY

OH 1499.206	SDG&E ELECTRIC STANDARDS	
UG 4299.206	12.47KV AND BELOW 3 PHASE, CABLE POLE, 1/C PER PHASE, UPSWEEP BRACKET CONSTRUCTION	DATE 1-1-93
SUPERCEDES 1429.4 (1-1-93)		APPD <i>JLB/BJ</i>

SCOPE: THIS STANDARD SHOWS ARMLESS TANGENT CONSTRUCTION FOR 12.47KV AND BELOW SINGLE-PHASE CABLE POLE WITH BRACKET MOUNTED TERMINALS FOR #2 UG CABLE USING NON-PORCELAIN TERMINALS.

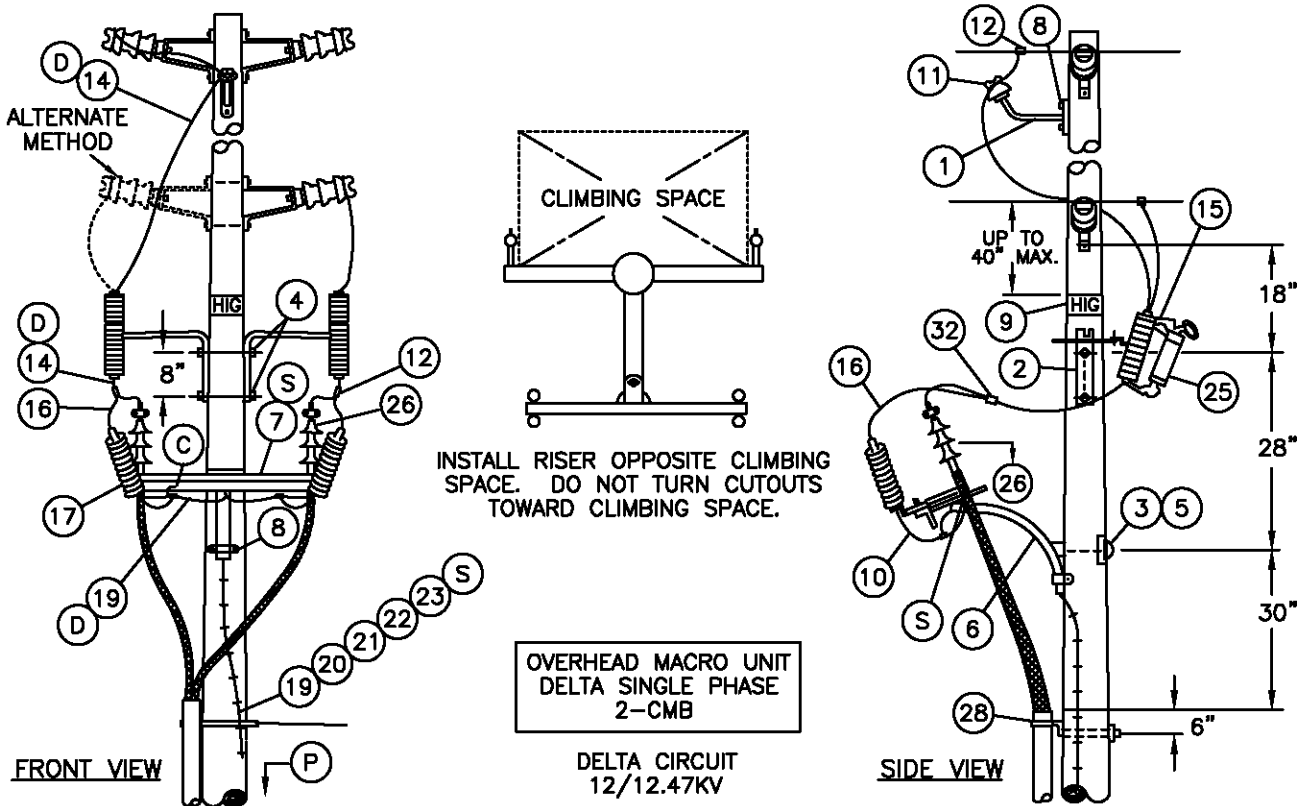
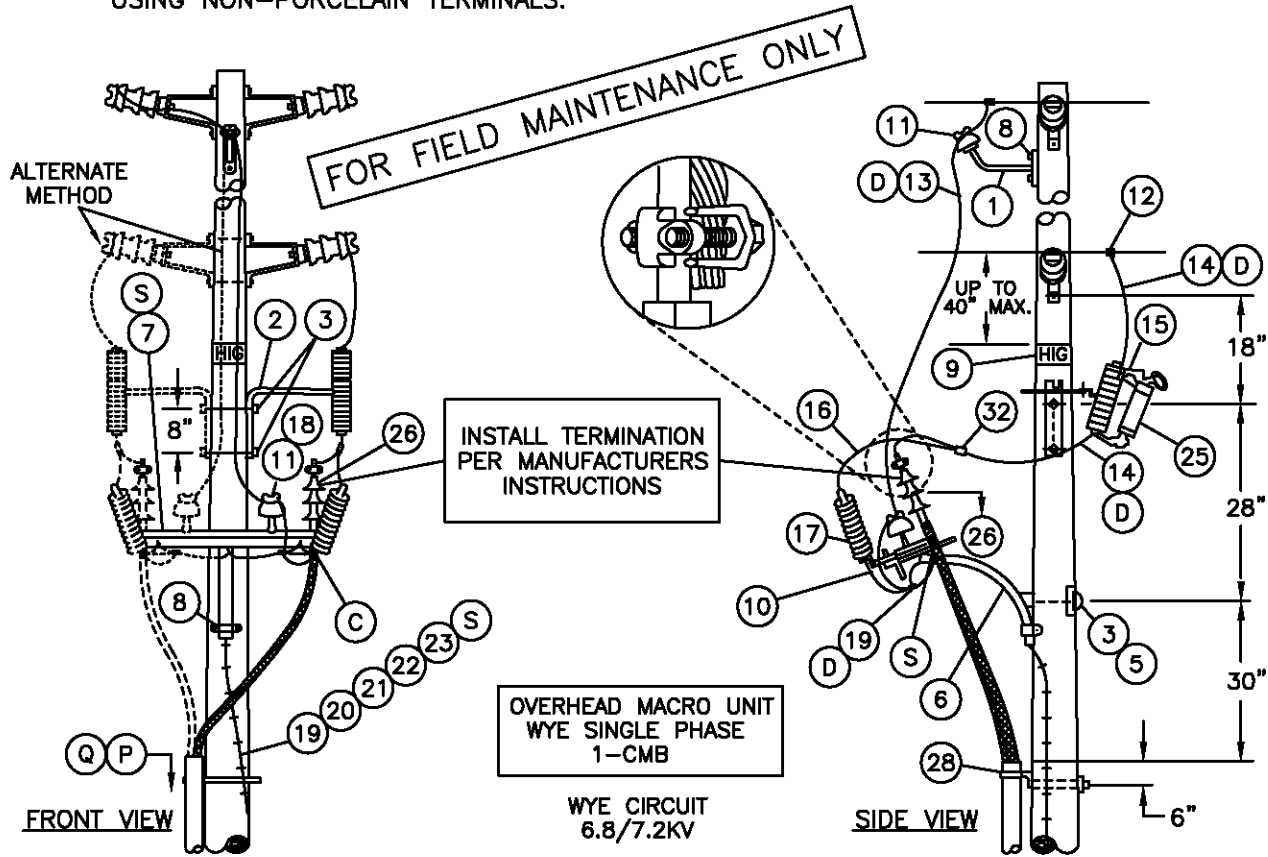

OH 1499.207
UG 4299.207
SUPERSEDES
4221.1 (10-20-05)

SDG&E ELECTRIC STANDARDS

BRACKET MOUNTED TERMINALS, 12.47KV AND BELOW,
SINGLE-PHASE ARMLESS TANGENT CONSTRUCTION,
NON-PORCELAIN TERMINALS

DATE 10-20-05
APPD PJA/JJ

BILL OF MATERIAL:

ITEM	DESCRIPTION	QUANTITY		CONST OR PAGE	STD OR NO	STOCK NUMBER	ASSEMBLY UNIT
		6.9-	12KV				
1	BRACKET, INSULATOR, 1" OR 1-3/8" LEAD THREAD	1	1	-		166144 166176	-
2	BRACKET, CUTOUT MOUNTING	1	2	-		166448	-
3	BOLT, MACH., GALV., 5/8" X (LENGTH AS REQ'D), 1 SQ. WASH 1 RD. WASH., 1 DBL. COIL SPRING WASH.	3	1	1392.1	&.2	-	-
4	BOLT, MACH., GALV., 5/8" X (LENGTH AS REQ'D), 2 RD. WASH, 1 DBL. COIL SPR. WASH.	-	2	1392.1	&.2	-	-
5	COVER, BOLT, PLASTIC, & 6-10D NAILS, GALV.	1	1	-		285696 491392	-
6	BRACKET, GALV., TERMINAL UPSWEEP, WITH PVC LINER	1	1	-		166856	-
7	BRACKET, TRIPLE TERMINAL	1	1	-		166676	-
8	SCREW, LAG, 1/2" X 4", GALV.	4	4	-		621568	-
9	SIGN, HIGH VOLTAGE, 8 GALV. ROOFING NAILS	2	2	-		647648 492192	-
10	FLEXIBLE ARRESTER GROUND STRAP	AS REQ'D		-		698754	-
11	INSULATOR, 12KV, PIN TYPE, (CLASS AS REQ'D)	2	1	750.3		-	-
12	CONNECTOR, WIRE COMPRESSION, (SIZE AND TYPE AS REQ'D)	3	4	783-796		-	-
13	WIRE, BARE STRANDED COPPER (OH NEUTRAL JUMPER) (D)	9'	-	711		-	-
14	WIRE, BARE STRANDED COPPER (OH JUMPER) (D)	6'	15'	715		-	-
15	CUTOUT BODY, FOR CURRENT-LIMITING FUSE	1	2	1212		297952	-
16	WIRE, BARE STRANDED COPPER, #6	2'	4'	-		813536	-
17	ARRESTER, LIGHTNING	1	2	1247.1	&.2	-	-
18	PIN, SHORT SHANK, 1" LEAD THREAD	1	-	-		532426	-
19	#4 CU SOLID GROUND WIRE, PVC COVERED	50'	50'	-		812490	GNDPVC
20	GROUND ROD, 5/8" X 8', COPPERWELD	1	1	-		603072	
21	COPPER BONDED GROUND CONNECTOR	1	1	-		259010	-
22	GROUND ENHANCING POWER SOLUTION (GEM)	AS REQ'D		-		424390	-
23	GALVANIZED STAPLES FOR PVC COVERED GROUND WIRE	AS REQ'D		-		678562	-
24							-
25	FUSE, CURRENT LIMITING, (SIZE AS SPECIFIED ON W.O.)	1	2	1207/4308		-	-
26	TERMINALS, UNDERGROUND CABLE (S)	1	2	4111		-	-
27	WIRE, BARE STRANDED COPPER, (UNDER TRIPLE TERM BRKT) (D)	-	3'	715		-	-
28	RISER CONSTRUCTION	AS REQ'D		1400/4200		-	-
29	BRACKET, LADDER ARM	AS REQ'D		1404/4204		167184	-
30	NUT, CLAMPING CHANNEL, W/SPRING, 1/2"	AS REQ'D		1404/4204		503488	-
31	CHANNEL, DOUBLE GALV. 24"	AS REQ'D		1404/4204		216700	-
32	HOT LINE CLAMP	2		788		227680	-

FOR FIELD MAINTENANCE ONLY

CABLE SIZE	UG MACRO UNIT PORCELAIN	
	W/O LADDER ARMS	W/LADDER ARMS
1C#2AL 3"BEND	CP-1#2	CP1#2L
2C#2AL 3"BEND	CP-2#2	CP2#2L
1C#2AL 2"BEND	C1#2-S	C1#2LS

DATE 6-30-06 APPD PJA/JJ	SDG&E ELECTRIC STANDARDS	OH 1499.208 UG 4299.208 SUPERSEDES 4221.2 (6-30-06)
	BRACKET MOUNTED TERMINALS, 12.47KV AND BELOW, SINGLE-PHASE ARMLESS TANGENT CONSTRUCTION, NON-PORCELAIN TERMINALS	

INSTALLATION:

- A. NEW CABLE POLES SHALL HAVE A STANDARD DEPTH OF 9'. IN MOST CASES THIS WILL REQUIRE A 5' TALLER POLE.
- B. USE THIS CONSTRUCTION FOR #2 CABLE.
- C. CONNECT ONE STRAND OF CONCENTRIC NEUTRAL TO SPLIT BOLT GROUND LUG.

D.

UG CABLE SIZE AWG OR KCMIL, AL	OH JUMPER COND SIZE, AWG OR KCMIL, CU	OH NEUT JUMPER SIZE			CABLE POLE NEUT SIZE (CU) UNDER POTHEAD ARM OR TRIPLE TERM BRKT
		CU	AL		
2	4	6	2	-	#6 PER PHASE

REFERENCE:

- Q. POLE STEPPING – SEE STANDARD 363/4205.
- P. POLE TOP CONSTRUCTION – SEE SECTION 400.
- Q. GROUNDING METHODS – SEE PAGE 1002.5.
- R. SEE STANDARD SECTION 1200/4300 FOR FUSING.
- S. SEE STANDARD 1407/4207 FOR NON-PORCELAIN TERMINAL MOUNTING BRACKET INSTRUCTIONS AND MATERIALS.

FOR FIELD MAINTENANCE ONLY

REVISION	SDG&E ELECTRIC STANDARDS	OH 1499.209
DATE 1-1-93	BRACKET MOUNTED TERMINALS, 12.47KV AND BELOW, SINGLE-PHASE ARMLESS TANGENT CONSTRUCTION, NON-PORCELAIN TERMINALS	UG 4299.209
APPD <i>JLB/BJ</i>		SUPERSEDES 4221.3 (1-1-93)

SCOPE: THIS STANDARD SHOWS ARMLESS DEADEND CONSTRUCTION FOR 12.47KV AND BELOW SINGLE-PHASE CABLE POLE WITH BRACKET MOUNTED TERMINALS FOR #2 UG CABLE USING NON-PORCELAIN TERMINALS.

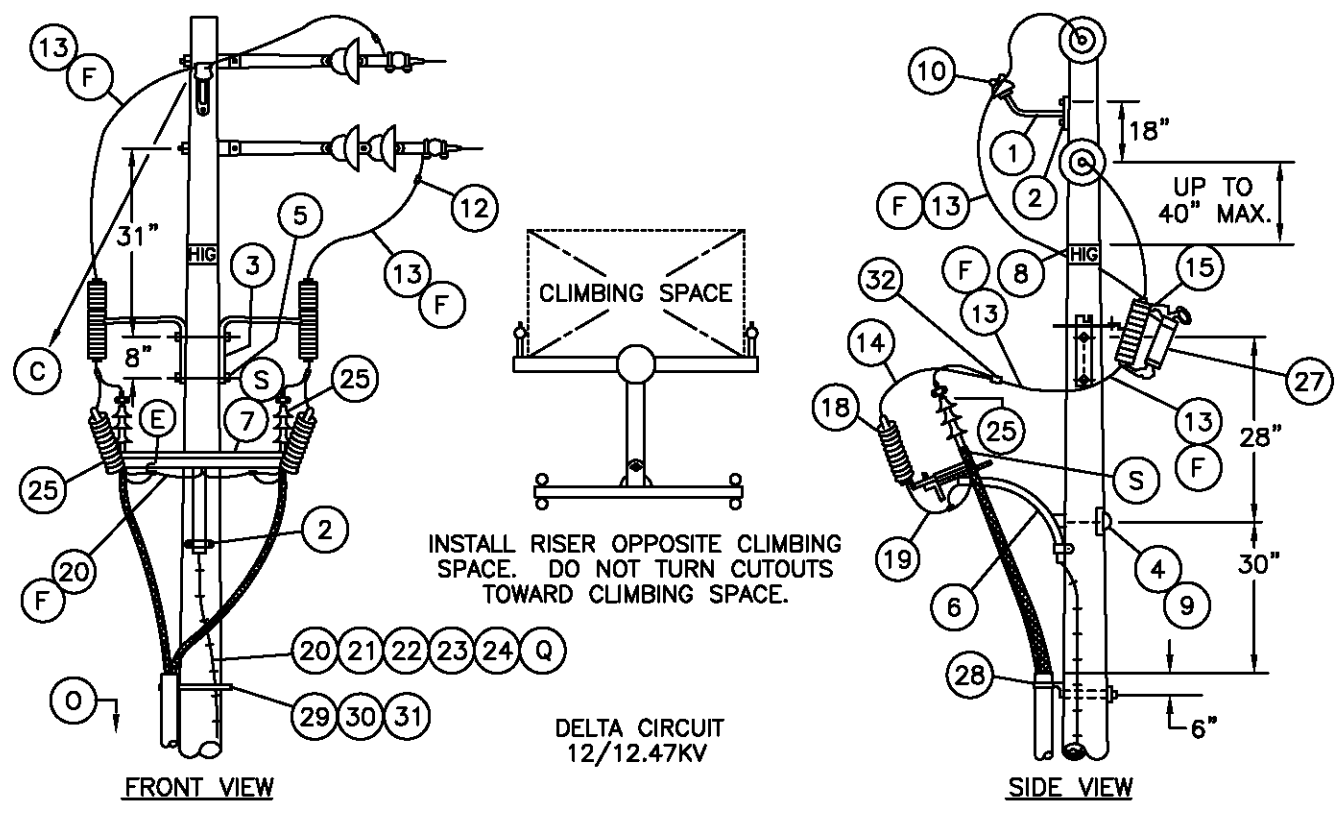
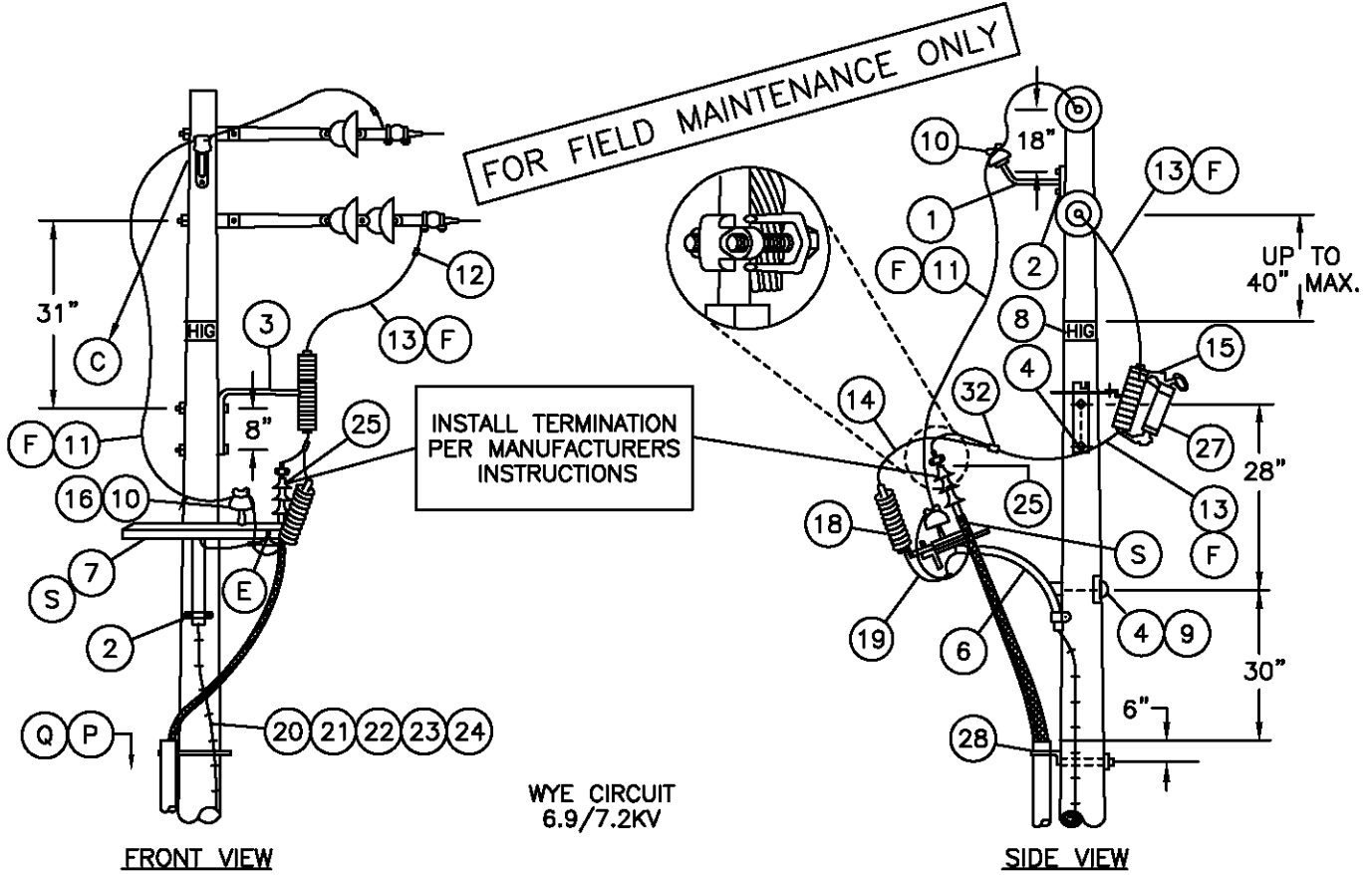

OH 1499.210
UG 4299.210
SUPERSEDES
4223.1 (10-20-05)

SDG&E ELECTRIC STANDARDS

BRACKET MOUNTED TERMINALS, 12.47KV AND BELOW,
SINGLE-PHASE ARMLESS DEADEND CONSTRUCTION,
NON-PORCELAIN TERMINALS

DATE 10-20-05
APPD PJA / JJ

BILL OF MATERIAL:

ITEM	DESCRIPTION	QUANTITY		CONST STD OR PAGE NO	STOCK NUMBER	ASSEMBLY UNIT
		7.2-	12KV			
1	BRACKET, INSULATOR, 1" OR 1-3/8" LEAD THREAD	1	1	-	166144 166176	-
2	SCREW, LAG, GALV, 1/2" X 4"	4	4	-	621568	-
3	BRACKET, CUTOUT MOUNTING	1	2	-	166448	-
4	BOLT, MACH, GALV, 5/8" X (LENGTH AS REQ'D), 1 SQ WASH, 1 RD WASH, 1 DBL COIL SPRING WASH	3	1	392.1 &.2	-	-
5	BOLT, MACH, GALV, 5/8" X (LENGTH AS REQ'D), 2 RD WASH, 1 DBL COIL SPRING WASH	-	2	392.1 &.2	-	-
6	BRACKET, GALV, TERMINAL UPSWEEP, WITH PVC LINER	1	1	-	166856	-
7	BRACKET, TRIPLE TERMINAL	1	1	-	166676	-
8	SIGN, HIGH VOLTAGE, 8 ROOFING NAILS, GALV	2	2	-	647648 492192	-
9	COVER, BOLT, PLASTIC, & 6-10D NAILS, GALV.	1	1	-	285696 491392	-
10	INSULATOR, 12KV, PIN TYPE, (CLASS AS REQ'D)	2	1	750.3	-	-
11	WIRE, BARE STRANDED CU OR AL (OH NEUTRAL JUMPER) (F)	12'	-	715	-	-
12	CONNECTOR, WIRE, COMPRESSION, (SIZE AS REQ'D)	AS REQ'D		783-786	-	-
13	WIRE, BARE STRANDED COPPER (OH JUMPER) (F)	6'	16'	715	-	-
14	WIRE, #6, BARE STRANDED COPPER	2'	4'	-	813536	-
15	CUTOUT, FOR CURRENT-LIMITING FUSE	1	2	1212	297952	-
16	PIN, SHORT SHANK, 1" LEAD THREAD	1	-	-	532426	-
17						-
18	ARRESTER, LIGHTNING	1	2	1247.1	-	-
19	FLEXIBLE ARRESTER GROUND STRAP	AS REQ'D		-	698754	-
20	#4 CU SOLID GROUND WIRE, PVC COVERED	50'	50'	-	812490	GNDPVC
21	GROUND ROD, 5/8" X 8', COPPERWELD	1	1	-	603072	
22	COPPER BONDED GROUND CONNECTOR	1	1	-	259010	-
23	GROUND ENHANCING POWER SOLUTION (GEM)	AS REQ'D		-	424390	-
24	GALVANIZED STAPLES FOR PVC COVERED GROUND WIRE	AS REQ'D		-	678562	-
25	TERMINAL AND UNDERGROUND CABLE	1	2	4111	-	-
26	WIRE, BARE STRANDED CU (UNDER TRIPLE TERM BRKT)	-	3'	715	-	-
27	FUSE, CURRENT-LIMITING, (SIZE AS SPECIFIED ON W.O.)	1	2	1207/4308	-	-
28	RISER CONSTRUCTION	-	-	1400/4200	-	-
29	BRACKET, LADDER ARM	AS REQ'D		1404/4204	167184	-
30	NUT, CLAMPING CHANNEL, W/SPRING, 1/2"	AS REQ'D		1404/4204	503488	-
31	CHANNEL, DOUBLE GALV. 24"	AS REQ'D		1404/4204	216700	-
32	HOT LINE CLAMP	2		788	227680	-

FOR FIELD MAINTENANCE ONLY

CABLE SIZE	UG MACRO UNIT PORCELAIN	
	W/O LADDER ARMS	W/LADDER ARMS
1C#2AL 3"BEND	CP-1#2	CP1#2L
2C#2AL 3"BEND	CP-2#2	CP2#2L
1C#2AL 2"BEND	C1#2-5	C1#2LS

DATE 6-30-06 APPD PBA/JJ	SDG&E ELECTRIC STANDARDS	OH 1499.211 UG 4299.211 SUPERSEDES 4223.2 (6-30-06)
	BRACKET MOUNTED TERMINALS, 12.47KV AND BELOW, SINGLE-PHASE ARMLESS DEADEND CONSTRUCTION, NON-PORCELAIN TERMINALS	

INSTALLATION:

- A. NEW CABLE POLES SHALL HAVE A STANDARD DEPTH OF 9'. IN MOST CASES THIS WILL REQUIRE A 5' TALLER POLE.
- B. THIS CONSTRUCTION TO BE USED WITH #2 CABLE.
- C. DO NOT ATTACH GUY HOOK TO TOP DEAD-END THRU BOLT.
- D. THIS CONSTRUCTION IS LIMITED TO CUL-DE-SAC APPLICATION WHERE NO FUTURE O.H. IS ANTICIPATED.
- E. CONNECT ONE STRAND OF CONCENTRIC NEUTRAL TO SPLIT BOLT GROUNDING LUG.

F

UG CABLE SIZE AWG OR KCMIL, AL	OH JUMPER COND SIZE, AWG OR KCMIL, CU	OH NEUT JUMPER SIZE			CABLE POLE NEUT SIZE (CU) UNDER POTHEAD ARM OR TRIPLE TERM BRKT
		CU	AL		
2	4	6	2	-	#6 PER PHASE

REFERENCE:

- O. POLE STEPPING - SEE STANDARD 363/4205.
- P. POLE TOP CONSTRUCTION - SEE SECTION 400.
- Q. GROUNDING METHODS - SEE PAGE 1002.5.
- R. SEE STANDARD SECTION 1200/4300 FOR FUSING.
- S. SEE STANDARD 1407/4207 FOR NON-PORCELAIN TERMINAL MOUNTING BRACKET INSTRUCTIONS AND MATERIALS.

FOR FIELD MAINTENANCE ONLY

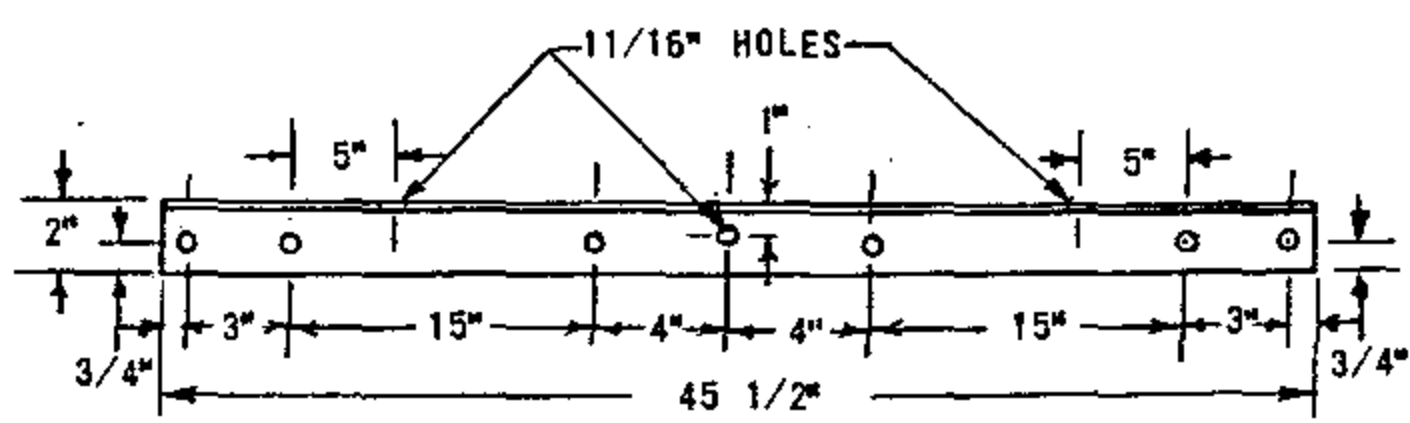
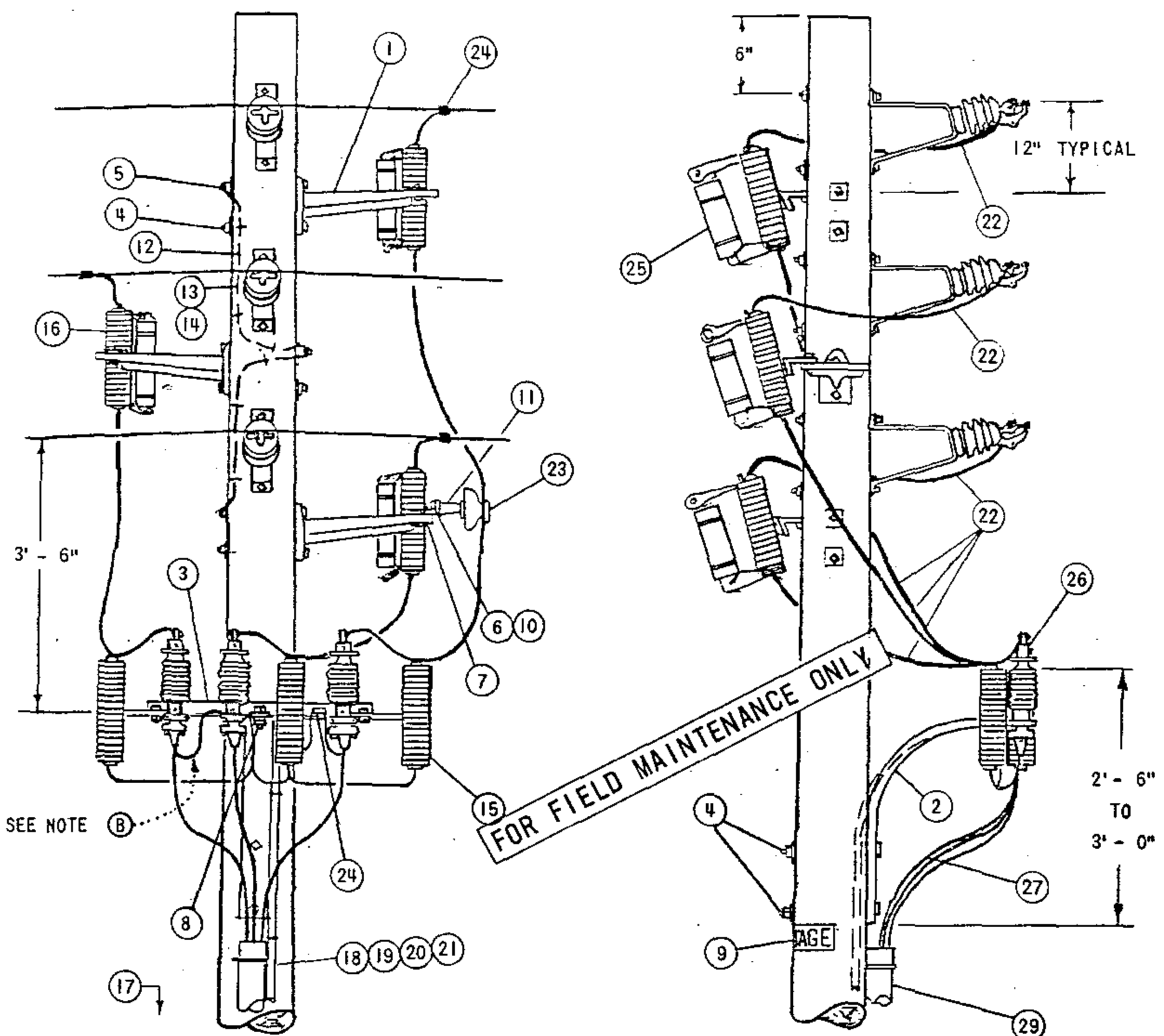

ALL HOLES 9/16" EXCEPT AS NOTED

FABRICATE FROM 2" X 2" X 3/16" STEEL ANGLE
HOT DIP GALVANIZE AFTER FABRICATION

ARMLESS TERMINAL MOUNTING BRACKET

DATE 8-27-82
APPD DRH

SDG&E ELECTRIC STANDARDS
BRACKET MOUNTED TERMINALS,
12KV 3 WIRE ARMLESS TANGENT CONSTRUCTION

OH 1499.301
UG 4299.301
SUPERSEDES
1437.1(11-16-81)

NOTES:

- (A) UNIT GROUND, COMPLETE, ORDER 603120 WITH GRAY MOULDING, 603135 WITH PLAIN MOULDING.
- (B) THE FIBERGLASS UPSWEEP TERMINAL BRACKET IS TO BE USED FOR UNDERGROUND CONDUCTORS 4/0 OR SMALLER. DO NOT USE FOR 500 KCM AND LARGER CONDUCTORS.
- (C) USE TWO-ROD GROUND SPACED A MINIMUM OF 6 FEET APART.
- D. CONNECT ONE STRAND OF CONCENTRIC NEUTRAL TO TERMINAL BOLT WITH DOUBLE NUT.
- (E) EXEMPT MATERIAL

FOR FIELD MAINTENANCE ONLY

ITEM	DESCRIPTION	QUANTITY	STOCK NO. OR CONSTR STD
INSTALLED BY OH CREWS UG CREWS	1	BRACKET, GALV., 4-HOLE, MOUNTING	3 166240
	2	BRACKET, FIBERGLASS, TERMINAL, UPSWEEP SEE NOTE (F)	1 166864
	3	BRACKET, ARMLESS, TERMINAL MOUNTING, SEE DETAIL PAGE 1437.1	1 166672
	4	MACH. BOLT, GALV., 5/8" X LENGTH AS REQ'D., 1-SQ. CURV. WASH., 1-DBL. COIL SPR. WASH. & 1-NUT (E)	5 PGS 139, 140
	5	MACH. BOLT, GALV., 5/8" X LENGTH AS REQ'D., 1-SQ., CURV. WASH., 1-DBL. COIL SPR. WASH., 2-FLAT RD. WASH. & 2-NUTS (E)	3 PGS 139, 140
	6	MACH. BOLT, GALV., 5/8" X 1 1/2", 1-LOCK WASH. (E)	1 PGS 139, 140
	7	MACH. BOLT, GALV., 1/2" X 1 1/2", 1-LOCK WASH. & 1-NUT (E)	1 PGS 139, 140
	8	MACH. BOLT, GALV., 5/8" X 2 1/2", 1-LOCK, 2-RD. WASH. & 2-NUTS (E)	1 PGS 139, 140
	9	HIGH VOLTAGE SIGN & 8-ROOFING NAILS, GALV. (E)	2 647648, 492224
	10	BRACKET, INSULATOR, MOUNTING ANGLE	1 166208
	11	PIN, INSULATOR, 12KV, 1" OR 1 3/8" LEAD THREAD	1 529248-529216
	12	WIRE, BOND, BARE SOLID ANNEALED, #8	6' 812928
	13	HARDWOOD MOULDING, 1" (OTHER THAN TOP CIRCUIT ON POLE)	6' 487200
	14	MOULDING STAPLES, GALV., 3" X 1 1/16" X 1/4" (OTHER THAN TOP CIRCUIT ON POLE)	6 678560
	15	LIGHTNING ARRESTER, 12KV	3 113248
	16	CUTOUT, FOR CURRENT-LIMITING FUSE	3 1200 SECTION
	17	GROUND ROD & CLAMP (A) (C)	2 603072-230016 (E)
	18	HARDWOOD MOULDING, 1" (A)	36' 487200
	19	STAPLES, MOULDING, GALV., 3" X 1 1/16" X 1/4" (A) (E)	24 678560
	20	STAPLES, FENCE, GALV., 1 1/4" (A) (E)	1/3# 678528
	21	WIRE, BARE STRANDED COPPER, #2 (B)	50' 813664
	22	WIRE, BARE STRANDED, COPPER, (SIZE AS REQ'D)	25'
	23	INSULATOR, 12KV, PIN TYPE (CLASS AS REQ'D)	1 429056-429152
	24	CONNECTOR, WIRE, COMPRESSION (SIZE AS REQ'D)	4
	25	FUSE, CURRENT-LIMITING SIZE AS SPECIFIED ON WORK ORDER	3 1200 SECTION
	26	CABLE TERMINAL	3 SEE UG STDS
	27	CABLE, PRIMARY	AS REQ'D SEE UG STDS
	28		
	29	RISER CONSTRUCTION	AS REQ'D 1400/4200 SECTION

OH 1499,302
 UG 4299,302
 SUPERSEDES
 1437.2 (11-16-81)

SDG&E ELECTRIC STANDARDS
 BRACKET MOUNTED TERMINALS,
 12KV 3 WIRE ARMLESS TANGENT CONSTRUCTION

DATE 8-27-82
 APPD *ARH*

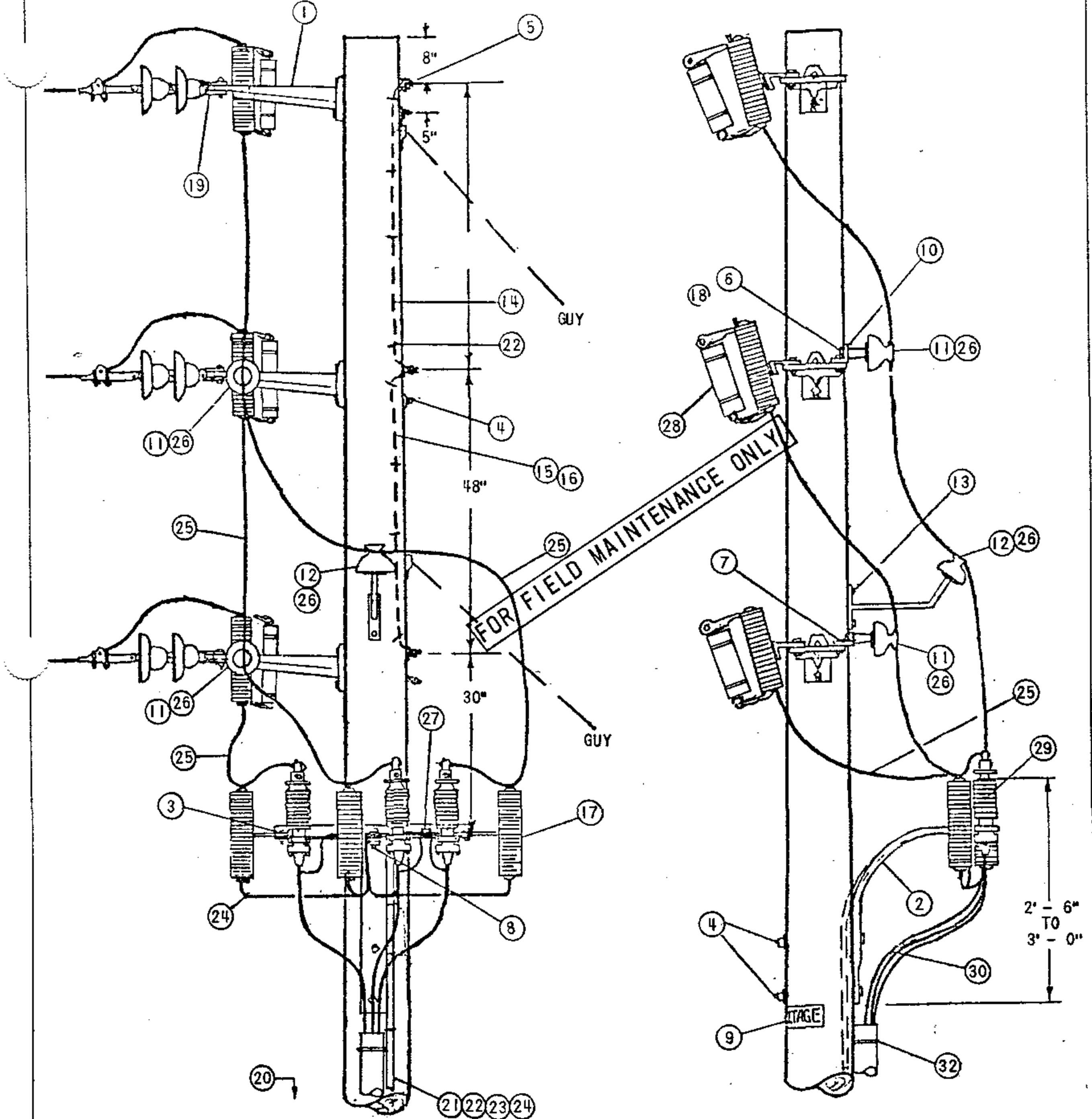

(DEAD ENDS OMITTED FOR CLARITY)

DATE 8-27-82
 APPD *LRH*

SDG&E ELECTRIC STANDARDS
 BRACKET MOUNTED TERMINALS, 12KV 3 WIRE,
 ARMLESS DEAD END CONSTRUCTION

OH 1499.303
 UG 4299.303
 SUPERSEDES
 1438.1(11-16-81)

NOTES:

- (A) UNIT GROUND COMPLETE ORDER 503120 WITH GRAY MOULDING, 603136 WITH PLAIN MOULDING.
- B. UNTWIST SUFFICIENT LENGTH OF #2 STRANDED WIRE TO CONNECT EACH ARRESTER AND POTHEAD (TERMINAL) GROUND WITH A SINGLE STRAND.
- (C) USE TWO-ROD GROUND SPACED A MINIMUM OF 6 FEET APART.
- D. THIS CONFIGURATION NOT TO BE USED WHERE A FUTURE EXTENSION IS ANTICIPATED
- (E) EXEMPT MATERIALS.
- F. THIS INSTALLATION DOES NOT INCLUDE GUYING MATERIAL
- (G) THE FIBERGLASS UPSWEEP TERMINAL BRACKET IS TO BE USED FOR UNDERGROUND CONDUCTORS 4/0 OR SMALLER. DO NOT USE FOR 500 KCM AND LARGER CONDUCTORS

FOR FIELD MAINTENANCE ONLY

ITEM	DESCRIPTION	QUANT	STOCK NO. OR CONSTR STDS
OH & F	1 BRACKET, GALV., 4-HOLE, MOUNTING SEE NOTE (G)	3	166240
	2 BRACKET, FIBERGLASS, TERMINAL, UPSWEEP	1	166864
	3 BRACKET, ARMLESS, TERMINAL MOUNTING (SEE DETAIL PG. 1437.1)	1	166672
	4 MACH. BOLT, GALV., 5/8" X LENGTH AS REQ'D., 1-SQ. CURV. WASH., 1-DBL. COIL SPR. WASH. & 1-NUT (E)	5	PGS 139, 140
	5 MACH. BOLT, GALV., 5/8" X LENGTH AS REQ'D., 1-SQ. CURV. WASH., 1-DBL. COIL SPR. WASH., 2-FLAT RD. WASH. & 2-NUTS (E)	3	PGS 139, 140
	6 MACH. BOLT, GALV., 5/8" X 1 1/2" (E)	2	PGS 139, 140
	7 MACH. BOLT, GALV., 1/2" X 1 1/2" (E)	2	PGS 139, 140
	8 MACH. BOLT, GALV., 5/8" X 2 1/2", 1-LOCK, 2-rd. WASH. & 2-NUTS (E)	1	PGS 139, 140
	9 HIGH VOLTAGE SIGN & 8-ROOFING NAILS, GALV. (E)	2	647648, 492192
	10 BRACKET, INSULATOR, MOUNTING ANGLE	2	PG 151
	11 PIN, INSULATOR, 12KV, 1" OR 1 3/8" LEAD THREAD	2	529248-529216
	12 BRACKET, INSULATOR, 1" OR 1 3/8" LEAD THREAD	1	166144-166176
	13 SCREW, LAG, GALV., 1/2" X 4" (E)	2	621568
	14 WIRE, BOND, BARE SOLID ANNEALED, #8	10'	812928
	15 HARDWOOD MOULDING, 1", (OTHER THAN TOP CIRCUIT ON POLE)	10'	487200
	U & D	16 MOULDING STAPLES, GALV., 3" X 1 1/16" X 1/4" (OTHER THAN TOP CIRCUIT ON POLE) (E)	6
17 LIGHTNING ARRESTER, 12KV		3	113248
18 CUTOUT, FOR CURRENT-LIMITING FUSE		3	1200 SECTION
19 CLEVIS		3	235776
20 GROUND ROD & CLAMP (C)		2	603072, 230016 (A)(E)
21 HARDWOOD MOULDING, 1"		36'	487200 (A)
22 STAPLES, MOULDING, GALV., 3" X 1 1/16" X 1/4" (E)		24	678560 (A)
23 STAPLES, FENCE, GALV., 1 1/4" (E)		32	678528 (A)
24 WIRE, BARE STRANDED, COPPER, #2		50'	813664
25 WIRE, BARE STRANDED, COPPER, (SIZE AS REQ'D)		25'	PGS 715-717
26 INSULATOR, 12KV, PIN TYPE, (CLASS 55-5 OR 56-1)		3	429056-429152
27 CONNECTOR, WIRE, COMPRESSION, (SIZE AS REQ'D)		1	PGS 783-787
UG C R E W S	28 FUSE, CURRENT-LIMITING AS SPECIFIED ON WORK ORDER	3	1200 SECTION
	29 CABLE TERMINAL	3	SEE UG STDS
	30 CABLE, PRIMARY	AS REQ'D	SEE UG STDS
	31		
	32 RISER CONSTRUCTION	AS REQ'D	1400/4200 SECTION

OH 1499,304
~~UG 4299,304~~
 SUPERSEDES
 1438,2 (11-16-81)

SD&E ELECTRIC STANDARDS
 BRACKET MOUNTED TERMINALS, 12KV 3 WIRE,
 ARMLESS DEAD END CONSTRUCTION

DATE 8-27-82
 APPD [Signature]

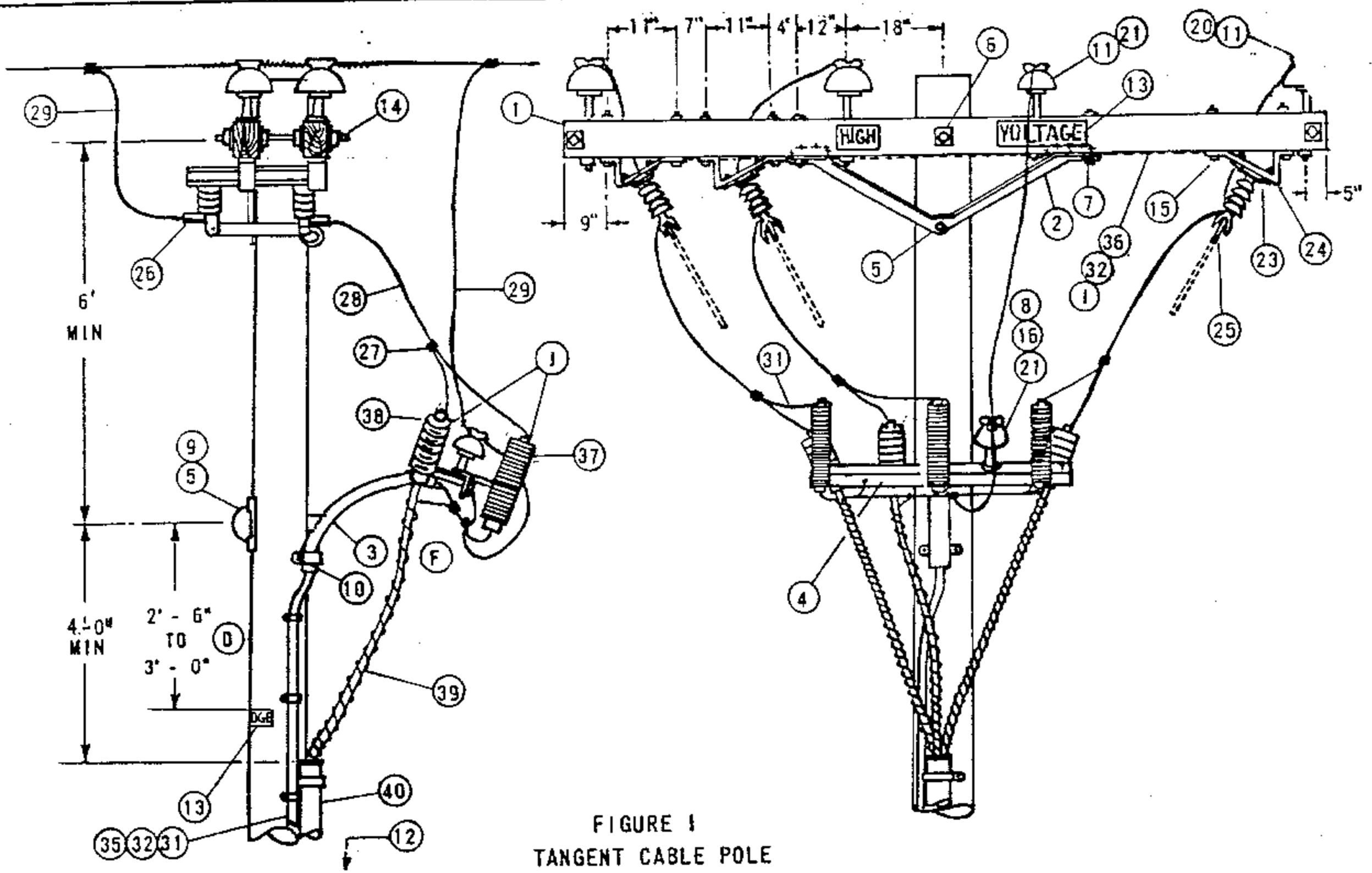

FIGURE 1
TANGENT CABLE POLE

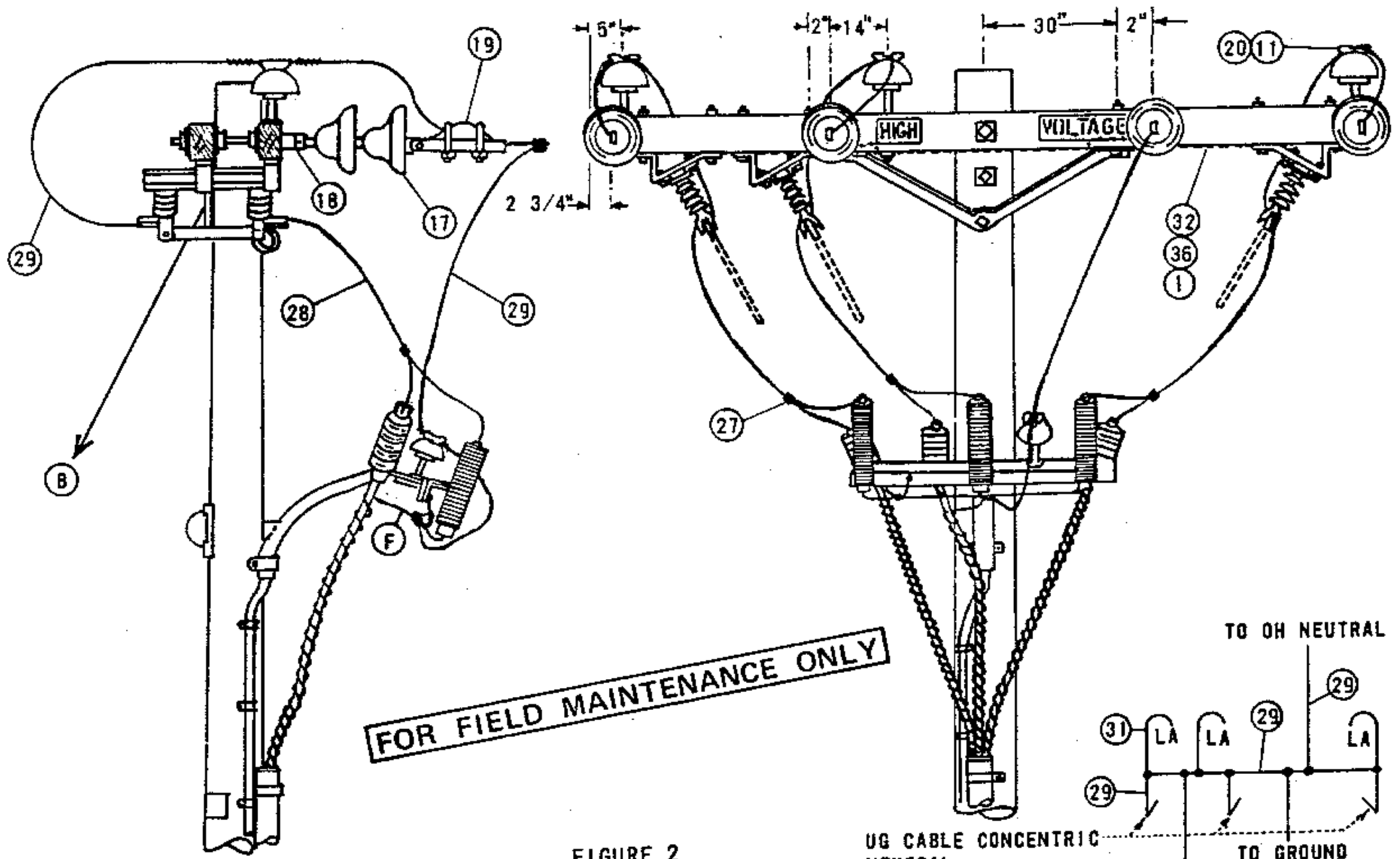
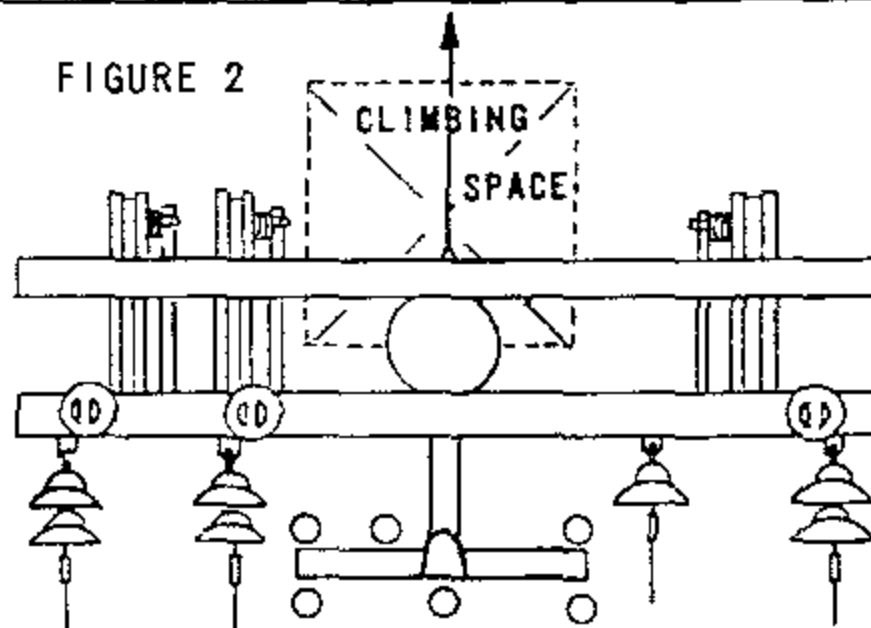
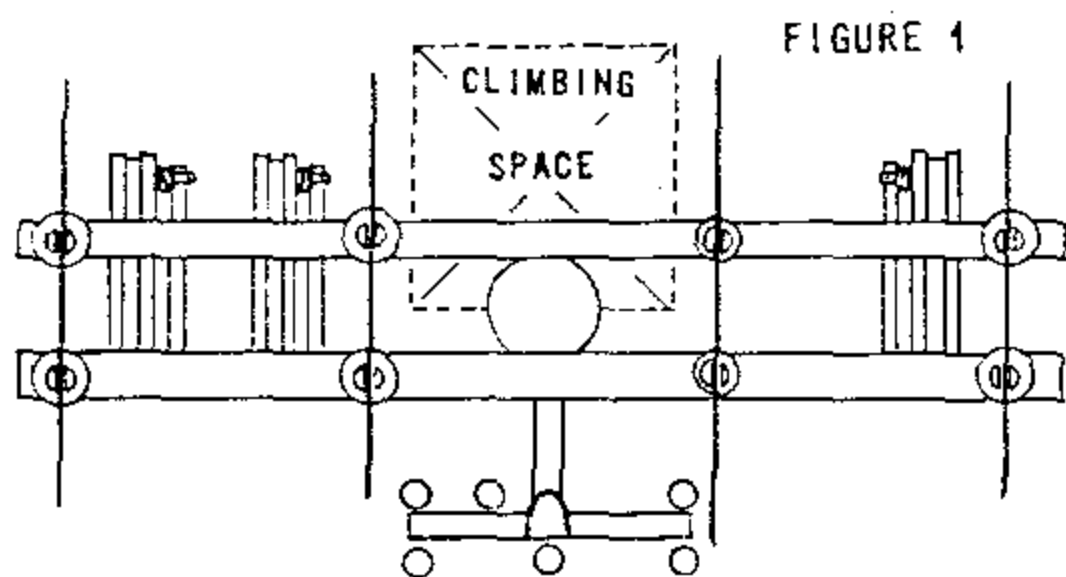

FIGURE 2
DEAD END CABLE POLE



NOTES:

- A. SEE PAGE 1406/4206 FOR G.O. 95 MINIMUM VERTICAL SEPARATION BETWEEN TOP OF RISER PROTECTION AND NEXT LOWER CONDUCTOR LEVEL.
- B. SEE PAGE 251 FOR ALLOWABLE CLIMBING SPACE OBSTRUCTIONS.
- C. USE TWO GROUND RODS SPACED A MINIMUM OF 6' APART.
- D. G.O. 95 DIMENSION.
- E. EXEMPT MATERIAL.
- F. INTERCONNECT TRIPLE TERMINAL BRACKET, LIGHTNING ARRESTER GROUND, CONCENTRIC NEUTRAL, AND OVERHEAD NEUTRAL.
- G. REDUCE QUANTITIES AS REQUIRED WHEN NOT USING NEUTRAL.
- H. THIS CONSTRUCTION TO BE USED WITH 350 KCMIL AND LARGER UNDERGROUND CABLE.
- I. INTERCONNECT SWITCH AND DEAD END BONDS PER G.O. 95 RULE 52.7 D
- J. ARRESTER AND CABLE TERMINAL POSITIONS MAY BE INTERCHANGED AT THE DISCRETION OF DISTRICT OPERATIONS PERSONNEL.

FOR FIELD MAINTENANCE ONLY

ITEM	DESCRIPTION	QUANTITY		STOCK NO. OR CONSTR STDS
		FIG 1	FIG 2	
1	CROSSARM, 3 3/4" X 5 3/4" X 12' - 0"	2	2	300 SECTION
2	BRACE, ANGLE, CROSSARM, 5'	2	2	164128
3	BRACKET, GALV, TERMINAL UPSWEEP, WITH PVC LINER, COMPLETE	1	1	166856
4	BRACKET, TRIPLE TERMINAL	1	1	166676
5	BOLT, MACH, GALV, 5/8" X (LENGTH AS REQ'D), 1 SQ WASH., 1 DBL COIL WASH. (E)	1	1	100 SECTION
6	BOLT, MACH, GALV, 5/8" X (LENGTH AS REQ'D), 2-SQ WASH., 1 DBL COIL WASH. (E)	1	1	100 SECTION
P 7	BOLT, MACH, GALV, 1/2" X 7", 1 RD WASH., 1 DBL COIL WASH. (E)	4	4	100 SECTION
T 8	BOLT, MACH, GALV, 5/8" X (LENGTH AS REQ'D), 1 LOCK WASH. (G) (E)	1	1	100 SECTION
F 9	COVER, BOLT, PLASTIC, & 6-100 NAILS (E)	1	1	285696
10	SCREW, LAG, GALV, 4" (E)	2	2	621568
11	PIN INSULATOR STRAIGHT 12KV (AS REQ'D BY ITEM 21) (G)	8	3	532704, 532448
12	STEPS, POLE (E)	16	16	692992
13	SIGN, HIGH VOLTAGE, & 8 ROOFING NAILS	3	3	647648, 492224
14	BOLT, SPACE, GALV, 5/8" X (LENGTH AS REQ'D) 4-SQ WASH., 2 DBL COIL WASH. (G) (E)	2	4	100 SECTION
15	BOLT, MACH, GALV, 1/2" X 8", 1 RD WASH., 1 DBL COIL WASH. (E)	12	12	100 SECTION
16	PIN, TRANSFORMER ADAPTER, 1" LEAD THREAD (G)	1	1	529248
17	INSULATOR, SUSPENSION, 12KV, CLEVIS (G)	-	7	700 SECTION
D 18	CLEVIS, DEAD END, 5/8" BOLT STEEL (G) (E)	-	4	235712
C 19	CLAMP, STRAIGHT LINE, D.E. (G)	-	4	700 SECTION
D 20	INSULATOR, LINE, 12KV	6	3	700 SECTION
21	INSULATOR, 12KV, NEUTRAL (G) (E)	3	1	429216
22				
23	BOLT MACH, GALV, 1/2" X 3" 1-LOCK WASH. (E)	12	12	100 SECTION
24	BRACKET, DISCONNECT ANGLE MOUNTING, 1/4" X 3" MILD STEEL	6	6	166542
25	SWITCH, HOOKSTICK DISCONNECT, 14.4KV, 400 A, 600 A.	3	3	1200 SECTION
26	TERMINAL, COMPRESSION	6	6	700 SECTION
27	CONNECTOR WIRE COMPRESSION (SIZE AS REQ'D) (E)	13	9	700 SECTION
28	WIRE, COPPER W.P., SIZE PER UG CABLE AMPACITY	15'	15'	700 SECTION
29	WIRE, BARE STRANDED COPPER, SIZE PER UG CABLE AMPACITY	22'	31'	700 SECTION
30				
U 31	WIRE, #6, BARE STRANDED COPPER	40'	40'	813536
C 32	STAPLES, FENCE, GALV, 1 1/4" (E)	40	40	678528
D 33				
34				
35	UNIT GROUND, COMPLETE (WITH GRAY MLOG, WITH PLAIN MLOG) (C)	1	1	603120, 603136
36	WIRE, #8, BARE SOLID ANNEALED COPPER	1 LB	1 LB	812928
37	ARRESTER, LIGHTNING	3	3	1200 SECTION
38	TERMINALS UG CABLE	3	3	SEE UG STDS
39	CABLE PRIMARY	AS REQ'D	SEE UG STDS	
40	RISER CONSTRUCTION	AS REQ'D	1400/4200 SECTION	

OH 1499.306
 UG 4299.306
 SUPERSEDES
 4233.2 (3-9-83)

SDG&E ELECTRIC STANDARDS

12.47KV AND BELOW CABLE POLE, UPSWEEP BRACKET, 3Ø,
 1/C PER PHASE, LINE ARM MOUNTED DISCONNECTS

DATE 3-9-83
 APPD *[Signature]*

SCOPE: THIS STANDARD SHOWS DEADEND CONSTRUCTION FOR 12.47KV AND BELOW, 3 PHASE CABLE POLE WITH CROSSARM MOUNTED TERMINALS FOR #2/0 AND SMALLER U.G. CABLE. THIS CONSTRUCTION IS TO BE USED IN CONTAMINATION DISTRICT 1 ONLY.

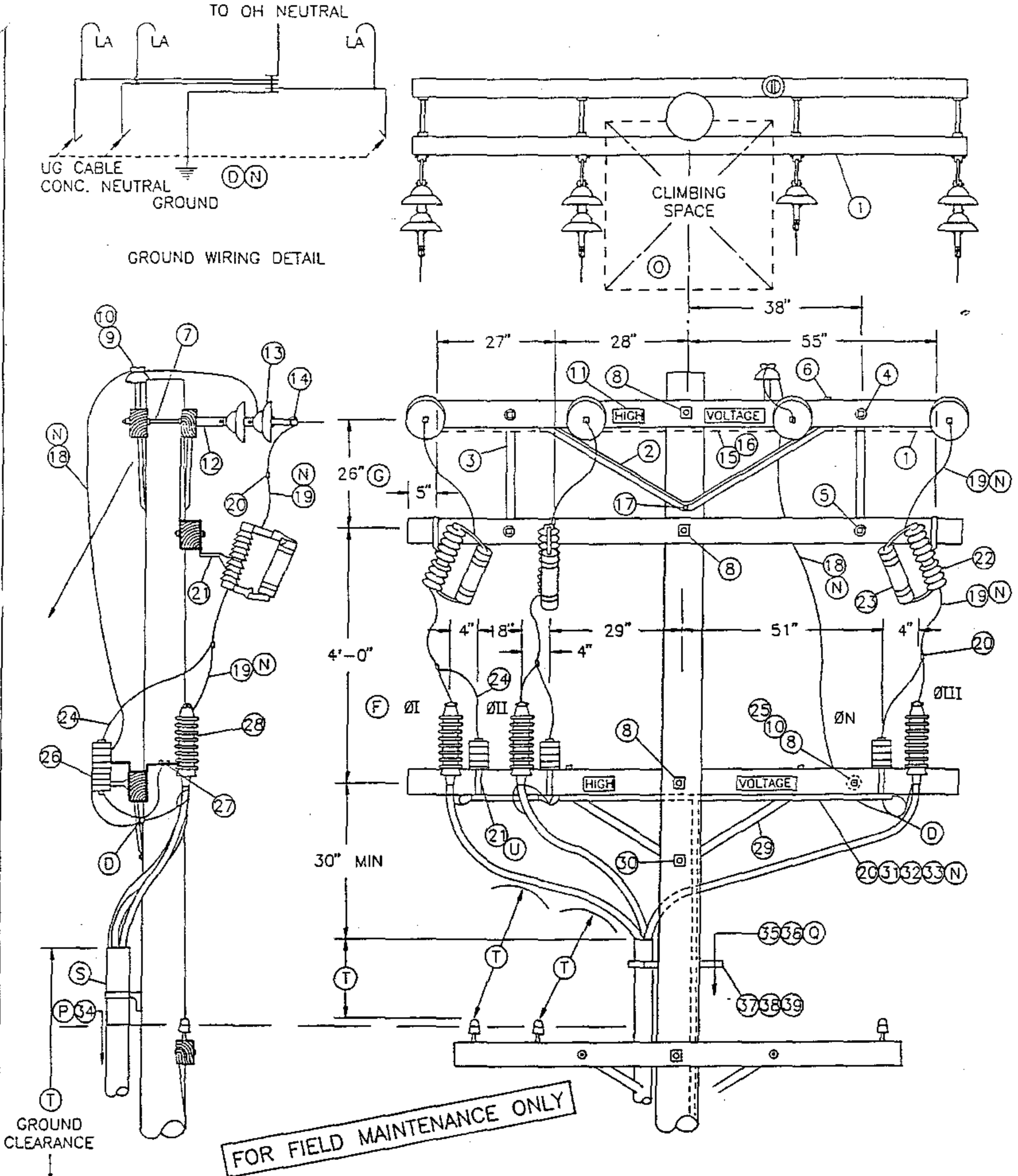

DATE 1-1-93
 APPD *JLB/ROJ*

SDG&E ELECTRIC STANDARDS
 CROSSARM CABLE POLE, 3Ø, 1/C PER PHASE
 DEADEND CONSTRUCTION, 12.47KV AND BELOW

OH 1499.307
~~UG 4299.307~~
 SUPERCEDES
 1439.1 (1-1-93)

BILL OF MATERIAL:

ITEM	DESCRIPTION	QUANTITY	CONST STD OR PAGE NO	STOCK NUMBER
1	CROSSARM, 3-3/4" X 5-3/4" X 10' - 0"	4	-	294128
2	BRACE, ANGLE, CROSSARM, 5' - 0"	2	-	164128
3	BRACE, FLAT, CROSSARM, 28"	2	-	164192
4	BOLT, WASHERHEAD, GALV, 3/8" X 4-1/2", 1 ROUND & 1 SPRING WASHER	2	392	-
5	BOLT, MACH, GALV, 1/2-1 X 5", 1 ROUND & 1 DOUBLE COIL, SPRING WASHER	2	392	-
6	BOLT, MACH, GALV, 1/2" X 7", 1 ROUND & 1 DOUBLE COIL SPRING WASHER	6	392	-
7	BOLT, SPACE, GALV, 5/8" X (LENGTH AS REQ'D), 2 ROUND, 4 SQUARE & 2 DOUBLE COIL SPRING WASHERS	4	392	-
8	BOLT, MACH, GALV, 5/8" X (LENGTH AS REQ'D), 2 SQUARE & 1 DOUBLE COIL SPRING WASHER	4	392	-
9	PIN, INSULATOR, STRAIGHT, 12KV, 1"	1	-	532704
10	INSULATOR, LINE, 12KV NEUTRAL	2	-	429216
11	SIGN, HIGH VOLTAGE & 9 ROOFING NAILS, GALV	4	-	647648
12	CLEVIS, DEAD END, 5/8" BOLT STEEL	4	-	235712
13	INSULATOR, SUSPENSION, 12KV, CLEVIS	7	750	-
14	CLAMP, STRAIGHT LINE, D.E.	4	741	-
15	WIRE, #8, BARE SOLID ANNEALED COPPER	10'	-	812928
16	STAPLES, FENCE, GALV, 1-1/4"	AS REQ'D	-	678528
17	BOLT, MACH, GALV, 5/3" X (LENGTH AS REQ'D) & 1 DOUBLE COIL SPRING WASHER	1	392	-
18	WIRE, COPPER, BARE STRANDED OR ACSR/AW BARE (OH NEUTRAL JUMPER)	10'	711-715	-
19	WIRE, COPPER, BARE STRANDED (OH JUMPERS)	18'	715	-
20	CONNECTOR, WIRE, COMPRESSION (SIZE AS REQ'D)	AS REQ'D	783-787	-
21	BRACKET, CUTOUT/ARRESTER, FOR CROSSARM MOUNTING	6	-	166070
22	CUTOUT, FOR CURRENT-LIMITING FUSE	3	1212	-
23	FUSE, CURRENT-LIMITING (SIZE AS SPECIFIED ON WORK ORDER)	3	1207	-
24	WIRE, BARE STRANDED COPPER, #6	14'	-	813536
25	PIN, TRANSFORMER ADAPTER, 1" LEAD THREAD	1	-	529248
26	ARRESTER, LIGHTNING	3	1247	-
27	BRACKET, CROSSARM, TERM (FOR #2 & #2/0 AL CABLE ONLY)	3	-	166060
28	TERMINALS, UNDERGROUND CABLE	3	4111	-
29	BRACE, ANGLE, CROSSARM, 4' - 0"	1	-	164032
30	BOLT, MACH, GALV, 5/8" X (LENGTH AS REQ'D), 1 SQUARE & 1 DOUBLE COIL SPRING WASHER	1	392	-
31	WIRE, BARE STRANDED COPPER (UNDER POTHEAD ARM) (CABLE POLE NEUTRAL)	10'	715	-
32	CONDUIT, PVC TYPE 2, SCHEDULE 40, 1"	10'	-	251200
33	STRAPS, PIPE, GALV, 1" & 2 - 6D NAILS, GALV	AS REQ'D	-	697792
34	RISER CONSTRUCTION	AS REQ'D	1400/4200	-
35	WIRE, #4, BARE STRANDED COPPER	45'	-	813760
36	UNIT GROUND, COMPLETE	1	-	603136
37	BRACKET, LADDER ARM	AS REQ'D	1404/4204	167184
38	NUT, CLAMPING CHANNEL, W/SPRING, 1/2"	AS REQ'D	1404/4204	503488
39	CHANNEL, DOUBLE GALV, 24"	AS REQ'D	1404/4204	216700

FOR FIELD MAINTENANCE ONLY

CABLE SIZE	UG MACRO UNIT	
	PORCELAIN W/LADDER ARMS	W/O LADDER ARMS
3C #2/0 AL	CP2/0L	CP#2/0
3C-3#2 AL	CP3#2L	CP-3#2

OH 1499.308
~~UG 4299.308~~
 SUPERCEDES
 1439.2 (1-1-93)

SDG&E ELECTRIC STANDARDS

CROSSARM CABLE POLE, 3Ø, 1/c PER PHASE
 DEADEND CONSTRUCTION, 12.47KV AND BELOW

DATE 1-1-93
 APPD *JLB/BJ*

INSTALLATION:

- A. NEW CABLE POLES SHALL HAVE A STANDARD DEPTH OF 9'. IN MOST CASES THIS WILL REQUIRE A 5' TALLER POLE.
- B. REDUCE QUANTITIES AS REQUIRED WHEN NOT USING NEUTRAL.
- C. USE THIS CONSTRUCTION FOR 2/0 AND SMALLER UNDERGROUND CABLE.
- D. INTERCONNECT OVERHEAD NEUTRAL, TERMINAL BASE, AND CONCENTRIC CABLE NEUTRAL CONDUCTOR TO LIGHTNING ARRESTER GROUND.
- E. EXEMPT MATERIAL.
- F. OMIT Ø II AND Ø N FOR SINGLE Ø 12KV CABLE POLE, OMIT Ø I AND Ø II FOR SINGLE Ø 6.9KV CABLE POLE.

(N)

UG CABLE SIZE AWG OR KCMIL, AL	OH JUMPER COND SIZE, AWG OR KCMIL, CU	OH NEUT JUMPER SIZE			CABLE POLE NEUT SIZE (CU) UNDER POTHEAD ARM OR TRIPLE TERM BRKT
		CU	AL		
2	4	6	2	-	#6 PER PHASE
2/0	4	6	2	-	#6 PER PHASE
350	4/0	1/0	3/0	-	#2 PER PHASE
750	500	4/0	336.4	OR SAME SIZE AS O.H. NEUT CONDUCTOR	1/0 PER PHASE
1000	500	4/0	336.4		1/0 PER PHASE

REFERENCE:

- O. ALLOWABLE WORKING AND CLIMBING SPACE - SEE STD. 251.
- P. POLE STEPPING - SEE STD. 363/4205.
- Q. GROUNDING METHODS - SEE PAGE 1002.5.
- R. SEE STANDARD SECTION 1200/4300 FOR FUSING.
- S. RISER POSITIONS - SEE STANDARD 1402/4202.
- T. MINIMUM VERTICAL SEPARATION AS PER G.O. 95 - SEE STD. 1406/4206.
- U. SEE STANDARD 1407/4207 FOR PORCELAIN TERMINAL MOUNTING BRACKET INSTRUCTIONS AND MATERIALS.

FOR FIELD MAINTENANCE ONLY

DATE 1-1-93 APPD <i>JLB/BJG</i>	SDG&E ELECTRIC STANDARDS CROSSARM CABLE POLE, 3Ø, 1/C PER PHASE DEADEND CONSTRUCTION, 12.47KV AND BELOW	OH 1499.309 UG 4299.309 SUPERCEDES 1439.3 (1-1-93)
------------------------------------	-------------------------------------------------------------------------------------------------------------------	------------------------------------------------------------------------

SCOPE: THIS STANDARD SHOWS THREE-PHASE CABLE POLE CONSTRUCTION USING NON-PORCELAIN TERMINALS FOR 350 KCMIL AND LARGER UG CABLE. (H)

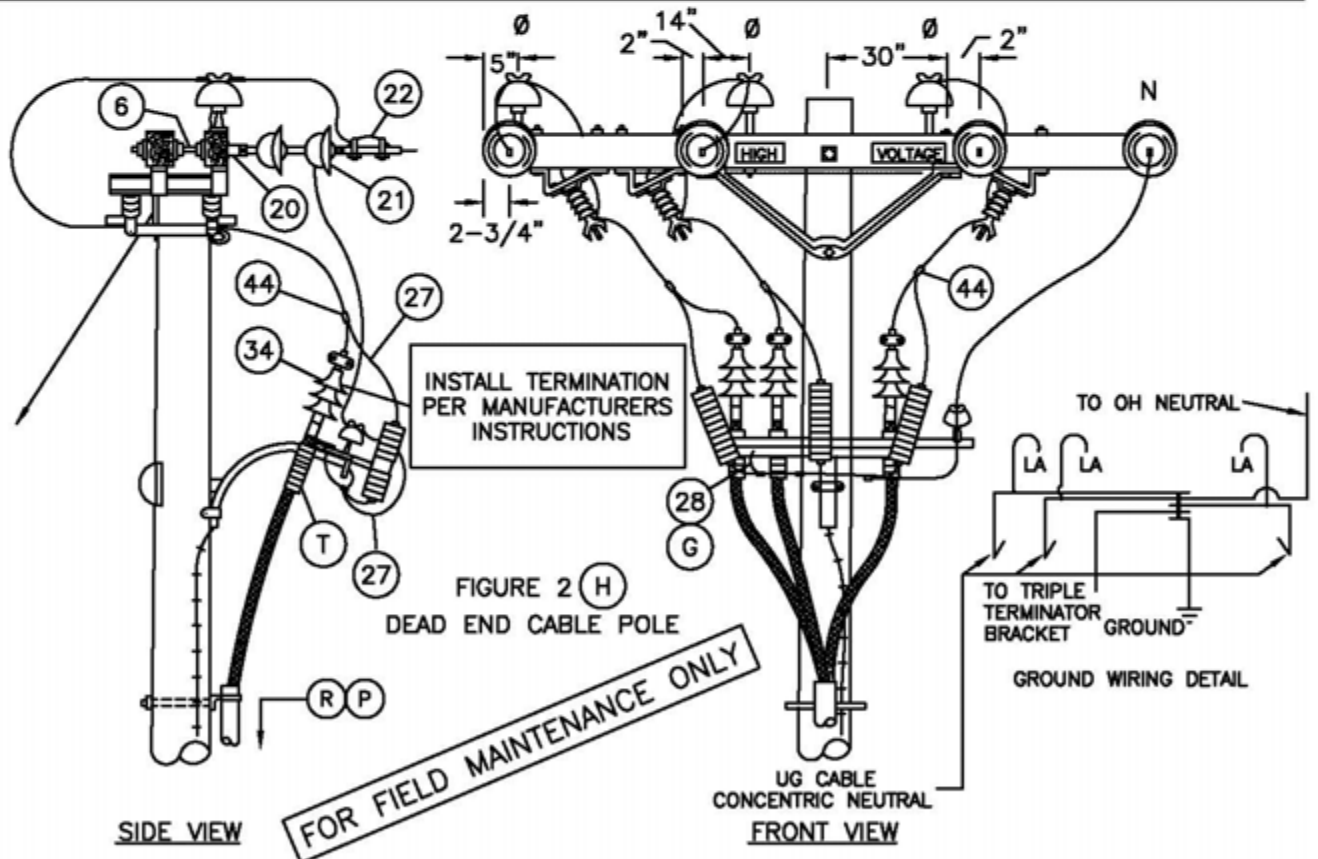
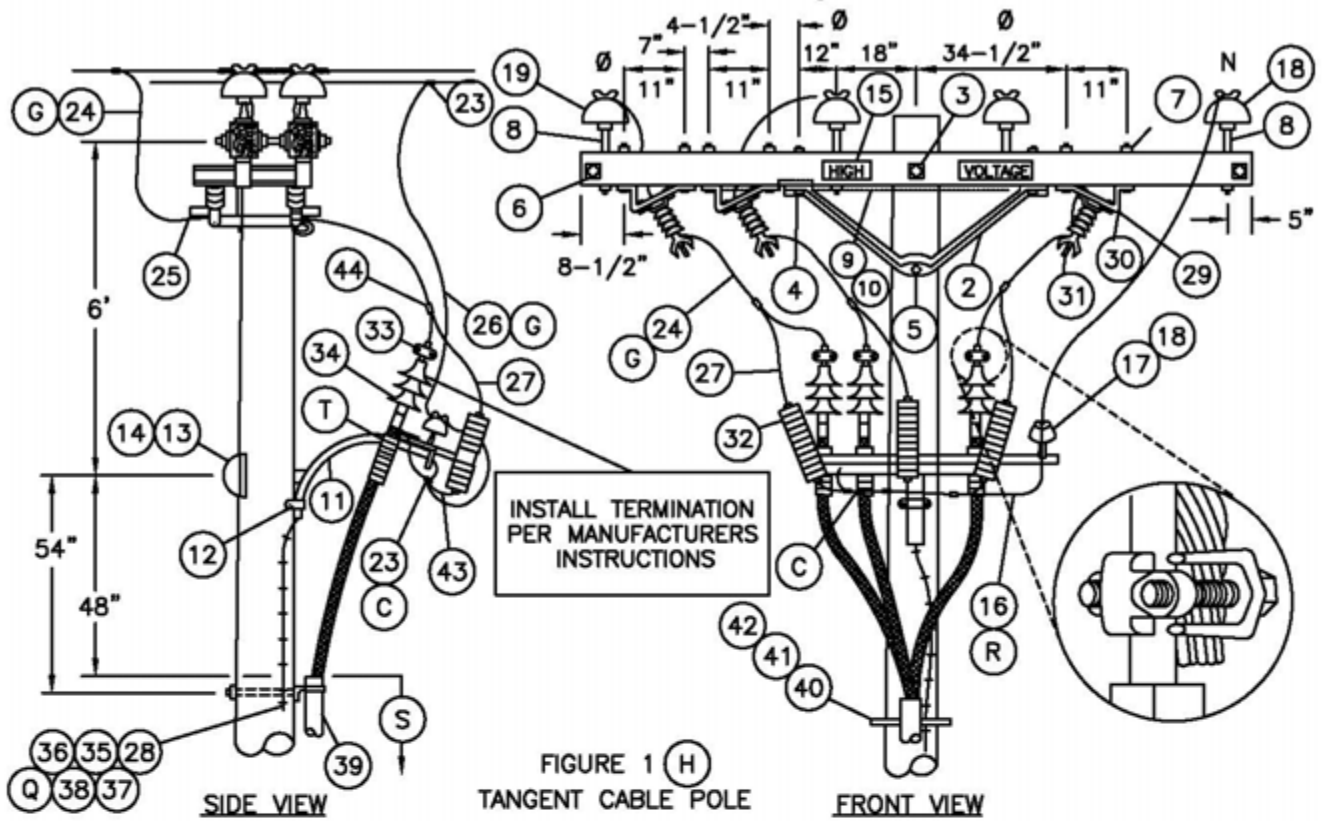

© 1998 - 2010 San Diego Gas & Electric Company. All rights reserved. Removal of this copyright notice without permission is not permitted under law.

DATE 10-20-05
APPD PJA/JJ

SDG&E ELECTRIC STANDARDS

12.47KV AND BELOW CABLE POLE, UPSWEEP BRACKET,
THREE-PHASE 1/C PER PHASE, LINE ARM MOUNTED
DISCONNECTS, NON-PORCELAIN TERMINALS

OH 1499.310
UG 4299.310
SUPERSEDES
1432.1 (10-20-05)

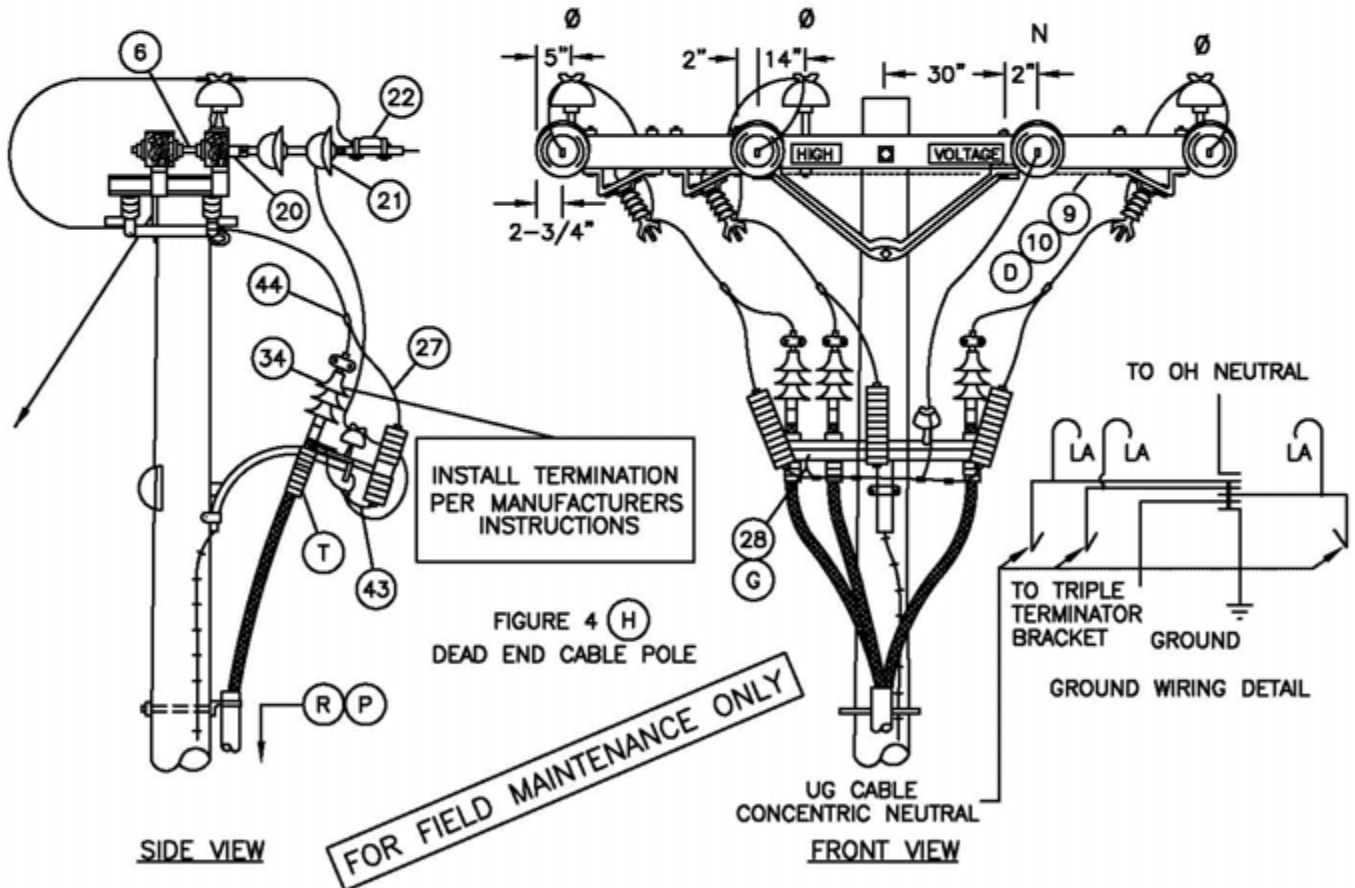
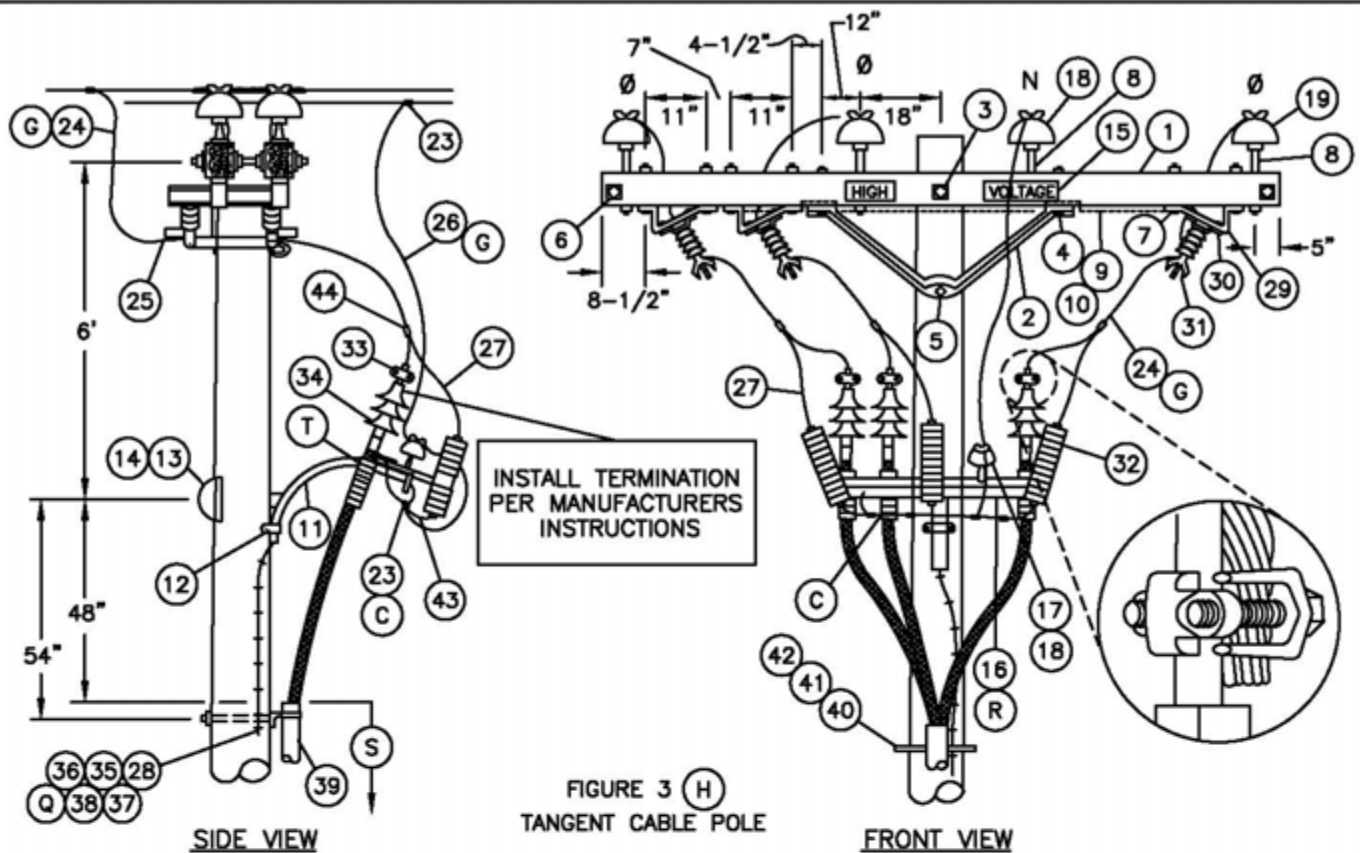

©1998 - 2005 San Diego Gas & Electric Company. All rights reserved. Removal of this copyright notice without permission is not permitted under law.

DATE 10-20-05 APPD PJA/JJ	SDG&E ELECTRIC STANDARDS 12.47KV AND BELOW CABLE POLE, UPSWEEP BRACKET, THREE-PHASE 1/C PER PHASE, LINE ARM MOUNTED DISCONNECTS, NON-PORCELAIN TERMINALS	OH 1499.311 UG 4299.311 SUPERSEDES 1432.2 (10-20-05)
------------------------------	------------------------------------------------------------------------------------------------------------------------------------------------------------------------------	---------------------------------------------------------------

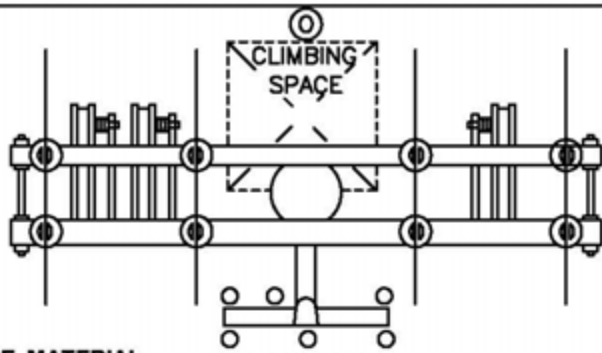

FIGURE 1

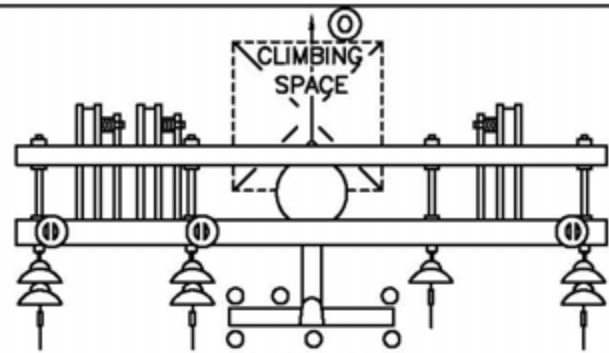

FIGURE 2

BILL OF MATERIAL:

ITEM	DESCRIPTION	QUANTITY		CONSTR STANDARD	STOCK NUMBER
		FIG 1	FIG 2		
1	CROSSARM, 3-3/4" X 5-3/4" X 12'-0" (F)	2	2		294160
2	BRACE, ANGLE, CROSSARM, 5'	2	2	-	164128
3	BOLT, MACH., GALV, 5/8" X (LENGTH AS REQ'D), 2 SQUARE AND 1 DOUBLE COIL SPRING WASHERS	1	1	392	-
4	BOLT, MACH, GALV, 1/2" X 7", 1 RD, 1 DBL COIL SPR WASH	4	4	392	-
5	BOLT, MACH, GALV, 5/8" X (LENGTH AS REQ'D), AND 1 DOUBLE COIL SPRING WASHER	1	1	392	-
6	BOLT, SPACE, GALV, 5/8" X (LENGTH AS REQ'D), 4 SQUARE, 2 ROUND AND 2 DOUBLE COIL SPRING WASHERS (E)	2	4	392	-
7	BOLT, MACH, GALV, 1/2" X 8", 1 ROUND AND 1 DOUBLE COIL SPRING WASHER	12	12	392	-
8	PIN, INSULATOR, STRAIGHT, 12KV, 1" OR 1-3/8" (E)	8	3	-	532704
		8	3	-	532448
9	WIRE, #8, BARE SOLID ANNEALED COPPER	15'	15'	-	812928
10	STAPLES, FENCE, GALV, 1-1/4"	AS REQ'D		-	678528
11	BRACKET, GALV, TERMINAL UPSWEEP (Q)	1	1	-	166856
12	SCREW, LAG, GALV, 4"	2	2	-	621568
13	BOLT, MACH, GALV, 5/8" X (LENGTH AS REQ'D), 1 SQUARE AND 1 DOUBLE COIL SPRING WASHER	1	1	392	-
14	COVER, BOLT, PLASTIC, AND 6 - 10D NAILS, GALV	1	1	-	285696 491392
15	SIGN, HIGH VOLTAGE, AND 9 ROOFING NAILS, GALV	2	2	-	647648
					492224
16	BRACKET, TRIPLE TERMINATOR	1	1	-	166676
17	PIN, SHORT SHANK, 1" LEAD THREAD (E)	1	1	-	532426
18	INSULATOR, 12KV, NEUTRAL (E)	3	1	-	429216
19	INSULATOR, LINE, 12KV, 1" OR 1-3/8" PIN	6	3	750	-
20	CLEVIS, DEAD END, 5/8" BOLT, STEEL (E)	-	4	-	235712
21	INSULATOR, SUSPENSION, 12KV, CLEVIS (E)	-	7	750	-
22	CLAMP, STRAIGHT LINE, D.E. (E)	-	4	741	-

FOR FIELD MAINTENANCE ONLY

OH 1499.312
UG 4299.312
SUPERSEDES
1432.2 (1-1-98)

SDG&E ELECTRIC STANDARDS
12.47KV AND BELOW CABLE POLE, UPSWEEP BRACKET,
THREE-PHASE 1/C PER PHASE, LINE ARM MOUNTED
DISCONNECTS, NON-PORCELAIN TERMINALS

DATE 1-1-98
APPD PJA / CMK

BILL OF MATERIAL: (CONT'D)

ITEM	DESCRIPTION	QUANTITY		CONSTR STANDARD	STOCK NUMBER	ASSEMBLY UNIT
		FIG 1	FIG 2			
23	CONNECTOR, WIRE COMPRESSION, (SIZE AS REQ'D)	AS REQ'D		783-786	-	-
24	WIRE, BARE STRANDED COPPER, (OH JUMPER) (G)	21'	30'	715	-	-
25	TERMINAL, COMPRESSION (SIZE AS REQ'D)	6	6	794-795	-	-
26	WIRE, BARE STRANDED COPPER, (OH NEUT JUMPER) (G)	9'	9'	715	-	-
27	WIRE, #6, BARE STRANDED COPPER	12'	12'	-	813536	-
28	#4 CU SOLID GROUND WIRE, PVC COVERED	50'	50'	-	812490	GNDPVC
29	BRACKET, DISCONNECT, ANGLE MOUNTING	6	6	-	166542	-
30	BOLT, MACH. GALV. 3/8" X 3", 2 RD WASH & 1 LOCK WASH	6	6	392	-	-
31	SWITCH, HOOKSTICK DISCONNECT, 14.4KV, 600 A OR 1200 A	3	3	1222	-	-
32	ARRESTER, LIGHTNING	3	3	1247	-	-
33	CONNECTOR, TWO BOLT, BRONZE (SIZE AS REQ'D)	3	3	4111	-	-
34	TERMINALS, UNDERGROUND CABLE (T)	3	3	4111	-	-
35	GROUND ROD, 5/8" X 8', COPPERWELD	1	1	-	603072	GNDPVC
36	COPPER BONDED GROUND CONNECTOR	1	1	-	259010	-
37	GROUND ENHANCING POWER SOLUTION (GEM)	AS REQ'D		-	424390	-
38	GALVANIZED STAPLES FOR PVC COVERED GROUND WIRE	AS REQ'D		-	678562	-
39	RISER CONSTRUCTION	AS REQ'D		1400/4200	-	-
40	BRACKET, LADDER ARM	AS REQ'D		1404/4204	167184	-
41	NUT, CLAMPING CHANNEL, W/SPRING, 1/2"	AS REQ'D		1404/4204	503488	-
42	CHANNEL, DOUBLE GALV., 24"	AS REQ'D		1404/4204	216700	-
43	FLEXIBLE ARRESTER GROUND STRAP	AS REQ'D		-	698754	-
44	HOT LINE CLAMP	3	3	788	227680	-

FOR FIELD MAINTENANCE ONLY

OVERHEAD MACRO UNIT
3NS-B

INSTALLATION:

- A. NEW CABLE POLES SHALL HAVE A STANDARD DEPTH OF 9'. IN MOST CASES, THIS WILL REQUIRE A 5' TALLER POLE.
- B. THIS CONSTRUCTION TO BE USED WITH 350 KCMIL AND LARGER UNDERGROUND CABLE.
- (C) INTERCONNECT OVERHEAD NEUTRAL, TRIPLE TERMINAL BRACKET AND CONCENTRIC CABLE NEUTRAL TO LIGHTNING ARRESTER GROUND.
- (D) INTERCONNECT SWITCH AND DEAD END BONDS PER G.O. 95 RULE 52.7 D.
- (E) REDUCE QUANTITIES AS REQUIRED WHEN NOT USING NEUTRAL.
- (F) WHEN ADDING THIS CONSTRUCTION TO AN EXISTING POLE WITH A 10' LINE ARM, AND SUFFICIENT POLE HEIGHT EXISTS, INSTALL 10' SWITCH ARMS AND ASSOCIATED HARDWARE BELOW THE LINE ARM TO AVOID CHANGING LINE ARM FROM 10' TO 12' (SEE O.H. STANDARD 1222. FIG. 1-B).

DATE 10-20-05 APPD PJA/JJ	SDG&E ELECTRIC STANDARDS	OH 1499.313 UG 4299.313 SUPERSEDES 1432.4 (10-20-05)
	12.47KV AND BELOW CABLE POLE, UPSWEEP BRACKET, THREE-PHASE 1/C PER PHASE, LINE ARM MOUNTED DISCONNECTS, NON-PORCELAIN TERMINALS	

INSTALLATION: (CON'T)

UG CABLE SIZE AWG OR KCMIL, AL	OH JUMPER COND SIZE, AWG OR KCMIL, CU	OH NEUT JUMPER SIZE			CABLE POLE NEUT SIZE (CU) UNDER POTHEAD ARM OR TRIPLE TERM BRKT
		CU	AL		
350	4/0	1/0	3/0	-	#2 PER PHASE
750	500	4/0	336.4	OR SAME SIZE AS O.H. NEUT CONDUCTOR	1/0 PER PHASE
1000	500	4/0	336.4		1/0 PER PHASE

BECAUSE THE PROPER SIZE CONNECTOR IS NOT ALWAYS AVAILABLE, THE JUMPER FROM THE OVERHEAD LINE CONDUCTOR TO THE HOOKSTICK SWITCH CAN BE THE SAME SIZE AS, OR LARGER THAN THAT OF THE OVERHEAD CONDUCTOR.

- (H) - USE FIGURE ONE AND TWO FOR ALL **NEW** CONSTRUCTION AND WHEN ADDING TO EXISTING CONSTRUCTION WITH NEUTRAL ON OUTSIDE PIN POSITION. SEE DESIGN MANUAL PAGE 5124.2.
- USE FIGURE THREE AND FOUR ON EXISTING CONSTRUCTION WITH NEUTRAL ON INSIDE PIN POSITION.

REFERENCE:

- (O) ALLOWABLE WORKING AND CLIMBING SPACE - SEE STD. 251
- (P) POLE STEPPING - SEE STD. 363.
- (Q) GROUNDING METHODS - SEE PAGE 1002.5.
- (R) RISER POSITIONS - SEE STANDARD 1402/4202.
- (S) MINIMUM VERTICAL SEPARATION AS PER G.O. 95 SEE STD. 1406/4206.
- (T) SEE STANDARD 1407/4207 FOR NON PORCELAIN TERMINAL MOUNTING INSTRUCTIONS AND MATERIALS.

FOR FIELD MAINTENANCE ONLY

OH 1499.314
UG 4299.314
SUPERSEDES
1432.5 (10-20-05)

SDG&E ELECTRIC STANDARDS

12.47KV AND BELOW CABLE POLE, UPSWEEP BRACKET,
THREE-PHASE 1/C PER PHASE, LINE ARM MOUNTED
DISCONNECTS, NON-PORCELAIN TERMINALS

DATE 9-20-05
APPD PJA/JJ

SCOPE: THIS STANDARD SHOWS CABLE POLE CONSTRUCTION USING PORCELAIN TERMINATIONS FOR 750 AND LARGER UNDERGROUND CABLE. (SEE STANDARD 1407/4207 FOR 350 KCMIL TERMINAL MOUNTING INFORMATION).

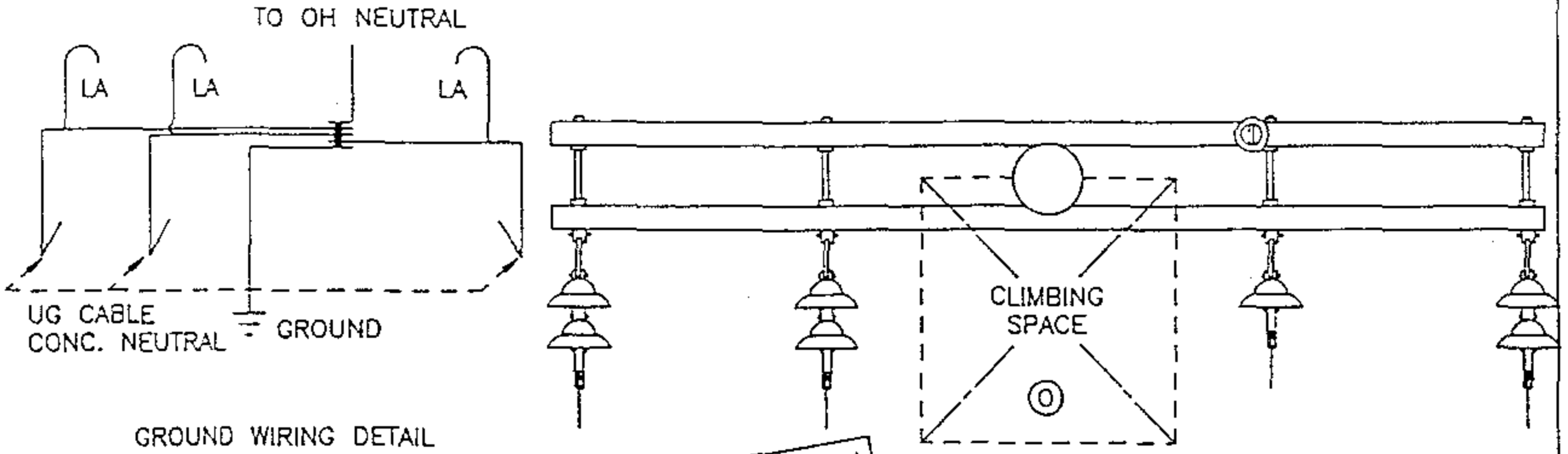

FOR FIELD MAINTENANCE ONLY

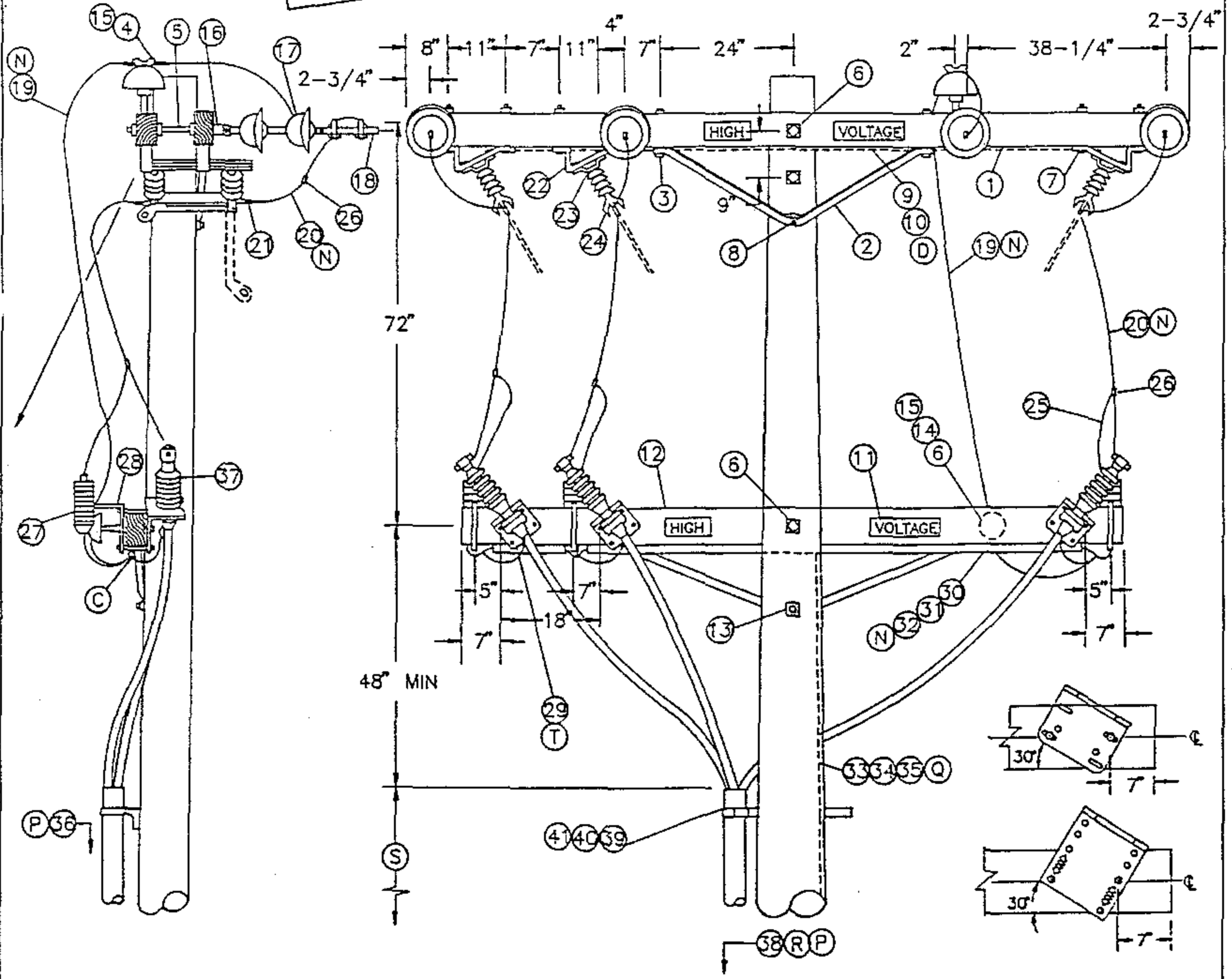

<p>DATE 1-1-93 APPD <i>JLB/BJ</i></p>	<p>SDG&E ELECTRIC STANDARDS</p> <p>12.47 KV AND BELOW DEAD END CABLE POLE ARM, 3Ø, 1/C PER Ø, HOOKSTICK SWITCHED</p>	<p>OH 1499.401 UG 4299.401 SUPERCEDES 1441.1 (1-1-93)</p>
-------------------------------------------	--------------------------------------------------------------------------------------------------------------------------	-----------------------------------------------------------------------

BILL OF MATERIAL:

ITEM	DESCRIPTION	QUANTITY	CONSTR STANDARD	STOCK NUMBER
1	CROSSARM, 3-3/4" X 5-3/4" X 12'-0" (G)	2	-	294160
2	BRACE, ANGLE, CROSSARM, 4'-0"	3	-	164032
3	BOLT, MACH, GALV, 1/2" X 7", 1 ROUND AND 1 DOUBLE COIL SPRING WASHER (E)	6	392	-
4	PIN, INSULATOR, STRAIGHT, 12KV, 1" LEAD THREAD (F)(E)	1	-	532704
5	BOLT, SPACE, GALV, 5/8" X (LENGTH AS REQ'D), 3 SQUARE, 2 ROUND AND 2 DOUBLE COIL SPRING WASHERS (F)(E)	4	392	-
6	BOLT, MACH, GALV, 5/8" X (LENGTH AS REQ'D), 2 SQUARE AND 1 DOUBLE COIL SPRING WASHERS (F)(E)	3	392	-
7	BOLT, MACH, GALV, 1/2" X 8", 1 ROUND AND 1 DOUBLE COIL SPRING WASHER (E)	12	392	-
8	BOLT, MACH, GALV, 5/8" X (LENGTH AS REQ'D) AND 1 DOUBLE COIL SPRING WASHER (E)	1	392	-
9	WIRE, #8, BARE SOLID ANNEALED COPPER	15'	-	812928
10	STAPLES, FENCE, GALV, 1-1/4" (E)	AS REQ'D	-	678528
11	SIGN, HIGH VOLTAGE AND 9 ROOFING NAILS, GALV (E)	4	-	647648 492224
12	CROSSARM, 3-3/4" X 5-3/4" X 10'-0"	1	-	294128
13	BOLT, MACH, GALV, 5/8" X (LENGTH AS REQ'D), 1 SQUARE AND 1 DOUBLE COIL SPRING WASHER (E)	1	392	-
14	PIN, TRANSFORMER LEAD ADAPTER, 1" (F)(E)	1	-	529248
15	INSULATOR, 12KV, NEUTRAL (F)(E)	2	-	429216
16	CLEVIS, DEAD END, 5/8" BOLT STEEL (F)(E)	4	-	235712
17	INSULATOR, SUSPENSION, 12KV, CLEVIS (F)	7	750	-
18	CLAMP, STRAIGHT LINE, D.E. (F)	4	741	-
19	WIRE, BARE STRANDED CU OR AL (OH NEUT JUMPER) (N)(F)	12'	711-715	-
20	WIRE, BARE STRANDED COPPER (OH JUMPER) (N)	25'	715	-
21	TERMINAL, COMPRESSION (E)	6	794-795	-
22	BRACKET, DISCONNECT, ANGLE MOUNTING	6	-	166542
23	BOLT, MACH, GALV, 3/8" X 3", 2 ROUND & 1 LOCK WASHER (E)	6	392	-
24	SWITCH, HOOKSTICK DISCONNECT, 14.4KV, 600 A OR 1200 A	3	1222	-
25	WIRE, #6, BARE STRANDED COPPER	12'	-	813536
26	CONNECTOR, WIRE, COMPRESSION (SIZE AS REQ'D) (E)	AS REQ'D	783-787	-
27	ARRESTER, LIGHTNING (N)	3	-	113248
28	BRACKET, CUTOUT/ARRESTER (E)	3	-	166070
29	BRACKET, TERMINAL MOUNTING	3	-	166674
30	CONDUIT, PVC TYPE 2, SCHEDULE 40, 1" (E)	10'	-	251200
31	STRAPS, PIPE, GALV, 1" AND 2 - 6D NAILS, GALV (E)	AS REQ'D	-	697792 491552
32	WIRE, BARE STRANDED COPPER (CP NEUT-UNDER POTHEAD ARM) (N)	15'	715	-
33	WIRE, #4, BARE STRANDED COPPER	45'	-	813760
34	STAPLES, FENCE, GALV, 1-1/4" (E)	AS REQ'D	-	678528
35	UNIT GROUND, COMPLETE (Q)	1	-	603136
36	TAGS, SWITCH NUMBER (E)	2	-	720704
37	TERMINALS, UNDERGROUND CABLE	3	4111	-
38	RISER CONSTRUCTION	AS REQ'D	1400/4200	-
39	BRACKET, LADDER ARM (E)	AS REQ'D	1404/4204	167184
40	NUT, CLAMPING CHANNEL, W/SPRING, 1/2" (E)	AS REQ'D	1404/4204	503488
41	CHANNEL, DOUBLE GALV, 24" (E)	AS REQ'D	1404/4204	216700

FOR FIELD MAINTENANCE ONLY

CABLE SIZE	UG MACRO UNIT
	W/LADDER ARMS
3C-#350	CP350L
3C-#750	CP750L
3C-#1000	CP-1KL

OH 1499.402
~~UG 4299.402~~
 SUPERCEDES
 1441.2 (1-1-93)

SDG&E ELECTRIC STANDARDS

12.47KV AND BELOW DEAD END CABLE POLE
 ARM, 3Φ, 1/C PER Φ, HOTSTICK SWITCHED

DATE 1-1-93
 APPD *JLB/BJ*

INSTALLATION:

- A. NEW CABLE POLES SHALL HAVE A STANDARD SETTING DEPTH OF 9'. IN MOST CASES THIS WILL REQUIRE A 5' TALLER POLE.
- B. THIS CONSTRUCTION TO BE USED WITH 350 KCMIL AND LARGER UNDERGROUND CABLE.
- C. INTERCONNECT OVERHEAD NEUTRAL, TERMINAL BASE, AND CONCENTRIC CABLE NEUTRAL CONDUCTOR TO LIGHTNING ARRESTER GROUND.
- D. INTERCONNECT SWITCH AND DEADEND BONDS PER G.O. 95 RULE 52.7D. BONDING SHOULD BE DONE IN ACCORDANCE WITH RULE 53.4.
- E. EXEMPT MATERIAL.
- F. REDUCE QUANTITIES AS REQUIRED WHEN NOT USING NEUTRAL.
- G. WHEN ADDING THIS CONSTRUCTION TO AN EXISTING POLE WITH A 10' LINE ARM, AND SUFFICIENT POLE HEIGHT EXISTS, INSTALL 10' SWITCH ARMS AND ASSOCIATED HARDWARE BELOW THE LINE ARM TO AVOID CHANGING LINE ARM FROM 10' TO 12' (SEE O.H. STANDARD 1222, FIG. 1-B).

(N)

UG CABLE SIZE AWG OR KCMIL, AL	OH JUMPER COND SIZE, AWG OR KCMIL, CU	OH NEUT JUMPER SIZE			CABLE POLE NEUT SIZE (CU) UNDER POTHEAD ARM OR TRIPLE TERM BRKT
		CU	AL		
2	4	6	2	--	#6 PER PHASE
2/0	4	6	2	--	#6 PER PHASE
350	4/0	1/0	3/0	--	#2 PER PHASE
750	500	4/0	336.4	OR SAME SIZE AS O.H. NEUT CONDUCTOR	1/0 PER PHASE
1000	500	4/0	336.4		1/0 PER PHASE

REFERENCE:

- O. ALLOWABLE WORKING AND CLIMBING SPACE - SEE STANDARD 251.
- P. POLE STEPPING - SEE STANDARD 363.
- Q. GROUNDING METHODS - SEE STANDARD 1002.
- R. RISER POSITIONS - SEE STANDARD 1402/4202.
- S. MINIMUM VERTICAL SEPARATION AS PER G.O. 95 - SEE STANDARD 1406/4206.
- T. SEE STANDARD 1407/4207 FOR PORCELAIN AND NON PORCELAIN TERMINAL MOUNTING BRACKET INSTRUCTIONS AND MATERIALS.

FOR FIELD MAINTENANCE ONLY

DATE 1-1-93 APPD <i>JLB/ROJ</i>	SDG&E ELECTRIC STANDARDS	OH 1499.403
	12.47KV AND BELOW DEAD END CABLE POLE ARM, 3Ø, 1/C PER Ø, HOOKSTICK SWITCHED	UG 4299.403 SUPERCEDES 1441.3 (1-1-93)

SCOPE: THIS STANDARD SHOWS A DEADEND CONSTRUCTION FOR 12.47 KV AND BELOW, THREE-PHASE CABLE POLE USING NON-PORCELAIN TERMINALS WITH A MEMCO GANG OPERATED SWITCH FOR 350 KCMIL AND LARGER U.G. CABLE.

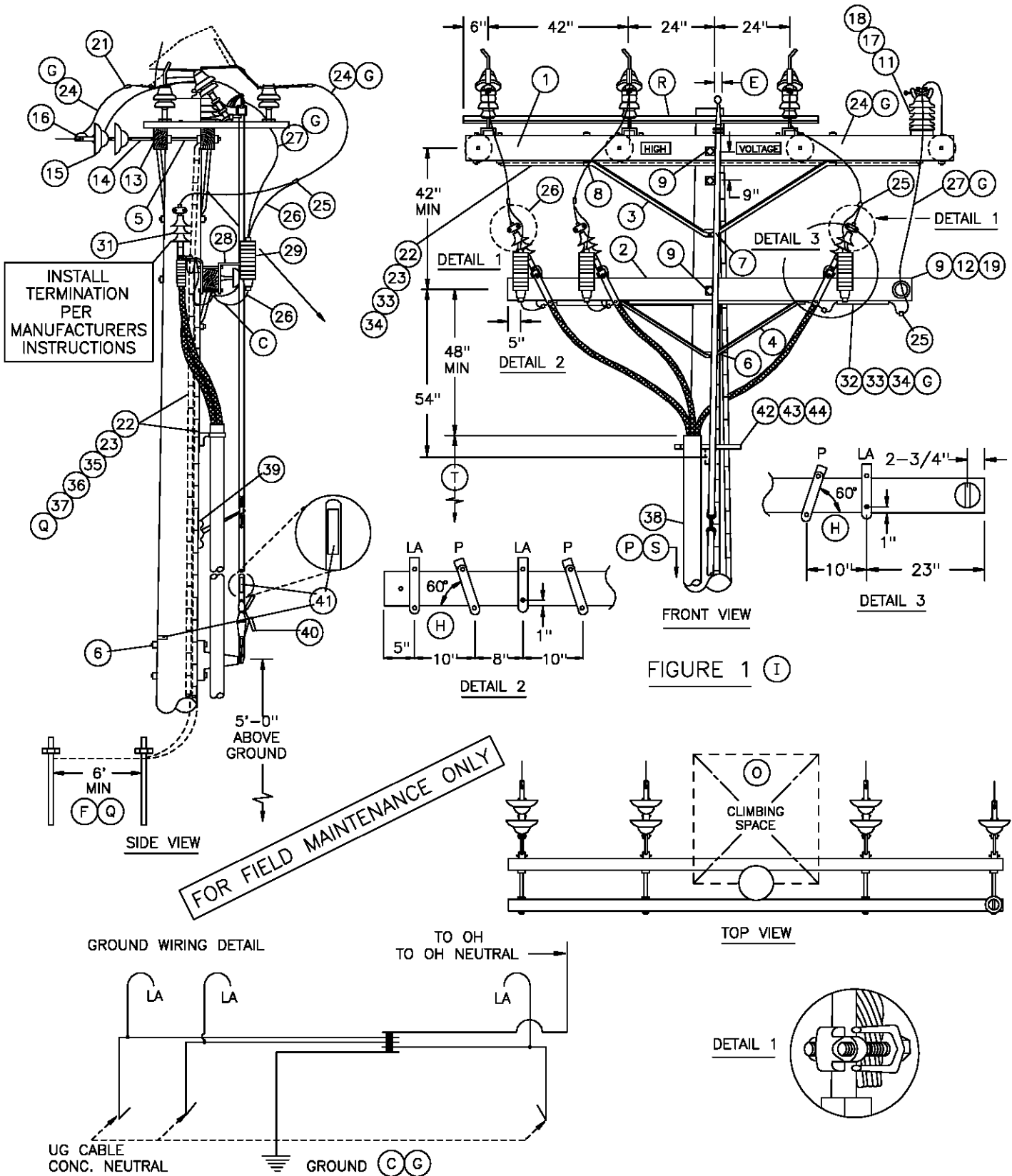

FIGURE 1 (I)

<p>OH 1499.404 UG 4299.404 SUPERSEDES 1443.1 (9-1-00)</p>	<p>SDG&E ELECTRIC STANDARDS 12.47KV AND BELOW DEAD END CABLE POLE THREE-PHASE, 1/C PER PHASE, GANG OPERATED SWITCHED, NON-PORCELAIN TERMINALS</p>	<p>DATE 1-1-96 APPD PJA / CMK</p>
--------------------------------------------------------------------------------------------------	----------------------------------------------------------------------------------------------------------------------------------------------------------------------------------------------	------------------------------------------------

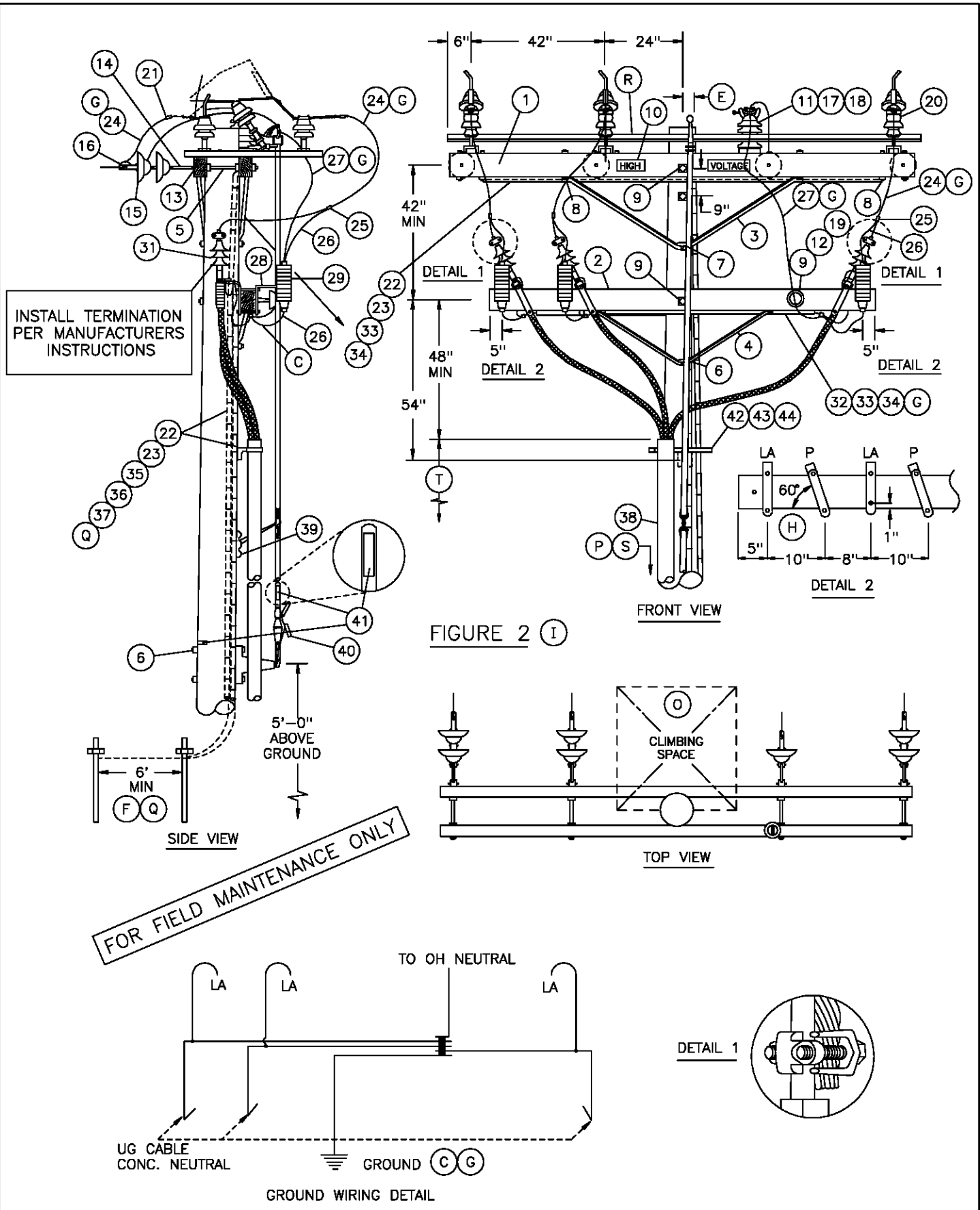

FIGURE 2 (I)

DATE 1-1-96
 APPD PJA/CLK

SDG&E ELECTRIC STANDARDS
 12.47KV AND BELOW DEAD END CABLE POLE THREE-PHASE,
 1/C PER PHASE, GANG OPERATED SWITCHED,
 NON-PORCELAIN TERMINALS

OH 1499.405
 UG 4299.405
 SUPERSEDES
 1443.2 (9-1-00)

BILL OF MATERIAL:

ITEM	DESCRIPTION	QUANTITY	CONST STD OR PAGE NO	STOCK NUMBER
1	CROSSARM, 3-3/4" X 5-3/4" X 12'-0"	2	380.2	-
2	CROSSARM, 3-3/4" X 5-3/4" X 10'-0"	1	380.2	-
3	BRACE, 6', ANGLE, GALV	2	-	164160
4	BRACE, 4', ANGLE, GALV	1	-	164032
5	BOLT, SPACE, GALV, 5/8" X (LENGTH AS REQ'D), 3 SQ WASH & 2 DBL COIL SPRING WASH (D)	4	392.1 &.2	-
6	BOLT, MACH, GALV, 5/8" X (LENGTH AS REQ'D), 1 SQ WASH & 1 DBL COIL SPRING WASH	3	392.1 &.2	-
7	BOLT, MACH, GALV, 5/8" X (LENGTH AS REQ'D) & 1 DBL COIL SPRING WASH	1	392.1 &.2	-
8	BOLT, MACH, GALV, 1/2" X 7", 1 RD WASH & 1 DBL COIL SPRING WASH	18	392.1 &.2	-
9	BOLT, MACH, GALV, 5/8" X (LENGTH AS REQ'D), 2 SQ WASH & 1 DBL COIL SPRING WASH	3	392.1 &.2	-
10	SIGN, HIGH VOLTAGE & 9 ROOFING NAILS, GALV	2	-	647648 492224
11	STUD, 7-1/2" X 5/8" & 1 DBL COIL SPRING WASH (D)	1	-	701760 798560
12	PIN, TRANSFORMER ADAPTER, 1", LEAD THREAD (D)	1	-	529248
13	CLEVIS, DEAD END, 5/8", BOLT STEEL (OPEN TYPE) (D)	4	-	235618
14	LINK, EXTENSION, 1/2" X 2" X 12" (D)	4	-	466240
15	INSULATOR, SUSPENSION, 12KV, CLEVIS (D)	7	750.3	-
16	CLAMP, STRAIGHT LINE, D.E. (D)	4	741-743	-
17	INSULATOR, VERTICAL POST (D)	1	-	428608
18	CLAMP, POST INSULATOR (D)	1	-	227824
19	INSULATOR, LINE, 12KV NEUTRAL (D)	1	-	429216
20	SWITCH, TPST TILTING INSULATOR, 600 AMP	1	-	709254
21	TERMINAL, COMPRESSION	6	794-795	-
22	WIRE, #4, BARE STRANDED, COPPER	110'	-	813760
23	STAPLES, FENCE, GALV, 1-1/4"	AS REQ'D	-	678528
24	WIRE, BARE STRANDED COPPER (OH JUMPERS) (D)	20'	715	-
25	CONNECTOR, WIRE, COMPRESSION (SIZE AS REQ'D)	AS REQ'D	783-787	-
26	WIRE, #6, BARE STRANDED COPPER	12'	-	813536
27	WIRE, BARE STRANDED CU OR ACSR/AW BARE (OH NEUT JUMPER) (D)(G)	10'	711-715	-

FOR FIELD MAINTENANCE ONLY

OVERHEAD MACRO UNIT
3NGMXP

UG MACRO UNIT	
CABLE SIZE	ON LADDER ARMS
3C-#350	NP350L
3C-#750C	NP750L
3C-#1000	N1000L

OH 1499.406
~~UG 4299.406~~
 SUPERSEDES
 1443.3 (9-1-00)

SDG&E ELECTRIC STANDARDS

12.4KV AND BELOW DEAD END CABLE POLE THREE-PHASE,
 1/C PER PHASE, GANG OPERATED SWITCHED,
 NON-PORCELAIN TERMINALS

DATE 1-1-98

APPD *PA/CAC*

BILL OF MATERIAL: (CONTINUED)

ITEM	DESCRIPTION	QUANTITY	CONSTR STANDARD	STOCK NUMBER
28	BRACKET, CUTOUT/ARRESTER, FOR CROSSARM MOUNTING	3	-	166070
29	ARRESTER, LIGHTNING	3	1247	-
30				
31	TERMINALS & UNDERGROUND CABLE (U)	3	4111	-
32	WIRE, BARE STRANDED COPPER (UNDER POTHEAD ARM) (G)	20'	715	-
33	CONDUIT, PVC, TYPE 2, SCHEDULE 40, 1-1/2"	21'	-	251232
34	STRAPS, PIPE, GALV, 1-1/2" & 6-D NAILS	AS REQ'D	-	697664 491552
35	MOULDING, OAK HARDWOOD, 1" X 8' LONG	11'	-	487200
36	STAPLES, MOULDING, GALV, 3" X 1-1/16" X 1/4"	AS REQ'D	-	678560
37	ROD & CLAMP, GROUND	2 2	-	230016 603072
38	RISER CONSTRUCTION	AS REQ'D	1400/4200	-
39	SCREW, LAG, 1/2" X 4"	2	-	621568
40	PADLOCK, MEDECO	1	-	514862
41	TAGS, SWITCH NUMBER	2	204/3104	-
42	BRACKET, LADDER ARM	AS REQ'D	1404/4204	167184
43	NUT, CLAMPING CHANNEL, W/SPRING, 1/2"	AS REQ'D	1404/4204	503488
44	CHANNEL, DOUBLE GALV, 24"	AS REQ'D	1404/4204	216700

FOR FIELD MAINTENANCE ONLY

INSTALLATION:

- A. NEW CABLE POLES SHALL HAVE A STANDARD SETTING DEPTH OF 9'. IN MOST CASES, THIS WILL REQUIRE A 5' TALLER POLE.
- B. THIS CONSTRUCTION TO BE USED WITH 350 KCMIL AND LARGER UNDERGROUND CABLE.
- (C) INTERCONNECT OVERHEAD NEUTRAL, TERMINAL BASE, AND CONCENTRIC CABLE NEUTRAL CONDUCTOR TO LIGHTNING ARRESTER GROUND.
- (D) REDUCE QUANTITIES AS REQUIRED WHEN NOT USING NEUTRAL.
- (E) OFFSET AS REQUIRED TO CLEAR ANCHOR GUY.
- (F) SWITCH GROUND AND LIGHTNING ARRESTER GROUND TO BE CONNECTED ON THE SAME GROUND ROD.

(G)

UG CABLE SIZE AWG OR KCMIL, AL	OH JUMPER COND SIZE, AWG OR KCMIL, CU	OH NEUT JUMPER SIZE			CABLE POLE NEUT SIZE (CU) UNDER POTHEAD ARM OR TRIPLE TERM BRKT
		CU	AL		
350	4/0	1/0	3/0	-	#2 PER PHASE
750	500	4/0	336.4	OR SAME SIZE AS O.H. NEUT CONDUCTOR	1/0 PER PHASE
1000	500	4/0	336.4		1/0 PER PHASE

- (H) TURN TOP OF BRACKET OUTWARD TO OBTAIN APPROX. 60° ANGLE.

	Indicates Latest Revision	Completely Revised	New Page	Information Removed
DATE 1-1-93 APPD <i>JLB/ROJ</i>	SDG&E ELECTRIC STANDARDS 12.4KV AND BELOW DEAD END CABLE POLE THREE-PHASE, 1/C PER PHASE, GANG OPERATED SWITCHED, NON-PORCELAIN TERMINALS			OH 1499.407 UG 4299.407 SUPERSEDES 1443.4 (9-1-00)

INSTALLATION: (CON'T)

- ① - USE FIGURE ONE FOR ALL **NEW** CONSTRUCTION AND WHEN ADDING TO EXISTING CONSTRUCTION WITH NEUTRAL ON OUTSIDE PIN POSITION.
- USE FIGURE TWO ON EXISTING CONSTRUCTION WITH NEUTRAL ON INSIDE PIN POSITION.

REFERENCE:

- ⓐ ALLOWABLE WORKING AND CLIMBING SPACE - SEE STD. 251.
- ⓑ POLE STEPPING - SEE STD. 363.
- ⓒ GROUNDING METHODS - SEE PAGE 1002.5.
- ⓓ GANG OPERATED SWITCH MOUNTING INSTRUCTIONS - SEE STD. SECTION 1200.
- ⓔ RISER POSITION - SEE STANDARD 1402/4202.
- ⓕ MINIMUM VERTICAL SEPARATION AS PER G.O. 95 - SEE STD. 1406/4206.
- ⓖ SEE STANDARD 1407/4207 FOR NON-PORCELAIN TERMINAL MOUNTING BRACKET INSTRUCTIONS AND MATERIALS.

FOR FIELD MAINTENANCE ONLY

	Indicates Latest Revision	Completely Revised	New Page	Information Removed
OH 1499.408 UC 4299.408 SUPERSEDES 1443.5 (9-1-00)	SDG&E ELECTRIC STANDARDS			DATE 1-1-93 APPD <i>JLB/ROJ</i>
	12.4KV AND BELOW DEAD END CABLE POLE THREE-PHASE, 1/C PER PHASE, GANG OPERATED SWITCHED, NON-PORCELAIN TERMINALS			

SCOPE: THIS STANDARD SHOWS A DEADEND CONSTRUCTION FOR 12.47 KV AND BELOW, THREE-PHASE CABLE POLE USING NON-PORCELAIN TERMINALS WITH A MEMCO GANG OPERATED SWITCH FOR 350 KCMIL AND LARGER U.G. CABLE.

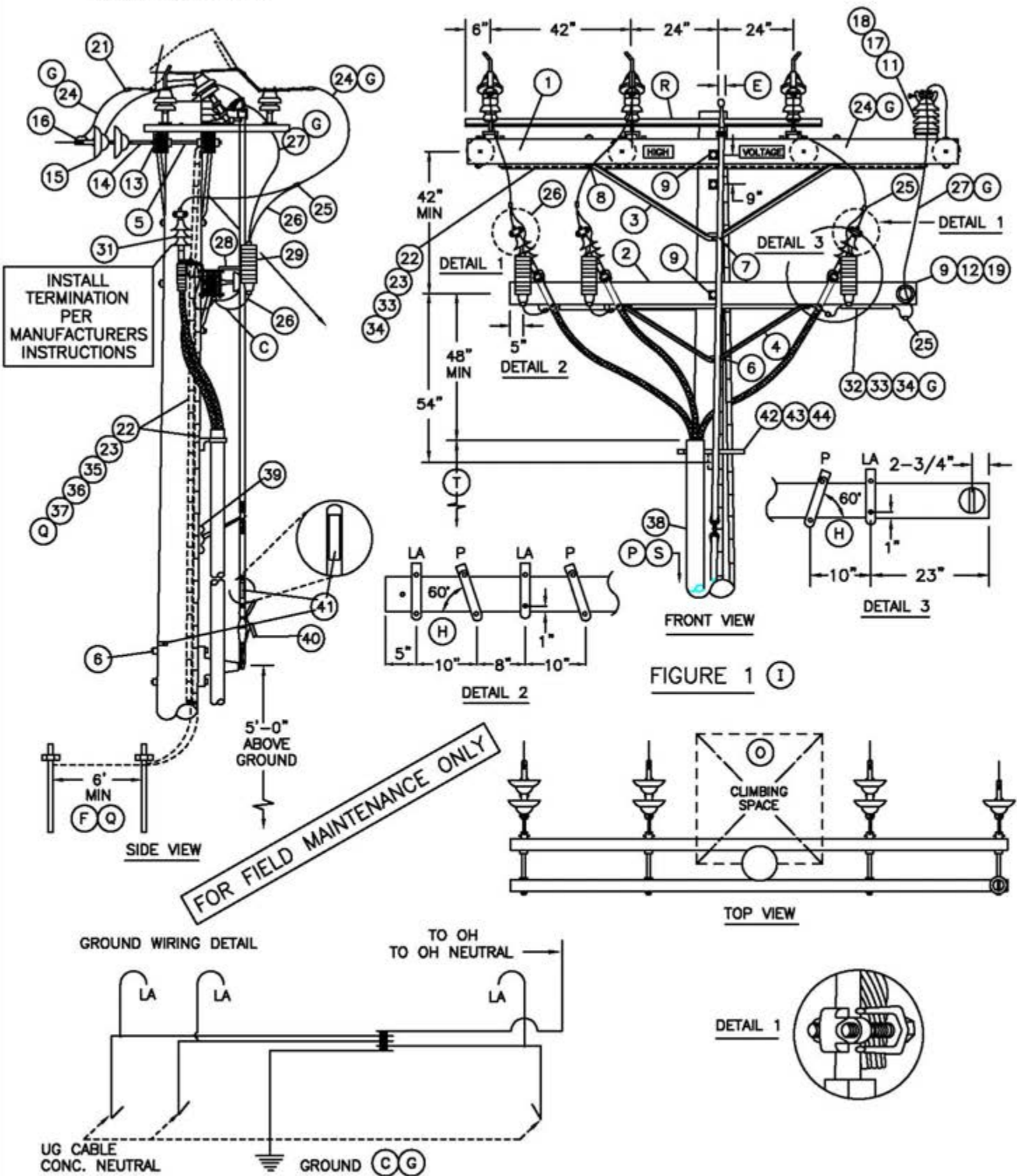

FOR FIELD MAINTENANCE ONLY

© 1998 - 2006 San Diego Gas & Electric Company. All rights reserved. Removal of this copyright notice without permission is not permitted under law.

DATE 1-1-96 APPD PJA/CJK	SDG&E ELECTRIC STANDARDS	OH 1499.409 UG 4299.404
	12.47KV AND BELOW DEAD END CABLE POLE THREE-PHASE, 1/C PER PHASE, GANG OPERATED SWITCHED, NON-PORCELAIN TERMINALS	

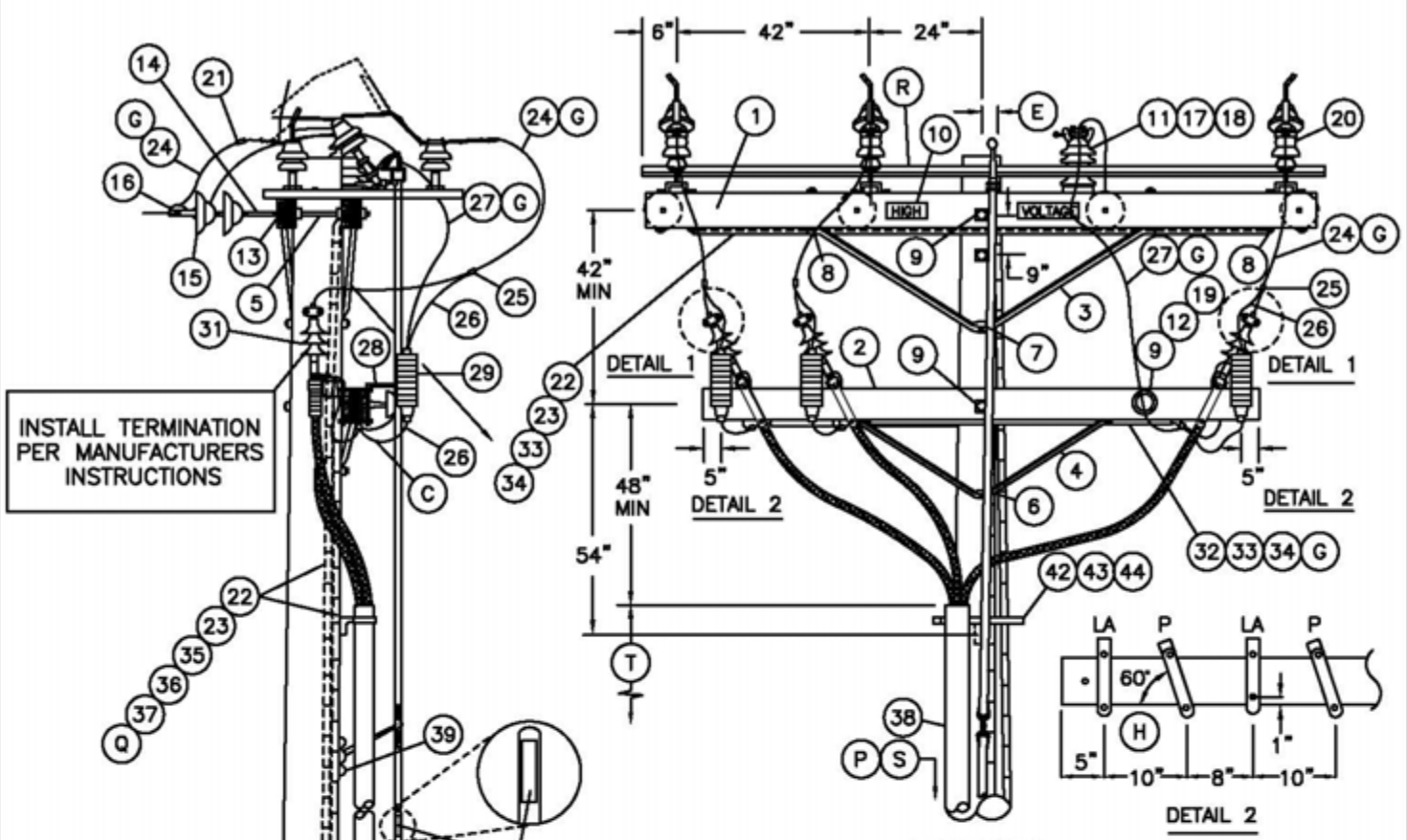
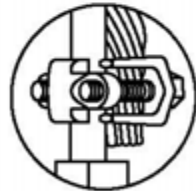
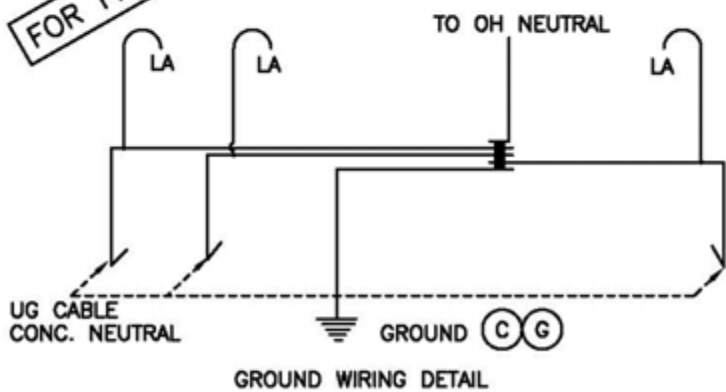

FIGURE 2 (I)

FOR FIELD MAINTENANCE ONLY



© 1998 - 2006 San Diego Gas & Electric Company. All rights reserved. Removal of this copyright notice without permission is not permitted under law.

OH 1499.410
UG 4299.405

SDG&E ELECTRIC STANDARDS
12.47KV AND BELOW DEAD END CABLE POLE THREE-PHASE,
1/C PER PHASE, GANG OPERATED SWITCHED,
NON-PORCELAIN TERMINALS

DATE 1-1-96
APPD PJA / CMK

BILL OF MATERIAL:

ITEM	DESCRIPTION	QUANTITY	CONST STD OR PAGE NO	STOCK NUMBER
1	CROSSARM, 3-3/4" X 5-3/4" X 12'-0"	2	380.2	-
2	CROSSARM, 3-3/4" X 5-3/4" X 10'-0"	1	380.2	-
3	BRACE, 6', ANGLE, GALV	2	-	164160
4	BRACE, 4', ANGLE, GALV	1	-	164032
5	BOLT, SPACE, GALV, 5/8" X (LENGTH AS REQ'D), 3 SQ WASH & 2 DBL COIL SPRING WASH	4	392.1 &.2	-
6	BOLT, MACH, GALV, 5/8" X (LENGTH AS REQ'D), 1 SQ WASH & 1 DBL COIL SPRING WASH	3	392.1 &.2	-
7	BOLT, MACH, GALV, 5/8" X (LENGTH AS REQ'D) & 1 DBL COIL SPRING WASH	1	392.1 &.2	-
8	BOLT, MACH, GALV, 1/2" X 7", 1 RD WASH & 1 DBL COIL SPRING WASH	18	392.1 &.2	-
9	BOLT, MACH, GALV, 5/8" X (LENGTH AS REQ'D), 2 SQ WASH & 1 DBL COIL SPRING WASH	3	392.1 &.2	-
10	SIGN, HIGH VOLTAGE & 9 ROOFING NAILS, GALV	2	-	647648 492224
11	STUD, 7-1/2" X 5/8" & 1 DBL COIL SPRING WASH	1	-	701760 798560
12	PIN, TRANSFORMER ADAPTER, 1", LEAD THREAD	1	-	529248
13	CLEVIS, DEAD END, 5/8", BOLT STEEL (OPEN TYPE)	4	-	235618
14	LINK, EXTENSION, 1/2" X 2" X 12"	4	-	466240
15	INSULATOR, SUSPENSION, 12KV, CLEVIS	7	750.3	-
16	CLAMP, STRAIGHT LINE, D.E.	4	741-743	-
17	INSULATOR, VERTICAL POST	1	-	428608
18	CLAMP, POST INSULATOR	1	-	227824
19	INSULATOR, LINE, 12KV NEUTRAL	1	-	429216
20	SWITCH, TPST TILTING INSULATOR, 600 AMP	1	-	709254
21	TERMINAL, COMPRESSION	6	794-795	-
22	WIRE, #4, BARE STRANDED, COPPER	110'	-	813760
23	STAPLES, FENCE, GALV, 1-1/4"	AS REQ'D	-	678528
24	WIRE, BARE STRANDED COPPER (OH JUMPERS)	20'	715	-
25	CONNECTOR, WIRE, COMPRESSION (SIZE AS REQ'D)	AS REQ'D	783-787	-
26	WIRE, #6, BARE STRANDED COPPER	12'	-	813536
27	WIRE, BARE STRANDED CU OR ACSR/AW BARE (OH NEUT JUMPER)	10'	711-715	-

FOR FIELD MAINTENANCE ONLY

OVERHEAD MACRO UNIT
3NGMXP

UG MACRO UNIT	
CABLE SIZE	ON LADDER ARMS
3C-#350	NP350L
3C-#750C	NP750L
3C-#1000	N1000L

© 1998 - 2006 San Diego Gas & Electric Company. All rights reserved. Removal of this copyright notice without permission is not permitted under law.

DATE 1-1-98 APPD PJA / CLK	SDG&E ELECTRIC STANDARDS 12.4KV AND BELOW DEAD END CABLE POLE THREE-PHASE, 1/C PER PHASE, GANG OPERATED SWITCHED, NON-PORCELAIN TERMINALS	OH 1499.411 UG 4299.406
-------------------------------	---------------------------------------------------------------------------------------------------------------------------------------------------------------	----------------------------

BILL OF MATERIAL: (CONTINUED)

ITEM	DESCRIPTION	QUANTITY	CONSTR STANDARD	STOCK NUMBER
28	BRACKET, CUTOUT/ARRESTER, FOR CROSSARM MOUNTING	3	-	166070
29	ARRESTER, LIGHTNING	3	1247	-
30				
31	TERMINALS & UNDERGROUND CABLE (U)	3	4111	-
32	WIRE, BARE STRANDED COPPER (UNDER POTHEAD ARM) (G)	20'	715	-
33	CONDUIT, PVC, TYPE 2, SCHEDULE 40, 1-1/2"	21'	-	251232
34	STRAPS, PIPE, GALV, 1-1/2" & 6-D NAILS	AS REQ'D	-	697664 491552
35	MOULDING, OAK HARDWOOD, 1" X 8' LONG	11'	-	487200
36	STAPLES, MOULDING, GALV, 3" X 1-1/16" X 1/4"	AS REQ'D	-	678560
37	ROD & CLAMP, GROUND	2 2	-	230016 603072
38	RISER CONSTRUCTION	AS REQ'D	1400/4200	-
39	SCREW, LAG, 1/2" X 4"	2	-	621568
40	PADLOCK, MEDECO	1	-	514862
41	TAGS, SWITCH NUMBER	2	204/3104	-
42	BRACKET, LADDER ARM	AS REQ'D	1404/4204	167184
43	NUT, CLAMPING CHANNEL, W/SPRING, 1/2"	AS REQ'D	1404/4204	503488
44	CHANNEL, DOUBLE GALV, 24"	AS REQ'D	1404/4204	216700

FOR FIELD MAINTENANCE ONLY

INSTALLATION:

- A. NEW CABLE POLES SHALL HAVE A STANDARD SETTING DEPTH OF 9'. IN MOST CASES, THIS WILL REQUIRE A 5' TALLER POLE.
- B. THIS CONSTRUCTION TO BE USED WITH 350 KCMIL AND LARGER UNDERGROUND CABLE.
- (C) INTERCONNECT OVERHEAD NEUTRAL, TERMINAL BASE, AND CONCENTRIC CABLE NEUTRAL CONDUCTOR TO LIGHTNING ARRESTER GROUND.
- (D) REDUCE QUANTITIES AS REQUIRED WHEN NOT USING NEUTRAL.
- (E) OFFSET AS REQUIRED TO CLEAR ANCHOR GUY.
- (F) SWITCH GROUND AND LIGHTNING ARRESTER GROUND TO BE CONNECTED ON THE SAME GROUND ROD.

(G)

UG CABLE SIZE AWG OR KCMIL, AL	OH JUMPER COND SIZE, AWG OR KCMIL, CU	OH NEUT JUMPER SIZE			CABLE POLE NEUT SIZE (CU) UNDER POTHEAD ARM OR TRIPLE TERM BRKT
		CU	AL		
350	4/0	1/0	3/0	-	#2 PER PHASE
750	500	4/0	336.4	OR SAME SIZE AS O.H. NEUT CONDUCTOR	1/0 PER PHASE
1000	500	4/0	336.4		1/0 PER PHASE

- (H) TURN TOP OF BRACKET OUTWARD TO OBTAIN APPROX. 60° ANGLE.

© 1998 - 2006 San Diego Gas & Electric Company. All rights reserved. Removal of this copyright notice without permission is not permitted under law.

OH 1499.412 UG 4299.407	SDG&E ELECTRIC STANDARDS 12.4KV AND BELOW DEAD END CABLE POLE THREE-PHASE, 1/C PER PHASE, GANG OPERATED SWITCHED, NON-PORCELAIN TERMINALS	DATE 1-1-93 APPD <i>JLB/BJ</i>
----------------------------	----------------------------------------------------------------------------------------------------------------------------------------------------	-----------------------------------

INSTALLATION: (CON'T)

- ① - USE FIGURE ONE FOR ALL **NEW** CONSTRUCTION AND WHEN ADDING TO EXISTING CONSTRUCTION WITH NEUTRAL ON OUTSIDE PIN POSITION.
- USE FIGURE TWO ON EXISTING CONSTRUCTION WITH NEUTRAL ON INSIDE PIN POSITION.

REFERENCE:

- ⓐ ALLOWABLE WORKING AND CLIMBING SPACE - SEE STD. 251.
- ⓑ POLE STEPPING - SEE STD. 363.
- ⓒ GROUNDING METHODS - SEE PAGE 1002.5.
- ⓓ GANG OPERATED SWITCH MOUNTING INSTRUCTIONS - SEE STD. SECTION 1200.
- ⓔ RISER POSITION - SEE STANDARD 1402/4202.
- ⓕ MINIMUM VERTICAL SEPARATION AS PER G.O. 95 - SEE STD. 1406/4206.
- ⓖ SEE STANDARD 1407/4207 FOR NON-PORCELAIN TERMINAL MOUNTING BRACKET INSTRUCTIONS AND MATERIALS.

FOR FIELD MAINTENANCE ONLY

© 1998 - 2006 San Diego Gas & Electric Company. All rights reserved. Removal of this copyright notice without permission is not permitted under law.

REVISION	SDG&E ELECTRIC STANDARDS	
DATE 1-1-93	12.4KV AND BELOW DEAD END CABLE POLE	OH 1499.413
APPD <i>JLB/RJG</i>	THREE-PHASE, 1/C PER PHASE,	UG 4299.408
	GANG OPERATED SWITCHED, NON-PORCELAIN TERMINALS	

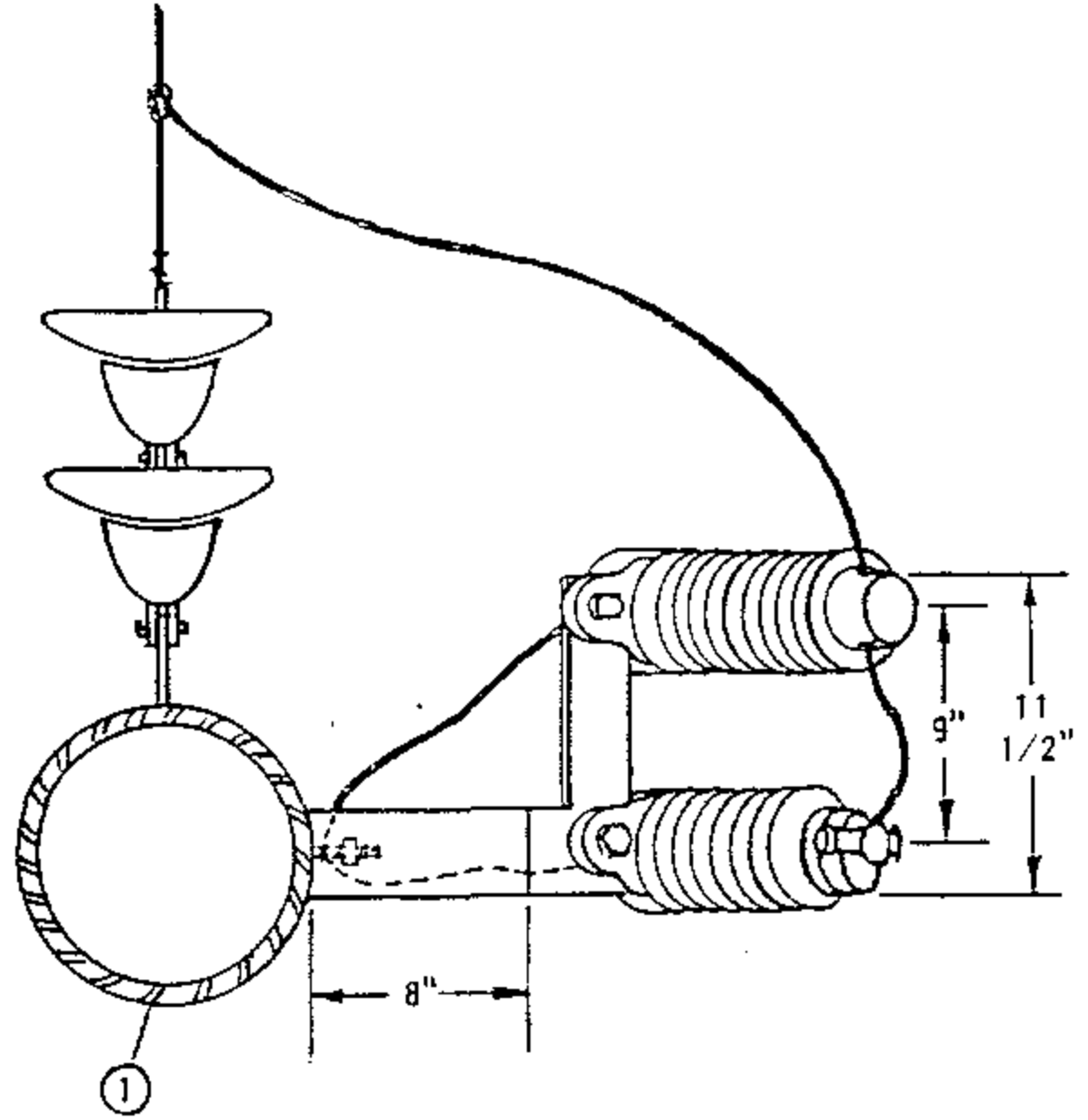
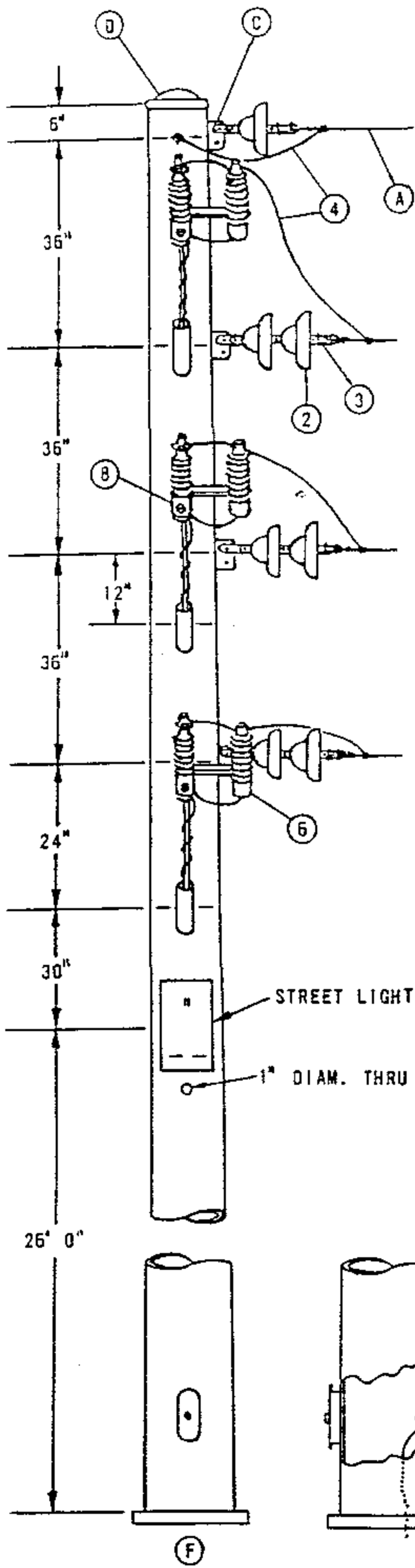

FOR FIELD MAINTENANCE ONLY

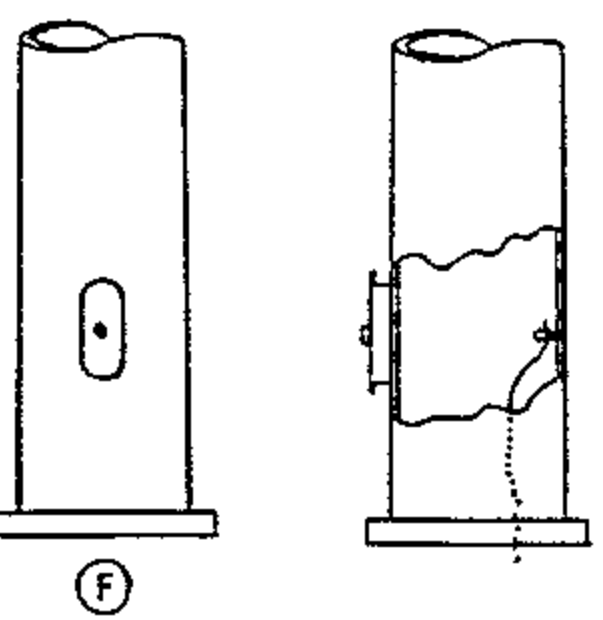
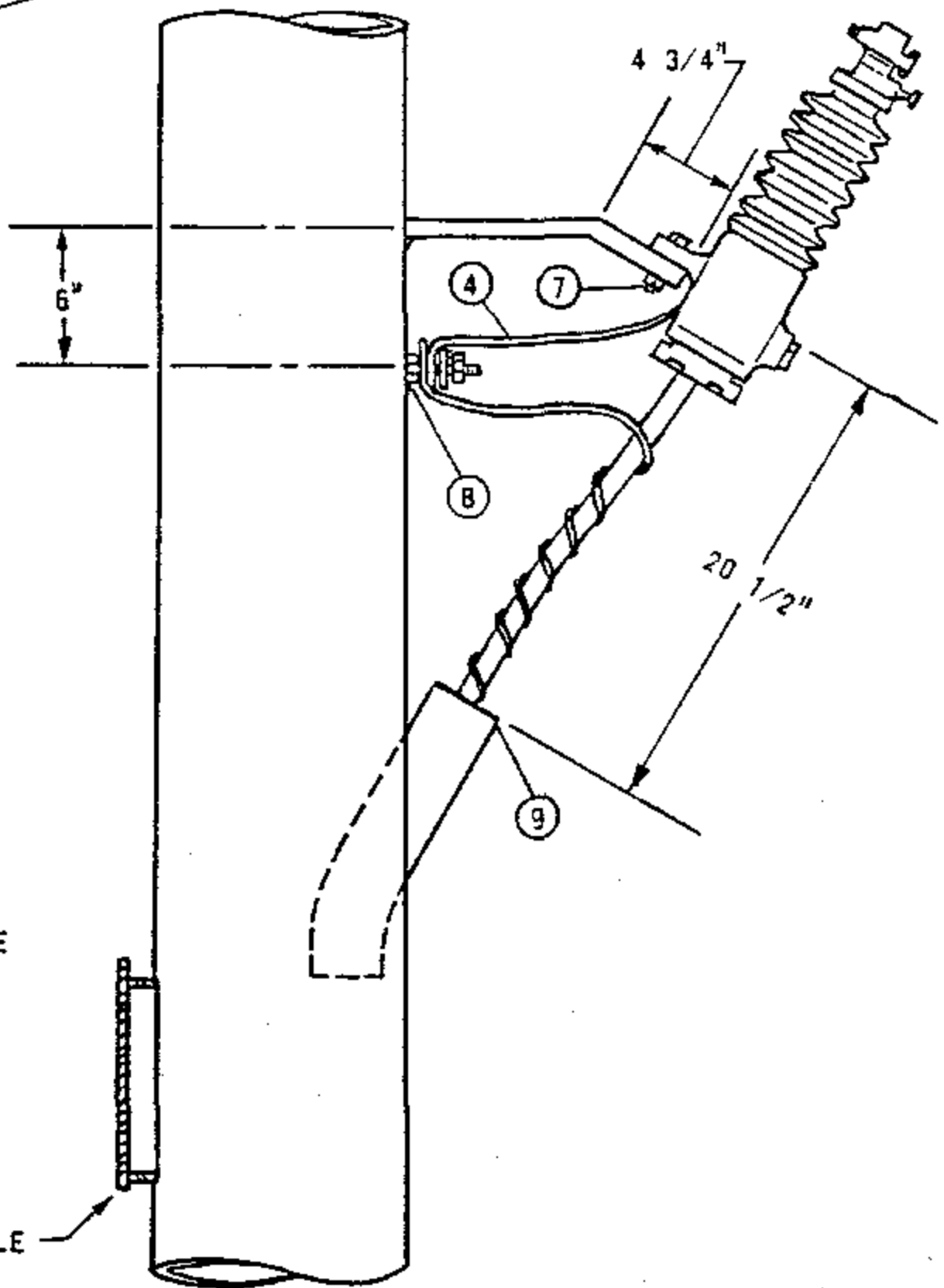

SDG&E ELECTRIC STANDARDS

CABLE POLE, STEEL, LIGHT DUTY

DATE 1-1-92
 APPD JLB/BOA

OH 1499.501
 UG 4299.501

FOR FIELD MAINTENANCE ONLY

NOTES:

- (A) THIS POLE IS DESIGNED FOR A MAXIMUM LOADED TENSION OF 850# PER CONDUCTOR, AND A MAXIMUM SPAN LENGTH OF 250'.
- (B) LIGHTNING ARRESTER GROUND, AND CONCENTRIC CABLE NEUTRAL ARE CONNECTED TO STUD AS SHOWN. BASE OF TERMINAL GROUNDED THROUGH MOUNTING BRACKET.
- (C) DEAD END TO BE ATTACHED TO TOP HOLE OF DEAD END ATTACHMENT PLATE.
- (D) TOP IS REMOVABLE.
- (E) EXEMPT MATERIAL.
- (F) SEE STANDARDS PAGES 1454/4241 FOR FOUNDATION CONSTRUCTION.
- G. SECTIONALIZING TO BE DONE ON ADJACENT POLE.
- H. THIS POLE IS NONCLIMBABLE.
- (I) TO BE USED FOR STREET LIGHT SECONDARY FROM UG SYSTEM.
- J. NO OVERHEAD ATTACHMENT THAN THOSE SHOWN MAY BE MADE TO THIS POLE.

ITEM	PTF/UCD	MATERIAL	QUANTITY	STOCK NO. OR CONSTR. STD.
1		POLE, LIGHT DUTY, STEEL CABLE, NONCLIMBABLE	1	552418
2		INSULATOR, SUSPENSION	7	700 SECTION
3		CLAMP, DEAD END	4	700 SECTION
4		WIRE, #2 WP COPPER	10'	812608
5		WIRE, #6 BS COPPER	8'	813536
6		ARRESTER, LIGHTNING	3	1200 SECTION
7		BOLT, MACH., GALV., 5/8" X 2", 1 LOCK WASHER. (E)	6	100 SECTION
8		TERMINAL, UNDERGROUND CABLE	3	SEE U.G. STDS.
9		GRIP, CABLE	3	394048

OH 1499.502 UG 4299.502	SDG&E ELECTRIC STANDARDS CABLE POLE, STEEL, LIGHT DUTY	DATE 1-1-92 APPD <i>JLB/BJ</i>
---------------------------------------	---------------------------------------------------------------	-----------------------------------

20 1/2" DIA. TO CENTER OF BOLTS

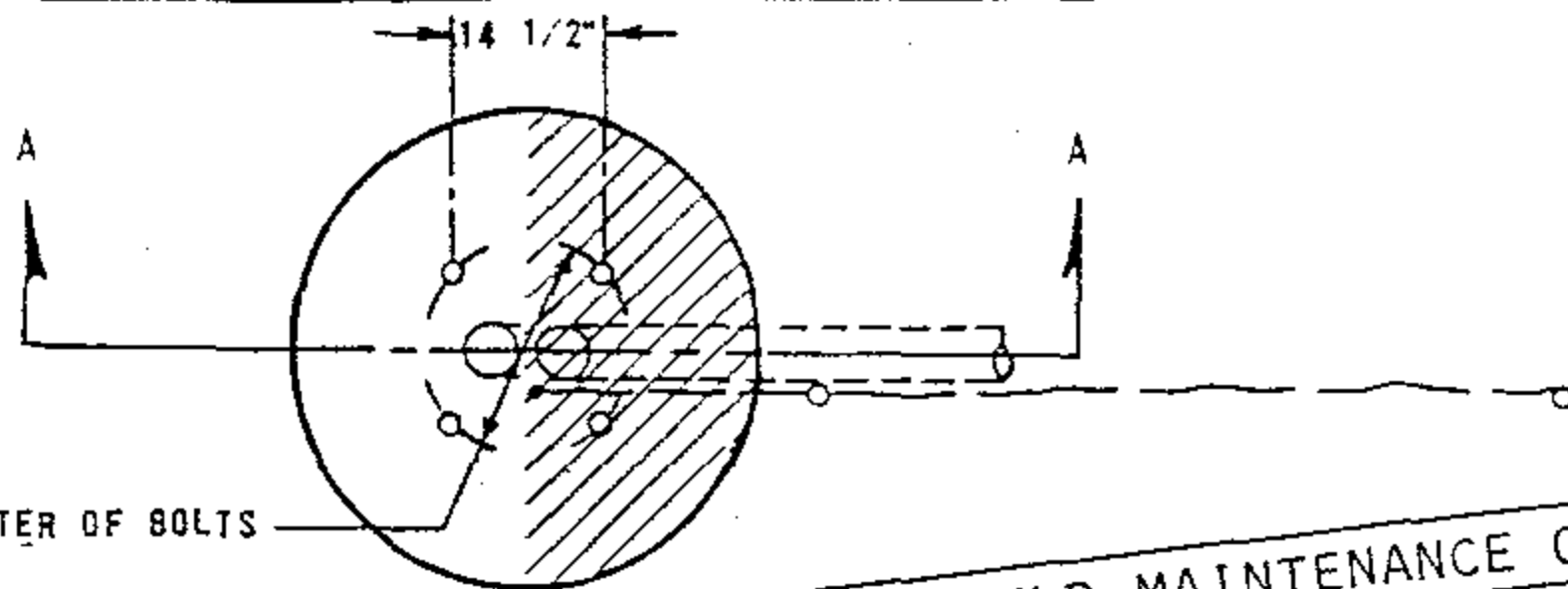

PLAN VIEW

FOR FIELD MAINTENANCE ONLY

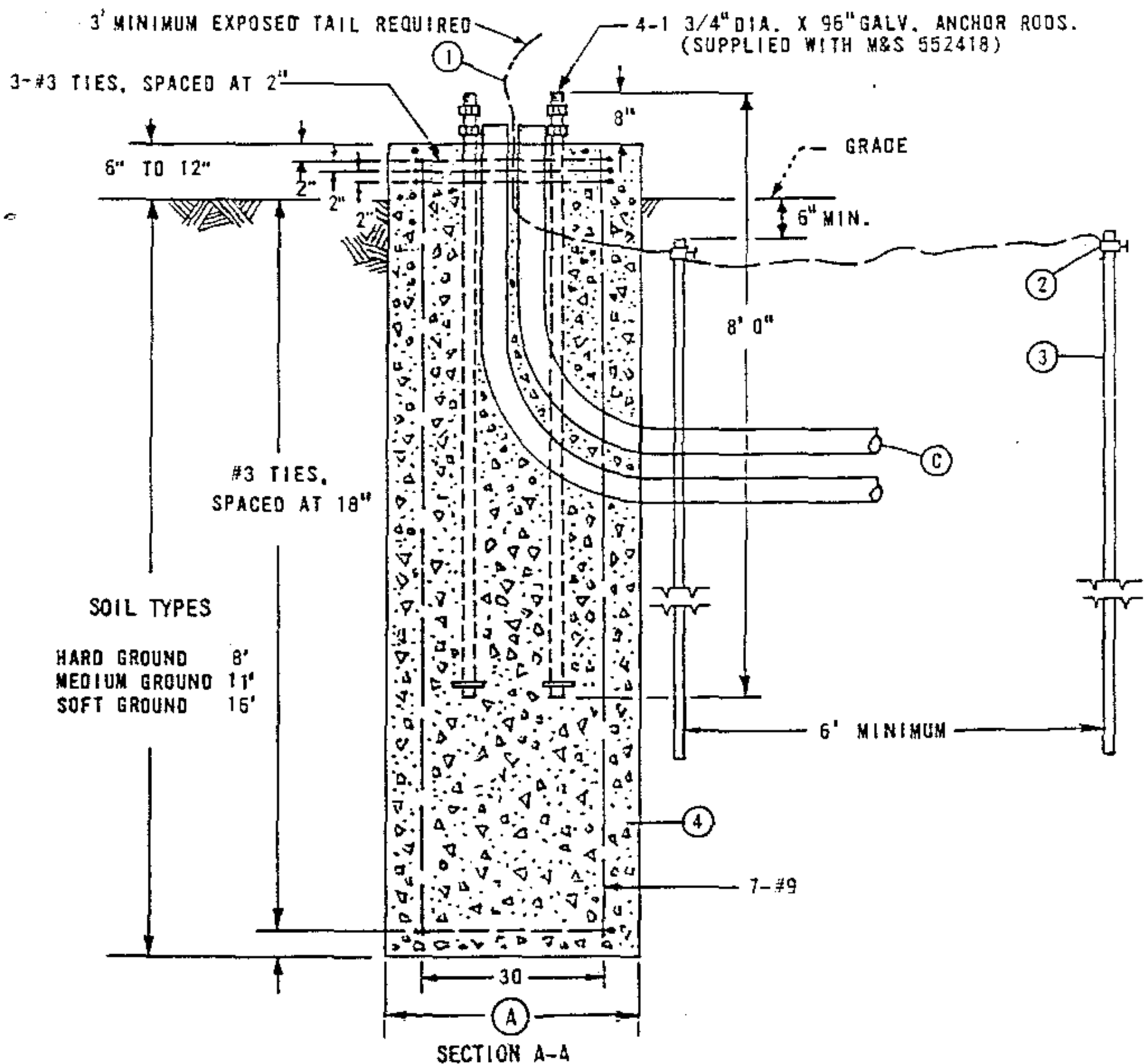

SOIL TYPES

HARD GROUND	8'
MEDIUM GROUND	11'
SOFT GROUND	16'

NOTES:

- (A) WHEN DIRECTION OF PULL OF THE OVERHEAD CONDUCTORS IS IN SHADED AREA IN THE PLAN VIEW, FOUNDATION DIAMETER SHALL BE 48". WHEN IN THE UNSHADED AREA THE FOUNDATION DIAMETER MAY BE REDUCED TO 42". DIAMETER REQUIRED ON WORK ORDER.
- B CONTACT CIVIL ENGINEERING FOR CONFIRMATION OF SOIL TYPES BEFORE DECIDING FOUNDATION DIMENSIONS.
- (C) TWO DUCTS TO BE INSTALLED IN FOUNDATION. THREE DUCTS ARE REQUIRED IF STREET LIGHT IS TO BE INSTALLED ON POLE.
- (E) EXEMPT MATERIAL.

ITEM	DESCRIPTION	QUANTITY	STOCK NO.	VOLUME OF CONCRETE (IN CUBIC YARDS)	
				DEPTH (IN FEET)	DIAMETER (IN INCHES)
1	WIRE, #2 BARE STRANDED COPPER	15'	813664	8	42
2	CLAMPS, GROUND (E)	2	230016		
3	RODS, GROUND	2	603072	11	48
4	CONCRETE	(SEE TABLE)	—	15	—

SDG&E ELECTRIC STANDARDS		OH 1499.503 UG 4299.503
DATE 1-1-92 APPD <i>JLB/BJ</i>	FOUNDATION, STEEL CABLE POLE, LIGHT DUTY	

SCOPE: THIS STANDARD SHOWS 6 OR 7 CONDUCTOR DEAD END CABLE POLE WITH HOOKSTICK SWITCHES FOR 750 KCMIL AND LARGER U.G. CABLE. (SEE STANDARD 1407/4207 FOR 350 KCMIL TERMINAL MOUNTING INFORMATION).

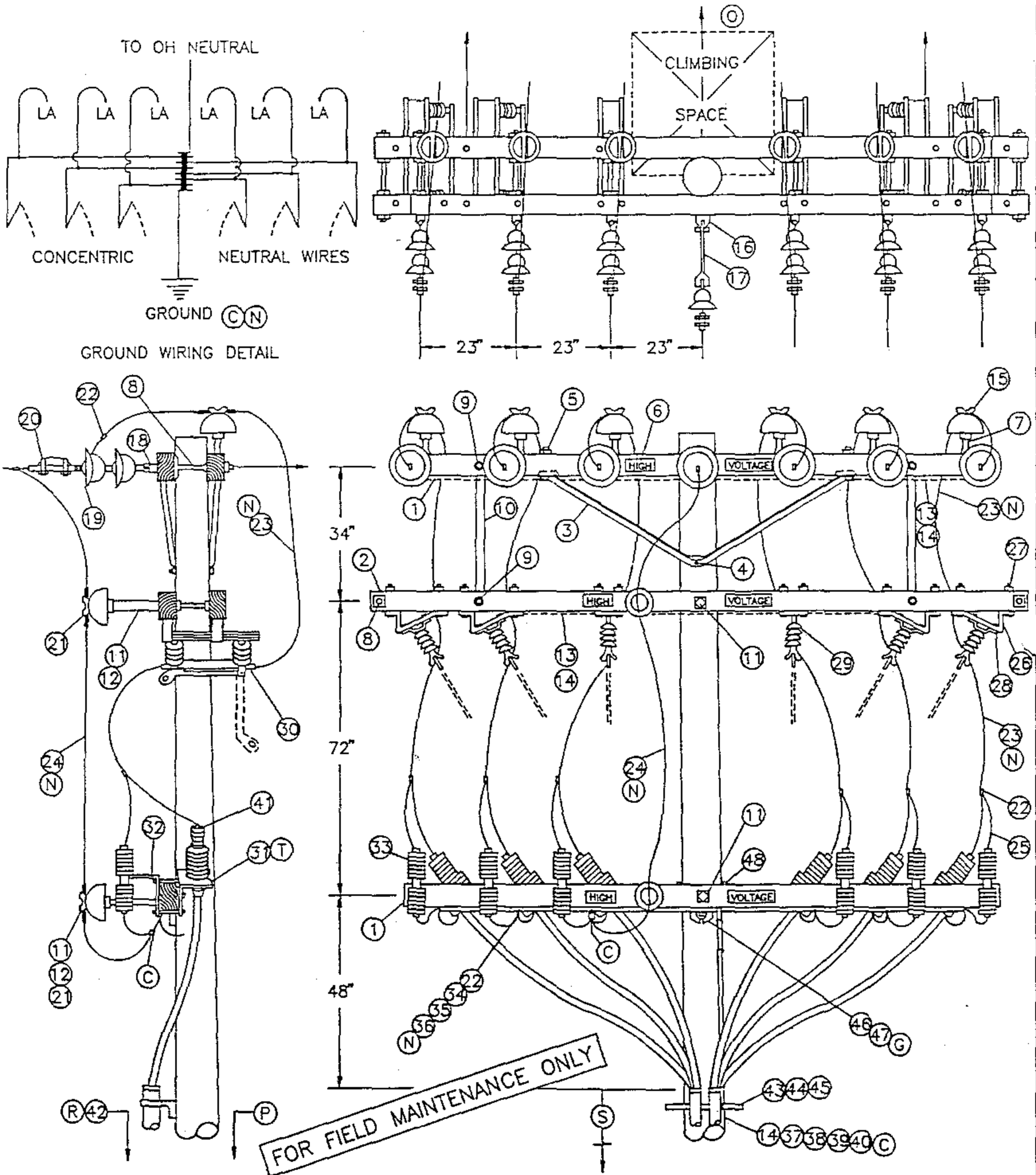

OH 1499.504
~~UG 4299.504~~
 SUPERCEDES
 1451.1 (1-1-93)

SDG&E ELECTRIC STANDARDS
 12.47KV AND BELOW DEAD END CABLE POLE, 6 OR 7 OH
 CONDUCTORS, 1 OR 2 TERMINALS PER CONDUCTOR,
 HOOKSTICK SWITCHED

DATE 1-1-93

APPD *JUB/ROJ*

BILL OF MATERIAL:

ITEM	DESCRIPTION	QUANTITY	CONST STD OR PG NO	STOCK NUMBER
1	CROSSARM, 3-3/4" X 5-3/4" X 12'-0"	3	-	294160
2	CROSSARM, 3-3/4" X 5-3/4" X 13'-6"	2	-	294368
3	BRACE, ANGLE, CROSSARM, 6'	3	-	164160
4	BOLT, MACH, GALV, 5/8" X (LENGTH AS REQ'D), 1 DBL COIL WASH	1	392.1&2	-
5	BOLT, MACH, GALV, 1/2" X 7", 1 RD & 1 DBL COIL WASH	4	392.1&2	-
6	SIGN, HIGH VOLTAGE & 8 ROOFING NAILS	6	-	647648 492224
7	PIN, INSULATOR, STRAIGHT, 12KV, 1" OR 1 3/8"	6	-	532704 532448
8	BOLT, SPACE, 5/8" X (LENGTH AS REQ'D), 3 SQ WASH & 2 DBL COIL WASH	8	392.1&2	-
9	BOLT, MACH, GALV, 5/8" X (LENGTH AS REQ'D), 1 RD WASH & 1 DBL COIL WASH	8	392.1&2	-
10	BRACE, VERTICAL, 36"	4	-	164224
11	BOLT, MACH, GALV, 5/8" X (LENGTH AS REQ'D), 2 SQ FLAT WASH & 1 DBL COIL WASH	5	392.1&2	-
12	PIN, TRANSFORMER ADAPTER, 1" LEAD THREAD	2	-	529248
13	WIRE, #8, BARE SOLID ANNEALED COPPER	2 LB	-	812928
14	STAPLES, FENCE, GALV, 1-1/4"	AS REQ'D	-	678528
15	INSULATOR, LINE, 12KV, 1" OR 1-3/8" PIN	6	750	-
16	CLEVIS, DEAD END, 3/4" BOLT, STEEL (OPEN TYPE)	1	-	235618
17	LINK, EXTENSION, 1/2" X 1-1/2" X 12"	1	-	466240
18	CLEVIS, DEAD END, 5/8" BOLT, STEEL (CLOSED TYPE)	6	-	235712
19	INSULATOR, SUSPENSION, 12KV	13	750	-
20	CLAMP, STRAIGHT LINE, D.E.	7	742-743	-
21	INSULATOR, LINE, 12KV, NEUTRAL	2	-	429216
22	CONNECTOR, WIRE, (SIZE & TYPE AS REQ'D)	AS REQ'D	783-787	-
23	WIRE, BARE STRANDED COPPER, (OH JUMPER)	72'	715-716	-
24	WIRE, BARE STRANDED CU OR AL, (OH NEUT JUMPER)	12'	711-716	-
25	WIRE, #6, BARE STRANDED COPPER	25'	-	813536
26	BRACKET, DISCONNECT, ANGLE MOUNTING, 1/4" X 3"	8	-	166542
27	BOLT, MACH, GALV, 1/2" X 8", 1 RD & 1 DBL COIL WASH	24	392.1&2	-
28	BOLT, MACH, GALV, 3/8" X 3"	8	392.1&2	-
29	SWITCH, DISCONNECT, 14.4KV, 600 A OR 1200 A	6	1205	-
30	COMPRESSION TERMINALS, CU, 2 HOLE (SIZE AS REQ'D)	12	794-795	-
31	BRACKET, POTHEAD MOUNTING	6	1400/4200	-
32	BRACKET, CUTOUT/ARRESTER, FOR CROSSARM MOUNTING	6	-	166070
33	ARRESTER, LIGHTNING	6	1247	-
34	CONDUIT, PVC, SCHEDULE 40, 1-1/2"	10'	-	251232
35	STRAPS, PIPE, GALV, 1" & 6D NAILS, GALV	AS REQ'D	-	697792 491552
36	WIRE, BARE STRANDED CU, (C.P. NEUTRAL SIZE)	35'	715-716	-
37	WIRE, #4, BARE STRANDED COPPER	45'	-	813760
38	STAPLES, MOULDING, GALV, 3" X 1-1/16" X 1/4"	AS REQ'D	-	678560
39	UNIT GROUND, COMPLETE	1	-	603136
40	CLAMP, 5/8", GROUND ROD	2	-	230016
41	TERMINALS, UNDERGROUND CABLE	6	4111	-
42	RISER CONSTRUCTION	AS REQ'D	1400/4200	-
43	BRACKET, LADDER ARM	AS REQ'D	1404/4204	167184
44	NUT, CLAMPING CHANNEL, W/SPRING, 1/2"	AS REQ'D	1404/4204	503488
45	CHANNEL, DOUBLE GALV, 24"	AS REQ'D	1404/4204	216700
46	BOLT, MACH, GALV, 5/8" X (LENGTH AS REQ'D), 1 SQUARE, 1 ROUND & 1 DOUBLE COIL SPRING WASHER	1	392	-
47	GAIN, CROSSARM, BRACELESS	1	-	369598
48	BOLT, MACH, GALV, 5/8" X 7", 1 ROUND & 1 DOUBLE COIL SPRING WASHER	2	392	-

FOR FIELD MAINTENANCE ONLY

CABLE SIZE	UG MACRO UNIT PORCELAIN
	W/LADDER ARMS
3C-#750 AL TWO RUNS	2R750L
3C-#1000 AL TWO RUNS	2R-1KL

DATE 1-1-93	SDG&E ELECTRIC STANDARDS	OH 1499.505
APPD <i>JLB/ROJ</i>	12.47KV AND BELOW DEAD END CABLE POLE, 6 OR 7 OH CONDUCTORS 1 OR 2 TERMINALS PER CONDUCTOR, HOOKSTICK SWITCHED	UG 4299.505 SUPERCEDES 1451.2 (1-1-93)

INSTALLATION:

- A. NEW CABLE POLES SHALL HAVE A STANDARD DEPTH OF 9'. IN MOST CASES THIS WILL REQUIRE A 5' TALLER POLE.
- B. THIS CONSTRUCTION TO BE USED WITH 350 KCMIL AND LARGER UNDERGROUND CABLE.
- C. INTERCONNECT OVERHEAD NEUTRAL, TERMINAL BASE, AND CONCENTRIC CABLE NEUTRAL CONDUCTOR TO LIGHTNING ARRESTER GROUND.
- D. REDUCE QUANTITIES AS REQUIRED WHEN NOT USING NEUTRAL .
- E. EXEMPT MATERIAL.
- F. INSTRUCTIONS TO INSTALL POTHEAD MOUNTING BRACKETS AND LIGHTNING ARRESTER BRACKETS.
- G. DO NOT CUT GAINS IN THE POLE WHEN INSTALLING THE VERTICALLY MOUNTED SECTIONALIZING SWITCH ARMS. THE GAIN HARDWARE USED HERE MAKE CUT GAINS UNNECESSARY.

(N)

UG CABLE SIZE AWG OR KCMIL, AL	OH JUMPER COND SIZE, AWG OR KCMIL, CU	OH NEUTRAL JUMPER SIZE CU OR AL	CABLE POLE NEUT SIZE (CU) UNDER POTHEAD ARM OR TRIPLE TERM BRKT
350	4/0	SAME SIZE	#2 PER PHASE
750	500	AS O.H. NEUT	1/0 PER PHASE
1000	500	CONDUCTOR	1/0 PER PHASE

REFERENCE:

- (O) ALLOWABLE WORKING AND CLIMBING SPACE - SEE STD. 251.
- (P) POLE STEPPING - SEE STD. 363.
- (Q) GROUNDING METHODS - SEE PAGE 1002.5.
- (R) RISER POSITIONS - SEE STANDARD 1402/4202.
- (S) MINIMUM VERTICAL SEPARATION AS PER .G.O. 95 - SEE STD. 1406/4206.
- (T) SEE STANDARD 1407/4207 FOR PORCELAIN AND NON PORCELAIN TERMINAL MOUNTING BRACKET INSTRUCTIONS AND MATERIALS.

FOR FIELD MAINTENANCE ONLY

OH 1499.506
~~UG 4299.506~~
 SUPERCEDES
 1451.3 (1-1-93)

SDG&E ELECTRIC STANDARDS

12.47KV AND BELOW DEAD END CABLE POLE,
 6 OR 7 OH CONDUCTORS
 1 OR 2 TERMINALS PER CONDUCTOR, HOOKSTICK SWITCHED

DATE 1-1-93

APPD *JLB/ROJ*

SCOPE: THIS STANDARD SHOWS A DEADEND CONSTRUCTION FOR 12.47 KV, THREE-PHASE CABLE POLE, WITH NEUTRAL, AND A HORIZONTAL MOUNTED SCADA-MATE SWITCH. (B)

NOTE: THIS INSTALLATION REQUIRES TRUCK ACCESS. CONTACT TELECOMMUNICATIONS BEFORE DESIGN BEGINS TO DETERMINE COMMUNICATIONS REQUIREMENT.

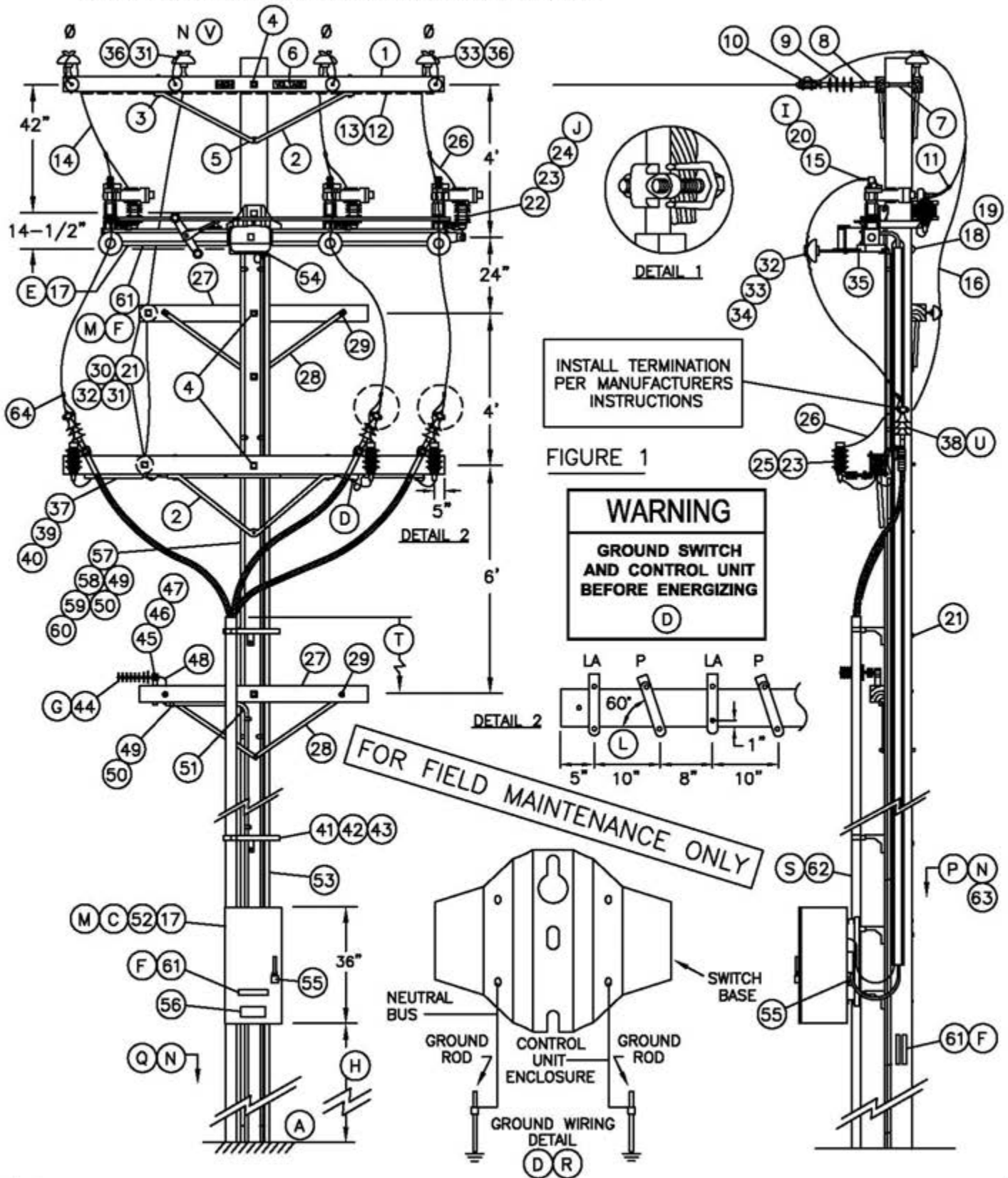

© 1998 - 2010 San Diego Gas & Electric Company. All rights reserved. Removal of this copyright notice without permission is not permitted under law.

1499.601
4299.601
SUPERSEDES
1445.1 (10-20-05)

SDG&E ELECTRIC STANDARDS

12.47 KV DEAD END CABLE POLE, THREE-PHASE
WITH NEUTRAL, HORIZONTAL SCADA-MATE SWITCH

DATE 10-20-05
APPD PJA/JJ

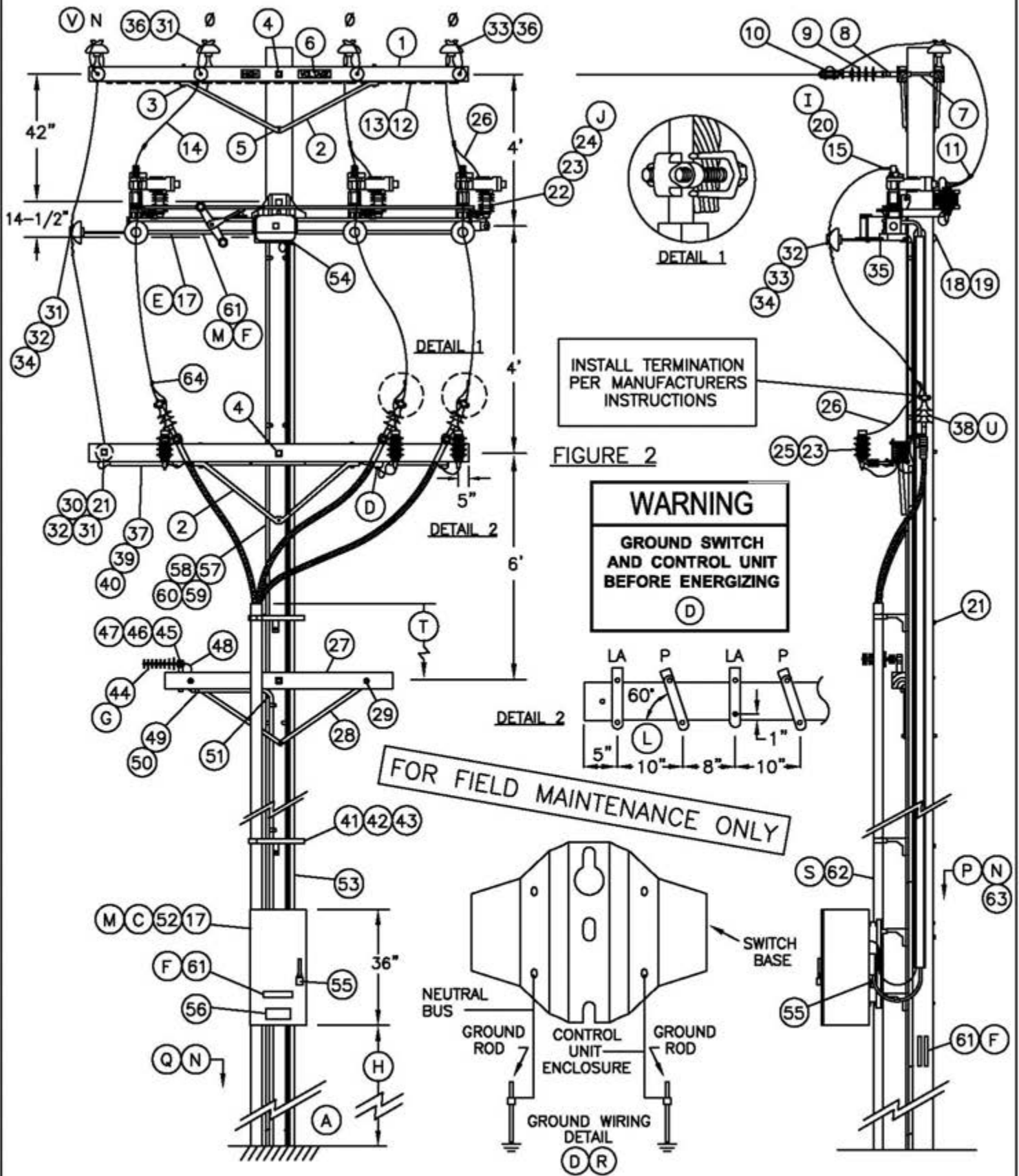

© 1998 - 2010 San Diego Gas & Electric Company. All rights reserved. Removal of this copyright notice without permission is not permitted under law.

DATE 10-20-05 APPD PJA/JJ	SDG&E ELECTRIC STANDARDS 12.47 KV DEAD END CABLE POLE, THREE-PHASE WITH NEUTRAL, HORIZONTAL SCADA-MATE SWITCH	1499.602 4299.602 SUPERSEDES 1445.2 (10-20-05)
------------------------------	---------------------------------------------------------------------------------------------------------------------	---------------------------------------------------------

BILL OF MATERIAL:

ITEM	DESCRIPTION	QUANTITY	CONSTR. STD	STOCK NUMBER	ASSEMBLY UNITS	
1	CROSSARM, 3-3/4" X 5-3/4" X 10'-0"	3	-	294128	4-	
2	BRACE, ANGLE, LINEARM=5'-0", PH ARM=4'-0"	4'	1	391	164032	4HUB
		5'	2	391	164128	5HUB
3	BOLT, MACH, GALV, 1/2" X 7", 1 ROUND AND 1 DOUBLE COIL SPRING WASHER	6	392	-	-	
4	BOLT, MACH, GALV, 5/8" X (LENGTH AS REQ'D), 2 SQUARE AND 1 DOUBLE COIL SPRING WASHER	4	392	-	-	
5	BOLT, MACH, GALV, 5/8" X (LENGTH AS REQ'D) AND 1 DOUBLE COIL SPRING WASHER	1	392	-	-	
6	SIGN, HIGH VOLTAGE, AND 9 ROOFING NAILS, GALV	2	-	647648	HV	
		-	-	492224		
7	BOLT, SPACE, GALV, 5/8" X (LENGTH AS REQ'D), 3 SQUARE, 2 ROUND, 2 DOUBLE COIL SPRING WASHERS AND 1 NUT	4	392	-	-	
8	CLEVIS, DEAD END, 5/8" BOLT STEEL (CLOSED TYPE)	4	-	235712	-	
9	INSULATOR, SUSPENSION, 12KV, CLEVIS	4	750	431650	4DE	
10	CLAMP, STRAIGHT LINE, D.E.	4	741-743	-	-	
11	CONNECTOR, WIRE COMPRESSION (SIZE AS REQ'D)	AS REQ'D	783-786	-	-	
12	WIRE, #8 BARE SOLID ANNEALED COPPER	12'	-	812928	BOND8	
13	STAPLE, FENCE, GALV, 1-1/4"	AS REQ'D	-	678528		
14	WIRE, BARE STRANDED COPPER (OH JUMPERS) (K)	45'	715	-	-	
15	TERMINAL, COMPRESSION LUG (I)	6	794-795	-	-	
16	WIRE, BARE STRANDED CU OR ACSR/AW BARE (OH NEUT JUMPER) (K)	14'	711-715	-	-	
17	SWITCH, SCADA-MATE, 14.4 KV, POLE MOUNTED, INCLUDING 35' CONTROL CABLE, CONTROL UNIT AND RTU (E)	1	-	704690	AUTOSW (F)	
18	BOLT, MACH, GALV, 5/8" X (LENGTH AS REQ'D), 1 SQUARE CURVED RIBBED AND 1 DOUBLE COIL SPRING WASHER	2	392	-	-	
19	COVER, BOLT, PLASTIC & 6 - 10D NAILS, GALV	2	-	285696	-	
		AS REQ'D	-	491392	-	
20	BOLT, STAINLESS STEEL, 1/2" X 1-1/2" WITH 2 FLAT & (I) 2 BELLEVILLE WASHERS & SILICONE BRONZE NUT	12	392	148672	-	
21	BOLT, MACH, GALV, 5/8" X (LENGTH AS REQ'D), 2 SQUARE & 1 DBL COIL SPRING WASHER	AS REQ'D	392	-	-	
22	BOLT, MACH, GALV, 1/2 X 2-1/2", 1 ROUND AND 1 LOCK WASHER	3	392	-	-	
23	ARRESTER, LIGHTNING (J)	6	-	113248	LA12C	
24	SERVICE POST CONNECTOR	3	-	262560	-	
25	BRACKET, CUTOUT/ARRESTER, FOR CROSSARM MOUNTING	3	-	166070	LA/B-C	
26	WIRE, #6, BARE STRANDED COPPER	FT	18'	715	813536	BS6C
		LB	2			
27	CROSSARM, 3-1/2" X 4-1/2" X 6'-0"	2	380.2	294112	2S	
28	BRACE, FLAT, CROSSARM, 28"	4	-	164192		
29	BOLT, MACH, GALV, 3/8" X 4-1/2" & 1 ROUND WASHER	4	392.2	-	-	
30	PIN, TRANSFORMER LEAD ADAPTER, 1"	2	-	529248	PS/01	
31	INSULATOR, 12KV NEUTRAL	3	-	429216	55-3C	
32	WIRE, TIE	AS REQ'D	760-764	-	-	
33	INSULATOR, 12KV, 55-5	6	750	429056	55-5C	
34	INSULATOR STANDOFF BRACKET, 1" X 30"	3 OR 4	394	166144	KBKT30	
35	"L" BRACKET, 2-1/2" X 2-1/2", GALV	3	-	166208	-	
36	INSULATOR PIN, 12KV, 1"	4	396	532704	PS1	
37	WIRE, BARE STRANDED COPPER (UNDER POTHEAD ARM) (K)	12'	715	-	-	

FOR FIELD MAINTENANCE ONLY

© 1998 - 2010 San Diego Gas & Electric Company. All rights reserved. Removal of this copyright notice without permission is not permitted under law.

1499.603
4299.603
SUPERSEDES
1445.3 (10-20-05)

SDG&E ELECTRIC STANDARDS

12.47 KV DEAD END CABLE POLE, THREE-PHASE
WITH NEUTRAL, HORIZONTAL SCADA-MATE SWITCH

DATE 7-9-03
APPD *PLA/MPB*

BILL OF MATERIAL: (CONT)

ITEM	DESCRIPTION	QUANTITY	CONSTR. STD	STOCK NUMBER	ASSEMBLY UNITS	
38	TERMINALS AND UNDERGROUND CABLE (U)	3	4111	-	-	
39	CONDUIT, PVC, TYPE 2, SCHEDULE 40, 1-1/2"	10'	-	251232	P11/2C	
40	STRAPS, PIPE, GALV, 1-1/2", & 2 - 6D NAILS, GALV	AS REQ'D	-	697664	-	
		AS REQ'D	-	491552		
41	BRACKET, LADDER ARM	AS REQ'D	1404/4204	167184	RSRARM	
42	NUT, CLAMPING CHANNEL, W/SPRING, 1/2"	AS REQ'D	1404/4204	503488		
43	CHANNEL, DOUBLE GALV, 24"	AS REQ'D	1404/4204	216700		
44	ANTENNA, SCADA, COMMUNICATION, BROADBAND AND CONNECTORS	1	-	109570	ANT	
45	NIPPLE, PIPE 2" X 7", ALUM.	1	-	-	ANTXMB	
46	BOLT, MACH, GALV. 1/2" X 9"	1	-	153184		
47	CENTERING WASHER, GALV.	2	-	795520		
48	CABLE, FLEXIBLE 1/2" COAXIAL SCADA ANTENNA	AS REQ'D	-	191906	ANTCAB	
49	CONDUIT, PVC, SCHEDULE 40, 1/2"	150'	-	251168	P1/2-C	
50	STRAPS, PIPE GALV, 1/2", & 6D NAILS, GALV	AS REQ'D	-	697728	-	
		AS REQ'D	-	490656	-	
51	ELBOW, PVC, 1/2"	1	-	-	-	
52	TRANSCEIVER, 12V DC	1	-	749500	SOTRAN	
53	U-GUARD, 2" X 10', POLYETHYLENE	3	-	249940	ZUMOLD	
54	GRIP, CONTROL CABLE	1	-	394018	-	
55	PADLOCK, SCHLAGE ELECTRIC SERIES	2	-	514848	-	
56	DECAL "SCADA" "INFORM S.C.O. UPON ENTRY"	1	207	301934	-	
57	WIRE, #2 BARE STRANDED COPPER	FT	100'	-	813664	BS2R
		LB	20#			
58	STAPLES, FENCE, GALV, 1-1/4" STAPLES, MOULDING, GALV, 3" X 1-1/16" X 1/4"	AS REQ'D	-	678528	-	
		AS REQ'D	-	678560	-	
59	GROUND ROD, 5/8" X 8' (D)(R)	2	1002	603072	ROD8	
60	COPPER BONDED GROUND CONNECTOR	2	1002	259010	-	
61	TAG, SWITCH NUMBER (F)	5	204	-	-	
62	RISER CONSTRUCTION (S)	AS REQ'D	1400/4200	-	-	
63	VISIBILITY STRIP (N)	4	208	304064	VSTRIP	
64	HOT LINE CLAMP	3	788	227680	-	

FOR FIELD MAINTENANCE ONLY

OH MACRO UNITS		
FIG.	NEUTRAL POSITION	MU
1	INSIDE	SMCPNI
2	OUTSIDE	SMCPNO

UG MACRO UNITS	
CABLE SIZE	W/LADDER ARMS
3C-#350	NP350L
3C-#750C	NP750L
3C-#1000	N1000L

INSTALLATION:

- (A) NEW CABLE POLES SHALL HAVE A STANDARD SETTING DEPTH OF 9'. IN MOST CASES, THIS WILL REQUIRE A 5' TALLER POLE.
- (B) THIS CONSTRUCTION TO BE USED WITH 350 KCMIL AND LARGER UNDERGROUND CABLE.
- (C) SCADA SWITCH CONTROL IS SELF POWERED FROM POLE TOP SWITCH UNIT. NO LOCAL SECONDARY IS REQUIRED. FAULT INDICATION IS INTEGRATED WITH THE SWITCH CONTROL - NO EXTERNAL FAULT INDICATORS ARE REQUIRED.

©1998 - 2010 San Diego Gas & Electric Company. All rights reserved. Removal of this copyright notice without permission is not permitted under law.

DATE 10-20-05 APPD PJA/JJ	SDG&E ELECTRIC STANDARDS	1499.604 4299.604 SUPERSEDES 1445.4 (10-20-05)
	12.47 KV DEAD END CABLE POLE, THREE-PHASE WITH NEUTRAL, HORIZONTAL SCADA-MATE SWITCH	

- (D) **NOTE:** BEFORE ENERGIZING SWITCH, CONNECT GROUND LEADS TO THE GROUNDING POINT PROVIDED ON SWITCH MOUNTING BRACKET. INTERCONNECT OVERHEAD NEUTRAL, TERMINAL BASE AND CONCENTRIC CABLE CONDUCTOR TO LIGHTNING ARRESTER GROUND. INSTALL TWO SEPARATE GROUND RUNS FROM BASE OF SWITCH TO BASE OF POLE, UNDER SEPARATE COVERS, IN ADJACENT POLE QUADRANTS. CONNECT EACH RUN TO A SEPARATE SET OF GROUND RODS. CONNECT CONTROL UNIT ENCLOSURE GROUND WIRE TO ONE OF THE GROUND RUNS AND POTHEAD UNDERARM NEUTRAL BUS TO THE OTHER. – SEE GROUND WIRING DETAIL.
- (E) WHEN MOUNTING SCADA SWITCH TO POLE, DISCARD POLE BAND. **DO NOT INSTALL POLE BAND.**
- (F) SCADA SWITCH ASSEMBLY UNIT WILL GENERATE TWO SWITCH NUMBERS—ONE FOR THE SF6 INTERRUPTER AND ANOTHER FOR THE MANUALLY OPERATED DISCONNECT. THE VISUAL BREAK, MANUALLY OPERATED DISCONNECT WILL ALWAYS BE A LINE SWITCH, NORMALLY CLOSED AND ASSIGNED THE LOWER OF THE SWITCH ASSIGNMENT NUMBERS. A TAG FOR THE MANUALLY OPERATED DISCONNECT WILL BE INSTALLED AT THE BASE OF THE POLE AND ON THE UNDERSIDE OF THE SWITCH BASE NEAR THE OPERATING LEVER. THE SF6 INTERRUPTER CAN BE EITHER A LINE SWITCH OR A TIE SWITCH. TAGS FOR THE SF6 INTERRUPTER WILL BE INSTALLED IN THREE LOCATIONS; AT THE BASE OF THE POLE, OUTSIDE OF THE CONTROL CABINET DOOR AND ANOTHER ON THE INSIDE OF THE DOOR. AN INTERRUPTER OPEN/CLOSED INDICATOR IS LOCATED ON ONE END OF THE SWITCH ARM.
- (G) PLANNER TO SPECIFY QUADRANT OF POLE FOR ANTENNA MOUNT WITH DATA FROM STANDARDS. POINTS LIST TO BE COMPLETED BY PLANNER AND SENT TO SENIOR ENGINEER, DISTRIBUTION OPERATIONS. SEE ELECTRIC STANDARDS TEAM FOR POINTS LIST FORMS.
- (H) RTU TO BE MOUNTED AT 10' FROM GROUND LEVEL TO BOTTOM OF RTU CABINET WHEN NOT SUBJECT TO TRAFFIC CONTACT. IF VULNERABLE TO VEHICLE DAMAGE, MOUNT RTU AT 13' – 6" FROM GROUND LEVEL TO BOTTOM OF RTU CABINET. CONSIDER LARGE VEHICLES PARKING PARALLEL TO CURB.
- (I) IF ATTACHING 1/0 OR 4/0 COPPER JUMPERS TO SCADA-MATE SWITCH, USE TWO BRONZE CABLE TAP LUGS (S/N 471296) IN PLACE OF BOLTS AND COMPRESSION LUG.
- (J) INSTALL LIGHTNING ARRESTERS ON THE VOLTAGE SENSOR SIDE OF SCADA-MATE SWITCH IN THE PARTIAL ARRESTER PROTECTION AREA. INSTALL LIGHTNING ARRESTERS ON BOTH SIDES OF SCADA-MATE SWITCH IN THE GENERAL ARRESTER PROTECTION AREA. REFER TO STANDARD PAGE 1247.2 FOR LIGHTNING ARRESTER APPLICATION MAP. LIGHTNING ARRESTERS ARE TO BE GROUNDED THROUGH THE SWITCH BASE.
- (K)

UG CABLE SIZE AWG OR KCMIL, AL	OH JUMPER COND SIZE, AWG OR KCMIL, CU	OH NEUT JUMPER SIZE			CABLE POLE NEUT SIZE (CU) UNDER POTHEAD ARM OR TRIPLE TERM BRKT
		CU	AL		
350	4/0	1/0	3/0	–	#2 PER PHASE
750	500	4/0	336.4	OR SAME SIZE AS O.H. NEUT CONDUCTOR	1/0 PER PHASE
1000	500	4/0	336.4		1/0 PER PHASE

- (L) TURN TOP OF BRACKET OUTWARD TO OBTAIN APPROXIMATELY 60° ANGLE.
- (M) CONTROL AND ANTENNA CONNECTIONS TO BE MADE BY SCADA PROJECT CREW. LINE CREW MOUNTS SWITCH TO POLE AND LEAVES CONTROL CABLE ON SITE.

REFERENCE:

- (N) REFLECTOR STRIPS ARE REQUIRED ON ALL SECTIONALIZING/TIE LINE SWITCHES – SEE STANDARD 208.
- O. FOR OPERATION OF SCADA-MATE SWITCH – SEE STANDARD PRACTICE 311.
- (P) ALLOWABLE WORKING AND CLIMBING SPACE – SEE STANDARD 251.
- (Q) POLE STEPPING – SEE O.H. STANDARD 363.
- (R) GROUNDING METHODS – SEE O.H. STANDARD 1002.
- (S) RISER POSITION – SEE STANDARD 1402/4202.
- (T) MINIMUM VERTICAL SEPARATION AS PER G.O. 95 – SEE STANDARD 1406/4206.
- (U) SEE STANDARD 1407/4207 FOR NON-PORCELAIN TERMINAL MOUNTING BRACKET INSTRUCTIONS AND MATERIALS.
- (V) ON ALL NEW CONSTRUCTION AND WHEN ADDING TO EXISTING CONSTRUCTION, NEUTRAL TO BE INSTALLED IN OUTSIDE PIN POSITION PER DESIGN MANUAL PAGE 5124.2.

FOR FIELD MAINTENANCE ONLY

© 1998 - 2010 San Diego Gas & Electric Company. All rights reserved. Removal of this copyright notice without permission is not permitted under law.

DATE 9-13-05 APPD PJA/JJ	SDG&E ELECTRIC STANDARDS	1499.605
	12.47 KV DEAD END CABLE POLE, THREE-PHASE WITH NEUTRAL, HORIZONTAL SCADA-MATE SWITCH	4299.605 SUPERSEDES 1445.5 (10-20-05)

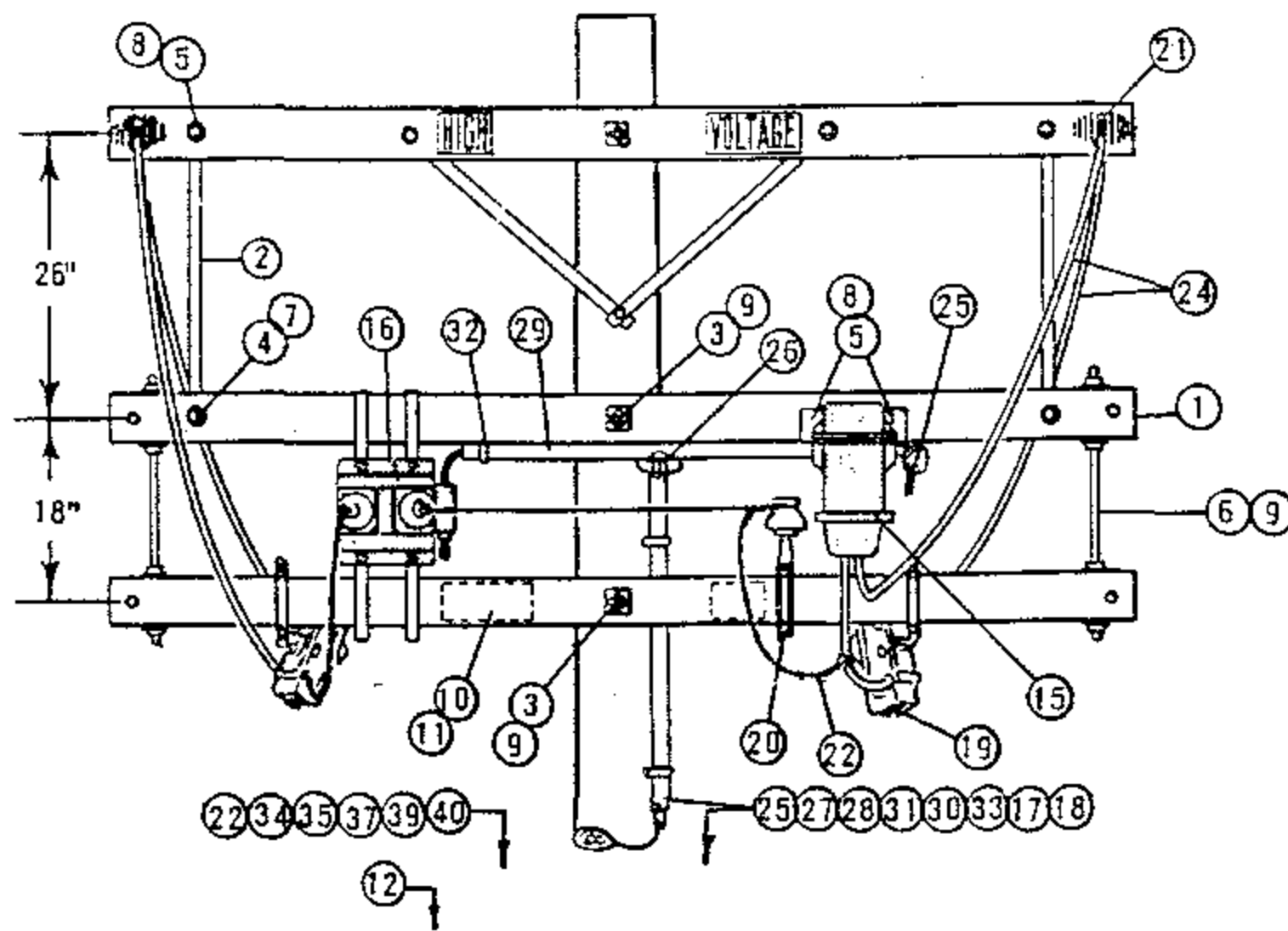

ELEVATION - LOAD SIDE

FOR FIELD MAINTENANCE ONLY

NOTE:

(A) NOT REQUIRED WHERE METER BOX HAS HUB.

ITEM P T F	M I	DESCRIPTION	QUANTITY	STOCK NO. OR CONSTR STD	ITEM P T F	M I	DESCRIPTION	QUANTITY	STOCK NO. OR CONSTR STD
2		BRACE, FLAT CROSSARM 26"	2	164192	25		WIRE, #12 TYPE TW CODED COPPER, 3 CONDUCTORS, 4' EACH	123'	-
3		BOLT, MACH 5/8" X 14"	2	154880	26		BODY, CONDUIT, 3/4" PVC TYPE "T", BLANK COVER	1	147664
4		BOLT, MACH 1/2" X 5"	2	153024	27		BODY, CONDUIT, 3/4" PVC TYPE LB, BLANK COVER (A)	1	146384
5		BOLT, MACH 3/8" X 4 1/2"	4	154368	28		CONDUIT, 3/4" PVC SCH 80	3'	251520
6		BOLT, SPACE 5/8" X 24"	2	156640	29		CONDUIT, 1" PVC SCH 40	4'	251200
7		WASHER, 1/2" ROUND	2	800192	30		CONDUIT, 2" PVC SCH 40	20'	251296
8		WASHER, 3/8" ROUND	4	800288	31		STRAP, PIPE 3/4" & 2-10D GALV NAILS	7	697888.491392
9		WASHER, 3" SQ FLAT	12	799072	32		STRAP, PIPE 1" & 2-8D GALV. NAILS	3	697792.491584
10		SIGN, HIGH VOLTAGE	1	647648	33		STRAP, PIPE 2" & 2-10D GALV NAILS	12	697856.491392
11		NAILS, ROOFING #8 GALV	8	492224	34		ROD, AND CLAMP, GROUND	1	630072.230016
12		POLE STEP	16	692992	35		MOULDING, HARDWOOD	3'	487200
13					36				
14					37		STAPLES, MOULDING 3" X 1 1/16" X 1/4"	2	678560
15		TRANSFORMER, CURRENT, WEST. TYPE WD 5KV, 5A	1	-	38				
16		TRANSFORMER, POTENTIAL, WEST. PTO, 2400/120V, HANGERS & BOLTS	1	-	39		NAILS, 20D, GALV	4	491456
17		METER, SINGLE PHASE POWER	1	-	40		STAPLES, FENCE 1 1/4" GALV	5	678528
18		CABINET, METER, TEST SWITCH, LAG SCREWS	1	161312	41				
19		CUTOUT, 5KV	2	PG 1211	42				
20		BRACKET, INSULATOR STAND OFF	1	166208					
21		CONNECTORS, SPLIT BOLT	7	PG 787					
22		WIRE, #6 BARE STRANDED COPPER	20'	813536					
23									

SDG & E ELECTRIC STANDARDS

POLETOP METERING, 2.4KV SINGLE PHASE

DATE 2-28-83
APPD JMT/ARH

1499.801
SUPERSEDES
1481 (2-28-83)

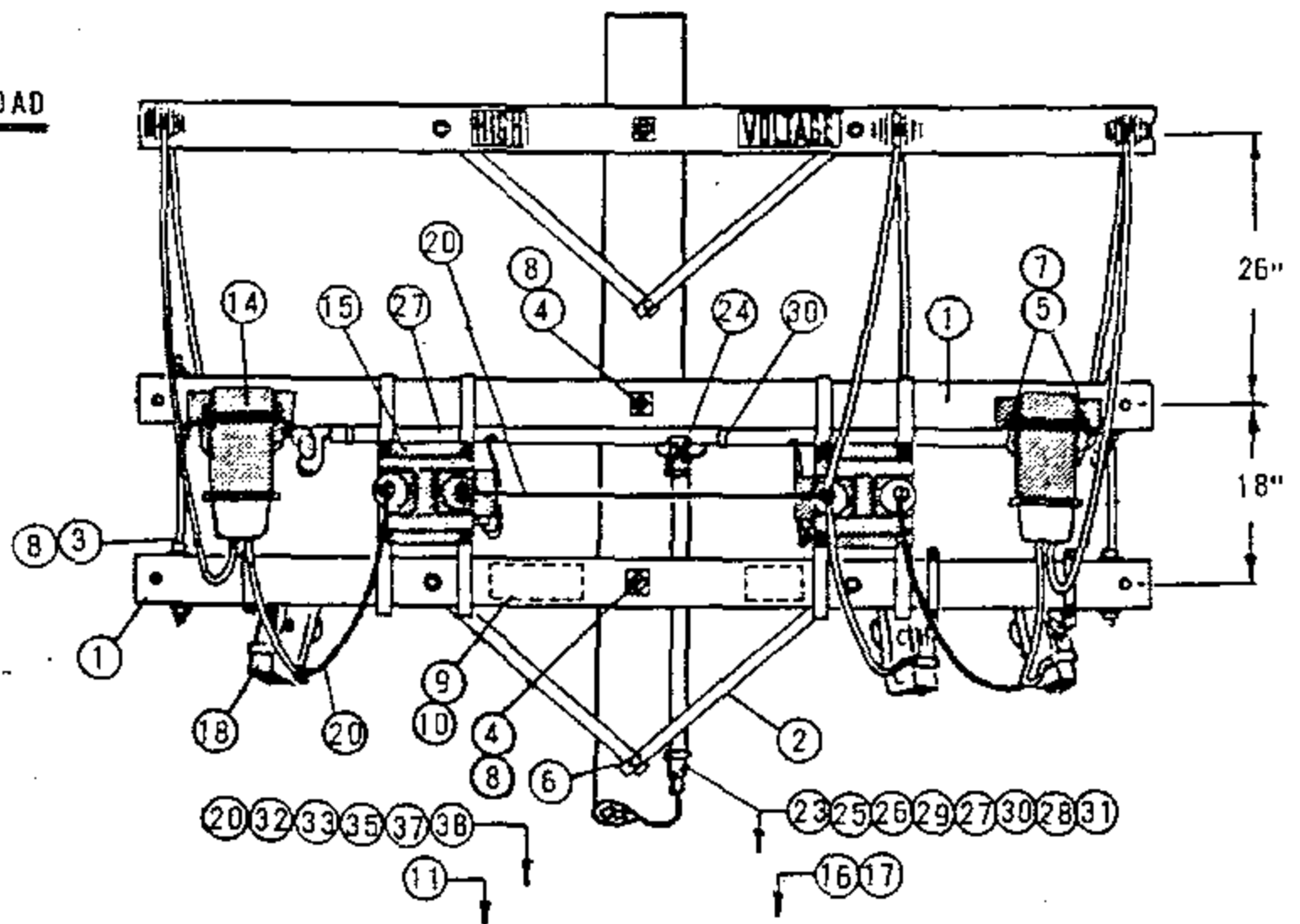
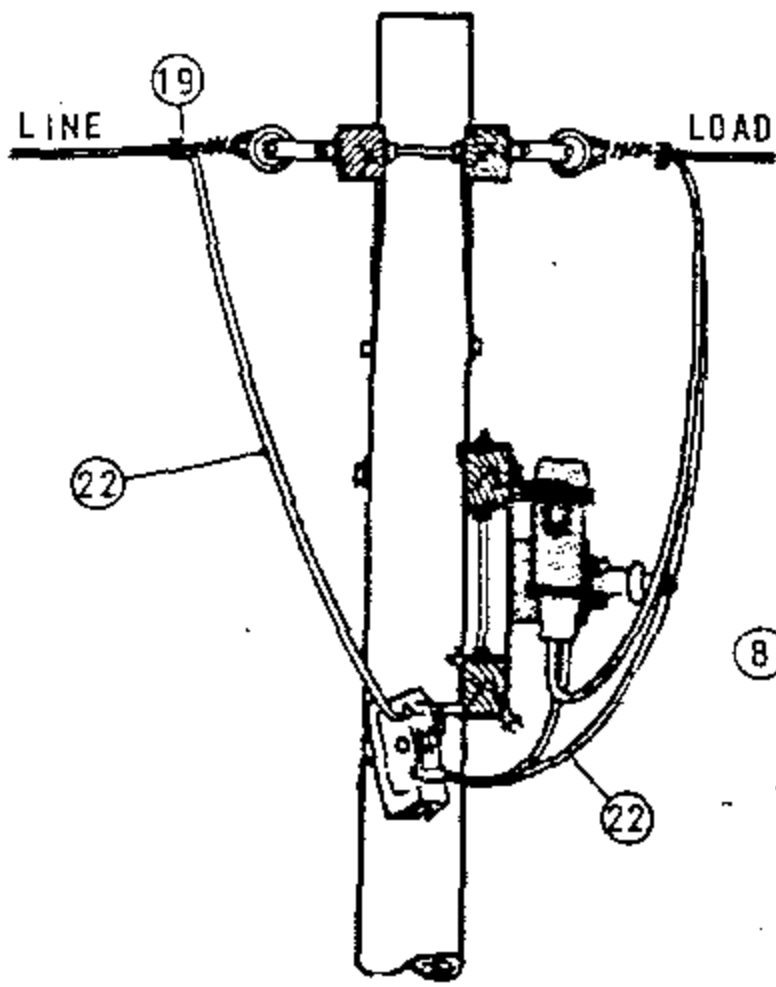

ELEVATION - LOAD SIDE

FOR FIELD MAINTENANCE ONLY

NOTE:
 (A) NOT REQUIRED WHERE METER BOX HAS HUB.

ITEM	DESCRIPTION	QUANTITY	STOCK NO. OR CONSTR STD	ITEM	DESCRIPTION	QUANTITY	STOCK NO. OR CONSTR STD
1	CROSSARM, 3 1/2" X 4 1/2" X 8' - 0"	2	PG 111 IT. 6	21			
2	BRACE, FLAT CROSSARM 28"	2	164192	22	WIRE, WP STRANDED COPPER, 5KV (SAME SIZE AS PRIMARY)	34'	700 SECTION
3	BOLT, SPACE 5/8" X "	2	PG 139	23	WIRE, #12 TYPE TW CODED CU 5 CONDUCTORS 46" EACH	230'	-
4	BOLT, MACH 5/8" X "	2	PG 139	24	BODY, CONDUIT, 3/4" PVC TYPE 'T', BLANK COVER	1	147664
5	BOLT, MACH 3/8" X 4 1/2"	4	154368	25	BODY, CONDUIT 3/4" PVC TYPE LB, BLANK COVER (A)	1	146384
6	SCREW, LAG 1/2" X 4"	1	621568	26	CONDUIT, 3/4" PVC SCH 80	31'	251520
7	WASHER, 3/8" ROUND	4	800288	27	CONDUIT, 1" PVC SCH 40	5'	251200
8	WASHER, 3" SQUARE FLAT	12	799072	28	CONDUIT, 2" PVC SCH 40	20'	251296
9	SIGN, HIGH VOLTAGE	1	647648	29	STRAP, 3/4" PIPE & 2-100 NAILS	7	697888, 491392
10	NAILS, ROOFING #8 GALV	8	492224	30	STRAP, 1" PIPE & 2-80 NAILS	3	697792, 491584
11	POLE STEPS	16	692992	31	STRAP, 2" PIPE & 2-100 NAILS	12	697856, 491392
12				32	ROD & CLAMP, GROUND	1	630072, 230016
13				33	MOULDING, HARDWOOD	3'	487200
14	TRANSFORMER, CURRENT WEST. TYPE CTD 5KV 5A, HANGERS & BOLTS	2	-	34			
15	TRANSFORMER, POTENTIAL WEST TYPE PTD 2400/120V, HANGER & BOLTS	2	-	35	STAPLES, MOULDING	2	678560
16	METER, THREE PHASE POWER	1	-	36			
17	CABINET, METER TEST SWITCH; LAG SCREWS FOR MOUNTING	1	161312	37	NAILS, 20D GALV	4	491456
18	CUTOUT, 5KV	2	PG 1211	38	STAPLES, FENCE 1 1/4" GALV	6	678528
19	CONNECTORS, SPLIT BOLT	9	PG 787				
20	WIRE, #6 BR STRANDED COPPER	18'	813536				

SDG & E ELECTRIC STANDARDS

POLETOP METERING, 2.4KV OPEN DELTA

1499.802
 SUPERSEDES
 1482 (2-28-82)

DATE 2-28-83
 APPD *WJ/ARH*

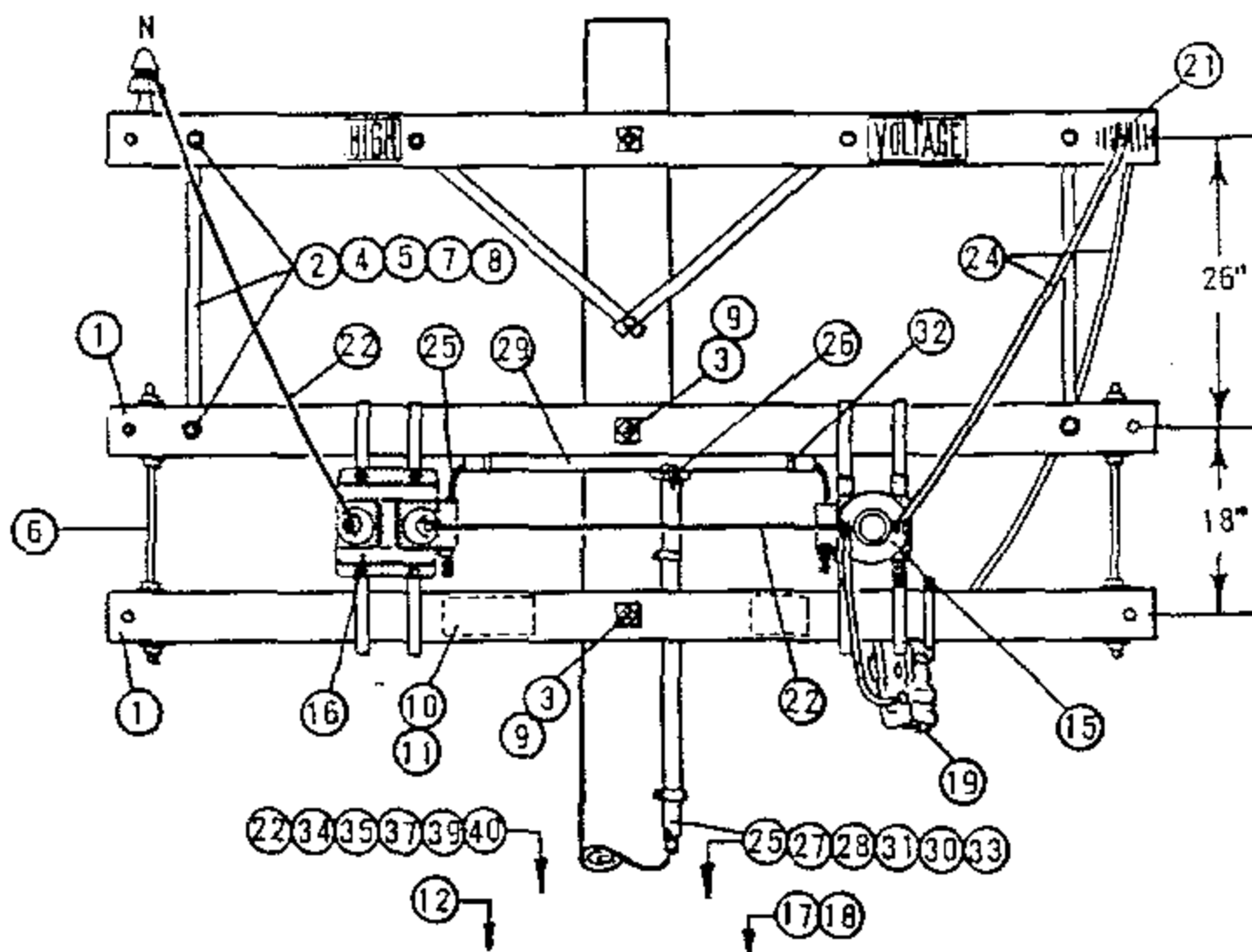

ELEVATION - LOAD SIDE

FOR FIELD MAINTENANCE ONLY

NOTE:

(A) NOT REQUIRED WHERE METER BOX HAS HUB.

ITEM P T F	M I	DESCRIPTION	QUANTITY	STOCK NO. OR CONSTR STD	ITEM P T F	M I	DESCRIPTION	QUANTITY	STOCK NO. OR CONSTR STD
2		BRACE, FLAT CROSSARM 28"	2	164192	25		WIRE, #12 TYPE TW CODED COPPER, 3 CONDUCTORS, 41' EACH	123'	-
3		BOLT, MACH 5/8" X 14"	2	154880	26		BODY, CONDUIT, 3/4" PVC TYPE "T", BLANK COVER	1	147664
4		BOLT, MACH 1/2" X 5"	2	153024	27		BODY, CONDUIT, 3/4" PVC TYPE LB, BLANK COVER (A)	1	146384
5		BOLT, MACH 3/8" X 4 1/2"	4	154368	28		CONDUIT, 3/4" PVC SCH 80	3'	251520
6		BOLT, SPACE 5/8" X 24"	2	156640	29		CONDUIT, 1" PVC SCH 40	4'	251200
7		WASHER, 1/2" ROUND	2	800192	30		CONDUIT, 2" PVC SCH 40	20'	251296
8		WASHER, 3/8" ROUND	4	800288	31		STRAP, PIPE 3/4" & 2-100 GALV NAILS	7	697888.491392
9		WASHER, 3" SQ FLAT	12	799072	32		STRAP, PIPE 1" & 2-80 GALV. NAILS	3	697792.491584
10		SIGN, HIGH VOLTAGE	1	647648	33		STRAP, PIPE 2" & 2-100 GALV NAILS	12	697856.491392
11		NAILS, ROOFING #8 GALV	8	492224	34		ROD, AND CLAMP, GROUND	1	630072.230016
12		POLE STEP	16	692992	35		MOULDING, HARDWOOD	3'	487200
13					36				486976.487008
14					37		STAPLES, MOULDING 3" X 1 1/16" X 1/4"	2	678560
15		TRANSFORMER, CURRENT WEST. TYPE WO 5KV, 5A	1	-	38				
16		TRANSFORMER, POTENTIAL, WEST. PTO, 2400/120V, HANGERS & BOLTS	1	-	39		NAILS, 20D, GALV	4	491456
17		METER, SINGLE PHASE POWER	1	-	40		STAPLES, FENCE 1 1/4" GALV	5	678528
18		CABINET, METER, TEST SWITCH, LAG SCREWS	1	161312	41				
19		CUTOUT, 5KV	2	PG 1211	42				
20									
21		CONNECTORS, SPLIT BOLT	7	PG 787					
22		WIRE, #6 BARE STRANDED COPPER	20'	819536					
23			10'	194304					

SDG & E ELECTRIC STANDARDS

DATE 2-28-83
APPD *WNT/ARH*

POLETOP METERING, 4KV SINGLE PHASE

1499.803
SUPERSEDES
1483 (2-28-83)

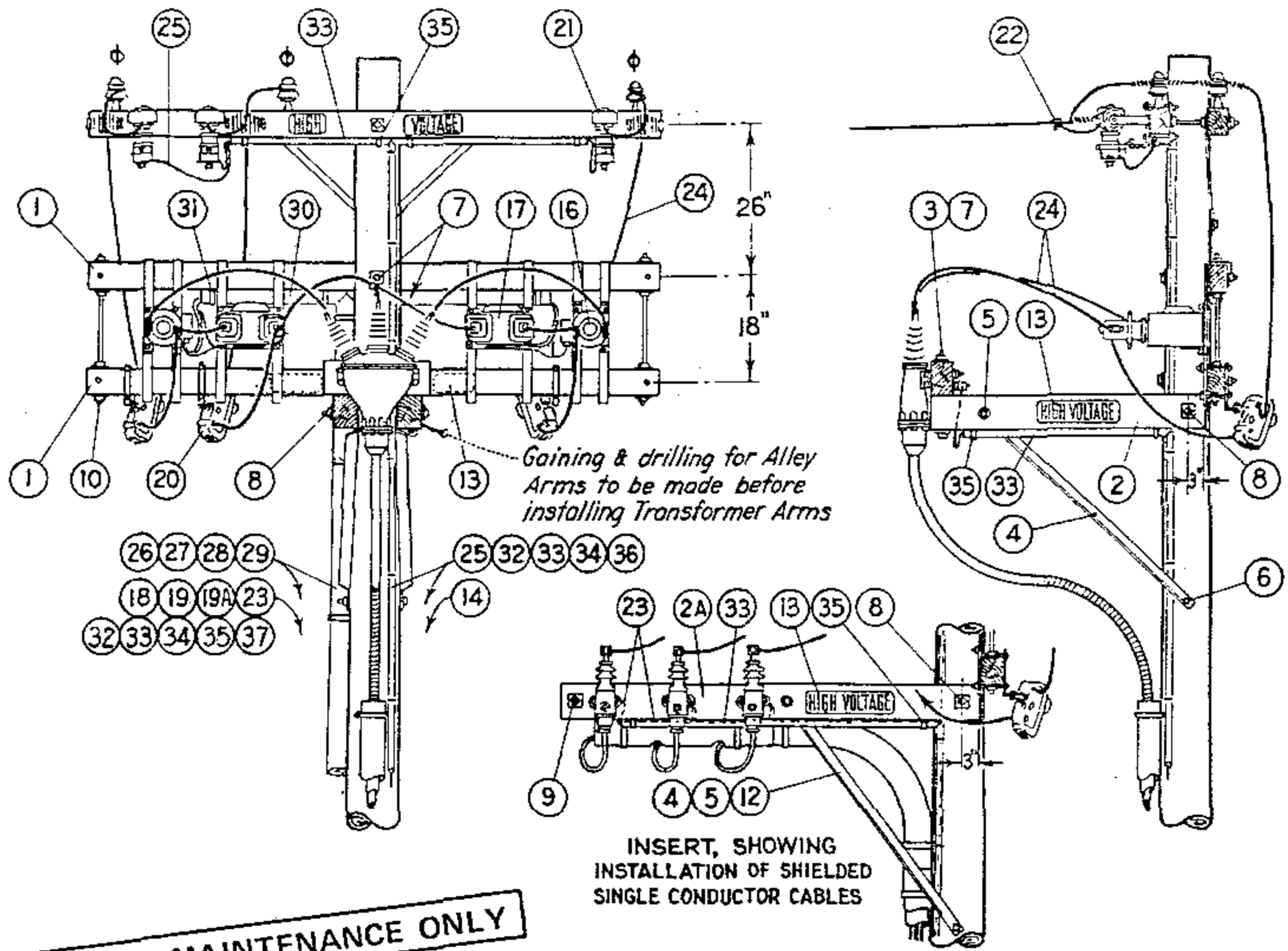

FOR FIELD MAINTENANCE ONLY

UNDERGROUND SERVICE

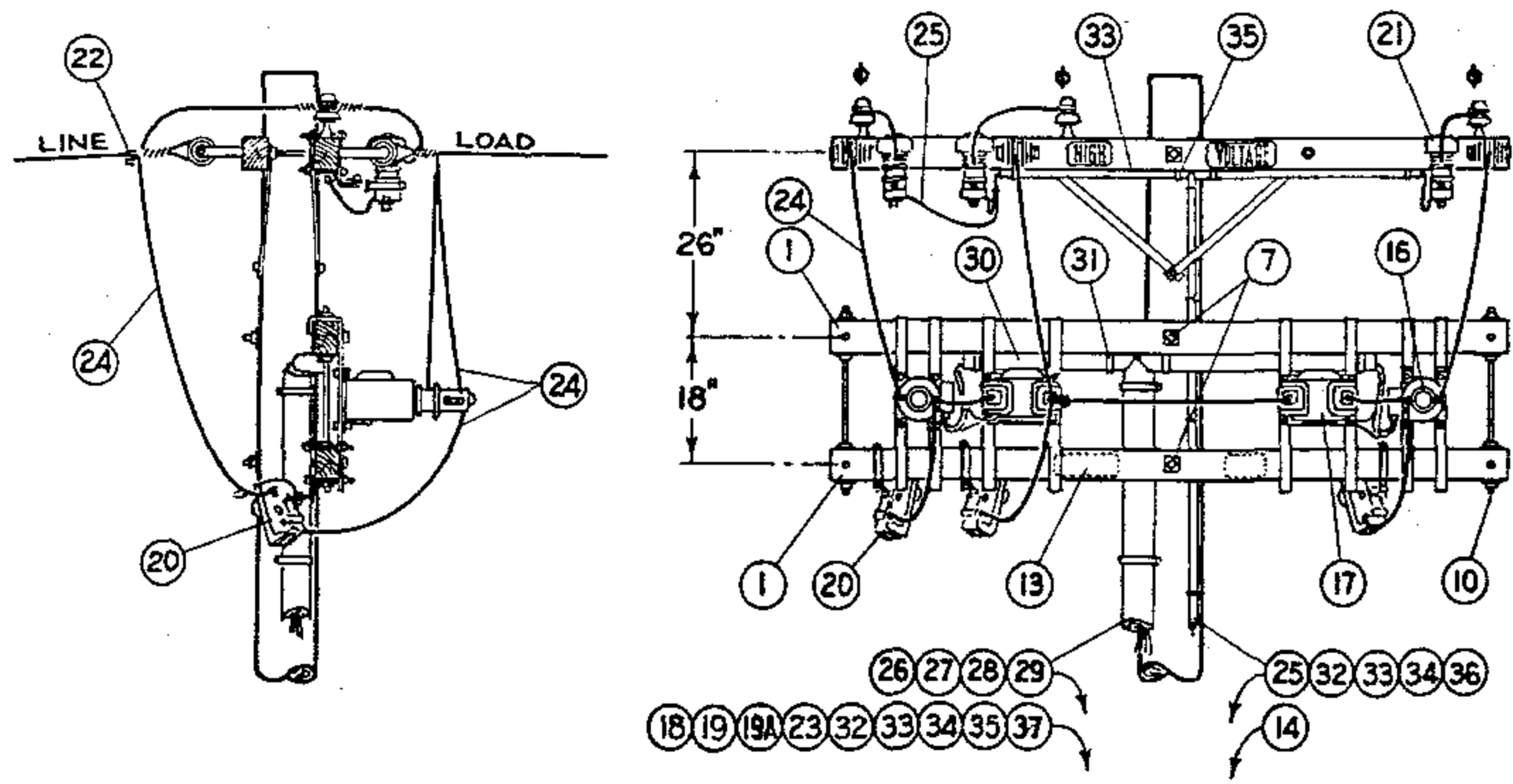

OVERHEAD SERVICE

SDG & E ELECTRIC STANDARDS

POLETOP METERING INSTALLATION, 4KV, 3 PHASE,
3 WIRE UG & OH SERVICES

1499.804
SUPERSEDES
1484.1 (2-28-83)

DATE 2-28-83
APPD *ONT/KR4*

FOR FIELD MAINTENANCE ONLY

NOTES:

- (A) USE ONLY ONE GROUND ROD FOR LIGHTNING ARRESTER GROUND AND ONE GROUND ROD FOR METER GROUND WHERE A RESISTANCE OF LESS THAN 25 OHMS CAN BE OBTAINED WITH EACH ROD.
- (B) DOUBLE METER CABINETS ARE REQUIRED FOR RKYAH METERING INSTALLATIONS.
- (C) UNTWIST SUFFICIENT LENGTH OF #2 STRANDED WIRE TO CONNECT EACH ARRESTER AND POTHEAD GROUND WITH A SINGLE STRAND.

ITEM	DESCRIPTION	QUANTITY			STOCK NO. OR CONSTR STDS	
		U.G. SERVICE		O.H.		
		P.I.L.C.	RUBBER LIKE	SERV.		
P. T. & F.	1	3 1/2" x 4 1/2" x 8'-0" Crossarm, 6 Pin	2	2	2	PG 111 IT. 2
	2	3 3/4" x 5 3/4" x 4'-0" Pothead Alley Arm	2	-	-	PG 112 IT. 3
	2A	3 3/4" x 5 3/4" x 6'-0" (10 Pin arm, cut in half)	-	2	-	PG 111 IT. 4
	3	3 3/4" x 5 3/4" x 18" Wood Block, Pothead Support	1	-	-	-
	4	Pothead Alley Arm Brace, 4'-0"	2	1	-	163808
	5	Mach. Bolt, Galv. 5/8" x 5", 1 rd. Washer & 1 Nut	2	1	-	PGS 139, 140
	6	Mach. Bolt, Galv., 5/8" x 10"	1	-	-	PGS 139, 154816
	7	Mach. Bolt, Galv. 5/8" x 14", 2 Sq. Washers & 1 Nut	4	2	2	PGS 139, 140
	8	Mach. Bolt, Galv. 5/8" x 18", 2 Sq. Washers & 1 Nut	1	1	-	PGS 139, 140
	9	Space Bolt, Galv. 5/8" x 20", 4 Sq. Washers & 4 Nuts	-	1	-	PGS 139, 140
	10	Space Bolts, Galv. 5/8" x 26", 4 Sq. Washers & 4 Nuts	2	2	2	PGS 139, 140
	11					
	12	Lag Screw, Galv. 5/8" x 5"	-	1	-	621600
	13	High Voltage Sign & Galv. Roofing Nails	3	3	1	647648, 492224
	14	Pole Steps	16	16	16	692992
15						
M. I.	16	Current Transformer, 5 Kv, Hangers & Bolts	2	2	2	-
	17	Potential Transformers, 4800/120V, Hangers & Bolts	2	2	2	-
	18	Meter Three Phase Power	1	1	1	-
	19	Meter Cabinet; Single, 15" x 30" x 10 1/2"; Double, 30" x 30" x 10 1/2"; Lag Screws for Mounting (B)	1	1	1	SINGLE 161312. DOUBLE 161184
	19A	Test Switch	1	1	1	710880-711008
	20	Cutout, Expulsion Fuse	3	3	3	PG 1211
	21	Lightning Arrester, 3 Kv.	3	3	3	113216
	22	Wire Connectors	5	5	8	PGS 783, 786
	23	#6 Bare Stranded Copper Wire, Meter Ground	14'	14'	14'	813536
	24	Bare Stranded Copper Wire, Size as Required	35'	35'	50'	PGS 715, 716, 717
	25	#2 Bare Stranded Copper Wire, L.A. Pothead Ground (C)	52'	52'	52'	813664
	26	#12 Type TW Coded Wire, 5 Conductors, 40' Each	200'	200'	200'	-
	27	Redwood Moulding	26'	26'	26'	PG 143 IT 1
	28	Moulding Straps, Galv.	13	13	13	697024
	29	3/4" Conduit, Rigid Iron; Pipe Strap & 2-8d Nails, Galv.	10'	10'	10'	251008, 696704
	30	2" Fibre Conduit	5'	5'	5'	251618
	31	2" Fibre Conduit Strap & 2-8d Nails, Galv.	4	4	4	PG 143, 491584
	32	Ground Rod and Clamp, incl. Conduit Ground Clamp (A)	4	4	4	603072, 230016
	33	Hardwood Moulding	52'	54'	49'	487200
	34	Moulding Staples, Galv., 3" x 1 1/8" x 1/4"	24	22	22	678560
	35	3/4" Pipe Straps, Galv. & 2 8d Nails, Galv.	8	9	6	697888, 491584
	36	1/4" Fence Staples, Galv.	14	12	12	678528
	37	3/4" Type "LB" Condulet	1	1	1	146144
38						

SDG & E ELECTRIC STANDARDS

**POLETOP METERING INSTALLATION, 4KV, 3 PHASE,
3 WIRE UG & OH SERVICES**

DATE 2-28-83

APPD *JAT/ARH*

1499.805

SUPERSEDES
1484.2 (2-28-83)

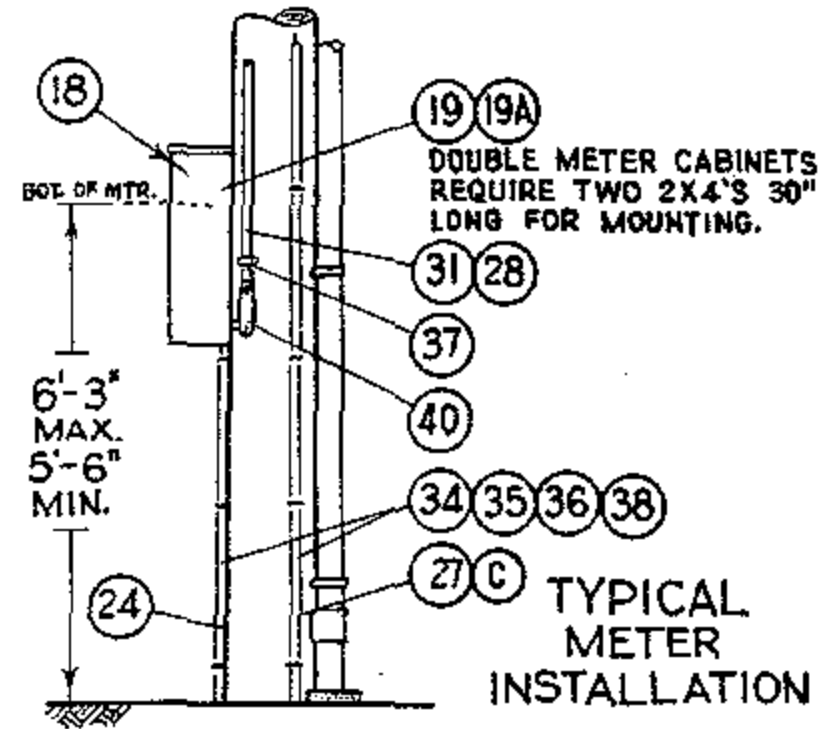
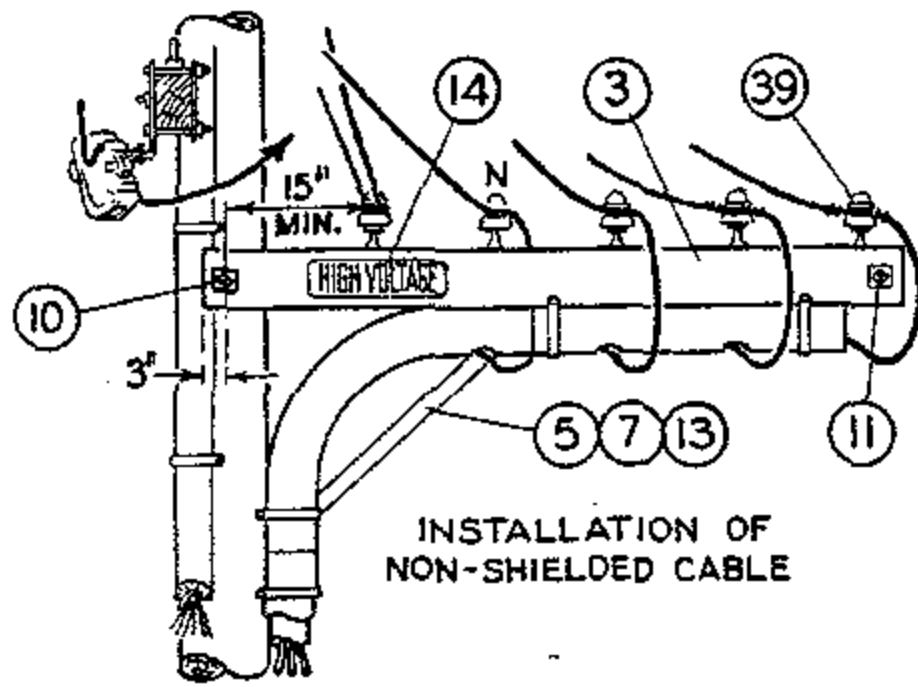

FOR FIELD MAINTENANCE ONLY

NOTES:

- (A) USE ONLY ONE GROUND ROD FOR LIGHTNING ARRESTER GROUND AND ONE GROUND ROD FOR METER GROUND WHERE A RESISTANCE OF LESS THAN 25 OHMS CAN BE OBTAINED WITH EACH ROD.
- (B) DOUBLE METER CABINETS ARE REQUIRED FOR RKVH METERING INSTALLATIONS.
- (C) UNTWIST SUFFICIENT LENGTH OF #2 STRANDED WIRE TO CONNECT EACH ARRESTER AND POTHEAD GROUND WITH A SINGLE STRAND.

ITEM	DESCRIPTION	QUANTITY				STOCK NO. OR CONSTR STDS
		U. G. SERVICE			O. H. SERV.	
		P. I. L. C.	SHIELD.	NON SHIELD.		
1	3 3/4" x 5 3/4" x 10'- 0" Standard Arm	2	2	2	2	PG 119 IT. 2
2	3 3/4" x 5 3/4" x 4'- 0" Pothead Alley Arm	2	-	-	-	PG 112 IT. 3
3	3 3/4" x 5 3/4" x 12'- 0" (12Kv. Arm, Cut in Half	-	1	1	-	PG 119 IT. 4
4	3 3/4" x 5 3/4" x 18" Wood Block, Pothead Support	1	-	-	-	-
5	Pothead Alley Arm Brace, 4'- 0"	2	1	1	-	16 38 08
6						
7	Machine Bolt, Galv., 5/8" x 5", 1 Round Washer & Nut	2	1	1	-	PGS 139, 140
8	Machine Bolt, Galv., 5/8" x 10"	1	-	-	-	PGS 139, 140
9	Machine Bolt, Galv., 5/8" x 14", 2 Square Washers & Nut	4	2	2	2	PGS 139, 140
10	Machine Bolt, Galv., 5/8" x 18", 2 Square Washers & Nut	1	1	1	-	PGS 139, 140
11	Space Bolt, Galv., 5/8" x 20", 4 Square Washers & 4 Nuts	-	1	1	-	PGS 139, 140
12	Space Bolt, Galv., 5/8" x 26", 4 Square Washers & 4 Nuts	2	2	2	2	PGS 139, 140
13	Lag Screw, Galv., 5/8" x 5"	-	1	1	-	6 2 16 00
14	High Voltage Sign & Galv. Roofing Nails	3	3	3	1	6 4 7 6 4 8, 4 9 2 2 2 4
15	Pole Steps	16	16	16	17	6 9 2 9 9 2
16	Current Transformer, 5Kv., Hangers & Bolts	3	3	3	3	-
17	Potential Transformer, 2400/120V, Hangers & Bolts	3	3	3	3	-
18	Meter, Three Phase, Maximum Demand and/or Rkvah Recording	1	1	1	1	-
19	Meter Cabinet; Single, 15" x 30" x 10 1/2"; Double, 30" x 30" x 10 1/2", Four Lag Screws for Mounting	(B) 1	1	1	1	SINGLE 16 1 3 1 2, DOUBLE 16 1 1 8 4
19A	Test Switch	1	1	1	1	7 1 0 8 8 0 - 7 1 1 0 0 8
20	Cutout, Expulsion Fuse	3	3	3	3	PG 12 1 1
21	Lightning Arrester, 3Kv.	3	3	3	3	1 1 3 2 1 6
22	Standoff Bracket	-	-	-	2	1 6 5 1 4 4
23	Wire Connectors	6	6	6	13	PGS 7 8 3, 7 8 6
24	#8 Bare Stranded Copper Wire, Meter Ground	14'	14'	14'	14'	8 1 3 5 3 6
25	Bare Stranded Copper Wire, Same Size as Line Neutral	14'	14'	14'	14'	PGS 7 1 5-7 1 7
26	Bare Stranded Copper Wire, Size as Required	47'	52'	33'	33'	PGS 7 1 5-7 1 7
27	#2 Bare Stranded Copper Wire, L. A. & Pothead Ground	(C) 52'	52'	52'	52'	8 1 3 6 6 4
28	#12 Type TW Coded Wire, 7 Conductors, 40' Each	280'	280'	280'	280'	-
29	Redwood Moulding	20'	20'	20'	20'	PG 1 4 3 IT 1
30	Moulding Strap, Galv.	11	11	11	11	6 9 7 0 2 4
31	3/4" Conduit, Rigid Iron; Pipe Straps & 8d Nails; Galv.	10'	10'	10'	10'	2 5 1 0 0 8, 6 9 6 7 0 4, 4 9 1 5 8 4
32	2" Fibre Conduit	8'	8'	8'	8'	2 5 1 6 1 6
33	2" Fibre Conduit Straps & 2 8d Nails; Galv.	6	6	4	4	PG 1 4 3, 4 9 1 5 8 4
34	Ground Rod & Clamp, Including Conduit Ground Clamp	(A) 4	(A) 4	(A) 4	(A) 4	6 0 3 0 7 2, 2 3 0 0 1 6
35	Hardwood Moulding, 1"	52'	55'	49'	49'	4 8 7 2 0 0
36	Moulding Staples, Galv., 3" x 1 1/8" x 1/4"	25	25	25	25	6 7 8 5 6 0
37	3/4" Pipe Straps, Galv. & 2 8d Nails, Galv.	8	9	8	8	6 9 7 8 8 8, 4 9 1 5 8 4
38	1 1/4" Fence Staples, Galv.	14	12	12	12	6 7 8 5 2 8
39	Insulator, 4Kv. and Steel Pin	2	2	5	2	PG 7 5 0, 5 3 2 6 0 8
40	3/4" Type "LB" Condulet	1	1	1	1	1 4 6 1 4 4
41						
42						

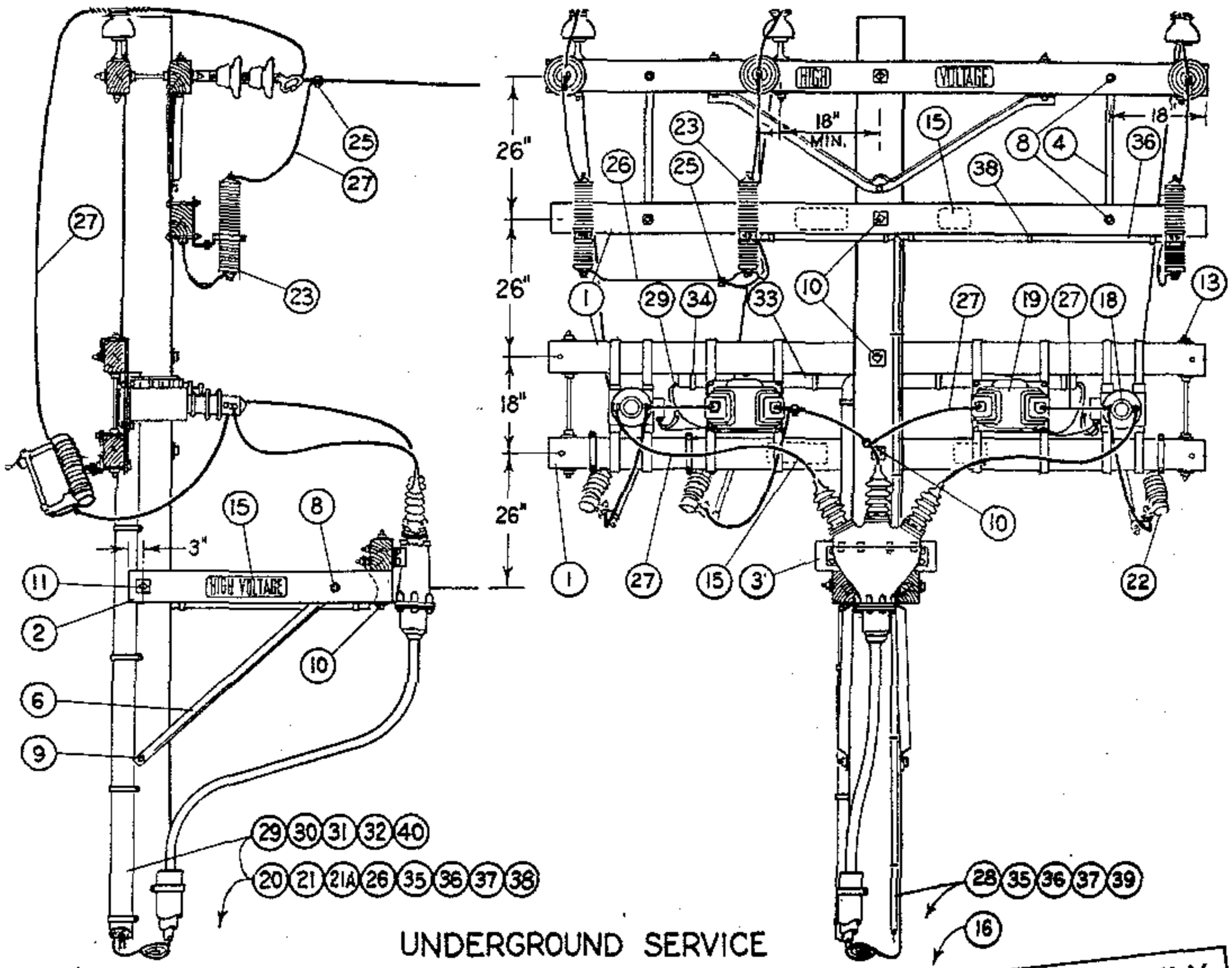

UNDERGROUND SERVICE

FOR FIELD MAINTENANCE ONLY

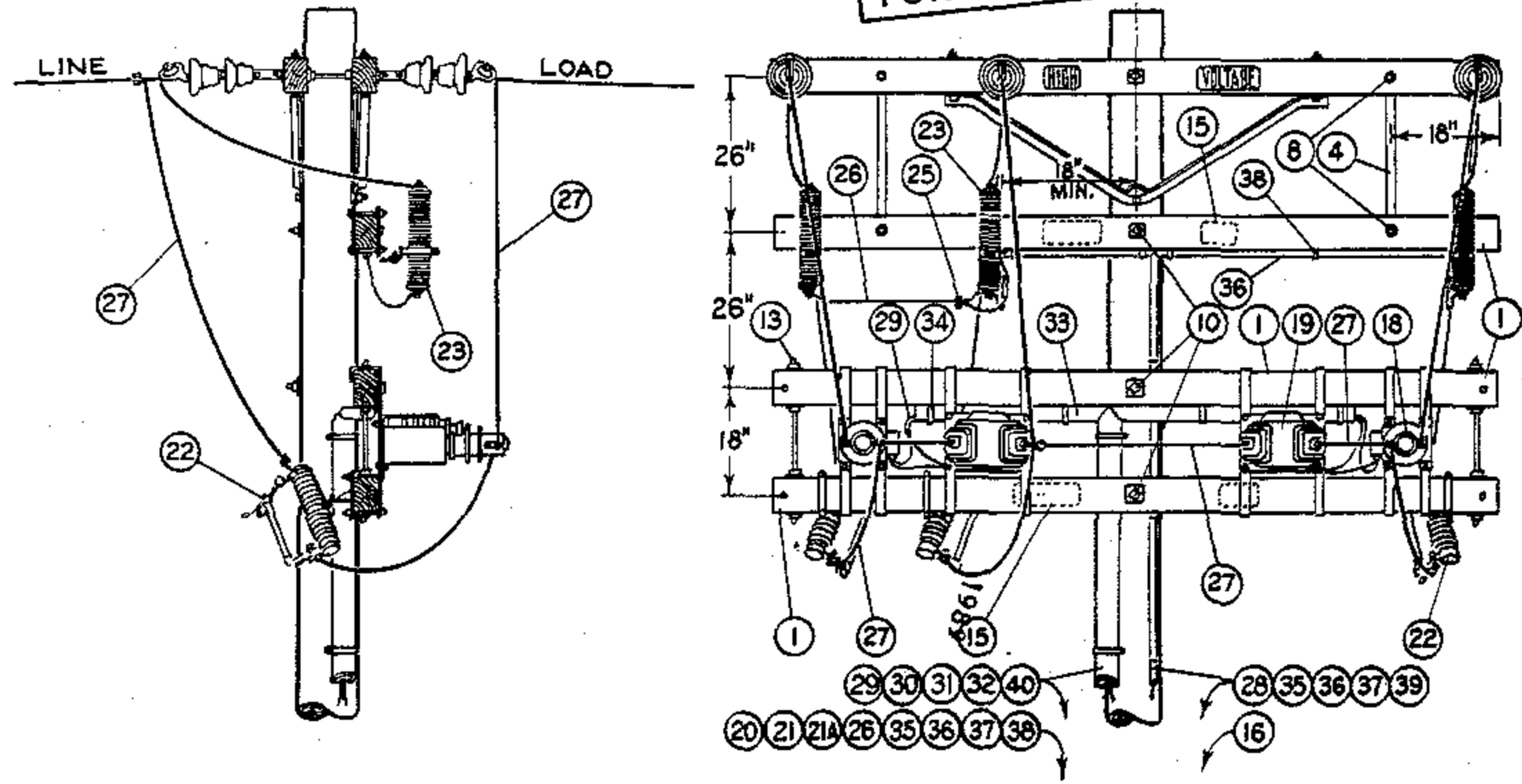

OVERHEAD SERVICE

SDG & E ELECTRIC STANDARDS

POLETOP METERING INSTALLATION, 12KV, 3 PHASE,
3 WIRE U.G. & O.H. SERVICES

1499.808
SUPERSEDES
1486.1 (2-28-83)

DATE 2-28-83
APPD *[Signature]*

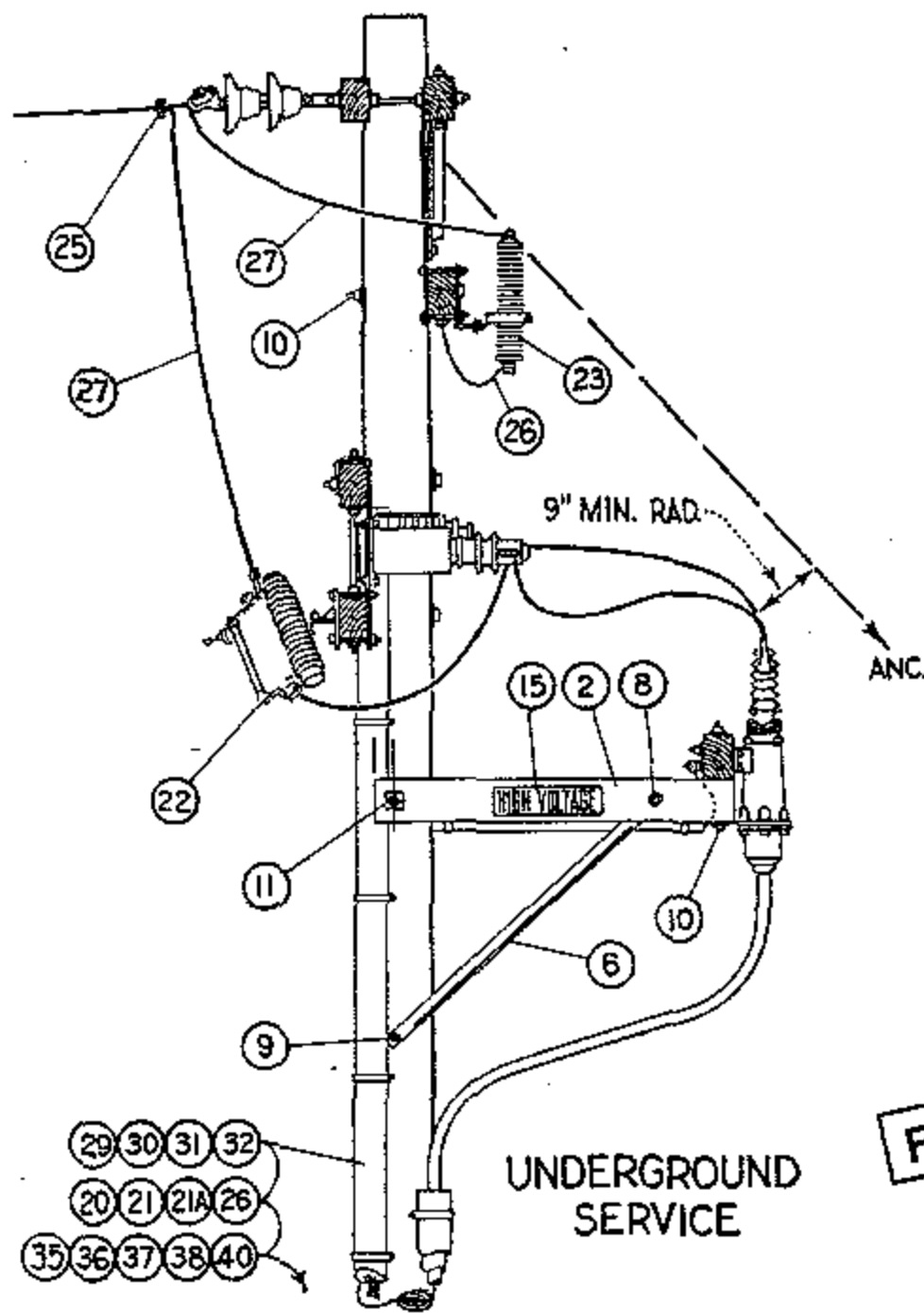

FOR FIELD MAINTENANCE ONLY

NOTES:

- (A) USE ONLY ONE GROUND ROD FOR LIGHTNING ARRESTER GROUND AND ONE GROUND ROD FOR METER GROUND WHERE RESISTANCE OF LESS THAN 25 OHMS CAN BE OBTAINED WITH EACH ROD.
- (B) DOUBLE METER CABINETS ARE REQUIRED FOR RKVH METERING INSTALLATIONS.

ITEM	DESCRIPTION	QUANTITY		STOCK NO. OR CONSTR STDS
		U.G. SERV.	O.H. SERV.	
P. 1	3 3/4" x 5 3/4" x 10'-0" Standard Arm	3	3	PG 119 IT. 2
2	3 3/4" x 5 3/4" x 4'-0" Pothead Alley Arm	2	-	PG 112 IT. 3
3	3 3/4" x 5 3/4" x 22" Wood Block, Pothead Support	1	-	-
4	Flat Crossarm Brace, 36"	2	2	164224
5				
6	Pothead Alley Arm Brace, 4'-0"	2	-	163808
7				
8	Mach. Bolt, Galv., 5/8" x 5", 1 rd Washer, & 1 Nut	9	4	PGS 139, 140
9	Mach. Bolt, Galv., 5/8" x 10"	1	-	PGS 139, 140
10	Mach. Bolt, Galv., 5/8" x 14", 2 Sq. Washers & 1 Nut	5	3	PGS 139, 140
11	Mach. Bolt, Galv., 5/8" x 18", 2 Sq. Washers & 1 Nut	1	-	PGS 139, 140
12				
13	Space Bolt, Galv., 5/8" x 26", 4 Sq. Washers & 4 Nuts	2	2	PGS 139, 140
14				PGS 1212, 1213
15	High Voltage Sign & Galv. Roofing Nails	2	2	647648, 492224
16	Pole Steps	14	15	692992
17				
18	Current Transformer, 15 KV, Hangers & Bolts	2	2	-
19	Potential Transformer, 12000/120 v, Hangers & Bolts	2	2	-
20	Meter, Three Phase Power	1	1	-
21	Meter Cabinet; Single, 15" x 30" x 10 1/2"; Double, 30" x 30" x 10 1/2"; Lag Screws for Mounting	(B) 1	1	SINGLE 161312, DOUBLE 161184
21A	Test Switch	1	1	710880-711008
22	Cutout, Expulsion Fuse	3	3	PGS 1212, 1213
23	Lightning Arrester, 12 Kv.	3	3	113216
24				
25	Wire Connectors	5	8	PGS 783, 786
26	#6 Bare Stranded Copper Wire - Meter Grnd. & L.A. Lateral	27'	27'	813536
27	Bare Stranded Copper Wire, Size as Required	55'	65'	PGS 715-717
28	#2 Bare Stranded Copper, Lightning Arrester Ground	54'	45'	813664
29	#12 Type TW Coded Copper Wire, 5 Conductors @ 34"	170'	170'	-
30	Redwood Moulding, C-54.1 #1	16'	16'	PG 143 IT. 1
31	Moulding Strap, Galv., C-54.1 #1A	8	8	697024
32	3/4" Conduit, Rigid Iron; Pipe Strap & 2-8d Nails, Galv.	10'	10'	251008, 696704, 491584
33	2" Fibre Conduit	6'	6'	251616
34	2" Pipe Straps & 2-8d Nails, Galv.	4	4	697856, 491584
35	Ground Rod & Clamp	(A) 4	(A) 4	603072, 230016
36	Hardwood Moulding, 1"	49'	45'	487200
37	Moulding Staples, Galv., 3" x 1 1/8" x 1/4"	30	30	678560
38	3/4" Pipe Strap & 2-8d Nails, Galv.	10	8	597888, 491584
39	1 1/4" Fence Staples, Galv.	12	12	678528
40	3/4" Type "LB" Condulet	1	1	146144

SDG & E ELECTRIC STANDARDS

DATE 2-28-83
APPD JMT/KRH

**POLETOP METERING INSTALLATION, 12KV, 3 PHASE,
3 WIRE U.G. & O.H. SERVICES**

**1499.809
SUPERSEDES
1486.2 (2-28-83)**

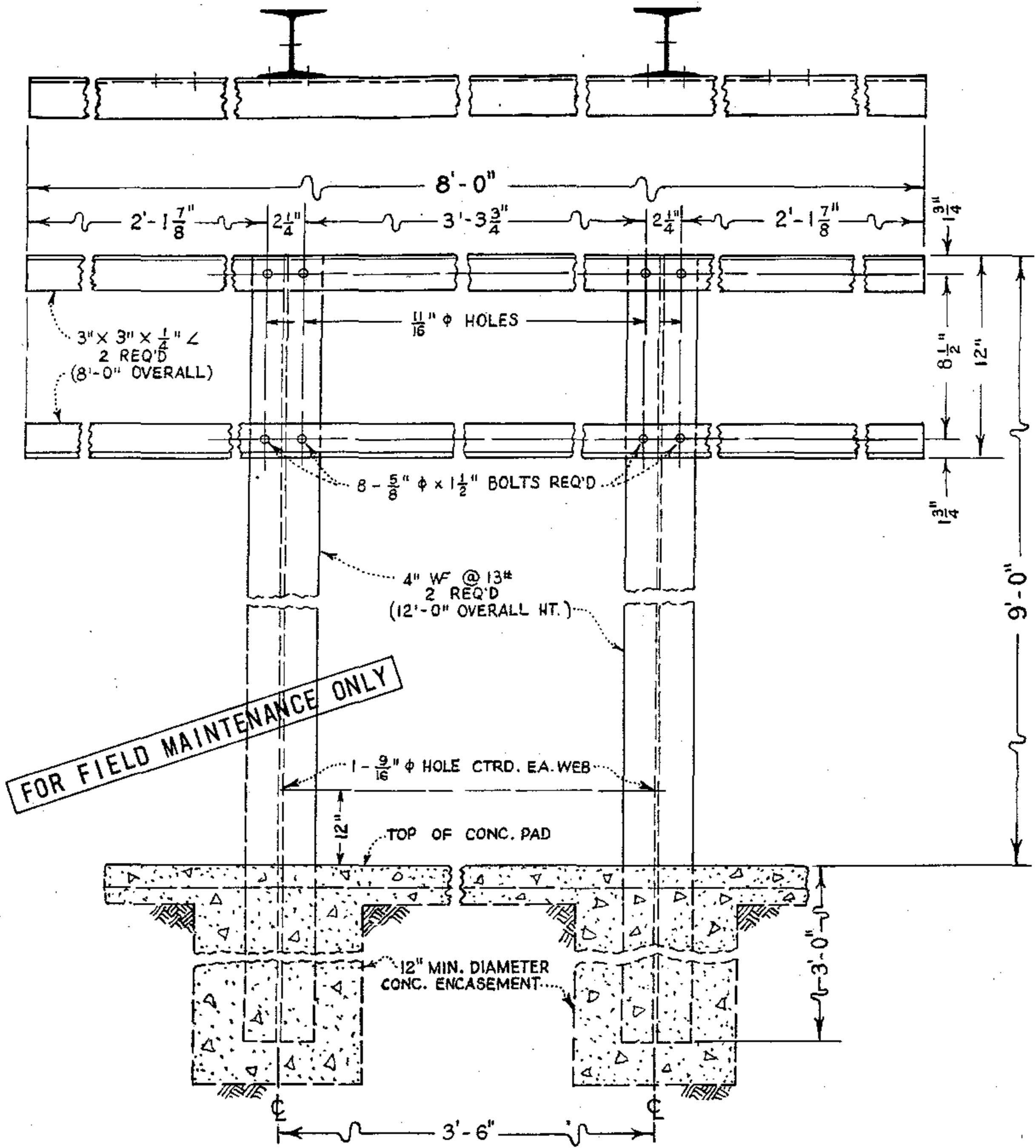

ALL STEEL TO BE HOT-DIP GALV. AFTER FABRICATION.

1499.810
SUPERSEDES
1489 (1-6-82)

SDG&E ELECTRIC STANDARDS

METERING RACK, CUSTOMER OWNED, CONSTRUCTION DETAILS

DATE 2-28-83
APPD *[Signature]*

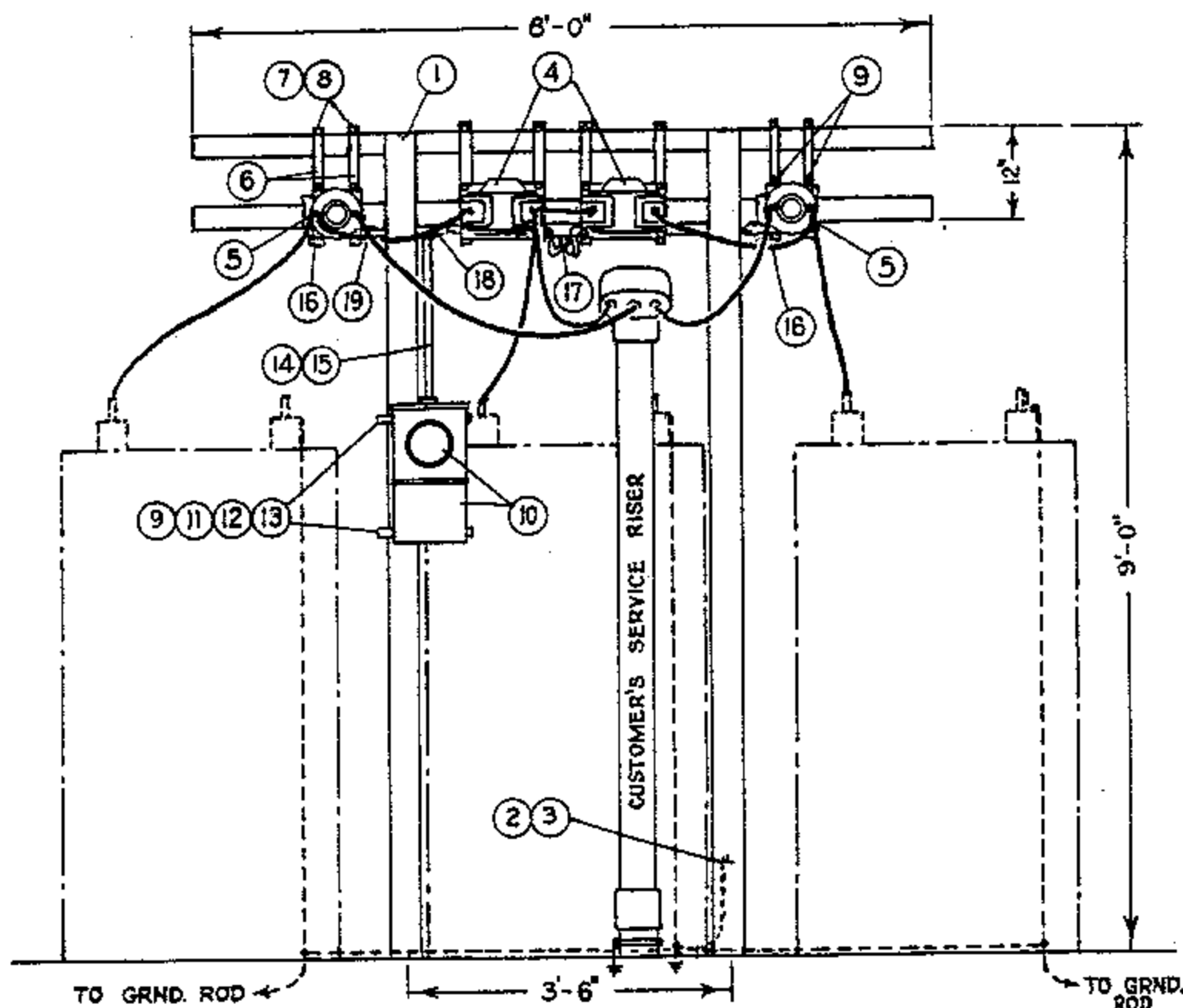

ELEVATION
3 WIRE, 3Ø SERVICE

FOR FIELD MAINTENANCE ONLY

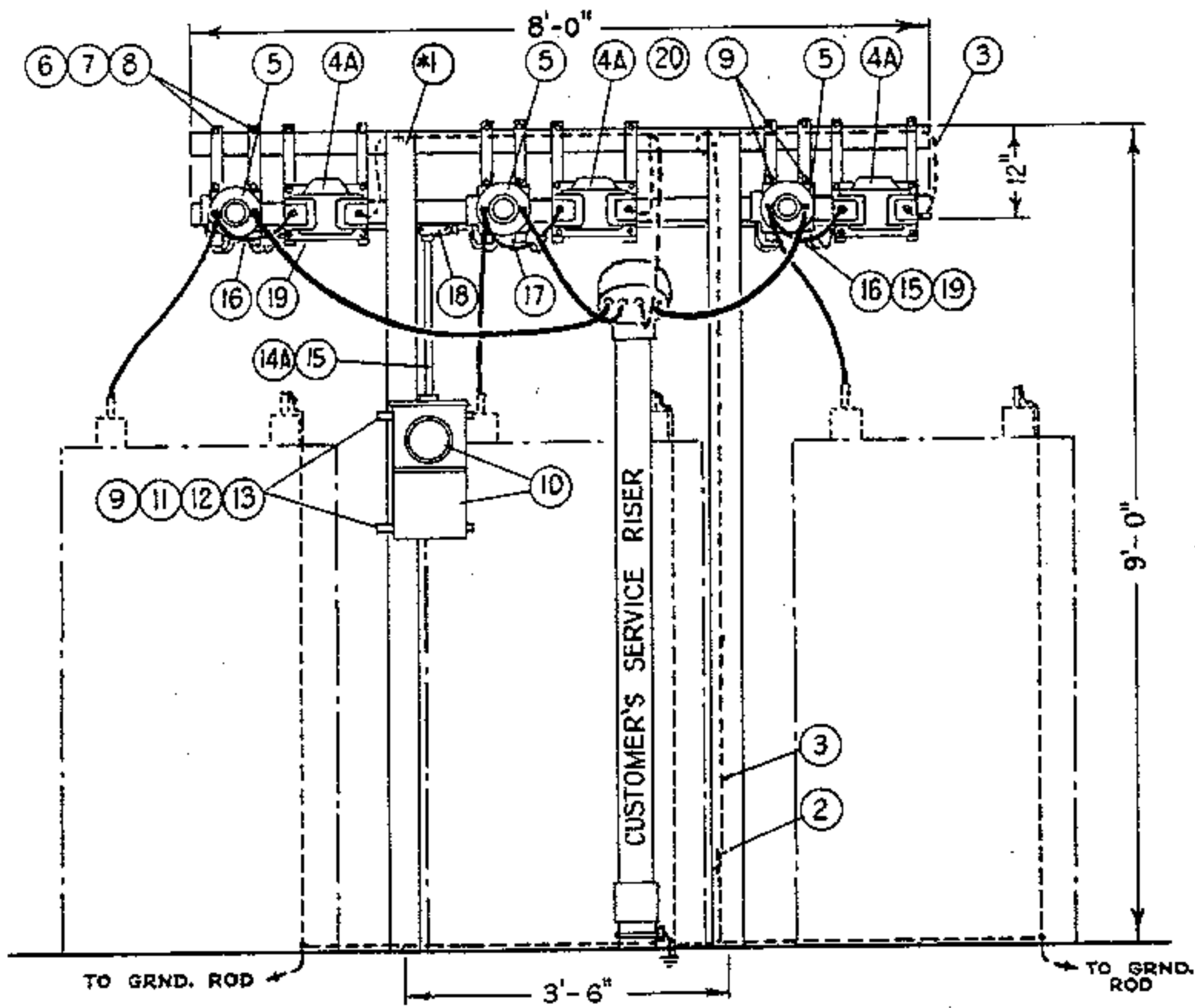

ELEVATION
4 WIRE, 3Ø SERVICE

SDG&E ELECTRIC STANDARDS

4KV METERING INSTALLATION ON RACK, FOR 3 WIRE AND 4 WIRE,
3Ø SERVICES

1499.901
SUPERSEDES
1490.1(11-16-81)

DATE 11-16-81
APPD *jes*

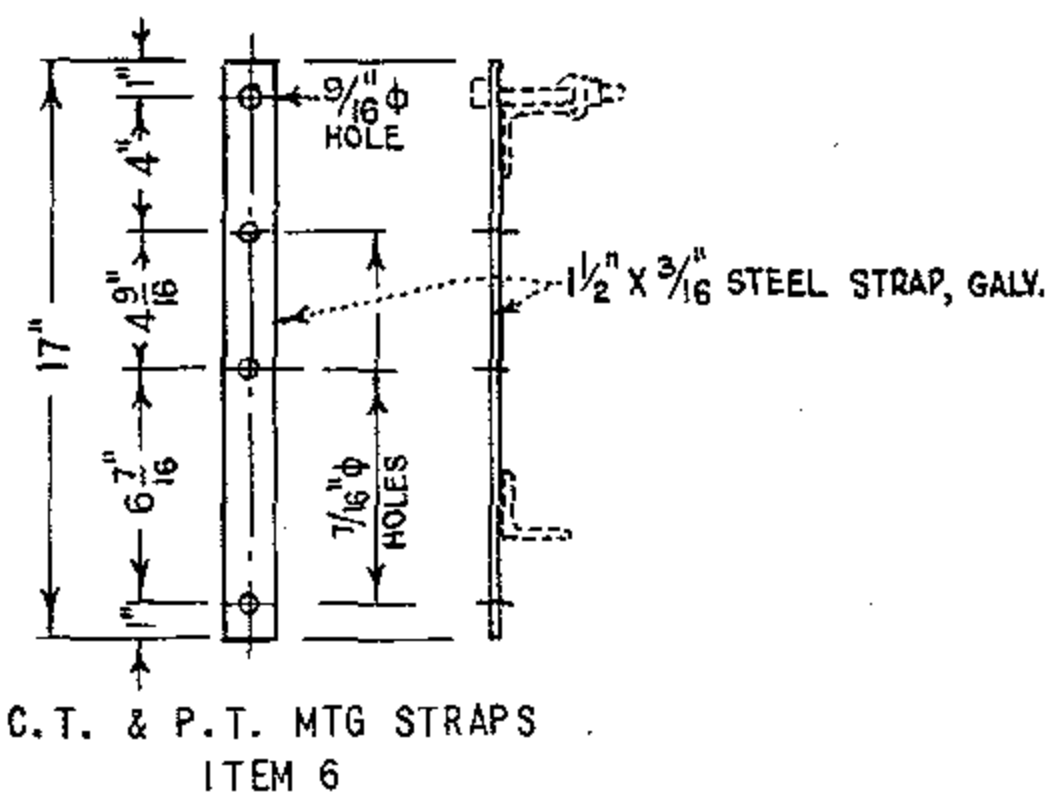
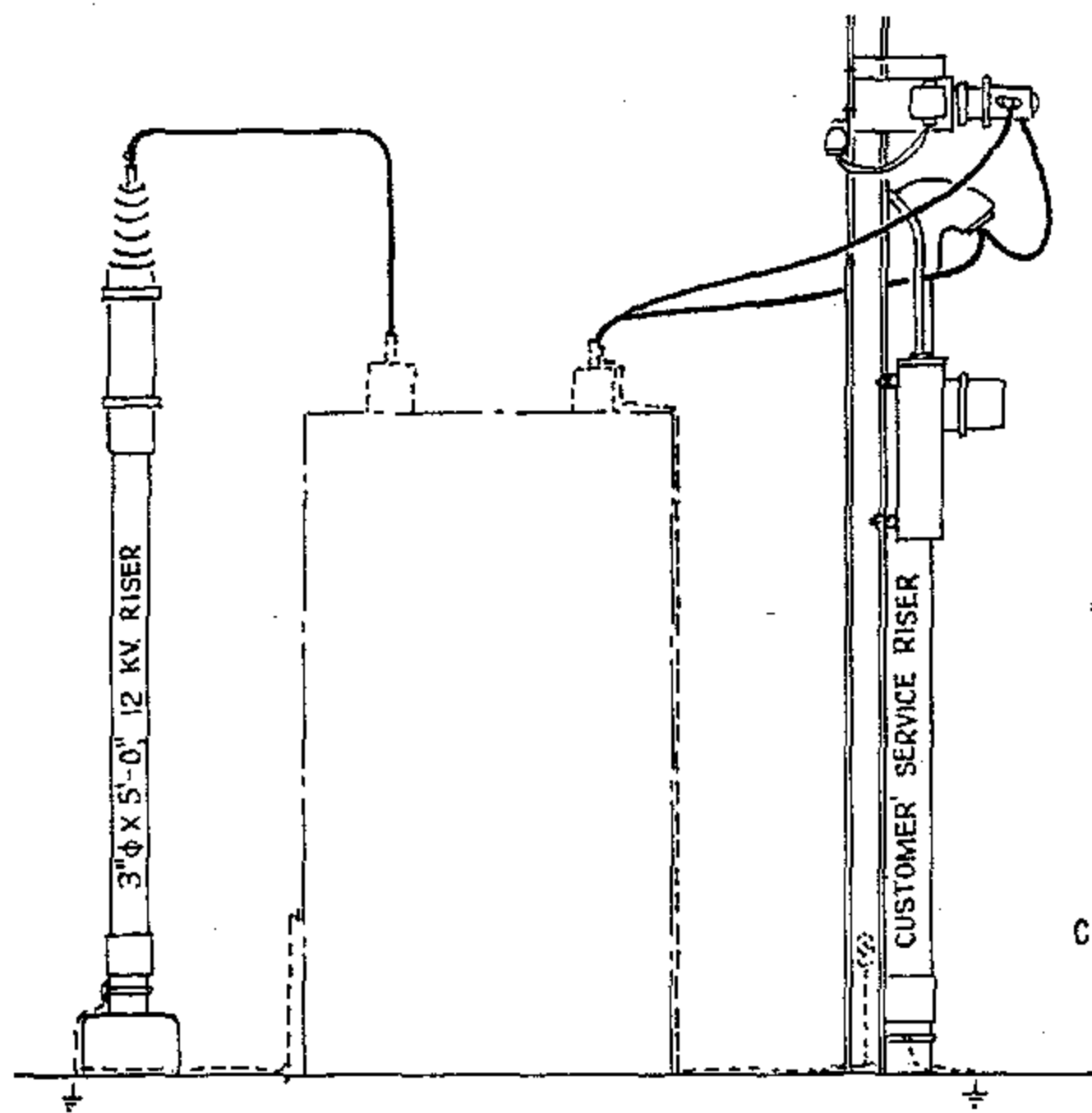

ELEVATION

FOR FIELD MAINTENANCE ONLY

NOTE:
 (A) TO BE FURNISHED AND INSTALLED BY CUSTOMER.

ITEM	DESCRIPTION	QUANTITY		STOCK NO. OR CONSTR STDS
		3 Wire	4 Wire	
1	Galv. Steel Metering Rack	(A) 1	(A) 1	PG 1479
2	Ground Connector, 1 bolt, single groove	1	1	230016
3	Ground Wire. Bare Strd. copper	5'	20'	PGS 715-716
4	Potential Transformer, 4800/120V, Base Mounted	2	-	-
4A	Potential Transformer, 2400/120V, Base Mounted	-	3	-
5	Current Transformer, 5 Kv. Base Mounted	2	3	-
6	P.T. & C.T. Straps, Galv., per detail	8	12	-
7	Mach. Bolts, Galv., 1/2" x 4", 2 washers & 1 nut	8	12	PG 139, 140
8	Nut Seats, Delta-Star	8	12	-
9	Mach. Bolts, Galv., 3/8" diam. X 1", 1 washer & 1 nut	20	24	PGS 139, 140
10	Meter & Meter Socket Box	1	1	-
11	Unistrut, type P-4000, galv.	30"	30"	-
12	Beam Grip, Delta-Star	4	4	392384
13	Cap Screw, Galv., 1/2" diam. x 13/16"	4	4	620320
14	5 - 1c #12 type TW Coded Wire	40"	-	-
14A	7 - 1c #12 type TW Coded Wire	-	64'	-
15	3/4" Conduit, Galv., Rigid Iron	6'	8'	251008
16	3/4" Condulet, Galv., Type "E" with 4 hole comp. cover	2	2	145568, 145376
17	3/4" Condulet, Galv., Type "C" with 4 hole comp. cover	1	1	145088, 145376
18	3/4" Condulet, Galv., Type "TR" with blank cover	1	1	-
19	Galv. steel conduit clamp	4	4	227104
20	Wire Connectors	-	2	PGS 783, 786

1499,902 SUPERSEDES 1490.2 (11-16-81)	SOG&E ELECTRIC STANDARDS 4KV METERING INSTALLATION ON RACK, FOR 3 WIRE AND 4 WIRE, 3Ø SERVICES	DATE 11-16-81 APPD <i>JEM</i>
---------------------------------------------	-----------------------------------------------------------------------------------------------------------------------	----------------------------------

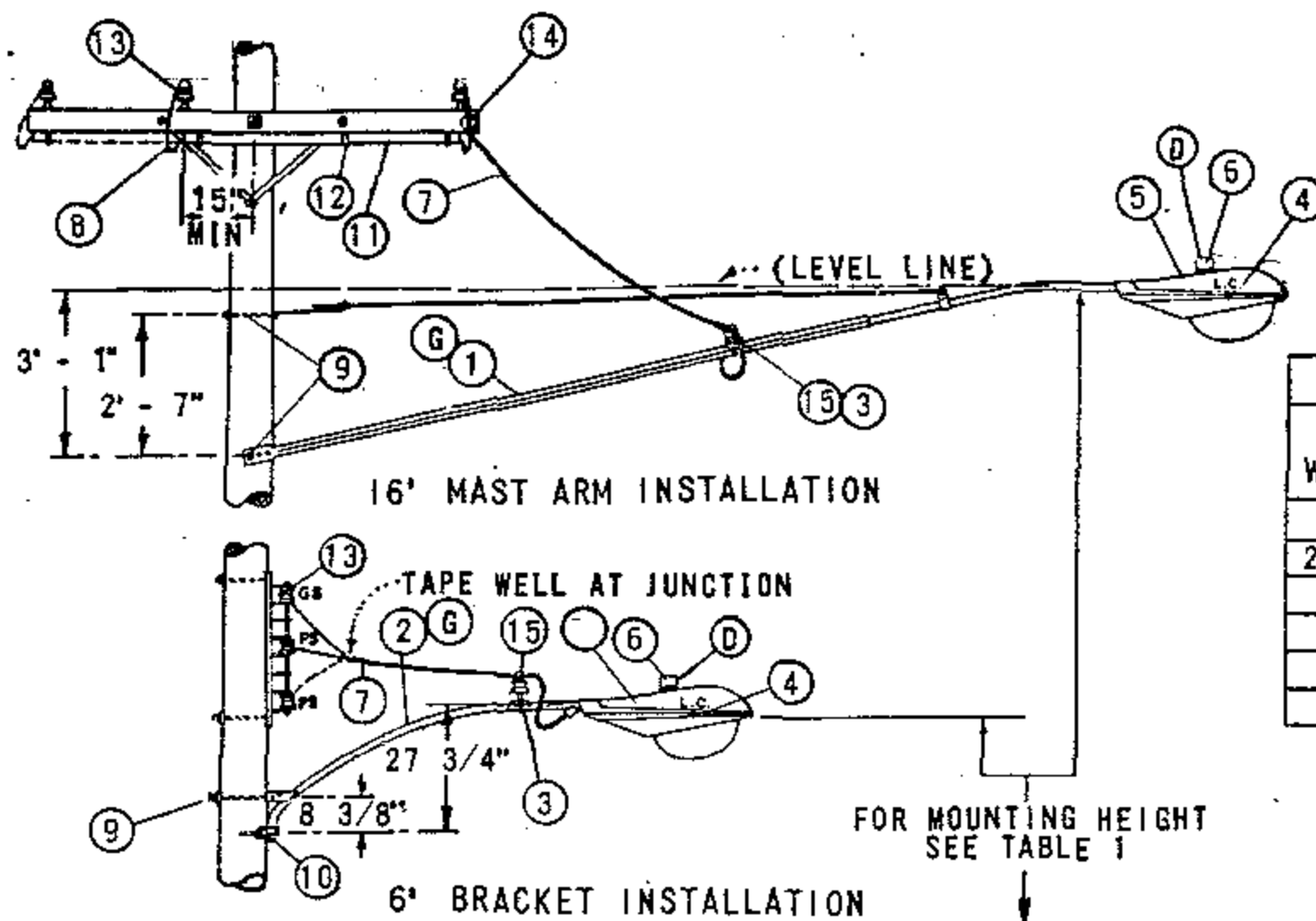

LAMP WATTAGE	MERCURY VAPOR MOUNTING HEIGHT
175	25' - 28'
250-400	30' - 32'
1000	35' - 37'

FOR FIELD MAINTENANCE ONLY

TABLE 2 (F)
MERCURY VAPOR STREET LIGHTING CODE

WATTS	LUMEN	MERCURY VAPOR STREET LIGHTING CODE			
		REGULATOR BALLAST		REACTOR BALLAST	
		BRACKET 6'	MAST ARM 16'	BRACKET 6'	MAST ARM 16'
175	7000	6AG	16AG	6AR	16AR
250	10000	6BG	16BG	6BR	16BR
400	20000	6CG	16CG	-	-
1000	55000	6DG	16DG		

NOTES:

- (A) REQUIRED FOR SECONDARY LINE ARM CONSTRUCTION ONLY.
- B. SEE STANDARDS PAGE 1509 FOR CLEARANCES.
- (C) 30" STREET LIGHTING BRACKET, STOCK NUMBER 167200 MAY BE SUBSTITUTED.
- (D) APPERTURE OF PHOTOELECTRIC CELL MUST BE SET TO FACE NORTH.
- (E) EXEMPT MATERIALS.
- (F) TABLE 2 IS PROVIDED FOR IDENTIFICATION OF LIGHTING INSTALLATIONS ON MAPS AND WORK ORDERS.
- (G) A MAXIMUM OF ONE HALF OF MOUNTING BRACKET MAY BE INSTALLED IN CLIMBING SPACE.

ITEM	DESCRIPTION	QUANTITY				STOCK NO. OR CONSTR STDS
		BALLAST				
		REGULATOR		REACTOR		
		6AG, 6BG, 6CG, 6DG	16AG, 16BG, 16CG, 16DG	6AR, 6BR	16AR, 16BR	
1	ARM, UPSWEEP MAST, 1 1/4" DIA, 16' - 0"	-	1	-	1	110880
2	BRACKET, UPSWEEP, 1 1/4" DIA, 6' - 0" (C)	1	-	1	-	167264
3	PIN, INSULATOR CLAMP (SUPPLIED WITH MAST ARM)	1	1	1	1	-
4	LAMP	1	1	1	1	PG. 1510
5	LUMINAIRE	1	1	1	1	PG. 1520, 1521
6	CONTROL, PHOTOELECTRIC, TWISTLOCK BASE 105 TO 280 VOLT	1	1	1	1	273888
7	WIRE, #8, 600V, FLEXIBLE R.C. DUPLEX	AS REQ'D				811776
8	WIRE, #12, TYPE THW, 600V, INSULATED COPPER (A)	25'	25'	25'	25'	810272
9	BOLT, MACH, GALV, 5/8" X 10", 2 SQ WASH. & 1 NUT (E)	1	2	1	2	PGS 139, 140
10	SCREW, LAG, GALV, 1/2" X 4" (E)	2	-	2	-	621568
11	CONDUIT, PLASTIC, PVC, TYPE 11, SCHEDULE 40 3/4" (A) (E)	7' - 4"	7' - 4"	7' - 4"	7' - 4"	251328
12	STRAP, PIPE, GALV, 2-100 NAILS, GALV, 3/4" (A) (E)	3	3	4	4	PG 143
13	CONNECTOR, WIRE (E)	2	2	2	2	PGS 783-787
14	CLEVIS, SECONDARY DEAD END (A)	1	1	1	1	235488
15	INSULATOR, PIN TYPE, TOP TIE, 4KV (CLASS 55-1) WHITE (E)	1	1	1	1	429024

SDG & E ELECTRIC STANDARDS

DATE 11-5-82
APPD JMT/ARA

LIGHTING INSTALLATION

1599.102
SUPERSEDES
1519 (11-5-82)

SCOPE: THIS STANDARD SHOWS MERCURY VAPOR LUMINAIRES USED TO PROVIDE ROADWAY AND DUSK TO DAWN LIGHTING, AND REPLACEMENT REFRACTORS.

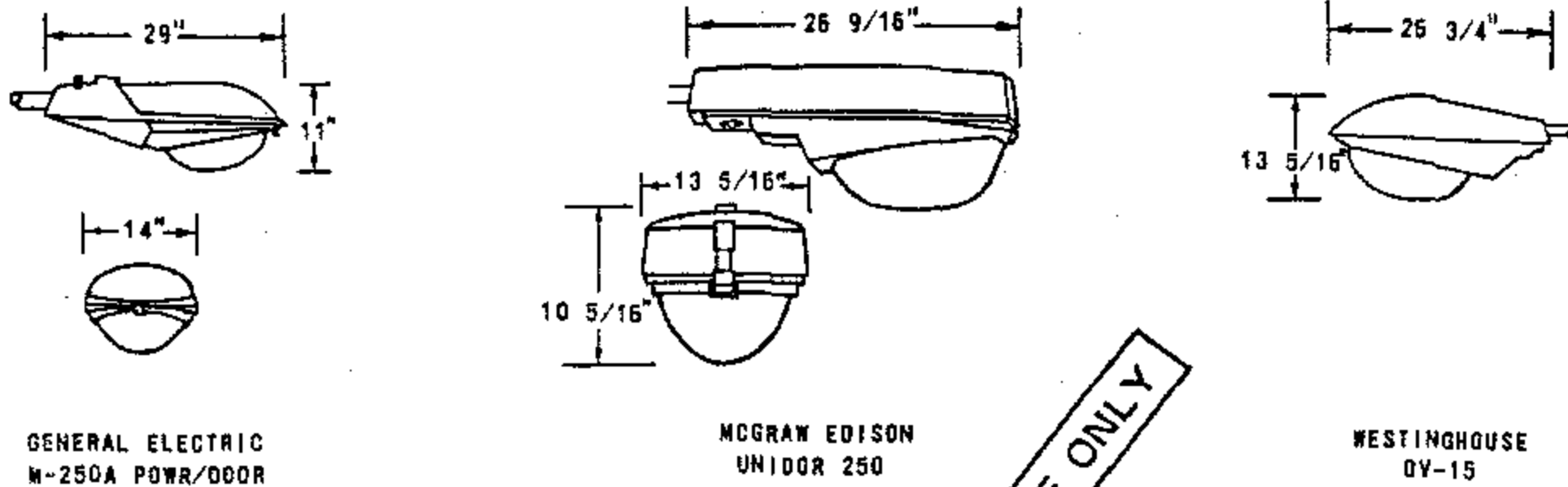

FIGURE 1

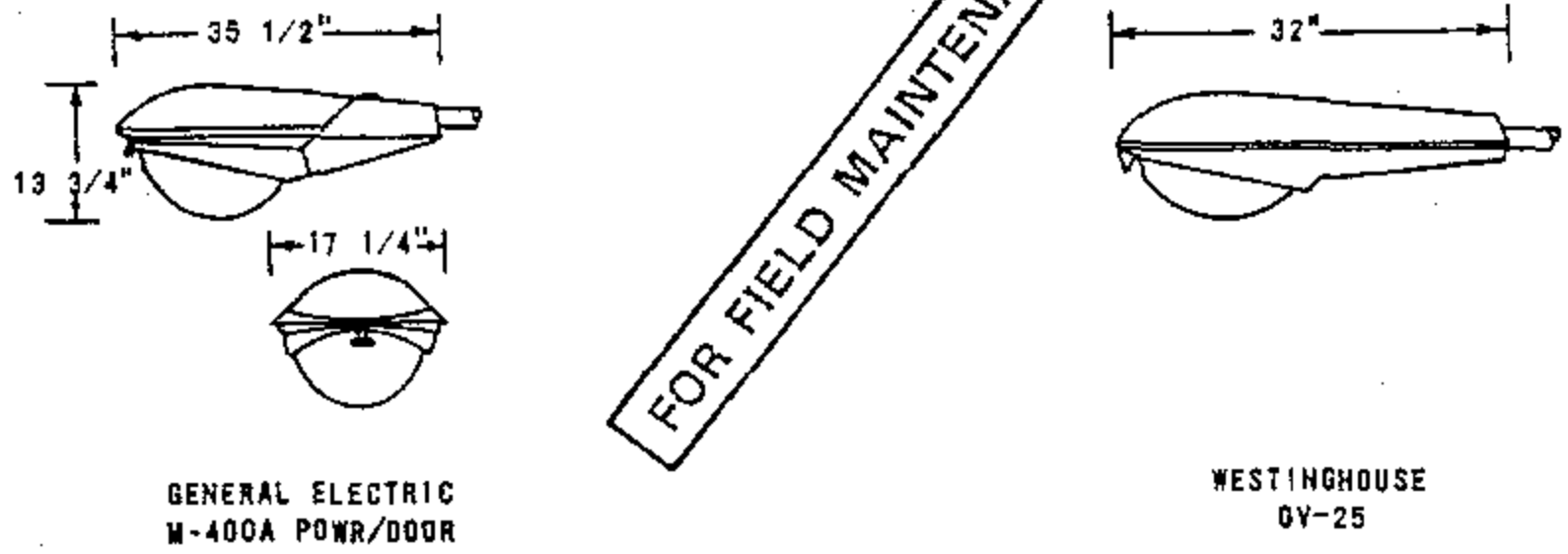

FIGURE 2

FOR FIELD MAINTENANCE ONLY

BILL OF MATERIAL:

FIG. NO.	STOCK NUMBER	LAMP SIZE WATTS	BALLAST		MANUFACTURER AND CATALOG NUMBER							
			TYPE	SOURCE VOLTAGE	GENERAL ELECTRIC		MCGRAW EDISON		WESTINGHOUSE		UNICORN ELECTRIC	
					TYPE	CAT. NO.	TYPE	CAT. NO.	TYPE	CAT. NO.	TYPE	CAT. NO.
1	473920	175	REGULATOR	120/240 (A)	M-250A	C727G002 (B)	UNIDOR	UU1104-120R	OV-15	B11A208G04		
	474048		REACTOR NPF	240	POWR/DOOR	C727G014 (B)	250	UU-1154R		B11A208G20		
	473910		SERIES	6.8 AMPS	M-250-R2	M2AR17CXSIGMS31038						-
2	474208	400	REGULATOR	120/240 (A)	M-400A	C723G001 (B)			OV-25	B58A303G04		
	473912		SERIES	6.8 AMPS	M-250-R2	M4AR40CXSIGMN32043						-

REPLACEMENT REFRACTORS FOR MERCURY VAPOR LUMINAIRES						
CONVENTIONAL LUMINAIRES		LAMP TYPE	LAMP WATTAGE	REPLACEMENT REFRACTOR		
MANUFACTURER	TYPE			TYPE	CATALOG NUMBER	STOCK NUMBER
GENERAL ELECTRIC	M-250A (C)	MV	175,250	GLASS	35-130583-01	579284
GENERAL ELECTRIC	M-400A (C)	MV	400	GLASS	35-231137-01	579298
				LEXAN	35-130015-02	579312
AMERICAN ELECTRIC	23 SERIES (C)	MV	175,250	GLASS	23-002	579284
AMERICAN ELECTRIC	25 SERIES (C)	MV	400	GLASS	25-003	578928 (F)
				LEXAN	25-003-8	- (F)
AMERICAN ELECTRIC	327 SERIES	MV	1000	GLASS	27-003	578938 (F)
WESTINGHOUSE	OV-15	MV	175,250	GLASS	484-D087-H01	578978 (F)
WESTINGHOUSE	OV-25 (C)	MV	400	GLASS	484-D338-H02	578040
				LEXAN	6716-D13-H01	579058 (F)

INSTALLATION:

- (A) FACTORY WIRED FOR 120 VOLTS, DO NOT WIRE FOR 240 VOLTS ON NEW INSTALLATIONS.
- (B) ASTRODOME UNITS ARE EQUIPPED WITH BUILT-IN PHOTOELECTRIC CELL, FOR REPLACEMENT SEE PAGE 1512/4412.
- (C) A GLASS OR A LEXAN REFRACTOR MAY BE USED ON THESE LUMINAIRES.
- D. LEXAN REFRACTORS TO BE USED IN HIGH VANDALISM AREAS ONLY.
- (F) ITEM IS NO LONGER PURCHASED.

OH 1599.201
~~UG 4499.201~~
 SUPERSEDES
 1520.1 (11-5-82)

SDG&E ELECTRIC STANDARDS

MERCURY VAPOR CONVENTIONAL LUMINAIRES
 AND REPLACEMENT REFRACTORS

DATE 1-1-89
 APPD PEA/DTE

SCOPE: THIS STANDARD SHOWS HIGH PRESSURE SODIUM VAPOR LUMINAIRES USED TO PROVIDE ROADWAY AND DUSK TO DAWN LIGHTING, REPLACEMENT BALLAST AND REFRACTORS.

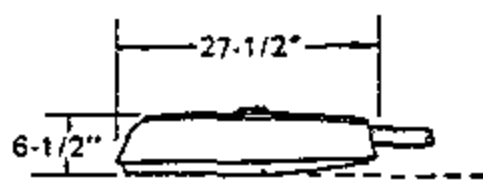

GENERAL ELECTRIC
M150 CUTOFF POWER/DOOR

FIGURE 1

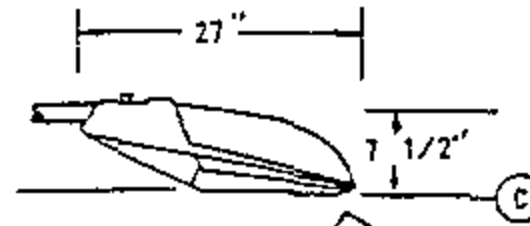
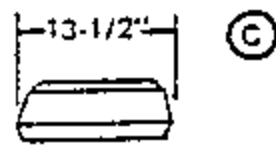

GENERAL ELECTRIC
M-250A CUTOFF POWER/DOOR

FIGURE 2

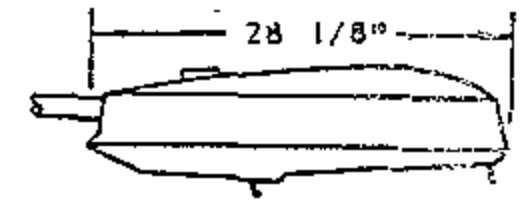

AMERICAN ELECTRIC
SERIES 213 CUTOFF
POWER/PAD

FIGURE 3

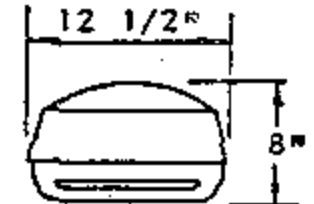

FOR FIELD MAINTENANCE ONLY

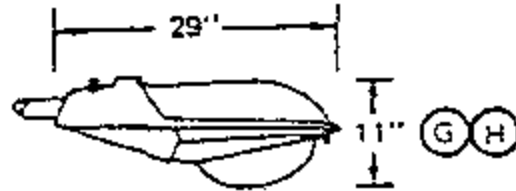

GENERAL ELECTRIC
M-250A POWER/DOOR

FIGURE 4

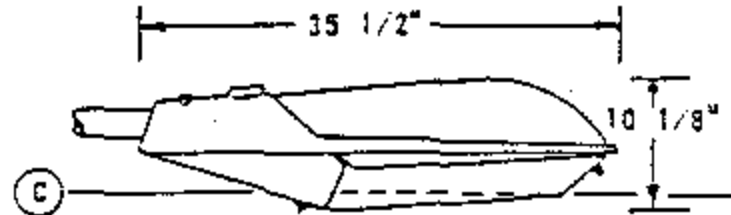

GENERAL ELECTRIC
M-400A CUTOFF
POWER/DOOR

FIGURE 5

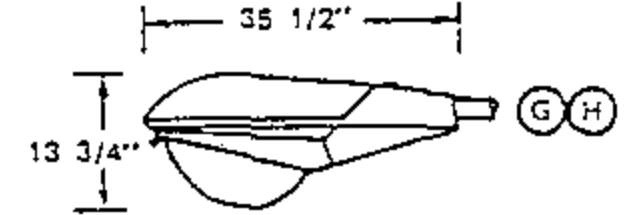
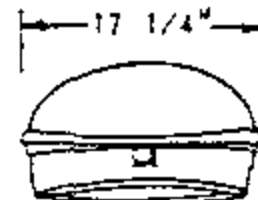

GENERAL ELECTRIC
M-400A POWER/DOOR

FIGURE 6

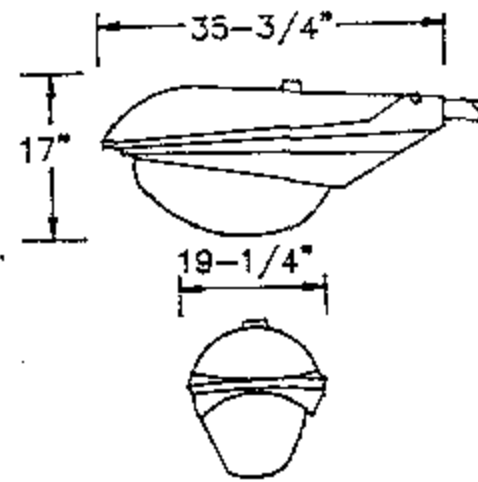
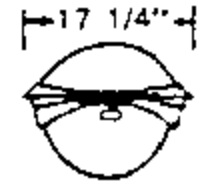

GENERAL ELECTRIC
M-1000

FIGURE 7

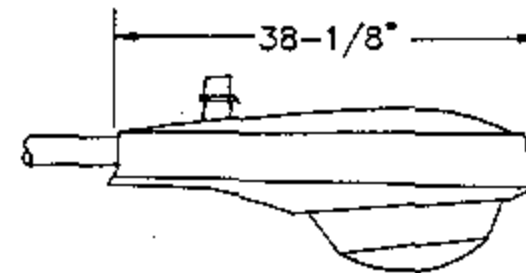

AMERICAN ELECTRIC
SERIES 327

FIGURE 8

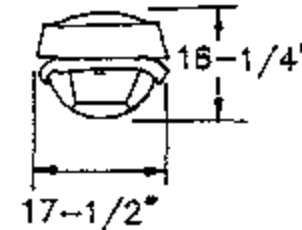

TABLE 1 (D)
HIGH PRESSURE SODIUM VAPOR (HPSV) LUMINAIRES - COMPLETE ASSEMBLY (EXCLUDING LAMP)

FIG. NO.	MANUFACTURER		LAMP SIZE WATTS	BALLAST		STOCK NUMBER
	GENERAL ELECTRIC	AMER. ELECT.		TYPE	SOURCE VOLTAGE	
1, 2 & 3	M 150 CUTOFF M 250A CUTOFF	SERIES 213	70	REACTOR	120	473382
	M 150 CUTOFF M 250A CUTOFF	SERIES 213	100		120	473376
	M 150 CUTOFF M 250A CUTOFF	SERIES 213	150		120	473344
4	M 250A	-	100	REACTOR	120	473924
5 & 6	M 400A	-	200	REGULATOR	120	473360
	M 400A CUTOFF	-	250	AUTO REGULATOR	120	473312
			400	REGULATOR	120	473280
6	M 400A	-	250	AUTO REGULATOR	120	473928
7 & 8	M 1000	SERIES 327	1000	AUTO REGULATOR	120	473248

SDG&E ELECTRIC STANDARDS

DATE 1-1-94

APPD PJA/ROJ

HIGH PRESSURE SODIUM VAPOR LUMINAIRE,
REPLACEMENT BALLAST AND REFRACTORS

OH 1599.203
~~UG 4499.203~~

BILL OF MATERIAL: (D)

TABLE 1. - HIGH PRESSURE SODIUM VAPOR (HPSV) LUMINAIRES - COMPLETE ASSEMBLY (EXCLUDING LAMP)

FIG. NO.	MANUFACTURER		LAMP SIZE WATTS	BALLAST		STOCK NUMBER
	GENERAL ELECTRIC	AMERICAN ELECTRIC		TYPE	SOURCE VOLTAGE	
1, 2, & 3	M 150 CUTOFF M 250A CUTOUT	SERIES 213	70	REACTOR	120	473382
	M 150 CUTOFF M 250A CUTOFF	SERIES 213	100		120	473376
	M 150 CUTOFF M 250A CUTOFF	SERIES 213	150		120	473344
4	M 250A	-	100	REACTOR	120	473924
5 & 6	M 400A	-	200	REGULATOR	120	473360
	M 400A CUTOFF		250	AUTO REGULATOR	120	473312
			400	REGULATOR	120	473280
6	M 400A	-	250	AUTO REGULATOR	120	473928
7 & 8	M 1000	SERIES 113	1000	AUTO REGULATOR	120	473248
9 & 10	M 250R2 CUTOFF	SERIES 113	70	REACTOR-NPF	120	473400
	M 250R2 CUTOFF	SERIES 113	100		120	473402
	M 250R2 CUTOFF	SERIES 113	150		120	473404
11	M 400R2 CUTOFF	-	200	HIGH REACTANCE-NPF	120	473406
	M 400R2 CUTOFF	-	250		120	473408
	M 400R2 CUTOFF	-	400	CWA	120	473410

FOR FIELD MAINTENANCE ONLY

© 1998 - 2007 San Diego Gas & Electric Company. All rights reserved. Removal of this copyright notice without permission is not permitted under law.

DATE 1-1-94 APPD PEA / DTE	SDG&E ELECTRIC STANDARDS	OH 1599.203B UG 4499.203B
	HIGH PRESSURE SODIUM VAPOR LUMINAIRES, REPLACEMENT BALLAST AND REFRACTORS	

TABLE 2

REPLACEMENT BALLAST FOR (HPSV) LUMINAIRES						
FIG. NO.	BALLAST		LAMP SIZE WATTS	MANUFACTURER		STOCK NUMBER
	TYPE	SOURCE VOLTAGE		MANUFACTURER	TYPE POWER/DOOR	
1, 2, 3 & 4	REACTOR	120	70	GE	M 150	121044 (B)
				GE	M 250A	121140 (B)
				AMERICAN ELECTRIC	SERIES 213	121172 (B)
		120	100	GE	M 150	121078 (B)
				GE	M 250A	121142
				AMERICAN ELECTRIC	SERIES 213	121174 (B)
		120	150	GE	M 150/ M250A2	121108
				GE	M 250A	121144
				AMERICAN ELECTRIC	SERIES 213	121178 (B)
5 & 6	REACTOR	120	150	GE	M 400A	121146
	REGULATOR	120	200	GE	M 400A	121204 (B)
				AMERICAN ELECTRIC	SERIES 25	121178 (B)
	AUTO REGULATOR	120	250	GE	M 400A/ M400A2	121148
				AMERICAN ELECTRIC	SERIES 25	121180 (B)
	REGULATOR	120	400	GE	M 400A/ M400A2	121150
				AMERICAN ELECTRIC	SERIES 25	121182 (B)
	9 & 10	REACTOR	120	70	GE	M 250R2
AMERICAN ELECTRIC					SERIES 113	121358 (B)
120			100	GE	M 250R2	121348 (B)
				AMERICAN ELECTRIC	SERIES 113	121360 (B)
120			150	GE	M 250R2	121350 (B)
				AMERICAN ELECTRIC	SERIES 113	121362 (B)
11	REGULATOR	120	200	GE	M 400R2	121352 (B)
				AMERICAN ELECTRIC	SERIES 125	121364 (B)
	AUTO REGULATOR	120	250	GE	M 400R2	121354 (B)
				AMERICAN ELECTRIC	SERIES 125	121366 (B)
	REGULATOR	120	400	GE	M 400R2	121356 (B)
				AMERICAN ELECTRIC	SERIES 125	121368 (B)

TABLE 3

REPLACEMENT REFRACTORS FOR HPSV LUMINAIRES					
CONVENTIONAL LUMINAIRES		LAMP TYPE	LAMP WATTAGE	REPLACEMENT REFRACTOR	
MANUFACTURER	TYPE			TYPE	STOCK NUMBER
GENERAL ELECTRIC	M-250A (I)	HPSV	100, 150	LEXAN	579248
GENERAL ELECTRIC	M-250A-CUTOFF	HPSV	70, 100, 150	GLASS	579282
GENERAL ELECTRIC	M-250R2	HPSV	70, 100, 150	GLASS	579104 (B)
GENERAL ELECTRIC	M-400A-CUTOFF	HPSV	250, 400	GLASS	578708
GENERAL ELECTRIC	M-400R2	HPSV	200, 250, 400	GLASS	578102
GENERAL ELECTRIC	M-1000	HPSV	1000	GLASS	578704 (B)
AMERICAN ELECTRIC	23 SERIES (I)	HPSV	100, 150	LEXAN	579248
AMERICAN ELECTRIC	25 SERIES CUTOFF	HPSV	250, 400	GLASS	- (B)
AMERICAN ELECTRIC	327 SERIES	HPSV	1000	GLASS	578938 (B)

INSTALLATION:

- A. ALL LUMINAIRES ARE TO BE WIRED FOR 120 VOLTS ONLY. APPLICATION OF 240 VOLTS TO THESE UNITS WILL CAUSE SEVERE BALLAST DAMAGE.
- (B) ITEM IS NO LONGER PURCHASED.
- (C) CUTOFF LUMINAIRES SHALL BE INSTALLED WITH THE OPTICAL ASSEMBLY (GLASSWARE) HORIZONTAL.
- (D) ITEMS IN TABLE 1 ARE FOR COMPLETE LUMINAIRE UNITS AND ARE NO LONGER PURCHASED.
- (F) STOCK NUMBERS IN TABLE 2 ARE FOR BALLAST ONLY AND MAY BE PURCHASED FOR PURPOSE OF REPLACEMENT.
- (G) ASTRODOME UNITS ARE EQUIPPED WITH BUILT-IN PHOTOELECTRIC CELL.
- (H) USE LEVELING PAD FOR PROPER ADJUSTMENT OF LUMINAIRE.
- (I) A GLASS OR A LEXAN REFRACTOR MAY BE USED ON THESE LUMINAIRES (LEXAN REFRACTORS TO BE USED IN HIGH VANDALISM AREAS ONLY).

REFERENCE:

- J. SEE STANDARD 1512/4412 FOR PHOTOELECTRIC CONTROL.
- K. SEE STANDARD 1514/4414 FOR IDENTIFICATION DECAL.

BILL OF MATERIAL: TABLE 4

REPLACEMENT STARTERS FOR HPSV LUMINAIRES				
MANUFACTURER		LAMP SIZE WATTS	SOURCE VOLTAGE	STOCK NUMBER
MANUFACTURER	TYPE			
AMERICAN ELECTRIC	SERIES 113	35-400	120	679130
GENERAL ELECTRIC	M 250R2	50-150	120	679132
GENERAL ELECTRIC	M 400R2	250-400	120	679134

FOR FIELD MAINTENANCE ONLY

© 1998 - 2007 San Diego Gas & Electric Company. All rights reserved. Removal of this copyright notice without permission is not permitted under law.

OH 1599.204
UG 4499.204

SDG&E ELECTRIC STANDARDS
HIGH PRESSURE SODIUM VAPOR LUMINAIRE,
REPLACEMENT BALLAST AND REFRACTORS

DATE 1-1-89
APPD PEA / DTE

SCOPE: THIS STANDARD SHOWS LOW PRESSURE SODIUM VAPOR (LPSV) LUMINAIRES USED TO PROVIDE ROADWAY AND DUSK TO DAWN LIGHTING, AND REPLACEMENT BALLAST.

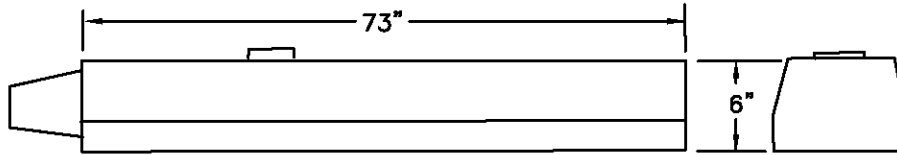

PACIFIC LIGHTING
SPAULDING
FIGURE 1

FOR FIELD MAINTENANCE ONLY

BILL OF MATERIAL:

TABLE 1: (C)

LOW PRESSURE SODIUM VAPOR (LPSV) LUMINAIRES - COMPLETE ASSEMBLY EXCLUDING LAMP					
FIG. NO.	MANUFACTURER	LAMP SIZE WATTS	BALLAST		STOCK NUMBER
			TYPE	SOURCE VOLTAGE	
1	SPAULDING/PACIFIC LIGHTING	35/55 (B)	HPF REACTOR	120	473800
		90			473802
		135			473804
		180			473806

BILL OF MATERIAL:

TABLE 2: (C)

REPLACEMENT BALLAST FOR LPSV LUMINAIRES					
FIG. NO.	BALLAST		LAMP SIZE WATTS	MANUFACTURER	STOCK NUMBER
	TYPE	VOLTAGE			
1	HPF REACTOR	120	35/55	SPAULDING/ PACIFIC LIGHTING	121310
			90		121308
			135 & 180		121306

INSTALLATION:

A. ALL LUMINAIRES ARE TO BE WIRED FOR 120 VOLTS ONLY. APPLICATION OF 240 VOLTS TO THESE UNITS WILL CAUSE SEVERE BALLAST DAMAGE.

(B) THIS LUMINAIRE WILL ACCEPT BOTH 35 WATT AND 55 WATT LAMPS.

(C) MANUFACTURERS IN THIS TABLE ARE NO LONGER PURCHASED.

REFERENCE:

D. SEE STANDARD 1512/4412 FOR PHOTOELECTRIC CONTROL.

E. SEE STANDARD 1514/4414 FOR IDENTIFICATION DECAL.

© 1998 - 2007 San Diego Gas & Electric Company. All rights reserved. Removal of this copyright notice without permission is not permitted under law.

DATE 3-2-06 APPD PEA / DTE	SDG&E ELECTRIC STANDARDS	OH 1599.210 UG 4499.210
	LOW PRESSURE SODIUM VAPOR LUMINAIRE AND REPLACEMENT BALLAST	

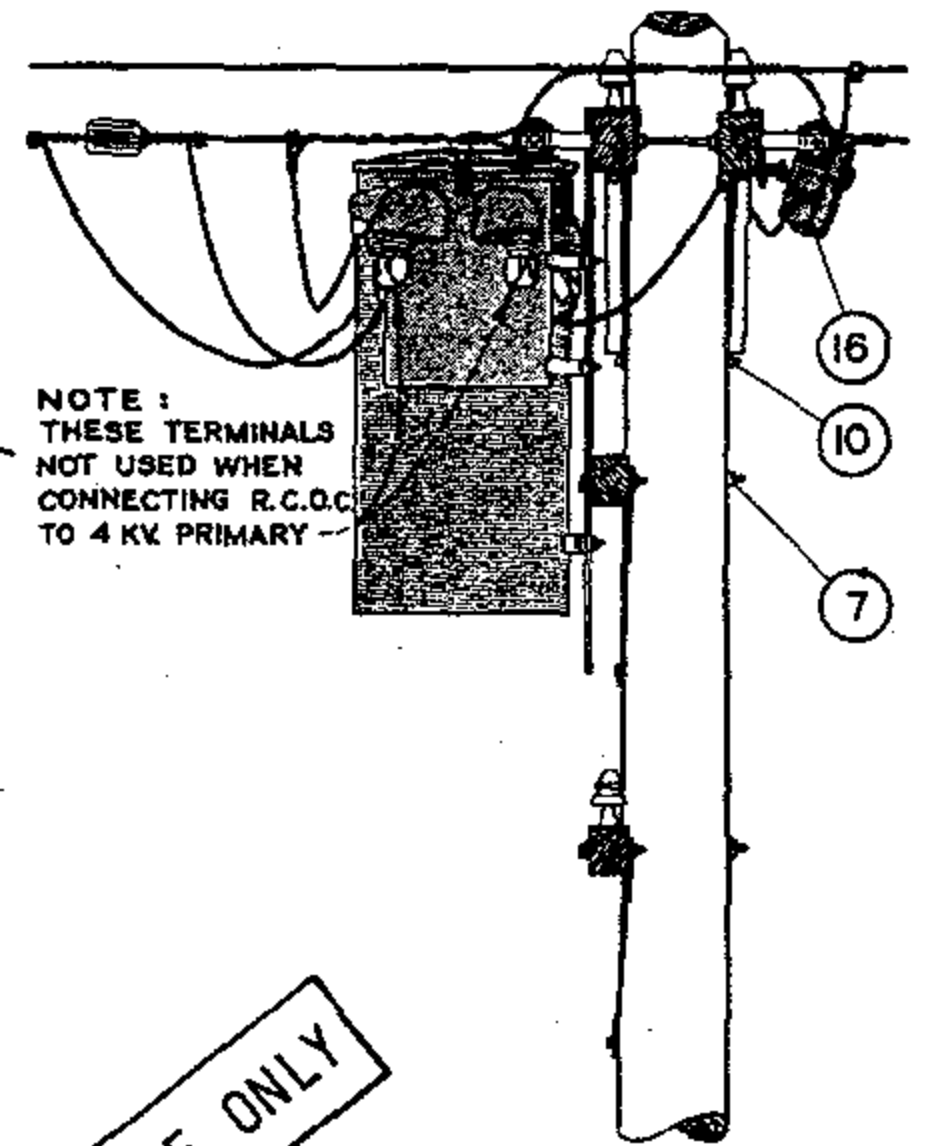
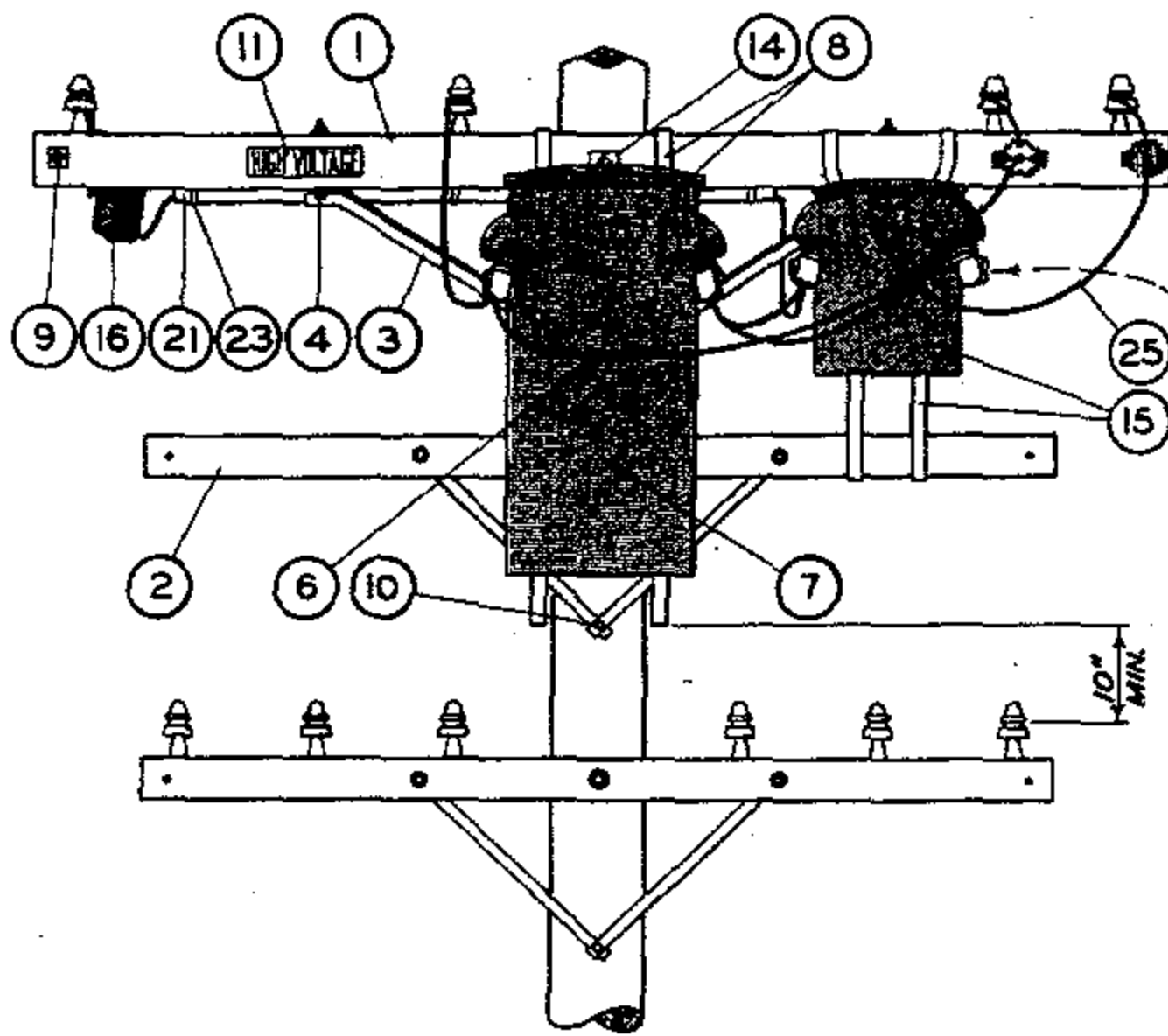

NOTE:
THESE TERMINALS
NOT USED WHEN
CONNECTING R.C.O.C.
TO 4 KV PRIMARY

THIS PAGE FOR FIELD MAINTENANCE ONLY

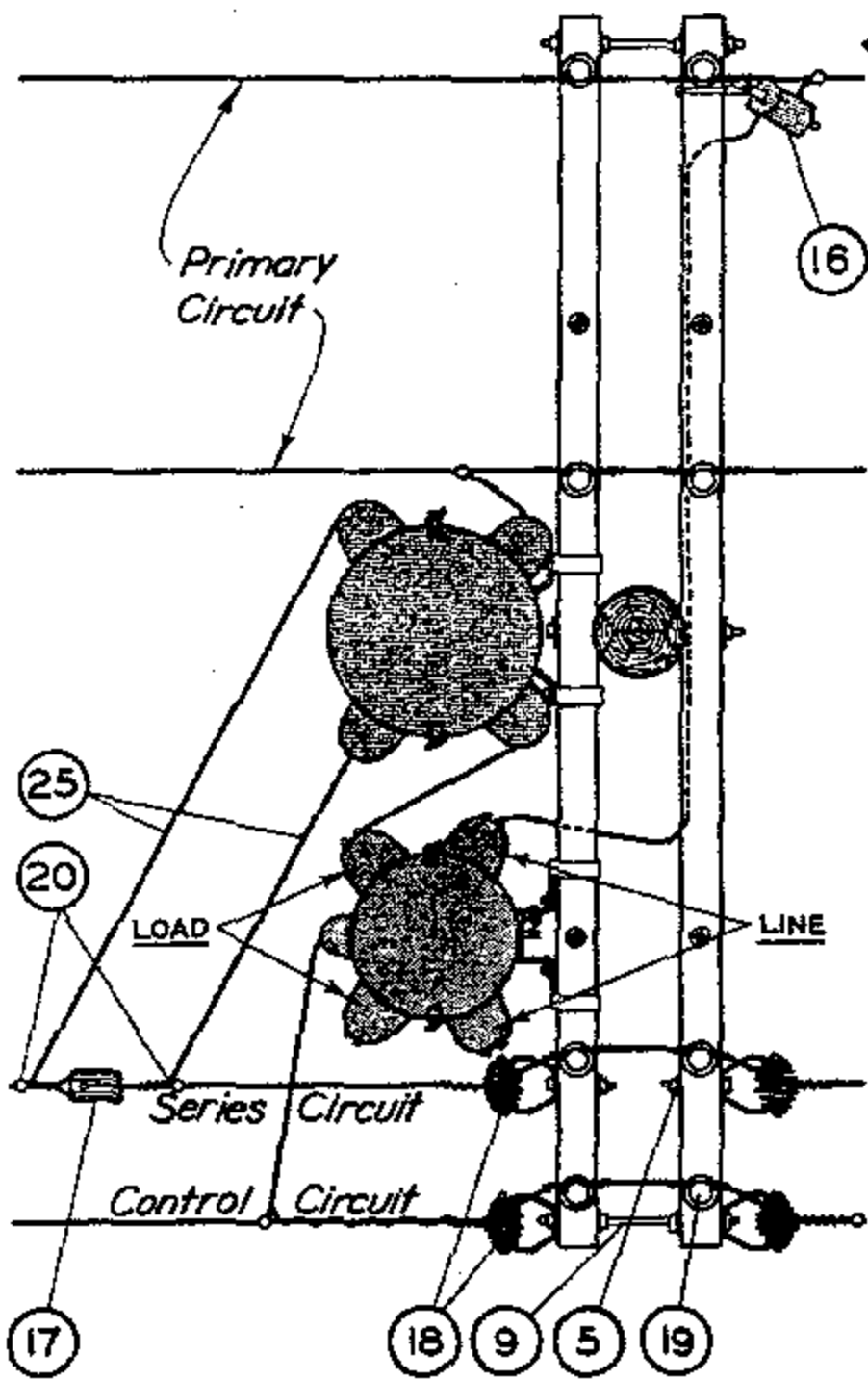

ITEM	DESCRIPTION	QUANTITY	CONSTR STDS STOCK NO OR
1	3-3/4"x 5-3/4"x 10'-0" Crossarm - 8 pin	2	PG 111 IT. 3
2	3-1/2"x 4-1/2"x 8'-0" Kick Arm	1	PG 111 IT. 2
3	Angle Crossarm Brace - 4' or 5'	2	16 40 32 OR 16 41 28
4	Mach. Bolt, Galv. 1/2"x 7" - 1 rd. washer & 1 nut	4	PGS 139. 140
5	Mach. Bolt, Galv. 5/8"x 5" - 1 rd. washer & 1 nut	2	PGS 139. 140
6	Mach. Bolt, Galv. 5/8"x 10" - 1 nut	1	PGS 139. 140
7	Mach. Bolt, Galv. 5/8"x 14" - 2 sq. washers & 1 nut	1	PGS 139. 140
8	Mach. Bolt, Galv. 5/8"x 18" - 2-3"x 4" washers & 1 nut	1	PGS 139. 140
9	Space Bolt, Galv. 5/8"x 18" - 4 washers & 4 nuts	2	PGS 139. 140
10	Lag Screw, Galv. 1/2"x 4"	1	6 21 56 8
11	High Voltage Sign & Nails #8, Roofing	1	6 47 6 48, 49 22 2 4
12	Pole Step	16	6 9 29 9 2
13			
14	R.O. Transformer & Hangers	1	PGS 1121.00-1121.12
15	R.C.O.C. Switch	1	27 4 5 6 0
16	G.E. Expulsion Fuse Cutout	1	PG 12 1 1
17	Insulator, Strain #508	1	4 3 0 8 8 0
18	Insulator, 4 Kv. D.E.	4	2 3 5 5 2 0
19	Insulator, D.G.D.P.	4	4 2 8 9 6 0
20	#6 Wire Connector Split Bolt	6	2 6 9 0 5 6
21	PVC Conduit, 1" diam.	5'	2 5 1 2 0 0
23	1-1/4" Pipe Strap with 2 - 6d Nails	3	6 9 7 6 9 6, 4 9 1 5 5 2
25	#6 R.C. Strand. Copper Wire - 5 Kv.	42'	8 1 4 1 1 2

DATE 4-30-82
APPD *UPH*

SDG&E ELECTRIC STANDARDS
SERIES CONTROLLED R.O. STREET LIGHT TRANSFORMER
AND R.C.O.C. SWITCH, LINE ARM POSITION, 4KV

1599.501
SUPERSEDES
1556 (4-30-82)

SCOPE: THIS STANDARD SHOWS 4KV CONSTANT CURRENT SERIES LIGHTING TRANSFORMER INSTALLATION AND SHALL ONLY BE USED WHEN AN EXISTING TRANSFORMER INSTALLATION MUST BE RELOCATED OR REBUILT TO MAINTAIN SERVICE TO AN EXISTING SERIES STREET LIGHTING SYSTEM.

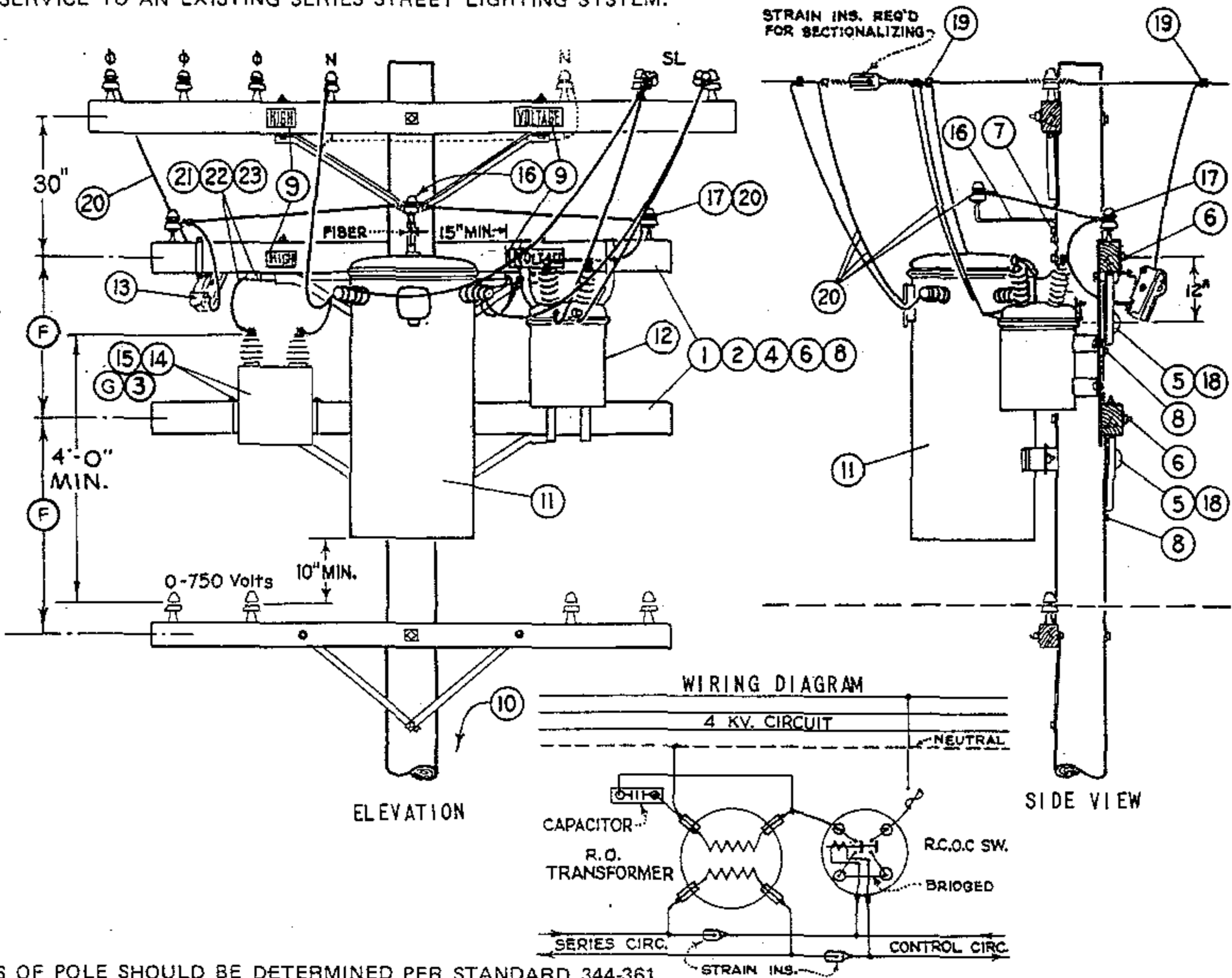

NOTES:
 - CLASS OF POLE SHOULD BE DETERMINED PER STANDARD 344-361.

BILL OF MATERIAL:

ITEM	DESCRIPTION	QUANT.	CONST STD OR PAGE NO	STOCK NO.
1	3 3/4" x 5 3/4" x 8'-0" Transformer Arm	2	PAGE 380.5 IT.4	294960
2	Angle Crossarm Brace, 4'-0"	2		164032
3	Mach. Bolt, Galv., 3/8" x 1 1/2", 2 rd. washers & 1 nut (E)	2	STDS 392	
4	Mach. Bolt, Galv., 1/2" x 7", 1 rd. washer & 1 nut (E)	4	STDS 392	
5	Mach. Bolt, Galv., 5/8" x 12", 1 sq. curv. wash. & 1 nut (E)	2	STDS 392	
6	Mach. Bolt, Galv., 5/8" x 14", 2 sq. washers & 1 nut (E)	2	STDS 392	
7	Lag Screw, Galv., 1/2" x 4"	1		621568
8	Lag Screw, Galv., 5/8" x 5"	2		621600
9	High Voltage Sign & 9 galv. roofing nails	1		647648, 492224
10	POLE STEPS (SEE STANDARD 363)	-		692992
11	R.O. Transformer with 2 pole bolt Adapter Plates & bolts	1	PG 1121	
12	R.C.O.C. Switch, paired hangers, adapter plates where req'd	1		274656 (A) (B)
13	Expulsion Fuse Indicating Cutout, 5 kv, 50A. (D)	1	SECTION 1200	
14	Capacitor, 2.4 kv., 15 or 25 kvar. (A)	1		207392 OR 207168
15	Mounting Strap and 1- 1/2" phi x 3 3/4" x 5 3/4" U" bolt (A)(C)	2		158432
16	Stand-Off Bracket with Insulator	1		166144, 429216 (E)
17	Insulator and 1" steel pin (E)	2	PG 750	532608
18	Cover Thru Bolt Plastic & Nails, Galv. (E)	2		285696, 492192
19	Wire Connector (E)	7	STDS. 783 - 787	
20	#6 D. B. W. R. Copper Wire	55'		812512
21	#6 R.C. Strand. Copper Wire, 5 kv.	7'		194304
22	1" PVC Conduit (E)	4'		251200
23	1 1/4" Pipe Strap and 2-6d nails, galv. (E)	3		697696, 491552

- INSTALLATION:**
- (A) NO LONGER PURCHASED.
 - (B) KEARNY MAINTENANCE WILL SUPPLY.
 - (C) SALVAGE FROM EXISTING INSTALLATIONS, MIRAMAR SALVAGE YARD HAS LIMITED SUPPLY.
 - (D) CAN BE SUBSTITUTED WITH 12KV 100A CUTOUT.
 - (E) EXEMPT MATERIAL.
 - (F) SPACE KICK ARM & BRACE TO CLEAR LOWER TRANSFORMERS THRU BOLT COVER.
 - (G) IF CAPACITOR FAILS OR STATION IS RELOCATED, DO NOT REPLACE CAPACITOR.

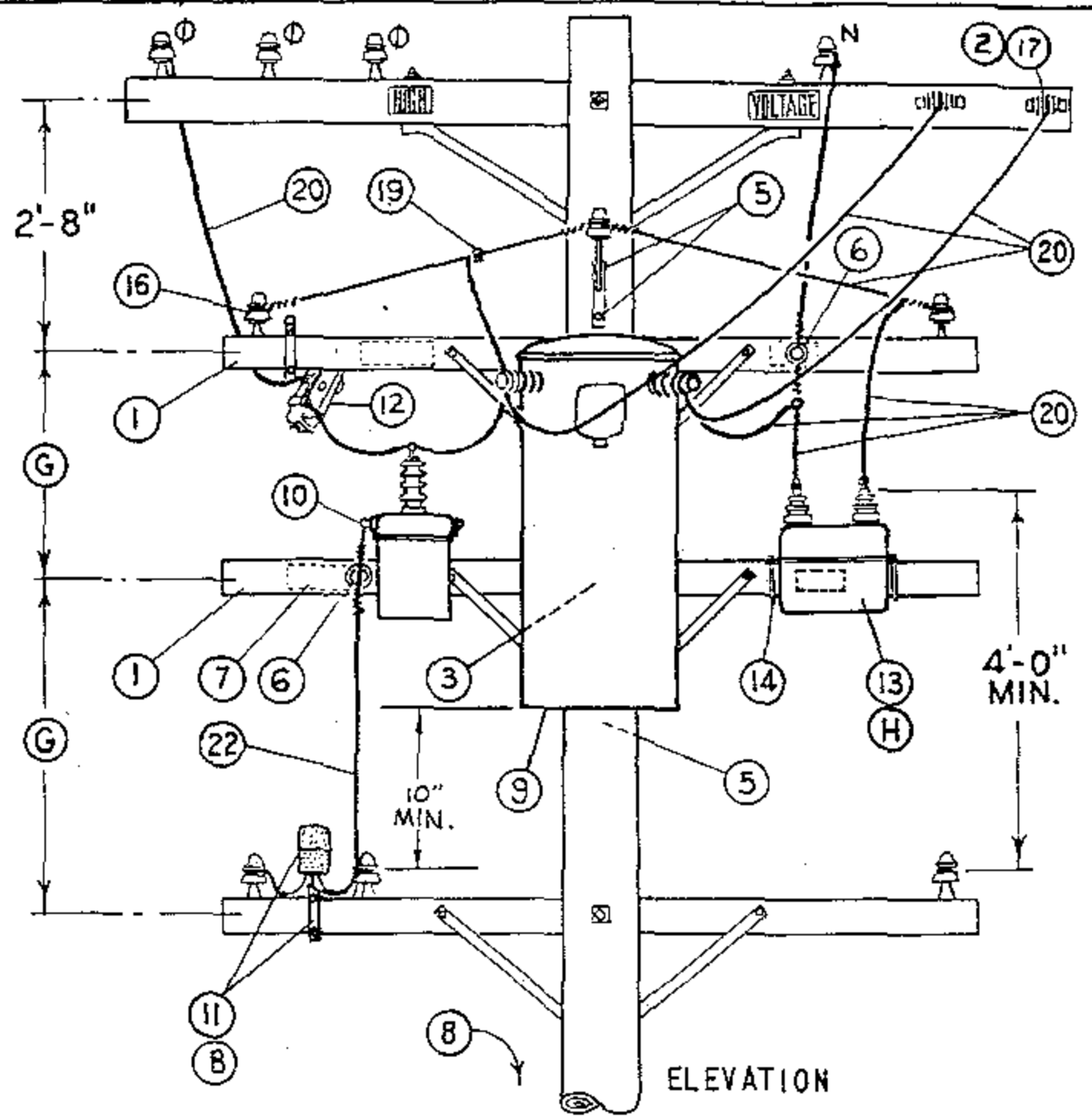
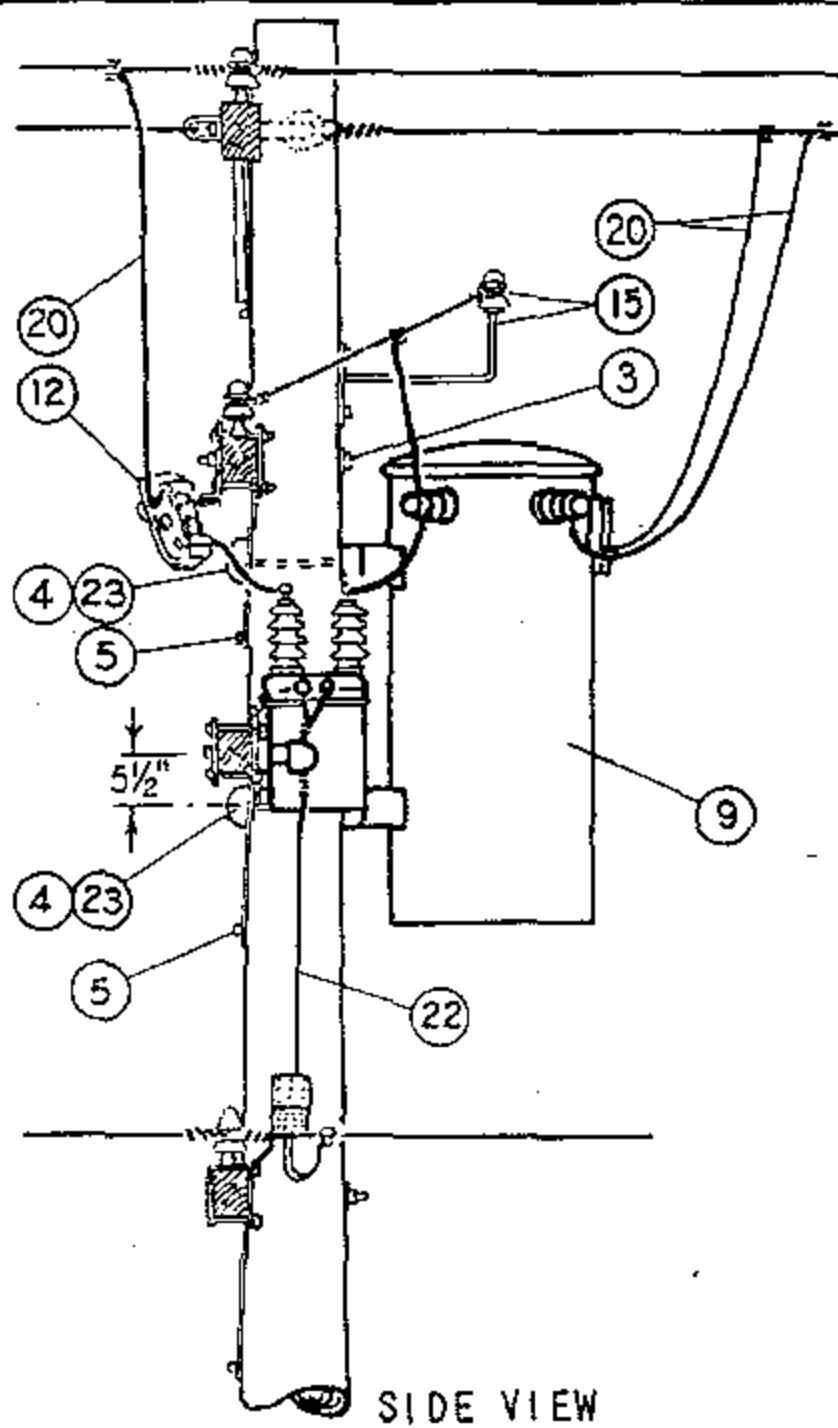

NOTES:

- CLASS OF POLE SHOULD BE DETERMINED PER STANDARD 344-361.

INSTALLATION:

- A. ROTATE COVER OF OIL SWITCH 180°, WHERE NECESSARY, TO POSITION MANUAL OPERATING LEVER ADJACENT TO CLIMBING SPACE.
- (B) FACE PHOTO CELL TO THE NORTH.
- (C) NO LONGER PURCHASED. SALVAGE FROM EXISTING INSTALLATION OR OBTAIN FROM KEARNY MAINTENANCE.
- (D) NO LONGER PURCHASED. SALVAGE FROM EXISTING INSTALLATION OR OBTAIN FROM MIRAMAR SALVAGE YARD.
- (E) EXEMPT MATERIAL.
- (F) CAN BE SUBSTITUTED WITH 12KV 100A CUTOUT.
- (G) SPACE KICK ARM & BRACE TO CLEAR LOWER TRANSFORMER THRU BOLT COVER.
- (H) IF CAPACITOR FAILS OR STATION IS RELOCATED, DO NOT REPLACE CAPACITOR.

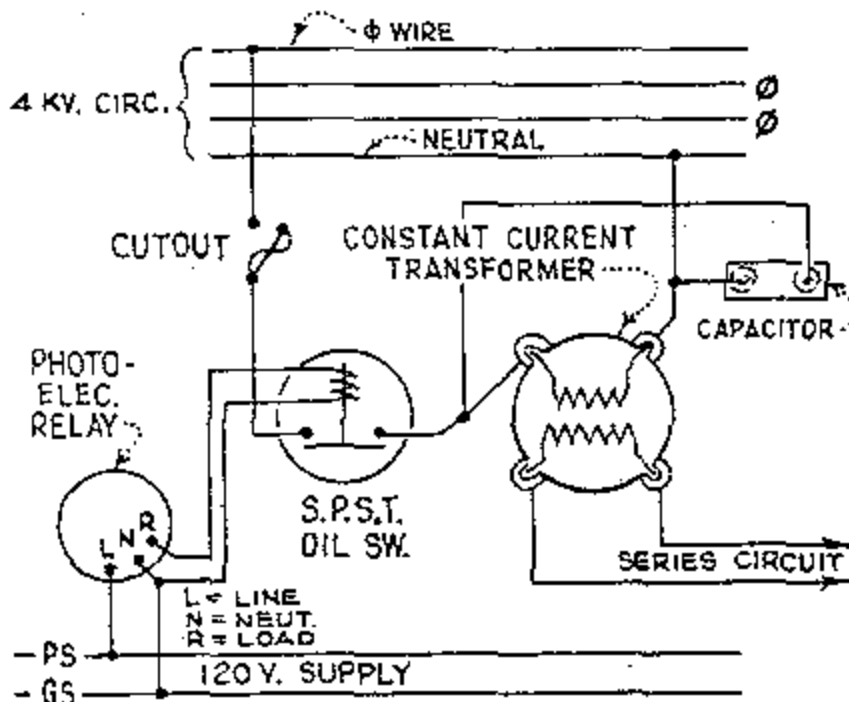

WIRING DIAGRAM

C.C. TRNSFMR. KW	CAPACITOR KVAR
7 1/2 (D)	15
10 (D)	15
15 (D)	15
25	25

ITEM	DESCRIPTION	QUANTITY	STOCK NO. OR CONSTR STDS
P.	1 3 1/2" x 4 1/2" x 8'-0" Crossarm	2	PG. 380.03 IT.1
	2 Mach. Bolt, Galv., 5/8" x 6", 1 sq. washer & 1 nut (E)	2	STD 139. 140
T.	3 Mach. Bolt, Galv., 5/8" x 16", 2 sq. washers & 1 nut (E)	2	STD 139. 140
	4 Mach. Bolt, Galv., 3/4" x 12", 1 sq. curved washers & 1 nut (E)	2	STD 139. 140
&	5 Lag Screw, Galv., 1/2" x 4" (E)	4	6 21568
F.	6 Pin, Transformer, Lead 1" Leadthread (E)	2	529248
	7 High Voltage Sign & 8 galv. roofing nails (E)	2	6 477 44. 49 222 4
	8 Pole Steps (E)	15	69 299 2
	9 C. C. Transformer, 2.4 kv., incl. 2 pole bolt adapter plates	1	PG -1121.12
	10 South Bend Controller Co. Oil Switch, S. P. S. T., 75 A., 2.4 kv. type SPR-1-120 spec. 6210 with #6222 X-arm Mtg. Bracket	1	27 4528 (C)
S.	11 Photoelectric Relay, 1000 W. min., 120 V.	1	273888 166432
L.	12 Cutout, 5 kv., 50 A. (F)	1	Section 1200
	13 Capacitor, Size per Table, 2.4 kv., 2-3/8" x 1" Mtg. Bolts & Washers (H)	1	207 328. 207 188
&	14 Capacitor Mounting Strap & "U" Bolt (D)	2	597... 158432
	15 Stand-Off Bracket with Insulator	1	166 144
S.	16 Insulator and 1" steel pin (E)	2	532608
S.	17 D.E. 4 kv. (E)	2	235520
	18		
	19 Wire Connector	9	STD 783-787
	20 #6 B. Strand. Copper Wire	50'	813536
	21		
	22 2-C #16, 600 V. Type "S" Neoprene Jacketed Super Service Cord	5'	814400
	23 Cover Thru Bolt Plastics & 4 - 10d Nails, galv. (E)	2	285696, 492192

SDG & E ELECTRIC STANDARDS

DATE 11-5-82
APPD JH7/ARH

PHOTOELECTRIC CONTROLLED REGULATED OUTPUT
STREET LIGHT TRANSFORMER INSTALLATION, 4KV

1599.503
SUPERCEDES
1555.2 (1-1-92)

SCOPE : THIS STANDARD SHOWS A CONSTANT CURRENT SERIES LIGHTING R.D. TRANSFORMER INSTALLATION. IT IS TO BE USED ON EXISTING INSTALLATIONS.

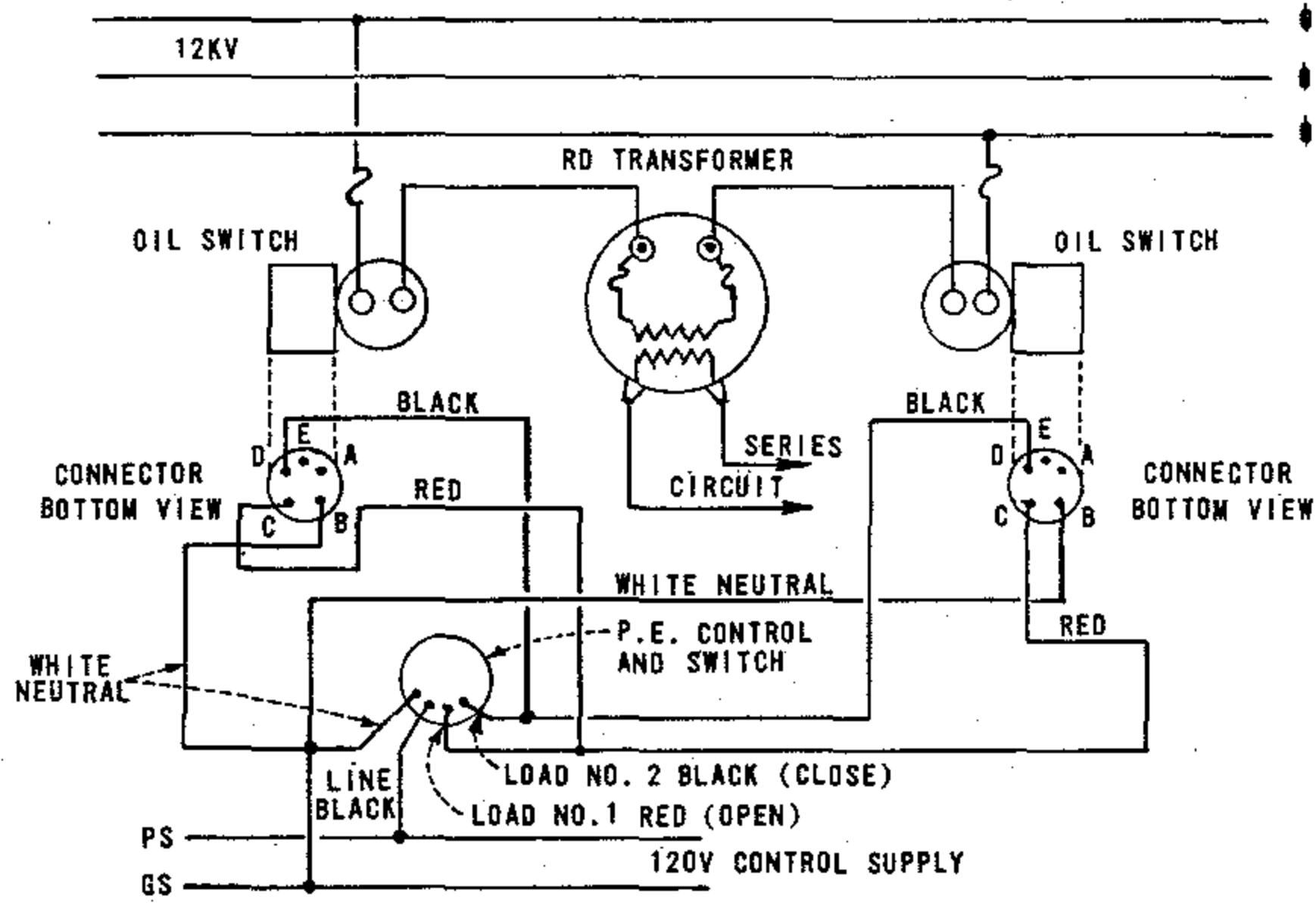
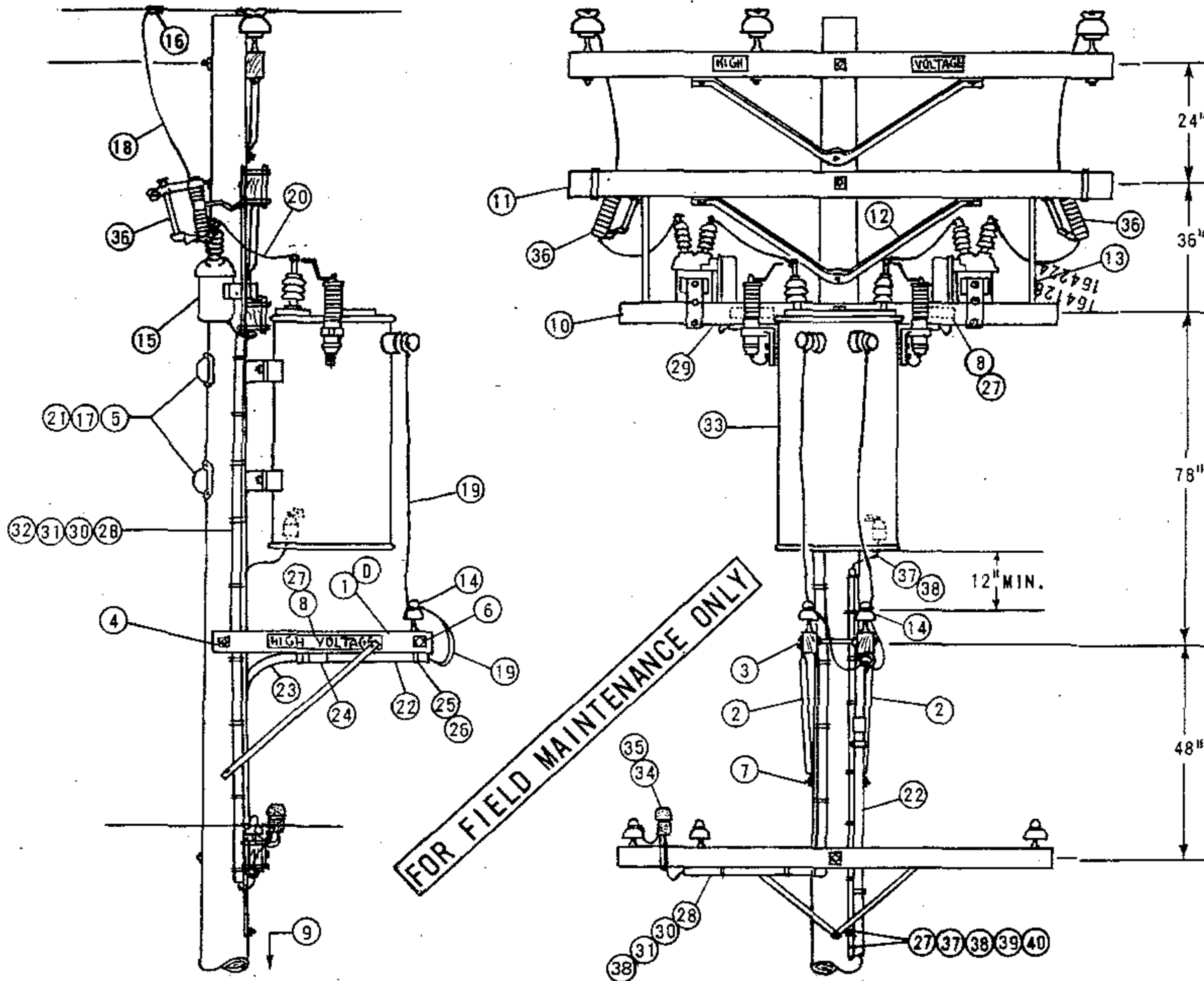

WIRING DIAGRAM

1599.601
SUPERSEDES
1562.1 (4-30-82)

SDG&E ELECTRIC STANDARDS

P.E. CONTROLLED
R.D. STREET LIGHT TRANSFORMER INSTALLATION, 12KV

DATE 4-30-82
APPD *UPH*

BILL OF MATERIAL :

ITEM		DESCRIPTION	QUANTITY	STOCK NO. OR CONSTR. STDS.
PTF	SL&SS			
1		CROSSARM, 3 1/2" X 4 1/2" X 4'-0" (D)	1	STD 380.05 IT. 3
2		BRACE, ALLEY ARM, 4'-0"	2	163808
3		BOLT, MACH. GALV., 5/8" X 5", 1 RD. WASHER & 1 NUT (E)	1	STD 139, 140
4		BOLT, MACH. GALV., 5/8" X 18", 2 SQ. WASHERS & 1 NUT (E)	1	STD 139, 140
5		BOLT, MACH. GALV., 3/4" X 12", 1 SQ. CURVED WASHER & 1 NUT	2	STD 139, 140
6		BOLT, SPACE, GALV., 5/8" X 20", 4 SQ. WASHERS & 4 NUTS (E)	1	STD 139, 140
7		SCREW, LAG, GALV., 5/8" X 5" (E)	1	621600
8		SIGN, HIGH VOLTAGE & NAILS, GALV ROOFING (E)	3	647648,
9		STEPS, POLE (E)	15	692992
10		CROSSARM, 3 3/4" X 5 3/4" X 8'	1	STD 380.01
11		CROSSARM, 3 3/4" X 5 3/4" X 10'	1	STD 380.1
12		BRACE, 5'-0"	1	
13		BRACE, STRUT, 36"	2	
14		INSULATOR, 4KV (E)	2	700 SECTION
15		SWITCH, OIL, NR, 15KV, 200 AMP	2	705568
16		CONNECTORS, COMPRESSION (E)	2	700 SECTION
17		NAILS, GALV, 10d (E)	6	491392
18		WIRE, COPPER #6/3 STRAND	10'	813536
19		CABLE, 1/C #6, 5KV XLP	60'	194304
20		WIRE, COPPER, #4 SOLID W.P.	10'	812480
21		COVER, PVC THRU BOLT (E)	2	285696
22		PIPE, PLASTIC 1 1/2" DIAM., PVC TYPE II, SCHEDULE 80, 20' LENGTHS (E)	1	251456
23		PIPE, 1 1/2" DIAM. PLASTIC, 90° ELBOW, PVC TYPE II, SCHEDULE 80	1	322464
24		COUPLING, 1 1/2" DIAM. PLASTIC PIPE, PVC (E)	3	280512
25		STRAP, PIPE 1 1/2" DIAM., GALV. (E)	AS REQ'D.	697664
26		NAILS, 10d GALV. (E)	AS REQ'D.	491392
27		CLAMP, GROUND ROD (E)	2	230016
28		CONDUIT, PVC, TYPE II, SCHEDULE 80, 1" (E)	25'	251424
29		PLUG, DISCONNECT CONDUCTOR, 5 TERMINAL (F)	2	544838
30		WIRE, COPPER, #12 TW, STRANDED WP, WHITE (F)	25'	810016
31		WIRE, COPPER, #12 TW, STRANDED WP, RED (F)	25'	809920
32		WIRE, COPPER, #12 TW, STRANDED WP, BLACK (F)	25'	809504
33		TRANSFORMER, R.D., 12KV, 25KVA	1	763426
34		MOUNTING BRACKET	1	166432
35		PHOTO ELECTRIC RELAY, 120 V., 1000 W MIN.	1	273920
36		CUTOUT, 12KV 100A	2	297888
37		WIRE, COPPER #6 B. STRD.	50'	813644
38		UNIT, GROUND (LTN'G ARR.) PLAIN/GREY	1	603136, 603120
39		STAPLE, FENCE 1 1/4" (E)	AS REQ'D	678520
40		STAPLE, MOULDING 3" X 1 1/16" X 1/4" (E)	AS REQ'D	678560

FOR FIELD MAINTENANCE ONLY

INSTALLATION :

- A. CLASS OF POLES SHOULD BE DETERMINED PER STDS 344-361.
- B. APERTURE OF PHOTOELECTRIC CELL MUST BE SET TO FACE NORTH.
- C. 12KV/6.6A CONSTANT CURRENT TRANSFORMER HAS INTERNAL FUSES.
- (D) WHEN THERE IS NO SECONDARY ON A POLE, A 6 PIN COMBINATION ARM FOR THE TWO WIRE SERIES AND THE SECONDARY MAY BE USED. THE 4' ALLEY ARMS WILL NOT BE NEEDED. IDENTIFY THE SECONDARY WITH 0-750 VOLT SIGNS.
- (E) EXEMPT MATERIAL.
- (F) 5 TERMINAL PLUGS AND WIRE TO BE FABRICATED BY KEARNY MAINTENANCE.
- G.
- H.

REFERENCE :

- I. G. O. 95 RULE 58.2 REQUIRES PRIMARY CONSTANT CURRENT SERIES LIGHTING CIRCUITS BE TREATED AS MORE THAN 750 VOLTS.
- J. S D G & E RULE DOES NOT ALLOW FOR CONSTANT CURRENT SERIES LIGHTING CIRCUITS OVER 750 VOLTS TO BE PLACED ON THE SAME ARM WITH 12KV.

DATE 4-30-82
APPD *ARH*

S D G & E ELECTRIC STANDARDS
P. E. CONTROLLED
R. D. STREET LIGHT TRANSFORMER INSTALLATION, 12KV

1599.602
SUPERSEDES
1562.2 (4-30-82)