

**2017**

**Agricultural Irrigation Products Catalog**



**Schumacher**  
IRRIGATION

Air Relief Valve.....	10	Pipe, Aluminum.....	41-42, 44, 46
Ball & Socket.....	94-99	Pipe, Nu-Flex Poly.....	40
Band & Hook/Latch.....	113-114	Pipe, PVC Underground.....	48-49
Band-It Tool & Accessories.....	31-32	Pipe, Towline.....	26
Butt-Weld Fittings	163	Pipe, Vacuum.....	47
Cam Loc.....	100-101	Pitot Tube.....	162
Chain.....	123	Pivot Parts.....	139-148
Clamp, Horseshoe.....	117	Pressure Guage.....	149
Clamp, Ringlock.....	116	Pressure Relief Valve.....	11
Clamps, Hose.....	32, 36-38	Primer Valve.....	195
Cone, Concentric.....	121, 163	Primer, Hand.....	196-198
Cone, Eccentric.....	122, 163	Primer, Intake Manifold.....	199
Coupler, Dresser.....	15, 18, 189	Primer, Power.....	196
Coupler, Ringlock.....	87-88	Pump Accessories.....	188-201
Coupler, Sprinkler.....	89-90	Pumps.....	174-187
Coupler, Twistlock.....	90	PVC Cement, Primer & Lube.....	23
Coupler, Underground.....	12-13	Reducer.....	17, 21, 108-109
Coupling, Riser Valve.....	92	Repair Coupler.....	14-15
Coupling, Saddle.....	92	Rings, Weld-on/Bolt-on.....	116
Coupling, Alum & Steel.....	154	Riser Valve J.....	9
Disc, Alum/Steel.....	117	Riser Valve L.....	9
Drains.....	26, 155	Riser Valve Tee.....	6-7
Draw Band.....	12	Riser, Sprinkler.....	27
Elbow, Suction.....	190	Rodent Door.....	23
Elbow, Surface.....	102-104	Saddle.....	12
Elbow, Underground.....	17, 19, 22	Screen Parts.....	192-194
Elbow, Weld-on.....	112, 163	Screen, Footvalve.....	189-190
End Cap.....	18, 20, 111	Screen, Self-Cleaning.....	191
End Plug.....	18, 110-111	Screen, Suction.....	190-192
Fiberglass Tape (Powr-Wrap).....	14	Siphon Tubes.....	40
Filter, Inline Screen.....	148	Sprinkler.....	61-65
Fittings, Hose.....	29-31, 59-60, 95, 99	Sprinkler Leveler & Elbow.....	33
Fittings, Malleable.....	156-162	Sprinkler Nozzle	63-69
Fittings, PVC.....	19-23	Storage Basket	93
Fittings, Surface.....	46, 102-111	T Pipe.....	5
Fittings, Underground.....	4-23	Tee, Surface.....	104-107
Flanges.....	21, 118-120	Tee, Underground.....	16, 20, 22
Gasket.....	12, 15, 166-169	Tee, Weld-on.....	112, 163
Gate Sock & Clip.....	52	Telescope.....	123
Gates.....	50-51	Towline.....	26-28
Generator.....	202	Trailers.....	58
Hose & Accessories.....	28-38, 58-60	Tubing, Steel & Aluminum.....	43
Hose Pull Coupler.....	29, 60	Valve Opener.....	152
Hose Splice.....	29-31, 59	Valve Stub & Accessories.....	150-153
Increaser.....	109	Valve Tee, Independent.....	152-153
Industrial Groove.....	91	Valve, Alfalfa.....	129
J Pipe.....	4	Valve, Ball.....	125
L Pipe.....	4	Valve, Check.....	131-133
Motor, Electric.....	202	Valve, Chemigation.....	136
Murphy Switch.....	200-201	Valve, Combo.....	133
Nipples, TOE.....	153	Valve, Gate.....	124-125, 129
Nipples, TBE.....	170-172	Valve, Inline Butterfly.....	134-135
		Valve, Low Pressure.....	130
		Valve, Surge Gate.....	131
		Valve, Wafer Butterfly.....	125-128
		Volume Gun.....	56, 66-68, 70-83
		Volume Gun Stand.....	55-57
		Water Meter.....	137-138
		Wheeline.....	33
		Z Pipe.....	5

## CLAIMS

Claims for shortages, defective or damaged goods must be made within five (5) days from receipt of shipment.

Damages occurring "in transit" are the responsibility of the freight company and should be noted on the bill of lading when the shipment is received. Submit a claim directly to the carrier as soon as possible.

## RETURNS AND CANCELLATIONS

Merchandise may be returned only at the option of SCHUMACHER IRRIGATION, INC. Merchandise authorized for return

- 1) must be returned freight prepaid,
- 2) must be in new re-saleable condition, and
- 3) is subject to a 15% restocking charge
- 4) custom-built fittings cannot be returned, unless approved by a Schumacher representative

Credit will be issued to your account when the items are received back at our office.

Orders may be cancelled at the option of SCHUMACHER IRRIGATION, INC. If the request is received prior to shipment. **Nonstandard/Custom-built** items may not be cancelled without substantial penalty after material is "in process of manufacture."

## GUARANTEE

All products are guaranteed against defect due to faulty workmanship or material. This guarantee is void when merchandise is used for purposes other than that for which it was designed or if improper pressures are maintained.

Always Open...  
**SchumacherIrrigation.com**  
*Your Irrigation Superstore*

## LIABILITY

SCHUMACHER IRRIGATION, INC. is not responsible for delays and losses beyond our control or for losses or damages due to application of equipment for uses other than that for which it is designed or for operation under pressures not recommended. Suitability of the merchandise for the job for which it is sold is the sole responsibility of the buyer regardless of advice or recommendations by the seller. SCHUMACHER IRRIGATION, INC. assumes no responsibility for system design or for any damages or losses due to lack of minimum water requirements for crops being irrigated with SCHUMACHER IRRIGATION, INC. equipment.

**1-800-246-3685** or 1-402-246-3685

## **BILLING AND LATE CHARGES**

All payments are due on the 10th of the following month from the date of the invoice. Account statements are sent at the end of each month. After 30 days the principal is subject to an annual finance charge of 18%.

## **FREIGHT**

- All prices are F.O.B. Platte Center, Nebraska.
- Standard items are usually shipped the same day the order is received.
- Shipments via UPS, Speedee, and FedEx are shipped prepaid and the freight charge is added to your order.
- Shipments via common carrier are shipped freight collect.
- Freight charges on pipe delivered by our driver: \$3.00 per loaded mile.
- Deliveries by car / pickup without trailer are \$1.00 per loaded mile.

Always Open...  
**SchumacherIrrigation.com**  
*Your Irrigation Superstore*

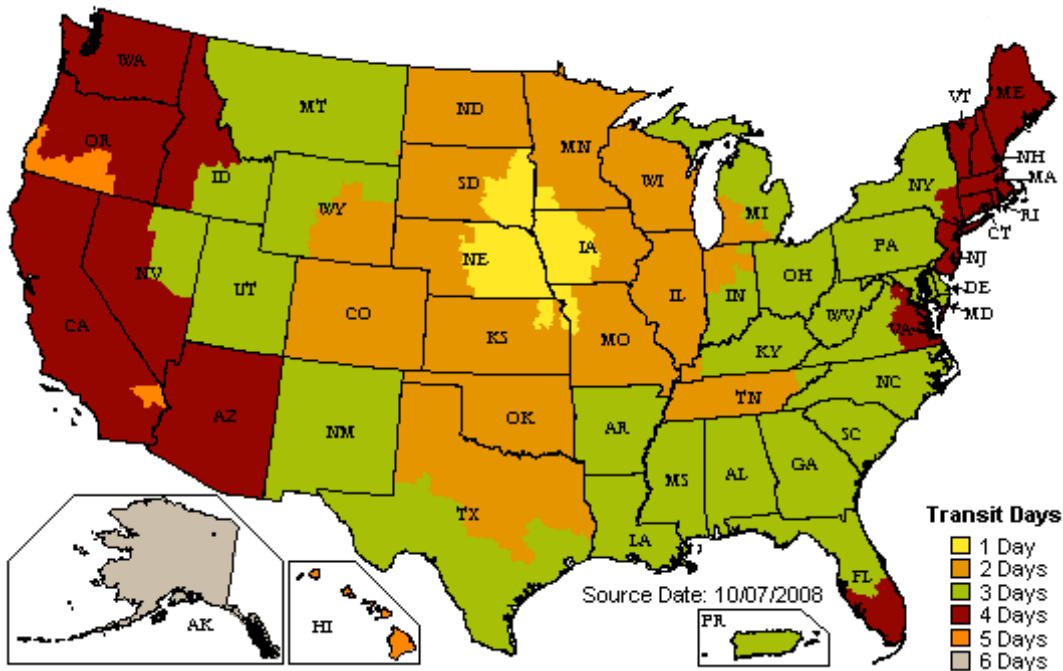

© Copyright 2014 Schumacher Irrigation, Inc. All Rights Reserved.

Prices subject to change without notice.

Material contained in this catalog may not be reproduced in whole or part without written permission from Schumacher Irrigation, Inc.

# Nursery/Greenhouse Irrigation Catalog

Also ask for your new Nursery/Greenhouse/Grower Catalog featuring drip/micro, sprinkler, and other irrigation products pertaining to the nursery & greenhouse industry.

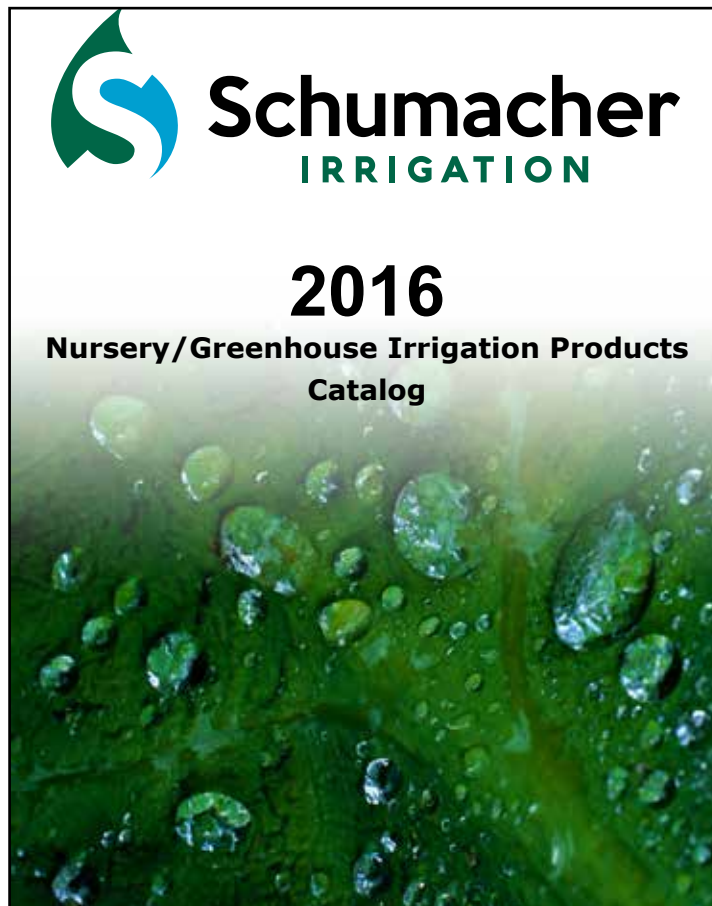

Always Open...

**SchumacherIrrigation.com**

*Your Irrigation Superstore*

To receive the Nursery/Greenhouse Irrigation Catalog:

**Call: 1-800-246-3685**









**or** Download the catalog at [www.schumacherirrigation.com](http://www.schumacherirrigation.com)

**or** Fax your request to 402-246-2072

**or** E-mail your request to [irrigate@schumacherirrigation.com](mailto:irrigate@schumacherirrigation.com)

## Section One



 Underground Risers	_____	4-9
 Air Relief Valves	_____	10
 Pressure Relief Valves	_____	11
 Underground Couplers	_____	12-13
 Repair Couplers	_____	14-15
 Steel Underground Fittings	_____	16-18
 PVC Underground Fittings	_____	19-22
 Drain Risers	_____	23
 PVC Glue, Primer & Lube	_____	23



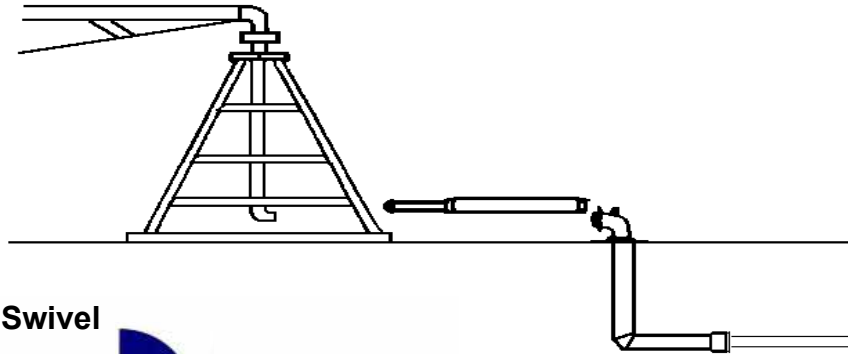

60"



**ELBOW**

Elbow on top swivels in a complete 360° circle to face any direction needed.

The above elbow is used along side the pivot pad. The elbow can be removed so that when the pivot is moved from one pad to another the "L" will be flush with the ground.



# UNDERGROUND RISERS

Product	Description	Part Number	Weight	List Price
---------	-------------	-------------	--------	------------

## J PIPE (GALV., STAINLESS OR PVC)

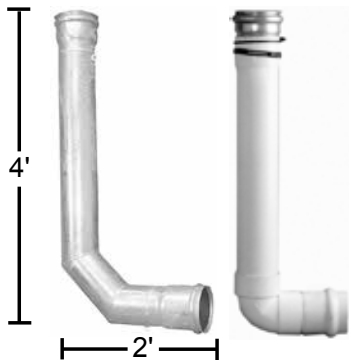

	Galvanized Steel			Stainless Steel			PVC #125		
Size	Part #	Weight	List	Part #	Weight	List	Part #	Weight	List
6" PIP	6-2000	36.0	<b>310.00</b>	9-8011		<b>695.00</b>	6-2724	12.1	<b>255.00</b>
8" PIP	6-2001	48.5	<b>365.00</b>	9-8012		<b>895.00</b>	6-2725	35.8	<b>340.00</b>
10" PIP	6-2002	61.7	<b>435.00</b>	9-8013		<b>1,100.00</b>	6-2726	31.5	<b>485.00</b>
12" PIP	6-2003	76.4	<b>535.00</b>				6-2727	39.5	<b>595.00</b>
<b>4" IPS</b>	8-1419	22.5	<b>279.00</b>						
<b>6" IPS</b>	6-2004	33.2	<b>310.00</b>	9-8014		<b>695.00</b>	6-2728	12.1	<b>255.00</b>
<b>8" IPS</b>	6-2005	48.5	<b>365.00</b>	9-8015		<b>895.00</b>	6-2729	36.0	<b>340.00</b>
<b>10" IPS</b>	6-2006	61.7	<b>435.00</b>	9-8016		<b>1100.00</b>	6-2730	31.5	<b>485.00</b>
<b>12" IPS</b>	6-2007	76.4	<b>535.00</b>				6-2731	39.5	<b>595.00</b>

J Pipe: 48" x 24"  
 Female Bottom PIP/IPS  
 Female RL OD Top  
 UPS Shippable.

\* Metric sizes available, please call.  
 \* 12 ga. tubing (optional 11,10, or 7)

## L PIPE (SHORT BASE) (GALV., STAINLESS OR PVC)

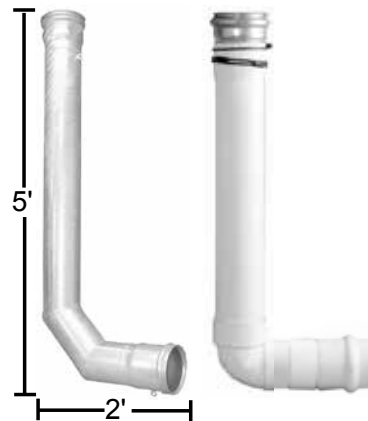

	Galvanized Steel			Stainless Steel			PVC #125		
Size	Part #	Weight	List	Part #	Weight	List	Part #	Weight	List
6" PIP	6-1981	41.1	<b>326.00</b>	9-8017	-	<b>759.00</b>	6-2716	20.9	<b>260.00</b>
8" PIP	6-1982	55.3	<b>383.00</b>	9-8018	-	<b>985.00</b>	6-2717	36.4	<b>345.00</b>
10" PIP	6-1983	70.2	<b>457.00</b>	9-8019	-	<b>1,259.00</b>	6-2718	52.7	<b>495.00</b>
12" PIP	6-1984	86.6	<b>562.00</b>				6-2719	72.8	<b>610.00</b>
<b>4" IPS</b>	8-1418	25.9	<b>293.00</b>						
<b>6" IPS</b>	6-1991	41.1	<b>326.00</b>	9-8020		<b>759.00</b>	6-2720	23.9	<b>260.00</b>
<b>8" IPS</b>	6-1992	55.3	<b>383.00</b>	9-8021		<b>985.00</b>	6-2721	41.6	<b>345.00</b>
<b>10" IPS</b>	6-1993	70.2	<b>457.00</b>	9-8022		<b>1,259.00</b>	6-2722	60.5	<b>495.00</b>
<b>12" IPS</b>	6-1994	86.6	<b>562.00</b>				6-2723	81.5	<b>610.00</b>

L Pipe: 60" x 24"  
 Female Bottom PIP/IPS  
 Female RL OD Top.

\* Metric sizes available, please call.  
 \* 12 ga. tubing (optional 11,10, or 7)

## L PIPE (LONG BASE) (GALVANIZED STEEL)

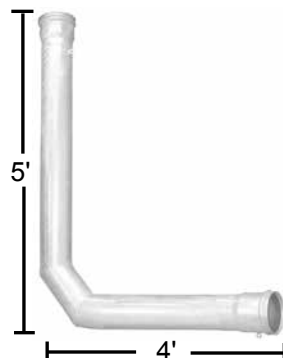

6" PIP	6-1981-L	54.7	<b>359.00</b>
8" PIP	6-1982-L	73.3	<b>421.00</b>
10" PIP	6-1983-L	92.8	<b>503.00</b>
12" PIP	6-1984-L	113.8	<b>618.00</b>
<b>4" IPS</b>	8-1418-L	34.9	<b>322.00</b>
<b>6" IPS</b>	6-1991-L	54.7	<b>359.00</b>
<b>8" IPS</b>	6-1992-L	73.3	<b>421.00</b>
<b>10" IPS</b>	6-1993-L	92.8	<b>503.00</b>
<b>12" IPS</b>	6-1994-L	113.8	<b>618.00</b>

L Pipe: 60" x 40"  
 Female Bottom PIP/IPS  
 Female RL OD Top.

\* Metric sizes available, please call.  
 \* 12 ga. tubing (optional 11,10, or 7)

# UNDERGROUND RISERS

Underground Fittings

**Z PIPE (SHORT BASE)**  
(GALV., STAINLESS OR PVC)

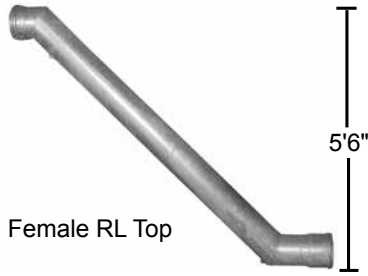

Female RL Top

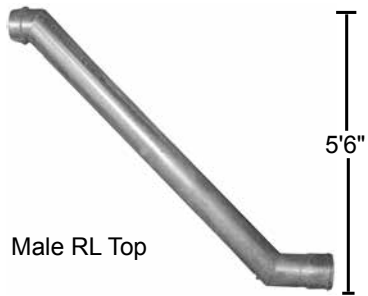

Male RL Top

Z Pipe: 15"x84"x15"  
Female Bottom PIP/IPS.  
Nipples & other acc. optional.

\* Metric sizes available, please call.  
\* 12 ga. tubing (optional 11, 10, or 7)

Product		Description		Part Number		Weight	List Price		
FRL	Galvanized Steel			Stainless Steel			PVC #125		
Size	Part #	Weight	List	Part #	Weight	List	Part #	Weight	List
6" PIP	6-1961	59.8	<b>355.00</b>	9-8029		<b>965.00</b>	6-2700	29.2	<b>379.00</b>
8" PIP	6-1962	80.0	<b>415.00</b>	9-8030		<b>1,255.00</b>	6-2701	53.3	<b>479.00</b>
10" PIP	6-1963	101.3	<b>530.00</b>	9-8031		<b>1,595.00</b>	6-2702	78.5	<b>599.00</b>
12" PIP	6-1968	124.0	<b>695.00</b>				6-2703	100.5	<b>799.00</b>
4" IPS	8-1416	38.3	<b>295.00</b>						
6" IPS	6-1971	59.8	<b>355.00</b>	9-8032		<b>965.00</b>	6-2704	33.8	<b>449.00</b>
8" IPS	6-1972	80.0	<b>415.00</b>	9-8033		<b>1,255.00</b>	6-2705	61.0	<b>579.00</b>
10" IPS	6-1973	101.3	<b>530.00</b>	9-8034		<b>1,595.00</b>	6-2706	91.3	<b>739.00</b>
12" IPS	6-1969	124.0	<b>695.00</b>				6-2707	107.3	<b>969.00</b>

MRL	Galvanized Steel			Stainless Steel			PVC #125		
Size	Part #	Weight	List	Part #	Weight	List	Part #	Weight	List
6" PIP	6-1964	61.4	<b>355.00</b>	9-8035		<b>965.00</b>	6-2708	29.2	<b>379.00</b>
8" PIP	6-1965	81.1	<b>415.00</b>	9-8036		<b>1,255.00</b>	6-2709	52.3	<b>479.00</b>
10" PIP	6-1966	102.8	<b>530.00</b>	9-8037		<b>1,595.00</b>	6-2710	79.0	<b>599.00</b>
12" PIP	6-1967	130.8	<b>695.00</b>				6-2711	97.5	<b>799.00</b>
4" IPS	8-1417	38.3	<b>295.00</b>						
6" IPS	6-1974	61.4	<b>355.00</b>	9-8038		<b>965.00</b>	6-2712	33.8	<b>449.00</b>
8" IPS	6-1975	81.1	<b>415.00</b>	9-8039		<b>1,255.00</b>	6-2713	60.0	<b>579.00</b>
10" IPS	6-1976	106.9	<b>530.00</b>	9-8040		<b>1,595.00</b>	6-2714	91.8	<b>739.00</b>
12" IPS	6-1977	130.8	<b>695.00</b>				6-2715	106.3	<b>969.00</b>

**T PIPE**  
(GALVANIZED OR STAINLESS STEEL)

T Pipe: 60" x 24"  
Double Female Bottom PIP/IPS  
Female RL OD Top

\* Metric sizes available, please call.  
\* 12 ga. tubing (optional 11,10, or 7)

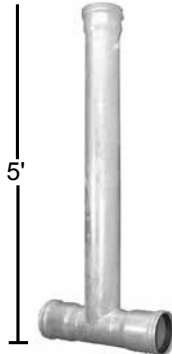

	Galvanized Steel			Stainless Steel		
Size	Part #	Weight	List	Part #	Weight	List
6" PIP	6-1986	42.0	<b>319.00</b>	9-8023		<b>735.00</b>
8" PIP	6-1987	56.5	<b>365.00</b>	9-8024		<b>995.00</b>
10" PIP	6-1988	72.7	<b>449.00</b>	9-8025		<b>1,295.00</b>
12" PIP	6-1989	76.4	<b>550.00</b>			
4" IPS	8-1420	25.5	<b>229.00</b>			
6" IPS	6-1996	42.0	<b>319.00</b>	9-8026		<b>735.00</b>
8" IPS	6-1997	56.5	<b>365.00</b>	9-8027		<b>995.00</b>
10" IPS	6-1998	72.7	<b>449.00</b>	9-8028		<b>1,295.00</b>
12" IPS	6-1990	89.4	<b>550.00</b>			

**RISER TEE (MPT TOP)**  
(GALVANIZED STEEL)

8"x8"x2"mpt x54", PIP

9-5319

-

**310.00**



-For use as air relief valve in the line.

# PIP RISER VALVE TEES



Product	Description	Part Number	Weight	List Price
---------	-------------	-------------	--------	------------

## PIP RISER VALVE TEE (GALVANIZED OR STAINLESS STEEL)

30", 36", 42", & 54"

The riser length is measured from the top of the mainline to the top of the valve.

Option: Male ends may be substituted for female.

\*Custom-Built Fittings will be made to order.

Other sizes available on request.  
Special discounts on quantity orders.  
Metric Sizes available.  
Please call for special requests.

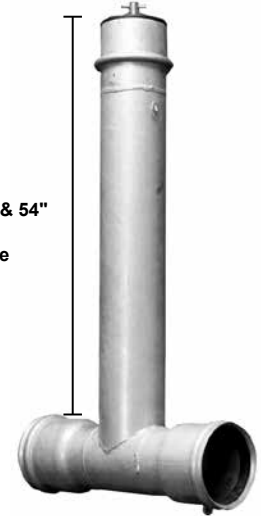

PIP						
4" Valve Top	Galvanized Steel			Stainless Steel		
Size	Part #	Weight	List	Part #	Weight	List
6"x6"x4"x30"	6-3921	27.2	210.00			
6"x6"x4"x36"	6-3922	29.5	226.00			
6"x6"x4"x42"	6-3923	31.7	240.00			
6"x6"x4"x54"	6-3924	33.8	255.00			
8"x8"x4"x30"	6-3931	32.3	259.00			
8"x8"x4"x36"	6-3932	34.6	275.00			
8"x8"x4"x42"	6-3933	36.8	290.00			
8"x8"x4"x54"	6-3934	41.3	305.00			
10"x10"x4"x30"	6-3941	39.5	295.00			
10"x10"x4"x36"	6-3942	41.7	305.00			
10"x10"x4"x42"	6-3943	44.0	320.00			
10"x10"x4"x54"	6-3944	48.5	335.00			
12"x12"x4"x30"	6-3951	44.6	330.00			
12"x12"x4"x36"	6-3952	46.9	345.00			
12"x12"x4"x42"	6-3953	49.1	360.00			
12"x12"x4"x54"	6-3954	53.6	375.00			

PIP						
6" Valve Top	Galvanized Steel			Stainless Steel		
Size	Part #	Weight	List	Part #	Weight	List
6"x6"x6"x30"	6-3961	36.0	259.00	9-8041	-	836.00
6"x6"x6"x36"	6-3962	39.4	279.00	9-8042	-	873.00
6"x6"x6"x42"	6-3963	42.8	299.00	9-8043	-	910.00
6"x6"x6"x54"	6-3964	49.6	319.00	9-8044	-	985.00
8"x8"x6"x30"	6-3971	41.4	305.00	9-8049	-	984.00
8"x8"x6"x36"	6-3972	44.8	325.00	9-8050	-	1,021.00
8"x8"x6"x42"	6-3973	48.2	345.00	9-8051	-	1,059.00
8"x8"x6"x54"	6-3974	55.0	365.00	9-8052	-	1,133.00
10"x10"x6"x30"	6-3981	49.0	340.00	9-8057	-	1,122.00
10"x10"x6"x36"	6-3982	52.4	360.00	9-8058	-	1,159.00
10"x10"x6"x42"	6-3983	55.8	380.00	9-8059	-	1,197.00
10"x10"x6"x54"	6-3984	62.6	400.00	9-8060	-	1,271.00
12"x12"x6"x30"	6-3991	54.5	419.00			
12"x12"x6"x36"	6-3992	57.9	439.00			
12"x12"x6"x42"	6-3993	61.3	459.00			
12"x12"x6"x54"	6-3994	68.1	479.00			

PIP						
8" Valve Top	Galvanized Steel			Stainless Steel		
Size	Part #	Weight	List	Part #	Weight	List
8"x8"x8"x30"	8-1300	58.0	495.00	9-8065	-	1,453.00
8"x8"x8"x36"	8-1301	62.5	505.00	9-8066	-	1,502.00
8"x8"x8"x42"	8-1302	67.0	515.00	9-8067	-	1,551.00
8"x8"x8"x54"	8-1303	76.0	525.00	9-8068	-	1,650.00
10"x10"x8"x30"	8-1308	66.3	525.00	9-8073	-	1,606.00
10"x10"x8"x36"	8-1309	70.8	535.00	9-8074	-	1,655.00
10"x10"x8"x42"	8-1310	75.3	545.00	9-8075	-	1,705.00
10"x10"x8"x54"	8-1311	84.3	555.00	9-8076	-	1,803.00
12"x12"x8"x30"	8-1316	72.6	575.00			
12"x12"x8"x36"	8-1317	77.1	585.00			
12"x12"x8"x42"	8-1318	81.6	595.00			
12"x12"x8"x54"	8-1319	90.6	605.00			

PIP						
10" Valve Top	Galvanized Steel			Stainless Steel		
Size	Part #	Weight	List	Part #	Weight	List
10"x10"x10"x30"	9-7857	74.9	605.00	9-8081	-	2,010.00
10"x10"x10"x36"	9-7859	80.6	615.00	9-8082	-	2,073.00
10"x10"x10"x42"	9-7861	86.2	625.00	9-8083	-	2,136.00
10"x10"x10"x54"	9-7863	97.5	645.00	9-8084	-	2,262.00
12"x12"x10"x30"	9-7865	81.2	660.00			
12"x12"x10"x36"	9-7867	86.9	670.00			
12"x12"x10"x42"	9-7869	92.5	680.00			
12"x12"x10"x54"	9-7871	103.8	699.00			

# IPS RISER VALVE TEES

Product	Description	Part Number	Weight	List Price
---------	-------------	-------------	--------	------------

## IPS RISER VALVE TEE (GALVANIZED OR STAINLESS STEEL)

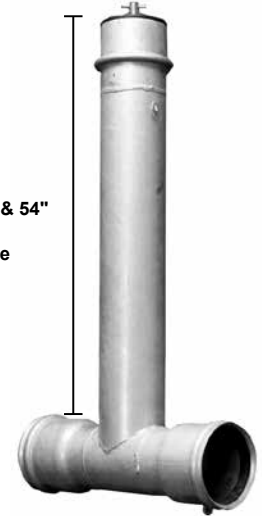

30", 36", 42", & 54"

The riser length is measured from the top of the mainline to the top of the valve.

Option: Male ends may be substituted for female.

\*Custom-Built Fittings will be made to order.

Other sizes available on request.  
Special discounts on quantity orders.  
Metric Sizes available.  
Please call for special requests.

Underground Fittings

IPS						
4" Valve Top	Galvanized Steel			Stainless Steel		
Size	Part #	Weight	List	Part #	Weight	List
4"x4"x4"x30	6-3915	17.8	189.00			
4"x4"x4"x36	6-3916	20.1	205.00			
4"x4"x4"x42	6-3917	22.3	219.00			
4"x4"x4"x54	6-3918	26.8	229.00			
6"x6"x4"x30"	6-3925	27.2	210.00			
6"x6"x4"x36"	6-3926	29.5	226.00			
6"x6"x4"x42"	6-3927	31.7	240.00			
6"x6"x4"x54"	6-6928	3.4	48.00			
8"x8"x4"x30"	6-3935	32.3	259.00			
8"x8"x4"x36"	6-3936	34.6	275.00			
8"x8"x4"x42"	6-3937	36.8	290.00			
8"x8"x4"x54"	6-3938	41.3	305.00			
10"x10"x4"x30"	6-3945	39.5	295.00			
10"x10"x4"x36"	6-3946	41.7	305.00			
10"x10"x4"x42"	6-3947	44.0	320.00			
10"x10"x4"x54"	6-3948	48.5	335.00			
12"x12"x4"x30"	6-3955	44.6	330.00			
12"x12"x4"x36"	6-3956	46.9	345.00			
12"x12"x4"x42"	6-3957	49.1	360.00			
12"x12"x4"x54"	6-3958	53.6	375.00			

IPS						
6" Valve Top	Galvanized Steel			Stainless Steel		
Size	Part #	Weight	List	Part #	Weight	List
6"x6"x6"x30"	6-3965	36.0	259.00	9-8045	-	857.00
6"x6"x6"x36"	6-3966	39.4	279.00	9-8046	-	894.00
6"x6"x6"x42"	6-3967	42.8	299.00	9-8047	-	931.00
6"x6"x6"x54"	6-3968	49.6	319.00	9-8048	-	1,006.00
8"x8"x6"x30"	6-3975	41.4	305.00	9-8053	-	994.00
8"x8"x6"x36"	6-3976	44.8	325.00	9-8054	-	1,031.00
8"x8"x6"x42"	6-3977	48.2	345.00	9-8055	-	1,068.00
8"x8"x6"x54"	6-3978	55.0	365.00	9-8056	-	1,143.00
10"x10"x6"x30"	6-3985	49.0	340.00	9-8061	-	1,153.00
10"x10"x6"x36"	6-3986	52.4	360.00	9-8062	-	1,190.00
10"x10"x6"x42"	6-3987	55.8	380.00	9-8063	-	1,227.00
10"x10"x6"x54"	6-3988	62.6	400.00	9-8064	-	1,301.00
12"x12"x6"x30"	6-3995	54.5	419.00			
12"x12"x6"x36"	6-3996	57.9	439.00			
12"x12"x6"x42"	6-3997	61.3	459.00			
12"x12"x6"x54"	6-3998	68.1	479.00			

IPS						
8" Valve Top	Galvanized Steel			Stainless Steel		
Size	Part #	Weight	List	Part #	Weight	List
8"x8"x8"x30"	8-1304	58.0	495.00	9-8069	-	1,462.00
8"x8"x8"x36"	8-1305	62.5	505.00	9-8070	-	1,511.00
8"x8"x8"x42"	8-1306	67.0	515.00	9-8071	-	1,561.00
8"x8"x8"x54"	8-1307	76.0	525.00	9-8072	-	1,659.00
10"x10"x8"x30"	8-1312	66.3	525.00	9-8077	-	1,637.00
10"x10"x8"x36"	8-1313	70.8	535.00	9-8078	-	1,686.00
10"x10"x8"x42"	8-1314	75.3	545.00	9-8079	-	1,735.00
10"x10"x8"x54"	8-1315	84.3	555.00	9-8080	-	1,833.00
12"x12"x8"x30"	8-1320	72.6	575.00			
12"x12"x8"x36"	8-1321	77.1	585.00			
12"x12"x8"x42"	8-1322	81.6	595.00			
12"x12"x8"x54"	8-1323	90.6	605.00			

IPS						
10" Valve Top	Galvanized Steel			Stainless Steel		
Size	Part #	Weight	List	Part #	Weight	List
10"x10"x10"x30"	9-7856	74.9	605.00	9-8085	-	2,040.00
10"x10"x10"x36"	9-7858	80.6	615.00	9-8086	-	2,103.00
10"x10"x10"x42"	9-7860	86.2	625.00	9-8087	-	2,166.00
10"x10"x10"x54"	9-7862	97.5	645.00	9-8088	-	2,293.00
12"x12"x10"x30"	9-7864	81.2	660.00			
12"x12"x10"x36"	9-7866	86.9	670.00			
12"x12"x10"x42"	9-7868	92.5	680.00			
12"x12"x10"x54"	9-7870	103.8	699.00			

# BOLT-ON SADDLES & RISERS

Product	Description	Part Number	Weight	List Price	
<b>SADDLE RISER</b> (POWDER COATED OR GALVANIZED)		36" 6"x4" x 36"	6-3820	22.0	<b>165.00</b>
		8"x4" x 36"	6-3821	24.0	<b>175.00</b>
		10"x4" x 36"	6-3822	26.0	<b>183.00</b>
		12"x4" x 36"	6-3823	28.0	<b>205.00</b>
	42"	6"x4" x 42"	6-3825	22.0	<b>225.00</b>
		8"x4" x 42"	6-3826	24.0	<b>225.00</b>
		10"x4" x 42"	6-3827	26.0	<b>200.00</b>
		12"x4" x 42"	6-3828	28.0	<b>210.00</b>

For PIP or IPS use.  
Steel powder coated or galvanized.

## SADDLE RISER (WITH PVC RISER)

- Lightweight
- Easy to install
- Durable
- Sunlight (UV) Inhibited
- UPS Shippable
- For PIP or IPS use
- Using 3"x36" & 48" PVC Riser Pipe
- Using 3" outlet on galvanized saddle
- Using 3" x4" galvanized valve stubs.



42"	6"x4" x 42"	6-3804	19.0	<b>213.00</b>
	8"x4" x 42"	6-3805	20.0	<b>225.00</b>
	10"x4" x 42"	6-3806	23.0	<b>245.00</b>
	12"x4" x 42"	6-3830	25.0	<b>263.00</b>
54"	6"x4" x 54"	6-3807	21.0	<b>217.00</b>
	8"x4" x 54"	6-3808	22.0	<b>229.00</b>
	10"x4" x 54"	6-3809	20.0	<b>249.00</b>
	12"x4" x 54"	6-3831	27.0	<b>267.00</b>

## SADDLE (GALVANIZED STEEL)



W/FPT				
6" x 3"	6" x 3"	6-3810	11.0	<b>117.00</b>
	8" x 3"	6-3811	12.0	<b>129.00</b>
	10" x 3"	6-3812	15.0	<b>149.00</b>
	12" x 3"	6-3813	17.0	<b>167.00</b>
	15" x 3"	9-7628	23.0	<b>181.00</b>
	18" x 3"	9-7629	28.0	<b>639.00</b>
6" x 4"	6" x 4"	6-3814	12.0	<b>128.00</b>
	8" x 4"	6-3815	13.0	<b>135.00</b>
	10" x 4"	6-3816	16.0	<b>155.00</b>
	12" x 4"	6-3817	18.0	<b>175.00</b>
8" x 6"	8" x 6"	9-7632	20.0	<b>173.00</b>
	10" x 6"	9-7633	22.0	<b>186.00</b>
	12" x 6"	9-7634	24.0	<b>205.00</b>
	15" x 6"	9-7635	26.0	<b>246.00</b>
	18" x 6"	9-7636	31.0	<b>700.00</b>

For OD, PIP or IPS use.

## PVC RISER PIPE

- 3" & 4" double male threaded
- High density polyethylene riser pipe w/UV inhibitor (SCH80)



3"x36" (for 42" riser)	6-3802	3.0	<b>15.00</b>
4"x36" (for 42" riser)	6-3790	-	<b>29.00</b>
3"x48" (for 54" riser)	6-3803	5.0	<b>19.00</b>
4"x48" (for 54" riser)	6-3791	-	<b>39.00</b>

# RISER VALVE J & L

Product	Description	Part Number	Weight	List Price
---------	-------------	-------------	--------	------------

## RISER VALVE J (GALVANIZED STEEL)

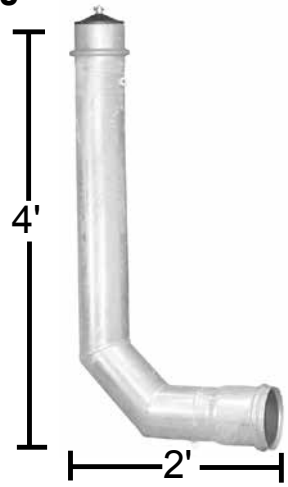

6"x4"	PIP x valve	9-7850	43.9	<b>385.00</b>
6"x6"	PIP x valve	6-4001	39.0	<b>369.00</b>
8"x4"	PIP x valve	9-7851	53.8	<b>455.00</b>
8"x6"	PIP x valve	9-7852	63.7	<b>480.00</b>
8"x8"	PIP x valve	6-4002	59.0	<b>575.00</b>
<b>6"x4"</b>	<b>IPS x valve</b>	9-7853	43.9	<b>385.00</b>
<b>6"x6"</b>	<b>IPS x valve</b>	6-4005	39.0	<b>369.00</b>
<b>8"x4"</b>	<b>IPS x valve</b>	9-7854	53.8	<b>455.00</b>
<b>8"x6"</b>	<b>IPS x valve</b>	9-7855	63.7	<b>480.00</b>
<b>8"x8"</b>	<b>IPS x valve</b>	6-4006	59.0	<b>575.00</b>

Underground Fittings

## RISER VALVE L (GALVANIZED STEEL)

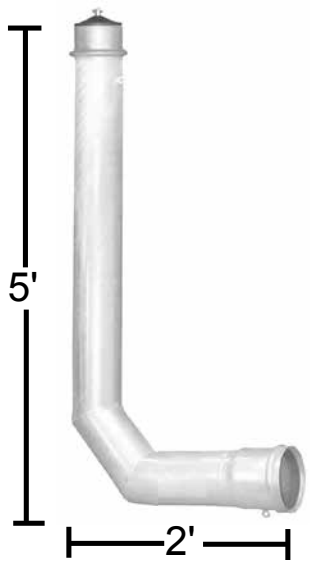

6"x4"	PIP x valve	8-1410	48.4	<b>404.00</b>
6"x6"	PIP x valve	8-1324	44.1	<b>387.00</b>
8"x4"	PIP x valve	8-1412	58.3	<b>478.00</b>
8"x6"	PIP x valve	8-1414	70.5	<b>504.00</b>
8"x8"	PIP x valve	8-1326	65.8	<b>604.00</b>
<b>6"x4"</b>	<b>IPS x valve</b>	8-1411	48.4	<b>404.00</b>
<b>6"x6"</b>	<b>IPS x valve</b>	8-1325	44.1	<b>387.00</b>
<b>8"x4"</b>	<b>IPS x valve</b>	8-1413	58.3	<b>478.00</b>
<b>8"x6"</b>	<b>IPS x valve</b>	8-1415	70.5	<b>504.00</b>
<b>8"x8"</b>	<b>IPS x valve</b>	8-1327	65.8	<b>604.00</b>

## STEEL NIPPLE (WELDED ON)



2"	6-2960	0.5	<b>25.00</b>
3"	6-2961	1.5	<b>33.00</b>
4"	6-2962	2.7	<b>42.00</b>

Nipples welded on for air relief, surge plug, etc.

## STEEL ARM (WELDED ON)



Male Thread	2"	6-2963	2.6	<b>55.00</b>
	3"	6-2934	5.5	<b>126.00</b>
	4"	6-2935	8.5	<b>165.00</b>
Female Thread	2"	6-2936	2.5	<b>55.00</b>
	3"	6-2937	5.4	<b>126.00</b>
	4"	6-2938	7.7	<b>165.00</b>

Elbow is welded on vertical risers for air relief, surge plug, etc.

# AIR RELIEF VALVES

Product	Description	Part Number	Weight	List Price	
<b>AIR RELIEF VALVE</b> (CAST ALUM)	<b>Standard</b>	1.5"	6-1909	1.2	<b>22.00</b>
		2"	6-1910	1.6	<b>29.00</b>
		3"	6-1912	3.1	<b>55.00</b>
		4"	6-1913	6.0	<b>125.00</b>
	<b>Continuous</b>	2"	9-7829	6.0	<b>221.00</b>
		3"	9-7830	9.7	<b>235.00</b>
		4"	9-7831	-	<b>259.00</b>

Venting air in any pressurized pipe is of major importance. Air relief valves help protect the irrigation system from serious head surges and water hammer.

Continuous Action Air Vents:

- \* Exhaust Large Volumes of Trapped Air from the Pipeline.
- \* Provide Continuous Air Release during system operation.

## AIR RELIEF VALVE

(NYLON / POLYPROPYLENE)



Guardian(Nylon)	1"	65ARIA100	9-6952	0.2	<b>43.00</b>
	2"	65ARIA2	9-6953	0.3	<b>58.00</b>
	3"	65ARIA3	9-6954	0.7	<b>165.00</b>
Continuous (Poly)	2"	65ARIB2PP	9-6951	1.1	<b>190.00</b>

Advantages

- Made of corrosion-resistant reinforced UV protected composite materials. No metal to rust or corrode.
- 5-year warranty

## TRI-ACTION VALVE

(CAST ALUMINUM)



1. Pressure Relief
2. Air Relief
3. Vacuum Relief

3"	0-50 psi	6-1915	17.0	<b>369.00</b>
3"	50-160 psi	6-1914	24.0	<b>369.00</b>

## TRI-ACTION VALVE PARTS

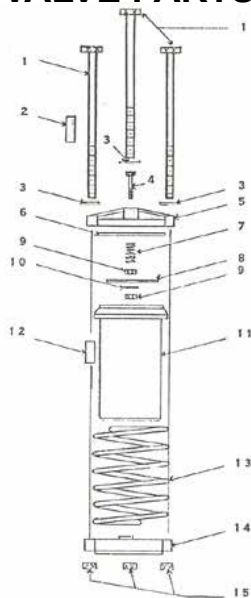

Hanger Bolt (3 req.)	1	9-7453	-	<b>15.00</b>
Decal	2	9-7454	-	<b>6.00</b>
Hanger Washer (3 req.)	3	9-7455	-	<b>1.50</b>
Valve Disc Stem	4	9-7456	-	<b>2.00</b>
Head Cap	5	9-7457	-	<b>35.00</b>
Cap Gasket	6	9-7458	-	<b>6.00</b>
Retainer Spring	7	9-7459	-	<b>3.00</b>
Valve Disc	8	9-7460	-	<b>6.50</b>
Stem Nut (2 req.)	9	9-7461	-	<b>1.50</b>
Washer	10	9-7462	-	<b>1.50</b>
Valve Body	11	9-7463	-	<b>155.00</b>
Gauge Indicator	12	9-7464	-	<b>7.50</b>
Compression Spring	13	9-7465	-	<b>157.00</b>
Hanger	14	9-7466	-	<b>62.00</b>
Hanger Bolt Nut (3 req.)	15	9-7467	-	<b>1.50</b>

# PRESSURE RELIEF VALVES

Product	Description	Part Number	Weight	List Price
---------	-------------	-------------	--------	------------

## PRESSURE RELIEF VALVE 4" FPT



4" FPT		Threads on Bolt				
Cast Alum.	50#			6-1919	5.5	170.00
	80#	9		6-1920	5.5	170.00
	100#	12		6-1921	5.5	170.00
	125#	3		6-1922	6.0	175.00
	160#			6-1923	6.0	175.00

Underground Fittings

## PRESSURE RELIEF VALVE 3" FPT

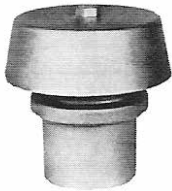

Cast Alum.



Steel Galv.

3" FPT						
Cast Alum.	80#			9-6822	6.0	175.00
Steel Galv.	85#			9-6823	-	155.00

## PRESSURE RELIEF VALVE FIELD SET (CAST IRON)



**Pressure Guard™**

2" FPT	PSI Range	Spring Color		
	0-25#	Gray	9-7832	145.00
	30-40#	Yellow	9-7833	155.00
	45-85#	Black	9-7834	138.00
	85-150#	Yellow/Blue	9-7835	189.00
2-1/2" FPT				
	0-25#	Gray	9-7836	165.00
	30-40#	Yellow	9-7837	179.00
	45-85#	Black	9-7838	159.00
	85-150#	Yellow/Blue	9-7839	219.00
3" FPT				
	0-25#	Gray	9-7840	150.00
	30-40#	Yellow	9-7841	189.00
	45-85#	Black	9-7842	145.00
	85-150#	Yellow/Blue	9-7843	215.00
4" FPT				
	0-25#	Gray	9-7844	190.00
	30-40#	Yellow	9-7845	218.00
	45-85#	Black	9-7846	185.00
	85-150#	Yellow/Blue	9-7847	245.00

Features:  
 \* Cast Iron Body  
 \* Brass Guide Bushing  
 \* Stainless Guide Rod



# UNDERGROUND COUPLERS



Product	Description	Part Number	Weight	List Price
---------	-------------	-------------	--------	------------

## COUPLER (WELD-ON)



		Black Steel			Powder Coated Steel			Stainless Steel		
Size	PVC OD	Part #	Weight	List	Part #	Weight	List	Part #	Weight	List
6" PIP	6.14"	9-5043	6.0	<b>36.00</b>	6-2231	6.0	<b>50.00</b>	9-5159	3.5	<b>110.00</b>
8" PIP	8.16"	9-5044	8.0	<b>45.00</b>	6-2232	8.0	<b>60.00</b>	9-5160	6.5	<b>165.00</b>
10" PIP	10.20"	9-5045	11.0	<b>65.00</b>	6-2233	11.0	<b>82.00</b>	9-8099	-	<b>211.00</b>
12" PIP	12.24"	9-5046	13.0	<b>80.00</b>	6-2234	13.0	<b>99.00</b>			
15" PIP	15.30"	9-7441	14.8	<b>165.00</b>	6-2235	14.0	<b>205.00</b>			
18" PIP	18.70"				6-2600	19.0	<b>358.00</b>			
<b>2" IPS</b>	2.375"				6-2217		<b>42.00</b>			
<b>2.5" IPS</b>	2.875"				6-2218		<b>42.00</b>			
<b>3" IPS</b>	3.50"				6-2219	2.0	<b>40.00</b>			
<b>4" IPS</b>	4.50"	9-5037	3.0	<b>30.00</b>	6-2220	3.0	<b>40.00</b>	9-5156	2.5	<b>55.00</b>
<b>6" IPS</b>	6.625"	9-5038	6.0	<b>36.00</b>	6-2221	6.0	<b>50.00</b>	9-5157	3.5	<b>110.00</b>
<b>8" IPS</b>	8.625"	9-5039	8.0	<b>45.00</b>	6-2222	8.0	<b>60.00</b>	9-5158	6.5	<b>165.00</b>
<b>10" IPS</b>	10.75"	9-5040	11.0	<b>65.00</b>	6-2223	11.0	<b>82.00</b>	9-8100	-	<b>226.00</b>
<b>12" IPS</b>	12.75"	9-5041	13.0	<b>80.00</b>	6-2224	13.0	<b>99.00</b>			
6" Metric	6.625"				6-2226		<b>44.30</b>			
8" Metric	7.87"				6-2227		<b>72.00</b>			
10" Metric	9.84"				6-2228		<b>81.50</b>			
12" Metric	12.41"				6-2229		<b>110.00</b>			

## GASKET (UNDERGROUND)



ROUND BACK:	Part #	Weight	List Price
6" PIP	6-4241	0.3	<b>10.00</b>
8" PIP	6-4242	0.6	<b>13.00</b>
10" PIP	6-4243	0.8	<b>18.50</b>
12" PIP	6-4244	1.0	<b>23.00</b>
15" PIP	6-4245	-	<b>27.00</b>
18" PIP	9-5291	-	<b>51.00</b>
<b>4" IPS</b>	6-4233	-	<b>9.50</b>
<b>6" IPS</b>	6-4234	0.3	<b>10.00</b>
<b>8" IPS</b>	6-4235	0.6	<b>13.00</b>
<b>10" IPS</b>	6-4236	0.8	<b>18.50</b>
<b>12" IPS</b>	6-4237	1.0	<b>23.00</b>



SQUARE BACK:	Part #	Weight	List Price
6" PIP	9-7645	1.8	<b>8.00</b>
8" PIP	9-7647	2.0	<b>11.00</b>
10" PIP	9-7638	2.3	<b>21.00</b>
12" PIP	9-7640	2.5	<b>26.00</b>
15" PIP	9-7641		<b>31.00</b>
18" PIP	9-7642		<b>65.00</b>
<b>4" IPS</b>	9-7643	1.3	<b>7.00</b>
<b>6" IPS</b>	9-7644	1.8	<b>9.00</b>
<b>8" IPS</b>	9-7646	2.0	<b>11.00</b>
<b>10" IPS</b>	9-7637	2.3	<b>22.00</b>
<b>12" IPS</b>	9-7639		<b>27.00</b>

## DRAW BAND (PAINTED STEEL)



6"	6-1704	0.6	<b>10.10</b>
8"	6-1705	0.7	<b>10.30</b>
10"	6-1706	0.9	<b>10.70</b>
12" (for 10" Newby boot)	6-1707	1.0	<b>11.00</b>
14"	6-1708	1.1	<b>11.50</b>
15"	6-1709	1.2	<b>13.50</b>

\*For #80 PIP plastic pipe, state other psi sizes.

# UNDERGROUND COUPLERS & MALE ENDS

Product	Description	Part Number	Weight	List Price
<b>WELD-ON MALE END</b> (POWDER COATED STEEL)	6" PIP	6-2281	3.5	<b>56.00</b>
	8" PIP	6-2282	6.5	<b>61.00</b>
	10" PIP	6-2283	10.5	<b>74.00</b>
	12" PIP	6-2284	12.5	<b>90.00</b>
	15" PIP	6-2285	14.0	<b>158.00</b>
	4" IPS	6-2289	2.5	<b>52.00</b>
	6" IPS	6-2290	3.5	<b>56.00</b>
	8" IPS	6-2291	6.5	<b>61.00</b>
	10" IPS	6-2292	10.5	<b>74.00</b>
	12" IPS	6-2293	12.5	<b>90.00</b>



## BOLT-ON COUPLER

(BLACK OR POWDER COATED STEEL)



9" long.  
Male weld-on x bolt-on coupler

Size	Black Steel			Powder Coated Steel		
	Part #	Weight	List	Part #	Weight	List
4" OD	9-5019	8.0	<b>57.00</b>			
6" PIP/OD	9-5023	11.0	<b>73.00</b>	6-4015	11.0	<b>100.00</b>
8" PIP/OD	9-5026	14.5	<b>86.00</b>	6-4016	14.0	<b>124.00</b>
10" PIP/OD	9-5029	18.5	<b>110.00</b>	6-4017	18.0	<b>167.00</b>
12" PIP/OD	9-5032	22.0	<b>175.00</b>	6-4018	22.0	<b>214.00</b>
15" PIP				6-4019	25.0	<b>340.00</b>
18.7" PIP				6-9787	30.0	<b>325.00</b>
20.4" PIP				9-5843	35.0	<b>350.00</b>
4" IPS	9-5021	8.0	<b>57.00</b>	6-4010	8.0	<b>67.00</b>
6" IPS	9-5024	11.0	<b>73.00</b>	6-4011	11.0	<b>100.00</b>
8" IPS	9-5027	14.5	<b>86.00</b>	6-4012	14.0	<b>124.00</b>
10" IPS	9-5030	18.5	<b>110.00</b>	6-4013	18.0	<b>167.00</b>
12" IPS	9-5033	22.0	<b>175.00</b>	6-4014	22.0	<b>214.00</b>

HALF BODY (POWDER COATED)	Size	Part Number	Weight	List Price
	4"	6-2045	6.0	<b>44.00</b>
	6"	6-2047	7.0	<b>71.00</b>
	8"	6-2048	9.0	<b>84.00</b>
	10"	6-2049	13.0	<b>109.00</b>
	12"	6-2062	16.0	<b>133.00</b>
	15"	9-5848	19.0	<b>168.00</b>
	18.7"	9-5849	22.0	<b>225.00</b>
	20.4"	9-5850	25.0	<b>250.00</b>



FLANGE PACK (SINGLE)	Size	Part Number	Weight	List Price
	4" OD	6-2027	3.0	<b>23.00</b>
	6" OD/PIP	6-2011	4.0	<b>29.00</b>
	8" OD/PIP	6-2012	4.5	<b>40.00</b>
	10" OD/PIP	6-2013	6.0	<b>58.00</b>
	12" OD/PIP	6-2014	7.5	<b>81.00</b>
	15" PIP	9-5851	8.0	<b>101.00</b>
	18.7" PIP	9-5852	18.0	<b>135.00</b>
	20.4" PIP	9-5853	22.0	<b>148.00</b>



See page 15 for IPS Flange Pack and Replacement Gaskets.

# REPAIR COUPLERS

Product	Description	Part Number	Weight	List Price
<b>REPAIR COUPLER</b> (PVC)	6" PIP	6-2261	4.0	<b>59.00</b>
	8" PIP	6-2262	6.0	<b>84.00</b>
	10" PIP	6-2263	10.0	<b>134.00</b>
	12" PIP	6-2267	15.0	<b>184.00</b>
	15" PIP	6-2268	20.0	<b>275.00</b>
	<b>6" IPS</b>	6-2264	4.0	<b>50.00</b>
	<b>8" IPS</b>	6-2265	6.0	<b>60.00</b>
	<b>10" IPS</b>	6-2266	10.0	<b>95.00</b>
	<b>12" IPS</b>	6-2269	15.0	<b>117.00</b>

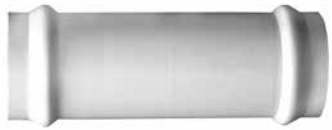

-100 psi maximum pressure.

-19" long

## PVC PIPE

(PLAIN X GASKET, 31" LONG)

	PSI			
6" PIP	#100	6-2294	4.8	<b>60.00</b>
8" PIP	#100	6-2295	8.4	<b>90.00</b>
10" PIP	#100	6-2296	13.2	<b>120.00</b>
12" PIP	#100	6-2297	19.3	<b>150.00</b>
15" PIP	#100	6-2298	30.1	<b>210.00</b>
<b>6" IPS</b>	<b>#125</b>	6-2299	5.5	<b>75.00</b>
<b>8" IPS</b>	<b>#125</b>	6-2300	9.4	<b>110.00</b>
<b>10" IPS</b>	<b>#125</b>	6-2301	14.6	<b>155.00</b>
<b>12" IPS</b>	<b>#125</b>	6-2302	20.5	<b>230.00</b>



## TELESCOPING REPAIR COUPLER

(PVC)

6" PIP	6-2610	8.8	<b>119.00</b>
8" PIP	6-2611	14.4	<b>174.00</b>
10" PIP	6-2612	23.2	<b>254.00</b>
12" PIP	6-2613	34.3	<b>334.00</b>
15" PIP	6-2614	50.1	<b>485.00</b>
<b>6" IPS</b>	6-2615	9.5	<b>170.00</b>
<b>8" IPS</b>	6-2616	15.4	<b>166.00</b>
<b>10" IPS</b>	6-2617	24.6	<b>216.00</b>
<b>12" IPS</b>	6-2618	35.5	<b>347.00</b>



\*Gasket included

\*100 psi maximum pressure.

## FULL REPAIR WRAP

OD 4" dia x 8" long	6-9829	11.0	<b>195.00</b>
<b>IPS 4" dia x 8" long</b>	6-9830	11.0	<b>200.00</b>
OD/PIP 6" dia x 8" long	6-9831	12.0	<b>240.00</b>
<b>IPS 6" dia x 8" long</b>	6-9832	12.0	<b>240.00</b>
OD/PIP 8" dia x 8" long	6-9833	13.0	<b>279.00</b>
<b>IPS 8" dia x 8" long</b>	6-9834	13.0	<b>279.00</b>
OD 10" dia x 8" long	6-9835	19.0	<b>279.00</b>
<b>IPS 10" dia x 8" long</b>	6-9836	19.0	<b>369.00</b>
OD/PIP 12" dia x 8" long	6-9837	20.0	<b>369.00</b>
<b>IPS 12" dia x 8" long</b>	6-9838	20.0	<b>420.00</b>



125 max psi

Ideal to stop leaks without cutting pipeline.

## FIBERGLASS TAPE

1/4" Pipe	1" Wide x 30" Long	6-9562	0.2	<b>10.00</b>
1/2" Pipe	1" Wide x 32" Long	6-9563	-	<b>17.00</b>
3/4" Pipe	2" Wide x 30" Long	6-9564	0.2	<b>12.00</b>
1" Pipe	2" Wide x 60" Long	6-9565	0.2	<b>15.00</b>
2" - 4" Pipe	3" Wide x 108" Long	6-9566	0.7	<b>25.00</b>
3" Pipe	8" Wide x 72" Long	6-9567	0.7	<b>40.00</b>
6" Pipe	4" Wide x 180" Long	6-9568	0.7	<b>40.00</b>
8" Pipe	4" Wide x 360" Long	6-9569	1.3	<b>70.00</b>
10" Pipe	6" Wide x 300" Long	6-9932	0.0	<b>150.00</b>



< 60 psi = 8 Layers/Wraps Min.

> 60 psi = 10 Layers/Wraps Min.

# REPAIR COUPLERS

Underground Fittings

Product	Description	Part Number	Weight	List Price
---------	-------------	-------------	--------	------------

## BOLT-ON REPAIR COUPLER (POWDER COATED STEEL)



-180 psi maximum pressure.  
-16" long



-16" Long  
-Fits OD, PIP, & IPS Flange Packs



2 Flange Packs Required per repair coupler.



<b>Complete</b>	6" PIP	6-2206	21.0	163.00
	8" PIP	6-2208	26.0	210.00
	10" PIP	6-2210	36.0	275.00
	12" PIP	6-2212	44.0	407.00
	15" PIP	6-2200	52.0	495.00
	18" PIP	6-9888	58.0	800.00
	4" IPS	6-2207	12.0	124.00
	6" IPS	6-2213	21.0	163.00
	8" IPS	6-2214	26.0	210.00
	10" IPS	6-2215	36.0	275.00
	12" IPS	6-2216	44.0	407.00

### Body Only

	4"	6-2033	8.0	78.00
	6"	6-2034	13.0	105.00
	8"	6-2035	17.0	130.00
	10"	6-2036	24.0	159.00
	12"	6-2037	29.0	245.00
	15"	6-2038	36.0	339.00

### Flange Pack (Single)

	6" OD/PIP	6-2011	4.0	29.00
	8" OD/PIP	6-2012	4.5	40.00
	10" OD/PIP	6-2013	6.0	58.00
	12" OD/PIP	6-2014	7.5	81.00
	15" PIP	9-5851	8.0	101.00
	18.7" PIP	9-5852	18.0	135.00
	20.4" PIP	9-5853	22.0	148.00
	4" IPS	6-2016	2.0	23.00
	6" IPS	6-2017	4.0	29.00
	8" IPS	6-2018	4.5	40.00
	10" IPS	6-2019	6.0	58.00
	12" IPS	6-2020	7.5	81.00

### Gasket (Bolt-on)

	6" OD/PIP	9-5837	-	8.00
	8" OD/PIP	9-5839	-	10.00
	10" OD/PIP	9-5829	-	20.00
	12" OD/PIP	9-5831	-	25.00
	15" PIP	9-5832	-	26.00
	18.7" PIP	9-5841	-	35.00
	20.4" PIP	9-5842	-	38.00
	4" IPS	9-5833	-	5.30
	6" IPS	9-5836	-	8.00
	8" IPS	9-5838	-	10.00
	10" IPS	9-5828	-	20.00
	12" IPS	9-5830	-	25.00

## REPAIR COUPLER (GALVANIZED STEEL)



\*Metric sizes available, please call.  
200 psi maximum pressure on 2" to 10".  
150 psi maximum pressure on 12" and 15".  
16" long

	6" PIP	6-2250	13.0	99.00
	8" PIP	6-2251	17.0	129.00
	10" PIP	6-2252	21.0	172.00
	12" PIP	6-2253	24.0	230.00
	15" PIP	6-2255	50.0	445.00
	4" IPS	6-2239	7.0	87.00
	6" IPS	6-2240	13.0	99.00
	8" IPS	6-2241	17.0	129.00
	10" IPS	6-2242	21.0	172.00
	12" IPS	6-2243	24.0	230.00

# STEEL UNDERGROUND FITTINGS

Product	Description	Part Number	Weight	List Price
<b>FLANGE ADAPTER</b> (GALVANIZED STEEL) 	6" PIP	6-4051	15.3	<b>115.00</b>
	8" PIP	6-4052	20.9	<b>135.00</b>
	10" PIP	6-4053	27.6	<b>165.00</b>
	12" PIP	6-4054	36.0	<b>199.00</b>
	4" IPS	6-4043	10.1	<b>75.00</b>
	6" IPS	6-4045	15.3	<b>115.00</b>
	8" IPS	6-4046	20.9	<b>135.00</b>
	10" IPS	6-4047	27.6	<b>165.00</b>
	12" IPS	6-4048	36.0	<b>199.00</b>

\*Metric sizes available, please call.

## SERVICE TEE

(GALVANIZED STEEL)



6"x6"x4" PIP	6-4064	17.4	<b>153.00</b>
8"x8"x3" PIP	9-5311	19.0	<b>144.00</b>
8"x8"x4" PIP	6-4065	27.5	<b>192.00</b>
4"x4"x2" IPS	6-4060	8.7	<b>149.00</b>
6"x6"x4" IPS	6-4061	17.4	<b>153.00</b>
8"x8"x4" IPS	6-4062	22.5	<b>192.00</b>

- Metric sizes available, please call.
- Other sizes also available
- male threaded also available

## TEE

(GALVANIZED STEEL)



6" PIP	6-4079	24.8	<b>169.00</b>
8" PIP	6-4080	33.0	<b>245.00</b>
10" PIP	6-4081	44.3	<b>355.00</b>
12" PIP	6-4082	66.2	<b>492.00</b>
15" PIP	6-4083	77.6	<b>935.00</b>
4" IPS	6-4073	13.5	<b>140.00</b>
6" IPS	6-4074	24.8	<b>169.00</b>
8" IPS	6-4075	33.0	<b>245.00</b>
10" IPS	6-4076	44.3	<b>355.00</b>
12" IPS	6-4077	66.2	<b>492.00</b>

## TEE, BOLT-ON

(GALVANIZED STEEL)



4" OD	9-7988	-	<b>339.00</b>
6" OD/PIP	9-7984	-	<b>445.00</b>
8" OD/PIP	9-7985	-	<b>495.00</b>
10" OD/PIP	9-7986	-	<b>645.00</b>
12" OD/PIP	9-7987	-	<b>840.00</b>
4" IPS	9-7979	-	<b>339.00</b>
6" IPS	9-7980	-	<b>445.00</b>
8" IPS	9-7981	-	<b>495.00</b>
10" IPS	9-7982	-	<b>645.00</b>
12" IPS	9-7983	-	<b>840.00</b>

## CROSS

(GALVANIZED STEEL)



6" PIP	6-4099	37.6	<b>305.00</b>
8" PIP	6-4100	50.0	<b>345.00</b>
10" PIP	6-4101	66.6	<b>465.00</b>
12" PIP	6-4102	79.2	<b>685.00</b>
15" PIP	6-4103	92.4	<b>1,137.00</b>
4" IPS	6-4093	21.0	<b>225.00</b>
6" IPS	6-4094	37.6	<b>305.00</b>
8" IPS	6-4095	50.0	<b>345.00</b>
10" IPS	6-4096	66.6	<b>465.00</b>
12" IPS	6-4097	79.2	<b>685.00</b>

- Metric sizes available, please call.
- Reducing sizes also available. Please call.

# STEEL UNDERGROUND FITTINGS

Product	Description	Part Number	Weight	List Price
<b>45° ELBOW</b> (GALVANIZED STEEL)	6" PIP	6-4130	22.2	<b>160.00</b>
	8" PIP	6-4131	29.5	<b>195.00</b>
	10" PIP	6-4132	39.0	<b>249.00</b>
	12" PIP	6-4133	46.4	<b>295.00</b>
	4" IPS	6-4137	12.8	<b>135.00</b>
	6" IPS	6-4138	22.2	<b>160.00</b>
	8" IPS	6-4139	29.5	<b>195.00</b>
	10" IPS	6-4140	39.0	<b>249.00</b>
	12" IPS	6-4141	46.4	<b>295.00</b>



11° and 22° are available at the same price.

<b>45° ELBOW, BOLT-ON</b> (GALVANIZED STEEL)	4" OD	9-7960	-	<b>255.00</b>
	6" OD/PIP	9-7956	-	<b>329.00</b>
	8" OD/PIP	9-7957	-	<b>361.00</b>
	10" OD/PIP	9-7958	-	<b>468.00</b>
	12" OD/PIP	9-7959	-	<b>595.00</b>
	4" IPS	9-7951	-	<b>255.00</b>
	6" IPS	9-7952	-	<b>329.00</b>
	8" IPS	9-7953	-	<b>361.00</b>
	10" IPS	9-7954	-	<b>468.00</b>
	12" IPS	9-7955	-	<b>595.00</b>



11° and 22° are available at the same price.

<b>90° ELBOW</b> (GALVANIZED STEEL)	6" PIP	6-4150	22.2	<b>175.00</b>
	8" PIP	6-4151	29.5	<b>225.00</b>
	10" PIP	6-4152	39.0	<b>295.00</b>
	12" PIP	6-4153	46.4	<b>350.00</b>
	4" IPS	6-4157	10.5	<b>145.00</b>
	6" IPS	6-4158	22.2	<b>175.00</b>
	8" IPS	6-4159	29.5	<b>225.00</b>
	10" IPS	6-4160	39.0	<b>295.00</b>
	12" IPS	6-4161	46.4	<b>350.00</b>



<b>90° ELBOW, BOLT-ON</b> (GALVANIZED STEEL)	4" OD	9-7974	-	<b>317.00</b>
	6" OD/PIP	9-7970	-	<b>400.00</b>
	8" OD/PIP	9-7971	-	<b>439.00</b>
	10" OD/PIP	9-7972	-	<b>558.00</b>
	12" OD/PIP	9-7973	-	<b>705.00</b>
	4" IPS	9-7965	-	<b>317.00</b>
	6" IPS	9-7966	-	<b>400.00</b>
	8" IPS	9-7967	-	<b>439.00</b>
	10" IPS	9-7968	-	<b>558.00</b>
	12" IPS	9-7969	-	<b>705.00</b>



# STEEL UNDERGROUND FITTINGS

Product	Description	Part Number	Weight	List Price	
<b>REDUCER/ADAPTER</b> (GALVANIZED STEEL) 	6" PIP x 4" IPS	6-4110	10.2	125.00	
	6" IPS x 6" PIP	6-4121	12.0	120.00	
	8" PIP x 6" PIP	6-4111	16.5	145.00	
	8" IPS x 8" PIP	6-4122	16.0	125.00	
	10" PIP x 8" PIP	6-4112	22.2	175.00	
	10" IPS x 10" PIP	6-4123	22.0	169.00	
	12" PIP x 10" PIP	6-4113	37.0	275.00	
	12" IPS x 12" PIP	6-4124	26.0	210.00	
<b>REDUCER, BOLT-ON</b> (POWDER COATED OR GALVANIZED STEEL) 	4" IPS x 4" OD	6-4020	13.0	124.00	
	6" IPS x 6" OD/PIP	6-4022	21.0	163.00	
	8" IPS x 6" OD/PIP	6-4024	27.5	199.00	
	8" IPS x 6" IPS	6-4026	27.5	199.00	
	8" IPS x 8" OD/PIP	6-4027	26.0	210.00	
	10" OD/PIP x 8" OD/PIP	6-4029	35.2	269.00	
	10" IPS x 8" IPS	6-4031	35.2	249.00	
	10" IPS x 10" OD/PIP	6-4032	-	275.00	
	12" OD/PIP x 10" OD/PIP	6-4034	44.0	379.00	
	12" IPS x 12" OD/PIP	6-4036	44.0	407.00	
<b>DOUBLE COUPLER</b> (GALVANIZED STEEL) 	6" PIP	6-4171	12.0	100.00	
	8" PIP	6-4172	16.0	120.00	
	10" PIP	6-4173	22.0	150.00	
	12" PIP	6-4174	26.0	189.00	
	15" PIP	6-4175	28.0	469.00	
	4" IPS	6-4179	6.0	95.00	
	6" IPS	6-4180	12.0	100.00	
	8" IPS	6-4181	16.0	120.00	
	10" IPS	6-4182	22.0	150.00	
	12" IPS	6-4183	26.0	189.00	
	<b>END PLUG</b> (GALVANIZED STEEL) 	6" PIP	6-4191	4.5	80.00
		8" PIP	6-4192	9.8	90.00
10" PIP		6-4193	14.5	105.00	
12" PIP		6-4188	18.3	130.00	
15" PIP		6-4189	14.0	260.00	
4" IPS		6-4197	2.9	75.00	
6" IPS		6-4198	4.5	80.00	
8" IPS	6-4199	9.8	90.00		
10" IPS	6-4200	14.5	105.00		
12" IPS	6-4201	18.3	130.00		
<b>END CAP</b> (GALVANIZED STEEL) 	6" PIP	6-4203	7.0	75.00	
	8" PIP	6-4204	11.3	85.00	
	10" PIP	6-4205	15.0	115.00	
	12" PIP	6-4206	18.8	139.00	
	15" PIP	6-4207	14.0	345.00	
	4" IPS	6-4211	3.4	65.00	
	6" IPS	6-4212	7.0	75.00	
	8" IPS	6-4213	11.3	85.00	
	10" IPS	6-4214	15.0	115.00	
	12" IPS	6-4215	18.8	139.00	

\*Metric sizes available, please call.

\*Metric sizes available, please call.

# SOLVENT PVC PIPE FITTINGS

Product	Description	Part Number	Weight	List Price
<b>90° ELBOW</b> (PVC-SOLVENT)	6" PIP	6-2311	4.0	<b>68.00</b>
	8" PIP	6-2312	8.0	<b>117.00</b>
	10" PIP	6-2313	8.0	<b>165.00</b>
	12" PIP	6-2314	14.0	<b>231.00</b>
	15" PIP	6-2320	20.0	<b>358.00</b>
	6" IPS	6-2560	4.0	<b>54.00</b>
	8" IPS	6-2561	6.0	<b>82.00</b>
	10" IPS	6-2562	8.0	<b>128.00</b>
	12" IPS	6-2563	14.0	<b>178.00</b>
	4" IPS A&H	6-2315	2.0	<b>22.00</b>
	6" PIP A&H	6-2316	1.5	<b>40.00</b>
	8" PIP A&H	6-2317	2.5	<b>48.00</b>
	10" PIP A&H	6-2318	3.0	<b>75.00</b>
	12" PIP A&H	6-2319	3.5	<b>114.00</b>



#100 psi test, except A&H which is #22/#50 psi test.

\*Metric sizes available, please call.

<b>45° ELBOW</b> (PVC-SOLVENT)	6" PIP	6-2321	1.0	<b>28.00</b>
	8" PIP	6-2322	2.0	<b>48.00</b>
	10" PIP	6-2323	2.5	<b>72.00</b>
	12" PIP	6-2324	3.0	<b>107.00</b>
	15" PIP	6-2330	4.0	<b>167.00</b>
	6" IPS	6-2550	1.0	<b>28.00</b>
	8" IPS	6-2551	2.0	<b>46.00</b>
	10" IPS	6-2552	2.5	<b>70.00</b>
	12" IPS	6-2553	3.0	<b>102.00</b>
	4" IPS A&H	6-2325	1.3	<b>18.00</b>
	6" PIP A&H	6-2326	1.5	<b>24.00</b>
	8" PIP A&H	6-2327	1.8	<b>30.00</b>
	10" PIP A&H	6-2328	2.0	<b>37.00</b>
	12" PIP A&H	6-2329	3.0	<b>57.00</b>



#100 psi test, except A&H which is #22/#50 psi test.

\*Metric sizes available, please call.

<b>22-1/2° ELBOW</b> (PVC-SOLVENT)	6" PIP	6-2270	1.0	<b>21.00</b>
	8" PIP	6-2271	2.0	<b>31.00</b>
	10" PIP	6-2272	2.5	<b>58.00</b>
	12" PIP	6-2273	3.0	<b>81.00</b>
	15" PIP	6-2274	4.0	<b>136.00</b>



#100 psi test.

\*Metric sizes available, please call.

**11°, 15°, 30° AND 60° ELBOWS AVAILABLE UPON REQUEST.  
PLEASE CALL.**

Underground Fittings

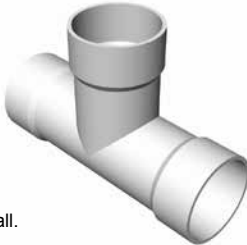

# SOLVENT PVC PIPE FITTINGS

Product	Description	Part Number	Weight	List Price	
<b>TEE</b> (PVC-SOLVENT)					
					
		6" PIP	6-2331	5.0	<b>56.00</b>
		8" PIP	6-2332	9.0	<b>83.00</b>
		10" PIP	6-2333	14.0	<b>132.00</b>
		12" PIP	6-2334	18.0	<b>211.00</b>
		15" PIP	6-2336	25.0	<b>362.00</b>
		4" IPS	6-2335	2.3	<b>33.00</b>
		6" IPS	6-2570	5.0	<b>76.00</b>
		8" IPS	6-2571	9.0	<b>96.00</b>
		10" IPS	6-2572	14.0	<b>134.00</b>
		12" IPS	6-2573	18.0	<b>210.00</b>

#100 psi test

\*Metric sizes available, please call.

## REDUCING TEE

(PVC-SOLVENT)



6" PIP x 4" IPS	6-2340	3.5	<b>42.00</b>
8" PIP x 4" IPS	6-2341	4.5	<b>55.00</b>
8" x 6" PIP	6-2342	8.5	<b>68.00</b>
6" x 4" IPS	6-2574	4.0	<b>49.00</b>
8" x 4" IPS	6-2575	5.0	<b>66.00</b>
8" x 6" IPS	6-2576	9.0	<b>85.00</b>

#100 psi test

\*Metric sizes available, please call.

## WYE

(PVC-SOLVENT)



6" PIP A&H	6-2601	-	<b>42.00</b>
8" PIP A&H	6-2602	-	<b>95.00</b>
10" PIP A&H	6-2603	-	<b>138.00</b>

Drain Only

## END CAP

(PVC-SOLVENT)



6" PIP	6-2410	1.5	<b>26.00</b>
8" PIP	6-2411	2.0	<b>33.00</b>
10" PIP	6-2412	2.5	<b>53.00</b>
12" PIP	6-2413	3.0	<b>69.00</b>
15" PIP	6-2414	4.0	<b>113.00</b>
6" IPS	6-2580	1.5	<b>23.00</b>
8" IPS	6-2581	2.0	<b>30.00</b>
10" IPS	6-2582	2.5	<b>47.00</b>
12" IPS	6-2583	3.0	<b>90.00</b>
6" PIP A&H	6-2420	0.2	<b>7.00</b>
8" PIP A&H	6-2421	0.6	<b>11.00</b>
10" PIP A&H	6-2422	2.5	<b>18.00</b>
12" PIP A&H	6-2423	3.0	<b>28.00</b>
15" PIP A&H	6-2424	4.0	<b>49.00</b>

#100 psi test, except A&H  
which is #22/#50 psi test.

\*Metric sizes available, please call.

## COUPLING

(PVC-SOLVENT)



6" PIP	6-2431	1.0	<b>18.00</b>
8" PIP	6-2432	2.0	<b>24.00</b>
10" PIP	6-2433	5.0	<b>38.00</b>
12" PIP	6-2428	7.0	<b>58.00</b>
15" PIP	6-2429	10.0	<b>100.00</b>
4" IPS	6-2430	0.5	<b>10.00</b>
6" IPS	6-2585	1.0	<b>14.00</b>
8" IPS	6-2586	2.0	<b>25.00</b>
10" IPS	6-2587	5.0	<b>40.00</b>
12" IPS	6-2588	7.0	<b>63.00</b>
4" IPS A&H	6-2434	0.4	<b>9.00</b>
6" PIP A&H	6-2435	0.8	<b>12.00</b>
8" PIP A&H	6-2436	1.5	<b>12.00</b>
10" PIP A&H	6-2437	3.0	<b>16.00</b>

#100 psi test, except A&H  
which is #22/#50 psi test.

\*Metric sizes available, please call.

# SOLVENT PVC PIPE FITTINGS

Underground Fittings

Product	Description	Part Number	Weight	List Price
---------	-------------	-------------	--------	------------

## REDUCER (PVC-SOLVENT)

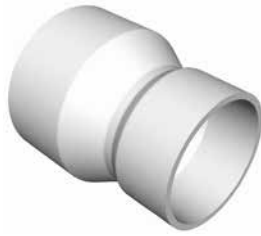

#100 psi test,  
Except A&H which is #22/#50 psi test.  
\*Metric sizes available, please call.

6" PIP x 4" IPS	6-2440	1.5	22.00
8" x 6" PIP	6-2441	2.0	33.00
10" x 8" PIP	6-2442	3.0	45.00
12" x 10" PIP	6-2438	4.0	65.00
15" x 12" PIP	6-2439	5.0	104.00
6" x 4" IPS	6-2590	1.5	18.00
8" x 6" IPS	6-2591	2.0	28.00
10" x 8" IPS	6-2592	3.0	56.00
12" x 10" IPS	6-2593	4.0	76.00
6" PIP x 4" IPS A&H	6-2443	0.6	15.00
8" x 6" PIP A&H	6-2444	1.5	18.00
10" x 8" PIP A&H	6-2445	2.0	28.00
12" x 10" PIP A&H	6-2446	2.5	40.00

## ADAPTER (PVC-SOLVENT)



#100 psi test

6" IPS x PIP	6-2451	1.5	21.00
8" IPS x PIP	6-2452	2.5	30.00
10" IPS x PIP	6-2453	5.0	50.00

## FLANGE (PVC-SOLVENT)



6" PIP	6-2480	5.6	78.50
8" PIP	6-2481	8.3	114.00
10" PIP	6-2482	14.3	159.75
12" PIP	6-2483	21.9	231.75
3" IPS	9-7659		32.00
4" IPS	6-2484	2.8	42.00
6" IPS	6-2485	4.7	63.50
8" IPS	6-2486	6.8	114.00
10" IPS	6-2487	11.6	191.75
12" IPS	6-2488	-	198.75

## FEMALE THREADED ADAPTER (PVC-SOLVENT)



#100 psi test, except  
A&H which is #22/#50 psi

6" PIP	6-2461	64.00
8" PIP	6-2462	95.00
10" PIP	6-2463	132.00
12" PIP	6-2464	153.00
4" IPS	6-2470	13.00
6" IPS	6-2471	41.00
8" IPS	6-2472	89.00
10" IPS	6-2473	110.00
12" IPS	6-2474	164.00

## MALE THREADED ADAPTER (PVC-SOLVENT)



#100 psi test, except A&H  
which is #22/#50 psi

6" PIP	6-2466	57.00
8" PIP	6-2467	80.00
10" PIP	6-2468	117.00
12" PIP	6-2469	138.00
4" IPS	6-2475	12.00
6" IPS	6-2476	28.00
8" IPS	6-2477	76.00
10" IPS	6-2478	118.00
12" IPS	6-2479	165.00



## BUSHING (PVC-SOLVENT)



IPS outside x PIP inside

6" PIP x IPS	6-2595	24.00
8" PIP x IPS	6-2596	30.00
10" PIP x IPS	6-2597	46.00
12" PIP x IPS	6-2598	70.00

**GASKETED PVC PIPE FITTINGS**

Product	Description	Part Number	Weight	List Price	
<b>90° ELBOW</b> (PVC-GASKETED)    #100 PSI Test	6" PIP	6-2350	-	<b>83.00</b>	
	8" PIP	6-2351	-	<b>133.00</b>	
	10" PIP	6-2352	-	<b>205.00</b>	
	12" PIP	6-2353	-	<b>291.00</b>	
	15" PIP	6-2354	-	<b>594.00</b>	
	6" IPS	6-2520	-	<b>108.00</b>	
	8" IPS	6-2521	-	<b>164.00</b>	
	10" IPS	6-2522	-	<b>238.00</b>	
	12" IPS	6-2523	-	<b>319.00</b>	
	<b>45° ELBOW</b> (PVC-GASKETED)    #100 PSI Test	6" PIP	6-2360	-	<b>74.00</b>
		8" PIP	6-2361	-	<b>104.00</b>
		10" PIP	6-2362	-	<b>150.00</b>
12" PIP		6-2363	-	<b>213.00</b>	
15" PIP		6-2364	-	<b>430.00</b>	
6" IPS		6-2510	-	<b>74.00</b>	
8" IPS		6-2511	-	<b>104.00</b>	
10" IPS		6-2512	-	<b>150.00</b>	
12" IPS		6-2513	-	<b>226.00</b>	
<b>22-1/2° ELBOW</b> (PVC-GASKETED)    #100 PSI Test		6" PIP	6-2355	-	<b>63.00</b>
	8" PIP	6-2356	-	<b>93.00</b>	
	10" PIP	6-2357	-	<b>137.00</b>	
	12" PIP	6-2358	-	<b>198.00</b>	
	15" PIP	6-2359	-	<b>327.00</b>	
	6" IPS	6-2500	-	<b>71.00</b>	
	8" IPS	6-2501	-	<b>86.00</b>	
	10" IPS	6-2502	-	<b>148.00</b>	
	12" IPS	6-2503	-	<b>197.00</b>	
	<b>TEE</b> (PVC-GASKETED)    #100 PSI Test	6" PIP	6-2365	-	<b>99.00</b>
8" PIP		6-2366	-	<b>132.00</b>	
10" PIP		6-2367	-	<b>201.00</b>	
12" PIP		6-2368	-	<b>273.00</b>	
15" PIP		6-2369	-	<b>493.00</b>	
6" IPS		6-2540	-	<b>85.00</b>	
8" IPS		6-2541	-	<b>151.00</b>	
10" IPS		6-2542	-	<b>219.00</b>	
12" IPS		6-2543	-	<b>304.00</b>	

**11°, 15°, 30° AND 60° ELBOWS AVAILABLE UPON REQUEST.**  
**#100 PSI TEST, EXCEPT A&H WHICH IS #22/#50 PSI TEST.**

# PVC DRAIN RISER & ACCESSORIES

Underground Fittings

Product	Description	Part Number	Weight	List Price	
<b>DRAINAGE RISER</b> (PVC-SOLVENT)	4" x 6"	6-2110	18.7	<b>255.00</b>	
	6" x 8"	6-2120	32.8	<b>360.00</b>	
	8" x 10"	6-2130	56.2	<b>549.00</b>	
	<b>Perforated Body Only</b>				
	6" x 7'4" #100	6-2110-C	14.4	<b>137.00</b>	
	8" x 7'4" #80	6-2120-C	25.9	<b>179.00</b>	
	10" x 7'4" #80	6-2130-C	43.6	<b>300.00</b>	
	12" x 6'4" #80	9-6958	48.2	<b>349.00</b>	



6", 8", 10" = 7'4" Long  
 12" = 6'4" Long

The Drainage Riser comes fully assembled and includes the appropriately sized:  
 - 90° elbow (A&H)  
 - increaser (A&H)  
 - cap (A&H)

The Drainage Riser is made to fit PIP (Plastic Irrigation Pipe).

The Drainage Riser is made to local Soil Conservation Office Specifications.

Other sizes are available on request.

<b>RODENT DOOR</b> (PAINTED STEEL)	4"	6-2181	0.2	<b>11.00</b>
	6"	6-2182	0.6	<b>12.00</b>
	8"	6-2183	0.8	<b>15.00</b>
	10"	6-2184	1.5	<b>22.00</b>
	12"	6-2185	2.3	<b>30.00</b>



<b>PRIMER</b> (Step 1 of 2)	1 quart	6-9170	2.0	<b>19.00</b>
--------------------------------	---------	--------	-----	--------------



Purple  
 It is highly recommended to apply primer on both pipe & socket before gluing to pre-soften & pre-prepare plastic pipe & fittings for bonding.

<b>PVC GLUE</b> (Step 2 of 2)	1 quart	6-9130	2.0	<b>22.00</b>
	1 gallon	6-9140	8.5	<b>67.00</b>



Gray, C-200, PVC 12, Heavy Body for larger diameters.  
 When primer is still wet, apply heavy amt of glue on pipe & lighter amt. in socket. Wipe off excess.

<b>PIPE LUBE</b>	1 quart	6-9160	2.0	<b>9.00</b>
	1 gallon	6-9150	8.5	<b>27.00</b>



One gallon of pipe lube will cover 50 8" pipe joints.

# WHY WAIT ON Custom Built Fittings

Fast, Low Cost Custom Built Irrigation & Industrial Fittings

Available in:

- Steel Powder Coat
- Steel Galvanized
- Aluminum
- Cast Aluminum
- PVC
- Stainless Steel #304









Call, fax, or e-mail your drawing, and we will  
send you a price.



## Section Two



Towline / Wheelmove

 Tow Line Parts	26-28
 3-Segment Adapters	28-29
 Hose Adapters	30-31
 Hose Accessories	32
 Wheel Move	33
 Discharge Hose	34
 Suction Hose	35
 Hose Clamps	36-38

Product	Description	Part Number	Weight	List Price
---------	-------------	-------------	--------	------------

## TOW COUPLER

4"

3-0310

6.3

70.00



All steel construction, zinc plated.  
Includes 2 Gaskets, 1 Quick Drain  
and 4 Half-Moon Pins.

## TOW COUPLER EAR

3/8"

3-0320

0.3

1.00



Made of formed steel.  
Welds to coupler body and holds half  
moon pin.

## TOW COUPLER SKID PAN

----

3-0330

0.6

3.00



Formed steel wear pan.  
Welds to bottom of coupler body.

## QUICK DRAIN

----

3-0340

0.0

1.50



Fits into bottom of coupler body to  
drain line when shut down.  
Cotter pin is included.

## GASKET (LINDSAY)

4" Drain  
4" Non-Drain

3-0350  
6-1614

0.3  
0.3

2.00  
3.20



Specify Drain or Non-Drain style.  
Fit coupler and stabilizer.  
**Stabilizer must have Non-Drain Gasket.**

## TOW LINE PIPE

4" x 40'

3-0380

35.6

189.00



Aluminum.  
Comes with Half-Moon Pins, Straps & Bolts installed.

Product	Description	Part Number	Weight	List Price
<b>HALF MOON CLAMP</b>	4"	3-0410	0.9	<b>4.00</b>



Galvanized steel.  
Attaches pipe to coupler with tow pins.

## HALF MOON BOLT & NUT

Bolt:	5/16" x 5/8"	3-0420	0.1	<b>0.06</b>
Nut:	5/16"	3-0430	0.1	<b>0.03</b>



Washer included with bolt.

## HALF MOON STRAP

1"	3-0440	0.2	<b>1.00</b>
----	--------	-----	-------------



Galvanized.  
Bolts to back side of half moon clamp to prevent clamp from pulling off of pipe.

## HALF MOON PIN

3/8"	3-0450	0.1	<b>1.50</b>
------	--------	-----	-------------



Hardened steel, plated.  
Connects tow line pipe to coupler and stabilizer.

## RISERS



1" Steel tubing. 3/4" Female x 1" Male.	6" FxM	3-0465	0.6	<b>6.00</b>
	12" FxM	3-0460	0.9	<b>7.25</b>
	18" FxM	3-0466	1.1	<b>8.25</b>
	24" FxM	3-0461	1.4	<b>9.25</b>
	30" FxM	3-0467	1.6	<b>10.50</b>
	36" FxM	3-0468	1.9	<b>11.50</b>
	40" FxM	3-0462	2.1	<b>11.50</b>
	48" FxM	3-0469	2.5	<b>14.00</b>
	60" FxM	3-0463	2.9	<b>16.00</b>
	72" FxM	3-0464	3.4	<b>18.50</b>

1" Steel tubing. 1" Male x 1" Male.	12" MxM	3-0470	0.9	<b>7.25</b>
	24" MxM	3-0471	1.4	<b>9.25</b>
	40" MxM	3-0472	2.1	<b>11.50</b>
	60" MxM	3-0473	2.9	<b>16.00</b>
	72" MxM	3-0474	3.4	<b>18.50</b>

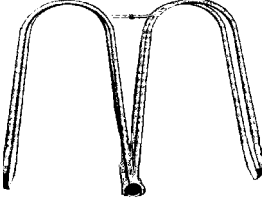

# TOW LINE PARTS

Product	Description	Part Number	Weight	List Price
<b>STABILIZER</b> 	Short: 4"x40'	3-0510	77.0	<b>395.00</b>
	Tall: 4"x60'	3-0520	118.0	<b>449.00</b>

All steel construction.  
Fit into tow line with half moon pins.  
Includes gaskets and pins.

<b>STABILIZER CONVERSION KIT</b> 	4"	3-0530	25.0	<b>210.00</b>
---	----	--------	------	---------------

Includes gaskets and pins.

<b>TOW PLUG</b> 	4"	3-0540	5.5	<b>35.00</b>
--	----	--------	-----	--------------

Fits into end coupler of tow line as hitch for towing.

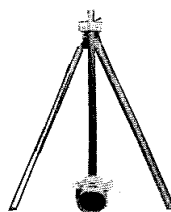
<b>TRIPOD</b> 	----	3-0550	5.0	<b>59.00</b>
---	------	--------	-----	--------------

All steel construction.  
Comes complete with Bolts & Nuts.  
Fits on riser to stabilize end of tow line while watering.

<b>COUPLER (SHUG GRIP)</b> 	<b>Steel:</b>	6"	9-7921	<b>215.00</b>
		8"	9-7923	<b>237.00</b>
	<b>Aluminum:</b>	6"	9-7922	<b>215.00</b>

<b>MALE END (SHUG GRIP)</b> 	<b>Steel:</b>	6" (5.5")	9-7924	<b>63.00</b>
		8"	9-7926	<b>118.00</b>
	<b>Aluminum:</b>	6" (5.5")	9-7925	<b>115.00</b>

<b>RING (SHUG GRIP)</b> 	<b>Steel:</b>	6"	9-7927	<b>30.00</b>
		8"	9-7928	<b>35.00</b>

# SHUG GRIP HOSE ADAPTERS

Product	Description	Part Number	Weight	List Price
---------	-------------	-------------	--------	------------

## COUPLING (SHUG GRIP)

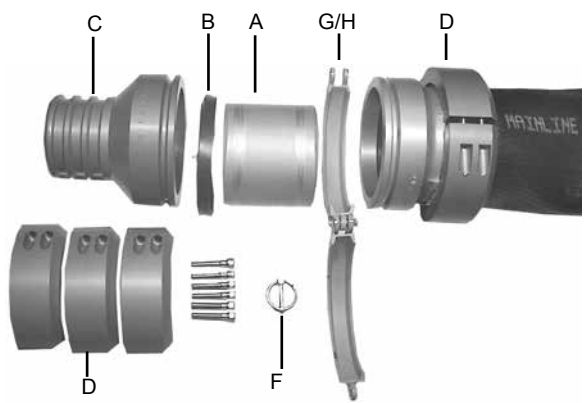

\*Complete sets include everything shown above  
 \*Can be pulled with water inside hose.

<b>Complete:</b>	4"	9-5844	-	<b>\$803.00</b>
	4-1/2"	9-5845	-	<b>856.00</b>
	5"	9-5846	-	<b>975.00</b>
	6"	6-9659	-	<b>790.00</b>
	8"	9-5207	-	<b>1,190.00</b>
<b>3-Seg Clamp:</b>	4"	D 6-9608	-	<b>232.00</b>
	4-1/2"	D 6-9609	3.3	<b>232.00</b>
	5"	D 6-9610	1.6	<b>232.00</b>
	6"	D 6-9611	4.5	<b>232.00</b>
	8"	D 9-5184	-	<b>265.00</b>
	<b>Coupler Body:</b>	4"	C 9-7468	-
4-1/2"		C 9-7469	-	<b>305.00</b>
5"		C 9-7470	-	<b>387.00</b>
5-1/2"		C 9-7471	-	<b>447.00</b>
6"		C 9-7472	-	<b>222.00</b>
8"		C 9-7473	-	<b>460.00</b>
<b>Sleeve:</b>		5-1/2" (4" thru 6")	A 9-7445	-
	8"	A 9-7446	-	<b>82.00</b>
<b>Gasket:</b>	5-1/2" (4" thru 6")	B 9-7447	-	<b>9.00</b>
	8"	B 9-7448	-	<b>10.00</b>
<b>Ring Band Lock:</b>	6" (4" thru 6")	G 9-7449	-	<b>55.00</b>
	6" w/Steel Pin (4" thru 6")	H 9-7450	-	<b>54.00</b>
	8" w/Steel Pin	H 9-7451	-	<b>78.00</b>
<b>Lynch Pin:</b>	5/16"	F 9-7452	-	<b>3.00</b>

Towline / Wheelmove

## HOSE FITTINGS



FRL

MRL

\*Includes 3 segment clamp

\*Cannot be pulled with water inside hose.

FRL	4"	Alum	6-9506	1.5	<b>127.00</b>
MRL	4"	Alum	6-9507	1.2	<b>120.00</b>
FRL	5"	Alum	6-9504	1.8	<b>265.00</b>
MRL	5"	Alum	6-9505	1.4	<b>255.00</b>
FRL	6"	Alum	6-9502	2.4	<b>440.00</b>
MRL	6"	Alum	6-9503	1.8	<b>430.00</b>
FRL 10 ga.	6"	Steel Gal.	6-9500	-	<b>435.00</b>
MRL 10 ga.	6"	Steel Gal.	6-9501	-	<b>435.00</b>

## FULL ADAPTER (ALUMINUM)



\*Includes 3 segment clamp

	4"		6-9889	-	<b>330.00</b>
	4-1/2"		6-9656	-	<b>340.00</b>
	5"		6-9657	-	<b>415.00</b>
	6"		6-9658	-	<b>436.00</b>
	8"		9-5246	-	<b>820.00</b>

## HALF ADAPTER



\* Weld-on  
 \* Includes 3 segment clamp

<b>Steel:</b>					
	4"	Steel	6-9648	-	<b>275.00</b>
	4-1/2"	Steel	6-9649	-	<b>300.00</b>
	5"	Steel	6-9650	-	<b>325.00</b>
	6"	Steel	6-9651	-	<b>385.00</b>
	8"	Steel	9-5877	-	<b>470.00</b>
<b>Aluminum:</b>					
	4"	Alum	6-9652	-	<b>90.00</b>
	4-1/2"	Alum	6-9653	-	<b>175.00</b>
	5"	Alum	6-9654	-	<b>215.00</b>
	6"	Alum	6-9655	-	<b>385.00</b>
	8"	Alum	9-5247	-	<b>452.00</b>
	10"	Alum	9-7929	-	<b>525.00</b>
	12"	Alum	9-7930	-	<b>630.00</b>

# HOSE ADAPTERS

Product	Description	Part Number	Weight	List Price		
<b>HOSE BARB - WELD-ON</b> (BLACK STEEL)		No. of Ribs				
		2"	2	3-0601	0.4	13.00
		2-1/2"	2	9-5014	0.6	14.00
		3"	2	3-0602	0.8	13.00
		4"	3	3-0603	1.8	14.00
		4-1/2"	2	3-0604	1.9	19.00
		5"	2	3-0605	2.0	20.00
		6"	3	3-0606	3.3	21.00
		8"	3	3-0607	5.4	35.00
		10"	2	3-0608	10.0	49.00
	12"	2	3-0609	12.1	60.00	
	16"	3	9-7553	18.8	137.00	



Weld-on.

<b>HOSE BARB - WELD-ON</b> (ALUMINUM)	3"	.050	3-0641	0.5	35.00
	4"	.072	3-0652	1.1	37.00
	5"	.078	3-0642	1.4	40.00
	6"	.058	3-0643	1.3	40.00
	8"	.064	3-0644	1.6	41.00



<b>HOSE BARB - WELD-ON</b> (THICK ALUMINUM)	4"		3-0636	1.5	92.00
	4-1/2"		3-0637	1.7	93.00
	5"		3-0638	1.9	95.00
	6"		3-0639	2.2	103.00
	8"		9-7803	-	130.00



Sharp Barbs

\*5" long & 1/4" thick

\*with small barbs (as shown) or spaced barbs

<b>HOSE BARB - WELD-ON</b> (CAST ALUMINUM)	6"		9-7794	2.6	45.00
	8"		9-7795	4.1	65.00
	10"		9-7796	6.0	85.00





<b>HOSE ADAPTER - FEMALE RL</b> (GALVANIZED STEEL)	3"		6-8050	3.4	28.00
	4"		6-8051	4.5	36.00
	5"		6-8052	5.6	46.00
	6"	12 ga.	3-0681	6.1	59.00
	8"	12 ga.	3-0683	9.9	85.00
	10"	12 ga.	3-0679	14.5	115.00
	12"	12 ga.	3-0664	16.0	195.00



<b>HOSE ADAPTER - MALE RL</b> (GALVANIZED STEEL)	3"		6-8053	3.0	26.00
	4"		6-8054	4.0	35.00
	5"		6-8055	5.0	46.00
	6"	12 ga.	3-0680	6.1	59.00
	8"	12 ga.	3-0682	9.9	85.00
	10"	12 ga.	3-0678	15.0	95.00
	12"	12 ga.	3-0663	14.0	180.00



# HOSE ADAPTERS

Product	Description	Part Number	Weight	List Price
<b>HOSE ADAPTER - B&amp;H</b> (GALVANIZED STEEL) 	Hose Barb x Male B & H 2"	6-8060	1.9	<b>33.00</b>
	Hose Barb x Male B & H 3"	6-8061	3.3	<b>38.00</b>
	Hose Barb x Male B & H 4"	6-8062	4.3	<b>43.00</b>
	Hose Barb x Male B & H 5"	6-8063	5.4	<b>66.00</b>
	Hose Barb x Male B & H 6"	9-5322	6.5	<b>81.00</b>
	Hose Barb x Female B & H 2"	6-8056	2.6	<b>29.00</b>
	Hose Barb x Female B & H 3"	6-8057	4.5	<b>34.00</b>
	Hose Barb x Female B & H 4"	6-8058	6.0	<b>38.00</b>
	Hose Barb x Female B & H 5"	6-8059	7.5	<b>55.00</b>
	Hose Barb x Female B & H 6"	9-5321	9.0	<b>64.00</b>

## HOSE MENDER

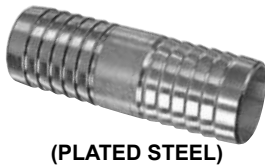

Size	Galvanized Steel			Plated Steel			Aluminum		
	Part #	Weight	List	Part #	Weight	List	Part #	Weight	List
1/2"				9-6835	0.1	<b>4.00</b>			
3/4"				9-6836	0.2	<b>4.50</b>			
1"				9-6837	0.3	<b>5.00</b>			
1-1/4"				9-6838	0.5	<b>7.00</b>			
1-1/2"				9-6839	0.5	<b>7.00</b>			
2"	6-8064	2.2	<b>18.00</b>	9-6840	0.8	<b>9.00</b>			
2-1/2"				9-6841	1.7	<b>18.00</b>			
3"	6-8065	3.8	<b>27.00</b>	9-6842	2.4	<b>18.00</b>	3-0645	0.5	<b>52.00</b>
4"	6-8066	5.0	<b>33.00</b>	9-6843	2.9	<b>21.00</b>	3-0653	1.1	<b>55.00</b>
5"	6-8067	6.3	<b>49.00</b>	9-6844	6.9	<b>67.00</b>	3-0646	1.4	<b>56.00</b>
6"	6-8068	7.5	<b>52.00</b>	9-6845	13.2	<b>55.00</b>	3-0647	1.3	<b>56.00</b>
8"	6-8069	14.0	<b>80.00</b>	9-6846	20.9	<b>113.00</b>	3-0648	1.6	<b>58.00</b>
10"	9-7892	16.0	<b>123.00</b>	9-6847		<b>215.00</b>			
12"	9-7893	-	<b>158.00</b>	9-6848		<b>320.00</b>			

\* Applications:  
 \* PVC lay flat for drip irrigation  
 \* Rubber discharge hose for medium pressure irrigation

## KING NIPPLE

(PLATED STEEL)



1/2"	6-7000	0.1	<b>2.50</b>
3/4"	6-7001	0.2	<b>2.60</b>
1"	6-7002	0.3	<b>2.90</b>
1-1/4"	6-7003	0.6	<b>4.50</b>
1-1/2"	6-7004	0.7	<b>6.10</b>
2"	6-7005	1.1	<b>6.00</b>
2-1/2"	6-7006	1.7	<b>15.50</b>
3"	6-7007	2.1	<b>15.00</b>
4"	6-7008	3.1	<b>18.00</b>
5"	6-7009	4.1	<b>34.50</b>
6"	6-7010	12.2	<b>72.50</b>
8"	6-7011	16.4	<b>97.50</b>
10"	6-7012	21.8	<b>172.00</b>
12"	6-7013	33.2	<b>250.00</b>

Towline / Wheelmove

# HOSE ACCESSORIES

Product	Description	Part Number	Weight	List Price
---------	-------------	-------------	--------	------------

## TOW HOSE



4" x 12'	3-0655	14.0	<b>325.00</b>
4" x 17'	3-0650	18.0	<b>379.00</b>

Maximum: #125 psi  
 Connects tow line to mainline.  
 Both ends Male with hook & band.  
 \*For other than standard fittings, add \$5.00/end to price.

## BAND-IT TOOL



6-9093	4.5	<b>172.00</b>
--------	-----	---------------

## PREFORMED JUNIOR ADAPTER



6-9094	-	<b>215.00</b>
--------	---	---------------

\*For use with above tool on preformed clamps

## BANDING (STAINLESS STEEL)



5/8" x 100'	6-9095	6.7	<b>167.00</b>
3/4" x 100'	9-7752	-	<b>183.00</b>

\* Other sizes are available, please call.  
 \* Standard-Duty Type 201 Stainless.

## BAND-IT BUCKLE



5/8"	6-9096	2.6	<b>98.00</b>
3/4"	9-7753	-	<b>103.00</b>

\* For use with above Stainless Steel boxed banding.  
 \* 100 Buckles/Box  
 \* Standard-Duty Buckle

## PREFORMED CLAMP



J215	3/4" wide x 5" ID	6-9097	0.3	<b>9.00</b>
J216	3/4" wide x 6" ID	6-9098	0.3	<b>10.00</b>

\*For use with above tool and jr. adapter  
 \*Stainless Steel  
 \* 25 per Box is available.

## GLUE (FOR HOSE FITTINGS)



1 Quart	Pliobond #20	9-6778	2.1	<b>49.00</b>
---------	--------------	--------	-----	--------------

# WHEEL MOVE (WHEELINE, SIDEROLL)

Product	Description	Part Number	Weight	List Price
<b>WHEEL MOVE</b> (COMPLETE)	4" x 1280'	5-0160	Call	Call
	5" x 1280'	5-0161	Call	Call



<b>WHEEL MOVE COUPLER SET</b> (CAST ALUMINUM)	4" Press-on	5-0167	8.0	85.00
	5" Weld-on	5-0168	6.3	92.00



<b>SPRINKLER LEVELER</b>	3/4"	5-0165	2.4	15.00
--------------------------	------	--------	-----	-------



<b>LEVELER ELBOW</b>	1" x 3/4"	5-0166	-	9.00
----------------------	-----------	--------	---	------



## WHEELS

Distance	# of Turns						
		4'	4" x 48"	18 ga.	5-0170	34.0	119.00
		4'	5" x 48"	18 ga.	5-0171	35.0	119.00
60'	4	5'	4" x 58"	18 ga.	5-0172	42.0	97.00
60'	4	5'	5" x 58"	18 ga.	5-0173	42.0	97.00
50'	3	6'	4" x 64"	18 ga.	5-0174	44.0	105.00
50'	3	6'	5" x 64"	18 ga.	5-0175	44.0	105.00
60'	3	7'	4" x 76"	18 ga.	5-0176	56.0	135.00
60'	3	7'	5" x 76"	18 ga.	5-0177	56.0	135.00
50'	2	8'	4" x 96"	16 ga.	5-0178	78.0	275.00
50'	2	8'	5" x 96"	16 ga.	5-0179	78.0	275.00
60'	2	10'	4" x 120"	16 ga.	5-0180	113.0	439.00
60'	2	10'	5" x 120"	16 ga.	5-0181	113.0	439.00



<b>WIND BRACE</b>	4" x 5'	5-0182	8.3	59.00
	4" x 6-7'	5-0183	9.8	64.00

	5" x 5'	5-0184	8.9	59.00
	5" x 6-7'	5-0185	9.8	64.00



Towline / Wheelmove

# DISCHARGE HOSE

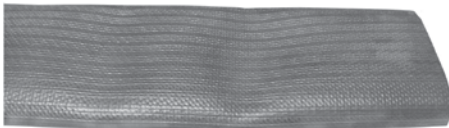
Product	Description	Part Number	Weight	List Price
<b>DISCHARGE HOSE</b> (BLACK RUBBER-HIGH PRESSURE)				
Flat Measurement				
	1-1/2" 150 max psi	2-1/2" 3-0590	0.8 /ft	<b>6.20/ft</b>
	2" 150 max psi	3-3/16" 3-0591	1.1 /ft	<b>6.80/ft</b>
	2-1/2" 150 max psi	4" 3-0592	1.5 /ft	<b>9.10/ft</b>
	3" 150 max psi	4-7/8" 3-0593	1.8 /ft	<b>9.20/ft</b>
	4" 200 max psi	6-1/4" 3-0651	0.8 /ft	<b>12.00/ft</b>
	4-1/2" 200 max psi	7-1/8" 3-0584	1.2 /ft	<b>17.00/ft</b>
	5" 200 max psi	7-7/8" 3-0597	1.0 /ft	<b>16.00/ft</b>
	6" 200 max psi	10" 3-0670	1.6 /ft	<b>19.00/ft</b>
	8" 200 max psi	13" 3-0671	2.9 /ft	<b>24.00/ft</b>
	10" 200 max psi	3-0585	5.1 /ft	<b>40.00/ft</b>
	12" 150 max psi	3-0586	5.8 /ft	<b>75.00/ft</b>
	16" 55 max psi	9-6850	3.5 /ft	<b>139.00/ft</b>

## Features:

1. Ideal for wheeline systems
2. Black rubber covering
3. Sized for use with irrigation fittings
4. Lightweight and flexible
5. Abrasion, UV, and kink resistant
6. Heavy duty discharge for use as a mainline for water and liquid manure, or agricultural and industrial sludge

## DISCHARGE HOSE

(ORANGE PVC-MEDIUM PRESSURE)



1-1/2" 150 max psi	3-0570	0.2 /ft	<b>1.60/ft</b>
2" 150 max psi	3-0571	0.3 /ft	<b>1.90/ft</b>
2-1/2" 150 max psi	3-0572	0.4 /ft	<b>2.50/ft</b>
3" 150 max psi	3-0573	0.5 /ft	<b>3.70/ft</b>
4" 125 max psi	3-0574	0.8 /ft	<b>6.20/ft</b>
6" 115 max psi	3-0575	1.2 /ft	<b>8.60/ft</b>
8" 70 max psi	3-0576	1.6 /ft	<b>16.10/ft</b>

## DISCHARGE HOSE

(BLUE PVC-LOW PRESSURE)



1-1/2" 70 max psi	3-0598	0.2 /ft	<b>0.70/ft</b>
2" 65 max psi	3-0594	0.2 /ft	<b>1.00/ft</b>
2-1/2" 60 max psi	3-0599	0.3 /ft	<b>1.30/ft</b>
3" 60 max psi	3-0595	0.4 /ft	<b>1.50/ft</b>
4" 60 max psi	3-0596	0.5 /ft	<b>2.00/ft</b>
5" 40 max psi	9-6817	0.7 /ft	<b>7.00/ft</b>
6" 45 max psi	3-0580	0.9 /ft	<b>3.60/ft</b>
8" 45 max psi	3-0581	1.3 /ft	<b>6.60/ft</b>
10" 35 max psi	3-0582	1.8 /ft	<b>21.00/ft</b>
12" 30 max psi	3-0583	2.0 /ft	<b>29.00/ft</b>
14" 30 max psi	6-9930	2.6 /ft	<b>50.00/ft</b>
16" 30 max psi	6-9931	3.1 /ft	<b>55.00/ft</b>

## Features:

1. Ideal for drip irrigation
2. No pig tailing
3. No snaking
4. Twisted yarn assures stability throughout the length of hose
5. Allows many times of use with the convenience of easy coiling for storage

Product	Description	Part Number	Weight	List Price
---------	-------------	-------------	--------	------------

## PVC SUCTION HOSE (CORRUGATED-RIGHT SPIRAL)



ID	OD			
1-1/2"	1.87"	6-0807	0.4 /ft	<b>3.00/ft</b>
2"	2.41"	6-0808	0.6 /ft	<b>4.00/ft</b>
2-1/2"	2.87"	3-0900	0.8 /ft	<b>6.00/ft</b>
3"	3.54"	6-0809	1.0 /ft	<b>8.00/ft</b>
4"	4.65"	3-0672	1.7 /ft	<b>12.00/ft</b>
5"	5.73"	3-0675	2.3 /ft	<b>24.00/ft</b>
6"	6.98"	3-0673	4.1 /ft	<b>25.00/ft</b>
8"	9.14"	3-0674	6.3 /ft	<b>45.00/ft</b>
10"	11.30"	3-0901	9.1 /ft	<b>88.00/ft</b>
12"	13.31"	3-0902	10.1 /ft	<b>100.00/ft</b>

\* Left Hand Spiral also available. Please call.

## PVC SUCTION HOSE (SMOOTH)



ID	OD			
1-1/2"	1.82"	6-0010	0.5 /ft	<b>2.20/ft</b>
2"	2.34"	6-0011	0.7 /ft	<b>3.20/ft</b>
2 1/2"	2.88"	6-9929	1.0 /ft	<b>4.50/ft</b>
3"	3.40"	6-0012	1.3 /ft	<b>5.50/ft</b>
4"	4.44"	6-0013	1.9 /ft	<b>9.00/ft</b>
5"	5.65"	6-0014	3.1 /ft	<b>16.50/ft</b>
6"	6.56"	6-0015	4.6 /ft	<b>22.00/ft</b>
8"	8.95"	6-0016	7.1 /ft	<b>41.00/ft</b>
10"	11.34"	3-0903	12.4 /ft	<b>105.00/ft</b>
12"	13.39"	3-0904	15.7 /ft	<b>131.00/ft</b>

## SUCTION HOSE (BLACK RUBBER)



ID	OD	DB Clamp#	Max PSI			
1-1/2"	1.89"	-	150	6-0800	0.8 /ft	<b>5.00/ft</b>
2"	2.40"	-	150	6-0801	1.0 /ft	<b>6.00/ft</b>
2-1/2"	3.00"	-	100	9-7723	1.8 /ft	<b>7.00/ft</b>
3"	3.46"	400	150	6-0802	1.5 /ft	<b>10.00/ft</b>
4"	4.49"	525	150	6-0803	2.1 /ft	<b>13.00/ft</b>
5"	5.55"	639	150	6-0804	3.3 /ft	<b>23.00/ft</b>
6"	6.54"	769	75	6-0805	3.8 /ft	<b>26.00/ft</b>
8"	8.70"	875	75	6-0806	6.5 /ft	<b>44.00/ft</b>
10"	10.71"	1125	45	3-0905	9.7 /ft	<b>65.00/ft</b>
12"	12.80"	1360	90	3-0906	14.1 /ft	<b>110.00/ft</b>

Towline / Wheelmove



# HOSE CLAMPS

Product	Description		Part Number	Weight	List Price		
	Millimeters	Inches					
<b>T-BOLT HOSE CLAMP</b> (ZINC PLATED)				<b>Box Qty</b>			
	26-28	1.02-1.10	0.75" Suction	3-0703	0.2	100	<b>2.00</b>
	29-31	1.14-1.22	1.0" Discharge	3-0704	0.2	100	<b>2.50</b>
	32-35	1.26-1.38	1.0" Suction	3-0705	0.2	100	<b>2.50</b>
	36-39	1.42-1.54		3-0706	0.2	100	<b>2.70</b>
	40-43	1.57-1.69	1.5" Discharge	3-0708	0.2	100	<b>4.20</b>
	44-47	1.73-1.85		9-5433	0.2	100	<b>5.00</b>
	48-51	1.89-2.01	1.5" Suction	3-0709	0.2	100	<b>4.50</b>
	52-55	2.05-2.17	2.0" Discharge	3-0710	0.2	50	<b>4.60</b>
	56-59	2.20-2.32		9-5434	0.2	50	<b>5.50</b>
	60-63	2.36-2.48	2.0" Suction	3-0712	0.2	50	<b>6.20</b>
	64-67	2.52-2.64		3-0713	0.2	50	<b>6.20</b>
	68-73	2.68-2.87	2.5" Discharge	3-0714	0.4	50	<b>6.40</b>
	74-79	2.91-3.11	2.5" Suction	3-0715	0.4	50	<b>6.40</b>
	80-85	3.15-3.35	3.0" Discharge	3-0716	0.4	50	<b>6.50</b>
	86-91	3.39-3.58	3.0" Suction	3-0717	0.4	50	<b>6.50</b>
	92-97	3.62-3.82		9-5435	0.4	50	<b>8.50</b>
	98-103	3.86-4.06		3-0719	0.4	50	<b>6.60</b>
	104-112	4.09-4.41	4.0" Discharge	3-0660	0.5	50	<b>7.00</b>
	113-121	4.45-4.76	4.5" Suction	3-0720	0.5	25	<b>7.00</b>
	122-130	4.80-5.12		3-0721	0.5	25	<b>9.50</b>
	131-139	5.16-5.47	5.0" Discharge	3-0722	0.7	25	<b>9.50</b>
	140-148	5.51-5.83	5.0" Suction	3-0723	0.7	25	<b>10.00</b>
	149-161	5.87-6.34	6.0" Discharge	3-0661	0.7	25	<b>10.00</b>
162-174	6.38-6.85	6.0" Suction	3-0724	0.8	25	<b>11.00</b>	
175-187	6.89-7.36	(For 6" Suction Boot)	3-0725	0.9	25	<b>11.00</b>	
188-200	7.40-7.87		3-0726	0.9	25	<b>11.50</b>	
201-213	7.91-8.39	8.0" Discharge	3-0662	0.9	25	<b>12.00</b>	
214-226	8.43-8.90	8.0" Suction	3-0727	1.0	25	<b>13.50</b>	
227-239	8.94-9.41	(For 8" Suction Boot)	3-0728	1.0	25	<b>13.50</b>	
240-252	9.45-9.92		3-0729	1.0	25	<b>15.00</b>	



**Zinc Plated Band, Bolt & Nut**

**Features:**

1. Double Galvanization
2. Allen screws allow for tightening in the points where there are space problems
3. Thorough spot welding with high resistance to corrosion
4. Use in agriculture, industry, construction, and wastewater
5. Can be used many times over
6. High resistance to corrosion

## T-BOLT HOSE CLAMP

(STAINLESS STEEL BAND W/ZINC PLATED HARDWARE)



**Stainless Steel Band,  
Zinc Plated Bolt & Nut  
(Hybrid)**

	Millimeters	Inches				
	29-31mm	1.14-1.22	1.0" Discharge	9-6886	0.1	<b>5.50</b>
	32-35mm	1.26-1.38	1.0" Suction	9-6887	0.1	<b>6.00</b>
	36-39mm	1.42-1.54		9-6888	0.1	<b>6.00</b>
	40-43mm	1.58-1.69	1.5" Discharge	9-6889	0.1	<b>6.00</b>
	44-47mm	1.73-1.85		9-6890	0.1	<b>8.00</b>
	48-51mm	1.89-2.01	1.5" Suction	9-6891	0.1	<b>8.50</b>
	52-55mm	2.05-2.17	2.0" Discharge	9-6892	0.1	<b>8.50</b>
	56-59mm	2.21-2.32		9-6893	0.1	<b>8.50</b>
	60-63mm	2.36-2.48	2.0" Suction	9-6894	0.1	<b>8.80</b>
	64-67mm	2.52-2.64		9-6895	0.1	<b>8.80</b>
	68-73mm	2.68-2.88	2.5" Discharge	9-6896	0.2	<b>12.50</b>
	74-79mm	2.91-3.11	2.5" Suction	9-6897	0.2	<b>12.50</b>
	80-85mm	3.15-3.35	3.0" Discharge	9-6898	0.2	<b>12.50</b>
	86-91mm	3.39-3.59	3.0" Suction	9-6899	0.2	<b>12.50</b>
	92-97mm	3.62-3.82		9-6900	0.2	<b>12.50</b>
	98-103mm	3.86-4.06		9-6901	0.2	<b>12.50</b>
	104-112mm	4.10-4.41	4.0" Discharge	9-6902	0.2	<b>12.90</b>
	113-121mm	4.45-4.77	4.0" Suction	9-6903	0.2	<b>12.90</b>
	122-130mm	4.81-5.12		9-6904	0.2	<b>12.90</b>
	131-139mm	5.16-5.48	5.0" Discharge	9-6905	0.3	<b>17.00</b>
	140-148mm	5.52-5.83	5.0" Suction	9-6906	0.3	<b>17.00</b>
	149-161mm	5.87-6.34	6.0" Discharge	9-6907	0.3	<b>17.50</b>
	162-174mm	6.38-6.86	6.0" Suction	9-6908	0.3	<b>17.50</b>
	175-187mm	6.90-7.37	(For 6" Suction Boot)	9-6909	0.3	<b>18.00</b>
	188-200mm	7.41-7.88		9-6910	0.4	<b>18.00</b>
	201-213mm	7.92-8.39	8.0" Discharge	9-6911	0.4	<b>19.00</b>
	214-226mm	8.43-8.90	8.0" Suction	9-6912	0.4	<b>19.00</b>
	226-239mm	8.90-9.42	(For 8" Suction Boot)	9-6913	0.4	<b>19.00</b>
	240-252mm	9.46-9.93		9-6914	0.4	<b>19.00</b>
	252-275mm	9.92-10.83	10" Discharge	9-7539		<b>24.00</b>
	317-330mm	12.48-12.99	12" Discharge	9-7540		<b>22.00</b>
	348-374mm	13.70-14.72	14" Discharge**	9-7541		<b>23.00</b>
	400-425mm	15.74-16.78	16" Discharge**	9-7542		<b>24.00</b>

\*\*The 14" and 16" Clamps are a two band/  
two bolt clamp.

Product	Description	Part Number	Weight	List Price		
<b>T-BOLT HOSE CLAMP</b> (ALL STAINLESS STEEL)    <b>All Stainless Steel Band, Bolt &amp; Nut</b>	<b>Millimeters Inches</b>					
	29-31mm 1.14-1.22	1.0" Discharge	6-9518	0.1	6.00	
	32-35mm 1.26-1.38	1.0" Suction	6-9519	0.1	6.00	
	36-39mm 1.42-1.54		6-9520	0.1	6.50	
	40-43mm 1.58-1.69	1.5" Discharge	6-9521	0.1	6.50	
	44-47mm 1.73-1.85		6-9522	0.1	7.00	
	48-51mm 1.89-2.01	1.5" Suction	6-9523	0.1	7.00	
	52-55mm 2.05-2.17	2.0" Discharge	6-9524	0.1	7.00	
	56-59mm 2.21-2.32		6-9525	0.1	7.00	
	60-63mm 2.36-2.48	2.0" Suction	6-9526	0.1	7.50	
	64-67mm 2.52-2.64		6-9527	0.1	7.50	
	68-73mm 2.68-2.88	2.5" Discharge	6-9528	0.2	11.00	
	74-79mm 2.91-3.11	2.5" Suction	6-9529	0.2	11.00	
	80-85mm 3.15-3.35	3.0" Discharge	6-9530	0.2	11.00	
	86-91mm 3.39-3.59	3.0" Suction	6-9531	0.2	11.00	
	92-97mm 3.62-3.82		6-9532	0.2	11.00	
	98-103mm 3.86-4.06		6-9533	0.2	11.00	
	104-112mm 4.10-4.41	4.0" Discharge	6-9534	0.2	12.00	
	113-121mm 4.45-4.77	4.0" Suction	6-9535	0.2	12.00	
	122-130mm 4.81-5.12		6-9536	0.2	12.00	
	131-139mm 5.16-5.48	5.0" Discharge	6-9537	0.3	16.00	
	140-148mm 5.52-5.83	5.0" Suction	6-9538	0.3	16.00	
	149-161mm 5.87-6.34	6.0" Discharge	6-9539	0.3	16.00	
	162-174mm 6.38-6.86	6.0" Suction	6-9540	0.3	16.00	
175-187mm 6.90-7.37	(For 6" Suction Boot)	6-9541	0.3	17.00		
188-200mm 7.41-7.88		6-9542	0.4	17.00		
201-213mm 7.92-8.39	8.0" Discharge	6-9543	0.4	17.00		
214-226mm 8.43-8.90	8.0" Suction	6-9544	0.4	18.00		
226-239mm 8.90-9.42	(For 8" Suction Boot)	6-9545	0.4	18.00		
240-252mm 9.46-9.93		6-9546	0.4	18.00		
<b>DOUBLE BOLT CLAMP</b>  	3" # 400	3.5"-3.81"	9-5801	1.5	12.00	
	4" # 463	4.06"-4.44"	3-0730	1.8	12.00	
	4-1/2" # 525	4.25"-4.94"	9-5802	2.3	17.00	
	5" #550	5.00"-5.50"	9-5864	2.1	17.00	
	5-1/2" #600	5.50"-6.06"	9-5865	3.0	17.00	
	6" # 675	6.13"-6.88"	3-0731	2.7	18.00	
	6-1/2" # 769	6.50"-7.56"	9-5803	3.8	22.00	
	7-7/8" #818	7.69"-8.19"	9-5866	5.1	28.00	
	8" # 875	8.25"-8.88"	3-0732	5.6	33.00	
	9" # 988	8.94"-9.88"	9-5804	6.2	38.00	
	10" # 1125	9.94"-11.38"	3-0733	9.6	57.00	
	12" # 1275	11.19"-13.00"	3-0734	9.5	67.00	
	13" # 1360	12.19"-14.00"	9-5805	15.4	84.00	
	14-1/2" #1450	13.19"-15.00"	9-5867	16.7	175.00	
	17" #1700	15.06"-17.50"	9-5868	20.9	210.00	
	<b>DOUBLE BOLT SPIRAL CLAMP</b>  	<b>Right Hand Spiral (CW)</b>				
		1.5"		9-5001	0.2	9.00
2"			6-9745	0.4	5.00	
2.5"			9-5003	0.5	12.00	
3"			6-9746	0.7	13.00	
4"			3-0800	1.0	17.50	
5"			3-0801	1.8	22.50	
6"			3-0802	2.0	20.00	
8"			3-0803	2.8	27.00	
10"		(For 10" Suction Boot)	9-5000	3.5	30.00	
12"			9-5002	4.1	39.00	
<b>Left Hand Spiral (CCW)</b>						
1.5"		9-7667	-	9.00		
2"		9-7668	-	5.00		
2.5"		9-7669	-	12.00		
3"		9-7670	-	13.00		
4"		9-7671	-	17.50		
5"		9-7672	-	22.50		
6"		9-7673	-	20.00		
8"		9-7674	-	27.00		
10"		9-7675	-	30.00		
12"		9-7676	-	39.00		

Towline / Wheelmove

# NU-FLEX TUBING & SIPHON TUBES

Product	Description	Part Number	Weight	List Price		
<b>OETIKER® CLAMP</b> (SINGLE EAR)		3/8"	.350-.414	9-6779	-	0.30
		7/16"	.381-.444	9-6780	-	0.30
		15/32"	.394-.486	9-6781	-	0.30
		1/2"	.453-.524	9-6782	-	0.30
		35/64"	.472-.551	9-6783	-	0.40
		9/16"	.496-.571	9-6784	-	0.40
		5/8"	.543-.618	9-6785	-	0.40
		21/32"	.547-.650	9-6786	-	0.40
		11/16"	.594-.669	9-6787	-	0.40
		23/32"	.618-.728	9-6788	-	0.40
		3/4"	.669-.779	9-6789	-	0.40
		13/16"	.716-.827	9-6790	-	0.40
		7/8"	.779-.890	9-6791	-	0.40
		15/16"	.839-.949	9-6792	-	0.40
		1"	.898-1.008	9-6793	-	0.40
		1-1/16"	.945-1.067	9-6794	-	0.40
		1-1/8"	1.004-1.126	9-6795	-	0.40
		1-3/16"	1.063-1.185	9-6796	-	0.40
		1-5/16"	1.181-1.303	9-6797	-	0.50
		1-3/8"	1.240-1.362	9-6798	-	0.50
		1-15/32"	1.358-1.480	9-6799	-	0.50
		1-9/16"	1.437-1.559	9-6800	-	0.50
		1-5/8"	1.492-1.614	9-6801	-	0.50
		1-11/16"	1.551-1.673	9-6802	-	0.50
		1-23-32"	1.610-1.732	9-6803	-	0.50
		1-3/4"	1.669-1.791	9-6804	-	0.60
		1-13/16"	1.728-1.850	9-6805	-	0.60
		1-7/8"	1.787-1.909	9-6806	-	0.60
	1-15/16"	1.846-1.968	9-6807	-	0.60	
	2"	1.905-2.028	9-6808	-	0.60	
	Pinch Clamp Tool	9-6809	-	45.00		



- Oetiker ear type clamps "Breathe" and adapt to the expansion and contraction of hose affected by thermodynamics or aging, no need to re-tighten
- Clamps are lightweight and compact, important when bulky screw-type clamps interfere with limited space applications
- Provides a tamper-proof seal without damage to the hose
- Made of zinc plated 1008/1010 carbon steel
- Features a mechanical lock at the joint instead of a spot weld, preventing failure due to corrosion
- Low pressure applications



## WORM-DRIVE CLAMP (STAINLESS STEEL BAND W/ZINC PLATED HARDWARE)



- 1/2" Wide Stainless Steel Band with Zinc plated Screw.
- Cold-formed stamped band thread, smoothed on the underside, combined with beveled band-edges protects hose from damage.
- The AISI-430 Stainless steel finish of the band and housing make this a very attractive clip.
- The maximum application pressure can vary depending on the type of hose used and the geometry of the coupling.

**Materials**





- Screw:  
Qst 36-3 Mild Steel (DIN 1.0213)  
Silver-white Cr3 Zinc-Plated

- Band & Housing:  
X6Cr17 Stainless Steel (DIN 1.4016) (AISI-430)

Millimeters	Inches		Box Qty	
16-27	0.63-1.06	9-7595	50	1.00
20-32	0.78-1.25	9-7596	50	1.00
25-40	0.99-1.38	9-7597	50	1.00
30-45	1.19-1.78	9-7598	50	1.00
32-50	1.25-1.97	9-7599	50	1.00
40-60	1.56-2.34	9-7600	50	1.50
50-70	1.97-2.75	9-7601	50	1.50
60-80	2.34-3.16	9-7602	50	1.50
70-90	2.75-3.53	9-7603	50	1.50
80-100	3.16-3.94	9-7604	50	1.50
90-110	3.54-4.33	9-7605	25	2.00
100-120	3.94-4.72	9-7606	25	2.00
110-130	4.33-5.12	9-7607	25	2.00
120-140	4.72-5.51	9-7608	25	2.00
130-150	5.12-5.91	9-7609	25	2.00
140-160	5.51-6.30	9-7610	25	2.50
150-170	5.91-6.69	9-7611	25	2.50
160-180	6.30-7.09	9-7612	25	2.50
170-190	6.69-7.48	9-7613	10	2.50
180-200	7.09-7.87	9-7614	10	3.00
190-210	7.48-8.27	9-7615	10	3.00
200-220	7.87-8.66	9-7616	10	3.00
210-230	8.27-9.06	9-7617	10	3.00
220-240	8.66-9.45	9-7618	10	3.00

## SECTION THREE



 Nu-Flex Tubing	40
 Siphon Tubes	40
 Sprinkler Pipe	41
 Mainline Pipe	42, 46
 Tubing	43
 Gated Pipe	44-45
 Pipe Accessories	46
 Vacuum Pipe	47
 PVC Underground Pipe	48-49
 Gates & Accessories	50-52

# NU-FLEX TUBING & SIPHON TUBES



Product	Description	Part Number	Weight	List Price
---------	-------------	-------------	--------	------------

## NU-FLEX LAYFLAT SURFACE TUBING

(FOR FLOOD/FURROW IRRIGATION)



Dia	Length	Mil	Max GPM		Wt.	
5"	500'	6	250	6-9798	19.0	105.00
5"	1000'	6	250	6-9799	38.0	195.00
9"	1320'	5	449	6-9801	73.0	235.00
9"	1320'	7	449	6-9802	101	235.00
10"	1000'	10	598	6-9804	95.0	410.00
12"	1320'	5	898	6-9805	98.0	315.00
12"	950'	7	898	6-9807	98.0	315.00
12"	1320'	7	898	6-9808	136.0	434.00
12"	1320'	8	898	9-7693	-	460.00
12"	1000'	10	898	6-9809	153.0	410.00
15"	1320'	5	1347	6-9810	126.0	402.00
15"	1320'	7	1347	6-9812	174.0	555.00
18"	850'	7	1750	6-9816	135.0	425.00
18"	600'	10	1750	6-9818	135.0	428.00
21"	700'	8	2200	6-9819	145.0	465.00
24"	700'	8	2650	6-9821	166.0	535.00

Slide Gate for Surface Tubing 9-5242 - 3.50

Call for other sizes, mil thicknesses and tools.

Advantages:

1. Low Cost
2. Reduced Labor Cost
3. New Product Every Season
4. Less friction loss than aluminum pipe
5. Can be used as mainline or gated pipe

## SIPHON TUBES

(ALUMINUM)

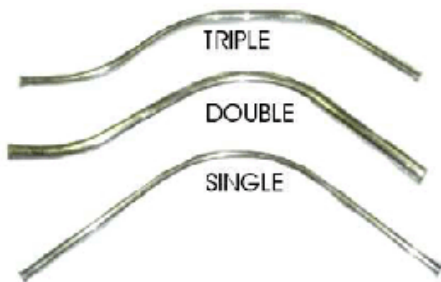

PVC Siphon tubes are also available, Call for Prices.

Size	Length	Single Bend		Double Bend		Triple Bend	
		Part #	List	Part #	List	Part #	List
1/2"	60"	9-5362	\$7.00	9-5379	\$6.00		
3/4"	54"			9-5380	10.00		
3/4"	60"	9-5363	10.00	9-5381	10.00	9-5405	\$10.00
3/4"	72"			9-5382	11.00	9-5406	11.00
1"	48"	9-5364	12.00				
1"	54"	9-5365	12.00	9-5383	12.00		
1"	60"	9-5366	12.00	9-5384	12.00	9-5407	12.00
1"	72"	9-5367	14.00	9-5385	14.00	9-5408	14.00
1"	90"					9-5409	19.00
1-1/4"	48"	9-5368	15.00				
1-1/4"	54"	9-5369	15.00	9-5386	15.00		
1-1/4"	60"	9-5370	15.00	9-5387	15.00	9-5410	15.00
1-1/4"	64"			9-5388	17.00		
1-1/4"	72"	9-5371	16.00	9-5389	17.00	9-5411	17.00
1-1/4"	90"					9-5412	19.00
1-1/2"	48"	9-5372	19.00				
1-1/2"	54"			9-5390	19.00		
1-1/2"	60"	9-5373	19.00	9-5391	19.00	9-5413	19.00
1-1/2"	64"			9-5392	24.00		
1-1/2"	72"	9-5374	22.00	9-5393	22.00	9-5414	22.00
1-1/2"	90"					9-5415	28.00
2"	48"	9-5375	26.00				
2"	54"			9-5394	26.00		
2"	60"	9-5376	26.00	9-5395	26.00	9-5416	26.00
2"	64"			9-5396	30.00		
2"	72"	9-5377	30.00	9-5397	30.00	9-5417	30.00
2"	90"					9-5418	38.00
3"	60"	9-5378	70.00	9-5398	70.00		
3"	72"			9-5399	92.00		
3"	90"			9-5400	108.00	9-5419	108.00
4"	72"			9-5401	136.00		
4"	96"			9-5402	160.00		
4"	120"					9-5420	229.00
5"	96"			9-5403	285.00	9-5421	285.00
5"	120"					9-5422	357.00
6"	96"			9-5404	360.00	9-5423	358.00
6"	120"					9-5424	453.00

# ALUMINUM & PVC SPRINKLER PIPE

Product	Description	Part Number	Weight	List Price
---------	-------------	-------------	--------	------------



## ALUMINUM



Aluminum press-on coupler with 1" riser outlet. Gasket and band & hook included. Price excludes riser and sprinkler.

2" x 20'	4-0530	.45/ft	Call
2" x 30'	4-0531	.42/ft	Call
2" x 40'	4-0532	.41/ft	Call
3" x 20'	4-0536	.65/ft	Call
3" x 30'	4-0537	.61/ft	Call
3" x 40'	4-0538	.60/ft	Call
4" x 20'	4-0533	.86/ft	Call
4" x 30'	4-0534	.82/ft	Call
4" x 40'	4-0535	.80/ft	Call

Pipe

## PVC W/SPIKE COUPLER



Has 3/4" riser outlet.  
 \*See page 53 for spike couplers

2" x 30'	4-3510	--	Call
2" x 40'	4-3511	--	Call
2-1/2" x 30'	4-3512	--	Call
2-1/2" x 40'	4-3513	--	Call

## PIECES/TRUCKLOAD:

	6"	8"	10"	12"
Hook & Band	255	143	90	63
Ringlock	195	120	87	63

# STANDARD ALUMINUM MAINLINE PIPE



Product	Description	Part Number	Weight	List Price
<b>PLAIN</b>	4" x 20' .050	4-0110	.79/ft	Call
	4" x 30' .050	4-0111	.77/ft	Call
	4" x 40' .050	4-0112	.76/ft	Call
	6" x 10' .051	4-0130	1.25/ft	Call
	6" x 15' .051	4-0131	1.20/ft	Call
	6" x 20' .051	4-0132	1.18/ft	Call
	6" x 30' .051	4-0133	1.15/ft	Call
	6" x 40' .051	4-0134	1.14/ft	Call
	8" x 10' .051	4-0160	1.73/ft	Call
	8" x 15' .051	4-0161	1.65/ft	Call
	8" x 20' .051	4-0162	1.62/ft	Call
	8" x 30' .051	4-0163	1.58/ft	Call
	8" x 40' .051	4-0164	1.56/ft	Call
	10" x 10' .051	4-0190	2.35/ft	Call
	10" x 15' .051	4-0191	2.20/ft	Call
	10" x 20' .051	4-0192	2.13/ft	Call
10" x 30' .051	4-0193	2.05/ft	Call	
10" x 40' .051	4-0194	2.01/ft	Call	

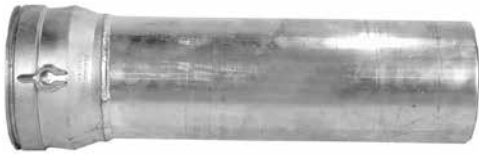

## BAND & HOOK



Pieces/Truckload:  
 4" - 575  
 6" - 255  
 8" - 143  
 10" - 90

Description	Part Number	Weight	List Price
4" x 20' .050	4-0120	.82/ft	Call
4" x 30' .050	4-0121	.79/ft	Call
4" x 40' .050	4-0122	.77/ft	Call
6" x 10' .051	4-0140	1.53/ft	Call
6" x 15' .051	4-0141	1.38/ft	Call
6" x 20' .051	4-0142	1.31/ft	Call
6" x 30' .051	4-0143	1.24/ft	Call
6" x 40' .051	4-0144	1.21/ft	Call
8" x 10' .051	4-0170	2.11/ft	Call
8" x 15' .051	4-0171	1.90/ft	Call
8" x 20' .051	4-0172	1.80/ft	Call
8" x 30' .051	4-0173	1.70/ft	Call
8" x 40' .051	4-0174	1.65/ft	Call
10" x 10' .051	4-0195	2.80/ft	Call
10" x 15' .051	4-0196	2.50/ft	Call
10" x 20' .051	4-0197	2.35/ft	Call
10" x 30' .051	4-0198	2.20/ft	Call
10" x 40' .051	4-0199	2.13/ft	Call

## RINGLOCK (STANDARD WALL)



Pieces/Truckload:  
 6" - 195  
 8" - 120  
 10" - 87

Description	Part Number	Weight	List Price
6" x 10' .051	4-0150	1.81/ft	Call
6" x 15' .051	4-0151	1.58/ft	Call
6" x 20' .051	4-0152	1.46/ft	Call
6" x 30' .051	4-0153	1.34/ft	Call
6" x 40' .051	4-0154	1.28/ft	Call
8" x 10' .051	4-0180	2.48/ft	Call
8" x 15' .051	4-0181	2.15/ft	Call
8" x 20' .051	4-0182	1.99/ft	Call
8" x 30' .051	4-0183	1.83/ft	Call
8" x 40' .051	4-0184	1.75/ft	Call
10" x 10' .051	4-0185	3.29/ft	Call
10" x 15' .051	4-0186	2.83/ft	Call
10" x 20' .051	4-0187	2.59/ft	Call
10" x 30' .051	4-0188	2.36/ft	Call
10" x 40' .051	4-0189	2.25/ft	Call

Product	Description	Part Number	Weight	List Price
<b>BLACK STEEL TUBING</b>	<b>Diameter (O.D.)</b>	<b>Gauge</b>	<b>Wall Thickness</b>	<b>Weight</b>
	2"	11 ga.	.125	4-0507 2.4 /ft <b>4.50/ft</b>
	2-1/2"	11 ga.	.125	4-0508 3.1 /ft <b>5.50/ft</b>
	3"	11 ga.	.083	4-0509 2.6 /ft <b>6.50/ft</b>
	4"	14 ga.	.083	9-5146 3.2 /ft <b>6.50/ft</b>
	4"	12 ga.	.105	4-0510 4.5 /ft <b>9.00/ft</b>
	4"	11 ga.	.125	9-5145 4.9 /ft <b>10.00/ft</b>
	4"	10 ga.	.135	9-5137 5.7 /ft <b>13.00/ft</b>
	5"	12 ga.	.105	4-0511 5.6 /ft <b>12.50/ft</b>
	5"	11 ga.	.125	9-5142 6.3 /ft <b>11.00/ft</b>
	5"	10 ga.	.135	9-5141 7.2 /ft <b>13.50/ft</b>
	6"	14 ga.	.083	9-5147 4.8 /ft <b>11.50/ft</b>
	6"	12 ga.	.105	4-0512 6.8 /ft <b>13.00/ft</b>
	6"	10 ga.	.135	9-5138 8.6 /ft <b>15.00/ft</b>
	6"	7 ga. (3/16")	.188	9-5151 11.6 /ft <b>24.00/ft</b>
	6-5/8"	12 ga.	.105	4-0513 7.9 /ft <b>15.00/ft</b>
	6-5/8"	10 ga.	.135	9-5139 9.6 /ft <b>17.00/ft</b>
	6-5/8"	7 ga. (3/16")	.188	9-5152 12.9 /ft <b>25.00/ft</b>
	8"	14 ga.	.083	9-5148 6.5 /ft <b>15.00/ft</b>
	8"	12 ga.	.105	4-0514 9.0 /ft <b>17.50/ft</b>
	8"	11 ga.	.125	9-5144 10.3 /ft <b>16.00/ft</b>
	8"	10 ga.	.135	9-5140 11.6 /ft <b>23.00/ft</b>
	8"	7 ga. (3/16")	.188	9-5153 15.6 /ft <b>32.00/ft</b>
	8-5/8"	12 ga.	.105	4-0515 12.2 /ft <b>21.50/ft</b>
10"	12 ga.	.105	4-0516 11.3 /ft <b>22.00/ft</b>	
10"	10 ga.	.135	9-5136 14.5 /ft <b>28.00/ft</b>	
10"	7 ga. (3/16")	.188	9-5150 19.7 /ft <b>40.00/ft</b>	
10-3/4"	10 ga.	.135	9-5287 15.6 /ft <b>31.00/ft</b>	
12"	12 ga.	.105	4-0517 13.6 /ft <b>28.50/ft</b>	
12"	10 ga.	.135	9-5307 17.5 /ft <b>38.00/ft</b>	
12-3/4"	10 ga.	.135	9-5288 18.6 /ft <b>39.00/ft</b>	



## STAINLESS STEEL 304 TUBING

6"	12 ga.	.105	9-8095	- /ft	<b>75.00/ft</b>
8"	12 ga.	.105	9-8096	- /ft	<b>99.00/ft</b>
12"	12 ga.	.105	9-8097	- /ft	<b>125.00/ft</b>

## ALUMINUM TUBING



Diameter (O.D.)	Wall	Weight
2"	.050	4-0540 0.36/ft <b>Call</b>
3"	.050	4-0541 0.54/ft <b>Call</b>
4"	.050	4-0520 0.73/ft <b>Call</b>
4"	.072	4-0542 1.05/ft <b>Call</b>
5"	.052	4-0543 0.94/ft <b>Call</b>
5"	.078	4-0544 1.42/ft <b>Call</b>
6"	.051	4-0521 1.10/ft <b>Call</b>
6"	.058	4-0522 1.26/ft <b>Call</b>
6"	.083	4-0545 1.81/ft <b>Call</b>
7"	.064	4-0546 1.64/ft <b>Call</b>
8"	.051	4-0523 1.50/ft <b>Call</b>
8"	.064	4-0524 1.88/ft <b>Call</b>
8"	.072	4-0547 2.11/ft <b>Call</b>
8"	.090	4-0548 2.78/ft <b>Call</b>
9"	.051	4-0621 1.75/ft <b>Call</b>
9"	.064	4-0529 2.24/ft <b>Call</b>
10"	.051	4-0525 1.90/ft <b>Call</b>
10"	.064	4-0526 2.38/ft <b>Call</b>
10"	.094	4-0549 3.44/ft <b>Call</b>
12"	.064	4-0550 2.86/ft <b>Call</b>
12"	.094	4-0551 4.19/ft <b>Call</b>

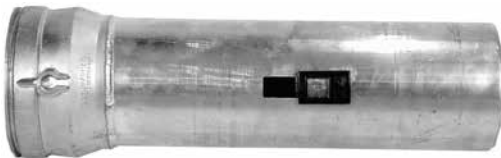
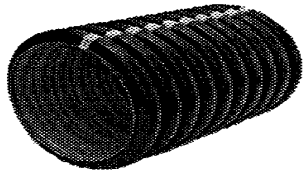

Product	Description	Part Number	Weight	List Price			
<b>ALUMINUM GATED PIPE - .051*</b>		<b>Gates/Pipe</b>					
		6" x 20' - 20"	12	4-0310	1.18/ft	Call	
		6" x 20' - 30"	8	4-0320	1.18/ft	Call	
		6" x 20' - 40"	6	4-0330	1.18/ft	Call	
		6" x 30' - 20"	18	4-0311	1.15/ft	Call	
		6" x 30' - 30"	12	4-0321	1.15/ft	Call	
		6" x 30' - 36"	10	4-0323	1.15/ft	Call	
		6" x 30' - 40"	40	4-0331	1.15/ft	Call	
		6" x 40' - 20"	24	4-0312	1.14/ft	Call	
		6" x 40' - 30"	16	4-0322	1.14/ft	Call	
		6" x 40' - 40"	12	4-0332	1.14/ft	Call	
			8" x 20' - 20"	12	4-0340	1.62/ft	Call
		8" x 20' - 30"	8	4-0350	1.62/ft	Call	
	8" x 20' - 40"	6	4-0360	1.62/ft	Call		
	8" x 30' - 20"	18	4-0341	1.58/ft	Call		
	8" x 30' - 30"	12	4-0351	1.58/ft	Call		
	8" x 30' - 36"	10	4-0353	1.58/ft	Call		
	8" x 30' - 40"	9	4-0361	1.58/ft	Call		
	8" x 40' - 20"	24	4-0342	1.56/ft	Call		
	8" x 40' - 30"	16	4-0352	1.56/ft	Call		
	8" x 40' - 40"	12	4-0362	1.56/ft	Call		
	10" x 20' - 20"	12	4-0370	2.13/ft	Call		
	10" x 20' - 30"	8	4-0380	2.13/ft	Call		
	10" x 20' - 40"	6	4-0390	2.13/ft	Call		
	10" x 30' - 20"	18	4-0371	2.05/ft	Call		
	10" x 30' - 30"	12	4-0381	2.05/ft	Call		
	10" x 30' - 36"	10	4-0383	2.05/ft	Call		
	10" x 30' - 40"	9	4-0391	2.05/ft	Call		
	10" x 40' - 20"	24	4-0372	2.01/ft	Call		
	10" x 40' - 30"	16	4-0382	2.01/ft	Call		
	10" x 40' - 40"	12	4-0392	2.01/ft	Call		
<b>CORRUGATED PLASTIC DRAINAGE PIPE</b>		3"	4-0700	--	Call		
			4"	4-0701	--	Call	
			5"	4-0702	--	Call	
			6"	4-0703	--	Call	
			8"	4-0704	--	Call	
			10"	4-0705	--	Call	
			12"	4-0706	--	Call	
			15"	4-0707	--	Call	
			18"	4-0708	--	Call	
			24"	4-0709	--	Call	
			<b>Smooth Interior:</b>	12"	4-0710	--	Call
				15"	4-0711	--	Call
			18"	4-0712	--	Call	
		24"	4-0713	--	Call		

Available perforated or non-perforated.  
Please call for fittings.

\* Quantity and Truckload Discounts available. Please Call.

# PVC SURFACE GATED PIPE

Product	Description	Part Number	Weight	List Price	
<b>PVC SURFACE GATED</b> (STANDARD WALL)	<u>Wall</u>				
	6" x 30' - plain	.12	4-3305	1.5/ft	Call
	6" x 30' - 20"	.12	4-3311	1.5/ft	Call
	6" x 30' - 30"	.12	4-3321	1.5/ft	Call
	6" x 30' - 36"	.12	4-3300	1.5/ft	Call
	6" x 30' - 40"	.12	4-3331	1.5/ft	Call
	8" x 30' - plain	.12	4-3306	2.0/ft	Call
	8" x 30' - 20"	.12	4-3341	2.0/ft	Call
	8" x 30' - 30"	.12	4-3351	2.0/ft	Call
	8" x 30' - 36"	.12	4-3301	2.0/ft	Call
8" x 30' - 40"	.12	4-3361	2.0/ft	Call	
10" x 30' - plain	.12	4-3307	2.5/ft	Call	
10" x 30' - 20"	.12	4-3371	2.5/ft	Call	
10" x 30' - 30"	.12	4-3381	2.5/ft	Call	
10" x 30' - 36"	.12	4-3302	2.5/ft	Call	
10" x 30' - 40"	.12	4-3391	2.5/ft	Call	
12" x 30' - plain	.12	4-3308	3.0/ft	Call	
12" x 30' - 20"	.12	4-3320	3.0/ft	Call	
12" x 30' - 30"	.12	4-3324	3.0/ft	Call	
12" x 30' - 36"	.12	4-3322	3.0/ft	Call	
12" x 30' - 40"	.12	4-3323	3.0/ft	Call	



Standard wall

\*Above w/b&h will take 20-25 psi  
 - Compatible w/Aluminum pipe and fittings  
 - Adjustable Telescopic Coupler

## PVC SURFACE GATED (LIGHT WALL)



Light wall

6" x 30' - plain	.10	4-3600	1.25/ft	Call
6" x 30' - 20"	.10	4-3601	1.25/ft	Call
6" x 30' - 30"	.10	4-3602	1.25/ft	Call
6" x 30' - 36"	.10	4-3603	1.25/ft	Call
6" x 30' - 40"	.10	4-3604	1.25/ft	Call
8" x 30' - plain	.09	4-3309	1.6/ft	Call
8" x 30' - 20"	.09	4-3330	1.6/ft	Call
8" x 30' - 30"	.09	4-3334	1.6/ft	Call
8" x 30' - 36"	.09	4-3402	1.6/ft	Call
8" x 30' - 40"	.09	4-3403	1.6/ft	Call
10" x 30' - plain	.10	4-3310	2.1/ft	Call
10" x 30' - 20"	.10	4-3404	2.1/ft	Call
10" x 30' - 30"	.10	4-3405	2.1/ft	Call
10" x 30' - 36"	.10	4-3406	2.1/ft	Call
10" x 30' - 40"	.10	4-3407	2.1/ft	Call

\*Above w/b&h will take 20-25 psi.

Pipe

Product	Description	Part Number	Weight	List Price	
<b>RINGLOCK</b> (HEAVY WALL)					
		<u>Wall</u> <u>Max PSI</u>			
		6" x 20' .058	150#	4-0220	1.53/ft
		6" x 30' .058	150#	4-0221	1.44/ft
		6" x 40' .058	150#	4-0222	1.39/ft
		8" x 20' .064	150#	4-0260	2.23/ft
		8" x 30' .064	150#	4-0261	2.11/ft
		8" x 40' .064	150#	4-0262	2.06/ft
		10" x 20' .064	125#	4-0290	2.79/ft
		10" x 30' .064	125#	4-0291	2.65/ft
	10" x 40' .064	125#	4-0292	2.58/ft	

Big Gun Female Coupler x Full Male Aluminum Ring. Ringlock Clamp included.

Product	Description	Part Number	Weight	List Price	
<b>TWIST LOCK PIPE</b>					
		<u>Wall</u> <u>Max PSI</u>			
		4" x 20' .050	150#	4-0715	--
		4" x 30' .050	150#	4-0716	--
		4" x 40' .050	150#	4-0717	--
		5" x 20' .051	150#	4-0718	--
		5" x 30' .051	150#	4-0719	--
		5" x 40' .051	150#	4-0720	--
		6" x 20' .058	150#	4-0721	--
		6" x 30' .058	150#	4-0722	--
		6" x 40' .058	150#	4-0723	--
		8" x 20' .064	125#	4-0724	--
		8" x 30' .064	125#	4-0725	--
	8" x 40' .064	125#	4-0726	--	

Product	Description	Part Number	Weight	List Price	
<b>REPLACEMENT COUPLER</b> (PVC SURFACE)		6"	4-3392	1.5	<b>35.00</b>
		8"	4-3393	3.0	<b>49.00</b>
		10"	4-3394	3.5	<b>52.00</b>
		12"	4-4400	4.0	<b>66.00</b>

Product	Description	Part Number	Weight	List Price	
<b>REPAIR SPLICER</b> (PVC SURFACE)		6"	4-3395	0.5	<b>12.00</b>
		8"	4-3396	1.0	<b>15.00</b>
		10"	4-3397	1.0	<b>20.00</b>
		12"	4-4401	1.5	<b>25.00</b>

Product	Description	Part Number	Weight	List Price	
<b>STEEL COLLAR</b> (PVC SURFACE)		6"	4-3398	1.3	<b>10.00</b>
		8"	4-3399	1.6	<b>12.00</b>
		10"	4-3400	2.0	<b>13.00</b>
		12"	4-3401	2.5	<b>15.00</b>

Product	Description	Part Number	Weight	List Price	
<b>CAPLOCK</b> (PVC SURFACE)		6"	4-4402	-	<b>33.00</b>
		8"	4-4403	-	<b>36.00</b>
		10"	4-4404	-	<b>40.00</b>
		12"	4-4405	-	<b>45.00</b>

## Features:

1. Easy to use
2. Saves time and money
3. Insert the plug and snap on the caplock

Product	Description	Part Number	Weight	List Price
<b>ALUMINUM VACUUM PIPE</b>				



-Tough, durable aluminum vacuum pipe is available in a number of types of connections.  
-We also manufacture vacuum fittings such as elbow, tees, end plugs, etc.

Size	Length	Wall	Type	Part #	List Price
4"	5'	0.072	Cast Alum Ball/Socket w/lever	9-5062	<b>164.00</b>
4"	10'	0.072	Cast Alum Ball/Socket w/lever	9-5063	<b>190.00</b>
4"	15'	0.072	Cast Alum Ball/Socket w/lever	9-5064	<b>219.00</b>
4"	20'	0.072	Cast Alum Ball/Socket w/lever	9-5065	<b>249.00</b>
4"	25'	0.072	Cast Alum Ball/Socket w/lever	9-5066	<b>279.00</b>
4"	30'	0.072	Cast Alum Ball/Socket w/lever	9-5067	<b>310.00</b>
6"	5'	0.083	Cast Alum Ball/Socket w/lever	9-5068	<b>279.00</b>
6"	10'	0.083	Cast Alum Ball/Socket w/lever	9-5069	<b>335.00</b>
6"	15'	0.083	Cast Alum Ball/Socket w/lever	9-5070	<b>399.00</b>
6"	20'	0.083	Cast Alum Ball/Socket w/lever	9-5071	<b>459.00</b>
6"	25'	0.083	Cast Alum Ball/Socket w/lever	9-5072	<b>519.00</b>
6"	30'	0.083	Cast Alum Ball/Socket w/lever	9-5073	<b>585.00</b>
8"	5'	0.094	Cast Alum Ball/Socket w/lever	9-5074	<b>525.00</b>
8"	10'	0.094	Cast Alum Ball/Socket w/lever	9-5075	<b>605.00</b>
8"	15'	0.094	Cast Alum Ball/Socket w/lever	9-5076	<b>700.00</b>
8"	20'	0.094	Cast Alum Ball/Socket w/lever	9-5077	<b>795.00</b>
8"	25'	0.094	Cast Alum Ball/Socket w/lever	9-5078	<b>900.00</b>
8"	30'	0.094	Cast Alum Ball/Socket w/lever	9-5079	<b>985.00</b>

Size	Length	Wall	Type	Part #	List Price
4"	5'	0.072	Cast Alum Ring Lock w/rc	9-5098	<b>125.00</b>
4"	10'	0.072	Cast Alum Ring Lock w/rc	9-5099	<b>150.00</b>
4"	15'	0.072	Cast Alum Ring Lock w/rc	9-5100	<b>180.00</b>
4"	20'	0.072	Cast Alum Ring Lock w/rc	9-5101	<b>210.00</b>
4"	25'	0.072	Cast Alum Ring Lock w/rc	9-5102	<b>240.00</b>
4"	30'	0.072	Cast Alum Ring Lock w/rc	9-5103	<b>270.00</b>
6"	5'	0.083	Cast Alum Ring Lock w/rc	9-5104	<b>180.00</b>
6"	10'	0.083	Cast Alum Ring Lock w/rc	9-5105	<b>240.00</b>
6"	15'	0.083	Cast Alum Ring Lock w/rc	9-5106	<b>300.00</b>
6"	20'	0.083	Cast Alum Ring Lock w/rc	9-5107	<b>365.00</b>
6"	25'	0.083	Cast Alum Ring Lock w/rc	9-5108	<b>425.00</b>
6"	30'	0.083	Cast Alum Ring Lock w/rc	9-5109	<b>485.00</b>
8"	5'	0.094	Cast Alum Ring Lock w/rc	9-5110	<b>230.00</b>
8"	10'	0.094	Cast Alum Ring Lock w/rc	9-5111	<b>330.00</b>
8"	15'	0.094	Cast Alum Ring Lock w/rc	9-5112	<b>420.00</b>
8"	20'	0.094	Cast Alum Ring Lock w/rc	9-5113	<b>520.00</b>
8"	25'	0.094	Cast Alum Ring Lock w/rc	9-5114	<b>610.00</b>
8"	30'	0.094	Cast Alum Ring Lock w/rc	9-5115	<b>705.00</b>

Pipe

# PVC UNDERGROUND PIPE



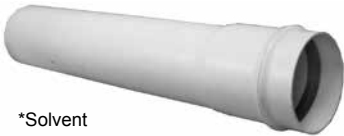
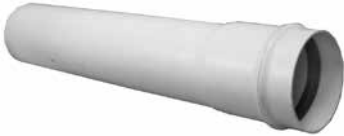
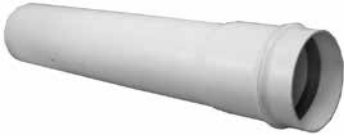
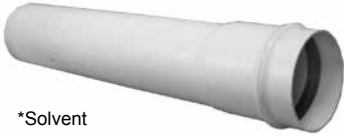

Product	Description		Part Number	Weight	List Price			
	Diameter	O D	I D	Thickness	SDR			
<b>50# PVC GASKETED PIPE</b>  *Solvent	*6" PIP	6.14	5.989	.760	81	4-0610	1.1/ft	Call
	8" PIP	8.16	7.958	.101	81	4-0650	1.7/ft	Call
	10" PIP	10.20	9.948	.126	81	4-0681	2.6/ft	Call
	12" PIP	12.24	11.938	.151	81	4-0691	3.8/ft	Call
	15" PIP	15.30	14.922	.189	81	4-0695	5.8/ft	Call
	*16" PIP	16.000	15.608	.196	81	4-0696	6.5/ft	Call
<b>80# PVC GASKETED PIPE</b> 	6" PIP	6.14	5.90	.12	51	4-0620	1.5/ft	Call
	8" PIP	8.16	7.84	.16	51	4-0660	2.6/ft	Call
	10" PIP	10.20	9.80	.20	51	4-0682	4.1/ft	Call
	12" PIP	12.24	11.76	.24	51	4-0692	6.1/ft	Call
	15" PIP	15.30	14.70	.30	51	4-0697	9.4/ft	Call
	18" PIP	18.70	17.96	.37	51	4-0800	14.3/ft	Call
	21" PIP	22.05	21.19	.43	51	4-0802	19.8/ft	Call
	24" PIP	24.80	23.83	.49	51	4-0804	26.1/ft	Call
27" PIP	27.95	26.86	.55	51	4-0806	33.6/ft	Call	
<b>100# PVC GASKETED PIPE</b> 	4" IPS	4.50	---	---	41	4-0644	1.0/ft	Call
	6" IPS	6.63	6.30	.162	41	4-0850	2.2/ft	Call
	8" IPS	8.63	8.21	.210	41	4-0851	3.6/ft	Call
	10" IPS	10.75	10.23	.262	41	4-0852	5.7/ft	Call
	12" IPS	12.75	12.13	.311	41	4-0853	8.0/ft	Call
	6" PIP	6.14	5.84	.150	41	4-0630	1.9/ft	Call
	8" PIP	8.16	7.76	.199	41	4-0670	3.3/ft	Call
	10" PIP	10.20	9.70	.249	41	4-0683	5.1/ft	Call
	12" PIP	12.24	11.64	.299	41	4-0693	7.5/ft	Call
	15" PIP	15.30	14.46	.373	41	4-0698	11.7/ft	Call
	18" PIP	18.7	17.78	.456	41	4-0801	17.6/ft	Call
	21" PIP	22.05	20.97	.538	41	4-0803	24.6/ft	Call
	24" PIP	24.8	23.59	.605	41	4-0805	32.4/ft	Call
	27" PIP	27.95	26.59	.683	41	4-0807	41.8/ft	Call
<b>125# PVC GASKETED PIPE</b>  *Solvent	1-1/4" IPS*	1.77	1.380	.197	32.5	4-3501	0.4/ft	Call
	2" IPS	2.38	2.229	.073	32.5	4-3504	0.3/ft	Call
	2-1/2" IPS	2.88	2.195	.088	32.5	4-0814	0.5/ft	Call
	3" IPS	3.50	2.830	.108	32.5	4-0815	0.7/ft	Call
	4" IPS	4.50	4.224	.138	32.5	4-0639	1.3/ft	Call
	6" IPS	6.63	6.217	.204	32.5	4-0855	2.7/ft	Call
	8" IPS	8.63	8.095	.265	32.5	4-0856	4.6/ft	Call
	10" IPS	10.75	10.088	.331	32.5	4-0857	7.1/ft	Call
	12" IPS	12.75	11.966	.392	32.5	4-0858	9.9/ft	Call
	6" PIP	6.14	5.762	.189	32.5	4-0640	2.3/ft	Call
	8" PIP	8.16	7.658	.251	32.5	4-0680	4.2/ft	Call
	10" PIP	10.20	9.572	.314	32.5	4-0684	6.4/ft	Call
	12" PIP	12.24	11.49	.377	32.5	4-0694	9.4/ft	Call
	15" PIP	15.30	14.36	.471	32.5	4-0699	14.8/ft	Call

All PVC is in 20' or 40' lengths. Gaskets are included. Call for installed prices.

Pieces/Truckload:	6"	8"	10"	12"
50# PIP	285	158	103	70
80/100/125# PIP	261	143	90	63
125/160# IPS	210	110	72	--

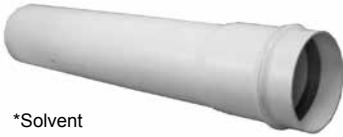
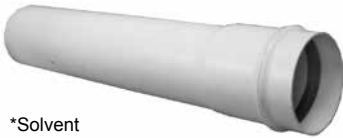
# PVC UNDERGROUND PIPE

Product	Description	Part Number	Weight	List Price				
<b>160# PVC GASKETED PIPE</b>  *Solvent	Diameter	OD	ID	Thickness SDR				
	1" IPS*	--	--	--	26	4-0816	--	Call
	1-1/4" IPS*	1.66	1.532	0.064	26	4-3502	0.2/ft	Call
	1-1/2" IPS	1.90	1.754	0.073	26	4-3503	0.3/ft	Call
	2" IPS	2.38	2.193	0.091	26	4-3505	0.4/ft	Call
	2-1/2" IPS	2.88	2.655	0.110	26	4-3506	0.6/ft	Call
	3" IPS	3.50	3.230	0.135	26	4-3508	0.9/ft	Call
	4" IPS	4.50	4.154	0.173	26	4-0671	1.6/ft	Call
	6" IPS	6.63	6.115	0.255	26	4-0672	3.4/ft	Call
	8" IPS	8.63	7.961	0.332	26	4-0673	5.7/ft	Call
10" IPS	10.75	9.924	0.413	26	4-0674	8.9/ft	Call	
12" IPS	12.75	11.77	0.490	26	4-0808	12.67/ft	Call	
<b>200# PVC GASKETED PIPE</b>  *Solvent	1/2" IPS*	.84	.716	0.022	13.5	4-0817	0.098/ft	Call
	3/4" IPS*	1.05	.930	0.060	21	4-0818	0.122/ft	Call
	1" IPS*	1.315	1.189	0.063	21	4-3500	0.164/ft	Call
	1-1/4" IPS*	1.660	1.502	0.079	21	4-0819	0.259/ft	Call
	1-1/2" IPS	1.900	1.720	0.090	21	4-0820	0.338/ft	Call
	2" IPS	2.375	2.149	0.113	21	4-3507	0.530/ft	Call
	2-1/2" IPS	2.875	2.601	0.137	21	4-0821	0.776/ft	Call
	3" IPS	3.500	3.166	0.167	21	4-0822	1.154/ft	Call
	4" IPS	4.500	4.072	0.214	21	4-0809	1.900/ft	Call
	6" IPS	6.625	5.993	0.316	21	4-0810	4.150/ft	Call
	8" IPS	8.625	7.805	0.410	21	4-0811	7.055/ft	Call
	10" IPS	10.75	9.728	0.500	21	4-0812	10.99/ft	Call
12" IPS	12.75	11.54	0.606	21	4-0813	15.53/ft	Call	
<b>SCHEDULE 40 PVC PIPE (SOLVENT)</b> 	1/2"	0.840	0.612	0.109	--	4-0823	0.164/ft	Call
	3/4"	1.050	0.824	0.113	--	4-0824	0.219/ft	Call
	1"	1.315	1.049	0.133	--	4-0825	0.325/ft	Call
	1-1/4"	1.660	1.380	0.140	--	4-0826	0.440/ft	Call
	1-1/2"	1.900	1.610	0.145	--	4-0827	0.526/ft	Call
	2"	2.375	2.067	0.154	--	4-0828	0.708/ft	Call
	2-1/2"	2.875	2.469	0.203	--	4-0829	1.123/ft	Call
	3"	3.500	3.068	0.216	--	4-0830	1.469/ft	Call
	4"	4.500	4.026	0.237	--	4-0831	2.090/ft	Call
	6"	6.625	6.065	0.280	--	4-0832	3.680/ft	Call
8"	8.625	7.962	0.332	--	4-0833	5.590/ft	Call	
<b>SCHEDULE 80 PVC PIPE (SOLVENT)</b> 	1/2"	0.840	0.546	0.147	--	4-0834	0.205/ft	Call
	3/4"	1.050	0.742	0.154	--	4-0835	0.278/ft	Call
	1"	1.315	0.957	0.179	--	4-0836	0.409/ft	Call
	1-1/4"	1.660	1.278	0.191	--	4-0837	0.567/ft	Call
	1-1/2"	1.900	1.500	0.200	--	4-0838	0.686/ft	Call
	2"	2.375	1.939	0.218	--	4-0839	0.949/ft	Call
	2-1/2"	2.875	2.323	0.276	--	4-0840	1.449/ft	Call
	3"	3.500	2.900	0.300	--	4-0841	1.938/ft	Call
	4"	4.500	3.826	0.337	--	4-0842	2.833/ft	Call
	6"	6.625	5.761	0.432	--	4-0843	5.446/ft	Call
8"	8.625	7.625	0.500	--	4-0844	8.270/ft	Call	

Pipe

All PVC is in 20' or 40' lengths. Gaskets are included. Call for installed prices.

Pieces/Truckload:	6"	8"	10"	12"
50# PIP	285	158	103	70
80/100/125# PIP	261	143	90	63
125/160# IPS	210	110	72	--

Product	Description	Part Number	Weight	List Price
<b>DAM GATE</b>	6"	4-0460	0.1	<b>1.30</b>
	8"-10"-12"	4-0461	0.1	<b>1.30</b>

Fits standard 1-1/4" x 2-5/8" Rectangle Hole



Features:

1. Quick easy installation
2. Designed for use in either PVC or aluminum pipe
3. Fits standard 1 1/4" x 2 5/8" rectangular openings
4. Fits Tex-Flo openings
5. New design allows easier slide adjustments
6. Spring tension is at the center for equal sealing at front and rear of the gate
7. Manufactured from special materials to minimize environmental effects
8. UV inhibitor is added to help protect against the sun's ultra violet radiation
9. Water flow 90 GPM at 6 feet of head

---

## KEYHOLE GATE

6"	4-0436	0.1	<b>1.50</b>
8"-10"	4-0441	0.1	<b>1.50</b>



Features:

1. The triad keyhole gate is a fresh approach to irrigation gate problems. The spring mechanism is so unique a patent has been applied for.
2. Easiest keyhole gate on the market to install.
3. Manufactured from specially selected materials to minimize environmental effects
4. Fits standard keyhole openings
5. Excellent water flow, 60 GPM at 6 feet of head

Product	Description	Part Number	Weight	List Price
<b>HASTINGS GATE</b>	Universal, 8"-9"-10"	4-0462	0.1	<b>1.50</b>
	Round Front, 6"	4-0463	0.1	<b>1.90</b>
	Round Front, 8"-9"-10"	4-0464	0.1	<b>1.90</b>
	Conversion, 1-5/8"x4-1/4" Hole	4-0465	0.2	<b>4.15</b>



**Universal** (will fit round front gate hole)



**Round Front**

Features:

1. Up to 85 GPM with a 42" head
2. Open, adjust and closes easily from a standing position with just the tap of a stick
3. Yellow Top: made of high strength, long-lasting natural polypropylene
4. Bottom: spring tension holds the gate firmly in any position in which the gate is set. Gasket is firmly molded to the bottom, holding it tightly against the pipe.
5. Gasket: new, improved design of molded synthetic rubber. This new material is more flexible, conforms more readily to the contour of the pipe

**NU-SLIDE GATE**

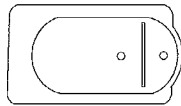

Rubber Bottom only	4-0495	-	<b>4.50</b>
Screw (need 2/gate)	4-0496	-	<b>0.45</b>

**OVAL GATE**

one size	4-0470	0.2	<b>2.20</b>
----------	--------	-----	-------------



Features:

1. Easily installed in a standard recessed oval hole (ames type)
2. Improved frame design
3. Flow rate 60 gallons per minute at 1 foot of head, full open
4. Easily adjustable slide regulates water flow
5. Manufactured from specially selected materials to improve weatherability



# GATES & GATE SOCKS

Product	Description	Part Number	Weight	List Price
<b>GATE SOCK CLIP</b> 	Round 6"	4-0480	0.2	<b>3.50</b>
	Round 8"	4-0481	0.2	<b>3.50</b>
	Round 10"	4-0482	0.2	<b>3.50</b>
	Round 12"	4-0483	0.2	<b>3.90</b>

## GATE SOCK



Vinyl Coated Polyester	4-0490	0.1	<b>4.95</b>
------------------------	--------	-----	-------------

\*36" long with closed end

## PIPE TURNER



6"	4-0475	10.3	<b>165.00</b>
8"	4-0476	11.3	<b>165.00</b>
9"	4-0477	12.3	<b>165.00</b>
10"	4-0478	12.3	<b>195.00</b>
12"	4-0479	12.8	<b>169.00</b>









## GATE TOOL



--	6-1814	-	<b>5.00</b>
----	--------	---	-------------

# SECTION FOUR



 Gun Stands & Carts	55-57
 Trailers, Travelers & Accs	58
 Traveler & Drag Hose	58
 Traveler Hose Menders	59
 Hose Pull Couplers	60
 Sprinklers	61-65
 Volume Guns	66-83
 Nozzles	69

# Traveler Parts

## Soft and Hard Hose Travelers

- Replacement Parts
- Cables
- Turbines
- Etc.

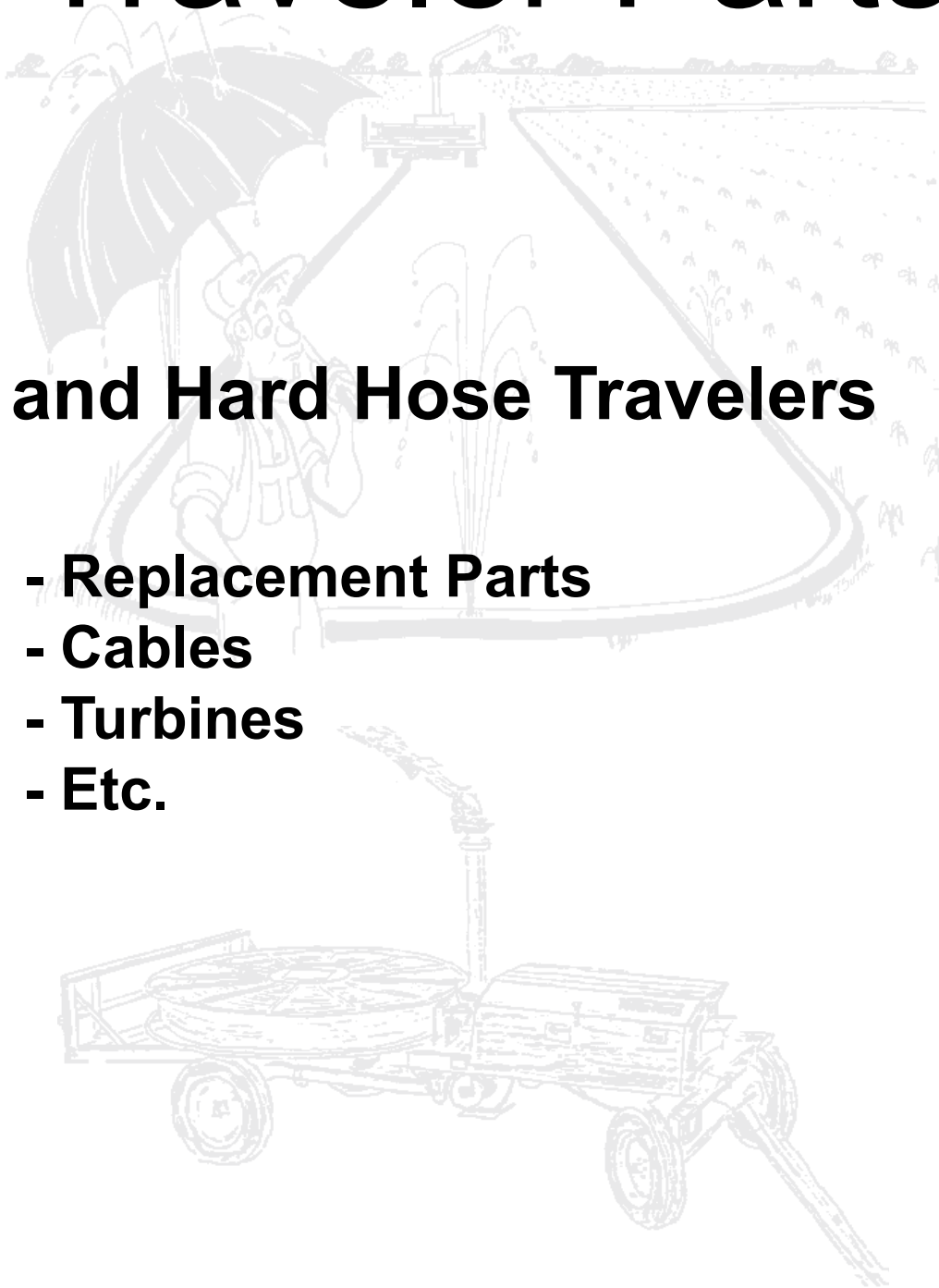

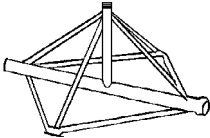
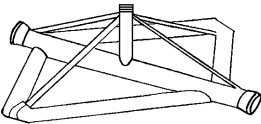
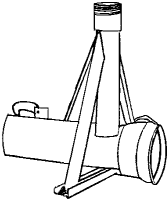
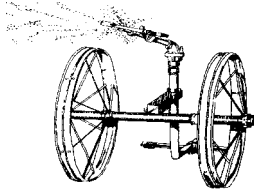
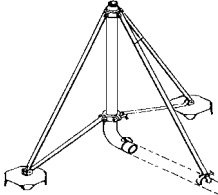
Product	Description	Part Number	Weight	List Price
<b>GUN STAND</b> <b>(FOLD DOWN - MODEL A)</b> <b>(ALUMINUM)</b>	4"	5-0110	40.0	425.00
<p>Hook style. Aluminum. With 3" male threaded top.</p> <p><u>Recommended Guns:</u> Nelson 100 Komet 101 River Skipper</p> 				
<b>GUN STAND</b> <b>(STANDARD - MODEL B)</b> <b>(ALUMINUM)</b>	6"	5-0120	48.0	780.00
<p><u>Ideal stand for:</u> 1. Hard to reach corners areas 2. Liquid manure applications 3. Pivot corners</p> <p>Ringlock. Aluminum. With 4" male threaded top. Water filled base for superior stability</p> <p><u>Recommended Guns:</u> Small Medium Large</p> 				
<b>GIANT SPRINKLER STAND</b> <b>(GALVANIZED STEEL)</b>	3" 4" 5" 6"	5-0130 5-0131 5-0132 5-0133	23.0 25.0 26.0 27.0	225.00 245.00 310.00 370.00
<p><u>Recommended Guns:</u> Nelson 100 Komet 101 River Skipper</p> <p>With male or female threaded top. Specify size.</p> 				
<b>GUN CART</b> <b>(GALVANIZED STEEL)</b>	4"	5-0140	116.0	825.00
<p>* With 2" FPT &amp; 2-1/2" MPT top. * Gun is not included. See pages 66-73. * Standard Profile * 57" Wheels * 4" Male B&amp;H and B&amp;L</p> <p><u>Recommended Guns:</u> Nelson 100 Komet 101 River Skipper</p> 				
<b>GUN STAND</b> <b>(MODEL LE)</b> <b>(ALUMINUM)</b>	3" 4" 5"	5-0150 9-7694 9-7695	20.0 - -	535.00 535.00 555.00
<p><u>Recommended Guns:</u> Nelson 100 Komet 101 River Skipper</p> <p>* With 2" FPT/2-1/2" MPT Top. * State mainline size when ordering. * 30" Riser Length.</p> 				

Gun Stands/Sprinklers

# SPRINKLER CARTS

Product	Description	Part Number	Weight	List Price
<b>SPRINKLER CART</b>	1000F w/Funny Sprinkler	9-7720	25.0	<b>270.00</b>
	1250K w/K-1 Sprinkler	9-7721	38.0	<b>430.00</b>
	1250H w/Hidra Sprinkler	9-7722	46.0	<b>585.00</b>

\* To order just the sprinkler see page 68.

### Model 1000F

1" Cart Body

Flow Range: 6 to 26 GPM

Pressure: 20 to 80 PSI

Coverage: Up to 120 Feet Diameter

25 lbs - Total Weight

All nozzles shown are included



3/4" Female Hose Swivel connection

### Model 1250K

1 1/4" Cart Body

Flow Range: 10 to 47 GPM

Pressure: 20 to 80 PSI

Coverage: Up to 150 Feet Diameter

38 lbs - Total Weight

All nozzles shown are included



1-1/4" MPT connection

### Model 1250H

1 1/4" Cart Body

Flow Range: 30 to 140 GPM

Pressure: 20 to 80 PSI

Coverage: Up to 200 Feet Diameter

46 lbs - Total Weight

All nozzles shown are included



1-1/4" MPT connection

PSI = Pressure at Sprinkler Nozzle  
GPM = Gallons Per Minute at Nozzle

#### 1000F Sprinkler Cart Performance

Sprinkler Performance

Nozzle size	PSI	GPM	Jet Length/Feet (One Direction)	Wetted Circle Diameter/Feet
5mm (.20")	22	5.3	42	84
	29	6	46	92
	44	7	50	100
	58	9	54	108
6mm (.24")	22	7	43	86
	29	8.5	48	96
	44	10	54	108
	58	12	58	116
7mm (.28")	22	10	46	92
	29	11	50	100
	44	14	56	112
	58	16	61	122
9mm (.35")	22	16.4	50	100
	29	19	54	108
	44	23	61	122
	58	26	64	128

#### 1250K Sprinkler Cart Performance

Sprinkler Performance

Nozzle size	PSI	GPM	Jet Length/Feet (One Direction)	Wetted Circle Diameter/Feet
7mm (.28")	22	10	46	92
	29	11	50	100
	44	14	56	112
	58	16	61	122
8mm (.315")	22	13	51	102
	29	15	56	112
	44	18	62	124
	58	21	67	134
9mm (.354")	22	16	54	108
	29	19	57	114
	44	23	64	128
	58	26	69	138
10mm (.394")	22	20	56	112
	28	23	59	118
	44	28	67	134
	58	33	72	144
12mm (.472")	22	29	56	112
	29	34	62	124
	44	41	68	136
	58	47	77	154

#### 1250H Sprinkler Cart Performance

Sprinkler Performance

Nozzle size	PSI	GPM	Jet Length/Feet (One Direction)	Wetted Circle Diameter/Feet
12mm (.47") w/ 5mm (.19") diffusor nozzle	29	40	65	130
	44	48	78	156
	58	56	88	176
	73	62	98	196
14mm (.55") w/ 5mm (.19") diffusor nozzle	29	52	69	138
	44	63	82	164
	58	73	95	190
	73	81	101	202
16mm (.63") w/ 5mm (.19") diffusor nozzle	29	65	72	144
	44	80	85	170
	58	93	98	196
	73	103	108	216
18mm (.70") w/ 5mm (.19") diffusor nozzle	44	100	92	184
	58	115	101	202
	73	128	112	224

# TRAVELING SPRINKLER & GUN ADAPTERS

Product	Description	Part Number	Weight	List Price
<b>TRAVELING SPRINKLER</b> (RAINCOACH™)				
<ul style="list-style-type: none"> <li>- 1" FHT Inlet</li> <li>- Economical Alternative for large turf areas</li> <li>- Brass, aluminum, and stainless steel construction provides unmatched durability</li> <li>- Combines 3/4" impact brass head with rotating sweep arms for full, even coverage</li> <li>- Includes six nozzle set</li> <li>- Allows for adjustable speed of travel for varied precipitation rates</li> <li>- Minimizes turf scarring with front roller</li> <li>- Equipped with 3/32" x 450' galvanized steel cable tow line</li> <li>- Provides stable operation on rough terrain with wide/long wheel base</li> <li>- Built-in valve shuts off water automatically at the end of run</li> <li>- FIVE YEAR WARRANTY</li> <li>- Throw: 110-145'</li> <li>- Flow: 11.5-22.4 GPM</li> <li>- PSI at Sprinkler: 55-75psi</li> </ul>		9-6812	56.0	<b>3,365.00</b>

## GUN OUTLET

(CAST ALUMINUM)



4"	2.5" fpt	9-5243	3.5	<b>105.00</b>
5"	2.5" fpt	9-5244	4.5	<b>115.00</b>
6"	2.5" fpt	9-5245	5.5	<b>170.00</b>

Small "Guns" may be used on this sturdy outlet.  
 The base is drilled for attaching a board for support of the sprinkler gun.

## ADAPTER

(GIANT SPRINKLER)



\* Use std 4" RLC

3" Weld On x 3" Male	6-9790	3.5	<b>58.00</b>
3" Weld On x 3" Female	6-9791	4.0	<b>95.00</b>
4" Weld On x 4" Male	8-1427	5.0	<b>65.00</b>
4" Weld On x 4" Female	8-1426	5.5	<b>105.00</b>
3" Ringlock Clamp	6-1047	1.4	<b>17.00</b>
4" Ringlock Clamp	6-1038	1.6	<b>18.00</b>

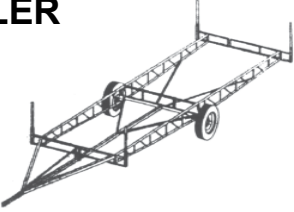
Product	Description	Part Number	Weight	List Price
<b>PIPE TRAILER</b> 	Single Tongue	5-0540	700.0	<b>1,995.00</b>
	Double Tongue	5-0550	735.0	<b>2,395.00</b>
Maximum capacity of 4,000 lbs. For pipe up to 40' in length <u>Dimensions:</u> -35' overall length -102" wide -21' from stake pocket to stake pocket -14' from tongue to front stake pocket				

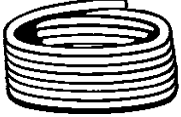
Product	Description	Part Number	Weight	List Price
<b>TRAVELER CABLE</b> 	5/16" x 1,350'	7x19	9-5183	- <b>600.00</b>
	3/8" x 1,350'	7x19	9-5182	- <b>970.00</b>
	7/16" x 2,700'	7x19	6-9585	- <b>Call</b>

Product	Description	Part Number	Weight	List Price
<b>BULLET STOP</b> 	5/16"	9-5181	-	<b>49.00</b>
	3/8"	9-5180	-	<b>28.00</b>

Product	For Hose Size		Part Number	Weight	List Price
	Hose Size	Part Number			
<b>FOAM PIG</b> 	6"	4-5-6"	9-5309	-	<b>34.00</b>
	7-1/4"	6"	9-6967	-	<b>27.00</b>
	8"	6-8"	9-5310	-	<b>38.00</b>
	10"	8-10"	9-6966	-	<b>58.00</b>

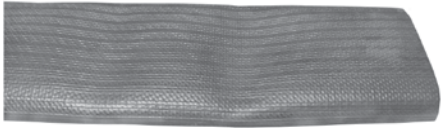
Product	Description	Part Number	Weight	List Price
<b>SOFT HOSE, TRAVELER (REPLACEMENT)</b> 	2 1/2" x 660'	6-9616	330.0	<b>Call</b>
	3" x 660'	6-9617	396.0	<b>Call</b>
	3 1/2" x 660'	6-9618	528.0	<b>Call</b>
	4" x 660'	5-0583	660.0	<b>Call</b>
	4-1/2" x 660'	5-0584	792.0	<b>Call</b>
	5" x 660'	6-9619	924.0	<b>Call</b>
	6" x 660'	6-9620	-	<b>Call</b>

10 year limited warranty  
 Cover allows maximum flexibility and good bend radius  
 Ease of repair and restoration of damaged hoses to full working performance  
 Long term storage stability and extended working life  
 Superior resistance to ozone and ultraviolet light

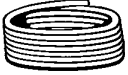
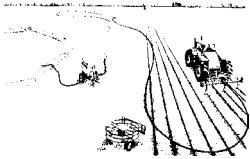
Product	Description	Part Number	Weight	List Price
<b>SLUDGE INJECTION HOSE (DRAG HOSE)</b>  L.W.T. 	4" x 660' (Sludge Injection)	5-0596	627.0	<b>Call</b>
	4-1/2" x 660' (Sludge Injection)	5-0597	666.6	<b>Call</b>
	5" x 660' (Sludge Injection)	9-7343	-	<b>Call</b>
	5-1/2" x 660' (Sludge Injection)	9-7582	-	<b>Call</b>
	6" x 660' (Sludge Injection)	9-7583	-	<b>Call</b>
	8" x 660' (Sludge Injection)	9-7827	-	<b>Call</b>
	10" x 660' (Sludge Injection)	9-7828	-	<b>Call</b>

# HOSE MENDERS

Product	Description	Part Number	Weight	List Price
<b>HOSE MENDER</b> (FOR HARD HOSE, BAND-IT)	Hose ID			
	2.1"	6-1827	-	350.00
	2.5"	6-1828	-	381.00
	3.0"	6-1829	-	606.00
	3.75"	6-1830	-	679.00
	4.1"	6-1831	-	676.00
	4.5"	6-1832	-	640.00
	5.0"	6-1833	-	695.00

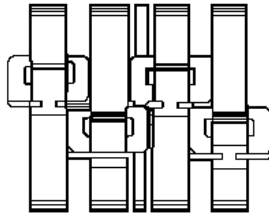

Product	Description	Part Number	Weight	List Price
<b>HOSE MENDER</b> (FOR HARD HOSE, SCREW)	Hose ID			
	0.90"	9-7682	-	225.00
	1.10"	9-7677	-	105.00
	1.18"	9-7573	-	125.00
	1.30"	9-7678	-	115.00
	1.40"	9-7679	-	120.00
	1.43"	9-7574	-	200.00
	1.60"	9-7680	-	150.00
	1.67"	9-7575	-	235.00
	1.80"	9-7681	-	200.00
	1.90"	9-7576	-	235.00
	2.00"	9-7683	-	240.00
	2.10"	6-1820	-	269.00
	2.30"	9-7686	-	370.00
	2.50"	6-1821	-	369.00
	2.70"	9-7684	-	485.00
	3.00"	6-1822	-	490.00
	3.30"	9-7577	-	485.00
	3.70"	6-9792	-	490.00
	4.00"	9-7685	-	580.00
4.10"	6-1824	-	675.00	
4.20"	9-7579	-	420.00	
4.50"	6-1825	-	575.00	
	4.60"	9-7580	-	450.00



\*Instructions Included

Product	Description	Part Number	Weight	List Price
<b>HOSE MENDER W/CLAMPS</b> (FOR SOFT HOSE)	Complete			
	Hose ID			
	2-1/2" w/clamps	5-0588	-	260.00
	3" w/clamps	5-0589	-	320.00
	3-1/2" w/clamps	5-0590	-	410.00
	4" w/8 Band-it Clamps	5-0585	9.5	130.00
	4-1/2" w/8 Band-it Clamps	5-0586	10.6	135.00
	5" w/8 Band-it Clamps	5-0591	-	200.00
6" w/8 Band-it Clamps	5-0592	-	210.00	



\*Instructions Included

Product	Description	Part Number	Weight	List Price
<b>Hard Mender Only (1/4" Wall x 10" Long)</b>	2-1/2" Steel	9-7570	-	32.00
	3" Steel	9-7571	-	35.00
	3-1/2" Steel	9-7572	-	145.00
	4" Steel	9-6763	7.1	59.00
	4-1/2" Steel	9-6764	8.3	65.00
	5" Steel	9-6765	-	95.00
	6" Steel	9-6766	-	100.00
	4" Aluminum	5-0600	2.9	115.00
	4-1/2" Aluminum	5-0601	3.0	189.00
	5" Aluminum	5-0602	3.7	225.00
	6" Aluminum	5-0603	4.0	197.00



Gun Stands/Sprinklers



# HOSE PULL COUPLER

Product	Description	Part Number	Weight	List Price
<b>HOSE PULL COUPLER</b>				
	Hose x Discharge			
	2.5" x 3" Cast Aluminum	6-1800	-	<b>275.00</b>
	3" x 3" Cast Aluminum	6-1801	-	<b>795.00</b>
	3" x 4" Cast Aluminum	6-1802	-	<b>495.00</b>
	4" x 4" Cast Aluminum	6-1804	11.0	<b>525.00</b>
	4.5" x 4" Cast Aluminum	6-1805	11.0	<b>595.00</b>
	4.5" x 5" Cast Aluminum	6-1806	-	<b>695.00</b>
	5" x 5" Cast Aluminum	6-1807	12.1	<b>525.00</b>
	6" x 6" Cast Aluminum	8-1446	-	<b>795.00</b>
	4.5" x 4" Steel	6-8041	118.0	<b>900.00</b>

\*Instructions Included  
 \*Clamps for 4/5"x4" HPC (1/2" Wide) #25229340  
 \* Cast Aluminum

## PLASTIC WEDGE (FOR HOSE PULL COUPLER)



4"	9-6833	-	<b>62.00</b>
4-1/2"	9-6834	-	<b>67.00</b>

## BACK TO BACK COUPLER W/CHAINS



3"	9-7568	5.0	<b>180.00</b>
4"	9-7344	6.0	<b>189.00</b>
5"	9-7345	7.0	<b>195.00</b>
6"	9-7346	8.5	<b>195.00</b>

\* Painted Steel

## WELD-ON COUPLER W/CHAINS



3"	9-7569	2.5	<b>65.00</b>
4"	9-7347	3.0	<b>69.00</b>
5"	9-7348	3.5	<b>70.00</b>
6"	9-7349	4.3	<b>70.00</b>

\* Black Steel

## 3 LINK CHAIN



9-7342	0.8	<b>20.00</b>
--------	-----	--------------

\* Weld to coupler for hose pull coupler connection.  
 \* Black Steel

Product	Description	Part Number	Weight	List Price
---------	-------------	-------------	--------	------------

## 1/2" BASE (BRASS)

20 JH w/nozzle-Rainbird	full / brass	7-0109	0.5	29.93
-------------------------	--------------	--------	-----	-------



20 JH

### 20 JH

Straight Bore Nozzle  
Stream Height 6'

PSI @ Nozzle	7/64"		1/8"		9/64"		5/32"	
	Rad.	GPM	Rad.	GPM	Rad.	GPM	Rad.	GPM
35	38	2.05	38	2.68	39	3.39	39	4.19
40	38	2.19	39	2.86	40	3.62	39	4.47
45	39	2.32	39	3.03	40	3.84	40	4.73
50	39	2.45	39	3.20	40	4.05	40	5.00
55	39	2.57	40	3.35	40	4.24	40	5.23
60	39	2.68	40	3.50	41	4.43	41	5.47

These sprinklers are widely used on all types of solid set systems, on center pivots, and in general field applications because of their construction and reliability. Excellent performance in low to medium application rates. Non-clog vane (mounted in entrance end of nozzle) in 20EJH model assures top performance under windy conditions.

- Small nozzle sizes; low flow rates
- "E" model has non-clog vane in nozzle for greater distance of throw
- Durable brass construction; excellent for many types of field applications
- Superior "H" bearing for longer life
- Standard trajectory angle for maximum distance of throw
- Low water application rate; ideal for heavy soils and slopes

Common Spacings Range:  
20 x 35 ft to 40 x 50 ft  
6 x 9 m to 12 x 15 m

## 1/2" BASE-PART TURN (PLASTIC)

429 PT, w/nozzle-Naan	part / plastic	7-0296	0.2	14.50
-----------------------	----------------	--------	-----	-------



429 PT

### 429 NOZZLES

PSI @ Nozzle	Orange Nozzle 7/64"		Green Nozzle 1/8"		Blue Nozzle 9/64"		Black Nozzle 5/32"	
	GPM	Dia.	GPM	Dia.	GPM	Dia.	GPM	Dia.
15			1.80	66	2.30	67	2.70	69
20	1.60	66	2.10	68	2.50	69	3.10	70
30	2.00	70	2.60	75	3.00	77	3.80	80
40	2.30	74	3.00	78	3.40	82	4.40	83
50	2.60	77	3.30	82	3.80	84	4.90	85
60	2.90	79	3.70	84	4.20	86	5.40	90

-1/2" mpt





Product	Description	Part Number	Weight	List Price
<b>1-1/4" BASE</b> (BRASS)	80 E (FULL CIRCLE)	9-7761	5.0	332.34
	85 EHD (PART TURN)	9-7762	5.3	379.40
	85 EHD-LA (PART TURN)	9-7763	5.3	379.40

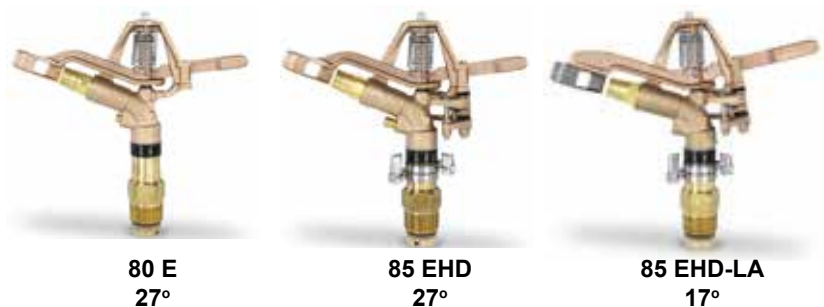

**Straight Bore Nozzle w/Spreader**  
Stream Height 14'

PSI @ Nozzle	11/32" x 7/32"	3/8" x 7/32"	13/32" x 7/32"	7/16" x 7/32"	15/32" x 7/32"
	Rad. GPM	Rad. GPM	Rad. GPM	Rad. GPM	Rad. GPM
25	61 23.30	62 26.50	64 29.60	66 32.90	66 36.40
30	64 25.60	65 29.10	68 32.40	69 36.10	72 40.00
35	67 27.70	68 31.40	72 35.10	74 39.00	77 43.30
40	69 29.60	71 33.60	75 37.60	77 41.80	80 46.30
45	71 31.50	73 35.70	77 39.90	79 44.40	82 49.20
50	73 33.20	75 37.70	79 62.10	81 46.80	94 51.90
55	75 34.90	77 39.70	81 44.30	83 49.10	86 54.70
60	77 36.50	79 41.40	83 46.60	86 51.50	88 57.20
65	79 38.00	81 43.20	84 48.60	87 53.80	90 59.80
70	81 40.10	83 44.90	86 50.40	89 55.90	91 62.10
75	82 41.00	84 46.70	87 52.40	90 57.90	93 64.30
80	83 42.60	86 48.30	89 54.30	92 60.00	94 66.70
85	85 43.80	87 49.80	90 56.00	93 62.00	96 68.80
90	86 45.70	89 51.40	92 57.90	95 63.90	97 70.70
95	87 46.60	90 53.00	93 59.60	96 65.80	98 72.80
100	88 47.90	91 54.50	94 61.20	97 67.50	99 74.80

These sprinklers are widely used as end guns on center pivot machines. Non-clog straightening vanes assure good coverage in the wind.

The 85EHD-LA was specifically developed for use in the highly abrasive water conditions normally experienced on center pivot machines. It gives excellent performance even in extreme winds due to a specially-drilled low angle (17 degree) body. In addition, these models are suitable for a wide variety of applications such as horse pastures, paddocks, arenas, feedlots, dust control, sod farms, or any other applications requiring the performance of a 1 1/4" / 32mm Sprinkler.

- Standard trajectory angle for maximum distance of throw
- Largest nozzle sizes and highest flow rates in brass part circle sprinklers
- "LA" model recommended for pivots and linears
- "ESHD" model has spreader nozzle; "EWSHD" model has plugged spreader outlet; "EHD-LA" has single nozzle body
- Durable heavy brass construction; excellent for many types of field applications
- "HD-LA" model has heavy duty features for longer life in dirty water
  - Heavier trip components
  - Locking friction collars
  - Stainless steel trip lever pads and trip stops
  - Stainless steel replaceable spoon
  - Superior "H" bearing

Common Spacings Ratings  
80 x80 ft to 140 x 140 ft  
24 x 24 m to 42 x 42 m

<b>1" BASE-PART TURN</b> (BRASS)	65JADJ-TNT	7-0160	3.6	290.18
-------------------------------------	------------	--------	-----	--------

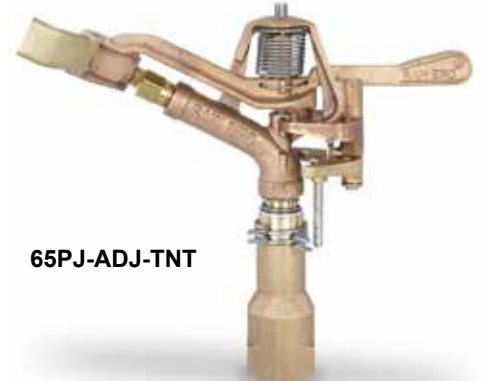

Part / full circle brass impact sprinklers  
Standard trajectory angle for maximum distance of throw  
Larger nozzle sizes and higher flow rates  
"PJ" arm eliminates side splash  
Adjustable diffuser pin for stream break-up

This sprinkler has a wide range of applications. Added versatility comes from an adjustable trip slip-pin that converts the sprinkler to full circle applications. The PJ precision jet arm eliminates side splash.

**Straight Bore Nozzle**  
Stream Height 10'

PSI @ Nozzle	1/4"	
	Rad.	GPM
50	57	12.90
55	57	13.60
60	58	14.20
65	62	14.90
70	63	15.40
75	64	16.00
80	65	16.50

Specifications:  
Bearing Size / Type - 1 in / 25 mm female NPT/BSP  
Body trajectory - 27 degrees

Materials:  
Body: Cast Bronze  
Arm: Cast Bronze  
Bearing Sleeve: Brass  
Bearing Nipple: Brass  
All Springs: Stainless Steel  
All Washers: Chemically Resistant



# NELSON VOLUME GUNS

Product	Description	Part Number	Weight	List Price
	F100 w/nozzle-Nelson	full	7-0230	20.5 <b>897.93</b>
	F150R w/nozzle-Nelson	full	7-0240	43.0 <b>1,848.42</b>
	F200 w/nozzle-Nelson	full	7-0280	56.0 <b>3,022.00</b>
	SR100 w/nozzle-Nelson	part	7-0295	26.5 <b>1,371.93</b>
	SR150 w/nozzle-Nelson	part	7-0250	49.0 <b>2,285.42</b>
	SR200 w/nozzle-Nelson	part	7-0290	78.0 <b>4,244.00</b>



Nelson SR100



Nelson SR150



Nelson SR200

\* Includes one nozzle on all guns.  
 \* Includes flg x fpt adapter on 150 & 200 guns.

## 100 TAPER BORE NOZZLE — 24° TRAJECTORY

PSI	0.5"		0.55"		0.6"		0.65"		0.7"		0.75"		0.8"		0.85"		0.9"		1.0"	
	GPM	DIAM. FT.	GPM	DIAM. FT.	GPM	DIAM. FT.	GPM	DIAM. FT.	GPM	DIAM. FT.	GPM	DIAM. FT.	GPM	DIAM. FT.	GPM	DIAM. FT.	GPM	DIAM. FT.	GPM	DIAM. FT.
40	47	191	57	202	66	213	78	222	91	230	103	240	118	250	134	256	152	262	—	—
50	50	205	64	215	74	225	87	235	100	245	115	256	130	265	150	273	165	280	204	300
60	55	215	69	227	81	240	96	250	110	260	126	270	143	280	164	288	182	295	224	316
70	60	225	75	238	88	250	103	263	120	275	136	283	155	295	177	302	197	310	243	338
80	64	235	79	248	94	260	110	273	128	285	146	295	165	305	189	314	210	325	258	354
90	68	245	83	258	100	270	117	283	135	295	155	306	175	315	201	326	223	335	274	362
100	72	255	87	268	106	280	123	293	143	305	163	316	185	325	212	336	235	345	289	372
110	76	265	92	278	111	290	129	303	150	315	171	324	195	335	222	344	247	355	304	380

## 150 TAPER BORE NOZZLE — 24° TRAJECTORY

PSI	0.7"		0.8"		0.9"		1.0"		1.1"		1.2"		1.3"		1.4"	
	GPM	DIAM. FT.	GPM	DIAM. FT.	GPM	DIAM. FT.	GPM	DIAM. FT.	GPM	DIAM. FT.	GPM	DIAM. FT.	GPM	DIAM. FT.	GPM	DIAM. FT.
50	100	250	130	270	165	290	205	310	255	330	300	345	350	360	408	373
60	110	265	143	285	182	305	225	325	275	345	330	365	385	380	446	396
70	120	280	155	300	197	320	245	340	295	360	355	380	415	395	483	412
80	128	290	165	310	210	335	260	355	315	375	380	395	445	410	516	427
90	135	300	175	320	223	345	275	365	335	390	405	410	475	425	547	442
100	143	310	185	330	235	355	290	375	355	400	425	420	500	440	577	458
110	150	320	195	340	247	365	305	385	370	410	445	430	525	450	605	471
120	157	330	204	350	258	375	320	395	385	420	465	440	545	460	632	481

## 200 TAPER BORE NOZZLE — 27° TRAJECTORY

PSI	1.05"		1.1"		1.2"		1.3"		1.4"		1.5"		1.6"		1.75"		1.9"	
	GPM	DIAM. FT.	GPM	DIAM. FT.	GPM	DIAM. FT.	GPM	DIAM. FT.	GPM	DIAM. FT.	GPM	DIAM. FT.	GPM	DIAM. FT.	GPM	DIAM. FT.	GPM	DIAM. FT.
60	250	345	285	355	330	375	385	390	445	410	515	430	585	445	695	470	825	495
70	270	360	310	380	355	395	415	410	480	430	555	450	630	465	755	495	890	515
80	290	375	330	395	380	410	445	430	515	450	590	470	675	485	805	515	950	535
90	310	390	350	410	405	425	475	445	545	465	625	485	715	505	855	535	1005	555
100	325	400	370	420	425	440	500	460	575	480	660	500	755	520	900	550	1060	575
110	340	410	390	430	445	450	525	470	605	495	695	515	790	535	945	565	1110	590
120	355	420	405	440	465	460	545	480	630	505	725	530	825	550	985	580	1160	605
130	370	425	425	445	485	465	565	485	655	515	755	540	860	560	1025	590	1210	620





Product	Description	Part Number	Weight	List Price
---------	-------------	-------------	--------	------------

## SMALL SPRINKLERS

### SIME

Funny	1" FPT	9-7717	-	76.00
K-1	1-1/4" FPT	9-7718	-	125.00
Hidra	1-1/2" FPT	9-7719	-	229.00



Funny Sprinkler

<b>FUNNY (28° Trajectory) 1" FNPT</b>									
PSI	Nozzle 5mm (.20")		Nozzle 6mm (.24")		Nozzle 7mm (.28")		Nozzle 9mm (.35")		Diameter
	GPM	Diameter	GPM	Diameter	GPM	Diameter	GPM	Diameter	
22	5.3	84	7	86	10	92	16.4	100	
29	6	92	8.5	96	11	100	19	108	
44	7	100	10	108	14	112	23	122	
58	9	108	12	116	16	122	26	128	



K-1 Sprinkler

<b>K1 (30° Trajectory) 1.25" FNPT Connection</b>									
PSI	Nozzle 8mm (.315")		Nozzle 9mm (.354")		Nozzle 10mm (.394")		Nozzle 12mm (.472")		Diameter
	GPM	Diameter	GPM	Diameter	GPM	Diameter	GPM	Diameter	
22	13	102	16	108	20	112	29	112	
29	15	112	19	114	23	118	34	124	
44	18	124	23	128	28	134	41	136	
58	21	134	26	138	33	144	47	154	



Hidra Sprinkler

<b>HIDRA (25° Trajectory) 1.5" FNPT Connection</b>									
PSI	Nozzle 12mm (.47")		Nozzle 14mm (.55")		Nozzle 16mm (.63")		Nozzle 18mm (.71")		Diameter
	GPM	Diameter	GPM	Diameter	GPM	Diameter	GPM	Diameter	
29	40	130	52	138	65	144	-	-	
44	48	156	63	164	80	170	100	184	
58	56	176	73	190	93	196	115	202	
73	62	196	81	202	103	216	128	224	
88	-	-	-	-	-	-	140	236	

## SMALL SPRINKLERS



### KOMET

#163	1-1/2" FPT	9-7826	-	325.00
------	------------	--------	---	--------



Noz PSI	Tabor Bore Nozzle									
	NOZZLE .31" 8 MM		NOZZLE .39" 10 MM		NOZZLE .47" 12 MM		NOZZLE .55" 14 MM		NOZZLE .63" 16 MM	
	GPM	DIA	GPM	DIA	GPM	DIA	GPM	DIA	GPM	DIA
40	26	141	35	154	47	167	61	175	77	182
50	29	151	39	165	53	179	68	188	86	197
60	32	159	43	177	58	190	75	200	94	210
70	34	165	46	185	62	198	81	208	101	218
80	36	173	50	193	67	208	87	216	109	224

# NOZZLES & PRESS REGULATORS

Product	Description	Part Number	Weight	List Price	
<b>NOZZLE</b> (FOR 3/4" SPRINKLER)  <p>Order vane separately.</p> 	Range 1/8"	.125	7-0360	-	1.70
	Range - 9/64"	.140625	7-0330	-	1.70
	Range - 5/32"	.15625	7-0331	-	1.70
	Range - 11/64"	.171875	7-0332	-	1.70
	Range - 3/16"	.1875	7-0333	-	1.70
	Range - 13/64"	.203125	7-0334	-	1.70
	Range - 7/32"	.21875	7-0335	-	1.70
	Range - 15/64"	.234375	7-0336	-	1.70
	Range - 1/4"	.25	7-0337	-	1.70
	Range - 17/64"	.265625	7-0338	-	1.70
	Range - 9/32"	.28125	7-0339	-	1.70
	Back Plug		7-0342	-	0.98
	Spreader - 7° - 3/32"	.09375	9-7804	-	1.34
	Spreader - 7° - 7/64"	.109375	9-7805	-	1.34
	Spreader - 7° - 1/8"	.125	9-7806	-	1.34
	Spreader - 7° - 9/64"	.140625	9-7807	-	1.34
	Spreader - 7° - 5/32"	.15625	9-7808	-	1.34
	Spreader - 7° - 11/64"	.171875	9-7809	-	1.34
	Spreader - 7° - 3/16"	.1875	9-7810	-	1.34
	Spreader - 7° - 13/64"	.20313	9-7812	-	1.34
	Spreader - 7° - 7/32"	.21875	9-7811	-	1.34
	Spreader - 20° - 3/32"	.09375	7-0340	-	1.70
	Spreader - 20° - 7/64"	.109375	7-0366	-	1.41
Spreader - 20° - 1/8"	.125	7-0341	-	1.70	
Spreader - 20° - 9/64"	.140625	7-0362	-	1.41	
Spreader - 20° - 5/32"	.15625	7-0361	-	1.41	
Spreader - 20° - 11/64"	.171875	7-0364	-	1.41	
Spreader - 20° - 3/16"	.1875	7-0365	-	1.41	
Spreader - 20° - 13/64"	.20313	9-7813	-	1.34	
Spreader - 20° - 7/32"	.21875	7-0363	-	1.41	
Vanes for #30 (push-in)		6-9692	-	0.60	

<b>NOZZLE</b> (FOR 1" SPRINKLER) 	Brass:	Range - 7/32"	.21875	7-0343	-	7.49
		Range - 1/4"	.25	7-0344	-	7.49
		Range - 9/32"	.28125	7-0345	-	7.49
		Range - 5/16"	.3125	7-0346	-	7.49
		Range - 11/32"	.34375	7-0347	-	7.49
		Range - 3/8"	.375	7-0348	-	7.49
		Range - 13/32"	.40625	7-0349	-	7.49

\*Above for Rainbird #65 & #70

Plastic:	Range - #14 - 7/32"	.21875	7-0350	-	2.05
	Range - #16 - 1/4"	.25	7-0351	-	2.05
	Range - #18 - 9/32"	.28125	7-0352	-	2.05
	Range - #20 - 5/16"	.3125	7-0353	-	2.05
	Range - #22 - 11/32"	.34375	7-0354	-	2.05
	Range - #24 - 3/8"	.3375	7-0355	-	2.05

\*Above for Senninger #7025

<b>BEARING ASSEMBLY</b> (FOR #30 RAINBIRD)			7-0356	-	10.80
---	--	--	--------	---	-------



Gun Stands/Sprinklers

# RIVER GEAR DRIVE SPRINKLERS



Product	Description	Part Number	Weight	List Price
<b>RIVER (P-190)</b>	River w/nozzle	part 7-0325	10.4	<b>395.00</b>



1 1/2" FPT base  
Includes 3 nozzles  
120' - 228' Diameter

River 190 28 Degree				
Nozzle Diameter		Pressure	Diameter	Discharge
Inch	MM	PSI	Feet	GPM
0.4	10	29	120	23
		37	132	26
		44	136	28
		56	150	33
0.47	12	37	136	38
		44	144	41
		51	156	44
		56	170	47
0.55	14	37	136	51
		44	150	56
		51	164	61
		66	176	68
0.63	16	44	164	73
		51	176	79
		56	188	84
		70	204	94
0.71	18	44	164	92
		56	204	107
		70	216	119
		85	228	131

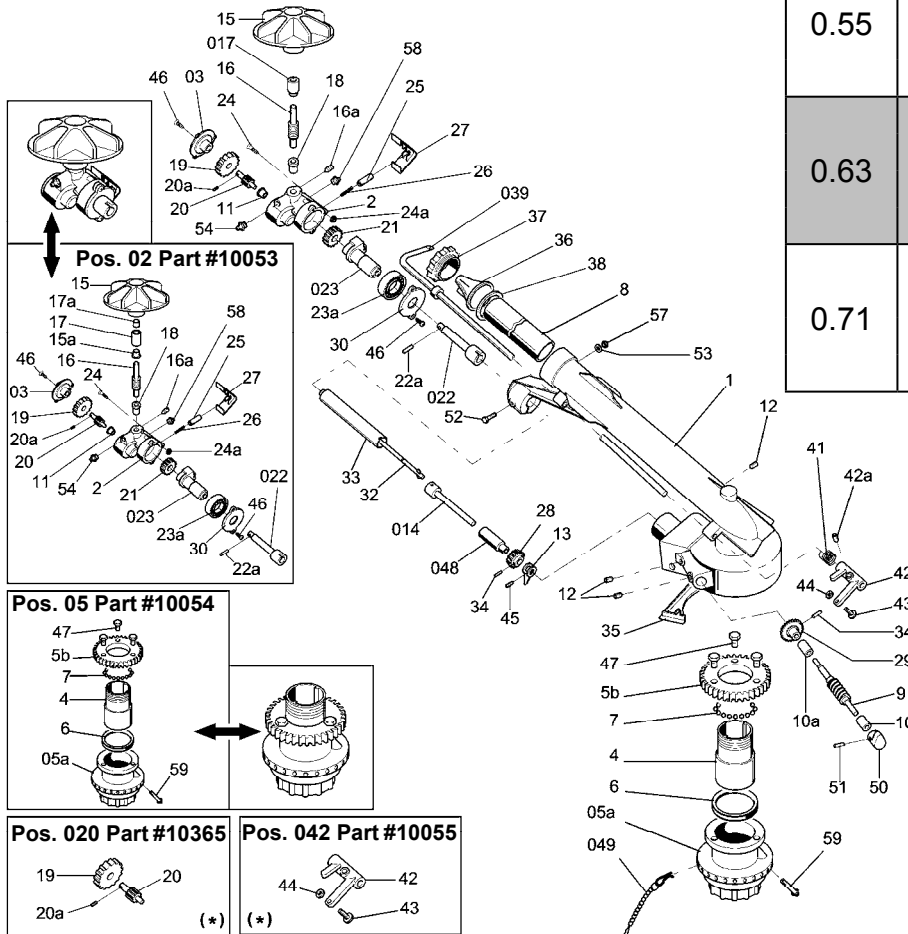

Gear-driven sprinklers are ideal for use on delicate seeds and plants or on heavy soils where light, gentle applications are required. Smooth running, continuous rotation makes these ideal for use on tripods, travelers or as an end sprinkler on pivots. All nozzles come complete with 22° and 28° trajectory nozzles. Companion flanges included.

- Advantages of "Sime" green Italian gear-driven volume sprinklers
- Smooth, continuous rotation with superior stream break-up and less vibration compared to impact driven guns.
  - Gentle sweeps are ideal for tender crops such as carrots, spinach, green beans, etc.
  - Give better coverage due to their rapid rotation (average 90 seconds).
  - Will run in lower temperatures without freezing.
  - Includes flip nozzles allowing one gun to have 22 & 28 degree capabilities.
  - Full & part-circle arc adjustments require no tools.
  - Priced lower than impact-driven volume guns.
  - Optional 25° nozzle available.

# RIVER GEAR DRIVE SPRINKLERS

## River

Pos #	Part #	Description	List Price
1	30168	Sprinkler Body	153.10
2	30169	Gearbox	40.30
02	10053	Whole Head	310.60
02am	10169	Complete American Gearbox	446.20
03	10378	Cover w/ Bearing	11.40
4	30172	Internal Body	46.60
05	10054	Complete Crown	192.50
05a	10380	Crown	78.80
5b	30175	Toothed Ring	36.30
6	30176	U-Packing	8.30
7	30177	Sphere (Requires 36)	0.40
8	30178	Rectifier	12.90
9	30620	Worm Carter	29.93
10	30180	External Body Bearing	7.50
10a	30181	Internal Body Bearing	5.60
11	30182	Pinion Bearing	4.80
12	30183	Grub Screw	1.60
13	30184	Inversion Lever	9.50
014	10084-S	Complete Shaft	17.00
15	30186	Propeller	26.30
15a	30677	Du-Bearing For Gearbox	8.00
16	30628	Endless Screw	35.00
16a	30187	Grub Screw	1.60
017	10293	Bearing House	26.30
17a	30189	Du Bearing	10.50
18	30190	Blind Bearing	12.60
19	30191	Toothed Wheel	22.90
20	30192	Gearbox Pinion	11.20
020	10365-S	Complete Pinion	35.00
20a	30193	Pin For Pinion	1.00
21	30109	Gearbox Gear	16.00
22	30195	Gearbox Shaft	13.20
022	10459	Pin Head	Call
22a	30196	Elastic Pin	1.00
023	10411	Gearbox Support	30.60
23a	30198	Ball Bearing	20.20
24	30199	Screw	0.80

Pos #	Part #	Description	List Price
25	30201	Spring House	5.10
26	30203	Inversion Spring	1.80
27	30204	Cover	2.80
28	30205	Gear Z11	15.75
29	30206	Gear Z14	9.50
30	30207	Cover	6.90
32	20031	Shafting Bar	10.10
33	20032	Shafting Bar Cover	8.10
34	30208	Elastic Pin	1.00
35	30209	Inversion Lever Cover	4.80
36	30210-10	Nozzle 10Mm (.0040"), River	10.50
36	30210-12	Nozzle 12Mm (.0047"), River	10.50
36	30210-14	Nozzle 14Mm (.0055"), River	10.50
36	30210-16	Nozzle 16Mm (.0063"), River	10.50
36	30210-18	Nozzle 18Mm (.0071"), River	10.50
36a	3010451	Rubber Nozzle	Call
37	30211	Nozzle Lock Ring	7.10
38	30567	Packing For Nozzle	1.60
039	10091-S	Complete Jet-Breaker	14.00
41	30214	Spring For Lever	4.00
42	30215	Stream Breaker Lever	9.30
042	10055	Complete Stream Breaker Lever	19.70
42a	30216	Grub Screw	1.00
43	30217	Screw For Lever	8.00
44	30218	Nut	3.20
45	30219	Grub Screw	1.60
46	30220	Screw	1.00
47	30221	Crown Screws 6x12	0.80
048	10398-S	Shaft Bearing	11.00
48a	30223	Washer	1.60
049	10087-S	Inversion Cotter Pin	10.90
50	30227	Cam	3.20
51	30228	Elastic Pin	0.40
52	30229	Screw	2.40
53	30230	Washer	0.40
54	30231	Grease Nipple	1.80
57	30232	Nut	0.40

Gun Stands/Sprinklers

# SKIPPER GEAR DRIVE SPRINKLERS



Product	Description	Part Number	Weight	List Price
<b>SKIPPER (P-191)</b>	Skipper w/nozzle high speed	part 7-0303	9.4 -	<b>410.00</b>
	Skipper Tool (to open gear box)	6-9582		<b>32.00</b>



1 1/2" FPT  
Includes 3 nozzles.  
144' - 268' Diameter

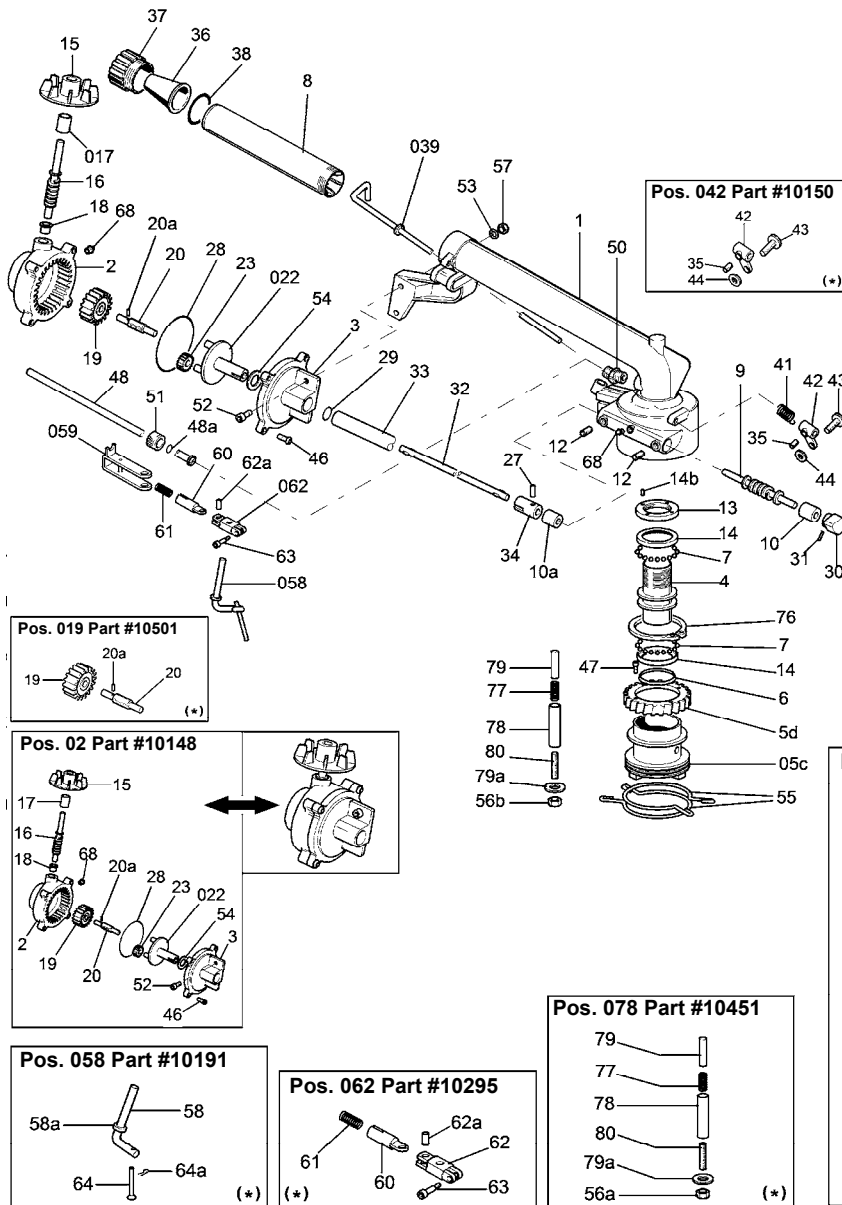

Skipper 191 28 Degree				
Nozzle Diameter		Pressure	Diameter	Discharge
Inch	MM	PSI	Feet	GPM
0.4	10	29	120	23
		37	132	26
		44	136	28
		56	150	33
0.47	12	29	144	42
		44	164	51
		56	184	59
		70	202	66
0.55	14	29	156	51
		44	176	66
		56	196	76
		70	216	86
0.63	16	29	170	68
		44	190	83
		56	208	96
		70	228	107
0.71	18	29	182	54
		44	202	106
		56	222	124
		70	242	137
0.78	20	29	196	93
		44	216	106
		56	242	124
		70	268	163
0.86	22	44	236	161
		51	254	186
		56	274	209
0.94	24	44	248	167
		51	262	193
		56	282	215

Deduct 2% for 25 deg and 5% for 22 deg nozzles.

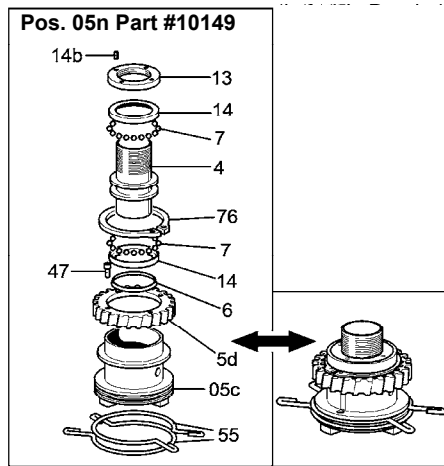

# SKIPPER GEAR DRIVE SPRINKLERS

**Skipper**

Pos #	Part #	Description	List Price
01	10402-S	Sprinkler Body	179.40
2	30737	Gearbox	40.30
02	10148-S	Complete Gearbox	279.90
02am	10170	Complete Head (Fast Rotation)	285.08
3	30738	Gearbox Cover	17.50
4	30739	Internal Body	43.30
05c	10473	Crown (New)	Call
5d	3010377	Ring Crown	43.00
5e-aus	3010489	Crown	Call
05e-aus	10461	Full Crown	Call
05n	10149-S	Complete Mounted Crown	Call
6	30743	J-Packing	8.30
7	30077	Sphere (Requires 22)	1.00
8	30178	Rectifier	12.90
9	30745	Body Endless Screw	38.00
10	30746	External Bearing	6.30
10a	30747	Internal Bearing	12.00
10b	30832	Bushing	6.30
11	30748	Pinion Bearing	4.80
12	30183	Grub Screw	1.60
13	20108	Threaded Ring For Crown	20.00
14	20109	Ball Bearing Ring	16.00
14b	30752	Grub Screw	1.00
15	30753	Propeller	23.60
15a	30831	Endless Screw	35.00
16	30628	Endless Screw	35.00
16a	30187	Grub Screw	1.60
017	10293	Bearing House	26.30
18	30190	Blind Bearing	12.60
19	3010533	Crown	Call
019	10501	Complete Pinion	Call
19a	30833	Crown	20.60
20	30755	Gearbox Pinion	11.50
20a	30193	Pin For Pinion	1.00
022	10255	Planetary Slow	30.30
022a	10256	Pad	22.05
23	30758	Slow Speed Gear	4.00
23a	30835	High Speed Gear	8.00
24	30836	High Speed Pinion	19.70
28	30613	O-Ring 2237	2.50
29	30678	O-Ring 121	1.00
30	30227	Cam	3.20
31	30228	Elastic Pin	0.40
32	20107	Shafting Bar	12.00
33	20162	Shafting Bar Cover	9.30
34	30185	Cap	7.88
35	30216	Grub Screw	1.00
36	30566-10	Nozzle, Standard 25°, 10mm (.0040")	11.50
36	30566-12	Nozzle, Standard 25°, 12mm (.0047")	11.50
36	30566-14	Nozzle, Standard 25°, 14mm (.0055")	11.50
36	30566-16	Nozzle, Standard 25°, 16mm (.0063")	11.50
36	30566-18	Nozzle, Standard 25°, 18mm (.0071")	11.50
36	30566-20	Nozzle, Standard 25°, 20mm (.0078")	11.50
36	30566-22	Nozzle, Standard 25°, 22mm (.0086")	11.50

Pos #	Part #	Description	List Price
36	30566-24	Nozzle, Standard 25°, 24mm (.0094")	11.50
36i	3010354-10	Nozzle, Flip 22°/28°, 10mm (.0040")	12.70
36i	3010354-12	Nozzle, Flip 22°/28°, 12mm (.0047")	12.70
36i	3010354-14	Nozzle, Flip 22°/28°, 14mm (.0055")	12.70
36i	3010354-16	Nozzle, Flip 22°/28°, 16mm (.0063")	12.70
36i	3010354-18	Nozzle, Flip 22°/28°, 18mm (.0071")	12.70
36i	3010354-20	Nozzle, Flip 22°/28°, 20mm (.0078")	12.70
36i	3010354-22	Nozzle, Flip 22°/28°, 22mm (.0086")	12.70
36i	3010354-24	Nozzle, Flip 22°/28°, 24mm (.0094")	12.70
36b	3010449	Nozzle	Call
37	30211	Nozzle Lock Ring	7.10
37a	3010443	Ring AU	Call
38	30567	Packing For Nozzle	1.60
039	10183-S	Jet-Breaker	25.00
41	30764	Jet-Breaker Ring	4.80
42	30765	Jet-Breaker Lever	8.80
042	10150	Complete Jet-Breaker Lever	27.00
43	30217	Screw For Lever	8.00
44	30218	Nut	3.20
46	30767	Screw	0.50
47	30768	Screw	0.50
48	20112	Secondary Pipe	26.00
48a	30734	O-Ring D.00 17,6 X 10 X 3,8	1.00
50	30770	Secondary Nozzle	19.80
51	30771	Ferrule	14.50
52	30578	Screw	1.60
53	30772	Washer	1.00
54	30773	Washer	2.50
55	30774	Inversion Ring	22.10
56	30837	Lever Protection	17.33
56a	30838	Sime Part	1.58
56b	30839	Nut M4	1.00
57	30511	Nut	1.60
058	10191-S	Central Shaft	27.80
059	10366	Inversion Fork	38.10
59a	30778	Pin For Fork	1.60
60	30779	Spring House	8.70
61	301093	Inversion Spring	4.00
062	10295	Complete Inversion Lever Clamp	34.80
62a	30782	Pin For Vice	4.00
63	30783	Screw	1.00
64a	30785	Spring For Bolt	1.60
65	30786	Bearing	3.10
66	30677	Du-Bearing For Gearbox	8.00
67	30189	Du Bearing	10.50
68	30233	Grease Nipple	0.90
75	30959	Washer D.00 5	1.60
76	3010378	Seeger	8.30
77	3010379	Spring	2.50
78	3010380	Spacer	2.80
078	10451	Complete Release	Call
79	3010381	Shafting Bar	4.10
79a	3010382	Washer	2.50
80	3010383	Prisoner	6.50

# MERCURY GEAR DRIVE SPRINKLERS



Product	Description	Part Number	Weight	List Price
<b>MERCURY (P-202)</b>	Mercury w/nozzle	part 7-0304	15.1	<b>670.00</b>



\*w/2" FPT base  
Included 3 nozzles.  
146' - 280' Diameter

Mercury 202 28 Degree				
Nozzle Diameter		Pressure	Diameter	Discharge
Inch	MM	PSI	Feet	GPM
0.4	10	29	120	23
		37	132	26
		44	136	28
		56	150	33
0.47	12	29	144	42
		44	164	51
		56	184	59
		70	202	66
0.55	14	29	156	51
		44	176	66
		56	196	76
		70	216	86
0.63	16	29	170	68
		44	190	83
		56	208	96
		70	228	107
0.71	18	44	184	105
		56	200	119
		70	216	130
		85	250	170
0.78	20	44	208	142
		56	228	165
		70	250	180
		85	276	203
0.86	22	44	220	161
		56	238	186
		70	262	209
		85	280	228
0.94	24	44	248	167
		56	262	193
		70	282	215

Deduct 2% for 25 deg and 5% for 22 deg nozzles.

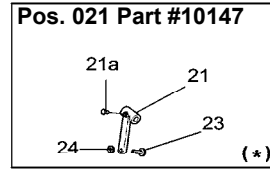
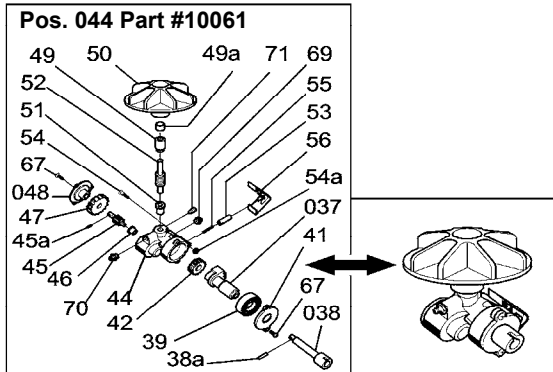
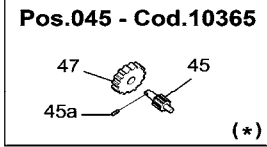
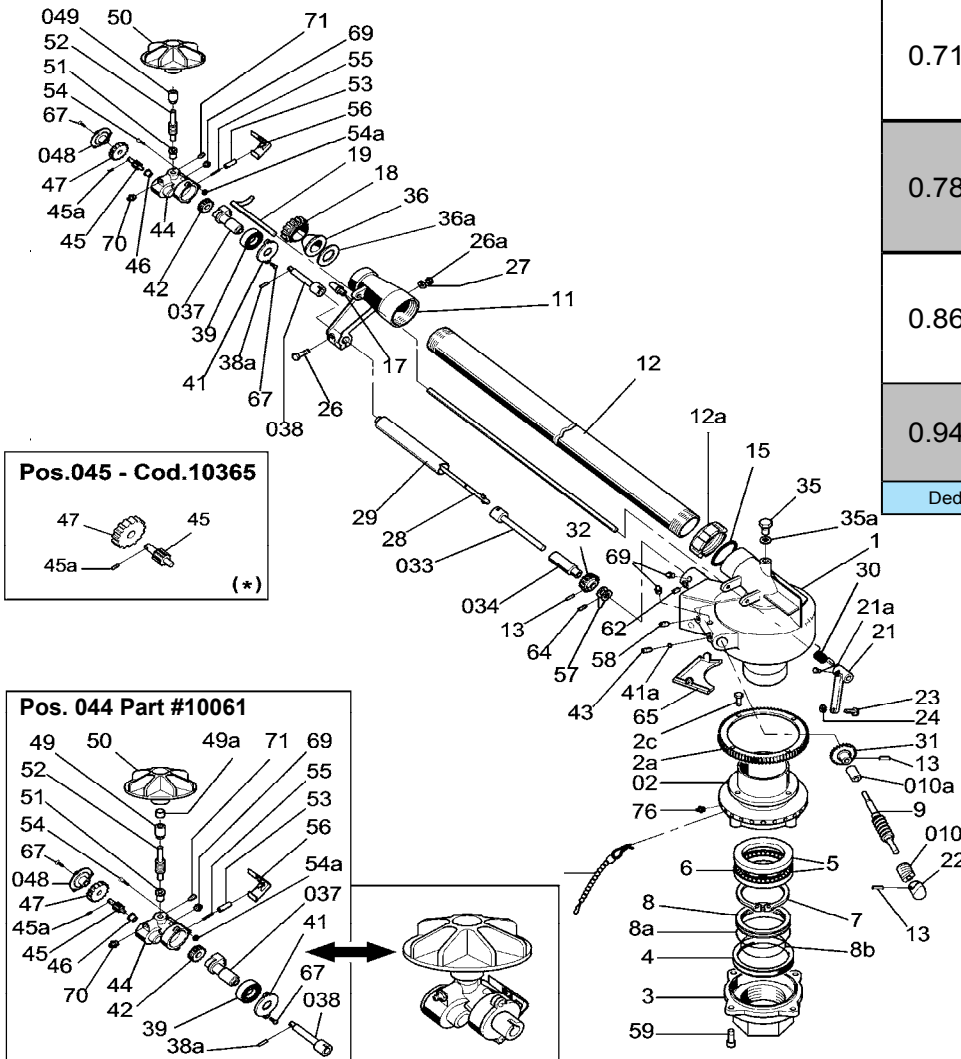

# MERCURY GEAR DRIVE SPRINKLERS

## Mercury

Pos #	Part #	Description	List Price
1	30681	Sprinkler Body	262.50
02	10474-S	Crown Body	Call
2a	30683	Toothed Ring	85.00
2c	30221	Crown Screws 6x12	0.80
3	30684	Body Support	78.80
4	30685	U-Packing	9.00
5	30686	Ball Bearing Ring	26.00
6	30077	Sphere (Requires 30)	1.00
7	30687	Fastener Ring	7.10
8	30688	U-Packing Ring	22.30
8a	30689	External O-Ring	3.10
8b	30690	Internal O-Ring	2.60
9	30691	Endless Screw Body	61.30
9a	30080	Washer	2.00
010	10397	Threaded Bearing	17.00
010a	10395	Internal Bearing	11.00
11	30693	Pipe Head	76.50
12	20098	Principal Pipe	83.10
012	10377-S	Complete Principal Pipe	196.90
12a	30527	Ferrule For Pipe	29.70
13	30208	Elastic Pin	1.00
15	30588	O-Ring	3.20
17	30087	Secondary Nozzle	6.50
18	30211	Nozzle Lock Ring	7.10
19	20096	Jet Breaker Bar	43.70
021	10147	Stream Breaker Lever	56.90
21a	30091	Screw	1.00
22	30871	Camme	11.10
23	30093	Screw For Lever	9.50
24	30094	Nut For Lever	4.80
26	30229	Screw	2.40
26a	30232	Nut	0.40
27	30230	Washer	0.40
28	20097	Shafting Bar	8.90
29	20144	Shafting Bar Cover	8.90
30	30697	Spring For Lever	6.50
31	30098	Lateral Bevel Pinion	33.50
32	30099	Central Bevel Pinion	26.30
033	10083-S	Shaft	24.10
034	10401-S	Shaft Bearing	18.40
34a	30223	Washer	1.60
35	30102	Plug	6.20
35a	30103	Washer	0.40
36	30566-10	Nozzle, Standard 25°, 10mm (.40")	11.50
36	30566-12	Nozzle, Standard 25°, 12mm (.47")	11.50
36	30566-14	Nozzle, Standard 25°, 14mm (.55")	11.50
36	30566-16	Nozzle, Standard 25°, 16mm (.63")	11.50
36	30566-18	Nozzle, Standard 25°, 18mm (.71")	11.50
36	30566-20	Nozzle, Standard 25°, 20mm (.78")	11.50
36	30566-22	Nozzle, Standard 25°, 22mm (.86")	11.50
36	30566-24	Nozzle, Standard 25°, 24mm (.94")	11.50

Pos #	Part #	Description	List Price
36i	3010354-10	Nozzle, Flip 22°/28°, 10mm (.40")	12.70
36i	3010354-12	Nozzle, Flip 22°/28°, 12mm (.47")	12.70
36i	3010354-14	Nozzle, Flip 22°/28°, 14mm (.55")	12.70
36i	3010354-16	Nozzle, Flip 22°/28°, 16mm (.63")	12.70
36i	3010354-18	Nozzle, Flip 22°/28°, 18mm (.71")	12.70
36i	3010354-20	Nozzle, Flip 22°/28°, 20mm (.78")	12.70
36i	3010354-22	Nozzle, Flip 22°/28°, 22mm (.86")	12.70
36i	3010354-24	Nozzle, Flip 22°/28°, 24mm (.94")	12.70
36a	30567	Packing For Nozzle	1.60
36b	3010449	Nozzle	Call
037	10411	Gearbox Support	30.60
38	30106	Gearbox Shaft	17.50
038	10458	Pin Head	Call
38a	30196	Elastic Pin	1.00
39	30198	Ball Bearing	20.20
40	30677	Du-Bearing For Gearbox	8.00
41	30207	Cover	6.90
41a	30108	Plug	4.00
42	30109	Gearbox Gear	16.00
43	30160	Grub Screw	1.60
44	30169	Gearbox	40.30
044	10061	Complete Gearbox	319.30
044am	10168	America Head	322.88
45	30192	Gearbox Pinion	11.20
045	10365-S	Complete Pinion	35.00
45a	30193	Pin For Pinion	1.00
46	30182	Pinion Bearing	4.80
47	30191	Toothed Wheel	22.90
048	10378	Cover w/ Bearing	11.40
049	10293	Bearing House	26.30
49a	30189	Du Bearing	10.50
50	30112	Propeller	26.30
51	30190	Blind Bearing	12.60
52	30628	Endless Screw	35.00
53	30201	Spring House	5.10
54	30199	Screw	0.80
54a	30200	Nut	0.40
55	30113	Inversion Spring	2.00
56	30204	Cover	2.80
57	30184	Inversion Lever	9.50
58, 62	30118	Grub Screw	1.60
59	30559	Screw	1.80
60	30699	Ring	5.20
061	10087-S	Inversion Cotter Pin	10.90
64	30219	Grub Screw	1.60
65	30120	Inversion Lever Cover	6.50
67	30220	Screw	1.00
69	30233	Grease Nipple	0.90
70	30231	Grease Nipple	1.80
71	30187	Grub Screw	1.60
76	30234	Grease Nipple	4.00



# BIG RIVER GEAR DRIVE SPRINKLERS



Product	Description	Part Number	Weight	List Price
<b>BIG RIVER (P-250)</b>	Big River w/nozzle-Green			<b>DISCONTINUED</b>

\*Companion flange included.



72 & 116mm flange base (companion flange included.)  
238' - 354' Diameter

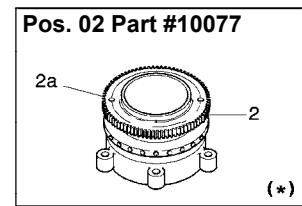
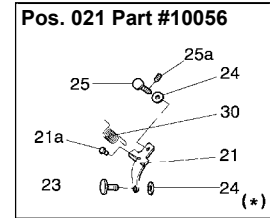
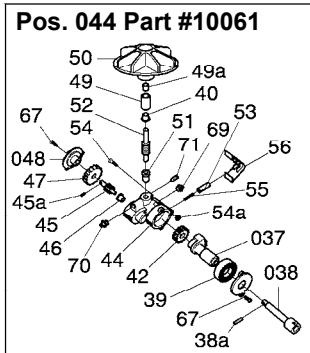
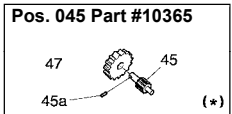
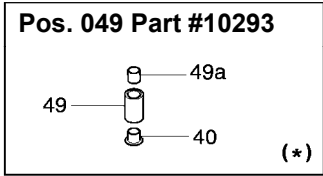
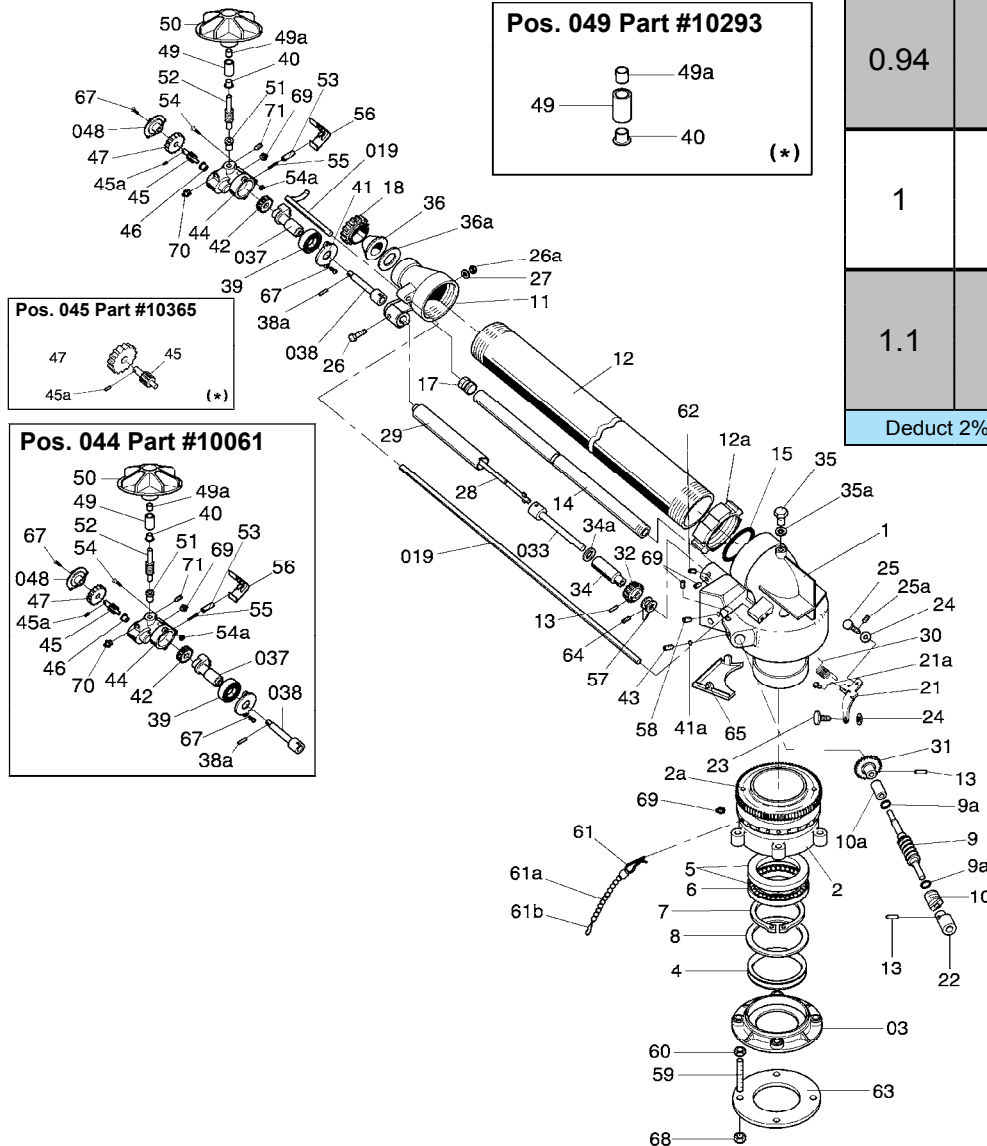

Big River 250 28 Degree				
Nozzle Diameter		Pressure	Diameter	Discharge
Inch	MM	PSI	Feet	GPM
0.71	18	44	196	119
		56	214	139
		70	230	124
		85	250	170
0.78	20	44	238	137
		56	264	159
		70	282	178
		85	300	194
0.86	22	56	268	186
		66	282	197
		70	294	208
		85	314	228
0.94	24	56	282	217
		66	294	230
		70	308	243
		85	328	266
1	26	56	294	250
		70	314	380
		85	338	307
		100	346	330
1.1	28	56	302	286
		70	320	319
		85	340	350
		100	354	378

Deduct 2% for 25 deg and 5% for 22 deg nozzles.

# BIG RIVER GEAR DRIVE SPRINKLERS

## Big River

Pos #	Part #	Description	List Price
1	30070	Sprinkler Body	382.70
02	10077-S	Crown	192.50
03	10080-S	Body Support	113.70
4	30075	U-Packing 90X76X8	13.60
5	30076	Ball Bearing Ring	34.00
6	30077	Sphere (Requires 43)	1.00
7	30078	Fastener Ring D. 78	10.00
8	30079	U-Packing Ring	10.00
9	30597	Worm Carter	61.43
9a	30080	Washer	2.00
010	10395	Internal Bearing	11.00
010	10394	Threaded Bearing	17.00
11	30083	Pipe Head	119.90
12	20022	Principal Pipe	105.00
012	10376	Complete Principal Pipe	258.10
12a	30084	Ferrule For Pipe	44.90
13	30208	Elastic Pin	1.00
14	20094	Secondary Pipe	28.40
15	30085	O-Ring For Pipe	3.50
16	30086	Elastic Pin	1.10
17	30125	Secondary Nozzle	7.10
18	30056	Nozzle Lock Ring	31.50
019	10090-S	Jet Breaker Bar	65.00
20	30181	Internal Body Bearing	5.60
021	10056	Stream Breaker Lever	67.80
21a	30091	Screw	1.00
22	30092	Camme	13.50
23	30093	Screw For Lever	9.50
24	30094	Nut For Lever	4.80
25	30095	Lever Upper Screw	9.50
25a	30096	Elastic Pin	0.50
26	30229	Screw	2.40
26a	30232	Nut	0.40
27	30230	Washer	0.40
28	20024	Shafting Bar	14.50
29	20025-S	Shafting Bar Cover	13.20
30	30059	Spring For Lever	6.50
31	30098	Lateral Bevel Pinion	33.50
32	30099	Central Bevel Pinion	26.30
033	10083-S	Shaft	24.10
034	10401-S	Shaft Bearing	18
34a	30223	Washer	1.60
35	30102	Plug	6.20
35a	30103	Washer	0.40
36	30063-18	Nozzle, Standard 25°, 18mm (.71)	11.50
36	30063-20	Nozzle, Standard 25°, 20mm (.78")	11.50
36	30063-22	Nozzle, Standard 25°, 22mm (.86")	11.50
36	30063-24	Nozzle, Standard 25°, 24mm (.94")	11.50
36	30063-26	Nozzle, Standard 25°, 26mm (1")	11.50
36	30063-28	Nozzle, Standard 25°, 28mm (1.10")	11.50
36	30063-30	Nozzle, Standard 25°, 30mm (1.2")	11.50

Pos #	Part #	Description	List Price
36i	3010448-18	Nozzle, Flip 22°/28°, 18mm (.71")	12.70
36i	3010448-20	Nozzle, Flip 22°/28°, 20mm (.78")	12.70
36i	3010448-22	Nozzle, Flip 22°/28°, 22mm (.86")	12.70
36i	3010448-24	Nozzle, Flip 22°/28°, 24mm (.94")	12.70
36i	3010448-26	Nozzle, Flip 22°/28° 26mm (1")	12.70
36i	3010448-28	Nozzle, Flip 22°/28°, 28mm (1.10")	12.70
36i	3010448-30	Nozzle, Flip 22°/28° 30mm (1.2")	12.70
36a	30064	Packing For Nozzle	2.50
36b	3010450	Rubber Nozzle	Call
037	10411	Gearbox Support	30.60
38	30106	Gearbox Shaft	17.50
038	10458	Pin Head	Call
38a	30196	Elastic Pin	1.00
39	30198	Ball Bearing	20.20
40	30677	Du-Bearing For Gearbox	8.00
41	30207	Cover	6.90
41a	30108	Plug	4.00
42	30109	Gearbox Gear	16.00
43	30110	Grub Screw	1.60
44	30169	Gearbox	40.30
044	10061	Complete Gearbox	319.30
044am	10168	America Head	322.88
45	30192	Gearbox Pinion	11.20
045	10365-S	Complete Pinion	35.00
45a	30193	Pin For Pinion	1.00
46	30182	Pinion Bearing	4.80
47	30191	Toothed Wheel	22.90
048	10378	Cover w/ Bearing	11.40
049	10293	Bearing House	26.30
49a	30189	Du Bearing	10.50
50	30112	Propeller	26.30
51	30190	Blind Bearing	12.60
52	30628	Endless Screw	35.00
53	30201	Spring House	5.10
54	30199	Screw	0.80
54a	30200	Nut	0.40
55	30113	Inversion Spring	2.00
56	30204	Cover	2.80
57	30184	Inversion Lever	9.50
58	30114	Grub Screw	1.60
59	30115	Stud Bolt	3.20
60	30116	Nut M 10X6	1.00
061	10087-S	Inversion Cotter Pin	10.90
62	30118	Grub Screw	1.60
63	30119	Body Support Packing	7.90
64	30219	Grub Screw	1.60
65	30120	Inversion Lever Cover	6.50
67	30220	Screw	1.00
68	30121	Nut M10X10	1.00
69, 76	30233	Grease Nipple	0.90
70	30231	Grease Nipple	1.80
71	30187	Grub Screw	1.60

# MARINER GEAR DRIVE SPRINKLERS



Product	Description	Part Number	Weight	List Price
<b>MARINER (P-401)</b>	Mariner w/nozzle-Green high speed part	7-0306	25.3	<b>1,075.00</b>



w/2 1/2" FPT base  
Includes 3 nozzles.  
274' - 440' Diameter  
One Speed (Two speed also available.)

Mariner 401 28 Degree				
Nozzle Diameter		Pressure	Diameter	Discharge
Inch	MM	PSI	Feet	GPM
1	26	44	274	173
		56	308	211
		70	336	244
		85	354	273
1.1	28	44	294	242
		56	320	280
		70	340	313
		85	362	343
1.2	30	56	382	319
		70	354	356
		85	374	390
		100	398	421
1.25	32	56	340	359
		70	368	402
		85	384	440
		100	404	475
1.35	34	70	374	451
		85	398	494
		100	420	533
		115	440	571

Deduct 2% for 25 deg and 5% for 22 deg nozzles.

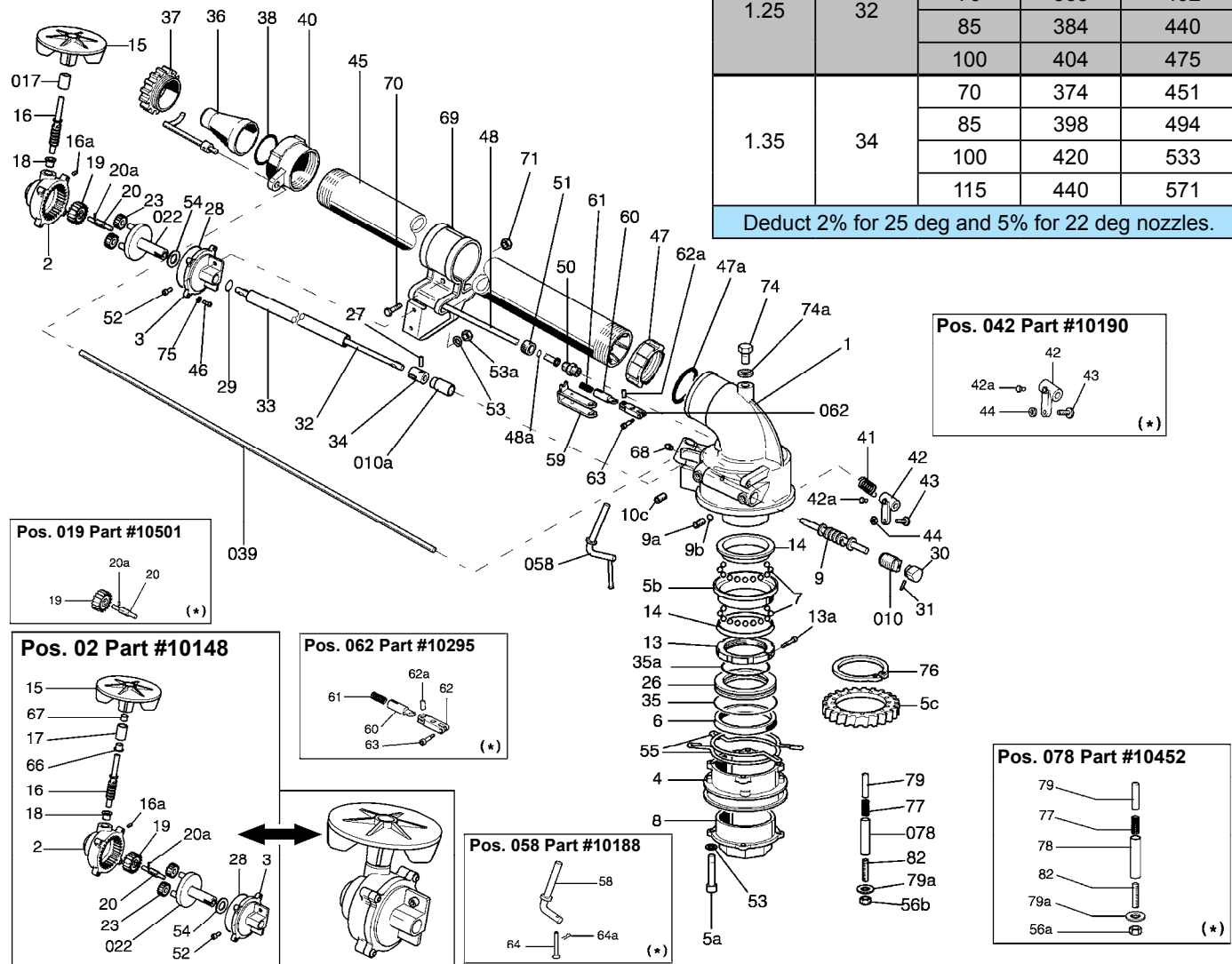

# MARINER GEAR DRIVE SPRINKLERS

## Mariner

Pos #	Part #	Description	List Price
01	10403-S	Sprinkler Body	437.40
2	30737	Gearbox	40.30
02	10148-S	Complete Gearbox	279.90
02am	10170	Complete Head	285.08
3	30738	Gearbox Cover	17.50
4	30862	Body Support	102.80
5	30863	Crown	118.50
5a	30945	Screw	4.00
5b	3010385	Ring Body Support	52.00
5c	3010363	Ring	80.10
6	30864	U-Packing Crown	13.20
7	30048	Sphere (Requires 52)	0.80
8	30865	Threaded Body Support	95.80
9	30866	Endless Screw	70.70
9a	30160	Grub Screw	1.60
9b	30108	Plug	4.00
010	10394	Threaded Bearing	17.00
010a	10404-S	Internal Bearing	10.00
10b	30080	Washer	2.00
10c	30114	Grub Screw	1.60
11	30748	Pinion Bearing	4.80
13	30868	Threaded Ring For Crown	40.30
13a	301014	Screw	1.60
14	30869	Ball Bearing Ring	43.70
15	30753	Propeller	23.60
16	30628	Endless Screw	35.00
16a	30187	Grub Screw	1.60
017	10293	Bearing House	26.30
18	30190	Blind Bearing	12.60
19	3010533	Crown	Call
019	10501	Complete Pinion	Call
20	30755	Gearbox Pinion	11.50
20a	30193	Pin For Pinion	1.00
022	10255	Planetary Slow	30.30
23	30758	Slow Speed Gear	4.00
26	30870	O-Ring	21.90
28	30613	O-Ring 2237	2.50
29	30678	O-Ring 121	1.00
30	30695	Cam	11.50
31	30208	Elastic Pin	1.00
32	20142	Shafting Bar	12.00
33	20145	Principal Pipe	12.00
34	30185	Cap	7.88
35	30946	O-Ring 3300	5.60
35a	30947	O-Ring 3262	4.80
36	30063-26	Nozzle, Standard 25°, 26mm (1")	11.50
36	30063-28	Nozzle, Standard 25°, 28mm (1.10")	11.50
36	30063-30	Nozzle, Standard 25°, 30mm (1.2")	11.50
36	30063-32	Nozzle, Standard 25°, 32mm (1.25")	11.50
36	30063-34	Nozzle, Standard 25°, 34mm (1.35")	11.50
37	30056	Nozzle Lock Ring	31.50
38	30064	Packing For Nozzle	2.50
039	10189-S	Jet-Breaker	61.30
40	30874	Pipe-Head	63.00
41	3010444	Jet Breaker Spring Lever	9.50

Pos #	Part #	Description	List Price
43	30093	Screw For Lever	9.50
44	30094	Nut For Lever	4.80
45	20127	Principal Pipe	98.40
46	30767	Screw	0.50
47	30877	Locking Ring For Pipe	38.60
47a	30949	O-Ring 3225	2.50
48	20136	Tube	18.90
48a	30734	O-Ring D. 17,6 X 10 X 3,8	1.00
50	30878	Secondary Nozzle	21.60
51	30771	Ferrule	14.50
52	30578	Screw	1.60
53	30557	Washer Grower D. 6	1.00
53a	30511	Nut	1.60
54	30773	Washer	2.50
55	30879	Inversion Ring	23.30
56	30968	Cover For Lever	19.00
56a	30973	Screw 4X30	1.00
56b	30839	Nut M4	1.00
058	10188	Central Shaft	40.00
059	10366	Inversion Fork	38.10
59a	30778	Pin For Fork	1.60
60	30779	Spring House	8.70
61	301093	Inversion Spring	4.00
062	10295	Complete Inversion Lever Clamp	34.80
62a	30782	Pin For Vice	4.00
63	30783	Screw	1.00
64a	30785	Spring For Bolt	1.60
65	30880	Inversion Lever Bearing	3.50
66	30677	Du-Bearing For Gearbox	8.00
67	30189	Du Bearing	10.50
68	30233	Grease Nipple	0.90
69	30881	Support	78.75
70	30426	Screw 8X25	10.50
71	30475	Nut 8X6	1.00
72	30724	Grub Screw	1.20
73a	30086	Elastic Pin	1.10
74	30102	Plug	6.20
74a	30103	Washer	0.40
75	30959	Washer D. 5	1.60
76	30049	Fastener Ring	13.10
77	3010358	Spring	2.40
78	3010359	Spacer	3.20
078	10452-S	Full Release	Call
79	3010360	Shafting Bar	4.10
79a	3010361	Washer	1.60
80	3010233	Area	Call
81	3010335	Bracket	Call
82	3010362	Prisoner	6.90
083	10110	Nut	Call
86	30447	Ring	Call
87	3010232	Lever	Call
88	20185	Pin	Call
90	20259-S	Roll	Call
93	30902	Lever	Call
95	30513	Screw	Call

Gun Stands/Sprinklers

# POLARIS GEAR DRIVE SPRINKLERS



Product	Description	Part Number	Weight	List Price
<b>POLARIS (P-400)</b>	Polaris			<b>DISCONTINUED</b>



90 & 150mm flange connection (companion flange included)  
302' - 418' Diameter

Polaris 200 28 Degree				
Nozzle Diameter		Pressure	Diameter	Discharge
Inch	MM	PSI	Feet	GPM
1	26	56	302	263
		70	230	295
		85	340	323
		100	362	348
1.1	28	56	314	300
		70	328	324
		85	354	366
		100	380	395
1.2	30	56	320	338
		70	340	378
		85	368	414
		100	384	446
1.25	32	70	362	423
		85	380	464
		100	394	500
		115	404	536
1.35	34	70	374	472
		85	394	517
		100	404	558
		115	418	598

Deduct 2% for 25 deg and 5% for 22 deg nozzles.

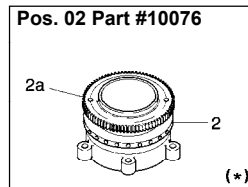
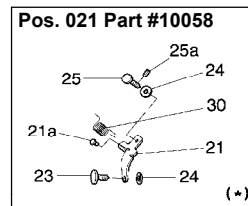
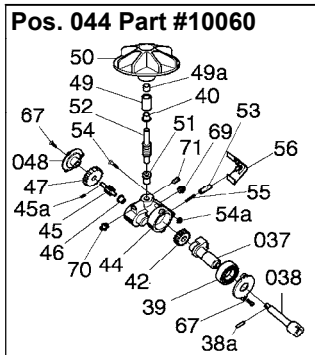
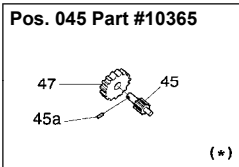
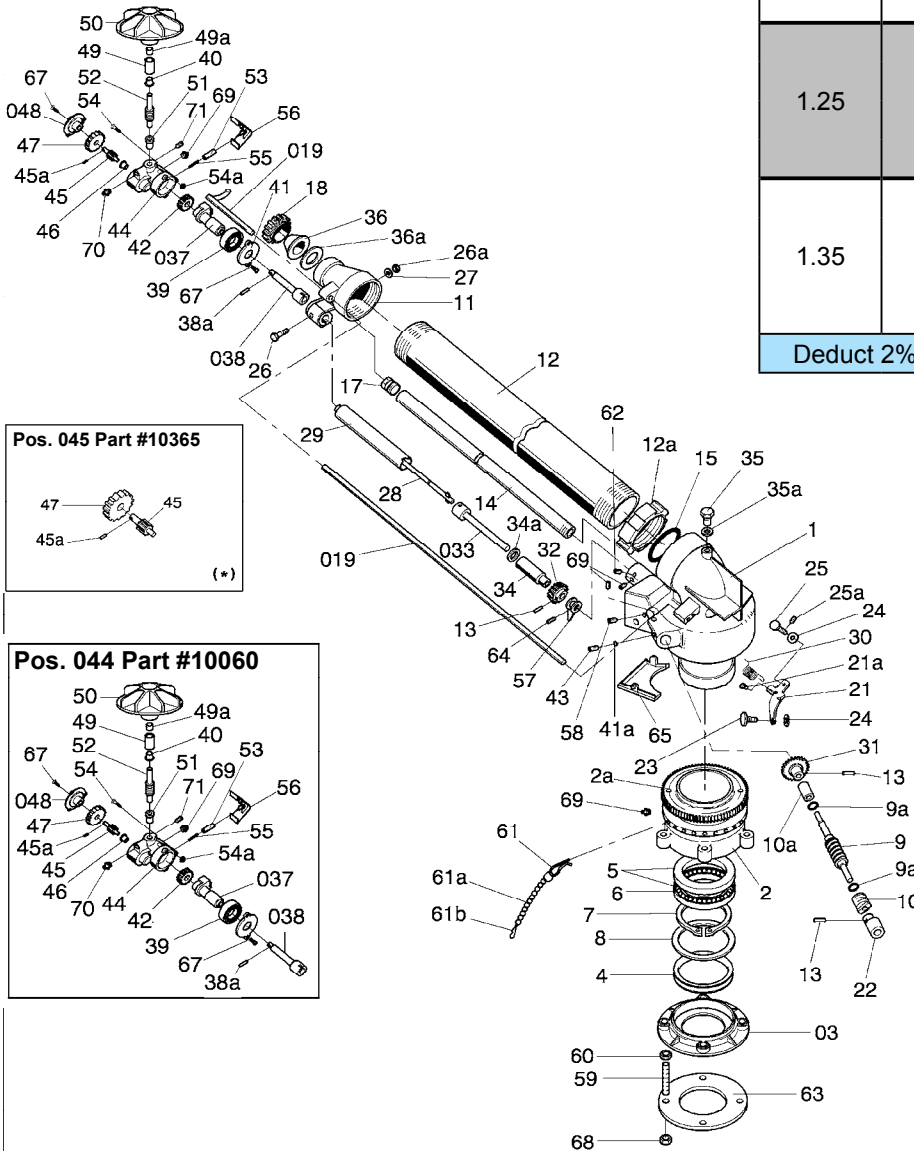

# POLARIS GEAR DRIVE SPRINKLERS

## Polaris

Pos #	Part #	Description	List Price
1	30041-S	Carter	280.00
02	10076	Crown	223.00
03	10079	Body Support	135.60
4	30046	U-Packing 117X98X11	16.20
5	30047	Ball Bearing Ring	39.30
6	30048	Sphere (Requires 36)	0.80
7	30049	Fastener Ring	13.10
8	30050	U-Packing Ring	8.10
9	30596	Endless Screw Body	80.00
9a	30080	Washer	2.00
010	10394	Threaded Bearing	17.00
010a	10396	Internal Bearing	15.00
11	30052	Pipe Head	140.00
12	20013	Principal Pipe	131.20
012	10375-S	Complete Principal Pipe	288.70
12a	30053	Threaded Ring For Pipe	59.10
13, 16	30208	Elastic Pin	1.00
14	20014	Secondary Pipe	35.00
15	30054	O-Ring	7.10
17	30125	Secondary Nozzle	7.10
18	30056	Nozzle Lock Ring	31.50
019	10089-S	Jet Breaker Bar	85.30
20	30057	Stream Breaker Bearing	4.40
021	10058	Stream Breaker Lever	67.80
21a	30091	Screw	1.00
22	30092	Camme	13.50
23	30093	Screw For Lever	9.50
24	30094	Nut For Lever	4.80
25	30095	Lever Upper Screw	9.50
25a	30096	Elastic Pin	0.50
26	30229	Screw	2.40
26a	30232	Nut	0.40
27	30230	Washer	0.40
28	20016	Shafting Bar	15.70
29	20017	Shafting Bar Cover	16.20
30	30059	Spring For Lever	6.50
31	30060	Lateral Bevel Pinion	39.80
32	30061	Central Bevel Pinion	29.10
033	10082	Shaft	28.00
034	10399	Shaft Bearing	21.90
34a	30223	Washer	1.60
35	30102	Plug	6.20
35a	30103	Washer	0.40

Pos #	Part #	Description	List Price
36	30063-32	Nozzle, Standard 25°, 32mm (1.25")	11.50
36	30063-34	Nozzle, Standard 25°, 34mm (1.35")	11.50
36a	30064	Packing For Nozzle	2.50
037	10411	Gearbox Support	30.60
38	30106	Gearbox Shaft	17.50
038	10458	Pin Head	Call
38a	30196	Elastic Pin	1.00
39	30198	Ball Bearing	20.20
40	30677	Du-Bearing For Gearbox	8.00
41	30207	Cover	6.90
41a	30108	Plug	4.00
42	30109	Gearbox Gear	16.00
43	30160	Grub Screw	1.60
44	30169	Gearbox	40.30
044	10060	Complete Gearbox	319.30
044am	10167	Gear	Call
45	30192	Gearbox Pinion	11.20
045	10365-S	Complete Pinion	35.00
45a	30193	Pin For Pinion	1.00
46	30182	Pinion Bearing	4.80
47	30191	Toothed Wheel	22.90
048	10378	Cover w/ Bearing	11.40
049	10293	Bearing House	26.30
49a	30189	Du Bearing	10.50
50	30112	Propeller	26.30
51	30190	Blind Bearing	12.60
52	30628	Endless Screw	35.00
53	30201	Spring House	5.10
54	30199	Screw	0.80
54a	30200	Nut	0.40
55	30066	Inversion Spring	2.10
56	30204	Cover	2.80
57	30184	Inversion Lever	9.50
58, 62	30118	Grub Screw	1.60
59	30115	Stud Bolt	3.20
60	30116	Nut M 10X6	1.00
061	10087-S	Inversion Cotter Pin	10.90
63	30068	Body Support Packing	13.00
64	30219	Grub Screw	1.60
65	30069	Inversion Lever Cover	7.60
67	30220	Screw	1.00
68	30121	Nut M10X10	1.00
69	30233	Grease Nipple	0.90

Gun Stands/Sprinklers

# GEMINI GEAR DRIVE SPRINKLERS



Product	Description	Part Number	Weight	List Price
<b>GEMINI (P-600 / P-1200)</b>	Gemini (2 speed high or low switch) part	7-0307	34.7	<b>1,365.00</b>



100 x 142mm flange connection (companion flange included)  
Includes 3 nozzles.  
368' - 510' Diameter

Gemini 1200 28 Degree				
Nozzle Diameter	Pressure	Diameter	Discharge	
Inch	MM	Feet	GPM	
1.2	30	56	328	319
		70	354	356
		85	374	390
		100	398	421
1.25	32	70	368	424
		85	84	464
		100	404	500
		115	426	536
1.35	34	70	380	472
		85	398	518
		100	420	558
		115	440	598
1.42	36	70	398	525
		85	420	574
		100	440	620
		115	458	664
1.5	38	85	434	635
		100	458	685
		115	472	733
		128	492	777
1.57	40	85	446	698
		100	472	753
		115	488	806
		128	510	855
1.65	42	88	460	717
		95	480	761
		100	500	783
		110	524	809
1.72	44	88	470	700
		95	480	730
		100	490	750
		110	500	810
1.8	46	88	474	825
		95	484	855
		100	494	875
		110	504	905
1.87	48	88	480	910
		95	490	940
		100	500	960
		110	510	995
1.95	50	88	500	925
		95	520	955
		100	540	1075
		110	570	1110

Deduct 2% for 25 deg and 5% for 22 deg nozzles.

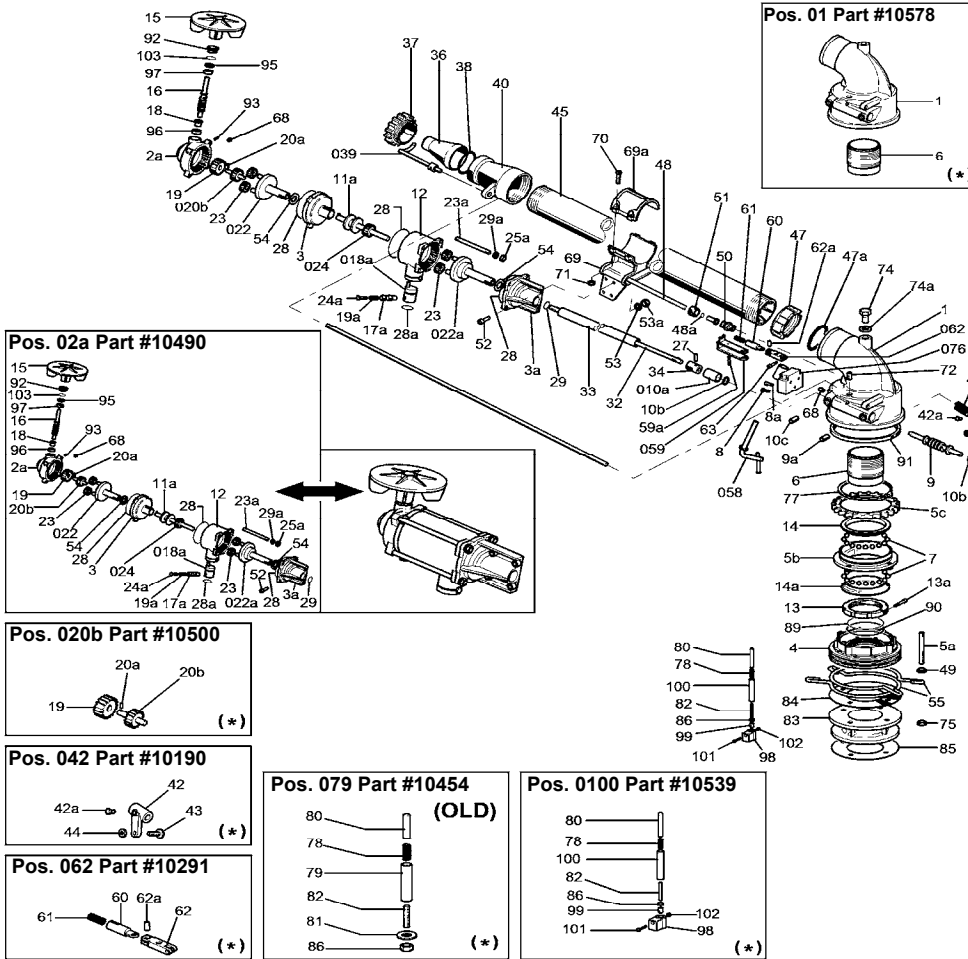



# GEMINI GEAR DRIVE SPRINKLERS

**Gemini**

Pos #	Part #	Description	List Price
1	3010760	Carter	Call
01	10578	Body	Call
2a	3010633	Head	Call
02a	10490	Complete Head	Call
3	301041	Gearbox Cover	23.00
3a	301042	Cover	26.30
4	3010761	Ring	Call
04	10390	Body Support	215.60
5	301045	Crown	301.80
5a	301046	Stud Bolt	9.50
5b	3010365	Ring	65.60
5c	3010366	Ring	63.00
6	20267	Body	Call
6-old	301047	J-Packing Crown	18.50
7	30048	Sphere (Requires 74)	0.80
8	301083	Screw 6X15 T.E.	1.60
8a	301084	Screw 6X15 T.C.E.I.	1.60
9	301048	Endless Screw	98.00
9a	30160	Grub Screw	1.60
9b	30108	Plug	4.00
010	10394	Threaded Bearing	17.00
010a	10404-S	Internal Bearing	10.00
10b	30080	Washer	2.00
10c	30118	Grub Screw	1.60
11	30748	Pinion Bearing	4.80
12	301050	Gearbox Central Body	76.60
13	3010762	Ring	Call
13a	301014	Screw	1.60
13-old	301052	Threaded Ring For Crown	72.80
14	301035	Spacer	Call
14a	3010763	Cover	Call
14-old	301053	Ball Bearing Ring	93.40
15	301054	Propeller	28.40
015br	10457	Propeller	Call
16	3010636	Screw	Call
16a	30187	Grub Screw	1.60
017	10293	Bearing House	26.30
17a	301055	Lever	15.00
17br	301053a	Bushing	Call
18	30031-S	Compass	7.50
018a	10294	Bush	47.50
19	30833	Crown	20.60
19a	30817	Spring	3.20
20	30836	High Speed Pinion	19.70
020b	10500	Pin	Call
20b	3010634	Pinion Pivot	Call
21a	301058	Pin	1.50
022	10285	Planetary	30.20
022a	10286	Second Planetary	106.10
23	30835	High Speed Gear	8.00
23a	301060	Stud Bolt	4.90
024	10287-S	Pinion	56.00
24a, 70	30965	Screw 6X30	3.20
25a, 86	30270	Nut	1.00
26	301063	O-Ring	53.00
28	30613	O-Ring 2237	2.50
28a	301064	O-Ring 123	1.00
29	30678	O-Ring 121	1.00
29a	30532	Washer Inox	1.00
30	30695	Cam	11.50
31, 73a	30208	Elastic Pin	1.00
32	20161	Shafting Bar	9.60
33	20156	Shafting Bar Cover	9.60
34	30185	Cap	7.88
35	301066	O-Ring	8.00
35a	301067	O-Ring	7.10
36	30063-30	Nozzle, Standard 25°, 30mm (1.2")	11.50
36	30063-32	Nozzle, Standard 25°, 32mm (1.25")	11.50
36	30063-34	Nozzle, Standard 25°, 34mm (1.35")	11.50
36	30063-36	Nozzle, Standard 25°, 36mm (1.42")	11.50
36	30063-38	Nozzle, Standard 25°, 38mm (1.50")	11.50
36	30063-40	Nozzle, Standard 25°, 40mm (1.57")	11.50
36	30063-42	Nozzle, Standard 25°, 42mm (1.65")	11.50

Pos #	Part #	Description	List Price
37	30056	Nozzle Lock Ring	31.50
38	30064	Packing For Nozzle	2.50
039	10288-S	Jet-Breaker	139.50
40	301068	Pipe-Head	83.10
41	3010444	Jet Breaker Spring Lever	9.50
042	10190	Jet-Breaker Lever	54.70
42a	30091	Screw	1.00
43	30093	Screw For Lever	9.50
44	30094	Nut For Lever	4.80
45	20158	Tube	70.88
47	30053	Threaded Ring For Pipe	59.10
47a	30054	O-Ring	7.10
48	20159	Secondary Pipe	32.30
48a	301069	O-Ring	1.60
49	30116	Nut M 10X6	1.00
50	301070	Secondary Nozzle	27.00
51	301071	Ferrule	16.00
52	30500	Screw 6X25	0.90
53	30557	Washer Crower D. 6	1.00
53a	30511	Nut	1.60
54	30773	Washer	2.50
55	301072	Inversion Ring	31.00
56	301073	Lever Protection	17.33
56a	301074	Sime Part	0.80
56b	30839	Nut M4	1.00
058	10188	Central Shaft	40.00
059	10290	Inversion Fork	41.60
59a	301077	Pin For Fork	1.60
60	301078	Spring House	16.00
61	301079	Inversion Spring	4.20
062	10291	Vice For Inversion Lever	48.10
62a	30782	Pin For Vice	4.00
63	30783	Screw	1.00
64	3010181	Gearbox Support	5.60
64a	30785	Spring For Bolt	1.60
66	30677	Du-Bearing For Gearbox	8.00
67	30189	Du Bearing	10.50
68	30233	Grease Nipple	0.90
69	3010646	Support	Call
69a	3010647	Clamp	Call
70-old	30521	Screw	1.80
71	3010648	Square Nuts	Call
71-old	30475	Nut 8X6	1.00
72	30724	Grub Screw	1.20
73	30057	Stream Breaker Bearing	4.40
74	30102	Plug	6.20
74a	30103	Washer	0.40
75	30121	Nut M10X10	1.00
076	10292	Levers Support	76.60
77	3010367	Seeger	15.10
78-old	301016	Spring	2.50
79-old	3010368	Spacer	3.20
079-old	10454	Disengagement	Call
80	3010369	Shafting Bar	4.40
81	3010370	Washer	1.60
82	3010855	Prisoner	Call
82-old	3010371	Prisoner	57.50
83	3010374	Flange	306.20
84	3010372	Gasket	9.50
85	3010772	Gasket	Call
85-old	3010373	Gasket	9.50
87	3010375	Screw 10X35	1.70
89	3010764	O-Ring	Call
89br	3010492	Bearing Cap	Call
90	3010765	O-Ring	Call
92	3010640	Ring	Call
93	30040-S	Grub Screwing	3.15
95	30030-S	Ring	12.00
96	3010613	Bearing	Call
97	30028-S	Bearing	24.50
98	3010653	Knob	Call
98-old, 103	3010570	O-Ring	Call
99	3010654	Nut	Call

Gun Stands/Sprinklers























# Schumacher Irrigation is your source for hard to find irrigation parts, and custom built irriga- tion fittings.



## Section Five



 Couplers and Male Ends	_____	87-90
 Industrial Groove	_____	91
 Storage Baskets	_____	93
 Ball & Sockets	_____	94-99
 Cam-Locs	_____	100-101
 Fittings (Elbows, Tees, Adapters, Ect)	_____	102-111
 Weld-on Elbows & Tees	_____	112
 Band & Hook/Latch & Accs	_____	113-115
 Weld-on Fittings (Rings, Discs, Flgs & Cones)	_____	116-122
 Telescopes	_____	123
 Valves	_____	124-136
 Water Meters & Accessories	_____	137-138
 Pivot Parts	_____	139-144
 Pivot Sprinklers & Accessories	_____	145-148
 Pressure Gauges	_____	149
 Valve Stubs & Accessories	_____	150-153
 Threaded Parts (Nipples, Couplings & Fittings)	_____	153-162, 170-172
 Drain Valves	_____	155
 Sch40 Butt Weld Fittings	_____	163
 Gaskets	_____	166-169



Product	Description	Part Number	Weight	List Price
---------	-------------	-------------	--------	------------

**COUPLER**  
 (BLACK STEEL)

Size	Standard Punch				Deep Punch			Extra Deep Punch			Extra-Extra Deep		
	Part #	Depth	Weight	List	Part #	Depth	List	Part #	Depth	List	Part #	Depth	List
2"	6-0120		1.0	<b>10.00</b>									
3"	6-0121		1.0	<b>11.00</b>	9-5198	3"	<b>15.00</b>	9-5007	4"	<b>18.00</b>			
4"	6-0122	2-3/4"	1.5	<b>15.00</b>	9-5199	4"	<b>17.50</b>	9-5008	4-1/2"	<b>20.00</b>	9-5200	7"	<b>32.00</b>
5"	6-0123		2.0	<b>16.00</b>	9-5201	4"	<b>22.00</b>	9-5009	5"	<b>23.00</b>			
6"	6-0124	4-1/4"	2.8	<b>17.00</b>	9-5010	5-7/8"	<b>26.00</b>	9-5202	8-1/2"	<b>45.00</b>			
6-5/8"	6-0128		3.8	<b>29.00</b>									
7"	6-0118		3.5	<b>24.00</b>									
8"	6-0125	4"	4.5	<b>22.00</b>	9-5011	5-1/2"	<b>43.00</b>	9-5203	11"	<b>59.00</b>			
8-5/8"	6-0129		6.0	<b>48.00</b>									
10"	6-0126	3"	5.5	<b>35.00</b>	9-5012	6"	<b>47.00</b>						
12"	6-0127		9.0	<b>51.00</b>	9-5013	6"	<b>43.00</b>						

**COUPLER-10GA.**  
 (BLACK OR GALV. STEEL)

10 Gauge

Size	10ga Black Steel			10ga Galvanized		
	Part #	Weight	List	Part #	Weight	List
4" Rd Back	9-7548		<b>17.50</b>			
4" Squ Back	6-8030	3.0	<b>28.00</b>			
6"	6-9662	4.5	<b>25.00</b>	6-9664	4.5	<b>29.00</b>
8"	6-9663	5.9	<b>31.00</b>	6-9665	5.9	<b>35.00</b>
10"	9-5305	7.2	<b>40.00</b>	9-8110		<b>48.00</b>
12"	9-7549		<b>61.00</b>	9-8111		<b>72.00</b>

**MALE RL END**  
 (BLACK OR GALV. STEEL)

12ga Black



10ga Black or Galv.

Size	12ga Black Steel			10ga Black Steel			10ga Galv Steel		
	Part #	Weight	List	Part #	Weight	List	Part #	Weight	List
3"	6-0169	1.2	<b>12.00</b>						
4" Flat Ring	6-0170	1.5	<b>13.00</b>						
4" Wide Ring				6-8112	3.0	<b>16.00</b>			
5"	6-0171	2.0	<b>15.00</b>						
6"	6-0172	2.8	<b>18.00</b>	6-9764	4.2	<b>25.00</b>	6-9766	4.2	<b>29.00</b>
7"	6-0176	3.5	<b>23.00</b>						
8"	6-0173	4.5	<b>24.00</b>	6-9765	5.9	<b>28.00</b>	6-9767	5.9	<b>34.00</b>
10"	6-0174	5.5	<b>35.00</b>	9-5306	6.7	<b>41.00</b>			
12"	6-0175	9.0	<b>50.00</b>	9-7662		<b>55.00</b>			

**STAINLESS STEEL RL ENDS**

Stainless Steel

Size	Stainless Steel Coupler			Stainless Steel Male End		
	Part #	Weight	List	Part #	Weight	List
4"	9-7518		<b>170.00</b>	9-7522	-	<b>170.00</b>
5"	9-7519		<b>80.00</b>	9-7523		<b>179.00</b>
6"	9-7520		<b>85.00</b>	9-7524		<b>120.00</b>
8"	9-7521		<b>120.00</b>	9-7525		<b>125.00</b>
10"	9-7891		<b>155.00</b>	9-8098		<b>185.00</b>

# COUPLERS

Product	Description	Part Number	Weight	List Price
<b>COUPLER</b> (CAST ALUMINUM)	3"	6-0114	1.3	21.00
	4"	6-0110	1.5	24.00
	5"	6-0115	1.8	29.00
	6"	6-0111	2.0	39.00
	7"	6-0109	2.5	36.00
	8"	6-0112	2.8	49.00
	10"	6-0113	3.3	59.00



\*Hook pocket on all sizes, 6-8-10" also take RLC  
\*6", 8" & 10" accept the standard RLC

## RL COUPLER SET- SCHUMACHER

(CAST ALUMINUM)



Set	4"	6-0145	4.4	57.00
Set	5"	6-0146	5.0	69.00
Set	6"	6-0130	5.3	75.00
Set	7"	6-0134	6.3	92.00
Set	8"	6-0131	7.0	92.00
Set	10"	6-0132	8.1	115.00
Set	12"	6-0133	10.0	170.00
Female HT,	4"	6-0147	1.5	23.00
Female HT,	5"	6-0148	1.8	30.00
Female HT,	6"	6-0150	2.4	32.00
Female HT,	7"	6-0153	2.5	40.00
Female HT,	8"	6-0151	2.8	41.00
Female HT,	10"	6-0152	3.5	52.00
Female HT,	12"	4-0015	5.5	80.00
Male HT,	4"	6-0149	1.2	16.00
Male HT,	5"	6-0154	1.4	20.00
Male HT,	6"	6-0160	1.8	23.00
Male HT,	7"	6-0163	1.9	27.00
Male HT,	8"	6-0161	2.0	29.00
Male HT,	10"	6-0162	2.3	36.00
Male HT,	12"	4-0016	3.5	58.00

Set Includes Standard Ringlock Clamp

## RL COUPLER SET- A&M

(CAST ALUMINUM)



Set RL,	6"	6-0080	5.3	82.00
Set RL,	8"	6-0081	7.0	103.00
Set RL,	10"	6-0082	8.1	113.00
Female RL,	6"	6-0089	2.4	37.00
Female RL,	8"	6-0090	2.8	46.00
Female RL,	10"	6-0091	3.5	58.00
Male RL,	6"	6-0086	1.8	22.00
Male RL,	8"	6-0087	2.0	32.00
Male RL,	10"	6-0088	2.3	28.00

Set Includes A&M Ringlock Clamp

## PRESS-ON RL COUPLER/ MALE END

(GALVANIZED STEEL)



3" Male	6-0201	2.0	17.00
4" Male	6-0202	2.5	19.00
5" Male	6-0203	3.5	22.00
6" Male	6-0210	4.0	24.00
7" Male	6-0204	5.0	32.00
8" Male	6-0211	7.0	35.00
10" Male	6-0212	11.0	43.00
12" Male	6-0205	14.0	56.00
3" Female	6-0223	2.0	18.00
4" Female	6-0224	2.5	20.00
5" Female	6-0225	3.5	25.00
6" Female	6-0220	4.0	27.00
7" Female	6-0226	5.5	36.00
8" Female	6-0221	8.0	36.00
10" Female	6-0222	10.5	53.00
12" Female	6-0227	15.0	72.00

Product	Description	Part Number	Weight	List Price
<b>HOLD BAND</b> (STEEL)	3"	6-0235	0.3	2.50
	4"	6-0236	0.3	3.50
	5"	6-0237	0.4	4.50
	6"	6-0230	0.5	6.00
	8"	6-0231	0.8	9.00
	10"	6-0232	0.9	12.00



<b>LATERAL COUPLER</b> (CAST ALUMINUM)	Press-on 2"	6-0241	1.3	30.00
	Press-on 3"	6-0242	1.6	32.00
	Press-on 4"	6-0240	2.0	42.00
	Weld-on 2"	6-0260	1.2	21.00
	Weld-on 3"	6-0261	1.6	22.00
	Weld-on 4"	6-0262	2.0	38.00



All couplers have 1" outlet.

<b>KNOB STYLE COUPLER</b> (PRESS-ON)(CAST ALUMINUM)	2" Lateral Press-on*	6-0263	1.0	32.00
	3" Lateral Weld-on*	6-0264	1.2	30.00
	4" Lateral Weld-on*	6-0265	1.8	37.00
	5" Mainline Weld-on	6-0266	3.2	41.00
	6" Mainline Weld-on	6-0267	3.9	54.00

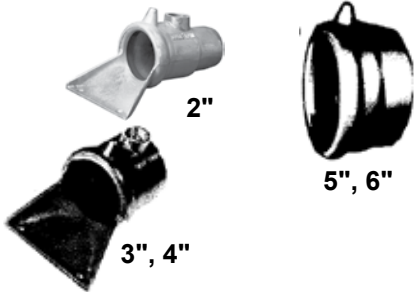

\*Lateral couplers have 1" outlet.

<b>COUPLER/MALE ENDS-ABC</b> (GALVANIZED STEEL)	<b>Female w/1" outlet:</b>	2"	6-0180	1.5	34.00
	-Press-on	3"	6-0181	3.3	53.00
	-Includes Spring & Gasket	4"	6-0182	5.5	78.00
	<b>Female Press-on:</b>	2"	6-0183	0.3	25.00
		3"	6-0184	2.0	43.00
		4"	6-0185	4.0	60.00
		5"	6-0186	7.3	77.00
	-Includes Spring & Gasket	6"	6-0187	9.5	106.00
		8"	6-0188	15.5	170.00
	<b>Male Press-on:</b>	2"	6-0189	0.5	21.00
		3"	6-0190	1.3	29.00
		4"	6-0191	2.0	35.00
		5"	6-0192	4.8	61.00
		6"	6-0193	6.3	75.00
		8"	6-0194	13.0	140.00



Call for prices on ABC Fittings.

<b>LATERAL COUPLER SET-BOLT-ON</b> (CAST ALUMINUM)	2"	6-0300	1.9	40.00
	3"	6-0301	2.8	51.00
	4"	6-0302	3.7	63.00
	5"	6-0303	4.8	85.00
	6"	6-0304	6.3	100.00



Has 1" Female threaded outlet.  
Includes band and hook.

# COUPLERS

Product	Description	Part Number	Weight	List Price	
<b>TWIST LOCK ENDS</b> (CAST ALUMINUM)	<b>Female:</b>	4"	6-0141	2.3	<b>43.00</b>
		5"	6-0142	3.3	<b>45.00</b>
		6"	6-0143	2.8	<b>50.00</b>
		8"	6-0144	7.0	<b>90.00</b>
	<b>Male:</b>	4"	6-0136	0.5	<b>16.50</b>
		5"	6-0137	0.9	<b>20.00</b>
		6"	6-0138	1.0	<b>26.00</b>
		8"	6-0139	2.3	<b>32.00</b>
	<b>Full Male End:</b>	6"	6-0135	2.8	<b>50.00</b>

\*200-lbs. max. pressure on all sizes except 8".

## DETACHABLE COUPLER SET

(CAST ALUMINUM)



Includes "2" band and hook assemblies

2"	6-0095	3.0	<b>47.00</b>
3"	6-0096	4.3	<b>61.00</b>
4"	6-0097	5.2	<b>65.00</b>
5"	6-0098	7.6	<b>89.00</b>
6"	6-0099	8.8	<b>107.00</b>

## DETACHABLE COUPLER-KNOB

(CAST ALUMINUM)



2"	6-9512	1.5	<b>44.00</b>
3"	6-9513	1.9	<b>58.00</b>
4"	6-9514	2.3	<b>69.00</b>
5"	6-9515	3.5	<b>89.00</b>
6"	6-9516	4.1	<b>120.00</b>
7"	6-9517	5.8	<b>130.00</b>

## SPIKE COUPLER

(PVC-SOLVENT)



2"	6-0305	1.5	<b>21.00</b>
2-1/2"	6-0306	2.0	<b>26.00</b>

- 3/4" riser outlet
- Ideal for row crops, nurseries, or orchards
- Spike riser locks male & female coupler halves and stabilizes the riser in a vertical position
- Substantial savings over aluminum or buried solid set systems
- Improved weatherability PVC compounds
- Highest UV inhibitors.
- Highest impact resistance.
- Easy off season storage, simply remove spike riser.
- Non-corrosive aluminum tubing spike riser
- Quad seal prevents water leakage around spike.
- Slotted male end allows for up to 1-1/4" expansion and contraction of PVC pipe.
- Chevron seal gasket.

# COUPLERS & ACCESSORIES

Product	Description	Part Number	Weight	List Price
<b>BOLT-ON CENTER RISER</b> (STEEL GALVANIZED)	3"	6-0255	3.0	15.00
	4"	6-0256	4.0	16.00



Has 1" Female threaded outlet.

## INDUSTRIAL GROOVE END



\*Galvanized Steel and Aluminum  
Groove Fittings Available.  
Please Inquire.

Steel	Part Number	Weight	List Price
2"	6-9721	0.8	12.00
2-1/2"	6-9722	1.5	29.00
3"	6-9723	1.0	12.00
4"	6-9724	1.8	16.00
5"	6-9725	2.3	23.00
6"	6-9726	2.8	24.00
8"	6-9727	4.3	37.00
10"	6-9728	6.5	52.00
12"	6-9729	8.5	72.00
Alum	Part Number	Weight	List Price
3"	6-9730	0.7	17.00
4"	6-9731	1.1	21.00
6"	6-9732	1.9	35.00
8"	6-9733	2.1	46.00
10"	6-9734	2.4	52.00
12"	6-9735	-	79.00

## INDUSTRIAL GROOVE CLAMP



1-1/2"	9-6776	2.1	8.00
2"	6-9736	2.7	17.00
2-1/2"	6-9737	-	20.00
3"	6-9738	2.5	10.00
4"	6-9739	3.5	13.00
5"	6-9740	10.6	57.00
6"	6-9741	6.7	22.00
8"	6-9742	12.5	40.00
10"	6-9743	31.0	105.00
12"	6-9744	35.0	115.00

\*Includes Gasket

## INDUSTRIAL GROOVE GASKET



\*Cut-Away View

1-1/2"	9-6777	-	10.80
2"	9-6767	-	3.40
2-1/2"	9-6768	-	14.20
3"	9-6769	-	4.10
4"	9-6770	-	4.60
5"	9-6771	-	8.00
6"	9-6772	-	5.80
8"	9-6773	-	15.00
10"	9-6774	-	23.00
12"	9-6775	-	26.00

Fittings



Product	Description	Part Number	Weight	List Price
<b>SADDLE COUPLING</b> (CAST ALUMINUM)	3/4"	6-0100	0.2	<b>6.00</b>
	1"	4-0011	0.2	<b>7.00</b>



\*Weld-on

## QUICK COUPLING RISER VALVE (CAST ALUMINUM)

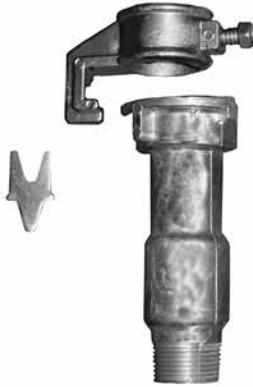

3/4" fpt x 3/4"	6-1579	0.7	<b>17.50</b>
1"mpt x 3/4"	6-1590	0.7	<b>17.50</b>
1"mpt x 1"	6-1591	0.8	<b>18.50</b>

3/4" Top outlet require 1.05"ODx.113"wall SCH40 pipe; 1" require 1.315"ODx.133"wall

## SPRINKLER DEFLECTOR (STEEL)



Bolts to riser	6-1524	1.4	<b>17.00</b>
----------------	--------	-----	--------------

# STORAGE BASKET

Product	Description	Part Number	Weight	List Price
<b>STORAGE BASKET</b> (GALVANIZED STEEL)	X-Large	9-7754	158	<b>295.00</b>

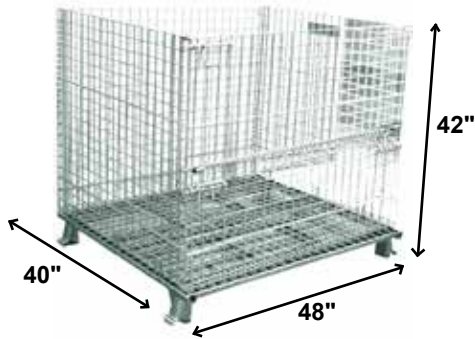

High-visibility parts storage for manufacturing and warehousing. Features reinforced under carriage and support legs, fully galvanized finish and collapsible, stackable design for efficient storage. Folds flat for space-saving storage, with front drop-gate for easy access.

**Features and Benefits:**

- \* 48" Wide x 40" Deep x 42" Overall Height, Outside measurements.
- \* Rugged 2-gauge 2"x2" wire mesh with reinforced under-structure.
- \* Front Drop Gate with side latches for parts accessibility and identification.
- \* Stackable up to 4 baskets high.
- \* 4000lbs capacity.



Fittings

# BALL & SOCKET COUPLERS (BAUER STYLE)



Product	Description	Part Number	Weight	List Price
---------	-------------	-------------	--------	------------

## BALL-BAUER STYLE



Galvanized also available.  
 8" (194) steel will fit to 8" (203) cast aluminum.  
 4" (108) steel will not fit to 4" (102) cast aluminum.

Size	Black Steel			Cast Aluminum			Stainless Steel		
	Part #	Weight	List	Part #	Weight	List	Part #	Weight	List
2"	6-5000	0.3	\$4.00	6-5032	0.3	\$16.00	9-5326	0.3	\$33.00
3"	6-5001	0.5	5.00	6-5033	0.5	21.00	9-5327	0.7	52.00
3-1/2"	6-5002	0.8	13.50				9-5328	0.8	55.00
4"	6-5003	1.4	11.00	6-5034	1.2	29.00	9-5329	1.5	102.00
5"	6-5005	1.9	13.50	6-5035	1.7	37.00	9-5330	1.8	105.00
6"	6-5006	2.3	17.50	6-5036	2.2	40.00	9-5331	2.3	155.00
8"	6-5007	4.4	32.00	6-8042	3.2	135.00	9-5332	4.3	267.00
10"	9-6955	10.2	35.00	9-6956	6.2	189.00			
12"	9-5816	8.7	103.00						
16"	9-7879	-	65.00						

## SOCKET-BAUER STYLE



5" (127) and 6" (152) alum./cast will fit to steel 5" (133) and 6" (159)

Size	Black Steel			Cast Aluminum			Stainless Steel		
	Part #	Weight	List	Part #	Weight	List	Part #	Weight	List
2"	6-5008	0.2	\$5.00	6-5038	0.3	\$25.00	9-5333	0.3	\$38.00
3"	6-5009	0.5	10.00	6-5039	0.7	35.00	9-5334	0.7	69.00
3-1/2"	6-5010	0.8	15.00				9-5335	0.9	75.00
4"	6-5011	1.5	15.00	6-5040	1.4	40.00	9-5336	1.5	117.00
5"	6-5013	2.2	23.50	6-5041	2.1	45.00	9-5337	2.0	149.00
6"	6-5014	2.5	31.00	6-5042	2.6	50.00	9-5338	2.3	225.00
8"	6-5015	5.2	59.00	6-8043	4.0	155.00	9-5339	4.3	290.00
10"	9-7304	8.3	130.00	9-7305	5.5	200.00			
12"	9-5817	13.6	227.00						
16"	9-7880	-	102.00						

## LEVER-BAUER STYLE (GALVANIZED STEEL)



133 and 159 will fit to alum. and cast 127 and 152

2"	50	2.44"	6-5024	1.0	17.00
3"	76	3.43"	6-5025	2.3	28.00
3-1/2"	89	4.33"	6-5026	3.8	39.00
4"	108	5.20"	6-5027	4.3	38.00
5"	127/133	6.20"	6-5029	9.0	55.00
6"	152/159	7.20"	6-5030	9.0	80.00
8"	194/203	9.25"	6-5031	13.3	115.00
*10"	250		9-6979	24.1	215.00
*12"	300		9-5818	35.6	350.00
16"	400		9-7881		237.00

\*Locking Bar (part # 9-7318) for 10", 12 and 16" Sold Separately

## LOCKING BAR (GALVANIZED STEEL)



10", 12", 16"	9-7318	1.9	35.00
---------------	--------	-----	-------

# BALL & SOCKET COUPLERS (BAUER STYLE)

Product	Description	Part Number	Weight	List Price
---------	-------------	-------------	--------	------------

## GASKET-BAUER STYLE (BAUER STYLE)



	MM	I.D.			
2"	50	2.44"	6-5016	0.1	1.10
3"	76	3.48"	6-5017	0.1	1.90
3-1/2"	89	4.26"	6-5018	0.2	6.50
4"	108	5.20"	6-5019	0.2	3.50
5"	127 / 133	5.98"	6-5021	0.2	6.70
6"	152 / 159	6.69"	6-5022	0.5	7.00
8"	194	8.66"	6-5023	0.6	11.50
10"	250	--	9-6969	1.1	15.00
12"	300	--	9-5819	1.6	22.00
16"	400		9-7882		17.00

## HOSE ADAPTER-BALL BAUER STYLE



Size	Galvanized Steel			Cast Aluminum			Stainless Steel		
	Part #	Weight	List	Part #	Weight	List	Part #	Weight	List
2"	3-0684	0.7	\$33.00				9-5340	0.7	\$73.00
3"	3-0685	1.3	35.00				9-5341	1.5	105.00
4"	3-0686	3.2	45.00				9-5342	3.1	200.00
5"	3-0688	4.2	65.00						
6"	3-0689	5.6	69.00	9-7885		103.00	9-5343	5.9	238.00
8"	3-0690	9.8	95.00	9-7886		212.00	9-5344	10.7	448.00
10"	9-6975	20.2	115.00	9-7887		299.00			
12"	9-6975	20.2	115.00						
16"	9-7883		150.00						

## HOSE ADAPTER-SOCKET BAUER STYLE (GALVANIZED STEEL)



Size	Galvanized Steel			Cast Aluminum			Stainless Steel		
	Part #	Weight	List	Part #	Weight	List	Part #	Weight	List
2"	3-0691	0.6	\$33.00				9-5345	0.7	\$80.00
3"	3-0692	1.3	35.00				9-5346	1.5	124.00
4"	3-0693	3.3	45.00				9-5347	3.1	244.00
5"	3-0695	4.2	65.00						
6"	3-0696	5.8	69.00	9-7888		107.00	9-5348	5.9	327.00
8"	3-0697	10.6	95.00	9-7889		231.00	9-5349	10.7	525.00
10"	9-6977	20.2	145.00	9-7890		310.00			
12"	9-7386	25.7	335.00						
16"	9-7884		185.00						

Fittings

# BALL & SOCKET FITTINGS (BAUER STYLE)

Product	Description	Part Number	Weight	List Price		
<b>90° ELBOW-BAUER STYLE</b> (GALVANIZED STEEL)		MM				
		2"	50	6-9038	3.5	<b>65.00</b>
		3"	76	6-9039	7.2	<b>105.00</b>
		3-1/2"	89	6-9040	11.0	<b>150.00</b>
		4"	108	6-9041	12.8	<b>155.00</b>
		5"	133	6-9042	23.5	<b>225.00</b>
		6"	159	6-9043	27.1	<b>279.00</b>
		8"	194	6-9044	47.4	<b>340.00</b>
		*10"	250	9-6963	62.3	<b>659.00</b>
		*12"	300	9-7387	84.0	<b>1,075.00</b>



\* Locking Bar (part # 9-7318) for 10" & 12" Lever is Sold Separately

<b>45° ELBOW-BAUER STYLE</b> (GALVANIZED STEEL)		2"	50	6-9045	3.5	<b>55.00</b>
		3"	76	6-9046	7.2	<b>107.00</b>
		3-1/2"	89	6-9047	10.8	<b>150.00</b>
		4"	108	6-9048	12.6	<b>155.00</b>
		5"	133	6-9049	20.2	<b>199.00</b>
		6"	159	6-9050	23.8	<b>255.00</b>
		8"	194	6-9051	47.4	<b>330.00</b>
		*10"	250	9-6961	54.9	<b>577.00</b>
		*12"	300	9-7388	73.8	<b>799.00</b>



\* Locking Bar (part # 9-7318) for 10" & 12" Lever is Sold Separately

<b>LINE TEE-STYLE</b> (GALVANIZED STEEL)		2"	50	6-9052	13.2	<b>90.00</b>
		3"	76	6-9053	15.2	<b>105.00</b>
		3-1/2"	89	6-9054	17.7	<b>195.00</b>
		4"	108	6-9055	20.1	<b>150.00</b>
		5"	133	6-9056	27.8	<b>195.00</b>
		6"	159	6-9057	30.5	<b>339.00</b>
		8"	194	6-9058	49.3	<b>450.00</b>
		*10"	250	9-6980	105.9	<b>920.00</b>
		*12"	300	9-7389	140.1	<b>1,625.00</b>

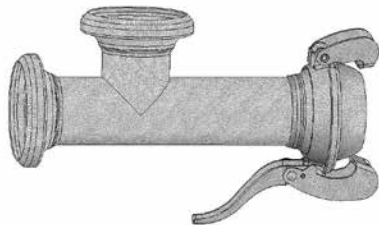

\* Locking Bar (part # 9-7318) for 10" & 12" Lever is Sold Separately

<b>END TEE-STYLE</b> (GALVANIZED STEEL)		2"	50	6-9059	13.2	<b>90.00</b>
		3"	76	6-9060	15.2	<b>105.00</b>
		3-1/2"	89	6-9061	17.7	<b>195.00</b>
		4"	108	6-9062	20.1	<b>150.00</b>
		5"	133	6-9063	27.8	<b>195.00</b>
		6"	159	6-9064	30.5	<b>339.00</b>
		8"	194	6-9065	49.3	<b>450.00</b>
		*10"	250	9-6965	105.9	<b>920.00</b>
		*12"	300	9-7390	140.1	<b>1,625.00</b>

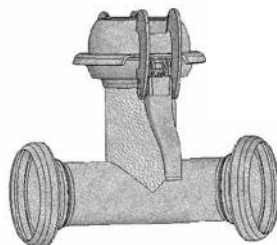

\* Locking Bar (part # 9-7318) for 10" & 12" Lever is Sold Separately

# BALL & SOCKET FITTINGS (BAUER STYLE)

Product	Description	Part Number	Weight	List Price		
<b>END PLUG-BAUER STYLE</b> (GALVANIZED STEEL)		MM				
		2"	50	6-9024	0.7	40.00
		3"	76	6-9025	1.1	40.00
		3-1/2"	89	6-9026	1.5	50.00
		4"	108	6-9027	2.1	50.00
		5"	133	6-9028	3.3	55.00
		6"	159	6-9029	3.6	60.00
		8"	194	6-9030	8.0	85.00
		10"	250	9-6964	14.6	115.00
		12"	300	9-7392	14.8	186.00



See previous page for lever.

Product	Description	Part Number	Weight	List Price		
<b>ADAPTER, MPT X BALL</b> <b>BAUER STYLE</b> (GALVANIZED STEEL)		2"	50	6-9010	3.1	75.00
		3"	76	6-9011	5.5	95.00
		3-1/2"	89	6-9012	6.0	123.00
		4"	108	6-9013	10.0	130.00
		5"	133	6-9014	14.7	169.00
		6"	159	6-9015	15.9	205.00
		8"	194	6-9016	25.2	325.00
		*10"	250	9-6949	40.0	475.00
		*12"	300	9-7393	51.1	865.00



\* Locking Bar (part # 9-7318) for 10" & 12" Lever is Sold Separately

Lever is included.

Product	Description	Part Number	Weight	List Price		
<b>ADAPTER, MPT X SOCKET</b> <b>BAUER STYLE</b> (GALVANIZED STEEL)		2"	50	6-9017	1.1	29.00
		3"	76	6-9018	1.8	37.00
		3-1/2"	89	6-9019	0.8	75.00
		4"	108	6-9020	3.5	55.00
		5"	133	6-9021	6.0	83.00
		6"	159	6-9022	7.8	85.00
		8"	194	6-9023	14.1	165.00
		10"	250	9-6950	8.3	360.00
		12"	300	9-7394	13.6	475.00



## BAUER STYLE DIMENSIONS (STEEL)

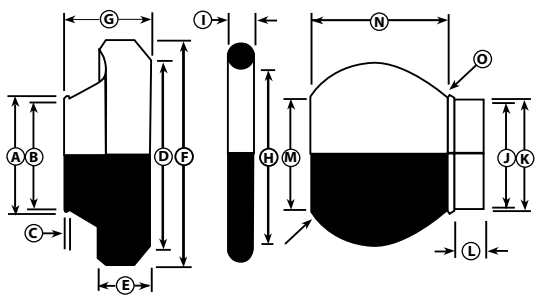

Size	MM	A	B	C	D	E	F	G	H	I	J	K	L	M	N	O
2"	50	2.01	1.91	0.24	2.83	0.67	3.27	1.22	2.44	0.37	1.91	2.01	0.28	1.97	2.17	2.76
3"	76	3.07	2.99	0.28	3.86	0.87	4.57	1.46	3.48	0.51	2.99	3.07	0.55	3.19	2.87	3.86
3-1/2"	89	3.62	3.50	-	4.76	0.98	5.40	1.85	4.26	0.51	3.50	3.62	0.55	3.66	2.99	4.72
4"	108	4.37	4.25	0.47	5.79	1.10	6.50	2.32	5.20	0.59	4.25	4.37	0.59	4.41	4.21	5.71
5"	133	5.39	5.20	0.47	6.42	1.34	7.52	2.13	5.98	0.71	5.20	5.39	0.67	5.39	3.78	6.26
6"	159	6.42	6.22	0.59	7.17	1.34	8.31	2.05	6.69	0.75	6.22	6.42	0.75	6.10	4.06	7.09
8"	194	7.95	7.64	0.71	9.09	1.34	10.51	2.99	8.66	0.75	7.64	7.87	0.67	7.87	5.00	9.06
10"	250	9.84	9.53	0.39	11.93	-	13.62	4.13	-	-	9.25	9.53	-	9.92	6.73	11.81
12"	300	11.81	11.42	0.47	13.70	-	15.78	4.21	-	1.10	11.54	11.81	-	11.81	6.89	13.46
16"	400	15.80	15.37	.39	17.77	-	20.09	4.79	-	-	15.29	15.76	-	15.29	8.27	17.61

Fittings

# BALL & SOCKET COUPLERS (100/200 STYLE)



Product	Description	Part Number	Weight	List Price
---------	-------------	-------------	--------	------------

## BALL/SOCKET-100/200 STYLE (BLACK STEEL)



Ball w/loose Ring	I.D.				
4" (100 mm)	3.94"	100 series	6-5044	1.8	12.50
6" (150 mm)	--	100 series	6-5045	4.6	29.00
8" (200 mm)	7.80"	200 series	6-5050	10.8	100.00
10" (250 mm)	9.96"	200 series	6-5051	17.8	103.00
12" (300 mm)	11.98"	200 series	6-5052	30.1	224.00
16" (400 mm)	--	200 series	9-7555	64.1	230.00



Socket w/lever attached					
4" (100 mm)	5.16"	100 series	6-5046	2.4	25.00
6" (150 mm)	--	100 series	6-5047	3.8	35.00
(3 Hook) 6" (150 mm)	--	100 series	9-6947	5.0	45.00
8" (200 mm)	9.69"	200 series	6-5053	9.8	125.00
(3 Hook) 8" (200 mm)	9.69"	200 series	9-7648	-	125.00
10" (250 mm)	11.70"	200 series	6-5054	13.4	115.00
*12" (300 mm)	14.66"	200 series	6-5055	30.3	227.00
**16" (400 mm)	--	200 series	9-7556	57.7	230.00

Gasket is included with socket.

\* Galvanized Steel Locking Bar (part # 9-7877) for 12" Lever is Sold Separately.  
 \*\* Galvanized Steel Locking Bar (part # 9-7878) for 16" Lever is Sold Separately.

### Sealing Ring Gasket



4" (100 mm)	4.75"	100 series	6-5048	0.2	2.00
6" (150 mm)	6.97"	100 series	6-5049	0.5	5.50
8" (200 mm)	9.21"	200 series	6-5056	0.6	10.00
10" (250 mm)	11.07"	200 series	6-5057	1.1	19.00
12" (300 mm)	13.99"	200 series	6-5058	1.3	22.00
16" (400 mm)	--	200 series	9-7557	3.3	30.00

### Locking Bar (Galvanized)



12" (300 mm)		200 series	9-7877	-	12.00
16" (400 mm)		200 series	9-7878	-	4.00

## 100/200 STYLE DIMENSIONS (STEEL)

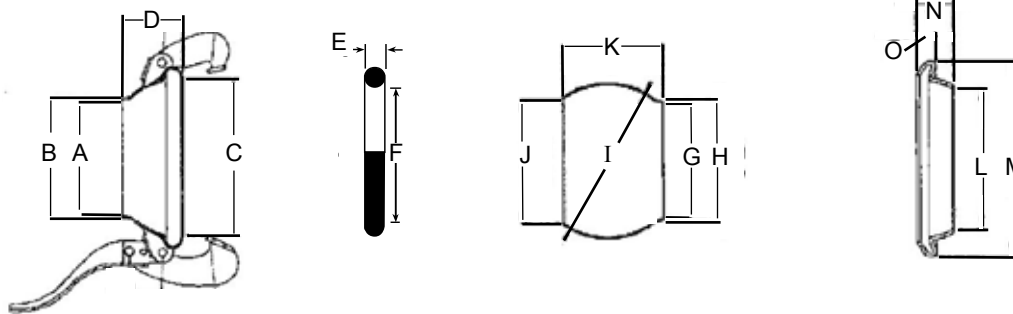

Size	MM	Socket				O Ring		Ball					Ring			
		A	B	C	D	E	F	G	H	I	J	K	L	M	N	O
4"	100	3.62	3.78	5.16	2.36			3.66	3.78	5.08	3.98	3.51	4.65	6.30	1.18	0.51
6"	150	5.44	5.63	7.17	2.76	0.57	6.97	5.44	5.63	6.90	5.59	4.14	6.66	8.78	1.50	0.59
8"	200	7.25	7.56	9.69	3.62	0.73	9.22	7.33	7.60	9.53	7.45	5.75	8.67	11.43	1.85	1.06
10"	250	9.38	9.73	11.86	4.33	0.87	11.07	9.22	9.57	11.82	9.93	6.74	11.15	14.11	2.40	1.30
12"	300	11.36	12.21	14.66	4.93	0.93	13.99	11.66	12.02	14.58	11.98	8.35	13.36	17.57	2.76	1.69
16"	400	15.91						15.91								

# BALL & SOCKET FITTINGS (100/200 STYLE)

Product	Description	Part Number	Weight	List Price
<b>HOSE ADAPTER-BALL</b> <b>100/200 STYLE</b> (GALVANIZED STEEL)	4" (100 mm)	100 series 6-9073	3.6	<b>49.00</b>
	6" (150 mm)	100 series 6-9074	7.9	<b>75.00</b>
	8" (200 mm)	200 series 6-9075	16.2	<b>170.00</b>
	10" (250 mm)	200 series 6-9076	27.8	<b>185.00</b>
	12" (300 mm)	200 series 6-9077	42.2	<b>295.00</b>
	16" (400 mm)	200 series 9-7558	82.9	<b>450.00</b>



<b>HOSE ADAPTER-SOCKET</b> <b>100/200 STYLE</b> (GALVANIZED STEEL)	4" (100 mm)	100 series 6-9078	4.2	<b>55.00</b>
	6" (150 mm)	100 series 6-9079	7.1	<b>75.00</b>
	8" (200 mm)	200 series 6-9080	15.2	<b>195.00</b>
	10" (250 mm)	200 series 6-9081	23.4	<b>199.00</b>
	*12" (300 mm)	200 series 6-9082	42.4	<b>340.00</b>
	**16" (400 mm)	200 series 9-7559	76.5	<b>475.00</b>



\* Locking Bar (part # 9-7318) for 12" Lever is Sold Separately  
 \*\* Straight Bar for 16" Lever is included

<b>90° ELBOW</b> <b>100/200 STYLE</b> (GALVANIZED STEEL)	4" (100 mm)	100 series 6-9083	9.9	<b>135.00</b>
	6" (150 mm)	100 series 6-9084	21.7	<b>185.00</b>
	8" (200 mm)	200 series 6-9085	34.8	<b>399.00</b>
	10" (250 mm)	200 series 6-9086	50.8	<b>445.00</b>
	12" (300 mm)	200 series 6-9087	86.5	<b>750.00</b>



<b>45° ELBOW</b> <b>100/200 STYLE</b> (GALVANIZED STEEL)	4" (100 mm)	100 series 6-9088	9.7	<b>125.00</b>
	6" (150 mm)	100 series 6-9089	18.4	<b>170.00</b>
	8" (200 mm)	200 series 6-9090	31.4	<b>350.00</b>
	10" (250 mm)	200 series 6-9091	43.4	<b>380.00</b>
	12" (300 mm)	200 series 6-9092	76.3	<b>665.00</b>





# CAM-LOC FITTINGS

Product	Description	Part Number	Weight	List Price			
<b>FEMALE THREAD X MALE CAM-LOC</b> (Cast Aluminum)		<u>Width</u>					
	<b>"A"</b> Series						
			1/2"	9-5889	0.1	3.50	
			3/4"	9-5890	0.1	3.50	
			1"	9-5891	0.1	4.00	
			1-1/4"	9-5892	0.2	5.00	
			1-1/2"	9-5893	0.3	5.00	
			2"	2-1/2"	6-6918	0.4	5.00
			2-1/2"	3"	6-6919	0.6	9.00
			3"	3-5/8"	6-6920	0.7	10.00
			4"	4-3/4"	6-6921	1.3	17.00
			5"	5-3/4"	6-6922	1.6	30.00
			6"	6-15/16"	6-6923	2.0	33.00
		8"	6-6897	10.9	125.00		
	10"	9-7584	9.9	285.00			



<b>FEMALE THREAD X FEMALE CAM-LOC</b> (Cast Aluminum)		1/2"	9-5904	0.2	7.80	
		3/4"	9-5905	0.2	7.50	
		1"	9-5906	0.4	8.50	
		1-1/4"	9-5907	0.7	10.50	
		1-1/2"	9-5908	0.8	10.00	
		2"	2-1/2"	6-6924	0.9	12.00
		2-1/2"	3"	6-6925	1.2	18.00
		3"	3-5/8"	6-6926	1.8	19.00
		4"	4-3/4"	6-6927	2.8	28.00
		5"	5-3/4"	6-6928	3.4	48.00
		6"	6-15/16"	6-6929	5.1	56.00
		8"	6-9788	9.5	220.00	
		10"	9-7585	12.5	455.00	



<b>MALE THREAD X MALE CAM-LOC</b> (Cast Aluminum)		1/2"	9-5914	0.1	4.90	
		3/4"	9-5915	0.2	4.50	
		1"	9-5916	0.2	5.00	
		1-1/4"	9-5917	0.3	6.50	
		1-1/2"	9-5918	0.5	5.50	
		2"	2-1/2"	6-6930	0.7	6.50
		2-1/2"	3"	6-6931	1.0	11.50
		3"	3-5/8"	6-6932	1.3	13.00
		4"	4-3/4"	6-6933	2.3	22.00
		5"	5-3/4"	6-6934	2.9	37.00
		6"	6-15/16"	6-6935	3.9	48.00
		8"	9-6959	7.9	145.00	
		10"	9-7586	10.6	312.00	



<b>MALE THREAD X FEMALE CAM-LOC</b> (Cast Aluminum)		1/2"	9-5894	0.2	6.50	
		3/4"	9-5895	0.2	7.00	
		1"	9-5896	0.4	8.50	
		1-1/4"	9-5897	0.6	10.00	
		1-1/2"	9-5898	0.7	10.00	
		2"	2-1/2"	6-6936	0.9	12.00
		2-1/2"	3"	6-6937	1.0	17.00
		3"	3-5/8"	6-6938	1.6	19.00
		4"	4-3/4"	6-6939	2.4	26.00
		5"	5-3/4"	6-6940	3.3	48.00
		6"	6-15/16"	6-6941	5.0	59.00
		8"	9-7587	8.0	210.00	
		10"	9-7588	12.1	460.00	



## CAM-LOC FITTINGS

\*Note: Plastic, Stainless Steel, and Brass Cam-Loc Fittings available, please call.  
 \*Note: Cam-Loc fittings can also be used for fast & easy suction fittings.  
 \* Please note: 5" & 8" mfg. by different companies may not interchange.

Working Pressure	
Size	MAX. (PSI)
1/2" through 2"	250
2 1/2" through 4"	150
5" through 6"	75
8" through 12"	50

Product	Description	Part Number	Weight	List Price		
<b>HOSE BARB X MALE CAM-LOC</b> (Cast Aluminum)  <b>"E"</b> Series	1/2"	9-5909	0.1	3.50		
	3/4"	9-5910	0.1	3.50		
	1"	9-5911	0.2	4.00		
	1-1/4"	9-5912	0.3	5.30		
	1-1/2"	9-5913	0.4	5.00		
	2"	2-1/2"	6-6900	0.6	6.00	
	2-1/2"	3"	6-6901	0.9	12.00	
	3"	3-5/8"	6-6902	1.3	12.00	
	4"	4-3/4"	6-6903	2.1	17.50	
	5"	5-3/4"	6-6914	3.6	40.00	
	6"	6-15/16"	6-6915	6.2	51.00	
8"	6-6899	10.0	235.00			
10"	9-7589	12.9	380.00			
<b>HOSE BARB X FEMALE CAM-LOC</b> (Cast Aluminum)  <b>"C"</b> Series	1/2"	9-5899	0.2	6.50		
	3/4"	9-5900	0.3	6.50		
	1"	9-5901	0.4	7.50		
	1-1/4"	9-5902	0.7	10.00		
	1-1/2"	9-5903	0.7	10.00		
	2"	2-1/2"	6-6904	1.0	11.00	
	2-1/2"	3"	6-6905	1.3	16.50	
	3"	3-5/8"	6-6906	2.2	18.50	
	4"	4-3/4"	6-6907	3.2	27.50	
	5"	5-3/4"	6-6916	3.9	52.00	
	6"	6-15/16"	6-6917	7.7	68.00	
8"	6-6898	15.5	285.00			
10"	9-7590	16.7	595.00			
<b>END CAP (DUST CAP) CAM-LOC</b> (Cast Aluminum)  <b>"DC"</b>	1/2"	9-5919	0.2	5.70		
	3/4"	9-5920	0.2	5.00		
	1"	9-5921	0.3	7.50		
	1-1/4"	9-5922	0.6	10.00		
	1-1/2"	9-5923	0.6	9.00		
	2"	2-1/2"	9-5924	0.8	10.00	
	2-1/2"	3"	9-5925	1.0	13.00	
	3"	3-5/8"	9-5926	1.3	18.00	
	4"	4-3/4"	9-5927	2.3	21.00	
	5"	5-3/4"	9-5928	3.1	42.00	
	6"	6-15/16"	9-5929	4.7	51.00	
8"	9-6832	9.0	205.00			
10"	9-7592	12.5	415.00			
<b>END PLUG (DUST PLUG) CAM-LOC</b> (Cast Aluminum)  <b>"DP"</b>	1/2"	9-5930	0.1	3.00		
	3/4"	9-5931	0.1	3.00		
	1"	9-5932	0.1	4.00		
	1-1/4"	9-5933	0.2	4.50		
	1-1/2"	9-5934	0.3	3.50		
	2"	2-1/2"	9-5935	0.3	4.50	
	2-1/2"	3"	9-5936	0.5	8.50	
	3"	3-5/8"	9-5937	0.7	7.50	
	4"	4-3/4"	9-5938	1.2	12.50	
	5"	5-3/4"	9-5939	1.5	23.00	
	6"	6-15/16"	9-5940	2.5	28.00	
8"	9-7593	4.0	99.00			
10"	9-7594	5.4	212.00			
<b>GASKET, CAM-LOC</b>		<u>OD</u>	<u>ID</u>			
	1/2"	1.024	0.669	9-6748	0.0	0.60
	3/4"	1.375	0.875	9-6749	0.0	0.60
	1"	1.563	1.063	9-6750	0.0	0.60
	1-1/4"	1.938	1.359	9-6751	0.0	0.60
	1-1/2"	2.188	1.625	9-6752	0.0	0.60
	2"	2.625	2.000	6-6908	0.0	0.60
	2-1/2"	3.125	2.375	6-6909	0.0	0.70
	3"	3.719	3.000	6-6910	0.0	0.70
	4"	4.875	4.000	6-6911	0.1	1.00
	5"	5.906	4.875	6-6912	0.1	2.10
6"	7.063	6.000	6-6913	0.1	2.50	
8"	9.125	8.000	9-5876	0.2	5.00	
10"	11.875	9.875	9-7591	0.4	15.00	

Fittings

# ELBOWS

Product	Description	Part Number	Weight	List Price	
<b>RINGLOCK ELBOW</b> (GALVANIZED STEEL)	<b>45°</b>	3" x 45°	9-7395	4.8	<b>89.00</b>
		4" x 45°	9-7396	7.5	<b>102.00</b>
		5" x 45°	9-7397	9.6	<b>120.00</b>
		6" x 45°	6-0310	11.3	<b>120.00</b>
		8" x 45°	6-0311	15.9	<b>140.00</b>
		10" x 45°	6-0312	19.3	<b>165.00</b>
		12" x 45°	9-7398	31.6	<b>250.00</b>
	<b>90°</b>	3" x 90°	9-7399	7.4	<b>125.00</b>
		4" x 90°	9-7400	12.0	<b>145.00</b>
		5" x 90°	9-7401	15.2	<b>150.00</b>
		6" x 90°	6-0320	23.9	<b>140.00</b>
		8" x 90°	6-0321	24.9	<b>180.00</b>
		10" x 90°	6-0322	30.6	<b>230.00</b>
		12" x 90°	9-7402	45.2	<b>310.00</b>

Ringlock clamp is not included.

## RINGLOCK ELBOW WITH 2" MALE THREAD

(GALVANIZED STEEL)



6" x 90°	9-8008	-	<b>165.00</b>
8" x 90°	9-8009	-	<b>205.00</b>
10" x 90°	9-8010	-	<b>255.00</b>

Ringlock clamp is not included.

## RINGLOCK 90° ELBOW MALE X MALE

(GALVANIZED STEEL)



3" x 90°	9-7403	7.6	<b>125.00</b>
4" x 90°	9-7404	12.0	<b>145.00</b>
5" x 90°	9-7405	15.2	<b>150.00</b>
6" x 90°	9-5350	14.8	<b>140.00</b>
8" x 90°	9-5351	23.1	<b>180.00</b>
10" x 90°	9-5352	30.7	<b>230.00</b>
12" x 90°	9-7406	45.2	<b>310.00</b>

Ringlock clamp is not included.

## RINGLOCK ELBOW

(CAST ALUMINUM)



<b>45°</b>	4" x 45°	9-7407	3.7	<b>96.00</b>
	5" x 45°	9-7408	4.7	<b>122.00</b>
	6" x 45°	6-0370	6.2	<b>145.00</b>
	8" x 45°	6-0371	8.3	<b>175.00</b>
	10" x 45°	6-0372	10.3	<b>215.00</b>
	12" x 45°	9-7409	14.5	<b>368.00</b>
	<b>90°</b>	4" x 90°	9-7410	4.4
5" x 90°		9-7411	5.5	<b>146.00</b>
6" x 90°		6-0380	8.2	<b>169.00</b>
8" x 90°		6-0381	10.8	<b>199.00</b>
10" x 90°		6-0382	15.3	<b>269.00</b>
12" x 90°		9-7412	20.0	<b>495.00</b>

Ringlock clamp is not included.



## TWIST LOCK ELBOW

(CAST ALUMINUM)



<b>45°</b>	6" x 45°	6-0313	5.6	<b>191.00</b>
<b>90°</b>	6" x 90°	6-0314	6.1	<b>225.00</b>

\*Call for other twist-lock sizes

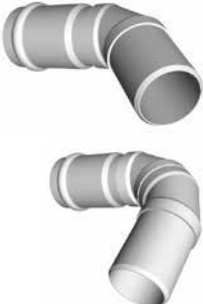
Product	Description	Part Number	Weight	List Price	
<b>HOOK STYLE ELBOW</b> (CAST ALUMINUM)					
	<b>45°</b>	2" x 45°	6-0390	3.0	<b>73.00</b>
		3" x 45°	6-0391	4.0	<b>89.00</b>
		4" x 45°	6-0392	5.0	<b>109.00</b>
	<b>90°</b>	2" x 90°	6-0395	3.0	<b>55.00</b>
		3" x 90°	6-0396	4.0	<b>71.00</b>
		4" x 90°	6-0397	5.0	<b>92.00</b>
<b>KNOB STYLE ELBOW</b> (CAST ALUMINUM)					
	<b>45°</b>	2" x 45°	6-0403	2.1	<b>89.00</b>
		3" x 45°	6-0404	2.8	<b>106.00</b>
		4" x 45°	6-0405	4.1	<b>135.00</b>
		5" x 45°	6-0406	6.9	<b>183.00</b>
		6" x 45°	6-0407	9.1	<b>215.00</b>
	<b>90°</b>	2" x 90°	6-0398	2.1	<b>64.00</b>
		3" x 90°	6-0399	2.8	<b>83.00</b>
		4" x 90°	6-0400	4.1	<b>110.00</b>
		5" x 90°	6-0401	6.9	<b>155.00</b>
		6" x 90°	6-0402	9.1	<b>189.00</b>
<b>PLAIN ELBOW</b> (ALUMINUM)					
	<b>45°</b>	2" x 45°	6-0354	1.7	<b>69.00</b>
		3" x 45°	6-0355	1.8	<b>75.00</b>
		4" x 45°	6-0350	2.6	<b>85.00</b>
		5" x 45°	6-0356	3.2	<b>89.00</b>
		6" x 45°	6-0351	3.3	<b>105.00</b>
		8" x 45°	6-0352	4.6	<b>110.00</b>
		10" x 45°	6-0353	5.6	<b>130.00</b>
		12" x 45°	6-9001	-	<b>315.00</b>
	<b>90°</b>	2" x 90°	6-0364	2.0	<b>79.00</b>
		3" x 90°	6-0365	2.3	<b>89.00</b>
		4" x 90°	6-0360	2.8	<b>89.00</b>
		5" x 90°	6-0366	4.6	<b>105.00</b>
		6" x 90°	6-0361	4.5	<b>125.00</b>
		8" x 90°	6-0362	6.5	<b>135.00</b>
		10" x 90°	6-0363	8.0	<b>165.00</b>
		12" x 90°	6-8021	-	<b>375.00</b>
<b>SURFACE ELBOW</b> (PVC)					
	<b>45°</b>	6" x 45°	6-0340	-	<b>75.00</b>
		8" x 45°	6-0341	-	<b>90.00</b>
		10" x 45°	6-0342	-	<b>115.00</b>
		12" x 45°	6-0343	-	<b>145.00</b>
	<b>90°</b>	6" x 90°	6-0344	-	<b>85.00</b>
		8" x 90°	6-0345	-	<b>105.00</b>
		10" x 90°	6-0346	-	<b>145.00</b>
		12" x 90°	6-0347	-	<b>185.00</b>

# FLANGED FITTINGS

Product	Description	Part Number	Weight	List Price
---------	-------------	-------------	--------	------------

## FLANGED ELBOW (GALVANIZED STEEL)



Size	Flanged 45°			Flanged 90°		
	Part #	Weight	List	Part #	Weight	List
4"	9-7941		<b>175.00</b>	9-7415	27.7	<b>165.00</b>
6"	9-7942		<b>195.00</b>	9-5825	39.0	<b>275.00</b>
8"	9-7943		<b>228.00</b>	9-5826	52.8	<b>325.00</b>
10"	9-7944		<b>275.00</b>	9-5827	67.1	<b>385.00</b>
12"	9-7945		<b>355.00</b>	9-7416	86.8	<b>485.00</b>

Also Available in Cast Aluminum, call for prices.

## FLANGE X RINGLOCK ELBOW (GALVANIZED STEEL)



Size	Flange x MRL			Flange x FRL		
	Part #	Weight	List	Part #	Weight	List
6"	9-7993		<b>266.00</b>	9-7996	-	<b>266.00</b>
8"	9-7994		<b>300.00</b>	9-7997	-	<b>300.00</b>
10"	9-7995		<b>360.00</b>	9-7998	-	<b>360.00</b>

Also Available in Cast Aluminum, call for prices.

## FLANGED TEE (GALVANIZED STEEL)



4"	9-7423	32.6	<b>215.00</b>
6"	9-5822	44.9	<b>259.00</b>
8"	9-5823	61.2	<b>320.00</b>
10"	9-5824	78.1	<b>432.00</b>
12"	9-7424	103.0	<b>500.00</b>

Also Available in Cast Aluminum, call for prices.

## FLANGED SPOOL (GALVANIZED STEEL)



4" x 4"	12" Long	9-7946	-	<b>115.00</b>
6" x 4"	3.5" Long	9-7999	-	<b>100.00</b>
6" x 6"	12" Long	9-7947	-	<b>130.00</b>
8" x 6"	3.5" Long	9-8000	-	<b>125.00</b>
8" x 8"	12" Long	9-7948	-	<b>158.00</b>
10" x 8"	3.5" Long	9-8001	-	<b>156.00</b>
10" x 10"	12" Long	9-7949	-	<b>195.00</b>
12" x 12"	12" Long	9-7950	-	<b>278.00</b>

Also Available in Aluminum, call for prices.

## FLANGE ADAPTERS (GALVANIZED STEEL)



4" Flange x 4" FRL	9-6830	8.6	<b>59.00</b>
6" Flange x 6" FRL	6-6450	12.1	<b>70.00</b>
8" Flange x 8" FRL	6-6451	17.4	<b>90.00</b>
10" Flange x 10" FRL	6-6449	22.1	<b>118.00</b>
12" Flange x 10" FRL	6-6448	32.0	<b>166.00</b>
4" Flange x 4" MRL	9-6831	8.6	<b>57.00</b>
6" Flange x 6" MRL	6-6459	12.1	<b>70.00</b>
8" Flange x 8" MRL	6-6549	17.4	<b>90.00</b>
10" Flange x 10" MRL	6-6458	22.1	<b>118.00</b>
12" Flange x 12" MRL	6-6457	32.0	<b>166.00</b>







Also Available in Cast Aluminum, call for prices.

## FLANGE X FRL INCREASERS - REDUCERS (GALVANIZED STEEL)



<b>Increaser</b>			
6" Flange x 8" FRL	9-8002	-	<b>111.00</b>
8" Flange x 10" FRL	9-8003	-	<b>150.00</b>
<b>Reducer</b>			
8" Flange x 6" FRL	9-8004	-	<b>115.00</b>
10" Flange x 8" FRL	9-8005	-	<b>140.00</b>

Also Available in Cast Aluminum, call for prices.

Product	Description	Part Number	Weight	List Price
<b>RINGLOCK END TEE</b> (GALVANIZED STEEL) 	3"	9-7417	9.0	150.00
	4"	9-7418	13.6	165.00
	5"	9-7419	17.0	192.00
	6"	6-0410	19.6	165.00
	8"	6-0411	27.1	215.00
	10"	6-0412	33.3	325.00
	12"	9-7420	52.0	359.00
Ringlock clamp is <u>not</u> included.				
<b>RINGLOCK END TEE</b> (CAST ALUMINUM) 	4"	9-7421	6.2	175.00
	5"	9-7422	7.5	205.00
	6"	6-0430	9.6	225.00
	8"	6-0431	13.4	285.00
	10"	6-0432	17.3	345.00
Ringlock clamp is <u>not</u> included.				
<b>PLAIN END TEE</b> (ALUMINUM) 	2"	6-0444	3.3	90.00
	3"	6-0445	3.6	90.00
	4"	6-0440	3.9	99.00
	5"	6-0446	6.6	120.00
	6"	6-0441	6.6	160.00
	8"	6-0442	8.9	185.00
	10"	6-0443	11.5	225.00
12"	6-8026	16.1	725.00	
<b>PLAIN END TEE</b> (SURFACE PVC) 	6"	6-0447	-	107.00
	8"	6-0448	-	135.00
	10"	6-0449	-	167.00
	12"	6-0453	-	225.00
<b>HOOK STYLE END TEE</b> (CAST ALUMINUM) 	2"	6-0450	2.6	82.00
	3"	6-0451	3.8	94.00
	4"	6-0452	4.8	165.00
<b>TWIST LOCK END TEE</b> (CAST ALUMINUM) 	6"	6-0316	9.1	255.00
<b>KNOB STYLE END TEE</b> (ALUMINUM) 	2"	6-0460	2.6	95.00
	3"	6-0461	3.5	99.00
	4"	6-0462	6.4	118.00
	*5"	6-0463	7.3	195.00
	*6"	6-0464	8.8	215.00

\* Fabricated Aluminum.

Fittings

# LINE TEES & Y TEES

Product	Description	Part Number	Weight	List Price
<b>RINGLOCK LINE TEE</b> (GALVANIZED STEEL)	3"	9-7426	9.0	<b>150.00</b>
	4"	9-7427	13.6	<b>165.00</b>
	5"	9-7428	17.0	<b>192.00</b>
	6"	6-0610	19.6	<b>165.00</b>
	8"	6-0611	27.1	<b>215.00</b>
	10"	6-0612	33.3	<b>325.00</b>
	12"	9-7429	52.0	<b>359.00</b>



<b>RINGLOCK LINE TEE</b> (CAST ALUMINUM)	4"	9-7430	6.2	<b>175.00</b>
	5"	9-7431	7.5	<b>205.00</b>
	6"	6-0630	9.6	<b>225.00</b>
	8"	6-0631	13.4	<b>285.00</b>
	10"	6-0632	17.3	<b>345.00</b>



<b>PLAIN LINE TEE</b> (ALUMINUM)	2"	6-0644	3.3	<b>90.00</b>
	3"	6-0645	3.6	<b>90.00</b>
	4"	6-0640	3.9	<b>99.00</b>
	5"	6-0646	6.6	<b>120.00</b>
	6"	6-0641	6.6	<b>160.00</b>
	8"	6-0642	8.9	<b>185.00</b>
	10"	6-0643	11.5	<b>225.00</b>
	12"	6-8025	16.1	<b>725.00</b>



<b>PLAIN LINE TEE</b> (SURFACE PVC)	6"	6-0647	-	<b>107.00</b>
	8"	6-0648	-	<b>135.00</b>
	10"	6-0649	-	<b>167.00</b>
	12"	6-0653	-	<b>225.00</b>



<b>TWIST LOCK LINE TEE</b> (CAST ALUMINUM)	6"	6-0317	9.1	<b>255.00</b>
---	----	--------	-----	---------------



<b>HOOK STYLE LINE TEE</b> (CAST ALUMINUM)	2"	6-0650	4.0	<b>86.00</b>
	3"	6-0651	5.0	<b>110.00</b>
	4"	6-0652	7.0	<b>145.00</b>



# LINE TEES & Y TEES

Product	Description	Part Number	Weight	List Price
<b>KNOB STYLE LINE TEE</b> (CAST ALUMINUM)	2"	6-0660	2.8	<b>95.00</b>
	3"	6-0661	3.8	<b>99.00</b>
	4"	6-0662	5.0	<b>118.00</b>
	5"	6-0663	11.9	<b>195.00</b>
	6"	6-0664	14.0	<b>215.00</b>



<b>PLAIN LINE Y TEE</b> (ALUMINUM)	6"	6-0550	-	<b>153.00</b>
	8"	6-0551	-	<b>175.00</b>
	10"	6-0552	-	<b>196.00</b>

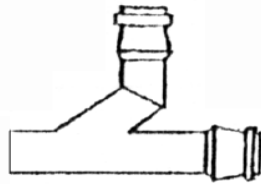

<b>PLAIN Y TEE</b> (ALUMINUM)	6"	6-0540	7.2	<b>220.00</b>
	8"	6-0541	9.6	<b>260.00</b>
	10"	6-0542	12.5	<b>329.00</b>
	12"	6-8027	-	<b>675.00</b>

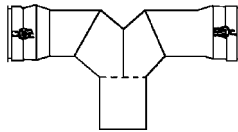

<b>RINGLOCK Y TEE</b> (GALVANIZED STEEL)	6"	6-0510	24.7	<b>300.00</b>
	8"	6-0511	33.8	<b>320.00</b>
	10"	6-0512	41.8	<b>355.00</b>

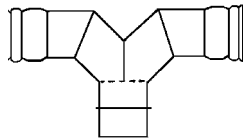

<b>RINGLOCK Y TEE</b> (ALUMINUM)	6"	6-0530	7.7	<b>269.00</b>
	8"	6-0531	10.5	<b>279.00</b>
	10"	6-0532	13.5	<b>359.00</b>





# REDUCERS

Product	Description	Part Number	Weight	List Price
<b>PLAIN REDUCER</b> (ALUMINUM)	3" x 2"	6-0614	1.8	<b>65.00</b>
	4" x 3"	6-0615	2.0	<b>65.00</b>
	5" x 4"	8-1428	3.7	<b>95.00</b>
	6" x 4"	6-0710	2.8	<b>74.00</b>
	8" x 4"	6-0713	7.2	<b>140.00</b>
	8" x 6"	6-0711	3.9	<b>80.00</b>
	10" x 8"	6-0712	4.0	<b>94.00</b>
	12" x 10"	6-9002	-	<b>325.00</b>



## RINGLOCK REDUCER

(GALVANIZED STEEL)

6" x 4"	6-0730	6.4	<b>90.00</b>
8" x 4"	6-0733	9.6	<b>180.00</b>
8" x 6"	6-0731	9.3	<b>105.00</b>
10" x 8"	6-0732	12.7	<b>135.00</b>



## HOOK STYLE REDUCER

(CAST ALUMINUM)

3" x 2"	6-0720	2.0	<b>55.00</b>
4" x 3"	6-0721	3.0	<b>59.00</b>



## KNOB STYLE REDUCER

(CAST ALUMINUM)

3" x 2"	6-0717	1.6	<b>85.00</b>
4" x 3"	6-0718	2.3	<b>104.00</b>
5" x 4"	6-0719	2.8	<b>126.00</b>
6" x 4"	6-0709	4.8	<b>138.00</b>



# REDUCER & INCREASERS

Product	Description	Part Number	Weight	List Price
<b>SURFACE REDUCER</b> (PVC)	8" x 6"	6-0714	-	<b>59.00</b>
	10" x 8"	6-0715	-	<b>72.00</b>
	12" x 10"	6-0716	-	<b>87.00</b>

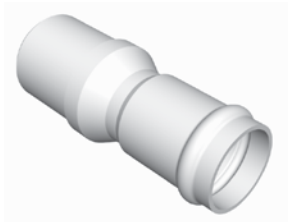

<b>PLAIN INCREASER</b> (ALUMINUM)	4" x 6"	6-0740	4.8	<b>90.00</b>
	6" x 8"	6-0741	6.3	<b>110.00</b>
	8" x 10"	6-0742	9.1	<b>140.00</b>
	10" x 12"	6-9003	-	<b>355.00</b>



<b>RINGLOCK INCREASER</b> (GALVANIZED STEEL)	6" x 8"	6-0760	11.3	<b>105.00</b>
	8" x 10"	6-0761	14.3	<b>135.00</b>



<b>SURFACE INCREASER</b> (PVC)	6" x 8"	6-0743	-	<b>59.00</b>
	8" x 10"	6-0744	-	<b>72.00</b>
	10" x 12"	6-0745	-	<b>87.00</b>

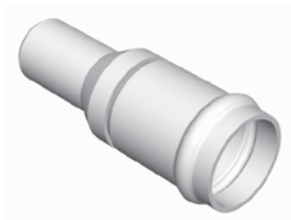

# END PLUGS

Product	Description	Part Number	Weight	List Price
<b>PLAIN END PLUG</b> (ALUMINUM)	4"	6-0810	1.4	<b>49.00</b>
	5"	6-0814	2.4	<b>59.00</b>
	6"	6-0811	2.5	<b>59.00</b>
	8"	6-0812	3.8	<b>65.00</b>
	10"	6-0813	4.6	<b>74.00</b>
	12"	6-8020	-	<b>125.00</b>



## RINGLOCK END PLUG

(GALVANIZED STEEL)



3"	9-7432	1.8	<b>45.00</b>
4"	9-7433	2.3	<b>50.00</b>
5"	9-7434	3.5	<b>55.00</b>
6"	6-0830	4.9	<b>55.00</b>
8"	6-0831	6.9	<b>65.00</b>
10"	6-0832	9.9	<b>100.00</b>
12"	9-7435	15.1	<b>110.00</b>

## RINGLOCK END PLUG

W/2" MPT  
(GALVANIZED STEEL)

4"	9-8006	-	<b>59.00</b>
5"	9-8007	-	<b>69.00</b>
6"	9-8113	-	<b>77.00</b>
8"	9-8114	-	<b>91.00</b>
10"	9-8115	-	<b>115.00</b>

## HOOK STYLE END PLUG

(CAST ALUMINUM)



2"	6-0821	1.0	<b>24.00</b>
3"	6-0822	1.5	<b>28.00</b>
4"	6-0820	2.0	<b>39.00</b>
5"	6-0823	3.0	<b>52.00</b>
6"	6-0824	4.0	<b>57.00</b>

## TWIST LOCK END PLUG

(CAST ALUMINUM)



6"	6-0315	3.5	<b>117.00</b>
----	--------	-----	---------------

# END PLUGS & END CAPS

Product	Description	Part Number	Weight	List Price
<b>KNOB STYLE END PLUG</b> (CAST ALUMINUM)	2"	6-0833	0.8	28.00
	3"	6-0834	1.3	29.00
	4"	6-0835	1.8	37.00
	5"	6-0836	2.3	49.00
	6"	6-0837	3.0	55.00



<b>SURFACE END PLUG</b> (PVC)	6"	6-0815	-	28.00
	8"	6-0816	-	34.00
	10"	6-0817	-	42.00
	12"	6-0818	-	54.00



<b>RINGLOCK END CAP</b> (GALVANIZED STEEL)	3"	9-7436	1.6	45.00
	4"	9-7437	2.3	50.00
	5"	9-7438	3.5	55.00
	6"	6-0870	4.1	78.00
	8"	6-0871	8.2	87.00
	12"	9-7439	9.9	100.00
		9-7440	15.1	110.00



<b>END PLUG COVER, W/HANDLE, WELD-ON</b> (CAST ALUMINUM)	6"	9-7620	1.5	43.00
	8"	9-7621	2.5	60.00
	10"	9-7622	3.3	68.00





Aluminum end plug cover fits coupler weld socket for fabricating end plugs.

# WELD-ON ELBOWS & TEES

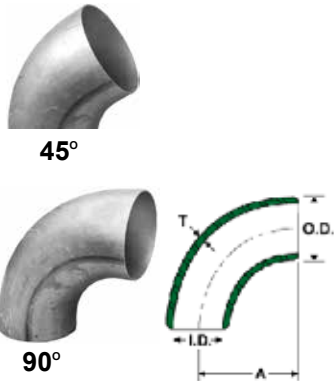







Product	Description	Part Number	Weight	List Price				
<b>SWEEPING ELBOW- WELD-ON (CAST ALUMINUM)</b>		<b>Cast Alum 45° Sweep</b>		<b>Cast Alum 90° Sweep</b>				
		Size	Part #	Weight	List	Part #	Weight	List
		3"	6-0270	1.0	<b>\$28.00</b>	6-0275	1.5	<b>\$48.00</b>
		4"	6-0271	1.0	<b>29.00</b>	6-0276	1.7	<b>52.00</b>
		5"	6-9943	1.5	<b>42.00</b>	6-9942	2.3	<b>68.00</b>
		6"	6-0272	2.0	<b>50.00</b>	6-0277	4.0	<b>82.00</b>
		8"	6-0273	3.5	<b>61.00</b>	6-0278	6.0	<b>98.00</b>
		10"	6-0274	4.8	<b>89.00</b>	6-0279	9.5	<b>150.00</b>
		12"	9-7413	5.5	<b>208.00</b>	9-7414	11.0	<b>345.00</b>

Product	Description	Part Number	Weight	List Price							
<b>SWEEPING ELBOW- WELD-ON (BLACK STEEL)</b>		<b>Black Steel 45° Sweep</b>			<b>Black Steel 90° Sweep</b>						
		Size	Part #	Thickness	Weight	List	Part #	Thickness	"A"	Weight	List
		2"	6-0075		2.0	<b>\$20.00</b>	6-0001			2.0	<b>\$26.00</b>
		3"	6-0076		4.0	<b>35.00</b>	6-0002			4.0	<b>33.00</b>
		4"	6-0077	.200"	5.5	<b>55.00</b>	6-0003	.200"	5.25"	5.7	<b>54.00</b>
		4-1/2"	9-7755	.134"	3.0	<b>15.00</b>	9-7758	.134"		6.0	<b>19.00</b>
		5"	9-8112		-	<b>50.00</b>	9-5017			-	<b>70.00</b>
		5-5/8"	9-7894	.188"		<b>24.00</b>	9-7897	.188"			<b>33.00</b>
		6"					9-7658	.072"	16.25"		<b>77.00</b>
		6"	6-0078	.190"	10.0	<b>59.00</b>	6-0004	.190"	8.50"	13.4	<b>83.00</b>
		6-5/8"	9-7756	.190"	6.0	<b>28.00</b>	9-7759	.190"		12.0	<b>41.00</b>
		8"	9-6813	.190"	15.0	<b>68.00</b>	6-9939	.190"	11.50"	24.5	<b>110.00</b>
		8-5/8"	9-7757	.190"	11.1	<b>55.00</b>	9-7760	.190"		22.1	<b>75.00</b>
		10"	9-7776	.190"		<b>75.00</b>	9-7777	.190"			<b>130.00</b>
		10-3/4"	9-7895	.250"		<b>107.00</b>	9-7898	.250"			<b>168.00</b>
		12-3/4"	9-7896	.250"		<b>145.00</b>	9-7899	.250"			<b>231.00</b>

Product	Description	Part Number	Weight	List Price				
<b>MITERED ELBOW- WELD-ON 10GA. (BLACK STEEL)</b>		<b>10ga 45° Mitered</b>			<b>10ga 90° Mitered</b>			
		Size	Part #	Weight	List	Part #	Weight	List
		3"	6-0280	1.5	<b>\$45.00</b>	6-0284	2.1	<b>\$65.00</b>
		4"	6-0281	3.6	<b>50.00</b>	6-0285	5.4	<b>65.00</b>
		6"	6-0282	6.1	<b>63.00</b>	6-0286	9.3	<b>99.00</b>
		8"	6-0283	10.8	<b>75.00</b>	6-0287	14.1	<b>115.00</b>
		10"	6-0268	12.3	<b>95.00</b>	6-0288	19.7	<b>140.00</b>
		12"	6-0269	15.9	<b>110.00</b>	6-0289	26.1	<b>195.00</b>

Product	Description	Part Number	Weight	List Price	
<b>WELD-ON TEE (CAST ALUMINUM)</b>		3"	9-7425	1.5	<b>65.00</b>
		4"	6-9940	2.0	<b>75.00</b>
		5"	6-9941	2.5	<b>82.00</b>
		6"	6-0290	3.0	<b>92.00</b>
		8"	6-0291	5.8	<b>125.00</b>
		10"	6-0292	8.0	<b>150.00</b>

Product	Description	Part Number	Weight	List Price	
<b>WELD-ON TEE (BLACK STEEL)</b>		4"	6-0293	11.5	<b>75.00</b>
		5"	6-0294	15.4	<b>80.00</b>
		6"	6-0295	14.3	<b>90.00</b>
		8"	6-0296	21.2	<b>99.00</b>
		10"	6-0297	29.0	<b>120.00</b>
		12"	6-0298	38.0	<b>145.00</b>

Product	Description	Part Number	Weight	List Price		
<b>SINGLE BAND &amp; HOOK</b> (GALVANIZED STEEL)  <p>Single Complete Assembly includes 1 band, 1 hook, 2 bolts, 2 nuts and 1 ferrule.</p>  <p>Single Band Only Assembly includes 1 band and 1 nut &amp; bolt</p>	Complete:	2"	6-0913	0.5	<b>9.50</b>	
		3"	6-0914	0.6	<b>10.50</b>	
		4"	6-0910	0.6	<b>11.50</b>	
		5"	6-0922	0.8	<b>12.50</b>	
		6"	6-0920	2.8	<b>13.50</b>	
		7"	6-0923	3.0	<b>15.00</b>	
		8"	6-0930	3.8	<b>16.00</b>	
		9"	6-0932	4.0	<b>18.00</b>	
		10"	6-0940	4.5	<b>18.50</b>	
		12"	6-0945	5.0	<b>20.00</b>	
		Band Only:	2"	6-0915	0.4	<b>6.00</b>
			3"	6-0916	1.3	<b>7.00</b>
			4"	6-0911	-	<b>8.00</b>
		5"	6-0924	1.9	<b>9.00</b>	
		6"	6-0921	2.2	<b>10.00</b>	
		7"	6-0925	-	<b>11.50</b>	
		8"	6-0931	2.8	<b>12.50</b>	
		9"	6-0933	2.1	<b>14.50</b>	
		10"	6-0941	3.4	<b>15.00</b>	
		12"	6-0942	-	<b>16.50</b>	
<b>DOUBLE BAND &amp; HOOK</b> (GALVANIZED STEEL)  <p>Double Complete Assembly includes 1 band, 2 hooks, 3 bolts, 3 nuts and 2 ferrules.</p>	Complete:	4"	6-0950	1.4	<b>28.00</b>	
		6"	6-0960	3.6	<b>30.00</b>	
		8"	6-0970	4.6	<b>33.00</b>	
		10"	6-0980	5.3	<b>35.00</b>	
		12"	6-0990	5.8	<b>36.00</b>	
		Band Only:	4"	6-0951	0.3	<b>22.00</b>
			6"	6-0961	2.5	<b>23.50</b>
			8"	6-0971	3.1	<b>25.20</b>
			10"	6-0981	3.7	<b>27.00</b>
			12"	6-0991	0.3	<b>28.00</b>
<b>HOOK</b> (GALVANIZED STEEL)    	Universal	6-0904	0.5	<b>4.00</b>		
	Anderson	4-0012	0.5	<b>4.20</b>		
	A&M Long	4-0013	-	<b>4.30</b>		
	A&M Short	4-0014	0.4	<b>4.30</b>		
<b>NUTS &amp; BOLTS</b> (FOR BAND & HOOK) 	Bolt, 3/8"x1-1/2"	Grade 5	6-0901	0.1	<b>0.30</b>	
	Nut, 3/8"	Grade 2	6-0902	-	<b>0.08</b>	
	Ferrule, 5/16" width		6-0903	-	<b>0.50</b>	
	Ferrule, 1/2" width		6-0899	-	<b>0.60</b>	
	Bolt, 3/4"x2" long	Grade 5	6-0905	0.4	<b>1.70</b>	
	Nut, 3/4"	Grade 2	6-0906	0.1	<b>0.50</b>	

Fittings

# BAND & LATCH ACCESSORIES

Product	Description	Part Number	Weight	List Price	
<b>BAND &amp; LATCH</b> (KNOB STYLE)		2"	6-0992	0.4	<b>9.00</b>
		3"	6-0993	0.5	<b>10.00</b>
		4"	6-0994	0.9	<b>13.50</b>
		5"	6-0995	1.6	<b>17.00</b>
		6"	6-0996	1.8	<b>21.00</b>



2", 3"



4", 5", 6"

<b>BAND ONLY</b> (KNOB STYLE)		2"	6-0953	0.6	<b>4.50</b>
		3"	6-0954	0.7	<b>5.20</b>
		4"	6-0955	0.8	<b>8.70</b>
		5"	6-0956	1.4	<b>12.00</b>
		6"	6-0957	1.7	<b>16.70</b>



2"-3"



5"-6"

\* Includes Nuts and Bolts

<b>LATCH ONLY</b> (KNOB STYLE)		CX, 2"-3"-4"	6-0946	0.3	<b>4.70</b>
		DX, 5"-6"	6-0952	0.3	<b>4.70</b>



CX



DX

<b>CARRIAGE BOLT &amp; NUT</b> (KNOB STYLE BAND & LATCH)		5/16" x 1" long (4" back)	6-0947	0.1	<b>0.20</b>
		5/16" x 1-1/2" long (2", 3", 4" front)	6-0962	0.1	<b>0.30</b>
		3/8" x 1-1/4" long (5", 6" back)(2 req)	6-0963	0.1	<b>0.30</b>
		3/8" x 1-3/4" long (5", 6" front)	6-0964	0.1	<b>0.50</b>
		Nut, 5/16"	6-0965	0.1	<b>0.10</b>
		Nut, 3/8"	6-0966	0.1	<b>0.15</b>









<b>BOLT KITS</b> (FOR CHEMIGATION VALVES)	<b>Bolt Kit-Flange (complete set of nuts, bolts, flat &amp; lock washers):</b>					
	2", 3"	(set of 4)	5/8"x 2" long	9-5882	-	<b>8.00</b>
	4"	(set of 8)	5/8"x2" long	9-5883	-	<b>13.00</b>
	5",6",8"	(set of 8)	3/4"x2" long	9-5884	4.9	<b>22.00</b>
	10", 12"	(set of 12)	7/8"x2" long	9-5881	10.7	<b>44.00</b>



<b>BOLT KITS</b> (FOR WAFER VALVES)	Bolt,	3/4" x 5-1/2"	Grade 5	9-5880		<b>3.80</b>
	<b>Standard Bolt Kit-WBV (complete set of nuts, bolts, flat &amp; lock washers)</b>					
	<b>For Steel Flanges:</b>					
	2", 3"	(set of 4)	5/8"x 4" long	9-5886	-	<b>10.00</b>
	4"	(set of 8)	5/8"x 4-1/2" long	9-5887	5.0	<b>29.00</b>
	5",6",8"	(set of 8)	3/4"x 5" long	9-5888	7.8	<b>30.00</b>
	10", 12"	(set of 12)	7/8"x 5-1/2" long	9-5885	17.7	<b>100.00</b>
	16"	(set of 16)	1" x 5-1/2"	9-7663	-	<b>115.00</b>
	18"	(set of 16)	1-1/8" x 5-1/2"	9-7664	-	<b>159.00</b>
	<b>Standard Bolt Kit-WBV (complete set of nuts, bolts, flat &amp; lock washers)</b>					
	<b>For PVC Flanges:</b>					
	2", 3"	(set of 4)	5/8"x 5" long	9-6864	-	<b>12.00</b>
	4"	(set of 8)	5/8"x 6" long	9-6865	-	<b>28.00</b>
	5",6",8"	(set of 8)	3/4"x 7" long	9-6866	-	<b>60.00</b>
	10", 12"	(set of 12)	7/8"x 8" long	9-6863	-	<b>120.00</b>



# BAND & LATCH ACCESSORIES

Product	Description	Part Number	Weight	List Price
<b>D RING - WELD-ON</b>	Steel	6-0841	-	11.00
				
<b>D RING - BOLT-ON</b> (CAST ALUMINUM)		6-0842	0.4	5.70
				
<b>BAIL RING</b>	6"w/Steel Bracket	6-0846	-	37.00
	6"w/Aluminum Bracket	6-0847	-	37.00
	3",4",5" w/Aluminum Bracket	6-0848	-	20.00
				
<b>LUG - WELD-ON</b> (ALUMINUM)	6" Aluminum	6-0849	0.2	7.00
	4" Aluminum	6-0851	0.1	4.50
	* To match above Bail Rings			
				
<b>LOCK PLATE STUB</b> (CAST ALUMINUM)		6-0843	-	5.50
				
	*Older ones are steel			
<b>KNOB - WELD-ON</b> (CAST ALUMINUM)		6-0844	0.1	4.50
				



Product	Description	Part Number	Weight	List Price
<b>RING - WELD-ON</b> (CAST ALUMINUM)	6"	6-1010	0.6	<b>12.50</b>
	8"	6-1011	0.9	<b>15.00</b>
	10"	6-1012	1.1	<b>19.50</b>



<b>RING - WELD-ON</b> (BLACK STEEL)	6"	6-1020	1.0	<b>9.00</b>
	8"	6-1021	1.1	<b>12.00</b>
	10"	6-1022	1.4	<b>14.00</b>



<b>RING - BOLT-ON</b> (PAINTED STEEL)	4"	9-5806	1.2	<b>12.00</b>
	6"	6-1032	1.7	<b>13.50</b>
	8"	6-1033	2.1	<b>15.00</b>
	10"	6-1035	2.6	<b>17.50</b>
	12"	9-5807	-	<b>19.00</b>



-Max. 50 psi

<b>RINGLOCK CLAMP</b> (PLATED STEEL)	<b>A&amp;M(small):</b>	6"	6-0083	2.0	<b>23.00</b>
		8"	6-0084	2.5	<b>25.00</b>
		10"	6-0085	3.5	<b>27.00</b>
	<b>Pierce(small):</b>	6"	6-1060	2.0	<b>21.00</b>
	<b>Standard:</b>	3"	6-1047	1.4	<b>17.00</b>
		4"	6-1038	1.6	<b>18.00</b>
		5"	6-1039	1.8	<b>19.00</b>
		6"	6-1040	2.0	<b>20.00</b>
		7"	6-1036	2.3	<b>25.00</b>
		8"	6-1041	2.7	<b>22.00</b>
		10"	6-1042	3.5	<b>27.00</b>
		12"	6-1037	5.3	<b>32.00</b>
<b>Oversized:</b>	6"	6-1043	2.0	<b>23.00</b>	
	8"	6-1044	2.5	<b>25.00</b>	



# RING ACCESSORIES & DISCS

Product	Description	Part Number	Weight	List Price
<b>HORSESHOE CLAMP</b> (PAINTED STEEL)	6"	6-1050	1.5	23.00
	7"	6-1054	1.6	19.00
	8"	6-1051	1.7	26.00
	10"	6-1052	2.1	29.00

Up to 50 psi



<b>BAIL SPRING</b>		6-1046	0.5	2.50
--------------------	--	--------	-----	------



<b>U - HOLDER FOR TELESCOPE</b>		6-0862	0.5	21.00
---------------------------------	--	--------	-----	-------



<b>LOCKING BLOCK</b>	Aluminum	6-0840	0.3	6.00
	Steel	6-0850	0.3	4.00



Steel



Aluminum

<b>U - HOLDER</b>	Aluminum	6-0861	0.1	9.00
	Steel	6-0860	0.3	3.00



## DISC - WELD-ON (ALUMINUM)



.090 wall thickness.

2"	6-1156	0.1	3.00
3"	6-1157	0.3	4.00
4"	6-1159	0.5	5.00
5"	6-1158	0.8	6.00
6"	6-1160	1.0	8.00
7"	9-5808	-	10.00
8"	6-1161	1.7	11.00
9"	9-5809	0.5	12.50
10"	6-1162	2.0	14.00
12"	6-1163	2.5	18.00

## DISC - WELD-ON (BLACK STEEL)



	Thickness			
2"	3/16"	6-1170	0.1	2.00
3"	3/16"	6-1171	0.2	3.00
4"	3/16"	6-1150	0.4	4.00
5"	3/16"	6-1172	1.1	5.00
6"	3/16"	6-1151	1.0	6.00
7"	1/4"	6-1173	2.8	9.00
8"	3/16"	6-1152	3.3	10.00
9"	1/4"	6-1175	4.6	11.00
10"	3/16"	6-1153	4.0	13.00
11"	1/4"	6-1176	6.8	17.00
12"	3/16"	6-1174	5.8	19.00

Fittings

# FLANGES

Product	Description	Part Number	Weight	List Price	
<b>FLANGE</b> (BLACK STEEL)	<b>OD Size</b>				
	2"	6-1104	3.5	<b>13.00</b>	
	2-1/2"	6-1105	4.5	<b>18.00</b>	
	3"	6-1106	5.3	<b>12.50</b>	
	4"	6-1107	7.1	<b>17.00</b>	
	5"	6-1108	8.2	<b>19.00</b>	
	6"	6-1110	9.3	<b>21.00</b>	
	8"	6-1111	12.9	<b>29.00</b>	
	10"	6-1112	16.6	<b>40.00</b>	
	12"	6-1109	23.0	<b>59.00</b>	
	14"	8-1440	26.5	<b>114.00</b>	
	16"	8-1441	31.0	<b>149.00</b>	
	18"	8-1442	32.0	<b>179.00</b>	
	20"	8-1443	37.5	<b>210.00</b>	
	22"	8-1444	38.5	<b>249.00</b>	
	24"	8-1445	51.0	<b>375.00</b>	
		<b>IPS Size</b>			
		4-1/2"	9-6915	6.6	<b>17.00</b>
		6-5/8"	6-9674	8.7	<b>21.00</b>
		8-5/8"	6-9675	11.7	<b>29.00</b>
		10-3/4"	6-9676	14.9	<b>40.00</b>
		12-3/4"	6-9677	22.1	<b>59.00</b>
		<b>For Valve Outlet</b>			
		6"	6-9678	6.1	<b>21.00</b>
		8"	6-9679	8.9	<b>29.00</b>
		10"	6-9680	-	<b>95.00</b>
		12"	6-9681	-	<b>165.00</b>



Includes Gasket

## Specifications:

- Carbon Steel (either A36 plate OR A283-C plate)
- Polyurethane coating (to avoid rust in transit)
- Mil finished plate x machined (125-250-rms) facing
- 1/2" thick; #150 psi test
- Full Face flanges; Standard Bolt Holes
- 1/16" red rubber flange gasket included
- DIN Flanges also available (please call)

Larger sizes available, please call for pricing and availability.

Size	Part #	Thickness	ID	OD	Bolt Circle	# of Holes	Hole Size	Bolt Size
2"	6-1104	1/2"	2-1/16"	6"	4-3/4"	4	3/4"	5/8"
2-1/2"	6-1105	1/2"	2-9/16"	7"	5-1/2"	4	3/4"	5/8"
3"	6-1106	1/2"	3-1/16"	7.5"	6"	4	3/4"	5/8"
4"	6-1107	1/2"	4-1/16"	9"	7-1/2"	8	3/4"	5/8"
4-1/2" IPS Size	9-6915	1/2"	4.57"	9"	7-1/2"	8	3/4"	5/8"
5"	6-1108	1/2"	5-1/16"	10"	8-1/2"	8	7/8"	3/4"
6"	6-1110	1/2"	6-1/16"	11"	9-1/2"	8	7/8"	3/4"
6-5/8" IPS Size	6-9674	1/2"	6.72"	11"	9-1/2"	8	7/8"	3/4"
6" For Valve Outlet	6-9678	1/2"	8-1/16"	11"	9-1/2"	8	7/8"	3/4"
8"	6-1111	1/2"	8-1/16"	13.5"	11-3/4"	8	7/8"	3/4"
8-5/8" IPS Size	6-9675	1/2"	8.72"	13.5"	11-3/4"	8	7/8"	3/4"
8" For Valve Outlet	6-9679	1/2"	10-1/16"	13.5"	11-3/4"	8	7/8"	3/4"
10"	6-1112	1/2"	10-1/16"	16"	14-1/4"	12	1"	7/8"
10-3/4" IPS Size	6-9676	1/2"	10.88"	16"	14-1/4"	12	1"	7/8"
10" For Valve Outlet	6-9680	1/2"	12-1/16"	16"	14-1/4"	12	1"	7/8"
12"	6-1109	1/2"	12-1/16"	19"	17"	12	1"	7/8"
12-3/4"	6-9677	1/2"	12.88"	19"	17"	12	1"	7/8"
12" For Valve Outlet	6-9681	1/2"	14.13"	19"	17"	12	1"	7/8"
14"	8-1440	1/2"	14.13"	21"	18-3/4"	12	1-1/8"	1"
16"	8-1441	1/2"	16.13"	23.5"	21-1/4"	16	1-1/8"	1"
18"	8-1442	1/2"	18.13"	25"	22-3/4"	16	1-1/4"	1-1/8"
20"	8-1443	1/2"	20.13"	27.5"	25"	20	1-1/4"	1-1/8"
22"	8-1444	1/2"	22.13"	29.5"	27-1/4"	20	1-3/8"	1-1/4"
24"	8-1445	1/2"	24.13"	32"	29-1/2"	20	1-3/8"	1-1/4"

Product	Description	Part Number	Weight	List Price
<b>FLANGE</b> (CAST ALUMINUM)  <p>Includes Gasket</p>	3"	6-1055	3.0	65.00
	4"	6-1116	4.2	67.00
	5"	6-1117	5.2	73.00
	6"	6-1113	6.3	78.00
	8"	6-1114	8.1	99.00
	10"	6-1115	12.3	151.00
	12"	6-1103	17.5	232.00

<b>FLANGE</b> (STAINLESS STEEL)  <p>Includes Gasket</p>	6"	9-8101	-	129.00
	8"	9-8102	-	182.00
	10"	9-8103	-	245.00

<b>FLANGE - SQUARE</b> (BLACK STEEL) 	4"	9-5466	3.0	15.00
	6"	9-5467	1.9	19.00
	8"	9-5468	3.1	23.00

	Size		Thickness	Part Number	Weight	List Price
	Size	Thickness				
<b>FLANGE GASKET</b> (RED RUBBER)  <p>(Full Face)</p>	2"	1/16"		6-1101	-	1.75
	2-1/2"	1/16"		9-6814	-	2.50
	3"	1/16"		6-1102	-	2.50
	4"	1/16"		6-1118	0.2	3.00
	5"	1/16"		6-1119	0.2	3.70
	6"	1/16"		6-1120	0.3	3.50
	8"	1/16"		6-1121	0.3	4.00
	10"	1/16"		6-1122	0.3	4.75
	12"	1/16"		6-1123	0.5	6.75
	14"	1/16"		9-7797	-	13.00
	16"	1/16"		9-7798	-	15.00
	18"	1/16"		9-7799	-	17.00
	20"	1/16"		9-7800	-	19.00
	24"	1/16"		9-7801	-	22.00
	2"	1/8"		6-9666	-	1.50
	2-1/2"	1/8"		9-7802	-	1.75
	3"	1/8"		6-9667	-	2.00
	4"	1/8"		6-9668	-	2.80
	5"	1/8"		6-9669	-	3.40
	6"	1/8"		6-9670	-	4.20
8"	1/8"		6-9671	-	5.80	
10"	1/8"		6-9672	-	7.20	
12"	1/8"		6-9673	-	10.50	
14"	1/8"		8-1340	-	17.00	
16"	1/8"		8-1341	-	21.00	
18"	1/8"		8-1342	-	24.00	
20"	1/8"		8-1343	-	28.00	
22"	1/8"		8-1344	-	30.00	
24"	1/8"		8-1345	-	45.00	

Fittings

# FLANGES

Product	Description	Part Number	Weight	List Price
<b>FLANGE - BLIND</b> (BLACK STEEL)		<u>OD</u>	<u>Thickness</u>	
	2"	6"	1/2"	6-9707 4.0 <b>22.00</b>
	2-1/2"	7"	1/2"	6-9708 5.5 <b>29.00</b>
	3"	7-1/2"	1/2"	6-9709 6.5 <b>25.00</b>
	4"	9"	1/2"	6-9710 9.2 <b>33.00</b>
	6"	11"	1/2"	6-9711 13.8 <b>47.00</b>
	8"	13-1/2"	1/2"	6-9712 21.3 <b>69.00</b>
	10"	16"	1/2"	6-9713 28.1 <b>110.00</b>
	12"	19"	1/2"	6-9714 42.3 <b>140.00</b>
	14"	21"	1/2"	9-7724 51.5 <b>165.00</b>
	16"	23-1/2"	1/2"	9-7725 60.0 <b>345.00</b>
	18"	25"	1/2"	9-7726 70.0 <b>220.00</b>
	20"	27-1/2"	1/2"	9-7727 90.0 <b>285.00</b>
	24"	32"	1/2"	9-7728 125.0 <b>380.00</b>



Includes Gasket

## FLANGE - FEMALE THREAD (CAST IRON)

Thread Size	OD	Thickness	Part Number	Weight	List Price
2"	6"	5/8"	6-9639	5.1	<b>27.00</b>
2-1/2"	7"	5/8"	6-9640	7.1	<b>30.00</b>
3"	7-1/2"	5/8"	6-9641	7.9	<b>35.00</b>
4"	9"	5/8"	6-9642	13.2	<b>39.00</b>
5"	10"	3/4"	6-9643	15.2	<b>60.00</b>
6"	11"	3/4"	6-9644	19.0	<b>65.00</b>
8"	13-1/2"	1"	6-9645	30.3	<b>110.00</b>
10"	16"	1"	6-9646	43.3	<b>175.00</b>
12"	19"	1"	6-9647	64.4	<b>225.00</b>



Includes Gasket

\* Female pipe thread ID

## FLANGE INSULATION KIT



Includes:

- \* Nitrile-Face Phenolic Full Face Flange Gasket
- \* Mylar Sleeves
- \* Phenolic Washers (single washer kit)
- \* Steel Washers (single washer kit)
- \* Bolts & Nuts NOT included

2"	9-6928	0.4	<b>18.00</b>
2-1/2"	9-6929	0.6	<b>22.00</b>
3"	9-6930	0.6	<b>24.00</b>
4"	9-6931	0.8	<b>38.00</b>
5"	9-6932	1.0	<b>39.00</b>
6"	9-6933	1.2	<b>46.00</b>
8"	9-6934	1.6	<b>60.00</b>
10"	9-6935	3.0	<b>87.00</b>
12"	9-6936	3.2	<b>110.00</b>
14"	9-6937	4.2	<b>135.00</b>
16"	9-6938	5.6	<b>175.00</b>
18"	9-6939	6.4	<b>195.00</b>
20"	9-6940	7.2	<b>230.00</b>
22"	9-6941	8.5	<b>260.00</b>
24"	9-6942	9.8	<b>290.00</b>

This cathodically insulated kit prevents stray currents which cause undue corrosion and eventual breakdown of the metal. Also prevents leakage.

Product	Description	Part Number	Weight	List Price
<b>CONE</b> (BLACK STEEL)	3" x 2" 14 Gauge	6-1185	0.5	7.00
	4" x 2" 14 Gauge	6-1186	1.0	9.50
	4" x 3" 14 Gauge	6-1187	0.5	6.00
	5" x 3" 14 Gauge	6-1188	1.5	12.00
	5" x 4" 14 Gauge	6-1189	0.7	11.00
	6" x 3" 14 Gauge	6-1190	2.0	18.00
	6" x 4" 14 Gauge	6-1130	1.2	13.00
	6" x 4" 10 Gauge	6-9747	2.3	18.00
	6" x 4" 7 Gauge	9-7873	-	24.00
	6" x 5" 14 Gauge	6-1191	0.9	12.00
	7" x 5" 14 Gauge	6-1192	1.0	16.00
	7" x 6" 14 Gauge	6-1193	1.0	14.00
	8" x 7" 12 Gauge	6-1194	1.4	15.00
	8" x 4" 14 Gauge	6-1131	2.5	32.00
	8" x 5" 14 Gauge	6-1195	3.0	26.00
	8" x 6" 12 Gauge	6-1132	2.5	19.00
	8" x 6" 10 Gauge	6-9748	3.2	21.00
	8" x 6" 7 Gauge	9-7874	-	32.00
	9" x 8" 12 Gauge	6-1196	1.7	18.00
	10" x 9" 12 Gauge	6-1197	2.2	23.00
	10" x 8" 12 Gauge	6-1133	3.2	24.00
	10" x 8" 10 Gauge	6-9749	4.1	31.50
	10" x 8" 7 Gauge	9-7875	-	45.00
	12" x 10" 12 Gauge	6-1138	4.0	30.00
12" x 10" 10 Gauge	6-9750	5.0	41.50	
12" x 10" 7 Gauge	9-7876	-	55.00	
12" x 8" 12 Gauge	6-1198	7.5	59.00	
14" x 10" 10 Gauge	6-8100	9.0	90.00	
14" x 12" 10 Gauge	6-8101	5.0	50.00	
15" x 10" 10 Gauge	9-7690	-	135.00	
16" x 10" 10 Gauge	9-7689	-	159.00	
16" x 12" 10 Gauge	6-8102	11.0	116.00	
16" x 14" 10 Gauge	6-8103	6.0	67.00	
18" x 14" 10 Gauge	6-8104	15.0	139.00	
18" x 16" 10 Gauge	6-8105	7.0	85.00	
20" x 16" 10 Gauge	6-8106	16.0	240.00	
20" x 18" 10 Gauge	6-8107	7.5	100.00	
22" x 18" 10 Gauge	6-8108	-	275.00	
22" x 20" 10 Gauge	6-8109	-	145.00	
24" x 20" 10 Gauge	6-8110	-	310.00	
24" x 22" 10 Gauge	6-8111	-	175.00	



**CONE**  
(STAINLESS STEEL)



8" x 6" 304 Stainless	9-8107	-	91.00
10" x 8" 304 Stainless	9-8108	-	115.00

**CONE**  
(CAST ALUMINUM)



3" x 2" Cast Aluminum	6-1125	0.3	11.00
4" x 2" Cast Aluminum	6-1126	0.3	12.00
4" x 3" Cast Aluminum	6-1127	1.5	16.00
5" x 4" Cast Aluminum	6-1128	0.8	18.00
6" x 4" Cast Aluminum	6-1134	1.8	30.00
6" x 5" Cast Aluminum	6-1129	1.0	28.00
8" x 4" Cast Aluminum	6-1135	4.1	92.00
8" x 6" Cast Aluminum	6-1136	2.3	41.00
8" x 7" Aluminum	6-1164	0.2	24.00
9" x 8" Aluminum	6-1165	-	38.00
10" x 8" Cast Aluminum	6-1137	4.0	55.00
12" x 10" Cast Aluminum	6-0865	5.0	80.00

Fittings

# ECCENTRIC CONES

Product	Description	Part Number	Weight	List Price
<b>ECCENTRIC CONE</b> (BLACK STEEL)	3" x 2"	6-1124	2.3	<b>33.00</b>
	4" x 2"	6-1139	3.0	<b>39.00</b>
	4" x 3"	6-1145	2.5	<b>37.00</b>
	5" x 3"	6-1146	3.8	<b>50.00</b>
	5" x 4"	6-1147	3.3	<b>48.00</b>
	6" x 3"	6-1148	5.0	<b>63.00</b>
	6" x 4"	6-1140	4.3	<b>61.00</b>
	6" x 5"	6-1149	3.8	<b>56.00</b>
	8" x 4"	6-1141	10.5	<b>79.00</b>
	8" x 5"	6-1154	10.0	<b>76.00</b>
	8" x 6"	6-1142	8.8	<b>71.00</b>
	10" x 6"	6-1180	14.0	<b>109.00</b>
	10" x 8"	6-1143	12.5	<b>109.00</b>
	12" x 6"	6-1181	15.0	<b>125.00</b>
	12" x 8"	6-1182	13.5	<b>118.00</b>
12" x 10"	6-1144	13.0	<b>114.00</b>	
14" x 12"	9-8109		<b>245.00</b>	

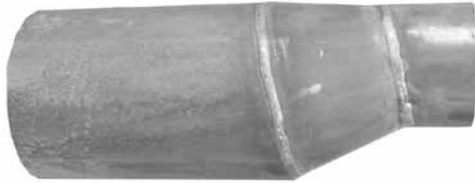

## ECCENTRIC CONE

(CAST ALUMINUM)

2-1/2" x 6"	6-1177	3.3	<b>76.00</b>
3" x 8"	6-1178	5.3	<b>110.00</b>

\*Can be cut to fit fabricated size.



# TELESCOPES & DROP PIPE

**Product Description Part Number Weight List Price**

## TELESCOPE (ALUMINUM)

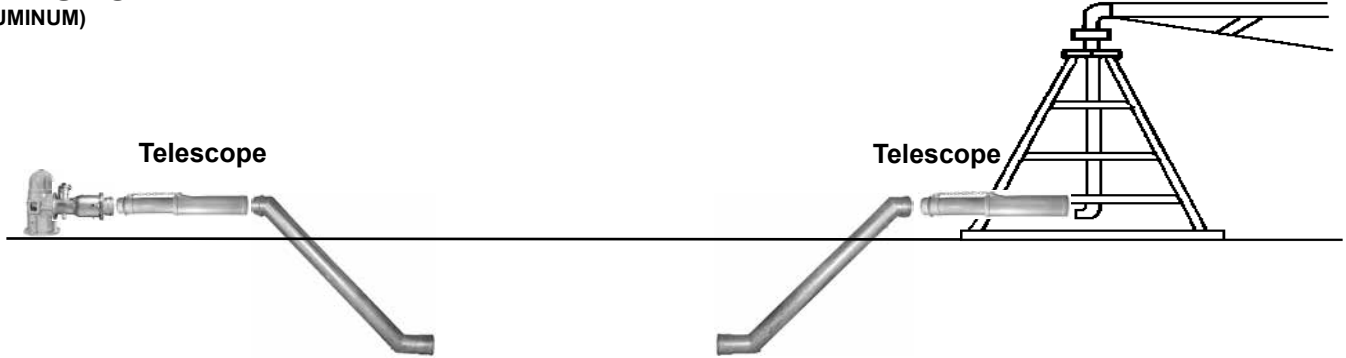

## RINGLOCK:



Heavy wall aluminum construction.  
Male x Female Ends.  
Includes gaskets and chain.  
Ringlock clamp **not** included.

6" x 2-4'	6-1220	15.5	<b>295.00</b>
6" x 5-10'	6-1221	26.5	<b>350.00</b>
6" x 10-20'	6-1222	44.7	<b>460.00</b>
8" x 2-4'	6-1223	20.5	<b>345.00</b>
8" x 5-10'	6-1224	33.7	<b>415.00</b>
8" x 10-20'	6-1225	55.6	<b>545.00</b>
10" x 2-4'	6-1226	21.7	<b>430.00</b>
10" x 5-10'	6-1227	37.1	<b>500.00</b>
10" x 10-20'	6-1228	62.7	<b>680.00</b>

**Double Chain Telescopes also available.**

Add Double Chain	DOUBLECHAIN	-	<b>63.00</b>
------------------	-------------	---	--------------

## DROP PIPE (ALUMINUM)

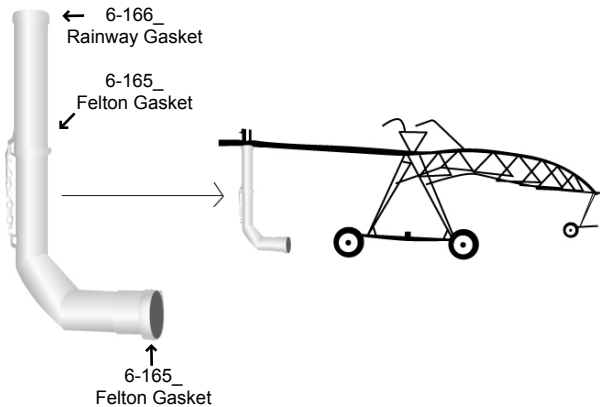

6" x 7-15'	6-1310	32.2	<b>505.00</b>
6" to 8" x 7-15'*	6-1320	39.3	<b>590.00</b>

Heavy wall aluminum construction. Female x Female ends.  
Complete with gaskets & chain.  
\*Larger fitting is on elbow end.  
Specify make & model of pivot when ordering.

**Drop Hose also available. Please call for price.**

## CHAIN



5/0 Size, Plated	3-0640	0.5 ft	<b>6.50/ft</b>
------------------	--------	--------	----------------

Horizontal Working Load Limit = 880 lbs.

Fittings



# GATE VALVES & BALL VALVES



Product	Description	Part Number	Weight	List Price
<b>FLANGED GATE VALVE</b> (CAST IRON)	3"	6-1347	57.0	<b>289.00</b>
	4"	6-1348	66.1	<b>425.00</b>
	5"	6-1349	153.0	<b>555.00</b>
	6"	6-2070	130.1	<b>595.00</b>
	8"	6-2080	213.0	<b>890.00</b>
	10"	6-1350	282.2	<b>1,425.00</b>
	12"	6-1351	392.0	<b>2,550.00</b>
	16"	9-7778	1,224.0	<b>5,575.00</b>



<b>FEMALE THREAD GATE VALVE</b> (BRASS)	1/2"	6-1336	0.6	<b>9.00</b>
	3/4"	6-1338	0.8	<b>13.00</b>
	1"	6-1339	1.2	<b>19.00</b>
	2"	6-1340	3.2	<b>49.00</b>
	3"	6-1341	9.9	<b>147.00</b>
	4"	6-1342	17.5	<b>265.00</b>



<b>IPS GASKETED GATE VALVE</b> (CAST IRON)	4" IPS gasketed	6-9717	70.0	<b>425.00</b>
	6" IPS gasketed	6-9718	132.0	<b>640.00</b>
	8" IPS gasketed	6-9719	214.0	<b>1,050.00</b>



With 2" operation nut

GATE VALVE (PVC)	Handle	Max PSI		
			Part Number	List Price
-IPS Slip x Slip (Solvent weld) -Unrestricted Flow -Quick Opening -Trouble Free Simplicity -Low Pressure -Low Vacuum -Low Cost	4" Metal	20 psi	9-5323	4.5 <b>145.00</b>
	6" Stainless Steel	10 psi	9-5324	16.0 <b>591.00</b>
	8" Stainless Steel	10 psi	9-5325	18.0 <b>827.00</b>
	10" Stainless Steel	10 psi	9-7691	53.0 <b>1,450.00</b>
	12" Stainless Steel	10 psi	9-7692	55.0 <b>1,550.00</b>



**Applications include:**

- Liquids
- Gases
- Dry Bulk/Solids
- Slurry

<b>ELECTRIC ON/OFF HYDRAULIC WAFER VALVE</b>	4"	9-7706	-	<b>620.00</b>
	6"	9-7707	-	<b>1,010.00</b>
	8"	9-7708	-	<b>1,495.00</b>



**With Solenoid Valve and 3-way Selector**

- Includes filter, 3-way selector, and solenoid.
- 120V AC Solenoid Standard
- Also available in 12v DC, 12v AC, 24v AC, or 24v DC solenoid.

# GATE VALVES & BALL VALVES

Product	Description	Part Number	Weight	List Price
---------	-------------	-------------	--------	------------

## FEMALE THREAD GATE VALVE (PVC)



1/2"	6-1352	0.5	<b>26.00</b>
3/4"	6-1353	0.5	<b>32.00</b>
1"	6-1354	0.7	<b>38.00</b>
2"	6-1355	2.0	<b>86.00</b>

## FEMALE THREAD BALL VALVE (BRASS)



1/2"	6-1331	0.5	<b>8.50</b>
3/4"	6-1332	0.4	<b>11.00</b>
1"	3-0560	0.8	<b>17.00</b>
2"	6-1333	1.6	<b>55.00</b>
3"	6-1334	13.5	<b>120.00</b>
4"	6-1335	11.6	<b>185.00</b>

## FEMALE THREAD BALL VALVE (PVC)



1/2"	6-1343	0.2	<b>2.00</b>
3/4"	6-1344	0.4	<b>3.00</b>
1"	6-1345	0.5	<b>4.00</b>
2"	6-1346	1.6	<b>11.00</b>
3"	6-9697	4.7	<b>54.00</b>
4"	6-9698	9.3	<b>101.00</b>

## WAFER VALVE - LEVER (PVC)



- Lightweight
- Highly Resistant to Corrosion
- Repairable
- EPDM Seal

	Max Psi			
2"	150	9-5854	9.0	<b>140.00</b>
3"	150	9-5855	12.0	<b>160.00</b>
4"	150	9-5856	16.0	<b>180.00</b>
6"	115	9-5857	26.0	<b>260.00</b>
8"	115	9-5858	43.0	<b>480.00</b>
10"	115	9-5859	30.0	<b>699.00</b>

## WAFER VALVE - GEAR (PVC)



- Lightweight
- Highly Resistant to Corrosion
- Repairable
- EPDM Seal

	Max Psi			
4"	150	9-5860	11.0	<b>436.00</b>
6"	115	9-5861	15.0	<b>535.00</b>
8"	115	9-5862	31.0	<b>795.00</b>
10"	115	9-5863	38.0	<b>1,070.00</b>

Fittings

# WAFER BUTTERFLY VALVES

Product	Description	Part Number	Weight	List Price
<b>WAFER VALVE - LEVER</b> 	<b>DUCTILE IRON DISC</b>			
	2"	9-7495	8.6	55.00
	2-1/2"	9-7496	9.0	62.00
	3"	9-7497	11.5	67.00
	4"	9-7501	12.9	89.00
	5"	9-7502	26.0	120.00
	6"	9-7503	17.0	129.00
	* 8"	9-7504	32.4	169.00
	* 10"	9-7505	48.0	260.00
	* 12"	9-7506	76.0	400.00
	<b>STAINLESS STEEL DISC</b>			
	2"	8-1351	8.6	70.00
	2-1/2"	8-1352	9.0	79.00
	3"	8-1353	11.5	95.00
4"	6-2050	12.9	110.00	
5"	6-2055	26.0	165.00	
6"	6-2051	17.0	175.00	
* 8"	6-2052	32.4	295.00	
* 10"	6-2053	48.0	495.00	
* 12"	6-2054	76.0	695.00	

-Max 200psi (2"-12")

\* Due to torque on the internal shaft 8", 10" and 12" Lever operated valves may not close 100%. For perfect water shut off, on these sizes, order the Gear operated valves listed below.

<b>WAFER VALVE - GEAR</b> 	<b>DUCTILE IRON DISC</b>			
	2"	9-7498	17.0	110.00
	2-1/2"	9-7499	18.0	113.00
	3"	9-7500	18.0	115.00
	4"	9-7507	21.0	119.00
	5"	9-7508	25.0	160.00
	6"	9-7509	31.3	169.00
	8"	9-7510	41.5	210.00
	10"	9-7511	68.0	295.00
	12"	9-7512	100.0	465.00
	14"	9-7513	134.0	779.00
	16"	9-7514	190.0	1,325.00
	18"	9-7515	240.0	1,685.00
	20"	9-7516	395.0	2,095.00
24"	9-7517	525.0	3,555.00	
30"	9-7649	-	7,250.00	
36"	9-7650	-	10,500.00	
<b>STAINLESS STEEL DISC</b>				
2"	8-1354	17.0	119.00	
2-1/2"	8-1355	18.0	125.00	
3"	8-1356	18.0	145.00	
4"	6-2056	21.0	189.00	
5"	6-2057	25.0	235.00	
6"	6-2058	31.3	205.00	
8"	6-2059	41.5	365.00	
10"	6-2060	68.0	595.00	
12"	6-2061	100.0	795.00	
14"	8-1205	122.0	1,210.00	
16"	8-1206	190.0	1,625.00	
18"	8-1207	240.0	2,789.00	
20"	8-1208	395.0	3,750.00	
24"	8-1209	525.0	6,495.00	

-Max 200psi (2"-12")

## Features:

- Perfect Shut Off liquid and gas in both directions
- Economic Alternatives to gate, ball and plug valves
- Corrosion Free - Stems and body are not in contact with the line media. Bodies are protected with epoxy coating.
- No Flange Gaskets for installation
- Self centering disc by axial movement due to the floating coupling
- Compact light weight wafer design (Flangeless Lug and U-Section)
- Anti Blow Out Stem - The upper stem is fully retained by the retainer plate under pressure in unlikely event of primary seal fail.
- Easy replaceable seat without any special tools
- Easy installation for each type of actuators; manual, pneumatic, hydraulic and electric
- Wide range of material for various conditions
- Maintenance Free
- Minimal flow loss and turbulence
- Reliable for flow control
- Self Cleaning

# WAFER BUTTERFLY VALVES

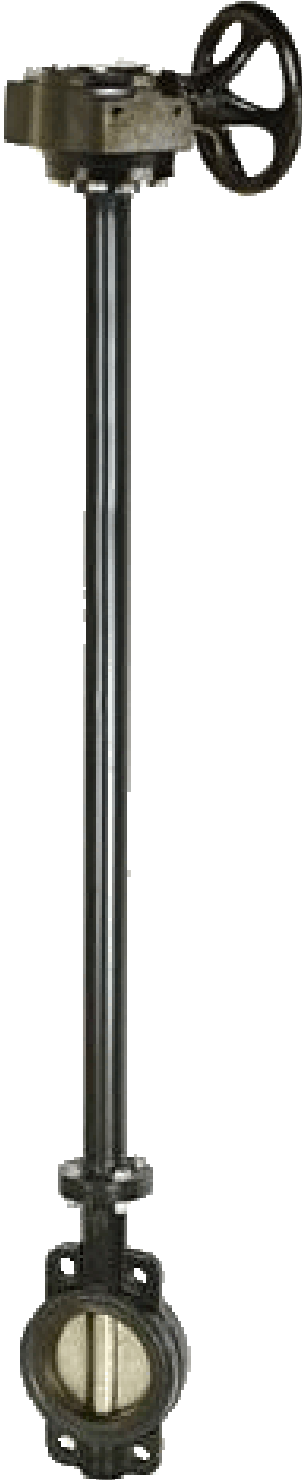
Product	Description	Part Number	Weight	List Price	
<b>WAFER VALVE W/EXT GEAR</b> 	<b>DUCTILE IRON DISC</b>				
	<b>Valve Size</b>	<b>Extension Length</b>			
	4"	24"	6-9882	29.0	260.00
	4"	36"	6-9883	32.0	280.00
	4"	48"	6-9884	35.0	300.00
	4"	60"	6-9885	38.0	320.00
	4"	72"	6-9886	41.0	340.00
	6"	24"	8-1380	45.0	310.00
	6"	36"	8-1381	48.0	315.00
	6"	48"	8-1382	51.0	340.00
	6"	60"	8-1383	55.0	365.00
	6"	72"	8-1384	59.0	390.00
	8"	24"	8-1385	55.0	465.00
	8"	36"	8-1386	58.0	485.00
	8"	48"	8-1387	61.0	505.00
	8"	60"	8-1388	65.0	525.00
	8"	72"	8-1389	69.0	545.00
	10"	24"	8-1390	75.0	555.00
	10"	36"	8-1391	78.0	575.00
	10"	48"	8-1392	81.0	595.00
	10"	60"	8-1393	85.0	615.00
	10"	72"	8-1394	89.0	635.00
	12"	24"	8-1395	87.0	750.00
	12"	36"	8-1396	90.0	775.00
	12"	48"	8-1397	93.0	800.00
	12"	60"	8-1398	97.0	825.00
	12"	72"	8-1399	101.0	850.00
	14"	24"	9-7375	153.4	1,025.00
	14"	36"	9-7376	158.9	1,050.00
	14"	48"	9-7377	164.4	1,075.00
	14"	60"	9-7378	169.9	1,100.00
	14"	72"	9-7379	175.2	1,140.00
16"	24"	9-7380	212.5	1,830.00	
16"	36"	9-7381	219.6	1,875.00	
16"	48"	9-7382	226.4	1,920.00	
16"	60"	9-7383	233.5	1,995.00	
16"	72"	9-7384	240.3	2,020.00	
<b>STAINLESS STEEL DISC</b>					
<b>Valve Size</b>	<b>Extension Length</b>				
4"	24"	9-7360	31.6	290.00	
4"	36"	9-7361	35.1	310.00	
4"	48"	9-7362	38.4	330.00	
4"	60"	9-7363	41.8	350.00	
4"	72"	9-7364	45.1	370.00	
6"	24"	9-7365	39.4	410.00	
6"	36"	9-7366	43.1	430.00	
6"	48"	9-7367	46.7	450.00	
6"	60"	9-7368	50.4	480.00	
6"	72"	9-7369	53.9	500.00	
8"	24"	9-7370	61.7	625.00	
8"	36"	9-7371	65.7	640.00	
8"	48"	9-7372	69.6	655.00	
8"	60"	9-7373	73.8	689.00	
8"	72"	9-7374	77.8	690.00	
10"	24"	9-7350	76.0	870.00	
10"	36"	9-7351	80.7	890.00	
10"	48"	9-7352	85.1	910.00	
10"	60"	9-7353	89.7	930.00	
10"	72"	9-7354	94.3	950.00	
12"	24"	9-7355	131.4	1,210.00	
12"	36"	9-7356	136.9	1,235.00	
12"	48"	9-7357	142.4	1,260.00	
12"	60"	9-7358	147.9	1,285.00	
12"	72"	9-7359	153.2	1,310.00	

Fittings

\* 2", 2-1/2", 3", and 5", 18", 20" and 24" Valves w/Extensions are also available.

\* Measurements are from center of valve to top.

\* Call for taller extensions, such as 96".

# WAFER BUTTERFLY VALVES

Product	Description	Part Number	Weight	List Price
<b>WAFER VALVE - 2" SQ NUT</b> (STAINLESS STEEL DISC) 	2"	6-9630	17.0	<b>325.00</b>
	2-1/2"	6-9631	18.0	<b>337.00</b>
	3"	6-9632	18.0	<b>360.00</b>
	4"	6-9633	22.0	<b>385.00</b>
	5"	6-9634	26.0	<b>435.00</b>
	6"	6-9635	37.0	<b>510.00</b>
	8"	6-9636	44.0	<b>620.00</b>
	10"	6-9637	62.0	<b>835.00</b>
	12"	6-9638	77.0	<b>1,050.00</b>

## WAFER VALVE - ELECTRIC



<u>DUCTILE IRON DISC</u>				
2"	9-7474	32.0	<b>1,185.00</b>	
2-1/2"	9-7475	33.0	<b>1,195.00</b>	
3"	9-7476	33.0	<b>1,260.00</b>	
4"	9-7477	39.0	<b>1,705.00</b>	
5"	9-7478	42.0	<b>1,735.00</b>	
6"	9-7479	59.0	<b>2,035.00</b>	
8"	9-7480	68.0	<b>2,570.00</b>	
10"	9-7481	90.0	<b>2,665.00</b>	
12"	9-7482	105.0	<b>3,775.00</b>	

<u>STAINLESS STEEL DISC</u>				
2"	6-8082	32.0	<b>1,215.00</b>	
2-1/2"	6-8083	33.0	<b>1,235.00</b>	
3"	6-8084	33.0	<b>1,250.00</b>	
4"	6-8085	39.0	<b>1,765.00</b>	
5"	6-8086	42.0	<b>1,795.00</b>	
6"	6-8087	59.0	<b>2,795.00</b>	
8"	6-8088	68.0	<b>2,900.00</b>	
10"	6-8089	90.0	<b>3,050.00</b>	
12"	6-8090	105.0	<b>3,250.00</b>	

- 110/120 volt (call for 24 volt DC & 50 hz)
- EPDM seat
- Epoxy coated cast iron body

## LEVER HANDLE - WAFER VALVE



2"/3"	9-7779	-	<b>19.00</b>
4"	9-7780	-	<b>21.00</b>
5"/6"	9-7781	-	<b>23.00</b>
8"	9-7782	-	<b>31.00</b>
10"	9-7783	-	<b>31.00</b>
12"	9-7784	-	<b>31.00</b>

\* Specify make of valve when ordering

## INDEX PLATE - WAFER VALVE



2"/3"	9-7785	-	<b>4.00</b>
4"/5"/6"	9-7786	-	<b>10.00</b>
8"/10"/12"	9-7787	-	<b>12.00</b>

\* Specify make of valve when ordering

## HAND WHEEL - WAFER VALVE



2"/3"	9-7788	-	<b>70.00</b>
4"	9-7789	-	<b>70.00</b>
5"/6"	9-7790	-	<b>70.00</b>
8"	9-7791	-	<b>110.00</b>
10"	9-7792	-	<b>110.00</b>
12"/14"	9-7793	-	<b>135.00</b>

\* Specify make of valve when ordering

## GEARBOX WITH WHEEL - WAFER VALVE



2"/3"	9-7820	-	<b>70.00</b>
4"	9-7821	-	<b>70.00</b>
5"/6"	9-7822	-	<b>110.00</b>
8"	9-7823	-	<b>110.00</b>
10"	9-7824	-	<b>110.00</b>
12"/14"	9-7825	-	<b>135.00</b>

\* Specify make of valve when ordering

Product	Description	Part Number	Weight	List Price
<b>ALFALFA VALVE STUB</b> (FOR PIP PVC PIPE)	*6"	6-2102	19.0	<b>180.00</b>
	8"	6-2103	29.0	<b>190.00</b>
	10"	6-2104	40.0	<b>275.00</b>
	12"	6-2105	55.0	<b>285.00</b>



\* Solid Arch  
\* Spigot for PIP PVC Pipe

<b>UNIVERSAL HYDRANT</b>	6" x 6"	6-2106	16.0	<b>505.00</b>
	8" x 8"	6-2107	23.0	<b>595.00</b>
	10" x 10"	6-2108	32.0	<b>695.00</b>
	12" x 12"	6-2109	34.0	<b>795.00</b>



Call for other sizes.

THREADED STEM GATE VALVE (BRASS)			<u>Max PSI</u>		List Price	
			Weight	Pressure		
* Comes in easy to assembly 4 piece construction with high tensile hexagonal bolts and nylock nuts * Works as an operating device in the slurry industry, ideal for usage in confined spaces.	4"	Threaded*	6-9890	45	20.9	<b>320.00</b>
	6"	Threaded*	6-9891	37	26.9	<b>479.00</b>



\* Includes Handle  
\* Option: Stainless Steel disc valves can take up to 60psi on 4", 6", & 8" Valves

FLANGED STEM GATE VALVE (BRASS)			<u>Max PSI</u>		List Price	
			Weight	Pressure		
* Comes in easy to assembly 4 piece construction with high tensile hexagonal bolts and nylock nuts * Works as an operating device in the slurry industry, ideal for usage in confined spaces.	4"	4-Bolt Flange*	9-5472	45	19.4	<b>395.00</b>
	6"	4-Bolt Flange*	9-5473	37	23.4	<b>475.00</b>
	8"	4-Bolt Flange*	9-5474	22	46.4	<b>885.00</b>



**O-Ring Gasket**

4", 6"	9-6970	-	<b>4.00</b>
8"	9-6971	-	<b>6.00</b>

<b>HANDLE - STEM GATE VALVE</b>	4"	9-6972	-	<b>25.00</b>
	6"	9-6973	6.4	<b>29.00</b>
	8"	9-6974	-	<b>48.00</b>



THREADED LEVER GATE VALVE (BRASS)			<u>Max PSI</u>		List Price
			Weight	Pressure	
* Works as an operating device in the slurry industry, ideal for usage in confined spaces.	2"	9-7702	45	4.0	<b>95.00</b>
	3"	9-7703	45	9.0	<b>179.00</b>
	4"	9-7704	45	15.0	<b>269.00</b>
	6"	9-7705	22	27.0	<b>470.00</b>



Fittings

# LOW PRESSURE VALVES

Product	Description	Part Number	Weight	List Price	
<b>LOW PRESSURE VALVE</b> (ALUMINUM)					
		6"	6-1460	10.0	<b>220.00</b>
		8"	6-1461	15.0	<b>265.00</b>
		10"	6-1462	20.0	<b>325.00</b>
		12"	6-8028	-	<b>335.00</b>



45 psi max pressure

## LOW PRESSURE END TEE VALVE

(ALUMINUM)

6"	6-1301	21.0	<b>485.00</b>
8"	6-1302	27.0	<b>590.00</b>
10"	6-1303	34.0	<b>675.00</b>

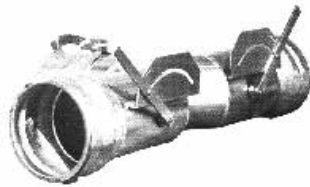

## LOW PRESSURE VALVE

(PVC)

6"	6-1356	-	<b>198.00</b>
8"	6-1357	-	<b>219.00</b>
10"	6-1358	-	<b>249.00</b>
12"	6-1359	-	<b>295.00</b>



## LOW PRESSURE VALVE KIT

6"	6-1473	-	<b>135.00</b>
8"	6-1474	9.9	<b>155.00</b>
10"	6-1475	-	<b>169.00</b>

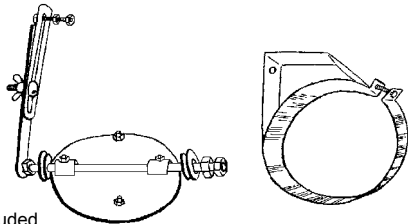

\* Instructions included

## RUBBER MOLDED DISC

(FOR LOW PRESSURE VALVE)

6"	6-1013	4.0	<b>55.00</b>
8"	6-1014	-	<b>68.00</b>
10"	6-1367	6.2	<b>89.00</b>



## RUBBER WASHER

(FOR LOW PRESSURE VALVE)

5/8"	6-1015	-	<b>1.00</b>
------	--------	---	-------------



Product	Description	Part Number	Weight	List Price
---------	-------------	-------------	--------	------------

## SURGE GATE VALVE



6"	6-1505	39.0	Call
8"	6-1506	46.0	Call
10"	6-1507	58.0	Call

## SWING CHECK VALVE - FPT (BRASS)



Female Threaded 3"	8-1330	7.3	141.00
--------------------	--------	-----	--------

## RINGLOCK CHECK VALVE



6"	6-1470	35.9	515.00
8"	6-1471	55.0	610.00
10"	6-1472	79.9	795.00

## CHECK VALVE - WELD ON (BLACK STEEL)

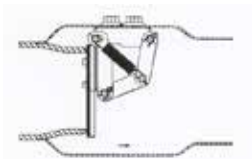

4"	6-1463	12.0	160.00
5"	6-1464	15.0	198.00
6"	6-1465	16.2	250.00
8"	6-1466	28.2	245.00
10"	6-1467	41.6	305.00
12"	6-1468	-	510.00

\*Galvanized or Epoxy-coated available at a nominal charge.

## CHECK VALVE - WELD ON (CAST ALUMINUM)

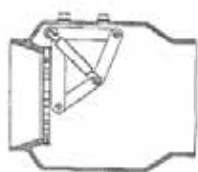

4"	6-9682	5.1	175.00
5"	6-9683	6.9	185.00
6"	6-9684	9.3	220.00
8"	6-9685	14.5	285.00
10"	6-9686	19.7	295.00

Fittings



# CHECK VALVES

Product	Description	Part Number	Weight	List Price	
<b>FLANGED CHECK VALVE</b> (GALVANIZED STEEL)					
		4"	6-1710	27.0	<b>279.00</b>
		5"	6-1711	29.0	<b>285.00</b>
		6"	6-1712	34.1	<b>345.00</b>
		8"	6-1713	56.6	<b>410.00</b>
		10"	6-1714	73.0	<b>490.00</b>
		12"	6-9751	106.0	<b>975.00</b>
		14"	8-1346	220.0	<b>3,515.00</b>
		16"	8-1347	325.0	<b>4,539.00</b>
		20"	8-1348	400.0	<b>6,510.00</b>
		22"	8-1349	-	<b>Call</b>
		24"	8-1350	638.0	<b>7,785.00</b>

## FLANGED CHECK VALVE (CAST ALUMINUM)



4"	6-9687	13.5	<b>335.00</b>
5"	6-9688	17.3	<b>370.00</b>
6"	6-9689	21.9	<b>395.00</b>
8"	6-9690	30.6	<b>530.00</b>
10"	6-9691	44.3	<b>650.00</b>

## WAFER CHECK VALVE (CAST IRON)



### DUCTILE IRON DISC

2"	9-7483	3.0	<b>105.00</b>
2 1/2"	9-7484	4.0	<b>115.00</b>
3"	9-7489	4.6	<b>80.00</b>
4"	9-7490	8.2	<b>100.00</b>
6"	9-7491	18.0	<b>165.00</b>
8"	9-7492	32.0	<b>265.00</b>
10"	9-7493	53.4	<b>380.00</b>
12"	9-7494	75.5	<b>500.00</b>
16"	9-7485	200.0	<b>1,200.00</b>
18"	9-7486	400.0	<b>1,160.00</b>
20"	9-7487	500.0	<b>1,290.00</b>
24"	9-7488		<b>1,920.00</b>

### STAINLESS STEEL DISC

2"	8-1400	3.0	<b>125.00</b>
2 1/2"	8-1401	4.0	<b>152.00</b>
3"	6-1770	4.6	<b>125.00</b>
4"	6-1771	8.2	<b>145.00</b>
6"	6-1772	18.0	<b>235.00</b>
8"	6-1773	32.0	<b>350.00</b>
10"	6-1774	53.4	<b>510.00</b>
12"	6-1775	75.5	<b>960.00</b>
16"	8-1402	200.0	<b>2,570.00</b>
18"	8-1403	300.0	<b>3,700.00</b>
20"	8-1404	400.0	<b>4,495.00</b>
24"	8-1405	500.0	<b>6,049.00</b>

# COMBO VALVES

Product	Description	Part Number	Weight	List Price
<b>WELD -ON COMBO VALVE</b> (GALVANIZED STEEL)	4"	6-1480	18.0	<b>380.00</b>
	6"	6-1481	25.0	<b>480.00</b>
	8"	6-1482	55.0	<b>620.00</b>
	10"	6-1483	77.0	<b>840.00</b>
	12"	6-1700	108.0	<b>940.00</b>



130 maximum psi

## HOOK STYLE COMBO VALVE

(GALVANIZED STEEL)

3"	6-1477	16.0	<b>415.00</b>
4"	6-1478	18.0	<b>490.00</b>
6"	6-1479	26.0	<b>546.00</b>
8"	6-1493	65.0	<b>700.00</b>



130 maximum psi

## RINGLOCK COMBO VALVE

(GALVANIZED STEEL)

4"	6-1476	17.0	<b>410.00</b>
6"	6-1484	27.0	<b>505.00</b>
8"	6-1485	58.0	<b>675.00</b>
10"	6-1486	88.0	<b>945.00</b>
12"	6-1701	120.0	<b>1,135.00</b>



130 maximum psi

## FLANGE COMBO VALVE

(GALVANIZED STEEL)

6"	6-1487	47.0	<b>660.00</b>
8"	6-1488	85.0	<b>895.00</b>
10"	6-1489	113.0	<b>1,025.00</b>
12"	6-1702	166.0	<b>1,559.00</b>



130 maximum psi

## COMBO VALVE PARTS



<b>Disc:</b>	4"	9-7770	-	<b>51.00</b>	
	6"	6-1490	5.3	<b>68.00</b>	
	8"	6-1491	7.8	<b>124.00</b>	
	10"	6-1492	9.8	<b>165.00</b>	
	12"	9-7771	-	<b>179.00</b>	
<b>Packing Ring Set:</b>	4"-6"	2-pieces /set	9-6815	-	<b>9.50</b>
	8"-12"	2-pieces /set	9-6816	-	<b>9.50</b>
<b>Packing Nut:</b>	4"-6"		9-7768	-	<b>9.00</b>
	8"-12"		9-7769	-	<b>18.00</b>
<b>Handle:</b>	4"		9-7764	-	<b>62.00</b>
	6"		9-7765	-	<b>68.00</b>
	8"-10"		9-7766	-	<b>90.00</b>
	12"		9-7767	-	<b>95.00</b>
<b>Hinge Pin:</b>	4"		9-7772	-	<b>9.00</b>
	6"		9-7773	-	<b>9.50</b>
	8"-10"		9-7774	-	<b>18.00</b>
	12"		9-7775	-	<b>18.00</b>

Fittings

# INLINE VALVE

Product	Description	Part Number	Weight	List Price
---------	-------------	-------------	--------	------------

## RINGLOCK INLINE VALVE (GALVANIZED STEEL)



	6"	6-1440	19.0	<b>320.00</b>
	8"	6-1441	29.0	<b>460.00</b>
	10"	6-1442	43.0	<b>629.00</b>

150 max. psi on 4", 6", & 8" valves  
80 max psi on 10" valves

## HOOK STYLE INLINE VALVE (GALVANIZED STEEL)



	4"	6-1450	14.0	<b>280.00</b>
	5"	6-1458	15.8	<b>300.00</b>
	6"	6-1451	24.0	<b>345.00</b>
	8"	6-1452	35.0	<b>470.00</b>
	10"	6-1459	41.0	<b>705.00</b>

150 max. psi on 4", 6", & 8" valves  
80 max psi on 10" valves

## WELD-ON INLINE VALVE (GALVANIZED STEEL)



	4"	6-1453	12.0	<b>235.00</b>
	5"	6-1454	13.5	<b>250.00</b>
	6"	6-1455	20.0	<b>285.00</b>
	8"	6-1456	31.0	<b>365.00</b>
	10"	6-1457	36.0	<b>515.00</b>

150 max. psi on 4", 6", & 8" valves  
80 max psi on 10" valves



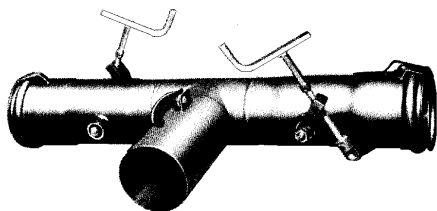



## HOOK STYLE INLINE VALVE TEE (GALVANIZED STEEL)

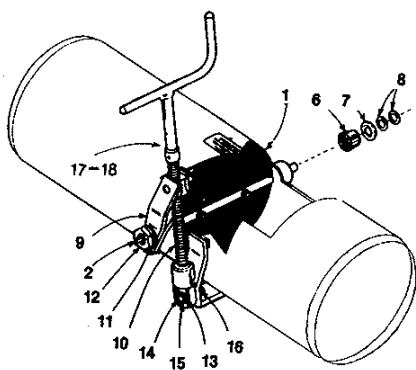

	4"	6-1443	26.0	<b>310.00</b>
	5"	6-1444	33.0	<b>678.00</b>
	6"	6-1445	47.0	<b>659.00</b>
	8"	6-1446	56.0	<b>1,130.00</b>

\*Also available in Ringlock  
\*Also available in Line Valve Tees.

150 max. psi on 4", 6", & 8" valves  
80 max psi on 10" valves

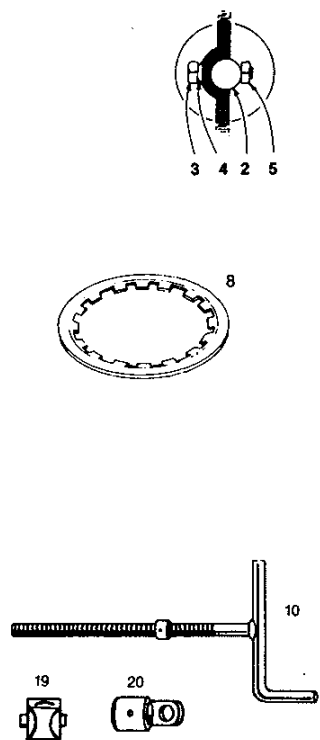
Product	Description	Part Number	Weight	List Price
	<b>Disc</b>	4" 1 6-1495	-	25.00
		5" 1 6-1496	-	38.00
		6" 1 6-1497	2.3	40.00
		8" 1 6-1498	4.1	64.00
		10" 1 6-1499	5.0	128.00
	<b>Shaft</b>	4" 2 6-4250	8" Long	25.00
		5" 2 6-4251	9" Long	29.00
		6" 2 6-4252	10" Long	38.00
		8" 2 6-4253	12" Long	40.00
		10" 2 6-4254	14" Long	47.00
	<b>Hex Bolt (req 2, 3 for 10")</b>	4"-5" 3 6-4255	-	1.25
		6"-8" 3 6-4256	-	2.20
		10" 3 6-4257	-	2.20
	<b>Washer (Req 2)</b>	4"-5" 4 6-4258	-	0.80
		6"-8" 4 6-4259	-	0.45
	<b>Hex Nut (Req 2)</b>	4"-5" 5 6-4260	-	0.70
		6"-8" 5 6-4261	-	0.85
	<b>Chevron Gasket (Req 2)</b>	4"-5" 6 6-4262	-	2.40
		6"-8"-10" 6 6-4263	-	2.70
	<b>Washer Reducer (Req 2)</b>	4"-5" 7 6-4264	-	0.70
		6"-8"-10" 7 6-4265	-	1.00
	<b>Retainer Ring (Req 4)</b>	4"-5" 8 6-4266	-	1.70
		6"-8"-10" 8 6-4267	-	2.00
	Arm Linkage (req 2)	9 6-4268	0.2	2.50
	Crank Assembly (includes 10, 17, 18, 19, 20)	6-4269	-	57.60
	Washer, Star	11 6-4270	-	0.70
	Jam Nut	12 6-4271	0.1	0.70
	Ferrule SS	13 6-4272	-	0.70
	Hex Bolt, Eg.	14 6-4273	-	0.40
	Washer SAE	15 6-4274	-	0.35
	Hex Nut, 3/8"	16 6-4275	-	0.20
	Collar (req 2)	17 6-4276	-	6.40
	Roll Pin (req 2)	18 6-4277	-	1.10
	Stem & Handle	10 6-4278	-	30.50
	Thrust Nut	19 6-4279	-	11.50
	Yoke	20 6-4280	0.4	8.10

## PLATE & SPRING ASSEMBLY

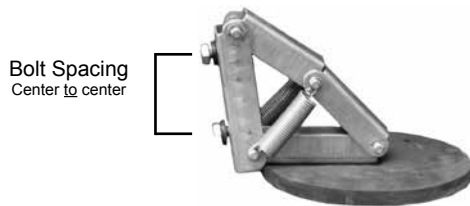

		Bolt Spacing			
4"	1-1/8"	6-1736	-	295.00	
4"	2"	6-1738	-	235.00	
4"	2-1/2"	9-6916	-	101.00	
5"	2-1/4"	6-1737	-	305.00	
5"	2-1/2"	9-6917	-	112.00	
6"	2-5/32"	6-1733	3.4	289.00	
6"	2-1/2"	6-1500	5.0	235.00	
6"	3-1/2"	9-5425	5.0	215.00	
8"	3"	6-1501	10.0	345.00	
8"	3-1/2"	6-1731	4.1	150.00	
10"	3-1/2"	9-5427	14.0	299.00	
10"	4-1/4"	6-1735	6.8	199.00	
10"	4-1/2"	6-1502	14.0	206.00	
12"	4-1/4"	9-7660	-	550.00	
12"	4-1/2"	9-7661	-	315.00	
<b>Springs Only</b>	4"	9-7550	-	8.00	
	6"	9-7551	-	12.00	
	8"	9-7619	-	12.00	
	10"	9-7552	-	12.00	

Fittings

Product	Description	Part Number	Weight	List Price
<b>RINGLOCK CHEMIGATION VALVE</b> (GALVANIZED STEEL)	4"	9-6826	47.2	<b>491.00</b>
	6"	6-1401	75.0	<b>609.00</b>
	8"	6-1402	100.7	<b>749.00</b>
	10"	6-1403	140.9	<b>919.00</b>
	12"	9-6829	184.8	<b>1,615.00</b>

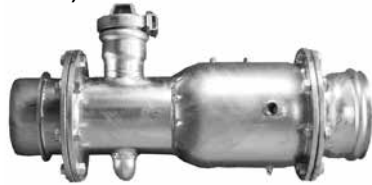

Includes: 2" ARV, 3/4" nuts & bolts, flange gaskets

<b>FLANGE X COUPLER CHEMIGATION VALVE</b> (GALVANIZED STEEL)	4"	9-6824	38.8	<b>421.00</b>
	6"	6-1360	63.0	<b>517.00</b>
	8"	6-1361	83.3	<b>637.00</b>
	10"	6-1362	118.8	<b>757.00</b>
	12"	9-6827	142.7	<b>1,449.00</b>



Includes: 2" ARV, 3/4" nuts & bolts, flange gaskets

<b>FLANGED CHEMIGATION VALVE</b> (GALVANIZED STEEL)	4"	9-6825	30.4	<b>349.00</b>
	6"	6-1370	46.0	<b>425.00</b>
	8"	6-1371	61.0	<b>525.00</b>
	10"	6-1372	86.0	<b>595.00</b>
	12"	9-6828	100.5	<b>1,195.00</b>



Includes: 2" ARV, & flange gaskets

<b>FLANGE ADAPTERS</b> (GALVANIZED STEEL)	4" Flange x FRL	9-6830	8.6	<b>59.00</b>
	6" Flange x FRL	6-6450	12.1	<b>70.00</b>
	8" Flange x FRL	6-6451	17.4	<b>90.00</b>
	10" Flange x FRL	6-6449	22.1	<b>118.00</b>
	12" Flange x FRL	6-6448	32.0	<b>166.00</b>
	4" Flange x MRL	9-6831	8.6	<b>57.00</b>
	6" Flange x MRL	6-6459	12.1	<b>70.00</b>
	8" Flange x MRL	6-6549	17.4	<b>90.00</b>
	10" Flange x MRL	6-6458	22.1	<b>118.00</b>
	12" Flange x MRL	6-6457	32.0	<b>166.00</b>



<b>INJECTION VALVE</b> (PVC-MISTER MIST'R)	6-1523	0.1	<b>55.00</b>
---	--------	-----	--------------



\* 3/4" Male Pipe Thread

\*15 psi release is standard (optional 9, 25, 65 or 80 psi available.)

Product	Description	Part Number	Weight	List Price		
<b>BOLT-ON WATER METER</b>						
		<u>Drill Size</u>	<u>GPM</u>	<u>NET</u>		
	4" OD / PIP	4"	50-900	6-1930	18.0	1,212.00
	6" OD / PIP	5"	90-1800	6-1931	22.0	1,266.00
	8" OD / PIP	5-1/8"	100-2250	6-1932	26.0	1,339.00
	10" OD / PIP	6"	0-2700	6-1933	30.0	1,435.00
	12" OD / PIP	7"	0-4000	6-1934	34.0	1,552.00

- Above includes an overrun bearing, anti-reverse & canopy boot for 3-year warranty.
- State wall thickness & O.D. when ordering.
- + or - 2% Accuracy
- (12ga = .072, .064)

## BOLT-ON WATER METER (REVERSE IMPELLER)



	4"	8-1431	14.0	<u>NET</u>
	6"	8-1432	19.0	1,367.00
	8"	8-1433	23.0	1,408.00
	10"	8-1434	26.0	1,482.00
	12"	8-1435	30.0	1,580.00
				1,703.00

For Liquid waste manure  
or other surface water application

- Above includes an overrun bearing, anti-reverse & canopy boot for 3-year warranty.
- State wall thickness & O.D. when ordering.
- + or - 2% Accuracy
- (12ga = .072, .064)

## FLO-WISE AG ROTOR

6", 8", 10" & 12"

9-7931

NET  
1,250.00



- Vertical or horizontal installation.
- No Vanes or Flow Conditioners Required.
- Battery operated, 3.6 Volt Lithium batteries (2 included).
- Sensor delivers an accuracy of +/- 2% of reading in a full pipe.
- 2 year manufacturer's warranty. 1 year warranty on replacement rotor.

## COMPONENTS FOR FLO-WISE AG ROTOR



<b>Aluminum , Weldolet</b>	6"	9-7932	<u>NET</u>
	8"	9-7933	70.00
	10"	9-7934	70.00
<b>Steel , Weldolet</b>	6"	9-7935	95.00
	8"	9-7936	95.00
	10"	9-7937	95.00
	12"	9-7938	95.00
	Battery (2 required)	9-7939	15.00
Replacement Rotor	9-7940	177.51	

Bolt-on Saddles are also available.



Product	Description	Part Number	Weight	List Price
---------	-------------	-------------	--------	------------

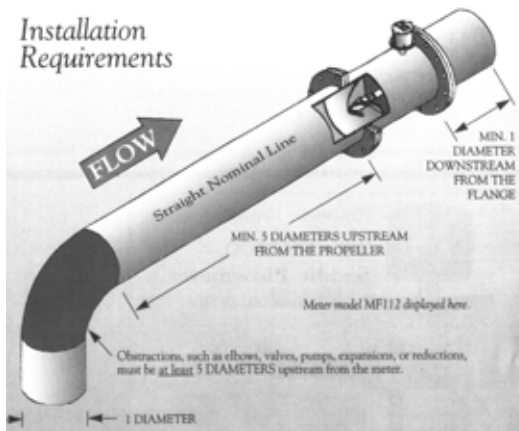

**Without Straightening Vanes:**

Install at least **10** times the diameter downstream from butterfly valves, elbows, cooling coils, tees, reducers, increasers, & other obstructions.

**With Straightening Vanes:**

Install at least **5** times the diameter downstream from butterfly valves, elbows, cooling coils, tees, reducers, increasers, & other obstructions.

**Jetting Flows:**

Check, Chemigation, and Combo valves create jetting flows inside the pipe that require a straightening vane and meter installation **10** times the diameter downstream from the valve.

**Reverse Impeller Meters:**

Reverse Impeller Meters require Bolt-on Vanes which allows for the passage of grass, debris and other solids. Upstream requirements are the same as listed above. The center of the meter hole has to be two pipe diameters from the end of the pipe to the end of the impeller, plus 16 inches.

Example: (10" Pipe x 2 diameters = 20") +16" = 36" from end of pipe to center of the meter hole.

**WATER METER FLOW TUBE (ALUMINUM)**



- Includes straightening vanes
- Call for Custom configurations

	Ringlock (M x F):	Ring-Ring		
	4"	5'	9-5295	- 219.00
	6"	6.5'	9-5296	- 249.00
	8"	8'	9-5297	- 295.00
	10"	10'	9-5298	- 350.00
	Flange x Flange:	Flg -Flg		
	4"	5'	9-5299	- 315.00
	6"	6.5'	9-5300	- 350.00
	8"	8'	9-5301	- 429.00
	10"	10'	9-5302	- 565.00

**STRAIGHTENING VANES (FOR WATER METERS)**



Aluminum , Weld-In	OD Pipe Size			
	4"	9-6868	-	29.00
	6"	9-6869	0.6	33.00
	8"	9-6870	-	35.00
	10"	9-6867	-	39.00
Steel , Weld-In	OD Pipe Size			
	4"	9-6877	-	45.00
	6"	9-6878	-	40.00
	8"	9-6879	-	45.00
	10"	9-6876	-	50.00
Steel , Bolt-On (Three per Set)	OD Pipe Size			
	4"	9-6873	-	95.00
	6"	9-6874	-	105.00
	(Stainless Steel) 8"	9-6875	-	175.00
	10"	9-6871	-	189.00
	12"	9-6872	-	195.00

**STRAIGHTENING VANE (FLOW STRAIGHTENER) (STAINLESS STEEL)**



OD Pipe Size				NET
6"	9-6880	-		332.00
8"	9-6881	-		360.00
10"	9-6882	-		389.00
IPS Pipe Size				NET
6"	9-6883	-		332.00
8"	9-6884	-		360.00
10"	9-6885	-		389.00

\* Bolt-on

Outside body is NOT included in price.

Flow straightener is a cone-shaped device that sits upstream from the meter and conditions the fluid to remove flow irregularities prior to measurement. The conditioned flow supports high accuracy flow measurement and virtually eliminates the need for space-consuming, costly upstream/downstream straight-pipe runs.

Product	Description	Part Number	Weight	List Price
---------	-------------	-------------	--------	------------

## DRIVE COUPLER ASSEMBLY



1" round x 1" square (Old Style Valley, Gifford Hill)	6-1531	2.5	25.00
1" round x 7/8" square (New Style Valley)	6-1532	2.5	25.00
1" round x 3/4" square (Gifford Hill, Olson, Lindsay, Electrogator)	6-1533	2.5	25.00
1" round w/kw x 3/4" square (Old Style Lockwood)	6-1534	2.5	25.00
1" round w/kw x 1" square (New Style Lockwood)	8-1422	2.5	24.00
1 1/8" round x 3/4" square	8-1423	2.5	24.00
1 1/8" round x 1" square (Gifford Hill)	8-1424	2.5	24.00



Puck Only	2-0046		5.00
-----------	--------	--	------

- Features:
1. Clover leaf style with live rubber insert absorbs shock and reduces wear on drive-line components.
  2. Casting design holds bolt in place and requires only one wrench to install.
  3. Aluminum alloy and five piece design makes this "U-Joint" easy to install or remove. No more rust.

## UNIVERSAL DRIVE COUPLING (PAINTED STEEL)

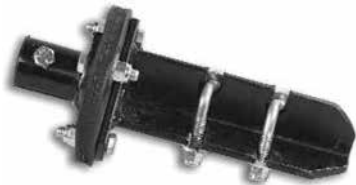

Small Disc, Mini, 3/4" to 1-1/8"	9-7848	32.00
Large Disk, Regular, 3/4" to 1"	9-7849	32.00

- Features:
1. The rubber disc absorbs shock from gear motors to wheel drive.
  2. The ends can be ordered to fit most any center pivot drive line.
  3. The round end is split for easy installation and a tight fit.
  4. The disc design allows for some misalignment on the drive line.
  5. The units are Made in the USA using top materials.

## PIVOT DRAINS



Plastic



Metal

<b>Quick Drain</b>			
Lindsay Type, 20-75 psi	2-1183	-	3.00
Lindsay Type, 5-30 psi	2-1184	-	Call
<b>Drain Valve</b>			
Star, Plastic	--	--	Call
Star, Metal	2-1182	-	Call

Fittings



# CENTER PIVOT PARTS

Product	Description	Part Number	Weight	List Price
<b>PIVOT RUBBER BOOT</b> 	4 PLY			
	6 5/8" x 16" long	7.01" OD 6-1535	3.5	38.00/ea
	6 5/8"/foot	7.01" OD 6-9580	-	38.70/ft
	7" x 16" long	2-1270	-	Call
	8" x 12" long	2-1271	-	48.00
	8-5/8"/foot	2-1272	-	65.00
	2 PLY			
	6"/foot	6.38" OD 6-9576	2.0	17.00
	6 5/8"/foot	7.01" OD 6-9577	2.2	21.00
	8"/foot	8.46" OD 6-9578	2.9	25.00
10"/foot	10.63" OD 6-9579	5.1	40.00	

## PIVOT CLAMP



4-1/2" Stainless Steel	2-1275	-	Call
5" Stainless Steel	2-1276	-	Call
6" Stainless Steel	2-1278	-	12.00
6 5/8" Stainless Steel	6-1536	0.5	11.00
7" Stainless Steel	2-1279	-	16.00
8" Stainless Steel	6-9581	0.2	19.00
8-5/8" Stainless Steel	2-1280	-	Call
10" Stainless Steel	2-1281	-	18.00

## PIVOT FLANGE GASKET



5-9/16"	2-1317	-	4.00
6" (5" id x 8" od)	9-5436	-	9.00
6-5/8" (6-5/8" id x 8" od)	9-5437	-	7.70
8", Lindsay Style	2-1319	-	5.00

## PIVOT WEIGHT



15" Polyethylene	6-9548	1.0	4.50
20" Polyethylene	6-9549	1.4	4.50
24" Polyethylene	6-9550	1.5	5.50
30" Polyethylene	6-9551	2.0	6.90
10" PVC (w/ fpt xfpt)	6-9552	2.0	8.10
11" PVC (w/ fpt xfpt)	6-9553	2.0	8.50
13.75" PVC (w/ fpt xfpt)	6-9554	2.5	6.00
16.5" PVC (w/ fpt xfpt)	6-9555	3.1	8.00

- Ends of pipe are rounded for attractive appearance and functionality
- Strong UV inhibitors added to weight for longevity

## PIVOT DROP ELBOW



Steel Galvanized

### Single, Steel Galv:

3/4", MxF	6-6701	-	7.10
3/4" MxM	2-1412	-	Call

### Single, PVC:

125 Degree, 3/4" FPT x Barb	2-1086	-	Call
125 Degree, 3/4" FxM	2-1088	-	Call
180 Degree, 3/4" FPT x Barb	--	-	Call
180 Degree, 3/4" MXF	2-1418	-	Call
180 Degree, 3/4" MXM	2-1417	-	Call
180 Degree, 3/4" MPT x Barb	2-1419	-	4.00

### Double, PVC:

125 Degree, 3/4" FPT x Barb	--	-	Call
125 Degree, 3/4" FxM	2-1408	-	6.50



PVC, Single



PVC, Double

- U Pipes have 6" radius
- M x M configuration is available
- PVC Drop Elbow has strong UV inhibitors for year round use.

Product	Description	Part Number	Weight	List Price
---------	-------------	-------------	--------	------------

## DROP RISER (GALVANIZED STEEL)



- 3/4" MPT x 3/4" FPT

Galvanized:			
24"	--	--	Call
30"	--	--	Call
36"	--	--	Call
42"	--	--	Call
48"	--	--	Call
54"	--	--	Call
60"	--	--	Call
66"	--	--	Call
72"	--	--	Call
78"	--	--	Call
84"	--	--	Call
90"	--	--	Call
96"	--	--	Call
102"	--	--	Call
108"	--	--	Call
114"	--	--	Call
120"	--	--	Call

## DROP RISER (POLYETHYLENE)



- 3/4" MPT x 3/4" FPT  
 - Strongest clamp on the market, 100% guaranteed.  
 - Strong UV inhibitors for year round use.  
 - These heavy duty drops are made from top quality polyethylene materials and the heaviest duty clamp on the market. These drops are engineered to withstand tough use conditions and are perfect for use in areas with corrosive water.

Poly PVC:			
24"	--		Call
30"	2-1436		Call
36"	2-1437		Call
42"	2-1438		Call
48"	2-1439		Call
54"	2-1440		Call
60"	2-1441		Call
66"	2-1442		Call
72"	2-1443		Call
78"	2-1444		Call
84"	2-1445		Call
90"	2-1446		Call
96"	2-1447		Call
102"	2-1448		Call
108"	--		Call
114"	--		Call
120"	--		Call

## END GUN BOOSTER PUMP (MOTOR & PUMP)



- All Parts are interchangeable with Berkeley Model #C2MPS  
 - With Leeson 2-HP (TEFC) 3-phase Motor, 460 volt

2-HP, 130 GPM (2-1/2" Suction x 2" Discharge)	2-1106	-	845.70
--	--------	---	--------

## END GUN BOOSTER PUMP (COMPONENTS)



Volute Case	2-1115	-	102.80
Motor Bracket	2-1111	-	86.90
Cast iron Impeller	2-1113	-	Call
Brass Impeller	2-1559	-	Call
Stainless Steel Impeller	2-1560	-	109.80
Motor Bracket Gasket	2-1110	-	2.60
Volute Gasket	2-1114	-	2.60
Impeller Spacer	2-1561	-	2.60
Mechanical Seal	2-1112	-	16.30
Motor Only, 2-HP, 3-Phase, 460V	2-1118	-	487.90

## PIVOT END GUN VALVE



\* Includes automatic drain and plug.

3/4"	9-7651	-	78.00
1"	9-7652	-	78.00
2"	9-7653	-	117.00
2" 90°	9-7654	-	117.00

Fittings

Product	Description	Part Number	Weight	List Price
---------	-------------	-------------	--------	------------

## UNIVERSAL DRIVE GEAR BOX



**Features**

1. Heavy-Duty gearbox with universal mounting.
2. Totally enclosed internal air expansion chamber.
3. High tensile strength worm shaft.
4. Most durable worm gear available.
5. One-piece high strength output shaft.
6. Heavy-duty taper roller bearings.
7. Extreme-duty ductile iron end caps.
8. New self-contained cartridge style input and output shaft seals eliminating oil leaks.
9. Plates seal cover for protection of unused input shaft

Description	Shaft Size	Gear Ratio	Type	Style
<b>Universal Gearbox</b>				
725-U Series	2-1/4" Short	<b>50:1</b>	Non-Tow	Universal
740-U Series	2-1/4" Short	<b>50:1</b>	Non-Tow	Universal
745-U Series	2-1/2" Short	<b>50:1</b>	Non-Tow	Universal
760-U Series	2-1/2" Short	<b>50:1</b>	Non-Tow	Universal
Durst	-	<b>50:1</b>	Non-Tow	Universal
TNT-2-U Series	2-1/4" Short	<b>50:1</b>	Towable	Universal
<b>Valley Style Gearbox</b>				
740-UV Series	2-1/4" Extended	<b>52:1</b>	Non-Tow	Valley
760-UV Series	2-1/2" Long	<b>52:1</b>	Non-Tow	Valley
Durst		<b>52:1</b>	Non-Tow	Valley
TNT-2-U Series	2-1/4" Extended	<b>52:1</b>	Towable	Valley
<b>*** Call For Pricing ***</b>				

## HELICAL GEAR MOTORS & STATOR ASSEMBLIES



**Features**

1. 460/380 Volt, 3 phase motor, 60/50 hz
2. Motor is thermally protected with automatic reset.
3. Class F2 Insulation, UL & CSA Certified.
4. Corrosion resistant finned aluminum motor frame.
5. Aluminum motor frame is sealed at junction points.
6. Integral heat-treated pinion gear on motor shaft.

<b>Complete Helical Gear Motor</b>			
Description	Gear Ratio	Motor HP	RPM
UMC	60:1	<b>3/4 HP</b>	29
UMC	50:1	<b>3/4 HP</b>	35
Durst	50:1	<b>3/4 HP</b>	34
UMC	40:1	<b>3/4 HP</b>	44
Durst	40:1	<b>3/4 HP</b>	43
UMC	30:1	<b>1.5 HP</b>	58
Durst	30:1	<b>1.5 HP</b>	57
UMC	25:1	<b>1.5 HP</b>	68
Durst	25:1	<b>1.5 HP</b>	68
UMC	20:1	<b>1.5 HP</b>	86
Durst	20:1	<b>1.5 HP</b>	86
<b>*** Call For Pricing ***</b>			



**Features**

1. 460/380 Volt, 3 phase motor, 60/50 hz
2. Available in 3/4 and 1-1/2 HP models
3. Class F insulation.
4. Totally interchangeable with Valmont Stators.
5. Includes the 4 mounting bolts, strain relief and wire nuts.
6. Aluminum motor frame resists corrosion.

<b>Replacement Stator</b>		
Description	Style	Motor HP
UMC	Power Saver	<b>3/4 HP</b>
Durst	Lindsay/Emerson	<b>3/4 HP</b>
Durst	Valley	<b>3/4 HP</b>
UMC	Power Saver	<b>1.5 HP</b>
Durst	Lindsay/Emerson	<b>1.5 HP</b>
Durst	Valley	<b>1.5 HP</b>
<b>*** Call For Pricing ***</b>		

Product	Description	Part Number	Weight	List Price
---------	-------------	-------------	--------	------------

## SPLINED GEARMOTOR, GEAR, & MOTOR MODULES (U.S. MOTORS)



Complete Splined Center Drive			
U.S. Motors #	Gear Ratio	Motor HP	RPM
7843	58:1	1 HP	30
A856	47:1	1 HP	37
A799	31:1	1.5 HP	56
*** Call For Pricing ***			

**Features**

1. 460/380 Volt, 3 Phase, 60/50 hz
2. Special CorroGuard insulation for longer motor life.
3. Stainless steel motor frame for corrosion resistance.
4. Motor is thermally protected.
5. Splined motor/gearbox design.



Splined Motor Module		
U.S. Motors #	Motor HP	RPM
A726	1 HP	1750
A728	1.5 HP	1750
*** Call For Pricing ***		

**Features**

1. Top quality gear motor from the most experienced American mfg of center pivot gear motors.
2. Designed to operate in extreme environments. The gear motor has a corrosion resistant housing and incorporates an inherit overload protection for the motor.
3. Simplicity, flexibility and reliability.
4. 100% of all motors are factory tested before packaging.



Splined Gear Module		
U.S. Motors #	Gear Ratio	RPM
A732	58:1	30
A730	47:1	37
A800	31:1	56
*** Call For Pricing ***		

## NEMA 56 C-FACE GEAR BOX & MOTOR

**Features**

1. Universal mounting pattern.
2. Multiple available ratios available.
3. Aluminum gearbox housing.
4. Includes key-way coupling for the motor to gearbox connection.
5. Includes 2 seal savers for the output shafts.
6. High strength aluminum bronze bull gear.



UMC 56 C-Face Gear Box		
UMC #	Gear Ratio	RPM
09333-154A	60:1	29
09333-151A	50:1	35
09333-153A	40:1	43
09333-152A	30:1	58
*** Call For Pricing ***		

**Features**

1. Fits on any NEMA 56 C flanged center drive gearbox
2. Stainless steel motor frame for corrosion resistance.
3. CorroGuard insulation for longer motor life.
4. Motor is thermally protected



UMC 56 C-Face Motor		
Description	Motor HP	RPM
U.S. #5622	1	1800
Bluffton #UF17565	1	1725
UMC	1.5	1725
U.S. #5624	1.5	1800
Bluffton #UF12317	1.5	1725
*** Call For Pricing ***		

Fittings

Product	Description	Part Number	Weight	List Price	
<b>PIVOT TIRE, MACH II (FIBERGLASS)</b>	<b><u>Tire Only</u></b>				
		11.2 x 24	9-7560	76.0	<b>535.00</b>
	For 8" Rim	14.9 x 24	9-7561	90.0	<b>599.00</b>
	For 10" Rim	14.9 x 24	9-7562	96.0	<b>690.00</b>
		11.2 x 38	9-7563	96.0	<b>662.00</b>
	<b><u>Tire &amp; Rim</u></b>				
	With 8" Rim	11.2 x 24	9-7564	180.0	<b>785.00</b>
	With 8" Rim	14.9 x 24	9-7565	195.0	<b>850.00</b>
	With 10" Rim	14.9 x 24	9-7566	205.0	<b>960.00</b>
	With 10" Rim	11.2 x 38	9-7567	270.0	<b>1,150.00</b>



#### Features



1. Superior Traction
2. Will Not Go Flat
3. Chemical, Fertilizer & UV Resistant
4. Less Stress on Drive Train Components
5. Price Comparable
6. Improved Tire Track

## PIVOT OR END TOWER LIGHT KIT



Rough duty light bulb kit, Complete	2-0536	Call
TOMAR Strobe light kit, Complete	2-0538	Call
Globe and pendant, 3/4" Fem	2-0549	Call
Globe and pendant, 1/2" Fem	2-0550	Call
Rough Duty Light, 75 watt	2-0547	Call
Screw in Strobe Light (Red, Green, Amber, Blue, Clear)	2-0543	Call

Universal light kit for installation at the pivot point or end tower. The kit comes complete with the flange adapter, extended gooseneck, shielded cable, globe assembly, and rough duty light assembly or TOMAR strobe light.

Product	Description	Part Number	Weight	List Price
<b>R3000 ROTATOR®</b>				
	R3000 Rotator Complete	2-1037		28.50
* Indicate 31 N Nozzle Size and Plate type when ordering. * The Orange Plate is considered the corn plate.				
<b>A3000 ACCELERATOR</b>				
	A3000 Accelerator Complete	2-1050		18.50
* Indicate 3TN Nozzle Size and Plate type when ordering.				
<b>D3000 SPRAYHEAD</b>				
	D3000 Sprayhead Complete	2-1063		5.70
* Indicate 3TN Nozzle Size and Plate type when ordering.				
<b>I-WOB™</b>				
	Standard-angle 9-groove, Black Deflector Standard-angle 6-groove, Grey Deflector Low-angle 9-groove, Blue Deflector Low-angle 6-groove, Blue Deflector Nozzles, Color Coded (#6-#24)	i-Wob-SA-9G-UP3 i-Wob-SA-6G-UP3 i-Wob-LA-9G-UP3 i-Wob-LA-6G-UP3 UP3 Nozzles		28.00 27.00 26.00 25.00 2.00
* Indicate UP3 Nozzle Size when ordering.				
<b>XI-WOB™</b>				
	6-Grooves, 10°, Blue Deflector 6-Grooves, 15°, Black Deflector 9-Grooves, 10°, Grey Deflector Top-of-Pipe, 6-Grooves, 5°, White Deflector Nozzles, Color Coded (#7-#24)	Xi-Wob-610-UP3 Xi-Wob-615-UP3 Xi-Wob-910-UP3 Xi-Wob-605-TOP-UP3 UP3 Nozzles		27.00 29.00 29.00 29.00 2.00
* Indicate UP3 Nozzle Size when ordering.				
<b>PIVOT-MASTER IMPACT SPRINKLER (6°)</b>				
	<b>Single Nozzle</b>			
	3006H	2.40 - 4.35 gpm	Nozzles #8-9	3006H-1-3/4" M PM 29.00
	4006H	3.80 - 7.70 gpm	Nozzles #10-12	4006H-1-3/4" M PM 29.00
	5006H	6.20 - 16.00 gpm	Nozzles #13-18	5006H-1-3/4" M PM 29.00
	<b>Double Nozzle</b>			
	4006H	4.55 - 15.08 gpm	Nozzles #10-12, #7-12	4006H-2-3/4" M PM 30.50
5006H	12.32 - 30.47 gpm	Nozzles #13-18, #7-18	5006H-2-3/4" M PM 30.50	
* Specify Nozzle Size when ordering. * With Brass Swivel & Stem				

# CENTER PIVOT REGULATORS

Product	Description	Part Number	Weight	List Price
<b>PRESSURE REGULATOR</b>				
<b>UNIVERSAL FLOW</b>				

**3/4" Barb x Square Thread**

<b>PSI</b>	<b>GPM</b>		
6	0.5-8	10167-001	8.72
10	0.5-10	10167-002	8.72
15	0.5-12	10167-003	8.72
20	0.5-12	10167-004	8.72
25	0.5-12	10167-005	8.72
30	0.5-12	10167-006	8.72
40	0.5-12	10167-007	8.72
50	0.5-12	10167-008	8.72

**3/4" FPT x Square Thread**

<b>PSI</b>	<b>GPM</b>		
6	0.5-8	9572-001	9.35
10	0.5-10	9572-002	9.35
15	0.5-12	9572-003	9.35
20	0.5-12	9572-004	9.35
25	0.5-12	9572-005	9.35
30	0.5-12	9572-006	9.35
40	0.5-12	9572-007	9.35
50	0.5-12	9572-008	9.35

**3/4" FPT x FPT**

<b>PSI</b>	<b>GPM</b>		
6	0.5-8	9491-001	10.40
10	0.5-10	9491-002	10.40
15	0.5-12	9491-003	10.40
20	0.5-12	9491-004	10.40
25	0.5-12	9491-005	10.40
30	0.5-12	9491-006	10.40
40	0.5-12	9491-007	10.40
50	0.5-12	9491-008	10.40

**3/4" FHT x MHT**

<b>PSI</b>	<b>GPM</b>		
6	0.5-8	9561-001	10.60
10	0.5-10	9561-002	10.60
15	0.5-12	9561-003	10.60
20	0.5-12	9561-004	10.60
25	0.5-12	9561-005	10.60
30	0.5-12	9561-006	10.60
40	0.5-12	9561-007	10.60
50	0.5-12	9561-008	10.60

**3/4" FPT x MHT**

<b>PSI</b>	<b>GPM</b>		
6	0.5-8	9581-001	10.60
10	0.5-10	9581-002	10.60
15	0.5-12	9581-003	10.60
20	0.5-12	9581-004	10.60
25	0.5-12	9581-005	10.60
30	0.5-12	9581-006	10.60
40	0.5-12	9581-007	10.60
50	0.5-12	9581-008	10.60

# CENTER PIVOT REGULATORS

Product	Description	Part Number	Weight	List Price
---------	-------------	-------------	--------	------------

## PRESSURE REGULATOR HI-FLOW

### 3/4" FPT x Square Thread



PSI	GPM	Part Number	List Price
6	0.5-8	9611-001	15.90
10	0.5-10	9611-002	15.90
15	0.5-12	9611-003	15.90
20	0.5-12	9611-005	15.90
25	0.5-12	9611-006	15.90
30	0.5-12	9611-007	15.90
40	0.5-12	9611-008	15.90
50	0.5-12	9611-009	15.90

### 3/4" FPT x FPT



PSI	GPM	Part Number	List Price
6	0.5-8	9071-001	16.30
10	0.5-10	9071-002	16.30
15	0.5-12	9071-003	16.30
20	0.5-12	9071-005	16.30
25	0.5-12	9071-006	16.30
30	0.5-12	9071-007	16.30
40	0.5-12	9071-008	16.30
50	0.5-12	9071-009	16.30

## PRESSURE REGULATOR



Size	PSI	Part Number	Weight	List Price
3/4" x 3/4"	15psi	7-0310	0.4	13.50
3/4" x 3/4"	20psi	7-0311	0.4	13.50
3/4" x 3/4"	25psi	7-0312	0.4	13.50
3/4" x 3/4"	30psi	7-0313	0.4	13.50
3/4" x 3/4"	40psi	7-0314	0.4	13.50
3/4" x 3/4"	50psi	7-0315	0.4	13.50
1-1/4" x 1"	10psi	7-0316	0.6	28.90
1-1/4" x 1"	15psi	7-0317	0.6	28.90
1-1/4" x 1"	20psi	7-0318	0.6	28.90
1-1/4" x 1"	30psi	7-0319	0.6	28.90
1-1/4" x 1"	40psi	7-0320	0.6	28.90
1-1/4" x 1"	50psi	7-0321	0.6	28.90

Both ends are Female threaded.  
Male available upon request.  
Also available as 1" x 1". Please call for price.

## PIVOT FLUSHER



Low Flow	(400-700 GPM)	9-7900	-	510.00
Standard Flow	(700-1000 GPM)	9-7901	-	510.00

- 2" Male Pipe Thread
- Dimensions: 12" x 17"
- Max Operating Pressure: 40 psi
- Min Operation Pressure: 12 psi (15-30 psi recommended)
- Closing Pressure: 7 psi
- Flows: 150 gpm @ 10 psi
- Does not require electricity
- Works automatically using water pressure
- Flushes while pivot pressurizes

Fittings



Product	Description	Part Number	Weight	List Price
<b>SCREEN, E-Z</b>	Square Grid	9-7316	-	<b>2.50</b>
	Bar Grid	9-7317	-	<b>2.50</b>



**Features:**

- Stops Nozzle Plugging on Even the Smallest Nozzles, 3/64" Hose Size
- Self Flushing Design-Never Needs Cleaning
- Can Be Used on Any System
- Two Sizes to Accommodate Nozzle Flow Rates
- Threaded Mounting

## INLINE SCREEN (STAINLESS STEEL 24 GA.)



Size	Outside Diameter of inlet of Screen			Length	Part #	Weight	List Price
	BE-Bullnose End	RE-Rolled End	OE-Open End				
2"	2"	2"	2"	18"	6-1513	0.5	39.00
3"	3"	3"	3"	18"	6-1514	0.5	39.00
4"	4"			36"	6-1510-BE	1.3	57.00
4"		3-7/8"		36"	6-1510-RE	1.3	57.00
4"			4"	36"	6-1510-OE	1.3	57.00
5"	4-7/8"			36"	6-1515-BE	2.0	71.00
5"		4-3/4"		36"	6-1515-RE	2.0	71.00
5"			5"	36"	6-1515-OE	2.0	71.00
6"	5-3/4"			36"	6-1511-BE	3.5	84.00
6"		5-5/8"		36"	6-1511-RE	3.5	84.00
6"			6"	36"	6-1511-OE	3.5	84.00
8"	7-3/4"			36"	6-1512-BE	5.0	103.00
8"		7-5/8"		36"	6-1512-RE	5.0	99.00
8"			8"	36"	6-1512-OE	5.0	103.00
10"	9-3/4"			36"	6-1469-BE	7.0	130.00
10"		9-5/8"		36"	6-1469-RE	7.0	130.00
10"			10"	36"	6-1469-OE	7.0	130.00

**Features:**

- Keeps sprinkler heads from plugging
- Makes couplers easier to connect and disconnect
- Works with large volumes of water up to 1000 gallons per minute.
- Collects large amounts of sand, gravel, and debris without cleaning.

\*Hole size = 3/32" (.09375"). Special order available on smaller .05" hole size.

## SCREEN FILTER, GALVANIZED

(FLANGE X FLANGE)

Size	GPM	Screen			
8"	1200	1/16"	9-7312	-	<b>2,385.00</b>
8"	1200	3/32"	9-7313	-	<b>2,385.00</b>
8"	1750	1/16"	9-7314	-	<b>3,560.00</b>
8"	1750	3/32"	9-7315	-	<b>3,560.00</b>



Product	Description	Part Number	Weight	List Price
<b>SOIL MOISTURE TESTER</b> <b>IRROMETER</b> Features: - 5 different lengths to choose from - Only the gauge is replaceable - Conserves water - Saves energy from pumping excessive water	Irrrometer: 6"	6-1504	0.8	125.00
	12"	6-1508	1.0	130.00
	18"	6-1509	1.1	135.00
	24"	6-1516	1.2	140.00
	36"	6-1517	1.5	150.00
	48"	6-1518	1.7	160.00
	Service Unit	6-1519	1.1	92.00



Recommended by the soil conservation departments of the USDA and local water conservation districts as an easy tool to prevent over-watering  
Optional service kit is required with the first installation of a tensiometer.  
This unit is not recommended for areas where the instrument could get easily hit or where there are a lot of stones in the soil.

## PRESSURE GAUGE 2-1/2" & 4" DIAL FACES

For Irrigation Water



- 1/4" brass male pipe thread base
- Stainless steel case
- Silicone filled gauge (on the liquid filled gauges)
- Glass lens

### Dry (2-1/2" Dial Face)

#0-30 PSI Dry	2-1/2"	6-9768	0.3	7.00
#0-100 PSI Dry		6-1520	0.3	9.00
#0-200 PSI Dry		6-1521	0.3	9.00

### Liquid Filled (2-1/2" Dial Face)

#0-15 PSI Liquid Filled	2-1/2"	6-9754	0.5	15.00
#0-30 PSI Liquid Filled		6-9755	0.5	15.00
#0-60 PSI Liquid Filled		6-9756	0.5	15.00
#0-100 PSI Liquid Filled		6-9757	0.5	15.00
#0-160 PSI Liquid Filled		6-1522	0.5	12.00
#0-200 PSI Liquid Filled		6-9758	0.5	15.00
#0-300 PSI Liquid Filled		6-9759	0.5	15.00

### Liquid Filled (4" Dial Face)

#0-15 PSI Liquid Filled	4"	9-5271	1.5	32.00
#0-30 PSI Liquid Filled		9-5274	1.5	32.00
#0-60 PSI Liquid Filled		9-5276	1.5	32.00
#0-100 PSI Liquid Filled		9-5270	1.5	32.00
#0-160 PSI Liquid Filled		9-5272	1.2	32.00
#0-200 PSI Liquid Filled		9-5273	1.5	32.00
#0-300 PSI Liquid Filled		9-5275	1.5	32.00

## PRESSURE GAUGE LIQUID MANURE



- 1/4" brass male pipe thread base
- Stainless steel case
- Silicone filled gauge (on the liquid filled gauges)
- Glass lens

### For Liquid Manure (2-1/2" Dial Face):

#0-160 PSI - Dry	2-1/2"	6-1578	0.5	62.00
#0-160 PSI - Liquid Filled		6-9570	0.5	55.00

Fittings

# VALVE STUBS

Product	Description	Part Number	Weight	List Price
<b>WELD-ON VALVE STUB</b> (BLACK STEEL)	3"	6-1377	2.0	<b>39.00</b>
	4"	6-1414	2.8	<b>39.00</b>
	5"	6-1378	3.8	<b>63.00</b>
	6"	6-1415	5.8	<b>50.00</b>
	8"	6-1416	15.0	<b>177.00</b>
	10"	6-9846	19.0	<b>350.00</b>



<b>WELD-ON VALVE STUB</b> (STAINLESS STEEL)	6"	9-8104		<b>256.00</b>
	8"	9-8105		<b>635.00</b>
	10"	9-8106		<b>975.00</b>



<b>WELD-ON VALVE STUB</b> (CAST ALUMINUM)	3"	6-1363	3.5	<b>55.00</b>
	4"	6-1364	3.5	<b>55.00</b>
	5"	6-1365	3.5	<b>85.00</b>
	6"	6-1366	4.5	<b>108.00</b>



<b>WELD-ON VALVE STUB WITH SADDLE</b> (CAST ALUMINUM)	4" x 4"	6-1373	3.5	<b>55.00</b>
	5" x 4"	6-1374	3.5	<b>55.00</b>
	6" x 4"	6-1411	3.5	<b>55.00</b>
	7" x 4"	6-1375	3.5	<b>55.00</b>
	8" x 4"	6-1412	3.5	<b>55.00</b>
	10" x 4"	6-1413	3.5	<b>55.00</b>
	12" x 4"	6-1376	3.5	<b>55.00</b>



<b>THREADED VALVE STUB</b> (GALVANIZED STEEL)	2" FPT x 3"	6-1421	4.0	<b>70.00</b>
	3" FPT x 3"	6-1423	4.5	<b>83.00</b>
	3" FPT x 4"	6-1424	5.0	<b>81.00</b>
	4" FPT x 4"	6-1420	6.0	<b>102.00</b>
	6" FPT x 6"	6-1425	8.5	<b>195.00</b>
	8" FPT x 8"	6-1426	28.0	<b>385.00</b>
	2" MPT x 3"	6-1427	4.0	<b>71.00</b>
	3" MPT x 3"	6-1428	4.5	<b>73.00</b>
	3" MPT x 4"	6-1429	5.0	<b>76.00</b>
	4" MPT x 4"	6-1399	6.0	<b>85.00</b>
	6" MPT x 6"	6-1388	9.0	<b>161.00</b>
	8" MPT x 8"	6-1387	25.0	<b>375.00</b>



Female



Male

<b>THREADED VALVE STUB</b> (CAST ALUMINUM)	4" FPT x 4"	6-9612	4.5	<b>71.00</b>
	6" FPT x 6"	6-9614	5.0	<b>205.00</b>
	4" MPT x 4"	6-9613	3.0	<b>72.00</b>
	6" MPT x 6"	6-9615	5.0	<b>275.00</b>



Female



Male

Product	Description	Part Number	Weight	List Price
<b>RISER VALVE DISC</b> 		<u>Hole Size</u>		
		3" 5/8"	6-1404	0.4 <b>12.90</b>
		4" 5/8"	6-1405	0.6 <b>8.00</b>
		5" 5/8"	6-1409	1.0 <b>16.50</b>
		6" 5/8"	6-1406	1.3 <b>25.00</b>
		8" 1"	6-1410	2.5 <b>64.50</b>
	10" 1"	9-7546	- <b>83.00</b>	

\* Domed

## RISER VALVE STEM



Disc Size	Diameter x Length	Part Number	Weight	List Price
4"	5/8" x 6-3/4"	6-1407	0.6	<b>8.00</b>
6"	5/8" x 9"	6-1408	0.7	<b>10.50</b>
8"	1" x 11"	6-1400	2.5	<b>39.00</b>
10"	1" x 13"	9-7547	-	<b>55.00</b>

\* Zinc Plated

## WELD-ON SADDLE (CAST ALUMINUM)



Outlet x Pipe	Part Number	Weight	List Price
3" x 3"	6-1592	0.4	<b>10.50</b>
3" x 4"	6-1593	0.4	<b>10.50</b>
3" x 5"	6-1594	0.4	<b>10.50</b>
3" x 6"	6-1595	0.4	<b>10.50</b>
4" x 4"	6-1596	0.5	<b>15.00</b>
4" x 5"	6-1597	0.5	<b>15.00</b>
4" x 6"	6-1598	0.5	<b>15.00</b>
4" x 8"	6-1599	0.5	<b>15.00</b>
5" x 5"	6-1600	0.8	<b>29.00</b>
5" x 6"	6-1601	0.8	<b>29.00</b>
5" x 7"	6-1602	0.8	<b>29.00</b>
5" x 8"	6-1603	0.8	<b>29.00</b>
5" x 10"	6-1604	0.8	<b>29.00</b>
6" x 6"	6-1605	1.0	<b>29.00</b>
6" x 8"	6-1606	0.5	<b>29.00</b>
8" x 8"	6-1607	1.0	<b>57.00</b>
10" x 10"	6-1608	1.0	<b>57.00</b>

## Call For:

- Flat Discs
- Stainless Steel Stems
- Brass Stems
- 8 Pitch Stems
- Hex Top Stems
- VTC Stems
- RVTC Stems
- Weld-in Spiders
- Replaceable Spiders
- Snap Rings
- Brass Nut

Fittings

# VALVE OPENERS INDEPENDENT VALVE TEES

Product	Description	Part Number	Weight	List Price
<b>VALVE OPENER</b>	3"	Cast Alum 6-1435	9.0	<b>125.00</b>
	4"	Cast Alum 6-1430	10.0	<b>144.00</b>
	6"	<b>Steel Gal.</b> 6-1431	15.0	<b>217.00</b>
	8"	<b>Steel Gal.</b> 6-1433	27.0	<b>280.00</b>
	10"	<b>Steel Gal.</b> 6-9752	34.0	<b>510.00</b>
	3" x 2"	Cast Alum 6-1434	8.0	<b>125.00</b>
	4" x 2"	Cast Alum 6-1436	10.0	<b>149.00</b>
	4" x 3"	Cast Alum 6-1437	10.0	<b>138.00</b>
	6" x 4"	<b>Steel Gal.</b> 6-1432	14.0	<b>187.00</b>



Cast Alum



Steel Gal.

Also available in Knob style.

## GUN STAND VALVE OPENER

4" x 3"	Cast Alum 6-1018	13.0	<b>245.00</b>
---------	------------------	------	---------------



Cast Alum

## VALVE OPENING TEE



3" x 2" x 2"	Cast Alum 6-1390	8.0	<b>165.00</b>
3" x 3" x 3"	Cast Alum 6-1391	9.0	<b>165.00</b>
4" x 2" x 2"	Cast Alum 6-1392	10.0	<b>168.00</b>
4" x 3" x 3"	Cast Alum 6-1393	11.0	<b>176.00</b>
4" x 4" x 4"	Cast Alum 6-1394	11.0	<b>198.00</b>
6" x 4" x 4"	<b>Steel Gal.</b> 6-1395	17.0	<b>231.00</b>
6" x 6" x 6"	<b>Steel Gal.</b> 6-1396	18.5	<b>277.00</b>
8" x 6" x 6"	<b>Steel Gal.</b> 6-1397	20.0	<b>386.00</b>
8" x 8" x 8"	<b>Steel Gal.</b> 6-1398	23.0	<b>390.00</b>

Also available in Knob style.

## VALVE OPENING PARTS



Roll Pin



5/8" and 7/8"



Yoke



3/4"

Yoke only	6-1438	<b>7.50</b>
Roll Pin for Yolk	6-1439	<b>0.70</b>
*Chevron Gasket - 5/8"	6-1240	<b>1.00</b>
**Chevron Gasket - 3/4"	6-1241	<b>1.00</b>
Chevron Gasket - 1"	6-1243	<b>2.00</b>

\*5/8" is for Alumax, A&M & Felton.

\*\*3/4" is for Ames, Alumax, Bush Hog, Irreco, Pierce, ShurRane & Western.

## HOOK STYLE INDEPENDENT VALVE TEE (ALUMINUM)

4" x 4"	6-1380	6.3	<b>159.00</b>
6" x 4"	6-1381	9.6	<b>181.00</b>
8" x 4"	6-1382	11.7	<b>199.00</b>
10" x 4"	6-1383	13.6	<b>221.00</b>



# NIPPLES, COUPLINGS & TEES

Product	Description	Part Number	Weight	List Price
<b>RINGLOCK INDEPENDENT VALVE TEE</b> (ALUMINUM)	6" x 4"	6-1384	9.0	205.00
	8" x 4"	6-1385	9.9	225.00
	10" x 4"	6-1386	11.7	255.00



## WELD-ON NIPPLE (BLACK STEEL)



<u>Black Steel:</u>		Length		
1/2"	1"	9-5820	-	1.50
3/4"	2"	6-1539	0.1	2.00
1"	2"	6-1540	0.4	2.75
1-1/4"	2"	6-1541	0.3	4.00
1-1/2"	2"	6-1542	0.4	6.50
2"	2-1/2"	6-1543	0.6	8.50
2-1/2"	2-1/2"	6-1548	0.9	11.00
3"	3"	6-1544	1.5	15.50
4"	4"	6-1545	2.8	23.00
5"	4"	6-1549	3.9	36.00
6"	4"	6-1546	5.3	40.00
8"	4"	6-1547	7.3	85.00
10"	4"	6-9660	-	172.00
12"	4"	6-9661	-	210.00

## WELD-ON NIPPLE (ALUMINUM)



1/2"		9-5821	0.2	6.50
3/4"		6-1703	0.2	7.10
1"		6-1554	0.3	8.00
1-1/4"		6-1555	0.3	9.50
1-1/2"		6-1556	0.3	14.00
2"		6-1550	0.3	19.50
2-1/2"		6-1557	0.4	34.00
3"		6-1551	0.6	18.00
4"		6-1552	0.9	25.00
5"		6-1553	1.1	52.00
6"		6-1558	1.4	75.00
8"		6-1559	3.0	122.00

## WHITE TEFLON TAPE



1/2" x 520"	9-7543	1.60
3/4" x 520"	9-7544	2.70
1" x 520"	9-7545	3.40

\*Industrial Teflon Thread sealing tape.  
 \*Chemically resistant.

## PIPE THREAD COMPOUND



1-Pint    1-Quart    1/2-Pint

1/2 Pint, 8 Fl. Oz	9-7442	10.00
1 Pint, 16 Fl. Oz	9-7443	16.00
1 Quart, 32 Fl. Oz	9-7444	28.00

Fittings

Product	Description	Part Number	Weight	List Price	
<b>WELD-ON HALF COUPLING</b> (BLACK STEEL)					
		1/8"	9-5879	0.0	1.00
		1/4"	9-5016	0.1	1.50
		3/8"	9-5279	0.0	1.70
		1/2"	9-5278	0.1	1.70
		3/4"	6-1586	0.1	1.80
		1"	6-1669	0.3	2.50
		1-1/4"	6-1587	0.2	3.20
		1-1/2"	6-1588	0.3	4.00
		2"	6-1571	0.5	5.50
		2-1/2"	6-1589	1.0	14.00
		3"	6-1572	1.4	10.00
		4"	6-1573	2.0	20.00
		5"	6-1574	3.6	60.00
		6"	6-1575	4.9	71.00
	8"	6-1576	-	97.00	
	10"	9-5154	-	135.00	

**FULL COUPLING**  
(BLACK STEEL)

	1/4"	9-5847	0.1	1.40
	3/8"	9-5872	0.1	2.60
	1/2"	6-9571	0.2	2.80
	3/4"	6-9572	0.3	3.50
	1"	6-9573	0.4	4.90
	1-1/4"	9-5870	0.5	6.20
	1-1/2"	9-5869	0.7	7.90
	2"	6-9574	1.1	11.30
	2-1/2"	9-5871	2.1	19.50
	3"	6-9575	3.4	27.30
	3-1/2"	9-5873	4.8	54.00
	4"	9-5874	4.6	53.00
	6"	9-5875	11.3	106.00

**WELD-ON HALF COUPLING**  
(ALUMINUM)

	1/4"	9-5303	0.1	4.50
	1/2"	9-5304	0.3	7.00
	3/4"	6-1740	0.3	7.00
	1"	6-1609	0.3	7.80
	1-1/4"	6-1585	0.4	10.00
	1-1/2"	6-1580	0.5	14.00
	2"	6-1581	1.0	19.50
	2-1/2"	6-1417	1.0	34.00
	3"	6-1582	1.4	33.00
	4"	6-1583	1.5	55.00
	5"	6-1584	1.5	104.00
	6"	6-1418	1.6	148.00



Product	Description	Part Number	Weight	List Price
<b>FLAPPER DRAIN GASKET</b>	Flapper Drain Gasket (complete)	6-1537	0.4	<b>8.00</b>
	1. Splash Nut	6-1813	0.1	<b>2.10</b>
	2. Rubber Flapper	6-1810	0.1	<b>1.75</b>
	3. Threaded Insert	6-1811	0.1	<b>2.50</b>
	4. Jam Nut	6-1812	0.1	<b>1.50</b>

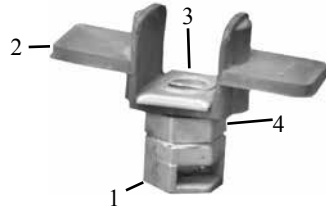

## MUSHROOM DRAIN W/CLIP (WESTERN)

6-1525 0.1 1.20



\* Clip (not pictured) is included

## MUSHROOM DRAIN (AMES)

6-1526 0.1 1.20



## 1" DRAIN VALVE

Pierce (1" mpt x 3/4" male hose thread)	#1	8-1447	0.1	<b>13.00</b>
Wade Rain (1" mpt)	#2	6-1538	0.4	<b>11.00</b>
Waterman (1-1/2" mpt x 3/4" mpt)	#3	8-1448	0.2	<b>22.00</b>
Pierce Giant Bridge Drain (1" mpt)	#4	9-7701	-	<b>10.00</b>



#1



#2



#3



#4



# IRON MALLEABLE FITTINGS (CLASS 150 LBS)



Product	Description	Part Number	Weight	List Price
---------	-------------	-------------	--------	------------

**BUSHING**  
(BLACK OR GALVANIZED STEEL)



Description	Black			Galvanized		
	Part Number	Weight	List Price	Part Number	Weight	List Price
1/4" X 1/8"	9-7035	0.1	2.30	9-5479	0.1	3.40
3/8 X 1/8	9-7210	0.1	2.30	9-5480	0.1	3.40
3/8" X 1/4"	9-7222	0.1	2.30	9-5481	0.1	3.40
1/2" X 1/8"	9-7015	0.1	2.30	9-5482	0.1	3.40
1/2" X 1/4"	9-7013	0.1	2.30	9-5483	0.1	3.40
1/2" X 3/8"	9-7016	0.1	2.30	9-5484	0.1	3.40
3/4 X 1/8	9-7186	0.2	2.30	9-5485	0.2	3.90
3/4" X 1/4"	9-7199	0.1	2.30	9-5486	0.1	3.50
3/4" X 3/8"	9-7200	0.1	2.30	9-5487	0.1	3.90
3/4"x1/2"	9-7261	0.1	2.10	8-1214	0.1	3.10
1 X 1/4	9-6984	0.2	2.80	9-5489	0.2	4.10
1 X 3/8	9-6987	0.2	2.90	9-5490	0.2	6.50
1"x1/2"	9-7250	0.2	2.20	8-1215	0.2	3.80
1"x3/4"	9-7251	0.2	2.20	8-1216	0.2	3.50
1-1/4 X 1/4	9-7084	0.3	3.70	9-5493	0.3	5.90
1-1/4 X 3/8	9-7085	0.3	3.30	9-5494	0.3	5.90
1 1/4"X1/2"	9-7098	0.3	3.10	9-5495	0.3	5.20
1 1/4"X3/4"	9-7101	0.4	2.80	9-5496	0.4	4.80
1-1/4"x1"	9-7254	0.3	2.80	8-1217	0.3	4.80
1-1/2 X 1/4	9-7048	0.4	4.30	9-5498	0.4	7.50
1-1/2 X 3/8	9-7049	0.2	4.20	9-5499	0.4	7.50
1 1/2"X1/2"	9-7062	0.4	3.50	9-5500	0.4	6.90
1 1/2"X3/4"	9-7065	0.4	3.50	9-5501	0.4	6.90
1-1/2"x1"	9-7252	0.4	3.10	8-1218	0.4	6.20
1-1/2"x1-1/4"	9-7253	0.3	3.60	8-1219	0.3	5.70
2"x1/4"	9-7144	0.2	7.00	9-5504	0.5	8.70
2 X 3/8	9-7128	0.2	5.30	9-5505	0.2	8.70
2"X1/2"	9-7143	0.5	5.30	9-5506	0.5	8.60
2"X3/4"	9-7147	0.6	4.50	9-5507	0.6	8.00
2"x1"	9-7255	-	4.20	8-1220	0.6	7.50
2"x1-1/4"	9-7257	0.7	4.20	8-1221	0.7	7.50
2"x1-1/2"	9-7256	0.6	4.70	8-1222	0.6	6.70
2-1/2 X 1/2	9-7150	-	7.70	9-5511	-	12.40
2-1/2 X 3/4	9-7157	1.0	7.70	9-5512	1.0	12.40
2-1/2 X 1	9-7148	1.0	7.70	9-5513	1.0	12.40
2-1/2 X 1-1/4	9-7153	1.0	7.70	9-5514	1.0	12.40
2-1/2 X 1-1/2	9-7151	1.1	7.20	9-5515	1.1	15.20
2-1/2"x2"	9-7258	0.9	7.10	8-1223	0.9	10.80
3" X 1/2"	9-7182	1.1	12.50	9-5517	1.1	28.00
3" X 1"	9-7180	1.4	10.70	9-5518	1.4	16.40
3" X 1-1/4"	9-7184	1.5	10.70	9-5519	1.5	16.50
3" X 1-1/2"	9-7183	1.6	10.40	9-5520	1.6	16.00
3"x2"	9-7259	1.9	9.80	8-1224	1.9	14.60
3"x2-1/2"	9-7260	1.8	9.90	8-1225	1.8	15.50
3-1/2"x3"	9-7319	-	16.00	9-5962	2.0	25.20
4" X 1"	9-7234	1.3	20.20	9-5523	2.6	34.00
4" X 1-1/4"	9-7236	1.2	20.20	9-5524	2.7	34.00
4" X 1-1/2"	9-7235	1.2	20.20	9-5525	2.8	21.00
4" X 2"	9-7237	2.6	19.30	9-5526	2.6	30.50
4" X 2-1/2"	9-7238	3.0	19.30	9-5527	3.0	34.50
4"x3"	9-7262	1.7	19.30	6-1760	2.8	32.00
6"x2"	9-7320	-	43.00	9-5963	6.2	57.80
6"x3"	9-7321	-	43.00	9-5964	6.6	59.60
6"x4"	9-7322	-	43.00	9-5965	6.8	58.40

Class 150 Pounds

# IRON MALLEABLE FITTINGS (CLASS 150 LBS)

Product	Description	Part Number	Weight		List Price		Part Number	Weight		List Price	
<b>45° ELBOW</b> (BLACK OR GALVANIZED STEEL)			Black				Galvanized				
	1/8"	9-7038	0.1	2.60	9-5579	0.1	3.60				
	1/4"	9-7024	0.1	2.70	9-5580	0.1	3.80				
	3/8"	9-7212	0.1	2.40	9-5581	0.1	3.20				
	1/2"	9-7264	0.2	2.10	8-1227	0.2	2.50				
	3/4"	9-7270	0.3	2.60	8-1228	0.3	3.50				
	1"	9-7263	0.5	3.30	8-1229	0.3	4.00				
	1-1/4"	9-7266	0.8	5.80	8-1230	0.8	7.20				
	1-1/2"	9-7265	1.0	7.10	8-1231	1.0	8.60				
	2"	9-7297	2.4	14.50	8-1232	1.6	12.80				
	2-1/2"	9-7268	2.9	30.30	8-1233	2.9	43.20				
	3"	9-7269	4.2	39.30	8-1234	4.2	63.00				
	4"	9-7271	7.0	76.40	8-1235	7.0	105.00				
6"	9-7241	16.5	220.00	9-5591	16.5	310.00					



Class 150 Pounds

Product	Description	Part Number	Weight		List Price		Part Number	Weight		List Price	
<b>90° ELBOW</b> (BLACK OR GALVANIZED STEEL)			Black				Galvanized				
	1/8"	9-7042	0.1	1.80	9-5566	0.1	2.50				
	1/4"	9-7028	0.1	1.70	9-5567	0.1	2.50				
	3/8"	9-7216	0.2	1.70	9-5568	0.2	2.50				
	1/2"	9-7273	0.2	1.30	8-1237	0.2	1.60				
	3/4"	9-7276	0.4	1.60	8-1238	0.4	1.90				
	1"	9-7272	0.6	2.80	8-1239	0.6	3.60				
	1-1/4"	9-7275	0.9	4.50	8-1240	0.9	5.50				
	1-1/2"	9-7274	1.1	5.90	8-1241	1.1	7.20				
	2"	9-7247	1.8	10.10	6-1761	1.8	12.00				
	2-1/2"	9-7323	-	19.00	6-1762	3.4	30.00				
	3"	9-7248	5.0	32.70	6-1763	5.0	51.00				
	4"	9-7249	8.9	69.60	6-1764	8.9	87.00				
6"	9-7244	20.7	230.80	9-5578	20.7	327.00					



Class 150 Pounds

Product	Description	Part Number	Weight		List Price		Part Number	Weight		List Price	
<b>TEE</b> (BLACK OR GALVANIZED STEEL)			Black				Galvanized				
	1/8"	9-7046	0.1	2.80	9-5776	0.1	3.60				
	1/4"	9-7033	0.1	2.60	9-5777	0.1	3.10				
	3/8"	9-7220	0.2	2.60	9-5778	0.2	3.10				
	1/2"	9-7294	0.3	1.70	8-1243	0.3	2.00				
	3/4"	9-7300	0.5	2.40	8-1244	0.5	3.20				
	1"	9-7293	0.8	4.20	8-1245	0.8	5.30				
	1-1/4"	9-7296	1.2	6.90	8-1246	1.2	8.30				
	1-1/2"	9-7295	1.6	8.60	8-1247	1.6	10.50				
	2"	9-7297	2.4	14.50	8-1248	2.4	17.50				
	2-1/2"	9-7298	4.5	29.90	8-1249	4.5	46.50				
	3"	9-7299	6.5	44.90	8-1250	6.5	54.50				
	4"	9-7301	11.3	105.40	8-1251	11.3	129.00				
6"	9-7246	27.0	250.00	9-5788	27.0	310.00					



Class 150 Pounds

Product	Description	Part Number	Weight		List Price		Part Number	Weight		List Price	
<b>LOCKNUT</b> (BLACK OR GALVANIZED STEEL)			Black				Galvanized				
	1/4"	9-7029	-	2.10	9-5598	-	1.40				
	1/2"	9-7008	0.0	1.70	9-5599	0.1	1.80				
	3/4"	9-7193	0.1	1.90	9-5600	0.1	2.10				
	1"	9-6995	0.1	3.50	9-5601	0.1	4.00				
	1-1/4"	9-7092	0.1	2.90	9-5602	0.2	3.70				
	1-1/2"	9-7056	0.2	4.10	9-5603	0.3	4.80				
	2"	9-7134	0.3	6.50	9-5604	0.4	8.50				
2-1/2"	9-7161	-	11.50	9-5605	-	19.50					



Class 150 Pounds

Fittings

Product	Description	Part Number	Weight	List Price	Part Number	Weight	List Price
<b>REDUCING COUPLING</b> (BLACK OR GALVANIZED STEEL)		Black			Galvanized		
	1/4" X 1/8"	9-7036	0.1	1.90	9-5619	0.1	2.60
	3/8 X 1/8	9-7211	0.1	2.10	9-5620	0.1	2.70
	3/8"x1/4"	9-7289	0.1	2.10	8-1253	0.1	2.60
	3/8"x1/2"	9-7288	0.1	1.80	8-1254	0.1	2.50
	1/2 X 1/8	9-7002	0.1	2.10	9-5622	0.1	3.00
	1/2" X 1/4"	9-7014	0.1	1.90	9-5623	0.1	2.40
	1/2" X 3/8"	9-7017	0.1	1.80	9-5624	0.1	2.30
	3/4 X 1/8	9-7187	0.2	2.40	9-5625	0.2	3.00
	3/4 X 1/4	9-7185	0.2	2.40	9-5626	0.2	3.00
	3/4" X 3/8"	9-7201	0.2	2.40	9-5627	0.2	3.00
	3/4" X 1/2"	9-7324	-	2.00	9-5959	0.2	2.60
	1 X 1/4	9-6985	0.3	3.70	9-5629	0.3	5.20
	1 X 3/8	9-6988	0.3	3.70	9-5630	0.3	5.20
	1"x1/2"	9-7277	0.3	3.20	8-1256	0.3	4.50
	1"x3/4"	9-7278	0.4	3.20	8-1255	0.4	4.00
	1-1/4 X 3/8	9-7086	-	5.40	9-5633	0.5	7.30
	1 1/4" X 1/2"	9-7097	0.5	4.60	9-5634	0.5	6.80
	1 1/4"X3/4"	9-7103	0.5	4.00	9-5635	0.5	5.50
	1-1/4"x1"	9-7281	0.6	4.00	8-1257	0.6	5.50
	1-1/2 X 3/8	9-7050	-	5.60	9-5637	0.6	7.80
	1 1/2" X 1/2"	9-7061	0.6	5.90	9-5638	0.6	8.00
	1 1/2"X3/4"	9-7067	0.7	6.60	9-5639	0.7	7.10
	1-1/2"x1"	9-7279	0.8	5.90	8-1258	0.8	7.10
	1-1/2"x1-1/4"	9-7280	0.8	5.10	8-1259	0.8	6.70
	2" X 1/2"	9-7139	1.0	9.60	9-5642	1.0	11.60
	2" X 3/4"	9-7141	1.0	8.50	9-5643	1.0	11.60
	2"x1"	9-7282	1.0	8.00	8-1260	1.0	10.00
	2"x1-1/4"	9-7284	1.1	8.50	8-1261	1.1	10.20
	2"x1-1/2"	9-7283	1.2	7.40	8-1262	1.2	9.70
	2-1/2" X 1"	9-7149	-	20.50	9-5960	1.8	29.80
	2-1/2 X 1-1/4	9-7154	1.8	21.50	9-5648	1.8	30.00
	2-1/2 X 1-1/2	9-7152	1.9	22.00	9-5649	1.9	31.00
2-1/2"x2"	9-7285	2.1	18.90	8-1263	2.1	30.00	
3" x 1"	9-7181	2.5	30.00	9-5651	2.5	31.00	
3" X 1-1/4"	9-7325	-	25.00	9-5961	2.6	40.40	
3"x1-1/2"	9-7171	2.7	29.40	9-5652	2.7	40.00	
3"x2"	9-7286	2.8	24.40	8-1264	2.8	38.00	
3"x2-1/2"	9-7287	3.1	29.40	8-1265	3.1	40.00	
4"x2"	9-7290	4.3	59.00	8-1266	4.3	86.00	
4"x2-1/2"	9-7291	4.8	59.00	8-1267	4.8	86.00	
4"x3"	9-7292	5.4	59.00	8-1268	5.4	86.00	
6"x3"	9-7239	9.4	130.90	9-5658	9.4	175.00	
6"x4"	9-7240	10.0	130.90	9-5659	10.0	155.00	

Class 150 Pounds

**COUPLING**  
(BLACK OR GALVANIZED STEEL)

		Black		Galvanized		
1/8"	9-7040	0.1	2.60	9-5529	0.1	3.00
1/4"	9-7026	0.1	2.20	9-5530	0.1	2.80
3/8"	9-7214	0.1	2.20	9-5531	0.1	2.80
1/2"	9-7006	0.2	1.80	9-5532	0.2	2.30
3/4"	9-7191	0.3	2.10	9-5533	0.3	2.60
1"	9-6993	0.4	3.10	9-5534	0.4	4.30
1 1/4"	9-7089	0.7	4.00	9-5535	0.7	5.90
1 1/2"	9-7053	0.9	5.40	9-5536	0.9	6.70
2"	9-7131	1.3	7.80	9-5537	1.3	9.70
2-1/2"	9-7159	2.3	21.40	9-5538	2.3	30.00
3"	9-7176	3.4	28.90	9-5539	3.4	39.50
4"	9-7229	5.6	57.60	9-5540	5.6	84.00
6"	9-7243	-	136.90	9-5541	11.8	194.00

Class 150 Pounds

# IRON MALLEABLE FITTINGS (CLASS 150 LBS)

Product	Description	Part Number	Weight		List Price		Part Number	Weight		List Price	
			Black	Galvanized	Black	Galvanized		Black	Galvanized	Black	Galvanized
<p><b>90° REDUCING ELBOW</b> (BLACK OR GALVANIZED STEEL)</p>  <p>Class 150 Pounds</p>	1/4X1/8	9-7037	0.1	3.40	9-5660	0.1	4.00	9-5660	0.1	4.00	
	3/8X1/4	9-7223	0.1	2.50	9-5661	0.1	3.60	9-5661	0.1	3.60	
	1/2X1/4	9-7023	0.2	2.40	9-5662	0.2	3.00	9-5662	0.2	3.00	
	1/2" X 3/8"	9-7018	0.2	2.40	9-5663	0.2	2.80	9-5663	0.2	2.80	
	3/4X1/4	9-7204	0.2	3.30	9-5664	0.2	4.30	9-5664	0.2	4.30	
	3/4X3/8	9-7209	0.3	3.30	9-5665	0.3	4.30	9-5665	0.3	4.30	
	3/4" X 1/2"	9-7198	0.2	2.50	9-5666	0.3	3.20	9-5666	0.3	3.20	
	1 X 3/8	9-6989	0.2	5.10	9-5667	0.4	6.60	9-5667	0.4	6.60	
	1" X 1/2"	9-7000	0.4	3.30	9-5668	0.4	4.40	9-5668	0.4	4.40	
	1" X 3/4"	9-7001	0.5	3.70	9-5669	0.5	4.10	9-5669	0.5	4.10	
	1-1/4"x1/2"	9-7099	0.6	6.80	9-5670	0.6	8.40	9-5670	0.6	8.40	
	1-1/4"x3/4"	9-7102	0.6	5.80	9-5671	0.6	8.30	9-5671	0.6	8.30	
	1-1/4" x 1"	9-7096	0.8	5.10	9-5672	0.8	6.90	9-5672	0.8	6.90	
	1-1/2"x1/2"	9-7063	0.7	8.60	9-5673	0.7	10.80	9-5673	0.7	10.80	
	1-1/2"x3/4"	9-7066	0.7	8.40	9-5674	0.7	10.60	9-5674	0.7	10.60	
	1-1/2" x 1"	9-7060	0.9	8.40	9-5675	0.9	10.60	9-5675	0.9	10.60	
	1-1/2"x1-1/4"	9-7064	1.1	8.40	9-5676	1.1	10.60	9-5676	1.1	10.60	
	2" x 1/2"	9-7140	0.9	12.40	9-5677	0.9	15.00	9-5677	0.9	15.00	
	2" x 3/4"	9-7142	1.1	12.40	9-5678	1.1	15.00	9-5678	1.1	15.00	
	2" x 1"	9-7138	1.3	12.10	9-5679	1.3	14.70	9-5679	1.3	14.70	
	2"x1-1/4"	9-7146	1.4	12.10	9-5680	1.4	14.70	9-5680	1.4	14.70	
	2"x1-1/2"	9-7145	1.6	10.60	9-5681	1.6	12.80	9-5681	1.6	12.80	
	2-1/2X1-1/2	9-7166	2.2	29.70	9-5682	2.2	46.80	9-5682	2.2	46.80	
	2-1/2 X 2	9-7155	2.5	29.20	9-5683	2.5	41.70	9-5683	2.5	41.70	
	3" X 2"	9-7326	-	40.00	9-5943	3.3	65.80	9-5943	3.3	65.80	
	3" X 2-1/2"	9-7327	-	40.00	9-5944	4.1	65.80	9-5944	4.1	65.80	
	4" X 3"	9-7328	-	68.00	9-5945	6.7	127.80	9-5945	6.7	127.80	

Product	Description	Weight		List Price		Part Number	Weight		List Price	
		Black	Galvanized	Black	Galvanized		Black	Galvanized		
<p><b>90° STREET ELBOW</b> (BLACK OR GALVANIZED STEEL)</p>  <p>Class 150 Pounds</p>	1/8"	9-7044	0.1	2.60	9-5751	0.1	3.40	9-5751	0.1	3.40
	1/4"	9-7031	0.1	2.60	9-5752	0.1	3.30	9-5752	0.1	3.30
	3/8"	9-7218	0.1	2.60	9-5753	0.1	3.30	9-5753	0.1	3.30
	1/2"	9-7010	0.2	2.70	9-5754	0.2	3.40	9-5754	0.2	3.40
	3/4"	9-7195	0.3	2.60	9-5755	0.3	3.30	9-5755	0.3	3.30
	1"	9-6997	0.5	3.80	9-5756	0.5	4.40	9-5756	0.5	4.40
	1 1/4"	9-7094	0.8	5.80	9-5757	0.8	7.50	9-5757	0.8	7.50
	1 1/2"	9-7058	1.1	7.70	9-5758	1.1	9.20	9-5758	1.1	9.20
	2"	9-7136	1.8	12.50	9-5759	1.8	16.00	9-5759	1.8	16.00
	2-1/2"	9-7163	3.3	30.80	9-5760	3.3	43.30	9-5760	3.3	43.30
	3"	9-7178	4.9	47.00	9-5761	4.9	65.40	9-5761	4.9	65.40
	4"	9-7232	9.2	76.60	9-5762	9.2	107.90	9-5762	9.2	107.90

Product	Description	Weight		List Price		Part Number	Weight		List Price	
		Black	Galvanized	Black	Galvanized		Black	Galvanized		
<p><b>45° STREET ELBOW</b> (BLACK OR GALVANIZED STEEL)</p>  <p>Class 150 Pounds</p>	1/8"	9-7045	0.1	4.10	9-5763	0.1	4.70	9-5763	0.1	4.70
	1/4"	9-7032	0.1	3.00	9-5764	0.1	4.00	9-5764	0.1	4.00
	3/8"	9-7219	0.1	3.50	9-5765	0.1	4.60	9-5765	0.1	4.60
	1/2"	9-7004	0.2	2.80	9-5766	0.2	3.50	9-5766	0.2	3.50
	3/4"	9-7189	0.3	4.30	9-5767	0.3	5.70	9-5767	0.3	5.70
	1"	9-6991	0.5	4.90	9-5768	0.5	7.10	9-5768	0.5	7.10
	1 1/4"	9-7087	0.7	8.60	9-5769	0.7	10.60	9-5769	0.7	10.60
	1 1/2"	9-7051	0.9	10.60	9-5770	0.9	12.80	9-5770	0.9	12.80
	2"	9-7129	1.5	17.90	9-5771	1.5	22.00	9-5771	1.5	22.00
	2-1/2"	9-7164	2.6	38.10	9-5772	2.6	51.80	9-5772	2.6	51.80
	3"	9-7329	-	49.00	9-5941	3.9	77.50	9-5941	3.9	77.50
	4"	9-7330	-	92.00	9-5942	7.0	126.00	9-5942	7.0	126.00

Fittings

### Product

## REDUCING TEE (BLACK OR GALVANIZED STEEL)



Class 150 Pounds

Left, Right, Top	Black			Galvanized		
Description	Part #	Weight	List Price	Part #	Weight	List Price
3/8x3/8x1/4	9-7224	-	3.40	9-5684	-	4.50
1/2x1/2x1/4	9-7020	0.2	2.90	9-5685	0.1	3.70
1/2x1/2x3/8	9-7022	0.3	3.60	9-5686	0.1	4.70
1/2x1/2x3/4	9-7021	0.4	4.20	9-5687	0.2	5.10
1/2x1/2x1	9-7019	0.5	5.40	9-5688	0.3	7.30
3/4x1/2x1/2	9-7202	0.4	3.80	9-5689	0.2	5.10
3/4x1/2x3/4	9-7203	0.5	4.20	9-5690	0.2	5.10
3/4x1/2x1	9-7331	-	4.00	9-5949	-	7.50
3/4x3/4x1/4	9-7207	0.4	4.10	9-5691	0.2	4.60
3/4x3/4x3/8	9-7208	0.4	4.30	9-5692	0.2	4.60
3/4x3/4x1/2	9-7206	0.5	3.70	9-5693	0.2	4.40
3/4x3/4x1	9-7205	0.6	4.80	9-5694	0.3	7.30
1x1/2x1/2	9-7116	0.5	5.40	9-5695	0.3	7.50
1x1/2x3/4	9-7117	0.6	6.30	9-5696	0.3	7.60
1x1/2x1	9-7115	0.7	5.40	9-5697	0.4	7.50
1x3/4x1/2	9-7120	0.6	5.30	9-5698	0.3	7.60
1x3/4x3/4	9-7121	0.6	5.00	9-5699	0.3	7.50
1 x 3/4 x 1	9-6986	0.7	5.40	9-5700	0.4	7.50
1 x 1 x 1/4	9-6982	0.5	5.30	9-5701	0.3	7.50
1 x 1 x 1/2	9-6981	0.6	4.70	9-5702	0.3	6.20
1 x 1 x 3/4	9-6983	0.7	4.70	9-5703	0.4	6.20
1x1x1-1/4	9-7119	1.0	8.80	9-5704	0.5	10.50
1x1x1-1/2	9-7118	1.1	13.20	9-5705	0.6	17.90
1x1x2	9-7332	-	16.00	9-5950	-	20.00
1-1/4"x1/2"x1-1/4"	9-7100	0.9	9.80	9-5706	0.5	11.70
1-1/4x3/4x1/2	9-7113	0.4	9.70	9-5707	0.4	11.60
1-1/4"x3/4"x3/4"	9-7105	0.7	9.80	9-5708	0.4	12.80
1-1/4"x3/4"x 1"	9-7104	0.5	9.00	9-5709	0.5	11.70
1-1/4x3/4x1-1/4	9-7114	1.0	8.90	9-5710	0.5	11.00
1 1/4x1x1/2	9-7110	0.4	9.00	9-5711	0.4	11.50
1 1/4x1x3/4	9-7112	0.9	8.60	9-5712	0.4	11.70
1-1/4 x 1 x 1	9-7083	1.0	8.60	9-5713	0.5	11.70
1-1/4x1x1-1/4	9-7111	1.1	10.00	9-5714	0.6	11.90
1-1/4x1x1-1/2	9-7333	-	10.00	9-5951	-	13.00

Left, Right Top	Black			Galvanized		
Description	Part #	Weight	List Price	Part #	Weight	List Price
1-1/4x1-1/4x3/8	9-7109	0.4	8.50	9-5715	0.4	12.20
1 1/4x1 1/4x1/2	9-7107	0.9	8.60	9-5716	0.4	10.20
1 1/4x1 1/4x3/4	9-7108	0.9	7.50	9-5717	0.5	9.60
1 1/4x1 1/4x1	9-7106	1.1	7.50	9-5718	0.6	9.60
1-1/4x1-1/4x1-1/2	9-7334	-	10.00	9-5952	-	18.10
1-1/4x1-1/4x2	9-7335	-	16.00	9-5953	-	20.00
1-1/2x1/2x1	9-7068	0.7	14.90	9-5719	0.7	17.10
1-1/2x1/2x1-1/2	9-7069	0.7	11.50	9-5720	0.7	16.00
1-1/2x3/4x1-1/2	9-7082	1.3	11.70	9-5721	0.7	14.70
1-1/2x1x3/4	9-7081	0.6	11.50	9-5722	0.6	14.50
1-1/2x1x1	9-7079	1.1	11.70	9-5723	0.6	14.70
1-1/2x1x1-1/2	9-7080	1.4	11.70	9-5724	0.7	14.70
1-1/2x1-1/4x1/2	9-7076	0.6	11.50	9-5725	0.6	14.50
1-1/2x1-1/4x1	9-7075	1.2	10.00	9-5726	0.6	14.40
1-1/2x1-1/4x1-1/4	9-7078	1.3	15.80	9-5727	0.7	20.60
1-1/2x1-1/4x1-1/2	9-7077	1.4	15.80	9-5728	0.7	20.60
1 1/2x1 1/2x1/2	9-7071	1.1	10.00	9-5729	0.6	12.60
1 1/2x1 1/2x3/4	9-7074	1.2	9.50	9-5730	0.6	11.90
1 1/2x1 1/2x1	9-7070	1.3	9.50	9-5731	0.7	11.90
1 1/2x1 1/2x1 1/4	9-7072	1.4	11.70	9-5732	0.8	14.70
1-1/2x1-1/2x2	9-7073	1.9	16.20	9-5733	1.0	18.40
2 x 1/2 x 1-1/4	9-7336	-	15.00	9-5956	-	18.40
2 x 1/2 x 2	9-7124	2.0	18.20	9-5734	1.0	20.80
2 x 1 x 1	9-7122	0.8	18.00	9-5735	0.8	20.60
2 x 1 x 2	9-7123	2.1	18.20	9-5736	1.1	20.80
2x1-1/4x1-1/4	9-7337	-	16.00	9-5954	-	20.80
2x1-1/2x1	9-7338	-	15.00	9-5955	-	20.50
2x1-1/2x1-1/2	9-7168	1.9	15.70	9-5737	1.1	20.20
2 x 2 x 1/2	9-7127	1.5	14.80	9-5738	0.9	19.20
2x2x3/4	9-7170	1.7	14.80	9-5739	0.9	17.30
2x2x1	9-7169	1.8	14.80	9-5740	1.0	17.30
2 x 2 x 1 1/4	9-7126	2.0	15.70	9-5741	1.1	20.20
2 x 2 x 1 1/2	9-7125	1.1	15.50	9-5742	1.1	19.90
2 x 2 x 2-1/2	9-7339	-	33.00	9-5958	-	54.00
2-1/2x2-1/2x1	9-7167	1.6	37.00	9-5743	1.6	54.70
2-1/2 x 2-1/2 x 2	9-7156	3.6	38.90	9-5744	1.8	55.30
3 x 3 x 1/2	9-7173	1.8	51.40	9-5745	1.8	90.50
3 x 3 x 1	9-7172	4.0	52.00	9-5746	2.0	75.10
3 x 3 x 1-1/4	9-7340	-	45.00	9-5947	-	76.50
3x3x1-1/2	9-7225	4.5	52.00	9-5747	2.4	75.10
3 x 3 x 2	9-7174	5.0	52.00	9-5748	2.7	75.10
4 x 4 x 1	9-7341	-	114.00	9-5948	-	160.60
4 x 4 x 2	9-7226	4.0	105.20	9-5749	4.0	145.00
4 x 4 x 3	9-7227	-	104.00	9-5750	-	148.50

# IRON MALLEABLE FITTINGS (CLASS 150 LBS)

**Product          Description    Part Number    Weight    List Price    Part Number    Weight    List Price**

**STREET TEE**  
(BLACK OR GALVANIZED STEEL)



Class 150 Pounds

	Black			Galvanized		
1/2"	9-7011	0.2	<b>5.80</b>	9-5773	0.3	<b>9.10</b>
3/4"	9-7196	0.3	<b>8.20</b>	9-5774	0.5	<b>12.20</b>
1"	9-6998	0.4	<b>10.50</b>	9-5775	0.8	<b>15.60</b>

**CROSS**  
(BLACK OR GALVANIZED STEEL)



Class 150 Pounds

	Black			Galvanized		
1/8"	9-7041	0.1	<b>5.30</b>	9-5555	0.1	<b>8.00</b>
1/4"	9-7027	0.2	<b>5.30</b>	9-5556	0.2	<b>8.00</b>
3/8"	9-7215	0.3	<b>5.40</b>	9-5557	0.3	<b>8.00</b>
1/2"	9-7007	0.4	<b>6.20</b>	9-5558	0.4	<b>8.00</b>
3/4"	9-7192	0.6	<b>7.50</b>	9-5559	0.6	<b>10.00</b>
1"	9-6994	0.9	<b>9.30</b>	9-5560	0.9	<b>13.50</b>
1 1/4"	9-7090	1.5	<b>15.00</b>	9-5561	1.5	<b>19.50</b>
1 1/2"	9-7054	1.9	<b>18.60</b>	9-5562	1.9	<b>23.50</b>
2"	9-7132	2.9	<b>30.90</b>	9-5563	2.9	<b>44.70</b>
2-1/2"	9-7160	-	<b>53.80</b>	9-5564	5.1	<b>84.50</b>
4"	9-7230	-	<b>163.70</b>	9-5565	12.6	<b>229.50</b>

**UNION**  
(BLACK OR GALVANIZED STEEL)



Class 150 Pounds

	Black			Galvanized		
1/8"	9-7047	0.2	<b>9.40</b>	9-5789	0.2	<b>11.10</b>
1/4"	9-7034	0.2	<b>8.90</b>	9-5790	0.2	<b>10.70</b>
3/8"	9-7221	0.3	<b>6.00</b>	9-5791	0.3	<b>7.10</b>
1/2"	9-7012	0.4	<b>5.80</b>	9-5792	0.4	<b>7.20</b>
3/4"	9-7197	0.60	<b>6.90</b>	9-5793	0.6	<b>8.50</b>
1"	9-6999	0.9	<b>9.00</b>	9-5794	0.9	<b>10.60</b>
1 1/4"	9-7095	1.3	<b>11.90</b>	9-5795	1.3	<b>14.40</b>
1 1/2"	9-7059	1.8	<b>14.50</b>	9-5796	1.8	<b>18.50</b>
2"	9-7137	2.6	<b>21.90</b>	9-5797	2.6	<b>24.70</b>
2-1/2"	9-7165	3.7	<b>52.80</b>	9-5798	3.7	<b>68.70</b>
3"	9-7179	4.7	<b>64.20</b>	9-5799	4.7	<b>97.60</b>
4"	9-7233	8.3	<b>158.60</b>	9-5800	8.3	<b>211.90</b>

**SQUARE HEAD PLUG**  
(BLACK OR GALVANIZED STEEL)



Class 150 Pounds

\* Bar plugs also available in sizes 4", 5", 6" & 8".

	Black			Galvanized		
1/8"	9-7043	0.1	<b>1.10</b>	9-5606	0.1	<b>1.90</b>
1/4"	9-7030	0.1	<b>1.10</b>	9-5607	0.1	<b>1.90</b>
3/8"	9-7217	0.1	<b>1.10</b>	9-5608	0.1	<b>1.90</b>
1/2"	9-7009	0.1	<b>1.20</b>	9-5609	0.1	<b>2.30</b>
3/4"	9-7194	0.1	<b>1.20</b>	9-5610	0.1	<b>2.30</b>
1"	9-6996	0.2	<b>1.50</b>	9-5611	0.2	<b>2.50</b>
1 1/4"	9-7093	0.3	<b>1.90</b>	9-5612	0.3	<b>3.90</b>
1 1/2"	9-7057	0.4	<b>2.60</b>	9-5613	0.4	<b>5.20</b>
2"	9-7135	0.6	<b>3.70</b>	9-5614	0.6	<b>6.70</b>
2-1/2"	9-7162	1.0	<b>6.80</b>	9-5615	1.0	<b>12.90</b>
3"	9-7177	1.4	<b>9.30</b>	9-5616	1.4	<b>18.50</b>
4"	9-7231	2.6	<b>19.60</b>	9-5617	2.6	<b>38.00</b>
6"	9-7245	6.6	<b>52.10</b>	9-5618	6.6	<b>75.50</b>

**FLOOR FLANGE**  
(BLACK OR GALVANIZED STEEL)



Class 150 Pounds

	Black			Galvanized		
1/2"	9-7003	0.3	<b>4.70</b>	9-5592	0.3	<b>10.00</b>
3/4"	9-7188	0.5	<b>5.10</b>	9-5593	0.5	<b>11.20</b>
1"	9-6990	0.6	<b>6.60</b>	9-5594	0.6	<b>12.30</b>
1 1/4"	9-7091	0.8	<b>7.10</b>	9-5595	0.8	<b>14.00</b>
1 1/2"	9-7055	1.1	<b>7.70</b>	9-5596	1.1	<b>17.50</b>
2"	9-7133	1.5	<b>10.00</b>	9-5597	1.5	<b>23.00</b>

Fittings

# ACCESSORIES

Product	Description	Part Number	Weight	List Price				
<b>CAP</b> (BLACK OR GALVANIZED STEEL)		Black		Galvanized				
		Part #	Weight	List Price	Part #	Weight	List Price	
		1/8"	9-7039	0.1	1.70	9-5542	0.1	2.20
		1/4"	9-7025	0.1	1.70	9-5543	0.1	2.20
		3/8"	9-7213	0.1	1.70	9-5544	0.1	2.20
		1/2"	9-7005	0.1	1.30	9-5545	0.1	1.70
		3/4"	9-7190	0.2	1.80	9-5546	0.2	2.40
		1"	9-6992	0.3	2.10	9-5547	0.3	2.60
		1 1/4"	9-7088	0.4	2.80	9-5548	0.4	3.80
		1 1/2"	9-7052	0.6	3.80	9-5549	0.6	4.90
		2"	9-7130	0.9	4.90	9-5550	0.9	6.10
		2-1/2"	9-7158	1.5	12.30	9-5551	1.5	19.50
		3"	9-7175	2.2	18.20	9-5552	2.2	23.50
		4"	9-7228	4.0	28.50	9-5553	4.0	47.00
6"	9-7242	9.2	80.10	9-5554	9.2	151.00		

Class 150 Pounds

## PITOT TUBE



6-1530 - 16.00

## PLUG (ZAMAC)



1/2"	3-0371	0.1	1.85
3/4"	3-0372	0.1	2.00
1"	3-0370	0.1	2.10

- \* Die cast zinc alloy
- \* Will not seize, rust or gall
- \* Precision machined threads to NPT standards
- \* Clean-Lightweight

## BELL REDUCER (ZAMAC)



Female x Female threaded.

3/4" x 1/2"	6-1568	0.2	2.80
1" x 1/2"	6-1569	0.2	3.30
1" x 3/4"	6-1570	0.2	3.30

- \* Die cast zinc alloy
- \* Will not seize, rust or gall
- \* Precision machined threads to NPT standards
- \* Clean-Lightweight

## BUSHING (ZAMAC)



Male x Female threaded.

3/4" x 1/2"	6-1565	0.1	2.60
1" x 1/2"	6-1566	0.2	3.00
1" x 3/4"	6-1567	0.2	2.85

- \* Die cast zinc alloy
- \* Will not seize, rust or gall
- \* Precision machined threads to NPT standards
- \* Clean-Lightweight

## SLEEVE COUPLING (ZAMAC)



1/2"	9-6821	0.2	3.00
3/4"	6-1741	0.2	2.50
1"	6-1742	0.2	3.50

- \* Die cast zinc alloy
- \* Will not seize, rust or gall
- \* Precision machined threads to NPT standards
- \* Clean-Lightweight

# SCH 40 BLACK BUTT-WELD FITTINGS

Product	Description	Part Number	Weight	List Price				
<b>90° ELBOW - SCH 40</b> (BLACK STEEL)	<u>Wall Thickness</u>	<u>OD</u>	<u>ID</u>	<u>"A"</u>				
	3"	.216	3.50	3.07	4.5	9-5231	4.8	16.00
	4"	.237	4.50	4.03	6.0	9-5233	8.9	26.00
	6"	.280	6.62	6.06	9.0	9-5235	24.0	58.00
	8"	.322	8.62	7.97	12.0	9-5237	47.8	110.00
	10"	.365	10.75	10.02	15.0	9-5227	83.4	220.00
	12"	.375	12.75	12.00	18.0	9-5229	123.0	275.00

-Long Radius

\* Other sizes available. Please Call.

Product	Description	Part Number	Weight	List Price				
<b>45° ELBOW - SCH 40</b> (BLACK STEEL)	<u>Wall Thickness</u>	<u>OD</u>	<u>ID</u>	<u>"B"</u>				
	3"	.216	3.50	3.07	2.0	9-5230	2.5	11.50
	4"	.237	4.50	4.03	2.5	9-5232	4.5	21.00
	6"	.280	6.62	6.06	3.75	9-5234	11.7	40.00
	8"	.322	8.62	7.97	5.0	9-5236	23.3	67.00
	10"	.365	10.75	10.02	6.25	9-5226	40.9	115.00
	12"	.375	12.75	12.00	7.5	9-5228	61.4	190.00

\* Other sizes available. Please Call.

Product	Description	Part Number	Weight	List Price				
<b>TEE - SCH 40</b> (BLACK STEEL)	<u>Wall Thickness</u>	<u>OD</u>	<u>ID</u>	<u>"C"</u>				
	3"	.216	3.50	3.07	3.38	9-5282	7.2	25.00
	4"	.237	4.50	4.03	4.12	9-5283	12.7	39.00
	6"	.280	6.62	6.06	5.62	9-5284	33.1	79.00
	8"	.322	8.62	7.97	7.0	9-5285	56.5	150.00
	10"	.365	10.75	10.02	8.5	9-5280	90.9	280.00
	12"	.375	12.75	12.00	10.0	9-5281	136.0	396.00

\* Other sizes available. Please Call.

Product	Description	Part Number	Weight	List Price	
<b>CONCENTRIC CONE - SCH 40</b> (BLACK STEEL)	<u>"H"</u>				
	3"x2"	3.5	9-5190	2.0	16.00
	3"x2-1/2"	3.5	9-5191	2.2	16.00
	4"x2-1/2"	4.0	9-5192	3.2	18.00
	4"x3"	4.0	9-5193	3.3	14.00
	6"x4"	5.5	9-5194	7.4	32.00
	6"x5"	5.5	9-5195	7.6	33.00
	8"x4"	6.0	9-5196	10.8	65.00
	8"x6"	6.0	9-5197	12.3	40.00
	10"x6"	7.0	9-5186	20.7	89.00
	10"x8"	8.0	9-5187	22.1	80.00
12"x10"	8.0	9-5188	32.4	115.00	
12"x8"	8.0	9-5189	30.5	115.00	

\* Other sizes available. Please Call.

Product	Description	Part Number	Weight	List Price	
<b>ECCENTRIC CONE - SCH 40</b> (BLACK STEEL)	<u>"H"</u>				
	3"x2"	3.5	9-5218	2.0	25.00
	3"x2-1/2"	3.5	9-5219	2.2	23.00
	4"x2-1/2"	4.0	9-5220	3.2	32.00
	4"x3"	4.0	9-5221	3.3	24.00
	6"x4"	5.5	9-5222	7.4	50.00
	6"x5"	5.5	9-5223	7.6	51.00
	8"x4"	6.0	9-5224	10.8	126.00
	8"x6"	6.0	9-5225	12.3	62.00
	10"x6"	7.0	9-5214	20.7	145.00
	10"x8"	8.0	9-5215	22.1	85.00
12"x10"	8.0	9-5216	32.4	130.00	
12"x8"	8.0	9-5217	30.5	210.00	

\* Other sizes available. Please Call.



**LABOR/REPAIR CHARGES**











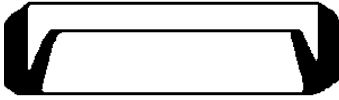

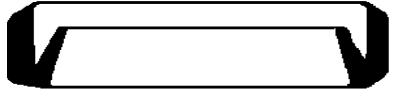

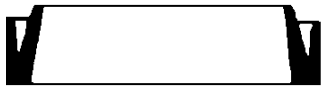
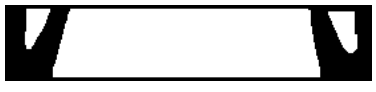

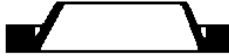

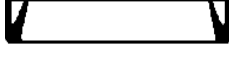
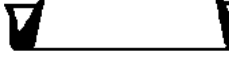
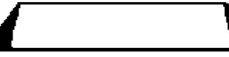
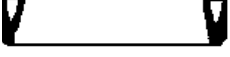

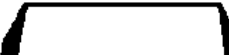
<b>Welding (per inch)</b> (Steel or Aluminum)	<b>Part Number</b> Weld/Inch		<b>List Price</b> 4.50/inch
<b>Weld Around</b> (Steel or Aluminum)	WA2	2"	\$17.00
	WA3	3"	17.00
	WA4	4"	19.00
	WA5	5"	21.00
	WA6	6"	21.00
	WA8	8"	23.00
	WA10	10"	27.00
	WA12	12"	29.00
	WA14	14"	32.00
	WA15	15"	32.00
	WA16	16"	38.00
	WA18	18"	42.00
	WA20	20"	46.00
	WA21	21"	48.00
WA22	22"	50.00	
WA24	24"	55.00	
<b>Diagonal Weld Around</b> (Steel or Aluminum)	DWA2	2"	25.50
	DWA3	3"	25.50
	DWA4	4"	28.50
	DWA5	5"	31.50
	DWA6	6"	31.50
	DWA8	8"	34.50
	DWA10	10"	40.50
	DWA12	12"	43.50
	DWA14	14"	48.00
	DWA15	15"	48.00
	DWA16	16"	57.00
	DWA18	18"	63.00
	DWA20	20"	69.00
	DWA21	21"	72.00
DWA22	22"	75.00	
DWA24	24"	82.50	
<b>Rout Gate Hole</b>	GATE		0.75
<b>Roll Aluminum Pipe End</b>			Call
<b>Labor/Hour</b>	Pump repair or any miscellaneous items. Labor		75.00
<b>Delivery</b>	<b>Car/pickup without trailer</b>	<b>Del Car</b>	1.00/mile, one way
	<b>Pickup/diesel with trailer</b>	<b>Del Truck</b>	3.00/mile, one way
<b>Cut Charge, Steel</b>	CS		15.00
<b>Cut Charge, Alum</b>	CA		15.00
<b>Diagonal Cut, Steel</b>	DCS		22.50
	DCA		22.50

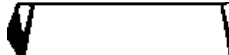

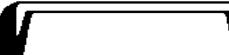
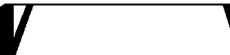
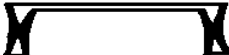

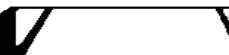

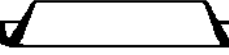
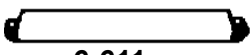
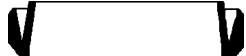
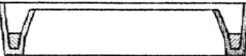







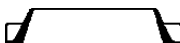
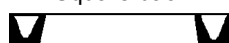
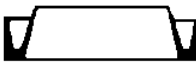
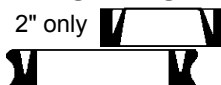
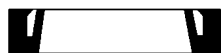
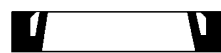
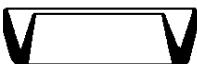

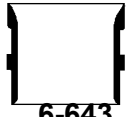

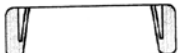
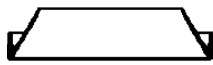
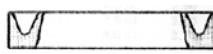
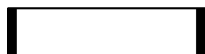
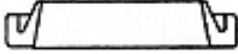
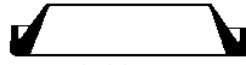
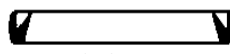
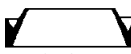
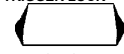

**CAN'T FIND A GASKET  
LISTED TO MATCH  
YOUR PIPE?**

**CALL OR SEND  
A SAMPLE!**

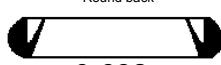
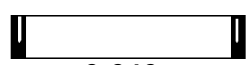
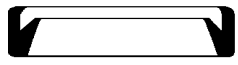
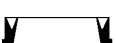
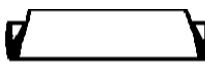
**MOST LIKELY  
ANOTHER GASKET  
WILL INTERCHANGE  
WITH YOURS!**

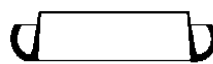
**PRICES AND SIZES ARE ON FOLLOWING PAGES**

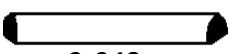
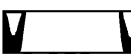
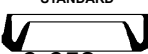
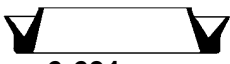
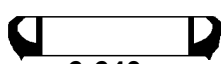
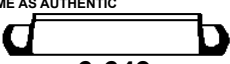
 <p><b>LINDSAY 6-161_</b> (4" LINDSAY SAME AS 4" GHEEN)</p>		 <p><b>PIERCE 6-162_</b> (SAME AS TEX FLO ROUNDBACK)</p>		 <p><b>GHEEN 6-163_</b> (4" GHEEN SAME AS 4" LINDSAY) (Cozad)</p>	
 <p><b>A &amp; M 6-164_</b></p>		 <p><b>FELTON 6-165_</b> (4" FELTON SAME AS 4" RAVIT)</p>		 <p><b>RAINWAY 6-166_</b></p>	
<p><b>ACE</b></p>  <p>6-600_</p>	<p><b>BEN GAR</b></p>  <p>6-606_</p>	<p><b>DRAGON</b></p>  <p>6-613_</p>	<p><b>FLEX-O-SEAL</b></p>  <p>6-616_</p>		
<p><b>AKRON</b></p>  <p>6-605_</p>	<p><b>CHAMPION</b></p>  <p>6-607_</p>	<p><b>DRESSER - Gheen</b></p>  <p>6-609_</p>	<p><b>HABCO</b></p>  <p>6-617_</p>		
<p><b>AMES - ABC</b></p>  <p>6-601_</p>	<p><b>CLOUDBURST 6-999_</b></p> 	<p><b>DRESSER - Naco</b></p>  <p>6-610_</p>	<p><b>IRECO - AE</b></p>  <p>6-618_</p>		
<p><b>AMES - Hi-Lo</b></p>  <p>6-602_</p>	<p><b>COBB</b></p>  <p>6-802_</p>	<p><b>FARMLAND - SBS</b></p>  <p>6-614_</p>	<p><b>IRECO - Steelume</b></p>  <p>6-619_</p>		
<p><b>AMES - Suction</b></p>  <p>6-603_</p>	<p><b>COMMETCO</b></p>  <p>6-608_</p>	<p><b>FARMLAND - Green Dot</b></p>  <p>6-615_</p>	<p><b>IRECO - Old Style</b></p>  <p>6-620_</p>		
<p><b>AULT</b></p>  <p>6-604_</p>	<p><b>DECOTO</b></p>  <p>6-611_</p>	<p><b>DIAMOND</b></p>  <p>6-612_</p>	<p><b>FIBERSTRONG</b></p>  <p>6-681_</p>	<p><b>MATHISON</b></p> <p>RING (Same as Race and Race) FULL</p>  <p>6-621_</p>  <p>6-622_</p>	

<b>MCDOWELL</b>  STANDARD <b>6-623_</b>  RING LOCK <b>6-670_</b>	<b>RACE &amp; RACE</b> DEMOUNTABLE  CONTRACTOR  <b>6-632_</b> <b>6-701_</b>	<b>SHUR-RANE</b> CHEVRON  <b>6-641_</b>	<b>TEX-FLO (HASTINGS)</b> Square back  <b>6-650_</b>	
<b>MIDWEST</b>  <b>6-624_</b>	<b>RAIN-CONTROL</b> 2" only  <b>6-633_</b>	<b>SHUR-RANE</b> OLD STYLE (SAME AS VERMEER)  <b>6-642_</b>	<b>VERMEER</b> (SAME AS SHUR-RAN OLD STYLE)  <b>6-651</b>	
<b>MOORE-RANE</b>  <b>6-625_</b>	<b>RAINBO</b>  <b>6-634_</b>	<b>STOUT - New Style</b> - (Ireco) - For male end of pipe  <b>6-643_</b>	<b>WADE RAIN Bolt-On</b>  <b>6-683_</b>	
<b>MOULTON 6-626_</b> 	<b>RAIN-OW</b>  <b>6-635_</b>	<b>STOUT - Old</b>  <b>6-644_</b>	<b>WADE RAIN New Style</b>  <b>6-652_</b>	
<b>OAKS 6-664_</b> 		<b>RAIN-FOR-RENT</b>  <b>6-636_</b>	<b>STOUT - Old</b> FOR ALUMINUM COUPLERS  <b>6-682_</b>	<b>WADE RAIN Old Style</b>  <b>6-653_</b>
<b>OLIVER 6-663_</b> 		<b>RAINMAKER</b>  <b>6-637_</b>	<b>STOUT - Seal Ring</b>  <b>6-645_</b>	<b>WEBSTER</b> ECONO LOCK  TRIGGER LOCK  <b>6-655_</b> <b>6-654_</b>
<b>PACIFIC 6-627_</b>  Speed lock - new style	<b>RAINWAY</b> Round back  <b>6-638_</b>	<b>STOUT - Towline seal</b>  <b>6-646_</b>	<b>WESTERN</b>  <b>6-656_</b>	
<b>PACIFIC 6-628_</b>  Speed lock - old style		<b>RAVIT</b> 4" RAVIT SAME AS 4"  <b>6-662_</b>	<b>STROLYTE</b>  <b>6-647_</b>	<b>WHEEL TRAC</b>  <b>6-657_</b>
<b>PORT-ALUM</b>  <b>6-630_</b>	<b>REDI-RAIN</b>  <b>6-639_</b>	<b>SURE-FLO</b>  <b>6-648_</b>	<b>WYSS</b> SEAL RING  STANDARD  <b>6-659_</b> <b>6-658_</b>	
<b>RACE &amp; RACE</b> SAME AS MATHISON RING  <b>6-631_</b>	<b>SHUR-RANE</b> Drain - New Style  <b>6-640_</b>	<b>TEX-FLO (HASTINGS)</b> Round back SAME AS AUTHENTIC  <b>6-649_</b>	<b>SPRING</b>  ABC  McDowell <b>6-660_</b> <b>6-661_</b>	

Fittings

# GASKETS



To complete the part number for each gasket size, use the part number in the first column and use the size code for the last digit. Examples: 4" Ace = 6-6004; 10" A&M = 6-1640.

		Size Code:	2	3	4	5	6	7	8	9	0	1
Part #	Brand Name	Type	2"	3"	4"	5"	6"	7"	8"	9"	10"	12"
6-164_	A&M		\$1.20	\$1.20	\$1.70	\$2.00	\$2.50	\$3.80	\$2.80		\$3.50	
6-600_	Ace				3.40		3.30		4.50		5.00	
6-605_	Akron		5.10	2.20	2.60	10.50	11.50		10.00			
6-601_	Ames	ABC	1.20	1.30	2.30	4.20	7.00	10.50	15.50			
6-602_	Ames	Hi-Lo				4.00	3.40	6.50	4.50	8.50	6.40	8.00
6-603_	Ames	Suction				28.00	18.10		22.60			
6-604_	Ault		2.50	2.10								
6-606_	Ben Gar						2.50	5.00	3.10		4.00	
6-607_	Champion		1.60	2.00	2.50	3.50	4.50		8.50			
6-999_	Cloudburst				4.00	4.70	5.60					
6-802_	Cobb		1.75	2.40	3.20							
6-608_	Commeco		2.30	2.90	3.30	3.90						
6-611_	Decoto				2.30	3.70						
6-612_	Diamond						2.50		3.00		5.00	6.00
6-613_	Dragon			2.20	2.60	3.50	4.10					
6-609_	Dresser	Gheen		3.60	4.60	5.60	4.80	73.00	6.00		7.00	33.00
6-610_	Dresser	Naco					8.00		17.00		18.00	13.00
6-614_	Farmland	SBS	1.20	1.30	2.00	3.10	3.70					
6-615_	Farmland	Green Dot		1.70	2.60	3.60	5.00		6.00			
6-165_	Felton (Felton, General Ind)		1.20	1.20	1.50	3.20	2.60	3.50	3.00		3.70	10.00
6-681_	Fiberstrong								6.00		8.00	10.00
6-616_	Flex-O-Seal			3.20	3.50	5.00	6.00		9.00			
6-163_	Gheen (Cozad)		1.60	1.30	1.70	3.00	3.00	6.10	3.80		4.70	7.50
6-617_	Habco					17.00	9.00		9.00		25.00	
6-618_	Ireco	AE	2.20	2.40	2.80	3.90						
6-619_	Ireco	Steelume	1.50	1.50	2.00	2.30	3.00	2.60	3.60		8.00	
6-620_	Ireco (Columbus)	Old Style	2.25	2.40	2.60	3.50	4.60	12.90	4.80		6.00	
6-161_	Lindsay				3.20		2.50		3.00			
6-622_	Mathison	Full	21.00	32.00	39.50	44.00	52.00					
6-621_	Mathison	Ring	2.50	6.10	6.50	6.70	7.40					
6-623_	McDowell		2.30	1.90	2.50	4.30	5.20	13.50	7.60		10.70	
6-670_	McDowell	Ringlock					6.00		8.00		18.00	
6-624_	Midwest					3.80	2.80		3.20		4.60	8.50
6-625_	Moore-Rain		1.90		2.40	3.50	4.50	6.20	5.50		6.80	11.00
6-626_	Moulton		2.70	2.90	3.80	4.50	5.90	8.90	9.50		11.50	
6-664_	Oaks				3.15	3.50	3.70					
6-663_	Oliver		1.75		2.40	2.80	3.60	4.30				
6-627_	Pacific Speedlock	New Style	2.00	2.30	2.60							
6-628_	Pacific Speedlock	Old Style	2.30	2.80	3.10	4.00	4.60		9.10			
6-629_	Pierce	Flatback	1.50	1.50	2.50	3.60	3.60		4.60		7.00	
6-162_	Pierce	Roundback	1.10	1.10	1.60	2.10	2.20	3.70	3.00	6.20	4.20	7.00
6-678_	Pierce	Triple Lip		1.50	2.00		3.00		6.00		8.00	9.00
6-630_	Port-Alum		2.00	2.20	2.80							
6-631_	Race & Race		2.00	2.50	3.00	3.70	4.00	4.50	6.20			
6-632_	Race & Race	Demountable	1.70	2.00	2.50	3.00	4.00		5.50			
6-701_	Race & Race	Contractor					4.50	4.80	5.20			
6-633_	Rain-Control (Hardie)		1.60		2.70	3.10	4.00		6.00			
6-634_	Rainbow				3.60	4.20	4.60		7.50			
6-635_	Rain-ow		2.00		3.00							
6-636_	Rain-for-Rent	Wosco	1.45	1.50	1.60	3.30	3.00	6.20	4.00		4.20	6.80
6-637_	Rainmaker		1.80	2.10	2.30	3.30	4.50					
6-638_	Rainway	Roundback	3.00	1.90								
6-166_	Rainway	Squareback	1.40	1.30	1.60	2.10	2.00	3.40	2.50		3.50	6.50
6-662_	Ravit		1.70	2.50	2.80	4.20	4.90					

To complete the part number for each gasket size, use the part number in the first column and use the size code for the last digit. Examples: 4" Redi-Rain = 6-6394; 10" Sure-Flo = 6-6480.

Size Code:			2	3	4	5	6	7	8	9	0	1
Part #	Brand Name	Type	2"	3"	4"	5"	6"	7"	8"	9"	10"	12"
6-639_	Redi-Rain		\$1.20	\$1.30	\$1.50	\$2.00	\$2.70		\$3.20		\$5.00	\$8.20
6-640_	Shur-Rane	Drain-New Style	1.40	1.50	2.00	3.30	4.80		6.20		7.00	
6-641_	Shur-Rane	Non-Drain(Chevron)		2.00	2.70	4.50	3.90	6.00	6.60		6.50	
6-642_	Shur-Rane	Old Style	1.90	2.00	2.60	3.40	4.20	5.70				
6-643_	Stout	New Style	2.00	2.20	2.60	3.30	3.80					
6-644_	Stout	Old Style	3.20	3.50	3.70	4.50	6.00					
6-682_	Stout	Old Style(Alum Cplr)	1.60	1.90	2.50	2.80	3.50					
6-645_	Stout	Seal Ring	1.50	1.70	2.30	3.00	3.50					
6-646_	Stout (Coover 3-1/2)	Towline Seal			2.30							
6-647_	Strolyte		2.00	2.20	2.60	3.00	3.60					
6-648_	Sure-Flo		2.90	2.40	3.00	4.20	4.70		12.30		17.20	
6-649_	Tex-Flo	Roundback					4.60		5.50	13.00	9.50	
6-650_	Tex-Flo	Squareback		1.20			3.50		3.90	5.00	6.50	6.80
6-651_	Vermeer			4.00	4.20	4.40						
6-683_	Wade Rain	Bolt-on	2.80	2.90	4.00	4.10	5.40					
6-652_	Wade Rain	New Style	1.10	1.20	1.90	3.00	3.70	4.90	5.50		8.00	
6-653_	Wade Rain	Old Style	3.00	3.50	4.70							
6-654_	Webster	Trigger Lock		3.40	3.90	4.40	5.20	8.20	8.90			
6-655_	Webster	Econo Lock	2.00	2.40	3.00	4.20	5.50	7.80	10.30			
6-656_	Western		1.50	1.60	2.00	2.30	2.90	10.50	3.60		6.70	10.00
6-657_	Wheel Trac		2.80	3.40								
6-658_	Wyss	Standard	1.70	2.00	2.40	2.90	3.50					
6-659_	Wyss	Seal Ring	1.70	1.90	2.50	3.60	4.00					
6-8008	Wade Rain Poweroll	4"			1.70							
6-8009	Wade Rain Poweroll	4.5"			2.80							
6-8015	Wade Rain Poweroll	5"				3.30						

### Odd Gasket Sizes:

Part #	Brand	Size	Price
6-6896	A&M	4-1/2"	\$4.00
6-1612	Pierce, Roundback	1-5/16"	1.90
6-1613	Pierce, Roundback	2-1/4"	1.90
6-1615	Pierce, Roundback	2-1/2"	1.90
6-1617	Pierce, Roundback	6-5/8"	4.20
6-1619	Pierce, Roundback	8-5/8"	22.00
6-6087	Commetco	2-1/2"	2.70
6-6197	Irreco, Steelume	5-1/4"	2.60
6-6371	Rainmaker	1-1/2"	1.00
6-6727	Gheen, Dresser	4-1/2"	7.00
6-6728	Gheen, Dresser	6-5/8"	9.00
6-6729	Gheen, Dresser	8-5/8"	11.00

### Wheeline Gaskets

Part #	Brand	Wall Middle to Middle	Price
6-8000	Western, Round	3/16" x 4-1/2"	\$2.20
6-8001	Western, WID-E-1	3/16" x 4-7/8"	3.60
6-8002	Alumax, Round	1/4" x 4-3/4"	2.20
6-8003	Alumax, Square	1/4" x 4-3/4"	2.20
6-8004	Trunnell, Quad 4	1/4" x 4-3/8"	1.70
6-8005	Trunnell, Quad 5	1/4" x 5-1/2"	1.70
6-8006	Trunnell, Quad 4	1/4" x 4-3/4"	1.70
6-8007	Western Steel	3/16" x 4-15/16"	3.10

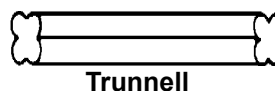

Trunnell



Western



Alumax - Round



Alumax - Square

### Springs:

Part #	Brand	2"	3"	4"	5"	6"	7"	8"
6-660_	Ames ABC	\$3.40	\$4.00	\$4.70	\$9.80	\$14.50	--	\$23.00
6-661_	McDowell	5.00	5.00	7.00	8.00	10.00	15.00	20.00

### Pierce Wedge-Tite:

For Bolt-on Flange Pack Repair & Dresser Couplers

Part #	Brand	4"	5"	6"	8"	10"	12"	15"
6-669_	NOM (ob)	\$7.00	\$9.00	\$8.00	\$10.00	\$20.00	\$15.00	
6-668_	PIP			8.00	9.00	10.00	15.00	42.00
6-667_	IPS	7.00		8.00	9.00	10.00	21.00	

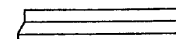

# NIPPLES, TBE, STEEL BLACK

## Black



### Steel Black Nipples

Steel Black	1/8"		1/4"		3/8"		1/2"		3/4"		1"		1-1/4"	
	Part Number	List Price	Part Number	List Price	Part Number	List Price	Part Number	List Price	Part Number	List Price	Part Number	List Price	Part Number	List Price
Close	9-6348	\$0.90	9-6365	\$1.00	9-6382	\$1.10	9-6399	\$0.90	9-6416	\$1.00	9-6433	\$1.50	9-6449	\$1.90
1-1/2" Long	9-6349	1.10	9-6366	1.10	9-6383	1.20	9-6400	0.90	9-6417	1.10				
2" Long	9-6350	1.10	9-6367	1.10	9-6384	1.20	9-6401	0.90	9-6418	1.10	9-6434	1.60	9-6450	2.20
2-1/2" Long	9-6351	1.20	9-6368	1.40	9-6385	1.60	9-6402	1.10	9-6419	1.30	9-6435	1.70	9-6451	2.30
3" Long	9-6352	1.20	9-6369	1.40	9-6386	1.60	9-6403	1.10	9-6420	1.30	9-6436	1.70	9-6452	2.30
3-1/2" Long	9-6353	1.50	9-6370	1.70	9-6387	1.80	9-6404	1.30	9-6421	1.60	9-6437	2.20	9-6453	2.70
4" Long	9-6354	1.50	9-6371	1.70	9-6388	1.80	9-6405	1.30	9-6422	1.60	9-6438	2.20	9-6454	2.70
4-1/2" Long	9-6355	2.90	9-6372	2.50	9-6389	2.60	9-6406	1.50	9-6423	2.00	9-6439	2.60	9-6455	3.20
5" Long	9-6356	2.90	9-6373	2.50	9-6390	2.60	9-6407	1.50	9-6424	2.00	9-6440	2.60	9-6456	3.20
5-1/2" Long	9-6357	3.10	9-6374	3.00	9-6391	2.90	9-6408	1.70	9-6425	2.20	9-6441	3.00	9-6457	3.90
6" Long	9-6358	3.10	9-6375	3.00	9-6392	2.90	9-6409	1.70	9-6426	2.20	9-6442	3.00	9-6458	3.90
7" Long	9-6359	4.30	9-6376	4.60	9-6393	5.20	9-6410	3.00	9-6427	3.70	9-6443	4.90	9-6459	6.20
8" Long	9-6360	4.30	9-6377	4.60	9-6394	5.20	9-6411	3.00	9-6428	3.70	9-6444	4.90	9-6460	6.20
9" Long	9-6361	4.90	9-6378	5.40	9-6395	5.80	9-6412	3.60	9-6429	4.30	9-6445	5.80	9-6461	7.40
10" Long	9-6362	4.90	9-6379	5.40	9-6396	5.80	9-6413	3.60	9-6430	4.30	9-6446	5.80	9-6462	7.40
11" Long	9-6363	5.00	9-6380	5.90	9-6397	6.60	9-6414	4.30	9-6431	4.80	9-6447	6.60	9-6463	8.40
12" Long	9-6364	5.00	9-6381	5.90	9-6398	6.60	9-6415	4.30	9-6432	4.80	9-6448	6.60	9-6464	8.40

TBE (threaded both ends)

### Steel Black Nipples

Steel Black	1-1/2"		2"		2-1/2"		3"		4"		6"		8"	
	Part Number	List Price	Part Number	List Price	Part Number	List Price	Part Number	List Price	Part Number	List Price	Part Number	List Price	Part Number	List Price
Close	9-6465	\$2.40	9-6481	\$3.20	9-6496	\$10.10	9-6510	\$12.00	9-6524	18.10	9-6537	38.70	9-7696	78.00
1-1/2" Long														
2" Long	9-6466	2.60												
2-1/2" Long	9-6467	2.90	9-6482	3.70										
3" Long	9-6468	2.90	9-6483	3.70	9-6497	10.40	9-6511	13.00						
3-1/2" Long	9-6469	3.20	9-6484	4.50	9-6498	12.20	9-6512	15.40						
4" Long	9-6470	3.20	9-6485	4.50	9-6499	12.20	9-6513	15.40	9-6526	20.90				
4-1/2" Long	9-6471	3.90	9-6486	5.20	9-6500	13.40	9-6514	17.00	9-6527	23.90				
5" Long	9-6472	3.90	9-6487	5.20	9-6501	13.40	9-6515	17.00	9-6528	23.90				
5-1/2" Long	9-6473	4.50	9-6488	6.00	9-6502	14.00	9-6516	18.50	9-6529	25.50				
6" Long	9-6474	4.50	9-6489	6.00	9-6503	14.00	9-6517	18.50	9-6530	25.50	9-6541	50.40	9-7697	105.00
7" Long	9-6475	7.10	9-6490	10.10	9-6504	17.70	9-6518	25.00	9-6531	29.50	9-6542	60.80		
8" Long	9-6476	7.10	9-6491	10.10	9-6505	17.70	9-6519	25.00	9-6532	29.50	9-6543	60.80	9-7698	140.00
9" Long	9-6477	8.30	9-6492	11.90	9-6506	19.90	9-6520	28.00	9-6533	33.50	9-6544	70.40		
10" Long	9-6478	8.30	9-6493	11.90	9-6507	19.90	9-6521	28.00	9-6534	33.50	9-6545	70.40	9-7699	150.00
11" Long	9-6479	9.60	9-6494	13.70	9-6508	22.20	9-6522	31.10	9-6535	39.30	9-6546	92.00		
12" Long	9-6480	9.60	9-6495	13.70	9-6509	22.20	9-6523	31.10	9-6536	39.30	9-6547	82.90	9-7700	180.00

TBE (threaded both ends)

# NIPPLES, TBE, STEEL GALVANIZED

## Galvanized



### Steel Galvanized Nipples

Steel Galvanized	1/8" Diameter		1/4" Diameter		3/8" Diameter		1/2" Diameter		3/4" Diameter		1" Diameter		1-1/4" Diameter	
	Part Number	List Price	Part Number	List Price	Part Number	List Price	Part Number	List Price	Part Number	List Price	Part Number	List Price	Part Number	List Price
Close	9-6548	1.10	9-6565	1.20	9-6582	1.30	9-6599	1.00	9-6616	1.30	9-6633	1.70	9-6649	2.30
1-1/2" Long	9-6549	1.50	9-6566	1.40	9-6583	1.50	9-6600	1.10	9-6617	1.40				
2" Long	9-6550	1.50	9-6567	1.40	9-6584	1.50	9-6601	1.10	9-6618	1.40	9-6634	2.00	9-6650	2.50
2-1/2" Long	9-6551	2.00	9-6568	1.80	9-6585	2.00	9-6602	1.30	9-6619	1.50	9-6635	2.20	9-6651	2.70
3" Long	9-6552	2.00	9-6569	1.80	9-6586	2.00	9-6603	1.30	9-6620	1.50	9-6636	2.20	9-6652	2.70
3-1/2" Long	9-6553	2.40	9-6570	2.20	9-6587	2.30	9-6604	1.60	9-6621	2.00	9-6637	2.60	9-6653	3.20
4" Long	9-6554	2.40	9-6571	2.20	9-6588	2.30	9-6605	1.60	9-6622	2.00	9-6638	2.60	9-6654	3.20
4-1/2" Long	9-6555	4.00	9-6572	2.90	9-6589	3.20	9-6606	1.90	9-6623	2.30	9-6639	3.20	9-6655	4.00
5" Long	9-6556	4.00	9-6573	2.90	9-6590	3.20	9-6607	1.90	9-6624	2.30	9-6640	3.20	9-6656	4.00
5-1/2" Long	9-6557	4.50	9-6574	3.30	9-6591	3.60	9-6608	2.20	9-6625	2.80	9-6641	3.70	9-6657	4.70
6" Long	9-6558	4.50	9-6575	3.30	9-6592	3.60	9-6609	2.20	9-6626	2.80	9-6642	3.70	9-6658	4.70
7" Long	9-6559	5.90	9-6576	5.60	9-6593	5.70	9-6610	3.80	9-6627	4.90	9-6643	6.10	9-6659	7.50
8" Long	9-6560	5.90	9-6577	5.60	9-6594	5.70	9-6611	3.80	9-6628	4.90	9-6644	6.10	9-6660	7.50
9" Long	9-6561	6.90	9-6578	6.50	9-6595	6.80	9-6612	4.50	9-6629	5.40	9-6645	7.00	9-6661	9.00
10" Long	9-6562	6.90	9-6579	6.50	9-6596	6.80	9-6613	4.50	9-6630	5.40	9-6646	7.00	9-6662	9.00
11" Long	9-6563	7.70	9-6580	7.30	9-6597	7.50	9-6614	5.10	9-6631	6.00	9-6647	8.20	9-6663	10.80
12" Long	9-6564	7.70	9-6581	7.30	9-6598	7.50	9-6615	5.10	9-6632	6.00	9-6648	8.20	9-6664	10.80

TBE (threaded both ends)

### Steel Galvanized Nipples

Steel Galvanized	1-1/2" Diameter		2" Diameter		2-1/2" Diameter		3" Diameter		4" Diameter		6" Diameter	
	Part Number	List Price	Part Number	List Price	Part Number	List Price	Part Number	List Price	Part Number	List Price	Part Number	List Price
Close	9-6665	\$2.70	9-6681	\$3.80	9-6696	\$11.40	9-6710	13.60	9-6724	20.40	9-6737	77.30
1-1/2" Long												
2" Long	9-6666	2.90										
2-1/2" Long	9-6667	3.20	9-6682	4.30								
3" Long	9-6668	3.20	9-6683	4.30	9-6697	11.80	9-6711	15.50				
3-1/2" Long	9-6669	4.10	9-6684	5.20	9-6698	13.70	9-6712	18.20				
4" Long	9-6670	4.10	9-6685	5.20	9-6699	13.70	9-6713	18.20	9-6726	24.40		
4-1/2" Long	9-6671	5.00	9-6686	6.70	9-6700	15.30	9-6714	21.20	9-6727	27.40		
5" Long	9-6672	5.00	9-6687	6.70	9-6701	15.30	9-6715	21.20	9-6728	27.40		
5-1/2" Long	9-6673	5.60	9-6688	7.70	9-6702	16.80	9-6716	22.40	9-6729	30.30		
6" Long	9-6674	5.60	9-6689	7.70	9-6703	16.80	9-6717	22.40	9-6730	30.30	9-6741	100.90
7" Long	9-6675	8.70	9-6690	12.60	9-6704	21.60	9-6718	30.20	9-6731	36.10	9-6742	121.20
8" Long	9-6676	8.70	9-6691	12.60	9-6705	21.60	9-6719	30.20	9-6732	36.10	9-6743	121.60
9" Long	9-6677	10.10	9-6692	14.80	9-6706	24.70	9-6720	34.50	9-6733	41.90	9-6744	140.90
10" Long	9-6678	10.10	9-6693	14.80	9-6707	24.70	9-6721	34.50	9-6734	41.90	9-6745	140.90
11" Long	9-6679	11.50	9-6694	16.90	9-6708	27.60	9-6722	38.80	9-6735	47.70	9-6746	183.50
12" Long	9-6680	11.50	9-6695	16.90	9-6709	27.60	9-6723	38.80	9-6736	47.70	9-6747	165.70

TBE (threaded both ends)



# NIPPLES, TBE, PVC SCH80



### PVC SCH80 Nipples

PVC SCH80	1/8"		1/4"		3/8"		1/2"		3/4"		1"		1-1/4"	
	Part Number	List Price	Part Number	List Price	Part Number	List Price	Part Number	List Price	Part Number	List Price	Part Number	List Price	Part Number	List Price
Close	9-5966	\$1.00	9-5997	\$1.00	9-6028	\$1.10	9-6059	\$1.00	9-6090	\$1.00	9-6121	\$1.30	9-6151	\$1.90
1-1/2" Long	9-5967	1.00	9-5998	1.00	9-6029	1.10	9-6060	1.00	9-6091	1.00				
2" Long	9-5968	1.10	9-5999	1.30	9-6030	1.40	9-6061	1.00	9-6092	1.00	9-6122	1.40	9-6152	1.90
2-1/2" Long	9-5969	1.20	9-6000	1.30	9-6031	1.40	9-6062	1.00	9-6093	1.10	9-6123	1.50	9-6153	2.10
3" Long	9-5970	1.20	9-6001	1.70	9-6032	1.40	9-6063	1.10	9-6094	1.10	9-6124	1.60	9-6154	2.20
3-1/2" Long	9-5971	1.30	9-6002	1.70	9-6033	2.00	9-6064	1.10	9-6095	1.30	9-6125	1.70	9-6155	2.50
4" Long	9-5972	1.30	9-6003	1.90	9-6034	2.10	9-6065	1.30	9-6096	1.50	9-6126	1.90	9-6156	2.50
4-1/2" Long	9-5973	1.50	9-6004	2.00	9-6035	2.10	9-6066	1.30	9-6097	1.50	9-6127	2.00	9-6157	2.90
5" Long	9-5974	1.50	9-6005	2.10	9-6036	2.30	9-6067	1.40	9-6098	1.80	9-6128	2.30	9-6158	2.90
5-1/2" Long	9-5975	1.70	9-6006	2.10	9-6037	2.30	9-6068	1.40	9-6099	1.80	9-6129	2.50	9-6159	3.20
6" Long	9-5976	1.70	9-6007	2.20	9-6038	2.40	9-6069	1.50	9-6100	1.90	9-6130	2.60	9-6160	3.20
7" Long	9-5977	2.00	9-6008	2.30	9-6039	2.40	9-6070	1.70	9-6101	1.90	9-6131	2.80	9-6161	3.70
8" Long	9-5978	2.20	9-6009	2.40	9-6040	2.60	9-6071	1.90	9-6102	2.20	9-6132	3.00	9-6162	3.80
9" Long	9-5979	2.30	9-6010	2.50	9-6041	2.80	9-6072	1.90	9-6103	2.30	9-6133	3.40	9-6163	4.20
10" Long	9-5980	2.70	9-6011	2.50	9-6042	2.90	9-6073	2.00	9-6104	2.50	9-6134	3.60	9-6164	4.50
11" Long	9-5981	2.90	9-6012	2.70	9-6043	3.00	9-6074	2.20	9-6105	2.70	9-6135	3.80	9-6165	4.80
12" Long	9-5982	2.90	9-6013	3.00	9-6044	3.20	9-6075	2.30	9-6106	2.80	9-6136	4.10	9-6166	5.10
13" Long	9-5983	3.70	9-6014	4.30	9-6045	4.60	9-6076	2.60	9-6107	3.10	9-6137	4.70	9-6167	5.90
14" Long	9-5984	4.00	9-6015	4.40	9-6046	4.80	9-6077	2.60	9-6108	3.10	9-6138	4.70	9-6168	6.10
15" Long	9-5985	4.30	9-6016	4.60	9-6047	5.00	9-6078	2.80	9-6109	3.20	9-6139	5.10	9-6169	6.40
16" Long	9-5986	4.70	9-6017	5.80	9-6048	5.20	9-6079	3.20	9-6110	3.60	9-6140	5.10	9-6170	6.70
17" Long	9-5987	4.90	9-6018	6.10	9-6049	5.30	9-6080	3.30	9-6111	3.70	9-6141	5.80	9-6171	7.40
18" Long	9-5988	5.00	9-6019	6.20	9-6050	5.50	9-6081	3.40	9-6112	3.70	9-6142	6.10	9-6172	8.00
19" Long	9-5989	5.30	9-6020	6.50	9-6051	5.70	9-6082	3.60	9-6113	4.20	9-6143	6.20	9-6173	8.90
20" Long	9-5990	5.70	9-6021	6.60	9-6052	5.80	9-6083	3.70	9-6114	4.40	9-6144	6.50	9-6174	9.10
22" Long	9-5991	6.00	9-6022	6.90	9-6053	6.30	9-6084	3.70	9-6115	4.60	9-6145	6.60	9-6175	9.30
24" Long	9-5992	6.60	9-6023	7.00	9-6054	6.40	9-6085	4.50	9-6116	5.40	9-6146	6.80	9-6176	9.40
30" Long	9-5993	8.40	9-6024	8.70	9-6055	8.70	9-6086	5.60	9-6117	7.40	9-6147	9.60	9-6177	12.30
36" Long	9-5994	9.90	9-6025	10.50	9-6056	11.10	9-6087	7.60	9-6118	9.20	9-6148	12.70	9-6178	13.40
42" Long	9-5995	11.50	9-6026	12.30	9-6057	12.50	9-6088	10.20	9-6119	10.80	9-6149	15.60	9-6179	17.00
48" Long	9-5996	13.20	9-6027	13.70	9-6058	14.10	9-6089	10.70	9-6120	12.10	9-6150	16.20	9-6180	17.70

### TBE (threaded both ends)

#### PVC SCH80 Nipples

PVC SCH80	1-1/2"		2"		2-1/2"		3"		4"		6"	
	Part Number	List Price	Part Number	List Price	Part Number	List Price	Part Number	List Price	Part Number	List Price	Part Number	List Price
Close	9-6181	\$2.00	9-6211	\$2.70	9-6240	\$9.20	9-6268	\$11.00	9-6296	\$17.90	9-6323	\$19.70
1-1/2" Long												
2" Long	9-6182	2.30										
2-1/2" Long	9-6183	2.40	9-6212	3.20								
3" Long	9-6184	2.60	9-6213	3.20	9-6241	10.50	9-6269	12.00				
3-1/2" Long	9-6185	2.90	9-6214	3.70	9-6242	12.00	9-6270	14.00	9-6297	22.50		
4" Long	9-6186	3.40	9-6215	4.40	9-6243	13.50	9-6271	16.00	9-6298	24.90		
4-1/2" Long	9-6187	3.40	9-6216	4.40	9-6244	13.50	9-6272	16.00	9-6299	24.90	9-6324	27.90
5" Long	9-6188	3.80	9-6217	4.80	9-6245	15.30	9-6273	17.90	9-6300	24.90	9-6325	30.60
5-1/2" Long	9-6189	3.80	9-6218	4.80	9-6246	15.30	9-6274	17.90	9-6301	24.90	9-6326	33.40
6" Long	9-6190	4.10	9-6219	5.90	9-6247	16.70	9-6275	22.40	9-6302	26.70	9-6327	36.40
7" Long	9-6191	4.60	9-6220	6.10	9-6248	17.60	9-6276	23.70	9-6303	29.30	9-6328	41.80
8" Long	9-6192	5.10	9-6221	6.50	9-6249	18.50	9-6277	24.40	9-6304	31.00	9-6329	47.40
9" Long	9-6193	5.40	9-6222	7.00	9-6250	21.40	9-6278	25.60	9-6305	31.20	9-6330	52.80
10" Long	9-6194	5.70	9-6223	7.60	9-6251	22.60	9-6279	27.90	9-6306	33.10	9-6331	58.70
11" Long	9-6195	6.10	9-6224	8.00	9-6252	24.50	9-6280	29.80	9-6307	37.40	9-6332	64.20
12" Long	9-6196	6.80	9-6225	8.60	9-6253	24.70	9-6281	30.40	9-6308	43.10	9-6333	69.60
13" Long	9-6197	7.00	9-6226	8.90	9-6254	26.70	9-6282	31.50	9-6309	44.70	9-6334	75.10
14" Long	9-6198	7.60	9-6227	9.10	9-6255	27.80	9-6283	34.10	9-6310	45.80	9-6335	80.60
15" Long	9-6199	7.90	9-6228	9.80	9-6256	29.80	9-6284	36.20	9-6311	48.00	9-6336	86.00
16" Long	9-6200	8.60	9-6229	10.50	9-6257	32.00	9-6285	38.40	9-6312	50.10	9-6337	91.50
17" Long	9-6201	8.80	9-6230	11.50	9-6258	32.50	9-6286	39.50	9-6313	53.30	9-6338	97.60
18" Long	9-6202	9.30	9-6231	12.80	9-6259	33.10	9-6287	41.50	9-6314	60.10	9-6339	102.40
19" Long	9-6203	10.40	9-6232	13.70	9-6260	36.90	9-6288	48.00	9-6315	60.70	9-6340	108.70
20" Long	9-6204	10.70	9-6233	13.90	9-6261	37.50	9-6289	50.60	9-6316	65.00	9-6341	113.40
22" Long	9-6205	10.80	9-6234	14.20	9-6262	40.70	9-6290	51.70	9-6317	67.10	9-6342	124.90
24" Long	9-6206	11.10	9-6235	14.30	9-6263	41.50	9-6291	57.00	9-6318	71.60	9-6343	135.80
30" Long	9-6207	15.20	9-6236	18.50	9-6264	50.60	9-6292	72.60	9-6319	85.30	9-6344	168.70
36" Long	9-6208	15.90	9-6237	24.50	9-6265	61.90	9-6293	75.10	9-6320	101.30	9-6345	202.30
42" Long	9-6209	21.40	9-6238	29.80	9-6266	71.50	9-6294	87.90	9-6321	123.60	9-6346	235.20
48" Long	9-6210	22.60	9-6239	31.60	9-6267	77.30	9-6295	98.10	9-6322	151.80	9-6347	268.20

PVC Sch80



### TBE (threaded both ends)

## Section Six



 Pumps	_____	174-183
 Pump Accessories	_____	188
 Dresser Couplers	_____	189
 Suction Pipe	_____	189
 Foot Valves	_____	189-190
 Suction Strainers	_____	190-194
 Discharge Priming Valves	_____	195
 Priming Pumps	_____	196-199
 Murphy Switches	_____	200-201
 Generator, Gearhead, & Accs	_____	202

Product	Description	Part Number	Weight	List Price
---------	-------------	-------------	--------	------------

## SINGLE-STAGE ENGINE MOUNT PUMPS

### BERKELEY

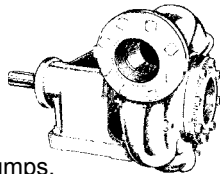

**Pedestal Mount:**

**@ 2200 rpm**

	GPM	PSI		
B3ZRM	250-850	60-45	-	120.0
<b>B3JRMBM</b>	400-900	130-110	-	150.0
B4JRMBH	600-1500	125-100	-	319.0

\*Call for other pumps.



**Direct Mount:**

**@ 2000 rpm**

	GPM	PSI		
B3JQBM	300-850	110-85	365.0	Call
B4JQBH	450-1500	100-70	400.0	Call
B4EYQBH	500-1400	190-130	620.0	Call
B6JQBM	750-2250	100-70	475.0	Call

\*Call for other pumps. Flywheel coupling NOT included.

### CORNELL

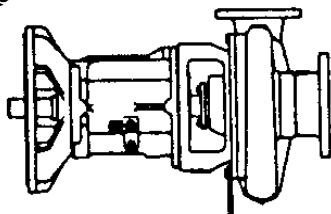

**Direct Mount:**

**@ 2200 rpm**

	GPM	PSI		
4RB	300-1500	95-65	520.0	Call
5RB	400-2200	104-70	715.0	Call
6RB	750-4000	100-75	815.0	Call
3HA	300-900	140-115	615.0	Call
5HH	300-1400	120-95	695.0	Call
6HH	1200-3600	155-120	845.0	Call

\*Call for other pumps. Flywheel coupling included.

\*6HH is rated at 2000 rpm.

\*Cornell pumps work well at 3,000 gpm's & higher.

## SLURRY & CHOPPER ENGINE MOUNT PUMPS

### CORNELL-SLURRY

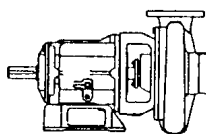

**@ 2000 rpm**

	GPM	PSI		
3HM	0-800	140-100	-	Call
4x4x14T	300-1500	130-100	-	Call

\*3HM has an open impeller & therefore will handle stringy material

\*4x4x14T has a 2-port impeller & therefore will not handle stringy material. (Excellent for hog manure)

### DODA-CHOPPER



**@ 2000 rpm**

	GPM	PSI	HP		
27 PD	300-900	72-10	37-54	-	Call
35 PD	300-1300	120-38	80-115	-	Call

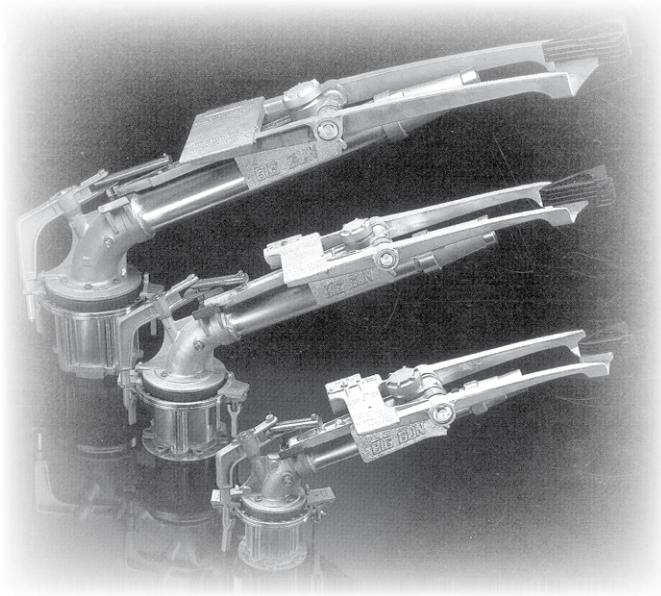

Always Open...  
**SchumacherIrrigation.com**  
*Your Irrigation Superstore*

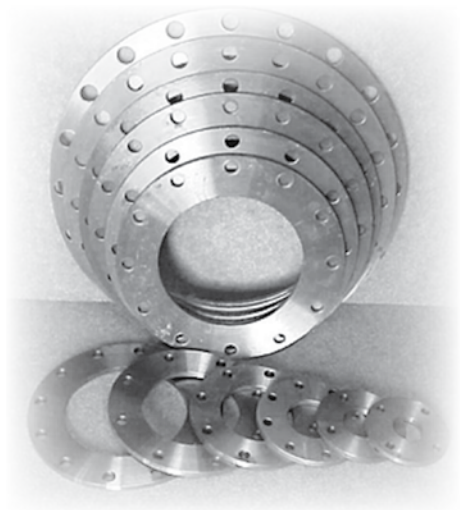

# FLOATING PUMPS

Product	Description	Part Number	Weight	List Price
<b>FLOATS</b> 	<u>W x L x H</u>	<u>Float Capacity (lbs)</u>	<u>Ship</u>	
	24"x36"x12"	335	UPS	9-6918 32.0 <b>105.00</b>
	24"x48"x12"	490	UPS	9-6919 34.0 <b>112.00</b>
	36"x48"x12"	470	CC	9-6920 41.0 <b>149.00</b>
	24"x48"x16"	700	UPS	9-6921 35.0 <b>129.00</b>
	24"x36"x18"	600	UPS	9-6922 32.0 <b>129.00</b>
	24"x48"x18"	650	CC	9-6923 41.0 <b>139.00</b>
	36"x48"x18"	1000	CC	9-6924 52.0 <b>199.00</b>
	24"x48"x24"	900	CC	9-6925 50.0 <b>188.00</b>

\* Thick-walled Molded Polyethylene Shell  
 \* Encapsulated Expanded Polystyrene Foam  
 \* 12 Year Warranty

## FLOATING PUMPS TURBI-FLOAT®

Floating Pumps

CALL



**Applications:**

- Irrigation
- Municipal
- Industrial
- Commercial

Group No.	Discharge Body	GPM	PSI
One	4"	100-525	61-26
Two	4"	100-525	94-10
Three	6"	400-1100	20-11
Four	6" & 8"	400-1200	67-23
Five	4" & 6"	400-1100	135-48
Six	8" & 10"	1100-3250	33-7
Seven	8"	1100-1750	93-28
Eight	10"	2250-3250	14-6
Nine	10"	2300-4000	63-32



Pump shown with optional wheel kit, which adds to the versatility and user-friendly qualities of the Turbi-Float® system. Further enhances installation and removal for service and site transfers, often eliminating the need for lifting equipment.

Product	Description	Part Number	Weight	List Price
---------	-------------	-------------	--------	------------

## DIESEL IRRIGATION PUMPING UNITS



Model	Engine	Pump	@2000 rpm		List Price
			GPM	PSI	
John Deere	4045T	B4JQBH	400-1500	104-70	Call
John Deere	4039T	B3JQBM	300-860	108-78	Call
John Deere	6059T	B4JQBH	400-1500	104-70	Call
John Deere	6059T	B6JQBM	750-2250	104-70	Call



### Horsepower Chart

MODEL	RPM						CONSUMPTION	SIZE	WEIGHT
	1800	2000	2100	2200	2300	2400			
4039D	57	62	65	67	67	67	.357 @ 1800	SAE4-10	1250
4045D	64	67	71	71	73	74	.347 @ 1800	SAE4-10	1300
4039T	76	82	84	85	88	88	.340 @ 1800	SAE4-10	1350
6059D	84	90	93	96	98	100	.350 @ 1800	SAE3-11	1400
4045T	88	92	93	94	95	96	.342 @ 1800	SAE4-10	1500
6068D	95	102	106	108	111	111	.345 @ 1800	SAE3-11	1500
6059T	112	121	126	128	133	135	.336 @ 1800	SAE3-11	1600
6068T	135	143	145	146	147	147	.344 @ 1800	SAE3-11	1650
6076T	165	165	165	165	--	--	.343 @ 1800	SAE3-11	2100
6076A	206	206	206	206	--	--	.337 @ 1800	SAE2-11	2200
6619A	242	244	246	--	--	--	.353 @ 1800	SAE1-11	2800

### UNITS INCLUDE:

- Engine
- Pump
- Radiator
- Core Guard
- Electric Start (complete w/cables)
- Cables
- Battery Box (without battery)
- Fuel Lift Pump
- 15' Fuel Line
- Standard Duty Air Cleaner
- Muffler
- Mounting Feet
- Vernier Throttle Control & Panel
- OFF Highway Trailer w/USED tires.
- Water Level Safety Switch (L-150)
- Loss of Prime Switch (20PW7)
- Exhaust Primer
- Flywheel Coupling
- Suction Flange (if required)
- Discharge Priming Valve
- Discharge Adapter
- Pressure Gauge
- Suction Adapter
- Dresser Coupler
- Suction Pipe
- Foot Valve w/screen

### OPTIONS:

- Skid Mount
- Battery
- Fuel Tank (30, 62 or 125 gallon)
- Extra Axle
- Screw jack for trailer

Pumps &amp; Accessories

# PTO PUMPS



Product	Description	Part Number	Weight	List Price
---------	-------------	-------------	--------	------------

## PTO IRRIGATION PUMPS

CAPRARI	Model	RPM	Inlet/Outlet	GPM	PSI	Part Number	Weight	Price
	D2/40	540	2"x2"	50-150	146-133	8-0221	200.0	Call
	D1/50	540	2"x2"	50-300	90-76	8-0232	365.0	Call
	D2/50	540	3"x2"	50-250	135-121	8-0222	215.0	Call
	D3/50	540	3"x2"	70-300	170-133	8-0223	230.0	Call
	D2/65	540	4"x4"	100-450	107-97	8-0224	360.0	Call
	D3/65	540	4"x4"	150-500	161-136	8-0225	270.0	Call
	D2/80	540	5"x4"	200-700	110-99	8-0227	275.0	Call
	DO4/80	540	5"x4"	200-700	167-143	8-0228	380.0	Call
	DMR80 3/2	540	5"x4"	200-800	192-140	8-0230	400.0	Call
	D01/125	540	8"x5"	500-1400	37-21	8-0234	430.0	Call



Gear Driven



### PUMP PERFORMANCE

Model	GPM	GPM																		Discharge NPT (F)	Suction NPT (F)		
		50	60	70	80	90	100	150	200	250	300	350	400	450	500	600	700	800	1000			1200	1400
D2/40	PSI HP	146 13	146 14	145 17	144 16	143 17	142 17	133 21														2"	2"
D1/50	PSI HP	90 9	90 9	90 10	91 10	91 10	91 11	90 13	87 15	87 17	76 19											2"	2"
D2/50	PSI HP	135 17	136 17	137 18	137 18	137 19	136 19	135 22	128 25	121 27												2"	3"
D3/50	PSI HP			170 24	170 25	170 26	170 26	167 30	160 35	150 38	133 41											2"	3"
D2/65	PSI HP						107 18	108 21	108 23	107 27	105 29	103 31	100 34	97 36								4"	4"
D3/65	PSI HP							161 29	160 34	156 38	154 42	151 46	146 50	142 53	136 55							4"	4"
D2/80	PSI HP								110 28	109 31	109 33	108 36	108 40	107 43	105 47	103 51	99					4"	5"
D04/80	PSI HP								167 44	167 49	166 53	165 57	163 62	160 66	159 69	152 77	143 84					4"	5"
DMR80 3/2	PSI HP								193 51	191 54	189 54	186 61	183 64	180 67	178 71	167 77	156 83	142 90				4"	5"
D01/125	PSI HP														37 17	36 19	35 21	34 22	30 23	25 25	21 26	5"	8"
	GPM	50	60	70	80	90	100	150	200	250	300	350	400	450	500	600	700	800	1000	1200	1400		



# ROVATTI PTO IRRIGATION PUMP

Product	Description	Part Number	Weight	List Price
---------	-------------	-------------	--------	------------

## ROVATTI IRRIGATION PUMP

ROVATTI	Model	Drive Shaft	RPM	Inlet/Outlet	GPM	PSI	HP	Part Number	Weight	Price
	*TOF-50	--	540	2"x2"	25-130	76-69	9-10	8-0235	45.0	Call
	T1-40-E	R300/90	540	2-1/2"x1-1/2"	50-130	150-140	13-20	8-0236	220.0	Call
	T2-40-E	R300/90	540	2-1/2"x1-1/2"	50-130	182-176	21-31	8-0237	255.0	Call
	T1-65-A-E	R300/90	540	2-1/2"x2"	100-260	88-80	12-19	8-0238	215.0	Call
	T1-50-E	R300/90	540	2-1/2"x2"	100-260	129-119	19-29	8-0239	240.0	Call
	T2-50-E	R300/90	540	2-1/2"x2"	100-330	149-125	24-39	8-0240	240.0	Call
	T2-65-E	R300/90	540	2-1/2"x2"	100-210	159-135	24-35	8-0241	250.0	Call
	T2-80-E	R300/90	540	3"x2-1/2"	160-460	101-86	18-32	8-0242	240.0	Call
	T2-85-E	R450/90	540	3"x2-1/2"	160-530	120-102	25-43	8-0243	250.0	Call
	T3-80A-E	R450/90	540	3"x2-1/2"	160-460	175-165	38-66	8-0244	300.0	Call
	T3-100A-E	R450/90	540	4"x3"	260-790	111-85	33-55	8-0245	290.0	Call
	T3-110-E	R600/90	540	4"x3"	260-920	134-108	46-83	8-1425	300.0	Call
	T4-100-E	R800/90.1	540	4"x3"	260-790	181-143	61-96	8-0246	375.0	Call
	T4-125-E	R800/90.1	540	5"x4"	530-1060	125-110	65-90	8-0248	375.0	Call
	MBN20-E	R450/90	540	8"x8"	1056-2640	37-25	40-55	9-7688	507.0	Call

TOF-50



Gear Driven

\*TOF-50 is mounted directly to tractor without drive shaft or cart.



## PUMP PERFORMANCE

Model	GPM	25	50	70	80	90	100	120	130	160	190	210	240	260	330	400	460	530	660	790	920	1060	1190	1320	1450	1580	1850	2110	2380	2640	Discharge FPT	Suction FPT								
*TOF-50	PSI	76	76	76	75	74	73	72	69																							2"	2"							
	HP	9	9	9	9	9	9	9	9																															
T1-40-E	PSI		150	149	148	147	145	143	140																									2-1/2"	1-1/2"					
	HP		13	14	15	16	18	19	20																															
T2-40-E	PSI		182	181	181	180	179	178	176																											2-1/2"	1-1/2"			
	HP		21	22	24	26	28	29	31																															
T1-65A-E	PSI					88	88	88	88	87	85	83	80																						2-1/2"	2"				
	HP					12	13	13	14	16	17	18	19																											
T1-50-E	PSI					129	129	129	128	127	125	122	119																							2-1/2"	2"			
	HP					19	20	21	23	25	26	28	29																											
T2-50-E	PSI					149	149	149	148	147	145	143	141	125																							2-1/2"	2"		
	HP					24	25	26	28	30	32	33	35	39																										
T2-65-E	PSI					159	158	157	153	146	135																										2-1/2"	2"		
	HP					24	25	27	30	32	35																													
T2-80-E	PSI								101	101	101	100	97	93	86																						3"	2-1/2"		
	HP								18	20	21	22	24	27	29	32																								
T2-85-E	PSI					120	120	120	120	119	118	115	110																									3"	2-1/2"	
	HP					25	26	28	30	32	35	39	41																											
T3-80A-E	PSI					175	175	175	175	175	173	170	165																									3"	2-1/2"	
	HP					38	40	42	44	46	53	60	66																											
T3-100A-E	PSI									111	111	109	107	104	94	85																						4"	3"	
	HP									33	36	39	43	46	51	55																								
T3-110-E	PSI									134	133	133	132	131	128	121																							4"	3"
	HP									46	50	55	59	63	70	77																								
T4-100-E	PSI										181	180	178	175	166	143																							4"	3"
	HP										61	66	70	74	90	96																								
T4-125-E	PSI														125	124	122	118	110																			5"	4"	
	HP														65	72	79	85	90																					
MBN20-E	PSI																					37	37	37	36	36	34	32	29	25							8"	8"		
	HP																					39	41	43	45	47	50	53	54	54										
Model	GPM	25	50	70	80	90	100	120	130	160	190	210	240	260	330	400	460	530	660	790	920	1060	1190	1320	1450	1580	1850	2110	2380	2640										

These rugged, high performance power-take-off (PTO) irrigation pumps are inexpensive and designed for easy mobility. Their unique water-cooled gearbox allows the gearbox oil to be kept at a constant low temperature. This important feature reduces gasket damage due to high oil temperatures.

The heavy-duty pump frame and dynamically balanced impeller is made of durable cast iron construction. A graphic rope packing seal provides shaft lubrication. A heavy-duty, bowed axle 2-wheel cart allows for easy mobility. Standard pump discharge is horizontal, but can be rotated vertically. 540 & 1000 rpm models are available.

PTO pumps are ideal for irrigators who do not want to maintain yet another engine on their farm. In addition to irrigation, these pumps are designed for a wide range of applications including water transfer, wash-down, tank filling, etc. These durable PTO pumps will give years of dependable service at affordable prices.

**Features:**

- Oversized bearings
- Replaceable wear ring
- 540 & 1000 rpm speeds
- Finest grade of cast iron for high efficiency
- Unique water-cooled gearbox for extended gear life



# PTO PUMPS

Product	Description	Part Number	Weight	List Price
<b>BERKELEY</b>				
	<b>Model</b>	<b>RPM</b>	<b>Inlet/Outlet</b>	<b>GPM</b>
	T1-B6ZRM-CCW	540	8"x6"	Get
				<b>PSI</b>
				Get
				<b>Part Number</b>
				9-7815
				<b>Weight</b>
				400.0
				<b>Price</b>
				Call



**MODEL T1-B6ZRM CCW (Flood Pump)**

P. T. O. RPM	PUMP Pulley Pitch Dia. (In.)	Pump RPM*	Capacity (Gallons Per Minute)								
				800	1000	1200	1400	1600	1800	2000	2200
540	4.6	2150	HEAD (FT.)	59	58	56	54	50	46	42	36
1000	5.0		BHP	23	24	26	27	28	29	30	31
540	5.0	2000	HEAD (FT.)	51	49	48	45	42	38	32	26
1000	5.4		BHP	19	20	21	22	23	24	25	25
540	5.4	1830	HEAD (FT.)	42	40	38	36	32	28	22	15
1000	6.0		BHP	15	16	17	18	18	19	19	19
540	6.0	1650	HEAD (FT.)	34	32	30	27	24	19	13	—
			BHP	11	12	13	14	14	15	15	—
			HEAD (FT.)								
			BHP								
NET POSITIVE SUCTION (NPSHR) HEAD REQUIRED (FT.)				11	11	12	12	12	13	13	14

## BERKELEY FLANGE KITS

Discharge Priming Valve Flange Kit	6"	9-7817	-	<b>480.00</b>
Suction Flange Kit	8" FPT	9-7818	-	<b>410.00</b>

Product	Description	Part Number	Weight	List Price
---------	-------------	-------------	--------	------------

## PTO CHOPPER PUMPS

Model	RPM	HP Req.	GPM	PSI	Part Number	List Price
-------	-----	---------	-----	-----	-------------	------------

### DODA-CHOPPER

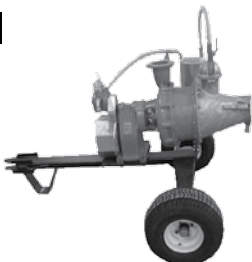

AFI-27	540	40-60	300-900	80-20	8-0252	Call
AFI-27	540	72-105	300-1000	130-55	8-0253	Call
AFI-27	1000	135-165	300-700	210-175	8-0254	Call
AFI-35	540	90-130	400-1300	135-55	8-0255	Call
AFI-35	1000	130-170	400-1300	175-80	8-0256	Call

\*Ideal for cattle manure with straw & hay  
 \*Mechanical seal.  
 \*AFI-L20 does not have a cutter blade

### ROVATTI-CHOPPER



TL2-85GA w/TC85	540	24-39	158-475	114-102	8-0268	Call
TL3-80GA w/TC80	540	37-53	158-343	172-156	8-0269	Call
TL3-110GA w/TC110	540	40-64	317-924	127-81	8-0270	Call
TL4-100GA w/TC100	540	62-94	264-686	183-156	8-0271	Call
TL4-100GA w/TC100	1000	62-94	264-686	183-156	8-0272	Call

\*Ideal for hog manure & light dairy.  
 \*Mechanical seal.

The Rovatti chopper/slurry pumps are high-pressure pumps with a unique "bolt-on" chopper system. These units are ideal to effectively transport your manure slurry to the application site. The rotating chopper blade will cut and shred straw and other solids to small particles suitable for pumping and spraying through a volume sprinkler. They will run at much lower horsepower requirements their competitors. For example the TL3-110GA at 540rpm requires only 41 to 64 horsepower, while the comparable Doda DAF1-L27 at 540rpm requires 72 to 105 horsepower.

- Features:
- Lubricated chopper shaft bushings
  - Chopper shaft shear pins to reduce risk of damage to the shaft and impeller
  - Special permanently lubricated mechanical seal for longer life
  - Oversized bearings
  - Replaceable wear ring
  - 540 & 1000 rpm speeds
  - Finest grade of cast iron for high efficiency
  - Unique water-cooled gearbox for extended gear life
  - Two-wheel cart for easy positioning and transport

- Optional Equipment Includes:
- Automatic priming system which enables you to pump in as little as 15 seconds
  - Quick Couplings for fast and easy pipe or hose hookup

Model	GPM	50	100	150	200	250	300	350	400	500	600	700	800	900	1000
TL2-85GA	PSI	112	113	114	114	114	113	111	109						
	HP	20	21	24	28	31	34	36	39						
TL3-80GA	PSI	173	173	172	171	170	163	155							
	HP	32	35	37	41	45	49	53							
TL3-110GA	PSI	126	127	128	129	129	129	127	124	119	112	106	97	84	65
	HP	30	32	34	36	37	40	43	44	48	52	56	60	63	64
TL4-100GA	PSI	184	184	183	183	182	181	179	178	173	166	153			
	HP	48	52	56	59	62	66	70	72	80	87	94			

\*will handle solids

Product	Description	Part Number	Weight	List Price
---------	-------------	-------------	--------	------------

## ELECTRIC MOTOR PUMPS

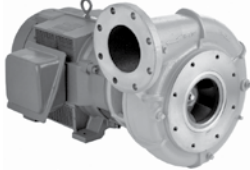
<b>BERKELEY</b>		Single Phase or Three Phase		Call
-----------------	---	-----------------------------	--	------

## CORNELL

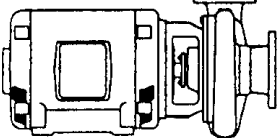
		Single Phase or Three Phase		Call
--	---	-----------------------------	--	------

## Submersible Pumps

### GOULDS/BERKELEY



- motor & pump comes disassembled.
- requires a panel box on single & three phase and a control box on single phase.
- heavy duty check valves required on all submersible pumps
- longer wire will be needed to connect to above ground panel.

Call

## Cooling Coil



75 hp	OD			
6"	6-5/8"	9-7711	-	1,475.00
8"	8-5/8"	9-7712	-	1,555.00
10"	10-3/4"	9-7713	-	1,610.00
125 hp	OD			
6"	6-5/8"	9-7714	-	2,080.00
8"	8-5/8"	9-7715	-	2,080.00
10"	10-3/4"	9-7716	-	2,145.00

NOTE:  
Cooling Coil Warranty will be void if there is no Bolted Compression Coupler or Flange between the Cooling Coil and the Pump Discharge.

- \* Painted Steel Body
- \* Copper Tubing and Brass Returns
- \* Standard Length 74"
- \* Plain Ends for easy customizing
- \* Pressure Tested

## Rubber Expansion Joints

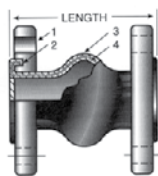

Single Sphere, 4"	6-8031	18.3	105.00
Single Sphere, 6"	6-8032	26.8	150.00
Single Sphere, 8"	6-8033	40.6	225.00
Single Sphere, 10"	6-8034	56.6	320.00
Single Sphere, 12"	6-8035	83.0	445.00
Double Sphere, 4"	6-8036	20.3	125.00
Double Sphere, 6"	6-8037	29.5	210.00
Double Sphere, 8"	6-8038	43.8	290.00
Double Sphere, 10"	6-8039	64.1	400.00
Double Sphere, 12"	6-8040	95.0	615.00

\*To accommodate pressure loads, relieve movement stress, reduce noise, isolate vibration, compensate for misalignments after system goes on stream and prolong the life of motive equipment.

Product	Description	Part Number	Weight	List Price
---------	-------------	-------------	--------	------------

## Gasoline Pumps

<b>HONDA</b>	3-1/2 hp, 1-1/2"	WH 15 X	8-0196	48.5	<b>1,125.00</b>
	5 hp, 2"	WH 20 X	8-0197	52.0	<b>1,289.00</b>
	5.5 hp, 2"	WMP 20 X	8-0198	52.0	<b>1,025.00</b>
	8 hp 3"	WT 30 X	6-9839	132.0	<b>2,499.00</b>
	11 hp 4"	WT 40 X	6-9840	172.0	<b>3,775.00</b>

**WH15X**

- High Pressure, Centrifugal, Self-Priming 1.5" Pump
- East-Start Honda OHV Commercial Engine
- 115 gal./min. Capacity
- Lightweight Aluminum Case
- Cast Iron Volute and Impeller
- Easy Carry Handle

**WH20X**

- High Pressure, Centrifugal, Self-Priming 2" Pump
- Easy-Start Honda OHV Commercial Engine
- 134 gal./min. Capacity
- Lightweight Aluminum Case
- Cast Iron Volute and Impeller
- Easy Carry Handle

**WMP20X**

- Multi-Purpose, Centrifugal Self-Priming 2" Pump
- Easy-Start Honda OHV Commercial Engine
- 220 gal./min. Capacity
- Thermoplastic Pump Housing for Chemical Capability
- Full Frame Protection
- Isolation Mounted Engine and Pump
- Protected by Honda Oil Alert®

# HONDA

## GENERATORS & PUMPS

**WT30X**

- Heavy-Duty 3" Construction Trash Pump
- Easy-Start Honda OHV Commercial Engine
- Full Frame Protection
- 319 gal./min. Capacity
- Solid Handling Capability Up to 1 1/16"
- Easy, Quick Clean-Out Port
- Easy-Service Wear Plate
- Protected by Honda Oil Alert®

**WT40X**

- Heavy-Duty 4" Construction Trash Pump
- Easy-Start Honda OHV Commercial Engine
- Full Frame Protection
- 604 gal./min. Capacity
- Solid Handling Capability Up to 1 1/16"
- Easy, Quick Clean-Out Port
- Easy-Service Wear Plate
- Protected by Honda Oil Alert®
- Self Priming

\*Call for other sizes and brands on these economical self-priming pumps.  
 \*15' max. Suction lift

Pumps &amp; Accessories

# **YOUR COMPLETE SUPPLY HOUSE FOR:**

## **POWER UNITS ENGINES MOTORS PUMPS ENGINE & PUMP PARTS & FITTINGS**

**Please call for all of your pumping needs. Just let us know your psi and gpm requirements over the phone, and our computer software will quickly choose the most efficient pump for your conditions.**

**John Deere, Cummins, Perkins, Isuzu, Lister, Deutz and other engines provide quality, dependable service for irrigation use.**

**INSTALLATION**  
**Suction Connection**  
**Suction Lift**

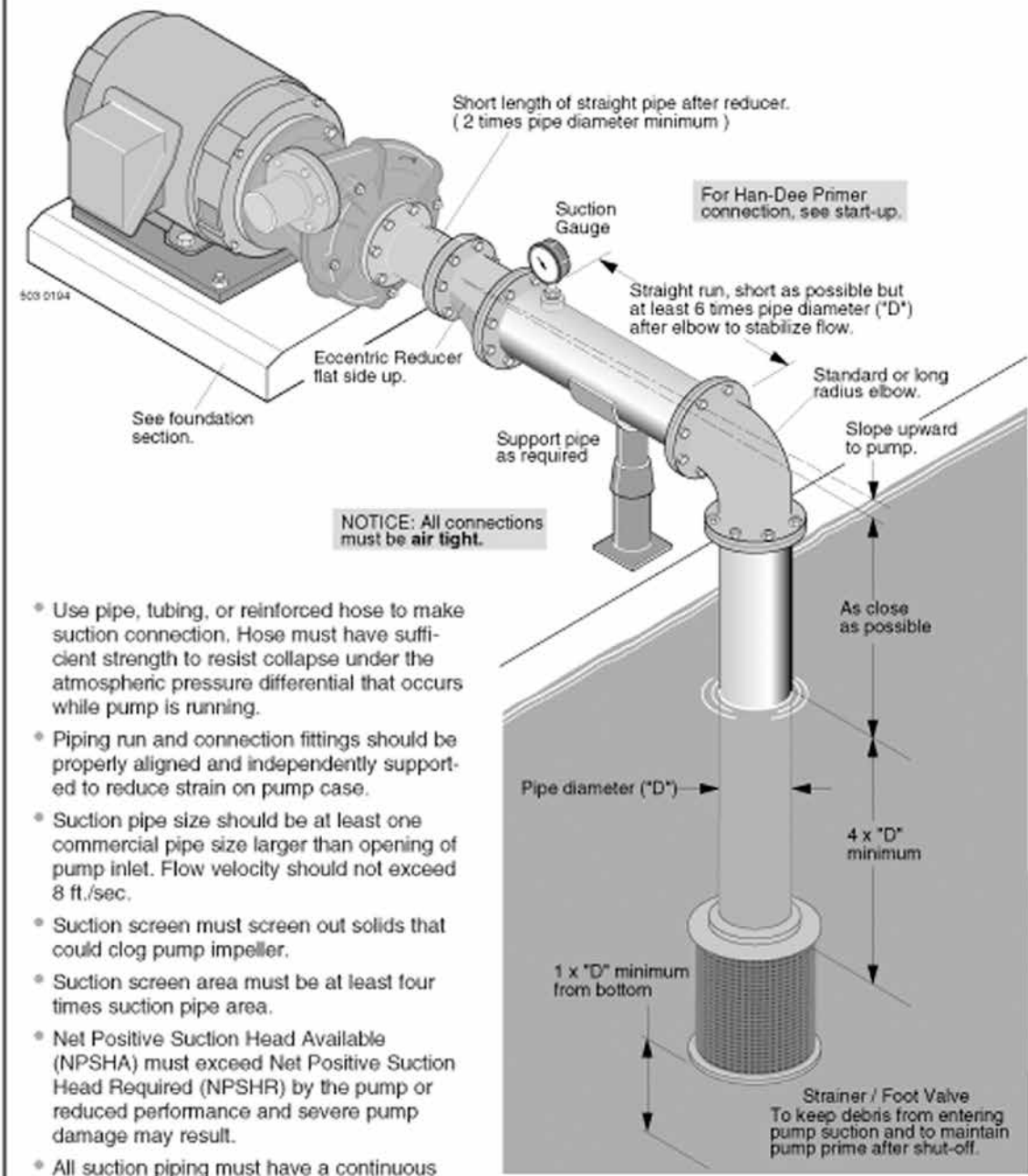

- Use pipe, tubing, or reinforced hose to make suction connection. Hose must have sufficient strength to resist collapse under the atmospheric pressure differential that occurs while pump is running.
- Piping run and connection fittings should be properly aligned and independently supported to reduce strain on pump case.
- Suction pipe size should be at least one commercial pipe size larger than opening of pump inlet. Flow velocity should not exceed 8 ft./sec.
- Suction screen must screen out solids that could clog pump impeller.
- Suction screen area must be at least four times suction pipe area.
- Net Positive Suction Head Available (NPSHA) must exceed Net Positive Suction Head Required (NPSHR) by the pump or reduced performance and severe pump damage may result.
- All suction piping must have a continuous rise to the pump suction inlet. A 1/4 inch per foot minimum slope is recommended.

**Recommended**

Pumps & Accessories



## TYPE "B" SINGLE STAGE CENTRIFUGAL PUMP Bearing Frame Mount

**CAST IRON IMPELLER**

**B3ZRM**

**Threaded Case (NPT)**

**Packing Construction**

**TABLE I**

B/M No.	Rotation	Volute Case	Impeller	Impeller Diameter
B85480	CW	H00689	M11215	9.00"
B85483	CCW	H00698	M06852	9.00"

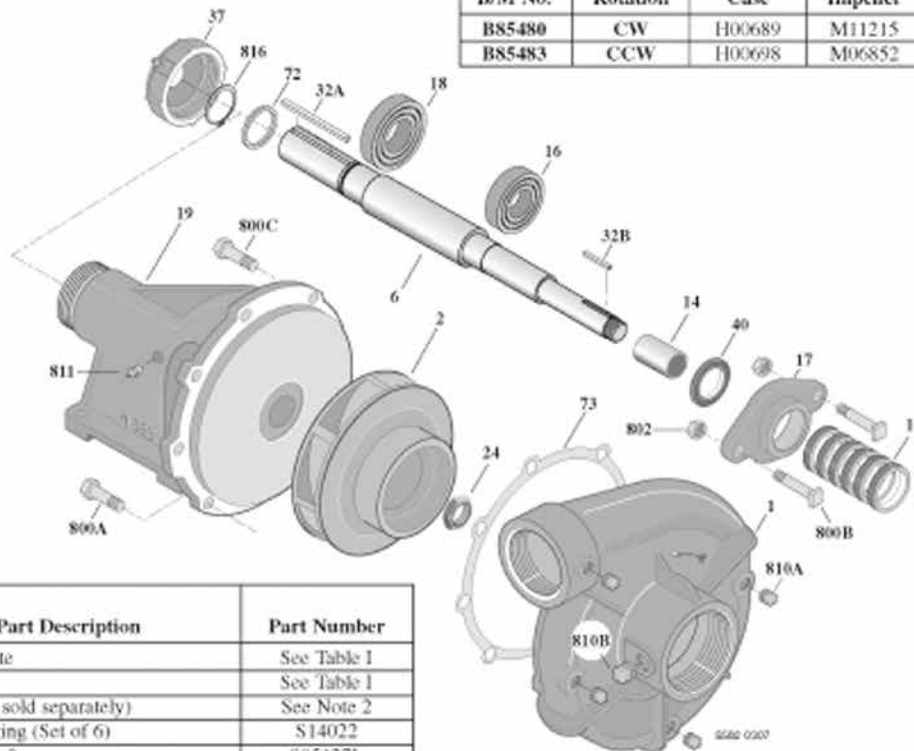

Item No.	Part Description	Part Number
1	Case, Volute	See Table 1
2	Impeller	See Table 1
6	Shaft (Not sold separately)	See Note 2
13	Ring, Packing (Set of 6)	S14022
14	Sleeve, Shaft	S05127L
16	Bearing, Ball	S13270
17	Gland, Packing (See Note 1)	S04948
18	Bearing, Ball	S13271
19	Frame	H00553
24	Locknut, Impeller (CW and CCW)	M10220
32A	Key, 1/4x2-1/8"	S24255
32B	Key, 3/16x1-1/4"	S34383
37	Outer Bearing Cap Assembly*	S19914
40	Slinger, Water	S12260
72	Ring, Thrust	S29218
73	Gasket, Volute	S05126
800A	Capscrew, Hex 3/8-16x7/8" (6 Req.)	S26825
800B	Bolt, Sq. Head 3/8-16x2-1/2" (2 Req.)	S23762
800C	Capscrew, Hex 3/8-16x1-1/8" (2 Req.)	S26827
802	Nut, Hex 3/8-16 (2 Req.)	S23343

\* Includes grease fitting and set screw.

Item No.	Part Description	Part Number
810A	Plug, Pipe 1/4 NPT (4 Req.)	S23715
810B	Plug, Pipe 1/2 NPT	S23717
811	Fitting, Grease	S23670
816	Ring, Retaining	S23010

1. A two piece (split) stainless steel packing gland is available for replacement, order part number **B82468**.
2. **Shaft Replacement Kit** available for this model. Berkeley part number **B85540** for CW, **B85539** for CCW.  
Pump Shaft sold in shaft replacement kit only.



## TYPE "B" SINGLE STAGE CENTRIFUGAL PUMP Bearing Frame Mount

**CAST IRON IMPELLER**

**B4JRMBH**

Flanged Case

Packing Construction

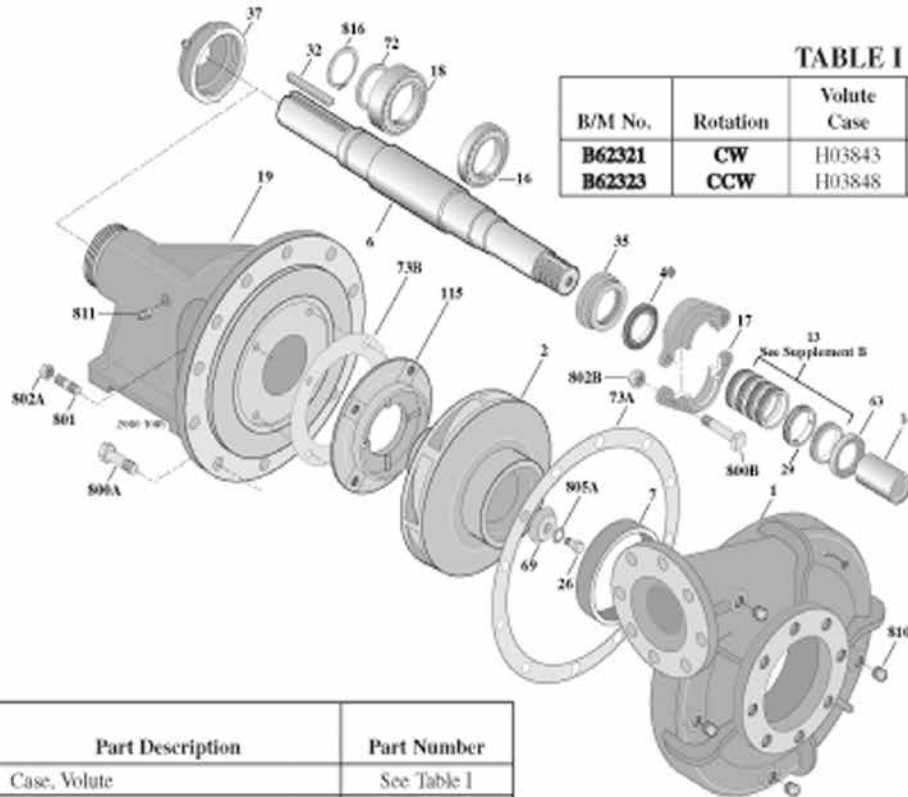

**TABLE I**

B/M No.	Rotation	Volute Case	Impeller	Impeller Diameter
<b>B62321</b>	<b>CW</b>	H03843	L05976	13.50"
<b>B62323</b>	<b>CCW</b>	H03848	L05974	13.50"

Item No.	Part Description	Part Number
1	Case, Volute	See Table I
2	Impeller	See Table I
6	Shaft (Not sold separately)	See Note 1
7	Ring, Wearing	S02894
13	Ring, Packing (Set of 4)	S13436
14	Sleeve, Shaft	S05974
16	Bearing, Ball	S15604
17	Gland, Packing	B82472
18	Bearing, Ball	S13396
19	Frame	H01599
26	Screw, Impeller 1/2-13x1-1/2"	S23623
29	Ring, Lantern	S18993
32	Key, 1/2x4"	S24214
35	Inner Bearing Cap	S05928
37	Outer Bearing Cap Assembly*	S35277
40	Slinger, Water	S10964
63	Bushing, Throat	S18992
69	Washer, Impeller	S19275
72	Ring, Thrust	S06519
73A	Gasket, Volute	S06271
73B	Gasket, Balance Ring	S09943
115	Ring, Balance	S12315

\* Includes grease fitting.

Item No.	Part Description	Part Number
800A	Capscrew, Hex 5/8-11x1-1/2" (12 Req.)	S26999
800B	Bolt, Sq. Head 1/2-13x2-3/4" (2 Req.)	S23794
801	Stud, 3/8-16x1-3/8" (4 Req.)	S09942
802A	Nut, Hex 3/8-16 (4 Req.)	S23103
802B	Nut, Hex 1/2-13x7/16" (2 Req.)	S23347
805A	Washer, Lock	S23038
810	Plug, Pipe 1/2 NPT (4 Req.)	S23717
811	Fitting, Grease (2 Req.)	S23670
816	Ring, Retaining	S23016

- Shaft Replacement Kit** available for this model. Berkeley part number **B07596** for CW, **B07597** for CCW. Pump Shaft sold in shaft replacement kit only.



# PUMP ACCESSORIES

Product	Description	Part Number	Weight	List Price	
<b>GLAND - BERKELEY</b> 	Small	B3Z & B6Z	8-1000	-	<b>165.00</b>
	Large	B4J	8-1001	-	<b>270.00</b>

<b>PACKING - BERKELEY</b>	Small - B3ZRM, B6ZRM 5/16"	S-14022	8-0410	0.2	<b>47.00</b>
	Large - B3JQBM, B4JRM BH 3/8"	S-13436	8-0412	0.7	<b>76.00</b>



<b>PACKING - PULLER</b>	Packing Puller		8-0413	-	<b>24.00</b>
-------------------------	----------------	--	--------	---	--------------



<b>PACKING - BRAIDED</b>	1/4" x 25' Box		9-6859	-	<b>57.00</b>
	5/16" x 18' Box		9-6860	-	<b>55.00</b>
	3/8" x 12' Box		9-6861	-	<b>45.00</b>



## SUCTION ADAPTER

(GALVANIZED STEEL)



-Install with eccentric dip downward (as shown).  
 -With 3/4" FPT outlet on top.  
 -Ball & sockets may be welded onto plain end-

Thrd	OD			
2" x 3"		8-0430	2.9	<b>62.00</b>
3" x 4"		8-0431	4.0	<b>75.00</b>
4" x 5"		8-0432	6.0	<b>95.00</b>
4" x 6"		8-0510	7.0	<b>110.00</b>
4" x 8"		8-0511	12.7	<b>137.00</b>
5" x 6"		8-0512	7.6	<b>125.00</b>
5" x 8"		8-0513	12.6	<b>140.00</b>
6" x 6"		8-0514	12.1	<b>95.00</b>
6" x 8"		8-0515	14.1	<b>139.00</b>
6" x 10"		8-0517	19.3	<b>182.00</b>
8" x 8"		8-0516	16.3	<b>180.00</b>
8" x 10"		8-0518	19.8	<b>260.00</b>

## DISCHARGE ADAPTER

(GALVANIZED STEEL)





Thrd	Cplr			
2" x 3"		8-0440	2.1	<b>62.00</b>
2" x 4"		8-0441	3.1	<b>71.00</b>
3" x 3"		8-0442	2.5	<b>60.00</b>
3" x 4"		8-0443	3.5	<b>75.00</b>
4" x 4"		8-0520	4.3	<b>60.00</b>
4" x 5"		8-0444	5.4	<b>95.00</b>
4" x 6"		8-0521	6.7	<b>97.00</b>
4" x 8"		8-0522	9.8	<b>125.00</b>
5" x 5"		8-0445	5.9	<b>79.00</b>
5" x 6"		8-0446	9.4	<b>115.00</b>
5" x 8"		8-0526	11.1	<b>165.00</b>
6" x 6"		8-0523	8.1	<b>79.00</b>
6" x 8"		8-0524	12.3	<b>129.00</b>
6" x 10"		8-0525	14.9	<b>212.00</b>

# DRESSER COUPLERS, SUCTION PIPE

Product	Description	Part Number	Weight	List Price
<b>DRESSER COUPLER - 6" LONG</b> (POWDER COATED)	3" OD	8-0550	4.0	64.00
	4" OD	8-0551	5.5	74.00
	5" OD	8-0552	6.5	85.00
	6" OD	8-0553	7.5	118.00
	8" OD	8-0555	9.0	129.00
	10" OD	8-0556	12.0	159.00
	12" OD	8-0557	21.0	225.00



<b>DRESSER COUPLER - 10" LONG</b> (POWDER COATED)	<b>Complete:</b>	4" OD	8-0530	8.0	81.00
		5" OD	8-0536	11.0	97.00
		6" OD	8-0531	13.0	114.00
		8" OD	8-0532	16.0	130.00
		10" OD	8-0533	23.0	185.00
		12" OD	8-0534	27.0	253.00
	<b>Body Only:</b>	4"	6-2039	4.0	30.00
		5"	6-2040	4.0	38.00
		6"	6-2041	5.0	44.00
		8"	6-2042	7.0	48.00
		10"	6-2043	9.0	61.00
		12"	6-2044	11.0	89.00
	<b>Flange Pack (Double):</b>	4" OD	6-2021	4.0	51.00
	<b>(for 10" long body)</b>	5" OD	6-2022	7.0	59.00
		6" OD	6-2023	8.0	70.00
	8" OD	6-2024	9.0	82.00	
	10" OD	6-2025	14.0	124.00	
	12" OD	6-2026	16.0	164.00	

Product	Description	Part Number	Weight	List Price
<b>SUCTION PIPE</b> (ALUMINUM)	6" x 45° .058	8-0540	37.8	275.00
	6" x 90° .058	8-0541	37.8	329.00
	8" x 45° .072	8-0542	63.3	449.00
	8" x 90° .072	8-0543	63.3	495.00
	10" x 90° .094	8-0545	103.2	845.00

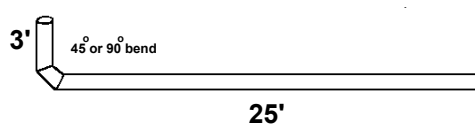

Product	ID	OD	Part Number	Weight	List Price
<b>SUCTION BOOT</b> (RUBBER)	6"	7"	8-0546	3.2	56.00
	8"	9"	8-0547	4.1	70.00
	10"	11"	8-0548	5.8	110.00
	*12"	13-1/2"	8-0549	15.5	235.00



\* For a 12" clamp: Put together two of the 162-174 T-bolt clamps.

<b>FOOT VALVE/SCREEN</b> (CAST IRON)	1-1/2"	6-9603	-	32.00
	2"	8-0706	4.7	50.00
	2-1/2"	8-0707	6.6	59.00
	3"	8-0708	9.1	74.00
	4"	6-9604	16.5	135.00
	6"	6-9605	36.3	295.00
	8"	6-9606	-	468.00



Pumps & Accessories

# INTAKE SCREENS & FITTINGS

Product	Description	Part Number	Weight	List Price
<b>SCREEN W/FOOT VALVE</b> 	3"	6-9844	7.0	<b>210.00</b>
	4"	8-0709	11.0	<b>252.00</b>
	5"	6-9845	14.0	<b>340.00</b>
	6"	8-0710	17.0	<b>418.00</b>
	8"	8-0711	26.5	<b>595.00</b>
	10"	8-0712	46.0	<b>1,010.00</b>

\*Foot Valve Drain Kit w/Cap 9-7666 **10.00**



-0.050 Screen wall thickness  
 -0.080 Screen available at additional cost  
 -Standard holes are 1/4" round  
 -Also available in 1/8" or 1/2" @ additional cost  
 Other sizes are also available. Please call.

\* Use garden hose to drain suction line.

## 90° SUCTION ELBOW (CAST ALUMINUM)



4" x 90°	8-0719	7.0	<b>159.00</b>
6" x 90°	8-0720	10.5	<b>242.00</b>
8" x 90°	8-0721	14.5	<b>370.00</b>
10" x 90°	8-0722	23.0	<b>585.00</b>

## 45° SUCTION ELBOW (CAST ALUMINUM)



4" x 45°	8-0729	6.0	<b>145.00</b>
6" x 45°	8-0730	9.0	<b>229.00</b>
8" x 45°	8-0731	12.0	<b>329.00</b>
10" x 45°	8-0732	17.0	<b>579.00</b>

## INTAKE STRAINER

-0.050 Screen wall thickness  
 -Standard holes are 1/4" round  
 -Also available in 1/8" or 1/2"  
 @ additional cost



With slide:	4"	6-9793	3.5	<b>61.00</b>
	5"	6-9794	4.5	<b>88.00</b>
	6"	10 5/8" x 7 1/4"	6.0	<b>105.00</b>
	8"	16 1/2" x 9 1/4"	11.0	<b>179.00</b>
	10"	23" x 11 1/2"	15.0	<b>239.00</b>

Note: Intake strainers are smaller than Jumbo.

Product	Description	Part Number	Weight	List Price
<b>JUMBO SCREEN - SINGLE</b> 	With slide:	Height x Width		
		6" 18" x 13 5/8"	8-0750	17.0 <b>375.00</b>
		8" 18" x 13 5/8"	8-0751	18.0 <b>375.00</b>
	10" 18" x 13 5/8"	8-0752	18.5 <b>375.00</b>	
	Without slide:	6" 18" x 13 5/8"	8-0760	14.5 <b>315.00</b>
		8" 18" x 13 5/8"	8-0761	14.0 <b>315.00</b>
10" 18" x 13 5/8"		8-0762	13.5 <b>315.00</b>	

-1/4" Standard Round Holes (also available in 1/8", 1/2", 3/4" or 1" @ additional cost)  
 -.080 Standard Wall Thickness (also available in .125 in 3/4" & 1" only @ additional cost)  
 -Easily and quickly attaches to the end of the aluminum suction pipe by drilling three holes in the tubing and inserting bolts.

<b>JUMBO SCREEN - DOUBLE</b> 	With slide:	Height x Width		
		6" 36" x 13 5/8"	8-0770	38.0 <b>610.00</b>
		8" 36" x 13 5/8"	8-0771	38.0 <b>610.00</b>
	10" 36" x 13 5/8"	8-0772	40.0 <b>610.00</b>	
	Without slide:	6" 36" x 13 5/8"	8-0780	21.5 <b>495.00</b>
		8" 36" x 13 5/8"	8-0781	21.0 <b>495.00</b>
10" 36" x 13 5/8"		8-0782	21.0 <b>495.00</b>	

-1/4" Standard Round Holes (also available in 1/8", 1/2", 3/4" or 1" @ additional cost)  
 -.080 Standard Wall Thickness (also available in .125 in 3/4" & 1" only @ additional cost)  
 -Easily and quickly attaches to the end of the aluminum suction pipe by drilling three holes in the tubing and inserting bolts.

<b>LIQUID MANURE SCREEN</b> 	4" 18"long x 14"wide	6-8095	17.0 <b>390.00</b>
	6" 18"long x 14"wide	6-8096	17.0 <b>390.00</b>
	8" 36"long x 14"wide	6-8097	25.0 <b>615.00</b>

- 1" holes, .125" thick screen w/corrosion resistant alloy and stainless steel bolts & nuts.  
 -Easily and quickly attaches to the end of the aluminum suction pipe by drilling three holes in the tubing and inserting bolts.

<b>SELF-CLEANING SCREEN (PERFECTION)</b> 	GPM	Ship		
	2"	50	UPS 9-7623	4.0
3"	160	UPS 9-7624	15.0	<b>490.00</b>
4"	325	UPS 8-0785	13.0	<b>565.00</b>
6"	625	UPS 8-0786	25.0	<b>1,225.00</b>
8"	1150	UPS 8-0787	34.0	<b>1,530.00</b>
10"	1500	UPS 8-0788	55.0	<b>2,120.00</b>
10" BB	1900	CC 9-7625	65.0	<b>2,500.00</b>
10" XL	2500	CC 9-7626	90.0	<b>2,835.00</b>
12" XL	2500	CC 9-7627	90.0	<b>2,950.00</b>

IMPORTANT: A partially closed gate valve on the discharge side of pump is required to provide adequate working pressure to the strainer while filling the irrigation line. Powder epoxy coated aluminum screen .093".

<b>SELF-CLEANING SCREEN (RIVERSCREEN)</b> 	GPM	Ship		NET Price
	4" 100-300	4' pontoon	CC 9-5428	200.0
6" 300-600	6' pontoon	CC 9-5429	225.0	<b>3,100.00</b>
8" 550-1050	8' pontoon	CC 9-5430	250.0	<b>3,400.00</b>
10" 825-1700	10' pontoon	CC 9-5431	275.0	<b>3,800.00</b>
12" 1200-2750	10' pontoon	CC 9-5438	240.0	<b>4,300.00</b>
Power Drive		UPS 9-5432	-	<b>210.00</b>
Motor Drive		9-7872	-	<b>1,000.00</b>
Foot Valve		9-6849		<b>650.00</b>

Floating screen. Requires only 4" of water. Must have current to operate, otherwise order the optional power drive.  
 8 mesh (.097") stainless steel screen. All SS Screws & Bolts

# FOOT VALVE PARTS

Product	Description	Part Number	Weight	List Price
<b>ROUND HOLE SCREEN</b> 	1-1/2"	6-9590	-	18.00
	2"	6-9591	-	20.00
	2-1/2"	6-9592	-	22.00
	3"	6-9593	2.7	29.00
	4"	6-9594	-	38.00
	6"	6-9595	-	97.00
	8"	6-9596	9.6	150.00

-Female pipe thread connection.

Product	Description	Part Number	Weight	List Price
<b>SQUARE HOLE SCREEN</b> 	1-1/2"	6-9597	-	23.00
	2"	6-9598	-	29.00
	2-1/2"	6-9599	-	36.00
	3"	6-9600	-	43.00
	4"	6-9601	-	45.00
	6"	6-9602	6.1	93.00

-Female pipe thread connection.

Product	Description	Part Number	Weight	List Price
<b>SUCTION FLANGE (CAST ALUMINUM)</b> 	4"	8-0818	-	17.00
	6"	8-0819	1.3	29.00
	8"	8-0820	1.6	45.00
	10"	8-0821	2.4	67.00

Product	Description	Part Number	Weight	List Price
<b>RING GASKET</b> 	4"	6-6484	-	3.00
	6"	6-6486	-	4.70
	8"	6-6488	-	12.30
	10"	6-6480	-	17.20

Product	Description	Part Number	Weight	List Price
<b>STANDARD FV BODY (CAST ALUMINUM)</b> 	4" x 45°	8-0824	-	135.00
	6" x 45°	8-0825	-	210.00
	8" x 45°	8-0826	-	325.00
	10" x 45°	8-0827	-	530.00

\*Does NOT include suction flange, ring gasket, valve flapper cover, valve flapper gasket, valve flapper weight or valve seat ring.

Product	Description	Part Number	Weight	List Price	
<b>VALVE FLAPPER COVER</b> 	4"	<u>OD</u> 4-1/2"	8-0828	0.8	9.50
	6"	6-1/2"	8-0829	-	13.50
	8"	8-1/2"	8-0830	3.0	23.00
	10"	10-1/2"	8-0831	-	39.00

Product	Description	Part Number	Weight	List Price		
<b>VALVE FLAPPER/GASKET</b> 	Rubber	2"	<u>OD</u> 5-5/8"	8-0713	-	12.00
		3"	6-3/8"	8-0714	0.2	17.00
		4"	7-3/4"	8-0715	0.3	23.00
		5"	8-7/8"	8-0716	0.3	26.00
		6"	9-3/4"	8-0717	0.6	34.00
		8"	11-3/4"	8-0718	-	50.00
		10"	13-7/8"	8-0725	1.5	116.00

# FOOT VALVE PARTS

Product	Description	Part Number	Weight	List Price	
<b>VALVE FLAPPER WEIGHT</b> 		<u>OD</u>			
	4"	2-1/2"	8-0832	0.2	5.50
	6"	4-1/2"	8-0833	-	10.00
	8"	6-1/2"	8-0834	-	13.50
	10"	8-1/2"	8-0835	-	23.00

## VALVE SEAT RING (CAST ALUMINUM)



4"	8-0837	-	31.00
6"	8-0838	-	56.00
8"	8-0839	3.5	61.00
10"	8-0840	-	110.00

## FOOT VALVE SCREEN



6-1/2" high x 7-1/4" wide	4"	8-0842	-	17.00
8-3/8" high x 9-1/4" wide	6"	8-0843	-	27.00
13-1/2" high x 11-1/4" wide	8"	8-0844	1.5	52.00
21" high x 13-5/8" wide	10"	8-0845	-	75.00

1/4" Standard Round Holes (also available in 1/8", 1/2", 3/4" or 1"  
 0.050 Standard Wall Thickness (also available in .080)

## BOTTOM DISC (CAST ALUMINUM)



4"	8-0846	1.4	25.00
6"	8-0847	-	49.00
8"	8-0848	3.4	59.00
10"	8-0849	5.4	105.00

## BOLT/NUT/WASHER



Screen Bolt/Nut	4" (3 req.)	1/4"x8"	8-0850	-	2.50
	6" (3 req.)	1/4"x10"	8-0851	-	3.50
	8" (3 req.)	1/4"x15-3/8"	8-0852	-	4.00
	10" (4 req.)	1/4"x22-7/8"	8-0853	-	5.50



Flange	2"-8" (4 req.)	5/16"x2-1/4"	8-0822	-	1.70
	10" (4 req.)	5/16"x2-1/2"	8-0823	-	2.00













Seat Body Bolt/Nut	4" (5 req.)	1/4"x1-1/2"	8-0841	-	1.00
	6" (8 req.)	1/4"x1-1/2"	8-0841	-	1.00
	8" (11 req.)	1/4"x1-1/2"	8-0841	-	1.00
	10" (12 req.)	1/4"x1-1/2"	8-0841	-	1.00







Cover Weight		1/4"x3/4"	8-0836	-	1.10
--------------	--	-----------	--------	---	------

# SUCTION FITTINGS & PARTS

Product	Description	Part Number	Weight	List Price
<b>ELBOW PARTS</b>				
<b>ELBOW</b> (CAST ALUMINUM)		4" x 45°	8-0814	- 110.00
		6" x 45°	8-0815	- 172.00
		8" x 45°	8-0816	- 239.00
		10" x 45°	8-0817	- 425.00
		4" x 90°	8-0810	- 125.00
		6" x 90°	8-0811	- 180.00
	8" x 90°	8-0812	- 265.00	
	10" x 90°	8-0813	- 455.00	
<b>FLANGE</b> (CAST ALUMINUM)				
	4"	8-0818	- 17.00	
	6"	8-0819	1.3 29.00	
	8"	8-0820	1.6 45.00	
	10"	8-0821	2.4 67.00	
<b>RING GASKET</b>				
	4"	6-6484	- 3.00	
	6"	6-6486	- 4.70	
	8"	6-6488	- 12.30	
	10"	6-6480	- 17.20	
<b>FLANGE BOLT/NUT/WASHER</b>				
	For 4", 6", 8" (4 req)	5/16"x2-1/4"	8-0822	- 1.70
	For 10" (4 req.)	5/16"x2-1/2"	8-0823	- 2.00

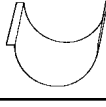
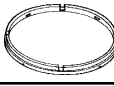
<b>INTAKE STRAINER PARTS</b>					
Ring Casting		<b>Ring Casting</b>	6"	8-0736	- 30.00
			8"	8-0737	- 51.00
			10"	8-0738	- 56.00
Bottom Disc Casting		<b>Bottom Disc Casting</b>	6"	8-0739	- 25.00
			8"	8-0740	- 49.00
			10"	8-0741	- 59.00
Strainer Screen		<b>Strainer Screen</b>	6" 10-5/8" h x 7-1/4" w	8-0742	- 26.00
			8" 16-1/2" h x 9-1/4" w	8-0743	1.5 39.00
			10" 23" h x 11-1/2" w	8-0744	2.5 86.00
Strainer Bolt & Nut		<b>Strainer Bolt &amp; Nut</b>	6" 12" long	8-0745	- 3.70
			8" 18" long	8-0746	- 5.00
			10" 25-1/4" long	8-0747	- 5.50
Slide		<b>Slide</b>	6"	8-0748	- 23.00
			8"	8-0749	- 40.50
			10"	8-0753	- 70.50
Ring Bolt		<b>Ring Bolt</b>		8-0754	0.0 1.50

<b>JUMBO STRAINER PARTS</b>				
<b>JUMBO STRAINER RING</b>		4"	8-0859	- 126.00
		6"	8-0860	- 126.00
		8"	8-0861	- 126.00
		10"	8-0862	- 126.00
<b>JUMBO STRAINER SCREEN</b>		18" h x 13-5/8" wide	8-0854	- 102.00
<b>JUMBO BOTTOM DISC</b>			8-0858	- 100.00
<b>JUMBO SLIDE</b>		For Single Jumbo Strainer	8-0855	4.3 58.00
		For Double Jumbo Strainer	8-0856	- 116.00
<b>JUMBO D-RING</b>			8-0863	2.4 110.00
<b>JUMBO STRAINER BOLT</b>		4 required 1/4" x 19-3/8" long	8-0857	- 6.00

Product	Description	Part Number	Weight	List Price
---------	-------------	-------------	--------	------------

## DISCHARGE PRIMING VALVE



3" x 4"	8-0640	20.0	<b>620.00</b>
4"	8-0650	36.0	<b>843.00</b>
5"	8-0655	55.0	<b>988.00</b>
6"	8-0660	70.0	<b>1,006.00</b>

## REPLACEMENT PARTS FOR DISCHARGE PRIMING VALVE

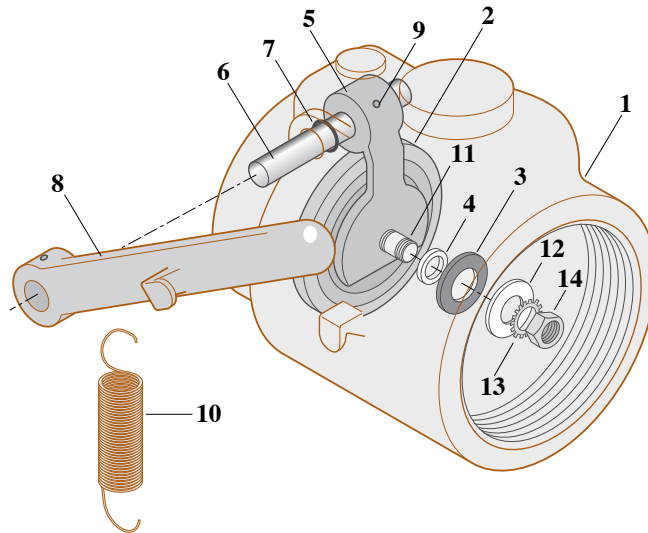

Item	Description	Part #	Key	List Price
Clack	3" x 4" 4.00" OD	8-0641	2	<b>125.00</b>
	4" x 4" 4.75" OD	8-0651	2	<b>235.00</b>
	5" x 5" 5.75" OD	8-0656	2	<b>275.00</b>
	6" x 6" 6.75" OD	8-0661	2	<b>295.00</b>
Valve Body	3" x 4"	8-1002	1	<b>685.00</b>
	4" x 4"	8-1003	1	<b>715.00</b>
	5" x 5"	8-1004	1	<b>1,330.00</b>
	6" x 6"	8-1005	1	<b>1,295.00</b>
Clack Hinge Handle Assembly	3" x 4" 3.00" C-C	8-1009	5, 6, 8	<b>295.00</b>
	4" x 4" 3.50" C-C	8-1010	5, 6, 8	<b>300.00</b>
	5" x 5" 4.00" C-C	8-1011	5, 6, 8	<b>325.00</b>
	6" x 6" 4.25" C-C	8-1012	5, 6, 8	<b>335.00</b>
'O' Ring	--	8-1013	7	<b>8.50</b>
Spring Pin (2 required)	--	8-1014	9	<b>8.50</b>
Spring	3" x 4"	8-1015	10	<b>17.50</b>
Spring	4"-5"-6"	8-1016	10	<b>20.00</b>
Grommet	--	8-1007	3	<b>8.50</b>
Spacer	--	8-1008	4	<b>25.00</b>
Bolt Stud	--	8-1017	11	<b>7.60</b>
Nut	--	6-0902	14	<b>0.08</b>
External Tooth Washer	--	8-1018	13	<b>3.30</b>
Flat Washer	--	9-6762	12	<b>3.20</b>

Pumps & Accessories



Product	Description	Part Number	Weight	List Price
<b>HAN-D PUMPERS</b>	#700 Han-D Pumper	6-9760	18.0	<b>660.00</b>
	#900 Han-D Pumper	6-9762	20.0	<b>765.00</b>



Uses include small or occasional jobs where it takes too long to setup on engine driven pump.

	Inlet / Outlet	Capacity	Max. Suction Lift	Max Discharge Head
Model 700	1.5" FPT	.5 gal/Stroke	20 feet	10 feet
Model 900	2" FPT	1 gal/Stroke	15 feet	10 feet

**Features:**

- Complete dewatering portable unit
- Lightweight, easy to use
- Cast aluminum body
- Pumps air, water, sewage, mud and many chemical products
- Ideal for priming large diameter pipes (i.e. 8", 10", 12" sizes)

## PARTS FOR #700 HAN-D PUMPERS

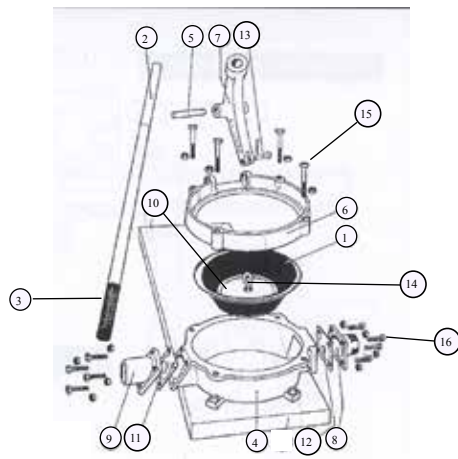

Item	Item #	Part #	List Price
Diaphragm - #700	1	6-9761	<b>82.00</b>
Handle	2	9-7729	<b>30.00</b>
Grip	3	9-7730	<b>9.00</b>
Pump Body	4	9-7731	<b>279.00</b>
Fulcrum Pin	5	9-7732	<b>15.00</b>
Retainer Ring	6	9-7733	<b>111.00</b>
Fulcrum	7	9-7734	<b>69.00</b>
Suction Flange	8	9-7735	<b>79.00</b>
Discharge Flange	9	9-7736	<b>83.00</b>
Diaphragm Plates (2-required)	10	9-7737	<b>26.00</b>
Discharge Valve	11	9-7738	<b>35.00</b>
Suction Valve	12	9-7739	<b>35.00</b>
Fastpin	13	9-7740	<b>4.00</b>
Eyebolt w/Nuts	14	9-7741	<b>3.60</b>
Bolt, 5/16" x 2" (4-required)	15	9-7742	<b>2.20</b>
Bolt, 5/16" x 1" (8-required)	16	9-7743	<b>1.70</b>
Nut, 5/16" (12-required)		9-7744	<b>1.40</b>

## PARTS FOR #900 HAN-D PUMPERS

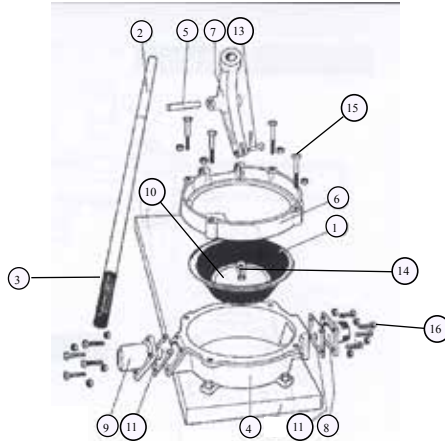

Item	Item #	Part #	List Price
Diaphragm - #900	1	6-9763	<b>88.00</b>
Handle	2	9-7729	<b>30.00</b>
Grip	3	9-7730	<b>9.00</b>
Pump Body	4	9-7745	<b>339.00</b>
Fulcrum Pin	5	9-7732	<b>15.00</b>
Retainer Ring	6	9-7746	<b>121.00</b>
Fulcrum	7	9-7747	<b>75.00</b>
Suction Flange	8	9-7748	<b>81.00</b>
Discharge Flange	9	9-7749	<b>88.00</b>
Diaphragm Plates (2-required)	10	9-7750	<b>26.00</b>
Suction/Discharge Valve	11	9-7751	<b>36.00</b>
Fastpin	13	9-7740	<b>4.00</b>
Eyebolt w/Nuts	14	9-7741	<b>3.60</b>
Bolt, 5/16" x 2" (4-required)	15	9-7742	<b>2.20</b>
Bolt, 5/16" x 1" (8-required)	16	9-7743	<b>1.70</b>
Nut, 5/16" (12-required)		9-7744	<b>1.40</b>

# POWER & HAND PRIMERS

Product	Description	Part Number	Weight	List Price
<b>HAND PRIMER</b>	#7	8-0610	7.0	<b>345.00</b>
	#9	8-0620	20.0	<b>490.00</b>

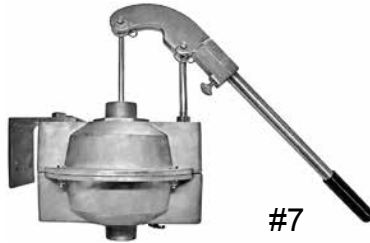

\*3/4" FPT &amp; 1-1/2" MPT Base

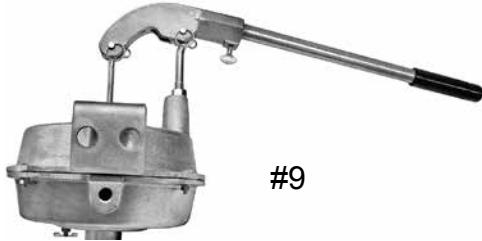

\*3/4" FPT Base

Call for prices on the #5 Hand Primer, part # DP5

**Features:**

- Quick hand priming of any type of centrifugal pump, siphon tube or pump situation
- Lightweight and easy to install
- Durable and dependable
- Reinforced diaphragms are long-lasting
- Provides up to 20 feet of suction lift with ease and leverage
- New style allows for Fulcrum Bracket to be adjusted at various angles for your convenience.

**Primer Capacity Chart**

Primer	# of Strokes to Prime Through 25' of 4" Suction			# of Strokes to Prime Through 25' of 6" Suction			# of Strokes to Prime Through 25' of 8" Suction		
	6.5' Lift	13' Lift	19.5' Lift	6.5' Lift	13' Lift	19.5' Lift	6.5' Lift	13' Lift	19.5' Lift
#7	6	15	32	12	33	65			
#9	4	9	20	10	23	45	17	37	77

**Primer Selection Chart:**

Primer	Pipe Size
#7	4", 5", & 6"
#9	6", 8" or larger

**Features:**

Lightweight and durable solid-cast aluminum body.  
 Reinforced diaphragms are long-lasting.  
 Steel mounting bracket allows for easy and dependable installation.  
 Fulcrum eyebolt can be adjusted at various angles for your convenience.

**POWER PRIMER**

35AC	6-9715	88.0	<b>3,335.00</b>
35DC (battery)	6-9716	85.0	<b>3,385.00</b>

**Features:**

- Converts centrifugal pumps to self-primers.
- Fast, efficient primer for pumps with high suction lifts.
- Requires minimum maintenance.
- Ideal for diesel or gasoline-powered engines.

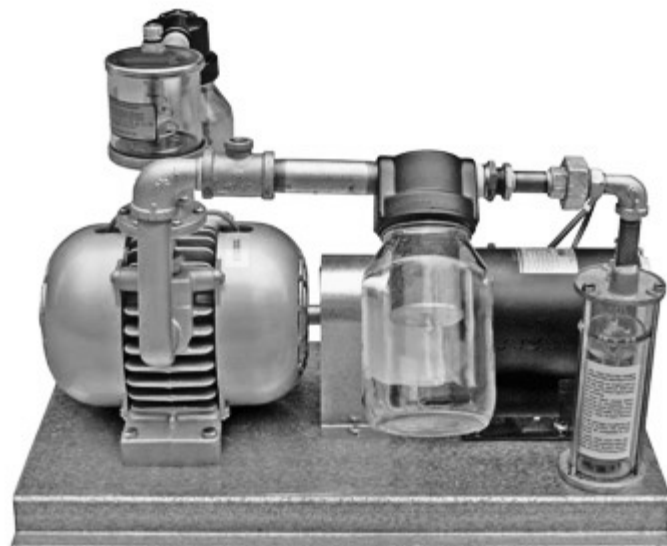

# HAND PRIMERS



Product	Description	Part Number	Weight	List Price
<b>PARTS FOR #7 HAND PRIMER</b>	<b>Item</b>	<b>Item #</b>	<b>Part #</b>	<b>List Price</b>
	Diaphragm - #7	3	8-0631	66.00
	Lower Housing	1	9-5353	132.00
	Check Valve (Disc)	9	9-5355	4.50
	Drain Cock	10	8-1102	10.00
	Upper Housing	2	9-5354	132.00
	Connecting Rod Assembly	7	8-1108	17.00
	Handle Bracket	13	8-1111	74.00
	Fast Pin (2 required)	11	8-1112	4.00
	Fulcrum Eyebolt	8	9-5357	18.00
	Mounting Bracket	4	9-5358	48.00
	Thumb Screw	12	9-5359	4.00
	Handle (Pipe)	14	9-5360	26.00
	Handle Grip	15	9-5361	10.00
	Bolt, Hex, 1/4"-20 x 1" (4 Required)	16	9-7655	1.00
	Nut, Hex, 1/4"-20 (4 Required)	16	9-7656	0.20
Washer, Split Lock, 1/4" (4 Required)	16	9-7657	0.50	

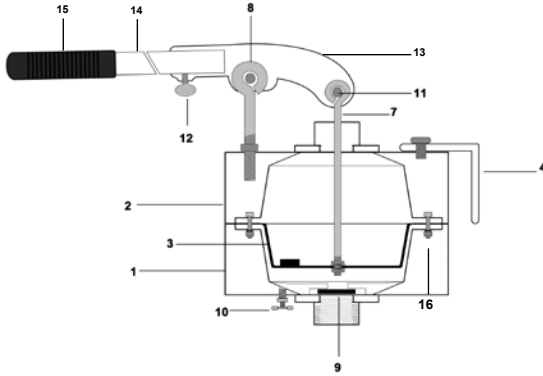

<b>PARTS FOR #9 HAND PRIMER</b>	<b>Item</b>	<b>Item #</b>	<b>Part #</b>	<b>List Price</b>
	Diaphragm - #9	3	8-0621	90.00
	Lower Housing	1	8-1100	151.00
	Check Valve (Disc)	9	9-5355	4.50
	Drain Cock	10	8-1102	10.00
	Upper Housing	2	8-1103	151.00
	Connecting Rod Assembly	7	8-1108	17.00
	Lock Nut, 1-1/2"	6	8-1109	18.00
	Fulcrum Eyebolt	8	8-1110	28.00
	Handle Bracket	13	8-1111	74.00
	Fast Pin (2 required)	11	8-1112	4.00
	Mounting Bracket	4	8-1113	48.00
	Thumb Screw	12	9-5359	4.00
	Handle (Pipe)	14	9-5360	26.00
	Handle Grip	15	9-5361	10.00
	Bolt, Hex, 1/4"-20 x 1" (4 Required)	16	9-7655	1.00
Nut, Hex, 1/4"-20 (4 Required)	16	9-7656	0.20	
Washer, Split Lock, 1/4" (4 Required)	16	9-7657	0.50	

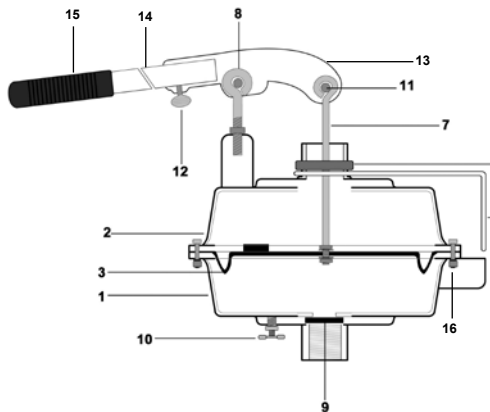

Primer Side	Pump Side	Part Number	Weight	List Price
3/4" MPT	x 3/4" MPT	8-0622	-	71.00

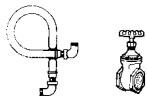

Diaphragm Type	Part Number	Weight	List Price
#5 Diaphragm B-183	8-0629	0.2	53.00
#6 Diaphragm	8-0611	0.4	45.00
#7 Diaphragm C-106	8-0631	1.0	66.00
#9 Diaphragm B-61	8-0621	1.9	90.00
Wade Rain #9-30-3	8-0613	0.3	24.00
Travis WPP-1D	8-0614	1.0	35.00



# INTAKE MANIFOLD PRIMER EXHAUST PRIMER

Product	Description	Part Number	Weight	List Price
<b>INTAKE MANIFOLD PRIMER</b>	MP1000 (Old Style)	8-0630	2.7	<b>365.00</b>
	MP2000 (New Style)	9-7910		<b>365.00</b>



MP1000 (Old Style)



MP2000 (New Style)







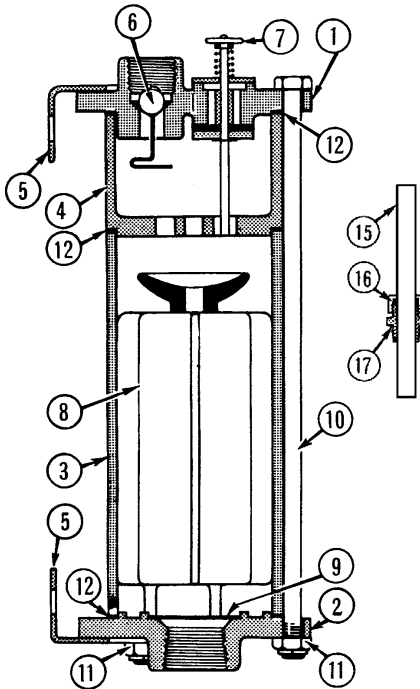



**Features:**

- Fast, efficient priming using engine manifold vacuum while engine runs at low speed.
- All working parts enclosed in fully transparent plastic housing permits observation of primer operation at all times.
- Lightweight plastic float with rubber "cup type" valve provides instant and positive closure as soon as priming is completed.
- Check valve prevents reverse flow during normal pump operation.
- Easy to operate...simply start engine and open one valve to begin priming.
- Can be readily installed on any gasoline or LPG engine of four or more cylinders to provide suction lifts up to 20 feet.
- Complete operation instructions are permanently attached to the primer, and detailed instructions for installation and maintenance are supplied with each unit.
- Connection hoses not included.

## PARTS FOR INTAKE MANIFOLD PRIMER



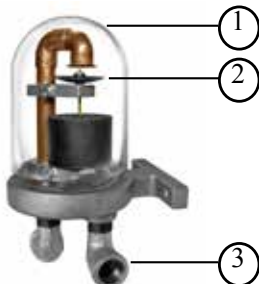

### MP1000 (Old Style)

Item	Item #	Part #	List Price
 Upper Housing	4	8-0633	<b>36.00</b>
 Lower Housing	3	8-0634	<b>45.00</b>
 Gaskets (3 in a set)	12	8-0635	<b>4.00</b>
 Top Cover Assembly	1/6/7	8-1120	<b>130.00</b>
 Lower Cover Assembly	2/9	8-1121	<b>77.00</b>
 Brackets	5	8-1122	<b>15.50</b>
 Tie Bolts & Nuts	10/11	8-1123	<b>12.50</b>
 Float Assembly	8	8-1124	<b>46.00</b>
 Angle Valve	14	8-1125	<b>44.00</b>
 Packing Gland Assembly	15/16/17	8-1126	<b>25.00</b>



### MP2000 (New Style)

Item	Item #	Part #	List Price
 Cover Jar	1	9-7914	<b>131.00</b>
 Umbrella Drain Valve	2	9-7915	<b>19.00</b>
 Street Elbow, 1/2" (2 Req.)	3	9-5754	<b>3.40</b>

\*Please note that any additional parts not seen here are factory install only. Do not attempt to replace any items not seen in the chart to the right.

Product	Description	Part Number	Weight	List Price
---------	-------------	-------------	--------	------------

**MAGNETIC SWITCH**

Murphy #117 DC (12/24 Volt)

6-0020

0.8

**59.00**Murphy #518APH (12 Volt)  
(has 6 prongs for Deutz diesels)

6-0021

0.7

**70.00**

A manually reset magnetic Circuit Breaker which is tripped by a switch gauge when a malfunction is detected. It is commonly used to break the ignition circuit of a distributor ignition engine or break power to a solenoid fuel valve when it receives a signal from the switch gauge.

**OIL PRESSURE GAUGE**

75 psi Murphy, #20P75

6-0022

0.5

**69.00**

100 psi Murphy, #20P100

6-0023

0.9

**68.00**

This is a basic engine or pump oil pressure switch gauge.

**ENGINE TEMPERATURE GAUGE**

Murphy 20T254, 250°F Water

6-0024

0.8

**82.00**

This Temperature switch gauge is available in various models and ranges to prevent engine damage from high water oil or cylinder head temperature.

**VACUUM/LOAD GAUGE**

Murphy 20V3

6-0025

0.6

**95.00**

Commonly used to monitor manifold vacuum for loss of load or overload on spark ignition engines, vacuum switch gauges are recommended for preset limit shutdown of irrigation engines.

**OIL LEVEL SAFETY GAUGE**

Murphy L129

6-0026

3.0

**165.00**

Combination high and low engine oil level switch gauge gives continuous indication of the oil level and condition. No need to shut down to check oil level. Adjustable high and low level contacts operate to shutdown engine or operate alarm when improper level exists.

Product	Description	Part Number	Weight	List Price
<b>WATER LEVEL SAFETY GAUGE</b>	Murphy , L150	6-0027	1.8	<b>120.00</b>



Coolant level SWITCHGAUGE can be visually checked with this water level SWITCHGAUGE. If the water level falls too low, contact is made and the engine shutdown system is activated (or alarm is sounded.)

<b>FUEL STOP SOLENOID</b>	Murphy, SV12	6-0028	1.4	<b>129.00</b>
---------------------------	--------------	--------	-----	---------------



- Solenoid Fuel Valve to shut off the fuel to Diesel engines upon engine or driven equipment malfunction.

<b>TIMER</b>	Murphy, 12T w/case (12 hour)	6-0019	4.7	<b>565.00</b>
	Murphy, 12T wo/case (12 hour)	6-0031	0.8	<b>480.00</b>



Murphy, 24T w/case (24 hour)	6-0017	4.7	<b>565.00</b>
Murphy, 24T wo/case (24 hour)	6-0018	1.5	<b>480.00</b>

- Timer switches are designed to automatically shut down engine when a pre-determined operating time is set.  
- Weatherproof case

<b>PUMP PRESSURE GAUGE</b>	Murphy, 20P7-15	9-5252	0.5	<b>75.00</b>
	Murphy, 20P7-30	9-5254	-	<b>75.00</b>
	Murphy, 20P7-50	9-5256	-	<b>75.00</b>
	Murphy, 20P7-75	In stock 9-5257	0.5	<b>75.00</b>
	Murphy, 20P7-100	In stock 9-5251	0.5	<b>75.00</b>
	<b>Murphy, 20P7-150</b>	In stock <b>9-5253</b>	0.5	<b>75.00</b>
	Murphy, 20P7-300	9-5255	-	<b>75.00</b>



Monitors Discharge Pressure to detect water supply failure or parted couplings.

<b>STANDARD MURPHY MOUNT PANEL</b>	Murphy, WD300-12	6-0030	5.0	<b>635.00</b>
------------------------------------	------------------	--------	-----	---------------



- Designed for mobile equipment such as trucks, tractors, and fork lifts  
-Open panel for under dash mounting.  
-Pressure, temperature, visual and audible alarms, before shutdown.

Murphy Toggle Switch, TF	6-9704	-	<b>24.00</b>
Murphy Amp Meter, 60060	6-9705	-	<b>30.00</b>
Murphy Stop Button, PB1285	6-9706	-	<b>13.00</b>

Pumps & Accessories

Product	Description	Part Number	Weight	List Price
<b>LIMA GENERATOR</b> 	5 KW	6-8010	150.0	<b>4,515.00</b>
	7.5 KW	6-8011	165.0	<b>5,250.00</b>
	10 KW	6-8012	245.0	<b>5,460.00</b>
	12 KW	6-8013	260.0	<b>5,880.00</b>
	15 KW	6-8014	275.0	<b>6,615.00</b>
	20 KW	9-7687	560.0	<b>8,750.00</b>

<b>WIRE</b> 	Aluminum, Single	6-6800	-	<b>Call</b>
	Aluminum, Triplexed	6-6801	-	<b>Call</b>
	Aluminum, Quadraplexed	6-6802	-	<b>Call</b>
	Aluminum, Tuf-Hide	6-6803	-	<b>Call</b>
	Underground Feeder, UF	6-6804	-	<b>Call</b>

<b>ELECTRIC MOTOR</b> 	Marathon			<b>Call</b>
	Baldor			<b>Call</b>
	Others			<b>Call</b>

Base is not included.

<b>GEAR HEAD</b> 	Amarillo			<b>Call</b>
	Johnson			<b>Call</b>
	Randolph			<b>Call</b>

<b>PROP-SHAFT GUARD</b> 	7" dia x 10" - 18"	6-9822	6.0	<b>60.00</b>
	7" dia x 24" - 42"	6-9823	12.0	<b>63.00</b>
	7" dia x 36" - 54"	6-9824	15.0	<b>68.00</b>
	7" dia x 36" - 66"	6-9825	18.0	<b>75.00</b>
	12" dia x 14" - 24"	6-9826	13.0	<b>90.00</b>
	12" dia x 36" - 66"	6-9827	27.0	<b>130.00</b>
	12" dia x 28" - 54"	6-9828	28.0	<b>142.00</b>

Unprotected prop-shaft on your irrigation wells can maim or kill almost instantly. Prevent potential tragedy, rest easy during pumping season with a Hastings Prop-Shaft guard permanently in place at each of your wells. They are simple and fast to install - using existing bolts on most pumps and engines. Once on, they stay on. You have easy full access for lubrication through a 2" slot on the underside. Formed from heavy-gauge galvanized steel, the guard will give your well a neat, clean appearance - and you will be assured of safety around the clock!

**Special Features:**

- Meets OSHA requirements
- Endorsed by farm safety authorities
- Protection against loss of life or limb
- Adapts to any internal combustion engine, gear head installation
- Slips easily over prop-shaft and bolts to engine and pump
- Complete access for lubrication through 2" wide opening running the length of guard
- Rigid construction from galvanized steel. Withstands abuse and stays neat-appearing year after year.

<b>AUTOMATIC TURBINE PUMP OILER</b> 	4 Gallon	6-8098	11.0	<b>502.00</b>
	7 Gallon	6-8099	15.0	<b>575.00</b>
	11 Gallon	9-7665	-	<b>665.00</b>
	Brass Needle Valve	9-7554	-	<b>69.00</b>

Advantages: Automatic operation assures lubrication whenever the pump is pumping, this helps avoid inadequate oil dripping which is the leading cause of turbine pump failure.

Inadequate drip oiling is the leading cause of pump failure. Continuous dripping wastes oil and causes contamination. This automatic valve assures lubrication when pump is running. Saves costly trips into the well. Manual mode for pre-season lubrication.

Product	Description	Part Number	Weight	List Price
---------	-------------	-------------	--------	------------

# Municipal/Industrial Hose & Fittings

Schumacher Irrigation, Inc. is "Your Liquid Solutions Provider"

We fabricate and distribute a full line of hose and accessories, couplings, clamps, fittings, valves, pumps, and suction and vacuum accessories for industry and liquid / waste water handling applications.

We pride ourselves on our same day service on both standard and custom parts. Please call us for quick and quality liquid solutions.



Conversions	
1 U.S. Gallon	= 231.00 cu. In
	= 0.1370 cu. Ft
	= 3.7850 liters
	= 0.0038 cu. Meters
	= 0.8330 Imp. Gal.
	= 0.0238 42-gal. Barrel
1 Imperial Gallon	= 1.20 U.S. Gal.
1 Cubic Foot	= 7.48 U.S. Gal.
	= 0.0283 cu. Meters
1 Barrel (Oil)	= 42.00 U.S. Gal.
1 Litre	= 0.2642 U.S. Gal.
1 Cubic Meter	= 35.3140 cu. Ft
	= 264.20 U.S. Gal.
1 Acre Foot	= 43,560.00 cu. Ft
	= 325,829.00 U.S. Gal.
1 Acre Inch	= 3,630.00 cu. Ft
	= 27,100.00 U.S. Gal.
Capacity	
1 Cubic Foot Per Second	= 449.00 GPM
1 Acre Foot Per Day	= 227.00 GPM
1 Acre Inch Per Hour	= 454.00 GPM
1 Litre Per Second	= 15.85 GPM
1 Cubic Meter Per Min.	= 264.20 GPM
1 Miner's Inch	= 9.00 GPM
1,000,000 Gal. Per Day	= 695.00 GPM
Head	
1 PSI	= 2.31 Ft. Head of Water
	= 2.04 In. Mercury
	= 0.07 Kg. Per sq. cm.
1 Foot of Water	= 0.43 PSI
	= 0.89 In. Mercury
1 Inch of Mercury (Vacuum)	= 1.13 Ft. of Water
1 Kilogram Per Square Cm	= 14.22 PSI
1 Atmosphere (at sea level)	= 14.70 PSI
	= 34.00 Ft. of Water
	= 10.35 Meters of Water
Weight	
1 U.S. Gallon of Water	= 8.33 Lbs
1 Cubin Foot of Water	= 62.35 Lbs
1 Kilogram or Litre	= 2.20 Lbs
1 Imperial Gallon	= 10.20 Lbs

Length	
1 Inch	= 2.54 Centimeters
1 Meter	= 3.28 Feet
1 Rod	= 16.50 Feet
1 Mile	= 5,280.00 Feet
Horsepower	
1 Horsepower	= 7.46 Kilowatts or 746 watts
	= 33,000.00 Ft lbs per minute
	= 550.00 ft lbs per second
Horsepower Input	= Horsepower input to motor 1.34 x kilowatts input to motor
Water Horsepower	= H.P. required to lift water at a definite rate to a given distance assuming 100% efficiency:
	$\frac{\text{GPM} \times \text{Total Head (in. ft.)}}{3960}$
	=
Brake Horsepower	= H.P. delivered by motor
	= H.P. required by pump
	= H.P. input x motor efficiency
	= 1.34 x KW input x motor efficiency
	$\frac{\text{Water H.P.}}{\text{Pump efficiency}}$
$\frac{\text{GPM times total head (ft)}}{3960 \times \text{pump efficiency}}$	
$\frac{\text{GPM times total head (psi)}}{103,000 \times \text{pump efficiency}}$	
Efficiency	
Efficiency	= Power output / Power input
Motor Efficiency	= H.P. output / K.W. input x 1.34
Pump Efficiency	= GPM x Total Head (Ft) / 3930 x B.H.P
Plant Efficiency	= GPM x Total Head (Ft) / 5300 x KW input



Product	Description	Part Number	Weight	List Price
---------	-------------	-------------	--------	------------

**PIPE DIMENSION CHART**

PIPE TYPE	LHD	80	100	125	CL63	CL100	CL125	CL160	CL200	SCH40 PVC	SCH80 PVC	C-900	SEWER	CASING	
O.D. SIZE	PIP	PIP	PIP	PIP	IPS	IPS	IPS	IPS	IPS	IPS	IPS		PVC	PVC	
4"	SDR	91	51	41	32.5	64	41	32.5	26	21	DWV/LP	DWV/LP	DR-18	SDR 35	SDR26
	O.D.					4.5	4.5	4.5	4.5	4.5	4.5	4.5	4.8	4.215	4.5
	I.D.					4.35	4.26	4.2	4.134	4.046	3.998	3.786	4.22	3.89	4.154
	WALL					0.07	0.11	0.138	0.173	0.214	0.237	0.337	0.267	0.125	0.173
	PSI					63	100	125	160	200	100/130	100/130	150	117.5	160
4 1/2"	O.D.														4.95
	I.D.														4.57
	WALL														0.19
	PSI														160
	O.D.					5.563	5.563	5.563	5.563	5.563	5.563	5.563			
5"	I.D.					5.37	5.27	5.19	5.109	4.99	5.017	4.767			5.135
	WALL					0.087	0.136	0.171	0.214	0.265	0.258	0.375			0.214
	PSI					63	100	125	160	200	100/130	100/130			160
	O.D.	6.14	6.14	6.14	6.14	6.625	6.625	6.625	6.625	6.625	6.625	6.625	6.9	6.275	6.625
	I.D.	6	5.88	5.81	5.73	6.4	6.27	6.18	6.07	5.94	6.031	5.709	6.08	5.742	6.115
6"	WALL	0.07	0.12	0.15	0.189	0.087	0.162	0.204	0.255	0.316	0.28	0.432	0.383	0.18	0.255
	PSI	43	80	100	125	63	100	125	160	200	100/130	100/130	150	117.5	160
	O.D.	8.16	8.16	8.16	8.16	8.625	8.625	8.625	8.625	8.625	8.625	8.625	9.05	8.4	8.625
	I.D.	7.984	7.81	7.73	7.62	8.33	8.17	8.05	7.921	7.74	7.943	7.565	7.97	7.665	7.962
	WALL	0.088	0.16	0.199	0.251	0.135	0.21	0.265	0.332	0.41	0.322	0.5	0.503	0.24	0.332
8"	PSI	43	80	100	125	63	100	125	160	200	100/130	100/130	150	117.5	160
	O.D.	10.2	10.2	10.2	10.2	10.75	10.75	10.75	10.75	10.75	10.75	10.75	11.1	10.5	10.75
	I.D.	9.98	9.77	9.66	9.52	10.41	10.18	10.04	9.86	9.65	9.976	9.492	11.63	9.563	9.87
	WALL	0.11	0.2	0.249	0.314	0.168	0.262	0.331	0.413	0.511	0.365	0.593	0.733	0.3	0.413
	PSI	43	80	100	125	63	100	125	160	200	100/130	100/130	150	117.5	160
10"	O.D.	12.24	12.24	12.24	12.24	12.75	12.75	12.75	12.75	12.75	12.75	12.75	13.2	12.5	12.75
	I.D.	11.97	11.72	11.6	11.43	12.32	12.08	11.91	11.7	11.45	11.89	11.29	11.63	11.36	11.7
	WALL	0.132	0.24	0.299	0.377	0.199	0.311	0.392	0.49	0.606	0.406	0.687	0.733	0.36	0.49
	PSI	43	80	100	125	63	100	125	160	200	100	100	150	117.5	160
	14"	O.D.						after 12" is pip size		14		14	14	15.3	same
I.D.									12.86		13.07	12.41	13.48	OD as	
WALL									0.538		0.437	0.75	0.85	pip after	
PSI									160		100	100	235	12"	
O.D.		15.3	15.3	15.3	15.3	15.3	15.3							15.3	
15"	I.D.	14.97	14.65	14.5	14.29	14.82	14.5							13.89	
	WALL	0.165	0.3	0.373	0.471	0.239	0.373							0.44	
	PSI	43	80	100	125	63	100							117.5	
	O.D.							16			16	16	17.4		
	I.D.							14.696			14.94	14.21	15.33		
16"	WALL							0.615			0.5	0.843	0.967		
	PSI							160			100	100	235		
	O.D.	18.36	18.701	18.701	18.701		18		18		18	18	19.5	18.701	
	I.D.	17.964	17.91	17.72	17.47		17.07		16.534		16.809	16.014	17.18	17.629	
	WALL	0.198	0.367	0.456	0.575		0.439		0.692		0.562	0.937	1.083	0.536	
18"	PSI	43	80	100	125		100		160		100	100	235	117.5	
	O.D.	20.4					20		20		20	20	21.6		
	I.D.	19.962					18.97		18.37		18.743	17.814	19.03		
	WALL	0.219					0.488		0.769		0.593	1.031	1.2		
	PSI	43					100		160		100	100	235		
20"	O.D.		22.047	22.047	22.047									22.047	
	I.D.		21.12	20.89	20.59									20.783	
	WALL		0.432	0.538	0.678									0.632	
	PSI		80	100	125									117.5	
	O.D.		24.803	24.803	24.803		24		24		24	24		24.8	
24"	I.D.		23.76	23.5	23.17		22.748		22.043		22.54	21.418		23.381	
	WALL		0.486	0.605	0.763		0.585		0.923		0.687	1.218		0.711	
	PSI		80	100	125		100		160		100	100		117.5	

Schumacher Irrigation, Inc.  
205 4th Street - PO Box 289  
Platte Center, NE 68653 USA

**Change Service Requested**

PRESORTED  
BOUND PRINTED MATTER  
U.S. Postage Paid  
Platte Center, NE  
Permit No. 5

Always Open...  
**SchumacherIrrigation.com**  
*Your Irrigation Superstore*



**Schumacher**  
**IRRIGATION**

**IRRIGATION AND LIQUID HANDLING SOLUTIONS**

800.246.3685 or 402.246.3685  
Fax: 402.246.2072

irrigate@schumacherirrigation.com  
www.schumacherirrigation.com

**EFFECTIVE JANUARY 1, 2017**

All prices are subject to  
change without notice.