

Installation Manual V3

NTP 8000 Series Master Clock



NTP 8000 Master Clock

Table of Contents

Table of Contents—	2-3
Wall Mount Installation —	4
Rack Mount Installation —	5
Installing the Master Clock with the Line Cord Receptacle—	6
AC Power Wiring using 14 AWG Romex Cable—	6
Rear View of Unit—	7
Installing the Remote Antenna—	7
Remote Antenna Mounting Instructions—	8
Basic Information—	9
2 Wire Digital Communication System Connection—	10
RS485 Communication System Connection—	11
Sync-Wire Communication System Connection—	12
Once-a-day Pulse Using Clock 1 or Clock 2—	13
Sync-Wire 59 Minute Correction—	14
Sync-Wire 58 Minute Corrections 1–4—	14
Sync-Wire National Time/Rauland Input—	15
Sync-Wire Rauland Digital—	15
Sync-Wire Dukane Digital—	16
Sync-Wire Once a Day Pulse—	16
GPS Antenna Installation—	17
Setting Master Clock to GPS Mode—	17
Fire Alarm Interface Installation—	18
Patch Cable Installation—	18
Error Codes on LED Display—	19
Setting the Time from the LCD Display—	20
Setting the Date from the LCD Display—	20
Add Events from the LCD Screen—	21
View/Edit Events Programming from the LCD Display—	22
Add Schedule Change from the LCD Display (max. 100)—	23
View/Edit Schedule Change from the LCD Display—	24
Activate Manually from the LCD Display—	24
Setting 12/24 Hour Mode from the LCD Display—	25
BELL Messaging from the LCD Display—	25
Numeric Messaging from the LCD Display—	26
Setting the Primary Time Source—	27
Setting the Secondary Time Source—	27

NTP 8000 Master Clock

Table of Contents

Sync-Wire Communication - Programming Clock 1 & 2 Circuits from the LCD Display—	28
Setting Daylight Savings Time from the LCD Display—	28
Sync-Wire Communication – Protocol Definitions—	29
Configuring the Zone Durations from the LCD Display—	30
RS485 Communication - Setting the Data Rate from the LCD Display—	31
Setting the User Password from the LCD Display—	31
Setting the Bias Seconds from the LCD Display—	32
Setting the Time Zone Offset from the LCD Display—	32
Setting or Viewing the IP Address from the LCD Display—	33
Setting the Subnet Mask from the LCD Display—	33
Setting the Gateway from the LCD Display—	34
Setting the DNS Address from the LCD Display—	34
Accessing the Web Interface (when connected via DHCP)—	35
Accessing the Web Interface (when using a static IP)—	35
Accessing the Web Interface (when using a crossover cable)—	35
Web Interface - Log In—	36
Web Interface - Date/Time—	37
Web Interface - Events—	38
Web Interface - Add/Edit Events (including Countdown mode)—	39
Web Interface - Add/Edit Events (including Countdown mode) continued —	40
Web Interface - Schedules—	41
Web Interface - Schedule Change (max. 100)—	42
Web Interface - Manual Control—	43
Web Interface - Settings—	44
Web Interface - System Settings—	45
Web Interface - DST—	46
Web Interface - Email—	47
Web Interface - Synchronization—	48
Web Interface - IP—	49
Web Interface - NTP Servers—	50
Web Interface - IP Status—	51
Web Interface - Clock Features—	52
Web Interface - Database—	53
Frequently Asked Questions—	54
Troubleshooting—	55
Compliances—	56

Wall Mount Installation

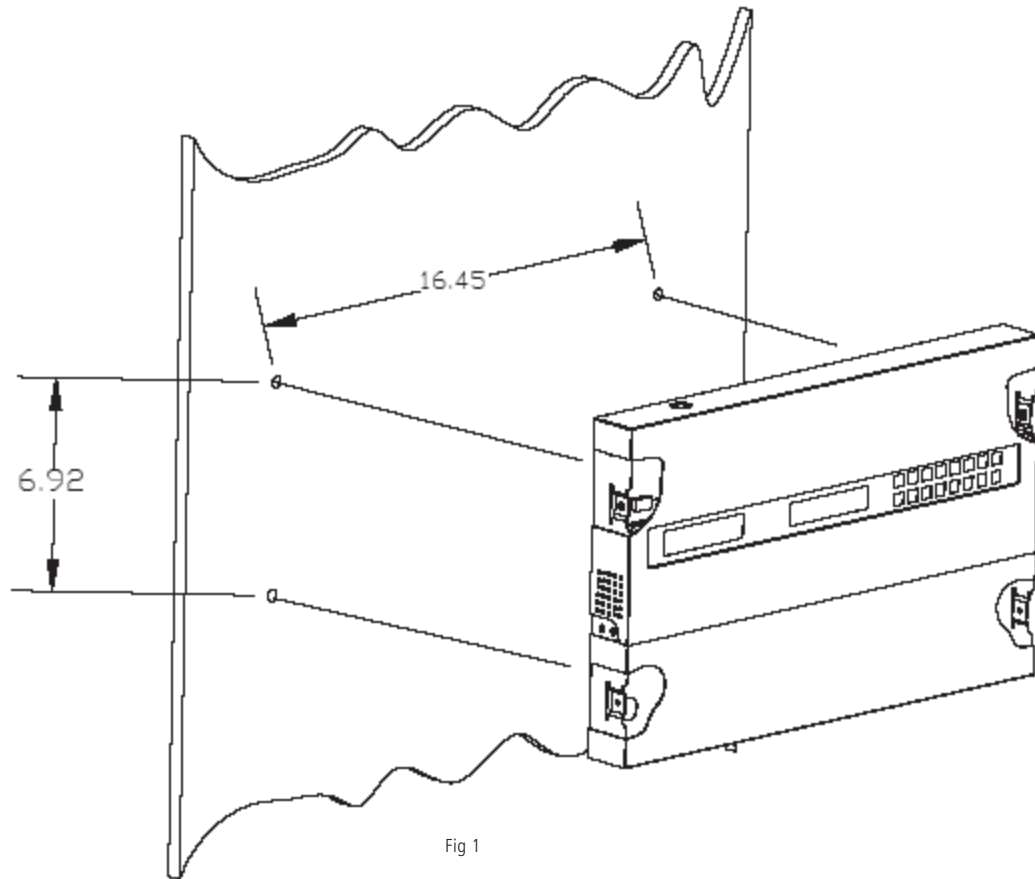

1. Place the supplied template on the wall where the master clock is being mounted.
2. Mark the center point of the top right hole. Drill the hole and install the supplied anchor from the mounting kit.
3. Install the screw into the anchor and hang the template from the top right hole.
4. Using a level and the LINE on the supplied template, mark the center of the three remaining holes.
5. Remove the template and drill out the three remaining holes and insert the anchors.
6. Insert the two top screws into the anchors, leaving 1/8" of thread exposed. Unscrew the bottom wiring cover on the master clock.
7. Line up the top keyholes on the back of the master clock with the two top screws. Slide the master clock into the keyholes and then lock it into place.
8. Insert the two remaining bottom screws.
9. Screw the wiring cover back into its original position.

Rack Mount Installation

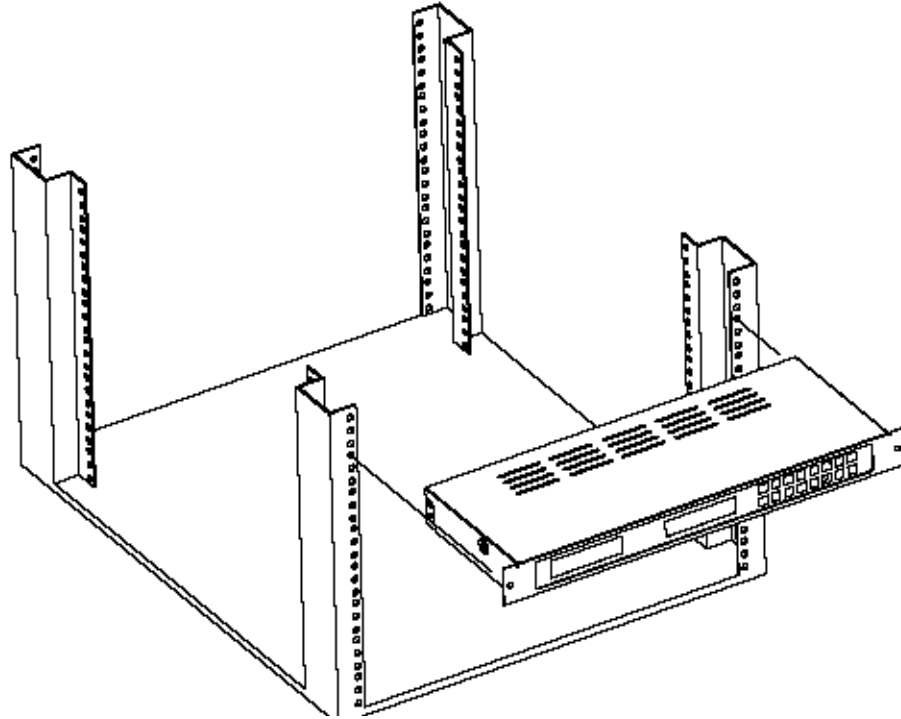

1. The master clock is 1U in size. Install the threaded nuts in the desired location in the rack rails.
2. Put the nylon washers on the two screws supplied.
3. Line up the master clock with the threaded nut.
4. Insert screws into the threaded nuts and tighten.

Before You Get Started

Installing the Master Clock with the Line Cord Receptacle

*This product is intended for commercial use only and not intended for use in a private residential area

*This product is to be installed in a restricted access location by qualified service personnel only

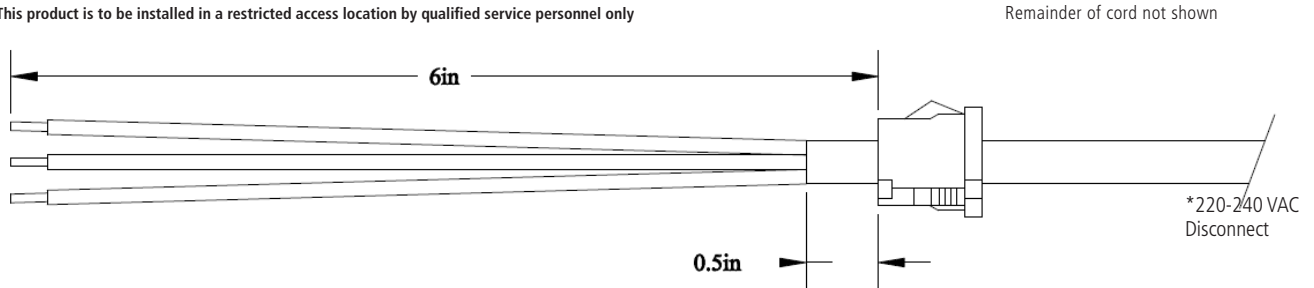

Caution! Do not plug in the power cord until the following steps are completed.

1. The square knockout on the wiring chassis must be removed.
2. The Heyco Bushing must be attached to the power cord as shown. Use pliers to push both halves of the bushing together while they lock.
3. Put the wires through the knockout and push the bushing into the metal until it locks tightly into place. The word Heyco on the bushing faces up.
4. Put each wire into the supplied connector and tighten the screws. The wiring label located on the chassis will show where to connect the wires.

* Power disconnect and/or protection is to be provided by the installer

AC Power Wiring using 14 AWG Romex Cable

*Note: For CE Compliant installation, use minimum 0.75mm² cable or approved grounded cordset

Caution! The AC Power Source must be turned OFF.

1. Remove a round knockout on the wiring chassis, preferably one near the AC Input Connector.
2. Install a standard 1/2" Romex Bushing and tighten in place.
3. Pass the Romex Cable through the Bushing and clamp in place. Do Not over tighten the screws.
4. Strip back the outside cable sheathing to expose the White, Black and Ground wires.
5. Strip back the insulation on the White and Black wire 1/4".
6. Put each wire into the supplied connector and tighten the screws. The wiring label located on the wiring chassis indicates where to connect the wires.

Rear View of Unit

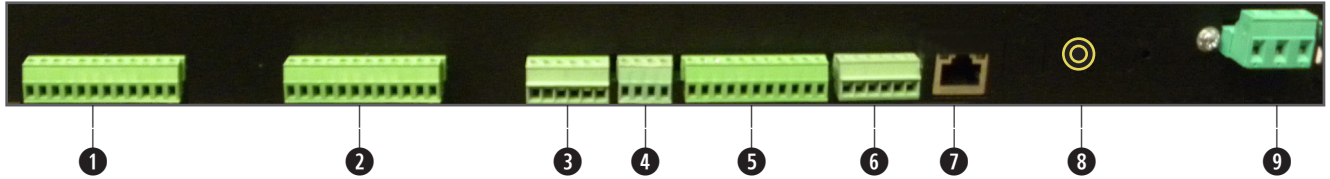

- ① **Zones 5-8** This terminal block is where connections are made for connecting zones 5-8 (when ordered)
- ② **Zones 1-4** This terminal block is where connections are made for connecting zones 1-4 (when ordered)
- ③ **Clock 1 & 2 Sync-Wire Outputs** This terminal block is where connections would be landed for Clock 1 and Clock 2 sync-wire communication relay outputs.
- ④ **RS485 Input/Output** This terminal block is where connections would be landed for RS485 communication to and from other Sapling systems.
- ⑤ **Inputs** This terminal block is where connections would be landed to use the NTP 8000 as a slave clock when being controlled by another system.
- ⑥ **Remote RF Antenna (Rack Mount only)** This terminal block is where the connection to an external RF antenna would terminate.
- ⑦ **Ethernet** This RJ45 jack is used for connecting the master clock to a network for programming and/or timekeeping capabilities.
- ⑧ **GPS Connector** This GPS connector is where the antenna for the GPS gets mounted to (GPS option only).
- ⑨ **Power Input** This power outlet is used to power up the NTP 8000 master clock.

NOTE: This device contains a lithium battery. Replace Battery With Varta, Part No. CR2032 Only. Use Of Another Battery May Present A Risk Of Fire Or Explosion. Batteries can be obtained and should be installed by the manufacturer.

WARNING: Battery May Explode If Mistreated. Do Not Recharge, Disassemble Or Dispose Of In Fire.

Installing the Remote Antenna

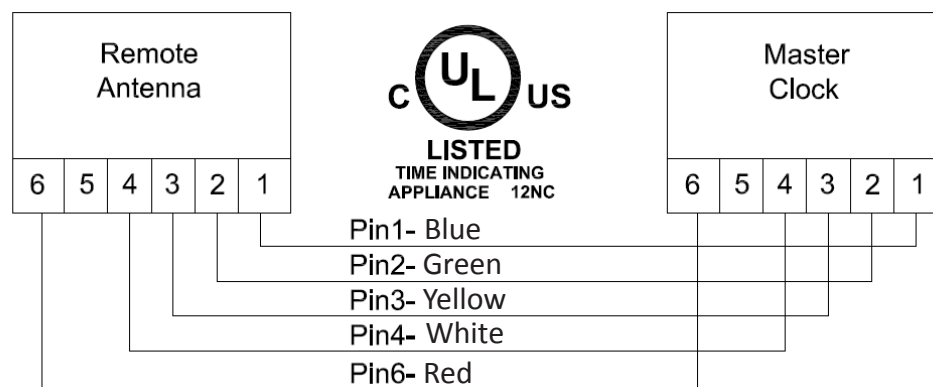

Connect the Remote Antenna to the Master Clock using the supplied 25 foot, 5 conductor 18 AWG cable. Use the wiring diagram and colors as shown above.

Strip the insulation back 1/4 inch on each wire. Use a bushing in the wiring chassis to pass the cable through and secure it, then insert wires into the conductor and tighten the screws.

For all input and output wiring use copper conductors only tightening torque for terminal block screws is 31 to 35 in/oz.

Remote Antenna Mounting Instructions

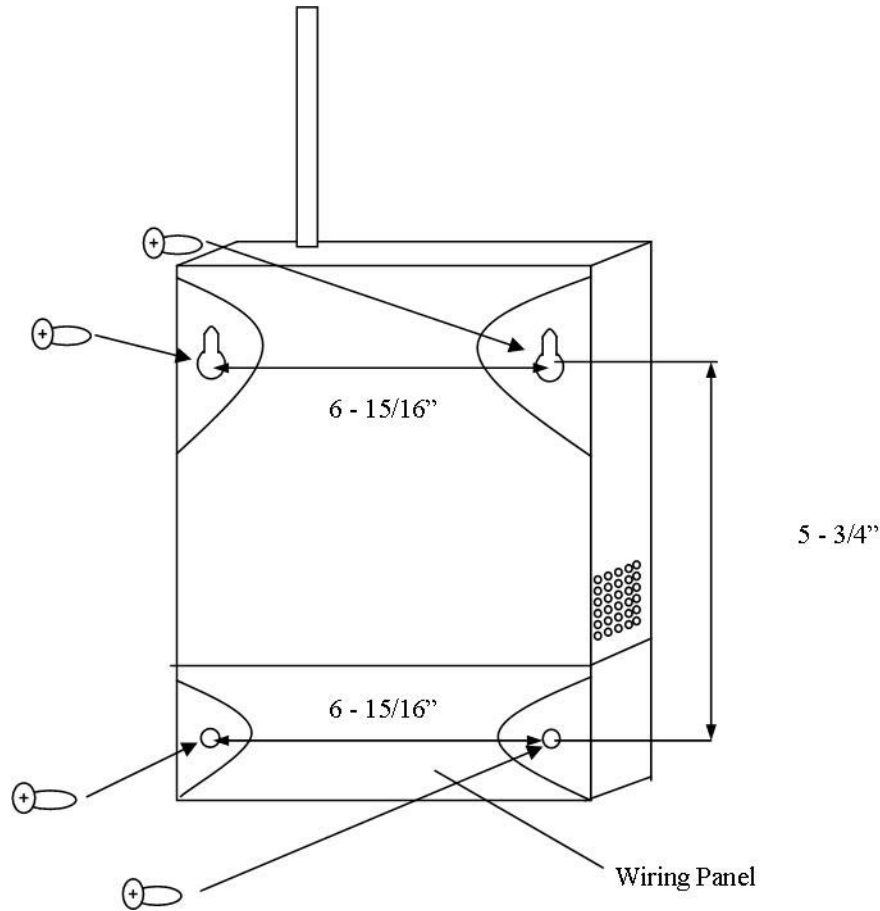

1. Place the supplied template on the wall where the remote antenna is being mounted.
2. Mark the center point of the top right hole. Drill the hole and install the supplied anchor from the mounting kit.
3. Install the screw into the anchor and hang the template from the top right hole.
4. Using a level and the LINE on the supplied template, mark the center of the three remaining holes.
5. Remove the template and drill out the three remaining holes and insert the anchors.
6. Insert the two top screws into the anchors, leaving 1/8" of thread exposed. Unscrew the bottom wiring cover on the remote antenna.
7. Line up the top keyholes on the back of the remote antenna with the two top screws. Slide the remote antenna into the keyholes and then lock it into place.
8. Insert the two remaining bottom screws.
9. Screw the wiring cover back into its original position.

Before You Get Started

Basic Information

Definitions

Event A pre-programmed action, such as ringing of bells at a specific time, which is triggered by a relay closure in one or more of the zones of the master clock. Each event is assigned a schedule number.

Schedule A series of programmed events. An example of a schedule would be a typical school day.

Zone Each zone is controlled by a relay closure where devices such as bells can be connected.

User programming features

All 8000 series user programming is to be done by using the 16-button keypad located on the front of the Sapling master clock or via the web interface software upgrade. The keypad is shown below:



The LCD display is 20 characters wide and consists of both a top and a bottom line. When the master is powered on, the LCD display should read:

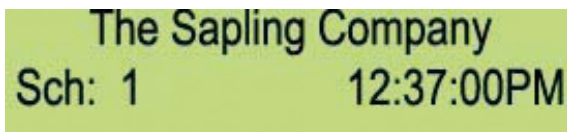

Accessing Features from the LCD Display

To enter the user programming mode, you will need to use the four digit user password. The default password is 1111. This may or may not be changed by the installing technician. Type in the four digit password on the keyboard. There is no need to press the YES/ENTER key after entering the password because the master clock will go straight to user programming upon verification of the password. Please note: your password will be hidden as you enter it. The * sign will appear instead of digits.

To Exit the Programming Mode from the LCD Display

If at any time during programming, you wish to exit programming mode, press the YES/ENTER key or the NO/CANCEL key, as appropriate, in response to the prompts on the LCD display. After scrolling through all the options and responding to all applicable prompts, the LCD display will then return to the main screen. There is a 20 second timeout if no buttons are pressed.

System Connections – Wired Systems

2 Wire Digital Communication System Connection

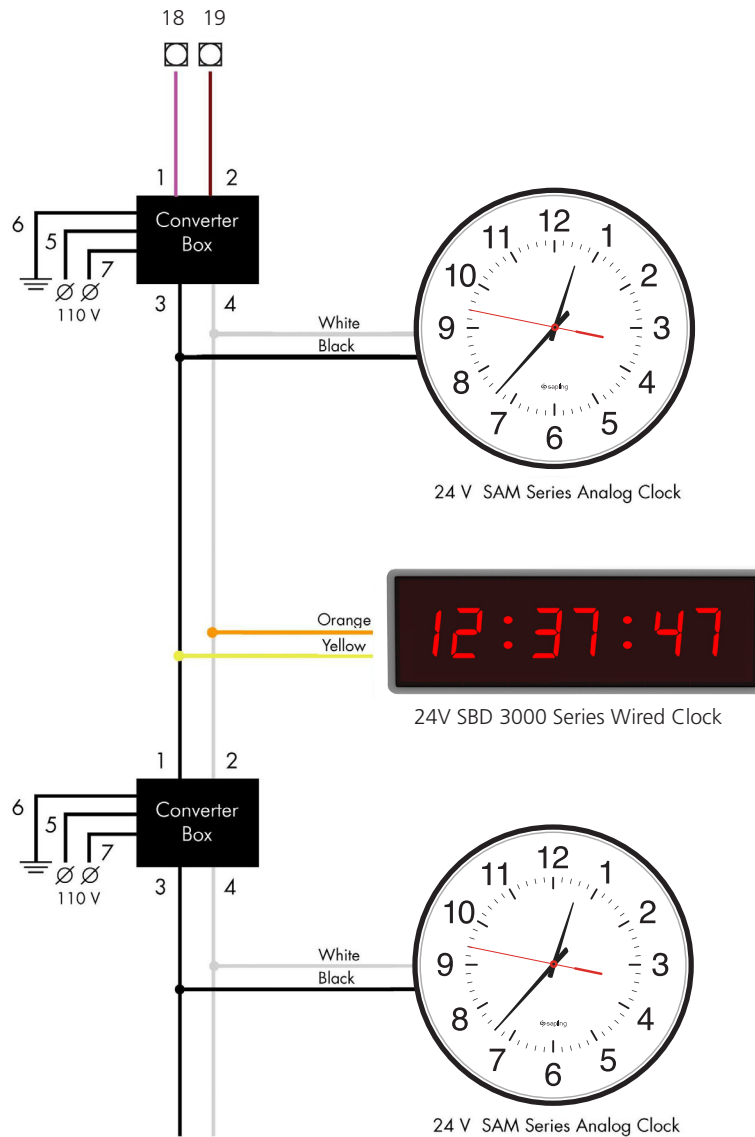

System Connections – Wired Systems

RS485 Communication System Connection

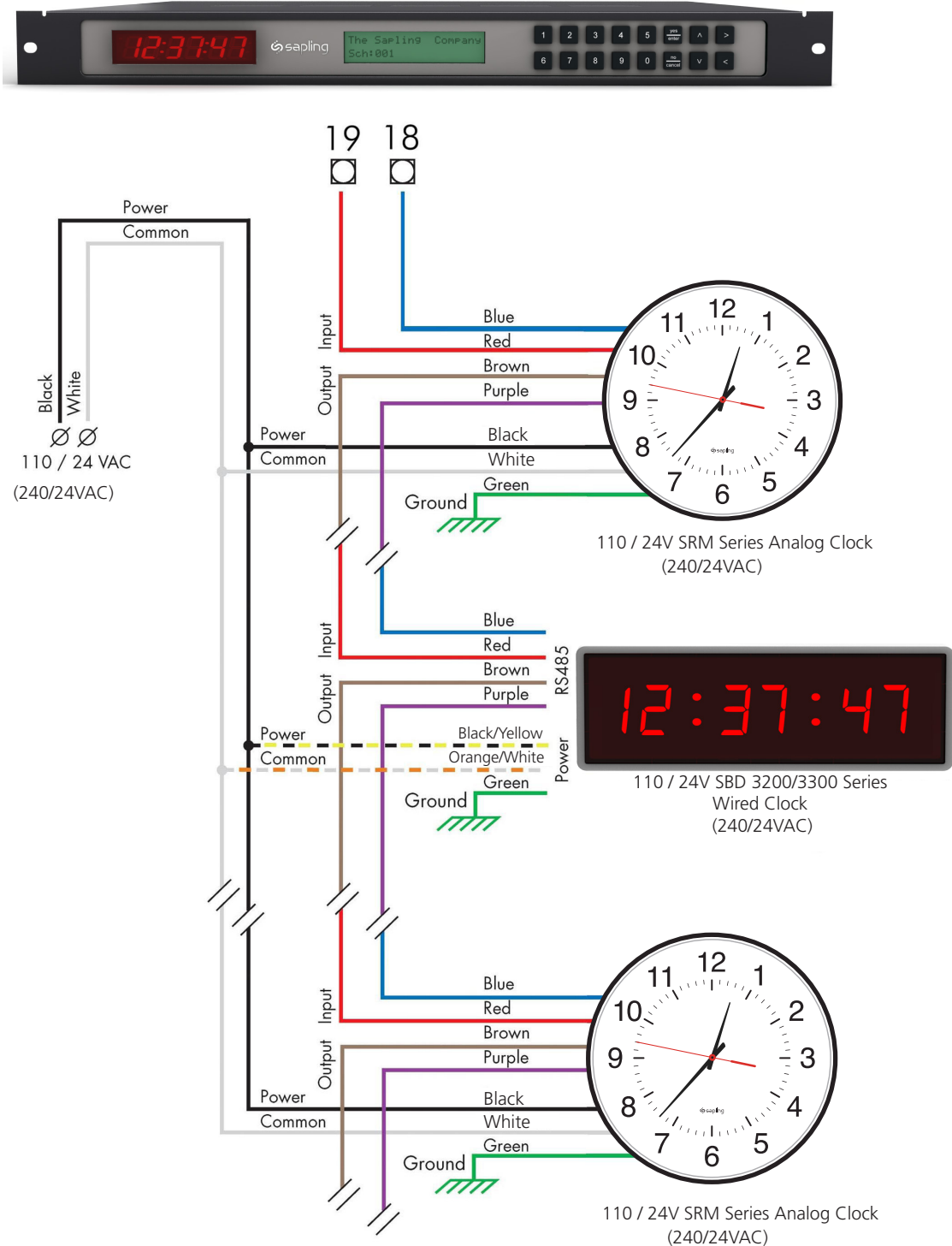

System Connections – Wired Systems

Sync-Wire Communication System Connection

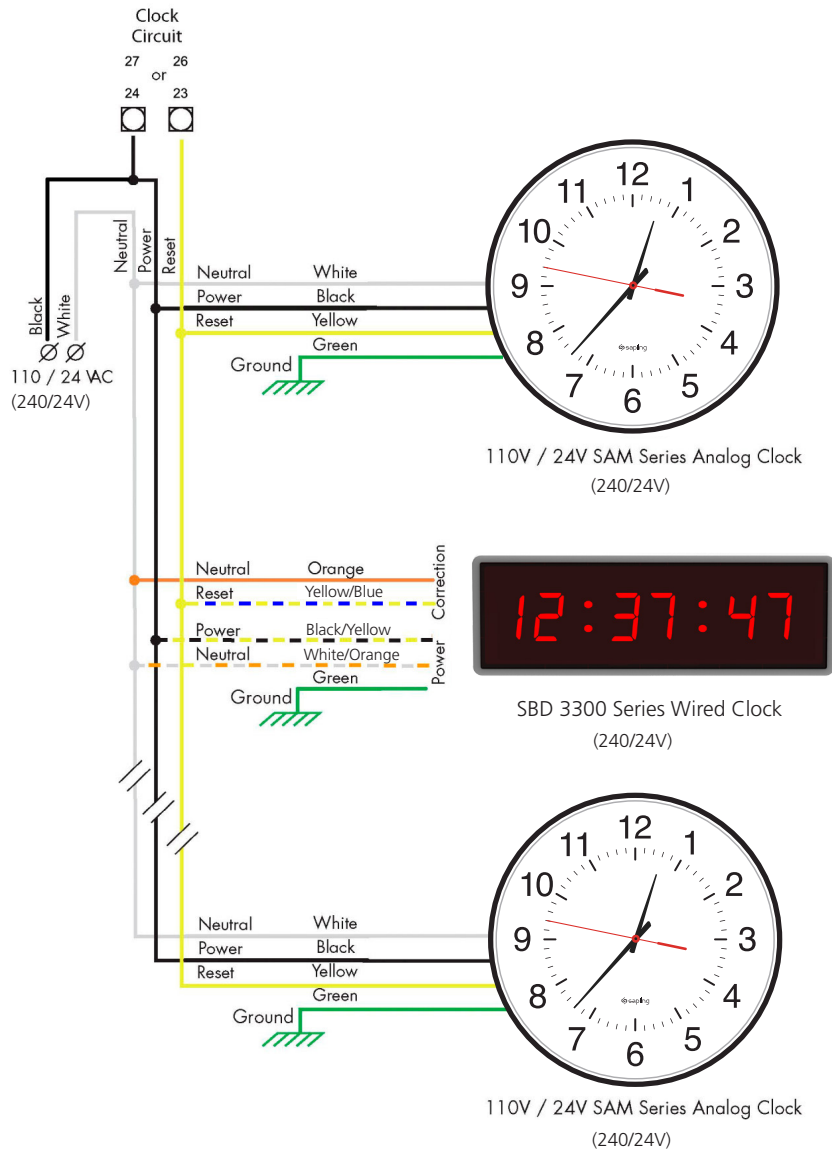
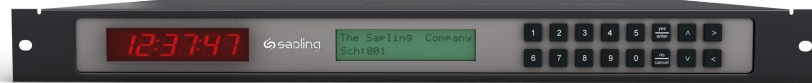

System Connections – Wired Systems

Once-a-day Pulse Using Clock 1 or Clock 2

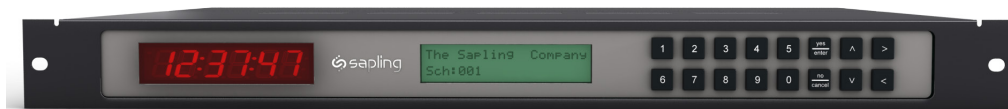

Clock Circuit

27 28
or
24 23



Intercom, paging system, or other device

Inputs – Sync-Wire Inputs Installation

Sync-Wire 59 Minute Correction

Dry Contact Closure

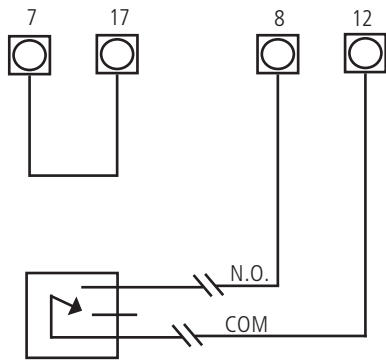

110VAC Interface
(240VAC)

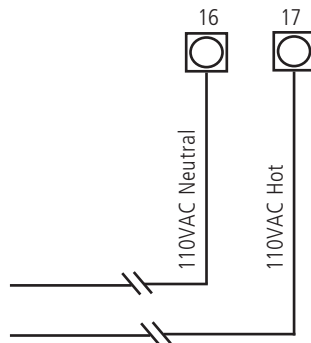

24VAC Interface

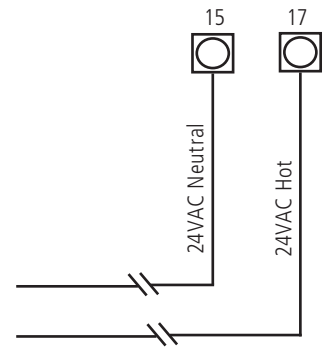

Sync-Wire 58 Minute Corrections 1-4

Dry Contact Closure

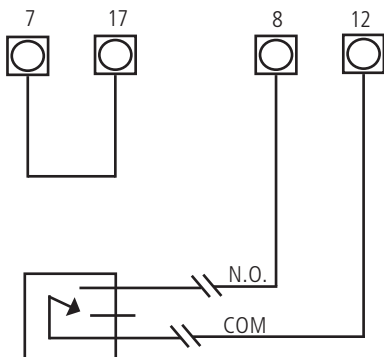

110VAC Interface
(240VAC)

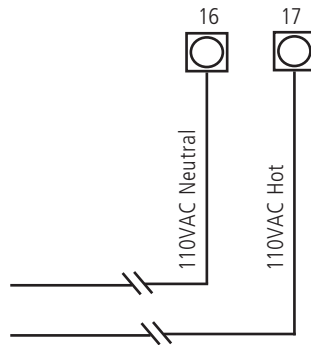

24VAC Interface

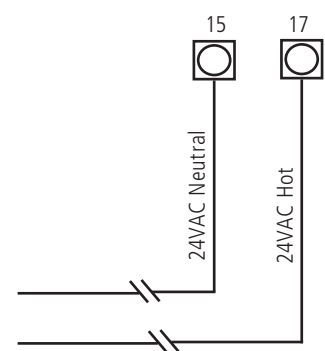

Inputs – Sync-Wire Inputs Installation

Sync-Wire National Time/Rauland Input

Dry Contact Closure

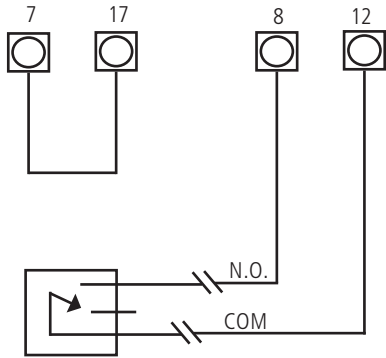

110VAC Interface (240VAC)

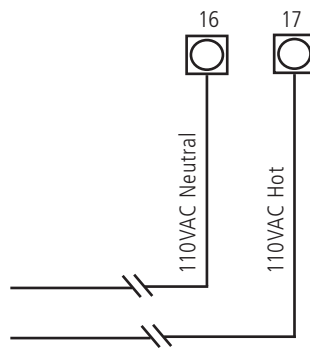

24VAC Interface

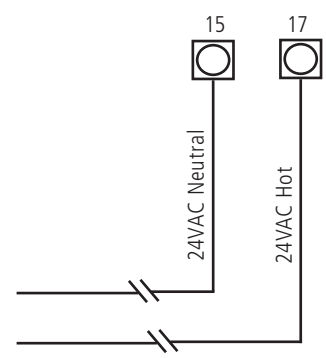

Sync-Wire Rauland Digital

Input

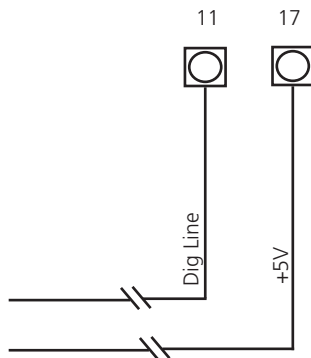

Output

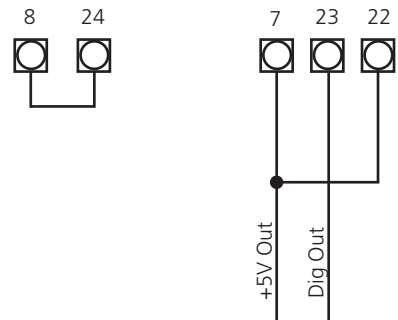

Inputs – Sync-Wire Inputs Installation

Sync-Wire Dukane Digital

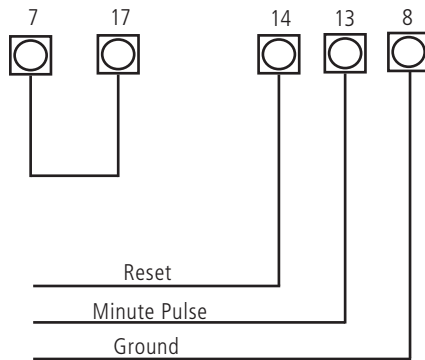

Sync-Wire Once a Day Pulse

Dry Contact Closure

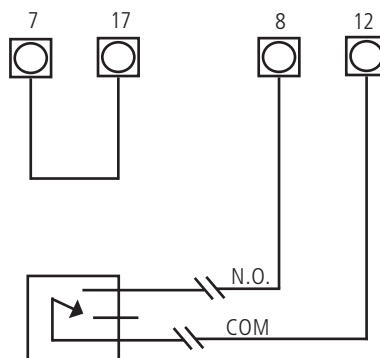

Inputs – GPS Installation

GPS Antenna Installation

Supplied by Sapling: GPS Dome, a 75' of RG58 as standard (refer to Figure 1.1). If needed, the following GPS cable is available at an additional cost:

- 150 foot (45.7 meters) Special GPS Cable - Part Number: E-ANT-CBL150F-1
- 300 foot (91.4 meters) Special GPS Cable - Part Number: E-ANT-CBL300F-1

Not supplied by Sapling: Steel or PVC piping with 1" -14" thread or 3/4" pipe thread, teflon tape, mounting plate and hardware for piping

*NOTE: Placement of antenna and height of piping needs to be on the rooftop of the building

- 1) Route cabling from the room in which the master clock will be located to the roof of the building, allowing the GPS dome (refer to Figure 1.1) to have a full 180 degrees view of the sky
- 2) Run cabling through piping and attach the end of the cabling to the bottom of the GPS dome via TNC connection.
- 3) Screw GPS dome onto the top of the piping. Be careful not to twist the cable. Use teflon tape on the pipe threads to tighten seal and prevent water damage.
- 4) Mount piping to the roof of the building with mounting plate and hardware supplied by the user.
- 5) Connect the RG58 or 59 cabling to the GPS input located on the back of the master clock via NTP 8000 connection.

Setting Master Clock to GPS Mode

Programming through NTP 8000 pushbuttons - Refer to page 27 for setting your master clock's time source to GPS from the LCD display.

Programming through the Web Interface - Refer to page 47 for setting your master clock's time source to GPS from the web interface.

Fig 1.1



Fire Alarm Interface Installation / Patch Cable Installation

Fire Alarm Interface Installation

The Fire Alarm Interface allows a relay closure to be connected to the NTP 8000 master clock that allows the user to interface the existing fire alarm with the Sapling's 3000 series digital clocks.

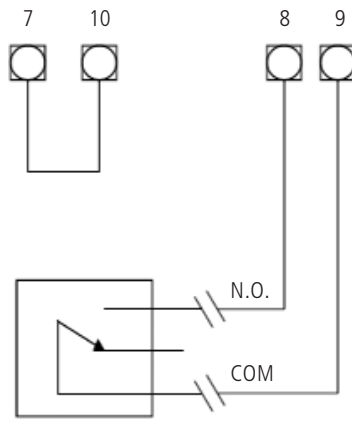

When a relay closure occurs on pins 8 and 9, "FirE" will display on the digital slave clocks connected using RS485 or two wire digital communication.

Patch Cable Installation



Fig 1.1

1. Connect a patch cable to the RJ45 port on the NTP 8000 Master Clock as shown in Fig 1.1.
2. Connect the other end of the patch cable to an Ethernet jack connected to the network.

Error Codes

Error Codes on LED Display

When one of the following errors occurs, one of the LED lights located above one of the six characters on the LED display will begin to flash. See figure below indicating the error each flashing light is associated with.

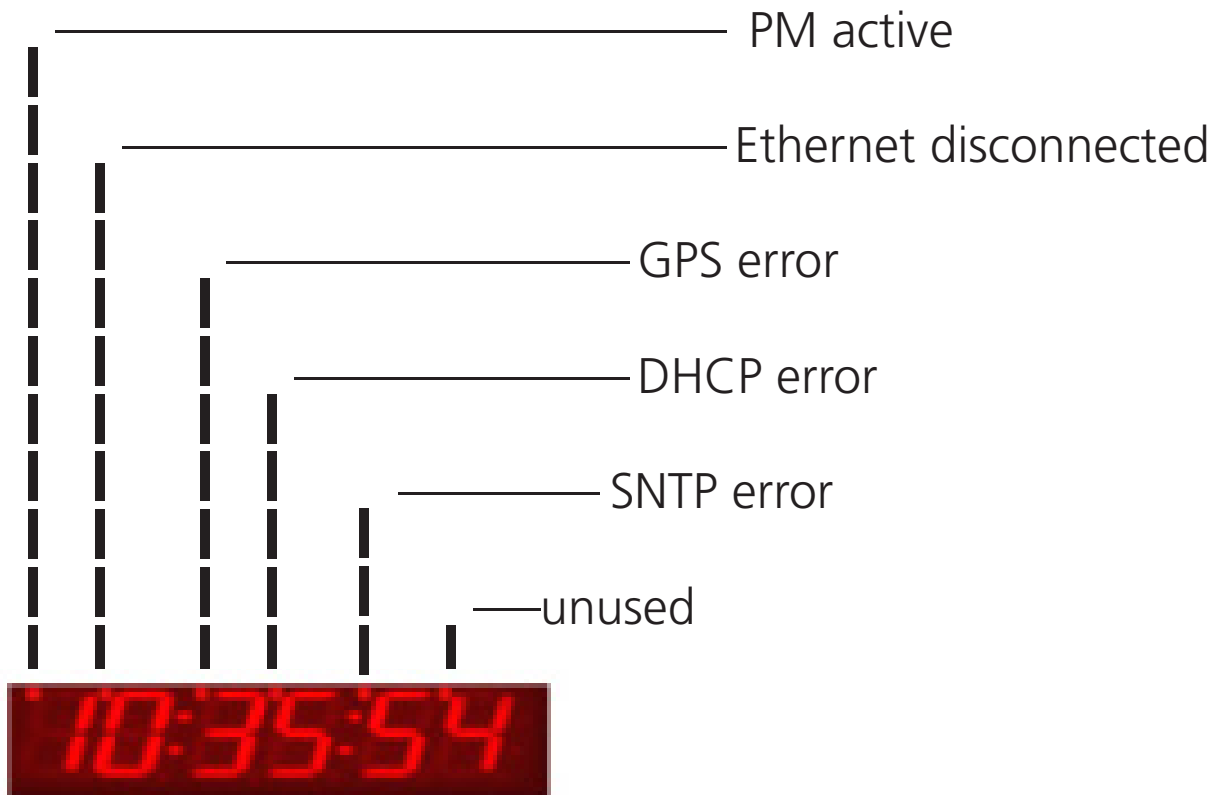

User Level Programming

Setting the Time from the LCD Display

1. Type in the user level password (default is 1111) at the main screen to enter user level programming.
2. The display should read "Set Time?", as displayed in Fig 2.1.
3. Press the YES/ENTER button.
4. Enter the time (in 24 hour mode) using the keypad. When completed, press the YES/ENTER button to confirm the selection.
5. To exit and return to the main screen, continue to press the NO/CANCEL button until the main screen appears.

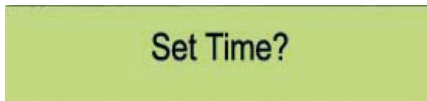

Fig 2.1

Setting the Date from the LCD Display

1. Type in the user level password (default is 1111) at the main screen to enter user level programming.
2. Press the NO/CANCEL button until the display reads "Set Date" as shown in Fig 2.2.
3. Press the YES/ENTER button.
4. Type in the desired date using the MM/DD/YYYY format.
5. Press the YES/ENTER button to confirm the date.
6. To exit and return to the main screen, continue to press the NO/CANCEL button until the main screen appears.

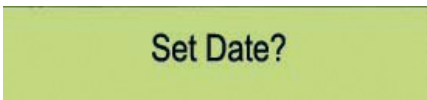

Fig 2.2

User Level Programming

Add Events from the LCD Screen

1. Type in the user level password (default is 1111) at the main screen to enter user level programming.
2. Press the NO/CANCEL button until the display reads "Add Events?" as shown in Fig 2.3.

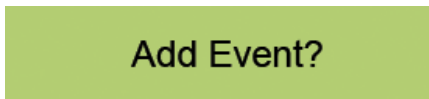

Fig 2.3

3. Press the YES/ENTER button to enter the event programming for the event.
4. The display should look similar to Fig 2.4.

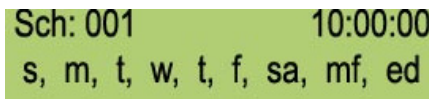

Fig 2.4

5. Type the three digit schedule number that the event should occur on.
6. Type the time that the event is to occur in 24 hour format.
7. Select the day(s) of the week that event is to occur on by using the ← and → keys and then pressing the YES/ENTER button to toggle each day. The day will capitalize to confirm the selection. (MF = Monday through Friday and ED = Everyday).
8. Press the ↓ key to go to the second screen. The display should look similar to Fig 2.5.



Fig 2.5

9. Use the ← and → buttons to scroll through each zone that the event is to occur. To scroll through the durations, continue to press the YES/ENTER button until the desired duration is set. The durations are:

N/A = Not Applicable (does nothing to the zone)	Dur 5* = Set the Relay to Close for Five Seconds
Always_Off = Turns the Relay Off	CStart** = Count Down Start
Always_On = Turns the Relay On	CStop** = Count Down Stop
Dur 3* = Set the Relay to Close for Three Seconds	

10. Press the ↓ button to confirm. The display should look similar to Fig 2.6. Press the YES/ENTER button to confirm the event.

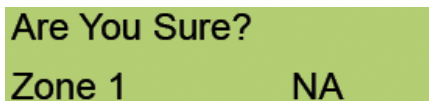

Fig 2.6

11. To continue adding events, follow steps 5 through 10.
12. To exit and return to the main screen, continue to press the NO/CANCEL button until the main screen appears.

* - Zone durations are configurable. See page 30 for details.

** - These options are only available if the countdown option is ordered.

User Level Programming

View/Edit Events Programming from the LCD Display

1. Type in the user level password (default is 1111) at the main screen to enter user level programming.
2. Press the NO/CANCEL button until the display reads "View/Edit Events?" as shown in Fig 2.7.



View/Edit Events?

Fig 2.7

3. Press the YES/ENTER button.
4. The first event will scroll across the top line of the LCD display as shown in Fig 2.8. Press the YES/ENTER button to edit the event.



Sch: 1	12:00:00
v: Next	Yes: Edit

Fig 2.8

5. To edit the event, follow the steps on page 21, steps 3-10.
6. To view the events, use the ↓ button to scroll between each event.
7. To exit and return to the main screen, continue to press the NO/CANCEL button until the main screen appears.

User Level Programming

Add Schedule Change from the LCD Display (max. 100)

1. Type in the user level password (default is 1111) at the main screen to enter user level programming.
2. Press the NO/CANCEL button until the display reads "Add Schedule Change?" as shown in Fig 2.9.



Add Schedule Change?

Fig 2.9

3. Press the YES/ENTER button.
4. Enter the schedule number that the master clock is to go to when the schedule change occurs. Then press the YES/ENTER button. See Fig 2.10.

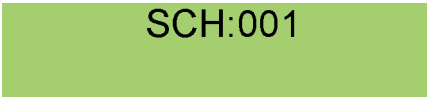

SCH:001

Fig 2.10

5. Enter the date (mm/dd/yyyy) that the schedule change is to occur on as shown in Fig 2.11. Then press the YES/ENTER button.

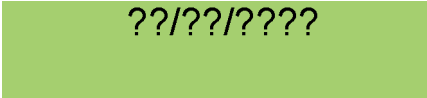

??/??/????

Fig 2.11

6. Enter the time, in 24 hour mode, that the schedule change should occur at as shown in Fig 2.12. Then press the YES/ENTER button.

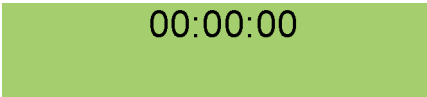

00:00:00

Fig 2.12

7. Press the YES/ENTER button to confirm the schedule change. See Fig 2.13.



Are You Sure?

Fig 2.13

8. To exit and return to the main screen, continue to press the NO/CANCEL button until the main screen appears.

User Level Programming

View/Edit Schedule Change from the LCD Display

1. Type in the user level password (default is 1111) at the main screen to enter user level programming.
2. Press the NO/CANCEL button until the display reads "View/Edit Schedule Change?" as shown in Fig 2.14.



Fig 2.14

3. The first schedule change will scroll across the top line of the LCD display as shown in Fig 2.15. Press the YES/ENTER button to edit the schedule change.



Fig 2.15

4. To edit the schedule change, follow the steps on page 23.
5. To view the schedule changes, use the ↓ button to scroll between each one.
6. To exit and return to the main screen, continue to press the NO/CANCEL button until the main screen appears.

Activate Manually from the LCD Display

1. Type in the user level password (default is 1111) at the main screen to enter user level programming.
2. Press the NO/CANCEL button until the display reads "Activate Manually?" as shown in Fig 2.16.



Fig 2.16

3. Press the YES/ENTER button.
4. The display should look similar to Fig 2.17. To scroll through the zones, use the ↑ and ↓ buttons. To change the duration for a specific zone, use the → button to change the setting.

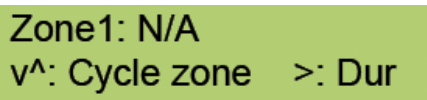

Fig 2.17

5. To confirm the selection, press the YES/ENTER buttons. See Fig 2.18.

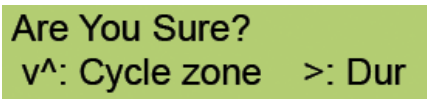

Fig 2.18

6. To exit and return to the main screen, continue to press the NO/CANCEL button until the main screen appears.

User Level Programming

Setting 12/24 Hour Mode from the LCD Display

1. Type in the user level password (default is 1111) at the main screen to enter user level programming.
2. Press the NO/CANCEL button until the screen shows "Set 12/24 Hour Mode?" as shown in Fig 2.19.



Set 12/24 Hour Mode?

Fig 2.19

3. Press the YES/ENTER button to enter the option.
4. Use the ↑ and ↓ buttons to scroll between "12 Hour Mode" and "24 Hour Mode".
5. Press the YES/ENTER button to confirm your selection.
6. To exit and return to the main screen, continue to press the NO/CANCEL button until the main screen appears.

BELL Messaging from the LCD Display

1. Type in the user level password (default is 1111) at the main screen to enter user level programming.
2. Press the NO/CANCEL button until the display reads "BELL Messaging?" as shown in Fig 2.20.



Set BELL Messages?

Fig 2.20

3. Press the YES/ENTER button to enter the next screen. The display should read "Zone:01 BELL: On" as shown in Fig 2.21.

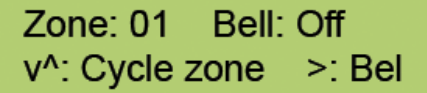

Zone: 01 Bell: Off
v^: Cycle zone >: Bel

Fig 2.21

4. Use the ↑ and ↓ buttons to scroll through each zone.
5. Press the → button to alternate the BELL function on and off.
6. Repeat steps 4 and 5, as desired, for each zone.
7. Press the YES/ENTER button when finished.
8. To exit and return to the main screen, continue to press the NO/CANCEL button until the main screen appears.

User Level Programming

Numeric Messaging from the LCD Display

1. Type in the user level password (default is 1111) at the main screen to enter user level programming.
2. Press the NO/CANCEL button until the display reads "Send Number Message?" as shown in Fig 2.22.

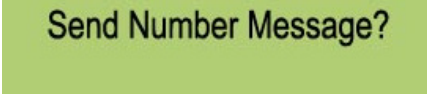

Send Number Message?

Fig 2.22

3. Press the YES/ENTER button to enter the next screen. The display should read "Enter Clock #?" as shown in Fig 2.23.



Enter Clock Number?

Fig 2.23

4. Press the YES/ENTER button to enter the next screen. Enter the clock number as shown in Fig 2.24.



Clock:000

Fig 2.24

5. Press the YES/ENTER button. The display should read "Zone: 00" as shown in Fig 2.25. Enter the zone number.



Zone:00

Fig 2.25

6. Press the YES/ENTER button to enter the next screen. The display should read "Message:0000" as shown in Fig 2.26.



Message:0000

Fig 2.26

7. Press the YES/ENTER button to confirm the selection.
8. To exit and return to the main screen, continue to press the NO/CANCEL button until the main screen appears.

Technician Level Programming

Setting the Primary Time Source

1. Type in 6063 at the main screen to enter the technician level menu mode.
2. Press the NO/CANCEL button until the display reads "Set Pri Time Source?" as shown in Fig 3.1.
3. Press the YES/ENTER button.
4. Use the ↑ and ↓ to scroll between all of the inputs. When the display reads the desired input, press the YES/ENTER button to confirm the selection. The supported input selections are displayed in Fig 3.2.
5. To exit and return to the main screen, continue to press the NO/CANCEL button until the main screen appears.



Fig 3.1

Real Time Clock	National Time/Rauland*
RS485	59 Minute Correction*
GPS	58 Minute Correction_1*
Once a Day Pulse*	58 Minute Correction_2*
Wireless Repeater	58 Minute Correction_3*
Rauland Digital	58 Minute Correction_4*
Dukane	(S)NTP

Fig 3.2

Setting the Secondary Time Source

1. Type in 6063 at the main screen to enter the technician level menu mode.
2. Press the NO/CANCEL button until the display reads "Set Sec Time Source?" as shown in Fig 3.3.
3. Press the YES/ENTER button.
4. Use the ↑ and ↓ to scroll between all of the inputs. When the display reads the desired input, press the YES/ENTER button to confirm the selection. The supported input selections are displayed in Fig 3.4.
5. To exit and return to the main screen, continue to press the NO/CANCEL button until the main screen appears.



Fig 3.3

Real Time Clock	National Time/Rauland*
RS485	59 Minute Correction*
GPS	58 Minute Correction_1*
Once a Day Pulse*	58 Minute Correction_2*
Wireless Repeater	58 Minute Correction_3*
Rauland Digital	58 Minute Correction_4*
Dukane	(S)NTP

Fig 3.4

* For protocol definitions, see page 29

Technician Level Programming

Sync-Wire Communication - Programming Clock 1 & 2 Circuits from the LCD Display

1. Type in 6063 at the main screen to enter the technician level menu mode.
2. Press the NO/CANCEL button until the screen shows "Change Clock 1 Circuit Selection?" as shown in Fig 3.5.
3. Press the YES/ENTER button.
4. Press the ↑ and ↓ buttons to scroll through each protocol. The protocols are shown in Fig 3.6.
5. When the desired protocol is selected, press the YES/ENTER button to confirm the selection.
6. Press the NO/CANCEL button to get back to the screen shown in Fig 3.5.
7. Press the NO/CANCEL button again to show "Change Clock 2 Circuit Selection?".
8. Repeat steps 3 - 5.
9. To exit and return to the main screen, continue to press the NO/CANCEL button until the main screen appears.

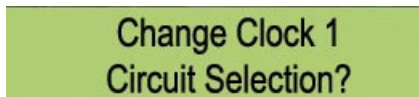

Fig 3.5

58 Minute Correction (1)*	59 Minute Correction*
58 Minute Correction (2)*	National Time/Rauland 1*
58 Minute Correction (3)*	National Time/Rauland 2*
58 Minute Correction (4)*	Once a Day Pulse*

Fig 3.6

* For protocol definitions, see page 29WW

Setting Daylight Savings Time from the LCD Display

1. Type in 6063 at the main screen to enter the technician level menu mode.
2. Press the NO/CANCEL button until the screen shows "Set Daylight Savings Time?" as shown in Fig 3.7.

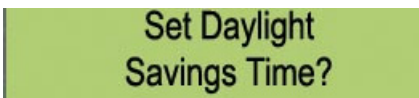

Fig 3.7

3. Press the YES/ENTER button.
4. Using the ↑ and ↓ buttons, scroll through "On" and "Off" as shown in Fig 3.8. For custom DST configurations, please use the web interface.

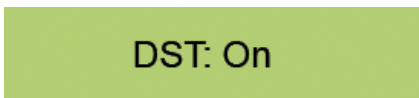

Fig 3.8

5. Press the YES/ENTER button to confirm the selection.
6. To exit and return to the main screen, continue to press the NO/CANCEL button until the main screen appears.

System Connections – Wired Systems

Sync-Wire Communication – Protocol Definitions

- | | |
|--|--|
| 1 - 58th minute (1) | The hourly correction for 55 seconds every hour from XX:58:05 to XX:59:00. The daily correction (5 a.m. & 5 p.m.) is ten correction cycles sent to the relay (each for 95 seconds) beginning at 5:05:00, 5:07:00, 5:09:00, 5:11:00, 5:13:00, 5:15:00, 5:17:00, 5:19:00, 5:21:00, and 5:23:00. |
| 2 - 58th minute (2) | The hourly correction for 60 seconds every hour from XX:58:00 to XX:59:00. The daily correction (5 a.m. & 5 p.m.) is twelve correction cycles sent to the relay (each for 65 seconds on and 25 seconds off) beginning at 5:05:00 to 5:22:35. |
| 3 - 58th minute (3) | The hourly correction for 60 seconds every hour from XX:58:00 to XX:59:00. The daily correction (5 a.m. & 5 p.m.) is twelve correction cycles sent to the relay (each for one minute on and two minutes off) beginning at 5:06:00. |
| 4 - 58th minute (4) | The hourly correction for 55 seconds every hour from xx:58:05 to XX:59:00. The daily correction (5 a.m. & 5 p.m.) is 12 correction cycles for 55 seconds. The timings will be 05:03:05, 05:07:05, 05:11:05, 05:15:05, 05:19:05, 05:23:05, 05:27:05, 05:31:05, 05:35:05, 05:39:05, 05:43:05 and 05:47:05. |
| 5 - 59th minute | The hourly correction for 8 seconds every hour from XX:57:54 to XX:58:02. The daily correction (5 a.m. & 5 p.m.) is a 14 second pulse from 5:57:54 to 5:58:08. |
| 6 - National Time & Rauland (1) | The hourly correction is for 25 seconds every hour from XX:00:00 to XX:00:25. The daily correction (6 a.m. & 6 p.m.) is 25 seconds on, 35 seconds off every minute for 24 minutes. |
| 7 - National Time & Rauland (2) | The hourly correction is for 25 seconds every hour from XX:00:00 to XX:00:25. The daily correction is a 24 minute pulse from 6:00:25 to 6:24:25 AM and PM. |
| 8 - Once a Day Pulse | The Once a Day Pulse allows the user to manually configure when the relay will close and for how long it needs to close for. |
| 9 - Rauland Digital | The Rauland Digital will reset the clock to 12:00:00AM and advance the clock one minute for every 0.5 seconds that the Dig line is shorted to ground. |

Technician Level Programming

Configuring the Zone Durations from the LCD Display

Each zone (relay) has two configurable durations that can be used during the programming of events. The default durations are three and five seconds.

1. Type in 6063 at the main screen to enter the technician level menu mode.
2. Press the NO/CANCEL button until the screen shows "Set Zone Durations?" as shown in Fig 3.9.

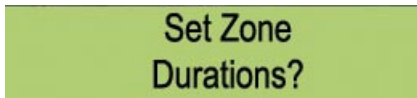

Fig 3.9

3. Press the YES/ENTER button.
4. Using the ↑ and ↓ buttons, scroll through each zone number and duration until the desired option is selected as shown in Fig 3.10.

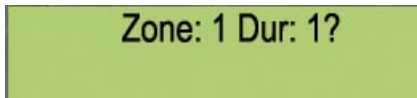

Fig 3.10

5. Press the YES/ENTER button.
6. Using the keypad, type in the new duration for the selected zone between 0001 - 3600 seconds as shown in Fig 3.11.

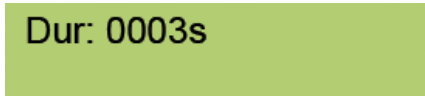



Fig 3.11

7. Press the YES/ENTER button to confirm the selection.
8. Repeat steps 4 - 7 for additional duration changes.
9. To exit and return to the main screen, continue to press the NO/CANCEL button until the main screen appears.

Technician Level Programming

RS485 Communication - Setting the Data Rate from the LCD Display

1. Type in 6063 at the main screen to enter the technician level menu mode.
2. Press the NO/CANCEL button until the display reads "Set the RS485 Rate" as shown in Fig 3.12.
3. Press the YES/ENTER button.
4. Enter the duration, in seconds, that the RS485 is to send communication.
5. Press the YES/ENTER button to confirm the selection.
6. To exit and return to the main screen, continue to press the NO/CANCEL button until the main screen appears.



Set the RS485 Rate?

Fig 3.12

Setting the User Password from the LCD Display

1. Type in 6063 at the main screen to enter the technician level menu mode.
2. Press the NO/CANCEL button until the screen shows "Set the User Password?" as shown in Fig 3.13.



Set User Password?

Fig 3.13

3. Press the YES/ENTER button. The display should look similar to Fig 3.14.



User Password 1111

Fig 3.14

4. Type in the new four digit password.
5. Press the YES/ENTER button.
6. To exit and return to the main screen, continue to press the NO/CANCEL button until the main screen appears.

Technician Level Programming

Setting the Bias Seconds from the LCD Display

The bias seconds allows the user to offset how many seconds, plus or minus, the time will be when receiving an input. This field can range between plus or minus 0-9999 seconds.

1. Type in 6063 at the main screen to enter the technician level menu mode.
2. Press the NO/CANCEL button until the screen shows "Set Bias Seconds?" as shown in Fig 3.15.

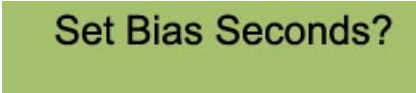

Set Bias Seconds?

Fig 3.15

3. Press the YES/ENTER button.
- 40 Set the bias seconds using the keypad between 0000 - 9999 seconds as shown in Fig 3.16. Use the ↑ and ↓ buttons to select positive or negative biasing.



Bias +0000 Seconds

Fig 3.16

5. Press the YES/ENTER button.
6. To exit and return to the main screen, continue to press the NO/CANCEL button until the main screen appears.

Setting the Time Zone Offset from the LCD Display

The time zone offset will allow the time zone to be offset when a (S)NTP or GPS connection is present. For a list of typical offsets, see Fig 4.1 on page 45.

1. Type in 6063 at the main screen to enter the technician level menu mode.
2. Press the NO/CANCEL button until the screen shows "Set Time Zone Offset?" as shown in Fig 3.17.



Set TimeZone Offset?

Fig 3.17

3. Press the YES/ENTER button.
4. Using the ↑ and ↓ buttons to select the positive or negative offset, then enter the time zone using the keypad as shown Fig 3.18. The default is -5.

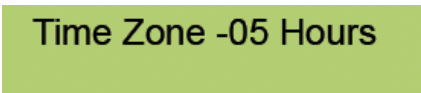

Time Zone -05 Hours

Fig 3.18

5. When the desired offset is chosen, press the YES/ENTER button to confirm the selection.
6. To exit and return to the main screen, continue to press the NO/CANCEL button until the main screen appears.

Technician Level Programming

Setting or Viewing the IP Address from the LCD Display

1. Type in 6063 at the main screen to enter the technician level menu mode.
2. Press the NO/CANCEL button until the display reads "Set IP Address?" as shown in Fig 3.19.
3. Press the YES/ENTER button.
4. Type in the 12 digit IP address using the keypad. (e.g. 192.168.000.012) Setting the IP address to 000.000.000.000 automatically sets the unit for DHCP enabled. Any other value disables DHCP and considers it a static IP.
5. To exit and return to the main screen, continue to press the NO/CANCEL button until the main screen appears.



The image shows a green rectangular LCD display with the text "Set IP Address?" in black, centered on the screen.

Fig 3.19

Note: If DHCP is enabled and is functioning, the displayed IP address will be the address of the unit which was assigned by the router. The master clock must be power cycled for network parameter changes to take effect.

Setting the Subnet Mask from the LCD Display

1. Type in 6063 at the main screen to enter the technician level menu mode.
2. Press the NO/CANCEL button until the display reads "Set Subnet Mask?" as shown in Fig 3.20.
3. Press the YES/ENTER button.
4. Type in the 12 digit gateway address using the keypad. (e.g. 255.255.255.000)
5. To exit and return to the main screen, continue to press the NO/CANCEL button until the main screen appears.



The image shows a green rectangular LCD display with the text "Set Subnet Mask?" in black, centered on the screen.

Fig 3.20

Note: If DHCP is enabled, then the router will likely overwrite this value. The unit must be power cycled for these changes to take effect.

Technician Level Programming

Setting the Gateway from the LCD Display

1. Type in 6063 at the main screen to enter the technician level menu mode.
2. Press the NO/CANCEL button until the display reads "Set Gateway Address?" as shown in Fig 3.21.
3. Press the YES/ENTER button.
4. Type in the 12 digit gateway address using the keypad. (e.g. 192.168.000.001)
5. To exit and return to the main screen, continue to press the NO/CANCEL button until the main screen appears.

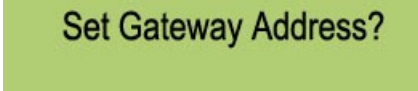

The image shows a green rectangular box with the text "Set Gateway Address?" in black, representing the LCD display of a device.

Fig 3.21

Note: If DHCP is enabled, then the router will likely overwrite this value. The unit must be power cycled for these changes to take effect.

Setting the DNS Address from the LCD Display

1. Type in 6063 at the main screen to enter the technician level menu mode.
2. Press the NO/CANCEL button until the display reads "Set DNS Address?" as shown in Fig 3.22.
3. Press the YES/ENTER button.
4. Type in the 12 digit gateway address using the keypad. (e.g. 192.168.000.001)
5. To exit and return to the main screen, continue to press the NO/CANCEL button until the main screen appears.



The image shows a green rectangular box with the text "Set DNS Address?" in black, representing the LCD display of a device.

Fig 3.22

Note: If DHCP is enabled, then the router will likely overwrite this value. The unit must be power cycled for these changes to take effect.

Web Interface Programming

***Please make sure that ports 123 and 80 in both directions are open on the firewall.**

Accessing the Web Interface (when connected via DHCP)

1. Plug in a patch cable to the unit, and then into a switch on your network.
2. Press the "9" and the "1" key simultaneously.
3. The IP address will display on the bottom line for about three to five seconds.
4. When finished viewing, press the NO/CANCEL button twice to get back to the main screen.
5. Open a web browser such as Internet Explorer or Firefox on a PC that's connected to the network.
6. In the address bar, type in the IP address and press Enter. This will access the log-in screen.

Accessing the Web Interface (when using a static IP)

1. Plug in a patch cable to the unit, and then into a switch on your network.
2. Following the instructions on page 33, enter the IP address.
3. Open a web browser such as Internet Explorer or FireFox on a PC that's connected to the network.
4. In the address bar, type in the IP address and press Enter. This will access the log-in screen.

Accessing the Web Interface (when using a crossover cable)

1. If you are accessing this on a laptop, turn off any wireless connections.
2. Click the "Start" button on the taskbar, then click on "Control Panel".
3. Double Click on "Network Connections".
4. Click the right mouse button on "Local Area Connection" and click "Properties".
5. Scroll to the bottom of the connections list and single click on "Internet Protocol (TCP/IP)".
6. Click on "Properties".
7. Under the General tab, click the radio button that says "Use the following IP address".
8. Enter the IP address of "192.168.0.122".
9. Set the subnet mask to "255.255.255.0".
10. Press 1111 on the keypad, then press the 6 and 3 key together simultaneously. The display will show, "sure enter crossover". Press YES/ENTER.
11. Power cycle the master clock.
12. Open a web browser such as Internet Explorer or FireFox on a PC that's connected to the network.
13. In the address bar, type in the IP address (192.168.0.123) and press Enter. This will access the log-in screen.

Web Interface Programming

Web Interface - Log In

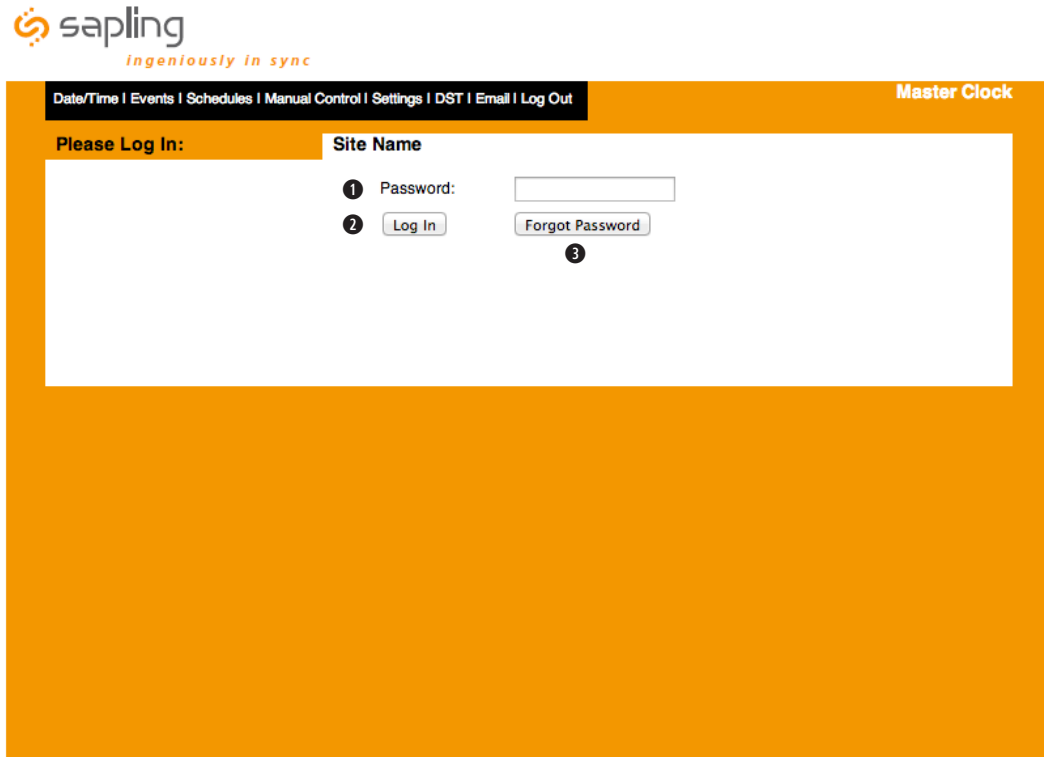

1. **Password** There are two levels of passwords that will enable the user to access features. The first level is the user level programming that includes features like setting the time, date, adding and editing events and schedule changes. The default password for the user level is 1111. It can be changed in the technician level. The technician level password is 6063 and gives you full access to all of the enabled features of the master clock.
2. **Log In** This button, when pressed, will attempt to log in to the master clock with the password that was entered in the field above.
3. **Forgot Password** This button, when pressed, will direct you to the tech support phone number.

After five minutes of inactivity once logged in, the master clock will automatically log the user out.

Web Interface Programming

Web Interface - Date/Time

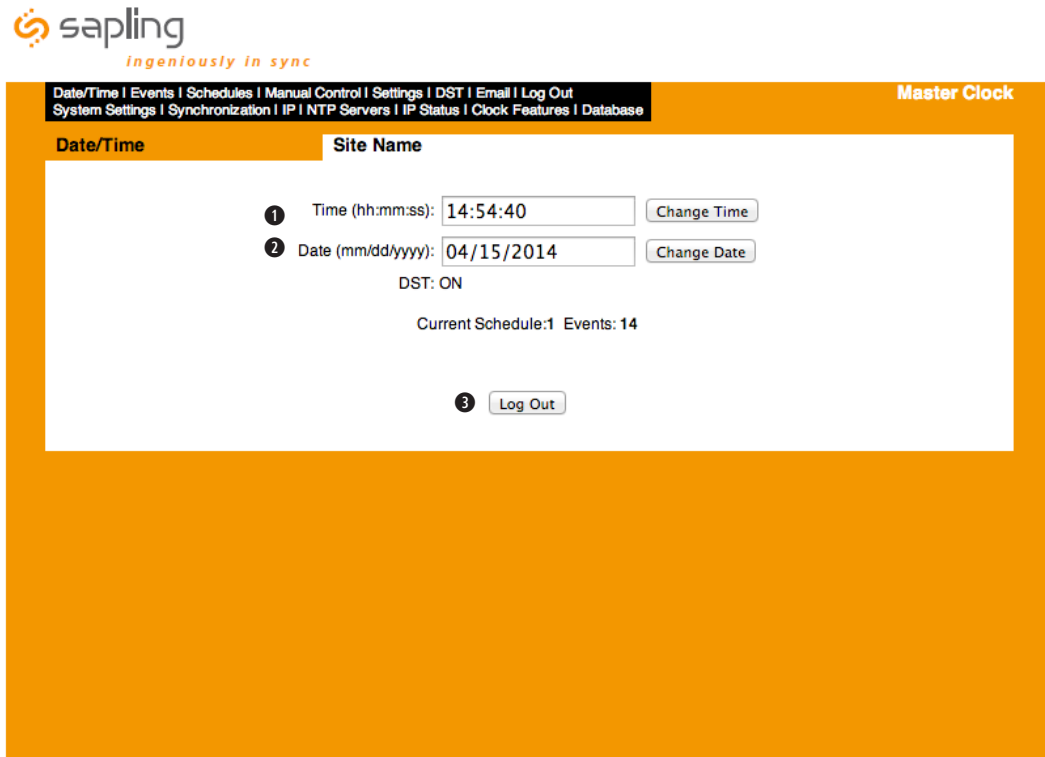

1. **Time** This field is where the current time is displayed. The time can be edited by clicking within the field, and typing in the desired time. The time must be entered in 24 hour format (HH:MM:SS). After typing in the desired time, click the Submit button to set the time on the unit (if there is no input connected).
2. **Date** This field is where the current date is displayed. The date can be edited by clicking within the field, and typing in the desired date. The date must be entered in mm/dd/yyyy format. After typing in the desired time, click the Submit button to set the date on the unit (if there is no input connected).
3. **Log Out** This button, when pressed, will log the user out of the browser interface.

Web Interface Programming

Web Interface - Events

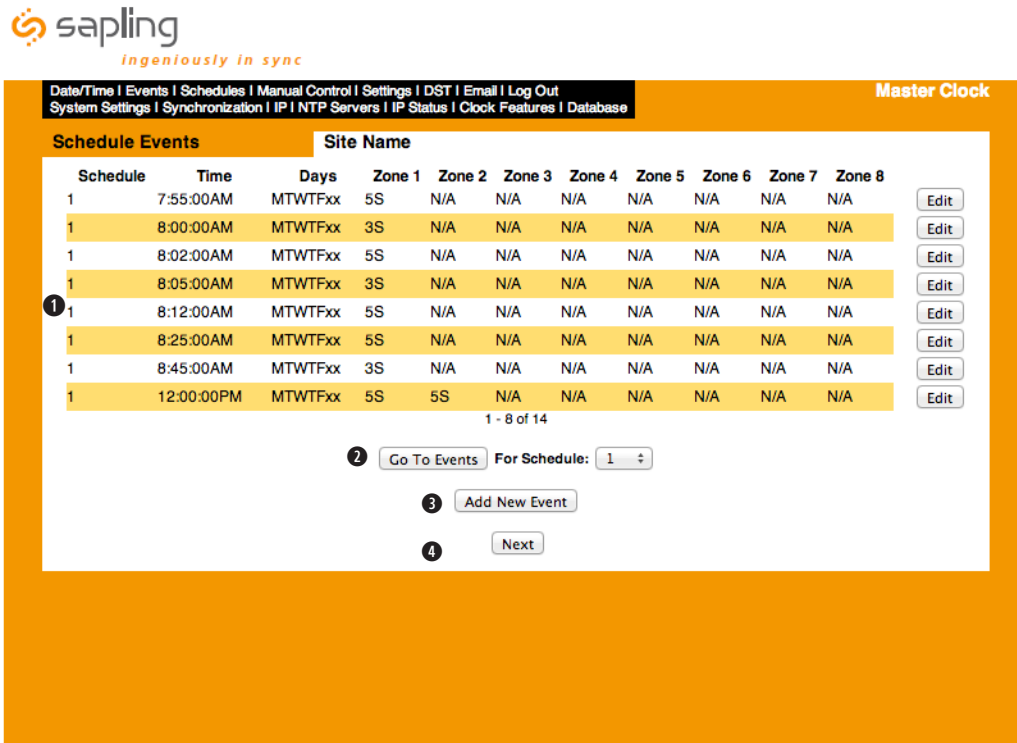

Sapling
ingeniously in sync

Date/Time | Events | Schedules | Manual Control | Settings | DST | Email | Log Out
 System Settings | Synchronization | IP | NTP Servers | IP Status | Clock Features | Database

Master Clock

Schedule Events | Site Name

Schedule	Time	Days	Zone 1	Zone 2	Zone 3	Zone 4	Zone 5	Zone 6	Zone 7	Zone 8	
1	7:55:00AM	MTWTFxx	5S	N/A	N/A	N/A	N/A	N/A	N/A	N/A	Edit
1	8:00:00AM	MTWTFxx	3S	N/A	N/A	N/A	N/A	N/A	N/A	N/A	Edit
1	8:02:00AM	MTWTFxx	5S	N/A	N/A	N/A	N/A	N/A	N/A	N/A	Edit
1	8:05:00AM	MTWTFxx	3S	N/A	N/A	N/A	N/A	N/A	N/A	N/A	Edit
1	8:12:00AM	MTWTFxx	5S	N/A	N/A	N/A	N/A	N/A	N/A	N/A	Edit
1	8:25:00AM	MTWTFxx	5S	N/A	N/A	N/A	N/A	N/A	N/A	N/A	Edit
1	8:45:00AM	MTWTFxx	3S	N/A	N/A	N/A	N/A	N/A	N/A	N/A	Edit
1	12:00:00PM	MTWTFxx	5S	5S	N/A	N/A	N/A	N/A	N/A	N/A	Edit

1 - 8 of 14

2 Go To Events For Schedule: 1

3 Add New Event

4 Next

- Event List** The list will display each event programmed in the master clock. It is sorted by schedule number and then by time. The Edit button on the right, when clicked, will bring the user back to the Add Scheduled Event screen with the existing data already entered in. This list will display ten events per page.
- Go To Events** This button, when pressed, will direct the user to the selected schedule's event list.
- Add New Event** This button, when pressed, will direct the user to the Add Scheduled Event screen and will allow the user to enter a new event.
- Next** This button, when pressed, will advance to the next list of ten events for viewing or editing purposes.

Web Interface Programming

Web Interface - Add/Edit Events (including Countdown mode)

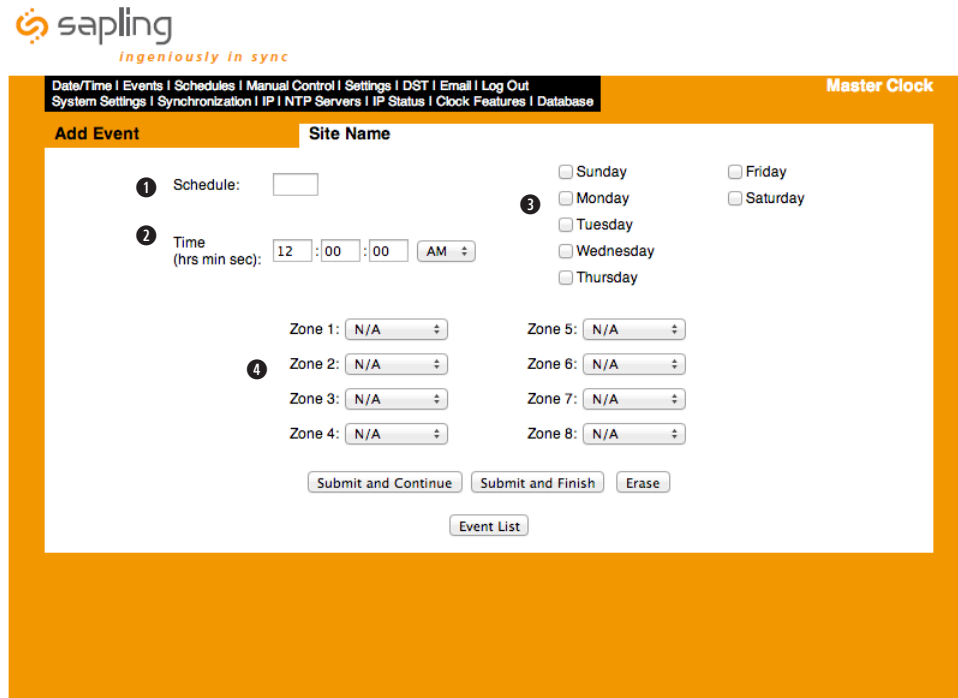

- Schedule** This field is where the user will enter which schedule they want the event to occur on.
- Time** These fields are where the user will enter the time in hour, minutes and seconds that the event is to occur.
- Days** These checkboxes, when checked, will determine what days of the week the event will occur on (at least one must be selected).
- Zone Duration/Countdown** These drop-down lists determine what duration the selected zone (relay) will close for, if any. There are five options:

Option	Description	Miscellaneous Notes
N/A	Not Applicable	An event can not have all zones set this way.
On	The zone (relay) will turn on.	
Off	The zone (relay) will turn off.	
Configured Duration 1	The zone (relay) will turn on for the configured duration which is set in the feature settings.	Ranges from 1 - 3600 seconds.
Configured Duration 2	The zone (relay) will turn on for the configured duration which is set in the feature settings.	Ranges from 1 - 3600 seconds.
*CStart	Starts the countdown feature.	Countdown has an 18 hour time limit and cannot proceed past midnight.
*CStop	Stops the countdown feature.	Countdown has an 18 hour time limit and cannot proceed past midnight.

* This feature provides the Sapling digital clocks with the ability to count down from a preset amount of time. Simply enter a event with a CStart to start the timer and a event with a CStop to stop the timer. The master clock will automatically calculate the difference in time between the CStart and CStop and will start counting down. There must be an event with a CStart and an event with a CStop in order for this to function.

*Instructions continued on next page.

Web Interface Programming

Web Interface - Add/Edit Events (including Countdown mode) (continued)

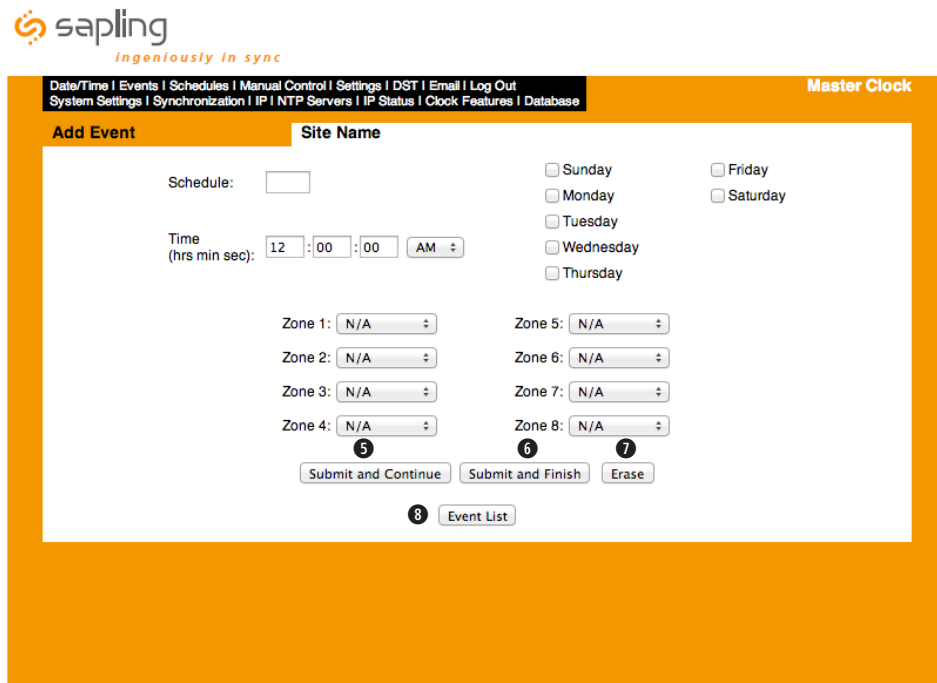

5. **Submit and Continue** This button, when pressed, will save the current event and will display a new add event screen that has the previous event's information already stored in the fields.
6. **Submit and Finish** This button, when pressed, will save the current event and then go back to the main menu.
7. **Erase** This button, when pressed, will erase the current event.
8. **Event List** This button, when pressed, will take the user back to the event list.

Web Interface Programming

Web Interface - Schedules

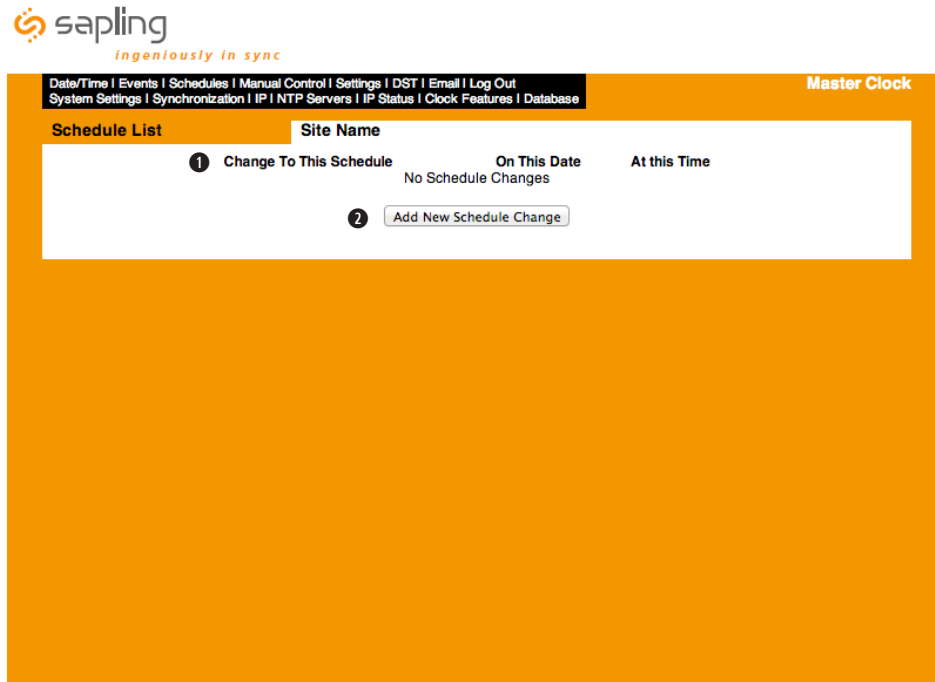

1. **Schedule Change List** This list displays and allows the user to edit a previously entered schedule change. The Edit button, when pressed, will bring the user back to the Add Schedule Change screen with the existing data already filled in.
2. **Add New Schedule Change** This button, when pressed, will bring the user to the Add Schedule Change screen.

Web Interface Programming

Web Interface - Schedule Change (max. 100)

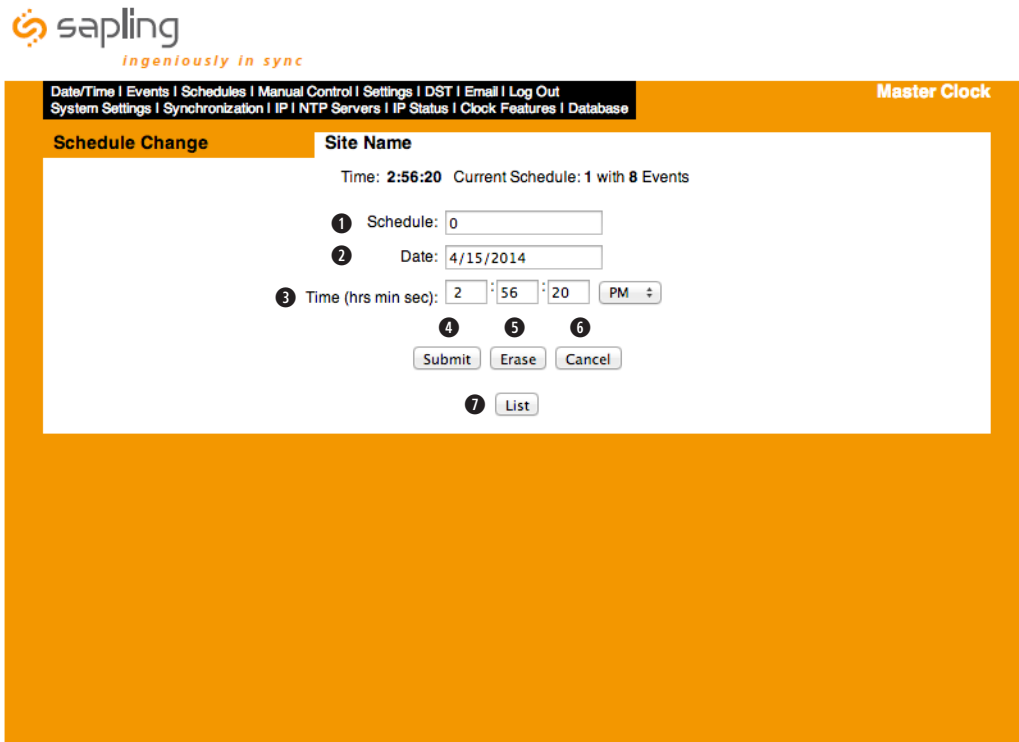

1. **Schedule** This field is where the user will enter which schedule they want the master clock to change to.
2. **Date** This field is where the user will enter which date they want the schedule change to occur.
3. **Time** These fields will determine what time the schedule change will occur.
4. **Submit** This button, when pressed, will save the proposed schedule change.
5. **Erase** This button, when pressed, will erase the displayed schedule change.
6. **Cancel** This button, when pressed, will clear out the fields and not save any of the information.
7. **List** This button, when pressed, will go back to the schedule change list.

Web Interface Programming

Web Interface - Manual Control

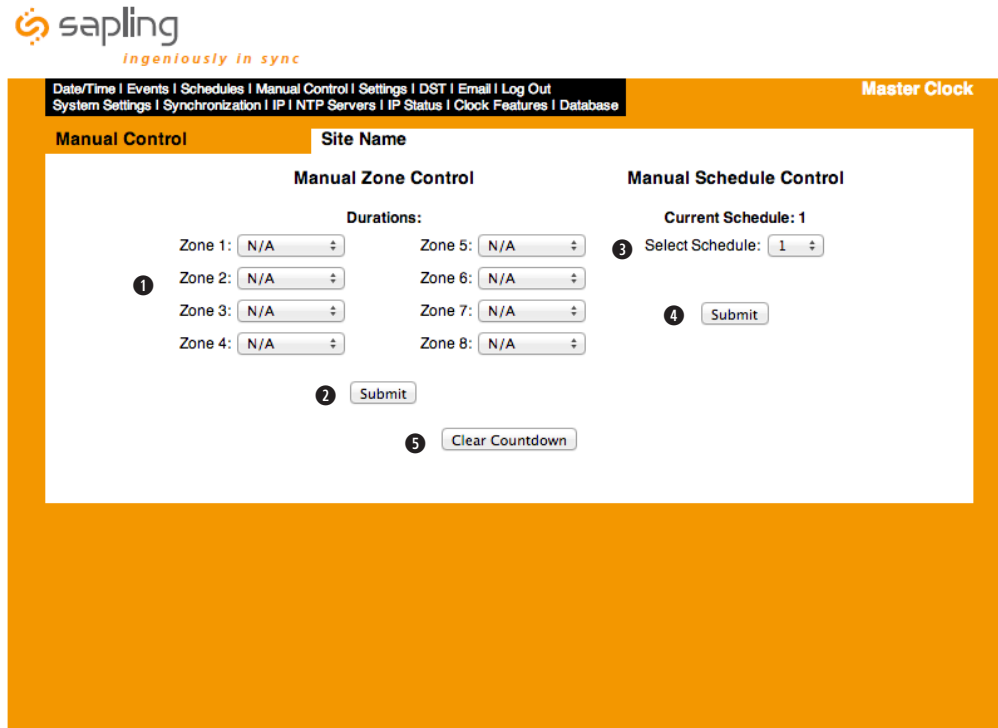

1. **Zone Durations** These drop-down lists determine what duration the selected zone (relay) will close for, if any. There are five options: N/A, On, Off, Configured Duration 1 and Configured Duration 2. Configured durations 1 & 2 can be set in the Clock Features pages. If the user wishes for the relay to go back to its normal state, they must set the zone back to off, submit it, and then set the zone to N/A, and submit it again.
2. **Submit** This button, when pressed, will submit the selected duration to the designated relay.
3. **Select Schedule** This drop-down list contains all of the schedules that are currently programmed. When the desired schedule is selected and submitted, the clock will immediately change to the designated schedule.
4. **Submit** This button, when pressed, will submit the schedule change.
5. **Clear Countdown** This button, when pressed, will clear any countdowns occurring on the digital clocks.

Web Interface Programming

Web Interface - Settings

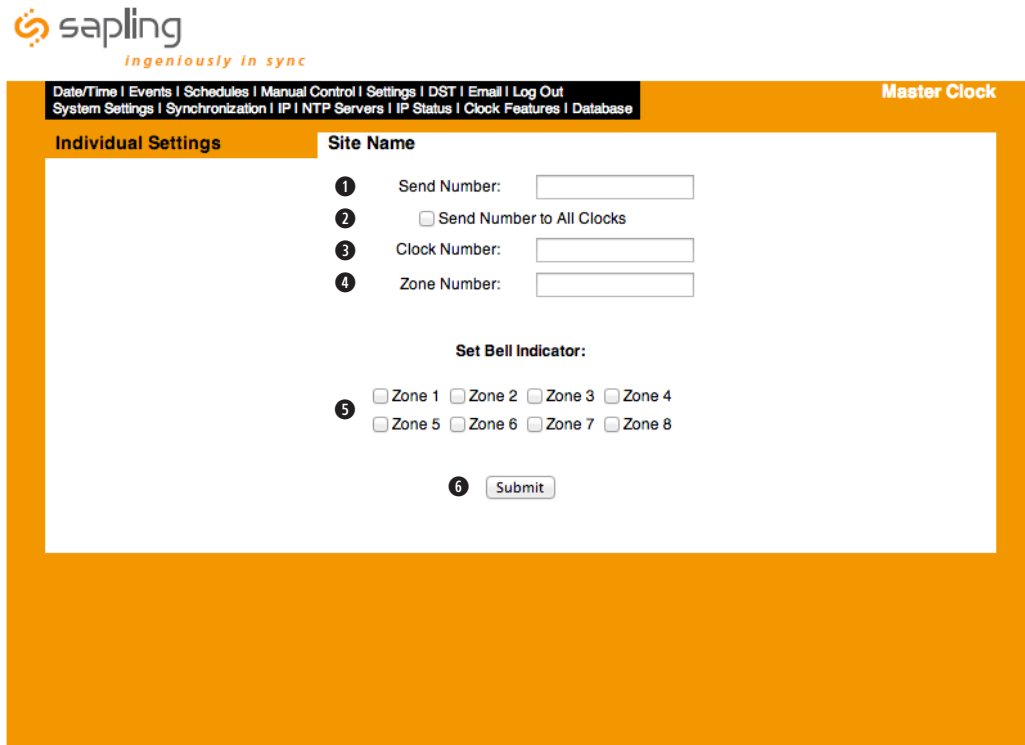

1. **Send Number** This field allows the user to designate which number will be sent to the corresponding digital slave clocks. It can be up to four numeric digits.
2. **Send Number to All Clocks** This checkbox, when checked, will send the value in the Send Number box to all of the digital slave clocks, regardless of zone or clock number when the Submit button is clicked.
3. **Clock Number** This field allows the user to enter the specific clock number to send the numeric message to. This is only applicable when using the SBD 3000 as a slave clock.
4. **Zone Number** This field allows the user to enter the zone number to send the numeric message to. This is only applicable when using the SBD 3200/3300 as a slave clock.
5. **Set Bell Indicator** The checkboxes, when checked, will display BELL on the digital slave clock displays. When a zone is selected, every time the relay closes, the message BELL will be sent to the digital slave clocks via 2 wire digital communication or RS485.
6. **Submit** This button, when clicked, will submit all information that has been selected.

Web Interface Programming

Web Interface - System Settings

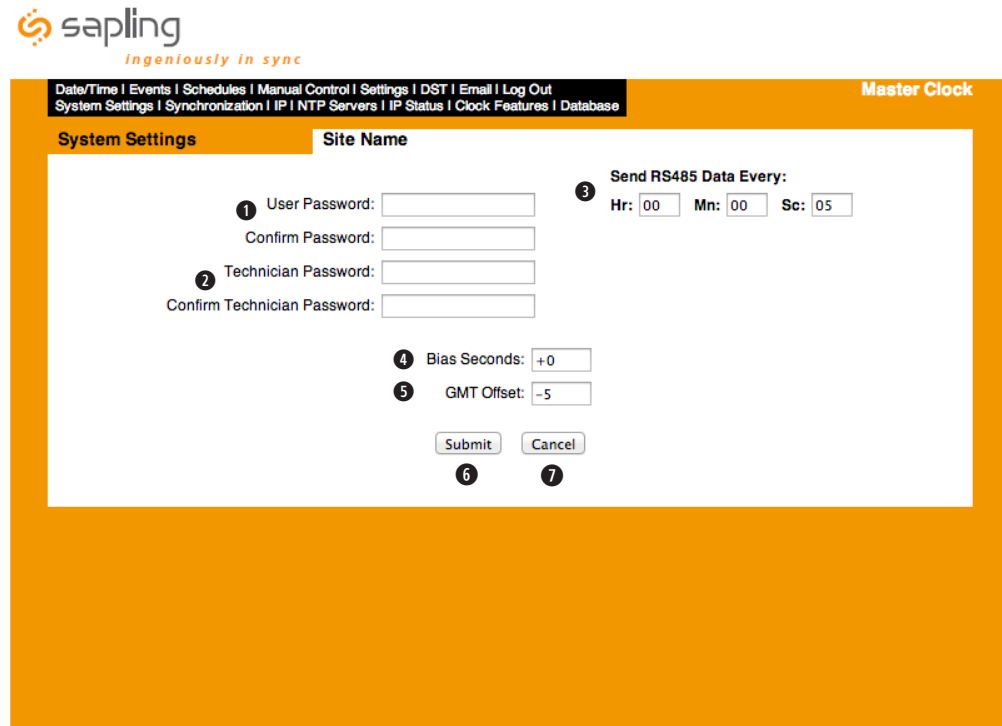

1. **User Password** This field allows the user to enter a new password for the user level programming. The password must be entered once in the User Password field and once in the Confirm Password field in order to be changed. The default User password is 1111.
2. **Technician Password** This field allows the user to enter a password for the technician level programming. The password must be entered once in the Technician Password field and once in the Confirm Technician Password field in order to be changed. The default Technician password is 6063
3. **RS485 Data Rate** These fields allow the user to set how often RS485 will be transmitted from the master clock.
4. **Bias Seconds** This field allows the user to offset how many seconds off, plus or minus, the time will be when receiving an input. This field can range between 0 - 9999 seconds.
5. **GMT Offset** This field sets the positive or negative offset for GMT time. For instance, eastern time zone is a negative five hour offset. See Fig 4.1 for typical offsets.

	Time in Greenwich	Local Time	Positive Offset	Negative Offset
Philadelphia (Eastern Standard Time)	12:00 p.m. (Noon)	7:00 a.m.	0	5
Chicago (Central Time)	12:00 p.m. (Noon)	6:00 a.m.	0	6
Denver (Mountain Time)	12:00 p.m. (Noon)	5:00 a.m.	0	7
Los Angeles (Pacific Time)	12:00 p.m. (Noon)	4:00 a.m.	0	8

Fig 4.1

6. **Submit** This button, when pressed, will save any changes made on the page.
7. **Cancel** This button, when pressed, will clear out any fields and not save any data.

Web Interface Programming

Web Interface - DST

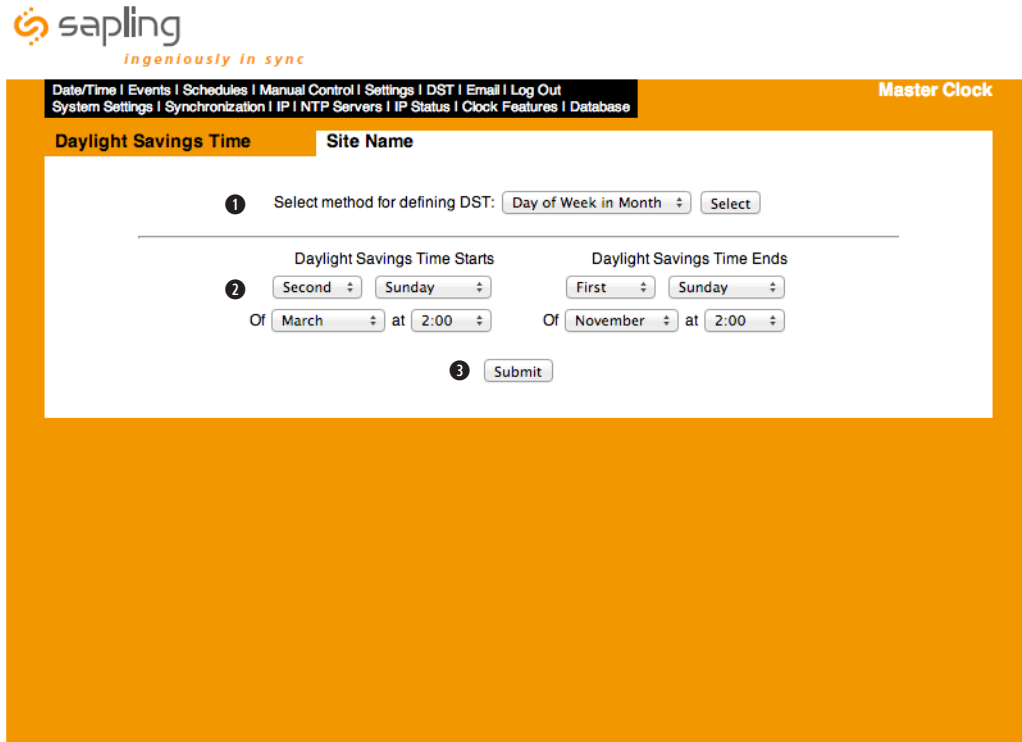

1. **Daylight Saving Time Selection** This drop down list gives four options for Daylight Saving Time:
 - None - When this option is selected, Daylight Saving Time is not applied at all.
 - By Country - When this option is selected, the Daylight Saving Time can be chosen based on country. i.e. Daylight Saving Time can be selected to follow the DST rules established in the United States
 - Day of Month - When this option is selected, Daylight Saving Time can be chosen based on what date and time it begins and ends. i.e. Daylight Saving Time can begin on March 28 at 2AM and end on November 1st at 2AM.
 - Day of Week in Month - When this option is selected, Daylight Saving Time can be chosen based on what week in what month and what time it begins and ends. i.e. Daylight Saving Time can begin on the second Sunday in March at 2AM and ends on the first Sunday in November at 2AM.
2. **Configuration Area** This area is where the configuration for Daylight Saving Time takes place. This area changes based on the selections from option 1.
3. **Submit** This button, when pushed, will save the Daylight Saving Time settings.

Web Interface Programming

Web Interface - Email

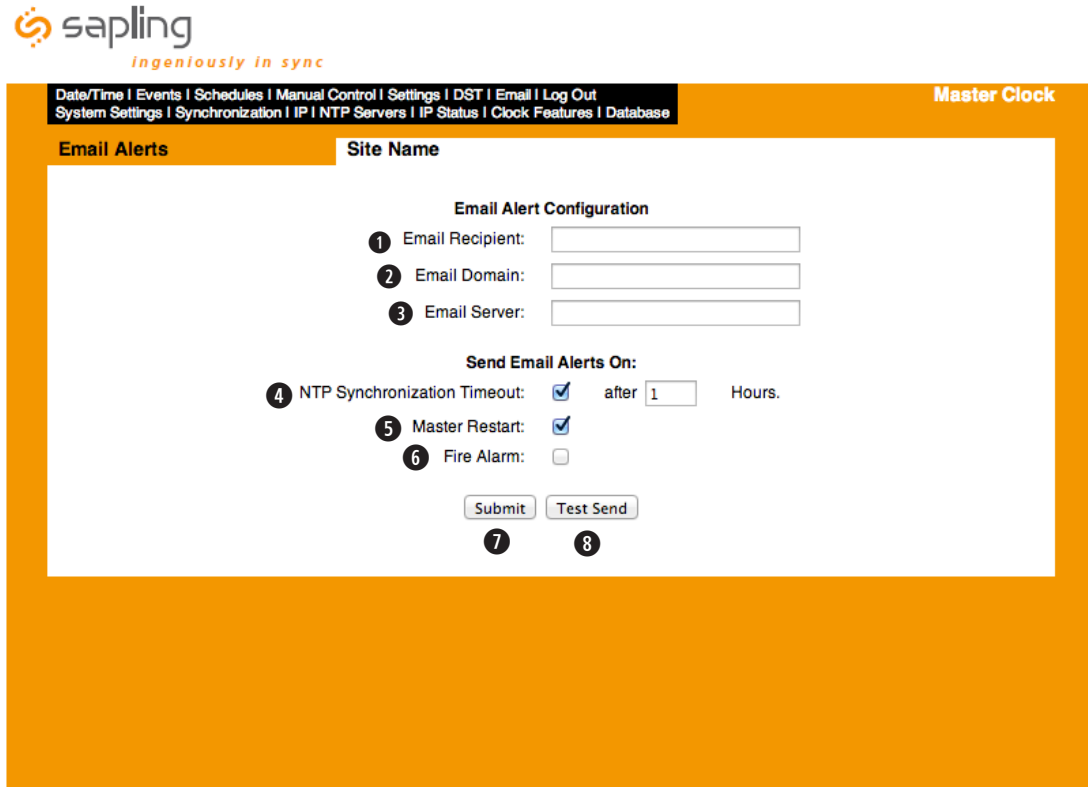

1. **Email Recipient** - This field is where the user name of the email recipient will be inserted. Do not enter the domain and suffix. (correct: johnsmith) (incorrect: johnsmith@domain.com)
2. **Email Domain** - This field is where the user will enter the domain name of the email server. (i.e. domain.com)
3. **Email Server** - This field is where the email server address will be placed. (i.e. server.domain.com)
4. **NTP Synchronization Timeout** - When checked, this will send an alert when the clock hasn't received a time synchronization within a predetermined amount of time, which will be selected by the user in the box to the right.
5. **Master Restart** - When checked, this will send an alert when the master clock has been restarted (power cycled).
6. **Fire Alarm** - When checked, this will send an email when a fire alarm has gone off and alerted the master clock.
7. **Submit** - When clicked, this will save all settings created above.
8. **Test Send** - When clicked, the user will receive a test email from the master clock.

Web Interface Programming

Web Interface - Synchronization

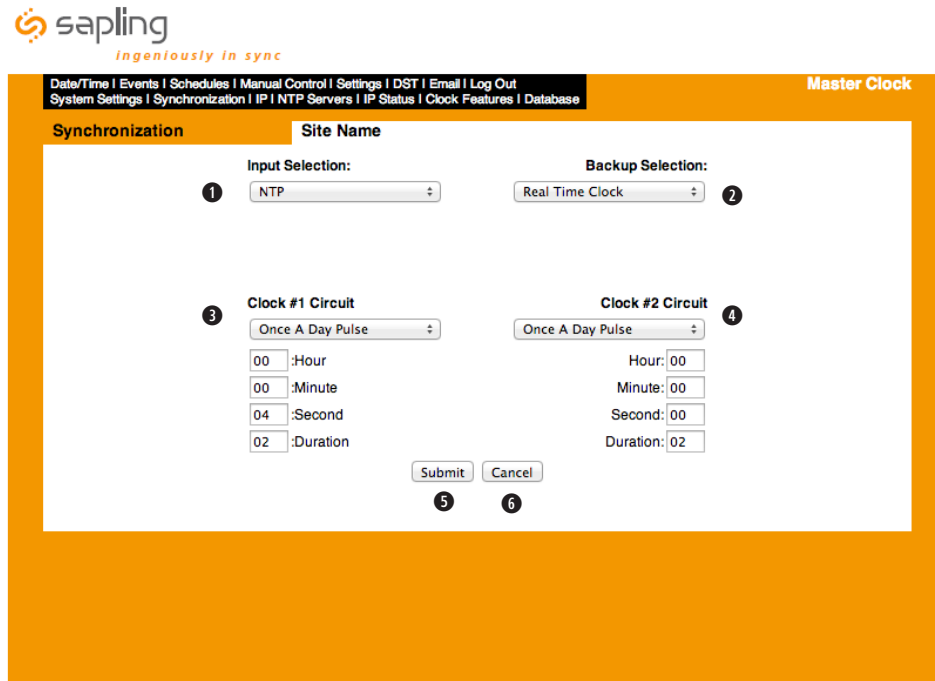

1. **Input Selection** This drop-down list allows the user to select which input will control the master clock. The choices are:

- Real Time Clock
- GPS
- NTP
- 59 Minute Sync
- 58 Minute Sync_1
- 58 Minute Sync_2
- 58 Minute Sync_3
- 58 Minute Sync_4
- National Time_Rauland
- Dukane Digital
- Rauland Digital
- Once a Day Pulse
- Wireless Repeater
- RS485

If Once a Day Pulse is selected, then fields for hours, minutes and seconds will appear. Enter the time (in 24 hour mode) that the clock is to go to when a once a day pulse is present. It must be a minimum of a one second pulse.

2. **Backup Selection** This drop-down list allows the user to select a backup input in case of the loss of the primary input. In order to use the Backup Selection, the following protocols cannot be used as both a primary and secondary input: 59 minute sync, 58 minute 1-4 sync, National Time/Rauland, Dukane Digital, Rauland Digital and once a day Pulse. An example of a configuration would be NTP being the primary input and 58 minute correction being a secondary input. Setting the primary source to 59 minute sync and the secondary source to Dukane digital would be an incorrect configuration.

3. **Clock #1 Circuit** This drop-down list allows the user to select the sync-wire output for the Clock #1 circuit. The choices are:

- 59 Minute Sync*
- 58 Minute Sync_1*
- 58 Minute Sync_2*
- 58 Minute Sync_3*
- 58 Minute Sync_4*
- National Time_Rauland_1*
- National Time_Rauland_2*
- Once a Day Pulse
- Rauland Digital

4. **Clock #2 Circuit** This drop-down list allows the user to select the sync-wire output for the Clock #2 circuit. See #3 above for the list of choices.

5. **Submit** This button, when pressed, will save all of the information to the master clock.

6. **Cancel** This button, when pressed, will clear out any changes made and will not save any data.

Note: GPS is only valid if the option is purchased.

* See page 29 for protocol definitions

Web Interface Programming

Web Interface - IP

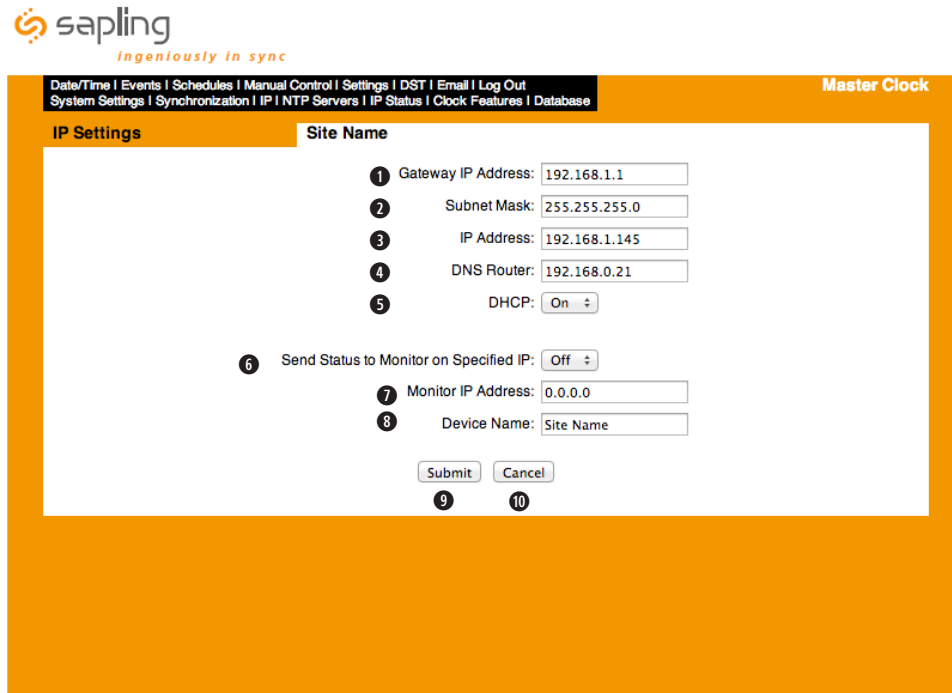

The screenshot shows the 'IP Settings' page in the Sapling web interface. The page has an orange header with the Sapling logo and the tagline 'ingeniously in sync'. Below the header is a navigation bar with links: Date/Time | Events | Schedules | Manual Control | Settings | DST | Email | Log Out | System Settings | Synchronization | IP | NTP Servers | IP Status | Clock Features | Database. The main content area is titled 'IP Settings' and 'Site Name'. It contains the following fields and controls:

- 1 Gateway IP Address: 192.168.1.1
- 2 Subnet Mask: 255.255.255.0
- 3 IP Address: 192.168.1.145
- 4 DNS Router: 192.168.0.21
- 5 DHCP: On
- 6 Send Status to Monitor on Specified IP: Off
- 7 Monitor IP Address: 0.0.0.0
- 8 Device Name: Site Name
- 9 Submit
- 10 Cancel

1. **Gateway IP Address*** This field allows the user to set the Gateway IP address for the master clock.
2. **Subnet Mask*** This field allows the user set the Subnet Mask for the master clock.
3. **IP Address*** This field allows the user to set the IP address for the device.
4. **DNS Router*** This field allows the user to set the DNS Router address. The default address will typically work for most applications, however some modification may be needed for certain networks.
5. **DHCP** This drop down list allows the user to turn DHCP on or off. DHCP allows the master clock to look for an IP address on its own if the network has a DHCP server.
6. **Send Status to Monitor on Specified IP** This setting allows the clock to send out its data in broadcast mode.
7. **Monitor IP Address** - This setting allows for the Monitor IP Address to be set so the monitor program can see the device across a large network.
8. **Device Name** This field allows the master clock to be named.
9. **Submit** This button, when pressed, will save all of the settings.
10. **Cancel** This button, when pressed, will not save any settings.

* These settings are overridden by the gateway if DHCP is turned on.

Web Interface Programming

Web Interface - NTP Servers

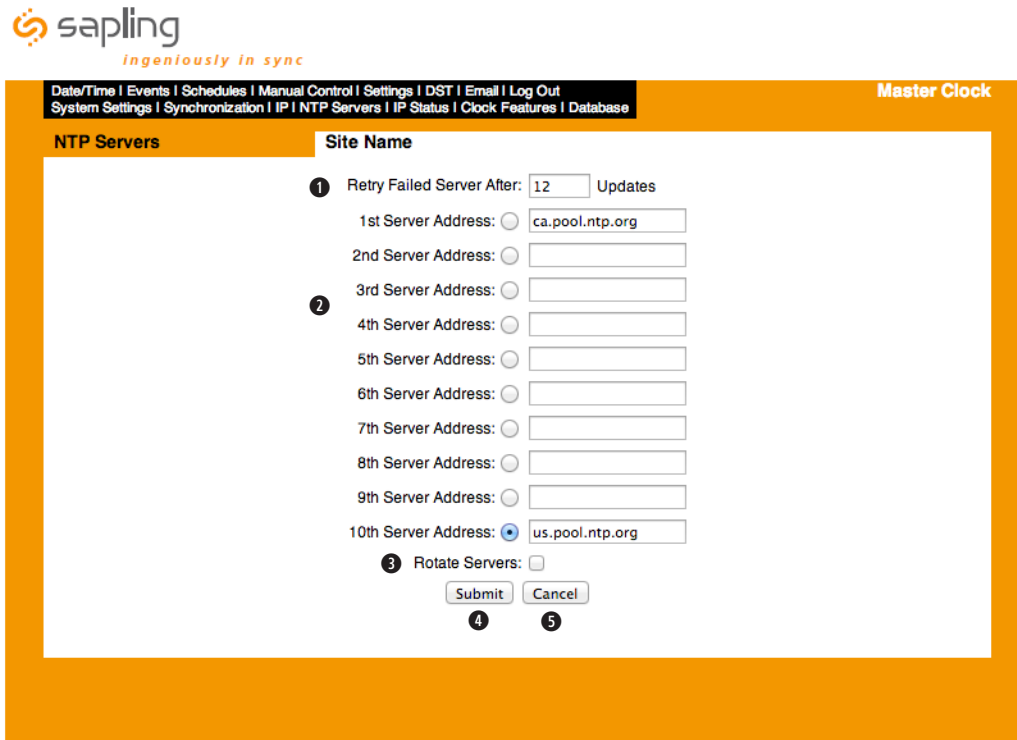

The screenshot shows the 'NTP Servers' configuration page. At the top, there is a navigation bar with links: Date/Time | Events | Schedules | Manual Control | Settings | DST | Email | Log Out | System Settings | Synchronization | IP | NTP Servers | IP Status | Clock Features | Database. The page title is 'Master Clock'. Below the title, there are two tabs: 'NTP Servers' (selected) and 'Site Name'. The main form area contains the following elements:

- 1** Retry Failed Server After: Updates
- 1st Server Address:
- 2nd Server Address:
- 3rd Server Address:
- 2** 4th Server Address:
- 5th Server Address:
- 6th Server Address:
- 7th Server Address:
- 8th Server Address:
- 9th Server Address:
- 10th Server Address:
- 3** Rotate Servers:
- 4** Submit
- 5** Cancel

1. **Retry Failed-Server After** This field allows the user to specify how many times it will attempt to access the time from a server before it moves on to the next one.
2. **Server Addresses** This field allows the user to specify which (S)NTP servers that the master clock will try to acquire time from. Any server that is highlighted in red is not functioning after several tries.
3. **Rotate Servers** This checkbox, when checked, allows the master clock to rotate through all the server addresses for constant time accuracy on a continual basis. There must be two server addresses for this option to work.
4. **Submit** This button, when pressed, will save all of the information to the master clock.
5. **Cancel** This button, when pressed, will clear out any changes made and will not save any data.

Web Interface Programming

Web Interface - IP Status

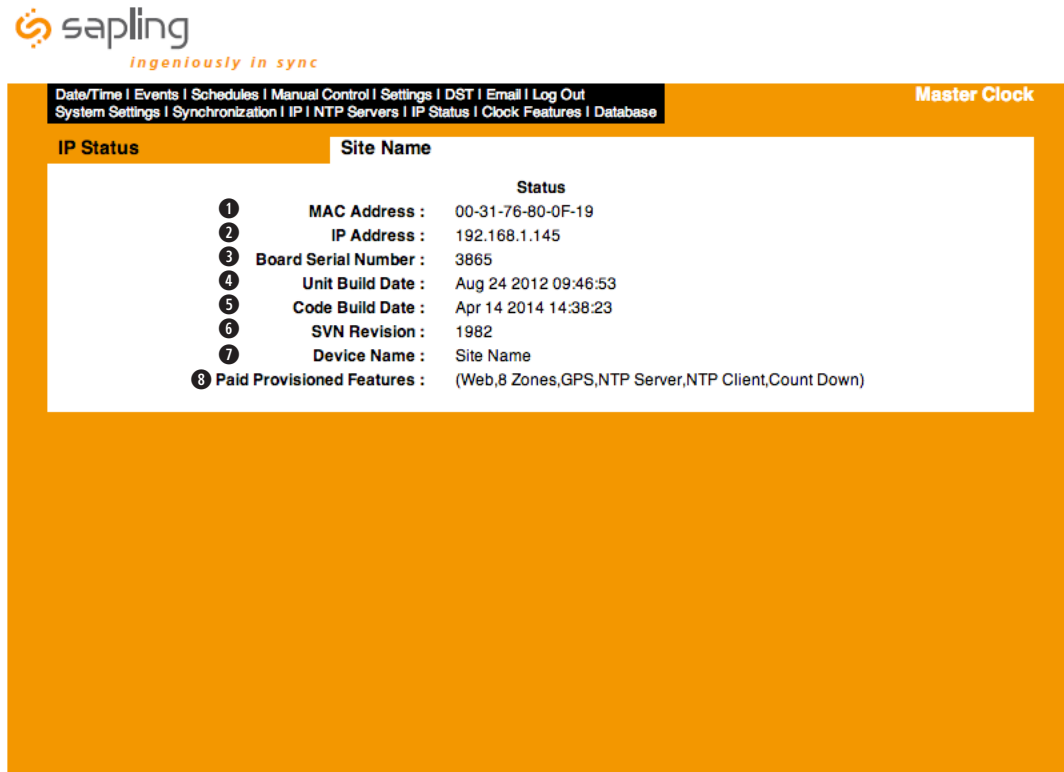

The screenshot shows the Sapling web interface. At the top left is the Sapling logo with the tagline 'ingeniously in sync'. A navigation menu is located at the top, containing links for Date/Time, Events, Schedules, Manual Control, Settings, DST, Email, Log Out, System Settings, Synchronization, IP, NTP Servers, IP Status, Clock Features, and Database. The 'IP Status' page is active, showing a 'Site Name' field and a 'Status' section. The status information is as follows:

Item	Value
1. MAC Address	00-31-76-80-0F-19
2. IP Address	192.168.1.145
3. Board Serial Number	3865
4. Unit Build Date	Aug 24 2012 09:46:53
5. Code Build Date	Apr 14 2014 14:38:23
6. SVN Revision	1982
7. Device Name	Site Name
8. Paid Provisioned Features	(Web,8 Zones,GPS,NTP Server,NTP Client,Count Down)

1. **MAC Address** This displays the MAC address for the master clock.
2. **IP Address** This display the IP address for the master clock.
3. **Board Serial Number** The displays the serial number of the master clock.
4. **Unit Build Date** This displays the date the unit was built.
5. **Code Build Date** This displays the date the software code was built.
6. **SVN Revision** This displays the software version number.
7. **Device Name** This displays the device name for the master clock.
8. **Paid Provisioned Features** This displays the additional features of the master clock.

Web Interface Programming

Web Interface - Clock Features

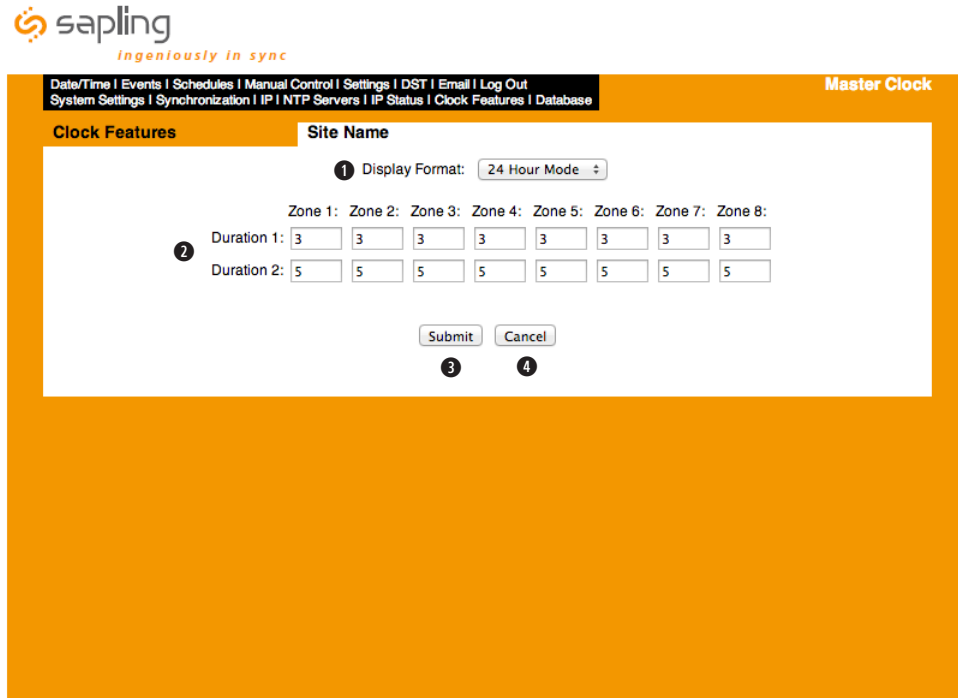

1. **Display Format** This drop-down list allows the user to select whether they want 12 hour or 24 hour mode to be displayed on the LCD and LED.
2. **Zone Durations** These fields allow the user to select the default durations for each zone. In this case, duration 1 is set for three (3) seconds and duration 2 is set for five (5) seconds.
3. **Submit** This button, when pressed, will save all of the information to the master clock.
4. **Cancel** This button, when pressed, will clear out any changes made and will not save any data.

Web Interface Programming

Web Interface - Database

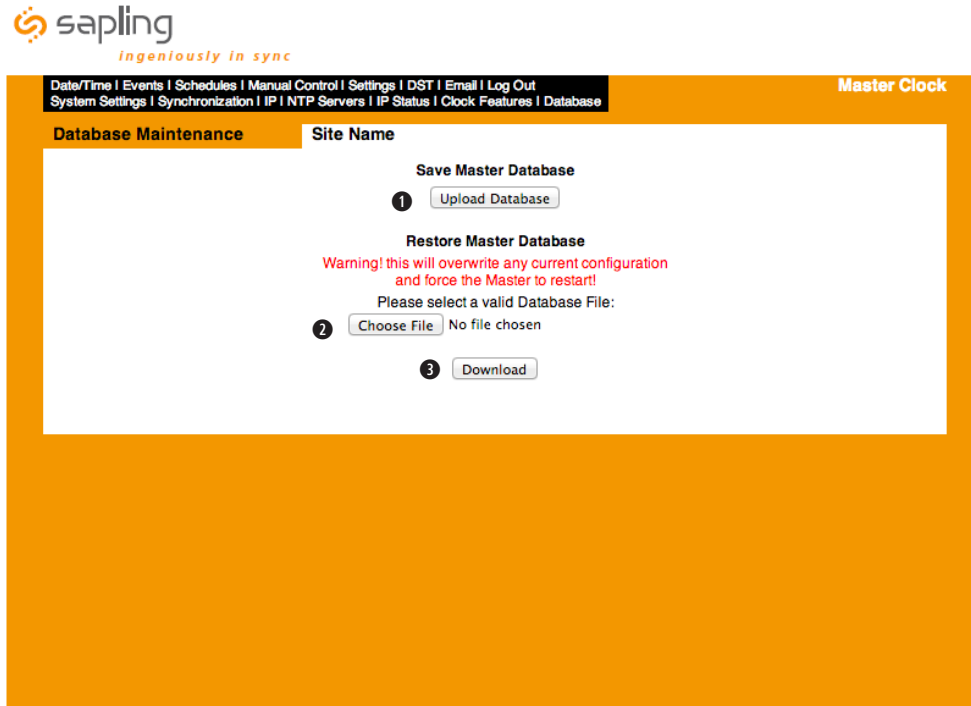

1. **Upload Database** This button, when pressed, will upload the current schedules and events, and place it in a file for backup purposes.
2. **Choose File** This button, when pressed, will allow the user to browse for the saved .db file that contains the saved events and schedules.
3. **Download** This button, when pressed, will download the selected file and reset the master clock with those events and schedules already configured.

Frequently Asked Questions

Does this master clock replace all of the existing master clocks made by Sapling?

Yes, the NTP 8000 Series will act as a direct replacement for the SMC, GPS, STR and SSM series master clocks. The NTP 8000 can have all the same functionalities of the aforementioned series depending on which options are ordered.

Can I use any (S)NTP server for downloading the time?

Yes, any site that sends out the (S)NTP protocol may be used as an input to the master clock.

What browsers are compatible with the NTP 8000 master clock browser?

The NTP 8000 browser is compatible with Microsoft Internet Explorer, Mozilla Firefox, Safari, Opera and Chrome.

Can I connect to the web browser through a cross-over cable?

Yes, the NTP 8000 can be accessed through a cross-over cable or via a LAN connection.

What are the length options I have with the GPS cable?

When the GPS option is purchased, a GPS Dome and a 75 foot (22.8 meters) of RG58 length of RG59 cabling is included. If needed, the following GPS cable is available at an additional cost:

- 150 foot (45.7 meters) Special GPS Cable - Part Number: E-ANT-CBL150F-1
- 300 foot (91.4 meters) Special GPS Cable - Part Number: E-ANT-CBL300F-1

Is there a Converter option like there was in the SSM and the GPS?

No, the Converter Box should be purchased separately from the unit when using a two wire digital communication system. The part number for the Converter Box is SCB-000-000-1 (110V) or SCB-000-000-2 (230V).

What inputs can the NTP 8000 accept?

The NTP 8000 can accept an input from a (S)NTP server, 59 minute correction, four different versions of the 58 minute correction, National Time/Rauland, Dukane digital, Rauland digital, Sapling Wireless Repeater, Once a Day pulse, GPS and Sapling's RS485 protocol.

Troubleshooting

The master clock will not power up. What do I do?

Make sure the power cord is securely connected to the power outlet and to the back of the NTP 8000 master clock. Upon being connected to power, the master clock should boot up instantly. There is not an on/off switch.

What do I do if I cannot connect to the browser?

Verify that the IP address your attempting to access is correct. If the IP address is correct, verify that there aren't any provisions in the firewall preventing you from accessing it. If all else fails, try connecting via a cross-over cable.

What do I do if the GPS isn't receiving a signal?

Check the antenna to make sure it is in an unobstructed area that is in complete view of the sky. Also, check to make sure the connections on each end of the cable are securely tightened. Lastly, verify that there are no kinks or breaks in the supplied GPS cable.

The bell isn't ringing when it's supposed to. Why?

In the view/edit events section, make sure that the bell is configured to the proper zone and the correct schedule is currently active. If it is, activate the zone manually to make sure that the relay is turning the bell on.

My sync-wire system doesn't seem to be getting the correct time. What should I do?

The clock 1 and clock 2 outputs control the sync-wire systems. Verify that the correct system is set for the designated clock circuit. Protocol details are listed on page 29.

What if I don't know what the password for the user level programming is?

The default password is 1111. The password may or may not have been changed by the installing technician. Contact the installation technician to obtain the password. If that's not possible, see page 31 for instructions on how to reset the password.

Why didn't my NTP 8000 change for Daylight Saving Time?

A few things could cause the NTP 8000 not to change for Daylight Saving Time. The first item to check is the date to verify if it's correct. If the date is not correct, the clock will not change. If the date is correct, verify that the clock is set for the correct version of Daylight Saving Time. See page 28 or 46 for more information.

Why didn't the clock change schedules when it was supposed to?

In the view/edit schedule change sections, verify that the time and date were accurate. Also, make sure the schedule that was supposed to be active is the correct schedule number.

Compliances



FCC Part 15b

Industry Canada

FCC Statement: Information to the user (for U.S. only)

This equipment has been tested and found to comply with the limits for a Class B digital device, pursuant to part 15 of the FCC Rules. These limits are designed to provide reasonable protection against harmful interference in a residential installation. This equipment generates, uses and can radiate radio frequency energy and, if not installed and used in accordance with the instructions, may cause harmful interference to radio communications. However, there is no guarantee that interference will not occur in a particular installation. If this equipment does cause harmful interference to radio or television reception, which can be determined by turning the equipment off and on, the user is encouraged to try to correct the interference by one or more of the following measures:

1. Reorient or relocate the receiving antenna.
2. Increase the separation between the equipment and receiver.
3. Connect the equipment into an outlet on a circuit different from that to which the receiver is connected.
4. Consult the dealer or an experienced radio/TV technician for help.

The user is cautioned that any changes or modifications not expressly approved by the party responsible for compliance could void the user's authority to operate the equipment.

This unit was tested with shielded cables on the peripheral devices. Shielded cables must be used with the unit to ensure compliance.

IC Statement (for Canada only)

This Class B digital apparatus complies with Canadian ICES-003.

CET appareil numérique de la classe B est conforme à la norme NMB-003 du Canada.

CE Declaration of Conformity

We, The Sapling Company certify and declare under our sole responsibility that the NTP 8000 conforms with the essential requirements of the EMC Directive 2004/108/EC and LVD 2006/95/EC, based on the following standards applied:

EN 55022: 2006

EN 61000-3-2: 2006

EN 61000-3-3: 1995 /A1: 2001 /A2:2005

EN 55024 : 1998 /A1:2001, A2:2003

EN 60950-1:2006 - Safety Part 1

EN 55024 : 1998 /A1:2001, A2:2003:

IEC 61000-4-2: 1995 IEC 61000-4-5: 1995

IEC 61000-4-3: 1995 IEC 61000-4-6: 1996

IEC 61000-4-4: 1995 IEC 61000-4-7: 1994