

Salamander Electric Stands



- Provide accessible, comfortable and ergonomically correct touchscreen positioning that enhances the user experience and improves productivity.
- ADA complaint design
- Fully concealed cable management allows clean and uncluttered installation
- Storage for electronic components, peripherals and accessories.
- Telescopic design allows compact position for transport and storage
- Durable construction. Made in USA of powder coated steel, Linak Motor components, Powder coated and/or veneered MDF panels
- Options available for peripheral equipment mounting, retractable cable reel, secure equipment storage cover, keyboard tray and more.
- Limited Lifetime Warranty



Electric Lift & Tilt Mobile Stand

FPS2/ELT/MS/GG

- Motorized electric lift and tilt with wired remote with independent lift/tilt control
- Range of travel, Center of screen:
Min – 33.33" (847 mm) and Max 58.92" (1497 mm)
- Superior mobility. High quality, commercial grade locking casters and integrated handles provide easy maneuverability and transport



Electric Lift Mobile Stand

FPS2/EL/MS/GG

- Motorized electric lift with wired remote
- Range of travel, Center of screen:
Min – 36.83" (935.5 mm) and Max 62.42" (1585.5 mm)
- Superior mobility. High quality, commercial grade locking casters and integrated handles provide easy maneuverability and transport



Electric Lift Wall Stand

FPS2W/EL/MS/GG

- Motorized electric lift with wired remote
- Range of travel, Center of screen:
Min – 34.01" (863.8 mm) and Max 59.6" (1513.8 mm)
- Interior equipment mounting area for electronic components, peripherals and accessories

Salamander Fixed Height Stands



- Ergonomic design. Adjustable height positioning (during set-up) provides best possible ergonomics and viewing
- Superior mobility. High quality commercial grade locking casters and integrated handles provide easy maneuverability and transport
- Fully concealed cable management allows clean, secure and uncluttered installation
- Internal storage for rack mounted (2RU) electronic components, peripherals and accessories
- Durable construction. Made in USA of powder coated steel
- Options available for peripheral equipment mounting, retractable cable reel, keyboard tray and more
- Limited Lifetime Warranty



Fixed Height Stand

FPS1/FH/MS/GG

- Range of travel, Center of screen: Min – 48.28" (1226 mm) and Max 58.28" (1480 mm)

Salamander XL Fixed Height Stands for 85" Surface Hub 2S

- Ergonomic design. Adjustable height positioning (during set-up) provides best possible ergonomics and viewing
- Superior mobility. High quality commercial grade locking casters and integrated handles provide easy maneuverability and transport
- Fully concealed cable management allows clean, secure and uncluttered installation
- Internal storage for rack mounted (2RU) electronic components, peripherals and accessories
- Durable construction. Made in USA of powder coated steel
- Options available for peripheral equipment mounting, retractable cable reel, keyboard tray and more
- Limited Lifetime Warranty



X-Large Fixed Height Stand

FPS1XL/FH/MS/GG

- Range of travel, Center of screen: Min – 48.28" (1226 mm) and Max 58.28 (1480 mm)

Salamander XL Electric Lift Stands for 85" Surface Hub 2S

- Provide accessible, comfortable and ergonomically correct touchscreen positioning that enhances the user experience and improves productivity.
- ADA complaint design
- Fully concealed cable management allows clean and uncluttered installation
- Storage for electronic components, peripherals and accessories.
- Telescopic design allows compact position for transport and storage
- Durable construction. Made in USA of powder coated steel, Linak Motor components, Powder coated and/or veneered MDF panels
- Options available for peripheral equipment mounting, retractable cable reel, secure equipment storage cover, keyboard tray and more.
- Limited Lifetime Warranty



X-Large Electric Lift Mobile Stand

FPS1XL/EL/MS/GG

- Motorized electric lift with wired remote
- Range of travel, Center of screen: Min – 36.83" (935.5 mm) and Max 62.42" (1585.5 mm)
- Superior mobility. High quality, commercial grade locking casters and integrated handles provide easy maneuverability and transport

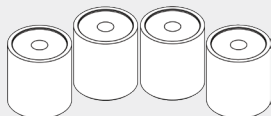

Surface Hub 2S 85" Mounting Adapter Kit

CA/MAC5

- Mount the SH2 85" to any VESA compliant wall mount or stand using the universal spacer kit. Call for details.
- Receive a **FREE** Mounting Adapter Kit with every Salamander FPS X-Large Stand.



Stand Accessories

*Compatible with Electric Lift Stands only.

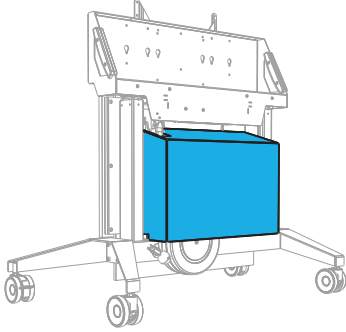

***Equipment Storage Cover – Graphite**
FPSA/SC/GT

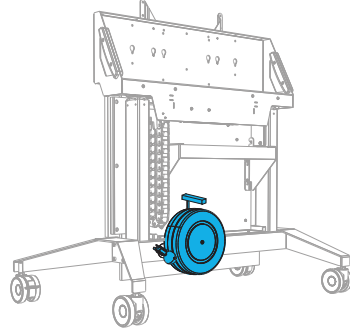

Cable Reel 30' Payout, 24" Tri-Tap Female End
FPSA/CR

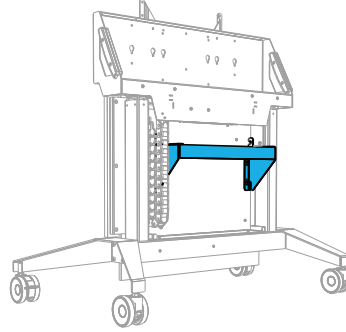

***19" Rack Mounting 3 RU**
RM/VR/3U

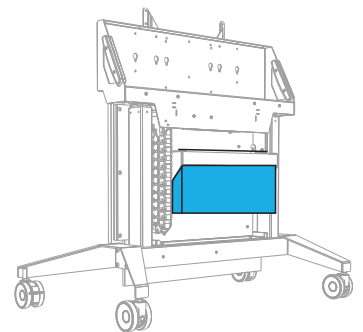

Power Distribution Unit
SA/RM/PDU

Retractable CAT6 Cable Reel
FPSA/CR/CAT6

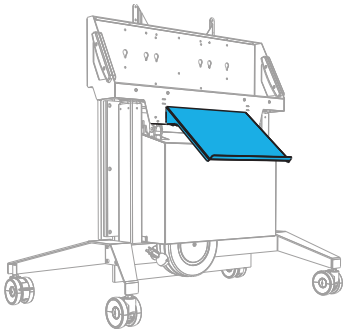

Keyboard Storage Shelf – Graphite
FPSA/KS/GT

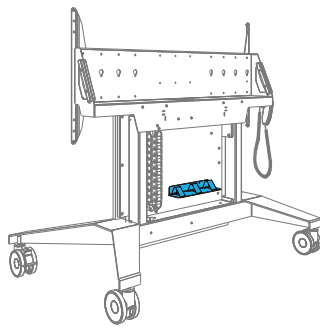

***Accessory Shelf with Straps**
FPSA/AS1

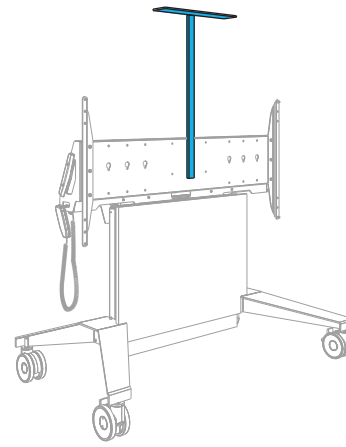

Camera Mount Shelf
FPSA/CS

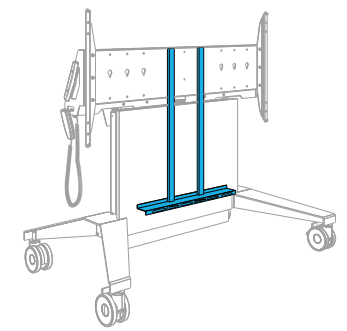

Speaker Bracket Kit
FPSA/SBK

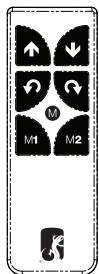

***Wireless RF Remote Control with Memory**
FPSA/RF1

ROAD CASE

FOR EASY DEPLOYMENT

Combine a mobile stand with a road case to provide secure and convenient transport of your display.

Accommodates Stand & Display

FPSA/RC/EL

