



ELECTRIC LIFT MOBILE STAND

FPS1/EL/GG



Take control of creative, presentation and collaboration work spaces. Salamander's beautiful and highly functional FPS Series Mobile Stands offer superior ergonomics complimenting any touch screen display with improved productivity, unrivaled flexibility and lifetime value.

A stylish, sleek and compact design moves easily between spaces. A thoughtful range of accessories provides even more utility and an improved user experience.

- Mobile stand for interactive display / touchscreen panel
- Motorized Electric Lift and wired remote
- ADA Compliant
- Compatible with most large displays including 70" Screens and Microsoft Surface Hub 2, see VESA pattern and weight limits.
- Cisco® Webex Board Compatible Stand Available, Model #FPS1/ELCS/GG
- Ergonomic design. Adjustable height positioning provides best possible ergonomics and viewing
- Superior mobility. High quality commercial grade locking casters and integrated handles provide easy maneuverability and transport
- Fully concealed cable management allows clean and uncluttered installation
- Range of travel, Center of screen : Min- 36.83" (935.5 mm) and Max 62.42" (1585.5 mm)
- Storage for electronic components, peripherals and accessories
- Telescopic design allows compact position for transport and storage
- Durable construction. Made in USA of powder coated steel, Linak Motor components, Powder coated and/or veneered MDF panels
- Options available for peripheral equipment mounting, retractable cable reel, secure equipment storage cover, keyboard tray and more
- Limited Lifetime Warranty





ELECTRIC LIFT MOBILE STAND

FPS1/EL/GG

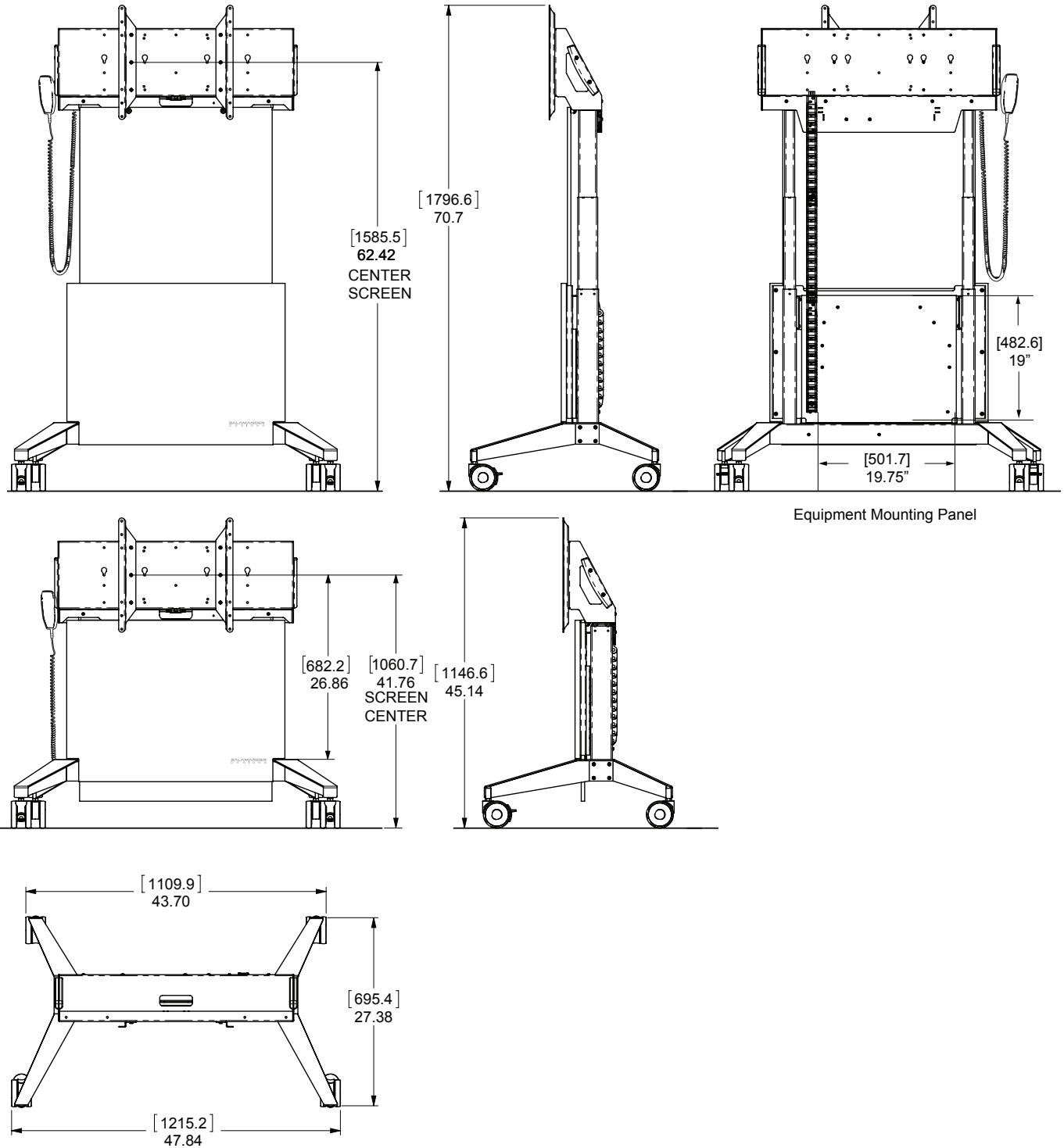



ELECTRIC LIFT MOBILE STAND

FPS1/EL/GG

PRODUCT SPECIFICATIONS	Metric (mm)		US/Imperial Inches		SHIPPING DIMENSIONS	
	Length	1215.2	47.84	1,219 mm	48 inch	
Overall Height Range	1146.6 - 1796.6	45.14 - 70.7	1,016 mm	40 inch		
Center of Screen Range of Travel	935.83 - 1585.5	36.83 - 62.42				
Depth	695.4	27.38	406 mm	16 inch		
Weight	61.23 kg	135 lbs	72.57 kg	160 lbs		
Max Load Capacity	79.38 kg	175 lbs				
UPC Number		634878507110				

VESA COMPLIANT MOUNT PATTERN

Horizontal - 200mm, 300mm, 400mm, 600mm
 Vertical - 200mm, 300mm, 400mm
 Panel Mounting - M4, M5, M6 Screws

Includes Microsoft Surface Hub 2 Mounting adapter (CA/MAC4) VESA 350mm x 350mm

Cisco® Webex Board Compatible Stand
 Available, Model #FPS1/ELCS/GG

CASTER WHEELS

4" (100mm) HD, Non Marking, Brakes on 2

ELECTRICAL INFORMATION

Input: 90V - 240V ~, 48 Hz - 63HZ
 Duty Cycle: 10% Max 2min / 18min

CABLE MANAGER CHAIN

1" x .75" x 34" (25 x 19 x 865mm)

POWER CABLE

IEC - Type Class 2, 2-prong
 USA Included: (PN 400-590)

Available:

EU (PN 400-591)

UK (PN 400-592)

New Zealand, Australia and others (PN 400-593)





ELECTRIC LIFT MOBILE STAND

FPS1/EL/GG

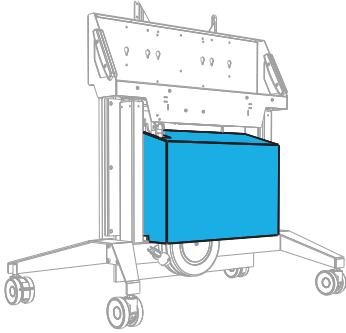

**Equipment Storage
Cover- Graphite**
FPSA/SC/GT

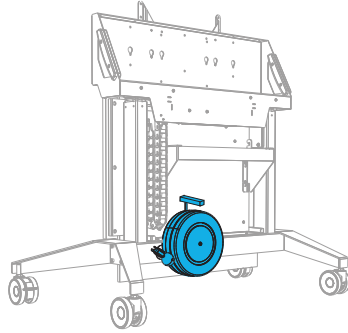

**Cable Reel 30' Payout, 24"
Tri-Tap Female End**
FPSA/CR

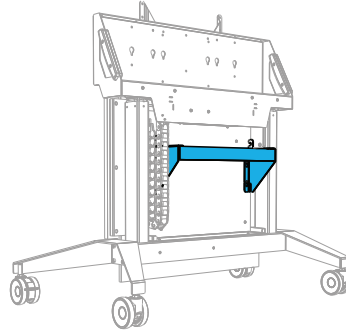

19" Rack Mounting 3 RU
RM/VR/3U

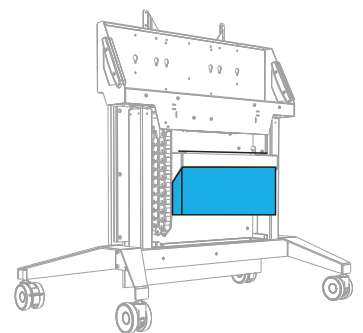

Power Distribution Unit
SA/RM/PDU

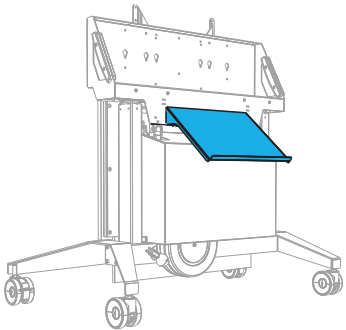

**Keyboard Storage
Shelf- Graphite**
FPSA/KS/GT

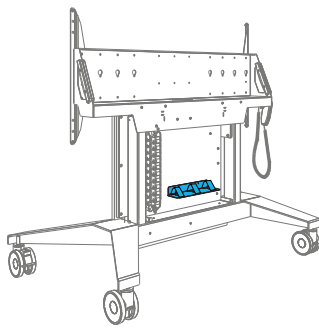

**Accessory Shelf
with Straps**
FPSA/AS1

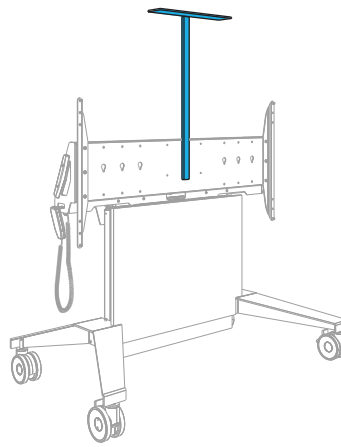

Camera Mount Shelf
FPSA/CS

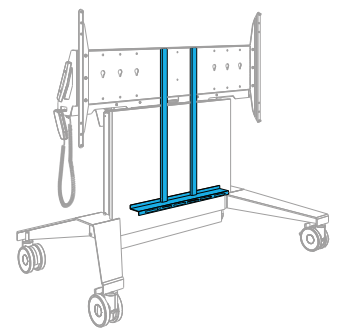

Speaker Bracket Kit
FPSA/SBK

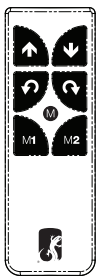

**Wireless RF Remote
Control with Memory**
FPSA/RF1

ROAD CASE
FOR EASY DEPLOYMENT

Combine a mobile stand with a road case to provide secure and convenient transport of your display.

Accommodates Stand & Display

FPSA/RC/EL

