



SAAB



IMPROVED PERFORMANCE, RELIABILITY AND FLEXIBILITY

R4A MkII Airborne AIS Transponder

The R4A MkII Airborne AIS transponder is the successor to the pioneering R4A transponder, which has been the preferred choice for qualified aircraft manufacturers and system integrators for more than 10 years.

The R4A MkII from Saab TransponderTech is fully interchangeable with the R4A but represents the latest generation of airborne AIS transponders, using state of the art Software Defined Radio (SDR) technology to achieve even further improved performance, reliability and flexibility.

The R4A MkII is developed specifically for airborne use, meeting the relevant requirements for on-board installation. R4A MkII can be installed either as a standalone unit or integrated with other on-board systems such as Mission Management Systems or Digital Map Generators.

Saab has been developing and producing military and commercial aircraft for more than 60 years, and the company has also a long tradition of integrating avionics. Based upon this knowledge and capability, every effort has been made to ensure the quality and reliability of the R4A MkII. We can also offer our customers access to Saab's global after sales support organisation.

The R4A MkII transponder is suitable for installation in a variety of aircraft, both aeroplanes and helicopters. The current applications vary from a standalone setup for a specific trial up to full integration into glass cockpits.



Installation of an R4A MkII significantly improves the situational awareness in Search and Rescue (SAR) and surveillance operations, and it is also an efficient tool for fleet management. The R4A MkII also supports encrypted communication using Saab's optional Secure AIS functionality.

Main features

- Full transceiver functionality, the transmission capability makes it possible to interrogate specific vessels.
- Selectable level of AIS operational mode (Autonomous transmission, User initiated transmission or Receive only).
- ARINC 429 interface for TSO approved GPS.
- Embedded DSC support for reception and transmission of any DSC symbols.
- Easy configuration and status check by Windows based configuration software.

R4A MkII Airborne AIS applications

- Search and Rescue (SAR); locate vessels in distress and communicate with them while help is on the way.
- Monitoring of Surface Traffic; to be able to keep track of AIS equipped vessels and their destinations.
- Maritime Surveillance/Coast Guard Patrol; together with radar systems, naval authorities can find vessels without AIS or with faulty AIS parameters, thus increasing security.
- Homing for Maritime Helicopter Operations; find the ship that the helicopters is supposed to land on.
- Fleet Management; to keep track of a fleet of helicopters serving for example oilrigs.
- Mission Control and Coordination; supports SAR and military operations involving several helicopters and vessels.

Optional functionality

- Saab Secure AIS, offering encrypted communication on a dedicated channel. This option also gives the possibility to manually or automatically download the transponders internal AIS target list to other units.
- NATO encryption modes according to STANAG 4668 Edition 2.
- Output of data over ARINC 429.
- The R4A MkII can be delivered together with Saab's Electronic Chart Display software "SeaWatch", if a quickly deployed standalone AIS solution is desired.

The R4A MkII transponder is extensively qualified towards RTCA DO-160G, to a level which makes it possible to install the unit in most compartments of an aircraft.

The transponder contains a controller, a GPS receiver, three independent VHF receivers and one transmitter, which alternates transmissions between the operating TDMA channels.

Technical specification

Physical

Size W x H x D:	280 x 85 x 144 (mm)
Weight:	≤ 2.3 kg

Power

Input (main):	28 VDC (MIL-C-38999 series 3)
Power Consumption:	≤ 20 W (60 W peak)

GPS Receiver

Receiver:	50 channels
Frequency:	L1 (1575 MHz)
Update Rate:	1 Hz

Cooling

No forced air cooling is required

Electrical Interfaces

4 RS422 Data Ports (MIL-C-38999 series 3)
1 Tx 2 Rx ARINC 429
Ethernet 10/100/1000 Mbit
GPS 1pps input
GPS 50 ohm antenna connector (TNC female) VHF 50 ohm antenna connector (N female)

Currently the R4A transponders operates daily in many aircraft types including helicopters, aeroplanes and UAVs. The transponder receives data from AIS equipped vessels and other AIS stations within VHF coverage of the aircraft, and if transmission is enabled data can also be sent to other units. The received data is output on standard AIS format and made available for processing by for example an external display system. The map to the right shows a plot from a flight test with FSR890, which is a Swedish military surveillance aircraft. The ships most far away are more than 200 nautical miles from the aircraft.

The R4A MkII Airborne AIS transponder is an excellent tool for improving situational awareness, and a powerful complement to an existing shore based AIS network.

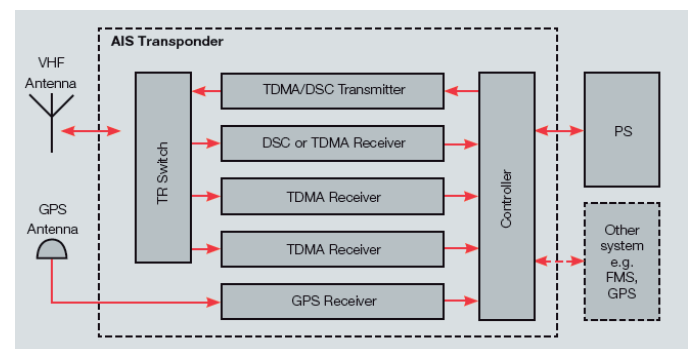

Plot from a flight test with Swedish military surveillance aircraft FSR890 at altitude 6000 m.

VHF Transceiver

Frequency:	155-163 MHz; Optional 136-166 MHz
Channel Bandwidth:	25 kHz
Output power:	1/12.5 W
Receiver sensitivity:	<-115dBm Marine Band (<-111dBm full frequency range)
Bit Rate:	9600 bps
Modulation:	GMSK/FM/FSK
Interval between position reports:	1-60 sec
One transmitter, Three receivers	

Applicable Standards

RTCA DO-160G Environmental Conditions and Test Procedures for Airborne Equipment
ITU-R recommendation for AIS (ITU-R M. 1371-5)
RTCA DO-178B Software Considerations in Airborne Systems
IEC 61993-2
IEC 61162
ARINC 429

