

MCE & MSCE

**Mini electric
cylinders & sliders**



Every care has been taken to ensure the accuracy of the information contained in this catalogue, but no liability can be accepted for any errors or omissions. We reserve the right to make changes without prior notice.

Any reproduction, even partial, is allowed only by written permission by Rollco.

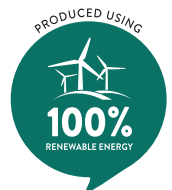

Index

PRODUCT OVERVIEW	4
Mini electric cylinder MCE & Mini Electric Slider MSCE	4
PRODUCT RANGE	6
Mini electric cylinder MCE	6
Mini electric slider MSCE	20
ACCESSORIES	36
Motor adapter VK	39
Motor side drive MSD with a timing belt	42
Rod eye SGS	45
Rod clevis SG	45
Clamping fixture	46
Self-aligning joint FK	47
Coupling piece KSZ	48
Slot nut	48
Centering ring	49
Flange mounting MAFL	49
Foot mounting MAHP	50
Swivel/clevis mount MASU	51
Swivel foot mounting MLG	52
Clevis foot mounting MLBU	52
Back mount ABM	53
Trunnion mount MZK	54
Trunnion support MLZ	54
Guiding unit GUC	55
Magnetic field sensor and the sensor holder HMG	60
TECHNICAL INFORMATION	62
Mini electric cylinder MCE	62
Mini electric slider MSCE	80
Motor types and sizes	101
Drive types	104
Drive-motor cables	106
Power and signal cables	108
MOUNTING EXAMPLES	109
x-y configuration with the x-axis: MCE + the guiding unit GUC	109
x-z configuration with the x-axis: MCE + the guiding unit GUC	110
x-y configuration with the x-axis: MSCE (y-axis is mounted to the front plate)	110
x-y configuration with the x-axis: MSCE (y-axis is mounted to the slide)	111
x-z configuration with the x-axis: MSCE (z-axis is mounted to the front plate)	111
SERVICE LIFE	112
Linear guiding	112
Ball screw drive	115
Mini electric cylinder MCE	117
Mini electric slider MSCE	117
CALCULATIONS	118
Load torque	118

Product overview

Mini electric cylinder MCE & Mini Electric Slider MSCE

Characteristics

Mini electric cylinder and sliders are small linear drives. The MCE has a piston rod and the MSCE has an integrated linear guiding system and slide.

By using an integrated precision ball screw drive, the rotary motion (rotation) of the drive shaft is converted to linear motion (translation) of the piston rod or slide with high mechanical efficiency and low internal friction.

High-performance features such as high speed, good positioning accuracy, and high repeatability are ensured through a precision ball screw drive and an anti-rotating piston rod device or a linear guiding system.

A preassembled standard motor (in-line with a motor adapter and a coupling or in-parallel with a motor side drive and a timing belt) together with the standard drive, makes the system plug and play ready. Compact dimensions and optimally selected motor combinations cover a wide range of applications.

The aluminium cylinder profile includes T-slots on the bottom for fixing the electric cylinder/slider, as well as side slots for clamping fixtures and magnetic field sensors.

Excellent price-performance ratio and a quick delivery time, due to standard lengths, are ensured.

Each MCE/MSCE is optimally pre-lubricated and ready for a maintenance-free operating process. MCE/MSCE allows relatively high load capacities and optimal cycles for moving the larger payloads at high speeds in both horizontal and vertical directions.

The aluminium profiles are manufactured according to the medium EN 12020-2 standard.

Motor adapter VK with a coupling and a motor

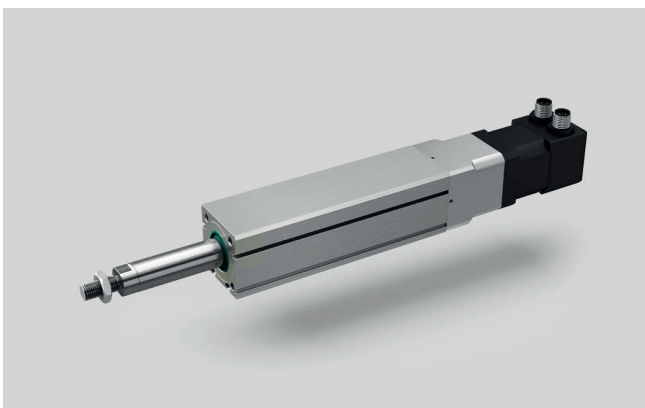

MCE

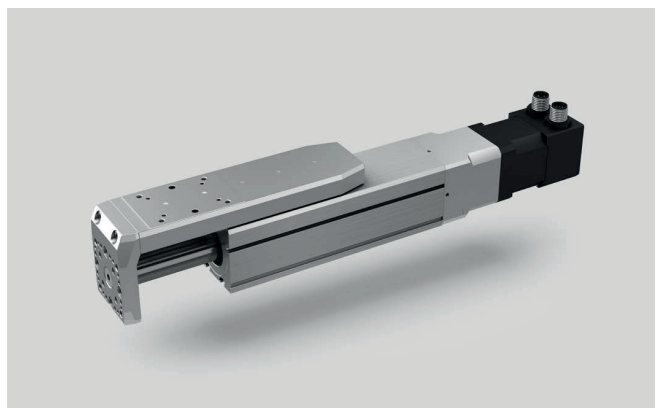

MSCE

Motor side drive with timing a belt and a motor

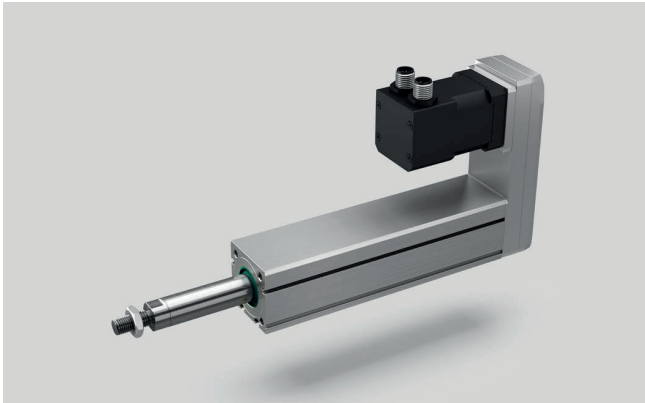

MCE

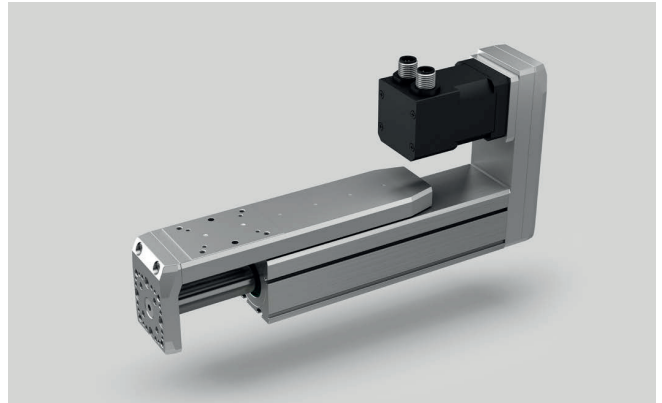

MSCE

Multi-axis system

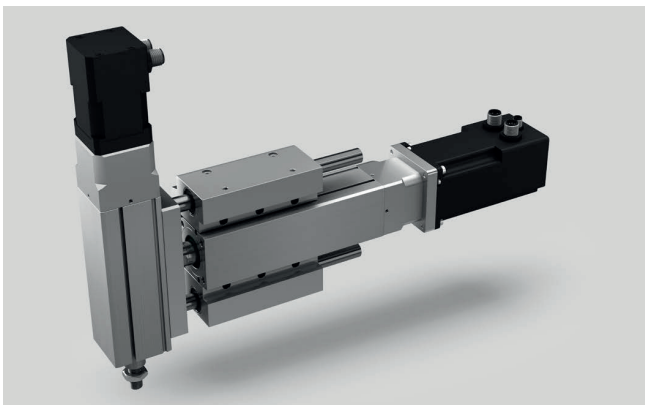

MCE (guiding unit GUC is used)

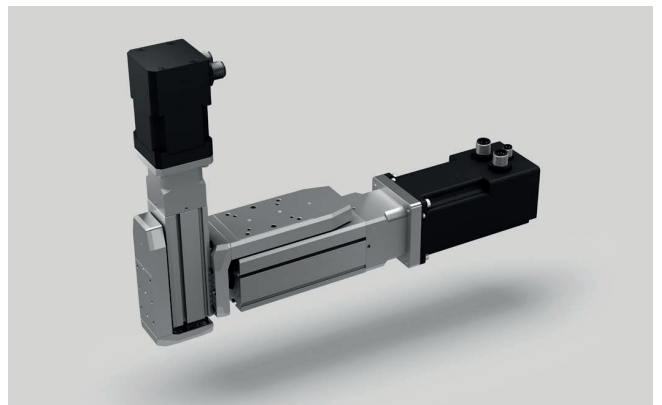

MSCE

Accessories

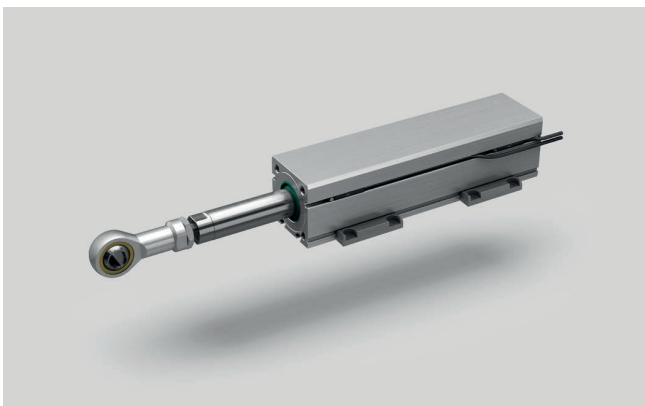

MCE (without a preassembled motor)

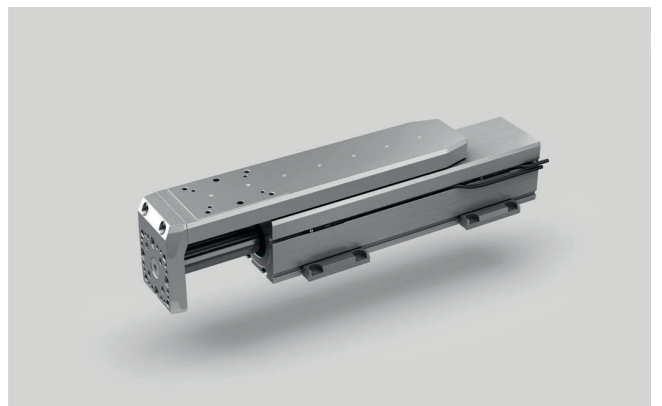

MSCE (without a preassembled motor)

Product range

Mini electric cylinder MCE

Mini electric cylinder MCE is a mini linear drive with a piston rod.

An optional standard motor (in-line with a motor adapter and a coupling or in-parallel with a motor sidedrive and a timing belt) together with the standard drive, makes the system plug and play ready. Compact dimensions and optimally selected motor combinations cover a wide range of applications.

The aluminium cylinder profile includes T-slots on the bottom for fixing the electric cylinder, as well as side slots for clamping fixtures and magnetic field sensors.

Options, such as female piston rod end and extended piston rod, together with a wide range of accessories make this product highly flexible. There is also an option of the mini electric cylinder without the preassembled motor if an individual motor is required.

For applications, where higher resistance to lateral loads or torsional moments is required, a guiding unit GUC can be used. By using the guiding unit, which offers high precision guiding and positioning, the mini electric cylinders can easily be combined to the multi-axis systems.

Each MCE is optimally pre-lubricated and ready for a maintenance-free operating process.

Designation	Maximum permissible axial load [N]	Maximum travel speed [m/s]	Maximum stroke [mm]	Maximum repeatability [mm]**	Dimensions	
					Width [mm]*	Height [mm]*
MCE 25	170	0,45	200	±0,015	25,0	25,0
MCE 32	375	0,60	200	±0,015	32,0	32,0
MCE 45	695	0,75	200	±0,015	45,0	45,0

* Cylinder profile.

** Valid for one-directional axial load.

Structural design

Combination with a standard motor and a motor adapter VK

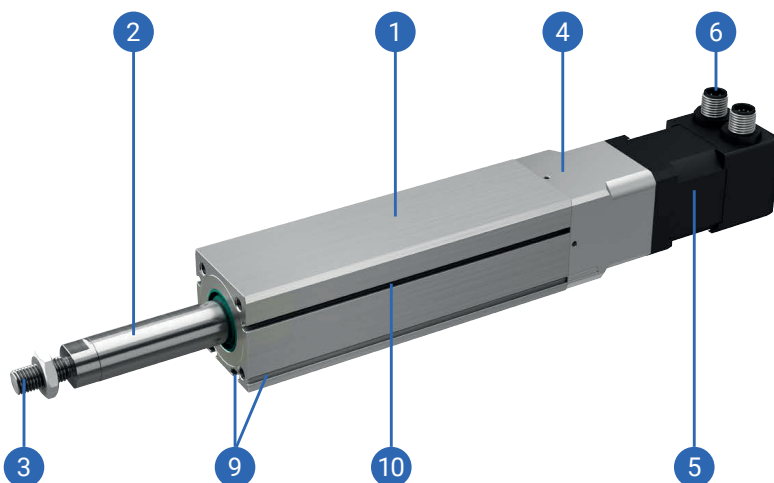

Combination with a standard motor and a motor side drive MSD

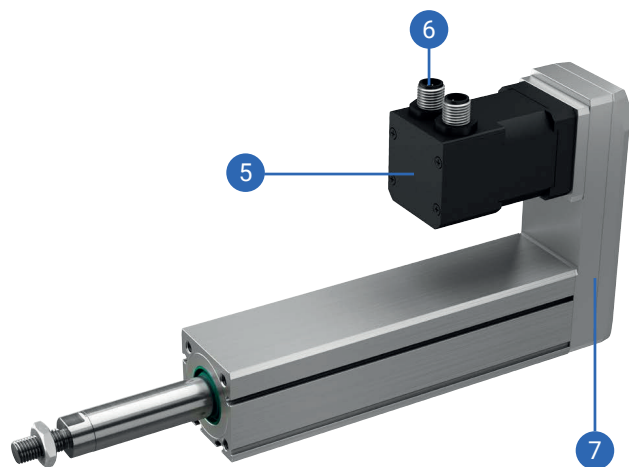

Without a motor

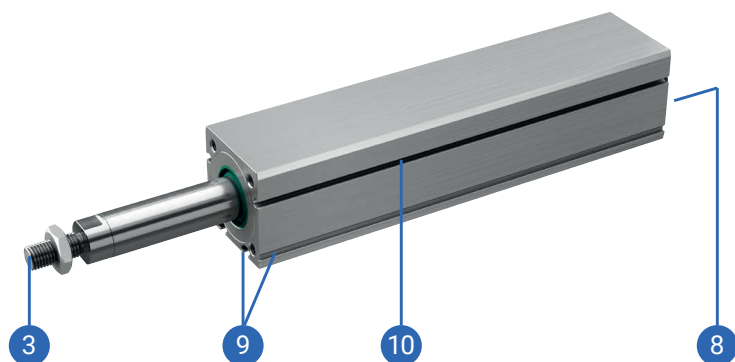

- 1 - Compact aluminium cylinder profile
- 2 - Piston rod (stainless steel) with an anti-rotation device
- 3 - Piston rod end (optionally a female thread is available)
- 4 - Motor adapter VK with a coupling
- 5 - Preassembled motor (with/without brake)
- 6 - Standard connectors (motor, encoder and brake - optionally)
- 7 - Motor side drive with a timing belt
- 8 - Drive shaft of a precision ball screw drive
- 9 - Slots for mounting
- 10 - Slots for the magnetic field sensors (size 32 and 45) or mounting the sensor holder (size 25)

Technical data

General technical data

Designation	Ball screw ⁴	Dynamic axial load capacity ¹	Axial backlash (BS) ²	Max. angle of piston rod rotation ³	Max. repeatability ⁵	Absolute stroke
	d × l [mm]	C _a [N]	[mm]	[°]	[mm]	[mm]
MCE 25	6 × 2	1900	≤ 0,05	≤ ±1	±0,015	25, 50, 75, 100, 125, 150, 175, 200
MCE 25	6 × 6	1700	≤ 0,05	≤ ±1	±0,015	25, 50, 75, 100, 125, 150, 175, 200
MCE 32	8 × 2	2000	≤ 0,06	≤ ±1	±0,015	25, 50, 75, 100, 125, 150, 175, 200
MCE 32	8 × 8	1500	≤ 0,06	≤ ±1	±0,015	25, 50, 75, 100, 125, 150, 175, 200
MCE 45	10 × 3	3500	≤ 0,06	≤ ±1	±0,015	25, 50, 75, 100, 125, 150, 175, 200
MCE 45	10 × 10	3200	≤ 0,06	≤ ±1	±0,015	25, 50, 75, 100, 125, 150, 175, 200

¹ Dynamic axial load capacity of the ball screw drive. This value is the basis for calculating the service life.

² Valid for ball screw drive in new condition.

³ Regarding to anti-rotation piston rod device in new condition.

⁴ d = ball screw nominal diameter, l = ball screw lead (for one revolution).

⁵ Valid for one-directional axial load.

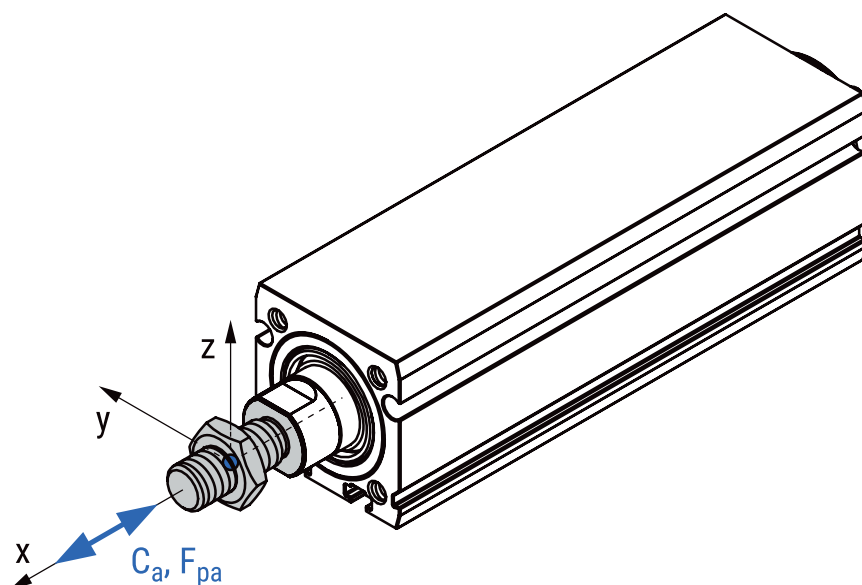

Drive data

Combination with a standard motor and a motor adapter VK

Designation	Ball screw d × l [mm]	Motor		Max. permissible axial load ^{1, 2} F _{pa} [N]	Max. permissible payload	
		Type	Size □ [mm]		Horizontal ^{2, 3} m _{ph} [kg]	Vertical ² m _{pv} [kg]
MCE 25 motor VK	6 × 2	Stepper	28	170	57	14
MCE 25 motor VK	6 × 6	Stepper	28	90	13	7,4
MCE 32 motor VK	8 × 2	Stepper	28	215	72	18
MCE 32 motor VK	8 × 2	Stepper	42	375	126	31
MCE 32 motor VK	8 × 8	Stepper	28	50	6,6	4,0
MCE 32 motor VK	8 × 8	Stepper	42	200	35	17
MCE 45 motor VK	10 × 3	Stepper	42	465	156	39
MCE 45 motor VK	10 × 3	Stepper	56	695	233	58
MCE 45 motor VK	10 × 10	Stepper	42	135	21	11
MCE 45 motor VK	10 × 10	Stepper	56	580	133	49

Designation	Ball screw d × l [mm]	Motor		Max. travel speed ² v _{max} [m/s]	Max. rotational speed n _{max} [rev/min]	Max. acceleration a _{max} [m/s ²]
		Type	Size □ [mm]			
MCE 25 motor VK	6 × 2	Stepper	28	0,100	3000	20
MCE 25 motor VK	6 × 6	Stepper	28	0,300	3000	20
MCE 32 motor VK	8 × 2	Stepper	28	0,094	2810	20
MCE 32 motor VK	8 × 2	Stepper	42	0,100	3000	20
MCE 32 motor VK	8 × 8	Stepper	28	0,400	3000	20
MCE 32 motor VK	8 × 8	Stepper	42	0,400	3000	20
MCE 45 motor VK	10 × 3	Stepper	42	0,150	3000	20
MCE 45 motor VK	10 × 3	Stepper	56	0,150	3000	20
MCE 45 motor VK	10 × 10	Stepper	42	0,492	2950	20
MCE 45 motor VK	10 × 10	Stepper	56	0,500	3000	20

¹ This value depends on the selected motor, travel speed and acceleration of the piston rod

² Valid for the entire stroke range. Guiding unit GUC is not taken into consideration.

³ Valid for the payload supported by an external guiding (coefficient of friction 0,1 is taken into consideration).

□ = Square cross section

PRODUCT RANGE

Combination with a standard motor and a motor side drive MSD

Designation	Ball screw d × l [mm]	Motor		Max. permissible axial load ^{1, 2} F _{pa} [N]	Max. permissible payload	
		Type	Size □ [mm]		Horizontal ^{2, 3} m _{ph} [kg]	Vertical ² m _{pv} [kg]
MCE 25 motor MSD	6 × 2	Stepper	28	170	57	14
MCE 25 motor MSD	6 × 6	Stepper	28	90	13	7,4
MCE 32 motor MSD	8 × 2	Stepper	28	180	60	15
MCE 32 motor MSD	8 × 2	Stepper	42	375	126	31
MCE 32 motor MSD	8 × 8	Stepper	28	40	6,8	3,1
MCE 32 motor MSD	8 × 8	Stepper	42	175	35	15
MCE 45 motor MSD	10 × 3	Stepper	42	400	134	33
MCE 45 motor MSD	10 × 3	Stepper	56	695	233	58
MCE 45 motor MSD	10 × 10	Stepper	42	120	20	10
MCE 45 motor MSD	10 × 10	Stepper	56	450	133	38

Designation	Ball screw d × l [mm]	Motor		Max. travel speed ² v _{max} [m/s]	Max. rotational speed n _{max} [rev/min]	Max. acceleration a _{max} [m/s ²]
		Type	Size □ [mm]			
MCE 25 motor MSD	6 × 2	Stepper	28	0,100	3000	20
MCE 25 motor MSD	6 × 6	Stepper	28	0,300	3000	20
MCE 32 motor MSD	8 × 2	Stepper	28	0,064	1920	20
MCE 32 motor MSD	8 × 2	Stepper	42	0,100	3000	20
MCE 32 motor MSD	8 × 8	Stepper	28	0,208	1560	20
MCE 32 motor MSD	8 × 8	Stepper	42	0,400	3000	20
MCE 45 motor MSD	10 × 3	Stepper	42	0,148	2960	20
MCE 45 motor MSD	10 × 3	Stepper	56	0,150	3000	20
MCE 45 motor MSD	10 × 10	Stepper	42	0,477	2860	20
MCE 45 motor MSD	10 × 10	Stepper	56	0,500	3000	20

¹ This value depends on the selected motor, travel speed and acceleration of the piston rod

² Valid for the entire stroke range. Guiding unit GUC is not taken into consideration.

³ Valid for the payload supported by an external guiding (coefficient of friction 0,1 is taken into consideration).

□ = Square cross section

Without a motor

Designation	Ball screw d × l [mm]	Max. permissible axial load ² F _{pa} [N]	Max. permissible payload		Max. drive torque M _p [Nm]	No load torque M ₀ [Nm]
			Horizontal ^{2, 3} m _{ph} [kg]	Vertical ² m _{pv} [kg]		
MCE 25	6 × 2	170	57	14	0,06	0,02
MCE 25	6 × 6	90	30	7	0,10	0,02
MCE 32	8 × 2	375	126	31	0,13	0,04
MCE 32	8 × 8	375	126	31	0,53	0,05
MCE 45	10 × 3	695	233	58	0,37	0,07
MCE 45	10 × 10	695	233	58	1,23	0,09

Designation	Ball screw d × l [mm]	Max. permissible radial load on shaft F _{pr} [N]	Max. travel speed ² v _{max} [m/s]	Max. rotational speed n _{max} [rev/min]	Max. acceleration a _{max} [m/s ²]
MCE 25	6 × 6	25	0,450	4500	20
MCE 32	8 × 2	50	0,150	4500	20
MCE 32	8 × 8	50	0,600	4500	20
MCE 45	10 × 3	100	0,225	4500	20
MCE 45	10 × 10	100	0,750	4500	20

¹ This value depends on the selected motor, travel speed and acceleration of the piston rod

² Valid for the entire stroke range. Guiding unit GUC is not taken into consideration.

³ Valid for the payload supported by an external guiding (coefficient of friction 0,1 is taken into consideration).

Recommended values of loads:

All the data of the dynamic load capacities (ball screw drive) stated in the tables above are theoretical without considering any safety factor. The safety factor depends on the application and its requested safety and service life.

We recommend a minimum dynamic safety factor of 5,0 or more. Please refer to the Ball screw drive section, where calculation of the safety factor of the ball screw drive and how the applied load affects the service life are presented.

Mass and mass moment of inertia

Designation	Ball screw d × l [mm]	Moved mass* m _{m, MCE} [kg]	Mass of the mini electric cylinder** m _{MCE} [kg]	Mass moment of inertia J _{MCE} [10 ⁻² kg cm ²]
MCE 25	6 × 2	0,06 + 0,0004 × Abs. stroke + 0,0004 × E	0,15 + 0,0013 × Abs. stroke + 0,0004 × E	0,28 + 0,0007 × Abs. stroke + 0,00004 × E + 0,1013 × m _{load}
MCE 25	6 × 6	0,06 + 0,0004 × Abs. stroke + 0,0004 × E	0,15 + 0,0013 × Abs. stroke + 0,0004 × E	0,33 + 0,0011 × Abs. stroke + 0,00036 × E + 0,9119 × m _{load}
MCE 32	8 × 2	0,12 + 0,0005 × Abs. stroke + 0,0005 × E	0,31 + 0,0023 × Abs. stroke + 0,0005 × E	0,70 + 0,0025 × Abs. stroke + 0,00005 × E + 0,1013 × m _{load}
MCE 32	8 × 8	0,12 + 0,0005 × Abs. stroke + 0,0005 × E	0,31 + 0,0023 × Abs. stroke + 0,0005 × E	0,88 + 0,0033 × Abs. stroke + 0,00077 × E + 1,6211 × m _{load}
MCE 45	10 × 3	0,20 + 0,0010 × Abs. stroke + 0,0010 × E	0,67 + 0,0043 × Abs. stroke + 0,0010 × E	2,77 + 0,0057 × Abs. stroke + 0,00022 × E + 0,2280 × m _{load}
MCE 45	10 × 10	0,20 + 0,0010 × Abs. stroke + 0,0010 × E	0,67 + 0,0043 × Abs. stroke + 0,0010 × E	3,23 + 0,0081 × Abs. stroke + 0,00249 × E + 2,5330 × m _{load}

* The moved mass is already considered in the equation for calculating the mass of the mini electric cylinder m_{MCE} and the mass moment of inertia J_{MCE}. The moved mass includes the mass of the piston rod with the internal anti-rotation device and ball nut.

** For combination with standard motor and motor adapter VK or motor side drive MSD this mass m_{MCE} should be increased by m_{VK+m} or m_{MSD+m} respectively.

Mass and moved mass of the guiding unit GUC are not included in the moved mass m_{m,MCE} in the mass m_{MCE} and in the mass moment of inertia J_{MCE}.

Please refer to the Guiding unit section for more information.

Abs. stroke	Absolute stroke [mm]
E	Extended piston rod [mm]
m_{load}	Applied mass to be moved [kg]

Additional mass of an electric cylinder when combining the motor with the motor adapter VK or the motor side drive MSD

Designation	Motor		Motor without a brake		Motor with a brake	
	Type	Size □ [mm]	Mass of the motor and motor adapter VK m_{VK+m} [kg]	Mass of the motor and motor side drive MSD m_{MSD+m} [kg]	Mass of the motor and motor adapter VK m_{VK+m} [kg]	Mass of the motor and motor side drive MSD m_{MSD+m} [kg]
MCE 25	Stepper	28	Available soon			
MCE 32	Stepper	28	Available soon			
MCE 32	Stepper	42	0,52	0,62	0,65	0,75
MCE 45	Stepper	42	0,57	0,71	0,70	0,84
MCE 45	Stepper	56	1,31	1,49	1,50	1,68

Planar moment of inertia

Designation	Cylinder profile	
	I_y [cm ⁴]	I_z [cm ⁴]
MCE 25	2,10	1,98
MCE 32	6,42	6,58
MCE 45	25,37	25,16

Holding torque of a motor brake

Type	Motor	Holding torque (brake) [Nm]
	Size □ [mm]	
Stepper	28	Available soon
Stepper	42	0,4
Stepper	56	1,0

□ = Square cross section

Dimensions

All dimensions are in mm. The scale of the drawings may not be equal.

MCE in combination with a standard motor and a motor adapter VK

- * E1: motor connection
- E2: encoder connection
- E3: brake connection
- ** ... + Abs. position

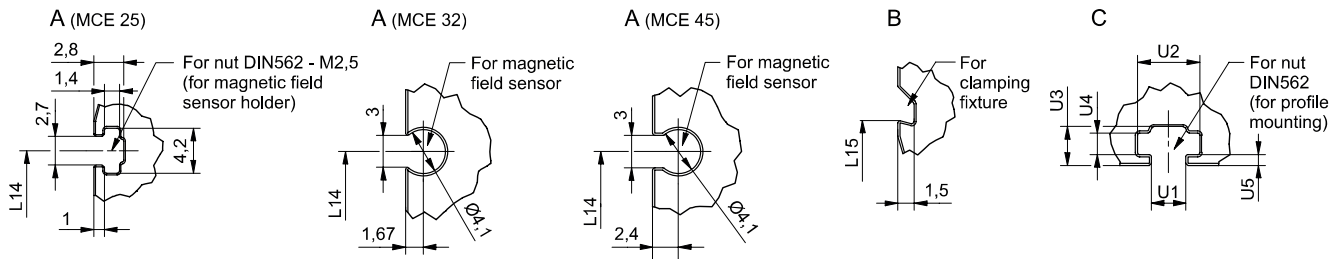
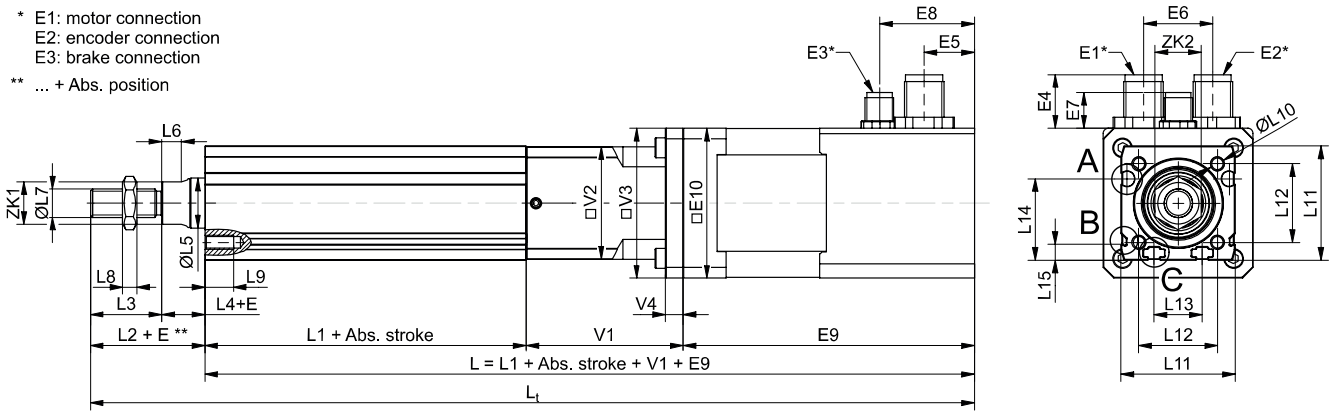

MCE in combination with a standard motor and a motor side drive MSD

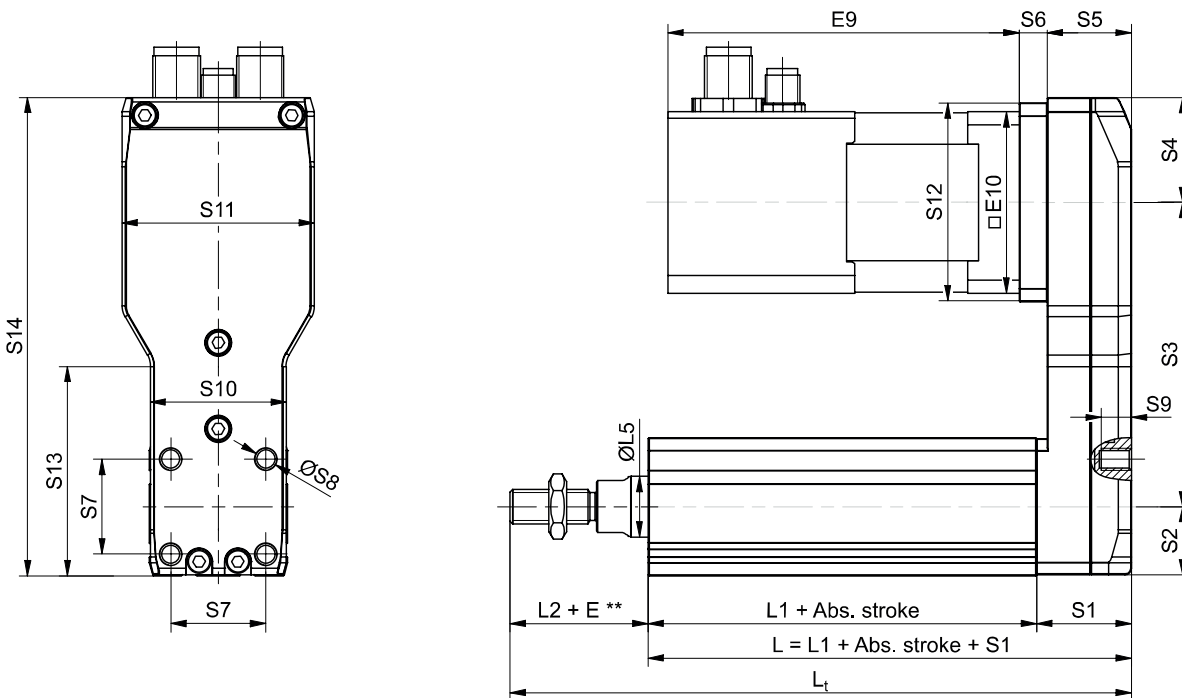

MCE without a motor

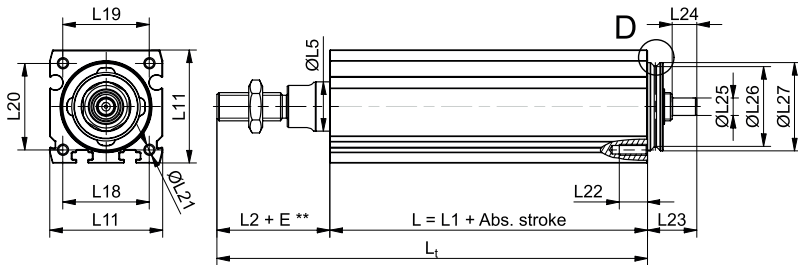

Female thread

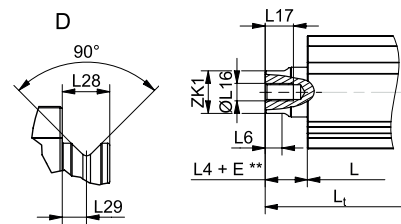

MCE dimensions

Designation	L1	L2	L3	L4	ØL5	L6	ØL7	L8	L9	ØL10	L11	L12
MCE 25	50	26	16	10	12	3,5	M6 x 1	3,2	8	M2,5	25	21
MCE 32	65	32	20	12	14	5,5	M8 x 1,25	4	8	M4	32	22
MCE 45	80	38	22	16	18	7	M10 x 1,25	5	12	M6	45	32

Designation	L13	L14	L15	ØL16	L17	L18	L19	L20	ØL21	L22	L23	L24
MCE 25	13,5	19,25	4,4	M4	8	19	17	18	M2,5	8	14	7
MCE 32	13,5	22,8	4,4	M5	8	24,5	24,5	24,5	M3	8	14	7
MCE 45	20	30,5	4,4	M6	12	34	34	34	M4	10	16	8

Designation	ØL25 (h7)	ØL26	ØL27 (h7)	L28	L29	ZK1	ZK2	U1	U2	U3	U4	U5
MCE 25	5	17,6	20	4,5	2,3	10	10	2,2	4,2	2,8	1,4	1
MCE 32	5	22,6	25	4,5	2,3	12	13	3,2	5,8	3,6	2	1
MCE 45	8	31,6	34	4,5	2,3	16	17	4,2	7,5	4,7	2,5	1,2

PRODUCT RANGE

Motor adapter VK and a motor side drive MSD dimensions

Designation	Motor		V1	□V2	□V3	V4	S1	S2	S3 (±0,5)	S4	S5
	Type	Size □ [mm]									
MCE 25	Stepper	28	35	24,5	28	5,5	22	12,5	52,5	18,25	19,5
MCE 32	Stepper	28	35	31,5	31,5	0	22	16,0	52,5	18,25	19,5
MCE 32	Stepper	42	40	31,5	42	5,5	22	16,0	70,5	24,25	19,5
MCE 45	Stepper	42	42	44,5	44,5	0	27,5	22,5	81	24,75	24,5
MCE 45	Stepper	56	46	44,5	56,4	9,5	27,5	22,5	88,5	33,25	24,5

Designation	Motor		S6	S7	ØS8	S9	S10	S11	S12	S13	S14
	Type	Size □ [mm]									
MCE 25	Stepper	28	5,5	18	M4	6	24,5	31,5	34	38,5	83,25
MCE 32	Stepper	28	5,5	22	M5	7	31,5	31,5	34	0	86,75
MCE 32	Stepper	42	6,5	22	M5	7	31,5	44,5	46	48	110,75
MCE 45	Stepper	42	6,5	32	M6	7	44,5	44,5	46	0	128,25
MCE 45	Stepper	56	6	32	M6	7	44,5	59,5	59,5	64,5	144,25

□ = Square cross section

Motor dimensions

Motor			E1	E2	E3	E4 (±1)	E5 (±0,3)	E6	E7 (±1)	E8 (±0,3)	E9 (±1)	□E10
Type	Size □ [mm]	Brake										
Stepper	28	-										Available soon
Stepper	28	with										Available soon
Stepper	42	-	M12 5-pole	M12 8-pole	-	14	14	19,5	-	-	70,4	42,3
Stepper	42	with	M12 5-pole	M12 8-pole	M8 3-pole	14	14	19,5	9	27	106,4	42,3
Stepper	56	-	M12 5-pole	M12 8-pole	-	14	13,4	23	-	-	98	56,4
Stepper	56	with	M12 5-pole	M12 8-pole	M8 3-pole	14	52,4	23	9	12	138	56,4

□ = Square cross section



Order code

MCE - 45 - 1003 - 150 - F - E20 - 0 - AB - AU - AA - AB - AA

Series:

MCE

Size:

- 25
- 32
- 45

Ball screw size:

- MCE 25: $\varnothing 6 \times 2, \varnothing 6 \times 6$
- MCE 32: $\varnothing 8 \times 2, \varnothing 8 \times 8$
- MCE 45: $\varnothing 10 \times 3, \varnothing 10 \times 10$

Absolute stroke [mm]:

- (Absolute stroke = Effective stroke + 2 × Safety stroke)
- 25, 50, 75, 100, 125, 150, 175, 200

Option 1:

- Leave blank: Standard (male thread)
- F: Female thread

Option 2:

- Leave blank: Without
- Extended piston rod E [mm]
(Max. extended piston rod: $E_{max} = 100$ mm)

Guiding unit:

- 0: Without a guiding unit
- B: With a guiding unit GUC (ball bushes)

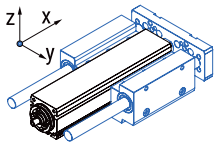

Guiding unit GUC requires a female thread on the piston rod end (Option 1 F).

Motor type and size:

- Leave blank: Without a motor

A

B

Motor type:

- A: Stepper motor without a brake
- B: Stepper motor with a brake

Motor size □:

- A: 28 mm (Available soon)
- B: 42 mm
- C: 56 mm

Available sizes:

- MSCE 25: 28
- MSCE 32: 28, 42
- MSCE 45: 42, 56

Motor mounting option:

- Leave blank: Without a motor

Mounting option:

- A: With a motor adapter VK
- B: With a motor side drive MSD facing up
- C: With a motor side drive MSD facing right
- D: With a motor side drive MSD facing down
- E: With a motor side drive MSD facing left

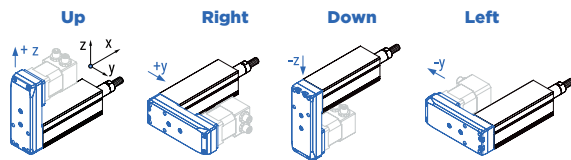

If a guiding unit GUC is considered, the motor side drive MSD can only be facing in the up or down directions, otherwise, the motor and the guiding unit may collide!

Direction of the motor connectors:

- U: Connectors facing up
- R: Connectors facing right
- D: Connectors facing down
- L: Connectors facing left

In combination with a motor adapter VK

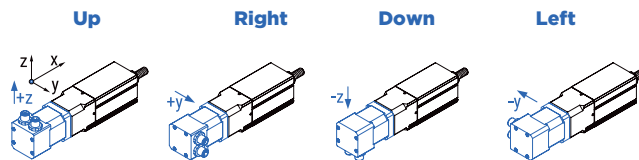

When using the motor side drive MSD, the connectors can not be facing the MCE otherwise, the connectors and MCE may collide. These combinations are: BD, CL, DU and ER.

In combination with a motor side drive MSD

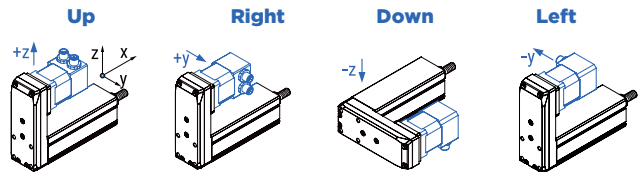

Drive option:

- Leave blank: Without a motor or drive

Drive type:

- A: Stepper

Drive protocol/control:

- A: EtherCAT
- B: Ethernet based communication
- C: Pulse-direction control

Drive-motor cables option:

- Leave blank: Without a motor or drive
- 00: Without the cables

Cables type:

- A: Robotic with a straight plug
- B: Robotic with an angled plug

Cables length:

- A: 3 m
- B: 5 m
- C: 10 m

Power and signal cables:

- Leave blank: Without a motor or drive

Power cable:

- 0: Without a power cable
- A: With a power cable

Signal cable:

- 0: Without a signal cable
- A: With a signal cable

Mini electric slider MSCE

Mini electric slider MSCE is a mini linear drive with an integrated linear guiding system and slide.

An optional standard motor (in-line with a motor adapter and a coupling or in-parallel with a motor side drive and a timing belt) together with the standard drive, makes the system plug and play ready. Compact dimensions and optimally selected motor combinations cover a wide range of applications.

The aluminium base profile includes T-slots on the bottom for fixing the electric slider, as well as side slots for clamping fixtures and magnetic field sensors.

The aluminium slide and the front plate of the electric slider allow a wide range of options for mounting the working tools and attaching additional accessories. There are prepared connection holes on the slide and the front plate for an easy combination of the MSCEs to the multiaxis system, which makes this product highly flexible. There is also an option of the mini electric slider without the preassembled motor if an individual motor is required.

Positioning rod together with the rod seal ensures the protection of the ball screw drive from dust and other contamination.

Each MSCE is optimally pre-lubricated and ready for a maintenance-free operating process.

Designation	Maximum permissible axial load [N]	Maximum travel speed [m/s]	Maximum stroke [mm]	Maximum repeatability [mm]***	Dimensions	
					Width [mm]*	Height [mm]**
MSCE 25	170	0,45	200	±0,015	25,0	36,5
MSCE 32	375	0,60	200	±0,015	32,0	45,0
MSCE 45	695	0,75	200	±0,015	45,0	60,5

* Base profile.

** Base profile + slide.

*** Valid for one-directional axial load.

Structural design

Combination with a standard motor and a motor adapter VK

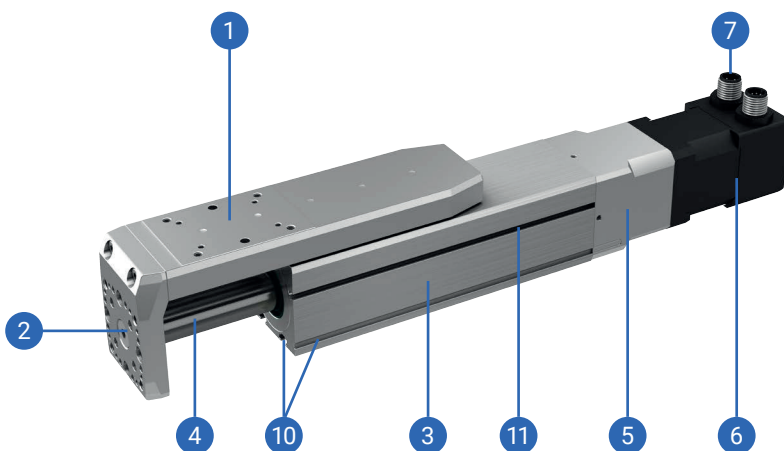

Combination with a standard motor and a motor side drive MSD

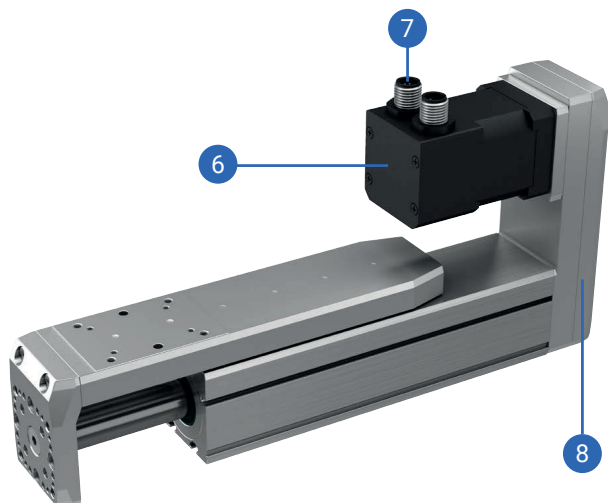

Without a motor

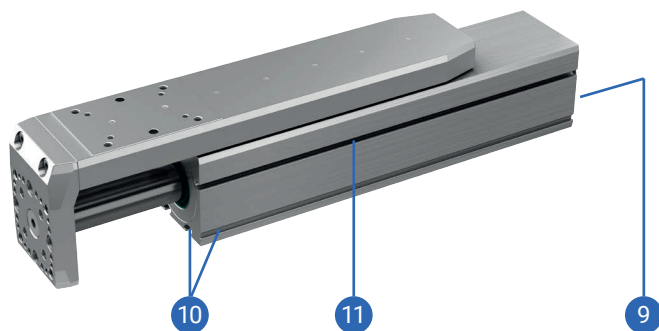

- 1 - Aluminium slide with an integrated linear guiding system
- 2 - Front plate
- 3 - Compact aluminium base profile
- 4 - Positioning rod
- 5 - Motor adapter VK with a coupling
- 6 - Preassembled motor (with/without a brake)
- 7 - Standard connectors (motor, encoder and a brake - optionally)
- 8 - Motor side drive with a timing belt
- 9 - Drive shaft of a precision ball screw drive
- 10 - Slots for mounting
- 11 - Slots for the magnetic field sensors (size 32 and 45) or mounting the sensor holder (size 25)

Technical data

General technical data

Designation	Ball screw ⁴ d × l [mm]	Dynamic axial load capacity ¹ C _a [N]	Dynamic load capacity ³ C [N]	Dynamic moments ³			Max. permissible loads				
				M _{dyn x} [Nm]	M _{dyn y} [Nm]	M _{dyn z} [Nm]	Forces		Moments		
							F _{py} [N]	F _{pz} [N]	M _{px} [Nm]	M _{py} [Nm]	M _{pz} [Nm]
MSCE 25	6 × 2	1900	1310	4,8	4,1	4,1	280	580	4,8	4,1	4,1
MSCE 25	6 × 6	1700	1310	4,8	4,1	4,1	280	580	4,8	4,1	4,1
MSCE 32	8 × 2	2000	2135	10,0	6,8	6,8	860	860	10,0	6,8	6,8
MSCE 32	8 × 8	1500	2135	10,0	6,8	6,8	860	860	10,0	6,8	6,8
MSCE 45	10 × 3	3500	3240	20,1	17,4	17,4	1000	1000	16,3	16,3	16,3
MSCE 45	10 × 10	3200	3240	20,1	17,4	17,4	1000	1000	16,3	16,3	16,3

Designation	Ball screw ⁴ d × l [mm]	Axial backlash (BS) ²	Max. repeatability ⁵	Absolute stroke
		[mm]	[mm]	[mm]
MSCE 25	6 × 2	≤ 0,05	±0,015	25, 50, 75, 100, 125, 150, 175, 200
MSCE 25	6 × 6	≤ 0,05	±0,015	25, 50, 75, 100, 125, 150, 175, 200
MSCE 32	8 × 2	≤ 0,06	±0,015	25, 50, 75, 100, 125, 150, 175, 200
MSCE 32	8 × 8	≤ 0,06	±0,015	25, 50, 75, 100, 125, 150, 175, 200
MSCE 45	10 × 3	≤ 0,06	±0,015	25, 50, 75, 100, 125, 150, 175, 200
MSCE 45	10 × 10	≤ 0,06	±0,015	25, 50, 75, 100, 125, 150, 175, 200

¹ Dynamic axial load capacity of the ball screw drive.

This value is the basis for calculating the service life.

² Valid for ball screw drive in new condition.

³ Dynamic load capacity and dynamic moments of the linear guiding system.

These values are the basis for calculating the service life.

⁴ d = ball screw nominal diameter, l = ball screw lead (for one revolution).

⁵ Valid for one-directional axial load.

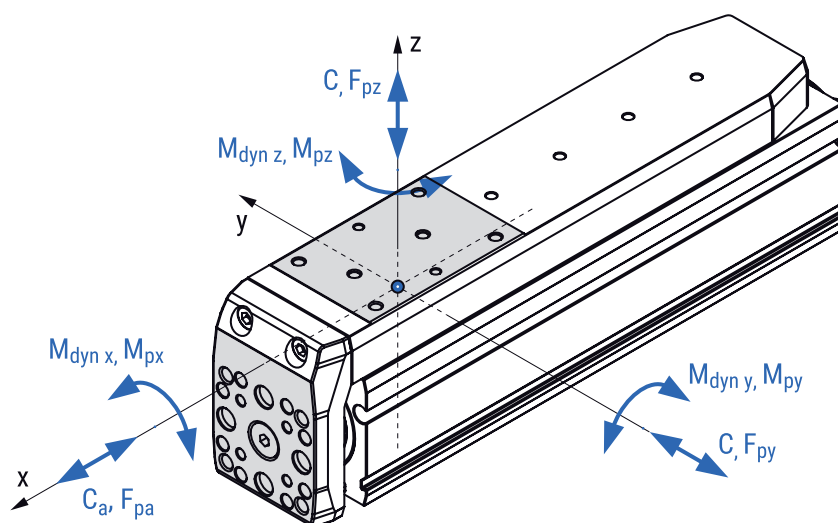

Drive data

Combination with a standard motor and a motor adapter VK

Designation	Ball screw d × l [mm]	Motor		Max. permissible axial load ^{1, 2} F _{pa} [N]	Max. permissible payload	
		Type	Size □ [mm]		Horizontal ^{2, 3} m _{ph} [kg]	Vertical ² m _{pv} [kg]
MSCE 25 motor VK	6 × 2	Stepper	28	170	57	14
MSCE 25 motor VK	6 × 6	Stepper	28	90	13	7,3
MSCE 32 motor VK	8 × 2	Stepper	28	185	62	15
MSCE 32 motor VK	8 × 2	Stepper	42	375	125	31
MSCE 32 motor VK	8 × 8	Stepper	28	45	6,4	3,4
MSCE 32 motor VK	8 × 8	Stepper	42	190	35	16
MSCE 45 motor VK	10 × 3	Stepper	42	450	150	37
MSCE 45 motor VK	10 × 3	Stepper	56	695	233	58
MSCE 45 motor VK	10 × 10	Stepper	42	125	21	10
MSCE 45 motor VK	10 × 10	Stepper	56	575	132	48

Designation	Ball screw d × l [mm]	Motor		Max. travel speed ² v _{max} [m/s]	Max. rotational speed n _{max} [rev/min]	Max. acceleration a _{max} [m/s ²]
		Type	Size □ [mm]			
MSCE 25 motor VK	6 × 2	Stepper	28	0,100	3000	20
MSCE 25 motor VK	6 × 6	Stepper	28	0,300	3000	20
MSCE 32 motor VK	8 × 2	Stepper	28	0,075	2240	20
MSCE 32 motor VK	8 × 2	Stepper	42	0,100	3000	20
MSCE 32 motor VK	8 × 8	Stepper	28	0,229	1720	20
MSCE 32 motor VK	8 × 8	Stepper	42	0,400	3000	20
MSCE 45 motor VK	10 × 3	Stepper	42	0,149	2980	20
MSCE 45 motor VK	10 × 3	Stepper	56	0,150	3000	20
MSCE 45 motor VK	10 × 10	Stepper	42	0,485	2910	20
MSCE 45 motor VK	10 × 10	Stepper	56	0,500	3000	20

¹ This value depends on the selected motor, travel speed and acceleration of the slide.

² Valid for the entire stroke range.

³ Valid for the payload to be pushed and supported by an external guiding (coefficient of friction 0,1 is taken into consideration).

□ = Square cross section

PRODUCT RANGE

Combination with a standard motor and a motor side drive MSD

Designation	Ball screw d × l [mm]	Motor		Max. permissible axial load ^{1, 2} F _{pa} [N]	Max. permissible payload	
		Type	Size □ [mm]		Horizontal ^{2, 3} m _{ph} [kg]	Vertical ² m _{pv} [kg]
MSCE 25 motor MSD	6 × 2	Stepper	28	170	57	14
MSCE 25 motor MSD	6 × 6	Stepper	28	80	13	6,5
MSCE 32 motor MSD	8 × 2	Stepper	28	150	50	12
MSCE 32 motor MSD	8 × 2	Stepper	42	375	125	31
MSCE 32 motor MSD	8 × 8	Stepper	28	35	6,6	2,5
MSCE 32 motor MSD	8 × 8	Stepper	42	175	35	14
MSCE 45 motor MSD	10 × 3	Stepper	42	380	127	31
MSCE 45 motor MSD	10 × 3	Stepper	56	695	233	58
MSCE 45 motor MSD	10 × 10	Stepper	42	115	19	9
MSCE 45 motor MSD	10 × 10	Stepper	56	450	132	37

Designation	Ball screw d × l [mm]	Motor		Max. travel speed ² v _{max} [m/s]	Max. rotational speed n _{max} [rev/min]	Max. acceleration a _{max} [m/s ²]
		Type	Size □ [mm]			
MSCE 25 motor MSD	6 × 2	Stepper	28	0,094	2810	20
MSCE 25 motor MSD	6 × 6	Stepper	28	0,281	2810	20
MSCE 32 motor MSD	8 × 2	Stepper	28	0,052	1560	20
MSCE 32 motor MSD	8 × 2	Stepper	42	0,100	3000	20
MSCE 32 motor MSD	8 × 8	Stepper	28	0,173	1300	20
MSCE 32 motor MSD	8 × 8	Stepper	42	0,400	3000	20
MSCE 45 motor MSD	10 × 3	Stepper	42	0,146	2920	20
MSCE 45 motor MSD	10 × 3	Stepper	56	0,150	3000	20
MSCE 45 motor MSD	10 × 10	Stepper	42	0,457	2740	20
MSCE 45 motor MSD	10 × 10	Stepper	56	0,500	3000	20

¹ This value depends on the selected motor, travel speed and acceleration of the slide.

² Valid for the entire stroke range.

³ Valid for the payload to be pushed and supported by an external guiding (coefficient of friction 0,1 is taken into consideration).

□ = Square cross section

Without a motor

Designation	Ball screw d × l [mm]	Max. permissible axial load ² F _{pa} [N]	Max. permissible payload		Max. drive torque M _p [Nm]	No load torque M ₀ [Nm]
			Horizontal ^{2, 3} m _{ph} [kg]	Vertical ² m _{pv} [kg]		
MSCE 25	6 × 2	170	57	14	0,06	0,03
MSCE 25	6 × 6	90	30	7	0,10	0,03
MSCE 32	8 × 2	375	125	31	0,13	0,05
MSCE 32	8 × 8	375	125	31	0,53	0,06
MSCE 45	10 × 3	695	233	58	0,37	0,08
MSCE 45	10 × 10	695	233	58	1,23	0,10

Designation	Ball screw d × l [mm]	Max. permissible radial load on shaft F _{pr} [N]	Max. travel speed ² v _{max} [m/s]	Max. rotational speed n _{max} [rev/min]	Max. acceleration a _{max} [m/s ²]
MSCE 25	6 × 6	25	0,450	4500	20
MSCE 32	8 × 2	50	0,150	4500	20
MSCE 32	8 × 8	50	0,600	4500	20
MSCE 45	10 × 3	100	0,225	4500	20
MSCE 45	10 × 10	100	0,750	4500	20

¹ This value depends on the selected motor, travel speed and acceleration of the slide.

² Valid for the entire stroke range.

³ Valid for the payload to be pushed and supported by an external guiding (coefficient of friction 0,1 is taken into consideration).

Recommended values of loads:

All the data of the dynamic load capacities (linear guiding system and ball screw drive) stated in the tables above are theoretical without considering any safety factor. The safety factor depends on the application and its requested safety and service life.

We recommend a minimum dynamic safety factor of 5,0 or more. Please refer to the Linear guiding and the Ball screw drive section, where the calculation of the safety factor of the ball screw drive and the linear guiding system and how the applied load affects the service life are presented.

Mass and mass moment of inertia

Designation	Ball screw		Moved mass*	Mass of the mini electric cylinder**	Mass moment of inertia
	d × l [mm]		$m_{m, MSCE}$ [kg]	m_{MSCE} [kg]	J_{MSCE} [10 ⁻² kg cm ²]
MSCE 25	6 × 2		0,10 + 0,0010 × Abs. stroke	0,20 + 0,0019 × Abs. stroke	0,29 + 0,0007 × Abs. stroke + 0,1013 × m_{load}
MSCE 25	6 × 6		0,10 + 0,0010 × Abs. stroke	0,20 + 0,0019 × Abs. stroke	0,36 + 0,0016 × Abs. stroke + 0,9119 × m_{load}
MSCE 32	8 × 2		0,18 + 0,0013 × Abs. stroke	0,40 + 0,0032 × Abs. stroke	0,71 + 0,0026 × Abs. stroke + 0,1013 × m_{load}
MSCE 32	8 × 8		0,18 + 0,0013 × Abs. stroke	0,40 + 0,0032 × Abs. stroke	0,99 + 0,0047 × Abs. stroke + 1,6211 × m_{load}
MSCE 45	10 × 3		0,36 + 0,0025 × Abs. stroke	0,88 + 0,0059 × Abs. stroke	2,81 + 0,0061 × Abs. stroke + 0,2280 × m_{load}
MSCE 45	10 × 10		0,36 + 0,0025 × Abs. stroke	0,88 + 0,0059 × Abs. stroke	3,63 + 0,0121 × Abs. stroke + 2,5330 × m_{load}

* The moved mass is already considered in the equation for calculating the mass of the mini electric slider mMSCE and the mass moment of inertia JMSCE. The moved mass includes the mass of the aluminium slide together with the front plate and positioning rod with the ball nut.

** For combination with standard motor and motor adapter VK or motor side drive MSD this mass mMSCE should be increased by mVK+m or mMSD+m respectively, see the table below.

Abs. stroke	Absolute stroke [mm]
m_{load}	Applied mass to be moved [kg]

Additional mass of an electric cylinder when combining the motor with the motor adapter VK or the motor side drive MSD

Designation	Motor		Motor without a brake		Motor with a brake	
	Type	Size □ [mm]	Mass of the motor and motor adapter VK m_{VK+m} [kg]	Mass of the motor and motor side drive MSD m_{MSD+m} [kg]	Mass of the motor and motor adapter VK m_{VK+m} [kg]	Mass of the motor and motor side drive MSD m_{MSD+m} [kg]
MSCE 25	Stepper	28	Available soon	Available soon	Available soon	Available soon
MSCE 32	Stepper	28	Available soon	Available soon	Available soon	Available soon
MSCE 32	Stepper	42	0,52	0,62	0,65	0,75
MSCE 45	Stepper	42	0,57	0,71	0,70	0,84
MSCE 45	Stepper	56	1,31	1,49	1,50	1,68

□ = Square cross section

Planar moment of inertia

Designation	Slide		Base profile	
	I_y [cm ⁴]	I_z [cm ⁴]	I_y [cm ⁴]	I_z [cm ⁴]
MSCE 25	0,08	0,88	2,10	1,98
MSCE 32	0,18	2,16	6,42	6,58
MSCE 45	0,40	7,34	25,37	25,16

Holding torque of a motor brake

Type	Motor	Holding torque (brake) [Nm]
	Size □ [mm]	
Stepper	28	Available soon
Stepper	42	0,4
Stepper	56	1,0

□ = Square cross section

PRODUCT RANGE

Dimensions

All dimensions are in mm. The scale of the drawings may not be equal.

MSCE in combination with a standard motor and a motor adapter VK

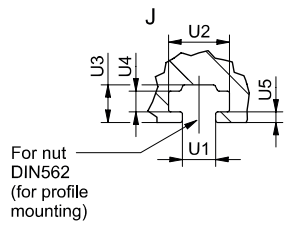
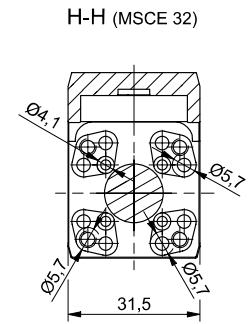
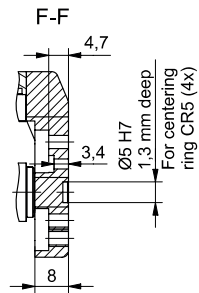
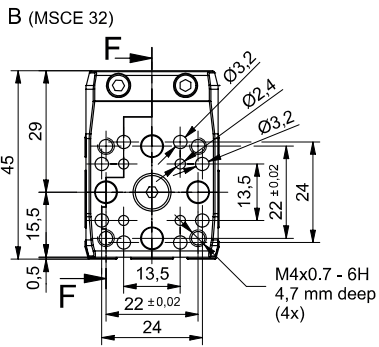
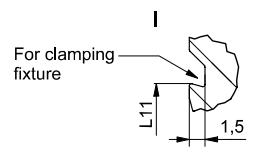
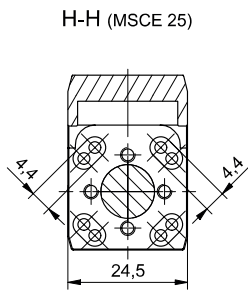
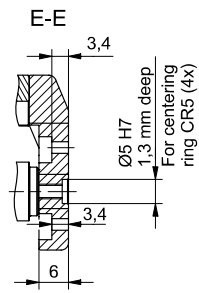
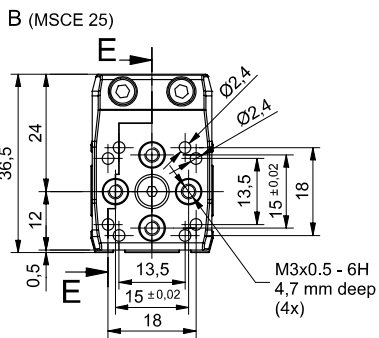
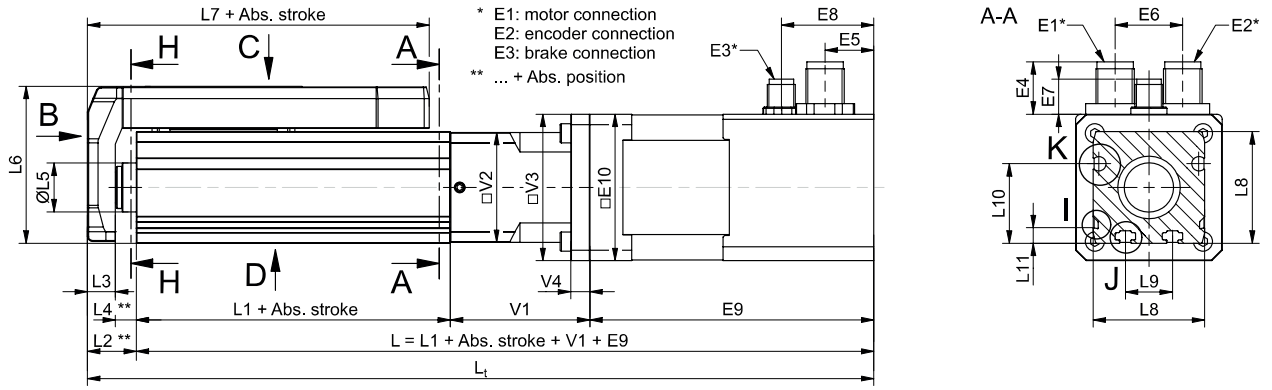

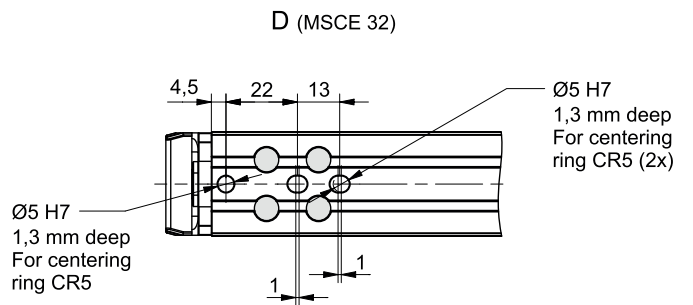
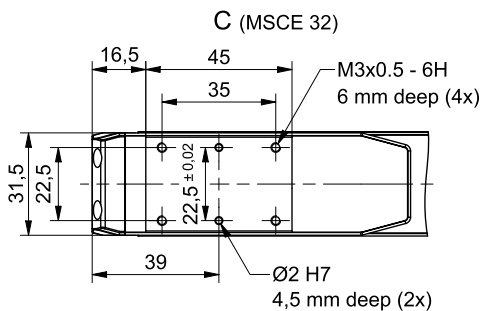
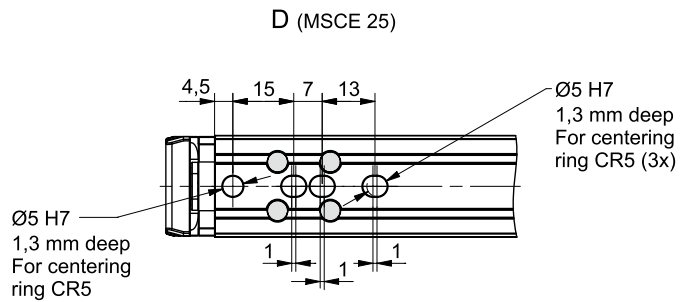
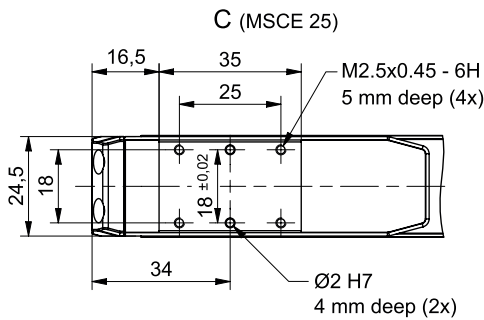
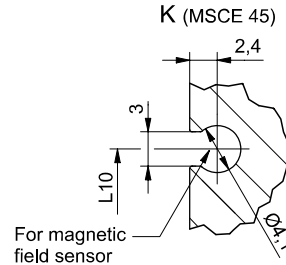
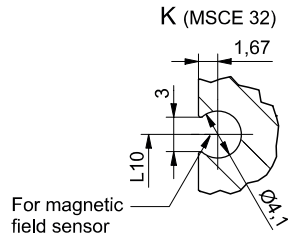
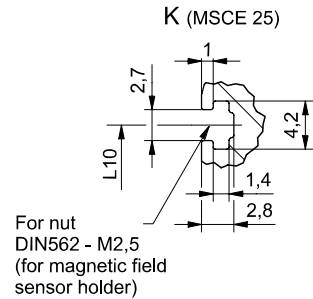
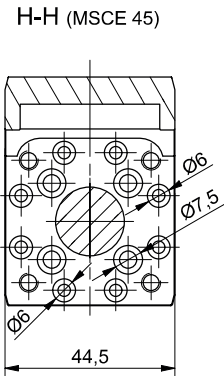
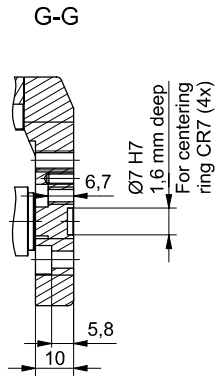
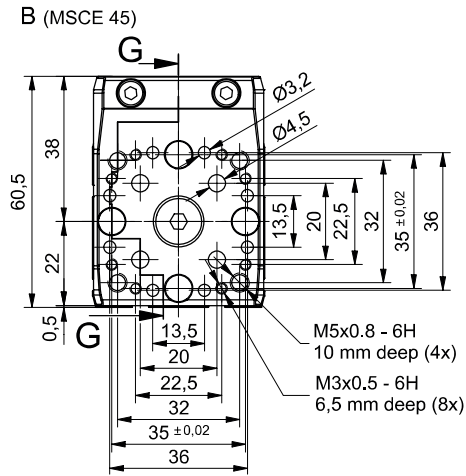

PRODUCT RANGE

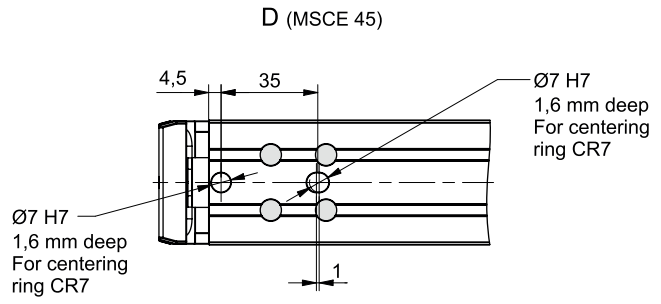
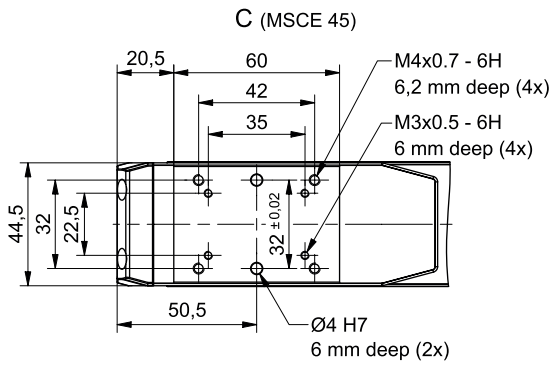

MSCE in combination with a standard motor and a motor adapter MSD

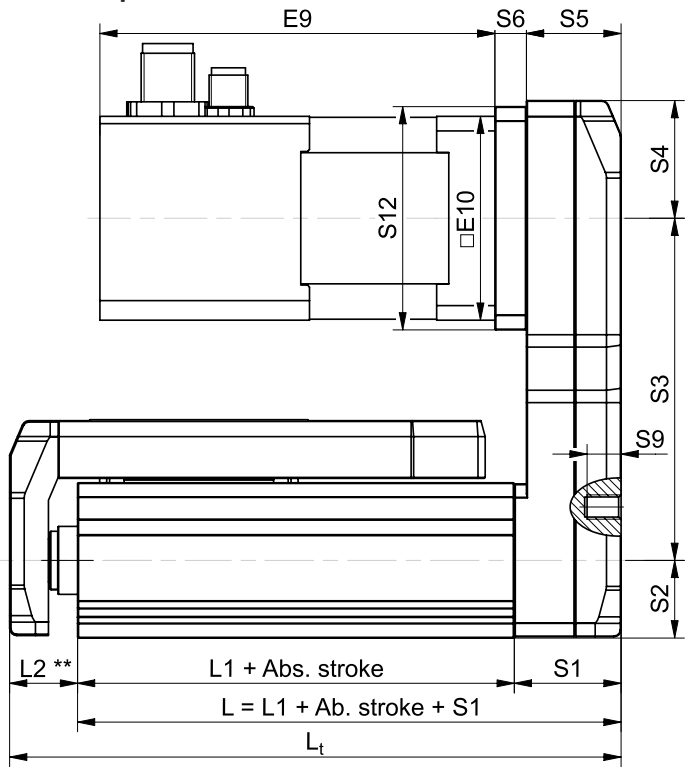
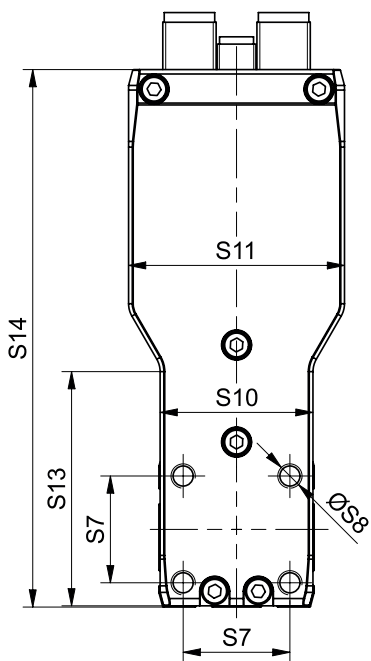

MSCE without a motor

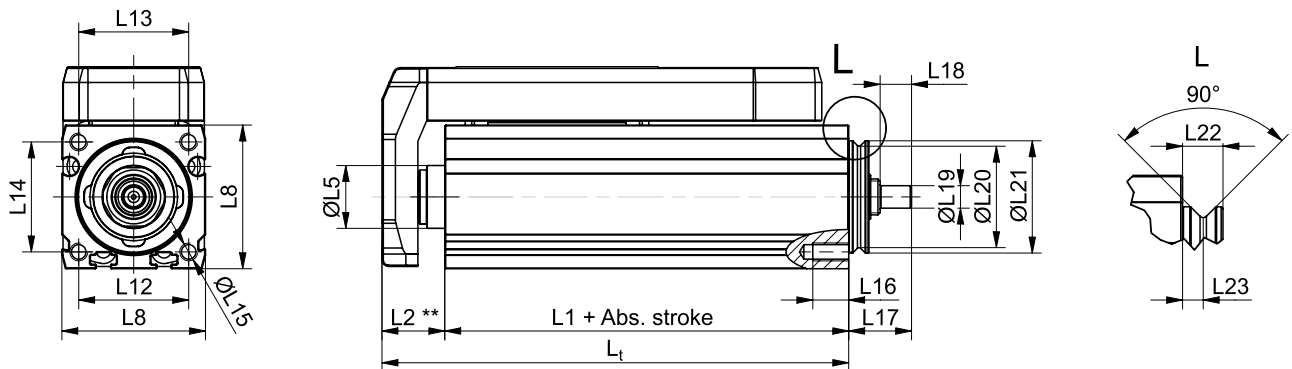

MSCE dimensions

Designation	L1	L2	L3	L4	ØL5	L6	L7	L8	L9	L10	L11	L12	L13	L14	ØL15
MSCE 25	50	12	6	6	12	36,5	58	25	13,5	19,25	4,4	19	17	18	M2,5
MSCE 32	65	14	8	6	14	45	73	32	13,5	22,8	4,4	24,5	24,5	24,5	M3
MSCE 45	80	18	10	8	18	60,5	91	45	20	30,5	4,4	34	34	34	M4

Designation	L16	L17	L18	ØL19 (h7)	ØL20	ØL21 (h7)	L22	L23	U1	U2	U3	U4	U5
MSCE 25	8	14	7	5	17,6	20	4,5	2,3	2,2	4,2	2,8	1,4	1
MSCE 32	8	14	7	5	22,6	25	4,5	2,3	3,2	5,8	3,6	2	1
MSCE 45	10	16	8	8	31,6	34	4,5	2,3	4,2	7,5	4,7	2,5	1,2

PRODUCT RANGE

Motor adapter VK and a motor side drive MSD dimensions

Designation	Motor		V1	□V2	□V3	V4	S1	S2	S3 (±0,5)	S4	S5
	Type	Size □ [mm]									
MSCE 25	Stepper	28	35	24,5	28	5,5	22	12,5	52,5	18,25	19,5
MSCE 32	Stepper	28	35	31,5	31,5	0	22	16,0	52,5	18,25	19,5
MSCE 32	Stepper	42	40	31,5	42	5,5	22	16,0	70,5	24,25	19,5
MSCE 45	Stepper	42	42	44,5	44,5	0	27,5	22,5	81	24,75	24,5
MSCE 45	Stepper	56	46	44,5	56,4	9,5	27,5	22,5	88,5	33,25	24,5

Designation	Motor		S6	S7	ØS8	S9	S10	S11	S12	S13	S14
	Type	Size □ [mm]									
MSCE 25	Stepper	28	5,5	18	M4	6	24,5	31,5	34	38,5	83,25
MSCE 32	Stepper	28	5,5	22	M5	7	31,5	31,5	34	0	86,75
MSCE 32	Stepper	42	6,5	22	M5	7	31,5	44,5	46	48	110,75
MSCE 45	Stepper	42	6,5	32	M6	7	44,5	44,5	46	0	128,25
MSCE 45	Stepper	56	6	32	M6	7	44,5	59,5	59,5	64,5	144,25

□ = Square cross section

Motor dimensions

Motor			E1	E2	E3	E4 (±1)	E5 (±0,3)	E6	E7 (±1)	E8 (±0,3)	E9 (±1)	□E10
Type	Size □ [mm]	Brake										
Stepper	28	-										Available soon
Stepper	28	with										Available soon
Stepper	42	-	M12 5-pole	M12 8-pole	-	14	14	19,5	-	-	70,4	42,3
Stepper	42	with	M12 5-pole	M12 8-pole	M8 3-pole	14	14	19,5	9	27	106,4	42,3
Stepper	56	-	M12 5-pole	M12 8-pole	-	14	13,4	23	-	-	98	56,4
Stepper	56	with	M12 5-pole	M12 8-pole	M8 3-pole	14	52,4	23	9	12	138	56,4

□ = Square cross section



Order code

MSCE - 45 - 1003 - 150 - AB - AU - AA - AB - AA

Series:

MSCE

Size:

- 25
- 32
- 45

Ball screw size:

- MSCE 25: $\varnothing 6 \times 2, \varnothing 6 \times 6$
- MSCE 32: $\varnothing 8 \times 2, \varnothing 8 \times 8$
- MSCE 45: $\varnothing 10 \times 3, \varnothing 10 \times 10$

Absolute stroke [mm]:

- (Absolute stroke = Effective stroke + 2 × Safety stroke)
- 25, 50, 75, 100, 125, 150, 175, 200

Motor type and size:

- Leave blank: Without a motor

A

B

Motor type:

- A: Stepper motor without a brake
- B: Stepper motor with a brake

Motor size

- A: 28 mm (Available soon)
- B: 42 mm
- C: 56 mm

Available sizes:

- MSCE 25: 28
- MSCE 32: 28, 42
- MSCE 45: 42, 56

Motor mounting option:

- Leave blank: Without a motor

Mounting option:

- A: With a motor adapter VK
- B: With a motor side drive MSD facing up
- C: With a motor side drive MSD facing right
- D: With a motor side drive MSD facing down
- E: With a motor side drive MSD facing left

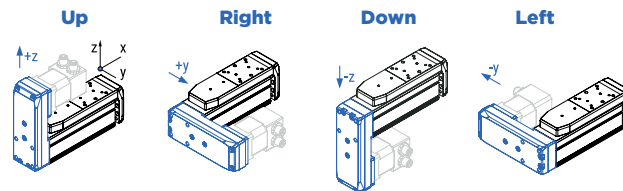

Direction of the motor connectors:

- U: Connectors facing up
- R: Connectors facing right
- D: Connectors facing down
- L: Connectors facing left

In combination with a motor adapter VK

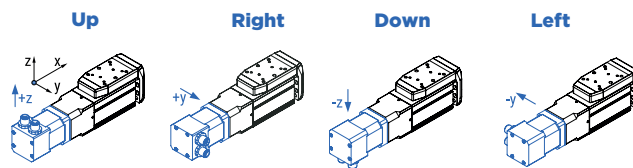

In combination with a motor side drive MSD

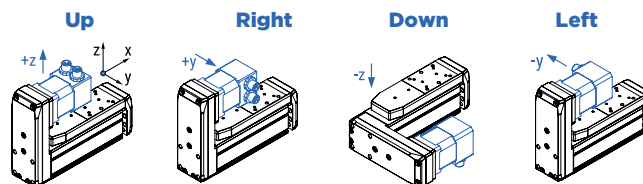

When using the motor side drive MSD, the connectors can not be facing the MCE otherwise, the connectors and MCE may collide. These combinations are: BD, CL, DU and ER.

Drive option:

- Leave blank: Without a motor or drive

Drive type:

- A: Stepper

Drive protocol/control:

- A: EtherCAT
- B: Ethernet based communication
- C: Pulse-direction control

Drive-motor cables option:

- Leave blank: Without a motor or drive
- 00: Without the cables

Cables type:

- A: Robotic with a straight plug
- B: Robotic with an angled plug

Cables length:

- A: 3 m
- B: 5 m
- C: 10 m

Power and signal cables:

- Leave blank: Without a motor or drive

Power cable:

- 0: Without a power cable
- A: With a power cable

Signal cable:

- 0: Without a signal cable
- A: With a signal cable

Accessories

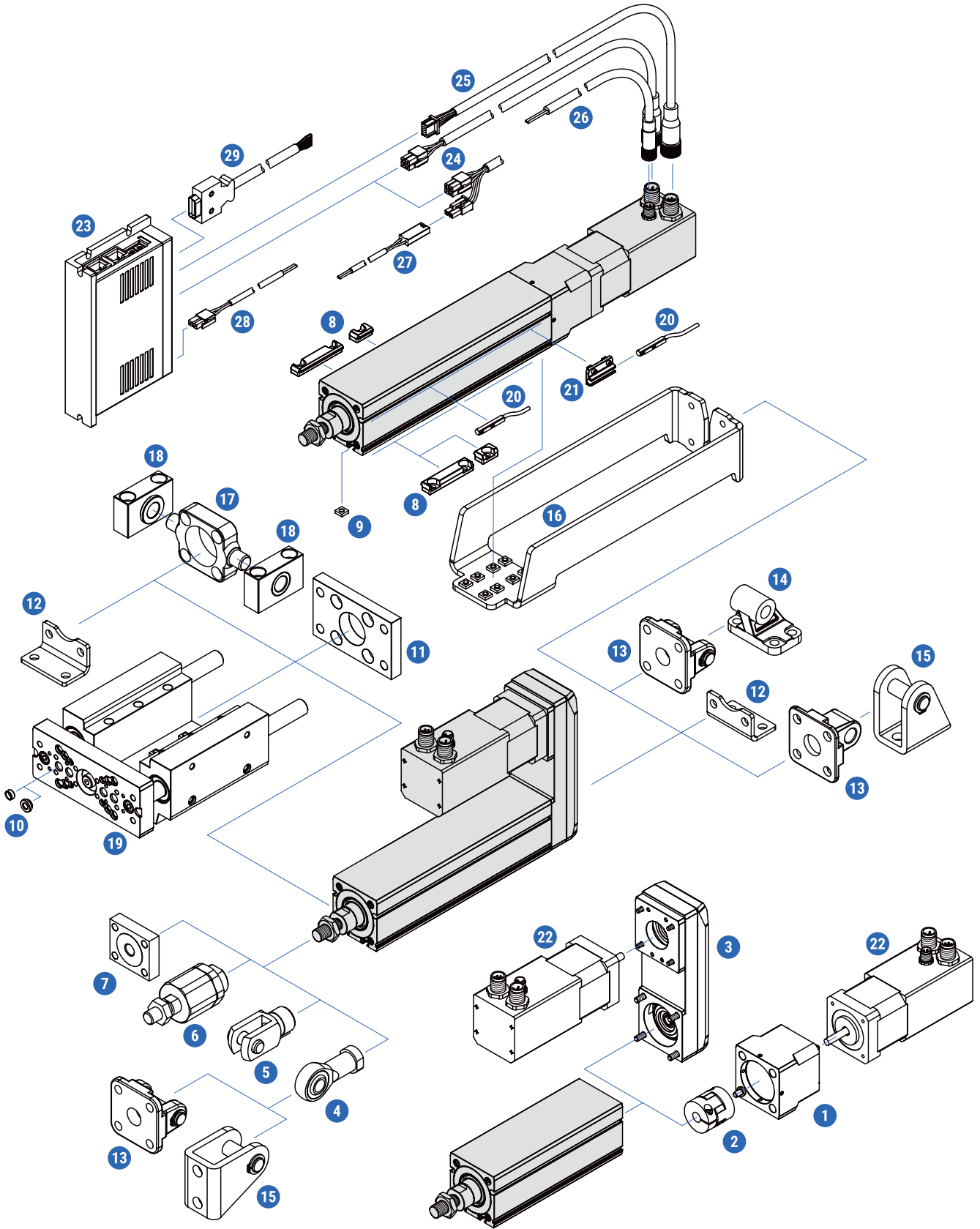

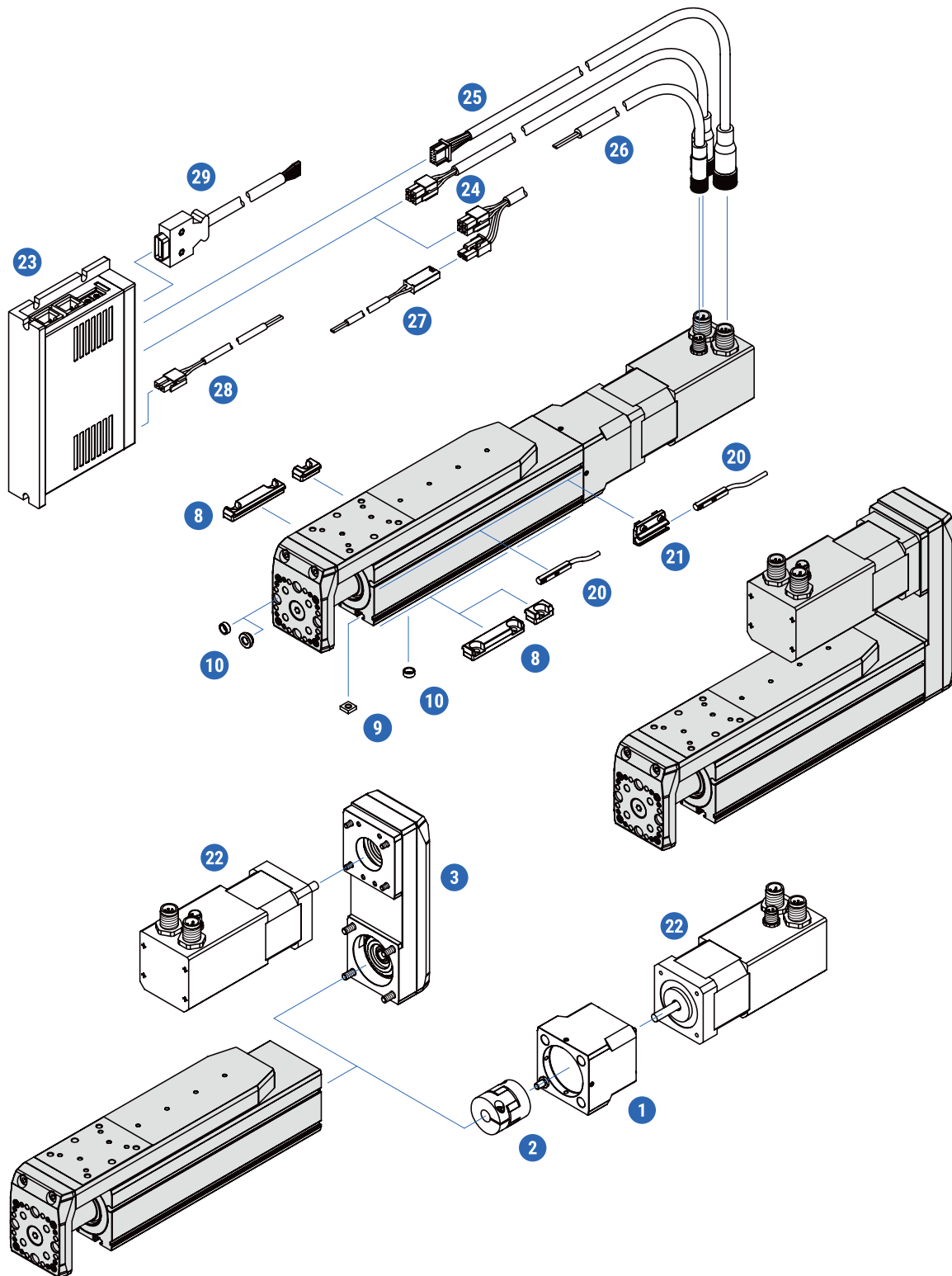

ACCESSORIES

#	Accessories	Compatible with MCE/MSCE size			Type
		25	32	45	
1	Motor adapter VK	•	•	•	Motor adapters
2	Coupling	•	•	•	Elastomer couplings
3	Motor side drive MSD	•	•	•	Motor side drives
4	Rod eye SGS	•	•	•	Piston rod accessories
5	Rod clevis SG	•	•	•	
6	Self-aligning joint FK	•	•	•	
7	Coupling piece KSZ	•	•	•	
8	Clamping fixture	•	•	•	Mounting attachment accessories
9	Slot nut	•	•	•	
10	Centering ring	•	•	•	
11	Flange mounting MAFL	•	•	•	
12	Foot mounting MAHP	•	•	•	
13	Swivel/clevis mount MASU	•	•	•	
14	Swivel foot mounting MLG	–	–	•	
15	Clevis foot mounting MLBU	•	•	–	
16	Back mount ABM	•	•	•	
17	Trunnion mount MZK	–	•	•	
18	Trunnion support MLZ	–	•	•	
19	Guiding unit GUC	•	•	•	Guiding units
20	Magnetic field sensor	•	•	•	Limit switches
21	Sensor holder HMG	•	–	–	
22	Motor	•	•	•	Motors
23	Drive	•	•	•	Drives
24	Motor cable	•*	•*	•	Cables
25	Encoder cable	•	•	•	
26	Brake cable	•*	•*	•	
27	Brake to terminal cable*	•	•	–	
28	Power cable	•	•	•	
29	Signal cable	•	•	•	

*For the stepper motor size of 28, the motor and brake cables are combined into one cable. For connectivity between the brake and terminal, an additional brake to terminal cable is used.

Motor adapter VK

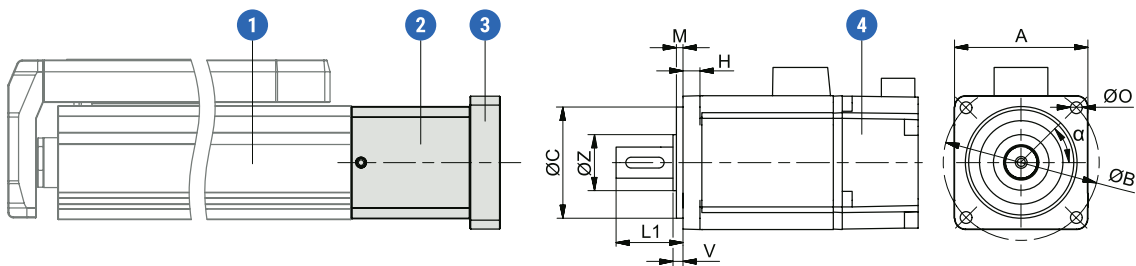

- 1 - MCE/MSCE
 - 2 - Motor adapter housing
 - 3 - Motor adapter flange
 - 4 - Motor
- } Motor adapter VK

Motor adapters VK are compatible with the following MCE/MSCE and couplings sizes:

Designation	Size	Compatible with
VK 25	25	EKL 2
VK 32	32	EKL 2
VK 45	45	EKL 5

Order code

VK - MG 32 - 42,3 - 43,8 - 22 - 2 - 24 - 4,5 - M3 - 0 - 0 - 45

<p>Motor adapter</p> <hr/> <p>Mini series: - MG</p> <hr/> <p>Size: - 25 - 32 - 45</p>	<table style="width: 100%; border-collapse: collapse;"> <tr> <td style="width: 10%; border-bottom: 1px solid black;">A</td> <td style="width: 10%; border-bottom: 1px solid black;">ØB</td> <td style="width: 10%; border-bottom: 1px solid black;">ØC</td> <td style="width: 10%; border-bottom: 1px solid black;">M</td> <td style="width: 10%; border-bottom: 1px solid black;">L1</td> <td style="width: 10%; border-bottom: 1px solid black;">H</td> <td style="width: 10%; border-bottom: 1px solid black;">ØO</td> <td style="width: 10%; border-bottom: 1px solid black;">V</td> <td style="width: 10%; border-bottom: 1px solid black;">ØZ</td> <td style="width: 10%; border-bottom: 1px solid black;">α</td> </tr> <tr> <td colspan="9" style="border-top: 1px solid black; text-align: center;">Motor dimensions [mm]</td> <td style="border-top: 1px solid black; text-align: center;">[°]</td> </tr> </table>	A	ØB	ØC	M	L1	H	ØO	V	ØZ	α	Motor dimensions [mm]									[°]
A	ØB	ØC	M	L1	H	ØO	V	ØZ	α												
Motor dimensions [mm]									[°]												

Dimension ØO is also used for tapped holes. In case of tapped holes, prefix M must be applied.

Compatibility of the standard motor adapters VK with the MCE/MSCE and standard motors

Designation	Motor			Motor shaft length		Motor shaft diameter	Motor mounting holes	Mass
	Type	Size □ [mm]	Standard	min	max	[mm]	∅O × H [mm]	m _{VK} [kg]
VK 25 - T1 - 108256	Stepper	28	NEMA 11	15	20	5,0	M2,5 × 2,5 (min.)	0,04
VK 32 - T1 - 108257	Stepper	28	NEMA 11	15	20	5,0	M2,5 × 2,5 (min.)	0,06
VK 32 - T2 - 108258	Stepper	42	NEMA 17	20	25	5,0	M3 × 4,5 (min.)	0,09
VK 45 - T1 - 108259	Stepper	42	NEMA 17	20	25	5,0	M3 × 4,5 (min.)	0,14
VK 45 - T2 - 108260	Stepper	56	NEMA 23	20	25	6,35	5 × 10,0 (max.)	0,18

The standard motor adapter VK is made out of one piece. It is important to note when ordering it, that the coupling is included.

□ = Square cross section

Note! If you order a custom motor adapter VK for a non-standard motor the coupling is not included.

Couplings

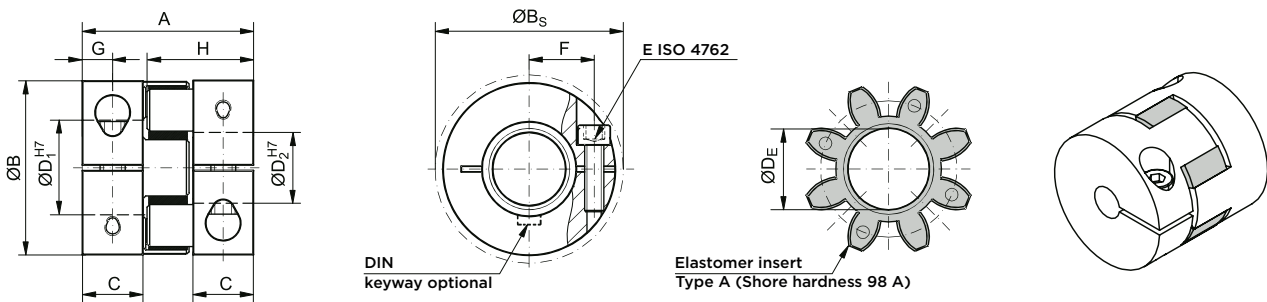

Technical data and dimensions

Designation	Rated torque [Nm]	Maximum torque* [Nm]	A	B	B _s	C	D ₁	D ₂	D _E	E
EKL 2	2	4	20	16	17	6	3	8	6,2	M2
EKL 5	9	18	26	25	25	8	4	12,7	10,2	M3

Designation	Tightening torque of the clamping screw [Nm]	F	G	H	Moment of inertia per hub [10 ⁻³ kg m ²]	Approximate weight [kg]	Speed standard [min ⁻¹]
EKL 2	0,6	5,5	3	12	0,0003	0,008	15000
EKL 5	2	8	4	16,7	0,002	0,02	15000

* Maximum transmittable torque of the clamping hub depends on the bore diameter.

Maximum transmittable and drive torque $M_{p,c}$ [Nm] depends on the bore diameter [mm]

Designation	Ø3	Ø4	Ø5	Ø8	Ø10	Ø12,7
EKL 2	0,2	0,8	1,5	2,5	-	-
EKL 5	-	1,5	2	8	8	10

Maximum transmittable and drive torque $M_{p,c}$ [Nm] limited to the size of the MCE/MSCE

Designation	MCE/MSCE		
	25	32	45
EKL 2	0,1	0,53	-
EKL 5	-	-	1,23

Order code

COUPLING - EKL5 - A - F5 - F6PFN

Coupling

Coupling type/size:

- 2
- 5

Elastomer insert type:

- A

Hole diameter

[mm]

Option:

- PFN: with the keyway
- Leave blank: without the keyway

Motor side drive MSD with a timing belt

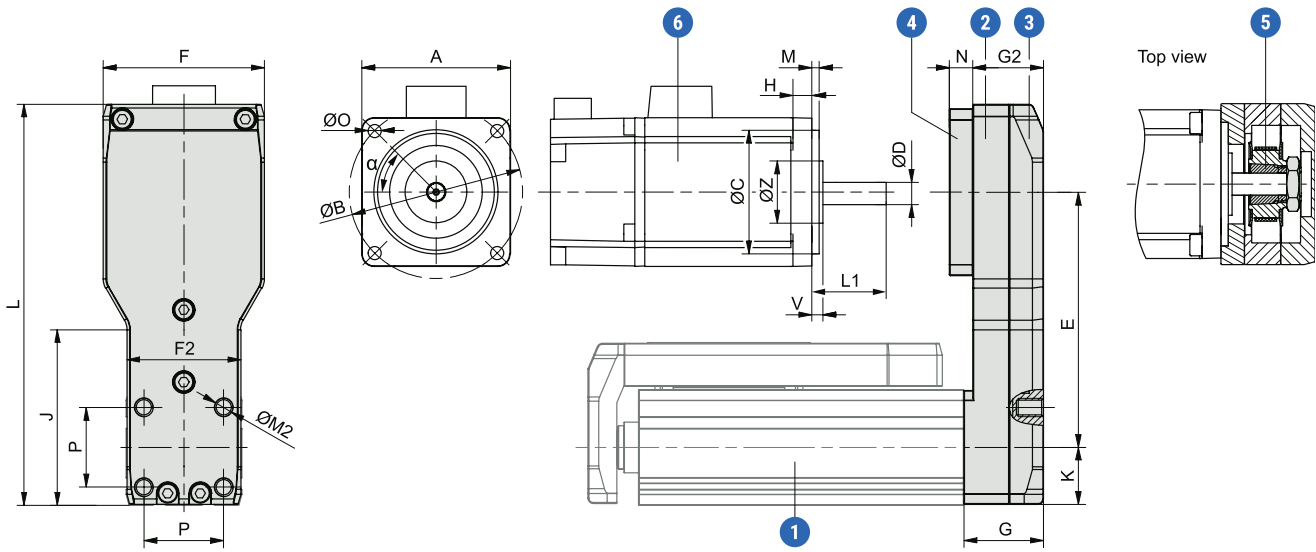

- 1 - MCE/MSCE
 - 2 - Motor side drive housing
 - 3 - Motor side drive cap
 - 4 - Motor side drive tensioning plate
 - 5 - Clamping set
 - 6 - Motor
- } Motor side drive MSD

Order code

MSD - MG 32 - T2 - 42,3 - 43,8 - 22 - 2 - 24 - 5 - 4,5 - M3 - 0 - 0 - 45

<p>Motor side drive</p> <p>Mini series: - MG</p> <p>Size: - 25 - 32 - 45</p> <p>Type</p>	<table border="0" style="width: 100%; border-collapse: collapse;"> <tr> <td style="width: 10%; border-bottom: 1px solid black;">A</td> <td style="width: 10%; border-bottom: 1px solid black;">ØB</td> <td style="width: 10%; border-bottom: 1px solid black;">ØC</td> <td style="width: 10%; border-bottom: 1px solid black;">M</td> <td style="width: 10%; border-bottom: 1px solid black;">L1</td> <td style="width: 10%; border-bottom: 1px solid black;">ØD</td> <td style="width: 10%; border-bottom: 1px solid black;">H</td> <td style="width: 10%; border-bottom: 1px solid black;">ØO</td> <td style="width: 10%; border-bottom: 1px solid black;">V</td> <td style="width: 10%; border-bottom: 1px solid black;">ØZ</td> <td style="width: 10%; border-bottom: 1px solid black;">α</td> </tr> <tr> <td colspan="10" style="border-top: 1px solid black; text-align: center;">Motor dimensions [mm]</td> <td style="border-top: 1px solid black; text-align: right;">[°]</td> </tr> </table>	A	ØB	ØC	M	L1	ØD	H	ØO	V	ØZ	α	Motor dimensions [mm]										[°]
A	ØB	ØC	M	L1	ØD	H	ØO	V	ØZ	α													
Motor dimensions [mm]										[°]													

Dimension ØO is also used for tapped holes. In case of tapped holes, prefix M must be applied.

Compatibility of the standard motor side drives MSD with the MCE/MSCE and standard motors

Designation	Motor			Motor shaft length		Motor shaft diameter	Motor mounting holes	Mass
	Type	Size □ [mm]	Standard	min	max	[mm]	ØO × H [mm]	m_{MSD} [kg]
MSD 25 - T1 - 108261	Stepper	28	NEMA 11	14	20	5,0	M2,5 × 2,5 (min.)	0,10
MSD 32 - T1 - 108262	Stepper	28	NEMA 11	14	20	5,0	M2,5 × 2,5 (min.)	0,12
MSD 32 - T2 - 108263	Stepper	42	NEMA 17	17,5	24	5,0	M3 × 4,5 (min.)	0,18
MSD 45 - T1 - 108264	Stepper	42	NEMA 17	20,5	28	5,0	M3 × 4,5 (min.)	0,28
MSD 45 - T2 - 108265	Stepper	56	NEMA 23	20	28	6,35	5 × 4,5 (min.) ~ 5,5 (max.)	0,36

Technical data

Designation	Type	Compatible with	Gear ratio i	Max. drive torque	Max. radial load on shaft*	No load torque	Mass moment of inertia	Mass ***
				$M_{p, MSD}$ [Nm]	$F_{r, MSD}$ [N]	$M_{0, MSD}$ [Nm]	J_{MSD} [10 ⁻⁶ kg m ²]	m_{MSD} [kg]
MSD 25 - T1 - 108261	T1	MCE/MSCE 25	1	0,10	15	0,010	0,39	0,10
MSD 32 - T1 - 108262	T1	MCE/MSCE 32	1	0,10	15	0,015	0,39	0,12
MSD 32 - T2 - 108263	T2	MCE/MSCE 32	1	0,25	15	0,015	1,04	0,18
MSD 45 - T1 - 108264	T1	MCE/MSCE 45	1	0,30	15	0,020	4,16	0,28
MSD 45 - T2 - 108265	T2	MCE/MSCE 45	1	0,80	45	0,020	4,20	0,36

Designation	Motor size limits [mm]					
	A max	ØB max	ØC max ****	min	L1 max	ØD max
MSD 25 - T1 - 108261	34	35	25	**	20	6,35
MSD 32 - T1 - 108262	34	35	25	**	20	6,35
MSD 32 - T2 - 108263	46	50	36	**	24	8
MSD 45 - T1 - 108264	46	50	36	**	28	8
MSD 45 - T2 - 108265	59,5	70	50	**	28	12,7

* This is the load which is linearly dependent on the maximum drive torque $M_{p, MSD}$ and is generated by the correct pretension of the belt. This load needs to be reduced in accordance with the capabilities of the motor.

** Minimum dimension L1 depends on the size of particular clamping set. Values can be found on the following table.

*** This is an average value. It could differ depending to the motor dimensions.

**** Keyway is not valid.

***** Higher value is also possible with thicker tensioning plate (dimension N increases).

□ = Square cross section

Dimensions

Designation	Type	Compatible with	Gear ratio i	E (±0,5)	F			G
					[mm]			
MSD 25 - T1 - 1	T1	MCE/MSCE 25	1	52,5	31,5	24,5	22	
MSD 32 - T1 - 1	T1	MCE/MSCE 32	1	52,5	31,5	31,5	22	
MSD 32 - T2 - 1	T2	MCE/MSCE 32	1	70,5	44,5	31,5	22	
MSD 45 - T1 - 1	T1	MCE/MSCE 45	1	81	44,5	44,5	27,5	
MSD 45 - T2 - 1	T2	MCE/MSCE 45	1	88,5	59,5	44,5	27,5	

Designation	G2	N*	J	K	L	P	ØM2
MSD 25 - T1 - 1	19,5	5,5	38,5	12,25	83	18	M4×6
MSD 32 - T1 - 1	19,5	5,5	0	15,75	86,5	22	M5×7
MSD 32 - T2 - 1	19,5	6,5	48	15,75	110,5	22	M5×7
MSD 45 - T1 - 1	24,5	6,5	0	22,25	128	32	M6×7
MSD 45 - T2 - 1	24,5	6,0	64,5	22,25	144	32	M6×7

* This is a standard value. It could differ depending to the motor dimensions M and L1.

Minimum dimension L1 [mm] depends on the motor shafts diameter ØD

Designation	Type	Compatible with	Gear ratio i	ØD [mm]			
				4	5	6	6,35
MSD 25 - T1 - 1	T1	MCE/MSCE 25	1	14	14	14	14
MSD 32 - T1 - 1	T1	MCE/MSCE 32	1	14	14	14	14
MSD 32 - T2 - 1	T2	MCE/MSCE 32	1	-	17,5	17,5	17,5
MSD 45 - T1 - 1	T1	MCE/MSCE 45	1	-	20,5	20,5	20,5
MSD 45 - T2 - 1	T2	MCE/MSCE 45	1	-	20	20	20

Designation	ØD [mm]							
	7	8	9	9,52	10	11	12	12,7
MSD 25 - T1 - 1	-	-	-	-	-	-	-	-
MSD 32 - T1 - 1	-	-	-	-	-	-	-	-
MSD 32 - T2 - 1	17,5	17,5	-	-	-	-	-	-
MSD 45 - T1 - 1	20,5	20,5	-	-	-	-	-	-
MSD 45 - T2 - 1	20	20	20,5	20,5	20,5	20,5	20,5	20,5

Rod eye SGS

Material: galvanized steel

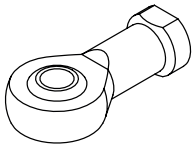

Simple support

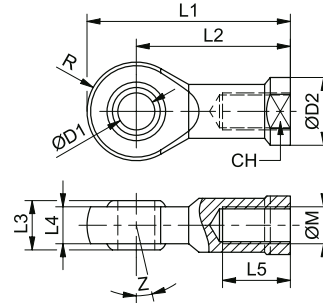
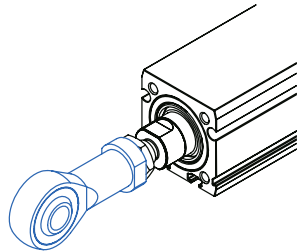

Designation	ØM	L1	L2	L3	L4	L5	ØD1 (H7)	ØD2	R	CH	Z	m	F _{max} [N]
SGS 25 - 9215	M6	40	30	9	6,75	12	6	13	10	11	13	0,03	F _{MCE}
SGS 32 - 9216	M8	48	36	12	9,00	16	8	16	12	14	14	0,05	F _{MCE}
SGS 45 - 9206	M10x1,25	57	43	14	10,50	20	10	19	14	17	13	0,08	F _{MCE}

Rod clevis SG

Material: galvanized steel

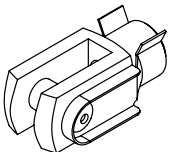

Simple support

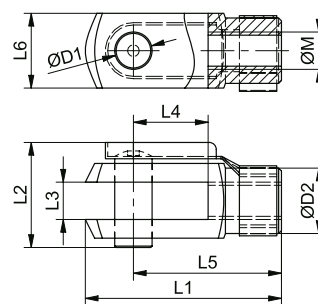
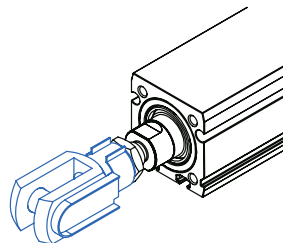

Designation	ØM	L1 (±0,5)	L2	L3 (B13)	L4 (±0,5)	L5	L6 (h11)	ØD1 (H9)	ØD2	m	F _{max} [N]
SG 25 - 9196	M6	31	16	6	12	24	12	6	10	0,02	F _{MCE}
SG 32 - 9197	M8	42	22	8	16	32	16	8	14	0,05	F _{MCE}
SG 45 - 9186	M10x1,25	52	26	10	20	40	20	10	18	0,09	F _{MCE}

Clamping fixture

Mini electric cylinder and slider can be mounted by using the clamping fixtures which are placed in the slot on the side of the profile. Clamping fixtures can also be mounted to the slide of the mini electric sliders MSCE (e.i. for multi-axis systems).

Material: powder coated zinc alloy

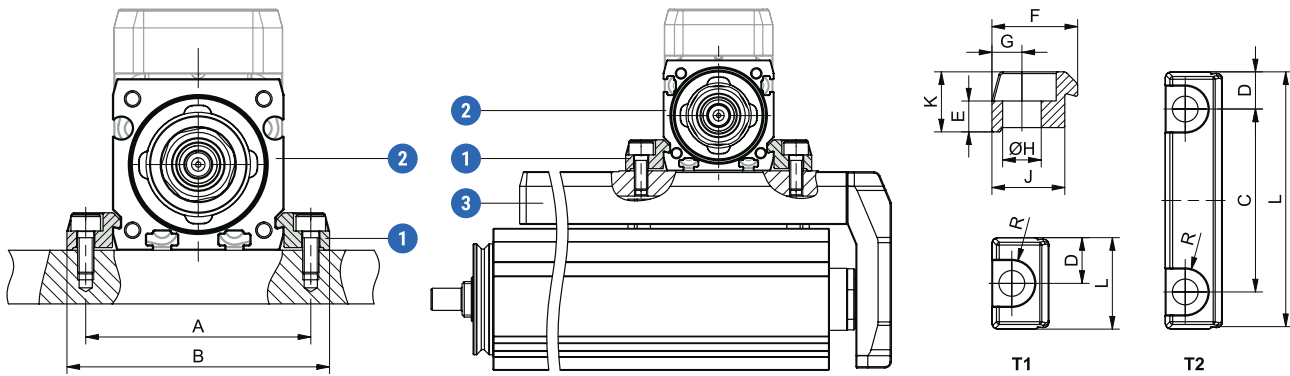

- 1 - Clamping fixture
- 2 - Profile of the MCE/MSCE
- 3 - Slide of the MSCE

The scale of the drawings may not be equal.

Designation	Compatible with	Clamping fixture			Mounting distance [mm]		Dimensions [mm]	
		For screw	Type	L [mm]	A (±0,1)	B	C	D
MG 25 - 108216	MCE/MSCE 25	M3	T1	16	35	42	-	8
MG 25 - 108218		M3	T2	32	35	42	22,5	4,75
MG 25 - 108217		M4	T1	16	35	42	-	8
MG 25 - 108219		M4	T2	45	35	42	32	6,5
MG 32 - 108216	MCE/MSCE 32	M3	T1	16	42	49	-	8
MG 32 - 108218		M3	T2	32	42	49	22,5	4,75
MG 32 - 108217		M4	T1	16	42	49	-	8
MG 32 - 108219		M4	T2	45	42	49	32	6,5
MG 45 - 108216	MCE/MSCE 45	M3	T1	16	55	62	-	8
MG 45 - 108218		M3	T2	32	55	62	22,5	4,75
MG 45 - 108217		M4	T1	16	55	62	-	8
MG 45 - 108219		M4	T2	45	55	62	32	6,5

Designation	Dimensions [mm]								Countersink for	Mounting to MSCE slide For MCE/MSCE	m [g]
	E	F	G	ØH	J	K	R				
MG 25 - 108216	3,6	10	3,5	3,4	8,5	7	3,25	DIN 912	-	6	
MG 25 - 108218	3,6	10	3,5	3,4	8,5	7	3,25	DIN 912	-	12	
MG 25 - 108217	2,5	10	3,5	4,5	8,5	7	4	DIN 912	-	5	
MG 25 - 108219	2,5	10	3,5	4,5	8,5	7	4	DIN 912	-	16	
MG 32 - 108216	3,6	10	3,5	3,4	8,5	7	3,25	DIN 912	25	6	
MG 32 - 108218	3,6	10	3,5	3,4	8,5	7	3,25	DIN 912	25	12	
MG 32 - 108217	2,5	10	3,5	4,5	8,5	7	4	DIN 912	-	5	
MG 32 - 108219	2,5	10	3,5	4,5	8,5	7	4	DIN 912	-	16	
MG 45 - 108216	3,6	10	3,5	3,4	8,5	7	3,25	DIN 912	25	6	
MG 45 - 108218	3,6	10	3,5	3,4	8,5	7	3,25	DIN 912	25	12	
MG 45 - 108217	2,5	10	3,5	4,5	8,5	7	4	DIN 912	32	5	
MG 45 - 108219	2,5	10	3,5	4,5	8,5	7	4	DIN 912	32	16	

Self-aligning joint FK

Material: galvanized steel

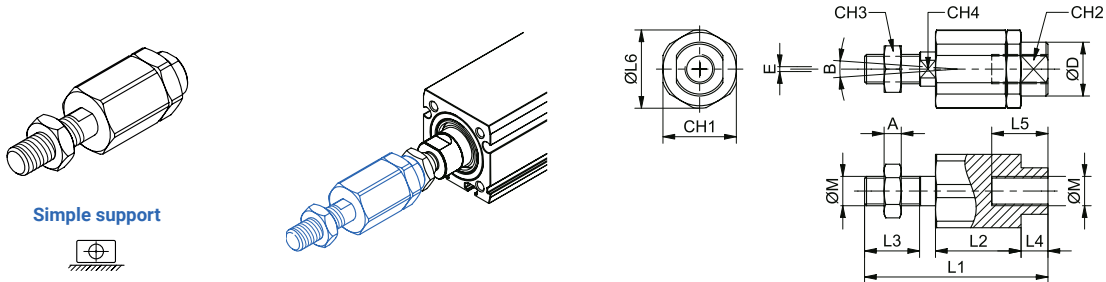

Simple support



Designation	ØM	L1	L2	L3	L4	L5	[mm]								E	B	m [kg]	F _{max} [N]
							ØL6	A	ØD	CH1	CH2	CH3	CH4					
FK 25 - 5473	M6	35	17,5	11	4	12,5	14,5	4	8,5	13	7	10	5	1	6	0,03	F _{MCE}	
FK 32 - 5474	M8	57	26	21	5	16	19	5	12,5	17	11	13	7	2	8	0,06	F _{MCE}	
FK 45 - 5466	M10x1,25	71,5	35	20	9	22	32	6	22	30	19	17	12	2	8	0,22	F _{MCE}	

Coupling piece KSZ

Material: galvanized steel

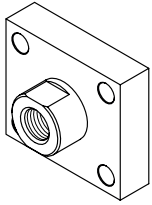

Fixed support

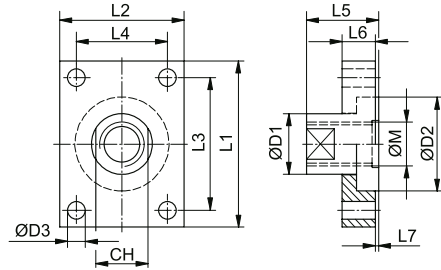
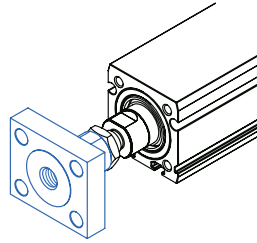

Designation	ØM	L1	L2	L3	L4	L5	L6	L7 (min.)	ØD1	ØD2	ØD3 (H3)	CH	m [kg]	F _{max} [N]
KSZ 25 - 5227	M6	30	25	20	15	16	8	0,1	12 ^{-0,1}	18	5,5	10	0,05	F _{MCE}
KSZ 32 - 5228	M8	35	30	25	20	22	8	0,1	14 ^{-0,1}	20	5,5	13	0,07	F _{MCE}
KSZ 45 - 5229	M10 x 1,25	40	35	30	25	20	10	0,1	17 ^{-0,2}	26	5,5	15	0,11	F _{MCE}

Slot nut

Mini electric cylinder and slider can be mounted by using the slot nuts which are placed in the slots on the bottom side of the profile.

Material: galvanized steel

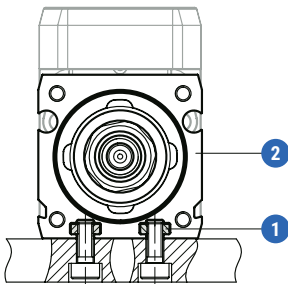

- 1 - Slot nut
- 2 - Profile of the MCE/MSCE

Designation	Nut type	m [g]
Slot nu 25 - 107082	DIN562 - M2	0,013
Slot nu 32 - 37303	DIN562 - M3	0,035
Slot nu 45 - 40682	DIN562 - M4	0,064

Centering ring

Material: stainless steel

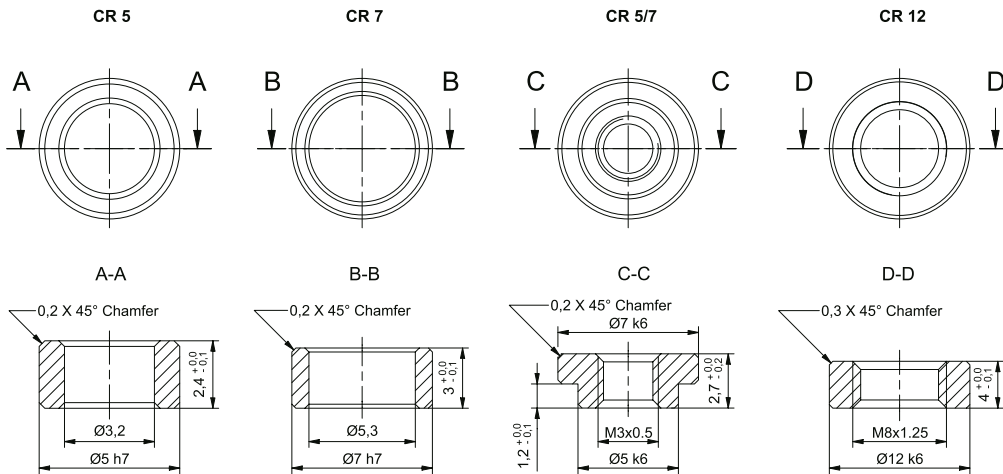

The scale of the drawings may not be equal.

Designation	m [g]
CR 5 - 107094	0,2
CR 7 - 23332	0,4
CR 5/7 - 107095	0,5
CR 12 - 49049	2,4

Flange mounting MAFL

Material: anodized aluminium

Mounting screws are included.

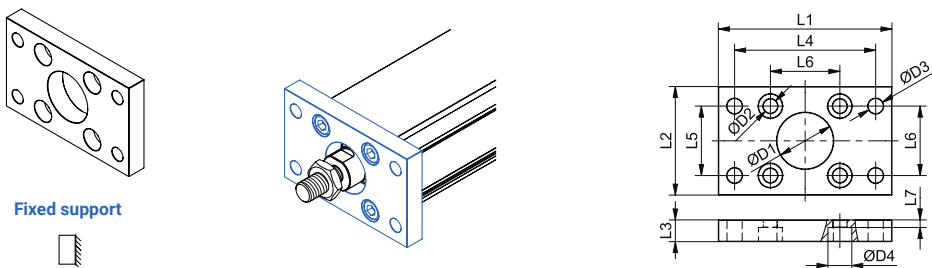

Designation	L1	L2	L3	L4	L5	L6	L7	ØD1	ØD2	ØD3	ØD4	m [kg]	F _{max} [N]
MAFL 25 - 108624	55	29	8	43	-	21	5,1	18	2,9	5,5	5,5	0,03	F _{MCE}
MAFL 32 - 108625	70	36	10	55	-	22	5,5	20	4,5	6,5	8,0	0,06	F _{MCE}
MAFL 45 - 108626	80	50	10	65	32	32	3,5	26	6,6	7,0	11,0	0,11	F _{MCE}

Foot mounting MAHP

Material: stainless steel

Set contains 2 pcs (i.e. for both front and rear mounting). Mounting screws are included.

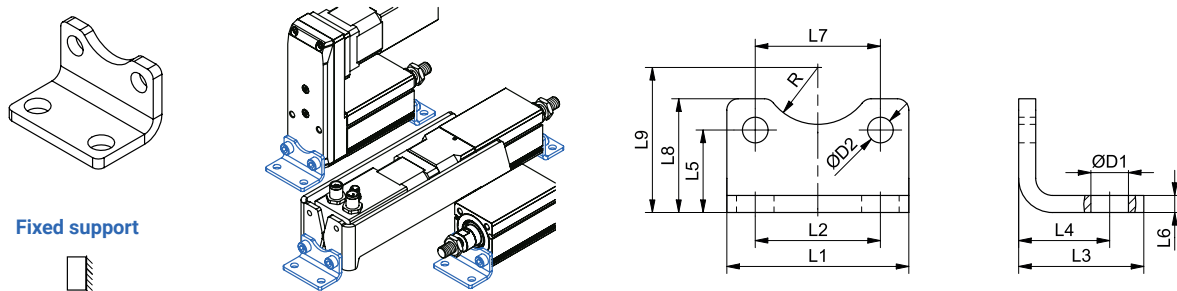

Fixed support



Designation	L1	L2	L3	L4	L5		L6	L7		
					Front	Rear		Front	Rear	
[mm]										
MAHP 25 - 108253	25	18	17,5	13	11,5	13	3	21	18	
MAHP 32 - 108254	32	22	22,0	16	14,5	14,5	3	22	22	
MAHP 45 - 108255	45	32	26,0	18	16	16	3	32	32	

Designation	L8	L9	ØD1	ØD2		R	m	F _{max}	
				Front	Rear				
[mm]									
								[kg]	[N]
MAHP 25 - 108253	17,5	22,0	5,5	2,8	4,5	9	0,04	F _{MCE}	
MAHP 32 - 108254	20,0	25,5	6,6	4,5	5,5	10	0,06	F _{MCE}	
MAHP 45 - 108255	24,0	32,0	6,6	6,6	6,6	13	0,11	F _{MCE}	

Swivel/clevis mount MASU

Material: aluminium, MASU 45 – aluminium + galvanized steel

Mounting screws are included.

Size 25, 32

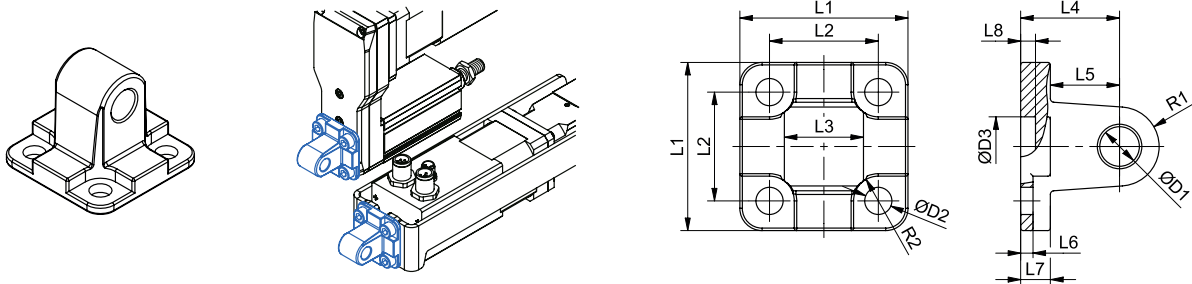

Size 45

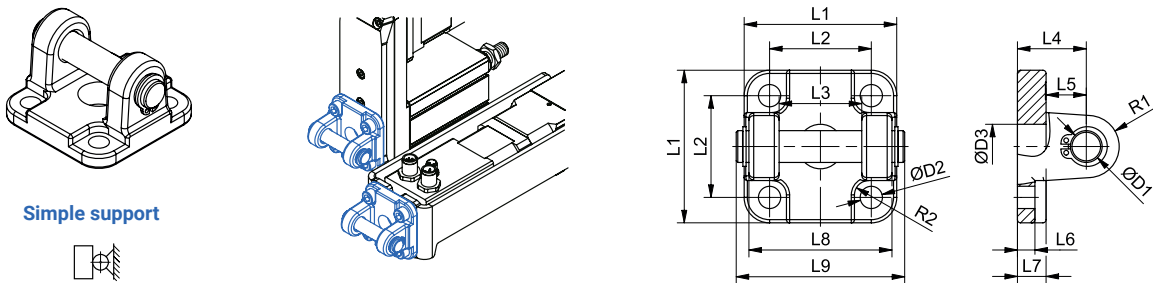

Designation	L1	L2	L3	L4	L5	L6	L7	L8	L9	R1	R2	ØD1	ØD2	ØD3	m	F _{max}
	(±0,2)			(±0,2)									(H11)	[kg]		
[mm]																
MASU 25 - 108243	27	18	12	16	10	2,6	6	3	-	6	4,5	6	4,5	10	0,02	F _{MCE}
MASU 32 - 108244	34	22	16	20	14	2,6	6	3	-	8	5,0	8	5,5	12	0,03	F _{MCE}
MASU 45 - 108245	48	32	26	22	13	5,5	9	45	53	10	5,5	10	6,6	14	0,12	F _{MCE}

Swivel foot mounting MLG

Material: aluminium

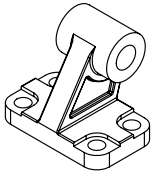

Simple support

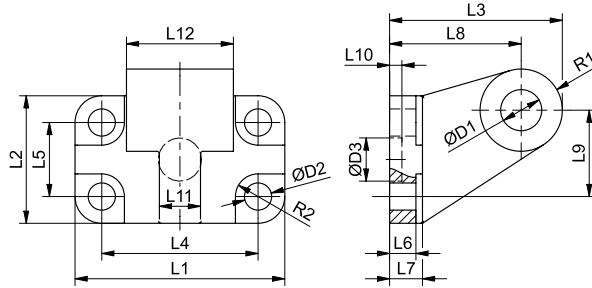
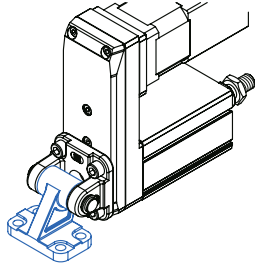

Designation	L1	L2	L3	L4	L5	L6	L7	L8	L9	L10 (+0,5/0)	L11	L12
[mm]												
MLG 45 - 108233	51	31	42	38	18	6,4	8	32	21	3	10	26

Designation	ØD1 (H9)	ØD2 (H13)	ØD3 (+0,5/0)	R1	R2	m	F _{max}	
[mm]								
							[kg]	[N]
MLG 45 - 108233	10	6,6	10,5	10	5,5	0,08	F _{MCE}	

Clevis foot mounting MLBU

Material: galvanized steel

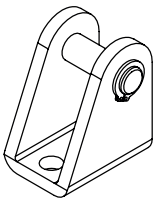

Simple support

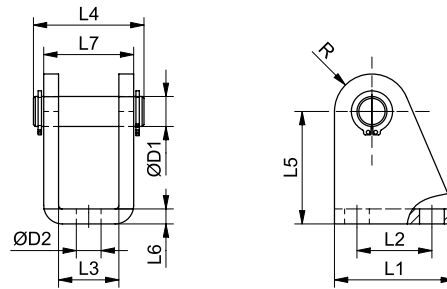
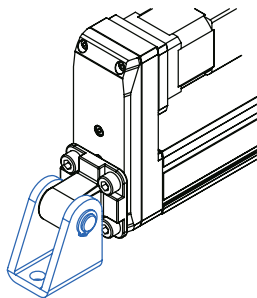

Designation	L1	L2	L3	L4 (+0,3/0)	L5 (±0,2)	L6 (±0,2)	L7	ØD1 (f7)	ØD2	R	m	F _{max}
[mm]												
											[kg]	[N]
MLBU 25 - 108227	25	15	12,1	23,0	27	3	18	6	5,5	7	0,04	F _{MCE}
MLBU 32 - 108226	32	20	16,1	29,5	30	4	24	8	6,6	10	0,08	F _{MCE}

Back mount ABM

Material: stainless steel

Mounting screws and nuts are included.

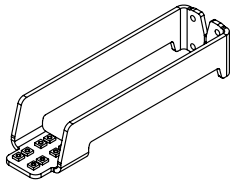

For fixed/simple support

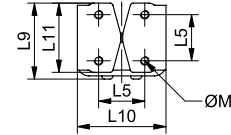
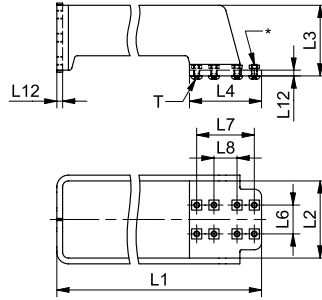
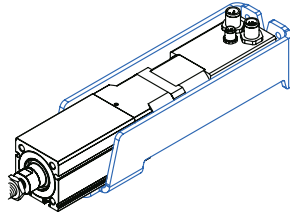
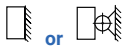

* MCE/MSCE mounting nuts and screws

Designation	Type	Compatibility (motor)		L1	L2	L3	L4	L5	L6
		Type	Size □ [mm]						
ABM 25 - T1 - 108239	T1	Stepper	28	165	30,5	27,5	35	18	13,5
ABM 32 - T1 - 108237	T1	Stepper	28	170	38,5	35,0	40	22	13,5
ABM 32 - T2 - 108238	T2	Stepper	42	200	46,0	35,0	40	22	13,5
ABM 45 - T1 - 108235	T1	Stepper	42	210	53,5	49,0	50	32	20,0
ABM 45 - T2 - 105320	T2	Stepper	56	245	64,9	49,0	50	32	20,0

Designation	L7	L8	L9	L10	L11	L12	ØM	T	m	F _{max}
				[mm]				[Nm]	[kg]	[N]
ABM 25 - T1 - 108239	28	12	29,8	35,5	27	2,5	M4	0,3	0,14	F _{MCE}
ABM 32 - T1 - 108237	28	12	37,7	44,5	34	3,0	M5	1,2	0,24	F _{MCE}
ABM 32 - T2 - 108238	28	12	37,7	52,0	34	3,0	M5	1,2	0,29	F _{MCE}
ABM 45 - T1 - 108235	40	16	52,7	61,5	48	4,0	M6	2,2	0,62	F _{MCE}
ABM 45 - T2 - 105320	40	16	52,7	72,9	48	4,0	M6	2,2	0,72	F _{MCE}

□ = Square cross section

Trunnion mount MZK

Material: galvanized steel

Mounting screws are included.

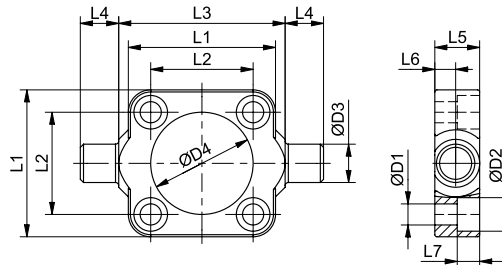
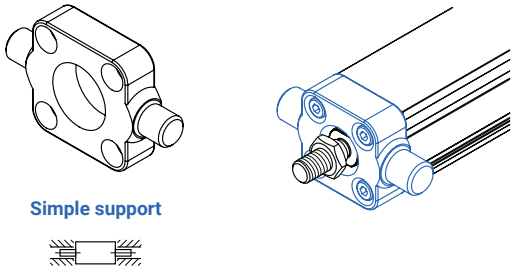

Designation	L1	L2	L3 (h14)	L4 (h14)	L5	L6 (+0,3/0)	L7 (±0,2)	ØD1	ØD2	ØD3 (e9)	ØD4	m	F _{max}
	[mm]												[kg]
MZK 32 - 108230	35	22	38	12	14	6,5	6	5,5	10,0	12	18	0,12	F _{MCE}
MZK 45 - 108231	46	32	52	12	14	6,5	7	6,6	10,5	12	32	0,17	F _{MCE}

Trunnion support MLZ

Material: galvanized steel + sinterized bronze

Set contains 2 pcs.

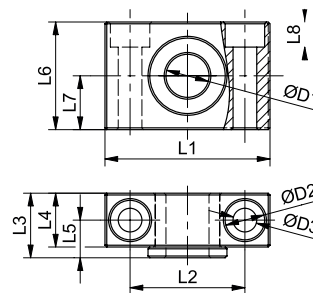
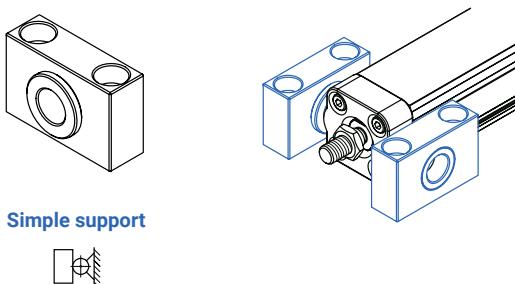

Designation	L1	L2 (±0,2)	L3	L4	L5	L6	L7 (±0,1)	L8 (±0,5)	ØD1 (F7)	ØD2	ØD3	m	F _{max}
	[mm]												[kg]
MLZ 32/45 - 108234	46	32	18	15	10,5	30	15	7	12	11	6,6	0,2	F _{MCE}

Guiding unit GUC

Material: body and plate – anodized aluminium, guides – hardened steel

Mounting (on the MCE profile) screws and nuts are included. Guiding unit GUC requires a female thread on the piston rod end.

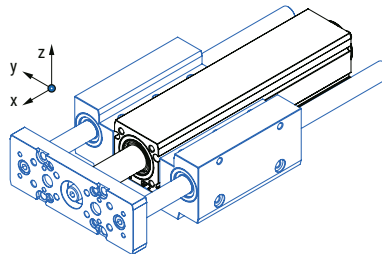
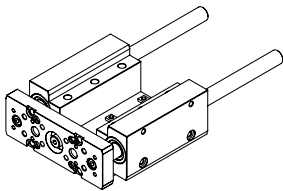

Technical data

Maximum lateral loading (in y and z directions) as a function of a load position

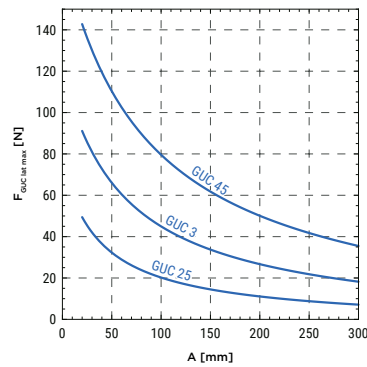
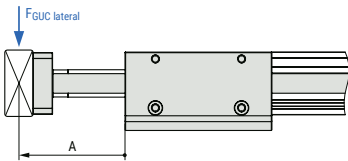

Mass and moved mass

Designation	Mass of GUC m_{GUC} [kg]	Moved mass of GUC* $m_{m, GUC}$ [kg]
GUC 25	$0,30 + 0,0008 \times (\text{Abs. stroke} + E)$	$0,10 + 0,0008 \times (\text{Abs. stroke} + E)$
GUC 32	$0,65 + 0,0013 \times (\text{Abs. stroke} + E)$	$0,20 + 0,0013 \times (\text{Abs. stroke} + E)$
GUC 45	$1,30 + 0,0018 \times (\text{Abs. stroke} + E)$	$0,42 + 0,0018 \times (\text{Abs. stroke} + E)$

* Moved mass of GUC is already considered in the equation for calculating the mass of GUC m_{GUC} .

Abs. stroke	Absolute stroke [mm]
E	Extended piston rod [mm]

Displacement (friction) force

Designation	Displacement force [N] GUC with ball bushes
GUC 25	3
GUC 32	3
GUC 45	3

Order code

GUC - 32 - 125 - BB

Guiding unit

Size:

- 25
- 32
- 45

GUC stroke: absolute stroke + extended piston rod E [mm]

Option:

- BB: with the ball bushes

GUC stroke: absolute stroke + extended piston rod E = max. 300 mm.
For the guiding unit stroke over 300 mm, please contact us.

Dimensions

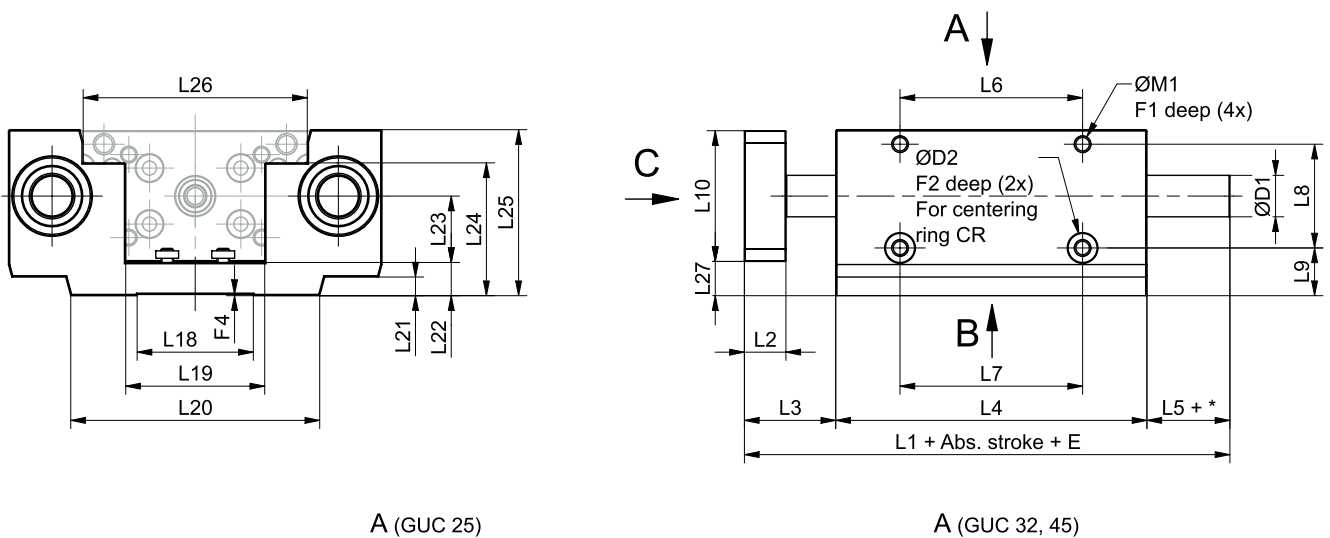

* ... + Abs. stroke + E

** MCE mounting nuts and screws (6x)

B (GUC 25)

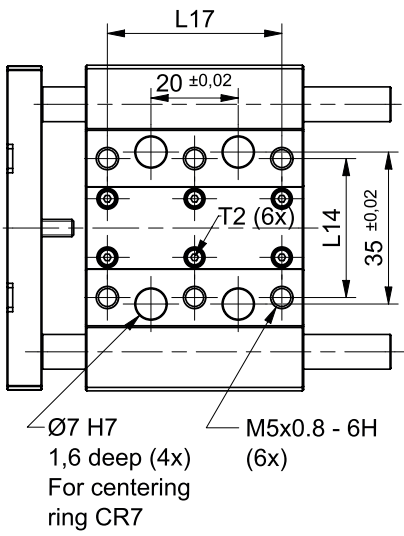

B (GUC 32)

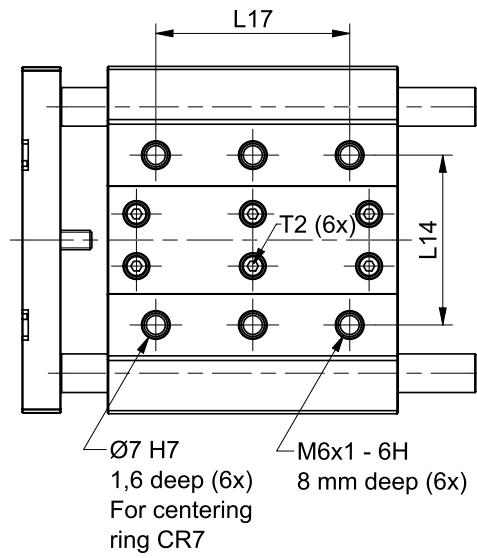

B (GUC 45)

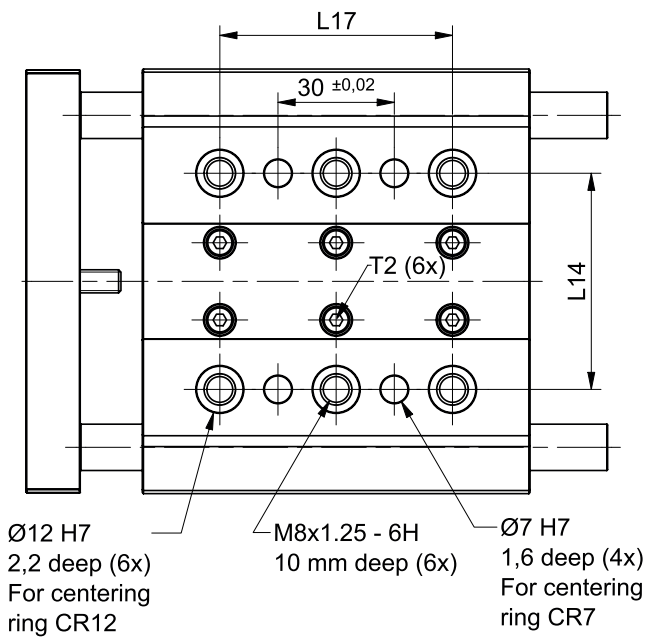

C (GUC 25)

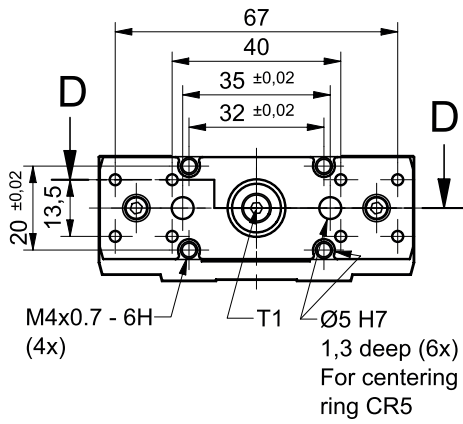

C (GUC 32)

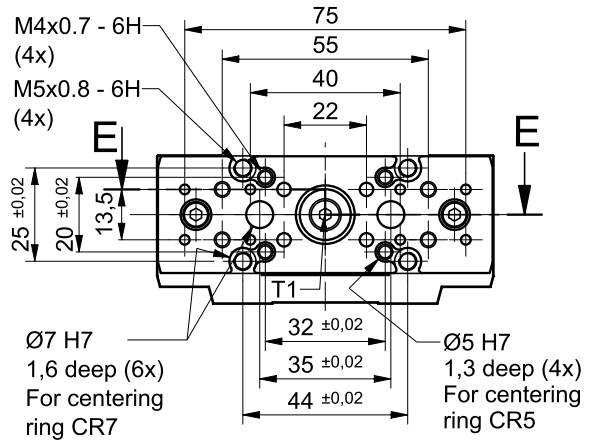

C (GUC 45)

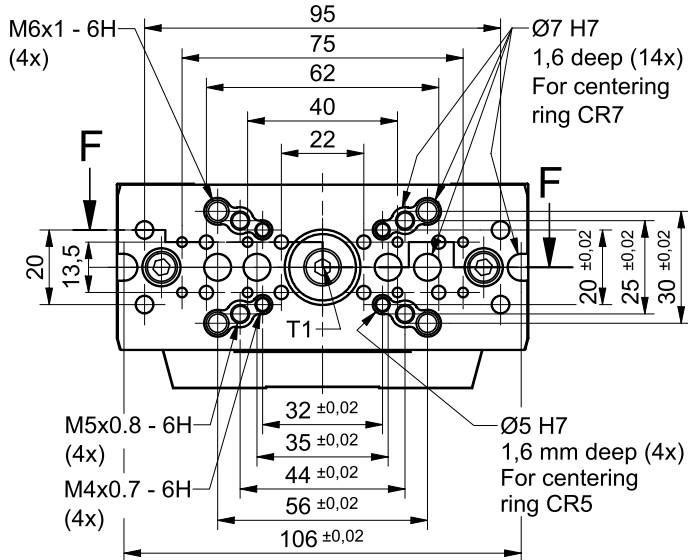

D-D

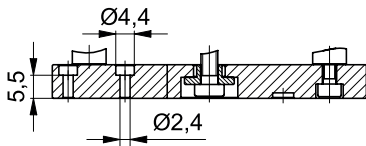

E-E

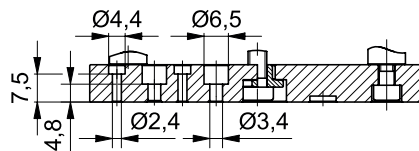

F-F

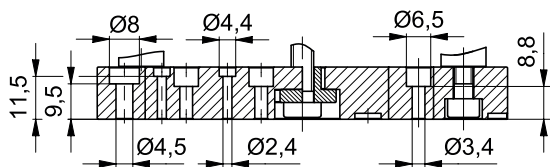

Designation	L1	L2	L3	L4	L5	L6	L7 ($\pm 0,02$)	L8	L9	L10	L11	L12	L13	L14
	[mm]													
GUC 25	88	8	18	50	20	32	32	20	7,5	24,5	74,5	75	57	32
GUC 32	117	10	22	75	20	44	44	25	11,5	31,5	89,5	90	69	44 $\pm 0,02$
GUC 45	150	14	30	100	20	56	56	30	17,5	44,5	109,5	110	86	56 $\pm 0,02$

Designation	L15	L16	L17	L18	L19	L20	L21	L22	L23	L24	L25	L26
	[mm]											
GUC 25	13,5	40	40	19	25,5	45	1,5	5	12,5	12,5	30	39
GUC 32	13,5	60	50 $\pm 0,02$	28	33,5	60	4,5	8	16,0	32,0	40	54
GUC 45	20,0	60	60 $\pm 0,02$	38	46,5	80	10,5	10	22,5	47,0	55	67

Designation	L27	L28	F1	F2	F3	F4	$\varnothing D1$	$\varnothing D2$ (H7)	$\varnothing D3$	$\varnothing M1$	$\varnothing M2$	$\varnothing M3$	T1	T2
	[mm]											[Nm]		
GUC 25	5,25	7,3	12	1,3	4,5	0,3	8	5	8,0	M3	M4	M5	2,8	0,3
GUC 32	8,25	8,0	12	1,6	-	0,3	10	7	5,1	M4	M5	-	5,6	1,2
GUC 45	10,25	10,5	12	1,6	-	0,3	12	7	6,6	M5	M6	-	9,6	2,2

Magnetic field sensor and the sensor holder HMG

Magnetic field sensors can be mounted by using the slot for the magnetic field sensor placed on the sides of the MCE/MSCE profile.

For the MCE/MSCE size of 25, mounting of the magnetic field sensor requires an HMG sensor holder.

MCE/MSCE 32, 45

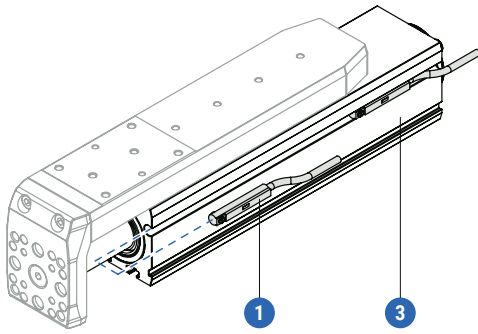

MCE/MSCE 25

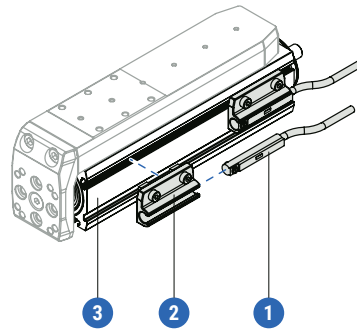

- 1 - Magnetic field sensor.
- 2 - Sensor holder HMG.
- 3 - Profile of the mini electric cylinder MCE or slider MSCE.

Magnetic field sensors

Characteristics

Function principle	Magnetic
Wiring method	3-wire type
Sensor type	PNP current sourcing
Operating voltage	5 - 30 V DC
Switching current	200 mA max.
Contact rating	6 W max.
Voltage drop	0,5 V @ 200 mA max.
Current consumption	6 mA @ 24 V DC max.
Leakage current	0,01 mA max.
Operating frequency	1000 Hz max.
Ambient temperature	-10 - +70 °C
Shock / Vibration	50 G / 9 G
Protection class	IP67
LED indicator	Green
Electrical connection	M8, 3-pin
Cable (diameter, material, length)	Ø2,8 mm, PUR, 150 mm
Extension cable	Energy chain compliant

Technical data

Designation	Switching function
SMO-40TP-K NC	NC-normally close
SMO-40TP-K NO	NO-normally open

Sensor holder HMG

Material: powder coated zinc alloy

Mounting (on the MCE/MSCE profile) screws and nuts are included.

Dimensions

Magnetic field sensor SMO-40TP-K NC/ SMO-40TP-K NO

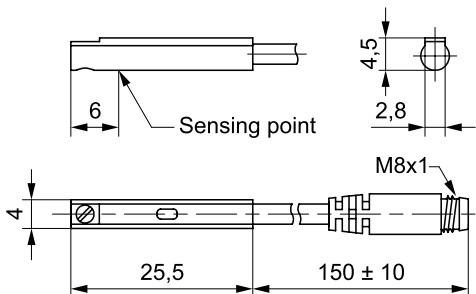

Extension cable

Straight connector

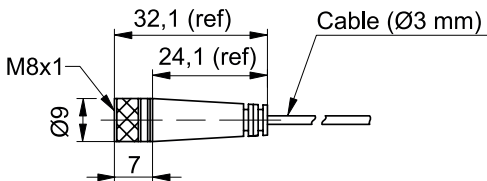

Angled connector

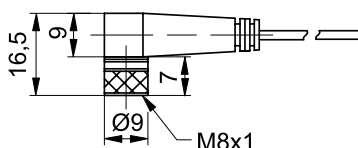

Sensor holder HMG

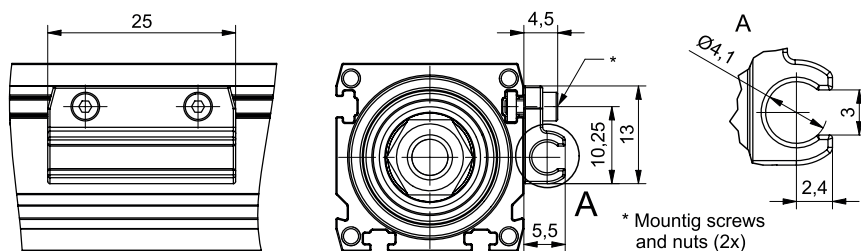

Designation	Type	Compatible with	Cable length [m]
SMO-40TP-K NC - 109125	Magnetic field sensor	MCE/MSCE series*	-
SMO-40TP-K NO - 12259	Magnetic field sensor	MCE/MSCE series*	-
HMG 25 - 109101	Sensor holder	MCE/MSCE 25	-
Cable - 8146	Straight connector extension cable	SMO-40TP-K NC/ SMO-40TP-K NO	2
Cable - 8147	Straight connector extension cable	SMO-40TP-K NC/ SMO-40TP-K NO	5
Cable - 9017	Angled connector extension cable	SMO-40TP-K NC/ SMO-40TP-K NO	2
Cable - 9019	Angled connector extension cable	SMO-40TP-K NC/ SMO-40TP-K NO	5

* Mounting of the magnetic field sensor on the MCE/MSCE 25 requires an HMG sensor holder.

Technical information

Mini electric cylinder MCE

Operating conditions

Ambient temperature	0 °C ~ +50 °C
Ambient temperature without a motor	0 °C ~ +60 °C
Protection class	IP40
Duty cycle	100 %
Maintenance	Life-time pre-lubricated

Maximum lateral loading as a function of the piston rod absolute position

On the following diagrams, the maximum lateral loads acting on the piston rod end as a function of the piston rod absolute position for different values of the absolute stroke are presented. There is also an extended piston rod (E) taken into consideration.

Values on the curves represent an absolute stroke of the cylinder. Diagrams consider the maximum travel speed of the particular size of the cylinder. When operating with lower travel speeds, the maximum lateral load may be higher.

Diagrams consider the maximum travel speed of the particular size of the cylinder. When operating with lower travel speeds, the maximum lateral load may be higher.

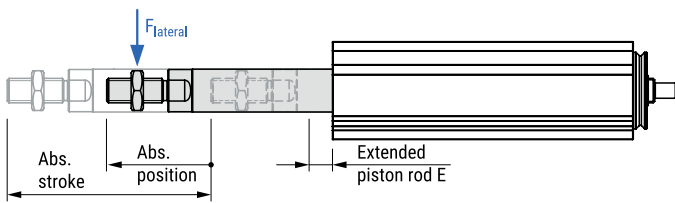

MCE 25

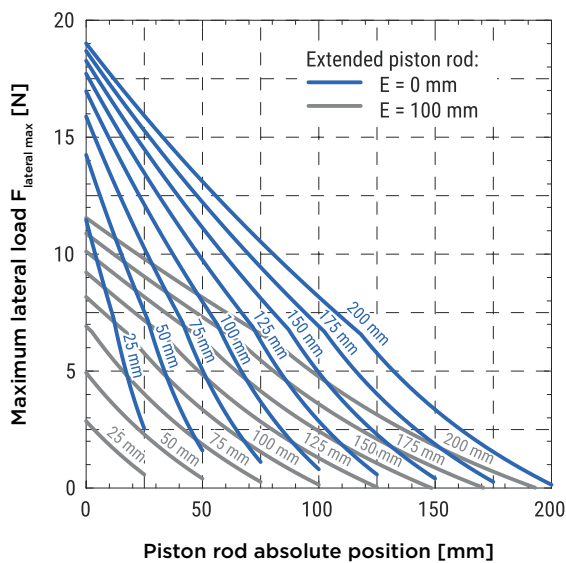

MCE 32

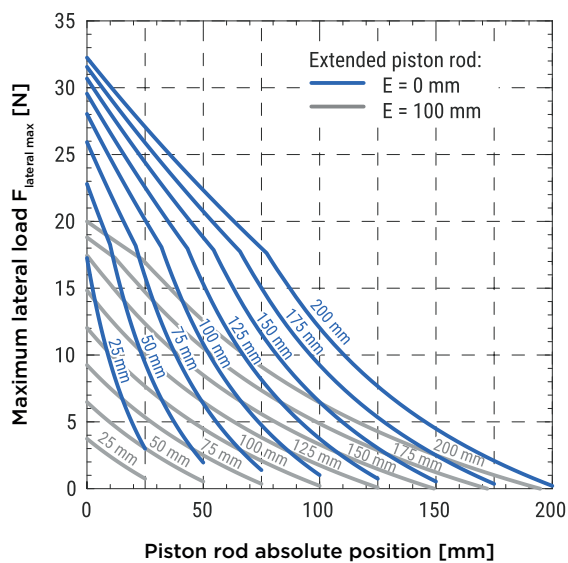

MCE 45

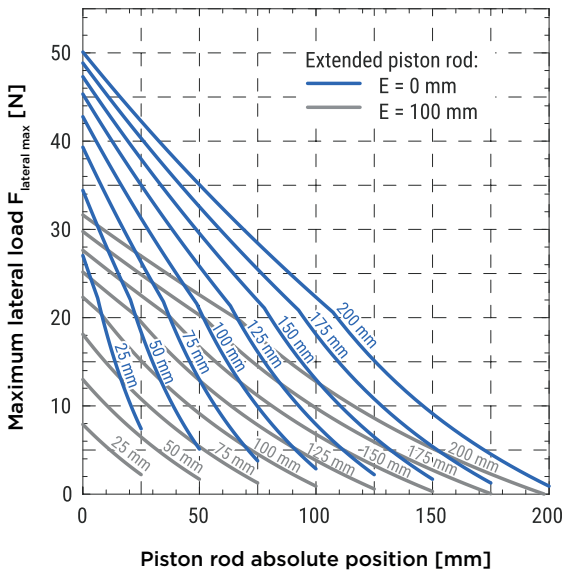

Maximum deflection of the piston rod end as a function of the cylinder absolute stroke

On the following diagrams, the maximum deflections of the piston rod end subjected to different lateral loads for different absolute positions (defined as a portion of the absolute stroke) are presented. There is also an extended piston rod (E) taken into consideration.

Values on the curves represent lateral load applied to the piston rod end.

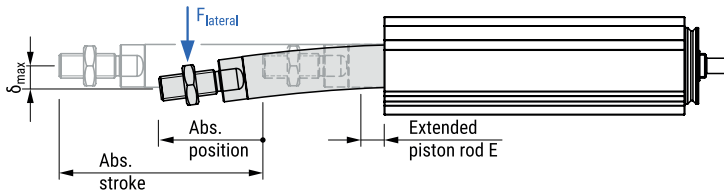

MCE 25

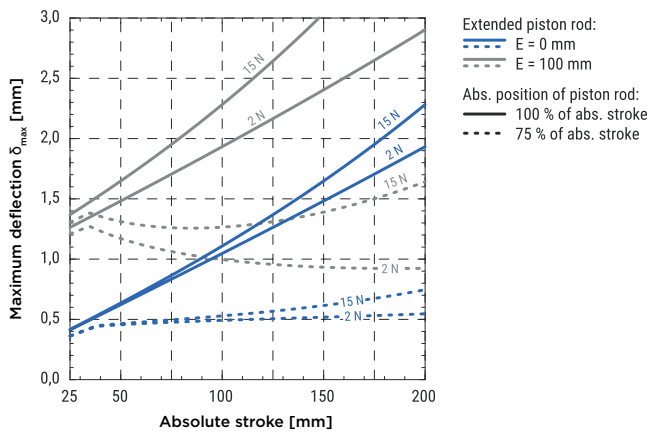

MCE 32

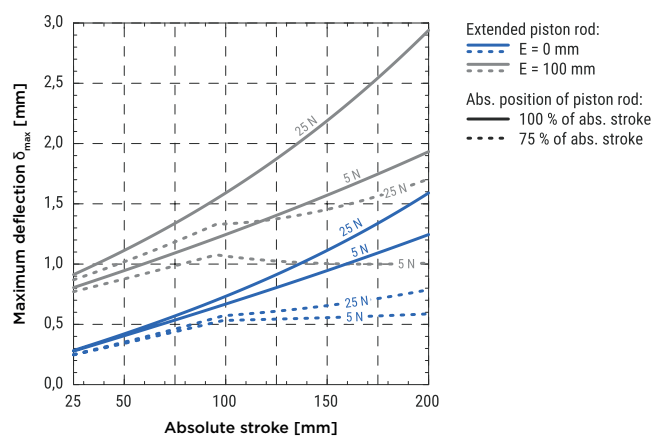

MCE 42

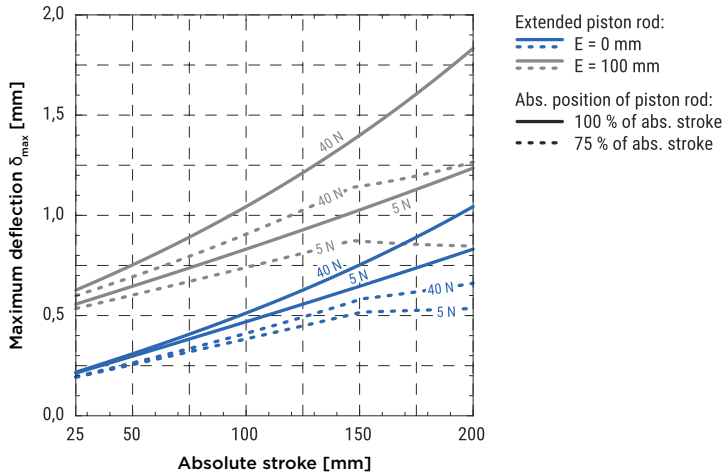

Maximum horizontal payload as a function of the travel speed and acceleration of the piston rod

On the following diagrams, the maximum horizontal payloads applied to the piston rod as a function of the travel speed for different accelerations, different ball screw leads and different combinations of the standard motors are presented. Motor adapter VK and a motor side drive MSD are also considered.

Diagrams are valid when the payload is supported by an external guiding (coefficient of friction 0,1 has been considered).

It should be noted that the diagrams are also valid for the case where a guiding unit GUC is considered.

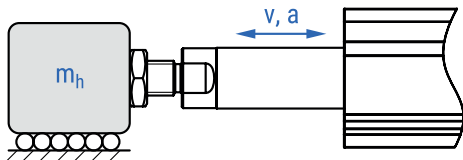

MCE 25

6 × 2 with a stepper motor □28

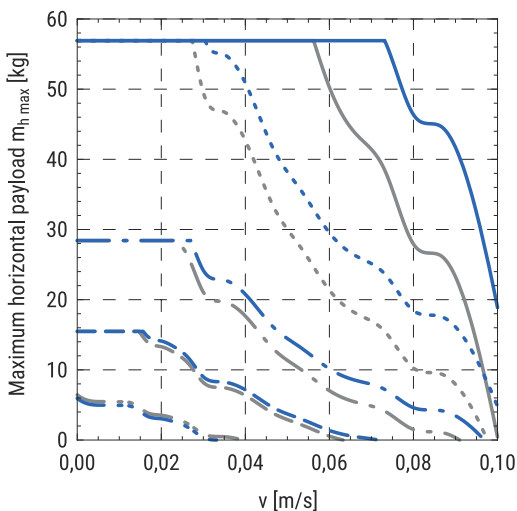

6 × 6 with a stepper motor □28

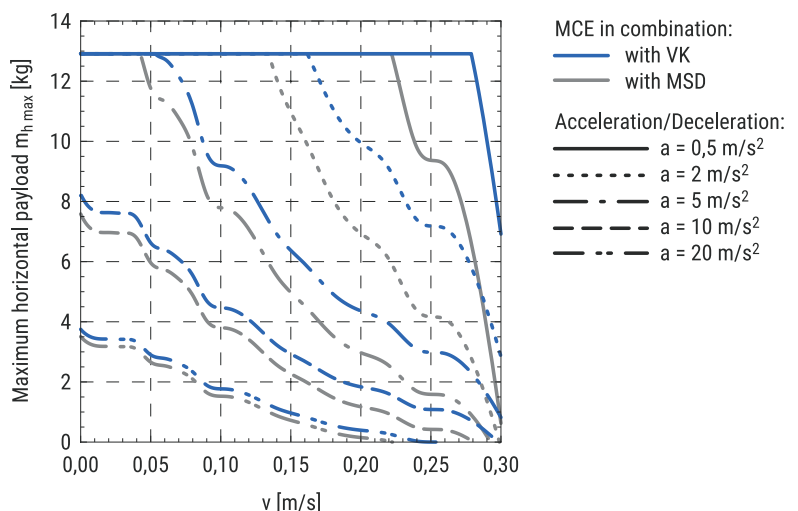

MCE 32

8 × 2 with a stepper motor □28

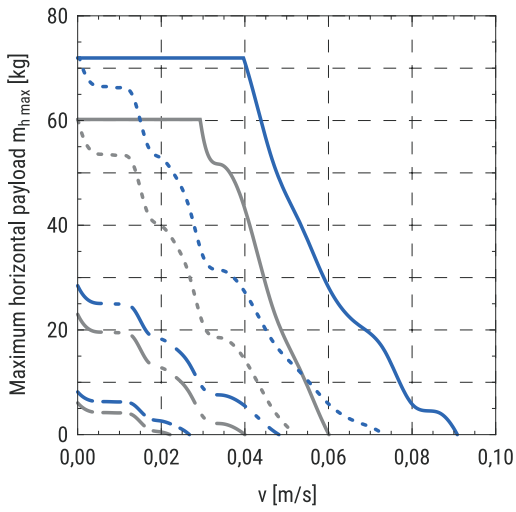

8 × 8 with a stepper motor □28

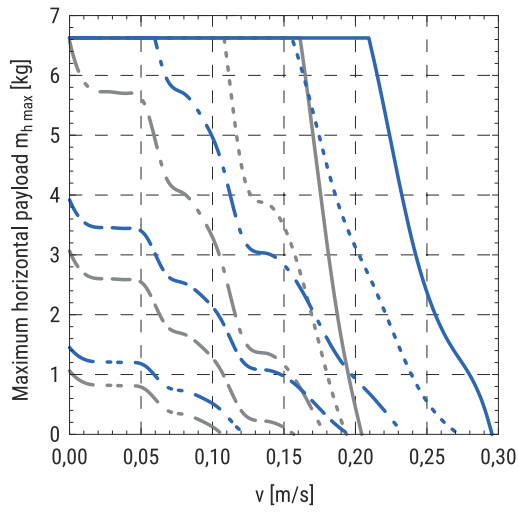

MCE in combination:
 — with VK
 - - with MSD

Acceleration/Deceleration:
 — a = 0,5 m/s²
 - - a = 2 m/s²
 - · - a = 5 m/s²
 - · - a = 10 m/s²
 - · - a = 20 m/s²

8 × 2 with a stepper motor □42

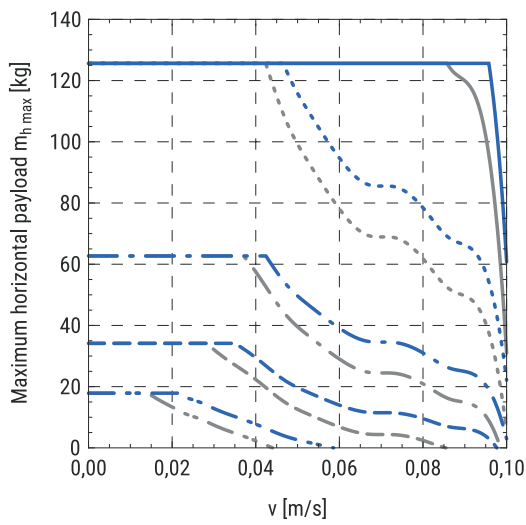

8 × 8 with a stepper motor □42

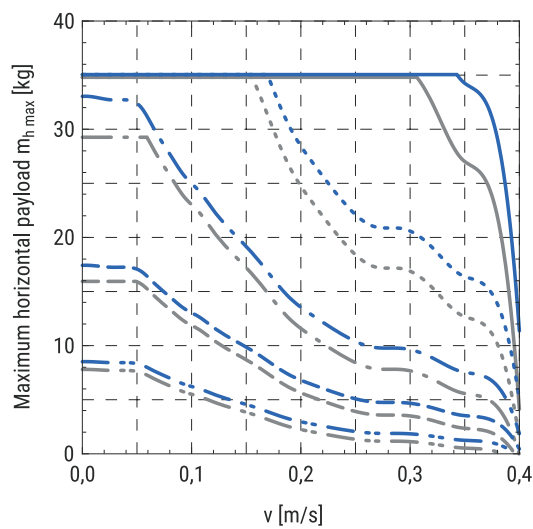

MCE in combination:
 — with VK
 - - with MSD

Acceleration/Deceleration:
 — a = 0,5 m/s²
 - - a = 2 m/s²
 - · - a = 5 m/s²
 - · - a = 10 m/s²
 - · - a = 20 m/s²

MCE 45

10 × 3 with a stepper motor □42

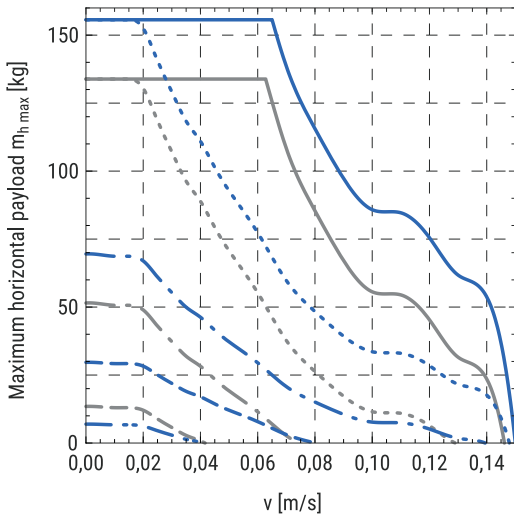

10 × 10 with a stepper motor □42

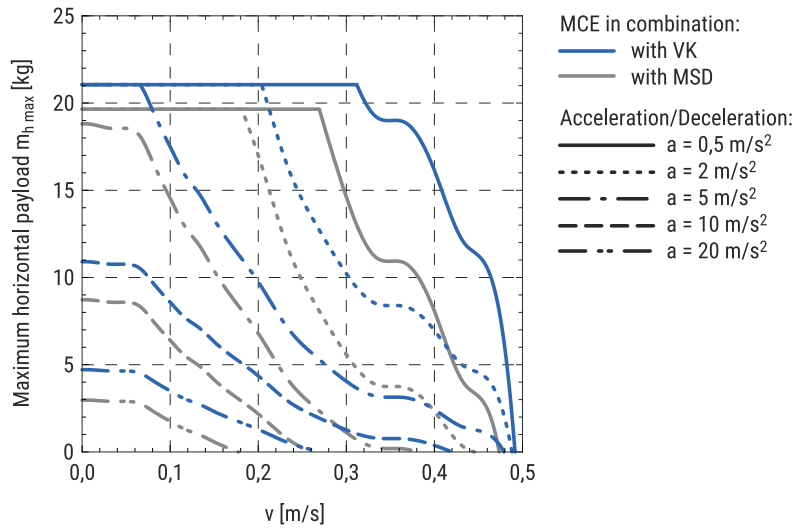

10 × 3 with a stepper motor □56

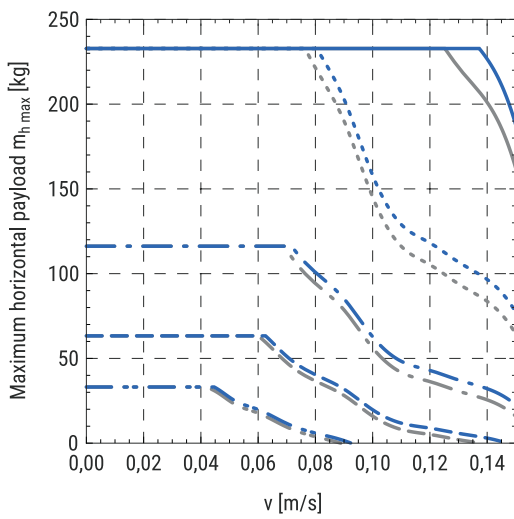

10 × 10 with a stepper motor □56

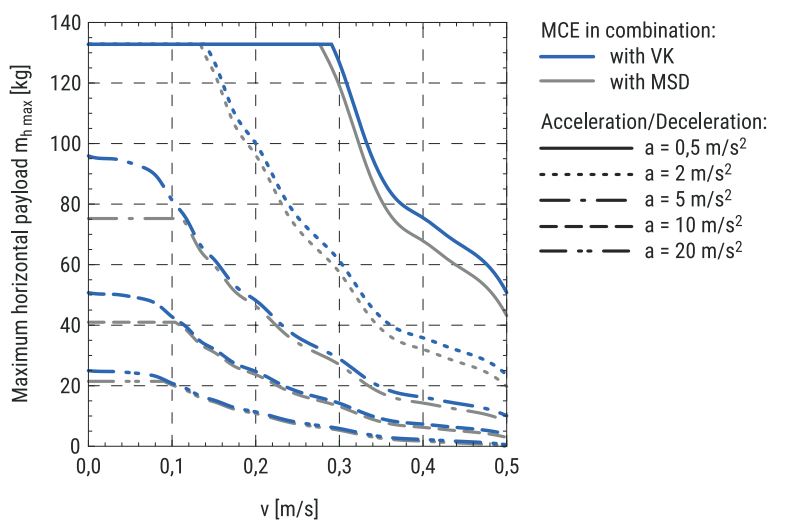

Maximum vertical payload as a function of the travel speed and acceleration of the piston rod

On the following diagrams, the maximum vertical payloads applied to the piston rod as a function of the travel speed for different accelerations, different ball screw leads and different combinations of the standard motors are presented. Motor adapter VK and a motor side drive MSD are also considered.

For the case that guiding unit GUC is taken into consideration, the value obtained from the diagram should be decreased by the moving mass of the guiding unit (please refer to the Guiding unit section).

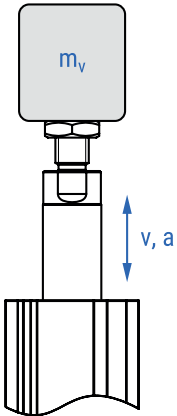

MCE 25

6 × 2 with a stepper motor □28

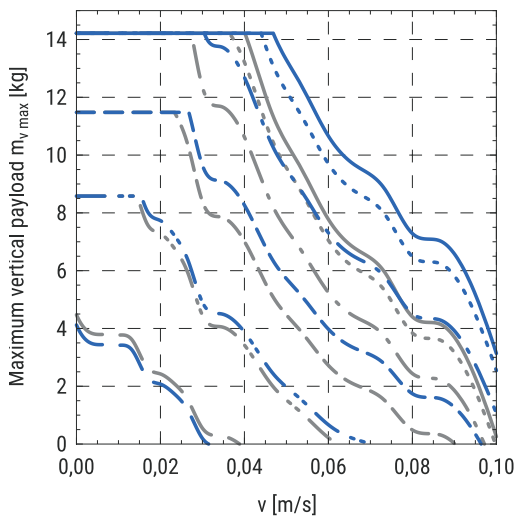

6 × 6 with a stepper motor □28

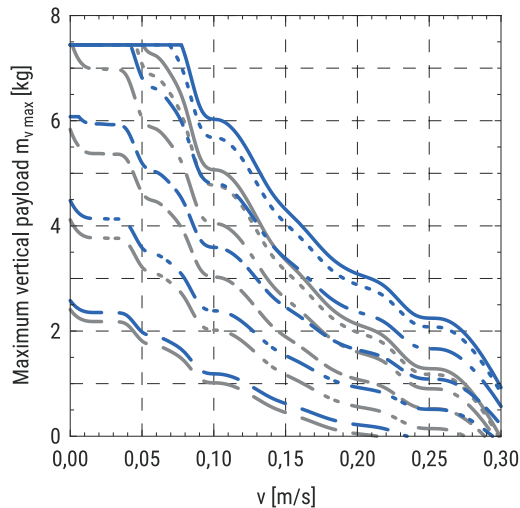

- MCE in combination:
- with VK
 - with MSD
- Acceleration/Deceleration:
- $a = 0 \text{ m/s}^2$
 - - - $a = 0,5 \text{ m/s}^2$
 - · - $a = 2 \text{ m/s}^2$
 - - - $a = 5 \text{ m/s}^2$
 - · - $a = 10 \text{ m/s}^2$
 - $a = 20 \text{ m/s}^2$

MCE 32

8 × 2 with a stepper motor □28

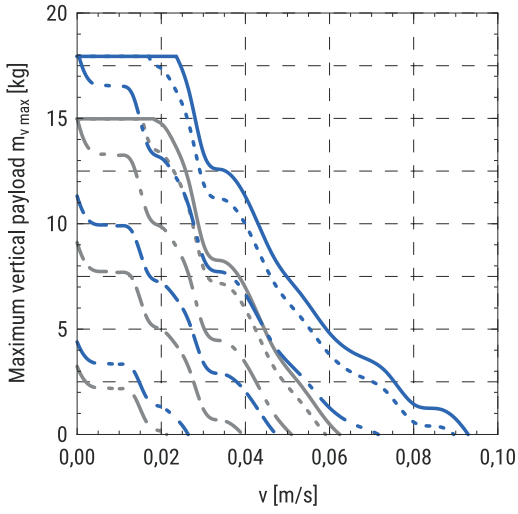

8 × 8 with a stepper motor □28

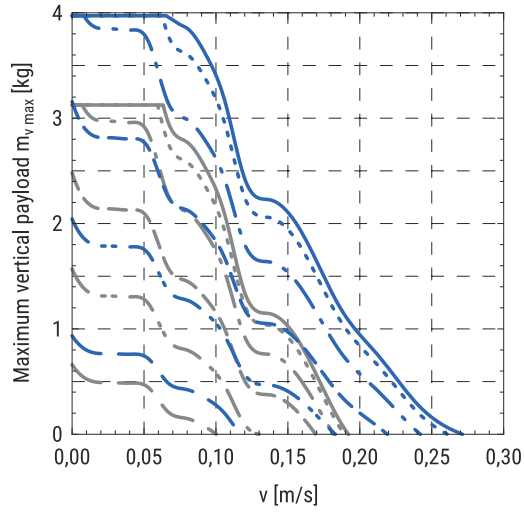

MCE in combination:

— with VK
— with MSD

Acceleration/Deceleration:

- $a = 0 \text{ m/s}^2$
- - - $a = 0,5 \text{ m/s}^2$
- · - $a = 2 \text{ m/s}^2$
- - - $a = 5 \text{ m/s}^2$
- · - $a = 10 \text{ m/s}^2$
- - - $a = 20 \text{ m/s}^2$

8 × 2 with a stepper motor □42

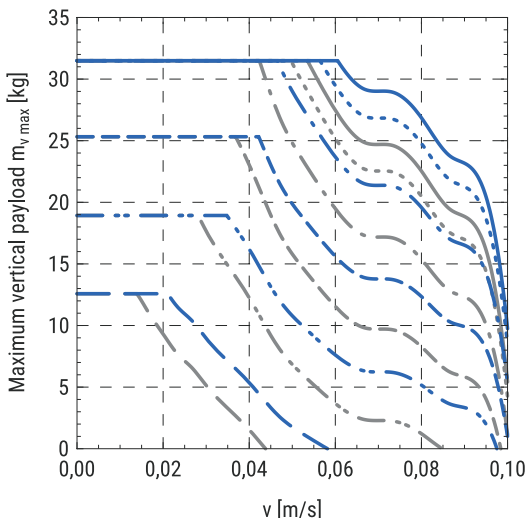

8 × 8 with a stepper motor □42

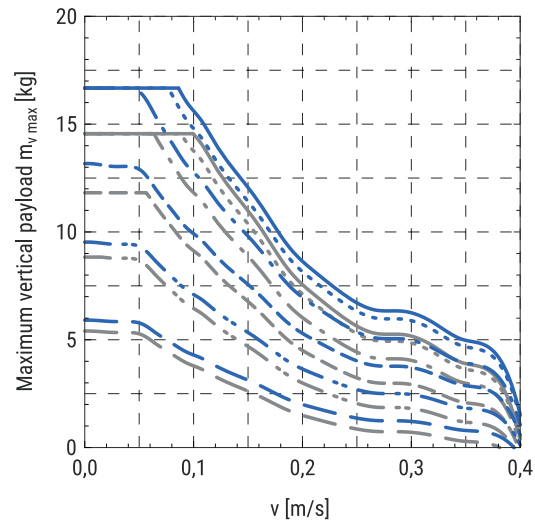

MCE in combination:

— with VK
— with MSD

Acceleration/Deceleration:

- $a = 0 \text{ m/s}^2$
- - - $a = 0,5 \text{ m/s}^2$
- · - $a = 2 \text{ m/s}^2$
- - - $a = 5 \text{ m/s}^2$
- · - $a = 10 \text{ m/s}^2$
- - - $a = 20 \text{ m/s}^2$

MCE 45

10 × 3 with a stepper motor □42

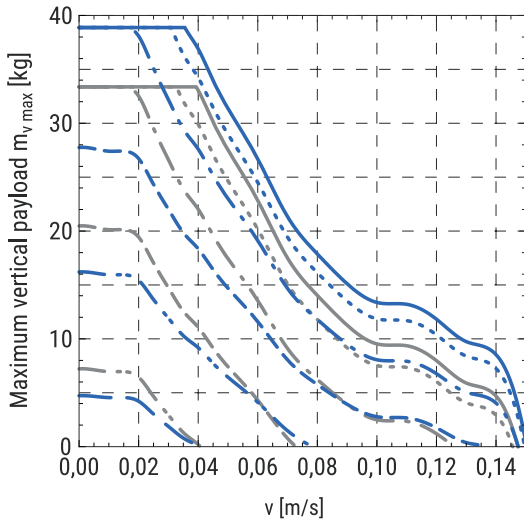

10 × 10 with a stepper motor □42

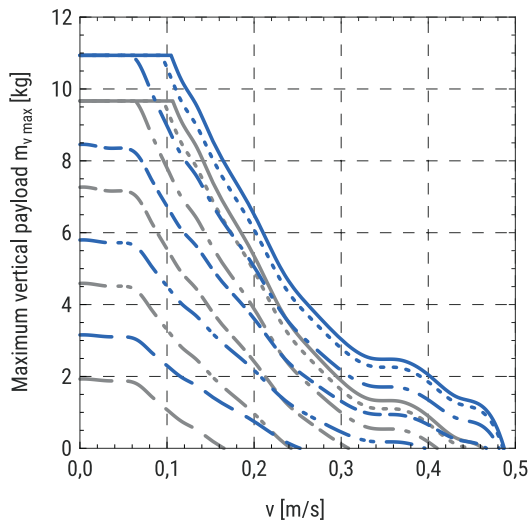

- MCE in combination:
- with VK
 - with MSD
- Acceleration/Deceleration:
- $a = 0 \text{ m/s}^2$
 - ⋯ $a = 0,5 \text{ m/s}^2$
 - - $a = 2 \text{ m/s}^2$
 - · - $a = 5 \text{ m/s}^2$
 - · · - $a = 10 \text{ m/s}^2$
 - · · · - $a = 20 \text{ m/s}^2$

10 × 3 with a stepper motor □56

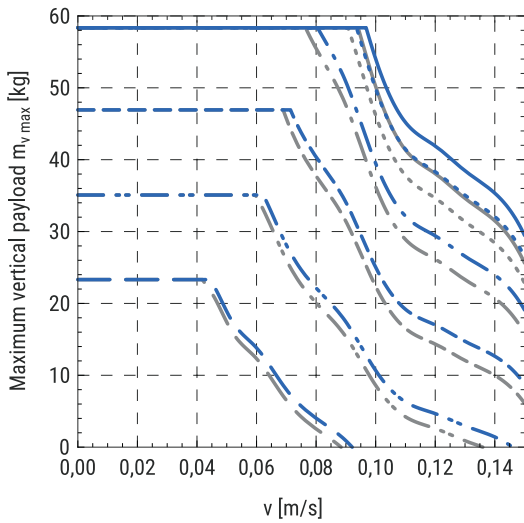

10 × 10 with a stepper motor □56

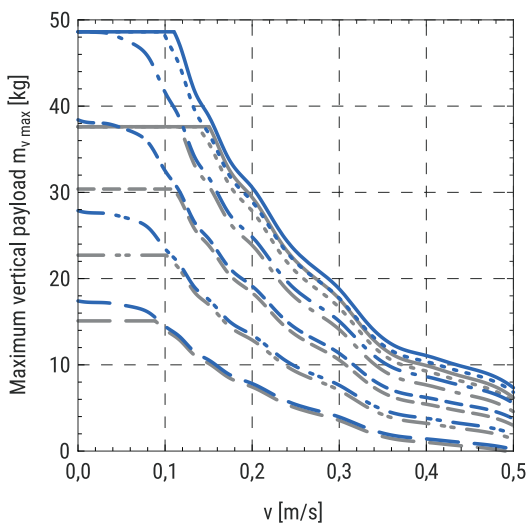

- MCE in combination:
- with VK
 - with MSD
- Acceleration/Deceleration:
- $a = 0 \text{ m/s}^2$
 - ⋯ $a = 0,5 \text{ m/s}^2$
 - - $a = 2 \text{ m/s}^2$
 - · - $a = 5 \text{ m/s}^2$
 - · · - $a = 10 \text{ m/s}^2$
 - · · · - $a = 20 \text{ m/s}^2$

Maximum axial load as a function of the travel speed and acceleration of the piston rod

On the following diagrams, the maximum axial load applied to the piston rod as a function of the travel speed for different accelerations, different ball screw leads and different combinations of the standard motors is presented. Motor adapter VK and a motor side drive MSD are also considered.

For the case where a guiding unit GUC is used, the value obtained from the diagram should be decreased by the moving mass of the guiding unit (please refer to the Guiding unit section) multiplied by the acceleration of the piston rod.

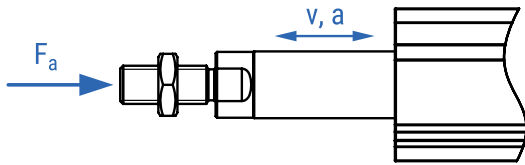

MCE 25

6 × 2 with a stepper motor □28

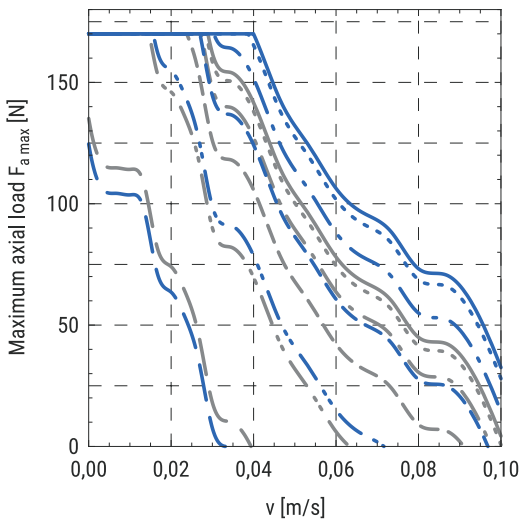

6 × 6 with a stepper motor □28

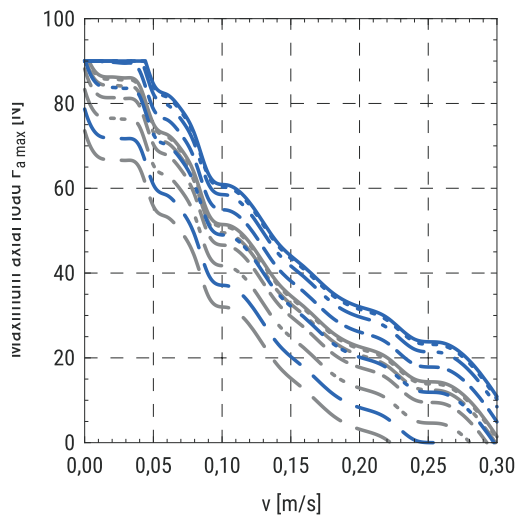

- MCE in combination:
- with VK
 - with MSD
- Acceleration/Deceleration:
- $a = 0 \text{ m/s}^2$
 - - - $a = 0,5 \text{ m/s}^2$
 - · - $a = 2 \text{ m/s}^2$
 - - - $a = 5 \text{ m/s}^2$
 - · - $a = 10 \text{ m/s}^2$
 - - - $a = 20 \text{ m/s}^2$

MCE 32

8 × 2 with a stepper motor □28

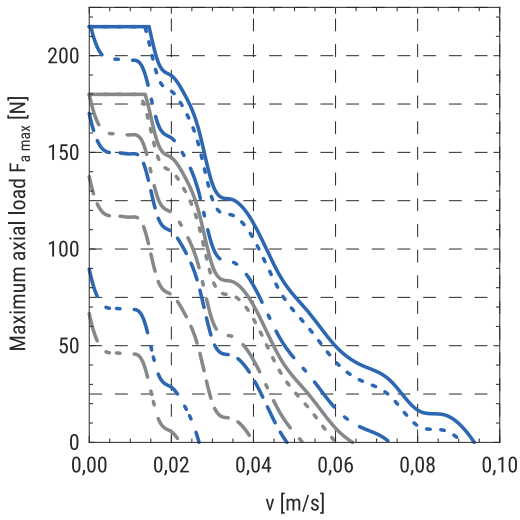

8 × 8 with a stepper motor □28

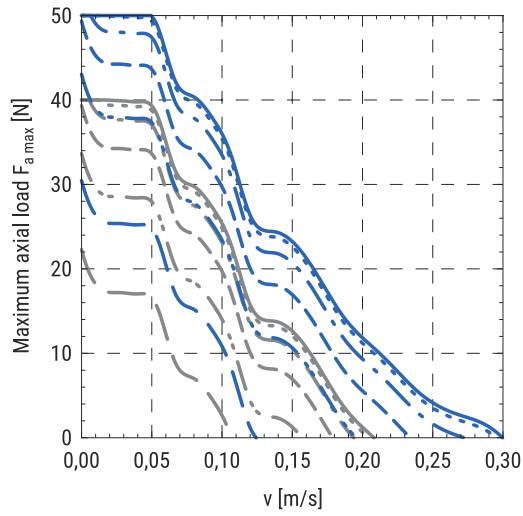

- MCE in combination:
- with VK
 - with MSD
- Acceleration/Deceleration:
- a = 0 m/s²
 - a = 0,5 m/s²
 - · - a = 2 m/s²
 - - - a = 5 m/s²
 - · · a = 10 m/s²
 - - - a = 20 m/s²

8 × 2 with a stepper motor □42

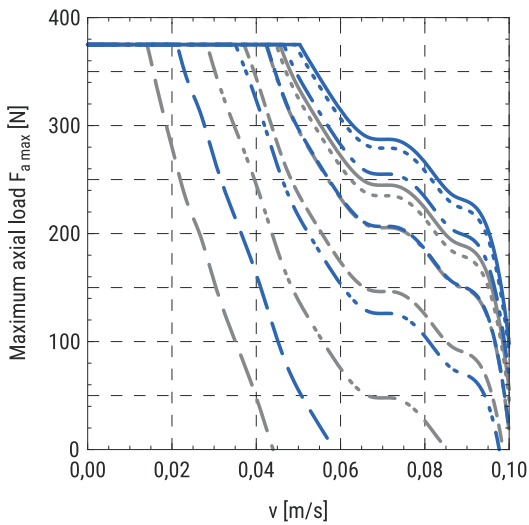

8 × 8 with a stepper motor □42

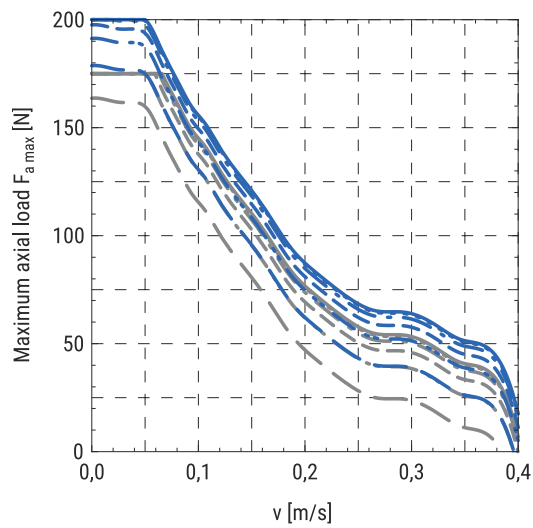

- MCE in combination:
- with VK
 - with MSD
- Acceleration/Deceleration:
- a = 0 m/s²
 - a = 0,5 m/s²
 - · - a = 2 m/s²
 - - - a = 5 m/s²
 - · · a = 10 m/s²
 - - - a = 20 m/s²

MCE 45

10 × 3 with a stepper motor □42

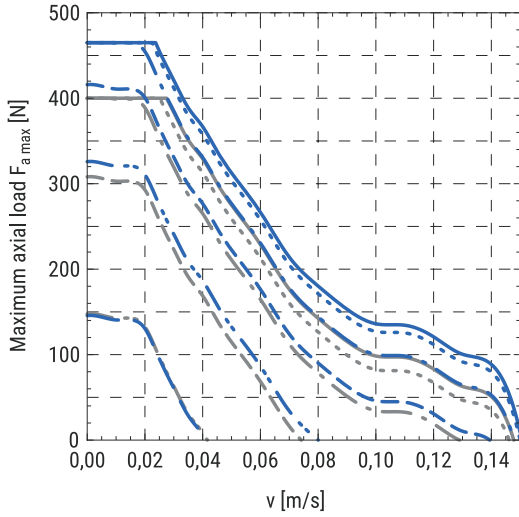

10 × 10 with a stepper motor □42

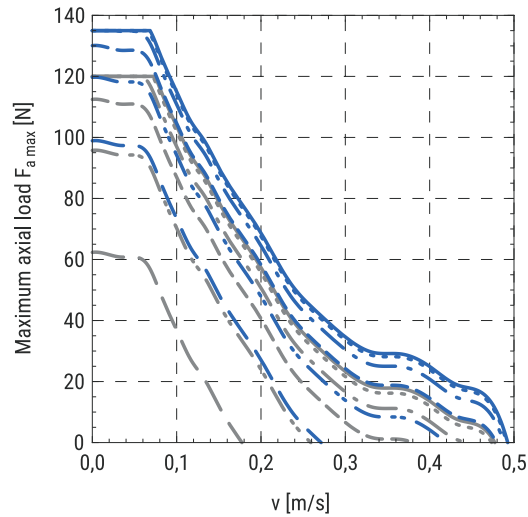

- MCE in combination:
- with VK
 - with MSD
- Acceleration/Deceleration:
- a = 0 m/s²
 - a = 0,5 m/s²
 - · - · a = 2 m/s²
 - - - - a = 5 m/s²
 - · · · a = 10 m/s²
 - - - - a = 20 m/s²

10 × 3 with a stepper motor □56

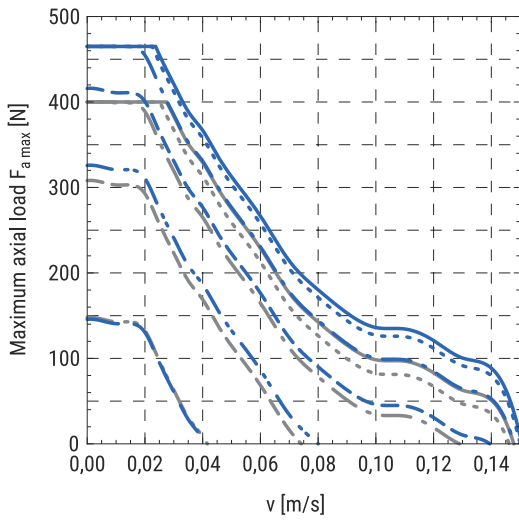

10 × 10 with a stepper motor □56

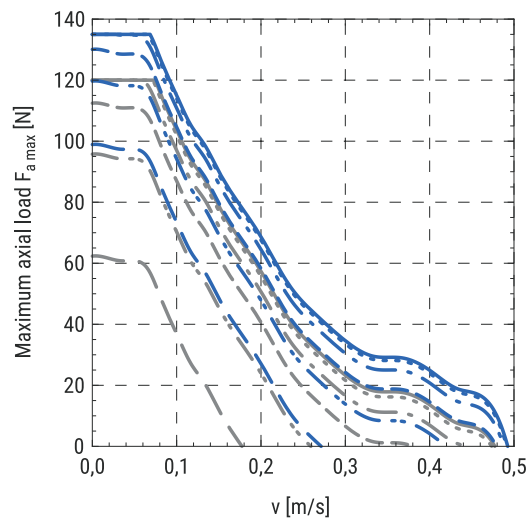

- MCE in combination:
- with VK
 - with MSD
- Acceleration/Deceleration:
- a = 0 m/s²
 - a = 0,5 m/s²
 - · - · a = 2 m/s²
 - - - - a = 5 m/s²
 - · · · a = 10 m/s²
 - - - - a = 20 m/s²

Maximum horizontal payload as a function of change of the position and positioning time of the piston rod

The following diagrams show the maximum payload that can be moved by a certain horizontal distance within a positioning time frame. Acceleration/deceleration time of 100 ms is taken into account.

Diagrams depend on the ball screw leads and different combinations of the standard motors. Motor adapter VK and a motor side drive MSD are also considered.

Diagrams are valid when the payload is supported by an external guiding (coefficient of friction 0,1 has been considered).

It should be noted that the diagrams are also valid for the case where a guiding unit GUC is considered.

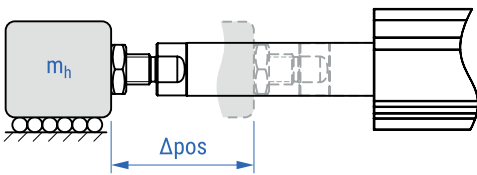

MCE 25

6 × 2 with a stepper motor □28

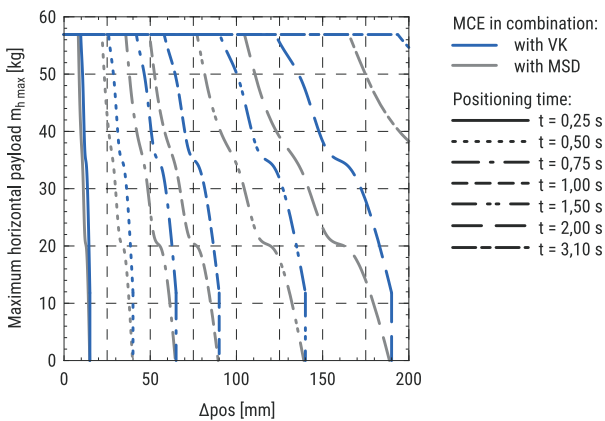

6 × 6 with a stepper motor □28

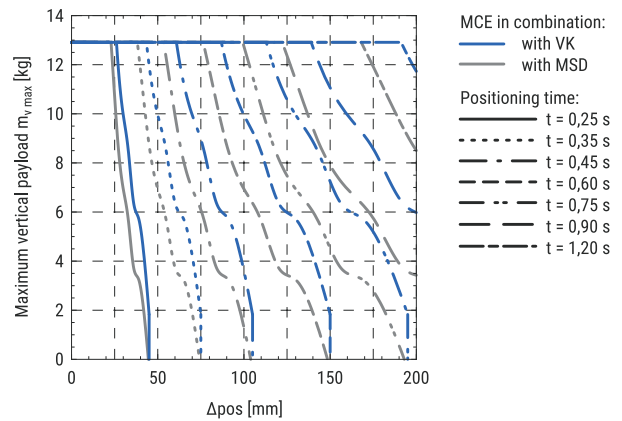

MCE 32

8 × 2 with a stepper motor □28

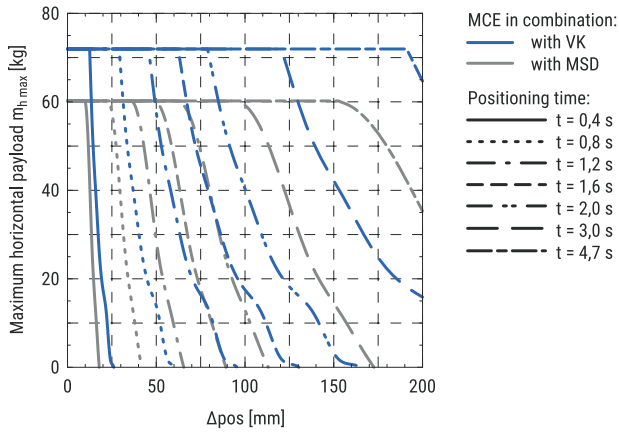

8 × 8 with a stepper motor □28

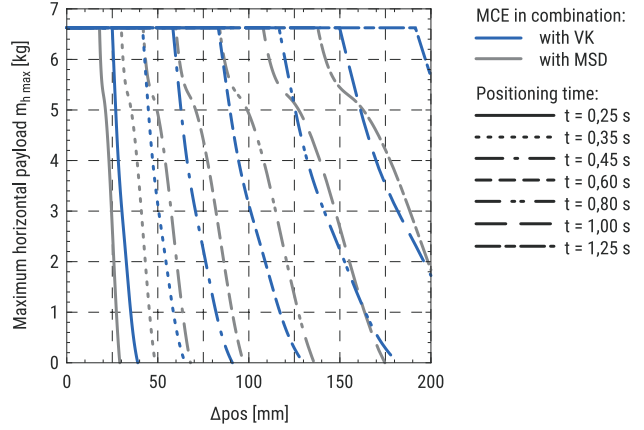

8 × 2 with a stepper motor □42

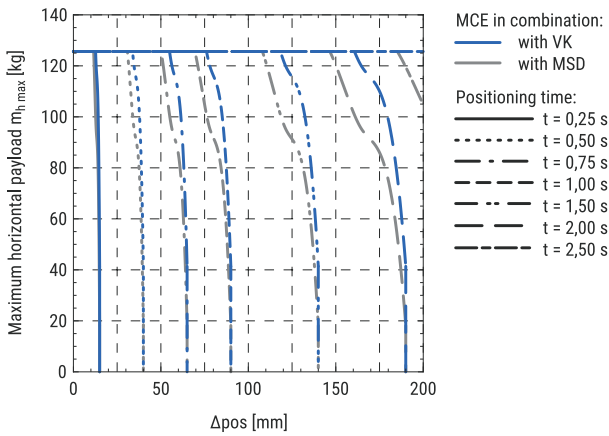

8 × 8 with a stepper motor □42

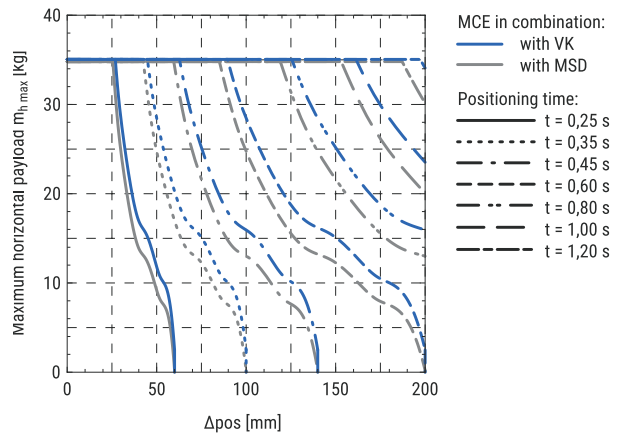

MCE 45

10 × 3 with a stepper motor □42

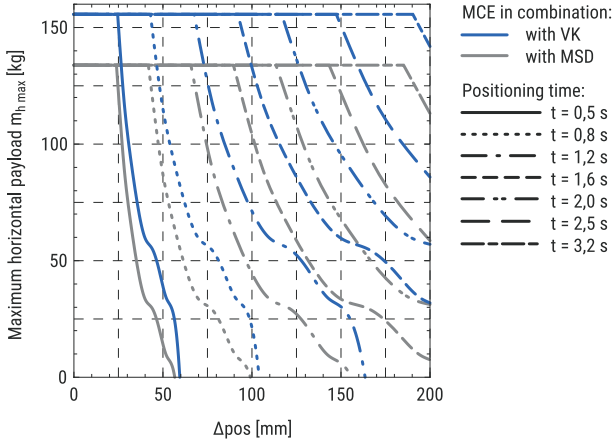

10 × 10 with a stepper motor □42

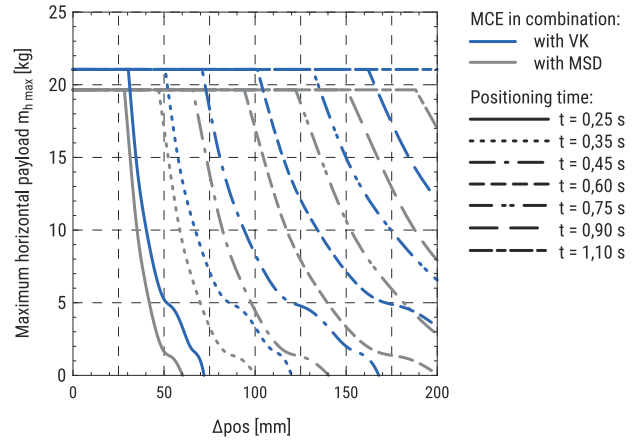

10 × 3 with a stepper motor □56

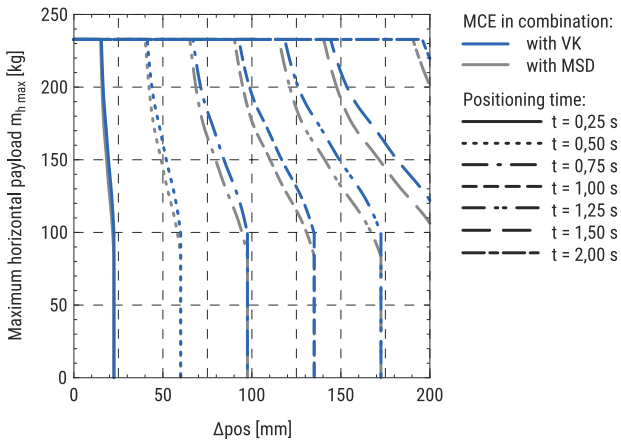

10 × 10 with a stepper motor □56

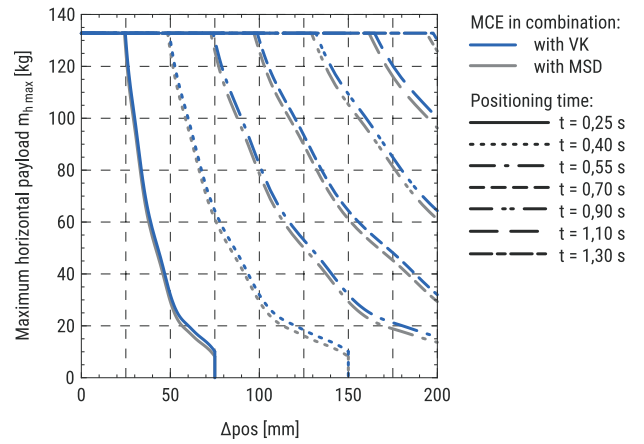

Maximum vertical payload as a function of change of the position and positioning time of the piston rod

The following diagrams show the maximum payload that can be moved by a certain vertical distance within a positioning time frame. Acceleration/deceleration time of 100 ms is taken into account.

Diagrams depend on the ball screw leads and different combinations of the standard motors. Motor adapter VK and a motor side drive MSD are also considered.

For the case where a guiding unit GUC is used, the value obtained from the diagram should be decreased by the moving mass of the guiding unit (please refer to the Guiding unit section).

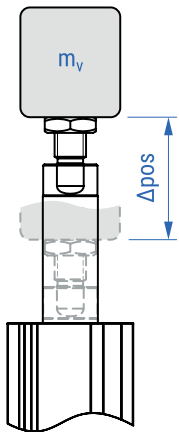

MCE 25

6 × 2 with a stepper motor □28

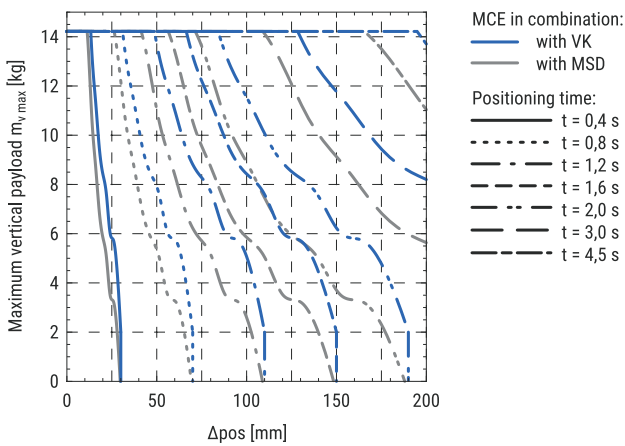

6 × 6 with a stepper motor □28

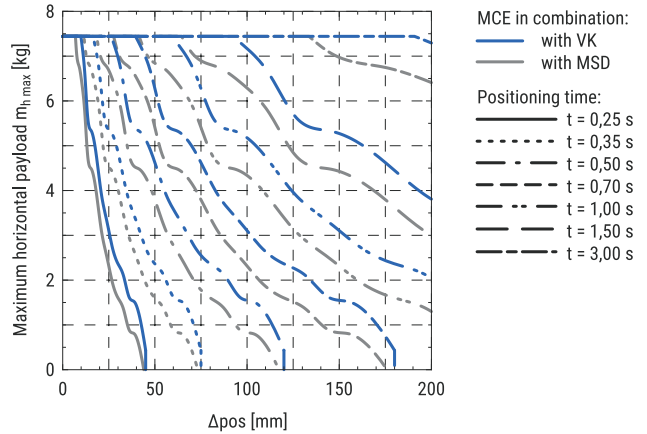

MCE 32

8 × 2 with a stepper motor □28

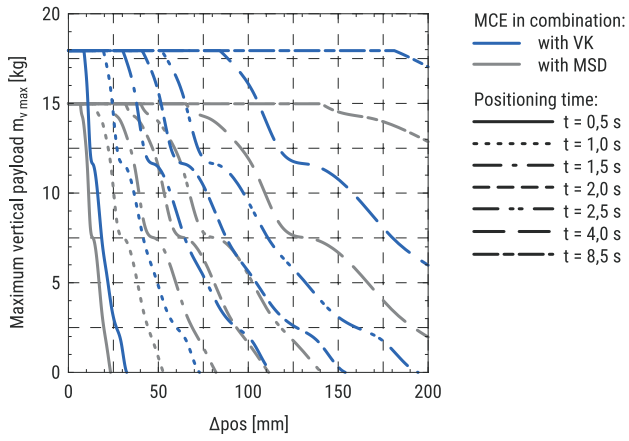

8 × 8 with a stepper motor □28

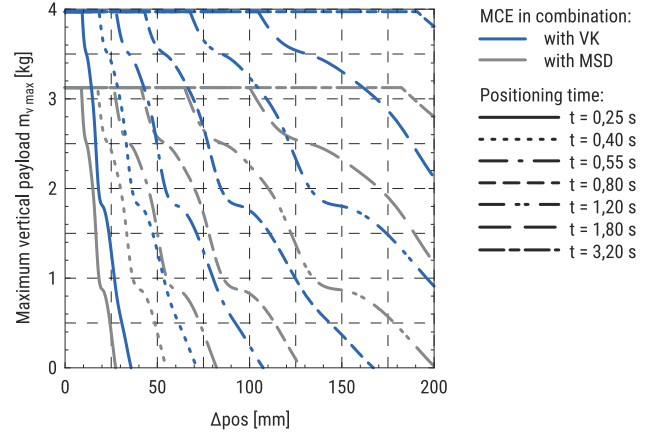

8 × 2 with a stepper motor □42

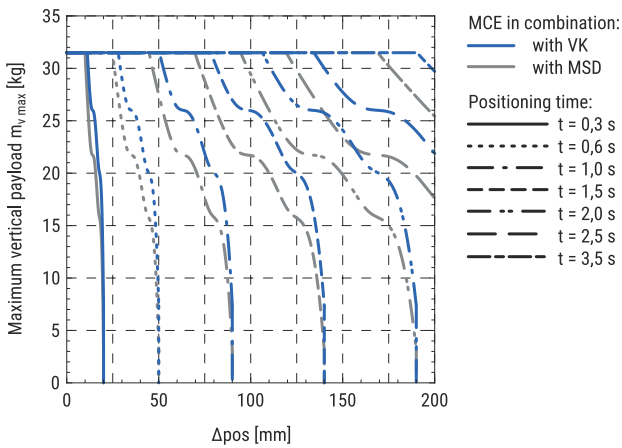

8 × 8 with a stepper motor □42

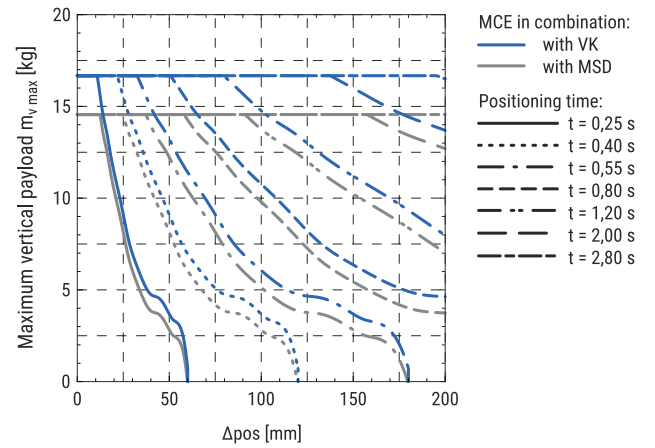

MCE 45

10 × 3 with a stepper motor □42

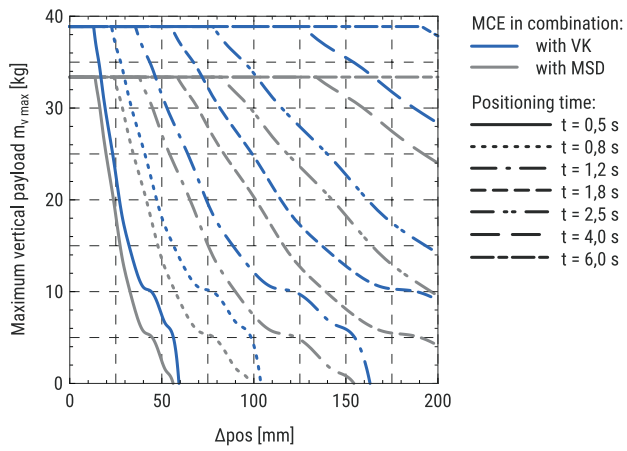

10 × 10 with a stepper motor □42

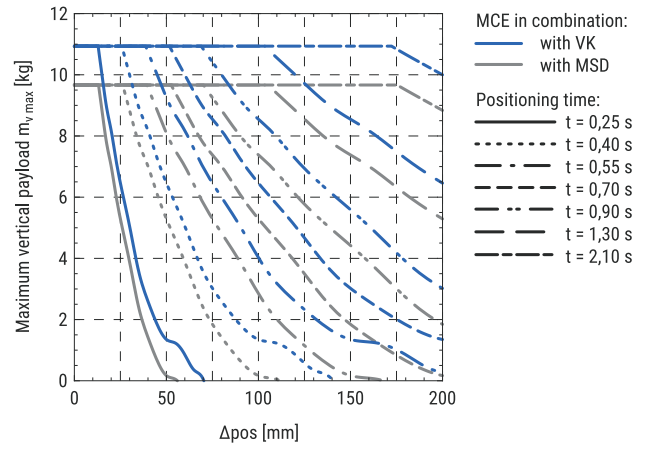

10 × 3 with a stepper motor □56

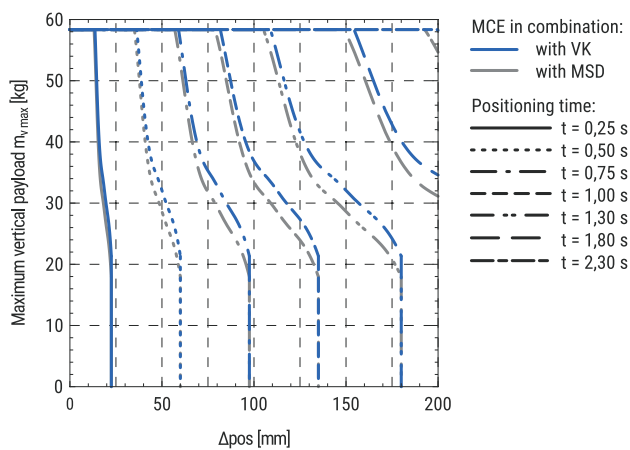

10 × 10 with a stepper motor □56

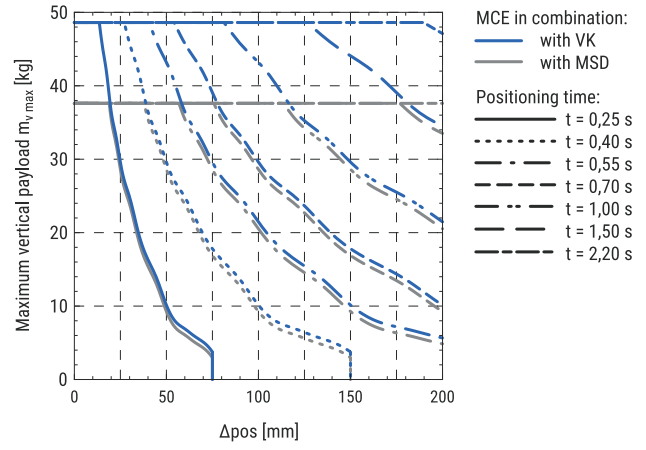

Absolute stroke and length of the MCE definition

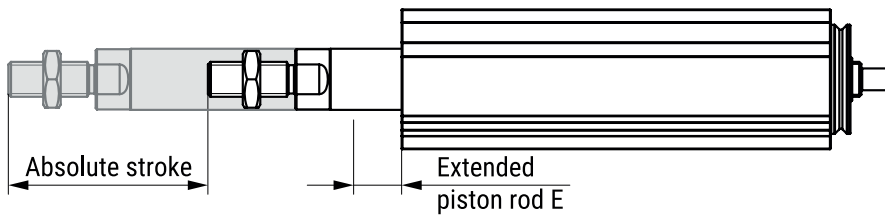

Absolute stroke definition

Absolute stroke = Effective stroke + 2 × Safety stroke

The electric cylinder MCE does not include any safety stroke.

Length definition

$L_t = L + L_2 + E + \text{Abs. position}$

Female thread:

$L_t = L + L_4 + E + \text{Abs. position}$

Abs. stroke	Absolute stroke [mm]
Abs. position	Absolute position [mm]
E	Extended piston rod [mm]
L	Length [mm]
L_t	Total length [mm]

$E_{\text{max}} = 100 \text{ mm.}$

Mini electric slider MSCE

Operating conditions

Ambient temperature	0 °C ~ +50 °C
Ambient temperature without a motor	0 °C ~ +60 °C
Protection class	IP40
Duty cycle	100 %
Maintenance	Life-time pre-lubricated

Maximum lateral loading as a function of the slide absolute position

On the following diagrams, the maximum lateral loads acting on the front plate as a function of the slide absolute position are presented. Both lateral loads in y and z directions are considered.

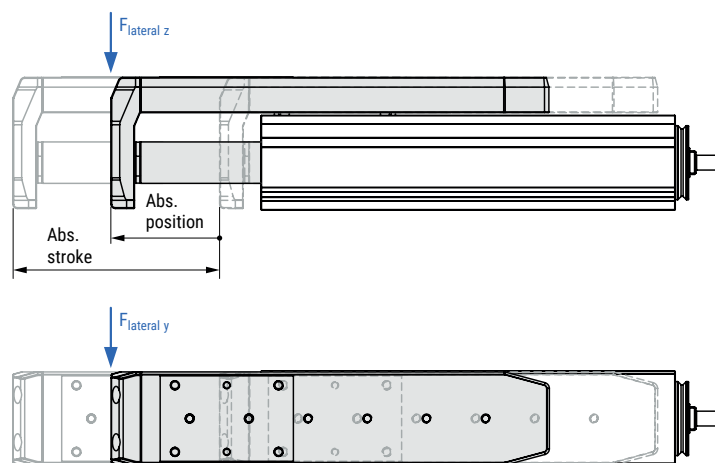

MSCE 25

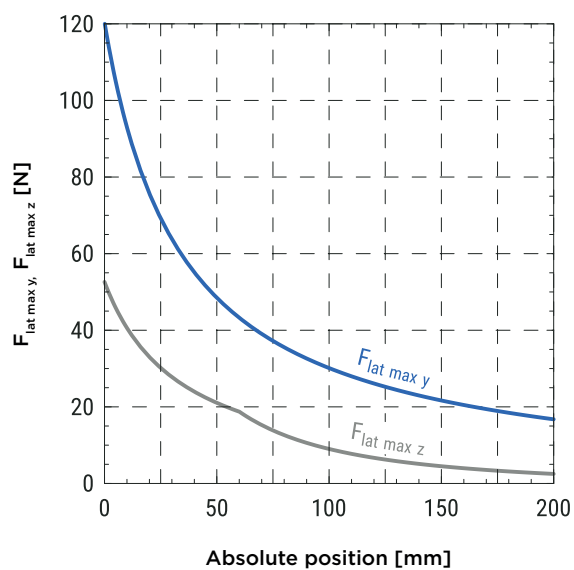

MSCE 32

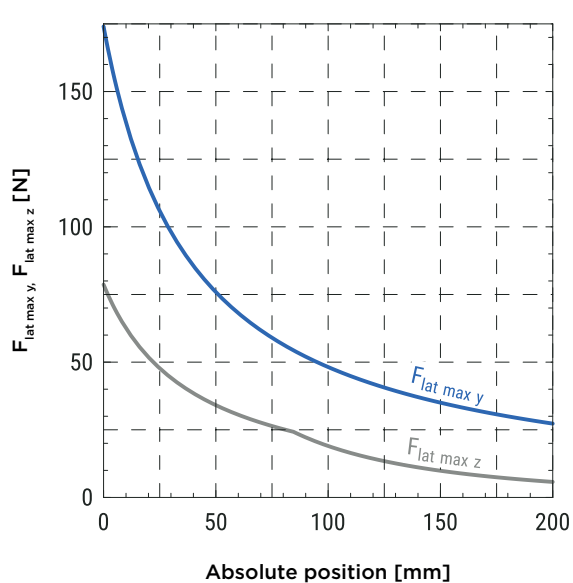

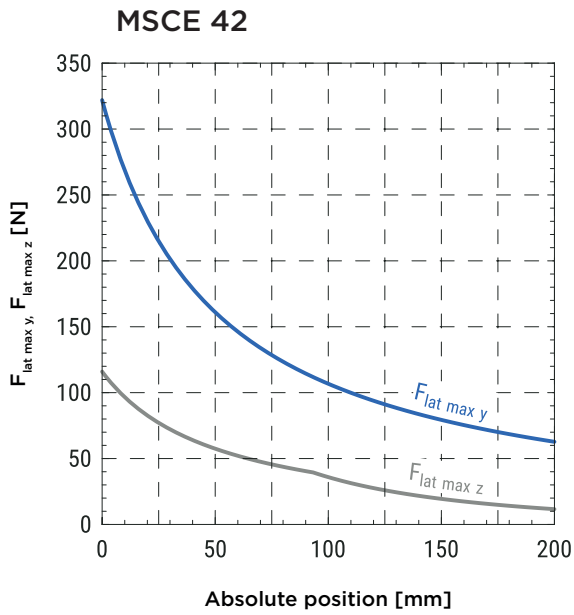

Angular deflections of the front plate as a function of the slide’s absolute position

On the following diagrams, angular deflections of the front plate subjected to the different torsional moments at different absolute positions of the slide are presented. Values on the curves represent the moment about the x-axis applied to the front plate.

The maximum permissible angular deflection ϕ_{max} must not be exceeded.

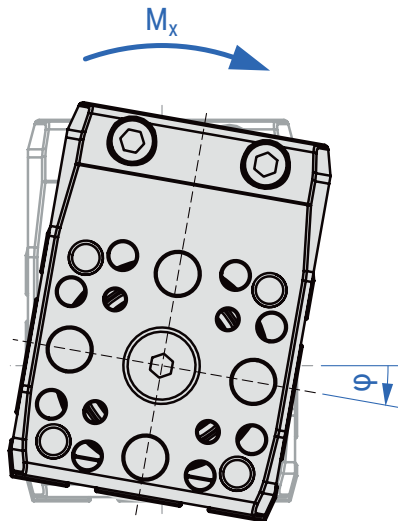

MSCE 25

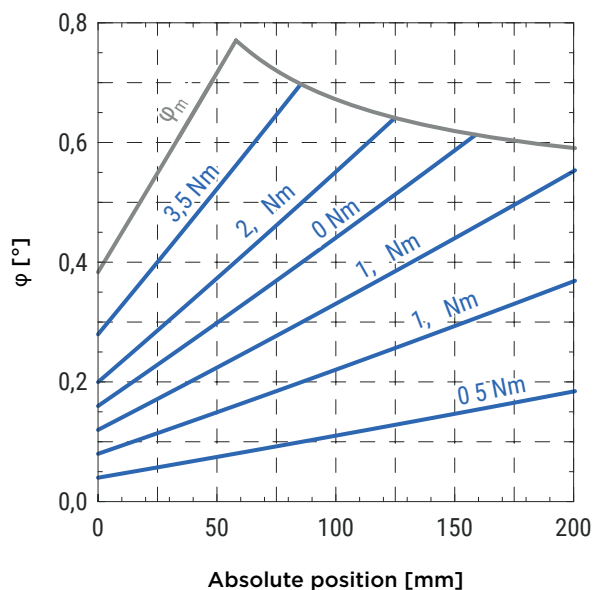

MSCE 32

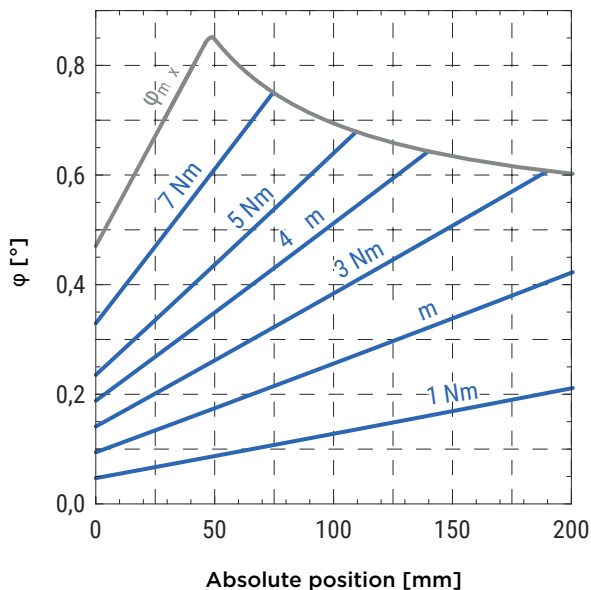

MSCE 45

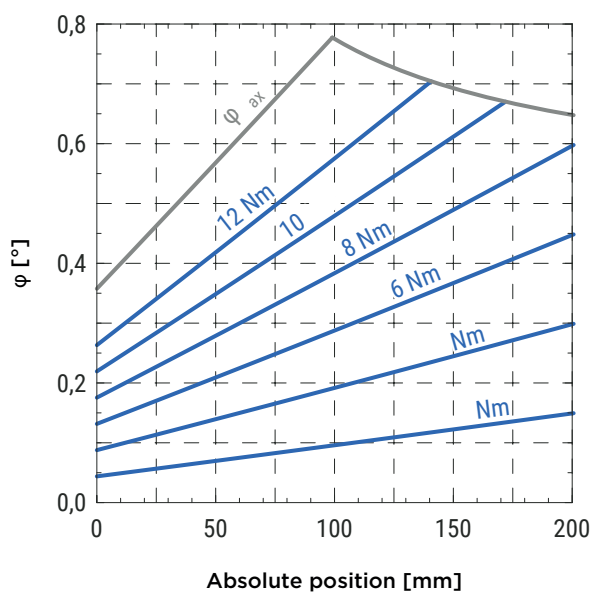

Deflections of the front plate as a function of the slide's absolute position

On the following diagrams, deflections of the front plate subjected to the different lateral loads at different absolute positions of the slide are presented. Both lateral loads in y and z directions are considered. Values on the curves represent the lateral load applied to the front plate.

The maximum permissible deflection ($\delta_{z\ max}$ or $\delta_{y\ max}$) must not be exceeded.

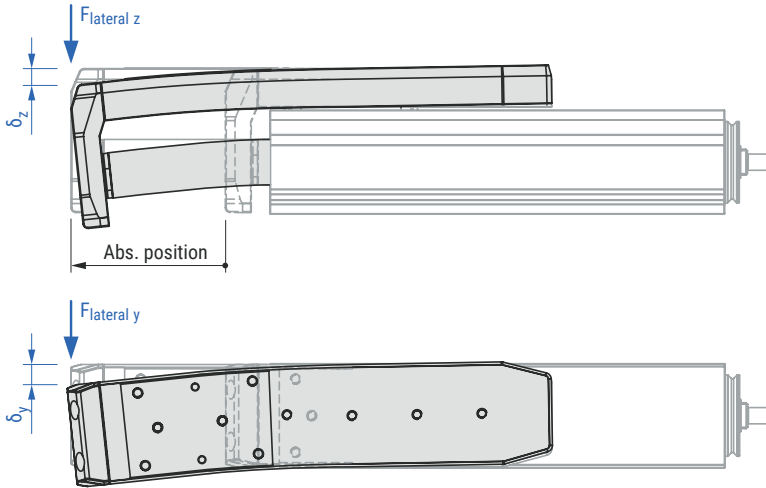

MSCE 25

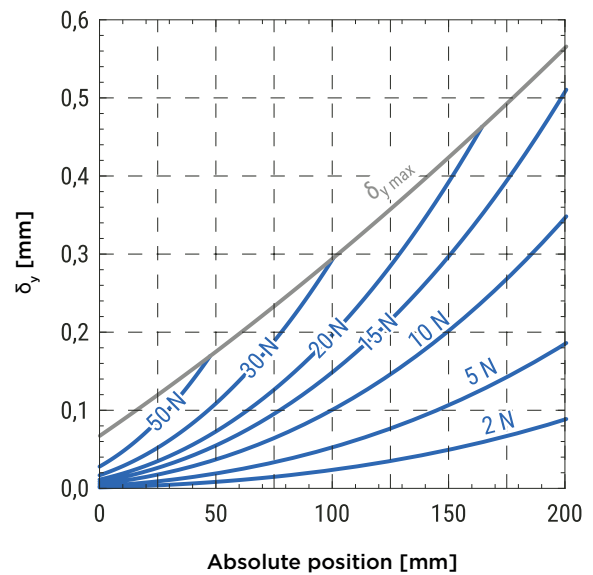
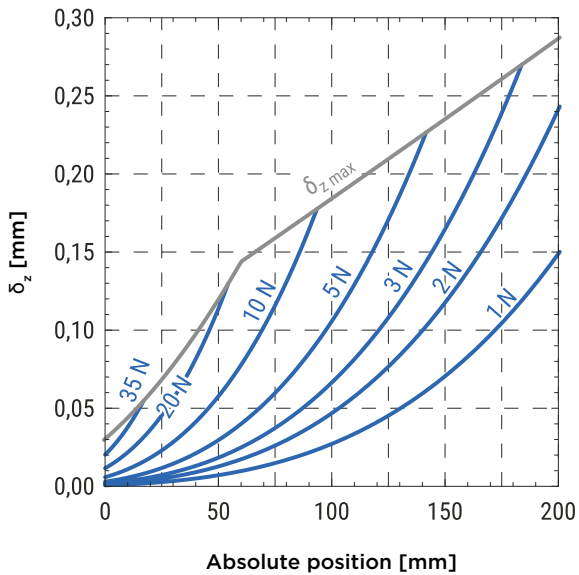

MSCE 32

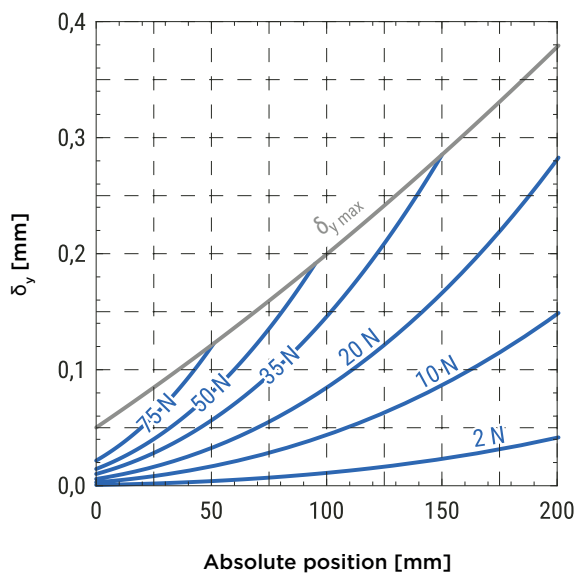
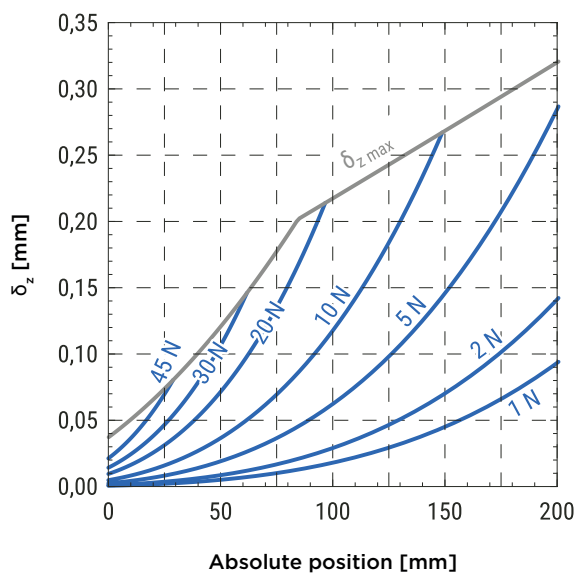

MSCE 45

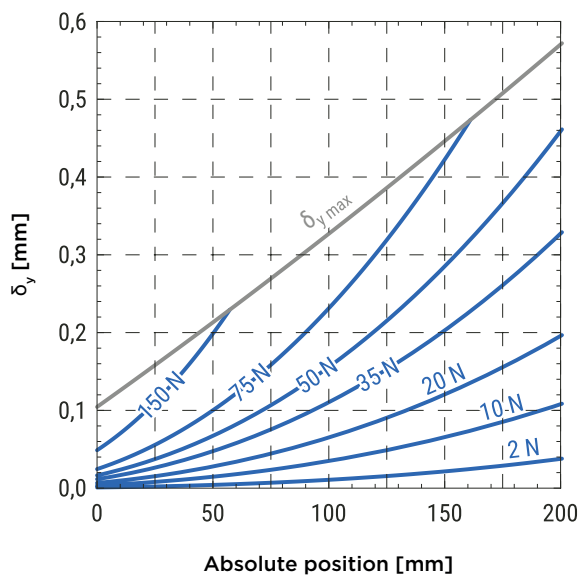
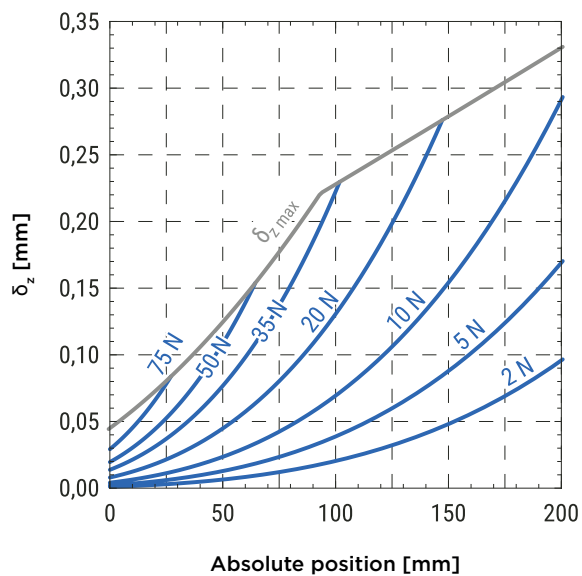

Maximum horizontal payload as a function of the travel speed and acceleration of the front plate

On the following diagrams, the maximum horizontal payloads applied to the front plate as a function of the travel speed for different accelerations, different ball screw leads, and different combinations of the standard motors are presented. Motor adapter VK and a motor side drive MSD are also considered.

Curves are valid for the payload to be pushed and supported by an external guiding (coefficient of friction 0,1 is taken into consideration).

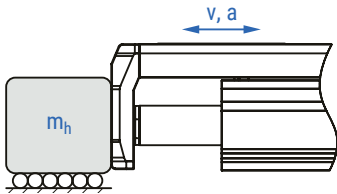

MSCE 25

6 × 2 with a stepper motor □28

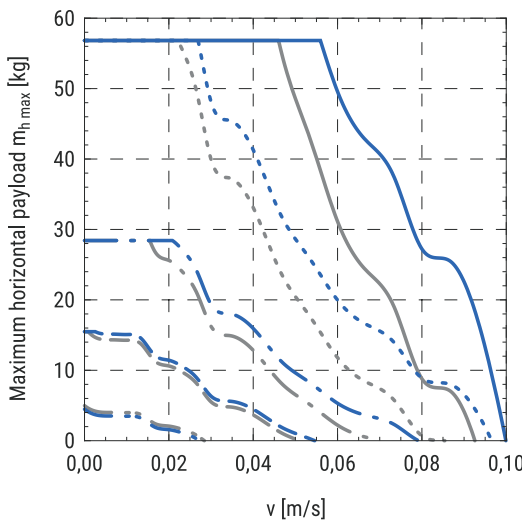

6 × 6 with a stepper motor □28

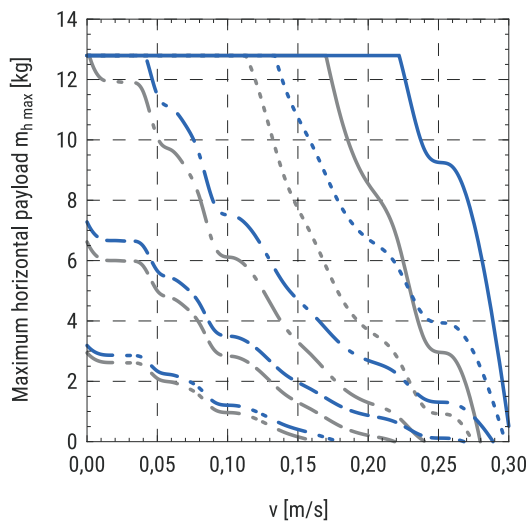

- MSCE in combination:
- with VK
 - - - with MSD
- Acceleration/Deceleration:
- a = 0,5 m/s²
 - - - a = 2 m/s²
 - · - a = 5 m/s²
 - - - a = 10 m/s²
 - · - a = 20 m/s²

MSCE 32

8 × 2 with a stepper motor □28

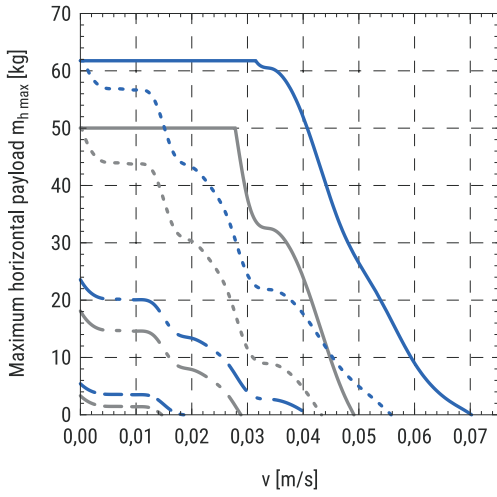

8 × 8 with a stepper motor □28

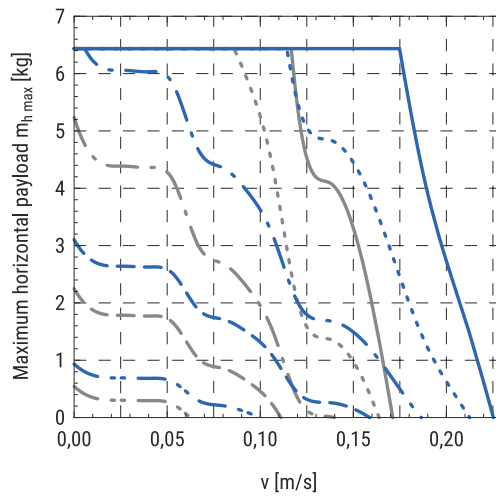

MSCE in combination:

- with VK
- with MSD

Acceleration/Deceleration:

- a = 0,5 m/s²
- - - a = 2 m/s²
- a = 5 m/s²
- - - a = 10 m/s²
- · - a = 20 m/s²

8 × 2 with a stepper motor □42

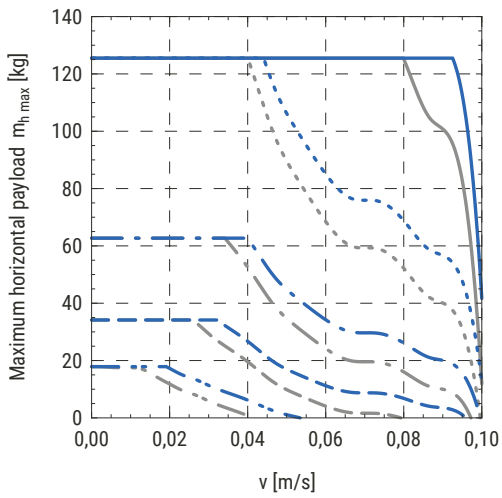

8 × 8 with a stepper motor □42

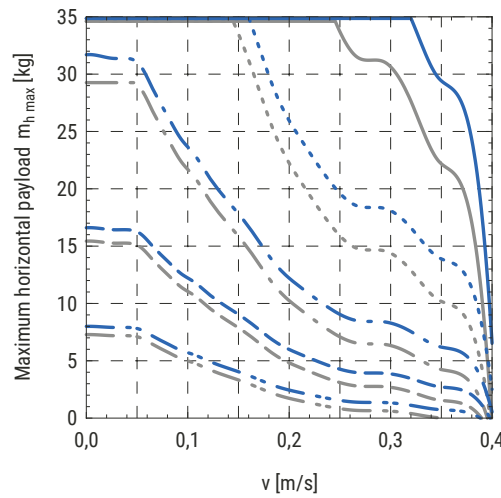

MSCE in combination:

- with VK
- with MSD

Acceleration/Deceleration:

- a = 0,5 m/s²
- - - a = 2 m/s²
- a = 5 m/s²
- - - a = 10 m/s²
- · - a = 20 m/s²

MSCE 45

10 × 3 with a stepper motor □42

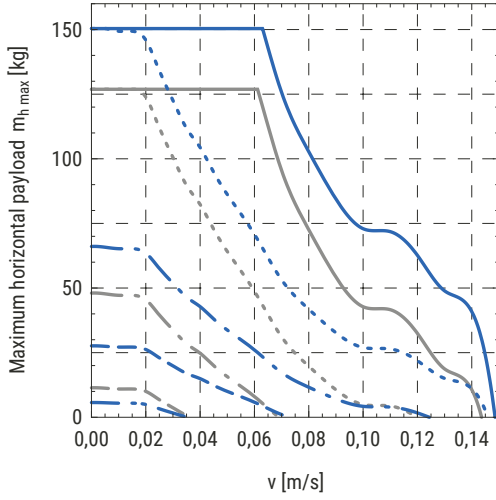

10 × 10 with a stepper motor □42

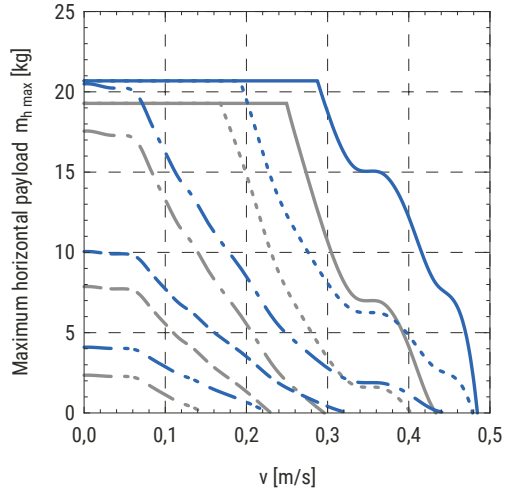

MSCE in combination:

- with VK
- with MSD

Acceleration/Deceleration:

- a = 0,5 m/s²
- - - a = 2 m/s²
- · - a = 5 m/s²
- - - a = 10 m/s²
- · - a = 20 m/s²

10 × 3 with a stepper motor □56

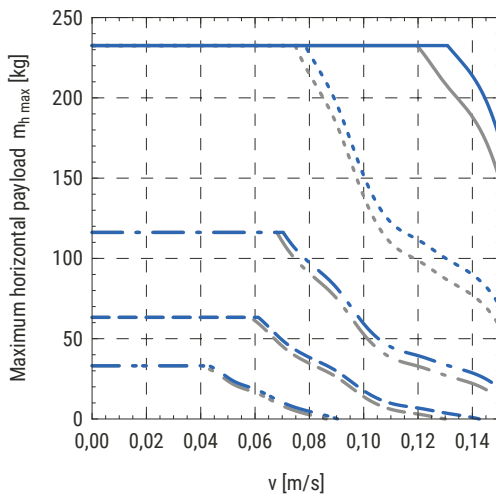

10 × 10 with a stepper motor □56

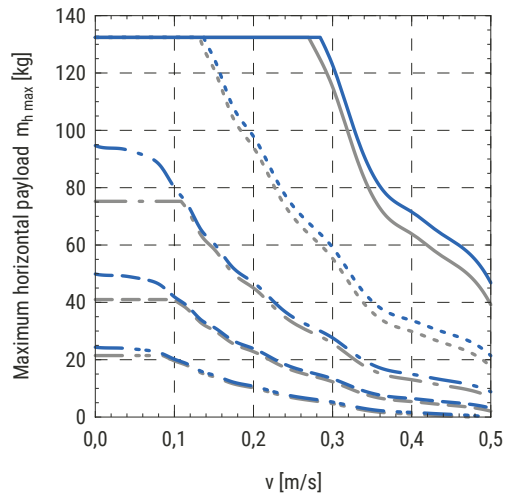

MSCE in combination:

- with VK
- with MSD

Acceleration/Deceleration:

- a = 0,5 m/s²
- - - a = 2 m/s²
- · - a = 5 m/s²
- - - a = 10 m/s²
- · - a = 20 m/s²

Maximum vertical payload as a function of the travel speed and acceleration of the front plate

On the following diagrams, the maximum vertical payloads applied to the front plate as a function of the travel speed for different accelerations, different ball screw leads, and different combinations of the standard motors are presented. Motor adapter VK and a motor side drive MSD are also considered.

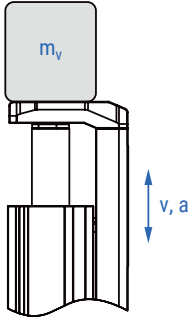

MSCE 25

6 × 2 with a stepper motor □28

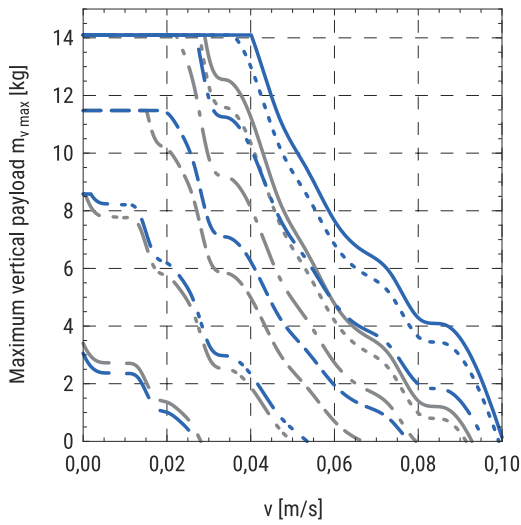

6 × 6 with a stepper motor □28

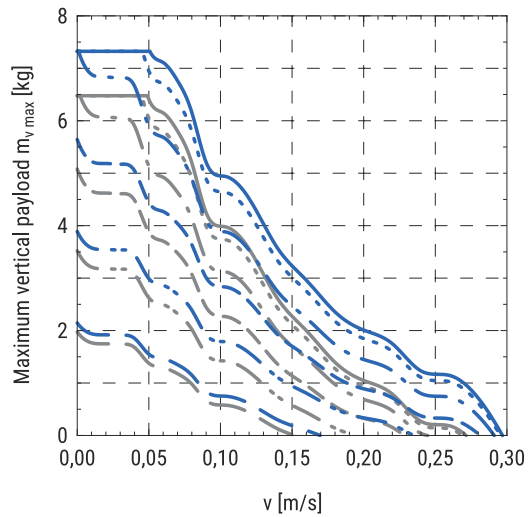

- MSCE in combination:
- with VK
 - with MSD
- Acceleration/Deceleration:
- $a = 0 \text{ m/s}^2$
 - $a = 0,5 \text{ m/s}^2$
 - · - $a = 2 \text{ m/s}^2$
 - - - $a = 5 \text{ m/s}^2$
 - · · $a = 10 \text{ m/s}^2$
 - $a = 20 \text{ m/s}^2$

MSCE 32

8 × 2 with a stepper motor □28

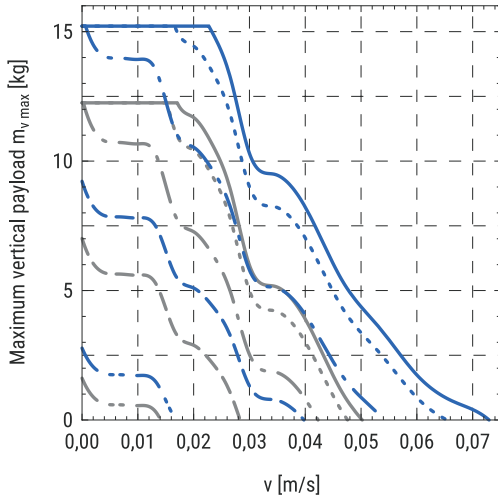

8 × 8 with a stepper motor □28

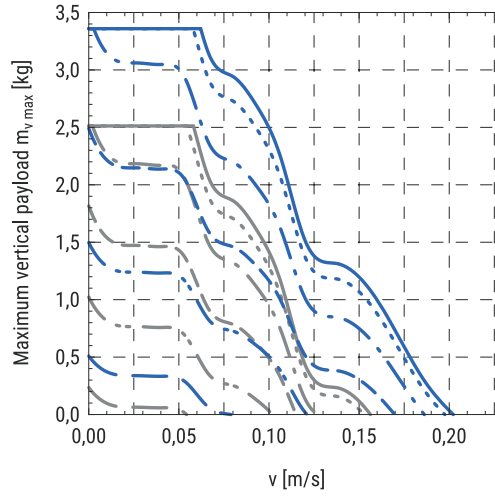

MSCE in combination:

- with VK
- with MSD

Acceleration/Deceleration:

- a = 0 m/s²
- a = 0,5 m/s²
- - - a = 2 m/s²
- - - a = 5 m/s²
- · - a = 10 m/s²
- - - a = 20 m/s²

8 × 2 with a stepper motor □42

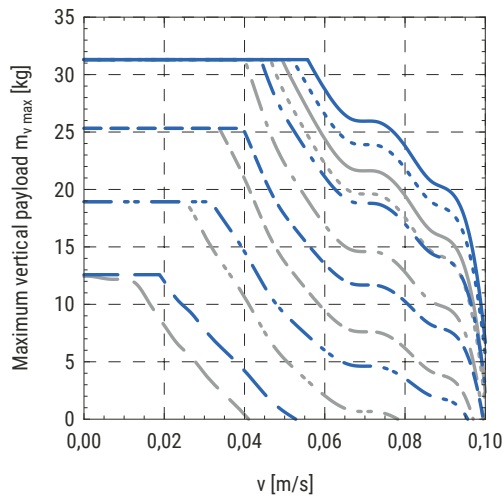

8 × 8 with a stepper motor □42

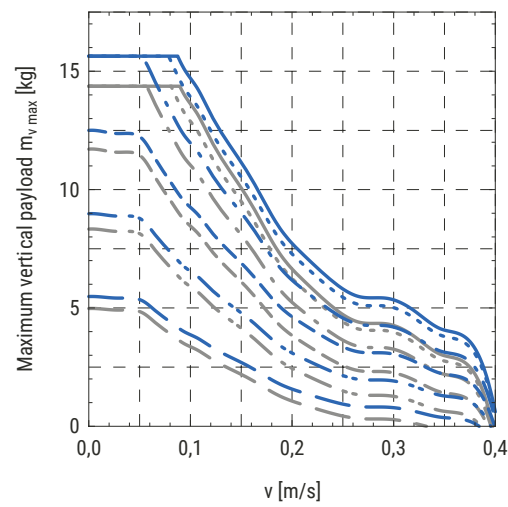

MSCE in combination:

- with VK
- with MSD

Acceleration/Deceleration:

- a = 0 m/s²
- a = 0,5 m/s²
- - - a = 2 m/s²
- - - a = 5 m/s²
- · - a = 10 m/s²
- - - a = 20 m/s²

MSCE 45

10 × 3 with a stepper motor □42

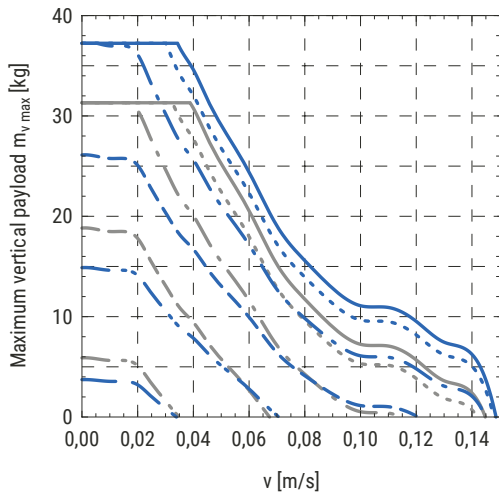

10 × 10 with a stepper motor □42

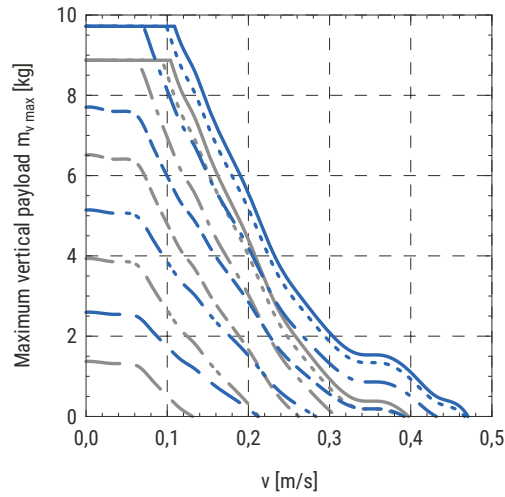

- MSCE in combination:
- with VK
 - with MSD
- Acceleration/Deceleration:
- $a = 0 \text{ m/s}^2$
 - - - $a = 0,5 \text{ m/s}^2$
 - · - $a = 2 \text{ m/s}^2$
 - - - $a = 5 \text{ m/s}^2$
 - · - $a = 10 \text{ m/s}^2$
 - - - $a = 20 \text{ m/s}^2$

10 × 3 with a stepper motor □56

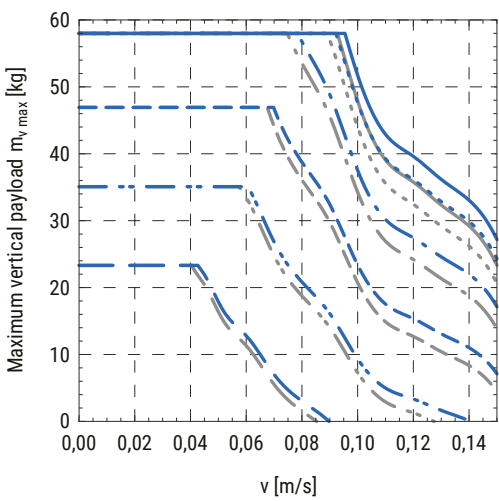

10 × 10 with a stepper motor □56

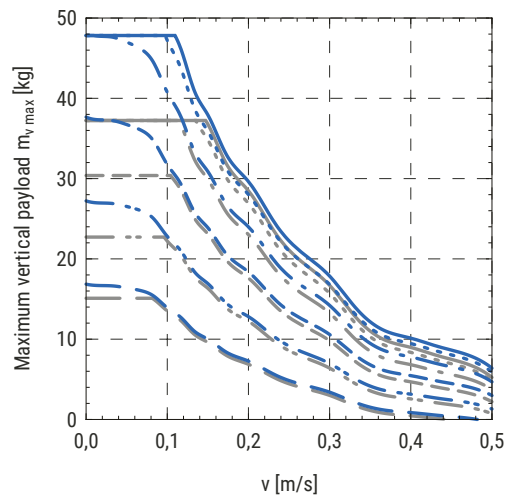

- MSCE in combination:
- with VK
 - with MSD
- Acceleration/Deceleration:
- $a = 0 \text{ m/s}^2$
 - - - $a = 0,5 \text{ m/s}^2$
 - · - $a = 2 \text{ m/s}^2$
 - - - $a = 5 \text{ m/s}^2$
 - · - $a = 10 \text{ m/s}^2$
 - - - $a = 20 \text{ m/s}^2$

Maximum axial load as a function of the travel speed and acceleration of the front plate

On the following diagrams, the maximum axial load applied to the front plate as a function of the travel speed for different accelerations, different ball screw leads and different combinations of the standard motors is presented. Motor adapter VK and a motor side drive MSD are also considered.

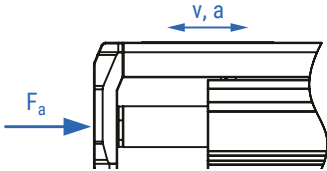

MSCE 25

6 × 2 with a stepper motor □28

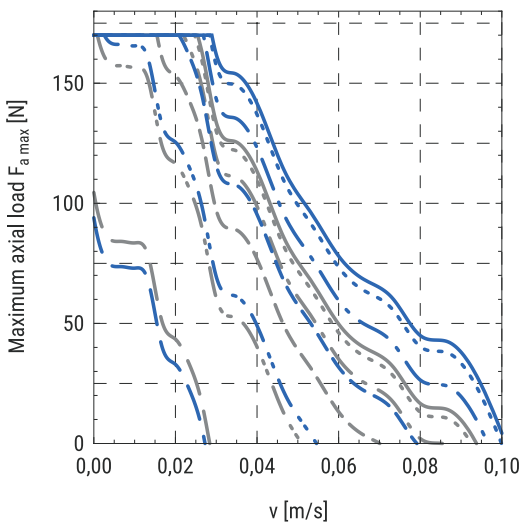

6 × 6 with a stepper motor □28

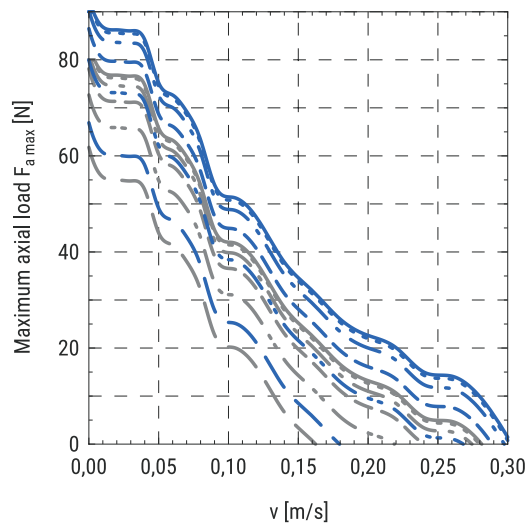

- MSCE in combination:
- with VK
 - - - with MSD
- Acceleration/Deceleration:
- a = 0 m/s²
 - - - a = 0,5 m/s²
 - · - a = 2 m/s²
 - - - a = 5 m/s²
 - · - a = 10 m/s²
 - - - a = 20 m/s²

MSCE 32

8 × 2 with a stepper motor □28

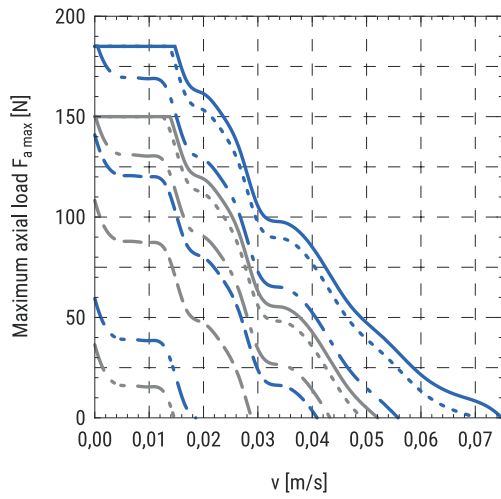

8 × 8 with a stepper motor □28

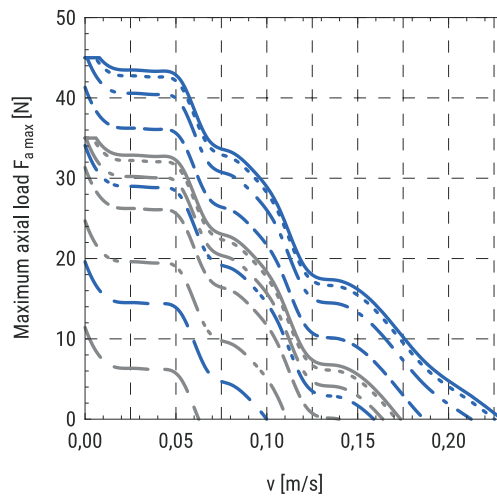

MSCE in combination:

- with VK
- with MSD

Acceleration/Deceleration:

- a = 0 m/s²
- a = 0,5 m/s²
- · - a = 2 m/s²
- - - a = 5 m/s²
- · · a = 10 m/s²
- - - a = 20 m/s²

8 × 2 with a stepper motor □42

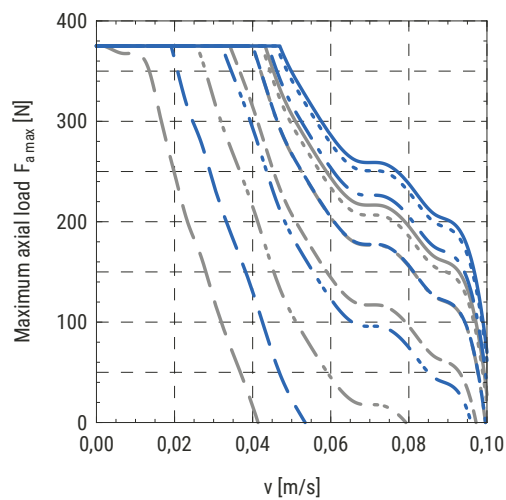

8 × 8 with a stepper motor □42

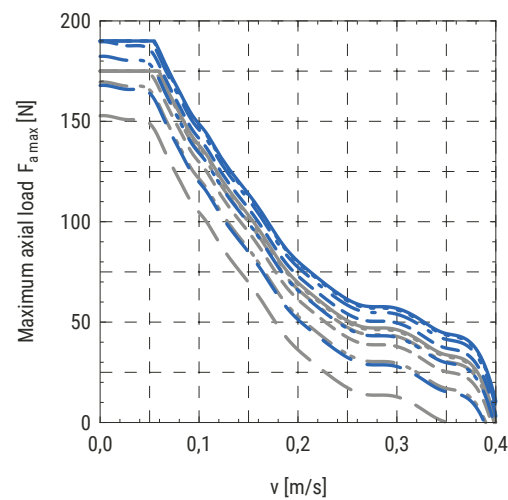

MSCE in combination:

- with VK
- with MSD

Acceleration/Deceleration:

- a = 0 m/s²
- a = 0,5 m/s²
- · - a = 2 m/s²
- - - a = 5 m/s²
- · · a = 10 m/s²
- - - a = 20 m/s²

MSCE 45

10 × 3 with a stepper motor □42

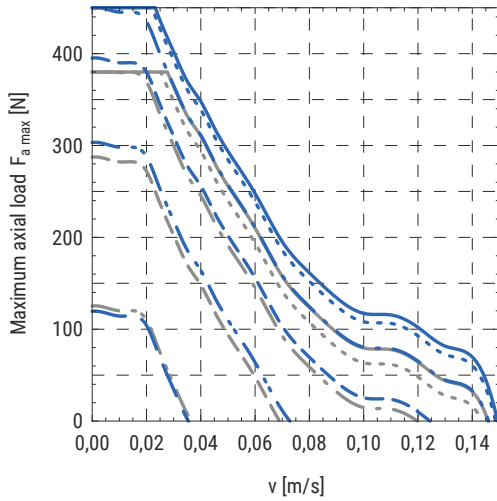

10 × 10 with a stepper motor □42

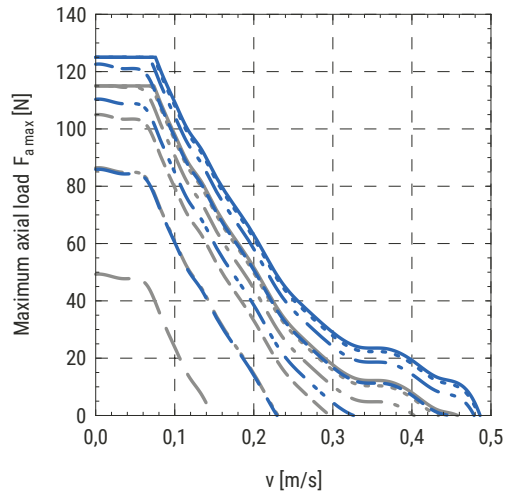

MSCE in combination:

- with VK
- with MSD

Acceleration/Deceleration:

- a = 0 m/s²
- a = 0,5 m/s²
- · - a = 2 m/s²
- - - a = 5 m/s²
- · · a = 10 m/s²
- - - a = 20 m/s²

10 × 3 with a stepper motor □56

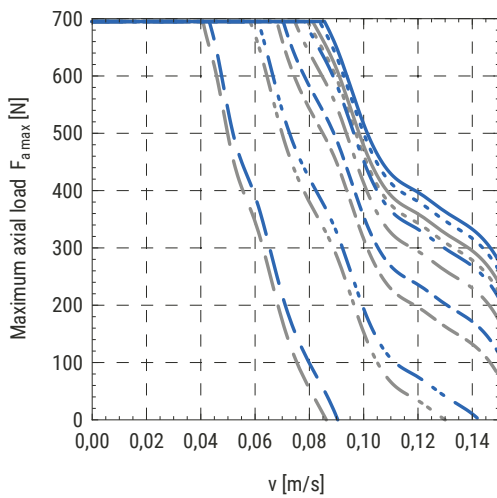

10 × 10 with a stepper motor □56

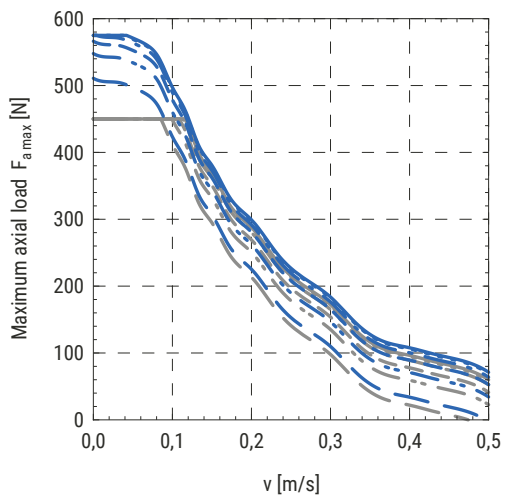

MSCE in combination:

- with VK
- with MSD

Acceleration/Deceleration:

- a = 0 m/s²
- a = 0,5 m/s²
- · - a = 2 m/s²
- - - a = 5 m/s²
- · · a = 10 m/s²
- - - a = 20 m/s²

Maximum horizontal payload as a function of change of the position and positioning time of the front plate

The following diagrams show the maximum payload that can be moved by a certain horizontal distance within a positioning time frame. Acceleration/deceleration time of 100 ms is taken into account.

Diagrams depend on the ball screw leads and different combinations of the standard motors. Motor adapter VK and a motor side drive MSD are also considered.

Curves are valid for the payload to be pushed and supported by an external guiding (coefficient of friction 0,1 is taken into consideration).

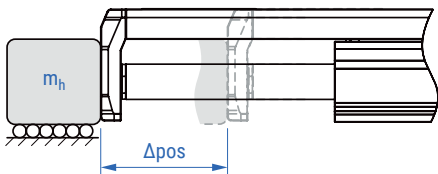

MSCE 25

6 × 2 with a stepper motor □28

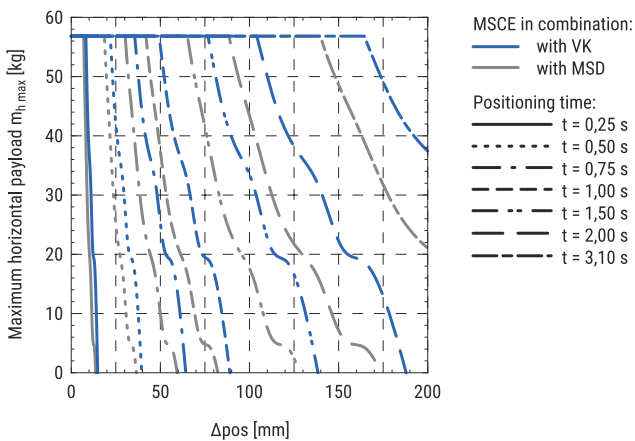

6 × 6 with a stepper motor □28

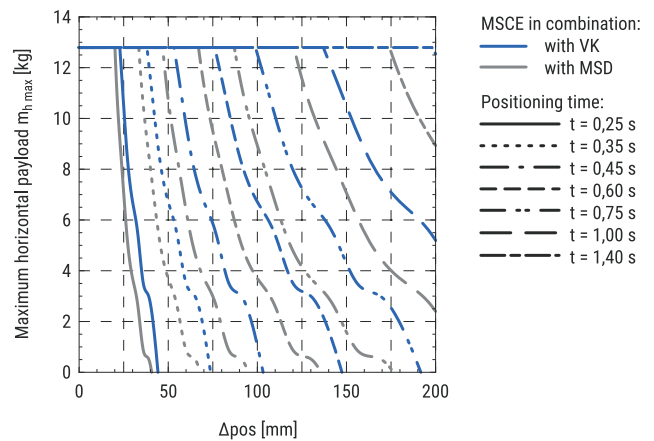

MSCE 32

8 × 2 with a stepper motor □28

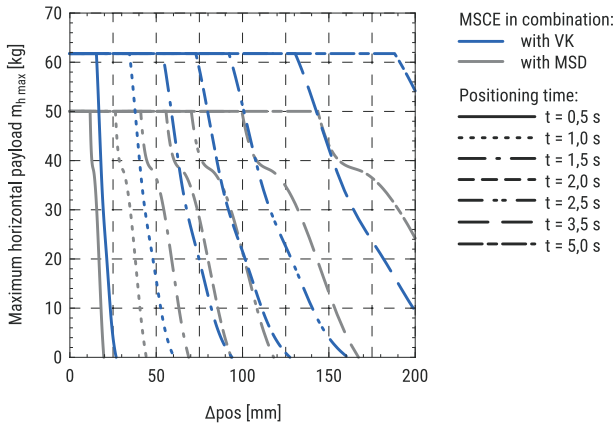

8 × 8 with a stepper motor □28

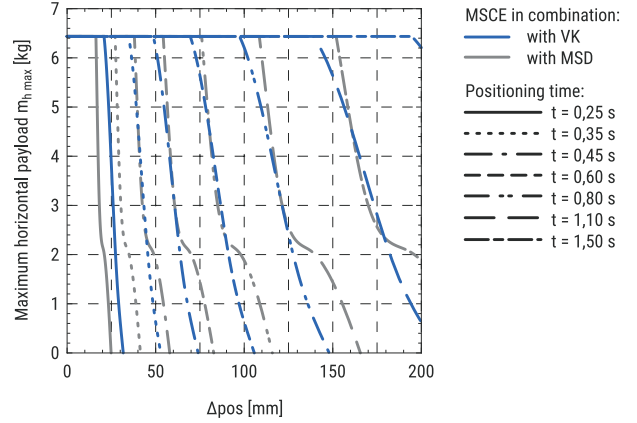

8 × 2 with a stepper motor □42

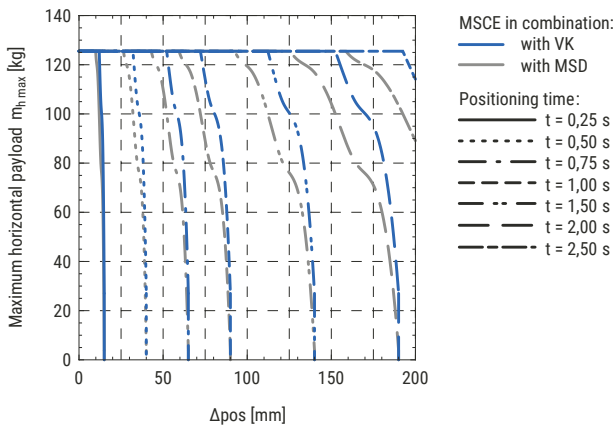

8 × 8 with a stepper motor □42

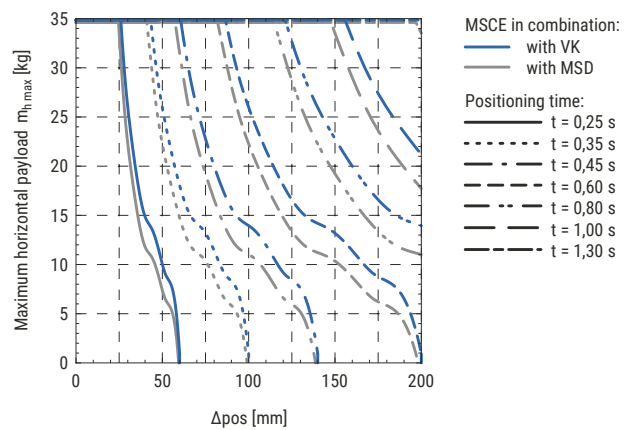

MSCE 45

10 × 3 with a stepper motor □42

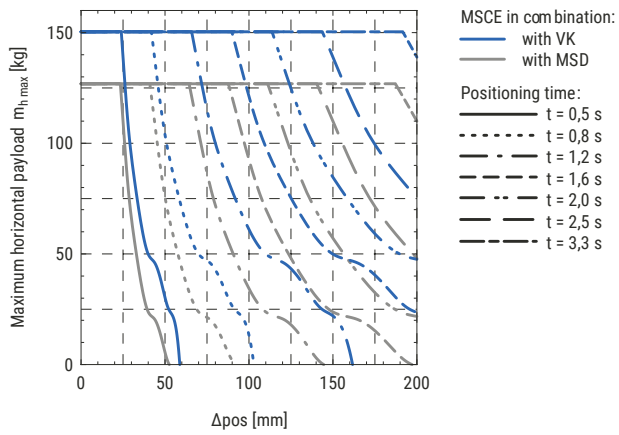

10 × 10 with a stepper motor □42

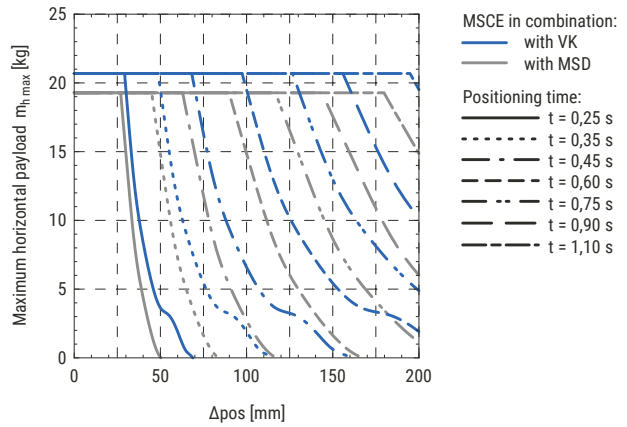

10 × 3 with a stepper motor □56

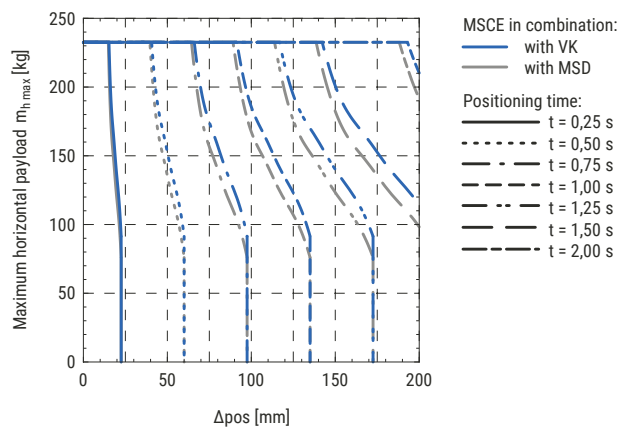

10 × 10 with a stepper motor □56

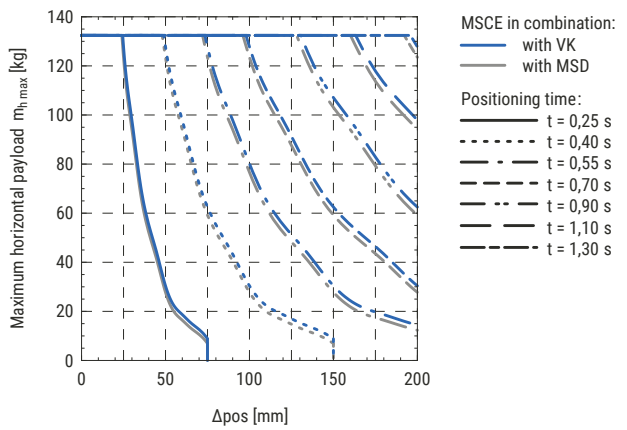

Maximum vertical payload as a function of change of the position and positioning time of the front plate

The following diagrams show the maximum payload that can be moved by a certain vertical distance within a positioning time frame. Acceleration/deceleration time of 100 ms is taken into account.

Diagrams depend on the ball screw leads and different combinations of the standard motors. Motor adapter VK and a motor side drive MSD are also considered.

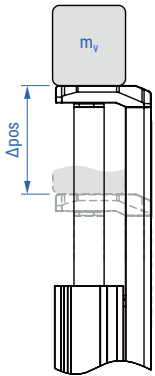

MSCE 25

6 × 2 with a stepper motor □28

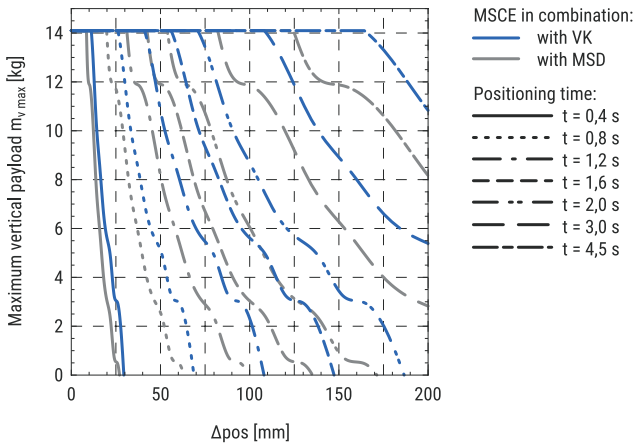

6 × 6 with a stepper motor □28

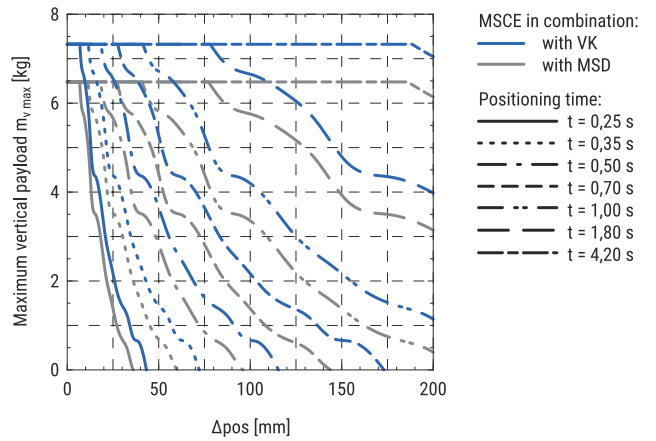

MSCE 32

8 × 2 with a stepper motor □28

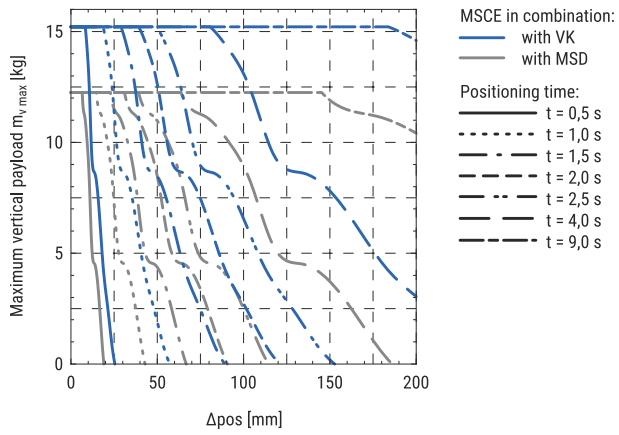

8 × 8 with a stepper motor □28

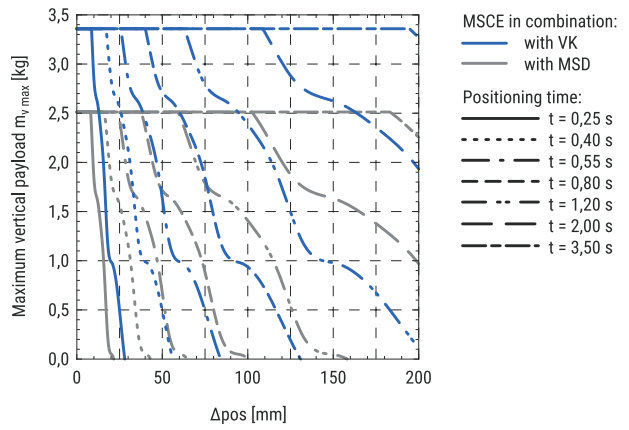

8 × 2 with a stepper motor □42

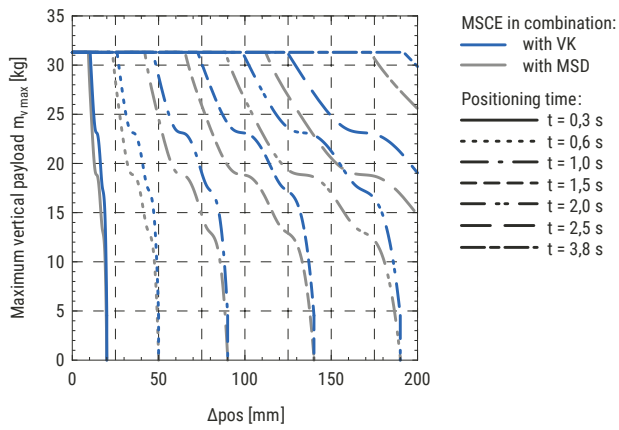

8 × 8 with a stepper motor □42

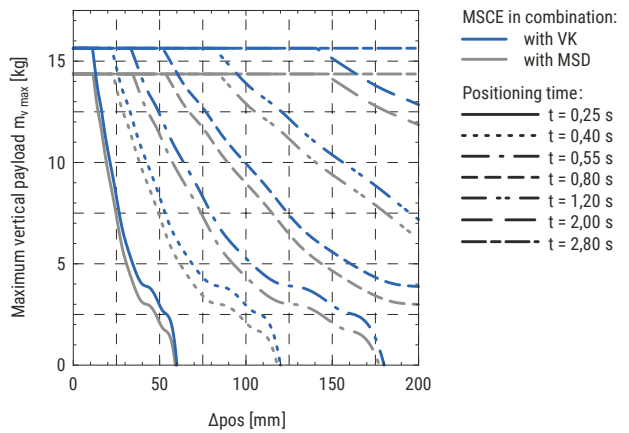

MSCE 45

10 × 3 with a stepper motor □42

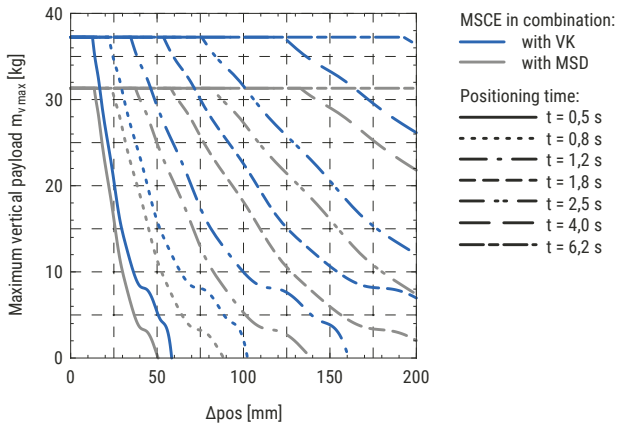

10 × 10 with a stepper motor □42

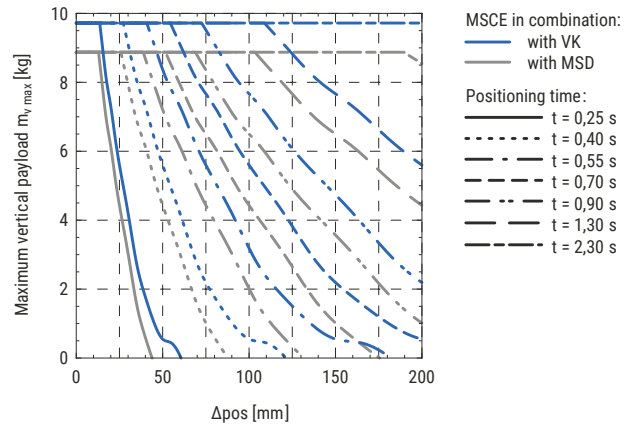

10 × 3 with a stepper motor □56

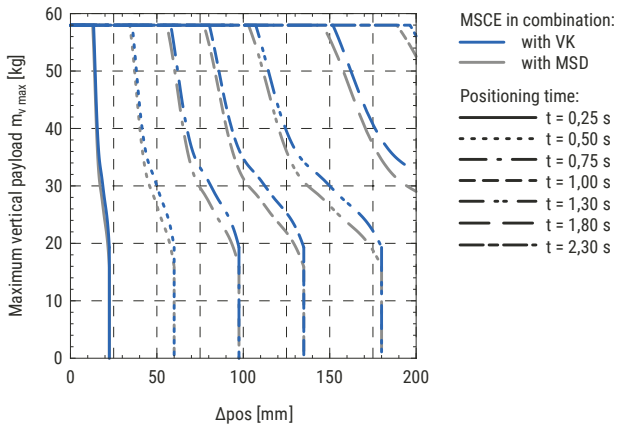

10 × 10 with a stepper motor □56

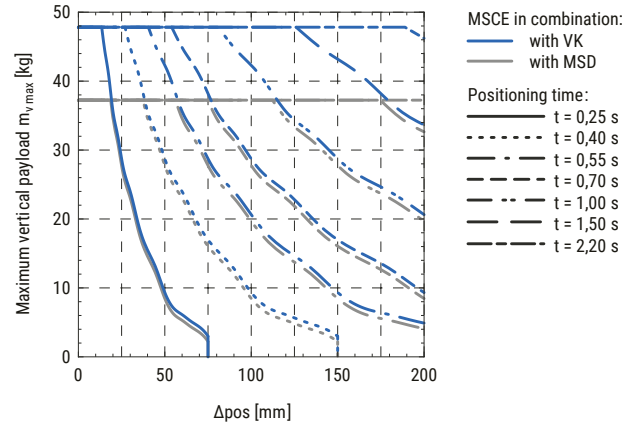

Absolute stroke and length of the MSCE definition

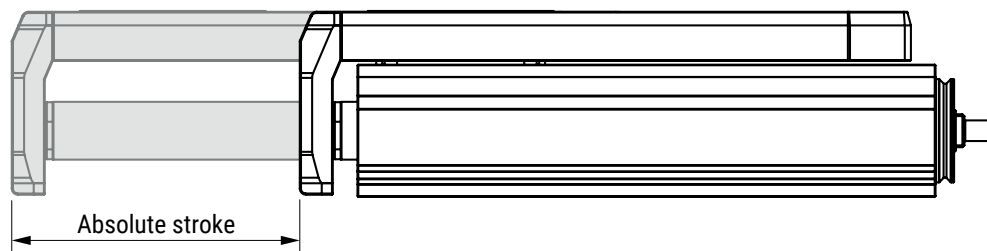

Absolute stroke definition

Absolute stroke = Effective stroke + 2 × Safety stroke

The electric slider MSCE does not include any safety stroke.

Length definition

$L_t = L + L_2 + \text{Abs. position}$

Length L and L_t are defined as it is presented on the dimensional drawings above, where lengths of a motor, motor adapter VK, and motor side drive MSD are also considered.

Abs. stroke	Absolute stroke [mm]
Abs. position	Absolute position [mm]
L	Length [mm]
L_t	Total length [mm]

Motor types and sizes

Motor identification

Designation	Motor		
	Type	Size □ [mm]	Brake
STMN-28-L-E*	Stepper	28	-
STMN-28-L-E-B*	Stepper	28	with
STMN-42-L-E	Stepper	42	-
STMN-42-L-E-B	Stepper	42	with
STMN-56-L-E	Stepper	56	-
STMN-56-L-E-B	Stepper	56	with

*Available soon.

□ = Square cross section

Motor pin allocation

Valid for stepper motor size of 42 and 56 mm. Stepper motor size of 28 mm is available soon.

Motor connector

Connector type: M12 5-pole

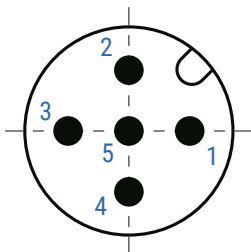

Pin	Function
1	A-
2	A+
3	B+
4	B-
5	Housing

Encoder connector

Connector type: M12 8-pole

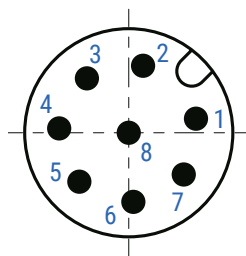

Pin	Function
1	A-
2	A+
3	B+
4	B-
5	GND
6	I-
7	I+
8	VCC (5 V)
Housing	GND/shielding

Brake connector

Connector type: M8 3-pole

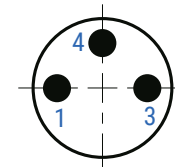

Valid only for motors with a brake.

Pin	Function
1	Brake +24V
3	Brake/GND
4	NC

Technical data

Motor

Designation	Voltage [V DC]	Current per phase [A]	Mass moment of inertia [kg cm ²]	Holding torque [Nm]	Step angle [°]
STMN-28-L-E			Available soon		
STMN-28-L-E-B			Available soon		
STMN-42-L-E	3,15	1,8	0,082	0,5	1,8 ± 5 %
STMN-42-L-E-B	3,15	1,8	0,095	0,5	1,8 ± 5 %
STMN-56-L-E	2,4	4,2	0,480	1,87	1,8 ± 5 %
STMN-56-L-E-B	2,4	4,2	0,501	1,87	1,8 ± 5 %

Designation	Resistance per phase [Ohm]	Inductance per phase [mH]	Voltage constant [mV/min ⁻¹]	Mass [kg]
STMN-28-L-E			Available soon	
STMN-28-L-E-B			Available soon	
STMN-42-L-E	1,75 ± 10 %	3,3 ± 20 %	23	0,44
STMN-42-L-E-B	1,75 ± 10 %	3,3 ± 20 %	23	0,57
STMN-56-L-E	0,58 ± 15 %	1,9 ± 20 %	32,5	1,14
STMN-56-L-E-B	0,58 ± 15 %	1,9 ± 20 %	32,5	1,33

Encoder

Designation	Type	Measuring principle	Interface	Resolution [cpr/ppr]	Operating voltage [V DC]
STMN-28-L-...					Available soon
STMN-42-L-...	Incremental	Opto-electrical	Line drive	500/2000	5
STMN-56-L-...	Incremental	Opto-electrical	Line drive	500/2000	5

Brake

Designation	Operating voltage [V DC]	Rated output [W]	Holding torque [Nm]	Mass moment of inertia [kg cm ²]
STMN-28-L-...				Available soon
STMN-42-L-...	24 (+6/-10 %)	8	0,4	0,013
STMN-56-L-...	24 (+6/-10 %)	10	1,0	0,021

Operating conditions

Ambient temperature	-10 °C ~ +50 °C
Ambient humidity	max. 85 % (non-condensing)
Protection class*	IP65
Duty cycle	100 %

*Except the shaft output.

Drive types

Drive identification and compatibility

Designation	Type	Drive Protocol/control	Compatible with
STDF-28-A-EC*	Stepper	EtherCat	STMN-28-L-...
STDF-42-A-EC	Stepper	EtherCat	STMN-42-L-...
STDF-56-A-EC	Stepper	EtherCat	STMN-56-L-...
STDF-28-A-EN*	Stepper	Ethernet based communication	STMN-28-L-...
STDF-42-A-EN	Stepper	Ethernet based communication	STMN-42-L-...
STDF-56-A-EN	Stepper	Ethernet based communication	STMN-56-L-...
STDF-28-A-PD*	Stepper	Pulse-direction control	STMN-28-L-...
STDF-42-A-PD	Stepper	Pulse-direction control	STMN-42-L-...
STDF-56-A-PD	Stepper	Pulse-direction control	STMN-56-L-...

*Available soon.

Technical data

Designation	Operating voltage [V DC]	Current consumption* [mA]	Rotational speed [rpm]	Supported resolution** [ppr]
STDF-...-EC	24 ± 10 %	max. 500	0 ~ 3000	500, 1000, 1600, 2000, 3600, 5000, 6400, 7200, 10000
STDF-...-EN	24 ± 10 %	max. 500	0 ~ 3000	500, 1000, 1600, 2000, 3600, 5000, 6400, 7200, 10000
STDF-...-PD	24 ± 10 %	max. 500	0 ~ 3000	500, 1000, 1600, 2000, 3600, 5000, 6400, 7200, 10000

Designation	Input signals	Output signals
STDF-...-EC	3 dedicated inputs (LIMIT+, LIMIT-, ORIGIN); 7 user inputs (Photocoupler)	6 user outputs (Photocoupler); Brake
STDF-...-EN	3 dedicated inputs (LIMIT+, LIMIT-, ORIGIN); 9 Programmable inputs (Photocoupler)	1 dedicated output (Compare out); 9 programmable outputs (Photocoupler); Brake
STDF-...-PD	Position command pulse; Servo on/off; Alarm reset (Photocoupler input)	In-position; Alarm (Photocoupler output); Encoder signal, brake

*Except the motor current.

**For the case that resolution is higher than the encoder's resolution, the motor shall operate by micro-step between pulses.

Operating conditions

Ambient temperature	0 °C ~ +50 °C
Ambient humidity	35 % - 85 % (non-condensing)
Vibration resistance	0,5 G
Duty cycle	100 %

Dimensions

Stepper drive → EtherCAT protocol

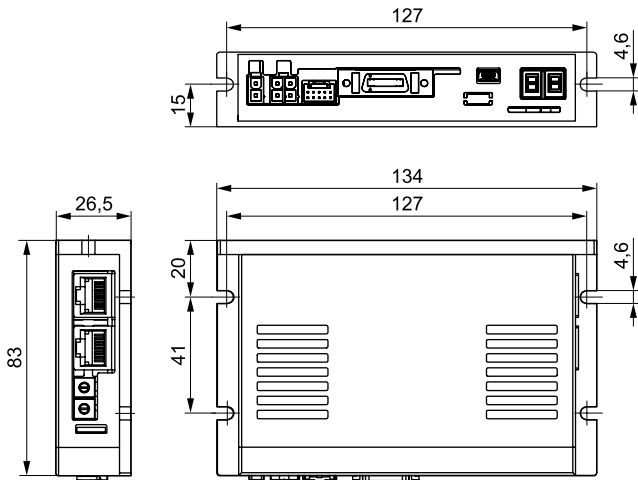

Stepper drive → Ethernet based communication

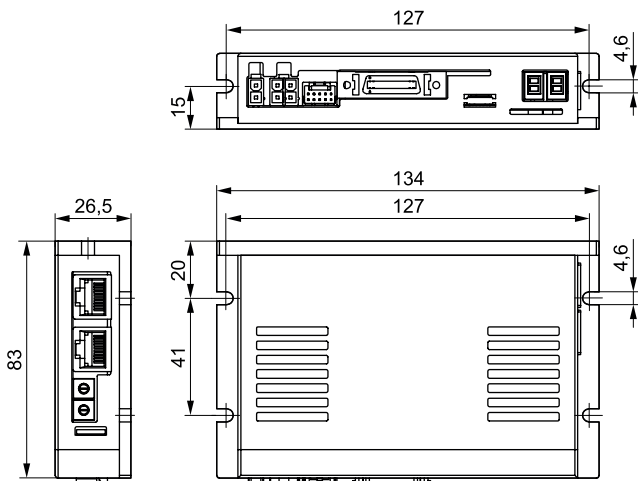

Stepper drive → Pulse-direction control

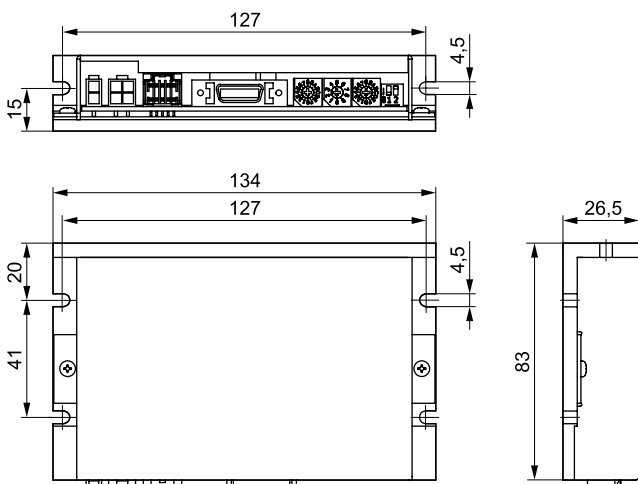

Drive-motor cables

Drive to motor cables in general consist of:

- 1 - a motor cable
- 2 - an encoder cable
- 3 - a brake cable (only if a motor with brake is used).

For the stepper motor size of 28 motor and brake cables are combined in one cable.

Additional cable, i.e. brake to terminal cable is included for the case of the motor (□28) with the brake.

Cables identification and compatibility

Designation	Cable type	Compatible with
STCF-M-_8-...*	Motor; Brake	STMN-28-...; STMN-28-...-B
STCF-M-_12-...	Motor	STMN-42-...; STMN-42-...-B; STMN-56-...; STMN-56-...-B
STCF-BT-02*	Brake to terminal	STMN-28-...-B
STCF-B-_8-...	Brake	STMN-42-...-B; STMN-56-...-B
STCF-E-_8-...*	Encoder	STMN-28-...; STMN-28-...-B
STCF-E-_12-...	Encoder	STMN-42-...; STMN-42-...-B; STMN-56-...; STMN-56-...-B

*Available soon.

Technical data

Stepper motor size of 28 mm

Available soon.

Stepper motor size of 42 and 56 mm

Designation	Length [m]	Cable diameter D [mm]	Material, color	Bending radius (dyn.) [mm]	Shielded?
STCF-M-_12-...	3, 5, 10	5,1	TPE, black	min. 7,5 × D	Yes
STCF-B-_8-...	3, 5, 10	4,5	TPE, black	min. 7,5 × D	Yes
STCF-E-_12-...	3, 5, 10	6,7	TPE, black	min. 7,5 × D	Yes

Operating conditions

Ambient temperature (fixed laying)	-40 °C ~ +70 °C
Ambient temperature (flexible application)	5 °C ~ +70 °C

Dimensions

Drive to motor cables for the stepper motors (only for the STDF and STMN motors).

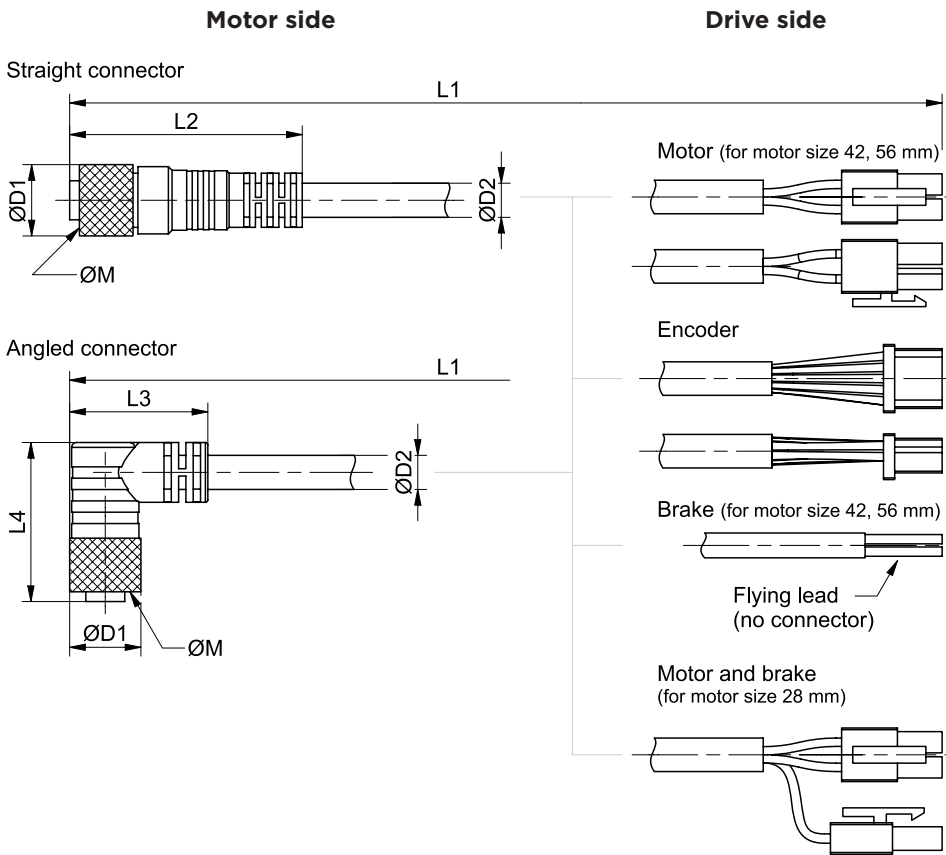

Brake to terminal cables

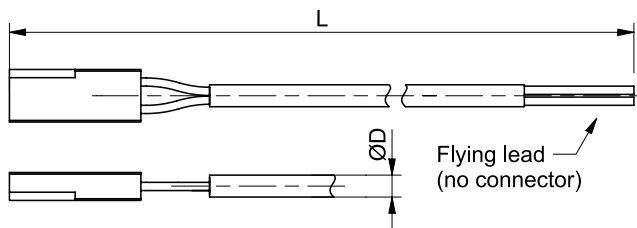

Motor, encoder, brake and brake to terminal cables

Designation	Cable type	L [m]	L1 [m]	L2 [mm]	L3 [mm]	L4 [mm]	ØD [mm]	ØD1 [mm]	ØD2 [mm]	ØM [mm]
STCF-M-_8-...	Motor	-	-	-	-	-	-	-	-	-
STCF-M-_12-...	Motor	-	3, 5, 10	47,7	28,4	32,6	-	14,6	5,1	M12
STCF-B-_8-...	Brake	-	3, 5, 10	41,7	30,9	25,2	-	9,9	4,5	M8
STCF-BT-02	Brake to terminal	2	-	-	-	-	Available soon	-	-	-
STCF-E-_8-...	Encoder	-	-	-	-	-	-	-	-	-
STCF-E-_12-...	Encoder	-	3, 5, 10	47,7	28,4	32,6	-	14,6	6,7	M12

Power and signal cables

Power cable is used for supplying the power from power supply to the drive. Signal cable is mandatory for the following cases:

- 1 - If a motor with brake is used
- 2 - If a pulse-direction drive control is used
- 3 - If the limit switches are used.

Cables identification and compatibility

Designation	Cable type	Compatible with
STCF-P-02	Power	STDF-...-EC; STDF-...-EN; STDF-...-PD
STCF-S-EC-02	Signal	STDF-...-EC
STCF-S-EN-02	Signal	STDF-...-EN
STCF-S-PD-02	Signal	STDF-...-PD

Technical data

Designation	Length [m]	Cable diameter [mm]	Material, color	Shielded?
STCF-P-02	2	4,6	PVC, black	Yes
STCF-S-EC-02	2	6,4	PVC, black	Yes
STCF-S-EN-02	2	6,9	PVC, black	Yes
STCF-S-PD-02	2	6,4	PVC, black	Yes

Dimensions

Power cables for the stepper motors (only for the STDF drives)

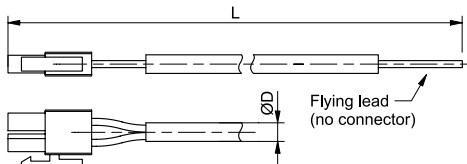

Signal cables for the stepper motors (only for the STDF drives)

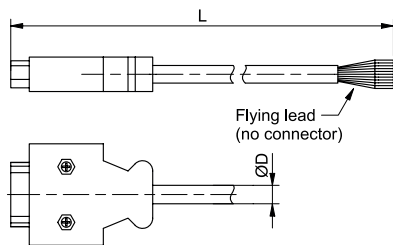

Designation	Cable type	L [m]	ØD [mm]
STCF-P-02	Power	2	4,6
STCF-S-EC-02	Signal	2	6,4
STCF-S-EN-02	Signal	2	6,9
STCF-S-PD-02	Signal	2	6,4

Mounting examples

Mini electric cylinders MCE and sliders MSCE can easily be combined to the multi-axis systems by using the standard accessories. Already prepared mounting holes on the front plate/slide of the MSCE, guiding unit GUC, and mounting slots on the profiles allow various combinations of MCE and MSCE without additional connection plates.

In the following, compatibility of the mini electric cylinders and sliders are presented.

For non-standard combinations, configurations, or custom connection elements, please contact us.

x-y configuration with the x-axis: MCE + the guiding unit GUC

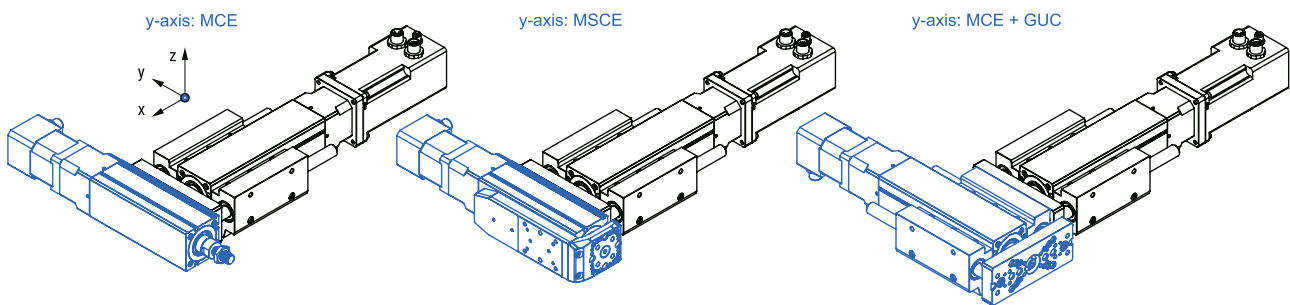

Mini electric cylinders and sliders can be combined by using the slot nuts together with the standard screws. For the case, where the y-axis is MCE+GUC, only the standard screws can be used.

Configuration		y-axis								
x-axis	Size	MCE			MSCE			MCE + GUC		
		25	32	45	25	32	45	25	32	45
MCE + GUC	25	•	-	-	•	-	-	•	-	-
	32	•	•	-	•	•	-	•	•	-
	45	•	•	•	•	•	•	•	•	•

x-z configuration with the x-axis: MCE + the guiding unit GUC

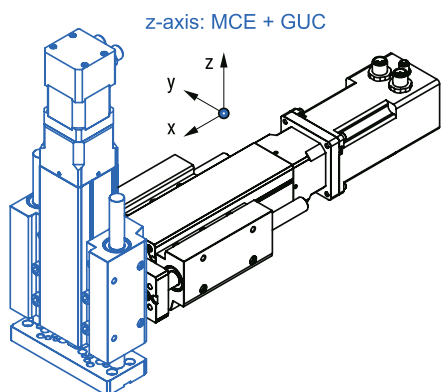

Mini electric cylinders with GUC can be combined by using the standard screws.

Configuration		z-axis MCE + GUC		
x-axis	Size	25	32	45
MCE + GUC	25	•	-	-
	32	•	•	-
	45	•	•	•

x-y configuration with the x-axis: MSCE (y-axis is mounted to the front plate)

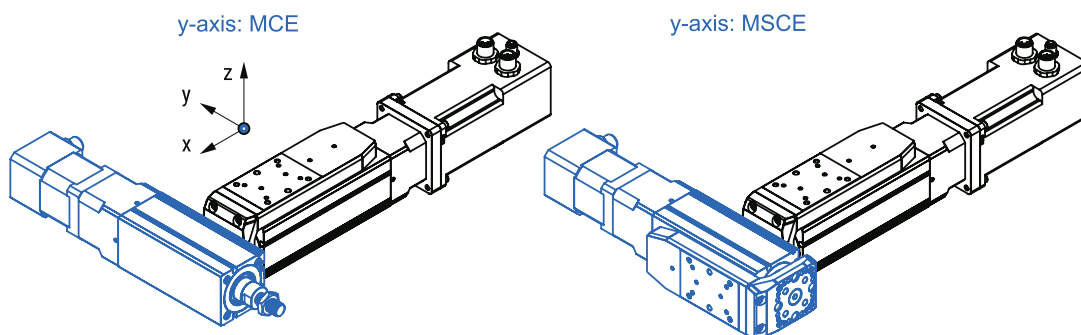

Mini electric cylinders and sliders can be combined by using the slot nuts together with the standard screws.

Configuration		y-axis					
x-axis	Size	MCE			MSCE		
		25	32	45	25	32	45
MSCE: front plate	25	•	-	-	•	-	-
	32	•	•	-	•	•	-
	45	•	•	•	•	•	•

x-y configuration with the x-axis: MSCE (y-axis is mounted to the slide)

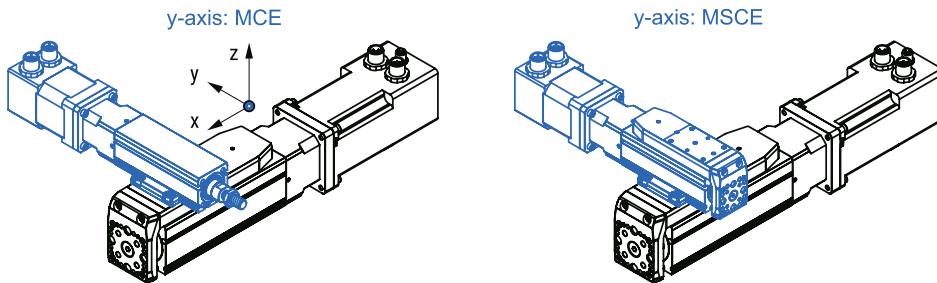

Mini electric cylinders and sliders can be combined by using the clamping fixtures together with the standard screws.

Configuration		y-axis						
x-axis	Size	25	MCE			MSCE		
			32	45	25	32	45	
MSCE: slide	25	-	-	-	-	-	-	
	32	•	-	-	•	-	-	
	45	•	•	-	•	•	-	

x-z configuration with the x-axis: MSCE (z-axis is mounted to the front plate)

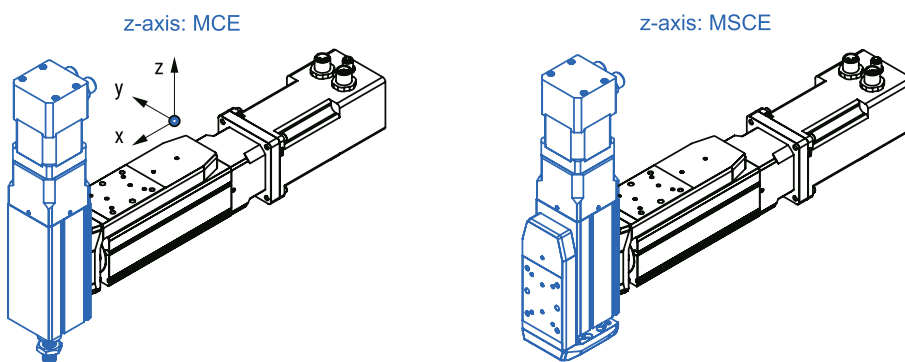

Mini electric cylinders and sliders can be combined by using the slot nuts together with the standard screws.

Configuration		z-axis						
x-axis	Size	25	MCE			MSCE		
			32	45	25	32	45	
MSCE: front plate	25	•	-	-	•	-	-	
	32	•	•	-	•	•	-	
	45	•	•	•	•	•	•	

Service life

Linear guiding

Dynamic load capacity, dynamic moments and maximum permissible loads of the linear guiding system integrated into the mini electric slider refer to the centre of the linear guides.

The applied loading condition needs to be calculated, with respect to the centre of the linear guides. The presented attachment distances, measured from the centre of the linear guides, together with an absolute position of the slider must be taken into consideration.

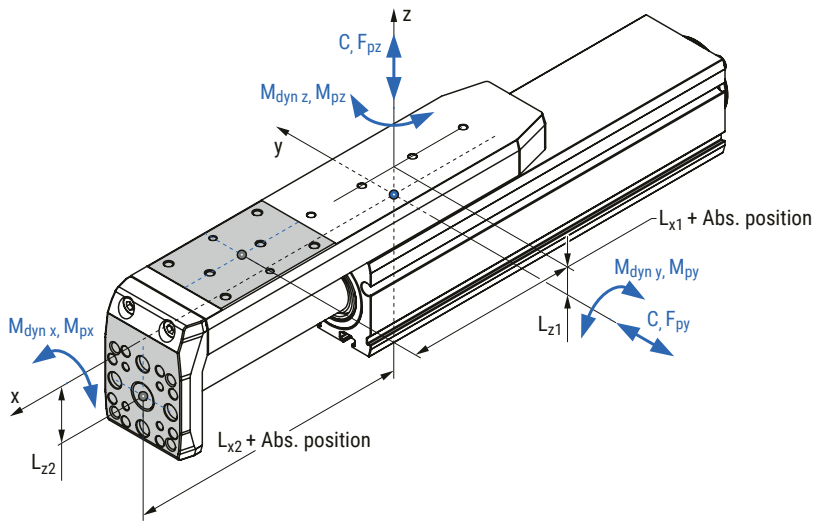

Valid for mini electric slider MSCE.

Designation	Attachment distances			
	Slide		Front plate	
	L_{x1} [mm]	L_{z1} [mm]	L_{x2} [mm]	L_{z2} [mm]
MSCE 25	0,0	7,5	34,0	-16,5
MSCE 32	0,0	7,7	39,0	-21,3
MSCE 45	0,0	10,6	50,5	-27,4

Abs. position	Absolute position [mm]
C	Dynamic load capacity [N]
$M_{dyn x}$	Dynamic moment about the x axis [Nm]
$M_{dyn y}$	Dynamic moment about the y axis [Nm]
$M_{dyn z}$	Dynamic moment about the z axis [Nm]
F_{py}	Max. permissible force in the y direction [N]
F_{pz}	Max. permissible force in the z direction [N]
M_{px}	Max. permissible moment about the x axis [Nm]
M_{py}	Max. permissible moment about the y axis [Nm]
M_{pz}	Max. permissible moment about the z axis [Nm]

Permissible load

Permissible load factor f_{pg}

A permissible load factor of the linear guiding system f_{pg} must never exceed the value of 1.

$$f_{pg} = \frac{|F_y|}{F_{py}} + \frac{|F_z|}{F_{pz}} + \frac{|M_x|}{M_{px}} + \frac{|M_y|}{M_{py}} + \frac{|M_z|}{M_{pz}} \leq 1$$

f_{pg}	Permissible load factor
F_y	Applied force in the y direction [N]
F_z	Applied force in the z direction [N]
M_x	Applied moment about the x axis [Nm]
M_y	Applied moment about the y axis [Nm]
M_z	Applied moment about the z axis [Nm]

Service life

Service life calculation

$$L_{km\ g} = \left(\frac{1}{f_{vm\ g}} \right)^3 \cdot 10^2$$

$L_{km\ g}$	Service life of the linear guiding system [km]
$f_{vm\ g}$	Mean load comparison factor

Mean load comparison factor $f_{vm\ g}$ as a function of service life $L_{km\ g}$

Diagram represents the theoretically determined service life of the linear guiding system when the mean load comparison factor $f_{vm\ g}$ is considered.

It should be noted that the application conditions may have a significant effect on the service life.

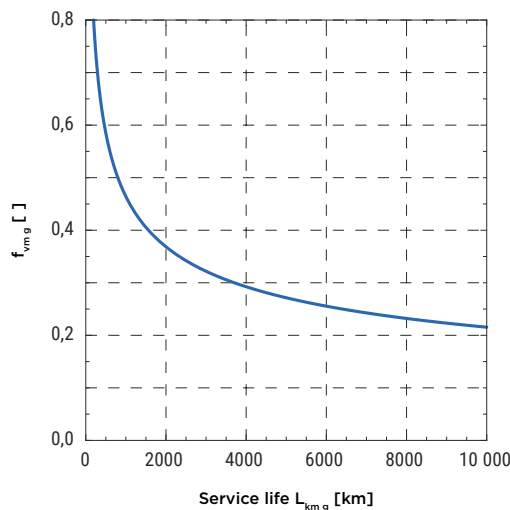

Mean load comparison factor f_{vmg}

$$f_{vmg} = \sqrt[3]{\frac{f_{v1g}^3 \cdot s_1 + f_{v2g}^3 \cdot s_2 + \dots + f_{vng}^3 \cdot s_n}{s_1 + s_2 + \dots + s_n}}$$

$f_{vi g}$	i-th load comparison factor of a given loading regime $f_{vg}(s)$, $i \in \{1, 2, \dots, n\}$
s_i	i-th travel path of a given loading regime $f_{vg}(s)$, $i \in \{1, 2, \dots, n\}$

Loading regime $f_{vg}(s)$

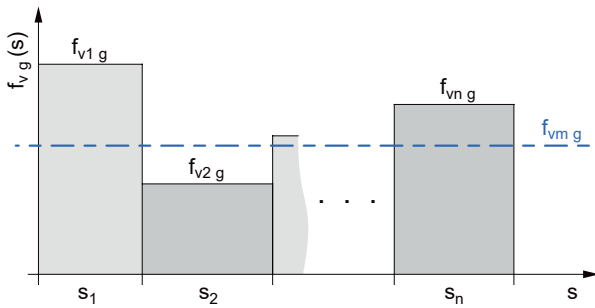

Load comparison factor f_{vg}

$$f_{vg} = \frac{|F_y|}{C} + \frac{|F_z|}{C} + \frac{|M_x|}{M_{dyn x}} + \frac{|M_y|}{M_{dyn y}} + \frac{|M_z|}{M_{dyn z}}$$

f_{vg}	Load comparison factor
----------	------------------------

Mean dynamic safety factor f_{smg}

The safety factor depends on the application and its requested safety. A minimum dynamic safety factor of 5,0 or more is recommended.

$$f_{smg} = \frac{1}{f_{vmg}}$$

f_{smg}	Mean dynamic safety factor
-----------	----------------------------

Ball screw drive

Valid for the mini electric cylinder MCE and the slider MSCE.

Permissible load

Permissible load factor $f_{p\ bs}$

A permissible load factor of the ball screw drive $f_{p\ bs}$ must never exceed the value of 1.

$$f_{p\ bs} = \frac{|F_x|}{F_{pa}} \leq 1$$

$f_{p\ bs}$	Permissible load factor
F_{pa}	Max. permissible axial load [N]
F_x	Applied force in the x direction [N]

Service life

Service life calculation

$$L_{km\ bs} = \left(\frac{1}{f_{vm\ bs}} \right)^3 \cdot l$$

$L_{km\ bs}$	Service life [km]
$f_{vm\ bs}$	Mean load comparison factor
l	Ball screw lead [mm]

Mean load comparison factor $f_{vm\ bs}$ as a function of service life $L_{km\ bs}$

Diagram represents the theoretically determined service life of the ball screw drive when the mean load comparison factor $f_{vm\ bs}$ is considered.

It should be noted that the application conditions may have a significant effect on the service life.

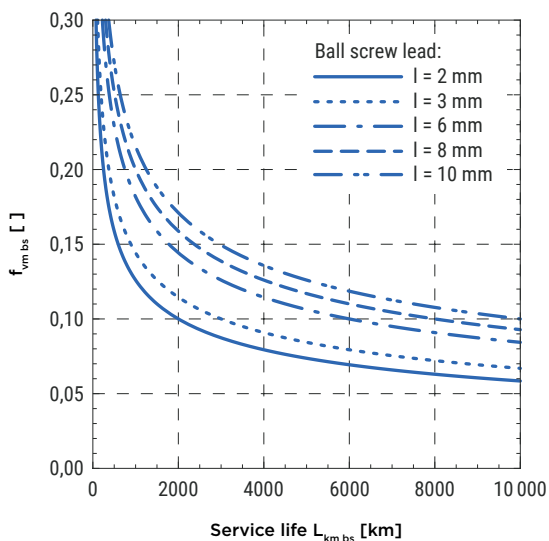

Mean load comparison factor $f_{vm\ bs}$

$$f_{vm\ bs} = \sqrt[3]{\frac{f_{v1\ bs}^3 \cdot s_1 + f_{v2\ bs}^3 \cdot s_2 + \dots + f_{vn\ bs}^3 \cdot s_n}{s_1 + s_2 + \dots + s_n}}$$

$f_{vi\ bs}$	i-th load comparison factor of a given loading regime $f_{v\ bs}(s)$, $i \in \{1, 2, \dots, n\}$
s_i	i-th travel path of a given loading regime $f_{v\ bs}(s)$, $i \in \{1, 2, \dots, n\}$

Loading regime $f_{v\ bs}(s)$

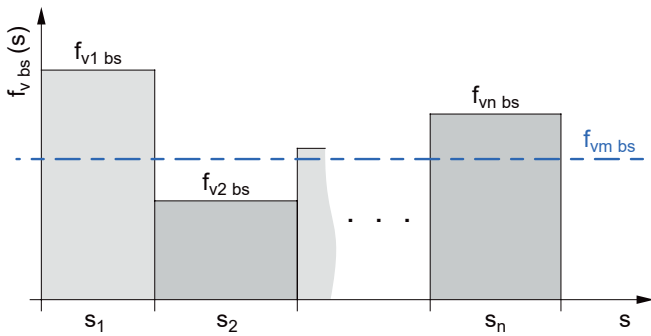

Load comparison factor $f_{v\ bs}$

$$f_{v\ bs} = \frac{|F_x|}{C_a}$$

$f_{v\ bs}$	Load comparison factor
C_a	Dynamic axial load capacity [N]

Mean dynamic safety factor $f_{sm\ bs}$

The safety factor depends on the application and its requested safety. A minimum dynamic safety factor of 5,0 or more is recommended.

$$f_{sm\ bs} = \frac{1}{f_{vm\ bs}}$$

$f_{sm\ bs}$	Mean dynamic safety factor
--------------	----------------------------

Mini electric cylinder MCE

Service life of the mini electric cylinder is the calculated service life of the ball screw drive $L_{km\ bs}$.

$$L_{km} = L_{km\ bs}$$

L_{km}	Service life of the mini electric cylinder or slider [km]
----------	---

Mini electric slider MSCE

Service life of the mini electric slider is the minimum value between the calculated service life of the linear guiding system $L_{km\ g}$ and the ball screw drive $L_{km\ bs}$.

$$L_{km} = \text{Min} [L_{km\ g}, L_{km\ bs}]$$

L_{km}	Service life of the mini electric cylinder or slider [km]
----------	---

Calculations

Load torque

The load torque is a function of an applied axial load (force) to the mini electric cylinder or slider and can be calculated as follows:

$$M_{load} = \frac{F_x \cdot l}{2000 \cdot \pi \cdot \eta}$$

M_{load}	Load torque [Nm]
F_x	Applied axial force [N]
l	Ball screw lead [mm]
η	Mechanical efficiency $\approx 0,9$

It should be noted that the load torque M_{load} must never exceed the maximum drive torque M_p (or $M_{p,MSD}$ if a motor side drive MSD is taken into consideration).

Rollco Products



COMPACT RAIL

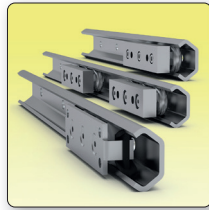

C-RAIL

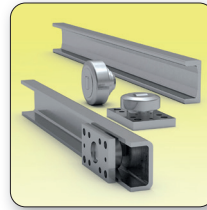

U-RAIL

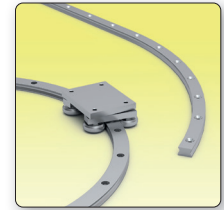

CURVI LINE

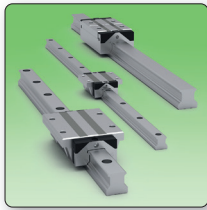

LINEAR RAIL
HRC/ARC/ERC

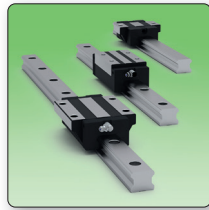

LINEAR RAIL SBI

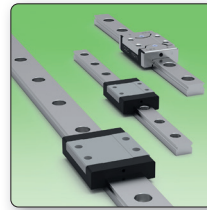

LINEAR MINIATURE
GUIDE

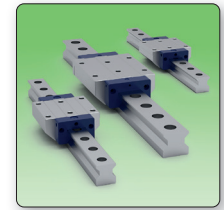

LINEAR ROLLER
GUIDE

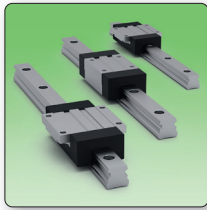

LINEAR RAIL
ALUMINIUM

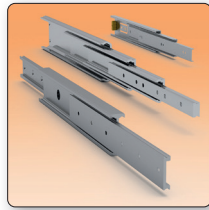

TELESCOPIC RAIL
LIGHT

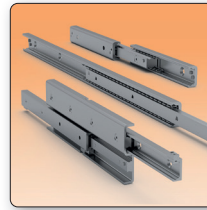

TELESCOPIC RAIL
HEAVY

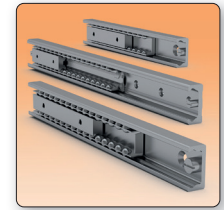

EASYSLIDE

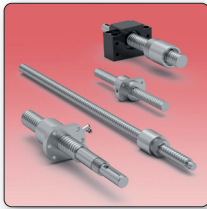

BALL SCREWS

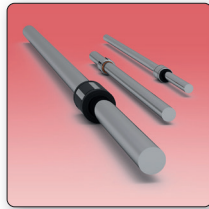

BALL BEARINGS
& STEEL SHAFTS

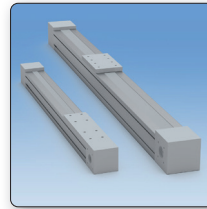

LINEAR UNIT RHL

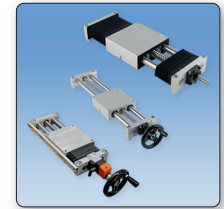

LINEAR UNIT QME

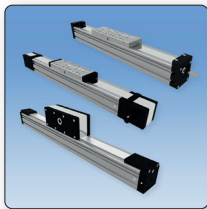

LINEAR UNITS CT & MT

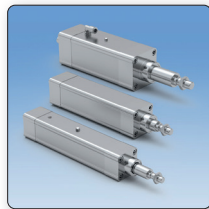

PNCE ELECTRO-
MECHANICAL CYLINDERS



MCE & MSCE MINI ELECTRIC
CYLINDERS & SLIDERS

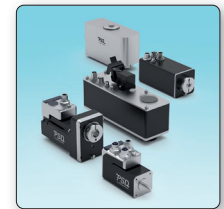

POSITIONING SYSTEMS

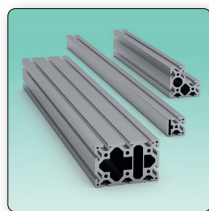

ALUMINIUM PROFILES



BELT CONVEYORS

**ALWAYS THE RIGHT
SOLUTION AT THE RIGHT TIME.**

ROLLCO

LINEAR SOLUTIONS **YOUR** WAY

With reliability, competence and commitment Rollco rapidly delivers the right solutions and components to create safe and cost-effective automation and linear movement.

Rollco AB
Box 22234
Ekvändan 3
250 24 Helsingborg
Sweden
Tel. +46 42 150040
www.rollco.se

Rollco A/S
Skomagervej 13 E
7100 Vejle
Denmark
Tel. +45 7552 2666
www.rollco.dk

Rollco Oy
Sarankulmankatu 12
33900 Tampere
Finland
Tel. +358 207 57 97 90
www.rollco.fi

Rollco Norge AS
Industrigata 6
3414 Lierstrada
Norway
Tel. +47 32 84 00 34
www.rollco.no

Rollco Taiwan
No. 28, Lane 125, Da-an Road
Shulin District 238
New Taipei City, Taiwan
Tel. +886-2-8687-2726
Fax +886-2-8687-2720
www.rollco-tw.com